



Compact Industrial Power Supplies

Single and Three Phase

DIN rail mountable

Short circuit protection

Internal input filter

Wide input voltage range

Power Factor Correction

Parallel operation/Redundant

High efficiency

Adjustable output voltage

RoHS compliant

Reaching new heights in automation

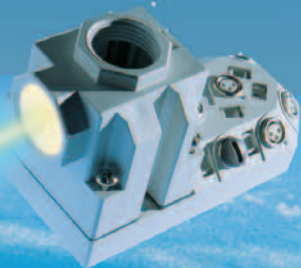

Contents:

- | | |
|--------------------------------|--------------|
| 1. Overview Power Supplies | page 4 |
| 2. Power Supplies | page 5 - 20 |
| 3. Current Control System LCCS | page 21 - 23 |

Welcome to the Lutze Group

Machine and System Installation Technology

1



LSC Wiring System

2

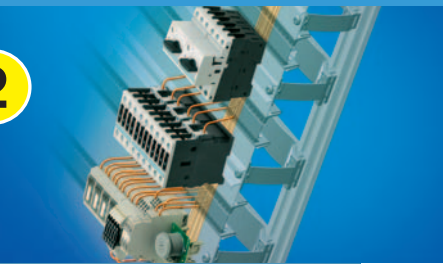

Suppression Technology, Interface, Conversion Technology and Power Supplies

3



Rail Technology and Automation

4



We have been developing and manufacturing electronic and electrical engineering solutions for controls and installations for more than 45 years.

Our basic concept as system suppliers, providing a comprehensive and well-matched product range with which we can generate innovative and customized solutions for our customers, has stood the test of time.

The close relationship between product development and customer requirements allows Lutze continuously to improve and develop our products for the various markets.

Lutze systems comply with the highest industrial standards; Lutze solutions mean improvement and innovation.

Our four product groups include components and concepts suitable for almost any control application. For more information on our products, please visit www.lutze.com.



Systematic Technology

Power Supplies • Overview



60W - 360W



10W - 18W



30W, 60W



120W



240W



480W, 960W

DC voltage supply, regulated

Rated power (W)		Input					Output (V)					Terminal			Part-No.	Type	Page								
10 W	15 W	18 W	30 W	50 W	60 W	120 W	240 W	480 W	960 W	AC 90-265 V	AC 170 - 364 V	AC 93 - 132 V/	AC 186 - 264 V	AC 3x340 - 576 V	5 V	12 V	15 V	24 V	48 V	Screw terminal pluggable	Screw terminal	Spring terminal			
•										•					2A					•			728761	DRA10-05A	5
•										•					0,84A					•			728766	DRA10-12A	5
•										•					2A						•		722761	DRA10-5	6
•										•					0,84A						•		722766	DRA10-12	6
•										•					0,67A						•		722773	DRA10-15	6
•										•					0,42A						•		722751	DRA10-24	6
	•									•					3A						•		722762	DRA18-5	7
	•									•					3A						•		728762	DRA18-5A	7
		•								•					1,5A						•		722767	DRA18-12	8
		•								•					1,2A						•		722774	DRA18-15	8
			•							•					0,75A						•		722752	DRA18-24	8
			•							•					6A						•		722763	DRA30-5A	9
				•						•					2,5A						•		722768	DRA30-12A	9
				•						•					1,25A						•		722753	DRA30-24A	9
				•						•					0,63A						•		722775	DRA30-48A	9
				•						•					6A						•		728763	DRA30-5	10
				•						•					2,5A						•		728768	DRA30-12	10
				•						•					1,25A						•		728753	DRA30-24	10
				•						•					0,63A						•		728775	DRA30-48	10
				•						•					2A	2A	2A				•		716213	NGP 24/2-6213	19
				•						•					10A						•		722764	DRA60-5A	11
				•						•					10A						•		728764	DRA60-5	11
				•						•					5A						•		728769	DRA60-12	12
				•						•					2,5A						•		728754	DRA60-24	12
				•						•					1,25A						•		728776	DRA60-48	12
				•						•					5A						•		722769	DRA60-12A	13
				•						•					2,5A						•		722754	DRA60-24A	13
				•						•					1,25A						•		722776	DRA60-48A	13
				•						•					10A						•		722770	DRA120-12FPB	14
				•						•					5A						•		722758	DRA120-24FPB	14
				•						•					2,5A						•		722777	DRA120-48FPB	14
				•						•					10A						•		722759	DRA240-24B	15
				•						•					5A						•		722778	DRA240-48B	15
				•						•					10A						•		722781	DRA240-24A	15
				•						•					20A						•		728782	DRA480-24	16
				•						•					20A						•		722782	DRA480-24	16
				•						•					10A						•		722779	DRA480-48	16
				•						•					20A						•		722805	WRA 480-24	17
				•						•					10A						•		722809	WRA 480-48	17
				•						•					40A						•		722806	WRA 960-24	18
				•						•					20A						•		722810	WRA 960-48	18

DC voltage supply, unregulated

Rated power (W)				Input			Output (V)					Terminal			Part-No.	Type	Page
60 W	120 W	240 W	360 W	AC 115 V (AC 104 - 196 V)	AC 230 V (AC 207 - 244 V)	AC 400 V (AC 360 - 424 V)	5 V	12 V	15 V	24 V	48 V	Screw terminal pluggable	Screw terminal	Spring terminal			
•				•	•	•					2,5A			•	722962	NG24/2,5-2962	20
	•			•	•	•					5A			•	722963	NG24/5-2963	20
		•		•	•	•					10A			•	722972	NG24/10-2972	20
			•	•	•	•					10A			•	722973	NG24/15-2973	20

Power supply · regulated, 10 W

Primary switchmode power supply, Single-phase, Class 2

Input: Wide range input AC 90 V - 265V; DC 120 V - 370 V

Output: 5 V / 12 V - adjustable



Dimensions

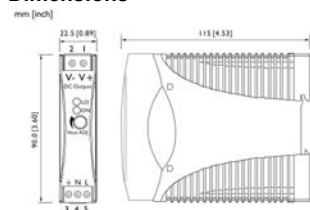

PIN assignment

- | | | |
|---|----|--|
| 1 | V+ | Positive output |
| 2 | V- | Negative output |
| 3 | ↓ | Ground this to minimize high-frequency emissions |
| 4 | N | Input |
| 5 | L | Input |

Derating

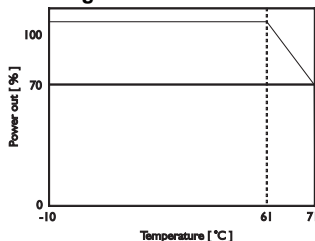

Parallel mode

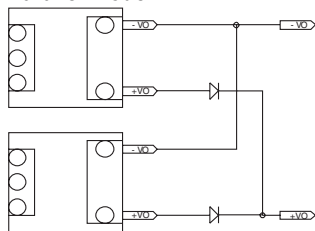

Description	Part-No.	Type	PU	
Screw terminal				
Output voltage/current	DC 5 V; 2 A	728761	DRA 10-05	1
	DC 12 V; 0.84 A	728766	DRA 10-12	1

Input	DRA 10-05	DRA 10-12
Voltage	AC 100–240 V	
Operation voltage range	AC 90–265 V / DC 120–370 V	
Line frequency	47 – 63 Hz	
Rated current	$V_{in}=115\text{ V}$; AC: 120 mA / $V_{in}=230\text{ V}$; AC: 70 mA	
Inrush current	$V_{in}=115\text{ V}$; AC: 10 A / $V_{in}=230\text{ V}$; AC: 18 mA	
Input fuse	T2A / AC 250 V internal	
Power Factor Correction P.F.C.	–	

Output	DRA 10-05	DRA 10-12
Rated voltage output	DC 5 V	DC 12 V
Rated current output	2 A	0.84 A
Voltage trim range	4.5–5.75 V	10.8–13.8 V
Accuracy	±1 %	
Line regulation	±1 %	
Load regulation	±2 %	
Transient recovery time	300 μs	
Temperature coefficient	±0.02 % / °C	
Ripple & Noise	50 mV	
Hold up time	$V_{in}=115\text{ V}$: 25 ms / $V_{in}=230\text{ V}$: 100 ms	

Status indication DC ON (LED green)	≥4.5 V	≥10.8 V
Status indication DC LOW (LED red)	<3.75–4.50 V	<9–10.8 V
Parallel mode	with external diodes	
Efficiency	73 %	75 %
Rated over load protection	110–135 %	
Over voltage protection	125–145 %	
Short circuit characteristics	Hiccup-mode	

General		
Switching frequency	min. 100 kHz	
Isolation voltage input/output	3 kVeff	
Isolation resistance at DC 500 V	100 M Ω	
Operation temperature range	–10°C – 70°C (Derating)	
Derating	–3% / °C starting at 61° C	
Storage temperature range	–25 °C – 85 °C	
M.T.B.F.	210000 h	
Relative humidity	20–95 % RH	
Dimensions	22.5 × 90.0 × 115.0 mm	
Cooling	Air convection	
Housing material	Plastic	
Field installation	rail TS 35 (EN 50022)	
Installation position	vertical	
IP rating	IP 20	
Protection class	2	
Weight (per unit)	0,12 kg/ 0.265 lbs	
Termination	Screw terminal: 0.2–2.0 mm ²	
Approvals	UL: UL 508 listed cUL: UL 60950-1, UL 1310 Class 2 TÜV: EN 60950-1 CE: EN 50081-1 / EN 55022 Class B, EN 6100-3-2, EN 601000-3-3, EN 50082-1 / EN 55024	

Monitoring	
DC ON Control (Rdy)	LED green/red
Switching voltage	–
Switching current	–
Switching capacity	–
Isolation voltage	–

Power supply - regulated, 10 W

Primary switchmode power supply, Single-phase, Class 2
Input: Wide range input AC 90 V - 265 V; DC 120 V - 370 V
Output: 5 V / 12 V / 15 V / 24 V - adjustable



Dimensions

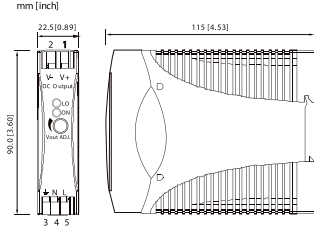

PIN assignment

1	V+	Positive output
2	V-	Negative output
3	↓	Ground this to minimize high-frequency emissions
4	N	Input
5	L	Input

Derating

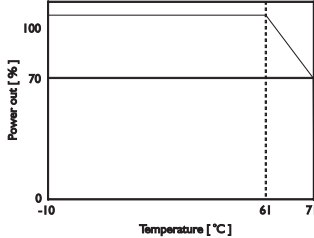

Parallel mode

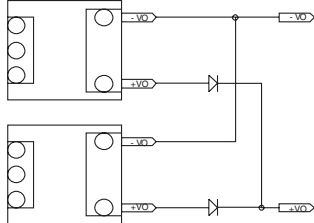

Description	Part-No.	Type	PU	
Spring terminal				
Output voltage/current	DC 5 V; 2 A	722761	DRA 10-05	1
	DC 12 V; 0.84 A	722766	DRA 10-12	1
	DC 15 V; 0.67 A	722773	DRA 10-15	1
	DC 24 V; 0.42 A	722751	DRA 10-24	1

Input	DRA 10-05	DRA 10-12	DRA 10-15	DRA 10-24
Voltage	AC 100–240 V			
Operation voltage range	AC 90–265 V / DC 120–370 V			
Line frequency	47 – 63 Hz			
Rated current	$V_{in}=115\text{ V}$; AC: 120 mA / $V_{in}=230\text{ V}$; AC: 70 mA			
Inrush current	$V_{in}=115\text{ V}$; AC: 10 A / $V_{in}=230\text{ V}$; AC: 18 mA			
Input fuse	T2A / AC 250 V internal			
Power Factor Correction P.F.C.	-			

Output	DRA 10-05	DRA 10-12	DRA 10-15	DRA 10-24
Rated voltage output	DC 5 V	DC 12 V	DC 15 V	DC 24 V
Rated current output	2 A	0.84 A	0.67 A	0.42 A
Voltage trim range	4.5–5.75 V	10.8–13.8 V	13.5–17.25 V	21.6–28.8 V
Accuracy	±1 %			
Line regulation	±1 %			
Load regulation	±2 %			
Transient recovery time	300 μs			
Temperature coefficient	±0.02 % / °C			
Ripple & Noise	50 mV			
Hold up time	$V_{in}=115\text{ V}$: 25 ms / $V_{in}=230\text{ V}$: 100 ms			

Status indication DC ON (LED green)	≥4.5 V	≥10.8 V	≥13.5 V	≥21.6 V
Status indication DC LOW (LED red)	<3.75–4.50 V	<9–10.8 V	<11.25–13.5 V	<18–21.6 V
Parallel mode	with external diodes			
Efficiency	73 %	75 %	76 %	77 %
Rated over load protection	110–135 %			
Over voltage protection	125–145 %			
Short circuit characteristics	Hiccup-mode			

General	
Switching frequency	min. 100 kHz
Isolation voltage input/output	3 kVeff
Isolation resistance at DC 500 V	100 MΩ
Operation temperature range	-10°C – 70°C (Derating)
Derating	-3% / °C starting at 61° C
Storage temperature range	-25°C – 85°C
M.T.B.F.	210000 h
Relative humidity	20–95 % RH

Dimensions	22.5 × 90.0 × 115.0 mm
Cooling	Air convection
Housing material	Plastic
Field installation	rail TS 35 (EN 50022)
Installation position	vertical
IP rating	IP 20
Protection class	2
Weight (per unit)	0,12 kg/ 0.265 lbs
Termination	Spring terminal: 0.2–2.0 mm ²
Approvals	UL: UL 508 listed cUL: UL 60950-1, UL 1310 Class 2 TÜV: EN 60950-1 CE: EN 50081-1 / EN 55022 Class B, EN 61000-3-2, EN 601000-3-3, EN 50082-1 / EN 55024

Monitoring	
DC ON Control (Rdy)	LED green/red
Switching voltage	-
Switching current	-
Switching capacity	-
Isolation voltage	-

Power supply · regulated, 15 W

Primary switchmode power supply, Single-phase, Class 2
Input: Wide range input AC 90 V - 265 V; DC 120 V - 370 V
Output: 5 V - adjustable



Dimensions

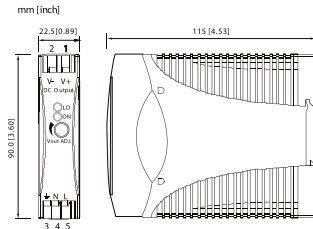

PIN assignment

1	V+	Positive output
2	V-	Negative output
3	↓	Ground this to minimize high-frequency emissions
4	N	Input
5	L	Input

Derating

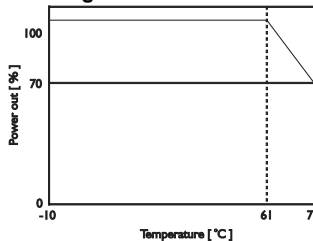

Parallel mode

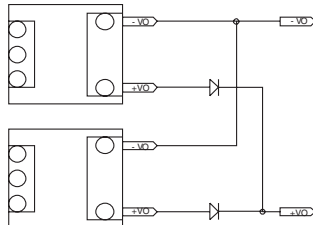

Description	Part-No.	Type	PU	
Screw terminal				
Output voltage/current	DC 5 V; 3 A	728762	DRA 18-05A	1
Spring terminal				
Output voltage/current	DC 5 V; 3 A	722762	DRA 18-05	1
Input				
		DRA 18-05A	DRA 18-05	
Voltage	AC 100–240 V			
Operation voltage range	AC 90–265 V / DC 120–370 V			
Line frequency	47 – 63 Hz			
Rated current	V _{in} = 115 V; AC: 170 mA / V _{in} = 230 V; AC: 90 mA			
Inrush current	V _{in} = 115 V; AC: 10 A / V _{in} = 230 V; AC: 18 mA			
Input fuse	T2A / AC 250 V internal			
Power Factor Correction P.F.C.	–			
Output				
Rated voltage output	DC 5 V			
Rated current output	3 A			
Voltage trim range	4.5–5.75 V			
Accuracy	±1 %			
Line regulation	±1 %			
Load regulation	±2 %			
Transient recovery time	300 µs			
Temperature coefficient	±0.02 % / °C			
Ripple & Noise	50 mV			
Hold up time	V _{in} = 115 V: 25 ms / V _{in} = 230 V: 75 ms			
Status indication DC ON (LED green)	≥4.5 V			
Status indication DC LOW (LED red)	<3.75–4.50 V			
Parallel mode	with external diodes			
Efficiency	77 %			
Rated over load protection	110–135 %			
Over voltage protection	125–145 %			
Short circuit characteristics	Hiccup-mode			
General				
Switching frequency	min. 100 kHz			
Isolation voltage input/output	3 kVeff			
Isolation resistance at DC 500 V	100 MΩ			
Operation temperature range	-10°C – 70°C (Derating)			
Derating	-3% / °C starting at 61 °C			
Storage temperature range	-25 °C – 85 °C			
M.T.B.F.	210000 h			
Relative humidity	20–95 % RH			
Dimensions	22.5 × 90.0 × 115.0 mm			
Cooling	Air convection			
Housing material	Plastic			
Field installation	rail TS 35 (EN 50022)			
Installation position	vertical			
IP rating	IP 20			
Protection class	2			
Weight (per unit)	0,15 kg/ 0.331 lbs			
Termination	Screw terminal: 0.2–2.0 mm ²		Spring terminal: 0.2–2.0 mm ²	
Approvals	UL: UL 508 listed cUL: UL 60950-1, UL 1310 Class 2 TÜV: EN 60950-1 CE: EN 50081-1 / EN 55022 Class B, EN 6100-3-2, EN 601000-3-3, EN 50082-1 / EN 55024			
Monitoring				
DC ON Control (Rdy)	LED green/red			
Switching voltage	–			
Switching current	–			
Switching capacity	–			
Isolation voltage	–			

Power supply · regulated, 18 W

Primary switchmode power supply, Single-phase, Class 2
Input: Wide range input AC 90 V - 265 V; DC 120 V - 370 V
Output: 12 V / 15 V / 24 V - adjustable



Dimensions

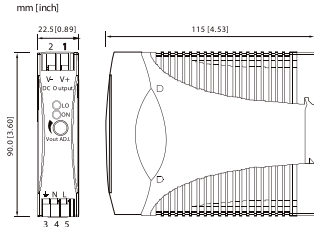

PIN assignment

1	V+	Positive output
2	V-	Negative output
3	↓	Ground this to minimize high-frequency emissions
4	N	Input
5	L	Input

Derating

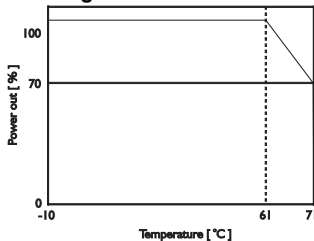

Parallel mode

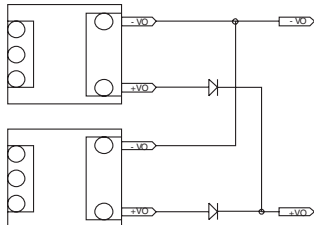

Description	Part-No.	Type	PU	
Spring terminal				
Output voltage/current	DC 12 V; 1.5 A	722767	DRA 18-12	1
	DC 15 V; 1.2 A	722774	DRA 18-15	1
	DC 24 V; 0.75 A	722752	DRA 18-24	1
Input				
	DRA 18-12	DRA 18-15	DRA 18-24	
Voltage	AC 100–240 V			
Operation voltage range	AC 90–265 V / DC 120–370 V			
Line frequency	47 – 63 Hz			
Rated current	V _{in} = 115 V; AC: 200 mA / V _{in} = 230 V; AC: 110 mA			
Inrush current	V _{in} = 115 V; AC: 10 A / V _{in} = 230 V; AC: 18 mA			
Input fuse	T2A / AC 250 V internal			
Power Factor Correction P.F.C.	–			
Output				
Rated voltage output	DC 12 V	DC 15 V	DC 24 V	
Rated current output	1.5 A	1.2 A	0.75 A	
Voltage trim range	10.8–13.8 V	13.5–17.25 V	21.6–28.8 V	
Accuracy	±1 %			
Line regulation	±1 %			
Load regulation	±2 %			
Transient recovery time	300 µs			
Temperature coefficient	±0.02 % / °C			
Ripple & Noise	50 mV			
Hold up time	V _{in} = 115 V: 25 ms / V _{in} = 230 V: 75 ms			
Status indication DC ON (LED green)	≥10.8 V	≥13.5 V	≥21.6 V	
Status indication DC LOW (LED red)	<9–10.8 V	<11.25–13.5 V	<18–21.6 V	
Parallel mode	with external diodes			
Efficiency	77 %			
Rated over load protection	110–135 %			
Over voltage protection	125–145 %			
Short circuit characteristics	Hiccup-mode			
General				
Switching frequency	min. 100 kHz			
Isolation voltage input/output	3 kVeff			
Isolation resistance at DC 500 V	100 MΩ			
Operation temperature range	–10°C – 70°C (Derating)			
Derating	–3% / °C starting at 61 °C			
Storage temperature range	–25 °C – 85 °C			
M.T.B.F.	210000 h			
Relative humidity	20–95 % RH			
Dimensions	22.5 × 90.0 × 115.0 mm			
Cooling	Air convection			
Housing material	Plastic			
Field installation	rail TS 35 (EN 50022)			
Installation position	vertical			
IP rating	IP 20			
Protection class	2			
Weight (per unit)	0.15 kg/ 0.331 lbs			
Termination	Spring terminal: 0.2–2.0 mm ²			
Approvals	UL: UL 508 listed cUL: UL 60950-1, UL 1310 Class 2 TÜV: EN 60950-1 CE: EN 50081-1 / EN 55022 Class B, EN 6100-3-2, EN 601000-3-3, EN 50082-1 / EN 55024			
Monitoring				
DC ON Control (Rdy)	LED green/red			
Switching voltage	–			
Switching current	–			
Switching capacity	–			
Isolation voltage	–			

Power supply · regulated, 30 W

Primary switchmode power supply, Single-phase, Class 2
Input: Wide range input AC 85 V - 264 V; DC 90 V - 375 V
Output: 5 V / 12 V / 24 V / 48 V - adjustable



Dimensions

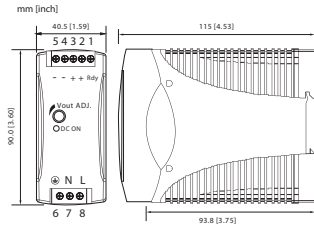

PIN assignment

- | | | |
|---|-----|--|
| 1 | RDY | DC OK output for relay |
| 2 | + | Positive output |
| 3 | + | Positive output |
| 4 | - | Negative output |
| 5 | - | Negative output |
| 6 | ↓ | Ground this to minimize high-frequency emissions |
| 7 | N | Input: neutral conductor |
| 8 | L | Input: phase conductor |

Derating

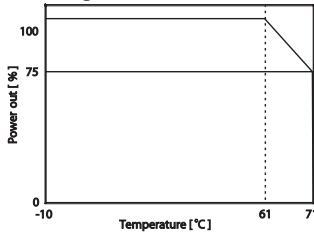

Parallel mode

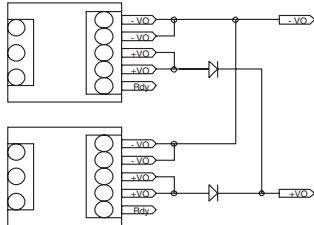

Description	Part-No.	Type	PU	
Screw terminal				
Output voltage/current	DC 5 V; 6 A	722763	DRA 30-05	1
	DC 12 V; 2.5 A	722768	DRA 30-12	1
	DC 24 V; 1.25 A	722753	DRA 30-24	1
	DC 48 V; 0.625 A	722775	DRA 30-48	1

Input	DRA 30-05	DRA 30-12	DRA 30-24	DRA 30-48
Voltage	AC 100–240 V			
Operation voltage range	AC 85–264 V / DC 90–375 V			
Line frequency	47 – 63 Hz			
Rated current	$V_{in}=115\text{ V}$; AC: 360 mA / $V_{in}=230\text{ V}$; AC: 190 mA			
Inrush current	$V_{in}=115\text{ V}$; AC: 20 A / $V_{in}=230\text{ V}$; AC: 40 mA			
Input fuse	T2A / AC 250 V internal			
Power Factor Correction P.F.C.	-			

Output	DRA 30-05	DRA 30-12	DRA 30-24	DRA 30-48
Rated voltage output	DC 5 V	DC 12 V	DC 24 V	DC 48 V
Rated current output	6 A	2.5 A	1.25 A	0.625 A
Voltage trim range	5–5.5 V	12–14 V	24–28 V	48–55 V
Accuracy	±1 %			
Line regulation	±0.5 %			
Load regulation	±0.5 %			
Transient recovery time	1.0 ms			
Temperature coefficient	±0.02 % / °C			
Ripple & Noise	50 mV			
Hold up time	$V_{in}=115\text{ V}$: 20 ms / $V_{in}=230\text{ V}$: 30 ms			

Status indication DC ON (LED green)	≥4 V	≥9.6 V	≥19.2 V	≥37 V
Status indication DC LOW (LED red)	-			
Parallel mode	with external diodes			
Efficiency	79 %	84 %	86 %	
Rated over load protection	120 – 136 %		110 – 140 %	
Over voltage protection	125–137 %			
Short circuit characteristics	Hiccup-mode			

General				
Switching frequency	min. 100 kHz			
Isolation voltage input/output	3 kVeff			
Isolation resistance at DC 500 V	100 MΩ			
Operation temperature range	-10°C – 70°C (Derating)			
Derating	-2.5% / °C starting at 61 °C			
Storage temperature range	-25 °C – 85 °C			
M.T.B.F.	210000 h			
Relative humidity	20–90% RH			
Dimensions	40.5 × 90.0 × 115.0 mm			
Cooling	Air convection			
Housing material	Plastic			
Field installation	rail TS 35 (EN 50022)			
Installation position	vertical			
IP rating	IP 20			
Protection class	-	2		
Weight (per unit)	0,29 kg/ 0.639 lbs			
Termination	Screw terminal: 0.2–2.0 mm ²			
Approvals	UL: UL 508 listed; cUL: UL 60950-1, UL 1310 Class 2; TÜV: EN 60950-1; CE: EN 61000-6-3 / EN 55022 Class B, EN 61000-3-2, EN 601000-3-3, EN 55024, EN 61000-6-2, EN 61000-4-2, EN 61000-4-3, EN 61000-4-4, EN 61000-4-5, EN 61000-4-6, EN 61000-4-8, EN 61000-4-11			

Monitoring				
DC ON Control (Rdy)	-	Open Collector		-
Switching voltage	-	DC 24 V		-
Switching current	-	≤ 35 mA		-
Switching capacity	-	-		-
Isolation voltage	-	none		-

Power supply · regulated, 30 W

Primary switchmode power supply, Single-phase, Class 2
Input: Wide range input AC 85 V - 264 V; DC 90 V - 375 V
Output: 5 V / 12 V / 24 V / 48 V - adjustable



Dimensions

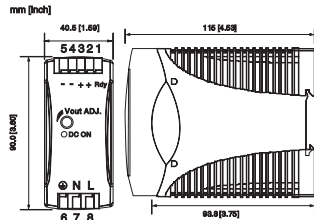

PIN assignment

1	RDY	DC OK output for relay
2	+	Positive output
3	+	Positive output
4	-	Negative output
5	-	Negative output
6	↓	Ground this to minimize high-frequency emissions
7	N	Input: neutral conductor
8	L	Input: phase conductor

Derating

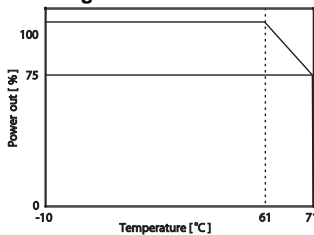

Parallel mode

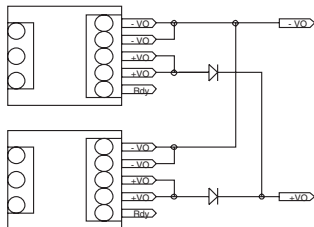

Description	Part-No.	Type	PU	
Spring terminal				
Output voltage/current	DC 5 V; 6 A	728763	DRA 30-05	1
	DC 12 V; 2.5 A	728768	DRA 30-12	1
	DC 24 V; 1.25 A	728753	DRA 30-24	1
	DC 48 V; 0.625 A	728775	DRA 30-48	1

Input	DRA 30-05	DRA 30-12	DRA 30-24	DRA 30-48
Voltage	AC 100–240 V			
Operation voltage range	AC 85–264 V / DC 90–375 V			
Line frequency	47 – 63 Hz			
Rated current	$V_{in}=115\text{ V}$; AC: 360 mA / $V_{in}=230\text{ V}$; AC: 190 mA			
Inrush current	$V_{in}=115\text{ V}$; AC: 20 A / $V_{in}=230\text{ V}$; AC: 40 mA			
Input fuse	T2A / AC 250 V internal			
Power Factor Correction P.F.C.	-			

Output	DRA 30-05	DRA 30-12	DRA 30-24	DRA 30-48
Rated voltage output	DC 5 V	DC 12 V	DC 24 V	DC 48 V
Rated current output	6 A	2.5 A	1.25 A	0.625 A
Voltage trim range	5–5.5 V	12–14 V	24–28 V	48–55 V
Accuracy	±1 %			
Line regulation	±0.5 %			
Load regulation	±0.5 %			
Transient recovery time	1.0 ms			
Temperature coefficient	±0.02 % / °C			
Ripple & Noise	50 mV			
Hold up time	$V_{in}=115\text{ V}$: 20 ms / $V_{in}=230\text{ V}$: 30 ms			

Status indication DC ON (LED green)	≥4 V	≥9.6 V	≥19.2 V	≥37 V
Status indication DC LOW (LED red)	-			
Parallel mode	with external diodes			
Efficiency	79 %	84 %	86 %	
Rated over load protection	110–140 %			
Over voltage protection	120–136 %	125–137 %		
Short circuit characteristics	Hiccup-mode			

General				
Switching frequency	min. 100 kHz			
Isolation voltage input/output	3 kVeff			
Isolation resistance at DC 500 V	100 MΩ			
Operation temperature range	-10°C – 70°C (Derating)			
Derating	-2.5% / °C starting at 61 °C			
Storage temperature range	-25 °C – 85 °C			
M.T.B.F.	210000 h			
Relative humidity	20–90% RH			
Dimensions	40.5 × 90.0 × 115.0 mm			
Cooling	Air convection			
Housing material	Plastic			
Field installation	rail TS 35 (EN 50022)			
Installation position	vertical			
IP rating	IP 20			
Protection class	-	2		
Weight (per unit)	0,29 kg/ 0.639 lbs			
Termination	Spring terminal: 0.2–2.0 mm ²			
Approvals	UL: UL 508 listed; cUL: UL 60950-1; TÜV: EN 60950-1; CE: EN 61000-6-3 / EN 55022 Class B, EN 6100-3-2, EN 601000-3-3, EN 55024, EN 61000-6-2, EN 61000-4-2, EN 61000-4-3, EN 61000-4-4, EN 61000-4-5, EN 6100-4-6, EN 61000-4-8, EN 61000-4-11			

Monitoring				
DC ON Control (Rdy)	-	Open Collector		-
Switching voltage	-	DC 24 V		-
Switching current	-	≤ 35 mA		-
Switching capacity	-	-		-
Isolation voltage	-	none		-

Power supply · regulated, 50 W

Primary switchmode power supply, Single-phase
Input: Wide range input AC 85 V - 264 V; DC 90 V - 375 V
Output: 5 V - adjustable



Dimensions

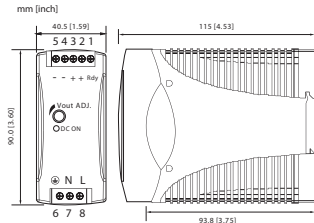

PIN assignment

1	RDY	DC OK output for relay
2	+	Positive output
3	+	Positive output
4	-	Negative output
5	-	Negative output
6	↓	Ground this to minimize high-frequency emissions
7	N	Input: neutral conductor
8	L	Input: phase conductor

Derating

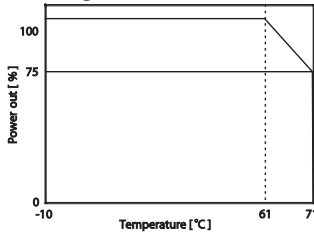

Parallel mode

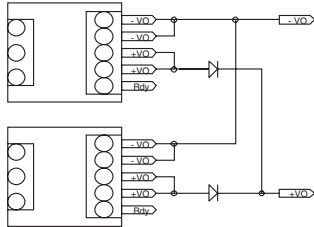

Description	Part-No.	Type	PU	
Screw terminal				
Output voltage/current	DC 5 V; 10 A	722764	DRA 60-05	1
Spring terminal				
Output voltage/current	DC 5 V; 10 A	728764	DRA 60-05A	1
Input				
		DRA 60-05	DRA 60-05A	
Voltage	-			
Operation voltage range	AC 85–264 V / DC 90–375 V			
Line frequency	47 – 63 Hz			
Rated current	V _{in} = 115 V; AC: 550 mA / V _{in} = 230 V; AC: 280 mA			
Inrush current	V _{in} = 115 V; AC: 30 A / V _{in} = 230 V; AC: 60 mA			
Input fuse	T2A / AC 250 V internal			
Power Factor Correction P.F.C.	-			
Output				
Rated voltage output	DC 5 V			
Rated current output	10 A			
Voltage trim range	5–5.5 V			
Accuracy	±1 %			
Line regulation	±0.5 %			
Load regulation	±0.5 %			
Transient recovery time	1.0 ms			
Temperature coefficient	±0.02 % / °C			
Ripple & Noise	50 mV			
Hold up time	V _{in} = 115 V: 20 ms / V _{in} = 230 V: 30 ms			
Status indication DC ON (LED green)	≥4 V			
Status indication DC LOW (LED red)	-			
Parallel mode	with external diodes			
Efficiency	79 %			
Rated over load protection	110–150 %			
Over voltage protection	120–136 %			
Short circuit characteristics	Hiccup-mode			
General				
Switching frequency	min. 100 kHz			
Isolation voltage input/output	3 kVeff			
Isolation resistance at DC 500 V	100 MΩ			
Operation temperature range	-10°C – 70°C (Derating)			
Derating	-2.5% / °C starting at 61 °C			
Storage temperature range	-25 °C – 85 °C			
M.T.B.F.	210000 h			
Relative humidity	20–90% RH			
Dimensions	40.5 × 90.0 × 115.0 mm	0.0 × 90.0 × 115.0 mm		
Cooling	Air convection			
Housing material	Plastic			
Field installation	rail TS 35 (EN 50022)			
Installation position	vertical			
IP rating	IP 20			
Protection class	-			
Weight (per unit)	0,36 kg/ 0.794 lbs			
Termination	Screw terminal 0.2–2.0 mm ²		Spring terminal 0.2–2.0 mm ²	
Approvals	UL: UL 508 listed; cUL: UL 60950-1; TÜV: EN 60950-1; CE: EN 61000-6-3 / EN 55022 Class B, EN 6100-3-2, EN 601000-3-4, EN 55024, EN 61000-6-2, EN 61000-4-2, EN 61000-4-3, EN 61000-4-4, EN 61000-4-5, EN 61000-4-6, EN 61000-4-8, EN 61000-4-11			
Monitoring				
DC ON Control (Rdy)	-			
Switching voltage	-			
Switching current	-			
Switching capacity	-			
Isolation voltage	-			

Power supply · regulated, 60 W

Primary switchmode power supply, Single-phase, Class 2
Input: Wide range input AC 85 V - 264 V; DC 90 V - 375 V
Output: 12 V / 24 V / 48 V - adjustable



Dimensions

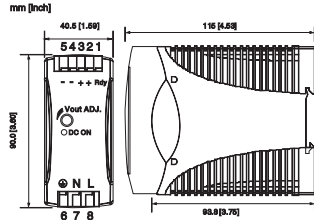

PIN assignment

1	RDY	DC OK output for relay
2	+	Positive output
3	+	Positive output
4	-	Negative output
5	-	Negative output
6	↓	Ground this to minimize high-frequency emissions
7	N	Input: neutral conductor
8	L	Input: phase conductor

Derating

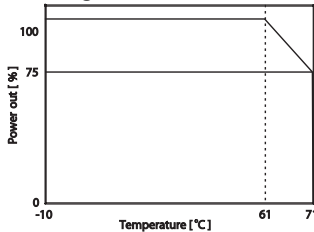

Parallel mode

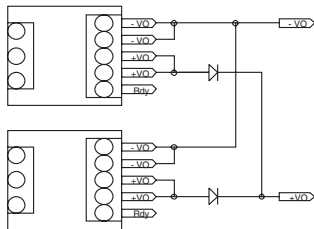

Description	Part-No.	Type	PU	
Spring terminal				
Output voltage/current	DC 12 V; 5 A	728769	DRA 60-12	1
	DC 24 V; 2.5 A	728754	DRA 60-24	1
	DC 48 V; 1.25 A	728776	DRA 60-48	1
Input				
	DRA 60-12	DRA 60-24	DRA 60-48	
Voltage	AC 100–240 V			
Operation voltage range	AC 85–264 V / DC 90–375 V			
Line frequency	47 – 63 Hz			
Rated current	V _{in} = 115 V; AC: 690 mA / V _{in} = 230 V; AC: 360 mA			
Inrush current	V _{in} = 115 V; AC: 30 A / V _{in} = 230 V; AC: 60 mA			
Input fuse	T2A / AC 250 V internal			
Power Factor Correction P.F.C.	–			
Output				
Rated voltage output	DC 12 V	DC 24 V	DC 48 V	
Rated current output	5 A	2.5 A	1.25 A	
Voltage trim range	12–14 V	24–28 V	48–55 V	
Accuracy	±1 %			
Line regulation	±0.5 %			
Load regulation	±0.5 %			
Transient recovery time	1.0 ms			
Temperature coefficient	±0.02 % / °C			
Ripple & Noise	50 mV			
Hold up time	V _{in} = 115 V: 20 ms / V _{in} = 230 V: 30 ms			
Status indication DC ON (LED green)	≥9.6 V	≥19.2 V	≥37 V	
Status indication DC LOW (LED red)	–			
Parallel mode	with external diodes			
Efficiency	86 %	89 %	89 %	
Rated over load protection	110–150 %			
Over voltage protection	125–138 %			
Short circuit characteristics	Hiccup-mode			
General				
Switching frequency	min. 100 kHz			
Isolation voltage input/output	3 kVeff			
Isolation resistance at DC 500 V	100 MΩ			
Operation temperature range	–10°C – 70°C (Derating)			
Derating	–2.5% / °C starting at 61 °C			
Storage temperature range	–25 °C – 85 °C			
M.T.B.F.	210000 h			
Relative humidity	20–90% RH			
Dimensions	40.5 × 90.0 × 115.0 mm			
Cooling	Air convection			
Housing material	Plastic			
Field installation	rail TS 35 (EN 50022)			
Installation position	vertical			
IP rating	IP 20			
Protection class	–	2		
Weight (per unit)	0,36 kg/ 0.794 lbs			
Termination	Spring terminal 0.2–2.0 mm ²			
Approvals	UL: UL 508 listed; cUL: UL 60950-1, UL 1310 Class 2; TÜV: EN 60950-1; CE: EN 61000-6-3 / EN 55022 Class B, EN 6100-3-2, EN 601000-3-3, EN 55024, EN 61000-6-2, EN 61000-4-2, EN 61000-4-3, EN 61000-4-4, EN 61000-4-5, EN 6100-4-6, EN 61000-4-8, EN 61000-4-11			
Monitoring				
DC ON Control (Rdy)	–	Open Collector	–	
Switching voltage	–	DC 24 V	–	
Switching current	–	≤ 35 mA	–	
Switching capacity	–	–	–	
Isolation voltage	–	none	–	

Power supply · regulated, 60 W

Primary switchmode power supply, Single-phase, Class 2
Input: Wide range input AC 85 V - 264 V; DC 90 V - 375 V
Output: 12 V / 24 V / 48 V - adjustable



Dimensions

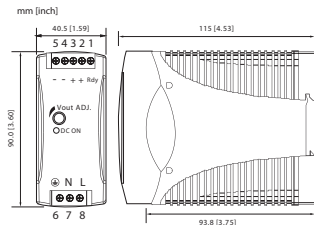

PIN assignment

1	RDY	DC OK output for relay
2	+	Positive output
3	+	Positive output
4	-	Negative output
5	-	Negative output
6	↓	Ground this to minimize high-frequency emissions
7	N	Input: neutral conductor
8	L	Input: phase conductor

Derating

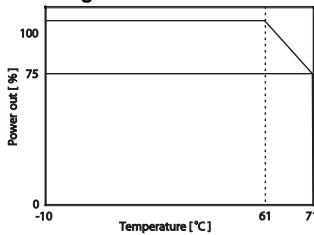

Parallel mode

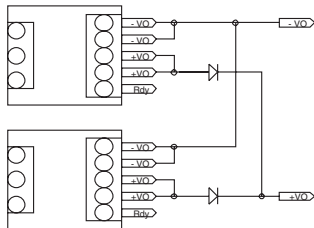

Description	Part-No.	Type	PU	
Screw terminal				
Output voltage/current	DC 12 V; 5 A	722769	DRA 60-12	1
	DC 24 V; 2.5 A	722754	DRA 60-24	1
	DC 48 V; 1.25 A	722776	DRA 60-48	1

Input	DRA 60-12	DRA 60-24	DRA 60-48
Voltage	AC 100–240 V		
Operation voltage range	AC 85–264 V / DC 90–375 V		
Line frequency	47 – 63 Hz		
Rated current	V _{in} = 115 V; AC: 690 mA / V _{in} = 230 V; AC: 360 mA		
Inrush current	V _{in} = 115 V; AC: 30 A / V _{in} = 230 V; AC: 60 mA		
Input fuse	T2A / AC 250 V internal		
Power Factor Correction P.F.C.	–		

Output	DRA 60-12	DRA 60-24	DRA 60-48
Rated voltage output	DC 12 V	DC 24 V	DC 48 V
Rated current output	5 A	2.5 A	1.25 A
Voltage trim range	12–14 V	24–28 V	48–55 V
Accuracy	±1 %		
Line regulation	±0.5 %		
Load regulation	±0.5 %		
Transient recovery time	1.0 ms		
Temperature coefficient	±0.02 % / °C		
Ripple & Noise	50 mV		
Hold up time	V _{in} = 115 V: 20 ms / V _{in} = 230 V: 30 ms		
Status indication DC ON (LED green)	≥9.6 V	≥19.2 V	≥37 V
Status indication DC LOW (LED red)	–		

Parallel mode	with external diodes		
Efficiency	86 %		89 %
Rated over load protection	110–150 %		
Over voltage protection	125–138 %		
Short circuit characteristics	Hiccup-mode		

General			
Switching frequency	min. 100 kHz		
Isolation voltage input/output	3 kVeff		
Isolation resistance at DC 500 V	100 MΩ		
Operation temperature range	-10°C – 70°C (Derating)		
Derating	-2.5% / °C starting at 61 °C		
Storage temperature range	-25 °C – 85 °C		
M.T.B.F.	210000 h		
Relative humidity	20–90% RH		
Dimensions	40.5 × 90.0 × 115.0 mm		
Cooling	Air convection		
Housing material	Plastic		
Field installation	rail TS 35 (EN 50022)		
Installation position	vertical		
IP rating	IP 20		
Protection class	–		2
Weight (per unit)	0,36 kg/ 0.794 lbs		
Termination	Screw terminal: 0.2–2.0 mm ²		
Approvals	UL: UL 508 listed; cUL: UL 60950-1, UL 1310 Class 2; TÜV: EN 60950-1; CE: EN 61000-6-3 / EN 55022 Class B, EN 6100-3-2, EN 601000-3-3, EN 55024, EN 61000-6-2, EN 61000-4-2, EN 61000-4-3, EN 61000-4-4, EN 61000-4-5, EN 6100-4-6, EN 61000-4-8, EN 61000-4-11		

Monitoring			
DC ON Control (Rdy)	–	Open Collector	–
Switching voltage	–	DC 24 V	–
Switching current	–	≤ 35 mA	–
Switching capacity	–	–	–
Isolation voltage	–	none	–

Power supply · regulated, 120 W

Primary switchmode power supply, PFC, Single-phase, screw terminal - pluggable
Input: Wide range input AC 93 - 132 V; DC 186 - 264 V, DC 210 - 370 V - adjustable
Output: 12 V / 24 V / 48 V - adjustable



Dimensions

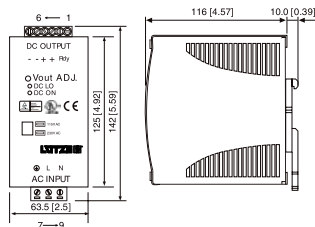

PIN assignment

Pin	Symbol	Description
1	RDY	Normal open relay contact for DC ON level control
2		
3	V+	Positive output
4	V+	Positive output
5	V-	Negative output
6	V-	Negative output
7	↓	Ground this to minimize high-frequency emissions
8	L	Input: phase conductor
9	N	Input: neutral conductor

Derating

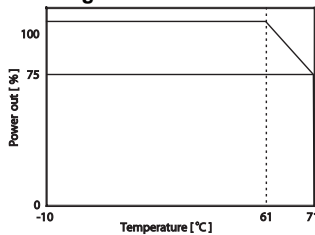

Parallel mode

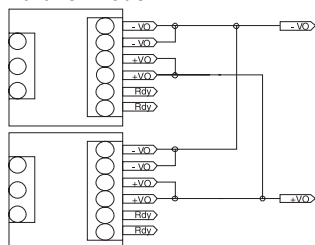

Description	Part-No.	Type	PU	
Screw terminal				
Output voltage/current	DC 12 V; 10 A	722770	DRA 120-12	1
	DC 24 V; 5 A	722758	DRA 120-24	1
	DC 48 V; 2.5 A	722777	DRA 120-48	1
Input				
Voltage	DRA 120-12	DRA 120-24	DRA 120-48	
	AC 115 / 230 V (manual switch)			
Operation voltage range	AC 93–132 V; AC 186–264 V / DC 210–370 V			
Line frequency	47 – 63 Hz			
Rated current	V _{in} = 115 V; AC: 1.25 A / V _{in} = 230 V; AC: 0.63 A			
Inrush current	V _{in} = 115 V; AC: 24 A / V _{in} = 230 V; AC: 48 mA			
Input fuse	T2A / AC 250 V internal			
Power Factor Correction P.F.C.	0,7			
Output				
Rated voltage output	DC 12 V	DC 24 V	DC 48 V	
Rated current output	10 A	5 A	2.5 A	
Voltage trim range	11.4–14.5 V	22.5–30 V	45–55 V	
Accuracy	±1 %			
Line regulation	±0.5 %			
Load regulation	Single ±1 %, Parallel ±5 %			
Transient recovery time	1.0 ms			
Temperature coefficient	±0.3 % / °C			
Ripple & Noise	50 mV			
Hold up time	V _{in} = 115 V: 25 ms / V _{in} = 230 V: 30 ms			
Status indication DC ON (LED green)	≥10–11 V	≥21–22 V	≥42–44 V	
Status indication DC LOW (LED red)	<10–11.2 V	20.5/22.5 V	<41–45 V	
Parallel mode	max. 3 units			
Efficiency	84 %	86 %	87 %	
Rated over load protection	105–125 %			
Over voltage protection	125–145 %			
Short circuit characteristics	Current limit			
General				
Switching frequency	min. 80 kHz			
Isolation voltage input/output	3 kVeff			
Isolation resistance at DC 500 V	100 MΩ			
Operation temperature range	-10°C – 70°C (Derating)			
Derating	-2.5% / °C starting at 61 °C			
Storage temperature range	-25 °C – 85 °C			
M.T.B.F.	210000 h			
Relative humidity	20–90% RH			
Dimensions	63.5 × 142.0 × 116.0 mm			
Cooling	Air convection			
Housing material	metal			
Field installation	rail TS 35 (EN 50022)			
Installation position	vertical			
IP rating	IP 20			
Protection class	–			
Weight (per unit)	0,86 kg/ 1.895 lbs			
Termination	Screw terminal: 0.2–2.0 mm ²			
Approvals	UL: UL 508 listed cUL: UL 60950-1 TÜV: EN 60950 CE: EN 50081-1; EN 55022 Class B EN 6100-3-2, EN 6100-3-3, EN 50082-1, EN 55024			
Monitoring				
DC ON Control (Rdy)	–	Normally open	–	
Switching voltage	–	DC 60 V	–	
Switching current	–	max. 300 mA	–	
Switching capacity	–	–	–	
Isolation voltage	–	DC 500 V	–	

Power supply · regulated, 240 W

Primary switchmode power supply, PFC, Single-phase

Input: Wide range input AC 93 - 132 V; AC 186 - 264 V, DC 210 - 370 V - automatic

Output: 24 V / 48 V - adjustable



Dimensions

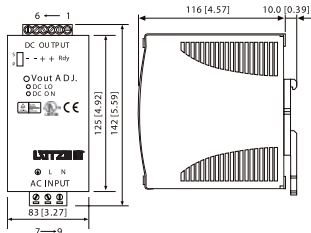

PIN assignment

1	RDY	Normal open relay contact for DC ON level control
2		
3	V+	Positive output
4	V+	Positive output
5	V-	Negative output
6	V-	Negative output
7	↓	Ground this to minimize high-frequency emissions
8	L	Input: phase conductor
9	N	Input: neutral conductor

Derating

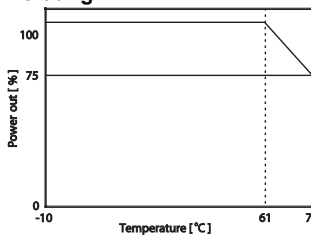

Parallel mode

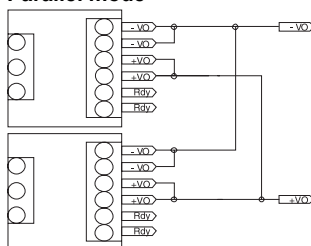

Description	Part-No.	Type	PU	
Screw terminal, pluggable				
Output voltage/current	DC 24 V; 10 A	722759	DRA 240-24B	1
	DC 48 V; 5 A	722778	DRA 240-48B	1
Screw terminal				
Output voltage/current	DC 24 V; 10 A	722781	DRA 240-24A	1
Input				
	DRA 240-24B	DRA 240-48B	DRA 240-24A	
Voltage	AC 115 / 230 V (auto select)			
Operation voltage range	AC 93–132 V; AC 186–264 V / DC 210–370 V			
Line frequency	47 – 63 Hz			
Rated current	V _{in} = 115 V; AC: 2.4 A / V _{in} = 230 V; AC: 1.2 A			
Inrush current	V _{in} = 115 V; AC: 30 A / V _{in} = 230 V; AC: 60 mA			
Input fuse	T6.3A / AC 250 V internal			
Power Factor Correction P.F.C.	0,7			
Output				
Rated voltage output	DC 24 V	DC 48 V	DC 24 V	
Rated current output	10 A	5 A	10 A	
Voltage trim range	22.5–28.5	47–56 V	22.5–28.5 V	
Accuracy	±1 %			
Line regulation	±0.5 %			
Load regulation	Single ±1 %, Parallel ±5 %			
Transient recovery time	1.0 ms			
Temperature coefficient	±0.3 % / °C			
Ripple & Noise	100 mV			
Hold up time	V _{in} = 115 V: 25 ms / V _{in} = 230 V: 30 ms			
Status indication DC ON (LED green)	< 17.6/19.4 V	<37–43 V	< 17.6/19.4 V	
Status indication DC LOW (LED red)	< 17.6/19.4 V	<37–43 V	< 17.6/19.4 V	
Parallel mode	max. 3 units at 90% load current, manual switch			
Efficiency	89 %	90 %	89 %	
Rated over load protection	105–145 %			
Over voltage protection	120–145 %			
Short circuit characteristics	Current limit			
General				
Switching frequency	min. 80 kHz			
Isolation voltage input/output	3 kVeff			
Isolation resistance at DC 500 V	100 MΩ			
Operation temperature range	-10°C – 70°C (Derating)			
Derating	-2.5% / °C starting at 61 °C			
Storage temperature range	-25 °C – 85 °C			
M.T.B.F.	210000 h			
Relative humidity	20–95% RH			
Dimensions	83.0 × 142.0 × 116.0 mm			
Cooling	Air convection			
Housing material	metal			
Field installation	rail TS 35 (EN 50022)			
Installation position	vertical			
IP rating	IP 20			
Protection class	–			
Weight (per unit)	1 kg/ 2.204 lbs			
Termination	Screw terminal: 0.5–4.0 mm ² , pluggable		Screw terminal: 0.2–2.0 mm ²	
Approvals				
UL: UL 508 listed				
cUL: UL 60950-1 approved				
TÜV: EN 60950-1; CE: EN 61000-6-3 / EN 55022 Class B				
EN 6100-3-2, EN 6100-3-3, EN 61000-6-2, EN 55024				
Monitoring				
DC ON Control (Rdy)	Normally open	–	Normally open	
Switching voltage	DC 60 V	–	DC 60 V	
Switching current	max. 300 mA	–	max. 300 mA	
Switching capacity	–	–	–	
Isolation voltage	DC 500 V	–	DC 500 V	

Power supply · regulated, 480 W

Primary switchmode power supply, PFC, Single-phase

Input: Wide range input AC 90 - 264 V; DC 120 - 370 V, DC 24 - 48 V - adjustable

Output: 24 V / 48 V - adjustable



Dimensions

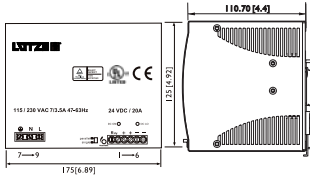

PIN assignment

1	RDY	Normal open relay contact for DC ON level control
2		
3	V+	Positive output
4	V+	Positive output
5	V-	Negative output
6	V-	Negative output
7	↓	Ground this to minimize high-frequency emissions
8	L	Input: phase conductor
9	N	Input: neutral conductor

Derating

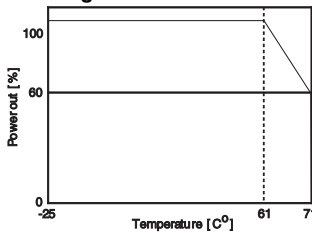

Parallel mode

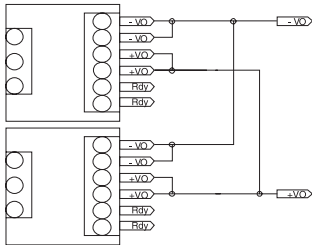

Description	Part-No.	Type	PU	
Screw terminal, pluggable				
Output voltage/current	DC 24 V; 20 A	728782	DRA 480-24B	1
Screw terminal				
Output voltage/current	DC 24 V; 20 A	722782	DRA 480-24A	1
	DC 48 V; 10 A	722779	DRA 480-48A	1

Input	DRA 480-24B	DRA 480-24A	DRA 480-48A
Voltage		AC 115 / 230 V (auto select)	
Operation voltage range		AC 90–264 V; DC 120–370 V	
Line frequency		47 – 63 Hz	
Rated current		V _{in} = 115 V; AC: 4.8 A / V _{in} = 230 V; AC: 2.45 A	
Inrush current		V _{in} = 115 V; AC: 25 A / V _{in} = 230 V; AC: 50 mA	
Input fuse		T10A / AC 250 V internal	
Power Factor Correction P.F.C.		0,99	
Output			
Rated voltage output	DC 24 V		DC 48 V
Rated current output	20 A		10 A
Voltage trim range	22.5–28.5 V		47–56 V
Accuracy		±1 %	
Line regulation		±0.5 %	
Load regulation		Single ±0.5 %, Parallel ±5 %	
Transient recovery time		1.0 ms	
Temperature coefficient		±0.02 % / °C	
Ripple & Noise		100 mV	
Hold up time		min. 30 ms	
Status indication DC ON (LED green)	< 17.6/19.4 V		<37/40 V
Status indication DC LOW (LED red)	< 17.6/19.4 V		<37–43 V
Parallel mode		max. 3 units at 90% load current, manual switch	
Efficiency	89 %		90 %
Rated over load protection		120–140 %	
Over voltage protection	125–137 %		119–131 %
Short circuit characteristics		Current limit	
General			
Switching frequency		min. 100 kHz	
Isolation voltage input/output		3 kVeff	
Isolation resistance at DC 500 V		100 MΩ	
Operation temperature range		-25°C – 71°C (Derating)	
Derating		-4% / °C starting at 61 °C	
Storage temperature range		-25 °C – 85 °C	
M.T.B.F.		210000 h	
Relative humidity		20–95% RH	
Dimensions		175.0 × 125.0 × 116.0 mm	
Cooling		Air convection	
Housing material		metal	
Field installation		rail TS 35 (EN 50022)	
Installation position		vertical	
IP rating		IP 20	
Protection class		–	
Weight (per unit)		1,92 kg/ 4.232 lbs	
Termination		Screw terminal: 0.2–5.0 mm ² - pluggable	Screw terminal: 0.2–5.0 mm ²
Approvals			
		UL: UL 508 listed	
		cUL: UL 60950-1 approved	
		TÜV: EN 60950-1; CE: EN 61000-6-3 / EN 55022 Class B	
		EN 6100-3-2, EN 6100-3-3, EN 61000-6-2, EN 55024	
Monitoring			
DC ON Control (Rdy)		Normally open	–
Switching voltage		DC 60 V	–
Switching current		max. 300 mA	–
Switching capacity		–	–
Isolation voltage		DC 500 V	–

Power supply · regulated, 480 W, 3-phase

Primary switchmode power supply, PFC, 3-phase, screw terminal
Input: Wide range input AC 340 - 576 V; DC 480 - 820 V
Output: 24 V / 48 V - adjustable



Dimensions

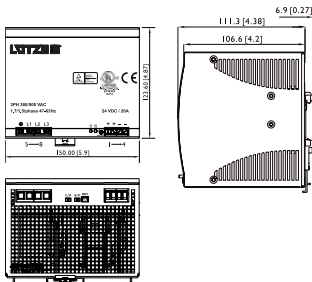

PIN assignment

1, 2	Vo+	Positive output
3, 4	Vo-	Negative output
5		Ground
6, 7, 8		Input terminal
	DC on	LED DC- ok
	DC low	LED DC- under voltage
	Rdy	Signal contact, only 24V

Derating

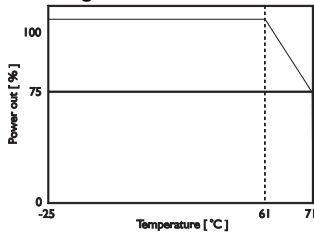

Parallel mode

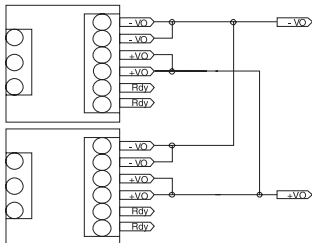

Description	Part-No.	Type	PU	
Screw terminal				
Output voltage/current	DC 24 V; 20 A	722805	WRA 480-24	1
	DC 48 V; 10 A	722809	WRA 480-48	1
Input				
	WRA 480-24		WRA 480-48	
Voltage	AC 380–500 V			
Operation voltage range	AC 340–576 V; DC 480–820 V			
Line frequency	47 – 63 Hz			
Rated current	$V_{in}=400\text{ V}$; AC: 1.5 A / $V_{in}=480\text{ V}$; AC: 1.2 A			
Inrush current	18 A			
Input fuse	T3, 15 A / internal per phase			
Power Factor Correction P.F.C.	0,7			
Output				
Rated voltage output	DC 24 V		DC 48 V	
Rated current output	20 A		10 A	
Voltage trim range	22.5 –28.5 V		47–56 V	
Accuracy	1 %			
Line regulation	±1 %			
Load regulation	Single ±1 %, Parallel ±5 %			
Transient recovery time	1.0 ms			
Temperature coefficient	±0.02 % / °C			
Ripple & Noise	100 mV			
Hold up time	min. 20 ms			
Status indication DC ON (LED green)	< 17.6/19.4 V		<37–43 V	
Status indication DC LOW (LED red)	< 17.6/19.4 V		<37–43 V	
Parallel mode	max. 3 units at 90% load current, manual switch			
Efficiency	90 %			
Rated over load protection	115–135 %			
Over voltage protection	125–137 %		125–142 %	
Short circuit characteristics	Current limit (C) / Hiccup-mode (D), with switch C/D			
General				
Switching frequency	min. 100 kHz			
Isolation voltage input/output	3 kVeff			
Isolation resistance at DC 500 V	100 MΩ			
Operation temperature range	-25°C – 71°C (Derating)			
Derating	-2.5% / °C starting at 61 °C			
Storage temperature range	-25 °C – 85 °C			
M.T.B.F.	210000 h			
Relative humidity	20–95% RH			
Dimensions	150.0 × 125.0 × 116.0 mm			
Cooling	Air convection			
Housing material	metal			
Field installation	rail TS 35 (EN 50022)			
Installation position	vertical			
IP rating	IP 20			
Protection class	-			
Weight (per unit)	1,75 kg/ 3.857 lbs			
Termination	Screw terminal: 0.2–5.0 mm ²			
Approvals	UL: UL 508 listed cUL: UL 60950-1 approved TÜV: EN 60950-1; CE: EN 61000-6-3 / EN 55022 Class B EN 6100-3-2, EN 6100-3-3, EN 61000-6-2, EN 55024			
Monitoring				
DC ON Control (Rdy)	Normally open		-	
Switching voltage	DC 60 V		-	
Switching current	max. 300 mA		-	
Switching capacity			-	
Isolation voltage	DC 500 V		-	

Power supply · regulated, 960 W, 3-phase

Primary switchmode power supply, PFC, 3-phase, screw terminal
Input: Wide range input AC 340 - 576 V; DC 480 - 820 V
Output: 24 V / 48 V - adjustable



Dimensions

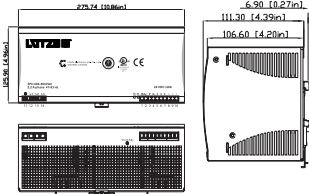

PIN assignment

1, 2	Rdy	Signal contact, only 24V
3, 4	P, G	Current share
5, 6, 7	Vo+	Positive output
8, 9, 10	Vo-	Negative output
11		Ground
12, 13, 14		Input terminal
	DC on	LED DC- ok
	DC low	LED DC- under voltage

Derating

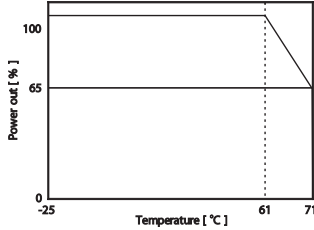

Parallel mode

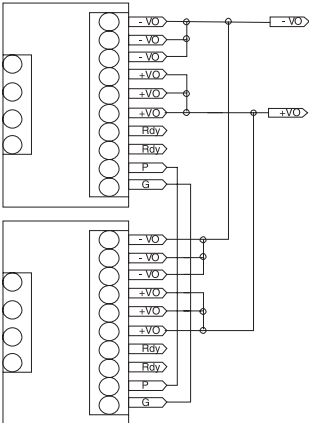

Description	Part-No.	Type	PU	
Screw terminal				
Output voltage/current	DC 24 V; 40 A	722806	WRA 960-24	1
	DC 48 V; 20 A	722810	WRA 960-48	1

Input	WRA 960-24	WRA 960-48
Voltage	AC 400–500 V	
Operation voltage range	AC 340–575 V; DC 480–820 V	
Line frequency	47 – 63 Hz	
Rated current	$V_{in} = 400 \text{ V}$; AC: 2,4 A / $V_{in} = 480 \text{ V}$; AC: 1,6 A	
Inrush current	30 A	
Input fuse	T6, 3 A / internal per phase	
Power Factor Correction P.F.C.	0,7	

Output	DC 24 V	DC 48 V
Rated voltage output	DC 24 V	DC 48 V
Rated current output	40 A	20 A
Voltage trim range	22.5–28.5 V	47–56 V
Accuracy	1 %	
Line regulation	±1 %	
Load regulation	Single ±1 %, Parallel ±5 %	
Transient recovery time	–	
Temperature coefficient	±0.02 % / °C	
Ripple & Noise	80 mV	
Hold up time	min. 20 ms	

Status indication DC ON (LED green)	>17.6–19.4 V	<37–43 V
Status indication DC LOW (LED red)	>17.6–19.4 V	<37–43 V
Parallel mode	max. 2 units at 90% load current, terminal P, G for current share	
Efficiency	92 %	
Rated over load protection	Rated over load protection: 110 % –130 %	
Over voltage protection	125–137 %	125–142 %
Short circuit characteristics	Current limit	

General		
Switching frequency	min. 100 kHz	
Isolation voltage input/output	3 kVeff	
Isolation resistance at DC 500 V	100 MΩ	
Operation temperature range	-25°C – 71°C (Derating)	
Derating	-3.5% / °C starting at 61°C	
Storage temperature range	-25 °C – 85 °C	
M.T.B.F.	210000 h	
Relative humidity	20–95% RH	
Dimensions	276.0 × 125.0 × 118.0 mm	
Cooling	Air convection	
Housing material	metal	
Field installation	rail TS 35 (EN 50022)	
Installation position	vertical	
IP rating	IP 20	
Protection class	–	
Weight (per unit)	3,2 kg/ 7.053 lbs	
Termination	Screw terminal: 0.2–5.0 mm ²	

Approvals	UL: UL 508 listed cUL: UL 60950-1 anerkannt TÜV: EN 60950-1; CE: EN 61000-6-3 / EN 55022 Class B EN 6100-3-2, EN 6100-3-3, EN 61000-6-2, EN 55024	
-----------	--	--

Monitoring		
DC ON Control (Rdy)	Normally open	–
Switching voltage	DC 60 V	–
Switching current	max. 300 mA	–
Switching capacity	–	–
Isolation voltage	DC 500 V	–

Power supply · regulated, 50 W

Primary switchmode power supply, Single-phase, spring terminal

Input: AC 170 – 264 V

Output: 10–24 V - adjustable



Dimensions

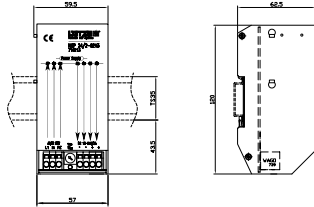

PIN assignment

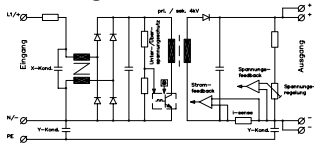

Description	Part-No.	Type	PU
Spring terminal			
Output voltage/current	DC 24 V; 2 A	716213	NGP 24/2-6213
			1
Input			
NGP 24/2-6213			
Voltage		AC 230 V	
Operation voltage range		AC 170–264 V	
Line frequency		47 – 63 Hz	
Rated current		V _{in} =230 V; AC: 350 mA	
Inrush current		V _{in} =230 V; AC: 10 A	
Input fuse		recommended back-up fuse: MT 1A / 250 V	
Power Factor Correction P.F.C.		–	
Output			
Rated voltage output		DC 24 V (delivery status)	
Rated current output		2 A	
Voltage trim range		10–24 V	
Accuracy		<1 %	
Line regulation		–	
Load regulation		–	
Transient recovery time		5.0 ms	
Temperature coefficient		–	
Ripple & Noise		160 mV	
Hold up time		V _{in} = 230 V: 10 ms	
Status indication DC ON (LED green)		Yes	
Status indication DC LOW (LED red)		–	
Parallel mode		No	
Efficiency		85 %	
Rated over load protection		110–150 %	
Over voltage protection		120–136 %	
Short circuit characteristics		Hiccup-mode	
General			
Switching frequency		min. 100 kHz	
Isolation voltage input/output		4 kVeff	
Isolation resistance at DC 500 V		– MΩ	
Operation temperature range		–	
Derating		No	
Storage temperature range		-40 °C – 85 °C	
M.T.B.F.		– h	
Relative humidity		20–80 % RH	
Dimensions		59.5 × 120.0 × 62.5 mm	
Cooling		Air convection	
Housing material		metal	
Field installation		rail TS 35 (EN 50022)	
Installation position		vertical	
IP rating		IP 20	
Protection class		1	
Weight (per unit)		0.24 kg/0.529 lbs	
Termination		Spring terminal 0.2–2.0 mm ²	
Approvals		CE: EN 55022; Class B; EN 50081-1; EN 50082-2 cULus submitted	
Monitoring			
DC ON Control (Rdy)		–	
Switching voltage		–	
Switching current		–	
Switching capacity		–	
Isolation voltage		–	

Power supply · unregulated, 60–360 W

Power supply unit, Single-phase, unregulated, screw terminal

Input: AC 115 V / 230 V / 400 V

Output: DC 24 V



Dimensions

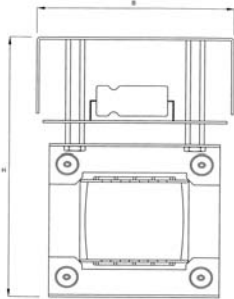

PIN assignment

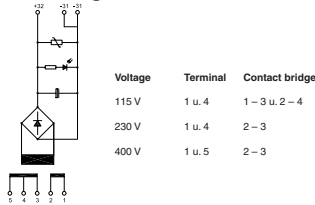

Description	Part-No.	Type	PU	
Screw terminal				
Rated voltage	DC 24V; 2.5A	722962	NG 24/2,5-2962	1
	DC 24V; 5A	722963	NG 24/5-2963	1
	DC 24V; 10A	722972	NG 24/10-2972	1
	DC 24V; 15A	722973	NG 24/15-2973	1

Input	NG 24/2,5-2962	NG 24/5-2963	NG 24/10-2972	NG 24/15-2973
Input voltage	AC 115 / 230 / 400V			
Operation voltage range	AC 104–196V / AC 207–224V / AC 360–424V			
Line frequency	47 – 63 Hz			
Rated current	1.6A / 0.6A / 0.4A	2.4A / 1.1A / 0.6A	5.0A / 2.4A / 1.8A	6.0A / 3.2A / 2.0A
Rated power	60 W	120 W	240 W	360 W
Recommended back-up fuse	115V: 4A / 230V: 2A / 400V: 1A	115V: 4A / 230V: 2A / 400V: 2A	115V: 6A / 230V: 4A / 400V: 2A	115V: 10A / 230V: 6A / 400V: 4A
Termination	Screw terminal with additional blade terminal: 0.5–6 mm2			

Output				
Rated voltage output	DC 24 V			
Rated current output	2.5 A	5 A	10 A	15 A
Voltage	at open-circuit 30.2 V, at full load: 20.4 V			
Line regulation	–			
Load regulation	–			
Transient recovery time	–			
Temperature coefficient	–			
Ripple & Noise	650 mV		1200 mV	
Hold up time	–			
Status indication DC ON (LED green)	Yes			
Status indication DC LOW (LED red)	–			
Parallel mode	with 90% load current			
Efficiency	73 %	77 %	80 %	
Rated over load protection	No			
Short circuit characteristics	–			
Output circuit	Varistor and capacitor			
Termination	Screw terminal 0.5–10 mm2			

General				
Switching frequency	–			
Isolation voltage input/output	4 kVeff			
Isolation class	T 40 / B			
Insulation class	according to VDE B, UL/CSA: class 130			
Operation temperature range	-25 °C – 50 °C			
Derating	–			
Storage temperature range	-40 °C – 80 °C			
Relative humidity	80% occasional condensation possible			
Dimensions	85 × 137 × 98 mm	106 × 160 × 113 mm	121 × 170 × 128 mm	151 × 200 × 145 mm
Cooling	Air convection			
Housing material	metal			
Field installation	Screw termination: 0.5–4.0 mm ²			
Assembly borehole	64 × 64.5 mm/M 5	83 × 80.5 mm/M 5	104 × 90 mm/M 5	90 × 122 mm/M 6
Cu application weight	0,62 kg/piece	0,6 kg/piece	0,9 kg/piece	1,5 kg/piece
Installation position	Optional			
IP rating	IP 00			
IP rating	I			
Weight (per unit)	2,3 kg/ 5.07 lbs	4,9 kg/ 10.80 lbs	7,5 kg/ 16.53 lbs	9 kg/ 19.84 lbs
Standards	Transformer compliant with IEC 61-558, Output limit values compliant with EN 61 131-2 EMC compliant with EN 50 081-1 and EN 50 082-2, Main connection compliant with EN 61 000-3-2			
Approvals	cULus			

Fixing

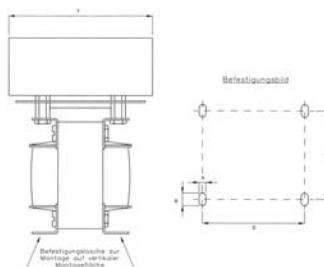

Interface technology • Current control system LCCS

Current control system up to 10A

Single channel version

rated current : adjustable DC 1-10A; Trip Characteristics: Fast, Intermediate, and Slow acting



Dimensions

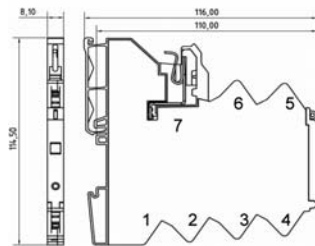

Pin assignment

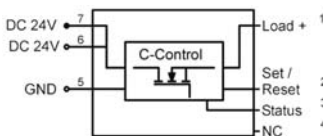

- 1: + Output
- 2: Control input (Set / Reset)
- 3: Status output
- 4: Optional: 1 wire bus (nc 716400)
- 5: 0V
- 6: + Supply (alternative)
- 7: + Supply

Description	Part number	Type	PU	
Spring terminal				
Rated voltage	DC 24V	716400	LCCS 7-6400	1

Input side			
Rated voltage	DC 24V		
Operating voltage range	DC 18V - 32V		
Rated current	DC 10A max. (control system 716400)		
System current max.	DC 40A via copper busbar 10 x 3 mm		
Reverse voltage protection	internal electronic		
Termination	spring terminal		

Control input (Set/Reset)			
Signal level	DC 24V (EN61131)		
Switch-off time (Reset)	pulse (trailing edge) > 100ms, < 800ms		
Switch-on time (Set)	pulse (trailing edge) > 1s		
Termination	Spring terminal: 0,25 - 2,5mm ²		

Output Side			
Switch method	MosFet		
Output current	max. DC 10A		
Voltage drop	< 170mV (10A)		
Status indication	green: ok; green flashing: 90% load, okred flashing: error and no acknowledge; red: error		
Switch on capacity	10.000µF		
Current range	1A - 10A (adjustable via switch in 1A steps)		
Cut-off time	Trip Characteristics: Fast, Intermediate, and Slow acting (adjustable via switch)		

Signal output			
Signal level	DC 24V, 10mA		
Switch method	DC 24V: supply voltage is ok, no error; DC 0V: error; output switch off Transistor, open collector with pull up resistor		

General data			
Housing material	PA 6.6 (UL94-0; NFF I2, F2)		
Field installation	rail TS 35 (EN50022)		
IP rating	IP 20		
Installation position	any		
Termination	Spring terminal: 0,25 - 2,5 mm ²		
Operation temperature range	-25°C - 60°C		
Storage temperature range	-40°C - 85°C		
Dimension (LxWxD)	8,1 x 114,5 x 116,0		
Weight	0.12 kg / 0.265 lbs		
Approvals	cULus, Class 1 Div 2 applied for		
Standards	EN 60950-1; EN6131-1,2; EN 60898; EN 60947-4-1; EN 50081		

Accessories	Part number	Type	PU
Terminal set (Supply- and end terminal)	716425	LCCS-ES 7-6425	1
Copper busbar 1 m	716426	LCCS-CU 7-6426	1
Copper busbar 1 m	716427	LCCS-AD 7-6427	1
Jumper comb 16pole, white	716428	LCCS-BKW 7-6428	5
Jumper comb 16pole, red	716429	LCCS-BKR 7-6429	5
Jumper comb 16pole, blau	716430	LCCS-BKB 7-6430	5
Identification plate (100pcs), white	716431	LCCS-BZW 7-6431	10
Identification plate (100pcs), red	716432	LCCS-BZR 7-6432	10
Identification plate (100pcs), blue	716433	LCCS-BKB 7-6433	10
Identification plate (100pcs), yellow	716434	LCCS-BZG 7-6434	10

Modular, flexible and safe: The Current Control System LCCS

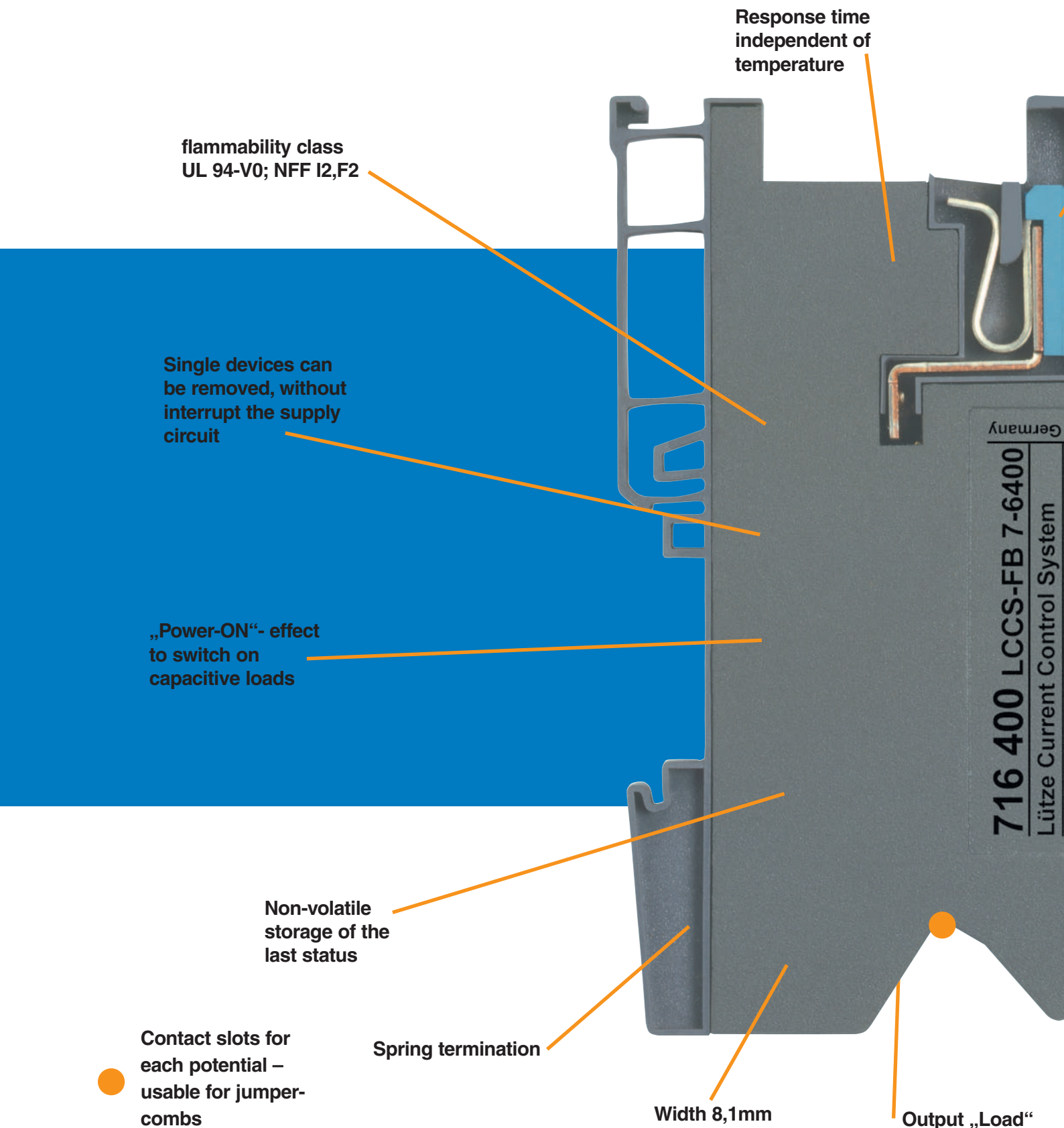

intelligent Lutze

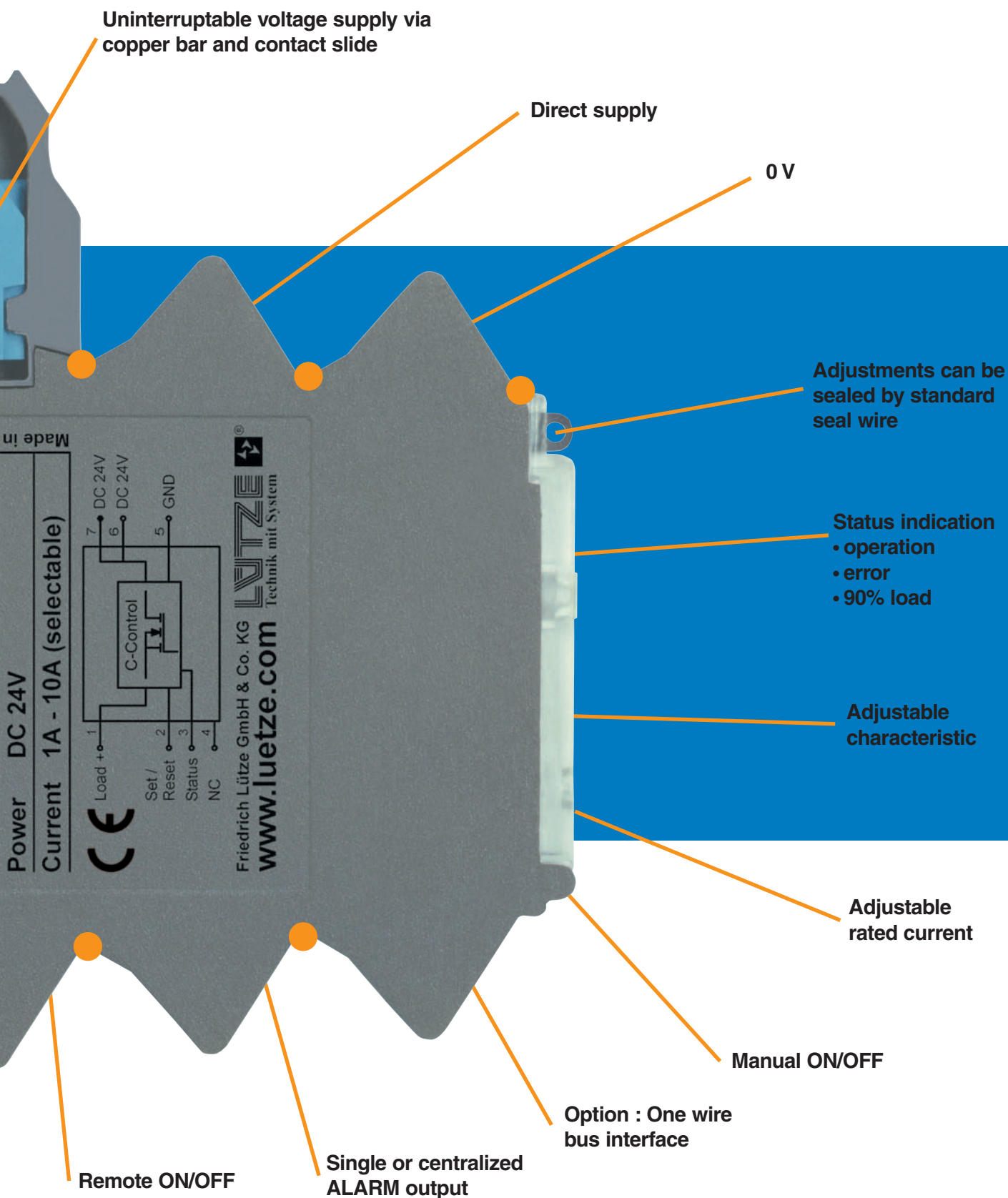

USA

LUTZE INC.
13330 South Ridge Drive
Charlotte, NC 28273
Tel.: (704) 504-0222
Fax: (704) 504-0223
info@lutze.com

Lutze systems for highest industrial standards:

- ▶ Prepopulated
C-track systems
- ▶ Lutze-LSC-wiring
systems for all
standard control
panels
- ▶ Powerful module and
interface technology
- ▶ Reliable suppression
technology
- ▶ Efficient power
supplies
- ▶ Automation systems
for harsh environments

Germany

Friedrich Lütze GmbH & Co. KG
Postfach 12 24 (PLZ 71366)
Bruckwiesenstraße 17-19
D-71384 Weinstadt
Tel.: +49 (0)71 51 60 53-0
Fax: +49 (0)71 51 60 53-277(-288)
info@luetze.de

United Kingdom

LÜTZE Ltd.
Unit 3 Sandy Hill Park
Sandy Way, Amington
Tamworth, Staffs, B77 4DU
Tel.: +44 (0)18 27 31333-0
Fax: +44 (0)18 27 31333-2
sales.gb@lutze.co.uk

Austria

LÜTZE Elektrotechnische
Erzeugnisse Ges.m.b.H.
Tel.: +43 (0)1 257 52 52-0
Fax: +43 (0)1 257 52 52-20
office@luetze.at

Switzerland

LÜTZE AG
Tel.: +41 (0)55 450 23 23
Fax: +41 (0)55 450 23 13
info@luetze.ch

France

LUTZE S.A.
Tél.: +33 (0)1 34 18 77 00
Fax: +33 (0)1 34 18 18 44
lutze@lutze.fr

Spain

LUTZE, S.L.
Tel.: +34 93 285 7480
Fax: +34 93 285 7481
info@lutze.es

www.lutze.com



Systematic Technology