

Maestro Wireless® Dimmers and Switches

The *Maestro Wireless* solution incorporates *Maestro Wireless* load controls, wireless sensors, and wireless remote controls, which provides a system that delivers energy savings, convenience, and ease of installation.

Maestro Wireless dimmers and switches use Lutron patented Clear Connect™ RF Technology, which enables wireless communication with Radio Powr Savr™ sensors and Pico® wireless controls for light control and general switched loads.

Features

- The *Maestro Wireless* solution provides dimming/switching of multiple load types, occupancy/vacancy sensing, daylight harvesting, and high-end trim.
- Lutron patented *Clear Connect* RF Technology works through walls and floors.
- Incorporates advanced features such as fade on/fade off, high-end trim, and rapid full on.
- Controls include Front Accessible Service Switch (FASS™) for safe lamp replacement.
- Two-wire dimmers and switches available for retrofit applications.
- Power failure memory: If power is interrupted, the control will return to its previously set level prior to interruption.

Receiving Devices

Maestro Wireless Controls

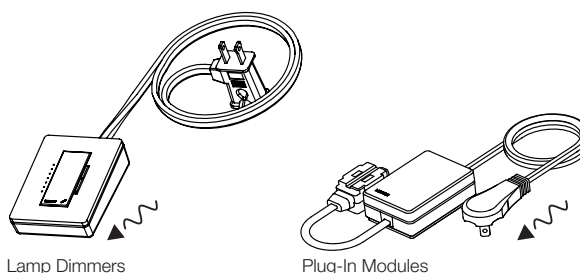
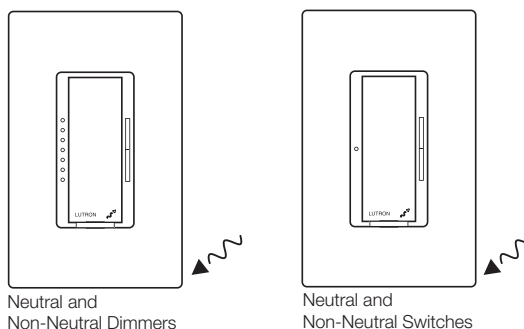

Transmitting Devices

Radio Powr Savr Sensors

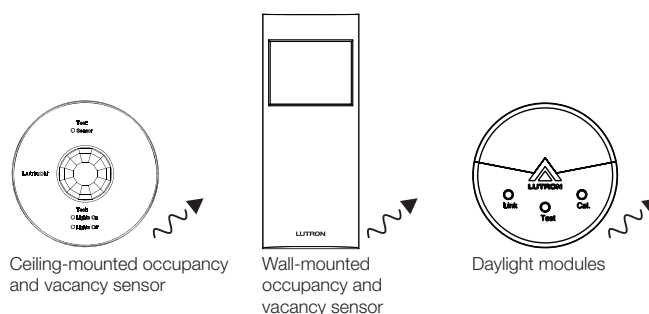

Pico Wireless Controls



Job Name:	Model Numbers:
Job Number:	

Maestro Wireless® Dimmers

Model Numbers

Dimmers

Halogen/Incandescent/Magnetic Low-voltage

MRF2-600M-XX	600 W Incandescent Dimmer 120 V~
MRF2-6MLV-XX	600 W/600 VA Incandescent/ MLV Dimmer 120 V~
MRF2-6ND-120-XX*	600 W/600 VA Spec Grade Neutral wire Dimmer 120 V~
MRF2-10D-120-XX	1000 W/1000 VA Spec Grade Dimmer 120 V~

3-wire Fluorescent

MRF2-F6AN-DV-XX*	6 A 3-wire Fluorescent Spec Grade Neutral wire Dimmer 120-277 V~
------------------	--

Electronic Low-Voltage Dimmer—

MRF2-6ELV-120-XX*	600 W ELV Dimmer 120 V~
-------------------	-------------------------

Dimmer



Companion Dimmer



* NEUTRAL WIRE REQUIRED.

Companion Controls

Claro® Gloss Finishes

MA-R-XX	Companion Dimmer 120 V~
MA-R-277-XX	Companion Dimmer 277 V~

Satin Colors® Satin Finishes

MSC-AD-XX	Companion Dimmer 120 V~
MSC-AD-277-XX	Companion Dimmer 277 V~

“XX” in the model number represents color/finish code.

Job Name:	Model Numbers:
Job Number:	

Dimmer Load Type and Capacity

Neutral Required

Control	Voltage	Load Type	Minimum Load	Maximum Load		
				Not Ganged	End of Gang	Middle of Gang
MRF2-6ND-120 ^{1,2,4}	120 V~	Incand.	25 W	600 W	500 W	400 W
		MLV ²	25 W/VA	450 W/ 600 VA	400 W/ 500 VA	300 W/ 400 VA
MRF2-6ELV ²	120 V~	ELV ²	5 W	600 W	500 W	400 W
MRF2-F6AN-DV ^{3,5}	120-277 V~	Lighting	1 ballast 0.05 A	6 A	5 A	3 A

No Neutral Required

Control	Voltage	Load Type	Minimum Load	Maximum Load		
				Not Ganged	End of Gang	Middle of Gang
MRF2-600M ^{1,4}	120 V~	Incand.	50 W	600 W	500 W	400 W
MRF2-6MLV ^{1,2,4}	120 V~	MLV ²	50 VA	450 W/ 600 VA	400 W/ 500 VA	300 W/ 400 VA
MRF2-10D-120 ^{1,2,4}	120 V~	Incand.	50 W	1000 W	800 W	650 W
		MLV ²	50 W/VA	800 W/ 1000 VA	600 W/ 800 VA	500 W/ 650 VA

¹ Dimmer Load Type: -6ND, -6MLV and -10D are designed for use with permanently installed incandescent, magnetic low-voltage, or tungsten halogen only. -600M is designed for use with permanently installed incandescent or tungsten halogen only. -6ELV is designed for use with permanently installed electronic low-voltage only. Do not install dimmers to control receptacles or motor-operated appliances.

² Low-Voltage Applications: Use -6ND, -6MLV and -10D with magnetic (core and coil) low-voltage transformers only. Not for use with electronic (solid-state) low-voltage transformers. Use -6ELV with electronic (solid-state) low-voltage transformers only. Operation of a low-voltage circuit with lamps inoperative or removed may result in transformer overheating and premature failure. Lutron strongly recommends the following:

- Do not operate low-voltage circuits without operative lamps in place.
- Replace burned-out lamps as quickly as possible.
- Use transformers that incorporate thermal protection or fused transformer primary windings to prevent transformer failure due to overcurrent.

³ Can control the following power boosters/load interfaces: Phase-adaptive Power Modules (PHPM-WBX-DV-WH), 3-wire Fluorescent Power Modules (PHPM-3F-DV-WH), Tu-Wire® Fluorescent Power Modules (PHPM-PA-DV-WH), and 0-10 V (GRX-TV).

⁴ Can control the following power booster/load interface: Hi-Power 2•4•6™ Boosters (HP-2, HP-4, HP-6) for control of most popular lighting sources including Lutron® 3-wire line voltage control fluorescent dimming ballasts (Hi-lume®, Hi-lume Compact SE™, Eco-10®, and EcoSystem®).

⁵ Dimmer Load Type: -F6AN is designed for use with permanently installed 3-wire line voltage control fluorescent ballasts or LED drivers only (Hi-lume, Hi-lume Compact SE, Eco-10, and EcoSystem).

Job Name:	Model Numbers:
Job Number:	

Maestro Wireless® Switches

Model Numbers

Switches

Lighting and motor loads

MRF2-6ANS-XX*	6 A Lighting/3 A Fan (1/10 HP motor), Electronic Switch 120 V~
MRF2-8ANS-120-XX*	8 A Lighting, 5.8 A Fan (1/4 HI motor), Spec Grade Electronic Switch 120 V~
MRF2-6ANS-277-XX*	6 A Lighting, Spec Grade Electronic Switch 277 V~
MRF2-8S-DV-XX	8 A Lighting, 3 A Fan (1/10 HF motor, 120 V~ only), Spec Grade Electronic Switch 120-277 V~, NO NEUTRAL WIRE REQUIRED

Switch



Companion Switch



* NEUTRAL WIRE REQUIRED.

Companion Controls

Claro® Gloss Finishes

MA-AS-XX	Companion Switch 120 V~
MA-AS-277-XX	Companion Switch 277 V~

Satin Colors® Satin Finishes

MSC-AS-XX	Companion Switch 120 V~
MSC-AS-277-XX	Companion Switch 277 V~

“XX” in the model number represents color/finish code.

Job Name:	Model Numbers:
Job Number:	

Switch Load Type and Capacity

Neutral Required

Control	Voltage	Load Type	Minimum Load	Maximum Load		
				Not Ganged	End of Gang	Middle of Gang
MRF2-8ANS-120 ^{1,3}	120 V~	Lighting	25 W	8 A	6.5 A	5 A
		Fan Motor	0.2 A	1/4 HP 5.8 A	1/4 HP 5.8 A	1/6 HP 4.4 A
MRF2-6ANS ¹	120 V~	Lighting	25 W	6 A	5 A	3.5 A
		Fan Motor	0.2 A	1/10 HP 3 A	1/10 HP 3 A	1/10 HP 3 A
MRF2-6ANS-277 ²	277 V~	Lighting	25 W	6 A	5 A	3.5 A

No Neutral Required

Control	Voltage	Load Type	Minimum Load	Maximum Load		
				Not Ganged	End of Gang	Middle of Gang
MRF2-8S-DV ²	120-277 V~	Incandescent/ Halogen	25 W	8 A	8 A/7 A ⁴	7 A
	120-277 V~	Fluorescent/ LED/CFL	40 W (LUT-MLC) ⁵	8 A	8 A/7 A ⁴	7 A
	120 V~	Fan Motor	0.4 A	1/10 HP 3 A	1/10 HP 3 A	1/10 HP 3 A

¹ Switch Load Type: -8ANS-120 is designed for use with permanently installed lighting loads and with fan motor loads up to 1/4 HP (5.8 A).

-6ANS is designed for use with permanently installed lighting loads and with fan motor loads up to 1/10 HP (3 A).

-8S-DV is designed for use with permanently installed lighting loads and with fan motor loads up to 1/10 HP (3 A, 120 V~ only).

² Switch Load Type: -6ANS-277 and -8S-DV are designed for use with permanently installed lighting loads.

³ For loads larger than 8 A @ 120 V~, the -8ANS-120 switch can be used with the PHPM-SW-DV-WH power booster. For loads larger than the MRF2-6ANS-277 capacity of 6 A @ 277 V~, the -8ANS-120 can also be used with the PHPM-SW-DV-WH power booster to switch 277 V~ loads. Please note that in this application, the -8ANS-120 switch is providing an input at 120 V~ and the power booster is switching 277 V~.

⁴ Maximum load for double gang application is 8 A. Triple gang application derates maximum load to 7 A.

⁵ The LUT-MLC ensures proper function with certain fluorescent, CFL, and LED load types.

Job Name:	Model Numbers:
Job Number:	

Specifications

Regulatory Approvals

- UL Listed.
- CSA Certified.
- FCC Approved. Complies with the limits for a Class B digital device, pursuant to Part 15 of the FCC Rules.
- Industry Canada Certified.

Power

Operating voltage:

120 V~ 50/60 Hz

277 V~ 50/60 Hz (-6ANS-277, -8S-DV, -F6AN-DV)

Key Design Features

Dimmers

- On a single-tap, lights fade UP or DOWN.
- On a double-tap, lights go to full ON.
- When ON, press and hold to engage 20-second fade to OFF.
- Light levels can be fine-tuned by pressing and holding the dimming rocker until the desired light level is reached.
- Two-wire dimmers available.

Switch

- On a single-tap, lights turn ON or OFF.
- Two-wire switches available.

All RF Local Controls

- Tested to withstand electrostatic discharge without damage or memory loss, in accordance with IEC 61000-4-2.
- Tested to withstand surge voltages without damage or loss of operation, in accordance with IEEE C62.41-1991 Recommended Practice on Surge Voltages in Low-Voltage AC Power Circuits.

- Controls always operate locally and do not require system control.
- Power failure memory: should power be interrupted, the control will return to its previously set level prior to the interruption when power is restored.
- Uses conventional 3-way and 4-way wiring.
- Multiple location control from Dimmer/Switch and up to 9 Companion Dimmer(s)/Switch(es).
- Use Lutron® Designer (Claro® and Satin Colors®) wallplates or designer-style wallplates from other manufacturers. Wallplates are sold separately.
- Lutron *Claro* and *Satin Colors* wallplates snap on with no visible means of attachment.
- Requires a 1-gang U.S. wallbox. 3½ in (89 mm) deep recommended, 2¼ in (57 mm) deep minimum.
- Green indicator lights.

System Communications and Capacity

- *Maestro Wireless* controls communicate with the Pico™ wireless controls and Radio Power Savr™ sensors through radio frequency (RF).
- *Maestro Wireless* local controls must be located within 60 ft (18 m) line of sight or 30 ft (9 m) through walls, of *Radio Power Savr* sensors.
- *Maestro Wireless* local controls must be located within 100 ft (30 m) line of sight or 30 ft (9 m) through walls, of a *Pico* wireless control.
- Up to 10 *Maestro Wireless* controls can be configured to work together.

Environment

- Ambient operating temperature: 32 °F to 104 °F (0 °C to 40 °C), 0%-90% humidity, non-condensing. Indoor use only.

Job Name:	Model Numbers:
Job Number:	

Operation

Dimmer

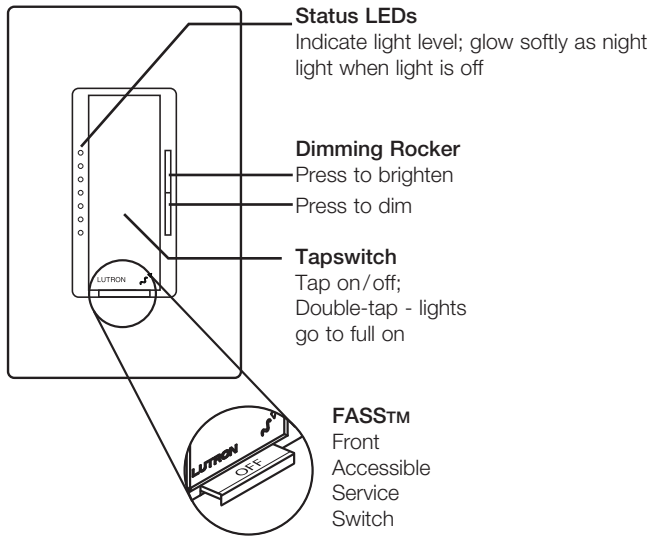

Switch

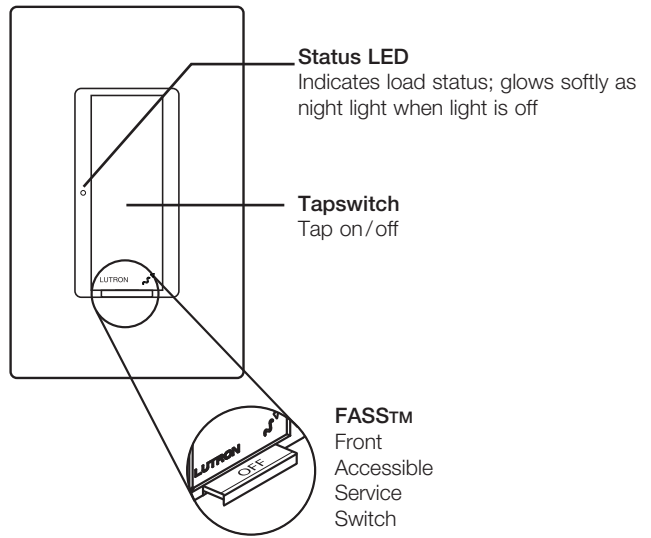

IMPORTANT NOTICE:

FASS - Front Accessible Service Switch - to service load, remove power by pulling the *FASS* switch out completely on either the Dimmer/Switch or Companion Dimmer/Switch. After servicing load, push the *FASS* switch back in fully to restore power to the control.

Mounting

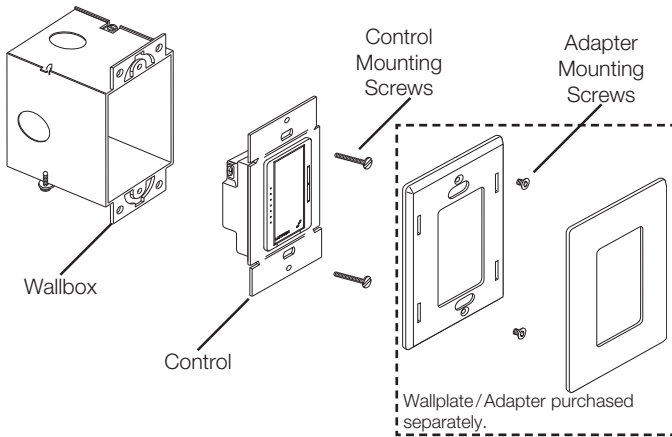

Job Name:

Model Numbers:

Job Number:

Dimensions

Front View

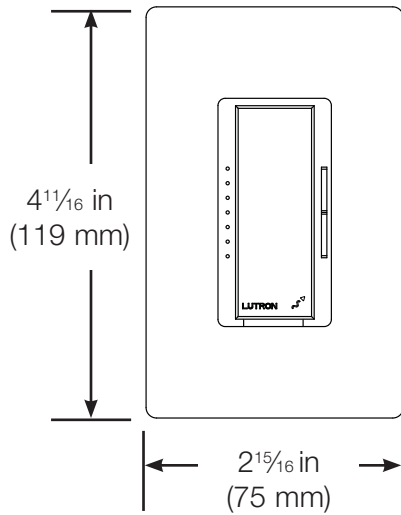

Side View

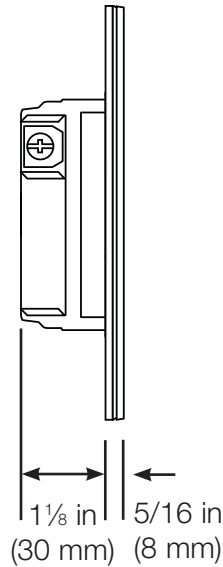

Ganging and Derating

When ganging with other controls in the same wallbox, derating is required. See Load Type and Capacity chart. Only -8ANS controls have fins that need to be removed for multigang installations. No other controls have fins, but they must still be be derated in multigang installations.

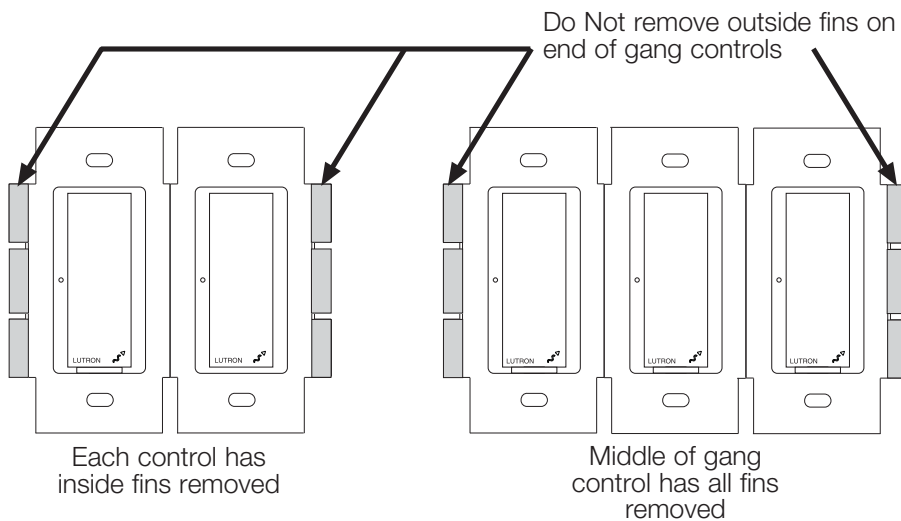

Job Name:

Model Numbers:

Job Number:

Wiring Diagrams

Single Location Installation

-600M, -6MLV, -10D

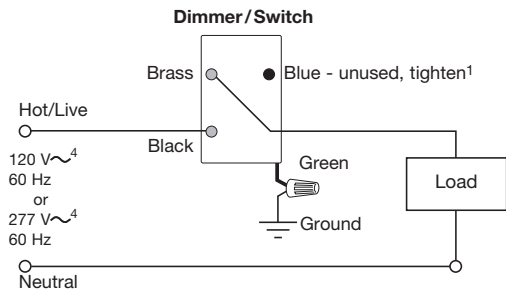

Single Location Installation with Neutral

-6ND, -6ELV, -6ANS-120, -8ANS-120, -6ANS-277

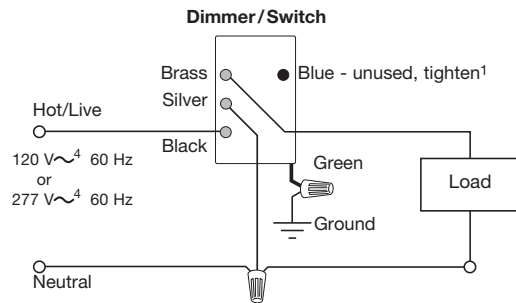

Multi-Location Installation²

-600M, -6MLV, -10D with MA-R/MSC-AD

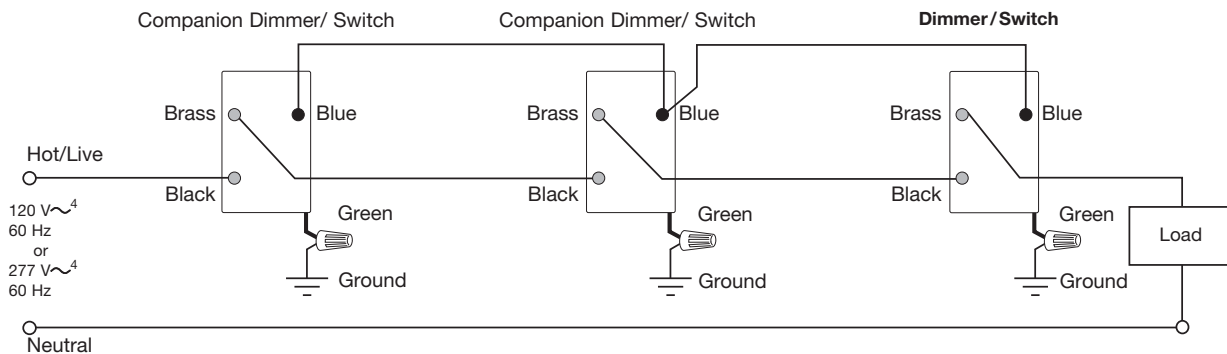

Multi-Location Installation with Neutral^{2,3}

-6ND, -6ELV with MA-R/MSC-AD; -6ANS-120, -8ANS-120 with MA-AS/MSC-AS; -6ANS-277 with MA-AS-277/MSC-AS-277

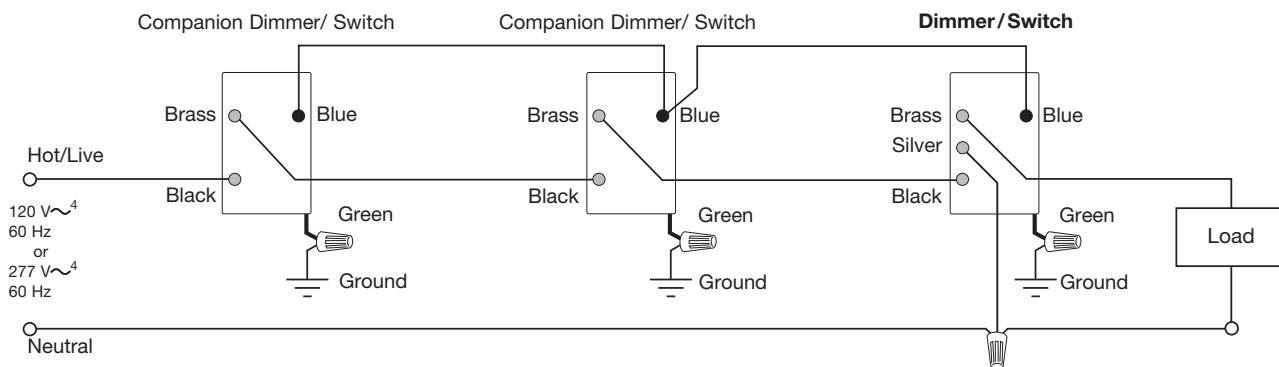

¹ When using controls in single location installations, tighten the blue terminal without any wires attached. **DO NOT** connect the blue terminal to any other wiring or to ground.

² Up to 9 *Maestro* Companion Dimmers/Switches may be connected to the *Maestro Wireless* Dimmer/Switch. Total blue terminal wire length may be up to 250 ft (76 m).

³ Neutral wire Dimmers/Switches must be connected on the Load side of a multi-location installation.

⁴ 120 V~ : -6ND, -6ANS-120, -8ANS-120, -6ELV-120

277 V~ : -6ANS-277, 8S-DV

⁵ Requires MA-AS/MSC-AS for 120 V~ applications, and MA-AS-277/MSC-AS-277 for 277 V~ applications.

Job Name:

Model Numbers:

Job Number:

Wiring Diagrams

Single Location Installation

-8S-DV³

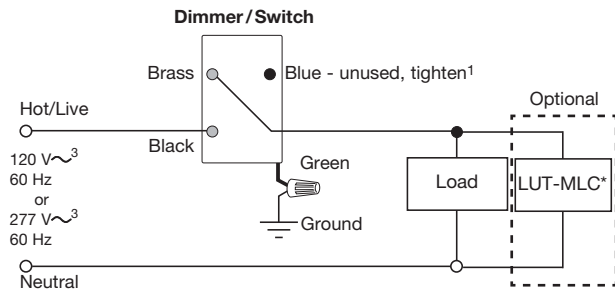

* A LUT-MLC ensures proper function when fluorescent, CFL, or LED loads are used. Install the LUT-MLC inside a load fixture or in a separate J-box of the circuit.

Multi-Location Installation²

-8S-DV^{4*} with MA-AS/MA-AS-277 or MSC-AS/MS-AS-277

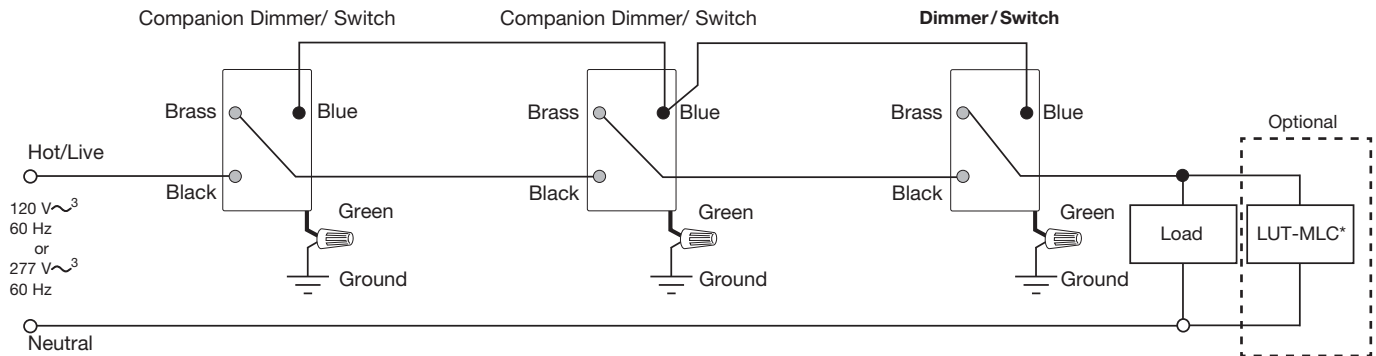

¹ When using controls in single location installations, tighten the blue terminal without any wires attached. **DO NOT** connect the blue terminal to any other wiring or to ground.

² Up to 9 *Maestro* Companion Dimmers/Switches may be connected to the *Maestro Wireless* Dimmer/Switch. Total blue terminal wire length may be up to 250 ft (76 m).

³ 120 V~ : -6ND, -6ANS-120, -8ANS-120, -6ELV-120
277 V~ : -6ANS-277, -8S-DV

⁴ Requires MA-AS/MS-AS for 120 V~ applications, and MA-AS-277/MS-AS-277 for 277 V~ applications.

Job Name:	Model Numbers:
Job Number:	

Wiring Diagrams

Single Location Installation with Neutral

-F6AN-DV

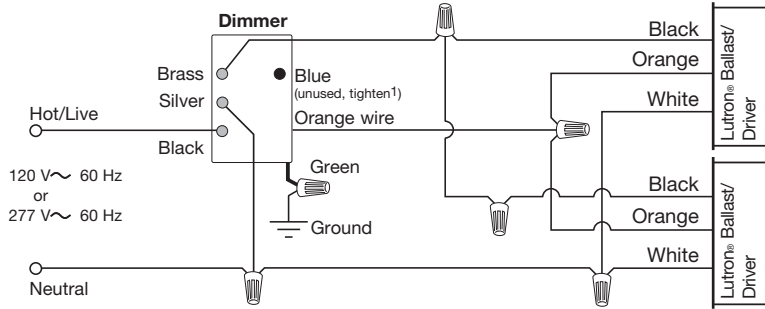

Multi-Location Installation with Neutral^{2,3}

-F6AN-DV with MA-R/MA-R-277 or MSC-AD/MS-C-AD-277⁴

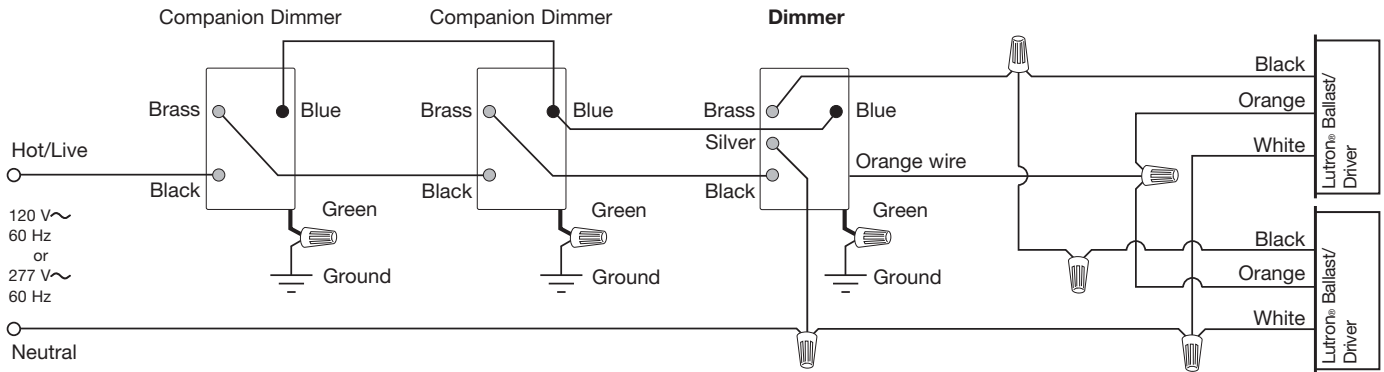

¹ When using controls in single location installations, tighten the blue terminal. **DO NOT** connect the blue terminal to any other wiring or to ground.

² Up to 9 *Maestro* Companion Dimmers may be connected to the *Maestro Wireless* Dimmer. Total blue terminal wire length may be up to 250 ft (76 m).

³ Neutral wire Dimmers must be connected on the Load side of a multi-location installation.

⁴ Requires MA-R/MS-C-AD for 120 V~ applications, and MA-R-277/MS-C-AD-277 for 277~ V applications.

Job Name:

Model Numbers:

Job Number:

Wiring Diagrams

Single Location Installation with Power Booster Single Feed

-6ANS-120, -8ANS-120 with PHPM-SW-DV-WH

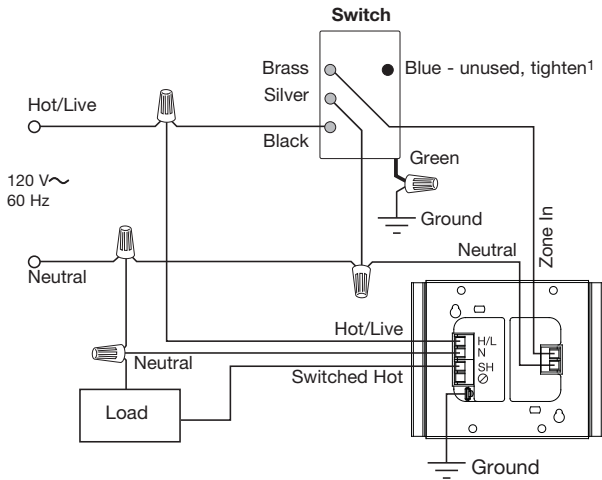

Single Location Installation with Power Booster Dual Feed

-6ANS-120, -8ANS-120 with PHPM-SW-DV-WH

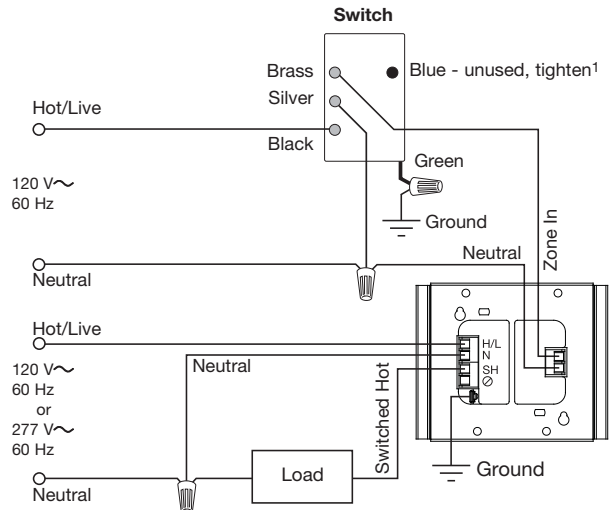

Multi-Location Installation with Power Booster^{2,3} Single Feed

-6ANS-120, -8ANS-120 with MA-AS/MSC-AS
and PHPM-SW-DV-WH

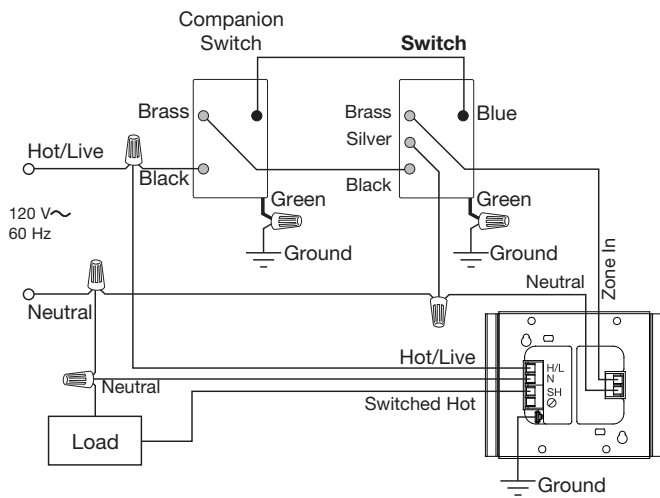

Multi-Location Installation with Power Booster^{2,3} Dual Feed

-6ANS-120, -8ANS-120 with MA-AS/MSC-AS
and PHPM-SW-DV-WH

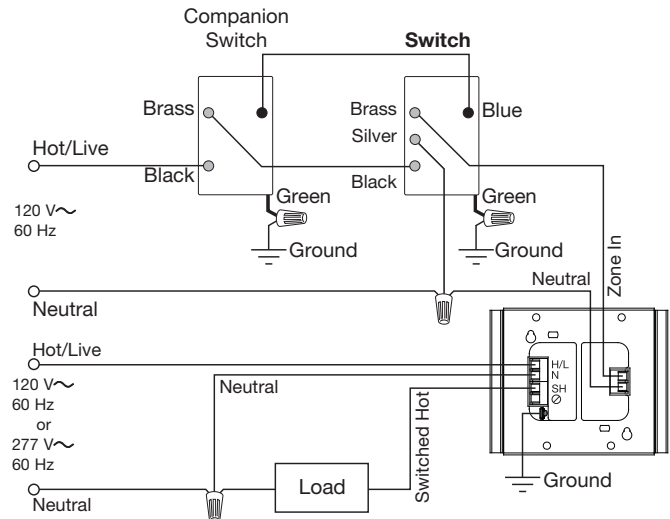

¹ When using controls in single location installations, tighten the blue terminal. **DO NOT** connect the blue terminal to any other wiring or to ground.

² Up to 9 *Maestro* Companion Switches may be connected to the *Maestro Wireless* Switch. Total blue terminal wire length may be up to 250 ft (76 m).

³ Neutral wire Switches must be connected on the Load side of a multi-location installation.

Job Name:

Model Numbers:

Job Number:

Wiring Diagrams

Single Location Installation with Power Booster Single Feed

-F6AN-DV with PHPM-3F-DV-WH, PHPM-PA-DV-WH, or PHPM-WBX-DV-WH

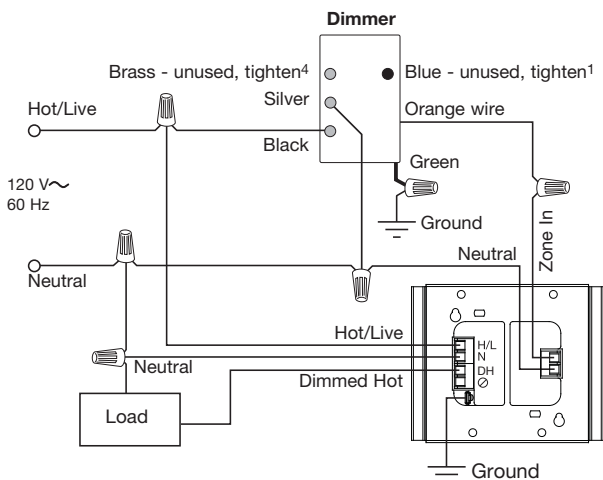

Single Location Installation with Power Booster Dual Feed

-F6AN-DV with PHPM-3F-DV-WH, PHPM-PA-DV-WH, or PHPM-WBX-DV-WH

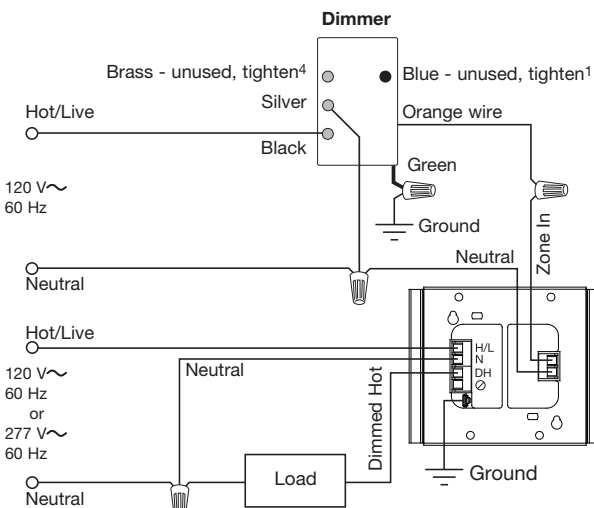

Multi-Location Installation with Power Booster^{2,3} Single Feed

-F6AN-DV with MA-R/MSC-AD and PHPM-3F-DV-WH, PHPM-PA-DV-WH, or PHPM-WBX-DV-WH

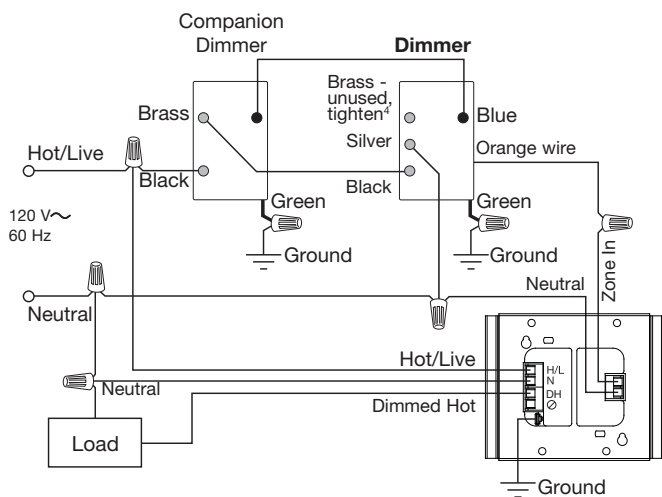

Multi-Location Installation with Power Booster^{2,3} Dual Feed

-F6AN-DV with MA-R/MSC-AD and PHPM-3F-DV-WH, PHPM-PA-DV-WH, or PHPM-WBX-DV-WH

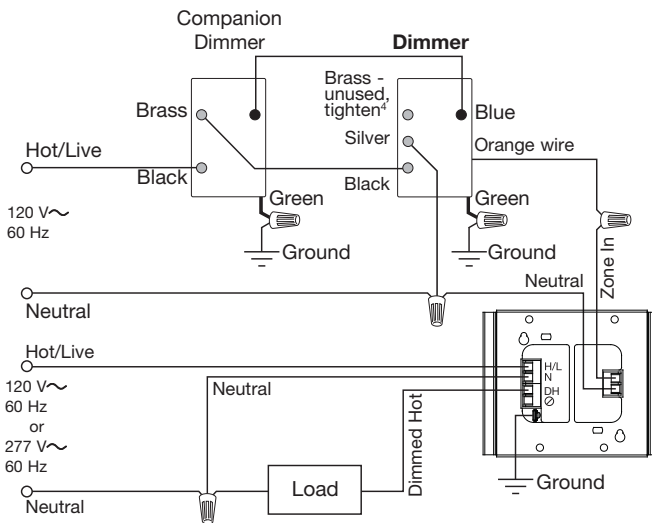

¹ When using controls in single location installations, tighten the blue terminal. **DO NOT** connect the blue terminal to any other wiring or to ground.

² Up to 9 *Maestro* Companion Dimmers may be connected to the *Maestro Wireless* Dimmer. Total blue terminal wire length may be up to 250 ft (76 m).

³ Neutral wire Dimmers must be connected on the Load side of a multi-location installation.

⁴ When using a PHPM, tighten the brass (Sw Hot) terminal of the -F6AN-DV. **DO NOT** connect the brass terminal to any other wiring or to ground.

Job Name:

Model Numbers:

Job Number:

Colors and Finishes

Gloss Finishes

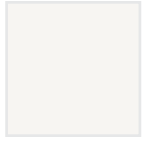

White
WH



Ivory
IV



Hot
HT



Merlot
MR



Plum
PL



Turquoise
TQ

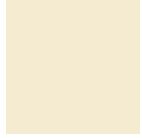

Almond
AL

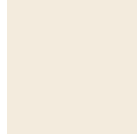

Light
Almond
LA



Taupe
TP

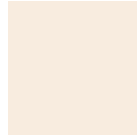

Eggshell
ES

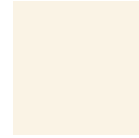

Biscuit
BI

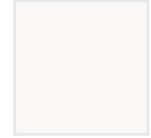

Snow
SW



Gray
GR



Brown
BR



Palladium
PD



Midnight
MN



Sienna
SI



Terracotta
TC



Black
BL



Greenbriar
GB



Bluestone
BG



Mocha
Stone
MS



Goldstone
GS

Due to printing limitations, colors and finishes shown cannot be guaranteed to perfectly match actual product colors.



Desert Stone
DS



Stone
ST



Limestone
LS

Metal Finish (wallplate only)



Stainless
Steel SS

When using Stainless Steel wallplates, it is recommended to order the controls in Black (BL) or Midnight (MN).

Job Name:

Model Numbers:

Job Number: