



## Table of Contents

.....

Overview .....	H2–H7
Conduit and Accessories .....	H8–H15
Ordinary Location Fittings .....	H16–H35
Hazardous Location Fittings .....	H36–H42
Strut and Accessories .....	H43–H46
Installation Products .....	H47–H55
Products for Corrosive Environments .....	H56–H60
Chemical Resistance.....	H61–H62
Specification Guide .....	H63–H64
CEC .....	H65–H73
Installation Guidelines .....	H74–H81
Industry Standards — NEMA .....	H82

## Overview

### Better by Design

Ocal-Blue™ PVC-coated conduit and fittings represent a complete corrosion protection package for your entire conduit system. This extensive product line includes the largest number of items in stock along with corrosion resistant supports and patching compounds. With Ocal™ PVC-coated conduit and fittings, you get corrosion protection that will extend the life of your electrical raceway system for years and years.



CAT. NO. <b>COND1-G</b>		<b>Ocal™ BLUE</b>	
 MADE IN U.S.A. QTY <b>1</b> PIECE(S)	<b>1" DARK GRAY 40 MIL</b> <b>PVC COATED HOT-DIP GALVANIZED</b> <b>ELECTRICAL RIGID METAL CONDUIT</b>		
	7 04508 26103 0		
OCAL IS A TRADEMARK OF THOMAS & BETTS CORPORATION		UL LISTED 4 ONB. @ 20-2807-20 SP PROPERTIES OF PVC INVESTIGATED AS PRIMARY CORROSION PROTECTION. PROPERTIES OF ZINC INVESTIGATED AS PRIMARY CORROSION PROTECTION. RESTRICTED FOR USE WITH THREADED FITTINGS ONLY CONSULT MANUFACTURER FOR PROPER INSTALLATION	
Memphis, TN 38125 www.tnb.com		<b>Thomas &amp; Betts</b>	

### A Complete Corrosion Protection Solution

- Industry leading thread protection through a hot-dipped galvanizing process, and industry leading UL Listed Type 4X PVC-coated conduit bodies.
- Meets the requirements of NEMA RN-1 without exception.
- A full undisturbed zinc coating under the PVC coating, fulfilling the requirement of NEMA RN-1 regarding the restriction of harmed or eroded zinc coating over the conduit.
- UL Listed and CSA Certified with both the zinc coating and the PVC coating investigated and listed per UL6 and CSA22.2 no.45.1 Standard.
- UL Listed including UV resistance testing.
- “Double-Coat” coated fittings, enhancing corrosion protection by applying coating to the interior and exterior of the fittings before PVC coating.

- Custom colors.
- On-site installation training and certification, and extended warranty on installations conducted by certified installers.

### Standards Met

- ANSI C80.1
- Federal Specification WW-C-581
- NEMA RN-1
- CSA C22.2 No. 45.1
- UL6

## Overview

### What is Corrosion?



#### Examples of corrosion

Corrosive elements cause millions of dollars in damage through lost time, materials and labor.



### Corrosion protection of electrical conduit systems

#### CORROSION PROTECTION OPTIONS

Chemical Categories	Chemical EXAMPLES	PVC	Urethane	304 Stainless Steel	316 Stainless Steel	Poly-carbonate	Cast Iron	Brass	Aluminum
<b>Compatibility Rating</b>									
<b>Solvents</b> (excluding alcohols and aliphatic)	Acetone, toluene, ketones, etc.	NR	NR	L	L	NR	L	L	L
<b>Fuels</b>	Jet fuel (alcohol based and aliphatic solvent based)	L	L	L	L	L	L	L	L
<b>Plating Solutions</b>	Chrome, nickel, copper brass, gold, zinc, etc.	L	F	F	F	F	NR	NR	NR
<b>Salts and Alkaline Materials</b>	Caustic soda, caustic potash, alkaline cleaners, etc.	L	F	L	L	F	NR	NR	NR
<b>Mild Acids</b>	Low-concentration hydrochloric, sulfuric, fruit acids, glycolic, citric, etc.	L	S	L	L	S	NR	NR	NR
<b>Strong or High-Purity Acids</b>	Nitric, hydrofluoric, etc.	S	S	F	F	S	NR	NR	NR
<b>Oxidizing Agents</b>	Bleach, chlorine, hydrogen peroxide, etc.	L	S	L	L	S	NR	NR	NR

#### CHEMICAL COMPATIBILITY LEGEND

Suitability Description	Compatibility Rating
Rated for all Fumes, Splash & Liquid	L
Rated only for Fumes & Splash	S
Rated for Fumes only	F
Not Recommended	NR

The chart **above** provides a general guide for the end-user to choose the most suitable material for his corrosion protection needs.

As you can see, PVC coated conduit and fittings are suitable for almost all applications. When it comes to PVC coated conduit systems, there is no higher quality than Ocal™.

## Overview

### Ocal™ Manufacturing Process

#### Introduction

Ocal™ is a complete PVC-coated conduit system that fully comply with all standards for proper use and protection in corrosive environments mandated by CSA 22.2 No. 45.1, UL6, NEMA RN-1 and ANSI C80.1. It is manufactured in the United States by Thomas & Betts in our Jonesboro, AR manufacturing facility.

#### The Process of Manufacturing PVC-Coated Conduit

- 1 • The process begins with 20-foot (6 meters) sticks of raw steel shell.
- 2 • The steel shell is cut, threaded and prepared for the hot-dip galvanizing process.
- 3 • The threaded shell is immersed in a molten zinc bath. This hot-dip galvanizing process enables the zinc to penetrate the steel, providing the best possible protection. After the conduit is extracted from the zinc bath, super-heated steam is blown through the interior and over the outside of the conduit to remove any slag. The ends of the conduit are heated enough to blow excess zinc out of the thread cavities.
- 4 • Prior to the exterior PVC coating, 2 mils (nominal) of blue urethane is applied to the inside diameter as well as the threads of each conduit. After priming, the conduit is heated and then rolled through liquid plastisol, achieving complete coverage of 40 mils in thickness.
- 5 • Standard colours include grey, white and blue. Custom colours are also available.



#### Superior Service

Our reputation for dependability and customer service have made Ocal™ the most trusted name in corrosion protection for the electrical industry.

CAT. NO. <b>COND1-G</b>		<b>Ocal™ BLUE</b>	
 MADE IN U.S.A. QTY <b>1</b> PIECE(S)	1" DARK GRAY 40 MIL PVC COATED HOT-DIP GALVANIZED ELECTRICAL RIGID METAL CONDUIT		UL LISTED 4 ONB. @ 20 -2807 -20 SP PROPERTIES OF PVC INVESTIGATED AS PRIMARY CORROSION PROTECTION. PROPERTIES OF ZINC INVESTIGATED AS PRIMARY CORROSION PROTECTION. RESTRICTED FOR USE WITH THREADED FITTINGS ONLY CONSULT MANUFACTURER FOR PROPER INSTALLATION
	 7 04508 26103 0		
	OCAL IS A TRADEMARK OF THOMAS & BETTS CORPORATION		
		Memphis, TN 38125 www.tnb.com	<b>Thomas &amp; Betts</b>

## Overview

### Complete Corrosion Protection

Ocal™ has developed a process for coating the interior and exterior of all fittings with a nominal 0.002 in. (2 mils) of blue urethane, which is baked on. This proprietary application of urethane enhances the corrosion protection of your system, even if you accidentally nick or cut the PVC coating during installation.

Flexible, overlapping sleeves on all Ocal™ fittings guarantee protection with a vapor- and moisture-tight seal at every connection.

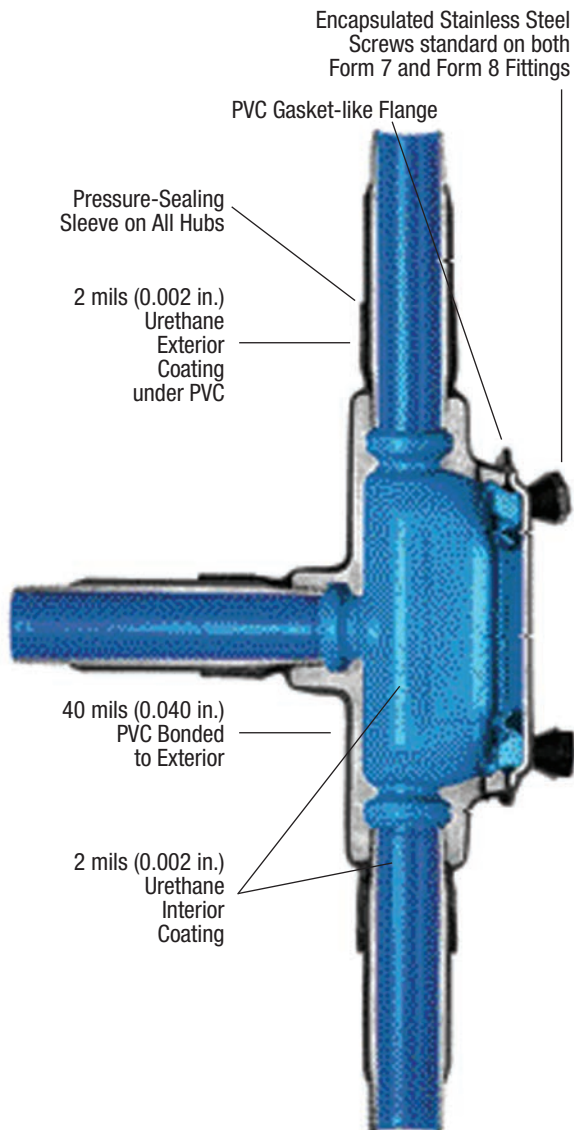
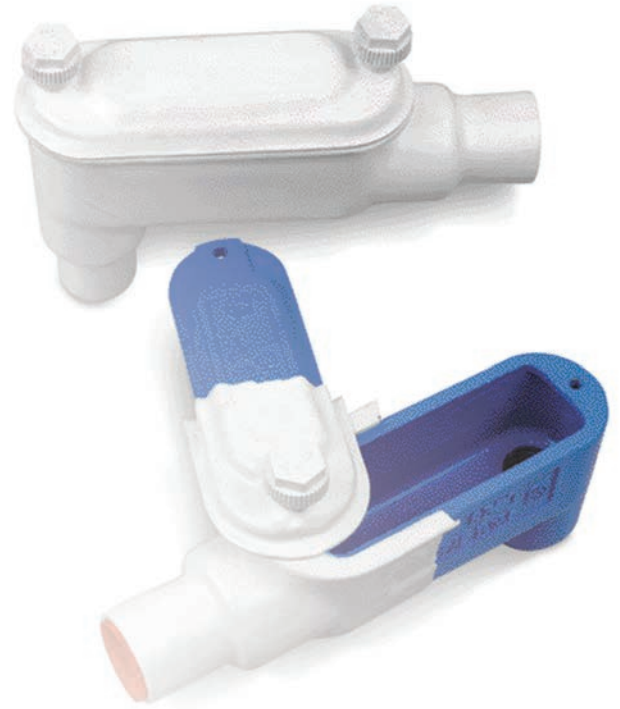

### The Process of Manufacturing PVC-Coated Fittings

- 1 • Fittings are cleaned and then sprayed inside and outside with a nominal 2 mils (0.002 in.) of blue urethane. This gives the fittings corrosion protection on the exterior as well as the interior — all fittings are “double-coated.”
- 2 • 40 mils (0.040 in.) of PVC is applied to the exterior of the fitting.
- 3 • Covers are coated with a molded flange, and conduit bodies are molded with a flat surface to ensure a superior seal.
- 4 • Standard colours include grey, white and blue. Custom colours also available.

## Overview

### Evaluating Corrosion Protection of PVC-Coated Conduit

When evaluating any electrical raceway conduit or fittings, applicable standards should be referenced. The three standards that address the design and performance of PVC-coated rigid steel conduit are ANSI C80.1, CSA 22.2 No. 45.1, UL6 and NEMA RN-1. ANSI C80.1, CSA 22.2 No. 45.1, UL and NEMA have determined the appropriate ASTM standards and test methods that apply.

#### Hot-Dip Galvanized Threads

Since electrical conduit systems breathe, the threads will be exposed to the corrosive environment for the duration of the installation. NEMA RN-1-2005 is the electrical industry's standard for PVC externally coated galvanized rigid steel conduit. Section 2.1 of this standard states, "Where unusually corrosive environments are encountered, it is recommended that threads be given additional protection suitable for the intended application." Hot-dip galvanizing is the process through which the steel shell is dipped in molten zinc, causing the zinc to penetrate the steel. Ocal™ hot-dip galvanizes the threads of the conduit, in addition to the conduit itself. This gives the threads the protection necessary in corrosive environments.

A compelling demonstration of the protection hot-dip galvanizing provides is shown at right, using a common corrosive agent, salt, on hot-dip galvanized threads versus threads that are spray galvanized. CSA 22.2 No. 45.1, UL6, the standard for rigid metal conduit, references ASTM B117 for evaluating protective coatings. At right are the results of a salt-fog test using the standard test method ASTM B117.

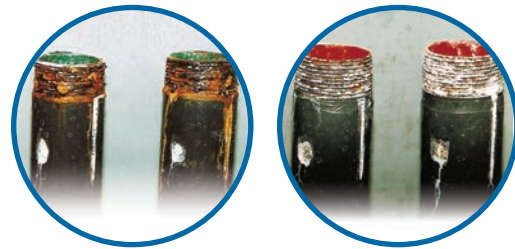

Examples of Spray-Galvanized (Hot-Galvanized) Threads after 42-day salt-fog test

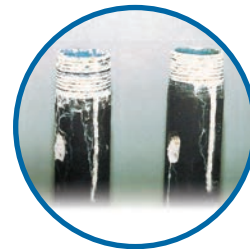

Examples of Hot-Dip Galvanized Threads after 42-day salt-fog test

### Galvanized conduit underneath the PVC coating – Preece Test

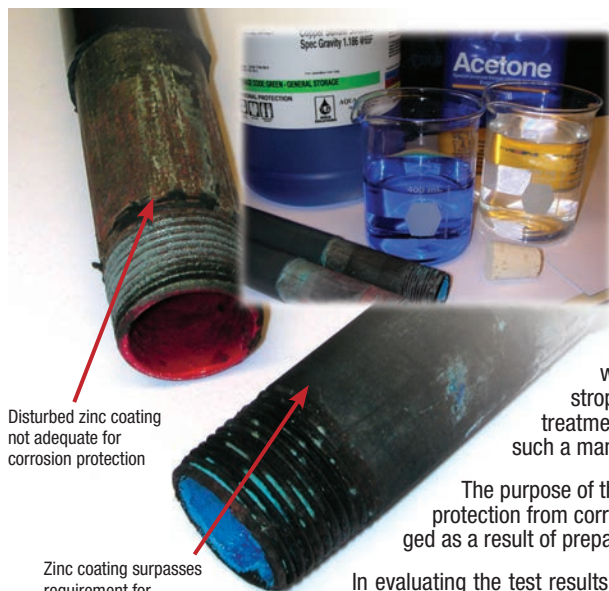

With so much riding on the integrity of their electrical conduit systems, facilities need the superior protection offered by the Thomas & Betts Ocal™ PVC-coated conduit systems. Ocal™ is a complete PVC-coated conduit system that complies fully with the design and performance standards for PVC-coated conduit set forth by CSA 22.2 No 45.1 UL6, NEMA RN-1 and ANSI C80.1.

ANSI C80.1, CSA 22.2 No. 45.1, UL6 and NEMA RN-1 have determined the appropriate ASTM standards and test methods that apply, and the Preece test is one test that must be passed to be in full compliance.

#### Why is the Preece test relevant to PVC-coated conduit?

In cases where the PVC protection is accidentally breached, resulting from cuts, scrapes, etc., it is critical to have a second line of defense — a zinc, or galvanized, coating. The zinc coating will significantly slow corrosion and allow more time for repairs. Conduit systems without adequate zinc protection underneath the PVC coating are most likely to suffer catastrophic corrosion damage. This is why NEMA RN-1 section 3.1.1 requires the proper and correct treatment of galvanized conduit before it is PVC coated. It states, "The surface shall be cleaned in such a manner that the galvanized surface of the conduit is not harmed or eroded."

The purpose of the Preece test is to evaluate the zinc coating on galvanized rigid conduit to ensure adequate protection from corrosion per UL6.2.2. The test will also determine if the surface of the conduit has been damaged as a result of preparation for PVC coating.

In evaluating the test results, the conduit receives a passing grade when the sample does not show a bright, adherent deposit of copper after four 60-second immersions in the copper sulfate solution. The conduit showing the bright, firmly adhering copper has failed to provide adequate zinc protection against corrosion.

The Preece test follows procedures set forth by UL6.2.2 and ASTM A239 and is the test recognized by CSA 22.2 No. 45.1, UL6, NEMA RN-1 and ANSI C80.1 to adequately assess zinc protection for rigid steel conduit. The Ocal™ line of PVC-coated conduit systems, manufactured by Thomas & Betts, complies with UL6, CSA 22.2 No. 45.1 NEMA RN-1 and ANSI C80.1 without exception.

## Overview

### Evaluating Adhesion of PVC Coating

The evaluation process for adhesion of PVC coating on conduit is governed by NEMA RN-1 section 3.8, Adhesion, which states, "The adhesion of the PVC coating to the conduit shall be greater than the strength of the coating itself." This adhesion test is straightforward and simple. There are no specialized conditions necessary to perform this test. Ocal™ routinely performs quality-control testing — including the adhesion test — on conduit as it rolls off the line. Conduit that passes this test demonstrates that the adhesion will provide years of trouble-free service.

The following demonstration shows Ocal™ PVC-coated conduit being subjected to the adhesion test.



Step 1 consists of two cuts through the plastic to the substrate along the length of the conduit, approximately 1/2 in. apart and 3 in. to 4 in. in length. A third, perpendicular cut crosses the lengthwise parallel cuts.



Step 2 calls for the edge of the PVC that was cut on the perpendicular to be carefully lifted to form a plastic tab.



In Step 3, the tab is pulled perpendicular to the conduit with a pair of pliers. The plastic tab will tear off rather than having any peeling effect or the coating separating from the substrate.



Step 4 is the evaluation of the test, which in this case, results in a passing grade for Ocal™. This result is more testimony to the fact that Ocal™ is "Better by Design."

## Results

With Ocal™ PVC-coated conduit and fittings, you get corrosion protection that will extend the life of your electrical raceway systems for years and years.



## Conduit and Accessories

The Ultimate in Corrosion Protection!

### OCAL-BLUE™ Conduit

- Hot-dip galvanized steel or aluminum conduit
- Nominal 0.002 in. (2 mils) blue urethane coating on interior
- Hot-dipped galvanized threads (steel)
- Minimum 0.040 in. (40 mils) PVC coating on exterior
- Colour-coded thread protectors
- Couplings shipped with conduit are packaged separately



Cat. No.		Pipe Size in. (mm)	Outside Diameter Steel Only in. (mm)	Outside Diameter With PVC in. (mm)	Nominal Wall Thickness Steel Only in. (mm)	Nominal Wall Thickness With PVC in. (mm)	Nominal Inside Diameter in. (mm)	Cross Section Area in Square in. (mm)	Length Without Couplings ft. (m)	Minimum Weight Per Foot Steel Only lb. (KG)
Steel	Aluminum									
COND1/2-	COND1/2SA-	1/2 (16)	0.84 (21.30)	0.92 (23.30)	0.10 (2.64)	0.14 (3.56)	0.63 (16.10)	0.30 (7.72)	9' 11-1/4" (3.03)	0.79 (35.83)
COND3/4-	COND3/4SA-	3/4 (21)	1.05 (26.70)	1.13 (28.70)	0.11 (2.71)	2.71 (3.73)	0.84 (21.20)	0.53 (13.53)	9' 11-1/4" (3.03)	1.05 (47.63)
COND1-	COND1SA-	1 (27)	1.32 (33.40)	1.40 (35.40)	0.13 (3.20)	0.17 (4.21)	1.06 (27.00)	0.86 (21.94)	9' 11" (3.02)	1.53 (69.40)
COND1-1/4-	COND1-1/4SA-	1-1/4 (35)	1.66 (42.20)	1.74 (44.10)	0.13 (3.37)	0.17 (4.39)	1.39 (35.40)	1.50 (37.97)	9' 11" (3.02)	2.01 (91.17)
COND1-1/2-	COND1-1/2SA-	1-1/2 (41)	1.90 (48.30)	1.98 (50.20)	0.14 (3.50)	0.18 (4.52)	1.62 (41.20)	2.04 (51.71)	9' 11" (3.02)	2.40 (112.95)
COND2-	COND2SA-	2 (53)	2.38 (60.30)	2.46 (62.30)	0.15 (3.70)	0.19 (4.72)	2.08 (52.90)	3.36 (85.21)	9' 11" (3.02)	3.32 (150.60)
COND2-1/2-	COND2-1/2SA-	2-1/2 (63)	2.88 (73.00)	2.96 (75.00)	0.19 (4.90)	0.23 (5.91)	2.49 (63.20)	4.80 (121.61)	9' 10-1/2" (3.01)	5.27 (239.05)
COND3-	COND3SA-	3 (78)	3.50 (88.90)	3.58 (90.90)	0.21 (5.20)	0.25 (6.22)	3.09 (78.50)	7.39 (187.80)	9' 10-1/2" (3.01)	6.83 (309.63)
COND3-1/2-	COND3-1/2SA-	3-1/2 (91)	4.00 (101.60)	4.08 (103.60)	0.22 (5.46)	0.26 (6.47)	3.57 (90.70)	9.87 (250.60)	9' 10-1/4" (3.00)	8.31 (376.94)
COND4-	COND4SA-	4 (103)	4.50 (114.30)	4.58 (116.30)	0.23 (5.71)	0.27 (6.73)	4.05 (102.90)	12.73 (323.34)	9' 10-1/4" (3.00)	9.73 (441.04)
*COND5-	COND5SA-	5 (129)	5.56 (141.30)	5.64 (143.30)	0.25 (6.22)	0.29 (7.23)	5.07 (128.90)	20.01 (508.15)	9' 10" (3.00)	13.14 (595.85)
*COND6-	COND6SA-	6 (155)	6.63 (168.30)	6.71 (170.30)	0.27 (6.75)	0.31 (7.87)	6.09 (154.80)	28.89 (733.83)	9' 10" (3.00)	17.46 (791.67)

Metric size designator (ANSI C80.1-1994). \* Not CSA certified.

Cat. No.	Size	Material	Colour
<b>COND</b>	<b>3/4</b>	<b>-</b>	<b>_ = space for colour identifier</b>
		Blank = Steel SA = Aluminum	G = Grey W = White B = Blue R = Red
<p>Catalogue No. Example: COND3/4-G is 3/4 in. steel conduit coated in grey PVC.</p>			<p>Custom colours also available - Std. min. quantities are required. Please contact your Regional Sales Office.</p>



## Conduit and Accessories

### Corrosion-Protected Connections for Conduit Sections

#### OCAL-BLUE™ Couplings

- Nominal 0.002 in. (2 mils) blue urethane coating on interior and threads
- Minimum 0.040 in. (40 mils) PVC coating bonded to exterior
- Couplings have straight threads (NPS), not tapered
- Molded ribs on outer coating for easy installation (up to and including 4 in. trade size)
- Couplings have pressure-sealing sleeves to protect your connection



Cat. No.		Coupling Size in. (mm)	Minimum Length of Metal in. (mm)	Total Minimum Length Including Sleeve in. (mm)	Weight Steel Only lb./kg
Steel	Aluminum				
CPL1/2-	CPL1/2SA-	1/2 (16)	1.50 (38.10)	3.75 (95.25)	0.13 (0.6)
CPL3/4-	CPL3/4SA-	3/4 (21)	1.53 (38.91)	3.75 (95.25)	0.19 (0.85)
CPL1-	CPL1SA-	1 (27)	1.91 (48.41)	4.94 (139.70)	0.33 (0.15)
CPL1-1/4-	CPL1-1/4SA-	1-1/4 (35)	1.91 (48.41)	5.50 (139.70)	0.43 (.19)
CPL1-1/2-	CPL1-1/2SA-	1-1/2 (41)	1.91 (48.41)	5.75 (146.05)	0.56 (.25)
CPL2-	CPL2SA-	2 (53)	1.94 (49.19)	5.94 (150.79)	0.77 (.35)
CPL2-1/2-	CPL2-1/2SA-	2-1/2 (63)	2.88 (73.10)	6.88 (174.70)	1.85 (.83)
CPL3-	CPL3SA-	3 (78)	3.03 (76.98)	7.03 (178.58)	2.70 (1.22)
CPL3-1/2-	CPL3-1/2SA-	3-1/2 (91)	3.09 (78.58)	7.09 (180.18)	3.78 (1.70)
CPL4-	CPL4SA-	4 (103)	3.19 (80.97)	7.19 (182.57)	3.08 (1.39)
*CPL5-	CPL5SA-	5 (129)	3.37 (85.69)	7.37 (187.29)	5.00 (2.25)
*CPL6-	CPL6SA-	6 (155)	3.44 (87.29)	7.44 (188.89)	8.00 (3.60)

Metric size designator (ANSI C80.1-1994). \*Not CSA certified.

Cat. No.	Size	Material	Colour
<b>CPL</b>	<b>3/4</b>	<b>SA-</b>	<b>_ = space for colour identifier</b>
		Blank = Steel	G = Grey
		SA = Aluminum	W = White
			B = Blue
			R = Red
<p><i>Catalogue No. Example:</i>  <b>CPL1SA-B</b> is 1 in. aluminum coupling coated in blue PVC.</p>			
<p>Custom colours also available - Std. min. quantities are required. Please contact your Regional Sales Office.</p>			

## Conduit and Accessories

### Join Threaded Conduit Where You Can't Use a Standard Coupling

#### OCAL-BLUE™ Double-Coat Split Couplings

Split couplings serve as speed unions for cost-effective joining of two separate lengths of threaded conduit. Like other Ocal™ fittings, they're double coated in urethane and PVC to safeguard your entire conduit system against corrosion.

- Malleable iron construction
- Nominal 0.002 in. (2 mils) blue urethane on both interior and exterior
- Minimum 0.040 in. (40 mils) PVC bonded to exterior
- Stainless steel hardware included



Cat. No.	Colour	
<b>TCC1-</b>	_ = space for colour identifier	
	G = Grey	
	W = White	
	B = Blue	
	R = Red	

Custom colours also available - Std. min. quantities are required. Please contact your Regional Sales Office.

NOTE — The use of standard couplings is recommended whenever possible over the use of split couplings, because standard couplings provide better overall corrosion protection.

Cat. No.	Pipe Size in. (mm)
TCC1- <u>  </u>	1/2 (16)
TCC2- <u>  </u>	3/4 (21)
TCC3- <u>  </u>	1 (27)
TCC4- <u>  </u>	1-1/4 (35)
TCC5- <u>  </u>	1-1/2 (41)
TCC6- <u>  </u>	2 (53)

Metric size designator (ANSI C80.1-1994). \* Not CSA certified.

Cat. No.	Pipe Size in. (mm)
TCC7- <u>  </u>	2-1/2 (63)
TCC8- <u>  </u>	3 (78)
TCC9- <u>  </u>	3-1/2 (91)
TCC10- <u>  </u>	4 (103)
*TCC12- <u>  </u>	5 (129)
*TCC14- <u>  </u>	6 (155)

## Speed Up Your Field Installations with Pre-Threaded Conduit Nipples!

#### OCAL-BLUE™ Nipples

- Made from Ocal™ PVC-coated steel or aluminum conduit
- Blue urethane coating over threads
- Nominal 0.002 in. (2 mils) blue urethane on interior
- Minimum 0.040 in. (40 mils) PVC coating on exterior
- Colour-coded thread protectors for easy identification of conduit size
- Available in 11 standard lengths — close and 2 in. to 12 in. with custom lengths available on request
- Close nipples are coated only in urethane



Cat. No.	Size X Length	Material	Colour	
<b>NPL</b>	<b>3/4 X 6</b>	—	_ = space for colour identifier	
		Blank = Steel SA = Aluminum	G = Grey	
			W = White	
			B = Blue	
			R = Red	

Catalogue No. Example:  
NPL3/4X6-G is 3/4 in. x 6 in. long steel nipple coated in grey PVC.

Custom colours also available - Std. min. quantities are required. Please contact your Regional Sales Office.

# Conduit and Accessories

## OCAL-BLUE™ NIPPLES (cont'd)



### PVC-Coated Conduit Nipples — Steel

Pipe Size in. (mm)	Nipple Length										
	Close	2 (50.8)	2-1/2 (63.5)	3 (76.2)	3-1/2 (88.9)	4 (101.6)	5 (127.0)	6 (152.4)	8 (203.2)	10 (254.0)	12 (304.8)
1/2 (6)	CLNPL1/2-	NPL1/2X2-	NPL1/2X21/2-	NPL1/2X3-	NPL1/2X31/2-	NPL1/2X4-	NPL1/2X5-	NPL1/2X6-	NPL1/2X8-	NPL1/2X10-	NPL1/2X12-
3/4 (21)	CLNPL3/4-	NPL3/4X2-	NPL3/4X21/2-	NPL3/4X3-	NPL3/4X31/2-	NPL3/4X4-	NPL3/4X5-	NPL3/4X6-	NPL3/4X8-	NPL3/4X10-	NPL3/4X12-
1 (27)	CLNPL1-	NPL1X2-	NPL1X21/2-	NPL1X3-	NPL1X31/2-	NPL1X4-	NPL1X5-	NPL1X6-	NPL1X8-	NPL1X10-	NPL1X12-
1-1/4 (35)	CLNPL11/4-	NPL11/4X2-	NPL11/4X21/2-	NPL11/4X3-	NPL11/4X31/2-	NPL11/4X4-	NPL11/4X5-	NPL11/4X6-	NPL11/4X8-	NPL11/4X10-	NPL11/4X12-
1-1/2 (41)	CLNPL11/2-	NPL11/2X2-	NPL11/2X21/2-	NPL11/2X3-	NPL11/2X31/2-	NPL11/2X4-	NPL11/2X5-	NPL11/2X6-	NPL11/2X8-	NPL11/2X10-	NPL11/2X12-
2 (53)	CLNPL2-	—	NPL2X21/2-	NPL2X3-	NPL2X31/2-	NPL2X4-	NPL2X5-	NPL2X6-	NPL2X8-	NPL2X10-	NPL2X12-
2-1/2 (63)	CLNPL21/2-	—	—	—	NPL21/2X31/2-	NPL21/2X4-	NPL21/2X5-	NPL21/2X6-	NPL21/2X8-	NPL21/2X10-	NPL21/2X12-
3 (78)	CLNPL3-	—	—	—	NPL3X31/2-	NPL3X4-	NPL3X5-	NPL3X6-	NPL3X8-	NPL3X10-	NPL3X12-
3-1/2 (91)	CLNPL31/2-	—	—	—	—	NPL31/2X4-	NPL31/2X5-	NPL31/2X6-	NPL31/2X8-	NPL31/2X10-	NPL31/2X12-
4 (103)	CLNPL4-	—	—	—	—	NPL4X4-	NPL4X5-	NPL4X6-	NPL4X8-	NPL4X10-	NPL4X12-
*5 (129)	CLNPL5-	—	—	—	—	—	NPL5X5-	NPL5X6-	NPL5X8-	NPL5X10-	NPL5X12-
*6 (155)	CLNPL6-	—	—	—	—	—	NPL6X5-	NPL6X6-	NPL6X8-	NPL6X10-	NPL6X12-

### PVC-Coated Conduit Nipples — Aluminum

Pipe Size in. (mm)	Nipple Length										
	Close	2 (50.8)	2-1/2 (63.5)	3 (76.2)	3-1/2 (88.9)	4 (101.6)	5 (127.0)	6 (152.4)	8 (203.2)	10 (254.0)	12 (304.8)
1/2 (6)	CLNPL1/2SA-	NPL1/2X2SA-	NPL1/2X21/2SA-	NPL1/2X3SA-	NPL1/2X31/2SA-	NPL1/2X4SA-	NPL1/2X5SA-	NPL1/2X6SA-	NPL1/2X8SA-	NPL1/2X10SA-	NPL1/2X12SA-
3/4 (21)	CLNPL3/4SA-	NPL3/4X2SA-	NPL3/4X21/2SA-	NPL3/4X3SA-	NPL3/4X31/2SA-	NPL3/4X4SA-	NPL3/4X5SA-	NPL3/4X6SA-	NPL3/4X8SA-	NPL3/4X10SA-	NPL3/4X12SA-
1 (27)	CLNPL1SA-	NPL1X2SA-	NPL1X21/2SA-	NPL1X3SA-	NPL1X31/2SA-	NPL1X4SA-	NPL1X5SA-	NPL1X6SA-	NPL1X8SA-	NPL1X10SA-	NPL1X12SA-
1-1/4 (35)	CLNPL11/4SA-	NPL11/4X2SA-	NPL11/4X21/2SA-	NPL11/4X3SA-	NPL11/4X31/2SA-	NPL11/4X4SA-	NPL11/4X5SA-	NPL11/4X6SA-	NPL11/4X8SA-	NPL11/4X10SA-	NPL11/4X12SA-
1-1/2 (41)	CLNPL11/2SA-	NPL11/2X2SA-	NPL11/2X21/2SA-	NPL11/2X3SA-	NPL11/2X31/2SA-	NPL11/2X4SA-	NPL11/2X5SA-	NPL11/2X6SA-	NPL11/2X8SA-	NPL11/2X10SA-	NPL11/2X12SA-
2 (53)	CLNPL2SA-	—	NPL2X21/2SA-	NPL2X3SA-	NPL2X31/2SA-	NPL2X4SA-	NPL2X5SA-	NPL2X6SA-	NPL2X8SA-	NPL2X10SA-	NPL2X12SA-
2-1/2 (63)	CLNPL21/2SA-	—	—	—	NPL21/2X31/2SA-	NPL21/2X4SA-	NPL21/2X5SA-	NPL21/2X6SA-	NPL21/2X8SA-	NPL21/2X10SA-	NPL21/2X12SA-
3 (78)	CLNPL3SA-	—	—	—	NPL3X31/2SA-	NPL21/2X4SA-	NPL3X5SA-	NPL3X6SA-	NPL3X8SA-	NPL3X10SA-	NPL3X12SA-
3-1/2 (91)	CLNPL31/2SA-	—	—	—	—	NPL31/2X4SA-	NPL31/2X5SA-	NPL31/2X6SA-	NPL31/2X8SA-	NPL31/2X10SA-	NPL31/2X12SA-
4 (103)	CLNPL4SA-	—	—	—	—	NPL4X4SA-	NPL4X5SA-	NPL4X6SA-	NPL4X8SA-	NPL4X10SA-	NPL4X12SA-
*5 (129)	CLNPL5SA-	—	—	—	—	—	NPL5X5SA-	NPL5X6SA-	NPL5X8SA-	NPL5X10SA-	NPL5X12SA-
*6 (155)	CLNPL6SA-	—	—	—	—	—	NPL6X5SA-	NPL6X6SA-	NPL6X8SA-	NPL6X10SA-	NPL6X12SA-

Metric size designator (ANSI C80.1-1994). \* Not CSA certified.

## Conduit and Accessories

Factory Bent to Save Time and Materials!

### OCAL-BLUE™ Standard-Radius Elbows

- Fabricated from Ocal™ PVC-coated conduit
- Standard radius is 90°, and is available for immediate shipment
- Colour-coded thread protectors for easy identification of conduit size
- Special radius and degrees (30°, 45° and 60°) not listed are also available upon request



### 90° Standard-Radius Elbows

Cat. No.		Pipe Size	Radius "R"	Offset "C"	Straight End "D"	Unbent Length	Weight Each Steel Only
Steel	Aluminum	in. (mm)	in. (mm)	in. (mm)	in. (mm)	in. (mm)	lb. (kg)
ELL1/2-_-	ELL1/2-_-SA-_-	1/2 (16)	4.00 (101.60)	6.00 (152.40)	2.00 (50.80)	10.28 (261.19)	0.67 (16.95)
ELL3/4-_-	ELL3/4-_-SA-_-	3/4 (21)	4.50 (114.30)	6.50 (165.10)	2.00 (50.80)	11.07 (281.14)	0.95 (24.07)
ELL1-_-	ELL1-_-SA-_-	1 (27)	5.75 (146.05)	8.00 (203.20)	2.25 (57.15)	13.53 (343.71)	1.77 (44.97)
ELL1-1/4-_-	ELL1-1/4-_-SA-_-	1-1/4 (35)	7.25 (184.15)	9.50 (241.30)	2.25 (57.15)	15.89 (403.56)	2.55 (64.80)
ELL1-1/2-_-	ELL1-1/2-_-SA-_-	1-1/2 (41)	8.25 (209.55)	11.00 (279.40)	2.75 (69.85)	18.46 (468.86)	3.98 (101.13)
ELL2-_-	ELL2-_-SA-_-	2 (53)	9.50 (241.30)	13.00 (330.20)	3.50 (88.90)	21.92 (556.83)	6.33 (160.86)
ELL2-1/2-_-	ELL2-1/2-_-SA-_-	2-1/2 (63)	10.50 (266.70)	14.00 (355.60)	3.50 (88.90)	23.49 (596.73)	9.65 (245.09)
ELL3-_-	ELL3-_-SA-_-	3 (78)	13.00 (330.20)	16.50 (419.10)	3.50 (88.90)	27.42 (696.48)	15.42 (391.77)
ELL3-1/2-_-	ELL3-1/2-_-SA-_-	3-1/2 (91)	15.00 (381.00)	20.75 (527.05)	5.75 (146.05)	35.06 (890.57)	23.30 (591.84)
ELL4-_-	ELL4-_-SA-_-	4 (103)	16.00 (406.40)	21.75 (552.45)	5.75 (146.05)	36.63 (930.47)	29.68 (753.80)
*ELL5-_-	ELL5-_-SA-_-	5 (129)	24.00 (609.60)	31.00 (787.40)	7.00 (177.80)	51.70 (1313.16)	60.82 (1544.89)
*ELL6-_-	ELL6-_-SA-_-	6 (155)	30.00 (762.00)	39.00 (990.60)	9.00 (228.60)	65.12 (1654.15)	85.69 (2176.51)

Metric size designator (ANSI C80.1-1994). \* Not CSA certified.

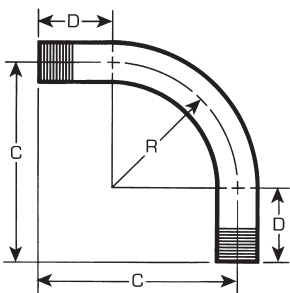

Cat. No.	Pipe Size	Angle	Material	Colour
<b>ELL</b>	<b>3/4</b>	-	-	- = space for colour identifier
		30 = 30°	Blank = Steel	G = Grey
		45 = 45°	SA = Aluminum	W = White
		60 = 60°		B = Blue
		Blank = 90°		R = Red

*Catalogue No. Example:*  
**ELL3/4SA-W** is a 3/4 in. trade size 90° aluminum elbow coated in white PVC.

Custom colours also available - Std. min. quantities are required. Please contact your Regional Sales Office.

## Conduit and Accessories

Choose the Size and Angle to Meet your Exact Requirements

### OCAL-BLUE™ Large-Radius Elbows

- Fabricated from Ocal™ PVC-coated conduit
- Standard radius in 90° available for immediate shipment
- Special radius and degrees not listed are also available upon request
- Colour-coded thread protectors for easy identification of conduit size



Cat. No.		Pipe Size in. (mm)	Radius "R"	Offset "C"	Straight End "D"	Unbent Length
Steel	Aluminum		in. (mm)	in. (mm)	in. (mm)	in. (mm)
LRELL_X12-_-	LRELL_X12-_-SA-	1 - 2-1/2 (27 - 63)	12.00 (304.80)	1.9 (533.40)	9.00 (228.60)	3.00 (914.40)
LRELL_X15-_-	LRELL_X15-_-SA-	1 - 3 (27 - 78)	15.00 (381.00)	2.00 (609.60)	9.00 (228.60)	3.6 (1066.80)
LRELL_X18-_-	LRELL_X18-_-SA-	1 - 4 (27 - 103)	18.00 (457.20)	2.4 (711.20)	10.00 (254.00)	4.00 (1219.20)
LRELL_X24-_-	LRELL_X24-_-SA-	1 - 4 (27 - 103)	24.00 (609.60)	2.11 (889.00)	11.00 (279.40)	4.11 (1498.60)
LRELL_X30-_-	LRELL_X30-_-SA-	1 - 6 (27 - 155)	30.00 (762.00)	3.5 (1041.40)	11.00 (279.40)	5.9 (1752.60)
LRELL_X36-_-	LRELL_X36-_-SA-	1 - 6 (27 - 155)	36.00 (914.40)	3.11 (1193.80)	11.00 (279.40)	6.6 (1981.20)
LRELL_X42-_-	LRELL_X42-_-SA-	1 - 6 (27 - 155)	42.00 (1066.80)	4.6 (1371.60)	12.00 (304.80)	7.6 (2286.00)
LRELL_X48-_-	LRELL_X48-_-SA-	1 - 6 (27 - 155)	48.00 (1219.20)	5.00 (1524.00)	12.00 (304.80)	8.6 (2590.80)
LRELL_X60-_-	LRELL_X60-_-SA-	2-1/2 - 6 (63 - 155)	60.00 (1524.00)	6.00 (1828.80)	12.00 (304.80)	9.10 (2997.20)

Metric size designator (ANSI C80.1-1994). #5 and 6 inch not CSA certified.

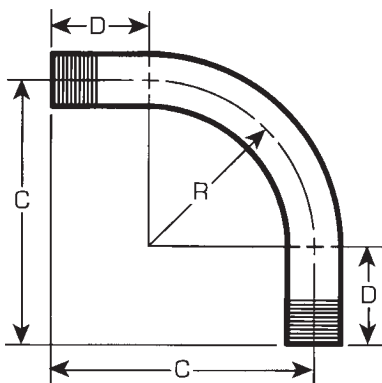

Cat. No.	Pipe Size	Radius	Angle	Material	Colour
<b>LRELL</b>	<b>X12</b>	-	-	-	<b>_ = space for colour identifier</b>
	1 = 1"	30 = 30°	Blank = Steel SA = Aluminum	G = Grey	
	2 = 2"	45 = 45°		W = White	
	etc.	60 = 60°		B = Blue	
		Blank = 90°		R = Red	

*Catalogue No. Example:*  
**LRELL3X18-45-G** is a 3" trade size steel elbow with a radius of 18" and an angle of 45°, coated in grey PVC

Custom colours also available - Std. min. quantities are required. Please contact your Regional Sales Office.

## Conduit and Accessories

PVC Coating Evenly Molded Around Saddle  
Prevents Exposure of Metal – an Ocal™ Exclusive!

### Ocal™ PVC-Coated Beam Clamps and U-Bolts

- Beam clamps support and attach conduit runs to structural beams
- Molded right-angle beam clamps and U-bolts provide extra protection
- Nuts are encapsulated, (RA) providing complete protection.
- Hex-shaped nuts fit standard wrenches
- Stainless steel hardware included
- Parallel (PAR) and edge (EC) clamps feature nominal 0.015 in. (15 mils) PVC coating for corrosion protection
- Right-Angle clamps (RA) and U-Bolts (UB) feature nominal 0.040 in. (40 mils) PVC coating for corrosion protection
- The coating is evenly molded around the saddle to prevent exposure to metal



Parallel (PAR)



Edge (EC)



Right Angle (RA)

Cat. No.	Size	Colour
<b>RA1-</b>	—	_ = space for colour identifier
		G = Grey
		W = White
		B = Blue
Custom colours also available - Std. min. quantities are required. Please contact your Regional Sales Office.		

### PVC-Coated Beam Clamps

Cat. No.			Pipe Size	
Right Angle	Parallel	Edge	in.	(mm)
RA1/2- <sub>_</sub>	PAR1/2- <sub>_</sub>	EC1/2- <sub>_</sub>	1/2	(16)
RA3/4- <sub>_</sub>	PAR3/4- <sub>_</sub>	EC3/4- <sub>_</sub>	3/4	(21)
RA1- <sub>_</sub>	PAR1- <sub>_</sub>	EC1- <sub>_</sub>	1	(27)
RA1-1/4- <sub>_</sub>	PAR1-1/4- <sub>_</sub>	EC1-1/4- <sub>_</sub>	1-1/4	(35)
RA1-1/2- <sub>_</sub>	PAR1-1/2- <sub>_</sub>	EC1-1/2- <sub>_</sub>	1-1/2	(41)
RA2- <sub>_</sub>	PAR2- <sub>_</sub>	EC2- <sub>_</sub>	2	(53)
RA2-1/2- <sub>_</sub>	PAR2-1/2- <sub>_</sub>	—	2-1/2	(63)
RA3- <sub>_</sub>	PAR3- <sub>_</sub>	—	3	(78)
RA3-1/2- <sub>_</sub>	PAR3-1/2- <sub>_</sub>	—	3-1/2	(91)
RA4- <sub>_</sub>	PAR4- <sub>_</sub>	—	4	(103)

### U-Bolts

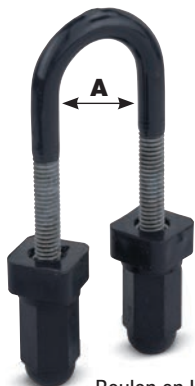

Boulon en U (UB)

Cat. No.	Size	Colour
<b>UB1-</b>	—	_ = space for colour identifier
		G = Grey
		W = White
		B = Blue
Custom colours also available - Std. min. quantities are required. Please contact your Regional Sales Office.		

Cat. No.	Pipe Size		"A" Dimension	
	in.	(mm)	in.	(mm)
UB1/2- <sub>_</sub>	1/2	(16)	1.38	(34.93)
UB3/4- <sub>_</sub>	3/4	(21)	1.56	(39.69)
UB1- <sub>_</sub>	1	(27)	1.84	(46.83)
UB1-1/4- <sub>_</sub>	1-1/4	(35)	2.19	(55.56)
UB1-1/2- <sub>_</sub>	1-1/2	(41)	2.50	(63.50)
UB2- <sub>_</sub>	2	(53)	2.97	(75.41)
UB2-1/2- <sub>_</sub>	2-1/2	(63)	3.47	(88.11)
UB3- <sub>_</sub>	3	(78)	4.09	(103.98)
UB3-1/2- <sub>_</sub>	3-1/2	(91)	4.59	(116.68)
UB4- <sub>_</sub>	4	(103)	5.09	(129.38)
UB5- <sub>_</sub>	5	(129)	6.63	(168.28)
UB6- <sub>_</sub>	6	(155)	8.00	(203.20)

Metric size designator (ANSI C80.1-1994).

## Conduit and Accessories

### Support Conduit on Walls and Structures

#### Pipe Straps — PVC Coated

- Available in malleable iron/stamped steel with nominal 0.015 in (15 mils) PVC coating in your choice of blue, white or grey
- Choose one- or two-hole versions
- Sized to allow for the extra thickness of the PVC coating

Colour	
Suffix = colour identifier	
G = Grey	
W = White	
B = Blue	
Custom colours also available - Std. min. quantities are required. Please contact your Regional Sales Office.	

#### Pipe Spacers — PVC Coated

Corrosion resistant PVC coated malleable iron. Pre-mountable, stackable to eliminate offsetting.

Spacers can be stacked for offsets on wall or into outlet box. Prevents conduit rusting from wall condensation. Eliminates offsetting of conduit.

One Hole Pipe Straps



Fig. 1



Fig. 2



Fig. 3



Fig. 4

Pipe Spacers



1350CR Serie



CB21/2-G

Two Hole Pipe Straps

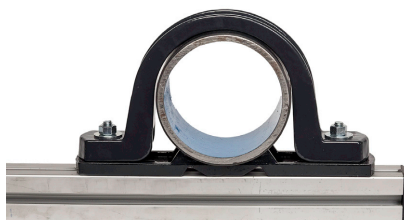

Fig. 5



Cat. No. Pipe Strap	Pipe Size (in.)	Material	Figure	Cat. No. Pipe Spacers
<b>One Hole Pipe Straps</b>				
1277CR*	1/2	Malleable iron	1	1350CR*
1278CR*	3/4	Malleable iron	1	
1HS1C-G**	1	Steel	2	
1HMS11/4-G**	1-1/4	Malleable iron	3	1351CR*
1280CR*	1-1/2	Malleable iron	1	
1HMS2-C-G	2	Malleable iron	4	
1HMS21/2-C-G	2-1/2	Malleable iron		CB21/2-G**
1HMS3-C-G	3	Malleable iron		CB3-G**
1HMS4-C-G	4	Malleable iron		CB4-G**

\* CSA Certified  
\*\* UL not applicable



Cat. No. Pipe Strap	Pipe Size (in.)	Material	Figure	Cat. No. Pipe Spacers
<b>Two Hole Pipe Straps</b>				
2HMS2-C-G	2	Malleable iron	5	2HMCB2-21/2-C-G
2HMS21/2-C-G	2-1/2	Malleable iron		
2HMS3-C-G	3	Malleable iron		2HMCB3-4-C-G
2HMS4-C-G	4	Malleable iron		

## Ordinary Location Fittings

Easy Access for Pulling, Splicing, Mounting and Maintenance!

### OCAL-BLUE™ Double-Coat Conduit Bodies

With OCAL-BLUE™ Double-Coat Conduit Bodies, you can connect sections of conduit — with or without 90° bends — and provide easy access for wire pulling, making splices in branch conductors and maintenance and future system changes. Conduit bodies can also serve as mounting outlets for wiring devices and lighting fixtures.

- Flat surface molded on conduit body seals with molded flange on cover
- Available in Form 7 and Form 8 ferrous as well as Mark 9 and Form 7 aluminum
- All OCAL-BLUE™ conduit bodies offer double corrosion protection — both bodies and covers coated inside and out with a nominal 0.002 in. (2 mils) blue urethane, then exterior coated with a nominal 0.040 in. (40 mils) PVC
- All threaded hubs fitted with pressure-sealing sleeves
- Conduit bodies ship complete with covers and encapsulated stainless steel screws
- Covers also sold separately for replacement or retrofit purposes



3/4 in. B Form 8 conduit body and cover



2-1/2 in. LB Form 8 conduit body and cover



2-1/2 in. LB Form 7 conduit body and cover



3/4 in. X Form 7 conduit body and cover



3/4 in. LB Mark 9 conduit body and cover

Cat. No.	Material	Colour
<b>LB27</b>	<b>-</b>	<b>_ = space for colour identifier</b>
	Blank = Steel	G = Grey
	SA = Aluminum	W = White
		B = Blue
		R = Red
<i>Catalogue No. Example:</i> <b>LB27-W</b> is 3/4 in. LB ferrous conduit body and cover coated in white PVC.		
Custom colours also available - Std. min. quantities are required. Please contact your Regional Sales Office.		



Up to and including 2 in.



## Ordinary Location Fittings

### OCAL-BLUE™ Conduit Bodies Quick Reference



Up to and including 2 in.

NOTE: Fittings shown uncoated			Size in. (mm) 1/2 in. to 2 in.*								
Shape	Style	1/2 (16)	3/4 (21)	1 (27)	1-1/4 (35)	1-1/2 (41)	2 (53)	2-1/2 (63)	3 (78)	3-1/2 (91)	4 (103)
	Form 7	C17-	C27-	C37-	C47-	C57-	C67-	C77-	C87-	—	—
	Form 8	C18-	C28-	C38-	C448-	C58-	C68-	C78-	C88-	—	—
	Mark 9	C19-	C29-	C39-	C49-	C59-	C69-	C789-	C889-	C989-	C1089-
	Form 7 Aluminum	C17SA-	C27SA-	C37SA-	C47SA-	C57SA-	C67SA-	C77SA-	C87SA-	—	—
	Form 7	L17-	L27-	L37-	L47-	L57-	L67-	—	—	—	—
	Form 7 Aluminum	L17SA-	L27SA-	L37SA-	L47SA-	L57SA-	L67SA-	—	—	—	—
	Double faced — may be use as LL or LR — has 2 openings. Not CSA certified										
	Form 7	LB17-	LB27-	LB37-	LB47-	LB57-	LB67-	LB777-	LB87-	LB97-	LB107-
	Form 8	LB18-	LB28-	LB38-	LB448-	LB58-	LB68-	LB78-	LB888-	LB98-	LB108-
	Mark 9	LB19-	LB29-	LB39-	LB49-	LB59-	LB69-	LB789-	LB889-	LB989-	LB1089-
	Form 7 Aluminum	LB17SA-	LB27SA-	LB37SA-	LB47SA-	LB57SA-	LB67SA-	LB777SA-	LB87SA-	LB97SA-	LB107SA-
	Form 7	LL17-	LL27-	LL37-	LL47-	LL57-	LL67-	LL777-	LL87-	LL97-	LL107-
	Form 8	LL18-	LL28-	LL38-	LL448-	LL58-	LL68-	LL78-	LL888-	—	—
	Mark 9	LL19-	LL29-	LL39-	LL49-	LL59-	LL69-	LL789-	LL889-	LL989-	LL1089-
	Form 7 Aluminum	LL17SA-	LL27SA-	LL37SA-	LL47SA-	LL57SA-	LL67SA-	LL777SA-	LL87SA-	LL97SA-	LL107SA-
	Form 7	LR17-	LR27-	LR37-	LR47-	LR57-	LR67-	LR777-	LR87-	LR97-	LR107-
	Form 8	LR18-	LR28-	LR38-	LR448-	LR58-	LR68-	LR78-	LR888-	—	—
	Mark 9	LR19-	LR29-	LR39-	LR49-	LR59-	LR69-	LR789-	LR889-	LR989-	LR1089-
	Form 7 Aluminum	LR17SA-	LR27SA-	LR37SA-	LR47SA-	LR57SA-	LR67SA-	LR777SA-	LR87SA-	LR97SA-	LR107SA-
	Form 7	T17-	T27-	T37-	T47-	T57-	T67-	T77-	T87-	T97-	T107-
	Form 8	T18-	T28-	T38-	T448-	T58-	T68-	T78-	T88-	—	—
	Mark 9	T19-	T29-	T39-	T49-	T59-	T69-	T789-	T889-	T989-	T1089-
	Form 7 Aluminum	T17SA-	T27SA-	T37SA-	T47SA-	T57SA-	T67SA-	T77SA-	T87SA-	T97SA-	T107SA-
	Form 7	TB17-	TB27-	TB37-	TB47-	TB57-	TB67-	—	—	—	—
	Form 8	TB18-	TB28-	TB38-	TB448-	TB58-	TB68-	—	—	—	—
	Mark 9	TB19-	TB29-	TB39-	TB49-	—	—	—	—	—	—
	Form 7 Aluminum	TB17SA-	TB27SA-	TB37SA-	TB47SA-	TB57SA-	TB67SA-	—	—	—	—
	Form 7	X17-	X27-	X37-	X47-	X57-	X67-	—	—	—	—
	Form 8	X18-	X28-	X38-	X448-	X58-	X68-	—	—	—	—
	Mark 9	X19-	X29-	X39-	—	—	—	—	—	—	—
	Form 7 Aluminum	X17SA-	X27SA-	X37SA-	X47SA-	X57SA-	X67SA-	—	—	—	—

\* PVC coated "OCAL-BLUE™" conduit bodies with covers for threaded rigid conduit series C, LB, LL, LR, T, TB and X with supports 28-4X, 38-4X, 448-4X, J8-4X and 6R-4X. Type 4X ratings in 1/2 in. (16) to 2 in. (53) trade size.

### OCAL-BLUE™ Conduit Body Covers

		Size in. (mm)									
	STYLE	1/2 (16)	3/4 (21)	1 (27)	1-1/4 (35)	1-1/2 (41)	2 (53)	2-1/2 (63)	3 (78)	3-1/2 (91)	4 (103)
	Form 7	170F-	270F-	370F-	470F-	570F-	670F-	870F-	870F-	970F-	970F-
	Form 8	180F-	280F-	380F-	480F-	580F-	680F-	880F-	880F-	980F-	980F-
	Mark 9	190-	290-	390-	490-	590-	690-	889-	889-	989-	989-
	Form 7 Aluminum	170SA-	270SA-	370SA-	470SA-	570SA-	670SA-	870SA-	870SA-	970SA-	970SA-

## Ordinary Location Fittings

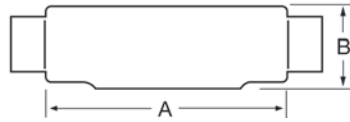

### C Form 7 Ferrous Conduit Bodies with Covers

Cat. No.	Hub Size in. (mm)	Dimensions in. (mm)*					Vol. Cap. (cu.in./cu.cm)
		A	B	C	D	E	
C17-	1/2 (16)	5.45 (138.43)	1.40 (35.56)	1.45 (36.83)	0.95 (24.13)	3.20 (81.28)	4.00 (65.55)
C27-	3/4 (21)	6.05 (153.67)	1.60 (40.64)	1.65 (41.91)	1.15 (29.21)	3.80 (96.52)	6.60 (108.15)
C37-	1 (27)	6.75 (171.45)	1.90 (48.26)	1.80 (45.72)	1.35 (34.29)	4.55 (115.57)	10.60 (173.70)
C47-	1-1/4 (35)	7.30 (185.42)	2.30 (58.42)	2.20 (55.88)	1.80 (45.72)	5.00 (127.00)	18.80 (308.08)
C57-	1-1/2 (41)	8.60 (218.44)	2.60 (66.04)	2.45 (62.23)	2.05 (52.07)	5.45 (138.43)	26.40 (432.62)
C67-	2 (53)	9.50 (241.30)	3.20 (81.28)	3.05 (77.47)	2.45 (62.23)	6.40 (162.56)	51.00 (835.74)
C77-	2-1/2 (63)	12.10 (307.34)	3.65 (92.71)	4.25 (107.95)	3.60 (91.44)	8.40 (213.36)	102.00 (1671.48)
C87-	3 (78)	12.10 (307.34)	4.40 (111.76)	4.25 (107.95)	3.60 (91.44)	8.40 (213.36)	132.00 (2163.09)

### C Mark 9 Aluminium Conduit Bodies with Covers

Cat. No.	Hub Size in. (mm)	Dimensions in. (mm)*					Vol. Cap. (cu.in./cu.cm)
		A	B	C	D	E	
C19-	1/2 (16)	5.00 (127.00)	1.38 (35.05)	1.38 (35.05)	1.19 (30.23)	3.31 (84.07)	—
C29-	3/4 (21)	5.69 (144.53)	1.63 (41.40)	1.56 (39.62)	1.38 (35.05)	3.94 (100.08)	—
C39-	1 (27)	6.59 (167.39)	1.88 (47.75)	1.75 (44.45)	1.50 (38.10)	4.56 (115.82)	—
C49-	1-1/4 (35)	7.50 (190.50)	2.50 (63.50)	2.19 (55.63)	1.94 (49.28)	5.31 (134.87)	—
C59-	1-1/2 (41)	8.25 (209.55)	2.75 (69.85)	2.50 (63.50)	2.25 (57.15)	6.00 (152.40)	—
C69-	2 (53)	10.50 (266.70)	3.44 (87.38)	3.19 (81.03)	2.88 (73.15)	8.06 (204.72)	—
C789-	2-1/2 (63)	15.63 (397.00)	4.44 (112.78)	5.00 (127.00)	4.25 (107.95)	10.88 (276.35)	—
C889-	3 (78)	15.63 (397.00)	4.81 (122.17)	5.00 (127.00)	4.25 (107.95)	10.88 (276.35)	—
C989-	3-1/2 (91)	18.75 (476.25)	5.69 (144.53)	6.25 (158.75)	5.44 (138.18)	13.44 (341.38)	—
C1089-	4 (103)	18.75 (476.25)	5.94 (150.88)	6.25 (158.75)	5.44 (138.18)	13.44 (341.38)	—

### C Form 8 Ferrous Conduit Bodies with Covers

Cat. No.	Hub Size in. (mm)	Dimensions in. (mm)*					Vol. Cap. (cu.in./cu.cm)
		A	B	C	D	E	
C18-	1/2 (16)	5.53 (140.49)	1.44 (36.51)	1.38 (34.93)	1.00 (25.40)	3.31 (84.14)	4.90 (80.30)
C28-	3/4 (21)	6.28 (159.54)	1.53 (38.89)	1.19 (30.16)	1.19 (30.16)	3.94 (100.01)	8.00 (131.10)
C38-	1 (27)	7.31 (185.74)	1.94 (49.21)	1.75 (44.45)	1.38 (34.93)	4.56 (115.89)	13.00 (213.03)
C448-	1-1/4 (35)	8.50 (215.90)	2.38 (60.33)	2.19 (55.56)	1.75 (44.45)	5.31 (134.94)	23.50 (385.10)
C58-	1-1/2 (41)	10.38 (263.53)	2.78 (70.64)	2.75 (69.85)	2.13 (53.98)	6.50 (165.10)	45.00 (737.42)
C68-	2 (53)	12.25 (311.15)	3.56 (90.49)	3.75 (95.25)	3.00 (76.20)	8.56 (217.49)	88.00 (1442.06)
C78-	2-1/2 (63)	15.63 (396.88)	4.44 (112.71)	5.00 (127.00)	4.25 (107.95)	10.88 (276.23)	110.00 (1802.58)
C88-	3 (78)	15.63 (396.88)	4.81 (122.24)	5.00 (127.00)	4.25 (107.95)	10.88 (276.23)	110.00 (1802.58)

### C Form 7 Aluminum Conduit Bodies with Covers

Cat. No.	Hub Size in. (mm)	Dimensions in. (mm)*					Vol. Cap. (cu.in./cu.cm)
		A	B	C	D	E	
C17SA-	1/2 (16)	5.45 (138.43)	1.40 (35.56)	1.45 (36.83)	0.95 (24.13)	3.20 (81.28)	4.00 (65.55)
C27SA-	3/4 (21)	6.05 (153.67)	1.60 (40.64)	1.65 (41.91)	1.15 (29.21)	3.80 (96.52)	6.60 (108.15)
C37SA-	1 (27)	6.75 (171.45)	1.90 (48.26)	1.80 (45.72)	1.35 (34.29)	4.55 (115.57)	10.60 (173.70)
C47SA-	1-1/4 (35)	7.30 (185.42)	2.30 (58.42)	2.20 (55.88)	1.80 (45.72)	5.00 (127.00)	18.80 (308.08)
C57SA-	1-1/2 (41)	8.60 (218.44)	2.60 (66.04)	2.45 (62.23)	2.05 (52.07)	5.45 (138.43)	26.40 (432.62)
C67SA-	2 (53)	9.50 (241.30)	3.20 (81.28)	3.05 (77.47)	2.45 (62.23)	6.40 (162.56)	51.00 (835.74)
C77SA-	2-1/2 (63)	12.10 (307.34)	3.65 (92.71)	4.25 (107.95)	3.60 (91.44)	8.40 (213.36)	102.00 (1671.48)
C87SA-	3 (78)	12.10 (307.34)	4.40 (111.76)	4.25 (107.95)	3.60 (91.44)	8.40 (213.36)	132.00 (2163.09)

Metric size designator (ANSI C80.1-1994). \* Dimensions shown are for uncoated conduit bodies.

## Ordinary Location Fittings

LB

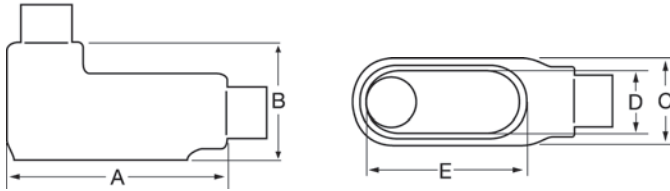

### LB Form 7 Ferrous Conduit Bodies with Covers

Cat. No.	Hub Size in. (mm)	Dimensions in. (mm)*					Vol. Cap. (cu.in./cu.cm)
		A	B	C	D	E	
LB17-	1/2 (16)	4.60 (116.84)	2.20 (55.88)	1.35 (34.29)	0.95 (24.13)	3.20 (81.28)	4.00 (65.55)
LB27-	3/4 (21)	5.25 (133.35)	2.40 (60.96)	1.65 (41.91)	1.15 (29.21)	3.80 (96.52)	6.60 (108.15)
LB37-	1 (27)	6.00 (152.40)	2.65 (67.31)	1.80 (45.72)	1.35 (34.29)	4.55 (115.57)	10.60 (173.70)
LB47-	1-1/4 (35)	6.45 (163.83)	3.20 (81.28)	2.20 (55.88)	1.80 (45.72)	5.00 (127.00)	18.80 (308.08)
LB57-	1-1/2 (41)	7.25 (184.15)	3.90 (99.06)	2.45 (62.23)	2.05 (52.07)	5.45 (138.43)	26.40 (432.62)
LB67-	2 (53)	8.30 (210.82)	4.45 (113.03)	3.10 (78.74)	2.45 (62.23)	6.40 (162.56)	51.00 (835.74)
LB77-	2-1/2 (63)	10.55 (267.97)	5.20 (132.08)	4.25 (107.95)	3.60 (91.44)	8.40 (213.36)	102.00 (1671.48)
LB87-	3 (78)	10.55 (267.97)	5.95 (151.13)	4.25 (107.95)	3.60 (91.44)	8.40 (213.36)	132.00 (2163.09)
LB97-	3-1/2 (91)	12.85 (326.39)	6.70 (170.18)	5.25 (133.35)	4.55 (115.57)	10.25 (260.35)	210.00 (3441.28)
LB107-	4 (103)	12.85 (326.39)	7.20 (182.88)	5.25 (133.35)	4.55 (115.57)	10.25 (260.35)	243.00 (3982.06)

### LB Mark 9 Aluminum Conduit Bodies with Covers

Cat. No.	Hub Size in. (mm)	Dimensions in. (mm)*					Vol. Cap. (cu.in./cu.cm)
		A	B	C	D	E	
LB19-	1/2 (16)	4.59 (116.68)	2.13 (53.98)	1.38 (34.93)	1.19 (30.16)	3.31 (84.14)	—
LB29-	3/4 (21)	5.25 (133.35)	2.41 (61.12)	1.56 (39.69)	1.38 (34.93)	3.94 (100.01)	—
LB39-	1 (27)	6.09 (154.78)	2.84 (72.23)	1.75 (44.45)	1.50 (38.10)	4.56 (115.89)	—
LB49-	1-1/4 (35)	7.03 (178.59)	3.47 (88.11)	2.19 (55.56)	1.94 (49.21)	5.31 (134.94)	—
LB59-	1-1/2 (41)	7.75 (196.85)	3.75 (95.25)	2.50 (63.50)	2.25 (57.15)	6.00 (152.40)	—
LB69-	2 (53)	10.03 (254.79)	4.47 (113.51)	3.19 (80.96)	2.88 (73.03)	8.06 (204.79)	—
LB79-	2-1/2 (63)	13.94 (354.01)	6.13 (155.58)	5.00 (127.00)	4.25 (107.95)	10.88 (276.23)	—
LB89-	3 (78)	13.94 (354.01)	6.50 (165.10)	5.00 (127.00)	4.25 (107.95)	10.88 (276.23)	—
LB99-	3-1/2 (91)	16.88 (428.63)	7.56 (192.09)	6.25 (158.75)	5.44 (138.11)	13.44 (341.31)	—
LB109-	4 (103)	16.88 (428.63)	7.81 (198.44)	6.25 (158.75)	5.44 (138.11)	13.44 (341.31)	—

### LB Form 8 Ferrous Conduit Bodies with Covers

Cat. No.	Hub Size in. (mm)	Dimensions in. (mm)*					Vol. Cap. (cu.in./cu.cm)
		A	B	C	D	E	
LB18-	1/2 (16)	4.94 (125.41)	2.22 (56.36)	1.38 (34.93)	1.00 (25.40)	3.31 (84.14)	4.90 (80.30)
LB28-	3/4 (21)	5.56 (141.29)	2.44 (61.93)	1.56 (39.69)	1.19 (30.16)	3.31 (84.14)	8.00 (131.10)
LB38-	1 (27)	6.50 (165.10)	2.81 (71.45)	1.75 (44.45)	1.38 (34.93)	4.56 (115.89)	13.00 (213.03)
LB448-	1-1/4 (35)	7.53 (191.29)	3.34 (84.93)	2.19 (55.56)	1.75 (44.45)	5.31 (134.94)	23.50 (385.10)
LB58-	1-1/2 (41)	9.13 (231.78)	4.03 (102.39)	2.75 (69.85)	2.13 (53.98)	6.50 (165.10)	45.00 (737.42)
LB68-	2 (53)	11.00 (279.40)	4.41 (111.92)	3.75 (95.25)	3.00 (76.20)	8.56 (217.49)	88.00 (1442.06)
LB78-	2-1/2 (63)	13.94 (354.01)	6.13 (155.58)	5.00 (127.00)	4.25 (107.95)	10.88 (276.23)	110.00 (1802.58)
LB888-	3 (78)	13.94 (354.01)	6.50 (165.10)	5.00 (127.00)	4.25 (107.95)	10.88 (276.23)	110.00 (1802.58)
LB98-	3-1/2 (91)	16.88 (428.63)	7.56 (192.09)	6.25 (158.75)	5.44 (138.11)	13.44 (341.31)	250.00 (4096.77)
LB108-	4 (103)	16.88 (428.63)	7.81 (198.44)	6.25 (158.75)	5.44 (138.11)	13.44 (341.31)	250.00 (4096.77)

### LB Form 7 Aluminum Conduit Bodies with Covers

Cat. No.	Hub Size in. (mm)	Dimensions in. (mm)*					Vol. Cap. (cu.in./cu.cm)
		A	B	C	D	E	
LB17SA-	1/2 (16)	4.60 (116.84)	2.20 (55.88)	1.35 (34.29)	0.95 (24.13)	3.20 (81.28)	4.00 (65.55)
LB27SA-	3/4 (21)	5.25 (133.35)	2.40 (60.96)	1.65 (41.91)	1.15 (29.21)	3.80 (96.52)	6.60 (108.15)
LB37SA-	1 (27)	6.00 (152.40)	2.65 (67.31)	1.80 (45.72)	1.35 (34.29)	4.55 (115.57)	10.60 (173.70)
LB47SA-	1-1/4 (35)	6.45 (163.83)	3.20 (81.28)	2.20 (55.88)	1.80 (45.72)	5.00 (127.00)	18.80 (308.08)
LB57SA-	1-1/2 (41)	7.25 (184.15)	3.90 (99.06)	2.45 (62.23)	2.05 (52.07)	5.45 (138.43)	26.40 (432.62)
LB67SA-	2 (53)	8.30 (210.82)	4.45 (113.03)	3.10 (78.74)	2.45 (62.23)	6.40 (162.56)	51.00 (835.74)
LB777SA-	2-1/2 (63)	10.55 (267.97)	5.20 (132.08)	4.25 (107.95)	3.60 (91.44)	8.40 (213.36)	102.00 (1671.48)
LB87SA-	3 (78)	10.55 (267.97)	5.95 (151.13)	4.25 (107.95)	3.60 (91.44)	8.40 (213.36)	132.00 (2163.09)
LB97SA-	3-1/2 (91)	12.85 (326.39)	6.70 (170.18)	5.25 (133.35)	4.55 (115.57)	10.25 (260.35)	210.00 (3441.28)
LB107SA-	4 (103)	12.85 (326.39)	7.20 (182.88)	5.25 (133.35)	4.55 (115.57)	10.25 (260.35)	243.00 (3982.06)

Metric size designator (ANSI C80.1-1994). \* Dimensions shown are for uncoated conduit bodies.

## Ordinary Location Fittings

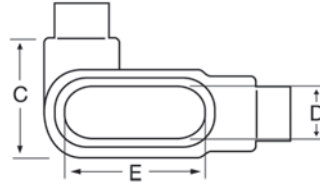
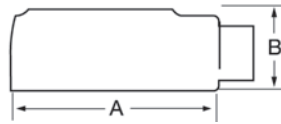

### LL Form 7 Ferrous Conduit Bodies with Covers

Cat. No.	Hub Size in. (mm)	Dimensions in. (mm)*					Vol. Cap. (cu.in./cu.cm)
		A	B	C	D	E	
LL17-	1/2 (16)	4.60 (116.84)	1.40 (35.56)	1.45 (36.83)	0.95 (24.13)	3.20 (81.28)	4.00 (65.55)
LL27-	3/4 (21)	5.25 (133.35)	1.60 (40.64)	1.65 (41.91)	1.15 (29.21)	3.80 (96.52)	6.60 (108.15)
LL37-	1 (27)	6.00 (152.40)	1.90 (48.26)	2.60 (66.04)	1.35 (34.29)	4.55 (115.57)	10.60 (173.70)
LL47-	1-1/4 (35)	6.45 (163.83)	2.30 (58.42)	3.05 (77.47)	1.80 (45.72)	5.00 (127.00)	18.60 (304.80)
LL57-	1-1/2 (41)	7.90 (200.66)	2.60 (66.04)	3.80 (96.52)	2.05 (52.07)	5.45 (138.43)	26.40 (432.62)
LL67-	2 (53)	8.30 (210.82)	3.20 (81.28)	4.25 (107.95)	2.45 (62.23)	6.40 (162.56)	51.00 (835.74)
LL777-	2-1/2 (63)	10.55 (267.97)	3.65 (92.71)	5.80 (147.32)	3.60 (91.44)	8.40 (213.36)	102.00 (1671.48)
LL87-	3 (78)	10.55 (267.97)	4.40 (111.76)	5.80 (147.32)	3.60 (91.44)	8.40 (213.36)	132.00 (2163.09)
LL97-	3-1/2 (91)	12.85 (326.39)	4.90 (124.46)	7.03 (178.56)	4.55 (115.57)	10.25 (260.35)	210.00 (3441.28)
LL107-	4 (103)	12.85 (326.39)	5.40 (137.16)	7.03 (178.56)	4.55 (115.57)	10.25 (260.35)	243.00 (3982.06)

### LL Mark 9 Aluminum Conduit Bodies with Covers

Cat. No.	Hub Size in. (mm)	Dimensions in. (mm)*					Vol. Cap. (cu.in./cu.cm)
		A	B	C	D	E	
LL19-	1/2 (16)	4.59 (116.68)	1.38 (34.93)	2.13 (53.98)	1.19 (30.16)	3.31 (84.14)	—
LL29-	3/4 (21)	5.25 (133.35)	1.63 (41.28)	2.38 (60.33)	1.38 (34.93)	3.94 (100.01)	—
LL39-	1 (27)	6.09 (154.78)	1.88 (47.63)	2.63 (66.68)	1.50 (38.10)	4.56 (115.89)	—
LL49-	1-1/4 (35)	7.03 (178.59)	2.50 (63.50)	3.09 (78.58)	1.94 (49.21)	5.31 (134.94)	—
LL59-	1-1/2 (41)	7.75 (196.85)	2.75 (69.85)	3.44 (87.31)	2.25 (57.15)	6.00 (152.40)	—
LL69-	2 (53)	10.03 (254.79)	3.44 (87.31)	4.13 (104.78)	2.88 (73.03)	8.06 (204.79)	—
LL789-	2-1/2 (63)	13.94 (354.01)	4.44 (112.71)	6.69 (169.86)	4.25 (107.95)	10.88 (276.23)	—
LL889-	3 (78)	13.94 (354.01)	4.81 (122.24)	6.69 (169.93)	4.25 (107.95)	10.88 (276.35)	—
LL989-	3-1/2 (91)	16.88 (428.63)	5.69 (144.46)	8.13 (206.38)	5.44 (138.11)	13.44 (341.31)	—
LL1089-	4 (103)	16.88 (428.63)	5.94 (150.81)	8.13 (206.38)	5.44 (138.11)	13.44 (341.31)	—

### LL Form 8 Ferrous Conduit Bodies with Covers

Cat. No.	Hub Size in. (mm)	Dimensions in. (mm)*					Vol. Cap. (cu.in./cu.cm)
		A	B	C	D	E	
LL18-	1/2 (16)	4.94 (125.41)	1.44 (36.51)	2.16 (54.77)	1.00 (25.40)	3.31 (84.14)	4.90 (80.30)
LL28-	3/4 (21)	5.56 (141.29)	1.69 (42.86)	2.31 (58.74)	1.19 (30.16)	3.94 (100.01)	8.00 (131.10)
LL38-	1 (27)	6.47 (164.31)	1.94 (49.21)	2.63 (66.68)	1.38 (34.93)	4.56 (115.89)	13.00 (213.03)
LL448-	1-1/4 (35)	7.53 (191.29)	2.38 (60.33)	3.16 (80.17)	1.75 (44.45)	5.31 (134.94)	23.50 (385.10)
LL58-	1-1/2 (41)	9.13 (231.78)	2.78 (70.64)	4.00 (101.60)	2.13 (53.98)	6.50 (165.10)	45.00 (737.42)
LL68-	2 (53)	11.00 (279.40)	3.56 (90.49)	5.00 (127.00)	3.00 (76.20)	8.56 (217.49)	88.00 (1442.06)
LL78-	2-1/2 (63)	13.94 (354.01)	4.44 (112.71)	6.69 (169.86)	4.25 (107.95)	10.88 (276.23)	110.00 (1802.58)
LL888-	3 (78)	13.94 (354.01)	4.81 (122.24)	6.69 (169.86)	4.25 (107.95)	10.88 (276.23)	110.00 (1802.58)

Metric size designator (ANSI C80.1-1994). \* Dimensions shown are for uncoated conduit bodies.

### LL Form 7 Aluminum Conduit Bodies with Covers

Cat. No.	Hub Size in. (mm)	Dimensions in. (mm)*					Vol. Cap. (cu.in./cu.cm)
		A	B	C	D	E	
LL17SA-	1/2 (16)	4.60 (116.84)	1.40 (35.56)	1.45 (36.83)	0.95 (24.13)	3.20 (81.28)	4.00 (65.55)
LL27SA-	3/4 (21)	5.25 (133.35)	1.60 (40.64)	1.65 (41.91)	1.15 (29.21)	3.80 (96.52)	6.60 (108.15)
LL37SA-	1 (27)	6.00 (152.40)	1.90 (48.26)	2.60 (66.04)	1.35 (34.29)	4.55 (115.57)	10.60 (173.70)
LL47SA-	1-1/4 (35)	6.45 (163.83)	2.30 (58.42)	3.05 (77.47)	1.80 (45.72)	5.00 (127.00)	18.60 (304.80)
LL57SA-	1-1/2 (41)	7.90 (200.66)	2.60 (66.04)	3.80 (96.52)	2.05 (52.07)	5.45 (138.43)	26.40 (432.62)
LL67SA-	2 (53)	8.30 (210.82)	3.20 (81.28)	4.25 (107.95)	2.45 (62.23)	6.40 (162.56)	51.00 (835.74)
LL777SA-	2-1/2 (63)	10.55 (267.97)	3.65 (92.71)	5.80 (147.32)	3.60 (91.44)	8.40 (213.36)	102.00 (1671.48)
LL87SA-	3 (78)	10.55 (267.97)	4.40 (111.76)	5.80 (147.32)	3.60 (91.44)	8.40 (213.36)	132.00 (2163.09)
LL97SA-	3-1/2 (91)	12.85 (326.39)	4.90 (124.46)	7.03 (178.56)	4.55 (115.57)	10.25 (260.35)	210.00 (3441.28)
LL107SA-	4 (103)	12.85 (326.39)	5.40 (137.16)	7.03 (178.56)	4.55 (115.57)	10.25 (260.35)	243.00 (3982.06)

## Ordinary Location Fittings

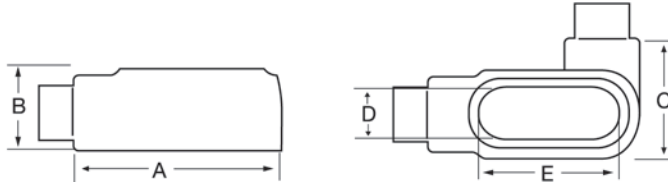

### LR Form 7 Ferrous Conduit Bodies with Covers

Cat. No.	Hub Size in. (mm)	Dimensions in. (mm)*					Vol. Cap. (cu.in./cu.cm)
		A	B	C	D	E	
LR17-	1/2 (16)	4.60 (116.84)	1.40 (35.56)	1.45 (36.83)	0.95 (24.13)	3.20 (81.28)	4.00 (65.55)
LR27-	3/4 (21)	5.25 (133.35)	1.60 (40.64)	1.65 (41.91)	1.15 (29.21)	3.80 (96.52)	6.60 (108.15)
LR37-	1 (27)	6.00 (152.40)	1.90 (48.26)	2.60 (66.04)	1.35 (34.29)	4.55 (115.57)	10.60 (173.70)
LR47-	1-1/4 (35)	6.45 (163.83)	2.30 (58.42)	3.05 (77.47)	1.80 (45.72)	5.00 (127.00)	18.80 (308.08)
LR57-	1-1/2 (41)	7.90 (200.66)	2.60 (66.04)	3.80 (96.52)	2.05 (52.07)	5.45 (138.43)	26.40 (432.62)
LR67-	2 (53)	8.30 (210.82)	3.20 (81.28)	4.25 (107.95)	2.45 (62.23)	6.40 (162.56)	51.00 (835.74)
LR777-	2-1/2 (63)	10.55 (267.97)	3.65 (92.71)	5.80 (147.32)	3.60 (91.44)	8.40 (213.36)	102.00 (1671.48)
LR87-	3 (78)	10.55 (267.97)	4.40 (111.76)	5.80 (147.32)	3.60 (91.44)	8.40 (213.36)	132.00 (2163.09)
LR97-	3-1/2 (91)	12.85 (326.39)	4.90 (124.46)	7.03 (178.56)	4.55 (115.57)	10.25 (260.35)	210.00 (3441.28)
LR107-	4 (103)	12.85 (326.39)	5.40 (137.16)	7.03 (178.56)	4.55 (115.57)	10.25 (260.35)	243.00 (3982.06)

### LR Mark 9 Aluminum Conduit Bodies with Covers

Cat. No.	Hub Size in. (mm)	Dimensions in. (mm)*					Vol. Cap. (cu.in./cu.cm)
		A	B	C	D	E	
LR19-	1/2 (16)	4.59 (116.68)	1.38 (34.93)	2.13 (53.98)	1.19 (30.16)	3.31 (84.14)	—
LR29-	3/4 (21)	5.25 (133.35)	1.63 (41.28)	2.38 (60.33)	1.38 (34.93)	3.94 (100.01)	—
LR39-	1 (27)	6.09 (154.78)	1.88 (47.63)	2.63 (66.68)	1.50 (38.10)	4.56 (115.89)	—
LR49-	1-1/4 (35)	7.03 (178.59)	2.50 (63.50)	3.09 (78.58)	1.94 (49.21)	5.31 (134.94)	—
LR59-	1-1/2 (41)	7.75 (196.85)	2.75 (69.85)	3.44 (87.31)	2.25 (57.15)	6.00 (152.40)	—
LR69-	2 (53)	10.03 (254.79)	3.44 (87.31)	4.13 (104.78)	2.88 (73.03)	8.06 (204.79)	—
LR789-	2-1/2 (63)	13.94 (354.01)	4.44 (112.71)	6.69 (169.86)	4.25 (107.95)	10.88 (276.23)	—
LR889-	3 (78)	13.94 (354.08)	4.81 (122.24)	6.69 (169.93)	4.25 (107.95)	10.88 (276.35)	—
LR989-	3-1/2 (91)	16.88 (428.63)	5.69 (144.46)	8.13 (206.38)	5.44 (138.11)	13.44 (341.31)	—
LR1089-	4 (103)	16.88 (428.63)	5.94 (150.81)	8.13 (206.38)	5.44 (138.11)	13.44 (341.31)	—

### LR Form 8 Ferrous Conduit Bodies with Covers

Cat. No.	Hub Size in. (mm)	Dimensions in. (mm)*					Vol. Cap. (cu.in./cu.cm)
		A	B	C	D	E	
LR18-	1/2 (16)	4.94 (125.41)	1.44 (36.51)	2.16 (54.77)	1.00 (25.40)	3.31 (84.14)	4.90 (80.30)
LR28-	3/4 (21)	5.56 (141.29)	1.69 (42.86)	2.31 (58.74)	1.19 (30.16)	3.94 (100.01)	8.00 (131.10)
LR38-	1 (27)	6.47 (164.31)	1.94 (49.21)	2.63 (66.68)	1.38 (34.93)	4.56 (115.89)	13.00 (213.03)
LR448-	1-1/4 (35)	7.53 (191.29)	2.38 (60.33)	3.16 (80.17)	1.75 (44.45)	5.31 (134.94)	23.50 (385.10)
LR58-	1-1/2 (41)	9.13 (231.78)	2.78 (70.64)	4.00 (101.60)	2.13 (53.98)	6.50 (165.10)	45.00 (737.42)
LR68-	2 (53)	11.00 (279.40)	3.56 (90.49)	5.00 (127.00)	3.00 (76.20)	8.56 (217.49)	88.00 (1442.06)
LR78-	2-1/2 (63)	13.94 (354.01)	4.44 (112.71)	6.69 (169.86)	4.25 (107.95)	10.88 (276.23)	110.00 (1802.58)
LR888-	3 (78)	13.94 (354.01)	4.81 (122.24)	6.69 (169.86)	4.25 (107.95)	10.88 (276.23)	110.00 (1802.58)

Metric size designator (ANSI C80.1-1994). \* Dimensions shown are for uncoated conduit bodies.

### LR Form 7 Aluminum Conduit Bodies with Covers

Cat. No.	Hub Size in. (mm)	Dimensions in. (mm)*					Vol. Cap. (cu.in./cu.cm)
		A	B	C	D	E	
LR17SA-	1/2 (16)	4.60 (116.84)	1.40 (35.56)	1.45 (36.83)	0.95 (24.13)	3.20 (81.28)	4.00 (65.55)
LR27SA-	3/4 (21)	5.25 (133.35)	1.60 (40.64)	1.65 (41.91)	1.15 (29.21)	3.80 (96.52)	6.60 (108.15)
LR37SA-	1 (27)	6.00 (152.40)	1.90 (48.26)	2.60 (66.04)	1.35 (34.29)	4.55 (115.57)	10.60 (173.70)
LR47SA-	1-1/4 (35)	6.45 (163.83)	2.30 (58.42)	3.05 (77.47)	1.80 (45.72)	5.00 (127.00)	18.80 (308.08)
LR57SA-	1-1/2 (41)	7.90 (200.66)	2.60 (66.04)	3.80 (96.52)	2.05 (52.07)	5.45 (138.43)	26.40 (432.62)
LR67SA-	2 (53)	8.30 (210.82)	3.20 (81.28)	4.25 (107.95)	2.45 (62.23)	6.40 (162.56)	51.00 (835.74)
LR777SA-	2-1/2 (63)	10.55 (267.97)	3.65 (92.71)	5.80 (147.32)	3.60 (91.44)	8.40 (213.36)	102.00 (1671.48)
LR87SA-	3 (78)	10.55 (267.97)	4.40 (111.76)	5.80 (147.32)	3.60 (91.44)	8.40 (213.36)	132.00 (2163.09)
LR97SA-	3-1/2 (91)	12.85 (326.39)	4.90 (124.46)	7.03 (178.56)	4.55 (115.57)	10.25 (260.35)	210.00 (3441.28)
LR107SA-	4 (103)	12.85 (326.39)	5.40 (137.16)	7.03 (178.56)	4.55 (115.57)	10.25 (260.35)	243.00 (3982.06)

## Ordinary Location Fittings

T

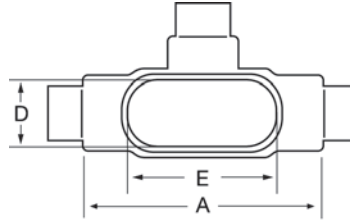
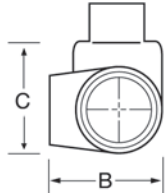

### T Form 7 Ferrous Conduit Bodies with Covers

Cat. No.	Hub Size in. (mm)	Dimensions in. (mm)*					Vol. Cap. (cu.in./cu.cm)
		A	B	C	D	E	
T17-	1/2 (16)	5.60 (142.24)	1.80 (45.72)	2.35 (59.69)	0.95 (24.13)	3.20 (81.28)	6.00 (98.32)
T27-	3/4 (21)	6.20 (157.48)	2.00 (50.80)	2.60 (66.04)	1.15 (29.21)	3.80 (96.52)	9.10 (149.12)
T37-	1 (27)	7.35 (186.69)	2.30 (58.42)	3.10 (78.74)	1.35 (34.29)	4.55 (115.57)	16.90 (276.94)
T47-	1-1/4 (35)	7.30 (185.42)	2.30 (58.42)	3.05 (77.47)	1.80 (45.72)	5.00 (127.00)	19.30 (316.27)
T57-	1-1/2 (41)	8.60 (218.44)	2.60 (66.04)	3.80 (96.52)	2.05 (52.07)	5.45 (138.43)	27.50 (450.64)
T67-	2 (53)	9.50 (241.30)	3.20 (81.28)	4.25 (107.95)	2.45 (62.23)	6.40 (162.56)	50.00 (819.35)
T77-	2-1/2 (63)	12.10 (307.34)	3.65 (92.71)	5.80 (147.32)	3.60 (91.44)	8.40 (213.36)	102.00 (1671.48)
T87-	3 (78)	12.10 (307.34)	4.40 (111.76)	5.80 (147.32)	3.60 (91.44)	8.40 (213.36)	132.00 (2163.09)
T97-	3-1/2 (91)	14.65 (372.11)	4.90 (124.46)	7.05 (179.07)	4.55 (115.57)	10.25 (260.35)	210.00 (3441.28)
T107-	4 (103)	14.65 (372.11)	5.40 (137.16)	7.05 (179.07)	4.55 (115.57)	10.25 (260.35)	243.00 (3982.06)

### T Mark 9 Aluminum Conduit Bodies with Covers

Cat. No.	Hub Size in. (mm)	Dimensions in. (mm)*					Vol. Cap. (cu.in./cu.cm)
		A	B	C	D	E	
T19-	1/2 (16)	5.00 (127.00)	1.38 (34.93)	2.13 (53.98)	1.19 (30.16)	3.31 (84.14)	—
T29-	3/4 (21)	5.69 (144.46)	1.63 (41.28)	2.38 (60.33)	1.38 (34.93)	3.94 (100.01)	—
T39-	1 (27)	6.59 (167.48)	1.88 (47.63)	2.63 (66.68)	1.50 (38.10)	4.56 (115.89)	—
T49-	1-1/4 (35)	7.50 (190.50)	2.50 (63.50)	3.09 (78.58)	1.94 (49.21)	5.31 (134.94)	—
T59-	1-1/2 (41)	8.25 (209.55)	2.75 (69.85)	3.44 (87.31)	2.25 (57.15)	6.00 (152.40)	—
T69-	2 (53)	10.50 (266.70)	3.44 (87.31)	4.13 (104.78)	2.88 (73.03)	8.06 (204.79)	—
T789-	2-1/2 (63)	15.63 (396.88)	4.44 (112.71)	6.69 (169.86)	4.25 (107.95)	10.88 (276.23)	—
T889-	3 (78)	15.63 (396.88)	4.81 (122.24)	6.69 (169.86)	4.25 (107.95)	10.88 (276.23)	—
T989-	3-1/2 (91)	18.75 (476.25)	5.69 (144.46)	8.13 (206.38)	5.44 (138.11)	13.44 (341.31)	—
T1089-	4 (103)	18.75 (476.25)	5.94 (150.81)	8.13 (206.38)	5.44 (138.11)	13.44 (341.31)	—

### T Form 8 Ferrous Conduit Bodies with Covers

Cat. No.	Hub Size in. (mm)	Dimensions in. (mm)*					Vol. Cap. (cu.in./cu.cm)
		A	B	C	D	E	
T18-	1/2 (16)	5.69 (144.46)	1.75 (44.45)	2.16 (54.77)	1.00 (25.40)	3.31 (84.14)	6.00 (98.32)
T28-	3/4 (21)	6.28 (159.54)	2.00 (50.80)	2.31 (58.74)	1.19 (30.16)	3.94 (100.01)	9.00 (147.48)
T38-	1 (27)	7.31 (185.74)	2.25 (57.15)	2.63 (66.68)	1.38 (34.93)	4.56 (115.89)	15.00 (245.81)
T448-	1-1/4 (35)	8.50 (215.90)	2.63 (66.68)	3.16 (80.17)	1.75 (44.45)	5.31 (134.94)	24.00 (393.29)
T58-	1-1/2 (41)	10.38 (263.53)	2.78 (70.64)	4.00 (101.60)	2.13 (53.98)	6.50 (165.10)	46.50 (762.00)
T68-	2 (53)	12.25 (311.15)	3.56 (90.49)	5.00 (127.00)	3.00 (76.20)	8.56 (217.49)	88.00 (1442.06)
T78-	2-1/2 (63)	15.63 (396.88)	4.44 (112.71)	6.69 (169.86)	4.25 (107.95)	10.88 (276.23)	110.00 (1802.58)
T88-	3 (78)	15.63 (396.88)	4.81 (122.24)	6.69 (169.86)	4.25 (107.95)	10.88 (276.23)	110.00 (1802.58)

Metric size designator (ANSI C80.1-1994). \* Dimensions shown are for uncoated conduit bodies.

### T Form 7 Aluminum Conduit Bodies with Covers

Cat. No.	Hub Size in. (mm)	Dimensions in. (mm)*					Vol. Cap. (cu.in./cu.cm)
		A	B	C	D	E	
T17SA-	1/2 (16)	5.60 (142.24)	1.80 (45.72)	2.35 (59.69)	0.95 (24.13)	3.20 (81.28)	6.00 (98.32)
T27SA-	3/4 (21)	6.20 (157.48)	2.00 (50.80)	2.60 (66.04)	1.15 (29.21)	3.80 (96.52)	9.10 (149.12)
T37SA-	1 (27)	7.35 (186.69)	2.30 (58.42)	3.10 (78.74)	1.35 (34.29)	4.55 (115.57)	16.90 (276.94)
T47SA-	1-1/4 (35)	7.30 (185.42)	2.30 (58.42)	3.05 (77.47)	1.80 (45.72)	5.00 (127.00)	19.30 (316.27)
T57SA-	1-1/2 (41)	8.60 (218.44)	2.60 (66.04)	3.80 (96.52)	2.05 (52.07)	5.45 (138.43)	27.50 (450.64)
T67SA-	2 (53)	9.50 (241.30)	3.20 (81.28)	4.25 (107.95)	2.45 (62.23)	6.40 (162.56)	50.00 (819.35)
T77SA-	2-1/2 (63)	12.10 (307.34)	3.65 (92.71)	5.80 (147.32)	3.60 (91.44)	8.40 (213.36)	102.00 (1671.48)
T87SA-	3 (78)	12.10 (307.34)	4.40 (111.76)	5.80 (147.32)	3.60 (91.44)	8.40 (213.36)	132.00 (2163.09)
T97SA-	3-1/2 (91)	14.65 (372.11)	4.90 (124.46)	7.05 (179.07)	4.55 (115.57)	10.25 (260.35)	210.00 (3441.28)
T107SA-	4 (103)	14.65 (372.11)	5.40 (137.16)	7.05 (179.07)	4.55 (115.57)	10.25 (260.35)	243.00 (3982.06)

## Ordinary Location Fittings

TB

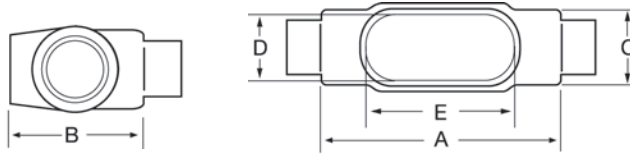

### TB Form 7 Ferrous Conduit Bodies with Covers

Cat. No.	Hub Size in. (mm)	Dimensions in. (mm)*					Vol. Cap. (cu.in./cu.cm)
		A	B	C	D	E	
TB17-	1/2 (16)	5.60 (142.24)	2.06 (52.32)	1.63 (41.40)	0.95 (24.13)	3.20 (81.28)	6.00 (98.32)
TB27-	3/4 (21)	6.20 (157.48)	2.31 (58.67)	1.81 (45.97)	1.15 (29.21)	3.80 (96.52)	9.10 (149.12)
TB37-	1 (27)	7.35 (186.69)	2.50 (63.50)	2.31 (58.67)	1.35 (34.29)	4.55 (115.57)	16.90 (276.94)
TB47-	1-1/4 (35)	7.30 (185.42)	3.19 (81.03)	2.25 (57.15)	1.80 (45.72)	5.00 (127.00)	19.30 (316.27)
TB57-	1-1/2 (41)	8.60 (218.44)	3.91 (99.31)	2.42 (61.47)	2.05 (52.07)	5.45 (138.43)	27.50 (450.64)
TB67-	2 (53)	9.50 (241.30)	4.50 (114.30)	3.06 (77.72)	2.45 (62.23)	6.40 (162.56)	52.80 (865.24)

### TB Mark 9 Aluminum Conduit Bodies with Covers

Cat. No.	Hub Size in. (mm)	Dimensions in. (mm)*					Vol. Cap. (cu.in./cu.cm)
		A	B	C	D	E	
TB19-	1/2 (16)	5.00 (127.00)	2.13 (53.98)	1.38 (34.93)	1.19 (30.16)	3.31 (84.14)	—
TB29-	3/4 (21)	5.69 (144.46)	2.41 (61.12)	1.56 (39.69)	1.38 (34.93)	3.94 (100.01)	—
TB39-	1 (27)	6.59 (167.48)	2.84 (72.23)	1.75 (44.45)	1.50 (38.10)	4.56 (115.89)	—
TB49-	1-1/4 (35)	7.50 (190.50)	3.47 (88.11)	2.19 (55.56)	1.94 (49.21)	5.31 (134.94)	—

### TB Form 8 Ferrous Conduit Bodies with Covers

Cat. No.	Hub Size in. (mm)	Dimensions in. (mm)*					Vol. Cap. (cu.in./cu.cm)
		A	B	C	D	E	
TB18-	1/2 (16)	5.69 (144.46)	2.63 (66.68)	1.38 (34.93)	1.00 (25.40)	3.31 (84.14)	6.00 (98.32)
TB28-	3/4 (21)	6.28 (159.54)	2.88 (73.03)	1.19 (30.16)	1.19 (30.16)	3.94 (100.01)	9.00 (147.48)
TB38-	1 (27)	7.31 (185.74)	3.25 (82.55)	1.75 (44.45)	1.38 (34.93)	4.56 (115.89)	15.00 (245.81)
TB448-	1-1/4 (35)	8.50 (215.90)	3.31 (84.14)	2.19 (55.56)	1.75 (44.45)	5.31 (134.94)	24.00 (393.29)
TB58-	1-1/2 (41)	10.38 (263.53)	3.69 (93.66)	2.75 (69.85)	2.13 (53.98)	6.50 (165.10)	46.50 (762.00)
TB68-	2 (53)	12.25 (311.15)	4.25 (107.95)	3.75 (95.25)	3.00 (76.20)	8.56 (217.49)	88.00 (1442.06)

### TB Form 7 Aluminum Conduit Bodies with Covers

Cat. No.	Hub Size in. (mm)	Dimensions in. (mm)*					Vol. Cap. (cu.in./cu.cm)
		A	B	C	D	E	
TB17SA-	1/2 (16)	5.60 (142.24)	2.06 (52.32)	1.63 (41.40)	0.95 (24.13)	3.20 (81.28)	6.00 (98.32)
TB27SA-	3/4 (21)	6.20 (157.48)	2.31 (58.67)	1.81 (45.97)	1.15 (29.21)	3.80 (96.52)	9.10 (149.12)
TB37SA-	1 (27)	7.35 (186.69)	2.50 (63.50)	2.31 (58.67)	1.35 (34.29)	4.55 (115.57)	16.90 (276.94)
TB47SA-	1-1/4 (35)	7.30 (185.42)	3.19 (81.03)	2.25 (57.15)	1.80 (45.72)	5.00 (127.00)	19.30 (316.27)
TB57SA-	1-1/2 (41)	8.60 (218.44)	3.91 (99.31)	2.42 (61.47)	2.05 (52.07)	5.45 (138.43)	27.50 (450.64)
TB67SA-	2 (53)	9.50 (241.30)	4.50 (114.30)	3.06 (77.72)	2.45 (62.23)	6.40 (162.56)	52.80 (865.24)

Metric size designator (ANSI C80.1-1994). \* Dimensions shown are for uncoated conduit bodies.

### \*\*L Form 7 Ferrous Conduit Bodies with Covers

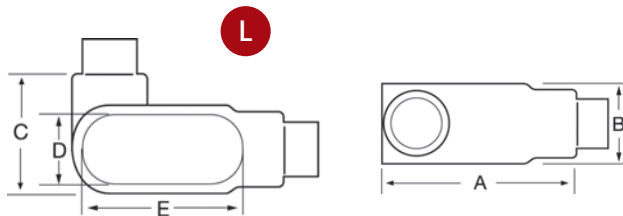

Metric size designator (ANSI C80.1-1994).  
 \*Dimensions shown are for uncoated conduit bodies.  
 \*\* Not CSA Certified.

Cat. No.	Hub Size in. (mm)	Dimensions in. (mm)*					Vol. Cap. (cu.in./cu.cm)
		A	B	C	D	E	
L17-	1/2 (16)	4.60 (116.84)	1.40 (35.56)	1.45 (36.83)	0.95 (24.13)	3.20 (81.28)	—
L27-	3/4 (21)	5.25 (133.35)	1.60 (40.64)	1.65 (41.91)	1.15 (29.21)	3.80 (96.52)	—
L37-	1 (27)	6.00 (152.40)	1.90 (48.26)	2.60 (66.04)	1.35 (34.29)	4.55 (115.57)	—
L47-	1-1/4 (35)	6.45 (163.83)	2.30 (58.42)	3.05 (77.47)	1.80 (45.72)	5.00 (127.00)	—
L57-	1-1/2 (41)	7.90 (200.66)	2.60 (66.04)	3.80 (96.52)	2.05 (52.07)	5.45 (138.43)	—
L67-	2 (53)	8.30 (210.82)	3.20 (81.28)	4.25 (107.95)	2.45 (62.23)	6.40 (162.56)	—

## Ordinary Location Fittings

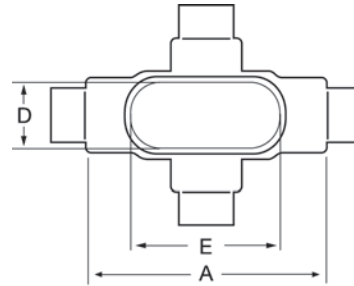
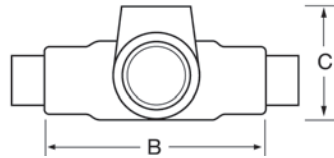

### X Form 7 Ferrous Conduit Bodies with Covers

Cat. No.	Hub Size in. (mm)	Dimensions in. (mm)*					Vol. Cap. (cu.in./cu.cm)
		A	B	C	D	E	
X17-	1/2 (16)	5.60 (142.24)	1.80 (45.72)	3.05 (77.47)	0.95 (24.13)	3.20 (81.28)	6.00 (98.32)
X27-	3/4 (21)	6.20 (157.48)	2.00 (50.80)	3.30 (83.82)	1.15 (29.21)	3.80 (96.52)	9.10 (149.12)
X37-	1 (27)	7.35 (186.69)	2.30 (58.42)	3.80 (96.52)	1.35 (34.29)	4.55 (115.57)	16.90 (276.94)
X47-	1-1/4 (35)	7.30 (185.42)	2.30 (58.42)	3.85 (97.79)	1.80 (45.72)	5.00 (127.00)	19.30 (316.27)
X57-	1-1/2 (41)	8.60 (218.44)	2.60 (66.04)	5.05 (128.27)	2.05 (52.07)	5.45 (138.43)	27.50 (450.64)
X67-	2 (53)	9.50 (241.30)	3.20 (81.28)	5.45 (138.43)	2.45 (62.23)	6.40 (162.56)	52.80 (865.24)

### X Mark 9 Aluminum Conduit Bodies with Covers

Cat. No.	Hub Size in. (mm)	Dimensions in. (mm)*					Vol. Cap. (cu.in./cu.cm)
		A	B	C	D	E	
X19-	1/2 (16)	5.69 (144.46)	2.91 (73.82)	1.75 (44.45)	1.00 (25.40)	3.31 (84.14)	—
X29-	3/4 (21)	6.28 (159.54)	3.06 (77.79)	2.00 (50.80)	1.19 (30.16)	3.94 (100.01)	—
X39-	1 (27)	7.31 (185.74)	3.50 (88.90)	2.25 (57.15)	1.38 (34.93)	4.56 (115.89)	—

### X Form 8 Ferrous Conduit Bodies with Covers

Cat. No.	Hub Size in. (mm)	Dimensions in. (mm)*					Vol. Cap. (cu.in./cu.cm)
		A	B	C	D	E	
X18-	1/2 (16)	5.69 (144.46)	1.75 (44.45)	2.91 (73.82)	1.00 (25.40)	3.31 (84.14)	6.00 (98.32)
X28-	3/4 (21)	6.28 (159.54)	2.00 (50.80)	3.06 (77.79)	1.38 (34.93)	3.94 (100.01)	9.00 (147.48)
X38-	1 (27)	7.31 (185.74)	2.25 (57.15)	3.50 (88.90)	1.38 (34.93)	4.56 (115.89)	15.00 (245.81)
X448-	1-1/4 (35)	8.50 (215.90)	2.63 (66.68)	4.13 (104.78)	1.75 (44.45)	5.31 (134.94)	24.00 (393.29)
X58-	1-1/2 (41)	10.38 (263.53)	2.47 (62.71)	5.25 (133.35)	2.13 (53.98)	6.50 (165.10)	46.50 (762.00)
X68-	2 (53)	12.25 (311.15)	3.56 (90.49)	6.25 (158.75)	3.00 (76.20)	8.56 (217.49)	88.00 (1442.06)

### X Form 7 Aluminum Conduit Bodies with Covers

Cat. No.	Hub Size in. (mm)*	Dimensions in. (mm)*					Vol. Cap. (cu.in./cu.cm)
		A	B	C	D	E	
X17SA-	1/2 (16)	5.60 (142.24)	1.80 (45.72)	3.05 (77.47)	0.95 (24.13)	3.20 (81.28)	6.00 (98.32)
X27SA-	3/4 (21)	6.20 (157.48)	2.00 (50.80)	3.30 (83.82)	1.15 (29.21)	3.80 (96.52)	9.10 (149.12)
X37SA-	1 (27)	7.35 (186.69)	2.30 (58.42)	3.80 (96.52)	1.35 (34.29)	4.55 (115.57)	16.90 (276.94)
X47SA-	1-1/4 (35)	7.30 (185.42)	2.30 (58.42)	3.85 (97.79)	1.80 (45.72)	5.00 (127.00)	19.30 (316.27)
X57SA-	1-1/2 (41)	8.60 (218.44)	2.60 (66.04)	5.05 (128.27)	2.05 (52.07)	5.45 (138.43)	27.50 (450.64)
X67SA-	2 (53)	9.50 (241.30)	3.20 (81.28)	5.45 (138.43)	2.45 (62.23)	6.40 (162.56)	52.80 (865.24)

Metric size designator (ANSI C80.1-1994). \* Dimensions shown are for uncoated conduit bodies.



## Ordinary Location Fittings

Unique Sealing Ring and Groove Design for Optimum Performance!

### OCAL-BLUE™ Double-Coat and Stainless Steel Hubs

- Captive sealing ring won't buckle or slip during installation and provides a complete 360° seal — even when conduit isn't perpendicular to the enclosure
- Hexagonal/splined body and locknut enables fast and easy installation
- Insulated throat molded from 105°C-rated thermoplastic, UL94V0 flammability rated
- Sharper and deeper teeth provide a more penetrating bite for improved bonding to the enclosure
- Zinc or copper-free aluminum with a nominal 0.040 in. (40 mils) PVC coating bonded to exterior
- Pressure-sealing sleeves protect your connections



STG6-G

PVC-Coated Zinc Grounded Hub



HUB1-1/4-G

PVC-Coated Zinc Hub

Cat. No.	Colour
<b>HUB-1</b>	<b>_ = space for colour identifier</b>
	<b>G = Grey</b>
	<b>W = White</b>
	<b>B = Blue</b>
	<b>R = Red</b>

Custom colours also available - Std. min. quantities are required. Please contact your Regional Sales Office.

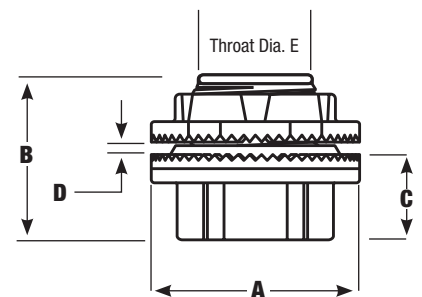

### Knockout Hubs

PVC-Coated Zinc Hub Cat. No.	PVC-Coated Aluminum Hub Cat. No.	PVC-Coated Zinc Grounded Hub Cat. No.	Pipe Size in. (mm)	Dimensions (Uncoated Hub)				
				A (Overall Dia.)	B	C	D (Max. Panel Thickness)	E (Throat Dia.)
HUB1/2- <u>  </u>	HUB1/2SA- <u>  </u>	STG1- <u>  </u>	1/2 (16)	1.44 (36.58)	1.56 (39.62)	0.88 (22.35)	0.19 (4.83)	0.59 (14.99)
HUB3/4- <u>  </u>	HUB3/4SA- <u>  </u>	STG2- <u>  </u>	3/4 (21)	1.44 (36.58)	1.59 (40.39)	0.91 (23.11)	0.19 (4.83)	0.78 (19.81)
HUB1- <u>  </u>	HUB1SA- <u>  </u>	STG3- <u>  </u>	1 (27)	2.00 (50.80)	1.81 (45.97)	1.06 (26.92)	0.25 (6.35)	1.00 (25.40)
HUB1-1/4- <u>  </u>	HUB1-1/4SA- <u>  </u>	STG4- <u>  </u>	1-1/4 (35)	2.38 (60.45)	1.88 (47.75)	1.06 (26.92)	0.25 (6.35)	1.31 (33.35)
HUB1-1/2- <u>  </u>	HUB1-1/2SA- <u>  </u>	STG5- <u>  </u>	1-1/2 (41)	2.75 (69.85)	1.88 (47.75)	1.06 (26.92)	0.25 (6.35)	1.53 (38.86)
HUB2- <u>  </u>	HUB2SA- <u>  </u>	STG6- <u>  </u>	2 (53)	3.25 (82.55)	1.94 (49.28)	1.16 (29.46)	0.25 (6.35)	1.97 (50.04)
HUB2-1/2- <u>  </u>	HUB2-1/2SA- <u>  </u>	STG7- <u>  </u>	2-1/2 (63)	3.75 (95.25)	2.56 (65.02)	1.56 (39.62)	0.25 (6.35)	2.41 (61.21)
HUB3- <u>  </u>	HUB3SA- <u>  </u>	STG8- <u>  </u>	3 (78)	4.38 (111.25)	2.44 (61.98)	1.59 (40.39)	0.25 (6.35)	2.97 (75.44)
HUB3-1/2- <u>  </u>	HUB3-1/2SA- <u>  </u>	STG9- <u>  </u>	3-1/2 (91)	5.00 (127.00)	2.72 (69.09)	1.63 (41.40)	0.25 (6.35)	3.41 (86.61)
HUB4- <u>  </u>	HUB4SA- <u>  </u>	STG10- <u>  </u>	4 (103)	5.50 (139.70)	2.72 (69.09)	1.63 (41.40)	0.25 (6.35)	3.88 (98.55)
HUB5- <u>  </u>	HUB5SA- <u>  </u>	STG11- <u>  </u>	5 (129)	6.88 (174.75)	3.03 (76.96)	1.94 (49.28)	0.25 (6.35)	4.94 (125.48)
HUB6- <u>  </u>	HUB6SA- <u>  </u>	STG12- <u>  </u>	6 (155)	7.69 (195.33)	3.16 (80.26)	2.00 (50.80)	0.31 (7.87)	6.00 (152.40)

## Ordinary Location Fittings

In Bulkhead and Through-Bulkhead Styles!



STTB2-G Bulkhead Fitting



STTTB2-G Through-Bulkhead Fitting

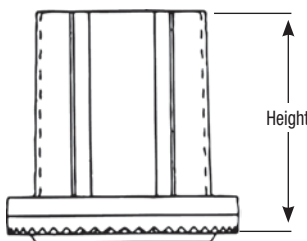
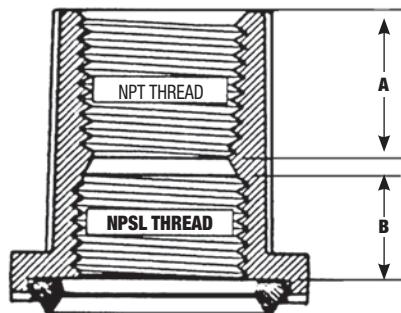
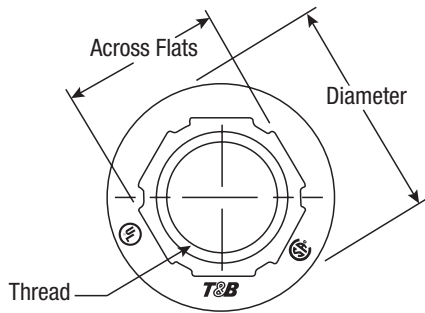

### Ocal™ PVC-Coated Bulkhead Fittings

- Zinc body and locknut with thermoplastic insulating throat and nitrile sealing ring
- Nominal 0.040 in. (40 mils) PVC coating bonded to exterior
- Pressure-sealing sleeves protect your connections

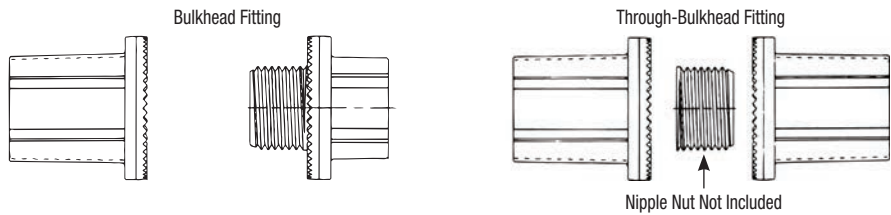

Bulkhead Fitting Cat. No.	Through-Bulkhead Fitting Cat. No.	Pipe Size in. (mm)	Thread	Height in. (mm)	Dia. in. (mm)	Across Flats in. (mm)	"A" in. (mm)	"B" in. (mm)
STTB1-	STTTB1-	1/2 (16)	1/2-14	1.41 (35.72)	1.44 (36.51)	1.00 (25.40)	0.75 (19.05)	0.50 (12.70)
STTB2-	STTTB2-	3/4 (21)	3/4-14	1.47 (37.31)	1.69 (42.86)	1.25 (31.75)	0.78 (19.84)	0.53 (13.49)
STTB3-	STTTB3-	1 (27)	1-11-1/2	1.69 (42.86)	2.00 (50.80)	1.53 (38.89)	0.91 (23.02)	0.59 (15.08)
STTB4-	STTTB4-	1-1/4 (35)	1-1/4-11-1/2	1.78 (45.24)	2.38 (60.33)	1.84 (46.83)	0.91 (23.02)	0.66 (16.67)
STTB5-	STTTB5-	1-1/2 (41)	1-1/2-11-1/2	1.81 (46.04)	2.75 (69.85)	1.13 (28.58)	0.91 (23.02)	0.66 (16.67)
STTB6-	STTTB6-	2 (53)	2-11-1/2	1.84 (46.83)	3.25 (82.55)	2.63 (66.68)	0.94 (23.81)	0.66 (16.67)
STTB7-	-	2-1/2 (63)	2-1/2-8	2.28 (57.94)	3.75 (95.25)	3.13 (79.38)	1.22 (30.96)	0.88 (22.23)
STTB8-	-	3 (78)	3-8	2.56 (65.09)	4.38 (111.13)	3.78 (96.04)	1.19 (30.16)	0.91 (23.02)
STTB9-	-	3-1/2 (91)	3-1/2-8	2.56 (65.09)	5.00 (127.00)	4.28 (108.74)	1.38 (34.93)	0.88 (22.23)
STTB10-	-	4 (103)	4-8	2.56 (65.09)	5.50 (139.70)	4.84 (123.03)	1.38 (34.93)	0.88 (22.23)
STTB11-	-	5 (129)	5-8	2.72 (69.06)	6.63 (168.28)	5.91 (150.02)	1.47 (37.31)	0.88 (22.23)
STTB12-	-	6 (155)	6-8	3.00 (76.20)	7.69 (195.26)	7.03 (178.58)	1.50 (38.10)	0.97 (24.61)

Metric size designator (ANSI C80.1-1994). Dimensions shown are for uncoated fittings.

Cat. No.	Colour
STTB1-	_ = space for colour identifier
	G = Grey
	W = White
	B = Blue

Custom colours also available - Std. min. quantities are required. Please contact your Regional Sales Office.

## Ordinary Location Fittings

The Ultimate Liquidtight Solution for Corrosive Environments!

### Ocal™ PVC-Coated Liquidtight Conduit Connectors

- Nominal 0.040 in. (40 mils) PVC coating bonded to exterior
- Pressure-sealing sleeves are designed to protect the connection
- Ocal™ uses only genuine T&B® liquidtight fittings to ensure quality installations

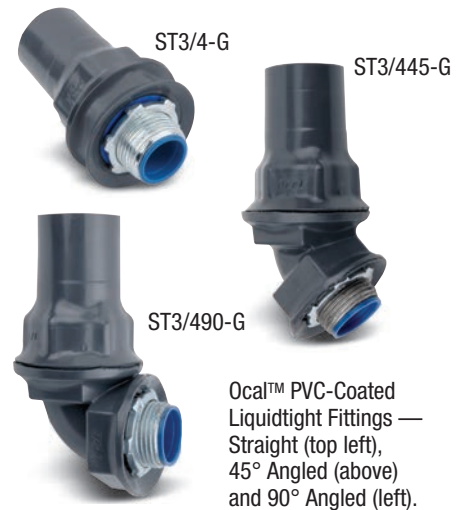

PVC-Coated Steel Straight Cat. No.	PVC-Coated Aluminum Straight Cat. No.	PVC-Coated Steel 45° Cat. No.	PVC-Coated Steel 90° Cat. No.	PVC-Coated Aluminum 90° Cat. No.	Pipe Size in. (mm)
ST3/8- <u>  </u>	ST3/8SA- <u>  </u>	ST3/845- <u>  </u>	ST3/890- <u>  </u>	ST3/890SA- <u>  </u>	3/8 (10)
ST1/2- <u>  </u>	ST1/2SA- <u>  </u>	ST1/245- <u>  </u>	ST1/290- <u>  </u>	ST1/290SA- <u>  </u>	1/2 (16)
ST3/4- <u>  </u>	ST3/4SA- <u>  </u>	ST3/445- <u>  </u>	ST3/490- <u>  </u>	ST3/490SA- <u>  </u>	3/4 (21)
ST1- <u>  </u>	ST1SA- <u>  </u>	ST145- <u>  </u>	ST190- <u>  </u>	ST190SA- <u>  </u>	1 (27)
ST1-1/4- <u>  </u>	ST1-1/4SA- <u>  </u>	ST1-1/445- <u>  </u>	ST1-1/490- <u>  </u>	ST1-1/490SA- <u>  </u>	1-1/4 (35)
ST1-1/2- <u>  </u>	ST1-1/2SA- <u>  </u>	ST1-1/245- <u>  </u>	ST1-1/290- <u>  </u>	ST1-1/290SA- <u>  </u>	1-1/2 (41)
ST2- <u>  </u>	ST2SA- <u>  </u>	ST245- <u>  </u>	ST290- <u>  </u>	ST290SA- <u>  </u>	2 (53)
ST2-1/2- <u>  </u>	ST2-1/2SA- <u>  </u>	ST2-1/245- <u>  </u>	ST2-1/290- <u>  </u>	ST2-1/290SA- <u>  </u>	2-1/2 (63)
ST3- <u>  </u>	ST3SA- <u>  </u>	ST345- <u>  </u>	ST390- <u>  </u>	ST390SA- <u>  </u>	3 (78)
ST4- <u>  </u>	ST4SA- <u>  </u>	ST445- <u>  </u>	ST490- <u>  </u>	ST490SA- <u>  </u>	4 (103)

Cat. No.	Material	Colour
ST3/4-	Blank = Steel/Iron SA = Aluminum	<u>  </u> = space for colour identifier
		G = Grey
		W = White
		B = Blue
		R = Red

Custom colours also available - Std. min. quantities are required. Please contact your Regional Sales Office.

## Ordinary Location Fittings

No Disassembly Required



- 1** Slide the fitting onto the conduit until it stops at the internal sliding bushing. Tighten and you're ready. No parts to reassemble!
- 2** With a wrench, tighten the gland nut to create a raintight seal around the conduit.
- 3** Thread the next length of conduit into the other end of the fitting and tighten. You're done!

### Ocal™ PVC-Coated XJG Rigid Conduit Expansion Couplings

When you install a rigid expansion coupling in a long conduit run, you normally need three hands, two strong backs and lots of patience. Now you can relax.

With the no-hassle XJG Rigid Conduit Expansion Coupling, installation's just a few turns and you're done.

The XJG Rigid Conduit Expansion Coupling features innovations that provide convenience to the installer, saving time and money on the job. No disassembly is needed during installation, requiring fewer tools and less opportunity for lost pieces. It also features a true internal bonding jumper, eliminating the need for external jumpers, so there are fewer parts to buy and install.

If you need a fitting that can give and take without a lot of hassle, reach for the XJG Rigid Conduit Expansion Coupling. It's the latest breakthrough in the industry's leading line of conduit fittings.



8" Movement Coupling shown uncoated

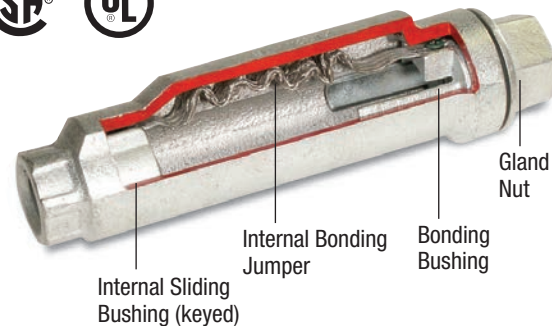

Coupling shown uncoated

### Innovative Design Makes Installations Easier.

- No disassembly necessary to install
- Fast, simple and requires fewer steps
- True internal bonding jumper — no external grounding strap required
- Tamper-proof internal jumper protected from the environment
- Exceed code requirements for long conduit runs to permit linear movement
- Double coated with a nominal 0.002 in. (2 mils) blue urethane, on both the interior and exterior, before PVC coating is applied
- A minimum of 0.040 in. (40 mils) PVC Coating is bonded to the exterior
- Pressure sealing sleeve to seal the connection

## Ordinary Location Fittings

### Ocal™ PVC-Coated XJG Rigid Conduit Expansion Couplings (cont'd)

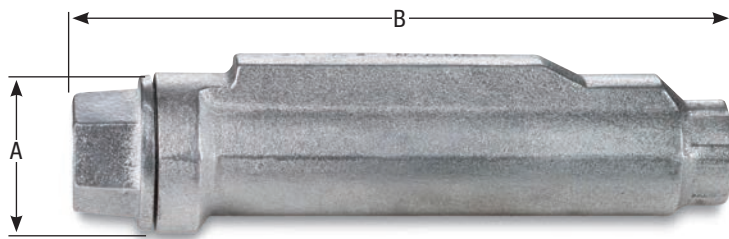

Coupling shown uncoated

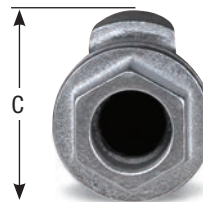

XJG24-G  
4 in. Movement



Cat. No.	Pipe Size in. (mm)	Movement in. (mm)	A Diameter in. (mm)	B Length in. (mm)	C Height in. (mm)
XJG24-	3/4 (21)	4.00 (101.60)	2.43 (61.72)	10.00 (254.00)	2.75 (69.85)
XJG28-	3/4 (21)	8.00 (203.20)	2.43 (61.72)	14.00 (355.60)	2.75 (69.85)
XJG34-	1 (27)	4.00 (101.60)	2.67 (67.82)	10.00 (254.00)	2.99 (75.95)
XJG38-	1 (27)	8.00 (203.20)	2.67 (67.82)	14.00 (355.60)	2.99 (75.95)
XJG44-	1-1/4 (35)	4.00 (101.60)	3.36 (85.34)	10.56 (268.22)	3.68 (93.47)
XJG48-	1-1/4 (35)	8.00 (203.20)	3.36 (85.34)	14.56 (369.82)	3.68 (93.47)
XJG54-	1-1/2 (41)	4.00 (101.60)	3.36 (85.34)	10.56 (268.22)	3.68 (93.47)
XJG58-	1-1/2 (41)	8.00 (203.20)	3.36 (85.34)	14.56 (369.82)	3.68 (93.47)
XJG64-	2 (53)	4.00 (101.60)	3.86 (98.04)	11.25 (285.75)	4.18 (106.17)
XJG68-	2 (53)	8.00 (203.20)	3.86 (98.04)	15.25 (387.35)	4.18 (106.17)
XJG74-	2-1/2 (63)	4.00 (101.60)	4.96 (125.98)	12.12 (307.85)	5.25 (133.35)
XJG78-	2-1/2 (63)	8.00 (203.20)	4.96 (125.98)	16.12 (409.45)	5.25 (133.35)
XJG84-	3 (78)	4.00 (101.60)	4.96 (125.98)	12.12 (307.85)	5.25 (133.35)
XJG88-	3 (78)	8.00 (203.20)	4.96 (125.98)	16.12 (409.45)	5.25 (133.35)
XJG94-	3-1/2 (91)	4.00 (101.60)	6.37 (161.80)	12.87 (326.90)	6.75 (171.45)
XJG98-	3-1/2 (91)	8.00 (203.20)	6.37 (161.80)	16.87 (428.50)	6.75 (171.45)
XJG104-	4 (103)	4.00 (101.60)	6.37 (161.80)	12.87 (326.90)	6.75 (171.45)
XJG108-	4 (103)	8.00 (203.20)	6.37 (161.80)	16.87 (428.50)	6.75 (171.45)
XJG1208-	5 (129)	8.00 (203.20)	7.99 (161.80)	18.87 (479.30)	8.56 (217.42)

Metric size designator (ANSI C80.1-1994). Dimensions shown are for uncoated coupling.

### Standard Materials / Finish

Body / Finish                      Ductiles iron with nominal 0.040 in. (40 mils) PVC exterior coating

Internal Bonding Jumper            Tinned copper braid

Cat. No.	Colour
<b>XJG24-</b>	<b>_ = space for colour identifier</b>
	<b>G = Grey</b>
	<b>W = White</b>
	<b>B = Blue</b>
	<b>R = Red</b>
Custom colours also available - Std. min. quantities are required. Please contact your Regional Sales Office.	

## Ordinary Location Fittings

Variety of Styles Offers Versatility!

### OCAL-BLUE™ Double-Coat FS and FD Series Device Boxes

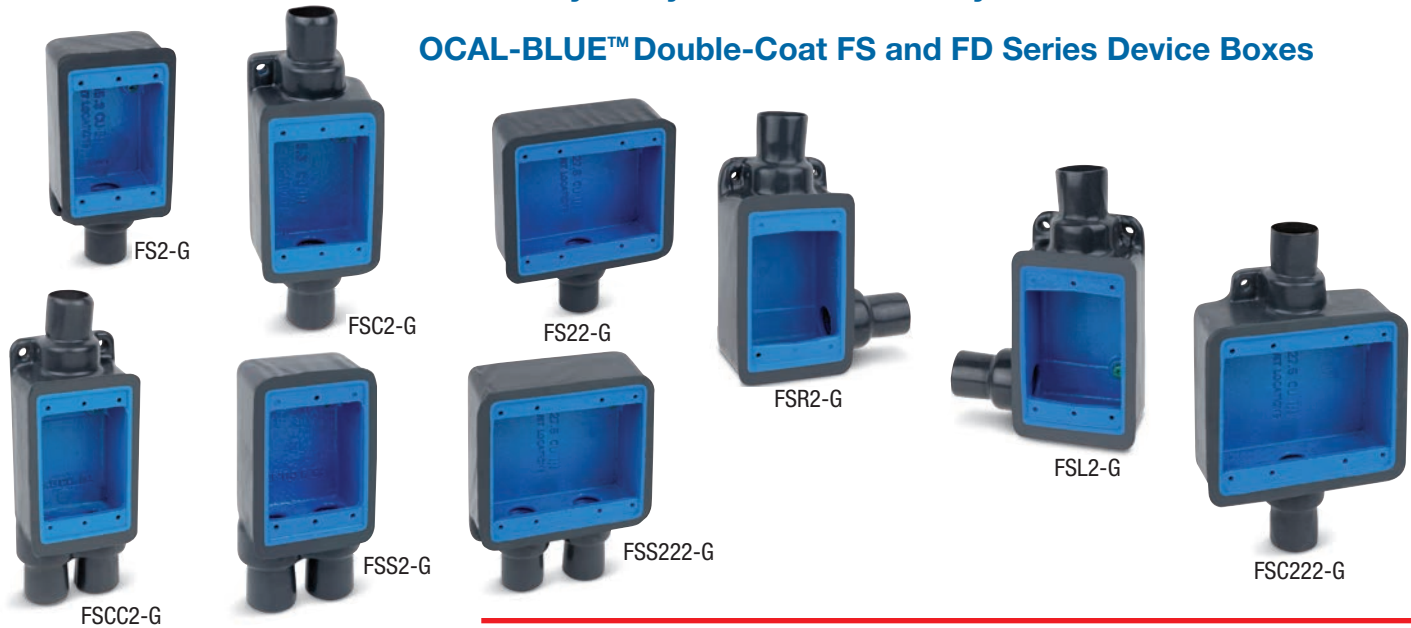

Install these boxes in conduit systems to accommodate wiring devices, act as pull boxes for conductors, provide openings to make splices and taps and provide access to conductors for maintenance and future system changes.

- Cast class 30 grey iron alloy boxes
- Coated with a nominal 0.002 in. (2 mils) blue urethane on both the interior and exterior before PVC coating is applied
- Nominal 0.040 in. (40 mils) PVC coating bonded to exterior
- PVC coating available in your choice of blue, white or grey
- Pressure sealing sleeves protect connections with conduit

Cat. No.	Colour
<b>FS1-</b>	<b>_ = space for colour identifier</b>
	G = Grey
	W = White
	B = Blue
Custom colours also available - Std. min. quantities are required. Please contact your Regional Sales Office.	

Dead End Cat. No.	Feed-Thru Cat. No.	Hub Right Cat. No.	Hub Left Cat. No.	Style	Pipe Size in. (mm)
<b>Single Gang</b>					
FS1- <u>  </u>	FSC1- <u>  </u>	FSR1- <u>  </u>	FSL1- <u>  </u>	Shallow	1/2 (16)
FS2- <u>  </u>	FSC2- <u>  </u>	FSR2- <u>  </u>	FSL2- <u>  </u>	Shallow	3/4 (21)
FS3- <u>  </u>	FSC3- <u>  </u>	—	—	Shallow	1 (27)
FD1- <u>  </u>	FDC1- <u>  </u>	FDR1- <u>  </u>	FDL1- <u>  </u>	Deep	1/2 (16)
FD2- <u>  </u>	FDC2- <u>  </u>	FDR2- <u>  </u>	FDL2- <u>  </u>	Deep	3/4 (21)
FD3- <u>  </u>	FDC3- <u>  </u>	—	—	Deep	1 (27)
—	FSCC2- <u>  </u>	—	—	Shallow	3/4 (21)
—	FDCC2- <u>  </u>	—	—	Deep	3/4 (21)
FSS2- <u>  </u>	—	—	—	Shallow	3/4 (21)
FDD2- <u>  </u>	—	—	—	Deep	3/4 (21)
<b>Double Gang</b>					
FS22- <u>  </u>	—	—	—	Shallow	3/4 (21)
FD22- <u>  </u>	—	—	—	Deep	3/4 (21)
FSS222- <u>  </u>	—	—	—	Shallow	3/4 (21)
FDS222- <u>  </u>	—	—	—	Deep	3/4 (21)
—	FSC222- <u>  </u>	—	—	Shallow	3/4 (21)
—	FDC222- <u>  </u>	—	—	Deep	3/4 (21)

Metric size designator (ANSI C80.1-1994).

## Ordinary Location Fittings

Designed for Use with Ocal™ FS and FD Series Boxes

### OCAL-BLUE™ Double-Coat FS and FD Series Covers



DS23-G



DS21G-G



DS32G-G



DS100G-G



CFSTF-G

Cat. No.	Description	Material
<b>Single Gang</b>		
DS23- <u>  </u>	Duplex Receptacle Cover	Steel
DS21G- <u>  </u>	Round Flush Receptacle Cover	Iron
DS32G- <u>  </u>	Toggle Switch Cover	Iron
DS100G- <u>  </u>	Blank Cover	Aluminum
<b>Single Gang — NEMA 3R Raintight when used with appropriate Ocal™ boxes</b>		
CWPDR-FS- <u>  </u>	Duplex Receptacle Cover — Box Mount — Horizontal	Aluminum
CFSDR- <u>  </u>	Duplex Receptacle Cover — Box Mount — Vertical	Aluminum
CFSHG- <u>  </u>	GFCI Receptacle Cover — Box Mount — Horizontal	Aluminum
CFSRG- <u>  </u>	GFCI Receptacle Cover — Box Mount — Vertical	Aluminum
CFSTF- <u>  </u>	Front Lever Switch Cover — Box Mount — NEMA 4	Aluminum
<b>Double Gang</b>		
S1002G- <u>  </u>	Blank Cover	Iron
S322G- <u>  </u>	2 Toggle Switch Cover	Iron
S232- <u>  </u>	2 Duplex Receptacle Cover	Stamped Steel
S232GFI- <u>  </u>	2 GFCI Receptacle Cover	Steel
<b>Double Gang — NEMA 3R Raintight when used with appropriate Ocal™ boxes</b>		
2CFST- <u>  </u>	2 Plunger-Style Switch Cover	Aluminum

PVC-coated covers in other styles and materials are available upon request. Contact your Regional Sales Office for more information.



CFSDR-G



CFSRG-G



CFSHG-G



CWPDR-FS-G



S232GFI-G



S1002G-G



S322G-G



S232-G



DS1282-G

Cat. No.	Colour
<b>DS23-</b>	<u>  </u> = space for colour identifier
	G = Grey
	W = White
	B = Blue
Custom colours also available - Std. min. quantities are required. Please contact your Regional Sales Office.	

## Ordinary Location Fittings

Make 90° Bends While Allowing Straight Pulls!

### OCAL-BLUE™ Double-Coat Pulling Elbows



LBD2200-G

LBD and LBH bodies are installed at 90° bends in rigid conduit to act as pull outlets for conductors that are stiff due to large size or type of insulation and to make 90° bends in conduit system while allowing straight wire pulls in either direction.

- Choose LBD Series for ordinary locations and LBH Series for hazardous locations
- Coated with a nominal 0.002 in. (2 mils) blue urethane on both interior and exterior
- Nominal 0.040 in. (40 mils) PVC coating bonded to exterior
- Pressure-sealing sleeves seal connections

Cat. No.	Colour
<b>LBD1100-</b>	<b>_ = space for colour identifier</b>
	G = Grey
	W = White
	B = Blue
Custom colours also available - Std. min. quantities are required. Please contact your Regional Sales Office.	

Ordinary LBD Series Cat. No.	Hazardous LBH Series Cat. No.	Pipe Size in. (mm)
LBD1100-	LBH10-	1/2 (16)
LBD2200-	LBH20-	3/4 (21)
LBD3300-	LBH30-	1 (27)
LBD4400-	LBH40-	1-1/4 (35)
LBD5500-	LBH50-	1-1/2 (41)
LBD6600-	LBH60-	2 (53)
LBD7700-	LBH70-	2-1/2 (63)
LBD8800-	LBH80-	3 (78)
LBD9900-	LBH90-	3-1/2 (91)
LBD10900-	LBH100-	4 (103)
LBD012-	—	5 (129)
LBD014-	—	6 (155)

Metric size designator (ANSI C80.1-1994).



BC3-G Mogul



BLB4-G Mogul



BUB3-G Mogul

### OCAL-BLUE™ Double-Coat Mogul Fittings

Install mogul fittings in conduit systems to act as pull outlets for conductors that are stiff due to large size or type of installation, to provide the longer openings needed when pulling large conductors, to prevent sharp bends and kinks in large conductors or to provide more splicing space.

- Nominal 0.002 in. (2 mils) blue urethane on both interior and exterior
- Nominal 0.040 in. (40 mils) PVC coating bonded to exterior
- Pressure-sealing sleeves protect connections



BG48-G Replacement Cover

Cat. No.	Colour
<b>BC3-</b>	<b>_ = space for colour identifier</b>
	G = Grey
	W = White
	B = Blue
Custom colours also available - Std. min. quantities are required. Please contact your Regional Sales Office.	

Mogul Fitting with Cover and Gasket				Replacement Cover BG Cat. No.	Pipe Size in. (mm)
BC Cat. No.	BLB Cat. No.	BUB Cat. No.	BT Cat. No.		
BC3-	BLB3-	BUB3-	BT3-	BG48-	1 (27)
BC4-	BLB4-	BUB4-	BT4-	BG48-	1-1/4 (35)
BC5-	BLB5-	BUB5-	BT5-	BG68-	1-1/2 (41)
BC6-	BLB6-	BUB6-	BT6-	BG68-	2 (53)
BC7-	BLB7-	BUB7-	BT7-	BG88-	2-1/2 (63)
BC8-	BLB8-	BUB8-	BT8-	BG88-	3 (78)
BC9-	BLB9-	BUB9-	BT9-	BG98-	3-1/2 (91)
BC10-	BLB10-	BUB10-	BT10-	BG98-	4 (103)

Metric size designator (ANSI C80.1-1994).



## Ordinary Location Fittings

Make 90° Bends in Limited Space!

### OCAL-BLUE™ Double-Coat Service Entrance Elbows

LBY Series elbows are installed in conduit systems within hazardous areas to make 90° bends where space is limited, to act as pull outlets and to provide access to conductors for maintenance and future system changes.

- Nominal 0.002 in. (2 mils) blue urethane on both interior and exterior
- Nominal 0.040 in. (40 mils) PVC coating bonded to exterior
- Pressure-sealing sleeves protect connections



LBY25-G

Ordinary LBD Series Cat. No.	Pipe Size in. (mm)
LBY15- <u>  </u>	1/2 (16)
LBY25- <u>  </u>	3/4 (21)
LBY35- <u>  </u>	1 (27)
LBY45- <u>  </u>	1-1/4 (35)
LBY55- <u>  </u>	1-1/2 (41)



LBY25-G

Cat. No.	Material	Colour
LBY15- <u>  </u>	SA = Aluminum	- = space for colour identifier
		G = Grey
		W = White
		B = Blue

Custom colours also available - Std. min. quantities are required. Please contact your Regional Sales Office.

Metric size designator (ANSI C80.1-1994).

## End or Change Directions in Conduit Runs

### OCAL-BLUE™ Double-Coat Malleable Elbows

EL Series elbows are installed at the end of conduit runs, in a box or a fitting hub to change direction in threaded rigid conduit run by 45° or 90°, or when terminating at a box or fitting.

- Nominal 0.002 in. (2 mils) blue urethane on both interior and exterior
- Nominal 0.040 in. (40 mils) PVC coating bonded to exterior
- Pressure-sealing sleeves protect connections

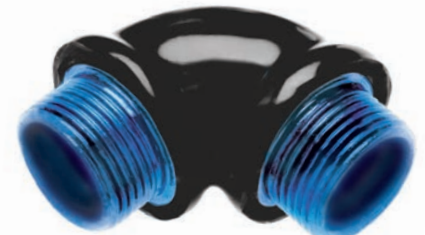

90° Male Cat. No.	90° Female Cat. No.	90° Male-Female Cat. No.	45° Female Cat. No.	Pipe Size in. (mm)
EL195- <u>  </u>	EL19- <u>  </u>	EL196- <u>  </u>	EL1- <u>  </u>	1/2 (16)
EL295- <u>  </u>	EL29- <u>  </u>	EL296- <u>  </u>	EL2- <u>  </u>	3/4 (21)
EL395- <u>  </u>	EL39- <u>  </u>	EL396- <u>  </u>	EL3- <u>  </u>	1 (27)
—	EL49- <u>  </u>	EL496- <u>  </u>	EL4- <u>  </u>	1-1/4 (35)
—	EL59- <u>  </u>	—	EL5- <u>  </u>	1-1/2 (41)
—	EL69- <u>  </u>	—	EL6- <u>  </u>	2 (53)
—	EL79- <u>  </u>	—	EL7- <u>  </u>	2-1/2 (63)
—	—	—	EL8- <u>  </u>	3 (78)
—	—	—	EL9- <u>  </u>	3-1/2 (91)
—	—	—	EL10- <u>  </u>	4 (103)

Cat. No.	Material	Colour
EL195- <u>  </u>	SA = Aluminum	- = space for colour identifier
		G = Grey
		W = White
		B = Blue

Custom colours also available - Std. min. quantities are required. Please contact your Regional Sales Office.

Metric size designator (ANSI C80.1-1994).

## Ordinary Location Fittings

Join Two Conduit Runs When Neither Can Rotate!

### OCAL-BLUE™ Double-Coat Threaded Erickson® 3-Piece Couplings

- Malleable iron and steel or copper-free aluminum
- Nominal 0.002 in. (2 mils) blue urethane coating on both interior and exterior
- Nominal 0.040 in. (40 mils) PVC coating bonded to exterior
- Free fitting threads ensure easy assembly
- Provide rigid in-line coupling with high-quality grounding — won't loosen under vibration
- Suitable for concrete-tight applications

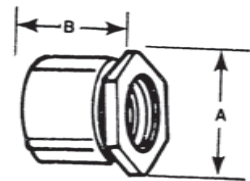

ERICSON3/4-G



ERICSON1-G



ERICSON3/4-G unassembled



Erickson® coupling before coating

Steel/ Malleable Iron Cat. No.	Copper Free Aluminum Cat. No.	Pipe Size in. (mm)	Dimensions in. (mm)	
			A	B
ERICSON1/2- <u>  </u>	ERICSON1/2SA- <u>  </u>	1/2 (16)	1.47 (37.34)	1.25 (31.75)
ERICSON3/4- <u>  </u>	ERICSON3/4SA- <u>  </u>	3/4 (21)	1.56 (39.62)	1.41 (35.81)
ERICSON1- <u>  </u>	ERICSON1SA- <u>  </u>	1 (27)	1.91 (48.51)	1.63 (41.40)
ERICSON1-1/4- <u>  </u>	ERICSON1-1/4SA- <u>  </u>	1-1/4 (35)	2.38 (60.45)	1.81 (45.97)
ERICSON1-1/2- <u>  </u>	ERICSON1-1/2SA- <u>  </u>	1-1/2 (41)	2.63 (66.80)	1.97 (50.04)
ERICSON2- <u>  </u>	ERICSON2SA- <u>  </u>	2 (53)	3.22 (81.79)	2.22 (56.39)
ERICSON2-1/2- <u>  </u>	ERICSON2-1/2SA- <u>  </u>	2-1/2 (63)	3.97 (100.84)	2.69 (68.33)
ERICSON3- <u>  </u>	ERICSON3SA- <u>  </u>	3 (78)	4.44 (112.78)	2.91 (73.91)
ERICSON3-1/2- <u>  </u>	ERICSON3-1/2SA- <u>  </u>	3-1/2 (91)	5.00 (127.00)	3.00 (76.20)
ERICSON4- <u>  </u>	ERICSON4SA- <u>  </u>	4 (103)	5.50 (139.70)	3.19 (81.03)
ERICSON5- <u>  </u>	ERICSON5SA- <u>  </u>	5 (129)	6.78 (172.21)	3.75 (95.25)
ERICSON6- <u>  </u>	ERICSON6SA- <u>  </u>	6 (155)	8.00 (203.20)	4.03 (102.36)

Metric size designator (ANSI C80.1-1994).

## Standard Materials / Finish

### Cat. No. ERICSON

Bushing & Case . . . . . Malleable iron  
 Ring . . . . . Steel and malleable iron  
 Finish . . . . . Nominal 0.002 in. (2 mils) blue urethane interior  
 and exterior coating with nominal  
 0.040 in. (40 mils) PVC exterior coating

### Cat. No. ERICSON\_SA

Bushing & Case . . . . . Copper-free aluminum  
 Ring . . . . . Copper-free aluminum  
 Finish . . . . . Nominal 0.002 in. (2 mils) blue urethane interior  
 and exterior coating with nominal  
 0.040 in. (40 mils) PVC exterior coating

Cat. No.	Size	Material	Colour
<b>ERICSON</b>	<b>1/2</b>	<b>-</b>	<b>_ = space for colour identifier</b>
		Blank = Steel SA = Aluminum	G = Grey W = White B = Blue
<i>Catalogue No. Example:</i> <b>ERICSON2SA-B</b> is 2 in. aluminum Erickson® coupling coated in blue PVC.			Custom colours also available - Std. min. quantities are required. Please contact your Regional Sales Office.

## Ordinary Location Fittings

Easily Join Two Different Sizes of Conduit!

### OCAL-BLUE™ Double-Coat Reducing Couplings

- Integral bushings in both ends prevent damage to wires
- Funnel-shaped interior guides wires from large to small conduit, making them easier to pull
- Nominal 0.002 in. (2 mils) blue urethane coating on both interior and exterior
- Nominal 0.040 in. (40 mils) PVC coating bonded to exterior
- Pressure-sealing sleeves protect connections

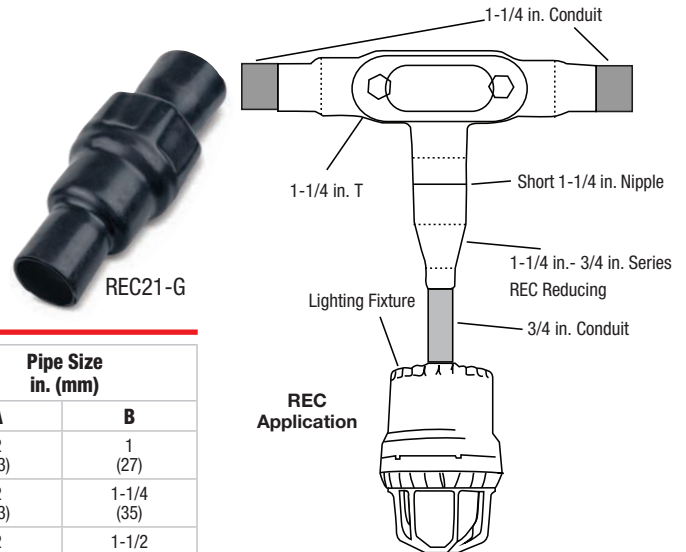

Cat. No.	Pipe Size in. (mm)	
	A	B
REC21-	3/4 (21)	1/2 (16)
REC31-	1 (27)	1/2 (16)
REC32-	1 (27)	3/4 (21)
REC42-	1-1/4 (35)	3/4 (21)
REC43-	1-1/4 (35)	1 (27)
REC52-	1-1/2 (41)	3/4 (21)
REC53-	1-1/2 (41)	1 (27)
REC54-	1-1/2 (41)	1-1/4 (35)
REC602-	2 (53)	3/4 (21)

Cat. No.	Pipe Size in. (mm)	
	A	B
REC603-	2 (53)	1 (27)
REC604-	2 (53)	1-1/4 (35)
REC605-	2 (53)	1-1/2 (41)
REC75-	2-1/2 (63)	1-1/2 (41)
REC86-	3 (78)	2 (53)
REC97-	3-1/2 (91)	2-1/2 (63)
REC108-	4 (103)	3 (78)
REC01210-	5 (129)	4 (103)

Metric size designator (ANSI C80.1-1994).

Cat. No.	Material	Colour
REC21-	SA = Aluminum	- = space for colour identifier
		G = Grey
		W = White
		B = Blue

Custom colours also available - Std. min. quantities are required. Please contact your Regional Sales Office.

## Reduce a Conduit Hub to a Smaller Size

OCAL-BLUE™ Urethane-Coated Reducing Bushings

Cat. No.	Pipe Size in. (mm)	
	A - Male	B - Female
RE21-G	3/4 (21)	1/2 (16)
RE31-G	1 (27)	1/2 (16)
RE32-G	1 (27)	3/4 (21)
RE41-G	1-1/4 (35)	1/2 (16)
RE42-G	1-1/4 (35)	3/4 (21)
RE43-G	1-1/4 (35)	1 (27)
RE51-G	1-1/2 (41)	1/2 (16)
RE52-G	1-1/2 (41)	3/4 (21)

Cat. No.	Pipe Size in. (mm)	
	A - Male	B - Female
RE53-G	1-1/2 (41)	1 (27)
RE54-G	1-1/2 (41)	1-1/4 (35)
RE61-G	2 (53)	1/2 (16)
RE62-G	2 (53)	3/4 (21)
RE63-G	2 (53)	1 (27)
RE64-G	2 (53)	1-1/4 (35)
RE65-G	2 (53)	1-1/2 (41)
RE73-G	2-1/2 (63)	1 (27)

Cat. No.	Pipe Size in. (mm)	
	A - Male	B - Female
RE74-G	2-1/2 (63)	1-1/4 (35)
RE75-G	2-1/2 (63)	1-1/2 (41)
RE76-G	2-1/2 (63)	2 (53)
RE83-G	3 (78)	1 (27)
RE84-G	3 (78)	1-1/4 (35)
RE85-G	3 (78)	1-1/2 (41)
RE86-G	3 (78)	2 (53)
RE87-G	3 (78)	2-1/2 (63)



RE32-G

Cat. No.	Pipe Size in. (mm)	
	A - Male	B - Female
RE96-G	3-1/2 (91)	2 (53)
RE97-G	3-1/2 (91)	2-1/2 (63)
RE98-G	3-1/2 (91)	3 (78)
RE106-G	4 (103)	2 (53)
RE107-G	4 (103)	2-1/2 (63)
RE108-G	4 (103)	3 (78)

Metric size designator (ANSI C80.1-1994).

Also available in Aluminum (SA).

## Hazardous Location Fittings

Provide Access to Wiring, Directional Changes in Conduit and More!



GUA

### Listings / Certifications†

- UL514A Wet Locations (when used with gasketed covers)
- UL886

### OCAL-BLUE™ Double-Coat GUA Series Conduit Boxes

GUA series conduit boxes are installed in hazardous areas to protect conductors, act as pull and splice boxes, provide access to conductors for maintenance and future system changes, act as mounting outlets for fixtures (with proper covers) or change conduit direction.

- Grade 60-45-10 ductile iron bodies and cast aluminum covers (iron covers also available)
- Nominal 0.002 in. (2 mils) blue urethane coating on both interior and exterior and nominal 0.040 in. (40 mils) PVC coating bonded to exterior
- All hubs have minimum 5 full threads, integral bushing and pressure-sealing sleeves
- All units furnished with internal grounding screw and ship complete with aluminum cover with O-ring gasket (covers also sold separately for replacement purposes)
- Explosion-proof, dust-ignition proof, raintight and suitable for use in the following environments:†
  - Class I, Divisions 1 & 2, Groups C and D
  - Class II, Division 1, Groups E, F and G
  - Class III, Divisions 1 & 2
  - NEMA 3, 4, 7 CD and 9 EFG



GUAB



GUAC

GUAT



GUAX

Cat. No.					Aluminum Cover Only	Iron Cover Only	Pipe Size in. (mm)	Cover Opening in. (mm)
GUA	GUAC	GUAT	GUAX	GUAB				
GUA14- <sub> </sub>	GUAC14- <sub> </sub>	GUAT14- <sub> </sub>	GUAX14- <sub> </sub>	GUAB14- <sub> </sub>	GUA04- <sub> </sub>	GUA04WOD- <sub> </sub>	1/2 (16)	2.00 (50.80)
GUA24- <sub> </sub>	GUAC24- <sub> </sub>	GUAT24- <sub> </sub>	GUAX24- <sub> </sub>	GUAB24- <sub> </sub>	GUA04- <sub> </sub>	GUA04WOD- <sub> </sub>	3/4 (21)	2.00 (50.80)
GUA16- <sub> </sub>	GUAC16- <sub> </sub>	GUAT16- <sub> </sub>	GUAX16- <sub> </sub>	GUAB16- <sub> </sub>	GUA06- <sub> </sub>	GUA06WOD- <sub> </sub>	1/2 (16)	3.00 (76.20)
GUA26- <sub> </sub>	GUAC26- <sub> </sub>	GUAT26- <sub> </sub>	GUAX26- <sub> </sub>	GUAB26- <sub> </sub>	GUA06- <sub> </sub>	GUA06WOD- <sub> </sub>	3/4 (21)	3.00 (76.20)
GUA36- <sub> </sub>	GUAC36- <sub> </sub>	GUAT36- <sub> </sub>	GUAX36- <sub> </sub>	GUAB36- <sub> </sub>	GUA06- <sub> </sub>	GUA06WOD- <sub> </sub>	1 (27)	3.00 (76.20)
—	—	GUAT37- <sub> </sub>	GUAX37- <sub> </sub>	—	GUA07- <sub> </sub>	GUA07WOD- <sub> </sub>	1 (27)	3.63 (92.20)
GUA47- <sub> </sub>	GUAC47- <sub> </sub>	GUAT47- <sub> </sub>	GUAX47- <sub> </sub>	GUAB47- <sub> </sub>	GUA07- <sub> </sub>	GUA07WOD- <sub> </sub>	1-1/4 (35)	3.63 (92.20)
—	GUAC49- <sub> </sub>	GUAT49- <sub> </sub>	GUAX49- <sub> </sub>	—	GUA09- <sub> </sub>	GUA09WOD- <sub> </sub>	1-1/4 (35)	5.00 (127.00)
GUA59- <sub> </sub>	GUAC59- <sub> </sub>	GUAT59- <sub> </sub>	GUAX59- <sub> </sub>	GUAB59- <sub> </sub>	GUA09- <sub> </sub>	GUA09WOD- <sub> </sub>	1-1/2 (41)	5.00 (127.00)
—	GUAC69- <sub> </sub>	GUAT69- <sub> </sub>	GUAX69- <sub> </sub>	GUAB69- <sub> </sub>	GUA09- <sub> </sub>	GUA09WOD- <sub> </sub>	2 (53)	5.00 (127.00)

Metric size designator (ANSI C80.1-1994). † Ratings prior to PVC coating.

## Hazardous Location Fittings

### OCAL-BLUE™ Double-Coat GUA Series Conduit Boxes (cont'd)



GUA4



GUA5



GUA6

Cat. No.	Material	Colour
<b>GUA14-</b>	SA = Aluminum	- = space for colour identifier
		G = Grey
		W = White
		B = Blue
		R = Red

Custom colours also available - Std. min. quantities are required. Please contact your Regional Sales Office.



GUA7



GUA8

Cat. No.					Aluminum Cover Only	Iron Cover Only	Pipe Size in. (mm)	Cover Opening in. (mm)
GUA4	GUA5	GUA6	GUA7	GUA8				
GUA14-	GUA14-	GUA14-	GUA14-	GUA14-	GUA04-	GUA04WOD-	1/2 (16)	2.00 (50.80)
GUA24-	GUA24-	GUA24-	GUA24-	GUA24-	GUA04-	GUA04WOD-	3/4 (21)	2.00 (50.80)
GUA16-	GUA16-	GUA16-	GUA16-	GUA16-	GUA06-	GUA06WOD-	1/2 (16)	3.00 (76.20)
GUA26-	GUA26-	GUA26-	GUA26-	GUA26-	GUA06-	GUA06WOD-	3/4 (21)	3.00 (76.20)
GUA36-	GUA36-	GUA36-	GUA36-	—	GUA06-	GUA06WOD-	1 (27)	3.00 (76.20)
—	GUA47-	GUA47-	GUA47-	—	GUA07-	GUA07WOD-	1-1/4 (35)	3.63 (92.20)
GUA49-	GUA49-	—	—	—	GUA09-	GUA09WOD-	1-1/4 (35)	5.00 (127.00)
—	GUA59-	—	GUA59-	—	GUA09-	GUA09WOD-	1-1/2 (41)	5.00 (127.00)
—	GUA69-	GUA69-	GUA69-	—	GUA09-	GUA09WOD-	2 (53)	5.00 (127.00)

Metric size designator (ANSI C80.1-1994).

## Hazardous Location Fittings

### Junction Boxes for Branch Conduits in Hazardous Locations

#### OCAL-BLUE™ Double-Coat External Hubs with Covers and Installed Green Ground Screw

- Accessible wiring chamber provides a convenient location to maintain or change a system, pull conductors and make splices
- Unique mounting pads and rugged protective housing ideal for installation of OEM devices or instruments
- Die-cast copper-free aluminum alloy A360 construction with precision cast and machined surfaces
- Precision NPT threaded hubs for trouble-free field installation
- Nominal 0.002 in. (2 mils) blue urethane coating on both interior and exterior and nominal 0.040 in. (40 mils) PVC coating bonded to exterior
- Explosion-proof, dust-ignition proof, raintight and suitable for use in the following environments:††
  - Class I, Divisions 1 & 2, Groups C and D
  - Class II, Division 1, Groups E, F and G
  - Class III, Divisions 1 & 2
  - NEMA 3, 4, 7 CD and 9 EFG (NEMA 4 rated when ordered with O-ring installed)



GAC



GAE



GAL



GALB



GAT

Cat. No.						Pipe Size in. (mm)	Cover Opening in. (mm)
Through-Feed W/Surf. Cover GAC	Dead End W/Surf. Cover GAE	L-Style W/Surf. Cover GAL	LB-Style W/Surf. Cover GALB	T-Style W/Surf. Cover GAT	Surface Cover Only GAS		
GAC-1-_ †	GAE-1-_ †	GAL-1-_ †	GALB-1-_ †	GAT-1-_ †	GAS-123-_ •	1/2 (16)	3.69 (93.73)
GAC-2-_ †	GAE-2-_ †	GAL-2-_ †	GALB-2-_ †	GAT-2-_ †	GAS-123-_ •	3/4 (21)	3.69 (93.73)
GAC-3-_ †•	GAE-3-_ †•	GAL-3-_ †•	GALB-3-_ †	GAT-3-_ †	GAS-123-_ •	1 (27)	3.69 (93.73)
GAC-4-_ †•	—	GAL-4-_ †•	GALB-4-_ †	GAT-4-_ †	GAS-4-_ •	1-1/4 (35)	3.91 (99.31)
GAC-5-_ †•	—	GAL-5-_ †•	GALB-5-_ †•	GAT-5-_ †	GAS-56-_ •	1-1/2 (41)	5.19 (131.83)
GAC-6-_ †•	—	GAL-6-_ †•	GALB-6-_ †•	GAT-6-_ †	GAS-56-_ •	2 (53)	5.19 (131.83)

† Suffix -OR: O-ring available for NEMA 4 rating. Consult your Regional Sales Office for lead time and price. • Made-to-order item. Consult factory for lead time and minimum quantities.

†† Ratings prior to PVC coating. Metric size designator (ANSI C80.1-1994).

## Hazardous Location Fittings

OCAL-BLUE™ Double-Coat External Hubs with Covers and Installed Green Ground Screw (cont'd)



GAX



GAFX

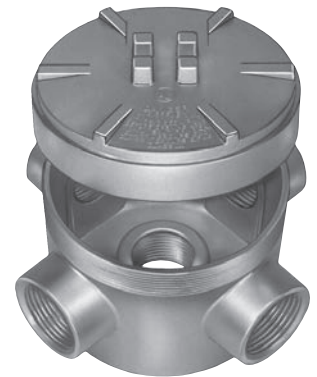

GAJU  
(shown uncoated)



GAS



GAD



GAJ  
(shown uncoated)

Cat. No.	Colour
<b>GAC1-</b>	<b>_ = space for colour identifier</b>
	G = Grey
	W = White
	B = Blue
Custom colours also available - Std. min. quantities are required. Please contact your Regional Sales Office.	

Cat. No.						Pipe Size in. (mm)	Cover Opening in. (mm)
X-Style W/Surf. Cover GAX	X-Style W/Flange & Surf. Cover GAFX	U-Style Surface W/Canopy Cover GAJU	Surface Cover Only GAS	Dome Cover Only (Class I, Gr. D) GAD	Canopy Cover Only GAJ		
GAX-1- <sub>†</sub>	GAFX-1- <sub>†</sub>	GAJU-1- <sub>•</sub>	GALB-1- <sub>†</sub>	GAD-123- <sub>•</sub>	GAJ-123- <sub>•</sub>	1/2 (16)	3.69 (93.73)
GAX-2- <sub>†</sub>	GAFX-2- <sub>†</sub>	GAJU-2- <sub>•</sub>	GALB-2- <sub>†</sub>	GAD-123- <sub>•</sub>	GAJ-123- <sub>•</sub>	3/4 (21)	3.69 (93.73)
GAX-3- <sub>†•</sub>	GAFX-3- <sub>†</sub>	GAJU-3- <sub>•</sub>	GALB-3- <sub>†</sub>	GAD-123- <sub>•</sub>	GAJ-123- <sub>•</sub>	1 (27)	3.69 (93.73)
GAX-4- <sub>†•</sub>	—	—	GALB-4- <sub>†</sub>	—	GAJ-4- <sub>•</sub>	1-1/4 (35)	3.91 (99.31)
GAX-5- <sub>†•</sub>	—	GAJU-5- <sub>•</sub>	GALB-5- <sub>†•</sub>	—	GAJ-56- <sub>•</sub>	1-1/2 (41)	5.19 (131.83)
GAX-6- <sub>†•</sub>	—	GAJU-6- <sub>•</sub>	GALB-6- <sub>†•</sub>	—	GAJ-56- <sub>•</sub>	2 (53)	5.19 (131.83)

• Made-to-order item. Consult your Regional Sales Office for lead time and minimum quantities. † Suffix -OR: O-ring available for NEMA 4 rating. Consult your Regional Sales Office for lead time and price. Metric size designator (ANSI C80.1-1994).

## Hazardous Location Fittings

Restrict the Passage of gGases, Vapors and Flames at Atmospheric Pressure and Normal Ambient Temperatures

### OCAL-BLUE™ Double-Coat Sealing Fittings

- Sealing fittings restrict the passage of gases, vapors, or flames from one portion of the electrical installation to another at atmospheric pressure and normal ambient temperatures. They prevent precompression or “pressure pilling” in conduit systems.
- Grey iron alloy body construction coated with nominal 0.002 in. (2 mils) blue urethane on both interior and exterior
- Nominal 0.040 in. (40 mils) PVC coating bonded to exterior — available in grey, white, blue or custom colours

- Explosion-proof, dust-ignition proof and suitable for use in the following environments:†
  - Class I, Divisions 1 & 2, Groups C and D
  - Class II, Division 1, Groups E, F and G
  - Class III, Divisions 1 & 2

### EYD Series Drain Sealing Fittings

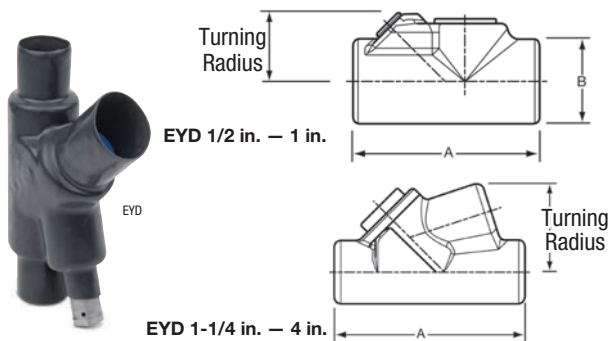

### EYS Series Sealing Fittings

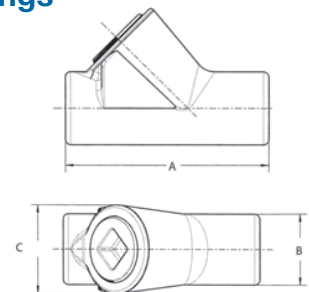

EYS1 — EYS5

Female Cat. No.	Male & Female Cat. No.	Pipe Size in. (mm)	Dimensions in. (mm)			Turning Radius in. (mm)
			A	B	C	
<b>Vertical Only</b>						
EYS1- <sub>-</sub>	EYS16- <sub>-</sub>	1/2 (16)	3.31 (84.07)	1.25 (31.75)	1.50 (38.10)	1.66 (42.16)
EYS2- <sub>-</sub>	EYS26- <sub>-</sub>	3/4 (21)	3.65 (92.71)	1.50 (38.10)	1.75 (44.45)	1.96 (49.78)
EYS3- <sub>-</sub>	EYS36- <sub>-</sub>	1 (27)	4.25 (107.95)	1.75 (44.45)	2.19 (55.63)	2.40 (60.96)
<b>Vertical or Horizontal</b>						
EYS11- <sub>-</sub>	EYS116- <sub>-</sub>	1/2 (16)	3.63 (92.20)	1.25 (31.75)	—	1.09 (27.69)
EYS21- <sub>-</sub>	EYS216- <sub>-</sub>	3/4 (21)	3.66 (92.96)	1.50 (38.10)	—	1.25 (31.75)
EYS31- <sub>-</sub>	EYS316- <sub>-</sub>	1 (27)	4.25 (107.95)	1.75 (44.45)	—	1.59 (40.39)
EYS4- <sub>-</sub>	EYS46- <sub>-</sub>	1-1/4 (35)	5.00 (127.00)	2.25 (57.15)	—	1.81 (45.97)
EYS5- <sub>-</sub>	EYS56- <sub>-</sub>	1-1/2 (41)	5.44 (138.18)	2.44 (61.98)	—	2.00 (50.80)
EYS6- <sub>-</sub>	EYS66- <sub>-</sub>	2 (53)	6.25 (158.75)	3.00 (76.20)	—	2.31 (58.67)
EYS7- <sub>-</sub>	EYS76- <sub>-</sub>	2-1/2 (63)	7.50 (190.50)	3.50 (88.90)	—	2.56 (65.02)
EYS8- <sub>-</sub>	EYS86- <sub>-</sub>	3 (78)	8.50 (215.90)	4.25 (107.95)	—	3.09 (78.49)
EYS9- <sub>-</sub>	EYS96- <sub>-</sub>	3-1/2 (91)	9.19 (233.43)	4.75 (120.65)	—	3.38 (85.85)
EYS10- <sub>-</sub>	EYS106- <sub>-</sub>	4 (103)	9.75 (247.65)	5.25 (133.35)	—	3.53 (89.66)

IMPORTANT: MUST BE USED WITH CHICOTM SEALING COMPOUND AND FIBER SEE PAGE H41.  
 † Ratings prior to PVC coating. EYSX and EYDX are expanded-fill styles. When ordering, add X to part number. For example: EYSX31-G, EYDX31-B. Metric size designator (ANSI C80.1-1994).

Female Cat. No.	Male & Female Cat. No.	Pipe Size in. (mm)	Dimensions in. (mm)		Turning Radius in. (mm)
			A	B	
EYD1- <sub>-</sub>	EYD16- <sub>-</sub>	1/2 (16)	3.81 (96.77)	1.50 (38.10)	1.75 (44.45)
EYD2- <sub>-</sub>	EYD26- <sub>-</sub>	3/4 (21)	4.08 (103.63)	1.75 (44.45)	1.98 (50.29)
EYD3- <sub>-</sub>	EYD36- <sub>-</sub>	1 (27)	4.85 (123.19)	2.19 (55.63)	2.19 (55.63)
EYD4- <sub>-</sub>	EYD46- <sub>-</sub>	1-1/4 (35)	5.00 (127.00)	2.25 (57.15)	1.80 (45.72)
EYD5- <sub>-</sub>	EYD56- <sub>-</sub>	1-1/2 (41)	5.44 (138.18)	2.44 (61.98)	2.00 (61.98)
EYD6- <sub>-</sub>	EYD66- <sub>-</sub>	2 (53)	6.25 (158.75)	3.00 (76.20)	2.32 (58.93)
EYD7- <sub>-</sub>	EYD76- <sub>-</sub>	2-1/2 (63)	7.50 (190.50)	3.50 (88.90)	2.69 (68.33)
EYD8- <sub>-</sub>	EYD86- <sub>-</sub>	3 (78)	8.50 (215.90)	4.25 (107.95)	3.15 (80.01)
EYD9- <sub>-</sub>	EYD96- <sub>-</sub>	3-1/2 (91)	9.19 (233.43)	4.75 (120.65)	3.38 (85.85)
EYD10- <sub>-</sub>	EYD106- <sub>-</sub>	4 (103)	9.75 (247.65)	5.25 (133.35)	3.64 (92.46)



## Hazardous Location Fittings

### OCAL-BLUE™ Double-Coat Sealing Fittings (cont'd)



#### EZS Series Sealing Fittings

Female Cat. No.	Male & Female Cat. No.	in. (mm)
EZS1- <u>  </u>	EZS16- <u>  </u>	1/2 (16)
EZS2- <u>  </u>	EZS26- <u>  </u>	3/4 (21)
EZS3- <u>  </u>	EZS36- <u>  </u>	1 (27)
EZS4- <u>  </u>	EZS46- <u>  </u>	1-1/4 (35)
EZS5- <u>  </u>	EZS56- <u>  </u>	1-1/2 (41)
EZS6- <u>  </u>	EZS66- <u>  </u>	2 (53)
EZS7- <u>  </u>	EZS76- <u>  </u>	2-1/2 (63)
EZS8- <u>  </u>	EZS86- <u>  </u>	3 (78)

Metric size designator (ANSI C80.1-1994).

#### EZD Series Sealing Fittings

Cat. No.	in. (mm)
EZD111- <u>  </u>	1/2 (16)
EZD211- <u>  </u>	3/4 (21)
EZD311- <u>  </u>	1 (27)
EZD411- <u>  </u>	1-1/4 (35)
EZD511- <u>  </u>	1-1/2 (41)
EZD611- <u>  </u>	2 (53)

Metric size designator (ANSI C80.1-1994).

Cat. No.	Colour
<b>EYS1-</b>	<u>  </u> = space for colour identifier
	G = Grey
	W = White
	B = Blue
Custom colours also available - Std. min. quantities are required. Please contact your Regional Sales Office.	

## Ensures Proper Functioning of EYS Sealing Fittings

### Chico™ Sealing Compound and Fiber

- Sealing compound mixes with water, pours easily and hardens in 60 — 70 minutes
- Fiber filler mineral wool holds sealing compound in place while it hardens



FIBER-X6



SEAL-A3

OCAL-BLUE™ Double-Coat EYS Sealing Fittings require fiber filler and sealing compound to function properly. Use Chico™ X Fiber Filler to form a dam around the sealing fitting's integral bushing, as well as at the end of the conduit and around conductors entering the hub. Chico™ A Sealing Compound expands slightly while hardening and bonds to the inner walls of the sealing fitting.

Cat. No.	Description
<b>SEAL-A3</b>	Chico™ A Sealing Compound, 1 lb. net wt./23 cu.in. vol.
<b>FIBER-X6</b>	Chico™ X Fiber Filler, 8 oz.
<b>SEALKIT-A4</b>	Chico™ A Sealing Compound, 1 lb. net wt./23 cu.in. vol., with 1 oz. Chico™ X Fiber Filler

Chico™ is a trademark of Cooper Technologies Company.

## Hazardous Location Fittings

### Explosion-Proof, Dust-Ignition Proof Three-Piece Couplings

#### OCAL-BLUE™ Double-Coat Conduit Unions

- Install in threaded thick-wall conduit systems in hazardous areas
- Use UNY male unions to connect conduit to a conduit fitting, junction box or device enclosure
- Use UNF female unions to connect conduit to conduit or to provide means for future modifications to the conduit system
- Nominal 0.002 in. (2 mils) blue urethane on interior and exterior
- Nominal 0.040 in. (40 mils) PVC coating bonded to exterior
- Pressure-sealing sleeves protect your connection
- Explosion-proof, dust-ignition proof and suitable for use in the following environments:†
  - Class I, Divisions 1 & 2, Groups A, B, C and D
  - Class II, Division 1, Groups E, F and G
  - Class III, Divisions 1 & 2



UNY Male 1/2 - 4 in.  
(shown uncoated)



UNY Male 5 - 6 in.  
(shown uncoated)



UNF Female 1/2 - 4 in.  
(shown uncoated)



UNF Female 5 - 6 in.  
(shown uncoated)

UNF205-G



#### UNY Male Unions

Cat. No.	Pipe Size in. (mm)	Overall Length in. (mm)	Overall Diameter in. (mm)
UNY105- <u>  </u>	1/2 (16)	2.39 (60.71)	1.50 (38.10)
UNY205- <u>  </u>	3/4 (21)	2.44 (61.98)	1.81 (38.10)
UNY305- <u>  </u>	1 (27)	2.75 (69.85)	2.00 (50.80)
UNY405- <u>  </u>	1-1/4 (35)	3.06 (77.72)	2.75 (69.85)
UNY505- <u>  </u>	1-1/2 (41)	3.63 (92.20)	3.06 (77.72)
UNY605- <u>  </u>	2 (53)	3.50 (88.90)	3.81 (96.77)
UNY705- <u>  </u>	2-1/2 (63)	4.81 (122.17)	4.31 (109.47)
UNY805- <u>  </u>	3 (78)	5.34 (135.64)	5.06 (128.52)
UNY905- <u>  </u>	3-1/2 (91)	5.50 (139.70)	5.69 (144.53)
UNY1005- <u>  </u>	4 (103)	5.63 (143.00)	6.19 (157.23)
UNY012- <u>  </u>	5 (129)	5.25 (133.35)	8.19 (208.03)
UNY014- <u>  </u>	6 (155)	5.38 (136.65)	9.31 (236.47)

Metric size designator (ANSI C80.1-1994).

#### UNF Female Unions

Cat. No.	Pipe Size in. (mm)	Overall Length in. (mm)	Overall Diameter in. (mm)
UNF105- <u>  </u>	1/2 (16)	1.88 (47.75)	1.50 (38.10)
UNF205- <u>  </u>	3/4 (21)	2.13 (54.10)	1.81 (45.97)
UNF305- <u>  </u>	1 (27)	2.16 (54.86)	2.00 (50.80)
UNF405- <u>  </u>	1-1/4 (35)	2.25 (57.15)	2.75 (69.85)
UNF505- <u>  </u>	1-1/2 (41)	2.75 (69.85)	3.06 (77.72)
UNF605- <u>  </u>	2 (53)	2.50 (63.50)	3.81 (96.77)
UNF705- <u>  </u>	2-1/2 (63)	3.50 (88.90)	4.31 (109.47)
UNF805- <u>  </u>	3 (78)	4.00 (101.60)	5.06 (128.52)
UNF905- <u>  </u>	3-1/2 (91)	4.16 (105.66)	5.69 (144.53)
UNF1005- <u>  </u>	4 (103)	4.25 (107.95)	6.19 (157.23)
UNF012- <u>  </u>	5 (129)	3.81 (96.77)	8.19 (208.03)
UNF014- <u>  </u>	6 (155)	3.81 (96.77)	9.31 (236.47)

† Ratings prior to PVC coating.

Cat. No.	Material	Colour
UNF105- <u>  </u>	<u>  </u>	<u>  </u> = space for colour identifier
Aluminum	SA =	G = Grey
		W = White
		B = Blue
		R = Red
Custom colours also available - Std. min. quantities are required. Please contact your Regional Sales Office.		

## Strut and Accessories

Rugged Steel Channels Protected by Corrosion-Resistant PVC!

### Ocal™ PVC-Coated Steel Strut

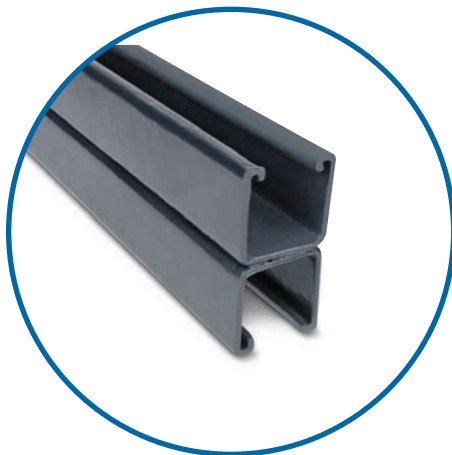

A12A

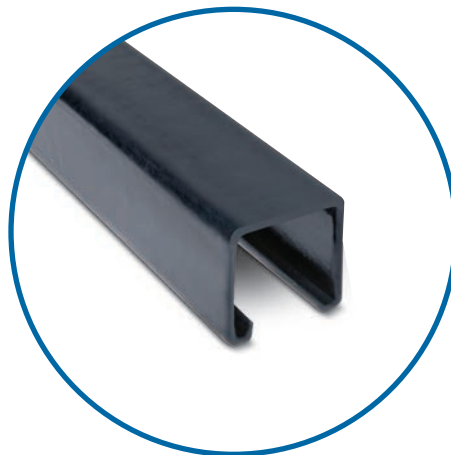

A12



A12P

- Channels cold formed from hot-rolled pickled and oiled strip steel
- Nominal 0.015 in. (15 mils) PVC coating
- PVC coating available in your choice of blue, white or grey standard colours
- Custom colours also available on request
- Sold in 10 ft. (3.048 m) lengths with standard length tolerance of  $\pm 1/8$  in. (3.18 mm)
- Choose between standard 15/8 in. (41.28 mm) and shallow 13/16 in. (20.64 mm) depths
- Available in both solid and punched styles
- Available in 316 stainless steel (contact your Regional Sales Office)
- Strut accessories also available PVC Coated (contact your Regional Sales Office)

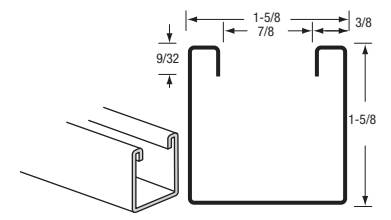

A12

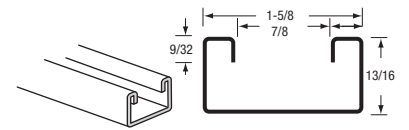

C14

Cat. No.	Material	Colour
<b>A12-</b>	<b>-</b>	<b>_ = space for colour identifier</b>
	SA = Aluminum	G = Grey W = White B = Blue
<i>Catalogue No. Example:</i> <b>C14P-W</b> is shallow punched strut channel coated in white PVC.		
<small>Custom colours also available - Std. min. quantities are required. Please contact your Regional Sales Office.</small>		

Cat. No.	Style	Steel Gauge (mm)	in. (mm)	
			W	H
A12- <u>  </u>	Standard	12 (2.65)	1.63 x 1.63 (41.28 x 41.28)	
A12A- <u>  </u>	Back to Back	12 (2.65)	1.63 x 3.25 (41.28 x 82.55)	
A12P- <u>  </u>	Standard Punched	12 (2.65)	1.63 x 1.63 (41.28 x 41.28)	
C14- <u>  </u>	Shallow	14 (1.89)	1.63 x 0.81 (41.28 x 20.64)	
C14P- <u>  </u>	Shallow Punched	14 (1.89)	1.63 x 0.81 (41.28 x 20.64)	

## Strut and Accessories

Continuously Threaded Rods for Use With Conduit Hangers and Strut to Suspend Overhead Conduit Runs

### Ocal™ PVC-Coated Steel Strut



PVC-Coated All-Thread Rod

#### All-Thread Rods

- All-thread steel rods coated with nominal 0.015 in. (15 mils) PVC in blue, white or grey; custom colours available on request
- Available in 1/4 in., 3/8 in. or 1/2 in. standard diameters and in 3-, 6- or 10-ft. standard lengths
- Also available uncoated in Type 316 stainless steel

#### Ocal™ PVC-Coated Steel All-Thread Rods

Cat. No.	Trade Size in. (mm)	Length ft. (m)
THR1/4X10- <u>  </u>	1/4 (6.35)	10.00 (3.05)
THR3/8X3- <u>  </u>	3/8 (9.53)	3.00 (0.91)
THR3/8X6- <u>  </u>	3/8 (9.53)	6.00 (1.83)
THR3/8X10- <u>  </u>	3/8 (9.53)	10.00 (3.05)
THR1/2X3- <u>  </u>	1/2 (12.70)	3.00 (0.91)
THR1/2X6- <u>  </u>	1/2 (12.70)	6.00 (1.83)
THR1/2X10- <u>  </u>	1/2 (12.70)	10.00 (3.05)

Cat. No.	Diameter X Length	Colour
<b>THR3/8X3-</b>		<u>  </u> = space for colour identifier
<i>Catalogue No. Example:</i> <b>NPL3/4X6-G</b> is 3/4 in. x 6 in. long steel nipple coated in grey PVC.	G = Grey	
	W = White	
	B = Blue	
Custom colours also available - Std. min. quantities are required. Please contact your Regional Sales Office.		

## Strut and Accessories

### Corrosion-Protected Clamps for Hanging Threaded Rod

#### Ocal™ PVC-Coated Hanger Rod Beam Clamps

- Malleable iron construction
- Nominal 0.015 in. (15 mils) PVC coating in blue, white, grey or custom colours
- 500, 502 and 503 also available uncoated in Type 316 stainless steel; add -SS316 to catalogue number to order (for example: 502-SS316)

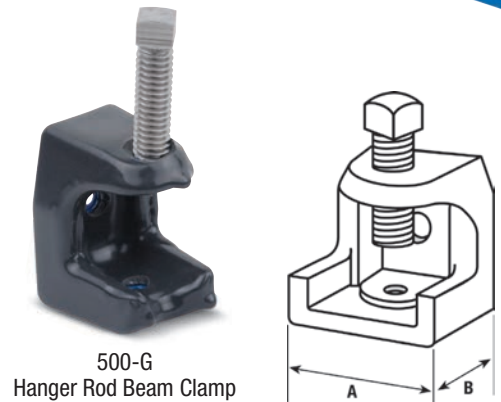

500-G  
Hanger Rod Beam Clamp

Cat. No.	Base "A" in. (mm)	Base "B" in. (mm)	Jaw Opening in. (mm)	Tapped Hole in. (mm)	Load Rating‡ lb. (kg)
500- <u>  </u>	1 (25.40)	1-1/4 (31.75)	15/16 (23.81)	1/4 - 20 (6.35 - 20)	450 (204.12)
501- <u>  </u>	1-1/2 (38.10)	1-5/8 (41.28)	7/8 (22.23)	15/16 - 18 (7.94 - 18)	800 (362.87)
502- <u>  </u>	2 (50.80)	2 (50.80)	1 (25.40)	3/8 - 16 (9.53 - 16)	1300 (589.67)
503- <u>  </u>	2-5/8 (66.68)	2-1/2 (63.50)	1 (25.40)	1/2 - 13 (12.70 - 13)	1300 (589.67)
508- <u>  </u>	2-1/2 (63.50)	2-3/8 (60.33)	2-1/8 (53.98)	1/2 - 13 (12.70 - 13)	1700 (771.11)

‡ Load ratings based on bottom hole of beam clamp with safety factor of three. Metric size designator (ANSI C80.1-1994).

Cat. No.	Colour
<b>500-</b>	<u>  </u> = space for colour identifier
	G = Grey
	W = White
	B = Blue

Custom colours also available - Std. min. quantities are required. Please contact your Regional Sales Office.

## Includes Stainless Steel Bolt and Nut for Fast, Easy Installation

#### Ocal™ PVC-Coated Mini Conduit Hangers

- Nominal 0.015 in. (15 mils) PVC coating in blue, white, grey or custom colours
- Rated for loads of up to 500 lb. (226.80 kg) with a safety factor of three

Cat. No.	Pipe Size in. (mm)
MINE1/2- <u>  </u>	1/2 (16)
MINE3/4- <u>  </u>	3/4 (21)
MINE1- <u>  </u>	1 (27)
MINE1-1/4- <u>  </u>	1-1/4 (35)
MINE1-1/2- <u>  </u>	1-1/2 (41)

Cat. No.	Pipe Size in. (mm)
MINE2- <u>  </u>	2 (53)
MINE2-1/2- <u>  </u>	2-1/2 (63)
MINE3- <u>  </u>	3 (78)
MINE3-1/2- <u>  </u>	3-1/2 (91)
MINE4- <u>  </u>	4 (103)

Metric size designator (ANSI C80.1-1994).



MINE3/4-G  
Mini Conduit  
Hanger

Cat. No.	Colour
<b>MINE1-</b>	<u>  </u> = space for colour identifier
	G = Grey
	W = White
	B = Blue

Custom colours also available - Std. min. quantities are required. Please contact your Regional Sales Office.

## Strut and Accessories

Designed for Easy Attachment of Conduit to Strut!



PVC-Coated Pipe Strap

### Pipe Straps for Strut

Just twist-insert these pipe straps anywhere you need them along the slot side of a channel. For additional flexibility, you can position the straps as closely as your pipe couplings permit.

- Combination slot and hex head bolt for flexibility of attachment
- Captivated square nut on shoulder enables easy one-handed tightening
- Use with either 1-5/8 in. or 1-1/2 in. strut for greater versatility
- Shipped pre-assembled for easier counting, sorting and handling
- Available with nominal 0.015 in. (15 mils) PVC coating in your choice of blue, white or grey standard colours (custom colours also available on request)
- Uncoated pipe straps are available by ordering Series 700 and adding Type 316 stainless steel

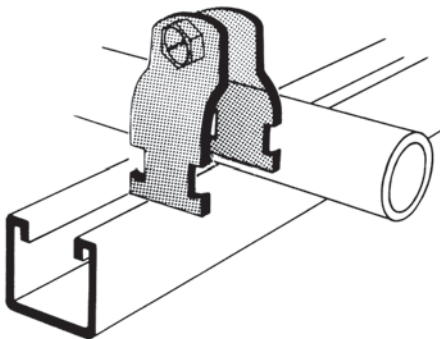
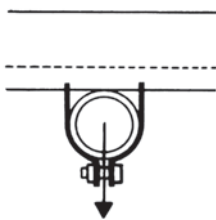

### Ocal™ PVC-Coated Strut Pipe Straps

Cat. No.	Pipe Size in. (mm)
SS1/2- <u>  </u>	1/2 (16)
SS3/4- <u>  </u>	3/4 (21)
SS1- <u>  </u>	1 (27)
SS1-1/4- <u>  </u>	1-1/4 (35)
SS1-1/2- <u>  </u>	1-1/2 (41)
SS2- <u>  </u>	2 (53)
SS2-1/2- <u>  </u>	2-1/2 (63)
SS3- <u>  </u>	3 (78)
SS3-1/2- <u>  </u>	3-1/2 (91)
SS4- <u>  </u>	4 (103)
SS5- <u>  </u>	5 (129)

Metric size designator (ANSI C80.1-1994).

Cat. No.	Colour
<b>SS1-</b>	<u>  </u> = space for colour identifier
	G = Grey
	W = White
	B = Blue
Custom colours also available - Std. min. quantities are required. Please contact your Regional Sales Office.	

## Installation Products

### The Right Tools for the Job!

Thomas & Betts Ocal™ PVC-Coated Conduit is designed to prevent corrosion from striking weak points in conduit systems. But any PVC-coated conduit system is only as good as the installation job. The wrong tools can result in incorrectly installed pipes and fittings or damage to PVC coating, creating those weak points where corrosion starts.

After careful research and evaluation, Thomas & Betts now offers you the very best installation tools available for PVC-coated conduit. These tools are ready for use on PVC-coated conduit right out of the box. What that means to you, the installer, is lower costs — in equipment, in installation time and in time you'd normally have to spend adapting standard tools for use on PVC-coated conduit.



### Hassle-Free Installation

- Count on Thomas & Betts to provide a hassle-free way for installers to get the right tools for the job in their hands — just another benefit of using Ocal™ products
- For more information on Ocal™ Installation Guidelines, see pages H74 – H81.



## Installation Products

.....  
Make Saddles, Offsets and Conventional Bends

### Hand Benders for PVC-Coated Conduit

Cat. No.	Conduit Size (in.)
35220	1/2
35225	3/4
2424A8	1





## Installation Products

High-Speed Threading — Up to 25 RPM!

### RHINO™ High-Performance Threading Machine

- Standard threading machine with built-in pipe cutter, reamer, foot-operated safety switch, 1/2 in. to 2 in. and 2-1/2 in. to 4 in. automatic die heads and precision alloy dies
- Heavy-duty, 115V AC/DC, 50/60 Hz motor develops up to 3hp
- Quiet operation — 85dB maximum noise level
- Easy to maintain and service
- Precision pipe cutter with dual guide for accuracy and control
- COLLINS™ SUPER GRIP R/L chucking system features 4 heavy-duty jaws, specially designed for PVC-coated conduit, at front and rear to automatically grip and center pipe



RHINO™ Threading Machine with optional wheeled stand

Cat. No.	Description
<b>RHINO™ High-Performance Threading Machine</b>	
P00551C	RHINO™ 1/2 in. — 4 in. Threading Machine with Jaws for PVC-Coated Conduit
R0TH00548	RHINO™ 1/2 in. — 4 in. Threading Machine with Jaws for PVC-Coated Conduit
<b>Replacement Threading Die Sets for RHINO™ Threading Machine</b>	
89101	1/2 in. — 3/4 in. Threading Die Set
89102	1 in. — 2 in. Threading Die Set
59912	2-1/2 in. — 4 in. Threading Die Set
<b>Replacement Jaws Sets for RHINO™ Threading Machine</b>	
P20305C	Jaw Set for PVC-Coated Conduit
R0TH02385	Jaw Set for Galvanized Rigid Conduit

## Portable and compact for mobile use and hard-to-reach spaces!

### SUPERTRONIC™ 2000 Power Threader

- Quick and easy production of precision-threaded joints to approved standards
- Dust-tight casing with sealed lubrication ensures long service life and low maintenance
- Optimized gearing for high-performance output with minimal energy consumption
- 15 — 25 rpm threading speed with 60 rpm rapid reverse for time savings
- Complete set includes SUPERTRONIC™ 2000, forged pipe clamp, thread-cutting spray, quick-change die heads with tempered-steel precision dies for 1/2 in., 3/4 in., 1 in., 1-1/4 in., 1-1/2 in. and 2 in. PVC-coated conduit and carrying case

Cat. No.	Description
P71259C	SUPERTRONIC™ 2000 Power Threader Set for 1/2 in., 3/4 in., 1 in., 1-1/4 in., 1-1/2 in. and 2 in. PVC-Coated Conduit



Rhino™, Collins™ and SUPERTRONIC™ are trademarks of Rothenberger AG.



Forged pipe clamp, shown at right, is included with the P71259C SUPERTRONIC™ 2000 Power Threader Set.

## Installation Products

Threads 1/2 in. to 2 in. Conduit in Seconds!

### MINI-COLLINS™ Electric Power Drive

- Lightweight, compact design goes anywhere — only 28 in. long and requires only 1-3/4 in. clearance in trenches, overhead and other tight spaces
- Easy to maintain — built-in fill plug eliminates disassembly of gearbox for oiling
- 115V, 15A reversible motor provides the power to make any turning job easier
- Tightens nuts, drives cable pullers, turns hoists and jacks, opens and closes valves and drives up to 6 in. geared threaders
- Compatible with RIDGID® 12R die heads
- Cat. No. 13158 Adapter enables SUPER CUT die heads (below) to be used with ROTHENBERGER® MINI-COLLINS™ and RIDGID® Model 700 portable threading machines



MINI-COLLINS™ Electric Power Drive



The two-piece 13158 adapter enables the use of SUPER CUT die heads with the MINI-COLLINS™. For dies up to 1-1/4 in. in size, use both pieces together, as shown at right. For larger dies, separate the two pieces, as shown at left, and use only the outer ring.

Cat. No.	Description
<b>MINI-COLLINS™ Electric Power Drive &amp; Accessories</b>	
<b>ROTH00074</b>	MINI-COLLINS™ Electric Power Drive
<b>13158</b>	MINI-COLLINS™ Adapter for SUPER CUT Die Heads
<b>ROTH00117</b>	MINI-COLLINS™ 1 in. Square Shaft Drive for Geared Threaders
<b>ROTH00119</b>	Steel Carrying Case for MINI-COLLINS™

Mini-Collins™ and Rothenberger® are trademarks of Rothenberger AG. Ridgid® is a trademark of Emerson Electric Co.

## Machined to thread PVC-coated conduit

### SUPER CUT Die Heads

- Optimized cutting geometry offers easy starting and excellent shaving discharge
- Purchase dies individually or choose the complete set, including ratchet handle, quick-change die heads, tempered-steel precision dies for 1/2 in., 3/4 in., 1 in., 1-1/4 in., 1-1/2 in. and 2 in. PVC-coated conduit and plastic carrying case
- Fit SUPERTRONIC™ 2000 power threader
- Use with MINI-COLLINS™ (above) or RIDGID® Model 700 with Catalogue No. 13158 adapter (above)
- Dies also sold separately

Cat. No.	Description
<b>P70905C</b>	Complete Die Set for 1/2 in. — 2 in.
<b>P70912C</b>	1/2 in. Die
<b>P70913C</b>	3/4 in. Die
<b>P70914C</b>	1 in. Die
<b>P70915C</b>	1-1/4 in. Die
<b>P70849C</b>	1-1/2 in. Die
<b>P70850C</b>	2 in. Die



## Installation Products

### Equipped With Chain or Bench Yoke Vise

#### Tri-Stand Vises

- Sturdy, stable frame collapses for easy mobility and storage
- Ceiling brace for overhead support enables you to secure frame even during difficult work
- Features recesses for bending tubes 3/8 in., 1/2 in. and 3/4 in. O.D

Cat. No.	Description	Pipe Capacity in. (mm)
<b>ROTH00076</b>	Tri-Stand with 6 in. Chain Vise (use with Ocal™ Jaws for PVC-coated conduit)	1/2 — 6 (16 — 155)
<b>P00076C</b>	Tri-Stand with Bench Yoke Vise (includes jaws designed for use with PVC-coated conduit)	1/2 — 3 (16 — 78)

Metric size designator (ANSI C80.1-1994).



## Superior Design and Construction for Faster, Safer Chain-Vise Clamping of PVC-Coated Conduit

### Ocal™ Half-Shell Clamps

If you already have a chain vise, now you can avoid the expense of purchasing a yoke vise with special jaws — or the trouble of making clamps out of PVC or steel pipe — to cut and thread PVC-coated conduit. These Half-Shell Clamps come in the full range of 1/2 in. to 6 in. trade sizes. Buy the individual sizes you need, or choose one of our convenient sets, which contain all the sizes from 1/2 in. to 2 in. or 2-1/2 in. to 4 in. in a handy carrying/storage case.

A unique internal design ensures secure clamping while protecting the integrity of the conduit's PVC coating. Cast from ductile iron for extreme strength and durability, Ocal™ Half-Shell Clamps offer you years of consistent, reliable service.

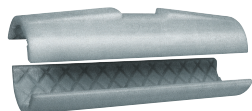

- Two-piece construction, cast from ductile iron for exceptional strength, durability and performance
- Cross-hatched interior surface grips conduit securely while safeguarding PVC jacket from damage
- Available individually in 1/2 in. through 6 in. trade sizes
- Also available in two convenient sets — 1/2 in. to 2 in. and 2-1/2 in. to 4 in.
- Each clamp clearly marked with trade size for easy identification
- Openings at each end enable hanging for handy storage

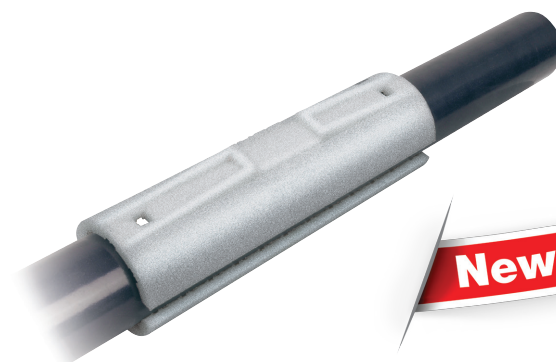

Cat. No.	Conduit Size	
	in.	(mm)
<b>Individual Half-Shell Clamps</b>		
<b>HLF-SHL-CLP1/2</b>	1/2	(16)
<b>HLF-SHL-CLP3/4</b>	3/4	(21)
<b>HLF-SHL-CLP1</b>	1	(27)
<b>HLF-SHL-CLP1-1/4</b>	1-1/4	(35)
<b>HLF-SHL-CLP1-1/2</b>	1-1/2	(41)
<b>HLF-SHL-CLP2</b>	2	(53)
<b>HLF-SHL-CLP2-1/2</b>	2-1/2	(63)
<b>HLF-SHL-CLP3</b>	3	(78)
<b>HLF-SHL-CLP3-1/2</b>	3-1/2	(91)
<b>HLF-SHL-CLP4</b>	4	(103)
<b>HLF-SHL-CLP5</b>	5	(129)
<b>HLF-SHL-CLP6</b>	6	(155)
<b>Half-Shell Clamp Set (in carrying/storage case)</b>		
<b>HLF-SHL-CLPSET1</b>	1/2 — 2	(16 — 53)

## Installation Products

Designed to Hold PVC-Coated Conduit Safely and Securely in a Yoke-Style Vise

### Ocal™ Jaws for PVC-Coated Conduit

- Replace the standard jaw inserts in a yoke vise
- Provide greater clamping force and prevents pipe from spinning during threading
- Machined aluminum construction
- Three-piece set

Cat. No.	Description	Weight	
		lb.	kg
JAWS23	Used with RIDGID No. 23 or No. 40A Yoke Vises	2.80	1.27
JAWS76	Used with Rothenberger Yoke Vise		

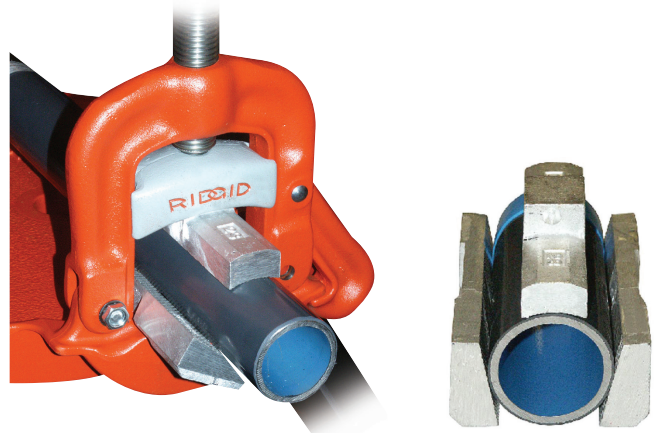

## Specially designed for cutting PVC-coated conduit

### Steel Pipe Cutters

- Easy pressure control transmits optimum force onto tube
- Hardened, high-alloy steel cutter wheel provides long service life and burr-free external cutting

Cat. No.	Description	Pipe O.D. (in.)
P70045C	Steel Pipe Cutter — Up to 2 in.	1/8 — 2
P70060C	Steel Pipe Cutter — Up to 4 in.	1/8 — 4



## Rapid and clean deburring!

### Ratchet Pipe Reamer

- Smooth running ratchet
- Tempered-steel cutting bit
- For steel tubes 1/4 in. to 2 in. O.D

Cat. No.	Description	Pipe O.D. (in.)
70289	Ratchet Pipe Reamer	1/4 — 2



## Installation Products

### Removable Aluminum Jaws for PVC-Coated Conduit

#### Ocal™ J-Wrenches

Use with our pliers, or purchase just the jaws and adapt your own!

Cat. No.	Description	Pipe Capacity (in.)
J442	12 in. J-Wrench with Jaws	1/2 to 1-1/4
J460	16 in. J-Wrench with Jaws	1-1/2 to 2-1/2
J42	12 in. Jaw Set only	1/2 to 1-1/4
J60	16 in. Jaw Set only	1-1/2 to 2-1/2



J42



J60



J460



J442



J460

## Jaws Grip PVC-Coated Pipe Securely Without Damaging the Plastic Coating!

### Aluminum Pipe Wrenches

- Extremely light aluminum alloy offers high strength but weighs 40% less than standard cast
- Self-clamping, spring-supported hook for easy, one-handed, ratchet-like use
- Scale on hook for quick preset of tube diameter



Cat. No.	Length in. (mm)	Steel Tube O.D. Max. in. (mm)
P70159C	10 (254)	1-1/2 (16)
P70160C	14 (356)	2 (53)
P70161C	18 (457)	2-1/2 (63)
P70162C	24 (610)	3 (78)

## Specially Coated Strap Won't Absorb Oil

### RIDGID® Strap Wrenches

Cat. No.	Handle Length in. (mm)	Strap Length in. (mm)	Strap Width in. (mm)	Pipe Capacity in. (mm)	Pipe Capacity (O.D.) in. (mm)	Weight lb. (kg)
31355	11.75 (298.45)	17.00 (431.80)	1.75 (44.45)	2.00 (50.80)	3.50 (88.90)	1.75 (.79)
31370	18.00 (457.20)	29.25 (742.95)	1.75 (44.45)	5.00 (127.00)	5.50 (139.70)	2.75 (1.25)



31370

31355

## Installation Products

### Accessories for Aluminum/Copper Code Conductors and Connectors

Copper colloidal surface treatment protects, lubricates and enhances conductivity of all electrical connections

#### KOPR-SHIELD® Joint Compound

- Unique, homogenized blend of pure, polished colloidal copper, rust and corrosion inhibitors
- Simultaneously protects, lubricates and enhances conductivity of mating surfaces
- Extremely adhesive compound flows smoothly into uneven contours and voids, ensuring easy application and complete, positive protection and lubrication
- Won't settle-out, thin, thicken, harden or dry out under the most severe environmental conditions
- Excellent temperature characteristics — can be brushed on at -45.5°C (-50°F) to 121°C (250°F) (other compounds either turn solid or run like water at these extremes) and remains intact at short terms even at 980°C (1,800°F)

Good connections are one of the most important aspects of electrical work. Mechanics know how much downtime is caused when fluids or oils leak into the raceway system or when they have to look for a weak link in a ground system caused by a high-resistance connection. Mechanics also know how much time is spent keeping contacts, switches, lugs and other connectors clean or replacing parts because of “green scourge” buildup. Thomas & Betts has the solution to improve connections made in thousands of electrical and raceway installations made each day by electricians everywhere Kopr-Shield®. Compound may be used to advantage in all electrical installations. When the environment is hostile to electrical and mechanical connections, Kopr-Shield® Compound is a must!

Kopr-Shield® is a trademark of Jet-Lube Inc.

#### Use Kopr-Shield® Compound for battery lugs and cables to:

- Prevent “green scourge” corrosion
- Reduce resistance
- Ease terminal installation and removal

#### Use Kopr-Shield® Compound for raceways to:

- Lubricate for ease of assembly and disassembly

#### Improve grounding continuity (exceeds code requirements)

#### Use Kopr-Shield® Compound for fuse clips to:

- Eliminate hot spots for even head distribution
- Prevent oxidation by preventing carbon path formation
- Lubricate for easy installation and removal of fuses

#### Use Kopr-Shield® Compound for wiping contacts, drum switches and slip rings to:

- Prevent galling, burning, pitting and discolouration
- Suppress arching and dissipation of coronas
- Lubricate for ease of operation



Cat. No.	Description	Std. Pkg.	Weight lb./content
201-31879	1-1/2 oz. Container with Brush	96	11.46
201-31879-1	4 oz. Container with Brush	24	38.54
CP8-TB	8 oz. Container with Brush	12	64.58
CP16	16 oz. Container with Brush	12	120.83
CP128	1 Gallon Can	4	952.00

## Fast-Drying, Air-Cure Patch for Ocal™ Conduit and Fittings

### Ocal™ Touch-Up Compounds

Cat. No.	Container	Size	Colour
<b>Exterior PVC Patch</b>			
SPRAY-G	Spray Can	12-1/2 oz. (0.37 liter)	Dark Grey
SPRAY-W	Spray Can	12-1/2 oz. (0.37 liter)	White
SPRAY-B	Spray Can	12-1/2 oz. (0.37 liter)	Light Blue
PATCHP-G	Brush Cap Can	1 pint (0.47 liter)	Dark Grey
PATCHP-W	Brush Cap Can	1 pint (0.47 liter)	White
PATCHP-B	Brush Cap Can	1 pint (0.47 liter)	Light Blue
PATCHG-G	Bottle	1 gallon (3.79 liter)	Dark Grey
PATCHG-W	Bottle	1 gallon (3.79 liter)	White
PATCHG-B	Bottle	1 gallon (3.79 liter)	Light Blue
<b>Interior Urethane Patch</b>			
URETHANEPATCH	Brush Cap Can	1 pint (0.47 liter)	Blue



## Installation Products

### A Better Patching Solution for Hot weather Applications!

#### Ocal™ Heat-Cure Patch

Even in the best of installations, the PVC jacket on PVC-coated conduit or fittings can be cut, nicked or abraded. To maintain corrosion protection, Ocal™ has added a new, thicker PVC patch to its offering of touch-up compounds.

Ideal for use in hot weather, Ocal™ Heat-Cure Patch offers a thicker consistency at high ambient temperatures than standard air-cure patches, ensuring better coverage and a more effective patch.

#### Ocal™ Heat-Cure Patch makes patching fast and easy.

- 1 Make sure the area to be patched is clean and dry
- 2 Squeeze the amount of patch material needed onto the area to be repaired
- 3 If necessary, spread and level the patch material with a putty knife
- 4 Apply heat with a heat gun or torch, such as the T&B® Portable Heat-Shrink Torch
- 5 Being careful not to overheat (260°C/500°F max.), apply heat for 2 minutes total, or at least 1 minute after surface of patch has turned glossy. (The patch material is a glossy liquid that turns flat with initial heat application and then turns glossy again as heating continues.)
- 6 Allow the patched area to air cool, or use a water quench



#### Heat-Cure Patch

Cat. No.	Colour	Size
PATCHT-G	Dark Grey	6 oz. (0.18 liter)
PATCHT-W	White	
PATCHT-B	Light Blue	

## Separate Controls Enable Precise Adjustment of Flame and Temperature!

#### T&B® Portable Heat-Shrink Torch

- (1,371°C) (2,500°F) output capacity satisfies virtually any heating, brazing or soldering requirement
- Dual fuel- and air-flow controls enable separate adjustment of temperature and flame precision
- Brass and steel construction provides durability
- Operates on standard butane lighter fluid (not included)

#### Specifications

Dimensions (without base) L x W x H: 3.90 in. x 1.40 in. x 5.40 in.  
99.06 mm x 35.56 mm x 137.16 mm

Weight (when filled): 9.88 oz.  
280.09g

Fuel Tank Capacity: 2.03 fl. oz.  
60.03 ml

Operating Time (per full fuel tank): Up to 220 minutes



#### Portable Heat-Shrink Torch

Cat. No.	Description
WT-PTORCH	Portable Heat-Shrink Torch

## Products for corrosive environments

Polymeric Fixtures for Class I, Zone 2, Groups IIC, IIB, IIA, Division 2, Groups A, B, C and D Wet and Marine Locations

### Hazlux® 1 – HID, Mogul Base, 50-175W

- Enclosed and gasketed
- Polymeric (fiberglass-reinforced polyester) guard with a variety of globe options
- High-pressure sodium, metal halide
- 50 to 175 watts, 120 to 480 volts
- Pendant, ceiling, wall, angle stanchion or straight stanchion mounting

#### Standards / Certifications

- CSA Class I, Zone 2, Groups IIC, IIB, IIA, Division 2, Groups A, B, C and D
- UL1598 Wet Locations
- UL1598 Marine Applications
- NEMA 4X



### Hazlite™ M1 – HID or Fluorescent, Medium or Bi-Pin Base, 9-100W

- Polymeric (fiberglass-reinforced polyester) guard with a variety of globe options
- Metal halide, high-pressure sodium or fluorescent lamp
- 9 to 100 watts, 120 to 277 volts
- Cone pendant, one-hub ceiling or two-hub ceiling mounting

#### Standards / Certifications

- CSA Class I, Zone 2, Groups IIC, IIB, IIA, Division 2, Groups A, B, C and D Hazardous Locations
- UL1598 Wet Locations
- UL1598 Marine Applications
- NEMA 4X



### Ordering Hazlux® Lighting Fixtures

To order or learn more about the many styles and varieties of Hazlux® fixtures for corrosive environments, please see our Hazlux® catalogue or visit [www.tnb.ca](http://www.tnb.ca)



## Products for corrosive environments

### Enclosed and Gasketed Fixtures for Class I, Zone 2, Groups IIC, IIB, IIA, Division 1, Class II, Wet and Marine Locations



#### Hazlux® 3 — HID, Mogul Base, 50-400W

- Enclosed and gasketed
- Cast copper-free aluminum housing — available with HazCote™ Kynar coating for extremely corrosive environments
- Variety of globe material options
- High-pressure sodium, metal halide
- 50 to 400 watts, 120 to 480 volts
- Cone top pendant, wall, ceiling, flexible pendant, ring, straight stanchion, angle stanchion or rigid pendant mounting

#### Standards / Certifications

- CSA Class I, Zone 2, Groups IIC, IIB, IIA, Division 2, Groups A, B, C and D
- EXN RII T3 (Restricted Drawing)
- CSA Class II, Divisions 1 & 2, Groups E, F and G
- CSA Class III
- UL1598 Wet Locations
- UL1598 Marine Applications
- NEMA 4X, IP66

## Explosion-Proof Fixtures for Class I, Division 1, Class II, Wet and Marine Locations

#### Hazlux® 5 — HID Explosion-Proof, Mogul Base, 50-400W

- Cast copper-free aluminum housing — available with HazCote™ Kynar coating for extremely corrosive environments
- High-pressure sodium, metal halide
- 50 to 400 watts, 120 to 480 volts
- Pendant, wall, ceiling, bulkhead or stanchion mounting

#### Standards / Certifications

- CSA Class I, Zone 2, Groups IIC, IIB, IIA, Division 2, Groups A, B, C and D
- CSA Class II, Divisions 1 & 2, Groups E, F and G
- UL1598 Wet Locations
- UL1598 Marine Applications
- NEMA 4X, IP66



### Ordering Hazlux® Lighting Fixtures

To order or learn more about the many styles and varieties of Hazlux® fixtures for corrosive environments, please see our Hazlux® catalogue or visit [www.tnb.ca](http://www.tnb.ca).

## Products for Corrosive Environments

### Ty-Rap® Stainless Steel Cable Ties



Type TYS  
Multi-Lok Stainless Steel  
Ties — Uncoated



Type TYS  
Multi-Lok Stainless Steel  
Ties — Coated

Cat. No.	Width in./(mm)	Length in./(mm)	Thickness in./(mm)	Max. Dia. Single Wrap in./(mm)	Max. Dia. Double Wrap in./(mm)
<b>Type TYS Multi-Lok Stainless Steel Cable Ties</b>					
<b>TYS6-280C</b>	0.28 / (7.00)	6 / (152)	0.01 / (.25)	1.9 / (48)	(Single wrap only)
<b>TYS9-280C</b>		9 / (229)		2.8 / (71)	
<b>TYS12-280C</b>		12 / (305)		3.8 / (96)	
<b>TYS18-280C</b>		18 / (457)		5.7 / (144)	
<b>TYS24-280C</b>		24 / (610)		7.6 / (193)	
<b>TYS6-470C</b>	0.47 / (12.00)	6 / (152)		1.9 / (48)	
<b>TYS9-470C</b>		9 / (229)		2.8 / (71)	
<b>TYS12-470C</b>		12 / (305)		3.8 / (96)	
<b>TYS18-470C</b>		18 / (457)		5.7 / (144)	
<b>TYS24-470C</b>		24 / (610)		7.6 / (193)	



Type LS  
Heavy-Duty Stainless Steel  
Ball-Lock Cable Ties —  
Coated

Cat. No. Uncoated 302/304 Grade Stainless Steel	Cat. No. Uncoated 316 Grade Stainless Steel	Length in./(mm)	Width in./(mm)	Max. Bundle Dia. (in./mm)	Tensile Strength (lb./N)	Recommended Tooling
<b>Type LS Heavy-Duty Stainless Steel Ball-Lock Cable Ties</b>						
<b>LS-4.6-200A</b>	<b>LS-4.6-200B</b>	7.9/201	0.18/4.6	2.0/51	200/444.8	DAS-250, CT6, CT3
<b>LS-4.6-360A</b>	<b>LS-4.6-360B</b>	14.2/360		4.0/102		
<b>LS-4.6-520A</b>	<b>LS-4.6-520B</b>	20.5/520		6.0/152		
<b>LS-4.6-680A</b>	<b>LS-4.6-680B</b>	26.7/679		8.0/203		
<b>LS-4.6-840A</b>	<b>LS-4.6-840B</b>	33.0/838		10.0/254		
<b>LS-7.9-200A</b>	<b>LS-7.9-200B</b>	7.9/201	0.31/7.9	2.0/51	450/1112.0	
<b>LS-7.9-360A</b>	<b>LS-7.9-360B</b>	14.2/360		4.0/102		
<b>LS-7.9-520A</b>	<b>LS-7.9-520B</b>	20.5/520		6.0/152		
<b>LS-7.9-680A</b>	<b>LS-7.9-680B</b>	26.7/679		8.0/203		
<b>LS-7.9-840A</b>	<b>LS-7.9-840B</b>	33.0/838		10.0/254		
<b>LS-7.9-1010A</b>	<b>LS-7.9-1010B</b>	41.3/1050		12.5/318		



Type SSR  
Reusable Stainless Steel  
Cable Ties

Cat. No.	Width in./(mm)	Length in./(mm)	Thickness in./(mm)	Max. Dia. Single Wrap in./(mm)	Max. Dia. Double Wrap in./(mm)
<b>Type SSR Reusable Stainless Steel Cable Ties</b>					
<b>SSR6-250C</b>	0.25 / (6.35)	6 / (152)	0.015 / (0.38)	1.5 / (38)	N/A
<b>SSR9-250C</b>		9 / (229)		2.5 / (63)	1.1 / (28)
<b>SSR12-250C</b>		12 / (305)		3.4 / (86)	1.5 / (38)
<b>SSR18-250C</b>		18 / (457)		5.4 / (137)	2.5 / (64)
<b>SSR24-250C</b>		24 / (610)		7.3 / (185)	3.5 / (89)
<b>SSR6-375C</b>	0.38 / (9.53)	6 / (152)		1.5 / (38)	N/A
<b>SSR9-375C</b>		9 / (229)		2.5 / (63)	1.1 / (28)
<b>SSR12-375C</b>		12 / (305)		3.4 / (86)	1.5 / (38)
<b>SSR18-375C</b>		18 / (457)		5.4 / (137)	2.5 / (64)
<b>SSR24-375C</b>		24 / (610)		7.3 / (185)	3.5 / (89)
<b>SSR30-375C</b>		30 / (762)	9.1 / (231)	4.4 / (112)	
<b>SSR36-375C</b>		36 / (914)	11.0 / (280)	5.3 / (135)	

SS Series also available in Type 316 stainless.

## Products for Corrosive Environments

### Ty-Rap® Stainless Steel Cable Ties (cont'd)

Stainless Steel Type	Coating or Finish	Min. Loop Tensile Strength Single Wrap lb./n.	Min. Loop Tensile Strength Double Wrap lb./n.	Application Tools Used	General Application
<b>Type TYS Multi-Lok Stainless Steel Cable Ties</b>					
316	Uncoated or Nylon 11 Coated Black	250/1112	(Single wrap only)	WTAE200	<ul style="list-style-type: none"> <li>• Self-locking</li> <li>• Cable bundling</li> </ul>
				WTAE200	
		WTAE200			
		WTAE201			
				WTC075	<ul style="list-style-type: none"> <li>• Hazardous and corrosive environments</li> </ul>
				WTC075	
				WTC075	
				WTC075	

Stainless Steel Type	Coating or Finish	Min. Loop Tensile Strength Single Wrap lb./n.	Min. Loop Tensile Strength Double Wrap lb./n.	Application Tools Used	General Application
<b>Type LS Heavy-Duty Stainless Steel Ball-Lock Cable Ties</b>					
316	Uncoated or Fully Polyester Coated Black	100/445	(Single wrap only)	DAS-250, CT6, CT3	<ul style="list-style-type: none"> <li>• Offshore drilling</li> <li>• Petrochemical processing</li> <li>• Shipbuilding</li> </ul>
		250/1112			<ul style="list-style-type: none"> <li>• Food &amp; Beverage processing</li> <li>• Pharmaceutical processing</li> </ul>

Stainless Steel Type	Coating or Finish	Min. Loop Tensile Strength Single Wrap lb./n.	Min. Loop Tensile Strength Double Wrap lb./n.	Application Tools Used	General Application
<b>Type SSR Reusable Stainless Steel Cable Ties</b>					
200/300	Nylon 11 Coated (Uncoated or other colours available on special order)	75/334	300/1334	WTAE200	<ul style="list-style-type: none"> <li>• Reusable</li> <li>• Cable bundling</li> <li>• Oil rigs</li> </ul>
		100/445	500/2224	WTC075	<ul style="list-style-type: none"> <li>• Telecommunications towers</li> <li>• Hazardous and corrosive environments</li> <li>• Cable trays</li> </ul>

Ty-Rap® Stainless Steel Cable Ties have passed a variety of mechanical, environmental and electrical tests. Other data can be made available upon request.



## Products for Corrosive Environments

Bundle Cables Up to 4 in. in Diameter in Harsh Environments



### Ty-Rap® Weather-Resistant Polypropylene Cable Ties

- Especially resistant to chemical exposure
- For use in temperatures ranging from - 40°C to 85°C (-40°F to 185°F)
- Black polypropylene body and head construction with stainless steel locking device

Bulk Pkg. Cat. No.	Width in./(mm)	Body Length in./(mm)	Max. Wire Bundle Dia. in./(mm)	Tensile Str. lb./n.	Bulk Pkg. Qty.
TYP23MX	0.09 / (2.29)	3.62 / (91.95)	0.63 / (16.00)	18 / (80.07)	1000
TYP25MX	0.18 / (4.57)	7.31 / (185.67)	1.75 / (44.45)	30 / (133.40)	1000
TYP28MX	0.18 / (4.57)	14.20 / (360.68)	4.00 / (101.60)	30 / (133.40)	1000
TYP27MX	0.27 / (6.86)	13.20 / (335.28)	3.50 / (88.90)	60 / (266.90)	500

### Ty-Rap® Cable Ties Chemical Resistance

The table below shows the resistance of Ty-Rap® cable tie materials to various chemicals. The table is designed to help you determine the cable tie material best suited for a particular chemical environment.

#### Resistance of Available Materials to Various Chemicals at Temperature of 21°C (70°F)

Reagents	Concentration	Weather-Resistant Poly-Propylene as used in TYP X Series	Stainless Steel as used in TYS Series
Arsenic Acid	40%	E	E
Acetaldehyde	50%	—	—
Acetone	100%	E	E
Aluminum Hydroxide	AQ	E	E
Ammonia	All	E	E
Ammonium Carbonate	5%	E	E
Ammonium Hydroxide	10%	E	E
Ammonium Nitrate	—	E	E
Ammonium Sulfate	10%	S	S
Barium Carbonate	All	E	E
Barium Chloride	5%	E	E
Barium Sulfate	10%	E	E
Barium Sulfide	10%	E	E
Benzene	100%	S	E
Benzoic Acid	100%	E	E
Butyric Acid	50%	E	E
Calcium Carbonate	AQ	E	E
Calcium Hydroxide	20%	E	E
Calcium Hydrochlorite	2%	F	F
Calcium Sulfate	2%	E	E
Carbon Tetrachloride	100%	F	E
Chlorine (WET)	—	F	F
Chlorine (DRY)	—	NR	F
Chloroacetic Acid	30%	—	F
Chloroform	100%	F	E
Chromic Acid	50%	F	F
Citric Acid	50%	E	E
Copper Cyanide	10%	E	E
Copper Nitrate	50%	E	E
Cider	—	E	E
Dichloroethane	100%	—	E
Diethyl Ether	100%	E	E
Ethyl Alcohol	100%	E	E
Ethyl Chloride	100%	F	E
Ethylene Glycol	100%	E	E
Ferric Hydroxide	All	E	E
Ferric Nitrate	10%	E	E
Ferrous Sulfate	10%	E	E

Reagents	Concentration	Weather-Resistant Poly-Propylene as used in TYP X Series	Stainless Steel as used in TYS Series
Fuel Oil	100%	—	E
Furfural	100%	F	E
Gallic Acid	AQ	—	E
Gasoline	100%	S	E
Glycerine	100%	E	E
Hydrocyanic Acid	All	E	E
Hydrogen Peroxide	30%	E	E
Hydrogen Sulfide	Dry	E	E
Iodoform	100%	—	E
Isopropyl Alcohol	100%	E	E
Jet Fuel	100%	S	E
Lactic Acid	10%	E	E
Lanolin	10%	E	E
Lead Acetate	5%	E	E
Linseed Oil	10%	E	E
Magnesium Carbonate	All	E	E
Magnesium Chloride	10%	F	F
Magnesium Nitrate	All	E	E
Malic Acid	AQ	E	E
Mercury	100%	E	E
Methyl Alcohol	100%	E	E
Methyl Chloride	100%	S	E
Methyl Ethyl Ketone	100%	E	E
Naphtha	100%	E	E
Nitric Acid	30%	E	E
Nitric Acid	30 – 70%	F	E
Nitrous Acid	5%	F	E
Oleic Acid	100%	E	E
Oxalic Acid	10%	E	E
Paraffin	100%	E	E
Petroleum Ether	100%	F	E
Phenol	90%	E	E
Phosphoric Acid	10%	E	E
Picric Acid	1%	E	E
Potassium Bromide	AQ	S	S
Potassium Carbonate 1%	—	E	—
Potassium Chlorate	AQ	E	E
Potassium Dichromate	40%	E	E

Reagents	Concentration	Weather-Resistant Poly-Propylene as used in TYP X Series	Stainless Steel as used in TYS Series
Potassium Ferrocyanide	25%	E	E
Potassium Hydroxide	5%	E	E
Potassium Iodide	All	E	E
Potassium Nitrate	50%	E	E
Potassium Permanganate	5%	E	E
Potassium Sulfate	5%	E	E
Potassium Sulfide	AQ	E	E
Propyl Alcohol	100%	E	E
Silver Nitrate	10%	E	E
Sodium Acetate	60%	E	E
Sodium Bicarbonate	All	E	E
Sodium Bisulfate	10%	E	E
Sodium Borate	All	E	E
Sodium Carbonate	5%	E	E
Sodium Chlorate	25%	E	E
Sodium Chloride	2%	E	E
Sodium Fluoride	5%	F	F
Sodium Hydroxide	10%	E	E
Sodium Hyposulfite	AQ	—	E
Sodium Nitrate	5%	E	E
Sodium Nitrite	AQ	E	E
Sodium Perchlorate	10%	—	E
Sodium Phosphate	5%	E	E
Sodium Sulfate	5%	E	E
Sodium Thiosulfate	5%	S	S
Stearic Acid	100%	E	E
Sulfur	100%	E	E
Sulfur Dioxide	All	E	E
Sulfuric Acid	Conc.	S	E
Sulfuric Acid	5%	F	F
Tannic Acid	10%	E	E
Tartaric Acid	50%	E	E
Tetrahydrofuran	100%	F	E
Toluene	100%	F	F
Xylene	100%	F	E
Zinc Chloride	70%	E	E
Zinc Nitrate	AQ	E	E
Zinc Sulfate	AQ	E	E

Ratings: E = Excellent S = Satisfactory F = Fair NR = Not Recommended (AQ=Aqueous)

# Chemical Resistance

## PVC Exterior Coating

Solutions	Conc.	Temp. °C (°F)	Recommended Exposure		
			Splashing	Liquid	Fumes
Acetic Acid	10%	49 (120)	no	no	no
Acid Copper Plating Solution		71 (160)	yes	yes	yes
Alkaline Cleaners		71 (160)	yes	yes	yes
Aluminum Chloride	Sat'd	71 (160)	yes	yes	yes
Aluminum Sulfate	Sat'd	71 (160)	yes	yes	yes
Alums	Sat'd	71 (160)	yes	yes	yes
Ammonium Chloride	Sat'd	71 (160)	yes	yes	yes
Ammonium Hydroxide	28%	49 (120)	yes	yes	yes
Ammonium Hydroxide	10%	49 (120)	yes	yes	yes
Ammonium Sulfate	Sat'd	71 (160)	yes	yes	yes
Ammonium Thiocyanate	Sat'd	71 (160)	yes	yes	yes
Amyl Alcohol	Any	90 (32)	yes	yes	yes
Arsenic Acids	Any	66 (150)	yes	yes	yes
Barium Sulfide	Sat'd	49 (120)	yes	yes	yes
Black Liquor	Sat'd	90 (32)	yes	yes	yes
Benzoic Acid	Sat'd	71 (160)	yes	yes	yes
Brass Plating Solution	Any	71 (160)	yes	yes	yes
Bromine Water	Sat'd	49 (120)	yes	yes	yes
Butyl Alcohol	Any	90 (32)	yes	yes	yes
Cadmium Plating Solution	Any	66 (150)	yes	yes	yes
Calcium Bisulfite	Any	66 (150)	yes	yes	yes
Calcium Chloride	Sat'd	71 (160)	yes	yes	yes
Calcium Hypochlorite	Sat'd	49 (120)	yes	yes	yes
Carbonic Acid	Sat'd	71 (160)	yes	yes	yes
Casein	Sat'd	90 (32)	yes	yes	yes
Castor Oil	Any	90 (32)	yes	yes	yes
Caustic Soda	35%	49 (120)	yes	yes	yes
Caustic Soda	10%	66 (150)	yes	yes	yes
Caustic Potash	35%	49 (120)	yes	yes	yes
Caustic Potash	10%	66 (150)	yes	yes	yes
Chlorine Water	Sat'd	90 (32)	yes	yes	yes
Chromium Plating Solution	Any	66 (150)	yes	yes	yes
Citric Acid	Sat'd	71 (160)	yes	yes	yes
Copper Cyanide Plating Sol (High Speed)	Any	71 (160)	yes	yes	yes
(with Alkali Cyanides)	Sat'd	71 (160)	yes	yes	yes
Copper Sulfate	Sat'd	71 (160)	yes	yes	yes
Coconut Oil	Sat'd	90 (32)	yes	yes	yes
Cottonseed Oil	Sat'd	90 (32)	yes	yes	yes
Disodium Phosphate	Sat'd	71 (160)	yes	yes	yes
Ethyl Alcohol	Any	90 (32)	yes	yes	yes
Ethylene Glycol	Any	90 (32)	yes	no	yes
Ferric Chloride	45%	49 (120)	yes	yes	yes
Ferrous Sulfate	Sat'd	66 (150)	yes	yes	yes
Fluoboric Acid	Any	66 (150)	yes	yes	yes
Formaldehyde	37%	49 (120)	yes	yes	yes
Formic Acid	85%	66 (150)	no	no	no
Gallic Acid	Sat'd	66 (150)	no	no	yes
Glucose	Any	66 (150)	yes	yes	yes
Glue	Any	66 (150)	yes	yes	yes
Glycerine	Any	90 (32)	yes	yes	yes
Gold Plating Solution	Any	66 (150)	yes	yes	yes
Hydrochloric Acid	10%	49 (120)	yes	no	yes
Hydrochloric Acid	21.5%	49 (120)	yes	no	yes
Hydrochloric Acid	37.5%	49 (120)	yes	no	yes
Hydrochloric Acid	37.5%	90 (32)	yes	no	yes
Hydrofluoric Acid	4%	60 (140)	yes	no	yes
Hydrofluoric Acid	10%	49 (120)	yes	no	yes
Hydrofluoric Acid	48%	49 (120)	yes	no	yes
Hydrogen Peroxide	30%	49 (120)	yes	yes	yes
Hydrogen Sulfide	Sat'd	49 (120)	yes	yes	yes
Hydroquinone	Any	90 (32)	yes	yes	yes
Indium Plating Solution	Any	66 (150)	yes	yes	yes
Lactic Acid	50%	49 (120)	yes	yes	yes
Lactic Acid	Any	90 (32)	yes	yes	yes

Solutions	Conc.	Temp. °C (°F)	Recommended Exposure		
			Splashing	Liquid	Fumes
Lead Plating Solution	Any	66 (150)	yes	yes	yes
Malic Acid	Any	32 (90)	yes	yes	yes
Methyl Alcohol	Any	32 (90)	yes	yes	yes
Mineral Oils	Any	32 (90)	yes	yes	yes
Nickel Acetate	Sat'd	71 (160)	yes	yes	yes
Nickel Plating Solution		71 (160)	yes	yes	yes
Nickel Salts	Sat'd	71 (160)	yes	yes	yes
Nitric Acid	35%	49 (120)	yes	no	yes
Nitric Acid	40%	32 (90)	yes	no	yes
Nitric Acid	60%	49 (120)	yes	no	yes
Nitric Acid/ Hydrofluoric Acid	15%	60 (140)	yes	yes	yes
Nitric Acid/ Hydrofluoric Acid	4%				
Nitric Acid/ Hydrofluoric Acid	16%	54 (130)	yes	yes	yes
Sodium Dichromate	13%				
Water	71%				
Oleic Acid	Any	32 (90)	yes	yes	yes
Oxalic Acid	Sat'd	49 (120)	yes	yes	yes
Oxalic Acid	Any	32 (90)	yes	yes	yes
Phenol	Sat'd	49 (120)	no	no	no
Phosphoric Acid	75%	66 (150)	yes	yes	yes
Phosphoric Acid	85%	49 (120)	yes	yes	yes
Phosphoric Acid	85%	71 (160)	yes	yes	yes
Potassium Acid Sulfate	Sat'd	66 (150)	yes	yes	yes
Potassium Antimonate	Sat'd	66 (150)	yes	yes	yes
Potassium Bisulfite	Sat'd	32 (90)	yes	yes	yes
Potassium Chloride	Sat'd	71 (160)	yes	yes	yes
Potassium Cuprocyanide	Sat'd	66 (150)	yes	yes	yes
Potassium Cyanide	Sat'd	71 (160)	yes	yes	yes
Potassium Dichromate	Sat'd	71 (160)	yes	yes	yes
Potassium Hypochlorite	Sat'd	32 (90)	yes	no	yes
Potassium Sulfide	Sat'd	66 (150)	yes	yes	yes
Potassium Thiosulfate	Sat'd	66 (150)	yes	yes	yes
Propyl Alcohol	Sat'd	66 (150)	yes	yes	yes
Rhodium Plating Solution	Sat'd	66 (150)	yes	yes	yes
Silver Plating Solution	Sat'd	66 (150)	yes	yes	yes
Soaps	Any	32 (90)	yes	yes	yes
Sodium Acid Sulfate	Sat'd	71 (160)	yes	yes	yes
Sodium Antimonate	Sat'd	66 (150)	yes	yes	yes
Sodium Bicarbonate	Sat'd	71 (160)	yes	yes	yes
Sodium Bisulfite	Sat'd	32 (90)	yes	yes	yes
Sodium Chloride	Sat'd	71 (160)	yes	yes	yes
Sodium Cyanide	Sat'd	71 (160)	yes	yes	yes
Sodium Dichromate	Sat'd	71 (160)	yes	yes	yes
Sodium Hydroxide	10%	66 (150)	yes	no	yes
Sodium Hydroxide	35%	49 (120)	yes	no	yes
Sodium Hydroxide	73%	71 (160)	no	no	no
Sodium Hypochlorite	Sat'd	32 (90)	yes	no	yes
Sodium Hypochlorite	15%	49 (120)	yes	no	yes
Sodium Sulfide	Sat'd	66 (150)	yes	yes	yes
Sodium Thiosulfate	Sat'd	66 (150)	yes	yes	yes
Sulfuric Acid	15%	49 (120)	yes	yes	yes
Sulfuric Acid	15%	71 (160)	yes	yes	yes
Sulfuric Acid	50%	49 (120)	yes	yes	yes
Sulfuric Acid	70%	32 (90)	yes	no	yes
Sulfuric Acid	98%	38 (100)	no	no	yes
Sulfurous Acid	2%	49 (120)	yes	no	yes
Sulfurous Acid	6%	49 (120)	yes	no	yes
Tannic Acid	Sat'd	32 (90)	yes	yes	yes
Tartaric Acid	Sat'd	32 (90)	yes	yes	yes
Tin Chloride Aqueous	Sat'd	66 (150)	yes	yes	yes
Tin Plating Solution	Sat'd	66 (150)	yes	yes	yes
Triethanolamine	Sat'd	66 (150)	yes	yes	yes
Trisodium Phosphate	Sat'd	66 (150)	yes	yes	yes
Water	Sat'd	66 (150)	yes	yes	yes
White Liquor		32 (90)	yes	yes	yes
Zinc Plating Solution		71 (160)	yes	yes	yes
Zinc Sulfate	Sat'd	71 (160)	yes	yes	yes

# Chemical Resistance

## Urethane Interior Coating

Solutions	Conc.	Temp. °C (°F)	Recommended Exposure		
			Splashing	Liquid	Fumes
Acetic Acid	10%	24 (75)	yes	no	yes
Acid Copper Plating Solution	Any	24 (75)	yes	no	yes
Alkaline Cleaners	Any	24 (75)	yes	no	yes
Aluminum Chloride	Sat'd	24 (75)	yes	no	yes
Aluminum Sulfate	Sat'd	24 (75)	yes	no	yes
Alums	Sat'd	24 (75)	yes	no	yes
Ammonium Chloride	Sat'd	24 (75)	yes	no	yes
Ammonium Hydroxide	28%	24 (75)	yes	no	yes
Ammonium Hydroxide	10%	24 (75)	yes	no	yes
Ammonium Sulfate	Sat'd	24 (75)	yes	no	yes
Ammonium Thiocyanate	Sat'd	24 (75)	yes	no	yes
Amyl Alcohol	Any	24 (75)	yes	yes	yes
Arsenic Acids	Any	24 (75)	yes	no	yes
Barium Sulfide	Sat'd	24 (75)	yes	no	yes
Black Liquor	Sat'd	24 (75)	yes	no	yes
Benzoic Acid	Sat'd	24 (75)	yes	no	yes
Brass Plating Solution	Any	24 (75)	yes	no	yes
Bromine Water	Sat'd	24 (75)	yes	no	yes
Butyl Alcohol	Any	24 (75)	yes	no	yes
Cadmium Plating Solution	Any	24 (75)	yes	no	yes
Calcium Bisulfite	Any	24 (75)	yes	no	yes
Calcium Chloride	Sat'd	24 (75)	yes	no	yes
Calcium Hypochlorite	Sat'd	24 (75)	yes	no	yes
Carbonic Acid	Sat'd	24 (75)	yes	no	yes
Casein	Sat'd	24 (75)	yes	no	yes
Castor Oil	Any	24 (75)	yes	yes	yes
Caustic Soda	35%	24 (75)	yes	no	yes
Caustic Soda	10%	24 (75)	yes	no	yes
Caustic Potash	35%	24 (75)	yes	no	yes
Caustic Potash	10%	24 (75)	yes	no	yes
Chlorine Water	Sat'd	24 (75)	yes	no	yes
Chromium Plating Solution	Any	24 (75)	yes	no	yes
Citric Acid	Sat'd	24 (75)	yes	no	yes
Copper Chloride (Cupric)	Sat'd	24 (75)	yes	no	yes
Copper Cyanide Plating Sol (High Speed)	Any	24 (75)	yes	no	yes
(with Alkali Cyanides)	Sat'd	24 (75)	yes	no	yes
Copper Sulfate	Sat'd	24 (75)	yes	no	yes
Coconut Oil	Sat'd	24 (75)	yes	yes	yes
Cottonseed Oil	Sat'd	24 (75)	yes	yes	yes
Disodium Phosphate	Sat'd	24 (75)	yes	no	yes
Ethyl Alcohol	Any	24 (75)	yes	no	yes
Ethylene Glycol	Any	24 (75)	yes	yes	yes
Ferric Chloride	45%	24 (75)	yes	no	yes
Ferrous Sulfate	Sat'd	24 (75)	yes	no	yes
Fluoboric Acid	Any	24 (75)	yes	no	yes
Formaldehyde	37%	24 (75)	yes	no	yes
Formic Acid	85%	24 (75)	yes	no	yes
Gallic Acid	Sat'd	24 (75)	yes	no	yes
Glucose	Any	24 (75)	yes	yes	yes
Glue	Any	24 (75)	yes	no	yes
Glycerine	Any	24 (75)	yes	yes	yes
Gold Plating Solution	Any	24 (75)	yes	no	yes
Hydrochloric Acid	10%	24 (75)	yes	no	yes
Hydrochloric Acid	21.5%	24 (75)	yes	no	yes
Hydrochloric Acid	37.5%	24 (75)	yes	no	yes
Hydrofluoric Acid	4%	24 (75)	yes	no	yes
Hydrofluoric Acid	10%	24 (75)	yes	no	yes
Hydrofluoric Acid	48%	24 (75)	yes	no	yes
Hydrogen Peroxide	30%	24 (75)	yes	no	yes
Hydrogen Sulfide	Sat'd	24 (75)	yes	no	yes
Hydroquinone	Any	24 (75)	yes	no	yes
Indium Plating Solution	Any	24 (75)	yes	no	yes
Lactic Acid	50%	24 (75)	yes	no	yes
Lactic Acid	Any	24 (75)	yes	no	yes

Solutions	Conc.	Temp. °C (°F)	Recommended Exposure		
			Splashing	Liquid	Fumes
Lead Plating Solution	Any	24 (75)	yes	no	yes
Malic Acid	Any	24 (75)	yes	no	yes
Methyl Alcohol	Any	24 (75)	yes	no	yes
Mineral Oils	Any	24 (75)	yes	yes	yes
Nickel Acetate	Sat'd	24 (75)	yes	no	yes
Nickel Plating Solution		24 (75)	yes	no	yes
Nickel Salts	Sat'd	24 (75)	yes	no	yes
Nitric Acid	35%	24 (75)	yes	no	yes
Nitric Acid	40%	24 (75)	yes	no	yes
Nitric Acid	60%	24 (75)	yes	no	yes
Nitric Acid/ Hydrofluoric Acid	15%	24 (75)	yes	no	yes
	4%				
Nitric Acid/ Sodium Dichromate	16%	24 (75)	yes	no	yes
	13%				
Water	71%				
Oleic Acid	Any	24 (75)	yes	no	yes
Oxalic Acid	Sat'd	24 (75)	yes	no	yes
	Any	24 (75)	yes	no	yes
Phenol	Sat'd	24 (75)	yes	no	yes
Phosphoric Acid	75%	24 (75)	yes	no	yes
Phosphoric Acid	85%	24 (75)	yes	no	yes
Potassium Acid Sulfate	Sat'd	24 (75)	yes	no	yes
Potassium Antimonate	Sat'd	24 (75)	yes	no	yes
Potassium Bisulfite	Sat'd	24 (75)	yes	no	yes
Potassium Chloride	Sat'd	24 (75)	yes	no	yes
Potassium Cuprocyanide	Sat'd	24 (75)	yes	no	yes
Potassium Cyanide	Sat'd	24 (75)	yes	no	yes
Potassium Dichromate	Sat'd	24 (75)	yes	no	yes
Potassium Hypochlorite	Sat'd	24 (75)	yes	no	yes
Potassium Sulfide	Sat'd	24 (75)	yes	no	yes
Potassium Thiosulfate	Sat'd	24 (75)	yes	no	yes
Propyl Alcohol	Sat'd	24 (75)	yes	no	yes
Rhodium Plating Solution	Sat'd	24 (75)	yes	no	yes
Silver Plating Solution	Sat'd	24 (75)	yes	no	yes
Soaps	Any	24 (75)	yes	no	yes
Sodium Acid Sulfate	Sat'd	24 (75)	yes	no	yes
Sodium Antimonate	Sat'd	24 (75)	yes	no	yes
Sodium Bicarbonate	Sat'd	24 (75)	yes	no	yes
Sodium Bisulfite	Sat'd	24 (75)	yes	no	yes
Sodium Chloride	Sat'd	24 (75)	yes	no	yes
Sodium Cyanide	Sat'd	24 (75)	yes	no	yes
Sodium Dichromate	Sat'd	24 (75)	yes	no	yes
Sodium Hydroxide	10%	24 (75)	yes	no	yes
Sodium Hydroxide	35%	24 (75)	yes	no	yes
Sodium Hydroxide	73%	24 (75)	yes	no	yes
Sodium Hypochlorite	Sat'd	24 (75)	yes	no	yes
Sodium Hypochlorite	15%	24 (75)	yes	no	yes
Sodium Sulfide	Sat'd	24 (75)	yes	no	yes
Sodium Thiosulfate	Sat'd	24 (75)	yes	no	yes
Sulfuric Acid	15%	24 (75)	yes	no	yes
Sulfuric Acid	50%	24 (75)	yes	no	yes
Sulfuric Acid	70%	24 (75)	yes	no	yes
Sulfuric Acid	98%	24 (75)	yes	no	yes
Sulfurous Acid	2%	24 (75)	yes	no	yes
Sulfurous Acid	6%	24 (75)	yes	no	yes
Tannic Acid	Sat'd	24 (75)	yes	no	yes
Tartaric Acid	Sat'd	24 (75)	yes	no	yes
Tin Chloride Aqueous	Sat'd	24 (75)	yes	no	yes
Tin Plating Solution	Sat'd	24 (75)	yes	no	yes
Triethanolamine	Sat'd	24 (75)	yes	no	yes
Trisodium Phosphate	Sat'd	24 (75)	yes	no	yes
Water	Sat'd	24 (75)	yes	no	yes
White Liquor		24 (75)	yes	no	yes
Zinc Plating Solution		24 (75)	yes	no	yes
Zinc Sulfate	Sat'd	24 (75)	yes	no	yes

## Specification Guide

### Section 26 05 33 – Underground Ducts and Raceways for Electrical Systems: Conduit Systems for Use in Corrosive Environments

#### Part 1 – General

##### 1.1 Summary

- A.** Section Includes: Furnishing, installation and assembly of PVC-coated electrical rigid metal conduit (ERMC) systems and stainless steel fittings.
- B.** Related Sections
  1. Section 26 05 29 — Hangers and Supports for Electrical Systems.

##### 1.2 References

- A.** National Electrical Manufacturers Association (NEMA)
  1. NEMA RN 1: Polyvinyl-Chloride (PVC) Externally Coated Galvanized Rigid Steel Conduit and Intermediate Metal Conduit.
- B.** National Fire Protection Association (NFPA)
  1. NFPA 70: National Electrical Code (NEC).
- C.** American Society for Testing and Materials (ASTM):
  1. ASTM A 239: Standard Practice for Locating the Thinnest Spot in a Zinc (Galvanized) Coating on Iron or Steel Articles.
- D.** Underwriters Laboratories, Inc. (UL)
  1. UL 6: Safety Standard for Rigid Metal Conduit.
  2. UL 514B: Safety Standard for Fittings for Conduit and Outlet Boxes.
- E.** American National Standards Institute (ANSI)
  1. ANSI C80.1: American National Standard for Rigid Steel Conduit — Zinc Coated.
- F.** Steel Tube Institute of North America
  1. Guidelines for Installing Steel Conduit/Tubing.

##### 1.3 Submittals

- A.** General: Submit in accordance with Section 01 33 00.
- B.** Product Data
  1. Manufacturer's descriptive literature and product specifications for each product.
  2. Manufacturer's installation literature and training guide.
  3. Manufacturer's product drawings, when applicable.

##### 1.4 Quality Assurance

- A.** Manufacturer Qualifications: Products shall be free of defects in material and workmanship.
- B.** Installer Qualifications: Installer shall be trained and certified based on the acceptable manufacturer's listed requirements.

#### Part 2 – Products

##### 2.1 General

- A.** Furnish PVC-coated ERMC of size as indicated. If not indicated, the smallest trade size shall be 3/4 in. The PVC-coated ERMC system shall include necessary PVC-coated fittings, boxes and covers to form a complete encapsulated system.

##### 2.2 Manufacturer

- A.** Acceptable Manufacturer: Thomas & Betts Limited; 700, avenue Thomas, Saint-Jean-sur-Richelieu, J2X 2M9 Tel: 450-347-5318. Web: www.tnb.ca
- B.** Substitutions: Not permitted
- C.** Requests for substitutions will be considered in accordance with provisions of Section 01 25 00.

##### 2.3 Materials/Components

###### A. PVC-Coated Rigid Steel Conduit

The PVC-coated rigid steel conduit shall be hot-dip galvanized inside and out with hot-dip galvanized threads. The interior galvanizing shall be listed per UL 6. The exterior galvanizing shall be listed per UL 6 as primary corrosion protection. Thread protectors shall be used on the exposed threads of the PVC-coated conduit. PVC-coated ERMC steel conduit shall comply with UL 6, ANSI C80.1 and NEMA RN 1 standards without exception. The PVC coating, in compliance with NEMA RN 1, shall be nominal 40 mils (0.04 in.) in thickness continuous over the entire length of the conduit except at the threads and be free of blisters, bubbles or pinholes. PVC shall be UL listed as a primary corrosion protection.

A blue urethane coating shall be uniformly and consistently applied to the interior of conduit. This internal coating shall be a nominal 2 mils (0.002 in.) thickness. All male threads on elbows and nipples shall be protected by this same application of urethane coating.

Coated couplings shall be used with coated conduit. The thickness of the coating on couplings shall be at least equal to the thickness of the coating on the conduit. Each coated coupling shall have a flexible PVC sleeve which extends from each end of the coupling and which will overlap the PVC coating on the conduit when the coupling has been installed on the conduit. The length of the sleeve extension(s) shall be at least equivalent to the nominal conduit size for sizes up through 2 in. For sizes 2 — 6 in., the length of the sleeve extension(s) shall be at least 2 in.

The PVC sleeve shall be a nominal thickness of 40 (0.04 in.) mils in thickness. The inside diameter of the overlapping sleeve shall be less than the outside diameter of the PVC-coated conduit.

###### B. PVC-Coated Rigid Aluminum Conduit

The PVC-coated ERMC aluminum conduit prior to coating shall be UL listed. The exterior of the conduit shall have a PVC coating of a minimum thickness of nominal 40 mils (0.04 in.) A blue urethane coating shall be uniformly and consistently applied to the interior of conduit. This internal coating shall be a nominal 2 mils (0.002 in.) thickness. All male threads on elbows and nipples shall be protected by this same application of urethane coating.

---> next page

## Specification Guide (cont'd)

Coated couplings shall be used with coated conduit. The thickness of the coating on couplings shall be at least equal to the thickness of the coating on the conduit. Each coated coupling shall have a flexible PVC sleeve which extends from each end of the coupling and which will overlap the PVC coating on the conduit when the coupling has been installed on the conduit. The length of the sleeve extension(s) shall be at least equivalent to the nominal conduit size for sizes up through 2 in. For sizes 2 — 6 in., the length of the sleeve extension(s) shall be at least 2 in.

The PVC sleeve shall be a nominal thickness of 40 mils (0.04 in.) in thickness. The inside diameter of the overlapping sleeve shall be less than the outside diameter of the PVC-coated conduit.

### C. PVC-Coated Ordinary Location Fittings

PVC-coated ferrous and aluminum fittings for general service and corrosive locations must be UL listed. The PVC coating shall be minimum 40 mils (0.04 in.) in thickness and be free of blisters, bubbles or pinholes. Female threads on fittings shall be protected by application of urethane coating.

All female ends of PVC-coated conduit fittings shall have a flexible PVC sleeve which extends from the female ends of the fitting and which will overlap the PVC coating on the conduit when the fitting has been installed on the conduit. The length of the sleeve extension(s) shall be at least equivalent to the nominal conduit size for sizes up through 2 in. For sizes 2 — 6 in., the length of the sleeve extension(s) shall be at least 2 in. The PVC sleeve shall be a nominal thickness of 40 mils (0.04 in.) in thickness. The inside diameter of the overlapping sleeve shall be less than the outside diameter of the PVC-coated conduit.

1. The PVC coating on all form 8 covers shall form a gasket-like flange of at least 5/16 in. wide and minimum 40 mils (0.04 in.) covering the top of the fitting around the opening and the bottom of the cover/matting with the flange of the fitting. A blue urethane coating shall be uniformly and consistently applied to the interior, exterior and threads of all conduit bodies, including but not limited to form 8 and form 7 conduit bodies. This coating shall be a nominal 2 mils (0.002 in.) thickness. Stainless steel encapsulated screws shall be supplied with all form 7 and form 8 fittings.
2. Rigid hubs shall have a nominal 40 mils (0.04 in.) PVC coating thickness with a nominal 2 mils (0.002 in.) of blue urethane on interior and threads. The male threads and locknut shall remain uncoated.
3. Liquid-tight fittings shall have an exterior PVC coating of a minimum thickness of nominal 40 mils (0.04 in.).

### D. PVC-Coated Hazardous Location Fittings

Hazardous location fittings prior to PVC coating must be UL listed. All female ends of PVC-coated conduit fittings shall have a flexible PVC sleeve which extends from the female ends of the fitting and which will overlap the PVC coating on the conduit when the fitting has been installed on the conduit. The length of the sleeve extension(s) shall be at least equivalent to the nominal conduit size for sizes up through 2 in. For sizes 2 — 6 in., the length of the sleeve extension(s) shall be at least 2 in. The PVC sleeve shall be a nominal thickness of 40 mils (0.04 in.) in thickness. The inside diameter of the overlapping sleeve shall be less than the outside diameter of the PVC-coated conduit.

### E. PVC-Coated Strut, Hangers and Clamps

Right-angle beam clamps and U-bolts shall be specially formed and sized to fit snugly the outside diameter of the PVC-coated conduit. Support products such as ferrous strut, beam clamps, pipe straps, clamp back spacers, conduit clamp hangers and all-thread rods shall have a minimum

15 mils (0.015 in.) PVC coating by the manufacturer of the ERMC conduit and system components.

### F. Stainless Steel Fittings

Stainless steel liquid-tight fittings shall be made of 304-grade stainless steel or better.

### G. Stainless Steel Strut, Hangers, Etc.

Stainless steel strut, beam clamps, pipe straps, clamp back spacers, conduit clamp hangers and all-thread rods shall be made of 304-grade stainless steel or better.

## Part 3 — Execution

### 3.1 Examination

- A. The PVC-coated ERMC and system components have been selected for use in an atmosphere considered to be corrosive for this project. The corrosive atmosphere is considered to be more damaging than merely the presence of moisture. Accordingly, conduit and the corresponding fittings for it must have PVC protection as described under Part 2 — Products. Conduit and fittings that are merely galvanized for this purpose are insufficient.

### 3.2 Preparation

- A. Preparation shall be done in accordance with manufacturer's printed instructions.

### 3.3 Installation

- A. Install in accordance with manufacturer's printed instructions and manufacturer's installation training.

### 3.4 Quality Control

- A. General: Comply with requirements of Section 01 45 13.

### 3.5 Manufacturer's Field Services

- A. Free on-site installation training course by company representative. This representative must conduct the on-site training course in order to qualify for the installation certificate. The time required for this training is estimated to be two (2) hours.
- B. After the on-site training installation, the representative shall then register the installer in his database and provide certification for installation.

## END OF SECTION

### Notes

1. Ocal™ PVC-coated conduit and fittings are not recommended for use in areas where they will be exposed to sustained temperatures above 200 degrees Fahrenheit or exposed to fire. Prolonged exposure to heat greater than 200 degrees Fahrenheit or exposure to fire may cause the plastic coatings to release harmful emissions, posing a potential health hazard to persons subjected to such emissions.
2. If subjected to sustained flame or sustained heat above 400 degrees Fahrenheit, PVC will burn. PVC is self-extinguishing at room temperature.



CEC

Table 1 – Allowable ampacity for single copper conductors in free air

Based on Ambient Temperature of 30°C\* (86°F)

Size AWG or kcmil	Allowable ampacity ↯					
	60°C — (140°F) ¥	75°C — (167°F) ¥	90°C — (194°F) ¥	110°C — (230°F) ¥	125°C — (257°F) ¥	200°C — (392°F) ¥
W	Types RW75, TW75	Types R90, RW90, T90 NYLON Single-conductor mineral-insulated cables §	See Note (3)	See Note (3)	Bare Wire	
14	20	20	20	40	—	—
12	25	25	25	50	—	—
10	40	40	40	65	—	—
8	55	65	70	85	30	35
6	80	95	100	120	40	45
4	105	125	135	160	50	60
3	120	145	155	180	65	75
2	140	170	180	210	75	85
1	165	195	210	245	100	115
0	195	230	245	285	120	135
00	225	265	285	330	135	150
000	260	310	330	385	155	175
0000	300	360	385	445	180	205
250	340	405	425	495	205	230
300	375	445	480	555	230	255
350	420	505	530	610	250	280
400	455	545	575	665	270	305
500	515	620	660	765	310	350
600	575	690	740	855	340	385
700	630	755	815	940	375	420
750	655	785	845	980	385	435
800	680	815	880	1020	395	450
900	730	870	940	—	425	480
1000	780	935	1000	1165	445	500
1250	890	1065	1130	—	485	545
1500	980	1175	1260	1450	520	585
1750	1070	1280	1370	—	545	615
2000	1155	1385	1470	1715	560	630

\* See Table 5A for the correction factors to be applied to the values in Columns 2 to 7 for ambient temperatures over 30°C.  
 ↯ The ampacity of single-conductor aluminum-sheathed cable is based on the type of insulation used on the copper conductor.  
 ¥ These are maximum allowable conductor temperatures for single conductors run in free air and may be used in determining the ampacity of other conductor types in Table 19, which are so run, as follows:  
 From Table 19 determine the maximum allowable conductor temperature for that particular type; then from Table 1 determine the ampacity under the column of corresponding temperature rating.  
 § These ratings are based on the use of 90°C insulation on the emerging conductors and for sealing. Where a deviation has been allowed in accordance with Rule 2-030, mineral-insulated cable may be used at higher temperatures without decrease in allowable ampacity, provided that insulation and sealing material approved for such higher temperature is used.

- Notes:**
- (1) The ratings of Table 1 may be applied to a conductor mounted on a plane surface of masonry, plaster, wood or any material having a conductivity not less than 0.4 W/(m°C).
  - (2) See Table 5B for correction factors where from 2 to 4 conductors are present and in contact.
  - (3) These ampacities are applicable only under special circumstances where the use of insulated conductors having this temperature rating is acceptable.

With the permission of Canadian Standards Association, material is reproduced from CSA Standard, C22.1-06: Canadian Electrical Code, Part I (20th Edition), Safety Standard for Electrical Installations, which is copyrighted by Canadian Standards Association, 178 Rexdale Blvd, Toronto, Ontario, M9W 1R3. While use of this material has been authorized, CSA shall not be responsible for the manner in which the information is presented, nor for any interpretations thereof. For more information on CSA or to purchase standards, please visit our website at [www.shopcsa.ca](http://www.shopcsa.ca) or call 1-800-463-6727.

CEC

Table 2 – Allowable ampacity for not more than 3 copper conductors in raceway or cable

Based on Ambient Temperature of 30°C\* (86°F)

Size AWG or kcmil	Allowable ampacity ~					
	60°C — (140°F) ¥	75°C — (167°F) ¥	90°C — (194°F) ¥	110°C — (230°F) ¥	125°C — (257°F) ¥	200°C — (392°F) ¥
	Type W	Types RW75, TW75	Types R90, RW90, T90 NYLON Mineral-insulated cables **	See Note	See Note	See Note
14	15	15	15	30	30	30
12	20	20	20	35	40	40
10	30	30	30	45	50	55
8	40	40	45	60	65	70
6	55 ~	65	65	80	85	95
4	70	85	85	105	115	120
3	80	100	105	120	130	145
2	100	115	120	135	145	165
1	110	130	140	160	170	190
0	125	150	155	190	200	225
00	145	175	185 ~	215	230	250
000	165	200	210	245	265	285
0000	195	230	235	275	310	340
250	215	255	265	315	335	—
300	240	285	295	345	380	—
350	260	310	325	390	420	—
400	280	335	345	420	450	—
500	320	380	395	470	500	—
600	355	420	455	525	545	—
700	385	460	490	560	600	—
750	400	475	500	580	620	—
800	410	490	515	600	640	—
900	435	520	555	—	—	—
1000	455	545	585	680	730	—
1250	495	590	645	—	—	—
1500	520	625	700	785	—	—
1750	545	650	735	—	—	—
2000	560	665	775	840	—	—

\* See Table 5A for the correction factors to be applied to the values in Columns 2 to 7 for ambient temperatures over 30°C.  
 ~ The ampacity of aluminum-sheathed cable is based on the type of insulation used on the copper conductor.  
 ¥ These are maximum allowable conductor temperatures for single conductors run in free air and may be used in determining the ampacity of other conductor types in Table 19, which are so run, as follows: From Table 19 determine the maximum allowable conductor temperature for that particular type; then from Table 2 determine the ampacity under the column of corresponding temperature rating.  
 \*\* These ratings are based on the use of 90°C insulation on the emerging conductors and for sealing. Where a deviation has been allowed in accordance with Rule 2-030, mineral-insulated cable may be used at higher temperatures without decrease in allowable ampacity, provided that insulation and sealing material approved for such higher temperature is used.  
 ~ For 3-wire 120/240 V and 120/208 V service conductors for single dwellings, or for feeder conductors supplying single dwelling units of row housing of apartment and similar buildings, and sized in accordance with Rules 8-200(1), 8-200(2), and 8-202(1), the allowable ampacity for sizes No. 6 and No. 2/0 AWG shall be 60 A and 200 A respectively. In this case, the 5% adjustment of Rule 8-106(1) cannot be applied.  
 ¥¥ See Table 5C for the correction factors to be applied to the values in Columns 2 to 7 where there are more than 3 conductors in a run of raceway or cable.  
**Notes:** These ampacities are applicable only under special circumstances where the use of insulated conductors having this temperature rating is acceptable.

With the permission of Canadian Standards Association, material is reproduced from CSA Standard, C22.1-06: Canadian Electrical Code, Part I (20th Edition), Safety Standard for Electrical Installations, which is copyrighted by Canadian Standards Association, 178 Rexdale Blvd, Toronto, Ontario, M9W 1R3. While use of this material has been authorized, CSA shall not be responsible for the manner in which the information is presented, nor for any interpretations thereof. For more information on CSA or to purchase standards, please visit our website at [www.shopcsa.ca](http://www.shopcsa.ca) or call 1-800-463-6727.

CEC

Table 3 – Allowable ampacity for single aluminum conductors in free air

Based on Ambient Temperature of 30°C\* (86°F)

Size AWG or kcmil	Allowable ampacity ↯					
	60°C — (140°F) ‡	75°C — (167°F) ‡	90°C — (194°F) ‡	110°C — (230°F) ‡	125°C — (257°F) ‡	200°C — (392°F) ‡
Type W	Types RW75, TW75	Types R90, RW90, T90 NYLON	See Note (3)	See Note (3)	Bare Wire	
12	20	20	20	40	40	45
10	30	30	30	50	55	60
8	45	45	45	65	70	80
6	60	75	80	95	100	105
4	80	100	105	125	135	140
3	95	115	120	140	150	165
2	110	135	140	165	175	185
1	130	155	165	190	205	220
0	150	180	190	220	240	255
00	175	210	220	255	275	290
000	200	240	255	300	320	335
0000	230	280	300	345	370	400
250	265	315	330	385	415	—
300	290	350	375	435	460	—
350	330	395	415	475	510	—
400	355	425	450	520	555	—
500	405	485	515	595	635	—
600	455	545	585	675	720	—
700	500	595	645	745	795	—
750	515	620	670	775	825	—
800	535	645	695	805	855	—
900	580	700	750	—	—	—
1000	625	750	800	930	990	—
1000	455	545	585	680	730	—
1250	495	590	645	—	—	—
1500	520	625	700	785	—	—
1750	545	650	735	—	—	—
2000	560	665	775	840	—	—

\* See Table 5A for the correction factors to be applied to the values in Columns 2 to 7 for ambient temperatures over 30°C.

↯ The ampacity of single-conductor aluminum-sheathed cable is based on the type of insulation used on the copper conductor.

‡ These are maximum allowable conductor temperatures for single conductors run in free air and may be used in determining the ampacity of other conductor types in Table 19, which are so run, as follows: From Table 19 determine the maximum allowable conductor temperature for that particular type; then from Table 3 determine the ampacity under the column of corresponding temperature rating.

Notes:

- (1) The ratings of Table 3 may be applied to a conductor mounted on a plane surface of masonry, plaster, wood or any material having a conductivity not less than 0.4 W/(m°C).
- (2) See Table 5B for correction factors where from 2 to 4 conductors are present and in contact.
- (3) These ampacities are applicable only under special circumstances where the use of insulated conductors having this temperature rating is acceptable.

With the permission of Canadian Standards Association, material is reproduced from CSA Standard, C22.1-06: Canadian Electrical Code, Part I (20th Edition), Safety Standard for Electrical Installations, which is copyrighted by Canadian Standards Association, 178 Rexdale Blvd, Toronto, Ontario, M9W 1R3. While use of this material has been authorized, CSA shall not be responsible for the manner in which the information is presented, nor for any interpretations thereof. For more information on CSA or to purchase standards, please visit our website at [www.shopcsa.ca](http://www.shopcsa.ca) or call 1-800-463-6727.

CEC

Table 4 – Allowable ampacity for not more than 3 aluminum conductors in raceway or cable

Based on Ambient Temperature of 30°C\* (86°F)

Size AWG or kcmil	Allowable ampacity ↯					
	60°C — (140°F) ¥	75°C — (167°F) ¥	90°C — (194°F) ¥	110°C — (230°F) ¥	125°C — (257°F) ¥	200°C — (392°F) ¥
Type W	Types RW75, TW75	Types R90, RW90, T90 NYLON	See Note	See Note	See Note	See Note
12	15	15	15	30	30	30
10	20	20	20	35	40	40
10	30	30	30	45	50	55
8	40	40	45	60	65	70
6	55 ↯↯	65	65	80	85	95
4	70	85	85	105	115	120
3	80	100	105	120	130	145
1	100	115	120	135	145	165
0	110	130	140	160	170	190
00	125	150	155	190	200	225
000	145	175	185 ↯↯	215	230	250
0000	165	200	210	245	265	285
250	195	230	235	275	310	340
300	215	255	265	315	335	—
350	240	285	295	345	380	—
400	260	310	325	390	420	—
500	280	335	345	420	450	—
600	320	380	395	470	500	—
700	355	420	455	525	545	—
750	385	460	490	560	600	—
800	400	475	500	580	620	—
900	410	490	515	600	640	—
1000	435	520	555	—	—	—
1250	455	545	585	680	730	—
1500	495	590	645	—	—	—
1750	520	625	700	785	—	—
2000	545	650	735	—	—	—
2000	560	665	775	840	—	—

\* See Table 5A for the correction factors to be applied to the values in Columns 2 to 7 for ambient temperatures over 30°C.

↯ The ampacity of aluminum-sheathed cable is based on the type of insulation used on the aluminum conductor.

¥ These are maximum allowable conductor temperatures for single conductors run in free air and may be used in determining the ampacity of other conductor types in Table 19, which are so run, as follows: From Table 19 determine the maximum allowable conductor temperature for that particular type; then from Table 2 determine the ampacity under the column of corresponding temperature rating.

¥¥ See Table 5C for the correction factors to be applied to the values in Columns 2 to 7 where there are more than 3 conductors in a run of raceway or cable.

↯↯ For 3-wire 120/240 V and 120/208 V service conductors for single dwellings, or for feeder conductors supplying single dwelling units of row housing of apartment and similar buildings, and sized in accordance with Rules 8-200(1), 8-200(2), and 8-202(1), the allowable ampacity for sizes No. 6 and No. 2/0 AWG shall be 60 A and 200 A respectively. In this case, the 5% adjustment of Rule 8-106(1) cannot be applied.

Notes: These ampacities are applicable only under special circumstances where the use of insulated conductors having this temperature rating is acceptable.

With the permission of Canadian Standards Association, material is reproduced from CSA Standard, C22.1-06: Canadian Electrical Code, Part I (20th Edition), Safety Standard for Electrical Installations, which is copyrighted by Canadian Standards Association, 178 Rexdale Blvd, Toronto, Ontario, M9W 1R3. While use of this material has been authorized, CSA shall not be responsible for the manner in which the information is presented, nor for any interpretations thereof. For more information on CSA or to purchase standards, please visit our website at [www.shopcsa.ca](http://www.shopcsa.ca) or call 1-800-463-6727.

CEC

Table 5A — Correction factors applying to Tables 1, 2, 3 and 4

Ampacity Factors for Ambient Temperature Above 30°C (86°F)

Ambient Temperature, °C	Correction factor					
	60°C — (140°F) ‡	75°C — (167°F) ‡	90°C — (194°F) ‡	110°C — (230°F) ‡	125°C — (257°F) ‡	200°C — (392°F) ‡
	Type W	Types RW75, TW75	Types R90, RW90, T90 NYLON	See Note (2)	See Note (2)	See Note (2)
40	0.82	0.88	0.90	0.94	0.95	1.00
45	0.71	0.82	0.85	0.90	0.92	1.00
50	0.58	0.75	0.80	0.87	0.89	1.00
55	0.41	0.65	0.74	0.83	0.86	1.00
60	—	0.58	0.67	0.79	0.83	0.91
70	—	0.35	0.52	0.71	0.76	0.87
75	—	—	0.43	0.66	0.72	0.86
80	—	—	0.30	0.61	0.69	0.84
90	—	—	—	0.50	0.61	0.80
100	—	—	—	—	0.51	0.77
120	—	—	—	—	—	0.69
140	—	—	—	—	—	0.59

Notes:

- (1) These correction factors apply, column for column, to Tables 1, 2, 3 and 4. The correction factors in Column 2 also apply to Table 57.
- (2) The ampacity of a given conductor type at these higher ambient temperatures is obtained by multiplying the appropriate value from Table 1, 2, 3 and 4 by the correction factor for that higher temperature.
- (3) These ampacities are applicable only under special circumstances where the use of insulated conductors having this temperature rating is acceptable.

With the permission of Canadian Standards Association, material is reproduced from CSA Standard, C22.1-06: Canadian Electrical Code, Part I (20th Edition), Safety Standard for Electrical Installations, which is copyrighted by Canadian Standards Association, 178 Rexdale Blvd, Toronto, Ontario, M9W 1R3. While use of this material has been authorized, CSA shall not be responsible for the manner in which the information is presented, nor for any interpretations thereof. For more information on CSA or to purchase standards, please visit our website at [www.shopcsa.ca](http://www.shopcsa.ca) or call 1-800-463-6727.

CEC

Table 6 – Maximum Number of Conductors of One Size in Trade Sizes of Conduit or Tubing

		Conductors												
Type	Conductor Size (AWG/ kcmil)	Metric Designator (Trade Size)												
		16 (1/2)	21 (3/4)	27 (1)	35 (1-1/4)	41 (1-1/2)	53 (2)	63 (2-1/2)	78 (3)	91 (3-1/2)	103 (4)	116 (4-1/2)	129 (5)	155 (6)
600 V Without jacket	14	8	15	25	43	59	97	139	200	200	200	200	200	200
	12	6	11	19	33	45	74	106	164	200	200	200	200	200
	10	5	8	14	24	33	55	78	121	162	200	200	200	200
R90XLPE RW75XLPE RW90XLPE	8	2	4	7	13	18	30	43	67	90	116	146	183	200
	6	1	3	5	10	13	22	32	50	67	86	108	136	196
	4	1	2	4	7	10	16	23	36	48	62	78	98	142
	3	1	1	3	6	8	14	19	30	41	53	66	83	120
	2	1	1	3	5	7	11	16	25	34	44	55	70	101
	1	1	1	1	3	5	8	12	19	25	33	41	52	75
	1/0	0	1	1	3	4	7	10	16	21	27	34	44	63
	2/0	0	1	1	2	3	6	8	13	17	23	29	36	53
	3/0	0	1	1	1	3	5	7	11	14	19	24	30	44
	4/0	0	0	1	1	1	4	6	9	12	15	20	25	36
	250	0	0	1	1	1	3	4	7	10	13	16	21	30
	300	0	0	1	1	1	2	4	6	8	11	14	18	25
	350	0	0	0	1	1	2	3	5	7	9	12	16	23
	400	0	0	0	1	1	1	3	5	7	8	11	14	20
	450	0	0	0	1	1	1	3	4	6	8	10	13	18
	500	0	0	0	1	1	1	2	4	5	7	9	11	17
	600	0	0	0	0	1	1	1	3	4	5	7	9	13
	700	0	0	0	0	1	1	1	3	4	5	6	8	12
	750	0	0	0	0	1	1	1	2	3	4	6	8	11
	800	0	0	0	0	1	1	1	2	3	4	5	7	10
	900	0	0	0	0	0	1	1	1	3	4	5	6	9
	1000	0	0	0	0	0	1	1	1	2	3	4	6	9
	1250	0	0	0	0	0	1	1	1	1	3	3	5	7
1500	0	0	0	0	0	0	1	1	1	1	3	4	6	
1750	0	0	0	0	0	0	1	1	1	1	2	3	5	
2000	0	0	0	0	0	0	1	1	1	1	1	3	4	
1000 V Without jacket	14	5	10	16	28	39	64	92	142	190	200	200	200	200
	12	4	8	13	23	31	52	74	114	153	197	200	200	200
	10	3	6	10	18	24	40	57	88	118	53	191	200	200
R90XLPE RW75XLPE RW90XLPE	8	2	4	7	13	18	30	43	67	90	116	146	183	200
	6	1	2	4	8	11	18	26	40	54	70	88	110	159
	4	1	1	3	6	7	13	19	30	40	52	65	82	118
	3	1	1	3	5	7	11	16	26	34	44	56	70	102
	2	1	1	2	4	6	10	14	22	29	38	47	60	86
	1	0	1	1	3	4	7	10	15	20	26	33	42	60
	1/0	0	1	1	2	3	6	8	13	17	22	28	35	51
	2/0	0	1	1	1	3	5	7	11	15	19	24	30	43
	3/0	0	0	1	1	2	4	6	9	12	16	20	25	37
	4/0	0	0	1	1	1	3	5	8	10	13	17	21	31
	250	0	0	1	1	1	3	4	6	8	11	14	17	25
	300	0	0	0	1	1	2	3	5	7	9	12	15	22
	350	0	0	0	1	1	1	3	5	6	8	11	13	20
	400	0	0	0	1	1	1	2	4	6	7	9	12	17
	450	0	0	0	1	1	1	2	4	5	7	8	11	16
	500	0	0	0	1	1	1	1	3	5	6	8	10	15
	600	0	0	0	0	1	1	1	3	4	5	7	8	12
700	0	0	0	0	1	1	1	2	3	4	6	7	11	
750	0	0	0	0	1	1	1	2	3	4	5	7	10	

With the permission of Canadian Standards Association, material is reproduced from CSA Standard, C22.1-06: Canadian Electrical Code, Part I (20th Edition), Safety Standard for Electrical Installations, which is copyrighted by Canadian Standards Association, 178 Rexdale Blvd, Toronto, Ontario, M9W 1R3. While use of this material has been authorized, CSA shall not be responsible for the manner in which the information is presented, nor for any interpretations thereof. For more information on CSA or to purchase standards, please visit our website at [www.shopcsa.ca](http://www.shopcsa.ca) or call 1-800-463-6727.

CEC

Table 6 – Maximum Number of Conductors of One Size in Trade Sizes of Conduit or Tubing (cont'd)

Type	Conductor Size (AWG kcmil)	Conductors													
		Metric Designator (Trade Size)													
		16 (1/2)	21 (3/4)	27 (1)	35 (1-1/4)	41 (1-1/2)	53 (2)	63 (2-1/2)	78 (3)	91 (3-1/2)	103 (4)	116 (4-1/2)	129 (5)	155 (6)	
1000V Without jacket	800	0	0	0	0	0	1	1	2	3	4	5	7	10	
	900	0	0	0	0	0	1	1	1	3	4	5	6	9	
	1000	0	0	0	0	0	1	1	1	2	3	4	5	8	
	1250	0	0	0	0	0	1	1	1	1	2	3	4	6	
R90XLPE RW75XLPE RW90XLPE (continued)	1500	0	0	0	0	0	0	1	1	1	1	3	3	5	
	1750	0	0	0	0	0	0	1	1	1	1	2	3	4	
	2000	0	0	0	0	0	0	0	1	1	1	1	3	4	
600V with jacket	14	5	10	16	28	39	64	92	152	190	200	200	200	200	
	12	4	8	13	23	31	52	74	114	153	197	200	200	200	
	10	3	6	10	18	24	40	57	88	118	153	191	200	200	
	8	1	3	6	10	14	24	34	53	71	91	115	144	200	
	6	1	1	3	6	9	15	21	33	45	58	72	91	132	
	4	1	1	3	5	7	11	16	25	34	44	55	69	101	
	3	1	1	2	4	6	10	14	22	30	38	48	60	87	
	2	1	1	1	3	5	8	12	19	25	33	41	52	75	
	1	0	1	1	2	4	6	8	13	17	22	28	36	52	
	1/0	0	1	1	1	3	5	7	11	15	19	24	31	44	
R90XLPE RW75XLPE RW90XLPE R90EP RW75EP RW90EP	2/0	0	0	1	1	2	4	6	9	13	16	21	26	38	
	3/0	0	0	1	1	1	3	5	8	11	14	18	22	32	
	4/0	0	0	1	1	1	3	4	7	9	12	15	19	27	
	250	0	0	0	1	1	1	3	5	7	9	11	14	21	
	300	0	0	0	1	1	1	3	4	6	8	10	12	18	
	350	0	0	0	1	1	1	2	4	5	7	9	11	16	
	400	0	0	0	1	1	1	1	3	5	6	8	10	15	
	450	0	0	0	0	1	1	1	3	4	6	7	9	13	
	500	0	0	0	0	1	1	1	3	4	5	7	8	12	
	600	0	0	0	0	1	1	1	2	3	4	5	7	10	
	700	0	0	0	0	0	1	1	1	3	4	5	6	9	
	750	0	0	0	0	0	1	1	1	3	3	4	6	8	
	800	0	0	0	0	0	1	1	1	2	3	4	5	8	
	900	0	0	0	0	0	1	1	1	2	3	4	5	7	
	1000	0	0	0	0	0	1	1	1	1	3	3	4	7	
	1250	0	0	0	0	0	0	1	1	1	1	2	3	5	
	1500	0	0	0	0	0	0	1	1	1	1	1	3	4	
	1750	0	0	0	0	0	0	0	1	1	1	1	2	4	
	2000	0	0	0	0	0	0	0	1	1	1	1	1	3	
	RWU90XLPE	14	4	7	11	20	28	46	66	102	136	175	200	200	200
12		3	6	9	17	23	38	54	84	113	145	182	200	200	
TWU	10	2	4	8	13	18	30	44	68	91	117	147	184	200	
	8	1	2	4	8	11	18	26	40	53	69	87	109	157	
	6	1	1	3	6	8	14	20	31	42	55	68	86	124	
TWU75	4	1	1	2	5	6	11	15	24	32	42	52	66	95	
	3	1	1	1	4	5	9	13	21	28	36	46	57	83	
	2	1	1	1	3	5	8	11	18	24	31	39	49	72	
	1	0	1	1	2	3	6	9	13	18	23	29	37	54	
	1/0	0	1	1	1	3	5	7	11	16	20	25	32	46	
	2/0	0	1	1	1	2	4	6	10	13	17	21	27	39	
	3/0	0	0	1	1	1	3	5	8	11	14	18	23	33	

With the permission of Canadian Standards Association, material is reproduced from CSA Standard, C22.1-06: Canadian Electrical Code, Part I (20th Edition), Safety Standard for Electrical Installations, which is copyrighted by Canadian Standards Association, 178 Rexdale Blvd, Toronto, Ontario, M9W 1R3. While use of this material has been authorized, CSA shall not be responsible for the manner in which the information is presented, nor for any interpretations thereof. For more information on CSA or to purchase standards, please visit our website at [www.shopcsa.ca](http://www.shopcsa.ca) or call 1-800-463-6727.

CEC

Table 6 – Maximum Number of Conductors of One Size in Trade Sizes of Conduit or Tubing (cont'd)

Type	Conductors													
	Conductor Size (AWG/kcmil)	Metric Designator (Trade Size)												
		16 (1/2)	21 (3/4)	27 (1)	35 (1-1/4)	41 (1-1/2)	53 (2)	63 (2-1/2)	78 (3)	91 (3-1/2)	103 (4)	116 (4-1/2)	129 (5)	155 (6)
RWU90XLPE	4/0	0	0	1	1	1	3	4	7	9	12	15	19	28
	250	0	0	0	1	1	2	3	6	8	10	12	16	23
TWU	300	0	0	0	1	1	1	3	5	7	9	11	14	20
	350	0	0	0	1	1	1	3	4	6	8	10	12	18
	400	0	0	0	1	1	1	2	4	5	7	9	11	16
TWU75 (continued)	450	0	0	0	1	1	1	1	3	5	6	8	10	15
	500	0	0	0	0	1	1	1	3	4	6	7	9	13
	600	0	0	0	0	1	1	1	2	3	5	6	7	11
	700	0	0	0	0	0	1	1	1	3	4	5	6	10
	750	0	0	0	0	0	1	1	1	3	4	5	6	9
	800	0	0	0	0	0	1	1	1	3	4	5	6	9
	900	0	0	0	0	0	1	1	1	2	3	4	5	8
	1000	0	0	0	0	0	1	1	1	1	3	4	5	7
	1250	0	0	0	0	0	0	1	1	1	2	3	4	6
	1500	0	0	0	0	0	0	1	1	1	1	2	3	5
	1750	0	0	0	0	0	0	1	1	1	1	1	3	4
	2000	0	0	0	0	0	0	0	0	1	1	1	2	4
	TW	14	8	15	25	43	59	97	139	200	200	200	200	200
12		6	11	19	33	45	74	106	164	200	200	200	200	200
TW75	10	5	8	14	24	33	55	78	121	162	200	200	200	200
	8	2	4	7	13	18	30	43	67	90	116	146	183	200
	6	1	2	4	8	11	18	26	40	54	70	88	110	159
	4	1	1	3	6	8	13	19	30	40	52	65	82	118
	3	1	1	3	5	7	11	16	26	34	44	56	70	102
	2	1	1	2	4	6	10	14	22	29	38	47	60	86
	1	0	1	1	3	4	7	10	15	20	26	33	42	60
	1/0	0	1	1	2	3	6	8	13	17	22	28	35	51
	2/0	0	1	1	1	3	5	7	11	15	19	24	30	43
	3/0	0	0	1	1	2	4	6	9	12	16	20	25	37
	4/0	0	0	1	1	1	3	5	8	10	13	17	21	31
	250	0	0	1	1	1	2	4	6	8	11	13	17	25
	300	0	0	0	1	1	1	3	5	7	9	12	15	21
	350	0	0	0	1	1	1	3	5	6	8	10	13	19
	400	0	0	0	1	1	1	2	4	6	7	9	12	17
	450	0	0	0	1	1	1	2	4	5	7	8	11	15
	500	0	0	0	1	1	1	1	3	5	6	8	10	14
	600	0	0	0	0	1	1	1	3	4	5	6	8	11
	700	0	0	0	0	1	1	1	2	3	4	5	7	10
	750	0	0	0	0	0	1	1	1	3	4	5	6	9
	800	0	0	0	0	0	1	1	1	3	4	5	6	9
	900	0	0	0	0	0	1	1	1	2	3	4	5	8
	1000	0	0	0	0	0	1	1	1	2	3	4	5	7
1250	0	0	0	0	0	0	1	1	1	2	3	4	5	
1500	0	0	0	0	0	0	1	1	1	1	2	3	5	
1750	0	0	0	0	0	0	1	1	1	1	2	3	4	
2000	0	0	0	0	0	0	0	1	1	1	1	2	4	

With the permission of Canadian Standards Association, material is reproduced from CSA Standard, C22.1-06: Canadian Electrical Code, Part I (20th Edition), Safety Standard for Electrical Installations, which is copyrighted by Canadian Standards Association, 178 Rexdale Blvd, Toronto, Ontario, M9W 1R3. While use of this material has been authorized, CSA shall not be responsible for the manner in which the information is presented, nor for any interpretations thereof. For more information on CSA or to purchase standards, please visit our website at [www.shopcsa.ca](http://www.shopcsa.ca) or call 1-800-463-6727.



CEC

Table 6 – Maximum Number of Conductors of One Size in Trade Sizes of Conduit or Tubing (cont'd)

Type	Conductors												
	Conductor Size (AWG/kcmil)	Metric Designator (Trade Size)											
		16 (1/2)	21 (3/4)	27 (1)	35 (1-1/4)	41 (1-1/2)	53 (2)	63 (2-1/2)	78 (3)	91 (3-1/2)	103 (4)	116 (4-1/2)	129 (5)
TWN75	14	12	22	36	62	85	140	200	200	200	200	200	200
	12	9	16	26	45	62	102	145	200	200	200	200	200
T90 Nylon	10	5	10	16	28	38	63	90	139	187	200	200	200
	8	3	5	9	16	22	36	52	80	100	138	173	200
	6	1	4	6	11	16	26	37	58	80	100	125	157
	4	1	2	4	7	9	16	23	35	47	61	77	96
	3	1	1	3	6	8	13	19	30	40	52	65	82
	2	1	1	2	5	7	11	16	25	34	43	55	69
	1	1	1	2	3	4	8	12	18	25	32	40	51
	1/0	0	1	1	3	4	7	10	15	21	27	34	42
	2/0	0	1	1	2	3	6	8	13	17	22	28	35
	3/0	0	1	1	1	3	5	7	11	14	19	23	29
	4/0	0	0	1	1	1	4	5	9	12	15	19	24
	250	0	0	1	1	1	3	4	7	10	12	16	20
	300	0	0	1	1	1	2	4	6	8	11	13	17
	350	0	0	0	1	1	2	3	5	7	9	12	15
	400	0	0	0	1	1	1	3	5	6	8	10	13
450	0	0	0	1	1	1	2	4	6	7	9	12	
500	0	0	0	1	1	1	2	4	5	7	9	11	

Notes:

- (1) The calculated values in this Table are based on conventional concentric Class B stranded conductors.
- (2) The calculated values in this Table are based on metallic conduit. Other types of raceway of the same nominal size may have different dimensions.
- (3) Some raceways are required to contain a separate bonding or grounding conductor. No allowance is made for extra conductors in this Table.

With the permission of Canadian Standards Association, material is reproduced from CSA Standard, C22.1-06: Canadian Electrical Code, Part I (20th Edition), Safety Standard for Electrical Installations, which is copyrighted by Canadian Standards Association, 178 Rexdale Blvd, Toronto, Ontario, M9W 1R3. While use of this material has been authorized, CSA shall not be responsible for the manner in which the information is presented, nor for any interpretations thereof. For more information on CSA or to purchase standards, please visit our website at [www.shopcsa.ca](http://www.shopcsa.ca) or call 1-800-463-6727.

## Installation Guidelines

### Ocal™ Recommended Installation Procedures

PVC-coated conduit is installed in much the same manner as conventional rigid galvanized steel conduit; however, certain precautions must be taken to protect the exterior coating and ensure satisfactory results. By following these guidelines and using the proper tooling, a damage-free installation can be achieved.

When an engineer has specified Ocal™ PVC-coated conduit, the intent is for the total run to be PVC coated. There are no exceptions to this rule. This means from the beginning of the run to its completion and all in between, no exposed metal shall be allowed.

### Clamping in a Yoke-Style Vise

The first step is the correct clamping of the PVC-coated conduit.

When you use a yoke-style vise, you should replace both the upper and lower jaw inserts with the specially designed Ocal™ jaw vise adapters. These adapters provide greater clamping force and prevent the pipe from spinning during the threading process. (See Catalogue No. JAWS76 or JAWS23 on page H52).

Your other option is to purchase a yoke-style vise already equipped with jaws designed specifically for PVC-coated conduit, such as the yoke-style tri-stand vise manufactured by Rothenberger (Catalogue No. P00076C) on page H51.

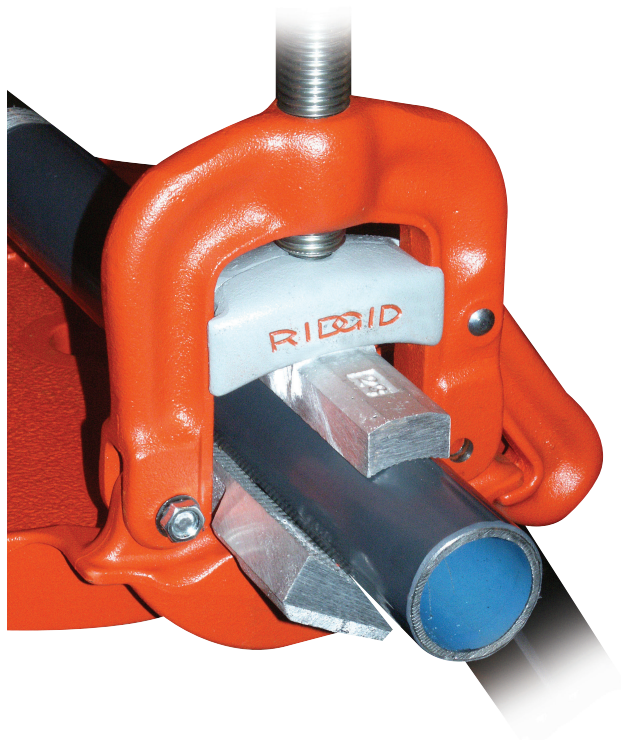

Yoke-Style Tri-Stand Vise with jaws designed for PVC-coated conduit P00076C (see page H51)

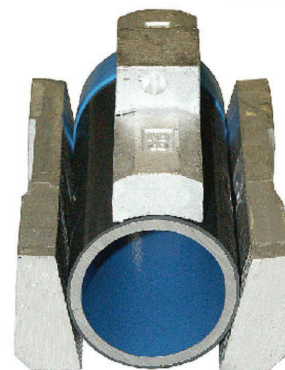

Ocal™ Jaw Vise Adapters JAWS23 or JAWS76 (see page H52)

## Installation Guidelines

### Clamping in a Chain-Style Vise

If a chain-style vise is used, the chain — as well as the jaw inserts — will tear the PVC coating when the threading force is applied.

To prevent this from happening, installers sometimes make “shells” from PVC pipe or standard rigid steel conduit that fit over the PVC-coated conduit. To save time and obtain more consistency, longer life and better protection, you can use the Ocal™ half-shell clamps featured on page H51.

Available in trade sizes 1/2 in. to 6 in., Ocal™ half-shell clamps are made from ductile iron for superior strength and durability. They feature a cross-hatched interior surface designed to safeguard the PVC coating while holding the conduit securely in a chain-style vise.

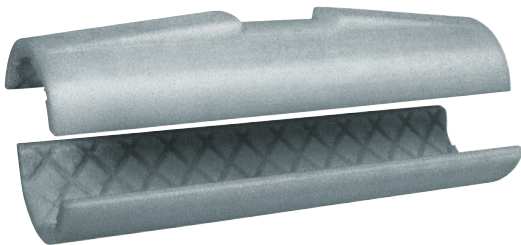

Half-Shell Clamps  
for conduit sizes 1/2 in. to 6 in.  
HLF-SHL-CLP-  
(see page H51)



Chain-Style Vise  
R0TH00076  
(see page H51)



Half-Shell Clamp Sets  
HLF-SHL-CLP-SET1  
(see page H51)

## Installation Guidelines

Better by Design

### Cutting with a Band Saw Cutter

A band saw cutter will cut the PVC coating flush with the end of the conduit. PVC material cut flush to the end of the conduit will not allow the die teeth to bite into the steel to start the threading process.

Therefore, before threading, you must remove approximately 1/4 in. of the PVC coating from the end of the conduit. Using a knife, whittle in a pencil-sharpening style, cutting the coating from the conduit. A wire brush may also be used to remove PVC coating.

A band saw cutter usually will not cut the conduit at a “perfect” 90° angle (the accuracy of this cut depends heavily on the skill of the operator).

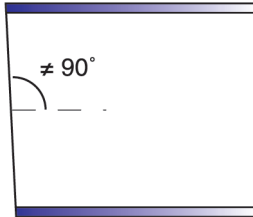

### Cutting with a Roller-Style Cutter

Although most personnel in the field prefer a band saw cutter, a roller-style cutter is the recommended tool for cutting Ocal™ PVC-coated conduit.

A roller-style cutter cuts the edge of the conduit at a bevel and removes 1/4 in. of the coating at the same time. In addition, a roller-style cutter provides an exact 90° cut in relation to the conduit. No additional removal of PVC coating is necessary.

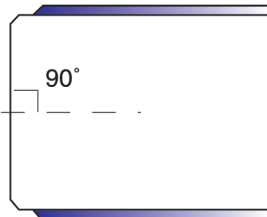

Steel Pipe Cutters  
P70045C  
P70060C  
(see page H52)



## Installation Guidelines



SUPER CUT Die Head Set  
P70905C (see page H50)

### Manual and Hand-Held Threading

PVC-coated conduit has a larger O.D. than uncoated conduit. Standard dies will not clear the additional thickness. Hand-held as well as power threading devices require a die head for the correct size conduit.

The standard die head is factory set for rigid conduit and will not fit over PVC coating. These die heads are available from OCAL™, machined for use with PVC-coated conduit. You can have standard dies machined as well.

If you have dies machined, you will need to adhere to the following procedure:

1. Remove the cover plate and the four die teeth.
2. Have the machinist remove 100 thousandths of an inch (1/10 in.) from the throat and collar diameter of the die head.
3. Replace the dies and cover.

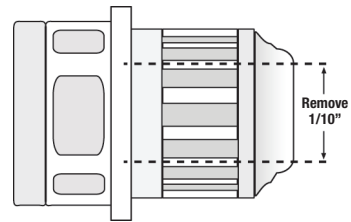

Throat & Collar Shown



Cover Plate Shown



The die teeth are cutting tapered threads and will become clogged with PVC and metal shavings.



To prevent clogging, use a knife and score the conduit lengthwise from the point where the threads will end to where they begin. This will allow the PVC and metal shavings to fall into the throat of the die head.



## Installation Guidelines

### Threading



Ridgid 12R



Rothenberger SUPERTRONIC™ 2000  
P71259C (see page H49)



Rothenberger MINI-COLLINS™  
ROTH00074  
(see page H50)



### Hand-Held Manual Threading

Manual, ratchet-style threaders, such as the Rothenberger SUPER CUT ratchet threader or Ridgid 12R, are typically used for smaller size conduit. The ratchet knob indicates forward and reverse. Die heads snap in from both sides and lock in place. (Ridgid 12R includes ratchet and handle only.)

### Hand-Held Powered Threading

The Rothenberger MINI-COLLINST™ and Ridgid 700 Power Drive are heavy-duty hand-held power tools typically used for conduit up to 2 in. in diameter. Hand-held power threaders such as the Rothenberger SUPERTRONIC™ 2000 are available with die heads for PVC-coated conduit. The Rothenberger MINI-COLLINST™ uses Rothenberger SUPER CUT dies, while the Ridgid 700 Power Drive is designed for Ridgid 12R dies. Optional tool cases are available.

Ream the conduit with approved reamers. Spiral and straight-style reamers are both acceptable.

The threads must be dressed per NEC Article 300.6 [a]: "Where unusually corrosive elements require additional protection, it is recommended that threads be zinc coated with a hot dipped process or equivalent."

Use a good quality degreaser and apply Ocal interior touch-up compound or T&B KOPR-SHIELD®.



Ridgid Reamers



Rothenberger  
Reamer  
70289  
(see page H52)



Ocal™ Urethane Patching Compound  
(see page H54)



KOPR-SHIELD®  
(see page H54)

## Installation Guidelines

### Geared Threading

Geared threaders will thread 2-1/2 in. through 6 in. PVC coated conduit. However, geared threaders are typically only used for 5 in. and 6 in. conduit. The cutting dies are adjustable and will not require pencil cutting the conduit.

The geared threader requires a clamp screw to secure the conduit, and the clamp screw will penetrate the PVC coating.

Make certain the clamp screw is tight; otherwise, it will slip around the conduit and tear the coating. After the threading process is complete, touch up the penetrated area with Ocal™ exterior PVC patching compound (see pages H54 – H55).

Ream the conduit and dress the threads as previously described.



Ridgid Geared Threader  
"Hog Head")



Rothenberger MINI-COLLINS™  
ROTH00074  
(see page H50)



Ridgid 700 Power Drive  
("Power Pony")

### Stationary Power Threading

#### Rothenberger RHINO™

The Rothenberger RHINO™ threading machine featured on page H49, Catalogue No. P00551C, which comes equipped with jaws for PVC-coated conduit up to 4 in., is the recommended choice for threading Ocal™ PVC-coated conduit.

With the Rothenberger RHINO™, you won't need to pencil cut or score the PVC because this machine uses a roller cutter and will remove 1/4 in. of the PVC coating. Cuttings will fall onto the screen on the lower portion of the machine.

Machines that use centrifugal force (slap chucks) — other than the Rothenberger RHINO™, Catalogue No. P00551C — to tighten the jaws around the conduit can be used, but only with shell clamps attached. These types of threaders will damage the PVC coating without the use of shell clamps.

#### Ridgid® Model 1224

Stationary power threading machines such as the Ridgid 1224 have the capacity to thread rigid conduit from 1/2 in. to 4 in. The standard jaw inserts with these units are intended to secure uncoated rigid conduit. The teeth of the standard jaw inserts will penetrate the PVC coating, but not bite into the steel. As a result, the standard jaw inserts will grind the PVC coating off the conduit. To prevent this, shell-style clamps or jaw inserts for coated conduit may be used.

- Shell Clamps — Range: 1/2 in. to 3-1/2 in.  
To properly clamp the conduit, the shell style clamps described earlier can be used on conduit sizes from 1/2 in. to 3-1/2 in. However, for 4 in. conduit, there is not enough room in the chuck to accommodate both the 4 in. conduit and shell clamps.
- Jaw inserts for coated conduit — Range: 1/2 in. to 4 in.  
The jaw inserts for coated conduit have teeth that will penetrate the PVC coating and bite into the conduit itself. Ridgid Catalogue No. 26187 is the jaw insert for coated conduit used in the Ridgid 1224 threading machine.



Rothenberger RHINO™  
P00551C  
(see page H49)



Ridgid 1224

## Installation Guidelines

### Stationary Power Threading (cont'd)

#### Ridgid® Model 1224 (cont'd)

The jaw inserts for coated conduit will leave slits in the PVC jacket. You will need to touch up slits with Ocal exterior PVC patching compound (see pages H54 – H55). Since an extra step is required with the special jaw inserts, most installers usually use them only for 4 in. conduit with the Ridgid 1224 threading machine.

Make sure the stationary machine is set up for NPT threading. All machines can cut straight threads; however, not all machines can cut both tapered and straight threads. Always make sure the thread cutting oil is clean and of the type recommended by the machine manufacturer.

#### Ridgid® Models 300 and 535

Stationary power threading machines such as the Ridgid 300 and Ridgid 535 have the capacity to thread rigid conduit from 1/2 in. to 2 in. The standard jaw inserts for these units are intended to secure uncoated rigid conduit. The teeth of the standard jaw inserts will penetrate the PVC coating, but not bite into the steel. As a result, the standard jaw inserts will grind the PVC coating off the conduit. To prevent this, shell style clamps or jaw inserts for coated conduit may be used.

- Shell Clamps — Range: 1/2 in. to 1-1/2 in.

To properly clamp the conduit, the shell style clamps described earlier can be used on conduit sizes from 1/2 in. to 1-1/2 in. However, for 2 in. conduit, there is not enough room in the chuck to accommodate both the 2 in. conduit and shell clamps

- Jaw Inserts for Coated Conduit — Range: 1/2 in. to 2 in.

The jaw inserts for coated conduit have teeth that will penetrate the PVC coating and bite into the conduit itself. Ridgid Catalogue No. 97365 is the jaw insert for coated conduit used in the Ridgid 300 and 535 threaders. The jaw inserts for coated conduit will leave slits in the PVC jacket. You will need to touch up these slits with Ocal exterior patching compound (see pages H54 — H55). Since an extra step is required with the special jaw inserts, most installers only use them for 2 in. conduit with the Ridgid 300 and 535 machines.

There is no need to pencil cut or score the PVC because these threading machines use a roller cutter and remove 1/4 in. of the PVC coating. Cuttings simply fall onto the screen on the lower portion of the machine.



Ridgid 1224

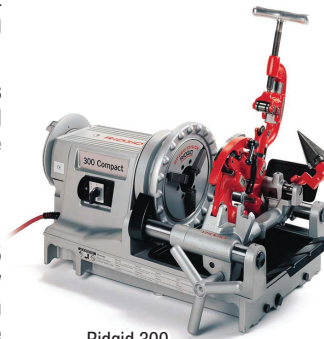

Ridgid 300 Compact Threader



Ridgid 300 Power Drive Complete



Ridgid Model 535



Ocal™ Heat-Cure Patch (see page H55)

Ocal™ Heat-Cure Patch offers a thicker consistency at higher ambient temperatures than standard air-cure compounds, ensuring better coverage and a more effective patch in warm weather applications.



Ocal™ Air-Cure Patching Compounds (see page H54)



## Installation Guidelines

### Bending

Never use any type of lubricant on the shoes. Use rubbing alcohol to clean the shoe prior to bending.

### Hand Bending

A standard hand bender can be used for saddles, offsets and conventional bending. For PVC-coated conduit, the next larger shoe size from the EMT size should be used. The chart below shows the catalogue numbers of the hand benders on page H48 and the corresponding size of PVC-coated conduit on which they should be used.

Cat. No.	Conduit Size (in.)
35220	1/2
35225	3/4
2424A8	1

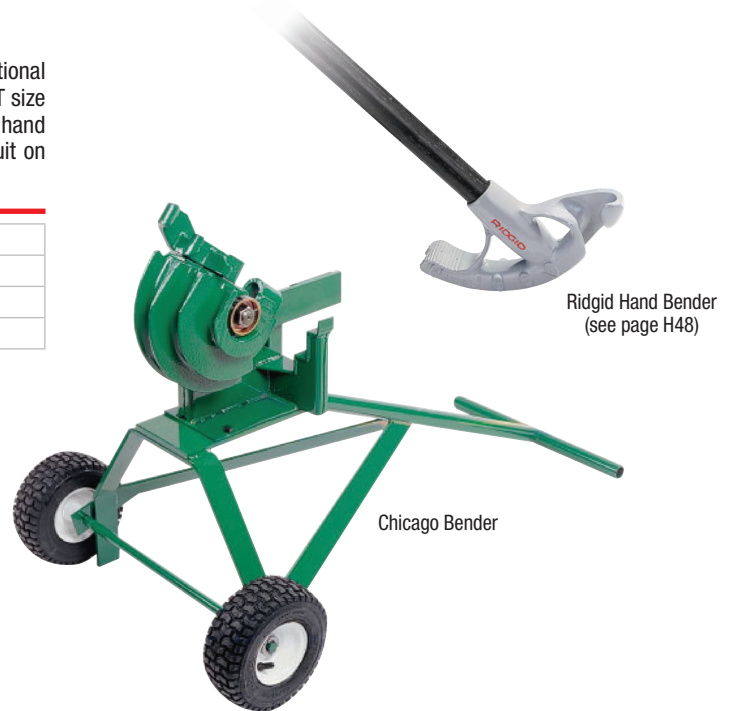

Ridgid Hand Bender  
(see page H48)

Chicago Bender

### Hydraulic Bending

This is the preferred style of bending for conduit size from 2-1/2 in. to 4 in. The shoe assembly should be of the design for PVC-coated conduit. The roller wheel and/or slide bar will accommodate PVC-coated conduit without the need for machining.

**Note:**

- Sequential bends can be manufactured by Ocal™ upon request



Shoe for Greenlee Hydraulic Bending Tool

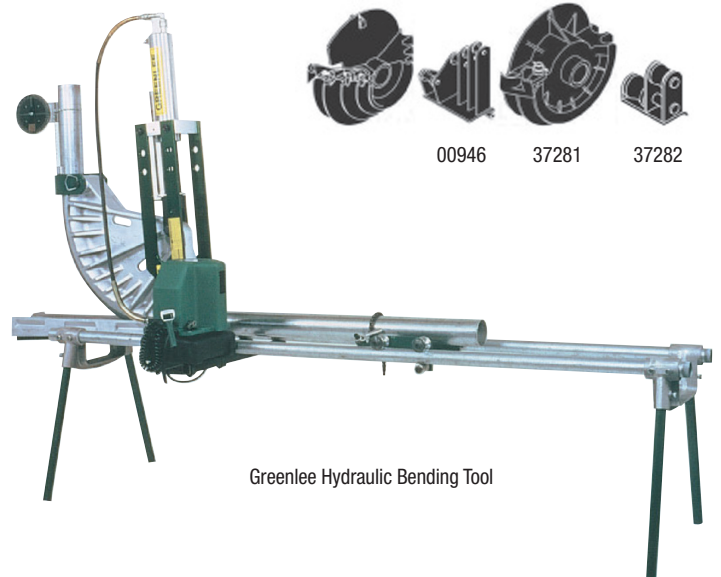

Greenlee Hydraulic Bending Tool

## Industry Standards — NEMA

### NEMA Standards Publication No. RN 1 — 2005

Underwriter Laboratories, Inc. (UL)  
 333 Pfingsten Road, Northbrook, IL 60062  
 UL 6-2007 Safety Standard for Electrical Rigid Metal Conduit — Steel

## Section 3 — External Coatings

### 3.1 Thickness

The thickness of polyvinyl chloride (PVC) coatings shall be a nominal 0.040 in. (1.02 mm). The tolerance on the coating thickness shall be +0.010 in. (+0.25 mm) or -0.005 in. (-0.13 mm).

### 3.2 Coating Material

The PVC coating shall have the properties specified in **Table 3-1**.

Properties of PVC Coatings — Table 3.1

Property	Minimum Requirement	ASTM Test Method
<b>Hardness:</b>		
Shore A	75	D 2240
Shore D	25	D 2240
<b>Tensile Strength</b>	2,000 psi	D 638
<b>Elongation</b>	200%	D 638
<b>Dielectric strength</b>	325 volts per mil	D 149
<b>Brittleness temperature</b>	5° F	D 1790

### 3.3 Application of Coating

#### 3.3.1 Cleaning

The exterior surface that is to receive the coating shall be free of grease, oil, dirt and other extraneous matter. **The surface shall be cleaned in such a manner that the galvanized surface of the conduit is not harmed or eroded.**

#### 3.3.2 Priming

The cleaned exterior surface shall be primed with an adhesive suitable for use with the PVC coating material to be applied.

#### 3.3.3 Coating

The PVC material shall be applied in powder, plastisol or pellet form by a manufacturing method which will produce a finished product conforming to these standards.

### 3.4 Elbows

Coated elbows shall be used with coated conduit. The thickness of the coating on elbows shall be in accordance with Section 3.1.

### 3.5 Couplings

Coated couplings shall be used with coated conduit. The thickness of the coating on couplings shall be at least equal to the thickness of the coating on the conduit.

Each coated coupling shall have a flexible PVC sleeve which extends from each end of the coupling and which will overlap the PVC coating on the conduit when the coupling has been installed on the conduit.

The length of the sleeve extension(s) shall be at least equivalent to the nominal conduit size for sizes up through NPS 2 (53). For sizes NPS 2-1/2 (63) through NPS 6 (155), the length of the sleeve extension(s) shall be at least 2 in. (50.8 mm).

The PVC sleeve shall be a nominal thickness of 0.040 in. (1.02 mm). The inside diameter (I.D.) of the overlapping sleeve shall be less than the outside diameter (O.D.) of the PVC-coated conduit.

### 3.6 Workmanship and Appearance

The PVC coating shall be free of blisters, bubbles, and pinholes. The PVC coating shall be continuous over the entire length of the conduit except at the threads and shall be holiday-free at the time of manufacture.

A holiday is herein defined as an electrical discontinuity of less than 80,000 ohms equivalent resistance sensed with a cellulose sponge wet with a suitable electrolyte and measured with an appropriate low voltage direct-current instrument. A suitable electrolyte is a solution containing tap water, 3.0% salt (sodium chloride) and 0.5% liquid detergent.

The inside of the PVC-coated conduit, couplings and elbows shall be free of the PVC coating material.

All sleeve extensions shall be square cut.

### 3.7 Performance Requirements

Typical physical requirements for PVC-coated conduit are given in **Table 3-2**.

Typical Physical Properties of PVC-Coated Rigid Conduit and IMC — Table 3.2

Property	Requirements*	Test Method
Abrasion resistance	200 hours, no failure	ASTM G6
Bendability, radius (at 73.4° ± 1.8°F) (at 23° ± 16.8°F)	9 in. (228.6 mm)	ASTM G10
Artificial weathering	Minimum 1,000 hours, no adverse effect	ASTM G153

\* The above requirements are based on testing a 0.040 in. (1.02 mm) PVC coating applied over NPS 3/4 (21) galvanized rigid steel conduit. See Section 1 for information on the ASTM test methods.

### 3.8 Adhesion

The adhesion of the PVC coating to the conduit shall be greater than the strength of the coating itself. This shall be determined by making two circumferential cuts, above 1/2 in. (12.7 mm) apart, through the plastic to the substrate. A third cut shall be made perpendicular to and crossing the circumferential cuts. The edge of the plastic shall be carefully lifted with a knife to form a plastic tab. This tab shall be pulled perpendicular to the conduit with a pair of pliers. The plastic tab shall tear rather than any additional coating film separating from the substrate.