

Rigid Non-Metallic Conduit Fittings (for use with Schedule 40 & 80 Conduit)



Expansion Fittings

E945 series expansion fittings are designed to compensate for length changes due to temperature variations in exposed conduit runs.

- Exclusive molded-in mid-point indicator on the piston
- Exclusive 2" expansion fitting with an 8" travel distance
- Two-piece molded design with lubricated seals for easier movement for the life of the product
- Ridges on the fitting for easier installation (sizes 2"-6" only)
- Male terminal adapter end design (½"-2" NPT Threads, and 2½"-6" NPSC threads)
- Two O-rings to prevent leakage
- Can be installed vertically or horizontally



COUPLING END CAT. NO.	MALE TERMINAL ADAPTER END CAT. NO.	SIZE (IN.)	STD. CTN.	TRAVEL LENGTH (IN.)
E945D	E945DX	½	20	4
E945E	E945EX	¾	15	4
E945F	E945FX	1	10	4
E945G	E945GX	1¼	5	4
E945H	E945HX	1½	5	4
E945J	E945JX	2	15	8
E945K	E945KX	2½	10	8
E945L	E945LX	3	10	8
E945M	E945MX	3½	5	8
E945N	E945NX	4	5	8
E945P	E945PX	5	1	8
E945R	E945RX	6	1	8

Short Expansion Couplings

Expand to a maximum of 2".

CAT. NO.	SIZE (IN.)	STD. CTN.
E955D	½	40
E955E	¾	40
E955F	1	25
E955G	1¼	15
E955H	1½	10
E955J	2	6



Couplings Standard Couplings

All socket fittings should be attached using Carlton® solvent cement.



Socket type for joining non-metallic conduit.

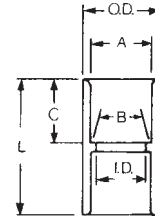

Except where noted by ▶

CAT. NO.	SIZE (IN.)	STD. CTN.	TYPICAL (IN.)		I.D. (IN.)	O.D. (IN.)	TYPICAL (IN.)	
			A	B			C	L
E940D	½	150	.852	.836	.728	1¼	1¼	1½
▶ CE940DR-CTN	½	75	.852	.836	.728	1¼	1¼	1½
E940E	¾	100	1.064	1.046	.840	1¾	¾	1¾
▶ CE940ER-CTN	¾	45	1.064	1.046	.840	1¾	¾	1¾
E940F	1	50	1.330	1.310	1.210	1¾	1½	2
▶ CE940F-UPC	1	50	1.330	1.310	1.210	1¾	1½	2
E940G	1¼	30	1.677	1.655	1.535	1¾	1	2½
E940H	1½	25	1.918	1.894	1.755	2¾	1¾	2¾
E940J	2	30	2.393	2.369	2.190	2¾	1¾	2½
E940K	2½	20	2.890	2.868	2.688	3¾	1¾	3¾
E940L	3	25	3.515	3.492	3.375	3¾	1¾	3¾
E940M	3½	20	4.015	3.992	3.780	4¾	1¾	3¾
E940N	4	15	4.515	4.491	4.265	5¾	1¾	3¾
E940P	5	8	5.593	5.553	5.097	6¾	1¾	4¾
E940R	6	5	6.658	6.614	6.115	7¾	2¾	4¾

▶ Canada only

Special Long Line Couplings



Long Line Couplings

CAT. NO.	SIZE (IN.)	STD. CTN.	STD. WT. (LBS.)	LENGTH (IN.)
E941H	1½	40	9	3.19
E941J	2	25	8	3.59
E941K	2½	15	8	4.29
E941L	3	15	14	6.44
E941N	4	10	15	6.96
E941PF	5	4	12	9.63
▶ E941RF	6	5	21	11.75

Fabricated Expansion Couplings



CAT. NO.	SIZE (IN.)	STD. CTN.	TRAVEL LENGTH (IN.)
E945KXL	2½	10	12

Non-Metallic Rigid Conduit, Fittings and Accessories

Rigid Non-Metallic Conduit Fittings (for use with Schedule 40 & 80 Conduit)

Couplings

Special Long Line Couplings —
Sleeve Couplings

Sleeve Coupling
(For Repair Work)
No Internal Stop



CAT. NO.	SIZE (IN.)	STD. CTN.	STD. WT. (LBS.)	LENGTH (IN.)
▶ E948H	1½	25	6	4
▶ E948J	2	25	5	3
▶ E948K	2½	25	16	6
▶ E948L	3	25	13	4
▶ E948N	4	10	8	6.5
▶ E948P	5	14	33	7
▶ E948R	6	6	16	6
▶ E948JR	2	15	8	6
▶ E948JS	2 (Sch. 40 Split Duct)	25	6	—
▶ E948KS7	2½ (Sch. 40 Split Duct)	25	19	7
▶ E948L12	3	1	1	12
▶ E948L6	3	15	15	6
▶ E948LS	3 (Sch. 40 Split Duct)	25	17	—
▶ E948N12	4	10	28	12
▶ E948N7	4	15	25	7
▶ E948NS	4 (Sch. 40 Split Duct)	10	15	—
▶ E948PS	5 (Sch. 40 Split Duct)	1	2	—
▶ E948R10	6	6	25	10
▶ E948R12	6	6	25	12
▶ E948RS	6 (Sch. 40 Split Duct)	1	2	—

Special Schedule 40 Swedge Couplings

CAT. NO.	SIZE (IN.)	STD. CTN.	STD. WT. (LBS.)
▶ E442K	2½	20	13
▶ E442R	6	6	27
▶ E442T	8	2	17

*Consult factory for additional sizes



Risers Schedule 40

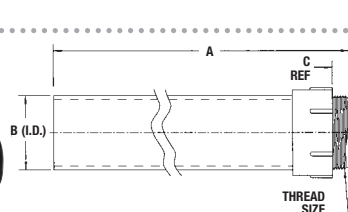

CAT. NO.	SIZE (IN.)	A (IN.) (LENGTH)	B (IN.)	C (IN.)	THREAD SIZE (IN.)	STD. CTN.	STD. WT. (LBS.)
▶ E954HX	1½	80.00	1.567	.950	1½ NPT	1	3.8
▶ E954J	2	60.00	2.024	.825	2 NPT	1	3.7
▶ E954JX	2	80.00	2.024	.825	2 NPT	1	5.0
▶ E954K	2½	60.00	2.418	.812	2½ NPSC	1	6.0
▶ E954KX	2½	80.00	2.418	.812	2½ NPSC	1	8.4
▶ E954L	3	60.00	3.012	.798	3 NPSC	1	8.7
▶ E954LX	3	80.00	3.012	.798	3 NPSC	1	11.0

Adapters

Female Adapters



Except where noted by ▶

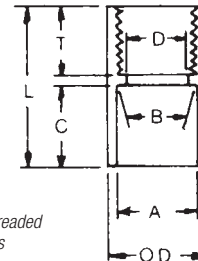

For adapting non-metallic conduits to threaded fittings, metallic systems. Female threads on one end, socket end on other.

CAT. NO.	SIZE (IN.)	STD. CTN.	TYPICAL (IN.)		MIN. D (IN.)	MAX. OD (IN.)	TYPICAL (IN.)		
			A	B			C	T	L
E942D	½	150	.852	.836	.620	1¼	1¼	¾	1¼
E942E	¾	100	1.064	1.046	.822	1½	1½	¾	1½
E942F	1	50	1.330	1.310	1.046	1¾	1¾	¾	1¾
E942G	1¼	30	1.677	1.655	1.377	2¼	1	¾	2
E942H	1½	25	1.918	1.894	1.607	2½	1½	¾	2½
E942J	2	30	2.393	2.369	2.064	2¾	1¾	1	2¾
E942K	2½	20	2.890	2.868	2.450	3½	1¾	1½	2¾
E942L	3	25	3.515	3.492	3.000	3¾	1¾	1½	3½
E942M	3½	20	4.015	3.992	3.500	4½	1¾	1½	3½
E942N	4	15	4.515	4.491	4.000	5¼	1¾	1½	3¾
▶ E942NX9*	4	15	(Call for information)						
E942P	5	8	5.593	5.553	5.047	6¼	1¾	1½	3¾
E942R	6	6	6.658	6.614	6.055	7¼	2½	1¾	3¾
▶ E942RX*	6	6	(Call for information)						

* Long Line Adapter

Male Terminal Adapters



For adapting non-metallic conduits to boxes, threaded fittings, metallic systems. Male threads on one end, socket end on other.

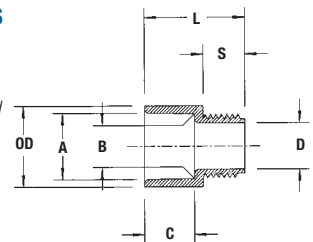

CAT. NO.	SIZE (IN.)	STD. CTN.	TYPICAL (IN.)		MIN. D (IN.)	MAX. OD (IN.)	TYPICAL (IN.)		
			A	B			C	S	L
E943D	½	150	.852	.836	.594	1.042	.652	.545	1.310
E943E	¾	125	1.064	1.046	.793	1.290	.809	.553	1.470
E943F	1	50	1.330	1.310	1.025	1.580	.965	.812	1.902
E943G	1¼	50	1.677	1.655	1.345	1.973	1.208	.816	1.986
E943H	1½	25	1.918	1.894	1.574	2.188	1.155	.802	2.105
E943J	2	50	2.393	2.369	1.998	2.713	1.145	.825	2.093
E943K	2½	25	2.890	2.868	2.400	3.290	1.490	.812	2.480
E943L	3	45	3.515	3.492	2.989	3.965	1.643	.797	2.660
E943M	3½	30	4.015	3.992	3.405	4.515	1.720	.802	2.740
E943N	4	20	4.515	4.491	3.895	5.065	1.788	.733	2.830
E943P	5	5	5.593	5.553	4.900	6.104	1.935	.990	3.200
E943R	6	10	6.658	6.614	5.900	7.288	2.128	.985	3.410

Rigid Non-Metallic Conduit Fittings (for use with Schedule 40 & 80 Conduit)



Adapters

Box Adapters for Enclosures



Adapts non-metallic conduit to all electrical enclosures by inserting adapter through knockout and cementing into Carlton couplings.

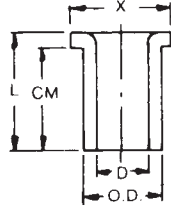

CAT. NO.	SIZE (IN.)	STD. CTN.	MIN D (IN.)	OD (IN.) TYPICAL	MAX X (IN.)	CM (IN.) TYPICAL	L (IN.) TYPICAL
E996D	1/2	100	.662	.840	1 1/4	2 3/2	2 7/2
E996E	3/4	100	.824	1.050	1 21/64	2 5/2	2 9/2
E996F	1	100	1.049	1.315	1 1/2	2 9/4	1 3/2
E996G	1 1/4	50	1.380	1.660	1 3/2	1 1/6	1 1/4
E996H	1 1/2	50	1.610	1.900	2 1/64	1 1/6	1 1/2
E996J	2	25	2.067	2.375	2 9/2	1 1/4	1 1/6
E996K	2 1/2	15	2.469	2.875	3 1/6	1 1/6	1 1/6
E996L	3	20	3.068	3.500	4 1/2	2	2 1/6
E996N	4	10	4.026	4.500	5 1/2	2 1/2	2 1/4

Threaded Adapters

CAT. NO.	SIZE (IN.)	STD. CTN.
E9842D ¹	1/2	25
E9842E ²	3/4	25

¹ Fits 3/4" sockets
² Fits 1" sockets



Reducers

Reducer Bushings



For connecting different sizes of conduit.
Bell x Spigot.

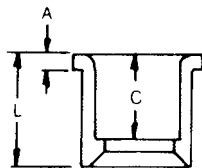

CAT. NO.	SIZE (IN.)	STD. CTN.	L (IN.) TYPICAL	A (IN.) TYPICAL	C (IN.) TYPICAL
E950ED	3/4 x 1/2	100	1 1/2	1 3/4	1 1/2
E950FD-CAR	1 x 1/2	25	1 11/2	3/6	5/64
E950FE	1 x 3/4	100	1 11/2	3/6	1 1/4
E950GE-CAR	1 1/4 x 3/4	10	1 11/2	3/6	1 1/4
E950GF	1 1/4 x 1	50	1 11/2	3/6	1 1/4
E950HF-CAR	1 1/2 x 1	10	1 11/2	3/6	1 1/4
E950HG-CAR	1 1/2 x 1 1/4	10	1 11/2	3/6	1 11/64
E950JG-CAR	2 x 1 1/4	10	1 3/4	7/2	1 11/64
E950JH-CAR	2 x 1 1/2	10	1 3/4	7/2	1 5/64
E950KJ-CAR	2 1/2 x 2	10	2 3/2	3/6	1 7/64
E950LJ-CAR	3 x 2	10	2 1/2	1/4	1 1/2
E950LK	3 x 2 1/2	25	1 11/6	1/4	1 11/6
E950NL	4 x 3	25	2 3/4	5/6	1 11/6

Plugs

Reducer Plugs

CAT. NO.	SIZE (IN.)	STD. CTN.	STD. WT. (LBS.)
E971C	3/4 x 1/2	100	2
E971D	1 x 3/4	100	3



Plugs (Polyethylene)

CAT. NO.	SIZE (IN.)	STD. CTN.	STD. WT. (LBS.)
P258H	1 1/2	50	2
P258K	2 1/2	25	1.5



Plugs with Pull Tabs (Polyethylene)

CAT. NO.	SIZE (IN.)	STD. CTN.	STD. WT. (LBS.)
P258JT	2	60	3
P258LT	3	30	3
P258NT	4	48	8
P258PT	5	30	6
P258RT	6	30	9



Fabricated Reducers



CAT. NO.	SIZE (IN.)	STD. CTN.	STD. WT. (LBS.)
Male x Male			
E952JH	1 1/2 x 2	48	20
E952KJ	2 1/2 x 2	48	26
E952LJ	3 x 2	36	21
E952LK	3 x 2 1/2	36	32
E952NL	4 x 3	15	21
E952NM	4 x 3 1/2	15	25
E952PN	5 x 4	12	27
E952RP	6 x 5	10	31
Male x Female			
E952NJF	4 x 2	15	16
E952RNF	6 x 4	10	28

SP® LR31146
UL LISTED E23018
Except where noted by ▶

Carlton® Non-Metallic Rigid Conduit, Fittings and Accessories

Carlton®

Rigid Non-Metallic Conduit Fittings (for use with Schedule 40 & 80 Conduit)

Caps Service Entrance Caps



UL US
LISTED
E13938

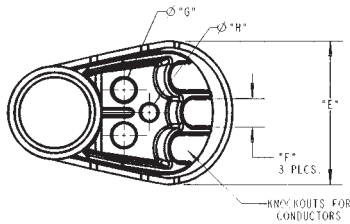

CAT. NO.	SIZE (IN.)	STD. CTN.	DIMENSIONS (IN.)			
			E	F	G	H
E998D	½	5	1.76	.45	.45	—
E998E	¾	20	1.76	.45	.45	—
E998E-CAR	¾	5	1.76	.45	.45	—
E998F	1	15	2.26	.59	.58	—
E998F-CAR	1	5	2.26	.59	.58	—
E998G-CAR	1¼	5	3.52	.74	.71	.50
E998H-CAR	1½	5	3.52	.74	.71	.50
E998J-CAR	2	5	4.26	.83	.78	.56
E998K-UPC	2½	2	7.47	1.70	1.31	1.00
E998L	3	2	7.47	1.70	1.31	1.00
E998N	4	2	10.45	2.25	1.88	1.31

End Caps

CAT. NO.	SIZE (IN.)	STD. CTN.	STD. WT. (LBS.)
▶ E958D	½	100	3
▶ E958E	¾	100	4
▶ E958F	1	75	5
▶ E958G	1¼	40	4
▶ E958H	1½	30	4
▶ E958J	2	25	5
▶ E958K	2½	10	4
▶ E958L	3	10	5
▶ E958N	4	5	17
▶ E958P	5	5	11
▶ E958R	6	5	13



PVC Riser Caps

CAT. NO.	SIZE (IN.)	STD. CTN.	STD. WT. (LBS.)
▶ E935J	2	25	3
▶ E935L	3	25	5
▶ E935N	4	25	7
▶ E935P	5	25	35
▶ E935R	6	10	7



Offsets Meter Offset

SP®
LR31146

UL LISTED
E23018
Except where noted by ▶

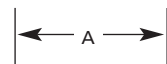

CAT. NO.	SIZE (IN.)	STD. CTN.	OFFSET (IN.)	A (IN.)
▶ E995G	1¼	15	0.758	4.230
▶ E995J	2	8	0.684	4.270

Offset

CAT. NO.	SIZE (IN.)	OFFSET (IN.)	STD. CTN.	STD. WT. (LBS.)
▶ E994D	½	.250	25	3
▶ E994E	¾	.250	25	3
▶ E994F	1	.500	50	12



End Bells End Bells

CAT. NO.	SIZE (IN.)	STD. CTN.	STD. WT. (LBS.)
E997F	1	50	2.6
E997G	1¼	35	2.5
E997H	1½	30	2.5
E997J	2	40	5.0
E997K	2½	30	2
E997L	3	50	10
E997M	3½	40	11
E997N	4	30	16
▶ E997P	5	15	8
▶ E997R	6	10	7
▶ E997T	8	3	15



Fabricated End Bells (Schedule 40)

CAT. NO.	SIZE (IN.)	STD. CTN.	STD. WT. (LBS.)
▶ E949J5	2 x 5	50	10
▶ E949J6	2 x 6	25	12
▶ E949JN	2 x 4	25	7
▶ E949JX	2 x 8	12	7
▶ E949LR	3 x 6	20	21
▶ E949N5	4 x 5	20	2
▶ E949NR	4 x 6	15	21
▶ E949R5	6 x 5	12	27
▶ E949RX	6 x 8	6	17



Carlton® Non-Metallic Rigid Conduit, Fittings and Accessories

Thomas & Betts

www.tnb.com

Corporate Office
Tel: 901.252.8000
800.816.7809
Fax: 901.252.1354

Customer Service
Tel: 800.816.7809
Fax: 800.816.7810

Technical Services
Tel: 888.862.3289
Fax: 901.252.1321

Tool Services
Tel: 800.284.8665



Rigid Non-Metallic Conduit Accessories, Conduit Bodies

Washers

Flat Sealing Washer

Where a waterproof termination is required into any enclosure (metallic or non-metallic), install the neoprene washer over the threads of a terminal adapter before inserting into the enclosure. Use a standard locknut or threaded bushing to secure the assembly.

CAT. NO.	SIZE (IN.)	STD. CTN.
▶ E943DW	½	125
▶ E943EW	¾	125
▶ E943FW	1	100
▶ E943GW	1¼	50
▶ E943HW	1½	50
▶ E943JW	2	25



Lock Nuts

PVC Lock Nut



CAT. NO.	SIZE (IN.)	STD. CTN.
▶ LT9LD	½	1200
▶ LT9LE	¾	700
▶ LT9LF	1	600



Pull Elbows

Access Pull Elbows

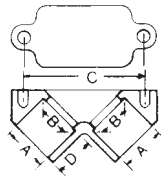

CAT. NO.	SIZE (IN.)	STD. CTN.	A (IN.) TYPICAL	B (IN.) TYPICAL	C (IN.) TYPICAL	D (IN.) TYPICAL
† E990D	½	75	.852	.836	2.187	.718
† E990E	¾	50	1.064	1.046	2.531	.781

Gasket included.

Sleeves

HOLFORM™ Concrete Sleeves

HOLFORM™ non-metallic concrete sleeve forms are the easy way to form holes in concrete. They install in seconds with nails, screws or staples and are easily removed. Concrete will not adhere to them. HOLFORMs are adjustable to any slab thickness.



LR31146
Except where noted by †



LISTED E23018
Except where noted by ▶

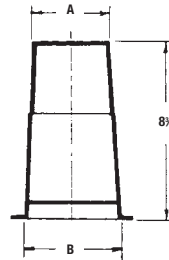

CAT. NO.	MIN. O.D. A (IN.)	B (IN.)	STD. CTN.	STD. WT. (LBS.)
† ▶ E92CSH	1½	1¼	20	3
† ▶ E92CSJ	2	2½	25	6
† ▶ E92CSL	3	3½	25	8
† ▶ E92CSN	4	4½	18	8
† ▶ E92CSP	5	5½	15	8
† ▶ E92CSR	6	6½	12	8

Conduit Bodies

Type X with Cover

Four knock-out type socket openings, 90° spacing. Available with ½" or ¾" socket outlets. Includes cover and gasket.

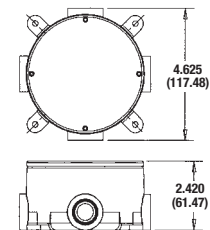
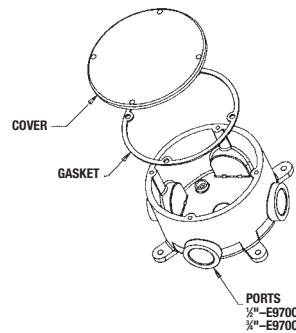

CAT. NO.	SIZE (IN.)	VOL. CU. IN.	STD. CTN.
▶ E970CD	½	15.16	15
E970CE	¾	15.16	15

Supplied with 4 stainless steel cover screws. Diameter ¼", Thickness ¼".
*Not designed for use with wiring devices or light fixtures.

Non-Metallic Rigid Conduit, Fittings and Accessories

Feature unthreaded hubs and textured lids with foam-in-place gaskets.

Conduit Bodies

Type LB

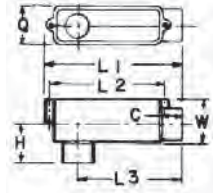

CAT. NO.	SIZE (IN.)	STD. CTN.	DIMENSIONS (IN.)							VOL. CU. IN.
			TYPICAL C	TYPICAL L1	TYPICAL L2	TYPICAL L3	MAX. H	MAX. Q	MAX. W	
E986D	1/2	25	1/16	4 1/16	3 1/2	3 1/16	1 1/16	1 1/2	1 1/2	4.0
E986E	3/4	15	2/32	6 1/2	5 1/2	4 29/32	1 1/2	1 1/4	2 1/2	12.0
E986F	1	10	29/32	6 3/2	5 1/2	4 29/32	1 1/2	1 1/4	2 1/2	12.0
E986G	1 1/4	10	1 1/2	7 3/2	6 1/2	6	2 1/2	2 1/2	2 3/4	32.0
E986H	1 1/2	10	1 1/2	7 3/2	6 1/2	6	2 1/2	2 1/2	2 3/4	32.0
E986J	2	10	1 1/2	9 3/2	8 1/2	7 1/4	2 1/2	3 1/2	3 1/2	63.0
▶ E986K	2 1/2	4	1 1/4	14 1/2	13 1/4	11 3/2	3 1/4	4 1/2	4 1/2	210.
▶ E986L	3	4	1 1/4	14 1/2	13 1/4	11 3/2	3 1/4	4 1/2	4 1/2	210.
▶ E986M	3 1/2	4	1 29/32	17 29/32	15 1/2	14 1/64	4 1/16	5 1/2	5 1/2	390.
▶ E986N	4	4	1 29/32	17 29/32	15 1/2	14 1/64	4 1/16	5 1/2	5 1/2	390.

Type E

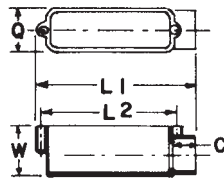

CAT. NO.	SIZE (IN.)	STD. CTN.	DIMENSIONS (IN.)				VOL. CU. IN.
			TYPICAL C	TYPICAL L1	TYPICAL L2	TYPICAL Q	
E988D	1/2	25	1/16	4 1/16	3 1/2	1 1/2	4.0
E988E	3/4	20	29/32	6 1/2	5 1/2	1 1/4	12.0
E988F	1	10	29/32	6 1/2	5 1/2	1 1/4	12.0
E988G	1 1/4	10	1 1/2	8	6 1/2	2 1/2	32.0
E988H	1 1/2	10	1 1/2	8	6 1/2	2 1/2	32.0
E988J	2	5	1 1/2	9 1/2	8 1/2	3 1/2	63.0

Type C

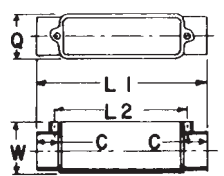
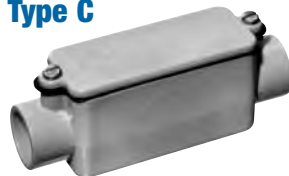

CAT. NO.	SIZE (IN.)	STD. CTN.	DIMENSIONS (IN.)					VOL. CU. IN.
			TYPICAL C	TYPICAL L1	TYPICAL L2	MAX. H	MAX. W	
E987D	1/2	25	1/16	4 1/16	3 1/2	1 1/2	4.0	
E987E-CAR	3/4	10	29/32	6 1/2	5 3/64	1 1/4	12.0	
E987F-CAR	1	10	29/32	6 1/2	5 1/2	1 1/4	12.0	
E987G	1 1/4	10	1 1/2	8 3/2	6 1/2	2 1/2	32.0	
E987H	1 1/2	10	1 1/2	8 3/2	6 1/2	2 1/2	32.0	
E987J	2	15	1 1/2	10 1/16	8 1/2	3 1/2	63.0	

Type LR

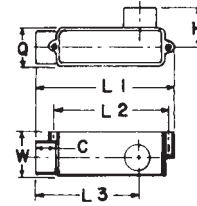
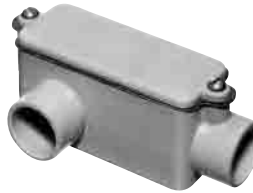

CAT. NO.	SIZE (IN.)	STD. CTN.	DIMENSIONS (IN.)							VOL. CU. IN.
			TYPICAL C	TYPICAL L1	TYPICAL L2	TYPICAL L3	MAX. H	MAX. Q	MAX. W	
E985D-CAR	1/2	10	1/16	4 1/16	3 1/2	3 1/16	1 1/16	1 1/2	1 1/2	4.0
E985E-CAR	3/4	10	29/32	6 1/2	5 1/2	4 29/32	1 1/2	1 1/4	2 1/2	12.0
E985F	1	10	29/32	6 1/2	5 1/2	4 29/32	1 1/2	1 1/4	2 1/2	12.0
E985G	1 1/4	10	1 1/2	7 3/2	6 1/2	6	2 1/2	2 1/2	2 3/4	32.0
E985H-CAR	1 1/2	5	1 1/2	7 3/2	6 1/2	6	2 1/2	2 1/2	2 3/4	32.0
E985J	2	10	1 1/2	9 1/2	8 1/2	7 1/4	2 1/2	3 1/2	3 1/2	63.0

Type T

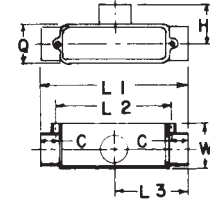

CAT. NO.	SIZE (IN.)	STD. CTN.	DIMENSIONS (IN.)							VOL. CU. IN.
			TYPICAL C	TYPICAL L1	TYPICAL L2	TYPICAL L3	MAX. H	MAX. Q	MAX. W	
E983D-CAR	1/2	10	1/16	4 1/16	3 1/2	2 1/2	1 1/16	1 1/2	1 1/2	4.0
E983E	3/4	15	29/32	6 1/2	5 1/2	4 1/16	1 1/2	1 1/4	2 1/2	12.0
E983F	1	20	29/32	6 1/2	5 1/2	3 1/16	1 1/2	1 1/4	2 1/2	12.0
E983G	1 1/4	10	1 1/2	8 3/2	6 1/2	4 3/64	2 1/2	2 1/2	2 3/4	32.0
E983H	1 1/2	10	1 1/2	8 3/2	6 1/2	4 3/64	2 1/2	2 1/2	2 3/4	32.0
E983J	2	10	1 1/2	10 1/16	8 1/2	5 1/2	2 1/2	3 1/2	3 1/16	63.0

Type LL

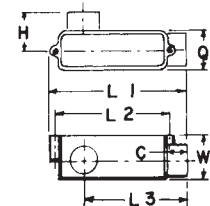

CAT. NO.	SIZE (IN.)	STD. CTN.	DIMENSIONS (IN.)							VOL. CU. IN.
			TYPICAL C	TYPICAL L1	TYPICAL L2	TYPICAL L3	MAX. H	MAX. Q	MAX. W	
E984D-CAR	1/2	10	1/16	4 1/16	3 1/2	3 1/16	1 1/16	1 1/2	1 1/2	4.0
E984E	3/4	20	29/32	6 1/2	5 1/2	4 29/32	1 1/2	1 1/4	2 1/2	12.0
E984F-CAR	1	10	29/32	6 1/2	5 1/2	4 29/32	1 1/2	1 1/4	2 1/2	12.0
E984G-CAR	1 1/4	5	1 1/2	7 3/2	6 1/2	6	2 1/2	2 1/2	2 3/4	32.0
E984H	1 1/2	10	1 1/2	7 3/2	6 1/2	6	2 1/2	2 1/2	2 3/4	32.0
E984J	2	10	1 1/2	9 1/2	8 1/2	7 1/4	2 1/2	3 1/2	3 1/2	63.0



LR31146



LISTED E11461

Except where noted by ▶



Molded Non-Metallic Junction Boxes — 6P Rated

Non-metallic junction boxes are UL Listed with a NEMA 6P rating per Section 314.29, Exception of the National Electrical Code® and CSA Certified per Section 12 of the Canadian Electrical Code. Manufactured from PVC or PPO thermoplastic molding compound and featuring foam-in-place gasketed lids attached with stainless steel screws, these rugged enclosures offer all the corrosion resistance and physical properties you need for direct burial applications.

Type 6P enclosures are intended for indoor or outdoor use, primarily to provide a degree of protection against contact with enclosed equipment, falling dirt, hose-directed water, entry of water during prolonged submersion at a limited depth and external ice formation.

- All Carlton® Junction Boxes are UL Listed/CSA Certified and maintain a minimum of a NEMA Type 4/4x Rating
- Part numbers with an asterisk (*) are UL Listed and maintain a NEMA Type 6P Rating and Type 4/4X Rating

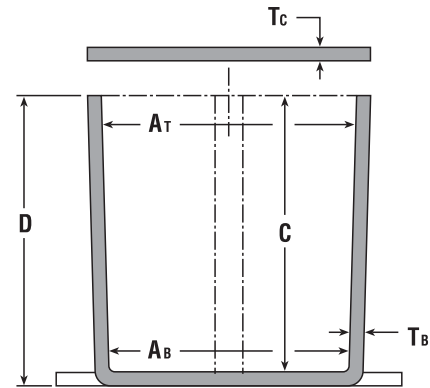
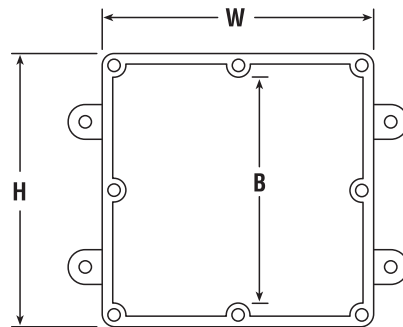
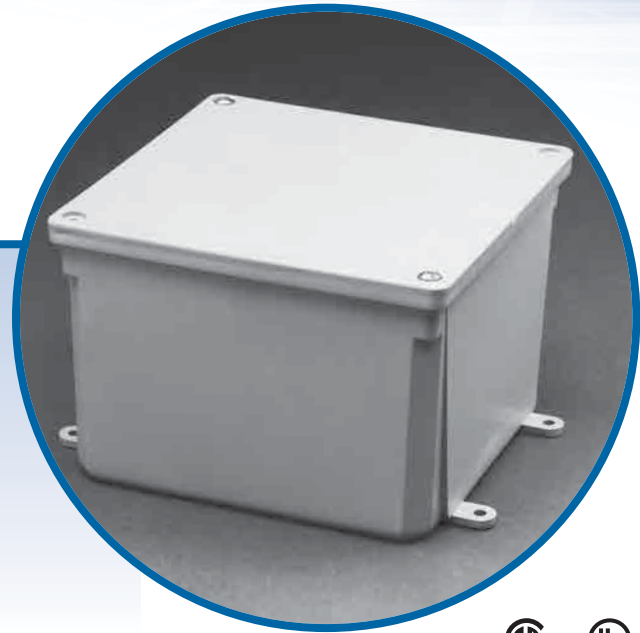

CAT. NO.	SIZE (IN.) H X W X D	STD. CTN.	DIMENSIONS (IN.)						MATERIAL		STD. WT. (LBS.)
			MIN. Ar	MIN. As	MIN. B	MIN. C	Ts	Tc	PVC	THERMO-PLASTIC	
E989NNJ*	4 x 4 x 2	10	3 ¹ / ₁₆	3 ¹ / ₁₆	N/A	2	.160	.155	X		3
E987N*	4 x 4 x 4	10	3 ¹ / ₁₆	3 ¹ / ₁₆	N/A	4	.160	.155	X		4
† E989NNR*	4 x 4 x 6	10	3 ¹ / ₁₆	3 ¹ / ₁₆	N/A	6	.160	.200	X		5
E989PPJ*	5 x 5 x 2	10	4 ¹ / ₁₆	4 ¹ / ₁₆	N/A	2	.110	.150		X	3
E987R-CAR*	6 x 6 x 4	2	6	5 ¹ / ₁₆	N/A	4	.190	.190		X	3
E989RRR-UPC*	6 x 6 x 6	8	5 ¹ / ₁₆	5 ¹ / ₁₆	N/A	6	.160	.150		X	14
E989N-CAR	8 x 8 x 4	1	8	8	N/A	4	.185	.190		X	2
E989SSX-UPC	8 x 8 x 7	2	7 ¹ / ₁₆	7 ¹ / ₁₆	N/A	7	.160	.150		X	6
E989UUN	12 x 12 x 4	3	11 ¹ / ₁₆	11 ¹ / ₁₆	11 ¹ / ₁₆	4	.160	.150		X	12
E989R-UPC	12 x 12 x 6	2	11 ¹ / ₁₆	11 ¹ / ₁₆	11 ¹ / ₁₆	6	.265	.185		X	10

Carlton® Non-Metallic Rigid Conduit, Fittings and Accessories

Corporate Office
Tel: 901.252.8000
800.816.7809
Fax: 901.252.1354

Customer Service
Tel: 800.816.7809
Fax: 800.816.7810

Technical Services
Tel: 888.862.3289
Fax: 901.252.1321

Tool Services
Tel: 800.284.8665

Thomas & Betts

www.tnb.com



Carlton®

Junction Boxes

Carlton® Non-Metallic Rigid Conduit, Fittings and Accessories

Large PVC Junction Boxes/ NEMA 4X

Large PVC Junction Boxes are fabricated from Type II PVC sheet. Reduce the use of steel boxes and keep your wiring connections clean, safe and dry using these high-quality, fully gasketed junction boxes.

Features and Benefits:

- PVC Type II material with “Uni-Body” construction and penetration welding providing a very strong, durable enclosure
- UL-94V-0 flame rating
- Suitable for exposure of up to 90°C
- PVC material enables the use of standard solvent cements for fitting attachment
- Junction boxes are available with or without mounting flanges
- Individual mounting feet are available and provided in kits of four
- Custom features such as windows or panel mounts are available
- Custom sizes are also available upon request
- Made in the USA

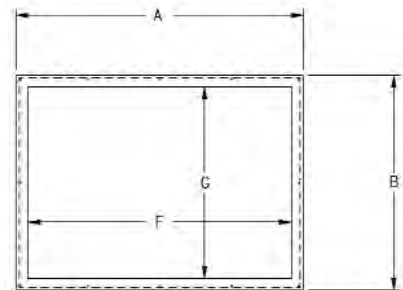
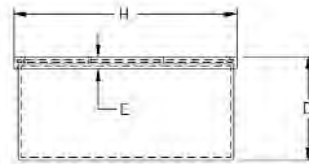
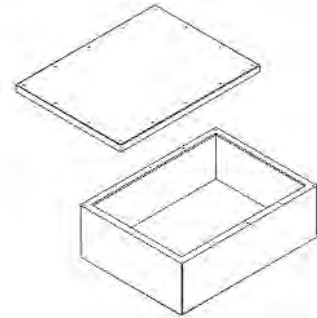
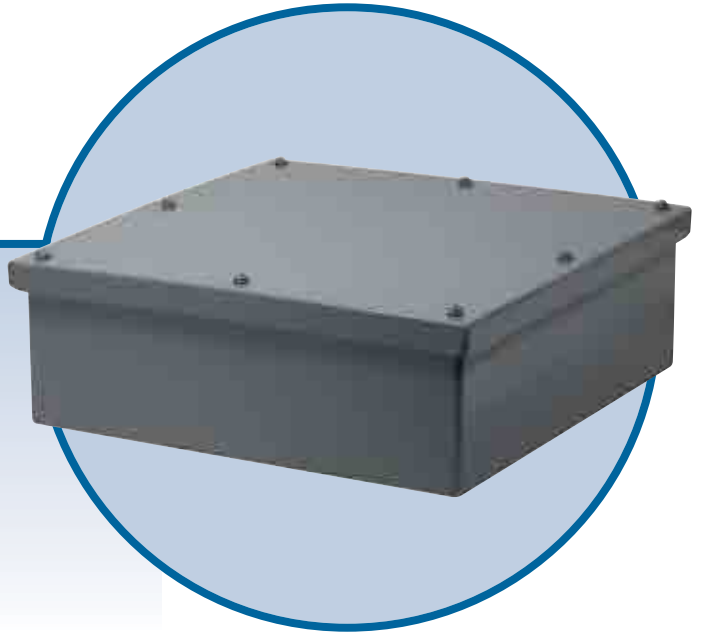

CAT. NO.	DIMENSIONS (IN.)								STD. WT. (LBS.)
	A	B	C	D	E	F	G	H	
EP12128	12	12	8	8.25	1.00	10.5	10.5	12.75	11
EP181812	18	18	12	12.25	1.00	16	16	18.75	21
EP201808	20	18	8	8.25	1.00	18	16	18.75	20
EP202008	20	20	8	8.25	1.00	18	18	20.75	22
EP241808	24	18	8	8.25	1.00	22	16	18.75	24
EP242008	24	20	8	8.25	1.00	21.5	17.5	20.75	25
EP242408	24	24	8	8.25	1.00	21.5	21.5	24.75	29
EP302408	30	24	8	8.25	1.00	27.5	21.5	24.75	34
EP362408	36	24	8	8.25	1.00	33.5	21.5	24.75	39

Accessories

CAT. NO.	DESCRIPTION	STD. WT. (LBS.)
ESMFK-1	“CleverMount” Mounting Feet (4 Feet and Fasteners)	5

Thomas & Betts

www.tnb.com

Corporate Office
Tel: 901.252.8000
800.816.7809
Fax: 901.252.1354

Customer Service
Tel: 800.816.7809
Fax: 800.816.7810

Technical Services
Tel: 888.862.3289
Fax: 901.252.1321

Tool Services
Tel: 800.284.8665



Single-Gang FS Boxes

Type FSE

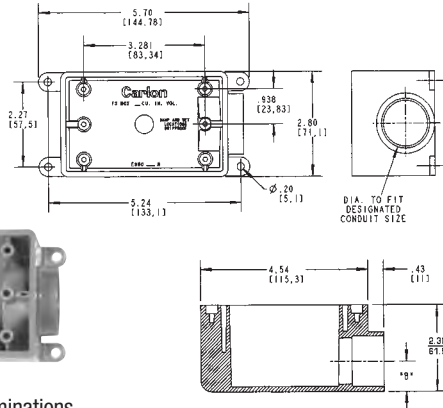

- For dead-end terminations
- All sizes take standard covers and accessories or devices
- Integral mounting feet provide easy mounting

CAT. NO.	SIZE (IN.)	VOL. CU. IN.	STD. CTN.
E980DFN	½	19	10
☛ C980DFN-CTN	½	18	12
E980EFN	¾	19	10
☛ C980EFN-CTN	¾	18	12
E980FFN	1	19	18
☛ C980FFN-CTN	1	18	8
E980FFN-CAR	1	19	10

☛ Canada Only

Type FSC

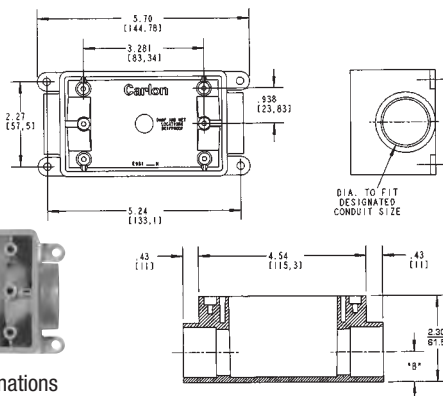

- For through terminations
- All sizes take standard covers and accessories or devices
- Detachable mounting feet provide easy mounting

CAT. NO.	SIZE (IN.)	VOL. CU. IN.	STD. CTN.
E981DFN	½	19	15
☛ C981DFN-CTN	½	18	12
E981EFN	¾	19	15
☛ C981EFN-CTN	¾	18	12
E981FFN	1	19	18
E981FFN-CAR	1	19	10
☛ C981FFN-CTN	1	18	8

☛ Canada Only

Type FSS

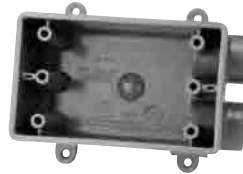
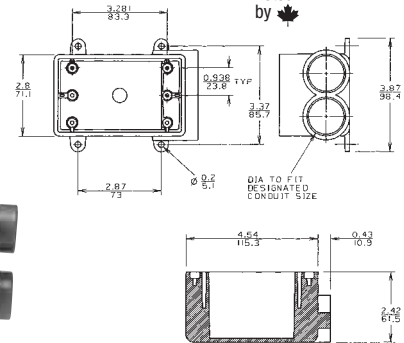

- For multiple dead-end circuit terminations or where additional support is required in stub-up applications
- All sizes take standard covers and accessories or devices
- Detachable mounting feet provide easy mounting

CAT. NO.	SIZE (IN.)	VOL. CU. IN.	STD. CTN.
E982DFN	½	19	10
☛ C982DFN-CTN	½	18	12
E982EFN	¾	19	10
☛ C982EFN-CTN	¾	18	12
E982FFN	1	19	10
☛ C982FFN-CTN	1	18	8

☛ Canada Only

Type FSCC

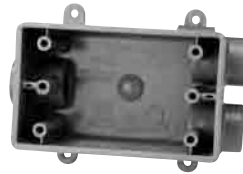
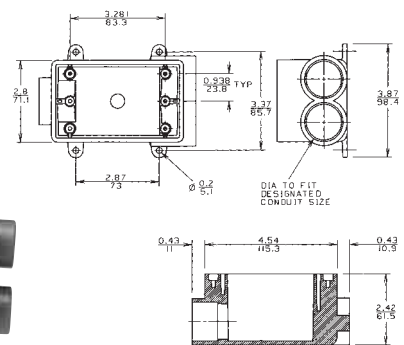

- For multiple through-circuit terminations or where additional support is required in stub-up applications
- All sizes take standard covers and accessories or devices
- Detachable mounting feet provide easy mounting

CAT. NO.	SIZE (IN.)	VOL. CU. IN.	STD. CTN.
E979DFN-CAR	½	19	10
☛ C979DFN	½	18	15
E979EFN-CAR	¾	19	10
☛ C979EFN	¾	18	15
E979FFN	1	19	15
☛ C979FFN	1	18	15

☛ Canada Only

Carlton® Non-Metallic Rigid Conduit, Fittings and Accessories

Single-Gang FD Deep Device Boxes



Type FD

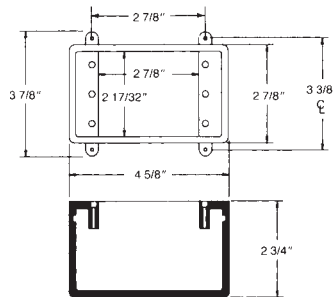
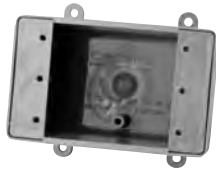

- For terminations where hub requirements vary according to application — hubs easily made with flared wood bit or hole saw
- All sizes take standard covers and accessories or devices
- Integral mounting feet provide easy mounting

CAT. NO.	SIZE (IN.)	VOL. CU. IN.	STD. CTN.
E9801	N/A	25	10
☛ CE9801-CTN	N/A	25	10
☛ C9801-347	N/A	25	10

☛ Canada Only

Type FDC

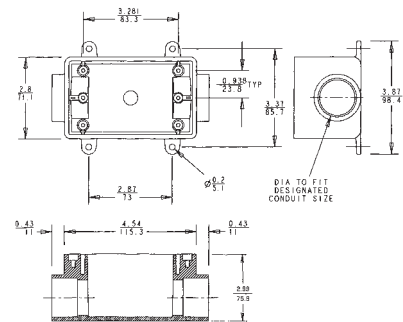

- For through terminations where large devices or additional wiring capacity is required
- All sizes take standard covers and accessories or devices
- Integral mounting feet provide easy mounting

CAT. NO.	SIZE (IN.)	VOL. CU. IN.	STD. CTN.
E9811DN	1/2	25	10
☛ C9811DN	1/2	25	10
E9811EN	3/4	25	10
☛ C9811EN	3/4	25	10
E9811FN	1	25	10
☛ C9811FN	1	25	10

☛ Canada Only

Type FDE

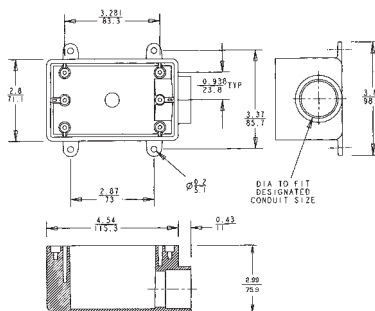

- For dead-end terminations where large devices or additional wiring capacity is required
- All sizes take standard covers and accessories or devices
- Integral mounting feet provide easy mounting

CAT. NO.	SIZE (IN.)	VOL. CU. IN.	STD. CTN.
E9801DN	1/2	25	10
☛ C9801DN	1/2	25	10
E9801EN	3/4	25	10
☛ C9801EN	3/4	25	10
E9801FN	1	25	10
☛ C9801FN	1	25	10

☛ Canada Only



Two-Gang FS Boxes

Type 2FSC

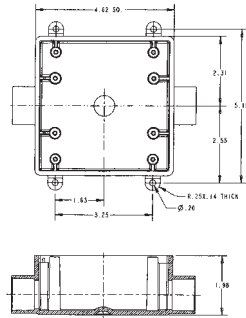
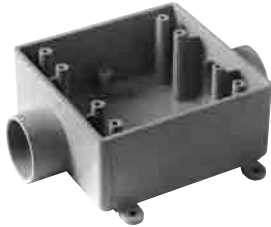

- For through terminations where two devices or additional wiring capacity is required
- All sizes take standard covers and accessories or devices
- Integral mounting feet provide easy mounting

CAT. NO.	SIZE (IN.)	VOL. CU. IN.	STD. CTN.
E9812D	½	32	10
☛ CE9812D-CTN	½	32	10
E9812E	¾	32	10
☛ CE9812E-CTN	¾	32	10
E9812F	1	32	10
☛ C9812F	1	32	10

☛ Canada Only

Type FS

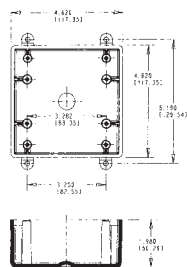

- For terminations where hub requirements vary according to application — hubs easily made with flared wood bit or hole saw
- All sizes take standard covers and accessories or devices
- Integral mounting feet provide easy mounting

CAT. NO.	SIZE (IN.)	VOL. CU. IN.	STD. CTN.
E9802	N/A	32	10
☛ CE9802	N/A	32	10

☛ Canada Only

Type 2FSE

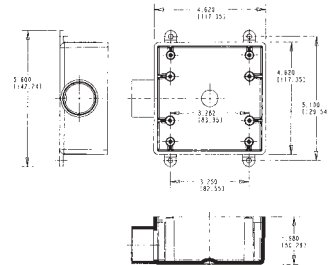
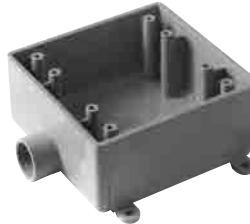

- For dead-end terminations where two devices or additional wiring capacity is required
- All sizes take standard covers and accessories or devices
- Integral mounting feet provide easy mounting

CAT. NO.	SIZE (IN.)	VOL. CU. IN.	STD. CTN.
E9802D	½	32	10
☛ CE9802D-CTN	½	32	10
E9802E	¾	32	10
☛ CE9802E-CTN	¾	32	10
E9802F	1	32	10
☛ C9802F	1	32	1

☛ Canada Only

Blank Covers

Single-Gang

- Fits Carlton® single-gang FS boxes
- Supplied with stainless steel mounting screws and gasket

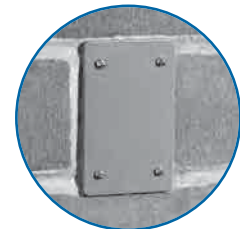

CAT. NO.	COLOR	STD. CTN.	STD. WT. (LBS.)
E980CN-CAR	Gray	12	1.60
E980CM-CAR	White	12	1.60

Two-Gang

- Fits Carlton® two-gang FS boxes, other non-metallic and metallic FS boxes
- Supplied with stainless steel mounting screws and gasket

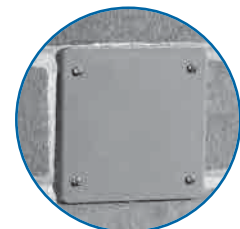

CAT. NO.	COLOR	STD. CTN.	STD. WT. (LBS.)
E9802CN-CAR	Gray	10	2.17

Carlton® Non-Metallic Rigid Conduit, Fittings and Accessories

Snap Strap™ Conduit Support Straps

Carlton's Snap Strap™ offers a unique support strap designed especially for the installation of PVC conduit. Also usable for installations of rigid steel. This high-strength, non-metallic clamp enables conduit to expand and contract freely, eliminating the bowing commonly seen from the expansion and contraction of conduit caused by varying temperature changes. Finished installations have a neat, attractive appearance on exposed applications.

To be used in accordance with conduit spacing requirements per the NEC®, Section 352.30 and 12-1114 of the CEC. This part is not supplied with screws.

- UV inhibited for use in direct sunlight

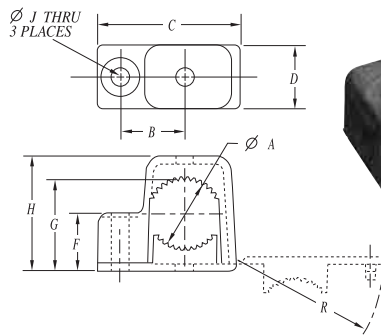

Single Mount

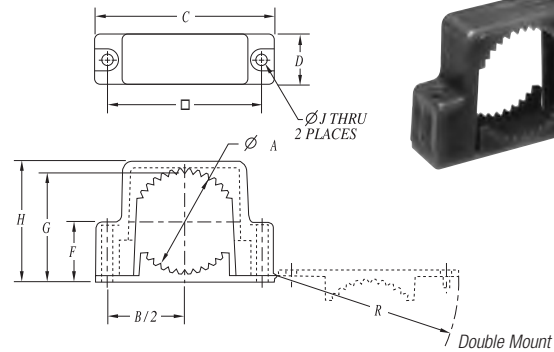

Double Mount

Single Mount

CAT. NO.	SIZE IN. (MM)	STD. CTN.	STD. WT. (LBS.)	DIMENSIONS IN. (MM)								
				A	B	C	D	F	G	H	J	R
E978DC-CAR	½ (16)	40	1	0.80 (20.3)	.75 (1.90)	1.63 (41.4)	0.75 (19.1)	.68 (14.9)	1.08 (25.1)	1.36 (34.5)	.21 (5.33)	1.67 (42.4)
E978EC-CAR	¾ (21)	40	3	1.00 (25.4)	.88 (22.4)	1.92 (48.7)	0.75 (19.1)	.79 (17.8)	1.29 (30.4)	1.58 (39.9)	.21 (5.33)	1.96 (49.8)
E978FC-CAR	1 (27)	30	4	1.20 (30.5)	1.02 (25.9)	2.17 (55.1)	0.75 (19.1)	.92 (21.1)	1.54 (36.3)	1.84 (46.7)	.21 (5.33)	2.22 (56.3)

Double Mount

CAT. NO.	SIZE IN. (MM)	STD. CTN.	STD. WT. (LBS.)	DIMENSIONS IN. (MM)								
				A	B	C	D	F	G	H	J	R
E978GC-CAR	1¼ (35)	15	4	1.66 (42.16)	2.75 (69.9)	3.23 (82.0)	1.00 (25.4)	1.07 (24.1)	1.90 (45.2)	2.15 (54.61)	.218 (5.54)	3.28 (83.3)
E978HC-CAR	1½ (41)	15	5	1.92 (48.77)	3.05 (77.5)	3.53 (89.7)	1.00 (25.4)	1.20 (27.4)	2.16 (51.8)	2.40 (60.96)	.218 (5.54)	3.58 (90.9)
E978JC-CAR	2 (53)	10	5	2.34 (59.44)	3.50 (88.9)	4.00 (101.6)	1.00 (25.4)	1.43 (33.3)	2.59 (63.0)	2.86 (72.64)	.218 (5.54)	4.06 (103.1)



Non-Metallic Clamps

Non-metallic clamps offer the same chemical resistance as Carlton® non-metallic conduits for a complete, corrosion-resistant system.

To be used in accordance with conduit spacing requirements per the NEC®, Section 352.30 and 12-1114 of the CEC.

- UV inhibited for use in direct sunlight

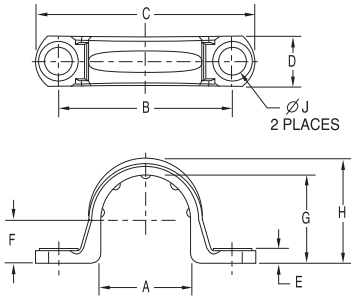

Conduit Clamp

Conduit Clamps

CAT. NO.	SIZE IN. (MM)	STD. CTN.	STD. WT. (LBS.)	DIMENSIONS IN. (MM)								
				A	B	C	D	E	F	G	H	J
E977DC	½ (16)	100	1.2	0.892 (22.6)	1.71 (43.4)	2.16 (54.8)	0.50 (12.7)	.14 (3.5)	.42 (10.6)	.866 (21.9)	1.04 (26.4)	.260 (6.6)
E977EC	¾ (21)	100	1.4	1.102 (27.9)	1.97 (50.0)	2.40 (60.9)	0.50 (12.7)	.14 (3.5)	.525 (13.3)	1.076 (27.3)	1.255 (31.8)	.260 (6.6)
E977FC	1 (27)	100	2	1.39 (35.3)	2.25 (57.1)	2.81 (71.3)	0.594 (15.0)	.14 (3.5)	.658 (16.7)	1.342 (34.0)	1.574 (39.9)	.260 (6.6)
E977GC	1¼ (35)	50	5	1.714 (43.5)	2.68 (68.0)	3.28 (83.3)	.64 (16.2)	.15 (3.8)	.83 (21.0)	1.687 (42.8)	1.89 (48.0)	.320 (8.1)
E977HC	1½ (41)	50	6	1.92 (48.7)	2.82 (71.6)	3.44 (87.3)	.70 (17.7)	.15 (3.8)	.97 (24.6)	1.93 (49.0)	2.12 (53.8)	.312 (7.9)
E977JC	2 (53)	25	4.5	2.54 (64.5)	3.54 (89.9)	4.18 (106.1)	.76 (19.3)	.16 (4.0)	1.05 (26.6)	2.29 (58.1)	2.49 (63.2)	.315 (8.0)
E977KC-CAR	2½ (63)	25	1.4	2.86 (72.6)	4.50 (114.3)	5.46 (138.7)	1.00 (25.4)	.20 (5.08)	1.43 (36.3)	2.86 (72.6)	3.12 (79.2)	.36 (9.14)
E977LC-CAR	3 (78)	20	1.4	3.47 (88.2)	5.00 (127.0)	6.00 (152.4)	1.00 (25.4)	.20 (5.08)	1.74 (44.3)	3.48 (88.4)	3.70 (94.0)	.36 (9.14)
E977NC-CAR	4 (103)	15	12.2	4.366 (110.9)	6.15 (156.2)	7.20 (182.9)	1.00 (25.4)	.20 (5.08)	2.32 (58.8)	4.50 (114.3)	4.70 (119.4)	.36 (9.14)

*NOTE: Some clamp applications require 2 screws, 2 nuts and 2 washers.

Non-Metallic Rigid Conduit, Fittings and Accessories

Carlton®

Clamps

Carlton® Masonry Pipe Clamps

Carlton® Masonry Pipe Clamps make installations faster and easier by eliminating the use of bolts and anchors. The one-piece design features an anchoring projection designed to push into a 5/16" drill hole.

The clamps are used to securely support pipe/conduit and electrical cables on concrete and masonry block, and unlike metallic clamps Carlton® Masonry Clamps won't rust or corrode.

Carlton® Masonry Pipe Clamps are available in sizes 1/2" and 3/4" and are ideal for commercial applications such as schools, hospitals, airports, condominiums, hotels, airports, office buildings and casinos.

Features

- One-piece design
- Material: Nylon PA6
- Color: Gray
- Flame resistance: V2
- Anchor length: 1.2" threaded
- Drill hole: 5/16"

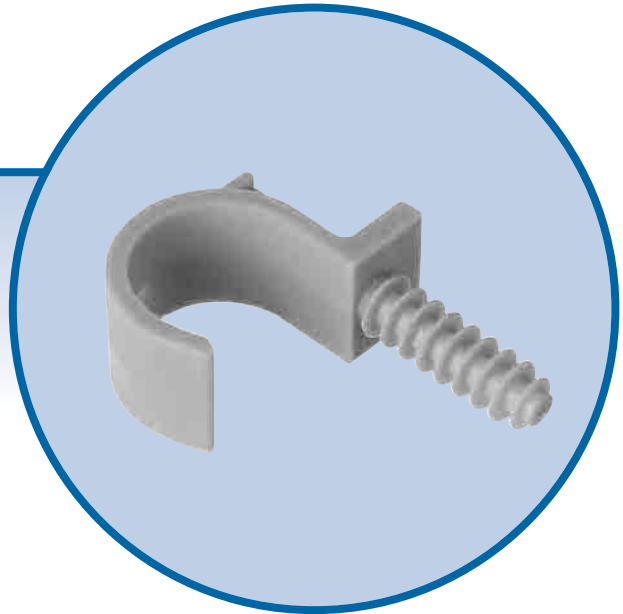

Installation:

1

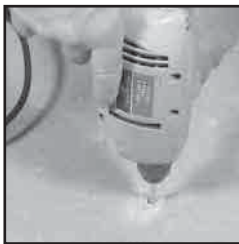

Using a 5/16" masonry drill bit, drill a hole into the concrete.

2



Tap clamp with hammer until fully inserted.

3

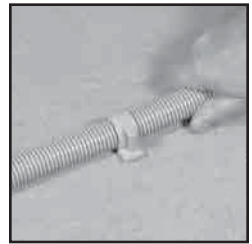

Hang desired conduit onto the clamp.

CAT. NO.	SIZE (IN.)	STD. CTN.	STD. WT. (LBS.)
E977NDC-CTN	1/2	12 (Equals 12 bags of 5 Clamps)	1.2
E977NEC-CTN	3/4	12 (Equals 12 bags of 5 Clamps)	1.3

Thomas & Betts

www.tnb.com

Corporate Office
Tel: 901.252.8000
800.816.7809
Fax: 901.252.1354

Customer Service
Tel: 800.816.7809
Fax: 800.816.7810

Technical Services
Tel: 888.862.3289
Fax: 901.252.1321

Tool Services
Tel: 800.284.8665

Corrosion Resistance of Carlton® Schedule 40 and Schedule 80 Fittings

Carlton Schedule 40 and Schedule 80 Fittings are generally acceptable for use in environments containing the chemicals **below**. These environmental-resistance ratings are based upon tests where the specimens were placed in complete submergence in the reagent listed. Schedule 40 and Schedule 80 Fittings can be used in many process areas where chemicals not on this list

are manufactured or used because worker safety requirements dictate that any air presence or splashing be at a very low level.

If there are any questions about specific suitability in a given environment, prototype samples should be tested under actual conditions.

CHEMICAL ENVIRONMENT					
Acetic Acid 0-20%	Bleach – 12.5% Active CL2	Cottonseed Oil	Hydrogen Phosphide	Palmitic Acid 10%	Sodium Cyanide
Acetic Acid 20-30%	Borax	Cresylic Acid 50%	Hydrogen Sulfide – Dry	Perchloric Acid 10%	Sodium Dichromate
Acetic Acid 30-60%	Boric Acid	Crude Oil – Sour	Hydrogen Sulfide – Aqueous Solution	Phenylhydrazine Hydrochloride	Sodium Ferricyanide
Acetic Acid 80%	Brine	Crude Oil – Sweet	Hydroquinone	Phosgene, Gas	Sodium Ferrocyanide
Acetic Acid – Glacial	Breeder Pellets – Dane. Fish	Deminerlized Water	Hydroxylamine Sulfate	Phosphoric Acid – 0-25%	Sodium Fluoride
Acetic Acid Vapors	Bromic Acid	Dextrin	Iodine	Phosphoric Acid – 25-50%	Sodium Hydroxide
Acetylene	Bromine – Water	Dextrose	Kerosene	Phosphoric Acid – 50-85%	Sodium Hypochlorite
Adipic Acid	Butane	Diglycolic Acid	Lactic Acid 28%	Photographic Chemicals	Sodium Nitrate
Alum	Butadiene	Disodium Phosphate	Lauric Acid	Plating Solutions	Sodium Nitrite
Aluminum Chloride	Butyl Alcohol	Ethyl Alcohol	Lauryl Chloride	Potassium Bicarbonate	Sodium Sulfate
Aluminum Fluoride	Butyl Phenol	Ethylene Glycol	Lauryl Sulfate	Potassium Bichromate	Sodium Sulfite
Aluminum Hydroxide	Butylene	Fatty Acids	Lead Acetate	Potassium Borate	Sodium Thiosulfate (Hypo)
Aluminum Oxychloride	Butyric Acid	Ferric Chloride	Lime Sulfur	Potassium Bromide	Stannic Chloride
Aluminum Nitrate	Calcium Bisulfite	Ferric Nitrate	Linoleic Acid	Potassium Carbonate	Stannous Chloride
Aluminum Sulfate	Calcium Carbonate	Ferric Sulfate	Linseed Oil	Potassium Chloride	Stearic Acid
Ammonia-Dry Gas	Calcium Chlorate	Ferrous Chloride	Lubricating Oils	Potassium Chromate	Sulfur
Ammonium Bifluoride	Calcium Chloride	Ferrous Sulfate	Magnesium Carbonate	Potassium Cyanide	Sulfur Dioxide – Gas Dry
Ammonium Carbonate	Calcium Hydroxide	Fluorine Gas – Wet	Magnesium Chloride	Potassium Dichromate	Sulfur Trioxide
Ammonium Chloride	Calcium Hypochlorite	Fluorine Gas – Dry	Magnesium Hydroxide	Potassium Ferricyanide	Sulfuric Acid – 0-10%
Ammonium Hydroxide 28%	Calcium Nitrate	Fluoroboric Acid	Magnesium Nitrate	Potassium Ferrocyanide	Sulfuric Acid – 10-75%
Ammonium Metaphosphate	Calcium Sulfate	Fluorosilicic Acid	Magnesium Sulfate	Potassium Fluoride	Sulfuric Acid – 75-90%
Ammonium Nitrate	Carbonic Acid	Formaldehyde	Maleic Acid	Potassium Hydroxide	Sulfurous Acid
Ammonium Persulfate	Carbon Dioxide Gas – Wet	Formic Acid	Malic Acid	Potassium Nitrate	Tannic Acid
Ammonium Phosphate – Neutral	Carbon Dioxide – Aqueous Solution	Fructose	Mercuric Chloride	Potassium Perborate	Tanning Liquors
Ammonium Sulfate	Carbon Monoxide	Gallic Acid	Mercuric Cyanide	Potassium Perchlorate	Tartaric Acid
Ammonium Sulfide	Caustic Potash	Gas – Coke Oven	Mercurous Nitrate	Potassium Permanganate 10%	Titanium Tetrachloride
Ammonium Thiocyanate	Caustic Soda	Gas – Natural (Dry)	Mercury	Potassium Persulfate	Triethanolamine
Amyl Alcohol	Chloracetic Acid	Gas – Natural (Wet)	Methyl Sulfate	Potassium Sulfate	Trimethyl Propane
Antraquinone	Chloral Hydrate	Gasoline – Sour	Methylene Chloride	Propane	Trisodium Phosphate
Antraquinonesulfonic Acid	Chlorine Gas (Dry)	Gasoline – Refined	Mineral Oils	Propyl Alcohol	Turpentine
Antimony Trichloride	Chlorine Gas (Moist)	Glucose	Naphthalene	Silicic Acid	Urea
Aqua Regia	Chlorine Water	Glycerine (Glycerol)	Nickel Chloride	Silver Cyanide	Vinegar
Arsenic Acid 80%	Chlorosulfonic Acid	Glycol	Nickel Nitrate	Silver Nitrate	Whiskey
Arylsulfonic Acid	Chrome Alum	Glycolic Acid	Nitric Acid, Anhydrous	Silver Plating Solutions	White Liquor (Paper Industry)
Barium Carbonate	Chromic Acid 10%	Green Liquor (Paper Industry)	Nitric Acid 20%	Sodium Acetate	Wines
Barium Chloride	Chromic Acid 30%	Heptane	Nitric Acid 40%	Sodium Arsenite	Zinc Chloride
Barium Hydroxide	Chromic Acid 40%	Hexanol, Tertiary	Nitric Acid 60%	Sodium Benzoate	Zinc Chromate
Barium Sulfate	Chromic Acid 50%	Hydrobromic Acid 20%	Nitrobenzene	Sodium Bicarbonate	Zinc Cyanide
Barium Sulfide	Citric Acid	Hydrochloric Acid 0% - 25%	Nitrous Oxide	Sodium Bisulfate	Zinc Nitrate
Beet – Sugar Liquor	Copper Chloride	Hydrochloric Acid 25% - 40%	Oils and Fats	Sodium Bisulfite	Zinc Sulfate
Benzene Sulfonic Acid 10%	Copper Cyanide	Hydrocyanic Acid or Hydrogen Cyanide	Oils – Petroleum – (See Type)	Sodium Bromide	
Benzoic Acid	Copper Fluoride	Hydrofluoric Acid 10%	Oleic Acid	Sodium Chlorate	
Bismuth Carbonate	Copper Nitrate	Hydrofluorosilicic Acid	Oxalic Acid	Sodium Chloride	
Black Liquor (Paper Industry)	Copper Sulfate				

Deep-Socket Schedule 40 Utility Elbows with Integral Belled Ends

Non-UL Listed

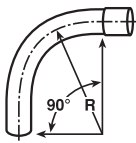
SEGMENT	CAT. NO.	NOM. DIA. (IN.)	RADIUS (IN.)	STD. CTN.	STD. WT. (LBS.)
90° SWEEP 	UC9BHB	1½	12	20	25.00
	UC9DHB	1½	24	1	2.13
	UC9FHB	1½	36	1	3.05
	UC9BJB	2	12	1	1.44
	UC9DJB	2	24	1	2.82
	UC9FJB	2	36	1	4.14
	UC9HJB	2	48	1	5.15
	UC9DKB	2½	24	1	5.00
	UC9FKB	2½	36	1	7.15
	UC9DLB	3	24	1	6.57
	UC9FLB	3	36	1	9.15
	UC9DNB	4	24	1	10.59
	UC9FNB	4	36	1	13.64
	UC9HNB	4	48	1	17.72
	UC9FRB	6	36	1	25.80
	UC9HRB	6	48	1	32.24

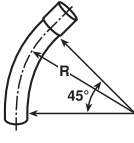
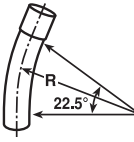
SEGMENT	CAT. NO.	NOM. DIA. (IN.)	RADIUS (IN.)	STD. CTN.	STD. WT. (LBS.)
45° ELBOW 	UC7FHB	1½	36	1	1.74
	UC7FJB	2	36	1	2.07
	UC7CKB	2½	18	1	2.27
	UC7FKB	2½	36	1	4.12
	UC7FLB	3	36	1	5.00
	UC7FNB	4	36	1	8.15
	UC7HNB	4	48	1	9.36
	UC7HRB	6	48	1	17.19
22½° ELBOW 	UC7ITB	8	60	1	33.00
	UC5CKB	2½	18	1	1.45
	UC5FKB	2½	36	1	2.49
	UC5FNB	4	36	1	5.18
	UC5FRB	6	36	1	11.82
	UC5HNB	4	48	1	5.57

Utility Elbow Bells (Dimensions in Inches)

TRADE SIZE	A AT ENTRANCE	B AT BOTTOM	C NOMINAL BELL
1½	1.921 ± .005	1.894 ± .006	2¾ ± ⅛
2	2.400 ± .005	2.369 ± .012	2¾ ± ⅛
2½	2.906 ± .005	2.868 ± .007	3 ± ⅛
3	3.538 ± .005	3.492 ± .008	3 ± ⅛
4	4.544 ± .005	4.491 ± .009	3¾ ± ⅛
5	5.614 ± .005	5.553 ± .010	4¾ ± ⅛
6	6.687 ± .005	6.614 ± .011	5¾ ± ⅛
8	8.687 ± .005	8.636 ± .005	6¾ ± ⅛

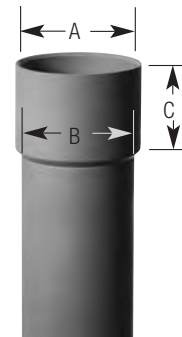



Rigid Non-Metallic Long Belled Utility Conduit

Non-UL Listed

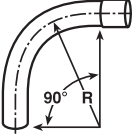
SEGMENT	CAT. NO.	NOM. DIA. (IN.)	RADIUS (IN.)	STD. CTN.	STD. WT. (LBS.)
90° ELBOW 	UC9CJBLB	2	18	1	1.3
	UC9DJBLB	2	24	1	1.4
	UC9DLBLB	3	24	1	5.0
	UC9DNBLB	4	24	1	5.8
	UC9DPBLB	5	24	1	8.5
	UC9FJBLB	2	36	1	2.2
	UC9FLBLB	3	36	1	5.2
	UC9FNBLB	4	36	1	7.8
	UC9FPBLB	5	36	1	11.1
	UC9FRBLB	6	36	1	9.6
	UC9HJBLB	2	48	1	2.8
	UC9HLBLB	3	48	1	12.0
	UC9HNBLB	4	48	1	9.7
	UC9HPBLB	5	48	1	13.7
	UC9HRBLB	6	48	1	18.1

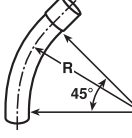
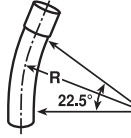
SEGMENT	CAT. NO.	NOM. DIA. (IN.)	RADIUS (IN.)	STD. CTN.	STD. WT. (LBS.)
45° ELBOW 	UC7CJBLB	2	18	1	1.3
	UC7DJBLB	2	24	1	1.4
	UC7DLBLB	3	24	1	5.0
	UC7DNBLB	4	24	1	5.8
	UC7DPBLB	5	24	1	8.5
	UC7FJBLB	2	36	1	2.2
	UC7FLBLB	3	36	1	5.2
	UC7FNBLB	4	36	1	7.8
	UC7FPBLB	5	36	1	11.1
	UC7FRBLB	6	36	1	9.6
	UC7HJBLB	2	48	1	2.8
	UC7HLBLB	3	48	1	6.6
UC7HNBLB	4	48	1	9.7	
UC7HPBLB	5	48	1	13.7	
UC7HRBLB	6	48	1	18.1	
22½° ELBOW 	UC5FRBLB	6	36	1	9.6

Long Belled Utility Elbow Bells (Dimensions in Inches)

TRADE SIZE	A AT ENTRANCE	B AT BOTTOM	C NOMINAL BELL
1½	1.918 ± .006	1.894 ± .006	2¼ ± ⅛
2	2.393 ± .006	2.369 ± .012	3¼ ± ⅛
2½	2.890 ± .007	2.868 ± .007	3¾ ± ⅛
3	3.515 ± .008	3.492 ± .008	4 ± ⅛
4	4.515 ± .009	4.491 ± .009	4¾ ± ⅛
5	5.593 ± .010	5.553 ± .010	5¾ ± ⅛
6	6.658 ± .011	6.614 ± .011	6¾ ± ⅛

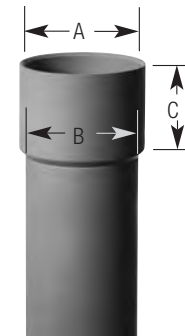

Carlton® Non-Metallic Rigid Conduit, Fittings and Accessories