

POWER-STRUT® Engineering Catalog

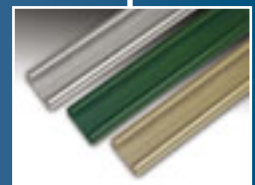

- Channels, Fittings, & Accessories
- Electrical Raceway Components
- Concrete Inserts
- Cush-A-Clamps®
- Power-Angles™
- Aickinstrut® Family of Fiberglass Channel & Accessories

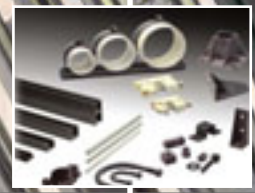

The Power to Build!

The present line of Power-Strut continuous slot metal framing is the result of over one half century of experience in metal framing.

This complete line includes channels, fittings and accessories for any framing or support solution... large or small, heavy or light.

Power-Strut is proud of the exacting standards of research, design, engineering and manufacturing that go into production of the Power-Strut system.

Maximum recommended load ratings for channels have been established through testing and are based on allowable stresses applicable to the Power-Strut Material Specification. Electrical Power-Strut products are listed by the Underwriters' Laboratories, Inc. (U.L.) and certified by the Canadian Standards Association (CSA.)

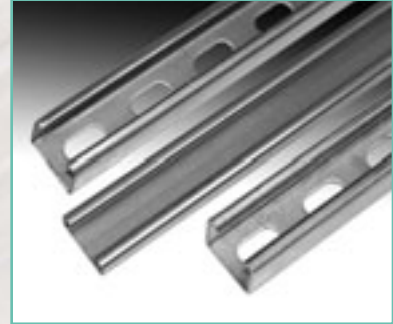

The Power-Strut Connection, Easy as 1 - 2 - 3...

1. Insert the clamping nut anywhere along the continuous slot channel. A 90° clockwise turn positions the grooves and teeth in the nut with the inserted edges of the channel.



2. The Power-Strut fitting provides the connection of channels.



3. Tighten the bolt(s) to secure the connection.



General Information

Product Overview	4-5
Example Applications	6-7
Finishes	8-9
Material Specifications	10
PowerStrut Profile Index	11-16
Aickinstrut Profile Index	16-18

PowerStrut Metal Channel

Overview	19
Pull-Out & Slip Loads	20
Product Profiles	20-21
PS 100 Channel	22-23
PS 150 Channel	24-25
PS 200 Channel	26-29
PS 210 Channel	30-31
PS 300 Channel	32-33
PS 400 Channel	34-35
PS 500 Channel	36-37
PS 520 Channel	38-39
PS 560 Channel	40-41
Accessories	42
Lateral Bracing	42

Fasteners

Overview & Product Usage Chart	43-44
Fasteners	45-48

Fittings

Overview	49
General Fittings	50-59
Wing Connectors	60-61
Post Bases	61-62
Trolleys	62
Brackets & Supports	62-65
Beam & "C" Clamps	65-68

Pipe & Conduit Clamps

Overview	69
Clamps	70-76
Pipe Rollers	77-78

Electrical

Overview	79
Channel Raceway	80
Example Applications	81-83
Electrical Fittings, Boxes, & Accessories	84-90

Concrete Inserts

Overview	91
Products	92-94

Junior Channel

Overview	95
PS 600J Channel	96
PS 700J Channel	97
Accessories	96-98

Power-Angle

Overview	99
Products	100
Loads, & Configurations	101-104

Aickinstrut - Non-metallic Fiberglass Channel & Accessories

Overview	105
Aickinstrut Specifications	106-107
Chemical Compatibility Table	108-109
General Information	110
Channel Profiles & Product Loading	111-113
Fittings	114-116
Pipe Clamps & Capping	117-120
Fasteners	120-122
Pipe Hangers, Accessories, & Supports	123-125
Post Bases	126

Aickinshape - Non-metallic Fiberglass Structural Shapes

Overview	127
Products	127-130
Sealers, Coatings & Promotional Materials	131

Aickingrate - Non-metallic Fiberglass Molded Grating

Overview	132
Specifications, Products & Loading	133-134

Aickingrate - Non-metallic Fiberglass Pultruded Grating

Overview	135
Specifications	135
"I" Bar Products	136-137
"T" Bar Products	138-139
Aickingrate Part Numbers	140
Stair Treads	141
Aickinplate, Accessories	142-143
Fiberglass Corrosion-Resistance Guide Table	144

Technical Data

Formulas	146-147
Beam Loads	148
Fitting Loads	149
Pipe Spacing	150-151
Channel & Trap Members	152
Tubing, Conduit, & Pipe Data	153-158
Flanges, Channels & I Beams	159-160
Conversion Table	161
Part Number Index	162-170

WARNING: Power-Strut products are carefully designed and manufactured to the listed standards, as applicable. However, Power-Strut reserves the right to revise product design without notification. Power-Strut products included in this catalog are intended for installation and service only as described or specified herein. Care should be exercised by installers and end-users to install, use and maintain these products properly to avoid any possible on-the-job accidents.

A Broad and Versatile Metal Framing Line Backed



More Than 8,000 Quality Products

The Power-Strut metal framing system can be regarded as a basic building material. Our metal framing system is an erector set concept, using channel and fittings to solve many applications. You can conceal metal framing in the basic structure of a building or run it along the surface of walls, ceilings and floors. An endless array of fittings provide freedom to work at virtually any angle along any surface to shape a support system that fits your exact needs.

Available finishes include hot-dipped galvanized, pregalvanized, electro-galvanized and painted, along with material choices of steel, stainless steel and aluminum.

Beyond its versatility as a basic building material, metal framing is popular for more exotic applications such as clean rooms, satellite dish supports, x-ray supports, storage racks, theater screens, tunnel stanchions and offshore platform catwalks. While the uses of metal framing are truly unlimited, they fall into three major categories.



Electrical Systems

Versatile metal framing is widely used by electrical contractors to support conduit, panel boxes, raceway systems and other electrical components. In addition, Power-Strut channel can be used as a wiring raceway. Products marked with the UL symbol in this catalog are listed by Underwriter's Laboratories for use in raceway applications.

Channel raceways or support systems can be attached to ceilings, wood or steel beams, inside columns or imbedded in concrete. Trapeze systems can support conduit from either the top or bottom.

As a lighting support system, metal framing helps assure proper alignment over long spans. As a raceway system, channel offers an opportunity to reduce construction costs through more efficient use of installation labor. The exceptional versatility of channel gives contractors more flexibility in solving miscellaneous problems which may arise at the job site.

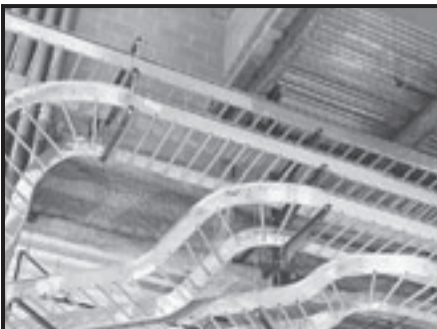

by a Leading Reputation for Quality and Service.



Mechanical Systems That Reduce Costs

For mechanical support of HVAC, plumbing and fire protection systems, the versatility of metal framing systems is unmatched. It is by far the most popular framing system with contractors because the wide variety of fittings and support devices available help solve virtually any support problem without expensive welding.

Piping stanchions, ceiling and wall-mounted supports and tunnel supports are common metal framing applications. Concrete insert, shelf bracket, wall and ceiling-mounted systems provide flexible solutions to any piping support applications.

In addition, pipe support products such as Power-Wrap and cushioned clamps provide insulation to prevent potential damage from noise, vibration, temperature variations and metal-to-metal contact.

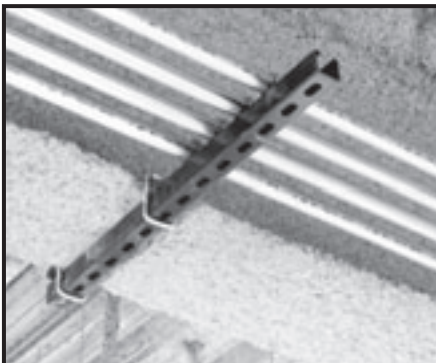

OEM Components and Maintenance

Metal Framing systems provide convenient solutions for maintenance and retrofit requirements in processing and manufacturing facilities. Also, Power-Strut products can be used as cost-effective components in OEM applications. For example, channel can be used as conveyor stands and side rails or provide framing for panel cabinetry products, or for generator, motor and pump supports.

The complete line of products and leading reputation for quality and service make Power-Strut your practical choice for metal framing. Contact your local Power-Strut representative for additional information.



Overhead Support Vertical to Horizontal

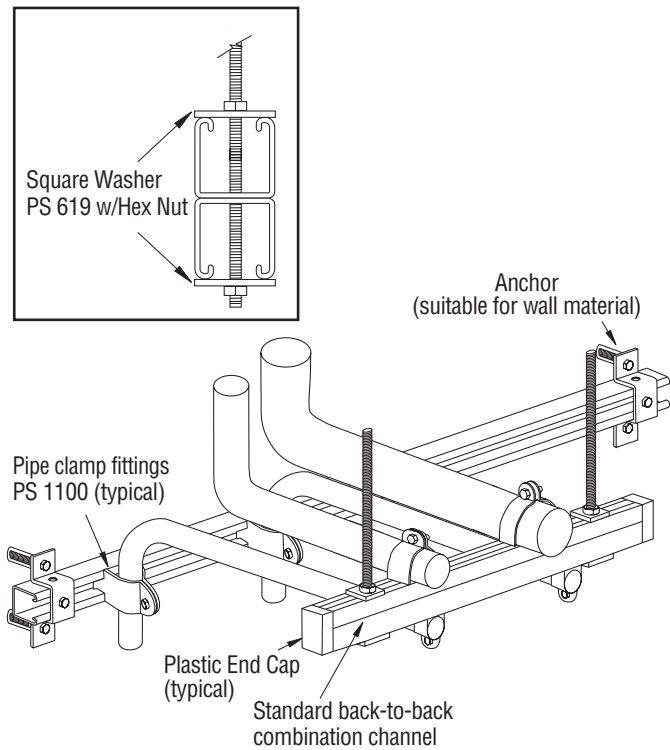

Wall Mount Organize & Control MultiShelf or Utility Support

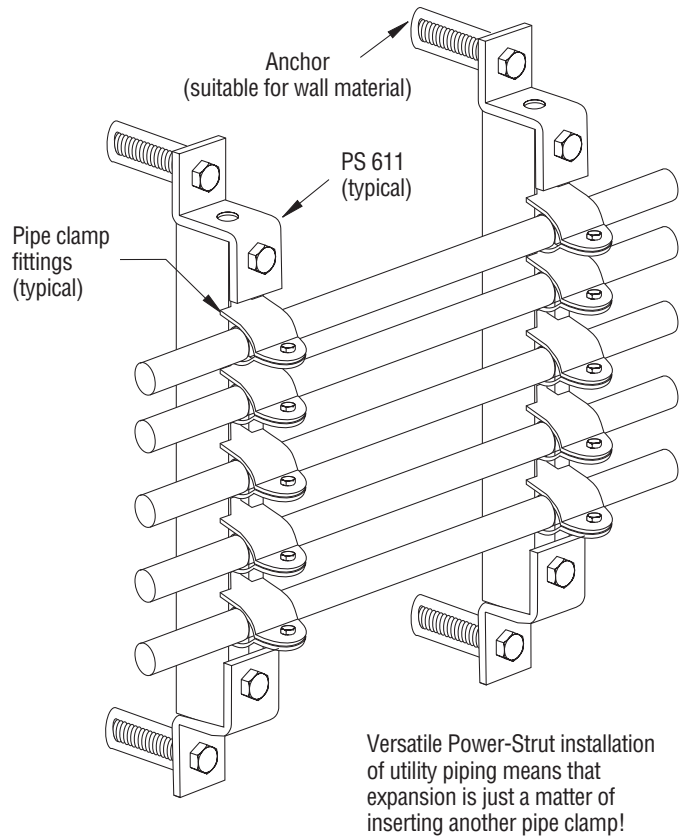

Overhead Multi-Use Support Systems Using Channel Attached to "I" Beams

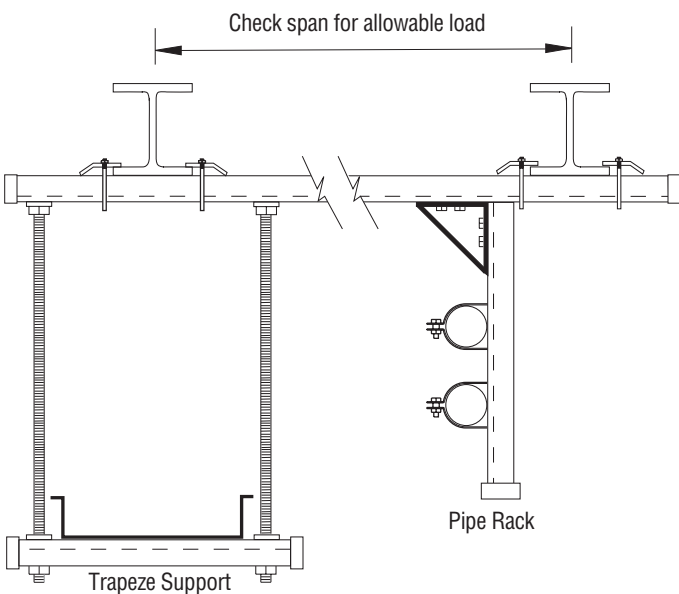

Wall Mounted Brackets

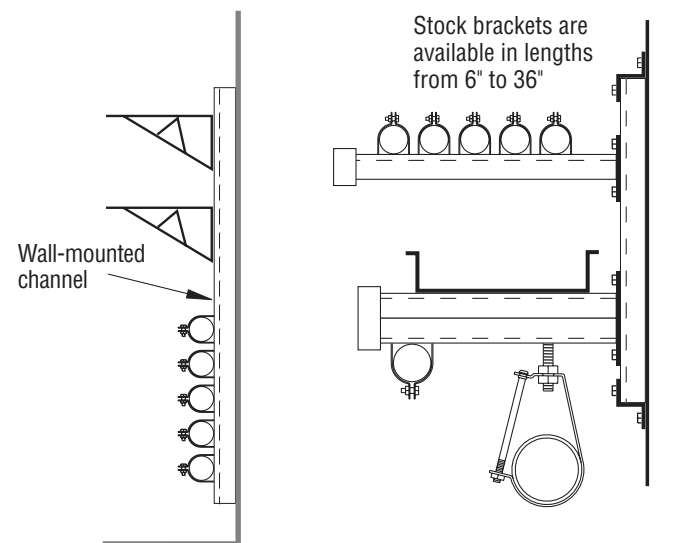

Standard Channel and Fitting Assembly

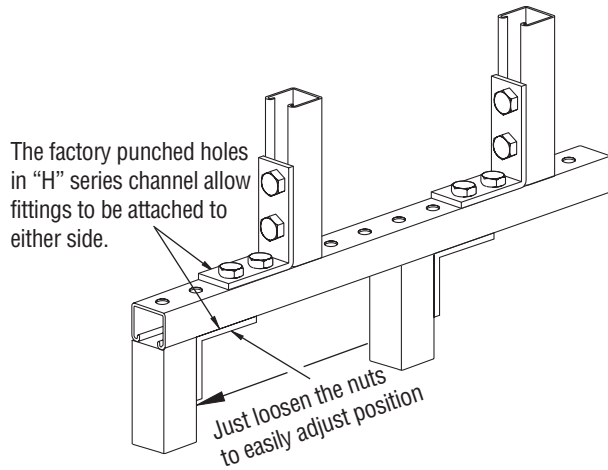

Supports for Threaded Rod Attachments Between Beams

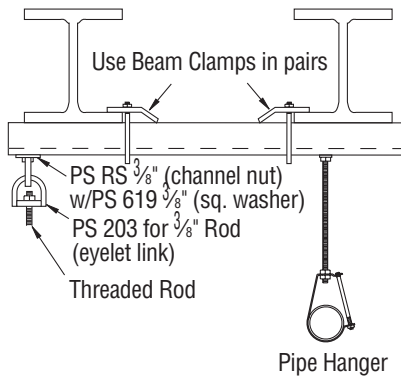

Select channel size based on load requirements

Supports for Threaded Rod Attachments to Single Beams

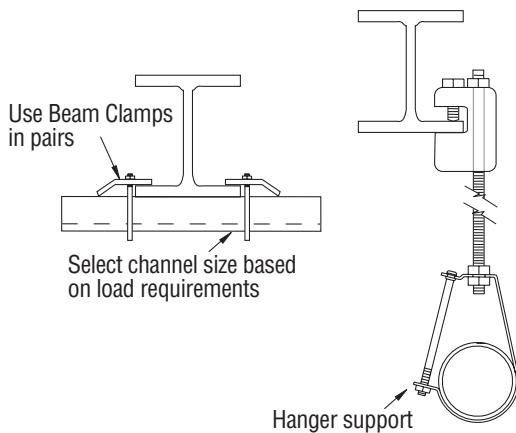

Trapeze Support System

Power-Strut metal framing is ideal for electrical and mechanical pipe support applications.

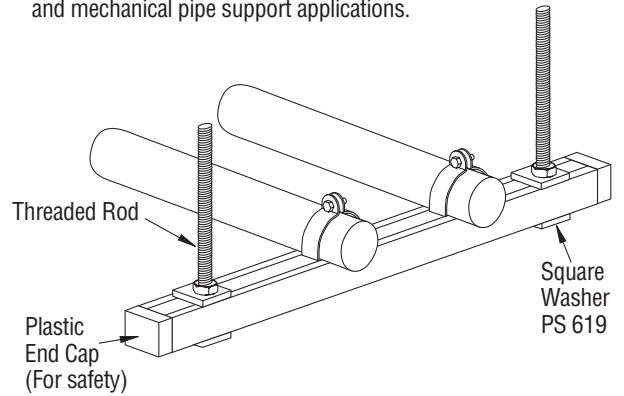

Acceptable Methods to Hang Channels

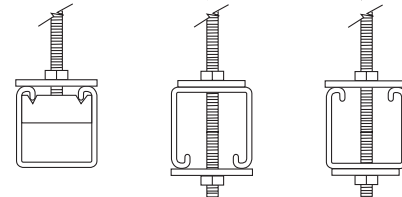

Pre-slotted channel allow through channel connections

Ganged Pipe Support

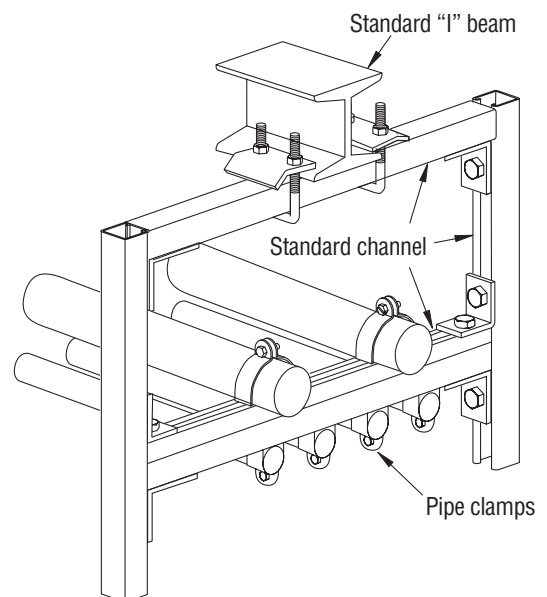

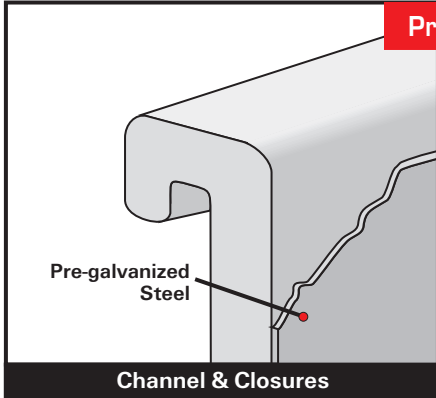

Pregalvanized (PG)

Material (steel strip) is coated with zinc by hot-dip process prior to roll-forming or press operations.

The zinc coating conforms to ASTM A653, Grade 90 General Requirement for Steel Sheet, Zinc-Coated (Galvanized) by Hot Dip Process.

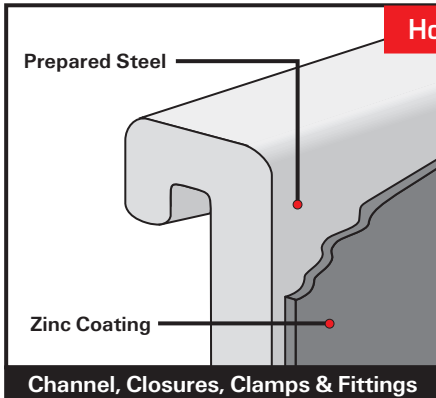

Hot-Dipped Galvanized (HG)

Material is coated with zinc after being roll-formed or after all manufacturing operations are completed, conforming to ASTM specification No. A123 or A153.

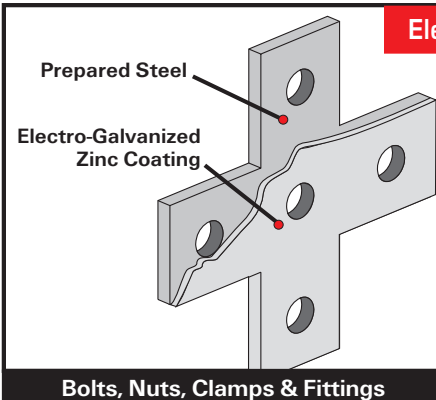

Electro-Galvanized (EG)

Fittings and hardware are electrolytically coated with zinc to commercial standards (ASTM-B633 Type III C1).

SC1 (mild) has a Zinc coating of 0.2 and is recommended for dry indoor use. SC1 is the standard finish thickness.

SC3 (Severe) has a Zinc coating of 0.5 mill and is the standard finish thickness only on UL Listed raceway products.

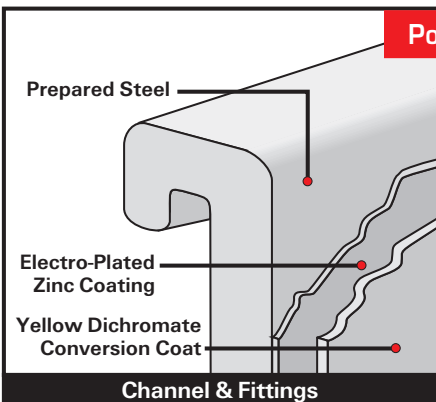

Power-Gold (ZD)

A Electro-galvanized zinc plate is applied with a cohesive molecular bond to the steel base metal, in compliance with the ASTM B633 standard. Yellow Dichromate is applied over the zinc and results in a gold appearance which acts as a nonporous barrier sealant.

SC1 (mild) has a Zinc coating of 0.2 and is recommended for dry indoor use. SC1 is the standard finish thickness

SC3 (Severe) has a Zinc coating of 0.5 mill and is the standard finish thickness only on UL Listed raceway products.

ZINC COATING

Power-Strut products are available in four types of zinc coatings:

- Electroplated (EG)
- Pregalvanized (PG)
- Hot-Dipped Galvanized (HG)
- Yellow Dichromate (ZD)

Zinc coatings offer two types of protection:

1. **Barrier:** The zinc coating protects the steel substrate from direct contact with the environment.
2. **Sacrificial:** The zinc coating will protect scratches, cut edges, etc. through an anodic sacrificial process.

The service life of zinc coating is directly related to the zinc coating thickness as shown below.

COMPARISON OF ZINC GALVANIZED FINISHES

Finish	Zinc Thickness
Hot-Dipped Galvanized	2.6 MIL
Pregalvanized	0.75 MIL
Electro-Galvanized (SC1)	0.2 MIL
Electro-Galvanized (SC3)	0.5 MIL
Power-Gold (SC1)	0.2 MIL
Power-Gold (SC3)	0.5 MIL

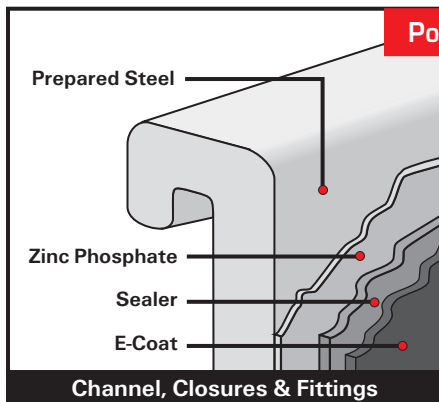

Power-Green® (GR)

Channel and parts are cleaned and phosphated. Immediately afterward, a uniform coat of rust-inhibiting thermoset epoxy paint is applied by cathodic electro-deposition and thoroughly baked.

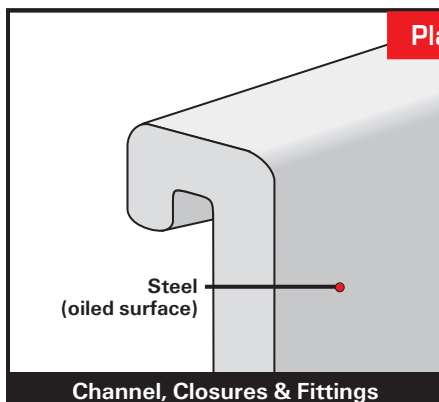

Plain (PL)

Plain finish designation means that the channel retains the oiled surface applied to the raw steel during the rolling process. The fittings have the original oiled surface of the bar-stock material.

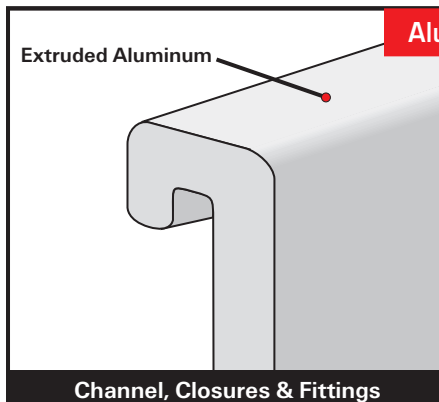

Aluminum (AL)

Channel is extruded aluminum in accordance with ASTM B221 Type 6063-T6.

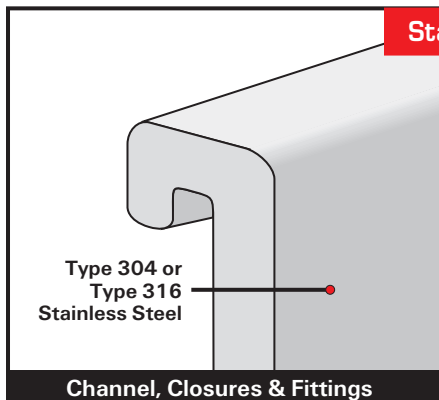

Stainless Steel (SS)

Material in accordance with ASTM A240 (Type 304 or type 316).

POWER-GREEN® TECHNICAL DATA

STEEL SUBSTRATE PREPARATION

Eight stage continuous cleaning, rinse, zinc phosphate conversion coating and sealer.

COATING

Thermoset epoxy

Color: Federal Highway Green
Color Tolerance Chart
PR Color No. 4.

Hardness: 2H+

Coating Process: Cathodic
Electrodeposition.

PERFORMANCE

Salt Spray:

Scribed: exceeds 400 hrs per
ASTM B117. (1/8 Creep)

Unscribed: exceeds 600 hours per
ASTM B117. (6% Red Rust)

ENVIRONMENTAL ISSUES

Formulated as a "heavy metal"- free coating (trace elements only).

Outgassing in service: essentially none at 350°F for 24 hrs.

Finishes (Ordering):

When ordering, add the finish to the part number.

Examples: PS 200-10 PG
PS 200-10 ZD
PS 200-10 GR
PS 200-10 HG

Materials:

Channel* & Closures – Pregalvanized

ASTM A653 Grade 33, Steel Sheet Zinc Coated by Hot Dip Process

Channel* – Plain, Painted or Hot Dip Galvanized

ASTM A-1011 Grade 33, Hot Rolled Carbon Steel Sheet and Strip, Structural Quality

Channel* – Stainless Steel

ASTM A-240, Type 304, Heat Resisting Chromium and Chromium-Nickel Stainless Steel Plate, Sheet, Strip for Pressure Vessel

Channel* – Aluminum

ASTM B-221, Type 6063 T6, Aluminum Alloy Extruded Bar, Rod, Wire, Shape and Tube

Closures – Plain, Painted or Hot Dip Galvanized

ASTM A1008, Steel, Strip, Carbon, Cold-Rolled

Fittings* – Steel

1/4" Nominal Thickness – ASTM A-575 and A576†
3/8" Nominal Thickness – A36 (Structural Steel)

Fittings* – Aluminum

ASTM B-209

Accessories – Steel

Less than 1/4" Nominal Thickness – ASTM A-569, 1008-1010 Grade, or (when Pre-Galvanized) ASTM A-527/Coating Designation G90

Pipe Clamps – Steel

A-1011SS Grade 33

Pipe Clamps – Stainless Steel

ASTM A-240, Type 304

Pipe Clamps – Aluminum

ASTM B-209, 5052, H32 Grade, Sheet and Plate

Channel Nuts

ASTM (3/8" & 1/2") A-576 Grade 1015M, A-675 (1/4") Grade 60, Case Hardened to RC25 min.

Hex Nuts and Bolts

ASTM A-563, Grade A and ASTM A-307, Grade A

Threaded

Low Carbon Steel
Yield = 32 ksi min.
Tensile = 52 ksi min

* Channel referenced is 1 5/8" wide, fittings referenced are for 1 5/8" channel.

† Some 1/4" fittings are produced from A-36 Structural Steel.

Product Load Testing

Product testing is an important Part of Power-Strut's Quality Assurance Program. We utilize our own testing facilities, as well as those of independent testing laboratories, to determine design loads with proper and adequate safety factors. These design loads are indicated, where applicable, throughout the catalog. Loads are based on AISI Specification For The Design Of Cold-Formed Steel Structural Members, 2001 Edition.











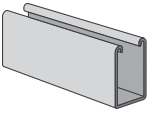
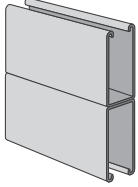
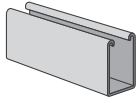
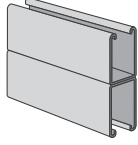
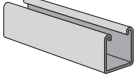
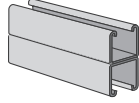
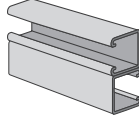
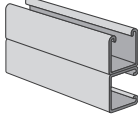
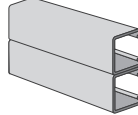
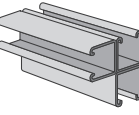
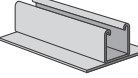
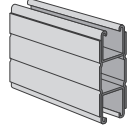
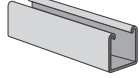
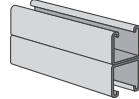
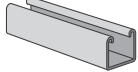
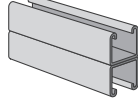
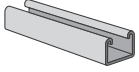
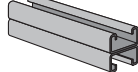
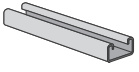
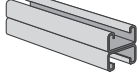
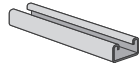
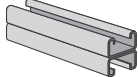
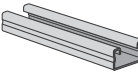
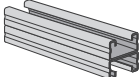
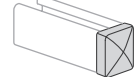
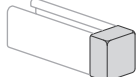
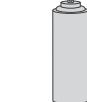







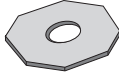

Destructive and non-destructive testing procedures are used to test for variables such as corrosion, conductivity, electro-static dissipation, ultra-violet resistance, wind resistance, dimensional accuracy, material integrity and slip resistance.

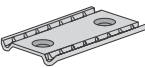
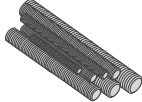
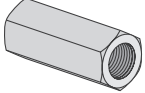
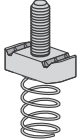
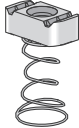
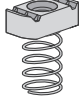
In short, if there's a specification to meet, Power-Strut will develop a test to quantify and verify it. Using design properties of the Power-Strut framing members, load data given in this catalog, and/or design procedures of the American Iron & Steel Institute Specification For The Design Of Cold-Formed Steel Structural Members, 2001 Edition, it is possible to design any type of structure within the capabilities of the system.

Assemblies or connections that cannot be calculated using provisions of the AISI specifications must be established by application-specific tests.



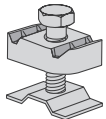
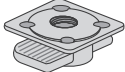

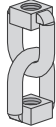
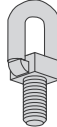
We reserve the right to make specification changes without notice.

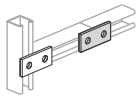
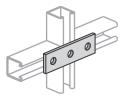
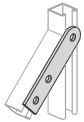
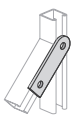
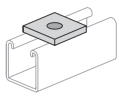
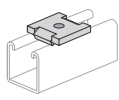
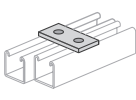
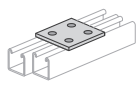
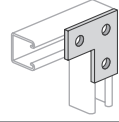
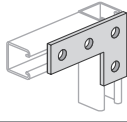
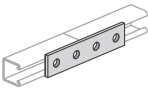
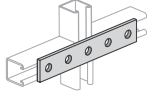
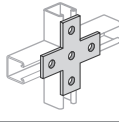
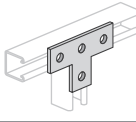
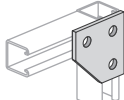
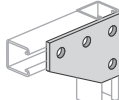
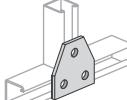
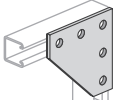
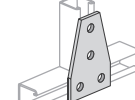
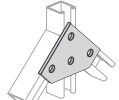
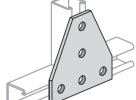
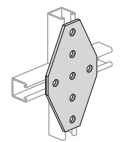
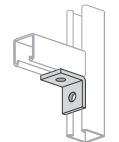
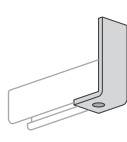

While every effort has been made to assure the accuracy of information contained in this catalog at the time of publication, we cannot accept responsibility for inaccuracies resulting from undetected errors or omissions.

Channel						
						
PS 100 22	PS 100 2T3 22	PS 150 24	PS 150 2T3 24	PS 200 26	PS 200 2T3 26	PS 200 2T2 28
						
PS 200 2T4 28	PS 200 2T5 28	PS 200 3T6 28	PS 200 PLA 29	PS 200 PLC 29	PS 210 30	PS 210 2T3 30
						
PS 300 32	PS 300 2T3 32	PS 400 34	PS 400 2T3 34	PS 500 36	PS 500 2T3 36	PS 520 38
						
PS 520 2T3 38	PS 560 40	PS 560 2T3 40	PS 6152 42	PS 6153 42	PS 9050 42	
Fasteners						
						
PS 6024 45	PS 6072 45	PS 6075 45	PS 6064 45	PS 6108 45	PS 6112 45	PS 83 45
						
PS 209 45	PS 230 46	PS 231 46	PS 211 46	PS 3281 46	PS 146 46	PS 135 46
						
PS 517 46	PS LS 47	PS RS 47	PS SS 47	PS NS 47	PS NS S 47	PS TG 47
						
PS ML 47	PS 3500 48	PS KW 48	PS 202 48	PS 203 48	PS 204 48	PS 205 48

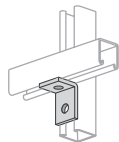
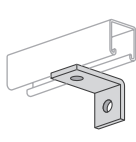
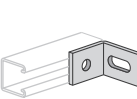
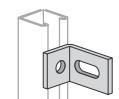
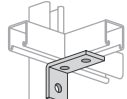
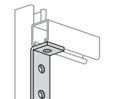
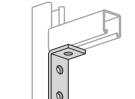
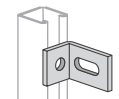
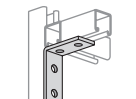
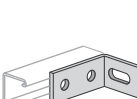
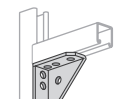
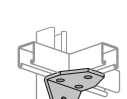
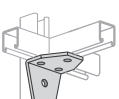
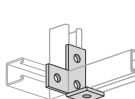
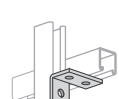
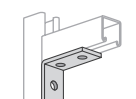
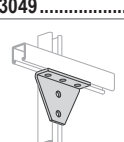
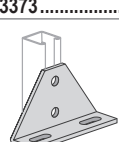
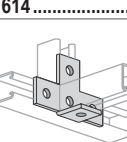
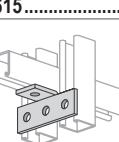
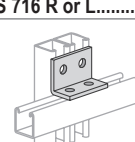
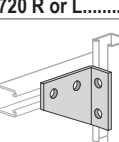
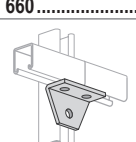
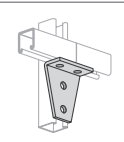
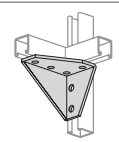
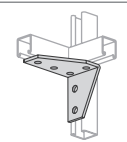
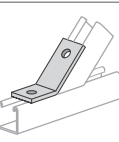
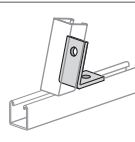
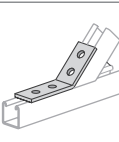
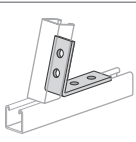
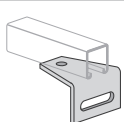
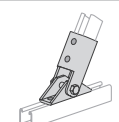
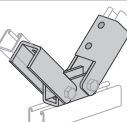
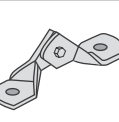
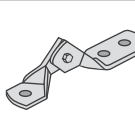
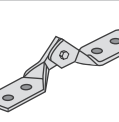
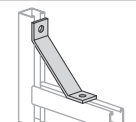
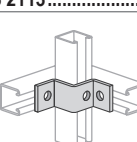
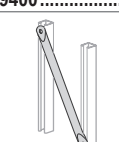
PICTORIAL TABLE OF CONTENTS

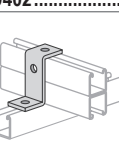
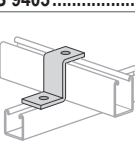
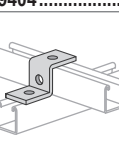
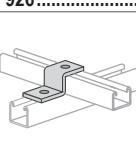
General Fittings

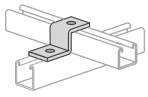
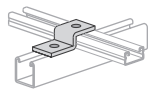
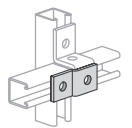
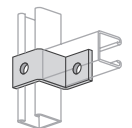
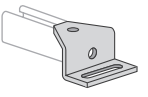
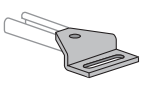
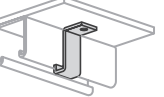
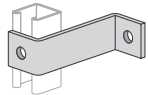
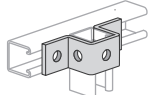
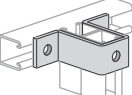
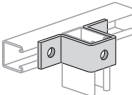
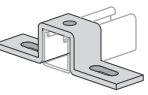
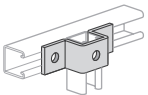
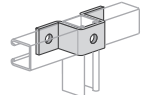
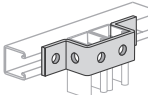
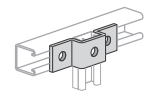
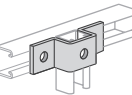
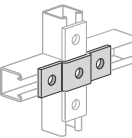
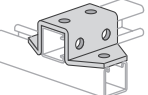
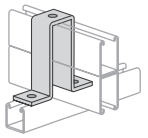
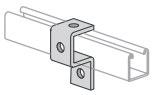
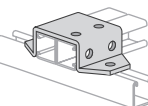
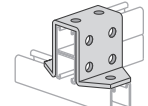
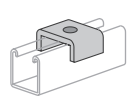
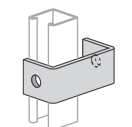
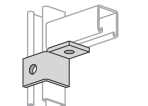
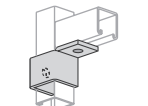
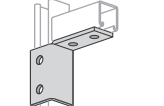
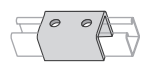
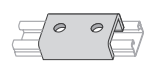
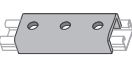
						
PS 601 50	PS 602 50	PS 617 50	PS 618 50	PS 619 50	PS 2504 50	PS 620 51
						
PS 621 51	PS 718 50	PS 719 50	PS 888 50	PS 889 50	PS 712 51	PS 714 51
						
PS 744 51	PS 750 51	PS 925 51	PS 2190 51	PS 747 51	PS 822 51	PS 854 51
						
PS 2112 51	PS 603 52	PS 921 52	PS 763 52	PS 764 52	PS 604 52	PS 2144 52
						
PS 806 52	PS 2520 52	PS 605 52	PS 606 53	PS 745 53	PS 2545 52	PS 607 53
						
PS 3049 53	PS 3373 53	PS 614 53	PS 615 53	PS 716 R or L 53	PS 720 R or L 53	PS 660 53
						
PS 927 54	PS 689 A & B 54	PS 713 53	PS 715 53	PS 622 54	PS 752 R or L 54	PS 746 54
						
PS 748 54	PS 3326 R or L 54	PS 2007 R or L 54	PS 633 55	PS 624 54	PS 781 55	PS 793 55
						
PS 2113 54	PS 9400 55	PS 9401 55	PS 9402 55	PS 9403 56	PS 9404 56	PS 926 54
						
PS 2054 55	PS 810 55	PS 812 56	PS 756 57	PS 2601 57	PS 611 57	PS 612 57

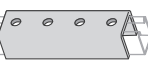
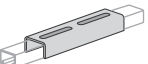
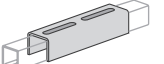
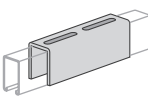
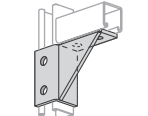
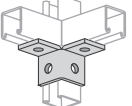
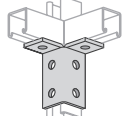
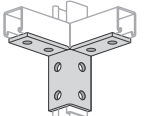
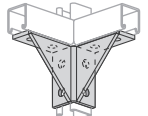
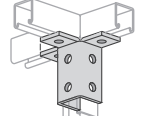
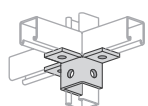
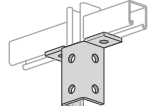
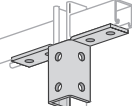
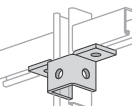
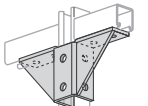
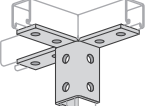
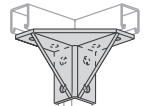
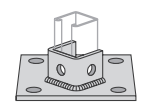
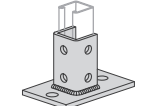
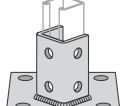
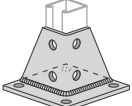
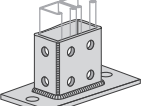
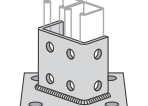
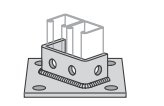
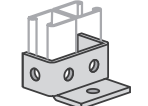
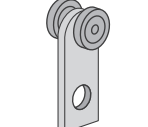
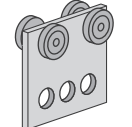
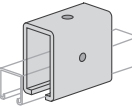
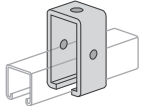
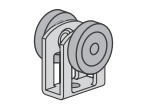
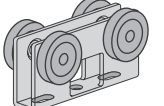
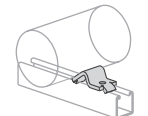
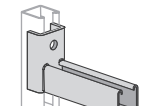
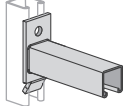
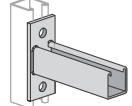
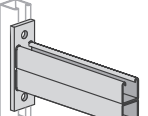
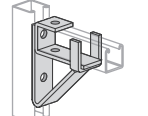
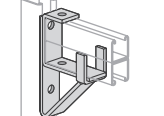
General Fittings (cont.)						
						
PS 711 57	PS 928 57	PS 609 57	PS 647 56	PS 692 56	PS 2523 56	PS 2532 56
						
PS 3060 56	PS 613 57	PS 679 57	PS 2648 57	PS 687A, B & C 58	PS 710 57	PS 2119 57
						
PS 721 58	PS 929 58	PS 978 58	PS 709 58	PS 733 58	PS 678 58	PS 677 58
						
PS 734 58	PS 735 58	PS 623 58	PS 993 59	PS 922 R or L 59	PS 2117 R or L 59	PS 2128 R or L 60
						
PS 631 59	PS 644 59	PS 645 59	PS 629 59	PS 616, PS 646 59	PS 804 59	PS 704 59
						
PS 1004 59	PS 2129 R or L 60	PS 665 60	PS 666 60	PS 667 60	PS 943 60	PS 670 61
						
PS 668 60	PS 821 60	PS 913 60	PS 923 60	PS 945 60	PS 669 61	PS 2514 60
						
PS 3013 & SQ 61	PS 3025 & FL 61	PS 3033 & SQ 61	PS 3040 61	PS 2064 61	PS 3064 62	PS 3029 62
						
PS 3041 61	PS 2521 62	PS 2522 62	PS 2528 1 62	PS 2528 62	PS 2524 62	PS 2525 62
						
PS 626 63	PS 661 T1 & T2 63	PS 808 T1 & T2 63	PS 651 63	PS 809 63	PS 708 63	PS 3164 64

PICTORIAL TABLE OF CONTENTS











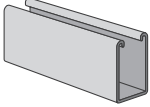
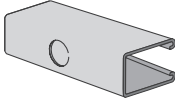



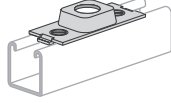
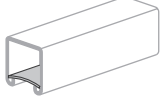

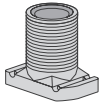
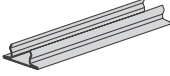
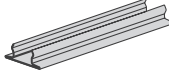
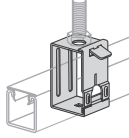
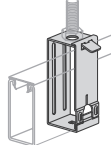
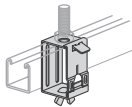
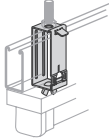

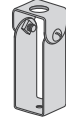
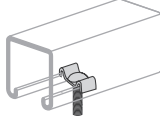
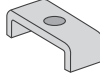
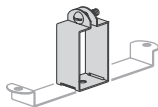
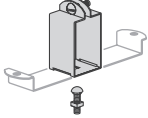
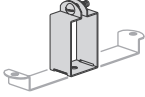
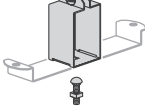
General Fittings (cont.)

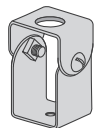
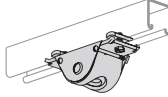
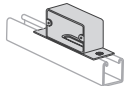
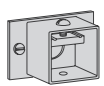
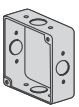
PS 732..... 63	PS 838 R or L..... 64	PS 3282..... 64	PS 825 R or L..... 4	PS 826..... 64	PS 2404 thru PS 2408..... 64	PS 2422..... 64
PS 2421..... 65	PS 855..... 65	PS 2651..... 65	PS 2657..... 65	PS 2656..... 65	PS 685..... 65	PS 686..... 66
PS 2653..... 66	PS 907, PS 998..... 66	PS 916..... 66	PS 684..... 66	PS 2622..... 66	PS 736..... 66	PS 2623..... 67
PS 3201..... 67	PS 2624..... 65	PS 871..... 67	PS 858..... 67	PS 865..... 67	PS 2654 & A..... 68	PS 2626..... 68
PS 135X..... 67	PS 85..... 67	PS 95..... 68	PS 86..... 68	PS 93..... 68	PS 94..... 68	

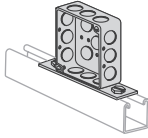
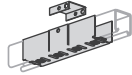
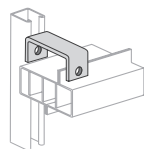
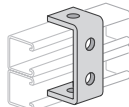
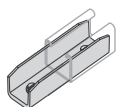
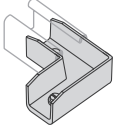
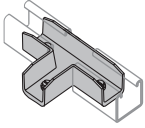
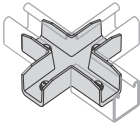
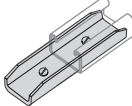
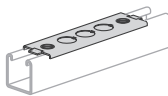
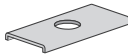
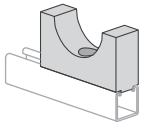
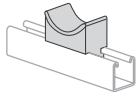
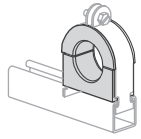
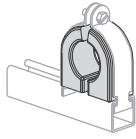
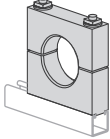
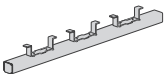
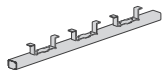
Pipe & Conduit Clamps

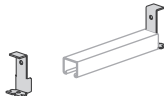
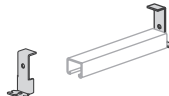
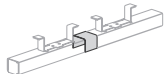
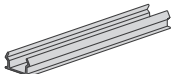
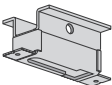

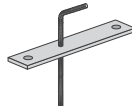
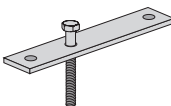







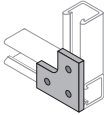
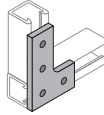
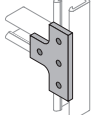
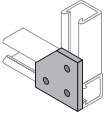
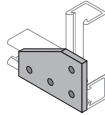
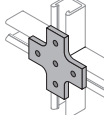
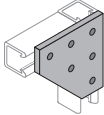
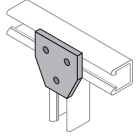
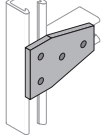
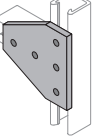
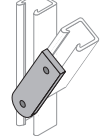
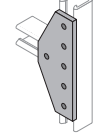
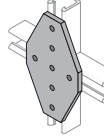
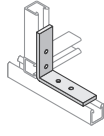
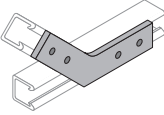
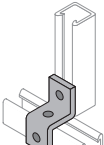
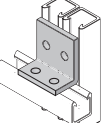
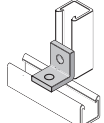
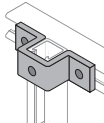
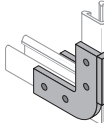
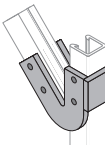
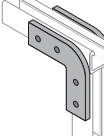
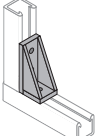
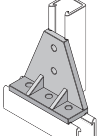
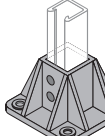
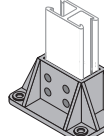
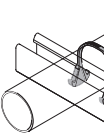

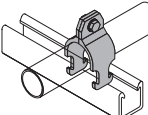
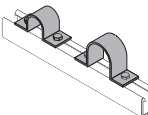
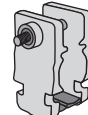
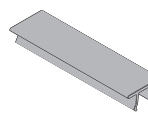

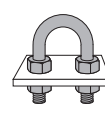
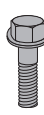
PS 1000..... 70	PS 1100 Series..... 70	PS 1300..... 70	PS 1200..... 71	PS 3138..... 72	PS 3126..... 72	PS 1450..... 72
PS 3792..... 75	PS 67..... 70	PS 69..... 71	PS 137..... 71	PS 51..... 72	PS 004T..... 74	PS UB..... 76
PS 004M..... 75	PS 270..... 72	PS 52E..... 75	PS MU..... 76	PS TP..... 73	PS CT..... 73	PS 1901..... 77
PS 815..... 77	PS 1911..... 77	PS 816..... 77	PS 1902..... 78	PS PP..... 78		

Electrical						
						
Solid Raceway 80	Knock-Out Raceway 80	Application Example 81-83	PS 655 Series 84	PS 2511, PS 2581 84	PS 2560, PS 2561 84	PS 2640 84
						
PS 803 84	PS 2625 84	PS 707 84	PS 707 & P 84	PS 2632 85	PS 2632D 85	PS 2631 85
						
PS 2631D 85	PS 3301 85	PS 807 85	PS 2636 86	PS 2637 86	PS 702 86	PS 703 86
						
PS 702 D 86	PS 703 D 86	PS 659 86	PS 658 86	PS 2621 87	PS 2639 87	PS 2662 87
						
PS 2660 87	PS 2661 87	PS 2094 87	PS 649 Series 88	PS 760 88	PS 671 88	PS 2800 88
						
PS 2802 88	PS 2801 88	PS 2803 88	PS 2700 88	PS 791 89	PS 2627 89	PS 1510 89
						
PS 1500 89	PS 722 90	PS 1610 90	PS 1801 89			
Concrete Inserts						
						
PS 349 92	PS 449 93	PS 656, PS 901 93	PS 653 92	PS 654 92	PS 1154 94	PS 6151 93
						
PS 285 94	PS 285 N 94	PS 152 94	PS 680 94	PS 3700 94		

PICTORIAL TABLE OF CONTENTS

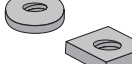

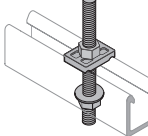
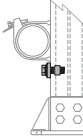
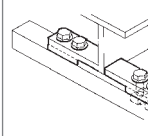
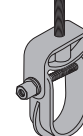
Junior Channel						
PS 600J..... 96	PS 700J..... 97	PS 3017..... 96	PS 4017..... 96	PS 2013..... 97	PS 2014..... 97	PS 2015..... 97
PS 2016..... 97	PS 2033..... 97	PS 2034..... 97	PS 2008..... 98	PS 2017..... 98	PS 2018..... 98	PS 2025..... 98
PS 2037..... 98	PS 2019..... 98	PS 2024..... 98	PS 2023 R or L..... 98	PS 2010..... 98	PS 2026..... 98	PS 2011..... 98
PS 2029..... 96	PS 2041..... 98					
Power-Angle®						
PA 158..... 100	PA 238..... 100	PA 318..... 100	PA 1SC, PA 1RC... 100	PA 1GP..... 100	PA 1SNB..... 100	PA 1RP..... 100
Fiberglass Aickin strut®						
20P-2000, 20V-2000 & 20E-2000..... 111	20P-2200, 20V-2200 & 20E-2200..... 111	20P-2300, 20V-2300 & 20E-2300..... 111	20P-2100, 20V-2100..... 111	20P-1500, 20V-1500..... 111	20P-1700, 20V-1700..... 111	20P-1800, 20V-1800..... 111
20P-1600, 20V-1600..... 111	20P-1000, 20V-1000, 20E-1000..... 111	20P-1200, 20V-1200, 20E-1200..... 111	20P-1300, 20V-1300, 20E-1300..... 111	20P-1100, 20V-1100..... 111	20P-2000-SST, 20V-2000-SST..... 111	20P-2200-SST, 20V-2200-SST..... 111
20P-2300-SST, 20V-2300-SST..... 111	20P-2100-SST, 20V-2100-SST..... 111	20P/V-2500, 20P/V-2800..... 114	20P/V-2502, 20P/V-2802..... 114	20P/V-2504, 20P/V-2804..... 114	20P/V-2506, 20P/V-2806..... 114	50PU-2616..... 114

Fiberglass Aickinstrut® (cont.)						
						
20P/V-2508, 20P/V-2808..... 114	20P/V-2510, 20P/V-2810R, 20P/V-2810L..... 114	20P/V-2512, 20P/V-212..... 114	20P/V-2514, 20P/V-2814..... 114	20P/V-2516, 20P/V-2816R, 20P/V-2816L..... 115	20P/V-2518, 20P/V-2818..... 115	20P/V-2520, 20P/V-2820..... 115
						
20P/V-2522, 20P/V-2822..... 115	20P/V-2524, 20P/V-2824..... 115	20P/V-2526, 20P/V-2826..... 115	20P/V-2528, 20P/V-2828..... 115	20P/V-2530, 20P/V-2830..... 115	20P/V-2534, 20P/V-2834..... 115	20P-2541, 20V-2541..... 115
						
20P/V-2540, 20P/V-2840..... 115	50PU-2611..... 115	20P-2542, 20V-2542..... 116	50PU-2611-SP..... 116	50PU-2613..... 116	50PU-1508, 50PU-2008..... 116	50PU-2045..... 116
						
50PU-2090..... 116	50PU-2636, 50PU- 2636A, 50PU-3636B, 50PU-2936..... 116	50PU-2538..... 116	20PU-5853, 20PU- 5854, 20PU-5855, 20 PP-5853, 20PP- 5854, 20PP-5855... 116	20PU-5903, 20PU- 5904, 20PU-5905, 20PU-5903, 20PP- 5904, 20PP-5905... 116	Adjustable Pipe Clamp..... 117	50PU-500SP..... 117
						
Rigid Pipe Clamps..... 118	Two-Hole Pipe Straps..... 118	Aickin-A-Grip..... 119	20E-5000..... 119	AIC-EC..... 119	Nonmetallic U-Bolts..... 120	Hex Flange Bolts.. 120
						
Hex Bolts..... 120	Vinyl Ester Square Head Bolts..... 121	Hex Nuts..... 121	Hex Flange Nuts... 121	Vinyl Ester Square Head Bolts..... 121	Flat Washers..... 121	All-Thread Washers..... 121
						
Heavy Duty Channel Nuts..... 122	Standard Duty Channel Nuts..... 122	Saddle Clips..... 122	Stop-Lock Assemblies..... 122	Fabricated Beam Clamps..... 122	Molded Clevis Hanger..... 123	Hand Lay-Up Clevis Hangers..... 123

PICTORIAL TABLE OF CONTENTS



Fiberglass Aickinstruct® (cont.)

Molded Beam Clamps..... 123	Cope-Glas Beam Clamps..... 123	Beam Clip..... 123	Threaded Rod..... 124	Rod Couplers..... 124	Duraclamp..... 124	Channel Hangers..... 124
Power-Rack Stanchions..... 125	Wall Brackets..... 125	Heavy Duty Post Base..... 126	Stands..... 126			

Fiberglass Aickinshapes®

Equal Leg Angle... 127	Channel..... 127	I-Beam..... 127	Wide Flange I-Beam..... 127	Flat Sheet..... 128	Embedment Angle 128	Square Tube..... 128
Square Bar..... 128	Rectangular Tube 128	Round Rod..... 128	Flat Strip..... 129	Round Tube..... 129	Door Frame..... 129	Threshold..... 129
Hat Section..... 129	Flight Channel..... 129	Toe Plate..... 130	Square Bar..... 130	Square Tube..... 130	Fixed Connector .. 130	Handrail Connectors..... 130

Fiberglass Sealers, Coatings & Promotional Material

Aickinzip..... 131	Aickincoat..... 131	Distributor Display..... 131	Distributor Literature Display..... 131	Adj. Pipe Clamp Sample..... 131	Rigid Pipe Clamp Sample..... 131	Aickinstruct Sample Box..... 131

Fiberglass AickinGrate®

1" Molded Grating..... 134	1" Molded Grating..... 134	1 1/2" Molded Grating..... 134	2" Molded Grating..... 134	"I" Bar Pultruded Grating..... 136-137	"T" Bar Pultruded Grating..... 138-139	Molded Stair Treads..... 141
Pultruded Stair Treads..... 141	Aickinplate..... 142	Molded Grating Clip..... 143	Pultruded Grating Clip..... 143	Molded Grating Floor Pedestals..... 143		

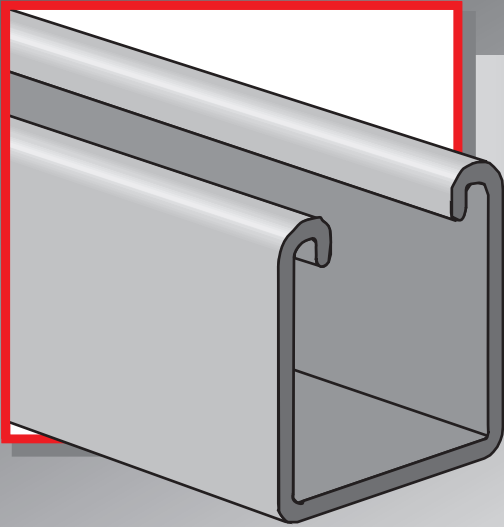

CHANNEL

Power-Strut channel sections are produced by multiple sets of forming rolls which cold-work strip steel into the channel configuration. This type of roll forming produces a uniform channel section held to the specifications of MFMA-4.

MATERIALS:

Plain and painted green channels are formed from structural quality strip steel which conforms to the requirements of ASTM A-1011 SS Grade 33. Pre-galvanized channel conforms to the requirements of ASTM A-653 Grade 33.

STANDARD LENGTHS:

Stock lengths are 10 and 20 feet. Special lengths are available upon request.

STANDARD FINISHES:

Standard Power-Strut channel is available in plain, painted green, zinc dichromate or pre-galvanized finishes.

ORDERING INFORMATION:

When ordering, add the length or size and finish to the part number. See page 8 - 9 for finish abbreviations and an example.

Type of Load	Safety Factor to Yield Strength	Safety Factor to Ultimate Strength
Beam Loads	1.67	2.0
Column Load	1.80	2.2

PS 100 – 1⁵/₈" x 3¹/₄" x 12 ga.

See Pages 22-23

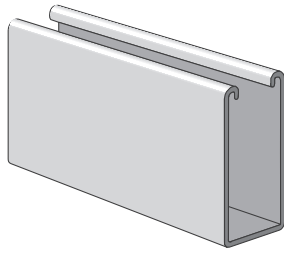

PS 210 – 1⁵/₈" x 1⁵/₈" x 14 ga.

See Pages 30-31

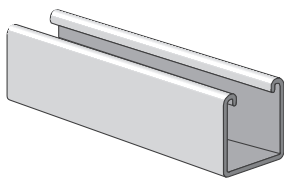

PS 500 – 1⁵/₈" x 1³/₁₆" x 14 ga.

See Pages 36-37

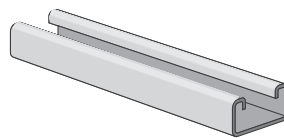

PS 600J – 1³/₁₆" x 1³/₁₆" x 19 ga.

See Junior Channel Page 96

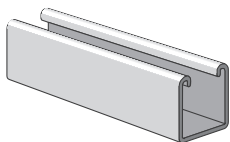

PS 700J – 1³/₁₆" x 1³/₃₂" x 19 ga.

See Junior Channel Page 97

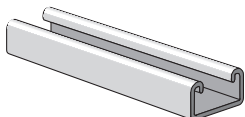

PS 150 – 1⁵/₈" x 2⁷/₁₆" x 12 ga.

See Pages 24-25

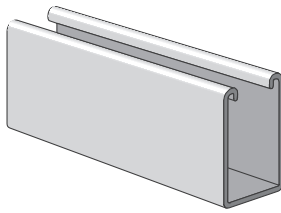

PS 300 – 1⁵/₈" x 1³/₈" x 12 ga.

See Pages 32 -33

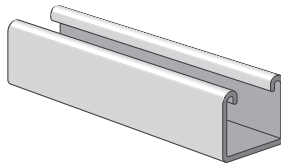

PS 520 – 1⁵/₈" x 1³/₁₆" x 12 ga.

See Pages 38-39

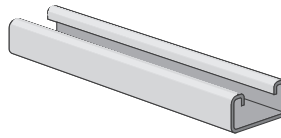

PS 200 – 1⁵/₈" x 1⁵/₈" x 12 ga.

See Pages 26-29

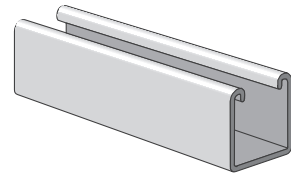

PS 400 – 1⁵/₈" x 1" x 12 ga.

See Pages 34-35

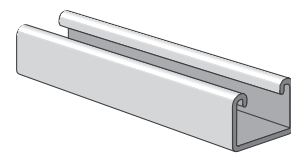

PS 560 – 1⁵/₈" x 1³/₁₆" x 16 ga.

See Pages 40-41

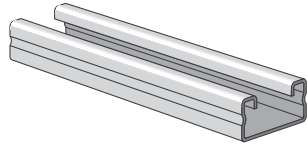

Maximum Allowable Pull-Out and Slip Loads

Channel Nut Size-Thread	Allowable Gauge Channel	Pull-Out Strength (Lbs.)	Resistance to Slip (Lbs.)	Torque Ft.-Lbs.
3/4"-10	12 Gauge PS 100 PS 150 PS 200 PS 300	2,500	1,700	*125
5/8"-11		2,500	1,500	*100
1/2"-13		2,000	1,500	50
5/16"-14		1,400	1,000	35
3/8"-16		1,000	800	19
5/16"-18		800	500	11
1/4"-20		600	300	6
1/2"-13	12 Gauge PS 400 PS 520	1,500	1,500	50
3/8"-16		1,000	800	19
5/16"-18		800	500	11
1/4"-20		600	300	6
1/2"-13	14 Gauge PS 210 PS 500	1,400	1,000	50
3/8"-16		1,000	750	19
5/16"-18		800	400	11
1/4"-20		600	300	6
1/2"-13	16 Gauge PS 560	1,000	1,000	50
3/8"-16		1,000	750	19
5/16"-18		800	400	11
1/4"-20		600	300	6

* May require 3/8" or 1/2" thick fitting.

Nut design loads include a minimum safety factor of 3.

Note: Refer to the Channel Nut Selection Chart on page 44 for the part number



Channel

Channel with Holes (H)

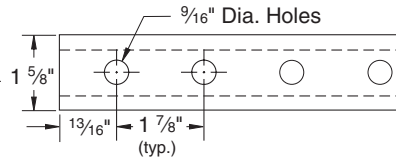
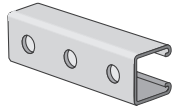

Available With These Select Channel Types:

PS 100	PS 150	PS 150 2T3	PS 200	PS 200 2T3	PS 210	PS 300	PS 300 2T3	PS 400	PS 500	PS 500 2T3	PS 520	PS 560
■	■		■		■	■		■	■		■	

Channel with Holes on Three Sides (H3)

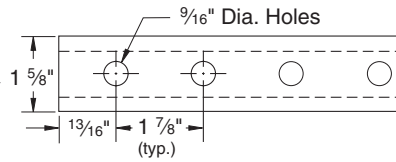
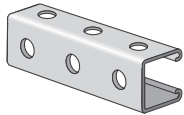

Available With These Select Channel Types:

PS 100	PS 150	PS 150 2T3	PS 200	PS 200 2T3	PS 210	PS 300	PS 300 2T3	PS 400	PS 500	PS 500 2T3	PS 520	PS 560
			■									

Channel with Slots (S)

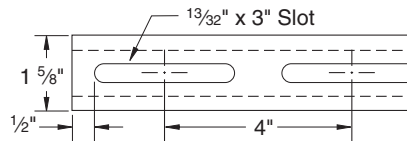
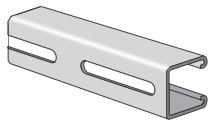

Available With These Select Channel Types:

PS 100	PS 150	PS 150 2T3	PS 200	PS 200 2T3	PS 210	PS 300	PS 300 2T3	PS 400	PS 500	PS 500 2T3	PS 520	PS 560
■	■		■		■	■		■	■		■	■

Channel with Elongated Holes (EH)

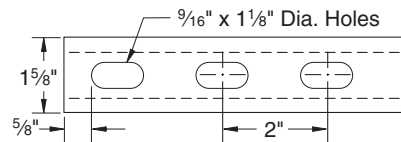
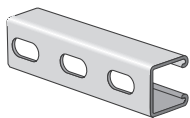

Available With These Select Channel Types:

PS 100	PS 150	PS 150 2T3	PS 200	PS 200 2T3	PS 210	PS 300	PS 300 2T3	PS 400	PS 500	PS 500 2T3	PS 520	PS 560
■	■	■	■	■	■	■	■	■	■	■	■	■

Channel with Knockouts (KO6)

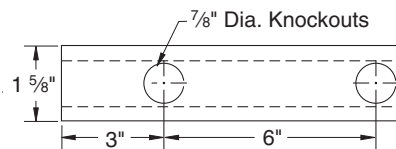
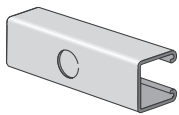

Available With These Select Channel Types:

PS 100	PS 150	PS 150 2T3	PS 200	PS 200 2T3	PS 210	PS 300	PS 300 2T3	PS 400	PS 500	PS 500 2T3	PS 520	PS 560
■	■		■		■							

Channel with Slotted Back (SB)

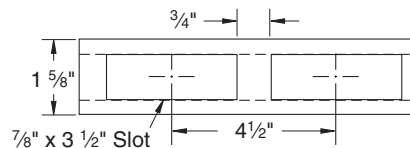
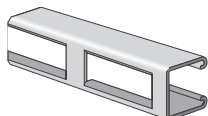

Available With These Select Channel Types:

PS 100	PS 150	PS 150 2T3	PS 200	PS 200 2T3	PS 210	PS 300	PS 300 2T3	PS 400	PS 500	PS 500 2T3	PS 520	PS 560
			■									

CHANNEL

Finish: Plain, Painted Green, or Pregalvanized Order By: No., Length and Finish



PS 100 - Steel Channel (1 5/8" x 3 1/4" x 12 ga.)

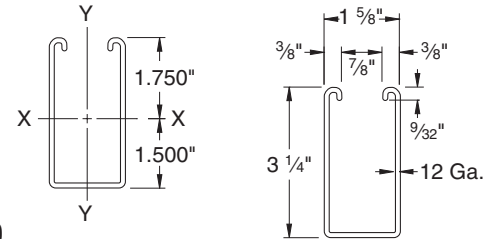
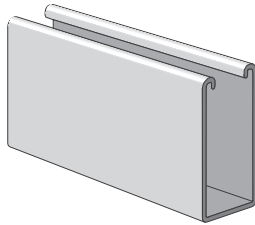

ELEMENTS OF SECTION – PS 100

Weight (lbs./100 ft.)	Area of Section (Inch ²)	X-X Axis			Y-Y Axis		
		Moment of Inertia (Inch ⁴)	Section Modulus (Inch ³)	Radius of Gyration (Inch)	Moment of Inertia (Inch ⁴)	Section Modulus (Inch ³)	Radius of Gyration (Inch)
305	0.897	1.098	0.627	1.107	0.433	0.533	0.695

PS 100 H - Channel with Holes

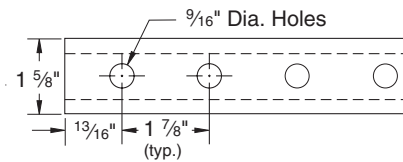
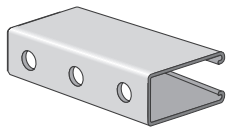

Weight: 300 lbs./100 ft.

PS 100 EH - Channel with Elongated Holes

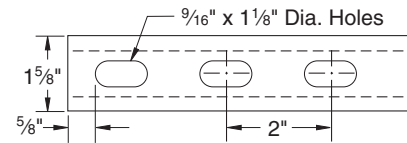
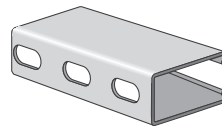

Weight: 300 lbs./100 ft.

PS 100 S - Channel with Slots

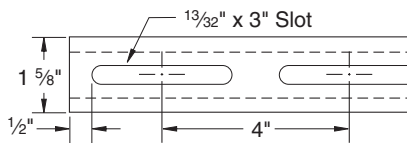
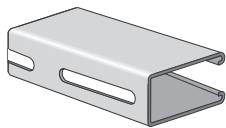

Weight: 300 lbs./100 ft.

PS 100 K06 - Channel with Knockouts

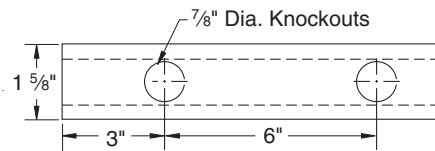
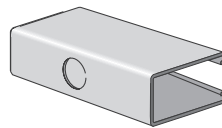

Weight: 305 lbs./100 ft.

PS 100 2T3 - Steel Channel (1 5/8" x 6 1/2" x 12 ga.)

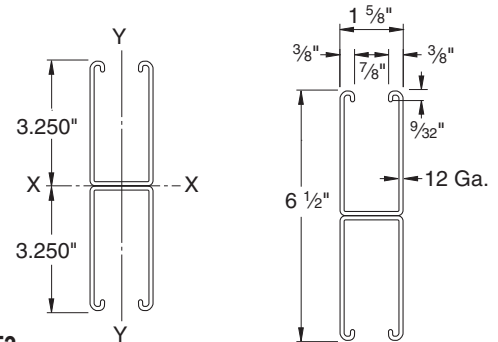
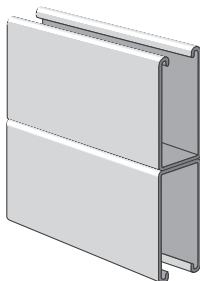

ELEMENTS OF SECTION – PS 100 2T3

Weight (lbs./100 ft.)	Area of Section (Inch ²)	X-X Axis			Y-Y Axis		
		Moment of Inertia (Inch ⁴)	Section Modulus (Inch ³)	Radius of Gyration (Inch)	Moment of Inertia (Inch ⁴)	Section Modulus (Inch ³)	Radius of Gyration (Inch)
610	1.793	6.226	1.916	1.864	0.866	1.066	0.695



Channel

PS 100 & PS 100 2T3 - Load Data

BEAM LOADING – PS 100

Span (in)	Max Allowable Uniform Load (lb)	Defl. at Uniform Load (in)	Uniform Loading at Deflection		
			Span/180 (lbs)	Span/240 (lbs)	Span/360 (lbs)
24	5,260	0.03	5,260	5,260	5,260
36	3,500	0.07	3,500	3,500	3,500
48	2,630	0.12	2,630	2,630	2,630
60	2,100	0.18	2,100	2,100	1,920
72	1,750	0.26	1,750	1,750	1,330
84	1,500	0.36	1,500	1,470	980
96	1,310	0.47	1,310	1,120	750
108	1,170	0.59	1,170	890	590
120	1,050	0.73	960	720	480
144	880	1.06	670	500	330
168	750	1.43	490	370	240
192	660	1.88	370	280	190
216	580	2.35	300	220	150
240	530	2.95	240	180	120

* Bearing load may govern capacity.

For concentrated load at center of span, divide uniform load by 2 and multiply corresponding deflection by 0.8. This load table is based on a solid channel section.

Loads include weight of channel, which must be deducted.

Loads must be multiplied by the applicable unbraced factor from page 42.

For Pierced Channels, reduce beam load values as follows:

PS-100-EH	15%	PS-100-S	15%
PS-100-H	10%	PS-100-K06	5%

COLUMN LOADING – PS 100

Unbraced Height (in)	Max. Allowable Load at Slot Face (lbs)	Maximum Column Load Applied at C.G.			
		K = 0.65 (lbs)	K = 0.80 (lbs)	K = 1.0 (lbs)	K = 1.2 (lbs)
24	5,650	16,870	15,180	12,850	10,600
36	4,690	13,140	10,600	7,650	5,660
48	3,560	9,550	6,860	4,790	3,660
60	2,730	6,680	4,790	3,450	2,710
72	2,160	4,980	3,660	2,710	2,170
84	1,760	3,950	2,960	2,240	1,820
96	1,500	3,270	2,500	1,930	1,580
108	1,310	2,800	2,170	1,690	1,390
120	1,170	2,450	1,930	1,510	**
144	980	1,980	1,580	**	**
168	850	1,670	1,340	**	**

** $K_L > 200$

Column loads are for allowable axial loads and must be reduced for eccentric loading.

PS100 – Crush Loads

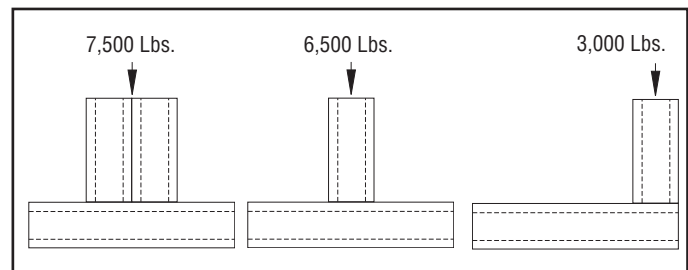

Resistance to Slip – 1,500 lbs. per bolt when 1/2" PS NS channel nuts are used.

Pull Out Strength – 2,000 lbs. per bolt when 1/2" PS NS channel nuts are used.

BEAM LOADING – PS 100 2T3

Span (in)	Max Allowable Uniform Load (lb)	Defl. at Uniform Load (in)	Uniform Loading at Deflection		
			Span/180 (lbs)	Span/240 (lbs)	Span/360 (lbs)
24	6,890 *	0.01	6,890 *	6,890 *	6,890 *
36	6,890 *	0.02	6,890 *	6,890 *	6,890 *
48	6,890 *	0.05	6,890 *	6,890 *	6,890 *
60	6,420	0.10	6,420	6,420	6,420
72	5,350	0.14	5,350	5,350	5,350
84	4,590	0.19	4,590	4,590	4,590
96	4,020	0.25	4,020	4,020	4,020
108	3,570	0.32	3,570	3,570	3,360
120	3,210	0.39	3,210	3,210	2,720
144	2,680	0.57	2,680	2,680	1,890
168	2,290	0.77	2,290	2,080	1,390
192	2,010	1.01	2,010	1,590	1,060
216	1,780	1.27	1,680	1,260	840
240	1,610	1.58	1,360	1,020	680

* Load limited by spot weld shear.

† Bearing load may govern capacity.

For concentrated load at center of span, divide uniform load by 2 and multiply corresponding deflection by 0.8.

Loads include weight of channel, which must be deducted.

Loads must be multiplied by the applicable unbraced factor from page 42.

COLUMN LOADING – PS 100 2T3

Unbraced Height (in)	Max. Allowable Load at Slot Face (lbs)	Maximum Column Load Applied at C.G.			
		K = 0.65 (lbs)	K = 0.80 (lbs)	K = 1.0 (lbs)	K = 1.2 (lbs)
24	10,670	39,230	38,030	36,210	34,240
36	10,350	36,450	34,240	31,200	28,260
48	9,940	33,220	30,200	26,430	23,190
60	9,290	29,950	26,430	22,470	19,380
72	8,560	26,880	23,190	19,380	16,450
84	7,860	24,140	20,520	17,040	12,090
96	7,220	21,790	18,370	13,330	9,250
108	6,600	19,790	16,450	10,530	7,310
120	5,760	18,130	13,330	8,530	**
144	4,390	14,020	9,250	**	**
168	3,420	10,300	6,800	**	**

** $K_L > 200$

Column loads are for allowable axial loads and must be reduced for eccentric loading.

CHANNEL

Finish: Plain, Painted Green, or Pregalvanized Order By: No., Length and Finish



PS 150 – Steel Channel (1 5/8" x 2 7/16" x 12 ga.)

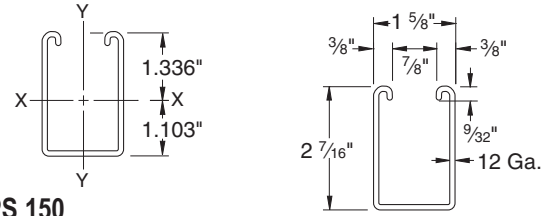
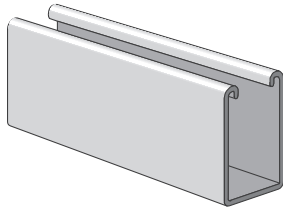

ELEMENTS OF SECTION – PS 150

Weight (lbs./100 ft.)	Area of Section (Inch ²)	X-X Axis			Y-Y Axis		
		Moment of Inertia (Inch ⁴)	Section Modulus (Inch ³)	Radius of Gyration (Inch)	Moment of Inertia (Inch ⁴)	Section Modulus (Inch ³)	Radius of Gyration (Inch)
247	0.726	0.522	0.390	0.848	0.334	0.411	0.679

PS 150 H - Channel with Holes

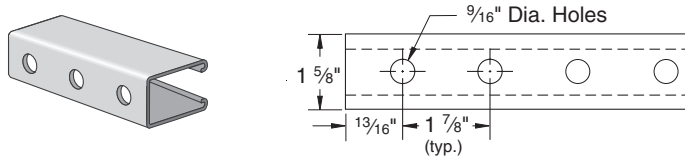

Weight: 242 lbs./100 ft.

PS 150 EH – Channel with Elongated Holes

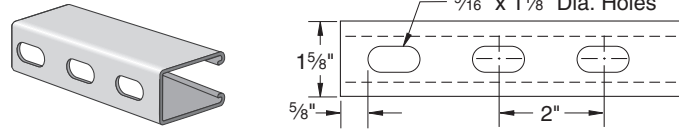

Weight: 242 lbs./100 ft.

PS 150 S - Channel with Slots

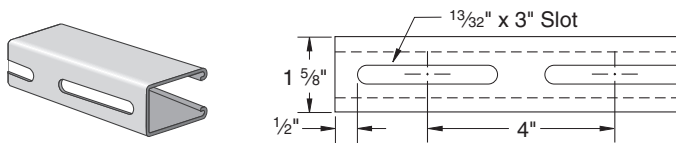

Weight: 242 lbs./100 ft.

PS 150 K06 – Channel with Knockouts

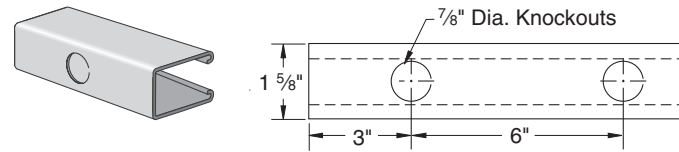

Weight: 247 lbs./100 ft.

PS 150 2T3 – Steel Channel (1 5/8" x 4 7/8" x 12 ga.)

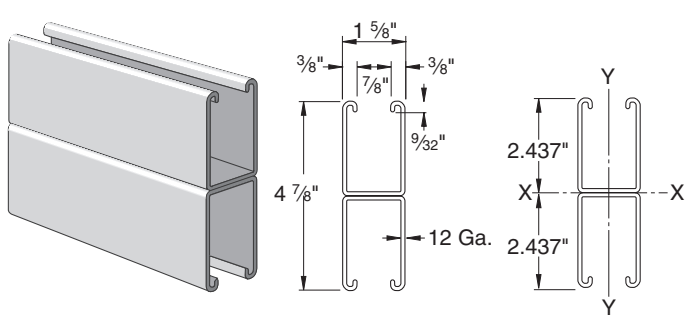

PS 150 2T3 EH – Channel with Elongated Holes

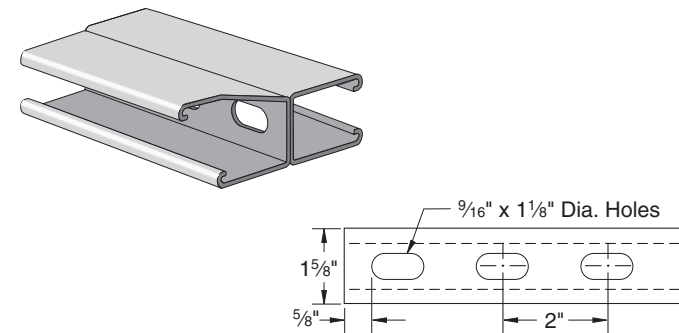

Weight: 494 lbs./100 ft.

ELEMENTS OF SECTION – PS 150 2T3

Weight (lbs./100 ft.)	Area of Section (Inch ²)	X-X Axis			Y-Y Axis		
		Moment of Inertia (Inch ⁴)	Section Modulus (Inch ³)	Radius of Gyration (Inch)	Moment of Inertia (Inch ⁴)	Section Modulus (Inch ³)	Radius of Gyration (Inch)
494	1.452	2.805	1.151	1.390	0.669	0.823	0.679



Channel

PS 150 & PS 150 2T3 - Load Data

BEAM LOADING – PS 150

Span (in)	Max Allowable Uniform Load (lb)	Defl. at Uniform Load (in)	Uniform Loading at Deflection		
			Span/180 (lbs)	Span/240 (lbs)	Span/360 (lbs)
24	3,270	0.04	3,270	3,270	3,270
36	2,180	0.09	2,180	2,180	2,180
48	1,640	0.15	1,640	1,640	1,420
60	1,310	0.24	1,310	1,310	910
72	1,090	0.34	1,090	950	630
84	940	0.47	930	700	470
96	820	0.61	710	530	360
108	730	0.78	560	420	280
120	650	0.95	460	340	230
144	550	1.39	320	240	160
168	470	1.89	230	170	120
192	410	2.46	180	130	90
216	360	3.07	140	110	70
240	330	3.86	110	90	60

* Bearing load may govern capacity.

This load table is based on a solid channel section.

For concentrated load at center of span, divide uniform load by 2 and multiply corresponding deflection by 0.8.

Loads include weight of channel, which must be deducted.

Loads must be multiplied by the applicable unbraced factor from page 42.

For Pierced Channels, reduce beam load values as follows:

- PS-150-EH 15%
- PS-150-S 15%
- PS-150-H 10%
- PS-150-K06 5%

COLUMN LOADING – PS 150

Unbraced Height (in)	Max. Allowable Load at Slot Face (lbs)	Maximum Column Load Applied at C.G.			
		K = 0.65 (lbs)	K = 0.80 (lbs)	K = 1.0 (lbs)	K = 1.2 (lbs)
24	4,640	13,840	12,570	10,840	9,190
36	3,970	11,050	9,190	7,030	5,370
48	3,180	8,420	6,390	4,620	3,630
60	2,550	6,250	4,620	3,450	2,780
72	2,120	4,790	3,630	2,780	2,260
84	1,810	3,890	3,010	2,330	1,910
96	1,580	3,290	2,580	2,020	1,650
108	1,400	2,860	2,260	1,770	1,440
120	1,270	2,530	2,020	1,580	**
144	1,060	2,070	1,650	**	**
168	920	1,750	1,380	**	**

** $K_L > 200$

Column loads are for allowable axial loads and must be reduced for eccentric loading.

PS150 – Crush Loads

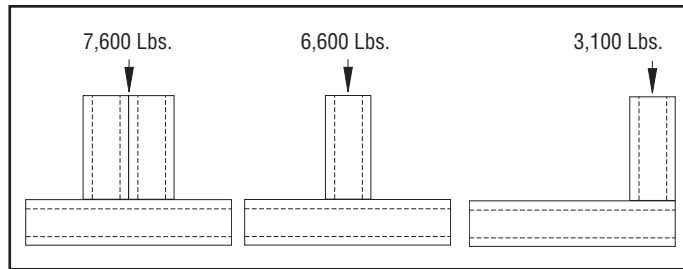

Resistance to Slip – 1,500 lbs. per bolt when 1/2" PS NS channel nuts are used.
Pull Out Strength – 2,000 lbs. per bolt when 1/2" PS NS channel nuts are used.

BEAM LOADING – PS 150 2T3

Span (in)	Max Allowable Uniform Load (lb)	Defl. at Uniform Load (in)	Uniform Loading at Deflection		
			Span/180 (lbs)	Span/240 (lbs)	Span/360 (lbs)
24	5,220 *	0.01	5,220 *	5,220 *	5,220 *
36	5,220 *	0.04	5,220 *	5,220 *	5,220 *
48	4,820	0.08	4,820	4,820	4,820
60	3,860	0.13	3,860	3,860	3,860
72	3,220	0.19	3,220	3,220	3,220
84	2,760	0.26	2,760	2,760	2,500
96	2,410	0.34	2,410	2,410	1,920
108	2,140	0.42	2,140	2,140	1,510
120	1,930	0.52	1,930	1,840	1,230
144	1,610	0.76	1,610	1,280	850
168	1,380	1.03	1,250	940	630
192	1,210	1.35	960	720	480
216	1,070	1.70	760	570	380
240	960	2.09	610	460	310

*Load limited by spot weld shear.

For concentrated load at center of span, divide uniform load by 2 and multiply corresponding deflection by 0.8.

Loads include weight of channel, which must be deducted.

Loads must be multiplied by the applicable unbraced factor from page 42.

COLUMN LOADING – PS 150 2T3

Unbraced Height (in)	Max. Allowable Load at Slot Face (lbs)	Maximum Column Load Applied at C.G.			
		K = 0.65 (lbs)	K = 0.80 (lbs)	K = 1.0 (lbs)	K = 1.2 (lbs)
24	8,580	31,810	30,880	29,520	28,100
36	8,350	29,700	28,100	26,000	24,070
48	8,080	27,390	25,330	22,910	20,940
60	7,720	25,170	22,910	20,510	17,170
72	7,270	23,190	20,940	17,170	12,700
84	6,780	21,510	18,740	13,430	9,330
96	6,130	20,110	15,630	10,290	7,150
108	5,450	17,750	12,700	8,130	5,650
120	4,800	15,260	10,290	6,590	**
144	3,760	10,830	7,150	**	**
168	2,970	7,950	5,250	**	**

** $K_L > 200$

Column loads are for allowable axial loads and must be reduced for eccentric loading.

For Pierced Channels, reduce beam load values as follows:

- PS-150 2T3-EH 15%

CHANNEL

Finish: Plain, Painted Green, or Pregalvanized Order By: No., Length and Finish



PS 200 – Steel Channel (1⁵/₈" x 1⁵/₈" x 12 ga.)

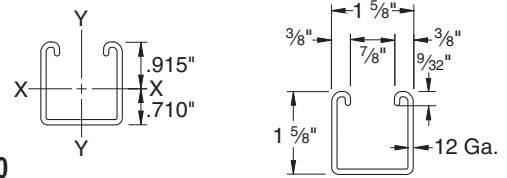
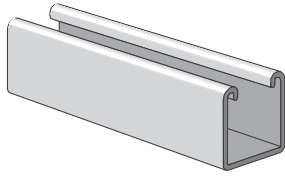

ELEMENTS OF SECTION – PS 200

Weight (lbs./100 ft.)	Area of Section (Inch ²)	X-X Axis			Y-Y Axis		
		Moment of Inertia (Inch ⁴)	Section Modulus (Inch ³)	Radius of Gyration (Inch)	Moment of Inertia (Inch ⁴)	Section Modulus (Inch ³)	Radius of Gyration (Inch)
189	0.555	0.185	0.202	0.577	0.236	0.290	0.651

PS 200 H - Channel with Holes

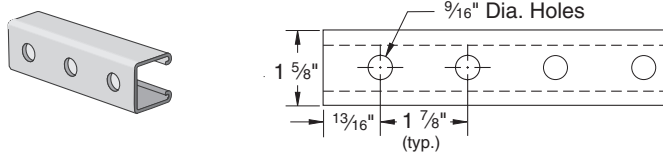

Weight: 186 lbs./100 ft.

PS 200 EH – Channel with Elongated Holes

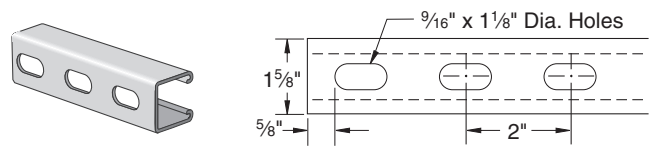

Weight: 185 lbs./100 ft.

PS 200 H3 - Channel with Holes

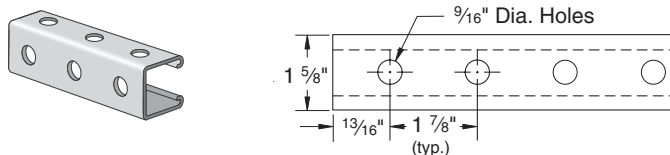

Weight: 175 lbs./100 ft.

PS 200 K06 – Channel with Knockouts

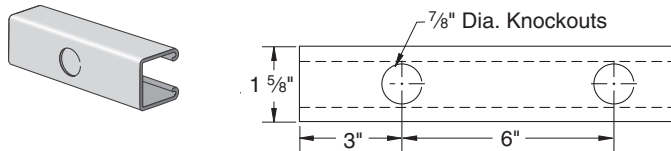

Weight: 189 lbs./100 ft.

PS 200 S - Channel with Slots

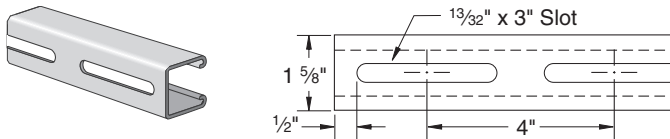

Weight: 185 lbs./100 ft.

PS 200 SB – Channel with Slotted Back

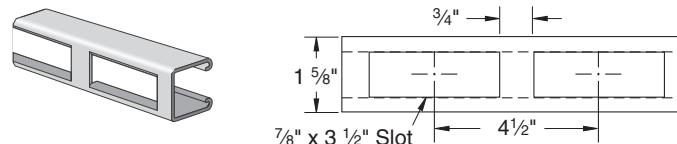

Weight: 173 lbs./100 ft.

PS 200 2T3 – Steel Channel (1⁵/₈" x 3¹/₄" x 12 ga.)

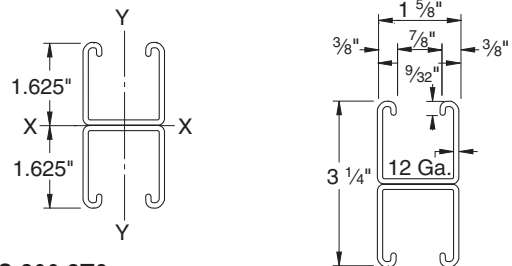
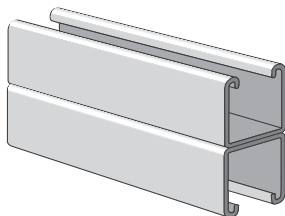

ELEMENTS OF SECTION – PS 200 2T3

Weight (lbs./100 ft.)	Area of Section (Inch ²)	X-X Axis			Y-Y Axis		
		Moment of Inertia (Inch ⁴)	Section Modulus (Inch ³)	Radius of Gyration (Inch)	Moment of Inertia (Inch ⁴)	Section Modulus (Inch ³)	Radius of Gyration (Inch)
378	1.111	0.928	0.571	0.914	0.471	0.580	0.651



Channel

PS 200 & PS 200 2T3 – Load Data

BEAM LOADING – PS 200

Span (in)	Max Allowable Uniform Load (lb)	Defl. at Uniform Load (in)	Uniform Loading at Deflection		
			Span/180 (lbs)	Span/240 (lbs)	Span/360 (lbs)
24	1,690	0.06	1,690	1,690	1,690
36	1,130	0.13	1,130	1,130	900
48	850	0.22	850	760	500
60	680	0.35	650	480	320
72	560	0.50	450	340	220
84	480	0.68	330	250	160
96	420	0.89	250	190	130
108	380	1.14	200	150	100
120	340	1.40	160	120	80
144	280	2.00	110	80	60
168	240	2.72	80	60	40
192	210	3.55	60	50	NR
216	190	4.58	50	40	NR
240	170	5.62	40	NR	NR

* Bearing load may govern capacity.

NR - Not Recommended

This load table is based on a solid channel section.

For concentrated load at center of span, divide uniform load by 2 and multiply corresponding deflection by 0.8.

Loads include weight of channel, which must be deducted.

Loads must be multiplied by the applicable unbraced factor from page 42.

For Pierced Channels, reduce beam load values as follows:

PS-200-EH 15% PS-200-S 15%

PS-200-H 10% PS-200-KO6 5%

PS-200-SB 30%

For Extruded Aluminum Channels, reduce beam load values 38%.

COLUMN LOADING – PS 200

Unbraced Height (in)	Max. Allowable Load at Slot Face (lbs)	Maximum Column Load Applied at C.G.			
		K = 0.65 (lbs)	K = 0.80 (lbs)	K = 1.0 (lbs)	K = 1.2 (lbs)
24	3,550	10,740	9,890	8,770	7,740
36	3,190	8,910	7,740	6,390	5,310
48	2,770	7,260	6,010	4,690	3,800
60	2,380	5,910	4,690	3,630	2,960
72	2,080	4,840	3,800	2,960	2,400
84	1,860	4,040	3,200	2,480	1,980
96	1,670	3,480	2,750	2,110	1,660
108	1,510	3,050	2,400	1,810	**
120	1,380	2,700	2,110	**	**
144	1,150	2,180	1,660	**	**

** $K_L > 200$

Column loads are for allowable axial loads and must be reduced for eccentric loading.

PS200 – Crush Loads

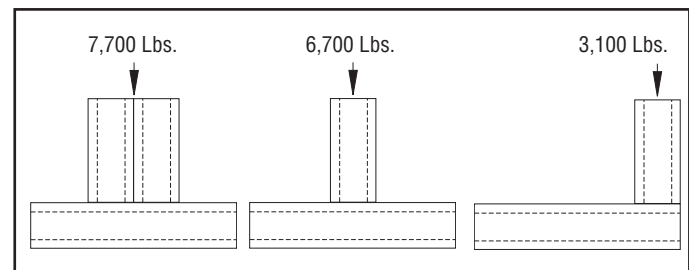

Resistance to Slip – 1,500 lbs. per bolt when 1/2" PS NS channel nuts are used.
Pull Out Strength – 2,000 lbs. per bolt when 1/2" PS NS channel nuts are used.

BEAM LOADING – PS 200 2T3

Span (in)	Max Allowable Uniform Load (lb)	Defl. at Uniform Load (in)	Uniform Loading at Deflection		
			Span/180 (lbs)	Span/240 (lbs)	Span/360 (lbs)
24	3,500 *	0.02	3,500 *	3,500 *	3,500 *
36	3,190	0.07	3,190	3,190	3,190
48	2,390	0.13	2,390	2,390	2,390
60	1,910	0.20	1,910	1,910	1,620
72	1,600	0.28	1,600	1,600	1,130
84	1,370	0.39	1,370	1,240	830
96	1,200	0.51	1,200	950	630
108	1,060	0.64	1,000	750	500
120	960	0.79	810	610	410
144	800	1.14	560	420	280
168	680	1.53	410	310	210
192	600	2.02	320	240	160
216	530	2.54	250	190	130
240	480	3.16	200	150	100

*Load limited by spot weld shear.

For concentrated load at center of span, divide uniform load by 2 and multiply corresponding deflection by 0.8. This load table is based on a solid channel section.

Loads include weight of channel, which must be deducted.

Loads must be multiplied by the applicable unbraced factor from page 42.

COLUMN LOADING – PS 200 2T3

Unbraced Height (in)	Max. Allowable Load at Slot Face (lbs)	Maximum Column Load Applied at C.G.			
		K = 0.65 (lbs)	K = 0.80 (lbs)	K = 1.0 (lbs)	K = 1.2 (lbs)
24	6,430	24,280	23,610	22,700	21,820
36	6,290	22,810	21,820	20,650	19,670
48	6,160	21,410	20,300	18,670	16,160
60	6,000	20,210	18,670	15,520	12,390
72	5,620	18,970	16,160	12,390	8,950
84	5,170	16,950	13,630	9,470	6,580
96	4,690	14,890	11,190	7,250	5,040
108	4,170	12,850	8,950	5,730	3,980
120	3,690	10,900	7,250	4,640	**
144	2,930	7,630	5,040	**	**

** $K_L > 200$

Column loads are for allowable axial loads and must be reduced for eccentric loading.

For Pierced Channels, reduce beam load values as follows:

PS 200 2T3 EH 15%

(See PS 200 2T3 EH on page 28.)

CHANNEL

Finish: Plain, Painted Green, or Pregalvanized Order By: No., Length and Finish



PS 200 2T3 EH – Channel with Elongated Holes

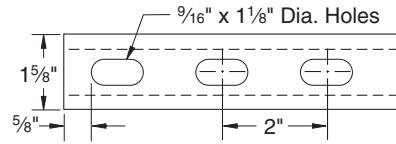
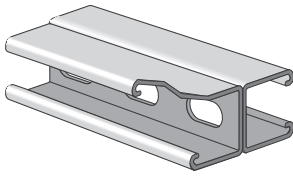

Weight: 370 lbs./100 ft.

PS 200 2T2 – Welded Steel Channel (1 5/8" x 3 1/4" x 12 ga.)

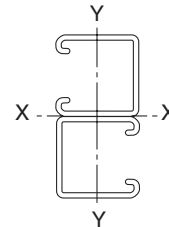
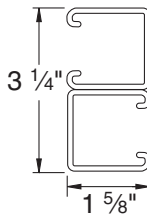
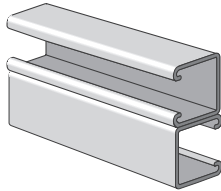

Weight: 378 lbs./100 ft.
Allowable Moment 18,640 In-Lbs

PS 200 2T4 – Welded Steel Channel (1 5/8" x 3 1/4" x 12 ga.)

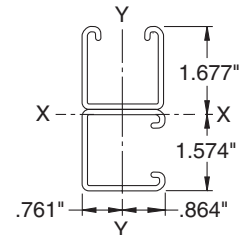
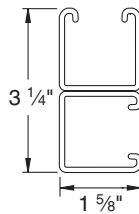
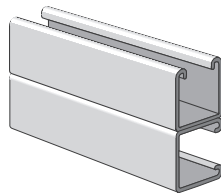

Weight: 378 lbs./100 ft.
Allowable Moment 15,950 In-Lbs

PS 200 2T5 – Welded Steel Channel (1 5/8" x 3 1/4" x 12 ga.)

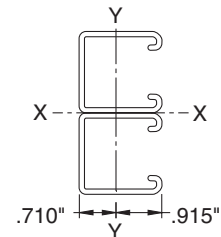
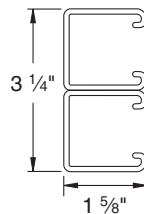
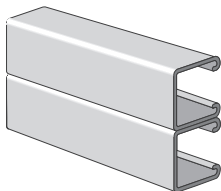

Weight: 378 lbs./100 ft.
Allowable Moment 18,640 In-Lbs

PS 200 3T6 – Welded Steel Channel (3 1/4" x 3 1/4" x 12 ga.)

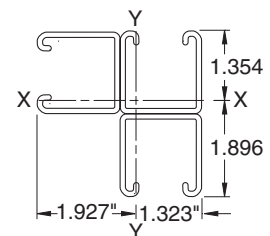
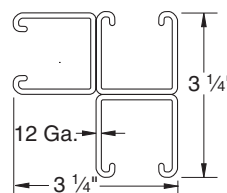
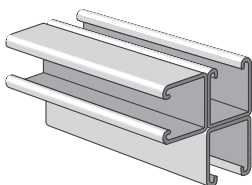

Weight: 566 lbs./100 ft.
Allowable Moment 18,680 In-Lbs

PS 200 PLA – Welded Steel Channel & Plate

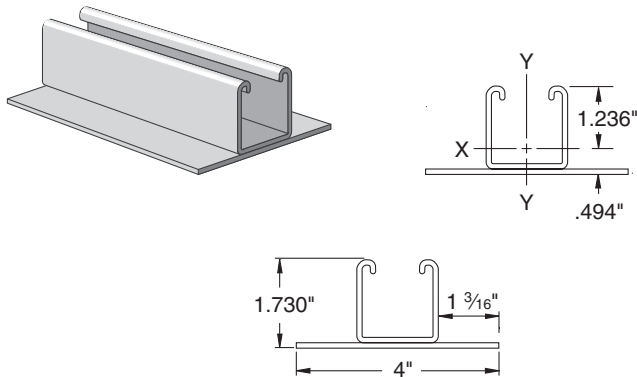

PS 200 PLC – Welded Steel Channel & Plate

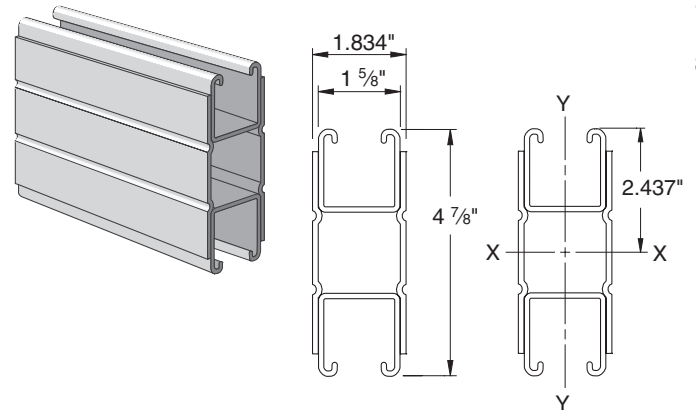

ELEMENTS OF SECTION

Part No.	Weight (lbs./100 ft.)	Area of Section (Inch ²)	X-X Axis			Y-Y Axis		
			Moment of Inertia (Inch ⁴)	Section Modulus (Inch ³)	Radius of Gyration (Inch)	Moment of Inertia (Inch ⁴)	Section Modulus (Inch ³)	Radius of Gyration (Inch)
PS 200 PLA	333	0.739	0.287	0.248	0.623	0.617	0.290	0.914
PS 200 PLC	668	1.965	4.068	1.669	1.439	1.092	1.190	0.745

PS 200 PLC – Load Data

BEAM LOADING – PS 200 PLC

Span (in)	Max Allowable Uniform Load (lb)	Defl. at Uniform Load (in)	Uniform Loading at Deflection		
			Span/180 (lbs)	Span/240 (lbs)	Span/360 (lbs)
24	9,100 *	0.01	9,100 *	9,100 *	9,100 *
36	9,100 *	0.05	9,100 *	9,100 *	9,100 *
48	7,000	0.08	7,000	7,000	7,000
60	5,600	0.13	5,600	5,600	5,600
72	4,660	0.19	4,660	4,660	4,660
84	4,000	0.26	4,000	4,000	3,630
96	3,500	0.34	3,500	3,500	2,780
108	3,110	0.43	3,110	3,110	2,200
120	2,800	0.52	2,800	2,670	1,780
144	2,330	0.75	2,330	1,850	1,230
168	2,000	1.03	1,810	1,360	910
192	1,750	1.34	1,390	1,040	690
216	1,550	1.69	1,100	820	550
240	1,400	2.10	890	670	440

COLUMN LOADING – PS 200 PLC

Unbraced Height (in)	Max. Allowable Load at Slot Face (lbs)	Maximum Column Load Applied at C.G.			
		K = 0.65 (lbs)	K = 0.80 (lbs)	K = 1.0 (lbs)	K = 1.2 (lbs)
24	11,420	36,800	33,890	30,440	27,600
36	10,600	30,840	27,600	24,400	22,160
48	9,860	26,400	23,560	21,060	19,470
60	9,160	23,370	21,060	19,160	18,020
72	8,610	21,310	19,470	18,020	17,140
84	8,170	19,890	18,410	17,260	15,240
96	7,790	18,890	17,670	16,760	11,670
108	7,460	18,160	17,140	13,280	9,220
120	7,150	17,590	16,760	10,750	7,470
144	5,660	16,840	11,670	7,470	**
168	4,520	12,990	8,570	**	**

** $K \geq 200$

Column loads are for allowable axial loads and must be reduced for eccentric loading.

*Load limited by spot weld shear.

† Bearing load may govern capacity.

For concentrated load at center of span, divide uniform load by 2 and multiply corresponding deflection by 0.8. This load table is based on a solid channel section.

Loads include weight of channel, which must be deducted.

Loads must be multiplied by the applicable unbraced factor from page 42.

CHANNEL

Finish: Plain, Painted Green, or Pregalvanized Order By: No., Length and Finish



PS 210 – Steel Channel (1 5/8" x 1 5/8" x 14 ga.)

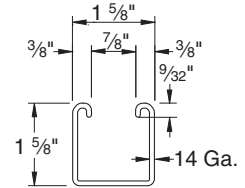
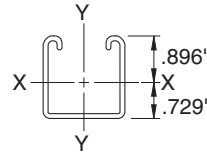
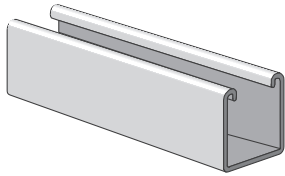

ELEMENTS OF SECTION – PS 210

Weight (lbs./100 ft.)	Area of Section (Inch ²)	X-X Axis			Y-Y Axis		
		Moment of Inertia (Inch ⁴)	Section Modulus (Inch ³)	Radius of Gyration (Inch)	Moment of Inertia (Inch ⁴)	Section Modulus (Inch ³)	Radius of Gyration (Inch)
142	0.418	0.145	0.162	0.589	0.176	0.217	0.650

PS 210 H - Channel with Holes

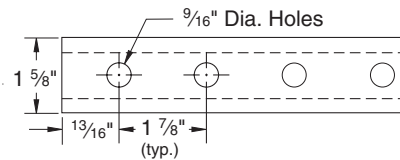
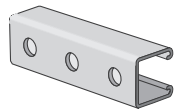

Weight: 137 lbs./100 ft.

PS 210 EH – Channel with Elongated Holes

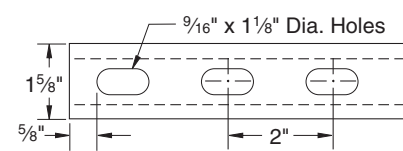
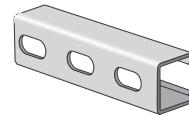

Weight: 137 lbs./100 ft.

PS 210 S - Channel with Slots

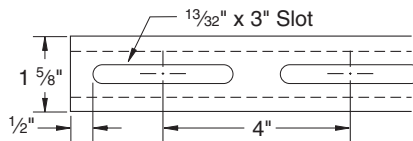
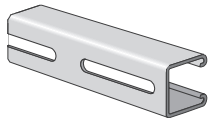

Weight: 137 lbs./100 ft.

PS 210 K06 – Channel with Knockouts

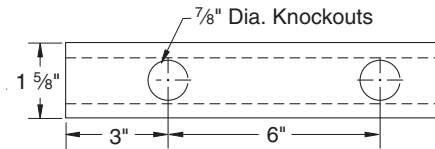
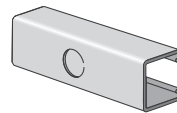

Weight: 141 lbs./100 ft.

PS 210 2T3 – Steel Channel (1 5/8" x 3 1/4" x 14 ga.)

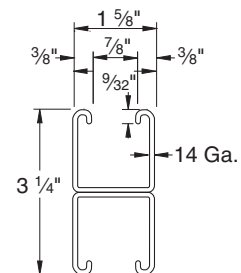
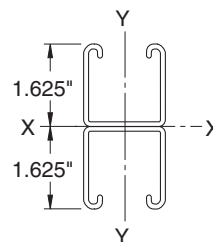
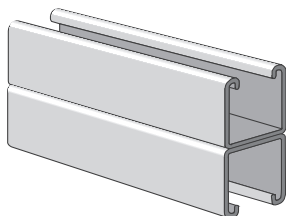

ELEMENTS OF SECTION – PS 210 2T3

Weight (lbs./100 ft.)	Area of Section (Inch ²)	X-X Axis			Y-Y Axis		
		Moment of Inertia (Inch ⁴)	Section Modulus (Inch ³)	Radius of Gyration (Inch)	Moment of Inertia (Inch ⁴)	Section Modulus (Inch ³)	Radius of Gyration (Inch)
284	0.835	0.733	0.451	0.937	0.353	0.434	0.650

PS 210 & PS 210 2T3 – Load Data
BEAM LOADING – PS 210

Span (in)	Max Allowable Uniform Load (lb)	Defl. at Uniform Load (in)	Uniform Loading at Deflection		
			Span/180 (lbs)	Span/240 (lbs)	Span/360 (lbs)
24	1,350	0.06	1,350	1,350	1,350
36	900	0.13	900	900	700
48	680	0.23	680	590	400
60	540	0.36	510	380	250
72	450	0.51	350	260	180
84	390	0.70	260	190	130
96	340	0.92	200	150	100
108	300	1.15	160	120	80
120	270	1.42	130	90	60
144	230	2.09	90	70	40
168	190	2.75	60	50	30
192	170	3.67	50	40	NR
216	150	4.61	40	30	NR
240	140	5.90	30	NR	NR

* Bearing load may govern capacity.

NR - Not Recommended

This load table is based on a solid channel section.

For concentrated load at center of span, divide uniform load by 2 and multiply corresponding deflection by 0.8.

Loads include weight of channel, which must be deducted.

Loads must be multiplied by the applicable unbraced factor from page 42.

For Pierced Channels, reduce beam load values as follows:

- PS-210-EH 15%
- PS-210-S 15%
- PS-210-H 10%
- PS-210-K06 5%

COLUMN LOADING – PS 210

Unbraced Height (in)	Max. Allowable Load at Slot Face (lbs)	Maximum Column Load Applied at C.G.			
		K = 0.65 (lbs)	K = 0.80 (lbs)	K = 1.0 (lbs)	K = 1.2 (lbs)
24	2,800	8,040	7,330	6,360	5,430
36	2,410	6,480	5,430	4,190	3,210
48	1,940	4,990	3,830	2,760	2,160
60	1,550	3,740	2,760	2,050	1,640
72	1,290	2,860	2,160	1,640	1,320
84	1,100	2,310	1,780	1,370	1,110
96	950	1,950	1,520	1,180	950
108	840	1,690	1,320	1,030	**
120	760	1,490	1,180	**	**
144	630	1,210	950	**	**

** $KL > 200$

Column loads are for allowable axial loads and must be reduced for eccentric loading.

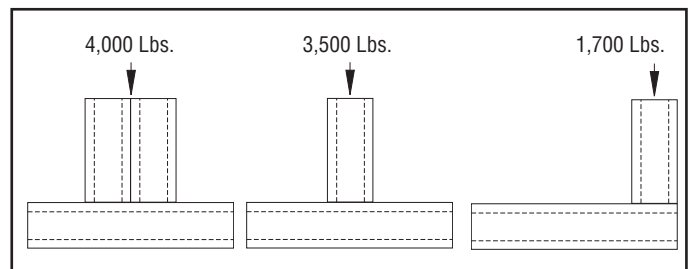
PS210 – Crush Loads

Resistance to Slip – 1,000 lbs. per bolt when 1/2" PS NS channel nuts are used.
 Pull Out Strength – 1,400 lbs. per bolt when 1/2" PS NS channel nuts are used.

BEAM LOADING – PS 210 2T3

Span (in)	Max Allowable Uniform Load (lb)	Defl. at Uniform Load (in)	Uniform Loading at Deflection		
			Span/180 (lbs)	Span/240 (lbs)	Span/360 (lbs)
24	2,180 *	0.02	2,180 *	2,180 *	2,180 *
36	2,180 *	0.06	2,180 *	2,180 *	2,180 *
48	1,890	0.13	1,890	1,890	1,890
60	1,510	0.20	1,510	1,510	1,280
72	1,260	0.28	1,260	1,260	890
84	1,080	0.39	1,080	980	650
96	950	0.51	950	750	500
108	840	0.64	790	590	400
120	760	0.79	640	480	320
144	630	1.13	440	330	220
168	540	1.54	330	250	160
192	470	2.00	250	190	130
216	420	2.55	200	150	100
240	380	3.16	160	120	80

*Load limited by spot weld shear.

† Bearing load may govern capacity.

For concentrated load at center of span, divide uniform load by 2 and multiply corresponding deflection by 0.8. This load table is based on a solid channel section.

Loads include weight of channel, which must be deducted.

Loads must be multiplied by the applicable unbraced factor from page 42.

COLUMN LOADING – PS 210 2T3

Unbraced Height (in)	Max. Allowable Load at Slot Face (lbs)	Maximum Column Load Applied at C.G.			
		K = 0.65 (lbs)	K = 0.80 (lbs)	K = 1.0 (lbs)	K = 1.2 (lbs)
24	5,010	18,250	17,700	16,880	16,030
36	4,860	16,990	16,030	14,770	13,620
48	4,700	15,610	14,380	12,930	11,750
60	4,480	14,280	12,930	11,490	9,290
72	4,210	13,100	11,750	9,290	6,700
84	3,880	12,090	10,220	7,090	4,930
96	3,480	11,170	8,390	5,430	3,770
108	3,060	9,640	6,700	4,290	2,980
120	2,680	8,170	5,430	3,480	**
144	2,090	5,710	3,770	**	**

** $KL > 200$

Column loads are for allowable axial loads and must be reduced for eccentric loading.

CHANNEL

Finish: Plain, Painted Green, or Pregalvanized Order By: No., Length and Finish



PS 300 – Steel Channel (1 5/8" x 1 3/8" x 12 ga.)

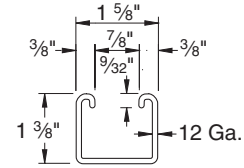
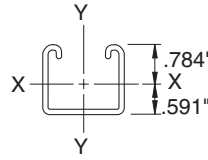
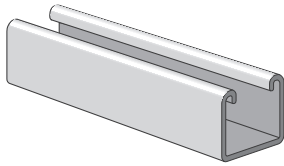

ELEMENTS OF SECTION – PS 300

Weight (lbs./100 ft.)	Area of Section (Inch ²)	X-X Axis			Y-Y Axis		
		Moment of Inertia (Inch ⁴)	Section Modulus (Inch ³)	Radius of Gyration (Inch)	Moment of Inertia (Inch ⁴)	Section Modulus (Inch ³)	Radius of Gyration (Inch)
170	0.500	0.120	0.153	0.489	0.203	0.250	0.638

PS 300 H - Channel with Holes

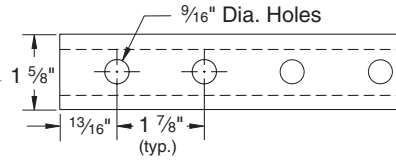
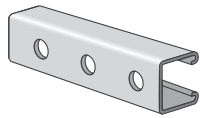

Weight: 165 lbs./100 ft.

PS 300 EH – Channel with Elongated Holes

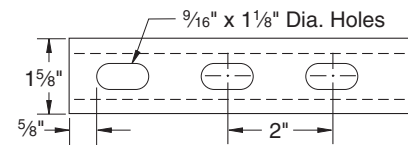
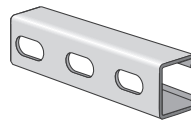

Weight: 165 lbs./100 ft.

PS 300 S - Channel with Slots

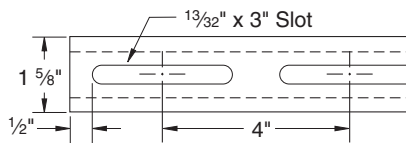
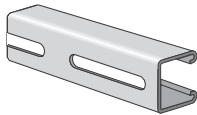

Weight: 165 lbs./100 ft.

PS 300 2T3 EH – Channel with Elongated Holes

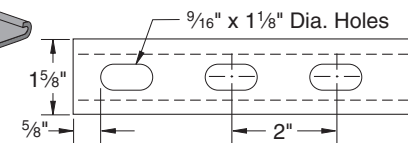
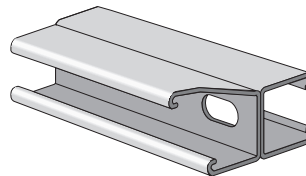

Weight: 340 lbs./100 ft.

PS 300 2T3 – Steel Channel (1 5/8" x 2 3/4" x 12 ga.)

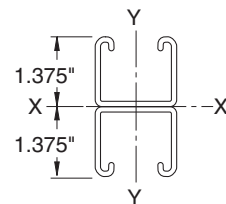
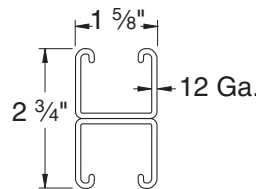
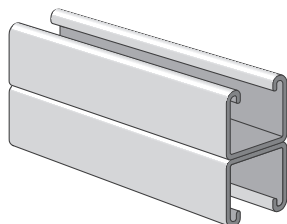

ELEMENTS OF SECTION – PS 300 2T3

Weight (lbs./100 ft.)	Area of Section (Inch ²)	X-X Axis			Y-Y Axis		
		Moment of Inertia (Inch ⁴)	Section Modulus (Inch ³)	Radius of Gyration (Inch)	Moment of Inertia (Inch ⁴)	Section Modulus (Inch ³)	Radius of Gyration (Inch)
340	1.000	0.591	0.430	0.769	0.407	0.501	0.638



PS 300 & PS 300 2T3 – Load Data

BEAM LOADING – PS 300

Span (in)	Max Allowable Uniform Load (lb)	Defl. at Uniform Load (in)	Uniform Loading at Deflection		
			Span/180 (lbs)	Span/240 (lbs)	Span/360 (lbs)
24	1,280	0.07	1,280	1,280	1,280
36	850	0.15	850	850	580
48	640	0.26	640	490	330
60	510	0.41	420	310	210
72	430	0.59	290	220	150
84	370	0.81	210	160	110
96	320	1.05	160	120	80
108	280	1.30	130	100	60
120	260	1.66	100	80	50
144	210	2.32	70	50	40
168	180	3.15	50	40	30
192	160	4.18	40	30	NR
216	140	5.21	NR	NR	NR
240	130	6.64	NR	NR	NR

* Bearing load may govern capacity.

NR - Not Recommended

This load table is based on a solid channel section.

For concentrated load at center of span, divide uniform load by 2 and multiply corresponding deflection by 0.8.

Loads include weight of channel, which must be deducted.

Loads must be multiplied by the applicable unbraced factor from page 42.

For Pierced Channels, reduce beam load values as follows:

- PS-300-EH 15%
- PS-300-S 15%
- PS-300-H 10%

COLUMN LOADING – PS 300

Unbraced Height (in)	Max. Allowable Load at Slot Face (lbs)	Maximum Column Load Applied at C.G.			
		K = 0.65 (lbs)	K = 0.80 (lbs)	K = 1.0 (lbs)	K = 1.2 (lbs)
24	3,180	9,690	8,980	8,050	7,210
36	2,920	8,160	7,210	6,130	5,240
48	2,590	6,820	5,810	4,730	3,860
60	2,300	5,740	4,730	3,690	2,990
72	2,040	4,850	3,860	2,990	2,270
84	1,830	4,100	3,240	2,400	**
96	1,650	3,530	2,770	1,840	**
108	1,450	3,080	2,270	**	**
120	1,250	2,710	1,840	**	**

** $K_L > 200$

Column loads are for allowable axial loads and must be reduced for eccentric loading.

PS300 – Crush Loads

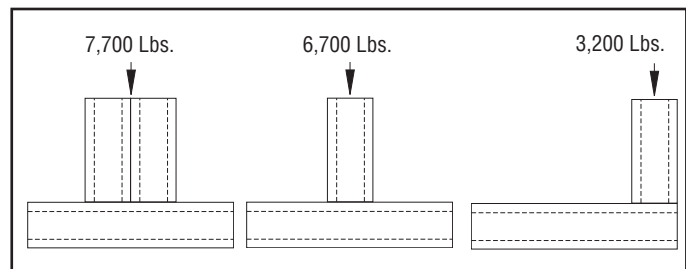

Resistance to Slip – 1,500 lbs. per bolt when 1/2" PS NS channel nuts are used.
Pull Out Strength – 2,000 lbs. per bolt when 1/2" PS NS channel nuts are used.

BEAM LOADING – PS 300 2T3

Span (in)	Max Allowable Uniform Load (lb)	Defl. at Uniform Load (in)	Uniform Loading at Deflection		
			Span/180 (lbs)	Span/240 (lbs)	Span/360 (lbs)
24	2,960 *	0.03	2,960 *	2,960 *	2,960 *
36	2,400	0.08	2,400	2,400	2,400
48	1,800	0.15	1,800	1,800	1,610
60	1,440	0.23	1,440	1,440	1,030
72	1,200	0.33	1,200	1,080	720
84	1,030	0.46	1,030	790	530
96	900	0.59	810	610	400
108	800	0.75	640	480	320
120	720	0.93	520	390	260
144	600	1.34	360	270	180
168	510	1.81	260	200	130
192	450	2.38	200	150	100
216	400	3.01	160	120	80
240	360	3.72	130	100	NR

*Load limited by spot weld shear.

† Bearing load may govern capacity.

For concentrated load at center of span, divide uniform load by 2 and multiply corresponding deflection by 0.8. This load table is based on a solid channel section.

Loads include weight of channel, which must be deducted.

Loads must be multiplied by the applicable unbraced factor from page 42.

COLUMN LOADING – PS 300 2T3

Unbraced Height (in)	Max. Allowable Load at Slot Face (lbs)	Maximum Column Load Applied at C.G.			
		K = 0.65 (lbs)	K = 0.80 (lbs)	K = 1.0 (lbs)	K = 1.2 (lbs)
24	5,740	21,780	21,200	20,430	19,720
36	5,620	20,520	19,720	18,830	17,680
48	5,520	19,400	18,570	16,570	14,260
60	5,330	18,510	16,570	13,670	10,810
72	5,030	16,850	14,260	10,810	7,730
84	4,630	14,990	11,930	8,180	5,680
96	4,190	13,090	9,720	6,260	4,350
108	3,720	11,230	7,730	4,950	**
120	3,300	9,460	6,260	4,010	**
144	2,620	6,590	4,350	**	**

** $K_L > 200$

Column loads are for allowable axial loads and must be reduced for eccentric loading.

For Pierced Channels, reduce beam load values as follows:

- PS-300 2T3 EH 15%

CHANNEL

Finish: Plain, Painted Green, or Pregalvanized Order By: No., Length and Finish



PS 400 – Steel Channel (1⁵/₈" x 1" x 12 ga.)

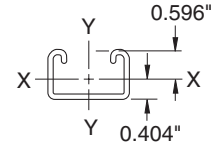
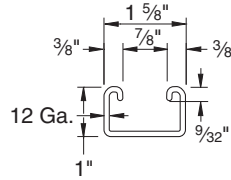
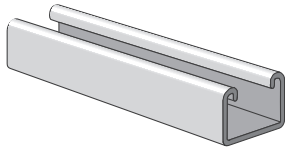

ELEMENTS OF SECTION – PS 400

Weight (lbs./100 ft.)	Area of Section (Inch ²)	X-X Axis			Y-Y Axis		
		Moment of Inertia (Inch ⁴)	Section Modulus (Inch ³)	Radius of Gyration (Inch)	Moment of Inertia (Inch ⁴)	Section Modulus (Inch ³)	Radius of Gyration (Inch)
144	0.424	0.053	0.092	0.354	0.161	0.198	0.616

PS 400 H - Channel with Holes

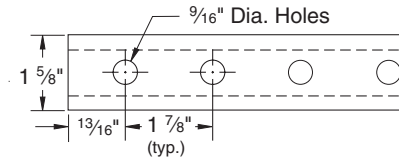
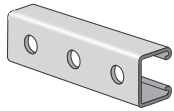

Weight: 136 lbs./100 ft.

PS 400 EH – Channel with Elongated Holes

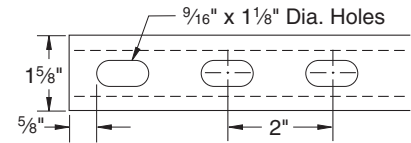
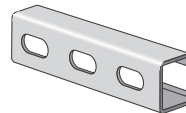

Weight: 136 lbs./100 ft.

PS 400 S - Channel with Slots

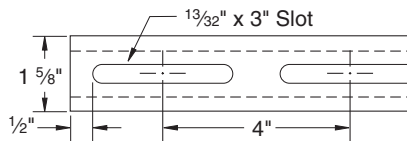
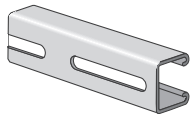

Weight: 136 lbs./100 ft.

PS 400 2T3 – Steel Channel (1⁵/₈" x 2" x 12 ga.)

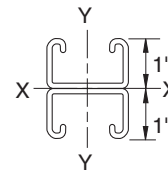
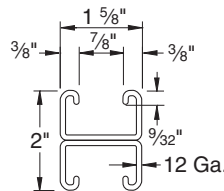
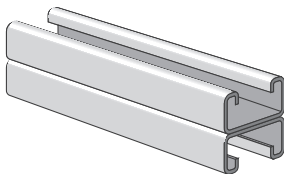

ELEMENTS OF SECTION – PS 400 2T3

Weight (lbs./100 ft.)	Area of Section (Inch ²)	X-X Axis			Y-Y Axis		
		Moment of Inertia (Inch ⁴)	Section Modulus (Inch ³)	Radius of Gyration (Inch)	Moment of Inertia (Inch ⁴)	Section Modulus (Inch ³)	Radius of Gyration (Inch)
288	0.849	0.255	0.255	0.548	0.322	0.396	0.616



Channel

PS 400 & PS 400 2T3 – Load Data

BEAM LOADING – PS 400

Span (in)	Max Allowable Uniform Load (lb)	Defl. at Uniform Load (in)	Uniform Loading at Deflection		
			Span/180 (lbs)	Span/240 (lbs)	Span/360 (lbs)
24	770	0.09	770	770	580
36	510	0.20	510	390	260
48	380	0.35	290	220	150
60	310	0.56	190	140	90
72	260	0.80	130	100	60
84	220	1.08	90	70	50
96	190	1.39	70	50	40
108	170	1.78	60	40	30
120	150	2.15	50	30	20
144	130	3.22	30	20	20
168	110	4.32	NR	NR	NR
192	100	5.87	NR	NR	NR
216	90	7.52	NR	NR	NR

* Bearing load may govern capacity.

NR - Not Recommended

This load table is based on a solid channel section.

For concentrated load at center of span, divide uniform load by 2 and multiply corresponding deflection by 0.8.

Loads include weight of channel, which must be deducted.

Loads must be multiplied by the applicable unbraced factor from page 42.

For Pierced Channels, reduce beam load values as follows:

- PS-400-EH 15%
- PS-400-S 15%
- PS-400-H 10%

COLUMN LOADING – PS 400

Unbraced Height (in)	Max. Allowable Load at Slot Face (lbs)	Maximum Column Load Applied at C.G.			
		K = 0.65 (lbs)	K = 0.80 (lbs)	K = 1.0 (lbs)	K = 1.2 (lbs)
24	2,620	8,280	7,760	7,140	6,580
36	2,470	7,210	6,580	5,310	4,030
48	2,180	6,200	4,870	3,280	2,280
60	1,770	4,760	3,280	2,100	**
72	1,420	3,450	2,280	**	**
84	1,150	2,530	1,670	**	**
96	**	1,940	**	**	**

** $K_L > 200$

Column loads are for allowable axial loads and must be reduced for eccentric loading.

PS400 – Crush Loads

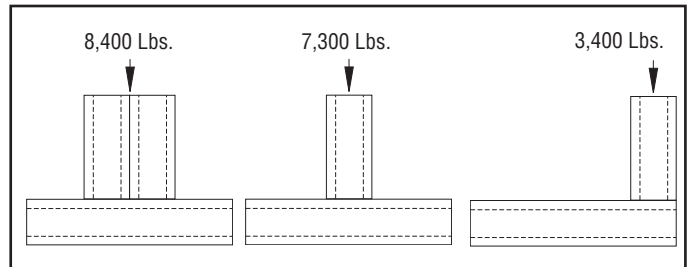

Resistance to Slip – 1,500 lbs. per bolt when 1/2" PS NS channel nuts are used.
Pull Out Strength – 2,000 lbs. per bolt when 1/2" PS NS channel nuts are used.

BEAM LOADING – PS 400 2T3

Span (in)	Max Allowable Uniform Load (lb)	Defl. at Uniform Load (in)	Uniform Loading at Deflection		
			Span/180 (lbs)	Span/240 (lbs)	Span/360 (lbs)
24	2,140 *	0.05	2,140 *	2,140 *	2,140 *
36	1,420	0.11	1,420	1,420	1,240
48	1,070	0.20	1,070	1,040	700
60	850	0.32	850	670	450
72	710	0.46	620	460	310
84	610	0.63	450	340	230
96	530	0.81	350	260	170
108	470	1.03	280	210	140
120	430	1.29	220	170	110
144	360	1.86	150	120	80
168	310	2.54	110	90	60
192	270	3.31	90	70	NR
216	240	4.19	70	NR	NR
240	210	5.03	60	NR	NR

*Load limited by spot weld shear.

† Bearing load may govern capacity.

For concentrated load at center of span, divide uniform load by 2 and multiply corresponding deflection by 0.8. This load table is based on a solid channel section.

Loads include weight of channel, which must be deducted.

Loads must be multiplied by the applicable unbraced factor from page 42.

COLUMN LOADING – PS 400 2T3

Unbraced Height (in)	Max. Allowable Load at Slot Face (lbs)	Maximum Column Load Applied at C.G.			
		K = 0.65 (lbs)	K = 0.80 (lbs)	K = 1.0 (lbs)	K = 1.2 (lbs)
24	4,720	18,310	17,840	17,300	16,760
36	4,640	17,360	16,760	15,260	13,610
48	4,470	16,280	14,720	12,460	10,170
60	4,230	14,590	12,460	9,610	6,980
72	3,930	12,750	10,170	6,980	4,840
84	3,520	10,880	7,990	5,130	3,560
96	3,070	9,050	6,130	3,920	**
108	2,690	7,340	4,840	3,100	**
120	2,360	5,940	3,920	**	**

** $K_L > 200$

Column loads are for allowable axial loads and must be reduced for eccentric loading.

CHANNEL

Finish: Plain, Painted Green, or Pregalvanized Order By: No., Length and Finish



PS 500 – Steel Channel (1 5/8" x 1 3/16" x 14 ga.)

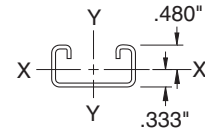
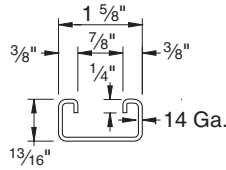
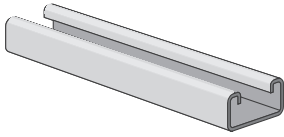

ELEMENTS OF SECTION – PS 500

Weight (lbs./100 ft.)	Area of Section (Inch ²)	X-X Axis			Y-Y Axis		
		Moment of Inertia (Inch ⁴)	Section Modulus (Inch ³)	Radius of Gyration (Inch)	Moment of Inertia (Inch ⁴)	Section Modulus (Inch ³)	Radius of Gyration (Inch)
98	0.290	0.026	0.054	0.298	0.107	0.132	0.609

PS 500 H - Channel with Holes

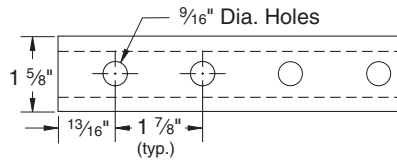
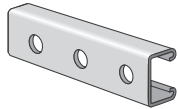

Weight: 87 lbs./100 ft.

PS 500 EH – Channel with Elongated Holes

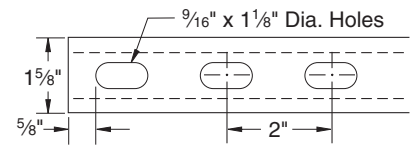
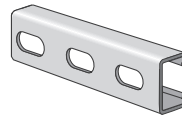

Weight: 87 lbs./100 ft.

PS 500 S - Channel with Slots

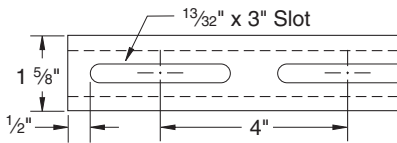
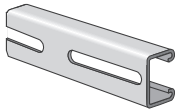

Weight: 87 lbs./100 ft.

PS 500 2T3 EH – Channel with Elongated Holes

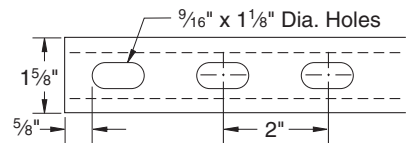
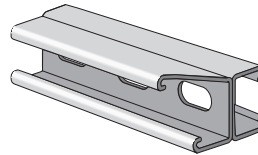

Weight: 174 lbs./100 ft.

PS 500 2T3 – Steel Channel (1 5/8" x 1 5/8" x 14 ga.)

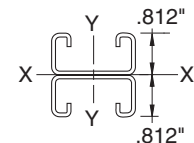
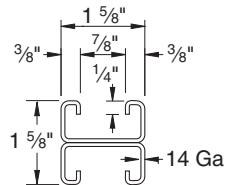
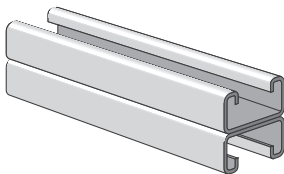

ELEMENTS OF SECTION – PS 500 2T3

Weight (lbs./100 ft.)	Area of Section (Inch ²)	X-X Axis			Y-Y Axis		
		Moment of Inertia (Inch ⁴)	Section Modulus (Inch ³)	Radius of Gyration (Inch)	Moment of Inertia (Inch ⁴)	Section Modulus (Inch ³)	Radius of Gyration (Inch)
197	0.579	0.117	0.143	0.449	0.214	0.264	0.608



Channel

PS 500 & PS 500 2T3 – Load Data

BEAM LOADING – PS 500

Span (in)	Max Allowable Uniform Load (lb)	Defl. at Uniform Load (in)	Uniform Loading at Deflection		
			Span/180 (lbs)	Span/240 (lbs)	Span/360 (lbs)
24	450	0.11	450	420	280
36	300	0.24	250	190	130
48	230	0.44	140	110	70
60	180	0.67	90	70	50
72	150	0.96	60	50	30
84	130	1.32	50	30	20
96	110	1.67	40	30	20
108	100	2.16	30	20	10
120	90	2.67	20	20	10

* Bearing load may govern capacity.

This load table is based on a solid channel section.

For concentrated load at center of span, divide uniform load by 2 and multiply corresponding deflection by 0.8.

Loads include weight of channel, which must be deducted.

Loads must be multiplied by the applicable unbraced factor from page 42.

For Pierced Channels, reduce beam load values as follows:

- PS-500-EH 15%
- PS-500-S 15%
- PS-500-H 10%

COLUMN LOADING – PS 500

Unbraced Height (in)	Max. Allowable Load at Slot Face (lbs)	Maximum Column Load Applied at C.G.			
		K = 0.65 (lbs)	K = 0.80 (lbs)	K = 1.0 (lbs)	K = 1.2 (lbs)
24	1,840	5,610	5,210	4,570	3,850
36	1,640	4,660	3,850	2,800	1,960
48	1,310	3,490	2,480	1,590	1,100
60	1,000	2,400	1,590	**	**
72	770	1,670	1,100	**	**

** $K_L > 200$

Column loads are for allowable axial loads and must be reduced for eccentric loading.

PS500 – Crush Loads

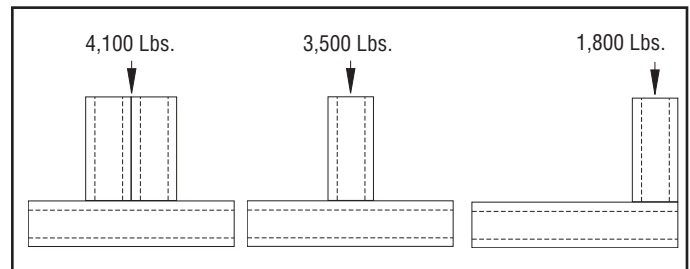

Resistance to Slip – 1,000 lbs. per bolt when 1/2" PS NS channel nuts are used.

Pull Out Strength – 1,400 lbs. per bolt when 1/2" PS NS channel nuts are used.

BEAM LOADING – PS 500 2T3

Span (in)	Max Allowable Uniform Load (lb)	Defl. at Uniform Load (in)	Uniform Loading at Deflection		
			Span/180 (lbs)	Span/240 (lbs)	Span/360 (lbs)
24	1,090 *	0.06	1,090 *	1,090 *	1,090 *
36	800	0.14	800	800	570
48	600	0.25	600	480	320
60	480	0.39	410	310	200
72	400	0.57	280	210	140
84	340	0.76	210	160	100
96	300	1.00	160	120	80
108	270	1.29	130	90	60
120	240	1.57	100	80	50

*Load limited by spot weld shear.

† Bearing load may govern capacity.

For concentrated load at center of span, divide uniform load by 2 and multiply corresponding deflection by 0.8. This load table is based on a solid channel section.

Loads include weight of channel, which must be deducted.

Loads must be multiplied by the applicable unbraced factor from page 42.

COLUMN LOADING – PS 500 2T3

Unbraced Height	Max Allowable Load at Slot Face	Max. Column Load Applied at C.G.			
		K = 0.65	K = 0.80	K = 1.0	K = 1.2
24	3,240	12,370	11,950	11,370	10,540
36	3,120	11,470	10,540	9,160	7,720
48	2,940	10,090	8,680	6,770	4,980
60	2,680	8,560	6,770	4,590	3,190
72	2,310	7,010	4,980	3,190	2,220
84	1,950	5,530	3,660	2,340	**
96	1,650	4,250	2,800	**	**
108	1,410	3,360	2,220	**	**

** $K_L > 200$

Column loads are for allowable axial loads and must be reduced for eccentric loading.

For Pierced Channels, reduce beam load values as follows:

- PS-500 2T3 EH 15%

CHANNEL

Finish: Plain, Painted Green, or Pregalvanized Order By: No., Length and Finish



PS 520 – Steel Channel (1⁵/₈" x 1³/₁₆" x 12 ga.)

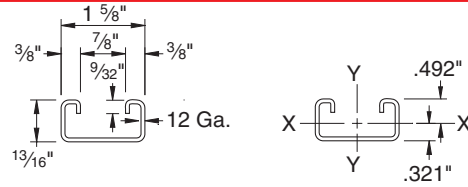
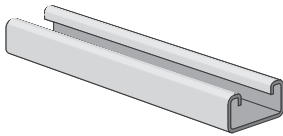

ELEMENTS OF SECTION – PS 520

Weight (lbs./100 ft.)	Area of Section (Inch ²)	X-X Axis			Y-Y Axis		
		Moment of Inertia (Inch ⁴)	Section Modulus (Inch ³)	Radius of Gyration (Inch)	Moment of Inertia (Inch ⁴)	Section Modulus (Inch ³)	Radius of Gyration (Inch)
131	0.384	0.031	0.064	0.283	0.138	0.170	0.599

PS 520 H - Channel with Holes

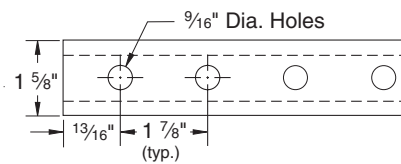
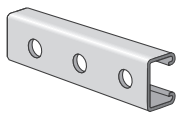

Weight: 120 lbs./100 ft.

PS 520 EH – Channel with Elongated Holes

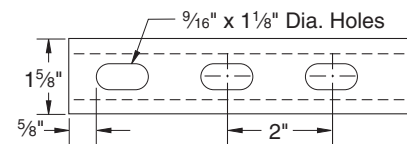
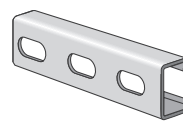

Weight: 120 lbs./100 ft.

PS 520 S - Channel with Slots

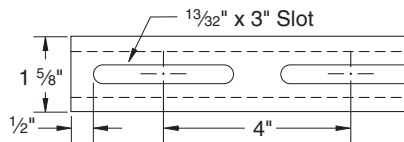
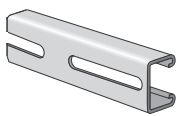

Weight: 118 lbs./100 ft.

PS 520 2T3 – Steel Channel (1⁵/₈" x 1⁵/₈" x 12 ga.)

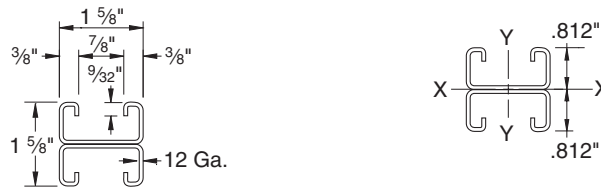
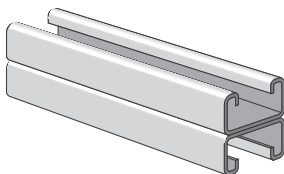

ELEMENTS OF SECTION – PS 520 2T3

Weight (lbs./100 ft.)	Area of Section (Inch ²)	X-X Axis			Y-Y Axis		
		Moment of Inertia (Inch ⁴)	Section Modulus (Inch ³)	Radius of Gyration (Inch)	Moment of Inertia (Inch ⁴)	Section Modulus (Inch ³)	Radius of Gyration (Inch)
262	0.770	0.146	0.180	0.436	0.277	0.340	0.599



PS 520 – Steel Channel (1⁵/₈" x 1³/₁₆" x 12 ga.)

BEAM LOADING – PS 520

Span (in)	Max Allowable Uniform Load (lb)	Defl. at Uniform Load (in)	Uniform Loading at Deflection		
			Span/180 (lbs)	Span/240 (lbs)	Span/360 (lbs)
24	540	0.11	540	510	340
36	360	0.24	300	220	150
48	270	0.43	170	130	80
60	220	0.68	110	80	50
72	180	0.96	70	60	40
84	150	1.27	60	40	30
96	130	1.65	40	30	20
108	120	2.16	30	20	20
120	110	2.72	30	20	NR
144	90	3.84	20	NR	NR
168	80	5.43	NR	NR	NR
192	70	7.09	NR	NR	NR

This load table is based on a solid channel section.

For concentrated load at center of span, divide uniform load by 2 and multiply corresponding deflection by 0.8.

Loads include weight of channel, which must be deducted.

Loads must be multiplied by the applicable unbraced factor from page 42.

For Pierced Channels, reduce beam load values as follows:

- PS-520-EH 15%
- PS-520-H 10%
- PS-520-S 15%

COLUMN LOADING – PS 520

Unbraced Height (in)	Max. Allowable Load at Slot Face (lbs)	Maximum Column Load Applied at C.G.			
		K = 0.65 (lbs)	K = 0.80 (lbs)	K = 1.0 (lbs)	K = 1.2 (lbs)
24	2,250	7,480	6,800	5,820	4,810
36	1,980	5,950	4,810	3,380	2,350
48	1,580	4,310	2,970	1,900	**
60	1,210	2,880	1,900	**	**
72	**	2,000	**	**	**

** KL/L > 200

Column loads are for allowable axial loads and must be reduced for eccentric loading.

PS520 – Crush Loads

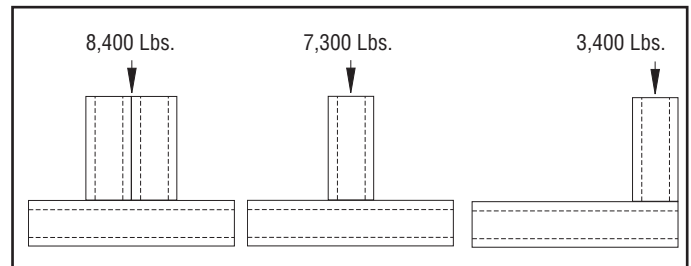

Resistance to Slip – 1,500 lbs. per bolt when 1/2" PS NS channel nuts are used.

Pull Out Strength – 1,500 lbs. per bolt when 1/2" PS NS channel nuts are used.

BEAM LOADING – PS 520 2T3

Span (in)	Max Allowable Uniform Load (lb)	Defl. at Uniform Load (in)	Uniform Loading at Deflection		
			Span/180 (lbs)	Span/240 (lbs)	Span/360 (lbs)
24	1,510	0.06	1,510	1,510	1,510
36	1,010	0.14	1,010	1,010	710
48	760	0.25	760	600	400
60	610	0.40	510	380	260
72	500	0.56	360	270	180
84	430	0.77	260	200	130
96	380	1.01	200	150	100
108	340	1.29	160	120	80
120	300	1.56	130	100	60
144	250	2.25	90	70	40
168	220	3.14	70	50	NR
192	190	4.05	50	NR	NR
216	170	5.16	NR	NR	NR
240	150	6.24	NR	NR	NR

This load table is based on a solid channel section.

For concentrated load at center of span, divide uniform load by 2 and multiply corresponding deflection by 0.8.

Loads include weight of channel, which must be deducted.

Loads must be multiplied by the applicable unbraced factor from page 42.

For Pierced Channels, reduce beam load values as follows:

COLUMN LOADING – PS 520 2T3

Unbraced Height (in)	Max. Allowable Load at Slot Face (lbs)	Maximum Column Load Applied at C.G.			
		K = 0.65 (lbs)	K = 0.80 (lbs)	K = 1.0 (lbs)	K = 1.2 (lbs)
24	4,140	16,490	15,980	14,970	13,810
36	3,980	15,100	13,810	11,910	9,940
48	3,730	13,190	11,260	8,650	6,270
60	3,390	11,090	8,650	5,780	4,010
72	2,950	8,970	6,270	4,010	2,790
84	2,510	6,980	4,610	2,950	**
96	2,130	5,340	3,530	**	**
108	1,820	4,220	2,790	**	**
120	**	3,420	**	**	**

** KL/L > 200

Column loads are for allowable axial loads and must be reduced for eccentric loading.

CHANNEL

Finish: Plain, Painted Green, or Pregalvanized Order By: No., Length and Finish



PS 560 – Steel Channel (1⁵/₈" x 1³/₁₆" x 16 ga.)

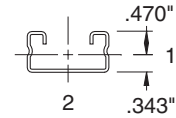
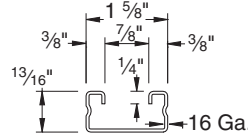
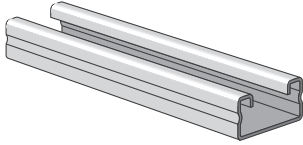

ELEMENTS OF SECTION – PS 560

Weight (lbs./100 ft.)	Area of Section (Inch ²)	X-X Axis			Y-Y Axis		
		Moment of Inertia (Inch ⁴)	Section Modulus (Inch ³)	Radius of Gyration (Inch)	Moment of Inertia (Inch ⁴)	Section Modulus (Inch ³)	Radius of Gyration (Inch)
83	0.244	0.023	0.049	0.306	0.092	0.113	0.613

PS 560 S - Channel with Slots

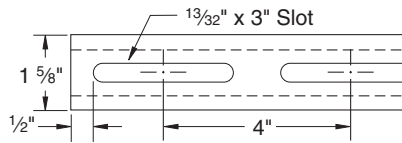
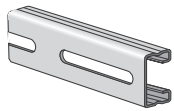

Weight: 79 lbs./100 ft.

PS 560 EH – Channel with Elongated Holes

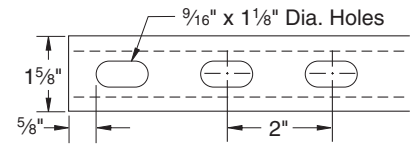
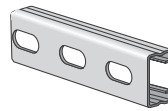

Weight: 79 lbs./100 ft.

PS 560 2T3 – Steel Channel (1⁵/₈" x 1⁵/₈" x 16 ga.)

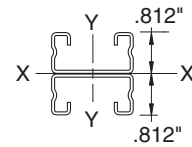
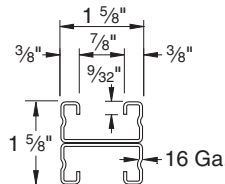
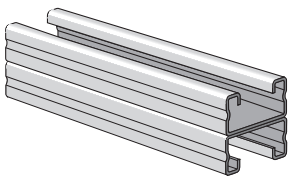

ELEMENTS OF SECTION – PS 560 2T3

Weight (lbs./100 ft.)	Area of Section (Inch ²)	X-X Axis			Y-Y Axis		
		Moment of Inertia (Inch ⁴)	Section Modulus (Inch ³)	Radius of Gyration (Inch)	Moment of Inertia (Inch ⁴)	Section Modulus (Inch ³)	Radius of Gyration (Inch)
166	0.478	0.104	0.128	0.462	0.183	0.225	0.613



Channel

PS 560 – Steel Channel (1⁵/₈" x 1³/₁₆" x 16 ga.)

BEAM LOADING – PS 560

Span (in)	Max Allowable Uniform Load (lb)	Defl. at Uniform Load (in)	Uniform Loading at Deflection		
			Span/180 (lbs)	Span/240 (lbs)	Span/360 (lbs)
24	410	0.11	410	370	250
36	270	0.24	220	170	110
48	200	0.43	120	90	60
60	160	0.67	80	60	40
72	140	1.01	60	40	30
84	120	1.38	40	30	20
96	100	1.72	30	20	20
108	90	2.20	20	20	10
120	80	2.68	20	10	10

* Bearing load may govern capacity.

This load table is based on a solid channel section.

For concentrated load at center of span, divide uniform load by 2 and multiply corresponding deflection by 0.8.

Loads include weight of channel, which must be deducted.

Loads must be multiplied by the applicable unbraced factor from page 42.

For Pierced Channels, reduce beam load values as follows:

- PS-520-EH 15%
- PS-520-S 15%

COLUMN LOADING – PS 560

Unbraced Height (in)	Max. Allowable Load at Slot Face (lbs)	Maximum Column Load Applied at C.G.			
		K = 0.65 (lbs)	K = 0.80 (lbs)	K = 1.0 (lbs)	K = 1.2 (lbs)
24	1,630	4,670	4,290	3,780	3,310
36	1,450	3,840	3,310	2,460	1,730
48	1,160	3,030	2,190	1,400	970
60	870	2,120	1,400	900	**
72	670	1,470	970	**	**

** $KL/r > 200$

Column loads are for allowable axial loads and must be reduced for eccentric loading.

PS560 – Crush Loads

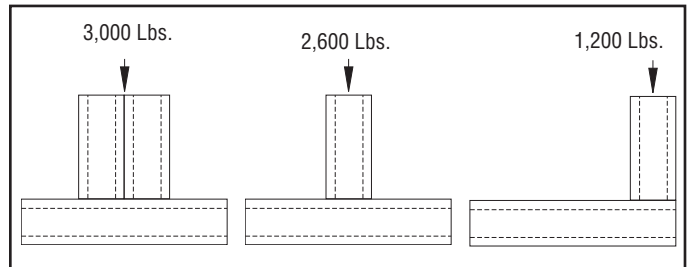

Resistance to Slip – 1,000 lbs. per bolt when 1/2" PS NS channel nuts are used.

Pull Out Strength – 1,000 lbs. per bolt when 1/2" PS NS channel nuts are used.

BEAM LOADING – PS 560 2T3

Span (in)	Max Allowable Uniform Load (lb)	Defl. at Uniform Load (in)	Uniform Loading at Deflection		
			Span/180 (lbs)	Span/240 (lbs)	Span/360 (lbs)
24	810 *	0.05	810 *	810 *	810 *
36	710	0.14	710	710	500
48	540	0.25	540	430	280
60	430	0.40	360	270	180
72	360	0.57	250	190	130
84	310	0.78	190	140	90
96	270	1.02	140	110	70
108	240	1.29	110	80	60
120	210	1.54	90	70	50
144	180	2.29	60	50	30

*Load limited by spot weld shear.

† Bearing load may govern capacity.

For concentrated load at center of span, divide uniform load by 2 and multiply corresponding deflection by 0.8. This load table is based on a solid channel section.

Loads include weight of channel, which must be deducted.

Loads must be multiplied by the applicable unbraced factor from page 42.

COLUMN LOADING – PS 560 2T3

Unbraced Height (in)	Max. Allowable Load at Slot Face (lbs)	Maximum Column Load Applied at C.G.			
		K = 0.65 (lbs)	K = 0.80 (lbs)	K = 1.0 (lbs)	K = 1.2 (lbs)
24	2,830	10,390	10,000	9,470	8,960
36	2,740	9,530	8,960	7,870	6,700
48	2,590	8,620	7,480	5,910	4,440
60	2,340	7,380	5,910	4,090	2,840
72	2,020	6,110	4,440	2,840	1,970
84	1,700	4,880	3,260	2,090	**
96	1,440	3,780	2,500	**	**
108	1,230	2,990	1,970	**	**

** $KL/r > 200$

Column loads are for allowable axial loads and must be reduced for eccentric loading.

PS 6153 - Strut Safety End Cap

(For OSHA Req'd End of Hand Rail)

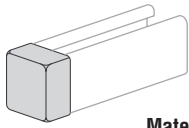

Material: Red Colored PVC

Part No.	Use With	Wt./100 pcs.
PS-6153-1	PS-100, PS200 2T3	5.0
PS-6153-2	PS-200,PS-210	2.8
PS-6153-3	PS-300	2.5
PS-6153-5	PS-500, PS-520, PS560	2.0

PS 6152 – Decorative End Cap

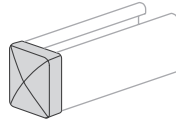

Finish: Electro-galvanized
Use With: PS-200, PS-210

Weight: 10 lbs./100 pcs.

PS 9050 – Green Touch-up Spray Paint



Aerosol can may be subject to shipping restrictions

Weight: 253 lbs./100 boxes

Lateral Bracing Load Reduction Charts

Lateral Bracing Factors										
Span		Single Channel								
Ft.	In	PS 100	PS 150	PS 200	PS 210	PS 300	PS 400	PS 500	PS 520	PS 560
2	24	0.98	0.99	1.00	1.00	1.00	1.00	1.00	1.00	1.00
3	36	0.85	0.89	0.94	0.89	0.96	1.00	0.98	1.00	0.94
4	48	0.70	0.77	0.88	0.78	0.91	0.98	0.94	1.00	0.88
5	60	0.55	0.67	0.82	0.68	0.88	0.96	0.91	1.00	0.83
6	72	0.44	0.58	0.78	0.59	0.84	0.94	0.89	0.98	0.79
7	84	0.38	0.51	0.75	0.52	0.82	0.92	0.86	0.97	0.75
8	96	0.33	0.46	0.71	0.47	0.79	0.91	0.84	0.96	0.72
9	108	0.30	0.42	0.69	0.43	0.77	0.89	0.82	0.95	0.69
10	120	0.28	0.40	0.66	0.40	0.75	0.87	0.80	0.93	0.66
12	144	0.24	0.36	0.61	0.36	0.70	0.84	0.76	0.91	0.60
14	168	0.22	0.32	0.55	0.32	0.66	0.81	0.73	0.89	0.55
16	192	0.21	0.30	0.51	0.30	0.62	0.78	0.69	0.86	0.50
18	216	0.19	0.28	0.47	0.28	0.58	0.75	0.65	0.84	0.47
20	240	0.18	0.26	0.44	0.26	0.54	0.72	0.61	0.81	0.43

Lateral Bracing Factors										
Span		Double Channel								
Ft.	In	PS 100 2T3	PS 150 2T3	PS 200 2T3	PS 210 2T3	PS 300 2T3	PS 400 2T3	PS 500 2T3	PS 520 2T3	PS 560 2T3
2	24	1.00	1.00	1.00	1.00	1.00	1.00	1.00	1.00	1.00
3	36	1.00	1.00	1.00	1.00	1.00	1.00	1.00	1.00	1.00
4	48	0.97	0.98	1.00	0.98	1.00	1.00	1.00	1.00	0.98
5	60	0.90	0.93	0.97	0.93	0.98	1.00	0.96	1.00	0.93
6	72	0.83	0.87	0.93	0.87	0.95	0.97	0.92	0.97	0.88
7	84	0.76	0.81	0.89	0.82	0.92	0.95	0.89	0.95	0.83
8	96	0.68	0.76	0.85	0.76	0.88	0.92	0.85	0.92	0.79
9	108	0.61	0.70	0.81	0.70	0.85	0.90	0.81	0.90	0.74
10	120	0.54	0.64	0.78	0.65	0.82	0.87	0.78	0.87	0.69
12	144	0.43	0.53	0.70	0.54	0.76	0.82	0.71	0.83	0.60
14	168	0.35	0.45	0.63	0.45	0.70	0.77	0.64	0.78	0.51
16	192	0.30	0.39	0.56	0.39	0.64	0.72	0.57	0.73	0.44
18	216	0.27	0.34	0.49	0.34	0.58	0.67	0.50	0.68	0.39
20	240	0.24	0.30	0.44	0.31	0.52	0.62	0.45	0.63	0.35

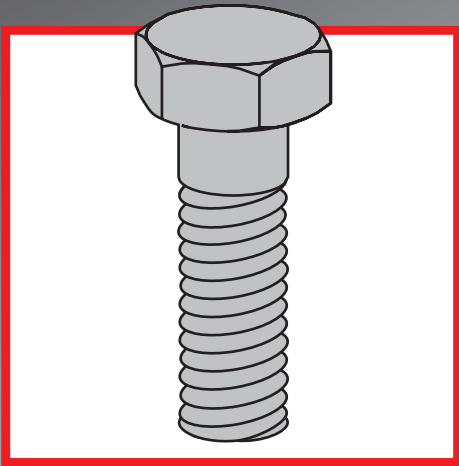

FASTENERS

Power-Strut Clamping Nuts are cold formed, with two grooves, each with six sharp teeth and then case hardened. These sharp hardened teeth bite into the inturned edges of the Power-Strut channel forming a strong vise-like connection giving greater strength and resistance to slippage.

MATERIAL:

Channel clamping nuts meet ASTM A576 GR1015M, and are case hardened. Hex head bolts meet SAE J429 GR 2. Square and hex nuts meet ASTM A563 GR A.

SCREW THREADS DATA:

All Power-Strut nuts and bolts are manufactured to meet the Unified Screw Threads standard, ANSI B1.1, Coarse Series UNC, class 2. Continuous Threaded Rod: Meets ASTM A-510.









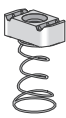

STANDARD FINISH:

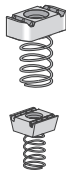
All fasteners have an electro-galvanized finish.

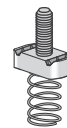
RECOMMENDED BOLT TORQUE:

Bolt Size	1/4"-20	5/16"-18	3/8"-16	1/2"-13	5/8"-11	3/4"-10
Rec. Torque Ft/Lbs	6	11	19	50	100	125
Max. Torque Ft/Lbs	7	15	25	70	125	135

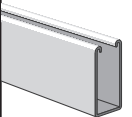
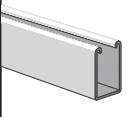
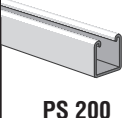
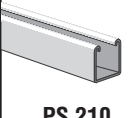
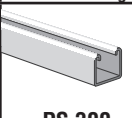
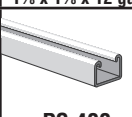
Channel Nut Selection Chart

Nuts Channel											
	PS LS	PS SS	PS RS	PS NS	PS NS S	PS 517	PS TG	PS 3281	PS 3500	PS ML	PS KW
 PS 100 1 1/2 x 3/4 x 12 ga.	✓			✓			✓	✓		✓	✓
 PS 150 1 1/2 x 2 1/4 x 12 ga.	✓			✓			✓	✓		✓	✓
 PS 200 1 1/2 x 1 1/2 x 12 ga.			✓	✓		✓	✓	✓	✓	✓	✓
 PS 210 1 1/2 x 1 1/2 x 14 ga.			✓	✓		✓	✓	✓	✓	✓	✓
 PS 300 1 1/2 x 1 1/2 x 12 ga.			✓	✓		✓	✓	✓	✓	✓	✓
 PS 400 1 1/2 x 1 x 12 ga.		✓		✓	✓		✓	✓		✓	✓
 PS 500 1 1/2 x 1 3/4 x 14 ga.		✓		✓*	✓		✓	✓		✓	✓
 PS 520 1 1/2 x 1 3/4 x 12 ga.		✓		✓*	✓		✓	✓		✓	✓
 PS 560 1 1/2 x 1 3/4 x 16 ga.		✓		✓*	✓		✓	✓		✓	✓

✓ Indicates Nuts To Be Used With The Channel

* 3/8" or smaller

PS 6024 – Hex Head Cap Screw

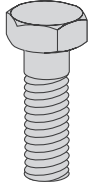

Size	Wt./100 pcs
1/4 x 3/4"	1.5
1/4 x 1"	1.8
1/4 x 1 1/4"	2.1
1/4 x 1 1/2"	2.4
3/8 x 3/4"	3.6
3/8 x 1"	4.2
3/8 x 1 1/4"	4.9
3/8 x 1 1/2"	5.6
3/8 x 2"	7.2
1/2 x 3/4"	8.1
1/2 x 1"	9.2
1/2 x 1 1/4"	10.4
1/2 x 1 1/2"	11.6
1/2 x 1 3/4"	13.0
1/2 x 2"	14.4

PS 6075 – Slotted Hex Head Machine Screw

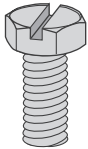

Size	Wt./100 pcs
1/4 x 3/4"	1.7
5/16 x 1"	2.6
5/16 x 1 1/4"	3.0
5/16 x 1 1/2"	3.4
3/8 x 1 1/4"	5.3

PS 6072 – Round Head Machine Screw

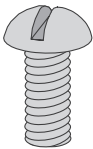

Size	Wt./100 pcs
1/4 x 3/4"	1.3
1/4 x 1"	1.6
1/4 x 1 1/4"	1.9
3/8 x 1"	4.4
3/8 x 1 1/4"	5.0
3/8 x 1 1/2"	5.6

PS 6064 – Square Head Cone Point Set Screw

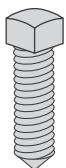

Size	Wt./100 pcs
3/8 x 1 1/2"	4.5
3/8 x 2"	6.1
1/2 x 1 1/2"	8.5
1/2 x 2"	11.4

Hanger rod stiffener assembly for 3/8" thru 5/8" threaded rod.

PS 83 – Hexagon Nut



Size	Wt./100 pcs
1/4"	0.7
3/8"	1.6
1/2"	3.8
5/8"	7.3
3/4"	11.9

PS 6108 – Square Nut



Size	Wt./100 pcs
1/4"	.9
5/16"	1.6
3/8"	2.6
1/2"	5.8

PS 209 – Flat Washer



Size Pcs.	Outside Diameter	Wt./100 pcs
1/4"	3/4"	0.7
3/8"	1"	1.5
1/2"	1 3/8"	3.9
5/8"	1 3/4"	7.7
3/4"	2"	11

PS 6112 - Oversize Square Nut

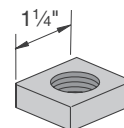

Size	Wt./100 pcs
1/4"-20	13
3/8"-16	14
1/2"-13	14
5/8"-11	12
3/4"-16	11
7/8"-11	10

FASTENERS

Finish: Electro-galvanized Order By: No., Size and Finish



PS 230 – Fender Washer



Size	Wt./100 pcs
1/4"	3.3
3/8"	3.0
1/2"	2.8

PS 211 – Lock Washer



Size	Wt./100 pcs
1/4"	0.3
3/8"	0.7
1/2"	1.5

PS 231 – Slot Adapter

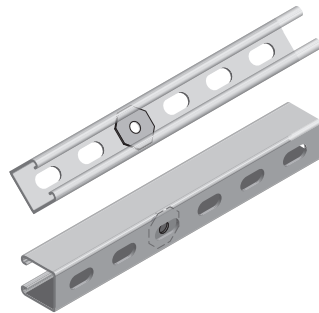
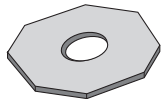

Size	Wt./100 pcs
1/4"	1.0
3/8"	1.5

PS 146 – Continuous Thread Rod

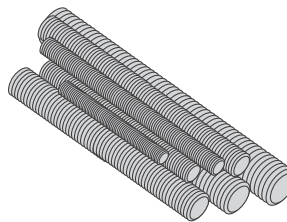

Finish: Plain or Electro-galvanized
Standard Length: 6' or 10';
 Other lengths available
 Low Carbon Steel
 Fy = 32,000 psi minimum
 Ft = 52,000 psi minimum

Rod Size	Wt./100 pcs.		
	6' Lengths	10' Lengths	12' Lengths
1/4"	73	121	146
3/8"	175	292	350
1/2"	319	531	638
5/8"	504	840	1,008
3/4"	740	1,234	1,480

PS 517 – Channel Nut with Stud

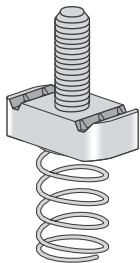

Size	Wt./100 pcs
1/4" x 1"	8.1
1/4" x 1 1/4"	8.3
1/4" x 1 1/2"	8.6
1/4" x 2"	9.1
3/8" x 1"	13.0
3/8" x 1 1/4"	14.0
3/8" x 1 1/2"	14.0
3/8" x 2"	15.0
1/2" x 1"	15.0
1/2" x 1 1/4"	16.0
1/2" x 1 1/2"	17.0
1/2" x 2"	19.0

Use With: PS 200, PS 210 and PS 300 channel.

Load Information: See the technical data section, page 158

PS 135 – Rod Coupling

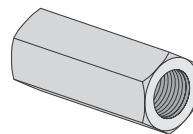

Rod Size	Max Load lbs.	Wt./100 pcs.
1/4"	240	2
3/8"	610	9
1/2"	1,130	10
5/8"	1,810	18
3/4"	2,710	28

PS 3281 – Double Conveyor Adjusting Nut

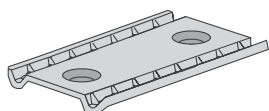

Size	Threads	Wt./100 pcs
3/8"	16	17.5

Use With: All 1 5/8" channel.

PS LS – Clamping Nut with Long Spring

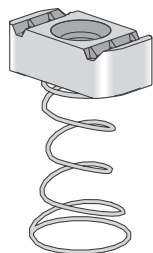

Size	Threads	Wt./100 pcs
1/4"	20	7.5
3/8"	16	10.2
1/2"	13	12.3
5/8"	11	15.8
3/4"	10	14.1

Use With: PS 100 and PS 150 Channel.

PS RS – Clamping Nut with Long Spring

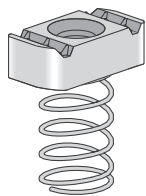

Size	Threads	Wt./100 pcs
#8-32	32	7.0
#10-24	24	7.2
#10-32	32	7.2
1/4"	20	7.1
5/16"	18	7.0
3/8"	16	9.9
1/2"	13	11.9

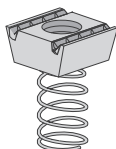

Size	Threads	Wt./100 pcs
5/8"	11	15.5
3/4"	10	13.8
7/8"	9	14.3

Use With: PS 200, PS 210 and PS 300 Channel.

PS SS – Clamping Nut with Short Spring

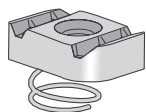

Size	Threads	Wt./100 pcs
#8-32	32	7.0
#10-24	24	7.0
#10-32	32	7.0
1/4"	20	6.9
5/16"	18	6.7
3/8"	16	9.6
1/2"	13*	8.8
5/8"	11*	11.5
3/4"	10*	10.0

Use With: PS 400, PS 500, PS 520, and PS 560 channel.

*PS SS 1/2" and PS SS 5/8" nuts have 3/8" body thickness.

PS NS – Clamping Nut without Spring

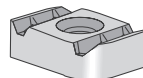

Size	Threads	Wt./100 pcs
#8-32	32*	8.0
#10-32		6.6
#10-24	24*	6.7
1/4"	20*	6.6
5/16"	18*	6.4
3/8"	16*	9.3
1/2"	13	11.4

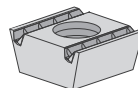

Size	Threads	Wt./100 pcs
5/8"	11	15.2
3/4"	10	13.0
7/8"	9	14.0

Use With: PS 100, PS 150, PS 200, PS 210 and PS 300 channel.

*Can be used with PS 400, PS 500, PS 520 and PS 560 channel.

PS NS S – Shallow Clamping Nut without Spring



Size	Threads	Wt./100 pcs
1/2"	13	6.9
5/8"	11	9.7
3/4"	10	8.4

Use With: PS 500, PS 520, and PS 560 channel.

PS TG – Top Grip™ Nut

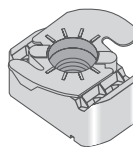

Part No.	Size	Threads	Wt./100 pcs
PSTG 1/4	1/4"	20	7
PSTG 3/8	3/8"	16	10
PSTG 1/2*	1/2"	13	8

Use With: All 1 5/8" Channel.

*PS TG 1/2" nut has a 3/8" body thickness

PS ML – Missing Link Multi-Purpose Strut Fastener

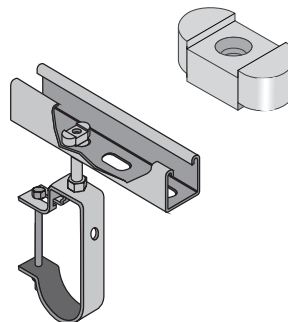

Use With: Any slotted channel.

Size	Threads	Wt./100 pcs
1/2"	13	6.9
5/8"	11	9.7
3/4"	10	8.4

FASTENERS

Finish: Electro-galvanized Order By: No., Size and Finish



PS 3500 3/8" - 5/8" – Seismic Rod Stiffener

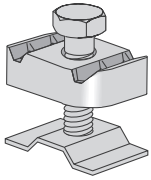

Part No.	Wt./100 pcs
PS 3500 3/8"-5/8"	16

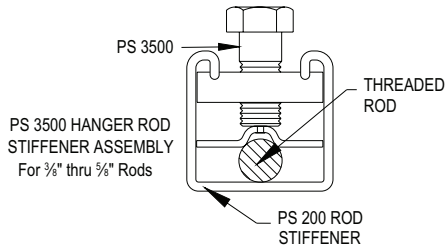

PS 202 – Eyelet

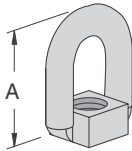

Rod Size	A	Stock Dia.	Max. Load lbs.	Wt. 100 pcs
3/8"	1 3/4"	3/8"	610	15
1/2"				18

PS 204 – Linked Eyelets

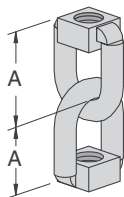

Rod Size	A	Stock Dia.	Max. Load lbs.	Wt./100 pcs
3/8"	1 7/16"	3/8"	610	23
1/2"	1 3/8"			32

PS KW – Kwik Washer™

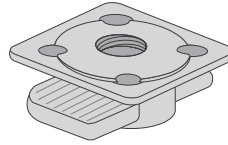

Size	Load Lbs	Wt./100 pcs
1/4"	250	1.2
3/8"	610	2.6
1/2"	1,130	9.3

Use With: Any channel.

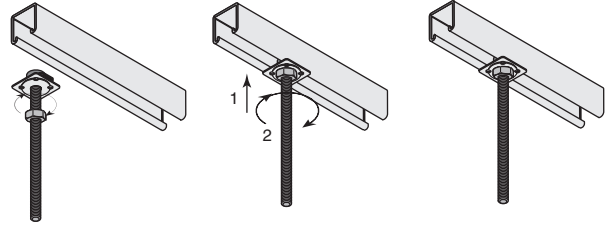

PS 205 – Eyelet with Stud

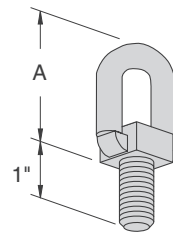

Thread Size	A	Stock Dia.	Max. Load lbs.	Wt./100 pcs
3/8"	1 13/16"	3/8"	610	16
1/2"	1 3/4"			20

PS 203 – Linked Eyelet with Stud

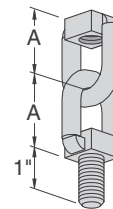

Rod Size	A	Stock Dia.	Max. Load lbs.	Wt./100 pcs
3/8"	1 7/16"	3/8"	610	27
1/2"	1 3/8"			45

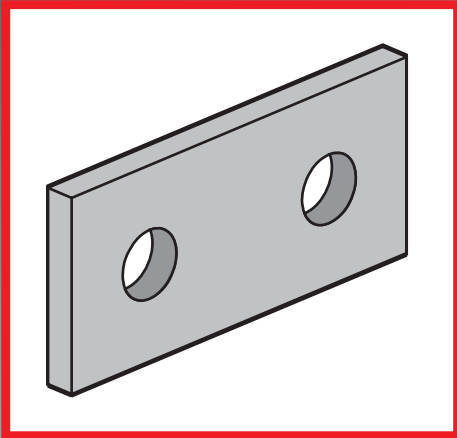

FITTINGS

Power-Strut has a wide variety of fittings to meet all of your application requirements

MATERIAL:

All Power-Strut fittings are formed in punch press dies from mild, pickled and oiled, bar or strip steel. Plain or electro-galvanized fittings meet the requirements for ASTM A575 and A-576, or ASTM A-36.

STANDARD DIMENSIONS:

Standard dimensions on all fittings are as follows except where otherwise indicated:

Fitting Thickness:	1/4"
Fitting Width:	1 5/8"
Hole Diameter:	9/16"
Hole Spacing:	1 7/8" on centers and 1 3/16" from ends.

STANDARD FINISH:

All Power-Strut fittings are available in painted green or electro-galvanized finish.

ORDERING INFORMATION:

When ordering, add the length or size and finish to the part number. See pages 8-9 for finish abbreviations and an example.

SET SCREW TORQUE:

BOLT SIZE	1/4"-20	5/16"-18	3/8"-16	1/2"-13	5/8"-11	3/4"-10
Set Screw Torque In/Lbs	40	60	125	250	400	665

Note: Caution should be taken not to overtighten the set screw

FITTINGS

Finish: Painted Green or Electro-galvanized Order By: No., Size and Finish



PS 619 – Square Washer

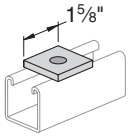

Rod Size	Hole Size	Wt./100 pcs
1/4"	11/32"	18
3/8"	7/16"	18
1/2"	9/16"	17
5/8"	11/16"	16
3/4"	13/16"	15

Note: Indicate rod size when ordering. For example, PS 619 1/2.

PS 2504 – Guided Square Washer

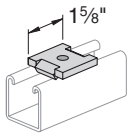

Rod Size	Hole Size	Wt./100 pcs
1/4"	11/32"	18
3/8"	7/16"	18
1/2"	9/16"	17

Note: Indicate rod size when ordering. For example, PS 2504 1/2.

PS 601 – Two-Hole Splice Plate

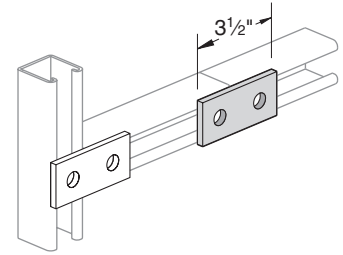

Weight/100 pcs: 38 lbs.

PS 602 – Three-Hole Splice Plate

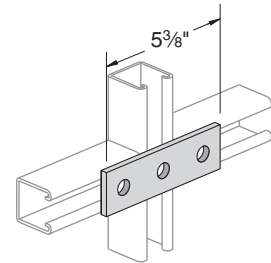

Weight/100 pcs: 50 lbs.

PS 618 – Two-Hole Swivel Plate

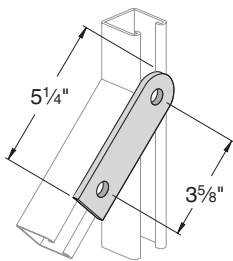

Weight/100 pcs: 55 lbs.

PS 617 – Three-Hole Swivel Plate

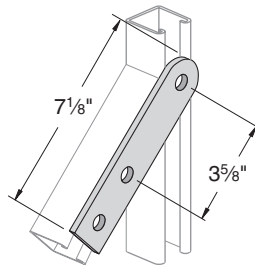

Weight/100 pcs: 75 lbs.

PS 888 – Four-Hole Splice Plate

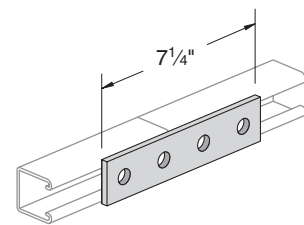

Weight/100 pcs: 78 lbs.

PS 889 – Five-Hole Splice Plate

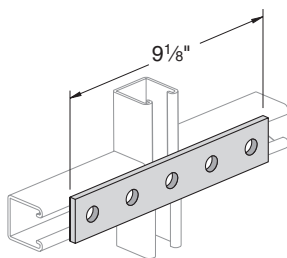

Weight/100 pcs: 94 lbs.

PS 718 – Flat Angle Plate

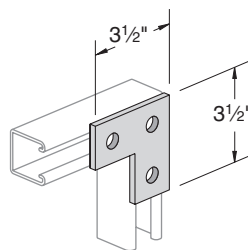

Weight/100 pcs: 58 lbs.

PS 719 – Flat Angle Plate

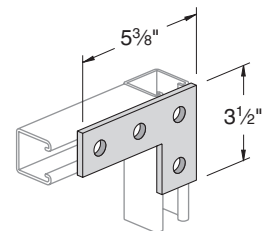

Weight/100 pcs: 80 lbs.

PS 620 – Two-Hole Connecting Plate

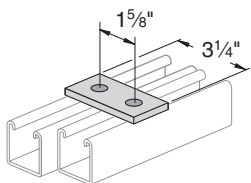

Weight/100 pcs: 35 lbs.

PS 712 – Cross Plate

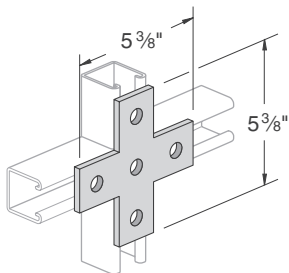

Weight/100 pcs: 105 lbs.

PS 2190 – Flat Corner Connector

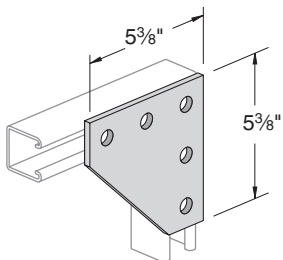

Weight/100 pcs: 150 lbs.

PS 854 – Flat Connector

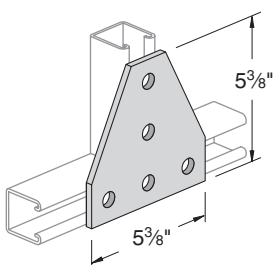

Weight/100 pcs: 148 lbs.

PS 621 – Four-Hole Connecting Plate

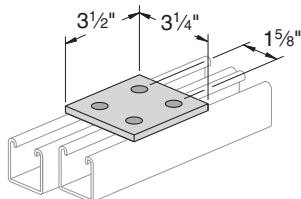

Weight/100 pcs: 73 lbs.

PS 744 – Flat Corner Connector

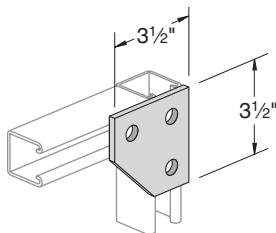

Weight/100 pcs: 70 lbs.

PS 925 – Three-Hole Joint Connector

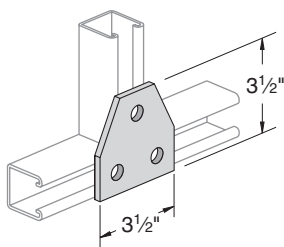

Weight/100 pcs: 70 lbs.

PS 2112 – Cross Connector

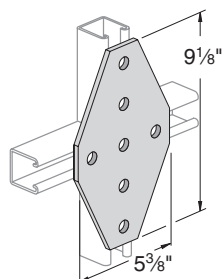

Weight/100 pcs: 240 lbs.

PS 714 – Tee Plate

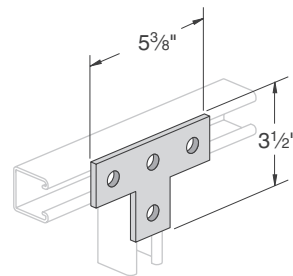

Weight/100 pcs: 80 lbs.

PS 750 – Four-Hole Corner Connector

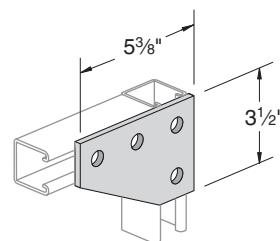

Weight/100 pcs: 105 lbs.

PS 747 – Symmetrical Four-Hole Connector

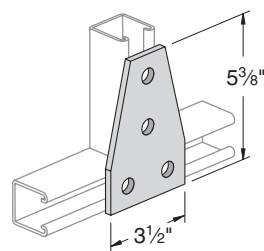

Weight/100 pcs: 105 lbs.

PS 822 – Double 45° Connector

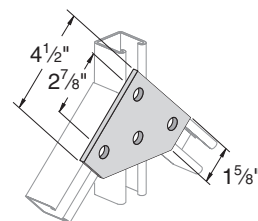

Weight/100 pcs: 112 lbs.



Fittings

FITTINGS

Finish: Painted Green or Electro-galvanized Order By: No., Size and Finish



PS 921 – One-Hole Angle

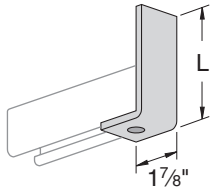

Part No.	L	Wt./100 pcs
PS 921 A	3 7/8"	61
PS 921 B	5 7/8"	84
PS 921 C	7 7/8"	107
PS 921 D	9 7/8"	130

PS 806 – Self-Aligning Two-Hole Angle

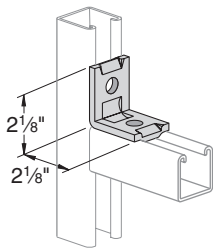

Weight/100 pcs: 40 lbs.

PS 605 – Three-Hole Corner Angle

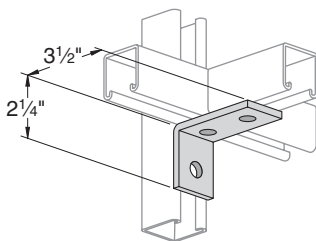

Weight/100 pcs: 58 lbs.

PS 603 – Two-Hole End Angle

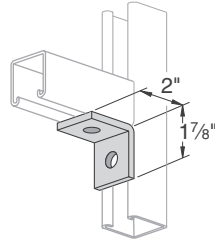

Weight/100 pcs: 38 lbs.

PS 2144 – Corner Angle

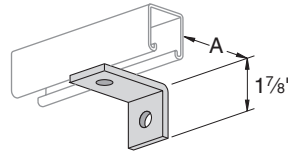

A	Wt./100 pcs
3"	49
3 1/2"	54
4"	61

PS 2520 – Slotted 90° Angle

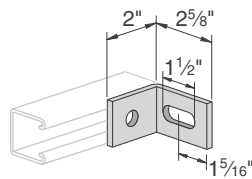

Weight/100 pcs: 42 lbs.

PS 604 – Two-Hole Corner Angle

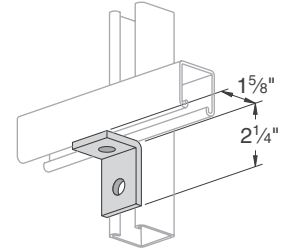

Weight/100 pcs: 38 lbs.

PS 763 – Slotted Adjustment Angle

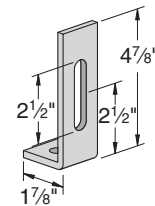

Weight/100 pcs: 65 lbs.

PS 764 – Slotted Adjustment Angle

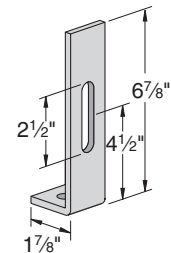

Weight/100 pcs: 85 lbs.

PS 2545 – Slotted 90° Angle

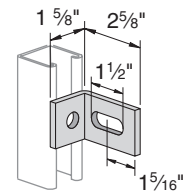

Weight/100 pcs: 38 lbs.

PS 3049 – Two-Hole Slotted 90° Angle

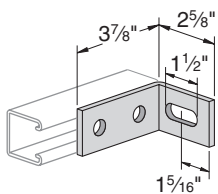

Weight/100 pcs: 66 lbs.

PS 607 – Four-Hole Corner Angle

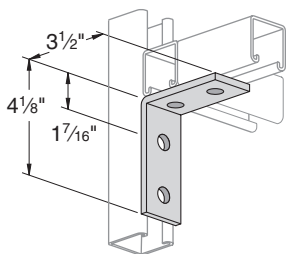

Weight/100 pcs: 78 lbs.

PS 614 – Four-Hole Joint Angle Connector

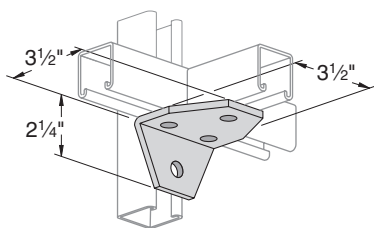

Weight/100 pcs: 103 lbs.

PS 716 R or L – Angle Tee Plate

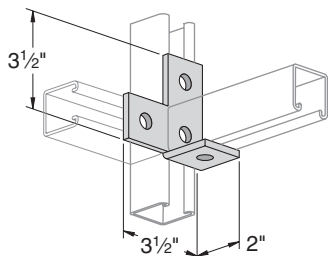

Note:
Specify R (Right) or L (Left) Right Hand Illustrated

Weight/100 pcs: 80 lbs.

PS 606 – Three-Hole Corner Angle

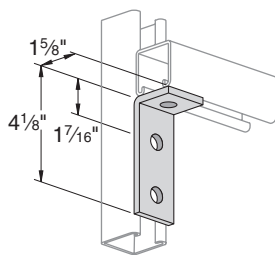

Weight/100 pcs: 58 lbs.

PS 660 – Four-Hole Corner Angle

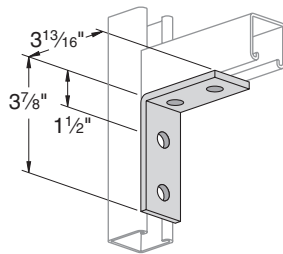

Weight/100 pcs: 78 lbs.

PS 615 – Five-Hole Joint Angle Connector

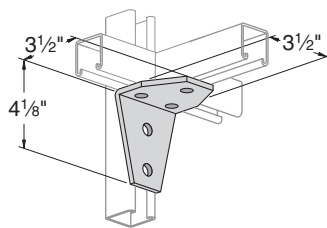

Weight/100 pcs: 135 lbs.

PS 713 – Cross Plate Angle

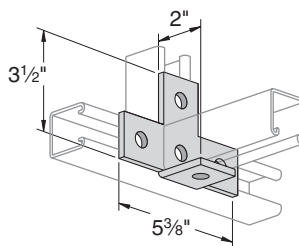

Weight/100 pcs: 105 lbs.

PS 745 – Three-Hole Corner Angle

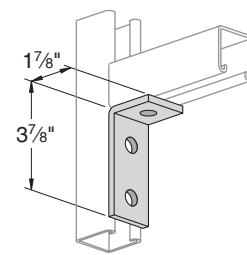

Weight/100 pcs: 58 lbs.

PS 3373 – Universal Corner Connector

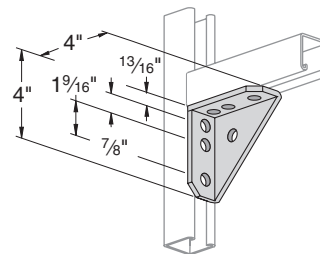

Weight/100 pcs: 134 lbs.

PS 720 R or L – Angle Plate Connector

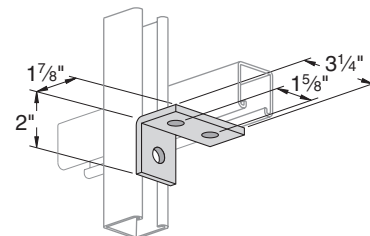

Note:
Specify R (Right) or L (Left) Right Hand Illustrated

Weight/100 pcs: 55 lbs.

PS 715 – Tee Plate 90° Angle

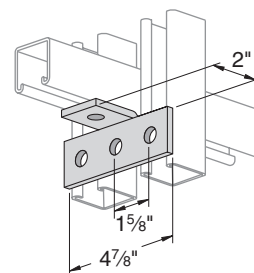

Weight/100 pcs: 71 lbs.



Fittings

FITTINGS

Finish: Painted Green or Electro-galvanized Order By: No., Size and Finish



PS 689A, PS 689B – Double-Slotted Corner Connector

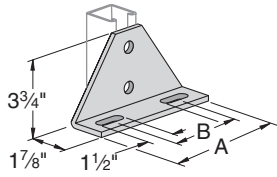

Part No.	A	B	Wt./100 pcs
PS 689 A	6 5/8"	4"	190
PS 689 B	8 5/8"	6"	242

PS 927 – Five-Hole Corner Connector

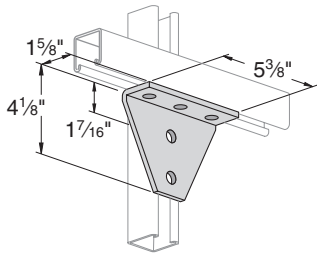

Weight/100 pcs: 154 lbs.

PS 2007 R or L – Six-Hole Corner Connector

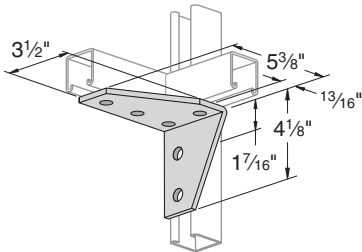

Note:
Specify R (Right) or L (Left) Right Hand Illustrated
Weight/100 pcs: 160 lbs.

PS 748 – Four-Hole Corner Joint Connector

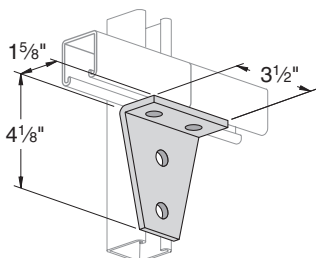

Weight/100 pcs: 105 lbs.

PS 746 – Three-Hole Corner Joint Connector

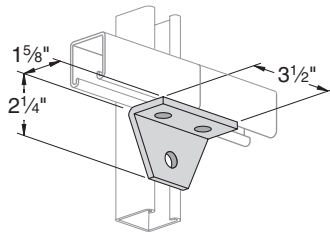

Weight/100 pcs: 70 lbs.

PS 752 R or L – Four-Hole Corner Connector

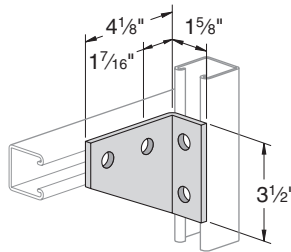

Note:
Specify R (Right) or L (Left) Right Hand Illustrated
Weight/100 pcs: 105 lbs.

PS 3326 R or L – Six-Hole Gussetted Corner Connector

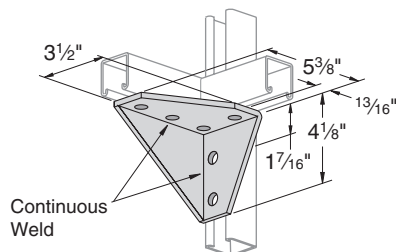

Note:
Specify R (Right) or L (Left) Right Hand Illustrated
Weight/100 pcs: 230 lbs.

PS 2113 – Slotted Corner Connector

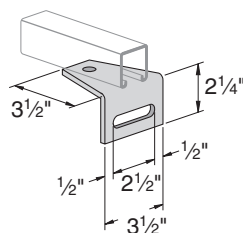

Weight/100 pcs: 97 lbs.

PS 622 – Four-Hole Corner Connector

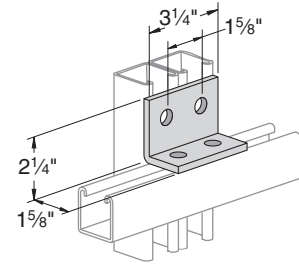

Weight/100 pcs: 75 lbs.

PS 624 – Two-Hole Closed Angle Connector

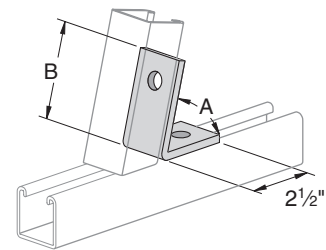

"B" In.	"A" Angle
3"	37 1/2°
3 1/8"	45°
3 1/4"	52 1/2°
3 1/2"	60°
3 3/4"	67 1/2°
3 7/8"	75°
4"	82 1/2°

Weight/100 pcs: 58 lbs.

PS 926 – Strut Brace

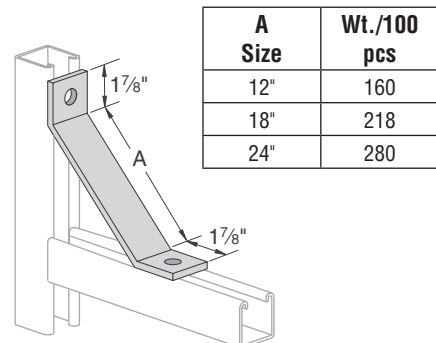

A Size	Wt./100 pcs
12"	160
18"	218
24"	280

PS 633 – Two-Hole Open Angle Connector

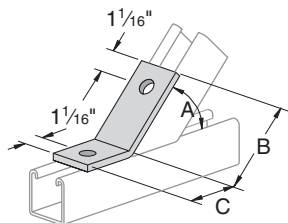

"A" Degree	"B" In.	"C" In.
82½°	3¾"	1 11/16"
75°	3¾"	
67½°	3½"	1¾"
60°	3¾"	1 7/8"
52½°	3¼"	2 1/16"
45°	3"	2 5/16"
37½°	2 11/16"	2 5/8"
30°	3 1/4"	2 1/16"
22½°	3 5/16"	
15°	3 5/16"	
7½°	3 5/16"	

Weight/100 pcs: 58 lbs.

PS 793 – Four-Hole Closed Angle Connector

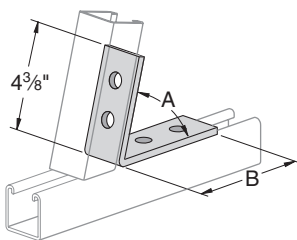

"A" Angle	"B" In.
37½°	4 7/8"
45°-	4 15/16"
52½°	
60°	5"
67½°	5 1/16"
75°	
82½°	

Weight/100 pcs: 100 lbs.

PS 781 – Four-Hole Open Angle Connector

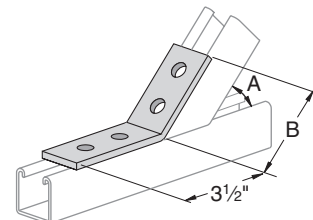

"A" Angle	"B" In.
7½°	3¾"
15°	
22½°	
30°	3 11/16"
37½°	
45°	
52½°	
60°	3 5/8"
67½°	
75°	
82½°	

Weight/100 pcs: 78 lbs.

PS 2054 – Corner Connector

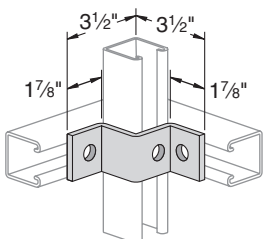

Use With: PS 200, PS 210

Weight/100 pcs: 66 lbs.

PS 9401 – Double Adjustable Brace

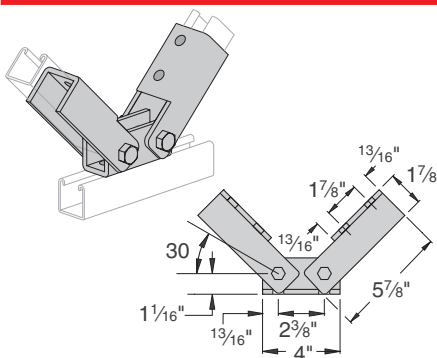

Weight/100 pcs: 307 lbs.

PS 9400 – Adjustable Brace

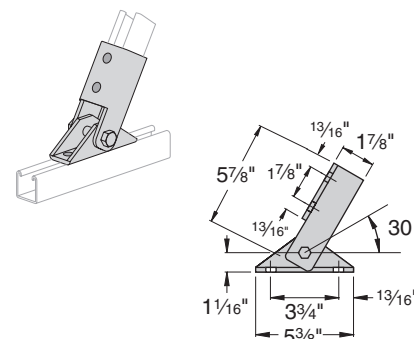

Weight/100 pcs: 307 lbs.

PS 810 – Diagonal Tube Brace

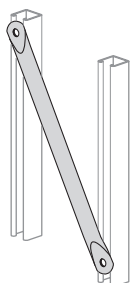

Part No.	A Size	Wt./100 pcs
PS 810 36	3'-0"	205
PS 810 42	3'-6"	237
PS 810 48	4'-0"	270

Note: 30° to 60° angle between the brace and channel is recommended for maximum effect.

Material: 1" dia. electric welded tubing

Stock Thickness: (.075) 14 ga.

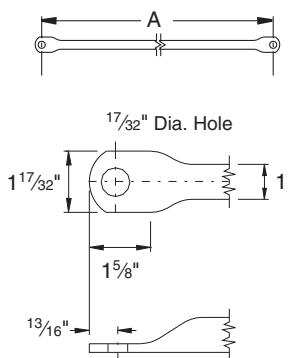

PS 9402 – Two-Hole Hinge Connector

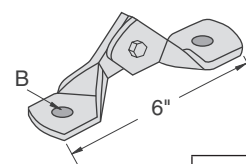

"B" Bolt Size	Wt./100 pcs
½"	108
5/8"	107
¾"	106

FITTINGS

Finish: Painted Green or Electro-galvanized Order By: No., Size and Finish



PS 9404 – Four-Hole Hinge Connector

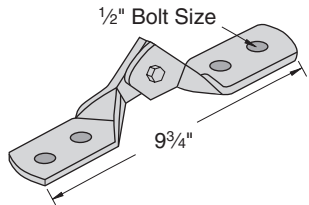

Part No.	Wt./100 pcs
PS 9404-1/2"	126

PS 692 – 1 5/8" Offset Zee Connector

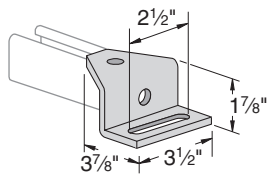

Weight/100 pcs: 102 lbs.

PS 2523 – Offset Adjustable Zee Connector

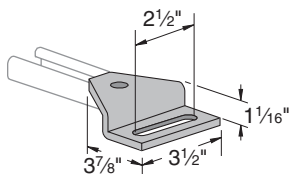

Use With: PS 500, PS 520, & PS 560

Weight/100 pcs: 70 lbs.

PS 2532 – Shelf Attachment Zee

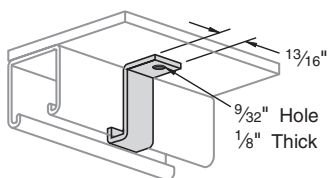

Stock Thickness: 1/8"

Use With: PS 200, PS 210

Weight/100 pcs: 9 lbs.

PS 9403 – Three-Hole Hinge Connector

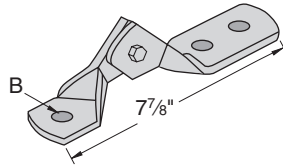

"B" Bolt Size	Wt./100 pcs
1/2"	108
5/8"	107
3/4"	106

Hinge Connect or Auto-Alignment Guides -

The unique edges of the two hinges have been designed to provide an alignment guide for 0°, 45° and 90° as shown in the drawings below.

This eliminates the need for measuring gages.

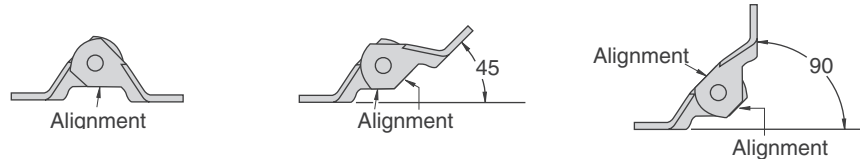

- Each half of the hinge is formed and welded for maximum strength.
- Hinged with Grade 5 bolt for superior strength.
- The nylon insert locknut prevents loosening of the hinge.

PS 812 – 45° Diagonal Tube Brace

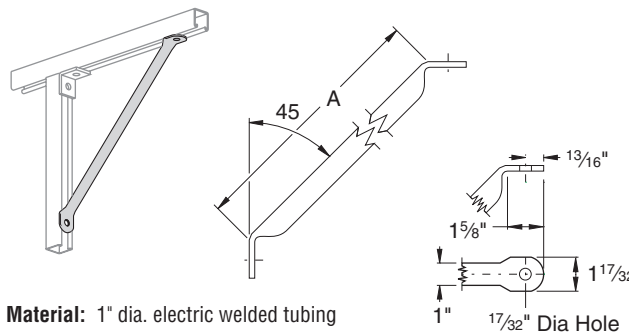

Material: 1" dia. electric welded tubing

Stock Thickness: (.075) 14 ga.

A Size	Wt./100 pcs
12"	88
18"	116
24"	149
30"	181
36"	214

Design Load:
Tension = 300 lbs.
Comp. = 1,500 lbs.

PS 3060 – Offset Connector

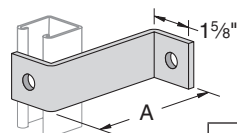

A	Wt./100 pcs
4"	81
5"	92
6"	104
7"	115
8"	127

PS 647 – 1 7/8" Offset Zee Connector

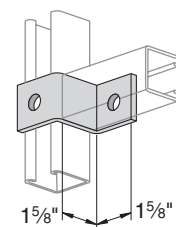

Use With: PS 200, PS 210

Weight/100 pcs: 55 lbs.

PS 756 – Zee Support

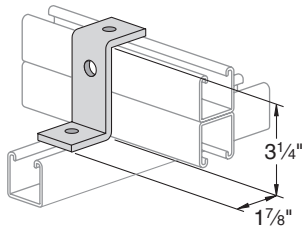

Use With: PS 100, PS 200 2T3, PS 210 2T3
Weight/100 pcs: 70 lbs.

PS 711 – Zee Support

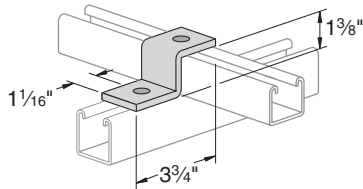

Use With: PS 300
Weight/100 pcs: 53 lbs.

PS 609 – Two-Hole Offset Plate Connector

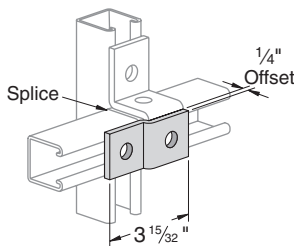

Weight/100 pcs: 38 lbs.

PS 613 – "U" Support

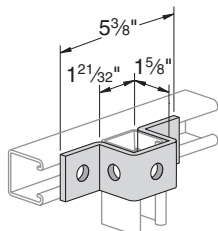

Use With: PS 200, PS 210

Weight/100 pcs: 88 lbs.

PS 2601 – Zee Support

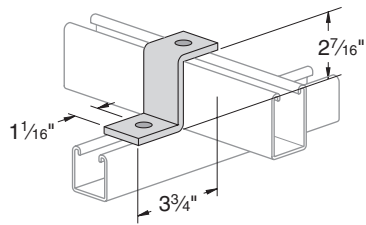

Use With: PS 150
Weight/100 pcs: 70 lbs.

PS 612 – Zee Support

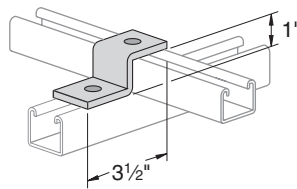

Use With: PS 400
Weight/100 pcs: 47 lbs.

PS 679 – "U" Support

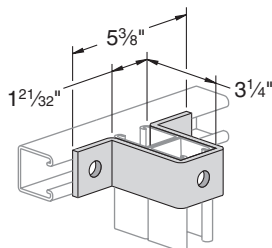

Use With: PS 100, PS 200 2T3, PS 210 2T3
Weight/100 pcs: 128 lbs.

PS 2119 – "U" Support

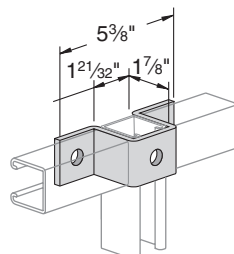

Use With: PS 200, PS 210

Weight/100 pcs: 95 lbs.

PS 611 – Zee Support

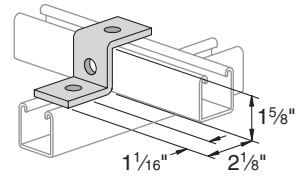

Use With: PS 200, PS 210
Weight/100 pcs: 55 lbs.

PS 928 – Zee Support

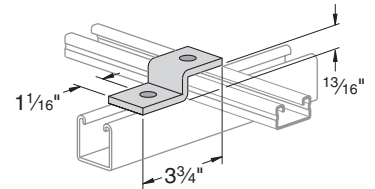

Use With: PS 500, PS 520 and PS 560
Weight/100 pcs: 47 lbs.

PS 2648 – "U" Support

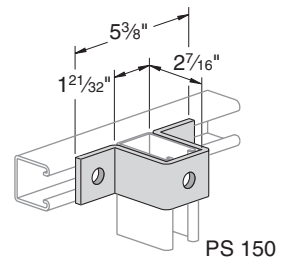

Use With: PS 150

Weight/100 pcs: 108 lbs.

PS 710 – "U" Support

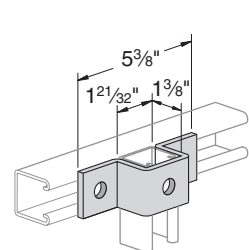

Use With: PS 300

Weight/100 pcs: 84 lbs.



Fittings

FITTINGS

Finish: Painted Green or Electro-galvanized **Order By:** No., Size and Finish



PS 978 - "U" Support

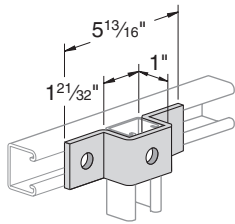

Use With: PS 400

Weight/100 pcs: 71 lbs.

PS 929 - "U" Support

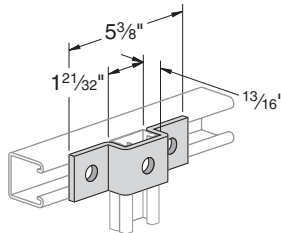

Use With: PS 500, PS 520 and PS 560

Weight/100 pcs: 71 lbs.

PS 721 - "U" Support

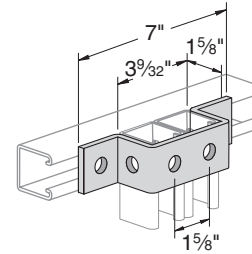

Use With: PS 100, PS 200 2T3, PS 210 2T3

Weight/100 pcs: 105 lbs.

PS 678 - Three-Hole "U" Support

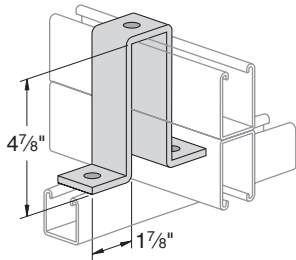

Use With: PS 150 2T3

Weight/100 pcs: 197 lbs.

PS 687A, PS 687B & PS 687C - Slotted "U" Support

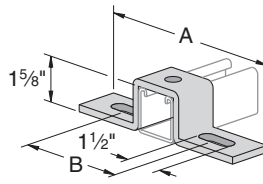

Use With: PS 200, PS 210

Order No.	'A' Length	'B' Length	Wt./100 pcs
PS 687A	7 1/4"	4 1/8"	105
PS 687B	8 1/2"	5 3/8"	120
PS 687C	10 3/8"	7 1/4"	130

PS 677 - Cup Support for Standard Single Strut

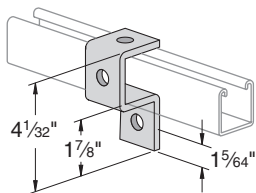

Use With: PS 200, PS 210

Weight/100 pcs: 76 lbs.

PS 733 - Six-Hole "U" Support

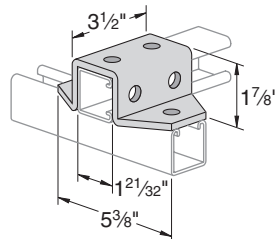

Use With: PS 200, PS 210

Weight/100 pcs: 171 lbs.

PS 734 - Eight-Hole "U" Support

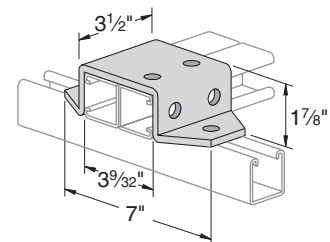

Use With: PS 200 2T3

Weight/100 pcs: 209 lbs.

PS 735 - Eight-Hole "U" Support

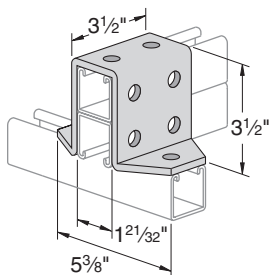

Use With: PS 200 2T3

Weight/100 pcs: 257 lbs.

PS 709 - Three-Hole Offset Plate Connection

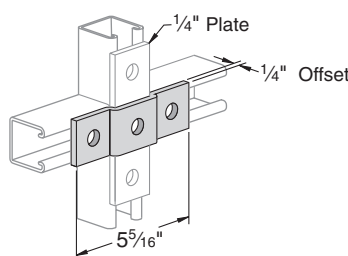

Weight/100 pcs: 58 lbs.

PS 623 - Saddle Washer

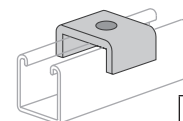

Bolt Size	Wt./100 pcs
1/4"	14
3/8"	
1/2"	13
5/8"	
3/4"	

Weight/100 pcs: 265 lbs.

PS 644 – Two-Hole Splice Clevis

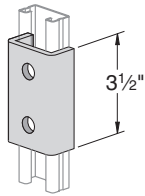

Use With: PS 500, PS 520 and PS 560

Weight/100 pcs: 85 lbs.

PS 631 – Two-Hole Splice Clevis

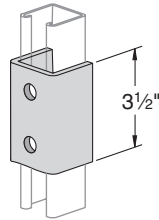

Use With: PS 200, PS 210

Weight/100 pcs: 128 lbs.

PS 645 – Three-Hole Splice Clevis

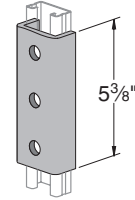

Use With: PS 500, PS 520 and PS 560

Weight/100 pcs: 130 lbs.

PS 629 – Three-Hole Splice Clevis

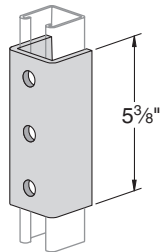

Use With: PS 200 and PS 210

Weight/100 pcs: 197 lbs.

PS 616, PS 646 – Four-Hole Splice Clevis

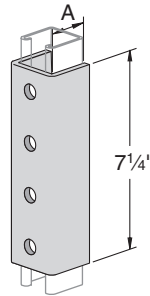

Part No.	A	For Use With	Wt./100 pcs
PS 616	1 1/16"	PS 200, PS 210	265
PS 646	1 3/16"	PS 500, PS 560	176
PS 616-100	3 3/16"	PS 100	390
PS 616-150	2 3/8"	PS 150	390

PS 804 – Slotted Joiner

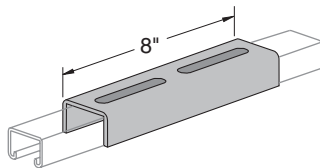

Stock Thickness: (.105)

Use With: PS 400S, PS 500S, PS 520S and PS 560S

Note: Order PS 6072 screws & PS 6108 nuts separately.

Weight/100 pcs: 80 lbs.

PS 704 – Slotted Joiner

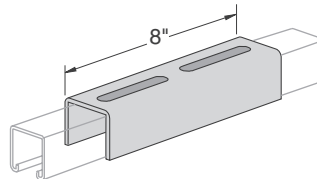

Stock Thickness: (.105)

Use With: PS 200S, PS 210S

Note: Order PS 6072 screws & PS 6108 nuts separately.

Weight/100 pcs: 197 lbs.

PS 1004 – Slotted Joiner

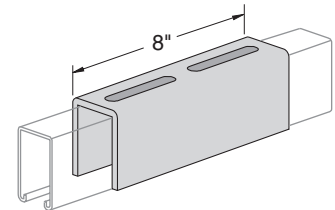

Stock Thickness: (.105)

Use With: PS 150S

Note: Order PS 6072 screws & PS 6108 nuts separately.

Weight/100 pcs: 140 lbs.

PS 993 – Inside Clevis Hanger

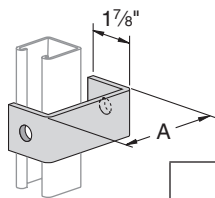

A Size	Wt./100 pcs
4"	78
5"	89
6"	101
7"	112
8"	124

PS 922 R or L – Two-Hole Corner Connector

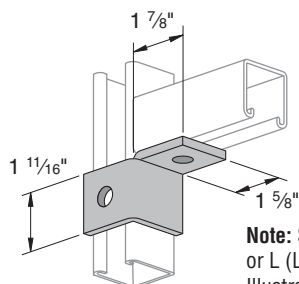

Weight/100 pcs: 60 lbs.

Note: Specify R (Right) or L (Left) Right Hand Illustrated

PS 2117 R or L – Wrap-Around Corner Connector

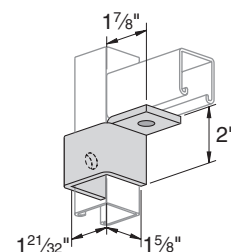

Weight/100 pcs: 75 lbs.

Note: Specify R (Right) or L (Left) Right Hand Illustrated

FITTINGS

Finish: Painted Green or Electro-galvanized Order By: No., Size and Finish



PS 2128 R or L – Four-Hole Corner Connector

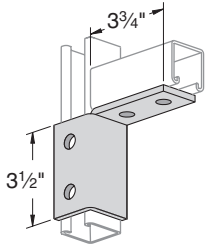

Note:
Specify R (Right) or L (Left) Right Hand Illustrated

Weight/100 pcs: 119 lbs.

PS 665 – Four-Hole Double Corner Connector

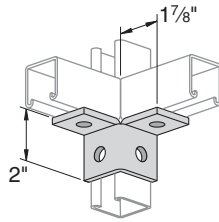

Weight/100 pcs: 76 lbs.

PS 923 – Five-Hole Double Wing Connector

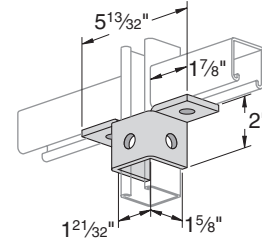

Weight/100 pcs: 93 lbs.

PS 666 – Six-Hole Double Corner Connector

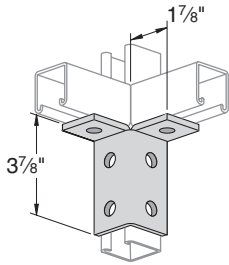

Weight/100 pcs: 115 lbs.

PS 667 – Eight-Hole Double Corner Connector

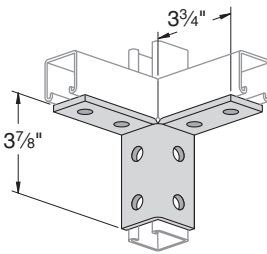

Weight/100 pcs: 155 lbs.

PS 821 – Eight-Hole Double Wing Connector

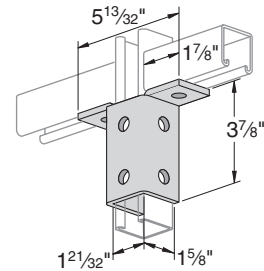

Weight/100 pcs: 150 lbs.

PS 913 – Ten-Hole Double Wing Connector

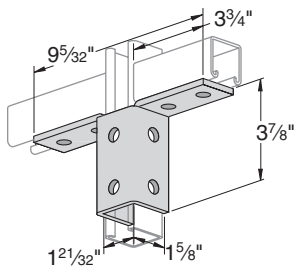

Weight/100 pcs: 193 lbs.

PS 2129 R or L – Single Corner Gussetted Connector

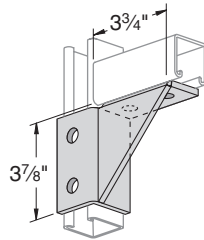

Note:
Specify R (Right) or L (Left) Right Hand Illustrated

Weight/100 pcs: 176 lbs.

PS 945 – Ten-Hole Gussetted Double Wing Connector

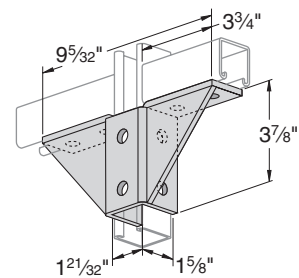

Weight/100 pcs: 274 lbs.

PS 943 – Eight-Hole Gussetted Double Corner Connector

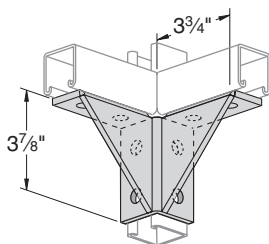

Weight/100 pcs: 217 lbs.

PS 2514 – Eight-Hole Gussetted Double Corner Connector

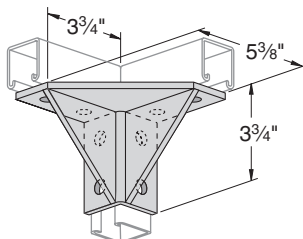

Weight/100 pcs: 315 lbs.

PS 668 – Six-Hole Triple Wing Connector

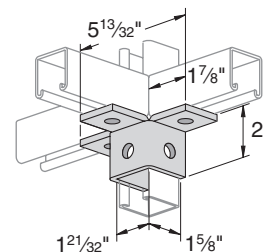

Weight/100 pcs: 113 lbs.

PS 670 – Nine-Hole Triple Wing Connector

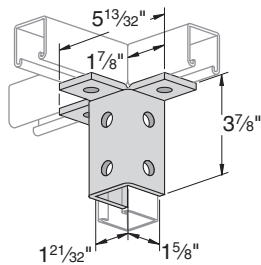

Weight/100 pcs: 177 lbs.

PS 669 – Twelve-Hole Triple Wing Connector

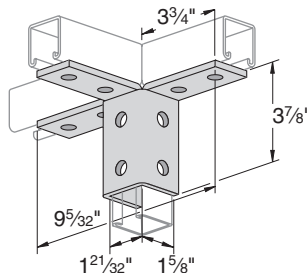

Weight/100 pcs: 230 lbs.

PS 3041 – Double-Column Post Base

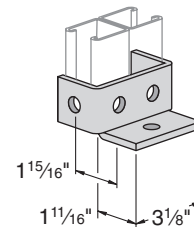

Use With: PS 100, PS 200 2T3, and PS 210 2T3.

Weight/100 pcs: 116 lbs

PS 3013, PS 3013 SQ – Post Base

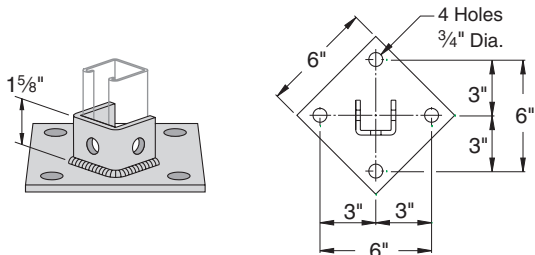

(PS 3013)

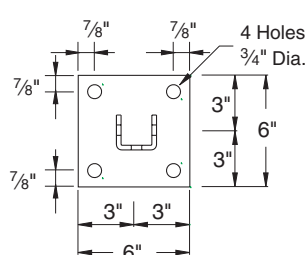

(PS 3013 SQ)

Weight/100 pcs: 307 lbs.

PS 3040 – Post Base

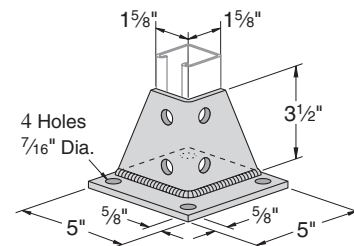

Weight/100 pcs: 297 lbs.

PS 3025, PS 3025 FL – Post Base

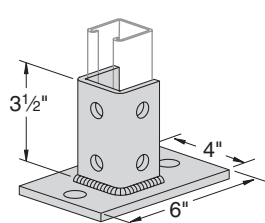

(PS 3025)

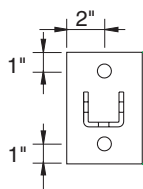

(PS 30 25 FL)

Weight/100 pcs: 358 lbs.

PS 2064 – Double-Column Post Base

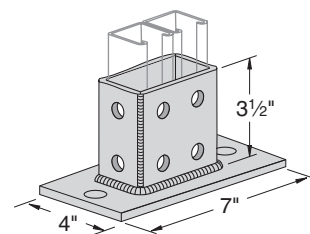

PS 3033, PS 3033 SQ – Post Base

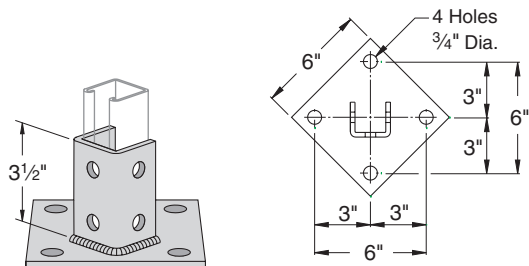

(PS 3033)

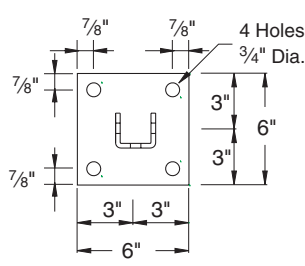

(PS 3033 SQ)

Weight/100 pcs: 373 lbs.

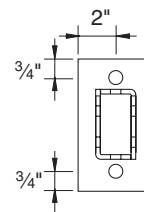

Use With: PS 100, PS 200 2T2, PS 200 2T3, PS 200 2T4 and PS 200 2T5

Weight/100 pcs: 311 lbs.

FITTINGS

Finish: Painted Green or Electro-galvanized Order By: No., Size and Finish



PS 3029 – Double-Column Post Base

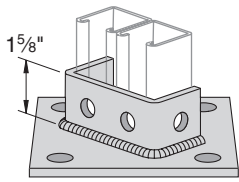

Use With: PS 100, PS 200 2T3, PS 210 2T3

Weight/100 pcs: 325 lbs.

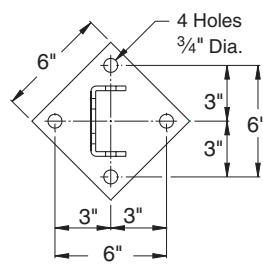

(PS 3029)

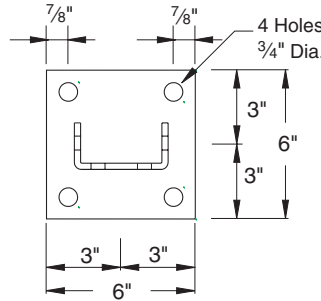

(PS 3029 SQ)

PS 3064 – Double-Column Post Base

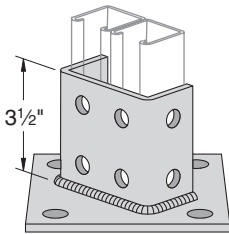

Use With: PS 100, PS 200 2T2, PS 200 2T3, PS 200 2T4 and PS 200 2T5

Weight/100 pcs: 408 lbs.

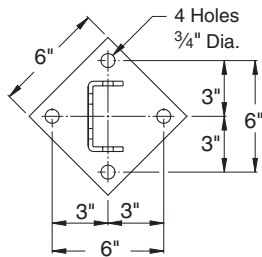

(PS 3064)

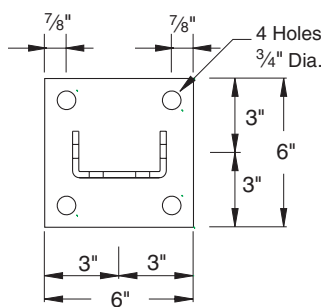

(PS 3064 SQ)

PS 2521 – Two-Wheel Trolley

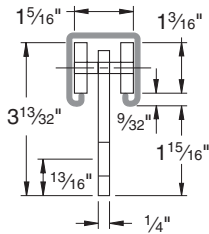
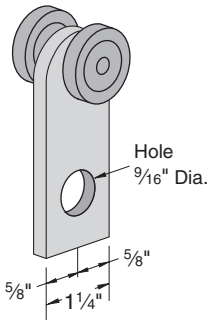

Weight/100 pcs: 46 lbs.

Material: Carbon Steel Wheels have stainless steel ball bearings

Finish: Electro-Galvanized

Use With: PS 200

Load Rating: 300 lbs.

FPM	RPM	Design Load In PS 200 Lbs
180	600	150
90	300	225
30	100	437

PS 2528 – Trolley Beam Standard Support

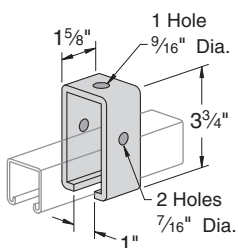

Use With: PS 200, PS 210

Load Rating: 600 lbs.

Weight/100 pcs: 102 lbs.

PS 2528 1 – Trolley Beam Heavy Support and Track Joiner

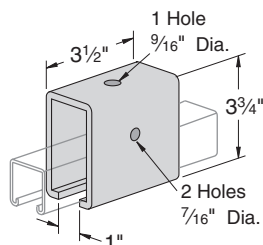

Use With: PS 200, PS 210

Load Rating: 2,500 lbs.

Weight/100 pcs: 220 lbs.

PS 2524 – Two-Bearing Light Duty Trolley

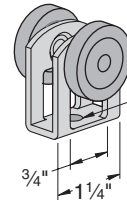

Load Rating: 50 lbs.

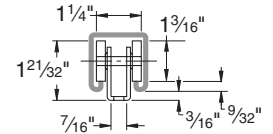

Weight/100 pcs: 21 lbs.

PS 2525 – Four-Bearing Light Duty Trolley

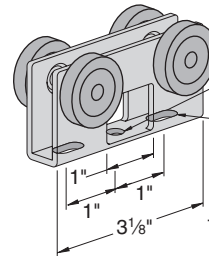

Load Rating: 100 lbs.

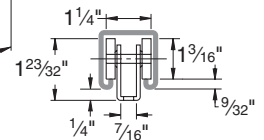

Weight/100 pcs: 55 lbs.

PS 2522 – Four-Wheel Trolley

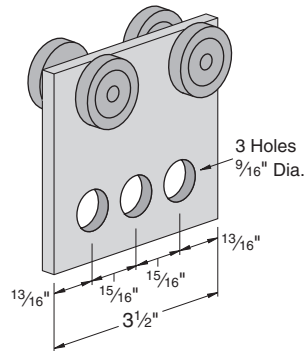

Material:

Carbon Steel Wheels have stainless steel ball bearings

Finish: Electro-Galvanized

Use With: PS 200

Load Rating: 600 lbs.

FPM	RPM	Design Load In PS 200 Lbs
180	600	300
90	300	450
30	100	600

Weight/100 pcs: 110 lbs.

PS 626 – Pipe Stop

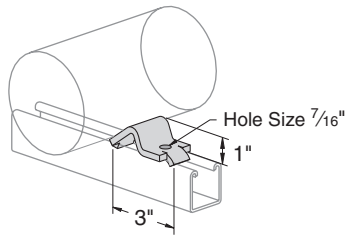

Clamp Requires bolt and channel nut sold separately.

Note: For use with 2" to 8" Pipe

Weight/100 pcs: 40 lbs.

PS 651 – Reversible Channel Bracket

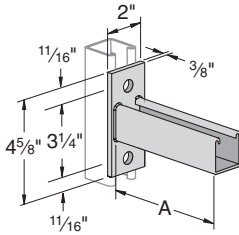

A Size	Uniform Load*	Wt./100 pcs
6"	1,200	185
12"	600	293
18"	400	401
24"	300	509
*Mounted on 12 Ga. Channel		

PS 708 – Single Channel Bracket Support

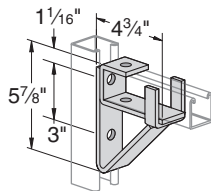

Use With: PS 200,
PS 210,
PS 500 2T3

Design Moment on Upright Channel:

- 16 ga. channel 3,200 in.-lbs.,
- 14 ga. channel 4,400 in.-lbs.
- 12 ga. channel 5,100 in.-lbs.

Note:

Moment is for fitting only.
Channel may determine overall capacity.

Weight/100 pcs: 235 lbs.

PS 661 T1, PS 661 T2 – Wrap-Around Channel Bracket

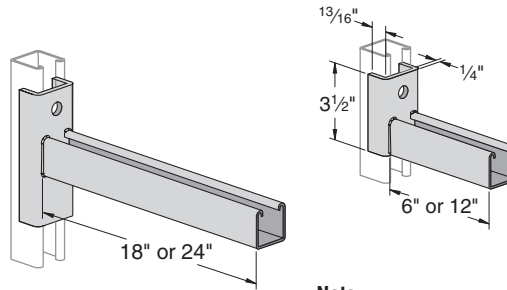

Note:
PS 661 T1 (Slot up) illustrated
PS 661 T2 (Slot down) not shown

Size	Uniform Load*	Wt./100 pcs
6"	1,600	191
12"	800	292
18"	600	436
24"	450	536
*Mounted on 12 Ga. Channel		



Fittings

PS 808 T1, PS 808 T2 – Interlocking Channel Bracket

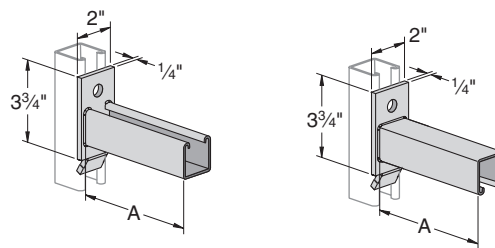

(PS 808 T1 - Slot Up)

(PS 808 T2 - Slot Down)

A Size	Uniform Load*	Wt./100 pcs
6"	1,200	161
12"	600	261
18"	400	361
24"	300	461
*Mounted on 12 Ga. Channel		

PS 809 – Double Channel Bracket

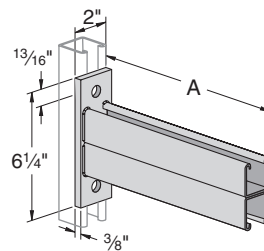

A Size	Uniform Load*	Wt./100 pcs
12"	2,000	502
18"	1,300	692
24"	1,000	882
30"	800	1,072
36"	650	1,262
*Mounted on 12 Ga. Channel		

PS 732 – Shelf Bracket

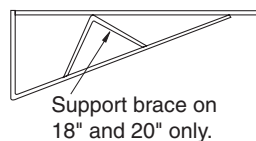
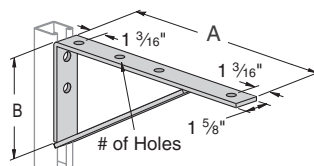

Size	A	B	# of Holes	Uniform Load*	Wt./100 pcs
8"	8 1/2"	4"	2	800	168
10"	10 1/2"		3		202
12"	12 1/2"	6"	4	900	258
14"	14 1/2"		4		292
16"	16 1/2"		4		1,200
18"	18 1/2"		4	416	
20"	20 1/2"		4	1,000	
*Mounted on 12 ga. channel					

BRACKETS



Finish: Painted Green, or Electro-galvanized Order By: No., Size and Finish

PS 3164 – Double Channel Bracket Support

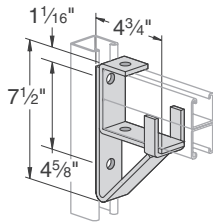

Use With: PS 200 2T3,
PS 210 2T3

Design Moment on Upright Channel:

- 16 ga. channel 6,500 in.-lbs.
- 14 ga. channel 9,100 in.-lbs.
- 12 ga. channel 13,000 in.-lbs.

Note:

Moment is for fitting only.
Channel may determine overall capacity.

Weight/100 pcs: 273 lbs.

PS 825 R or L – Single Pipe Axle Support

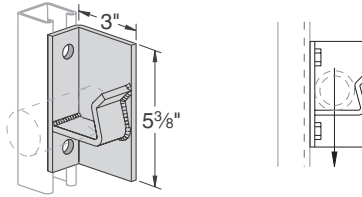

Right Hand Illustrated

Load Rating: 2,000 lbs.

Note:

Specify R (Right) or L (Left) when ordering.

Weight/100 pcs.: 220 lbs.

PS 826 – Double Pipe Axle Support

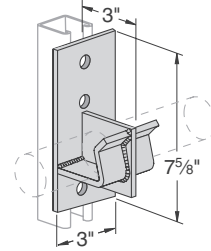

Load Rating: 4,000 lbs.

Weight/100 pcs.: 310 lbs.

PS 838 R or L – Shelf Bracket

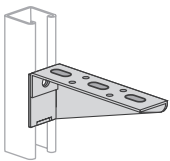

A Size	Stamped Ident. No.	B	Wt./100 pcs
6"	121892	1 ⁵ / ₁₆ "	58
8"	121893	2 ⁷ / ₁₆ "	83
10"	121894	2 ¹⁵ / ₁₆ "	114
12"	121895	3 ⁷ / ₁₆ "	49
14"	121896	3 ¹⁵ / ₁₆ "	174
16"	121897	4 ⁷ / ₁₆ "	225
18"	121898	4 ¹⁵ / ₁₆ "	255
20"	121899	5 ⁷ / ₁₆ "	295
22"	121900	5 ¹⁵ / ₁₆ "	361
24"	121901	6 ⁷ / ₁₆ "	396
26"	121902	6 ¹⁵ / ₁₆ "	456
28"	121903	7 ⁷ / ₁₆ "	479
30"	121904	7 ¹⁵ / ₁₆ "	544

Stock Thickness: .105

Note: Specify R (Right) or L (Left) when ordering.
Right Hand Illustrated

Uniform Load Rating:
275 Lbs. when mounted on 12 ga. channel.

PS 3282 – Cable Tray Strut Bracket

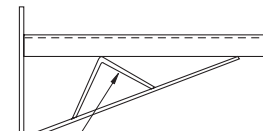
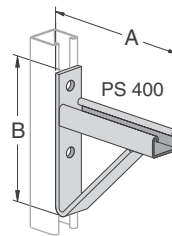

Support brace on 24", 30" and 36" only.

Note: PS 400 channel welded to 1/4" stock

A	B	Uniform Load*	Wt./100 pcs
12"	8 ³ / ₄ "	1,900	388
18"		1,000	506
24"			763
30"	11 ¹ / ₄ "	900	1,012
36"		800	1,083

*Mounted on 12 ga. channel.

PS 2404 thru PS 2408 – Wall Ladder Bracket

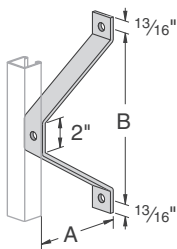

Part No.	A	B	Wt./100 pcs
PS 2404	2 ³ / ₈ "	6"	113
PS 2405	4 ³ / ₈ "	8"	164
PS 2406	6 ³ / ₈ "	10"	216
PS 2407	8 ³ / ₈ "	12"	267
PS 2408	10 ³ / ₈ "	14"	318

PS 2422 – 37 1/2° Degree Stair Tread Support

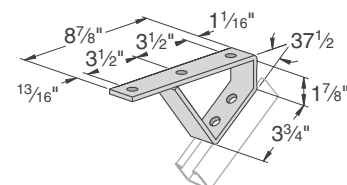

Weight/100 pcs: 213 lbs.



Fittings

PS 2421 – 45° Degree Stair Tread Support

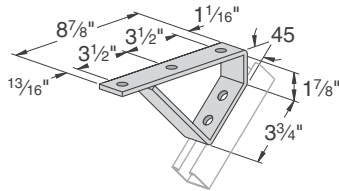

Weight/100 pcs: 220 lbs.

PS 855 – Angular “I” Beam Clamp

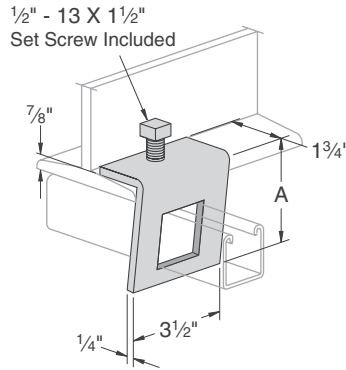

Part No.	Use With	A	Load Rating	Wt./100 pcs.
PS 855-1	PS 200, PS 210	3 1/2"	500	107
PS 855-2	PS 500			98

Use in pairs only

PS 2657 – Double U Beam Clamp

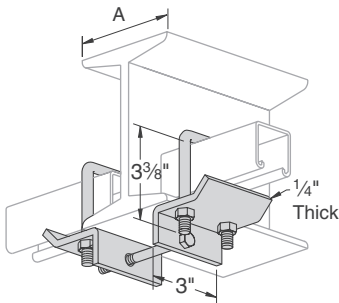

Specify 6" or 12" max. flange width (Example: PS 2657 T1-6")

T1 Use with:
PS 200, PS 210, PS 300, PS 400, PS 500, PS 520

T2 Use with:
PS 100, PS 150, PS 200 2T3

T3 Use with:
PS 150 2T3, PS 100 2T3

Part No.	"A" Beam Flange Width
PS 2657 T1-6	4" - 6"
PS 2657 T1-9	6" - 9"
PS 2657 T1-12	9" - 12"
PS 2657 T1-15	12" - 15"
PS 2657 T1-18	15" - 18"
PS 2657 T2-6	4" - 6"
PS 2657 T2-9	6" - 9"
PS 2657 T2-12	9" - 12"
PS 2657 T2-15	12" - 15"
PS 2657 T2-18	15" - 18"
PS 2657 T3-6	4" - 6"
PS 2657 T3-9	6" - 9"
PS 2657 T3-12	9" - 12"
PS 2657 T3-15	12" - 15"
PS 2657 T3-18	15" - 18"

Weight/100 pcs: 280 lbs.

PS 2656 – U Bolt Beam Clamp With Hook

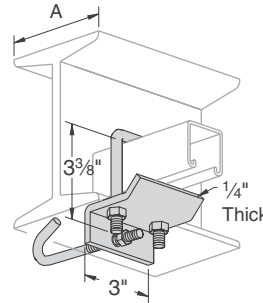

Specify 6" or 12" max. flange width (Example: PS 2656 T1-6")

T1 Use with:
PS 200, PS 210, PS 300, PS 400, PS 500, PS 520

T2 Use with:
PS 100, PS 150, PS 200 2T3

T3 Use with:
PS 150 2T3, PS 100 2T3

Part No.	"A" Beam Flange Width
PS 2656 T1-6	4" - 6"
PS 2656 T1-9	6" - 9"
PS 2656 T1-12	9" - 12"
PS 2656 T1-15	12" - 15"
PS 2656 T1-18	15" - 18"
PS 2656 T2-6	4" - 6"
PS 2656 T2-9	6" - 9"
PS 2656 T2-12	9" - 12"
PS 2656 T2-15	12" - 15"
PS 2656 T2-18	15" - 18"
PS 2656 T3-6	4" - 6"
PS 2656 T3-9	6" - 9"
PS 2656 T3-12	9" - 12"
PS 2656 T3-15	12" - 15"
PS 2656 T3-18	15" - 18"

Weight/100 pcs: 143 lbs.

PS 685 – Beam Clamp

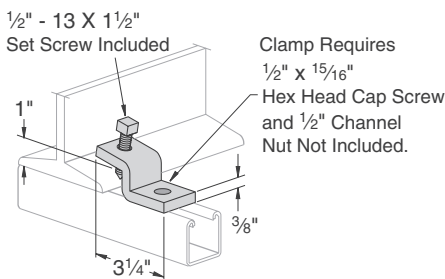

Stock Thickness: 3/8"
Load Rating: 450 lbs.

Use in pairs only

Weight/100 pcs: 63 lbs.

PS 2651 – Beam Clamp

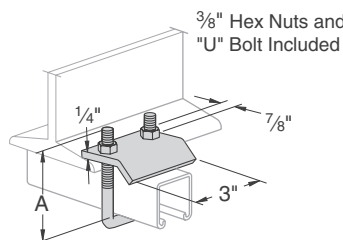

Part No.	Use With	A	Load Rating	Wt./100 pcs.
PS 2651 T1	PS 200, PS 210 PS 300, PS 400 PS 500, PS 520	3 3/8"	1,000	83
PS 2651 T2	PS 100, PS 150 PS 200 2T3	5"		92
PS 2651 T3	PS 150 2T3 PS 100 2T3	8 1/4"		112

Use in pairs only

BEAM CLAMPS

Finish: Painted Green, or Electro-galvanized **Order By:** No. and Finish **Note:** Use in pairs or with other support



PS 686 – Beam Clamp

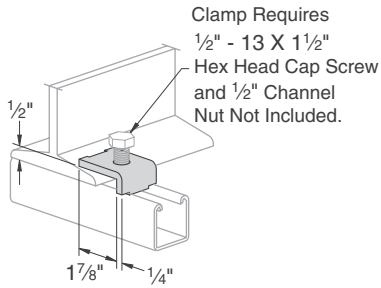

Load Rating:
Use in pairs only 600 lbs. with 12 ga. channel
500 lbs. with 14 ga. channel
Weight/100 pcs: 26 lbs.

PS 684 – "I" Beam Clamp

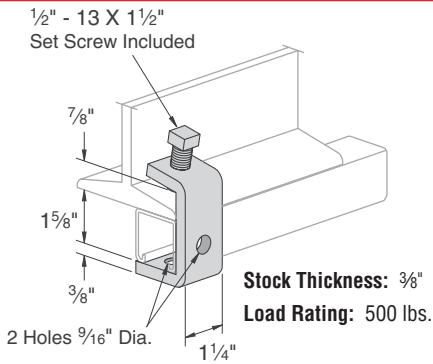

Weight/100 pcs: 94 lbs.

PS 916 – "I" Beam Clamp

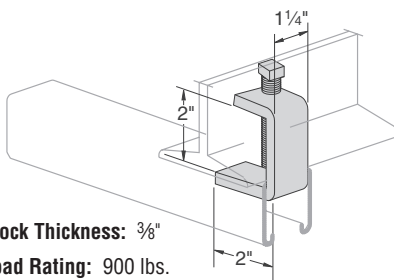

Weight/100 pcs: 72 lbs.

PS 2624 – Wood Beam Hanger

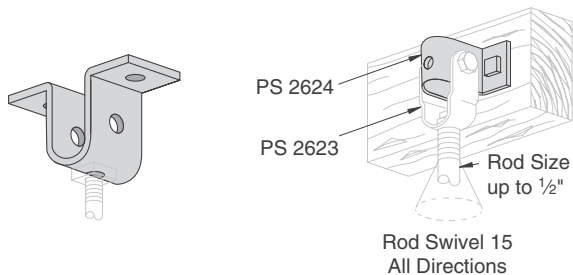

Weight/100 pcs: 22 lbs.

PS 2653 – Purlin Clamp

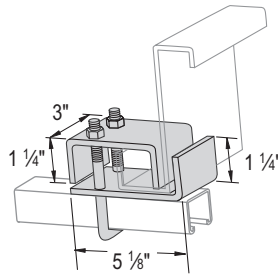

Part No.	Use With	Load Rating	Wt./100 pcs.
PS 2653 T1	PS 200, PS 210, PS 300	1,200	175
PS 2653 T2	PS 100, PS 150, PS 200 2T3		179
PS 2653 T3	PS 100 2T3		179

PS 907, PS 998 – "I" Beam Clamp

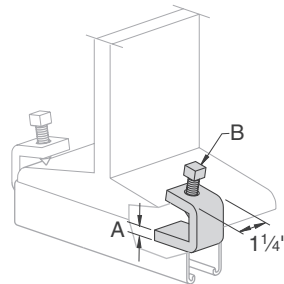

Part No.	Stock Thickness	Set Screw	Load Rating lbs.	Wt./100 pcs.
PS 907	1/4"	3/8"	450	26
PS 998	3/8"	1/2"	1,000	64

Load rating is based on 2 clamps
Use in pairs only

Maximum flange thickness is 1"

PS 736 – Hook Rod Assembly

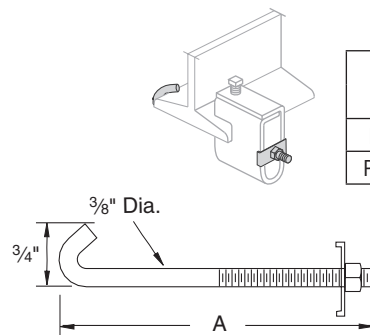

Part No.	Flange Width		A Size	Wt./100 pcs
	Max	Min		
PS 736 J6	7"	3"	8 5/8"	24
PS 736 J10	11"	7"	12 5/8"	33

PS 2622 – Beam Clamp

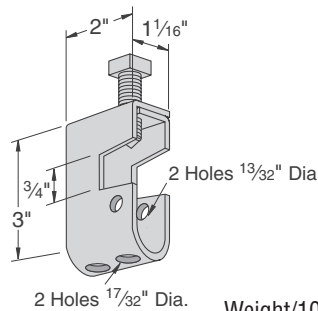

Assembly including PS 736 also available.

Order PS 2622/J6 or PS 2622/J10

Load Rating: 300 lbs.

Note:
Adaptable for 1/4", 3/8" & 1/2" rod with PS 3201.

Weight/100 pcs: 41 lbs.

PS 85 – Rod or Insulator Support

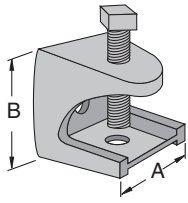

Rod Size	A	B	Load Ratings	Wt./100 pcs
1/4"	1 1/8"	1 1/4"	150	23
3/8"	2"	2"	350	95
1/2"	2 5/8"	2 1/4"	400	195

Flange Thickness: 7/8" Maximum

Material: Malleable Iron

PS 2626 – Beam Clamp

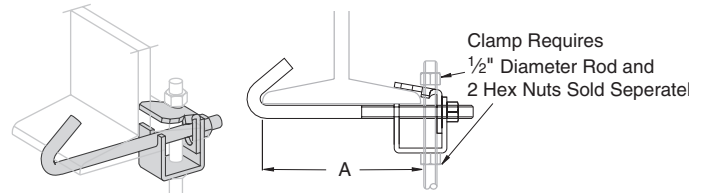

Finish: Plain, painted green or electro-galvanized

Load Rating: 500 lbs.

Part No.	"A" Range	Wt./100 pcs
PS 2626 6	2 1/2" - 6"	125
PS 2626 9	5 1/2" - 9"	140
PS 2626 12	8 1/2" - 12"	171

PS 2623 – Swivel Adaptor

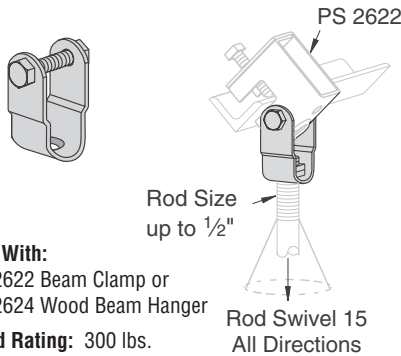

Use With:
PS 2622 Beam Clamp or
PS 2624 Wood Beam Hanger
Load Rating: 300 lbs.

Rod Swivel 15
All Directions

PS 871 – Safety Anchor Strap

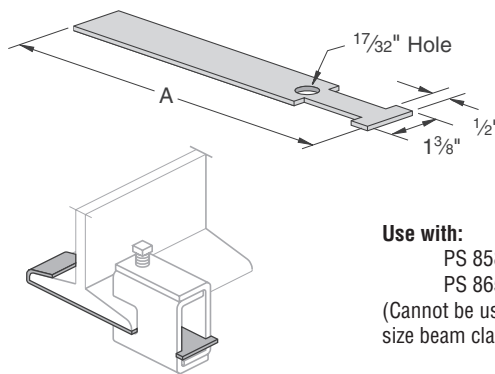

Use with:
PS 858,
PS 865
(Cannot be used with 5/8" rod size beam clamps and larger)

"A" Length	Wt./100 pcs
9"	33
12"	45
15"	57

PS 135X – Light Duty Beam Clamp

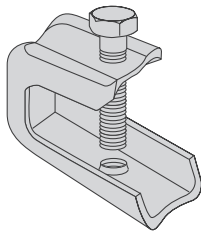

Material: Steel
Use With: 1/4" rod
Load Rating: 75 lbs.

Weight/100 pcs: 14 lbs.

PS 3201 – Swivel Nut

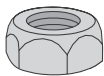

Use With:
PS 2622 Beam Clamp

Rod Size	Wt./100 pcs
1/4"	4
3/8"	4
1/2"	3

Weight/100 pcs: 31 lbs.

PS 858 – Heavy Duty Beam Clamp

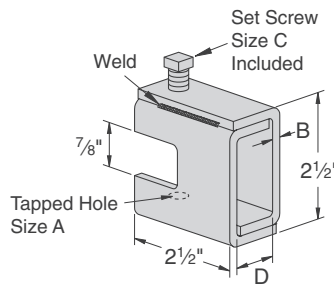

Weld is not continuous it is either 1 1/4" - 1 3/4" long or 2 spot welds.
All welds are on the top and bottom.

Part No.	"A" Rod Size	B	C	D	Load Ratings lbs.	Wt./100 pcs
PS 858 1/4	1/4" - 20	1/8"	3/8" x 1 1/2"	7/8"	650	67
PS 858 5/16	5/16" - 18				67	
PS 858 3/8	3/8" - 16	3/16"	1/2" x 1 1/2"	1 5/16"	1,100	100
PS 858 1/2	1/2" - 13	1/4"			1,600	130
PS 858 5/8	5/8" - 11	5/16"	5/8" x 1 1/2"	1 5/16"	2,400	160
PS 858 3/4	3/4" - 10					160

For beams under 7/8" thick flange.

PS 865 – Wide Throat Heavy Duty Beam Clamp

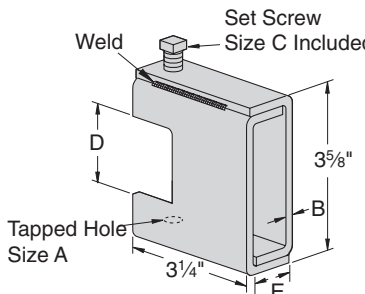

Weld is not continuous it is either 1 1/4" - 1 3/4" long or 2 spot welds. All welds are on the top and bottom.

Part No.	Rod Size	B	C	D	E	Load Ratings lbs.	Wt./100 pcs
PS 865 3/8	3/8"	3/16"	1/2"	1 1/16"	29/32"	1,100	151
PS 865 1/2	1/2"	1/4"			15/16"	1,600	195
PS 865 5/8	5/8"	5/16"	5/8"		1 5/16"	2,400	225

For beams between 3/4" (19) to 1 5/8" (41) thick flanges.

BEAM CLAMPS

Finish: Painted Green, or Electro-galvanized **Order By:** No. and Finish **Note:** Use in pairs or with other support



PS 95 – “C” Clamp

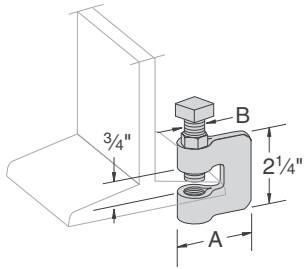

Rod Size	A	B	Load Rating	Wt./100 pcs
3/8"	2 5/16"	3/8"	330	35
1/2"	2 1/4"	1/2"	380	41
5/8"	2 3/8"	5/8"	450	67
3/4"	2 1/4"	1/2"	500	72

Material: Steel

PS 86 – “C” Clamp

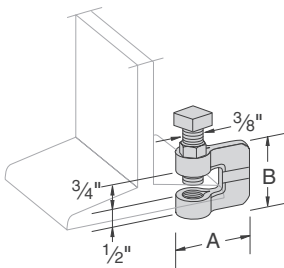

Rod Size	A	B	Load Rating	Wt./100 pcs
3/8"	1 11/16"	1 3/4"	400	38
1/2"	1 23/32"			52
5/8"	1 15/16"	2"	450	68
3/4"	2 1/32"			600

Material: Malleable Iron, Steel Set Screw

PS 2654 & PS 2654A – Column Attachment

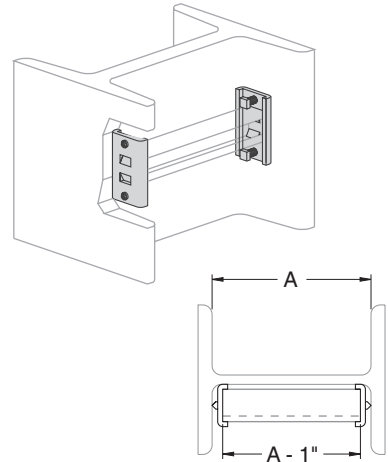

PS 2654 Use with PS 200

PS 2654A Use with PS 500

Slip Rating: 800 lbs.

Note: Column attachment can only be used in pairs.

Weight/100 pcs: 41 lbs.

PS 93 – Universal “C” Clamp

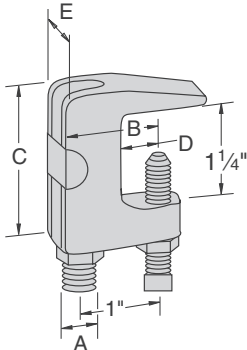

At least one full thread must be exposed

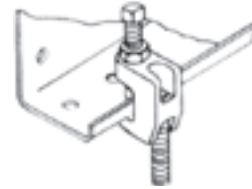

Material: Malleable Iron, Steel Set Screw

Part No.	Rod Size A	DIMENSIONS (Inches)				Max. Pipe Size	Max. Load (Lbs.)	Wt/100 pcs
		B	C	D	E			
PS 93 3/8	3/8	1 5/8	2	3/4	7/8	2	400	28
PS 93 1/2	1/2	1 5/8	2	3/4	7/8	3 1/2	500	34

• Maximum temperature of 450° F

PS 94 – Wide Throat Top Beam “C” Clamp

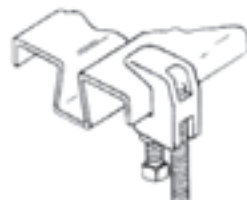
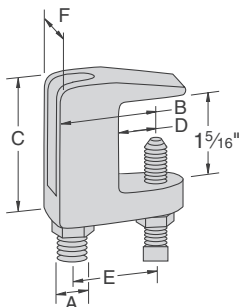

At least one full thread must be exposed

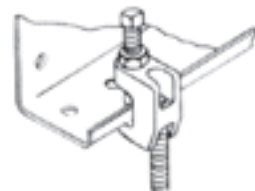

Material: Malleable Iron, Steel Set Screw

Part No.	Rod Size A	DIMENSIONS (Inches)					Max Pipe Size	Max. Load (Lbs.)	Wt/100 pcs
		B	C	D	E	F			
PS 94 5/8	5/8	1 3/4	2 1/4	3/4	1 1/4	1	5	600	66
PS 94 3/4	3/4	1 7/8	2 3/8	3/4	1 3/8	1 1/4	8	800	83

• Maximum temperature of 450° F

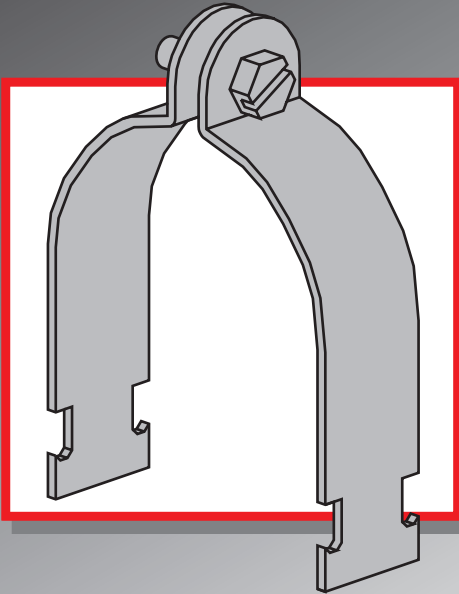

PIPE & CONDUIT CLAMPS

Power-Strut pipe, conduit and O.D. tubing clamps are formed in punch press dies in a wide selection of sizes to meet every requirement.

MATERIAL:

Power-Strut pipe, conduit and O.D. tubing clamps are made on punch press dies from hot rolled, pickled and oiled steel which conforms to the ASTM A-1008, A-1011 SS, A-575 and A-576 standards. Select sizes of O.D. tubing clamps are available in stainless steel or aluminum.

STANDARD FINISH:

All steel clamps are electro-galvanized. Select sizes of O.D. tubing clamps are available in copper plated finish. PVC coatings are available upon special request.

ORDERING INFORMATION:

When ordering, add the length or size and finish to the part number. See pages 8-9 for finish abbreviations and an example.

RECOMMENDED BOLT TORQUE:

Bolt Size	1/4"-20	5/16"-18	3/8"-16	1/2"-13	5/8"-11	3/4"-10
Rec. Torque Ft/Lbs	6	11	19	50	100	125
Max. Torque Ft/Lbs	7	15	25	70	125	135

PIPE & CONDUIT CLAMPS

Finish: Electro-galvanized Order By: No., and Finish



PS 1000 – EMT Conduit Clamp

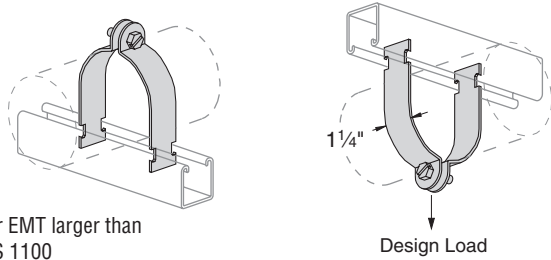

Note: For EMT larger than 2" use PS 1100

EMT Size	Stock Thickness	Hanging Load Rating/lbs.	Wt./100 pcs
1/2"	.060	400	11
3/4"			12
1"	.075	600	15
1 1/4"			18
1 1/2"	.105	800	29
2"			33

PS 1300 – Universal Clamp for EMT, IMC & GRC

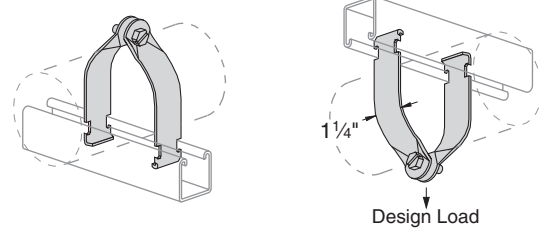

Nominal Size	Fits O.D.	Stock Thickness	Hanging Load Rating/lbs.	Wt./100 pcs
1/2"	0.706-0.840	.060	250	10
3/4"	0.922-1.050	.060	400	11
1"	1.163-1.315			12
1 1/4"	1.510-1.660	.075	400	18
1 1/2"	1.740-1.900	.075	500	20
2"	2.197-2.375			22

PS 1100, PS 1116, PS 1117 – Standard Pipe Clamp (GRC, IMC and SCH 40/SCH 80 steel pipe)

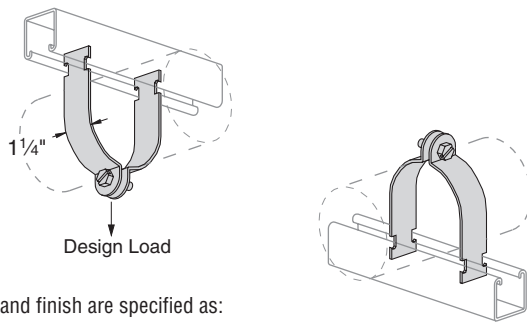

Material and finish are specified as:

- 1100 AL Alum. clamp, EG fasteners
- 1100 HG Clamp, Stainless Steel fasteners
- 1116 Alum. clamp and fasteners
- 1117 Alum. clamp, Stainless Steel fasteners
- 1100SS Stainless Steel clamp and fasteners

Pipe Size	Stock Thickness	Hanging Load Rating/lbs.	Wt./100 pcs
3/8"	.060	400	10
1/2"			11
3/4"	.075	600	15
1"			17
1 1/4"			19
1 1/2"	.105	800	29
2"			34
2 1/2"			40
3"			47
3 1/2"	.125	1,000	62
4"			67
5"			80
6"			102
8"			130
10"	.135	1,000	143
12"			174

PS 67 – "J" Pipe or Conduit Hanger

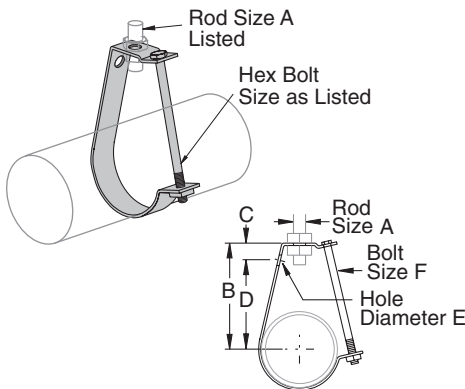

Notes:
 Plastic Coated hanger is available ("N" Suffix).
 Please contact factory for additional information.
 Maximum operating temperature is 300°F
 Minimum safety factor of five (5) on ultimate load.

Conduit Size	A Rod Size	B	C	D	E	F	Load Rating/lbs.	Wt./100 pcs
1/2"	3/8	2 5/8	1	2	1 3/32	1/4 x 2 1/4	400	20
3/4"		2 7/8		2 1/4				21
1"		3		2 3/8				24
1 1/4"		3 1/4		2 1/2				27
1 1/2"	1/2	3 1/2	1 1/8	2 5/8	9/16	1/4 x 3	800	29
2"		3 3/4		2 5/8		1/4 x 3 1/2		33
2 1/2"		4 3/8		3 5/8		3/8 x 4 1/2		71
3"		4 7/8		4		3/8 x 5		78
3 1/2"	5/8	5 1/8	1 1/8	4 1/4	5/16	3/8 x 6	1,200	85
4"		6 1/8		5 1/8		3/8 x 7 1/2		178
5"		6 3/4		5 3/4		3/8 x 8 1/2		199
6"		7 3/4		1 1/4		6 1/2		3/8 x 10
8"	7 7/8	9 1/4	1 1/4	8			1,200	449

PS 1200 – O.D. Tubing Clamp

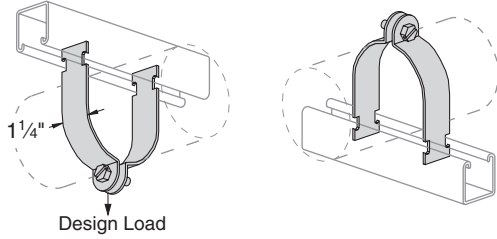

Please contact factory for sizes & finishes not shown.

Note: Additional Available Finishes
 SS - Stainless Steel
 CC - Copper Coated

O.D. Size	Stock Thickness	Hanging Load Rating/lbs.	Wt./100 pcs
1/4"	.060	400	8
3/8"			8
1/2"			9
5/8"			10
3/4"			11
7/8"			12
1"	.075	600	14
1 1/8"			15
1 1/4"			16
1 3/8"			17
1 1/2"			18
1 5/8"			19
1 3/4"	.105	800	29
1 7/8"			28
2"			31
2 1/8"			32
2 1/4"			33
2 3/8"			34
2 1/2"			35
2 5/8"			37
2 3/4"			38
2 7/8"			40
3"	41		

O.D. Size	Stock Thickness	Hanging Load Rating/lbs.	Wt./100 pcs
3 1/8"	.105	800	43
3 1/4"			45
3 3/8"			46
3 1/2"			47
3 5/8"			56
3 3/4"			58
3 7/8"	.125	1,000	60
4"			62
4 1/8"			62
4 1/4"			64
4 3/8"			66
4 1/2"			67
4 5/8"			70
4 3/4"			72
4 7/8"			73
5"			74
5 1/8"	76		
5 1/4"	77		
5 3/8"	78		
5 1/2"	79		
5 5/8"	.135	1,000	88
5 3/4"			90
5 7/8"			92

O.D. Size	Stock Thickness	Hanging Load Rating/lbs.	Wt./100 pcs
6"	.135	1,000	94
6 1/8"			96
6 1/4"			98
6 3/8"			99
6 1/2"			100
6 5/8"			102
6 3/4"			104
6 7/8"			106
7"			108
7 1/8"			110
7 1/4"			112
7 3/8"			114
7 1/2"			116
7 5/8"			117
7 3/4"			119
7 7/8"			121
8"	123		
8 1/8"	125		
8 1/4"	126		
8 3/8"	128		
8 1/2"	129		
8 5/8"	130		



Pipe & Conduit Clamps

PS 137 – Long Tangent “U” Bolt

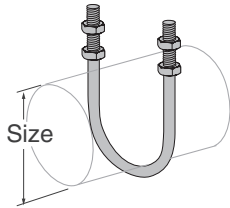

Size	Wt./100 pcs
1/2"	21
3/4"	28
1"	29
1 1/4"	31
1 1/2"	33
2"	36
2 1/2"	78
3"	88
3 1/2"	94
4"	102

PS 69 – E-Z Grip Hanger

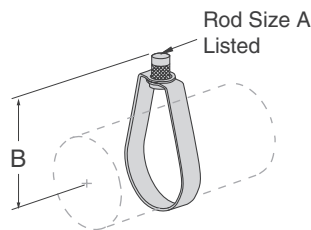

Size	A Rod Size	B	Load Rating Lbs/650	Wt./100 pcs
1/2"	3/8"	2 1/4"	300	9
3/4"		2 5/16"		9
1"		2 7/16"		10
1 1/4"		2 5/8"		10
1 1/2"		2 3/4"		10
2"		3 1/4"		11
2 1/2"	1/2"	4"	525	25
3"		4 3/8"		27
4"		4 1/16"		600
5"	1/2"	5 5/16"	1000	53
6"		6 7/16"		100
7"		8"		100

PIPE & CONDUIT CLAMPS

Finish: Electro-galvanized Order By: No., and Finish



PS 3138 – Parallel Run Pipe Clamp

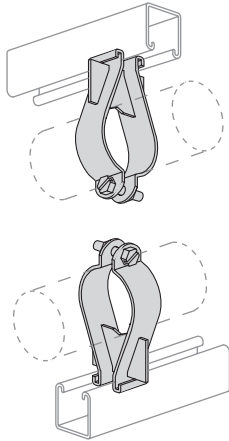

Pipe Size	Load Rating/lbs.	Wt./100 pcs
3/8"	300	27
1/2"		29
3/4"		30
1"	400	31
1 1/4"		38
1 1/2"	500	40
2"		47
2 1/2"		66
3"		78
3 1/2"		87
4"	90	

PS 270 – Conduit Clamp

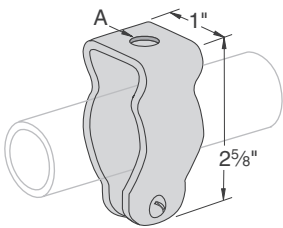

Size	A Diameter	Wt./100 pcs
3/8"	1/4"	6
1/2"		6
3/4"		8
1"		9
1 1/4"		11
1 1/2"		19
2"		27

PS 1450 – One-Hole Clamp for O.D. Tubing

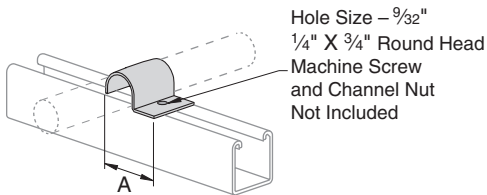

Hole Size – 9/32"
1/4" X 3/4" Round Head
Machine Screw and Channel Nut
Not Included

O.D. Size	A	Thickness Gages	Wt./100 pcs
1/4"	1 3/16"	16	4
3/8"	1 5/16"		5
1/2"	1 7/16"		6
5/8"	1 5/8"	14	8
3/4"	1 3/4"		9
7/8"	1 7/8"		10
1"	2"		11

PS 3126 – One-Piece Pipe Strap

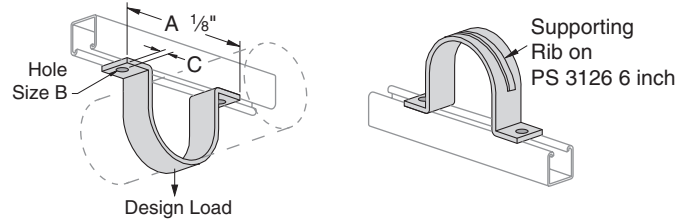

Pipe Size	A	B	C	Design Load/lbs.	Wt./100 pcs
1/2"	2 7/8"	9/32"	7/16"	500	23
3/4"	3 1/8"				26
1"	3 3/8"				31
1 1/4"	3 3/4"				35
1 1/2"	3 7/8"				39
2"	5 3/4"	7/16"	1 1/16"	1,000	94
2 1/2"	6 1/4"				114
3"	6 7/8"				133
3 1/2"	7 3/8"				152
4"	7 7/8"				176
5"	9"				198
6"	10"	225			

PS 51 – Right Angle Pipe or Conduit Clamp

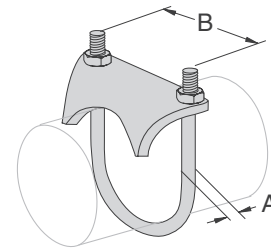

Material: Malleable Iron

Size	A Diameter	B	Wt./100 pcs
3/8"	5/16"	1 5/16"	25
1/2"		1 3/16"	41
3/4"		1 7/16"	42
1"		1 11/16"	47
1 1/4"		2"	54
1 1/2"	3/8"	2 5/16"	57
2"		2 3/16"	85
2 1/2"		3 3/8"	106
3"		4 1/8"	110
3 1/2"		4 5/8"	128
4"		5 1/8"	140

PS TP-025 thru PS TP-100 – Cush-A-Grip®

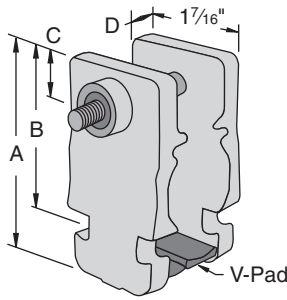

Part No.	Nominal Pipe Size	Dimensions (In.)				Hex Head Cap Screw & Lock Nut	Wt/100 pcs Lbs
		"A"	"B"	"C"	"D"		
PS TP-025	1/4	1 ⁵ / ₁₆	1 ³ / ₈	3/8	3/16	1/4-20 x 1 1/2"	4
PS TP-625	3/8	2 ³ / ₈	1 ⁵ / ₈	7/16	1/4	1/4-20 x 2"	6
PS TP-875	1/2	2 ⁹ / ₁₆	1 ¹³ / ₁₆		5/16		8
PS TP-100	3/4	2 ¹¹ / ₁₆	1 ⁵ / ₈	5/16	8		

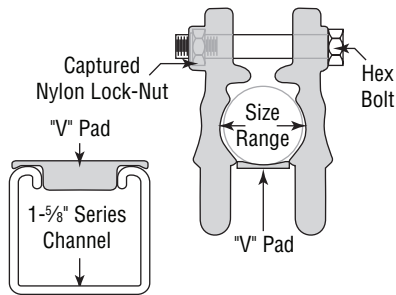

Includes: Cushion, V-pad, and Hardware.
Materials: Cushion: Thermoplastic elastomer.
Hardware: Stainless Steel with Captured Nylon Locknut
Temperature Rating: -40°F to +275°F

Tube Sizes

Part No.	O.D. Tube Sizes			Diameters	PullOut Load/Lbs	Slip Load/Lbs
PS TP-025	1/4	3/8	1/2	0.25 - 0.54	500	40
PS TP-625	5/8	3/4	7/8	0.62 - 0.87		
PS TP-875	7/8	1	1 1/8	0.87 - 1.12		
PS TP-100	1	1 1/8	1 1/4	1.00 - 1.31		

Pipe Sizes

Part No.	Nominal Pipe Sizes		Diameters	PullOut Load/Lbs	Slip Load/Lbs
PS TP-025	1/4		0.25 - 0.54	500	40
PS TP-625	3/8	1/2	0.62 - 0.87		
PS TP-875	3/4		0.87 - 1.12		
PS TP-100	3/4	1	1.00 - 1.31		



PS CT-3/8 thru PS CT1-4-1/8 – Cush-A-Therm™

The only airtight, crush-resistant insulation clamp on the market.

- Maintains thermal barrier protection
- Prevents condensation
- Properly supports pipe and tube
- Absorbs vibration

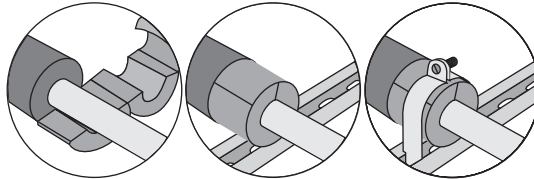

1. Insulation slides over pipes
2. Pipe hanger inserts are put in place and glued to insulation.
3. Joints are wrapped and sealed with ProTape.

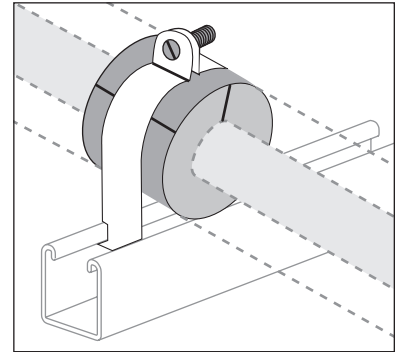

Nominal 3/4" Wall

Part No.	Hole Size	Copper Nom. I.D.	O.D.	IPS	O.D.	Length
PS CT-3/8	3/8 ID	1/4	3/8	-	1.81	2.17
PS CT-1/2	1/2 ID	3/8	1/2	1/4	1.89	
PS CT-5/8	5/8 ID	1/2	5/8	3/8	2.05	
PS CT-3/4	3/4 ID	5/8	3/4	-	2.22	
PS CT-7/8	7/8 ID	3/4	7/8	1/2	2.44	
PS CT-1-1/8	1 1/8 ID	1	1 1/8	3/4	2.76	2.56
PS CT-1-3/8	1 3/8 ID	1 1/4	1 3/8	1	3.19	
PS CT-1-5/8	1 5/8 ID	1 1/2	1 5/8	1 1/4	3.35	
PS CT-2-1/8	2 1/8 ID	2	2 1/8	-	3.86	2.96
PS CT-2-1/2	2 1/2 ID	2 1/4	2 3/8	2	4.29	
PS CT-2-5/8	2 5/8 ID	2 1/2	2 5/8	-	4.87	
PS CT-3-1/8	3 1/8 ID	3	3 1/8	-	5.00	3.35
PS CT-3-5/8	3 5/8 ID	3 1/2	3 5/8	-	5.94	3.94
PS CT-4-1/8	4 1/8 ID	4	4 1/8	3 1/2	6.14	

Nominal 1" Wall

Part No.	Hole Size	Copper Nom. I.D.	O.D.	IPS	O.D.	Length
PS CT1-5/8	5/8 ID	1/2	5/8	3/8	2.54	2.17
PS CT1-3/4	3/4 ID	5/8	3/4	-	2.82	
PS CT1-7/8	7/8 ID	3/4	7/8	1/2	2.82	
PS CT1-1-1/8	1 1/8 ID	1	1 1/8	3/4	3.06	2.56
PS CT1-1-3/8	1 3/8 ID	1 1/4	1 3/8	1	3.33	
PS CT1-1-5/8	1 5/8 ID	1 1/2	1 5/8	1 1/4	3.65	
PS CT1-2-1/8	2 1/8 ID	2	2 1/8	-	4.16	2.96
PS CT1-2-3/8	2 3/8 ID	2 1/4	2 3/8	2	3.92	
PS CT1-2-5/8	2 5/8 ID	2 1/2	2 5/8	-	4.87	2.96
PS CT1-3-1/8	3 1/8 ID	3	3 1/8	-	5.14	3.35
PS CT1-3-5/8	3 5/8 ID	3 1/2	3 5/8	-	6.48	3.94
PS CT1-4-1/8	4 1/8 ID	4	4 1/8	3 1/2	6.48	

PIPE & CONDUIT CLAMPS

Finish: Electro-galvanized Order By: No., and Finish



PS 004T – PS 106N – Cush-a-Clamp® Assembly Pipe & Tube Series

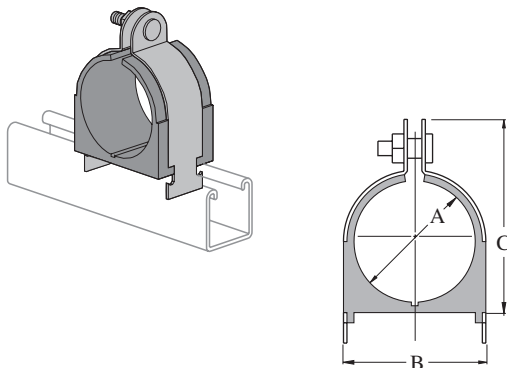

Clamp: Electro-galvanized or stainless steel

Cushion: Thermoplastic elastomer resistant to the effects of most oils, chemicals and industrial cleaning compounds in temperatures from -50°F to 275°F.
UV Resistant

Includes: Cushion, Clamp and Hardware

Controlled Squeeze: Parts with the letter "T" have a Controlled Squeeze shoulder Bolt. Available on tube sizes 1/4" thru 1 3/8"

Pipe Series					
Part No.	Pipe Size (Nominal)	Dimensions			Wt./100 pcs
		A	B	C	
PS 009N	1/4"	0.54	0.98	1.34	13
PS 011N	3/8"	0.67	1.13	1.54	14
PS 014N	1/2"	0.84	1.29	1.82	15
PS 017N	3/4"	1.05	1.50	2.08	17
PS 021N	1"	1.31	1.76	2.34	19
PS 027N	1 1/4"	1.66	2.17	2.73	35
PS 030N	1 1/2"	1.90	2.35	2.86	41
PS 038N	2"	2.37	2.82	3.67	49
PS 046N	2 1/2"	2.87	3.32	4.17	57
PS 056N	3"	3.50	3.95	4.79	55
PS 064N	3 1/2"	4.00	4.45	5.42	88
PS 072N	4"	4.50	4.95	5.92	110
PS 089N	5"	5.56	6.01	6.92	130
PS 106N	6"	6.62	7.07	8.23	140

Tube Series						
Part No.	Copper & Steel Tube O. D. Size	Copper Water Pipe (Nominal)	Dimensions			Wt./100 pcs
			A	B	C	
PS 004T	1/4"		0.25	0.62	0.98	10
PS 006T	3/8"	1/4"	0.37	0.82	1.13	11
PS 008T	1/2"	3/8"	0.50	0.94	1.34	13
PS 010T	5/8"	1/2"	0.62	1.06	1.54	14
PS 012T	3/4"	5/8"	0.75	1.2	1.68	14
PS 014T	7/8"	3/4"	0.87	1.31	1.82	15
PS 016T	1"		1.00	1.44	1.95	17
PS 018T	1 1/8"	1"	1.12	1.57	2.08	18
PS 020T	1 1/4"		1.25	1.70	2.21	18
PS 022T	1 3/8"	1 1/4"	1.37	1.82	2.34	20
PS 024N	1 1/2"		1.50	1.95	2.47	33
PS 026N	1 5/8"	1 1/2"	1.62	2.07	2.60	35
PS 028N	1 3/4"		1.75	2.20	2.73	37
PS 030N	1 7/8"		1.87	2.32	2.86	39
PS 032N	2"		2.00	2.45	3.04	41
PS 034N	2 1/8"		2.12	2.57	3.23	46
PS 038N	2 3/8"		2.37	2.82	3.67	47
PS 040N	2 1/2"		2.50	2.94	3.79	49
PS 042N	2 5/8"		2.62	3.07	3.92	51
PS 046N	2 7/8"		2.87	3.32	4.17	55
PS 048N	3"		3.00	3.57	4.42	57
PS 050N	3 1/8"		3.12	3.57	4.42	60
PS 056N	3 1/2"		3.50	3.95	4.79	55
PS 058N	3 5/8"		3.62	4.2	5.11	70
PS 064N	4"		4.00	4.45	5.42	88
PS 066N	4 1/8"		4.12	4.57	5.54	94
PS 072N	4 1/2"		4.50	4.95	5.92	110
PS 082N	5 1/8"		5.12	5.57	6.54	125
PS 098N	6 1/8"		6.12	6.57	7.54	130

PS 3792 – Power-Wrap™

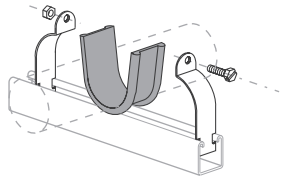

Material: EPDM
Stock Thickness: 1/8"
Stock Length: 25 ft./box
Service Temp: -70° to 350° F

Weight/100 boxes: 253 lbs.

PS 52E – Parallel Pipe and Conduit Clamp

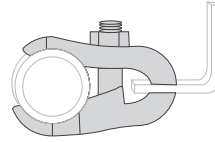

Material: Malleable Iron

Size	Wt./100 pcs
1/2"	59
3/4"	64
1"	70
1 1/4"	72
1 1/2"	93
2"	128
2 1/2"	135
3"	155
3 1/2"	190
4"	205

PS 004M – PS 038M – Cush-a-Clamp® Assembly Omega Series

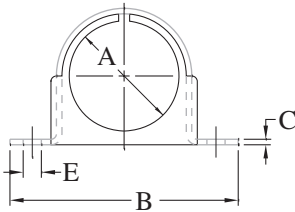
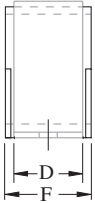
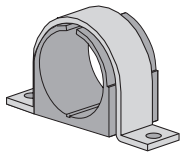

Includes: clamp and cushion.
Materials
Clamp: ZD or Stainless Steel
Cushion: Thermoplastic elastomer

Part No.	Copper Tubing O.D. Size	Water Pipe (Nominal)	Pipe Size (Nominal)	Dimensions						Wt./100 pcs		
				A	B	C	D	E	F			
PS 004M	1/4"	–	–	0.25	1.81	0.06	0.62	0.20	0.78	3.4		
PS 006M	3/8"	1/4	–	0.37	1.90			0.20	0.81	4.0		
PS 008M	1/2"	3/8	1/4"	0.50	2.20		0.75	0.26	0.98	5.5		
PS 010M	5/8"	1/2	3/8"	0.62	2.32					6.0		
PS 012M	3/4"	5/8	–	0.75	2.41					6.5		
PS 014M	7/8"	3/4	1/2"	0.87	2.56					7.1		
PS 016M	1"	–	–	1.00	2.68					7.8		
PS 018M20	–	–	3/4"	1.05	2.68					8.1		
PS 018M21	1 1/8"	1	–	1.12	2.82		8.4					
PS 020M	1 1/4"	–	–	1.25	3.00		0.08	1.25	0.26	17		
PS 021M	–	–	1"	1.31	3.12	20						
PS 022M	1 3/8"	1 1/4	–	1.37	3.12	19						
PS 024M	1 1/2"	–	–	1.50	3.65	20						
PS 026M	1 5/8"	1 1/2	–	1.62	3.77	23						
PS 027M	–	–	1 1/4"	1.66	3.90	0.10				1.25	0.33	32
PS 028M	1 3/4"	–	–	1.75	3.90							32
PS 030M	1 7/8"	–	1 1/2"	1.87	4.02							34
PS 032M	2"	–	–	2.00	4.15							36
PS 034M	2 1/8"	–	–	2.12	4.40							41
PS 038M	–	–	2"	2.37	4.71		44					

Note: Cannot be used on slot side of metal framing channel.



PIPE & CONDUIT CLAMPS

Finish: Electro-galvanized Order By: No., and Finish



PS MU-1/4 thru PS MU-4 – Mustang Universal One-Piece Pipe, Conduit (GRC, EMT & IMC) and Tubing Clamps

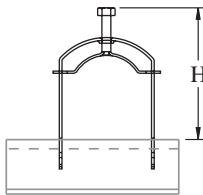
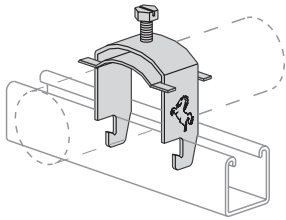

Part No.	Nominal Trade Size	OD		Height Above Channel "H"	
		Min	Max	Min	Max.
PS MU-1/4	1/4"	0.250"	0.540"	1 3/4"	2"
PS MU-3/8	3/8"	0.500"	0.675"	1 7/8"	2 1/8"
PS MU-1/2	1/2"	0.625"	0.840"	2"	2 1/4"
PS MU-3/4	3/4"	0.875"	1.050"	2 1/4"	2 1/2"
PS MU-1	1"	1.125"	1.315"	2 1/2"	2 3/4"
PS MU-1-1/4	1 1/4"	1.375"	1.660"	2 3/4"	3 1/8"
PS MU-1-1/2	1 1/2"	1.625"	1.900"	3"	3 3/8"
PS MU-2	2"	2.000"	2.375"	3 1/2"	3 7/8"
PS MU-2-1/2	2 1/2"	2.500"	2.875"	4 1/4"	4 5/8"
PS MU-3	3"	3.000"	3.500"	4 7/8"	5 3/8"
PS MU-3-1/2	3 1/2"	3.625"	4.000"	5 3/8"	5 7/8"
PS MU-4	4"	4.125"	4.500"	5 7/8"	6 3/8"

Note:
Available in 14 ga. Electro-galvanized steel

PS UB 1/2 – PS UB 10 – Cush-a-Clamp® Assembly U-Bolt Series

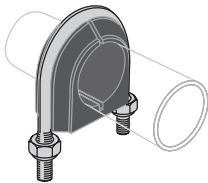

Includes: U-bolt, cushion, and hardware.
Materials: U-Bolt: Electrogalvanized finish or Type 316 SS
Cushion: Thermoplastic elastomer
Note: Not intended for use with metal framing components due to the length of the thread.

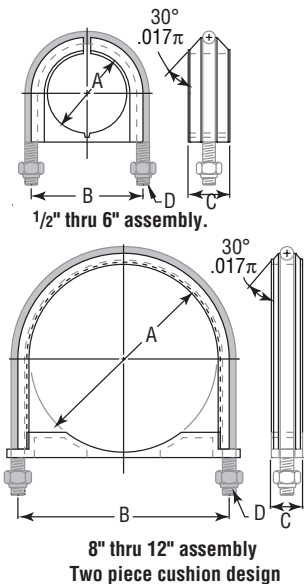

Part No.	Pipe Size	Dimensions				Wt./100 Pcs
		A	B	C	D	
PS UB 1/2	1/2"	0.84	1.60	0.68	1/4-20 UNC-2B	9
PS UB 3/4	3/4"	1.05	1.80			10
PS UB 1	1"	1.31	2.05			12
PS UB 1-1/4	1 1/4"	1.66	2.55	1.24	3/8-16 UNC-2B	32
PS UB 1-1/2	1 1/2"	1.90	2.80			36
PS UB 2	2"	2.37	3.35			42
PS UB 2-1/2	2 1/2"	2.87	3.90	1.24	1/2-13 UNC-2B	72
PS UB 3	3"	3.50	4.55			84
PS UB 3-1/2	3 1/2"	4.00	5.05			93
PS UB 4	4"	4.50	5.50			102
PS UB 5	5"	5.56	6.56	1.44	5/8-11 UNC-2B	123
PS UB 6	6"	6.62	7.75			243
PS UB 8	8"	8.62	9.82			293
PS UB 10	10"	10.75	12.16	1.65	3/4-10 UNC-2B	492

PS 1901 – Two-Piece Pipe Roller

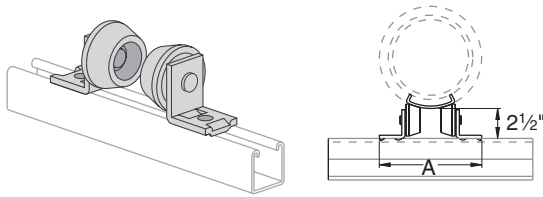

Use With: 1/2"-4" pipe

Load Rating: 500 lbs.

Material:

Bracket - steel;
Roller - cast iron (or aluminum)

Finish: Green or galvanized;
Roller - plain

Weight/100 pair: 268 lbs.

Chart for Dimension A								
Pipe Size	No Insulation	Insulation Thickness						
		1"	1 1/2"	2"	2 1/2"	3"	4"	
1/2"	6 1/2"	6 1/2"	-	-	-	-	-	
3/4"			6 5/8"	6 7/8"				
1"			6 7/8"	7 1/8"	7 3/8"			
1 1/4"				7 3/8"	7 1/2"			
1 1/2"		6 5/8"	7 1/8"	7 3/8"	7 1/2"	8"		
2"			7"	7 1/2"	7 3/4"	7 7/8"		8 1/8"
2 1/2"		7 1/4"		7 5/8"	7 7/8"	8"		8 3/8"
3"				7 7/8"	8"	8 3/8"		9"
3 1/2"		7 1/4"	7 5/8"	7 7/8"	8"	8 3/8"		9"
4"		6 5/8"	7 1/4"	7 5/8"	7 7/8"	8"		8 3/8"



PS 815 – Two-Piece, Heavy Duty Pipe Roller

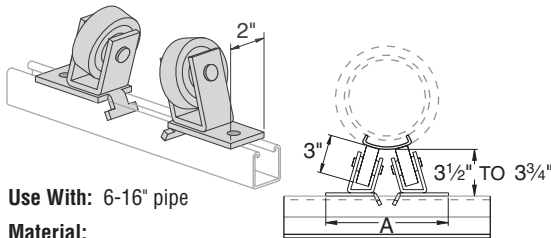

Use With: 6-16" pipe

Material:

Bracket - steel; Roller - cast iron

Finish: Green or galvanized; Roller - plain

Load Rating: 1500 lbs.

Weight/100 pair: 680 lbs.

Chart for Dimension A							
Pipe Size	No Insulation	Insulation Thickness					
		1"	1 1/2"	2"	2 1/2"	3"	4"
6"	9 1/2"	10 1/4"	10 1/2"	10 3/4"	11"	11 3/8"	11 7/8"
8"	10 1/8"	-	11"	11 3/8"	11 3/4"	12"	12 1/2"
10"	10 3/4"		11 5/8"	12"	12 1/4"	12 1/2"	13"
12"	11 1/4"		12 1/8"	12 1/2"	12 3/4"	13"	13 1/2"
14"	11 5/8"		12 1/2"	12 7/8"	13"	13 3/8"	14"
16"	12 1/8"		13"	13 3/8"	13 7/8"	14"	14 1/2"

Pipe & Conduit Clamps

PS 1911 – Pipe Roller

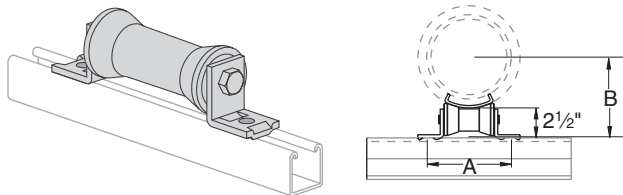

Material: Brackets and shaft - steel; Rollers - cast iron

Finish: Brackets - painted green or galvanized; Shaft - electro-galvanized;
Rollers - plain

Load Rating: 950 lbs.

Size	Fits Pipe Size	A	B	Wt./100 pcs
2 – 3-1/2"	2"	5"	3"	160
	2 1/2"		3 1/4"	
	3"		3 5/8"	
4 – 6"	3 1/2"	5"	3 7/8"	215
	4"	5 7/8"	4 5/16"	
	5"	4 7/8"		
8 – 10"	6"	5 7/8"	5 7/16"	525
	8"	8 5/16"	7 1/8"	
	10"		8 1/4"	
12 – 14"	12"	10 7/8"	9 7/8"	1,025
	14"		10 1/2"	

PS 816 – Three Piece, Heavy Duty Pipe Roller

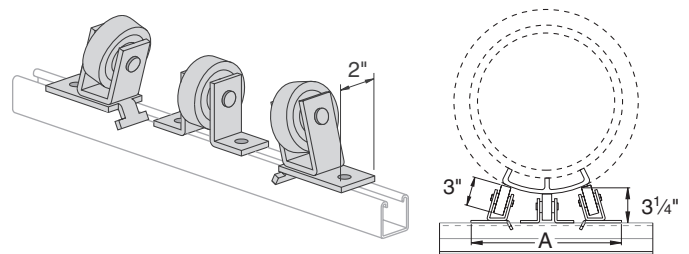

Use With: 16-24" pipe

Material: Brackets - steel; Roller - cast iron

Finish: Brackets - painted green or galvanized; Roller - plain

Load Rating: 2,000 lbs.

Chart for Dimension A					
Pipe Size	Insulation Thickness				
	1 1/2"	2"	2 1/2"	3"	4"
16"	-		13 7/8"	14"	14 1/2"
18"	13 5/8"	14"	14 1/8"	14 1/2"	15"
20"	14 1/8"	14 1/2"	14 3/4"	15"	15 1/2"
24"	15 1/4"	15 1/2"	15 5/8"	16 1/8"	16 3/8"

Weight/100 units: 1,046 lbs.

ROLLERS

Order By: No. and Finish



PS 1902 – Pipe-Roller Assembly

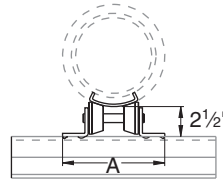
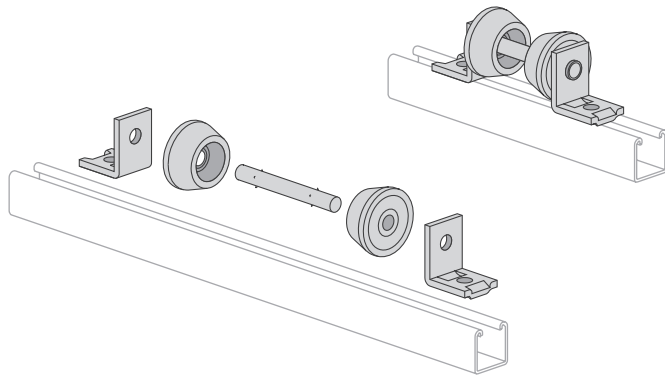

Material:

Brackets and shaft - steel;
Rollers - cast iron

Finish:

Brackets - painted green or galvanized;
Shaft - electro-galvanized; Rollers - plain

Load Rating: 750 lbs.

Part No.	A	Wt./100 pcs.
PS 1902 - 1"-2"	6¾"	299
PS 1902 - 2½"-3½"	7½"	304
PS 1902 - 4"-6"	8½"	311
PS 1902 - 8"	9⅞"	319

Pipe Size	No Insulation	Insulation Thickness					
		1"	1½"	2"	2½"	3"	4"
½"	PS 1902 - 1"-2"	PS 1902 - 1"-2"	PS 1902 - 1"-2"	PS 1902 - 2½"-3½"	-	-	-
¾"							
1"							
1¼"		PS 1902 - 2½"-3½"	PS 1902 - 2½"-3½"	PS 1902 - 2½"-3½"	PS 1902 - 2½"-3½"	-	-
1½"							
2"		PS 1902 - 4"-6"	PS 1902 - 4"-6"	PS 1902 - 4"-6"	PS 1902 - 4"-6"	PS 1902 - 4"-6"	PS 1902 - 4"-6"
2½"							
3"							
3½"							
4"	PS 1902 - 8"	PS 1902 - 8"	PS 1902 - 8"	PS 1902 - 8"	PS 1902 - 8"	PS 1902 - 8"	
5"							
6"							
8"	PS 1902 - 8"	PS 1902 - 8"	PS 1902 - 8"	PS 1902 - 8"	PS 1902 - 8"	PS 1902 - 8"	

PS PP – Power-Pier

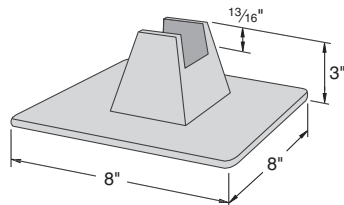

The Power-Pier Rooftop support system provides a simple and versatile way to support and manage pipe, tubing, conduit, HVAC systems, and the like. The Power-Pier system supports without roof surface penetration and allows the parts to remain off the surface

Part Number	Power-Pier Bases Qty.	Description
PS PP	4	Power-Pier Base Only (4 Bases & Hardware)
PS-SPSS-6 HG	4	PS PP + 4 Pcs PS 500 EH HG @ 6" Long for up to 3½" Pipe
PS-SPSS-10HG	4	PS PP + 4 Pcs PS 500 EH HG @ 10" Long for 4" to 8" Pipe
PS-MPDS-26HG	4	PS PP + 2 Pcs PS 200 EH HG @ 26" Long for Trapeze
PS-MPDS-38HG	4	PS PP + 2 Pcs PS 200 EH HG @ 38" Long for Trapeze
PS-MPDS-50HG	4	PS PP + 2 Pcs PS 200 EH HG @ 50" Long for Trapeze
PS-MPDS-62HG	4	PS PP + 2 Pcs PS 200 EH HG @ 62" Long for Trapeze

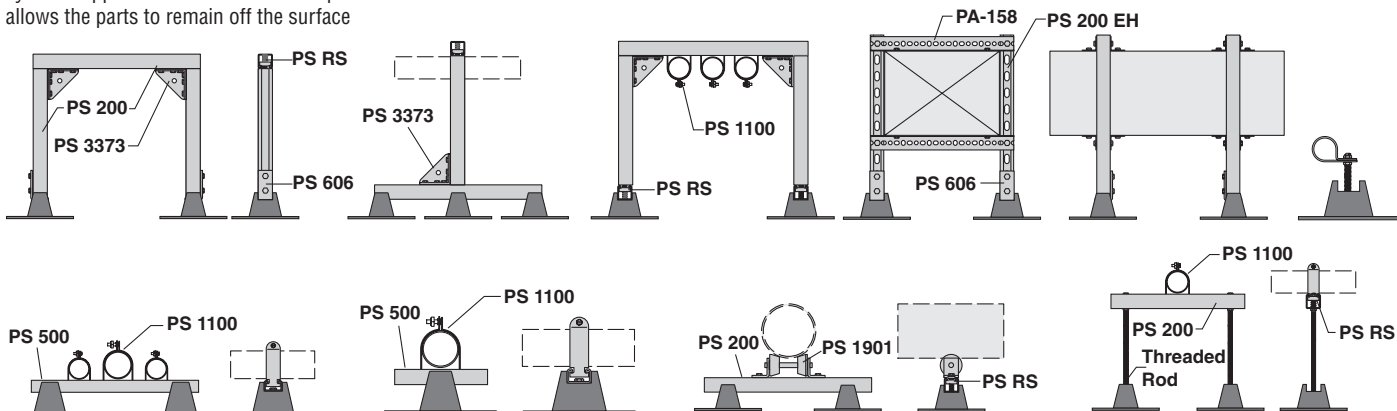

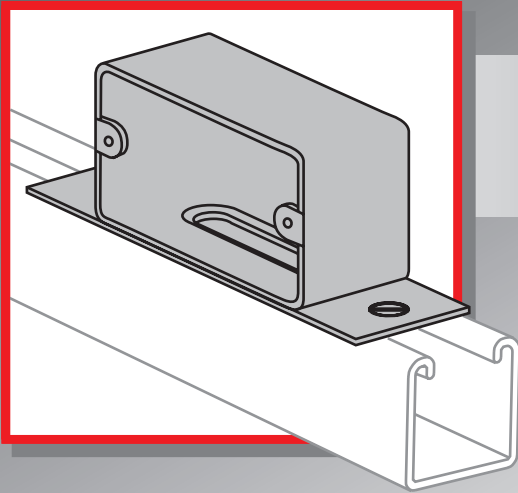

ELECTRICAL

Power-Strut offers a versatile means of supporting lighting, conduits, cable and other portions of an electrical system. Power-Strut is listed as an electrical raceway by Underwriters laboratories as specified by the National Electric Code (Article 384), and CSA approved in accordance with the Canadian Electrical Code (Part 1).

MATERIAL:

Power-Strut electrical raceways are cold formed from low carbon steel and meet the requirements of ASTM A-1011 Grade 33 in painted green or ASTM A-653 Grade 33 in pre-galvanized material. Plain or electro-galvanized fittings conform to the ASTM A-635 or ASTM A-36 standards while pre-galvanized fittings meet the requirements of ASTM A-653 Grade 33.

STANDARD LENGTHS:

Standard lengths of electrical raceway are 10 and 20 feet. The Power-Strut closure strips are available only in 10 foot lengths.

STANDARD FINISH:

Electrical raceway channel is available in a painted green or pre-galvanized finish. All Power-Strut fittings are available in painted green or electro-galvanized finish. Many fittings are available in pre-galvanized.

ORDERING INFORMATION:

When ordering, add the length or size and finish to the part number. See pages 8-9 for finish abbreviations and an example.

LISTINGS:

UL File No. E27817 - Channel & Closure Strips
UL File No. E27818 - Fittings
CSA File No. 091312

ELECTRICAL

Finish: Painted Green or Pregalvanized Stock Length: 10' & 20' Order By: No., Size and Finish



Solid Raceway*

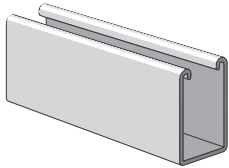

Part No.	Section Height
PS 100	3/4"
PS 150	2 7/16"
PS 200	1 5/8"
PS 210	1 5/8"
PS 300	1 3/8"
PS 400	1"
PS 500	1 3/16"

Knock-Out Raceway*

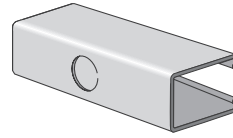

Part No.	Section Height
PS 100 K06	3/4"
PS 150 K06	2 7/16"
PS 200 K06	1 5/8"
PS 210 K06	1 5/8"
PS 300 K06	1 3/8"
PS 400 K06	1"

Maximum Number of Wires Types AVB, FEP, FEBP, RH, RHH, RHW, RUH, RUW, T, TW, THHN, THWN, THW, XHHW

	Raceway Part Numbers	Wt./ 100 Ft.	Height of Section Inches	Wire Size AWG*				
				14	12	10	8	6
Table A – Maximum number of conductors when raceway is installed to support and supply electric discharge type lighting fixtures when raceway wiring is suitable for at least 75 C. EXCEPTION: Wire suitable for 60 C may be used when clearance between raceway and fixtures is at least 1/2 inch.	PS 100, PS 100 K06	305	3/4"	10	10	8	6	4
	PS 150, PS 150 K06	247	2 7/16"	10	10	8	6	4
	PS 200, PS 200 K06	190	1 5/8"	6	6	5	4	2
	PS 210, PS 210 K06	141	1 5/8"	6	6	5	4	2
	PS 300, PS 300 K06	170	1 3/8"	5	4	4	3	2
	PS 400, PS 400 K06	146	1"	4	3	0	0	0
	PS 500	97	1 3/16"	4	3	0	0	0
Table B – Maximum number of conductors when raceway is installed to support and supply electric discharge type lighting fixtures when raceway wiring is suitable for at least 75 C and clearance between raceway and fixtures is at least 1/8 inch.	PS 100, PS 100 K06	305	3/4"	10	10	10	9	6
	PS 150, PS 150 K06	247	2 7/16"	10	10	10	8	6
	PS 200, PS 200 K06	190	1 5/8"	10	10	8	6	3
	PS 210, PS 210 K06	141	1 5/8"	10	10	8	6	3
	PS 300, PS 300 K06	170	1 3/8"	10	10	6	4	2
	PS 400, PS 400 K06	146	1"	6	6	0	0	0
	PS 500	97	1 3/16"	6	6	0	0	0
Table C – Maximum number of conductors when raceway is not employed with fixtures OR where the clearance between the raceway and fixtures is greater than 1/2 inch.	PS 100, PS 100 K06	305	3/4"	50	42	35	20	13
	PS 150, PS 150 K06	247	2 7/16"	36	29	25	14	9
	PS 200, PS 200 K06	190	1 5/8"	22	18	15	9	5
	PS 210, PS 210 K06	141	1 5/8"	24	20	17	10	6
	PS 300, PS 300 K06	170	1 3/8"	18	15	13	7	5
	PS 400, PS 400 K06	146	1"	11	9	7	4	3
	PS 500	97	1 3/16"	9	7	6	4	2
Table D – CSA Certified Maximum number of wires Types R, RW, RWU, T, TW	PS 100, PS 100 K06	305	3/4"	10	10	8	6	4
	PS 150, PS 150 K06	247	2 7/16"	10	10	8	6	4
	PS 200, PS 200 K06	190	1 5/8"	8	8	5	4	3
	PS 210, PS 210 K06	141	1 5/8"	8	8	5	4	3
	PS 300, PS 300 K06	170	1 3/8"	8	6	5	3	2
	PS 400, PS 400 K06	146	1"	4	3	0	0	0
	PS 500	97	1 3/16"	4	3	0	0	0

*In all cases, the snap-in-cover, PS 707, is required to complete raceway enclosures.

Also UL Listed: PS 100 2T3, PS 150 2T3, PS 200 2T3, PS 210 2T3, PS 300 2T3, PS 400 2T3, and PS 500 2T3

To Install Channel

1. Suspend and align PS-2632 Channel hanger from threaded rod at pre-determined level.



2. At floor working level install wiring in channel raceway and add a channel closure strip.



3. Lay raceway into pre-hung channel hanger. Close snap fastening door which securely locks raceway into position.

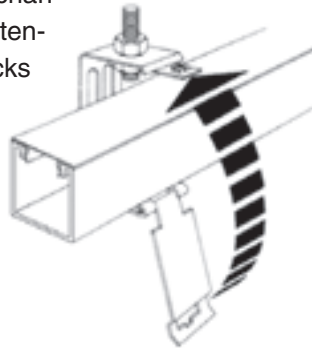

To Install Fluorescent Fixture

1. Attach PS2631 Fixture Hanger to fixture with quick assembly wing-nut leaving door open.

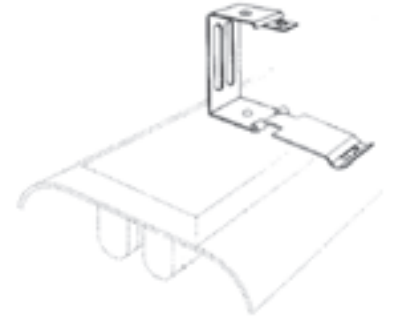

2. Hook fixture over raceway. Close snap fastening door which securely locks fixture into position. Plug in fixture.

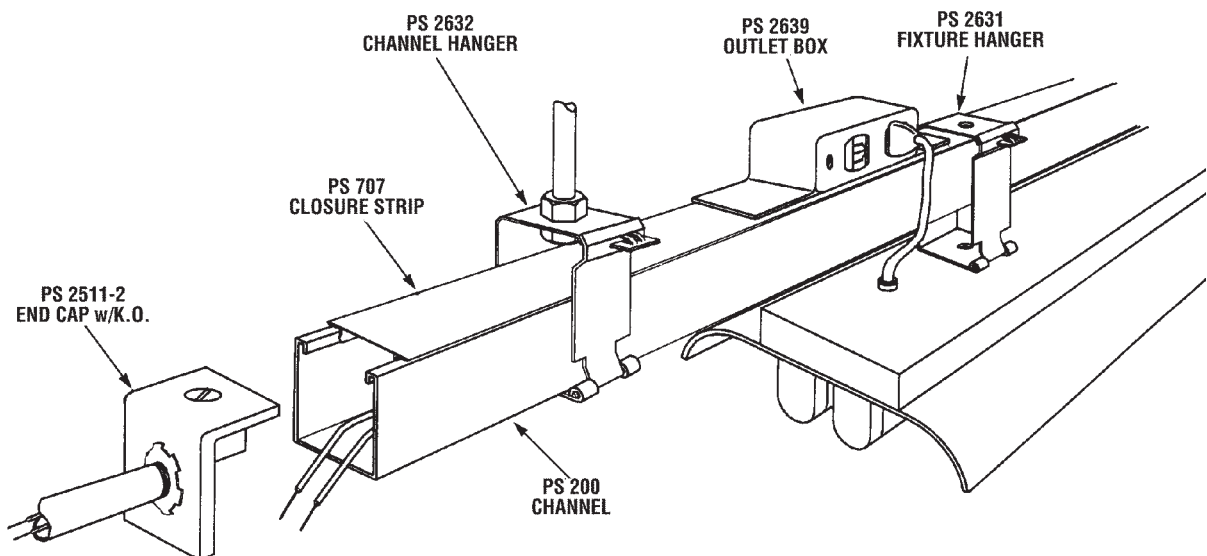
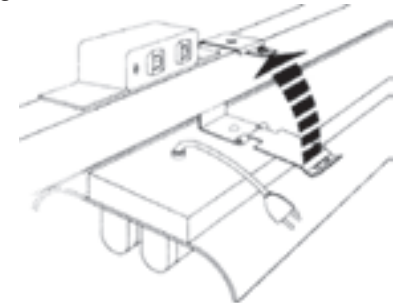

Complete installation in minutes. No screw, bolts or cotter pins to lose.

Knock-out Fluorescent Raceway System

Listed by Underwriter's Laboratories, Inc. Fixture is attached to slot-up channel with chase nipple, locknut and bushing through knock-outs in bottom of channel. Conduit connector fitting PS-2560 holds channel and fixture to pipe or rod.

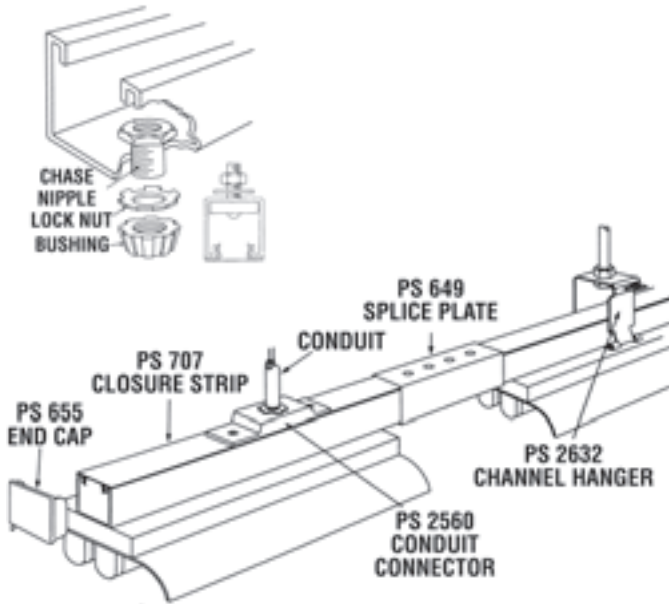

Basic Fluorescent Support System

Slot-down channel holds fixture firmly in place with spring nut and bolt. Fixtures may be added or relocated without changing the basic assembly.

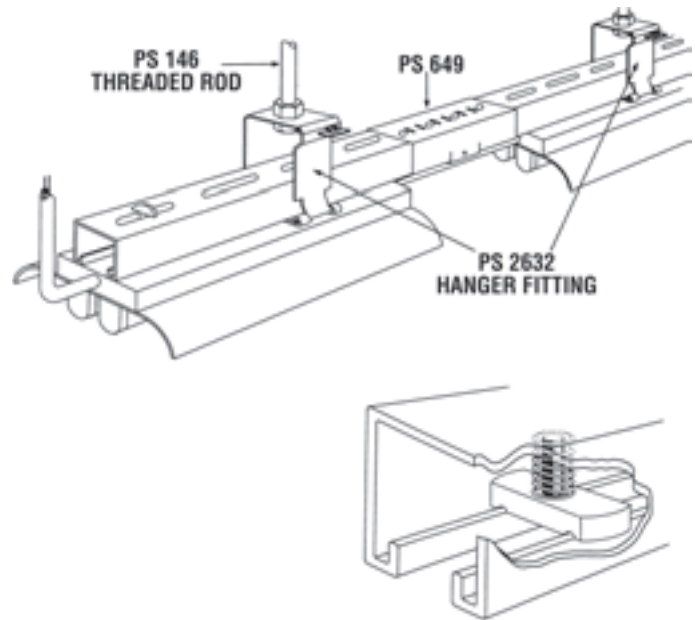

Economy Raceway System Fluorescent

In this slot-down system the circuits run through the fixtures and only enter the channel where there is a break in the fixture run. At that point the fiber wire retainer holds wires in place and snap-in closure strip covers the area.

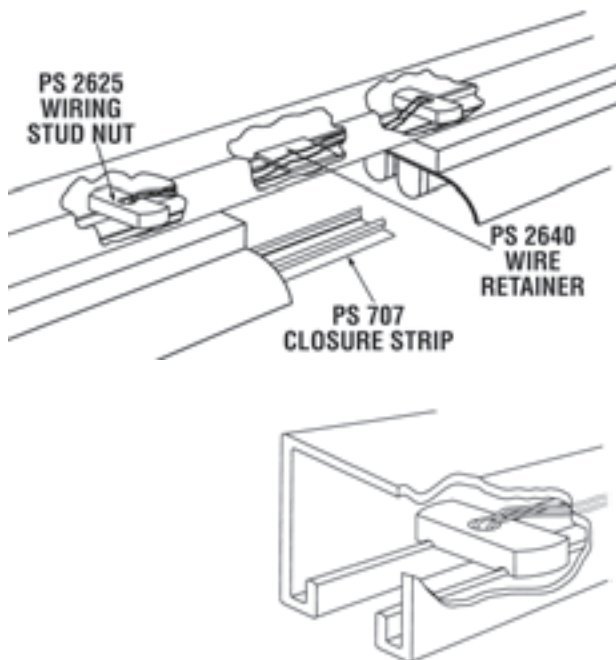

Knock-out Mercury Vapor Raceway System

Listed by Underwriter's Laboratories, Inc. Fixture is attached to slot-up channel with chase nipple, locknut and bushing through knock-outs in bottom of channel. Conduit connector fitting PS-2561 holds channel and fixture to pipe or rod.

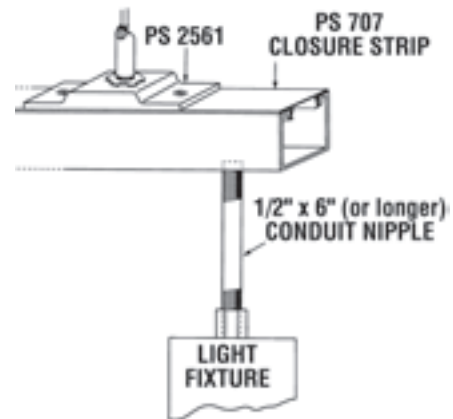

Basic Mercury Vapor Support System

PS 3301 Clevis Hanger for use with PS 150, PS 200

In this slot up or down system, the fixture is supported by PS-3301 clevis hanger which is designed for use with both 1 $\frac{3}{8}$ " and 2 $\frac{7}{16}$ " deep channels.

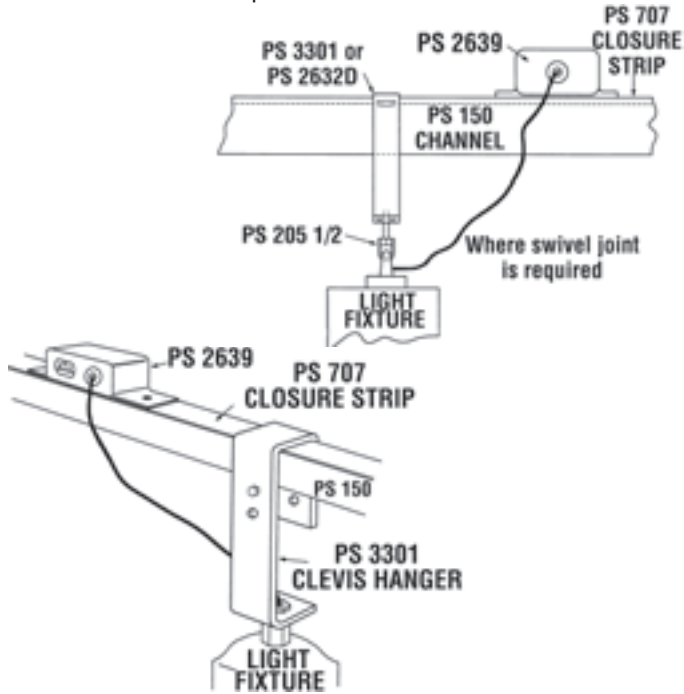

Slot Down Mercury Vapor System

In this slot down system the mercury vapor ballast is wired directly to the system.

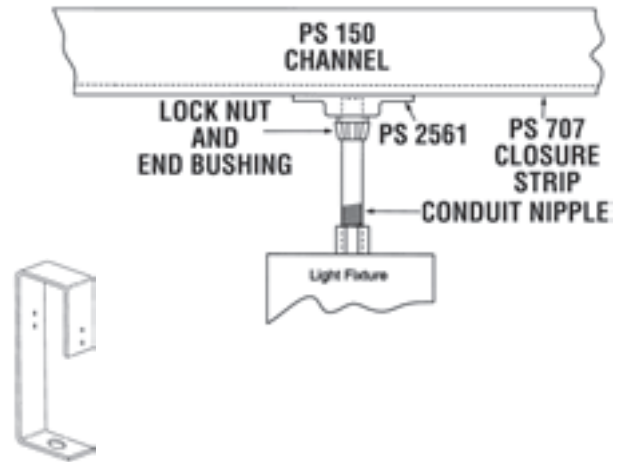

Electrical

Slotted Support System

This system is designed for maximum ease of attaching fixture through slotted channel with shoulder bolt and provides positive alignment.

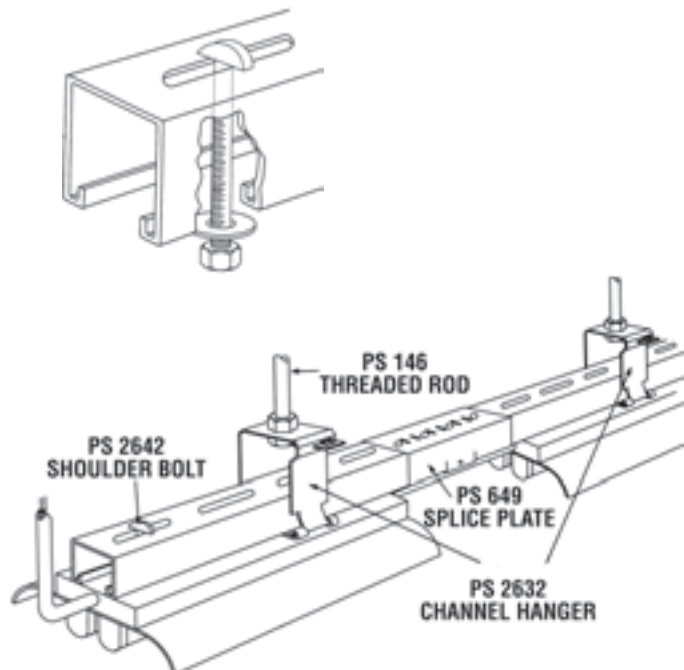

Grid System

This system is used where fixtures are hung at right angles to Power-Strut raceways and support channels. Any of the features of the above systems can be adapted to this system. Ideal for egg-crate type drop ceiling installations.

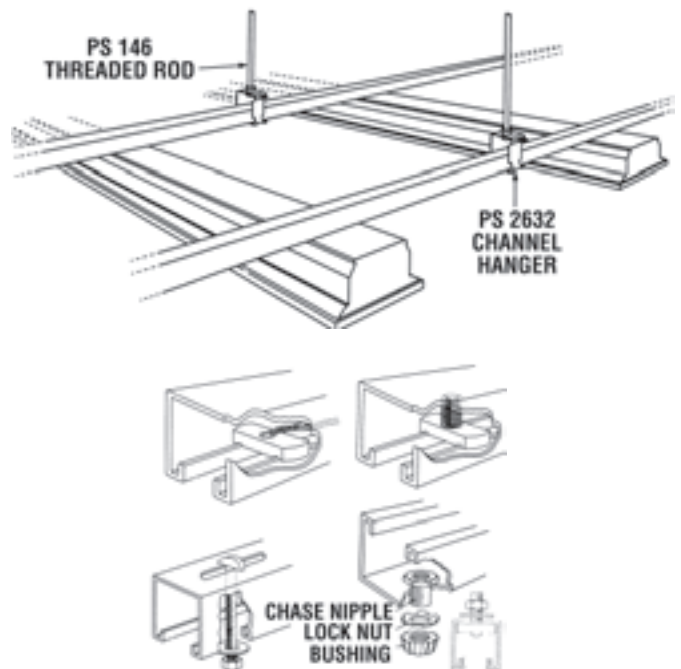

ELECTRICAL

Finish: Painted Green or Pregalvanized Stock Length: 10' & 20' Order By: No., Size and Finish



PS 655, PS 656, PS 901, PS 902, PS 930, PS 2580, PS 2585 – Raceway End Caps

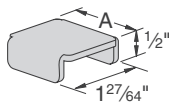

Part No.	Use With	Finish	A	Wt./100 pcs
PS 902	PS 100	EG	3 1/4"	22
PS 2580	PS 150		2 7/16"	18
PS 655	PS 200		1 5/8"	11
PS 2585	PS 210		1 5/8"	12
PS 656	PS 300		1 3/8"	15
PS 901	PS 400		1"	11
PS 930	PS 500		1 9/16"	5

PS 2560, PS 2561 – Conduit Connector Fitting

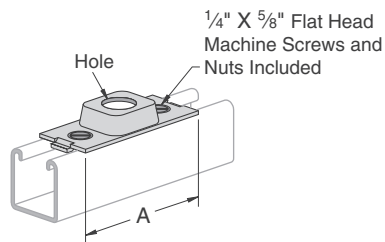

Stock Size: (.060)

Assembly: Connector Fitting, 2 Nuts, 2 Bolts

Part No.	Use With	A	Hole	Design Load (lbs.)	Wt./100 pcs
PS 2560	1/2 Conduit"	4"	7/8"	400	36
PS 2561	3/4 Conduit"	5 1/8"	1 3/32"	200	36

PS 803 – Fixture Wiring Nipple

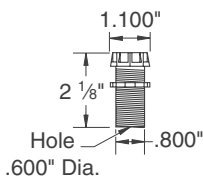

Assembly: 1/2" x 2" rigid conduit nipple
Bushing Locknut

Weight/100 pcs: 14 lbs.

PS 707, PS 707 P – Raceway Closure Strip

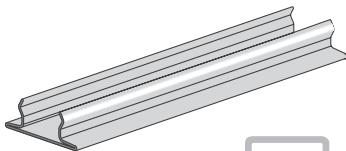

Material/Finish:

PS 707 P - Green and gray

PS 707 - Painted green and pre-galvanized

Stock Size: (.040) GRN, (.040) PGAL

Stock Length: 10 ft.

Use With: All 1 5/8" wide channel.

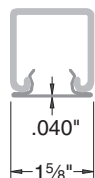

Weight 47 Lbs./ft.

PS 2511, PS 2581 – End Cap With Knock-Out



1/4" X 5/8" Flat Head Machine Screw and Nut Included

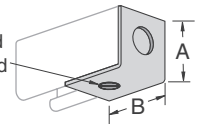

Assembly:

End Cap Part, 1 Machine Screw, 1 Nut
Specify 1/2" or 3/4" knock-out

Part No.	Use With	Finish	A	B	Wt./100 pcs
PS 2511-1	PS 100	EG	3 1/4"	1 3/4"	3.1
PS 2511-2	PS 200, PS 210		1 5/8"	1 3/4"	2.7
PS 2511-3	PS 300		1 3/8"	1 3/4"	2.6
PS 2581	PS 150		2 7/16"	2"	3.0

PS 2625 – Wiring Stud Nut

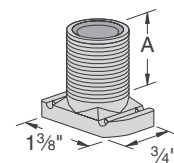

Material: Sintered Iron

Size: 1/2" - 14 Amer. Std, conduit thread

Part No.	A	Identification No.
PS 2625-1/2	1 5/16"	121961
PS 2625-2-5/8	5/8"	121960

Weight/100 pcs: 10 lbs.

PS 2640 – Wire Retainer

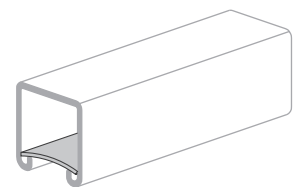
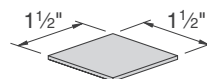

Material: Polypropylene

Weight/100 pcs: .30 lbs.

PS 707 – Aluminum Raceway Closure Strip

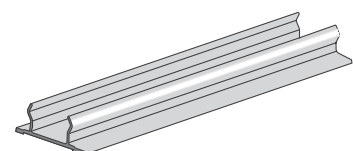

Material:

6063-T6 Aluminum, Copper Free, Extruded

Stock Size: (.051)

Stock Length: 10 ft.

Use With: All 1 5/8" wide channel

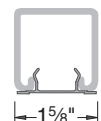

Weight 21 Lbs./ft.

PS 2632 – Swing Gate Channel Hanger

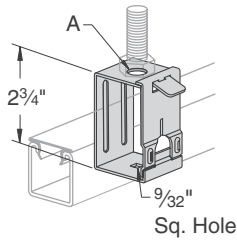

A Dia.	Use With
9/16"	1/2" Rod
7/8"	1/2" Conduit

Finish: Electro-galvanized
 Use With: PS 200, PS 210, PS 300, PS 400 and PS 500
 Load Rating: 90 lbs.

Weight/100 pcs: 25 lbs.

PS 2631 – Swing Gate Fixture Hanger

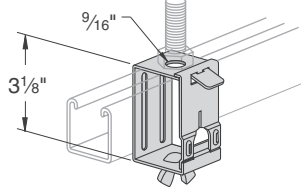

Use With: PS 200, PS 210, PS 300, PS 400 and PS 500
 Load Rating: 90 lbs.
 Note: Includes Bolt and Wing Nut for connection to fluorescent fixtures.

Weight/100 pcs: 27 lbs.

PS 3301 – Mercury Vapor Fixture Hanger

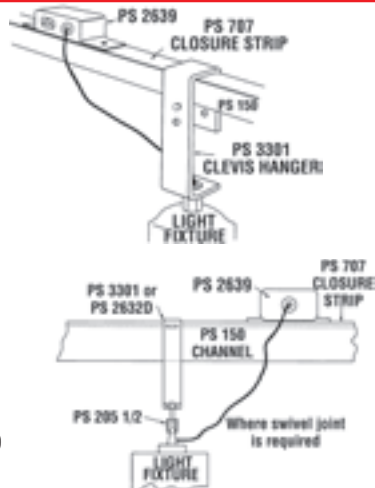
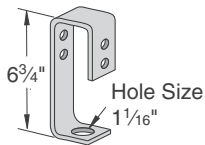

Finish: Electro-galvanized
 Stock Size: 1/4"
 Use With: PS 150, PS 200, PS 210
 Note: Supports fixture in slot up or down system.

Weight/100 pcs: 154 lbs.

PS 2632D – Swing Gate Channel Hanger

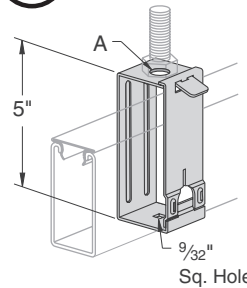

A Dia.	Use With
9/16"	1/2" Rod
7/8"	1/2" Conduit

Finish: Electro-galvanized
 Use With: PS 100, PS 150, PS 200 2T3, and PS 210 2T3
 Load Rating: 90 lbs.

Weight/100 pcs: 34 lbs.

PS 2631D – Swing Gate Fixture Hanger

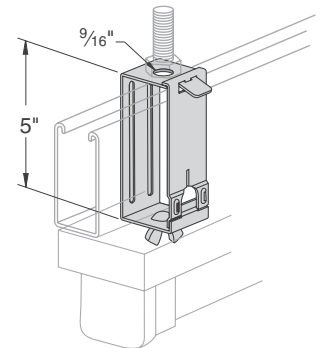

Use With: PS 100, PS 150, PS 200 2T3, PS 210 2T3
 Load Rating: 90 lbs.
 Note: Includes Bolt and Wing Nut for connection to fluorescent fixtures.

Weight/100 pcs: 36 lbs.

PS 807 – Channel Hanger

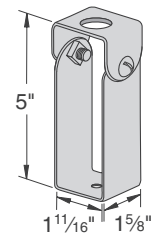

Use With: PS 100, PS 150
 Load Rating: 150 lbs.
 Note: Washers supplied to adapt to 3/8" or 1/2" rod

Weight/100 pcs: 35 lbs.

PS 2636 – Fixture Stud Nut

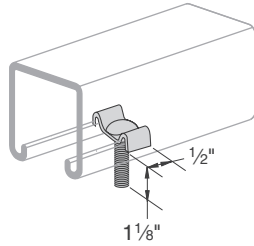

Size: 1/4" x 20 thread, 1 1/4" long

Weight/100 pcs: 5 lbs.

PS 702 – Fluorescent Fixture Hanger

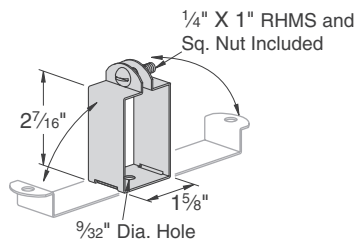

Hanger provides more than 1/2" space between channel and fixtures.

Use hanger for PS 200, PS 210 & PS 300.

Load Rating: 120 lbs.

Weight/100 pcs: 19 lbs.

PS 702 D – Fluorescent Fixture Hanger

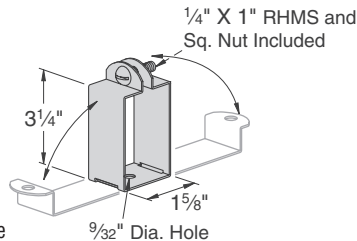

Hanger provides more than 1/2" space between channel and fixtures.

Use hanger for PS 150.

Load Rating: 120 lbs.

Weight/100 pcs: 20 lbs.

PS 659 – Channel Hanger

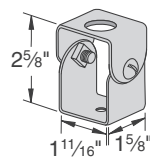

Use With: PS 400, PS 500

Load Rating: 150 lbs.

Note: Washers supplied to adapt to 3/8" or 1/2" rod

Weight/100 pcs: 28 lbs.

PS 2637 – Fixture Nut

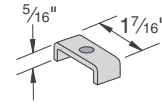

Size: Tapped for 1/4" - 20 thread

Weight/100 pcs: 2 lbs.

PS 703 – Fluorescent Fixture Hanger

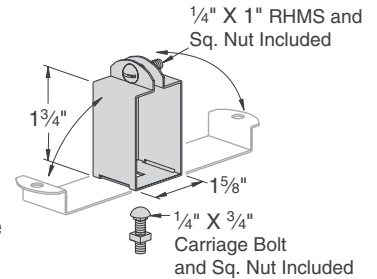

Hanger provides more than 1/8" space between channel and fixtures.

Use hanger for PS 200 & PS 210.

Load Rating: 120 lbs.

Weight/100 pcs: 17 lbs.

PS 703 D – Fluorescent Fixture Hanger

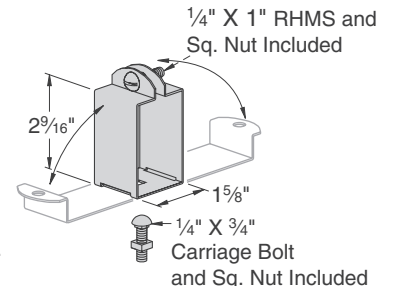

Hanger provides more than 1/8" space between channel and fixtures.

Use hanger for PS 150.

Load Rating: 120 lbs.

Weight/100 pcs: 18 lbs.

PS 658 – Channel Hanger

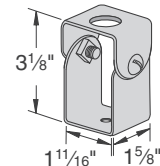

Use With: PS 200, PS 210, PS 300

Load Rating: 150 lbs.

Note: Washers supplied to adapt to 3/8" or 1/2" rod

Weight/100 pcs: 30 lbs.

PS 2621 – Conduit Swing Fitting

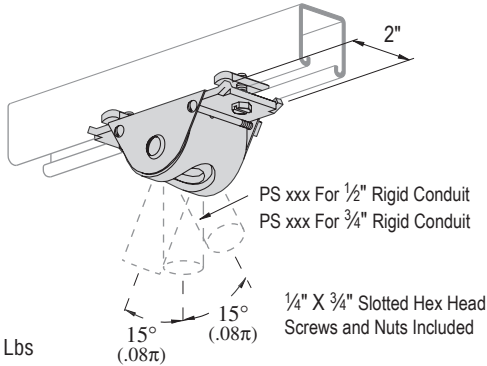

Design Load: 300 Lbs

Note:

Conduit hanger fittings allow a free swivel of 15° in one direction.

Fitting may be mounted to the slot side of the channel or to the back

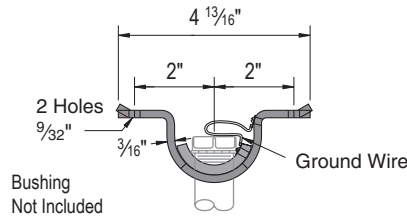

Weight/100 pcs: 396 lbs.

PS 2094 – 4" Receptacle Box With Knock-outs

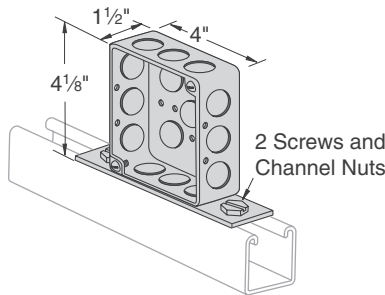

Stock Size: (.075)

Assembly: 1 Box, 2 Screws

Weight/100 pcs: 93 lbs.

PS 2639 – Outlet Box

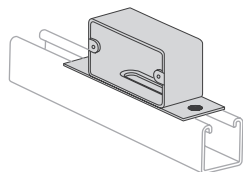

Stock Size: (.075)

Assembly: 1 Box, 2 Screws, 2 Channel Nuts

Weight/100 pcs: 88 lbs.

PS 2662 A – Hub Assembly

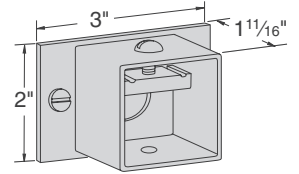
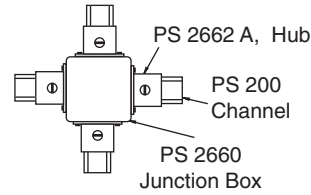

Use With: PS 200, PS 210

Assembly: 1 Hub, 2 Screws, 1 Bolt, 1 Nut

Note: Add hub assemblies to the basic PS 2660 unit assembly to make 1, 2, 3 or 4-way junction box.

Identification No. 122022

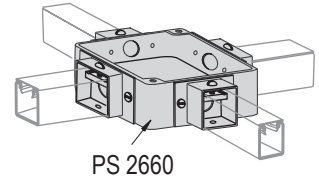

Weight/100 pcs: 27 lbs.

PS 2660 – Junction Box

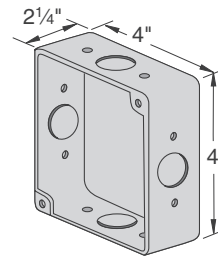

Note:

Add hub assemblies PS 2662-A to make 1, 2, 3 or 4-way junction box.

Weight/100 pcs: 113 lbs.

PS 2661 – Junction Box Cover

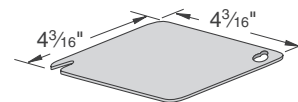

Weight/100 pcs: 30 lbs.



ELECTRICAL

Finish: Painted Green or Pregalvanized Stock Length: 10' & 20' Order By: No., Size and Finish



PS 649, PS 693, PS 694, PS 805, PS 942, PS 2582 – Electrical Joiner

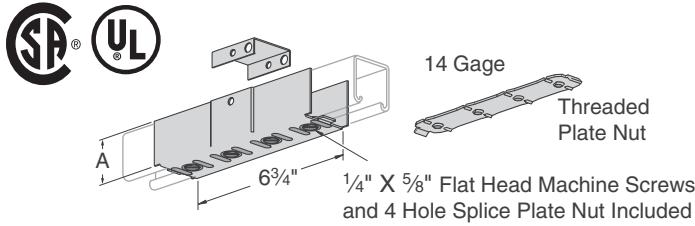

Stock Size: (.060)

Assembly: 1 Splice Plate Clevis (GRN),
1 Tapped Plate (EG), 1 Backplate (GRN),
4 Flat Head Machine Screws (EG).

Part No.	A	Use With	Finish	Wt./100 pcs
PS 805		PS 100	EG, GRN	106
PS 2582	1 5/8"	PS 150	EG	103
PS 649		PS 200, PS 210	EG, GRN	100
PS 694	1 3/8"	PS 300		97
PS 693	1 1/16"	PS 400		97
PS 942	1 3/16"	PS 500, PS 520		80

PS 2700 – Inside Strut Joiner

Material: Extruded aluminum
Jam screws included

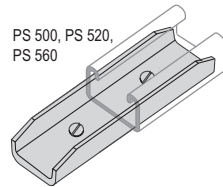

Weight/100 pcs: 12 lbs.

PS 2800 – Inside Strut Joiner

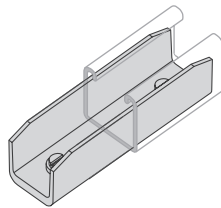

Material: Cast aluminum or electro-galvanized
Jam screws included
Note: electro-galvanized is not UL Listed

Weight/100 pcs: 20 lbs.

PS 2803 – “Cross” Inside Strut Joiner

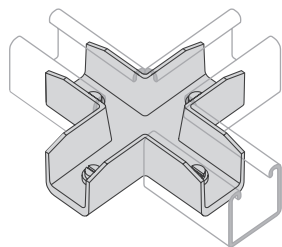

Material: Cast aluminum
Jam screws included

Weight/100 pcs: 45 lbs.

PS 671 – Strut Suspension Member

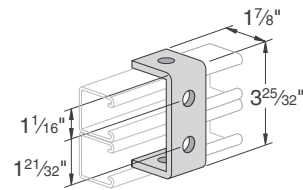

Weight/100 pcs: 70 lbs.

PS 2802 – “Elbow” Inside Strut Joiner

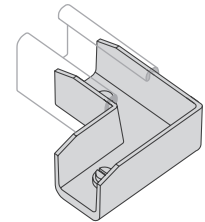

Material: Cast aluminum
Jam screws included

Weight/100 pcs: 27 lbs.

PS 2801 – “T” Inside Strut Joiner

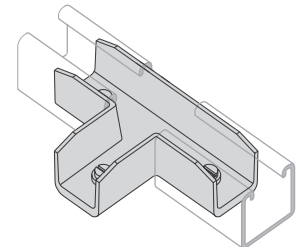

Material: Cast aluminum
Jam screws included

Weight/100 pcs: 35 lbs.

PS 791 – Electrical Box Adapter Plate

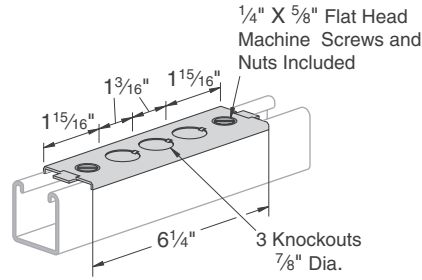

Stock Size: (.060)

Assembly: 1 Plate, 2 Screws, 2 Channel Nuts

Weight/100 pcs: 35 lbs.

PS 1510 – Maple Cable Saddle

Use With: All 1 5/8" Channel

Assembly:

Maple Part, 1 Spring Nut, 1 Flat Head Screw

Note: Specify Cable Diameter

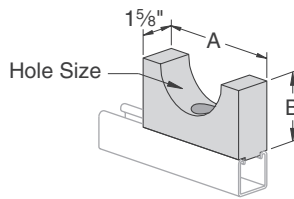

Cable Size	A	B	Wt./100 pcs
0" – 1"	3"	1 3/4"	31
1" – 1 1/2"	3 1/2"	2"	38
1 1/2" – 2"	4"	2 1/4"	47
2" – 2 1/2"	4 1/2"	2 1/2"	57
2 1/2" – 3"	5"	2 3/4"	68
3" – 3 1/2"	5 1/2"	3"	80
3 1/2" – 4"	6"	3 1/4"	94

PS 1801 – Square Maple Cable Clamps

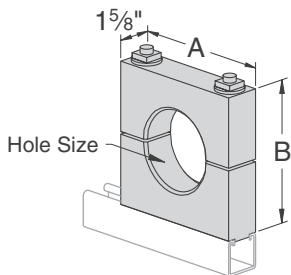

Inside Diameter Size	A & B	Wt./100 pcs
0" – 1"	3 1/2"	84
1" – 1 1/2"	4"	102
1 1/2" – 2"	4 1/2"	121
2" – 2 1/2"	5 1/2"	165
2 1/2" – 3"	6"	189
3" – 3 1/2"	6 1/2"	215
3 1/2" – 4"	7"	243

Use With: All 1 5/8" Wide Channels.

Assembly: Maple Part, 2 Stud Bolts, 2 Washers, 2 Spring Nuts, 2 Square Nuts

Note: Special maple clamps can be made to order. Specify Cable Diameter.

PS 2627 – Spacer Clevis

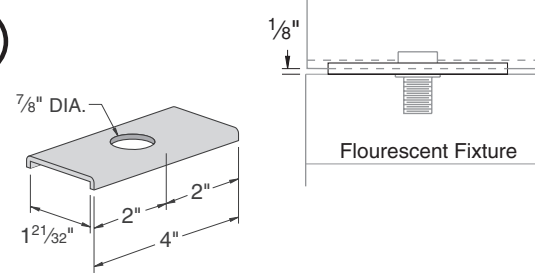

Material: 12 gage

Weight/100 pcs: 24 lbs.

PS 1500 – Porcelain Cable Rack Insulators

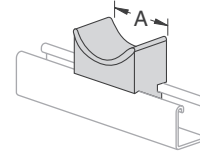

Cable Diameter	A	Wt./100 pcs
3"	3"	75
4 1/2"	4"	95



Electrical

Use With: All 1 5/8" channel

PS 760 – Bus Duct Connection Clevis

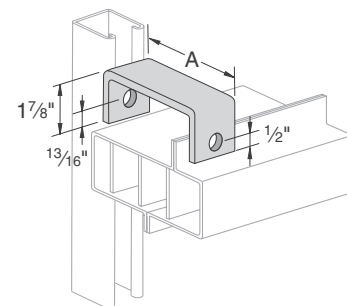

Part No.	Outside Width	Inside Width	Wt./100 pcs
PS 760-1	2 13/32"	1 29/32"	57
PS 760-2	3 25/32"	3 9/32"	73
PS 760-3	4 3/4"	4 1/4"	84

Weight/100 pcs: 93 lbs.

PS 722 – Porce -A- Clamp™

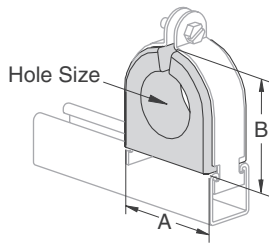

Porce -A- Clamp™

- Non-Breakable TPE Material
- U.V. Resistant
- U.L. Listed
- Electro-galvanized or Stainless Steel Clamps
- Tapered Flange to Protect Cable
- Dielectric Strength 640 Volts Per Mil.
- One Piece
- Replaces Porcelain & Maple Cable Clamp
- For use in accordance with National Electrical Code ANSI/NFPA 70.

Replaces the two piece PS 723 Porcelain Cable Clamp

Includes: Everdur Hardware

Patents Pending

Strap Material: Electro-galvanized steel or stainless steel

Use With: All 1 5/8" channel

Temperature Range: -50°F to +275°F

Part No.	Hole Size	A	B	Wt./100 pcs			
PS722 3/8"	3/8"	1 7/8"	1 15/32"	25			
PS722 1/2"	1/2"						
PS722 5/8"	5/8"						
PS722 3/4"	3/4"	2 3/8"	2 1/32"	37			
PS722 7/8"	7/8"						
PS722 1"	1"						
PS722 1 1/8"	1 1/8"						
PS722 1 1/4"	1 1/4"						
PS722 1 3/8"	1 3/8"	2 7/8"	2 17/32"	58			
PS722 1 1/2"	1 1/2"						
PS722 1 5/8"	1 5/8"						
PS722 1 3/4"	1 3/4"						
PS722 1 7/8"	1 7/8"	4"	3 5/8"	76			
PS722 2"	2"						
PS722 2 1/8"	2 1/8"						
PS722 2 1/4"	2 1/4"						
PS722 2 3/8"	2 3/8"						
PS722 2 1/2"	2 1/2"	4 1/2"	4 1/8"	90			
PS722 2 5/8"	2 5/8"						
PS722 2 3/4"	2 3/4"						
PS722 2 7/8"	2 7/8"						
PS722 3"	3"	5 1/8"	4 5/8"	109			
PS722 3 1/8"	3 1/8"						
PS722 3 1/4"	3 1/4"						
PS722 3 3/8"	3 3/8"						
PS722 3 1/2"	3 1/2"						
PS722 3 5/8"	3 5/8"	6 1/8"	5 11/32"	130			
PS722 3 3/4"	3 3/4"						
PS722 3 7/8"	3 7/8"						
PS722 4"	4"						
PS722 4 1/8"	4 1/8"						
PS722 4 1/4"	4 1/4"						
PS722 4 3/8"	4 3/8"						
PS722 4 1/2"	4 1/2"						
PS722 4 3/4"	4 3/4"				7 1/4"	6 3/4"	160
PS722 4 7/8"	4 7/8"						
PS722 5"	5"						
PS722 5 1/8"	5 1/8"						
PS722 5 1/4"	5 1/4"						
PS722 5 3/8"	5 3/8"						

PS 1610 – Maple Cable Clamp

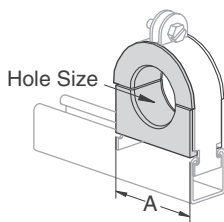

Use With: All 1 5/8" Wide Channel

Assembly: Maple Part, Pipe Clamp Assembly

Note: Specify Cable Diameter

Inside Diameter	A	PS 1100 Size	Wt./100 pcs
0 to 5/8"	1 5/16"	1"	24
1/2 to 1"	1 15/16"	1 1/2"	42
3/4 to 1 1/2"	2 3/8"	2"	54
1 1/4 to 1 3/4"	3 1/2"	3"	65
1 1/2 to 2 1/4"	4"	3 1/2"	84
2 to 2 1/2"	4 1/2"	4"	107
2 1/4 to 3"	5 9/16"	5"	123
3 to 4"	6 5/8"	6"	163

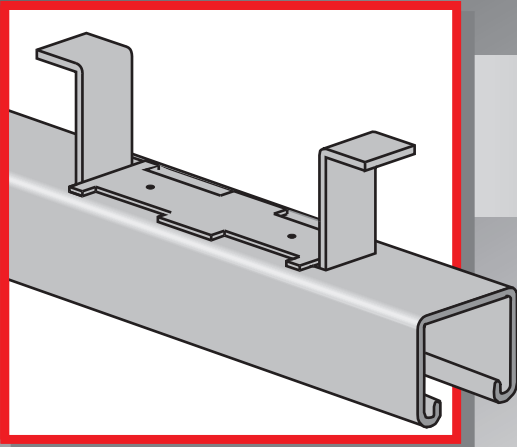

CONCRETE INSERTS

A selection of heavy-duty to light-duty “continuous” and “spot” concrete inserts is available for use in pre-cast, pre-stressed or poured-in-place concrete floors, walls or ceilings.

MATERIAL:

Power-Strut continuous slotted concrete inserts are cold formed from structural quality strip steel.

STANDARD LENGTHS:

Standard lengths are 10 or 20 feet. Non-standard lengths from 3 inches to 20 feet are also available.

STANDARD FINISH:

Power-Strut continuous-slotted concrete inserts are available in plain or pre-galvanized finishes. Closure strips (CS) are made of plastic and end caps (EC) are pre-galvanized.

ORDERING INFORMATION:

When ordering, add the length or size and finish to the part number. See pages 8-9 for finish abbreviations and an example.

CONCRETE INSERTS

Finish: Plain, Hot-Dipped Galvanized, or Pregalvanized **Stock Length:** 20', Other lengths made to order
Stock Thickness: .105 (12 ga.) **Order By:** No., Size, Length and Finish



PS 349 – Continuous Concrete Insert (1 5/8" x 1 3/8")

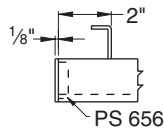
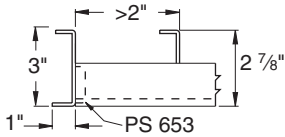
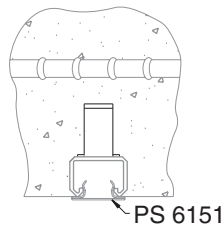
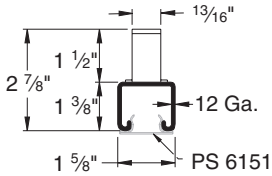
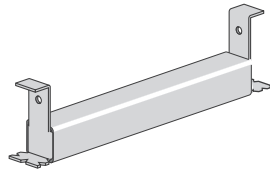
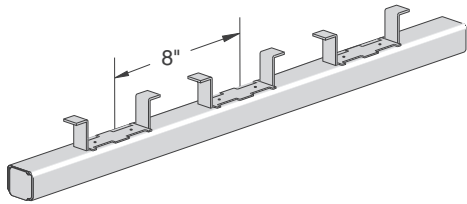

Choice of end cap is based on the distance from the end of the insert to the first anchor as shown below.

Furnished with steel end caps and plastic closure strips installed

- Use channel nuts designed for PS 300 Channel.
- Nail or anchor the inserts to forms every 16" to 24"

Part No.	End Cap	Wt./100 pcs - PLN	Load Data*	
PS 349 3" CS/EC	PS 653	72	500 lbs.	
PS 349 4" CS/EC		87	600 lbs.	
PS 349 6" CS/EC		117	800 lbs.	
PS 349 8" CS/EC		147	1,200 lbs.	
PS 349 1' CS/EC		194	2,000 lbs./ft.	
PS 349 1'4" CS/EC	PS 656	253		
PS 349 1'8" CS/EC	PS 653	312		
PS 349 2' CS/EC	PS 656	371		
PS 349 2'8" CS/EC		490		
PS 349 3' CS/EC	PS 653	549		
PS 349 4' CS/EC	PS 656	727		
PS 349 5' CS/EC	PS 653	905		
PS 349 6' CS/EC	PS 656	1,082		
PS 349 7' CS/EC	PS 653	1,260		
PS 349 8' CS/EC	PS 656	1,438		
PS 349 9' CS/EC	PS 653	1,615		
PS 349 10' CS/EC	PS 656	1,793		
PS 349 12' CS/EC		2,148		
PS 349 14' CS/EC		2,504		
PS 349 16' CS/EC		2,859		
PS 349 18' CS/EC		3,215		
PS 349 20' CS/EC		3,570		
PS 349 10' W/O	Insert Only	1,777		*uniform recommended loading on inserts in 3,000 psi concrete.
PS 349 20' W/O		3,554		

PS 653 – Type 'B' End Cap

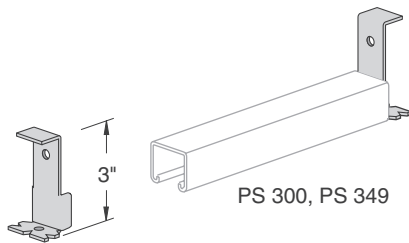

Finish: Pre-galvanized

Weight/100 pcs: 14 lbs.

PS 654 – Type 'B' End Cap

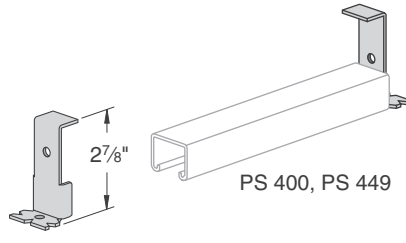

Finish: Pre-galvanized

Weight/100 pcs: 12 lbs.

PS 1154 – Splice Connection

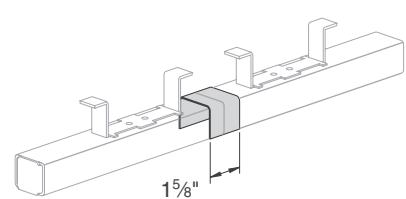

Use With: PS 349

Weight/100 pcs: 10 lbs.

PS 449 – Continuous Concrete Insert (1 5/8" x 1")

Choice of end cap is based on the distance from the end of the insert to the first anchor as shown below.

Furnished with steel end caps and plastic closure strips installed

- Use channel nuts designed for PS 400 Channel.
- Nail or anchor the inserts to forms every 16" to 24"

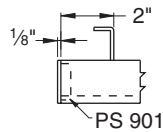
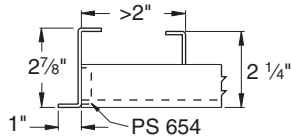
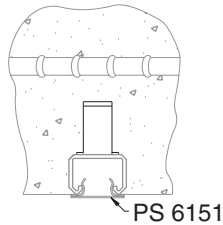
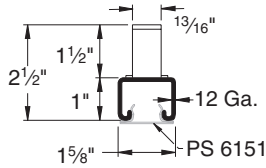
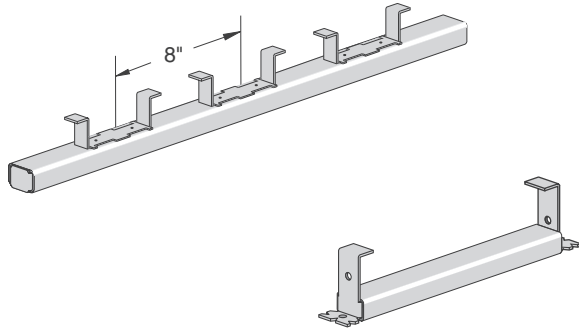

Part No.	End Cap	Wt./100 pcs - PLN	Load Data*
PS 449 3" CS/EC	PS 654	62	1,500 lbs./ft.
PS 449 4" CS/EC		74	
PS 449 6" CS/EC		99	
PS 449 8" CS/EC		124	
PS 449 1' CS/EC		163	
PS 449 1'4" CS/EC	PS 901	213	
PS 449 1'8" CS/EC	PS 654	263	
PS 449 2' CS/EC	PS 901	313	
PS 449 2'8" CS/EC		414	
PS 449 3' CS/EC	PS 654	464	
PS 449 4' CS/EC	PS 901	615	
PS 449 5' CS/EC	PS 654	766	
PS 449 6' CS/EC	PS 901	916	
PS 449 7' CS/EC	PS 654	1,079	
PS 449 8' CS/EC	PS 901	1,218	
PS 449 9' CS/EC	PS 654	1,368	
PS 449 10' CS/EC	PS 901	1,519	
PS 449 12' CS/EC		1,820	
PS 449 14' CS/EC		2,122	
PS 449 16' CS/EC		2,423	
PS 449 18' CS/EC		2,725	
PS 449 20' CS/EC		3,026	
PS 449 10' W/O	Insert Only	1,507	*uniform recommended loading on inserts in 3,000 psi concrete.
PS 449 20' W/O		3,014	



Concrete Inserts

PS 656, PS 901 – Type 'A' End Cap



Part No.	Use With Insert	Finish	Wt./100 pcs
PS 656	PS 349	PGAL	8
PS 901	PS 449		6

PS 6151 – Plastic Closure Strip

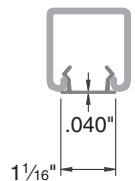
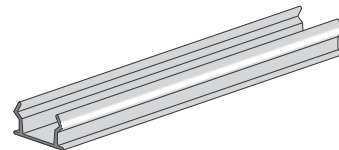

Material: Plastic

Stock Length: 10 ft.

Use With: All 1 5/8" channel and inserts to prevent concrete seepage

Weight/100 pcs: 47 lbs.

CONCRETE INSERTS



PS 152 – Screw Concrete Insert

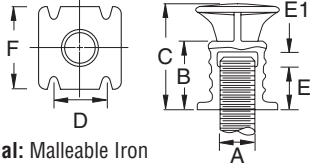
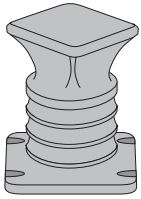

Material: Malleable Iron
Finish: Black

Part No.	Rod Size "A"	B	C	D	E	E ¹	F	Load Rating	Wt./100 pcs
PS 152 3/8"	3/8"	1 1/32"	2 1/4"	1"	1/2"	3/8"	1 5/8"	600	31
PS 152 1/2"	1/2"				5/8"			1,130	32
PS 152 5/8"	5/8"	1 7/32"	2 1/2"	1 1/4"	5/8"	7/16"	2"	1,260	37
PS 152 3/4"	3/4"	1 5/8"			2,500			64	
PS 152 7/8"	7/8"	-	-	-	-	-	-	2,500	71

PS 680 – Concrete Deck Insert

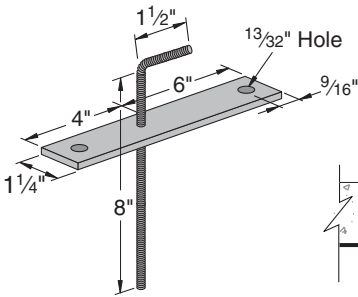

Note:
Rod is electro-galvanized and plate is plain.

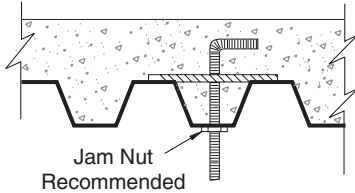

Part No.	Load Rating	Wt./100 pcs
PS 680-3/8"	610	86
PS 680-1/2"	1,130	105
PS 680-5/8"	1,810	130

PS 3700 – Concrete Deck Insert

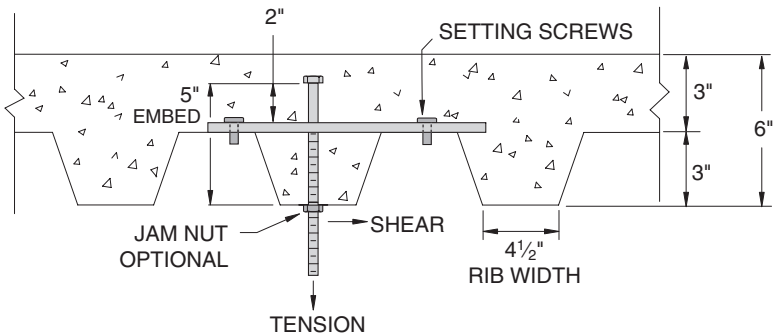
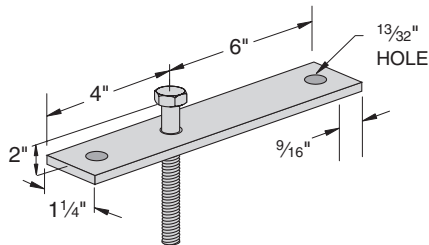

Part No.	Tension Load Rating/Lbs	Shear Load Rating/Lbs	Wt./100 pcs
PS 3700-3/8"	850	600	89
PS 3700-1/2"	1,380	1,000	111
PS 3700-3/4"	1,920	1,760	141

PS 285 – Light Weight Concrete Insert

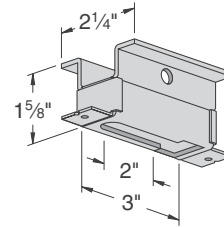

Finish: Plain or Electro-galvanized

Part No.	Rod Size	Load Rating	Wt./100 pcs
PS 285 1/4"	1/4"	230	46
PS 285 3/8"	3/8"	400	49
PS 285 1/2"	1/2"		49

PS 285 N – Concrete Insert Nut (for use with PS 285)

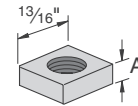

Finish: Plain or Electro-galvanized

Part No.	Rod Size	A	Wt./100 pcs
PS 285 N	1/4"	5/16"	6
PS 285 N	3/8"		5
PS 285 N	1/2"	7/16"	6
PS 285 N	5/8"		7

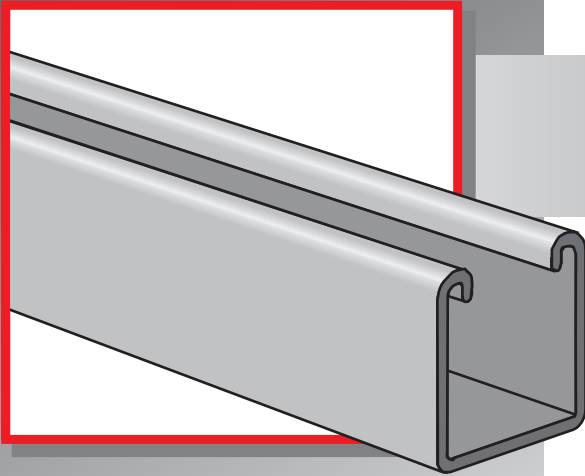

JUNIOR CHANNEL

Power-Strut junior channel sections are cold formed from prime quality cold rolled steel. Junior channel fittings are punched from hot rolled, pickled and oiled steel.

■ STANDARD LENGTHS:

Standard length is 10 feet at a tolerance of $\pm 1/16$ inches. Shorter lengths are available for a small cutting charge.

■ STANDARD DIMENSIONS FOR FITTINGS:

Fitting Thickness:	1/8"
Fitting Width:	13/16"
Hole Diameter:	9/32"
Hole Spacing:	1 1/16" on centers and 13/32" from end.

■ STANDARD FINISH:

PS 600J and PS 700J junior channels are available in a galvanized or painted green finish. All junior channel fittings are available in electro-galvanized finish.

■ ORDERING INFORMATION:

When ordering, add the length or size and finish to the part number. See pages 8-9 for finish abbreviations and an example.

JUNIOR CHANNEL



Finish: Electro-galvanized Stock Width: 1 3/16" Stock Thickness: 1/8" Stock Length: 10'
 Order By: No., Size and Finish Hole Spacing: 1 3/32" from end, 1 1/16" on center Hole Diameter: 9/32"

PS 600J – Channel (1 3/16" x 1 3/16" x 19 ga.)

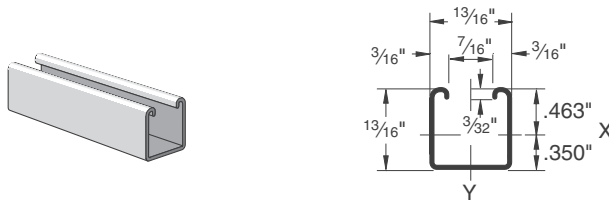

BEAM LOADING – PS 600J

Span (in)	Max Allowable Uniform Load (lbs)	Defl. at Uniform Load (in)	Uniform Loading at Deflection		
			Span/180 (lbs)	Span/240 (lbs)	Span/360 (lbs)
18	230	0.06	230	230	180
24	170	0.11	170	150	100
30	140	0.18	130	100	70
36	110	0.24	90	70	50
42	100	0.35	70	50	30
48	80	0.42	50	40	30
54	80	0.60	40	30	20
60	70	0.72	30	20	20

* Bearing load may govern capacity.

For concentrated load at center of span, divide uniform load by 2 and multiply corresponding deflection by 0.8. This load table is based on a solid channel section.

COLUMN LOADING – PS 600J

Unbraced Height (in)	Max. Allowable Load at Slot Face (lbs)	Maximum Column Load Applied at C.G.			
		K = 0.65 (lbs)	K = 0.80 (lbs)	K = 1.0 (lbs)	K = 1.2 (lbs)
18	600	1,660	1,400	1,100	860
24	490	1,300	1,010	740	590
30	420	990	740	560	450
36	340	770	590	450	370
42	300	630	490	380	310
48	260	540	420	330	270
54	240	470	370	290	**
60	210	410	330	**	**

** $KL/r > 200$

Column loads are for allowable axial loads and must be reduced for eccentric loading.

ELEMENTS OF SECTION

Weight (lbs./100 ft.)	Area of Section (Inch ²)	X-X Axis			Y-Y Axis		
		Moment of Inertia (Inch ⁴)	Section Modulus (Inch ³)	Radius of Gyration (Inch)	Moment of Inertia (Inch ⁴)	Section Modulus (Inch ³)	Radius of Gyration (Inch)
36	0.107	0.009	0.020	0.295	0.012	0.029	0.333

PS 3017 – Junior Channel Nuts **PS 4017 – Junior Channel Nuts** **PS 2029 – End Cap**



Size	Wt./100 pcs
8-32	1
10-32	1
10-24	1
1/4"	1

Use With: PS 600J channel



Size	Wt./100 pcs
8-32	1
10-32	1
10-24	1
1/4"	1

Use With: PS 700J channel



Use With: PS 600J

Weight/100 pcs: 2 lbs.

Finish: Electro-galvanized Stock Width: 1 3/16" Stock Thickness: 1/8" Stock Length: 10'
 Order By: No., Size and Finish Hole Spacing: 1 3/32" from end, 1 13/32" on center Hole Diameter: 9/32"

PS 700J – Channel (1 3/16" x 1 3/32" x 19 ga.)

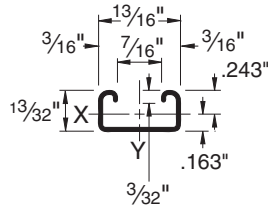
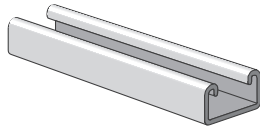

* Bearing load may govern capacity.

** K > 200

Column loads are for allowable axial loads and must be reduced for eccentric loading. For concentrated load at center of span, divide uniform load by 2 and multiply corresponding deflection by 0.8. This load table is based on a solid channel section.

BEAM LOADING – PS 700J

Span (in)	Max Allowable Uniform Load (lbs)	Defl. at Uniform Load (in)	Uniform Loading at Deflection		
			Span/180 (lbs)	Span/240 (lbs)	Span/360 (lbs)
18	80	0.12	60	50	30
24	60	0.22	40	30	20
30	50	0.36	20	20	10
36	40	0.50	20	10	10

COLUMN LOADING – PS 700J

Unbraced Height (in)	Max. Allowable Load at Slot Face (lbs)	Maximum Column Load Applied at C.G.			
		K = 0.65 (lbs)	K = 0.80 (lbs)	K = 1.0 (lbs)	K = 1.2 (lbs)
18	420	1,200	990	720	510
24	330	900	640	410	280
30	260	620	410	**	**
36	200	430	280	**	**

ELEMENTS OF SECTION

Weight (lbs./100 ft.)	Area of Section (Inch ²)	X-X Axis			Y-Y Axis		
		Moment of Inertia (Inch ⁴)	Section Modulus (Inch ³)	Radius of Gyration (Inch)	Moment of Inertia (Inch ⁴)	Section Modulus (Inch ³)	Radius of Gyration (Inch)
25	0.074	0.002	0.007	0.150	0.007	0.017	0.307

PS 2013 – Square Washer

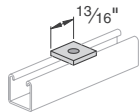

Weight/100 pcs: 2 lbs.

PS 2014 – Two-Hole Splice Plate

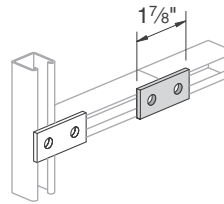

Weight/100 pcs: 5 lbs.

PS 2015 – Three-Hole Splice Plate

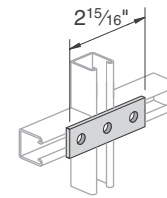

Weight/100 pcs: 8 lbs.

PS 2016 – Four-Hole Splice Plate

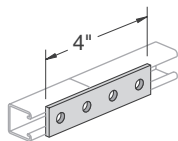

Weight/100 pcs: 11 lbs.

PS 2033 – Flat Angle Plate

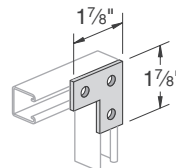

Weight/100 pcs: 8 lbs.

PS 2034 – Tee Plate

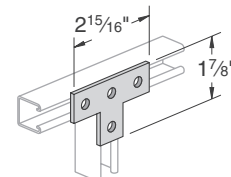

Weight/100 pcs: 11 lbs.

PS 2008 – Two-Hole Corner Angle

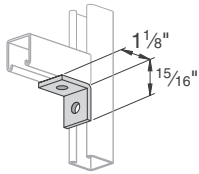

Weight/100 pcs: 5 lbs.

PS 2017 – Two-Hole Corner Angle

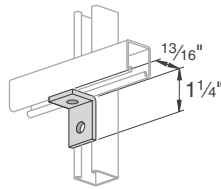

Weight/100 pcs: 5 lbs.

PS 2018 – Three-Hole Corner Angle

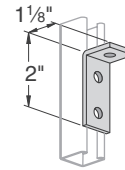

Weight/100 pcs: 8 lbs.

PS 2025 – Three-Hole Corner Angle

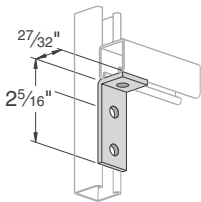

Weight/100 pcs: 8 lbs.

PS 2037 – Three-Hole Corner Angle

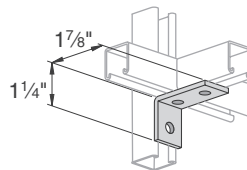

Weight/100 pcs: 8 lbs.

PS 2019 – Four-Hole Corner Angle

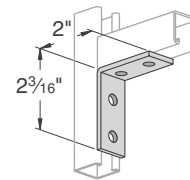

Weight/100 pcs: 11 lbs.

PS 2024 – Four-Hole Corner Angle

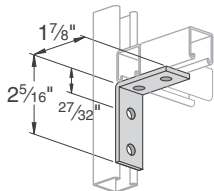

Weight/100 pcs: 11 lbs.

PS 2023 R or L – Four-Hole Shelf Bracket

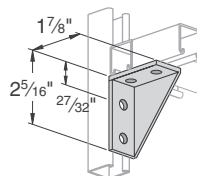

Weight/100 pcs: 19 lbs.

Note:
Specify R (right) or L (left) when ordering
Right Hand Illustrated

PS 2010 – Zee Support

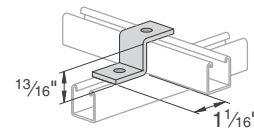

Use With: PS 600J

Weight/100 pcs: 7 lbs

PS 2026 – Zee Support

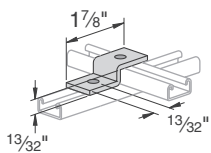

Use With: PS 700J

Weight/100 pcs: 6 lbs.

PS 2011 – "U" Support

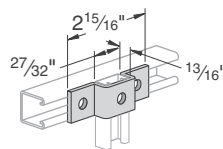

Use With: PS 600J

Weight/100 pcs: 12 lbs.

PS 2041 – Tubing Clamps

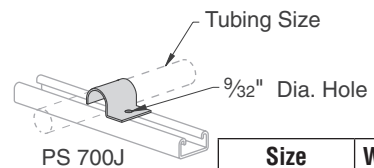

Size Tubing O.D.	Wt./100 pcs
1/4"	2
3/8"	
1/2"	
5/8"	
3/4"	3
7/8"	
1"	

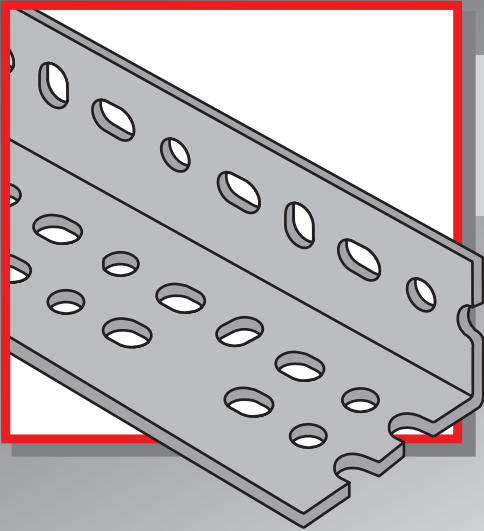

POWER-ANGLE®

A complete support system that's versatile, economical and easy to use.

- *No drilling, welding or special tools necessary.*
- *Fast, efficient bolt-together construction*
- *Easy to change and adjust*

■ STANDARD LENGTHS:

Standard lengths are 10' and 12'. Slotted angle is shipped in ten-piece bundles complete with 75 pieces of $\frac{3}{8}$ " - 16 x $\frac{3}{4}$ " hex head bolts and $\frac{3}{8}$ " nuts.

■ STANDARD FINISH:

Available in two durable, long-lasting finishes; pre-galvanized or Power-Green™.

■ ORDERING INFORMATION:

When ordering, add the length or size and finish to the part number. See pages 8-9 for finish abbreviations and an example.

Finish: Pregalvanized or Acrylic Green Stock Thickness: .075(14 ga.) Stock Length: 10 & 12 Feet
 Order By: No., Length and Finish

PA 158 – Light Duty
 (1½" x 1⅝" x 14 ga.)

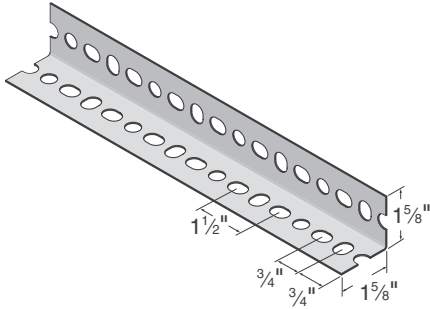

Weight/100 ft.: 66 lbs.

PA 238 – Medium Duty
 (1⅝" x 2⅜" x 14 ga.)

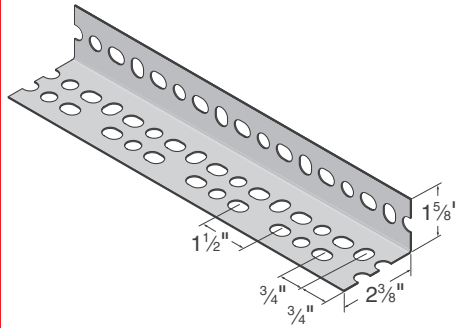

Weight/100 ft.: 80 lbs.

PA 318 – Heavy Duty
 (1⅝" x 3⅛" x 12 ga.)

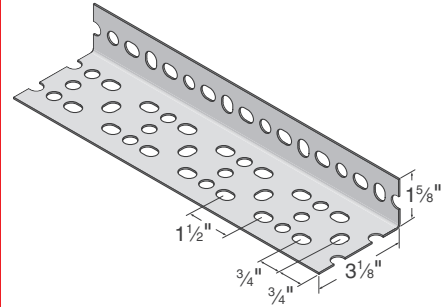

Note: Includes Serrated Nuts & Bolts

Weight/100 ft.: 130 lbs.

PA 1SC – Swivel Caster

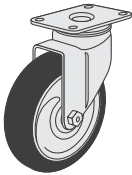

Weight/100 pcs: 170 lbs.

PA 1RC – Rigid Caster



Weight/100 pcs: 110 lbs.

PA 1RP – Slotted Strap

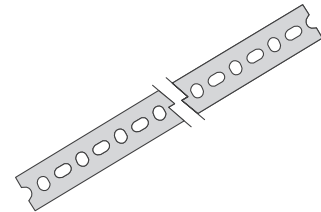

Weight/100 pcs: 35 lbs.

PA 1GP – Gusset Plate

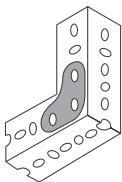

Weight/100 pcs: 9 lbs.

PA 1SNB – Serrated Nuts & Bolts

(Package of 75 nuts and 75 bolts)

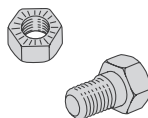

Weight/100 pcs: 7 lbs.

Beam Load Calculations

The beam loading depends on which slotted angle is used and the manner in which the beam is constructed. The diagrams on the next page show how individual slotted angle components can be combined to form a beam. The loading for each beam configuration is shown in the beam loading tables on the following pages.

Example - Load "A"

Load "A" is supported by two 48" sections of PA-238 (1⁵/₈" x 2³/₈"). The 48" row of Table 2 (page 103) indicates what each beam configuration will support. Since the columns are sorted from lowest to highest load, the first configuration that satisfies the requirement is "J" which will support 1,110 lbs.

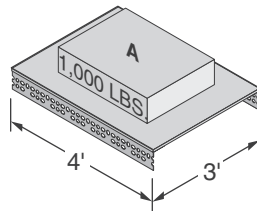

Example - Load "B"

Load "B" is supported by two 36" sections of PA-238 (1⁵/₈" x 2³/₈"). The 36" row of Table 2 (Page 103) indicates what each beam configuration will support. Since the columns are sorted from lowest to highest load, the first configuration that satisfies the requirement is "I" which will support 1,100 lbs.

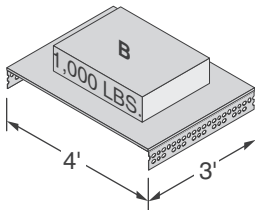

Example - Load "C"

Load "C" is supported by all four beam sections. The load is distributed uniformly on two 3' and two 4' beams which total 14' of supporting beam length. Dividing the 1,000 lb. load by 14-feet equals 72 lbs. per foot. Using the two longest (weakest) lengths, calculate the total weight as follows:

$$2 \text{ (beams)} \times 4' \text{ (length)} \times 72 \text{ lbs./ft.} = 576 \text{ lbs. total weight}$$

The 36" row of Table 2 (Page 103) indicates what each beam configuration will support. Since the columns are sorted from lowest to highest load, the first configuration that satisfies the requirement is "H" which will support 680 lbs. and is adequate for this requirement. The 3-foot beams configured in the same manner will support the load because they are shorter and stronger.

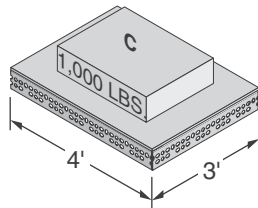

Transverse Stiffeners

When supporting concentrated loads, the capacity of a pair of slotted-angle beams can be increased by the addition of transverse stiffeners. These should be placed immediately under the load bearing point. The slotted-angle segment used as the stiffener is bolted into place using a metal connector at each junction.

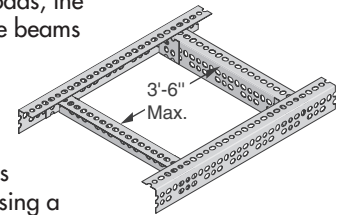

Beams that are 6' long or less require only one stiffener in the center of the span. Seven-foot beams need two stiffeners placed 2' from each end. Eight-foot beams require two stiffeners 2'6" from the ends. For beams with a nine-foot span, it is necessary to have three stiffeners at 2'3" intervals. Ten-foot beams need three stiffeners with 2'6" spacings.

For maximum effectiveness, transverse stiffeners should never be spaced more than 3'6" apart.

Note: All loads based on actual physical testing. Documentation available on request.

Column Load Calculations

Column sections are calculated as described in the following example: (Assumes use of PA-238 1⁵/₈" x 2⁵/₈", material.)

Since all load areas are supported equally by the 4-columns, the calculations are based on a single-column section.

Section MN is one-fourth of "X", or 250 pounds. Column section NP supports one-fourth of "Y" (250 pounds) plus the load supported by MN, or a total of 500 pounds. Section PQ supports one-fourth of "Z" (250 pounds) plus the 500 pound load on section NP, or a total of 750 pounds.

Column loads are based on free and unbraced column lengths. Since MN, NP and PQ are each 3' long, the load requirement is for a 36" section that will bear 750 pounds safely. A reference to Table 5 (Page 104) indicates that all sections designated "A" will support 2,280 lbs. and meet the necessary requirements.

Note: To simplify assembly, we recommend using the same size material as for the horizontal members. This would be found in Table 2 to match the 14 gauge 1⁵/₈" x 2⁵/₈" material selected for the beams of this structure.

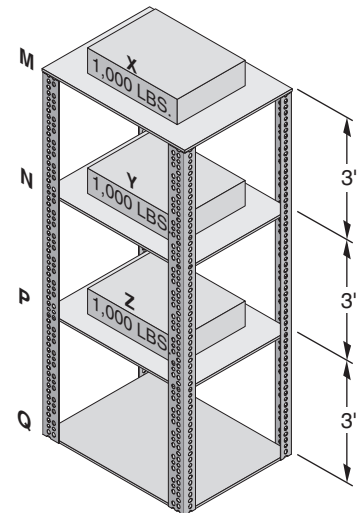

Power-Angle®

Beam Configurations (See corresponding letters in table on following page for load data)

G – Two Single Pieces (Up)

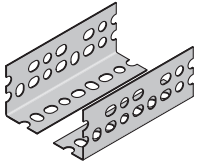

H – Two Single Pieces (Level)

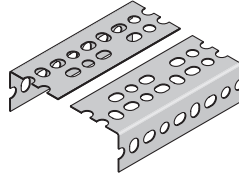

I – Two Single Pieces (Down)

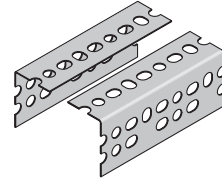

J – Two Z-Sections

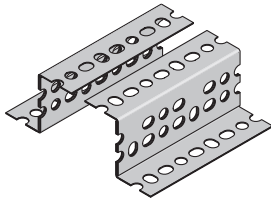

K – Two Narrow Channels

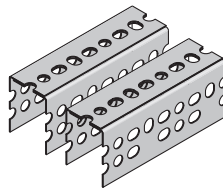

L – Two Broad Channels

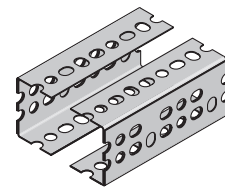

M – Two T-Sections

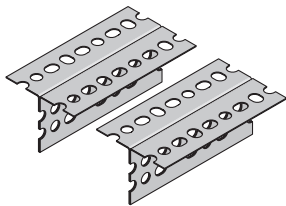

N – Two I-Section

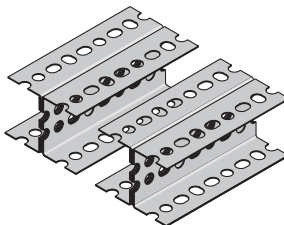

O – Two J-Sections

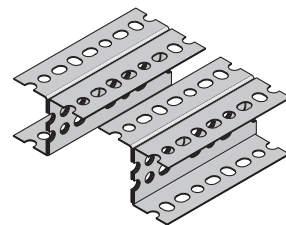

Beam Configurations With Stiffeners (See corresponding letters in table on following page for load data)

P – Single Pieces w/Stiffener

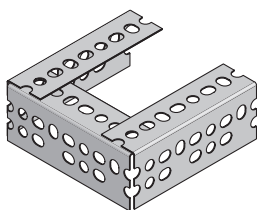

Q – T-Sections w/Stiffener

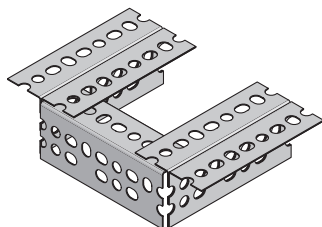

R – Z-Sections w/Stiffener

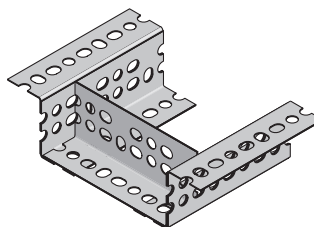

R – I-Sections w/Stiffener

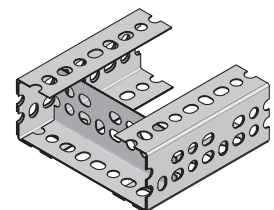

Beam Loads PA 158 – Light Duty (1⁵/₈" x 1⁵/₈" x 14 ga.)

Table 1

Beam Span (Inches)	Beam Configuration (See Previous Page) Beam Load in Pounds*						
	G	H	I	P	L	R	M
	24	550	830	830	920	1,600	1,700
36	370	560	560	610	1,070	1,130	1,230
48	280	420	420	460	800	850	920
60	220	330	330	370	640	680	740
72	180	280	280	310	530	570	610
84	•	240	240	260	460	490	530
96	•	210	210	230	400	430	460
108	•	•	•	•	360	380	410
120	•	•	•	•	320	340	370

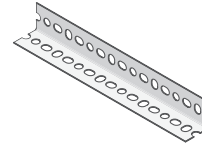

Beam Loads PA 238 – Medium Duty (1⁵/₈" x 2³/₈" x 14 ga.)

Table 2

Beam Span (Inches)	Beam Configuration (See Previous Page) - Beam Load in Pounds*											
	G	H	I	P	J	L	R	M	K	Q	O	N
24	700	1,020	1,660	1,740	2,220	3,170	3,230	3,490	3,590	3,630	6,060	7,560
36	460	680	1,100	1,160	1,480	2,110	2,150	2,320	2,390	2,420	4,040	5,040
48	350	510	830	870	1,110	1,580	1,620	1,740	1,800	1,810	3,030	3,780
60	280	410	660	700	890	1,270	1,290	1,390	1,440	1,450	2,420	3,020
72	230	340	550	580	740	1,060	1,080	1,160	1,200	1,210	2,020	2,520
84	•	290	470	500	630	910	920	1,000	1,030	1,040	1,730	2,160
96	•	260	410	440	550	790	810	870	900	910	1,520	1,890
108	•	•	•	•	490	700	720	770	800	810	1,350	1,680
120	•	•	•	•	440	630	650	700	720	730	1,210	1,510

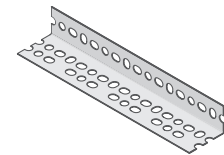

Beam Loads PA 318 – Heavy Duty (1⁵/₈" x 3¹/₈" x 12 ga.)

Table 3

Beam Span (Inches)	Beam Configuration (See Previous Page) - Beam Load in Pounds*											
	G	H	I	P	J	L	R	M	K	Q	O	N
24	1,790	1,610	4,300	4,960	6,520	7,910	8,070	9,920	9,990	10,170	14,600	16,120
36	1,200	1,070	2,870	3,310	4,350	5,270	5,380	6,610	6,660	6,780	9,730	10,750
48	900	810	2,150	2,480	3,260	3,950	4,030	4,960	4,990	5,080	7,300	8,060
60	720	640	1,720	1,980	2,610	3,160	3,230	3,970	4,000	4,070	5,840	6,450
72	600	540	1,430	1,650	2,170	2,640	2,690	3,310	3,330	3,390	4,870	5,370
84	•	460	1,230	1,420	1,860	2,260	2,300	2,830	2,850	2,910	4,170	4,610
96	•	400	1,080	1,240	1,630	1,980	2,020	2,480	2,500	2,540	3,650	4,030
108	•	•	•	1,100	1,450	1,760	1,790	2,200	2,220	2,260	3,240	3,580
120	•	•	•	990	1,300	1,580	1,610	1,980	2,000	2,030	2,920	3,220

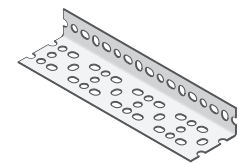

* Based on simple beam condition with uniform loads on parallel beams.
To determine concentrated load capacity at mid-span, multiply uniform load by 0.5.

Column Sections

(See corresponding letters in table on for load data)

A – Single Piece

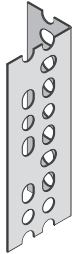

B – T-Section

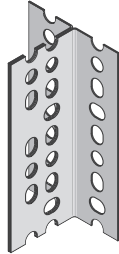

B – Broad Channel Section

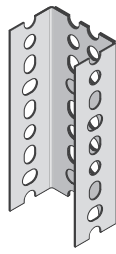

B – Narrow Channel Section

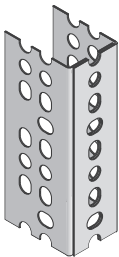

C – Uneven T-Section

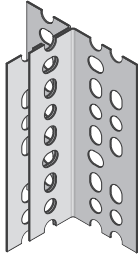

C – Uneven Channel Section

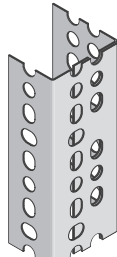

D – Dual Channel Section

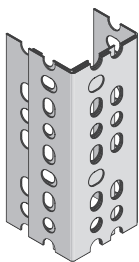

D – T-Channel Section

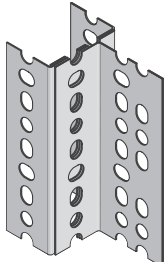

D – T-Channel Section

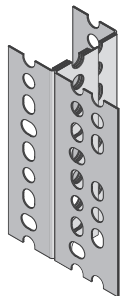

E – I-Section

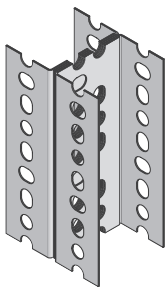

F – Uneven I-Section

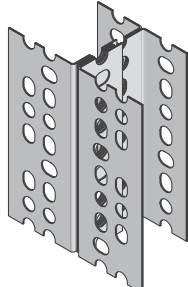

Column Load

PA 158 – Light Duty (1⁵/₈" x 1⁵/₈" x 14 ga.)

Table 4

Column Height (Inches)	Column Load in Pounds*	
	Column Sections (See Left Side of Page)	
	A	B
36"	1,450	3,850
48"	1,150	3,500
60"	950	3,000
72"	750	2,500

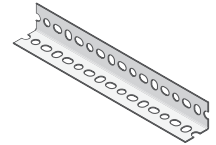

PA 238 – Medium Duty (1⁵/₈" x 2³/₈" x 14 ga.)

Table 5

Column Height (Inches)	Column Load in Pounds*					
	Column Sections (See Left Side of Page)					
	A	B	C	D	E	F
36"	2,280	4,760	4,940	7,270	9,520	9,865
48"	1,970	4,490	4,680	6,920	8,970	9,330
60"	1,520	3,995	4,310	6,370	7,990	8,620
72"	1,070	3,140	3,870	5,840	6,280	7,715
84"	660	2,340	3,665	4,930	4,660	6,740
96"	•	1,750	2,700	3,850	3,500	5,365
108"	•	•	2,060	2,870	•	4,115
120"	•	•	1,610	2,690	•	3,210

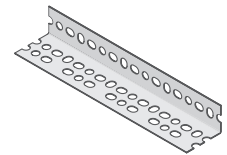

PA 318 – Heavy Duty (1⁵/₈" x 3¹/₈" x 12 ga.)

Table 6

Column Height (Inches)	Column Load in Pounds*					
	Column Sections (See Left Side of Page)					
	A	B	C	D	E	F
36"	3,470	7,970	8,770	12,560	15,940	17,550
48"	2,870	7,360	8,580	11,970	14,750	17,150
60"	1,970	6,570	8,180	11,360	13,160	16,360
72"	1,280	5,270	7,690	10,480	10,560	15,360
84"	•	3,670	6,970	9,470	7,370	13,970
96"	•	2,580	6,260	8,370	5,170	12,570
108"	•	•	5,460	6,880	•	10,970
120"	•	•	4,460	5,370	•	8,960

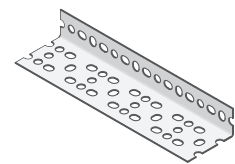

* Column Loads are concentric without intermediate lateral support.

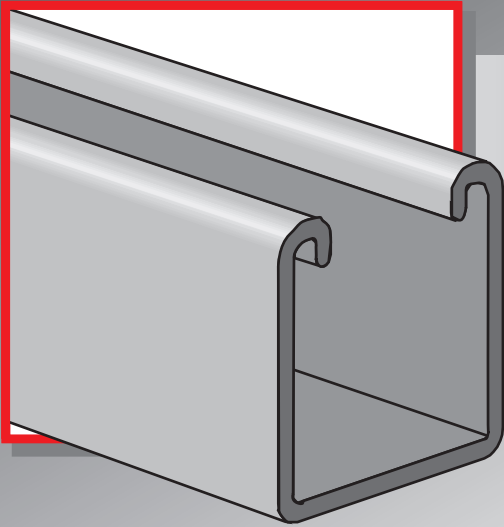

FIBERGLASS

The installation of fiberglass channel and accessories is similar to the installation of metallic channel and accessories. All standard installation practices and procedures apply. In general, special handling is not required.

Fabrication of Aickinstrut components requires just three simple operations; cutting, drilling and sealing.

Aickinstrut Specifications

AICKINSTRUT FABRICATION

The installation of fiberglass channel and accessories is similar to the installation of metallic channel and accessories. All standard installation practices and procedures apply. In general, special handling is not required. Fabrication of Aickinstrut components requires just three simple operations; cutting, drilling and sealing as described below.

Cutting – Cutting can be accomplished with a wide variety of saws. Hand held saws, such as hack saws (24 to 32 teeth per inch) are suitable when a few number of cuts are required. For frequent cutting, a circular power saw with a carbide-tipped masonry blade yields the best results and the greatest number of cuts. When using a power saw, dust filter masks, gloves and long sleeve clothing should be worn.

Drilling – Any standard twist bit, even when used with battery-powered drills will work well. Carbide-tipped drill bits are recommended.

Sealing – To protect against future migration of corrosive elements into the cut sections, all cuts and holes should be properly sealed using Aickincoat or Aickinzip.

LABOR SAVINGS

Aickinstrut fiberglass structural members can be cut and drilled at a much faster rate than steel. Typically, fiberglass can be fabricated in less than half the time. As a result, substantial labor savings will be realized. Also, Aickinstrut products average 1/3 the weight of their steel counterparts, making them much easier to handle on the job site.

RELATIVE MATERIAL COSTS

Aickinstrut materials are advantageously priced relative to specialty metals traditionally used in corrosive environments. Aickinstrut, even though slightly more expensive than pre-galvanized channel, can be used with the knowledge that it will not have to be maintained regularly or replaced after a brief time. Should pre-galvanized channel have to be replaced once, its cost far outweighs the expense of doing the initial installation with Aickinstrut.

MATERIAL

The finished Aickinstrut application will utilize a combination of materials from the following resin families:

Material Code	Material
E	PVC (extruded)
P	Polyester (pultruded)
V	Vinyl ester (pultruded)
PU	Polyurethane (injection molded)
PP	Polypropylene (injection molded)
N	Nylon (injection molded)

The ability of each material to handle high and low temperatures, chemical exposures and static loads is covered in each of the following sections. By using these criteria, you will be able to select the optimal Aickinstrut Channel, Fittings and Accessories for your particular applications.

OPERATING ENVIRONMENT

In order to design an Aickinstrut system for your application, consideration should be given to the maximum operating conditions. These “worst case” conditions will determine which type of Aickinstrut materials are best suited for your application. The three “worst case” operating conditions to consider are:

- Temperature
- Chemical Environment
- Loading

Temperature Ranges – Aickinstrut is supplied in six different materials covering distinct temperature ranges. Materials should be chosen which meet or exceed the minimum and maximum temperatures for your applications.

Material Code	Low Temperature	High Temperature
E	-25°F	130°F
P	-35°F	200°F
V	-35°F	200°F
PU	-40°F	140°F
PP	-30°F	150°F
N	-20°F	150°F

The temperature ranges indicated are meant to be used only as a general guideline. Continual exposure to elevated temperatures reduces the strength properties of plastics and glass reinforced fiberglass. Actual resin test data confirms that a 50% reduction in strength occurs at the extreme high temperature levels.

Chemical Resistance – Each resin family has its own specifications regarding its performance against corrosion resistance. Use the following chart to determine which Aickinstrut material system will provide the best performance for your particular application. The results in the chart are based upon immersion for a 24 hour period. This is typically the “worst case” exposure to corrosion. Less severe contact such as spills, splashes and vapor condensate will exceed the performance results listed in the table.

Loading – Channel loading is defined on pages 112. Additional loading and design limitations for fittings and accessories are described in the appropriate section for that part.

Aickinstrut Specifications**1.0 SCOPE**

- 1.1 This specification covers the requirements for the Aickinstrut Nonmetallic Channel Framing System.

2.0 MATERIAL

- 2.1 FRP channel shall be of pultruded glass reinforced polyester or vinyl ester resin having the physical property values listed in this catalog.
- 2.2 PVC channel shall be of extruded polyvinyl chloride having the physical property values listed in this catalog.
- 2.3 Some accessories shall be of injection molded, 40% long glass fiber reinforced polyurethane, polypropylene or nylon.

3.0 COMPOSITION

- 3.1 Glass reinforced channel shall have a synthetic surfacing veil applied on exterior surfaces to improve weatherability and inhibit ultraviolet degradation. An ultraviolet stabilizer shall be incorporated in the resin formulation to further inhibit ultraviolet degradation.
- 3.2 PVC channel shall be manufactured from a U.V. stabilized resin and incorporate dark gray pigment to improve weatherability and inhibit ultraviolet degradation.

4.0 STRUCTURAL DESIGN

- 4.1 Channel shall incorporate Aickinstrut's patented flange profile design which allows full and positive interlocking contact of channel accessories and prohibits premature flange failure from torqued accessories.
- 4.2 Channel profile dimensions shall be:
 $1\frac{5}{8}'' \times 1\frac{5}{8}'' \times \frac{1}{8}''$,
 $1\frac{1}{2}'' \times 1\frac{1}{2}'' \times \frac{1}{8}''$, or
 $1\frac{1}{2}'' \times 1\frac{1}{8}'' \times \frac{1}{8}''$.
- 4.3 All $1\frac{5}{8}'' \times 1\frac{5}{8}''$ channel profiles shall have a minimum pull out resistance of 1,000 pounds when load is applied over a $\frac{3}{8}''$ long section of the inside flanges.

- 4.4 Channel section lengths shall be supplied in 10' or 20' lengths ($\pm\frac{1}{8}''$).

- 4.5 Universal Pipe Clamps shall have full interlocking contact with interior channel flanges to maximize pull-out resistance and be adjustable to accommodate a minimum $\frac{3}{4}''$ variance in piping or conduit O.D. sizes.

5.0 STANDARDS

- 5.1 Glass reinforced and PVC channels covered in this specification shall have a flame spread rating of 25 or less when tested per ASTM E84 and meet the requirements of UL 94V0 thereby qualifying them as Class 1 material in the Uniform Building Code.
- 5.2 Glass reinforced channels covered in this specification shall comply with the requirements of ASTM D 3917 and ASTM D 4385 which govern the dimensional tolerance and visual defects of pultruded shapes.

6.0 GENERAL

- 6.1 Aickinstrut Nonmetallic Channel Framing shall be furnished as a system which includes all the necessary fasteners, channel splice plates, brackets, sealants, hangers, pipe clamps, etc.
- 6.2 Nonmetallic fasteners shall be manufactured from long glass fiber reinforced polyurethane to ensure maximum strength and corrosion resistance.
- 6.3 All components of the Aickinstrut Channel Framing System shall be nonmetallic except where type 316 stainless steel hardware is used as part of the assembly.
- 6.4 Aickinstrut is manufactured by Aickinstrut, a subsidiary of T. J. Cope, Philadelphia, Pennsylvania, 1-800-426-4293.
- 6.5 The manufacturer shall not have had less than 10 years experience in manufacturing strut systems.
- 6.6 All products are manufactured in the United States of America.



Chemical Compatibility Table

Chemical	Series E (Rigid PVC) 70°-160°F		Series P (Poly/Glass) 70°-160°F		Series V (Vinyl/Glass) 70°-160°F		Series K (PVDF) 70°-160°F		Series PU (Polyurethane) 70°-160°F		Series N (Nylon) 70°-160°F	
Acetic Acid, Up to 10%	R	R	R	R	R	R	R	R	R	-	NR	NR
Acetic Acid, Up to 50%	R	R	R	R	R	R	R	R	R	-	NR	NR
Acetone, Up to 10%	NR	NR	NR	NR	NR	NR	NR	NR	R	-	R	R
Aluminum Hydroxide	R	R	R	R	R	R	R	R	R	-	NR	NR
Ammonium Hydroxide (Aqueous Ammonia), Up to 5%	R	R	NR	NR	R	R	R	R	R	-	-	-
Ammonium Hydroxide, Up to 10%	R	R	NR	NR	R	150°	R	R	R	-	-	-
Ammonium Hydroxide, Up to 20%	R	R	NR	NR	R	150°	R	R	R	-	-	-
Ammonium Nitrate	R	NR	R	R	R	R	R	R	R	-	-	-
Ammonium Phosphate	R	R	R	NR	R	R	R	R	R	-	-	-
Ammonium Sulfide, saturated	R	R	NR	NR	R	120°	R	R	R	-	-	-
Aqua Regia, fumes	NR	NR	NR	NR	R	150°	R	R	NR	-	-	-
Benzene	NR	NR	NR	NR	NR	NR	NR	R	R	R	R	R
Benzoic Acid	R	R	R	R	R	R	R	R	R	-	-	-
Bromine, wet gas	R	NR	NR	NR	R	100°	R	R	-	-	-	-
Butylene Glycol, Up to 100%	R	R	R	R	R	R	R	R	R	-	R	R
Butyric Acid, Up to 50%	NR	NR	R	R	R	R	R	R	R	-	-	-
Calcium Hydroxide	R	R	R	NR	R	R	R	R	R	-	-	-
Calcium Hypochlorite	R	R	R	NR	R	R	R	R	R	-	NR	NR
Chlorine, Dry Gas	NR	NR	NR	NR	R	R	R	R	-	-	-	-
Chlorine, Wet Gas	NR	NR	NR	NR	R	R	R	R	-	-	-	-
Chlorine, Liquid	NR	NR	NR	NR	NR	NR	R	R	-	-	-	-
Chlorine, Water	NR	NR	R	R	R	R	R	R	R	-	NR	NR
Chromic Acid, Up to 5%	R	R	NR	NR	R	R	R	R	-	-	R	R
Copper Chloride	R	R	R	R	R	R	R	R	R	-	-	-
Copper Cyanide	R	R	R	NR	R	R	R	R	R	-	-	-
Copper Fluoride	R	R	R	NR	R	R	R	R	R	-	-	-
Copper Nitrate	R	R	R	R	R	R	R	R	R	-	-	-
Copper Sulfate	R	R	R	R	R	R	R	R	R	-	-	-
Dechlorinated Brine Storage	R	R	-	-	R	R	R	R	R	-	-	-
Esters, Fatty Acid	NR	NR	R	R	R	R	R	R	R	-	-	-
Ferric Chloride	R	R	R	R	R	R	R	R	R	-	-	-
Ferrous Chloride	R	R	R	R	R	R	R	R	R	-	-	-
Fluoboric Acid	R	R	R	120°	R	R	R	R	-	-	-	-
Fluosilicic Acid, Up to 10%	NR	NR	NR	NR	R	R	R	R	-	-	NR	NR
Fluosilicic Acid, Up to 32%	NR	NR	NR	NR	R	100°	R	R	-	-	-	-
Formic Acid, Up to 10%	R	R	NR	NR	R	R	R	R	R	-	NR	NR
Formic Acid, Up to 50%	R	R	NR	NR	R	100°	R	R	R	-	-	-
Gasoline, Aviation	R	NR	R	NR	R	R	R	R	R	-	-	-
Green Liquor, Pulp Mill	R	R	-	-	R	R	R	R	-	-	-	-
Hydrochloric Acid Up to 15%	R	R	R	NR	R	R	R	R	R	-	-	-
Hydrochloric Acid Up to 37%	R	R	R	NR	R	R	R	R	R	-	-	-
Hydrofluoric Acid, Up to 10%	R	R	NR	NR	R	150°	R	R	-	-	-	-
Hydrofluoric Acid, Up to 20%	R	NR	NR	NR	R	100°	R	R	-	-	-	-
Hydrogen Chloride, Wet Gas	NR	NR	R	NR	R	R	R	R	NR	-	-	-
Hydrogen Sulfide, Wet Gas	R	R	R	NR	R	R	R	R	R	-	-	-

Legend: "NR" indicates "Not Recommended" for use;
 "R" indicates "Recommended";
 "-" indicates no information available

Chemical Compatibility Table

Chemical	Series E (Rigid PVC) 70°-160°F		Series P (Poly/Glass) 70°-160°F		Series V (Vinyl/Glass) 70°-160°F		Series K (PVDF) 70°-160°F		Series PU (Polyurethane) 70°-160°F		Series N (Nylon) 70°-160°F	
	R	R	R	NR	R	R	R	R	R	-	-	-
Lactic Acid	R	R	R	NR	R	R	R	R	R	-	-	-
Lead Nitrate	R	R	-	-	R	R	R	R	R	-	-	-
Magnesium Hydroxide	R	R	NR	NR	R	R	R	R	R	-	R	R
Nickel Sulfate, Low pH	R	R	NR	NR	R	R	R	R	R	-	-	-
Nickel Sulfate, High pH	R	R	NR	NR	R	R	R	R	R	-	-	-
Nitric Acid, Up to 5%	R	R	NR	NR	R	150°	R	R	R	-	-	-
Nitric Acid, Up to 35%	R	R	NR	NR	R	150°	R	R	R	-	-	-
Nitric Acid, Vapor	R	R	NR	NR	R	R	R	R	-	-	-	-
Perchloric Acid, Up to 10%	NR	NR	NR	NR	R	150°	R	R	-	-	NR	NR
Pickling Liquids, 3-5% H2SO4	R	R	R	R	R	R	R	R	R	-	-	-
Phosphoric Acid	R	R	NR	NR	R	R	R	R	R	-	NR	NR
Phosphoric Acid, Super or Poly (115%, P20%)	R	R	NR	NR	R	R	R	R	-	-	-	-
Phosphoric Acid Vapor or Condensate	R	R	NR	NR	R	R	R	R	-	-	-	-
Potassium Chloride	R	R	R	R	R	R	R	R	R	-	-	-
Potassium Nitrate	R	R	R	R	R	R	R	R	R	-	-	-
Potassium Persulfate	R	R	NR	NR	R	R	R	R	R	-	-	-
Silver Cyanide, Up to 5%	R	R	NR	NR	R	R	R	R	R	-	-	-
Sodium Hydroxide, Up to 25%	R	R	NR	NR	R	150°	R	R	R	-	-	-
Sodium Hydroxide, up to 50%	R	R	NR	NR	R	180°	R	R	-	-	R	R
Sodium Hypochlorite, Up to 15%	R	R	NR	NR	R	150°	R	R	R	-	NR	NR
Sodium Nitrate	R	R	R	R	R	R	R	R	R	-	-	-
Sodium Sulfate	R	R	R	NR	R	R	R	R	R	-	-	-
Sodium Sulfide	R	R	NR	NR	R	R	R	R	R	-	-	-
Sulfuric Acid, Up to 25%	R	R	R	R	R	R	R	R	R	-	NR	NR
Sulfuric Acid, Up to 50%	R	R	NR	NR	R	R	R	R	R	-	-	-
Sulfuric Acid, Up to 70%	R	R	NR	NR	R	R	R	R	R	-	NR	NR
Sulfuric Acid, Up to 75%	NR	NR	NR	NR	R	120°	R	R	-	-	NR	NR
Sulfuric Acid, Up to 80%	NR	NR	NR	NR	NR	NR	NR	NR	-	-	NR	NR
Sulfuric Acid, Vapor	R	R	R	NR	R	R	R	R	-	-	-	-
Trichlorethylene, Fumes	NR	NR	NR	NR	R	120°	R	R	NR	-	-	-
Trisodium Phosphate	R	R	R	NR	R	R	R	R	R	-	-	-
Urea	R	R	R	NR	R	150°	R	R	R	-	R	R
Vegetable Oils	R	R	R	R	R	R	R	R	R	-	R	R
Vinegar	R	R	R	R	R	R	R	R	R	R	R	R
White Liquor, Pulp Mill	R	R	-	-	R	R	R	R	-	-	-	-

Note: The recommendations contained in this table are made without guarantee of representation as to results. Since the actual use by others is beyond our control, no guarantee, expressed or implied, is made by T.J. Cope, Inc. as to effects of such use or results to be obtained nor does T.J. Cope, Inc. assume any liability arising out of the use by others of the products referenced in this table. Nor is the information herein to be construed as absolutely complete since additional information may be needed or desirable when particular or exceptional conditions or circumstances exist or because of applicable laws or government regulations. We suggest that you evaluate these recommendations and suggestions in your own laboratory prior to use. Our responsibility for claims arising from breach of warranty, negligence, or otherwise is limited to the purchase price of the material.

Legend: "NR" indicates "Not Recommended" for use; "R" indicates "Recommended"; "-" indicates no information available

Channel

CHANNEL FRAMING

All Aickinstrut channels, except the SST series, incorporate a patented flange design which provides reliable fastening and interlocking of Aickinstrut components and accessories.

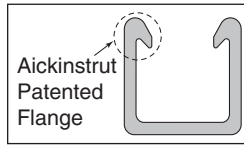

Channels are provided in standard lengths of 10' with longer lengths available upon request. Aickinstrut single channels come packaged in boxes of 100' while the double channels are packaged in boxes containing 40'.

Aickinstrut channel is available in three materials:

- Polyester (P material),
- Vinyl Ester (V material) and
- PVC (E material)

POLYESTER AND VINYL ESTER MATERIALS

The polyester and vinyl ester channels are manufactured from the pultrusion process. In this process, the component is made by reinforcing a polymer resin (polyester or vinyl ester) with multiple strands of glass filament, alternating layers of glass mat and U.V. resistant surfacing veils. The glass is drawn through the liquid resin, which coats and saturates the fibers. The combination of resin, glass and veil is then continuously guided and pulled (pultruded) through a heated die that determines the shape of the component.

In the die, the resin is cured to form a permanent, reinforced part which can be cut to a specific length. Since the hardened fiberglass pultrusion is reinforced with an internal arrangement of permanently bonded continuous glass fibers, it possesses great strength.

In addition, pultruded fiberglass components exhibit exceptional corrosion and fire resistance. These attributes make fiberglass the material of choice for many harsh industrial applications.

The polyester and vinyl ester channels are color coded. Polyester channels are colored gray and the vinyl ester channels are colored beige.

PVC MATERIALS

The PVC channels are manufactured from the extrusion process. In this process, the component is made by a PVC resin mixture being continuously fed through a heated die that determines the shape of the component.

In the die, the resin is cured to form a permanent, extruded part that can be cut to a specific length. Unlike pultruded components, extruded components do not incorporate glass-reinforcement; consequently, they do not exhibit the same beam strength as their pultruded counterparts. PVC components, however, exhibit exceptional corrosion and fire resistance. These features make PVC channels an excellent alternative when excessive beam strength is not required. PVC channels are color coded dark gray.

CHANNEL AVAILABILITY CHART

The following chart illustrates the availability of materials in the different channel profiles.

Channel Profile	Polyester (P)	Vinyl Ester (V)	PVC (E)
Series 2000, 2200, 2300	X	X	X
Series 1500, 1700, 1800	X	X	N/A
Series 1000, 1200, 1300	X	X	X
Series 2100	X	X	N/A
Series 1600	X	X	N/A
Series 1100	X	X	N/A

CONCRETE EMBEDMENT CHANNEL PART NO. – 20E-2300

In certain applications, it is necessary to embed a corrosion resistant channel into a new pouring of concrete. For these applications, Aickinstrut concrete embedment channel is recommended. Aickinstrut embedment channel is available in three material types; PVC, polyester and vinyl ester. The PVC embedment channel is extruded as one piece while the polyester and vinyl ester embedment channel is a two piece bonded type design. The PVC embedment channel is available in the 1⁵/₈" and 1¹/₈" profiles while polyester and vinyl ester embedment channels are available in all three profiles (1⁵/₈", 1¹/₂" & 1¹/₈").

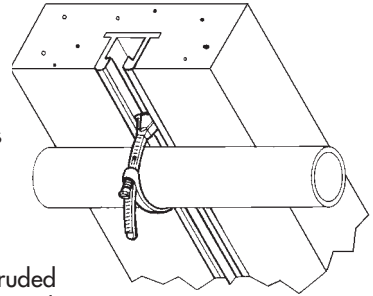

The embedment channel utilizes two continuous protruding flanges in the profile base to retain the channel in the concrete. Mounting the embedment channel flush with the concrete surface is a convenient way to secure piping, conduits or electrical enclosures to a wall or ceiling. The PVC embedment channel is extremely high in strength. When embedded in 3,000 PSI concrete, the concrete will fail before the channel is pulled out.

AICKINSTRUT SST CHANNEL

Aickinstrut SST Fiberglass Channel incorporates a standard channel profile that will accommodate metallic pipe straps and clamps. SST channel is available in polyester or vinyl ester resin. All standard styles (solid, slotted, concrete insert and back-to-back) are also available. Please contact the factory for loading information for the SST Channel.

Note: Aickinstrut SST Channel is not compatible with the Aickinstrut pipe clamps, channel nuts, and grooved fittings shown in this catalog. Please contact Aickinstrut for information on a complete line of compatible clamps and channel nuts.

HEAVY DUTY CHANNEL – AICKINSTRUT PROFILE

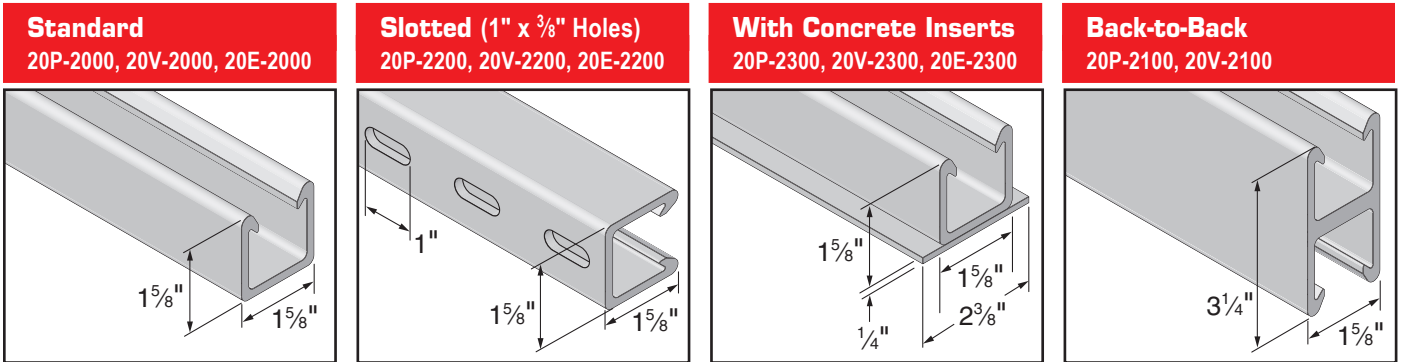

MEDIUM DUTY CHANNEL – AICKINSTRUT PROFILE

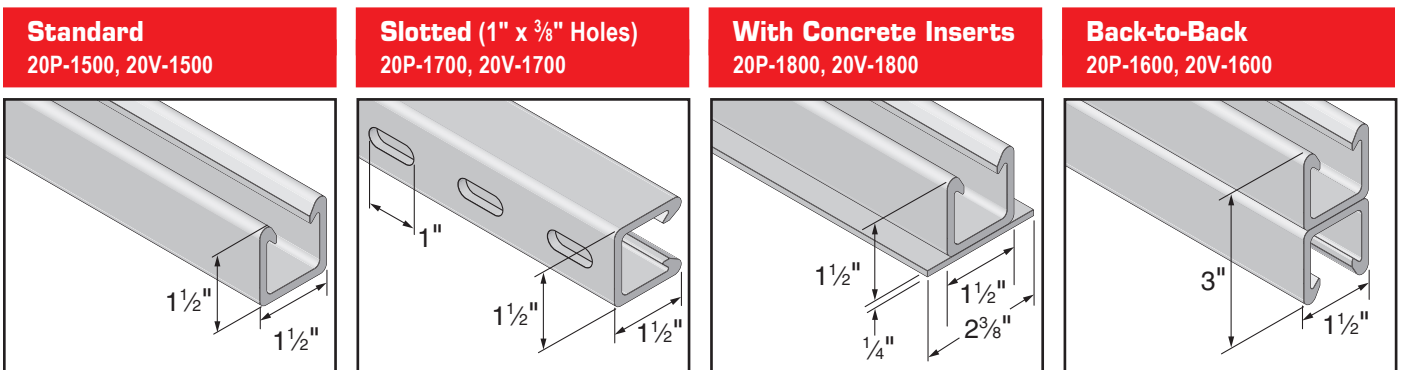

LIGHT DUTY CHANNEL – AICKINSTRUT PROFILE

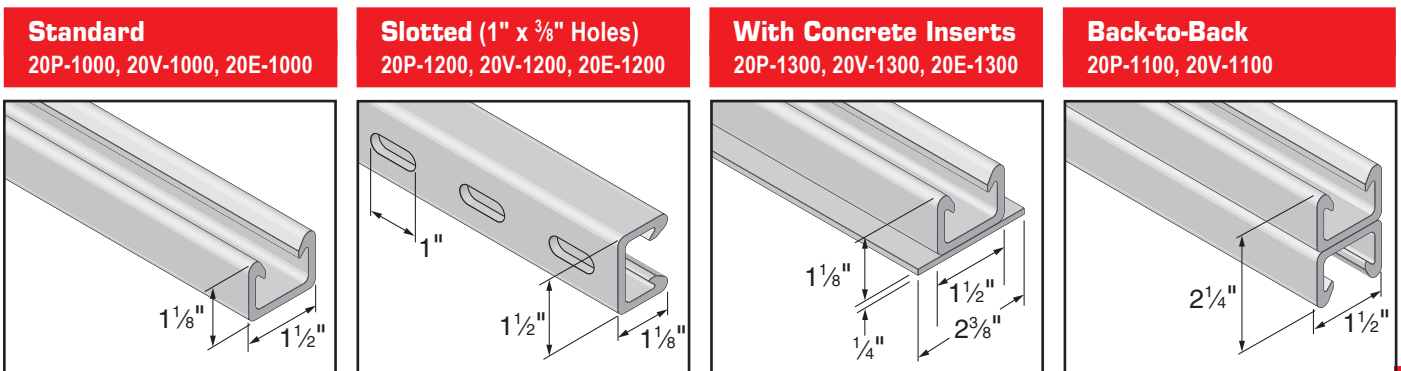

HEAVY DUTY CHANNEL – STANDARD PROFILE

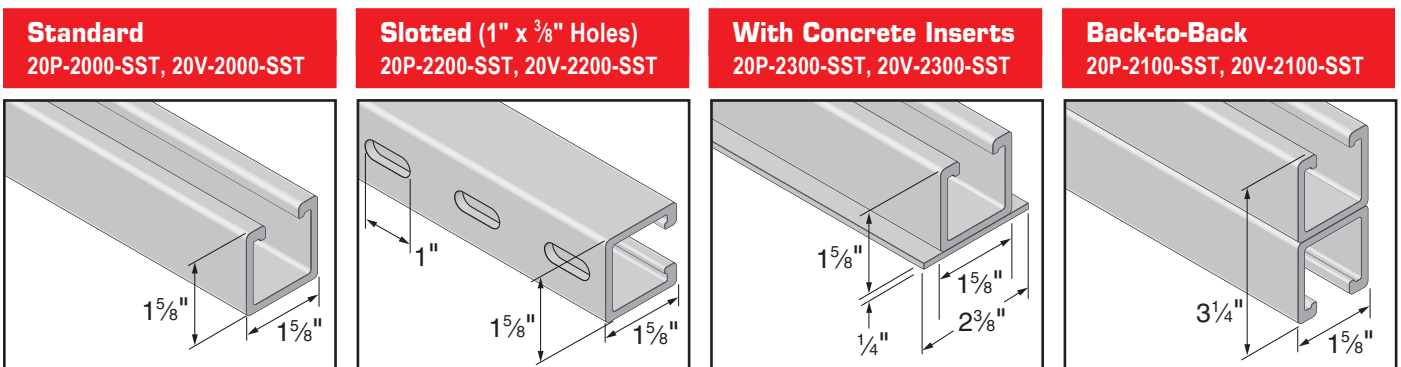

Channel Loading

Flange Loading

Pull-out strength is the channel's resistance to a clamp or fastener inserted under the flange and put under tension. For additional information concerning specific channels, materials and their pull-out strengths, refer to the channel flange pull-out chart on the right.

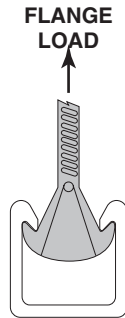

Heavy Duty Channel	Pull-Out Strength*
20V-2000	449
20P-2000	360
20E-2000	260
Medium Duty Channel	Pull-Out Strength*
20V-1500	229
20P-1500	219
Light Duty Channel	Pull-Out Strength*
20E-1000	239
20P-1000	213
20V-1000	213

*Values shown represent a 3:1 safety factor

Section Properties

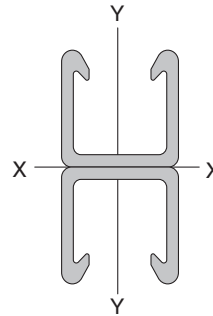
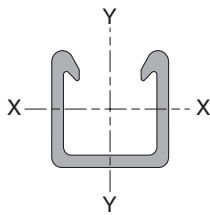

Section Number	Height (in.)	Width (in.)	Weight (lbs./ft.)	Area (in. ²)	X - X Axis				Y - Y Axis		
					I (in. ⁴)	R (in.)	C ¹ (in.)	C ² (in.)	I (in. ⁴)	R (in.)	C (in.)
2000	1½	1½	0.82	1.06	0.31	0.54	0.70	0.93	0.42	0.63	0.82
2100	3½	1½	1.64	2.12	1.77	0.91	1.63	1.63	0.85	0.63	0.82
1500	1½	1½	0.55	0.71	0.19	0.52	0.62	0.88	0.25	0.59	0.75
1600	3	1½	1.10	1.42	1.02	0.85	1.50	1.50	0.49	0.59	0.75
1000	1½	1½	0.47	0.61	0.10	0.40	0.51	0.62	0.22	0.60	0.75
1100	2½	1½	0.94	1.22	0.42	0.59	1.13	1.13	0.44	0.60	0.75

Beam Loading – PVC

The data listed in the Beam Loading Chart reflects testing conducted on Polyester (Type P) and vinyl ester (Type V) channels. PVC (Type E) material will differ from the Polyester/Vinyl ester Beam Loading Chart. To obtain the beam loading for PVC channel, reduce the load as follows:

$$\text{PVC Beam Load} = \frac{\text{(Polyester/Vinyl Ester Beam Load)}}{4}$$

Note: PVC is not recommended for lengths over 24"

Polyester/Vinyl Ester Beam Loading Chart

Span	Part No.	Max. Uniform Beam Load (Safety Factor - 3:1) Load (lbs.)	Uniform Load at Defl. of 1/360 Span Deflection (in.)	Maximum Column Load (lbs.)	Deflection (in.)	Load (lbs.)
12" Span	20P/V-2100	5,559	0.028	5,559	0.033	9,454
	20P/V-1600	4,836	0.043	3,778		7,007
	20P/V-1100	3,804	0.082	1,556		5,961
	20P/V-2000	3,561	0.102	1,159		5,160
	20P/V-1500	1,950	0.093	700		3,439
	20P/V-1000	1,629	0.151	359		2,759
18" Span	20P/V-2100	3,706	0.064	2,914	0.050	8,866
	20P/V-1600	3,224	0.096	1,697		6,501
	20P/V-1100	2,536	0.183	691		5,509
	20P/V-2000	2,374	0.230	515		4,704
	20P/V-1500	1,300	0.209	311		3,136
	20P/V-1000	1,086	0.340	160		2,351
24" Span	20P/V-2100	2,780	0.113	1,639	0.067	8,181
	20P/V-1600	2,418	0.171	944		5,909
	20P/V-1100	1,902	0.326	389		4,979
	20P/V-2000	1,781	0.410	290		4,168
	20P/V-1500	975	0.371	175		2,778
	20P/V-1000	815	0.605	90		1,862
30" Span	20P/V-2100	2,224	0.177	1,049	0.083	7,405
	20P/V-1600	1,934	0.267	604		5,236
	20P/V-1100	1,522	0.509	249		4,375
	20P/V-2000	1,424	0.640	185		3,553
	20P/V-1500	780	0.580	112		2,369
	20P/V-1000	652	0.945	57		1,298
36" Span	20P/V-2100	1,853	0.254	730	0.100	6,451
	20P/V-1600	1,612	0.384	420		4,482
	20P/V-1100	1,268	0.734	173		3,698
	20P/V-2000	1,187	0.922	129		2,859
	20P/V-1500	650	0.836	78		1,906
	20P/V-1000	543	1.360	40		901
48" Span	20P/V-2100	1,390	0.452	410	0.133	4,534
	20P/V-1600	1,209	0.683	236		2,809
	20P/V-1100	951	1.304	97		2,254
	20P/V-2000	890	1.638	72		1,636
	20P/V-1500	488	1.486	44		1,091
	20P/V-1000	407	2.418	22		507
60" Span	20P/V-2100	1,112	0.707	262	0.167	2,902
	20P/V-1600	967	1.067	151		1,798
	20P/V-1100	761	2.038	62		1,442
	20P/V-2000	712	2.560	46		1,047
	20P/V-1500	390	2.321	28		698
	20P/V-1000	326	3.779	14		324
72" Span	20P/V-2100	927	1.018	182	0.200	2,015
	20P/V-1600	806	1.536	105		1,248
	20P/V-1100	634	2.935	43		1,001
	20P/V-2000	594	3.686	32		727
	20P/V-1500	325	3.343	19		485
	20P/V-1000	272	5.441	10		225



FIBERGLASS



Channel Fittings

AickinStrut Channel Fittings are required to fabricate an AickinStrut structure and are easily attached to AickinStrut Channels with channel nuts and polyurethane fasteners. The fittings are offered in two types; fabricated (cut from flat stock) or molded. Fabricated fittings are made from either polyester or vinyl ester material. All molded fittings with the exception of the post bases are molded in polyurethane. Post bases are also offered in polypropylene.

The 2500 Series Fittings are manufactured from 1/2" flat material. The 2800 Series Fittings are manufactured from 3/8" flat material and feature grooves which stabilize the fittings when mounted to the open side of the channel. All channel fittings are provided with 13/32" holes which accommodate 3/8" hardware, however several of the new molded fittings come with 9/16" holes 50PU-2616, 50PU-2611, and 50PU-2613. Larger diameter holes can be provided upon special request.

Legend

R = Right Hand

L = Left Hand

P Series Fittings are Grey

V Series Fittings are Beige

2500 Series - Flat

2800 Series - Grooved

Note: Illustrations depict grooved channel fittings.

20P-2500, 20V-2500 (Flat)
20P-2800, 20V-2800 (Grooved)

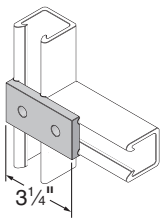

20P-2502, 20V-2502 (Flat)
20P-2802, 20V-2802 (Grooved)

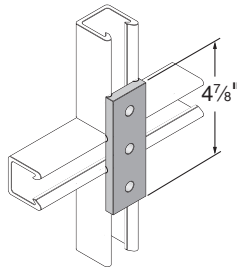

20P-2504, 20V-2504 (Flat)
20P-2804, 20V-2804 (Grooved)

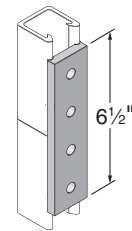

20P-2506, 20V-2506 (Flat)
20P-2806, 20V-2806 (Grooved)

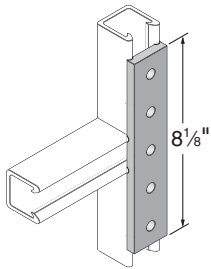

50PU-2616

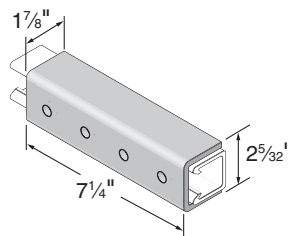

Note: 9/16" diameter holes

20P-2508, 20V-2508 (Flat)
20P-2808, 20V-2808 (Grooved)

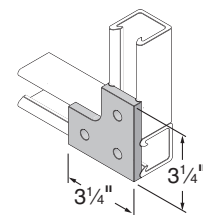

20P-2510, 20V-2510 (Flat)
20P-2810R, 20V-2810R (Grvd)
20P-2810L, 20V-2810L (Grvd)

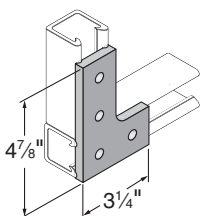

20P-2512, 20V-2512 (Flat)
20P-2812, 20V-2812 (Grooved)

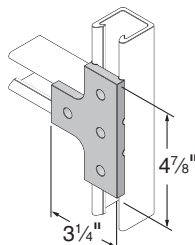

20P-2514, 20V-2514 (Flat)
20P-2814, 20V-2814 (Grooved)

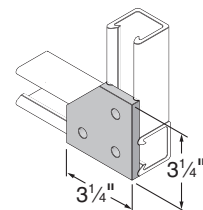

20P-2516, 20V-2516 (Flat)
20P-2816R, 20V-2816R (Grvd)
20P-2816L, 20V-2816L (Grvd)

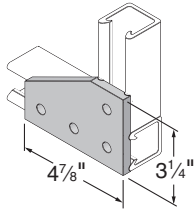

20P-2518, 20V-2518 (Flat)
20P-2818, 20V-2818 (Grooved)

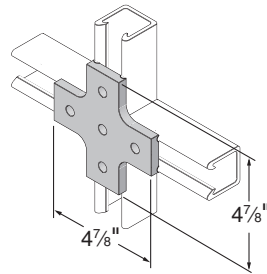

20P-2520, 20V-2520 (Flat)
20P-2820, 20V-2820 (Grooved)

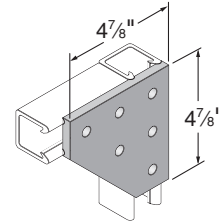

20P-2522, 20V-2522 (Flat)
20P-2822, 20V-2822 (Grooved)

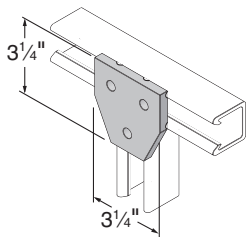

20P-2524, 20V-2524 (Flat)
20P-2824, 20V-2824 (Grooved)

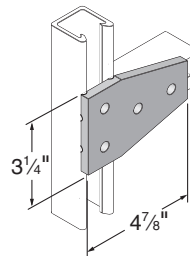

20P-2526, 20V-2526 (Flat)
20P-2826, 20V-2826 (Grooved)

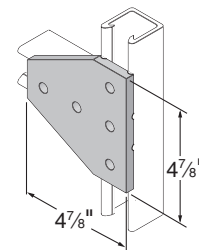

20P-2528, 20V-2528 (Flat)
20P-2828, 20V-2828 (Grooved)

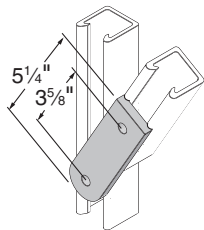

20P-2530, 20V-2530 (Flat)
20P-2830, 20V-2830 (Grooved)

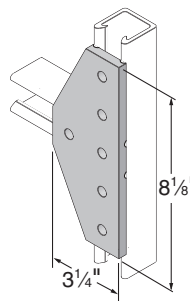

20P-2534, 20V-2534 (Flat)
20P-2834, 20V-2834 (Grooved)

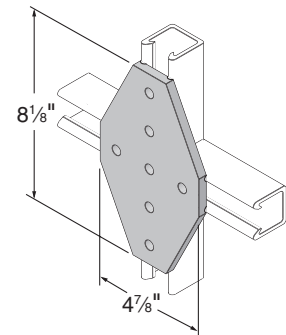

20P-2541, 20V-2541 (Flat)

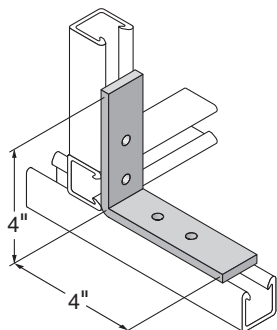

20P-2540, 20V-2540 (Flat)
20P-2840, 20V-2840 (Grooved)

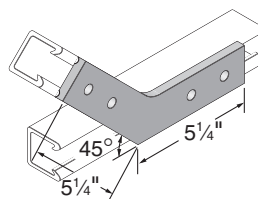

50PU-2611 (Flat)

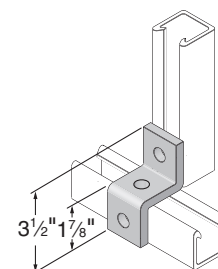

Fiberglass

20P-2542, 20V-2542 (Flat)

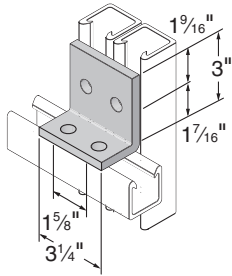

50PU-2611-SP

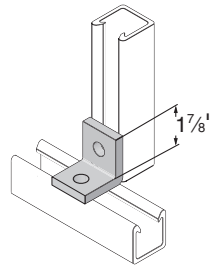

Note: 9/16" diameter holes

50PU-2613 (Flat)

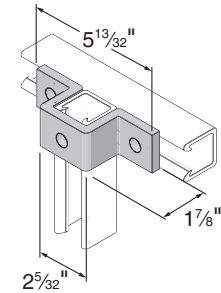

Note: 9/16" diameter holes

50PU-1508 (1 1/2") 50PU-2008 (1 5/8")

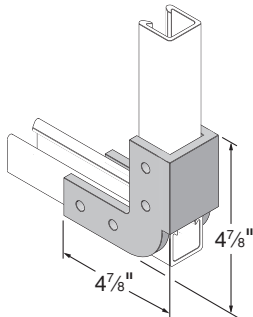

50PU-2045 (1 5/8")

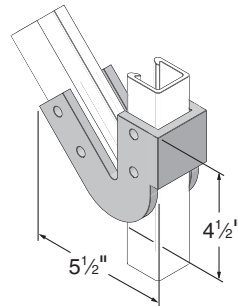

50PU-2090 (1 5/8")

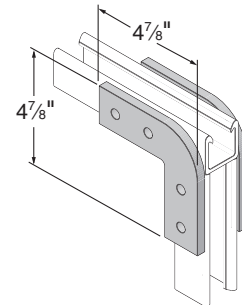

50PU-2636¹, 50PU-2636A², 50PU-2636B³, 50PU-2936⁴

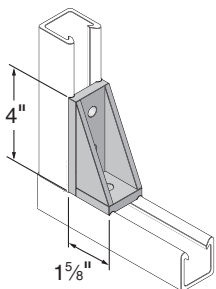

- 1) 50PU-2636 – Flat, without splines
- 2) 50PU-2636A – Splines on long side only
- 3) 50PU-2636B – Splines on short side only
- 4) 50PU-2936 – Splines on both long and short sides

50PU-2538 (Flat)

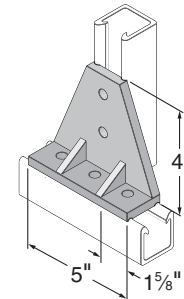

20PU-5853 (1 5/8"), 20PU-5854 (1 1/2"), 20PU-5855 (1 5/8"), 20PP-5853 (1 5/8"), 20PP-5854 (1 1/2"), 20PP-5855 (1 1/2")

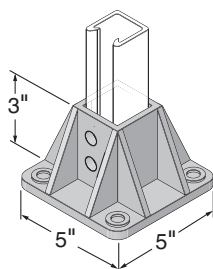

20PU-5903 (3 1/4"), 20PU-5904 (3"), 20PU-5905 (2 1/4"), 20PP-5903 (3 1/4"), 20PP-5904 (3"), 20PP-5905 (2 1/4")

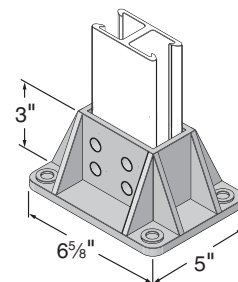

Aickinclamps Design Load Information

There are two types of piping system loadings, overhead (Type 1) and vertical (Type 2) as described below. All Aickinstrut pipe straps and clamps show the recommended loading for both types of loading.

TYPE 1 DESIGN LOAD

The design load shown represents pipes supported below the strut. The design loads shown are based on a minimum ultimate failure safety factor of 3:1.

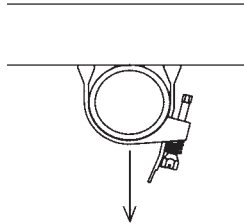

TYPE 2 DESIGN LOAD

The design loading shown can be achieved with the addition of a vertical stop lock assembly (Part #200-4219) installed directly beneath the pipe clamp. The adjacent illustration shows how the vertical stop lock assembly provides additional support for pipe and how it can be used to achieve full Type 2 design loads.

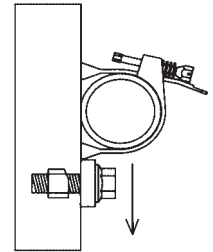

Design loads are based on a minimum clamp slip safety factor of 3:1. It is recommended that stop lock assemblies be used for all vertical pipe support applications.

Adjustable Pipe Clamps

Aickinstrut Adjustable Pipe Clamps are manufactured from glass-reinforced polyurethane and are adjustable to accommodate a wide range of outside diameters. They can be utilized with a variety of piping systems including: PVC, fiberglass, copper, rigid steel conduit and PVC coated rigid steel conduit. Aickinclamps sized 6½" – 20" are to be used only in non-load bearing applications. These are applications where the weight of the pipe is being supported by Aickinstrut structural members (see figure on right).

Aickinclamps can safely be used in temperatures up to 160°F. For operating temperatures of 160-230°F, it is recommended to use PVDF clamps. PVDF clamps are available as a special order. Contact the factory for pricing and availability. Care should be taken not to exceed 3 ft./lbs. of torque on the adjustable pipe straps.

Part Number	O.D. Pipe Size (in.)	Design Load (lbs.)*		Torque (ft./lbs.)
		Type 1	Type 2	
200-3100	½ – 1½	135	65	10 in./lbs.
200-3110	1½ – 2¼			
200-3120	2¼ – 3¼	145	70	
200-3130	3 – 4			
200-3140	4 – 6½	215	70	3
200-3150	6½ – 8			
200-3160	8 – 10	Non-Load Bearing		
200-3170	10 – 12			
200-3180	12 – 14			
200-3190	14 – 16			
200-3200	16 – 18			
200-3210	18 – 20			

*Design loads shown represent a 3:1 safety factor.

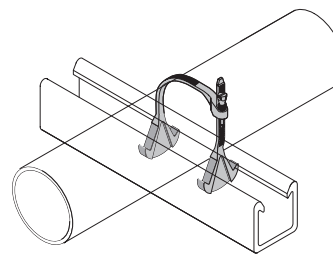

200-3100 to 200-3140

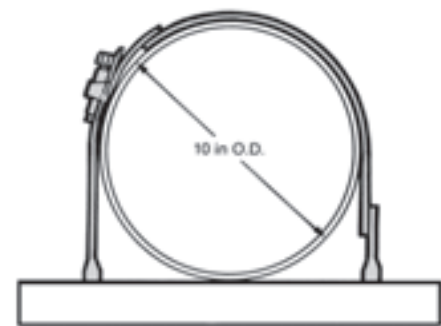

200-3150 to 200-3210

50PU-500SP – Channel Spacers

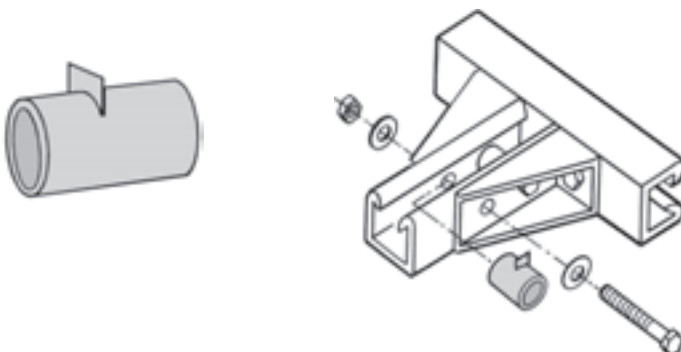

Channel spacers are designed to prevent wall compression under heavy loading conditions. Such loading occurs during the torquing of hardware for channel fittings. The spacers are molded from polyurethane and will accommodate 3/8" and 1/2" bolts. The spacers are designed to be used only with 1 5/8" and 1 1/2" channels.

FIBERGLASS



Pipe Clamps

Rigid Pipe Clamps

Aickinstrut Rigid Pipe Clamps resemble the more traditional style of pipe clamps. These clamps are made from glass-reinforced polyurethane and are sized based on the pipe inside diameter or nominal size.

Polyurethane clamps are recommended for applications up to 160°F. For high temperature applications (up to 230°F), PVDF clamps are available as a special order. Contact the factory for pricing and availability.

Care should be taken not to exceed the recommended torque values of the rigid pipe clamps.

Part No.	Nominal Size (in.)	PVC Sch. 80 & Rigid Metal	Design Loads (lbs.)*		FRP Bolt Size (in.)	FRP Bolt Torque (ft./lbs.)
			Type 1	Type 2		
PCR-050	1/2	0.840	225	90	3/8 x 1/4	3
PCR-075	3/4	1.050				
PCR-100	1	1.315				
PCR-125	1 1/4	1.660				
PCR-150	1 1/2	1.900				
PCR-200	2	2.375				
PCR-250	2 1/2	2.875				
PCR-300	3	3.500	300	125		
PCR-400	4	4.500				
PCR-600	6	6.625				
PCR-800	8	8.625				

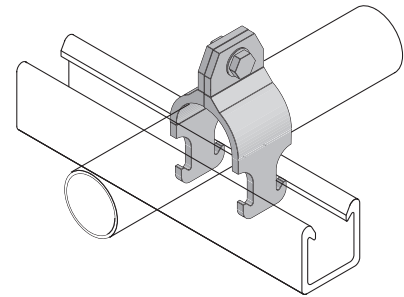

*Design loads shown represent a 3:1 safety factor.

Two Hole Pipe Straps

Aickinstrut Two Hole Pipe Straps are designed for use in securing pipe, conduit and ducts to Aickinstrut Channel. Two hole fiberglass straps can also be used independently from the channel for surface mounting. All sizes of the straps are suitable for load bearing applications.

glass reinforced polyester resin. For extreme chemical environments, the straps can be manufactured from vinyl ester resin. Larger diameter straps for special applications are also available. Contact the factory for pricing and availability of vinyl ester and large diameter straps. Two hole pipe straps should not be torqued above recommended values.

The two hole pipe straps are manufactured from a fire-retardant,

Part No.	Dimension		Bolt Size (in.)	Material Size (in.)	Design Load (lbs.)*		Torque (ft./lbs.)			
	A (in.)	B (in.)			Type 1	Type 2				
PS050	0.840	4.840	1/2	1/4 X 1 1/8	135	50	4			
PS075	1.050	5.050								
PS100	1.315	5.315								
PS150	1.900	5.900								
PS200	2 3/8	6.375								
PS250	2 7/8	6.875			175	60				
PS300	3 1/2	7.500								
PS350	4	8.000								
PS400	4 1/2	8.500			3/8	3/8 X 1 1/8		225	125	10
PS500	5 9/16	9.563								
PS600	6 5/8	10.625								
PS800	8 5/8	12.625	250	150						
PS1000	10 3/4	15.750								
PS1200	12 3/4	16.250								
PS1400	14	18.000								
PS1600	16	20.000								
PS1800	18	23.000								

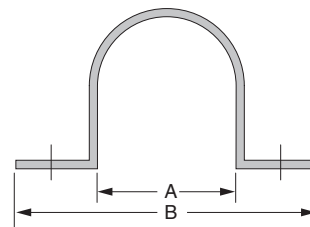
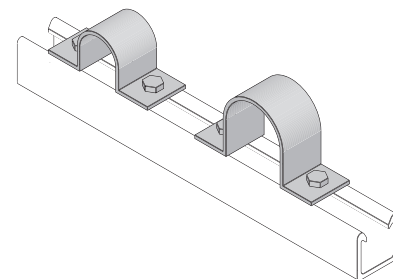

When bolting onto 1 1/2" or 1 1/2" channel a 1 1/4" long bolt is required.

*Design loads shown represent a 3:1 safety factor.

Notes: Bolts and channel nuts are sold separately.

Aickin-A-Grip (SST Style Channel Only)

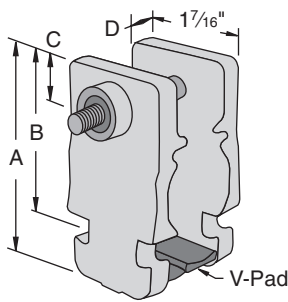

Part No.	Nominal Pipe Size	Dimensions (In.)				Hex Head Cap Screw & Lock Nut	Wt/100 pcs Lbs
		"A"	"B"	"C"	"D"		
PS TP-025	1/4	1 15/16	1 3/8	3/8	3/16	1/4-20 x 1 1/2"	4
PS TP-625	3/8	2 3/8	1 5/8	7/16	1/4		6
PS TP-875	1/2	2 9/16	1 13/16				8
PS TP-100	3/4	2 11/16	1 15/16	5/16	8		

Includes: Cushion, V-pad, and Hardware.
Materials: Cushion: Thermoplastic elastomer.
Hardware: Stainless Steel with Captured Nylon Locknut
Temperature Rating: -40°F to +275°F
Note: For use with SST Style Strut only

Multi-Size Adjustment Capability
 Allows Four Clamp Sizes to Fit
 Seventeen Sizes of Tube & Pipe.

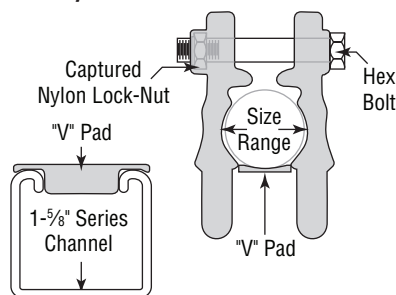

FEATURE

- Ten sizes of tube;
Five sizes of pipe...
Using just four sizes of clamp.
- Diameters from .25" to 1.31"
- Metric Sizes from 6mm to 32mm
- Non-Conducting
- Corrosion Resistant
- UV Resistant
- Temperature

ADVANTAGE

- Reduces Inventory SKU's
- Fewer parts needed on the job.
- Simplifies take-offs & component requirements on projects using both Tube & Pipe Sizes
- High pull out and slip loads

BENEFIT

- Lowers Inventory Costs.
- Always have the right clamp on hand when you need it.
- Job Costing made easier & more accurate.

Tube Sizes

Part No.	O.D. Tube Sizes			Diameters	PullOut Load/Lbs	Slip Load/Lbs
PS TP-025	1/4	3/8	1/2	0.25 - 0.54		
PS TP-625	5/8	3/4	7/8	0.62 - 0.87		
PS TP-875	7/8	1	1 1/8	0.87 - 1.12		
PS TP-100	1	1 1/8	1 1/4	1.00 - 1.31		

Pipe Sizes

Part No.	Nominal Pipe Sizes	Diameters	PullOut Load/Lbs	Slip Load/Lbs		
PS TP-025	1/4	-			500	40
PS TP-625	3/8	1/2				
PS TP-875	3/4	-				
PS TP-100		1				

Nominal Pipe Size	Water Filled Weight	Code Required Support Spacing ⁽³⁾	Pipe Load At Support	Safety Factors from Allowed Value	
(Sch 40)	(lbs/ft)	(ft)	(lbs)	Pullout	Slip
1/4"	0.470	7	3	150	12
3/8"	0.651		5	110	9
1/2"	0.983		7	70	6
3/4"	1.361		10	50	4
1"	2.055		14	30	3

⁽¹⁾ Based on preliminary testing
⁽²⁾ SF = 5 to Ultimate Load
⁽³⁾ Per MSS-SP69 & ASME B31.1 for water filled pipe

20E-5000 – Channel Capping Strip

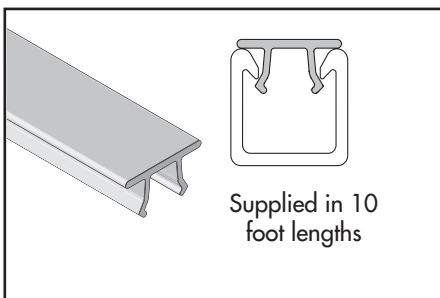

Channel Capping Strip is made from PVC and installs simply by pressing it onto the channel opening. It is designed to be used when a cover is desired for the channel opening (such as concrete embedment channel).

AIC-EC – Channel End Cap

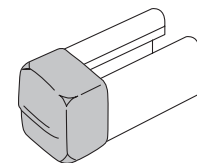

The Aickin-End Cap is made from red PVC and designed for 1 5/8" channel. End caps are desired when the ends of the channel need to be enclosed. The Aickin-End Cap easily installs by pressing it onto the end of the channel opening.

FIBERGLASS



Pipe Clamps

Nonmetallic U-bolts

Aickinstrut Nonmetallic U-Bolts provide a corrosion resistant alternative to traditional metallic U-Bolts. Made from glass-reinforced polyurethane, these bolts will outlast stainless steel in most corrosive applications. Nonmetallic U-Bolts have oversized diameters which allow them to hold steel conduit and plastic pipe.

Each U-Bolt comes with two polyurethane hex nuts. Additional nuts and washers can be purchased separately.

The U-Bolts can also be installed to allow for thermal expansion and contraction of plastic pipe as shown here.

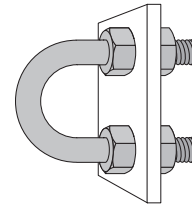

Note: Plate not included. Illustration purpose only

Part No.	Size	"A"	"B"	"C"	"D"	"TL"	Load (lbs.)*	Torque (in./lbs.)*
UB-050	1/2	0.937	0.375	1.568	2.412	1.25	135	40
UB-075	3/4	1.125		1.662	2.600			
UB-100	1	1.375		1.787	2.850			
UB-125	1 1/4	1.687		1.943	3.162			
UB-150	1 1/2	2.000		2.100	3.475			
UB-200	2	2.437	0.500	2.468	4.187	1.50	80	
UB-250	2 1/2	2.937		2.718	4.687			
UB-300	3	3.562		3.031	5.312			
UB-350	3 1/2	4.062		3.281	5.812			
UB-400	4	4.562		3.531	6.312			
UB-600	6	6.750		0.625	5.750			9.875

*Torque and load values shown represent a 3:1 safety factor.

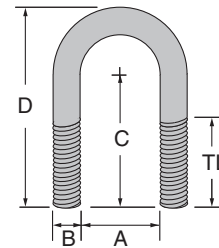

Fiberfast Bolts

Fiberfast bolts are provided in two styles and five diameters (1/4", 3/8", 1/2", 5/8" and 3/4") and range in length from 1 1/4" to 3 1/2". The flanged style incorporates a molded washer collar which eliminates the need for a washer. The flanged style is provided for 1/4" and 1/2" diameter bolts. Flanged bolts are available in 3/8" diameter as a special order item. The hex head style is provided for all 3/8", 5/8" and 3/4" diameter bolts. All Fiberfast bolts are not fully

threaded, therefore, shoulder length (nonthreaded portion) dimensions have been provided. Fiberfast bolts are ideal for mechanical connections that require a high degree of corrosion resistance. The 3/8" diameter fasteners are recommended for all channel fitting mechanical connections. All Fiberfast bolts are manufactured from glass-reinforced polyurethane and are packaged in bags containing 25 pieces.

Hex Flange Bolts

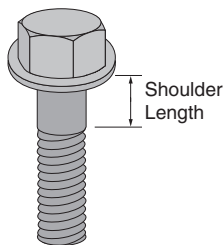

Part No.	Size	Thread Shear (lbs.)*	Shank Shear (lbs.)*	Shoulder Length	Torque (ft./lbs.)
250PU-075	1/4 x 3/4	110	210	Full Thread	10 In./lbs.
250PU-100	1/4 x 1			1/2	
250PU-150	1/4 x 1 1/2			Full Thread	
500PU-125	1/2 x 1 1/4			3/4	
500PU-150	1/2 x 1 1/2	450	870	1	8
500PU-200	1/2 x 2			2 3/16	
500PU-250	1/2 x 2 1/2				
500PU-300	1/2 x 3				
500PU-350	1/2 x 3 1/2				

*Thread shear values shown represent a 3:1 safety factor.

Hex Bolts

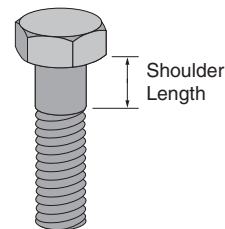

Part No.	Size	Thread Shear (lbs.)*	Shank Shear (lbs.)*	Shoulder Length (in.)	Torque (ft./lbs.)
375PU-125	3/8 x 1 1/4	250	470	Full Thread	3
375PU-150	3/8 x 1 1/2			1/4	
375PU-200	3/8 x 2			1/2	
375PU-250	3/8 x 2 1/2			3/4	
375PU-300	3/8 x 3			1	
625PU-125	5/8 x 1 1/4	700	1,360	1/4	12
625PU-150	5/8 x 1 1/2				
625PU-200	5/8 x 2				
625PU-250	5/8 x 2 1/2				
625PU-300	5/8 x 3				
625PU-350	5/8 x 3 1/2				
				1 1/4	

*Thread shear values shown represent a 3:1 safety factor.

Vinyl Ester Square Head Bolts

Vinyl ester square head bolts are used for concrete mounting and general purpose fastening applications. The square head bolts are constructed from vinyl ester all-thread rod and vinyl ester square nuts. The units are bonded together with a durable two part urethane adhesive. The square head bolts are offered in 3/8" diameter but can be supplied in other diameters as a special order. Contact the factory for pricing and availability of special diameter square head bolts.

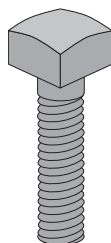

Part No.	Size	Thread Shear (lbs.)*	Torque (ft./lbs.)*
375V-100	3/8 x 1	250	10
375V-125	3/8 x 1 1/4		
375V-150	3/8 x 1 1/2		
375V-175	3/8 x 1 3/4		
375V-200	3/8 x 2		
375V-250	3/8 x 2 1/2		
375V-300	3/8 x 3		
375V-350	3/8 x 3 1/2		
375V-400	3/8 x 4		

*Thread shear values shown represent a 3:1 safety factor.

Fiberfast Hex Nuts

Aickinstrut hex nuts are available in two styles; hex and hex flange nuts. The Aickinstrut hex nut is similar in design to the conventional hex nut and is preferred for channel fitting connections. The Aickinstrut hex flange nut is preferred for applications that require additional thread engagement (such as with all-thread rod) or

maximum thread shear strength. All nuts are manufactured from glass-reinforced polyurethane and are packaged in bags containing 25 pieces. All hex and hex flange nuts are available in PVDF and Polypropylene and metric sizes as a special order. Contact the factory for pricing and availability.

Hex Nuts

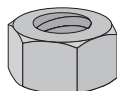

Part No.	Size	Thread Shear (lbs.)*	Height	Torque (ft./lbs.)
250PU-000	1/4-20	150	0.218	10 in./lbs.
375PU-000	3/8-16	460	0.328	3
500PU-000	1/2-13	800	0.437	8
625PU-000	5/8-11	1,000	0.546	12
750PU-000	3-10		0.640	15
1000PU-000	1-8	1,100	0.859	17

*Thread shear values shown represent a 3:1 safety factor.

Hex Flange Nuts

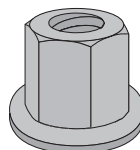

Part No.	Size	Thread Shear (lbs.)*	Height	Torque (ft./lbs.)
375PU-FN-000	3/8-16	500	0.750	3
500PU-FN-000	1/2-13	1,200	0.855	8
625PU-FN-000	5/8-11	2,200	1.220	12
750PU-FN-000	3/4-10	2,900	1.590	15
1000PU-FN-000	1-8		1.750	17

*Thread shear values shown represent a 3:1 safety factor.

Vinyl Ester Square Nuts

Square nuts are manufactured from pultruded vinyl ester square stock. They are recommended for applications that require high thread shear values. Square nuts are packaged in bags containing 25 pieces.

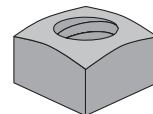

Part No.	Size	Thread Shear (lbs.)*	Height	Torque (ft./lbs.)
375V-000	3/8-16	1,300	0.437	10
500V-000	1/2-13	1,700	0.562	
625V-000	5/8-11		0.687	
750V-000	3/4-10		0.812	
1000V-000	1-8		0.937	

*Thread shear values shown represent a 3:1 safety factor.

Flat Washers

Flat Washers are made from PVC and are available for 1/4" diameter through 1". PVC washers are recommended for connections that utilize hex nuts and bolts. PVC washers are packaged in bags containing 25 pieces.

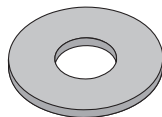

Part No.	Size	Outside Diameter
250E-999	1/4	0.49
375E-999	3/8	1.00
500E-999	1/2	1.25
625E-999	5/8	1.50
750E-999	3/4	1.50
1000E-999	1	2.25

All-Thread Washers

Aickinstrut All-Thread Washers are flat fiberglass washers for use with FRP all-thread rods. All-Thread rod washers are 1/4" thick with a 1 7/8" diameter and are available in polyester or vinyl ester resin. To order vinyl ester, add the suffix "V" to the part number. To order square washers add the suffix "-SQ" to the part number.

Part No. *	All-Thread Rod Size (in.)
WR375	3/8
WR500	1/2
WR625	5/8
WR750	3/4

* Add the suffix "V" to the part number to specify vinyl ester Example "WR500V"

* Add the suffix "-SQ" to the part number to specify square washer Example "WR500-SQ"

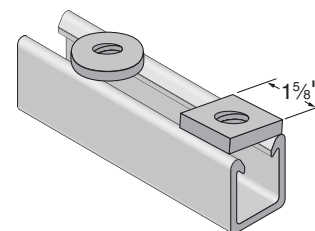

FIBERGLASS



Fasteners

Channel Nuts

Channel nuts are provided in two types; Standard Duty and Heavy Duty. Standard Duty channel nuts are designed for light duty applications that do not require high thread shear values. Standard duty channel nuts can also be used with all sizes of Aickinstrut Channel. Heavy duty channel nuts are designed to be used where high thread shear values or spring nuts are required. Heavy duty

channel nuts can not be used with Series 1000 Channel (light duty). All channel nuts are manufactured from glass-reinforced polyurethane and are packaged in bags containing 50 pieces. Channel nuts are also available in PVDF as a special order. Contact the factory for pricing and availability.

Heavy Duty Channel Nuts

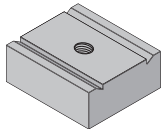

Part No.	Size	Thread Shear (lbs.)*	Torque (ft./lbs.)
375PU-CNHD	3/8-16	1,400	8
500PU-CNHD	1/2-13		
625PU-CNHD	5/8-11		10
750PU-CNHD	3/4-10		
10PU-CNMHD	10 mm		8
12PU-CNMHD	12 mm		
16PU-CNMHD	16 mm		10
20PU-CNMHD	20 mm		

*Thread shear values shown represent a 3:1 safety factor.

Standard Duty Channel Nuts

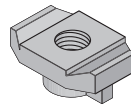

Part No.	Size	Thread Shear (lbs.)*	Torque (ft./lbs.)
250PU-CN	1/4-20	460	2
312PU-CN	5/16-18		
375PU-CN	3/8-16		3
500PU-CN	1/2-13		
10PU-CN	10 mm		8
12PU-CN	12 mm		
10PU-CNS	#10 Screw		N/A

*Thread shear values shown represent a 3:1 safety factor.

Saddle Clips

Aickinstrut Saddle Clips make fastening through Aickinstrut channel much easier. The clips mate with the exterior of the channel flanges and are secured with threaded rods and nuts. The saddle clips are manufactured from glass reinforced polyurethane and are supplied in bags of 50 pieces.

Part No.	Size
200-4226	3/8
200-4217	1/2
200-4341	5/8
200-4342	3/4

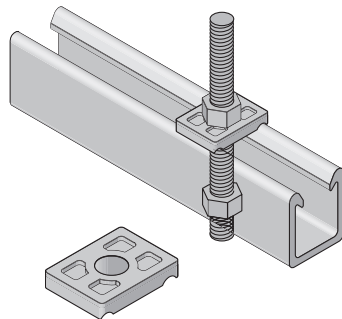

Stop-Lock Assemblies

Aickinstrut Stop-Lock Assemblies reduce the chance of pipe slippage when running supports vertically. Stop-Locks are recommended for applications that are subject to vibration, have regular contact with fluids or are vertically mounted (Type 2). The Stop-Locks fit all three sizes of channel. Stop-Locks are offered with a 3/8", 1/2" and 5/8" bolt size. The 5/8" Stop-Lock Assembly is supplied with a heavy duty channel nut (the 5/8" Stop-Lock Assembly will not work with the 1000 Series Channel).

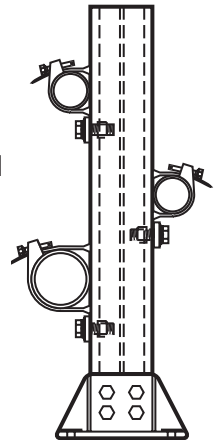

The Stop-Lock Assemblies' components are manufactured from glass-reinforced polyurethane.

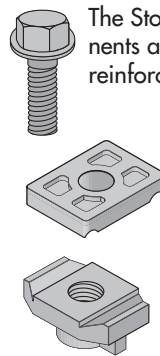

Part No.	Size	Force Resistance (lbs.)*	Torque (ft./lbs.)
200-4227	3/8	200	7
200-4219	1/2	220	12
200-4343	5/8	250	15

*Force resistance values shown represents a 3:1 safety factor.

Fabricated Beam Clamps

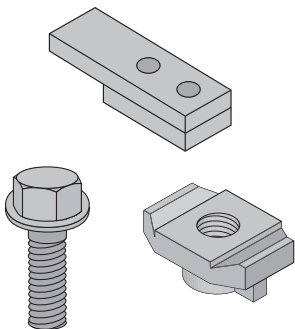

Part No.	Flange Thickness	Thread Shear (lbs.)*	Torque (ft./lbs.)
20V-2BC-25	1/4	600	10
20V-2BC-37	3/8		
20V-2BC-50	1/2		

*Design load values shown represent a 3:1 safety factor. Bolts and channel nuts are 1/2" diameter.

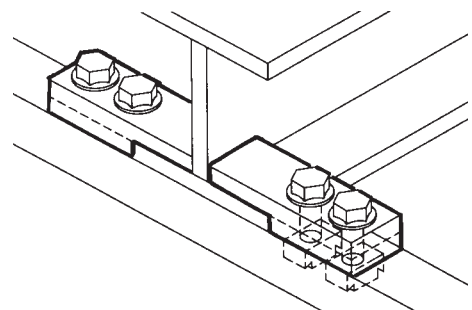

Clevis Hangers

Clevis hangers are available in two styles; molded and hand lay-up. The molded clevis hangers are manufactured from glass-reinforced polyurethane and are available for sizes 1/2" through 6".

The hand lay-up clevis hangers are manufactured from glass-reinforced vinyl ester resin and are available for sizes 1" through 24".

Molded Clevis Hangers

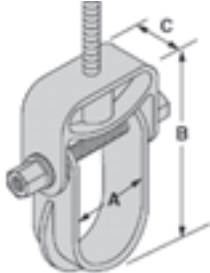

Part No.	Nominal Diameter	Max. Pipe O.D.	"A"	"B"	"C"	Hanger Rod	Load (lbs.)*
CVHPU-100	1/2 - 1	1	1.500	4.25	1.25	1/2	670
CVHPU-150	1/4 - 1 1/2	1 1/2	2.000	5.14			730
CVHPU-200	1 1/2 - 2	2	2.500	6.52			1,150
CVHPU-400	2 1/2 - 4	4	5.125	10.00	1.50	1/2	1,170
CVHPU-600	4 1/2 - 6	6	6.750	12.33			1,170

*Design load values shown represent a 3:1 safety factor.

Hand Lay-Up Clevis Hangers

Part No.	Size Range A (In.)	Dimensions (in.)				Hanger Rod	Trans Rod	Spreader Rod O.D.	Loads (lbs.)*		
		T	H	H1	W						
100-1500	1 - 1 1/2	1/8	2 3/4	1 7/8	1 1/2	1/2	3/8	1/2	60		
100-1501	1 1/2 - 2		3 1/2	2 3/8	2				60		
100-1502	2 - 2 5/8		4 3/4	3					90		
100-1503	2 1/2 - 3 1/4		5 1/2	3 5/8	120						
100-1504	3 - 3 7/8	1/8	7	4 1/4	2	5/8	1/2	160			
100-1505	4 - 5 1/8	3/16	8 1/2	5 5/8				250			
100-1506	6 - 7 1/8	1/4	10 7/8	7 1/2	3	5/8	1/2	300			
100-1507	8 - 9 1/4		14	9 3/4				350			
100-1508	10 - 11 3/8	1/4	18	12	4	5/8	1/2	450			
100-1509	12 - 13 1/2		21 1/2	14 1/8				5	3/4	3/4	600
100-1510	14 - 15 3/4		24 1/2	16 1/2							700
100-1511	16 - 18	3/8	27 3/8	19 1/2	6	3/4	3/4	750			
100-1512	19 - 21		34 1/2	22 1/2				800			
100-1513	21 - 22	1/2	35 1/2	24	6	3/4	3/4	850			
100-1514	22 - 24		41	28				900			

*Design load values shown represent a 3:1 safety factor.

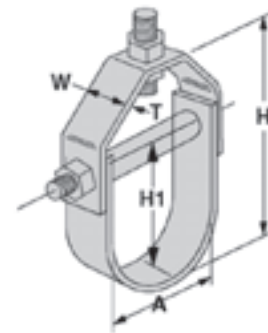

Beam Clamps

Aickinstruct beam clamps are available in two styles; molded and fabricated. The molded beam clamps are manufactured from glass-reinforced polyurethane and can accommodate 3/8", 1/2" and 5/8" hanger rod sizes. The molded beam clamps utilize the traditional "C" clamp style design. The fabrication beam clamps are manufactured from vinyl ester flat stock and utilize polyurethane bolts and channel nuts for clamping. Fabricated beam clamps are available for attaching to 1/4", 3/8" and 1/2" thick beam

flanges. Each fabricated beam clamp assembly includes four (4) 1/2" standard duty channel nuts, four (4) 1/2" Polyurethane bolts and two (2) attachment clips.

All Aickinstruct beam clamps allow easy attachment of threaded rod to "I" beams or other structural assemblies.

Molded Beam Clamps

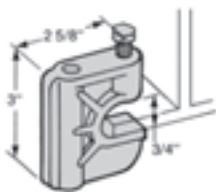

Part No.	Size	Thread Shear (lbs.)*	Torque (ft./lbs.)
375PU-BC	3/8	400	10
500PU-BC	1/2		

*Design load values shown represent a 3:1 safety factor.

Cope-Glas Beam Clamps

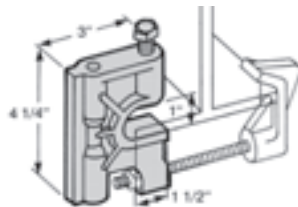

Note: Beam clamp clip must be purchased separately. Illustration purpose only

Part No.	Size	Thread Shear (lbs.)*	Torque (ft./lbs.)
RGBC-1	3/8	500	10
RGBC-2	1/2		
RGBC-3	5/8		

Beam Clip - 375PU-BCCLP (3/8")



Fiberglass

FIBERGLASS



Pipe Supports

Threaded Rod

Pultruded threaded rods are an excellent choice for hanging and fastening AickinStrut Channel. These rods can also be used with either the AickinStrut vinyl ester square nuts, polyurethane hex nuts, hex flange nuts and AickinStrut channel nuts. All FRP threaded rod is manufactured from pultruded vinyl ester resin and is gray in color.

The standard rod lengths are 4' and 8'. Special lengths and threading are also available. Contact the factory for pricing and availability.

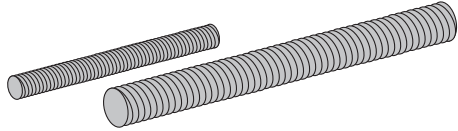

Part No.	Size	Weight	Thread Shear (lbs.)*	Torque (ft./lbs.)
200-3827	3/8-16	0.07	415	5
200-3828	1/2-13	0.12	570	10
200-3829	5/8-11	0.18	1,260	40
200-3830	3/4-10	0.28	1,700	50
200-3831	1-8	0.50	3,000	60

* Thread shear values shown represent a 3:1 safety factor.
 * To order eight foot lengths, add suffix "-96" to part number (EX: 200-3827-96)

Duraclamp C-Clamps

Duraclamps are glass-reinforced polyurethane C-Clamps that are designed to replace steel C-Clamps in areas where corrosion is a problem. The individual Duraclamp components can also be purchased separately.

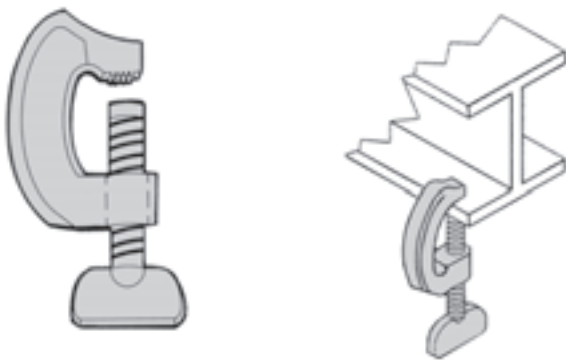

Part No.	Description	Thread Shear (lbs.)*	Torque (ft./lbs.)
390N-150	"C"-Clamp	25	17
390N-BLT	Bolt	N/A	
390N-CLP	"C"	25	N/A

*Design load values shown represent a 3:1 safety factor.
Note: Bolt Dimension is 5/8" x 2 1/2"

A-Konnector Rod Couplers

A-Konnectors provide an excellent means for extending AickinStrut FRP all-thread rods beyond their standard lengths. A-Konnectors are manufactured from glass-reinforced polyurethane and are colored gray. A-Konnectors are packaged in bags containing 25 pieces.

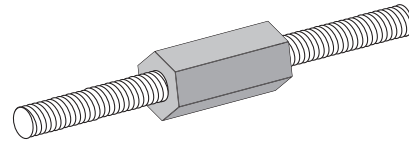

Part No.	Size	Length	Thread Shear (lbs.)*
200-3840	3/8-16	2 1/4	800
200-3841	1/2-13		870
200-3842	5/8-11		1,500
200-3843	3/4-10		

* Thread shear values shown represent a 3:1 safety factor.

Channel Hangers

AIC-CH-P (Polyester)
 AIC-CH-V (Vinyl Ester)

The Aickin-Channel Hanger is designed to support fiberglass structural "C" channel that is being used as a raceway system for cables, tubing or small diameter piping. The Aickin-Channel Hanger is available in either polyester or vinyl ester resin and is simply supported from a 1/2" FRP all-thread rod and beam clamp (not provided). The Channel Hanger will accommodate "C" channel width sizes 2" through 8".

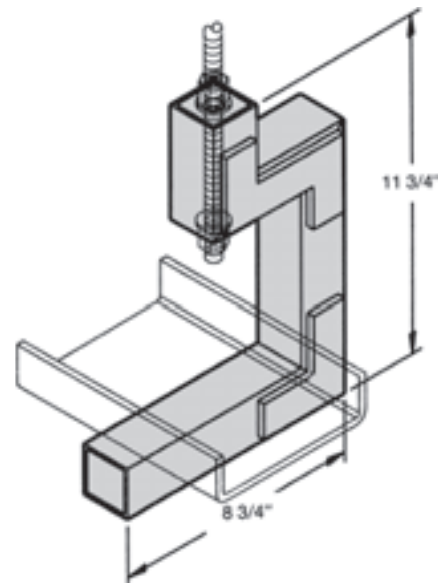

Power-Rack Stanchions

The Power-Rack Stanchion is the new alternative to traditional iron cable stanchions used for utility and industrial cable supports. Made entirely from glass-reinforced nylon, these stanchions out-perform metallic supports against corrosion. The extended life-span of the Power-Rack Stanchions makes them the logical choice over metallic cable supports. The Power-Rack Stanchion is available in two different lengths and four different arm lengths. The unique interlocking design allows the arm to "lock" into nine different levels on the 14¼" stanchions and fourteen on the 17½" stanchion. Glass-reinforced polyurethane stanchions are available as a special order. Contact the factory for pricing and availability.

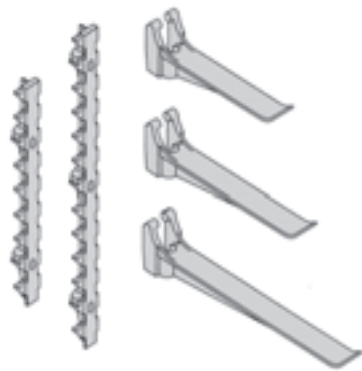

Dimensions – The stanchion back is designed with 9/16" wide x 15/16" long holes to accept fasteners for mounting. There are two mounting holes in the 21¾" long stanchion and three mounting holes in the 335/16" long stanchion. Thickness at the slotted mounting holes is 17/8". The mounting holes are spaced on 12" centers and require 1/2" diameter fasteners.

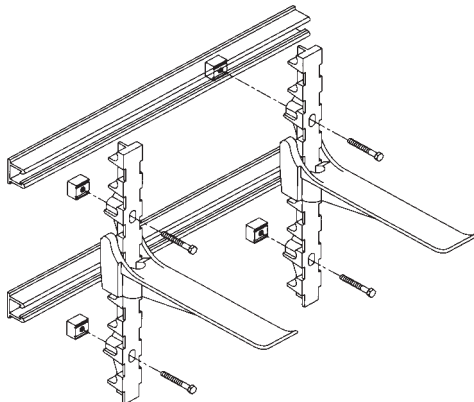

Installation – The Power-Rack Stanchions can be anchored into existing concrete structures using any good quality industrial anchoring system. For new concrete structures, the Power-Rack Stanchions can be mounted to Aickinstrut concrete embedment channel and attached with 1/2" channel nuts and 1/2"x 3" Fiberfast Bolts.

Fire Retardance – Power-Rack materials meet or exceed the requirements of UL94 HB.

Loading – The recommended allowable loads on Power-Rack Stanchions vary depending upon the position of the arm. Following the guidelines listed below will ensure a safe, reliable installation.

- Total load on any one arm should not exceed 800 lbs.
- The sum of the loads on any arm multiplied by their distances to the wall stanchion should not exceed 1200 in./lbs.

Example – A cable weighing 200 lbs. is positioned on an arm at a distance of 5" from the wall stanchion.

If the total load is less than 800 lbs and the sum of the load multiplied by their distances to the wall stanchion does not exceed 1200 in./lbs., then the system is adequate. In this case,

Total load (200<800 lbs) = OK

Tot. moment (200x5 in. = 1000<1200 in./lbs.) = OK

Part No.	Description	Weight	Load (lbs.)*
20N-ARM08	8" Arm	1.00	800
20N-ARM14	14¼" Arm	1.16	
20N-ARM17	17½" Arm	1.45	
20N-ARM23	23¾" Arm	1.86	
20N-STA21	21¾" Stanchion	1.49	N/A
20N-STA33	335/16" Stanchion	2.31	

*Design load values shown represent a 3:1 safety factor.

Wall Brackets

Aickin-Brackets are available in a wide variety of sizes and configurations. These wall brackets are made entirely from Aickinstrut material and are specifically designed to meet the customers requirements. They are ideal for customizing the support of piping, cables, tubing, conduits or cable trays. These brackets are available in either polyester or vinyl ester resin types and will work with all the Aickinstrut accessory items. Consult the factory for design, pricing and availability information.

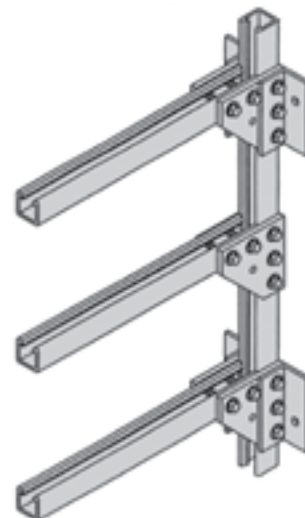

FIBERGLASS

Instrument & Pipe Stands



Heavy Duty Post Base

20PU-5852 (2" Square), 20PU-5852 RD (2" Round)
20PU-5853 HD (1⁵/₈" Sq.), 20PU-5854 HD (1¹/₂" Sq.)

The Aickinstrut heavy duty post base is designed for applications that require a stronger base attachment than the standard Aickinstrut post base. Made from polyurethane, the heavy duty post base is available with four different openings: 1¹/₂", 1⁵/₈", 2" square and 2" Schedule 80 round. The heavy duty post base is ideal for mounting fiberglass channel, handrails and instrument stands in corrosive environments. The standard color is gray, but special colors are available upon request.

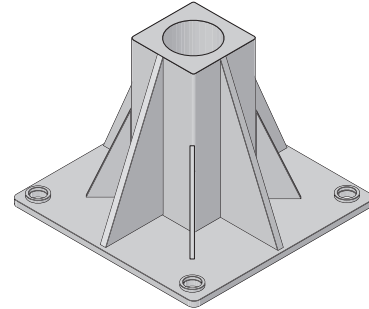
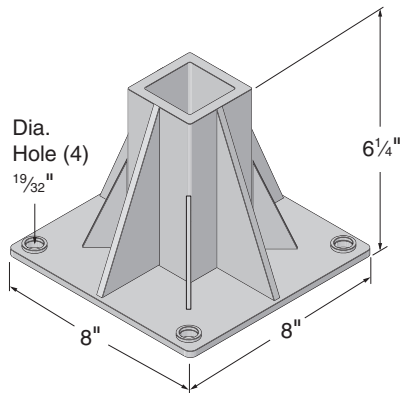

Instrument & Pipe Stands

Aickin-Instrument and Pipe Stands are available in polyester or vinyl ester resin types and are designed to meet specific customer requirements. These stands are ideal for supporting instruments and enclosures in corrosive environments. The stands utilize the Aickinstrut Heavy Duty Post Base and either 2" x 2" x 1/4" square tube or 2" Schedule 80 pipe to support the instruments or enclosures. These stands can be designed or configured to meet any application. Consult the factory for design, pricing and availability information.

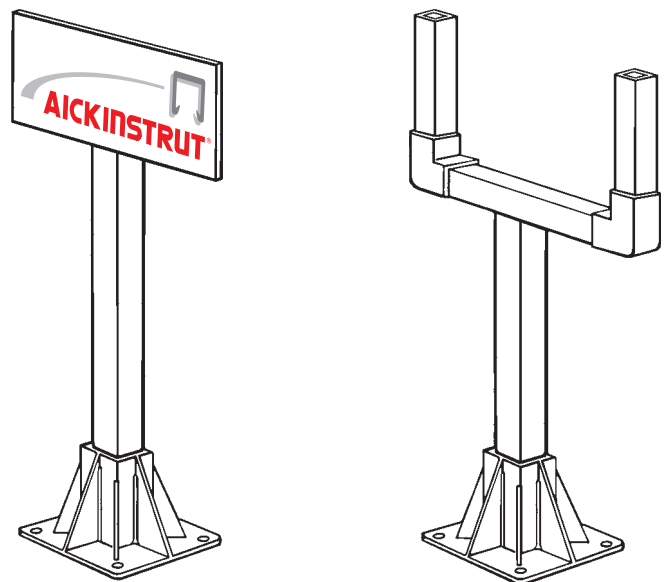

AICKINSHAPE® STRUCTURAL SHAPES

General purpose pultruded structural shapes can be used as a complement to Aickinstrut Channel Framing projects. The shapes are ideal for structural bracing, handrails, handrail kickplates, shims and supporting grating. Structural shapes are available in either polyester or vinyl ester resin and are provided in 20' lengths. Additional structural shapes not listed in this catalog are available. Contact the factory for pricing, availability and minimums. Special sizes and colors can be run based upon quantity.

NOTES

ST - Standard Isophthalic Polyester Resin; O = (Olive Green)
 FR - Isophthalic Polyester Fire Retardant Resin; P = (Dark Gray)
 VE - Vinyl Ester Fire Retardant Resin; V = (Beige)

■ Stock Item; ◆ Stocked in Yellow

In part numbers shown below, replace "X" with resin and color code (O, P, V).

I.E.: 18P-1200-20 Polyester Gray 2" x 1/4" Equal Leg Angle

Equal Leg Angle

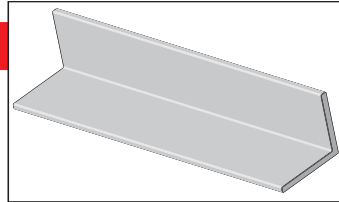

Size	Resin			#/Lin. Ft.	Part No.
	ST	FR	VE		
1 x 1/8	■	■	■	0.21	18X-1100-20
1 1/4 x 1/8	-	-	-	0.23	18X-1110-20
1 1/2 x 3/16	■	■	■	0.37	18X-1120-20
1 1/2 x 1/4	■	■	■	0.51	18X-1130-20
2 x 1/4	■	■	■	0.68	18X-1200-20
3 x 1/4	■	■	■	1.04	18X-1300-20
3 x 3/8	■	■	■	1.65	18X-1310-20
3 x 1/2	-	-	-	2.15	18X-1320-20
4 x 1/4	■	■	■	1.41	18X-1400-20
4 x 3/8	■	■	■	2.23	18X-1410-20
4 x 1/2	■	■	■	2.92	18X-1420-20
6 x 3/8	■	■	■	3.44	18X-1500-20
6 x 1/2	■	■	■	4.50	18X-1510-20

I-Beam

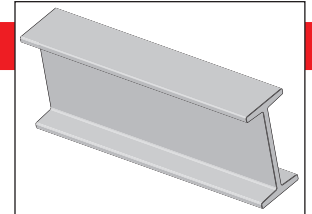

Size	Resin			#/Lin. Ft.	Part No.
	ST	FR	VE		
3 x 2 x 1 1/2 x 1/4	-	-	-	1.18	18X-2100-20
3 x 1 1/2 x 1/4	-	-	-	1.11	18X-2300-20
4 x 2 x 1/4	■	■	■	1.46	18X-2400-20
6 x 3 x 1/4	■	■	■	2.24	18X-2600-20
6 x 3 x 3/8	-	-	-	3.29	18X-2800-20
8 x 4 x 3/8	■	■	■	4.46	18X-2110-20
8 x 4 x 1/2	-	-	-	5.85	18X-2130-20
10 x 5 x 3/8	-	-	-	5.78	18X-2160-20
10 x 5 x 1/2	-	■	■	7.41	18X-2180-20
12 x 6 x 1/2	-	■	■	8.97	18X-2210-25
18 x 3/8 x 4 1/2 x 1/2	-	-	-	8.48	18X-2230-20
24 x 3/8 x 7 1/2 x 3/4	-	-	-	15.20	18X-2240-20

Channel

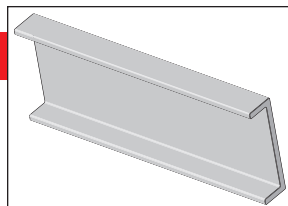

Size (In.)	Resin			#/Lin. Ft.	Part No.
	ST	FR	VE		
2 x 9/16 x 1/8	■	■	-	0.25	18X-2916-20
3 x 7/8 x 1/4	■	■	-	0.77	18X-3078-20
3 x 1 x 1/4	■	■	■	0.87	18X-3114-20
3 x 1 1/2 x 1/4	-	■	■	1.07	18X-3112-20
3 x 1 1/2 x 1 3/16 x 1/8	-	-	-	0.65	18X-31316-20
4 x 1 1/8 x 1/4	■	■	■	1.11	18X-4118-20
4 x 1 3/8 x 3/16	■	■	■	0.86	18X-4138-20
6 x 1 5/8 x 1/4	■	■	■	1.64	18X-6158-20
6 x 1 11/16 x 3/8	■	■	■	2.52	18X-61116-20
8 x 2 3/16 x 3/8	■	■	■	3.40	18X-82316-20
10 x 2 3/4 x 1/2	■	■	■	5.65	18X-10234-20

Wide Flange I-Beam

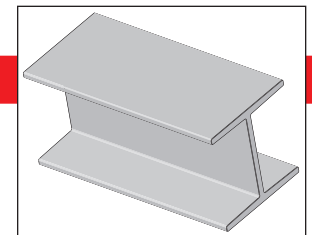

Size	Resin			#/Lin. Ft.	Part No.
	ST	FR	VE		
3 x 3 x 1/4	■	■	■	1.69	18X-2200-20
4 x 4 x 1/4	■	■	■	2.10	18X-2500-20
6 x 6 x 1/4	■	■	■	3.41	18X-2700-20
6 x 6 x 3/8	■	■	■	5.05	18X-2900-20
8 x 8 x 3/8	■	■	■	6.49	18X-2120-20
8 x 8 x 1/2	-	■	■	8.70	18X-2140-20
10 x 10 x 3/8	-	-	-	8.74	18X-2170-20
10 x 10 x 1/2	-	■	■	10.90	18X-2190-25
12 x 12 x 1/2	-	■	■	13.20	18X-2220-25



FIBERGLASS

Structural Shapes



Flat Sheet

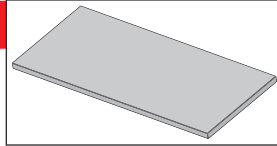

Size	Resin			#/Lin. Ft.	Part No.
	ST	FR	VE		
1/8 x 48 x 96	■	■	■	1.14	18X-4100
3/16 x 48 x 96	■	■	■	1.71	18X-4200
1/4 x 48 x 96	■	■	■	2.34	18X-4300
3/8 x 48 x 96	■	■	■	3.54	18X-4400
1/2 x 48 x 96	■	■	■	4.68	18X-4500
5/8 x 48 x 96	-	-	-	5.79	18X-4600
3/4 x 48 x 96	-	-	-	6.94	18X-4700
1 x 48 x 96	-	-	-	9.27	18X-4800

Square Bar

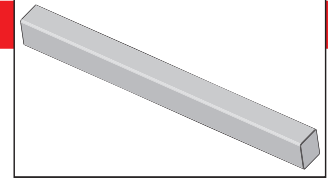

Size	Resin			#/Lin. Ft.	Part No.
	ST	FR	VE		
1 x 1	■	-	-	0.87	18X-5100-20
1 1/4 x 1 1/4	-	◆	-	1.31	18X-5125-20
1 1/2 x 1 1/2	-	◆	-	1.98	18X-5150-20
2 x 2	-	-	-	3.12	18X-5200-20

Embedment Angle

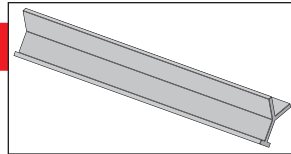

Size	Resin			#/Lin. Ft.	Part No.
	ST	FR	VE		
1 x 1 1/2 x 1/4	-	-	■	1.00	18X-111214-20
1 1/2 x 1 1/2 x 1/4	-	-	■	1.10	18X-11211214-20
2 x 1 1/2 x 1/4	-	-	■	1.20	18X-211214-20

Rectangular Tube

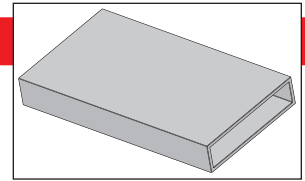

Size	Resin			#/Lin. Ft.	Part No.
	ST	FR	VE		
4 x 1 x 1/8	-	-	-	0.85	18X-4118-20
4 x 1/8 x 2 x 1/4	■	■	■	1.52	18X-418214-20
4 3/8 x 1 3/8 x 1/8 x 3/16	-	-	-	1.18	18X-438138-20
4 1/2 x 1 3/4 x 1/8 x 3/16	-	-	-	1.29	18X-412138-20
5 x 2 x 1/8	-	-	-	1.32	18X-5218-20
5 1/8 x 2 1/8 x 3/16	-	-	-	1.32	18X-518218-20
6 1/2 x 1/4 x 2 x 1/2	-	-	-	3.77	18X-612212-20
6 x 4 x 1/4	-	■	-		18X-6414-20

Square Tube

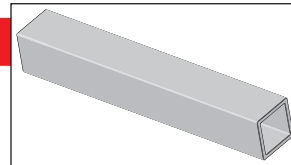

Size	Resin			#/Lin. Ft.	Part No.
	ST	FR	VE		
1 x 1/8	■	■	■	0.32	18X-3100-20
1 1/8 x 1/8	-	-	-	0.37	18X-3200-20
1 1/4 x 1/8	-	-	-	0.41	18X-3300-20
1 1/4 x 1/4	-	-	-	0.68	18X-3310-20
1 1/2 x 1/8	■	◆	◆	0.54	18X-3400-20
1 1/2 x 1/4	-	-	■	0.98	18X-3410-20
1 3/4 x 1/8	-	◆	◆	0.63	18X-3500-20
1 3/4 x 1/4	-	◆	◆	1.10	18X-3510-20
2 x 1/8	■	◆	◆	0.69	18X-3600-20
2 x 1/4	■	◆	◆	1.40	18X-3610-20
2 1/4 x 1/8	-	◆	-	0.83	18X-3800-20
2 1/4 x 1/4	-	-	-	1.56	18X-3810-20
2 1/2 x 1/4	-	◆	-	1.79	18X-3900-20
3 x 1/8	-	-	-	1.12	18X-3110-20
3 x 1/4	■	■	■	2.15	18X-3111-20
4 x 1/4	■	■	■	2.93	18X-3120-20
4 x 3/8	■	-	-	4.24	18X-3121-20
6 x 3/8	■	■	■	6.42	18X-3140-20
Toe Plate					
4 x 5/8 x 1/8	-	◆	◆	0.49	18X-3130-20

Round Rod

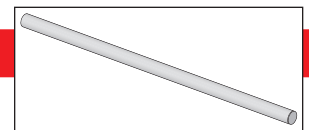

Size	Resin			#/Lin. Ft.	Part No.
	ST	FR	VE		
1/8	■	-	-	0.01	18X-70018-20
3/16	■	-	-	0.02	18X-700316-20
1/4	■	-	-	0.04	18X-70014-20
5/16	■	-	-	0.07	18X-700516-20
0.35	-	-	-	0.08	18X-70035-20
3/8	■	-	■	0.09	18X-70038-20
1/2	■	-	■	0.17	18X-70012-20
5/8	■	-	■	0.27	18X-70058-20
3/4	■	-	■	0.39	18X-70034-20
13/16	-	-	-	0.46	18X-7001316-20
1	■	-	■	0.66	18X-70100-20
1 1/4	■	-	-	1.08	18X-70114-20
1 1/2	■	-	-	1.56	18X-70112-20
2	-	-	-	2.56	18X-70200-20
2 1/2	-	-	-	4.10	18X-70212-20
3	-	-	-	5.70	18X-70300-20

Flat Strip

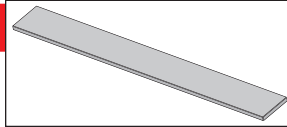

Size	Resin			#/Lin. Ft.	Part No.
	ST	FR	VE		
5/8 x 1/4	■	-	-	0.11	18X-605814-96
3/4 x 1/4	■	-	-	0.14	18X-603414-96
1 x 1/8	-	-	-	0.11	18X-6118-96
1 1/4 x 3/16	-	-	-	0.19	18X-6114316-96
1 1/2 x 3/8	-	-	-	0.50	18X-611238-96
1 1/2 x 1	-	-	-	1.32	18X-61121-96
1 3/4 x 1/4	■	-	-	0.38	18X-613414-96
2 x 1/2	-	-	-	0.88	18X-6212-96
2 x 1	-	-	-	1.76	18X-6210-96
2 1/2 x 3/16	-	-	-	0.34	18X-6212316-96
3 x 1/4	-	-	-	0.66	18X-6314-96
3 x 3/8	-	-	-	0.99	18X-6338-96
3 x 1/2	-	-	-	1.32	18X-6312-96
4 x 1/8	-	-	-	0.44	18X-6418-96
6 x 1/4	-	-	-	1.32	18X-6614-96
6 x 1/2	-	-	-	2.16	18X-6612-96

Round Tube

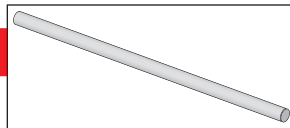

Size (In.)	Resin			#/Lin. Ft.	Part No.
	ST	FR	VE		
1 x .100	-	-	-	0.22	18X-7100-20
1 x 1/8	■	■	-	0.25	18X-7118-20
1 1/4 x 3/32	-	-	-	0.27	18X-7114332-20
1 1/4 x 1/8	-	-	-	0.32	18X-711418-20
1 1/4 x 1/4	-	-	-	0.60	18X-711414-20
1 1/2 x 1/8	■	■	-	0.45	18X-711218-20
1 1/2 x 1/4	-	■	-	0.79	18X-711214-20
1 3/4 x 1/8	-	-	-	0.47	18X-713418-20
1 3/4 x 1/4	-	-	-	0.94	18X-713414-20
2 x 1/4	■	■	■	1.12	18X-7214-20
3 x .100	-	-	-	0.89	18X-7300-20
3 x 1/4	-	-	-	1.68	18X-7314-20
3 x 1/2	■	-	-	2.98	18X-7312-20
4.89 x 1/8	-	-	-	2.32	18X-7418-20
4.89 x 3/16	-	-	-	2.97	18X-74316-20

Special Shapes

Door Frame

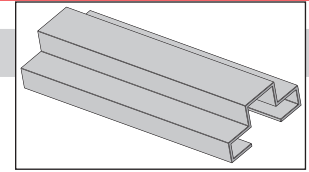

Profile/Size	Resin			#/Lin. Ft.	Part No.
	ST	FR	VE		
5 3/4 x 2 5/8 x 3/16	-	-	-	1.60	18X-DF-20

Threshold

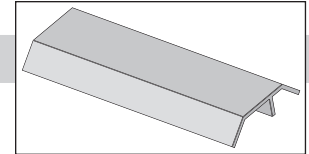

Profile/Size	Resin			#/Lin. Ft.	Part No.
	ST	FR	VE		
5 1/2 x 1/4	-	-	-	1.05	18X-TH-20

Hat Section

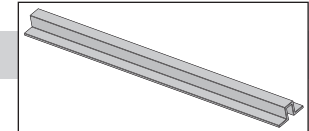

Profile/Size	Resin			#/Lin. Ft.	Part No.
	ST	FR	VE		
2 x 7/8 x .140	-	-	-	0.34	18X-HS-20

Flight Channel

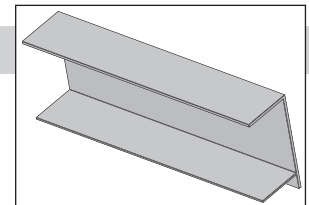

Profile/Size	Resin			#/Lin. Ft.	Part No.
	ST	FR	VE		
3 x 6 x 1/8 x 3/16	■	-	-	1.31	18X-93618316-20
3 x 8 x 1/8 x 3/16	■	-	-	1.43	18X-93818316-20



Handrail Components

Toe Plate†

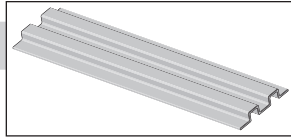

Size (in.)	#/Lin. Ft.	Part No.
4 x 5/8 x 1/8	0.49	18X-3130-20

Square Bar†

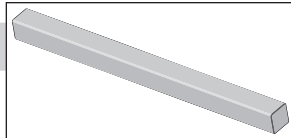

Size (in.)	#/Lin. Ft.	Part No.
1 1/4 x 1 1/4	1.31	18X*-5125-20
1 1/2 x 1 1/2	1.98	18X-5150-20

Square Tube†

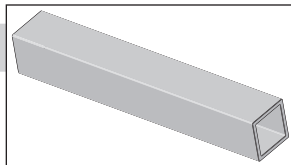

Size (in.)	#/Lin. Ft.	Part No.
1 1/4 x 1 1/4	0.68	18X-3310-20
1 1/2 x 1 1/8	0.54	18X-3400-20
1 3/4 x 1 1/8	0.63	18X-3500-20
1 3/4 x 1 1/4	1.10	18X-3510-20
2 x 1 1/8	0.69	18X-3600-20
2 x 1 1/4	1.40	18X-3610-20
2 1/4 x 1 1/8	0.83	18X-3800-20
2 1/2 x 1 1/4	1.69	18X-3900-20

Fixed Connector†

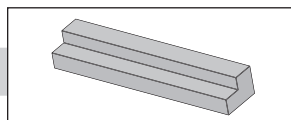

Size (in.)	#/Ea.	Part No.
4 1/4 x 1 1/4	0.87	AIC-FC-414
4 1/2 x 1 1/2	1.32	AIC-FC-412

Handrail Connectors

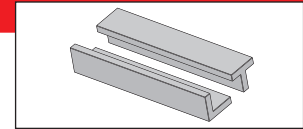

Fixed 90°

Size (In.)	Resin			#/Ea.	Part No.
	ST	FR	VE		
1 1/4	-	*†	-	0.87	AIC-FIXED-90-1-1/4
1 1/2	-	*†	-	1.32	AIC-FIXED-90-1-1/2

Adjustable 90°

Size (In.)	ST	FR	VE	#/Ea.	Part No.
1 1/4	-	-	-		AIC-ADJ-90-1-1/4
1 1/2	-	-	-		AIC-ADJ-90-1-1/2

Fixed "T"

Size (In.)	ST	FR	VE	#/Ea.	Part No.
1 1/4	-	-	-		AIC-FIXED-T-1-1/4
1 1/2	-	-	-		AIC-FIXED-T-1-1/2

600-2200 - Aickinzap



Aickinzap is an acrylic spray that provides a corrosion resistant coating when applied to cut sections of Aickinstrut. Aickinzap is supplied in a 12 oz. can and is recommended for use as a sealant for Aickinstrut polyester and vinyl ester materials after cutting or drilling. Aickinzap is the quickest, most convenient method for sealing after fabrication.

600-1500 (Quart), 600-1600 (Gallon) - Aickincoat



Aickincoat is a “brush-on” corrosion resistant sealant that should be applied to all cut or drilled surfaces of fiberglass to seal exposed areas from corrosion. Aickincoat dries into a clear, hard, glossy coating that restores weathered fiberglass surfaces and provides an excellent barrier from ultraviolet degradation. It is available in quart and gallon cans.

Custom Fabrication and Promotional Material

Promotional materials are available for select individuals, including stocking distributors, end users, OEM's, contractors, specifying engineers, consultants and sales representatives. Please contact the factory for availability.

AICK-DIST-DISP



The Aickin Distributor Display is a counter top display for stocking distributors. This display features multiple channel sizes and materials, adjustable and rigid pipe straps, U-bolts, molded and fabricated channel fittings, post bases, clevis hangers and fasteners. All of these materials are then assembled to form a comprehensive, compact display which becomes an excellent sales tool.

AJPSS2 - Aickin Adjustable Pipe Clamp Sample



The Aickin Adjustable Pipe Clamp Sample is a desk top sample that displays the Aickin Adjustable Pipe Strap clamping a piece of PVC pipe onto a section of Aickinstrut Channel.

ARPS2 - Aickin Rigid Pipe Clamp Sample



The Aickin Rigid Pipe Clamp Sample is a desk top sample that displays the rigid pipe strap clamping a piece of PVC pipe onto a section of Aickinstrut Channel.

Aickin Distributor Literature Displays (Hanging) AICK-LIT-DISP (Counter Stand) AICK-LIT-DISP-CS

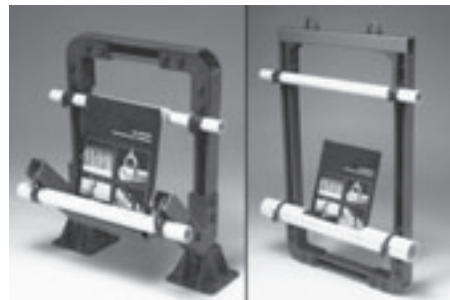

The Aickin Distributor Literature Display is offered in two designs; wall hanging and counter standing. The wall hanging design is meant to be hung from the two top U-bolts while the counter standing design is a free standing counter display. Both displays incorporate Aickinstrut channel in their design and utilize the PVC display pipe as the literature container.

Aickin Sample Box - AICK-SAMP-CART



The Aickin Sample Box is a convenient plastic carrying case with a complete sampling of the Aickinstrut product line.

Each Sample Box includes:

PVC strut sample (20E-2000), Polyester strut sample (20P-2000), Polyester slotted strut sample (20P-1100), Vinyl ester strut sample (20V-1500), Polyester solid channel fitting (20V-2500), Vinyl ester grooved channel fitting (20V-2802), Saddle Clip (200-4226), Fiberfast bolts (250PU-000, 375PU-125 & 500PU-000), Fiberfast nuts (250PU-000, 375PU-125 & 500PU-CN), Square nut (500V-000), PVC washers (375E-999 & 500E-999), Standard duty channel nuts (375PU-CN & 500PU-CN), Heavy duty channel nut (500PU-CNHD), Adjustable pipe clamp (200-3110), Rigid pipe clamp (PCR-125), FRP threaded rod samples (200-3827 & 200-3828)



Aickingrate Fiberglass Grating was developed as a corrosion resistant alternative to traditional metallic grating. Aickingrate will not rust, resists corrosion, lasts longer than metal and is maintenance free. Aickingrate never requires painting and can be installed with standard hand tools.

Other valuable Aickingrate features include:

- Availability of polyester or vinyl ester fire retardant resin systems, which offer superior corrosion resistance, strength and fire protection.
- Applied grit anti-slip surface on molded grating, which provides superior traction.
- Panels are strong and flexible providing a comfortable working surface that enhances safety while reducing worker fatigue.
- Panels are lightweight, easy to install and easy to remove for maintenance.
- UV inhibitors are added to the base resin systems providing optimum protection from the effects of weathering. Pultruded grating is further enhanced with the addition of a synthetic surfacing veil.

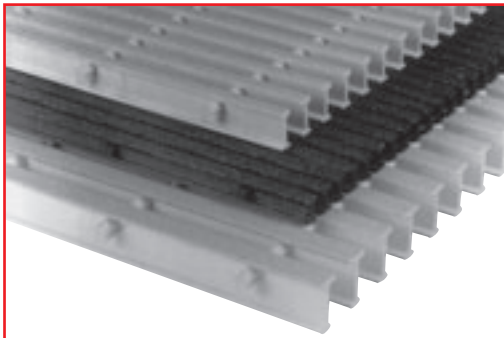

Aickingrate pultruded and molded gratings are ideal for the following applications:

- Aquariums
- Chemical & Petrochemical
- Food & Beverage
- Marine
- Mining
- Offshore
- Plating
- Power Generation & Utilities
- Pulp & Paper
- Recreation & Pools
- Transportation
- Water & Wastewater

Aickingrate pultruded and molded gratings are practical, economical solutions for applications where metallic gratings are not well suited. Aickingrate offers the best solution for your industrial flooring needs.

Because Aickingrate is marketed with Aickinstrut Non-Metallic Strut Support Systems and Aickinshapes Non-Metallic Structural Shapes, the customer has the benefit of purchasing all of these items from a single source, thereby minimizing start-up and delivery delays.

Aickingrate stands ready to provide customer assistance through its network of distributors and mechanical sales representatives.

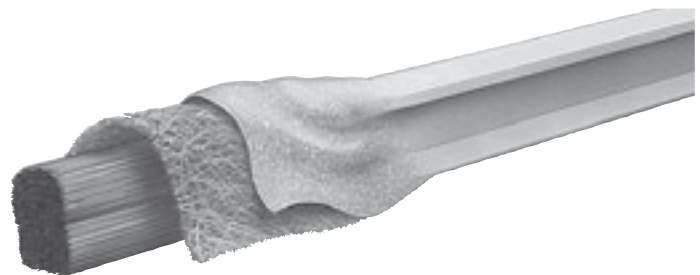

AICKINGRATE® Fiberglass Grating

Aickingrate molded grating is a one piece, glass-reinforced design available in standard sized 3' x 10' and 4' x 12' panels. Each panel is composed of non-flame retardant polyester resin, flame retardant polyester resin or vinyl ester resin and continuous fiberglass rovings for optimum strength and corrosion resistance. All Aickingrate molded grating is provided with an applied grit anti-skid surface. This anti-skid surface is applied onto the meniscus surface of each panel providing an

extremely long lasting, effective, anti-skid surface. Standard meniscus surface grating is also available upon request.

Aickingrate molded grating does not rust, never requires painting and resists corrosion. The panels have a high strength-to-weight ratio and are maintenance free. They also are lightweight and can easily be installed without heavy equipment. Fabricating Aickingrate can easily be accomplished with standard tools.

Aickingrate is ideal for work platforms. The resiliency designed into each panel reduces worker leg and back pain and lowers overall worker fatigue resulting in increased productivity. These worker anti-fatigue benefits make Aickingrate ideal for platforms, catwalks, flooring, work stations and mezzanines.

Resin Systems

Polyester

The Aickingrate polyester resin system has two flame spread ratings. The fire retardant system has a rating of 25 or less based on the requirements of ASTM E 84. The non-fire retardant system is not rated. Both systems are designed for applications that will see moderate exposure to corrosive elements. These resin systems are ideal when a cost-effective, corrosion resistant, system is required.

Standard Colors: Green & Yellow

Special colors are available upon request.

Vinyl Ester

The Aickingrate vinyl ester resin system has a flame spread rating of 25 or less based on the requirements of ASTM E 84 (**contact the factory for applications that require a flame spread rating of 10 or less**). It is designed to resist the highly corrosive acids and caustics found in the harshest chemical environments. This premium grade resin system is ideal in extremely harsh, wet, caustic conditions and will maintain its structural integrity at elevated temperatures. Aickingrate vinyl ester molded grating is the system to choose in extremely corrosive conditions.

Standard Colors: Orange & Dark Gray

Special colors are available upon request.

Special Optional Surfaces

The standard Aickingrate surface is an applied, sealed grit top. The other optional Aickingrate surface is a meniscus surface that also provides optimum skid resistance.

Meniscus

This "concave surface" grating provides excellent slip resistance and is recommended for light traffic applications.

Anti-Skid

This "applied-grit" surface is ideal for high traffic applications that require superior skid resistance.

Loading and Deflection

The load & deflection data is intended for use only as a guide. The Aickingrate standard panel sizes are 3' x 10' and 4' x 12'. The bearing bars run across the panels making the span 3 or 4 feet. Once the design load and deflection are determined, you can calculate the maximum allowable span from the tables.

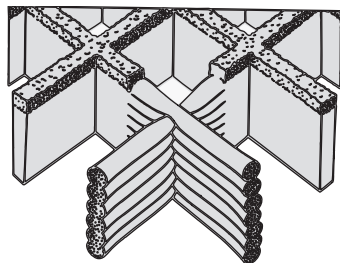

LOADING CONSIDERATIONS

Occasionally, Aickingrate will be subjected to heavy loads from wheeled traffic. For these applications, it is not recommended to use Aickingrate where solid steel or hard rubber wheels can cause sharp impact or chipping of the embedded grit surface. For the same reason, avoid dropping or sliding heavy loads on Aickingrate.

Load & Deflection Application Data	Concentrated Load (lbs.)	Suggested Deflection (in.)
Occasional Foot Traffic (Inspections, etc.)	250	.250-.375
Workman with Tools (Maintenance)	300	.250-.375
Heavy Foot Traffic	400	.250-.375
Carts/Nonmotorized Vehicles	800	.250-.375
Motorized Traffic (Light)	1,500	.250-.375



Grating Size

HEIGHT (MESH SIZE)

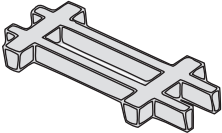
	Panel Size:	3' x 10' & 44" x 8'	Space Between Bars	3/4" x 3-5/8"
	Panel Weight:	83 lbs. & 83 lbs.	Bar Thickness:	
	Weight Per Ft.:	2.75 lbs. sq/ft	Bearing Bar	1/4"
	Open Area:	69%	Cross Bar	3/8"

1" (1" X 4")

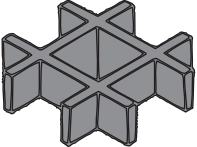
	Panel Size:	4' x 12', 4' x 10'	Space Between Bars	1-1/4" x 1-1/4"
	Panel Weight:	120 lbs. & 100 lbs.	Bar Thickness:	
	Weight Per Ft.:	2.5 lbs. sq/ft	Bearing Bar	1/4"
	Open Area:	70%	Cross Bar	1/4"

1' (1-1/2" X 1-1/2")

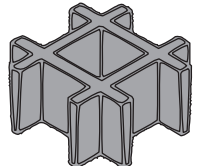
	Panel Size:	4' x 12', 4' x 10'	Space Between Bars	1-1/4" x 1-1/4"
	Panel Weight:	180 lbs. & 150 lbs.	Bar Thickness:	
	Weight Per Ft.:	3.75 lbs. sq/ft	Bearing Bar	1/4"
	Open Area:	70%	Cross Bar	1/4"

1-1/2" (1-1/2" X 1-1/2")

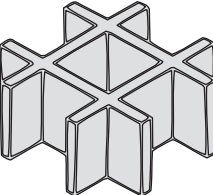
	Panel Size:	4' x 12', 4' x 10'	Space Between Bars	1-3/4" x 1-3/4"
	Panel Weight:	192 lbs. & 160 lbs.	Bar Thickness:	
	Weight Per Ft.:	4.0 lbs. sq/ft	Bearing Bar	1/4"
	Open Area:	70%	Cross Bar	1/4"

2" (2" X 2")

1. Material

1.1 All molded grating will be fiberglass roving reinforced and constructed from non-fire retardant polyester, fire retardant polyester or vinyl ester resin.

2. Composition

2.1 Glass content will be 35% by weight so as to achieve maximum corrosion resistance.

2.2 Fire-retardant grating will have a flame spread rating of 25 or less per the requirements of ASTM E 84.

2.3 Grating shall comply with all applicable provisions of the following flammability standards:

- ASTM D-635 (Rate of Burning)
- ASTM E 84 (Surface Burning)
- UL 94 V0 (Flammability Standard)

2.4 Standard colors shall include the following:

- Polyester: Green & Yellow
- Vinyl ester: Orange & Dark Gray

2.5 Special colors are available upon customer request.

3. Structural Design

3.1 Grating shall have the following grid patterns:

- 1" x 4" (1" thick)
- 1 1/2" x 1 1/2" (1" thick)
- 1 1/2" x 1 1/2" (1 1/2" thick)
- 2" x 2" (2" thick)

3.2 Grating shall be provided in standard 3' x 10' & 4' x 12' panels.

3.3 Specially cut & fabricated grating sections will be available upon customer request.

3.4 Open areas will range from 69% to 70% depending on the selected grid pattern.

3.5 Standard surface shall be a sealed, applied grit top surface with meniscus surface available upon request.

3.6 Load and deflection values shall be as stated in this catalog.

3.7 Weights per sq/ft shall be as stated in this catalog.

4. General

4.1 Grating will be inspected prior to shipment and will be free from visual defects such as delaminations, blisters, surface crazing and voids.

4.2 Cut grating will be sealed prior to shipment.

4.3 Use of grating accessories shall be approved by the manufacturer and installed in accordance with the manufacturers' instructions.

4.4 Product substitutions other than Aickingrate must meet or exceed the performance standards set forth in this catalog.

4.5 Grating supplied shall be Aickingrate as manufactured by:
Aickinstrut/T.J. Cope

AICKINGRATE® Pultruded Grating

Aickingrate pultruded grating is constructed of pultruded "I" or "T" bars which are available in varying heights (1", 1-1/2" & 2"). Each pultruded bar is connected together with recessed tie bars and covered with an anti-skid, grit top surface to provide sure footing. Each pultruded bar incorporates a synthetic surfacing veil on its exterior. The surfacing veil provides a resin rich surface which allows the grating to withstand hostile environments and inhibit ultraviolet degradation. The standard panel size is 4' x 12'.

The pultruded grating is available in the following resin systems:

Polyester

This resin system offers a low flame spread rating of 15 or less and is designed for applications where there is moderate exposure to corrosive elements.

Vinyl Ester

This resin system offers a low flame spread rating of 15 or less and is designed for prolonged exposure in acidic and alkaline type environments.

Aickingrate pultruded grating is more corrosion resistant than conventional metal grating. The lightweight, maintenance free panels make it less expensive to install than metal grating. The low installation cost combined with the maintenance free life of pultruded grating make its overall life cycle costs lower than that of metal grating.

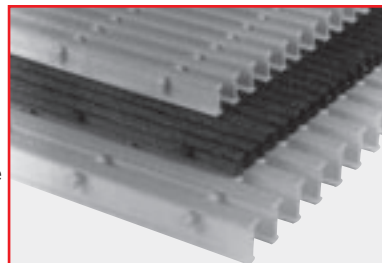

Aickingrate pultruded grating exceeds the requirements for gratings used in the following applications:

- Aquariums and Zoos
- Chemical
- Food and Beverage
- Offshore and Marine
- Petroleum Processing
- Plating Facilities
- Pulp and Paper
- Water and Wastewater

Typical uses for Aickingrate pultruded grating would include:

- Flooring
- Ramps
- Platforms
- Stairs
- Walkways
- Trench Covers
- Catwalks
- Assembly Lines

Aickingrate Pultruded Specifications

1. Material

All pultruded grating shall be constructed of glass reinforced, fire retardant polyester resin. Vinyl ester resin is available as a special order.

2. Composition

All pultruded glass reinforced grating shall have a synthetic veil applied on all exterior surfaces to improve weatherability and inhibit ultraviolet degradation. An ultraviolet stabilizer shall be incorporated in the resin formulation to further inhibit ultraviolet degradation.

Grating will have a flame spread rating of 15 per the requirements ASTM E 84.

Grating shall comply with all applicable provisions of the following flammability standards:

ASTM D-635 (Rate of Burning)

ASTM E 84 (Surface Burning)

UL 94 V0 (Flammability Standard)

2.4 Standard colors shall include the following:

Polyester (I-bar & T-bar): Yellow

Polyester (Wide T-bar): Dark Gray

2.5 Special colors are available upon customer request.

3. Structural Design

3.1 Grating shall have the following bar types and heights:

I-bar - (1", 1 1/2" & 2" heights)

T-bar - (2" height)

Wide T-bar - (1" & 1 1/2" heights)

3.2 Grating shall be provided in standard 4' x 12' panels.

3.3 Specially cut & fabricated grating sections are available upon customer request.

3.4 Standard available "open areas" will be the following:

I-bar - (40% & 60%)

T-bar - (33% & 50%)

Wide T-bar - (25% & 38%)

3.5 Special "open areas" are available upon customer request.

3.6 Grating shall be manufactured from thermally cured pultruded structural load and tie bar components.

3.7 Grating shall be provided with a recessed tie bar design and grit top surface for maximum skid resistance.

3.8 Grating shall be an assembled and bonded notched tie bar system to provide both a mechanical and bonded panel connection.

3.9 Load, deflection and panel weight values shall be as stated in this catalog.

4. General

4.1 Grating will be inspected prior to shipment and will be free from visual defects.

4.2 All cut ends will be sealed prior to shipment.

4.3 Grating shall be fully supported according to the manufacturer guidelines.

4.4 Use of grating accessories shall be approved by the manufacturer and installed in accordance with the manufacturers' instructions.

4.5 Product substitutions other than Aickingrate must meet or exceed the performance standards set forth in this catalog.

4.6 Grating supplied shall be Aickingrate as manufactured by: Aickinstrut/T.J. Cope

"T" Bar 1" THICK, 60% OPEN AREA

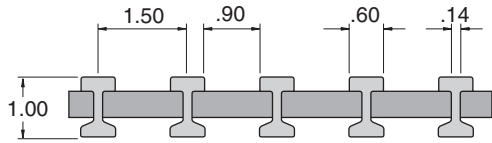

of Bars/ft. of Width - 8
 Load Bar Depth 1"
 Load Bar Centers 1-1/2" Open Area 60%
 Approx. Weight 2.62 lbs./ft²

"T" Bar 1" THICK, 40% OPEN AREA

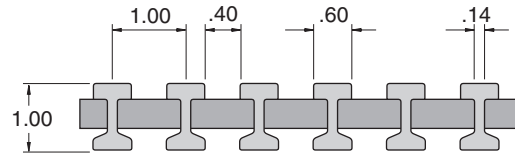

of Bars/ft. of Width - 12
 Load Bar Depth 1"
 Load Bar Centers 1" Open Area 40%
 Approx. Weight 3.41 lbs./ft²

LOAD TYPES

ENGINEERING PROPERTIES PER FT OF WIDTH

A=2.64 in² I=0.33 in⁴ S=0.63 in³

Average EI=1,700,000 lb/in² (Span ≥24")

A=Cross Sectional Area I=Moment of Inertia S=Section Modulus

Average EI=Modulus of Elasticity x Moment of Inertia (avg. value other varying spans)

Clear Span (in.)	Load Type	Load Required For a Specified Deflection (Note 2)		Max. Recom. Load (Note 1) All Resin Systems [Load (Deflection)]
		0.250"	0.375"	
12	U	-	-	4576 (0.09")
	C	-	-	4576 (0.14")
18	U	-	-	3051 (0.25")
	C	-	-	4576 (0.40")
24	U	1059	1589	2288 (0.54")
	C	1331	1997	3833 (0.72")
30	U	458	686	1830 (1.00")
	C	716	1075	3067 (1.07")
36	U	241	362	1525 (1.58")
	C	453	680	2556 (1.41")
42	U	135	202	1252 (2.32")
	C	300	450	2190 (1.86")
48	U	87	131	958 (2.75")
	C	218	327	1917 (2.20")
54	U	50	75	757 (3.85")
	C	138	208	1704 (3.08")
60	U	30	45	613 (5.15")
	C	93	140	1533 (4.12")
66	U	18	27	507 (7.02")
	C	64	96	1394 (5.46")
72	U	13	19	426 (8.22")
	C	49	73	1278 (6.58")

U Uniform Load - lbs/ft²
 C Concentrated Line Load - lbs/ft of Width

NOTES:

1. MAX RECOMMENDED LOAD represents a 2:1 factor of safety on ULTIMATE CAPACITY.
2. The allowable loads in this table are for STATIC LOAD CONDITIONS at ambient temperatures only. Allowable loads for impact or dynamic conditions should be a minimum of ONE-HALF the values shown. Long term loads will result in added deflection due to creep in the material and will also require higher safety factors to ensure acceptable performance. For applications at elevated temperatures, consult factory. The designer is further referenced to ASCE Structural Plastics Design Manual.

LOAD TYPES

ENGINEERING PROPERTIES PER FT OF WIDTH

A=3.96 in² I=0.50 in⁴ St=0.96 in³

Average EI=2,500,000 lb/in² (Span ≥24")

A=Cross Sectional Area I=Moment of Inertia S=Section Modulus

Average EI=Modulus of Elasticity x Moment of Inertia (avg. value other varying spans)

Clear Span (in.)	Load Type	Load Required For a Specified Deflection (Note 2)		Max. Recom. Load (Note 1) All Resin Systems [Load (Deflection)]
		0.250"	0.375"	
12	U	-	-	6864 (0.09)
	C	-	-	6864 (0.14)
18	U	-	-	4576 (0.25)
	C	-	-	6864 (0.40)
24	U	1589	2383	2432 (0.54)
	C	2000	3000	5750 (0.72)
30	U	686	1030	2746 (1.00)
	C	1075	1612	4600 (1.07)
36	U	362	543	2288 (1.58)
	C	958	1438	3833 (1.41)
42	U	200	300	1878 (2.32)
	C	442	662	3286 (1.86)
48	U	131	196	1438 (2.75)
	C	327	491	2875 (2.20)
54	U	74	111	1136 (3.85)
	C	208	312	2556 (3.08)
60	U	45	67	920 (5.15)
	C	140	209	2300 (4.12)
66	U	27	41	760 (7.02)
	C	96	144	2091 (5.46)
72	U	19	29	639 (8.22)
	C	73	109	1917 (6.58)

U Uniform Load - lbs/ft²
 C Concentrated Line Load - lbs/ft of Width

NOTES:

1. MAX RECOMMENDED LOAD represents a 2:1 factor of safety on ULTIMATE CAPACITY.
2. The allowable loads in this table are for STATIC LOAD CONDITIONS at ambient temperatures only. Allowable loads for impact or dynamic conditions should be a minimum of ONE-HALF the values shown. Long term loads will result in added deflection due to creep in the material and will also require higher safety factors to ensure acceptable performance. For applications at elevated temperatures, consult factory. The designer is further referenced to ASCE Structural Plastics Design Manual.

"I" Bar 1½" THICK, 60% OPEN AREA

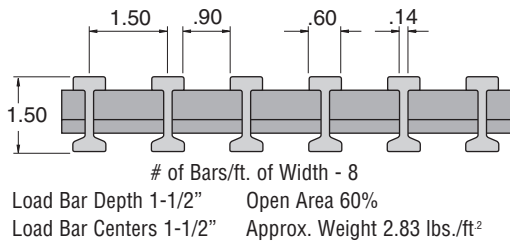

"I" Bar 1½" THICK, 40% OPEN AREA

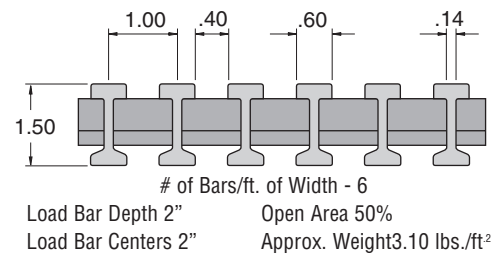

LOAD TYPES

ENGINEERING PROPERTIES PER FT OF WIDTH

A=3.20 in² I=0.94 in⁴ St=1.20 in³

Average EI=4,600,000 lb/in² (Span ≥24")

A=Cross Sectional Area I=Moment of Inertia S=Section Modulus

Average EI=Modulus of Elasticity x Moment of Inertia (avg. value other varying spans)

Clear Span (in.)	Load Type	Load Required For a Specified Deflection (Note 2)		Max. Recom. Load (Note 1) All Resin Systems [Load (Deflection)]
		0.250"	0.375"	
12	U	-	-	8190 (0.07)
	C	-	-	8190 (0.11)
18	U	-	-	5460 (0.17)
	C	-	-	8190 (0.28)
24	U	2925	-	4095 (0.35)
	C	3676	5515	6250 (0.43)
30	U	1232	1847	3276 (0.66)
	C	1923	2885	5000 (0.65)
36	U	666	1000	2730 (1.02)
	C	1247	1871	4167 (0.83)
42	U	357	535	2041 (1.43)
	C	780	1170	3571 (1.15)
48	U	219	329	1563 (1.78)
	C	548	822	3125 (1.43)
54	U	193	290	1852 (2.40)
	C	363	544	2778 (1.92)
60	U	81	122	1000 (3.09)
	C	253	380	2500 (2.47)
66	U	50	75	826 (4.08)
	C	179	268	2273 (3.18)
72	U	37	55	694 (4.71)
	C	138	208	2083 (3.77)

U Uniform Load - lbs/ft²
C Concentrated Line Load - lbs/ft of Width

NOTES:

1. MAX RECOMMENDED LOAD represents a 2:1 factor of safety on ULTIMATE CAPACITY.
2. The allowable loads in this table are for STATIC LOAD CONDITIONS at ambient temperatures only. Allowable loads for impact or dynamic conditions should be a minimum of ONE-HALF the values shown. Long term loads will result in added deflection due to creep in the material and will also require higher safety factors to ensure acceptable performance. For applications at elevated temperatures, consult factory. The designer is further referenced to ASCE Structural Plastics Design Manual.

LOAD TYPES

ENGINEERING PROPERTIES PER FT OF WIDTH

A=4.80 in² I=1.44 in⁴ St=1.80 in³

Average EI=7,000,000 lb/in² (Span ≥24")

A=Cross Sectional Area I=Moment of Inertia S=Section Modulus

Average EI=Modulus of Elasticity x Moment of Inertia (avg. value other varying spans)

Clear Span (in.)	Load Type	Load Required For a Specified Deflection (Note 2)		Max. Recom. Load (Note 1) All Resin Systems [Load (Deflection)]
		0.250"	0.375"	
12	U	-	-	14,400 (0.07)
	C	-	-	12,285 (0.11)
18	U	-	-	8190 (0.17)
	C	-	-	12,285 (0.28)
24	U	4388	-	6143 (0.35)
	C	5515	8272	9375 (0.43)
30	U	1847	2771	4914 (0.66)
	C	2885	4327	7500 (0.65)
36	U	1000	1500	4095 (1.02)
	C	1871	2807	6250 (0.83)
42	U	535	803	3061 (1.43)
	C	1170	1754	5357 (1.15)
48	U	327	491	2344 (1.78)
	C	822	1234	4688 (1.43)
54	U	193	290	1852 (2.40)
	C	544	816	4167 (1.92)
60	U	122	182	1500 (3.09)
	C	380	569	3750 (2.47)
66	U	76	114	1240 (4.08)
	C	268	403	3409 (3.18)
72	U	55	83	1042 (4.71)
	C	207	311	3125 (3.77)

U Uniform Load - lbs/ft²
C Concentrated Line Load - lbs/ft of Width

NOTES:

1. MAX RECOMMENDED LOAD represents a 2:1 factor of safety on ULTIMATE CAPACITY.
2. The allowable loads in this table are for STATIC LOAD CONDITIONS at ambient temperatures only. Allowable loads for impact or dynamic conditions should be a minimum of ONE-HALF the values shown. Long term loads will result in added deflection due to creep in the material and will also require higher safety factors to ensure acceptable performance. For applications at elevated temperatures, consult factory. The designer is further referenced to ASCE Structural Plastics Design Manual.



"T" Bar 2" THICK, 50% OPEN AREA

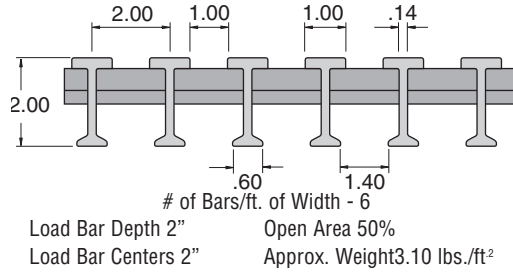

"T" Bar 2" THICK, 33% OPEN AREA

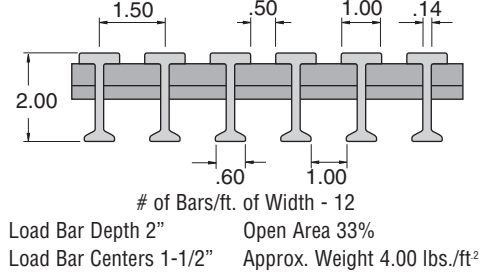

LOAD TYPES

ENGINEERING PROPERTIES PER FT OF WIDTH

A=3.20 in² I=1.68 in⁴ St=1.96 in³ Sb=1.47 in³

Average EI=7,600,000 lb/in² (Span ≥24")

A=Cross Sectional Area I=Moment of Inertia S=Section Modulus (Top, Bottom)

Average EI=Modulus of Elasticity x Moment of Inertia (avg. value other varying spans)

Clear Span (in.)	Load Type	Load Required For a Specified Deflection (Note 2)		Max. Recom. Load (Note 1) All Resin Systems [Load (Deflection)]
		0.250"	0.375"	
12	U	-	-	10,800 (0.06)
	C	-	-	10,800 (0.10)
18	U	-	-	7200 (0.17)
	C	-	-	10,800 (0.27)
24	U	4737	-	5400 (0.29)
	C	5934	8900	10,800 (0.46)
30	U	2000	3000	4320 (0.54)
	C	3117	4676	8667 (0.69)
36	U	1071	1607	3600 (0.84)
	C	2000	3000	7222 (0.90)
42	U	553	829	3086 (1.40)
	C	1209	1814	6190 (1.28)
48	U	343	514	2700 (1.97)
	C	857	1286	5417 (1.58)
54	U	211	316	2140 (2.54)
	C	592	887	4815 (2.03)
60	U	137	206	1733 (3.16)
	C	428	642	4333 (2.53)
66	U	94	140	1433 (3.83)
	C	328	492	3939 (3.00)
72	U	71	106	1204 (4.24)
	C	266	399	3611 (3.39)

U Uniform Load - lbs/ft²
C Concentrated Line Load - lbs/ft of Width

NOTES:

1. MAX RECOMMENDED LOAD represents a 2:1 factor of safety on ULTIMATE CAPACITY.
2. The allowable loads in this table are for STATIC LOAD CONDITIONS at ambient temperatures only. Allowable loads for impact or dynamic conditions should be a minimum of ONE-HALF the values shown. Long term loads will result in added deflection due to creep in the material and will also require higher safety factors to ensure acceptable performance. For applications at elevated temperatures, consult factory. The designer is further referenced to ASCE Structural Plastics Design Manual.

LOAD TYPES

ENGINEERING PROPERTIES PER FT OF WIDTH

A=4.28 in² I=2.24 in⁴ St=2.61 in³ Sb=1.96 in³

Average EI=9,200,000 lb/in² (Span ≥24")

A=Cross Sectional Area I=Moment of Inertia S=Section Modulus (Top, Bottom)

Average EI=Modulus of Elasticity x Moment of Inertia (avg. value other varying spans)

Clear Span (in.)	Load Type	Load Required For a Specified Deflection (Note 2)		Max. Recom. Load (Note 1) All Resin Systems [Load (Deflection)]
		0.250"	0.375"	
12	U	-	-	14,400 (0.06)
	C	-	-	14,400 (0.10)
18	U	-	-	9600 (0.17)
	C	-	-	14,400 (0.28)
24	U	6316	-	7200 (0.29)
	C	7784	11676	14,167 (0.45)
30	U	2667	4000	5760 (0.54)
	C	4167	6250	11,333 (0.68)
36	U	1429	2143	4800 (0.84)
	C	2668	4000	9444 (0.88)
42	U	737	1106	4114 (1.39)
	C	1613	2419	8095 (1.25)
48	U	458	686	3542 (1.94)
	C	1143	1714	7083 (1.55)
54	U	281	421	2798 (2.49)
	C	789	1184	6296 (1.99)
60	U	183	274	2267 (3.10)
	C	571	857	5667 (2.48)
66	U	125	187	1873 (3.75)
	C	438	657	5152 (2.94)
72	U	95	142	1574 (4.16)
	C	355	533	4722 (3.33)

U Uniform Load - lbs/ft²
C Concentrated Line Load - lbs/ft of Width

NOTES:

1. MAX RECOMMENDED LOAD represents a 2:1 factor of safety on ULTIMATE CAPACITY.
2. The allowable loads in this table are for STATIC LOAD CONDITIONS at ambient temperatures only. Allowable loads for impact or dynamic conditions should be a minimum of ONE-HALF the values shown. Long term loads will result in added deflection due to creep in the material and will also require higher safety factors to ensure acceptable performance. For applications at elevated temperatures, consult factory. The designer is further referenced to ASCE Structural Plastics Design Manual.

Aickingrate Wide T-Bar pultruded grating provides a lightweight, non-skid, durable alternative to metallic grating used for pedestrian walkway traffic.

This low-cost grating is an excellent alternative to metal grating for wet areas with high volumes of foot traffic.

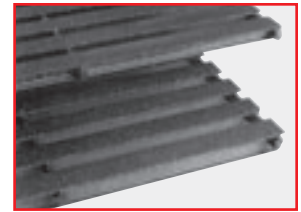

The Aickingrate Wide T-Bar grit-top grating offers excellent protection for pedestrian traffic particularly in wet environments.

WIDE "T" Bar 1" THICK, 38% OPEN AREA

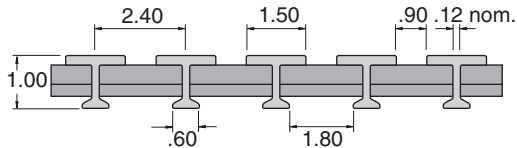

of Bars/ft. of Width - 5
 Load Bar Depth 1" Open Area 38%
 Load Bar Centers 2.4" Approx. Weight 1.90 lbs./ft²

WIDE "T" Bar 1" THICK, 25% OPEN AREA

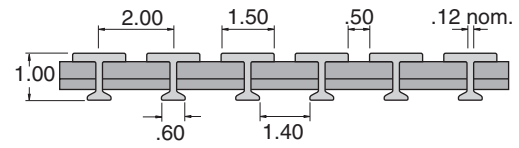

of Bars/ft. of Width - 6
 Load Bar Depth 1" Open Area 25%
 Load Bar Centers 2" Approx. Weight 2.30 lbs./ft²

LOAD TYPES

ENGINEERING PROPERTIES PER FT OF WIDTH

A=1.76 in² I=.23 in⁴ S-top=.35 in³ S-bot=.22 in³

Average EI=1,200,000 lb/in² (Span ≥24")

A=Cross Sectional Area I=Moment of Inertia S=Section Modulus (Top, Bottom)

Average EI=Modulus of Elasticity x Moment of Inertia (avg. value other varying spans)

LOAD TYPES

ENGINEERING PROPERTIES PER FT OF WIDTH

A=2.11 in² I=.27 in⁴ S-top=.42 in³ S-bot=.27 in³

Average EI=1,340,000 lb/in² (Span ≥24")

A=Cross Sectional Area I=Moment of Inertia S=Section Modulus (Top, Bottom)

Average EI=Modulus of Elasticity x Moment of Inertia (avg. value other varying spans)

Clear Span (in.)	Load Type	Load Required For a Specified Deflection (Note 2)		Max. Recom. Load (Note 1) All Resin Systems [Load (Deflection)]
		0.250"	0.375"	
12	U	-	-	2730 (0.08)
	C	-	-	2730 (0.12)
18	U	-	-	1820 (0.22)
	C	-	-	2587 (0.34)
24	U	742	1113	1365 (0.46)
	C	933	1399	1940 (0.52)
30	U	312	468	1092 (0.87)
	C	491	737	1552 (0.79)
36	U	154	231	862 (1.40)
	C	290	435	1293 (1.12)
42	U	84	126	663 (1.89)
	C	184	276	1109 (1.50)
48	U	50	75	485 (2.43)
	C	125	188	970 (1.94)

U Uniform Load - lbs/ft²
 C Concentrated Line Load - lbs/ft of Width

NOTES:

1. MAX RECOMMENDED LOAD represents a 2:1 factor of safety on ULTIMATE CAPACITY.
2. The allowable loads in this table are for STATIC LOAD CONDITIONS at ambient temperatures only. Allowable loads for impact or dynamic conditions should be a minimum of ONE-HALF the values shown. Long term loads will result in added deflection due to creep in the material and will also require higher safety factors to ensure acceptable performance. For applications at elevated temperatures, consult factory. The designer is further referenced to ASCE Structural Plastics Design Manual.

Clear Span (in.)	Load Type	Load Required For a Specified Deflection (Note 2)		Max. Recom. Load (Note 1) All Resin Systems [Load (Deflection)]
		0.250"	0.375"	
12	U	-	-	3276 (0.08)
	C	-	-	3276 (0.12)
18	U	-	-	2184 (0.22)
	C	-	-	3104 (0.34)
24	U	890	1335	1638 (0.46)
	C	1119	1679	2328 (0.52)
30	U	374	562	1310 (0.87)
	C	589	884	1862 (0.79)
36	U	185	277	1035 (1.40)
	C	348	522	1552 (1.12)
42	U	100	150	760 (1.89)
	C	221	332	1330 (1.50)
48	U	60	90	582 (2.43)
	C	150	226	1164 (1.94)

U Uniform Load - lbs/ft²
 C Concentrated Line Load - lbs/ft of Width

NOTES:

1. MAX RECOMMENDED LOAD represents a 2:1 factor of safety on ULTIMATE CAPACITY.
2. The allowable loads in this table are for STATIC LOAD CONDITIONS at ambient temperatures only. Allowable loads for impact or dynamic conditions should be a minimum of ONE-HALF the values shown. Long term loads will result in added deflection due to creep in the material and will also require higher safety factors to ensure acceptable performance. For applications at elevated temperatures, consult factory. The designer is further referenced to ASCE Structural Plastics Design Manual.

FIBERGLASS



AICKINGRATE PART NUMBERS

To order Aickingrate, use the following part number scheme to create the correct part number.

* To order non-fire retardant polyester, add suffix "NFR" to end of part number.

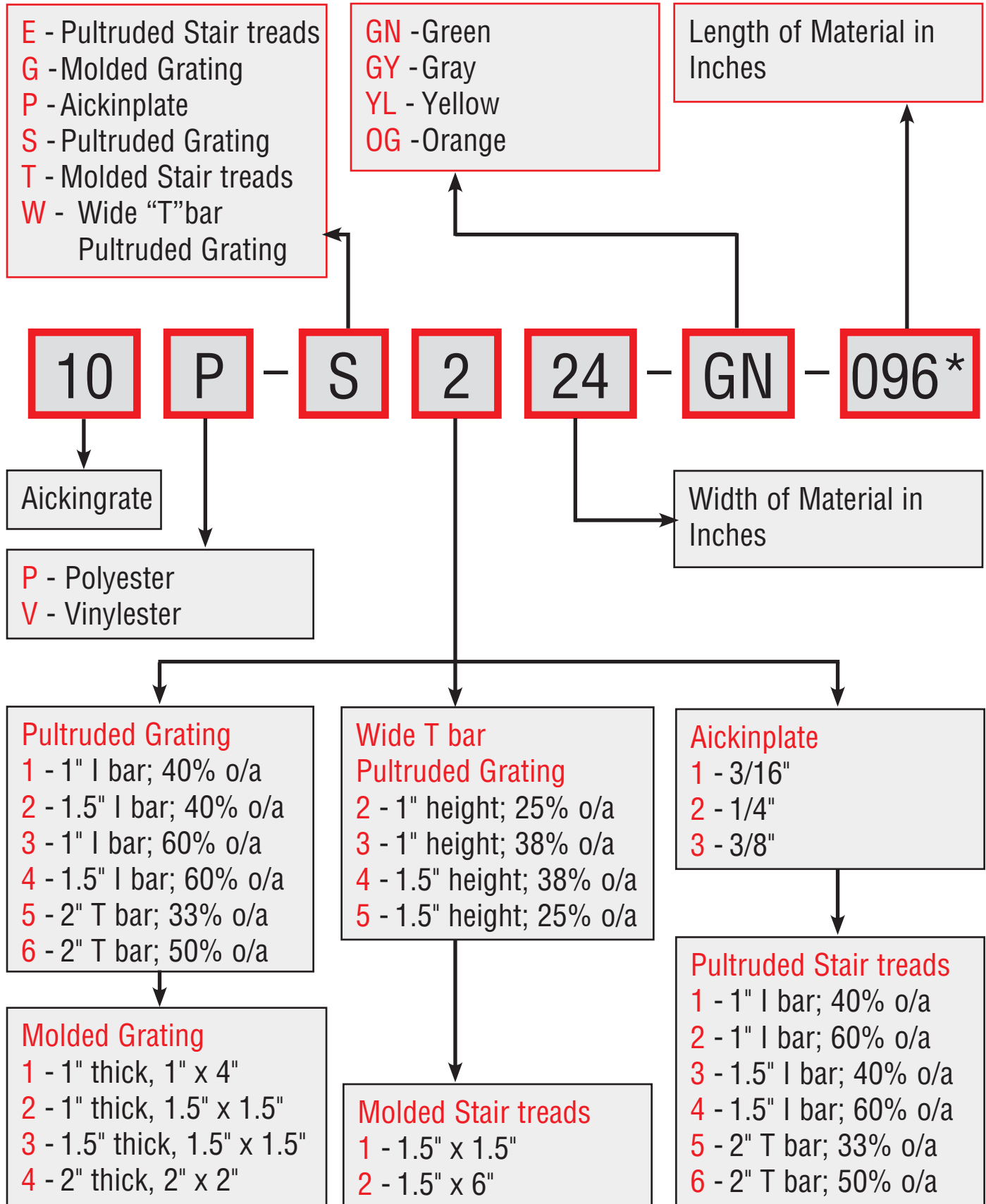

Aickengrate Stair Trends are available in either molded or pultruded designs. Both designs incorporate an anti-skid, grit top surface.

Molded Stair Treads

Molded stair treads are available in the same resin formulations as the standard molded grating panels. Each panel incorporates an applied, grit surface with an extra-thick, dark colored nosing. This leading edge color contrast increases the stair tread visibility and prevents slips and falls on stairways.

All stair treads are 1½" thick and provided in a 1½" square mesh configuration. The standard stair tread panel size is 22½" x 120". Each panel weighs approximately 105 pounds.

Standard Colors: Green, Yellow, Gray and Orange

Special colors are available upon request.

Aickengrate stair tread panels can be cut with the same tools that are used on the Aickengrate molded grating panels.



Use fiberglass or steel support angle, or wooden ledger..

Two standard hold-down clips bolt to angle support at each end. Use Aickengrate grating clips.

Leading edge in contrasting color for easy visual identification.

Use fiberglass or steel channel, or wooden stringer.

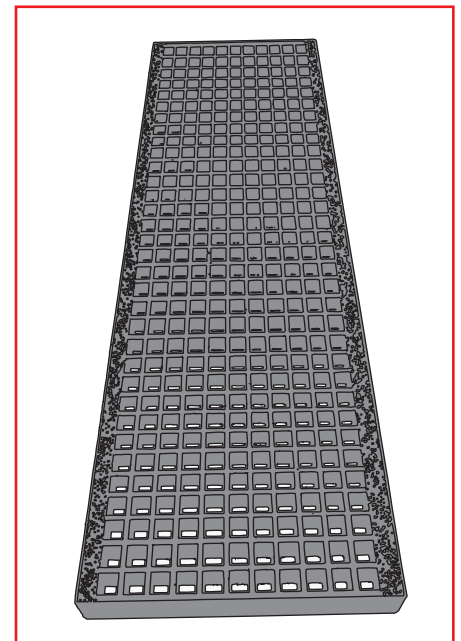

Panel size: 22-½" x 120"
Approx. Weight: 105 lbs.

Pultruded Stair Treads

Pultruded stair treads incorporate the same performance characteristics as the Aickengrate pultruded grating panels. All stair treads are slip-resistant, non-conductive and offer a high level of safety, strength and corrosion resistance.

Pultruded stair treads are available in either polyester or vinyl ester resin types. The standard stair tread panel size is 1' x 10'. Stair treads are available in 1", 1½" & 2" depths. The available bar shapes are "I" bar and "T" bar. All pultruded stair treads

incorporate a color contrast nosing to allow for quick and easy visual distinction, which prevents slips and falls.

Standard Colors: Yellow (Polyester), Gray (Vinyl ester)

Tread Type	Concentrated Load (lbs.)	Span (in.)	18	24	30	36	42	48
		Span/150	.12	.16	.20	.24	.28	.32
1" Deep, I-Bar	250		.03	.08	.14	.22	.34	.46
60% Open Area	500		.07	.15	.28	.44	.68	.92
1.5" Deep, I-Bar	250		.01	.02	.04	.06	.09	.13
60% Open Area	500		.02	.04	.08	.11	.18	.26
2" Deep, T-Bar	250		.01	.02	.03	.04	.06	.09
50% Open Area	500		.02	.04	.06	.09	.12	.18
1" Deep, I-Bar	250		.02	.05	.10	.16	.24	.33
40% Open Area	500		.05	.11	.20	.32	.49	.65
1.5" Deep, I-Bar	250		.01	.01	.03	.04	.06	.09
40% Open Area	500		.02	.03	.05	.07	.12	.17
2" Deep, T-Bar	250		.01	.01	.02	.03	.05	.07
33% Open Area	500		.02	.03	.04	.06	.09	.14

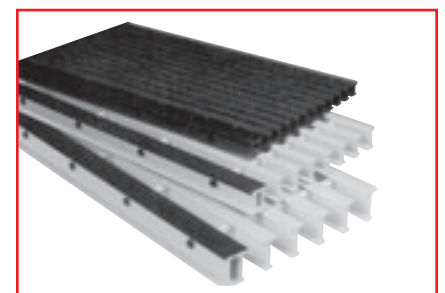

AICKINPLATE

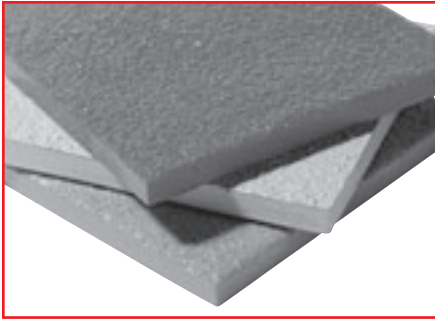

Aickinplate is a molded, non-skid fiberglass plate that offers an economical, safe solution for slippery walking surfaces. The non-skid surface provides excellent traction even when oil or other slippery liquids are present. Because Aickinplate is molded from fiberglass, it provides superior corro-

sion resistance and never requires painting. Aickinplate is a structural floor plate that is non-porous and cleans easily with water.

Aickinplate is easy to fabricate. It can be cut with masonry blades and drilled with standard carbide-tipped drill bits. The standard panel size is 4' x 8' and they are available in three thicknesses: 3/16", 1/2" and 3/8". All panels will be constructed from both non-fire retardant or fire retardant polyester resin and fire retardant vinyl ester resins. A USDA approved, polyester resin Aickinplate is available.

Some typical Aickinplate applications would be:

- Fishing boat decks
- Packing plant floors
- Swimming pools
- Work platforms

Standard Colors:

Green, Gray, Yellow, & Orange

Special colors are available upon request.

Note: Install clips a maximum of every 48" and use at least 8 clips per 4' x 12' panel.

Capacity

Aickinplate 3/16"	Panel Weight	45 lbs.	12 (in.)	Use on flat
	Weight/Sq. Ft.	1.4 lbs.	18	solid surface only
			24	
Aickinplate 1/4"	Panel Weight	60 lbs.	12 (in.)	199 lbs.
	Weight/Sq. Ft.	1.8 lbs.	18	98
			24	62
Aickinplate 3/8"	Panel Weight	85 lbs.	12 (in.)	583 lbs.
	Weight/Sq. Ft.	2.6 lbs.	18	304
			24	203

Grating clips are specially designed to fasten and secure grating panels to support structures. All grating clips are made from 316 Stainless Steel.

Molded Grating Clips

M-Clips

Type M-clips secure panels to a support and restrain panel movement in all direc-

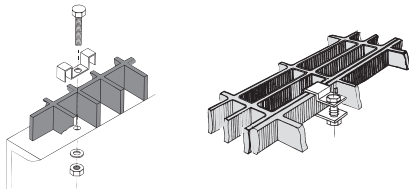

tions. M-Clips can also be installed with self-tapping screws when attaching to metal supports.

Part numbers	Aickingrate mesh configuration
M-1	1" thick, 1" x 4"
M-2	1" thick, 1½" x 1½"
M-3	1½" thick, 1½" x 1½"
M-4	2" thick, 2" x 2"

C-Clips

Used for joining two unsupported grating panel ends.

Part numbers	Grating panel thickness
C-1	1"
C-2	1½"
C-3	2"

Pultruded Grating Clips

Part numbers	Grating panel thickness
MI-4	"I" bar, 40% open area, 1" & 1½" thick
MI-6	"I" bar, 60% open area, 1" & 1½" thick
MT-3	"T" bar, 33% open area, 2" thick
MT-5	"T" bar, 50% open area, 2" thick
MTW-381	Wide "T" bar, 38% open area, 1" thick
MTW-3815	Wide "T" bar, 38% open area, 1½" thick

Type M

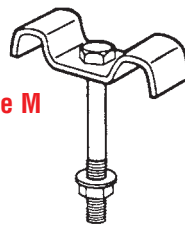

RT-Clips

Part numbers RT-25
Grating panel thickness
Wide "T" bar, 25% open area, 1 & 1½" thick

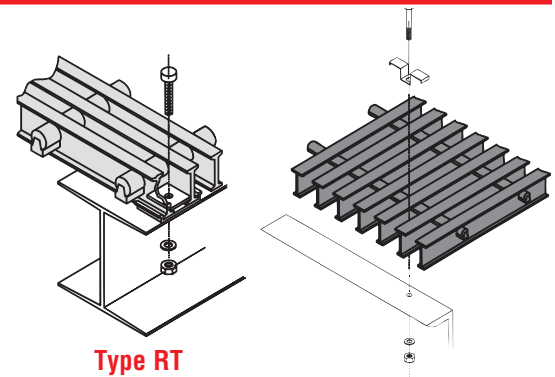

Type MI, MT, MTW

Molded Grating Floor Pedestals

Aickingrate floor pedestals are an economic method for providing an elevated Aickingrate molded flooring system. Pedestal supported flooring systems are extremely versatile and can be modified or moved to meet wash-down requirements. Pedestals are designed for a maximum height of 12 inches without braces.

Part numbers	Style
P-ADJ	Adjustable (5"-12")
P-STA	Stationary (3"-12")

Pedestal Placement Table for Aickingrate Molded Grating

Aickingrate Mesh Configuration	A 300 lbs. Concentrated Load will Produce a .250" Deflection with Pedestals Spaced as Indicated Below		A 300 lbs. Concentrated Load will Produce a Deflection indicated below with Pedestals Spaced		
	4' x 4'	3' x 3'	2' x 2'		
1" Thick, 1" x 4"	27" x 27"	(1)	(1)	.200 in.	
1" Thick, 1-½" x 1-½"	28" x 28"	(1)	(1)	.180 in.	
1-½" Thick, 1-½" x 1-½"	48" x 48"	.250	.140	.065 in.	
2" Thick, 2" x 2"	48" x 72"	.120	.080	.040 in.	

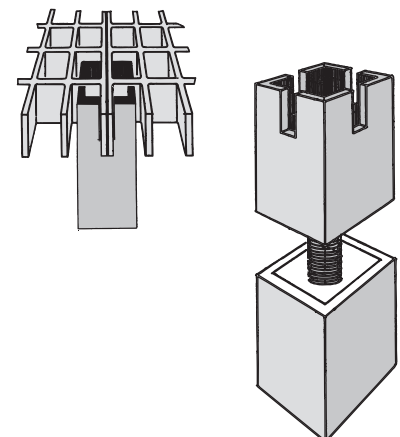

CORROSION-RESISTANCE GUIDE

The information contained in this table is intended to only be used as a guide for molded & pultruded grating. Because actual conditions may differ, the end-user must determine if the grating will withstand the intended environment.

Chemical Environment	% Concentration	Temp. °F	POLY	VE
Acetic Acid	50	Max.	C	C
Acetone	100	75	I	N
Alcohols	100	120	I	I
Aluminum	All	Max.	C	C
Aluminum Chloride	All	Max.	C	C
Aluminum Fluoride	20	75	I	I
Ammonium Hydroxide	30	75	I	N
Ammonium Salts - Neutral	All	120	C	S
Ammonium Salts - Aggressive	All	75	T	N
Aromatic Solvents	All	75	N	N
Barium Salts	All	Max.	C	C
Benzene	100	140	I	N
Black Liquor (Pulp Mill)	All	Max.	I	N
Bleach Liquor (Pulp Mill)	All	Max.	I	N
Calcium Hydroxide	25	Max.	S	I
Calcium Hypochlorite	All	Max.	I	N
Calcium Salts	All	Max.	C	C
Carbon Tetrachloride	100	75	S	N
Chlorinated Hydrocarbons	100	75	T	T
Chlorine Dioxide	Sat.	140	S	N
Chlorine Water	Sat.	120	I	N
Chlorine, Wet	Sat.	Max.	N	N
Chlorobenzene	100	75	N	N
Chlorobenzene	All	Up to 100	N	N
Chloroform	100	75	N	N
Chromic Acid	50	140	I	N
Citric Acid	All	Max.	C	C
Copper Cyanide Plating	All	125	S	I
Copper Salts	All	Max.	C	C
Crude Oil (Sweet or Sour)	All	Max.	C	C
Dichlorobenzene	100	75	N	N
Ethers		75	N	N
Ferric Chloride	100	Max.	C	C
Ferric Salts	All	Max.	C	C
Fluoride Salts + HCl	All	75	I	N
Fluosilicic Acid	10	75	S	I
Formaldehyde	37	150	S	I
Formic Acid	25	100	S	I
Fuel (Diesel, Jet, Gasoline)	All	100	C	C
Glycerine	100	Max.	C	C
Green Liquor (Pulp Mill)	All	Max.	I	N
Hydrobromic Acid	48	Max.	I	N
Hydrochloric Acid	10	Max.	S	S
Hydrochloric Acid	30	Max.	I	I
Hydrochloric Acid (Concentrated)	All	Up to 180	N	N

Chemical Environment	% Concentration	Temp. °F	POLY	VE
Hydrocyanic Acid	All	Max.	S	I
Hydrofluoric Acid	20	75	N	N
Hydrogen Peroxide	30	75	S	N
Lactic Acid	100	Max.	C	C
Lime Slurry	Sat.	Max.	C	C
Lithium Salts	All	Max.	C	C
Magnesium Salts	All	Max.	C	I
Maleic Acid	100	Max.	S	I
Mercury Chloride	100	Max.	C	C
Nickel Salts	All	Max.	C	C
Nitric Acid	20	120	I	I
Nitric Acid	35	100	I	N
Nitric Acid	40	Ambient	N	N
Nitric Hydrofluoric	20:2	75	N	N
Nitrous Acid	10	75	C	C
Ozone for Sewage Treatment		100	C	C
Perchloroethylene	100	75	I	N
Phenol	10	75	I	N
Phenol	88	Ambient	N	N
Phosphoric Acid	85	Max.	C	S
Phosphoric Acid, Super	115	Max.	S	N
Potassium Hydroxide	10	120	S	N
Potassium Salts	All	Max.	C	C
Silver Nitrate	100	Max.	C	C
Sodium Cyanide	All	75	S	I
Sodium Hydroxide	50	Max.	I	N
Sodium Hydroxide	10	Max.	N	N
Sodium Hypochlorite (Stable)	10	100	S	I
Sodium Salts-Neutral	All	Max.	C	C
Sodium Salts-Aggressive	All	75	T	N
Sulfur Dioxide	Sat.	Max.	S	S
Sulfuric Acid	25	Max.	S	I
Sulfuric Acid	50	Max.	S	N
Sulfuric Acid	75	100	I	N
Toluene	100	120	I	N
Trichloroethane 1,1,1	All	75	I	N
Trisodium Phosphate	50	Max.	I	N
Water (Fresh, Salt, Moderate, D.I.)	100	Max.	C	C
Wet Chlorine/Hydrochloric Acid	10-20	Up to 350	N	N
White Liquor (Pulp Mill)	All	Max.	S	N
Zinc Chloride Plating	All	75	S	N
Zinc Salts	100	Max.	C	C

C=Continuous exposure of the grating to the Chemical Environment listed at the temperature listed.

S=Frequent exposure of the grating to splashes and spills from the Chemical Environment listed with that environment at the temperature listed.

I=Infrequent exposure of the grating to splashes and spills from the Chemical Environment listed with that environment at the temperature listed and the spill immediately cleaned up or washed from the grating.

N=Not recommended for the concentrations and temperatures listed.

T=Test

Consult Aickingrate for corrosion recommendations at concentrations, temperatures or chemicals not listed in this guide.

Max. Temp. is 180°F for Vinylester 150°F for Polyester.

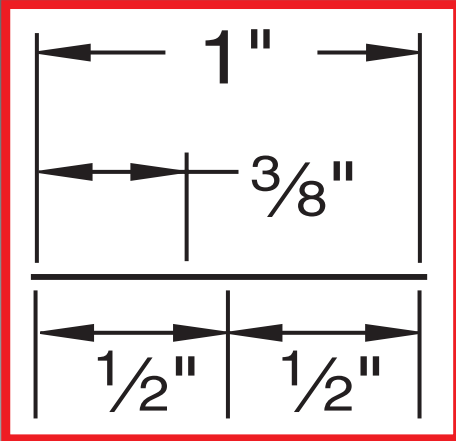

TECHNICAL DATA

Beam Diagrams and Formulas:

- Nomenclature
- Cantilever Beams
- Simple Beams
- Beams fixed at one end, supported at other
- Beams fixed at both ends

Beam Load (Static) Conversion Factors

Design Load Data For Power-Strut Channel Connections

Pipe Spacing Tables

NFPA 13 Compliance Tables

Section Modulus Required for Trapeze Members

Electrical Metallic Tubing Data

Conduit Spacing

Conduit & Pipe Data

- Steel Rigid
- Intermediate Metal
- Steel Pipe
- Copper Tube
- Cast Iron
- PVC

Spacing of Hangers:

- Copper Tubing
- Steel Pipe
- PMC Plastic Pipe

Load Tables

- Threaded Hot Rolled Steel Rod
- Wide Flange Beams
- Channels – American Standard
- I-Beams – American Standard

Unit Conversions

Part Number Index



The information presented below is a direct reproduction from portions of the 8th Edition of THE MANUAL OF STEEL CONSTRUCTION by express permission of the American Institute of Steel Construction.

Beam Diagrams and Formulas (Nomenclature)

E	Modulus of Elasticity of steel at 29,000 ksi.
I	Moment of Inertia of Beam (inch ⁴).
Mmax	Maximum Moment (kip inch)
M1	Maximum moment in left section of beam (kip inch)
M2	Maximum moment in right section of beam (kip inch)
Mx	Moment at distance x from end of beam (kip inch)
P	Concentrated Load (kips)
R	End beam reaction for any condition of symmetrical loading (kips)
R1	Left end beam reaction (kips)
R2	Right end or intermediate beam reaction (kips)
V	Maximum vertical shear for any condition of symmetrical loading (kips)
V1	Maximum vertical shear in left section of beam (kips)
V2	Vertical shear at right reaction point, or to left of intermediate reaction point of beam (kips)
Vx	Vertical shear at distance x from end of beam (kips)
a	Measured distance along beam (inch)
b	Measured distance along beam which may be greater or less than "a" (inch)
L	Total length of beam between reaction points (inch)
W	Uniformly distributed load per unit of length (lbs)
x	Any distance measured along beam from left reaction (inch)
x1	Any distance measured along overhang section of beam from nearest reaction point(in).
Δmax	Maximum deflection (inch)
Δa	Deflection at point of load (inch)
Δx	Deflection at point x distance from left reaction (inch)

Beam Diagrams and Formulas (Cantilever Beams)

CANTILEVER BEAMS

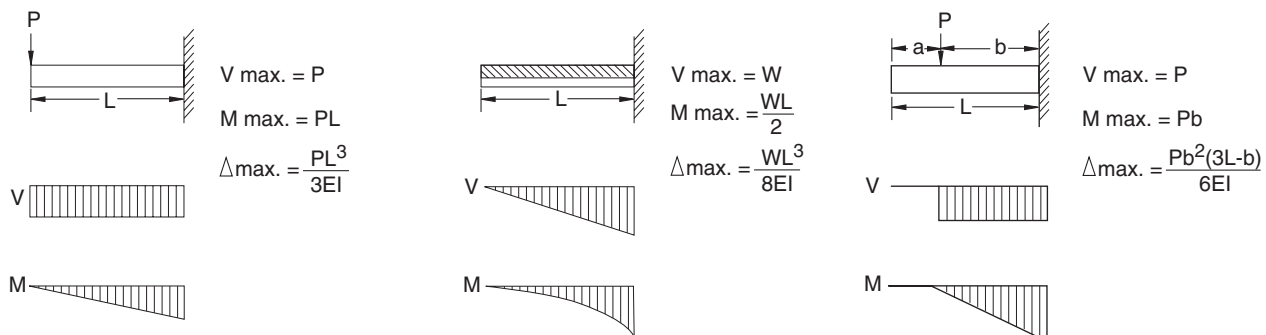

The information presented below is a direct reproduction from portions of the 8th Edition of THE MANUAL OF STEEL CONSTRUCTION by express permission of the American Institute of Steel Construction.

Beam Diagrams and Formulas (Simple Beams)

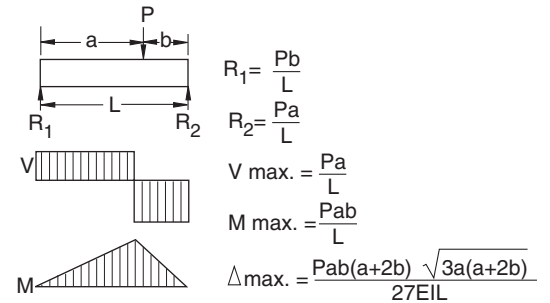
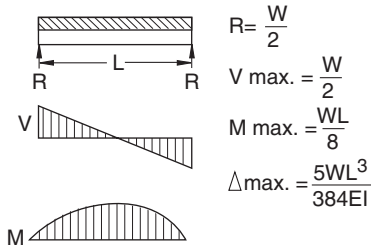
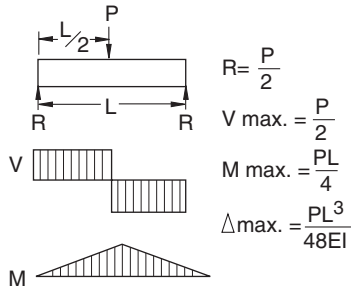

Beam Diagrams and Formulas (Beams fixed at one end, supported at other)

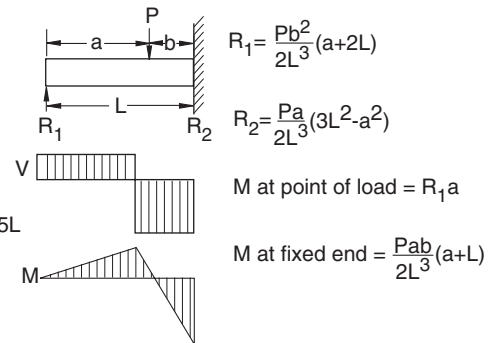
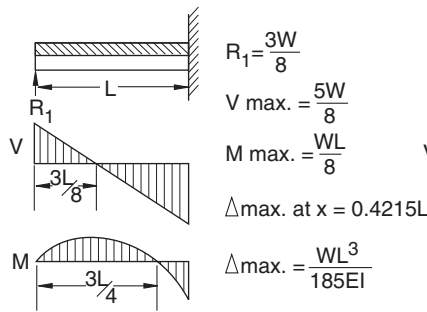
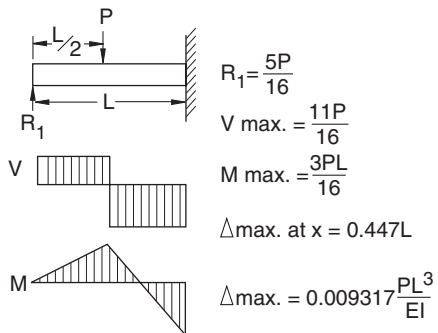



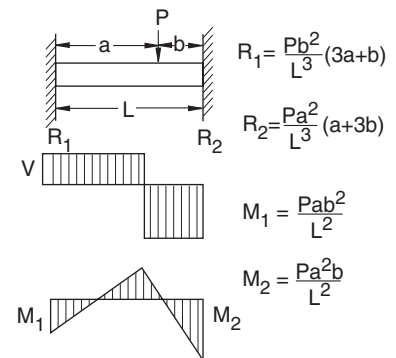
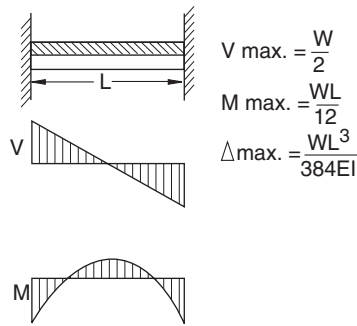
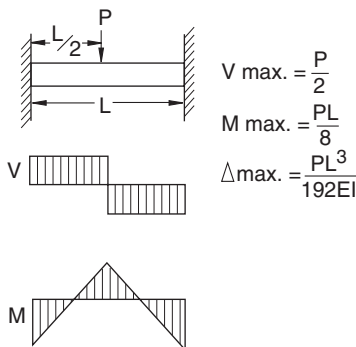





Beam Diagrams and Formulas (Beams fixed at both ends)

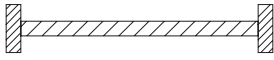

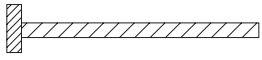
Beam Load (Static) Conversion Factors

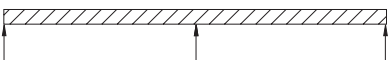
Power-Strut beam loads shown for various channels throughout this catalog are for single span, simple beams, with uniform loads. Loading or other support conditions can be calculated by multiplying the channel beam load by the appropriate factor listed below.

LOAD AND SUPPORT CONDITION	LOAD FACTOR	DEFLECTION FACTOR
1. Simple Beam, Uniform Load 	1.00	1.00
2. Simple Beam, Concentrated Load at Center 	0.50	0.80
3. Simple Beam, Two Equal Concentrated Loads at 1/4 pts 	1.00	1.10
4. Beam Fixed at Both Ends, Uniform Load 	1.50	0.30
5. Beam Fixed at Both Ends, Concentrated Load at Center 	1.00	0.40
6. Cantilever Beam, Uniform Load 	0.25	2.40
7. Cantilever Beam, Concentrated Load at End 	0.12	3.20
8. Continuous Beam, Two Equal Spans, Uniform Load on One Span 	1.30	0.92
9. Continuous Beam, Two Equal Spans, Uniform Load on Both Ends 	1.00	0.42
10. Continuous Beam, Two Equal Spans, Concentrated Load at Center of One Span 	0.62	0.71
11. Continuous Beam, Two Equal Spans, Concentrated Load at Center of Each Span 	0.67	0.48

Example solutions

1.) To determine the load and deflection of a PS-200 simple beam 72" long, with a concentrated load at the center of span:
 From the PS-200 Beam Load Chart (page 27), the maximum uniform load for a 72" span is 560# with a deflection of .50".
 Multiply the above factors: Load = 560 x .50 = 280#
 Defl. = .50 x .80 = .40"

2.) To determine the load and deflection of a PS-200-2T3 cantilever beam 24" long with a concentrated load at end:
 From the PS-200-2T3 Beam Load Chart (page 27), the maximum uniform load for a 24" span is 3130# with a deflection of .03".
 Multiply the above factors: Load = 3130# x .12 = 376#
 Defl. = .03 x 3.20 = .096"

PS 603 – PS-200 1500#, PS-210 1000#

Channel	Load (lbs)
PS 200	1,500
PS 210	1,000

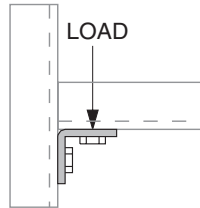

Both Ends Supported

PS 605 – PS-200 1500, #PS-210 1000#

Channel	Load (lbs)
PS 200	1,500
PS 210	1,000

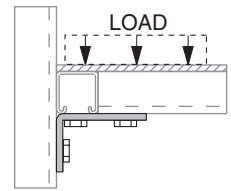

Both Ends Supported

PS 603 – PS-200 1000#, PS-210 650#

Channel	Load (lbs)
PS 200	1,000
PS 210	650

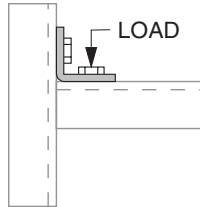

Both Ends Supported

PS 3373 - PS-200 3000#, PS-210 2000#

Channel	Load (lbs)
PS 200	3,000
PS 210	2,000

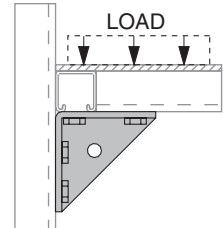

Both Ends Supported

PS 745 – PS-200 2000#, PS-210 1500#

Channel	Load (lbs)
PS 200	2,000
PS 210	1,500

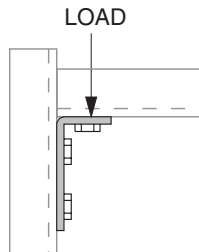

Both Ends Supported

PS 607 – PS-200 2000#, PS-210 2000#

Channel	Load (lbs)
PS 200	2,000
PS 210	

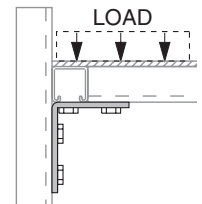

Both Ends Supported

PS 604 – 500#

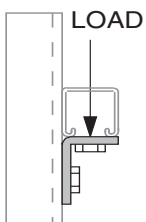

PS 606 – 500#

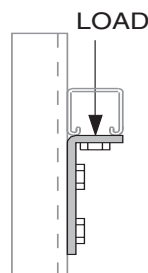

PS-601 - PS-210 1000#, PS-210 800#

Channel	Load (lbs)
PS 200	1,000
PS 210	800

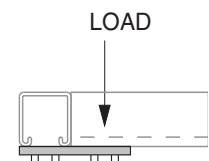

Both Ends Supported

- 1.) Safety Factor = 2-1/2 based on ultimate strength of connection.
- 2.) Load Diagrams indicate design loads for 12 ga. (listed as PS-200) and for 14 ga. (listed as PS-210) channels.

Tables of Pipe Spacing

This chart, developed by Julius Getlan of Seelye Stevenson Value & Knect, consulting engineers, New York City, enables one to quickly determine the centerline-to-centerline dimension between any two size pipes on a rack. Select the smaller pipe size at top and select the other at the side of the table. Where the appropriate columns intersect, the dimension is given.

These factors are included in the dimensions given:

- O.D. of flanges and fittings.
- 1" insulation over flanges and fittings.
- All fractional dimensions less than 1/4" were increased to the next larger 1/4".
- Clear space between fittings as follows:
 1. 1" between piping 3" and smaller.
 2. 1 1/2" between a pipe 3" and smaller and a pipe 4" or larger.
 3. 2" between piping 4" and larger.

Normal Pipe Dia. (In.)		Normal Pipe Diameter, Inches										
		3/4"		1"			1 1/4"			1 1/2"		
		T	S	T	F	S	T	F	S	T	F	S
3/4	T	4 3/4	-	-	-	-	-	-	-	-	-	-
	S	4 1/2	4 1/4	-	-	-	-	-	-	-	-	-
1	T	5	4 3/4	5 1/4	-	-	-	-	-	-	-	-
	F	6	5 3/4	6 1/4	7 1/4	-	-	-	-	-	-	-
	S	4 3/4	4 1/2	5	6	4 1/2	-	-	-	-	-	-
1 1/4	T	5 1/4	5	5 1/2	6 1/2	5	5 1/2	-	-	-	-	-
	F	6 1/4	6	6 1/2	7 1/2	6 1/4	6 3/4	7 3/4	-	-	-	-
	S	4 3/4	4 1/2	5	6	4 1/2	5 1/4	6 1/4	4 3/4	-	-	-
1 1/2	T	5 1/4	5	5 1/2	6 1/2	5 1/4	5 3/4	6 3/4	5 1/4	5 3/4	-	-
	F	6 1/2	6 1/4	6 3/4	7 3/4	6 1/4	6 3/4	8	6 1/2	7	8	-
	S	5	4 3/4	5 1/4	6 1/4	4 3/4	5 1/4	6	5	5 1/2	6 1/2	5
2	T	5 3/4	5 1/2	6	7	5 1/2	6	7 1/4	5 3/4	6 1/4	7 1/4	5 3/4
	F	7	6 3/4	7 1/4	8 1/4	6 3/4	7 1/4	8 1/2	7	7 1/2	8 1/2	7
	S	5 1/4	5	5 1/2	6 1/2	5	5 1/2	6 3/4	5 1/4	5 3/4	6 3/4	5 1/4
2 1/2	T	6	5 3/4	6 1/4	7 1/4	6	6 1/2	7 1/2	6	6 1/2	7 3/4	6 1/4
	F	7 1/2	7 1/4	7 3/4	8 3/4	7 1/4	7 3/4	9	7 1/2	8	9	7 1/2
	S	5 1/2	5 1/4	5 3/4	6 3/4	5 1/4	5 3/4	7	5 1/2	6	7	5 1/2
3	T	6 1/4	6	6 1/2	7 1/2	6 1/4	6 3/4	7 3/4	6 1/4	6 3/4	8	6 1/2
	F	7 3/4	7 1/2	8	9	7 1/2	8	9 1/4	7 3/4	8 1/4	9 1/4	7 3/4
	S	5 3/4	5 1/2	6	7	5 1/2	6	7 1/4	5 3/4	6 1/4	7 1/4	5 3/4
4	T	7 1/2	7 1/4	7 3/4	8 3/4	7 1/4	7 3/4	9	7 1/2	8	9	7 1/2
	F	9	8 3/4	9 1/4	10 1/4	8 3/4	9 1/4	10 1/2	9	9 1/2	10 1/2	9
	S	6 3/4	6 1/2	7	8	6 1/2	7	8 1/4	6 3/4	7 1/4	8 1/4	6 3/4
5	T	8	7 3/4	8 1/4	9 1/4	7 3/4	8 1/4	9 1/2	8	8 1/2	9 1/2	8
	F	9 1/2	9 1/4	9 3/4	10 3/4	9 1/4	9 3/4	11	9 1/2	10	11	9 1/2
	S	7 1/4	7	7 1/2	8 1/4	7	7 1/2	8 3/4	7 1/4	7 3/4	8 3/4	7 1/4
6	T	8 3/4	8 1/2	9	10	8 1/2	9	10 1/4	8 3/4	9 1/4	10 1/4	8 3/4
	F	10	9 3/4	10 1/4	11 1/4	9 3/4	10 1/4	11 1/2	10	10 1/2	11 1/2	10
	S	7 3/4	7 1/2	8	9	7 1/2	8	9 1/4	7 3/4	8 1/4	9 1/4	7 3/4
8	T	8 3/4	9 1/2	10	11	9 3/4	10 1/2	11 1/4	9 3/4	10 1/4	11 1/2	10
	F	11 1/4	11	11 1/2	12 1/2	11	11 1/2	12 3/4	11 1/4	11 3/4	12 3/4	11 1/4
10	T	11 1/4	11	11 1/2	12 1/2	11	11 1/2	12 3/4	11 1/4	11 3/4	12 3/4	11 1/4
	F	12 1/2	12 1/4	12 3/4	13 3/4	12 1/4	12 3/4	14	12 1/2	13	14	12 1/2
12	T	12 1/4	12	12 1/2	13 1/2	12	12 1/2	13 3/4	12 1/4	12 3/4	13 3/4	12 1/4
	F	14	13 3/4	14 1/4	15 1/4	13 3/4	14 1/4	15 1/2	14	14 1/2	15 1/2	14

T – denotes threaded IPS pipe.
 F – denotes flanged fittings on pipe.
 S – denotes soldered or brazed tubing.



Tables of Pipe Spacing (cont.)

Nominal Pipe Dia. (In.)	Nominal Pipe Diameter, Inches												
	2"			2½"			3"			4"			
	T	F	S	T	F	S	T	F	S	T	F	S	
2	T	6½	–	–	–	–	–	–	–	–	–	–	–
	F	7¾	9	–	–	–	–	–	–	–	–	–	–
	S	6	7¼	5½	–	–	–	–	–	–	–	–	–
2½	T	7	8¼	6½	7¼	–	–	–	–	–	–	–	–
	F	8¼	9½	7¾	8¾	10	–	–	–	–	–	–	–
	S	6¼	7½	5¾	6¾	8	6	–	–	–	–	–	–
3	T	7¼	8½	6¾	7½	9	7	7¾	–	–	–	–	–
	F	8½	9¾	8	9	10¼	8¼	9¼	10½	–	–	–	–
	S	6½	7¾	6	7	8¼	6¼	7¼	8½	6½	–	–	–
4	T	8¼	9½	7¾	8¾	10	8	9	10¼	8¼	10	–	–
	F	9¾	11	9¼	10¼	11½	9½	10½	11¾	9¾	11½	13	–
	S	7½	8¾	7	8	9¼	7¼	8¼	9½	7½	9¼	10¾	8½
5	T	8¾	10	8¼	9¼	10½	8½	9½	10¾	8¾	10¼	12	9¾
	F	10¼	11½	9¾	10¾	12	10	11	12¼	10¼	12	13½	11¼
	S	8	9¼	7½	8½	9¾	7¾	8¾	10	8	9¾	11¼	9
6	T	9½	10¾	9	10	11¼	9¼	10¼	11½	9½	11¼	12¾	10½
	F	10¾	12	10¼	11¼	12½	10½	11½	12¼	10¾	12½	14	11¾
	S	8½	9¾	8	9	10¼	8¼	9¼	10½	8½	10¼	11¾	9½
8	T	10¾	12	10½	11	12½	10½	11¼	12¾	10¾	12½	14	11¾
	F	12	13¼	11½	12½	13¾	11¾	12¾	14	12	13¾	15¼	13
10	T	12	13¼	11½	12½	13¾	11¾	12¾	14	12	13¾	15¼	13
	F	13¼	14½	12¾	13¾	15	13	14	15¼	13¼	15	16½	14¼
12	T	13	14¼	12½	13½	14¾	12¾	13¾	15	13	14¾	16¼	14
	F	14¾	16	14¼	15¼	16½	14½	15½	16¾	14¾	16½	18	15¾

Nominal Pipe Dia. (In.)	Nominal Pipe Diameter, Inches												
	5"			6"			8"		10"		12"		
	T	F	S	T	F	S	T	F	T	F	T	F	
5	T	11	–	–	–	–	–	–	–	–	–	–	–
	F	12½	14	–	–	–	–	–	–	–	–	–	–
	S	10¼	11¾	9½	–	–	–	–	–	–	–	–	–
6	T	11¾	13¼	11	12½	–	–	–	–	–	–	–	–
	F	13	14½	12¼	13¼	15	–	–	–	–	–	–	–
	S	10¾	12¼	10	11½	12¾	10½	–	–	–	–	–	–
8	T	13	14½	12¼	13¾	15	12¾	14¾	–	–	–	–	–
	F	14¼	15¾	13½	15	16¼	14	16¼	17 ½	–	–	–	–
10	T	14¼	15¾	13½	15	16¼	14	16¼	17½	17½	–	–	–
	F	15½	17	14¾	16¼	17½	15¼	17½	18¾	18¾	20	–	–
12	T	15¼	16¾	14½	16	17¼	15	17¼	18½	18½	19¾	19½	–
	F	17	18¼	16¼	17¾	19	16¾	14	20¼	20¼	21½	21¼	29

T – denotes threaded IPS pipe.
 F – denotes flanged fittings on pipe.
 S – denotes soldered or brazed tubing.

Minimum Size Power-Strut Channel - To Comply with NFPA 13 Table 2-6.1 5(a) 1996 Edition

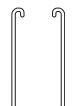
Channel Size	Sect. Mod. (in ³)
 <p>PS-200 1⁵/₈" x 1⁵/₈" x 12 ga.</p>	.202
 <p>PS-150 1⁵/₈" x 2⁷/₁₆" x 12 ga.</p>	.391
 <p>PS-100 1⁵/₈" x 3³/₄" x 12 ga.</p>	.628

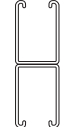
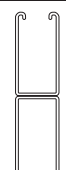
Channel Size	Sect. Mod. (in ³)
 <p>PS-150 2T3 1⁵/₈" x 4⁷/₈" x 12 ga.</p>	1.153
 <p>PS-100 2T3 1⁵/₈" x 6¹/₂" x 12 ga.</p>	1.716

Section Modulus Required for Trapeze Members (in.³)

Span of Trapeze	Pipe Size											
	1"	1 ¹ / ₄ "	1 ¹ / ₂ "	2"	2 ¹ / ₂ "	3"	3 ¹ / ₂ "	4"	5"	6"	8"	10"
1 ft. 6 in.	0.08	0.09	0.09	0.09	0.10	0.11	0.12	0.13	0.15	0.18	0.24	0.32
	0.08	0.09	0.09	0.10	0.11	0.12	0.13	0.15	0.18	0.22	0.30	0.41
2 ft. 0 in.	0.11	0.12	0.12	0.13	0.13	0.15	0.16	0.17	0.20	0.24	0.32	0.43
	0.11	0.12	0.12	0.13	0.15	0.16	0.18	0.20	0.24	0.29	0.40	0.55
2 ft. 6 in.	0.14	0.14	0.15	0.16	0.17	0.18	0.20	0.21	0.25	0.30	0.40	0.54
	0.14	0.15	0.15	0.16	0.18	0.21	0.22	0.25	0.30	0.36	0.50	0.68
3 ft. 0 in.	0.17	0.17	0.18	0.19	0.20	0.22	0.24	0.26	0.31	0.36	0.48	0.65
	0.17	0.18	0.18	0.20	0.22	0.25	0.27	0.30	0.36	0.43	0.60	0.82
4 ft. 0 in.	0.22	0.23	0.24	0.25	0.27	0.29	0.32	0.34	0.41	0.48	0.64	0.87
	0.22	0.24	0.24	0.26	0.29	0.33	0.36	0.40	0.48	0.58	0.80	1.09
5 ft. 0 in.	0.28	0.29	0.30	0.31	0.34	0.37	0.40	0.43	0.51	0.59	0.80	1.08
	0.28	0.29	0.30	0.33	0.37	0.41	0.45	0.49	0.60	0.72	1.00	1.37
6 ft. 0 in.	0.33	0.35	0.36	0.38	0.41	0.44	0.48	0.51	0.61	0.71	0.97	1.30
	0.34	0.35	0.36	0.39	0.44	0.49	0.54	0.59	0.72	0.87	1.20	1.64
7 ft. 0 in.	0.39	0.40	0.41	0.44	0.47	0.52	0.55	0.60	0.71	0.83	1.13	1.52
	0.39	0.41	0.43	0.46	0.51	0.58	0.63	0.69	0.84	1.01	1.41	1.92
8 ft. 0 in.	0.44	0.46	0.47	0.50	0.54	0.59	0.63	0.68	0.81	0.95	1.29	1.73
	0.45	0.47	0.49	0.52	0.59	0.66	0.72	0.79	0.96	1.16	1.61	2.19
9 ft. 0 in.	0.50	0.52	0.53	0.56	0.61	0.66	0.71	0.77	0.92	1.07	1.45	1.95
	0.50	0.53	0.55	0.59	0.66	0.74	0.81	0.89	1.08	1.30	1.81	2.46
10 ft. 0 in.	0.56	0.58	0.59	0.63	0.68	0.74	0.79	0.85	1.02	1.19	1.61	2.17
	0.56	0.59	0.61	0.65	0.74	0.82	0.90	0.99	1.20	1.44	2.01	2.74

PS-100

PS-150 2T3

PS-100 2T3

Exceeds Section Modulus for Channel Shown Above

Top values are for Schedule 10 pipe; bottom values are for Schedule 40 Pipe.

Electrical Metallic Tubing Data

Nom. Size EMT Conduit	OD Conduit	Conduit Wt. lbs./ft	Approx. Max Wt. (lbs.ft.) Conduit and Conductor Not Lead Covered
½	0.706	0.29	0.54
¾	0.922	0.45	1.16
1	1.163	0.65	1.83
1¼	1.510	0.96	2.96
1½	1.740	1.11	3.68
2	2.197	1.41	4.45
2½	2.875	2.15	6.41
3	3.500	2.60	9.30
3½	4.000	3.25	12.15
4	4.500	3.90	15.40

Application Engineering Data – Conduit Spacings

Spacings in inches between centers of conduits. The light face figures are the minimum dimensions to provide clearance between locknuts. The more liberal spacings printed in bold face type should be used whenever possible.

Size	Size												
	½"	¾"	1"	1¼"	1½"	2"	2½"	3"	3½"	4"	4½"	5"	6"
½"	1⅜	-	-	-	-	-	-	-	-	-	-	-	-
	1⅝												
¾"	1⅝	1⅞	-	-	-	-	-	-	-	-	-	-	-
	1½	1⅝											
1"	1½	1⅝	1¾	-	-	-	-	-	-	-	-	-	-
	1¾	1⅞	2										
1¼"	1¾	1⅞	2	2¼	-	-	-	-	-	-	-	-	-
	2	1⅞	2¼	2½									
1½"	1⅝	2¼	2⅜	2⅞	2¾	-	-	-	-	-	-	-	-
	2⅞	2¼	2⅝	2⅞									
2"	2⅜	2⅝	2½	2¾	2⅞	3⅞	-	-	-	-	-	-	-
	2⅝	2½	2¾	3	3⅞								
2½"	2⅞	2⅞	2¾	3	3⅞	3⅝	3⅝	3⅝	-	-	-	-	-
	2⅝	2¾	3	3¼	3⅞	3⅝	4						
3"	2⅜	2⅝	3⅞	3⅝	3⅞	3¾	4	4⅝	-	-	-	-	-
	3	3⅞	3⅝	3⅝	3¾	4	4⅝	4¾					
3½"	3⅞	3¼	3⅝	3⅝	3¾	4⅞	4⅝	4⅝	4⅝	4⅝	-	-	-
	3⅝	3½	3⅝	3⅞	4	4⅝	4⅝	5	5⅝				
4"	3⅞	3⅞	3⅞	3⅝	4⅞	4⅝	4⅝	4⅝	4⅝	5¼	5⅞	-	-
	3¾	3⅞	4	4¼	4⅞	4¾	5	5⅝	5⅝	6			
4½"	3¾	3⅞	4	4¼	4⅞	4⅝	4⅞	5¼	5⅞	5⅞	6⅞	-	-
	4	4⅞	4¼	4½	4¾	5	5¼	5⅝	6	6¼	6½		
5"	4⅞	4¼	4⅞	4⅞	4¾	5	5¼	5⅞	5⅞	6⅞	6½	6⅞	6⅞
	4⅝	4½	4⅝	4⅞	5	5⅝	5⅝	6	6¼	6⅞	7	7¼	7¼
6"	4¾	4⅞	5	5¼	5⅞	5⅝	5⅞	6⅞	6½	6⅞	7⅞	7⅞	8⅞
	5	5⅞	5¼	5½	5⅞	6	6¼	6⅞	7	7¼	7⅞	8	8⅞

Steel Rigid Conduit Data

Nom. Size Rigid Conduit	OD Conduit	OD Coupling	Wt. Conduit W/C Pkg. lbs./ft	Approx. Max Wt.(lbs./ft.) Conduit and Conductor	
				Lead Covered	Not Lead Covered
½"	0.840	1.010	0.80	1.17	1.04
¾"	1.050	1.250	1.09	1.75	1.40
1"	1.315	1.525	1.65	2.62	2.35
1¼"	1.660	1.869	2.15	4.31	3.58
1½"	1.900	2.155	2.58	5.89	4.55
2"	2.375	2.650	3.52	8.53	7.21
2½"	2.875	3.250	5.67	11.51	10.22
3"	3.500	3.870	7.14	16.51	14.51
3½"	4.000	4.500	8.60	19.05	17.49
4"	4.500	4.875	10.00	24.75	21.48
5"	5.563	6.000	13.20	35.87	30.83
6"	6.625	7.200	17.85	50.69	43.43

Maximum weight equals weight of rigid conduit plus weight of heaviest conductor combination as specified by the 1996 edition of the "National Electric Code Handbook."

Intermediate Metal Conduit Data

Nom. Size Rigid Conduit	OD Conduit	OD Coupling	Wt. Conduit W/C Pkg. lbs./ft	Approx. Max Wt.(lbs./ft.) Conduit and Conductor	
				Lead Covered	Not Lead Covered
½"	0.815	1.010	0.60	0.97	0.84
¾"	1.029	1.250	0.82	1.48	1.13
1"	1.290	1.525	1.16	2.13	1.86
1¼"	1.638	1.869	1.50	3.66	2.93
1½"	1.883	2.115	1.82	5.13	3.79
2"	2.360	2.650	2.42	7.43	6.11
2½"	2.857	3.250	4.28	10.12	8.83
3"	3.476	3.870	5.26	14.63	12.63
3½"	3.971	4.500	6.12	16.57	15.01
4"	4.466	4.875	6.82	21.57	18.30

1 Cubic ft. of water weighs 62.35 lbs.

1 Gallon US weighs 8.335 lbs.

Steel Pipe Data – Schedule 40 & 80

Nominal Pipe Size	Sch. No.	O.D.	Wall Thick	Wt./Ft.	Wt. of Water/Ft
3/8"	40	0.675	0.091	0.567	0.083
	80		0.126	0.738	0.061
1/2"	40	0.840	0.109	0.850	0.132
	80		0.147	1.087	0.101
3/4"	40	1.050	0.133	1.130	0.230
	80		0.154	1.473	0.186
1"	40	1.315	0.133	1.678	0.374
	80		0.179	2.171	0.311
1 1/4"	40	1.660	0.140	2.272	0.647
	80		0.199	2.996	0.555
1 1/2"	40	1.900	0.145	2.717	0.882
	80		0.200	3.631	0.765
2"	40	2.375	0.154	3.652	1.452
	80		0.218	5.022	1.279
2 1/2"	40	2.875	0.203	5.790	2.072
	80		0.276	7.660	1.834
3"	40	3.500	0.216	7.570	3.200
	80		0.300	10.250	2.860
3 1/2"	40	4.000	0.226	9.110	4.280
	80		0.318	12.510	3.850
4"	40	4.500	0.237	10.790	5.510
	80		0.337	14.980	4.980
5"	40	5.563	0.258	14.620	8.660
	80		0.375	20.780	7.870
6"	40	6.625	0.280	18.970	12.510
	80		0.432	28.570	11.290
8"	40	8.625	0.322	28.550	21.600
	80		0.500	43.390	19.800
10"	40	10.750	0.365	40.480	34.100
	80		0.593	64.400	31.100
12"	40	12.750	0.406	53.600	48.500
	80		0.687	88.600	44.000
14"	40	14.000	0.437	63.000	58.500
	80		0.750	107.000	51.200
16"	40	16.000	0.500	83.000	76.500
	80		0.843	137.000	69.700
18"	40	18.000	0.563	105.000	97.200
	80		0.937	171.000	88.500
20"	40	20.000	0.593	123.000	120.400
	80		1.031	209.000	109.400
24"	40	24.000	0.687	171.000	174.200
	80		1.218	297.000	158.200
30"	20	30.000	0.500	158.000	286.000
36"	API	36.000	0.500	190.000	417.000



Copper Tube Data

Type L					
Tube Size	Nom O.D. Tubing	O.D.	Wall Thick	Wt./Ft. Lbs.	Wt. of Water/Ft. Lbs.
1/4"	3/8"	0.375	0.030	0.126	0.034
3/8"	1/2"	0.500	0.035	0.198	0.062
1/2"	5/8"	0.625	0.040	0.285	0.100
5/8"	3/4"	0.750	0.042	0.362	0.151
3/4"	7/8"	0.875	0.045	0.455	0.209
1"	1 1/8"	1.125	0.050	0.655	0.357
1 1/4"	1 3/8"	1.375	0.055	0.884	0.546
1 1/2"	1 5/8"	1.625	0.060	1.140	0.767
2"	2 1/8"	2.125	0.070	1.750	1.341
2 1/2"	2 5/8"	2.625	0.080	2.480	2.064
3"	3 1/8"	3.125	0.090	3.330	2.949
3 1/2"	3 5/8"	3.625	0.100	4.290	3.989
4"	4 1/8"	4.125	0.110	5.380	5.188
5"	5 1/8"	5.125	0.125	7.610	8.081
6"	6 1/8"	6.125	0.140	10.200	11.616
8"	8 1/8"	8.125	0.200	19.290	20.289
10"	10 1/8"	10.125	0.250	30.100	31.590
12"	12 1/8"	12.125	0.280	40.400	45.426

Type K					
Tube Size	Nom O.D. Tubing	O.D.	Wall Thick	Wt./Ft. Lbs.	Wt. of Water/Ft. Lbs.
1/4"	3/8"	0.375	0.035	0.145	0.032
3/8"	1/2"	0.500	0.005	0.269	0.055
1/2"	5/8"	0.625	0.049	0.344	0.094
5/8"	3/4"	0.750	0.049	0.418	0.144
3/4"	7/8"	0.875	0.065	0.641	0.188
1"	1 1/8"	1.125	0.065	0.839	0.337
1 1/4"	1 3/8"	1.375	0.065	1.040	0.527
1 1/2"	1 5/8"	1.625	0.072	1.360	0.743
2"	2 1/8"	2.125	0.083	2.060	1.310
2 1/2"	2 5/8"	2.625	0.095	2.920	2.000
3"	3 1/8"	3.125	0.109	4.000	2.960
3 1/2"	3 5/8"	3.625	0.120	5.120	3.900
4"	4 1/8"	4.125	0.134	6.510	5.060
5"	5 1/8"	5.125	0.160	9.670	8.000
6"	6 1/8"	6.125	0.192	13.870	11.200
8"	8 1/8"	8.125	0.271	25.900	19.500
10"	10 1/8"	10.125	0.338	40.300	30.423
12"	12 1/8"	12.125	0.405	57.800	43.675

Spacing of Hangers for Copper Tubing

Tube Size	1/2"	3/4"	1"	1 1/4"	1 1/2"	2"	2 1/2"	3"	3 1/2"	4"	5"	6"	8"	10"	12"
Span in Ft.	6	8	8	10	10	10	12	12	12	12	12	14	14	18	19

Spacing of Hangers for Steel Pipe

Nominal Pipe Size, Inches	1/2"	3/4"	1"	1 1/4"	1 1/2"	2"	2 1/2"	3"	3 1/2"	4"	5"	6"	8"	10"	12"	14"	16"	18"	20"	24"
Maximum Span, Ft.*	5	6	7	7	9	10	11	12	13	14	16	17	19	2	23	25	27	28	30	32
Recommended Hanger Rod Sizes	3/8"	3/8"	3/8"	3/8"	3/8"	3/8"	1/2"	1/2"	1/2"	5/8"	5/8"	3/4"	7/8"	7/8"	7/8"	1"	1"	1 1/4"	1 1/2" or Trapeze	

The above spacing and capacities are based on pipe filled with water.
 Additional valves and fittings increase the load and therefore closer hanger spacing is required.

* Many codes and specifications state "pipe hangers must be spaced every 10 ft., regardless of size".
 Follow local specifications.

PVC Plastic Pipe Data – Schedule 40 & 80

Nom. Tube Size	Sch. No.	O.D.	Wall Thick	Wt./Ft. Lbs.	Wt. of Water/Ft.Lbs.
1/8"	40	0.405	0.068	0.043	0.025
	80		0.095	0.055	0.016
1/4"	40	0.540	0.088	0.074	0.045
	80		0.119	0.094	0.031
3/8"	40	0.675	0.091	0.100	0.083
	80		0.126	0.129	0.061
1/2"	40	0.840	0.109	0.150	0.132
	80		0.147	0.150	0.101
3/4"	40	1.050	0.113	0.199	0.230
	80		0.154	0.259	0.186
1"	40	1.315	0.133	0.295	0.374
	80		0.179	0.382	0.311
1 1/4"	40	1.660	0.140	0.400	0.647
	80		0.191	0.527	0.555
1 1/2"	40	1.990	0.145	0.478	0.882
	80		0.200	0.639	0.765
2"	40	2.375	0.154	0.643	1.452
	80		0.218	0.884	1.279

Nom. Tube Size	Sch. No.	O.D.	Wall Thick	Wt./Ft. Lbs.	Wt. of Water/Ft.Lbs.
2 1/2"	40	2.875	0.203	1.020	2.072
	80		0.276	1.350	1.834
3"	40	3.500	0.216	1.333	3.200
	80		0.300	1.804	2.860
3 1/2"	40	4.000	0.226	1.598	4.280
	80		0.318	2.195	3.850
4"	40	4.500	0.237	1.899	5.510
	80		0.337	2.636	4.980
5"	40	5.563	0.258	2.770	8.660
	80		0.375	4.126	7.870
6"	40	6.625	0.280	3.339	12.150
	80		0.432	5.028	11.290
8"	40	8.625	0.322	5.280	21.600
	80		0.500	8.023	19.800
10"	40	10.750	0.366	7.505	34.100
	80		0.593	11.894	31.100
12"	40	12.750	0.406	10.023	48.500
	80		0.687	16.365	44.000

Spacing of Hangers for PMC Plastic Pipe

Sch. 40	Support Spacings in Feet at Temperatures Shown Above									
Pipe Size	20°F	40°F	60°F	80°F	100°F	110°F	120°F	130°F	140°F	150°F
1/2" – 3/4"	5.00	4.75	4.50	4.25	4.00	3.75	3.33	3.00	2.66	2.00
1" – 1 1/4"	5.50	5.25	5.00	4.66	4.33	4.00	3.75	3.33	2.80	2.25
1 1/2" – 2"	5.80	5.50	5.25	5.00	4.66	4.33	3.80	3.50	3.00	2.50
2 1/2"	6.66	6.33	6.00	5.50	5.25	4.80	4.50	4.00	3.50	2.80
3"	6.80	6.50	6.25	5.80	5.50	5.25	4.75	4.25	3.66	3.00
4"	7.33	7.00	6.50	6.25	5.80	5.50	5.00	4.50	3.80	3.25
6"	7.80	7.50	7.00	6.80	6.33	5.80	5.33	4.80	4.25	3.50

Sch. 40	Support Spacings in Feet at Temperatures Shown Above									
Pipe Size	20°F	40°F	60°F	80°F	100°F	110°F	120°F	130°F	140°F	150°F
1/2" – 3/4"	5.75	5.50	5.25	4.80	4.50	4.33	3.80	3.50	3.00	2.50
1"	6.33	6.00	5.75	5.33	5.00	4.60	4.33	3.80	3.33	2.75
1 1/4" – 1 1/2"	6.66	6.33	6.00	5.66	5.25	4.80	4.50	4.00	3.50	3.00
2"	7.00	6.50	6.25	6.00	5.50	5.12	4.75	4.33	3.66	3.12
2 1/2"	7.80	7.50	7.00	6.66	6.33	5.80	5.33	4.75	4.25	3.33
3"	8.20	7.75	7.33	7.00	6.50	6.00	5.50	5.00	4.33	3.50
4"	8.66	8.25	7.80	7.33	6.80	6.33	5.80	5.25	4.66	3.75
6"	9.80	9.33	8.80	8.33	7.80	7.33	6.50	6.00	5.12	4.25



Cast Iron Pipe Data

Nom. Tube Size	Class	O.D.	Wall Thick	Wt./ Ft.	Wt. of Water Ft. Lbs.
3"	150	3.96	0.32	12.20	3.73
4"	150	4.80	0.35	16.40	5.72
6"	150	6.90	0.38	25.70	12.80
8"	150	9.05	0.41	36.70	23.10
10"	150	11.10	0.44	48.70	35.50
12"	150	13.20	0.48	62.90	51.00
14"	150	15.30	0.51	78.80	69.30
16"	150	17.40	0.54	95.00	90.30
18"	150	19.50	0.58	114.70	114.00
20"	150	21.60	0.62	135.90	141.50
24"	150	25.80	0.73	190.40	201.00
30"	150	32.00	0.85	277.30	312.00
36"	150	38.30	0.94	368.90	449.00
42"	150	44.50	1.05	479.10	612.00
48"	150	50.80	1.14	595.20	803.00

Mechanical Joint Pipe Class 150. Approximately same weight for Bell & Spigot. Flange cast iron pipe add weight of flanges.

Nom. Pipe Size	O.D.	Wall Thick	Wt./Ft. Lbs.	Wt. of Water/Ft. Lbs.
1½"	1.84	0.12	0.64	0.89
2"	2.34	0.14	0.94	1.45
3"	3.41	0.17	1.60	3.19
4"	4.53	0.20	2.60	5.79
6"	6.66	0.24	4.70	12.78
Heavy Schedule				
1"	1.31	0.16	0.60	0.35
1½"	1.84	0.17	0.87	0.76
2"	2.34	0.17	1.10	1.36
3"	3.41	0.20	2.00	3.06
4"	4.53	0.26	3.40	5.44
6"	6.66	0.33	6.30	12.42

Spacing of Hangers for glass pipe support every 8-10 ft. Pad all hangers. Use only clevis or trapeze, do not tie down pipe.

Load Carrying Capacities of Threaded Hot Rolled Steel Rod

Conforming To ASTM A575 And A576

Nominal Rod Dia.	Root Area Sq. (In.)	Maximum Safe Load, Pounds 650° (lbs.)
⅜"	0.068	730
½"	0.126	1,350
⅝"	0.202	2,160
¾"	0.302	3,230
⅞"	0.419	4,480
1"	0.552	5,900

Low Carbon Steel
 Fy = 32,000 psi minimum
 Ft = 52,000 psi minimum

Threaded Rod Loads for Structural Applications		
(Based on AISC, Steel Construction Manual, ASD, 9th Edition. Per AISC, Allowed Tensile Stress = 0.33 * Fu)		
Nominal Dia.	Nominal Area In ²	Allowed Tension Load Lbs
¼"	0.049	840
⅜"	0.110	1,890
⅞"	0.150	2,570
½"	0.196	3,360
⅝"	0.307	5,260
¾"	0.442	7,580
⅞"	0.601	10,310
1"	0.785	13,470

I-Beam - "W" Shape

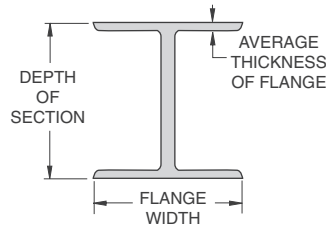

Depth of Section	Wt/ Foot	Flange Width	Avg. Flange
5"	16	5"	0.360"
	19		0.430"
6"	12	4"	0.280"
	16	4"	0.405"
	20	6"	0.365"
	25		0.455"
8"	13	4"	0.255"
	15		0.315"
	18	5¼"	0.330"
	21		0.400"
	24	6½"	0.400"
	28		0.465"
	31	8"	0.435"
	35		0.495"
	40	8½"	0.560"
	48		0.685"
58	8¼"	0.810"	
67		0.935"	
10"	15	4"	0.270"
	17		0.330"
	19		0.395"
	22	5¾"	0.360"
	26		0.440"
	30		0.510"
	33	8"	0.435"
	39		0.530"
	45		0.620"
	49	10"	0.560"
	54		0.615"
	60	10⅝"	0.680"
	68		0.770"
	77	10¼"	0.870"
	88		0.990"
100	10¾"	1.120"	
112		1.250"	
12"	16	4"	0.265"
	19		0.350"
	22		0.425"
	26	6½"	0.380"
	30		0.440"
	35	6⅝"	0.520"
	40	8"	0.515"
	45		0.575"
	50	8⅛"	0.640"
	53	10"	0.575"
	58		0.640"
	65	12"	0.605"
72		0.670"	

Depth of Section	Wt/ Foot	Flange Width	Avg. Flange
12" (Cont.)	79	12⅝"	0.735"
	87		0.810"
	96		0.900"
	106	12¼"	0.990"
	120	12¾"	1.105"
	136		1.250"
	152	12½"	1.400"
	190	12⅝"	1.735"
14"	22	5"	0.335"
	26		0.420"
	30	6¾"	0.385"
	34		0.455"
	38		0.515"
	43	8"	0.530"
	48		0.595"
	53		0.660"
	61	10"	0.645"
	68		0.720"
	74	10⅝"	0.785"
	82		0.855"
	90	14½"	0.710"
	99	14⅝"	0.780"
	109		0.860"
	120		0.940"
	132	14¾"	1.030"
	145	15½"	1.090"
	159	15⅝"	1.190"
	176		1.310"
193	15¾"	1.440"	
211		1.560"	
233	15⅝"	1.720"	
257	16"	1.890"	
283	16⅛"	2.070"	
311	16¼"	2.260"	
342	16⅝"	2.470"	
370	16½"	2.660"	
398	16⅝"	2.845"	
426	16¾"	3.035"	
16"	26	5½"	0.345"
	31		0.440"
	36	7"	0.430"
	40		0.505"
	45		0.565"
	50	7⅛"	0.630"
	57		0.715"
	67	10¼"	0.665"
	77		0.760"
	89	10⅝"	0.875"

Depth of Section	Wt/ Foot	Flange Width	Avg. Flange	
18"	40		0.525"	
	46		0.605"	
	50	7½"	0.570"	
	55		0.630"	
	60		0.695"	
	65	7⅝"	0.750"	
	71		0.810"	
	76	11"	0.680"	
	86	11⅝"	0.770"	
	97		0.870"	
	106	11¼"	0.940"	
	119		1.060"	
	21"	44	6½"	0.450"
		50		0.535"
57			0.650"	
62		8¼"	0.615"	
68			0.685"	
73			0.740"	
83		8⅝"	0.835"	
93			0.930"	
111		12¾"	0.875"	
122			0.960"	
147		12½"	1.150"	
24"	55	7"	0.505"	
	62		0.590"	
	68	9"	0.585"	
	76		0.680"	
	84		0.770"	
	94	9⅞"	0.875"	
	104	12¾"	0.750"	
	117		0.850"	
	131	12⅞"	0.960"	
	146		1.090"	
	162	13"	1.220"	
27"	84	10"	0.640"	
	94		0.745"	
	102		0.830"	
	114	10⅝"	0.930"	
	146	14"	0.975"	
	161		1.080"	
	178	14⅞"	1.190"	
30"	99	10½"	0.670"	
	108		0.760"	
	116		0.850"	
	124		0.930"	
	132		1.000"	
	173	15"	1.065"	
	191		1.185"	
	211	15⅝"	1.315"	

Channels – American Standard

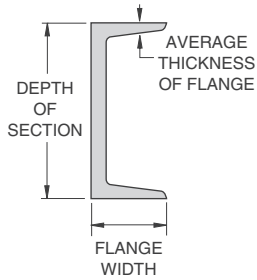

Depth of Section	Weight/Foot	Flange Width	Avg. Flange Thickness
3"	4.10	1 ³ / ₈ "	0.273"
	5.00	1 ¹ / ₂ "	
	6.00	1 ⁵ / ₈ "	
4"	5.40	1 ⁵ / ₈ "	0.296"
	7.25	1 ³ / ₄ "	
5"	6.70	1 ³ / ₄ "	0.320"
	9.00	1 ⁷ / ₈ "	
6"	8.20	1 ⁷ / ₈ "	0.343"
	10.50	2"	
	13.00	2 ¹ / ₈ "	
7"	9.80	2 ¹ / ₈ "	0.366"
	12.25	2 ¹ / ₄ "	
	14.75		
8"	11.50	2 ¹ / ₄ "	0.390"
	13.75	2 ³ / ₈ "	
	18.75	2 ¹ / ₂ "	
9"	13.40	2 ³ / ₈ "	0.413"
	15.00	2 ¹ / ₂ "	
	20.00	2 ⁵ / ₈ "	
10"	15.30	2 ⁵ / ₈ "	0.436"
	20.00	2 ³ / ₄ "	
	25.00	2 ⁷ / ₈ "	
	30.00	3"	
12"	20.70	3"	0.501"
	25.00		
	30.00		
15"	33.90	3 ³ / ₈ "	0.650"
	40.00	3 ¹ / ₂ "	
	50.00	3 ³ / ₄ "	
18"	42.70	4"	0.625"
	45.80		
	51.90		

I-Beams – "S" Shape

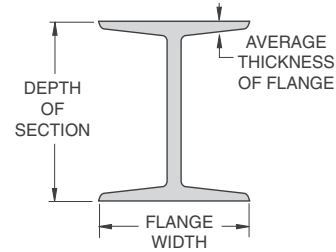

Depth of Section	Weight/Foot	Flange Width	Avg. Flange Thickness
3"	5.70	2 ³ / ₈ "	0.260"
	7.50	2 ¹ / ₂ "	
4"	7.70	2 ⁵ / ₈ "	0.293"
	9.50	2 ³ / ₄ "	
5"	10.00	3"	0.326"
	14.75	3 ¹ / ₄ "	
6"	12.50	3 ³ / ₈ "	0.359"
	17.25	3 ⁵ / ₈ "	
7"	15.30	3 ⁵ / ₈ "	0.392"
	20.00	3 ⁷ / ₈ "	
8"	18.40	4"	0.426"
	23.00	4 ¹ / ₈ "	
10"	25.40	4 ⁵ / ₈ "	0.491"
	35.00	5"	
12"	31.80	5"	0.544"
	35.00	5 ¹ / ₈ "	
	40.80	5 ¹ / ₄ "	
15"	50.00	5 ¹ / ₂ "	0.659"
	42.90	5 ¹ / ₂ "	
18"	54.70	5 ⁵ / ₈ "	0.622"
	70.00	6"	
20"	54.70	6"	0.691
	70.00	6 ¹ / ₄ "	
	66.00	6 ¹ / ₄ "	
	75.00	6 ³ / ₈ "	
24"	86.00	7"	0.795
	96.00	7 ¹ / ₄ "	
24"	80.00	7"	0.871
	90.00	7 ¹ / ₈ "	
	100.00	7 ¹ / ₄ "	
	106.00	7 ³ / ₈ "	
	121.00	8"	

Unit Conversions

English to Metric			Metric to English		
To Convert From	To	Multiply By	To Convert From	To	Multiply By
Length					
Inch [in]	Millimeter [mm]	25.400 000	Millimeter [mm]	Inch [in]	0.039 370
Foot [ft]	Meter [m]	0.304 800	Meter [m]	Foot [ft]	3.280 840
Yard [yd]	Meter [m]	0.914 400	Meter [m]	Yard [yd]	1.093 613
Mile (U.S. Statute) [mi]	Kilometer [km]	1.609 347	Kilometer [km]	Mile (U.S. Statute) [mi]	0.621 370
Area					
Square Inch [in ²]	Square Millimeter [mm ²]	645.16	Square Millimeter [mm ²]	Square Inch [in ²]	0.001550
Square Foot [ft ²]	Square Meter [m ²]	0.092 903	Square Meter [m ²]	Square Foot [ft ²]	10.763 915
Square Yard [yd ²]	Square Meter [m ²]	0.836 127	Square Meter [m ²]	Square Yard [yd ²]	1.195 991
Square Mile [mi ²] (U.S. Statute)	Square Kilometer [km ²]	2.589 998	Square Kilometer [km ²]	Square Mile [mi ²] (U.S. Statute)	0.386 101
Acre	Square Meter [m ²]	4,046.873	Square Meter [m ²]	Acre	0.000 247
Acre	Hectare	0.404 687	Hectare	Acre	2.471 046
Volume					
Cubic Inch [in ³]	Cubic Millimeter [mm ³]	16,387.06	Cubic Millimeter [mm ³]	Cubic Inch [in ³]	0.000061
Cubic Foot [ft ³]	Cubic Meter [m ³]	0.028 317	Cubic Meter [m ³]	Cubic Foot [ft ³]	35.314 662
Cubic Yard [yd ³]	Cubic Meter [m ³]	0.764 555	Cubic Meter [m ³]	Cubic Yard [yd ³]	1.307 950
Gallon (U.S. Liquid) [gal]	Litre [l]	3.785 412	Litre [l]	Gallon (U.S. Liquid) [gal]	0.264 172
Quart (U.S. Liquid) [qt]	Litre [l]	0.946 353	Litre [l]	Quart (U.S. Liquid) [qt]	1.056 688
Mass					
Ounce (Avoirdupois) [oz]	Gram [g]	28.349 520	Gram [g]	Ounce (Avoirdupois) [oz]	0.035 274
Pound (Avoirdupois) [lb]	Kilogram [kg]	0.453 592	Kilogram [kg]	Pound (Avoirdupois) [lb]	2.204 624
Short Ton	Kilogram [kg]	907.185	Kilogram [kg]	Short Ton	0.00110
Force					
Ounce-Force	Newton [N]	0.278 014	Newton [N]	Ounce-Force	3.596 941
Pound-Force [lbf]	Newton [N]	4.448 222	Newton [N]	Pound-Force [lbf]	0.224 809
Bending Moment					
Pound-Force-Inch [lbf-in]	Newton-Meter [N-m]	0.112 985	Newton-Meter [N-m]	Pound-Force-Inch [lbf-in]	8.850 732
Pound-Force-Foot [lbf-ft]	Newton-Meter [N-m]	1.355 818	Newton-Meter [N-m]	Pound-Force-Foot [lbf-ft]	0.737 562
Pressure, Stress					
Pound-Force per Square Inch [lbf/in ²]	Kilopascal [kPa]	6.894 757	Kilopascal [kPa]	Pound-Force per Square Inch [lbf/in ²]	0.145 038
Foot of Water (39.2 F)	Kilopascal [kPa]	2.988 980	Kilopascal [kPa]	Foot of Water (39.2 F)	0.334 562
Inch of Mercury (32 F)	Kilopascal [kPa]	3.386 380	Kilopascal [kPa]	Inch of Mercury (32 F)	0.295 301
Energy, Work, Heat					
Foot-Pound-Force [ft-lbf]	Joule [J]	1.355 818	Joule [J]	Foot-Pound-Force [ft-lbf]	0.737 562
British Thermal Unit [Btu]	Joule [J]	1,055.056	Joule [J]	British Thermal Unit [Btu]	0.000948
Calorie [cal]	Joule [J]	4.186 800	Joule [J]	Calorie [cal]	0.238 846
Kilowatt Hour [kW-h]	Joule [J]	3,600,000	Joule [J]	Kilowatt Hour [kW-h]	2.78 ⁻⁷
Power					
Foot-Pound-Force /Second [ft-lbs/s]	Watt [W]	1.355 818	Watt [W]	Foot-Pound-Force /Second [ft-lbs/s]	0.737 562
British Thermal Unit /Hour [Btu/h]	Watt [W]	0.293 071	Watt [W]	British Thermal Unit /Hour [Btu/h]	3.412 142
Horsepower (550 Ft. Lbf/s) [hp]	Kilowatt [kW]	0.745 700	Kilowatt [kW]	Horsepower (550 Ft. Lbf/s) [hp]	1.341 022
Angle					
Degree	Radian [rad]	0.017 453	Radian [rad]	Degree	57.295 788
Temperature					
Degree Fahrenheit [F]	Degree Celsius [C]	(F° -32)/1.8	Degree Celsius [C]	Degree Fahrenheit [F]	1.8xC° +32

Metal Framing Part Number Index

Part Number or Description	Page	Part Number or Description	Page	Part Number or Description	Page
Metal Framing Components					
PS CT	73	PS 200 3T6	28	PS 520 EH	38
PS KW	48	PS 200 3T6	28	PS 520 H	38
PS LS	47	PS 200 EH	26	PS 520 S	38
PS ML	47	PS 200 EH 2T3	28	PS 560	40
PS MU	76	PS 200 H	26	PS 560 2T3	40
PS NS	47	PS 200 H3	26	PS 560 EH	40
PS NS S	47	PS 200 K06	26	PS 560 H	40
PS PP	78	PS 200 PLA	29	PS 560 S	40
PS RS	47	PS 200 PLC	29	PS 600J	96
PS SS	47	PS 200 PLC	29	PS 601	50
PS TG	47	PS 200 S	26	PS 602	50
PS TP	73	PS 200 SB	26	PS 603	52
PS UB	76	PS 202	48	PS 604	52
PS 004M - PS 038M	75	PS 203	48	PS 605	52
PS 004T - PS 106N	74	PS 204	48	PS 606	53
PS 51	72	PS 205	48	PS 607	53
PS 52E	75	PS 209	45	PS 609	57
PS 67	70	PS 210	30	PS 611	57
PS 69	71	PS 210	30	PS 612	57
PS 83	45	PS 210 2T3	30	PS 613	57
PS 85	67	PS 210 EH	30	PS 614	53
PS 86	68	PS 210 H	30	PS 615	53
PS 93	68	PS 210 K06	30	PS 616	59
PS 94	68	PS 210 S	30	PS 617	50
PS 95	68	PS 211	46	PS 618	50
PS 100	22	PS 230	46	PS 619	50
PS 100	22	PS 231	46	PS 620	51
PS 100 2T3	22	PS 270	72	PS 621	51
PS 100 EH	22	PS 285	94	PS 622	54
PS 100 H	22	PS 285 N	94	PS 623	58
PS 100 K06	22	PS 300	32	PS 624	54
PS 100 S	22	PS 300	32	PS 626	63
PS 135	46	PS 300 2T3	32	PS 629	59
PS 135X	67	PS 300 2T3 EH	32	PS 631	59
PS 137	71	PS 300 EH	32	PS 633	55
PS 146	46	PS 300 H	32	PS 644	59
PS 150	24	PS 300 K06	32	PS 645	59
PS 150	24	PS 300 S	32	PS 646	59
PS 150 2T3	24	PS 349	92	PS 647	56
PS 150 2T3 EH	24	PS 400	34	PS 649	88
PS 150 EH	24	PS 400	34	PS 651	63
PS 150 H	24	PS 400 2T3	34	PS 653	92
PS 150 K06	24	PS 400 EH	34	PS 654	92
PS 150 S	24	PS 400 H	34	PS 655	84
PS 152	94	PS 400 K06	34	PS 656	84
PS 200	26	PS 400 S	34	PS 656	93
PS 200	26	PS 449	93	PS 658	86
PS 200 2T2	28	PS 500	36	PS 659	86
PS 200 2T2	28	PS 500 2T3	36	PS 660	53
PS 200 2T3	26	PS 500 2T3 EH	36	PS 661 T1	63
PS 200 2T4	28	PS 500 EH	36	PS 661 T2	63
PS 200 2T4	28	PS 500 H	36	PS 665	60
PS 200 2T5	28	PS 500 S	36	PS 666	60
PS 200 2T5	28	PS 517	47	PS 667	60
PS 200 2T5	28	PS 520	38	PS 668	60
		PS 520 2T3	38	PS 669	61

Metal Framing Part Number Index

Part Number or Description	Page	Part Number or Description	Page	Part Number or Description	Page
PS 670	.61	PS 781	.55	PS 1450	.72
PS 671	.88	PS 791	.89	PS 1500	.89
PS 677	.58	PS 793	.55	PS 1510	.89
PS 678	.58	PS 803	.84	PS 1610	.90
PS 679	.57	PS 804	.59	PS 1801	.89
PS 680	.94	PS 805	.88	PS 1901	.77
PS 684	.66	PS 806	.52	PS 1902	.78
PS 685	.65	PS 807	.85	PS 1911	.77
PS 686	.66	PS 808 T1	.63	PS 2007	.54
PS 687A	.58	PS 808 T2	.63	PS 2008	.98
PS 687B	.58	PS 809	.63	PS 2010	.98
PS 687C	.58	PS 810	.55	PS 2011	.98
PS 689A	.54	PS 812	.56	PS 2013	.97
PS 689B	.54	PS 815	.77	PS 2014	.97
PS 692	.56	PS 816	.77	PS 2015	.97
PS 693	.88	PS 821	.60	PS 2016	.97
PS 694	.88	PS 822	.51	PS 2017	.98
PS 700J	.97	PS 825	.64	PS 2018	.98
PS 702	.86	PS 826	.64	PS 2019	.98
PS 702 D	.86	PS 838	.64	PS 2023	.98
PS 703	.86	PS 854	.51	PS 2024	.98
PS 703 D	.86	PS 855	.65	PS 2025	.98
PS 704	.59	PS 858	.67	PS 2026	.98
PS 707	.84	PS 865	.67	PS 2029	.96
PS 707	.84	PS 871	.67	PS 2033	.97
PS 707 P	.84	PS 888	.50	PS 2034	.97
PS 708	.63	PS 889	.50	PS 2037	.98
PS 709	.58	PS 901	.84	PS 2041	.98
PS 710	.57	PS 901	.93	PS 2054	.55
PS 711	.57	PS 902	.84	PS 2064	.61
PS 712	.51	PS 907	.66	PS 2094	.87
PS 713	.53	PS 913	.60	PS 2112	.51
PS 714	.51	PS 916	.66	PS 2113	.54
PS 715	.53	PS 921	.52	PS 2117	.59
PS 716	.53	PS 922	.59	PS 2119	.57
PS 718	.50	PS 923	.60	PS 2128	.60
PS 719	.50	PS 925	.51	PS 2129	.60
PS 720	.53	PS 926	.54	PS 2144	.52
PS 721	.58	PS 927	.54	PS 2190	.51
PS 722	.90	PS 928	.57	PS 2404 thru PS 2408	.64
PS 732	.63	PS 929	.58	PS 2421	.65
PS 733	.58	PS 930	.84	PS 2422	.64
PS 734	.58	PS 942	.88	PS 2504	.50
PS 735	.58	PS 943	.60	PS 2511	.84
PS 736	.66	PS 945	.60	PS 2514	.60
PS 744	.51	PS 978	.58	PS 2520	.52
PS 745	.53	PS 993	.59	PS 2521	.62
PS 746	.54	PS 998	.66	PS 2522	.62
PS 747	.51	PS 1000	.70	PS 2523	.56
PS 748	.54	PS 1004	.59	PS 2524	.62
PS 750	.51	PS 1100	.70	PS 2525	.62
PS 752	.54	PS 1116	.70	PS 2528	.62
PS 756	.57	PS 1117	.70	PS 2528 1	.62
PS 760	.89	PS 1154	.92	PS 2532	.56
PS 763	.52	PS 1200	.71	PS 2545	.52
PS 764	.52	PS 1300	.70	PS 2560	.84



Metal Framing, Power-Angle & Fiberglass Framing Part Number Index

Part Number or Description	Page	Part Number or Description	Page	Part Number or Description	Page
PS 2561	84	PS 3282	64	20V-2542	116
PS 2580	84	PS 3301	85	20P-2800, 20V-2800	114
PS 2581	84	PS 3326	54	20P-2802, 20V-2802	114
PS 2582	88	PS 3373	53	20P-2804, 20V-2804	114
PS 2585	84	PS 3500	46	20P-2806, 20V-2806	114
PS 2601	57	PS 3700	94	20P-2808, 20V-2808	114
PS 2621	87	PS 3792	75	20P-2810R, 20V-2810R	114
PS 2622	66	PS 4017	96	20P-2810L, 20V-2810L	114
PS 2623	67	PS 6024	45	20P-2812, 20V-2812	114
PS 2624	66	PS 6064	46	20P-2814, 20V-2814	114
PS 2625	84	PS 6072	45	20P-2816R, 20V-2816R	115
PS 2626	67	PS 6075	45	20P-2816L, 20V-2816L	115
PS 2627	89	PS 6108	45	20P-2818, 20V-2818	115
PS 2631	85	PS 6112	45	20P-2820, 20V-2820	115
PS 2631D	85	PS 6151	93	20P-2822, 20V-2822	115
PS 2632	85	PS 6152	42	20P-2824, 20V-2824	115
PS 2632D	85	PS 6153	42	20P-2826, 20V-2826	115
PS 2636	86	PS 9050	42	20P-2828, 20V-2828	115
PS 2637	86	PS 9400	55	20P-2830, 20V-2830	115
PS 2639	87	PS 9401	55	20P-2834, 20V-2834	115
PS 2640	84	PS 9402	55	20P-2840, 20V-2840	115
PS 2648	57	PS 9403	56	20E-5000	119
PS 2651	65	PS 9404	56	20PU-5853 (1 $\frac{5}{8}$ "), 20PU-5854 (1 $\frac{1}{2}$ "),	116
PS 2653	66	PS 33010	83	20PP-5854 (1 $\frac{5}{8}$ "), 20PP-5855 (1 $\frac{1}{2}$ ")	116
PS 2654	68	Power-Angle			
PS 2654A	68	PA 1SC	100	20PU-5855 (1 $\frac{5}{8}$ "), 20PP-5853 (1 $\frac{5}{8}$ "),	116
PS 2656	65	PA 1GP	100	20PU-5903 (3 $\frac{1}{4}$ "), 20PU-5904 (3"),	116
PS 2657	65	PA 1RC	100	20PP-5904 (3"), 20PP-5905 (2 $\frac{1}{4}$ ")	116
PS 2660	87	PA 1SNB	100	20PU-5905 (2 $\frac{1}{4}$ "), 20PP-5903 (3 $\frac{1}{4}$ "),	116
PS 2661	87	PA 1RP	100	50PU-1508	116
PS 2662 A	87	PA 158	100	50PU-2008	116
PS 2700	88	PA 238	100	50PU-2045 (1 $\frac{5}{8}$ ")	116
PS 2800	88	PA 318	100	50PU-2538	116
PS 2801	88	Fiberglass Framing			
PS 2802	88	20P-2500, 20V-2500	114	50PU-2611	115
PS 2803	88	20P-2502, 20V-2502	114	50PU-2611-SP	116
PS 3013	61	20P-2504, 20V-2504	114	50PU-2613	116
PS 3013 SQ	61	20P-2506, 20V-2506	114	50PU-2616	116
PS 3017	96	20P-2508, 20V-2508	114	50PU-26361, 50PU-2636A2,	
PS 3025	61	20P-2510, 20V-2510	114	50PU-2636B3, 50PU-29364	116
PS 3025 FL	61	20P-2512, 20V-2512	114	50PU-500SP	117
PS 3029	62	20P-2514, 20V-2514	114	50PU-2090	116
PS 3029 SQ	62	20P-2516, 20V-2516	115	100-1500	123
PS 3033	61	20P-2518, 20V-2518	115	100-1501	123
PS 3033 SQ	61	20P-2520, 20V-2520	115	100-1502	123
PS 3040	61	20P-2522, 20V-2522	115	100-1503	123
PS 3041	61	20P-2524, 20V-2524	115	100-1504	123
PS 3049	53	20P-2526, 20V-2526	115	100-1505	123
PS 3060	56	20P-2528, 20V-2528	115	100-1506	123
PS 3064	62	20P-2530, 20V-2530	115	100-1507	123
PS 3064 SQ	62	20P-2534, 20V-2534	115	100-1508	123
PS 3126	72	20P-2540, 20V-2540	115	100-1509	123
PS 3138	72	20P-2541, 20V-2541	115	100-1510	123
PS 3164	64	20P-2542	116	100-1511	123
PS 3201	67			100-1512	123
PS 3281	46			100-1513	123
				100-1514	123
				200-3100	117

Fiberglass Framing & Structural Shapes Part Number Index

Part Number or Description	Page	Part Number or Description	Page	Part Number or Description	Page
200-3110	117	250PU-CN	122	750PU-CNHD	122
200-3120	117	312PU-CN	122	750PU-FN-000	121
200-3130	117	375E-999	121	750V-000	121
200-3140	117	375PU-000	121	AIC-CH-P	124
200-3150	117	375PU-125	120	AIC-CH-V	124
200-3160	117	375PU-150	120	AIC-EC	119
200-3170	117	375PU-200	120	CVHPU-100	123
200-3180	117	375PU-250	120	CVHPU-150	123
200-3190	117	375PU-300	120	CVHPU-200	123
200-3200	117	375PU-BC	123	CVHPU-400	123
200-3210	117	375PU-BCCL	123	CVHPU-600	123
200-3827	124	375PU-CN	122	NCP-025	119
200-3828	124	375PU-CNHD	122	NCP-100	119
200-3829	124	375PU-FN-000	121	NCP-625	119
200-3830	124	375V-000	121	NCP-875	119
200-3831	124	375V-100	121	NCT-025	119
200-3840	124	375V-125	121	NCT-100	119
200-3841	124	375V-150	121	NCT-625	119
200-3842	124	375V-175	121	NCT-875	119
200-3843	124	375V-200	121	PCR-050	118
200-4217	122	375V-250	121	PCR-075	118
200-4219	122	375V-300	121	PCR-100	118
200-4226	122	375V-350	121	PCR-125	118
200-4227	122	375V-400	121	PCR-150	118
200-4341	122	390N-150	124	PCR-200	118
200-4342	122	390N-BLT	124	PCR-250	118
200-4343	122	390N-CLP	124	PCR-300	118
375PU-BCCLP	123	500E-999	121	PCR-400	118
1000E-999	121	500PU-000	121	PCR-600	118
1000PU-000	121	500PU-125	120	PCR-800	118
1000PU-FN-000	121	500PU-150	120	PS050	118
1000V-000	121	500PU-200	120	PS075	118
10PU-CN	122	500PU-250	120	PS100	118
10PU-CNMHD	122	500PU-300	120	PS150	118
10PU-CNS	122	500PU-350	120	PS200	118
12PU-CN	122	500PU-BC	123	PS250	118
12PU-CNMHD	122	500PU-CN	122	PS300	118
16PU-CNMHD	122	500PU-CNHD	122	PS350	118
20E-5000	119	500PU-FN-000	121	PS400	118
20N-ARM08	125	500V-000	121	PS500	118
20N-ARM14	125	600-1500	131	PS600	118
20N-ARM17	125	600-1600	131	PS800	118
20N-ARM23	125	600-2200	131	PS1000	118
20N-STA21	125	625E-999	121	PS1200	118
20N-STA33	125	625PU-000	121	PS1400	118
20PU-5852, 20PU-5852 RD	126	625PU-125	120	PS1600	118
20PU-5853 HD, 20PU-5854 HD	126	625PU-150	120	PS1800	118
20PU-CNMHD	122	625PU-200	120	RGBC-1	123
20V-2BC-25	122	625PU-250	120	RGBC-2	123
20V-2BC-37	122	625PU-300	120	RGBC-3	123
20V-2BC-50	122	625PU-350	120	UB-050	120
250E-999	121	625PU-CNHD	122	UB-075	120
250PU-000	121	625PU-FN-000	121	UB-100	120
250PU-075	120	625V-000	121	UB-125	120
250PU-100	120	750E-999	121	UB-150	120
250PU-150	120	750PU-000	121	UB-200	120



Fiberglass Structural Shapes & Fiberglass Grating Part Number Index & Keyword Index

Part Number or Description	Page	Part Number or Description	Page	Part Number or Description	Page
UB-250	120	18X-3130-20	130	18X-7314-20	129
UB-300	120	18X-3140-20	128	18X-7418-20	129
UB-350	120	18X-3200-20	128	18X-10234-20	127
UB-400	120	18X-3300-20	128	18X-31316-20	127
UB-600	120	18X-3310-20	128	18X-61116-20	127
WR375	121	18X-3310-20	130	18X-61121-96	129
WR500	121	18X-3400-20	128	18X-70012-20	128
WR625	121	18X-3400-20	130	18X-70014-20	128
WR750	121	18X-3410-20	128	18X-70018-20	128
AIC-EC	119	18X-3500-20	128	18X-70034-20	128
		18X-3500-20	130	18X-70035-20	128
		18X-3510-20	128	18X-70038-20	128
		18X-3510-20	130	18X-70058-20	128
		18X-3600-20	128	18X-70100-20	128
		18X-3600-20	130	18X-70112-20	128
		18X-3610-20	128	18X-70114-20	128
		18X-3610-20	130	18X-70200-20	128
		18X-3800-20	128	18X-70212-20	128
		18X-3800-20	130	18X-70300-20	128
		18X-3810-20	128	18X-74316-20	129
		18X-3900-20	128	18X-82316-20	127
		18X-3900-20	130	18X-111214-20	128
		18X-4100	128	18X-211214-20	128
		18X-4118-20	127	18X-412138-20	128
		18X-4118-20	128	18X-418214-20	128
		18X-4138-20	127	18X-438138-20	128
		18X-4200	128	18X-518218-20	128
		18X-4300	128	18X-603414-96	129
		18X-4400	128	18X-605814-96	129
		18X-4500	128	18X-611238-96	129
		18X-4600	128	18X-612212-20	128
		18X-4700	128	18X-613414-96	129
		18X-4800	128	18X-700316-20	128
		18X-5100-20	128	18X-700516-20	128
		18X-5125-20	128	18X-711214-20	129
		18X* -5125-20	130	18X-711218-20	129
		18X-5150-20	128	18X-711414-20	129
		18X-5150-20	130	18X-711418-20	129
		18X-5200-20	128	18X-713414-20	129
		18X-5218-20	128	18X-713418-20	129
		18X-6118-96	129	18X-6114316-96	129
		18X-6158-20	127	18X-6212316-96	129
		18X-6210-96	129	18X-7001316-20	128
		18X-6212-96	129	18X-7114332-20	129
		18X-6312-96	129	18X-11211214-20	128
		18X-6314-96	129	18X-93618316-20	129
		18X-6338-96	129	18X-93818316-20	129
		18X-6414-20	128	18X-DF-20	129
		18X-6418-96	129	18X-HS-20	129
		18X-6612-96	129	18X-TH-20	129
		18X-6614-96	129	AIC-ADJ-90-1½	130
		18X-7100-20	129	AIC-ADJ-90-1¼	130
		18X-7118-20	129	AIC-FC-412	130
		18X-7214-20	129	AIC-FC-414	130
		18X-7300-20	129	AIC-FIXED-90-1½	130
		18X-7312-20	129	AIC-FIXED-90-1¼	130
				AIC-FIXED-T-1½	130
				AIC-FIXED-T-1¼	130

Fiberglass Structural Shapes

18X-1100-20	127
18X-1110-20	127
18X-1120-20	127
18X-1130-20	127
18X-1200-20	127
18X-1300-20	127
18X-1310-20	127
18X-1320-20	127
18X-1400-20	127
18X-1410-20	127
18X-1420-20	127
18X-1500-20	127
18X-1510-20	127
18X-2100-20	127
18X-2110-20	127
18X-2120-20	127
18X-2130-20	127
18X-2140-20	127
18X-2160-20	127
18X-2170-20	127
18X-2180-20	127
18X-2190-25	127
18X-2200-20	127
18X-2210-25	127
18X-2220-25	127
18X-2230-20	127
18X-2240-20	127
18X-2300-20	127
18X-2400-20	127
18X-2500-20	127
18X-2600-20	127
18X-2700-20	127
18X-2800-20	127
18X-2900-20	127
18X-2916-20	127
18X-3078-20	127
18X-3100-20	128
18X-3110-20	128
18X-3111-20	128
18X-3112-20	127
18X-3114-20	127
18X-3120-20	128
18X-3121-20	128
18X-3130-20	128

Keyword Index

Part Number or Description	Page	Part Number or Description	Page	Part Number or Description	Page
Keyword Index					
1½" Offset Zee Connector	56	Channel Icons	11	Channel Nut Selection Chart	42
1¾" Offset Zee Connector	56	Channel Nut with Stud	47	Channel Nuts	122
37 ½° Degree Stair Tread Support	64	Channel Spacers	117	Channel with Elongated Holes	21, 22, 25, 27, 28, 30, 35, 38, 40, 41, 44-46, 48
4" Receptacle Box With Knock-outs	87	Channel with Holes	21, 22, 25, 28, 35, 38, 41, 44, 46, 48	Channel with Holes on Three Sides (H3)	21
45° Diagonal Tube Brace	56	Channel with Knockouts	21, 22, 25, 28, 35, 38, 41	Channel with Slots	21, 22, 25, 28, 35, 38, 41, 44, 46, 48
45° Degree Stair Tread Support	65	Channel with Slotted Back	21, 28	Channels – American Standard	160
Adjustable Brace	55	Channels – Chemical Compatibility Table	118-119	Chemical Compatibility Table	118-119
Adjustable Pipe Clamps	117	Clamping Nut with Long Spring	47	Clamping Nut with Short Spring	47
Aickin Distributor Literature Displays	131	Clamping Nut without Spring	47	Clevis Hanger for use with PS 150, PS 20	83
Aickinclamps Design Load Information	117	Clevis Hangers	123	Column Attachment	68
Aickingrate Pultruded Specifications	135	Concrete Deck Insert	94	Concrete Insert Nut (for use with PS 285)	94
Aickingrate® Fiberglass Grating	133	Concrete Inserts Icons	15	Conduit Clamp	72
AickinGrate® Icons	18	Conduit Connector Fitting	84	Conduit Spacings	153
AickinGrate® Pultruded Grating	135	Conduit Swing Fitting	87	Conduit Swing Fitting	87
Aickinplate	142	Continuous Concrete Insert (1½" x 1")	93	Continuous Concrete Insert (1½" x 1¾")	92
Aickinshape® Structural Shapes	127	Continuous Thread Rod	46	Cope-Glas Beam Clamps	123
Aickinshapes® Icons	18	Copper Tube Data	156	Corner Angle	52
Aickinstrut Back-to-Back Channel	111	Corner Connector	55	Cross Connector	51
Aickinstrut Beam Loading – PVC	112	Cross Connector	51	Cross Inside Strut Joiner	88
Aickinstrut Channel Profiles	111	Cross Plate	51	Cross Plate Angle	53
Aickinstrut Chemical Compatibility Table	108-109	Cup Support for Standard Single Strut	58	Cush-a-Clamp® Assembly Omega Series	75
Aickinstrut Flange Loading	112	Cush-a-Clamp® Assembly Pipe & Tube Series	74	Cush-a-Clamp® Assembly U-Bolt Series	76
Aickinstrut Polyester/Vinyl Ester Beam Loading	113	Cush-A-Grip®	73	Cush-A-Therm™	73
Aickinstrut Rigid Pipe Clamp Sample	131	Custom Fabrication and Promotional Material	131	Decorative End Cap	42
Aickinstrut Sample Box	131	Design Load Data	149	Design Load Data	149
Aickinstrut Section Properties	112	Diagonal Tube Brace	55	Double 45° Connector	51
Aickinstrut Slotted Channel (1" x ¾" Holes)	111	Double Adjustable Brace	55	Double Channel Bracket	63
Aickinstrut Specifications	106-107, 116-117	Double Channel Bracket Support	64	Double Channel Bracket Support	64
Aickinstrut Standard Channel	111	Double Column Post Base	61-62	Double Conveyor Adjusting Nut	46
Aickinstrut Technical Information	110	Double Pipe Axle Support	64	Double U Beam Clamp	65
Aickinstrut With Concrete Inserts	111	Double U Beam Clamp	65	Double-Column Post Base	69-70
Aickinstrut® Icons	16-18				
Aickinzap	131				
A-Konnector Rod Couplers	124				
All-Thread Washers	121				
Aluminum (AL)	9				
Aluminum Raceway Closure Strip	84				
Angle Plate Connector, R or L	53				
Angle Tee Plate, R or L	53				
Angular "I" Beam Clamp	65				
Basic Fluorescent Support System	82				
Basic Mercury Vapor Support System	83				
Beam Clamp	65-67, 74, 75, 77, 133				
Beam Clip	123				
Beam Load (Static) Conversion Factors	148				
Bus Duct Connection Clevis	89				
"C" Clamp	68				
Cable Tray Strut Bracket	64				
Capacity	142				
Cast Iron Pipe Data	158				
Channel (1¾" x 1¾" x 19 ga.)	96-97				
Channel Capping Strip	119				
Channel End Cap	119				
Channel Hanger	85-86, 95-96				

Keyword Index

Part Number or Description	Page	Part Number or Description	Page
Double-Slotted Corner Connector	54	Four-Wheel Trolley	62
Duraclamp C-Clamps	124	Ganged Pipe Support	7
Economy Raceway System Fluorescent	82	General Fittings Icons	12-14
Eight-Hole "U" Support	58	Grating Size	134
Eight-Hole Double Corner Connector	60	Green Touch-up Spray Paint	42
Eight-Hole Double Wing Connector	60	Grid System	83
Eight-Hole Gussetted Double Corner Connector	60	Guided Square Washer	50
Elbow Inside Strut Joiner	88	Gusset Plate	100
Electrical Box Adapter Plate	89	Hand Lay-Up Clevis Hangers	123
Electrical Icons	15	Heavy Duty Beam Clamp	67
Electrical Joiner	88	Heavy Duty Channel Nuts	122
Electrical Metallic Tubing Data	153	Heavy Duty Power-Angle (1 $\frac{5}{8}$ " x 3 $\frac{1}{8}$ " x 12 ga.)	100
Electrical Systems	4	Hex Bolts	120
Electro-Galvanized (EG)	8	Hex Flange Bolts	120
EMT Conduit Clamp	70	Hex Flange Nuts	121
End Cap	96	Hex Head Cap Screw	45
End Cap With Knock-Out	84	Hex Nuts	121
Eyelet	48	Hexagon Nut	45
Eyelet with Stud	48	Hook Rod Assembly	66
E-Z Grip Hanger	71	Hot Rolled Steel Rod	158
Fabricated Beam Clamps	122	Hot-Dipped Galvanized (HG)	8
Fasteners Icons	11	Hub Assembly	87
Fender Washer	46	"I" Bar 1" Thick, 40% Open Area	136
Fiberfast Bolts	120	"I" Bar 1" Thick, 60% Open Area	136
Fiberfast Hex Nuts	121	"I" Bar 1 $\frac{1}{2}$ " Thick, 40% Open Area	137
Fiberglass AickinGrate® Icons	18	"I" Bar 1 $\frac{1}{2}$ " Thick, 60% Open Area	137
Fiberglass Aickinshapes® Icons	18	"I" Beams – American Standard	160
Fiberglass Aickinstrut® Icons	16-18	"I" Beam Clamp	66
Fiberglass Framing	163	Inside Clevis Hanger	59
Fiberglass Sealers, Coatings	131	Inside Strut Joiner	88
Finishes (Ordering):	9	Interlocking Channel Bracket	63
Five-Hole Corner Connector	54	Intermediate Metal Conduit Data	154
Five-Hole Double Wing Connector	60	"J" Pipe or Conduit Hanger	70
Five-Hole Joint Angle Connector	53	Junction Box	87
Five-Hole Splice Plate	50	Junction Box Cover	87
Fixture Nut	86	Junior Channel Icons	16
Fixture Stud Nut	86	Junior Channel Nuts	96
Fixture Wiring Nipple	84	Knock-out Fluorescent Raceway System	82
Flat Angle Plate	50, 58, 97, 107	Knock-out Mercury Vapor Raceway System	82
Flat Connector	51	Knock-Out Raceway	80
Flat Corner Connector	51	Kwik Washer	48
Flat Washer	53, 131	Ladder Rung	65
Fluorescent Fixture Hanger	86	Light Duty Beam Clamp	67
Four-Bearing Light Duty Trolley	62	Light Duty Power-Angle (1 $\frac{5}{8}$ " x 1 $\frac{5}{8}$ " x 14 ga.)	100
Four-Hole Closed Angle Connector	55	Light Weight Concrete Insert	94
Four-Hole Connecting Plate	51	Linked Eyelet with Stud	48
Four-Hole Corner Angle	53, 61, 98, 108	Linked Eyelets	48
Four-Hole Corner Connector	51, 54, 59, 60, 62, 68	Load Carrying Capacities of Threaded	133
Four-Hole Corner Joint Connector	54	Loading and Deflection	46
Four-Hole Double Corner Connector	60	Lock Washer	71
Four-Hole Hinge Connector	56	Long Tangent "U" Bolt	90
Four-Hole Joint Angle Connector	53	Maple Cable Clamp	89
Four-Hole Open Angle Connector	55	Maple Cable Saddle	10
Four-Hole Shelf Bracket, R or L	98	Materials Specifications	20
Four-Hole Splice Clevis	59	Maximum Allowable Pull-Out and Slip Loads	80
Four-Hole Splice Plate	50, 58, 97, 107	Maximum Number of Wires Types	80

Keyword Index

Part Number or Description	Page	Part Number or Description	Page
Mechanical Systems That Reduce Costs	5	Rigid Pipe Clamps	118
Medium Duty Power-Angle (1½" x 2¾" x 14 ga.)	100	Rod Coupling	46
Mercury Vapor Fixture Hanger	85	Rod or Insulator Support	67
Minimum Size Power-Strut Channel	152	Round Head Machine Screw	45
Missing Link Multi-Purpose Strut Fastener	47	Saddle Clips	122
Molded Beam Clamps	123	Saddle Washer	58
Molded Clevis Hangers	123	Safety Anchor Strap	67
Molded Grating Clips	143	Screw Concrete Insert	94
Molded Grating Floor Pedestals	143	Section Modulus for Trapeze Members	152
Molded Stair Treads	141	Seismic Rod Stiffener	46
Mustang Universal One-Piece Pipe & Conduit Clamp	76	Self-Aligning Two-Hole Angle	52
Nine-Hole Triple Wing Connector	61	Serrated Nuts & Bolts	100
Nonmetallic U-bolts	120	Shallow Clamping Nut without Spring	47
O.D. Tubing Clamp	71	Shelf Attachment Zee	56
OEM Components and Maintenance	5	Shelf Bracket	63-64
Offset Adjustable Zee Connector	56	Single Channel Bracket Support	63
Offset Connector	56	Single Corner Gussetted Connector, R or L	60
One-Hole Angle	52	Single Pipe Axle Support, R or L	64
One-Hole Clamp for O.D. Tubing	72	Six-Hole Gussetted Corner Connector, R or L	54
One-Piece Pipe Strap	72	Six-Hole "U" Support	58
Outlet Box	87	Six-Hole Corner Connector, R or L	54
Overhead Multi-Use Support Systems	6	Six-Hole Double Corner Connector	60
Overhead Support Vertical to Horizontal	6	Six-Hole Triple Wing Connector	60
Oversize Square Nut	45	Slot Adapter	46
Parallel Pipe and Conduit Clamp	75	Slot Down Mercury Vapor System	83
Parallel Run Pipe Clamp	72	Slotted "U" Support	58
Pipe & Conduit Clamps Icons	14	Slotted 90° Angle	52
Pipe Roller	77	Slotted Adjustment Angle	52
Pipe Stop	63	Slotted Corner Connector	54
Pipe-Roller Assembly	78	Slotted Hex Head Machine Screw	45
Plain (PL)	9	Slotted Joiner	59
Plastic Closure Strip	93	Slotted Strap	100
Porce -A- Clamp™	90	Slotted Support System	83
Porcelain Cable Rack Insulators	89	Solid Raceway	80
Post Base	61	Spacer Clevis	89
Power-Angle Beam Load Calculations	101	Spacing of Hangers for Copper Tubing	156
Power-Angle Column Load Calculations	101	Spacing of Hangers for PMC Plastic Pipe	157
Power-Angle Transverse Stiffeners	101	Spacing of Hangers for Steel Pipe	156
Power-Angle® Icons	16	Splice Connection	92
Power-Gold (ZD)	8	Square Head Cone Point Set Screw	46
Power-green® (GR)	9	Square Maple Cable Clamps	89
Power-Pier	78	Square Nut	45
Power-Rack Stanchions	125	Square Washer	50, 58, 97, 107
Power-Wrap™	75	Stainless Steel (SS)	9
Pregalvanized (PG)	8	Standard Channel and Fitting Assembly	7
Promotional Material Icons	18	Standard Duty Channel Nuts	122
Pultruded Grating Clips	143	Standard Pipe Clamp (GRC, IMC, Sch. 40, & Sch. 80)	70
Pultruded Stair Treads	141	Steel Channel (1½" x 1" x 12 ga.)	41-42
Purlin Clamp	66	Steel Channel (1½" x 1¾" x 12 ga.)	38
PVC Plastic Pipe Data – Schedule 40 & 80	157	Steel Channel (1½" x 1¾" x 14 ga.)	36
Raceway Closure Strip	84	Steel Channel (1½" x 1¾" x 16 ga.)	40
Raceway End Caps	84	Steel Channel (1½" x 1¾" x 12 ga.)	32
Resin Systems	133	Steel Channel (1½" x 1½" x 12 ga.)	28-29, 39, 47
Reversible Channel Bracket	63	Steel Channel (1½" x 1½" x 14 ga.)	35-36, 45
Right Angle Pipe or Conduit Clamp	72	Steel Channel (1½" x 1½" x 16 ga.)	40
Rigid Caster	100	Steel Channel (1½" x 2" x 12 ga.)	34



Keyword Index

Part Number or Description	Page	Part Number or Description	Page
Steel Channel (1½" x 2¾" x 12 ga.)	32	Two-Hole Splice Plate	50, 58, 97, 107
Steel Channel (1½" x 2⅞" x 12 ga.)	25-26	Two-Piece Pipe Roller	77
Steel Channel (1½" x 3¼" x 12 ga.)	22-23, 30	Two-Piece, Heavy Duty Pipe Roller	77
Steel Channel (1½" x 3¼" x 14 ga.)	30	Two-Wheel Trolley	62
Steel Channel (1½" x 4⅞" x 12 ga.)	26	Type 'A' End Cap	93
Steel Channel (1½" x 6½" x 12 ga.)	24	Type 'B' End Cap	92
Steel Pipe Data – Schedule 40 & 80	155	U-Bolt Beam Clamp With Hook	65
Steel Rigid Conduit Data	154	"U" Support	57, 58, 65-66, 98, 108
Stop-Lock Assemblies	122	Unit Conversions	161
Strut Brace	54	Universal "C" Clamp	68
Strut Safety End Cap	42	Universal Clamp for EMT, IMC & GRC	70
Strut Suspension Member	88	Universal Corner Connector	53
Supports for Threaded Rod	7	Using Channel Attached to "I" Beams	6
Swing Gate Channel Hanger	85	Vinyl Ester Square Head Bolts	121
Swing Gate Fixture Hanger	85	Vinyl Ester Square Nuts	121
Swivel Adaptor	67	Wall Ladder Bracket	64
Swivel Caster	100	Wall Mount MultiShelf or Utility Support	6
Swivel Nut	67	Wall Mounted Brackets	6
Symmetrical Four-Hole Connector	51	Welded Steel Channel (1½" x 3¼" x 12 ga.)	31-33
"T" Bar 2" Thick, 33% Open Area	138	WIDE "T" Bar 1" Thick, 25% OPEN AREA	139
"T" Bar 2" Thick, 50% Open Area	138	WIDE "T" Bar 1" Thick, 38% OPEN AREA	139
"T" Inside Strut Joiner	88	Wide Flange Beams	159
Tables of Pipe Spacing	160-161	Wide Throat Heavy Duty Beam Clamp	67
Tee Plate	51, 59, 97, 107	Wide Throat Top Beam "C" Clamp	68
Tee Plate 90° Angle	53	Wire Retainer	84
Ten-Hole Double Wing Connector	60	Wiring Stud Nut	84
Ten-Hole Gussetted Double Wing Connector	60	Wood Beam Hanger	66
Threaded Rod	124	Wrap-Around Channel Bracket	63
Three Piece, Heavy Duty Pipe Roller	77	Wrap-Around Corner Connector, R or L	59
Three-Hole "U" Support	58	Zee Support	57, 65, 98, 108
Three-Hole Corner Angle	52-53, 60-61, 98, 108		
Three-Hole Corner Joint Connector	54		
Three-Hole Hinge Connector	56		
Three-Hole Joint Connector	51		
Three-Hole Offset Plate Connection	58		
Three-Hole Splice Clevis	59		
Three-Hole Splice Plate	50, 58, 97, 107		
To Install Channel or Fluorescent Fixture	81		
Top Grip™ Nut	47		
Trapeze Support System	7		
Trolley Beam Heavy Support and Track Joiner	62		
Trolley Beam Standard Support	62		
Tubing Clamps	98		
Twelve-Hole Triple Wing Connector	61		
Two Hole Pipe Straps	118		
Two-Bearing Light Duty Trolley	62		
Two-Hole Closed Angle Connector	54		
Two-Hole Connecting Plate	51		
Two-Hole Corner Angle	52, 60, 98, 108		
Two-Hole Corner Connector	59		
Two-Hole End Angle	52		
Two-Hole Hinge Connector	55		
Two-Hole Offset Plate Connector	57		
Two-Hole Open Angle Connector	55		
Two-Hole Slotted 90° Angle	53		
Two-Hole Splice Clevis	59		

Registered Trademarks of Power-Strut®:

"Power Angle",

"Cush-A-Clamp", "Cush-A-Grip", &
"Cush-A-Therm" are Registered
Trademarks of ZSi.

We reserve the right to make specification changes without notice.

While every effort has been made to assure the accuracy of information contained in this catalog at the time of publication, we cannot accept responsibility for inaccuracies resulting from undetected errors or omissions.

ALLIED ELECTRICAL™ Group



Allied Electrical Conduit

Steel Conduit

- Rigid (GRC)
- IMC

Aluminum Conduit

- Rigid
- Aluminum Elbows
- Aluminum Couplings

Steel EMT

- True Color™ EMT
- Fire Alarm™
- Blue EMT
- E-Z Pull® EMT

Kwik Products

- Kwik-Fit® EMT (built-in set-screw coupling)
- Kwik-Couple® IMC/GRC (built-in 3 piece rotating coupling)
- Kwik-Fit® Compression EMT (built-in compression fitting)

PVC

- Rigid PVC
- Schedule - 40 & 80 Products
- EB/DB Duct
- Fittings, Spacers, & Accessories

AFC Cable Systems®

AC & MC Cable

- MC TUFF® Lightweight Steel (MC) Cable
- MC TUFF® IG (MC) Cable with Isolated Ground
- MC-Lite® Metal Clad Aluminum (MC) Cable
- HCF-90® & HCF-Lite®
- AC-90® & AC-Lite®
- Fire Alarm/Control Cable™
- Home Run Cable®
- Parking Deck/Lot Cable™
- Super Neutral Cable®

Flexible Conduit

- LIQUID-TUFF™ Liquid-Tight Flexible Conduit
- Full and Reduced Wall Flexible Metal Conduit

Fittings

- EMT Steel Compression & Set-Screw Fittings
- Liquid-Tight Metallic & Non-Metallic Fittings
- MC/AC Cable Connectors

AFC Accessories

- Lighting, Power, & Appliance Whips
- Temp-Lites®
- Bare Armored Ground

ACS/Uni-Fab

- Modular Lighting Systems
- Raised Floor Assemblies
- Pre-Fab Assemblies
- Custom Fabrication

Power-Strut® Framing Systems

Channel

- Steel Channel
- Aluminum Channel
- Stainless Steel Channel
- Fiberglass Channel
- Junior Strut

Fittings & Accessories

- Strut Brackets
- Strut Fittings
- Pipe Clamps
- Threaded Rods
- Fiberglass Fittings
- Junior Strut Fittings
- Concrete Inserts
- Power-Angle® Slotted Angles

Finishes

- Pre-Galvanized Channel
- Power-Green® Channel
- Hot-Dip Galv. Channel
- Power-Gold™ Channel

Cope® Cable Tray Systems

Aluminum Tray

- Aluminum Ladder Tray
- Aluminum Hat Tray
- Aluminum Trof Tray
- Aluminum Channel
- Aluminum Fittings

Steel Tray

- Steel Ladder Tray
- Steel Hat Tray
- Steel Trof Tray
- Steel Channel
- Steel Fittings

Fiberglass Tray

- Cope-glas™ Fiberglass Tray
- Fiberglass Fittings

Wire Basket

- CAT-TRAY™ Wire Basket
- CAT-TRAY™ Accessories







Center Hung Tray

- Centipede® Center Hung Tray
- Centipede® Accessories

Other Cope Products

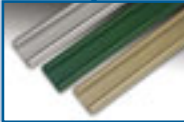
- Cable Channel

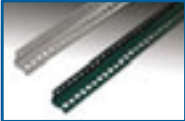
POWER-STRUT® Framing Systems Family of Innovative Products

<ul style="list-style-type: none"> • CHANNELS 		<ul style="list-style-type: none"> • BRACKETS & INSERTS 	
<ul style="list-style-type: none"> • VARIETY OF FINISHES 		<ul style="list-style-type: none"> • PLATES 	
<ul style="list-style-type: none"> • CLAMPS 		<ul style="list-style-type: none"> • POWER-ANGLE® Slotted Angles 	
<ul style="list-style-type: none"> • PIPE CLAMPS 		<ul style="list-style-type: none"> • AICKINSTRUT® Non-Metallic Framing System 	

- **POWER-STRUT®**
16100 S. Lathrop Avenue
Harvey, IL 60426
Tel. 800-882-5543
Fax 708-339-0615