



Commercial Products Catalog

Electrical products for commercial, light industrial and residential applications

COOPER  Crouse-Hinds



For more than a century, companies have relied on Cooper Crouse-Hinds for solutions they can trust to grow their business.

By integrating a comprehensive line of electrical and instrumentation products with expert support, industry insights, and local availability, Cooper Crouse-Hinds **enhances safety and productivity** in the most demanding industrial, harsh, and hazardous environments worldwide. This philosophy is at the core of every product we develop and every solution we engineer.



COOPER Crouse-Hinds

 **CEAG**

 **MTL**
Instruments

PAULUHN

 **CROUSE-HINDS**
COMMERCIAL
PRODUCTS

The more demanding the environment, the more likely you are to find our products at the center of operations.

Cooper Crouse-Hinds manufactures over 100,000 products for NEC, IEC and ABS applications across the globe, including

- Conduit and cable fittings
- Enclosures
- Motor Controls and Electrical Apparatus
- Industrial and Marine Lighting
- Plugs & Receptacles
- Signals and Alarms
- Wireless and Solar Power
- Commercial Fittings and Outlet Boxes
- Electronic components and protection equipment for process control

Cooper Crouse-Hinds Commercial Products



Quality, breadth of offering and innovative products that deliver real value. Products that deliver long, dependable service, labor savings and lower installed cost, all from a single dependable source.

New Products & Technology Leadership

We've put together nearly 50 new commercial solutions over the last several years to help you succeed. From zinc die cast fittings and weatherproof to PRE-formance™ and Solar Combiners, we have a full roster of choices all with the Cooper Crouse-Hinds quality, innovation and reliability.

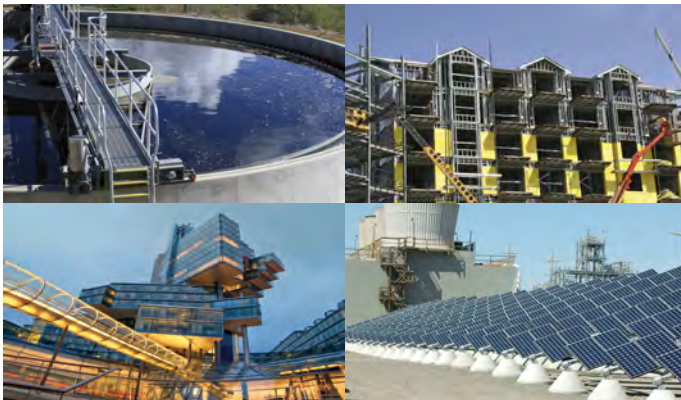

The product information published in our catalogs and literature is not guaranteed. It has been compiled with care and is sufficiently accurate for most purposes. It is subject to change without notice. Occasionally, it may be necessary to modify the materials, finishes, or other components of the product. These changes will in no way reduce the performance or function for which the product is intended.

All statements, technical information and recommendations contained herein are based on information and test we believe to be reliable. The accuracy or completeness thereof are not guaranteed. In accordance with Cooper Crouse-Hinds' Terms and Conditions of Sale, and since conditions of use are outside our control, the purchaser should determine the suitability of the product for his/her intended use and assumes all risk and liability whatsoever in connection therewith.

All sales of Cooper Crouse-Hinds products are specifically subject to the Terms and Conditions of Sale as shown on Cooper Crouse-Hinds distributor price sheets.

Table of Contents

Commercial Fittings. 3 - 120

- EMT
- Rigid/IMC
- Conduit Outlet Bodies & Covers
- Hubs
- Liquidtight
- AC/MC/FMC
- NM Sheathed
- Service Entrance
- PVC
- Stainless Steel

Outlet Boxes & Covers. 121 - 172

- 4" Square Boxes & Covers
- 4-11/16" Boxes & Covers
- Utility & Switch Boxes
- Gang Boxes & Masonry Boxes
- Ceiling Pans
- Octagon Boxes & Covers
- Outlet Box Accessories
- Non-metallic Boxes & Covers

PRE-formance™ 173 - 192

- Basic
- Custom
- Complete

Weatherproof 193 - 208

- Outlet Boxes & Covers
- Vaporproof Lighting

Enclosures. 209 - 248

- W-Series Junction Boxes
- Conduit Expansion Joints
- Fiberglass Enclosures
- HomeRunner™

Solar. 249 - 256

- Solar Combiner Boxes
- Solar Pass Through Boxes
- Solar Cord Grips

Thin Wall Conduit Fittings (For EMT Conduit)

Set Screw Type Fittings - Steel



SET SCREW TYPE FITTINGS

Features:

- Tri-head screws may be installed using a slotted, phillips or Robertson head screwdriver
- Male Hub Threads - NPSM
- Steel Locknuts
- Heavy Steel Walls
- Standard Material: Steel
- Standard Finish: Zinc Plated
- Concrete Tight when taped

Straight Connectors – Insulated

UL File No. E-22132



Cat. #	Size	Unit Qty.	Wt. Lbs. Per 100
1450	1/2"	50	9
1451	3/4"	25	14
1452	1"	20	23
1453*	1 1/4"	10	46
1454*	1 1/2"	10	50
1455*	2"	5	78
1456*†	2 1/2"	2	130
1457*†	3"	1	140
1458*†	3 1/2"	1	180
1459*†	4"	1	225

*Two Tightening Screws

†UL and cUL Listed for EMT, IMC and Rigid Conduit

Straight Connectors – Non-Insulated

UL File No. E-22132



Cat. #	Size	Unit Qty.	Wt. Lbs. Per 100
450S	1/2"	50	9
451	3/4"	25	15
452	1"	20	23
453*	1 1/4"	10	46
454*	1 1/2"	10	50
455*	2"	5	77
456*†	2 1/2"	2	130
457*†	3"	1	140
458*†	3 1/2"	1	180
459*†	4"	1	225

*Two Tightening Screws

†UL and cUL Listed for EMT, IMC and Rigid Conduit

Couplings

UL File No. E-22132



Cat. #	Size	Unit Qty.	Wt. Lbs. Per 100
460	1/2"	50	9
461	3/4"	25	16
462	1"	20	23
463*	1 1/4"	10	42
464*	1 1/2"	10	50
465*	2"	5	77
466*†	2 1/2"	2	130
467*†	3"	1	140
468*†	3 1/2"	1	240
469*†	4"	1	250

*Four Tightening Screws

†UL and cUL Listed for EMT, IMC and Rigid Conduit

EMT Fittings

Thin Wall Conduit Fittings (For EMT Conduit)

Set Screw Type Fittings - Space-Saver



SPACE-SAVER EMT SET-SCREW CONNECTORS - STEEL

UL File No. E22132

EMT Fittings

Applications:

- Use to join EMT conduit to box or enclosure

Features:

- Male threads on locknut allow for more room inside the box
- Smooth pulling surface won't strip cable – no bushing or insulated throat required
- Angled teeth on locknut bite into enclosure, preventing loosening from vibration
- Knurled wrenching surface for easy tightening
- Zinc electroplated for corrosion resistance
- Concrete tight when taped

SET-SCREW CONNECTOR

- Tri-head set screw may be installed using a slotted, Phillips, or Robertson head screwdriver

Certifications and Compliances:

- UL Listed
- CUL Listed



Set Screw Type Connector

Cat. #	Size	Unit Qty.	Wt. Lbs. Per 100
Set Screw Connector			
SSBC50	1/2"	100	8
SSBC75	3/4"	50	12
SSBC100	1"	25	12



Cooper Crouse-Hinds Space Saver EMT Connector (on right) provides maximum useable space inside the box unlike a traditional connector with bushing.



Traditional EMT connector protrudes inside box and creates the cumbersome and labor intensive need to clip the device mounting screw to install device.



The Space Saver EMT Connector's low profile design eliminates this cumbersome and labor intensive requirement.

Thin Wall Conduit Fittings (For EMT Conduit)

Set Screw Type Fittings - Made in the USA



MADE IN THE USA FITTINGS

Applications:

Made in the USA conduit fittings are used:

- To join EMT to a box or enclosure
- To couple two ends of EMT conduit

Features:

- All connectors available with or without insulated throat
- Hex surfaces on fitting body and compression nut for easy wrenching
- Couplings utilize a ridge center stop for easy identification of adequate conduit sealing within the coupling
- Set screw connectors and couplings utilize a #2 combination head screw for secure installation
- Thick, steel conduit locknut provides a strong, secure installation
- Made in the USA

Certifications and Compliances:

- cULus Listed
- Set screw connectors & couplings - concrete tight when tapped

Standard Materials and Finishes:

- 1/2" - 2" Steel
- 2 1/2" - 4" Malleable Iron
- Zinc electroplated

Straight Connectors – Insulated

UL File No. E-22132



Cat. #	Size	Unit Qty.	Wt. Lbs. Per 100
1450US	1/2"	50	10
1451US	3/4"	25	14
1452US	1"	20	23
1453US	1 1/4"	5	40
1454US	1 1/2"	5	52
1455US	2"	20	80
1456US	2 1/2"	6	142
1457US	3"	6	183
1458US	3 1/2"	3	250
1459US	4"	3	283

Straight Connectors – Non-Insulated

UL File No. E-22132



Cat. #	Size	Unit Qty.	Wt. Lbs. Per 100
450SUS	1/2"	50	10
451US	3/4"	25	14
452US	1"	20	23
453US	1 1/4"	5	40
454US	1 1/2"	5	52
455US	2"	20	80
456US	2 1/2"	6	142
457US	3"	6	183
458US	3 1/2"	3	250
459US	4"	3	283

Couplings

UL File No. E-22132



Cat. #	Size	Unit Qty.	Wt. Lbs. Per 100
460US	1/2"	50	10
461US	3/4"	25	15
462US	1"	10	24
463US	1 1/4"	5	44
464US	1 1/2"	5	68
465US	2"	20	90
466US	2 1/2"	5	158
467US	3"	3	217
468US	3 1/2"	2	250
469US	4"	2	283

EMT Fittings

Thin Wall Conduit Fittings (For EMT Conduit)

Set Screw Type Fittings - Zinc Die Cast



EMT Fittings

SET SCREW TYPE FITTINGS – ZINC DIE CAST

Features:

- Tri-head Set Screw may be installed using a slotted, Phillips or Robertson head screwdriver
- Concrete Tight when taped

Standard Materials:

- Zinc

Standard Finishes:

- Natural

Straight Connectors – Insulated

UL File No. E-22132



Cat. #	Size	Unit Qty.	Wt. Lbs. Per 100
1450DC	1/2"	50	5
1451DC	3/4"	25	8
1452DC	1"	25	11
1453DC*	1 1/4"	10	20
1454DC*	1 1/2"	10	25
1455DC*	2"	5	37
1456DC*	2 1/2"	12	59
1457DC*	3"	12	78
1458DC*	3 1/2"	6	101
1459DC*	4"	6	120

*Two Tightening Screws

Straight Connectors – Non-Insulated

UL File No. E-22132



Cat. #	Size	Unit Qty.	Wt. Lbs. Per 100
450DC	1/2"	50	5
451DC	3/4"	25	7
452DC	1"	25	11
453DC*	1 1/4"	10	21
454DC*	1 1/2"	10	25
455DC*	2"	5	36
456DC*	2 1/2"	12	58
457DC*	3"	12	77
458DC*	3 1/2"	6	98
459DC*	4"	6	117

*Two Tightening Screws

Couplings

UL File No. E-22132



Cat. #	Size	Unit Qty.	Wt. Lbs. Per 100
460DC	1/2"	50	5
461DC	3/4"	25	7
462DC	1"	20	13
463DC*	1 1/4"	10	18
464DC*	1 1/2"	10	28
465DC*	2"	5	36
466DC*	2 1/2"	12	64
467DC*	3"	12	81
468DC*	3 1/2"	6	98
469DC*	4"	6	116

*Four Tightening Screws

Offset Connectors – Non-Insulated

UL File No. E-22132



Cat. #	Size	Unit Qty.	Wt. Lbs. Per 100
2400	1/2"	10	11
2401	3/4"	10	18
2402	1"	10	25

Thin Wall Conduit Fittings (For EMT Conduit)

Compression Type Fittings - Steel



COMPRESSION TYPE FITTINGS – STEEL

Applications:

Thinwall conduit fittings are used:

- To join EMT to a box or enclosure
- To couple two ends of EMT conduit

Features:

- Compression Type
- Male Hub Threads - NPSM
- Steel Locknuts
- Heavy Steel Walls
- Standard Material: Steel
- Standard Finish: Zinc Plated

Concrete Tight Straight Connectors – Insulated

UL File No. E-22132



Cat. #	Size	Unit Qty.	Wt. Lbs. Per 100
1650	1/2"	50	11
1651	3/4"	25	16
1652	1"	25	25
1653	1 1/4"	10	43
1654	1 1/2"	10	54
1655	2"	5	76
1656	2 1/2"	2	190
1657	3"	1	300
1658	3 1/2"	1	330
1659	4"	1	360

Straight Connectors – Non-Insulated

UL File No. E-22132



Cat. #	Size	Unit Qty.	Wt. Lbs. Per 100
650S	1/2"	50	9
651S	3/4"	25	16
652	1"	25	25
653	1 1/4"	10	43
654	1 1/2"	10	54
655	2"	5	76
656	2 1/2"	2	190
657	3"	1	300
658	3 1/2"	1	280
659	4"	1	360

Couplings

UL File No. E-22132



Cat. #	Size	Unit Qty.	Wt. Lbs. Per 100
660S	1/2"	50	12
661S	3/4"	25	18
662	1"	25	27
663	1 1/4"	10	46
664	1 1/2"	10	63
665	2"	5	92
666	2 1/2"	2	250
667	3"	1	410
668	3 1/2"	1	390
669	4"	1	485

EMT Fittings

Thin Wall Conduit Fittings (For EMT Conduit)

Compression Type Fittings - Space Saver



EMT Fittings

SPACE-SAVER EMT COMPRESSION CONNECTORS - STEEL

UL File No. E22132

Applications:

- Use to join EMT conduit to box or enclosure

Features:

- Male threads on locknut allow for more room inside the box
- Smooth pulling surface won't strip cable – no bushing or insulated throat required
- Angled teeth on locknut bite into enclosure, preventing loosening from vibration
- Knurled wrenching surface for easy tightening
- Zinc electroplated for corrosion resistance
- Concrete tight when taped

COMPRESSION CONNECTOR

- The split compression ring assures solid attachment to the conduit and good ground continuity
- The hex surface on the compression nut provide for easy wrenching to quickly and easily tighten the nut

Certifications and Compliances:

- UL Listed
- CUL Listed



Cooper Crouse-Hinds Space Saver EMT Connector (on right) provides maximum useable space inside the box unlike a traditional connector with bushing.

Traditional EMT connector protrudes inside box and creates the cumbersome and labor intensive need to clip the device mounting screw to install device.

The Space Saver EMT Connector's low profile design eliminates this cumbersome and labor intensive requirement.



Compression Connector

Cat. #	Size	Unit Qty.	Wt. Lbs. Per 100
Compression Connector			
SSC50	1/2"	50	8
SSC75	3/4"	25	12
SSC100	1"	25	12

SPACE-SAVER EMT RAIN TIGHT COMPRESSION CONNECTORS - STEEL

UL File No. E22132

Applications:

- Use to join EMT conduit to box or enclosure

Features:

- The only Space Saver EMT compression connector UL Listed Raintight
- Male threads on the lock nut maximize space in box or enclosure and provides a smooth pulling surface eliminating the need for a bushing or insulated throat fitting
- No disassembly of the gland nut is required for installation of the conduit.
- Hex shaped gland nut allows for easy wrenching, providing a fast tight application
- Distinct black gland nut allows inspectors to tell at a glance that the fitting is raintight
- Gasket seals installation for raintight connection between box and the connector

Certifications and Compliances:

- UL Listed UL Standard 514B
- cUL Listed cUL Standard C22.2 No. 18
- Listed Raintight
- Concrete Tight

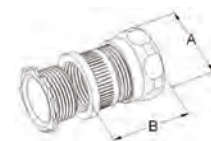

Cat. #	Size	Unit Qty.	Wt. Lbs. Per 100	Dim A	Dim. B
Compression Connector					
SSRT50	1/2"	50	13	1 1/8	1 3/8
SSRT75	3/4"	25	18	1 3/8	1 5/8
SSRT100	1"	25	26	1 11/16	1 13/16

Thin Wall Conduit Fittings (For EMT Conduit)

Compression Type Fittings - Made in the USA



MADE IN THE USA FITTINGS

Applications:

Made in the USA conduit fittings are used:

- To join EMT to a box or enclosure
- To couple two ends of EMT conduit

Features:

- All connectors available with or without insulated throat
- Hex surfaces on fitting body and compression nut for easy wrenching
- Couplings utilize a ridge center stop for easy identification of adequate conduit sealing within the coupling
- Set screw connectors and couplings utilize a #2 combination head screw for secure installation
- Thick, steel conduit locknut provides a strong, secure installation
- Made in the USA

Certifications and Compliances:

- cULus Listed
- Compression connectors & couplings - concrete tight

Standard Materials and Finishes:

- 1/2" - 2" Steel
- 2 1/2" - 4" Malleable Iron
- Zinc electroplated

Connector – Insulated

UL File No. E-22132



Cat. #	Size	Unit Qty.	Wt. Lbs. Per 100
1650US	1/2"	50	8
1651US	3/4"	25	12
1652US	1"	20	19
1653US	1 1/4"	5	30
1654US	1 1/2"	5	46
1655US	2"	5	55
1656US	2 1/2"	5	242
1657US	3"	3	307
1658US	3 1/2"	3	390
1659US	4"	2	492

Connector – Non-Insulated

UL File No. E-22132



Cat. #	Size	Unit Qty.	Wt. Lbs. Per 100
650SUS	1/2"	50	8
651SUS	3/4"	25	12
652US	1"	20	19
653US	1 1/4"	5	30
654US	1 1/2"	5	46
655US	2"	5	55
656US	2 1/2"	5	242
657US	3"	3	307
658US	3 1/2"	3	390
659US	4"	2	492

Couplings

UL File No. E-22132



Cat. #	Size	Unit Qty.	Wt. Lbs. Per 100
660SUS	1/2"	50	8
661SUS	3/4"	25	13
662US	1"	20	19
663US	1 1/4"	5	30
664US	1 1/2"	5	46
665US	2"	5	60
666US	2 1/2"	5	360
667US	3"	3	405
668US	3 1/2"	2	545
669US	4"	2	635

EMT Fittings

Thin Wall Conduit Fittings (For EMT Conduit)

Compression Type Fittings - Raintight



COMPRESSION TYPE FITTINGS – RAINTIGHT CONNECTORS

Applications:

- The Cooper Crouse-Hinds Raintight EMT connectors are used to join EMT conduit to a box or enclosure in Raintight environments.
- The design prevents water see page into conduit, box or enclosure.

Features and Benefits:

- All steel construction with zinc electroplate finish provides for durable corrosion resistance
- Flat surface on Gland nut provides smooth, flat surface for easy wrenching
- Distinct black gland nut provides quick raintight identification
- Integral gasketed compression ring secures and seals for reliable installation
- Interior shoulder conduit stop provides positive seating of conduit inside the body
- Gasket on male threads of box connector seals installation for raintight connection between the box and the connector
- Available in insulated and non-insulated versions to meet any customer preference
- Angled teeth on locknut for secure bite into enclosure
- Extruded locknut with shoulder provides more threads for more secure installation
- Concrete tight
- Standard material: Steel
- Standard finish: Zinc plated

Certifications and Compliances:

- UL Listed
- cUL Listed
- Concrete Tight
- Raintight

Straight Connectors – Insulated – Raintight

UL File No. E-22132



Cat. #	Size	Unit Qty.	Wt. Lbs. Per 100
1650RT	1/2"	50	11
1651RT	3/4"	25	17
1652RT	1"	25	23
1653RT	1 1/4"	10	41
1654RT	1 1/2"	10	50
1655RT	2"	5	67
1656RT	2 1/2"	2	177
1657RT	3"	1	234
1658RT	3 1/2"	1	330
1659RT	4"	1	360

Straight Connectors – Non-Insulated – Raintight

UL File No. E-22132



Cat. #	Size	Unit Qty.	Wt. Lbs. Per 100
650RT	1/2"	50	11
651RT	3/4"	25	17
652RT	1"	25	23
653RT	1 1/4"	10	41
654RT	1 1/2"	10	50
655RT	2"	5	67
656RT	2 1/2"	2	177
657RT	3"	1	234
658RT	3 1/2"	1	280
659RT	4"	1	360

Couplings – Raintight

UL File No. E-22132



Cat. #	Size	Unit Qty.	Wt. Lbs. Per 100
660RT	1/2"	50	14
661RT	3/4"	25	21
662RT	1"	25	28
663RT	1 1/4"	10	49
664RT	1 1/2"	10	60
665RT	2"	5	79
666RT	2 1/2"	2	187
667RT	3"	1	245
668RT	3 1/2"	1	390
669RT	4"	1	485

Thin Wall Conduit Fittings (For EMT Conduit)

Compression Type Fittings - Zinc Die Cast



COMPRESSION TYPE FITTINGS – ZINC DIE CAST

Features:

- The split compression ring assures solid attachment to the conduit and good ground continuity
- The hex surfaces on the compression nut provide for easy wrenching to quickly and easily tighten the nut
- Concrete tight

Standard Materials:

- Zinc

Standard Finishes:

- Natural

Straight Connectors – Insulated

UL File No. E-22132



Cat. #	Size	Unit Qty.	Wt. Lbs. Per 100
1650DC	1/2"	50	8
1651DC	3/4"	25	11
1652DC	1"	15	17
1653DC	1 1/4"	10	31
1654DC	1 1/2"	10	39
1655DC	2"	5	56
1656DC	2 1/2"	12	93
1657DC	3"	12	120
1658DC	3 1/2"	6	149
1659DC	4"	6	172

Straight Connectors – Non-Insulated

UL File No. E-22132



Cat. #	Size	Unit Qty.	Wt. Lbs. Per 100
650DC	1/2"	50	8
651DC	3/4"	25	11
652DC	1"	15	17
653DC	1 1/4"	10	31
654DC	1 1/2"	10	39
655DC	2"	5	56
656DC	2 1/2"	12	93
657DC	3"	12	120
658DC	3 1/2"	6	149
659DC	4"	6	172

Couplings

UL File No. E-22132



Cat. #	Size	Unit Qty.	Wt. Lbs. Per 100
660DC	1/2"	50	11
661DC	3/4"	25	16
662DC	1"	15	22
663DC	1 1/4"	10	40
664DC	1 1/2"	10	48
665DC	2"	5	64
666DC	2 1/2"	12	124
667DC	3"	12	144
668DC	3 1/2"	6	190
669DC	4"	6	228

EMT Fittings

Thin Wall Conduit Fittings (For EMT Conduit)

Combination Couplings



EMT Fittings

COMBINATION COUPLINGS – STEEL

Standard Materials:

- Steel

Standard Finishes:

- Zinc plated

EMT (Set Screw) to Rigid (Set Screw)

UL File No. E-19189



Cat. #	Size	Unit Qty.	Wt. Lbs. Per 100
420	1/2"	25	17
421	3/4"	20	25
422	1"	10	37

COMBINATION COUPLINGS – STEEL

Concrete Tight

EMT (Compression) To Rigid (Threaded)

UL File No. E-19189



Cat. #	Size	Unit Qty.	Wt. Lbs. Per 100
690S	1/2" – 1/2"	25	9
691	3/4" – 3/4"	20	13
692	1" – 1"	10	19

COMBINATION COUPLINGS – ZINC DIE CAST

EMT (Set Screw) to FMC (Clamp)

UL File No. E-19189



Cat. #	Size	Unit Qty.	Wt. Lbs. Per 100
780DC	1/2" – 3/8"	50	8

FLEXIBLE METALLIC COMBINATION COUPLINGS – ZINC DIE CAST

Set Screw Squeeze Type

EMT (Set Screw) To FMC (Clamp)

UL File No. E-19189



Cat. #	Trade Size	Unit Qty.	Wt. Lbs. Per 100
FECS38DC	1/2" to 3/8"	50	34
FECS50DC	1/2" to 1/2"	25	22
FECS75DC	3/4" to 3/4"	25	36

Compression Coupling

EMT (Compression) To FMC (Screw-in)

UL File No. E-19189



Cat. #	Trade Size	Unit Qty.	Wt. Lbs. Per 100
FECC50DC	1/2"	50	41
FECC75DC	3/4"	25	31
FECC100DC	1"	25	46

ACC SERIES COMBINATION COUPLINGS – STEEL

Applications:

- ACC combination couplings are used to join EMT conduit to armored cable, metal clad cable or flexible metallic conduit.

Features and Benefits:

- Dual gripping saddle design on the coupling safely secures cable or conduit in place and prevents loosening from vibration
- Steel compression ring & nut provide a strong, secure termination point for EMT conduit.
- Tri-head set screw may be installed using a slotted, Phillips or Robertson head screwdriver.
- Steel combination coupling is zinc electroplated for corrosion resistance.

Certifications and Compliances:

- UL Listed
- cUL Listed

Materials and Finishes:

- Body: Steel – Zinc electroplated
- Saddle: Steel – Zinc electroplated
- Screw: Steel – Zinc electroplated

Compression Coupling:

AC/MC, FMC to EMT



Cat. #	Trade Size	Cable Opening		Unit Qty.
		Max.	Min.	
ACC38	3/8"	0.656	0.437	25
ACC50	1/2"	0.937	0.750	10
ACC75	3/4"	1.125	0.906	10

Set-Screw Coupling:



Cat. #	Trade Size	Unit Qty.	Wt. Lbs. Per 100
ACCSS38*	3/8"	25	9
ACCSS50	1/2"	10	12
ACCSS75	3/4"	10	14

*not UL Listed

Thin Wall Conduit Fittings (For EMT Conduit)



EMT Elbows with Integral Coupling and Pulling Elbows

EMT ELBOWS WITH INTEGRAL COUPLING

Applications:

- Used to make a 45° or 90° bend between two lengths of thin-wall or EMT conduit without the use of additional couplings

Features:

- Curvature of the conduit is used to fit specific locations and/or make turns or change directions
- Concrete tight when taped
- EMT elbows have integral set-screw couplings that replace traditional EMT coupling fittings used to connect the elbows to conduit so there is no longer a need for additional components or extra steps in installation – saving the contractor time and money!
- Made of steel and zinc plated for corrosion resistance

Certifications and Compliances:

- UL Listed
- cUL Listed

EMT Elbows with Integral Coupling



Cat. #	Size	Unit Qty.	Wt. Lbs. Per 100
90 Degree Elbow			
ELB5090	1/2"	50	28
ELB7590	3/4"	50	46
ELB10090	1"	20	78
ELB12590	1 1/4"	20	150
ELB15090	1 1/2"	15	184
ELB20090	2"	10	250
45 Degree Elbow			
ELB5045	1/2"	50	20
ELB7545	3/4"	50	36
ELB10045	1"	20	59
ELB12545	1 1/4"	20	100
ELB15045	1 1/2"	15	153
ELB20045	2"	10	181

90 DEGREE PULLING ELBOWS – ZINC DIE CAST

Applications:

- To connect EMT to form a 90° bend, or to connect EMT to box or enclosure
- Removable cover and gasket facilitate wire pulling

EMT To Box

UL File No. E-19189



Cat. #	Size	Unit Qty.	Wt. Lbs. Per 100
850EB DC	1/2"	20	17
875EB DC	3/4"	15	24
8100EB DC	1"	6	54
8125EB DC	1 1/4"	3	80

EMT To EMT

UL File No. E-19189



Cat. #	Size	Unit Qty.	Wt. Lbs. Per 100
850EE DC	1/2"	20	15
875EE DC	3/4"	15	22
8100EE DC	1"	6	52
8125EE DC	1 1/4"	3	80

Thin Wall Conduit Fittings (For EMT Conduit)

Straps, Clamps, Clampbacks/Spacers



STRAPS – STEEL GALVANIZED

Two Hole

UL File No. E-184283

EMT Fittings



Cat. #	Size	Unit Qty.	Wt. Lbs. Per 100
497 1	1/2"	250	2
497 2	3/4"	150	3
497 3	1"	100	5
497 4	1 1/4"	50	8
497 5	1 1/2"	50	13
497 6	2"	25	14
496 9	2 1/2"	25	19
496 10	3"	25	23
496 11	3 1/2"	25	93
496 12	4"	10	108

CLAMPS – MALLEABLE IRON

UL File No. E-184283



Cat. #	Size	Unit Qty.	Wt. Lbs. Per 100
516*	2 1/2"	5	104
517*	3"	2	120
518*	3 1/2"	2	150
519*	4"	2	220

*Also for use with Rigid/IMC Conduit

CLAMPBACKS/SPACERS – MALLEABLE IRON

Applications:

- Provides space between conduit and mounting surface

Standard Materials:

- Malleable Iron

Standard Finishes:

- Zinc plated

UL File No. E-184283



Cat. #	Size	Unit Qty.	Wt. Lbs. Per 100
CB1	1/2"	25	8
CB2	3/4"	25	10
CB3	1"	25	12
CB4	1 1/4"	25	21
CB5	1 1/2"	25	42
CB6	2"	10	40
CB7	2 1/2"	10	49
CB8	3"	10	62
CB9	3 1/2"	10	91
CB10	4"	10	110
CB11†	5"	5	135
CB12†	6"	5	225

†Not UL Listed

CLAMPS "SNAP-ON" – STEEL

Applications:

- To support EMT conduit to mounting surface

Heavy Gauge

UL File No. E-184283



Cat. #	Size	Unit Qty.	Wt. Lbs. Per 100
200	1/2"	100	5
201	3/4"	100	6
202	1"	100	6
203	1 1/4"	50	13
204	1 1/2"	25	17
205	2"	25	20
206*	2 1/2"	25	64
207*	3"	25	71
208*	3 1/2"	10	120
209*	4"	10	130

*Not UL Listed

Thin Wall Conduit Fittings (For EMT Conduit)

Nailing Straps - Steel



NAILING STRAPS – CAST STEEL

Applications:

- To secure EMT conduit, flexible metallic conduit, armored cable and metal clad cable to mounting surface

Standard Materials:

- Cast steel

Standard Finishes:

- Zinc plated



Cat. #	Conduit Sizes		Wt. Lbs. Per 100
	EMT	Rigid	
NS 1	1/2"	3/8"	2
NS 2	3/4"	1/2"	2
NS 3	1"	3/4"	3

Dimensions

Cat. #	A	B	C	D
NS 1	3/16	1	1 7/8	3/4
NS 2	3/4	1 1/4	2	15/16
NS 3	3/16	1 1/2	2 1/2	1 1/8

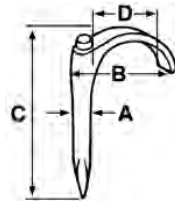

NAILING STRAPS – STAMPED STEEL

Applications:

- To secure EMT conduit

Certifications:

- UL File No. E184283

Standard Materials:

- Pre-galvanized stamped steel



Cat. #	Conduit Sizes		Unit Qty.	Wt. Lbs. Per 100
	EMT	Rigid		
NSS1	1/2"	3/8"	100	2
NSS2	3/4"	1/2"	100	2
NSS3	1"	3/4"	100	3

EMT Fittings

Rigid/Intermediate Grade Conduit Fittings

Compression Fittings - Type CPR



Rigid Fittings

TYPE CPR COMPRESSION FITTINGS

Applications:

Use type CPR compression fittings for:

- Both IMC and metallic rigid conduit.
- New work in poured concrete.
- Maintenance, repairs and alterations.
- Connections at panels and boxes.
- New, altered or damaged stubups.
- Applicable locations where field threading is impractical or undesirable.

Features and Benefits:

- UL Listed for use with IMC as well as metallic rigid conduit.
- Unequalled versatility for the installer.
- Unique gland ring design tightens up in fewer turns; provides outstanding pull-out strength; saves time and adds confidence.
- Advanced, thoughtful design and premium materials team up for an installation you can be proud of.

Certifications and Compliances:

- UL 514B Fittings for Conduit and Outlet Boxes

Standard Materials:

- Bodies – malleable iron
- Compression nuts – iron
- Compression rings – zinc plated steel
- Locknuts – zinc plated steel
- Insuliners – glass-reinforced polypropylene

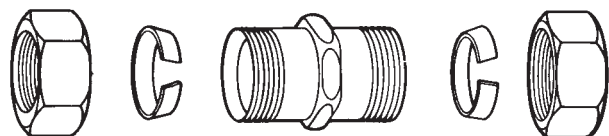

Straight Connectors – Insulated

UL File No. E-19189



Cat. #	Size	Unit Qty.	Wt. Lbs. Per 100
CPR11	1/2"	50	19
CPR12	3/4"	25	23
CPR13	1"	10	42
CPR14	1 1/4"	10	64
CPR15	1 1/2"	5	87
CPR16	2"	5	113
CPR17	2 1/2"	2	130
CPR18	3"	1	220
CPR19	3 1/2"	1	280
CPR20	4"	1	320

Straight Connectors – Non-Insulated

UL File No. E-19189



Cat. #	Size	Unit Qty.	Wt. Lbs. Per 100
CPR1	1/2"	50	19
CPR2	3/4"	25	23
CPR3	1"	10	42
CPR4	1 1/4"	10	64
CPR5	1 1/2"	5	87
CPR6	2"	5	113
CPR7	2 1/2"	2	130
CPR8	3"	1	220
CPR9	3 1/2"	1	280
CPR10	4"	1	320

Couplings

UL File No. E-19189



Cat. #	Size	Unit Qty.	Wt. Lbs. Per 100
CPR21	1/2"	25	26
CPR22	3/4"	20	38
CPR23	1"	10	59
CPR24	1 1/4"	5	85
CPR25	1 1/2"	5	124
CPR26	2"	2	162
CPR27	2 1/2"	2	220
CPR28	3"	1	320
CPR29	3 1/2"	1	380
CPR30	4"	1	440

Rigid/Intermediate Grade Conduit Fittings

Set Screw Type Fittings - Steel



SET SCREW TYPE FITTINGS - STEEL

Straight Connectors – Insulated

UL File No. E-19189



Cat. #	Size	Unit Qty.	Wt. Lbs. Per 100
150S	1/2"	50	16
151	3/4"	25	27
152	1"	5	40
153	1 1/4"	10	50
154	1 1/2"	5	76
155*	2"	2	110
1456*	2 1/2"	2	210
1457*	3"	1	282
1458*	3 1/2"	1	380
1459*	4"	1	400
160I*†	5"	1	850
161I*†	6"	1	1100

*Two Tightening Screws
†Malleable Iron

Couplings

UL File No. E-19189



Cat. #	Size	Unit Qty.	Wt. Lbs. Per 100
160	1/2"	25	27
161	3/4"	20	40
162	1"	5	52
163	1 1/4"	10	70
164	1 1/2"	5	104
165*	2"	2	160
466*	2 1/2"	2	300
467*	3"	1	400
468*	3 1/2"	1	500
469*	4"	1	600
170C*†	5"	1	1500
171C*†	6"	1	1800

*Four Tightening Screws
†Malleable Iron

1456 – 1459, 456 – 459 & 466 – 469 are UL and cUL Listed for EMT, Rigid, and IMC conduit.

Straight Connectors – Non-Insulated

UL File No. E-19189



Cat. #	Size	Unit Qty.	Wt. Lbs. Per 100
150P	1/2"	50	16
151P	3/4"	25	26
152P	1"	5	40
153P	1 1/4"	10	50
154P	1 1/2"	5	76
155P*	2"	2	110
456*	2 1/2"	2	210
457*	3"	1	281
458*	3 1/2"	1	380
459*	4"	1	400
160P*†	5"	1	850
161P*†	6"	1	1100

*Two Tightening Screws
†Malleable Iron

Rigid Fittings

Rigid/Intermediate Grade Conduit Fittings Concrete Tight

Set Screw Type Fittings - Raintight (SSR Series)



Rigid Fittings

SET SCREW TYPE FITTINGS - RAIN TIGHT

Applications:

Rainboot™ connectors and couplings are used with rigid conduit for IMC, steel or aluminum. Outdoors or indoors. Use Rainboot fittings for:

- Conduit systems expansion and alterations.
- Maintenance and repair operations.
- New, altered or damaged stubups.
- Connections at panels and boxes.
- Embedment in concrete.
- Installations in tight quarters: near corners, walls, ceilings, overhangs, obstacles or adjacent raceways.
- Situations where threading equipment or heavy pipe wrenches are impractical.
- Conduit systems in NEC wet locations.

Features and Benefits:

- The only line of rigid/IMC threadless fittings suitable for raintight applications.
- The only alternative to field threading in NEC wet locations.
- May be installed in any position.
- Tough and durable, long lasting, trouble free installations.
- Requires only a 3/8" wrench for installation.
- Full line – 1/2" through 2".
- Faster, easier method to install raintight rigid/IMC raceway systems.

Certifications and Compliances:

- UL 514B – Fittings for cable and conduit

Standard Materials:

- Bodies
Connectors – 1/2" – 2" steel
Couplings – 1/2" – 2" steel
- Boots – injection molded PVC attached with special epoxy.
- Setscrews hardened steel coated with special sealing resin compound.

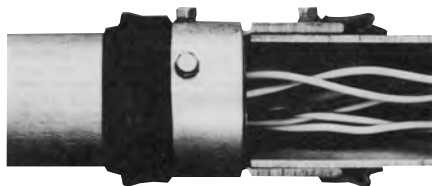

Straight Connectors – Insulated



Cat. #	Size	Unit Qty.	Wt. Lbs. Per 100
SSR11	1/2"	20	20
SSR12	3/4"	20	30
SSR13	1"	20	40
SSR14	1 1/4"	5	64
SSR15	1 1/2"	5	85
SSR16	2"	4	97

Straight Connectors – Non-Insulated



Cat. #	Size	Unit Qty.	Wt. Lbs. Per 100
SSR1	1/2"	20	21
SSR2	3/4"	20	23
SSR3	1"	20	40
SSR4	1 1/4"	5	64
SSR5	1 1/2"	5	85
SSR6*	2"	4	96

*Two Tightening Screws
For sealing at enclosure, use Type SG sealing gaskets

Couplings



Cat. #	Size	Unit Qty.	Wt. Lbs. Per 100
SSR21	1/2"	20	31
SSR22	3/4"	20	45
SSR23	1"	5	64
SSR24	1 1/4"	5	86
SSR25	1 1/2"	4	116
SSR26†	2"	4	165

†Four Tightening Screws

Rigid/Intermediate Grade Conduit Fittings

Split Conduit Couplings and Combination Couplings



SPLIT CONDUIT COUPLINGS

Applications:

- Provides a quick and easy method of joining two pieces of threaded rigid or IMC conduit.

Features:

- Concrete Tight
- Suitable for use in Class I, Division 2 Areas

Body – Ductile Iron
Clamping Hardware – ElectroGalvanized Steel
Gasket-Neoprene



Cat. #	Size	Unit Qty.	Wt. Lbs. Per 100
TCC1	1/2"	10	39
TCC2	3/4"	10	45
TCC3	1"	10	68
TCC4	1 1/4"	5	82
TCC5	1 1/2"	5	116
TCC6	2"	5	111
TCC7	2 1/2"	2	283
TCC8	3"	2	323
TCC9	3 1/2"	1	395
TCC10	4"	1	506
TCC12	5"	1	944
TCC14	6"	1	1218

COMBINATION COUPLINGS – STEEL

Concrete Tight
EMT (Compression) To Rigid (Threaded)

UL File No. E-19189



Cat. #	Size	Unit Qty.	Wt. Lbs. Per 100
690S	1/2" – 1/2"	25	9
691	3/4" – 3/4"	20	13
692	1" – 1"	10	19

COMBINATION COUPLINGS - ZINC PLATED STEEL

Concrete Tight
EMT (Set Screw) To Rigid (Set Screw)

UL File No. E-19189



Cat. #	Size	Unit Qty.	Wt. Lbs. Per 100
420	1/2" – 1/2"	25	17
421	3/4" – 3/4"	20	25
422	1" – 1"	10	37

COMBINATION COUPLINGS - MALLEABLE IRON

Flexible Steel (Squeeze Type) To Rigid (Threaded)

UL File No. E-19189



Cat. #	Size	Unit Qty.	Wt. Lbs. Per 100
65	1/2" – 1/2"	10	17
66	3/4" – 3/4"	10	22
67	1" – 1"	5	31
68	1 1/4" – 1 1/4"	5	31

Rigid/Intermediate Grade Conduit Fittings

Conduit Couplings



Rigid Fittings

THREE PIECE CONDUIT COUPLINGS - MALLEABLE IRON

Applications:

- Used to join two lengths of threaded conduit. Couples conduit when conduit cannot be turned.

Standard Materials:

- Heavy duty casting

Standard Finishes:

- Zinc Plated

Options:

Mechanically galvanized

Suffix
HDG

Malleable Iron (Concrete Tight)

UL File No. E-19189



Cat. #	Size	Unit Qty.	Wt. Lbs. Per 100
190M	1/2"	25	23
191	3/4"	25	35
192	1"	10	60
193	1 1/4"	5	91
194	1 1/2"	5	167
195	2"	5	215
196	2 1/2"	2	430
197	3"	1	463
198	3 1/2"	1	655
199	4"	1	800
188†	5"	1	1200
189†	6"	1	2100

†Not UL Listed

RIGID CONDUIT COUPLINGS - STEEL

Applications:

- Used to join two lengths of threaded rigid or IMC conduit. They can be used in both indoor and outdoor applications

Standard Materials:

- Galvanized steel

Galvanized steel



Cat. #	Size	Unit Qty.	Wt. Lbs. Per 100
RC50	1/2"	10	12
RC75	3/4"	10	18
RC100	1"	10	29
RC125	1 1/4"	5	38
RC150	1 1/2"	5	52
RC200	2"	5	69
RC250	2 1/2"	2	181
RC300	3"	1	220
RC350	3 1/2"	1	377
RC400	4"	1	298
RC500	5"	1	477
RC600	6"	1	684

Rigid/Intermediate Grade Conduit Fittings

Rigid Elbows



RIGID ELBOWS - STEEL

Applications:

- Used in conjunction with rigid couplings (CCH catalog numbers RC50-RC400) to make a 45° or 90° bend between two lengths of threaded rigid or IMC conduit.

Features:

- Curvature of the conduit is used to fit specific locations and/or make turns or change directions in the installation
- Can be used in both indoor and outdoor applications, offering the customer increased flexibility
- Made of steel and galvanized for corrosion resistance

Certifications and Compliances:

- UL Listed
- cUL Listed

Rigid Elbows



Cat. #	Size	Unit Qty.	Wt. Lbs. Per 100
90 Degree Elbow			
RLB5090	1/2"	50	76
RLB7590	3/4"	50	113
RLB10090	1"	20	197
RLB12590	1 1/4"	20	312
RLB15090	1 1/2"	10	440
RLB20090	2"	10	660
RLB25090	2 1/2"	1	1180
RLB30090	3"	1	1650
RLB35090	3 1/2"	1	2700
RLB40090	4"	1	3300
45 Degree Elbow			
RLB5045	1/2"	50	70
RLB7545	3/4"	50	103
RLB10045	1"	25	161
RLB12545	1 1/4"	20	236
RLB15045	1 1/2"	15	306
RLB20045	2"	10	470
RLB25045	2 1/2"	1	800
RLB30045	3"	1	1301
RLB35045	3 1/2"	1	1601
RLB40045	4"	1	2101

Rigid Fittings

Rigid/Intermediate Grade Conduit Fittings

Mogul Pulling Elbows



MOGUL PULLING ELBOWS - DIE CAST COPPER-FREE ALUMINUM

Applications:

- Used as a chamber for containing heavy-duty conductors
- For use as a chamber for containing a 90° turn in large stiff conductors to change conductor direction or to enter buildings
- For use as a pull box for pulling large conductors
- For use as a chamber for making splices and taps
- Can be used as an accessible opening to accommodate future changes of the system



Features & Benefits:

- Large dome cover permits easy, straight through pull
- Dimension from center-line of back hub to bushing of end hub exceeds six times the trade diameter of the conduit
- Tapered threads provide easy assembly, tight construction
- Heavy-duty machine screws for cover
- Cover gasket provides long dependable service and protection against the elements; such as fuel, oil and water
- Smooth design and finish make handling easy and complement any construction job
- Body and Cover: Die-cast copper-free aluminum
- Gasket—Fuel, oil, and water resistant flex seal



Cooper Crouse-Hinds mogul pulling elbows facilitate wire pulling in 90° bends to allow changes in conductor direction. The pulling elbows can also be used to allow conductor entrance into buildings. With the smooth finish and large dome cover, wires can be easily pulled through without compromising the wire insulation. The gasketed cover creates a raintight chamber and the copper-free aluminum construction provides increased corrosion resistance, making the mogul pulling elbow ideal for any outdoor application.

Certifications & Compliances:

- UL Standard: 514A
- NEC: Article 314
- CSA C22.2 No. 18
- CEC: 22.1

Standard Finishes:

- Corrosion-resistant metallic paint

Ordering Information

Catalog No.	Size	Dimensions				Max Wire Size	Unit Qty.	Wt. Lbs Per 100
		A	B	C	D			
LBNEC3	1"	9 ²¹ / ₃₂ "	3 ¹⁷ / ₃₂ "	2 ¹ / ₂ "	7 ¹ / ₂ "	2 AWG	2	146
LBNEC4	1 ¹ / ₄ "	9 ²¹ / ₃₂ "	3 ¹⁷ / ₃₂ "	2 ¹ / ₂ "	7 ¹ / ₂ "	2 AWG	2	132
LBNEC5	1 ¹ / ₂ "	14 ¹⁷ / ₃₂ "	5 ¹³ / ₃₂ "	3 ³ / ₈ "	12 ¹ / ₂₀ "	250 kcmil	1	258
LBNEC6	2"	14 ¹⁷ / ₃₂ "	5 ¹³ / ₃₂ "	3 ³ / ₈ "	12 ¹ / ₂₀ "	250 kcmil	1	230
LBNEC7	2 ¹ / ₂ "	22"	7 ¹⁷ / ₃₂ "	4 ¹ / ₂ "	18 ⁹ / ₃₂ "	500 kcmil	1	1003
LBNEC8	3"	22"	7 ¹⁷ / ₃₂ "	4 ¹ / ₂ "	18 ⁹ / ₃₂ "	500 kcmil	1	938
LBNEC9	3 ¹ / ₂ "	28 ²⁷ / ₃₂ "	8 ¹⁵ / ₁₆ "	5 ¹ / ₂ "	24 ¹ / ₈ "	900 kcmil	1	2158
LBNEC10	4"	28 ²⁷ / ₃₂ "	8 ¹⁵ / ₁₆ "	5 ¹ / ₂ "	24 ¹ / ₈ "	900 kcmil	1	2060

Dimensions

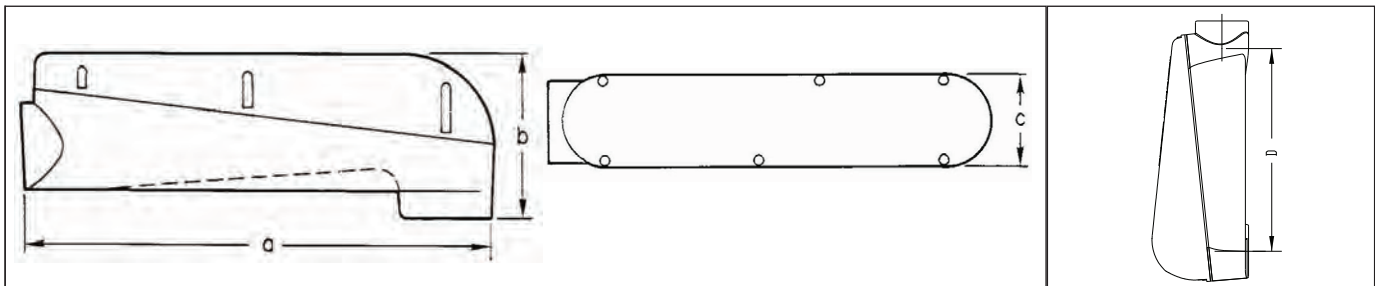

Rigid/Intermediate Grade Conduit Fittings



90° Pull Elbows

90 DEGREE PULL ELBOWS – MALLEABLE IRON

Features:

- Raintight
- Furnished with Neoprene gasketed steel cover
- Furnished with Steel lock nut
- Furnished with Stamped Steel cover
- Threaded for rigid conduit and IMC
- For outdoor use
- Standard Finish: Zinc plated

Gasketed - Rigid to Box (Male To Female)

UL File No. E-19189



Cat. #	Size	Unit Qty.	Wt. Lbs. Per 100
810	1/2"	20	34
811	3/4"	10	56
812	1"	5	88
813	1 1/4"	2	92
814	1 1/2"	2	200
815	2"	1	344

Rigid to Rigid (Female To Female)

UL File No. E-19189



Cat. #	Size	Unit Qty.	Wt. Lbs. Per 100
820	1/2"	20	36
821	3/4"	10	49
822	1"	5	94
823	1 1/4"	2	140
824	1 1/2"	2	200
825	2"	1	344

90 DEGREE PULL ELBOWS – ZINC DIE CAST

Applications:

- For connecting threaded rigid or IMC to form a 90° bend, or for connecting rigid or IMC to box or enclosure
- Removable cover and gasket facilitate wire pulling

Standard Materials:

- Body – zinc
- Gasket – neoprene
- Cover – aluminum

Gasketed – Rigid to Box (Male To Female)

UL File No. E-19189



Cat. #	Size	Unit Qty.	Wt. Lbs. per 100
850RB DC	1/2"	20	17
875RB DC	3/4"	15	25
8100RB DC	1"	6	53
8125RB DC	1 1/4"	3	80

Rigid to Rigid (Female To Female)

UL File No. E-19189



Cat. #	Size	Unit Qty.	Wt. Lbs. Per 100
850RR DC	1/2"	20	15
875RR DC	3/4"	15	23
8100RR DC	1"	6	50
8125RR DC	1 1/4"	3	80

Rigid Fittings

Rigid/Intermediate Grade Conduit Fittings

Insulating and Throat Bushings



Rigid Fittings

THROAT BUSHINGS - MALLEABLE IRON

Threaded 105°C Rated Plastic Throat Liner

UL File No. E-19189



Cat. # Insulated	Size	Unit Qty.	Wt. Lbs. Per 100
1031	1/2"	100	3
1032	3/4"	100	4
1033	1"	50	7
1034	1 1/4"	50	15
1035	1 1/2"	10	19
1036	2"	20	22
1037	2 1/2"	10	44
1038	3"	10	54
1039	3 1/2"	5	72
1040	4"	5	95
1041*	5"	1	100
1042*	6"	1	127

*Not UL Listed

Threadless 105°C Rated Plastic Throat Liner

UL File No. E-19189



Cat. #	Size	Unit Qty.	Wt. Lbs. Per 100
S1031	1/2"	100	3
S1032	3/4"	100	4
S1033	1"	50	7
S1034	1 1/4"	50	15
S1035	1 1/2"	10	19
S1036	2"	20	22
S1037	2 1/2"	10	44
S1038	3"	10	54
S1039	3 1/2"	5	72
S1040	4"	5	95
S1041	5"	1	100
S1042	6"	1	127

INSULATED THROAT BUSHINGS - MALLEABLE IRON

Features:

- Plastic liner will not chip, crack, swell or shrink. It resists corrosion, chemicals and temperature extremes.

Standard Materials:

- Body – Malleable Iron
- Insuliner – ULTEM1000 rated at 150°C

Standard Finishes:

- Body – Zinc Plated

150°C Rated

Threaded

UL File No. E-19189



Cat. #	Trade Size	Unit Qty.	Wt. Lbs. per 100
H1031	1/2"	100	6
H1032	3/4"	100	8
H1033	1"	50	11
H1034	1 1/4"	50	14
H1035	1 1/2"	10	17
H1036	2"	20	24
H1037	2 1/2"	10	51
H1038	3"	10	62
H1039	3 1/2"	5	85
H1040	4"	5	104
H1041	5"	1	130
H1042	6"	1	167

INSULATED THROAT BUSHINGS

150°C Rated

Threadless Set Screw Type

UL File No. E-19189



Cat. #	Trade Size	Unit Qty.	Wt. Lbs. Per 100
HS1031	1/2"	100	6
HS1032	3/4"	100	7
HS1033	1"	50	10
HS1034	1 1/4"	50	13
HS1035	1 1/2"	10	15
HS1036	2"	20	21
HS1037	2 1/2"	10	42
HS1038	3"	10	51
HS1039	3 1/2"	5	65
HS1040	4"	5	80
HS1041	5"	1	100
HS1042	6"	1	128

Rigid/Intermediate Grade Conduit Fittings

Grounding Bushings



INSULATED THROAT BUSHINGS - ZINC DIE CAST

150°C Rated – Zinc Die Cast

Threaded
UL File No. E-19189



Cat. #	Trade Size	Unit Qty.	Wt. Lbs. per 100
H1031DC	1/2"	100	2
H1032DC	3/4"	100	3
H1033DC	1"	50	5
H1034DC	1 1/4"	50	7
H1035DC	1 1/2"	20	9
H1036DC	2"	10	11
H1037DC	2 1/2"	10	27
H1038DC	3"	5	33
H1039DC	3 1/2"	5	39
H1040DC	4"	2	46

NON-INSULATED THROAT BUSHINGS - MALLEABLE IRON

Features:

- Used with locknut to terminate threaded rigid conduit or IMC to enclosure

Threaded 105°C Rated Non-insulated



Non-Insulated

Cat. #	Size	Unit Qty.	Wt. Lbs. Per 100
1031NI	1/2"	100	3
1032NI	3/4"	100	4
1033NI	1"	50	7
1034NI	1 1/4"	50	15
1035NI	1 1/2"	10	19
1036NI	2"	20	22
1037NI	2 1/2"	10	44
1038NI	3"	10	54
1039NI	3 1/2"	5	72
1040NI	4"	5	95

NON-INSULATED THROAT BUSHINGS - ZINC DIE CAST

Features:

- Used with locknut to terminate threaded rigid conduit or IMC to enclosure

Threaded



Cat. #	Trade Size	Unit Qty.	Wt. Lbs. per 100
1031DC	1/2"	100	2
1032DC	3/4"	100	3
1033DC	1"	50	5
1034DC	1 1/4"	50	7
1035DC	1 1/2"	20	9
1036DC	2"	10	10
1037DC	2 1/2"	10	26
1038DC	3"	5	32
1039DC	3 1/2"	5	37
1040DC	4"	2	43

INSULATING BUSHINGS

Standard Materials:

- Plastic

UL File No. E-19189



Rated 105°C Cat. #	Rated 150°C Cat. #	Trade Size	Unit Qty.	Wt. Lbs. Per 100
931	H 931	1/2"	50	1
932	H 932	3/4"	50	1
933	H 933	1"	50	2
934	H 934	1 1/4"	50	3
935	H 935	1 1/2"	25	3
936	H 936	2"	25	4
937	H 937	2 1/2"	10	8
938	H 938	3"	10	10
939	H 939	3 1/2"	5	11
940	H 940	4"	5	11
941	H 941	5"	5	40
942	H 942	6"	5	42

Rigid Fittings

Rigid/Intermediate Grade Conduit Fittings

Grounding Bushings



INSULATED THROAT GROUNDING BUSHINGS - MALLEABLE IRON

Applications:

- For use on threaded rigid/IMC conduit to provide a means of grounding conduit through an insulated bushing

105°C Rated Plastic Throat Liner Aluminum Lug – For Copper Or Aluminum Grounding Conductors – Threaded

UL File No. E-6225



Cat. #	Trade Size	Lug Size	Unit Qty.	Wt. Lbs. Per 100
GLL1	1/2"	#4 - #14	50	5
GLL2	3/4"	#4 - #14	50	9
GLL3	1"	#4 - #14	50	12
GLL4	1 1/4"	#4 - #14	25	19
GLL4 10	1 1/4"	#1/0 - #8	25	23
GLL5	1 1/2"	#4 - #14	10	24
GLL5 10	1 1/2"	#1/0 - #8	10	28
GLL6	2"	#4 - #14	10	26
GLL6 10	2"	#1/0 - #8	10	32
GLL7	2 1/2"	#1/0 - #8	10	53
GLL7 30	2 1/2"	#3/0 - #6	10	60
GLL7 250	2 1/2"	250MCM - #6	10	67
GLL8	3"	#1/0 - #8	5	70
GLL8 30	3"	#3/0 - #6	5	72
GLL8 250	3"	250MCM - #6	5	76
GLL9	3 1/2"	#3/0 - #6	1	100
GLL9 250	3 1/2"	250MCM - #6	1	100
GLL10	4"	#3/0 - #6	1	110
GLL10 250	4"	250MCM - #6	1	120
GLL11	5"	#3/0 - #6	1	140
GLL11 250	5"	250MCM - #6	1	143
GLL12	6"	#3/0 - #6	1	160
GLL12 250	6"	250MCM - #6	1	163

105°C Rated Plastic Throat Liner Copper Lug – For Copper Grounding Conductors – Threaded

UL File No. E-6225



Cat. #	Trade Size	Lug Size	Unit Qty.	Wt. Lbs. Per 100
GLL1C	1/2"	#4 - #14	50	8
GLL2C	3/4"	#4 - #14	50	12
GLL3C	1"	#4 - #14	50	14
GLL4 10C	1 1/4"	#4 - #14	25	19
GLL4C	1 1/4"	#1/0 - #8	25	30
GLL5 10C	1 1/2"	#4 - #14	10	21
GLL5C	1 1/2"	#1/0 - #8	10	32
GLL6C	2"	#4 - #14	10	29
GLL6 10C	2"	#1/0 - #8	10	40
GLL7C	2 1/2"	#1/0 - #8	10	65
GLL7 30C	2 1/2"	#3/0 - #6	10	88
GLL7 250C	2 1/2"	250MCM - #6	10	97
GLL8C	3"	#1/0 - #8	5	77
GLL8 30C	3"	#3/0 - #6	5	100
GLL8 250C	3"	250MCM - #6	5	109
GLL9C	3 1/2"	#3/0 - #6	1	125
GLL9 250C	3 1/2"	250MCM - #6	1	134
GLL10C	4"	#3/0 - #6	1	145
GLL10 250C	4"	250MCM - #6	1	154
GLL11C	5"	#3/0 - #6	1	165
GLL11 250C	5"	250MCM - #6	1	174
GLL12C	6"	#3/0 - #6	1	195
GLL12 250C	6"	250MCM - #6	1	204

Rigid/Intermediate Grade Conduit Fittings

Grounding Bushings



INSULATED THROAT GROUNDING BUSHINGS - MALLEABLE IRON

Applications:

- For use on threaded rigid/IMC conduit to provide a means of grounding conduit through an insulated bushing

Aluminum Lug – For Copper Or Aluminum Grounding Conductors – Threadless – Set Screw Type 105°C Rated Plastic Throat Liner

UL File No. E-6225



lazylug™

Cat. #	Trade Size	Lug Size	Unit Qty.	Wt. Lbs. Per 100
GLS1	1/2"	#4 - #14	50	5
GLS2	3/4"	#4 - #14	50	9
GLS3	1"	#4 - #14	50	12
GLS4	1 1/4"	#4 - #14	25	19
GLS4 10	1 1/4"	#1/0 - #8	25	23
GLS5	1 1/2"	#4 - #14	10	24
GLS5 10	1 1/2"	#1/0 - #8	10	28
GLS6	2"	#4 - #14	10	26
GLS6 10	2"	#1/0 - #8	10	32
GLS7	2 1/2"	#1/0 - #8	10	53
GLS7 30	2 1/2"	#3/0 - #6	10	60
GLS7 250	2 1/2"	250MCM - #6	10	67
GLS8	3"	#1/0 - #8	5	70
GLS8 30	3"	#3/0 - #6	5	72
GLS8 250	3"	250MCM - #6	5	76
GLS9	3 1/2"	#3/0 - #6	1	100
GLS9 250	3 1/2"	250MCM - #6	1	100
GLS10	4"	#3/0 - #6	1	110
GLS10 250	4"	250MCM - #6	1	120
GLS11	5"	#3/0 - #6	1	140
GLS11 250	5"	250MCM - #6	1	143
GLS12	6"	#3/0 - #6	1	160
GLS12 250	6"	250MCM - #6	1	163

Copper Lug – For Copper Grounding Conductors – Threadless – Set Screw Type 105°C Rated Plastic Throat Liner

UL File No. E-6225



lazylug™

Cat. #	Trade Size	Lug Size	Unit Qty.	Wt. Lbs. Per 100
GLS1C	1/2"	#4 - #14	50	8
GLS2C	3/4"	#4 - #14	50	12
GLS3C	1"	#4 - #14	50	14
GLS4C	1 1/4"	#4 - #14	25	19
GLS4 10C	1 1/4"	#1/0 - #8	25	30
GLS5C	1 1/2"	#4 - #14	10	21
GLS5 10C	1 1/2"	#1/0 - #8	10	32
GLS6C	2"	#4 - #14	10	29
GLS6 10C	2"	#1/0 - #8	10	40
GLS 7C	2 1/2"	#1/0 - #8	10	65
GLS7 30C	2 1/2"	#3/0 - #6	10	88
GLS7 250C	2 1/2"	250MCM - #6	10	97
GLS8C	3"	#1/0 - #8	5	77
GLS8 30C	3"	#3/0 - #6	5	100
GLS8 250C	3"	250MCM - #6	5	109
GLS9C	3 1/2"	#3/0 - #6	1	125
GLS9 250C	3 1/2"	250MCM - #6	1	134
GLS10C	4"	#3/0 - #6	1	145
GLS10 250C	4"	250MCM - #6	1	154
GLS11C	5"	#3/0 - #6	1	165
GLS11 250C	5"	250MCM - #6	1	174
GLS12C	6"	#3/0 - #6	1	195
GLS12 250C	6"	250MCM - #6	1	204

Rigid Fittings

Rigid/Intermediate Grade Conduit Fittings

Grounding Bushings



Rigid Fittings

INSULATED THROAT GROUNDING BUSHINGS - MALLEABLE IRON

Features:

- Resilient plastic liner, resists corrosion, chemicals and temperature extremes
- Insuliner – ULTEM1000 rated at 150°C
- 1 Set screw provided with each fitting locks bushing in any desired position
- External stainless steel hardware as standard

Standard Finishes:

- Zinc Plated

150°C Rated

Aluminum Lug – For Copper Or Aluminum Grounding Conductors – Threaded

UL File No. E-6225



Cat. #	Trade Size	Lug Size	Unit Qty.	Wt. Lbs. Per 100
HGLL 1	1/2"	#4 – #14	50	9
HGLL 2	3/4"	#4 – #14	50	11
HGLL 3	1"	#4 – #14	50	14
HGLL 4	1 1/4"	#4 – #14	25	17
HGLL4 10	1 1/4"	#1/0 – #8	25	24
HGLL 5	1 1/2"	#4 – #14	10	20
HGLL5 10	1 1/2"	#1/0 – #8	10	24
HGLL 6	2"	#4 – #14	10	27
HGLL6 10	2"	#1/0 – #8	10	31
HGLL 7	2 1/2"	#1/0 – #8	10	58
HGLL7 30	2 1/2"	#3/0 – #6	10	67
HGLL7 250	2 1/2"	250MCM – #6	10	70
HGLL 8	3"	#1/0 – #8	5	69
HGLL8 30	3"	#3/0 – #6	5	78
HGLL8 250	3"	250MCM – #6	5	81
HGLL 9	3 1/2"	#3/0 – #6	1	101
HGLL9 250	3 1/2"	250MCM – #6	1	104
HGLL 10	4"	#3/0 – #6	1	120
HGLL10 250	4"	250MCM – #6	1	123
HGLL 11	5"	#3/0 – #6	1	145
HGLL 11 250	5"	250MCM – #6	1	150
HGLL 12	6"	#3/0 – #6	1	185
HGLL 12 250	6"	250MCM – #6	1	186

150°C Rated

Copper Lug – For Copper Grounding Conductors – Threaded

UL File No. E-6225



Cat. #	Trade Size	Lug Size	Unit Qty.	Wt. Lbs. Per 100
HGLL1C	1/2"	#4 – #14	50	12
HGLL2C	3/4"	#4 – #14	50	14
HGLL3C	1"	#4 – #14	50	17
HGLL4C	1 1/4"	#4 – #14	25	20
HGLL4 10C	1 1/4"	#1/0 – #8	25	32
HGLL5C	1 1/2"	#4 – #14	10	23
HGLL5 10C	1 1/2"	#1/0 – #8	10	35
HGLL 6C	2"	#4 – #14	10	30
HGLL6 10C	2"	#1/0 – #8	10	42
HGLL7C	2 1/2"	#1/0 – #8	10	69
HGLL7 30C	2 1/2"	#3/0 – #6	10	92
HGLL7 250C	2 1/2"	250MCM – #6	10	101
HGLL8C	3"	#1/0 – #8	5	80
HGLL8 30C	3"	#3/0 – #6	5	103
HGLL8 250C	3"	250MCM – #6	5	112
HGLL9C	3 1/2"	#3/0 – #6	1	126
HGLL9 250C	3 1/2"	250MCM – #6	1	135
HGLL10C	4"	#3/0 – #6	1	145
HGLL10 250C	4"	250MCM – #6	1	155
HGLL 11C	5"	#3/0 – #6	1	171
HGLL11 250C	5"	250MCM – #6	1	180
HGLL 12C	6"	#3/0 – #6	1	210
HGLL 12 250C	6"	250MCM – #6	1	317

INSULATED THROAT GROUNDING BUSHINGS - ZINC DIE CAST

150°C Rated Plastic Throat Liner

Aluminum Lug – for Copper or Aluminum Grounding Conductors

UL File No. E-6225



Cat. #	Trade Size	Unit Qty.	Wt. Lbs. Per 100
GLL1 DC	1/2"	50	3
GLL2 DC	3/4"	40	4
GLL3 DC	1"	25	5
GLL4 DC	1 1/4"	25	9
GLL5 DC	1 1/2"	25	10
GLL6 DC	2"	10	14
GLL7 DC	2 1/2"	5	25
GLL8 DC	3"	5	33
GLL9 DC	3 1/2"	4	38
GLL10 DC	4"	4	44

Rigid/Intermediate Grade Conduit Fittings

Grounding Bushings



INSULATED THROAT GROUNDING BUSHINGS - MALLEABLE IRON

150°C Rated

Set Screw Type – Aluminum Lug – For Copper Or
Aluminum
Grounding Conductors – Threadless

UL File No. E-6225



Cat. #	Trade Size	Lug Size	Unit Qty.	Wt. Lbs. Per 100
HGLS1	1/2"	#4 – #14	50	9
HGLS2	3/4"	#4 – #14	50	10
HGLS3	1"	#4 – #14	50	13
HGLS4	1 1/4"	#4 – #14	25	16
HGLS4 10	1 1/4"	#1/0 – #8	25	20
HGLS5	1 1/2"	#4 – #14	10	18
HGLS5 10	1 1/2"	#1/0 – #8	10	22
HGLS6	2"	#4 – #14	10	24
HGLS6 10	2"	#1/0 – #8	10	28
HGLS7	2 1/2"	#1/0 – #8	10	50
HGLS7 30	2 1/2"	#3/0 – #6	10	58
HGLS7 250	2 1/2"	250MCM – #6	10	60
HGLS8	3"	#1/0 – #8	5	58
HGLS8 30	3"	#3/0 – #6	5	67
HGLS8 250	3"	250MCM – #6	5	70
HGLS9	3 1/2"	#3/0 – #6	1	80
HGLS9 250	3 1/2"	250MCM – #6	1	85
HGLS10	4"	#3/0 – #6	1	90
HGLS10 250	4"	250MCM – #6	1	100
HGLS11	5"	#3/0 – #6	1	115
HGLS11 250	5"	250MCM – #6	1	120
HGLS12	6"	#3/0 – #6	1	145
HGLS12 250	6"	250MCM – #6	1	150

Features:

- Resilient plastic liner resists corrosion, chemicals and temperature extremes
- Insuliner – ULTEM1000 rated at 150°C
- 2 Set-screws provided with each fitting, locks bushings in any desired position

Standard Finishes:

- Body – Zinc Plated

150°C Rated

Set Screw Type – Copper Lug – For Copper
Grounding Conductors – Threadless

UL File No. E-6225



Cat. #	Trade Size	Lug Size	Unit Qty.	Wt. Lbs. Per 100
HGLS1C	1/2"	#4 – #14	50	12
HGLS2C	3/4"	#4 – #14	50	13
HGLS3C	1"	#4 – #14	50	16
HGLS4C	1 1/4"	#4 – #14	25	19
HGLS4 10C	1 1/4"	#1/0 – #8	25	31
HGLS5C	1 1/2"	#4 – #14	10	21
HGLS5 10C	1 1/2"	#1/0 – #8	10	33
HGLS6C	2"	#4 – #14	10	27
HGLS6 10C	2"	#1/0 – #8	10	39
HGLS7C	2 1/2"	#1/0 – #8	10	60
HGLS7 30C	2 1/2"	#3/0 – #6	10	83
HGLS7 250C	2 1/2"	250MCM – #6	10	92
HGLS8C	3"	#1/0 – #8	5	70
HGLS8 30C	3"	#3/0 – #6	5	92
HGLS8 250C	3"	250MCM – #6	5	100
HGLS9C	3 1/2"	#3/0 – #6	1	105
HGLS9 250C	3 1/2"	250MCM – #6	1	115
HGLS10C	4"	#3/0 – #6	1	100
HGLS10 250C	4"	250MCM – #6	1	130
HGLS11C	5"	#3/0 – #6	1	140
HGLS11 250C	5"	250MCM – #6	1	150
HGLS12C	6"	#3/0 – #6	1	170
HGLS12 250C	6"	250MCM – #6	1	180

Rigid Fittings

Rigid/Intermediate Grade Conduit Fittings

Bushing Pennies and Nailing Straps



Rigid Fittings

BUSHING PENNIES – STEEL

Applications:

- A penny under a bushing will seal the end of conduit during construction.



Cat. #	Size	Unit Qty.	Wt. Lbs. Per 100
90	1/2"	100	1
91	3/4"	100	1
92	1"	100	1
93	1 1/4"	50	1
94	1 1/2"	50	2
95	2"	50	3
96	2 1/2"	50	5
97	3"	50	7
98	3 1/2"	50	10
99	4"	50	14

NAILING STRAPS – STAMPED STEEL

Applications:

- To secure Rigid/IMC conduit

Certifications:

- UL File No. E184283

Standard Materials:

- Pre-galvanized stamped steel



Cat. #	Conduit Sizes		Unit Qty.	Wt. Lbs. Per 100
	EMT	Rigid		
NSS1	1/2"	3/8"	100	2
NSS2	3/4"	1/2"	100	2
NSS3	1"	3/4"	100	3

NAILING STRAPS – CAST STEEL

Standard Materials:

- Cast Steel

Standard Finishes:

- Zinc plated

Support rigid conduit and IMC to mounting surface



Cat. #	Conduit Sizes		Unit Qty.	Wt. Lbs. Per 100
	EMT	Rigid		
NS 1	1/2"	3/8"	100	2
NS 2	3/4"	1/2"	100	2
NS 3	1"	3/4"	100	3

Dimensions

In Inches:

Cat. #	A	B	C	D
NS 1	3/16	1	1 7/8	3/4
NS 2	3/4	1 1/4	2	1 5/16
NS 3	3/16	1 1/2	2 1/2	1 1/8

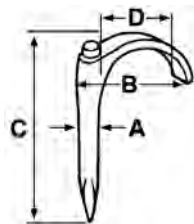

Rigid/Intermediate Grade Conduit Fittings

Conduit Clamps, Straps, Hangers



CLAMPS – MALLEABLE IRON

Applications:

- To support rigid conduit and IMC to mounting surface

Options:

Description

Hot dipped galvanized

Suffix
HDG

UL File No. E-184283



Cat. #	Size	Unit Qty.	Wt. Lbs. Per 100
510	1/2"	100	6
511	3/4"	50	8
512	1"	50	13
513	1 1/4"	25	20
514	1 1/2"	20	30
515	2"	10	64
516*	2 1/2"	5	104
517*	3"	2	120
518*	3 1/2"	2	150
519*	4"	2	220
520†	5"	1	380
521†	6"	1	690

*Also for use with Thinwall (EMT) Conduit
†Not UL Listed

CLAMPBACKS/SPACERS – MALLEABLE IRON

Applications:

- To provide space between conduit and mounting surface

Options:

Description

Hot dipped galvanized

Suffix
HDG

UL File No. E-184283



Cat. #	Size	Unit Qty.	Wt. Lbs. Per 100
CB1	1/2"	25	8
CB2	3/4"	25	10
CB3	1"	25	12
CB4	1 1/4"	25	21
CB5	1 1/2"	25	42
CB6	2"	10	40
CB7	2 1/2"	10	49
CB8	3"	10	62
CB9	3 1/2"	10	91
CB10	4"	10	110
CB11†	5"	5	135
CB12†	6"	5	225

†Not UL Listed

STRAPS – STEEL GALVANIZED

Applications:

- Used to secure rigid conduit or IMC to mounting surface

Two Hole

UL File No. E-184283



Cat. #	Size	Unit Qty.	Wt. Lbs. Per 100
496 2	3/8"	250	2
496 3	1/2"	150	2
496 4	3/4"	100	3
496 5	1"	50	7
496 6	1 1/4"	50	8
496 7	1 1/2"	50	10
496 8	2"	25	15
496 9	2 1/2"	25	19
496 10	3"	25	23
496 11	3 1/2"	25	93
496 12	4"	10	108

CLAMPS "SNAP-ON" – STEEL

Applications:

- To support rigid conduit and IMC to mounting surface

Light Gauge



Cat. #	Conduit Sizes Rigid	Size of Strap Inside	Unit Qty.	Wt. Lbs. Per 100
566	1/4"	.540	500	2
567	3/8"	.675	200	2

Heavy Gauge

UL File No. E-184283



Cat. #	Size	Unit Qty.	Wt. Lbs. Per 100
410*	1/2"	100	5
411*	3/4"	50	6
412*	1"	50	11
413*	1 1/4"	50	13
414	1 1/2"	25	20
415	2"	25	22
206*	2 1/2"	25	64
207*	3"	25	71
208*	3 1/2"	10	120
209*	4"	10	130

*CSA Certified

Rigid/Intermediate Grade Conduit Fittings

Conduit Clamps, Straps, Hangers



Rigid Fittings

CABLE AND CONDUIT HANGERS – STEEL

Certifications and Compliances:

- UL Listed

With Bolt



Cat. #	Conduit Size EMT	Conduit Sizes Rigid	Unit Qty.	Wt. Lbs. Per 100
0B	1/2"	3/8" & 1/2"	100	6
1B	3/4"	3/4"	100	6
2B	1"	1"	100	8
2 1/2 B	1 1/4"	—	100	10
3 B	1 1/2"	1 1/4"	100	11
4 B	—	1 1/2"	100	16
5 B	2"	2"	50	23
6 B	2 1/2"	2 1/2"	50	29
7 B	3"	3"	25	31
8 B	3 1/2"	3 1/2"	10	38
9 B	4"	4"	10	38

CABLE AND CONDUIT HANGERS - STEEL

Applications:

- Used to provide mechanical support to conduit and raceway systems

Certifications and Compliances:

- UL Listed
- cUL Listed

With Extruded Hole and Bolt



Cat. #	Description	Unit Qty.	Wt. Lbs. Per 100
0BX	3/8 AND 1/2 RGD 1/2 EMT	100	6
1BX	3/4 RGD 3/4 EMT	100	7
2BX	1 RGD 1 EMT	100	11
2 1/2BX	1 1/4 EMT	100	10
3BX	1 1/4 RGD 1 1/2 EMT	100	13
4BX	1 1/2 RGD	100	16
5BX	2 RGD 2 EMT	50	17

BEAM CLAMPS/INSULATOR SUPPORTS – MALLEABLE IRON

Standard Finishes:

- Zinc Plated

UL File No. E-184283



Cat. #	Base Size	Jaw Open	Max. Wt. Support	Tapped Holes	Unit Qty.	Wt. Lbs. Per 100
528	3/4"	5/8"	230	10 – 24	25	14
529	3/4"	5/8"	230	1/4" – 20	25	13
530	1"	3/4"	230	10 – 24	25	23
531	1"	3/4"	230	1/4" – 20	25	24
532	1 1/2"	3/4"	290	3/16" – 18	50	47
533	2"	7/8"	330	3/8" – 16	25	81
534	2 1/2"	7/8"	800	1/2" – 13	25	155

BEAM CLAMPS/INSULATOR SUPPORTS – STEEL



Cat. #	Base Size	Jaw Opening	Tapped Holes	Unit Qty.	Wt. Lbs. Per 100
529 S	3/4"	5/8"	1/4" – 20	50	13

CONDUIT CLAMPS - RIGHT ANGLE TYPE

Applications:

- Right Angle – to attach the conduit run at a 90° angle to a beam or structural member
- Parallel Type – to attach the conduit run parallel to a beam or structural member



Cat. #	Trade Size	Load Rating Lbs.	Wt. Lbs. Per 100
RAC50HD	1/2"	30	37
RAC75HD	3/4"	50	40
RAC100HD	1"	60	42
RAC125HD	1 1/4"	75	49
RAC150HD	1 1/2"	80	54
RAC200HD	2"	100	71
RAC250HD	2 1/2"	125	95
RAC300HD	3"	165	107
RAC350HD	3 1/2"	200	120
RAC400HD	4"	330	131

Rigid/Intermediate Grade Conduit Fittings

Conduit Clamps, Straps, Hangers



PARALLEL TYPE CONDUIT CLAMPS - ELECTROGALVANIZED IRON



Cat. #	Trade Size	Load Rating Lbs.	Wt. Lbs. Per 100
PARC50HD	1/2"	30	50
PARC75HD	3/4"	50	53
PARC100HD	1"	60	60
PARC125HD	1 1/4"	75	70
PARC150HD	1 1/2"	80	82
PARC200HD	2"	100	132
PARC250HD	2 1/2"	125	192
PARC300HD	3"	165	194
PARC350HD	3 1/2"	200	216
PARC400HD	4"	330	232

EDGE TYPE CONDUIT CLAMPS - ELECTROGALVANIZED IRON

Applications:

- Edge Type – to attach the conduit run at a 90° angle to a thin beam or structural member



Cat. #	Trade Size	Unit Qty.	Wt. Lbs. Per 100
ETC50HD	1/2"	50	63
ETC75HD	3/4"	50	69
ETC100HD	1"	50	82
ETC125HD	1 1/4"	25	95
ETC150HD	1 1/2"	25	108
ETC200HD	2"	25	121
ETC250HD	2 1/2"	25	153
ETC300HD	3"	10	214

J TYPE CONDUIT BEAM CLAMPS - IRON

Features:

JCC Series conduit beam clamps are:

- Available in 1/2" to 4" sizes
- Suitable for IMC, EMT and rigid conduit
- Designed to exceed UL load requirements
- Made from ductile iron with an electrogalvanized finish
- Designed to support conduit on vertical or horizontal beams

UL File No. E-184283



Cat. #	Size	Max Weight Support	Unit Qty.	Wt. Lbs. Per 100
JCC1	1/2"	150	25	35
JCC2	3/4"	150	25	43
JCC34	1" & 1 1/4"	225	10	90
JCC56	1 1/2" & 2"	300	5	190
JCC78	2 1/2" & 3"	500	2	380
JCC910	3 1/2" & 4"	700	2	575

HEAVY-DUTY CONDUIT U-BOLTS WITH HEX NUTS - ELECTROGALVANIZED IRON



Cat. #	Trade Size	Thread Size	Unit Qty.	Wt. Lbs. Per 100
UBM50HD	1/2"	5/16" – 18	200	12
UBM75HD	3/4"	5/16" – 18	200	14
UBM100HD	1"	5/16" – 18	100	17
UBM125HD	1 1/4"	5/16" – 18	50	19
UBM150HD	1 1/2"	5/16" – 18	50	21
UBM200HD	2"	3/8" – 16	50	28
UBM250HD	2 1/2"	3/8" – 16	25	37
UBM300HD	3"	3/8" – 16	25	42
UBM350HD	3 1/2"	3/8" – 16	20	46
UBM400HD	4"	3/8" – 16	20	51

Rigid/Intermediate Grade Conduit Fittings



Conduit Locknuts

CONDUIT LOCKNUTS

3/8" - 2" Steel, 2 1/2" - 6" Malleable Iron
UL File No. E-19189

Rigid Fittings



Cat. #	Size	Unit Qty.	Wt. Lbs. Per 100
10	3/8"	100	1
11	1/2"	100	1
12	3/4"	100	2
13	1"	50	3
14	1 1/4"	100	4
15	1 1/2"	50	5
16	2"	50	7
17	2 1/2"	20	10
18	3"	10	15
19	3 1/2"	10	18
20	4"	5	22
22	5"	2	79
23	6"	1	166

THIN CONSTRUCTION LOCKNUTS - STEEL



Cat. #	Size	Unit Qty.	Wt. Lbs. Per 100
11X	1/2"	500	1
12X	3/4"	100	1
13X	1"	50	3
14X	1 1/4"	100	3
15X	1 1/2"	50	4
16X	2"	50	4
17X	2 1/2"	25	10
18X	3"	20	15
19X	3 1/2"	10	18
20X	4"	10	22

CONDUIT LOCKNUTS - ALUMINUM



Cat. #	Size	Unit Qty.	Wt. Lbs. Per 100
11 SA	1/2"	100	1
12 SA	3/4"	100	1
13 SA	1"	50	1
14 SA	1 1/4"	100	2
15 SA	1 1/2"	50	2
16 SA	2"	50	3
17 SA	2 1/2"	20	9
18 SA	3"	10	13
19 SA	3 1/2"	10	16
20 SA	4"	5	52

CONDUIT LOCKNUTS - ZINC DIE CAST



Cat. #	Size	Unit Qty.	Wt. Lbs. Per 100
11DC	1/2"	400	1
12DC	3/4"	250	1
13DC	1"	100	2
14DC	1 1/4"	60	3
15DC	1 1/2"	50	5
16DC	2"	30	8
17DC	2 1/2"	20	10
18DC	3"	15	15
19DC	3 1/2"	10	16
20DC	4"	10	19

GROUNDING LOCKNUTS - STEEL

Applications:

- For use with bushing to bond 1/2" to 4" rigid conduit to boxes, cabinets or other enclosures, only where a locknut is exposed.

UL File No. E-6225



Cat. #	Size	Unit Qty.	Wt. Lbs. Per 100
GL 11	1/2"	100	2
GL 12	3/4"	50	3
GL 13	1"	50	4
GL 14	1 1/4"	50	6
GL 15	1 1/2"	50	7
GL 16	2"	25	9
GL 17	2 1/2"	20	28
GL 18	3"	10	38
GL 19	3 1/2"	10	48
GL 20	4"	5	52

SELF RETAINING PVC GASKET WITH STEEL RING

UL File no. E-22133



Cat. #	Conduit Size	Unit Qty.	Wt. Lbs. Per 100
SG1	3/8" - 1/2"	100	1
SG2	3/4"	50	2
SG3	1"	50	2
SG4	1 1/4"	25	2
SG5	1 1/2"	25	4
SG6	2"	25	3
SG7	2 1/2"	10	5
SG8	3"	10	10
SG9	3 1/2"	10	12
SG10	4"	10	10
SG11	5"	5	15
SG12	6"	5	22

Rigid/Intermediate Grade Conduit Fittings

Sealing Locknuts



SEALING LOCKNUTS

UL File No. E-19189

Applications

Only one Sealing Locknut is required to:

- Functionally replace rigid threaded enclosure connectors.
- Provide raintight, watertight, or oiltight seal in any position.
- Provide positive ground connection.
- Provide economies in installation and fitting costs.

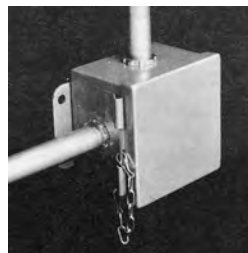
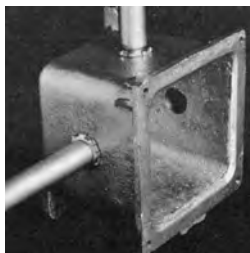

Features And Benefits:

- Integrally fused PVC gasket provides positive seal against water, oils and other liquids.
- Designed for use with raintight, watertight and oiltight enclosures, NEMA 2, 3, 3R, 4 and 12.
- UL Listed Raintight.
- UL Listed Liquidtight.
- Can be used with either sheet metal or standard cast metal boxes.
- CSA Certified watertight.
- 1/2" – 2" Heavy-duty steel.
- 2 1/2" – 6" Malleable iron.
- U.S. Patent #4022262

Cat. #	Size	Unit Qty.	Wt. Lbs. Per 100
SL1	1/2"	100	1
SL2	3/4"	50	2
SL3	1"	25	4
SL4	1 1/4"	25	4
SL5	1 1/2"	25	5
SL6	2"	25	8
SL7	2 1/2"	10	28
SL8	3"	10	38
SL9	3 1/2"	10	46
SL10	4"	5	52
SL11	5"	2	125
SL12	6"	1	140

Rigid Fittings

Rigid/Intermediate Grade Conduit Fittings

Conduit Bushed Nipples Offset Conduit Nipples



Rigid Fittings

CONDUIT BUSHED NIPPLES – MALLEABLE IRON AND ZINC DIE CAST

Malleable Iron and Zinc Die Cast

Non-Insulated and Insulated Threaded NPSM for rigid conduit and IMC

UL File No. E-19189



Applications:

- Used thru knockout to connect box to conduit coupling.
- Used with a locknut to connect two boxes side by side or back to back.
- Used with a locknut to connect fixture housing to continuous runs.

Cat. # Non-insulated Malleable Iron	Cat. # Insulated Malleable Iron	Cat. # Non-insulated Zinc Die Cast	Size	Unit Qty.	Wt. Lbs. Per 100 Non-insulated Malleable Iron	Wt. Lbs. Per 100 Insulated Malleable Iron	Wt. Lbs. Per 100 Non-insulated Zinc Die Cast
50*	1050*	50D	1/2"	50	3	3	4
51	1051	51D	3/4"	25	8	4	5
52	1052	52D	1"	10	13	11	10
53	1053	53D	1 1/4"	10	19	19	11
54	1054	54D	1 1/2"	10	30	30	20
55	1055	55D	2"	10	37	37	30
56	1056	56D	2 1/2"	5	68	72	40
57	1057	57D	3"	5	92	96	49
58	1058	58D	3 1/2"	1	130	113	68
59	1059	59D	4"	1	200	187	70
60†	1060		5"	1	350	350	
61†	1061		6"	1	425	450	

*Steel
†Not UL Listed

OFFSET CONDUIT NIPPLES – MALLEABLE IRON AND ZINC DIE CAST

Features:

- Threaded NPSM for rigid conduit and IMC
- Standard Finish on Malleable Iron: Zinc Plated
- USE: To offset the axis of raceways 3/4 of an inch

UL File No. E-19189



Cat. # Malleable	Cat. # Zinc Die Cast	Size	Unit Qty.	Wt. Lbs. Per 100
300	300DC	1/2"	25	24
301	301DC	3/4"	25	34
302	302DC	1"	10	49
303	303DC	1 1/4"	10	54
	304DC	1 1/2"	5	40
	305DC	2"	2	60

Rigid/Intermediate Grade Conduit Fittings

Push Plugs, Snap-In Blanks, Reducing Washers



PUSH PLUGS – PLASTIC*



Cat. #	Size	Unit Qty.	Wt. Lbs. Per 100
PPC 50	1/2"	100	1
PPC 75	3/4"	100	1
PPC 100	1"	50	1
PPC 125	1 1/4"	50	1
PPC 150	1 1/2"	25	1
PPC 200	2"	25	1
PPC 250	2 1/2"	100	2
PPC 300	3"	100	3
PPC 350	3 1/2"	50	6
PPC 400	4"	50	8

*Temperature Rating: 180° – 200°F
Tensile Strength: 600 – 2300 PSI

KNOCKOUT REDUCING WASHERS – STEEL



Cat. #	Size	Unit Qty.	Wt. Lbs. Per 100
342	3/4" – 1/2"	100	1
343	1" – 1/2"	100	2
344	1" – 3/4"	100	2
345	1 1/4" – 1/2"	100	3
346	1 1/4" – 3/4"	100	2
347	1 1/4" – 1"	100	2
348	1 1/2" – 1/2"	50	5
349	1 1/2" – 3/4"	50	4
350S	1 1/2" – 1"	50	4
351	1 1/2" – 1 1/4"	50	3
352	2" – 1/2"	50	7
353	2" – 3/4"	50	7
354	2" – 1"	50	6
355	2" – 1 1/4"	50	5
356	2" – 1 1/2"	50	3
360	2 1/2" – 1/2"	25	7
361	2 1/2" – 3/4"	25	7
362	2 1/2" – 1"	25	7
363	2 1/2" – 1 1/4"	25	7
364	2 1/2" – 1 1/2"	25	7
365	2 1/2" – 2"	25	7
366	3" – 1"	25	14
367	3" – 1 1/4"	25	14
368	3" – 1 1/2"	25	14
369	3" – 2"	25	14
370 S	3" – 2 1/2"	25	14
371	3" – 1 1/2"	25	25
372	3 1/2" – 2"	25	25
373	3 1/2" – 2 1/2"	25	25
374	3 1/2" – 3"	25	25
375	4" – 2"	25	35
376	4" – 2 1/2"	25	35
377	4" – 3"	25	35
378	4" – 3 1/2"	25	35

KNOCKOUT SNAP-IN BLANKS – STEEL



Cat. #	Size	Unit Qty.	Wt. Lbs. Per 100
335	1/2"	100	2
336	3/4"	100	2
337	1"	50	2
338	1 1/4"	50	3
339	1 1/2"	50	5
340	2"	20	7

CONCRETE SLAB INSERTS - 90 DEGREE

Application:

- For use with Rigid and IMC
- For conduit installed in poured concrete slabs
- 90 Degree design eliminates the need to bend conduit
- Provides flush threaded conduit hub for connecting Rigid and IMC conduit and allows future access to conduit system
- Used in in-slab ceiling & floor poured applications

Standard Materials:

- Zinc Die Cast



Cat. #	EMT	Unit Qty.	Wt. Lbs. Per 100
ESL75	3/4"	5	41
ESL100	1"	5	57

Dimensions

In Inches:

Cat. #	A	B	C	D	E	F	G
ESL75	4.55	3.72	3.49	3.15	2.13	1.14	0.20
ESL100	4.68	3.84	3.46	3.10	2.44	1.47	0.19

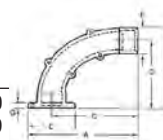

Rigid Fittings

Rigid/Intermediate Grade Conduit Fittings

Reducers & Plugs



Rigid Fittings

CONDUIT REDUCERS – STEEL/IRON



Cat. #	Size	Unit Qty.	Wt. Lbs. Per 100
Steel			
251	3/4" – 1/2"	50	4
252	1" – 1/2"	25	13
253	1 1/4" – 1/2"	10	30
254	1 1/2" – 1/2"	10	43
255	2" – 1/2"	5	83
260	1" – 3/4"	25	7
261	1 1/4" – 3/4"	10	23
262	1 1/2" – 3/4"	10	40
263	2" – 3/4"	5	79
268	1 1/4" – 1"	10	18
269	1 1/2" – 1"	10	27
270 S	2" – 1"	5	66
275	1 1/2" – 1 1/4"	10	13
276	2" – 1 1/4"	5	24
281	2" – 1 1/2"	5	27
Iron			
282	2 1/2" – 1"	10	120
283	2 1/2" – 1 1/4"	10	130
285	2 1/2" – 2"	10	150
288	3" – 1 1/2"	5	210
289	3" – 2"	2	160
290M	3" – 2 1/2"	5	120
291	3 1/2" – 2"	2	200
292	3 1/2" – 2 1/2"	2	225
293	3 1/2" – 3"	2	150
294	4" – 2"	2	270
295	4" – 2 1/2"	2	270
296	4" – 3"	2	260
297	4" – 3 1/2"	2	160
298	5" – 4"	1	385
299	6" – 5"	1	475

PLUGS – CAST IRON

Recessed



Cat. #	Size	Unit Qty.	Wt. Lbs. Per 100
PLG1M	1/2"	50	6
PLG2M	3/4"	50	11
PLG3M	1"	25	22
PLG4M	1 1/4"	25	34
PLG5M	1 1/2"	10	48
PLG6M	2"	10	82
PLG7M	2 1/2"	2	150
PLG8M	3"	2	222
PLG9M	3 1/2"	1	340
PLG10M	4"	1	380

Square Head



Cat. #	Size	Unit Qty.	Wt. Lbs. Per 100
PLG15M	1/2"	50	12
PLG25M	3/4"	50	16
PLG35M	1"	25	25
PLG45M	1 1/4"	25	34
PLG55M	1 1/2"	10	48
PLG65M	2"	10	80
PLG75M	2 1/2"	1	116
PLG85M	3"	1	185
PLG95M	3 1/2"	1	232
PLG105M	4"	1	310

Series 5 Die Cast Aluminum Conduit Outlet Bodies, Covers and Gaskets



Cooper Crouse-Hinds® Series 5 die cast copper-free aluminum conduit bodies, covers and gaskets are available for use with rigid or EMT conduit (with set screw). Conduit bodies are available in trade sizes 1/2"-4"; in the most popular conduit body shapes (C, LB, LL, LR, T) and 1/2"-2" in TB & X shapes. The Series 5 family is available as components or pre-packaged in various configurations as a SnapPack™ assembly. In addition, Series 5 is completely interchangeable with other manufacturers.



Applications:

- Act as pull outlets for conductors being installed
- Provide openings for making splices and taps in conductors
- Act as mounting outlets for lighting fixtures and wiring devices
- Connect conduit sections
- Provide taps for branch conduit runs
- Make 90° bends in conduit runs
- Provide for access to conductors for maintenance and future system changes

Features/Benefits:

- Die cast copper-free aluminum construction is lightweight and corrosion resistant for long reliable service
- Epoxy powder coat finish provides additional corrosion resistance in an aesthetically pleasing appearance
- Conduit bodies are supplied with threaded hubs for use with Rigid/IMC conduit or as a combination body (threaded and with set screws for use with EMT or Rigid/IMC conduit on trade sizes)
- Domed aluminum cover provides additional cubic capacity
- SnapPack™ available in choice of 3 configurations to match customer preferences.

Certifications & Compliances:

- UL Listed
- cUL Listed
- UL File No. E-15022

Standard Materials:

- Bodies—Copper-Free Aluminum with epoxy powder paint
- Covers—Aluminum with stainless steel screws, natural finish
- Gaskets—Neoprene

Series 5 Features:

- **Integral gasket covers.** The new sheet aluminum covers feature a raised dome with stainless steel screws supplied with nylon washers and a gasket for simplifying installation—reducing inventory and labor costs. These innovative covers are UL and cUL Listed and are NEMA 4 Rated.



- **SnapPack™.** Designed for ordering and receiving convenience, the SnapPack combines a body, gasket, and sheet aluminum cover in a single assembly.

- Rigid body with traditional cover and gasket (e.g. LB15 CGN)
- Combination body with traditional cover and gasket (e.g. LB15 MTC)
- **NEMA 4** rigid body with new integral gasketed cover (e.g. X15 ICG)



Series 5

Series 5 Die Cast Aluminum Conduit Outlet Bodies, Covers and Gaskets



Series 5



TYPE LB

Trade Size	Outlet Body		SnapPack			Internal Col.In Cu. In.	Unit Qty	Weight Lbs Per 100*	Max # of Conductors
	Rigid/IMC Cat#	Combo EMT, Rigid/IMC Cat#	Rigid/IMC Body, Traditional Cover, and Gasket Cat#	Combo EMT, Body, Traditional Cover, and Gasket Cat#	NEMA 4 Rigid/IMC Body and Integral Cover & Gasket Cat#				
1/2"	LB15	LB15 MT	LB15 CGN	LB15 MTC	LB15 ICG	4.35	10	26	-
3/4"	LB25	LB25 MT	LB25 CGN	LB25 MTC	LB25 ICG	7.3	10	48	3 # 6 AWG
1"	LB35	LB35 MT	LB35 CGN	LB35 MTC	LB35 ICG	12.2	5	64	3 # 4 AWG
1 1/4"	LB45	LB45 MT	LB45 CGN	LB45 MTC	-	32.3	2	140	3 # 2 AWG
1 1/2"	LB55	LB55 MT	LB55 CGN	LB55 MTC	-	33.8	2	160	3 # 1/0 AWG
2"	LB65	LB65 MT	LB65 CGN	LB65 MTC	-	71.2	1	260	3 # 1/0 AWG
2 1/2"	LB75	LB75 MT*†	-	-	-	71.2	1	500	3 # 300 MCM
3"	LB85	LB85 MT*†	-	-	-	183.5	1	600	3 # 350 MCM
3 1/2"	LB95	LB95 MT*†	-	-	-	304.9	1	900	3 # 350 MCM
4"	LB105	LB105 MT*†	-	-	-	308	1	1000	3 # 350 MCM

†Combo EMT, Rigid/IMC Fittings greater than 2" trade size are SET-SCREW ONLY (not combination threaded and set-screw)

*Weight Lbs Per 100 is listed for outlet body only



TYPE LR

Trade Size	Outlet Body		SnapPack			Internal Col.In Cu. In.	Unit Qty	Weight Lbs Per 100*	Max # of Conductors
	Rigid/IMC Cat#	Combo EMT, Rigid/IMC Cat#	Rigid/IMC Body, Traditional Cover, and Gasket Cat#	Combo EMT, Body, Traditional Cover, and Gasket Cat#	NEMA 4 Rigid/IMC Body and Integral Cover & Gasket Cat#				
1/2"	LR15	LR15 MT	LR15 CGN	LR15 MTC	LR15 ICG	4.35	10	26	-
3/4"	LR25	LR25 MT	LR25 CGN	LR25 MTC	LR25 ICG	7.3	10	48	3 # 6 AWG
1"	LR35	LR35 MT	LR35 CGN	LR35 MTC	LR35 ICG	12.2	5	64	3 # 4 AWG
1 1/4"	LR45	LR45 MT	LR45 CGN	LR45 MTC	-	35.8	2	140	3 # 2 AWG
1 1/2"	LR55	LR55 MT	LR55 CGN	LR55 MTC	-	35.8	2	160	3 # 1/0 AWG
2"	LR65	LR65 MT	LR65 CGN	LR65 MTC	-	69.7	1	260	3 # 1/0 AWG
2 1/2"	LR75	-	-	-	-	69.7	1	500	3 # 300 MCM
3"	LR85	-	-	-	-	186	1	600	3 # 350 MCM
3 1/2"	LR95	-	-	-	-	306	1	900	3 # 350 MCM
4"	LR105	-	-	-	-	308	1	1000	3 # 350 MCM

*Weight Lbs Per 100 is listed for outlet body only

Series 5 Die Cast Aluminum Conduit Outlet Bodies, Covers and Gaskets



Series 5



TYPE LL

Trade Size	Outlet Body		SnapPack			Internal Col. In.	Unit Qty	Weight Lbs Per 100*	Max # of Conductors
	Rigid/IMC Cat#	Combo EMT, Rigid/IMC Cat#	Rigid/IMC Body, Traditional Cover, and Gasket Cat#	Combo EMT, Body, Traditional Cover, and Gasket Cat#	NEMA 4 Rigid/IMC Body and Integral Cover & Gasket Cat#				
1/2"	LL15	LL15 MT	LL15 CGN	LL15 MTC	LL15 ICG	4.35	10	30	-
3/4"	LL25	LL25 MT	LL25 CGN	LL25 MTC	LL25 ICG	7.3	10	48	3 # 6 AWG
1"	LL35	LL35 MT	LL35 CGN	LL35 MTC	LL35 ICG	12.2	5	64	3 # 4 AWG
1 1/4"	LL45	LL45 MT	LL45 CGN	LL45 MTC	-	35.8	2	140	3 # 2 AWG
1 1/2"	LL55	LL55 MT	LL55 CGN	LL55 MTC	-	35.8	2	160	3 # 1/0 AWG
2"	LL65	LL65 MT	LL65 CGN	LL65 MTC	-	69.7	1	270	3 # 1/2 AWG
2 1/2"	LL75	-	-	-	-	69.7	1	500	3 # 300 MCM
3"	LL85	-	-	-	-	186	1	600	3 # 350 MCM
3 1/2"	LL95	-	-	-	-	306	1	900	3 # 350 MCM
4"	LL105	-	-	-	-	308	1	1000	3 # 350 MCM

*Weight Lbs Per 100 is listed for outlet body only



TYPE C

Trade Size	Outlet Body		SnapPack			Internal Col. In.	Unit Qty	Weight Lbs Per 100*	Max # of Conductors
	Rigid/IMC Cat#	Combo EMT, Rigid/IMC Cat#	Rigid/IMC Body, Traditional Cover, and Gasket Cat#	Combo EMT, Body, Traditional Cover, and Gasket Cat#	NEMA 4 Rigid/IMC Body and Integral Cover & Gasket Cat#				
1/2"	C15	C15 MT	C15 CGN	C15 MTC	C15 ICG	4.35	10	27	-
3/4"	C25	C25 MT	C25 CGN	C25 MTC	C25 ICG	7.3	10	40	3 # 6 AWG
1"	C35	C35 MT	C35 CGN	C35 MTC	C35 ICG	12.2	5	64	3 # 4 AWG
1 1/4"	C45	C45 MT	C45 CGN	C45 MTC	-	32.3	2	165	3 # 2 AWG
1 1/2"	C55	C55 MT	C55 CGN	C55 MTC	-	33.8	2	150	3 # 1/0 AWG
2"	C65	C65 MT	C65 CGN	C65 MTC	-	69.5	1	270	3 # 1/2 AWG
2 1/2"	C75	-	-	-	-	69.5	1	500	3 # 300 MCM
3"	C85	-	-	-	-	188	1	600	3 # 350 MCM
3 1/2"	C95*	-	-	-	-	307	1	900	3 # 350 MCM
4"	C105*	-	-	-	-	309	1	1000	3 # 350 MCM

Series 5 Die Cast Aluminum Conduit Outlet Bodies, Covers and Gaskets



Series 5



TYPE T

Trade Size	Outlet Body		SnapPack			Internal Col.In Cu. In.	Unit Qty	Weight Lbs Per 100*	Max # of Conductors
	Rigid/IMC Cat#	Combo EMT, Rigid/IMC Cat#	Rigid/IMC Body, Traditional Cover, and Gasket Cat#	Combo EMT, Body, Traditional Cover, and Gasket Cat#	NEMA 4 Rigid/IMC Body and Integral Cover & Gasket Cat#				
1/2"	T15	T15 MT	T15 CGN	T15 MTC	T15 ICG	4.35	10	27	-
3/4"	T25	T25 MT	T25 CGN	T25 MTC	T25 ICG	7.3	10	40	3 # 6 AWG
1"	T35	T35 MT	T35 CGN	T35 MTC	T35 ICG	12.2	5	64	3 # 4 AWG
1 1/4"	T45	T45 MT	T45 CGN	T45 MTC	-	33.1	2	165	3 # 2 AWG
1 1/2"	T55	T55 MT	T55 CGN	T55 MTC	-	33.1	2	150	3 # 1/0 AWG
2"	T65	T65 MT	T65 CGN	T65 MTC	-	67	1	270	3 # 1/2 AWG
2 1/2"	T75	-	-	-	-	67	1	500	3 # 300 MCM
3"	T85	-	-	-	-	175	1	600	3 # 350 MCM
3 1/2"	T95*	-	-	-	-	298	1	900	3 # 350 MCM
4"	T105*	-	-	-	-	300	1	1000	3 # 350 MCM



TYPE TB

Trade Size	Outlet Body		SnapPack			Internal Col.In Cu. In.	Unit Qty	Weight Lbs Per 100*	Max # of Conductors
	Rigid/IMC Cat#	Combo EMT, Rigid/IMC Cat#	Rigid/IMC Body, Traditional Cover, and Gasket Cat#	Combo EMT, Body, Traditional Cover, and Gasket Cat#	NEMA 4 Rigid/IMC Body and Integral Cover & Gasket Cat#				
1/2"	TB15	-	-	-	TB15 ICG	4.5	10	29	-
3/4"	TB25	-	-	-	TB25 ICG	7.5	10	42	3 # 6 AWG
1"	TB35	-	-	-	TB35 ICG	10.8	5	58	3 # 4 AWG
1 1/4"	TB45	-	-	-	-	32.3	2	110	3 # 2 AWG
1 1/2"	TB55	-	-	-	-	34.2	2	109	3 # 2 AWG
2"	TB65	-	-	-	-	71.4	1	192	3 # 1/0 AWG



TYPE X

Trade Size	Outlet Body		SnapPack			Internal Col.In Cu. In.	Unit Qty	Weight Lbs Per 100*	Max # of Conductors
	Rigid/IMC Cat#	Combo EMT, Rigid/IMC Cat#	Rigid/IMC Body, Traditional Cover, and Gasket Cat#	Combo EMT, Body, Traditional Cover, and Gasket Cat#	NEMA 4 Rigid/IMC Body and Integral Cover & Gasket Cat#				
1/2"	X15	-	-	-	X15 ICG	4.5	10	31	-
3/4"	X25	-	-	-	X25 ICG	7.5	10	47	3 # 6 AWG
1"	X35	-	-	-	X35 ICG	10.8	5	62	3 # 4 AWG
1 1/4"	X45	-	-	-	-	32.3	2	118	3 # 2 AWG
1 1/2"	X55	-	-	-	-	34.2	2	118	3 # 2 AWG
2"	X65	-	-	-	-	71.4	1	213	3 # 1/0 AWG

*Weight Lbs Per 100 is listed for outlet body only

Series 5 Die Cast Aluminum Conduit Outlet Bodies, Covers and Gaskets



Series 5

INTEGRAL GASKET COVERS

Aluminum Cover
with Neoprene
Integral Gasket



Trade Size	Cat. #	Unit Qty.	Weight Lbs. Per 100
1/2"	150G	50	6
3/4"	250G	50	7
1"	350G	50	8
1 1/4" - 1 1/2"	450G	50	17
2"	650G	25	26
2 1/2" - 3"	850G	10	80
3 1/2" - 4"	950G	10	145

1/2" - 3" are NEMA 4 Rated

ALUMINUM COVERS

Aluminum



Trade Size	Cat. #	Unit Qty.	Weight Lbs. Per 100
1/2"	150	50	5
3/4"	250	50	6
1"	350	50	7
1 1/4" - 1 1/2"	450	50	15
2"	650	25	24
2 1/2" - 3"	850	10	78
3 1/2" - 4"	950	10	140

1/2" - 3" are NEMA 4 Rated

GASKETS

Neoprene



Trade Size	Cat. #	Unit Qty.	Weight Lbs. Per 100
1/2"	GASK015N	50	2
3/4"	GASK025N	50	2
1"	GASK035N	50	3
1 1/4" - 1 1/2"	GASK045N	50	6
2"	GASK065N	25	10
2 1/2" - 3"	GASK085N	10	20
3 1/2" - 4"	GASK095N	10	30

TYPE LB DIMENSIONS—THREADED & SET SCREW

Trade Size	A	B	C	D	E	F
1/2"	1.31	3.87	0.50	2.11	4.24	1.07
3/4"	1.53	4.67	0.75	2.38	4.97	1.28
1"	1.74	5.37	1.00	2.74	5.79	1.56
1 1/4"	2.49	7.23	1.25	3.50	7.79	1.99
1 1/2"	2.49	7.23	1.50	3.65	7.81	2.27
2"	3.10	9.46	2.00	4.24	10.20	2.91
2 1/2"	4.44	12.22	2.50	5.75	13.14	3.43
3"	4.44	12.22	3.00	6.41	13.14	4.13
3 1/2"	5.42	14.83	3.50	7.11	15.46	4.65
4"	5.42	14.83	4.00	7.20	15.46	5.16

TYPE LR DIMENSIONS—THREADED & SET SCREW

Trade Size	A	B	C	D	E	F
1/2"	1.31	3.87	0.50	2.06	4.40	1.40
3/4"	1.53	4.67	0.75	2.28	5.07	1.64
1"	1.74	5.37	1.00	2.51	5.94	1.90
1 1/4"	2.49	7.23	1.25	3.50	7.87	2.85
1 1/2"	2.49	7.23	1.50	3.50	7.87	2.85
2"	3.10	9.46	2.00	3.83	9.88	3.41
2 1/2"	4.50	12.22	2.50	6.00	13.14	4.00
3"	4.65	12.22	3.00	6.10	13.00	4.70
3 1/2"	5.42	14.83	3.50	6.40	15.45	5.43
4"	5.42	14.83	4.00	6.40	15.45	5.43

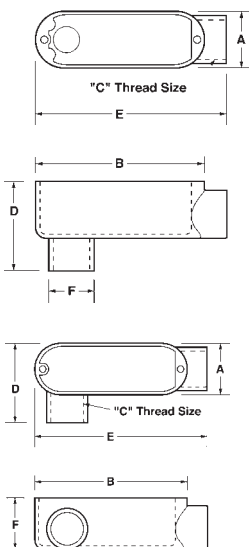

Series 5 Die Cast Aluminum Conduit Outlet Bodies, Covers and Gaskets



Series 5

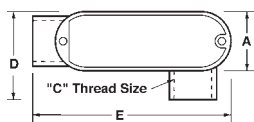

TYPE LL DIMENSIONS—THREADED & SET SCREW

Trade Size	A	B	C	D	E	F
1/2"	1.31	3.87	0.50	2.06	4.40	1.40
3/4"	1.53	4.67	0.75	2.28	5.07	1.64
1"	1.74	5.37	1.00	2.68	5.94	1.90
1 1/4"	2.49	7.23	1.25	3.50	7.87	2.85
1 1/2"	2.49	7.23	1.50	3.50	7.87	2.85
2"	3.10	9.46	2.00	3.83	10.20	3.41
2 1/2"	4.50	12.22	2.50	6.00	13.14	4.00
3"	4.65	12.22	3.00	6.10	13.00	4.70
3 1/2"	5.42	14.83	3.50	6.05	15.35	5.43
4"	5.42	14.83	4.00	6.05	15.35	5.43

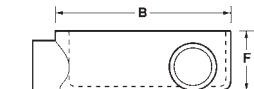

TYPE C DIMENSIONS—THREADED & SET SCREW

Trade Size	A	B	C	D	E	F
1/2"	1.31	3.87	0.50	1.40	4.82	1.07
3/4"	1.53	4.67	0.75	1.64	5.50	1.35
1"	1.74	5.37	1.00	1.90	6.44	1.67
1 1/4"	2.49	7.23	1.25	2.73	8.45	2.27
1 1/2"	2.49	7.23	1.50	2.73	8.45	2.27
2"	3.10	9.46	2.00	3.41	10.71	2.91
2 1/2"	4.50	12.22	2.50	4.30	14.00	3.50
3"	4.65	12.22	3.00	4.66	13.80	4.13
3 1/2"	5.42	14.83	3.50	5.36	16.10	5.30
4"	5.42	14.83	4.00	5.36	16.10	5.30

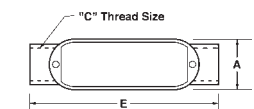

TYPE T DIMENSIONS—THREADED & SET SCREW

Trade Size	A	B	C	D	E	F
1/2"	1.31	3.87	0.50	1.40	4.82	1.07
3/4"	1.53	4.67	0.75	1.64	5.40	1.35
1"	1.74	5.37	1.00	1.90	6.33	1.15
1 1/4"	2.49	7.23	1.25	2.73	8.45	2.27
1 1/2"	2.49	7.23	1.50	2.73	8.45	2.27
2"	3.10	9.46	2.00	3.41	10.71	2.91
2 1/2"	4.50	12.22	2.50	4.00	14.00	3.50
3"	4.65	12.22	3.00	4.66	13.80	4.13
3 1/2"	5.42	14.83	3.50	5.40	16.00	5.30
4"	5.42	14.83	4.00	5.40	16.00	5.30

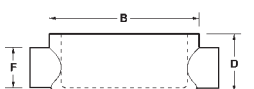

TYPE TB DIMENSIONS—THREADED & SET SCREW

Trade Size	A	B	C	D	E	F
1/2"	1.31	3.92	0.50	2.10	4.72	1.07
3/4"	1.53	4.64	0.75	2.40	5.51	1.28
1"	1.74	5.38	1.00	2.77	6.47	1.56
1 1/4"	2.49	7.24	1.25	3.53	8.25	1.99
1 1/2"	2.49	7.24	1.50	3.53	8.25	2.27
2"	3.10	9.50	2.00	4.50	10.50	2.91

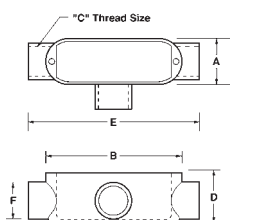

TYPE X DIMENSIONS—THREADED & SET SCREW

Trade Size	A	B	C	D	E	F
1/2"	1.31	3.92	0.50	1.37	4.72	1.07
3/4"	1.53	4.64	0.75	1.63	5.51	1.28
1"	1.74	5.38	1.00	1.88	6.47	1.56
1 1/4"	2.49	7.24	1.25	2.51	8.25	1.99
1 1/2"	2.49	7.24	1.50	2.50	8.25	2.27
2"	3.10	9.50	2.00	3.40	10.50	2.91

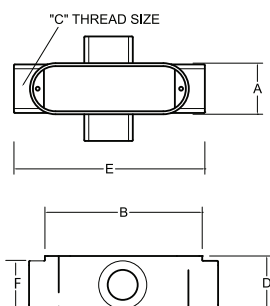
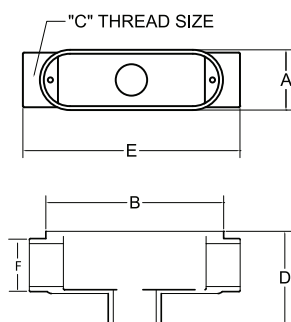

Form 5 Conduit Outlet Bodies, Covers & Gaskets - Malleable Iron



Applications:

Form 5 Malleable Iron Conduit Bodies are used in conduit systems to:

- Act as pull outlets for conductors being installed
- Provide openings for making splices and taps in conductors
- Act as mounting outlets for lighting fixtures and wiring devices
- Connect conduit sections
- Provide taps for branch conduit runs
- Make 90 degree bends in conduit runs
- Provide for access to conductors for maintenance and future system changes

Features:

- Interchangeable with Appleton Form 35 Conduit Bodies
- Built-in rollers on 1¼" to 4" C and LB bodies to facilitate wire pulling
- Smooth and rounded integral bushings for protection of wire insulation
- Solid neoprene gaskets may be converted to open type by pulling out perforated center section
- Stainless steel cover screws
- Domed sheet steel covers provide additional cubic capacity
- Integral gasket cover provides NEMA 4 rating

Certifications and Compliances:

- UL File No. E-15022
- UL Standard 514B
- cUL to CSA Standard C22.2 No. 18

Standard Materials:

- Bodies – Malleable iron
- Gaskets – Neoprene
- Covers – sheet steel or malleable
- Cover screws – stainless steel

Standard Finishes:

- Malleable iron – electrogalvanized and aluminum acrylic paint
- Neoprene – natural
- Sheet steel – electrogalvanized
- Stainless steel – natural

Options:

Conduit Bodies & Cast Covers
Hot dipped galvanized

Suffix
HDG



Form 5

Form 35 is a registered trademark of Appleton Electric/EGS.

Form 5 Conduit Outlet Bodies, Covers & Gaskets - Malleable Iron



Options:

Description

‡Snapack™ - packaged body and integral gasket cover
Available on all configurations (1/2" - 2")

Suffix
CG

TYPE LB ‡



Cat.#	Size	Internal Vol. in Cu. In.	Unit Qty.	Wt. Lbs. Per 100	Max. # of Conductors
LB50M	1/2"	4.5	10	71	N/A
LB75M	3/4"	7.5	10	97	3 #6 AWG
LB100M	1"	12.5	10	143	3 #4 XHHW
LB125M*	1 1/4"	32.0	5	287	3 #2 XHHW
LB150M*	1 1/2"	35.3	5	331	3 #1/0 XHHW
LB200M*	2"	73.0	1	534	3 #4/0 XHHW
LB250M*	2 1/2"	142.0	1	1105	3 #300 MCM XHHW
LB300M*	3"	173.0	1	1160	3 #400 MCM XHHW
LB350M*	3 1/2"	292.0	1	1989	3 #500 MCM XHHW
LB400M*	4"	324.0	1	2099	3 #500 MCM XHHW

*1 1/2" - 4" LB and C Bodies supplied with built in rollers to facilitate wire pulling.

TYPE LL ‡



Cat.#	Size	Internal Vol. in Cu. In.	Unit Qty.	Wt. Lbs. Per 100	Max. # of Conductors
LL50M	1/2"	4.5	10	76	N/A
LL75M	3/4"	7.5	10	95	3 #6 AWG
LL100M	1"	12.5	10	138	3 #4 XHHW
LL125M	1 1/4"	32.0	5	309	3 #2 XHHW
LL150M	1 1/2"	33.0	5	332	3 #2 XHHW
LL200M	2"	68.0	1	497	3 #4/0 XHHW
LL250M	2 1/2"	142.0	1	1105	3 #300 MCM XHHW
LL300M	3"	173.0	1	1437	3 #350 MCM XHHW
LL350M	3 1/2"	292.0	1	2321	3 #350 MCM XHHW
LL400M	4"	324.0	1	2431	3 #350 MCM XHHW

TYPE C ‡



Cat.#	Size	Internal Vol. in Cu. In.	Unit Qty.	Wt. Lbs. Per 100	Max. # of Conductors
C50M	1/2"	4.5	10	98	N/A
C75M	3/4"	7.5	10	118	3 #6 AWG
C100M	1"	12.5	10	170	3 #4 XHHW
C125M*	1 1/4"	35.0	5	309	3 #2 XHHW
C150M*	1 1/2"	35.3	5	368	3 #1/0 XHHW
C200M*	2"	75.0	1	552	3 #4/0 XHHW
C250M*	2 1/2"	153.0	1	1216	3 #300 MCM XHHW
C300M*	3"	181.0	1	1437	3 #300 MCM XHHW
C350M*	3 1/2"	290.0	1	2210	3 #350 MCM XHHW
C400M*	4"	320.0	1	2321	3 #350 MCM XHHW

*1 1/4" - 4" LB and C Bodies supplied with built in rollers to facilitate wire pulling.

TYPE LR ‡



Cat.#	Size	Internal Vol. in Cu. In.	Unit Qty.	Wt. Lbs. Per 100	Max. # of Conductors
LR50M	1/2"	4.5	10	71	N/A
LR75M	3/4"	7.5	10	100	3 #6 AWG
LR100M	1"	12.5	10	157	3 #4 XHHW
LR125M	1 1/4"	32.0	5	332	3 #2 XHHW
LR150M	1 1/2"	35.3	5	345	3 #2 XHHW
LR200M	2"	68.0	1	626	3 #4/0 XHHW
LR250M	2 1/2"	142.0	1	1105	3 #300 MCM XHHW
LR300M	3"	173.0	1	1437	3 #350 MCM XHHW
LR350M	3 1/2"	292.0	1	2321	3 #350 MCM XHHW
LR400M	4"	324.0	1	2500	3 #350 MCM XHHW

TYPE T ‡



Cat.#	Size	Internal Vol. in Cu. In.	Unit Qty.	Wt. Lbs. Per 100	Max. # of Conductors
T50M	1/2"	6.0	10	111	N/A
T75M	3/4"	9.5	10	137	3 #6 AWG
T100M	1"	15.0	10	196	3 #4 XHHW
T125M	1 1/4"	33.0	5	332	3 #2 XHHW
T150M	1 1/2"	36.0	5	368	3 #1 XHHW
T200M	2"	76.0	1	663	3 #2/0 XHHW
T250M	2 1/2"	142.0	1	1271	3 #300 MCM XHHW
T300M	3"	173.0	1	1547	3 #300 MCM XHHW
T350M	3 1/2"	292.0	1	2542	3 #350 MCM XHHW
T400M	4"	324.0	1	2542	3 #350 MCM XHHW

Form 5 Conduit Outlet Bodies, Covers & Gaskets - Malleable Iron



TYPE TB ‡



Cat.#	Size	Internal Vol. in Cu. In.	Unit Qty.	Wt. Lbs. Per 100	Max. # of Conductors
TB50M	1/2"	6.0	10	88	N/A
TB75M	3/4"	9.5	10	120	3 #6 AWG
TB100M	1"	15.0	10	197	3 #6 AWG
TB125M	1 1/4"	33.0	5	342	3 #6 AWG
TB150M	1 1/2"	36.0	5	420	3 #4 XHHW
TB200M	2"	76.0	1	691	3 #1/0 XHHW

TYPE X ‡



Cat.#	Size	Internal Vol. in Cu. In.	Unit Qty.	Wt. Lbs. Per 100	Max. # of Conductors
X50M	1/2"	6.0	10	139	N/A
X75M	3/4"	9.5	10	172	3 #6 AWG
X100M	1"	15.0	10	247	3 #4 XHHW
X125M	1 1/4"	33.0	5	416	3 #2 XHHW
X150M	1 1/2"	36.0	5	463	3 #1/0 XHHW
X200M	2"	76.0	1	833	3 #2/0 XHHW

SHEET STEEL COVERS

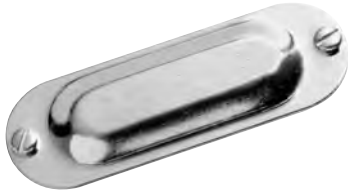

Cat. #	Size	Unit Qty.	Wt. Lbs. Per 100
K50S	1/2"	50	9
K75S	3/4"	50	13
K100S	1"	25	19
K125S	1 1/4" & 1 1/2"	20	31
K200S	2"	5	50
K250S	2 1/2" & 3"	5	94
K350S	3 1/2" & 4"	5	138

CAST IRON COVERS



Cat. #	Size	Unit Qty.	Wt. Lbs. Per 100
K50CM	1/2"	50	23
K75CM	3/4"	50	31
K100CM	1"	25	41
K125CM	1 1/4" & 1 1/2"	20	91
K200CM	2"	5	208
K250CM	2 1/2" & 3"	5	358
K350CM	3 1/2" & 4"	5	550

NEOPRENE GASKETS - PERFORATED CENTER



Cat. #	Size	Unit Qty.
GK50N	1/2"	100
GK75N	3/4"	100
GK100N	1"	50
GK125N	1 1/4" & 1 1/2"	25
GK200N	2"	25
GK250N	2 1/2" & 3"	25
GK350N	3 1/2" & 4"	25

INTEGRAL GASKET COVER - SHEET STEEL



Cat. #	Size	Unit Qty.	Wt. Lbs. Per 100
K50SG	1/2"	50	14
K75SG	3/4"	50	16
K100SG	1"	25	46
K125SG	1 1/4" & 1 1/2"	20	62
K200SG	2"	5	70
K250SG	2 1/2" & 3"	5	190
K350SG	3 1/2" & 4"	5	340

Form 5

Form 5 Conduit Outlet Bodies, Covers & Gaskets - Malleable Iron



DIMENSIONS (In Inches):

Form 5 Iron LB

Size	1/2	3/4	1	1 1/4	1 1/2	2	2 1/2	3	3 1/2	4
A	1.34	1.50	1.80	2.60	2.60	3.12	4.31	4.31	5.62	5.62
B	4.68	5.37	6.20	8.12	8.12	10.50	13.60	13.87	16.25	16.60
C	2.05	2.25	2.65	2.75	2.83	4.42	5.40	5.90	6.90	7.21

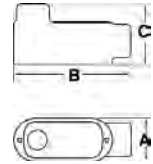

Form 5 Iron LL

Conduit	1/2	3/4	1	1 1/4	1 1/2	2	2 1/2	3	3 1/2	4
A	2.05	2.25	2.65	2.75	3.50	4.12	5.71	5.87	7.13	7.13
B	4.68	5.37	6.20	8.12	8.12	10.50	13.60	13.87	16.50	16.50
C	1.37	1.70	1.90	2.75	2.83	3.31	3.90	4.75	6.81	7.19

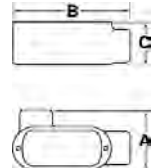

Form 5 Iron LR

Conduit	1/2	3/4	1	1 1/4	1 1/2	2	2 1/2	3	3 1/2	4
A	2.05	2.25	2.65	2.75	3.50	4.12	5.71	5.87	6.10	6.95
B	4.68	5.37	6.20	8.12	8.12	10.50	13.60	13.87	6.25	16.25
C	1.37	1.70	1.90	2.75	2.83	3.31	3.90	4.75	5.62	5.62

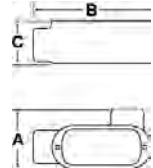

Form 5 Iron C

Conduit	1/2	3/4	1	1 1/4	1 1/2	2	2 1/2	3	3 1/2	4
A	1.34	1.50	1.80	2.60	2.60	3.12	4.31	4.31	4.88	4.88
B	5.38	6.00	7.05	9.00	9.00	11.50	15.00	15.12	18.13	18.13
C	1.37	1.70	1.90	2.75	2.83	3.31	3.90	4.75	5.19	5.56

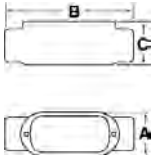

Form 5 Iron T

Conduit	1/2	3/4	1	1 1/4	1 1/2	2	2 1/2	3	3 1/2	4
A	2.05	2.25	2.65	2.75	3.50	4.12	5.71	5.87	6.81	7.15
B	5.38	6.00	7.05	9.00	9.00	11.50	15.00	15.12	18.13	18.13
C	1.34	1.50	1.80	2.60	2.60	3.12	4.31	4.31	5.19	5.56

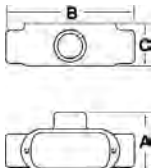

Form 5 Iron TB

Conduit	1/2	3/4	1	1 1/4	1 1/2	2
A	1.34	1.50	1.80	2.60	2.60	3.12
B	5.38	6.00	7.05	9.00	9.00	11.50
C	2.05	2.25	2.65	2.75	2.83	4.42

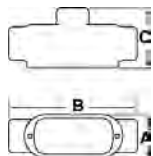

Form 5 Type X

Conduit	1/2	3/4	1	1 1/4	1 1/2	2
A	2.79	2.93	3.56	4.43	4.43	5.4
B	5.41	6.08	7.1	9.1	9.1	11.75
C	1.75	1.97	2.25	2.55	2.75	3.45

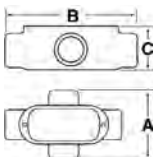

Form 5

Cast Device Boxes



FS and FD Boxes

Applications:

Cast device boxes are installed to:

- Accommodate wiring devices
- Act as pull boxes for conductors in a conduit system
- Provide openings to make splices and taps in conductors
- Use indoors and outdoors
- Use in applications where boxes may be subjected to rough use

Features:

- Green ground screw is located on the flange of the box for easy ground wire termination and is standard on boxes
- Suitable for use in wet locations when used with gasket and flat blank covers
- Mounting lugs standard
- Tapered threaded hubs (NPT) with integral bushing
- Available as shallow (FS) or deep (FD) configuration.
- Ample wiring room provided in either FS or FD configuration
- Wide selection of surface or flush covers available in three materials (sheet malleable, steel, aluminum)
- Malleable iron construction provides high tensile strength for strong, dependable service
- Covers are individually bagged and supplied with screws



Cast Device Boxes

Certifications and Compliances:

- c UL us
- c CSA us

Standard Materials:

- Malleable iron

Standard Finishes:

- Malleable iron – zinc electroplate

FS BOXES



FSM1



Cat. #	Trade Size	Unit Qty.	Wt. Lbs. Per 100
FSM1	1/2"	5	222
FSM2	3/4"	5	234
FSM3	1"	5	243

FD BOXES



FDM1



Cat. #	Trade Size	Unit Qty.	Wt. Lbs. Per 100
FDM1	1/2"	2	278
FDM2	3/4"	2	273
FDM3	1"	2	284

FS and FD Dimensions

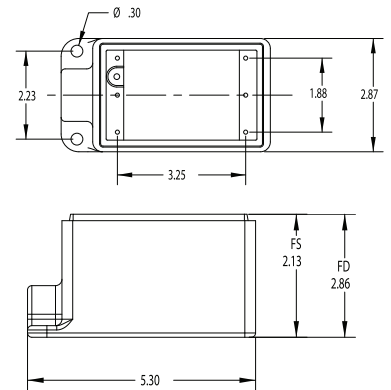

FSC BOXES



FSCM1



Cat. #	Trade Size	Unit Qty.	Wt. Lbs. Per 100
FSCM1	1/2"	5	234
FSCM2	3/4"	5	241
FSCM3	1"	5	250

FDC BOXES



FDCM1



Cat. #	Trade Size	Unit Qty.	Wt. Lbs. Per 100
FDCM1	1/2"	2	313
FDCM2	3/4"	2	294
FDCM3	1"	2	306

FSC and FDC Dimensions

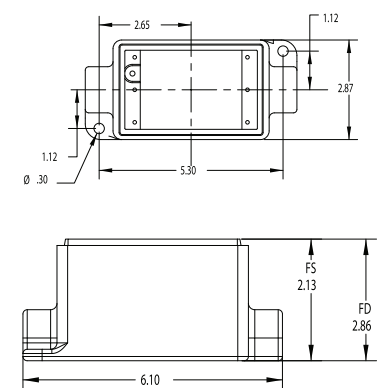

Cast Device Boxes



FS and FD Covers

Cast Device Covers - Malleable

FS AND FD COVERS - MALLEABLE

Cast Device Boxes



FBCM1

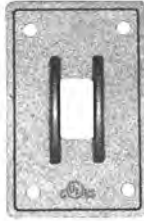

SWCM1



RCM1

Cat. #	Description	Unit Qty.	Wt. Lbs. Per 100
FBCM1	Malleable Iron Flat Blank Cover	25	56
SWCM1	Malleable Iron Switch Cover	25	63
RCM1	Malleable Iron Duplex Receptacle Cover	25	55

FS AND FD COVERS - STEEL



FBCS1



SWCS1



RCS1



GFICS1



Cat. #	Description	Unit Qty.	Wt. Lbs. Per 100
FBCS1	Steel Flat Blank Cover	25	18
SWCS1	Steel Switch Cover	25	16
RCS1	Steel Duplex Receptacle Cover	25	13
GFICS1	Steel GFCI Cover	25	12

FS AND FD COVERS - ALUMINUM



FBCA1



FSGSK1

Cat. #	Description	Unit Qty.	Wt. Lbs. Per 100
FBCA1	Aluminum Flat Blank Cover	25	9

Cat. #	Description	Unit Qty.	Wt. Lbs. Per 100
FSGSK1	Neoprene Gasket	25	3.5

Applications:

- Myers™ Scru-tite® and Ground hub are used in the termination of electrical circuits through wall of the enclosure
- Ideal for pharmaceutical, chemical and food processing, pulp/paper and nuclear industries.
- Resistant to a variety of chemicals, including acetic, citric and salt water.
- The O-ring is a special "Viton (75)" and has excellent chemical resistance.
- Hub is provided with a stainless steel ground nut.

Features:

- Vibration proof
- Grounding screw for added safety
- Captive o-ring gasket
- No welding
- Posi-Lok insulated throat (insuliner)
- Fit standard knockouts
- Easy installation
- Controlled thread lengths
- NPSL on male thread
- No sharp edges (along parting line)



Certifications and Compliances:

- NEC/CEC:
 - Class I, Division 2
 - Class II, Division 1 & 2
 - Class III, Division 1 & 2
- UL Listed – UL Standard 514B
- CSA Certified – Certified by UL to CSA standard C22.2 No. 18
- NEMA Type 2, 3, 3R, 4, 4X, 12 (std hub)
- NEMA Type 2, 3, 3R, 4, 4X, 12 (ground hub)

Standard Materials:

- Nut: Zamek-2, Zamek-3, Aluminium (Al 360), Stainless (316)
- Body: Zamek-2, Zamek-3, Aluminium (Al 360), Stainless (316)
- Insuliner: Lexan
- O-Ring: Gasket Vi Ton
- Ground Screw: Steel

Standard Finishes:

- Aluminum: Natural
- Zinc: Natural

Optional Materials and Finishes:

- Stainless: Natural
- Zinc: Chrome-plate

Hub Basic Scru-Tite® – NEMA 2, 3, 3R, 4, 4X and 12

Zinc
UL File No. E-27258



Cat. #	Size	Unit Qty.	Wt. Lbs. Per 100
ST 03†	3/8"	25	12
ST 1†	1/2"	25	20
ST 2†	3/4"	25	32
ST 3†	1"	25	40
ST 4†	1 1/4"	10	60
ST 5†	1 1/2"	10	70
ST 6†	2"	10	90
ST 7†	2 1/2"	5	200
ST 8	3"	2	250
ST 9	3 1/2"	2	300
ST 10	4"	2	350
ST 11*	5"	1	600
ST 12*	6"	1	800

†Optional Nickel-Chrome Plate Finish. Add suffix -CP. See price list.
*Not supplied with insulator.

Hub Basic Scru-Tite® – NEMA 2, 3, 3R, 4, 4X and 12

Aluminum
UL File No. E-27258



Cat. #	Size	Unit Qty.	Wt. Lbs. Per 100
STA 1	1/2"	25	8
STA 2	3/4"	25	16
STA 3	1"	25	16
STA 4	1 1/4"	10	30
STA 5	1 1/2"	10	30
STA 6	2"	10	50
STA 7	2 1/2"	5	80
STA 8	3"	2	100
STA 9	3 1/2"	2	150
STA 10	4"	2	150
STA 11	5"	1	300
STA 12	6"	1	300

Stainless Steel Ground Hub – NEMA 2, 3, 3R, 4, 4X and 12

Stainless Steel – Type 316
UL File No. E-59509



Cat. #	Size	Unit Qty.	Wt. Lbs. Per 100
SSTG 1	1/2"	10	20
SSTG 2	3/4"	10	30
SSTG 3	1"	10	43
SSTG 4	1 1/4"	5	55
SSTG 5	1 1/2"	5	73
SSTG 6	2"	5	95
SSTG 7	2 1/2"	2	—
SSTG 8	3"	2	—
SSTG 9	3 1/2"	2	—
SSTG 10	4"	2	—

Ground Hub – NEMA 2, 3, 3R, 4, 4X and 12

Zinc
UL File No. E-59509



Max. Copper
Grd. Wire Size

Cat. #	Size	Unit Qty.	Wt. Lbs. Per 100	CSA	UL
STG 1	1/2"	25	20	#8	#8
STG 2	3/4"	25	30	#8	#8
STG 3	1"	25	43	#8	#8
STG 4	1 1/4"	10	55	#8	#8
STG 5	1 1/2"	10	73	#6	#8
STG 6	2"	10	95	#4	#8
STG 7	2 1/2"	5	190	#2	#6
STG 8	3"	2	263	1 / 0	#6
STG 9	3 1/2"	2	300	2 / 0	#6
STG 10	4"	2	350	2 / 0	#4
STG 11*	5"	1	625	2 / 0	#2
STG 12*	6"	1	750	3 / 0	#1

*Not supplied with insulator

Ground Hub Basic Scru-Tite®

Zinc
ATEX Approval with DEMKO 07 ATEX 0618172U
II 2 G Ex e II Class I, Zone 1, AEx e II
UL File No. 187273 Class I, Zone 1, Ex e II



Cat. #	Size	Unit Qty.	Wt. Lbs. Per 100
STGK 1	1/2"	10	20
STGK 2	3/4"	10	30
STGK 3	1"	10	43
STGK 4	1 1/4"	5	55
STGK 5	1 1/2"	5	73
STGK 6	2"	5	95

Stainless Steel – Type 316

ATEX Approval with DEMKO 07 ATEX 0618172U
II 2 G Ex e II Class I, Zone 1, AEx e II
UL File No. E-187273 Class I, Zone 1, Ex e II



Cat. #	Size	Unit Qty.	Wt. Lbs. Per 100
SSTGK 1	1/2"	10	20
SSTGK 2	3/4"	10	30
SSTGK 3	1"	10	43
SSTGK 4	1 1/4"	5	55
SSTGK 5	1 1/2"	5	73
SSTGK 6	2"	5	95

Ground Nut

Zinc



Cat. #	Size	Unit Qty.	Wt. Lbs. Per 100	Max. Copper Grd. Wire Size	
				CSA	UL
STGN 1	1/2"	25	6	#8	#8
STGN 2	3/4"	25	10	#8	#8
STGN 3	1"	25	13	#8	#8
STGN 4	1 1/4"	10	15	#8	#8
STGN 5	1 1/2"	10	23	#6	#8
STGN 6	2"	10	30	#4	#8

Ground Hub – NEMA 2, 3, 3R, 4, 4X and 12

Aluminum – Type 360



Max. Copper
Grd. Wire Size

Cat. #	Size	Unit Qty.	Wt. Lbs. Per 100	CSA	UL
STAG 1	1/2"	25	10	#8	#8
STAG 2	3/4"	25	14	#8	#8
STAG 3	1"	25	18	#8	#8
STAG 4	1 1/4"	10	25	#8	#8
STAG 5	1 1/2"	10	33	#6	#8
STAG 6	2"	10	45	#4	#8
STAG 7	2 1/2"	5	90	#2	#6
STAG 8	3"	2	125	1 / 0	#6
STAG 9	3 1/2"	2	138	2 / 0	#6
STAG 10	4"	2	150	2 / 0	#4
STAG 11	5"	1	325	3 / 0	#2
STAG 12	6"	1	350	3 / 0	#1

Ground Nut

Aluminum



Max. Copper
Grd. Wire
Size
CSA

Cat. #	Size	Unit Qty.	Wt. Lbs. Per 100	CSA	UL
STAGN 1	1/2"	25	3	#8	#8
STAGN 2	3/4"	25	5	#8	#8
STAGN 3	1"	25	6	#8	#8
STAGN 4	1 1/4"	10	8	#8	#8
STAGN 5	1 1/2"	10	10	#6	#8
STAGN 6	2"	10	13	#4	#8

Cap-Off

Zinc



Cat. #	Size	Unit Qty.	Wt. Lbs. Per 100
STC 1	1/2"	25	13
STC 2	3/4"	25	20
STC 3	1"	25	28
STC 4	1 1/4"	10	40
STC 5	1 1/2"	10	53
STC 6	2"	10	70

Cap-Off

Aluminum



Cat. #	Size	Unit Qty.	Wt. Lbs. Per 100
STAC 1	1/2"	25	6
STAC 2	3/4"	25	8
STAC 3	1"	25	12

Through-Bulkhead Fitting

Zinc



Cat. #	Size	Unit Qty.	Wt. Lbs. Per 100
STTB 1*	1/2"	5	30
STTB 2*	3/4"	5	50
STTB 3*	1"	5	70
STTB 4*	1 1/4"	5	85
STTB 5*	1 1/2"	5	110
STTB 6*	2"	5	160
STTB 7	2 1/2"	4	244
STTB 8	3"	2	312
STTB 9	3 1/2"	2	350
STTB 10	4"	2	400

*UL Listed

Through-Bulkhead Fitting

Aluminum

Packaged as two pieces unassembled



Cat. #	Size	Unit Qty.	Wt. Lbs. Per 100
STTBA 1*	1/2"	5	20
STTBA 2*	3/4"	5	35
STTBA 3*	1"	5	30
STTBA 4*	1 1/4"	5	40
STTBA 5*	1 1/2"	5	50
STTBA 6*	2"	5	70
STTBA 7	2 1/2"	4	106
STTBA 8	3"	2	138

*UL Listed

Through-Bulkhead Fitting without nipples

Zinc

Packaged as two pieces unassembled



Cat. #	Size	Unit Qty.	Wt. Lbs. Per 100
STTTB 1	1/2"	5	35
STTTB 2	3/4"	5	60
STTTB 3	1"	5	75
STTTB 4	1 1/4"	5	85
STTTB 5	1 1/2"	5	120
STTTB 6	2"	5	170

Through-Bulkhead Fitting without nipples

Aluminum



Cat. #	Size	Unit Qty.	Wt. Lbs. Per 100
STTTBA 1	1/2"	5	15
STTTBA 2	3/4"	5	25
STTTBA 3	1"	5	35
STTTBA 4	1 1/4"	5	40
STTTBA 5	1 1/2"	5	50
STTTBA 6	2"	5	75

Non-Hazardous Drain Plug

Stainless Steel
UL File No. E-23223



Cat. #	Size	Unit Qty.	Wt. Lbs. Per 100
SSTC 1	1/2"	25	13
SSTC 1CD	1/2"	10	13

Note: SSTC-1 is for knockouts and is supplied with a locknut and straight threads. SSTC-1CD is for threaded openings and is supplied without locknut and NPT threads. Not gasketed to allow for water drainage

Non-Hazardous Drain Plug

Aluminum
UL File No. E-23223



Cat. #	Size	Unit Qty.	Wt. Lbs. Per 100
STAC 1ST	1/2"	25	6
STAC 1CD	1/2"	25	6

Note: STAC-1ST is for knockouts and is supplied with a locknut and straight threads. STAC-1CD is for threaded openings and is supplied without locknut and NPT threads. Not gasketed to allow for water drainage

Metric To NPT Adapter

Zinc



Cat. #	Size	Unit Qty.	Wt. Lbs. Per 100
STM 1	M20 to 1/2"	25	12
STM 2	M25 to 3/4"	25	32
STM 3	M32 to 1"	25	32
STM 4	M40 to 1 1/4"	10	40
STM 5	M50 to 1 1/2"	10	50
STM 6	M63 to 2"	10	70

Note: The Myers Metric to NPT hub adapter is used to convert a threaded metric entry to a NPT entry. The female thread is NPT and the male thread is metric.

Metric To NPT Adapter

Stainless Steel



Cat. #	Size	Unit Qty.	Wt. Lbs. Per 100
SSTM 1	M20 to 1/2"	10	12
SSTM 2	M25 to 3/4"	10	20
SSTM 3	M32 to 1"	10	32
SSTM 4	M40 to 1 1/4"	5	40
SSTM 5	M50 to 1 1/2"	5	50
SSTM 6	M63 to 2"	5	70

SCHEDULE OF DIMENSIONS

Pipe Size	Cat. #	A	B	C	D	E		F	G	H	J "O" Ring		K	
						Min.	Max.				C.S.	O.D.	Min.	Max.
1/4	ST 02	1 3/2	1 5/16	2 1/32	1/8	.350	.364	1/4 NPT	1/4 NPS	60°	3/21	3/4	3 5/64	9/16
3/8	ST 03†	1 3/2	1 1/8	2 1/32	1/8	.468	.493	3/8 NPT	3/8 NPS	60°	3/32	1 5/16	4 3/64	1 1/16
1/2	ST 1†	1 11/32	1 7/16	1 3/16	3/16	.591	.622	1/2 NPT	1/2 NPS	60°	1/8	1 1/2	5 5/64	7/8
3/4	ST 2†	1 15/32	1 23/32	2 3/32	3/16	.783	.824	3/4 NPT	3/4 NPS	60°	1/8	1 7/16	1 1/16	1 1/8
1	ST 3†	1 21/32	2	1 1/32	1/4	.997	1.049	1 NPT	1 NPS	60°	1/8	1 3/4	1 21/64	1 3/8
1 1/4	ST 4†	1 11/16	2 3/8	1 1/32	1/4	1.311	1.380	1 1/4 NPT	1 1/4 NPS	60°	1/8	2 1/8	1 43/64	1 3/4
1 1/2	ST 5†	1 11/16	2 3/4	1 1/32	1/4	1.529	1.610	1 1/2 NPT	1 1/2 NPS	60°	1/8	2 1/2	1 59/64	2
2	ST 6†	1 3/4	3 1/4	1 3/32	1/4	1.964	2.067	2 NPT	2 NPS	60°	1/8	3	2 23/64	2 1/2
2 1/2	ST 7†	2 1/32	3 3/4	1 9/32	1/4	2.346	2.469	2 1/2 NPT	2 1/2 NPS	60°	1/8	3 1/2	2 57/64	3
3	ST 8	2 5/16	4 3/8	1 3/8	1/4	2.915	3.068	3 NPT	3 NPS	45°	1/8	4 1/8	3 39/64	3 3/8
3 1/2	ST 9	2 3/8	5	1 7/16	1/4	3.371	3.548	3 1/2 NPT	3 1/2 NPS	45°	1/8	4 3/8	4 1/64	4 1/8
4	ST 10	2 7/16	5 1/2	1 1/2	1/4	3.825	4.026	4 NPT	4 NPS	45°	1/8	5 1/8	4 39/64	4 3/8
5	ST 11*	2 15/16	6 1/8	2	1/4	4.795	5.047	5 NPT	5 NPS	45°	1/8	6 1/2	5 37/64	5 1/16
6	ST 12*	3	7 1/16	2	5/16	5.762	6.065	6 NPT	6 NPS	45°	1/8	7 1/4	6 41/64	6 3/4

Conduit Hubs

*Not supplied with insulator.

Options:

Description

† Optional Nickel-Chrome Plate Finish. See price list.

Suffix
-CP

Tolerance		Cat. #	Material
Decimal	+/- .010	ST	Zinc
Fractional	+/- 1/16	STA	Aluminium
Angular & Draft	+/- 2°	SSTG	Stainless

Dimensions and materials specified are subject to change without prior notice.

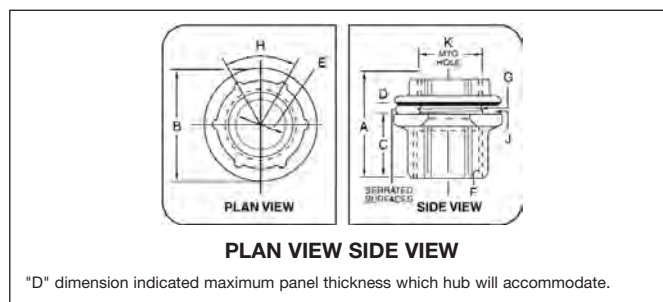

SPACING CHART FOR MYERS HUBS

CONDUIT OR PIPE SIZE

HOLE SIZE.	COND. SIZE.	1/4	3/8	1/2	3/4	1	1 1/4	1 1/2	2	2 1/2	3	3 1/2	4	5	6
9/16	1/4	1 1/16													
1 1/16	3/8	1 9/32	1 1/4												
7/8	1/2	1 5/16	1 13/32	1 9/16											
1 1/8	3/4	1 7/16	1 17/32	1 11/16	1 13/16										
1 3/8	1	1 9/32	1 11/16	1 27/32	1 31/32	2 1/8									
1 3/4	1 1/4	1 25/32	1 7/8	2 1/32	2 5/32	2 5/16	2 1/2								
2	1 1/2	1 31/32	2 1/16	2 7/32	2 11/32	2 1/2	2 11/16	2 7/8							
2 1/2	2	2 7/32	2 5/16	2 15/32	2 19/32	2 3/4	2 15/16	3 3/8	3 3/8						
3	2 1/2	2 15/32	2 9/16	2 23/32	2 27/32	3	3 3/16	3 3/8	3 3/8	3 7/8					
3 5/8	3	2 25/32	2 7/8	3 1/32	3 5/32	3 5/16	3 1/2	3 11/16	3 15/16	4 3/16	4 1/2				
4 1/8	3 1/2	3 3/32	3 3/16	3 11/32	3 15/32	3 5/8	3 9/16	4	4 1/4	4 1/2	4 13/16	5 1/8			
4 5/8	4	3 11/32	3 7/16	3 19/32	3 23/32	3 7/8	4 1/16	4 1/4	4 1/2	4 3/4	5 1/16	5 3/8	5 3/4		
5 1/16	5	4 7/32	4 1/8	4 9/32	4 13/32	4 3/16	4 3/4	4 15/16	5 3/16	5 7/16	5 3/4	6 1/16	6 3/16	7 1/8	
6 3/4	6	4 13/32	4 1/2	4 21/32	4 25/32	4 15/16	5 1/8	5 5/16	5 9/16	5 13/16	6 1/8	6 7/16	6 11/16	7 3/8	7 3/4
		19/32	1 1/16	2 7/32	3 1/32	1 1/8	1 1/16	1 1/2	1 3/4	2	2 5/16	2 5/8	2 7/8	3 3/16	3 15/16

Minimum space from center of pipe or conduit to nearest obstruction.

- Dimensions in dark gray shaded squares are centers for conduits of same size.
Example: How close may 3 conduits be spaced?
Answer 4 1/2"
- Dimensions in lighter gray shaded squares are for centers of conduits NOT of the same size.
Example: What is the minimum spacing for 2" and 3/4" conduit?
Read down column marked 3/4" to figure opposite 2" and find dimensions is 2 11/32".
- Minimum spacing dimensions as shown will give approximately 1/8" clearance between locking nuts.

Features and Benefits:

- Commercial Hubs are a dependable low profile hub that meet the requirements of UL standards
- Neoprene-grade chloroprene gasket firms into an elastic compound (similar to rubber) and provides environmental protection for industrial applications
- Medium viscosity flame retardant insuliner provides a smooth pulling surface
- Cast threads to meet UL standards and allow quick and easy installation
- Hex surfaces on the body make tightening with a wrench easy
- Thinner, lighter weight construction
- Available in standard and grounded version to meet customer preferences

Certifications and Compliances:

- UL and cUL Listed
- UL File No. E-19189

Standard Material & Finishes:

- Body & Nut: Corrosion resistant Zamek-2 & Zamek-3 Type Zinc
- Gasket: neoprene-grade chloroprene
- Insuliner: Lexan920A, medium viscosity flame retardant grade
- Finish - Natural



The use of rigid/IMC conduit remains the preferred choice in many applications because of the physical protection of conductors and long service life of the installation. Consequently, the need to terminate conduit into a box or enclosure creates the need for a hub.

The Commercial Hub has been developed to provide a light-weight hub that installs quickly and easily, providing a secure termination.

CHB HUBS ORDERING AND DIMENSIONAL INFORMATION

Cat. No.	Trade Size	A	B	C	Unit Qty	Wt. Lbs Per 100
CHB1	1/2"	1 7/32"	39/64"	1 7/16"	25	14
CHB2	3/4"	1 1/2"	2 1/32"	1 39/64"	25	20
CHB3	1"	1 57/64"	13/16"	1 55/64"	25	33
CHB4	1 1/4"	2 1/4"	53/64"	2"	10	43
CHB5	1 1/2"	2 35/64"	55/64"	2 7/64"	10	56
CHB6	2"	3 3/64"	3 1/32"	2 7/32"	10	71
CHB7	2 1/2"	3 9/16"	1 1/64"	2 5/8"	2	135
CHB8	3"	4 3/16"	1 1/64"	2 11/64"	2	156
CHB9	3 1/2"	4 25/32"	3 1/32"	2 4 1/64"	2	193
CHB10	4"	5 23/64"	1 1/64"	2 4 1/64"	1	229

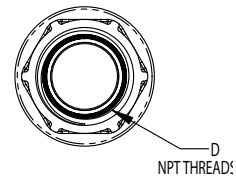
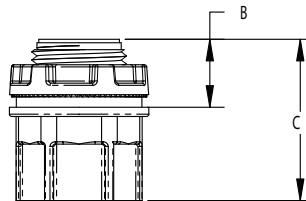
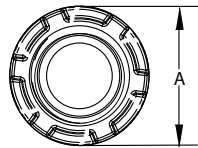

CHG GROUNDED HUBS ORDERING AND DIMENSIONAL INFORMATION

Cat. No.	Trade Size	A	B	C	D	Unit Qty	Wt. Lbs Per 100
CHG1	1/2"	1 7/32"	39/64"	1 7/16"	1 34/64"	25	14
CHG2	3/4"	1 1/2"	2 1/32"	1 39/64"	1 55/64"	25	21
CHG3	1"	1 57/64"	13/16"	1 55/64"	2 5/64"	25	34
CHG4	1 1/4"	2 1/4"	53/64"	2"	2 9/32"	10	45
CHG5	1 1/2"	2 35/64"	55/64"	2 7/64"	2 23/64"	10	59
CHG6	2"	3 7/64"	3 1/32"	2 7/32"	2 25/64"	10	75
CHG7	2 1/2"	3 9/16"	1 1/64"	2 5/8"	2 49/64"	2	145
CHG8	3"	4 3/16"	1 1/64"	2 41/64"	2 53/64"	2	161
CHG9	3 1/2"	4 25/32"	3 1/32"	2 41/64"	2 15/16"	2	196
CHG10	4"	5 23/64"	1 1/64"	2 41/64"	2 31/32"	1	234

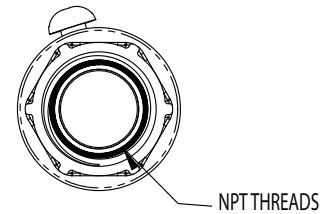
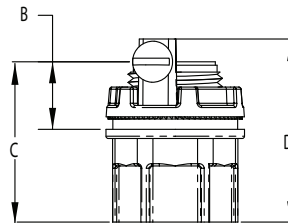
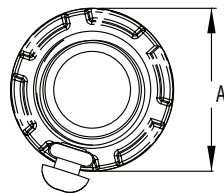

CHGN GROUND NUT ORDERING AND DIMENSIONAL INFORMATION

Cat. No.	Trade Size	A	B	Ground Screw Size	Unit Qty	Wt. Lbs Per 100
CHGN1	1/2"	1 7/32"	2 1/32"	10 - 32	25	4
CHGN2	3/4"	1 1/2"	53/64"	10 - 32	25	5
CHGN3	1"	1 57/64"	59/64"	10 - 32	25	10
CHGN4	1 1/4"	2 1/4"	3 1/32"	1 1/4 - 20	10	11
CHGN5	1 1/2"	2 35/64"	63/64"	1 1/4 - 20	10	14
CHGN6	2"	3 7/64"	63/64"	1 1/4 - 20	10	16
CHGN7	2 1/2"	3 9/16"	1"	1 1/4 - 20	2	22
CHGN8	3"	4 3/16"	1 5/64"	1 1/4 - 20	2	29
CHGN9	3 1/2"	4 25/32"	1 7/64"	1 1/4 - 20	2	31
CHGN10	4"	5 23/64"	1 5/32"	1 1/4 - 20	1	40

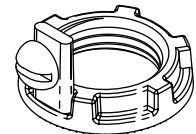
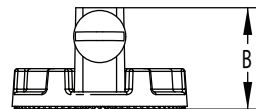
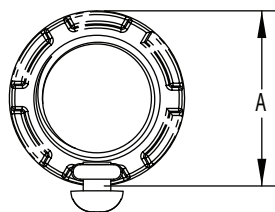

CONDUIT HUBS - MALLEABLE IRON

Applications:

- Ideal for terminating electrical conduit through the walls of enclosures.
- Designed for use indoors or outdoors with rigid conduit and IMC, specific applications include food processing plants, distilleries, breweries, sewage disposal plants, chemical plants, paper processing mills and refineries.



Features:

- Male thread type
- Tapered female thread for rigid conduit and IMC
- Recessed O-ring gasket assures raintight and secure environmental connections
- Insulated throat provides smooth pulling surface
- Locking screw on the nut doubles as a grounding screw for added safety
- Complete size range from 1/2" to 6"
- Hubs fit standard knockouts. No special tools required

Certifications and Compliances:

- Class I, Division 2
- Class II, Divisions 1 & 2
- Class III, Divisions 1 & 2
- UL Listed – UL Standard 514B
- cUL Listed – Certified by UL to CSA Standard C22.2 No. 18
- NEMA: FB-1
- Suitable for wet locations

Options:

Mechanically galvanized Suffix HDG

Cat. #	Trade Size	Unit Qty.	UL	
			UL	cUL
			Wt. Lbs. Per 100	
MHUB1	1/2"	25	18	
MHUB2	3/4"	25	25	
MHUB3	1"	5	50	
MHUB4	1 1/4"	5	25	
MHUB5	1 1/2"	2	20	
MHUB6	2"	1	10	
MHUB7	2 1/2"	1	10	
MHUB8	3"	1	5	
MHUB9	3 1/2"	1	5	
MHUB10	4"	1	2	
MHUB11	5"	1	1	
MHUB12	6"	1	1	

CONDUIT HUBS - IRON SPACE SAVER

Applications:

- Ideal for terminating electrical conduit through the walls of enclosures.
- Designed for use indoors or outdoors with rigid conduit and IMC, specific applications include food processing plants, distilleries, breweries, sewage disposal plants, chemical plants, paper processing mills and refineries.

Features:

- Male thread is on the nut for space saving.
- Quick and easy when installing rigid conduit nipple between two existing enclosures.
- Insulated throat provides smooth pulling surface.
- Furnished with SG sealing gasket.
- Hub fits standard knockouts. No special tools required.



Certifications and Compliances:

- Class I, Division 2
- Class II, Divisions 1 & 2
- Class III, Division 1 & 2
- UL Listed - UL Standard 514B.
- cUL Listed - Certified by UL to CSA Standard C22.2 No. 18.
- NEMA: FB-1
- Suitable for wet locations.

Standard Materials & Finishes:

- Material: Malleable Iron
- Finish: Zinc Electroplate

Dimensions

In Inches:

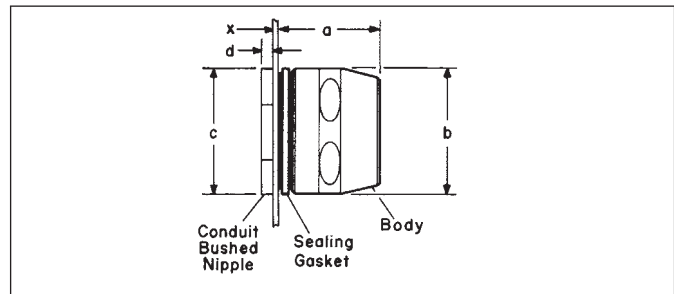

Cat. #	Conduit Size	Unit Qty.	Wt. Lbs. Per 100	UL				
				a	b	c	d	x
HUB1	1/2"	25	18	1	1 1/4	1	1/8	9/64
HUB2	3/4"	10	25	1 1/8	1 9/16	1 3/8	5/32	1/4
HUB3	1"	5	50	1 3/8	1 7/8	1 5/8	3/16	9/32
HUB4	1 1/4"	5	25	1 1/2	2 5/16	2	1/4	7/16
HUB5	1 1/2"	2	20	1 5/8	2 1/2	2 3/8	1/4	7/16
HUB6	2"	1	10	1 11/16	3	2 13/16	1/4	7/16
HUB7	2 1/2"	1	10	2 3/16	3 5/8	3 7/16	1/4	7/16
HUB8	3"	1	5	2 7/16	4 1/4	4 1/16	1/4	7/16
HUB9	3 1/2"	1	5	2 7/16	4 3/4	4 11/16	5/16	3/4
HUB10	4"	1	2	2 9/16	5 1/4	5 1/16	5/16	1 1/8

Note: Dimension "x" is maximum wall thickness of box that will meet the requirement for three full threads engagement of nipple and fitting body when box connector or rigid conduit hub is installed in a knockout or slip hole.

Liquidtight Conduit Fittings

Liquidator™ Liquidtight Flexible Metallic Conduit Fittings



Cooper Crouse-Hinds® liquidtight product line offers high-quality, high-performance fittings. Designed to the toughest standards and integrating the latest technology, not only do you get a reliable and durable product, you also get one that reduces installation time and cost. Our versatile lines of liquidtight fittings are designed for a wide range of applications. Choose from our Liquidator™, LiQuik™, Zinc Die Cast, Non-Metallic or Low Profile liquidtight fittings.



Applications:

Typical applications for liquidtight conduit and liquidtight fittings include the wiring of machine tools, motors, transformers, food processing equipment, robotics, air conditioning units, illuminated store front signs and billboards, etc. The flexible metallic conduit and fittings protect conductors from mechanical damage due to vibration and movement, and seal out cutting oils, coolants, water, dust, etc. Applications such as these can be found in, but are not limited to, industries such as:

- Machine tool manufacturers
- Electric power generating plants
- Waste treatment facilities
- Paint manufacturing facilities
- Automobile manufacturing facilities
- Aerospace industries
- Breweries
- Food processing plants
- Dairies
- Pulp and paper mills
- Petroleum refineries
- Chemical and petrochemical plants

Certifications and Compliances:

- UL Listed liquidtight flexible metal conduit fittings are suitable for use in the following hazardous locations under NEC, Class I, Division 2; Class II, Division 1 and 2; and Class III, Division 1 and 2, and are suitable for grounding in sizes 3/8" through 1 1/4" under NEC.
- UL Standards: 514B, 467
- cUL Standard: C22.2 No. 18F
- UL File No. E-19189

Standard Materials:

- Body – Straight: 3/8" through 6" malleable iron, or 3/8" through 4" aluminum
- 45° – 3/8" through 4" malleable iron
- 90° – 3/8" through 4" – malleable iron or aluminum
- Gland nut – malleable iron or aluminum
- Ferrule – 3/8" through 6" – steel
- Gland nut sealing ring – polyethylene
- Sealing gasket – thermoplastic elastomer
- Locknut – steel or aluminum

Standard Finishes:

- Malleable iron – zinc electroplate
- Polyethylene, thermoplastic elastomer, aluminum and die cast – natural

Product Features	User Benefits
<ul style="list-style-type: none"> • UL Listed, cUL Certified. 	Assurance of safe and reliable performance. End user peace of mind.
<ul style="list-style-type: none"> • Provides protection in wet locations. 	Meets NEC and UL requirements for use in wet locations. Reduces downtime and replacement costs.
<ul style="list-style-type: none"> • Available in various configurations in various trade sizes and materials. 	Complete selection of styles and sizes. Easy selection from one source, saves time and money.
<ul style="list-style-type: none"> • Hex surfaces on gland nut and body. 	Easy wrenching. Fast, easy installation results in labor savings.
<ul style="list-style-type: none"> • Thermoplastic elastomer sealing gasket effectively seals out water, oil, dust and dirt. 	Eliminates leakage, potential downtime and replacement costs.
<ul style="list-style-type: none"> • Lock nut bites into box. 	Provides a reliable ground and safety of personnel and equipment. Won't vibrate loose.
<ul style="list-style-type: none"> • Cupped long grounding ferrule is distortion-free. 	Provides excellent pullout strength, prevents conduit popout and provides grounding for safety of personnel and equipment.

Liquidtight Fittings Selection Chart

Family	Material	Size/Range	Configurations	Typical Applications
Liquidator	Malleable Iron	3/8"–6"	Straight, 45°, 90°	Tough, industrial, corrosive for STANDARD APPLICATIONS
Liquidator Aluminum LT-SA	Copper-free Aluminum	3/8"–4"	Straight & 90°*	Tough, industrial, corrosive applications where ALUMINUM MATERIAL PREFERRED
LTK Low Profile	Steel/Malleable Iron	3/8"–2"	Straight, 45°, 90°	Tough, industrial, corrosive applications with SPACE RESTRICTIONS
LTQ LiQuik	Malleable Iron	3/8"–2"	Straight, 45°, 90°	Tough, industrial, corrosive applications needing NO DISASSEMBLY INSTALLATIONS
LTDC Zinc Die Cast	Zinc Die Cast	3/8"–4"	Straight & 90°	Tough, industrial, corrosive applications where ZINC DIE CAST MATERIAL PREFERRED
LTNM Non-Metallic	Nylon	3/8"–2"	Straight & 90°	Tough, industrial, corrosive for use with NON-METALLIC TYPE B LIQUIDTIGHT CONDUIT

* 90° LT-SA available in 3/8"–2" only

Liquidtight Conduit Fittings

Liquidator™ Liquidtight Flexible Metallic Conduit Fittings



Liquidtight



Straight Connectors

Malleable Iron							Aluminum	
Conduit Size	Non-Insulated Cat. No.	Insulated Cat. No.	Non-Insulated with Aluminum Grounding Lug Cat. No.	Insulated with Aluminum Grounding Lug Cat. No.	Insulated with Copper Grounding Lug Cat. No.	Lug Size	Non-Insulated Aluminum Cat. No.	Non-Insulated with Aluminum Grounding Lug Cat. No.
3/8"	LT38	LTB38	LT38G	LTB38G	LTB38GC	#4-#14	LT38-SA	LT38G-SA
1/2"	LT50	LTB50	LT50G	LTB50G	LTB50GC	#4-#14	LT50-SA	LT50G-SA
3/4"	LT75	LTB75	LT75G	LTB75G	LTB75GC	#4-#14	LT75-SA	LT75G-SA
1"	LT100	LTB100	LT100G	LTB100G	LTB100GC	#4-#14	LT100-SA	LT100G-SA
1 1/4"	LT125	LTB125	LT125G	LTB125G	LTB125GC	#4-#14	LT125-SA	LT125G-SA
1 1/2"	LT150	LTB150	LT150G	LTB150G	LTB150GC	#4-#14	LT150-SA	LT150G-SA
2"	LT200	LTB200	LT200G	LTB200G	LTB200GC	#4-#14	LT200-SA	LT200G-SA
2 1/2"	LT250	LTB250	LT250G	LTB250G	LTB250GC	#1/0-#8	LT250-SA	LT250G-SA
3"	LT300	LTB300	LT300G	LTB300G	LTB300GC	#1/0-#8	LT300-SA	LT300G-SA
3 1/2"	LT350	LTB350	LT350G	LTB350G	LTB350GC	#3/0-#6	LT350-SA	LT350G-SA
4"	LT400	LTB400	LT400G	LTB400G	LTB400GC	#3/0-#6	LT400-SA	LT400G-SA
5"	LT500†	LTB500†	LT500G†	LTB500G†	—	250MCM-#6	—	—
6"	LT600†	LTB600†	LT600G†	LTB600G†	—	250MCM-#6	—	—

†Not UL Listed or CSA Certified



45° Angle Connectors

Malleable Iron							Aluminum
Conduit Size	Non-Insulated Cat. No.	Insulated Cat. No.	Non-Insulated with Aluminum Grounding Lug Cat. No.	Insulated with Aluminum Grounding Lug Cat. No.	Insulated with Copper Grounding Lug Cat. No.	Lug Size	Non-Insulated Aluminum Cat. No.
3/8"	LT3845	LTB3845	LT3845G	LTB3845G	LTB3845GC	#4-#14	—
1/2"	LT5045	LTB5045	LT5045G	LTB5045G	LTB5045GC	#4-#14	—
3/4"	LT7545	LTB7545	LT7545G	LTB7545G	LTB7545GC	#4-#14	—
1"	LT10045	LTB10045	LT10045G	LTB10045G	LTB10045GC	#4-#14	—
1 1/4"	LT12545	LTB12545	LT12545G	LTB12545G	LTB12545GC	#4-#14	—
1 1/2"	LT15045	LTB15045	LT15045G	LTB15045G	LTB15045GC	#4-#14	—
2"	LT20045	LTB20045	LT20045G	LTB20045G	LTB20045GC	#4-#14	—
2 1/2"	LT25045	LTB25045	LT25045G	LTB25045G	LTB25045GC	#1/0-#8	—
3"	LT30045	LTB30045	LT30045G	LTB30045G	LTB30045GC	#1/0-#8	—
3 1/2"	LT35045	LTB35045	LT35045G	LTB35045G	LTB35045GC	#3/0-#6	—
4"	LT40045	LTB40045	LT40045G	LTB40045G	LTB40045GC	#3/0-#6	—

Liquidtight Conduit Fittings

Liquidator™ Liquidtight Flexible Metallic Conduit Fittings



Liquidtight

90° Angle Connectors

Malleable Iron

Aluminum

Conduit Size	Malleable Iron						Aluminum	
	Non-Insulated Cat. No.	Insulated Cat. No.	Non-Insulated with Aluminum Grounding Lug Cat. No.	Insulated with Aluminum Grounding Lug Cat. No.	Insulated with Copper Grounding Lug Cat. No.	Lug Size	Non-Insulated Aluminum Cat. No.	Non-Insulated with Aluminum Grounding Lug Cat. No.
3/8"	LT3890	LTB3890	LT3890G	LTB3890G	LTB3890GC	#4-#14	LT3890-SA	LT3890G-SA
1/2"	LT5090	LTB5090	LT5090G	LTB5090G	LTB5090GC	#4-#14	LT5090-SA	LT5090G-SA
3/4"	LT7590	LTB7590	LT7590G	LTB7590G	LTB7590GC	#4-#14	LT7590-SA	LT7590G-SA
1"	LT10090	LTB10090	LT10090G	LTB10090G	LTB10090GC	#4-#14	LT10090-SA	LT10090G-SA
1 1/4"	LT12590	LTB12590	LT12590G	LTB12590G	LTB12590GC	#4-#14	LT12590-SA	LT12590G-SA
1 1/2"	LT15090	LTB15090	LT15090G	LTB15090G	LTB15090GC	#4-#14	LT15090-SA	LT15090G-SA
2"	LT20090	LTB20090	LT20090G	LTB20090G	LTB20090GC	#4-#14	LT20090-SA	LT20090G-SA
2 1/2"	LT25090	LTB25090	LT25090G	LTB25090G	LTB25090GC	#1/0-#8	LT25090-SA	LT25090G-SA
3"	LT30090	LTB30090	LT30090G	LTB30090G	LTB30090GC	#1/0-#8	LT30090-SA	LT30090G-SA
3 1/2"	LT35090	LTB35090	LT35090G	LTB35090G	LTB35090GC	#3/0-#6	LT35090-SA	LT35090G-SA
4"	LT40090	LTB40090	LT40090G	LTB40090G	LTB40090GC	#3/0-#6	LT40090-SA	LT40090G-SA

Liquidtight Conduit Fittings

Liquidator™ Liquidtight Flexible Metallic Conduit Fittings



Non-Insulated Malleable Iron Dimensions (in inches)

Liquidtight

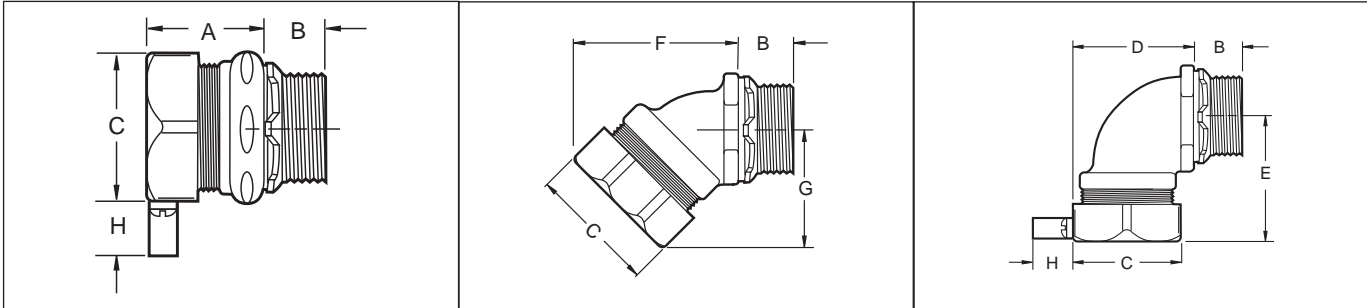

Trade Size	A	B	C	D	E	F	G	H
3/8"	1 1/8"	1/2"	1 1/8"	1 5/16"	1 5/8"	1 15/16"	1 1/2"	3/4"
1/2"	1 1/4"	1/2"	1 1/4"	1 7/16"	1 5/8"	2"	1 1/2"	3/4"
3/4"	1 1/4"	1/2"	1 9/16"	1 5/8"	1 3/4"	2 3/16"	1 7/16"	3/4"
1"	1 7/16"	5/8"	1 13/16"	2 5/16"	2 1/8"	2 1/2"	1 13/16"	3/4"
1 1/4"	1 1/2"	1 1/16"	2 1/4"	2 3/8"	2 1/4"	2 13/16"	2 3/16"	3/4"
1 1/2"	1 5/8"	3/4"	2 7/16"	3 1/16"	2 3/8"	3"	2 7/16"	3/4"
2"	1 3/4"	3/4"	3"	3 3/16"	2 3/4"	3 11/16"	2 13/16"	3/4"
2 1/2"	2 3/16"	1"	4"	8 5/16"	8 3/16"	7 5/16"	4 7/16"	1 1/8"
3"	2 1/2"	1 1/8"	4 3/16"	9 13/16"	9 3/8"	7 7/8"	5 1/2"	1 1/8"
3 1/2"	2 5/8"	1 3/16"	5 1/4"	11 3/16"	11 1/4"	9 5/8"	5 15/16"	1 1/2"
4"	2 3/4"	1 1/4"	5 3/4"	13"	12 3/16"	11 1/16"	8 5/16"	1 1/2"
5"	3 3/8"	1 7/16"	6 1/16"					1 11/16"
6"	3 3/8"	1 1/2"	7 3/4"					1 11/16"

Non-Insulated Aluminum Dimensions

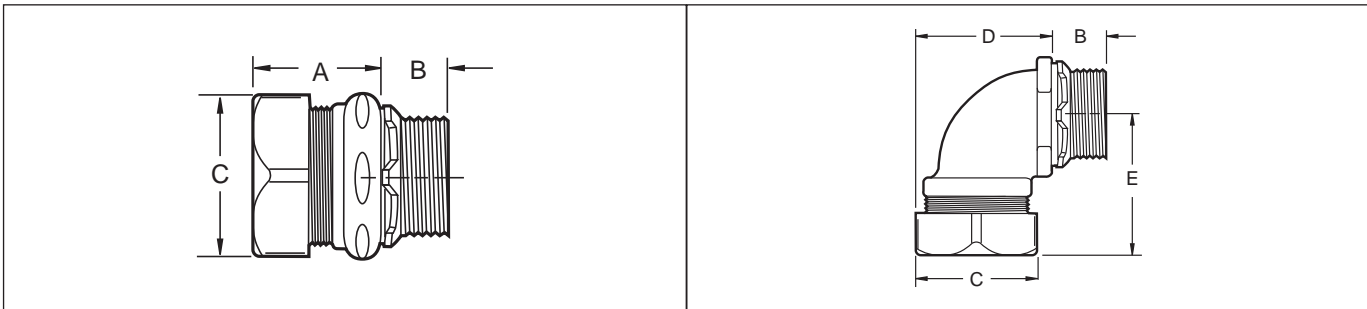

Trade Size	A	B	C	D	E
3/8"	1 3/16"	19/32"	1 1/4"	1 7/16"	1 3/8"
1/2"	1 5/16"	19/32"	1 1/4"	1 1/2"	1 3/8"
3/4"	1 5/16"	19/32"	1 1/2"	1 11/16"	1 1/2"
1"	1 7/16"	13/16"	1 3/4"	2"	1 13/16"
1 1/4"	1 9/16"	13/16"	2 1/4"	2 7/16"	2 5/32"
1 1/2"	1 13/16"	13/16"	2 1/2"	2 13/16"	2 7/16"
2"	1 3/4"	7/8"	3"	3 3/16"	2 7/8"
2 1/2"	2 1/4"	1 1/16"	3 3/4"		
3"	2 7/16"	1 1/8"	4 1/2"		
3 1/2"	2 7/8"	1 3/16"	5 1/8"		
4"	2 15/16"	1 1/4"	5 5/8"		

Liquidtight Conduit Fittings



Liquidtight Fittings - Zinc Die Cast

ZINC DIE CAST LIQUIDTIGHT FITTING

Applications:

To terminate and seal liquidtight flexible metal conduit to oiltight, liquidtight, or raintight box or enclosure. Connectors can be used with tapered thread female entry or unthreaded knockout using the provided sealing washer and lock nut.

Features:

- Furnished with lock nut and sealing ring
- Liquidtight/Raintight/Oiltight
- Suitable for wet locations

Standard Materials:

- Zinc Die Cast

Standard Finishes:

- Natural

Straight Connectors – Non-Insulated



Cat. #	Conduit Size	Unit Qty.	A	B	C	D
LT38DC	3/8"	25	1.07	.96	.62	.47
LT50DC	1/2"	25	1.07	1.08	.62	.47
LT75DC	3/4"	15	1.07	1.33	.82	.47
LT100DC	1"	8	1.34	1.56	1.02	.57
LT125DC	1 1/4"	5	1.15	1.94	1.36	.71
LT150DC	1 1/2"	4	1.52	2.19	1.60	.71
LT200DC	2"	2	1.54	2.66	2.07	.71
LT250DC	2 1/2"	1	2.20	3.28	2.51	1.06
LT300DC	3"	1	2.22	3.80	3.13	1.06
LT350DC	3 1/2"	1	2.36	4.28	3.58	1.06
LT400DC	4"	1	2.44	4.78	4.05	1.06

Straight Connectors – Insulated

UL File No. E-19189



Cat. #	Conduit Size	Unit Qty.	A	B	C	D
LTB38DC	3/8"	25	1.44	.96	.62	.47
LTB50DC	1/2"	25	1.44	1.08	.62	.47
LTB75DC	3/4"	15	1.56	1.33	.82	.47
LTB100DC	1"	8	2.01	1.56	1.02	.57
LTB125DC	1 1/4"	5	2.18	1.94	1.36	.71
LTB150DC	1 1/2"	4	2.19	2.19	1.60	.71
LTB200DC	2"	2	2.21	2.66	2.07	.71
LTB250DC	2 1/2"	1	2.89	3.28	2.51	1.06
LTB300DC	3"	1	2.93	3.80	3.13	1.06
LTB350DC	3 1/2"	1	3.07	4.28	3.58	1.06
LTB400DC	4"	1	3.15	4.78	4.05	1.06

90° Angle Connectors – Non-Insulated

UL File No. E-19189



Cat. #	Conduit Size	Unit Qty.	A	B	C	D
LT3890DC	3/8"	25	.62	.81	.92	1.22
LT5090DC	1/2"	25	.62	.91	1.02	1.22
LT7590DC	3/4"	15	.80	1.15	1.27	1.36
LT10090DC	1"	8	1.02	1.38	1.48	1.73
LT12590DC	1 1/4"	5	1.36	1.77	1.93	2.11
LT15090DC	1 1/2"	4	1.61	2.01	2.17	2.43
LT20090DC	2"	2	2.08	2.58	2.68	2.93
LT25090DC	2 1/2"	1	2.51	3.15	3.21	3.62
LT30090DC	3"	1	3.13	3.67	3.74	4.28
LT35090DC	3 1/2"	1	3.58	4.17	4.23	4.84
LT40090DC	4"	1	4.06	4.74	4.75	5.37

90° Angle Connectors – Insulated



Cat. #	Conduit Size	Unit Qty.	A	B	C	D
LTB3890DC	3/8"	25	.62	.81	.92	1.22
LTB5090DC	1/2"	25	.62	.91	1.02	1.22
LTB7590DC	3/4"	15	.80	1.15	1.27	1.36
LTB10090DC	1"	8	1.02	1.38	1.48	1.73
LTB12590DC	1 1/4"	5	1.36	1.77	1.93	2.11
LTB15090DC	1 1/2"	4	1.61	2.01	2.17	2.43
LTB20090DC	2"	2	2.08	2.58	2.68	2.93
LTB25090DC	2 1/2"	1	2.51	3.15	3.21	3.62
LTB30090DC	3"	1	3.13	3.67	3.74	4.28
LTB35090DC	3 1/2"	1	3.58	4.17	4.23	4.84
LTB40090DC	4"	1	4.06	4.74	4.75	5.37

Liquidtight

Liquidtight Fittings Accessories

SELF RETAINING PVC GASKET WITH STEEL RING

UL File no. E-22133

Liquidtight



Cat. #	Conduit Size	Unit Qty.	Wt. Lbs. Per 100
SG1	3/8" - 1/2"	100	1
SG2	3/4"	50	2
SG3	1"	50	2
SG4	1 1/4"	25	2
SG5	1 1/2"	25	4
SG6	2"	25	3
SG7	2 1/2"	10	5
SG8	3"	10	10
SG9	3 1/2"	10	12
SG10	4"	10	10
SG11	5"	5	15
SG12	6"	5	22

COMBINATION COUPLINGS FOR COUPLING LIQUIDTIGHT TO THREADED RIGID/IMC CONDUIT



Cat. #	Conduit Size	Unit Qty.	Wt. Lbs. Per 100
LTR38*	3/8"	25	17
LTR50	1/2"	25	29
LTR75	3/4"	25	33
LTR100	1"	5	59
LTR125	1 1/4"	2	105
LTR150	1 1/2"	2	105
LTR200	2"	1	160

*For 3/8" Liquidtight to 1/2" Rigid/IMC

COMBINATION COUPLINGS FOR COUPLING LIQUIDTIGHT TO THREADED RIGID/IMC - GROUNDING TYPE - ALUMINUM LUG



Cat. #	Conduit Size	Lug Size	Unit Qty.	Wt. Lbs. Per 100
LTR38G*	3/8"	#4 - #14	25	24
LTR50G	1/2"	#4 - #14	25	30
LTR75G	3/4"	#4 - #14	25	35
LTR100G	1"	#4 - #14	5	59
LTR125G	1 1/4"	#4 - #14	5	81
LTR150G	1 1/2"	#4 - #14	2	107
LTR200G	2"	#4 - #14	1	162

*For 3/8" Liquidtight to 1/2" Rigid/IMC

Note: For other connector and lug combinations, consult factory.
Copper lugs are available also. Consult factory for details.

WIRE MESH GRIPS FOR LIQUIDTIGHT METALLIC CONDUIT FITTINGS



Applications:

- Wire mesh grips are used with Liquidator liquidtight conduit fittings to prevent conduit pullout due to stress, tension, strain, vibration, or movement.
- Typical applications include the wiring of machine tools, motors, transformers, food processing, equipment, robotics, or any application that requires a flexible liquidtight conduit connection.

Materials:

- Nut - Malleable iron, Ring - Aluminum, Mesh - Stainless steel

Wire Mesh Grip - Dimensions

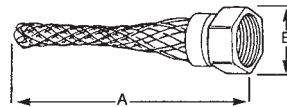

Cat. #	Conduit Size	Dimensions		Unit Qty.	Wt. Lbs. Per 100
		A	B		
WMG38	3/8"	6 7/16"	1 1/4"	10	10
WMG50	1/2"	6 7/8"	1 7/16"	10	12
WMG75	3/4"	6 15/16"	1 5/8"	10	17
WMG100	1"	8 3/16"	1 15/16"	10	21
WMG125	1 1/4"	10 3/4"	2 3/8"	2	37
WMG150	1 1/2"	11 13/16"	2 3/4"	2	56
WMG200	2"	14 7/16"	3 5/16"	1	79

REPLACEMENT LIQUIDTIGHT FERRULES

For Liquidator Liquidtight Fittings Only



Cat. #	Conduit Size	Unit Qty.
FEA38	3/8"	100
FEA50	1/2"	100
FEA75	3/4"	100
FEA100	1"	100
FEA125	1 1/4"	50
FEA150	1 1/2"	50
FEA200	2"	10
FEA250	2 1/2"	10
FEA300	3"	10
FEA350	3 1/2"	10
FEA400	4"	10

Liquidtight Conduit Fittings



LiQuik™ Liquidtight Fittings

LiQuik™ LIQUIDTIGHT FITTINGS



No disassembly required! The LiQuik™ liquidtight fittings are quick and easy to install in 2 steps, offering huge labor saving potential. Available in trade sizes 3/8"-2" straight, 45° and 90°; in insulated or non-insulated. Product features a black gland nut for easy identification and no disassembly required.

Traditional Assembly Installation



1. Slide nut over conduit.



2. Slide compression ring over conduit.



3. Thread ferrule inside the conduit.



4. Slide the conduit assembly inside body.



5. Slide compression nut and ring towards the connector.



6. Tighten the nut.

New LiQuik Assembly Installation In Just 2 Steps:



1. Slide conduit inside the fully assembled connector.



2. Turn the connector assembly so the ferrule threads engage the spirals in the conduit. The pins in the ferrule are locked inside the holes in the connector body, preventing the ferrule from turning. Tighten the nut against the connector.

LiQuik™ Liquidtight Fittings – Straight, Non-Insulated



Cat. #	Conduit Size	KO Size	Unit Qty.	Wt. Lbs. Per 100	Dimensions		
					A	B	C
LTQ38	3/8"	1/2"	25	15	1 1/8"	1/2"	1 1/8"
LTQ50	1/2"	1/2"	25	18	1 1/4"	1/2"	1 1/4"
LTQ75	3/4"	3/4"	25	29	1 1/4"	1/2"	1 9/16"
LTQ100	1"	1"	5	40	1 7/16"	5/8"	1 13/16"
LTQ125	1 1/4"	1 1/4"	5	55	1 1/2"	1 1/16"	2 1/4"
LTQ150	1 1/2"	1 1/2"	2	71	1 5/8"	3/4"	2 7/16"
LTQ200	2"	2"	1	99	1 3/4"	3/4"	3"

LiQuik™ Liquidtight Fittings – Straight, Insulated



Cat. #	Conduit Size	KO Size	Unit Qty.	Wt. Lbs. Per 100	Dimensions		
					A	B	C
LTQB38	3/8"	1/2"	25	16	1 1/8"	9/16"	1 1/8"
LTQB50	1/2"	1/2"	25	18	1 1/4"	9/16"	1 1/4"
LTQB75	3/4"	3/4"	25	29	1 1/4"	9/16"	1 9/16"
LTQB100	1"	1"	5	40	1 7/16"	1 1/16"	1 13/16"
LTQB125	1 1/4"	1 1/4"	5	56	1 1/2"	3/4"	2 1/4"
LTQB150	1 1/2"	1 1/2"	2	71	1 5/8"	13/16"	2 7/16"
LTQB200	2"	2"	1	100	1 3/4"	13/16"	3"

LiQuik™ Liquidtight Fittings – 45°, Insulated and Non-Insulated



Cat. #	Conduit Size	KO Size	Unit Qty.	Wt. Lbs. Per 100
Non-Insulated				
LTQ5045	1/2"	1/2"	25	29
LTQ7545	3/4"	3/4"	10	41
LTQ10045	1"	1"	10	70
Insulated				
LTQB5045	1/2"	1/2"	25	29
LTQB7545	3/4"	3/4"	10	33
LTQB10045	1"	1"	10	70

LiQuik™ Liquidtight Fittings – 90°, Insulated and Non-Insulated



Cat. #	Conduit Size	KO Size	Unit Qty.	Wt. Lbs. Per 100
Non-Insulated				
LTQ5090	1/2"	1/2"	25	33
LTQ7590	3/4"	3/4"	10	41
LTQ10090	1"	1"	10	76
Insulated				
LTQB5090	1/2"	1/2"	25	33
LTQB7590	3/4"	3/4"	10	48
LTQB10090	1"	1"	10	76

Replacement LiQuik™ Ferrules

Cat. #	Conduit Size	Wt. Lbs. Per 100
LTQF38	3/8"	100
LTQF50	1/2"	100
LTQF75	3/4"	100
LTQF100	1"	100
LTQF125	1 1/4"	50
LTQF150	1 1/2"	50
LTQF200	2"	10

LTK Low Profile Liquidtight Fittings

Low Profile Liquidtight Fittings

Applications:

- Flexible metallic (liquidtight) conduit used with Cooper Crouse-Hinds® Liquidtight fittings is designed to protect conductors from mechanical damage due to vibration and movement while sealing out cutting oils, coolants, water, dust, etc.
- Typical applications include the wiring of machine tools, motors, transformers, food processing equipment, robotics, air conditioning units, illuminated signs, etc.
- The low profile liquidtight fittings are designed specifically for OEM applications that require close side-by-side mounting of multiple liquidtight fittings in tight spaces.

Certifications and Compliances:

- NEC:
 - Class I, Division 2 (Zone 2)
 - Class II, Division 1 and 2
 - Class III, Division 1 and 2
- UL Standards: 514B, 467
- CSA Standard: C22.2 No. 18

Standard Materials:

- Body – steel (straight fittings), malleable iron (angle fittings)
- Gland nut – steel
- Ferrule – steel
- Gland nut sealing ring – nylon
- Sealing gasket – polypropylene

Standard Finishes:

- Steel – zinc electroplate
- Malleable iron – zinc electroplate
- Nylon – natural
- Polypropylene – natural

Liquidtight

Replacement Ferrules

Conduit Size	Cat. #
3/8"	LTKF38
1/2"	LTKF50
3/4"	LTKF75
1"	LTKF100
1 1/4"	LTKF125
1 1/2"	LTKF150
2"	LTKF200

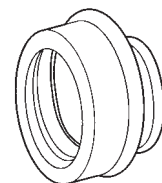

Ordering & Dimensional Information

Straight Connectors — Steel

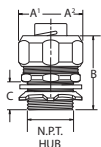

Conduit Size	Non-Insulated Cat. No.	Insulated Cat. No.	Over Round Corner A ¹	Hex A ²	B	N.P.T. Thread Length C
3/8"	LTK38	LTBK38	1 3/32"	1 1/32"	1 3/16"	19/32"
1/2"	LTK50	LTBK50	1 3/16"	1 1/8"	1 11/32"	19/32"
3/4"	LTK75	LTBK75	1 7/16"	1 3/8"	1 7/16"	19/32"
1"	LTK100	LTBK100	1 3/4"	1 11/16"	1 5/8"	2 1/32"
1 1/4"	LTK125	LTBK125	2 5/32"	2 1/16"	1 27/32"	43/64"
1 1/2"	LTK150	LTBK150	2 3/8"	2 9/32"	2"	23/32"
2"	LTK200	LTBK200	2 7/8"	2 25/32"	2 1/8"	23/32"

45° Angle Connectors — Malleable Iron

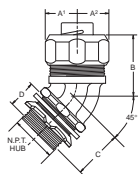

Conduit Size	Non-Insulated Cat. No.	Insulated Cat. No.	Over Round Corner A ¹	Hex A ²	B	C	N.P.T. Thread Length D
3/8"	LTK3845	LTBK3845	1 3/32"	1 1/32"	1 7/32"	1 1/32"	19/32"
1/2"	LTK5045	LTBK5045	1 3/16"	1 1/32"	1 5/16"	1 1/32"	19/32"
3/4"	LTK7545	LTBK7545	1 7/16"	1 3/8"	1 3/8"	1 1/8"	13/32"
1"	LTK10045	LTBK10045	1 3/4"	1 11/16"	1 21/32"	1 1/4"	2 1/32"
1 1/4"	LTK12545	LTBK12545	2 5/32"	2 1/16"	1 23/32"	1 11/32"	1 1/16"
1 1/2"	LTK15045	LTBK15045	2 3/8"	2 9/32"	2"	1 15/32"	23/32"
2"	LTK20045	LTBK20045	2 7/8"	2 25/32"	2 9/32"	1 5/8"	23/32"

90° Angle Connectors — Malleable Iron

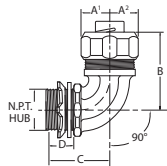

Conduit Size	Non-Insulated Cat. No.	Insulated Cat. No.	Over Round Corner A ¹	Hex A ²	B	C	N.P.T. Thread Length D
3/8"	LTK3890	LTBK3890	1 3/32"	1 1/32"	1 19/32"	1 1/4"	9/16"
1/2"	LTK5090	LTBK5090	1 3/16"	1 1/8"	1 21/32"	1 1/4"	9/16"
3/4"	LTK7590	LTBK7590	1 7/16"	1 3/8"	1 25/32"	1 17/32"	9/16"
1"	LTK10090	LTBK10090	1 3/4"	1 11/16"	2 3/16"	1 27/32"	2 1/32"
1 1/4"	LTK12590	LTBK12590	2 5/32"	2 1/16"	2 3/8"	1 15/16"	1 1/16"
1 1/2"	LTK15090	LTBK15090	2 3/8"	2 9/32"	2 5/8"	2 3/32"	23/32"
2"	LTK20090	LTBK20090	2 7/8"	2 25/32"	3 1/16"	2 13/32"	23/32"

Space Saver Liquidtight Fittings

SPACE SAVER LIQUIDTIGHT FITTING

Features & Benefits:

- Liquidtight, Raintight, Oiltight for protection and long life in wet, dusty and corrosive environments
- Compact, slim diameter for tight space and neat appearance
- Male threads on the nut maximize space in box or enclosure and provides a smooth pulling surface eliminating the need for a bushing or insulated throat fitting- saving time & money
- Reusable, long ferrule prevents pull out and tight bend conduit "pop out"
- Hex shaped gland nut is allows for easy wrenching, providing a fast tight installation
- Split sealing ring allows sealing ring to be installed after installation of ferrule and is reversible to ensure correct installation. Impossible to install incorrectly!
- Grooved design on rubber gasket allows for a snug, captive fit ensuring the gasket will not fall off during installation
- Available with optional aluminum grounding lug for easy ground wire termination

Certifications & Compliances:

- UL Listed
- cUL Listed

Standard Materials:

- Body: Malleable Iron
- Locknut: Steel
- Gasket: Rubber
- Lug: Aluminum

Standard Finishes:

- Zinc Plated

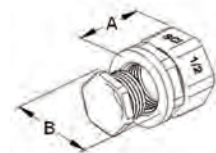

Cat. #	Size	KO Size	Unit Qty	Wt. Lbs./100	A	B	C
SFLT38	3/8"	1/2"	25	19	1 3/8"	1 3/16"	
SFLT50	1/2"	1/2"	25	21	1 3/8"	1 5/16"	
SFLT75	3/4"	3/4"		31	1 1/2"	1 9/16"	
SFLT100	1"	1"	5	44	1 5/8"	1 7/8"	

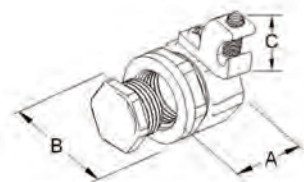

Cat. #	Size	KO Size	Unit Qty	Wt. Lbs./100	A	B	C
SFLT38G	3/8"	1/2"	25	23	1 3/8"	1 3/16"	3/4"
SFLT50G	1/2"	1/2"	25	26	1 3/8"	1 5/16"	3/4"
SFLT75G	3/4"	3/4"		36	1 1/2"	1 9/16"	3/4"
SFLT100G	1"	1"	5	48	1 5/8"	1 7/8"	3/4"

Liquidtight

Non-Metallic Liquidtight Fittings

NON-METALLIC LIQUIDTIGHT CONDUIT FITTINGS

Applications:

- For use with nonmetallic Type B liquidtight conduit to terminate and seal conduit to liquidtight, oiltight, or raintight box or enclosure.
- Typical applications include wiring motors, transformers, processing equipment, pumps, etc.



LT38NM



LT38NMBL

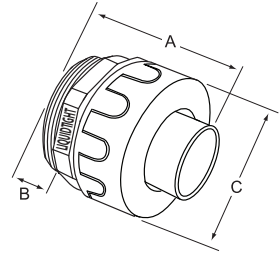

Features:

- Liquidtight, Raintight Oiltight
- Furnished with locknut and sealing ring
- Corrosion resistant
- Suitable for wet locations
- No-Spin ferrule
- 90° has smooth interior to prevent abrasion of conductors
- Molded of Type Nylon 6
- Flammability classification 94V-2; temperature index of 125° C
- No disassembly required
- No threading of conduit or tubing required to install



LT3890NM



LT3890NMBL

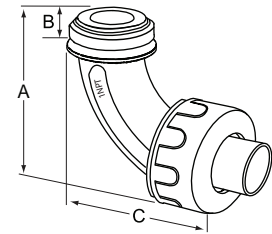

Standard Materials:

- Body – Nylon
- Locknut – Steel

Cat. #	Cat. #	Trade Size	Unit Qty.	Certification	Wt. Lbs. Per 100	A	B	C
STRAIGHT								
GRAY	BLACK							
LT38NM	LT38NMBL	3/8"	25	cULus	5	2.000"	0.540"	1.400"
LT50NM	LT50NMBL	1/2"	25	cULus	5	2.000"	0.540"	1.400"
LT75NM	LT75NMBL	3/4"	10	cULus	7	2.200"	0.635"	1.700"
LT100NM	LT100NMBL	1"	5	cULus	14	2.280"	0.740"	2.000"
LT125NM	LT125NMBL	1 1/4"	5	cULus	20	2.44"	0.76"	2.4"
LT150NM	LT150NMBL	1 1/2"	2	cULus	30	2.700"	0.800"	2.670"
LT200NM	LT200NMBL	2"	2	cULus	40	2.990"	0.850"	3.280"
90° ANGLE								
GRAY	BLACK							
LT3890NM	LT3890NMBL	3/8"	10	cULus	5	2.120"	0.500"	3.120"
LT5090NM	LT5090NMBL	1/2"	10	cULus	5	2.120"	0.500"	3.120"
LT7590NM	LT7590NMBL	3/4"	10	cULus	10	2.500"	0.520"	3.600"
LT10090NM	LT10090NMBL	1"	5	cULus	16	3.125"	0.700"	4.125"
LT12590NM	LT12590NMBL	1 1/4"	5	cULus	28	4.450"	0.760"	5.200"
LT15090NM	LT15090NMBL	1 1/2"	2	cULus	40	4.750"	0.800"	5.200"
LT20090NM	LT20090NMBL	2"	2	cULus	50	5.420"	0.860"	5.800"

Non-Metallic Liquidtight Fittings

MULTI-ANGLE CONNECTORS

Features:

- Swivel design can change from a 0 degree to a 90 degree angle
- No disassembly required
- Eliminate inventory by using the swivel design as a straight or 90 degree connector



LT50U90NM

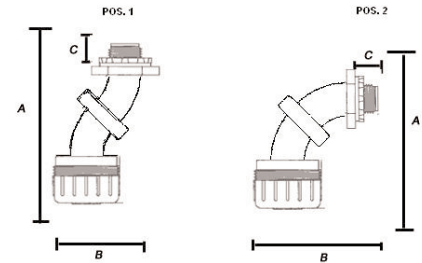

Liquidtight

Cat. #	Trade Size	Unit Qty.	Certification	Wt. Lbs. Per 100	A	B	C
LT50U90NM	1/2"	10	cULus	10	Pos 1 = 3.350" / Pos 2 = 3.025"	Pos 1 = 2.15" / Pos 2 = 2.395"	Pos 1 = .5" / Pos 2 = .5
LT75U90NM	3/4"	10	cULus	15	Pos 1 = 4.30" / Pos 2 = 3.850"	Pos 1 = 2.65" / Pos 2 = 3.350"	Pos 1 = .520" / Pos 2 = .520

SCREW ON CONNECTORS

Features:

- 1 piece design
- Design allows for excellent liquidtight seal and optimum pull strength without compression nut

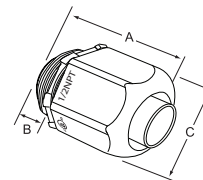

LT50NMSCR

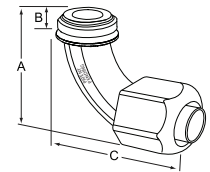

LT5090NMSCR

Cat. #	Trade Size	Unit Qty.	Certification	Wt. Lbs. Per 100	A	B	C
STRAIGHT CONNECTOR							
LT50NMSCR	1/2"	25	cULus	5	1.750"	0.500"	1.250"
LT75NMSCR	3/4"	25	cULus	7	1.800"	0.625"	1.500"
90° ANGLE CONNECTOR							
LT5090NMSCR	1/2"	10	cULus	7	1.875"	0.500"	3.125"
LT7590NMSCR	3/4"	10	cULus	9	2.375"	0.625"	3.500"

LIQUIDTIGHT WHIPS

Features:

- Available in 1/2" and 3/4" conduit size
- 4 FT and 6 FT lengths
- Easy installation
- Assembled with all UL components
- Resists corrosion, oil and water
- 1/2" filled with three #10 AWG THHN copper stranded wire
- 3/4" filled with one #10 AWG THHN copper stranded wire and two #8 AWG THHN copper stranded wire



LTWHP50NM4

Cat. #	Trade Size	Unit Qty.	Certification	Wt. Lbs. Per 100
4 FOOT				
LTWHP50NM4	1/2"	24	Listed Components	138
LTWHP75NM4	3/4"	24	Listed Components	188
6 FOOT				
LTWHP50NM6	1/2"	24	Listed Components	196
LTWHP75NM6	3/4"	12	Listed Components	267

Non-Metallic Liquidtight Fittings

UL TYPE B FLEXIBLE, NON-METALLIC LIQUIDTIGHT CONDUIT

Applications:

- For use with nonmetallic liquidtight fittings to terminate and seal conduit to liquidtight, oiltight, or raintight box or enclosure.
- Typical applications include wiring motors, transformers, processing equipment, pumps, etc.

Features:

- Resists abrasion, oil, water, acid and metal shavings
- Smooth inside for easier wire pulling, no hazardous sharp edges or burrs, will not damage conductors
- Corrosion resistant for tough environmental conditions
- Suitable for wet locations
- Quick installation, cuts with utility knife or PVC cutter
- 90° has smooth interior to prevent abrasion of conductors



LTCOND38NM100 - GRAY

LTCOND38NMBL100 - BLACK

Standard Materials:

- Integral rigid and flexible PVC construction

Cat. #	Cat. #	Trade Size	Certification	Wt. Lbs. Per 100 Ft.	Coil / Reel Size	O.D. Min - Max	I.D. Min - Max
Type B 80°C Dry 60°C Wet 70°C - GRAY		Type B 105°C Dry 60°C Wet 70°C - BLACK					
LTCOND38NM100	LTCOND38NMBL100	3/8"	UL and CSA	13	100 FT	.690 - .710"	.484 - .504"
LTCOND50NM100	LTCOND50NMBL100	1/2"	UL and CSA	15	100 FT	.820 - .840"	.622 - .642"
LTCOND75NM100	LTCOND75NMBL100	3/4"	UL and CSA	20	100 FT	1.030 - 1.050"	.820 - .840"
LTCOND100NM100	LTCOND100NMBL100	1"	UL and CSA	27	100 FT	1.290 - 1.315"	1.041 - 1.066"
LTCOND125NM100	LTCOND125NMBL100	1 1/4"	UL and CSA	35	100 FT	1.630 - 1.660"	1.380 - 1.410"
LTCOND150NM50	LTCOND150NMBL50	1 1/2"	UL and CSA	46	50 FT	1.865 - 1.900"	1.575 - 1.600"
LTCOND200NM50	LTCOND200NMBL50	2"	UL and CSA	66	50 FT	2.340 - 2.375"	2.020 - 2.045"
LTCOND38NM1200		3/8"	UL and CSA	14	1200 FT	.690 - .710"	.484 - .504"
LTCOND50NM1000		1/2"	UL and CSA	17	1000 FT	.820 - .840"	.622 - .642"
LTCOND75NM800		3/4"	UL and CSA	22	800 FT	1.030 - 1.050"	.820 - .840"
LTCOND100NM500		1"	UL and CSA	30	500 FT	1.290 - 1.315"	1.041 - 1.066"

NON-METALLIC LIQUIDTIGHT ELECTRICAL TUBING

Features:

- Quick installation. Cuts with utility knife or PVC cutter
- Suitable for use in high vibration or flexing applications
- Resists corrosion, oil and water
- Maximum flexibility. Can be used in extremely tight areas
- Resists abuse, pulling and crushing



ET25NM100

Cat. #	Trade Size	Certification	Wt. Lbs. Per 100 Ft.	Coil / Reel Size	O.D. Min - Max	I.D. Min - Max
Non-Metallic Electrical Tubing						
ET25NM100	1/4"	UL	8	100 FT	.560 - .575"	.385 - .405"
ET38NM100	3/8"	UL and CSA	9	100 FT	.690 - .710"	.484 - .504"
ET50NM100	1/2"	UL and CSA	10	100 FT	.820 - .840"	.622 - .642"
ET75NM100	3/4"	UL and CSA	14	100 FT	1.030 - 1.050"	.820 - .840"
ET100NM100	1"	UL and CSA	19	100 FT	1.290 - 1.315"	1.041 - 1.066"
ET125NM100	1 1/4"	UL and CSA	22	100 FT	1.630 - 1.660"	1.380 - 1.410"
ET150NM50	1 1/2"	UL and CSA	28	50 FT	1.865 - 1.900"	1.575 - 1.600"
ET200NM50	2"	UL and CSA	42	50 FT	2.340 - 2.375"	2.020 - 2.045"

Cord And Cable Connectors

CG Series Color-Coded Cord Grips



Applications:

CG Series color-coded grips with neoprene bushings are for use with portable cords, including S, SO, STO, ST, SJ, SJT, SJTO, and SVO.

CG cord grips are installed to:

- Provide a means for passing a cord into an enclosure
- Form a watertight seal for cord
- Provide pullout protection for cord, ensuring a secure connection

Features:

- Neoprene bushings are color coded by cable diameter for quick and easy identification of proper cord grip.
- Rugged construction protects cord from damage.
- Compact design permits close spacing of fittings on panel applications.
- Tightening one nut creates watertight seal.
- Male tapered thread NPT.
- Straight cord grips available in steel or aluminum, 45° and 90° cord grips available in malleable iron.

Certifications and Compliances:

- UL Standard: 514B
- UL File No. E-23223
- CSA Standard: C22.2 No. 18
- Suitable for NEMA 4 enclosures and other wet locations
- Suitable for use in Class I, Div. 2 hazardous locations when installed in accordance with NEC 501.10(B)(2).

Standard Materials:

- Body – Straight: 1/2" through 1 1/2" steel, or 1/2" through 1" aluminum
- Body – 45° – 1/2" through 1" malleable iron
- Body – 90° – 1/2" through 1" malleable iron
- Nut – steel or aluminum
- Bushing – neoprene

Standard Finishes:

- Body (steel or malleable Iron) – electrogalvanized
- Body (aluminum) – natural
- Nut (steel) – electrogalvanized
- Nut (aluminum) – natural

Cord & Cable

Straight Connector

Steel Cat. #	Alum. Cat. #	Trade Size	Color Size	Cable Range Min.	Cable Range Max.	Unit Qty.	Wt. Lbs.* Per 100
CG50 250	CG50 250SA	1/2"	Red	0.15	0.25	25	10
CG50 350	CG50 350SA	1/2"	White	0.25	0.35	25	10
CG50 450	CG50 450SA	1/2"	Blue	0.35	0.45	25	10
CG50 560	CG50 560SA	1/2"	Green	0.45	0.56	25	10
CG50 650	CG50 650SA	1/2"	Brown	0.55	0.65	25	10
CG75 250	CG75 250SA	3/4"	Red	0.15	0.25	10	14
CG75 350	CG75 350SA	3/4"	White	0.25	0.35	10	14
CG75 450	CG75 450SA	3/4"	Blue	0.35	0.45	10	14
CG75 560	CG75 560SA	3/4"	Green	0.45	0.56	10	14
CG75 650	CG75 650SA	3/4"	Brown	0.55	0.65	10	14
CG75 750	CG75 750SA	3/4"	Yellow	0.65	0.75	10	14
CG75 850	CG75 850SA	3/4"	Purple	0.75	0.85	10	14
CG100 560	CG100 560SA	1"	Green	0.45	0.56	5	20
CG100 650	CG100 650SA	1"	Brown	0.55	0.65	5	20
CG100 750	CG100 750SA	1"	Yellow	0.65	0.75	5	20
CG100 850	CG100 850SA	1"	Purple	0.75	0.85	5	20
CG100 950	CG100 950SA	1"	Gray	0.85	0.95	5	20
CG100 1050	CG100 1050SA	1"	Black	0.95	1.05	5	20
CG125 850		1 1/4"	Purple	0.75	0.85	5	40
CG125 950		1 1/4"	Gray	0.85	0.95	5	40
CG125 1050		1 1/4"	Black	0.95	1.05	5	40
CG125 1150		1 1/4"	Orange	1.05	1.15	5	40
CG125 1250		1 1/4"	Red	1.15	1.25	5	40
CG125 1375		1 1/4"	White	1.25	1.375	5	40
CG150 1050		1 1/2"	Black	0.95	1.05	2	70
CG150 1150		1 1/2"	Orange	1.05	1.15	2	70
CG150 1250		1 1/2"	Red	1.15	1.25	2	70
CG150 1375		1 1/2"	White	1.25	1.375	2	70



*Wt. Lbs. Per 100 is for steel connectors only

Cord And Cable Connectors

CG Series Color-Coded Cord Grips



Cord & Cable

45° Connector

Steel Cat. #	Trade Size	Color Size	Cable Range Min.	Cable Range Max.	Unit Qty.	Wt. Lbs. Per 100
CG5045 250	1/2"	Red	0.15	0.25	10	24
CG5045 350	1/2"	White	0.25	0.35	10	24
CG5045 450	1/2"	Blue	0.35	0.45	10	24
CG5045 560	1/2"	Green	0.45	0.56	10	24
CG5045 650	1/2"	Brown	0.55	0.65	10	24
CG7545 250	3/4"	Red	0.15	0.25	10	36
CG7545 350	3/4"	White	0.25	0.35	10	36
CG7545 450	3/4"	Blue	0.35	0.45	10	36
CG7545 560	3/4"	Green	0.45	0.56	10	36
CG7545 650	3/4"	Brown	0.55	0.65	10	36
CG7545 750	3/4"	Yellow	0.65	0.75	10	36
CG7545 850	3/4"	Purple	0.75	0.85	10	36
CG10045 560	1"	Green	0.45	0.56	5	68
CG10045 650	1"	Brown	0.55	0.65	5	68
CG10045 750	1"	Yellow	0.65	0.75	5	68
CG10045 850	1"	Purple	0.75	0.85	5	68
CG10045 950	1"	Gray	0.85	0.95	5	68
CG10045 1050	1"	Black	0.95	1.05	5	68



90° Connector

Steel Cat. #	Trade Size	Color Size	Cable Range Min.	Cable Range Max.	Unit Qty.	Wt. Lbs. Per 100
CG5090 250	1/2"	Red	0.15	0.25	10	26
CG5090 350	1/2"	White	0.25	0.35	10	26
CG5090 450	1/2"	Blue	0.35	0.45	10	26
CG5090 560	1/2"	Green	0.45	0.56	10	26
CG5090 650	1/2"	Brown	0.55	0.65	10	26
CG7590 250	3/4"	Red	0.15	0.25	10	48
CG7590 350	3/4"	White	0.25	0.35	10	48
CG7590 450	3/4"	Blue	0.35	0.45	10	48
CG7590 560	3/4"	Green	0.45	0.56	10	48
CG7590 650	3/4"	Brown	0.55	0.65	10	48
CG7590 750	3/4"	Yellow	0.65	0.75	10	48
CG7590 850	3/4"	Purple	0.75	0.85	10	48
CG10090 560	1"	Green	0.45	0.56	5	68
CG10090 650	1"	Brown	0.55	0.65	5	68
CG10090 750	1"	Yellow	0.65	0.75	5	68
CG10090 850	1"	Purple	0.75	0.85	5	68
CG10090 950	1"	Gray	0.85	0.95	5	68
CG10090 1050	1"	Black	0.95	1.05	5	68



Cord And Cable Connectors CG Series Color-Coded Cord Grips



Cord Grips Dimensional Information

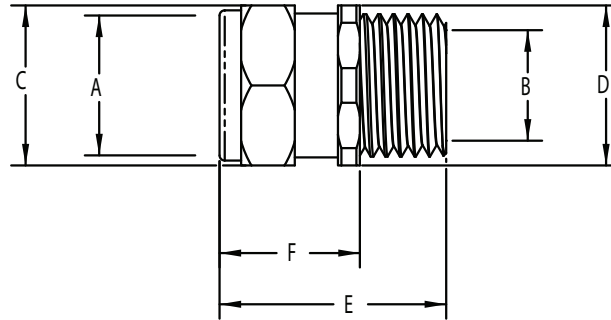

Cat. #	Size	A		B	C	D	E	F
		MIN.	MAX.	MAX. CABLE	CROSS CORNER	HEX BODY	OVERALL LENGTH	EXPOSED LENGTH
CG50 250SA	1/2	0.150	0.250	0.640	1.070	0.975	1 ⁵ / ₁₆	1 ³ / ₁₆
CG50 350SA	1/2	0.250	0.350	0.640	1.070	0.975	1 ⁵ / ₁₆	1 ³ / ₁₆
CG50 450SA	1/2	0.350	0.450	0.640	1.070	0.975	1 ⁵ / ₁₆	1 ³ / ₁₆
CG50 560SA	1/2	0.450	0.560	0.640	1.070	0.975	1 ⁵ / ₁₆	1 ³ / ₁₆
CG50 650SA	1/2	0.560	0.650	0.640	1.070	0.975	1 ⁵ / ₁₆	1 ³ / ₁₆
CG75 250SA	3/4	0.150	0.250	0.687	1.070	1.220	1 ⁵ / ₁₆	1 ³ / ₁₆
CG75 350SA	3/4	0.250	0.350	0.687	1.070	1.220	1 ⁵ / ₁₆	1 ³ / ₁₆
CG75 450SA	3/4	0.350	0.450	0.687	1.070	1.220	1 ⁵ / ₁₆	1 ³ / ₁₆
CG75 560SA	3/4	0.450	0.560	0.687	1.070	1.220	1 ⁵ / ₁₆	1 ³ / ₁₆
CG75 650SA	3/4	0.560	0.650	0.687	1.070	1.220	1 ⁵ / ₁₆	1 ³ / ₁₆
CG75 750SA	3/4	0.650	0.750	0.845	1.330	1.220	1 ⁵ / ₁₆	1 ¹ / ₃₂
CG75 850SA	3/4	0.750	0.850	0.845	1.330	1.220	1 ⁵ / ₁₆	1 ¹ / ₃₂
CG100 560SA	1	0.450	0.560	0.937	1.330	1.500	1 ³ / ₄	1 ¹ / ₈
CG100 650SA	1	0.560	0.650	0.937	1.330	1.500	1 ³ / ₄	1 ¹ / ₈
CG100 750SA	1	0.650	0.750	0.937	1.330	1.500	1 ³ / ₄	1 ¹ / ₈
CG100 850SA	1	0.750	0.850	0.937	1.330	1.500	1 ³ / ₄	1 ¹ / ₈
CG100 950SA	1	0.850	0.950	1.050	1.625	1.500	1 ⁷ / ₈	1 ³ / ₁₆
CG100 1050SA	1	0.950	1.050	1.050	1.625	1.500	1 ⁷ / ₈	1 ³ / ₁₆

Cord & Cable

NCG Non-Metallic Cord Grips

Cord & Cable

NCG SERIES NONMETALLIC CORD GRIPS

Applications:

For use with portable cord, NCG Series watertight cord grips terminate and protect conductors from mechanical damage due to vibration and movement. A neoprene bushing seals out oils, coolants, water, dust and other abusive agents. NCG cord grips may be used with types S, SO, STO, SJ, SJT, SJTO and SVO portable cords.

Typical applications include the termination of wiring for:

- Machine tools
- Motors
- Transformers
- Food processing equipment
- Robotics
- Air conditioning units
- Illuminated signs
- Terminal boxes
- Control cabinets

Features:

- Available in 3/8" to 1" trade sizes.
- Neoprene bushings cover a large cable range, reducing the number of different fittings required.
- Polyamide nonmetallic construction stands up to most corrosive environments.
- Polyamide locknut available, order separately.
- UL listed and cUL third party certified.
- Rain-tight and watertight construction for outdoor use.
- Tightening one nut creates watertight seal.

Certifications and Compliances:

- UL Standard 514B
- cUL to CSA Standard C22.2 No.18
- IP 68
- NEMA 4X Watertight
- Zone 2, Division 2 use per Code

Standard Materials:

- Cable gland body and nut – polyamide 6
- Bushing – neoprene
- Locknut – polyamide 6

Cat. #	Trade Size	Cable Range Inches (MM)
NCG38 35	3/8"	0.1–0.35 (2.5–8)
NCG50 50	1/2"	0.20–0.50 (5–12)
NCG75 75	3/4"	0.35–0.75 (9–18)
NCG100 100	1"	0.55–1.00 (14–25)



Locknuts – must be ordered separately

Cat. #	Trade Size	Std. Pkg.
10N	3/8"	25
11N	1/2"	25
12N	3/4"	25
13N	1"	20



Cord And Cable Connectors



NCGS Non-Metallic Solar Cord Grips

Applications:

Cooper Crouse-Hinds Solar Cord Grips are used in both commercial and residential grid-tied PV solar applications and are designed to accommodate the entry of multiple PV wires coming into a combiner or pass through box. The Solar Cord Grips provide mechanical strain relief as well as a liquid tight seal around the solar panel wires.

Features:

- Multi-hole cord grip to allow for entry of multiple PV wires.
- Solar cord grips offer customer flexibility by allowing the termination from 1 to 13 PV wires in a single connector.
- Skinned over glands provide a durable, liquid tight seal around the wires.
- No disassembly required for installation.
- Accommodates USE-2, 12AWG and 10AWG wire.
- Temperature rating: -22°F (-30°C) to 212°F (100°C) to meet the most demanding environmental conditions.



Photo shown with steel locknut
(locknuts must be ordered separately)

Certifications and Compliances:

- UL/cUL listed
- IP68
- Flammability rating: 94-V2

Standard Materials:

- 6% nylon with TPE/Buna N sealing glands



Ordering Information:

Cat. #	Trade Size	Description
NCGS39	1"	9 Hole Solar Cord Grip
NCGS413	1 1/4"	13 Hole Solar Cord Grip

Locknut Ordering Information:

Material	Cat. No.	Trade Size
Steel	13	1"
	14	1 1/4"
Aluminum	13 SA	1"
	14 SA	1 1/4"
Non-metallic	13N	1"
	14N	1 1/4"
Zinc	13DC	1"
	14DC	1 1/4"

Cord & Cable

ACB Series

ACB SERIES – STEEL

Applications:

- ACB Series Connectors are used to connect armored cable, metal clad cable or flexible metallic conduit to a box or enclosure.

Features and Benefits:

- Dual gripping saddle design on the connector safely secures cable or conduit in place and prevents loosening from vibration.
- Insulated throat provides a smooth pulling surface that won't strip cable.
- Angled teeth on locknut bite into enclosure, preventing loosening from vibration.
- Tri-head set screw may be installed using a slotted, Phillips or Robertson head Screwdriver.
- Steel connector is zinc electroplated for corrosion resistance.

Certifications and Compliances:

- UL Listed
- cUL Listed

Materials and Finishes:

- Body: Steel – Zinc electroplated
- Saddle: Steel – Zinc electroplated
- Screw: Steel – Zinc electroplated
- Insulated throat: Thermoplastic – Natural



Straight Connectors

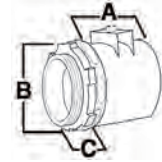

Cat. #	Trade Size	Cable Opening		Unit Qty.	Dimensions		
		Max.	Min.		A	B	C
ACB38*	3/8"	0.656	0.437	50	1 3/16"	1 1/4"	1/2"
ACB50*	1/2"	0.937	0.750	25	1 3/8"	1 1/4"	7/16"
ACB75	3/4"	1.125	0.906	10	1 3/8"	1 7/16"	7/16"
ACB100	1"	1.468	1.250	5	1 9/16"	1 13/16"	1/2"
ACB125	1 1/4"	1.500	1.312	5	2 3/16"	2 1/8"	5/8"
ACB150	1 1/2"	1.750	1.562	5	2 7/16"	2 1/2"	5/8"
ACB200	2"	2.031	1.812	1	2 9/16"	3"	5/8"
ACB250	2 1/2"	3.062	2.812	1	2 11/16"	3 5/8"	13/16"
ACB300	3"	3.562	3.312	1	2 13/16"	4 1/4"	15/16"
ACB350	3 1/2"	4.060	3.620	1	2 15/16"	3 3/4"	1"
ACB400	4"	4.560	4.120	1	3"	5 3/16"	1 1/16"

45° Connectors†

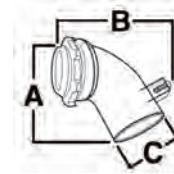

Cat. #	Trade Size	Cable Opening		Unit Qty.	Dimensions		
		Max.	Min.		A	B	C
ACB3845*	3/8"	0.656	0.437	50	1 13/16"	1 13/16"	15/16"
ACB5045*	1/2"	0.937	0.750	25	2 1/8"	2 1/8"	1 1/4"
ACB7545	3/4"	1.125	0.906	10	2 3/8"	2 3/8"	1 7/16"

†45° not available in 1" size

90° Connectors

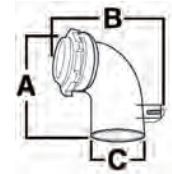

Cat. #	Trade Size	Cable Opening		Unit Qty.	Dimensions		
		Max.	Min.		A	B	C
ACB3890*	3/8"	0.656	0.437	50	1 3/4"	2 1/16"	1"
ACB5090*	1/2"	0.937	0.750	25	2 1/8"	2 1/4"	1 1/4"
ACB7590	3/4"	1.125	0.906	10	2 1/2"	2 1/2"	1 3/8"
ACB10090	1"	1.468	1.250	5	2 13/16"	2 7/8"	1 11/16"

*UL approved for use with aluminum interlocking grounding metal clad cable, Type MCIA (Southwire MCAP™)
MCAP™ is a registered trademark of Soutwire Company.

Space Saver ACB Series & Quick-Lok®

SPACE SAVER ACB SERIES – STEEL

Features:

- Male threads on locknut allow for more room inside the box
- Smooth pulling surface eliminates the need for insulated throat fittings and/or conduit bushings
- Angled teeth on locknut bite into enclosure, preventing loosening from vibration
- Dual gripping saddle design on the fitting safely secures cable or conduit in place and prevents loosening from vibration
- Tri-head set screw may be installed using a slotted, Philips, or Robertson head screwdriver
- Steel fitting is zinc electroplated for corrosion resistance
- Suitable for use with steel or aluminum cables



Certifications and Compliances:

- UL Listed
- cUL Listed

UL File No. E-22132

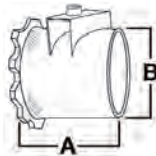

Cat. #	Trade Size	KO Size	Cable Opening		Unit Qty.	Wt. Lbs. Per 100	Dimensions	
			Max.	Min.			A	B
SSACB38*	3/8"	1/2"	0.640	0.280	50	9	1 3/8"	3/4"
SSACB50*	1/2"	1/2"	0.930	0.635	25	12	1 3/8"	1 1/16"
SSACB75	3/4"	3/4"	1.125	0.810	20	14	1 1/2"	1 1/4"
SSACB100	1"	1"	1.405	0.775	5	30	2"	1 9/16"

*UL approved for use with aluminum interlocking grounding metal clad cable, Type MCIA (Southwire MCAP™)
MCAP™ is a registered trademark of Southwire Company.

QUICK-LOK® CONNECTORS – STEEL

Features:

- No Locknut required
- Single-unit or duplex construction with captive clamp
- Connects 50 MC, AC, and Flex RW cable sizes with just three fittings
- Easy to install: tilt, insert and snap down
- Single unit construction eliminates loose component parts, integral green plastic insulated throat bushing provides maximum protection for wire installation



AC/MC Fittings

Standard Materials:

- Tubular Steel

Standard Finishes:

- Zinc plated

UL File No. E-19188



Cat. #	Trade Size	Unit Qty.	Wt. Lbs. Per 100
QLK50S*	1/2" single	50 For 14 / 4 to 1 0/ 3 For 3/8" FMC	9
QLK50D	1/2" duplex	25 For 14 / 4 to 10 / 3	11
QLK75*	3/4"	25 For 10 / 3 to 6 / 3 For 3/8" and 1/2" FMC	11.5

*UL approved for use with aluminum interlocking grounding metal clad cable, Type MCIA (Southwire MCAP™)
MCAP™ is a registered trademark of Southwire Company.

Set Screw, Clamp & Duplex Type - Malleable Iron

SET SCREW TYPE – MALLEABLE IRON

UL File No. E-19188



Cat. #	Trade Size	Diam. of Opening for Cable	Diam. of Bushed Hole	Unit Qty.	Wt. Lbs. Per 100
702V	3/8"	5/8"	7/16"	100	7
For 2 conductor No.'s 14, 12 3 conductor No.'s 14, 12 4 conductor No. 14, 5/16" flex					

DUPLEX TYPE – MALLEABLE IRON

UL File No. E-19188



Cat. #	Trade Size	Diam. of Opening for Cable	Diam. of Bushed Hole	Unit Qty.	Wt. Lbs. Per 100
Straight 699*	3/8"	5/8"	9/16"	25	20
90 Degree 700*	3/8"	5/8"	9/16"	25	14

*UL Listed as grounding means.

CLAMP TYPE 45° ANGLE – MALLEABLE IRON

Features:

- Male hub treads – NPSM

Standard Materials:

- Malleable Iron
- Steel locknut
- Stamped steel covers

Standard Finishes:

- Zinc Plated

Clamp Type 45° Angle – Non-Insulated

UL File No. E-19188 or E-19189



Cat. #	Trade Size	Diam. of Opening for Cable	Diam. of Bushed Hole	Unit Qty.	Wt. Lbs. Per 100
723	3/8"	21/32"	17/32"	50	14
For 2 conductor No.'s 14, 12, 10 3 conductor No.'s 14, 12, 10 4 conductor No.'s 14, 12 Flexible metallic conduit 5/16" and 3/8"					
735	1/2"	15/16"	9/16"	25	18
For 2 conductor No. 8 Flexible metallic conduit 1/2"					
737	3/4"	1 1/8"	25/32"	25	24
For 2 conductor No.'s 6, 4 3 conductor No.'s 6, 4 Flexible metallic conduit 3/4"					

Clamp Type 45° Angle – Insulated

UL File No. E-19188 or E-19189



Cat. #	Trade Size	Diam. of Opening for Cable	Diam. of Bushed Hole	Unit Qty.	Wt. Lbs. Per 100
1723	3/8"	21/32"	17/32"	50	14
1735	1/2"	15/16"	9/16"	25	17
1737	3/4"	1 1/8"	25/32"	25	24

AC/MC Fittings

Set Screw & Duplex Type - Zinc Die Cast Combination Couplings - Steel



SET SCREW TYPE – ZINC DIE CAST

UL File No. E-19188

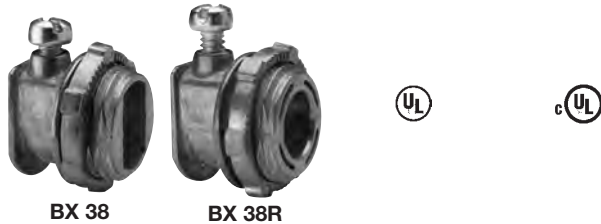

BX 38

BX 38R

Cable Opening

Cat. #	Trade Size	Desc.	Max.	Min.	Unit Qty.	Wt. Lbs. Per 100
BX38	3/8"	Oval	.469	.610	50	5
BX38R	3/8"	Round	.460	.600	50	5

SET SCREW TYPE – ZINC DIE CAST

UL File No. E-19188



ACMF

ACB38DC

Cable Opening

Cat. #	Trade Size	Min.	Max.	Unit Qty.	Wt. Lbs. Per 100
ACMF38	3/8"	.469	.610	100	25
ACB38DC	3/8"	.468	.610	50	35

DUPLEX TYPE – ZINC DIE CAST

UL File No. E-19188



Cat. #	Trade Size	Diam. of Opening for Cable	Diam. of Bushed Hole	Unit Qty.	Wt. Lbs. Per 100
2699*	3/8"	5/8"	9/16"	25	13

*UL Listed as grounding means.

ACC SERIES COMBINATION COUPLINGS – STEEL

Applications:

- ACC combination couplings are used to join EMT conduit to armored cable, metal clad cable or flexible metallic conduit.

Features and Benefits:

- Dual gripping saddle design on the coupling safely secures cable or conduit in place and prevents loosening from vibration
- Steel compression ring & nut provide a strong, secure termination point for EMT conduit.
- Tri-head set screw may be installed using a slotted, Phillips or Robertson head screwdriver.
- Steel combination coupling is zinc electroplated for corrosion resistance.

Certifications and Compliances:

- UL Listed
- cUL Listed

Materials and Finishes:

- Body: Steel – Zinc electroplated
- Saddle: Steel – Zinc electroplated
- Screw: Steel – Zinc electroplated

Compression Coupling:

AC/MC, FMC to EMT



Cable Opening

Cat. #	Trade Size	Max.	Min.	Unit Qty.
ACC38	3/8"	0.656	0.437	25
ACC50	1/2"	0.937	0.750	10
ACC75	3/4"	1.125	0.906	10

Set-Screw Coupling:



Cat. #	Trade Size	Unit Qty.	Wt. Lbs. Per 100
ACCSS38*	3/8"	25	9
ACCSS50	1/2"	10	12
ACCSS75	3/4"	10	14

*not UL Listed

AC/MC
Fittings

CLAMPS "SNAP-ON" – STEEL

Light Gauge



AC/MC Fittings

Cat. #	Conduit Sizes Rigid	Size of Strap Inside	Unit Qty.	Wt. Lbs. Per 100
566	1/4"	.540	500	2
567BX	3/8"	.675	100	14

ANTI-SHORT BUSHINGS



Cat. #	FMC Trade Size	Armored Cable Size	Unit Qty.
ASB 0	5/16"	14 - 2, 14 - 3, 12 - 2	100
ASB 1	3/8"	14 - 4, 12 - 3, 6 - 1, 4 - 1	100
ASB 2	7/16"	12 - 4, 10 - 2, 10 - 3, 2 - 1	50
ASB 3	1/2"	10 - 4, 8 - 2, 8 - 3, 1 - 1	50
ASB 4	3/4"	8 - 4, 6 - 4, 6 - 3, 6 - 2, 4 - 3, 4 - 2	50
ASB 5	1"	3 - 1, 2 - 1, 2 - 1 / 0, 1 - 300 MCM, 1 - 350 MCM, 1 - 400 MCM, 1 - 450 MCM, 1 - 500 MCM	25
ASB 6	1 1/4"	4 - 1, 4 - 1 / 0, 4 - 2 / 0, 3 - 1 / 0, 3 - 2 / 0, 3 - 3 / 0, 2 - 2 / 0, 2 - 3 / 0, 2 - 4 / 0, 1 - 600 MCM, 1 - 650 MCM, 1 - 700 MCM, 1 - 750 MCM, 1 - 800 MCM, 1 - 900 MCM	10
ASB 7	1 1/2"	4 - 3 / 0, 4 - 4 / 0, 3 - 4 / 0, 3 - 250 MCM, 3 - 300 MCM, 2 - 250 MCM, 2 - 300 MCM, 2 - 350 MCM, 1 - 1000 MCM	10
ASB 8	2" to 2 1/2"	4 - 250 MCM, 4 - 300 MCM, 4 - 350 MCM, 4 - 400 MCM, 4 - 450 MCM, 4 - 500 MCM, 3 - 350 MCM, 3 - 400 MCM, 3 - 450 MCM, 3 - 500 MCM, 2 - 400 MCM, 2 - 450 MCM, 2 - 500 MCM	10

Bushings are packed in clear poly bags.
Anti-short bushings have a temperature rating of 90°C

Flexible Metallic Conduit Fittings

ACB Series



ACB SERIES – STEEL

Applications:

- ACB Series Connectors are used to connect armored cable, metal clad cable or flexible metallic conduit to a box or enclosure.

Features and Benefits:

- Dual gripping saddle design on the connector safely secures cable or conduit in place and prevents loosening from vibration.
- Insulated throat provides a smooth pulling surface that won't strip cable.
- Angled teeth on locknut bite into enclosure, preventing loosening from vibration.
- Tri-head set screw may be installed using a slotted, Phillips or Robertson head Screwdriver.
- Steel connector is zinc electroplated for corrosion resistance.

Certifications and Compliances:

- UL Listed
- cUL Listed

Materials and Finishes:

- Body: Steel – Zinc electroplated
- Saddle: Steel – Zinc electroplated
- Screw: Steel – Zinc electroplated
- Insulated throat: Thermoplastic – Natural



Straight Connectors

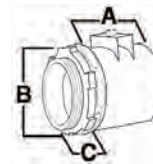

Cat. #	Trade Size	Cable Opening		Unit Qty.	Dimensions		
		Max.	Min.		A	B	C
ACB38*	3/8"	0.656	0.437	50	1 3/16"	1 1/4"	1/2"
ACB50*	1/2"	0.937	0.750	25	1 3/8"	1 1/4"	7/16"
ACB75	3/4"	1.125	0.906	10	1 3/8"	1 7/16"	7/16"
ACB100	1"	1.468	1.250	5	1 9/16"	1 13/16"	1/2"
ACB125	1 1/4"	1.500	1.312	5	2 3/16"	2 1/8"	5/8"
ACB150	1 1/2"	1.750	1.562	5	2 7/16"	2 1/2"	5/8"
ACB200	2"	2.031	1.812	1	2 9/16"	3"	5/8"
ACB250	2 1/2"	3.062	2.812	1	2 11/16"	3 3/8"	13/16"
ACB300	3"	3.562	3.312	1	2 13/16"	4 1/4"	1 5/16"
ACB350	3 1/2"	4.060	3.620	1	2 15/16"	3 3/4"	1"
ACB400	4"	4.560	4.120	1	3"	5 3/16"	1 1/16"

45° Connectors†

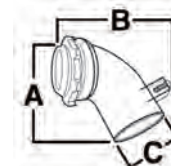

Cat. #	Trade Size	Cable Opening		Unit Qty.	Dimensions		
		Max.	Min.		A	B	C
ACB3845*	3/8"	0.656	0.437	50	1 13/16"	1 13/16"	15/16"
ACB5045*	1/2"	0.937	0.750	25	2 1/8"	2 1/8"	1 1/4"
ACB7545	3/4"	1.125	0.906	10	2 3/8"	2 3/8"	1 7/16"

†45° not available in 1" size

90° Connectors

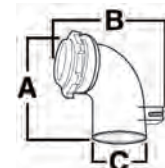

Cat. #	Trade Size	Cable Opening		Unit Qty.	Dimensions		
		Max.	Min.		A	B	C
ACB3890*	3/8"	0.656	0.437	50	1 3/4"	2 1/16"	1"
ACB5090*	1/2"	0.937	0.750	25	2 1/8"	2 1/4"	1 1/4"
ACB7590	3/4"	1.125	0.906	10	2 1/2"	2 1/2"	1 3/8"
ACB10090	1"	1.468	1.250	5	2 13/16"	2 7/8"	1 11/16"

*UL approved for use with aluminum interlocking grounding metal clad cable, Type MCIA (Southwire MCAP™)
MCAP™ is a registered trademark of Southwire Company.

FMC Fittings

Flexible Metallic Conduit Fittings

Space Saver ACB Series & Quick-Lok®



FMC Fittings

SPACE SAVER ACB SERIES – STEEL

Features:

- Male threads on locknut allow for more room inside the box
- Smooth pulling surface eliminates the need for insulated throat fittings and/or conduit bushings
- Angled teeth on locknut bite into enclosure, preventing loosening from vibration
- Dual gripping saddle design on the fitting safely secures cable or conduit in place and prevents loosening from vibration
- Tri-head set screw may be installed using a slotted, Philips, or Robertson head screwdriver
- Steel fitting is zinc electroplated for corrosion resistance
- Suitable for use with steel or aluminum cables



Certifications and Compliances:

- UL Listed
- cUL Listed

UL File No. E-22132

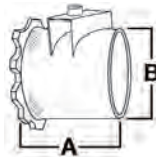

Cat. #	Trade Size	KO Size	Cable Opening		Unit Qty.	Wt. Lbs. Per 100	Dimensions	
			Max.	Min.			A	B
SSACB38*	3/8"	1/2"	0.640	0.280	50	9	1 3/8"	3/4"
SSACB50*	1/2"	1/2"	0.930	0.635	25	12	1 3/8"	1 1/16"
SSACB75	3/4"	3/4"	1.125	0.810	10	14	1 1/2"	1 1/4"
SSACB100	1"	1"	1.405	0.775	5	30	2"	1 9/16"

*UL approved for use with aluminum interlocking grounding metal clad cable, Type MCIA (Southwire MCAP™)
MCAP™ is a registered trademark of Soutwire Company.

QUICK-LOK® CONNECTORS – STEEL

Features:

- No Locknut required
- Single-unit or duplex construction with captive clamp
- Connects 50 MC, AC, and Flex RW cable sizes with just three fittings
- Easy to install: tilt, insert and snap down
- Single unit construction eliminates loose component parts, integral green plastic insulated throat bushing provides maximum protection for wire installation



Standard Materials:

- Tubular Steel

Standard Finishes:

- Zinc plated

UL File No. E-19188



Cat. #	Trade Size	Unit Qty.	Wt. Lbs. Per 100
QLK50S*	1/2" single	50 For 14 / 4 to 10 / 3 For 3/8" FMC	9
QLK50D	1/2" duplex	25 For 14 / 4 to 10 / 3	11
QLK75*	3/4"	25 For 10 / 3 to 6 / 3 For 3/8" and 1/2" FMC	11.5

*UL approved for use with aluminum interlocking grounding metal clad cable, Type MCIA (Southwire MCAP™)
MCAP™ is a registered trademark of Soutwire Company.

Flexible Metallic Conduit Fittings

Squeeze Type



SQUEEZE TYPE – MALLEABLE IRON

Standard Materials:

- Malleable Iron
- Steel Locknut

Standard Finishes:

- Zinc plated

Squeeze Type* - Non-Insulated

UL File No. E-19189



Cat. #	Trade Size	Diam. of Opening for Cable	Diam. of Bushed Hole	Unit Qty.	Wt. Lbs. Per 100
707†§	3/8"	5/8"	3/8"	100	7
708‡	1/2"	15/16"	5/8"	50	14
709	3/4"	1 1/8"	3/4"	20	22
710	1"	1 3/8"	1"	20	31
711	1 1/4"	1 21/32"	1 5/16"	10	46
712	1 1/2"	1 7/8"	1 1/2"	5	79
713	2"	2 1/2"	2"	2	101
714	2 1/2"	2 7/8"	2 3/8"	2	161
715	3"	3 9/16"	3"	1	220
721	3 1/2"	4"	2 13/32"	1	470
722	4"	4 19/32"	3 31/32"	1	610

*UL Listed flexible metallic conduit fittings are suitable as grounding means under NEC 350-5 and suitable for hazardous location use per Class I, Division 2, NEC 501-4(b).

†Suitable for use with armored cable.

‡Suitable for use with metal clad cable.

§ UL approved for use with aluminum interlocking grounding metal clad cable, Type MCIA (Southwire MCAP™)

MCAP™ is a registered trademark of Soutwire Company.

Straight – Insulated*

UL File No. E-19189



Cat. #	Trade Size	Diam. of Opening for Cable	Diam. of Bushed Hole	Unit Qty.	Wt. Lbs. Per 100
1707†§	3/8"	5/8"	3/8"	100	8
1708‡	1/2"	15/16"	5/8"	50	14
1709	3/4"	1 1/8"	3/4"	20	17
1710	1"	1 3/8"	1"	20	26
1711	1 1/4"	1 21/32"	1 5/16"	10	42
1712	1 1/2"	1 7/8"	1 1/2"	5	77
1713	2"	2 1/2"	2"	2	100
1714	2 1/2"	2 7/8"	2 3/8"	2	160
1715	3"	3 9/16"	3"	1	221
1721	3 1/2"	4"	3 13/32"	1	470
1722	4"	4 19/32"	3 31/32"	1	610

*UL Listed flexible metallic conduit fittings are suitable as grounding means under NEC 350-5 and suitable for hazardous location use per Class I, Division 2, NEC 501-4(b).

†Suitable for use with armored cable.

‡Suitable for use with metal clad cable.

§ UL approved for use with aluminum interlocking grounding metal clad cable, Type MCIA (Southwire MCAP™)

MCAP™ is a registered trademark of Soutwire Company.

SQUEEZE TYPE – ZINC DIE CAST

Squeeze Type* – Straight – Non-Insulated



Cat. #	Trade Size	Unit Qty.	Wt. Lbs. Per 100
707DC	3/8"	50	6
708DC	1/2"	25	8
709DC	3/4"	25	11
710DC	1"	10	16
711DC	1 1/4"	10	21
712DC	1 1/2"	5	28
713DC	2"	4	36
714DC	2 1/2"	2	85
715DC	3"	1	109
721DC	3 1/2"	1	144
722DC	4"	1	183

*UL Listed flexible metallic conduit fittings are suitable as grounding means under NEC 350-5 and suitable for hazardous location use per Class I, Division 2, NEC 501-4(b).

Squeeze Type* – Straight – Insulated

UL File No. E-19188



Cat. #	Trade Size	Unit Qty.	Wt. Lbs. Per 100
1707DC	3/8"	50	6
1708DC	1/2"	25	8
1709DC	3/4"	25	11
1710DC	1"	10	16
1711DC	1 1/4"	10	21
1712DC	1 1/2"	5	28
1713DC	2"	4	36
1714DC	2 1/2"	2	85
1715DC	3"	1	109
1721DC	3 1/2"	1	144
1722DC	4"	1	183

*UL Listed flexible metallic conduit fittings are suitable as grounding means under NEC 350-5 and suitable for hazardous location use per Class I, Division 2, NEC 501-4(b).

FMC Fittings

Flexible Metallic Conduit Fittings

Clamp Type



FMC Fittings

CLAMP TYPE 45° ANGLE – MALLEABLE IRON

Features:

- Male hub treads – NPSM

Standard Materials:

- Malleable Iron
- Steel locknut
- Stamped steel covers

Standard Finishes:

- Zinc Plated

Clamp Type 45° Angle – Non-Insulated

UL File No. E-19188 or E-19189



Cat. #	Trade Size	Diam. of Opening for Cable	Diam. of Bushed Hole	Unit Qty.	Wt. Lbs. Per 100
723*	3/8"	21/32"	17/32"	50	14
		For 2 conductor No.'s 14, 12, 10 3 conductor No.'s 14, 12, 10 4 conductor No.'s 14, 12 Flexible metallic conduit 5/16" and 3/8"			
735	1/2"	15/16"	9/16"	25	18
		For 2 conductor No. 8 Flexible metallic conduit 1/2"			
737	3/4"	1 1/8"	25/32"	25	24
		For 2 conductor No.'s 6, 4 3 conductor No.'s 6, 4 Flexible metallic conduit 3/4"			

*UL approved for use with aluminum interlocking grounding metal clad cable, Type MCIA (Southwire MCAP™)
MCAP™ is a registered trademark of Soutwire Company.

Clamp Type 45° Angle – Insulated

UL File No. E-19188 or E-19189



Cat. #	Trade Size	Diam. of Opening for Cable	Diam. of Bushed Hole	Unit Qty.	Wt. Lbs. Per 100
1723*	3/8"	21/32"	17/32"	50	14
1735	1/2"	15/16"	9/16"	25	17
1737	3/4"	1 1/8"	25/32"	25	24

*UL approved for use with aluminum interlocking grounding metal clad cable, Type MCIA (Southwire MCAP™)
MCAP™ is a registered trademark of Soutwire Company.

CLAMP TYPE 90° ANGLE – MALLEABLE IRON

Clamp Type* 90° Angle – Non-Insulated

UL File No. E-19188 or E-19189



Cat. #	Trade Size	Diam. of Opening for Cable	Diam. of Bushed Hole	Unit Qty.	Wt. Lbs. /100
724†§	3/8"	21/32"	17/32"	50	15
		For 2 conductor No.'s 14, 12, 10 3 conductor No.'s 14, 12, 10 4 conductor No.'s 14, 12 Flexible metallic conduit 5/16" and 3/8"			
736†	1/2"	15/16"	9/16"	25	19
738†	3/4"	1 1/8"	13/16"	20	31
739	1"	1 13/32"	1"	5	50
740	1 1/4"	1 21/32"	1 1/4"	2	113
741	1 1/2"	1 7/8"	1 1/2"	1	188
742	2"	2 1/2"	1 15/16"	1	236
744	2 1/2"	3"	2 1/2"	1	400
745	3"	3 1/2"	3"	1	600
746	3 1/2"	4"	3 13/32"	1	1150
747	4"	4 19/32"	3 31/32"	1	1460

*UL Listed flexible metallic conduit fittings are suitable as grounding means under NEC 350-5 and suitable for hazardous location use per Class I, Division 2, NEC 501-4(b).
†Suitable for use with armored cable.

§ UL approved for use with aluminum interlocking grounding metal clad cable, Type MCIA (Southwire MCAP™)
MCAP™ is a registered trademark of Soutwire Company.

Clamp Type 90° Angle – Insulated

UL File No. E-19188 or E-19189



Cat. #	Trade Size	Diam. of Opening for Cable	Diam. of Bushed Hole	Unit Qty.	Wt. Lbs. /100
1736†	1/2"	15/16"	9/16"	25	19
1738†	3/4"	1 1/8"	13/16"	20	31
1739	1"	1 13/32"	1"	5	50
1740	1 1/4"	1 21/32"	1 1/4"	2	113
1741	1 1/2"	1 7/8"	1 1/2"	1	188
1742	2"	2 1/2"	1 15/16"	1	236
1744	2 1/2"	3"	2 1/2"	1	400
1745	3"	3 1/2"	3"	1	600
1746	3 1/2"	4"	3 13/32"	1	1150
1747	4"	4 19/32"	3 31/32"	1	1460

†Suitable for use with armored cable.

Flexible Metallic Conduit Fittings

Squeeze, Set Screw & Duplex Type



SQUEEZE TYPE – ZINC DIE CAST

Squeeze Type* 90° Angle – Non-Insulated
UL File No. 19189



Cat. #	Trade Size	Unit Qty.	Wt. Lbs. Per 100
724DC	3/8"	50	8
736DC	1/2"	25	11
738DC	3/4"	10	15
739DC	1"	5	25
740DC	1 1/4"	10	41
741DC	1 1/2"	1	117
742DC	2"	1	119
744DC	2 1/2"	1	286
745DC	3"	1	405
746DC	3 1/2"	1	560
747DC	4"	1	642

*UL Listed flexible metallic conduit fittings are suitable as grounding means under NEC 350-5 and suitable for hazardous location use per Class I, Division 2, NEC 501-4(b).

Squeeze Type* 90° Angle – Insulated
UL File No. 19189



Cat. #	Trade Size	Unit Qty.	Wt. Lbs. Per 100
1724DC	3/8"	50	8
1736DC	1/2"	25	11
1738DC	3/4"	10	15
1739DC	1"	5	25
1740DC	1 1/4"	10	41
1741DC	1 1/2"	1	117
1742DC	2"	1	119
1744DC	2 1/2"	1	286
1745DC	3"	1	405
1746DC	3 1/2"	1	560
1747DC	4"	1	642

*UL Listed flexible metallic conduit fittings are suitable as grounding means under NEC 350-5 and suitable for hazardous location use per Class I, Division 2, NEC 501-4(b).

SET SCREW TYPE – MALLEABLE IRON

UL File No. E-19188



Cat. #	Trade Size	Diam. of Opening for Cable	Diam. of Bushed Hole	Unit Qty.	Wt. Lbs. Per 100
702V§	3/8"	5/8"	7/16"	100	7
For 2 conductor No.'s 14, 12 3 conductor No.'s 14, 12 4 conductor No. 14, 9/16" flex					

§ UL approved for use with aluminum interlocking grounding metal clad cable, Type MCIA (Southwire MCAP™)
MCAP™ is a registered trademark of Soutwire Company.

DUPLEX TYPE – MALLEABLE IRON

UL File No. E-19188



Cat. #	Trade Size	Diam. of Opening for Cable	Diam. of Bushed Hole	Unit Qty.	Wt. Lbs. Per 100
Straight					
699*§	3/8"	5/8"	9/16"	25	20
90 Degree					
700*§	3/8"	5/8"	9/16"	25	14

*UL Listed as grounding means.

§ UL approved for use with aluminum interlocking grounding metal clad cable, Type MCIA (Southwire MCAP™)
MCAP™ is a registered trademark of Soutwire Company.

FMC Fittings

Flexible Metallic Conduit Fittings

Set Screw, Duplex & Screw-In Type - Zinc Die Cast



FMC Fittings

SET SCREW TYPE – ZINC DIE CAST

UL File No. E-19188



Cable Opening

Cat. #	Trade Size	Desc.	Min.	Max.	Unit Qty.	Wt. Lbs. Per 100
BX38R	3/8"	Round	.460	.600	50	5

SET SCREW TYPE – ZINC DIE CAST

UL File No. E-19188



Cable Opening

Cat. #	Trade Size	Min.	Max.	Unit Qty.	Wt. Lbs. Per 100
ACB38DC	3/8"	.465	.610	50	35

DUPLEX TYPE – ZINC DIE CAST

UL File No. E-19188

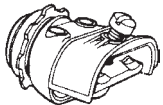

Cat. #	Trade Size	Diam. of Opening for Cable	Diam. of Bushed Hole	Unit Qty.	Wt. Lbs. Per 100
2699*	3/8"	5/8"	9/16"	25	13

*UL Listed as grounding means.

SET SCREW FLEX CONNECTOR – ZINC DIE CAST

Angled Set Screw

UL File No. E-19189



Cat. #	Trade Size	Unit Qty.	Wt. Lbs. Per 100
702DC	1/2"	25	23
703DC	3/4"	25	35

SCREW-IN TYPE – ZINC DIE CAST

Straight Connectors – Non-Insulated

UL File No. E-19189



Cat. #	Trade Size	Unit Qty.	Wt. Lbs. Per 100
770DC	3/8"	80	5
771DC	1/2"	60	5
772DC	3/4"	35	9
773DC	1"	15	13
774DC	1 1/4"	10	24
775DC	1 1/2"	6	35
776DC	2"	3	52

Couplings

UL File No. 19189



Cat. #	Trade Size	Unit Qty.	Wt. Lbs. Per 100
791DC	1/2"	40	4
792DC	3/4"	25	8
793DC	1"	15	12
794DC	1 1/4"	10	21
795DC	1 1/2"	6	31
796DC	2"	3	44

Flexible Metallic Conduit Fittings

Combination Couplings



ACC SERIES COMBINATION COUPLINGS – STEEL

Applications:

- ACC combination couplings are used to join EMT conduit to armored cable, metal clad cable or flexible metallic conduit.

Features:

- Dual gripping saddle design on the coupling safely secures cable or conduit in place and prevents loosening from vibration
- Steel compression ring & nut provide a strong, secure termination point for EMT conduit.
- Tri-head set screw may be installed using a slotted, Phillips or Robertson head screwdriver.
- Steel combination coupling is zinc electroplated for corrosion resistance.

Certifications and Compliances:

- UL Listed
- cUL Listed

Materials and Finishes:

- Body: Steel – Zinc electroplated
- Saddle: Steel – Zinc electroplated
- Screw: Steel – Zinc electroplated

Compression Coupling:



Cat. #	Trade Size	Cable Opening		Unit Qty.
		Max.	Min.	
ACC38	3/8"	0.656	0.437	25
ACC50	1/2"	0.937	0.750	10
ACC75	3/4"	1.125	0.906	10

Set-Screw Coupling:



Cat. #	Trade Size	Unit Qty.	Wt. Lbs. Per 100
ACCSS38*	3/8"	25	9
ACCSS50	1/2"	10	12
ACCSS75	3/4"	10	14

*not UL Listed

COMBINATION COUPLINGS – ZINC DIE CAST

EMT (Set Screw) to Flexible Steel (Clamp)*

UL File No. E-19189



Cat. #	Trade Size	Unit Qty.	Wt. Lbs. Per 100
780DC	1/2" to 3/8"	50	8

*UL Listed flexible metallic conduit fittings are suitable as grounding means under NEC 350-5 and suitable for hazardous location use per Class I, Division 2, NEC 501-4(b).

SET SCREW SQUEEZE TYPE COMBINATION COUPLINGS – ZINC DIE CAST

Set Screw Squeeze Type

UL File No. E-19189



Cat. #	Trade Size	Unit Qty.	Wt. Lbs. Per 100
FECS38DC	1/2" to 3/8"	50	34
FECS50DC	1/2" to 1/2"	25	22
FECS75DC	3/4" to 3/4"	25	36

SCREW-IN TYPE COMPRESSION COMBINATION COUPLINGS – ZINC DIE CAST

UL File No. E-19189



Cat. #	Trade Size	Unit Qty.	Wt. Lbs. Per 100
FECC50DC	1/2"	50	41
FECC75DC	3/4"	25	31
FECC100DC	1"	25	46

FMC Fittings

Flexible Metallic Conduit Fittings

Clamps & Anti-Short Bushings



CLAMPS "SNAP-ON" – STEEL

Light Gauge



FMC Fittings

Cat. #	Conduit Sizes Rigid	Size of Strap Inside	Unit Qty.	Wt. Lbs. Per 100
566	1/4"	.540	500	2
567BX	3/8"	.675	100	14

ANTI-SHORT BUSHINGS



Cat. #	FMC Trade Size	Armoured Cable Size	Unit Qty.
ASB 0	5/16"	14 - 2, 14 - 3, 12 - 2	100
ASB 1	3/8"	14 - 4, 12 - 3, 6 - 1, 4 - 1	100
ASB 2	7/16"	12 - 4, 10 - 2, 10 - 3, 2 - 1	50
ASB 3	1/2"	10 - 4, 8 - 2, 8 - 3, 1 - 1	50
ASB 4	3/4"	8 - 4, 6 - 4, 6 - 3, 6 - 2, 4 - 3, 4 - 2	50
ASB 5	1"	3 - 1, 2 - 1, 2 - 1 / 0, 1 - 300 MCM, 1 - 350 MCM, 1 - 400 MCM, 1 - 450 MCM, 1 - 500 MCM	25
ASB 6	1 1/4"	4 - 1, 4 - 1 / 0, 4 - 2 / 0, 3 - 1 / 0, 3 - 2 / 0, 3 - 3 / 0, 2 - 2 / 0, 2 - 3 / 0, 2 - 4 / 0, 1 - 600 MCM, 1 - 650 MCM, 1 - 700 MCM, 1 - 750 MCM, 1 - 800 MCM, 1 - 900 MCM	10
ASB 7	1 1/2"	4 - 3 / 0, 4 - 4 / 0, 3 - 4 / 0, 3 - 250 MCM, 3 - 300 MCM, 2 - 250 MCM, 2 - 300 MCM, 2 - 350 MCM, 1 - 1000 MCM	10
ASB 8	2" to 2 1/2"	4 - 250 MCM, 4 - 300 MCM, 4 - 350 MCM, 4 - 400 MCM, 4 - 450 MCM, 4 - 500 MCM, 3 - 350 MCM, 3 - 400 MCM, 3 - 450 MCM, 3 - 500 MCM, 2 - 400 MCM, 2 - 450 MCM, 2 - 500 MCM	10

Note: Bushings are packed in clear poly bags.
Anti-short bushings have a temperature rating of 90°C

Non-Metallic Sheathed Cable Connectors

Clamp, Set Screw & Duplex Type



CLAMP TYPE – STEEL

UL File No. E-22132



Clamp Opening

Cat. #	K.O. Size	Min.	Max.	Width	Unit Qty.	Wt. Lbs. Per 100
631	3/4"	33/64"	13/16"	13/16"	20	14
			For 2 conductor No.'s 8, 6 3 conductor No.'s 8, 6			
632	1"	3/8"	1 1/64"	1 1/64"	10	21
			For 2 conductor No.'s 8, 6 3 conductor No.'s 8, 6			

CLAMP TYPE – ZINC DIE CAST

UL File No. E-302794



Cat. #	Trade Size	K.O. Size	Unit Qty.	Wt. Lbs. Per 100
759DC	3/8"	1/2"	100	4
			For 2 conductor No.'s 14, 12, 10 3 conductor No.'s 14, 12	
2631	3/4"	3/4"	50	9
			For 3 conductor No.'s 8, 6	
2632	1"	1"	25	12
			For 3 conductor No.'s 6, 4	
2633	1 1/4"	1 1/4"	10	22
			For 3 conductor No.'s 3, 2	
2670	1 1/2"	1 1/2"	5	25
			For 3 conductor No. 2 / 0	
2671	2"	2"	10	40
			For 3 conductor No. 4 / 0	

SET SCREW TYPE - ZINC DIE CAST

UL File No. E-19188



Cat. #	Trade Size	Diam. of Opening for Cable	Diam. of Bushed Hole	Unit Qty.	Wt. Lbs. Per 100
ACB38DC	3/8"			50	35

DUPLEX TYPE – ZINC DIE CAST

UL File No. E-19188



Cat. #	Trade Size	Diam. of Opening for Cable	Diam. of Bushed Hole	Unit Qty.	Wt. Lbs. Per 100
2699*	3/8"	5/8"	9/16"	25	13

*UL Listed as grounding means.

NM Sheathed

Service Entrance and Grounding Fittings

Service Entrance Elbows & Connectors



SERVICE ENTRANCE ELBOWS – ALUMINUM

Gasketed

UL File No. E-19189



Service Entrance / Groundings

Cat. #	Size	Unit Qty.	Std. Pkg.	Wt. Lbs. Per 100
SLB1	1/2"	10	50	25
SLB2	3/4"	10	50	30
SLB3	1"	5	25	51
SLB4	1 1/4"	2	10	83
SLB5	1 1/2"	1	5	117
SLB6	2"	1	5	192

SERVICE ENTRANCE CABLE CONNECTORS – MALLEABLE IRON

Non-watertight for Oval Cable

UL File No. E-22134



Clamp Opening Width

Cat. #	K.O. Size	Min.	Max.	Wt. Lbs. Per 100
631	3/4"	33/64"	13/16"	14
			For 2 conductor No.'s 8, 6 3 conductor No.'s 8, 6	
632	1"	3/8"	1 1/64"	21
			For 2 conductor No.'s 8, 6 3 conductor No.'s 8, 6	

SERVICE ENTRANCE CABLE CONNECTORS – ZINC DIE CAST

Non-watertight for Oval Cable

UL File No. E-10438



Clamp Opening

Cat. #	K.O. Size	Min.	Max.	Width	Unit Qty.	Wt. Lbs. Per 100
2631	3/4"	.300"	.075"	.075"	50	9
2632	1"	.350"	.920"	.920"	25	12
2633	1 1/4"	.335"	.960"	.960"	10	22
2670	1 1/2"	.350"	1.00"	1.00"	5	25
2671	2"	.700"	1.30"	1.30"	10	40

SERVICE ENTRANCE CABLE WATERTIGHT CONNECTORS – ZINC DIE CAST

UL File No. E-22134



Applications:

- Service Entrance Cable Watertight connectors are used for sealing and terminating Oval Type SE or USE cable to a threaded entry of a watertight box or enclosure



Cat. #	Size	Description	Unit Qty.	Wt. Lbs. Per 100
WTC50U	1/2"	USE Watertight Connector	12 1/2	24
WTC75U	3/4"	USE Watertight Connector	12 2/3	38
WTC1004	1"	Watertight Connector 3#4	10	21
WTC1006	1"	Watertight Connector 3#6	10	21
WTC1008	1"	Watertight Connector 3#8	10	22
WTC1251	1 1/4"	Watertight Connector 3#1	10	38
WTC1252	1 1/4"	Watertight Connector 3#2	5	38
WTC1253	1 1/4"	Watertight Connector 3#3	5	39
WTC1501	1 1/2"	Watertight Connector 3#1/0	5	57
WTC1502	1 1/2"	Watertight Connector 3#2/0	5	57
WTC2001	2"	Watertight Connector 3#1/0	5	88
WTC2002	2"	Watertight Connector 3#2/0	10	93
WTC2003	2"	Watertight Connector 3#3/0	5	87
WTC2004	2"	Watertight Connector 3#4/0	5	85
WTC2004A	2"	Watertight Connector 3#4/0	5	84

Service Entrance and Grounding Fittings

Straps, Clamps & Service Entrance Caps



PERFORATED STRAP – STEEL

10 Foot Coils

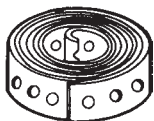

Cat. #	Description	Unit Qty.	Wt. Lbs. Per 100
3000	3/4" x .035 Galvanized 1/4" holes – 1/2" to 1" Centers	10	10

GROUND CLAMP – ZINC DIE CAST

For Bare or Insulated Wire or Armored Grounding Cable



Cat. #	Grounding Conductor Electrode Clamping Range	Lug Conductor Range	Unit Qty.	Wt. Lbs. Per 100
141DC	1/2", 3/4", 1"	#8 – #2	25	16

GROUND CLAMP – BRONZE PLATED

For Bare or Insulated Wire or Armored Grounding Cable



Cat. #	Grounding Conductor Electrode Clamping Range	Lug Conductor Range	Unit Qty.	Wt. Lbs. Per 100
141PDC	1/2", 3/4", 1"	#8 – #2	25	16

SERVICE ENTRANCE CAPS

Applications:

- Use in overhead service entrance
- Mounts on top of EMT, Rigid or IMC conduit
- Serves as a connecting point for service entrance wires
- Available in Clamp Type, Set-Screw, Threaded and Mast Type styles



UL File No. E-153721



Cat. #	Size	Unit Qty.	Wt. Lbs. Per 100
Clamp Type			
EHC1	1/2"	15	11
EHC2	3/4"	10	21
EHC3	1"	7	27
EHC4	1 1/4"	5	32
EHC5	1 1/2"	3	53
EHC6	2"	8	89
EHC7	2 1/2"	3	300
EHC8	3"	3	322
EHC9	3 1/2"	2	513
EHC10	4"	2	519
Threaded Type			
EHT1	1/2"	15	19
EHT2	3/4"	10	24
EHT3	1"	7	24
EHT4	1 1/4"	5	28
EHT5	1 1/2"	3	51
EHT6	2"	8	81
EHT7	2 1/2"	3	272
EHT8	3"	3	298
EHT9	3 1/2"	2	538
EHT10	4"	2	541
Set Screw Type			
EHSS1	1/2"	15	15
EHSS2	3/4"	10	18
EHSS3	1"	7	24
EHSS4	1 1/4"	5	28
EHSS5	1 1/2"	3	58
EHSS6	2"	8	86
EHSS7	2 1/2"	3	308
EHSS8	3"	3	308
EHSS9	3 1/2"	2	517
EHSS10	4"	2	517
Mast Type			
EHMT1	1 1/4" – 2"	2	45
EHMT2	1 1/4" – 2"	1	75
EHMT3	1 1/2" – 2 1/2"	2	73
EHMT4	2" – 2 1/2"	1	75

Service Entrance / Groundings

Cable Fittings Reference Chart



Reference Chart

Cat. #	AC	MC	FMC	NM	SE	FLEX to EMT	AC/FLEX to EMT	Cable Ranges	Armored Cables Steel & Aluminum	Metal Clad Cables Steel & Aluminum	Conduit Cable Type
631				•	•			For 2 conductor No.'s 8, 6 3 conductor No.'s 8, 6			
632				•	•			For 2 conductor No.'s 8, 6 3 conductor No.'s 8, 6			
699	•	•	•					AC 0.470min / 12/4max FE & AL MCI 0.470min / 0.500max FE	14/2, 14/3, 14/4, 12/2, 12/3, 12/4 .470/.560	ST: 14/2, 14/3, 14/4, 12/2, .470/.500	FE RWFMC
700	•	•	•								
707	•	•	•					AC 0.560, MCI 0.500 FE & AL	12/4	AL: 14/4 ST: 12/3	FE RWFMC
708		•	•					MCI 0.870 AL		AL: 6/3	FE RWFMC
709			•								FE RWFMC
710			•								FE RWFMC
711			•								FE RWFMC
712			•								FE RWFMC
713			•								FE RWFMC
714			•								FE RWFMC
715			•								FE RWFMC
721			•								FE RWFMC
722			•								FE RWFMC
723	•	•	•					AC 0.470min / 12/4max FE & AL MCI 0.470min / 0.640max FE MCI 0.500min / 0.630max AL	14/2, 14/3, 14/4, 12/2, 12/3, 12/4, .470/.550	AL: 14/4, 12/2, 12/3, 12/4, 10/2, 10/3, 10/4, 8/2, .500/.630 ST: 14/2, 14/3, 14/4, 12/2, 12/3, 12/4, 10/2, 10/3, 10/4, 8/2, .470/.630	FE RWFMC
724	•	•	•					AC 0.460min / 12/4max FE & AL MCI 0.500min / 0.630max FE MCI 0.500min / 0.640max AL	14/2, 14/3, 14/4, 12/2, 12/3, 12/4, .460/.550	AL: 14/4, 12/2, 12/3, 12/4, 10/2, 10/3, 10/4, 8/2, .500/.630 ST: 12/3, 12/4, 10/2, 10/3, 10/4, 8/2, .500/.630	FE RWFMC
735			•								FE RWFMC
736			•								FE RWFMC
737	•	•	•					AC 0.990 FE & AL MCI 0.950min / 1.020max FE & AL	4/3	6/4, 4/3 .950/1.020	FE RWFMC
738	•	•	•					AC 0.920min / 4/3max FE & AL MCI 0.840 FE MCI 0.880min / 1.030max AL	6/4, 4/3, .920/1.100	AL: 6/3, 6/4, 4/3, .880/1.030 ST: 6/3	FE RWFMC
739			•								FE RWFMC
740			•								FE RWFMC
741			•								FE RWFMC
742			•								FE RWFMC
744			•								FE RWFMC
745			•								FE RWFMC
746			•								FE RWFMC
747			•								FE RWFMC

AC = Armored Cable MCI = Metal/Clad Interlocked FE RWFMC = Steel Reduced/Wall Flexible Metallic Conduit
FE = Steel AL = Aluminum FEFMC = Steel Flexible Metallic Conduit

Cable Fittings Reference Chart



Cat. #	AC	MC	FMC	NM	SE	FLEX to EMT	AC/FLEX to EMT	Cable Ranges	Armored Cables Steel & Aluminum	Metal Clad Cables Steel & Aluminum	Conduit Cable Type
1707	•	•	•					AC 0.560, MCI 0.500 FE & AL			FE RWFMC
1708		•	•					MCI 0.870 AL		AL: 6/3	FE RWFMC
1709			•								FE RWFMC
1710			•								FE RWFMC
1711			•								FE RWFMC
1712			•								FE RWFMC
1713			•								FE RWFMC
1714			•								FE RWFMC
1715			•								FE RWFMC
1721			•								FE RWFMC
1722			•								FE RWFMC
1723			•					AC 0.470min / 12/4max FE & AL MCI 0.470min / 0.640max FE MCI 0.500min / 0.630max AL	14/2, 14/3, 14/4, 12/2, 12/3, 12/4, .470/.550	AL: 14/4, 12/2, 12/3, 12/4, 10/2, 10/3, 10/4, 8/2, .500/.630 ST: 14/2, 14/3, 14/4, 12/2, 12/3, 12/4, 10/2, 10/3, 10/4, 8/2, .470/.630	FE RWFMC
1735			•								FE RWFMC
1736			•								FE RWFMC
1737	•	•	•					AC 0.990 FE & AL MCI 0.950min / 1.020max FE & AL	4/3	6/4, 4/3, .950/1.020	FE RWFMC
1738	•	•	•					AC 0.920min / 4/3max FE & AL MCI 0.840 FE MCI 0.880min / 1.030max AL	6/4, 4/3, .920/1.100	AL: 6/3, 6/4, 4/3, .880/1.030 ST: 6/3	FE RWFMC
1739			•								FE RWFMC
1740			•								FE RWFMC
1741			•								FE RWFMC
1742			•								FE RWFMC
1744			•								FE RWFMC
1745			•								FE RWFMC
1746			•								FE RWFMC
1747			•								FE RWFMC
2631				•	•			For 3 conductor No.'s 8, 6			
2632				•	•			For 3 conductor No.'s 6, 4			
2633				•	•			For 3 conductor No.'s 3, 2			
2670				•	•			For 3 conductor No. 2/0			
2671				•	•			For 3 conductor No. 4/0			
2699	•	•	•								
1707DC			•								
1708DC			•								
1709DC			•								
1710DC			•								
1711DC			•								
1712DC			•								
1713DC			•								
1714DC			•								
1715DC			•								
1721DC			•								
1722DC			•								
1724DC			•								
1736DC			•								
1738DC			•								

Reference Chart

AC = Armored Cable MCI = Metal/Clad Interlocked FE RWFMC = Steel Reduced/Wall Flexible Metallic Conduit
FE = Steel AL = Aluminum FEFMC = Steel Flexible Metallic Conduit

Cable Fittings Reference Chart



Reference Chart

Cat. #	AC	MC	FMC	NM	SE	FLEX to EMT	AC/ FLEX to EMT	Cable Ranges	Armored Cables Steel & Aluminum	Metal Clad Cables Steel & Aluminum	Conduit Cable Type
1739DC			•								
1740DC			•								
1741DC			•								
1742DC			•								
1744DC			•								
1745DC			•								
1746DC			•								
1747DC			•								
702V	•	•	•								
707DC			•								
708DC			•								
709DC			•								
710DC			•								
711DC			•								
712DC			•								
713DC			•								
714DC			•								
715DC			•								
721DC			•								
722DC			•								
724DC			•								
736DC			•								
738DC			•								
739DC			•								
740DC			•								
741DC			•								
742DC			•								
744DC			•								
745DC			•								
746DC			•								
747DC			•								
759DC				•				For 2 conductor No.s 14, 12, 10 3 conductor No.'s 14, 12			
770DC			•								
771DC			•								
772DC			•								
773DC			•								
774DC			•								
775DC			•								
776DC			•								
780DC						•					
791DC			•								
792DC			•								
793DC			•								
794DC			•								
795DC			•								
796DC			•								

AC = Armored Cable MCI = Metal/Clad Interlocked FE RWFMC = Steel Reduced/Wall Flexible Metallic Conduit
FE = Steel AL = Aluminum FEFMC = Steel Flexible Metallic Conduit

Cable Fittings Reference Chart



Reference Chart

Cat. #	AC	MC	FMC	NM	SE	FLEX to EMT	AC/ FLEX to EMT	Cable Ranges	Armored Cables Steel & Aluminum	Metal Clad Cables Steel & Aluminum	Conduit Cable Type
ACB100	•	•	•					AC 0.930min / 1/4max FE & AL MCI 0.960min / 1.468max FE & AL	6/4, 4/3, 4/4, 3/2, 3/3, 2/3, 2/4, 1/3, 1/4, .930/1.468	6/4, 4/3, 4/4, 3/3, 3/4, .960/1.468	FEFMC
ACB125	•	•	•								FEFMC
ACB150	•	•	•								FEFMC
ACB200	•	•	•								FEFMC
ACB250	•	•	•								FEFMC
ACB300	•	•	•								FEFMC
ACB350	•	•	•								FEFMC
ACB38	•	•	•					AC 0.450min / 10/2max FE & AL MCI 0.450min / 0.660max FE & AL	14/2, 14/3, 14/4, 12/2, 12/3, 12/4, 10/2, .450/.660	14/2, 14/3, 14/4, 12/2, 12/3, 12/4, 10/2, .450/.660	FEFMC
ACB400	•	•	•								
ACB50	•	•	•					AC 0.550min / 6/3max FE & AL MCI 0.640min / 0.920max FE & AL	12/4, 10/2, 10/3, 10/4, 8/2, 8/3, 8/4, 6/2, 6/3, .550/.920	10/2, 10/3, 10/4, 8/2, 8/3, .640/.920	FEFMC
ACB75	•	•	•					AC 0.930min / 4/3max FE AC 0.680min / 4/3max AL MCI 0.730min / 1.075max FE MCI 0.930min / 1.075max AL	AL: 8/3, 8/4, 6/2, 6/3, 6/4, 4/2, 4/3, .680/1.075 ST: 6/4, 4/2, 4/3, .930/1.075	AL: 6/4, 4/3, 3/3, .930/1.075 ST: 8/3, 8/4, 6/2, 6/3, 6/4, 4/3, 3/3, .730/1.075	FEFMC
ACC38						•	•				
ACC50						•	•				
ACC75						•	•				
ACCSS38						•	•				
ACCSS50						•	•				
ACCSS75						•	•				
ASB 0	•		•					14/2, 14/3, 12/2			
ASB 1	•		•					14/4, 12/3, 6/1, 4/1			
ASB 2	•		•					12/2, 10/2, 10/3, 2/1			
ASB 3	•		•					10/4, 8/2, 8/3, 1/1			
ASB 4	•		•					8/4, 6/4, 6/3, 6/2, 4/3, 4/2			
ASB 5	•		•					3/1, 2/1, 2-1/0, 1-300 MCM, 1-350 MCM, 1-400 MCM, 1-450 MCM, 1-500 MCM			
ASB 6	•		•					4/1, 4-1/0, 4-2/0, 3-1/0, 3-2/0, 3-3/0, 2-2/0, 2-3/0, 2-4/0, 1-600 MCM, 1-650 MCM, 1-700 MCM, 1-750 MCM, 1-800 MCM, 1-900 MCM,			
ASB 7	•		•					4-3/0, 4-4/0, 3-4/0, 3-250 MCM, 3-300 MCM, 2-250MCM, 2-300 MCM, 2-350 MCM, 1-1000 MCM			
ASB 8	•		•					4-250 MCM, 4-300 MCM, 4-350 MCM, 4-400 MCM, 4-450 MCM, 4-500 MCM, 3-350 MCM, 3-400 MCM, 3-450 MCM, 3-500 MCM, 2-400 MCM, 2-450 MCM, 2-500 MCM			

AC = Armored Cable MCI = Metal/Clad Interlocked FE RWFMC = Steel Reduced/Wall Flexible Metallic Conduit
FE = Steel AL = Aluminum FEFMC = Steel Flexible Metallic Conduit

Cable Fittings Reference Chart



Reference Chart

Cat. #	AC	MC	FMC	NM	SE	FLEX to EMT	AC/ FLEX to EMT	Cable Ranges	Armored Cables Steel & Aluminum	Metal Clad Cables Steel & Aluminum	Conduit Cable Type
QLK50D	•	•	•						14/2, 14/3, 14/4, 12/2, 12/3, 12/4	14/2, 14/3, 14/4, 12/2, 12/3, 12/4, 10/2	
QLK50S	•	•	•						14/2, 14/3, 14/4, 12/2, 12/3, 12/4, 10/2, 10/3	14/2, 14/3, 14/4, 12/2, 12/3, 12/4, 10/2	
QLK75	•	•	•						10/4, 10/5, 8/3, 8/4, 6/3	10/3, 10/4, 8/2, 8/3, 6/2,	
SSACB38	•	•	•					AC 0.450min / 10/2max FE & AL MCI 0.450min / 0.660max FE & AL	14/2, 14/3, 14/4, 12/2, 12/3, 12/4, 10/2, .450/.660	.450/.660	FEFMC
SSACB50	•	•	•					AC 0.550min / 6/3max FE & AL MCI 0.640min / 0.920max FE & AL	12/4, 10/2, 10/3, 10/4, 8/2, 8/3, 8/4, 6/2, 6/3, .550/.920	.640/.3920	FEFMC
SSACB75	•	•	•					AC 0.930min / 4/3max FE AC 0.680min / 4/3max AL MCI 0.730min / 1.075max FE MCI 0.930min / 1.075max AL	8/3, 8/4, 6/2, 6/3, 6/4, 4/2, 4/3, .930/1.075	AL: .930/1.075 ST: .730/1.075	FEFMC
SSACB100	•	•	•					AC 0.930min / 1/4max FE & AL MCI 0.960min / 1.468max FE & AL	6/4, 4/3, 4/4, 3/3, 3/4, 2/3, 2/4, 1/3, 1/4, .930/1.468	.960/1.468	FEFMC
ACB3845	•	•	•					AC 0.450min / 10/2max FE & AL MCI 0.450min / 0.660max FE & AL	14/2, 14/3, 14/4, 12/2, 12/3, 12/4, 10/2, .450/.660	14/2, 14/3, 14/4, 12/2, 12/3, 12/4, 10/2, .450/.660	FEFMC
ACB5045	•	•	•					AC 0.550min / 6/3max FE & AL MCI 0.640min / 0.920max FE & AL	12/4, 10/2, 10/3, 10/4, 8/2, 8/3, 8/4, 6/2, 6/3, .550/.920	10/2, 10/3, 10/4, 8/2, 8/3, .640/.920	FEFMC
ACB7545	•	•	•					AC 0.930min / 4/3max FE AC 0.680min / 4/3max AL MCI 0.730min / 1.075max FE MCI 0.930min / 1.075max AL	AL: 8/3, 8/4, 6/2, 6/3, 6/4, 4/2, 4/3, .680/1.075 ST: 6/4, 4/2, 4/3, .930/1.075	AL: 6/4, 4/3, 3/3, .930/1.075 ST: 8/3, 8/4, 6/2, 6/3, 6/4, 4/3, 3/3, .730/1.075	FEFMC
ACB3890	•	•	•					AC 0.450min / 10/2max FE & AL MCI 0.450min / 0.660max FE & AL	14/2, 14/3, 14/4, 12/2, 12/3, 12/4, 10/2, .450/.660	14/2, 14/3, 14/4, 12/2, 12/3, 12/4, 10/2, .450/.660	FEFMC
ACB5090	•	•	•					AC 0.550min / 6/3max FE & AL MCI 0.640min / 0.920max FE & AL	12/4, 10/2, 10/3, 10/4, 8/2, 8/3, 8/4, 6/2, 6/3, .550/.920	10/2, 10/3, 10/4, 8/2, 8/3, .640/.920	FEFMC
ACB7590	•	•	•					AC 0.930min / 4/3max FE AC 0.680min / 4/3max AL MCI 0.730min / 1.075max FE MCI 0.930min / 1.075max AL	AL: 8/3, 8/4, 6/2, 6/3, 6/4, 4/2, 4/3, .680/1.075 ST: 6/4, 4/2, 4/3, .930/1.075	AL: 6/4, 4/3, 3/3, .930/1.075 ST: 8/3, 8/4, 6/2, 6/3, 6/4, 4/3, 3/3, .730/1.075	FEFMC
ACB10090	•	•	•					AC 0.930min / 1/4max FE & AL MCI 0.960min / 1.468max FE & AL	6/4, 4/3, 4/4, 3/2, 3/3, 2/3, 2/4, 1/3, 1/4, .930/1.468	6/4, 4/3, 4/4, 3/3, 3/4, .960/1.468	FEFMC
BX38	•	•	•						14/2	14/2	FEFMC
BX38R	•	•	•						10/4	10/2	FEFMC
FECC50DC						•					
FECC75DC						•					
FECC100DC						•					
FECS38DC						•					
FECS75DC						•					
702DC			•								
703DC			•								
ACMF38	•	•	•					14-2 through 10-2 FE or AL 14-2 OD .470 through 10-3 OD .610 14-2 OD .469 through 10-3 OD.600 MCI			FE RWFMC
ACB38DC	•	•	•	•	•			14-2 OD .465 through 10-3 OD .500 FE 14-2 OD .480 through 10-3 OD .585 AL 0.475 through 0.600 MCI 0.468 through 0.610 ALMCI For 12/2 through 10/3 Oval NMSE Cable	14/2, 10/3	14/2, 10/3	FEFMC
567BX	•	•	•								

AC = Armored Cable MCI = Metal/Clad Interlocked FE RWFMC = Steel Reduced/Wall Flexible Metallic Conduit
FE = Steel AL = Aluminum FEFMC = Steel Flexible Metallic Conduit

Adapters

Applications:

- PVC Fittings are installed in PVC conduit systems and provide the ability to:
- Connect or make bends in two lengths of PVC conduit
- Terminate PVC conduit into a box or enclosure
- Provide openings for making splices and taps in PVC conduit systems
- Schedule 40 and 80: Female Adapters, Male Adapters, Couplings, Pull Elbows, Meter Offsets, Reducers, End Bells, Caps, Service Entrance Heads, Straps, FS and FD Boxes, Conduit Outlet Bodies
- Schedule 40 only: Standard Radius Elbows, Special Radius Elbows

Certifications and Compliances:

- UL Listed
- CSA Listed - See product for specific details regarding CSA listing (there are a few exceptions)
- UL Flame Rated to UL 94V-0

FEMALE ADAPTERS



FA50NM

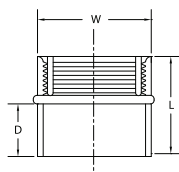

Cat. #	Trade Size	Unit Qty.	Std. Pkg.	Wt. Lbs. Per 100	W	L	D
FA50NM	1/2"	200	200	3	1"	1 7/16"	1 1/16"
FA75NM	3/4"	125	125	4	1 1/4"	1 5/8"	1 1/16"
FA100NM	1"	70	70	8	1 9/16"	1 - 7/8"	7/8"
FA125NM	1 1/4"	40	40	11	2"	1 15/16"	15/16"
FA150NM	1 1/2"	30	30	14	2 1/4"	2 1/8"	15/16"
FA200NM	2"	40	40	17	2 11/16"	2 1/8"	15/16"
FA250NM	2 1/2"	20	20	35	3 5/16"	3"	1 3/16"
FA300NM	3"	40	40	52	4"	3 3/16"	1 1/4"
FA350NM	3 1/2"	30	30	59	4 1/2"	3"	1 3/16"
FA400NM	4"	20	20	74	5"	3 3/4"	1 3/8"
FA500NM	5"	10	10	120	6 1/8"	3 11/16"	1 5/16"
FA600NM	6"	8	8	178	7 1/4"	4 3/8"	1 5/8"

MALE ADAPTERS



MA50NM

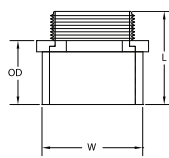

1/2" thru 1 1/2"

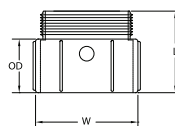

2" and larger



Cat. #	Trade Size	Unit Qty.	Std. Pkg.	Wt. Lbs. Per 100	W	L	D
MA50NM	1/2"	200	200	3	1 1/16"	1 11/16"	1 1/8"
MA75NM	3/4"	125	125	5	1 1/4"	1 3/4"	1 3/16"
MA100NM	1"	70	70	7	1 5/8"	2 3/16"	1 1/2"
MA125NM	1 1/4"	40	40	10	2"	2 1/8"	1 9/16"
MA150NM	1 1/2"	30	30	13	2"	2 1/16"	1 5/16"
MA200NM	2"	40	40	15	2 11/16"	2 3/16"	1 3/8"
MA250NM	2 1/2"	20	20	34	3 5/16"	2 7/8"	2"
MA300NM	3"	40	40	45	3 15/16"	3"	2 3/16"
MA350NM	3 1/2"	30	30	60	4 1/2"	3 3/16"	2 9/16"
MA400NM	4"	20	20	75	5"	3 7/16"	2 9/16"
MA500NM	5"	10	10	160	6 1/4"	4 3/4"	3"
MA600NM	6"	8	8	163	7 5/16"	4 15/16"	2 11/16"

COUPLINGS



CP50NM

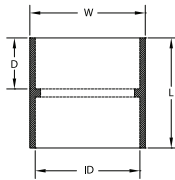

Cat. #	Trade Size	Unit Qty.	Std. Pkg.	Wt. Lbs. Per 100	W	L	ID	D
CP50NM	1/2"	200	200	3	1 1/16"	1 1/2"	7/8"	5/8"
CP75NM	3/4"	125	125	4	1 5/16"	1 9/16"	1 1/16"	5/8"
CP100NM	1"	70	70	8	1 3/8"	2"	1 5/16"	1"
CP125NM	1 1/4"	40	40	12	2"	2 1/8"	1 11/16"	1"
CP150NM	1 1/2"	30	30	14	2 1/4"	2 3/8"	1 15/16"	1 1/8"
CP200NM	2"	40	40	19	2 11/16"	2 7/16"	2 3/8"	1 1/4"
CP250NM	2 1/2"	20	20	38	3 1/4"	3 1/2"	2 7/8"	1 3/4"
CP300NM	3"	40	40	61	4"	3 7/8"	3 1/2"	1 3/16"
CP350NM	3 1/2"	30	30	71	4 1/8"	4"	4"	1 5/16"
CP400NM	4"	20	20	87	5"	4 3/16"	4 1/2"	2"
CP500NM	5"	10	10	150	5 5/8"	5 5/8"	5 5/8"	2 1/2"
CP600NM	6"	8	8	228	7 1/4"	6 3/8"	6 5/8"	3"

PULL ELBOWS



PE50

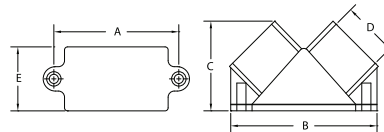

Cat. #	Trade Size	Unit Qty.	Std. Pkg.	Wt. Lbs. Per 100	A	B	C	D	E
PE50	1/2"	75	75	9	2 1/8"	2 5/8"	1 1/2"	7/8"	1 1/8"
PE75	3/4"	50	50	12	2 1/2"	3"	1 5/8"	1 1/16"	1 5/16"

METER OFFSETS



303PVC

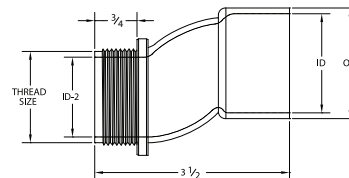

Cat. #	Trade Size	Unit Qty.	Std. Pkg.	Wt. Lbs. Per 100	Thread Size	ID	ID-2	OD
303PVC	1 1/4"	15	15	19	1 1/4"	1 5/8"	1 3/8"	2"
305PVC	2"	8	8	28	2"	2 3/8"	2"	2 3/16"

Elbows

90 DEGREE ELBOW



EL5090STDNM

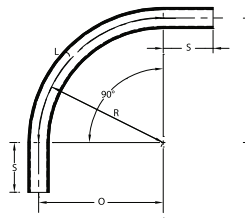

Cat. #	Trade Size	Unit Qty.	Std. Pkg.	Wt. Lbs. Per 100	R	O	H	S MIN	L
EL5090STDNM	1/2"	50	50	16	4"	4"	4"	1 1/2"	6 1/4"
EL7590STDNM	3/4"	35	35	26	4 1/2"	4 1/2"	4 1/2"	1 1/2"	7 1/8"
EL10090STDNM	1"	20	20	45	5 3/4"	5 3/4"	5 3/4"	1 7/8"	9"
EL12590STDNM	1 1/4"	30	30	68	7 1/4"	7 1/2"	7 1/4"	2"	11 3/8"
EL15090STDNM	1 1/2"	30	30	97	8 1/4"	8 3/4"	8 1/4"	2"	13"
EL20090STDNM	2"	15	15	143	9 1/2"	9 1/2"	9 1/2"	2"	15"
EL25090STDNM	2 1/2"	18	18	239	10 1/2"	10 1/2"	10 1/2"	3"	16 1/2"
EL30090STDNM	3"	14	14	393	13"	13"	13"	3 3/8"	20 3/8"
EL35090STDNM	3 1/2"	12	12	500	15"	15"	15"	3 1/4"	23 1/2"
EL40090STDNM	4"	10	10	740	16"	16"	16"	3 3/8"	25 1/8"
EL50090STDNM	5"	30	30	1876	24"	24"	24"	3 5/8"	37 5/8"
EL60090STDNM	6"	25	25	1256	30"	30"	30"	3 3/4"	47 1/8"

45 DEGREE ELBOW



EL5045STDNM

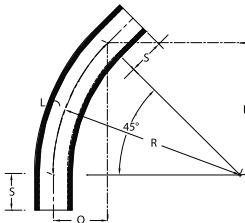

Cat. #	Trade Size	Unit Qty.	Std. Pkg.	Wt. Lbs. Per 100	R	O	H	S MIN	L
EL5045STDNM	1/2"	50	50	10	4"	1 3/16"	2 7/8"	1 1/2"	3 3/8"
EL7545STDNM	3/4"	25	25	18	4 1/2"	1 5/16"	3 3/16"	1 1/2"	3 1/2"
EL10045STDNM	1"	20	20	28	5 3/4"	1 11/16"	4"	1 7/8"	4 1/2"
EL12545STDNM	1 1/4"	25	25	44	7 1/4"	2 1/8"	5 5/8"	2"	5 11/16"
EL15045STDNM	1 1/2"	20	20	49	8 1/4"	2 3/8"	5 7/8"	2"	6 1/2"
EL20045STDNM	2"	10	10	98	9 1/2"	2 13/16"	6 3/4"	2"	7 1/2"
EL25045STDNM	2 1/2"	20	20	161	10 1/2"	2 9/16"	7 3/8"	3"	8 1/4"
EL30045STDNM	3"	8	8	248	13"	3 13/16"	9 3/16"	3 1/8"	10 1/4"
EL35045STDNM	3 1/2"	5	5	340	15"	4 3/8"	10 5/8"	3 1/4"	11 7/8"
EL40045STDNM	4"	20	20	445	16"	4 11/16"	11 1/8"	3 3/8"	12 5/8"
EL50045STDNM	5"	30	30	688	24"	7"	17"	3 5/8"	18 3/8"
EL60045STDNM	6"	25	25	1040	30"	8 13/16"	21 1/4"	3 3/4"	23 3/8"

PVC Fittings

Elbows and Reducers

SPECIAL RADIUS ELBOWS

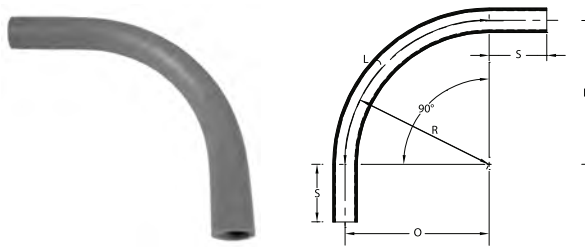

EL29024NM



PVC Fittings

Cat. #	Trade Size	Description	Unit Qty.	Std. Pkg.	Wt. Lbs. Per 100	R	O	H	S MIN	L
EL29024NM	2"	24" R	1	1	263	24"	24"	24"	1½"	37¾"
EL29036NM	2"	36" R	1	1	381	36"	36"	36"	2"	56½"
EL29048NM	2"	48" R	1	1	500	48"	48"	48"	2"	75⅝"
EL39024NM	3"	24" R	1	1	599	24"	24"	24"	3⅛"	37¾"
EL39036NM	3"	36" R	1	1	881	36"	36"	36"	3⅛"	56½"
EL39048NM	3"	48" R	1	1	1115	48"	48"	48"	3⅛"	75⅝"
EL49024NM	4"	24" R	1	1	892	24"	24"	24"	3⅝"	37¾"
EL49036NM	4"	36" R	1	1	1260	36"	36"	36"	3⅝"	56½"
EL49048NM	4"	48" R	1	1	1628	48"	48"	48"	3⅝"	75⅝"
EL59036NM	5"	36" R	1	1	1760	36"	36"	36"	3⅝"	56½"
EL59048NM	5"	48" R	1	1	2260	48"	48"	48"	3⅝"	75⅝"
EL69036NM	6"	36" R	1	1	2354	36"	36"	36"	3¾"	56½"
EL69048NM	6"	48" R	1	1	2865	48"	48"	48"	3¾"	75⅝"

REDUCERS

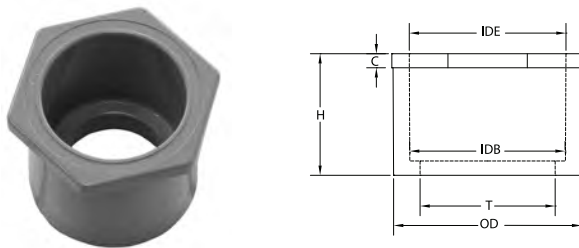

RED7550



Cat. #	Trade Size	Unit Qty.	Std. Pkg.	Wt. Lbs. Per 100	H	C	T	OD	IDE	IDB
RED7550	¾" x ½"	100	100	3	1.00"	0.12"	0.63"	1.05"	0.85"	0.84"
RED10075	1" x ¾"	100	100	4	1.18"	0.12"	0.83"	1.32"	1.06"	1.05"
RED125100	1¼" x 1"	50	50	8	1.42"	0.14"	1.06"	1.66"	1.33"	1.31"
RED150125	1½" x 1¼"	50	50	6	1.37"	0.18"	1.39"	1.90"	1.68"	1.66"
RED200150	2" x 1½"	25	25	20	1.60"	0.25"	1.62"	2.38"	1.92"	1.89"
RED250200	2½" x 2"	25	25	28	1.90"	0.25"	2.08"	2.88"	2.39"	2.37"
RED300250	3" x 2½"	25	25	40	2.25"	0.25"	2.48"	3.50"	2.89"	2.87"
RED400300	4" x 3"	20	20	90	2.60"	0.37"	3.08"	4.50"	3.52"	3.49"
RED400350	4" x 3½"	20	20	45	2.60"	0.40"	3.60"	4.50"	4.02"	3.99"

Bells and Caps

END BELLS



EB50NM

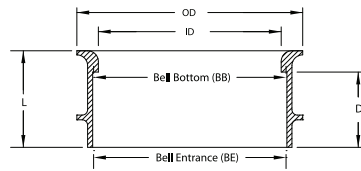

Cat. #	Trade Size	Unit Qty.	Std. Pkg.	Wt. Lbs. Per 100	L	D	BB	BE	ID	OD
EB50NM	1/2"	100	100	17	1.00"	0.75"	0.836 ± .004	0.852 ± .004	0.63"	1.25"
EB75NM	3/4"	100	100	17	1.00"	0.75"	1.046 ± .004	1.065 ± .004	0.88"	1.50"
EB100NM	1"	50	50	17	1.25"	1.00"	1.310 ± .005	1.330 ± .005	1.06"	1.75"
EB125NM	1 1/4"	50	50	35	1.31"	1.00"	1.655 ± .005	1.677 ± .005	1.38"	2.13"
EB150NM	1 1/2"	50	50	35	1.56"	1.25"	1.894 ± .006	1.918 ± .006	1.63"	2.50"
EB200NM	2"	40	40	35	1.56"	1.38"	2.369 ± .006	2.393 ± .006	2.06"	2.81"
EB250NM	2 1/2"	30	30	60	1.88"	1.50"	2.868 ± .007	2.890 ± .007	2.50"	3.38"
EB300NM	3"	50	50	155	2.06"	1.63"	3.492 ± .008	3.515 ± .008	3.00"	4.13"
EB350NM	3 1/2"	50	50	207	2.25"	1.81"	3.992 ± .008	4.015 ± .008	3.50"	4.63"
EB400NM	4"	50	50	207	2.38"	1.81"	4.491 ± .009	4.515 ± .009	4.00"	5.13"
EB500NM	5"	25	25	207	2.44"	1.81"	5.553 ± .010	4.593 ± .010	5.06"	6.38"
EB600NM	6"	15	15	155	2.88"	2.19"	6.614 ± .011	6.658 ± .011	6.06"	7.38"

CAPS



EC50NM

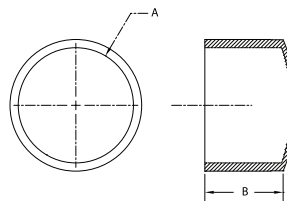

Cat. #	Trade Size	Unit Qty.	Std. Pkg.	Wt. Lbs. Per 100	A	B
EC50NM	1/2"	100	100	2	7/8"	7/8"
EC75NM	3/4"	100	100	4	1 1/16"	1 1/16"
EC100NM	1"	50	50	7	1 3/8"	1 1/4"
EC125NM	1 1/4"	25	25	8	1 11/16"	1 5/16"
EC150NM	1 1/2"	25	25	14	1 15/16"	1 9/16"
EC200NM	2"	50	50	15	2 3/8"	1 5/8"
EC250NM	2 1/2"	25	25	27	2 7/8"	2"
EC300NM	3"	25	25	51	3 9/16"	2 3/8"
EC350NM	3 1/2"	25	25	64	4"	2 5/16"
EC400NM	4"	25	25	74	4 1/2"	2 3/8"

SERVICE ENTRANCE

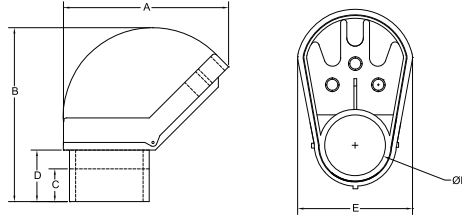

EH50NM



PVC Fittings

Cat. #	Trade Size	Unit Qty.	Std. Pkg.	Wt. Lbs. Per 100	A	B	C	D	E	ØF
EH50NM	1/2"	10	10	7	2.88"	2.88"	0.75"	0.63"	2.19"	0.09"
EH75NM	3/4"	10	10	10	2.88"	2.88"	0.88"	0.44"	2.13"	1.06"
EH100NM	1"	20	20	10	3.31"	3.63"	1.00"	0.75"	2.38"	1.33"
EH125NM	1 1/4"	20	20	35	5.00"	5.00"	1.25"	1.38"	3.31"	1.67"
EH150NM	1 1/2"	20	20	95	6.50"	6.50"	1.75"	2.00"	4.25"	1.99"
EH200NM	2"	5	5	110	6.50"	6.50"	1.75"	2.00"	4.25"	2.38"
EH250NM	2 1/2"	5	5	380	15.00"	8.25"	1.88"	1.00"	8.25"	2.89"
EH300NM	3"	5	5	410	12.25"	9.38"	1.75"	1.00"	8.25"	3.52"
EH350NM	3 1/2"	5	5	433	12.50"	11.00"	2.00"	3.13"	8.00"	4.02"
EH400NM	4"	1	1	1375	16.00"	11.00"	2.75"	2.50"	10.25"	4.52"

STRAPS

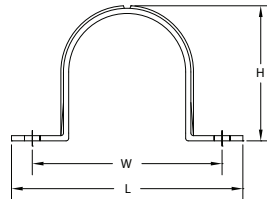

ST50PVC



Cat. #	Trade Size	Unit Qty.	Std. Pkg.	Wt. Lbs. Per 100	W	L	H
ST50PVC	1/2"	300	300	1	2 ³ / ₁₆ "	1 ¹¹ / ₁₆ "	1"
ST75PVC	3/4"	200	200	1	2 ¹ / ₂ "	2"	1 ¹ / ₄ "
ST100PVC	1"	200	200	2	2 ¹³ / ₁₆ "	2 ¹ / ₄ "	1 ¹ / ₂ "
ST125PVC	1 1/4"	200	200	3	3 ¹ / ₈ "	2 ¹ / ₂ "	1 ¹³ / ₁₆ "
ST150PVC	1 1/2"	200	200	3	3 ³ / ₈ "	2 ¹¹ / ₁₆ "	2 ¹ / ₈ "
ST200PVC	2"	200	200	4	4"	3 ⁵ / ₁₆ "	2 ⁹ / ₁₆ "
ST250PVC	2 1/2"	100	100	9	5 ¹ / ₂ "	4 ⁹ / ₁₆ "	3"
ST300PVC	3"	100	100	10	6"	5 ¹ / ₈ "	3 ³ / ₁₆ "
ST400PVC	4"	100	100	13	7"	6"	4 ⁵ / ₈ "

Junction and FD Boxes

ROUND JUNCTION BOXES



R5075JBOX

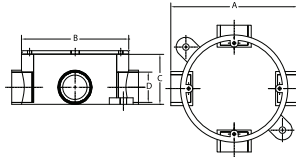

PVC Boxes

Cat. #	Trade Size	Unit Qty.	Std. Pkg.	Wt. Lbs. Per 100	A	B	C	D
R5075JBOX	1/2"	15	15	65	4 3/4"	4 1/16"	1 7/8"	1 1/16"

JUNCTION BOXES



NM442JB

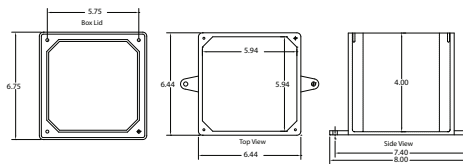

6 x 6 x 4

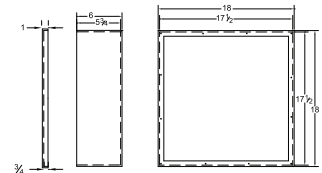

18 x 18 x 6



Cat. #	Trade Size	Unit Qty.	Std. Pkg.	Wt. Lbs. Per 100
NM442JB	4x4x2	10	10	81
NM552JB	5x5x2	10	10	108
NM446JB	4x4x6	10	10	150
NM887JB	8x8x7	4	4	523
NM444JB	4x4x4	10	10	106
NM664JB	6x6x4	10	10	208
NM666JB	6x6x6	5	5	234
NM884JB	8x8x4	5	5	329
NM886JB	8x8x6	4	4	383
NM12124JB	12x12x4	2	2	747
NM12126JB	12x12x6	2	2	796
NM16146JB	16x14x6	1	1	1194
NM18186JB	18x18x6	1	1	1546
NM24188JB	24x18x8	1	1	2000
NM241812JB	24x18x12	1	1	2200
NM24248JB	24x24x8	1	1	2450
NM36248JB	36x24x8	1	1	4500

TYPE FD - BLANK



FDBLANK

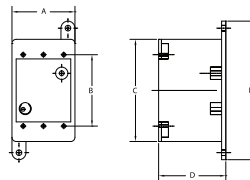

Cat. #	Trade Size	Unit Qty.	Std. Pkg.	Wt. Lbs. Per 100	A	B	C	D	E
FDBLANK	-	10	10	58	2.81"	3.31"	4.56"	3.00"	6.38"

One and Two Gang Device Boxes

PVC Boxes

TYPE FSE - ONE GANG



FSE50

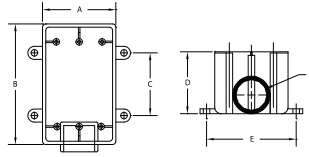

TYPE FSE - TWO GANG



FSE502

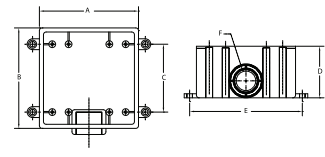

Cat. #	Trade Size	Unit Qty.	Std. Pkg.	Wt. Lbs. Per 100	A	B	C	D	E	F
ONE GANG										
FSE50	1/2"	10	10	46	2 ⁷ / ₈ "	4 ⁹ / ₁₆ "	2 ⁵ / ₈ "	2 ³ / ₈ "	3 ⁷ / ₁₆ "	7 ⁸ / ₁₆ "
FSE75	3/4"	10	10	46	2 ⁷ / ₈ "	4 ⁹ / ₁₆ "	2 ⁵ / ₈ "	2 ³ / ₈ "	3 ⁷ / ₁₆ "	1 ¹ / ₁₆ "
FSE100	1"	10	10	44	2 ⁷ / ₈ "	4 ⁹ / ₁₆ "	2 ⁵ / ₈ "	2 ³ / ₈ "	3 ⁷ / ₁₆ "	1 ⁵ / ₁₆ "
TWO GANG										
FSE502	1/2"	5	5	58	4 ⁹ / ₁₆ "	4 ⁹ / ₁₆ "	3 ¹ / ₄ "	2 ³ / ₈ "	5 ¹ / ₄ "	7 ⁸ / ₁₆ "
FSE752	3/4"	5	5	58	4 ⁹ / ₁₆ "	4 ⁹ / ₁₆ "	3 ¹ / ₄ "	2 ³ / ₈ "	5 ¹ / ₄ "	1 ¹ / ₁₆ "
FSE1002	1"	5	5	58	4 ⁹ / ₁₆ "	4 ⁹ / ₁₆ "	3 ¹ / ₄ "	2 ³ / ₈ "	5 ¹ / ₄ "	1 ⁵ / ₁₆ "

TYPE FSC - ONE GANG



FSC50

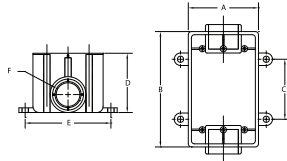

Cat. #	Trade Size	Unit Qty.	Std. Pkg.	Wt. Lbs. Per 100	A	B	C	D	E	F
ONE GANG										
FSC50	1/2"	10	10	42	2 ¹³ / ₁₆ "	4 ⁹ / ₁₆ "	2 ⁵ / ₈ "	2 ¹⁵ / ₁₆ "	3 ¹ / ₂ "	7 ⁸ / ₁₆ "
FSC75	3/4"	10	10	42	2 ¹³ / ₁₆ "	4 ⁹ / ₁₆ "	2 ⁵ / ₈ "	2 ¹⁵ / ₁₆ "	3 ¹ / ₂ "	1 ¹ / ₁₆ "
FSC100	1"	10	10	42	2 ¹³ / ₁₆ "	4 ⁹ / ₁₆ "	2 ⁵ / ₈ "	2 ¹⁵ / ₁₆ "	3 ¹ / ₂ "	1 ⁵ / ₁₆ "
TWO GANG										
FSC502	1/2"	5	5	76	4 ⁹ / ₁₆ "	4 ⁹ / ₁₆ "	3 ¹ / ₄ "	2 ³ / ₈ "	5 ¹ / ₄ "	7 ⁸ / ₁₆ "
FSC752	3/4"	5	5	76	4 ⁹ / ₁₆ "	4 ⁹ / ₁₆ "	3 ¹ / ₄ "	2 ³ / ₈ "	5 ¹ / ₄ "	1 ¹ / ₁₆ "
FSC1002	1"	5	5	76	4 ⁹ / ₁₆ "	4 ⁹ / ₁₆ "	3 ¹ / ₄ "	2 ³ / ₈ "	5 ¹ / ₄ "	1 ⁵ / ₁₆ "

TYPE FSS - ONE GANG



FSS50

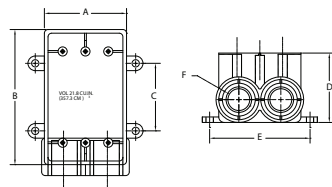

TYPE FSS - TWO GANG



FSS502

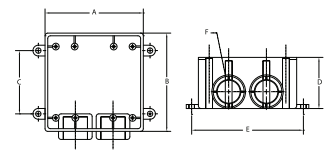

Cat. #	Trade Size	Unit Qty.	Std. Pkg.	Wt. Lbs. Per 100	A	B	C	D	E	F
ONE GANG										
FSS50	1/2"	10	10	52	2 ¹³ / ₁₆ "	4 ⁵ / ₈ "	2 ⁵ / ₈ "	2 ³ / ₈ "	3 ¹ / ₂ "	7 ⁸ / ₁₆ "
FSS75	3/4"	10	10	52	2 ¹³ / ₁₆ "	4 ⁵ / ₈ "	2 ⁵ / ₈ "	2 ³ / ₈ "	3 ¹ / ₂ "	1 ¹ / ₁₆ "
FSS100	1"	10	10	52	2 ¹³ / ₁₆ "	4 ⁵ / ₈ "	2 ⁵ / ₈ "	2 ³ / ₈ "	3 ¹ / ₂ "	1 ⁵ / ₁₆ "
TWO GANG										
FSS502	1/2"	5	5	72	4 ⁹ / ₁₆ "	4 ⁹ / ₁₆ "	3 ¹ / ₄ "	2 ³ / ₈ "	5 ¹ / ₄ "	7 ⁸ / ₁₆ "
FSS752	3/4"	5	5	72	4 ⁹ / ₁₆ "	4 ⁹ / ₁₆ "	3 ¹ / ₄ "	2 ³ / ₈ "	5 ¹ / ₄ "	1 ¹ / ₁₆ "
FSS1002	1"	5	5	72	4 ⁹ / ₁₆ "	4 ⁹ / ₁₆ "	3 ¹ / ₄ "	2 ³ / ₈ "	5 ¹ / ₄ "	1 ⁵ / ₁₆ "

PVC Junction and Device Boxes



One and Two Gang Device Boxes

TYPE FSCC - ONE GANG



FSCC50

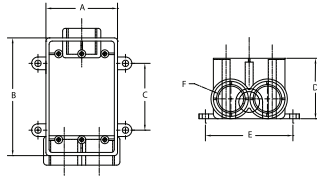

TYPE FSCC - TWO GANG



FSCC502

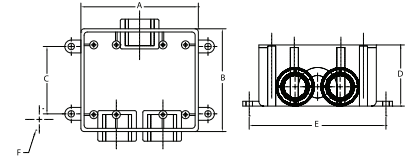

PVC Boxes

Cat. #	Trade Size	Unit Qty.	Std. Pkg.	Wt. Lbs. Per 100	A	B	C	D	E	F
ONE GANG										
FSCC50	1/2"	10	10	54	2 ¹³ / ₁₆ "	4 ⁵ / ₈ "	2 ⁵ / ₈ "	2 ³ / ₈ "	3 ⁷ / ₁₆ "	7/ ₈ "
FSCC75	3/4"	10	10	54	2 ¹³ / ₁₆ "	4 ⁵ / ₈ "	2 ⁵ / ₈ "	2 ³ / ₈ "	3 ⁷ / ₁₆ "	1 ¹ / ₁₆ "
FSCC100	1"	10	10	54	2 ¹³ / ₁₆ "	4 ⁵ / ₈ "	2 ⁵ / ₈ "	2 ³ / ₈ "	3 ⁷ / ₁₆ "	1 ⁵ / ₁₆ "
TWO GANG										
FSCC502	1/2"	5	5	76	4 ⁹ / ₁₆ "	4 ⁹ / ₁₆ "	3 ¹ / ₄ "	2 ³ / ₈ "	5 ¹ / ₄ "	7/ ₈ "
FSCC752	3/4"	5	5	76	4 ⁹ / ₁₆ "	4 ⁹ / ₁₆ "	3 ¹ / ₄ "	2 ³ / ₈ "	5 ¹ / ₄ "	1 ¹ / ₁₆ "
FSCC1002	1"	5	5	76	4 ⁹ / ₁₆ "	4 ⁹ / ₁₆ "	3 ¹ / ₄ "	2 ³ / ₈ "	5 ¹ / ₄ "	1 ⁵ / ₁₆ "

TYPE FDC - ONE GANG



FDC50

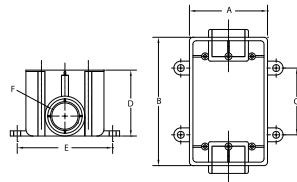

Cat. #	Trade Size	Unit Qty.	Std. Pkg.	Wt. Lbs. Per 100	A	B	C	D	E	F
FDC50	1/2"	10	10	64	2.81"	4.56"	2.63"	2.94"	3.50"	0.88"
FDC75	3/4"	10	10	64	2.81"	4.56"	2.63"	2.94"	3.50"	1.06"
FDC100	1"	10	10	64	2.81"	4.56"	2.63"	2.94"	3.50"	1.31"

TYPE FDE - ONE GANG



FDE50

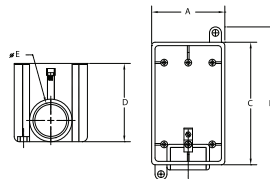

Cat. #	Trade Size	Unit Qty.	Std. Pkg.	Wt. Lbs. Per 100	A	B	C	D	E
FDE50	1/2"	10	10	60	2.69"	5.88"	4.50"	2.88"	0.88"
FDE75	3/4"	10	10	60	2.69"	5.88"	4.50"	2.88"	1.06"
FDE100	1"	10	10	54	2.69"	5.88"	4.50"	2.88"	1.31"

BLANK COVERS



FSBLANK

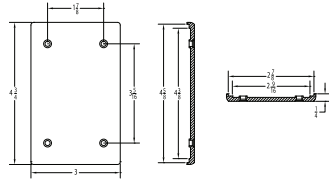

FSBLANK2

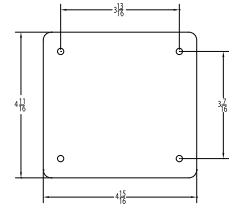

Cat. #	Description	Unit Qty.	Std. Pkg.	Wt. Lbs. Per 100	A	B	C	D	E	F
FSBLANK	ONE GANG	50	50	11	1 7/8"	4 3/4"	3 5/16"	3"	2 7/8"	2 9/16"
FSBLANK2	TWO GANG	25	25	22	3 1/4"	4 7/8"	4 7/8"	1/4"		

SWITCH COVERS

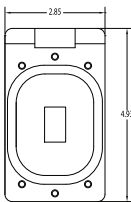

TP7214PVC

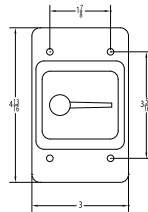

TP7280PVC

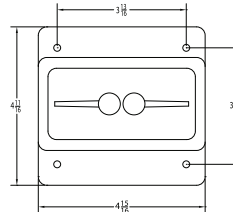

TP7268PVC

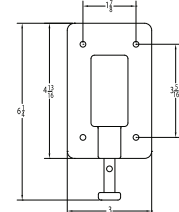

Cat. #	Description	Unit Qty.	Std. Pkg.	Wt. Lbs. Per 100
TP7214PVC	SWITCH COVER FOR FS BOXES	10	10	32
TP7280PVC	SINGLE TOGGLE SWITCH COVER	10	10	28
TP7268PVC	DOUBLE TOGGLE SWITCH COVER	10	10	36
TP7230PVC	PLUNGER SWITCH	10	10	25

Receptacle Covers

RECEPTACLE COVERS

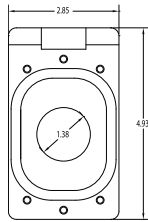

TP7218PVC15

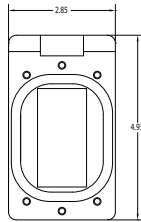

TP7240PVC

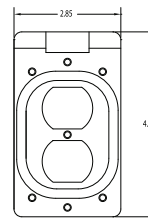

TP7288PVC



Cat. #	Description	Unit Qty.	Std. Pkg.	Wt. Lbs. Per 100
TP7218PVC15	SINGLE RECEPTACLE COVER 15A	10	10	32
TP7218PVC20	SINGLE RECEPTACLE COVER 20A	10	10	34
TP7218PVC30	SINGLE RECEPTACLE COVER 30A	10	10	32
TP7218PVC50	SINGLE RECEPTACLE COVER 50A	10	10	34
TP7240PVC	GFCI COVER FOR FS BOX	10	10	32
TP7288PVC	DUPLEX COVER RECEPTACLE	10	10	32

RECEPTACLE AND SWITCH COVERS

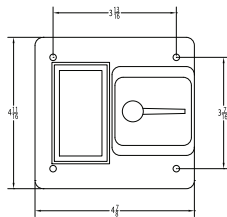

TP7224PVC

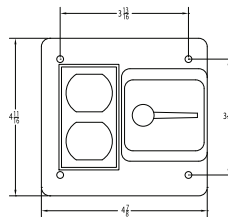

TP7229PVC

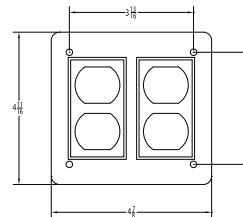

TP7228PVC



Cat. #	Description	Unit Qty.	Std. Pkg.	Wt. Lbs. Per 100
TP7224PVC	GFI & TOGGLE SWITCH COVER	10	10	34
TP7228PVC	DOUBLE DUPLEX COVER 2-GANG	10	10	79
TP7229PVC	DUPLEX AND TOGGLE SWITCH COVER	10	10	32

PVC Covers

PVC Conduit Bodies



Conduit Bodies

TYPE LB



LB50NM

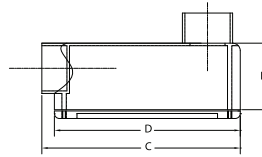
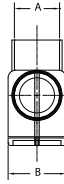

Cat. #	Trade Size	Internal Vol. In. Cu. In.	Unit Qty.	Std. Pkg.	Wt. Lbs. Per 100	A	B	C	D	E
LB50NM	1/2"	4.3	25	25	21	7/8"	1 5/16"	4 3/16"	4"	1 7/16"
LB75NM	3/4"	6.5	15	15	28	1 1/16"	1 1/2"	4 15/16"	4 5/8"	1 5/8"
LB100NM	1"	11.8	10	10	36	1 3/16"	1 3/4"	5 7/8"	5 3/8"	2"
LB125NM	1 1/4"	25	10	10	76	1 11/16"	2 1/2"	7 9/16"	7 7/16"	2 3/8"
LB150NM	1 1/2"	36.5	10	10	96	1 7/8"	5 5/8"	8 9/16"	8"	2 3/4"
LB200NM	2"	63.5	5	5	164	2 3/8"	3 1/8"	9 13/16"	9 9/16"	3 3/8"
LB250NM	2 1/2"	198	5	5	460	2 7/8"	4 5/8"	15"	12 7/8"	4 9/16"
LB300NM	3"	198	5	5	484	3 9/14"	4 5/8"	15 1/16"	12 7/8"	4 9/16"
LB350NM	3 1/2"	305	4	4	667	4"	5 5/8"	16 3/16"	12 7/8"	5 1/2"
LB400NM	4"	305	4	4	630	4"	5 5/8"	16 3/16"	12 7/8"	5 1/2"

TYPE LL



LL50NM

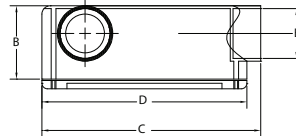
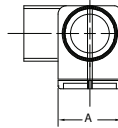

Cat. #	Trade Size	Internal Vol. In. Cu. In.	Unit Qty.	Std. Pkg.	Wt. Lbs. Per 100	A	B	C	D	E
LL50NM	1/2"	4.3	25	25	21	1.31"	1.44"	4.25"	4.00"	0.88"
LL75NM	3/4"	6.5	15	15	28	1.50"	1.63"	4.94"	4.63"	1.06"
LL100NM	1"	11.8	10	10	40	1.75"	2.00"	6.00"	5.38"	1.31"
LL125NM	1 1/4"	25	10	10	82	2.44"	2.44"	7.63"	7.19"	1.63"
LL150NM	1 1/2"	36.5	10	10	102	2.63"	2.81"	8.56"	8.00"	1.94"
LL200NM	2"	63.5	5	5	164	3.06"	3.44"	9.88"	9.58"	2.38"
LL250NM	2 1/2"	198	5	5	484	4.63"	4.63"	14.94"	12.75"	2.88"
LL300NM	3"	198	5	5	532	4.63"	4.63"	15.00"	12.81"	3.50"
LL350NM	3 1/2"	305	4	4	800	4.63"	5.50"	16.19"	12.81"	4.00"
LL400NM	4"	305	4	4	665	5.63"	5.50"	15.94"	12.81"	4.50"

PVC Conduit Bodies

Conduit Bodies



TYPE LR

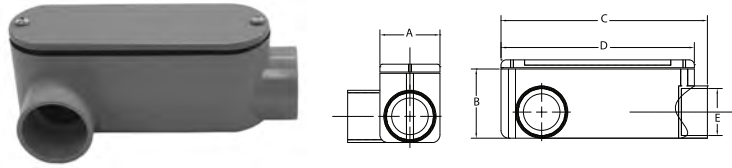

LR50NM



Cat. #	Trade Size	Internal Vol. In. Cu. In.	Unit Qty.	Std. Pkg.	Wt. Lbs. Per 100	A	B	C	D	E
LR50NM	1/2"	4.3	25	25	22	1.31"	1.44"	4.25"	4.00"	0.88"
LR75NM	3/4"	6.5	15	15	29	1.50"	1.63"	4.94"	4.63"	1.06"
LR100NM	1"	11.8	10	10	42	1.75"	2.00"	6.00"	5.38"	1.31"
LR125NM	1 1/4"	25	10	10	80	2.44"	2.44"	7.63"	7.19"	1.63"
LR150NM	1 1/2"	36.5	10	10	100	2.63"	2.81"	8.56"	8.00"	1.94"
LR200NM	2"	63.5	5	5	160	3.06"	3.44"	9.88"	9.58"	2.38"
LR250NM	2 1/2"	198	5	5	384	4.63"	4.63"	14.94"	12.75"	2.88"
LR300NM	3"	198	5	5	560	4.63"	4.63"	15.00"	12.81"	3.50"
LR350NM	3 1/2"	305	4	4	713	4.63"	5.50"	16.19"	12.81"	4.00"
LR400NM	4"	305	4	4	775	5.63"	5.50"	15.94"	12.81"	4.50"

TYPE T

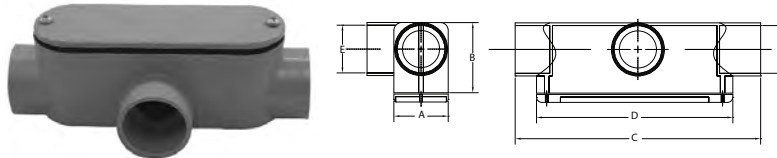

T50NM



Cat. #	Trade Size	Internal Vol. In. Cu. In.	Unit Qty.	Std. Pkg.	Wt. Lbs. Per 100	A	B	C	D	E
T50NM	1/2"	4.3	25	25	19	1 5/16"	1 1/2"	4 5/8"	4"	7/8"
T75NM	3/4"	6.5	15	15	26	1 1/2"	1 11/16"	5 3/8"	4 5/8"	1 1/16"
T100NM	1"	11.8	10	10	37	1 3/4"	2"	6 9/16"	5 3/8"	1 5/16"
T125NM	1 1/4"	25	10	10	71	2 1/2"	2 1/2"	8 3/16"	7 3/16"	1 11/16"
T150NM	1 1/2"	36.5	10	10	93	2 5/8"	2 3/16"	9 1/4"	8"	1 15/16"
T200NM	2"	63.5	5	5	156	3 1/8"	3 3/8"	10 3/8"	9 1/2"	2 3/8"
T250NM	2 1/2"	198	2	2	494	4 5/8"	4 5/8"	19"	12 7/8"	3 1/2"
T300NM	3"	198	2	2	452	4 5/8"	4 5/8"	19"	12 7/8"	3 1/2"
T350NM	3 1/2"	305	1	1	883	5 9/16"	5 9/16"	20 3/8"	13 3/4"	4"
T400NM	4"	305	1	1	898	5 9/16"	5 9/16"	20 3/8"	13 3/4"	4 1/2"

PVC Conduit Bodies

PVC Conduit Bodies



Conduit Bodies

TYPE C

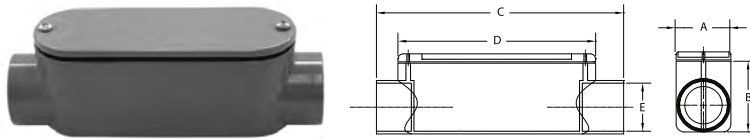

C50NM



PVC Conduit Bodies

Cat. #	Trade Size	Internal Vol. In. Cu. In.	Unit Qty.	Std. Pkg.	Wt. Lbs. Per 100	A	B	C	D	E
C50NM	1/2"	4.3	25	25	20	1 ⁵ / ₁₆ "	1 ¹ / ₂ "	4 ⁵ / ₈	4	7/8
C75NM	3/4"	6.5	15	15	28	1 ¹ / ₂ "	1 ¹¹ / ₁₆ "	5 ³ / ₈	4 ⁵ / ₈	1 ¹ / ₁₆
C100NM	1"	11.8	10	10	38	1 ³ / ₄ "	2"	6 ⁹ / ₁₆	5 ³ / ₈	1 ⁵ / ₁₆
C125NM	1 ¹ / ₄ "	25	10	10	76	2 ¹ / ₂ "	2 ¹ / ₂ "	8 ⁹ / ₁₆	7 ³ / ₁₆	1 ¹¹ / ₁₆
C150NM	1 ¹ / ₂ "	36.5	10	10	96	2 ⁵ / ₈ "	2 ¹³ / ₁₆ "	9 ¹ / ₄	8	1 ¹⁵ / ₁₆
C200NM	2"	63.5	5	5	164	3 ¹ / ₈ "	3 ³ / ₈ "	10 ³ / ₈	9 ¹ / ₂	2 ³ / ₈
C250NM	2 ¹ / ₂ "	198	5	5	435	4 ⁵ / ₈ "	4 ⁵ / ₈ "	19	12 ⁷ / ₈	2 ⁷ / ₈
C300NM	3"	198	5	5	532	4 ⁵ / ₈ "	4 ⁵ / ₈ "	19	12 ⁷ / ₈	3 ¹ / ₂
C350NM	3 ¹ / ₂ "	305	4	4	605	5 ⁹ / ₁₆ "	5 ⁹ / ₁₆ "	20 ³ / ₈	13 ⁷ / ₈	4
C400NM	4"	305	4	4	580	5 ⁹ / ₁₆ "	5 ⁹ / ₁₆ "	20 ³ / ₈	13 ⁷ / ₈	4 ¹ / ₂

TYPE E

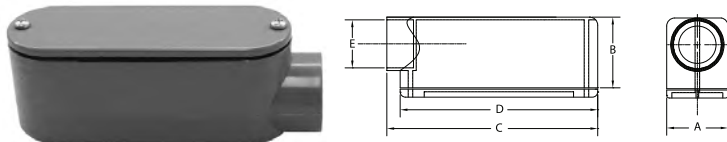

E50NM



Cat. #	Trade Size	Internal Vol. In. Cu. In.	Unit Qty.	Std. Pkg.	Wt. Lbs. Per 100	A	B	C	D	E
E50NM	1/2"	4.3	25	25	21	1 ⁵ / ₁₆ "	1 ⁷ / ₁₆ "	4 ¹ / ₄	4	7/8
E75NM	3/4"	6.5	15	15	28	1 ¹ / ₂ "	1 ⁵ / ₈ "	4 ¹⁵ / ₁₆	4 ⁵ / ₈	1 ¹ / ₁₆
E100NM	1"	11.8	10	10	38	1 ³ / ₄ "	2"	6	5 ³ / ₈	1 ⁵ / ₁₆
E125NM	1 ¹ / ₄ "	25	10	10	80	2 ⁷ / ₁₆ "	2 ⁷ / ₁₆ "	7 ⁵ / ₈	7 ³ / ₁₆	1 ⁵ / ₈
E150NM	1 ¹ / ₂ "	36.5	10	10	92	2 ⁵ / ₈ "	2 ¹³ / ₁₆ "	8 ⁹ / ₁₆	8	1 ¹⁵ / ₁₆
E200NM	2"	63.5	5	5	156	3 ¹ / ₁₆ "	3 ¹ / ₁₆ "	9 ⁷ / ₈	9 ¹ / ₂	2 ³ / ₈
E250NM	2 ¹ / ₂ "	198	5	5	468	4 ⁵ / ₈ "	4 ⁵ / ₈ "	15	12 ¹³ / ₁₆	2 ¹ / ₂
E300NM	3"	198	5	5	324	4 ⁵ / ₈ "	4 ⁵ / ₈ "	15	12 ¹³ / ₁₆	3 ¹ / ₂
E350NM	3 ¹ / ₂ "	305	4	4	555	5 ⁵ / ₈ "	5 ¹ / ₂ "	16 ³ / ₁₆	12 ¹³ / ₁₆	4
E400NM	4"	305	4	4	480	5 ⁵ / ₈ "	5 ¹ / ₂ "	16 ³ / ₁₆	12 ¹³ / ₁₆	4 ¹ / ₂

Condulet® Conduit Outlet Bodies, Covers and Gaskets - Stainless Steel



Cooper Crouse-Hinds Condulet® stainless steel fittings deliver power where you need it, saving you time and money throughout the life of your facility.

Superior resistance to corrosion and heat, combined with unmatched strength, make stainless steel Condulet bodies and boxes a long-term solution for even the most extreme environments.

Applications:

Conduit outlet bodies are installed in conduit systems to:

- Act as pull outlets for conductors being installed
- Provide openings for making splices and taps in conductors
- Act as mounting outlets for lighting fixtures and wiring devices
- Connect conduit sections
- Provide taps for branch conduit runs
- Make 90° bends in conduit runs
- Provide for access to conductors for maintenance and future system changes

Features:

- Self-healing properties of stainless steel fittings help reduce the penetration of rust/corrosion and eliminate damage to the fitting
- Stainless steel fittings retain their strength in extreme heat and extreme cold conditions
- Fitting surface is easy to maintain and keep clean
- Easy cleaning capabilities make these fittings perfect for food processing and other hygienic areas where wash downs are common
- Superior strength and durability greatly reduce replacement of fittings - this will lower your total cost of ownership and increase your return on investment
- Stainless steel fittings do not require harsh environment-damaging cleaners to keep them looking like new
- Conduit hubs have tapered threads and feature integral bushing for protection of wire insulation
- Outlet bodies designed to match conduit size for neat, compact installations

Certifications and Compliances:

- UL Standard 514A
- CSA Standard C22.2 No. 18.1-04
- Raintight - when installed with cover and gasket

Standard Materials:

- Bodies - 316 stainless steel
- Covers - 316 stainless steel
- Cover Screws - 316 stainless steel
- Gasket - neoprene



Dimension

A	Overall length
B	Overall height
C	Overall width
D	Width of opening
E	Length of opening

Ordering Information - conduit body supplied with cover and gasket

T Conduit Body, Cover and Gasket



Catalog Number	Trade Size	A	B	C	D	E
T18SS	1/2"	5.56	1.75	1.31	1.02	3.15
T28SS	3/4"	6.61	2.00	1.63	1.27	3.92
T38SS	1"	7.53	2.31	1.78	1.42	4.61
T58SS	1 1/2"	9.37	2.75	2.47	2.03	6.12
T68SS	2"	11.50	3.38	3.13	2.50	8.00

LB Conduit Body, Cover and Gasket



Catalog Number	Trade Size	A	B	C	D	E
LB18SS	1/2"	4.86	1.35	1.31	1.02	3.15
LB28SS	3/4"	5.75	1.63	1.63	1.27	3.94
LB38SS	1"	6.48	2.00	1.78	1.42	4.55
LB58SS	1 1/2"	8.38	2.75	2.47	2.03	6.13
LB68SS	2"	10.50	3.38	3.13	2.50	8.00

TB Conduit Body, Cover and Gasket



Catalog Number	Trade Size	A	B	C	D	E
TB28SS	3/4"	6.61	2.88	1.63	1.27	3.95
TB38SS	1"	7.53	3.23	1.78	1.42	4.61
TB58SS	1 1/2"	9.37	3.75	2.47	2.03	6.12
TB68SS	2"	11.50	4.38	3.13	2.50	8.00

C Conduit Body, Cover and Gasket



Catalog Number	Trade Size	A	B	C	D	E
C18SS	1/2"	5.56	1.38	1.31	1.02	3.15
C28SS	3/4"	6.56	1.63	1.63	1.27	3.94
C38SS	1"	7.50	2.00	1.78	1.42	4.61

LL Conduit Body, Cover and Gasket



Catalog Number	Trade Size	A	B	C	D	E
LL28SS	3/4"	5.72	1.63	1.63	1.27	3.95
LL38SS	1"	6.59	2.00	1.78	1.42	4.61

LR Conduit Body, Cover and Gasket



Catalog Number	Trade Size	A	B	C	D	E
LR28SS	3/4"	5.72	1.63	1.63	1.27	3.95
LR38SS	1"	6.59	2.00	1.78	1.42	4.61

Condulet® Stainless Steel Conduit Device Boxes, Covers and Gaskets



Cooper Crouse-Hinds Condulet® Stainless Steel Device Boxes deliver power where you need it, saving you time and money throughout the life of your facility.

Superior resistance to corrosion and heat, combined with unmatched strength, make stainless steel Condulet bodies and boxes a long-term solution for even the most extreme environments.

Applications:

Cast device boxes are installed in conduit systems to:

- Accommodate wiring devices
- Act as pull boxes for conductors in a conduit system
- Provide openings to make splices and taps in conductors
- Provide access to conductors for maintenance and future system changes
- Connect conduit systems

Features:

- Self-healing properties of stainless steel fittings help reduce the penetration of rust/corrosion and eliminate damage to the fitting
- Stainless steel fittings retain their strength in extreme heat and extreme cold conditions
- Fitting surface is easy to maintain and keep clean
- Easy cleaning capabilities make these fittings perfect for food processing and other hygienic areas where wash downs are common
- Superior strength and durability greatly reduce replacement of fittings - this will lower your total cost of ownership and increase your return on investment
- Stainless steel fittings do not require harsh environment-damaging cleaners to keep them looking like new
- Internal green grounding screw - standard
- Tapered threads for protection of wire insulation
- Wide selection of covers available
- Single or double conduit entry
- Ample wiring room provided for easy installations

Certifications and Compliances:

- UL Standard 514A
- CSA Standard C22.2 No. 18.1-04
- Raintight - when installed with cover and gasket

Standard Materials:

- Bodies - 316 stainless steel
- Covers - 316 stainless steel
- Cover Screws - 316 stainless steel
- Gasket - neoprene



Condulet® Stainless Steel Conduit Device Boxes, Covers and Gaskets



Conduit Bodies

Dimension

- A Length of box
- B Overall length (including hubs)
- C Width of box
- D Overall width (including hubs)
- E Height of box
- F Overall height (including hubs)

Ordering Information

FDC Device Body



Catalog Number	Trade Size	A	B	C	D	E	F
FDC2SS	¾"	4.63	6.19	2.94	2.94	3.03	3.03

FDS Device Body



Catalog Number	Trade Size	A	B	C	D	E	F
FDS2SS	¾"	4.63	5.41	2.94	2.94	3.03	3.03

FDA Device Body



Catalog Number	Trade Size	A	B	C	D	E	F
FDA2SS	¾"	4.63	4.63	2.94	2.94	3.03	3.80

FDX Device Body



Catalog Number	Trade Size	A	B	C	D	E	F
FDX2SS	¾"	4.63	6.19	2.94	4.50	3.03	3.03

Ordering Information - Device Box Cover and Gasket

Blank Cover

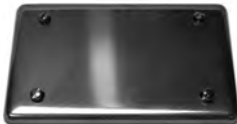

Catalog Number
DS7000BC

Blank Formed Cover



Catalog Number
DS7000BF

Switch Formed Cover



Catalog Number
DS7000SF

Receptacle Formed Cover



Catalog Number
DS7000RF

Locknuts & Bushings

Stainless Steel Fittings



Coope Crouse-Hinds Stainless Steel fittings deliver unbeatable corrosion protection where you need it, saving you time and money throughout the life of your facility.

Superior resistance to corrosion and heat, combined with unmatched strength, make stainless steel fittings a long term solution for even the most extreme environments.

Features:

- Self healing properties of stainless steel fittings help reduce the penetration of rust/corrosion and eliminate damage to the fitting
- Stainless steel fittings retain their strength in extreme heat and extreme cold conditions
- Fitting surface is easy to maintain and keep clean
- Easy cleaning capabilities make these fittings perfect for food processing and other hygienic areas where washdowns are common
- Superior strength and durability greatly reduce replacement of fittings. This will lower your total cost of ownership and increase your return on investment
- Stainless steel fittings do not require harsh environment-damaging cleaners to keep them looking like new
- Stainless Steel fittings are ideal for industrial MRO and OEM applications in food and beverage, pharmaceutical, petrochemical, waste water, salt water, and other corrosive environments.

Standard Materials:

- Fittings - 316 stainless steel
- Conduit, nipples, couplings and elbows - 316 stainless steel, 304 stainless steel
- Conduit hangers - 316 stainless steel, 301 stainless steel

LOCKNUTS



11SS

Features:

- 316 Stainless Steel Locknuts can be used with conduit or NPS threaded pipe.
- Precision-machined threads allow for easy installation.
- Heavy stock thickness and specially designed tabs tighten securely and will not easily loosen even in the most severe applications.

Cat. #	Trade Size	Unit Qty.	Std. Pkg.	Wt. Lbs. Per 100	Threads Per Inch
11SS	1/2"	1000	1000	2	14
12SS	3/4"	500	500	3	14
13SS	1"	500	500	5	11 1/2
15SS	1 1/2"	100	100	10	11 1/2
16SST	2"	100	100	21	11 1/2

HEX HEAD REDUCING BUSHINGS



RBSS21

Cat. #	Trade Size	Unit Qty.	Std. Pkg.	Wt. Lbs. Per 100	Length	Hex Nut Size
RBSS21	3/4 - 1/2	100	100	15	0.95	1.20
RBSS31	1 - 1/2	100	100	21	1.07	1.40
RBSS32	1 - 3/4	100	100	17	1.07	1.40
RBSS51	1 1/2 - 1/2	50	50	70	1.50	2.05
RBSS52	1 1/2 - 3/4	50	50	68	1.50	2.05
RBSS53	1 1/2 - 1	50	50	61	1.50	2.05
RBSS61	2 - 1/2	25	25	81	1.30	2.42
RBSS62	2 - 3/4	25	25	81	1.42	2.50
RBSS63	2 - 1	25	25	81	1.32	2.43
RBSS65	2 - 1 1/2	25	25	68	1.42	2.50

Plugs, Clamps and U-Bolts

HEX HEAD PLUGS



PLG50SS

Cat. #	Trade Size	Unit Qty.	Std. Pkg.	Wt. Lbs. Per 100	Length	Hex Nut Size
PLG50SS	1/2"	100	100	11	1	0.93
PLG75SS	3/4"	100	100	16	1.03	1.17
PLG100SS	1"	100	100	25	1.16	1.51
PLG150SS	1 - 1/2"	50	50	58	1.62	2.1
PLG200SS	2"	50	50	100	1.56	2.6

BEAM CLAMPS



531SS

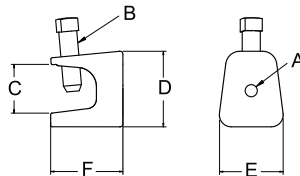

Features:

- This heavy-duty "electrician's" style beam clamp is cast in stainless for superior strength and corrosion resistance.
- Designed for use on I-beams, channels, and other structural members, this beam clamp provides firm fixturing without drilling holes.
- Attachment holes in the back and bottom permit a wide variety of applications.

Cat. #	Trade Size	Unit Qty.	Std. Pkg.	Wt. Lbs. Per 100	A	B	C	D	E	F
531SST	1 5/16"	50	50	25	1/4" - 20	5/16" - 18	7/8"	1 3/8"	1"	1 5/16"
533SST	2"	25	25	80	3/8" - 16	1/2" - 13	1 3/16"	1 7/8"	1 7/8"	2"
534SST	2 1/4"	25	25	148	1/2" - 13	5/8" - 11	1 3/16"	2 3/16"	2 1/8"	2 1/4"

U-BOLTS



UBM50SS

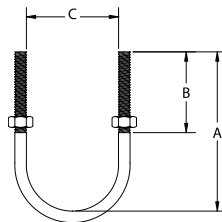

Cat. #	Trade Size	Unit Qty.	Std. Pkg.	Wt. Lbs. Per 100	A	B	C	Size & Pitch	Load Rtg (Lbs)
UBM50SS	1/2"	100	100	13	2.41"	1.50"	0.94"	5/16" - 18	950
UBM75SS	3/4"	100	100	14	2.73"	1.50"	1.15"	5/16" - 18	950
UBM100SS	1"	100	100	15	3.04"	1.50"	1.41"	5/16" - 18	950
UBM125SS	1 1/4"	50	50	16	3.16"	1.50"	1.76"	5/16" - 18	950
UBM150SS	1 1/2"	50	50	18	3.48"	1.50"	2.00"	5/16" - 18	950
UBM200SS	2"	50	50	30	4.30"	1.75"	2.49"	3/8" - 16	1250
UBM250SS	2 1/2"	50	50	34	4.80"	1.75"	2.99"	3/8" - 16	1250
UBM300SS	3"	50	50	38	5.36"	1.75"	3.61"	3/8" - 16	1250
UBM350SS	3 1/2"	50	50	40	5.80"	1.75"	4.11"	3/8" - 16	1250
UBM400SS	4"	50	50	45	6.50"	1.75"	4.61"	3/8" - 16	1250

Stainless Steel Fittings

Straps



ONE HOLE STRAPS

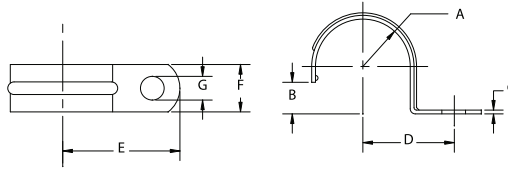

410SS

Stainless Steel Fittings

Cat. #	Trade Size	Unit Qty.	Std Pkg.	Wt. Lbs. Per 100	A	B	C	D	E	F	G
410SS	1/2"	400	400	4	0.420"	0.390"	0.075"	0.937"	1.375"	0.625"	0.250"
411SS	3/4"	200	200	5	0.525"	0.500"	0.090"	1.031"	1.562"	0.750"	0.250"
412SS	1"	100	100	7	0.655"	0.620"	0.090"	1.125"	1.812"	0.875"	0.312"
413SS	1 1/4"	50	50	10	0.830"	0.800"	0.100"	1.500"	2.000"	0.875"	0.375"
414SS	1 1/2"	50	50	14	0.950"	0.920"	0.125"	1.875"	2.500"	1.000"	0.437"
415SS	2"	25	25	20	1.185"	1.150"	0.125"	2.125"	2.750"	1.125"	0.562"
206SS	2 1/2"	25	25	42	1.437"	1.400"	0.150"	2.562"	3.312"	1.250"	0.562"
207SS	3"	10	10	51	1.750"	1.700"	0.150"	2.875"	3.625"	1.250"	0.562"
208SS	3 1/2"	10	10	70	2.000"	1.950"	0.180"	3.250"	4.000"	1.250"	0.562"
209SS	4"	10	10	78	2.250"	2.200"	0.180"	3.500"	4.250"	1.250"	0.562"

TWO HOLE STRAPS

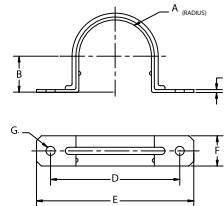

496 2SS

Cat. #	Trade Size	Unit Qty.	Std Pkg.	Wt. Lbs. Per 100	A	B	C	D	E	F	G
496 2SS	3/8"	400	400	2	0.35"	0.32"	.024-.030"	1.56"	2"	0.5"	0.188"
496 3SS	1/2"	200	200	2	0.42"	0.39"	.024-.030"	1.78"	2.25"	0.56"	0.188"
496 4SS	3/4"	200	200	3	0.52"	0.5"	.024-.030"	2.18"	2.62"	0.62"	0.188"
496 5SS	1"	100	100	4	0.65"	0.62"	.033-.038"	2.53"	3.2"	0.75"	0.25"
496 6SS	1 1/4"	50	50	6	0.83"	0.8"	.033-.038"	3.16"	4"	0.87"	0.25"
496 7SS	1 1/2"	50	50	9	0.95"	0.92"	.043-.050"	3.37"	4.2"	0.93"	0.25"
496 8SS	2"	50	50	12	1.18"	1.15"	.043-.050"	4.25"	5.12"	1"	0.375"
496 9SS	2 1/2"	25	25	16	1.43"	1.4"	.053-.060"	4.95"	5.87"	1"	0.375"
496 10SS	3"	25	25	20	1.75"	1.7"	.053-.060"	5.5"	6.5"	1"	0.375"
496 11SS	3 1/2"	25	25	29	2.00"	1.95"	.068-.075"	6.18"	7.12"	1"	0.437"
496 12SS	4"	25	25	32	2.25"	2.2"	.068-.075"	6.81"	7.75"	1"	0.437"

Clamps

RIGHT ANGLE CLAMPS



RAC50SS

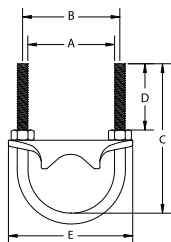

Features:

- Designed to fit pipe/rigid conduit as well as PVC-coated rigid conduit, right angle clamps firmly fix pipe to the flange of a structural member without drilling holes.
- Cast in CF8M(316) with 316SS U-bolt and nuts, these clamps are designed for both strength and corrosion resistance.

Stainless Steel Fittings

Cat. #	Trade Size	Unit Qty.	Std. Pkg.	Wt. Lbs. Per 100	A	B	C	D	E
RAC50SS	1/2"	50	50	34	0.94"	1.25"	2.41"	1.5"	2.0"
RAC75SS	3/4"	50	50	36	1.15"	1.46"	2.73"	1.5"	2.13"
RAC100SS	1"	50	50	44	1.41"	1.72"	3.04"	1.5"	2.63"
RAC125SS	1 1/4"	25	25	51	1.76"	2.07"	3.16"	1.5"	2.88"
RAC150SS	1 1/2"	25	25	61	2.00"	2.31"	3.48"	1.5"	3.37"
RAC200SS	2"	25	25	97	2.49"	2.87"	4.3"	1.75"	4.62"
RAC250SS	2 1/2"	25	25	125	2.99"	3.37"	4.8"	1.75"	4.62"
RAC300SS	3"	10	10	148	3.61"	3.99"	5.36"	1.75"	5.27"
RAC350SS	3 1/2"	10	10	163	4.11"	4.49"	5.8"	1.75"	5.75"
RAC400SS	4"	10	10	178	4.61"	4.99"	6.5"	1.75"	6.25"

PARALLEL CLAMPS



PARC75SS

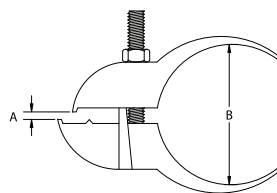

Features:

- Parallel Clamps are used to run pipe or conduit along the flange of I-beams or channels simply and easily without drilling holes.
- The 100% stainless (CF8M & 316SS) design offers superb corrosion resistance and strength.
- These clamps will fit both rigid conduit and PVC-Coated rigid conduit and are available in 3/4" and 1" trade sizes.

Cat. #	Trade Size	Unit Qty.	Std. Pkg.	Wt. Lbs. Per 100	A	B	Overall Width
PARC75SS	3/4"	50	50	58	2.89"	1.38"	1.1
PARC100SS	1"	50	50	60	3.12"	1.38"	1.1

CONDUIT HANGERS



OBSS316

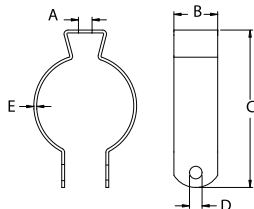

Stainless Steel 316

Cat. #	Trade Size	Unit Qty.	Std. Pkg.	Wt. Lbs. Per 100	A	B	C	D	E
0BSS316	1/2"	100	100	7	0.255"	0.75"	1.90"	0.275"	0.050"
1BSS316	3/4"	100	100	9	0.255"	0.875"	2.10"	0.275"	0.050"
2BSS316	1"	100	100	10	0.255"	0.875"	2.40"	0.275"	0.060"
3BSS316	1 1/4"	50	50	11	0.255"	0.875"	2.80"	0.275"	0.060"
4BSS316	1 1/2"	50	50	18	0.320"	1.00"	3.25"	0.275"	0.060"
5BSS316	2"	25	25	26	0.320"	1.25"	3.75"	0.275"	0.060"

With Bolt



Stainless Steel 301

Cat. #	Description	Unit Qty.	Wt. Lbs. Per 100
0BSS	3/8 and 1/2 RGD 1/2 EMT hanger with bolt	100	6
1BSS	3/4 RGD 3/4 EMT hanger with bolt	100	7
2BSS	1 RGD 1 EMT hanger with bolt	100	11
2 1/2 BSS	1 1/4 EMT hanger with bolt	100	10
3BSS	1 1/4 RGD 1 1/2 EMT hanger with bolt	100	13
4BSS	1 1/2 RGD hanger with bolt	100	16
5BSS	2 RGD 2 EMT hanger with bolt	50	17
6BSS	2 1/2 RGD 2 1/2 EMT hanger with bolt	50	32
7BSS	3 RGD 3 EMT hanger with bolt	25	39
8BSS	3 1/2 RGD 3 1/2 EMT hanger with bolt	10	41
9BSS	4 RGD 4 EMT hanger with bolt	10	44

Elbows

CONDUIT



RCOND50 304SS



Features:

- Stainless Steel threaded conduit polished to a bright finish to further increase corrosion resistance and provide enhanced aesthetic appearance.
- Provided in 10' lengths with coupling attached and color coded thread protector for the opposite end.
- Custom sizes are also available

Stainless Steel Fittings

Cat. #	Trade Size	Unit Qty.	Std Pkg.	Wt. Lbs. Per 100	Threads	ID	OD	Wall Thickness	Length without Coupling	Est. Weight per Foot
RCOND50 304SS	1/2"	1	1	85	14	0.622"	0.84"	0.104"	9' 11 1/4"	0.85
RCOND75 304SS	3/4"	1	1	113	14	0.824"	1.05"	0.107"	9' 11 1/4"	1.13
RCOND100 304SS	1"	1	1	168	11 1/2"	1.049"	1.31"	0.126"	9' 11"	1.68
RCOND150 304SS	1 1/2"	1	1	272	11 1/2"	1.610"	1.90"	0.138"	9' 11"	2.72
RCOND200 304SS	2"	1	1	365	11 1/2"	2.067"	2.37"	0.146"	9' 11"	3.65
RCOND250 304SS	2 1/2"	1	1	5500	8	2.469"	2.87"	0.193"	9' 10 1/2"	*
RCOND300 304SS	3"	1	1	7200	8	3.068"	3.5"	0.205"	9' 10 1/2"	*
RCOND400 304SS	4"	1	1	10000	8	4.026"	4.5"	0.225"	9' 10 3/4"	*
RCOND50 316SS	1/2"	1	1	85	14	0.622"	0.84"	0.104"	9' 11 1/4"	0.85
RCOND75 316SS	3/4"	1	1	113	14	0.824"	1.05"	0.107"	9' 11 1/4"	1.13
RCOND100 316SS	1"	1	1	168	11 1/2"	1.049"	1.31"	0.126"	9' 11"	1.68
RCOND150 316SS	1 1/2"	1	1	272	11 1/2"	1.610"	1.90"	0.138"	9' 11"	2.72
RCOND200 316SS	2"	1	1	365	11 1/2"	2.067"	2.37"	0.146"	9' 11"	3.65
RCOND250 316SS	2 1/2"	1	1	5500	8	2.469"	2.87"	0.193"	9-10-1/2"	*
RCOND300 316SS	3"	1	1	7200	8	3.068"	3.5"	0.205"	9-10-1/2"	*
RCOND400 316SS	4"	1	1	10000	8	4.026"	4.5"	0.225"	9-10-3/4"	*

STANDARD RADIUS ELBOWS



RLB50 304SS

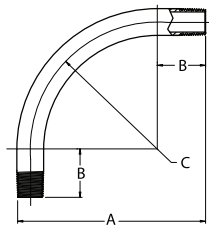

Features:

- Designed for use with stainless threaded rigid conduit.
- These stainless steel elbows are polished to a bright finish for increased corrosion resistance and improved appearance.

Cat. #	Trade Size	Unit Qty.	Std. Pkg.	Wt. Lbs. Per 100	Radius "C"	Offset "A"	Straight End "B"
RLB5090 304SS	1/2"	1	1	76	4"	6.5"	2.12"
RLB7590 304SS	3/4"	1	1	109	4.5"	7.25"	2.75"
RLB10090 304SS	1"	1	1	188	5.75"	8.63"	2.88"
RLB15090 304SS	1 1/2"	1	1	422	8.25"	11.63"	3.38"
RLB20090 304SS	2"	1	1	611	9.5"	13.31"	3.81"
RLB5090 316SS	1/2"	1	1	76	4"	6.5"	2.12"
RLB7590 316SS	3/4"	1	1	109	4.5"	7.25"	2.75"
RLB10090 316SS	1"	1	1	188	5.75"	8.63"	2.88"
RLB15090 316SS	1 1/2"	1	1	422	8.25"	11.63"	3.38"
RLB20090 316SS	2"	1	1	611	9.5"	13.31"	3.81"

Nipples

CONDUIT NIPPLES



NPL50200 304SS



Features:

- Designed for use with stainless threaded rigid conduit.
- These nipples are polished to a bright finish for increased corrosion resistance and improved appearance.

Cat. #	Trade Size	Unit Qty.	Std. Pkg.	Wt. Lbs. Per 100
NPL50CL 304SS	1/2" x CLOSE	1	1	5
NPL50200 304SS	1/2" x 2"	1	1	12
NPL50250 304SS	1/2" x 2 1/2"L	1	1	14
NPL50300 304SS	1/2" x 3"	1	1	18
NPL50350 304SS	1/2" x 3 1/2"L	1	1	21
NPL50400 304SS	1/2" x 4"	1	1	24
NPL50500 304SS	1/2" x 5"	1	1	31
NPL50600 304SS	1/2" x 6"	1	1	38
NPL50800 304SS	1/2" x 8"	1	1	51
NPL501000 304SS	1/2" x 10"L	1	1	66
NPL501200 304SS	1/2" x 12"L	1	1	79
NPL50CL 316SS	1/2" x CLOSE	1	1	5
NPL50200 316SS	1/2" x 2"	1	1	12
NPL50250 316SS	1/2" x 2 1/2"L	1	1	14
NPL50300 316SS	1/2" x 3"	1	1	18
NPL50350 316SS	1/2" x 3 1/2"L	1	1	21
NPL50400 316SS	1/2" x 4"	1	1	24
NPL50500 316SS	1/2" x 5"	1	1	31
NPL50600 316SS	1/2" x 6"	1	1	38
NPL50800 316SS	1/2" x 8"	1	1	51
NPL501000 316SS	1/2" x 10"L	1	1	66
NPL501200 316SS	1/2" x 12"L	1	1	79
NPL75CL 304SS	3/4" x CLOSE	1	1	8
NPL75200 304SS	3/4" x 2"	1	1	14
NPL75250 304SS	3/4" x 2 1/2"L	1	1	19
NPL75300 304SS	3/4" x 3"	1	1	23
NPL75350 304SS	3/4" x 3 1/2"L	1	1	27
NPL75400 304SS	3/4" x 4"	1	1	30
NPL75500 304SS	3/4" x 5"	1	1	41
NPL75600 304SS	3/4" x 6"	1	1	50
NPL75800 304SS	3/4" x 8"	1	1	68
NPL751000 304SS	3/4" x 10"L	1	1	83
NPL751200 304SS	3/4" x 12"L	1	1	103
NPL75CL 316SS	3/4" x CLOSE	1	1	8
NPL75200 316SS	3/4" x 2"	1	1	14
NPL75250 316SS	3/4" x 2 1/2"L	1	1	19
NPL75300 316SS	3/4" x 3"	1	1	23
NPL75350 316SS	3/4" x 3 1/2"L	1	1	27
NPL75400 316SS	3/4" x 4"	1	1	30
NPL75500 316SS	3/4" x 5"	1	1	41
NPL75600 316SS	3/4" x 6"	1	1	50
NPL75800 316SS	3/4" x 8"	1	1	68
NPL751000 316SS	3/4" x 10"L	1	1	83
NPL751200 316SS	3/4" x 12"L	1	1	103
NPL100CL 304SS	1" x CLOSE	1	1	13
NPL100200 304SS	1" x 2"	1	1	23
NPL100250 304SS	1" x 2 1/2"L	1	1	26
NPL100300 304SS	1" x 3"	1	1	31
NPL100350 304SS	1" x 3 1/2"L	1	1	41
NPL100400 304SS	1" x 4"	1	1	51

Cat. #	Trade Size	Unit Qty.	Std. Pkg.	Wt. Lbs. Per 100
NPL100500 304SS	1" x 5"L	1	1	62
NPL100600 304SS	1" x 6"L	1	1	72
NPL100800 304SS	1" x 8"L	1	1	97
NPL1001000 304SS	1" x 10"L	1	1	135
NPL1001200 304SS	1" x 12"L	1	1	152
NPL100CL 316SS	1" x CLOSE	1	1	13
NPL100200 316SS	1" x 2"	1	1	23
NPL100250 316SS	1" x 2 1/2"L	1	1	26
NPL100300 316SS	1" x 3"	1	1	31
NPL100350 316SS	1" x 3 1/2"L	1	1	41
NPL100400 316SS	1" x 4"	1	1	51
NPL100500 316SS	1" x 5"	1	1	62
NPL100600 316SS	1" x 6"	1	1	72
NPL100800 316SS	1" x 8"	1	1	97
NPL1001000 316SS	1" x 10"L	1	1	135
NPL1001200 316SS	1" x 12"L	1	1	152
NPL150200 304SS	1 1/2" x 2"	1	1	25
NPL150250 304SS	1 1/2" x 2 1/2"L	1	1	47
NPL150300 304SS	1 1/2" x 3"	1	1	53
NPL150350 304SS	1 1/2" x 3 1/2"L	1	1	64
NPL150400 304SS	1 1/2" x 4"	1	1	75
NPL150500 304SS	1 1/2" x 5"	1	1	88
NPL150600 304SS	1 1/2" x 6"	1	1	114
NPL150800 304SS	1 1/2" x 8"	1	1	151
NPL1501000 304SS	1 1/2" x 10"L	1	1	176
NPL1501200 304SS	1 1/2" x 12"L	1	1	243
NPL150200 316SS	1 1/2" x 2"	1	1	25
NPL150250 316SS	1 1/2" x 2 1/2"L	1	1	47
NPL150300 316SS	1 1/2" x 3"	1	1	53
NPL150350 316SS	1 1/2" x 3 1/2"L	1	1	64
NPL150400 316SS	1 1/2" x 4"	1	1	75
NPL150500 316SS	1 1/2" x 5"	1	1	88
NPL150600 316SS	1 1/2" x 6"	1	1	114
NPL150800 316SS	1 1/2" x 8"	1	1	151
NPL1501000 316SS	1 1/2" x 10"L	1	1	176
NPL1501200 316SS	1 1/2" x 12"L	1	1	243
NPL200200 304SS	2" x 2"	1	1	33
NPL200250 304SS	2" x 2 1/2" L	1	1	47
NPL200300 304SS	2" x 3"	1	1	60
NPL200350 304SS	2" x 3 1/2" L	1	1	80
NPL200400 304SS	2" x 4"	1	1	100
NPL200500 304SS	2" x 5"	1	1	127
NPL200600 304SS	2" x 6"	1	1	152
NPL200800 304SS	2" x 8"	1	1	204
NPL2001000 304SS	2" x 10"L	1	1	254
NPL2001200 304SS	2" x 12" L	1	1	305
NPL200200 316SS	2" x 2"	1	1	33
NPL200250 316SS	2" x 2 1/2" L	1	1	47
NPL200300 316SS	2" x 3"	1	1	60
NPL200350 316SS	2" x 3 1/2" L	1	1	80
NPL200400 316SS	2" x 4"	1	1	100
NPL200500 316SS	2" x 5"	1	1	127
NPL200600 316SS	2" x 6"	1	1	152
NPL200800 316SS	2" x 8"	1	1	204
NPL2001000 316SS	2" x 10"L	1	1	254
NPL2001200 316SS	2" x 12" L	1	1	305

Stainless Steel Fittings

Couplings

COUPLINGS



RC50 304SS

Features:

- Designed for use with stainless threaded rigid conduit.
- These stainless steel elbows are polished to a bright finish for increased corrosion resistance and improved appearance.

Stainless Steel Fittings

Cat. #	Trade Size	Unit Qty.	Std. Pkg.	Wt. Lbs. Per 100	Length	Outside Dia.
RC50 304SS	1/2"	1	1	18	1.625"	1.01"
RC75 304SS	3/4"	1	1	26	1.650"	1.25"
RC100 304SS	1"	1	1	28	2.000"	1.53"
RC150 304SS	1 1/2"	1	1	51	2.063"	2.16"
RC200 304SS	2"	1	1	69	2.125"	2.65"
RC250 304SS	2 1/2"	1	1	178	3.188"	3.25"
RC300 304SS	3"	1	1	229	3.313"	3.87"
RC400 304SS	4"	1	1	313	3.516"	4.88"
RC50 316SS	1/2"	1	1	18	1.625"	1.01"
RC75 316SS	3/4"	1	1	26	1.650"	1.25"
RC100 316SS	1"	1	1	28	2.000"	1.53"
RC150 316SS	1 1/2"	1	1	51	2.063"	2.16"
RC200 316SS	2"	1	1	69	2.125"	2.65"
RC250 316SS	2 1/2"	1	1	178	3.188"	3.25"
RC300 316SS	3"	1	1	229	3.313"	3.87"
RC400 316SS	4"	1	1	313	3.516"	4.88"

3-PIECE COUPLINGS



191SS

Features:

- Designed to join and connect threaded ends of rigid conduit where neither length of conduit can be turned.
- These Stainless Steel Three piece couplings are polished to a bright finish for increased corrosion resistance and improved appearance.

Cat. #	Trade Size	Unit Qty.	Std. Pkg.	Wt. Lbs. Per 100	Overall Length	Major Nut Dia.	Major Body Dia.
191SS	3/4"	50	50	33	1.51"	1.51"	1.31"
192SS	1"	50	50	33	1.51"	1.66"	1.66"

Switch & Outlet Boxes – Technical Data



Outlet Boxes

Article 314 of the National Electrical Code® (NEC®) covers the installation and use of boxes. The article includes table references that guide the electrician in the selection of the proper size box necessary to safely accommodate electrical service requirements. The box capacity table is reproduced in part from NEC as a quick reference and guide. The NEC should be consulted for complete details.

Cooper Crouse-Hinds products are produced in accordance with the requirements of UL-514-A, UL-514-B, UL-514-C and are classified for fire resistance according to the standard, Fire Tests of Building Construction and Materials, ANSI/UL 263, ASTM E 119 and NFPA 251. This listing is based on products when used in a fire rated (2 HR) wall or ceiling. Cooper Crouse-Hinds steel boxes are listed with U.L. File #E23156 and Cooper Crouse-Hinds nonmetallic boxes are listed with U.L. File #E102328 and U.L. (2 HR. fire rated) File #R9933.

Cooper Crouse-Hinds switch and outlet boxes comply with the requirements of NEMA standard OS-1, NFPA 70-370 and Federal Spec. #W-J-800E.

Under File #E23156, Cooper Crouse-Hinds concentric and "Moon" KO style boxes, the following is stated "Suitable for bonding without any additional bonding means around concentric (or Eccentric) knockouts where used in circuits above or below 250V."

Wall thickness on all Steel boxes is 0.0625"

Table 314.16(A) Metal Boxes

Box Dimension, Inches	Min. Cu. In.	Maximum Number of Conductors (arranged by AWG size)						
		No. 18	No. 16	No. 14	No. 12	No. 10	No. 8	No. 6
Trade Size or Type	Cap.							
4 x 1¼ Round or Octagonal	12.5	8	7	6	5	5	4	2
4 x 1½ Round or Octagonal	15.5	10	8	7	6	6	5	3
4 x 2⅞ Round or Octagonal	21.5	14	12	10	9	8	7	4
4 x 1¼ Square	18.0	12	10	9	8	7	6	3
4 x 1½ Square	21.0	14	12	10	9	8	7	4
4 x 2⅞ Square	30.3	20	17	15	13	12	10	6
4 ¹¹ / ₁₆ x 1¼ Square	25.5	17	14	12	11	10	8	5
4 ¹¹ / ₁₆ x 2½ Square	29.5	19	16	14	13	11	9	5
4 ¹¹ / ₁₆ x 2⅞ Square	42.0	28	24	21	18	16	14	8
3 x 2 x 1½ Device	7.5	5	4	3	3	3	2	1
3 x 2 x 2 Device	10.0	6	5	5	4	4	3	2
3 x 2 x 2¼ Device	10.5	7	6	5	4	4	3	2
3 x 2 x 2½ Device	12.5	8	7	6	5	5	4	2
3 x 2 x 2¾ Device	14.0	9	8	7	6	5	4	2
3 x 2 x 3½ Device	18.0	12	10	9	8	7	6	3
4 x 2⅞ x 1½ Device	10.3	6	5	5	4	4	3	2
4 x 2⅞ x 1⅞ Device	13.0	8	7	6	5	5	4	2
4 x 2⅞ x 2⅞ Device	14.5	9	8	7	6	5	4	2
3¾ x 2 x 2½ Masonry Box/Gang	14.0	9	8	7	6	5	4	2
3¾ x 2 x 3½ Masonry Box/Gang	21.0	14	12	10	9	8	7	4
FS-Minimum Internal Depth 1¾ Single Cover Gang	13.5	9	7	6	6	5	4	2
FD-Minimum Internal Depth 2⅞ Single Cover Gang	18.0	12	10	9	8	7	6	3
FS-Minimum Internal Depth 1¾ Single Cover Gang	18.0	12	10	9	8	7	6	3
FD-Minimum Internal Depth 2⅞ Multiple Cover Gang	24.0	16	13	12	10	9	8	4

Table 314.16(B) Volume Required per Conductor

Size of Conductor	Free Space Within Box for Each Conductor
No. 18	1.5 cubic inches
No. 16	1.75 cubic inches
No. 14	2 cubic inches
No. 12	2.25 cubic inches
No. 10	2.5 cubic inches
No. 8	3 cubic inches
No. 6	5 cubic inches

For SI units: one cubic inch = 16.4 cm³.

Reprinted with permission from NFPA 70-2005, the National Electrical Code®, Copyright® 2005 National Fire Protection Association, Quincy MA 02269. This reprinted material is not the complete and official position of the National Fire Protection Association, on the referenced subject which is represented only by the standard in its entirety. National Electrical Code® and NEC® are registered trademarks of the National Fire Protection Association, Inc., Quincy, MA 02269.

COOPER CROUSE-HINDS OUTLET BOXES & COVERS

Cooper Crouse-Hinds has assembled one of the most complete outlet box products lines in the business. We've been leading in quality and selection for decades and throughout the Cooper Crouse-Hinds Steel Outlet Box offering, you will find innovative products and solutions that save labor, cut material costs and increase productivity.

We have a complete offering of:

- 4" and 4¹/₁₆" square drawn and welded boxes
- 4" square and 4¹/₁₆", switch, masonry, utility, outlet, ceiling, fan and gangable boxes
- Drawn boxes available with concentric knockouts, combining 1/2" and 3/4" knockout
- Complete line of covers, partitions, extension rings and accessories
- Uni-Mount™ Covers
- PRE-formance™ products
- Pre-assembled boxes which includes Uni-Mount cover attached to 4" square box
- Pre-fabricated boxes which includes Uni-Mount cover attached to 4" square box with ground screw and lead installed
- Fire alarm boxes and covers



BRACKETS USED ON COOPER CROUSE-HINDS BOXES

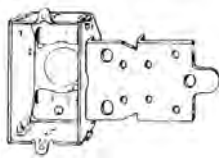

"F" BRACKET

Mounts on face of stud. See catalog number for set back. For wood studs.

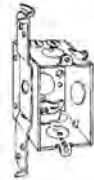

"D" BRACKET

Side mount bracket with set up hook & guide tabs for automatic positioning. Standard bracket set back is 5/8". For wood and metal studs.



"S" BRACKET

Side mount brackets with set up hook for wood or metal studs. Standard bracket set back is 5/8".

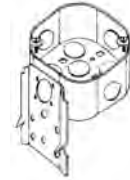

"C" BRACKET

Ceiling box bracket for wood studs.



"VS" BRACKET

Plain flat mounted bracket for use on wood or metal studs. No set back.

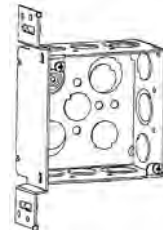

"VMS" BRACKET

Side bracket for use with wood or metal studs. Provides set up tabs to position on face of stud.

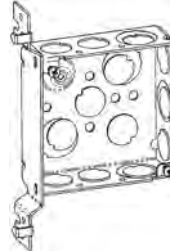

"VP" BRACKET

Side bracket with set up hooks for wood studs.

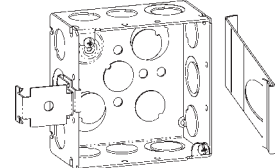

"SSB" BRACKET

Positions box on either side of a steel stud.

CLAMPS USED ON COOPER CROUSE-HINDS BOXES

Cat. # TP900

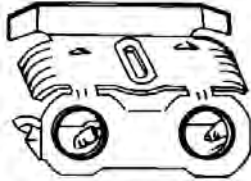

MC-BX

FOR ARMORED & METAL CLAD (MCI) CABLE

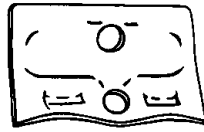

NM-1

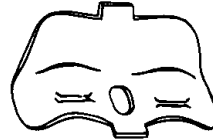

NM-2

FOR NONMETALLIC CABLE

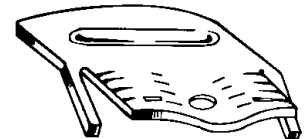

NM-4

Outlet Boxes

MOUNTING EARS

Cat. # TP901

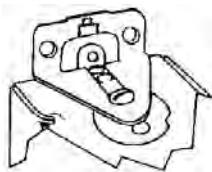

ONE SCREW EAR

Cat. # TP902



TWO SCREW EAR

Mounting ears are available on many of our switch boxes. They are set forward in 1/8" the "old way" position. Two-screw ears are generally used on shallow boxes and one-screw ears on deep boxes.

COOPER CROUSE-HINDS BOX ENTRY DETAILS



1/2" Conduit KO



3/4" Conduit KO



1" Conduit KO



Concentric 1/2" and 3/4" KO



Eccentric 1/2" and 3/4" KO

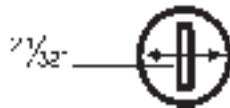

Cable Pry-outs always in pairs.

Knockouts and Pry-outs

Cooper Crouse-Hinds conduit KOs have standard trade size dimensions. KOs are uniform and true for attachment of cable or conduit connectors. Pry-outs for cable entrance are slotted – a twist with screwdriver removes them. KOs and Pry-outs are precision stamped to permit easy removal, but remain sufficiently strong and sturdy when not removed.

Cooper Crouse-Hinds 4" sq. drawn boxes feature a 1/2" and 3/4" "inverted" concentric KO – easily removed. Our 4" sq. welded feature our 1/2" eccentric KO which also features easy removability of both the 1/2" and 3/4" KOs.

Note: These KOs are suitable for bonding without bonding jumpers around concentric (or eccentric) knockouts where used in circuits above or below 250V.

4" SQUARE OUTLET BOXES AND COVERS

Outlet Boxes



Features:

- Ideal for exposed work applications, providing an easy method for the installation of electrical devices (switches, receptacles, fans, lights, etc.)
- Raised ground screw location in the welded boxes saves time in installation
- Available with pre-installed ground screws and pigtails for increased labor savings
- Knockouts are suitable for use without a bonding jumper in circuits above or below 250 volts
- Available in two depths for differing cubic capacity requirements
- Welded or drawn construction to match customer preference
- Extensive cover offering to meet various customer applications and needs

Applications:

- For use with conduit
- Can be ceiling mounted to be used as a junction box or to mount lighting fixtures
- Available in red for fire alarm applications

Certifications and Compliances:

- UL Listed

4" SQUARE OUTLET BOXES – 18.0 CUBIC INCH CAPACITY

1 1/4" DEEP – FOR CONDUIT

UL LISTED

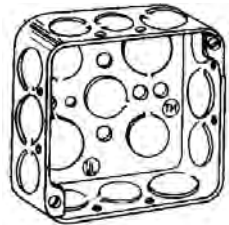

TP408

KNOCKOUTS

Cat. #	Bracket	Description	Sides	Bottom	Unit Qty.	Wt. Lbs. Per 100
TP408	—	Drawn	12 – 1/2"	5 – 1/2"	50	61

Steel Square Boxes



4" SQUARE OUTLET BOXES – 22.0 CUBIC INCH CAPACITY (WELDED)† 21.0 CUBIC INCH CAPACITY (DRAWN)

1½" DEEP – FOR CONDUIT

UL LISTED

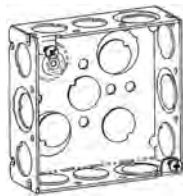

TP404/TP404PF

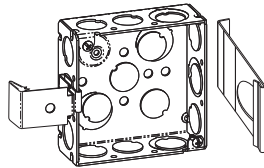

TP404SSB



TP404RED



TP425



TP467

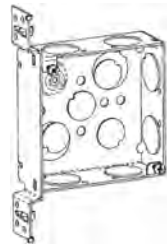

TP469



TP830*

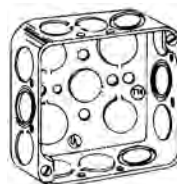

TP405

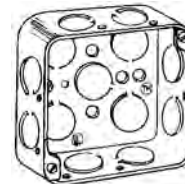

TP412
TP839*



TP410



TP414RED

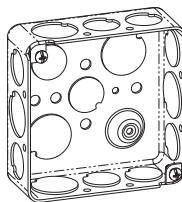

TP414

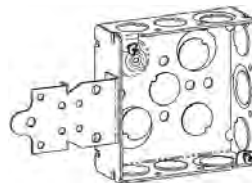

TP418



TP423RED



TP423

KNOCKOUTS

Cat. #	Metal Stud Sizes	Bracket	Description	Sides	Bottom	Unit Qty.	Wt. Lbs. Per 100
TP404**	—	—	Welded	8 - ½", 4 - ½" + ¾" E	2 - ½", 2 - ½" + ¾" E	50	72
TP404RED	—	—	Welded	8 - ½", 4 - ½" + ¾" E	2 - ½", 2 - ½" + ¾" E	50	72
TP404PF†**	—	—	Welded	8 - ½", 4 - ½" + ¾" E	2 - ½", 2 - ½" + ¾" E	50	72
TP404SSB	—	SSB	Welded	8 - ½", 4 - ½" + ¾" E	2 - ½", 2 - ½" + ¾" E	50	83
TP425**	—	"VP"	Welded	6 - ½", 3 - ½" + ¾" E	2 - ½", 2 - ½" + ¾" E	25	82
TP423**	All	"VMS"	Welded	6 - ½", 3 - ½" + ¾" E	2 - ½", 2 - ½" + ¾" E	25	81
TP423RED	All	"VMS"	Welded	6 - ½", 3 - ½" + ¾" E	2 - ½", 2 - ½" + ¾" E	25	81
TP405	—	—	Drawn	4 - ½", 6 - ½" & ¾" C	3 - ½", 2 - ¾"	50	67
TP410	—	—	Drawn	12 - ½"	5 - ½"	50	67
TP412	—	—	Drawn	8 - ¾"	3 - ½", 2 - ¾"	50	67
TP414	—	—	Drawn	8 - ½", 4 - ¾"	3 - ½", 2 - ¾"	50	67
TP414RED	—	—	Drawn	8 - ½", 4 - ¾"	3 - ½", 2 - ¾"	50	67
TP418	—	"F", Set Flush	Welded	6 - ½", 3 - ½" + ¾" E	2 - ½", 2 - ½" + ¾" E	25	84
TP467	—	—	Welded	8 - ¾"	2 - ½", 2 - ½" + ¾" E	50	72
TP469	ALL	"VMS"	Welded	6 - ¾"	2 - ½", 2 - ½" + ¾" E	25	81
Air Plenum							
TP830*	—	—	Drawn	8 - ½", 4 - ¾"	3 - ½", 2 - ¾"	50	72
TP839*	—	—	Drawn	8 - ¾" C	3 - ½", 2 - ¾"	50	72

*For Air Plenum (No Mounting Holes) - Not UL Listed

**cUL Listed

† All welded 4" square outlet boxes have a raised dimple for ground screw

‡ TP404PF includes ground screw with pigtail lead

Steel Boxes

4" SQUARE OUTLET BOXES – 22.0 CUBIC INCH CAPACITY

1½" DEEP
FOR NONMETALLIC CABLE – CLAMPS IN EACH END

UL LISTED

Steel Boxes

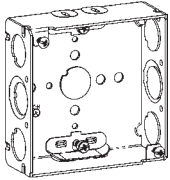

TP444

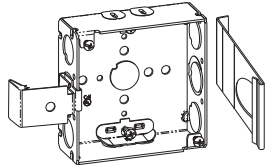

TP444SSB

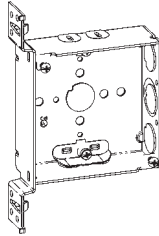

TP449

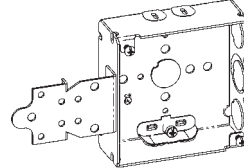

TP446

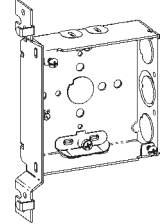

TP445

KNOCKOUTS

Cat. #	Bracket	Description	Sides	Bottom	Unit Qty.	Wt. Lbs. Per 100
TP444	—	Welded	4 – Cable, 4 – ½", 2 – ½" & ¾" E	1 – ½"	50	77
TP444SSB	SSB	Welded	4 – Cable, 4 – ½", 2 – ½" & ¾" E	1 – ½"	50	88
TP446	"F", Set Flush	Welded	4 – Cable, 2 – ½", 1 – ½" & ¾" E	1 – ½"	25	88
TP445	"VP"	Welded	4 – Cable, 2 – ½", 1 – ½" & ¾" E	1 – ½"	25	85
TP449	"VMS"	Welded	4 – Cable, 2 – ½", 1 – ½" & ¾" E	1 – ½"	25	85

4" SQUARE OUTLET BOXES – 22.0 CUBIC INCH CAPACITY

1½" DEEP
FOR ARMORED & METAL CLAD (MCI) CABLE – CLAMPS IN EACH END

UL LISTED

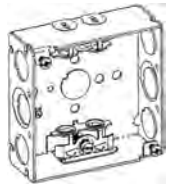

TP454

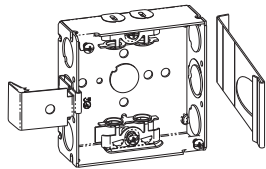

TP454SSB

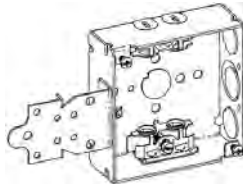

TP456

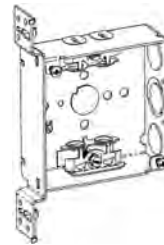

TP459

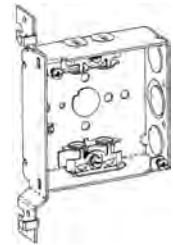

TP461

KNOCKOUTS

Cat. #	Bracket	Description	Sides	Bottom	Unit Qty.	Wt. Lbs. Per 100
TP459	"VMS"	Welded	4 – Cable, 2 – ½", 1 – ½" & ¾" E	1 – ½"	25	89
TP454*	—	Welded	4 – Cable, 4 – ½", 2 – ½" & ¾" E	1 – ½"	50	81
TP454PF†	—	Welded	4 – Cable, 4 – ½", 2 – ½" & ¾" E	1 – ½"	50	81
TP454SSB*	SSB	Welded	4 – Cable, 4 – ½", 2 – ½" & ¾" E	1 – ½"	25	82
TP456*	"F", Set Flush	Welded	4 – Cable, 2 – ½", 1 – ½" & ¾" E	1 – ½"	25	92
TP456PF†	"F", Set Flush	Welded	4 – Cable, 2 – ½", 1 – ½" & ¾" E	1 – ½"	25	92
TP461*	"VP"	Welded	4 – Cable, 2 – ½", 1 – ½" & ¾" E	1 – ½"	25	89

†TP catalog numbers ending in PF includes ground screw with pigtail lead

4" SQUARE OUTLET BOXES – 30.3 CUBIC INCH CAPACITY

2 1/8" DEEP WITH CONDUIT KOs

UL LISTED

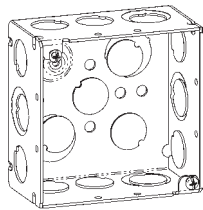

TP403/TP403PF

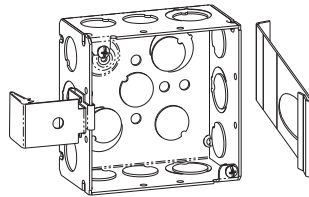

TP403SSB

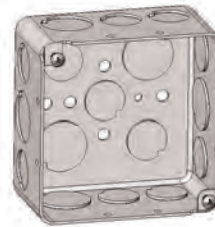

TP434

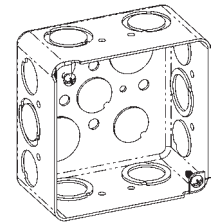

TP438
TP831*

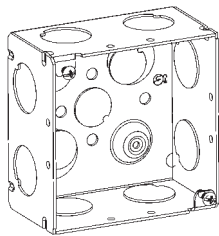

TP432

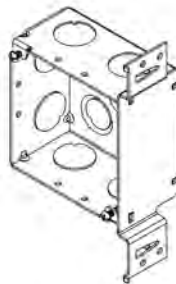

TP432VMS

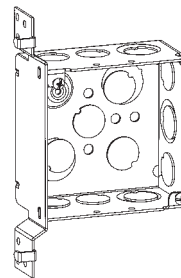

TP437

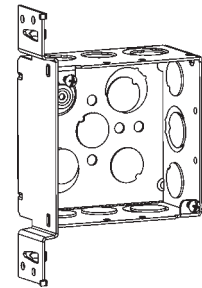

TP451



TP403RED



TP434RED



TP451RED

KNOCKOUTS

Cat. #	Bracket	Description	Sides	Bottom	Unit Qty.	Wt. Lbs. Per 100
TP403**	—	Welded	8 - 1/2", 4 - 1/2" & 3/4" E	2 - 1/2", 2 - 1/2" & 3/4" E	25	84
TP403RED	—	Welded	8 - 1/2", 4 - 1/2" & 3/4" E	2 - 1/2", 2 - 1/2" & 3/4" E	25	84
TP403PF†**	—	Welded	8 - 1/2", 4 - 1/2" & 3/4" E	2 - 1/2", 2 - 1/2" & 3/4" E	25	84
TP403SSB	SSB	Welded	8 - 1/2", 4 - 1/2" & 3/4" E	2 - 1/2", 2 - 1/2" & 3/4" E	25	95
TP432**	—	Welded	8 - 3/4"	2 - 1/2", 2 - 1/2" & 3/4" E	25	84
TP432VMS	"VMS"	Welded	6 - 3/4"	2 - 1/2", 2 - 1/2" & 3/4" E	25	99
TP436	—	Welded	8 - 1"	2 - 1/2", 2 - 1/2" & 3/4" E	25	84
TP434	—	Drawn	8 - 1/2", 4 - 3/4"	3 - 1/2", 2 - 3/4"	25	84
TP434RED	—	Drawn	8 - 1/2", 4 - 3/4"	3 - 1/2", 2 - 3/4"	25	84
TP438	—	Drawn	4 - 1/2", 6 - 1/2" & 3/4" C	3 - 1/2", 2 - 3/4"	25	84
TP438PF†	—	Drawn	4 - 1/2", 6 - 1/2" & 3/4" C	3 - 1/2", 2 - 3/4"	25	84
TP451	"VMS"	Welded	6 - 1/2", 3 - 1/2" & 3/4" E	2 - 1/2", 2 - 1/2" & 3/4" E	25	96
TP451PF†	"VMS"	Welded	6 - 1/2", 3 - 1/2" & 3/4" E	2 - 1/2", 2 - 1/2" & 3/4" E	25	96
TP451RED	"VMS"	Welded	6 - 1/2", 3 - 1/2" & 3/4" E	2 - 1/2", 2 - 1/2" & 3/4" E	25	96
TP437	"VP"	Welded	6 - 1/2", 3 - 1/2" & 3/4" E	2 - 1/2", 2 - 1/2" & 3/4" E	25	98

Air Plenum

TP831*	—	Drawn	8 - 1/2", 4 - 3/4"	3 - 1/2", 2 - 3/4"	25	90
--------	---	-------	--------------------	--------------------	----	----

*For Air Plenum (No Mounting Holes) - Not UL Listed

†TP catalog numbers ending in PF includes ground screw with pigtail lead

**cUL Listed

Steel Boxes

4" SQUARE OUTLET BOXES – 30.3 CUBIC INCH CAPACITY 2 1/8" DEEP

FOR NONMETALLIC CABLE – CLAMPS IN EACH END

UL LISTED

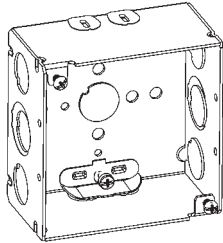

TP450

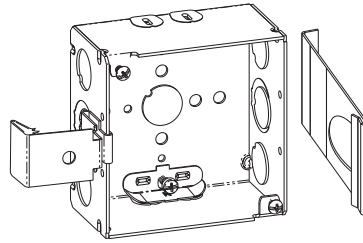

TP450SSB

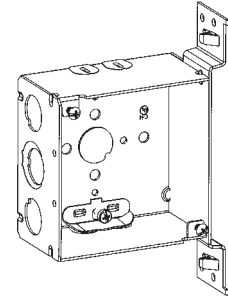

TP452

KNOCKOUTS

Cat. #	Bracket	Description	Sides	Bottom	Unit Qty.	Wt. Lbs. Per 100
TP450	—	Welded	4 – Cable, 4 – 1/2", 2 – 1/2" & 3/4" E	1 – 1/2"	25	90
TP450SSB	SSB	Welded	4 – Cable, 4 – 1/2", 2 – 1/2" & 3/4" E	1 – 1/2"	25	101
TP452	"VMS"	Welded	4 – Cable, 2 – 1/2", 1 – 1/2" & 3/4" E	1 – 1/2"	25	104

4" SQUARE OUTLET BOXES – 30.3 CUBIC INCH CAPACITY

2 1/8" DEEP

FOR ARMORED & METAL CLAD (MCI) CABLE – CLAMPS IN EACH END

UL LISTED

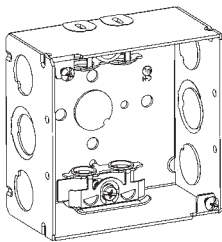

TP431

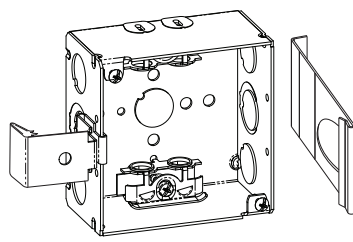

TP431SSB

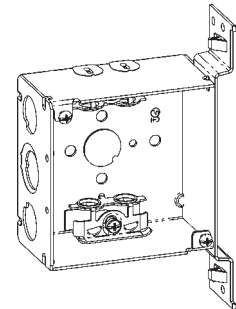

TP440

KNOCKOUTS

Cat. #	Metal Stud Sizes	Bracket	Description	Sides	Bottom	Unit Qty.	Wt. Lbs. Per 100
TP431*	—	—	Welded	4 – Cable, 4 – 1/2", 2 – 1/2" & 3/4" E	1 – 1/2"	25	91
TP431PF†	—	—	Welded	4 – Cable, 4 – 1/2", 2 – 1/2" & 3/4" E	1 – 1/2"	25	91
TP431SSB*	—	SSB	Welded	4 – Cable, 4 – 1/2", 2 – 1/2" & 3/4" E	1 – 1/2"	25	102
TP440*	All	"VMS"	Welded	4 – Cable, 2 – 1/2", 1 – 1/2" & 3/4" E	1 – 1/2"	25	103

†TP catalog numbers ending in PF includes ground screw with pigtail lead

*UL approved for use with aluminum interlocking grounding metal clad cable, Type MCIA (Southwire MCAP™)

MCAP™ is a registered trademark of Southwire Company.

4" SQUARE TWO-DEVICE BOXES – 30.3 CUBIC INCH CAPACITY

2 1/8" DEEP

UL LISTED



TP391



TP395

KNOCKOUTS

Cat. #	Bracket	Description	Sides	Bottom	Std. Unit Pkg.	Wt. Lbs. Per 100
TP391	"VS", Set 7/8"	Drawn	6 - 1/2", 3 - 3/4"	3 - 1/2", 2 - 3/4"	25	95
TP395	—	Drawn	8 - 1/2", 4 - 3/4"	3 - 1/2", 2 - 3/4"	25	84

4" SQUARE EXTENSION RINGS

1 1/2" DEEP WITH CONDUIT KNOCKOUTS – 21.0 CUBIC INCH CAPACITY

2 1/8" DEEP WITH CONDUIT KNOCKOUTS – 30.3 CUBIC INCH CAPACITY

UL LISTED



TP424

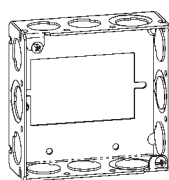

TP422



TP426



TP428RED



TP443 (2 1/8" Deep)

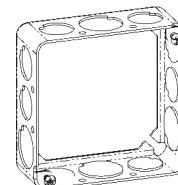

TP428, TP833*

KNOCKOUTS

Cat. #	Sides	Bottom	Unit Qty.	Wt. Lbs. Per 100
TP424	12 - 1/2"	—	50	46
TP422	8 - 1/2", 4 - 1/2" + 3/4" E	—	50	50
TP426	8 - 3/4"	—	50	46
TP428	8 - 1/2", 4 - 3/4"	—	50	46
TP428RED	8 - 1/2", 4 - 3/4"	—	50	46
TP443	8 - 1/2", 4 - 3/4"	—	25	66
TP465	8 - 1"	—	25	60
TP833*	8 - 1/2", 4 - 3/4"	—	50	48

*For Air Plenum (No Mounting Holes). Requires the use of TP854, purchase separately - Not UL Listed

FLEXIBLE FIXTURE HANGERS

Cooper Crouse-Hinds TPSFH square flexible fixture hangers are used in commercial or light industrial applications where HID high bay and low bay lighting fixtures are used. Specific applications include storage facilities, shipping warehouses, retail and DIY facilities.

Features and Benefits:

- Suitable for use with 1/2" or 3/4" fixture conduit stems these hangers allow the conduit stem of the fixture (luminaire) to swing in any direction. Maximum swing angle is 26° from vertical max slope angles 22 1/2°
- Available for attachment to 4" square steel boxes.
- Quickly and easily attached by two screws.
- Hangers are drilled and tapped for use with 3/4" conduit stem as standard and come supplied with a 3/4" - 1/2" reducer for 1/2" conduit stem applications.

Certifications and Compliances:

- UL Listed – UL 1598
- CSA C22.2 No. 250
- Suitable for Damp Locations

Standard Materials and Finishes:

- Material: Sheet Steel
- Finish: Zinc Chromate for corrosion resistance



Description	Support Wt. (lbs)	Cat. #
For use with 4" Square boxes	50	TPSFH12

Steel Square Covers



COVERS FOR 4" SQUARE BOXES – CUBIC INCH CAPACITY (SEE BELOW)

UL LISTED

#8-32 screw used on covers

Steel Boxes

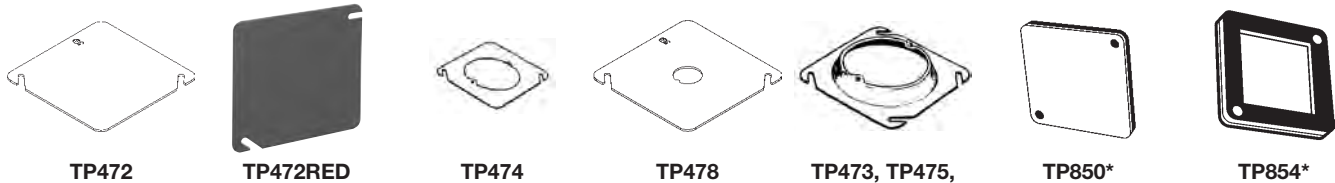

Cat. #	Description	Unit Qty.	Wt. Lbs. Per 100	Capacity Cu. In.
TP472†	Flat Blank	50	31	—
TP472RED	Flat Blank	50	31	—
TP474	Flat Blank, Open With Ears 2 ³ / ₄ "	50	21	—
TP478†	Flat with 1/2" ko	50	31	—
TP487	Flat with 3/4" ko	50	29	—
TP473	Raised 1/4", Open With Ears 2 ³ / ₄ "	50	23	1.3
TP476†	Raised 1/2", Open With Ears 2 ³ / ₄ "	50	26	4.0
TP477	Raised 5/8", Open With Ears 2 ³ / ₄ "	50	27	5.0
TP475	Raised 3/4", Open With Ears 2 ³ / ₄ "	25	31	6.0
TP479	Raised 1", Open With Ears 2 ³ / ₄ "	25	34	7.0
TP483	Raised 1 1/4", Open With Ears 2 ³ / ₄ "	25	37	8.5

Air Plenum

TP850*	Flat Blank Gasketed With Captive Screws	25	31	—
TP854*	Flat Ring Double Gasketed	25	12	—

*For Air Plenum (No Mounting Holes) - Not UL Listed
†CSA Certified

MUD RINGS FOR 4" SQUARE STEEL OUTLET BOXES

UL LISTED



Cat. #	Description	Unit Qty.	Wt. Lbs. Per 100	Capacity Cu. In.
ONE DEVICE				
TP480	Flat	50	20	—
TP482	1/4" Raised	50	21	1.8
TP484	1/2" Raised	50	23	3.8
TP489	5/8" Raised	50	26	4.3
TP486	3/4" Raised	50	30	5.5
TP488	1" Raised	50	34	6.8
TP490	1 1/4" Raised	25	39	8.5
AMR1*	3/4" - 1 1/2" Raised Adjustable	25	47	-
TWO DEVICE				
TP494	Flat	50	12	—
TP496‡	1/4" Raised	50	13	3.0
TP498‡	1/2" Raised	50	18	6.0
TP499‡	5/8" Raised	50	22	8.0
TP500‡	3/4" Raised	50	24	9.0
TP501	1 1/4" Raised	25	31	14.0
TP502	1" Raised	25	30	11.7
AMR2*	5/8" - 1 1/2" Raised Adjustable	25	50	-

‡ Slotted design for use with 4" square box partitions
*ETL Listed

SMARTGUARD™ PROTECTIVE PLATES

Applications:

- For use with single-, two-, three-, four- and five-gang commercial or residential boxes/plaster rings; with or without devices, switches, GFCI, etc. installed
- Commercial or residential ceiling boxes
- 6" commercial or residential lighting "cans"
- 14" or 24" wide breaker boxes

Features and Benefits:

- Seals out sheetrock mud, sanding dust and paint overspray to keep the electrical box and its wiring free from contaminants
- Router resistant material provides mechanical protection to box and wiring and speeds up trim process
- Clear material makes visual inspection quick and easy
- Less expensive and easier to use than metallic alternatives
- Reduces risk of call backs and expense of rework because of wire and box damage

Material:

- High-impact, router-resistant PVC

SmartGuard



Cat. #	Description	Std. Unit	Wt. Lbs.
	Pre-Fabricated Box, Cover, Ground Screw and Lead Assembly	Pkg.	Per 100
SGMR1	SmartGuard 1G Mud Ring Blank	50	1
SGD1	SmartGuard 1G Mud Ring w/Device Installed	50	1
SGT1	SmartGuard 1G Mud Ring w/Toggle Installed	50	2
SGMR2	SmartGuard 2G Mud Ring Blank	25	1
SGD2	SmartGuard 2G Mud Ring w/Device Installed	25	3
SGT2	SmartGuard 2G Mud Ring w/Toggle Installed	25	3
SGMR3	SmartGuard 3G Mud Ring Blank	20	3
SGMR4	SmartGuard 4G Mud Ring Blank	10	4
SGMR5	SmartGuard 5G Mud Ring Blank	5	5
SGR1	SmartGuard 1G PVC Resi Box	50	1
SGR2	SmartGuard 2G PVC Resi Box	25	2
SGR3	SmartGuard 3G PVC Resi Box	20	3
SGR4	SmartGuard 1G Mud Ring Blank	10	3
SGR03	SmartGuard 3 1/2" NM Resi Ceiling Box	20	1
SGR04	SmartGuard 4" NM Resi Ceiling Box	20	1
SGMB1	SmartGuard Meter Base Cover	5	3
SGP14	SmartGuard Panel/Breaker Box 14" Wide	1	125
SGP20	SmartGuard Panel/Breaker Box 20" Wide	1	219
SGD1 BULK	SmartGuard 1G Mud Ring w/Device Installed—Bulk	1000	1
SGT1 BULK	SmartGuard 1G Mud Ring w/Toggle Installed—Bulk	1000	2
SGD2 BULK	SmartGuard 2G Mud Ring w/Device Installed—Bulk	500	3
SGT2 BULK	SmartGuard 2G Mud Ring w/Toggle Installed—Bulk	500	3
SGMR0	SmartGuard 3" Round Comm. Ceiling Box	25	1
SGLV14	SmartGuard Low Voltage Serv Ctr 14" Wide	1	125
SGH6	SmartGuard lighting can 6"—Halo	10	3
SGJ6	SmartGuard lighting can 6"—Juno	10	3
SGCK1	SmartGuard Contractor Kit (150-1G, 50-2G, 20-3G, 10-4G, 5-5G, 25-3" ceiling)	1	50
SGRK1	SmartGuard Residential Kit (150-1G, 50-2G, 20-3G, 10-4G, 20-3-1/2" ceiling, 20-4" ceiling)	1	50

METALGUARD™ PROTECTIVE PLATES

Applications:

- For use with single-, two-, three- and four-gang commercial or residential boxes/plaster rings; with or without devices, switches, GFCI, etc. installed
- Commercial or residential ceiling boxes

Features and Benefits:

- Seals out sheetrock mud, sanding dust and paint overspray to keep the electrical box and its wiring free from contaminants
- Heavy duty reusable metallic plate provides mechanical protection to box and wiring and speeds up trim process
- Easy to install. All you have to do is push them in! They come out easy—just put a screwdriver into the slot in front, turn and pull them out
- Reduces risk of call backs and expense of rework because of wire and box damage
- MetalGuard serves as a guide for router in cutting out boxes

Material & Finish:

- 18 gauge steel
- Natural finish



Cat. #	Description	Std. Unit Pkg.	Wt. Lbs. Per 100
	Pre-Fabricated Box, Cover, Ground Screw and Lead Assembly		
MGRK	Contractor Kit (120-1G, 40-2G, 20-3G, 5-4G, and 20-Rnd)	1	-
MGR1	1G Residential Wire Protector	60	-
MGR2	2G Residential Wire Protector	20	-
MGR3	3G Residential Wire Protector	20	-
MGR4	4G Residential Wire Protector	5	-
MGR0	Rnd Residential Wire Protector	20	-
MGMR1	1G Wire Protector for Commercial MR	50	-
MGMR2	2G Wire Protector for Commercial MR	50	-
MGMR0	Rnd Wire Protector for Commercial MR	50	-
MGS1	Gangable Spacer Wire Protector	100	-

4" SQUARE SURFACE COVERS – 5.5 CUBIC INCH CAPACITY

RAISED 1/2"

UL LISTED



TP503



TP504



TP506



TP508



TP510



TP512



TP507, TP514
TP519



TP516



TP509, TP518



TP513



TP511



TP515



TP517

Cat. #	Description	Unit Qty.	Wt. Lbs. Per 100
TP503†	Raised Blank	50	35
TP504†	For One Toggle Switch, One Single Receptacle 1 ¹⁹ / ₃₂ " Dia.	50	31
TP506†	For One Toggle Switch, One Duplex Receptacle	50	31
TP508	For Two Toggle Switches	50	35
TP510	For Two Duplex Receptacles	50	26
TP512	For One Toggle Switch	50	35
TP507	For One 20 Amp, Single Receptacle 1 ¹⁹ / ₃₂ " Dia.	50	37
TP514	For One Single Receptacle 1 ¹⁹ / ₃₂ " Dia.	50	34
TP519†	For One 30 Amp. Twist-Lock Single Receptacle 1 ²³ / ₃₂ " Dia.	50	37
TP516	For One Duplex Receptacle	50	31
TP509	For One 30 – 60 Amp. Receptacle (4-wire) 2 ⁷ / ₁₆ " Dia.	50	23
TP518	For One 30 – 50 Amp. Receptacle 2 ⁹ / ₆₄ " Dia.	50	34
TP513	For One GFCI Receptacle	50	31
TP511	For Two GFCI Receptacles	50	26
TP515	For One Toggle Switch, One GFCI Receptacle	50	31
TP517	For One Duplex Receptacle, One GFCI Receptacle	50	26

† CSA Certified

UNI-MOUNT™ COVERS

The Unimount combines the features of a mounting device plate with those of a box support; giving you one universal plate for all of your needs. Specifically designed for use with metal or wood studs:

The new and improved version incorporates four small holes on the left side (support side) of the bracket. These holes allow for the attachment of box mounting brackets to allow for use of both sides of the stud. The holes are strategically located to accept either the B-Line BB423 bracket or the Caddy H23 bracket. Additionally, the viewing hole has been significantly enlarged (and is now diamond shaped) to make it even easier to find mark lines on the stud.

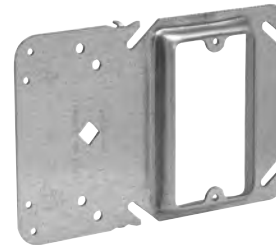

Steel Boxes

- Guide tabs ensure consistent alignment on stud
- Stud alignment hole ensures consistent mounting height
- Rigid bracket design eliminates the need for far side support
- Available as a single or two device cover
- Universal design fits all 4" Square boxes
- Available in 1/2", 5/8" and 3/4" raised.
- Can be ordered preassembled to popular 4" square boxes.
- Fast and easy installation
- Can be used in multiple applications, resulting in less items to stock.
- Less labor intensive.
- Less material handling.
- No multiple assemblies to handle.
- Can be used in Class 2 communications outlets for low voltage without a box.
- UL Listed and CSA certified.*

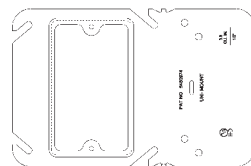
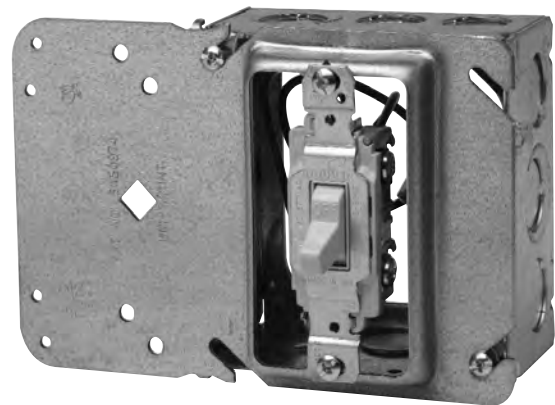

Single Gang

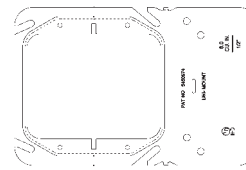

Two Gang

Cat. #	Description	Capacity Cu. In.	Unit Qty.	Wt. Lbs. Per 100
SINGLE GANG				
TP30000	1/2" Raised	3.8	50	43
TP31000	5/8" Raised	4.3	50	46
TP32000	3/4" Raised	5.5	50	50
TWO GANG				
TP35000	1/2" Raised	6	50	38
TP36000	5/8" Raised	8	50	52
TP37000	3/4" Raised	9	50	54
LOW PROFILE SCREWS - REDUCES RISK OF SHEETROCK BULGE				
TP710	L.P. Screws	—	1000	.5

* CSA requires a far side support.

TILE WALL COVERS FOR 4" SQUARE BOXES – CUBIC INCH CAPACITY (SEE BELOW)

UL LISTED

Steel Boxes

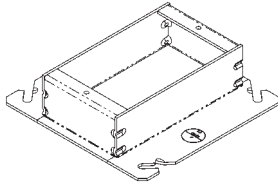

TP524

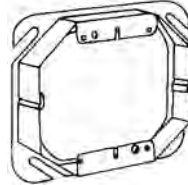

TP534

Applications:

- Typically used with tile or brick

Cat. #	Description	Unit Qty.	Wt. Lbs. Per 100	Capacity Cu. In.
ONE DEVICE				
TP520	1/2" Raised	50	30	3.7
TP522	3/4" Raised	50	36	5.5
TP524	1" Raised	50	40	7.4
TP526	1 1/4" Raised	25	46	9.3
TP528	1 1/2" Raised	25	50	11.0
TP530	2" Raised	25	62	14.8
TWO DEVICE				
TP532	1/2" Raised	10	24	5
TP534	3/4" Raised	10	30	7.8
TP536	1" Raised	10	36	10.3
TP538	1 1/4" Raised	10	44	13
TP540	1 1/2" Raised	10	50	15.5
TP542	2" Raised	10	66	20.8

4" SQUARE BOX PARTITIONS



TP860

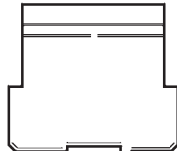

TP861

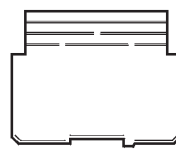

TP862

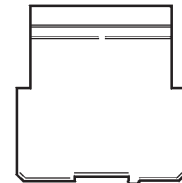

TP863

Cat. #	Description	Unit Qty.	Wt. Lbs. Per 100
FOR 1 1/2" DEEP BOX WITH SQUARE CUT TILE WALL TWO-GANG COVERS			
TP860	For 1/2", 3/4", 1" Raised Covers	25	13
TP861	For 1 1/4", 1 1/2", 2" Raised Covers	25	18
FOR 2 1/8" DEEP BOX WITH SQUARE CUT TILE WALL TWO-GANG COVERS			
TP862	For 1/2", 3/4", 1" Raised Covers	25	16
TP863	For 1 1/4", 1 1/2", 2" Raised Covers	25	21

4¹¹/₁₆" SQUARE OUTLET BOXES AND COVERS

Applications:

- For use with conduit
- For use in commercial and industrial applications, where larger sized conductor or wiring devices are needed and additional volume is required
- Can be ceiling mounted to be used as a junction box or to mount lighting fixtures
- Available in red for fire alarm applications

Features:

- Ideal for exposed work applications, providing an easy method for the installation of electrical devices (switches, receptacles, fans, lights, etc.)
- Raised ground screw location in the welded boxes saves time in installation
- Concentric knockouts have a 1/2" and 3/4" knockout in the same location for customer flexibility
- Knockouts are suitable for use without a bonding jumper in circuits above or below 250 volts
- Available in two depths for differing cubic capacity requirements
- Welded or drawn construction to match customer preference
- Extensive cover offering to meet various customer applications and needs



Steel Boxes

Certifications and Compliances:

- UL Listed

4¹¹/₁₆" SQUARE OUTLET BOXES – 29.5 CUBIC INCH CAPACITY

1¹/₂" DEEP WITH CONDUIT KOs

UL LISTED



TP523



TP548



TP549

Cat. #	Description	KNOCKOUTS		Unit Qty.	Wt. Lbs. Per 100
		Sides	Bottom		
29.5 CUBIC INCH CAPACITY					
TP523	Welded	12 – 1/2" & 3/4" C	2 – 1/2", 2 – 3/4"	25	99
TP523PF†	Welded	12 – 1/2" & 3/4" C	2 – 1/2", 2 – 3/4"	25	99
TP548	Drawn	8 – 1/2", 4 – 3/4"	3 – 1/2", 2 – 3/4"	25	84
TP549	Drawn	6 – 1/2", 6 – 1/2" & 3/4" C	3 – 1/2", 2 – 3/4"	25	84

†TP catalog numbers ending in PF includes ground screw with pigtail lead

4¹¹/₁₆" SQUARE OUTLET BOXES – 42.0 AND 44.0 CUBIC INCH CAPACITY

2¹/₈" DEEP WITH CONDUIT KOs

UL LISTED

Steel Boxes



TP563



TP554
TP842*



TP556
TP832*



TP556RED



TP558
TP835*



TP560
TP836*



TP562



TP557



TP521



TP525

KNOCKOUTS

Cat. #	Description	Brackets	Sides	Bottom	Unit Qty.	Wt. Lbs. Per 100
42.0 CUBIC INCH CAPACITY						
TP563	Drawn	—	6 - 1/2", 6 - 1/2" & 3/4" C	3 - 1/2", 2 - 3/4"	25	104
TP554	Drawn	—	8 - 3/4"	3 - 1/2", 2 - 3/4"	25	104
TP556	Drawn	—	8 - 1/2", 4 - 3/4"	3 - 1/2", 2 - 3/4"	25	104
TP556PF†	Drawn	—	8 - 1/2", 4 - 3/4"	3 - 1/2", 2 - 3/4"	25	104
TP556RED	Drawn	—	8 - 1/2", 4 - 3/4"	3 - 1/2", 2 - 3/4"	25	104
TP558	Drawn	—	4 - 3/4", 4 - 1"	3 - 1/2", 2 - 3/4"	25	104
TP560	Drawn	—	8 - 1"	3 - 1/2", 2 - 3/4"	25	104
TP562‡	Drawn	—	4 - 1 1/4"	3 - 1/2", 2 - 3/4"	25	104
TP557	Drawn	"VS"	4 - 1/2", 5 - 1/2" & 3/4" C	3 - 1/2", 2 - 3/4"	25	120
44.0 CUBIC INCH CAPACITY						
TP521	Welded	—	12 - 1/2" & 3/4" C	2 - 1/2", 2 - 3/4"	25	115
TP521PF†	Welded	—	12 - 1/2" & 3/4" C	2 - 1/2", 2 - 3/4"	25	115
TP525**	Welded	—	12 - 1/2" & 3/4" E	2 - 1/2", 2 - 1/2", 3/4" E	25	115
Air Plenum						
TP835*		—	4 - 3/4", 4 - 1"	3 - 1/2", 2 - 3/4"	25	115
TP836*		—	8 - 1"	3 - 1/2", 2 - 3/4"	25	115
TP842*		—	12 - 3/4"	3 - 1/2", 2 - 3/4"	25	115
TP832*		—	8 - 1/2", 4 - 3/4"	3 - 1/2", 2 - 3/4"	25	115

*For Air Plenum (No Mounting Holes) - Not UL Listed

**Raised ground bump contains holes for 2 ground screws

†TP catalog numbers ending in PF includes ground screw with pigtail lead

‡ Not UL Listed

4^{11/16}" SQUARE EXTENSION RINGS

1^{1/2}" DEEP WITH CONDUIT KOs - 29.5 CUBIC INCH CAPACITY

2^{1/8}" DEEP WITH CONDUIT KOs - 42.0 CUBIC INCH CAPACITY

UL LISTED

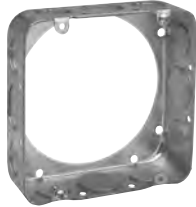

TP550

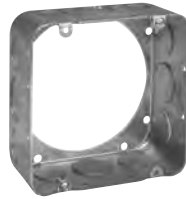

TP564
TP837*



TP564RED

Cat. #	Description	KNOCKOUTS Sides	Bottom	Unit Qty.	Wt. Lbs. Per 100
1 ^{1/2} " Deep TP550		8 - 1/2", 4 - 3/4"	—	25	66
2 ^{1/8} " Deep TP564 TP564RED		8 - 1/2", 4 - 3/4" 8 - 1/2", 4 - 3/4"	— —	25 25	84 84
Air Plenum TP837*	2 ^{1/8} " Deep	8 - 1/2", 4 - 3/4"	—	25	115

Note: *For Air Plenum (No Mounting Holes) - Not UL Listed
TP837 requires the use of TP852, purchased separately.

Steel Square Covers



4^{11/16}" SQUARES COVERS – CUBIC INCH CAPACITY (SEE BELOW)

UL LISTED

Steel Boxes



TP568

TP568RED

TP569, TP570,
TP571,
TP573, TP575

TP574 – TP582,
TP529, TP531

TP584, TP586,
TP589, TP593,
TP541, TP543

TP851*

TP852*

Cat. #	Description	Unit Qty.	Wt. Lbs. Per 100	Capacity Cu. In.
FLAT AND RAISED				
TP568†	Flat Blank	25	40	—
TP568RED	Flat Blank	25	40	—
TP569‡	½" Raised, With Ears 2¾"	25	36	3.3
TP570	Raised ⅝", With Ears 2¾"	25	38	3.8
TP571‡	¾" Raised, With Ears 2¾"	25	40	5.0
TP572†	Flat, With ½" KO	25	40	—
TP573‡	1" Raised, With Ears 2¾"	25	44	7.0
TP575‡	1¼" Raised, With Ears 2¾"	25	48	9.0
AIR PLENUM				
TP851*	Flat Blank Gasketed Captive Screws	50	42	—
TP852*	Flat Ring Double Gasketed	25	20	—
ONE DEVICE				
TP574	¼" Raised	25	32	1.8
TP576	½" Raised	25	36	3.3
TP578	¾" Raised	25	42	5.0
TP579	⅝" Raised	25	39	4.5
TP580	1" Raised	25	46	6.8
TP582	1¼" Raised	25	52	8.5
TP529	1½" Raised	25	64	11.3
TP531	2" Raised	25	76	15.0
TWO DEVICE				
TP590‡	Flat	25	21	—
TP583‡	¼" Raised	25	26	3.0
TP584	½" Raised	25	30	6.0
TP587	⅝" Raised	25	32	8.0
TP586	¾" Raised	25	34	8.8
TP589	1" Raised	25	38	11.7
TP593	1¼" Raised	25	42	14.0
TP541	1½" Raised	25	63	18.8
TP543	2" Raised	25	79	24.5

*For Air Plenum (No Mounting Holes)

†CSA Certified

‡ Not UL Listed

4^{11/16}" SQUARE SURFACE COVERS – 9.0 CUBIC INCH CAPACITY

1/2" RAISED



TP720



TP722



TP724
TP730
TP736



TP726



TP728



TP732



TP734



TP738



TP740

Steel Boxes

Cat. #	Description	Unit Qty.	Wt. Lbs. Per 100
TP720	For One Toggle Switch	10	52
TP722	For One Duplex Receptacle	10	49
TP724	For One Single Receptacle 1 ^{13/32} " Dia.	10	53
TP730	For One 20 Amp Single Receptacle 1.620" Dia.	10	50
TP736	For One 1.730" Dia. Power Outlet	10	51
TP726	For Two Toggle Switches	10	52
TP728	For Two Duplex Receptacles	10	44
TP732	For One 2.125" Dia. Range/Dryer Receptacle	10	48
TP734	For One 2.480" Dia. Power Outlet	10	45
TP738	For One Ground Fault Interrupter	10	45
TP740	For One GFI Receptacle & One Toggle	25	45
TP741	For Two GFI Receptacles	10	43

UTILITY BOXES – CUBIC INCH CAPACITY (SEE BELOW)

4" LONG x 2 1/8" WIDE

UL LISTED

Steel Boxes

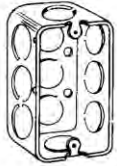

TP588, TP647

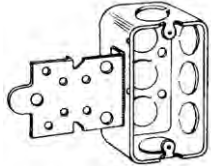

TP591

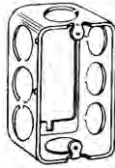

TP592, TP600,
TP602



TP598
TP605

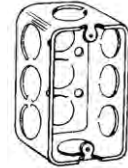

TP594, TP596,
TP604, TP606,

Cat. #	Bracket	KNOCKOUTS		Unit Qty.	Wt. Lbs. Per 100
		Sides	Bottom		
1 1/4" DEEP – 8.5 CUBIC INCH CAPACITY					
TP647	—	8 – 1/2"	3 – 1/2"	50	40
1 1/2" DEEP – 10.3 CUBIC INCH CAPACITY					
TP588	—	8 – 1/2"	3 – 1/2"	50	42
TP591	"F", Set 1/4"	5 – 1/2"	3 – 1/2"	50	51
1 1/2" DEEP EXTENSION RINGS – 10.3 CUBIC INCH CAPACITY					
TP592	—	8 – 1/2"	—	50	36
1 7/8" DEEP – 13.0 CUBIC INCH CAPACITY					
TP594	—	8 – 1/2"	3 – 1/2"	50	50
TP596	—	6 – 3/4"	3 – 1/2"	50	50
TP598	"S", SET 1/2"	5 – 1/2"	3 – 1/2"	50	60
1 7/8" DEEP EXTENSION RINGS – 13.0 CUBIC INCH CAPACITY					
TP600	—	8 – 1/2"	—	50	41
TP602	—	6 – 3/4"	—	50	41
2 1/8" DEEP – 14.5 CUBIC INCH CAPACITY					
TP604	—	8 – 1/2"	3 – 1/2"	50	56
TP606	—	6 – 3/4"	3 – 1/2"	50	56
TP605	"S", Set 1/2"	5 – 1/2"	3 – 1/2"	50	66

UTILITY BOX COVERS

UL LISTED



TP608



TP610



TP612

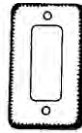

TP613

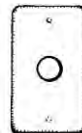

TP614

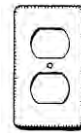

TP616



TP618

Cat. #	Description	Unit Qty.	Wt. Lbs. Per 100
TP608*	Blank	100	10
TP610*	For 20 and 30 AMP, Twist Lock, 1 19/32" Diameter	100	9
TP612*	Single Receptacle, 1 19/32" Diameter	100	9
TP613*	For GFCI Device	100	7
TP614*	1/2" KO	100	10
TP616*	Duplex Receptacle	100	8
TP618*	One Toggle Switch	100	10

*CSA Certified

1" DEEP - NON-GANGABLE - 6.5 CUBIC INCH CAPACITY

1¹⁵/₁₆" WIDE x 3³/₄" LONG

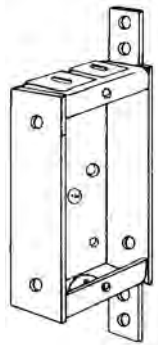

TP101

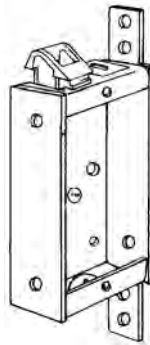

TP103

KNOCKOUTS

Cat. #	Bracket	Plastic Clamp	Conduit	Cable	Unit Qty.	Wt. Lbs. Per 100
TP101	"S"	No	1 - 1/2"	2	25	38
TP103	"S"	Yes	1 - 1/2"	2	25	39

1 1/2" DEEP - NON-GANGABLE - 7.5 CUBIC INCH CAPACITY

2" WIDE x 3" LONG

UL LISTED

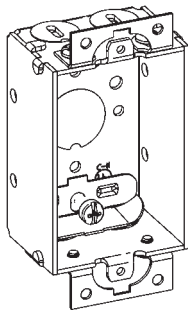

TP100

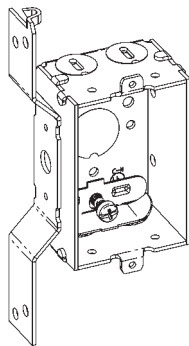

TP104

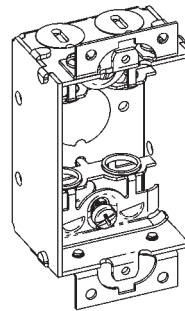

TP106

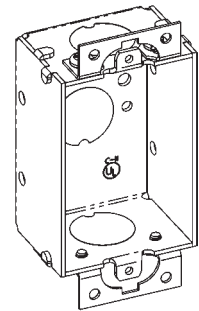

TP114

KNOCKOUTS

Cat. #	Bracket	Ears	Each End	Each Side	Bottom	Unit Qty.	Wt. Lbs. Per 100
FOR NONMETALLIC CABLE - CLAMPS IN EACH END							
TP100	—	Yes	2 - Cable	—	1 - 1/2"	50	43
TP104	"S", set 1/2"	—	2 - Cable	—	1 - 1/2"	50	50
FOR ARMORED & METAL CLAD (MCI) CABLE - CLAMPS IN EACH END							
TP106*	—	Yes	2 - Cable	—	1 - 1/2"	50	44
FOR CONDUIT - NO CLAMPS, FLUSH DEVICE							
TP114	—	Yes	1 - 1/2"	—	1 - 1/2"	50	39

*UL approved for use with aluminum interlocking grounding metal clad cable, Type MCIA (Southwire MCAP™) MCAP™ is a registered trademark of Southwire Company.

Steel Switch Boxes



2" DEEP – GANGABLE – 10.0 CUBIC INCH CAPACITY

2" WIDE x 3" LONG

UL LISTED

Steel Boxes

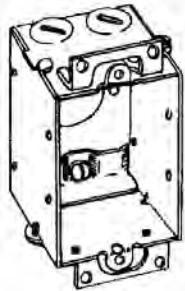

TP116

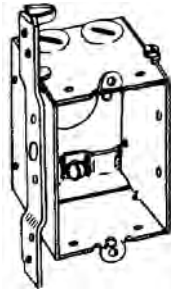

TP118

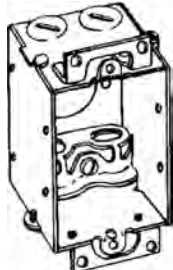

TP120

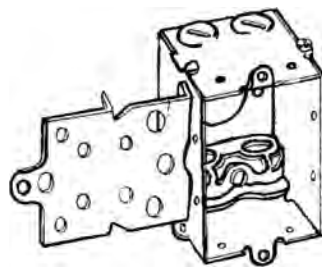

TP123

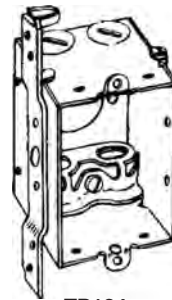

TP124

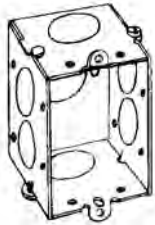

TP126

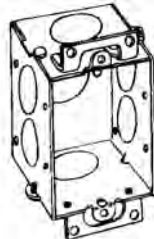

TP130

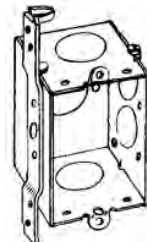

TP132

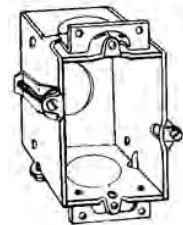

TP131
Hold-Tite

KNOCKOUTS

Cat. #	Bracket	Ears	Each End	Each Side	Bottom	Unit Qty.	Wt. Lbs. Per 100
FOR NONMETALLIC CABLE – CLAMPS IN EACH END							
TP116	—	Yes	2 – Cable	—	1 – 1/2"	50	53
TP118	"S", Set 5/8"	—	2 – Cable	—	1 – 1/2"	50	60
FOR ARMORED & METAL CLAD (MCI) CABLE – CLAMPS IN EACH END							
TP120*	—	Yes	2 – Cable	—	1 – 1/2"	50	54
TP123*	"F", Set 1/2"	—	2 – Cable	—	1 – 1/2"	50	63
TP124*	"S", Set 5/8"	—	2 – Cable	—	1 – 1/2"	50	61
FOR CONDUIT – NO CLAMPS, FLUSH DEVICE							
TP126	—	—	1 – 1/2"	2 – 1/2"	1 – 1/2"	50	47
TP130	—	Yes	1 – 1/2"	2 – 1/2"	1 – 1/2"	50	48
TP132	"S", Set 5/8"	—	1 – 1/2"	2 – 1/2", 1 Side	1 – 1/2"	50	58
TP131	Hold-Tite	Yes	1 – 1/2"-T	—	1 – 1/2"	50	52

*UL approved for use with aluminum interlocking grounding metal clad cable, Type MCIA (Southwire MCAP™)
MCAP™ is a registered trademark of Southwire Company.

2 1/4" DEEP – GANGABLE – BEVELED CORNERS 10.5 CUBIC INCH CAPACITY

2" WIDE x 3" LONG

UL LISTED

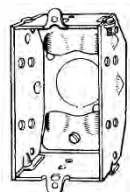

TP134

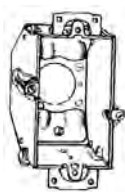

TP137 Hold-Tite

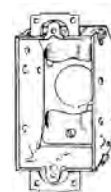

TP138

KNOCKOUTS

Cat. #	Description	Ears	Bumps	Each End	Each Side	Bottom	Unit Qty.	Wt. Lbs. Per 100
CLAMP SCREWS THROUGH BEVELED CORNERS								
TP134	Gangable	—	Yes	2 – Cable	—	1 – 1/2"	50	51
TP137	Gangable	Yes	—	2 – Cable	—	1 – 1/2"	50	57
TP138	Gangable	Yes	—	2 – Cable	—	1 – 1/2"	50	55

2 1/2" DEEP – GANGABLE – 12.5 CUBIC INCH CAPACITY

2" WIDE x 3" LONG

UL LISTED

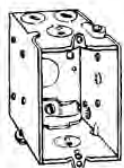

TP158 (Pigtail included not shown in picture)

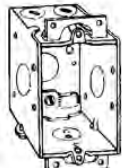

TP162

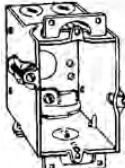

TP163

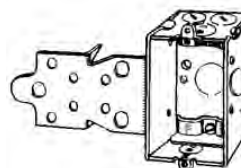

TP164
TP168

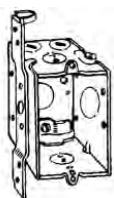

TP170

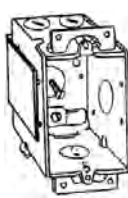

TP161

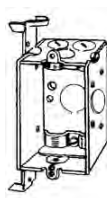

TP172



TP174



TP171

KNOCKOUTS

Cat. #	Bracket	Ears	Ground Pigtail	Leveling Bumps	Each End	Each Side	Bottom	Unit Qty.	Wt. Lbs. Per 100
FOR NONMETALLIC CABLE - CLAMPS IN EACH END									
TP115*	—	—	—	Yes	2 – Cable, 1 – 1/2"	—	1 – 1/2"	50	59
TP158	—	Yes	Yes	—	2 – Cable	1 – 1/2"	1 – 1/2"	50	63
TP161	Snap-In	Yes	—	—	2 – Cable	1 – 1/2"	—	50	73
TP162	—	Yes	—	—	2 – Cable	1 – 1/2"	1 – 1/2"	50	62
TP163	Hold-Tite	Yes	—	—	2 – Cable	—	1 – 1/2"	50	65
TP164	"F", Set 1/2"	—	—	—	2 – Cable, 1 – 1/2"	1 – 1/2"	1 – 1/2"	50	71
TP168	"F", Set 1/4"	—	—	—	2 – Cable, 1 – 1/2"	1 – 1/2"	1 – 1/2"	50	71
TP170	"S", Set 5/8"	—	—	—	2 – Cable, 1 – 1/2"	1 – 1/2"	1 – 1/2"	50	69
TP172	"D", Set 5/8"	—	—	—	2 – Cable, 1 – 1/2"	1 – 1/2"	1 – 1/2"	50	70
TP174	"D", Set 5/8"	—	Yes	—	2 – Cable, 1 – 1/2"	1 – 1/2"	1 – 1/2"	50	71
TP171	"VP", Set 1/2"	—	—	—	2 – Cable, 1 – 1/2"	1 – 1/2"	1 – 1/2"	50	73

*Not UL Listed

Steel Switch Boxes



2 1/2" DEEP – GANGABLE – 12.5 CUBIC INCH CAPACITY

2" WIDE x 3" LONG FOR ARMORED & METAL CLAD (MCI) CABLE – CLAMPS IN EACH END

UL LISTED

Steel Boxes

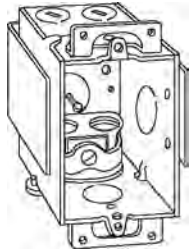

TP177

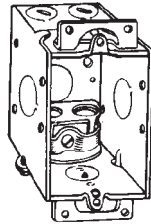

TP178

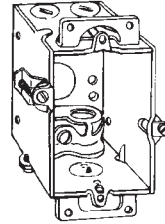

TP179
Hold-Tite

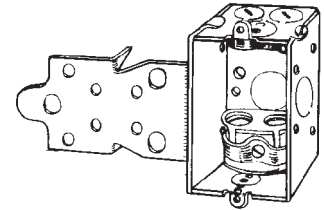

TP180

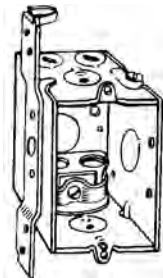

TP184

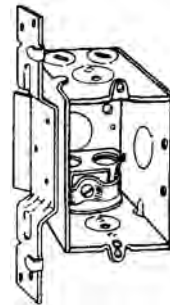

TP185

KNOCKOUTS

Cat. #	Bracket	Ears	Each End	Each Side	Bottom	Unit Qty.	Wt. Lbs. Per 100
TP177*	Snap-In	Yes	2 – Cable	1 – 1/2"	—	50	74
TP178*	—	Yes	2 – Cable	1 – 1/2"	1 – 1/2"	50	63
TP179*	Hold-Tite	Yes	2 – Cable	—	1 – 1/2"	50	66
TP180*	"F", Set 1/2"	—	2 – Cable, 1 – 1/2"	1 – 1/2"	1 – 1/2"	50	72
TP184*	"S", Set 5/8"	—	2 – Cable, 1 – 1/2"	1 – 1/2"	1 – 1/2"	50	70
TP185*	"VP", Set 1/2"	—	2 – Cable, 1 – 1/2"	1 – 1/2"	1 – 1/2"	50	74

*UL approved for use with aluminum interlocking grounding metal clad cable, Type MCIA (Southwire MCAP™)
MCAP™ is a registered trademark of Soutwire Company.

GANG BOXES SET BACK 1/2"

2 1/2" DEEP – 3 3/4" HIGH – 1/2" AND 3/4" CONCENTRIC KOs

UL LISTED

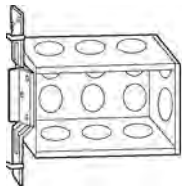

TP632

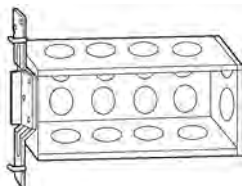

TP633



TP637



TP638

KNOCKOUTS

Cat. #	Gang	Bracket	Width	Each End	Each Side	Bottom	Unit Qty.	Wt. Lbs. Per 100	Capacity Cu. In.
TP632	3	VP	5 9/16"	2	3	6	5	143	46.5
TP633	4	VP	7 3/8"	2	4	8	5	179	62.0
TP637	3	VS	5 9/16"	2	3	6	5	143	46.5
TP638	4	VS	7 3/8"	2	4	8	5	179	62.0

2 1/2" DEEP "EC" BOXES – GANGABLE – CUBIC INCH CAPACITY (SEE BELOW)

2" WIDE x 3" LONG
CLAMPS IN EACH END

UL LISTED



TP188

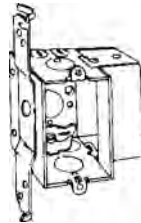

TP190

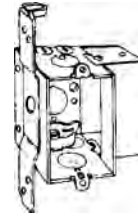

TP196

Note: The Cubic Capacity of any of our new work 2 1/2" Deep Switch Boxes can be increased to 18 cubic inches simply by adding our "EC" Extender to the sides of the box. This provides 5.5 extra cubic inches of space necessary to conform to revisions in the National Electrical Code. "EC" boxes are stocked factory assembled in popular styles, however the "EC" Extender can be ordered separately for "Instant-On" assembly on the job with Cooper Crouse-Hinds Switch Boxes.

KNOCKOUTS

Cat. #	Bracket	Each End	Each Side	Bottom	Unit Qty.	Wt. Lbs. Per 100	Capacity Cu. In.
TP188	—	—	—	—	50	32	5.5
FOR NONMETALLIC CABLE							
TP190	"D", Set 5/8"	2 – Cable, 1 – 1/2"	—	1 – 1/2"	25	89	18.0
TP196	"S", Set 5/8"	2 – Cable, 1 – 1/2"	—	1 – 1/2"	25	89	18.0

2 1/2" DEEP – GANGABLE – 12.5 CUBIC INCH CAPACITY

2" WIDE x 3" LONG
FOR CONDUIT – NO CLAMPS

UL LISTED

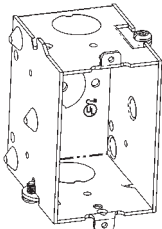

TP214

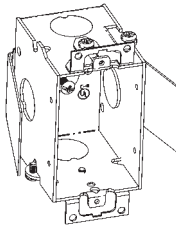

TP216

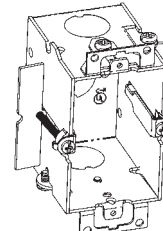

TP217

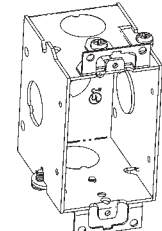

TP218

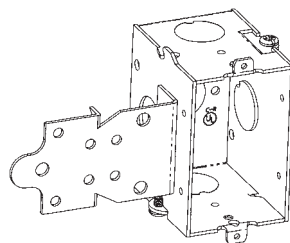

TP220

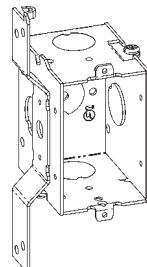

TP222

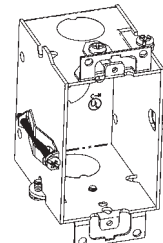

TP224

KNOCKOUTS

Cat. #	Bracket	Ears	Leveling Bumps	Each End	Each Side	Bottom	Unit Qty.	Wt. Lbs. Per 100
TP214	—	—	Yes	1 – 1/2"	—	1 – 1/2"	50	55
TP216	Snap-In	Yes	—	1 – 1/2"	1 – 1/2"	—	50	69
TP217	—	Yes	—	1 – 1/2"	—	1 – 1/2"	50	64
TP218	—	Yes	—	1 – 1/2"	1 – 1/2"	1 – 1/2"	50	58
TP220	"F", Set 1/2"	—	—	1 – 1/2"	1 – 1/2", 1 Side	1 – 1/2"	50	66
TP222	"S", Set 5/8"	—	—	1 – 1/2"	1 – 1/2", 1 Side	1 – 1/2"	50	65
TP224	Hold-Tite	Yes	—	1 – 1/2"	—	1 – 1/2"	50	61

Steel Switch Boxes



2³/₄" DEEP – GANGABLE – 14.0 CUBIC INCH CAPACITY

2" WIDE x 3" LONG

UL LISTED

Steel Boxes

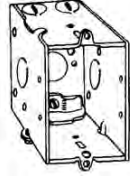

TP660

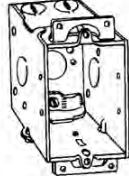

TP662

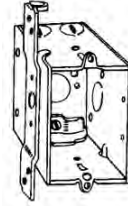

TP664



TP668

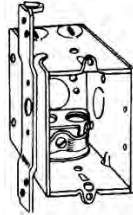

TP670

Cat. #	Bracket	Ears	KNOCKOUTS			Unit Qty.	Wt. Lbs. Per 100
			Each End	Each Side	Bottom		
FOR NONMETALLIC CABLE – CLAMPS IN EACH END							
TP660	—	—	2 – Cable	1 – 1/2"	1 – 1/2"	50	62
TP662	—	Yes	2 – Cable	1 – 1/2"	1 – 1/2"	50	67
TP664	"S", Set 5/8"	—	2 – Cable	1 – 1/2"	1 – 1/2"	50	70
FOR ARMORED & METAL CLAD (MCI) CABLE – CLAMPS IN EACH END							
TP668*	—	Yes	2 – Cable	1 – 1/2"	1 – 1/2"	50	68
TP670*	"S", Set 5/8"	—	2 – Cable	1 – 1/2"	1 – 1/2"	50	71

*UL approved for use with aluminum interlocking grounding metal clad cable, Type MCIA (Southwire MCAP™)
MCAP™ is a registered trademark of Southwire Company.

2³/₄" DEEP – GANGABLE – 14.0 CUBIC INCH CAPACITY

2" WIDE x 3" LONG
FOR CONDUIT – NO CLAMPS

UL LISTED

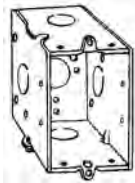

TP672
TP674

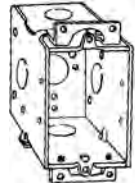

(TP676 – 1 screw ear)
(TP678 – 2 screw ear)

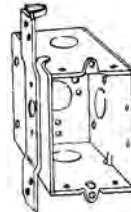

TP680
TP677

KNOCKOUTS

Cat. #	Bracket	Ears	Each End	Each Side	Bottom	Unit Qty.	Wt. Lbs. Per 100
TP672	—	—	1 – 1/2"	1 – 1/2"	1 – 1/2"	50	59
TP674	—	—	1 – 3/4"	1 – 3/4"	1 – 1/2"	50	59
TP676	—	Yes	1 – 1/2"	1 – 1/2"	1 – 1/2"	50	61
TP678	—	Yes	1 – 3/4"	1 – 3/4"	1 – 1/2"	50	61
TP680	"S", Set 5/8"	—	1 – 1/2"	1 – 1/2", 1 Side	1 – 1/2"	50	70
TP677	"S", Set 5/8"	—	1 – 3/4"	1 – 3/4", 1 Side	1 – 1/2"	50	70

3¹/₂" DEEP – GANGABLE – 18.0 CUBIC INCH CAPACITY

2" WIDE x 3" LONG
FOR NONMETALLIC CABLE – CLAMPS IN EACH END

UL LISTED

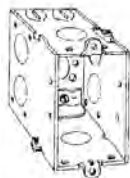

TP236

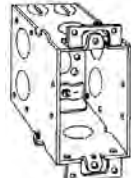

TP238

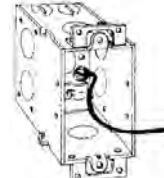

TP239

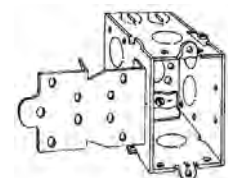

TP240

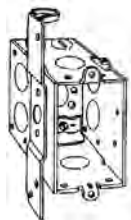

TP242

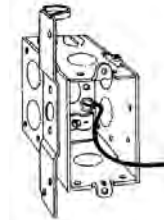

TP243

KNOCKOUTS

Cat. #	Bracket	Ground Pigtail	Ears	Each End	Each Side	Bottom	Unit Qty.	Wt. Lbs. Per 100
TP236	—	—	—	2 – Cable, 1 – 1/2"	2 – 1/2"	1 – 1/2"	25	78
TP238	—	—	Yes	2 – Cable, 1 – 1/2"	2 – 1/2"	1 – 1/2"	25	80
TP239	—	Yes	Yes	2 – Cable, 1 – 1/2"	2 – 1/2"	1 – 1/2"	25	81
TP240	"F", Set 1/2"	—	—	2 – Cable, 1 – 1/2"	2 – 1/2"	1 – 1/2"	25	88
TP242	"S", Set 7/8"	—	—	2 – Cable, 1 – 1/2"	2 – 1/2"	1 – 1/2"	25	87
TP243	"S", Set 7/8"	Yes	—	2 – Cable, 1 – 1/2"	2 – 1/2"	1 – 1/2"	25	88

3 1/2" DEEP – GANGABLE – 18.0 CUBIC INCH CAPACITY

2" WIDE x 3" LONG

FOR ARMORED & METAL CLAD (MCI) CABLE – CLAMPS IN EACH END

UL LISTED

Steel Boxes

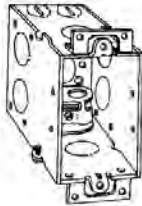

TP244

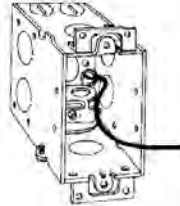

TP249

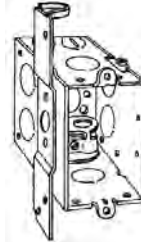

TP246

KNOCKOUTS

Cat. #	Bracket	Ground Pigtail	Ears	Each End	Each Side	Bottom	Unit Qty.	Wt. Lbs. Per 100
TP244*	—	—	Yes	2 – Cable, 1 – 1/2"	2 – 1/2"	1 – 1/2"	25	81
TP249*	—	Yes	Yes	2 – Cable, 1 – 1/2"	2 – 1/2"	1 – 1/2"	25	82
TP246*	"S", Set 7/8"	—	—	2 – Cable, 1 – 1/2"	2 – 1/2"	1 – 1/2"	25	88

*UL approved for use with aluminum interlocking grounding metal clad cable, Type MCI (Southwire MCAP™)
MCAP™ is a registered trademark of Southwire Company.

3 1/2" DEEP – GANGABLE – 18.0 CUBIC INCH CAPACITY

2" WIDE x 3" LONG

FOR CONDUIT – NO CLAMPS

UL LISTED

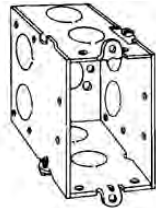

TP248
TP250

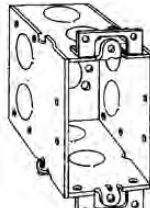

TP252

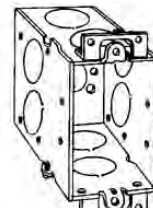

TP254

KNOCKOUTS

Cat. #	Bracket	Ears	Each End	Each Side	Bottom	Unit Qty.	Wt. Lbs. Per 100
TP248	—	—	2 – 1/2"	2 – 1/2"	1 – 1/2"	25	74
TP250	—	—	2 – 3/4"	2 – 3/4"	1 – 1/2"	25	74
TP252	—	Yes	2 – 1/2"	2 – 1/2"	1 – 1/2"	25	76
TP254	—	Yes	2 – 3/4"	2 – 3/4"	1 – 1/2"	25	76

Steel Gang Boxes



Steel Boxes

GANG BOXES

1 5/8" DEEP x 4 1/2" HIGH
1/2" & 3/4" KOs

UL LISTED

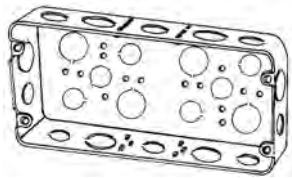

TP630

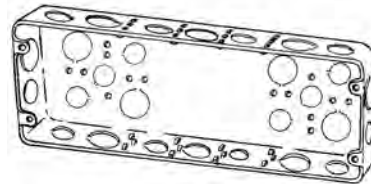

TP640

KNOCKOUTS

Cat. #	Gang	Cubic Inches	Width	Each Side	Each End	Bottom	Unit Qty.	Wt. Lbs. Per 100
TP629	2	45	6 13/16"	2 - 1/2", 2 - 3/4"	1 - 1/2", 1 - 3/4"	3 - 1/2", 2 - 3/4"	5	45
TP630	3	58	8 3/8"	3 - 1/2", 2 - 3/4"	1 - 1/2", 1 - 3/4"	6 - 1/2", 4 - 3/4"	5	58
TP631	4	70	10 7/16"	3 - 1/2", 3 - 3/4"	1 - 1/2", 1 - 3/4"	6 - 1/2", 4 - 3/4"	5	70
TP640	5	85	12 1/4"	4 - 1/2", 3 - 3/4"	1 - 1/2", 1 - 3/4"	6 - 1/2", 4 - 3/4"	1	85
TP641	6	95	14 1/16"	4 - 1/2", 4 - 3/4"	1 - 1/2", 1 - 3/4"	6 - 1/2", 4 - 3/4"	1	95

GANG BOXES

2 1/2" DEEP x 4 1/2" HIGH
3/4" & 1" KOs

UL LISTED

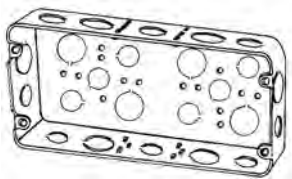

TP871

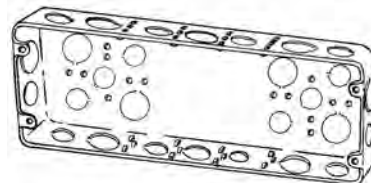

TP873

KNOCKOUTS

Cat. #	Gang	Cubic Inches	Width	Each Side	Each End	Bottom	Unit Qty.	Wt. Lbs. Per 100
TP870	2	71	6 13/16"	2 - 3/4", 1 - 1"	1 - 3/4", 1 - 1"	3 - 1/2", 2 - 3/4"	10	147
TP871	3	90	8 3/8"	4 - 3/4", 1 - 1"	1 - 3/4", 1 - 1"	6 - 1/2", 4 - 3/4"	10	183
TP872	4	110	10 7/16"	2 - 3/4", 2 - 1"	1 - 3/4", 1 - 1"	6 - 1/2", 4 - 3/4"	5	216
TP873	5	132	12 1/4"	3 - 3/4", 2 - 1"	1 - 3/4", 1 - 1"	6 - 1/2", 4 - 3/4"	5	263
TP874	6	150	14 1/16"	3 - 3/4", 3 - 1"	1 - 3/4", 1 - 1"	6 - 1/2", 4 - 3/4"	5	282

GANG BOX PARTITIONS



TP876



TP877

Cat. #	Description	Unit Qty.	Wt. Lbs. Per 100
TP876	For 1 5/8" Deep Box	25	19
TP877	For 2 1/2" Deep Box	50	24

Steel Gang Box Covers



GANG BOX COVERS

RAISED $13/16$ " FOR PLASTER

UL LISTED

Steel Boxes

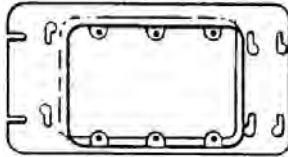

TP653

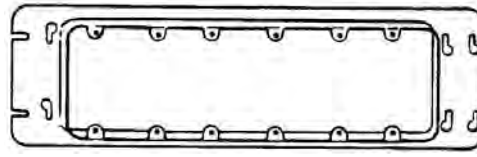

TP667

Cat. #	Gang	Length	Unit Qty.	Wt. Lbs. Per 100	Capacity Cu. In.
TP657	2	7"	5	53	8.5
TP653	3	$8^{13}/16$ "	5	60	13.5
TP655	4	$10^{5}/8$ "	5	66	18.3
TP661	5	$12^{7}/16$ "	5	75	23.0
TP667	6	$14^{1}/4$ "	5	85	28.3

GANG BOX COVERS, FLAT, BLANK

UL LISTED



TP803



TP806

Cat. #	Gang	Length	Unit Qty.	Wt. Lbs. Per 100
TP802	2	7"	5	66
TP803	3	$8^{13}/16$ "	5	85
TP804	4	$10^{5}/8$ "	5	94
TP805	5	$12^{7}/16$ "	1	122
TP806	6	$14^{1}/4$ "	1	132

MASONRY BOXES

2½" DEEP × 3¾" HIGH
 ½" AND ¾" CONCENTRIC KOs
 UL LISTED

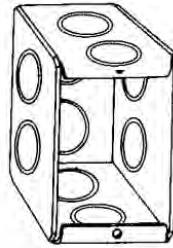

TP682

Cat. #	Gang	Width	KNOCKOUTS			Unit Qty.	Wt. Lbs. Per 100	Capacity Cu. In.
			Each Side	Each End	Bottom			
TP682	1	1 ¹⁵ / ₁₆ "	2	1	2	20	70	15.5
TP683	2	3 ³ / ₄ "	2	2	4	10	103	31.0
TP684	3	5 ⁹ / ₁₆ "	2	3	6	5	129	46.5
TP685	4	7 ³ / ₈ "	2	4	8	5	165	62.0
TP686	5	9 ³ / ₁₆ "	2	5	10	5	189	77.5
TP687	6	11"	2	6	12	1	230	93.0

MASONRY BOXES

3½" DEEP × 3¾" HIGH
 ½" AND ¾" CONCENTRIC KOs
 UL LISTED

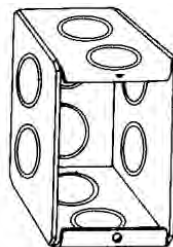

TP690

Cat. #	Gang	Width	KNOCKOUTS			Unit Qty.	Wt. Lbs. Per 100	Capacity Cu. In.
			Each Side	Each End	Bottom			
TP690	1	1 ¹⁵ / ₁₆ "	2	2	2	20	84	22.0
TP691	2	3 ³ / ₄ "	2	4	4	10	120	44.0
TP692	3	5 ⁹ / ₁₆ "	2	6	6	10	155	66.5
TP693	4	7 ³ / ₈ "	2	8	8	5	207	88.0
TP694	5	9 ³ / ₁₆ "	2	10	10	5	235	110.0
TP695	6	11"	2	12	12	1	287	132.0

MASONRY BOX PARTITIONS

Cat. #	Description	Unit Qty.	Wt. Lbs. Per 100
TP820	Nonmetallic Partition for 2½" Deep Masonry Boxes	25	3
TP821	Nonmetallic Partition for 3½" Deep Masonry Boxes	25	4

GANGABLE MASONRY BOXES

UL LISTED

Features:

- The gangable feature allows the option of creating a multiple gang box from a single gang box by simply removing the combo head screw holding the side with a #2 bit and connecting the two (or more) boxes together re-using the screws
- Non-metallic partitions (ordered separately) install quickly and easily without tools in multi-gang boxes and are used to separate power and control circuits within the same box, as required by the National Electrical Code®

Steel Boxes



KNOCKOUTS

Cat. #	Width	Each Side	Each End	Bottom	Unit Qty.	Wt. Lbs. Per 100	Capacity Cu. In.
2 1/2" DEEP x 3 3/4" HIGH, 1/2" AND 3/4" CONCENTRIC KOs							
TP671	1 15/16"	2	2	2	20	63	15.5
3 1/2" DEEP x 3 3/4" HIGH, 1/2" AND 3/4" CONCENTRIC KOs							
TP675	1 15/16"	2	2	2	20	82	22.0

GANGABLE MASONRY BOX PARTITIONS

Cat. #	Description	Unit Qty.	Wt. Lbs. Per 100
TP654	Nonmetallic Partition for 2 1/2" Deep Gangable Masonry Boxes	25	4
TP656	Nonmetallic Partition for 3 1/2" Deep Gangable Masonry Boxes	25	6

Steel Octagon Boxes & Ceiling Pans



Steel Boxes

3 1/4" ROUND CEILING PAN* – 4.0 CUBIC INCH CAPACITY

1/2" DEEP
CLAMPS IN BOTTOM
FIXTURE RATED
UL LISTED



TP266

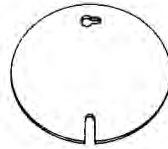

TP270

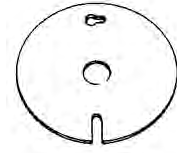

TP272

KNOCKOUTS

Cat. #	Cable	Conduit	Unit Qty.	Wt. Lbs. Per 100
TP266	4 – Cable	1 – 1/2"	50	30
3 1/4" ROUND COVERS				
TP270	Flat Blank		100	18
TP272	Flat, 1/2" KO in Center		100	18

4" ROUND CEILING PANS* – 6.0 CUBIC INCH CAPACITY

1/2" DEEP
FIXTURE RATED
UL LISTED

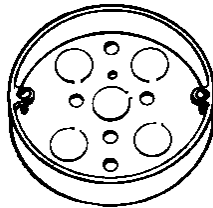

TP269

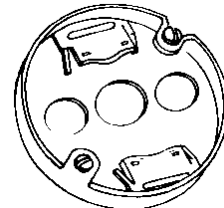

TP267

KNOCKOUTS

Cat. #	Description	KNOCKOUTS		Unit Qty.	Wt. Lbs. Per 100
		Sides	Bottom		
TP269	KOs Only	—	5 – 1/2"	50	35
TP267	KOs and Clamps	—	4 – Cable, 3 – 1/2"	50	39

*Weight limit for 3 1/4" and 4" octagon outlet boxes and ceiling pans is 50lbs for fixture. Not suitable for fans.

Steel Octagon Boxes & Ceiling Pans



3 1/4" OCTAGON OUTLET BOXES* – 11.5 CUBIC INCH CAPACITY

1 1/2" DEEP
FIXTURE RATED

UL LISTED

Steel Boxes



TP256

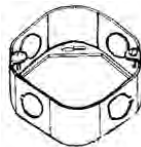

TP258

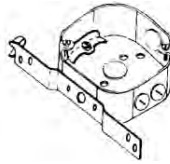

TP259

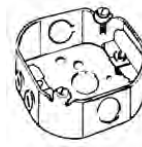

TP260

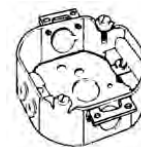

TP264

KNOCKOUTS

Cat. #	Description	Sides	Bottom	Unit Qty.	Wt. Lbs. Per 100
FOR CONDUIT – NO CLAMPS					
TP256	—	4 – 1/2"	1 – 1/2"	50	41
TP258	Extension Ring	4 – 1/2"	—	50	31
FOR NONMETALLIC CABLE WITH CLAMPS					
TP259	"S" Bracket, Set 1/2"	4 – Cable, 1 – 1/2"	1 – 1/2"	50	53
TP260	—	4 – Cable, 2 – 1/2"	1 – 1/2"	50	44
TP264	Two Screw Ears	4 – Cable, 2 – 1/2"	1 – 1/2"	50	47

4" OCTAGON OUTLET BOXES† – 15.5 CUBIC INCH CAPACITY

1 1/2" DEEP
FOR CONDUIT – NO CLAMPS
FIXTURE RATED

UL LISTED

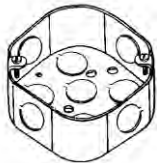

TP274, TP276,
TP278, TP834*

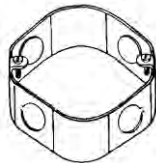

TP273

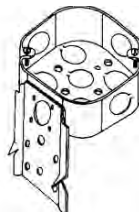

TP280

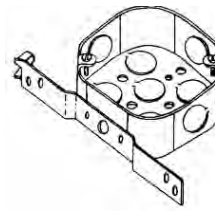

TP282

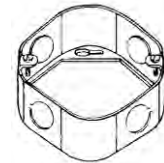

TP284, TP286

KNOCKOUTS

Cat. #	Description	Sides	Bottom	Unit Qty.	Wt. Lbs. Per 100
TP274	—	4 – 1/2"	5 – 1/2"	50	50
TP273	Blank Bottom	4 – 1/2"	—	50	51
TP276	—	4 – 3/4"	3 – 1/2", 2 – 3/4"	50	50
TP278	—	2 – 1/2", 2 – 3/4"	3 – 1/2", 2 – 3/4"	50	50
TP280	"C" Bracket	4 – 1/2"	5 – 1/2"	50	60
TP282	"S" Bracket, Set 1/2"	3 – 1/2"	5 – 1/2"	50	58
Air Plenum					
TP834*	For Air Plenum	4 – 1/2"	5 – 1/2"	50	52

OCTAGON EXTENSION RINGS – (SLOT & KEY PERMIT MOUNTING WITHOUT REMOVING BOX SCREWS)

TP284‡	—	4 – 1/2"	—	50	36
TP286‡	—	2 – 1/2", 2 – 3/4"	—	50	36

*For Air Plenum (No Mounting Holes) - Not UL Listed

† Weight limit for 3 1/4" and 4" octagon outlet boxes and ceiling pans is 50lbs for fixture. Not suitable for fans

‡ CSA Certified

Steel Octagon Boxes & Ceiling Pans



Steel Boxes

4" OCTAGON OUTLET BOXES† – 15.5 CUBIC INCH CAPACITY

1½" DEEP

FOR ARMORED & METAL CLAD (MCI) CABLE – CLAMPS IN EACH END

FIXTURE RATED

UL LISTED

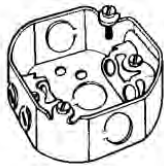

TP310

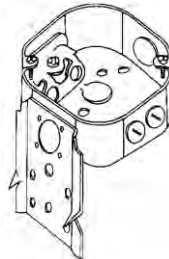

TP312

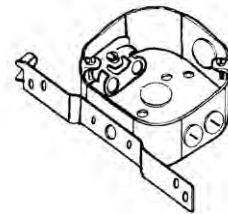

TP314

KNOCKOUTS

Cat. #	Description	KNOCKOUTS		Unit Qty.	Wt. Lbs. Per 100
		Sides	Bottom		
TP310*	—	4 – Cable, 2 – ½"	1 – ½"	50	57
TP312*	"C" Bracket	4 – Cable, 2 – ½"	1 – ½"	50	66
TP314*	"S" Bracket, Set ½"	4 – Cable, 1 – ½"	1 – ½"	50	64

*UL approved for use with aluminum interlocking grounding metal clad cable, Type MCIA (Southwire MCAP™)
MCAP™ is a registered trademark of Soutwire Company.

4" OCTAGON OUTLET BOXES – 15.5 CUBIC INCH CAPACITY

1½" DEEP

FOR NONMETALLIC CABLE – WITH CLAMPS

FIXTURE RATED

UL LISTED

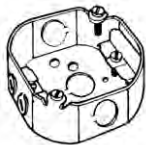

TP298

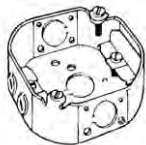

TP300



TP302

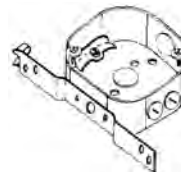

TP304

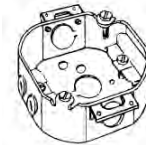

TP306

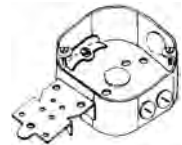

TP308

KNOCKOUTS

Cat. #	Description	KNOCKOUTS		Unit Qty.	Wt. Lbs. Per 100
		Sides	Bottom		
TP298	—	4 – Cable, 2 – ½"	1 – ½"	50	56
TP300	With Side Nail Holes	4 – Cable, 2 – ½"	1 – ½"	50	55
TP302	"C" Bracket	4 – Cable, 2 – ½"	1 – ½"	50	65
TP304	"S" Bracket, Set ½"	4 – Cable, 1 – ½"	1 – ½"	50	64
TP306	Two Screw Ears	4 – Cable, 2 – ½"	1 – ½"	50	58
TP308	"F" Bracket, Set ½"	4 – Cable, 1 – ½"	1 – ½"	50	64

Steel Octagon Boxes & Ceiling Pans



4" OCTAGON OUTLET BOXES – 21.5 CUBIC INCH CAPACITY

2 1/8" DEEP
FOR CONDUIT – NO CLAMPS

FIXTURE RATED

UL LISTED

Steel Boxes

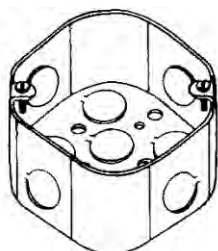

TP288, TP290, TP294

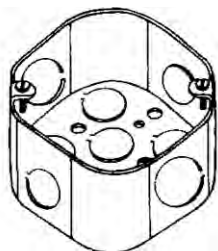

TP292, TP838*



TP292RED

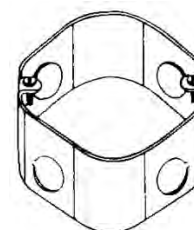

TP339

Cat. #	Description	KNOCKOUTS		Unit Qty.	Wt. Lbs. Per 100
		Sides	Bottom		
TP288	—	4 – 1/2"	3 – 1/2", 2 – 3/4"	25	64
TP288PF†	—	4 – 1/2"	3 – 1/2", 2 – 3/4"	25	64
TP290	—	4 – 3/4"	3 – 1/2", 2 – 3/4"	25	64
TP290PF†	—	4 – 3/4"	3 – 1/2", 2 – 3/4"	25	64
TP292	—	2 – 1/2", 2 – 3/4"	3 – 1/2", 2 – 3/4"	25	64
TP292PF†	—	2 – 1/2", 2 – 3/4"	3 – 1/2", 2 – 3/4"	25	64
TP292RED	—	2 – 1/2", 2 – 3/4"	3 – 1/2", 2 – 3/4"	25	64
TP294	—	4 – 1"	3 – 1/2", 2 – 3/4"	25	64
TP339	Blank Bottom	4 – 1/2"	—	25	65
Air Plenum					
TP838*	Plenum	2 – 1/2", 2 – 3/4"	3 – 1/2", 2 – 3/4"	25	62

*For Air Plenum (No Mounting Holes) - Not UL Listed

†TP catalog numbers ending in PF includes ground screw with pigtail lead

4" OCTAGON OUTLET BOXES – 21.5 CUBIC INCH CAPACITY

2 1/8" DEEP – WITH CABLE CLAMPS

FIXTURE RATED

UL LISTED

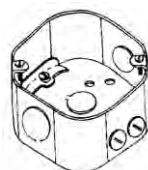

TP316



TP318

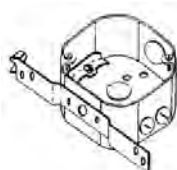

TP320

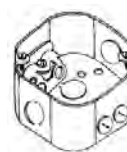

TP317

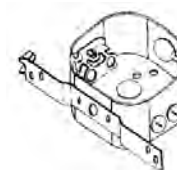

TP338

Cat. #	Description	KNOCKOUTS		Unit Qty.	Wt. Lbs. Per 100
		Sides	Bottom		
FOR NONMETALLIC CABLE					
TP316	—	4 – Cable, 2 – 1/2"	1 – 1/2"	25	68
TP318	"C" Bracket	4 – Cable, 2 – 1/2"	1 – 1/2"	25	88
TP320	"S" Bracket, Set 1/2"	4 – Cable, 1 – 1/2"	1 – 1/2"	25	81
FOR ARMORED & METAL CLAD (MCI) – CABLE-CLAMPS IN EACH END					
TP317*	—	4 – Cable, 2 – 1/2"	1 – 1/2"	25	69
TP338*	"S" Bracket, Set 1/2"	4 – Cable, 1 – 1/2"	1 – 1/2"	25	82
TP338PF†	"S" Bracket, Set 1/2"	4 – Cable, 1 – 1/2"	1 – 1/2"	25	82

†TP catalog numbers ending in PF includes ground screw with pigtail lead

*UL approved for use with aluminum interlocking grounding metal clad cable, Type MCIA (Southwire MCAP™)
MCAP™ is a registered trademark of Southwire Company.

4" OCTAGON BOX AND ADJUSTABLE BAR SETS – 15.5 CUBIC INCH CAPACITY

1½" DEEP BOX SETS

FIXTURE RATED

UL LISTED

Weight Limits: 35 lbs. at 16", 15 lbs. at 24"

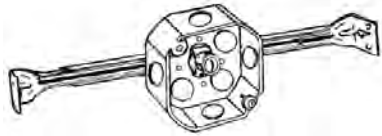

TP372



TP377



TP367

Cat. #	Stud Spacing	Stud	Unit Qty.	Wt. Lbs. Per 100
FOR CONDUIT – NO CLAMPS				
TP372*	16" – 24"	Yes	25	85
FOR NONMETALLIC CABLE – WITH CLAMPS				
TP377	16" – 24"	—	25	102
FOR ARMORED & METAL CLAD (MCI) CABLE – CLAMPS IN EACH END				
TP367	16" – 24"	Yes	25	100
TP367PF†	16" – 24"	Yes	25	100

*4" Octagon Box and Adjustable Bar Sets have ½" KOs for conduit
 †TP catalog numbers ending in PF includes ground screw with pigtail lead

ADJUSTABLE BAR HANGERS

HOLDING PRONG . . . HOLDS BOX IN PLACE FOR NAILING – DESIGN RESISTS BENDING AND TWISTING – TP354 AND TP356 HAVE LOCKING TABS TO HOLD BAR IN POSITION

UL LISTED

Weight Limits: 50 lbs. at 16", 21 lbs. at 24".

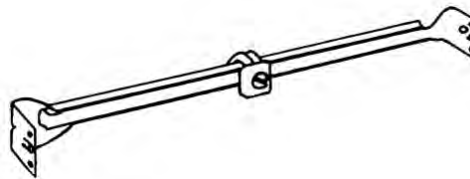

TP356

Cat. #	Stud Spacing	Length	Stud	Unit Qty.	Wt. Lbs. Per 100
TP356	16" & 24"	14" – 22½"	—	50	41

4" OCTAGON BOX COVERS – CUBIC CAPACITY (SEE BELOW)

UL LISTED

Steel Boxes



TP322
TP853*



TP323



TP326, TP331,
TP332, TP333



TP328

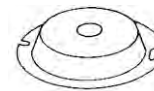

TP330



TP329



TP335



TP334



TP336

Cat. #	Description	Capacity Cu. In.	Unit Qty.	Wt. Lbs. Per 100
TP322†	Flat Blank – Octagon Shape	—	50	22
TP323†	Flat Blank – Round Shape	—	50	24
TP333	Raised 1", Open With Ears 2 ³ / ₄ "	7.0	25	30
TP332	Raised 1/2", Open With Ears 2 ³ / ₄ "	3.3	50	22
TP326	Raised 5/8", Open With Ears 2 ³ / ₄ "	3.8	50	20
TP331	Raised 3/4", Open With Ears 2 ³ / ₄ "	5.0	50	26
TP328†	Flat With 1/2" KO – Octagon Shape	—	50	22
TP330	Raised 5/8", With 1/2" KO	3.8	50	31
TP329†	Flat With 1/2" KO – Round Shape	—	50	24
TP335	Flat, For Toggle Switch	—	50	23
TP334‡	Flat, Single Receptacle 1 ¹³ / ₃₂ "	—	50	21
TP336	Flat, For Duplex Receptacle	—	50	18

Air Plenum

TP853*‡ Flat, Blank With PVC Gasket

*For Air Plenum (No Mounting Holes)

†CSA Certified

‡ Not UL Listed

FLEXIBLE FIXTURE HANGERS

Cooper Crouse-Hinds TPRFH flexible fixture hangers are used in commercial or light industrial applications where HID high bay and low bay lighting fixtures are used. Specific applications include storage facilities, shipping warehouses, retail and DIY facilities.

Features and Benefits:

- Suitable for use with 1/2" or 3/4" fixture conduit stems these hangers allow the conduit stem of the fixture (luminaire) to swing in any direction. Maximum swing angle is 26° from vertical max slope angles 22 1/2°
- Available for attachment to round or octagonal steel boxes.
- Quickly and easily attached by two screws.
- Hangers are drilled and tapped for use with 3/4" conduit stem as standard and come supplied with a 3/4" – 1/2" reducer for 1/2" conduit stem applications.

Standard Materials and Finishes:

- Material: Sheet Steel
- Finish: Zinc Chromate for corrosion resistance



Description	Support Wt. (lbs)	Cat. #
For use with 4" Round or Octagon Boxes	50	TPRFH12

Certifications and Compliances:

- UL Listed – UL 1598
- CSA C22.2 No. 250
- Suitable for Damp Locations

4" OCTAGON CONCRETE BOXES AND HUNG CEILING BOXES*

UL LISTED

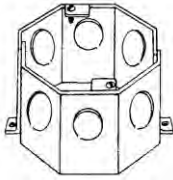

TP620, TP622, TP628

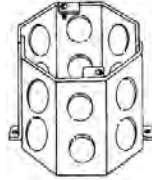

TP635, TP636, TP644

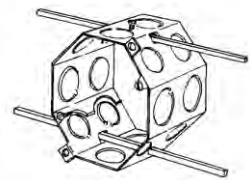

TP623, TP624
(bars not included)

Steel Boxes

Cat. #	Depth	KNOCKOUTS	Unit Qty.	Wt. Lbs. Per 100	Capacity Cu. In.
TP620	2"	1/2" & 3/4" Single Row	25	60	23.0
TP622	2 1/2"	1/2" & 3/4" Single Row	25	72	29.0
TP628	3"	1/2" & 3/4" Single Row	20	85	35.0
TP634	3"	1" & 3/4" Single Row	20	77	30.3
TP635	3 1/2"	1/2" Double Row	20	93	43.0
TP636	3 1/2"	1/2" & 3/4" Double Row	20	93	43.0
TP639	3 1/2"	1" & 3/4" Double Row	20	89	41.0
TP642	4"	1" & 3/4" Double Row	20	106	47.0
TP644	4"	1/2" & 3/4" Double Row	20	113	47.0
HUNG CEILING BOXES (WITH TP650 COVER, ORDER BARS SEPARATELY)					
TP623	3 1/2"	1/2" Double Row	20	93	43.0
TP624	3 1/2"	1/2" & 3/4" Double Row	20	93	43.0

*Weight limit for 4" octagon concrete boxes is 50lbs. Not suitable for fans.
†Not UL Listed

4" FAN RATED OCTAGON CONCRETE BOX UL LISTED



TP643



Applications:

- Octagon concrete boxes are used in poured deck applications.
- Typical construction includes high-rises, apartments, condominiums and restaurants with outdoor dining areas.
- They are installed on wooden or steel forms and concrete poured around.
- Upon removal of the forms the box is flush with the concrete.
- It is common, and continuing to become even more so, to have ceiling fans mounted to these boxes. Because of the additional mounting support boss this new box is suitable for use with fans of up to 70 pounds and fixtures up to 90 pounds.

Features:

1. The TP643 fan rated concrete box is made from two piece welded construction and is supplied with two rows of 1/2" & 3/4" dedicated KO's.
2. The box is also supplied with two external mounting ears which are used to secure the box to the forms.
3. The fan (or fixture) is held securely in place by the two 10-32 x 1 1/2" long pan head screws and lock washers. The screws attach to the specially designed boss.
4. There are two 8-32 x 1/2" screws provided for attachment of a box plate/cover (TP648, TP649, or TP650 – ordered separately).
5. Mounting support boss & locknuts allows the TP643 box to be used with fans of up to 70 pounds and fixtures up to 90 pounds.

Cat. #	Depth	KNOCKOUTS	Unit Qty.	Wt. Lbs. Per 100	Capacity Cu. In.
TP643	4"	1/2" & 3/4"	20	102	46.0

CONCRETE BOX PLATES

UL LISTED



TP648



TP649



TP650



TP652

Cat. #	Description	Unit Qty.	Wt. Lbs. Per 100
TP648	No Stud 3 – 1/2" & 2 – 3/4" KOs	50	28
TP649	Flat, Blank	50	28
TP650	3/8" Stud 2 – 1/2" & 2 – 3/4" KOs	50	33
TP652	Single Receptacle	50	24

CEILING FAN BOXES AND SUPPORTS- CUBIC INCH CAPACITY (SEE BELOW)

UL LISTED

Weight Limits: TP261 – 35 lbs. max. for fans, 50 lbs. max. for fixture. TP301 – Fan is supported independent of outlet box, mounting screws go through box and into joist. Box will support fans up to 70 lbs. and fixtures up to 90 lbs. TP275 – 70 lbs. max. for fans, 90 lbs. max for fixtures.

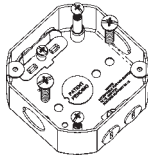

TP275



TP261

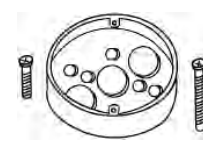

TP301

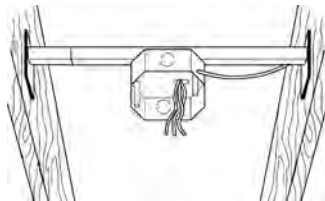

TP315

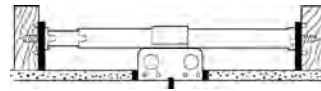

TP379

KNOCKOUTS

WEIGHT LIMITS

Cat. #	Description	Stud Spacing	Cubic In. Capacity	KNOCKOUTS		Unit Qty.	Wt. Lbs. Per 100	WEIGHT LIMITS	
				Sides	Bottom			Fans	Fixtures
TP275	1½" Deep, Clamps and Mounting Screws (polybagged)	—	15.5	4 – Cable, 2 – ½"	1 – ½"	20	66.6	70 lbs.	90 lbs.
TP315†	Fan Box with New Work Bar Hanger	16" – 24"	15.5	2 – ½"	2 – ½"	12	192	35 lbs.	50 lbs.
TP379	1½" Deep with Fan Brace Old Work Bar Hanger	16" – 24"	15.5	4 – ½"	2 – ½"	12	207	35 lbs.	50 lbs.
TP261	⅝" Deep with External Clamp and Mounting Screws (polybagged)	—	8.0	—	2 – ½"	20	50	35 lbs.	50 lbs.
TP301*	½" Deep, 4" Round, with NM Snap-In Connector, mtg. screws, Protective Cover (no bag)	—	6.8	—	3 – ½"	20	51	70 lbs.*	90 lbs.*

*TP301 fan is supported independent of outlet box

†TP315 comes with Romex clamp installed on one side. The other 3 sides have a ½" KO, a bagged MC clamp and screw and a bagged plastic NM connector

CEILING FAN BOXES – PVC

UL LISTED

Weight Limits: Fans and fixtures are supported independent of outlet box. Mounting screws go through box and into joist. Box will support up to 70 lbs. for fans and 90 lbs. for fixtures. Provided with Romex connector

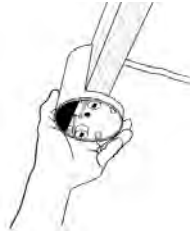

TP1300

Cat. #	Description	Capacity Cu. In.	Knockouts	Integral Clamp	Unit Qty.	Wt. Lbs. Per 100
TP1300	4 ¹ / ₁₆ " diam., 1/2" deep pan section, 4" deep overall – with mtg. hardware & external clamp, protective cover	14.0	3 – 1/2"	1	24	34

NONMETALLIC CEILING FAN BOXES

2³/₁₆" DEEP

UL LISTED

With clamps for nonmetallic cable.
All mounting hardware supplied, suitable for support of fans weighing up to 35 lbs.



TP16511

Features:

- Made of heavy-duty, engineered thermoplastic material
- Offers the labor-saving feature of quick entry and integral clamping
- Eliminates the need to use a screwdriver to break open pry-outs
- The easy access entry-point serves as a wire clamp, eliminating time required to mechanically secure the wire to the box

Cat. #	Diameter	Mounting Method	Capacity Cu. In.	No. of Clamp Openings	Unit Qty.	Wt. Lbs. Per 100
TP16511	4"	Nails only	22.5	6	25	21

GROUNDING DEVICES

GROUNDING SCREW AND PIGTAIL



TP711



TP701



TP704

Cat. #	Description	Std. Pkg.	Unit Qty.	Wt. Lbs. Per 100
TP701	Grounding Screw with 8" Insulated No. 12 Stranded Wire	1000	1000	2
TP711	Grounding Screw with 8" Insulated No. 12 Copper Wire	1000	1000	2
TP704	#10-32 x 3/8" Grounding Screw	1000	1000	.5

GROUNDING CLIP



TP706

Cat. #	Description	Std. Pkg.	Unit Qty.	Wt. Lbs. Per 100
TP706	For Grounding Switch & Outlet Boxes Using Nonmetallic Sheathed Cables No. 14 & No. 12, with Grounding Wire	1000	100	.5

OLD WORK CLIP



TP651

Cat. #	Description	Std. Pkg.	Unit Qty.	Wt. Lbs. Per 100
TP651	Clips lock old-work steel switch boxes tightly to wall. Two required per box.	250 sets	25 sets	4

REPLACEMENT PARTS

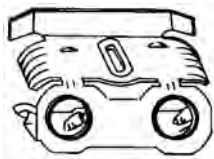

TP900

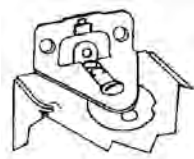

TP901



TP902

Cat. #	Description	Unit Qty.	Wt. Lbs. Per 100
TP900	MC-BX Clamp with Screws	200	17.3
TP901	One Screw Mounting Ear with Screws	200	3.2
TP902	Two Screw Mounting Ear with Screws	200	2.7

LOW PROFILE MOUNTING SCREWS

Cat. #	Description	Capacity Cu. In.	Unit Qty.	Wt. Lbs. Per 100
LOW PROFILE SCREWS - REDUCES RISK OF SHEETROCK BULGE				
TP710	L.P. Screws	—	1000	.5

Steel Boxes

HOLD-IT SWITCH BOX SUPPORTS

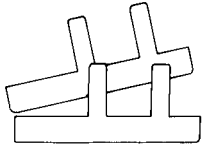

FIG. 1



FIG. 2

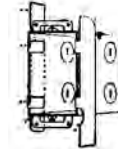

FIG. 3

Cat. #	Description	Unit Qty.	Wt. Lbs. Per 100
TP708	Two metal holders for mounting old-work switch boxes in all types of wall materials	500 Sets	5

SWITCH BOX EXTENSION



TP709

Cat. #	Description	Unit Qty.	Capacity Cu. In.	Wt. Lbs. Per 100
TP709*	Fits snugly inside all 3" x 2" width boxes. Maximum adjustable depth 7.8". Furnished with mounting screws.	50	3.5	13

*Not UL Listed

P-300 STEEL STUD SAFETY PLATE

- Meets requirement of National Electric Code
- Same size as face of stud
- No nails required
- Protects electrical cable and copper water pipes

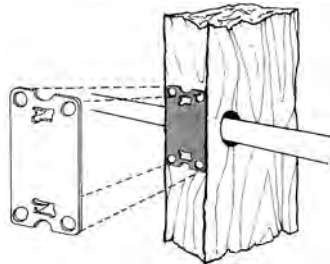

Cat. #	Description	Unit Qty.	Wt. Lbs. Per 100
TP659	2" x 3 1/2" Steel Plate	100	11

"BACK TO BACK" BOX CONNECTOR – ZINC DIE CAST



Applications:

For use as a short raceway between two boxes

Cat. #	Size	Unit Qty.	Wt. Lbs. Per 100
5050	1/2"	25	8



Applications:

Cooper Crouse-Hinds nonmetallic switch and outlet boxes are used:

- In branch circuit wiring as a splice point
- To mount wiring devices such as switches and receptacles
- To provide mechanical protection for wiring systems and electrical devices

Features:

- Available for use with wood or metal studs to meet any construction preference
- Quick entry feature on all nonmetallic boxes offers labor savings – no need to break out knockouts – simply push the nonmetallic cable into the box. No tools are required. No need to remove knockouts.
- Unique configuration of this quick entry feature on single gang boxes provides a self-feeding feature that eliminates the need to reach inside the box to pull the wire out.
- Integral labor saving clamping feature on two, three & four gang boxes. The multiple gang box unique entry also serves as a clamp, eliminating the need to mechanically secure the cable inside the box. There are no separate clamps or screws to install or tighten. Each entry into the multiple gang boxes has the quick entry feature allowing the installer to simply push the cable into the box without the need for tools or removal of knock-outs, so the cable can be inserted where it is required.

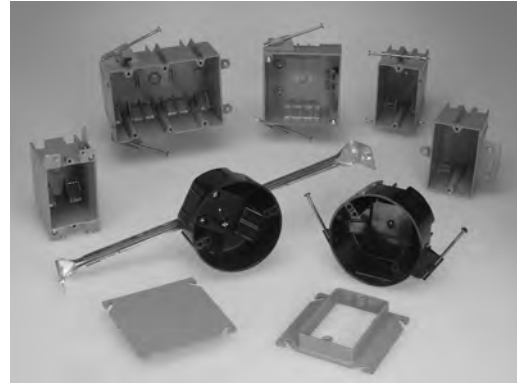

Certifications and Compliances:

- UL Listed File No. E102328
- Classified for use in fire rated (2 HR) wall or ceiling. Fire Rating No. R9933.

Standard Materials:

- PVC-Polyvinyl Chloride compound

SWITCH BOXES – ANGLED NAILS

UL LISTED



TP1600



TP1800



TP2000



TP2300

Cat. #	Bracket or Nails	Capacity Cu. In.	H	W	D	Unit Qty.	Wt. Lbs. Per 100
TP1600	Nails	16.0	3 ³ / ₄ "	2 ¹ / ₄ "	2 ¹ / ₂ "	100	21
TP1800	Speed-Mount & Nails	18.0	3 ³ / ₄ "	2 ¹ / ₄ "	2 ³ / ₄ "	100	23
TP1802	Nails	18.0	3 ¹¹ / ₁₆ "	2 ¹ / ₄ "	2 ³ / ₄ "	100	20
TP2000	Nails	20.3	3 ³ / ₄ "	2 ¹ / ₄ "	3 ³ / ₁₆ "	100	25
TP2002	Speed-Mount & Nails	20.3	3 ¹¹ / ₁₆ "	2 ¹ / ₄ "	3 ¹ / ₈ "	100	21
TP2300	Nails	22.5	3 ³ / ₄ "	2 ¹ / ₄ "	3 ⁷ / ₁₆ "	50	27
TP2302	Speed-Mount & Nails	22.5	3 ¹¹ / ₁₆ "	2 ¹ / ₄ "	3 ⁷ / ₁₆ "	50	23

SWITCH BOXES – INTEGRAL CLAMPS

UL LISTED



TP1690
(Old Work)

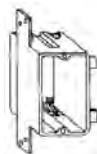

TP2020
(For Wood or Metal Studs)



TP2030
(For Wood or Metal Studs)

Cat. #	Bracket or Nails	Capacity Cu. In.	H	W	D	Unit Qty.	Wt. Lbs. Per 100
TP1832	Speed-Mount & Bracket	18.0	3 ¹¹ / ₁₆ "	2 ¹ / ₄ "	2 ³ / ₄ "	100	18
TP1690	Swing Clips & Integral Clamps	16.0	3 ⁵ / ₈ "	2 ⁵ / ₁₆ "	2 ³ / ₄ "	50	20
TP2020	Side Bracket (5/8" offset)	20.3	3 ¹¹ / ₁₆ "	2 ¹ / ₄ "	3 ³ / ₁₆ "	50	24
TP2030	Face Bracket (1/2" offset)	20.3	3 ¹¹ / ₁₆ "	2 ¹ / ₄ "	3 ³ / ₁₆ "	50	24
TP2332	Speed-Mount & Bracket	22.5	3 ¹¹ / ₁₆ "	2 ¹ / ₄ "	3 ⁷ / ₁₆ "	50	23

3" DEEP SWITCH BOXES – TWO GANG

UL LISTED

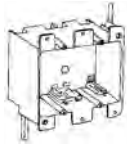

TP3490
(Old Work)



TP3600



TP3630



TP3635

PVC Boxes

Cat. #	Bracket or Nails	Capacity Cu. In.	H	W	D	Unit Qty.	Wt. Lbs. Per 100
TP3490	Swing Clips	34.0	3 ⁹ / ₁₆ "	4"	3 ³ / ₁₆ "	25	29
TP3600	Nails	36.0	3 ³ / ₄ "	4"	3"	25	37
TP3602	Speed-Mount & Nails	36.0	3 ⁷ / ₈ "	3 ⁷ / ₈ "	3 ¹ / ₆ "	25	34
TP3630*	Brackets	36.0	3 ³ / ₄ "	4"	3"	25	37
TP3632	Speed-Mount & Brackets	36.0	3 ⁷ / ₈ "	3 ⁷ / ₈ "	3 ¹ / ₆ "	25	32
TP3635*	Brackets & Nails	36.0	3 ³ / ₄ "	4"	3"	25	39

*Face Bracket on PVC Boxes are offset 1/2" unless stated otherwise

2¹¹/₁₆" DEEP SWITCH BOXES – THREE GANG

UL LISTED



TP4600

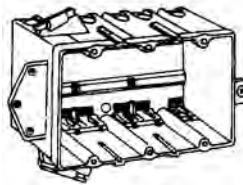

TP4630

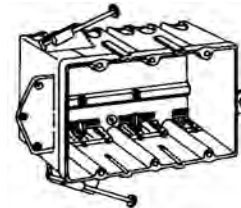

TP4635

Cat. #	Bracket or Nails	Capacity Cu. In.	Unit Qty.	Wt. Lbs. Per 100
TP4600	Nails	46.0	20	45
TP4602	Speed-Mount & Nails	54.0	20	42
TP4630*	Brackets	46.0	20	43
TP4632	Speed-Mount & Brackets	54.0	20	40
TP4635*	Brackets & Nails	46.0	20	46

2¹¹/₁₆" DEEP SWITCH BOXES – FOUR GANG

UL LISTED



TP6100



TP6135

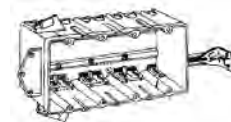

TP6180

Cat. #	Bracket or Nails	Capacity Cu. In.	Unit Qty.	Wt. Lbs. Per 100
TP6100†	Nails	61.0	4	65
TP6102	Speed-Mount & Nails	72.0	4	53
TP6132	Speed-Mount & Bracket	72.0	4	51
TP6135*†	Nails & Brackets	61.0	4	66
TP6180*†	Nails, Brackets & Bar Support	61.0	4	87

*Face Bracket on PVC Boxes are offset 1/2" unless otherwise stated

†Not 2-Hour Fire Rated

LOW VOLTAGE PARTITION – TWO, THREE OR FOUR GANG PVC



TP1000

Cat. #	Bracket or Nails	Capacity Cu. In.	Unit Qty.	Wt. Lbs. Per 100
TP1000	—	—	20	3

Far Side Support – For use with Speed-Mount™ Switchboxes



Applications:

- Far Side Support is designed for use with Speed-Mount™ switchboxes used with either wood or metal studs to provide a quick, easy economical way for far side support.

How to use:

- The multi-gang Speed-Mount™ boxes have a molded-in-hole in the back for attaching the TPFSS. The molded-in-hole has two flats as you look at the back of the box. There are also two flats on the TPFSS. To install, simply align the flats and push the TPFSS into the hole. Turn ¼ turn to lock into place.
- The TPFSS is designed for use with steel studs with a depth of 3/8". For use with 2 × 4 wood studs, simply break off the tip at the notch of the TPFSS using a pair of pliers.

Cat. #	Capacity Cu. In.	Description	Bracket or Nails	Unit Qty.
TPFSS	—	—	—	100

4" SQUARE WITH INTEGRAL CLAMPS – 20.3 CUBIC INCH CAPACITY

1⁵/₈" DEEP

UL LISTED

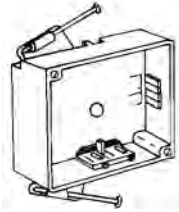

TP1900

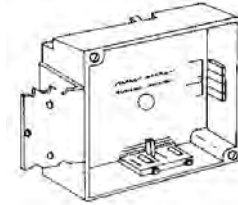

TP1930

PVC Boxes

Cat. #	Bracket	Capacity Cu. In.	Unit Qty.	Wt. Lbs. Per 100
TP1900	—	20.3	50	26
TP1930	"F" Bracket	20.3	50	40

4" SQUARE PVC DEVICE COVERS

UL LISTED



TP1009

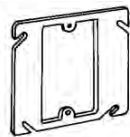

TP1010



TP1020

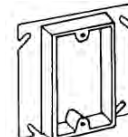

TP1013, TP1014



TP1023, TP1024

Cat. #	Raised	Capacity Cu. In.	Unit Qty.	Wt. Lbs. Per 100
TP1009	—	—	50	9
TP1010	—	—	50	6
TP1020	—	—	50	4
TP1013	1/2"	3.8	50	8
TP1014	5/8"	4.8	50	8
TP1023	1/2"	5.8	50	8
TP1024	5/8"	7.0	50	8

3 1/2" NONMETALLIC CEILING BOXES

2 7/8" DEEP

UL LISTED

Weight limit is 50 lbs for fixture except where indicated.

Fan support or fixture support

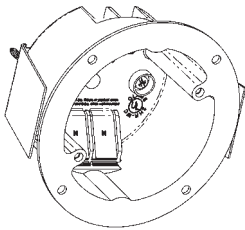

TP16200,
(TP16201 – 2 1/8" Deep)
Old Work

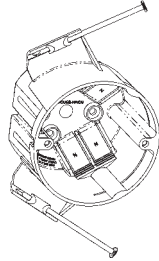

TP16310
TP16311

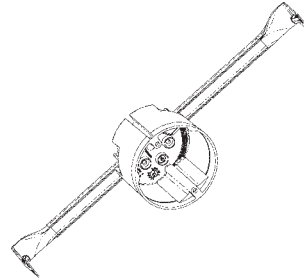

TP16307
TP16308

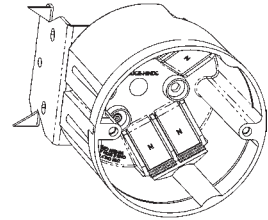

TP16317
TP16318

Cat. #	Clamps	Ground Plate	Bracket/Bar Hgr.	Capacity Cu. In.	No. of Clamp Openings	Std. Unit Pkg.	Wt. Lbs. Per 100
TP16200†	Yes	—	Snap	16.0	4	50	27
TP16201†	Yes	Yes	Snap	16.0	4	50	29
TP16310*	Yes	—	Nails	19.3	4	50	18
TP16311*	Yes	Yes	Nails	19.3	4	50	20
TP16307*‡	Yes	—	14"–22-1/2"	19.3	4	25	57
TP16308*‡	Yes	Yes	14"–22-1/2"	19.3	4	25	59
TP16317*	Yes	—	"B"	19.3	4	50	26
TP16318*	Yes	Yes	"B"	19.3	4	50	20

*Nail Bracket is set 1 1/8" back from the face of the box.

† Weight limit 15lbs for ceiling mounted fixtures and 6lbs for wall mounted fixtures.

‡ Weight limit 15lbs at 24" stud spacing, 35lbs at 16" stud spacing.

LAMPHOLDER



TP16099

Standard Materials:

- Plastic molded of heat and impact resistant material that prevents discoloring and reduces breakage

Cat. #	Description	Std. Unit Pkg.	Wt. Lbs. Per 100
TP16099	Lampholder, Keyless, feed thru	50	23

4" NONMETALLIC CEILING BOXES

UL LISTED

Weight limit is 50 lbs for fixture except where indicated

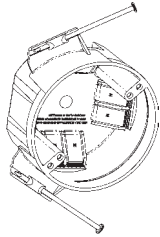

TP16111, TP16110

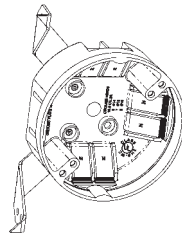

TP16012, TP16112

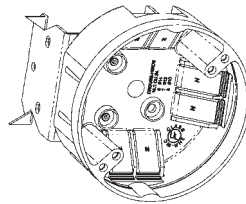

TP16007, TP16107

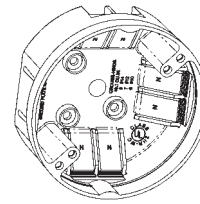

TP16002



TP16022, TP16023

Ceiling Boxes

Cat. #	Clamps	Ground Plate	Bracket/Bar Hgr.	Capacity Cu. In.	No. of Cable Pry-outs	Std. Unit Pkg.	Wt. Lbs. Per 100
1 1/2" DEEP							
TP16002	Yes	—	—	14.8	4	50	12
TP16003	Yes	Yes	—	14.8	4	50	14
TP16012	Yes	—	"V"	14.8	4	50	24
TP16007	Yes	—	"B"	14.8	4	50	26
TP16008	Yes	Yes	"B"	14.8	4	50	28
TP16022*	Yes	—	14"-22-1/2"	14.8	4	25	56
TP16023*	Yes	Yes	14"-22-1/2"	14.8	4	25	58
2 3/4" DEEP							
TP16111	Yes	—	Nails	20.3	4	50	19
TP16110	Yes	Yes	Nails	22.5	4	50	21
TP16112	Yes	—	"V"	20.8	4	50	27
TP16113	Yes	Yes	"V"	20.8	4	50	29
TP16107	Yes	—	"B"	20.8	4	50	28
TP16108	Yes	Yes	"B"	20.8	4	50	30
TP16122*	Yes	—	14"-22-1/2"	20.8	4	20	59
TP16123*	Yes	Yes	14"-22-1/2"	20.8	4	20	61

*Weight limit 15 lbs at 24" stud spacing, 35 lbs at 16" stud spacing.

NONMETALLIC CEILING FAN BOXES

2 3/16" DEEP

UL LISTED

With clamps for nonmetallic cable.

All mounting hardware supplied, suitable for support of fans weighing up to 35 lbs.

Made of heavy-duty, engineered thermoplastic material

Offers the labor-saving feature of quick entry and integral clamping

Eliminates the need to use a screwdriver to break open pry-outs

The easy access entry-point serves as a wire clamp, eliminating time required to mechanically secure the wire to the box



TP16511

Cat. #	Diameter	Mounting Method	Capacity Cu. In.	No. of Clamp Openings	Unit Qty.	Wt. Lbs. Per 100
TP16511	4"	Nails only	22.5	6	25	21

CEILING FAN BOXES – PVC

UL LISTED

Weight Limits: Fans and fixtures are supported independent of outlet box. Mounting screws go through box and into joist. Box will support up to 70 lbs. for fans and 90 lbs. for fixtures. Provided with Romex connector



TP1300

Ceiling Boxes

Cat. #	Description	Capacity Cu. In.	Knockouts	Integral Clamp	Std. Unit Pkg.	Wt. Lbs. Per 100
TP1300	4 ¹ / ₁₆ " diam., 1/2" deep pan section, 4" deep overall – with mtg. hardware & external clamp, protective cover	14.0	3 – 1/2"	1	24	34

ROUND BLANK COVER – PVC

4³/₄" DIA.

(FOR 3¹/₂" AND 4" ROUND CEILING BOXES)



TP1040, TP1045

Cat. #	Color	Screws	Std. Unit Pkg.	Wt. Lbs. Per 100
TP1040	Gray	—	100	10
TP1045*	White	White	100	12

*TP1045 includes two white-headed wood and two #8-32" machine screws.

PRE-formance™

Giving you the convenience of a pre-fabricated product-plus the flexibility to accommodate job-site requirements.

Contractors are continually looking for ways to improve job site efficiency and properly align skilled resources to meet tight commercial construction project deadlines. PRE-formance™ delivers the pre-engineered & pre-assembled combination of mounting method, outlet box, plaster ring, devices and leads to simplify branch wiring installation.



PRE-formance™

Certifications and Compliances:

- UL Listed and cUL Listed



Basic

- Available with the most popular drawn & welded boxes with ground screw and pigtail lead already installed
- Patented Uni-mount™ cover combines plaster ring & mounting method
- Standard Pre-fabricated assemblies with mounting brackets, boxes, mud rings, ground screw and pigtail leads
- Available from stock



Custom

- Cafeteria style selection of Cooper Crouse-Hinds extensive line of mounting brackets, boxes, plaster rings, wiring devices, push-in connectors, and other associated branch wiring accessories
- Assembled-to-order pre-fabricated products for both AC/MC & EMT applications
- Can be ordered with devices, customer specified connectors and cable whips attached to suit almost any customer application
- Assembled from stock components to meet tight job requirements



Complete

- The most complete turn-key solution for commercial construction projects. The process begins with your architectural and electrical engineering drawings and delivers a total pre-fabricated branch wiring system: custom produced, labeled, packaged by room and floor, and delivered to your exact location.
- Ideal for hotel projects, assisted living facilities, dormitories, barracks and office buildings
- Job specific labeling included with every cable run indicates starting position, ending position, device and mounting type, cable size, length, path, drawing number and date
- Safe, secure transmission of drawings to secure file exchange server where our technical team completes a preliminary take-off analysis.
- Innovative PRE-formance products are designed by contractors for contractors to give you the ease of wiring & job site flexibility to get the job done right & on-time!
- Includes mounting brackets & open back boxes that are designed with pre-fabrication, productivity & job site speed in mind.
- Contractors can realize 30 to 40% labor savings over traditional "stick-build" wiring methods for greatly improved jobsite efficiency

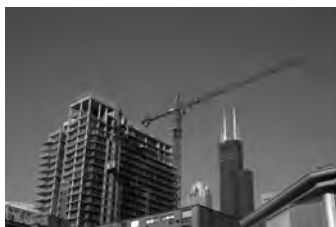
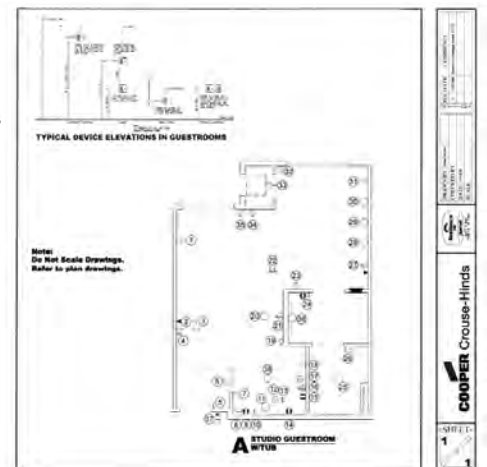

For more information on all PRE-formance products or how to submit drawings for quotation, please email CCHPREformance@cooperindustries.com or call 315-477-5592

Uni-Mount™ Assemblies

Cooper Crouse-Hinds Pre-Fabricated Boxes take labor savings to a whole new level! Includes the Uni-Mount™ cover attached to a 4" square box with ground screw and lead installed.

Step 1 – Receive Uni-Mount™ Pre-Fabricated Box (Includes Uni-Mount cover attached to box with ground screw + lead installed)

Step 2 – Attach to wood or metal stud. You're done!



PRE-formance™

UL and cUL Listed



UL File No. E-23156

Pre-Fabricated Box Features:

- Uni-Mount provides a secure box support and features a built-in plaster ring
- Can be field assembled with outlet box for power applications or used without a box for low voltage applications
- Pre-fabricated Uni-Mount is available with most popular outlet boxes with a choice of 1/2", 5/8" or 3/4" raised cover and includes ground screw and lead
- Rigid bracket design eliminates the need for far-side support
- Guide tabs ensure alignment on studs

Uni-Mount Features:

- Uni-Mount combines the features of a mounting device plate with those of a box support; giving you one universal plate for all of your needs. Specifically designed for use with metal or wood studs.
- New and improved Uni-Mount incorporates four small holes on the left side (support side) of the bracket. These holes allow for the attachment of box mounting brackets to allow for use of both sides of the stud. The holes are strategically located to accept either the B-Line BB423 bracket. Additionally, the viewing hole has been significantly enlarged (and is now diamond shaped) to make it even easier to find mark lines on the stud.



TP404
1 1/2" Deep – Welded
22.0" Cubic Capacity

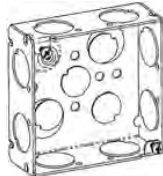

TP403
2 1/8" Deep – Welded
22.0" Cubic Capacity

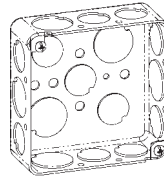

TP414
1 1/2" Deep – Welded
21.0" Cubic Capacity

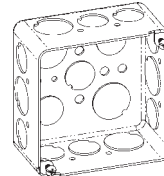

TP434
2 1/8" Deep – Welded
30.3" Cubic Capacity

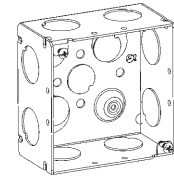

TP436
2 1/8" Deep – Welded
30.3" Cubic Capacity

Cat. #	Description	Capacity Cu. In.	Unit Qty.	Wt. Lbs. Per 100
For Conduit				
TP30404PF	1 1/2" Deep Welded Box, 1/2" Raised Single Gang Uni-Mount Cover, ground screw and lead	25.8	25	115
TP30414PF	1 1/2" Deep Drawn Box, 1/2" Raised Single Gang Uni-Mount Cover, ground screw and lead	24.8	25	110
TP31404PF	1 1/2" Deep Welded Box, 5/8" Raised Single Gang Uni-Mount Cover, ground screw and lead	26.3	25	118
TP31414PF	1 1/2" Deep Drawn Box, 5/8" Raised Single Gang Uni-Mount Cover, ground screw and lead	25.3	25	113
TP32404PF	1 1/2" Deep Welded Box, 3/4" Raised Single Gang Uni-Mount Cover, ground screw and lead	27.5	25	122
TP32414PF	1 1/2" Deep Drawn Box, 3/4" Raised Single Gang Uni-Mount Cover, ground screw and lead	26.5	25	117
TP35404PF	1 1/2" Deep Welded Box, 1/2" Raised Two Gang Uni-Mount Cover, ground screw and lead	28.0	25	110
TP35414PF	1 1/2" Deep Drawn Box, 1/2" Raised Two Gang Uni-Mount Cover, ground screw and lead	27.0	25	105
TP36404PF	1 1/2" Deep Welded Box, 5/8" Raised Two Gang Uni-Mount Cover, ground screw and lead	30.0	25	124
TP36414PF	1 1/2" Deep Drawn Box, 5/8" Raised Two Gang Uni-Mount Cover, ground screw and lead	29.0	25	119
TP37404PF	1 1/2" Deep Welded Box, 3/4" Raised Two Gang Uni-Mount Cover, ground screw and lead	31.0	25	126
TP37414PF	1 1/2" Deep Drawn Box, 3/4" Raised Two Gang Uni-Mount Cover, ground screw and lead	30.0	25	121
TP30403PF	2 1/8" Deep Welded Box, 1/2" Raised Single Gang Uni-Mount Cover, ground screw and lead	34.1	25	107
TP30434PF	2 1/8" Deep Drawn Box, 1/2" Raised Single Gang Uni-Mount Cover, ground screw and lead	34.1	25	127
TP31403PF	2 1/8" Deep Welded Box, 5/8" Raised Single Gang Uni-Mount Cover, ground screw and lead	34.6	25	110
TP31434PF	2 1/8" Deep Drawn Box, 5/8" Raised Single Gang Uni-Mount Cover, ground screw and lead	34.6	25	130
TP31436PF	2 1/8" Deep Welded Box, 5/8" Raised Single Gang Uni-Mount Cover, ground screw and lead	26.3	25	130
TP32403PF	2 1/8" Deep Welded Box, 3/4" Raised Single Gang Uni-Mount Cover, ground screw and lead	35.8	25	114
TP32434PF	2 1/8" Deep Drawn Box, 3/4" Raised Single Gang Uni-Mount Cover, ground screw and lead	35.8	25	134
TP35403PF	2 1/8" Deep Welded Box, 1/2" Raised Two Gang Uni-Mount Cover, ground screw and lead	36.3	25	102
TP35434PF	2 1/8" Deep Drawn Box, 1/2" Raised Two Gang Uni-Mount Cover, ground screw and lead	36.3	25	122
TP36403PF	2 1/8" Deep Welded Box, 5/8" Raised Two Gang Uni-Mount Cover, ground screw and lead	38.3	25	116
TP36434PF	2 1/8" Deep Drawn Box, 5/8" Raised Two Gang Uni-Mount Cover, ground screw and lead	38.3	25	136
TP37403PF	2 1/8" Deep Welded Box, 3/4" Raised Two Gang Uni-Mount Cover, ground screw and lead	39.3	25	118
TP37434PF	2 1/8" Deep Drawn Box, 3/4" Raised Two Gang Uni-Mount Cover, ground screw and lead	39.3	25	138

Cat. #	Description	Capacity Cu. In.	Unit Qty.	Wt. Lbs. Per 100
Pre-Fabricated Box, Cover, Ground Screw and Lead Assembly				
For AC/MC Cable				
TP30454PF	1½" Deep Welded Box assembled to ½" Raised Single Gang Uni-Mount Cover	24.8	25	114
TP31454PF	1½" Deep Welded Box assembled to ⅝" Raised Single Gang Uni-Mount Cover	25.3	25	117
TP32454PF	1½" Deep Welded Box assembled to ¾" Raised Single Gang Uni-Mount Cover	26.5	25	121
TP35454PF	1½" Deep Welded Box assembled to ½" Raised Two Gang Uni-Mount Cover	27.0	25	109
TP36454PF	1½" Deep Welded Box assembled to ⅝" Raised Two Gang Uni-Mount Cover	29.0	25	123
TP37454PF	1½" Deep Welded Box assembled to ¾" Raised Two Gang Uni-Mount Cover	30.0	25	125
TP30431PF	2⅝" Deep Welded Box assembled to ½" Raised Single Gang Uni-Mount Cover	34.1	25	134
TP31431PF	2⅝" Deep Welded Box assembled to ⅝" Raised Single Gang Uni-Mount Cover	34.6	25	137
TP32431PF	2⅝" Deep Welded Box assembled to ¾" Raised Single Gang Uni-Mount Cover	35.8	25	141
TP35431PF	2⅝" Deep Welded Box assembled to ½" Raised Two Gang Uni-Mount Cover	36.3	25	129
TP36431PF	2⅝" Deep Welded Box assembled to ⅝" Raised Two Gang Uni-Mount Cover	38.3	25	143
TP37431PF	2⅝" Deep Welded Box assembled to ¾" Raised Two Gang Uni-Mount Cover	39.3	25	145



Open Back Box

Innovative Open Back Boxes maximize working area to reduce wiring time and eliminate interference problems. Eliminates the need for disassembly at the job site. All open back box assemblies are shipped with TP472 flat, blank back covers.

Cat. #	Description	Capacity Cu. In.	Unit Qty.	Wt. Lbs. Per 100
Pre-Fabricated Open Back Box, Cover, Ground Screw and Lead Assembly				
For Conduit				
TP3040DPF	2⅝" Deep Welded Open Back Box, ½" Raised Single Gang Uni-Mount Cover, ground clip, lead, and back cover	34.1	25	107
TP3140DPF	2⅝" Deep Welded Open Back Box, ⅝" Raised Single Gang Uni-Mount Cover, ground clip, lead, and back cover	34.1	25	110
TP3240DPF	2⅝" Deep Welded Open Back Box, ¾" Raised Single Gang Uni-Mount Cover, ground clip, lead, and back cover	34.1	25	114
TP3540DPF	2⅝" Deep Welded Open Back Box, ½" Raised Two Gang Uni-Mount Cover, ground clip, lead, and back cover	34.1	25	112
TP3640DPF	2⅝" Deep Welded Open Back Box, ⅝" Raised Two Gang Uni-Mount Cover, ground clip, lead, and back cover	34.1	25	116
TP3740DPF	2⅝" Deep Welded Open Back Box, ¾" Raised Two Gang Uni-Mount Cover, ground clip, lead, and back cover	34.1	25	118

Additional Uni-Mount / box configurations available. Consult factory for details.
Remove the PF for boxes without ground screw and lead.
For stranded wire replace PF with PFA

For more information on all PRE-formance products or how to submit drawings for quotation, please email CCHPREformance@cooperindustries.com or call 315-477-5592

Single Sided Assemblies

Single Sided Direct Mount Assemblies - all catalog numbers contain a single sided direct mount bracket (for 2½" and 3½" studs), 4" square steel box, mud ring, 8" insulated solid ground wire with ground screw or clip and SmartGuard™



PRE-formance™

UL and cUL Listed
UL File No. E-324733



Cat. #	Description
Pre-Fabricated Box, Cover, Ground Screw and Lead Assembly	
PFH3 40D58	BB423 Single sided bracket, Open back 2½" deep box with pigtail, ⅝" raised 1G mud ring
PFH3 40D75	BB423 Single sided bracket, Open back 2½" deep box with pigtail, ¾" raised 1G mud ring
PFH3 40DAR*	BB423 Single sided bracket, Open back 2½" deep box with pigtail, Adjustable 1G mud ring
PFH3 4D58	BB423 Single sided bracket, TP403 2½" deep box with pigtail, ⅝" raised 1G mud ring
PFH3 4D75	BB423 Single sided bracket, TP403 2½" deep box with pigtail, ¾" raised 1G mud ring
PFH3 4DAR*	BB423 Single sided bracket, TP403 2½" deep box with pigtail, Adjustable 1G mud ring
PFH3 4S58	BB423 Single sided bracket, TP404 1½" deep box with pigtail, ⅝" raised 1G mud ring
PFH3 4S75	BB423 Single sided bracket, TP404 1½" deep box with pigtail, ¾" raised 1G mud ring
PFH3 40D258	BB423 Single sided bracket, Open back 2½" deep box with pigtail, ⅝" raised 2G mud ring
PFH3 40D275	BB423 Single sided bracket, Open back 2½" deep box with pigtail, ¾" raised 2G mud ring
PFH3 4D258	BB423 Single sided bracket, TP403 2½" deep box with pigtail, ⅝" raised 2G mud ring
PFH3 4D275	BB423 Single sided bracket, TP403 2½" deep box with pigtail, ¾" raised 2G mud ring
PFH3 4S258	BB423 Single sided bracket, TP404 1½" deep box with pigtail, ⅝" raised 2G mud ring
PFH3 4S275	BB423 Single sided bracket, TP404 1½" deep box with pigtail, ¾" raised 2G mud ring

- Double Sided Direct Mount Assemblies also available. Substitute PFH3 with PF3DS (BB73).
- 4" and 6" Far side supports are available. Replace PFH3 (for 2½" and 3½" studs) with PFH4 (4") (BB44) or PFH6 (6") (BB46). For double sided, replace PF3DS with PF4DS (BB74) or PF6DS (BB76).
- Refer to the PRE-formance Catalog Numbering System at the end of this section for additional assembly options and configurations.

Floor Mount Assemblies

Floor Mount Assemblies - all catalog numbers contain a 18" floor mount bracket, 4" square steel box, mud ring, 8" insulated solid ground wire with ground screw or clip and SmartGuard™



UL and cUL Listed
UL File No. E-324733



Cat. #	Description
Pre-Fabricated Box, Cover, Ground Screw and Lead Assembly	
PF18FM 40D58	BFM184 Floor mount bracket, Open back 2½" deep box with pigtail, ⅝" raised 1G mud ring
PF18FM 40D75	BFM184 Floor mount bracket, Open back 2½" deep box with pigtail, ¾" raised 1G mud ring
PF18FM 40DAR*	BFM184 Floor mount bracket, Open back 2½" deep box with pigtail, Adjustable 1G mud ring
PF18FM 4D58	BFM184 Floor mount bracket, TP403 2½" deep box with pigtail, ⅝" raised 1G mud ring
PF18FM 4D75	BFM184 Floor mount bracket, TP403 2½" deep box with pigtail, ¾" raised 1G mud ring
PF18FM 4DAR*	BFM184 Floor mount bracket, TP403 2½" deep box with pigtail, Adjustable 1G mud ring
PF18FM 4S58	BFM184 Floor mount bracket, TP404 1½" deep box with pigtail, ⅝" raised 1G mud ring
PF18FM 4S75	BFM184 Floor mount bracket, TP404 1½" deep box with pigtail, ¾" raised 1G mud ring
PF18FM 40D258	BFM184 Floor mount bracket, Open back 2½" deep box with pigtail, ⅝" raised 2G mud ring
PF18FM 40D275	BFM184 Floor mount bracket, Open back 2½" deep box with pigtail, ¾" raised 2G mud ring
PF18FM 4D258	BFM184 Floor mount bracket, TP403 2½" deep box with pigtail, ⅝" raised 2G mud ring
PF18FM 4D275	BFM184 Floor mount bracket, TP403 2½" deep box with pigtail, ¾" raised 2G mud ring
PF18FM 4S258	BFM184 Floor mount bracket, TP404 1½" deep box with pigtail, ⅝" raised 2G mud ring
PF18FM 4S275	BFM184 Floor mount bracket, TP404 1½" deep box with pigtail, ¾" raised 2G mud ring

- Refer to the PRE-formance Catalog Numbering System at the end of this section for additional assembly options and configurations.
- *Not UL Listed. All components are third party certified.

Telescoping Slider Assemblies

Telescoping Slider Assemblies - all catalog numbers contain a 11-18" telescoping slider bracket, 4" square steel box, mud ring, 8" insulated solid ground wire with ground screw and SmartGuard™



UL and cUL Listed



UL File No. E-324733

PRE-formance™

Cat. #	Description
Pre-Fabricated Box, Cover, Ground Screw and Lead Assembly	
PF16TS 4D58	BB216TS Telescoping slider bracket, TP403 2 1/8" deep box with pigtail, 5/8" raised 1G mud ring
PF16TS 4D75	BB216TS Telescoping slider bracket, TP403 2 1/8" deep box with pigtail, 3/4" raised 1G mud ring
PF16TS 4DAR	BB216TS Telescoping slider bracket, TP403 2 1/8" deep box with pigtail, Adjustable 1G mud ring
PF16TS 4S58	BB216TS Telescoping slider bracket, TP404 1 1/2" deep box with pigtail, 5/8" raised 1G mud ring
PF16TS 4S75	BB216TS Telescoping slider bracket, TP404 1 1/2" deep box with pigtail, 3/4" raised 1G mud ring
PF16TS 4D258	BB216TS Telescoping slider bracket, TP403 2 1/8" deep box with pigtail, 5/8" raised 2G mud ring
PF16TS 4D275	BB216TS Telescoping slider bracket, TP403 2 1/8" deep box with pigtail, 3/4" raised 2G mud ring
PF16TS 4D2AR	BB216TS Telescoping slider bracket, TP403 2 1/8" deep box with pigtail, adjustable 2G mud ring
PF16TS 4S258	BB216TS Telescoping slider bracket, TP404 1 1/2" deep box with pigtail, 5/8" raised 2G mud ring
PF16TS 4S275	BB216TS Telescoping slider bracket, TP404 1 1/2" deep box with pigtail, 3/4" raised 2G mud ring

- 15"-16" Telescoping slider assemblies are available. Replace PF16TS (BB216TS) with PF24TS (BB224TS).
- Refer to the PRE-formance Catalog Numbering System at the end of this section for additional assembly options and configurations.

Multi-Mount Assemblies

Multi-Mount Assemblies - all catalog numbers contain a 16" stud spanning Multiple Mount Bracket. Each Position may contain a 4" square steel box, mud ring, 8" insulated solid ground wire with ground screw and SmartGuard™



UL and cUL Listed



UL File No. E-324733

Cat. #	Description
Pre-Fabricated Box, Cover, Ground Screw and Lead Assembly	
PF3MM 4D58 X X	BB816 Multiple box bracket, 1st Position TP403 2 1/8" deep box with pigtail, 5/8" raised 1G mud ring, 2nd and 3rd positions open
PF3MM 4D75 X X	BB816 Multiple box bracket, 1st Position TP403 2 1/8" deep box with pigtail, 3/4" raised 1G mud ring, 2nd and 3rd positions open
PF3MM 4D258 X X	BB816 Multiple box bracket, 1st Position TP403 2 1/8" deep box with pigtail, 5/8" raised 2G mud ring, 2nd and 3rd positions open
PF3MM 4D275 X X	BB816 Multiple box bracket, 1st Position TP403 2 1/8" deep box with pigtail, 3/4" raised 2G mud ring, 2nd and 3rd positions open
PF3MM 4D58 5DN58 X	BB816 Multiple box bracket, 1st Position TP403 2 1/8" deep box with pigtail, 5/8" raised 1G mud ring, 2nd position TP525 4 11/16" Square 2 1/8" Deep box, 5/8" raised 1G mud ring, no pigtail, 3rd position open
PF3MM 4D75 5DN75 X	BB816 Multiple box bracket, 1st Position TP403 2 1/8" deep box with pigtail, 3/4" raised 1G mud ring, 2nd position TP525 4 11/16" Square 2 1/8" Deep box, 3/4" raised 1G mud ring, no pigtail, 3rd position open
PF3MM 4D258 5DN58 X	BB816 Multiple box bracket, 1st Position TP403 2 1/8" deep box with pigtail, 5/8" raised 2G mud ring, 2nd position TP525 4 11/16" Square 2 1/8" Deep box, 5/8" raised 1G mud ring, no pigtail, 3rd position open
PF3MM 4D275 5DN75 X	BB816 Multiple box bracket, 1st Position TP403 2 1/8" deep box with pigtail, 3/4" raised 2G mud ring, 2nd position TP525 4 11/16" Square 2 1/8" Deep box, 3/4" raised 1G mud ring, no pigtail, 3rd position open
PF3MM 4D58 X X	BB816 Multiple box bracket, 1st Position Open back 2 1/8" deep box with pigtail, 5/8" raised 1G mud ring, 2nd and 3rd positions open
PF3MM 4D75 X X	BB816 Multiple box bracket, 1st Position Open back 2 1/8" deep box with pigtail, 3/4" raised 1G mud ring, 2nd and 3rd positions open
PF3MM 4D258 X X	BB816 Multiple box bracket, 1st Position Open back 2 1/8" deep box with pigtail, 5/8" raised 2G mud ring, 2nd and 3rd positions open
PF3MM 4D275 X X	BB816 Multiple box bracket, 1st Position Open back 2 1/8" deep box with pigtail, 3/4" raised 2G mud ring, 2nd and 3rd positions open
PF3MM 4D58 5DN58 X	BB816 Multiple box bracket, 1st Position Open back 2 1/8" deep box with pigtail, 5/8" raised 1G mud ring, 2nd position TP525 4 11/16" Square 2 1/8" Deep box, 5/8" raised 1G mud ring, no pigtail, 3rd position open
PF3MM 4D75 5DN75 X	BB816 Multiple box bracket, 1st Position Open back 2 1/8" deep box with pigtail, 3/4" raised 1G mud ring, 2nd position TP525 4 11/16" Square 2 1/8" Deep box, 3/4" raised 1G mud ring, no pigtail, 3rd position open
PF3MM 4D258 5DN58 X	BB816 Multiple box bracket, 1st Position Open back 2 1/8" deep box with pigtail, 5/8" raised 2G mud ring, 2nd position TP525 4 11/16" Square 2 1/8" Deep box, 5/8" raised 1G mud ring, no pigtail, 3rd position open
PF3MM 4D275 5DN75 X	BB816 Multiple box bracket, 1st Position Open back 2 1/8" deep box with pigtail, 3/4" raised 2G mud ring, 2nd position TP525 4 11/16" Square 2 1/8" Deep box, 3/4" raised 1G mud ring, no pigtail, 3rd position open

- Refer to the PRE-formance Catalog Numbering System at the end of this section for additional assembly options and configurations.

Open Bracket Assemblies

Open Bracket Assemblies - all catalog numbers contain a 16" stud spanning Open Bracket. Each Position may contain a 4" square steel box, mud ring, 8" insulated solid ground wire with ground screw and SmartGuard™

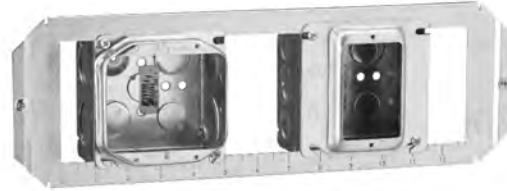

UL and cUL Listed
UL File No. E-324733



Cat. #	Description Pre-Fabricated Box, Cover, Ground Screw and Lead Assembly
PF16BO 4D58 X X	BB716 Open bracket, 1st Position TP403 2 1/8" deep box with pigtail, 5/8" raised 1G mud ring, 2nd and 3rd positions open
PF16BO 4D75 X X	BB716 Open bracket, 1st Position TP403 2 1/8" deep box with pigtail, 3/4" raised 1G mud ring, 2nd and 3rd positions open
PF16BO 4D258 X X	BB716 Open bracket, 1st Position TP403 2 1/8" deep box with pigtail, 5/8" raised 2G mud ring, 2nd and 3rd positions open
PF16BO 4D275 X X	BB716 Open bracket, 1st Position TP403 2 1/8" deep box with pigtail, 3/4" raised 2G mud ring, 2nd and 3rd positions open
PF16BO 4D58 5DN58 X	BB716 Open bracket, 1st Position TP403 2 1/8" deep box with pigtail, 5/8" raised 1G mud ring, 2nd position TP525 4 1/16" Square 2 1/8" Deep box, 5/8" raised 1G mud ring, no pigtail, 3rd position open
PF16BO 4D75 5DN75 X	BB716 Open bracket, 1st Position TP403 2 1/8" deep box with pigtail, 3/4" raised 1G mud ring, 2nd position TP525 4 1/16" Square 2 1/8" Deep box, 3/4" raised 1G mud ring, no pigtail, 3rd position open
PF16BO 4D258 5DN58 X	BB716 Open bracket, 1st Position TP403 2 1/8" deep box with pigtail, 5/8" raised 2G mud ring, 2nd position TP525 4 1/16" Square 2 1/8" Deep box, 5/8" raised 1G mud ring, no pigtail, 3rd position open
PF16BO 4D275 5DN75 X	BB716 Open bracket, 1st Position TP403 2 1/8" deep box with pigtail, 3/4" raised 2G mud ring, 2nd position TP525 4 1/16" Square 2 1/8" Deep box, 3/4" raised 1G mud ring, no pigtail, 3rd position open
PF16BO 40D58 X X	BB716 Open bracket, 1st Position Open back 2 1/8" deep box with pigtail, 5/8" raised 1G mud ring, 2nd and 3rd positions open
PF16BO 40D75 X X	BB716 Open bracket, 1st Position Open back 2 1/8" deep box with pigtail, 3/4" raised 1G mud ring, 2nd and 3rd positions open
PF16BO 40D258 X X	BB716 Open bracket, 1st Position Open back 2 1/8" deep box with pigtail, 5/8" raised 2G mud ring, 2nd and 3rd positions open
PF16BO 40D275 X X	BB716 Open bracket, 1st Position Open back 2 1/8" deep box with pigtail, 3/4" raised 2G mud ring, 2nd and 3rd positions open
PF16BO 40D58 5DN58 X	BB716 Open bracket, 1st Position Open back 2 1/8" deep box with pigtail, 5/8" raised 1G mud ring, 2nd position TP525 4 1/16" Square 2 1/8" Deep box, 5/8" raised 1G mud ring, no pigtail, 3rd position open
PF16BO 40D75 5DN75 X	BB716 Open bracket, 1st Position Open back 2 1/8" deep box with pigtail, 3/4" raised 1G mud ring, 2nd position TP525 4 1/16" Square 2 1/8" Deep box, 3/4" raised 1G mud ring, no pigtail, 3rd position open
PF16BO 40D258 5DN58 X	BB716 Open bracket, 1st Position Open back 2 1/8" deep box with pigtail, 5/8" raised 2G mud ring, 2nd position TP525 4 1/16" Square 2 1/8" Deep box, 5/8" raised 1G mud ring, no pigtail, 3rd position open
PF16BO 40D275 5DN75 X	BB716 Open bracket, 1st Position Open back 2 1/8" deep box with pigtail, 3/4" raised 2G mud ring, 2nd position TP525 4 1/16" Square 2 1/8" Deep box, 3/4" raised 1G mud ring, no pigtail, 3rd position open

• Refer to the PRE-formance Catalog Numbering System at the end of this section for additional assembly options and configurations.

T-Bar Assemblies

T-Bar Assemblies - all catalog numbers contain BA50 T-Bar fastener, 4" square or octagon box

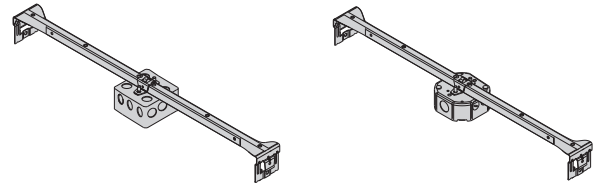

UL and cUL Listed
UL File No. E-324733



Cat. #	Description Pre-Fabricated Box, Cover, Ground Screw and Lead Assembly
PFBH24 4SN	BA50 Bar hanger, TP404 1 1/2" deep box
PFBH24 4DN	BA50 Bar hanger, TP403 2 1/8" deep box
PFBH24 278N	BA50 Bar hanger, TP278 1 1/2" deep octagon box
PFBH24 292N	BA50 Bar hanger, TP292 2 1/8" deep octagon box

For more information on all PRE-formance products or how to submit drawings for quotation, please email CCHPREformance@cooperindustries.com or call 315-477-5592

Uni-Mount™ Assemblies with Wiring Devices

Cooper Crouse-Hinds PRE-formance Uni-Mount Assemblies - All catalog numbers contain a Uni-mount cover (TP31000-37000), 4" square open back box, an 8" insulated solid box ground wire with ground clip, one or two pre-wired Cooper Wiring Devices with leads, push-in connectors, and device protect plates.



Uni-Mount assemblies with wiring devices are shipped standard with open back boxes. Open back boxes maximize the working area to reduce wiring time and eliminate interference problems. They virtually eliminate the need for disassembly at the job site. Open back boxes are available in either 1 1/2" or 2 1/8" deep with 1/2" & 3/4" eccentric knockouts. All 4" square open back box assemblies are shipped with TP472 flat, blank back covers.

- All assemblies are shown with ivory colored devices. At the end of the catalog number, replace the "V" with "W" for white colored device. Other device colors and types are available. Consult factory for details.

UL and cUL Listed
UL File No. E324733



PRE-formance™

Commonly ordered catalog examples are listed below

See Uni-Mount assembly catalog numbering system at the end of the Uni-Mount assembly pages for more information on how to construct catalog numbers for almost any customer application

Duplex Receptacle



Commercial Grade Receptacle	Industrial Grade Receptacle	Hospital Grade Receptacle		
Assembly Catalog Number with CR20V Commercial Grade 20A Duplex Receptacle Installed	Assembly Catalog Number with 5362V Industrial Grade 20A Duplex Receptacle Installed	Assembly Catalog Number with 8300V Hospital Grade 20A Duplex Receptacle Installed	4" Square Steel Open Back Box	Uni-Mount
Single 20A Duplex Receptacle				
TP3140D C20DV	TP3140D I20DV	TP3140D H20DV	2 1/8" Deep	5/8" Single Gang
TP3140S C20DV	TP3140S I20DV	TP3140S H20DV	1 1/2" Deep	5/8" Single Gang
TP3240D C20DV	TP3240D I20DV	TP3240D H20DV	2 1/8" Deep	3/4" Single Gang
TP3240S C20DV	TP3240S I20DV	TP3240S H20DV	1 1/2" Deep	3/4" Single Gang
Double 20A Duplex Receptacle				
TP3640D C20DDV	TP3640D I20DDV	TP3640D H20DDV	2 1/8" Deep	5/8" Two Gang
TP3640S C20DDV	TP3640S I20DDV	TP3640S H20DDV	1 1/2" Deep	5/8" Two Gang
TP3740D C20DDV	TP3740D I20DDV	TP3740D H20DDV	2 1/8" Deep	3/4" Two Gang
TP3740S C20DDV	TP3740S I20DDV	TP3740S H20DDV	1 1/2" Deep	3/4" Two Gang

GFCI Receptacle



Specification Grade GFCI Receptacle	Hospital Grade GFCI Receptacle			
Assembly Catalog Number with VGF20 Specification Grade 20A GFCI Receptacle Installed	Assembly Catalog Number with VGFH20V Hospital Grade 20A GFCI Receptacle Installed	4" Square Steel Open Back Box	Uni-Mount	
Single 20A GFCI Receptacle				
TP3140D S20GV	TP3140D H20GV	2 1/8" Deep	5/8" Single Gang	
TP3140S S20GV	TP3140S H20GV	1 1/2" Deep	5/8" Single Gang	
TP3240D S20GV	TP3240D H20GV	2 1/8" Deep	3/4" Single Gang	
TP3240S S20GV	TP3240S H20GV	1 1/2" Deep	3/4" Single Gang	
Double 20A GFCI Receptacle				
TP3640D S20GGV	TP3640D H20GGV	2 1/8" Deep	5/8" Two Gang	
TP3640S S20GGV	TP3640S H20GGV	1 1/2" Deep	5/8" Two Gang	
TP3740D S20GGV	TP3740D H20GGV	2 1/8" Deep	3/4" Two Gang	
TP3740S S20GGV	TP3740S H20GGV	1 1/2" Deep	3/4" Two Gang	

Uni-Mount™ Assemblies with Wiring Devices

Commonly ordered catalog examples are listed below

See Uni-Mount assembly catalog numbering system at the end of the Uni-Mount assembly pages for more information on how to construct catalog numbers for almost any customer application

PRE-formance™

Single Pole Switch



Commercial Grade Single Pole Switch	Industrial Grade Single Pole Switch	4" Square Steel Open Back Box	Uni-Mount
Assembly Catalog Number with CS120V Commercial Grade 20A Single Pole Switch Installed	Assembly Catalog Number with AH1221V Industrial Grade 20A Single Pole Switch Installed		
Single 20A Single Pole Switch			
TP3140D C20SPV	TP3140D I20SPV	2 1/8" Deep	5/8" Single Gang
TP3140S C20SPV	TP3140S I20SPV	1 1/2" Deep	5/8" Single Gang
TP3240D C20SPV	TP3240D I20SPV	2 1/8" Deep	3/4" Single Gang
TP3240S C20SPV	TP3240S I20SPV	1 1/2" Deep	3/4" Single Gang
Double 20A Single Pole Switch			
TP3640D C20SPSPV	TP3640D I20SPSPV	2 1/8" Deep	5/8" Two Gang
TP3640S C20SPSPV	TP3640S I20SPSPV	1 1/2" Deep	5/8" Two Gang
TP3740D C20SPSPV	TP3740D I20SPSPV	2 1/8" Deep	3/4" Two Gang
TP3740S C20SPSPV	TP3740S I20SPSPV	1 1/2" Deep	3/4" Two Gang

Three Way Switch



Commercial Grade Three Way Switch	Industrial Grade Three Way Switch	4" Square Steel Open Back Box	Uni-Mount
Assembly Catalog Number with CS320V Commercial Grade 20A Three Way Switch Installed	Assembly Catalog Number with AH1223V Industrial Grade 20A Three Way Switch Installed		
Single 20A Three Way Switch			
TP3140D C203WV	TP3140D I203WV	2 1/8" Deep	5/8" Single Gang
TP3140S C203WV	TP3140S I203WV	1 1/2" Deep	5/8" Single Gang
TP3240D C203WV	TP3240D I203WV	2 1/8" Deep	3/4" Single Gang
TP3240S C203WV	TP3240S I203WV	1 1/2" Deep	3/4" Single Gang
Double 20A Three Way Switch			
TP3640D C203W3WV	TP3640D I203W3WV	2 1/8" Deep	5/8" Two Gang
TP3640S C203W3WV	TP3640S I203W3WV	1 1/2" Deep	5/8" Two Gang
TP3740D C203W3WV	TP3740D I203W3WV	2 1/8" Deep	3/4" Two Gang
TP3740S C203W3WV	TP3740S I203W3WV	1 1/2" Deep	3/4" Two Gang

- All open back box assemblies are shipped with TP472 flat, blank back covers, ground clip and lead.
- Other box types, device colors, mud ring depths, brackets and assembly configurations are available. Consult factory for details.
- To change the color of device from Ivory (as shown) to white, substitute V (Ivory) with W (White). For ex. TP3140D C20DV becomes TP3140D C20DW.
- All receptacles are shipped standard ground up. Add suffix DN for ground down.
- All assemblies shipped standard with metal device protect plates, add suffix SG for SmartGuard plastic protect plate.
- Pre-installed connectors available on all assembly types. Consult factory for details

For more information on all PRE-formance products or how to submit drawings for quotation, please email CCHPREformance@cooperindustries.com or call 315-477-5592

Uni-Mount™ Assemblies with Wiring Devices

PRE-formance™ Catalog Numbering System for Uni-Mount™ Assemblies with Devices

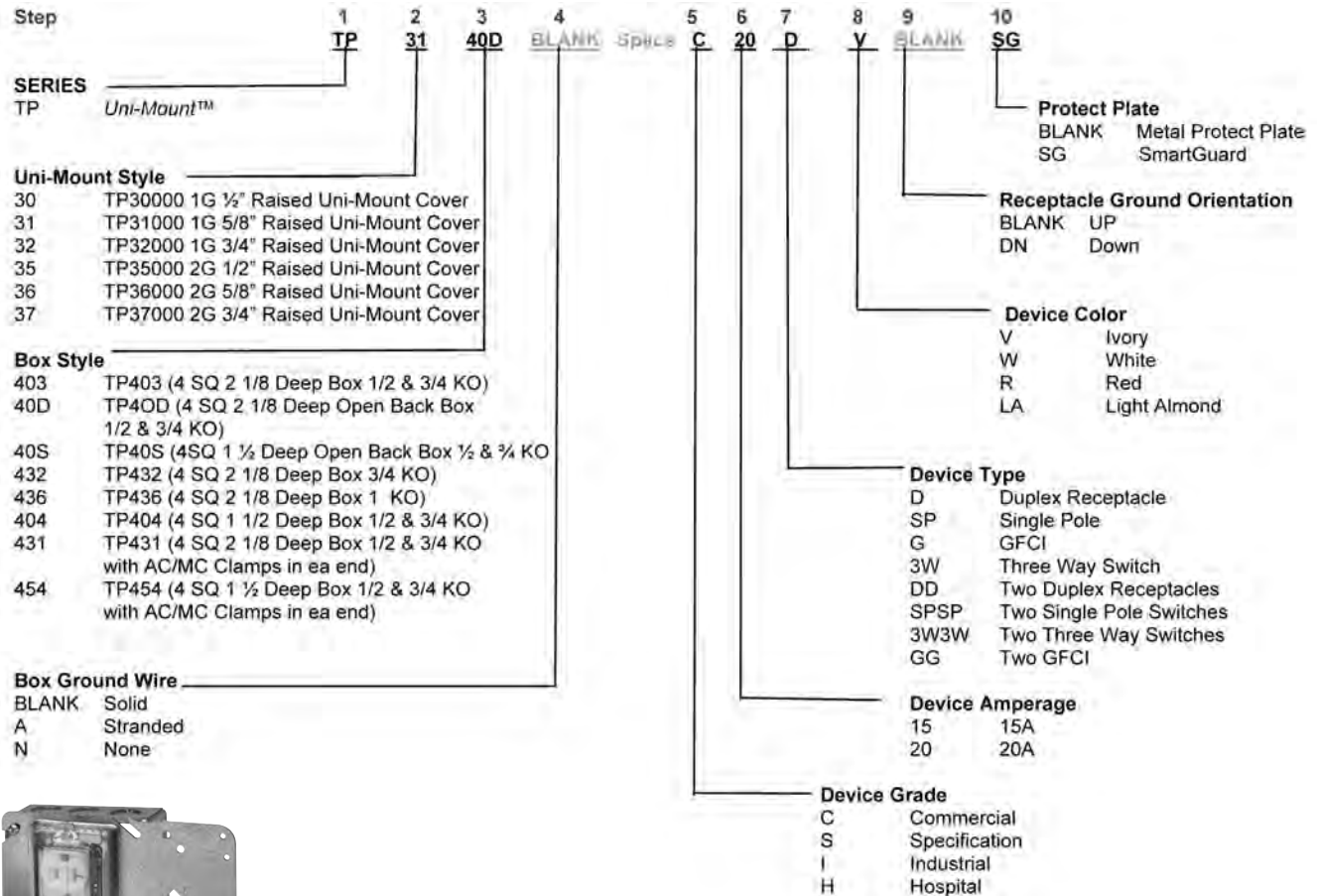

PRE-formance™



TP3140D C20DVSG

Standard Cooper Wiring Devices used in PRE-formance Assemblies

CCH Wiring Device Nomenclature (without color suffix)	CWD Catalog Number used (shown without color suffix)	Description	CCH Wiring Device Nomenclature (without color suffix)	CWD Catalog Number used (shown without color suffix)	Description
C20D	CR20	Commercial Grade 20A Duplex Receptacle	C20SP	CS120	Commercial Grade 20A Single Pole Switch
I20D	5362	Industrial Grade 20A Duplex Receptacle	I20SP	AH1221	Industrial Grade 20A Single Pole Switch
H20D	8300	Hospital Grade 20A Duplex Receptacle	C203W	CS320	Commercial Grade 20A Three Way Switch
S20G	VGf20	Specification Grade 20A GFCI Receptacle	I203W	AH1223	Industrial Grade 20A Three Way Switch
H20G	VGfH20	Hospital Grade 20A GFCI Receptacle			

For more information on all PRE-formance products or how to submit drawings for quotation, please email CCHPREformance@cooperindustries.com or call 315-477-5592

Single Sided Assemblies with Wiring Devices

Cooper Crouse-Hinds PRE-formance Single Sided Assemblies - All catalog numbers contain a single sided bracket (BB4-23 for 3 1/2" and 2 1/2" studs), 4" square box, an 8" insulated solid box ground wire with ground clip, one or two pre-wired Cooper Wiring Devices with leads and push-in connectors, and device protect plates

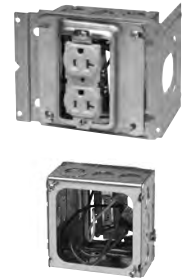

PRE-formance™

Single Sided Assemblies with wiring devices are shipped standard with open back boxes. Open back boxes maximize the working area to reduce wiring time and eliminate interference problems. They virtually eliminate the need for disassembly at the job site. Open back boxes are available in either 1 1/2" or 2 1/8" deep with 1/2" & 3/4" eccentric knockouts. All 4" square open back box assemblies are shipped with TP472 flat, blank back covers.

- All assemblies are shown with ivory colored devices. At the end of the catalog number, replace the "V" with "W" for white colored device. Other device colors and types are available. Consult factory for details. Double sided direct mount assemblies are also available. Substitute PFH3 with PF3DS (BB73 double sided bracket)
- 4" and 6" Far side supports are available. Replace PFH3 (for 2 1/2" and 3 1/2" studs) with PFH4 (4") (BB44) or PFH6 (6") (BB46). For double sided, replace PF3DS with PF4DS (BB74) or PF6DS (BB76).

UL and cUL Listed
UL File No. E-324733



Commonly ordered catalog examples are listed below

See assembly catalog numbering system at the end of this section for more information on how to construct catalog numbers for almost any customer application

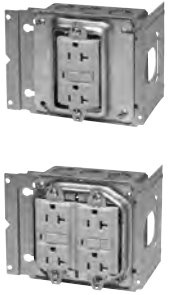
	Commercial Grade Receptacle	Industrial Grade Receptacle	Hospital Grade Receptacle		
Duplex Receptacle 	Assembly Catalog Number with CR20V Commercial Grade 20A Duplex Receptacle Installed	Assembly Catalog Number with 5362V Industrial Grade 20A Duplex Receptacle Installed	Assembly Catalog Number with 8300V Hospital Grade 20A Duplex Receptacle Installed	4" Square Steel Open Back Box	Mud Ring
	Single 20A Duplex Receptacle				
	PFH3 40D58C20DV	PFH3 40D58I20DV	PFH3 40D58H20DV	2 1/8" Deep	5/8" Single Gang
	PFH3 40S58C20DV	PFH3 40S58I20DV	PFH3 40S58H20DV	1 1/2" Deep	5/8" Single Gang
	PFH3 40D75C20DV	PFH3 40D75I20DV	PFH3 40D75H20DV	2 1/8" Deep	3/4" Single Gang
	PFH3 40S75C20DV	PFH3 40S75I20DV	PFH3 40S75H20DV	1 1/2" Deep	3/4" Single Gang
	Double 20A Duplex Receptacle				
	PFH3 40D258C20DDV	PFH3 40D258I20DDV	PFH3 40D258H20DDV	2 1/8" Deep	5/8" Two Gang
	PFH3 40S258C20DDV	PFH3 40S258I20DDV	PFH3 40S258H20DDV	1 1/2" Deep	5/8" Two Gang
	PFH3 40D275C20DDV	PFH3 40D275I20DDV	PFH3 40D275H20DDV	2 1/8" Deep	3/4" Two Gang
PFH3 40S275C20DDV	PFH3 40S275I20DDV	PFH3 40S275H20DDV	1 1/2" Deep	3/4" Two Gang	
GFCI Receptacle 	Specification Grade GFCI Receptacle	Hospital Grade GFCI Receptacle			
	Assembly Catalog Number with VGF20 Specification Grade 20A GFCI Receptacle Installed	Assembly Catalog Number with VGFH20V Hospital Grade 20A GFCI Receptacle Installed		4" Square Steel Open Back Box	Mud Ring
	Single 20A GFCI Receptacle				
	PFH3 40D58S20GV	PFH3 40D58H20GV		2 1/8" Deep	5/8" Single Gang
	PFH3 40S58S20GV	PFH3 40S58H20GV		1 1/2" Deep	5/8" Single Gang
	PFH3 40D75S20GV	PFH3 40D75H20GV		2 1/8" Deep	3/4" Single Gang
	PFH3 40S75S20GV	PFH3 40S75H20GV		1 1/2" Deep	3/4" Single Gang
	Double 20A GFCI Receptacle				
	PFH3 40D258S20GGV	PFH3 40D258H20GGV		2 1/8" Deep	5/8" Two Gang
	PFH3 40S258S20GGV	PFH3 40S258H20GGV		1 1/2" Deep	5/8" Two Gang
PFH3 40D275S20GGV	PFH3 40D275H20GGV		2 1/8" Deep	3/4" Two Gang	
PFH3 40S275S20GGV	PFH3 40S275H20GGV		1 1/2" Deep	3/4" Two Gang	

Single Sided Assemblies with Wiring Devices

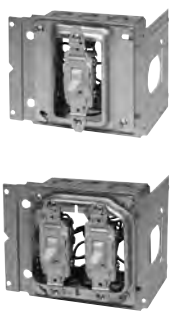
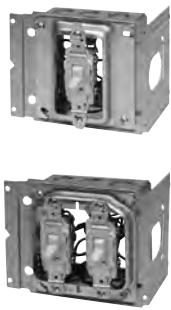
Single Pole Switch	Commercial Grade	Industrial Grade	4" Square Steel Open Back Box	Mud Ring
	Single Pole Switch	Single Pole Switch		
	Assembly Catalog Number with CS120V Commercial Grade 20A Single Pole Switch Installed	Assembly Catalog Number with AH1221V Industrial Grade 20A Single Pole Switch Installed		
	Single 20A Single Pole Switch			
	PFH3 40D58C20SPV	PFH3 40D58I20SPV	2 1/8" Deep	5/8" Single Gang
	PFH3 40S58C20SPV	PFH3 40S58I20SPV	1 1/2" Deep	5/8" Single Gang
	PFH3 40D75C20SPV	PFH3 40D75I20SPV	2 1/8" Deep	3/4" Single Gang
	PFH3 40S75C20SPV	PFH3 40S75I20SPV	1 1/2" Deep	3/4" Single Gang
	Double 20A Single Pole Switch			
	PFH3 40D258C20SPSPV	PFH3 40D258I20SPSPV	2 1/8" Deep	5/8" Two Gang
	PFH3 40S258C20SPSPV	PFH3 40S258I20SPSPV	1 1/2" Deep	5/8" Two Gang
PFH3 40D275C20SPSPV	PFH3 40D275I20SPSPV	2 1/8" Deep	3/4" Two Gang	
PFH3 40S275C20SPSPV	PFH3 40S275I20SPSPV	1 1/2" Deep	3/4" Two Gang	
Three Way Switch	Commercial Grade	Industrial Grade	4" Square Steel Open Back Box	Mud ring
	Three Way Switch	Three Way Switch		
	Assembly Catalog Number with CS320V Commercial Grade 20A Three Way Switch Installed	Assembly Catalog Number with AH1223V Industrial Grade 20A Three Way Switch Installed		
	Single 20A Three Way Switch			
	PFH3 40D58C203WV	PFH3 40D58I203WV	2 1/8" Deep	5/8" Single Gang
	PFH3 40S58C203WV	PFH3 40S58I203WV	1 1/2" Deep	5/8" Single Gang
	PFH3 40D75C203WV	PFH3 40D75I203WV	2 1/8" Deep	3/4" Single Gang
	PFH3 40S75C203WV	PFH3 40S75I203WV	1 1/2" Deep	3/4" Single Gang
	Double 20A Three Way Switch			
	PFH3 40D258C203W3WV	PFH3 40D258I203W3WV	2 1/8" Deep	5/8" Two Gang
	PFH3 40S258C203W3WV	PFH3 40S258I203W3WV	1 1/2" Deep	5/8" Two Gang
	PFH3 40D275C203W3WV	PFH3 40D275I203W3WV	2 1/8" Deep	3/4" Two Gang
	PFH3 40S275C203W3WV	PFH3 40S275I203W3WV	1 1/2" Deep	3/4" Two Gang

- All open back box assemblies are shipped with TP472 flat, blank back covers, ground clip and lead.
- Double Sided Direct Mount Assemblies also available. Substitute PFH3 with PF3DS (BB73).
- Other box types, device colors, mud ring depths, brackets and assembly configurations are available. Consult factory for details.
- To change the color of device from Ivory (as shown) to white, substitute V (Ivory) with W (White). For ex. PFH3 40D58C20DV becomes PFH3 40D58C20DW.
- All receptacles are shipped standard ground up. Add suffix DN for ground down.
- All assemblies shipped standard with metal device protect plates, add suffix SG for SmartGuard plastic protect plate.
- Pre-installed connectors available on all assembly types. Consult factory for details

For more information on all PRE-formance products or how to submit drawings for quotation, please email CCHPREformance@cooperindustries.com or call 315-477-5592

Floor Mount Assemblies with Wiring Devices

Cooper Crouse-Hinds PRE-formance Floor Mount Assemblies - All catalog numbers contain a floor mount bracket (BFM18-4) which positions device at 18" on center, 4" square Box, an 8" insulated solid box ground wire with ground clip, one or two pre-wired Cooper Wiring Devices with leads and push-in connectors, and device protect plates.



Floor mount assemblies with wiring devices are shipped standard with open back boxes. Open back boxes maximize the working area to reduce wiring time and eliminate interference problems. They virtually eliminate the need for disassembly at the job site. Open back boxes are available in either 1½" or 2⅞" deep with ½ & ¾ eccentric knockouts. All 4" square open back box assemblies are shipped with TP472 flat, blank back covers.

- All assemblies are shown with ivory colored devices. At the end of the catalog number, replace the "V" with "W" for white colored device. Other device colors and types are available. Consult factory for details.

UL and cUL Listed
UL File No. E324733



Commonly ordered catalog examples are listed below

See assembly catalog numbering system at the end of this section for more information on how to construct catalog numbers for almost any customer application

Duplex Receptacle	Commercial Grade Receptacle	Industrial Grade Receptacle	Hospital Grade Receptacle	4" Square Steel Open Back Box	Mud Ring	
	Assembly Catalog Number with CR20V Commercial Grade 20A Duplex Receptacle Installed	Assembly Catalog Number with 5362V Industrial Grade 20A Duplex Receptacle Installed	Assembly Catalog Number with 8300V Hospital Grade 20A Duplex Receptacle Installed			
	Single 20A Duplex Receptacle					
	PF18FM 40D58C20DV	PF18FM 40D58I20DV	PF18FM 40D58H20DV	2⅞" Deep	5/8" Single Gang	
	PF18FM 40S58C20DV	PF18FM 40S58I20DV	PF18FM 40S58H20DV	1½" Deep	5/8" Single Gang	
	PF18FM 40D75C20DV	PF18FM 40D75I20DV	PF18FM 40D75H20DV	2⅞" Deep	¾" Single Gang	
	PF18FM 40S75C20DV	PF18FM 40S75I20DV	PF18FM 40S75H20DV	1½" Deep	¾" Single Gang	
	Double 20A Duplex Receptacle					
	PF18FM 40D258C20DDV	PF18FM 40D258I20DDV	PF18FM 40D258H20DDV	2⅞" Deep	5/8" Two Gang	
	PF18FM 40S258C20DDV	PF18FM 40S258I20DDV	PF18FM 40S258H20DDV	1½" Deep	5/8" Two Gang	
	PF18FM 40D275C20DDV	PF18FM 40D275I20DDV	PF18FM 40D275H20DDV	2⅞" Deep	¾" Two Gang	
PF18FM 40S275C20DDV	PF18FM 40S275I20DDV	PF18FM 40S275H20DDV	1½" Deep	¾" Two Gang		

Cooper Crouse-Hinds PRE-formance Universal Floor Mount Assemblies - All catalog numbers contain an adjustable Floor Mount bracket (Standard item is shipped pre-set at 18" on center but is also available at other customer specified heights. All catalog numbers contain a 4" Square Box, an 8" insulated solid box ground wire with ground clip, far side support, flat strap for stud spanning support, one or two pre-wired Cooper Wiring Devices with leads and push-in connectors, and device protect plates.

All assemblies are shown with ivory colored devices. At the end of the catalog number, replace the "V" with "W" for white colored device. Other device colors and types are available. Consult factory for details.

UL and cUL Listed
UL File No. E324733



Commonly ordered catalog examples are listed below

See assembly catalog numbering system at the end of this section for more information on how to construct catalog numbers for almost any customer application

Duplex Receptacle	Commercial Grade Receptacle	Industrial Grade Receptacle	Hospital Grade Receptacle	4" Square Steel Open Back Box	Mud Ring	
	Assembly Catalog Number with CR20V Commercial Grade 20A Duplex Receptacle Installed	Assembly Catalog Number with 5362V Industrial Grade 20A Duplex Receptacle Installed	Assembly Catalog Number with 8300V Hospital Grade 20A Duplex Receptacle Installed			
	Single 20A Duplex Receptacle					
	PFUBV18 40D58C20DV	PFUBV18 40D58I20DV	PFUBV18 40D58H20DV	2 1/8" Deep	5/8" Single Gang	
	PFUBV18 40S58C20DV	PFUBV18 40S58I20DV	PFUBV18 40S58H20DV	1 1/2" Deep	5/8" Single Gang	
	PFUBV18 40D75C20DV	PFUBV18 40D75I20DV	PFUBV18 40D75H20DV	2 1/8" Deep	3/4" Single Gang	
	PFUBV18 40S75C20DV	PFUBV18 40S75I20DV	PFUBV18 40D75H20DV	1 1/2" Deep	3/4" Single Gang	
	Double 20A Duplex Receptacle					
	PFUBV18 40D258C20DDV	PFUBV18 40D258I20DDV	PFUBV18 40D258H20DDV	2 1/8" Deep	5/8" Two Gang	
	PFUBV18 40S258C20DDV	PFUBV18 40S258I20DDV	PFUBV18 40S258H20DDV	1 1/2" Deep	5/8" Two Gang	
	PFUBV18 40D275C20DDV	PFUBV18 40D275I20DDV	PFUBV18 40D275H20DDV	2 1/8" Deep	3/4" Two Gang	
	PFUBV18 40S275C20DDV	PFUBV18 40S275I20DDV	PFUBV18 40S275H20DDV	1 1/2" Deep	3/4" Two Gang	

- All open back box assemblies are shipped with TP472 flat, blank back covers, ground clip and lead.
- Other box types, device colors, mud ring depths, brackets and assembly configurations are available. Consult factory for details.
- To change the color of device from Ivory (as shown) to white, substitute V (Ivory) with W (White). For ex. PF18FM 40D58C20DV becomes PF18FM 40D58C20DW.
- All receptacles are shipped standard ground up. Add suffix DN for ground down.
- All assemblies shipped standard with metal device protect plates, add suffix SG for SmartGuard plastic protect plate.
- Pre-installed connectors available on all assembly types. Consult factory for details

For more information on all PRE-formance products or how to submit drawings for quotation, please email CCHPREformance@cooperindustries.com or call 315-477-5592

Telescoping Slider Assemblies with Wiring Devices

Cooper Crouse-Hinds PRE-formance Telescoping Slider Assemblies - All catalog numbers contain a Telescoping Slider Bracket (BB216TS 11"-18"), 4" square traditional closed back box, an 8" insulated stranded box ground wire with ground screw, one or two pre-wired Cooper Wiring Devices with leads and push-in connectors, and device protect plates

PRE-formance™

- All assemblies are shown with ivory colored devices. At the end of the catalog number, replace the "V" with "W" for white colored device. Other device colors and types are available. Consult factory for details.
- 15"-26" Telescoping Slider assemblies are available. Replace PF16TS (BB216TS) with PF24TS (BB224TS).



UL and cUL Listed



UL File No. E324733

Commonly ordered catalog examples are listed below

See assembly catalog numbering system at the end of this section for more information on how to construct catalog numbers for almost any customer application

	Commercial Grade Receptacle	Industrial Grade Receptacle	Hospital Grade Receptacle		
Duplex Receptacles 	Assembly Catalog Number with CR20V Commercial Grade 20A Duplex Receptacle Installed	Assembly Catalog Number with 5362V Industrial Grade 20A Duplex Receptacle Installed	Assembly Catalog Number with 8300V Hospital Grade 20A Duplex Receptacle Installed	4" Square Steel Box (Not Open Back)	Mud Ring
	Single 20A Duplex Receptacle				
	PF16TS 4DA58C20DV	PF16TS 4DA58I20DV	PF16TS 4DA58H20DV	2 1/8" Deep	5/8" Single Gang
	PF16TS 4SA58C20DV	PF16TS 4SA58I20DV	PF16TS 4SA58H20DV	1 1/2" Deep	5/8" Single Gang
	PF16TS 4DA75C20DV	PF16TS 4DA75I20DV	PF16TS 4DA75H20DV	2 1/8" Deep	3/4" Single Gang
	PF16TS 4SA75C20DV	PF16TS 4SA75I20DV	PF16TS 4SA75H20DV	1 1/2" Deep	3/4" Single Gang
	Double 20A Duplex Receptacle				
	PF16TS 4DA258C20DDV	PF16TS 4DA258I20DDV	PF16TS 4DA258H20DDV	2 1/8" Deep	5/8" Two Gang
	PF16TS 4SA258C20DDV	PF16TS 4SA258I20DDV	PF16TS 4SA258H20DDV	1 1/2" Deep	5/8" Two Gang
	PF16TS 4DA275C20DDV	PF16TS 4DA275I20DDV	PF16TS 4DA275H20DDV	2 1/8" Deep	3/4" Two Gang
PF16TS 4SA275C20DDV	PF16TS 4SA275I20DDV	PF16TS 4SA275H20DDV	1 1/2" Deep	3/4" Two Gang	
GFCI Receptacles 	Specification Grade GFCI Receptacle	Hospital Grade GFCI Receptacle			
	Assembly Catalog Number with VGF20 Specification Grade 20A GFCI Receptacle Installed	Assembly Catalog Number with VGFH20V Hospital Grade 20A GFCI Receptacle Installed	4" Square Steel Box (Not Open Back)	Mud Ring	
	Single 20A GFCI Receptacle				
	PF16TS 4DA58S20GV	PF16TS 4DA58H20GV	2 1/8" Deep	5/8" Single Gang	
	PF16TS 4SA58S20GV	PF16TS 4SA58H20GV	1 1/2" Deep	5/8" Single Gang	
	PF16TS 4DA75S20GV	PF16TS 4DA75H20GV	2 1/8" Deep	3/4" Single Gang	
	PF16TS 4SA75S20GV	PF16TS 4SA75H20GV	1 1/2" Deep	3/4" Single Gang	
	Double 20A GFCI Receptacle				
	PF16TS 4DA258S20GGV	PF16TS 4DA258H20GGV	2 1/8" Deep	5/8" Two Gang	
	PF16TS 4SA258S20GGV	PF16TS 4SA258H20GGV	1 1/2" Deep	5/8" Two Gang	
PF16TS 4DA275S20GGV	PF16TS 4DA275H20GGV	2 1/8" Deep	3/4" Two Gang		
PF16TS 4SA275S20GGV	PF16TS 4SA275H20GGV	1 1/2" Deep	3/4" Two Gang		

Telescoping Slider Assemblies with Wiring Devices

Single Pole Switch

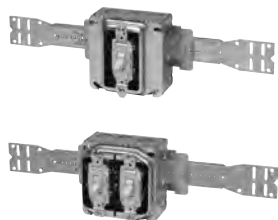

Commercial Grade Single Pole Switch	Industrial Grade Single Pole Switch	4" Square Steel Box (Not Open Back)	Mud Ring
Assembly Catalog Number with CS120V Commercial Grade 20A Single Pole Switch Installed	Assembly Catalog Number with AH1221V Industrial Grade 20A Single Pole Switch Installed		
Single 20A Single Pole Switch			
PF16TS 4DA58C20SPV	PF16TS 4DA58I20SPV	2 1/8" Deep	5/8" Single Gang
PF16TS 4SA58C20SPV	PF16TS 4SA58I20SPV	1 1/2" Deep	5/8" Single Gang
PF16TS 4DA75C20SPV	PF16TS 4DA75I20SPV	2 1/8" Deep	3/4" Single Gang
PF16TS 4SA75C20SPV	PF16TS 4SA75I20SPV	1 1/2" Deep	3/4" Single Gang
Double 20A Single Pole Switch			
PF16TS 4DA258C20SPSPV	PF16TS 4DA258I20SPSPV	2 1/8" Deep	5/8" Two Gang
PF16TS 4SA258C20SPSPV	PF16TS 4SA258I20SPSPV	1 1/2" Deep	5/8" Two Gang
PF16TS 4DA275C20SPSPV	PF16TS 4DA275I20SPSPV	2 1/8" Deep	3/4" Two Gang
PF16TS 4SA275C20SPSPV	PF16TS 4SA275I20SPSPV	1 1/2" Deep	3/4" Two Gang

Three Way Switch

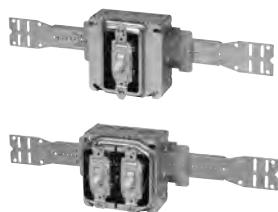

Commercial Grade Three Way Switch	Industrial Grade Three Way Switch	4" Square Steel Box (Not Open Back)	Mud Ring
Assembly Catalog Number with CS320V Commercial Grade 20A Three Way Switch Installed	Assembly Catalog Number with AH1223V Industrial Grade 20A Three Way Switch Installed		
Single 20A Three Way Switch			
PF16TS 4DA58C203WV	PF16TS 4DA58I203WV	2 1/8" Deep	5/8" Single Gang
PF16TS 4SA58C203WV	PF16TS 4SA58I203WV	1 1/2" Deep	5/8" Single Gang
PF16TS 4DA75C203WV	PF16TS 4DA75I203WV	2 1/8" Deep	3/4" Single Gang
PF16TS 4SA75C203WV	PF16TS 4SA75I203WV	1 1/2" Deep	3/4" Single Gang
Double 20A Three Way Switch			
PF16TS 4DA258C203W3WV	PF16TS 4DA258I203W3WV	2 1/8" Deep	5/8" Two Gang
PF16TS 4SA258C203W3WV	PF16TS 4SA258I203W3WV	1 1/2" Deep	5/8" Two Gang
PF16TS 4DA275C203W3WV	PF16TS 4DA275I203W3WV	2 1/8" Deep	3/4" Two Gang
PF16TS 4SA275C203W3WV	PF16TS 4SA275I203W3WV	1 1/2" Deep	3/4" Two Gang

- Other box types, device colors, mud ring depths, brackets and assembly configurations are available. Consult factory for details.
- To change the color of device from Ivory (as shown) to white, substitute V (Ivory) with W (White). For ex. PF16TS 4DAC20DV becomes PF16TS 4DAC20DW.
- All receptacles are shipped standard ground up. Add suffix DN for ground down.
- All assemblies shipped standard with metal device protect plates, add suffix SG for SmartGuard plastic protect plate.
- Pre-installed connectors available on all assembly types. Consult factory for details
- Telescoping Slider bracket assemblies are shipped with traditional closed back box, ground screw and stranded leads on box and devices.
- Device leads and push-in connectors are left inside the box and will not be pulled out of knockouts prior to shipment unless specified by customer.

For more information on all PRE-formance products or how to submit drawings for quotation, please email CCHPREformance@cooperindustries.com or call 315-477-5592

Cooper Crouse-Hinds PRE-formance Multi Mount Assemblies - All catalog numbers contain a multiple mount bracket (available in either 16" stud spanning or 24" stud spanning). Each position may contain an outlet box, an 8" insulated solid box ground wire with ground screw or clip, one or two pre-wired Cooper Wiring Devices with leads and push-in connectors, and device protect plates.

PRE-formance™

UL and cUL Listed



UL File No. E324733

Commonly ordered catalog examples are listed below

See assembly catalog numbering system at the end of this section for more information on how to construct catalog numbers for almost any customer application



PF3MM 40D58C20DV 5D58 X

3MM Bracket

BB816 3 hole Multiple Mount Bracket for 16" Stud spacing

4MM Bracket (not shown)

BB824 4 hole Multiple Mount Bracket for 24" Stud spacing



PFUBH 40D58C20DV

UBH Bracket

UBH Universal Horizontal Bracket for 8 - 24" stud spacing



PF16BO 40D58C20DV X 40D258C20DDV

16BO Bracket

BB716 Open Mount Bracket for 16" Stud spacing

24BO Bracket (not shown)

BB724 Open Mount Bracket for 24" Stud spacing

Commonly Ordered Catalog Numbers	Description
PF3MM 40D58C20DV 5DN58 X	Assembly - BB816 Multiple Box Bracket, 4" square open back box with ground clip, lead and back cover, TP489 5/8" raise 1G mud ring, pre-wired CR20V 20A commercial duplex receptacle ivory with leads and push-in connectors and protect plate (not shown), 2nd position TP525 4 1/16" box, TP579 4 1/16" 5/8" raise 1G mud ring, no ground wire
PF16BO 40D58C20DV X 40D58C20DDV	Assembly - BB716 Open Bracket, 4" square open back box with ground clip, lead and back cover, TP489 5/8" raise 1G mud ring, pre-wired CR20V 20A commercial duplex receptacle ivory with leads, push-in connectors and protect plate, 2nd position open, 3rd position 4" square open back box with ground clip, lead and back cover, TP499 5/8" raise 2G mud ring, two pre-wired CR20v 20A commercial duplex receptacles ivory with leads, push-in connectors and protect plates
PFUBH 40D58C20DV	Assembly - Universal Bracket Mounted Horizontally, 4" square open back box with ground clip, lead and back cover, TP489 5/8" Raise 1G mud ring, pre-wired CR20V 20A commercial duplex receptacle ivory with leads, push-in connectors and protect plate (not shown)

- All open back box assemblies are shipped with TP472 flat, blank back covers, ground clip and lead.
- Other box types, device colors, mud ring depths, brackets and assembly configurations are available. Consult factory for details.
- To change the color of device from Ivory (as shown) to white, substitute V (Ivory) with W (White).
- All receptacles are shipped standard ground up. Add suffix DN for ground down.
- All assemblies shipped standard with metal device protect plates, add suffix SG for SmartGuard plastic protect plate.
- Pre-installed connectors available on all assembly types. Consult factory for details

PRE-formance™

Catalog Numbering System for additional assembly configurations

Positions 2 and 3 are only added for multi-mount or open mount assemblies. Insert a space, replace "X", and repeat steps 3-11 for additional boxes on assembly. If 1st or 2nd positions are blank, then insert "X" and use steps 3-11 in position where box is required.

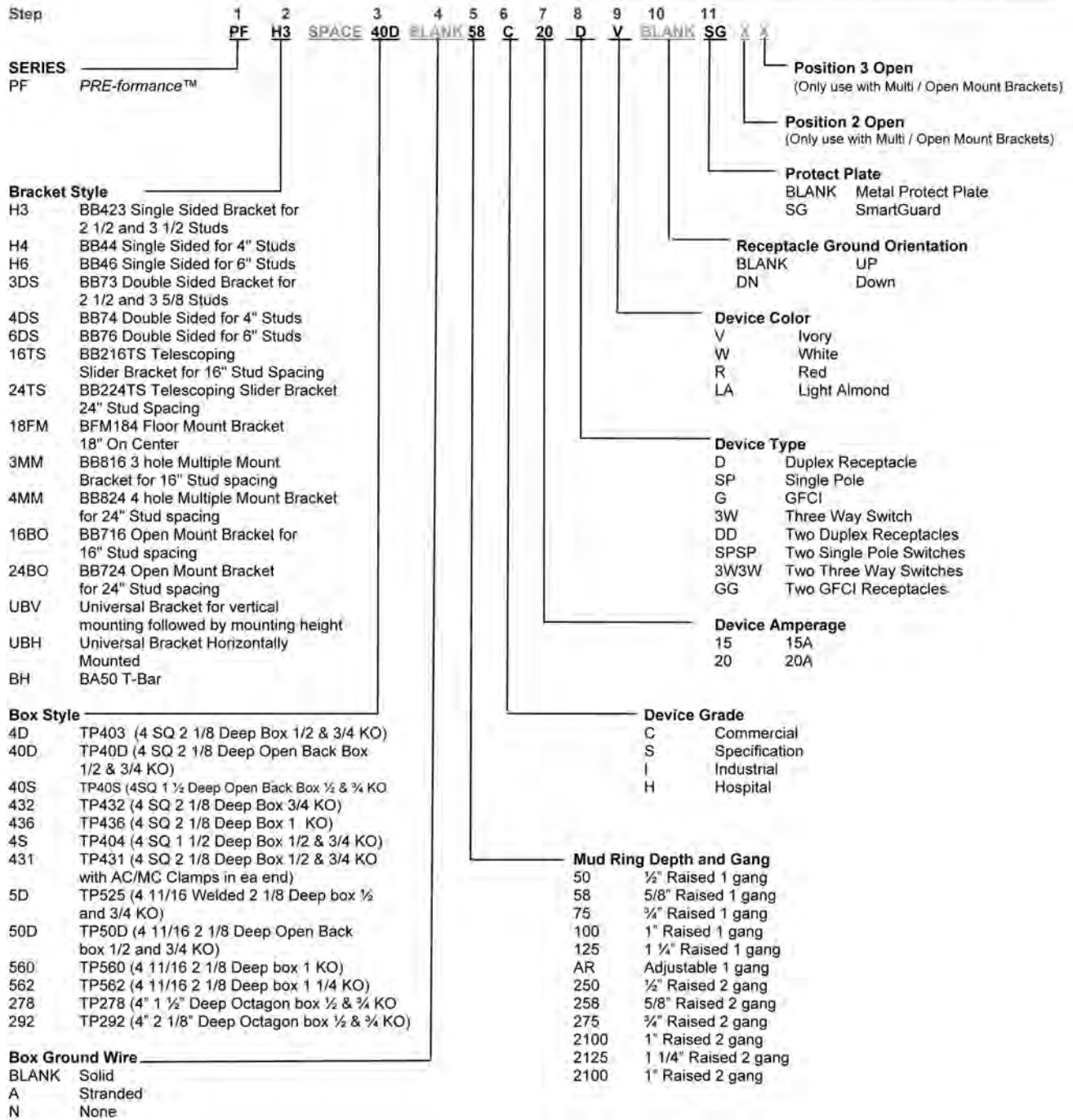

PRE-formance™



PFH3 40D58C20DVSG (protect plate not shown)

Standard Cooper Wiring Devices used in PRE-formance Assemblies

CCH Wiring Device Nomenclature (without color suffix)	CWD Catalog Number used (shown without color suffix)	Description	CCH Wiring Device Nomenclature (without color suffix)	CWD Catalog Number used (shown without color suffix)	Description
C20D	CR20	Commercial Grade 20A Duplex Receptacle	C20SP	CS120	Commercial Grade 20A Single Pole Switch
I20D	5362	Industrial Grade 20A Duplex Receptacle	I20SP	AH1221	Industrial Grade 20A Single Pole Switch
H20D	8300	Hospital Grade 20A Duplex Receptacle	C203W	CS320	Commercial Grade 20A Three Way Switch
S20G	VGf20	Specification Grade 20A GFCI Receptacle	I203W	AH1223	Industrial Grade 20A Three Way Switch
H20G	VGfH20	Hospital Grade 20A GFCI Receptacle			

For more information on all PRE-formance products or how to submit drawings for quotation, please email CCHPREformance@cooperindustries.com or call 315-477-5592

PRE-formance™

Complete

Ideal for hotels, condos, commercial and retail offices, hospitals and apartments

PRE-formance Complete delivers:

- Total prefabricated branch wiring system custom produced with Cooper components, labeled, packaged by room and floor, delivered to your exact location
- Lower total cost of ownership
- Skill set allocation to match job requirements
- Elimination of job site material "piles" and inefficient searching for pieces and parts at the job site
- Elimination of job site "engineering"
- Reduction of overages and scrap, including expensive wire and cable



PRE-formance™

PRE-formance Complete quotation process provides:

- Safe, secure transmission of drawings to secure file exchange server, CDs, or hard copy drawings if customer prefers, where our technical team (consisting of engineers and former contractors) completes a preliminary take-off analysis.
- A clearly defined, mutually agreed upon scope of work proposal easily identifies inclusions and exclusions and includes formal approval/sign-off procedures to ensure a clear, mutual understanding before work begins. Our team of engineers provides technical support and will answer your questions throughout the entire process. Mutual understanding of the requirements is an integral part of the process.



Product receipt and installation made fast, easy and accurate.

- Unique, custom data layout table gets applied and shipped to each CAD drawing for each and every different room or area type
- Simplifies installation, eliminates guess work and helps eliminate job-site engineering
- Job specific labeling included with every cable run indicates starting position, ending position, device type, mounting type, cable size, cable length, box type, cable path, drawing number and date

For more information on all PRE-formance products or how to submit drawings for quotation, please email CCHPREformance@cooperindustries.com or call 315-477-5592

HomeRunner™ Box

Commercial construction screw cover junction box with patented clamps



Applications:

The Cooper Crouse-Hinds HomeRunner™ Junction Box is designed specifically for commercial construction applications to provide a spacious, flexible junction box for terminating Home Run and other electrical wiring. Its patented clamping design and flexibility make it the most convenient, labor savings junction box available.

- The HomeRunner Junction Box has extensive built-in features for maximum job site flexibility and efficiency
- It can be used to terminate multiple wiring methods including AC, MC, MCI-A, NM or EMT
- Designed for use in commercial construction projects, it is ideal for hotels, motels, condos, assisted living centers, etc.

Features and Call-outs:

1. Patented clamping system - provides maximum flexibility and maximum grip. Third party certified for use with AC, MC, MCI-A or Non-metallic sheathed cable
2. 8 x 8 welded steel construction - provides strong, dependable service and large cubic capacity (177 cu. in.) for ease of wiring
3. Combination eccentric knockouts - on sides for quick & easy access, combination ko's in the back of the box are ideal of applications where joist spacing is too tight for side entry
4. Terminal cup washer and flanged nut - quick, easy service ground termination or attachment of grounding bus-bar, if desired
5. 2 cover options - square for surface mounted applications or oversized for flush mount applications
6. Extensive mounting flexibility - pre-drilled holes in side and back for direct mounting or optimal mounting bracket (purchased separately)
7. Far-side support snaps on quickly and easily and is perforated which allows for adjustment in dual thickness, fire-rated walls

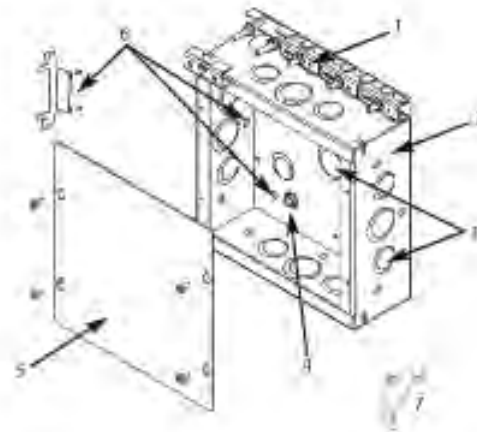

Certifications and Compliances:

- For US & Canada : CSA File #248782
- Certified to UL50 & UL514B and CSA C22.2, No. 18.3-04 & No. 40-M1989

Standard Materials:

- Pre-galvanized steel

Cat.#	Description	Dimensions	Knockouts	Wire Fill	Built-In Clamps	Cubic Volume	Unit Qty.	Wt. Per 100
HR080803	Homerunner Box	8"H x 8"W x 3"D	(10) 1/2 and 3/4 eccentric, (7) 3/4 & 1 eccentric	(7) 14 AWG, (6) 12 AWG, (5) 10 AWG	(1) 10/3 to 10/12, (5) 1/2 to 10/3	177	5	400
HRC0808S	Surface Mount Cover for Homerunner Box	8"H x 8"W x .06"D					5	100
HRC0808F	Flush Mount Cover for Homerunner Box	9.38"H x 9.38"W x .06"D					5	160
HRSB1	Stud Bracket for Homerunner Box						20	35

Features and Benefits:

- Durable die cast aluminum construction for long product life
- Powder paint finish for corrosive environments
- Plugs supplied as standard with 1/2" and 3/4" hubs are non-metallic, 1" hubs are zinc die cast
- Boxes supplied with mounting feet
- Tapered NPT hubs

Materials and Finishes:

- Boxes: Die Cast Aluminum
- Self Closing Covers: Zinc Die Cast
- Toggle Switch Covers: Stamped Aluminum
- Blank Covers: Steel

Certifications and Compliances:

- UL Standard UL514A
- UL Listed File No. E15022
- cUL Standard CSA-C22.2 No 18.1-04
- Suitable for wet locations

SINGLE GANG – 18.0 CUBIC INCH CAPACITY – 2" DEEP CAST ALUMINUM – UL LISTED FOR WET LOCATIONS



TP7010 – TP7012



TP7026, TP7034



TP7042, TP7050



TP7058, TP7066

Cat. #	Description	Outlet Holes	Color	Unit Qty.	Wt. Lbs. Per 100
TP7010	With Lugs	3 – 1/2"	Gray	50	58.3
TP7011	With Lugs	3 – 1/2"	White	50	58.3
TP7012	With Lugs	3 – 1/2"	Bronze	50	58.3
TP7018	With Lugs	3 – 3/4"	Gray	50	58.3
TP7026	With Lugs	4 – 1/2"	Gray	50	58.3
TP7034	With Lugs	4 – 3/4"	Gray	50	58.3
TP7042	With Lugs	5 – 1/2"	Gray	50	58.3
TP7050	With Lugs	5 – 3/4"	Gray	50	58.3
TP7058	Side Entry, With Lugs	5 – 1/2"	Gray	50	58.3
TP7066	Side Entry, With Lugs	5 – 3/4"	Gray	50	58.3

SINGLE GANG – 24.0 CUBIC INCH CAPACITY – 2 5/8" DEEP CAST ALUMINUM – UL LISTED FOR WET LOCATIONS



TP7074, TP7078, TP7082

Cat. #	Description	Outlet Holes	Color	Unit Qty.	Wt. Lbs. Per 100
TP7074	With Lugs	3 – 1/2"	Gray	25	80
TP7078	With Lugs	3 – 3/4"	Gray	25	80
TP7082	With Lugs	3 – 1"	Gray	25	80

Weatherproof Outlet Boxes



TWO GANG – 30.5 CUBIC INCH CAPACITY

2" DEEP, ALL TWO GANG BOXES HAVE 2 MOUNTING LUGS AS STANDARD
CAST ALUMINUM – UL LISTED FOR WET LOCATIONS

Weatherproof



TP7086 – TP7090



TP7094, TP7098



TP7102, TP7106



TP7110, TP7114



TP7118, TP7122

Cat. #	Description	Unit Qty.	Color	Wt. Lbs. Per 100
TP7086	3 – 1/2" Holes	10	Gray	83.3
TP7087	3 – 1/2" Holes	10	White	83.3
TP7088	3 – 1/2" Holes	10	Bronze	83.3
TP7090	3 – 3/4" Holes	10	Gray	83.3
TP7094	4 – 1/2" Holes	10	Gray	83.3
TP7098	4 – 3/4" Holes	10	Gray	83.3
TP7102	5 – 1/2" Holes	10	Gray	83.3
TP7106	5 – 3/4" Holes	10	Gray	83.3
TP7110	7 – 1/2" Holes	10	Gray	83.3
TP7114	7 – 3/4" Holes	10	Gray	83.3
TP7118	5 – 1/2" Holes	10	Gray	83.3
TP7122	5 – 3/4" Holes	10	Gray	83.3

TWO AND THREE GANG DEEP

2 5/8" DEEP, ALL BOXES ARE STANDARD WITH MOUNTING LUGS
CAST ALUMINUM – UL LISTED FOR WET LOCATIONS



TP7126, TP7130, TP7134



TP7137, TP7138, TP7142

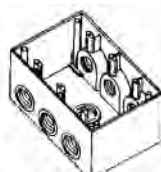

TP7143, TP7144

Cat. #	Description	Color	Unit Qty.	Capacity Cu. In.	Wt. Lbs. Per 100
TWO GANG DEEP WEATHERPROOF OUTLET BOXES					
TP7126	5 – 1/2" Holes	Gray	6	37	140
TP7130	5 – 3/4" Holes	Gray	6	37	140
TP7134	5 – 1" Holes	Gray	6	37	140
TP7137	7 – 1/2" Holes	Gray	6	37	140
TP7138	7 – 3/4" Holes	Gray	6	37	140
TP7142	7 – 1" Holes	Gray	6	37	140
THREE GANG DEEP WEATHERPROOF OUTLET BOXES					
TP7143	7 – 3/4" Holes	Gray	5	59	159
TP7144	7 – 1" Holes	Gray	5	59	159

Dimensions

In Inches:

Single Gang Boxes	Single Gang Deep Boxes	Two Gang Boxes	Two Gang Deep Boxes
<p>Top view: 1 7/8" (width), 2 5/16" (height), 3 3/32" (total height), 4 9/16" (height to center), 1 5/8" (height to bottom), 2 7/8" (width to center), 2" (height to bottom), 1 1/16" (height to bottom).</p> <p>Bottom view: 2" (height), 1 1/16" (height to bottom).</p>	<p>Top view: 1 7/8" (width), 3 3/32" (height), 4 1/16" (height to center), 2 7/8" (width to center).</p> <p>Bottom view: 1 1/2" (width to center), 2 1/32" (height to bottom), 7/8" (height to bottom).</p>	<p>Top view: 3 1/32" (width), 3 3/8" (height), 4 1/16" (height to center), 3 3/8" (height to center), 1 13/16" (width to center).</p> <p>Bottom view: 4 3/8" (width to center), 2 1/16" (height to bottom), 2 1/32" (height to bottom).</p>	<p>Top view: 3 9/16" (width), 3 3/8" (height), 4 1/2" (height to center), 1 13/16" (width to center).</p> <p>Bottom view: 4 1/2" (width to center), 2 1/32" (height to bottom), 1/8" (height to bottom).</p>
TP7010 – TP7071	TP7074 – TP7082	TP7086 – TP7122	TP7126 – TP7142

Weatherproof

ONE & TWO GANG WEATHERPROOF EXTENSIONS

1" DEEP, DIE-CAST ALUMINUM EXTENSION RING
GASKET AND MOUNTING SCREWS INCLUDED WITH COVER
UL LISTED FOR WET LOCATIONS



TP7120



TP7123

Cat. #	Description	Color	Unit Qty.	Capacity Cu. In.	Wt. Lbs. Per 100
TP7120	Single Gang	Gray	25	9	27.2
TP7123	Two Gang	Gray	10	10	27.2

EXTENSION ADAPTER

DIE-CAST ALUMINUM, UL LISTED FOR WET LOCATIONS 3 CLOSURE PLUGS,
MOUNTING SCREW AND GASKET INCLUDED WITH COVER



Cat. #	Description	Color	Unit Qty.	Capacity Cu. In.	Wt. Lbs. Per 100
TP7173	4 – 1/2" Holes	Gray	25	13.0	23.6
TP7174	4 – 3/4" Holes	Gray	25	13.0	27.8

Weatherproof Outlet Boxes



4" ROUND – 15.5 CUBIC INCH CAPACITY

1½" DEEP, DIE-CAST ALUMINUM, UL LISTED FOR WET LOCATIONS
 4 CLOSURE PLUGS AND GROUND SCREW INCLUDED WITH BOX
 GASKET AND 2 MOUNTING SCREWS INCLUDED WITH COVER

Weatherproof



Cat. #	Side Holes	Back Hole	Unit Qty.	Color	Wt. Lbs. Per 100
TP7146	4 – ½"	½"	25	Gray	79.2
TP7148	4 – ½"	½"	25	White	79.2
TP7149	4 – ½"	½"	25	Bronze	79.2
TP7150	4 – ¾"	¾"	25	Gray	79.2
TP7158	Blank Cover Plate		50	Gray	20.8
WITH BLANK PLATE					
TP7147	4 – ½"	½"	24	Gray	100
TP7151	4 – ¾"	¾"	24	Gray	100
2" DEEP ROUND WEATHERPROOF OUTLET BOX EXTENSION (18.3 CUBIC INCH CAPACITY)					
TP7152	4 – ½"	—	25	Gray	58.3

Dimensions

In Inches:

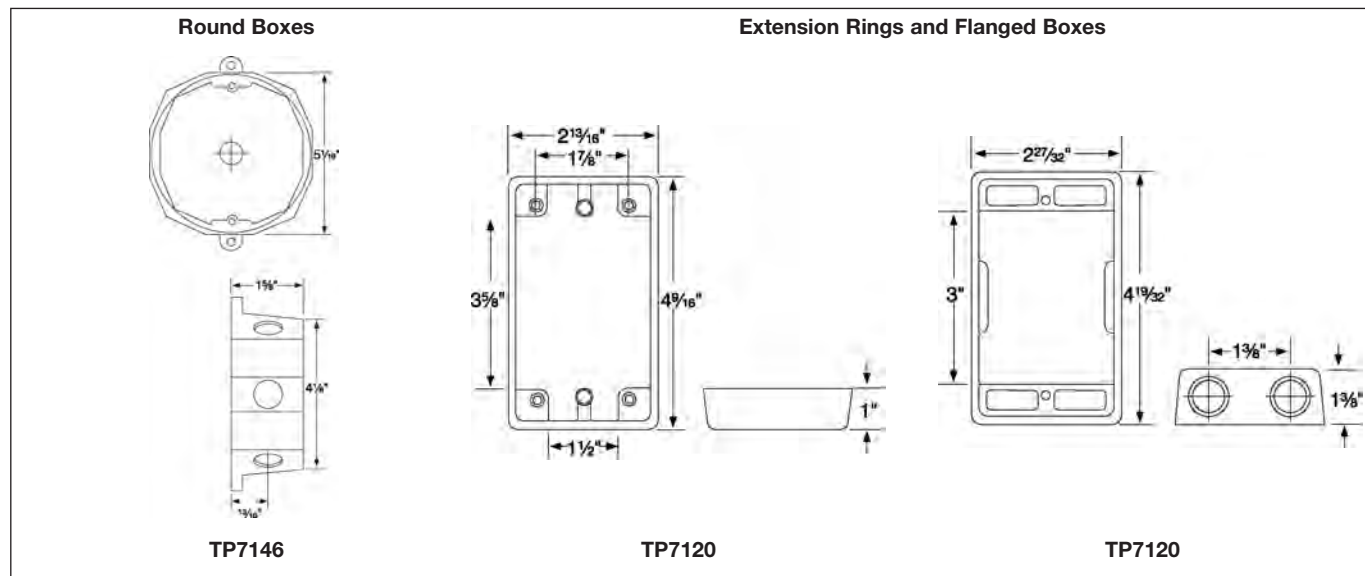

CLOSURE PLUGS – ZINC DIE-CAST*

Cat. #	Description	Color	Unit Qty.	Wt. Lbs. Per 100
TP7940	1/2"	Gray	100	1.5
TP7942	1/2"	Bronze	100	1.5
TP7944	3/4"	Gray	50	2.1
TP7948	1"	Gray	50	3

*CSA certified



ONE GANG

SELF-CLOSING COVERS WITH GASKETS UL LISTED, DIE-CAST ALUMINUM



TP7199



TP7202



TP7206 – TP7209



TP7218



TP7236 - TP7238



TP7240 - TP7242



TP7244



TP7232

Cat. #	Description	Color	Unit Qty.	Wt. Lbs. Per 100
TP7199	One Gang Vertical Duplex Cover	Gray	50	61.1
TP7202	One Gang – For Single Receptacle or Switch – 1.52" Dia. Opening	Gray	25	42.0
TP7206	One Gang – For Duplex Receptacle or Combination Switch	Natural	50	38.0
TP7207	One Gang – For Duplex Receptacle or Combination Switch	Gray	50	38.0
TP7208	One Gang – For Duplex Receptacle or Combination Switch	White	50	38.0
TP7209	One Gang – For Duplex Receptacle or Combination Switch	Bronze	50	38.0
TP7214	One Gang Vertical – For Single Receptacle or Switch 1.62" Dia. Opening	Gray	25	61.1
TP7218	One Gang – For 20, 30 and 50 A Receptacles (2.125" Dia.)	Gray	25	55.6
TP7232	One Gang Stay Open – For Duplex Receptacles, Switches or Combination Devices, Non UL Listed	Natural	50	38.0
TP7233	One Gang Stay Open – For Duplex Receptacles, Switches or Combination Devices, Non UL Listed	Gray	50	38.0
TP7236	One Gang – For Horizontal GFI Devices	Gray	25	42
TP7237	One Gang – For Horizontal GFI Devices	White	25	42
TP7238	One Gang – For Horizontal GFI Devices	Bronze	25	42
TP7240	One Gang – For Vertical GFI Devices	Gray	25	54
TP7241	One Gang – For Vertical GFI Devices	White	25	54
TP7242	One Gang – For Vertical GFI Devices	Bronze	25	54

Weatherproof

TWO GANG

**SELF-CLOSING GFI COVERS WITH GASKETS
UL LISTED, DIE-CAST ALUMINUM**

Weatherproof



TP7220



TP7224



TP7228



TP7248



TP7252

Cat. #	Description	Color	Unit Qty.	Wt. Lbs. Per 100
TP7220	Two Gang – For Two Single Receptacles and/or Switches	Gray	10	66.7
TP7224	Two Gang – For One Single Receptacle or Switch and One Duplex Receptacle, Switch or Combination Device	Gray	10	62.0
TP7228	Two Gang – For Two Duplex Receptacles, Switches or Combination Device	Gray	10	61.1
TP7244	Two Gang – For Vertical GFI Devices and One Single Switch or Receptacle	Gray	10	61.1
TP7248	Two Gang – For One Vertical GFI Device and One Duplex Receptacle, Switch or Combination Device	Gray	10	61.1
TP7252	Two Gang – For Two GFI Devices	Gray	10	55.6

ONE & TWO GANG

**TOGGLE SWITCH COVERS
WITH GASKETS STAMPED ALUMINUM
UL LISTED**



TP7260
5/8" Thick



TP7268

Cat. #	Description	Unit Qty.	Wt. Lbs. Per 100
TP7260	One Gang With 15A 125V Single Pole Switch	50	27.8
TP7268	Two Gang	10	16.7
TP7272	Two Gang With 2 – 15A 125V Single Pole Switch	10	33.3
TP7276	Two Gang With 2 – 15A 125V 3-Way Switch	10	33.3
TP7280	One Gang Extended Switch Cover – (for use with Standard Switch)	50	34.1

WHILE-IN-USE COVERS

FOR ONE & TWO GANG BOXES "CONSTANT USE" DUPLEX/GFI COVER UL & CSA LISTED, POLYCARBONATE

Single gang covers have a patented design with moveable hinges that reposition easily for vertical or horizontal mounting, with no tools required.



Cooper Crouse-Hinds' new while-in-use covers offer a rugged versatile design that protects against various elements such as rain, snow, and ice. They are available in gray and white, single gang, single gang deep, and double gang to offer 98 different configurations! The single gang covers have a patented design with moveable hinges that reposition easily for vertical or horizontal mounting, with no tools required. They are great for use with vending machines, holiday lighting, portable signs, outdoor lighting, outdoor hot tubs, and more!

Features:

- Rugged UV resistant polycarbonate cover and back protects device inside from rain, sleet, and snow without cracking or breaking and is non-corrosive and non-conductive
- Covers have a versatile product design with moveable hinges that reposition for vertical/horizontal mounting, which reduces the number of SKUs
- Each cover includes a pre-mounted neoprene gasket on the back, ensuring the gasket cannot fall off or be improperly positioned during installation - assuring a weatherproof installation every time!
- Available in 1 Gang, Self-closing Cover, Standard (3.25") and Deep (4.75") depths
- Available in 2 Gang, Self-closing Cover, Standard (3.25") depth
- Meets and exceeds outdoor lighting requirements
- Lockable cover (with customer added locking device) adds security
- Available in both gray and white to meet customer preference

Certifications and Compliances:

- UL and cUL Listed
- Meets NEMA 3R requirements

Standard Materials:

- Cover, Back, and Hinges: Polycarbonate
- Gasket: Neoprene

Weatherproof

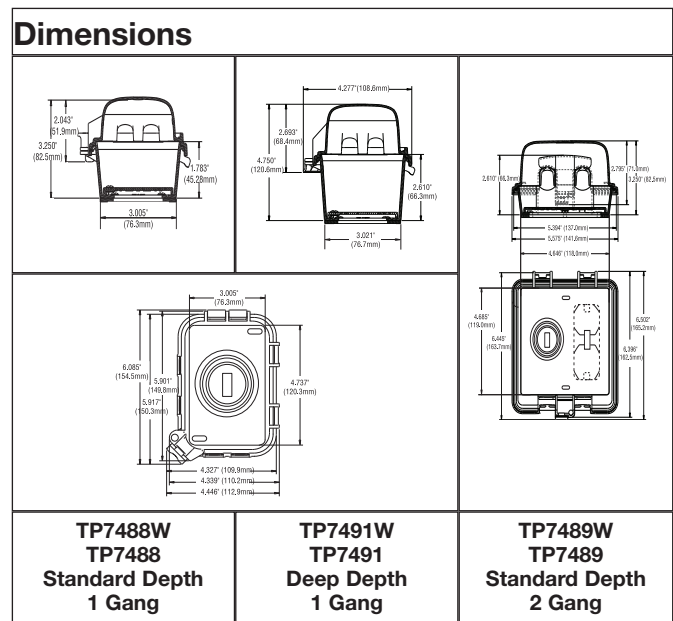

Ordering Information

Catalog No.	Description	# of Configurations using inserts & moveable hinges	Color	Unit Qty.	Wt. Lbs. Per 100
TP7488	1 Gang, 3.25" Standard Depth, Self-closing Cover, Horizontal/Vertical Mount	16	Gray	6	45
TP7491	1 Gang, 4.75" Deep Depth, Self-closing Cover, Horizontal/Vertical Mount	16	Gray	3	48
TP7489	2 Gang, 3.25" Standard Depth, Self-closing Cover, Vertical Mount	66	Gray	4	77
TP7488W	1 Gang, 3.25" Standard Depth, Self-closing Cover, Horizontal/Vertical Mount	16	White	6	45
TP7491W	1 Gang, 4.75" Deep Depth, Self-closing Cover, Horizontal/Vertical Mount	16	White	3	48
TP7489W	2 Gang, 3.25" Standard Depth, Self-closing Cover, Vertical Mount	66	White	4	77

Weatherproof Outlet Covers



BLANK STEEL

WITH GASKETS
UL LISTED FOR WET LOCATIONS

Weatherproof



TP7292 – TP7294



TP7296 – TP7298

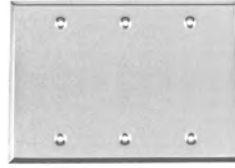

TP7295



TP7158 – 7160

Cat. #	Description	Color	Unit Qty.	Wt. Lbs. Per 100
TP7292	One Gang	Gray	100	8.3
TP7293	One Gang	White	100	8.3
TP7294	One Gang	Bronze	100	8.3
TP7296	Two Gang	Gray	50	12.5
TP7297	Two Gang	White	50	12.5
TP7298	Two Gang	Bronze	50	12.5
TP7295	Three Gang	Gray	25	17
TP7158	Blank Round	Gray	50	21
TP7159	Blank Round	White	50	21
TP7160	Blank Round	Bronze	50	21

ROUND AND RECTANGULAR

WITH GASKETS, DIE-CAST ALUMINUM, UL LISTED FOR WET LOCATIONS
FOR USE WITH WEATHERPROOF LAMPHOLDERS



TP7300 – 7302



TP7308 – 7310



TP7312 – 7314



TP7320 – 7322

Cat. #	Description	No. of Outlet Holes	Color	Unit Qty.	Wt. Lbs. Per 100
TP7300	4½" Round	1 – ½"	Gray	25	20.8
TP7301	4½" Round	1 – ½"	White	25	20.8
TP7302	4½" Round	1 – ½"	Bronze	25	20.8
TP7308*	4½" Round	3 – ½"	Gray	25	33.3
TP7309*	4½" Round	3 – ½"	White	25	33.3
TP7310*	4½" Round	3 – ½"	Bronze	25	33.3
TP7312	Rectangular	1 – ½"	Gray	25	33.3
TP7313	Rectangular	1 – ½"	White	25	33.3
TP7314	Rectangular	1 – ½"	Bronze	25	33.3
TP7316	Rectangular	2 – ½"	Gray	25	33.3
TP7317	Rectangular	2 – ½"	White	25	33.3
TP7318	Rectangular	2 – ½"	Bronze	25	33.3
TP7320	Rectangular	3 – ½"	Gray	25	33.3
TP7321	Rectangular	3 – ½"	White	25	33.3
TP7322	Rectangular	3 – ½"	Bronze	25	33.3

*Comes with closure plug

LAMP HOLDERS AND ACCESSORIES

DIE-CAST ALUMINUM CONSTRUCTION, UP TO 150 WATTS, WITH LAMP GASKET, UL LISTED



TP7162 – TP7165



TP7166



TP7176

Weatherproof

Cat. #	Description	Color	Unit Qty.	Wt. Lbs. Per 100
TP7162	Universal Par Lampholder	Natural	36	47.2
TP7163	Universal Par Lampholder	Gray	36	47.2
TP7164	Universal Par Lampholder	White	36	47.2
TP7165	Universal Par Lampholder	Bronze	36	47.2
TP7166	Universal Par Lampholder With External Gasket	Gray	36	50
TP7170	External Gasket Only	—	100	3
TP7176	Clamp-On Guard	—	24	50

WEATHERPROOF LAMP HOLDERS AND ACCESSORIES

DIE-CAST ALUMINUM CONSTRUCTION, UP TO 150 WATTS, WITH LAMP GASKET, UL LISTED



TP7178



TP7186



TP7188
(Aluminum)

Cat. #	Description	Color	Unit Qty.	Wt. Lbs. Per 100
TP7178	Par Lampholder With Reflector	Gray	6	166.7
TP7186	Portable Par Lampholder With 6' Cord	Gray	12	100
TP7188	2 1/2" Outside Diameter Pole Fitter with 1/2" Male Thread	Gray	24	50

LAMP HOLDER COMBINATIONS

DIE-CAST ALUMINUM CONSTRUCTION, WITH GASKETS, UL LISTED



TP7330 – TP7332

Cat. #	Description	Color	Unit Qty.	Wt. Lbs. Per 100
TP7330	2 Par Lampholders and 3-Hole Round Cover	Gray	10	137.5
TP7331	2 Par Lampholders and 3-Hole Round Cover	White	10	137.5
TP7332	2 Par Lampholders and 3-Hole Round Cover	Bronze	10	137.5

Dimensions

In Inches:

Single Gang, Duplex Receptacle Covers

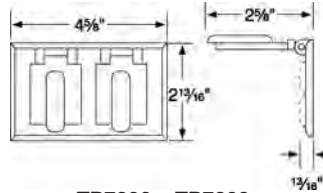

TP7206 - TP7209

Single Gang, Single Receptacle Covers - Vertical Mount

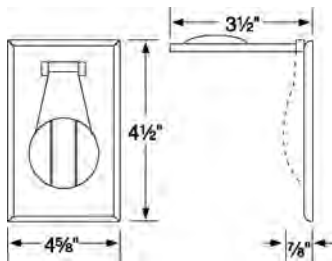

TP7202

Two Gang, Single Receptacle Covers

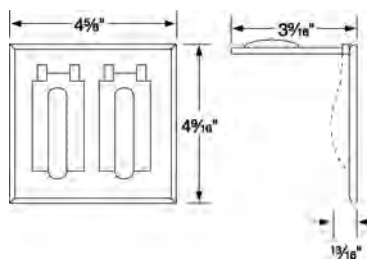

TP7220

Single Gang, Duplex Receptacle Covers - Vertical Mount

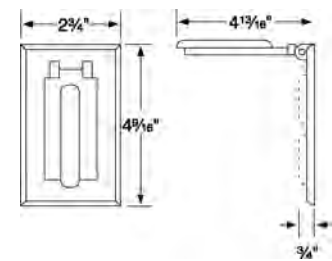

TP7199

Two Gang, Duplex Receptacle Covers

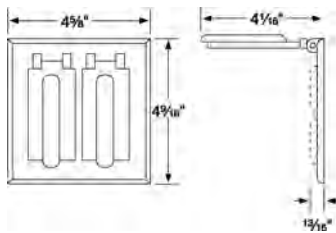

TP7228

Single Gang, GFCI Covers Horizontal Mount

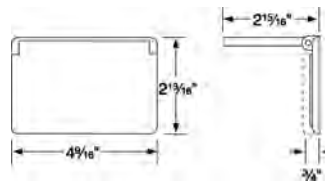

TP7236 - TP7238

Single Gang, GFCI Covers Vertical Mount

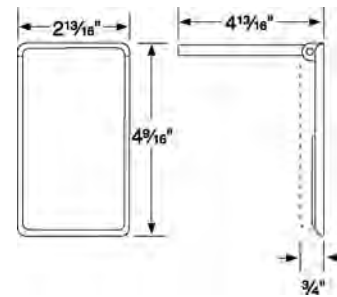

TP7240 - TP7242

Weatherproof

Weatherproof Outlet Covers



Dimensions In Inches:

Lampholders

<p>Two Gang, GFCI Covers</p> <p>TP7248</p>	<p>Blank Covers</p> <p>TP7292 - TP7294</p>	<p>Blank Covers</p> <p>TP7296 - TP7298</p>
---	---	---

<p>Blank Covers</p> <p>TP7158</p>	<p>Single Gang, Switch Covers Vertical Mount</p> <p>TP7256</p>	<p>Lampholders</p> <p>TP7162 - TP7165</p>
--	---	--

<p>Hooded Lampholder</p> <p>TP7178</p>	<p>Rectangular Lampholder Covers</p> <p>TP7312 - TP7322</p>	<p>Round Lampholder Covers</p> <p>TP7300 - TP7310</p>
---	--	--

Flexible Fixture Hangers

Cooper Crouse-Hinds TPSFH & TPRFH flexible fixture hangers are used in commercial or light industrial applications where HID high bay and low bay lighting fixtures are used. Specific applications include storage facilities, shipping warehouses, retail and DIY facilities.

Features and Benefits:

- Suitable for use with 1/2" or 3/4" fixture conduit stems these hangers allow the conduit stem of the fixture (luminaire) to swing in any direction. Maximum swing angle is 26° from vertical max slope angles 22 1/2°
- Available in two styles; one for attachment to round or octagonal steel boxes, the other for attachment to 4" square steel boxes.
- Both styles are quickly and easily attached by two screws.
- Hangers are drilled and tapped for use with 3/4" conduit stem as standard and come supplied with a 3/4" - 1/2" reducer for 1/2" conduit stem applications.

Certifications and Compliances:

- UL Listed – UL 1598
- CSA C22.2 No. 250
- Suitable for Damp Locations

Materials and Finishes:

- Material: Sheet Steel
- Finish: Zinc Chromate for corrosion resistance

Swiv-L-Drop™ Canopy Fixture Hangers

The Swiv-L-Drop Canopy hanger utilizes a patented spring design to provide vibration and shock protection for pendant mounted fixtures in both horizontal and vertical directions. Designed to fit 3" or 4" outlet boxes the Swiv-L-Drop is for use with 1/2" fixture conduit stems. The smooth, white canopy provides an aesthetically pleasing appearance and installs quickly and easily without the use of tools.

Certifications and Compliances:

- UL Listed – UL 1598
- Suitable for Dry Locations

Materials and Finishes:

- Material: Sheet Steel
- Finish: Canopy – painted white

Sway Adapters

The Sway Adapter installs quickly and easily to pendant mounted fixtures and compensates for shocks and motion due to movements, vibration, earthquakes or other sources by allowing for lateral movement up to 45 degrees. The Sway Adapter can be used independently or in conjunction with the Swiv-L-Drop hanger. The Sway Adapter is also finished in an aesthetically pleasing white painted finish and is designed for use with 1/2" conduit stems and has 3/8" male threads.

Certifications and Compliances:

- UL Listed – UL 1598
- Suitable for Dry Locations

Materials and Finishes:

- Material: Sheet Steel
- Finish: sway adapter – painted white



Description	Support Wt. (lbs)	Cat. #
For use with 4" Round or Octagon Boxes	50	TPRFH12
For use with 4" Square boxes	50	TPSFH12



Description	Support Wt. (lbs)	Cat. #
Swiv-L-Drop Canopy Hanger for use with 3" or 4" Outlet boxes for use with 1/2" Conduit Stems. Painted.	50*	S 1 1/2 PAINTED
Swiv-L-Drop Canopy Hanger for use with 3" or 4" Outlet boxes for use with 1/2" Conduit Stems. Unpainted.	50*	S 1 1/2 UNPAINTED
For use with 3/8" Conduit Stems. Painted.	50*	S 1 3/8 PAINTED
For use with 3/8" Conduit Stems. Unpainted.	50*	S 1 3/8 UNPAINTED

*65 lbs. rated with a minimum 12-inch stem if fully supported by other than an outlet box.



Description	Cat. #
Sway adapter for use with 1/2" Conduit Stem (male thread is 3/8")	SA 1W

Key Features and Benefits:

- Durable die cast housing and guard for long product life
- Powder paint finish for corrosive environments
- Available in pendant, box and wall mounts
- Fixtures may be purchased complete or as components
- Fixtures constructed of Die-Cast Aluminum, Screw on Guards are Zinc Die-Cast
- Heat Resistant Clear Globe Available on 100 watt series
- Wire Guard Available

Certifications and Compliances:

- UL Standard UL1598
- UL Listed File No. E15625
- cUL Standard CSA-C22.2 No 250.0
- Suitable for Wet Locations
- 100W max incandescent series is UL approved for 27W max SBCFL (equivalent to 100W incandescent)
- 200W max incandescent series is UL approved for 42W max SBCFL (equivalent to 200W incandescent)

Clear glass is standard, colors are available, plastic (polycarbonate) globes which are virtually unbreakable are available in colors and are used as an alternative to glass globe-guard combinations (not recommended to exceed 60 watts).

VAPOR PROOF FIXTURES – GASKETED CORROSION RESISTANT

DIE-CAST CONSTRUCTION, GLASS GLOBES, DIE-CAST GUARDS, UL LISTED



TP7600,
TP7601,

TP7800,
TP7801,
TP7860

TP7610,
TP7611,
TP7805

TP7620,
TP7621

TP7810,
TP7811

TP7630,
TP7815

TP7640

TP7820

TP7650,
TP7825

Cat. #	Description	Hole Size	Watts	Std. Unit Carton	Wt. Lbs. Per 100
4" BOX MOUNTED					
TP7600*	Clear Globe, Cast Guard	1/2"	100	1	325
TP7601	Clear Globe, Cast Guard	3/4"	100	1	324
TP7800	Clear Globe, Wire Guard	1/2"	200	1	516.7
TP7801	Clear Globe, Wire Guard	3/4"	200	1	516
TP7860	Fluorescent Clear Globe, Wire Guard	1/2"	13	1	413
TP7610	Clear Globe	1/2"	100	1	258.3
TP7611	Clear Globe	3/4"	100	1	258
TP7805	Clear Globe	1/2"	200	1	283.3
PENDANT MOUNT					
TP7620	Clear Globe, Cast Guard	1/2"	100	1	300
TP7621	Clear Globe, Cast Guard	3/4"	100	1	299
TP7810	Clear Globe, Wire Guard	1/2"	200	1	350
TP7811	Clear Globe, Wire Guard	3/4"	200	1	349
TP7630	Clear Globe	1/2"	100	1	208.4
TP7815	Clear Globe	1/2"	200	1	258.4
SURFACE MOUNT, FITS 3" and 4" ROUND BOXES					
TP7640	Clear Globe, Cast Guard	—	100	1	275
TP7820	Clear Globe, Wire Guard	—	200	1	333.3
TP7650	Clear Globe	—	100	1	216.7
TP7825	Clear Globe	—	200	1	180

*Suitable for base-up applications

Vapor Proof Lighting Incandescent



Vapor Proof



TP7670, TP7835



TP7825

Cat. #	Description	Watts	Std. Unit Carton	Wt. Lbs. Per 100
RIGHT ANGLE BRACKET FIXTURES				
TP7660	Clear Globe, Cast Guard	100	1	300
TP7830	Clear Globe, Wire Guard	200	1	516.7
TP7670	Clear Globe	100	1	200
TP7835	Clear Globe	200	1	400
BOX MOUNTED				
TP7680	Clear Globe, Cast Guard	100	1	350
TP7840	Clear Globe, Wire Guard	200	1	560
TP7825	Clear Globe	200	1	450
FLUORESCENT				
TP7870	Clear Globe, Wire Guard	13	1	462

VAPOR PROOF COMPONENTS



Pendant



Ceiling Box Cap



Ceiling Box



Right Angle



Right Angle/Box

Cat. #	Description	Watts	Std. Unit Carton	Wt. Lbs. Per 100
PENDANT CAP, PORCELAIN SOCKET GASKET AND SCREWS				
TP7496	Gray, 1/2"	100	10	18
TP7497	Gray, 3/4"	100	10	18
TP7498	Gray, 1/2"	200	10	10
TP7499	Gray, 3/4"	200	10	10
CEILING BOX CAP, SOCKET GASKET AND SCREWS				
TP7447	Gray	100	10	12
TP7479	Gray	200	10	12
CEILING MOUNT BOX WITH GASKETS, PORCELAIN SOCKET AND SCREWS				
TP7450	Gray, 1/2"	100	10	19
TP7478	Gray, 3/4"	100	10	19
TP7451	Gray, 1/2"	200	10	19
TP7479	Gray, 3/4"	200	10	19
RIGHT ANGLE BRACKET GASKET, SOCKET, SCREWS				
TP7445	Gray	100	10	21
TP7446	Gray	200	6	12
RIGHT ANGLE BRACKET ATTACHED BOX, GASKET, SOCKET AND SCREWS				
TP7440	Gray, 1/2"	100	1	3

VAPOR PROOF FIXTURE ACCESSORIES



TP7460 – TP7466



TP7468 – TP7472



TP7474, TP7475



TP7476



TP7477

Vapor Proof

Cat. #	Description	Watts	Std. Unit Carton	Wt. Lbs. Per 100
TP7460	Glass Clear Globe, 130 °F Max	100	12	98
TP7462	Glass Amber Globe	100	12	120
TP7463	Glass Blue Globe	100	12	120
TP7464	Glass Green Globe	100	12	120
TP7466	Glass Clear Globe	200	6	200
TP7468	Lexan Clear Prismatic	75	12	58.4
TP7469	Lexan Blue Prismatic	60	12	58.4
TP7470	Lexan Red Prismatic	75	12	58.4
TP7471	Lexan Amber Prismatic	75	12	58.4
TP7472	Lexan White	75	12	58.4
TP7474	Bayonet Mount Die-Cast Guard	100	12	108.4
TP7475	Wire Guard	200	6	183.4
TP7476	Clamp-On Wire Guard	100	12	62.5
TP7477	Adapter Plate	—	12	62.5

VAPOR PROOF DIMENSIONS

100 WATT DIMENSIONS

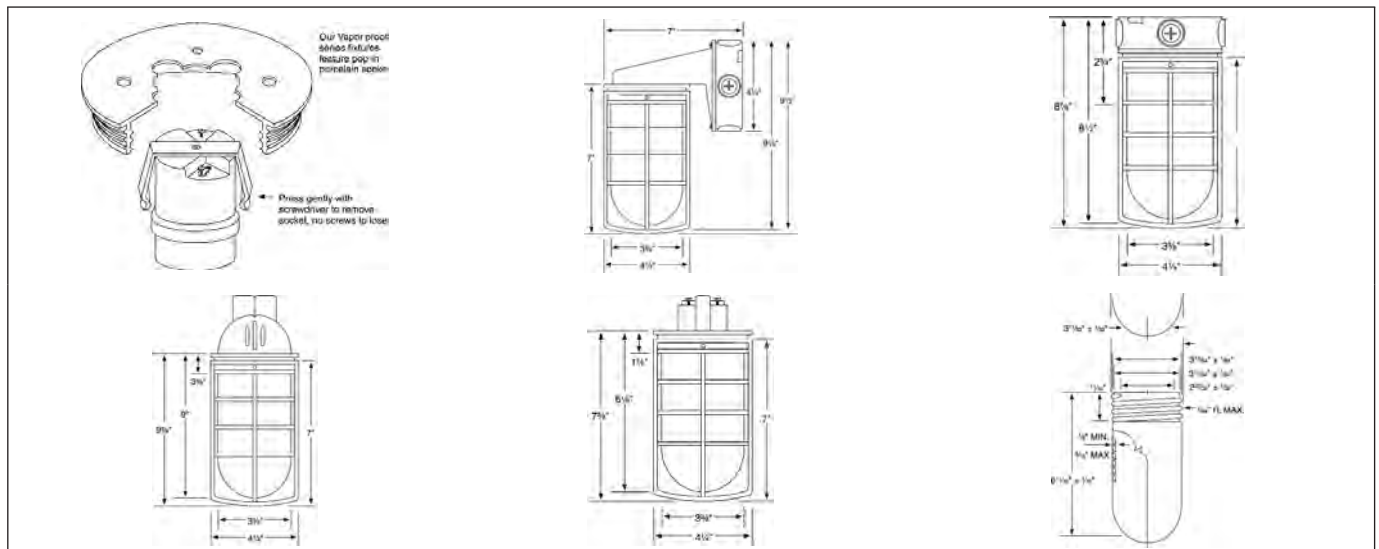

200 WATT

Cat. #	Length	Overall Width	Depth
TP7830	12 1/2"	5 1/2"	6 1/8"
TP7840	12 1/2"	5 1/2"	8"
TP7820	7 1/2"	4 1/2"	—
TP7810	11 1/2"	5 1/2"	—
TP7800	10 3/4"	5 1/2"	—

PHOTOELECTRIC LIGHTING CONTROLS

Photoelectric



TP7925



TP7927 - TP7928

Applications:

- Use for sunset activated automatic control of night lighting
- May be used to control outdoor lighting and signs

Features:

- Durable weatherproof construction
- Built-in time delay prevents operation triggered by temporary light flashes

Cat. #	Description	Std. Unit Pkg.	Wt. Lbs. Per 100
TP7925	1200W Swivel Photo Cell 120V	10	8.3
TP7927	300W Photo Cell 120V	10	8.3
TP7928	1000W Photo Cell 208 - 277V	10	8.3

Application and Selection

Applications:

Junction boxes, designed for hazardous and non-hazardous locations, are used in a variety of industries to perform the following functions:

- As a pull box
- To provide enclosures for splices and taps
- As a mounting box for multi-device control stations
- For housing apparatus, instruments, and other devices

Considerations for Selection:

- Environmental location – the physical location of the junction box will call for proper construction of the box to meet National Electrical Code requirements and will affect the material and finish needed to meet weather and corrosive conditions, if present.
- Number and size of conductors – combined with the function to be performed (i.e., splicing, pull box), determines the amount of space needed, and therefore, the required physical dimensions of the box.
- Conduit layout – determines the number, size, and location of the conduit openings in the box. It will also determine the type of mounting required (i.e., flush or surface positioning of the box).
- Flexibility required – if changes in the electrical system are anticipated, the box chosen should be easily adaptable, either by construction or size to the future system.

Options and Accessories:

A wide variety of options and accessories for special application are available for the various junction box families. These can be selected once the type of junction box has been determined. These options are shown on the individual pages. Some of the options available include:

- Special covers
- Hinged covers
- Materials and finishes
- Equipment mounting plates
- Conduit or device openings
- *Corro-free*™ epoxy powder coat – information available on request

Quick Selector Chart

Junction Boxes	Environmental Capability/Type Designation	Size Range† L, W, D Inside	Max. Conduit Opening Size	Mtg.	Cover Type	Cover Material
WAB	Raintight/Type 3, 4 Dust-tight/Type 12	4 x 4 x 2 to 72 x 30 x 16	5	Surface	Unflanged	Steel
WCB	Raintight/Type 3, Watertight/Type 4, Dust-tight/Type 12	4 x 4 x 2 to 72 x 30 x 16	5	Surface	Overlapping	Cast iron
WJB	Raintight/Type 3, Watertight/Type 4	4 x 4 x 3 to 72 x 30 x 16	6	Surface	Flanged	Steel
WJBF	Raintight/Type 3, Watertight/Type 4	4 x 4 x 4 to 72 x 30 x 16	6	Flush	External flanged recessed sidewalk	Steel (checkered)
WEB	Raintight/Type 3	4 x 4 x 3 to 36 x 36 x 12	6	Flush	Internal Flanged	Steel

†Length and width are inside dimensions. Depth is inside dimension without cover.

Drilled and Tapped Conduit Openings or Slip Holes:

All W-Series cast-iron junction boxes may be ordered with drilled and tapped conduit openings or slip holes - subject to minimum spacing limitations.

To order a box from the factory with conduit openings, consult factory.

WJBF Checkered Cover Sidewalk Junction Boxes

Heavy Duty
External Flanged for Flush Mounting

Weatherproof
Watertight
Raintight
NEMA 3, 4, 5
Cl. II, Groups E, F, G
Cl. III



W-Series Boxes

Applications:

WJBF boxes are primarily designed for surface mounting. WJBF heavy duty junction boxes are installed in conduit systems to:

- Act as pull box for conductors
- Provide openings and space for making splices and taps in conductors
- Provide for branch conduit runs
- Provide access to conductors for maintenance and future system changes
- Enclose and protect electrical equipment

Features:

- Covers are suitable for vehicular traffic (H20 loading)
- Neoprene gasket cemented to cover
- Wide range of drilled and tapped conduit entrance sizes and locations permits extreme flexibility of use in conduit system
- Internal equipment mounting pads may be drilled and tapped for 1/4" - 20 mounting screws
- Blind tapped into internal mounting pads
- Mounting straps are standard on smaller sized boxes up to 8x8x6, for larger sizes consult factory

Certifications and Compliances:

- CSA Standard C22.2 No. 25
- Weatherproof
- Watertight
- NEMA 3, 4, 5
- NEMA 250
- CEC:
 - Class II, Division 1, Groups E, F, G
 - Class III
 - Encl. 3, 4, 5
- H20 Vehicle Load Rating*

*Self certify to H20 vehicle load rating equivalent to 16,000 lbs. on cover center.

Standard Materials:

- *Feraloy*® iron alloy body
- Heavy-gauge steel (checkered) - cover, mounting straps
- Neoprene gaskets
- Stainless steel cover screws

Standard Finishes:

- *Feraloy* iron alloy and heavy-gauge steel - hot-dip galvanized

Options:

Description

Factory installed mounting plate
Material - all sizes, cast aluminum
Drilled and tapped conduit holes and slip holes available, Consult Factory

Suffix

MP
SA

Size Ranges:

- 4" x 4" x 2" to 72" x 30" x 16"

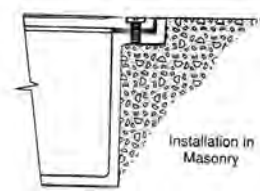

Ordering Information:

Cat. #	Wall Thickness (in.)	Length (in.)	Width (in.)	Depth (in.)
WJBF040404	1/4	4	4	4
WJBF060404	1/4	6	4	4
WJBF060604	1/4	6	6	4
WJBF060606	1/4	6	6	6
WJBF080604	1/4	8	6	4
WJBF080606	1/4	8	6	6
WJBF080804	1/4	8	8	4
WJBF080806	1/4	8	8	6
WJBF080808	1/4	8	8	8
WJBF100806	1/4	10	8	6
WJBF100808	1/4	10	8	8
WJBF101006	1/4	10	10	6
WJBF101008	1/4	10	10	8
WJBF120606	1/4	12	6	6
WJBF120806	1/4	12	8	6
WJBF120808	1/4	12	8	8
WJBF120810	5/16	12	8	10
WJBF121206	1/4	12	12	6
WJBF121208	1/4	12	12	8
WJBF121212	5/16	12	12	12
WJBF121218	5/16	12	12	18
WJBF140806	1/4	14	8	6
WJBF141410	5/16	14	14	10
WJBF161206	1/4	16	12	6
WJBF161208	1/4	16	12	8
WJBF161606	1/4	16	16	6
WJBF180806	1/4	18	8	6
WJBF180808	1/4	18	8	8
WJBF181006	5/16	18	10	6
WJBF181206	5/16	18	12	6
WJBF181208	5/16	18	12	8
WJBF181210	3/8	18	12	10
WJBF181212	5/16	18	12	12
WJBF181218	3/8	18	12	18
WJBF181806	3/8	18	18	6
WJBF181808	3/8	18	18	8
WJBF181812	3/8	18	18	12
WJBF181818	3/8	18	18	18
WJBF241208	3/8	24	12	8
WJBF241212	3/8	24	12	12
WJBF241808	3/8	24	18	8
WJBF241810	3/8	24	18	10
WJBF241812	3/8	24	18	12
WJBF241818	3/8	24	18	18
WJBF242412	3/8	24	24	12
WJBF242418	3/8	24	24	18
WJBF242424	3/8	24	24	24
WJBF302412	3/8	30	24	12
WJBF302418	3/8	30	24	18
WJBF362418	3/8	36	24	18
WJBF362424	3/8	36	24	24

Larger sizes available up to 72" x 30" x 16" - Consult Factory

WJB Junction Boxes

Heavy Duty
Flanged for Surface Mounting

Weatherproof
 Watertight
 Raintight
 NEMA 3, 4, 5
 Cl. II, Groups E, F, G
 Cl. III



Applications:

WJB boxes are primarily designed for surface mounting. WJB heavy duty junction boxes are installed in conduit systems to:

- Act as pull box for conductors
- Provide openings and space for making splices and taps in conductors
- Provide for branch conduit runs
- Provide access to conductors for maintenance and future system changes
- Enclose and protect electrical equipment

Features:

- Covers are suitable for vehicular traffic (H2O loading)
- Neoprene cover gasket.
- Wide range of drilled and tapped conduit entrance sizes and locations permits extreme flexibility of use in conduit system.
- Internal equipment mounting pads may be drilled and tapped for 1/4" - 20 mounting screws.
- Blind tapped into internal mounting pads.
- Mounting straps are standard on smaller sized boxes up to 8x8x6, for larger sizes consult factory

Certifications and Compliances:

- CSA Standard C22.2 No. 25
- Weatherproof
- Watertight*
- NEMA 3, 4, 5
- NEMA 250
- CEC:
 - Class II, E, F, G
 - Class III
 - Encl. 3, 4, 5
- H2O Vehicle Load Rating

Standard Materials:

- *Feraloy*® iron alloy body
- Heavy-gauge steel – cover and mounting straps
- Neoprene gaskets
- Stainless steel cover screws

Standard Finishes:

- *Feraloy* iron alloy and heavy-gauge steel – hot-dip galvanized

Options:

Description	Suffix
Factory installed mounting plate	MP
Material - all sizes, cast aluminum	SA
Drilled and tapped conduit holes and slip holes available, Consult Factory	

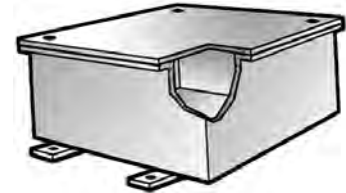
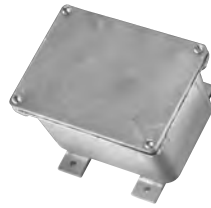

Ordering Information:

Cat. #	Wall Thickness (in.)	Length (in.)	Width (in.)	Depth (in.)
WJB040403	1/4	4	4	3
WJB040404	1/4	4	4	4
WJB060404	1/4	6	4	4
WJB060604	1/4	6	6	4
WJB060606	1/4	6	6	6
WJB080604	1/4	8	6	4
WJB080606	1/4	8	6	6
WJB080804	1/4	8	8	4
WJB080806	1/4	8	8	6
WJB080808	1/4	8	8	8
WJB100806	1/4	10	8	6
WJB100808	1/4	10	8	8
WJB101006	1/4	10	10	6
WJB101008	1/4	10	10	8
WJB120606	1/4	12	6	6
WJB120806	1/4	12	8	6
WJB120808	1/4	12	8	8
WJB120810	1/4	12	8	10
WJB121206	5/16	12	12	6
WJB121208	5/16	12	12	8
WJB121212	5/16	12	12	12
WJB121218	5/16	12	12	18
WJB140806	5/16	14	8	6
WJB141410	5/16	14	14	10
WJB161206	5/16	16	12	6
WJB161208	5/16	16	12	8
WJB161606	5/16	16	16	6
WJB180806	5/16	18	8	6
WJB180808	5/16	18	8	8
WJB181006	5/16	18	10	6
WJB181206	5/16	18	12	6
WJB181208	5/16	18	12	8
WJB181210	5/16	18	12	10
WJB181212	5/16	18	12	12
WJB181218	5/16	18	12	18
WJB181806	3/8	18	18	6
WJB181808	3/8	18	18	8
WJB181812	3/8	18	18	12
WJB181818	3/8	18	18	18
WJB241208	3/8	24	12	8
WJB241212	3/8	24	12	12
WJB241808	3/8	24	18	8
WJB241810	3/8	24	18	10
WJB241812	3/8	24	18	12
WJB241818	3/8	24	18	18
WJB242412	9/16	24	24	12
WJB242418	9/16	24	24	18
WJB242424	9/16	24	24	24
WJB302412	9/16	30	24	12
WJB302418	9/16	30	24	18
WJB362418	9/16	36	24	18
WJB362424	9/16	36	24	24

Larger sizes available up to 72" x 30" x 16" - Consult Factory

W-Series Boxes

WAB Junction Boxes

Dust-tight
Weatherproof
NEMA 3, 4, 12



Heavy Duty Unflanged for Surface Mounting

Applications:

Where a heavy duty dustproof, weatherproof enclosure is desired, WAB boxes are installed in conduit system to:

- Act as pull box for conductors
- Provide openings and space for making splices and taps in conductors
- Provide for branch conduit runs
- Provide access to conductors for maintenance and future system changes
- Enclose and protect electrical devices

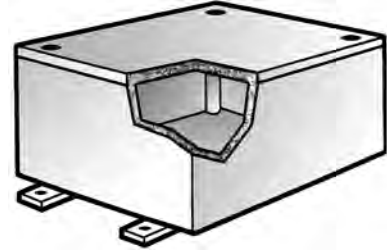

W-Series
Boxes

Features:

- Flat neoprene cover gasket.
- Wide range of drilled and tapped and slip hole conduit entrance sizes and locations permits extreme flexibility of use in conduit system.
- Internal equipment mounting pads available blind tapped for 1/4" - 20 mounting screws.
- Blind tapped into internal mounting pads.
- Mounting straps are standard on smaller sized boxes up to 8x8x6, for larger sizes consult factory

Certifications and Compliances:

- Dust-tight
- Weatherproof
- NEMA 3, 4, 12
- NEMA 250

Standard Materials:

- Feraloy® iron alloy body
- Heavy-gauge steel cover
- Neoprene gaskets
- Stainless steel cover screws
- Steel mounting straps

Standard Finishes:

- Feraloy iron alloy and heavy gauge steel - hot dip galvanized

Options:

Description

Factory installed mounting plate
Material - all sizes, cast aluminum
Drilled and tapped conduit holes and
slip holes available, Consult Factory

Suffix

MP
SA

Size Ranges:

- 4" x 4" x 2" to 72" x 30" x 16"

Ordering Information:

Cat. #	Wall Thickness (in.)	Length (in.)	Width (in.)	Depth (in.)
WAB040402	5/32	4	4	2
WAB040403	3/16	4	4	3
WAB040404	1/4	4	4	4
WAB050503	1/4	5	5	3
WAB050504	1/4	5	5	4
WAB060403	1/4	6	4	3
WAB060404	7/32	6	4	4
WAB060603	1/4	6	6	3
WAB060604	3/16	6	6	4
WAB060606	9/32	6	6	6
WAB080403	5/16	8	4	3
WAB080604	7/32	8	6	4
WAB080606	5/16	8	6	6
WAB080804	5/16	8	8	4
WAB080806	5/16	8	8	6
WAB080808	5/16	8	8	8
WAB090604	5/16	9	6	4
WAB100604	1/4	10	6	4
WAB100804	1/4	10	8	4
WAB100806	9/32	10	8	6
WAB101006	1/4	10	10	6
WAB120604	9/32	12	6	4
WAB120606	9/32	12	6	6
WAB120806	9/32	12	8	6
WAB120808	3/8	12	8	8
WAB121204	9/32	12	12	4
WAB121206	9/32	12	12	6
WAB121208	9/32	12	12	8
WAB160606	1/4	16	6	6
WAB161208	5/16	16	12	8
WAB181206	5/16	18	12	6
WAB181208	5/16	18	12	8
WAB181210	3/8	18	12	10
WAB181806	3/8	18	18	6
WAB181812	7/16	18	18	12
WAB241212*	7/16	24	12	12
WAB242408*	1/32	24	24	8

*NEMA 3 only. For NEMA 4 in these sizes, use WCB
Larger sizes available up to 72" x 30" x 16" - Consult Factory

WCB Junction Boxes

**Heavy Duty
Overlapping Cover for
Surface Mounting**

Dust-tight
Weatherproof
Watertight
Raintight
NEMA 3, 4, 12



Applications:

Where a heavy duty dust-tight, weatherproof, raintight, or watertight enclosure is desired, WCB boxes are installed in conduit systems to:

- Act as pull box for conductors
- Provide openings and space for making splices and taps in conductors
- Provide for branch conduit runs
- Provide access to conductors for maintenance and future system changes
- Enclose and protect electrical devices

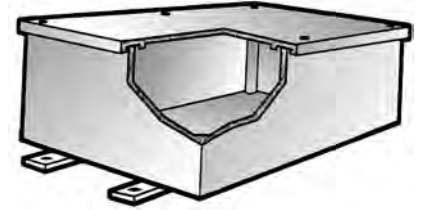

Features:

- Flat neoprene cover gasket.
- Overlapping cover sheds environment.
- Wide range of drilled and tapped and slip hole conduit entrance sizes and locations permits maximum flexibility of use in conduit system.
- Internal equipment mounting pads available blind tapped for 1/4" – 20 mounting screws.
- Blind tapped into internal mounting pads.
- Mounting straps are standard on smaller sized boxes up to 8x8x6, for larger sizes consult factory

Certifications and Compliances:

- Dust-tight
- Weatherproof
- Raintight
- Watertight
- NEMA 3, 4, 12
- NEMA 250

Standard Materials:

- *Feraloy*® iron alloy cover and body
- Neoprene gaskets
- Stainless steel cover screws
- Steel mounting straps

Standard Finishes:

- *Feraloy* iron alloy – hot dip galvanized

Options:

Description	Suffix
Factory installed mounting plate	MP
Material - all sizes, cast aluminum	SA
Drilled and tapped conduit holes and slip holes available, Consult Factory	

Size Ranges:

- 4" x 4" x 2" to 72" x 30" x 16"

Ordering Information:

Cat. #	Wall Thickness (in.)	Length (in.)	Width (in.)	Depth (in.)
WCB040402	5/32	4	4	2
WCB040403	3/16	4	4	3
WCB040404	1/4	4	4	4
WCB050503	1/4	5	5	3
WCB050504	1/4	5	5	4
WCB060403	1/4	6	4	3
WCB060404	7/32	6	4	4
WCB060603	1/4	6	6	3
WCB060604	3/16	6	6	4
WCB060606	9/32	6	6	6
WCB080403	5/16	8	4	3
WCB080604	7/32	8	6	4
WCB080606	5/16	8	6	6
WCB080804	5/16	8	8	4
WCB080806	5/16	8	8	6
WCB080808	5/16	8	8	8
WCB090604	5/16	9	6	4
WCB100604	1/4	10	6	4
WCB100804	1/4	10	8	4
WCB100806	9/32	10	8	6
WCB101006	1/4	10	10	6
WCB120604	9/32	12	6	4
WCB120606	9/32	12	6	6
WCB120806	9/32	12	8	6
WCB120808	3/8	12	8	8
WCB121204	9/32	12	12	4
WCB121206	9/32	12	12	6
WCB121208	9/32	12	12	8
WCB160606	1/4	16	6	6
WCB161208	5/16	16	12	8
WCB181206	5/16	18	12	6
WCB181208	5/16	18	12	8
WCB181210	3/8	18	12	10
WCB181806	3/8	18	18	6
WCB181812	7/16	18	18	12
WCB241212	7/16	24	12	12
WCB242408	11/32	24	24	8

Larger sizes available up to 72" x 30" x 16" - Consult Factory

W-Series
Boxes

WEB Junction Box

Heavy Duty

Internal Recess Flange

for Flush Mounting

Dust-tight
Raintight
NEMA 3



Applications:

WEB Junction Boxes are installed:

- Where a heavy duty, dust-tight or raintight enclosure is desired
- To act as pull box for conductors
- To provide openings and space for making splices and taps in conductors
- To provide for branch conduit runs
- To provide access to conductors for maintenance and future system changes
- To enclose and protect electrical devices

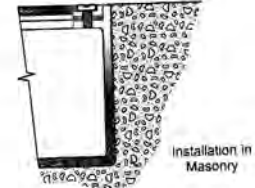
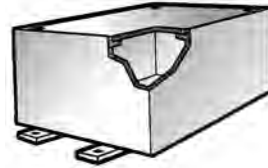

W-Series Boxes

Features:

- Flat neoprene cover gasket
- Internal equipment mounting pads
- Stainless steel cover screws
- Internal ground screw

Certifications and Complies:

- NEMA 250
- NEMA 3

Standard Materials:

- *Feraloy*[®] iron alloy body, hot dip galvanized
- Heavy-gauge steel cover, hot dip galvanized
- Stainless steel cover screws
- Neoprene gaskets

Ordering Information:

Cat. #	Wall Thickness (in.)	Length (in.)	Width (in.)	Depth (in.)
WEB040403	7/32	4	4	3
WEB040404	1/4	4	4	4
WEB060604	9/32	6	6	4
WEB060606	1/4	6	6	6
WEB080804	9/32	8	8	4
WEB080806	1/4	8	8	6
WEB121206	9/32	12	12	6
WEB160606	9/32	16	6	6
WEB160806	1/4	16	8	6
WEB180808	5/16	18	8	8
WEB240606	9/32	24	6	6
WEB240808	5/16	24	8	8
WEB241010	3/8	24	10	10
WEB241210	5/16	24	12	10
WEB241212	5/16	24	12	12
WEB241812	3/8	24	18	12
WEB361212	3/8	36	12	12
WEB361812	3/8	36	18	12
WEB362412	7/16	36	24	12
WEB363612	7/16	36	36	12

Options:

Description

All boxes are available with optional mounting plate
Material - all sizes, cast aluminum
Drilled and tapped conduit holes and slip holes available, Consult Factory

Suffix

MP
SA

XD Expansion/Deflection Coupling

- Watertight
- Corrosion-Resistant



Applications:

XD couplings can be installed indoors, outdoors, buried underground, or embedded in concrete in non-hazardous areas. XD's are used with standard rigid conduit or PVC rigid conduit. (PVC requires rigid metal conduit nipples and rigid metal-to-PVC conduit adapters.) XD's provide a flexible and watertight connection for protection of conduit wiring systems from damage due to movement.

Typical applications include:

- Underground conduit feeder runs
- Runs between sections of concrete subject to relative movement
- Runs between fixed structures
- Conduit entrances in high-rise buildings
- Bridges
- Marinas, docks, piers

Features:

- XD couplings accommodate the following movements without collapsing or fracturing the conduit, and damaging the wires it contains:
 1. Axial expansion or contraction up to $\frac{3}{4}$ "
 2. Angular misalignment of the axes of the coupled conduit runs in any direction to 30°
 3. Parallel misalignment of the axes of coupled conduit runs in any direction to $\frac{3}{4}$ "
- Inner sleeve maintains constant I.D. in any position and provides a smooth insulated wireway for protection of wire insulation
- Watertight flexible neoprene outer jacket is corrosion resistant and protects the grounding strap and the attachment points of the hubs
- Tinned copper flexible braid grounding straps assure grounding continuity
- Stainless steel jacket clamps for strength and corrosion resistance
- Standard tapered electrical threads fit standard rigid conduit

Certifications and Compliances:

- UL standards: 514B

Standard Materials:

- Integral hub bushing protects insulation of conductors
- Hubs – *Feraloy*® iron alloy
- Outer jacket – molded neoprene
- Jacket clamps – stainless steel
- Inner sleeve – molded plastic
- Grounding straps – tinned copper flexible braid

Standard Finishes:

- *Feraloy* – electrogalvanized
- Neoprene – natural (black)
- Molded plastic – natural (brown)

Options:

Hot dipped galvanized

HDG

Size Ranges:

- 1" to 6" (Smaller sizes can be obtained by using reducing bushings)

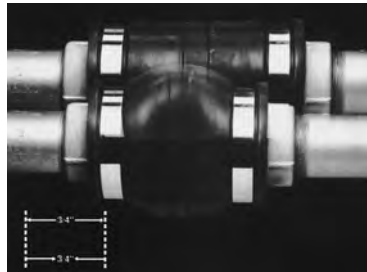

1. Axial expansion/contraction.

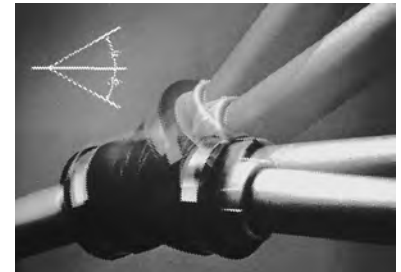

2. Angular misalignment.



3. Parallel misalignment.

XD Hub Size	Cat. #	Hub Size	Cat. #
1	XD3	3	XD8
1 1/4	XD4	3 1/2	XD9
1 1/2	XD5	4	XD010
2	XD6	5	XD012
2 1/2	XD7	6	XD014

Hub Size	a	b
1	7	3 ¹⁵ / ₁₆
1 - 1/4	7 ³ / ₈	4 ¹ / ₄
1 1/2	7 ¹ / ₄	4 ¹ / ₂
2	7 ¹ / ₄	4 ¹⁵ / ₁₆
2 1/2	7 ¹ / ₂	5 ⁵ / ₁₆
3	7 ⁵ / ₈	5 ¹⁵ / ₁₆
3 1/2	7 ³ / ₄	6 ¹ / ₂
4	7 ⁷ / ₈	6 ¹⁵ / ₁₆
5	7 ³ / ₄	8
6	8 ³ / ₈	9

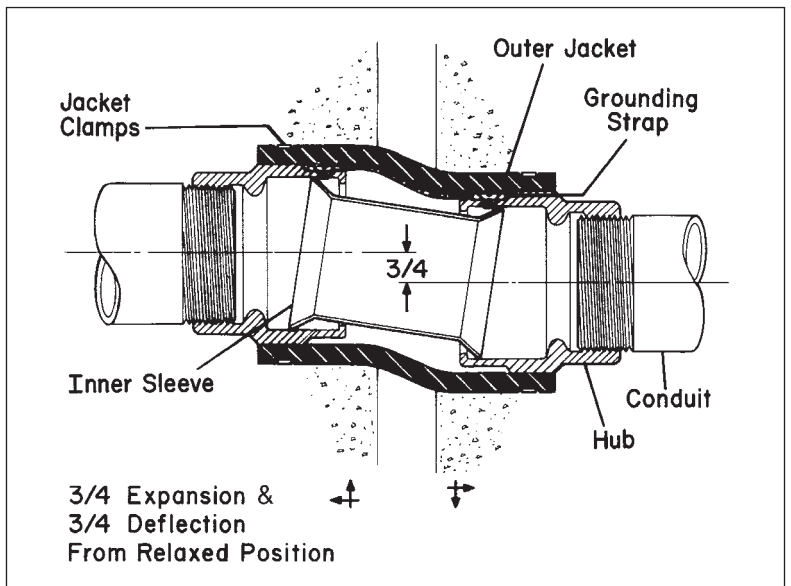
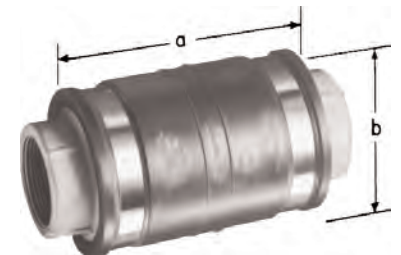

XD Coupling

XJG Conduit Expansion Joints With Internal Grounding For Rigid Metal Conduit and IMC

- Wet Locations



Applications:

XJG expansion couplings are used with rigid metal conduit and IMC:

- Without the need for an external bonding jumper and clamps (up to 4")
- To couple together two (2) sections of conduit subject to longitudinal movement
- In long conduit runs to permit linear movement caused by thermal expansion and contraction.
- On long conduit runs to prevent conduit from buckling and ensuing circuit failures
- Indoors or outdoors where conduit expansion occurs and there are wide temperature ranges
- In conduit runs that cross structural joints
- In conduit runs to prevent damage to conduit supports such as in a building or on a bridge
- With optional redundant visible grounding strap

XJG Coupling

Certifications and Complies:

- UL Standard: 514B
- CSA Standard: C22.2 No. 18
- NEC Articles 250-77 and 300-7 (b)
- NEMA FB1
- Wet Locations

Materials and Finishes:

Body

- Steel-electrogalvanized
- Copper-free aluminum - natural
- *Feraloy*® iron alloy - electrogalvanized (5" + 6" only)

Reducer

- 1/2" through 1" - Steel - electrogalvanized
- 1 1/4" through 6" - *Feraloy*® iron alloy - electrogalvanized and aluminum paint
- Copper-free aluminum - natural

Gland Nut

- 1/2" through 1" - Steel - electrogalvanized
- 1 1/4" through 6" - *Feraloy*® iron alloy - electrogalvanized and aluminum paint
- Copper-free aluminum - natural

Packing

- Teflon® (trademark of E.I. DuPont Co.)

Washer

- Steel - electrogalvanized
- Copper-free aluminum - natural

Gasket

- Vellum

Bushing

- 1/2" through 1" - Steel - electrogalvanized
- 1 1/4" through 6" - *Feraloy*® iron alloy - electrogalvanized and aluminum paint
- Copper-free aluminum - natural



Patented Design

XJG – For use with rigid metal conduit and IMC

Conduit Size	Maximum Conduit Movement	Cat. #	Optional Bonding Jumper†	A Diameter	B Length	Bonding Jumper Length
1/2	4	XJG14	BJ14	1.75	6.75	20"
	8	XJG18	BJ18	1.75	10.75	30"
3/4	4	XJG24	BJ24	2.12	6.75	20"
	8	XJG28	BJ28	2.12	10.75	30"
1	4	XJG34	BJ34	2.43	7.25	20"
	8	XJG38	BJ38	2.43	11.25	30"
1 1/4	4	XJG44	BJ44	3.19	7.56	24"
	8	XJG48	BJ48	3.19	11.56	30"
1 1/2	4	XJG54	BJ54	3.68	7.87	24"
	8	XJG58	BJ58	3.68	11.87	30"
2	4	XJG64	BJ64	4.75	8.25	24"
	8	XJG68	BJ68	4.75	12.25	30"
2 1/2	4	XJG74	BJ74	4.87	9.31	24"
	8	XJG78	BJ78	4.87	13.31	36"
3	4	XJG84	BJ84	5.37	10.00	30"
	8	XJG88	BJ88	5.37	14.00	36"
3 1/2	4	XJG94	BJ94	6.62	9.81	30"
	8	XJG98	BJ98	6.62	13.81	36"
4	4	XJG104	BJ104	6.62	9.81	30"
	8	XJG108	BJ108	6.62	13.81	36"
5	8	XJ128‡	—	7.64	15.50	—
6	8	XJ148‡	—	9.56	16.00	—

†XJG expansion couplings use a metallic bushing and ground springs to create a high integrity internal ground connection. External ground straps offer a redundant ground path and easy visible indication of ground
‡XJ128 and XJ148 are not internally grounded. A pair of 36" bonding jumpers are provided with fitting.

Ground Springs

- Phosphor bronze - electrogalvanized

Ground Strap

- Braided tinned copper

U-Bolts

- Malleable iron – electrogalvanized

Options:

Description

Available in copper-free aluminum
Not available on 5" and 6" sizes
Hot dipped galvanized
Available with redundant† ground strap for visible indication of grounding – order separately (BJ Series)

Suffix

SA

HDG

Size Ranges:

- 1/2" through 6" conduit size
- 4" and 8" maximum conduit movement

Dimensions

In Inches:

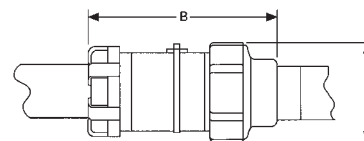

XJG shown with optional bonding jumper

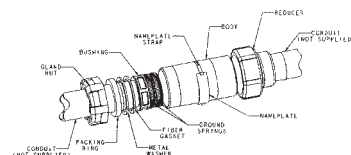

XJG-EMT Conduit Expansion Joints With Internal Grounding For EMT Conduit



Applications:

- XJG expansion couplings are used with EMT Conduit:
- Without the need for an external bonding jumper and clamps
 - To couple together two (2) sections of conduit subject to longitudinal movement
 - In long conduit runs to permit linear movement caused by thermal expansion and contraction.
 - On long conduit runs to prevent conduit from buckling and ensuing circuit failures
 - Indoors or outdoors where conduit expansion occurs and there are wide temperature ranges
 - In conduit runs that cross structural joints
 - In conduit runs to prevent damage to conduit supports such as in a building or on a bridge
 - With optional redundant visible grounding strap

Certifications and Compliances:

- UL Standard: 514B
- CSA Standard: C22.2 No. 18
- NEC Articles 250-77 and 300-7 (b)
- NEMA FB1

Materials and Finishes:

Body

- Steel-electrogalvanized
- Copper-free aluminum - natural

Reducer

- 1/2" through 1" - Steel - electrogalvanized
- 1 1/4" through 4" - *Feraloy*[®] iron alloy - electrogalvanized and aluminum paint

Gland Nut

- 1/2" through 1" - Steel - electrogalvanized
- 1 1/4" through 4" - *Feraloy*[®] iron alloy - electrogalvanized and aluminum paint

Packing

- Teflon[®] (trademark of E.I. DuPont Co.)

Washer

- Steel - electrogalvanized

Gasket

- Vellum

Bushing

- 1/2" through 1" - Steel - electrogalvanized
- 1 1/4" through 4" - *Feraloy*[®] iron alloy - electrogalvanized and aluminum paint

Ground Springs

- Phosphor bronze - electrogalvanized

Ground Strap

- Braided tinned copper

U-Bolts

- Malleable iron – electrogalvanized

Options:

Available with redundant† ground strap for visible indication of grounding – order separately (BJ Series)

Size Ranges:

- 1/2" through 4" conduit size
- 4" maximum conduit movement

XJG-EMT – for use with EMT conduit



Conduit Size	Maximum Conduit Movement	Cat. #	Optional Bonding Jumper	A Diameter	B Length
1/2"	4"	XJG14 EMT	BJ14	1 3/4"	10 3/4"
3/4"	4"	XJG24 EMT	BJ24	2 7/8"	11"
1"	4"	XJG34 EMT	BJ34	2 7/16"	11 1/2"
1 1/4"	4"	XJG44 EMT	BJ44	3 1/8"	15 1/4"
1 1/2"	4"	XJG54 EMT	BJ54	3 5/8"	15 1/2"
2"	4"	XJG64 EMT	BJ64	4 3/4"	15 1/2"
2 1/2"	4"	XJG74 EMT	BJ74	4 7/8"	18 3/4"
3"	4"	XJG84 EMT	BJ84	5 5/8"	19 7/8"
3 1/2"	4"	XJG94 EMT	BJ94	6 5/8"	21 1/4"
4"	4"	XJG104 EMT	BJ104	6 5/8"	21 1/4"



XJG shown with optional bonding jumper

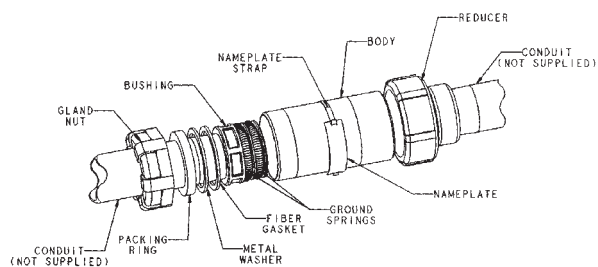

†XJG expansion couplings use a metallic bushing and ground springs to create a high integrity internal ground connection. External ground straps offer a redundant ground path and easy visible indication of ground

XJG-EMT

XJGD Combination Expansion/Deflection Coupling and Expansion Joint Internally Grounded

- Wet Locations



Applications:

XJGD combination fittings are used with rigid metal conduit and IMC:

- To accommodate axial expansion, angular misalignment and parallel misalignment
- To couple together two (2) sections of conduit subject to longitudinal movement
- To maintain a ground connection without the need for an external bonding jumper and clamps
- In long conduit runs to prevent conduit from buckling and causing circuit failures
- Indoors or outdoors where conduit expansion occurs and there are wide temperature swings
- In conduit runs that cross structural joints
- In conduit runs to prevent damage to conduit supports such as in a building or on a bridge

XJGD Ordering Information



Hub Size	Maximum Conduit Movement	Cat. #	A Diameter	B Length
1"	4"	XJGD34	3 ¹⁵ / ₁₆ "	17 ³ / ₄ "
1 ¹ / ₄ "	4"	XJGD44	4 ¹ / ₄ "	18 ¹ / ₈ "
1 ¹ / ₂ "	4"	XJGD54	4 ¹ / ₂ "	18 ⁵ / ₈ "
2"	4"	XJGD64	4 ¹⁵ / ₁₆ "	19 ¹ / ₄ "
2 ¹ / ₂ "	4"	XJGD74	5 ⁵ / ₁₆ "	20 ³ / ₄ "
3"	4"	XJGD84	5 ¹⁵ / ₁₆ "	21 ⁵ / ₈ "
3 ¹ / ₂ "	4"	XJGD94	6 ¹ / ₂ "	21 ⁵ / ₈ "
4"	4"	XJGD104	8"	27 ³ / ₄ "

XJGD Coupling

Certifications and Compliances:

- UL standard: 514B

Standard Materials:

- Body, Hubs, Gland Nut, Washer, Bushing – *Feraloy*[®]
- Packing – Teflon[®]
- Gasket – vellum
- Ground Spring – phosphor bronze
- Outer Jacket – molded neoprene
- Jacket Clamps – stainless steel
- Inner Sleeve – molded plastic
- Ground Straps – tinned copper braid

Standard Finishes:

- *Feraloy*[®] – electrogalvanized

HomeRunner™ Box

Commercial construction screw cover junction box with patented clamps



Applications:

The Cooper Crouse-Hinds HomeRunner™ Junction Box is designed specifically for commercial construction applications to provide a spacious, flexible junction box for terminating Home Run and other electrical wiring. Its patented clamping design and flexibility make it the most convenient, labor savings junction box available.

- The HomeRunner Junction Box has extensive built-in features for maximum job site flexibility and efficiency
- It can be used to terminate multiple wiring methods including AC, MC, MCI-A, NM or EMT
- Designed for use in commercial construction projects, it is ideal for hotels, motels, condos, assisted living centers, etc.

Features and Call-outs:

1. Patented clamping system - provides maximum flexibility and maximum grip. Third party certified for use with AC, MC, MCI-A or Non-metallic sheathed cable
2. 8 x 8 welded steel construction - provides strong, dependable service and large cubic capacity (177 cu. in.) for ease of wiring
3. Combination eccentric knockouts - on sides for quick & easy access, combination ko's in the back of the box are ideal of applications where joist spacing is too tight for side entry
4. Terminal cup washer and flanged nut - quick, easy service ground termination or attachment of grounding bus-bar, if desired
5. 2 cover options - square for surface mounted applications or oversized for flush mount applications
6. Extensive mounting flexibility - pre-drilled holes in side and back for direct mounting or optimal mounting bracket (purchased separately)
7. Far-side support snaps on quickly and easily and is perforated which allows for adjustment in dual thickness, fire-rated walls



Home Runner

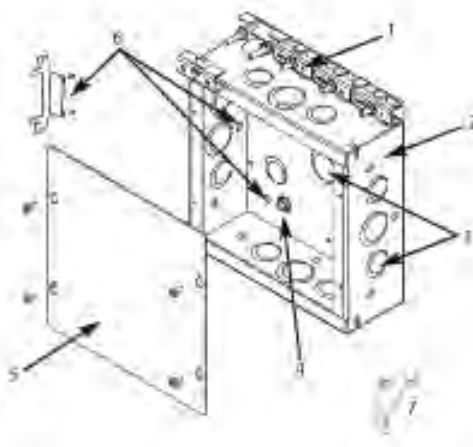

Certifications and Compliances:

- For US & Canada : CSA File #248782
- Certified to UL50 & UL514B and CSA C22.2, No. 18.3-04 & No. 40-M1989

Standard Materials:

- Pre-galvanized steel

Cat.#	Description	Dimensions	Knockouts	Wire Fill	Built-In Clamps	Cubic Volume	Unit Qty.	Wt. Per 100
HR080803	Homerunner Box	8"H x 8"W x 3"D	(10) 1/2 and 3/4 eccentric, (7) 3/4 & 1 eccentric	(7) 14 AWG, (6) 12 AWG, (5) 10 AWG	(1) 10/32 to 10/12, (5) 1/2 to 10/3	177	5	400
HRC0808S	Surface Mount Cover for Homerunner Box	8"H x 8"W x .06"D					5	100
HRC0808F	Flush Mount Cover for Homerunner Box	9.38"H x 9.38"W x .06"D					5	160
HRSB1	Stud Bracket for Homerunner Box						20	35

Reliability you can count on for the most corrosive applications

Partnering with Cooper Crouse-Hinds and our dedicated team of industry experts can help you succeed. Since 1897, we have led the development of safer, more reliable ways to power the most challenging harsh and hazardous areas. Cooper Crouse-Hinds has long been established as a leader in enclosures for Hazardous, Industrial and Commercial applications. Enclosures are engineered and manufactured to perform through the most corrosive conditions needed by OEMs, MRO, Waste Water Treatment Facilities and Chemical Plants. These exceptionally durable, corrosion resistant enclosures can withstand extreme abuse and exposure to chemicals, water, and extreme conditions.

Enclosure knowledge and experience with:





- Products that deliver superior performance
- Low maintenance choices, like durable non-metallic enclosures with features designed to provide optimum protection in the harshest environments
- Dedicated and expert sales support to help select products that perform reliably and cost effectively

A commitment to safety and productivity

Cooper Crouse-Hinds is helping more industrial facility owners, operators and engineers succeed each day – safely and cost effectively. It's part of our commitment to focus on industries where our experience, expertise and products can make the biggest impact.







Quick Selection Guide

CATALOG SERIES	PRODUCT GROUP & SIZE	MATERIALS	NUMBER OF SIZES	ENVIRONMENTAL RATING
	Small Line Series 3" x 3" to 17" x 3"	<ul style="list-style-type: none"> • Fiberglass reinforced thermoset polyester • Poured polyurethane seamless gasket • Recessed captive stainless steel screws • 304 stainless steel used on all external hardware 	11	UL/cUL CSA Std C22.2 NEMA Types 1, 3R, 4X, 6P, 12
	Pushbutton Series 6" x 3" to 1 3.5" x 11.5" Inline and multi-hole configurations, 30mm and 22mm configurations offered	<ul style="list-style-type: none"> • Fiberglass reinforced thermoset polyester • Poured polyurethane seamless gasket • Recessed captive stainless steel screws • 304 stainless steel used on all external hardware 	21	UL/cUL CSA Std C22.2 NEMA Types 1, 3, 4X, 6P, 12
	Junction Box Series 6" x 4" to 20" x 16"	<ul style="list-style-type: none"> • Fiberglass reinforced thermoset polyester • Poured polyurethane seamless gasket • Recessed captive stainless steel screws • 304 stainless steel used on all external hardware 	76	UL/cUL CSA Std C22.2 NEMA Types 1, 3, 4X, 6P, 12
	Raised Cover Series 6" x 4" to 20" x 16"	<ul style="list-style-type: none"> • Fiberglass reinforced thermoset polyester • Poured polyurethane seamless gasket • Stainless steel screws • 304 stainless steel used on all external hardware 	33	UL/cUL CSA Std C22.2 NEMA Types 1, 3, 4X, 6P, 12
	Advantage Series 6" x 6" to 20" x 16"	<ul style="list-style-type: none"> • Fiberglass reinforced thermoset polyester • Poured polyurethane seamless gasket • Stainless steel screws • 304 stainless steel used on all external hardware 	36	UL/cUL CSA Std C22.2 NEMA Types 1, 3, 3S, 4X, 12, 13

Fiberglass Enclosures



Quick Selection Guide

CATALOG SERIES	PRODUCT GROUP & SIZE	MATERIALS	NUMBER OF SIZES	ENVIRONMENTAL RATING
	Wall Mount Series 3R & 4X Series 16" x 10" to 48" x 36" NEMA 3R or 4X	<ul style="list-style-type: none"> Fiberglass reinforced thermoset polyester Poured polyurethane seamless gasket Stainless steel screws 304 stainless steel used on all external hardware 	28	UL/cUL CSA Std C22.2 (3R) NEMA Types 1, 3R (4X) NEMA Types 1, 3, 3R, 4X, 12
	Wall Mount Series Large Series 48" x 36" to 72" x 49" Large & Free-standing enclosures with double door options	<ul style="list-style-type: none"> Fiberglass reinforced thermoset polyester Poured polyurethane seamless gasket Stainless steel screws 304 stainless steel used on all external hardware 	7	UL/cUL CSA Std C22.2 NEMA Types 1, 3, 3R, 4X, 12
	Disconnect & Circuit Breaking Series 16" x 10" to 36" x 30" Industrial Control System applications	<ul style="list-style-type: none"> Fiberglass reinforced thermoset polyester Poured polyurethane seamless gasket Stainless steel screws 304 stainless steel used on all external hardware 	6	UL/cUL CSA Std C22.2 NEMA Types 1, 3, 3R, 4X, 12
	Xtra Deep Series 6" x 4" to 20" x 16" Extra Deep Cover	<ul style="list-style-type: none"> Fiberglass reinforced thermoset polyester Poured polyurethane seamless gasket Recessed captive stainless steel screws 304 stainless steel used on all external hardware 	11	UL/cUL CSA Std C22.2 NEMA Types 1, 3, 4X, 12
	<p>Cooper Crouse-Hinds has a full line of Krydon material enclosures. These solid, one-piece construction enclosures are made of a proprietary formulation of fiberglass reinforced polyester that has high impact strength, is fire retardant, heat resistant and withstands weathering.</p> <p>Krydon enclosures are:</p> <ul style="list-style-type: none"> Strong and durable while providing longer service life for equipment Class I, Division 2 Groups B,C,D rating on many Krydon products Are available in an expansive range of product groups Are available in hundreds of sizes and options 			

Fiberglass

Fiberglass Enclosures Small Line Series



Small Line Series

The Cooper Crouse-Hinds Small Line Series offer a lightweight, compact, versatile solution for applications requiring tight or confined spaces. The Small Line Series houses everything from terminal blocks to small positional control. Available in a choice of two body styles, these enclosures are made of fiberglass reinforced polyester and have a memory retaining polyurethane gasket and stainless steel screws for exceptional corrosion and chemical resistance. The Small Line Series will hold up under the most extreme conditions and provide protection in adverse environments such as water, steam, vapor or chemicals.

Features & Benefits:

- Lift-off cover design with 4 cover screws
- Memory retaining continuous polyurethane gasket
- Captive stainless steel cover screws
- Chemical resistant fiberglass reinforced polyester
- Submersible, non-corrosive design
- Water-tight, dust-tight
- Non-conductive, impact resistant, UV resistant
- Material cuts, drills, punches, and saws with ease and accuracy
- Rounded edges, minimal protrusions or exposed pocket areas for assembly of dust and debris
- Smooth surface, no color variations, swirls or color pockets, no voids

Certification & Compliances:

- UL/cUL 50, Types 1, 3R, 4X, 6P, 12
- UL File Number E57656
- CSA Std C22.2 - File 244248 Types 1, 3R, 4X, 6P, 12
- NEMA Standard 250 - Types 1, 3R, 4X, 6P, 12
- Temperature Range - (-76°F to +250°F) (-60°C to +120°C)
- Flammability Rating - UL94-5V
- Non-flame propagating







Materials and Finishes:

- Hot compression molded fiberglass reinforced thermoset polyester
- Poured polyurethane seamless gasket provides water-tight dust-tight environmental seal
- Captive stainless steel screws
- 304 stainless steel used on all external hardware

Options:

- Mounting feet kit available for field installation. Order part number FSJMTGFTKIT

Ordering Information

			
	FSJBS	FSJS	NPT Size
Inside H x W x D	4 Cover Screws With a Beveled Cover Design	4 Cover Screws With a Flat Cover Design	Mounting Plate**
3.13 x 3.03 x 2.70	FSJBS030302		
5.38 x 3.03 x 2.87	FSJBS050302		
6.00 x 3.19 x 3.63	FSJBS060404		
7.82 x 3.03 x 2.87	FSJBS080302		
8.26 x 3.19 x 3.63	FSJBS080404		
8.75 x 3.03 x 2.87	FSJBS090302		
10.51 x 3.19 x 3.63	FSJBS110404		
13.19 x 3.03 x 2.87	FSJBS140302		
16.75 x 3.03 x 2.87	FSJBS170302		
6.90 x 5.90 x 2.88		FSJS070603	FMP0706
9.15 x 5.90 x 2.88		FSJS090603	FMP0906

* Flat Cover

** Available in: Aluminum (SA), Fiberglass (FG), Carbon Steel (C), and Stainless Steel (SS)
To order, add the suffix to the end of the part number

Dimensional Drawings

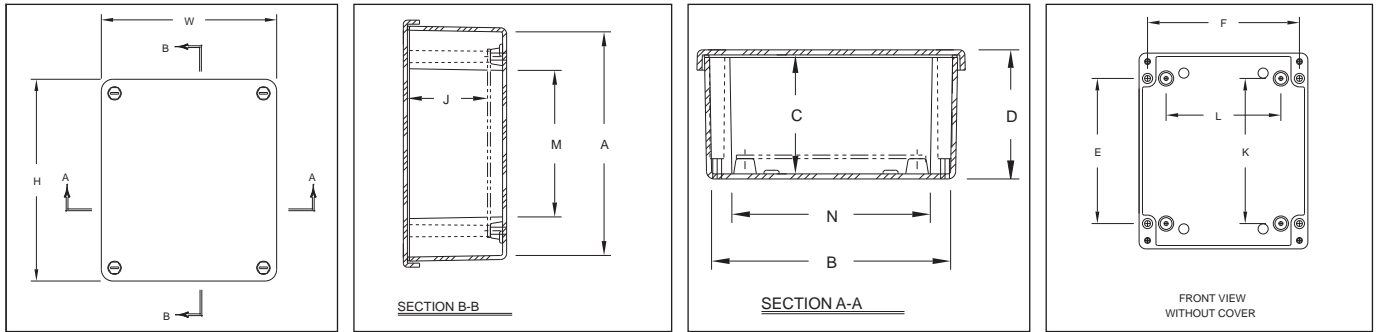

Small Line Series

FSJS Configuration Dimensions In Inches (mm)

Catalog Number	Overall H x W x D	Inside A x B x C	Mounting E x F	J	K	L	M	N	Weight
FSJS070603	7.63 x 6.63 x 3.19 (194 x 168 x 81)	6.90 x 5.90 x 2.88 (175 x 150 x 73)	5.37 x 5.63 (137 x 143)	2.48 (63)	5.3 (137)	4.25 (108)	4.52 (115)	4.9 (124)	3 lbs.
FSJS090603	9.87 x 6.63 x 3.19 (251 x 168 x 81)	9.15 x 5.90 x 2.88 (232 x 150 x 73)	7.62 x 5.63 (194 x 143)	2.48 (63)	7.62 (194)	4.25 (108)	6.77 (172)	4.9 (124)	3 lbs.

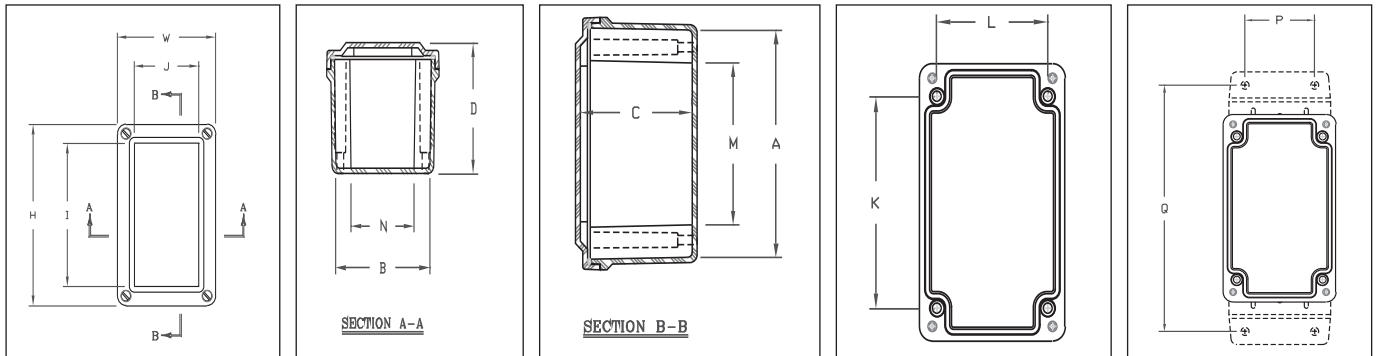

FSJBS Configuration Dimensions In Inches (mm)

Catalog Number	Overall H x W x D	Inside A x B x C	I	J	K	L	M	N	Weight
FSJBS030302	3.72 x 3.63 x 2.95 (95 x 92 x 75)	3.13 x 3.03 x 2.70 (79 x 77 x 69)	0 (0)	0 (0)	2.31 (59)	2.75 (70)	1.59 (40)	2.03 (52)	1 lb.
FSJBS050302	5.97 x 3.63 x 3.14 (152 x 92 x 80)	5.38 x 3.03 x 2.87 (137 x 77 x 73)	4.72 (120)	2.38 (61)	4.56 (116)	2.75 (70)	3.84 (98)	2.03 (52)	1 lb.
FSJBS060404	6.63 x 3.81 x 3.89 (168 x 97 x 99)	6.00 x 3.19 x 3.63 (153 x 81 x 92)	5.31 (135)	2.50 (64)	4.88 (124)	2.94 (75)	4.13 (105)	2.19 (56)	2 lbs.
FSJBS080302	8.41 x 3.63 x 3.14 (214 x 92 x 80)	7.82 x 3.03 x 2.87 (199 x 77 x 73)	7.16 (182)	2.38 (60)	7.00 (178)	2.75 (70)	6.28 (160)	2.03 (52)	2 lbs.
FSJBS080404	8.88 x 3.81 x 3.89 (225 x 97 x 99)	8.26 x 3.19 x 3.63 (210 x 81 x 92)	7.56 (192)	2.50 (64)	7.13 (181)	2.94 (75)	6.38 (162)	2.19 (56)	2 lbs.
FSJBS090302	9.35 x 3.63 x 3.14 (237 x 92 x 80)	8.75 x 3.03 x 2.87 (222 x 77 x 73)	8.10 (206)	2.38 (60)	7.94 (202)	2.75 (70)	7.22 (183)	2.03 (52)	2 lbs.
FSJBS110404	11.13 x 3.81 x 3.89 (283 x 97 x 99)	10.51 x 3.19 x 3.63 (267 x 81 x 92)	9.81 (249)	2.50 (64)	9.37 (238)	2.94 (75)	8.63 (219)	2.19 (56)	2 lbs.
FSJBS140302	13.78 x 3.63 x 3.14 (350 x 92 x 80)	13.19 x 3.03 x 2.87 (335 x 77 x 73)	12.53 (318)	2.38 (60)	12.37 (314)	2.75 (70)	11.66 (296)	2.03 (52)	2 lbs.
FSJBS170302	17.35 x 3.63 x 3.14 (441 x 92 x 80)	16.75 x 3.03 x 2.87 (426 x 77 x 73)	16.10 (409)	2.38 (60)	15.94 (405)	2.75 (70)	15.22 (387)	2.03 (52)	3 lbs.

Fiberglass Enclosures Pushbutton Series



Pushbutton Series

The Cooper Crouse-Hinds Pushbutton Series offer a solution for applications requiring an enclosure with multiple pre-drilled openings for pushbuttons available in 30mm and 22mm configurations. The notched keyhole design and the ability to order up to 25 holes, makes this versatile series a perfect match for your general purpose electrical and control station applications. Available in a choice of two body designs, these enclosures are made of fiberglass reinforced polyester and have a memory retaining polyurethane gasket and stainless steel screws for exceptional corrosion and chemical resistance. The Pushbutton Series will hold up under the most extreme conditions and provide protection in adverse conditions such as water, steam, vapor or chemicals.



Features & Benefits:

- Lift-off cover design with 4 cover screws
- Memory retaining continuous polyurethane gasket
- Captive stainless steel cover screws
- Full metal grounding strap
- Notched key hole design
- Chemical resistant fiberglass reinforced polyester
- Submersible, non-corrosive design
- Water-tight, dust-tight
- Non-conductive, impact resistant, UV resistant
- Material cuts, drills, punches, and saws with ease and accuracy
- Rounded edges, minimal protrusions or exposed pocket areas for assembly of dust and debris
- Smooth surface, no color variations, swirls or color pockets, no voids

Certification & Compliances:

- UL/cUL 50, Types 1, 3, 4X, 6P, 12
- UL File Number E57656
- CSA Std C22.2 - File 244248 Types 1, 3, 4X, 6P, 12
- NEMA Standard 250 - Types 1, 3, 4X, 6P, 12
- Temperature Range - (-76°F to +250°F) (-60°C to +120°C)
- Flammability Rating - UL94-5V
- Non-flame propagating

Materials and Finishes:

- Hot compression molded fiberglass reinforced thermoset polyester
- Poured polyurethane seamless gasket provides water-tight dust-tight environmental seal
- Captive stainless steel screws
- 304 stainless steel used on all external hardware
- Stainless steel beaded cover retention chain on the FPBM series

Options:

- Mounting feet kit available for field installation. Order part number FSJMTGFTKIT

Ordering Information

Inside H x W x D	Holes	30mm Pushbutton	Inside H x W x D	22mm Pushbutton	Inside H x W x D	Holes	30mm Multi-Hole Pushbutton	Mounting Plate*
6.00 x 3.19 x 3.63	1	FPB31	6.00 x 3.19 x 3.63	FPB21	5.72 x 5.72 x 4.45	4	FMP0606C	FMP0606
6.00 x 3.19 x 3.63	2	FPB32	6.00 x 3.19 x 3.63	FPB22	7.73 x 5.74 x 4.45	6	FMP0806C	FMP0806
8.26 x 3.19 x 3.63	3	FPB33	6.00 x 3.19 x 3.63	FPB23	9.73 x 7.73 x 3.98	9	FMP1008C	FMP1008
10.51 x 3.19 x 3.63	4	FPB34	8.26 x 3.19 x 3.63	FPB24	9.73 x 7.73 x 3.98	12	FMP1008C	FMP1008
13.19 x 3.03 x 2.87	5	FPB35	10.51 x 3.19 x 3.63	FPB25	11.79 x 9.80 x 4.94	16	FMP1210C	FMP1210
16.75 x 3.03 x 2.87	6	FPB36	10.51 x 3.19 x 3.63	FPB26	11.79 x 9.80 x 4.94	20	FMP1210C	FMP1210
16.75 x 3.03 x 2.87	7	FPB37	13.19 x 3.03 x 2.87	FPB27	13.53 x 11.55 x 5.94	25	FMP1412C	FMP1412

* Available in: Aluminum (SA), Fiberglass (FG), Carbon Steel (C), and Stainless Steel (SS)
To order, add the suffix to the end of the part number

Fiberglass Enclosures Pushbutton Series



Dimensional Drawings

Pushbutton Series

30mm

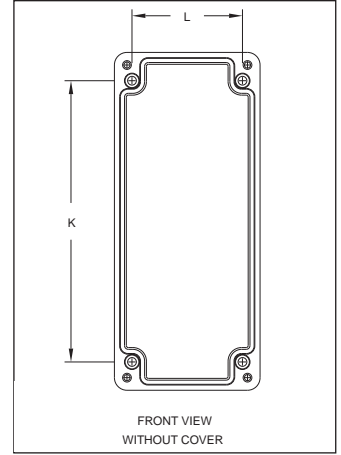
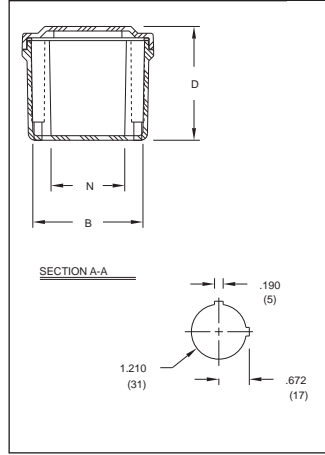
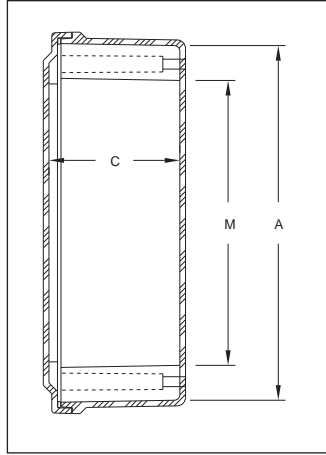
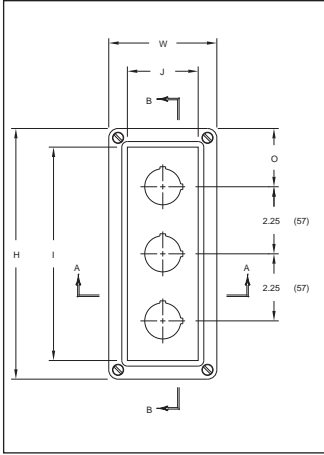

22mm

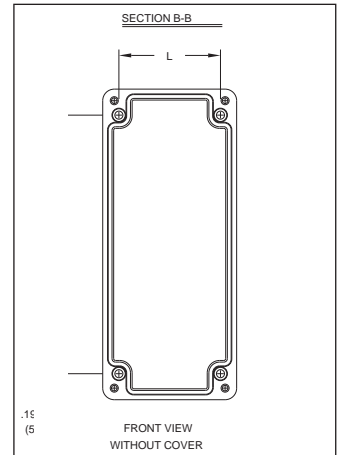
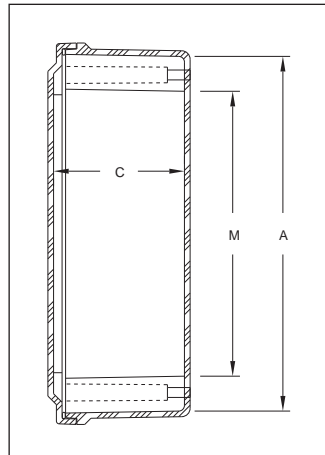
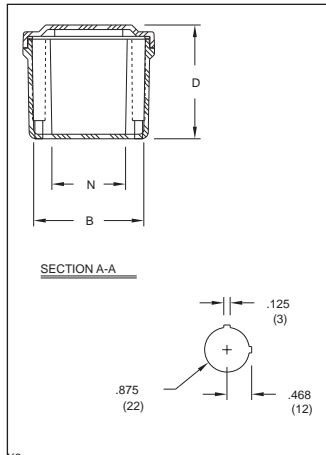
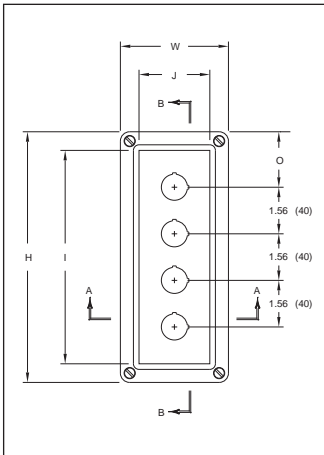

Multi-Hole

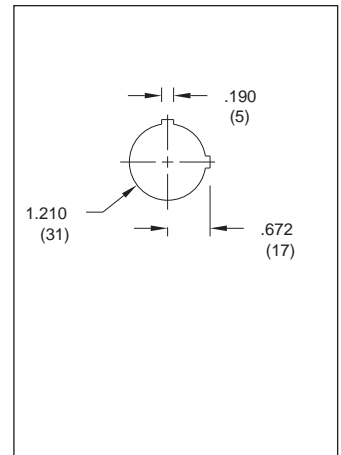
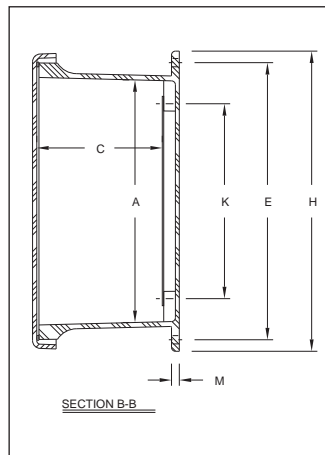
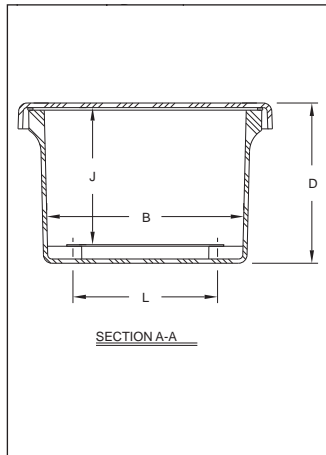
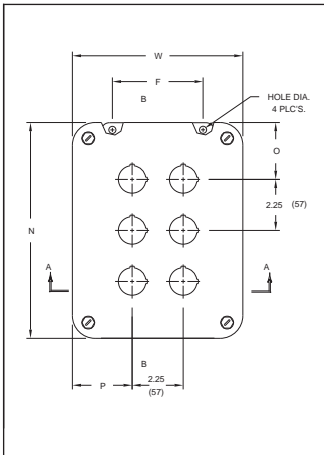

Fiberglass Enclosures Pushbutton Series



Pushbutton Series

30mm Pushbutton Series - Configuration Dimensions In Inches (mm)

Catalog Number	Overall H x W x D	Inside A x B x C	I	J	K	L	M	N	O	Weight
FPB31	6.63 x 3.81 x 3.89 (168 x 97 x 99)	6.00 x 3.19 x 3.63 (153 x 81 x 92)	5.31 (135)	2.5 (64)	4.88 (124)	2.94 (75)	4.13 (105)	2.19 (56)	3.31 (84)	2 lbs.
FPB32	6.63 x 3.81 x 3.89 (168 x 97 x 99)	6.00 x 3.19 x 3.63 (153 x 81 x 92)	5.31 (135)	2.5 (64)	4.88 (124)	2.94 (75)	4.13 (105)	2.19 (56)	2.19 (56)	2 lbs.
FBP33	8.88 x 3.81 x 3.89 (225 x 97 x 99)	8.26 x 3.19 x 3.63 (210 x 81 x 92)	7.56 (192)	2.5 (64)	7.13 (181)	2.94 (75)	6.38 (162)	2.19 (56)	2.19 (56)	2 lbs.
FPB34	11.13 x 3.81 x 3.89 (283 x 97 x 99)	10.51 x 3.19 x 3.63 (267 x 81 x 92)	9.81 (249)	2.5 (64)	9.37 (238)	2.94 (75)	8.63 (219)	2.19 (56)	2.19 (56)	2 lbs.
FBP35	13.78 x 3.63 x 3.14 (350 x 92 x 80)	13.19 x 3.03 x 2.87 (335 x 77 x 73)	12.53 (318)	2.38 (60)	12.37 (314)	2.75 (70)	11.66 (296)	2.03 (52)	2.39 (61)	2 lbs.
FBP36	17.35 x 3.63 x 3.14 (441 x 92 x 80)	16.75 x 3.03 x 2.87 (426 x 77 x 73)	16.1 (409)	2.38 (60)	15.94 (405)	2.75 (70)	15.22 (387)	2.03 (52)	3.05 (77)	3 lbs.
FBP37	17.35 x 3.63 x 3.14 (441 x 92 x 80)	16.75 x 3.03 x 2.87 (426 x 77 x 73)	16.1 (409)	2.38 (60)	15.94 (405)	2.75 (70)	15.22 (387)	2.03 (52)	1.92 (49)	3 lbs.

22mm Pushbutton Series - Configuration Dimensions In Inches (mm)

Catalog Number	Overall H x W x D	Inside A x B x C	I	J	K	L	M	N	O	Weight
FPB21	6.63 x 3.81 x 3.89 (168 x 97 x 99)	6.00 x 3.19 x 3.63 (153 x 81 x 92)	5.31 (135)	2.5 (64)	4.88 (124)	2.94 (75)	4.13 (105)	2.19 (56)	3.31 (84)	2 lbs.
FPB22	6.63 x 3.81 x 3.89 (168 x 97 x 99)	6.00 x 3.19 x 3.63 (153 x 81 x 92)	5.31 (135)	2.5 (64)	4.88 (124)	2.94 (75)	4.13 (105)	2.19 (56)	2.53 (64)	2 lbs.
FPB23	6.63 x 3.81 x 3.89 (168 x 97 x 99)	6.00 x 3.19 x 3.63 (153 x 81 x 92)	5.31 (135)	2.5 (64)	4.88 (124)	2.94 (75)	4.13 (105)	2.19 (56)	1.75 (44)	2 lbs.
FPB24	8.88 x 3.81 x 3.89 (225 x 97 x 99)	8.26 x 3.19 x 3.63 (210 x 81 x 92)	7.56 (192)	2.5 (64)	7.13 (181)	2.94 (75)	6.38 (162)	2.19 (56)	2.09 (53)	2 lbs.
FPB25	11.13 x 3.81 x 3.89 (283 x 97 x 99)	10.51 x 3.19 x 3.63 (267 x 81 x 92)	9.81 (249)	2.5 (64)	9.37 (238)	2.94 (75)	8.63 (219)	2.19 (56)	2.44 (62)	2 lbs.
FPB26	11.13 x 3.81 x 3.89 (283 x 97 x 99)	10.51 x 3.19 x 3.63 (267 x 81 x 92)	9.81 (249)	2.5 (64)	9.37 (238)	2.94 (75)	8.63 (219)	2.19 (56)	1.66 (42)	3 lbs.
FPB27	13.78 x 3.63 x 3.14 (350 x 92 x 80)	13.19 x 3.03 x 2.87 (335 x 77 x 73)	12.53 (318)	2.38 (60)	12.37 (314)	2.75 (70)	11.66 (296)	2.03 (52)	2.20 (56)	3 lbs.

Multi-Hole Pushbutton Series - Configuration Dimensions In Inches (mm)

Catalog Number	Overall H x W x D	Inside A x B x C	Mounting E x F	J	K	L	M	N	O	P	Hole Dia.	Weight
FPBM34	7.50 x 7.50 x 4.75 (191 x 191 x 121)	5.72 x 5.72 x 4.45 (145 x 145 x 113)	6.75 x 4 (171 x 101)	4 (101)	4.25 (108)	4.25 (108)	0.25 (6)	7.52 (191)	2.64 (67)	2.64 (67)	0.31 (8)	2.75 lbs.
FPBM36	9.62 x 7.50 x 4.74 (244 x 191 x 121)	7.73 x 5.74 x 4.45 (196 x 146 x 113)	8.88 x 4 (225 x 101)	4 (101)	6.25 (159)	4.25 (108)	0.25 (6)	9.5 (242)	2.64 (67)	2.51 (64)	0.31 (8)	3.5 lbs.
FPBM39	11.62 x 9.41 x 4.25 (295 x 239 x 108)	9.73 x 7.73 x 3.98 (247 x 196 x 101)	10.75 x 6 (273 x 152)	3.5 (89)	8.25 (209)	6.25 (159)	0.25 (6)	11.35 (288)	3.43 (87)	2.45 (62)	0.31 (8)	5 lbs.
FPBM312	11.62 x 9.41 x 4.25 (295 x 239 x 108)	9.73 x 7.73 x 3.98 (247 x 196 x 101)	10.75 x 6 (273 x 152)	3.5 (89)	8.25 (209)	6.25 (159)	0.25 (6)	11.35 (288)	2.3 (58)	2.45 (62)	0.31 (8)	5 lbs.
FPBM316	13.56 x 11.43 x 5.21 (344 x 291 x 132)	11.79 x 9.80 x 4.94 (299 x 249 x 125)	12.75 x 8 (324 x 203)	4.5 (114)	10.25 (260)	8.25 (209)	0.25 (6)	13.41 (341)	3.33 (85)	2.3 (58)	0.31 (8)	6.5 lbs.
FPBM320	13.56 x 11.43 x 5.21 (344 x 291 x 132)	11.79 x 9.80 x 4.94 (299 x 249 x 125)	12.75 x 8 (324 x 203)	4.5 (114)	10.25 (260)	8.25 (209)	0.25 (6)	13.41 (341)	2.2 (56)	2.1 (53)	0.31 (8)	6.5 lbs.
FPBM325	15.50 x 13.50 x 6.25 (394 x 343 x 159)	13.53 x 11.55 x 5.94 (344 x 293 x 151)	14.62 x 10 (371 x 254)	5.37 (137)	12.25 (311)	10.25 (260)	0.25 (6)	15.47 (393)	3.24 (82)	2.25 (57)	0.31 (8)	8.5 lbs.

Fiberglass Enclosures Junction Box Series



The Cooper Crouse-Hinds Junction Box Series offer an extensive selection to the industrial application requiring a vast number of configurations and sizes. The Junction Box Series is available in 12 different sizes, each offering a multitude of durable cover options with features such as stainless steel hinges, padlock covers and windows. These enclosures are made of fiberglass reinforced polyester and have a poured polyurethane seamless gasket that provides a watertight and dust-tight environmental seal for exceptional corrosion and chemical resistance. The durable Junction Box Series will hold up under the most extreme applications and provide protection and reliability in the most adverse conditions.

Features & Benefits:

- Memory retaining continuous polyurethane gasket
- Captive stainless steel cover screws
- Chemical resistant fiberglass reinforced polyester
- Submersible, non-corrosive design
- Water-tight, dust-tight
- Non-conductive, impact resistant, UV resistant
- Material cuts, drills, punches, and saws with ease and accuracy
- Rounded edges, minimal protrusions or exposed pocket areas for assembly of dust and debris
- Smooth surface, no color variations, swirls or color pockets, no voids
- Stainless steel retention chain on screw cover series
- Full-length stainless steel hinges on the hinge cover series

Certification & Compliances:

- UL/cUL 50, Types 1, 3, 4X, 6P, 12
- UL File Number E57656
- CSA Std C22.2 - File 244248 Types 1, 3, 4X, 6P, 12
- NEMA Standard 250 - Types 1, 3, 4X, 6P, 12
- Temperature Range - (-76°F to +250°F) (-60°C to +120°C)
- Flammability Rating - UL94-5V
- Window flammability - UL94V-0
- Non-flame propagating



Junction Box Series

Materials and Finishes:

- Hot compression molded fiberglass reinforced thermoset polyester
- Poured polyurethane seamless gasket provides water-tight dust-tight environmental seal
- Captive stainless steel screws
- 304 stainless steel used on all external hardware
- Molded in mounting flange
- Panel mounting capability for fixed rear panel
- Bosses utilize threaded brass inserts accepting 10-32 screws

Ordering Information

Inside H x W x D	4 Cover Screws With Lift Off Cover	2 Cover Screws With a Hinged Cover	Hinged Cover With a Padlock Latch	2 Cover Screws With a Hinged Cover With Window	Hinged Cover With a Window & Padlock Latch	Fiberglass Hinged Cover With a Window & Padlock Latch	Mounting Plate*
5.84 x 3.85 x 4.45	FJS060404	FJHS060404	FJHP060404	FJHSW060404	FJHPW060404		FMP0604
5.72 x 5.72 x 4.45	FJS060604	FJHS060604	FJHP060604	FJHSW060604	FJHPW060604		FMP0606
7.73 x 5.74 x 4.45	FJS080604	FJHS080604	FJHP080604	FJHSW080604	FJHPW080604	FJFHPW080604	FMP0806
7.73 x 7.73 x 4.82	FJS080804	FJHS080804	FJHP080804	FJHSW080804	FJHPW080804	FJFHPW080804	FMP0808
9.73 x 7.73 x 3.98	FJS100804	FJHS100804†	FJHP100804	FJHSW100804	FJHPW100804	FJFHPW100804	FMP1008
11.79 x 9.80 x 4.94	FJS121005	FJHS121005	FJHP121005	FJHSW121005	FJHPW121005	FJFHPW121005	FMP1210
11.70 x 11.70 x 6.29	FJS121206	FJHS121206	FJHP121206	FJHSW121206	FJHPW121206	FJFHPW121206	FMP1212
14.00 x 7.00 x 6.56	FJS140707	FJHS140707	FJHP140707	FJHSW140707	FJHPW140707	FJFHPW140707	FMP1407
13.53 x 11.55 x 5.94	FJS141206	FJHS141206	FJHP141206	FJHSW141206	FJHPW141206	FJFHPW141206	FMP1412
15.63 x 13.60 x 5.94	FJS161406	FJHS161406	FJHP161406	FJHSW161406	FJHPW161406	FJFHPW161406	FMP1614
17.69 x 15.69 x 8.45	FJS181608‡	FJHS181608‡	FJHP181608‡	FJHSW181608‡	FJHPW181608‡	FJFHPW181608‡	FMP1816
19.72 x 15.72 x 8.45	FJS201608‡	FJHS201608‡	FJHP201608‡	FJHSW201608‡	FJHPW201608‡	FJFHPW201608‡	FMP2016

* Available in: Aluminum (SA), Fiberglass (FG), Carbon Steel (C), and Stainless Steel (SS)
 To order, add the suffix to the end of the part number
 † Available with the deep cover option, please add a "D" to the part number. For example, FJDHS100804
 ‡ Not available with a 6P rating

Fiberglass Enclosures Junction Box Series



Dimensional Drawings

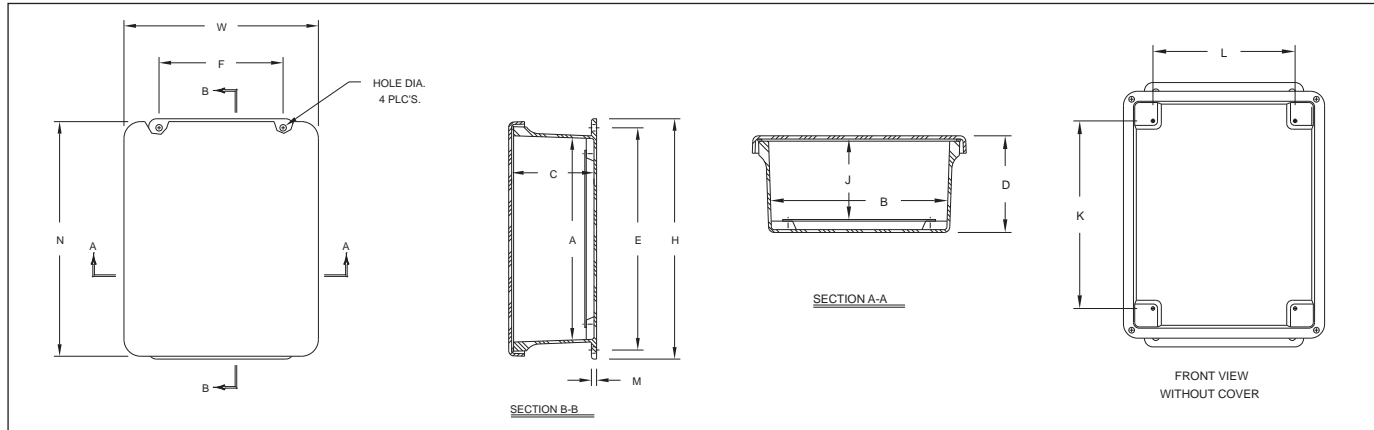

Configuration Dimensions In Inches (mm)

Catalog Number	Overall H x W x D	Inside A x B x C	Window Area	Mounting E x F	J	K	L	M	N	Hole Dia.	Weight
FJS060404 FJHS060404 FJHP060404 FJHPW060404 FJHSW060404	7.50 x 5.43 x 4.75 (191 x 138 x 121)	5.84 x 3.85 x 4.45 (148 x 98 x 113)	4.25 x 2.25 (108 x 57)	6.75 x 2 (171 x 51)	4 (101)	4.25 (108)	2.25 (57)	0.25 (6)	7.39 (188)	0.31 (8)	2.5 lbs.
FJS060604 FJHS060604 FJHP060604 FJHPW060604 FJHSW060604	7.50 x 7.50 x 4.75 (191 x 191 x 121)	5.72 x 5.72 x 4.45 (145 x 145 x 113)	4.25 x 4.25 (108 x 108)	6.75 x 4 (171 x 101)	4 (101)	4.25 (108)	4.25 (108)	0.25 (6)	7.52 (191)	0.31 (8)	2.75 lbs.
FJS080604 FJHS080604 FJHP080604 FJHPW080604 FJHSW080604 FJFHPW080604	9.62 x 7.50 x 4.74 (244 x 191 x 121)	7.73 x 5.74 x 4.45 (196 x 146 x 113)	6.25 x 4.25 (159 x 108)	8.88 x 4 (225 x 101)	4 (101)	6.25 (159)	4.25 (108)	0.25 (6)	9.5 (242)	0.31 (8)	3.5 lbs.
FJS080804 FJHS080804 FJHP080804 FJHPW080804 FJHSW080804 FJFHPW080804	9.56 x 9.38 x 4.89 (243 x 238 x 124)	7.73 x 7.73 x 4.64 (196 x 196 x 118)	8.75 x 6.00 (222 x 152)	8.75 x 6.00 (222 x 152)	4.06 (103)	6.25 (159)	6.25 (159)	0.25 (6)	9.37 (238)	0.31 (8)	1.71 lbs.
FJS100804 FJHS100804 FJHP100804 FJHPW100804 FJHSW100804 FJFHPW100804	11.62 x 9.41 x 4.25 (295 x 239 x 108)	9.73 x 7.73 x 3.98 (247 x 196 x 101)	8.25 x 6.25 (210 x 159)	10.75 x 6 (273 x 152)	3.5 (89)	8.25 (209)	6.25 (159)	0.25 (6)	11.35 (288)	0.31 (8)	5 lbs.
FJDS100804* FJDHS100804* FJDHP100804* FJDHPW100804* FJDHSW100804* FJDFHPW100804*	11.62 x 9.37 x 5.06 (295 x 238 x 129)	9.73 x 7.73 x 4.83 (247 x 196 x 123)	8.25 x 6.25 (210 x 159)	10.75 x 6 (273 x 152)	4.37 (111)	8.25 (209)	6.25 (159)	0.25 (6)	11.37 (289)	0.31 (8)	5 lbs.
FJS121005 FJHS121005 FJHP121005 FJHPW121005 FJHSW121005 FJFHPW121005	13.56 x 11.43 x 5.21 (344 x 291 x 132)	11.79 x 9.80 x 4.94 (299 x 249 x 125)	10.25 x 8.25 (260 x 210)	12.75 x 8 (324 x 203)	4.5 (114)	10.25 (260)	8.25 (209)	0.25 (6)	13.41 (341)	0.31 (8)	6.5 lbs.

*Deep cover - center of cover raised 3/4".

Fiberglass Enclosures Junction Box Series



Junction Box Series

Configuration Dimensions In Inches (mm)

Catalog Number	Overall H x W x D	Inside A x B x C	Window Area	Mounting E x F	J	K	L	M	N	Hole Dia.	Weight
FJS121206 FJHS121206 FJHP121206 FJHPW121206 FJHSW121206 FJFHPW121206	13.56 x 13.38 x 6.36 (344 x 340 x 161)	11.70 x 11.70 x 6.11 (297 x 297 x 155)	12.75 x 10.00 (324 x 254)	12.75 x 10.00 (324 x 254)	5.53 (140)	10.25 (260)	10.25 (260)	0.25 (6)	13.38 (340)	0.31 (8)	3.2 lbs.
FJS140707 FJHS140707 FJHP140707 FJHPW140707 FJHSW140707 FJFHPW140707	15.87 x 8.75 x 6.81 (403 x 222 x 173)	14.00 x 7.00 x 6.56 (356 x 178 x 167)	12.75 x 5.75 (324 x 146)	15 x 5 (381 x 127)	6.12 (156)	12.25 (311)	5.25 (133)	0.25 (6)	15.75 (400)	0.31 (8)	6.25 lbs.
FJS141206 FJHS141206 FJHP141206 FJHPW141206 FJHSW141206 FJFHPW141206	15.50 x 13.50 x 6.25 (394 x 343 x 159)	13.53 x 11.55 x 5.94 (344 x 293 x 151)	12.25 x 10.25 (311 x 260)	14.62 x 10 (371 x 254)	5.37 (137)	12.25 (311)	10.25 (260)	0.25 (6)	15.47 (393)	0.31 (8)	8.5 lbs.
FJS161406 FJHS161406 FJHP161406 FJHPW161406 FJHSW161406 FJFHPW161406	17.53 x 15.46 x 6.23 (445 x 393 x 158)	15.63 x 13.60 x 5.94 (397 x 345 x 151)	14.25 x 12.25 (362 x 311)	16.75 x 12 (425 x 305)	5.36 (136)	14.25 (362)	12.25 (311)	0.25 (6)	17.45 (443)	0.31 (8)	11.5 lbs.
FJS181608 FJHS181608 FJHP181608 FJHPW181608 FJHSW181608 FJFHPW181608	19.62 x 17.61 x 8.82 (498 x 447 x 224)	17.69 x 15.69 x 8.45 (449 x 399 x 215)	16.25 x 14.25 (413 x 362)	18.88 x 12 (479 x 305)	7.99 (203)	16.25 (413)	14.25 (362)	0.25 (6)	19.61 (498)	0.31 (8)	19.25 lbs.
FJS201608 FJHS201608 FJHP201608 FJHPW201608 FJHSW201608 FJFHPW201608	22.00 x 17.68 x 8.83 (559 x 449 x 224)	19.72 x 15.72 x 8.45 (501 x 399 x 215)	18.25 x 14.25 (464 x 362)	21.25 x 10.00 (540 x 254)	8 (203)	18.25 (464)	14.25 (362)	0.25 (6)	21.68 (551)	0.31 (8)	20.25 lbs.

Fiberglass Enclosures Raised Cover Series



Raised Cover Series

The Cooper Crouse-Hinds Raised Cover Series offer a solution for applications requiring an enclosure with a “raised” or “deeper” cover. The deeper cover is suitable for panel mounting and for use as an operator interface in industrial equipment control stations when required. The deeper cover allows every cubic inch of valuable internal enclosure space to be used. These enclosures are made of fiberglass reinforced polyester and have a poured polyurethane seamless gasket that provides a water-tight and dust-tight environmental seal for exceptional corrosion and chemical resistance. The Raised Cover Series will hold up under the most extreme applications and provide protection and reliability in high-end electronics applications, harsh corrosive environments, and industrial applications both indoors and out.



Features & Benefits:

- Memory retaining continuous polyurethane gasket
- Molded in mounting flange
- Captive stainless steel cover screws
- Chemical resistant fiberglass reinforced polyester
- Submersible, non-corrosive design
- Water-tight, dust-tight
- Non-conductive, impact resistant, UV resistant
- Material cuts, drills, punches, and saws with ease and accuracy
- Rounded edges, minimal protrusions or exposed pocket areas for assembly of dust and debris
- Smooth surface, no color variations, swirls or color pockets, no voids





Certification & Compliances:

- UL/cUL 50, Types 1, 3, 4X, 6P, 12
- UL File Number E57656
- CSA Std C22.2 - File 244248 Types 1, 3, 4X, 6P, 12
- NEMA Standard 250 - Types 1, 3, 4X, 6P, 12
- Temperature Range - (-76°F to +250°F) (-60°C to +120°C)
- Flammability Rating - UL94-5V
- Non-flame propagating

Materials and Finishes:

- Hot compression molded fiberglass reinforced thermoset polyester
- Poured polyurethane seamless gasket provides water-tight dust-tight environmental seal
- Captive stainless steel screws
- 304 stainless steel used on all external hardware
- Molded in mounting flange
- Panel mounting capability for fixed rear panel
- Bosses utilize threaded brass inserts accepting 10-32 screws

Ordering Information

				
Inside H x W x D	4 Cover Screws With Lift Off Cover	2 Cover Screws With a Hinged Cover	Hinged Cover With a Padlock Latch	Mounting Plate*
5.84 x 3.85 x 5.95	FRCJS060406	FRCJHS060406	FRCJHP060406	FMP0604
5.72 x 5.72 x 5.95	FRCJS060606	FRCJHS060606	FRCJHP060606	FMP0606
7.73 x 5.74 x 5.95	FRCJS080606	FRCJHS080606	FRCJHP080606	FMP0806
7.73 x 7.73 x 4.82	FRCJS080805	FRCJHS080805	FRCJHP080805	FMP0808
9.73 x 7.73 x 6.36	FRCJS100806	FRCJHS100806	FRCJHP100806	FMP1008
11.79 x 9.80 x 6.32	FRCJS121006	FRCJHS121006	FRCJHP121006	FMP1210
11.70 x 11.70 x 6.29	FRCJS121208	FRCJHS121208	FRCJHP121208	FMP1212
13.53 x 11.55 x 7.45	FRCJS141208	FRCJHS141208	FRCJHP141208	FMP1412
15.63 x 13.60 x 7.45	FRCJS161408	FRCJHS161408	FRCJHP161408	FMP1614
17.69 x 15.69 x 10.31	FRCJS181610	FRCJHS181610	FRCJHP181610	FMP1816
19.72 x 15.72 x 10.33	FRCJS201610	FRCJHS201610	FRCJHP201610	FMP2016

* Available in: Aluminum (SA), Fiberglass (FG), Carbon Steel (C), and Stainless Steel (SS)
To order, add the suffix to the end of the part number

Fiberglass Enclosures Raised Cover Series



DIMENSIONAL DRAWINGS

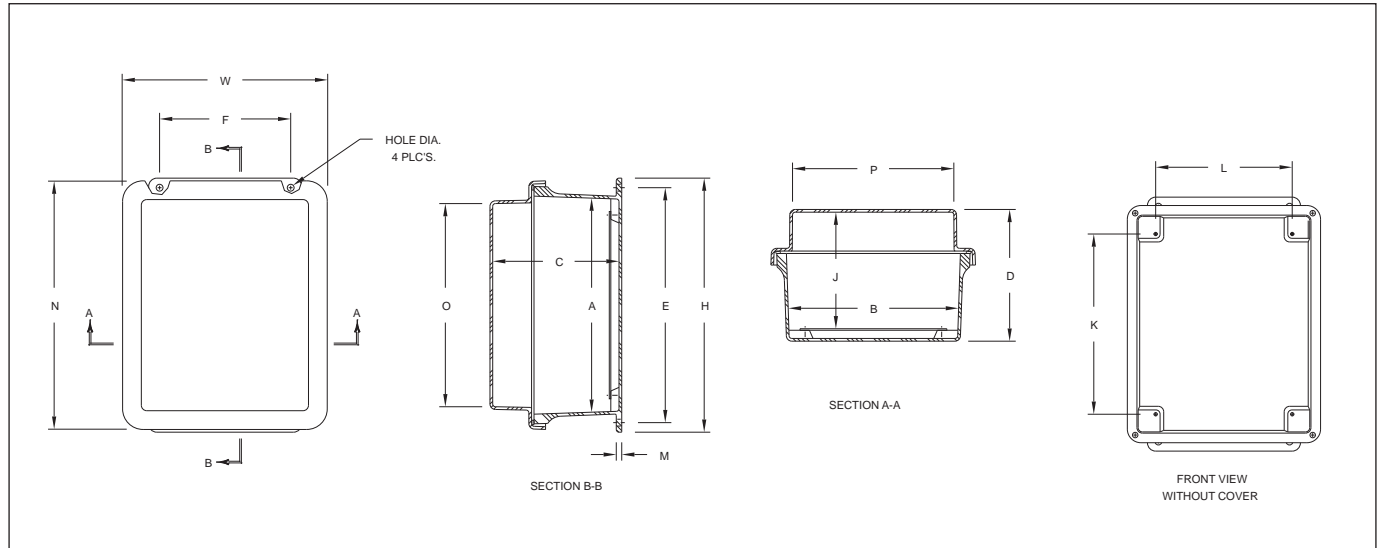

Raised Cover Series

Configuration Dimensions In Inches (mm)

Catalog Number	Overall H x W x D	Inside A x B x C	Mounting E x F	J	K	L	M	N	O	P	Hole Dia.	Weight
FRCJS060406 FRCJHS060406 FRCJHP060406	7.50 x 5.47 x 6.22 (191 x 139 x 158)	5.84 x 3.85 x 5.95 (148 x 98 x 151)	5.84 x 3.85 x 5.95 (148 x 98 x 151)	5.49 (140)	4.25 (108)	2.25 (57)	0.25 (6)	7.45 (189)	5.31 (135)	3.34 (85)	0.31 (8)	2.5 lbs.
FRCJS060606 FRCJHS060606 FRCJHP060606	7.50 x 7.52 x 6.22 (191 x 191 x 158)	5.72 x 5.72 x 5.95 (145 x 145 x 151)	6.75 x 4 (171 x 101)	5.49 (140)	4.25 (108)	4.25 (108)	0.25 (6)	7.52 (191)	5.34 (136)	5.31 (135)	0.31 (8)	2.75 lbs.
FRCJS080606 FRCJHS080606 FRCJHP080606	9.62 x 7.46 x 6.22 (244 x 190 x 158)	7.73 x 5.74 x 5.95 (196 x 146 x 151)	8.88 x 4 (225 x 101)	5.49 (140)	6.25 (159)	4.25 (108)	0.25 (6)	9.36 (238)	7.25 (185)	5.28 (134)	0.31 (8)	3.5 lbs.
FRCJS080805 FRCJHS080805 FRCJHP080805	9.56 x 9.38 x 6.26 (243 x 238 x 159)	7.73 x 7.73 x 6.01 (196 x 196 x 153)	8.75 x 6.00 (222 x 152)	5.43 (138)	6.25 (159)	6.25 (159)	0.25 (6)	9.37 (238)	7.17 (182)	7.17 (182)	0.31 (8)	4 lbs.
FRCJS100806 FRCJHS100806 FRCJHP100806	11.62 x 9.37 x 6.61 (295 x 238 x 168)	9.73 x 7.73 x 6.36 (247 x 196 x 162)	10.75 x 6 (273 x 152)	5.91 (150)	8.25 (209)	6.25 (159)	0.25 (6)	11.38 (289)	9.3 (236)	7.38 (188)	0.31 (8)	5 lbs.
FRCJS121006 FRCJHS121006 FRCJHP121006	13.56 x 11.43 x 6.61 (344 x 291 x 168)	11.79 x 9.80 x 6.32 (299 x 249 x 161)	12.75 x 8 (324 x 203)	5.87 (149)	10.25 (260)	8.25 (209)	0.25 (6)	13.41 (341)	11.2 (284)	9.23 (234)	0.31 (8)	6.5 lbs.
FRCJS121208 FRCJHS121208 FRCJHP121208	13.56 x 13.38 x 7.73 (344 x 340 x 196)	11.70 x 11.70 x 7.48 (297 x 297 x 190)	12.75 x 10.00 (324 x 254)	6.90 (175)	10.25 (260)	10.25 (260)	0.25 (6)	13.38 (340)	11.17 (284)	11.17 (284)	0.31 (8)	7.4 lbs.
FRCJS141208 FRCJHS141208 FRCJHP141208	15.50 x 13.38 x 7.69 (394 x 340 x 195)	13.53 x 11.55 x 7.45 (344 x 293 x 189)	14.62 x 10 (371 x 254)	6.87 (174)	12.25 (311)	10.25 (260)	0.25 (6)	15.42 (392)	13.2 (335)	11.16 (284)	0.31 (8)	8.5 lbs.
FRCJS161408 FRCJHS161408 FRCJHP161408	17.53 x 15.43 x 7.71 (445 x 392 x 196)	15.63 x 13.60 x 7.45 (397 x 345 x 189)	16.75 x 12 (425 x 305)	6.87 (174)	14.25 (362)	12.25 (311)	0.25 (6)	17.43 (443)	15.2 (386)	13.24 (336)	0.31 (8)	11.5 lbs.
FRCJS181610 FRCJHS181610 FRCJHP181610	19.62 x 17.48 x 10.62 (498 x 444 x 270)	17.69 x 15.69 x 10.31 (449 x 399 x 262)	18.88 x 12 (479 x 305)	9.86 (250)	16.25 (413)	14.25 (362)	0.25 (6)	19.49 (495)	17.25 (438)	15.25 (387)	0.31 (8)	19.25 lbs.
FRCJS201610 FRCJHS201610 FRCJHP201610	22.00 x 17.56 x 10.64 (559 x 446 x 270)	19.72 x 15.72 x 10.33 (501 x 399 x 262)	21.25 x 10.00 (540 x 254)	9.87 (251)	18.25 (464)	14.25 (362)	0.25 (6)	21.56 (548)	19.31 (490)	15.39 (391)	0.31 (8)	20.25 lbs.

Fiberglass Enclosures Xtra Deep Series



Xtra Deep Series

The Cooper Crouse-Hinds Xtra Deep Series offer a solution for applications requiring an extra deep enclosure. The deep, durable enclosure has nearly equal capacity in both the cover and the base, giving you ample room for your cover or mounting plate components. The fiberglass reinforced polyester enclosure with flange mount base, stainless steel hardware and poured polyurethane seamless gasket provides exceptional corrosion and chemical resistance in a water-tight and dust-tight environmental seal. The Xtra Deep Series will hold up under the most extreme applications and provide protection and reliability in high-end electronics applications, harsh corrosive environments, and industrial applications both indoors and out.



Features & Benefits:

- Memory retaining continuous polyurethane gasket
- Integral mounting flange
- Molded in panel mounting inserts
- Chemical resistant fiberglass reinforced polyester
- Non-corrosive design
- Full length stainless steel hinge
- Water-tight, dust-tight
- Non-conductive, impact resistant, UV resistant
- Material cuts, drills, punches, and saws with ease and accuracy
- Rounded edges, minimal protrusions or exposed pocket areas for assembly of dust and debris
- Smooth surface, no color variations, swirls or color pockets, no voids

Certification & Compliances:

- UL/cUL 50, Types 1, 3, 4X, 12
- UL File Number E57656
- CSA Std C22.2 - File 244248 Types 1, 3, 4X, 12
- NEMA Standard 250 - Types 1, 3, 4X, 12
- Temperature Range - (-76°F to +250°F) (-60°C to +120°C)
- Flammability Rating - UL94-5V
- Non-flame propagating

Materials and Finishes:

- Hot compression molded fiberglass reinforced thermoset polyester
- Poured polyurethane seamless gasket provides water-tight dust-tight environmental seal
- 304 stainless steel used on all external hardware
- Molded in mounting flange
- Panel mounting capability for fixed rear panel
- Bosses utilize threaded brass inserts accepting 10-32 screws

Ordering Information

Inside H x W x D	Padlockable Twist Latch	Mounting Plate*
5.84 x 3.85 x 8.81	FXDJ060408	FMP0604
5.72 x 5.72 x 8.81	FXDJ060608	FMP0606
7.73 x 5.74 x 8.82	FXDJ080608	FMP0806
7.73 x 7.73 x 9.18	FXDJ080808	FMP0808
9.73 x 7.73 x 7.84	FXDJ100808	FMP1008
11.79 x 9.80 x 9.81	FXDJ121010	FMP1210
11.70 x 11.70 x 12.12	FXDJ121212	FMP1212
13.50 x 11.55 x 11.81	FXDJ141212	FMP1412
15.63 x 13.60 x 11.81	FXDJ161412	FMP1614
17.69 x 15.69 x 16.81	FXDJ181617	FMP1816
19.71 x 15.71 x 16.81	FXDJ201617	FMP2016

* Available in: Aluminum (SA), Fiberglass (FG), Carbon Steel (C), and Stainless Steel (SS)
To order, add the suffix to the end of the part number

Dimensional Drawings

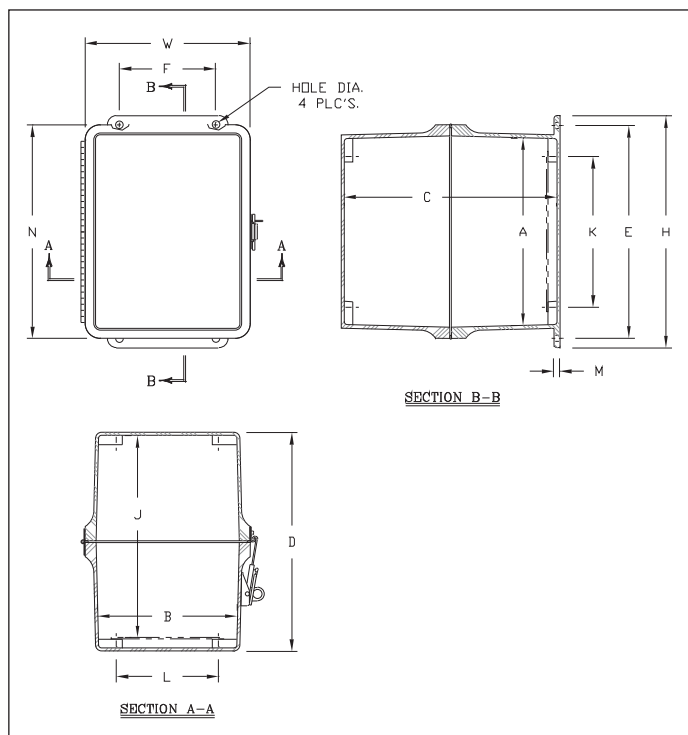

Configuration Dimensions In Inches (mm)

Catalog Number	Overall H x W x D	Inside A x B x C	Mounting E x F	J	K	L	M	N	Hole Dia.	Weight
FXDJ060408	7.50 x 4.94 x 9.07 (190 x 125 x 230)	5.84 x 3.85 x 8.81 (148 x 98 x 224)	6.75 x 2.00 (171 x 51)	8.36 (212)	4.25 (108)	2.25 (57)	0.25 (6)	6.89 (175)	0.31 (8)	3 lbs.
FXDJ060608	7.50 x 6.88 x 9.07 (190 x 175 x 230)	5.72 x 5.72 x 8.81 (145 x 145 x 224)	6.75 x 4.00 (171 x 101)	8.36 (212)	4.25 (108)	4.25 (108)	0.25 (6)	6.89 (175)	0.31 (8)	3 lbs.
FXDJ08608	9.62 x 6.84 x 9.07 (244 x 174 x 230)	7.73 x 5.74 x 8.82 (196 x 146 x 224)	8.88 x 4.00 (225 x 101)	8.37 (213)	6.25 (159)	4.25 (108)	0.25 (6)	8.87 (225)	0.31 (8)	4 lbs.
FXDJ080808	9.56 x 8.84 x 9.43 (243 x 224 x 239)	7.73 x 7.73 x 9.18 (196 x 196 x 233)	8.75 x 6.00 (222 x 152)	8.60 (219)	6.25 (159)	6.25 (159)	0.25 (6)	8.84 (224)	0.31 (8)	5 lbs.
FXDJ100808	11.62 x 8.81 x 8.09 (295 x 224 x 206)	9.73 x 7.73 x 7.84 (247 x 196 x 199)	10.75 x 6.00 (273 x 152)	7.39 (188)	8.25 (209)	6.25 (159)	0.25 (6)	10.86 (276)	0.31 (8)	6 lbs.
FXDJ121010	13.56 x 10.83 x 10.06 (344 x 275 x 256)	11.79 x 9.80 x 9.81 (299 x 249 x 249)	12.75 x 8.00 (324 x 203)	9.36 (238)	10.25 (260)	8.25 (209)	0.25 (6)	12.95 (329)	12.95 (329)	8 lbs.
FXDJ121212	13.56 x 12.84 x 12.37 (344 x 326 x 314)	11.70 x 11.70 x 12.12 (297 x 297 x 308)	12.75 x 10.00 (324 x 254)	11.54 (293)	10.25 (260)	10.25 (260)	0.25 (6)	12.84 (326)	0.31 (8)	9 lbs.
FXDJ141212	15.50 x 12.83 x 12.06 (394 x 326 x 306)	13.50 x 11.55 x 11.81 (343 x 293 x 300)	14.62 x 10.00 (371 x 254)	11.23 (285)	12.25 (311)	10.25 (260)	0.25 (6)	14.88 (378)	0.31 (8)	12 lbs.
FXDJ161412	17.53 x 14.88 x 12.05 (445 x 378 x 306)	17.53 x 14.88 x 12.05 (445 x 378 x 306)	16.75 x 12.00 (425 x 305)	11.23 (285)	14.25 (362)	12.25 (311)	0.25 (6)	16.95 (431)	0.31 (8)	14 lbs.
FXDJ181617	19.62 x 16.91 x 17.19 (498 x 429 x 436)	17.69 x 15.69 x 16.81 (449 x 398 x 427)	18.88 x 12.00 (479 x 305)	16.36 (415)	16.25 (413)	14.25 (362)	0.25 (6)	18.91 (480)	0.31 (8)	22 lbs.
FXDJ201617	22.00 x 17.00 x 17.21 (558 x 431 x 437)	19.71 x 15.71 x 16.81 (501 x 399 x 427)	21.25 x 10.00 (540 x 254)	16.36 (415)	18.25 (464)	14.25 (362)	14.25 (362)	21.00 (533)	0.31 (8)	25 lbs.

Fiberglass Enclosures Advantage Series



Advantage Series

The Cooper Crouse-Hinds Advantage Series offer is our most extensive selection of durable industrial non-metallic boxes. Available in a wide range of options, the Advantage Series is available in over 36 various configurations with options such as stainless steel hinges or stainless steel pull latches each with or without clear covers. These enclosures are made of fiberglass reinforced polyester and have a poured polyurethane seamless gasket that provides a water-tight and dust-tight environmental seal for exceptional corrosion and chemical resistance. The resilient Advantage Series will provide high impact resistance in the most extreme conditions and provide protection and reliability in the most adverse applications.



Features & Benefits:

- Memory retaining continuous polyurethane gasket
- No penetrating hardware
- Chemical resistant fiberglass reinforced polyester
- Non-corrosive design
- Water-tight, dust-tight
- Non-conductive, impact resistant, UV resistant
- Material cuts, drills, punches, and saws with ease and accuracy
- Rounded edges, minimal protrusions or exposed pocket areas for assembly of dust and debris
- Smooth surface, no color variations, swirls or color pockets, no voids

Certification & Compliances:

- UL/cUL 50, Types 1, 3, 3S, 4X, 12, 13
- UL File Number E57656
- CSA Std C22.2 - File 244248 Types 1, 3, 3S, 4X, 12, 13
- NEMA Standard 250 - Types 1, 3, 3S, 4X, 12, 13
- Temperature Range - (-76°F to +250°F) (-60°C to +120°C)
- Flammability Rating - UL94-5V
- Non-flame propagating
- IP66

Materials and Finishes:

- Hot compression molded fiberglass reinforced thermoset polyester
- Poured polyurethane seamless gasket provides water-tight dust-tight environmental seal
- 304 stainless steel used on all external hardware
- Panel mounting capability for fixed rear panel
- Bosses utilize threaded brass inserts accepting 10-32 screws

Options:

- Mounting feet kit available for field installation. Order part number FAMTGFTKIT

Ordering Information

Inside H x W x D	2 Cover Screws With a Hinged Cover	Hinged Cover With a Padlock Latch	2 Cover Screws With a Clear Hinged Cover	Hinged Clear Cover With a Padlock Latch	Cover Panel With Mounting Hardware	Mounting Plate
7.41 x 7.79 x 4.31	FAHS060604	FAHP060604	FAHSCC060604	FAHPCC060604	FACP0606SA	FMP0606
9.41 x 7.79 x 4.31	FAHS080604	FAHP080604	FAHSCC080604	FAHPCC080604	FACP0806SA	FMP0806
9.39 x 9.76 x 4.31	FAHS080804	FAHP080804	FAHSCC080804	FAHPCC080804	FACP0808SA	FMP0808
11.42 x 9.79 x 6.31	FAHS100806	FAHP100806	FAHSCC100806	FAHPCC100806	FACP1008SA	FMP1008
13.45 x 11.83 x 6.31	FAHS121006	FAHP121006	FAHSCC121006	FAHPCC121006	FACP1210SA	FMP1210
15.49 x 13.86 x 6.34	FAHS141206	FAHP141206	FAHSCC141206	FAHPCC141206	FACP1412SA	FMP1412
15.49 x 13.86 x 8.34	FAHS141208	FAHP141208	FAHSCC141208	FAHPCC141208	FACP1412SA	FMP1412
17.58 x 15.96 x 8.34	FAHS161408	FAHP161408	FAHSCC161408	FAHPCC161408	FACP1614SA	FMP1614
19.77 x 18.15 x 10.34	FAHS181610	FAHP181610			FACP1816SA	FMP1816
21.79 x 18.16 x 10.34	FAHS201610	FAHP201610			FACP2016SA	FMP2016

Dimensional Drawings

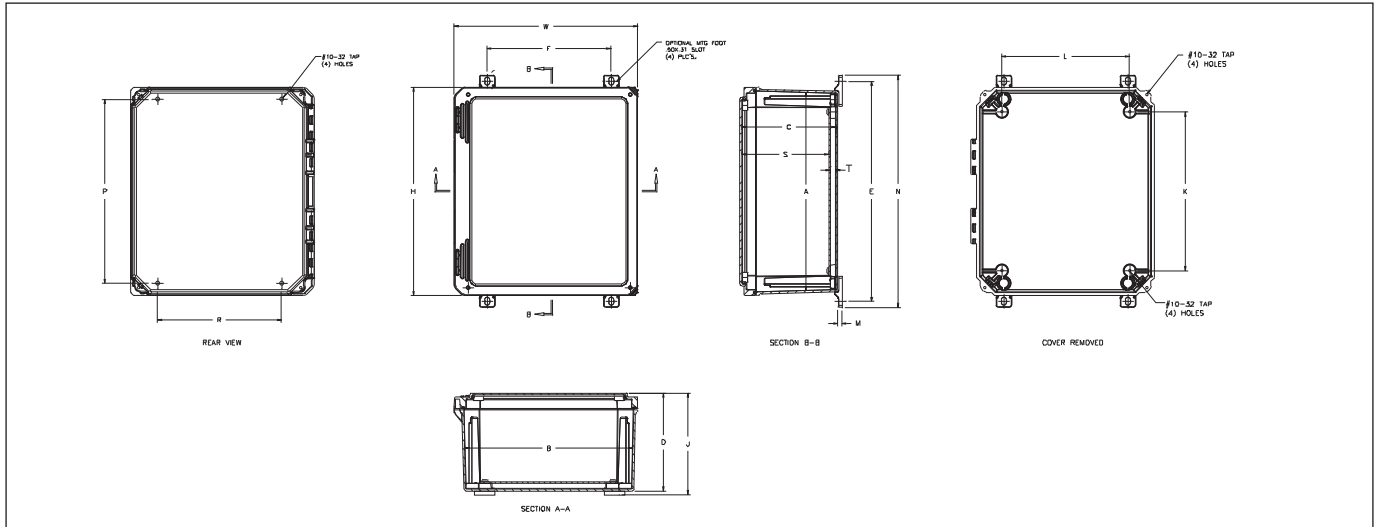

Advantage Series

Configuration Dimensions In Inches (mm)

Catalog Number	Overall H x W x D	Inside A x B x C	Mounting P x R	K	L	S	T	Opt. Mtg. Feet E x F	N	J	M	Weight
FAHS060604 FAHP060604 FAHSCC060604 FAHPCC060604	7.41H (188.3) 9.79W (248.6) 4.31D (109.5)	6.77 x 6.77 x 4.06 (171.9 x 171.9 x 103.2)	5.93 x 4.00 (150.6 x 101.6)	4.25 (108)	4.25 (108)	3.60 (91.5)	0.38 (9.6)	8.24 x 4.00 (209.2 x 101.6)	9.02 (229.0)	4.56 (115.8)	0.25 (6.35)	2.5 lbs.
FAHS080604 FAHP080604 FAHSCC080604 FAHPCC080604	9.41H (239.1) 9.79W (248.6) 4.31D (109.5)	8.77 x 6.77 x 4.06 (222.7 x 171.9 x 103.2)	7.91 x 4.00 (200.9 x 101.6)	6.25 (159)	4.25 (108)	3.60 (91.5)	0.38 (9.6)	10.21 x 4.00 (259.3 x 101.6)	10.98 (279.0)	4.56 (115.8)	0.25 (6.35)	3.0 lbs.
FAHS080804 FAHP080804 FAHSCC080804 FAHPCC080804	9.39H (238.5) 9.76W (248.0) 4.31D (109.5)	8.74 x 8.74 x 4.06 (222.1 x 222.1 x 103.2)	7.91 x 6.00 (200.9 x 152.4)	6.25 (159)	6.25 (159)	3.60 (91.5)	0.38 (9.6)	10.21 x 6.00 (259.3 x 152.4)	10.98 (279.0)	4.56 (115.8)	0.25 (6.35)	3.5 lbs.
FAHS100806 FAHP100806 FAHSCC100806 FAHPCC100806	11.42H (290.1) 9.79W (248.6) 6.31D (160.3)	10.73 x 8.73 x 6.06 (272.5 x 221.7 x 153.9)	9.89 x 6.00 (251.2 x 152.4)	8.25 (210)	6.25 (159)	5.60 (142.3)	0.38 (9.6)	12.19 x 6.00 (309.6 x 152.4)	12.96 (329.3)	6.56 (166.6)	0.25 (6.35)	4.5 lbs.
FAHS121006 FAHP121006 FAHSCC121006 FAHPCC121006	13.45H (341.6) 11.83W (300.5) 6.31D (160.3)	12.69 x 10.69 x 6.06 (322.3 x 271.5 x 153.9)	11.88 x 8.00 (301.7 x 203.2)	10.25 (260)	8.25 (210)	5.60 (142.3)	0.38 (9.6)	14.18 x 8.00 (360.2 x 203.2)	14.95 (379.7)	6.56 (166.6)	0.25 (6.35)	6.0 lbs.
FAHS141206 FAHP141206 FAHSCC141206 FAHPCC141206	15.49H (393.4) 13.86W (352.0) 6.34D (161.0)	14.72 x 12.72 x 6.06 (373.9 x 323.1 x 153.9)	13.91 x 10.00 (353.3 x 254.0)	12.25 (311)	10.25 (260)	5.60 (142.3)	0.38 (9.6)	16.21 x 10.00 (411.7 x 254.0)	16.98 (431.4)	6.59 (167.4)	0.25 (6.35)	8.0 lbs.
FAHS141208 FAHP141208 FAHSCC141208 FAHPCC141208	15.49H (393.4) 13.86W (352.0) 8.34D (211.8)	14.66 x 12.66 x 8.06 (372.4 x 321.6 x 204.7)	13.88 x 10.00 (352.5 x 254.0)	12.25 (311)	10.25 (260)	7.60 (193.2)	0.38 (9.6)	16.19 x 10.00 (411.2 x 254.0)	16.96 (430.9)	8.59 (218.2)	0.25 (6.35)	9.5 lbs.
FAHS161408 FAHP161408 FAHSCC161408 FAHPCC161408	17.58H (446.6) 15.96W (405.4) 8.34D (211.8)	16.69 x 14.69 x 8.06 (424.0 x 373.1 x 204.7)	15.96 x 12.00 (405.4 x 304.8)	14.25 (362)	12.25 (311)	7.60 (193.2)	0.38 (9.6)	18.26 x 12.00 (464.0 x 304.8)	19.04 (483.5)	8.59 (218.2)	0.25 (6.35)	11.5 lbs.
FAHS181610 FAHP181610	19.77H (502.2) 18.15W (461.0) 10.34D (262.6)	18.63 x 16.63 x 10.06 (473.2 x 422.4 x 255.5)	17.94 x 14.00 (455.6 x 355.6)	16.25 (413)	14.25 (362)	9.60 (243.9)	0.38 (9.6)	20.24 x 14.00 (514.3 x 355.6)	21.02 (533.8)	10.59 (268.9)	0.25 (6.35)	16.0 lbs.
FAHS201610 FAHP201610	21.79H (553.5) 18.16W (461.2) 10.34D (262.6)	20.63 x 16.63 x 10.06 (524.0 x 422.4 x 255.5)	19.96 x 14.00 (506.9 x 355.6)	18.25 (463)	14.25 (362)	9.59 (243.7)	0.38 (9.6)	22.26 x 14.00 (565.6 x 355.6)	23.04 (585.1)	10.59 (268.9)	0.25 (6.35)	17.5 lbs.

Fiberglass Enclosures

Wall Mount & Large Fiberglass Enclosure Series



The Cooper Crouse-Hinds Wall Mount and Large Fiberglass Enclosure Series offer a solution for applications requiring a large enclosure especially suited for indoor or outdoor use and to provide protection against falling dirt, rain, sleet, snow, and windblown dust. The fiberglass reinforced polyester Wall Mount Series is available in NEMA 3R and 4X configurations and the poured polyurethane seamless gasket provides a watertight and dust-tight environmental seal for exceptional corrosion and chemical resistance.

Enclosure Series

Features & Benefits:

- Memory retaining continuous polyurethane gasket
- Lightweight
- Integral mounting feet
- Molded in panel mounting inserts
- Stainless steel full length continuous hinge
- Built in padlock hasp
- Chemical resistant fiberglass reinforced polyester
- Water-tight, dust-tight
- Non-conductive, impact resistant, UV resistant
- Rain shield protection against incidental water ingress for NEMA 3R enclosures
- Material cuts, drills, punches, and saws with ease and accuracy
- Rounded edges, minimal protrusions or exposed pocket areas for assembly of dust and debris
- Smooth surface, no color variations, swirls or color pockets, no voids



Certification & Compliances:

3R Series

- UL/cUL 50, Types 1, 3R
- UL File Number E57656
- CSA Std C22.2 - File 244248 Types 1, 3R
- NEMA Standard 250 - Types 1, 3R
- Temperature Range - (-76°F to +250°F) (-60°C to +120°C)
- Flammability Rating - UL94-5V
- Non-flame propagating

4X Series

- UL/cUL 50, Types 1, 3, 3R, 4X, 12
- UL File Number E57656
- CSA Std C22.2 - File 244248 Types 1, 3, 3R, 4X, 12
- NEMA Standard 250 - Types 1, 3, 3R, 4X, 12
- Temperature Range - (-76°F to +250°F) (-60°C to +120°C)
- Flammability Rating - UL94-5V
- Non-flame propagating

Large Fiberglass

- UL/cUL 50, Types 1, 3, 3R, 4X, 12
- UL File Number E57656
- CSA Std C22.2 - File 244248 Types 1, 3, 3R, 4X, 12
- NEMA Standard 250 - Types 1, 3, 3R, 4X, 12
- IP55 & IP66
- Temperature Range - (-76°F to +250°F) (-60°C to +120°C)
- Flammability Rating - UL94-5V
- Non-flame propagating







Materials and Finishes:

- Hot compression molded fiberglass reinforced polyester hand layup FRP
- Poured polyurethane seamless gasket provides water-tight dust-tight environmental seal
- 304 stainless steel used on all external hardware
- Bosses utilize threaded brass inserts accepting 10-32 screws

Fiberglass Enclosures Wall Mount & Large Fiberglass Enclosure Series



Ordering Information:

		
Inside H x W x D	Stainless Steel Hinged, Latched Down Cover	Mounting Plate*
15.92 x 10.27 x 8.53	F4WMSHL161007	FMPWM1610
19.70 x 16.04 x 13.24	F4WMSHL201612	FMPWM2016
24.00 x 12.87 x 7.33	F4WMSHL241206	FMPWM2412
24.00 x 12.87 x 11.33	F4WMSHL241210	FMPWM2412
24.05 x 20.39 x 9.25	F4WMSHL242008	FMPWM2420
24.05 x 24.39 x 11.25	F4WMSHL242410	FMPWM2424
24.05 x 24.39 x 13.25	F4WMSHL242412	FMPWM2424
29.90 x 20.14 x 7.23	F4WMSHL302006	FMPWM3020
29.90 x 20.14 x 9.23	F4WMSHL302008	FMPWM3020
29.90 x 20.14 x 11.23	F4WMSHL302010	FMPWM3020
29.90 x 20.14 x 13.23	F4WMSHL302012	FMPWM3020
30.46 x 25.47 x 8.12	F4WMSHL302407	FMPWM3024
30.46 x 25.47 x 11.27	F4WMSHL302410	FMPWM3024
30.46 x 25.47 x 13.10	F4WMSHL302412	FMPWM3024
36.31 x 31.69 x 9.36	F4WMSHL363008	FMPWM3630
36.31 x 31.69 x 11.36	F4WMSHL363010	FMPWM3630
36.31 x 31.69 x 13.36	F4WMSHL363012	FMPWM3630
		
19.70 x 16.04 x 7.24	F3WMSHL201606	FMPWM2016
24.05 x 24.39 x 11.25	F3WMSHL242410	FMPWM2424
29.90 x 20.14 x 9.23	F3WMSHL302008	FMPWM3020
29.90 x 20.14 x 11.23	F3WMSHL302010	FMPWM3020
30.46 x 25.47 x 11.27	F3WMSHL302410	FMPWM3024
30.46 x 25.47 x 13.10	F3WMSHL302412	FMPWM3024
36.31 x 31.69 x 9.36	F3WMSHL363008	FMPWM3630
36.31 x 31.69 x 11.36	F3WMSHL363010	FMPWM3630
36.31 x 31.69 x 13.36	F3WMSHL363012	FMPWM3630
48.33 x 36.22 x 13.25	F3WMSHL483612	FMPWM4836
48.33 x 32.22 x 17.25	F3WMSHL483616	FMPWM4836
		
48.33 x 36.22 x 13.25	F4LSHL483612	FMPWM4836
48.33 x 32.22 x 17.25	F4LSHL483616	FMPWM4836
60.62 x 36.13 x 13.44	F4LSHL603612	FMPWM6036
60.62 x 36.13 x 17.44	F4LSHL603616	FMPWM6036
36.12 x 48.12 x 13.00	F4LSHLDD364812	FMPWM3648
72.00 x 25.00 x 25.88	F4LSHLFS722525	FMPWM7225
72.00 x 49.00 x 25.88	F4LSHLFSD724925	FMPWM7249

* Available in: Aluminum (SA), Fiberglass (FG), Carbon Steel (C), and Stainless Steel (SS).
To order, add the suffix to the end of the part number

Number of Latches

Inside Enclosure Dimensions	3R Stainless Steel Hinge	4X Stainless Steel Hinge
161007	2	2
201606	2	2
201612	2	2
241206	2	2
241210	2	2
242008	2	4
242410	2	2
242412	2	2
302006		
302008	2	5
302010		
302012		
302407		
302410	2	5
302412		
363008		
363010	3	5
363012		
483612	3	10
483616		

Enclosure Series

Fiberglass Enclosures Wall Mount & Large Fiberglass Enclosure Series



Dimensional Drawings

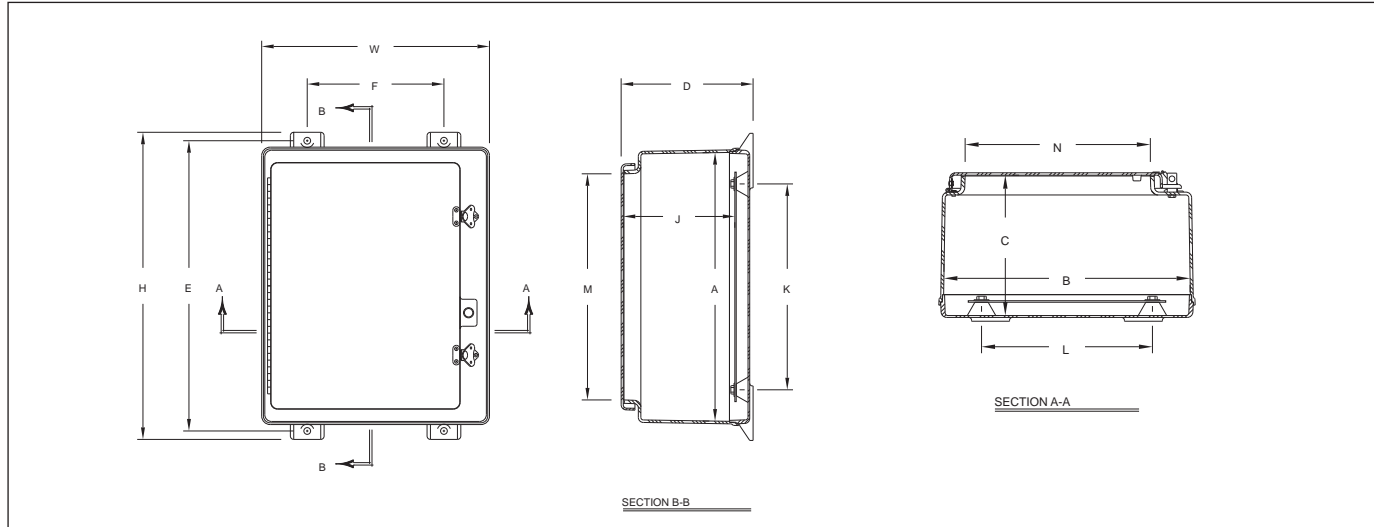

Wall Mount Series - NEMA 4X Configuration Dimensions In Inches (mm)

Catalog Number	Overall H x W x D	Inside A x B x C	Mounting E x F	J	K	L	Enclosure Opening M x N	Weight
F4WMSHL161007	18.75 x 10.96 x 9.03 (476 x 278 x 229)	15.92 x 10.27 x 8.53 (404 x 261 x 217)	17.50 x 7.00 (444 x 178)	7.8 (198)	12 (305)	7.5 (191)	13.14 x 6.00 (334 x 152)	12 lbs.
F4WMSHL201612	22.75 x 16.87 x 13.77 (578 x 429 x 350)	19.70 x 16.04 x 13.24 (500 x 407 x 336)	21.50 x 10.12 (546 x 257)	12.26 (312)	15.25 (387)	11.25 (286)	16.75 x 12.19 (425 x 310)	24 lbs.
F4WMSHL241206	26.95 x 13.72 x 7.98 (685 x 348 x 203)	24.00 x 12.87 x 7.33 (610 x 327 x 186)	25.75 x 6.25 (654 x 159)	6.33 (161)	19.25 (489)	7.25 (184)	21.00 x 8.37 (533 x 213)	21 lbs.
F4WMSHL241210	26.95 x 13.72 x 11.99 (685 x 348 x 304)	24.00 x 12.87 x 11.33 (610 x 327 x 288)	25.75 x 6.25 (654 x 159)	10.33 (262)	19.25 (489)	7.25 (184)	21.00 x 8.37 (533 x 213)	25 lbs.
F4WMSHL242008	27.00 x 21.24 x 9.90 (686 x 539 x 252)	24.05 x 20.39 x 9.25 (611 x 518 x 235)	25.75 x 14.00 (654 x 356)	8.25 (209)	19.25 (489)	15.25 (387)	21.25 x 16.00 (540 x 406)	32 lbs.
F4WMSHL242410	27.00 x 25.24 x 11.90 (686 x 641 x 302)	24.05 x 24.39 x 11.25 (611 x 619 x 286)	25.75 x 17.87 (654 x 454)	10.25 (260)	19.25 (489)	19.25 (489)	21.25 x 20.00 (540 x 508)	42 lbs.
F4WMSHL242412	27.00 x 25.24 x 13.90 (686 x 641 x 353)	24.05 x 24.39 x 13.25 (611 x 619 x 336)	25.75 x 17.87 (654 x 454)	12.25 (311)	19.25 (489)	19.25 (489)	21.25 x 20.00 (540 x 508)	43 lbs.
F4WMSHL302006	32.86 x 20.99 x 7.89 (835 x 533 x 200)	29.90 x 20.14 x 7.23 (760 x 511 x 184)	30.75 x 14.25 (806 x 362)	6.23 (158)	25.25 (641)	15.25 (387)	27.00 x 16.50 (686 x 419)	34 lbs.
F4WMSHL302008	32.86 x 20.99 x 9.89 (835 x 533 x 251)	29.90 x 20.14 x 9.23 (760 x 511 x 234)	31.75 x 14.25 (806 x 362)	8.23 (209)	25.25 (641)	15.25 (387)	27.00 x 16.50 (686 x 419)	36 lbs.
F4WMSHL302010	32.86 x 20.99 x 11.89 (835 x 533 x 302)	29.90 x 20.14 x 11.23 (760 x 511 x 285)	31.75 x 14.25 (806 x 362)	10.23 (260)	25.25 (641)	15.25 (387)	27.00 x 16.50 (686 x 419)	39 lbs.
F4WMSHL302012	29.90 x 20.14 x 13.23 (760 x 511 x 336)	29.90 x 20.14 x 13.23 (760 x 511 x 336)	31.75 x 14.25 (806 x 362)	12.23 (311)	25.25 (641)	15.25 (387)	27.00 x 16.50 (686 x 419)	48 lbs.
F4WMSHL302407	33.41 x 26.32 x 8.81 (849 x 668 x 224)	30.46 x 25.47 x 8.12 (774 x 647 x 206)	32.25 x 18.50 (819 x 470)	7.12 (181)	25.25 (641)	19.25 (489)	27.38 x 21.25 (695 x 540)	45 lbs.
F4WMSHL302410	33.41 x 26.32 x 11.95 (849 x 668 x 304)	30.46 x 25.47 x 11.27 (774 x 647 x 286)	32.25 x 18.50 (819 x 470)	10.27 (261)	25.25 (641)	19.25 (489)	27.38 x 21.25 (695 x 540)	50 lbs.
F4WMSHL302412	33.41 x 26.32 x 13.79 (849 x 668 x 350)	30.46 x 25.47 x 13.10 (774 x 647 x 333)	32.25 x 18.50 (819 x 470)	12.1 (307)	25.25 (641)	19.25 (489)	27.38 x 21.25 (695 x 540)	54 lbs.
F4WMSHL363008	39.31 x 32.50 x 10.05 (999 x 826 x 255)	36.31 x 31.69 x 9.36 (922 x 805 x 238)	38.13 x 23.88 (968 x 606)	8.36 (212)	31.25 (794)	25.25 (641)	33.25 x 27.25 (845 x 692)	75 lbs.
F4WMSHL363010	39.31 x 32.50 x 12.05 (999 x 826 x 306)	36.31 x 31.69 x 11.36 (922 x 805 x 289)	38.13 x 23.88 (968 x 606)	10.36 (263)	31.25 (794)	25.25 (641)	33.25 x 27.25 (845 x 692)	78 lbs.
F4WMSHL363012	39.31 x 32.50 x 14.05 (999 x 826 x 357)	36.31 x 31.69 x 13.36 (922 x 805 x 339)	38.13 x 23.88 (968 x 606)	12.36 (314)	31.25 (794)	25.25 (641)	33.25 x 27.25 (845 x 692)	81 lbs.

Fiberglass Enclosures Wall Mount & Large Fiberglass Enclosure Series



Enclosure Series

Wall Mount Series - NEMA 3R Configuration Dimensions In Inches (mm)

Catalog Number	Overall H x W x D	Inside A x B x C	Mounting E x F	J	K	L	Enclosure Opening M x N	Weight
F3WMSHL201606	22.75 x 16.87 x 8.27 (578 x 429 x 210)	19.17 x 16.04 x 7.24 (500 x 407 x 184)	21.50 x 10.12 (546 x 257)	6.26 (159)	15.25 (387)	11.25 (286)	16.75 x 12.19 (425 x 310)	17 lbs.
F3WMSHL242410	27.00 x 25.24 x 11.90 (686 x 641 x 302)	24.05 x 24.39 x 11.25 (611 x 619 x 286)	25.75 x 17.87 (654 x 454)	10.25 (260)	19.25 (489)	19.25 (489)	21.25 x 20.00 (540 x 508)	42 lbs.
F3WMSHL302008	32.86 x 20.99 x 9.89 (835 x 533 x 251)	29.90 x 20.14 x 9.23 (760 x 511 x 234)	31.75 x 14.25 (806 x 362)	8.23 (209)	25.25 (641)	15.25 (387)	27.00 x 16.50 (686 x 419)	36 lbs.
F3WMSHL302010	32.86 x 20.99 x 11.89 (835 x 533 x 302)	29.90 x 20.14 x 11.23 (760 x 511 x 285)	31.75 x 14.25 (806 x 362)	10.23 (260)	25.25 (641)	15.25 (387)	27.00 x 16.50 (686 x 419)	39 lbs.
F3WMSHL302410	33.41 x 26.32 x 11.95 (849 x 668 x 304)	30.46 x 25.47 x 11.27 (774 x 647 x 286)	32.25 x 18.50 (819 x 470)	10.27 (261)	25.25 (641)	19.25 (489)	27.38 x 21.25 (695 x 540)	50 lbs.
F3WMSHL302412	33.41 x 26.32 x 13.79 (849 x 668 x 350)	30.46 x 25.47 x 13.10 (774 x 647 x 333)	32.25 x 18.50 (819 x 470)	12.10 (307)	25.25 (641)	19.25 (489)	27.38 x 21.25 (695 x 540)	54 lbs.
F3WMSHL363008	39.31 x 32.50 x 10.05 (999 x 826 x 255)	36.31 x 31.69 x 9.36 (922 x 805 x 238)	38.13 x 23.88 (968 x 606)	8.36 (212)	31.25 (794)	25.25 (641)	33.25 x 27.25 (845 x 692)	75 lbs.
F3WMSHL363010	39.31 x 32.50 x 12.05 (999 x 826 x 306)	36.31 x 31.69 x 11.36 (922 x 805 x 289)	38.13 x 23.88 (968 x 606)	10.36 (263)	31.25 (794)	25.25 (641)	33.25 x 27.25 (845 x 692)	78 lbs.
F3WMSHL363012	39.31 x 32.50 x 14.05 (999 x 826 x 357)	36.31 x 31.69 x 13.36 (922 x 805 x 339)	38.13 x 23.88 (968 x 606)	12.36 (314)	31.25 (794)	25.25 (641)	33.25 x 27.25 (845 x 692)	81 lbs.

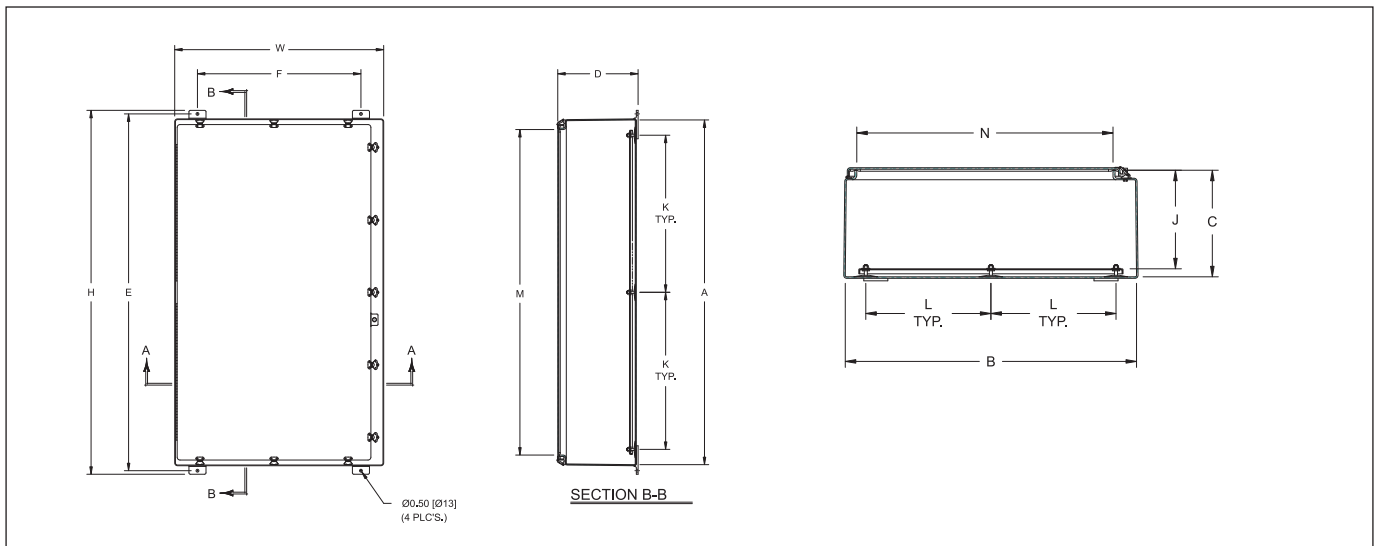

NEMA 3R Dimensional Drawing
F3WMSHL483612 and F3WMSHL483616

F3WMSHL483612	51.29 x 36.62 x 13.93 (1303 x 930 x 354)	48.33 x 36.22 x 13.25 (1228 x 920 x 336)	50.12 x 28.50 (1273 x 724)	12.25 (311)	21.63 (549)	31.25 (794)	45.25 x 32.00 (1149 x 813)	146 lbs.
F3WMSHL483616	51.29 x 36.62 x 17.93 (1303 x 930 x 456)	48.33 x 32.22 x 17.25 (1228 x 920 x 438)	50.12 x 28.50 (1273 x 724)	16.25 (413)	21.63 (549)	31.25 (794)	45.25 x 32.00 (1149 x 813)	164 lbs.

Wall Mount Series / NEMA 3R Chart reflects the Dimensional Drawings from the previous page.

Fiberglass Enclosures Wall Mount & Large Fiberglass Enclosure Series



Enclosure Series

Large Fiberglass Enclosures Series - Configuration Dimensions In Inches (mm)

Catalog Number	Overall H x W x D	Inside A x B x C	Mounting E x F	J	K	L	Enclosure Opening M x N	Weight
F4LSHL483612*	51.29 x 36.62 x 13.93 (1303 x 930 x 354)	48.33 x 36.22 x 13.25 (1228 x 920 x 336)	50.12 x 28.50 (1273 x 724)	12.25 (311)	21.63 (549)	31.25 (794)	45.25 x 32.00 (1149 x 813)	146 lbs.
F4LSHL483616*	51.29 x 36.62 x 17.93 (1303 x 930 x 456)	48.33 x 32.22 x 17.25 (1228 x 920 x 438)	50.12 x 28.50 (1273 x 724)	16.25 (413)	21.63 (549)	31.25 (794)	45.25 x 32.00 (1149 x 813)	164 lbs.
F4LSHL603612*	64.00 x 36.50 x 14.12 (1627 x 927 x 359)	60.62 x 36.13 x 13.44 (1540 x 918 x 441)	62.75 x 28.75 (1594 x 730)	12.44 (316)	27.63 (702)	31.25 (794)	57.25 x 32.00 (1454 x 813)	177 lbs.
F4LSHL603616*	64.00 x 36.50 x 18.12 (1627 x 927 x 460)	60.62 x 36.13 x 17.44 (1540 x 918 x 443)	62.75 x 28.75 (1594 x 730)	16.44 (418)	27.63 (702)	31.25 (794)	57.25 x 32.00 (1454 x 813)	198 lbs.
F4SHLDD364812	39.50 x 48.50 x 13.62 (1003 x 1232 x 346)	36.12 x 48.12 x 13.00 (917 x 1222 x 330)	38.25 x 40.5 (972 x 1029)	11.94 (303)	14.50 (368)	20.00 (508)	32.00 x 20.75 (813 x 527)	146 lbs.
F4SHLFS722525	72.50 x 25.50 x 26.38 (1841 x 648 x 492)	72.00 x 25.00 x 25.88 (1829 x 635 x 657)		24.88 (632)	15.50 (388)	19.00 (483)	64.75 x 21.00 (1645 x 533)	226 lbs.
F4SHLFSDD724925	72.50 x 49.50 x 26.38 (1842 x 1257 x 670)	72.00 x 49.00 x 25.88 (1829 x 1245 x 654)		24.88 (628)	15.50 (394)	20.00 (508)	64.75 x 21.00 (1645 x 533)	350 lbs.

* F4LSHL483612, F4LSHL483616, F4LSHL603612 and F4LSHL603616 reflective of the above chart

Wall Mount & Large Fiberglass Enclosures Series – Dimensional Drawings

F4LSHDD364812

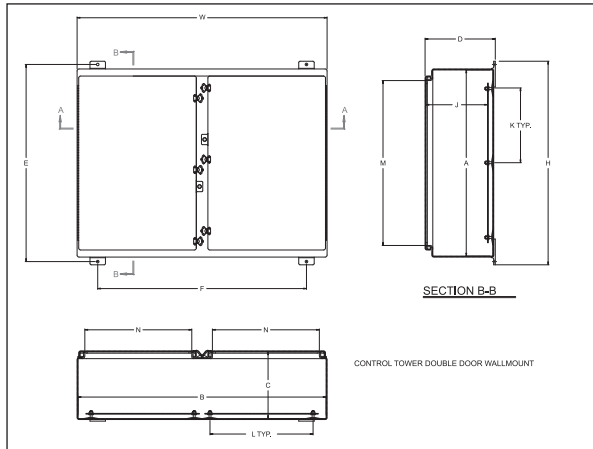

F4LSHLFS722525

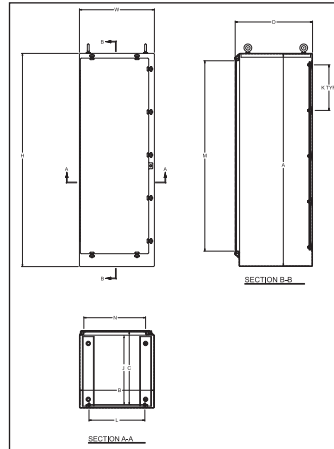

F4LSHLFSDD724925

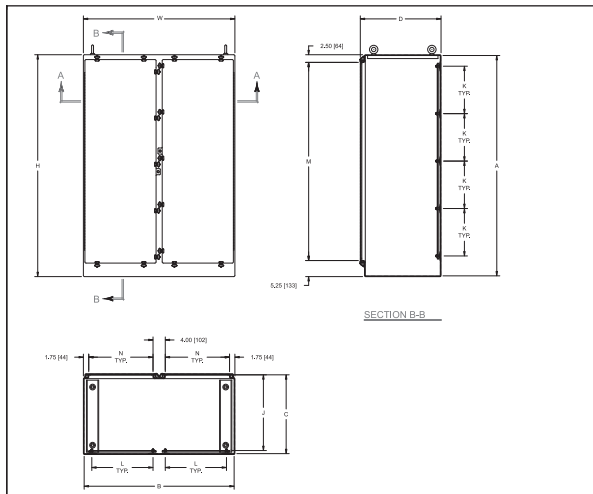

Fiberglass Enclosures Disconnect and Circuit Breaker Series



The Cooper Crouse-Hinds Disconnect and Circuit Breaker Series are used in larger industrial control systems and machine tool control panels where a disconnect is desirable in extreme environmental conditions. This durable NEMA 4X rated enclosure provides protection from falling dirt, rain, sleet, snow, windblown dust, splashing water, and hose-directed water; and will be undamaged by the external formation of ice on the enclosure. The poured polyurethane seamless gasket and fiberglass reinforced polyester enclosure provides exceptional corrosion and chemical resistance in adverse conditions.

Features & Benefits:

- Integral mounting feet
- Stainless steel full length continuous hinge
- Padlockable in off position
- Lightweight
- Memory retaining continuous polyurethane gasket
- Molded in panel mounting inserts
- Chemical resistant fiberglass reinforced polyester
- Non-corrosive design
- Environmentally sealed Type 4X disconnect handle
- Water-tight, dust-tight
- Non-conductive, impact resistant, UV resistant
- Material cuts, drills, punches, and saws with ease and accuracy
- Rounded edges, minimal protrusions or exposed pocket areas for assembly of dust and debris
- Smooth surface, no color variations, swirls or color pockets, no voids

Certification & Compliances:

- UL/cUL 50, Types 1, 3, 3R, 4X, 12
- UL File Number E57656
- CSA Std C22.2 - File 244248 Types 1, 3, 3R, 4X, 12
- NEMA Standard 250 - Types 1, 3, 3R, 4X, 12
- Temperature Range - (-76°F to +250°F) (-60°C to +120°C)
- Flammability Rating - UL94-5V
- Non-flame propagating





Breaker Series

Materials and Finishes:

- Hot compression molded fiberglass reinforced thermoset polyester
- Poured polyurethane seamless gasket
- 304 stainless steel used on all external hardware
- Panel mounting capability for fixed rear panel
- Bosses utilize threaded brass inserts

Ordering Information

		
Inside H x W x D	Disconnect	Mounting Plate*
16 x 10 x 8	FDC161008	FMPC1610
20 x 16 x 9	FDC201608	FMPC2016
24 x 12 x 11	FDC241212	FMPC2412
24 x 24 x 11	FDC242412	FMPC2424
30 x 24 x 11	FDC302412	FMPC3024
36 x 30 x 11	FDC363012	FMPC3630

* Available in: Aluminum (SA), Fiberglass (FG), Carbon Steel (C), and Stainless Steel (SS)
To order, add the suffix to the end of the part number

Fiberglass Enclosures Disconnect and Circuit Breaker Series



Dimensional Drawings

Breaker Series

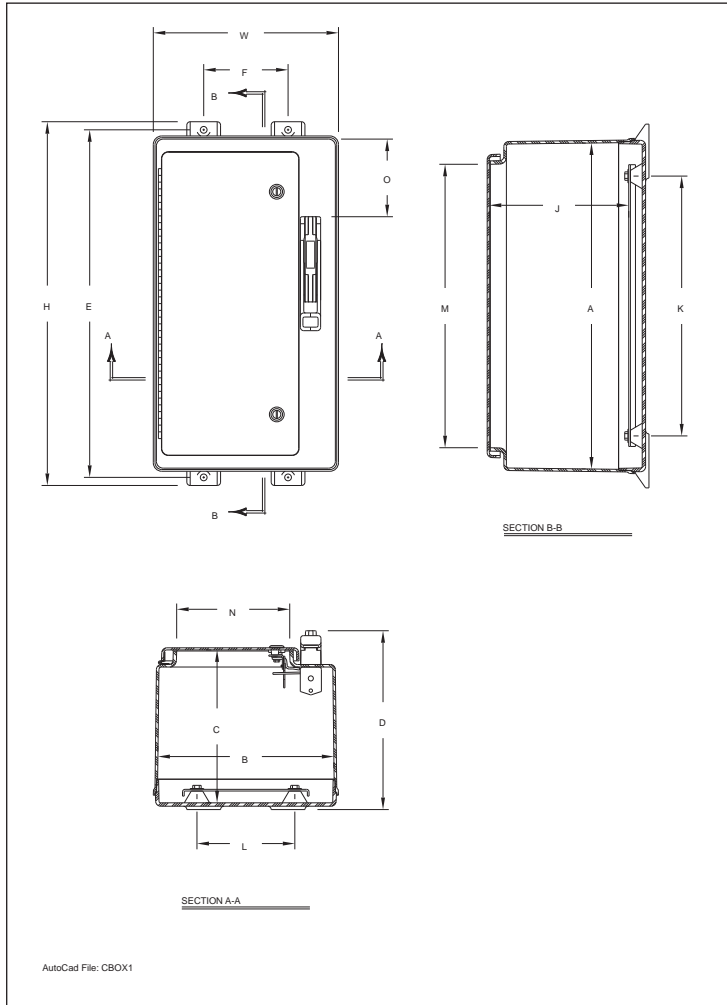



Configuration Dimensions In Inches (mm)

Catalog Number	Overall H x W x D	Inside A x B x C	Mounting E x F	J	K	L	Opening Enclosure M x N	O	Weight
FDC161008	18.75 x 10.96 x 10.25 (476 x 278 x 260)	15.92 x 10.27 x 8.53 (404 x 261 x 217)	17.50 x 7.00 (444 x 178)	7.8 (198)	12 (305)	7.5 (191)	13.14 x 6.00 (334 x 152)	3.50 (89)	13 lbs.
FDC201608	22.75 x 16.87 x 11.00 (578 x 429 x 279)	19.70 x 16.04 x 9.24 (500 x 407 x 235)	21.50 x 10.12 (546 x 257)	8.26 (210)	15.25 (387)	11.25 (286)	16.75 x 12.19 (425 x 310)	3.50 (89)	23 lbs.
FDC241212	26.95 x 13.72 x 13.25 (685 x 348 x 337)	24.00 x 12.87 x 11.33 (610 x 327 x 288)	25.75 x 6.25 (654 x 159)	10.33 (262)	19.25 (489)	7.25 (184)	21.00 x 8.37 (533 x 213)	5.75 (146)	26 lbs.
FDC242412	27.00 x 25.24 x 13.19 (686 x 641 x 335)	24.05 x 24.39 x 11.25 (611 x 619 x 286)	25.75 x 17.87 (654 x 454)	10.25 (260)	19.25 (489)	19.25 (489)	21.25 x 20.00 (540 x 508)	5.75 (146)	40 lbs.
FDC302412	33.41 x 26.32 x 13.19 (849 x 668 x 335)	30.46 x 25.47 x 11.27 (774 x 647 x 286)	32.25 x 18.50 (819 x 470)	10.27 (261)	25.25 (641)	19.25 (489)	27.38 x 21.25 (695 x 540)	12.25 (311)	51 lbs.
FDC363012	39.31 x 32.50 x 13.31 (999 x 826 x 338)	36.31 x 31.69 x 11.36 (922 x 805 x 289)	38.13 x 23.88 (968 x 606)	10.36 (263)	31.25 (794)	25.25 (641)	33.25 x 27.5 (845 x 692)	12.25 (311)	79 lbs.

*Disconnect, fuse block, breaker, yoke, switches, or other internal components are not furnished with enclosure.

Drain & Breather Vent

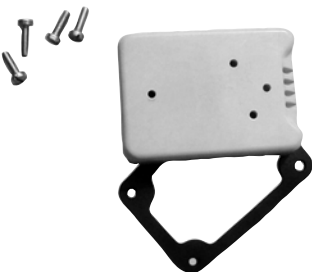
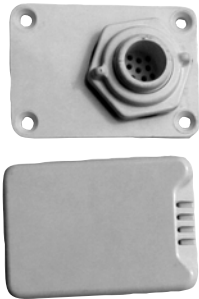

			
<p>CHDV - Drain Vent</p>	<p>CHDVKIT - Drain Vent Kit</p>	<p>CHDVKIT4X - Drain Vent Kit 4X</p>	<p>CHBVKIT4X - Breather Vent Kit 4X</p>

Breaker Series

Encapsulated Screws

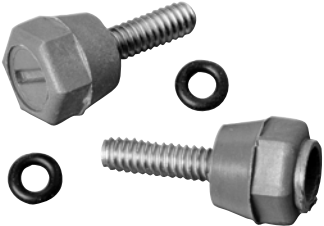
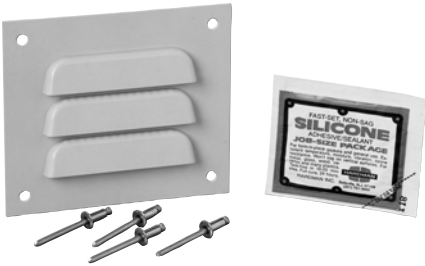

Louver Plate Vent

Carrying Handle

		
<p>CHENCAP2PK CHENCAP4PK</p>	<p>CHLP1 CHLPKIT</p>	<p>CHHANDLE</p>

Stainless Steel Screws

Corrosion Inhibitor

	
<p>CHSS2PK CHSS4PK</p>	<p>CHCI21 Radius of Protection: 2 ft. Normal Life Span: 1 yr.</p>

Fiberglass Hole Plug Assembly



Catalog Number	Fits	Hole Dia. Range
FPLG1KIT	1/2" Dia. Hole	.50" - .56"
	5/8" Dia. Hole	.63" - .69"
	3/4" Dia. Hole	.75" - .81"
FPLG2KIT	22mm PB,	.88" - 1.00"
	1/2" Conduit	1.06" - 1.12"
	3/4" Conduit	1.22" - 1.28"
FPLG3KIT	1" Conduit	1.38" - 1.50"
	1 1/4" Conduit	1.69" - 1.75"
FPLG4KIT	1 1/2" Conduit	2.00" - 2.12"
	2" Conduit	2.50" - 2.56"
FPLG5KIT	2 1/2" Conduit	3.00"
FPLG6KIT	3" Conduit	3.62"
FPLG7KIT	3 1/2" Conduit	4.12"
FPLG8KIT	4" Conduit	4.62"

Fiberglass Enclosure Mounting Plate Options

Aluminum (SA)
Back Panels
Grade Aluminum
3003 H14 - No Finish

Fiberglass (FG)
Back Panels
All FG Back Panels
UL 94 V-0 Rated

Stainless Steel (SS)
Back Panels
Stainless Steel
Grade 304

Carbon Steel (C)
Back Panels
Carbon Steel
Grade 1010 HRS -
Painted White Enamel

Mounting Plates for Disconnect & Circuit Breaker Dimensions

Only Available in Carbon Steel (C)

	BA	BB	BK	BL	Panel Thickness BT	Panel Type	Hole Dia.	# of Holes	Weight (Carbon Steel) Suffix: C	Fits Typical Enclosure Size
FMPC1610	13.00 (330)	8.50 (216)	12.00 (305)	7.50 (191)	0.08 (2)	Flat	0.31 (8)	4	3.3 lbs.	16 x 10 Disconnect Enclosure
FMPC2016	16.88 (429)	13.38 (340)	15.25 (387)	11.25 (286)	0.13 (2)	Formed	0.31 (8)	4	7.3 lbs.	20 x 16 Disconnect Enclosure
FMPC2412	20.88 (530)	9.38 (238)	19.25 (489)	7.25 (184)	0.13 (2)	Formed	0.50 (13)	4	6.5 lbs.	24 x 12 Disconnect Enclosure
FMPC2424	20.88 (530)	21.38 (543)	19.25 (489)	19.25 (489)	0.13 (2)	Formed	0.50 (13)	4	14 lbs.	24 x 24 Disconnect Enclosure
FMPC3024	26.88 (683)	21.38 (543)	25.25 (641)	19.25 (489)	0.13 (2)	Formed	0.50 (13)	4	19 lbs.	30 x 24 Disconnect Enclosure
FMPC3630	32.88 (835)	27.38 (695)	31.25 (794)	25.25 (641)	0.13 (2)	Formed	0.50 (13)	5	27 lbs.	36 x 30 Disconnect Enclosure

Fiberglass Enclosures Accessories



Breaker Series

Mounting Plates for NEMA 3R, NEMA 4X & Large Fiberglass Enclosure Dimensions

Catalog Number	BA	BB	BK	BL	BT (SA)	BT (C)	Panel Type	Hole Dia.	# of Holes	Weight (Aluminum) Suffix: SA	Weight (Carbon Steel) Suffix: C
FMPWM1610SA FMPWM1610C	13.00 (330)	8.50 (216)	12.00 (305)	7.50 (191)	0.090 (2)	0.105 (3)	Flat	0.31 (8)	4	1 lb	3.3 lbs
FMPWM2016SA FMPWM2016C	17.00 (432)	13.00 (330)	15.25 (387)	11.25 (286)	0.090 (2)	0.105 (3)	Flat	0.50 (13)	4	2 lbs	6.7 lbs
FMPWM2412SA FMPWM2412C	21.00 (533)	9.00 (229)	19.25 (489)	7.25 (184)	0.090 (2)	0.105 (3)	Flat	0.50 (13)	4	4.5 lbs	8.7 lbs
FMPWM2420SA FMPWM2420C	21.00 (533)	17.00 (432)	19.25 (489)	15.25 (387)	0.13 (3)	0.105 (3)	Flat	0.50 (13)	4	5 lbs	10.8 lbs
FMPWM2424SA FMPWM2424C	21.00 (533)	21.00 (533)	19.25 (489)	19.25 (489)	0.13 (3)	0.105 (3)	Flat	0.50 (13)	4	5.5 lbs	13.4 lbs
FMPWM3020SA FMPWM3020C	27.00 (686)	17.00 (432)	25.25 (641)	15.25 (387)	0.13 (3)	0.105 (3)	Flat	0.50 (13)	4	5.8 lbs	14 lbs
FMPWM3024SA FMPWM3024C	27.00 (686)	21.00 (533)	25.25 (641)	19.25 (489)	0.13 (3)	0.105 (3)	Flat	0.50 (13)	4	7 lbs	17 lbs
FMPWM3630SA FMPWM3630C	33.00 (838)	27.00 (686)	31.25 (794)	25.25 (641)	0.13 (3)	0.105 (3)	Flat	0.50 (13)	4	11 lbs	27 lbs
FMPWM3636SA FMPWM3636C	31.00 (787)	33.00 (838)	29.00 (737)	31.00 (787)	0.13 (3)	0.105 (3)	Formed	0.50 (13)	6	13 lbs	33 lbs
FMPWM3648SA FMPWM3648C	31.00 (787)	22.00 (559)	29.00 (737)	20.00 (508)	0.13 (3)	0.105 (3)	Flat	0.50 (13)	8	22 lbs	41 lbs
FMPWM4836SA FMPWM4836C	45.00 (1143)	33.00 (838)	43.25 (1099)	31.25 (794)	0.13 (3)	0.105 (3)	Formed	0.50 (13)	8	22 lbs	47 lbs
FMPWM6036SA FMPWM6036C	57.00 (1448)	33.00 (838)	55.25 (1403)	31.25 (794)	0.13 (3)	0.105 (3)	Formed	0.50 (13)	8	23 lbs	60 lbs
FMPWM7225SA FMPWM7225C	64.00 (1626)	21.00 (533)	62.00 (1575)	19.00 (483)	0.13 (3)	0.105 (3)	Formed	0.50 (13)	10	30 lbs	43 lbs
FMPWM7249SA FMPWM7249C	64.00 (1626)	22.00 (559)	62.00 (1575)	20.00 (508)	0.13 (3)	0.105 (3)	Formed	0.50 (13)	10	38 lbs	91 lbs

Mounting Plates for FSJ, FPB, FJ, FRCJ, FXDJ, FA Series Enclosures

Catalog Number	BA	BB	BK	BL	BT (SA)	BT (FG)	BT (SS)	BT (C)	Panel Type	Hole Dia.	# of Holes	Weight (Aluminum) Suffix: SA	Weight (Fiberglass) Suffix: FG	Weight (Stainless) Suffix: SS	Weight (Carbon Steel) Suffix: C
FMP0604SA FMP0604FG FMP0604SS FMP0604C	4.88 (124)	2.88 (73)	4.25 (108)	2.25 (57)	0.080 (2)	0.125 (3)	0.060 (2)	0.075 (2)	Flat	0.25 (6)	4	2 oz.	2 oz.	5 oz.	5 oz.
FMP0808SA FMP0808FG FMP0808SS FMP0808C	6.88 (175)	6.88 (175)	6.25 (159)	6.25 (159)	0.080 (2)	0.125 (3)	0.060 (2)	0.075 (2)	Flat	0.25 (6)	4	5 oz.	5 oz.	15 oz.	15 oz.
FMP0906SA FMP0906FG FMP0906SS FMP0906C	8.25 (210)	4.88 (124)	7.63 (194)	4.25 (108)	0.080 (2)	0.125 (3)	0.060 (2)	0.075 (2)	Flat	0.25 (6)	4	5 oz.	n/a	n/a	14 oz.
FMP1008SA FMP1008FG FMP1008SS FMP1008C	8.88 (225)	6.88 (175)	8.25 (210)	6.25 (159)	0.080 (2)	0.125 (3)	0.060 (2)	0.075 (2)	Flat	0.25 (6)	4	8 oz.	8 oz.	19 oz.	21 oz.
FMP1210SA FMP1210FG FMP1210SS FMP1210C	10.88 (276)	8.88 (225)	10.25 (260)	8.25 (210)	0.080 (2)	0.125 (3)	0.060 (2)	0.075 (2)	Flat	0.25 (6)	4	12 oz.	14 oz.	30 oz.	33 oz.
FMP1212SA FMP1212FG FMP1212SS FMP1212C	10.88 (276)	10.88 (276)	10.25 (260)	10.25 (260)	0.080 (2)	0.125 (3)	0.060 (2)	0.075 (2)	Flat	0.25 (6)	4	16 oz.	18 oz.	37 oz.	38 oz.

Mounting Plates for FSJ, FPB, FJ, FRCJ, FXDJ, FA Series Enclosures

Breaker Series

Catalog Number	BA	BB	BK	BL	BT (SA)	BT (FG)	BT (SS)	BT (C)	Panel Type	Hole Dia.	# of Holes	Weight (Aluminum) Suffix: SA	Weight (Fiberglass) Suffix: FG	Weight (Stainless) Suffix: SS	Weight (Carbon Steel) Suffix: C
FMP0606SA FMP0606FG FMP0606SS FMP0606C	4.88 (124)	4.88 (124)	4.25 (108)	4.25 (108)	0.080 (2)	0.125 (3)	0.060 (2)	0.075 (2)	Flat	0.25 (6)	4	3 oz.	3 oz.	8 oz.	8 oz.
FMP0706SA FMP0706FG FMP0706SS FMP0706C	6 (152)	4.88 (124)	5.38 (137)	4.25 (108)	0.080 (2)	0.125 (3)	0.060 (2)	0.075 (2)	Flat	0.25 (6)	4	4 oz.	n/a	n/a	10 oz.
FMP0806SA FMP0806FG FMP0806SS FMP0806C	6.88 (175)	4.88 (124)	6.25 (159)	4.25 (108)	0.080 (2)	0.125 (3)	0.060 (2)	0.075 (2)	Flat	0.25 (6)	4	4 oz.	4 oz.	12 oz.	12 oz.
FMP1407SA FMP1407FG FMP1407SS FMP1407C	12.88 (327)	5.88 (149)	12.25 (311)	5.25 (133)	0.080 (2)	0.125 (3)	0.060 (2)	0.075 (2)	Flat	0.25 (6)	4	14 oz.	14 oz.	32 oz.	34 oz.
FMP1412SA FMP1412FG FMP1412SS FMP1412C	12.88 (327)	10.88 (276)	12.25 (311)	10.25 (260)	0.080 (2)	0.125 (3)	0.060 (2)	0.075 (2)	Flat	0.25 (6)	4	18 oz.	20 oz.	45 oz.	48 oz.
FMP1614SA FMP1614FG FMP1614SS FMP1614C	14.88 (378)	12.88 (327)	14.25 (362)	12.25 (311)	0.080 (2)	0.125 (3)	0.060 (2)	0.075 (2)	Flat	0.25 (6)	4	24 oz.	23 oz.	60 oz.	66 oz.
FMP1816SA FMP1816FG FMP1816SS FMP1816C	16.88 (429)	14.88 (378)	16.25 (413)	14.25 (362)	0.080 (2)	0.125 (3)	0.060 (2)	0.075 (2)	Flat	0.25 (6)	4	31 oz.	32 oz.	88 oz.	87 oz.
FMP2016SA FMP2016FG FMP2016SS FMP2016C	18.88 (479)	14.88 (378)	18.25 (463)	14.25 (362)	0.080 (2)	0.125 (3)	0.060 (2)	0.075 (2)	Flat	0.25 (6)	4	36 oz.	34 oz.	98 oz.	97 oz.

Cover Panel Dimensions

Catalog Number	A	B	C	D	Panel Thk.	Panel Type	Hole Dia.	# of Holes
FACP0606SA	5.64 (143)	5.64 (143)	5.02 (127)	5.02 (127)	0.080 (2)	Flat	0.25 (6)	4
FACP0806SA	7.68 (195)	5.64 (143)	7.05 (179)	5.02 (127)	0.080 (2)	Flat	0.25 (6)	4
FACP0808SA	7.68 (195)	7.68 (195)	7.05 (179)	7.05 (179)	0.080 (2)	Flat	0.25 (6)	4
FACP1008SA	9.71 (247)	7.71 (196)	9.08 (231)	7.08 (180)	0.080 (2)	Flat	0.25 (6)	4
FACP1210SA	11.74 (298)	9.74 (247)	11.12 (282)	9.12 (232)	0.080 (2)	Flat	0.25 (6)	4
FACP1412SA	13.78 (350)	11.78 (299)	13.15 (334)	11.15 (283)	0.080 (2)	Flat	0.25 (6)	4
FACP1614SA	15.81 (402)	13.81 (351)	15.18 (386)	13.18 (334)	0.080 (2)	Flat	0.25 (6)	4
FACP1816SA	17.94 (456)	15.94 (405)	17.31 (440)	15.31 (389)	0.080 (2)	Flat	0.25 (6)	4
FACP2016SA	19.76 (502)	15.76 (400)	19.13 (486)	15.13 (384)	0.080 (2)	Flat	0.25 (6)	4

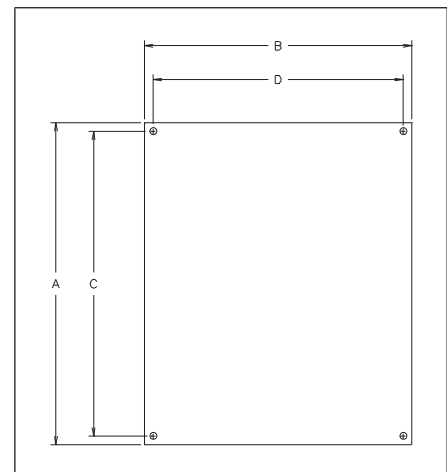

Note: Cover panel kit includes cover panel and mounting hardware.

Fiberglass Enclosures

Custom Built Solutions for Fast Delivery



Custom Modification Offering

Please consult the factory for a quotation on the following custom modifications that we are pleased to offer to help meet the needs of our customers:

- Custom molded colors
- Gasketed windows for the FJ, FRC and the Wall Mount Series
- Custom sizes
- Special hole patterns for drilling and tapping configurations
- Dead front and sub panels
- Silk screening capabilities
- Terminal kits and DIN rails available

Custom Built Lighting & Power Panelboards

Motor control, power distribution products and custom control panels designed and built to our customers' unique needs and delivered when they are required.

Overview:

Fiberglass panelboards rated for outdoor NEMA 3R and 4X environments.

Ratings:

120/208V 3 Phase, 4 Wire

QOB® circuit breakers, single or two-pole 120/240 VAC; three-pole 240 VAC

Trip ratings:

- 10 to 70 amps, single-pole
- 10 to 125 amps, two-pole
- 10 to 100 amps, three-pole

480Y/277V 3 Phase, 4 Wire

EDB® circuit breakers, single or two-pole 277 VAC; three-pole 480Y/277 VAC

Trip ratings:

- 15 to 70 amps, single-pole
- 15 to 125 amps, two-pole
- 15 to 125 amps, three-pole

Certifications:

- NEMA 1, 3, 3R, 4X and 12
- UL Standard: 67
- CSA Standard: C22.2



Gasketed Window
FJ, FRC & Wall Mount Series



Custom
Solutions

For more information on Fiberglass Enclosures or for Custom Built Solutions email:
fiberglassenclosures@cooperindustries.com

Fiberglass Enclosures

Custom Built Solutions for Fast Delivery



Custom Built Heavy Duty Disconnects (Circuit Breaker, Fusible and Non-Fusible)

Applications:

Fiberglass Heavy Duty Disconnects are for use in disconnecting motor, lighting and other circuits.

Certifications:

- NEMA/EEMAC: 1, 3, 3R, 4X and 12
- UL Standard: 508
- CSA Standard: C22.2

Electrical Ratings Ranges:

- 3-pole, 60Hz, 600 VAC
- Starters - NEMA sizes 0, 1, 2
- Breakers - 15 - 800 Amp Rating
- Switches - 30, 60, 100, 200 Amp



Custom Built Control Stations

Overview:

The Pushbutton Series offers an enclosure solution where multiple pre-drilled openings for 30mm pushbuttons are required. Enclosures are available in sizes ranging from 6" x 3" to 13.5" x 11.5" with notched keyhole design and the ability to order up to 25 holes, making this solution a perfect choice for your control station applications.

Certifications and Compliances:

- UL/cUL 50, Types 1, 3, 4X, 6P, 12
- UL Standard: 508
- CSA Std C22.2 - File 244248 Types 1, 3, 4X, 6P, 12
- NEMA Standard 250 - Types 1, 3, 4X, 6P, 12

Electrical Ratings Ranges:

- Pushbutton stations and selector switches - heavy duty 600 VAC maximum
- Pilot lights, selector switches, push buttons - 120 to 600 VAC; 24 VAC/DC



For more information on Fiberglass Enclosures or for Custom Built Solutions email:
fiberglassenclosures@cooperindustries.com

Combiners and disconnects that offer superior resistance and durability from harsh weather and abusive solar environments

Leading the way in Solar Technology

Cooper Crouse-Hinds combiner boxes and disconnects for the solar market integrate a comprehensive line of electrical products with expert support, industry insights, and local availability to improve safety and productivity in the most demanding industrial, commercial and residential environments worldwide.

Solar Background Information

A solar array may be one panel or many in series, and may range from a single 12 volt panel up to multi-panel high voltage array for grid-tie systems. Grid-tie systems can go as high as 1000 VDC, while battery systems are typically 12, 24, or 48 V.

Higher voltage systems (over 48 V) have different NEC code requirements than those for low voltage battery systems, and the two types are NOT interchangeable.

Cooper Crouse-Hinds Solar Combiners are designed for higher voltage circuits used in grid-tie applications. All meet NEC requirements and are made in accordance with UL requirements. Cooper Crouse-Hinds Solar Combiners have additional breakers, disconnects, and fuses for the combined high current buss.

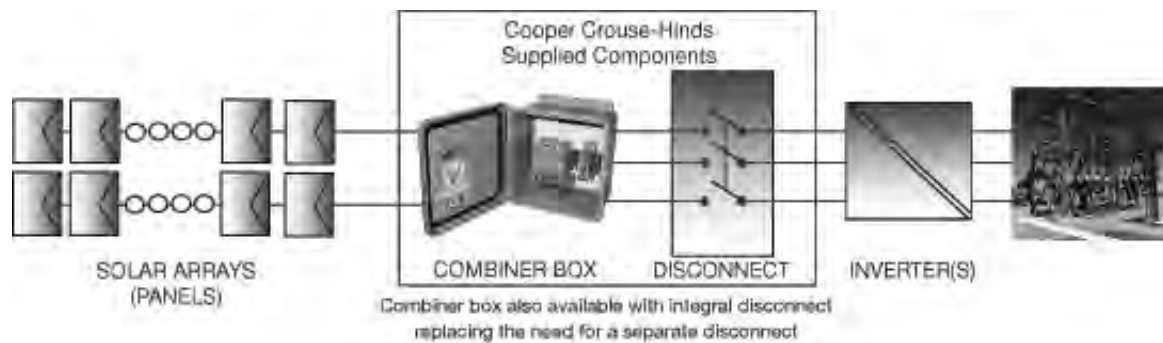

Cooper Crouse-Hinds Product Offering

Solar Combiners

Cooper Crouse-Hinds Solar Combiners are used to group input wires/circuits from several arrays and/or solar panels. The combined circuit results in fewer output circuits and combines them into one main buss or feed going to the inverter saving labor and material costs.

Solar Recombiners

Cooper Crouse-Hinds Recombiner boxes are used in larger photovoltaic systems. A Recombiner box effectively groups the output wires from several combiner boxes into one main output feed which then goes to the inverter.

Solar Disconnects

The National Electrical Code® requires a disconnect switch which provides circuit interruption to the down stream inverter. The disconnect can be internally mounted in the combiner or externally mounted between the combiner and inverter. The disconnect switch can be located at one of two places: either inside the building nearest the point of entrance of the system conductors, or outside the building. If the solar disconnect is not located near the utility company's meter, then a plaque is required by the front door stating where the solar disconnect is located.

Solar Cable Assemblies

A comprehensive offering of solar cable assemblies are also available in molded to cable or mechanical termination configurations. Typical conductor size is #12 or #10. Available in standard or custom cable lengths. Consult factory for more details.

Cooper Crouse-Hinds Solar Protection for Fiberglass Enclosures

The Cooper Crouse-Hinds solar protection formula provides the enclosure the strength and durability to provide long, dependable service even in the most demanding environmental conditions. Cooper Crouse-Hinds fiberglass enclosures retain gloss and color even when exposed to harsh UV light and offer superior resistance to chemicals and are fire retardant.

A special UV absorber is added into this solar protection formula and works to absorb UV energy and release it without damaging the fiberglass enclosure thus providing increased protection of the polyester material and increased resistance to the damaging effects of UV radiation. For additional information on Cooper Crouse-Hinds Solar Protection, choose Fiberglass Enclosures from: <http://www.crouse-hinds.com/contractorcorner>

- Built to UL1741 standards
- NEMA 4X (fiberglass and stainless steel)
- NEMA 3R (painted steel)
- Made in America

Application:

Cooper Crouse-Hinds Solar Combiner Solutions are designed and built to minimize system costs by providing maximum flexibility. Solar Combiner Solutions offer a range of 1 to 48 input circuits, with a durable non-metallic (NEMA 4X) enclosure, engineered and manufactured to perform in the harshest environmental conditions. Built in accordance with UL1741 standard; providing peace of mind and plenty of wiring room for ease of installation.

Features:

- **RATED FOR 600 VDC - CONTINUOUS DUTY**
- Built to UL 1741 Standards
- 90°C output terminals
- Fiberglass enclosures provided as standard; also available in NEMA 3R painted steel or NEMA 4X stainless steel
- Touch-Safe fuse holders and power distribution blocks for safe operation
- Configured for positive and negative grounded arrays
- Optional 1000VDC rated

Materials and Finishes:

- Hot compression molded fiberglass reinforced thermoset polyester
- Non-conductive, impact resistant, UV resistant, flame retardant
- Captive cover screws can't be dropped or lost
- Poured polyurethane seamless gasket provides water-tight, dusttight environmental seal
- Stainless steel used on all external hardware

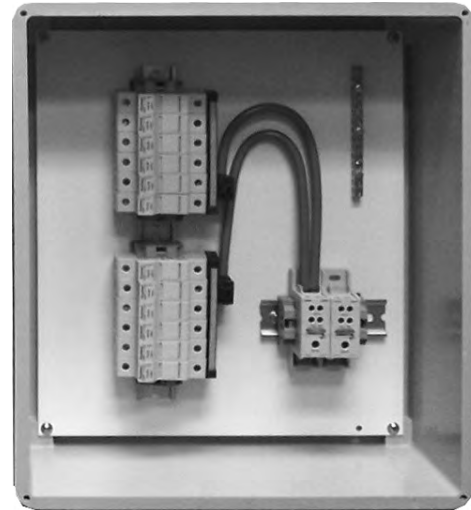

SOLAR COMBINER CATALOG NUMBERING SYSTEM						
BASE SOLAR COMBINER		WITH OPTIONAL FACTORY SUPPLIED FUSES		WITH OPTIONAL INTEGRAL DISCONNECT		WITH OPTIONAL SURGE PROTECTION
CCBF	12	F	15	CB	200	SP

Enclosure Type	Number of Input Circuit	Fused	Fuse Amperage	Integral Disconnect	Trip Rating for Integral Disconnect	Surge Protection	
CCBF (Fiberglass N4X) CCBS (Painted Steel N3R) CCBSS (Stainless Steel N4X)	01 (1 input circuit) 02 (2 input circuit) 03 (3 input circuit) 04 (4 input circuit) 05 (5 input circuit) 06 (6 input circuit) Offered up to 48 circuits	F (Fuses provided) BLANK (Fuses not supplied by factory)	08 (8A fuse) 10 (10A fuse) 12 (12A fuse) 15 (15A fuse) BLANK (Fuses not provided by factory)	CB (Circuit Breaker for use with 1 - 48 input circuits) DS (Disconnect Switch for use with 1 - 48 input circuits) BLANK (No integral disconnect)	Circuit Breaker 30 (30A) 50 (50A) 100 (100A) 125 (125A) 150 (150A) 175 (175A) 200 (200A) 225 (225A) 250 (250A) 400 (400A) See Table 1 BLANK (No integral disconnect)	Disconnect Switch 100 (100A) 200 (200A) 400 (400A) See Table 2 BLANK (No integral disconnect)	SP (Surge protection) <ul style="list-style-type: none"> • Rated 15kA (10/350µs) per pole Type I • Small size takes up minimal space in the enclosure (Only 1.5 inches wide) • Highest fault current clearing, 100kA without backup fuses • Thermal and short circuit fusing BLANK (No surge protection)

Solar Combiners with Integral Disconnects

- Built to UL1741 standards
- NEMA 4X (fiberglass and stainless steel)
- NEMA 3R (painted steel)
- Made in America



Application:

Cooper Crouse-Hinds Solar Combiners with Integral Disconnects provide all the strong and durable features of our standard Solar Combiners and are available with 1-48 input circuits. Integral disconnects save material costs, installation time and labor by joining the combiner box and disconnect within one enclosure and eliminating the need for a disconnect in a separate enclosure.

Features:

- **RATED FOR 600 VDC - CONTINUOUS DUTY**
- Built to UL 1741 Standards
- 90°C output terminals
- Fiberglass enclosures provided as standard; also available in NEMA 3R painted steel or NEMA 4X stainless steel
- Touch-Safe fuse holders and power distribution blocks for safe personnel operation
- Configured for positive and negative grounded arrays

Materials and Finishes:

- Hot compression molded fiberglass reinforced thermoset polyester
- Non-conductive, impact resistant, UV resistant, flame retardant
- Captive cover screws can't be dropped or lost
- Poured polyurethane seamless gasket provides water-tight, dusttight environmental seal
- Stainless steel used on all external hardware



Solar

Integral Disconnect Rating:

To determine the rating of the integral disconnect, simply multiply the number of input circuits by the ampacity rating of each fuse in these circuits. Round to the next (higher) trip rating. In **NO** case can the max current exceed the trip rating of the disconnect switch or breaker. Example: a 12 string combiner box with every input circuit with a fuse rated at 8 Amps is $12 \times 8 = 96$. Required rating for the switch or circuit breaker would be 100 Amps.

SOLAR COMBINER CATALOG NUMBERING SYSTEM							
BASE SOLAR COMBINER		WITH OPTIONAL FACTORY SUPPLIED FUSES		WITH OPTIONAL INTEGRAL DISCONNECT		WITH OPTIONAL SURGE PROTECTION	
CCBF	12	F	15	CB	200	SP	
Enclosure Type CCBF (Fiberglass N4X) CBS (Painted Steel N3R) CCBSS (Stainless Steel N4X)	Number of Input Circuit 01 (1 input circuit) 02 (2 input circuit) 03 (3 input circuit) 04 (4 input circuit) 05 (5 input circuit) 06 (6 input circuit) Offered up to 48 circuits	Fused F (Fuses provided) BLANK (Fuses not supplied by factory)	Fuse Amperage 08 (8A fuse) 10 (10A fuse) 12 (12A fuse) 15 (15A fuse) BLANK (Fuses not provided by factory)	Integral Disconnect CB (Circuit Breaker for use with 1 - 48 input circuits) DS (Disconnect Switch for use with 1 - 48 input circuits) BLANK (No integral disconnect)	Trip Rating for Integral Disconnect Circuit Breaker 30 (30A) 50 (50A) 100 (100A) 125 (125A) 150 (150A) 175 (175A) 200 (200A) 225 (225A) 250 (250A) 400 (400A) See Table 1 BLANK (No integral disconnect)	Disconnect Switch 100 (100A) 200 (200A) 400 (400A) See Table 2 BLANK (No integral disconnect)	Surge Protection SP (Surge protection) • Rated 15kA (10/350µs) per pole Type I • Small size takes up minimal space in the enclosure (Only 1.5 inches wide) • Highest fault current clearing, 100kA without backup fuses • Thermal and short circuit fusing BLANK (No surge protection)

Solar Recoiners and Disconnect Switches

- Built to UL1741 standards
- NEMA 4X (fiberglass and stainless steel)
- NEMA 3R (painted steel)
- Made in America



Solar

RECOMBINERS

Application:

In large Photovoltaic (PV) systems, multiple combiner boxes are often necessary, and the outputs of these combiner boxes may need to be combined again—recombined—before reaching a central inverter. Cooper Crouse-Hinds Recombiner boxes allow for ease of installation saving time, labor and most importantly system costs.

Ordering Information:

Consult Factory for ordering information

DISCONNECTS

Application:

Cooper Crouse-Hinds Solar Disconnect Solutions are used as a disconnecting means and rated for 600 VDC/AC. The disconnects are offered separately in a sheet steel enclosure or as an integral mounted device to the Cooper Crouse-Hinds Combiner Solutions, offering reduced space and cost of installation, the ability to disconnect power from a remote location, and provide short circuit protection.

Features:

- Switches are heavy duty 3-Pole, with visible blades; a quick make-and-break mechanism with reinforced, positive pressure type blade and jaw construction. Fusible types have fuse clips with steel reinforcing springs of positive pressure type. Pressure connectors are used for wire connectors.
- Switch enclosure covers are interlocked with the body and operating mechanism and cannot be opened when the switch is closed ("ON"). When the switch is open ("OFF"), the switch cannot be put in a closed ("ON") position with the door open.
- The switch operating handle may be padlocked in the "ON" or "OFF" position. In addition, the interlock construction has been designed to allow the door of the unit to be padlocked. This feature allows operation while preventing unqualified or unauthorized entry.



Enclosure Certification & Compliances:

- NEMA Types 3R
- UL Standard 98

Materials and Finishes:

- Enclosure – sheet steel
- Operating handle – non-metallic
- Other exterior parts – stainless steel

Electrical Rating Ranges:

- 3 and 4† Pole; fusible or non-fusible; 240 VAC/250 VDC; 600 VAC/600 VDC
- 30, 60, 100, 200 or 400 amperes†

Disconnect Switches Ordering Information Specifications

	30 Amp	60 Amp	100 Amp	200 Amp
Heavy Duty Disconnect Switch - 600 VDC 3-Pole	Sheet Steel	Sheet Steel	Sheet Steel	Sheet Steel
Catalog Number - Fusible	CH361R	CH362R	CH363R	CH364R
Catalog Number - Non-fusible	CHU361R	CHU362R	CHU363R	CHU364R

† For 4-Pole, 400 Amp or disconnect switches in a fiberglass or stainless steel enclosure - Consult Factory.

Technical Information

- Built to UL1741 standards
- NEMA 4X (fiberglass and stainless steel)
- NEMA 3R (painted steel)
- Made in America



Solar

Combiner Technical Information

Number of input circuits	1 TO 4	5 TO 6	7 TO 12	13 TO 20	21 TO 24	25 TO 28	29 TO 37	38 TO 48
Catalog number (i.e. CCBF12)	CCBF (1-4)	CCBF (5-6)	CCBF (7-12)	CCBF (13 TO 20)	CCBF (21 TO 24)	CCBF (21 TO 28)	CCBF (29 TO 41)	CCBF (42 TO 48)
Maximum Input Fuse Rating (A)	15	15	15	15	15	15	15	15
Maximum Continuous Operating Current (A)	60	90	180	300	360	420	555	720
SCCR at 600VDC (KAIC)	10	10	10	10	10	10	10	10
Maximum Voltage (VDC)	600	600	600	600	600	600	600	600
Operating Voltage Range - Combiner Only (VDC)	0-600	0-600	0-600	0-600	0-600	0-600	0-600	0-600
Operating Voltage Range - Combiner With Integral Disconnect (VDC)	0-600	0-600	0-600	0-600	0-600	0-600	0-600	0-600
Positive Input Wire Size (AWG)	#8-#18	#8-#18	#8-#18	#8-#18	#8-#18	#8-#18	#8-#18	#8-#18
Positive Input Terminal Torque (in-lbs)	16-22	16-22	16-22	16-22	16-22	16-22	16-22	16-22
Negative Input Wire Size (AWG)	#10-#14	#10-#14	#4-#14	#4-#14	#4-#14	#4-#14	#4-#14	#4-#14
Negative Input Terminal Torque (in-lbs)	20	35	35	35	35	35	35	35
Positive Output Wire Size (AWG)	1/8-#10	1/8-#10	350kcmil-#6	(2) 300kcmil-#4	(2) 350kcmil-#6	(2) 350kcmil-#6	(2) 600kcmil-#2	(2) 600kcmil-#2
Positive Output Terminal Torque (in-lbs)	35	35	120	275	120	120	500	500
Negative Output Wire Size (AWG)	3/8-#8	500kcmil-#6	350kcmil-#6	(2) 300kcmil-#4	(2) 350kcmil-#6	(2) 350kcmil-#6	(2) 600kcmil-#2	(2) 600kcmil-#2
Negative Output Terminal Torque (in-lbs)	120	500	120	275	120	120	500	500
Ground Output Wire Sizes (AWG)	#4-#14	#4-#14	250-#6	250-#6	250-#6	250-#6	250-#6	250-#6
Ground Output Terminal Torque (in-lbs)	20-35	20-35	275	275	275	275	275	275
Enclosure Nema Rating	3/3R/4/4X	3/3R/4/4X	3/3R/4/4X	3/3R/4/4X	3/3R/4/4X	3/3R/4/4X	3/3R/4/4X	3/3R/4/4X
Enclosure Size	12X10X5	12X10X5	16X14X6	18X16X8	20X16X8	24X20X8	30X20X6	36X30X8
Maximum # of inputs	4	6	12	20	24	28	37	48

Technical Information

- Built to UL1741 standards
- NEMA 4X (fiberglass and stainless steel)
- NEMA 3R (painted steel)
- Made in America



Solar

Overcurrent Protection - PV Fuse-Links

Current Rating	Energy Integrals (A2s)		Power Loss (watts)	
	Pre-Arcing	Total at 1000V	0.8 In	In.
8A	3	32	0.5	2.0
10A	7	50	0.6	2.1
12A	10	100	1.3	2.6
15A	20	200	1.8	3.0

Combiner Dimensional Information

# of Input Circuits	Enclosure Size Inches (HxWxD)	Overall Dimensions Inches (HxWxD)	Inside Dimensions Inches (HxWxD)	Mounting Dimensions Inches (HxW)	Approximate Weight (lbs)
1-6	12x10x5	13.56 x 11.43 x 5.21	11.79 x 9.80 x 4.94	12.75 x 8.00	10
7-12	16x14x6	17.53 x 15.46 x 6.23	15.63 x 13.60 x 5.94	16.75 x 12.00	18
13-20	18x16x8	19.62 x 17.61 x 8.82	17.69 x 15.69 x 8.45	18.88 x 12.00	27
21-24	20x16x8	22.00 x 17.68 x 8.83	19.72 x 15.72 x 8.45	21.25 x 10.00	33
25-28	24x20x8	27.00 x 21.24 x 9.90	24.05 x 20.39 x 9.25	25.75 x 14.00	47
29-37	30x20x6	32.86 x 20.99 x 7.89	29.90 x 20.14 x 7.23	30.75 x 14.25	60
38-48	36x30x8	39.31 x 32.50 x 10.05	36.31 x 31.69 x 9.36	38.13 x 23.88	112

Applications:

Cooper Crouse-Hinds Solar Pass Through Boxes (sometimes referred to as “transition boxes”) are used in residential applications to provide a low profile, cost effective way to group input wires/circuits from several arrays and/or solar panels and transition from solar (PV) cable to regular building wire. The Pass Through Box was designed for PV applications where over current protection is not necessary due to the low power rating of the PV string.

Features:

- Rated 600VDC continuous duty
- Constructed in accordance with UL 1741 standards providing spacious wiring room for quick easy wire termination
- Factory installed multi-hole solar cord grip provides dependable secure wire termination to enclosure and saves field installation – eliminating the need for enclosure drilling – saving time & labor
- Fiberglass enclosure (UV absorbing) provided as standard offering long dependable service in the most environmental conditions
- Available in N3R sheet steel enclosures – consult factory
- Light weight design offers easy mounting capabilities. Optional mounting feet are available for increased customer flexibility



Certifications and Compliances:

- NEMA 4X

Materials and Finishes:

- Hot compression molded fiberglass reinforced thermoset polyester
- Non-Conductive, impact resistant, UV resistant, flame retardant
- Poured Polyurethane seamless gasket provides water-tight, dust-tight environmental seal
- Stainless steel used on all external hardware

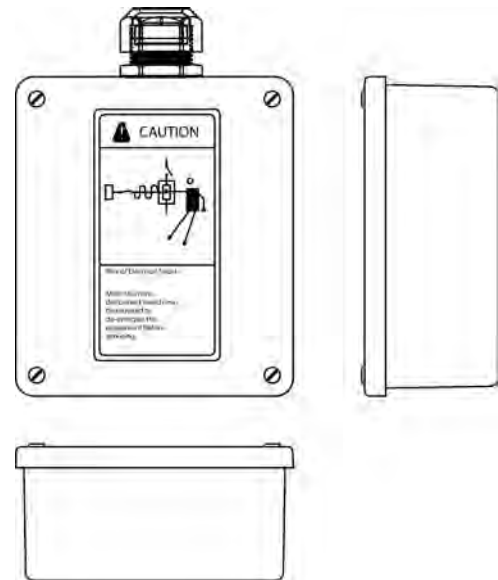

Solar Pass Through Box Ordering Information

Cat. #	Description
CPBF03	3 Circuit Pass Through Box
CPBF04	4 Circuit Pass Through Box

For additional configurations, please consult factory

Cord And Cable Connectors



Solar Non-Metallic Cord Grips

Applications:

Cooper Crouse-Hinds Solar Cord Grips are used in both commercial and residential grid-tied PV solar applications and are designed to accommodate the entry of multiple PV wires coming into a combiner or pass through box. The Solar Cord Grips provide mechanical strain relief as well as a liquid tight seal around the solar panel wires.

Features:

- Multi-hole cord grip to allow for entry of multiple PV wires.
- Solar cord grips offer customer flexibility by allowing the termination from 1 to 13 PV wires in a single connector.
- Skinned over glands provide a durable, liquid tight seal around the wires.
- No disassembly required for installation.
- Accommodates USE-2, 12AWG and 10AWG wire.
- Temperature rating: -22°F (-30°C) to 212°F (100°C) to meet the most demanding environmental conditions.



Photo shown with steel locknut
(locknuts must be ordered separately)

Certifications and Compliances:

- UL/cUL listed
- IP68
- Flammability rating: 94-V2

Standard Materials:

- 6% nylon with TPE/Buna N sealing glands



Ordering Information:

Cat. #	Trade Size	Description
NCGS39	1"	9 Hole Solar Cord Grip
NCGS413	1 1/4"	13 Hole Solar Cord Grip

Locknut Ordering Information:

Material	Cat. No.	Trade Size
Steel	13	1"
	14	1 1/4"
Aluminum	13 SA	1"
	14 SA	1 1/4"
Non-metallic	13N	1"
	14N	1 1/4"
Zinc	13DC	1"
	14DC	1 1/4"

Catalog Number	Page	Catalog Number	Page	Catalog Number	Page	Catalog Number	Page
0B	.32	1452DC	.6	1656US	.9	193	.20
0BSS	.117	1452US	.5	1657	.7	194	.20
0BSS316	.117	1453	.3	1657DC	.11	195	.20
0BX	.32	1453DC	.6	1657RT	.10	196	.20
1B	.32	1453US	.5	1657US	.9	197	.20
1BSS	.117	1454	.3	1658	.7	198	.20
1BSS316	.117	1454DC	.6	1658DC	.11	199	.20
1BX	.32	1454US	.5	1658RT	.10	2B	.32
10	.34	1455	.3	1658US	.9	2BSS	.117
10N	.74	1455DC	.6	1659	.7	2BSS316	.117
1031	.24	1455US	.5	1659DC	.11	2BX	.32
1031DC	.25	1456	.3, 17	1659RT	.10	2 1/2 B	.32
1031NI	.25	1456DC	.6	1659US	.9	2 1/2BSS	.117
1032	.24	1456US	.5	16DC	.34	2 1/2BX	.32
1032DC	.25	1457	.3, 17	16SST	.114	20 SA	.34
1032NI	.25	1457DC	.6	16X	.34	206SS	.116
1033	.24	1457US	.5	17	.34	207SS	.116
1033DC	.25	1458	.3, 17	17 SA	.34	208SS	.116
1033NI	.25	1458DC	.6	1707	.83	209SS	.116
1034	.24	1458US	.5	1707DC	.83	20	.34
1034DC	.25	1459	.3, 17	1708	.83	20DC	.34
1034NI	.25	1459DC	.6	1708DC	.83	20X	.34
1035	.24	1459US	.5	1709	.83	22	.34
1035DC	.25	14DC	.34, 256	1709DC	.83	23	.34
1035NI	.25	14X	.34	170C	.17	200	.14
1036	.24	15	.34	1710	.83	201	.14
1036DC	.25	15 SA	.34	1710DC	.83	202	.14
1036NI	.25	150	.43	1711	.83	203	.14
1037	.24	150G	.43	1711DC	.83	204	.14
1037DC	.25	150P	.17	1712	.83	205	.14
1037NI	.25	150S	.17	1712DC	.83	206	.14, 31
1038	.24	151	.17	1713	.83	207	.14, 31
1038DC	.25	151P	.17	1713DC	.83	208	.14, 31
1038NI	.25	152	.17	1714	.83	209	.14, 31
1039	.24	152P	.17	1714DC	.83	250	.43
1039DC	.25	153	.17	1715	.83	250G	.43
1039NI	.25	153P	.17	1715DC	.83	251	.38
1040	.24	154	.17	171C	.17	252	.38
1040DC	.25	155	.17	1721	.83	253	.38
1040NI	.25	154P	.17	1721DC	.83	254	.38
1041	.24	155P	.17	1722	.83	255	.38
1042	.24	15DC	.34	1722DC	.83	260	.38
1050	.36	15SS	.114	1723	.78, 84	261	.38
1051	.36	15X	.34	1724DC	.85	262	.38
1052	.36	16	.34	1735	.78, 84	263	.38
1053	.36	16 SA	.34	1736	.84	268	.38
1054	.36	160	.17	1736DC	.85	269	.38
1055	.36	160I	.17	1737	.78, 84	270 S	.38
1056	.36	160P	.17	1738	.84	275	.38
1057	.36	161	.17	1738DC	.85	276	.38
1058	.36	161I	.17	1739	.84	281	.38
1059	.36	161P	.17	1739DC	.85	282	.38
1060	.36	162	.17	1740	.84	283	.38
1061	.36	163	.17	1740DC	.85	285	.38
11	.34	164	.17	1741	.84	288	.38
11DC	.34	165	.17	1741DC	.85	289	.38
11N	.74	1650	.7	1742	.84	290M	.38
11 SA	.34	1650DC	.11	1742DC	.85	291	.38
11SS	.114	1650RT	.10	1744	.84	292	.38
11X	.34	1650US	.9	1744DC	.85	293	.38
12	.34	1651	.7	1745	.84	294	.38
12DC	.34	1651DC	.11	1745DC	.85	295	.38
12N	.74	1651RT	.10	1746	.84	296	.38
12 SA	.34	1651US	.9	1746DC	.85	297	.38
12SS	.114	1652	.7	1747	.84	298	.38
12X	.34	1652DC	.11	1747DC	.85	299	.38
13	.34, 256	1652RT	.10	17DC	.34	2400	.6
13 SA	.34, 256	1652US	.9	17X	.34	2401	.6
13DC	.34, 256	1653	.7	18	.34	2402	.6
13N	.74, 256	1653DC	.11	18 SA	.34	2631	.89, 90
13SS	.114	1653RT	.10	18DC	.34	2632	.89, 90
13X	.34	1653US	.9	18X	.34	2633	.89, 90
14	.34, 256	1654	.7	188	.20	2670	.89, 90
14 SA	.34, 256	1654DC	.11	189	.20	2671	.89, 90
141DC	.91	1654RT	.10	19	.34	2699	.79, 86, 89
141PDC	.91	1654US	.9	19DC	.34	3 B	.32
1450	.3	1655	.7	19 SA	.34	3BSS	.117
1450DC	.6	1655DC	.11	19X	.34	3BSS316	.117
1450US	.5	1655RT	.10	190M	.20	3BX	.32
1451	.3	1655US	.9	191	.20	300	.36
1451DC	.6	1656	.7	192	.20	300DC	.36
1451US	.5	1656DC	.11	191SS	.120	301	.36
1452	.3	1656RT	.10	192SS	.120	301DC	.36

Catalog Number	Page	Catalog Number	Page	Catalog Number	Page	Catalog Number	Page
302	.36	453US	.5	51	.36	656RT	.10
302DC	.36	454	.3	51D	.36	656US	.9
303	.36	454DC	.6	529 S	.32	657	.7
303DC	.36	454US	.5	52	.36	657DC	.11
303PVC	.98	455	.3	52D	.36	657RT	.10
304DC	.36	455DC	.6	53	.36	657US	.9
305DC	.36	455US	.5	53D	.36	658	.7
305PVC	.98	456	.3, 17	54	.36	658DC	.11
335	.37	456DC	.6	54D	.36	658RT	.10
336	.37	456US	.5	55	.36	658US	.9
337	.37	457	.3, 17	55D	.36	659	.7
338	.37	457DC	.6	56	.36	659DC	.11
339	.37	457US	.5	56D	.36	659RT	.10
340	.37	458	.3, 17	57	.36	659US	.9
342	.37	458DC	.6	57D	.36	660DC	.11
343	.37	458US	.5	58	.36	660RT	.10
344	.37	459	.3, 17	58D	.36	660S	.7
345	.37	459DC	.6	59	.36	660SUS	.9
346	.37	459US	.5	59D	.36	661DC	.11
347	.37	460	.3	510	.31	661RT	.10
348	.37	460DC	.6	511	.31	661S	.7
349	.37	460US	.5	512	.31	661SUS	.9
350	.43	461	.3	513	.31	662	.7
350G	.43	461DC	.6	514	.31	662DC	.11
350S	.37	461US	.5	515	.31	662RT	.10
351	.37	462	.3	516	.14, 31	662US	.9
352	.37	462DC	.6	517	.14, 31	663	.7
353	.37	462US	.5	518	.14, 31	663DC	.11
354	.37	463	.3	519	.14, 31	663RT	.10
355	.37	463DC	.6	520	.31	663US	.9
356	.37	463US	.5	521	.31	664	.7
360	.37	464	.3	528	.32	664DC	.11
361	.37	464DC	.6	529	.32	664RT	.10
362	.37	464US	.5	530	.32	664US	.9
363	.37	465	.3	531	.32	665	.7
364	.37	465DC	.6	531SST	.115	665DC	.11
365	.37	465US	.5	532	.32	665RT	.10
366	.37	466	.3, 17	533	.32	665US	.9
367	.37	466DC	.6	533SST	.115	666	.7
368	.37	466US	.5	534	.32	666DC	.11
369	.37	467	.3, 17	534SST	.115	666RT	.10
370 S	.37	467DC	.6	566	.31, 80, 88	666US	.9
371	.37	467US	.5	567	.31	667	.7
372	.37	468	.3, 17	567BX	.80, 88	667DC	.11
373	.37	468DC	.6	5050	.164	667RT	.10
374	.37	468US	.5	6 B	.32	667US	.9
375	.37	469	.3, 17	6BSS	.117	668	.7
376	.37	469DC	.6	60	.36	668DC	.11
377	.37	469US	.5	61	.36	668RT	.10
378	.37	496 10	.14, 31	65	.19	668US	.9
3000	.91	496 10SS	.116	66	.19	669	.7
4 B	.32	496 11	.14, 31	67	.19	669DC	.11
4BSS	.117	496 11SS	.116	68	.19	669RT	.10
4BSS316	.117	496 12	.14, 31	631	.89, 90	669US	.9
4BX	.32	496 12SS	.116	632	.89, 90	690S	.12, 19
410	.31	496 2	.31	650	.43	691	.12, 19
410SS	.116	496 2SS	.116	650DC	.11	692	.12, 19
411	.31	496 3	.31	650G	.43	699	.78, 85
411SS	.116	496 3SS	.116	650RT	.10	7 B	.32
412	.31	496 4	.31	650S	.7	7BSS	.117
412SS	.116	496 4SS	.116	650SUS	.9	700	.78, 85
413	.31	496 5	.31	651DC	.11	702DC	.86
413SS	.116	496 5SS	.116	651RT	.10	702V	.78, 85
414	.31	496 6	.31	651S	.7	703DC	.86
414SS	.116	496 6SS	.116	651SUS	.9	707	.83
415	.31	496 7	.31	652	.7	707DC	.83
415SS	.116	496 7SS	.116	652DC	.11	708	.83
420	.12, 19	496 8	.31	652RT	.10	708DC	.83
421	.12, 19	496 8SS	.116	652US	.9	709	.83
422	.12, 19	496 9	.14, 31	653	.7	709DC	.83
450	.43	496 9SS	.116	653DC	.11	710	.83
450DC	.6	497 1	.14	653RT	.10	710DC	.83
450G	.43	497 2	.14	653US	.9	711	.83
450S	.3	497 3	.14	654	.7	711DC	.83
450SUS	.5	497 4	.14	654DC	.11	712	.83
451	.3	497 5	.14	654RT	.10	712DC	.83
451DC	.6	497 6	.14	654US	.9	713	.83
451US	.5	5 B	.32	655	.7	713DC	.83
452	.3	5BSS	.117	655DC	.11	714	.83
452DC	.6	5BSS316	.117	655RT	.10	714DC	.83
452US	.5	5BX	.32	655US	.9	715	.83
453	.3	50	.36	656	.7	715DC	.83
453DC	.6	50D	.36	656DC	.11	721	.83

Catalog Number	Page	Catalog Number	Page	Catalog Number	Page	Catalog Number	Page
721DC	.83	96	.30	C125M CG	.41	CG100 950SA	.71
722	.83	97	.30	C125NM	.110	CG10045 1050	.72
722DC	.83	98	.30	C15	.41	CG10045 560	.72
723	.78, 84	99	.30	C15 CGN	.41	CG10045 650	.72
724	.84	931	.25	C15 ICG	.41	CG10045 750	.72
724DC	.85	932	.25	C15 MT	.41	CG10045 850	.72
735	.78, 84	933	.25	C15 MTC	.41	CG10045 950	.72
736	.84	934	.25	C150M	.46	CG10090 1050	.72
736DC	.85	935	.25	C150M CG	.41	CG10090 560	.72
737	.78, 84	936	.25	C150NM	.110	CG10090 650	.72
738	.84	937	.25	C18SS	.111	CG10090 750	.72
738DC	.85	938	.25	C200M	.46	CG10090 850	.72
739	.84	939	.25	C200M CG	.41	CG10090 950	.72
739DC	.85	940	.25	C200NM	.110	CG125 1050	.71
740	.84	941	.25	C25	.41	CG125 1150	.71
740DC	.85	942	.25	C25 CGN	.41	CG125 1250	.71
741	.84	950	.43	C25 ICG	.41	CG125 1375	.71
741DC	.85	950G	.43	C25 MT	.41	CG125 850	.71
742	.84	ACB100	.76, 81	C25 MTC	.41	CG125 950	.71
742DC	.85	ACB10090	.76, 81	C250M	.46	CG150 1050	.71
744	.84	ACB125	.76, 81	C250NM	.110	CG150 1150	.71
744DC	.85	ACB150	.76, 81	C28SS	.111	CG150 1250	.71
745	.84	ACB200	.76, 81	C300M	.46	CG150 1375	.71
745DC	.85	ACB250	.76, 81	C300NM	.110	CG50 250	.71
746	.84	ACB300	.76, 81	C35	.41	CG50 250SA	.71
746DC	.85	ACB350	.76, 81	C35 CGN	.41	CG50 350	.71
747	.84	ACB38	.76, 81	C35 ICG	.41	CG50 350SA	.71
747DC	.85	ACB3845	.76, 81	C35 MT	.41	CG50 450	.71
759DC	.89	ACB3890	.76, 81	C35 MTC	.41	CG50 450SA	.71
770DC	.86	ACB38DC	.79, 86, 89	C350M	.46	CG50 560	.71
771DC	.86	ACB400	.76, 81	C350NM	.110	CG50 560SA	.71
772DC	.86	ACB50	.76, 81	C38SS	.111	CG50 650	.71
773DC	.86	ACB5045	.76, 81	C400M	.46	CG50 650SA	.71
774DC	.86	ACB5090	.76, 81	C400NM	.110	CG5045 250	.72
775DC	.86	ACB75	.76, 81	C45	.41	CG5045 350	.72
776DC	.86	ACB7545	.76, 81	C45 CGN	.41	CG5045 450	.72
780DC	.12, 87	ACB7590	.76, 81	C45 MT	.41	CG5045 560	.72
791DC	.86	ACC38	.12, 79, 87	C45 MTC	.41	CG5045 650	.72
792DC	.86	ACC50	.12, 79, 87	C50M	.46	CG5090 250	.72
793DC	.86	ACC75	.12, 79, 87	C50M CG	.41	CG5090 350	.72
794DC	.86	ACCS38	.12, 79, 87	C50NM	.110	CG5090 450	.72
795DC	.86	ACCS50	.12, 79, 87	C55	.41	CG5090 560	.72
796DC	.86	ACCS75	.12, 79, 87	C55 CGN	.41	CG5090 650	.72
8 B	.32	ACMF38	.79	C55 MT	.41	CG75 250	.71
8BSS	.117	AMR1	.130	C55 MTC	.41	CG75 250SA	.71
810	.23	AMR2	.130	C65	.41	CG75 350	.71
811	.23	ASB 0	.80, 88	C65 CGN	.41	CG75 350SA	.71
812	.23	ASB 1	.80, 88	C65 MT	.41	CG75 450	.71
813	.23	ASB 2	.80, 88	C65 MTC	.41	CG75 450SA	.71
814	.23	ASB 3	.80, 88	C75	.41	CG75 560	.71
815	.23	ASB 4	.80, 88	C75M	.46	CG75 560SA	.71
820	.23	ASB 5	.80, 88	C75M CG	.41	CG75 650	.71
821	.23	ASB 6	.80, 88	C75NM	.110	CG75 650SA	.71
822	.23	ASB 7	.80, 88	C85	.41	CG75 750	.71
823	.23	ASB 8	.80, 88	C85 CGN	.41	CG75 750SA	.71
824	.23	BJ104	.216	C95	.41	CG75 850	.71
825	.23	BJ108	.216	C95 CGN	.41	CG75 850SA	.71
850	.43	BJ14	.216	CB1	.14, 31	CG7545 250	.72
850EB DC	.13	BJ18	.216	CB10	.14, 31	CG7545 350	.72
850EE DC	.13	BJ24	.216	CB11	.14, 31	CG7545 450	.72
850G	.43	BJ28	.216	CB12	.14, 31	CG7545 560	.72
850RB DC	.23	BJ34	.216	CB2	.14, 31	CG7545 650	.72
850RR DC	.23	BJ38	.216	CB3	.14, 31	CG7545 750	.72
875EB DC	.13	BJ44	.216	CB4	.14, 31	CG7545 850	.72
875EE DC	.13	BJ48	.216	CB5	.14, 31	CG7590 250	.72
875RB DC	.23	BJ54	.216	CB6	.14, 31	CG7590 350	.72
875RR DC	.23	BJ58	.216	CB7	.14, 31	CG7590 450	.72
8100EB DC	.13	BJ64	.216	CB8	.14, 31	CG7590 560	.72
8100EE DC	.13	BJ68	.216	CB9	.14, 31	CG7590 650	.72
8100RB DC	.23	BJ74	.216	CCBF	.251	CG7590 750	.72
8100RR DC	.23	BJ78	.216	CCBS	.251	CG7590 850	.72
8125EB DC	.13	BJ84	.216	CCBSS	.251	CH361R	.252
8125EE DC	.13	BJ88	.216	CG100 1050	.71	CH362R	.252
8125RB DC	.23	BJ94	.216	CG100 1050SA	.71	CH363R	.252
8125RR DC	.23	BJ98	.216	CG100 560	.71	CH364R	.252
9 B	.32	BX38	.79	CG100 560SA	.71	CHB1	.56
9BSS	.117	BX38R	.79, 86	CG100 650	.71	CHB10	.56
90	.30	C100M	.46	CG100 650SA	.71	CHB2	.56
91	.30	C100M CG	.41	CG100 750	.71	CHB3	.56
92	.30	C100NM	.110	CG100 750SA	.71	CHB4	.56
93	.30	C105	.41	CG100 850	.71	CHB5	.56
94	.30	C105 CGN	.41	CG100 850SA	.71	CHB6	.56
95	.30	C125M	.46	CG100 950	.71	CHB7	.56

Catalog Number	Page	Catalog Number	Page	Catalog Number	Page	Catalog Number	Page
CHB8	.56	DS7000BF	.113	EL12545STDNM	.99	F4WMSHL161007	.236, 238
CHB9	.56	DS7000RF	.113	EL12590STDNM	.99	F4WMSHL201612	.236, 238
CHBVKIT4X	.243	DS7000SF	.113	EL15045STDNM	.99	F4WMSHL241206	.236, 238
CHCI21	.243	E100NM	.110	EL15090STDNM	.99	F4WMSHL241210	.236, 238
CHDV	.243	E125NM	.110	EL20045STDNM	.99	F4WMSHL242008	.236, 238
CHDVKIT	.243	E150NM	.110	EL20090STDNM	.99	F4WMSHL242410	.236, 238
CHDVKIT4X	.243	E200NM	.110	EL25045STDNM	.99	F4WMSHL242412	.236, 238
CHENCAP2PK	.243	E250NM	.110	EL25090STDNM	.99	F4WMSHL302006	.236, 238
CHENCAP4PK	.243	E300NM	.110	EL29024NM	.100	F4WMSHL302008	.236, 238
CHG1	.57	E350NM	.110	EL29036NM	.100	F4WMSHL302010	.236, 238
CHG10	.57	E400NM	.110	EL29048NM	.100	F4WMSHL302012	.236, 238
CHG2	.57	E50NM	.110	EL30045STDNM	.99	F4WMSHL302407	.236, 238
CHG3	.57	E75NM	.110	EL30090STDNM	.99	F4WMSHL302410	.236, 238
CHG4	.57	EB100NM	.101	EL35045STDNM	.99	F4WMSHL302412	.236, 238
CHG5	.57	EB125NM	.101	EL35090STDNM	.99	F4WMSHL363008	.236, 238
CHG6	.57	EB150NM	.101	EL39024NM	.100	F4WMSHL363010	.236, 238
CHG7	.57	EB200NM	.101	EL39036NM	.100	F4WMSHL363012	.236, 238
CHG8	.57	EB250NM	.101	EL39048NM	.100	FA100NM	.97
CHG9	.57	EB300NM	.101	EL40045STDNM	.99	FA125NM	.97
CHGN1	.57	EB350NM	.101	EL40090STDNM	.99	FA150NM	.97
CHGN10	.57	EB400NM	.101	EL49024NM	.100	FA200NM	.97
CHGN2	.57	EB500NM	.101	EL49036NM	.100	FA250NM	.97
CHGN3	.57	EB50NM	.101	EL49048NM	.100	FA300NM	.97
CHGN4	.57	EB600NM	.101	EL50045STDNM	.99	FA350NM	.97
CHGN5	.57	EB75NM	.101	EL50090STDNM	.99	FA400NM	.97
CHGN6	.57	EC100NM	.101	EL5045STDNM	.99	FA500NM	.97
CHGN7	.57	EC125NM	.101	EL5090STDNM	.99	FA50NM	.97
CHGN8	.57	EC150NM	.101	EL59036NM	.100	FA600NM	.97
CHGN9	.57	EC200NM	.101	EL59048NM	.100	FA75NM	.97
CHHANDLE	.243	EC250NM	.101	EL60045STDNM	.99	FACP0606SA	.234, 246
CHLP1	.243	EC300NM	.101	EL60090STDNM	.99	FACP0806SA	.234, 246
CHLPKIT	.243	EC350NM	.101	EL69036NM	.100	FACP0808SA	.234, 246
CHSS2PK	.243	EC400NM	.101	EL69048NM	.100	FACP1008SA	.234, 246
CHSS4PK	.243	EC50NM	.101	EL7545STDNM	.99	FACP1210SA	.234, 246
CHU361R	.252	EC75NM	.101	EL7590STDNM	.99	FACP1412SA	.234, 246
CHU362R	.252	EH100NM	.102	ELB10045	.13	FACP1614SA	.234, 246
CHU363R	.252	EH125NM	.102	ELB10090	.13	FACP1816SA	.234, 246
CHU364R	.252	EH150NM	.102	ELB12545	.13	FACP2016SA	.234, 246
CP100NM	.98	EH200NM	.102	ELB12590	.13	FAHP060604	.234, 235
CP125NM	.98	EH250NM	.102	ELB15045	.13	FAHP080604	.234, 235
CP150NM	.98	EH300NM	.102	ELB15090	.13	FAHP080804	.234, 235
CP200NM	.98	EH350NM	.102	ELB20045	.13	FAHP100806	.234, 235
CP250NM	.98	EH400NM	.102	ELB20090	.13	FAHP121006	.234, 235
CP300NM	.98	EH50NM	.102	ELB5045	.13	FAHP141206	.234, 235
CP350NM	.98	EH75NM	.102	ELB5090	.13	FAHP141208	.234, 235
CP400NM	.98	EHC1	.91	ELB7545	.13	FAHP161408	.234, 235
CP500NM	.98	EHC10	.91	ELB7590	.13	FAHP181610	.234, 235
CP50NM	.98	EHC2	.91	ESL75	.37	FAHP201610	.234, 235
CP600NM	.98	EHC3	.91	ESL100	.37	FAHPCC060604	.234, 235
CP75NM	.98	EHC4	.91	ET100NM100	.70	FAHPCC080604	.234, 235
CPBF03	.255	EHC5	.91	ET125NM100	.70	FAHPCC080804	.234, 235
CPBF04	.255	EHC6	.91	ET150NM50	.70	FAHPCC100806	.234, 235
CPR1	.16	EHC7	.91	ET200NM50	.70	FAHPCC121006	.234, 235
CPR10	.16	EHC8	.91	ET25NM100	.70	FAHPCC141206	.234, 235
CPR11	.16	EHC9	.91	ET38NM100	.70	FAHPCC141208	.234, 235
CPR12	.16	EHMT1	.91	ET50NM100	.70	FAHPCC161408	.234, 235
CPR13	.16	EHMT2	.91	ET75NM100	.70	FAHS060604	.234, 235
CPR14	.16	EHMT3	.91	ETC100HD	.33	FAHS080604	.234, 235
CPR15	.16	EHMT4	.91	ETC125HD	.33	FAHS080804	.234, 235
CPR16	.16	EHSC1	.91	ETC150HD	.33	FAHS100806	.234, 235
CPR17	.16	EHSC2	.91	ETC200HD	.33	FAHS121006	.234, 235
CPR18	.16	EHSS1	.91	ETC250HD	.33	FAHS141206	.234, 235
CPR19	.16	EHSS10	.91	ETC300HD	.33	FAHS141208	.234, 235
CPR2	.16	EHSS2	.91	ETC50HD	.33	FAHS161408	.234, 235
CPR20	.16	EHSS3	.91	ETC75HD	.33	FAHS181610	.234, 235
CPR21	.16	EHSS4	.91	F3WMSHL201606	.237, 239	FAHS201610	.234, 235
CPR22	.16	EHSS5	.91	F3WMSHL242410	.237, 239	FAHSCC060604	.234, 235
CPR23	.16	EHSS6	.91	F3WMSHL302008	.237, 239	FAHSCC080604	.234, 235
CPR24	.16	EHSS7	.91	F3WMSHL302010	.237, 239	FAHSCC080804	.234, 235
CPR25	.16	EHSS8	.91	F3WMSHL302410	.237, 239	FAHSCC100806	.234, 235
CPR26	.16	EHSS9	.91	F3WMSHL302412	.237, 239	FAHSCC121006	.234, 235
CPR27	.16	EHT1	.91	F3WMSHL363008	.237, 239	FAHSCC141206	.234, 235
CPR28	.16	EHT10	.91	F3WMSHL363010	.237, 239	FAHSCC141208	.234, 235
CPR29	.16	EHT2	.91	F3WMSHL363012	.237, 239	FAHSCC161408	.234, 235
CPR3	.16	EHT3	.91	F3WMSHL483612	.237, 239	FBCA1	.50
CPR30	.16	EHT4	.91	F3WMSHL483616	.237, 239	FBCM1	.50
CPR4	.16	EHT5	.91	F4LSHL483612	.237	FBCS1	.50
CPR5	.16	EHT6	.91	F4LSHL483616	.237	FDA2SS	.113
CPR6	.16	EHT7	.91	F4LSHL603612	.237	FDBLANK	.103
CPR7	.16	EHT8	.91	F4LSHL603616	.237	FDC100	.105
CPR8	.16	EHT9	.91	F4LSHLDD364812	.237	FDC161008	.241, 242
CPR9	.16	EL10045STDNM	.99	F4LSHLFS722525	.237	FDC201608	.241, 242
DS7000BC	.113	EL10090STDNM	.99	F4LSHLFSDDD724925	.237	FDC241212	.241, 242

Catalog Number	Page	Catalog Number	Page	Catalog Number	Page	Catalog Number	Page
FDC242412	241, 242	FJHSW080804	227, 228	FMPWM1610SA	245	FRCJS121006	230, 231
FDC2SS	113	FJHSW100804	227, 228	FMPWM2016C	245	FRCJS121208	230, 231
FDC302412	241, 242	FJHSW121005	227, 228	FMPWM2016SA	245	FRCJS141208	230, 231
FDC363012	241, 242	FJHSW121206	227, 229	FMPWM2412C	245	FRCJS161408	230, 231
FDC50	105	FJHSW140707	227, 229	FMPWM2412SA	245	FRCJS181610	230, 231
FDC75	105	FJHSW141206	227, 229	FMPWM2420C	245	FRCJS201610	230, 231
FDCM1	49	FJHSW161406	227, 229	FMPWM2420SA	245	FSBLANK	106
FDCM2	49	FJHSW181608	227, 229	FMPWM2424C	245	FSBLANK2	106
FDCM3	49	FJHSW201608	229	FMPWM2424SA	245	FSC100	104
FDE100	105	FJS060404	227, 228	FMPWM3020C	245	FSC1002	104
FDE50	105	FJS060604	227, 228	FMPWM3020SA	245	FSC50	104
FDE75	105	FJS080604	227, 228	FMPWM3024C	245	FSC502	104
FDM1	49	FJS080804	227, 228	FMPWM3024SA	245	FSC75	104
FDM2	49	FJS100804	227, 228	FMPWM3630C	245	FSC752	104
FDM3	49	FJS121005	227, 228	FMPWM3630SA	245	FSCC100	105
FDS2SS	113	FJS121206	227, 229	FMPWM3636C	245	FSCC1002	105
FDX2SS	113	FJS140707	227, 229	FMPWM3636SA	245	FSCC50	105
FEA100	64	FJS141206	227, 229	FMPWM3648C	245	FSCC502	105
FEA125	64	FJS161406	227, 229	FMPWM3648SA	245	FSCC75	105
FEA150	64	FJS181608	227, 229	FMPWM4836C	245	FSCC752	105
FEA200	64	FJS201608	227, 229	FMPWM4836SA	245	FSCM1	49
FEA250	64	FMP0604	232	FMPWM6036C	245	FSCM2	49
FEA300	64	FMP0604C	245	FMPWM6036SA	245	FSCM3	49
FEA350	64	FMP0604FG	245	FMPWM7225C	245	FSE100	104
FEA38	64	FMP0604SA	245	FMPWM7225SA	245	FSE1002	104
FEA400	64	FMP0604SS	245	FMPWM7249C	245	FSE50	104
FEA50	64	FMP0606C	226	FMPWM7249SA	245	FSE502	104
FEA75	64	FMP0606FG	246	FPB21	224	FSE75	104
FECC100DC	12, 87	FMP0606SA	246	FPB22	224	FSE752	104
FECC50DC	12, 87	FMP0606SS	246	FPB23	224	FSGSK1	50
FECC75DC	12, 87	FMP0706C	246	FPB24	224	FSJS030302	222, 223
FECS38DC	12, 87	FMP0706SA	246	FPB25	224	FSJS050302	222, 223
FECS50DC	12, 87	FMP0806C	226	FPB26	224	FSJS060404	222, 223
FECS75DC	12, 87	FMP0806FG	246	FPB27	224	FSJS080302	222, 223
FJFHPW080604	227, 228	FMP0806SA	246	FPB31	224	FSJS080404	222, 223
FJFHPW080804	227, 228	FMP0806SS	246	FPB32	224	FSJS090302	222, 223
FJFHPW100804	227, 228	FMP0808C	245	FPB33	224	FSJS110404	222, 223
FJFHPW121005	227, 228	FMP0808FG	245	FPB34	224	FSJS140302	222, 223
FJFHPW121206	227, 229	FMP0808SA	245	FPB35	224	FSJS170302	222, 223
FJFHPW140707	227, 229	FMP0808SS	245	FPB36	224	FSJMTGFTKIT	222
FJFHPW141206	227, 229	FMP0906C	245	FPB37	224	FSJS070603	222, 223
FJFHPW161406	227, 229	FMP0906FG	245	FPBM312	226	FSJS090603	222, 223
FJFHPW181608	227, 229	FMP0906SA	245	FPBM316	226	FSM1	49
FJFHPW201608	227, 229	FMP0906SS	245	FPBM320	226	FSM2	49
FJHP060404	227, 228	FMP1008C	224	FPBM325	226	FSM3	49
FJHP060604	227, 228	FMP1008FG	245	FPBM34	226	FSS100	104
FJHP080604	227, 228	FMP1008SA	245	FPBM36	226	FSS1002	104
FJHP080804	227, 228	FMP1008SS	245	FPBM39	226	FSS50	104
FJHP100804	227, 228	FMP1210C	224	FPLG1KIT	244	FSS502	104
FJHP121005	227, 228	FMP1210FG	245	FPLG2KIT	244	FSS75	104
FJHP121206	227, 229	FMP1210SA	245	FPLG3KIT	244	FSS752	104
FJHP140707	227, 229	FMP1210SS	245	FPLG4KIT	244	FXDJ060408	232
FJHP141206	227, 229	FMP1212C	245	FPLG5KIT	244	FXDJ060608	232
FJHP161406	227, 229	FMP1212FG	245	FPLG6KIT	244	FXDJ080608	232
FJHP181608	227, 229	FMP1212SA	245	FPLG7KIT	244	FXDJ080808	232
FJHP201608	227, 229	FMP1212SS	245	FPLG8KIT	244	FXDJ100808	232
FJHPW060404	227, 228	FMP1407C	246	FRCJHP060406	230, 231	FXDJ121010	232
FJHPW060604	227, 228	FMP1407FG	246	FRCJHP060606	230, 231	FXDJ121212	232
FJHPW080604	227, 228	FMP1407SA	246	FRCJHP080606	230, 231	FXDJ141212	232
FJHPW080804	227, 228	FMP1407SS	246	FRCJHP080805	230, 231	FXDJ161412	232
FJHPW100804	227, 228	FMP1412C	226	FRCJHP100806	230, 231	FXDJ181617	232
FJHPW121005	227, 228	FMP1412FG	246	FRCJHP121006	230, 231	FXDJ201617	232
FJHPW121206	227, 229	FMP1412SA	246	FRCJHP121208	230, 231	GASK015N	43
FJHPW140707	227, 229	FMP1412SS	246	FRCJHP141208	230, 231	GASK025N	43
FJHPW141206	227, 229	FMP1614C	246	FRCJHP161408	230, 231	GASK035N	43
FJHPW161406	227, 229	FMP1614FG	246	FRCJHP181610	230, 231	GASK045N	43
FJHPW181608	227, 229	FMP1614SA	246	FRCJHP201610	230, 231	GASK065N	43
FJHPW201608	227, 229	FMP1614SS	246	FRCJHS060406	230, 231	GASK085N	43
FJHS060404	227, 228	FMP1816C	246	FRCJHS060606	230, 231	GASK095N	43
FJHS060604	227, 228	FMP1816FG	246	FRCJHS080606	230, 231	GFICS1	50
FJHS080604	227, 228	FMP1816SA	246	FRCJHS080805	230, 231	GK100N	47
FJHS080804	227, 228	FMP1816SS	246	FRCJHS100806	230, 231	GK125N	47
FJHS100804	227, 228	FMP2016C	246	FRCJHS121006	230, 231	GK200N	47
FJHS121005	227, 228	FMP2016FG	246	FRCJHS121208	230, 231	GK250N	47
FJHS121206	227, 229	FMP2016SA	246	FRCJHS141208	230, 231	GK350N	47
FJHS140707	227, 229	FMP2016SS	246	FRCJHS161408	230, 231	GK50N	47
FJHS141206	227, 229	FMPC1610	241, 244	FRCJHS181610	230, 231	GK75N	47
FJHS161406	227, 229	FMPC2016	241, 244	FRCJHS201610	230, 231	GL 11	34
FJHS181608	227, 229	FMPC2412	241, 244	FRCJS060406	230, 231	GL 12	34
FJHS201608	227, 229	FMPC2424	241, 244	FRCJS060606	230, 231	GL 13	34
FJHSW060404	227, 228	FMPC3024	241, 244	FRCJS080606	230, 231	GL 14	34
FJHSW060604	227, 228	FMPC3630	241, 244	FRCJS080805	230, 231	GL 15	34
FJHSW080604	227, 228	FMPWM1610C	245	FRCJS100806	230, 231	GL 16	34

Catalog Number	Page	Catalog Number	Page	Catalog Number	Page	Catalog Number	Page
GL 17	.34	GLS5	.27	HGLL4 10C	.28	HUB10	.58
GL 18	.34	GLS5 10	.27	HGLL4C	.28	HUB2	.58
GL 19	.34	GLS5 10C	.27	HGLL5 10	.28	HUB3	.58
GL 20	.34	GLS5C	.27	HGLL5 10C	.28	HUB4	.58
GLL 1	.26	GLS6	.27	HGLL5C	.28	HUB5	.58
GLL 10	.26	GLS6 10	.27	HGLL6 10	.28	HUB6	.58
GLL 11	.26	GLS6 10C	.27	HGLL6 10C	.28	HUB7	.58
GLL 12	.26	GLS6C	.27	HGLL7 250	.28	HUB8	.58
GLL 2	.26	GLS7	.27	HGLL7 250C	.28	HUB9	.58
GLL 3	.26	GLS7 250	.27	HGLL7 30	.28	JCC1	.33
GLL 4	.26	GLS7 250C	.27	HGLL7 30C	.28	JCC2	.33
GLL 5	.26	GLS7 30	.27	HGLL7C	.28	JCC34	.33
GLL 6	.26	GLS7 30C	.27	HGLL8 250	.28	JCC56	.33
GLL 6C	.26	GLS8	.27	HGLL8 250C	.28	JCC78	.33
GLL 7	.26	GLS8 250	.27	HGLL8 30	.28	JCC910	.33
GLL 8	.26	GLS8 250C	.27	HGLL8 30C	.28	K100CM	.47
GLL 9	.26	GLS8 30	.27	HGLL8C	.28	K100S	.47
GLL1 DC	.28	GLS8 30C	.27	HGLL9 250	.28	K100SG	.47
GLL10 250	.26	GLS8C	.27	HGLL9 250C	.28	K125CM	.47
GLL10 250C	.26	GLS9	.27	HGLL9C	.28	K125S	.47
GLL10 DC	.28	GLS9 250	.27	HGLS 11	.29	K125SG	.47
GLL10C	.26	GLS9 250C	.27	HGLS 12	.29	K200CM	.47
GLL11 250	.26	GLS9C	.27	HGLS 7C	.29	K200S	.47
GLL11 250C	.26	H 931	.25	HGLS1	.29	K200SG	.47
GLL11C	.26	H 932	.25	HGLS10	.29	K250CM	.47
GLL12 250	.26	H 933	.25	HGLS10 250	.29	K250S	.47
GLL12 250C	.26	H 934	.25	HGLS10 250C	.29	K250SG	.47
GLL12C	.26	H 935	.25	HGLS10C	.29	K350CM	.47
GLL1C	.26	H 936	.25	HGLS11 250	.29	K350S	.47
GLL2 DC	.28	H 937	.25	HGLS11 250C	.29	K350SG	.47
GLL2C	.26	H 938	.25	HGLS11C	.29	K50CM	.47
GLL3 DC	.28	H 939	.25	HGLS12 250	.29	K50S	.47
GLL3C	.26	H 940	.25	HGLS12 250C	.29	K50SG	.47
GLL4 10	.26	H 941	.25	HGLS12C	.29	K75CM	.47
GLL4 10C	.26	H 942	.25	HGLS1C	.29	K75S	.47
GLL4 DC	.28	H1031	.24	HGLS2	.29	K75SG	.47
GLL4C	.26	H1031DC	.25	HGLS2C	.29	LB100M	.46
GLL5 10	.26	H1032	.24	HGLS3	.29	LB100M CG	.46
GLL5 10C	.26	H1032DC	.25	HGLS3C	.29	LB100NM	.108
GLL5 DC	.28	H1033	.24	HGLS4	.29	LB105	.40
GLL5C	.26	H1033DC	.25	HGLS4 10	.29	LB105 CGN	.40
GLL6 10	.26	H1034	.24	HGLS4 10C	.29	LB105 MT	.40
GLL6 10C	.26	H1034DC	.25	HGLS4C	.29	LB105 MTC	.40
GLL6 DC	.28	H1035	.24	HGLS5	.29	LB125M	.46
GLL7 250	.26	H1035DC	.25	HGLS5 10	.29	LB125M CG	.46
GLL7 250C	.26	H1036	.24	HGLS5 10C	.29	LB125NM	.108
GLL7 30	.26	H1036DC	.25	HGLS5C	.29	LB15	.40
GLL7 30C	.26	H1037	.24	HGLS6	.29	LB15 CGN	.40
GLL7 DC	.28	H1037DC	.25	HGLS6 10	.29	LB15 ICG	.40
GLL7C	.26	H1038	.24	HGLS6 10C	.29	LB15 MT	.40
GLL8 250	.26	H1038DC	.25	HGLS6C	.29	LB15 MTC	.40
GLL8 250C	.26	H1039	.24	HGLS7	.29	LB150M	.46
GLL8 30	.26	H1039DC	.25	HGLS7 250	.29	LB150M CG	.46
GLL8 30C	.26	H1040	.24	HGLS7 250C	.29	LB150NM	.108
GLL8 DC	.28	H1040DC	.25	HGLS7 30	.29	LB18SS	.111
GLL8C	.26	H1041	.24	HGLS7 30C	.29	LB200M	.46
GLL9 250	.26	H1042	.24	HGLS8	.29	LB200M CG	.46
GLL9 250C	.26	HGLL 1	.28	HGLS8 250	.29	LB200NM	.108
GLL9 DC	.28	HGLL 10	.28	HGLS8 250C	.29	LB25	.40
GLL9C	.26	HGLL 11	.28	HGLS8 30	.29	LB25 CGN	.40
GLS 7C	.27	HGLL 11 250	.28	HGLS8 30C	.29	LB25 ICG	.40
GLS1	.27	HGLL 11C	.28	HGLS8C	.29	LB25 MT	.40
GLS10	.27	HGLL 12	.28	HGLS9	.29	LB25 MTC	.40
GLS10 250	.27	HGLL 12 250	.28	HGLS9 250	.29	LB250M	.46
GLS10 250C	.27	HGLL 12 250C	.28	HGLS9 250C	.29	LB250NM	.108
GLS10C	.27	HGLL 12C	.28	HGLS9C	.29	LB28SS	.111
GLS11	.27	HGLL 2	.28	HR080803	.192, 219	LB300M	.46
GLS11 250	.27	HGLL 3	.28	HRC0808F	.192, 219	LB300NM	.108
GLS11 250C	.27	HGLL 4	.28	HRC0808S	.192, 219	LB35	.40
GLS11C	.27	HGLL 5	.28	HRSB1	.192, 219	LB35 CGN	.40
GLS12	.27	HGLL 6	.28	HS1031	.24	LB35 ICG	.40
GLS12 250	.27	HGLL 6C	.28	HS1032	.24	LB35 MT	.40
GLS12 250C	.27	HGLL 7	.28	HS1033	.24	LB35 MTC	.40
GLS12C	.27	HGLL 8	.28	HS1034	.24	LB350M	.46
GLS1C	.27	HGLL 9	.28	HS1035	.24	LB350NM	.108
GLS2	.27	HGLL10 250	.28	HS1036	.24	LB38SS	.111
GLS2C	.27	HGLL10 250C	.28	HS1037	.24	LB400M	.46
GLS3	.27	HGLL10C	.28	HS1038	.24	LB400NM	.108
GLS3C	.27	HGLL11 250C	.28	HS1039	.24	LB45	.40
GLS4	.27	HGLL1C	.28	HS1040	.24	LB45 CGN	.40
GLS4 10	.27	HGLL2C	.28	HS1041	.24	LB45 MT	.40
GLS4 10C	.27	HGLL3C	.28	HS1042	.24	LB45 MTC	.40
GLS4C	.27	HGLL4 10	.28	HUB1	.58	LB50M	.46

Catalog Number	Page	Catalog Number	Page	Catalog Number	Page	Catalog Number	Page
LB50M CG	.46	LL55 MT	.41	LT10090 SA	.61	LT350	.60
LB50NM	.108	LL55 MTC	.41	LT10090DC	.63	LT350 SA	.60
LB55	.40	LL65	.41	LT10090G	.61	LT35045	.60
LB55 CGN	.40	LL65 CGN	.41	LT10090G SA	.61	LT35045G	.60
LB55 MT	.40	LL65 MT	.41	LT10090NM	.68	LT35090	.61
LB55 MTC	.40	LL65 MTC	.41	LT10090NMBL	.68	LT35090DC	.63
LB58SS	.111	LL75	.41	LT100DC	.63	LT35090 SA	.61
LB65	.40	LL75 CGN	.41	LT100G	.60	LT35090G	.61
LB65 CGN	.46	LL75M	.46	LT100G SA	.60	LT35090G SA	.61
LB65 MT	.40	LL75M CG	.41	LT100NM	.68	LT350DC	.63
LB65 MTC	.46	LL75NM	.108	LT100NMBL	.68	LT350G	.60
LB68SS	.111	LL85	.41	LT125	.60	LT350G SA	.60
LB75	.40	LL85 CGN	.41	LT125 SA	.60	LT38	.60
LB75 CGN	.46	LL95	.41	LT12545	.60	LT38 SA	.60
LB75 MT	.40	LL95 CGN	.41	LT12545G	.60	LT3845	.60
LB75 MTC	.46	LR100M	.46	LT12590	.61	LT3845G	.60
LB75M	.46	LR100M CG	.40	LT12590 SA	.61	LT3890	.61
LB75M CG	.46	LR100NM	.109	LT12590DC	.63	LT3890 SA	.61
LB75NM	.108	LR105	.40	LT12590G	.61	LT3890DC	.63
LB85	.40	LR105 CGN	.40	LT12590G SA	.61	LT3890G	.61
LB85 CGN	.46	LR125M	.46	LT12590NM	.68	LT3890NM	.68
LB85 MT	.40	LR125M CG	.40	LT12590NMBL	.68	LT3890NMBL	.68
LB85 MTC	.46	LR125NM	.109	LT125DC	.63	LT38DC	.63
LB95	.40	LR15	.40	LT125G	.60	LT38G	.60
LB95 CGN	.46	LR15 CGN	.40	LT125G SA	.60	LT38G SA	.60
LB95 MT	.40	LR15 ICG	.40	LT125NM	.68	LT38NM	.68
LB95 MTC	.46	LR15 MT	.40	LT125NMBL	.68	LT38NMBL	.68
LBNEC10	.22	LR15 MTC	.40	LT150	.60	LT400	.60
LBNEC3	.22	LR150M	.46	LT150 SA	.60	LT400 SA	.60
LBNEC4	.22	LR150M CG	.40	LT15045	.60	LT40045	.60
LBNEC5	.22	LR150NM	.109	LT15045G	.60	LT40045G	.60
LBNEC6	.22	LR200M	.46	LT15090	.61	LT40090	.61
LBNEC7	.22	LR200M CG	.40	LT15090 SA	.61	LT40090DC	.63
LBNEC8	.22	LR200NM	.109	LT15090DC	.63	LT40090 SA	.61
LBNEC9	.22	LR25	.40	LT15090G	.61	LT40090G	.61
LL100M	.46	LR25 CGN	.40	LT15090G SA	.61	LT40090G SA	.61
LL100M CG	.41	LR25 ICG	.40	LT15090NM	.68	LT400DC	.63
LL100NM	.108	LR25 MT	.40	LT15090NMBL	.68	LT400G	.60
LL105	.41	LR25 MTC	.40	LT150DC	.63	LT400G SA	.60
LL105 CGN	.41	LR250M	.46	LT150G	.60	LT50	.60
LL125M	.46	LR250NM	.109	LT150G SA	.60	LT50 SA	.60
LL125M CG	.41	LR28SS	.111	LT150NM	.68	LT500	.60
LL125NM	.108	LR300M	.46	LT150NMBL	.68	LT500G	.60
LL15	.41	LR300NM	.109	LT200	.60	LT5045	.60
LL15 CGN	.41	LR35	.40	LT200 SA	.60	LT5045G	.60
LL15 ICG	.41	LR35 CGN	.40	LT20045	.60	LT5090	.61
LL15 MT	.41	LR35 ICG	.40	LT20045G	.60	LT5090 SA	.61
LL15 MTC	.41	LR35 MT	.40	LT20090	.61	LT5090DC	.63
LL150M	.46	LR35 MTC	.40	LT20090 SA	.61	LT5090G	.61
LL150M CG	.41	LR350M	.46	LT20090DC	.63	LT5090G SA	.61
LL150NM	.108	LR350NM	.109	LT20090G	.61	LT5090NM	.68
LL200M	.46	LR38SS	.111	LT20090G SA	.61	LT5090NMBL	.68
LL200M CG	.41	LR400M	.46	LT20090NM	.68	LT5090NMSCR	.69
LL200NM	.108	LR400NM	.109	LT20090NMBL	.68	LT50DC	.63
LL25	.41	LR45	.40	LT200DC	.63	LT50G	.60
LL25 CGN	.41	LR45 CGN	.40	LT200G	.60	LT50G SA	.60
LL25 ICG	.41	LR45 MT	.40	LT200G SA	.60	LT50NM	.68
LL25 MT	.41	LR45 MTC	.40	LT200NM	.68	LT50NMBL	.68
LL25 MTC	.41	LR50M	.46	LT200NMBL	.68	LT50NMSCR	.69
LL250M	.46	LR50M CG	.40	LT250	.60	LT50U90NM	.69
LL250NM	.108	LR50NM	.109	LT250 SA	.60	LT600	.60
LL28SS	.111	LR55	.40	LT25045	.60	LT600G	.60
LL300M	.46	LR55 CGN	.40	LT25045G	.60	LT75	.60
LL300NM	.108	LR55 MT	.40	LT25090	.61	LT75 SA	.60
LL35	.41	LR55 MTC	.40	LT25090DC	.63	LT7545	.60
LL35 CGN	.41	LR65	.40	LT25090 SA	.61	LT7545G	.60
LL35 ICG	.41	LR65 CGN	.40	LT25090G	.61	LT7590	.61
LL35 MT	.41	LR65 MT	.40	LT25090G SA	.61	LT7590 SA	.60
LL35 MTC	.41	LR65 MTC	.40	LT250DC	.63	LT7590DC	.63
LL350M	.46	LR75	.40	LT250G	.60	LT7590G	.61
LL350NM	.108	LR75 CGN	.40	LT250G SA	.60	LT7590G SA	.60
LL38SS	.111	LR75M	.46	LT300	.60	LT7590NM	.68
LL400M	.46	LR75M CG	.40	LT300 SA	.60	LT7590NMBL	.68
LL400NM	.108	LR75NM	.109	LT30045	.60	LT7590NMSCR	.69
LL45	.41	LR85	.40	LT30045G	.60	LT75DC	.63
LL45 CGN	.41	LR85 CGN	.40	LT30090	.61	LT75G	.60
LL45 MT	.41	LR95	.40	LT30090DC	.63	LT75G SA	.60
LL45 MTC	.41	LR95 CGN	.40	LT30090 SA	.61	LT75NM	.68
LL50M	.46	LT100	.60	LT30090G	.61	LT75NMBL	.68
LL50M CG	.41	LT100 SA	.60	LT30090G SA	.61	LT75NMSCR	.69
LL50NM	.108	LT10045	.60	LT300DC	.63	LT75U90NM	.69
LL55	.41	LT10045G	.60	LT300G	.60	LTB100	.60
LL55 CGN	.41	LT10090	.61	LT300G SA	.60	LTB10045	.60

Catalog Number	Page	Catalog Number	Page	Catalog Number	Page	Catalog Number	Page
LTB10045G	.60	LTB38DC	.63	LTK12545	.66	MA500NM	.97
LTB10045GC	.60	LTB38G	.60	LTK12590	.66	MA50NM	.97
LTB10090	.61	LTB38GC	.60	LTK150	.66	MA600NM	.97
LTB10090DC	.63	LTB400	.60	LTK15045	.66	MA75NM	.97
LTB10090G	.61	LTB40045	.60	LTK15090	.66	MGMR0	.132
LTB10090GC	.61	LTB40045G	.60	LTK200	.66	MGMR1	.132
LTB100DC	.63	LTB40045GC	.60	LTK20045	.66	MGMR2	.132
LTB100G	.60	LTB40090	.61	LTK20090	.66	MGR0	.132
LTB100GC	.60	LTB40090DC	.63	LTK38	.66	MGR1	.132
LTB125	.60	LTB40090G	.61	LTK3845	.66	MGR2	.132
LTB12545	.60	LTB40090GC	.61	LTK3890	.66	MGR3	.132
LTB12545G	.60	LTB400DC	.63	LTK50	.66	MGR4	.132
LTB12545GC	.60	LTB400G	.60	LTK5045	.66	MGRK	.132
LTB12590	.61	LTB400GC	.60	LTK5090	.66	MGS1	.132
LTB12590DC	.63	LTB50	.60	LTK75	.66	MHUB1	.58
LTB12590G	.61	LTB500	.60	LTK7545	.66	MHUB10	.58
LTB12590GC	.61	LTB500G	.60	LTK7590	.66	MHUB11	.58
LTB125DC	.63	LTB5045	.60	LTKF100	.66	MHUB12	.58
LTB125G	.60	LTB5045G	.60	LTKF125	.66	MHUB2	.58
LTB125GC	.60	LTB5045GC	.60	LTKF150	.66	MHUB3	.58
LTB150	.60	LTB5090	.61	LTKF200	.66	MHUB4	.58
LTB15045	.60	LTB5090DC	.63	LTKF38	.66	MHUB5	.58
LTB15045G	.60	LTB5090G	.61	LTKF50	.66	MHUB6	.58
LTB15045GC	.60	LTB5090GC	.61	LTKF75	.66	MHUB7	.58
LTB15090	.61	LTB50DC	.63	LTQ100	.65	MHUB8	.58
LTB15090DC	.63	LTB50G	.60	LTQ10045	.65	MHUB9	.58
LTB15090G	.61	LTB50GC	.60	LTQ10090	.65	NCG100 100	.74
LTB15090GC	.61	LTB600	.60	LTQ125	.65	NCG38 35	.74
LTB150DC	.63	LTB600G	.60	LTQ150	.65	NCG50 50	.74
LTB150G	.60	LTB75	.60	LTQ200	.65	NCG75 75	.74
LTB150GC	.60	LTB7545	.60	LTQ38	.65	NCGS39	.256
LTB200	.60	LTB7545G	.60	LTQ50	.65	NCGS413	.256
LTB20045	.60	LTB7545GC	.60	LTQ5045	.65	NM12124JB	.103
LTB20045G	.60	LTB7590	.61	LTQ5090	.65	NM12126JB	.103
LTB20045GC	.60	LTB7590DC	.63	LTQ75	.65	NM16146JB	.103
LTB20090	.61	LTB7590G	.61	LTQ7545	.65	NM18186JB	.103
LTB20090DC	.63	LTB7590GC	.61	LTQ7590	.65	NM241812JB	.103
LTB20090G	.61	LTB75DC	.63	LTQB100	.65	NM24188JB	.103
LTB20090GC	.61	LTB75G	.60	LTQB10045	.65	NM24248JB	.103
LTB200DC	.63	LTB75GC	.60	LTQB10090	.65	NM36248JB	.103
LTB200G	.60	LTBK100	.66	LTQB125	.65	NM442JB	.103
LTB200GC	.60	LTBK10045	.66	LTQB150	.65	NM444JB	.103
LTB250	.60	LTBK10090	.66	LTQB200	.65	NM446JB	.103
LTB25045	.60	LTBK125	.66	LTQB38	.65	NM552JB	.103
LTB25045G	.60	LTBK12545	.66	LTQB50	.65	NM664JB	.103
LTB25045GC	.60	LTBK12590	.66	LTQB5045	.65	NM666JB	.103
LTB25090	.61	LTBK150	.66	LTQB5090	.65	NM884JB	.103
LTB25090DC	.63	LTBK15045	.66	LTQB75	.65	NM886JB	.103
LTB25090G	.61	LTBK15090	.66	LTQB7545	.65	NM887JB	.103
LTB25090GC	.61	LTBK200	.66	LTQB7590	.65	NPL1001000 304SS	.119
LTB250DC	.63	LTBK20045	.66	LTQF100	.65	NPL1001000 316SS	.119
LTB250G	.60	LTBK20090	.66	LTQF125	.65	NPL1001200 304SS	.119
LTB250GC	.60	LTBK38	.66	LTQF150	.65	NPL1001200 316SS	.119
LTB300	.60	LTBK3845	.66	LTQF200	.65	NPL100200 304SS	.119
LTB30045	.60	LTBK3890	.66	LTQF38	.65	NPL100200 316SS	.119
LTB30045G	.60	LTBK50	.66	LTQF50	.65	NPL100250 304SS	.119
LTB30045GC	.60	LTBK5045	.66	LTQF75	.65	NPL100250 316SS	.119
LTB30090	.61	LTBK5090	.66	LTR100	.64	NPL100300 304SS	.119
LTB30090DC	.63	LTBK75	.66	LTR100G	.64	NPL100300 316SS	.119
LTB30090G	.61	LTBK7545	.66	LTR125	.64	NPL100350 304SS	.119
LTB30090GC	.61	LTBK7590	.66	LTR125G	.64	NPL100350 316SS	.119
LTB300DC	.63	LTCOND100NM100	.70	LTR150	.64	NPL100400 304SS	.119
LTB300G	.60	LTCOND100NM500	.70	LTR150G	.64	NPL100400 316SS	.119
LTB300GC	.60	LTCOND100NMBL10	.70	LTR200	.64	NPL100500 304SS	.119
LTB350	.60	LTCOND125NM100	.70	LTR200G	.64	NPL100500 316SS	.119
LTB35045	.60	LTCOND125NMBL10	.70	LTR38	.64	NPL100600 304SS	.119
LTB35045G	.60	LTCOND150NM50	.70	LTR38G	.64	NPL100600 316SS	.119
LTB35045GC	.60	LTCOND150NMBL50	.70	LTR50	.64	NPL100800 304SS	.119
LTB35090	.61	LTCOND200NM50	.70	LTR50G	.64	NPL100800 316SS	.119
LTB35090DC	.63	LTCOND200NMBL50	.70	LTR75	.64	NPL100CL 304SS	.119
LTB35090G	.61	LTCOND38NM100	.70	LTR75G	.64	NPL100CL 316SS	.119
LTB35090GC	.61	LTCOND38NM1200	.70	LTWHP50NM4	.69	NPL1501000 304SS	.119
LTB350DC	.63	LTCOND38NMBL100	.70	LTWHP50NM6	.69	NPL1501000 316SS	.119
LTB350G	.60	LTCOND50NM100	.70	LTWHP75NM4	.69	NPL1501200 304SS	.119
LTB350GC	.60	LTCOND50NM1000	.70	LTWHP75NM6	.69	NPL1501200 316SS	.119
LTB38	.60	LTCOND50NMBL100	.70	MA100NM	.97	NPL150200 304SS	.119
LTB3845	.60	LTCOND75NM100	.70	MA125NM	.97	NPL150200 316SS	.119
LTB3845G	.60	LTCOND75NM800	.70	MA150NM	.97	NPL150250 304SS	.119
LTB3845GC	.60	LTCOND75NMBL100	.70	MA200NM	.97	NPL150250 316SS	.119
LTB3890	.61	LTK100	.66	MA250NM	.97	NPL150300 304SS	.119
LTB3890DC	.63	LTK10045	.66	MA300NM	.97	NPL150300 316SS	.119
LTB3890G	.61	LTK10090	.66	MA350NM	.97	NPL150350 304SS	.119
LTB3890GC	.61	LTK125	.66	MA400NM	.97	NPL150350 316SS	.119

Catalog Number	Page	Catalog Number	Page	Catalog Number	Page	Catalog Number	Page
NPL150400 304SS	119	PARC250HD	33	PF16TS 4SA275H20DDV	186	PFH3 40D258C203W3WV	183
NPL150400 316SS	119	PARC300HD	33	PF16TS 4SA275H20GGV	186	PFH3 40D258C20DDV	182
NPL150500 304SS	119	PARC350HD	33	PF16TS 4SA275I203W3WV	187	PFH3 40D258C20SPSPV	183
NPL150500 316SS	119	PARC400HD	33	PF16TS 4SA275I20DDV	186	PFH3 40D258H20DDV	182
NPL150600 304SS	119	PARC50HD	33	PF16TS 4SA275I20SPSPV	187	PFH3 40D258H20GGV	182
NPL150600 316SS	119	PARC75HD	33	PF16TS 4SA275S20GGV	186	PFH3 40D258I203W3WV	183
NPL150800 304SS	119	PARC75SS	117	PF16TS 4SA58C203WV	187	PFH3 40D258I20DDV	182
NPL150800 316SS	119	PE50	98	PF16TS 4SA58C20DV	186	PFH3 40D258I20SPSPV	183
NPL2001000 304SS	119	PE75	98	PF16TS 4SA58C20SPV	187	PFH3 40D258S20GGV	182
NPL2001000 316SS	119	PF16BO 40D258 5DN58 X	178	PF16TS 4SA58H20DV	186	PFH3 40D275	176
NPL2001200 304SS	119	PF16BO 40D258 X X	178	PF16TS 4SA58H20GV	186	PFH3 40D275C203W3WV	183
NPL2001200 316SS	119	PF16BO 40D275 5DN75 X	178	PF16TS 4SA58I203WV	187	PFH3 40D275C20DDV	182
NPL200200 304SS	119	PF16BO 40D275 X X	178	PF16TS 4SA58I20DV	186	PFH3 40D275C20SPSPV	183
NPL200200 316SS	119	PF16BO 40D58 5DN58 X	178	PF16TS 4SA58I20SPV	187	PFH3 40D275H20DDV	182
NPL200250 304SS	119	PF16BO 40D58 X X	178	PF16TS 4SA58S20GV	186	PFH3 40D275H20GGV	182
NPL200250 316SS	119	PF16BO 40D75 5DN75 X	178	PF16TS 4SA75C203WV	187	PFH3 40D275I203W3WV	183
NPL200300 304SS	119	PF16BO 40D75 X X	178	PF16TS 4SA75C20DV	186	PFH3 40D275I20DDV	182
NPL200300 316SS	119	PF16BO 4D258 5DN58 X	178	PF16TS 4SA75C20SPV	187	PFH3 40D275I20SPSPV	183
NPL200350 304SS	119	PF16BO 4D258 X X	178	PF16TS 4SA75H20DV	186	PFH3 40D275S20GGV	182
NPL200350 316SS	119	PF16BO 4D275 5DN75 X	178	PF16TS 4SA75H20GV	186	PFH3 40D58	176
NPL200400 304SS	119	PF16BO 4D275 X X	178	PF16TS 4SA75I203WV	187	PFH3 40D58C203WV	183
NPL200400 316SS	119	PF16BO 4D58 5DN58 X	178	PF16TS 4SA75I20DV	186	PFH3 40D58C20DV	182
NPL200500 304SS	119	PF16BO 4D58 X X	178	PF16TS 4SA75I20SPV	187	PFH3 40D58C20SPV	183
NPL200500 316SS	119	PF16BO 4D75 5DN75 X	178	PF16TS 4SA75S20GV	186	PFH3 40D58H20DV	182
NPL200600 304SS	119	PF16BO 4D75 X X	178	PF18FM 40D258	176	PFH3 40D58H20GV	182
NPL200600 316SS	119	PF16TS 4D258	177	PF18FM 40D258C20DDV	184	PFH3 40D58I203WV	183
NPL200800 304SS	119	PF16TS 4D275	177	PF18FM 40D258H20DDV	184	PFH3 40D58I20DV	182
NPL200800 316SS	119	PF16TS 4D2AR	177	PF18FM 40D258I20DDV	184	PFH3 40D58I20SPV	183
NPL501000 304SS	119	PF16TS 4D58	177	PF18FM 40D275	176	PFH3 40D58S20GV	182
NPL501000 316SS	119	PF16TS 4D75	177	PF18FM 40D275C20DDV	184	PFH3 40D75	176
NPL501200 304SS	119	PF16TS 4DA258C203W3WV	187	PF18FM 40D275H20DDV	184	PFH3 40D75C203WV	183
NPL501200 316SS	119	PF16TS 4DA258C20DDV	186	PF18FM 40D275I20DDV	184	PFH3 40D75C20DV	182
NPL50200 304SS	119	PF16TS 4DA258C20SPSPV	187	PF18FM 40D58	176	PFH3 40D75C20SPV	183
NPL50200 316SS	119	PF16TS 4DA258H20DDV	186	PF18FM 40D58C20DV	184	PFH3 40D75H20DV	182
NPL50250 304SS	119	PF16TS 4DA258H20GGV	186	PF18FM 40D58H20DV	184	PFH3 40D75H20GV	182
NPL50250 316SS	119	PF16TS 4DA258I203W3WV	187	PF18FM 40D58I20DV	184	PFH3 40D75I203WV	183
NPL50300 304SS	119	PF16TS 4DA258I20DDV	186	PF18FM 40D75	176	PFH3 40D75I20DV	182
NPL50300 316SS	119	PF16TS 4DA258I20SPSPV	187	PF18FM 40D75C20DV	184	PFH3 40D75I20SPV	183
NPL50350 304SS	119	PF16TS 4DA258S20GGV	186	PF18FM 40D75H20DV	184	PFH3 40D75S20GV	182
NPL50350 316SS	119	PF16TS 4DA275C203W3WV	187	PF18FM 40D75I20DV	184	PFH3 40DAR	176
NPL50400 304SS	119	PF16TS 4DA275C20DDV	186	PF18FM 40DAR	176	PFH3 40S258C203W3WV	183
NPL50400 316SS	119	PF16TS 4DA275C20SPSPV	187	PF18FM 40S258C20DDV	184	PFH3 40S258C20DDV	182
NPL50500 304SS	119	PF16TS 4DA275H20DDV	186	PF18FM 40S258H20DDV	184	PFH3 40S258C20SPSPV	183
NPL50500 316SS	119	PF16TS 4DA275H20GGV	186	PF18FM 40S258I20DDV	184	PFH3 40S258H20DDV	182
NPL50600 304SS	119	PF16TS 4DA275I203W3WV	187	PF18FM 40S275C20DDV	184	PFH3 40S258H20GGV	182
NPL50600 316SS	119	PF16TS 4DA275I20DDV	186	PF18FM 40S275H20DDV	184	PFH3 40S258I203W3WV	183
NPL50800 304SS	119	PF16TS 4DA275I20SPSPV	187	PF18FM 40S275I20DDV	184	PFH3 40S258I20DDV	182
NPL50800 316SS	119	PF16TS 4DA275S20GGV	186	PF18FM 40S58C20DV	184	PFH3 40S258I20SPSPV	183
NPL50CL 304SS	119	PF16TS 4DA58C203WV	187	PF18FM 40S58H20DV	184	PFH3 40S258S20GGV	182
NPL50CL 316SS	119	PF16TS 4DA58C20DV	186	PF18FM 40S58I20DV	184	PFH3 40S275C203W3WV	183
NPL751000 304SS	119	PF16TS 4DA58C20SPV	187	PF18FM 40S75C20DV	184	PFH3 40S275C20DDV	182
NPL751000 316SS	119	PF16TS 4DA58H20DV	186	PF18FM 40S75H20DV	184	PFH3 40S275C20SPSPV	183
NPL751200 304SS	119	PF16TS 4DA58H20GV	186	PF18FM 40S75I20DV	184	PFH3 40S275H20DDV	182
NPL751200 316SS	119	PF16TS 4DA58I203WV	187	PF18FM 4D258	176	PFH3 40S275H20GGV	182
NPL75200 304SS	119	PF16TS 4DA58I20DV	186	PF18FM 4D275	176	PFH3 40S275I203W3WV	183
NPL75200 316SS	119	PF16TS 4DA58I20SPV	187	PF18FM 4D58	176	PFH3 40S275I20DDV	182
NPL75250 304SS	119	PF16TS 4DA58S20GV	186	PF18FM 4D75	176	PFH3 40S275I20SPSPV	183
NPL75250 316SS	119	PF16TS 4DA75C203WV	187	PF18FM 4DAR	176	PFH3 40S275S20GGV	182
NPL75300 304SS	119	PF16TS 4DA75C20DV	186	PF18FM 4S258	176	PFH3 40S58C203WV	183
NPL75300 316SS	119	PF16TS 4DA75C20SPV	187	PF18FM 4S275	176	PFH3 40S58C20DV	182
NPL75350 304SS	119	PF16TS 4DA75H20DV	186	PF18FM 4S58	176	PFH3 40S58C20SPV	183
NPL75350 316SS	119	PF16TS 4DA75H20GV	186	PF18FM 4S75	176	PFH3 40S58H20DV	182
NPL75400 304SS	119	PF16TS 4DA75I203WV	187	PF3MM 40D258 5DN58 X	177	PFH3 40S58H20GV	182
NPL75400 316SS	119	PF16TS 4DA75I20DV	186	PF3MM 40D258 X X	177	PFH3 40S58I203WV	183
NPL75500 304SS	119	PF16TS 4DA75I20SPV	187	PF3MM 40D275 5DN75 X	177	PFH3 40S58I20DV	182
NPL75500 316SS	119	PF16TS 4DA75S20GV	186	PF3MM 40D275 X X	177	PFH3 40S58I20SPV	183
NPL75600 304SS	119	PF16TS 4DAR	177	PF3MM 40D58 5DN58 X	177	PFH3 40S58S20GV	182
NPL75600 316SS	119	PF16TS 4S258	177	PF3MM 40D58 X X	177	PFH3 40S75C203WV	183
NPL75800 304SS	119	PF16TS 4S275	177	PF3MM 40D75 5DN75 X	177	PFH3 40S75C20DDV	182
NPL75800 316SS	119	PF16TS 4S58	177	PF3MM 40D75 X X	177	PFH3 40S75C20SPV	183
NPL75CL 304SS	119	PF16TS 4S75	177	PF3MM 4D258 5DN58 X	177	PFH3 40S75H20DV	182
NPL75CL 316SS	119	PF16TS 4SA258C203W3WV	187	PF3MM 4D258 X X	177	PFH3 40S75H20GGV	182
NS 1	15, 30	PF16TS 4SA258C20DDV	186	PF3MM 4D275 5DN75 X	177	PFH3 40S75I203WV	183
NS 2	15, 30	PF16TS 4SA258C20SPSPV	187	PF3MM 4D275 X X	177	PFH3 40S75I20DV	182
NS 3	15, 30	PF16TS 4SA258H20DDV	186	PF3MM 4D58 5DN58 X	177	PFH3 40S75I20SPV	183
NSS1	15, 30	PF16TS 4SA258H20GGV	186	PF3MM 4D75 5DN75 X	177	PFH3 40S75S20GV	182
NSS2	15, 30	PF16TS 4SA258I203W3WV	187	PF3MM 4D75 5DN75 X	177	PFH3 4D258	176
NSS3	15, 30	PF16TS 4SA258I20DDV	186	PF3MM 4D75 X X	177	PFH3 4D275	176
PARC100HD	33	PF16TS 4SA258I20SPSPV	187	PFBH24 278N	178	PFH3 4D58	176
PARC100SS	117	PF16TS 4SA258S20GGV	186	PFBH24 292N	178	PFH3 4D75	176
PARC125HD	33	PF16TS 4SA275C203W3WV	187	PFBH24 4DN	178	PFH3 4DAR	176
PARC150HD	33	PF16TS 4SA275C20DDV	186	PFBH24 4SN	178	PFH3 4S258	176
PARC200HD	33	PF16TS 4SA275C20SPSPV	187	PFH3 40D258	176	PFH3 4S275	176

Catalog Number	Page	Catalog Number	Page	Catalog Number	Page	Catalog Number	Page
PFH3 4S58	176	RAC75HD	32	RLB30045	21	SLB1	90
PFH3 4S75	176	RAC75SS	117	RLB30090	21	SLB2	90
PFUBV18 40D258C20DDV	185	RBSS21	114	RLB35045	21	SLB3	90
PFUBV18 40D258H20DDV	185	RBSS31	114	RLB35090	21	SLB4	90
PFUBV18 40D258I20DDV	185	RBSS32	114	RLB40045	21	SLB5	90
PFUBV18 40D275C20DDV	185	RBSS51	114	RLB40090	21	SLB6	90
PFUBV18 40D275H20DDV	185	RBSS52	114	RLB5045	21	SSACB100	77, 82
PFUBV18 40D275I20DDV	185	RBSS53	114	RLB5090	21	SSACB38	77, 82
PFUBV18 40D58C20DV	185	RBSS61	114	RLB5090 304SS	118	SSACB50	77, 82
PFUBV18 40D58H20DV	185	RBSS62	114	RLB5090 316SS	118	SSACB75	77, 82
PFUBV18 40D58I20DV	185	RBSS63	114	RLB7545	21	SSBC100	4
PFUBV18 40D75C20DV	185	RBSS65	114	RLB7590	21	SSBC50	4
PFUBV18 40D75H20DV	185	RC100	20	RLB7590 304SS	118	SSBC75	4
PFUBV18 40D75I20DV	185	RC100 304SS	120	RLB7590 316SS	118	SSC100	8
PFUBV18 40S258C20DDV	185	RC100 316SS	120	S 1 1/2 PAINTED	204	SSC50	8
PFUBV18 40S258H20DDV	185	RC125	20	S 1 1/2 UNPAINTED	204	SSC75	8
PFUBV18 40S258I20DDV	185	RC150	20	S 1 3/8 PAINTED	204	SSLT100	67
PFUBV18 40S275C20DDV	185	RC150 304SS	120	S 1 3/8 UNPAINTED	204	SSLT100G	67
PFUBV18 40S275H20DDV	185	RC150 316SS	120	S1031	24	SSLT38	67
PFUBV18 40S275I20DDV	185	RC200	20	S1032	24	SSLT38G	67
PFUBV18 40S58C20DV	185	RC200 304SS	120	S1033	24	SSLT50	67
PFUBV18 40S58H20DV	185	RC200 316SS	120	S1034	24	SSLT50G	67
PFUBV18 40S58I20DV	185	RC250	20	S1035	24	SSLT75	67
PFUBV18 40S75C20DV	185	RC250 304SS	120	S1036	24	SSLT75G	67
PFUBV18 40S75H20DV	185	RC250 316SS	120	S1037	24	SSR1	18
PFUBV18 40S75I20DV	185	RC300	20	S1038	24	SSR11	18
PLG100SS	115	RC300 304SS	120	S1039	24	SSR12	18
PLG105M	38	RC300 316SS	120	S1040	24	SSR13	18
PLG10M	38	RC350	20	S1041	24	SSR14	18
PLG150SS	115	RC400	20	S1042	24	SSR15	18
PLG15M	38	RC400 304SS	120	SA 1W	204	SSR16	18
PLG1M	38	RC400 316SS	120	SG1	34, 64	SSR2	18
PLG200SS	115	RC50	20	SG10	34, 64	SSR21	18
PLG25M	38	RC50 304SS	120	SG11	34, 64	SSR22	18
PLG2M	38	RC50 316SS	120	SG12	34, 64	SSR23	18
PLG35M	38	RC500	20	SG2	34, 64	SSR24	18
PLG3M	38	RC600	20	SG3	34, 64	SSR25	18
PLG45M	38	RC75	20	SG4	34, 64	SSR26	18
PLG4M	38	RC75 304SS	120	SG5	34, 64	SSR3	18
PLG50SS	115	RC75 316SS	120	SG6	34, 64	SSR4	18
PLG55M	38	RCM1	50	SG7	34, 64	SSR5	18
PLG5M	38	RCOND100 304SS	118	SG8	34, 64	SSR6	18
PLG65M	38	RCOND100 316SS	118	SG9	34, 64	SSRT100	8
PLG6M	38	RCOND150 304SS	118	SGCK1	131	SSRT500	8
PLG75M	38	RCOND150 316SS	118	SGD1	131	SSRT75	8
PLG75SS	115	RCOND200 304SS	118	SGD1 BULK	131	SSTC 1	54
PLG7M	38	RCOND200 316SS	118	SGD2	131	SSTC 1CD	54
PLG85M	38	RCOND250 304SS	118	SGD2 BULK	131	SSTG 1	51
PLG8M	38	RCOND250 316SS	118	SGH6	131	SSTG 10	51
PLG95M	38	RCOND300 304SS	118	SGJ6	131	SSTG 2	51
PLG9M	38	RCOND300 316SS	118	SGLV14	131	SSTG 3	51
PPC 100	37	RCOND400 304SS	118	SGMB1	131	SSTG 4	51
PPC 125	37	RCOND400 316SS	118	SGMR0	131	SSTG 5	51
PPC 150	37	RCOND50 304SS	118	SGMR1	131	SSTG 6	51
PPC 200	37	RCOND50 316SS	118	SGMR2	131	SSTG 7	51
PPC 250	37	RCOND75 304SS	118	SGMR3	131	SSTG 8	51
PPC 300	37	RCOND75 316SS	118	SGMR4	131	SSTG 9	51
PPC 350	37	RCS1	50	SGMR5	131	SSTG 10	51
PPC 400	37	RED10075	100	SGP14	131	SSTGK 1	52
PPC 50	37	RED125100	100	SGP20	131	SSTGK 2	52
PPC 75	37	RED150125	100	SGR03	131	SSTGK 3	52
QLK50D	77, 82	RED200150	100	SGR04	131	SSTGK 4	52
QLK50S	77, 82	RED250200	100	SGR1	131	SSTGK 5	52
QLK75	77, 82	RED300250	100	SGR2	131	SSTGK 6	52
R5075JBOX	103	RED400300	100	SGR3	131	SSTM 1	54
RAC100HD	32	RED400350	100	SGR4	131	SSTM 2	54
RAC100SS	117	RED7550	100	SGRK1	131	SSTM 3	54
RAC125HD	32	RLB10045	21	SGT1	131	SSTM 4	54
RAC125SS	117	RLB10090	21	SGT1 BULK	131	SSTM 5	54
RAC150HD	32	RLB10090 304SS	118	SGT2	131	SSTM 6	54
RAC150SS	117	RLB10090 316SS	118	SGT2 BULK	131	SSTM4	54
RAC200HD	32	RLB12545	21	SL1	35	ST 02	55
RAC200SS	117	RLB12590	21	SL10	35	ST 03	51, 55
RAC250HD	32	RLB15045	21	SL11	35	ST 1	51, 55
RAC250SS	117	RLB15090	21	SL12	35	ST 10	51, 55
RAC300HD	32	RLB15090 304SS	118	SL2	35	ST 11	51, 55
RAC300SS	117	RLB15090 316SS	118	SL3	35	ST 12	51, 55
RAC350HD	32	RLB20045	21	SL4	35	ST 2	51, 55
RAC350SS	117	RLB20090	21	SL5	35	ST 3	51, 55
RAC400HD	32	RLB20090 304SS	118	SL6	35	ST 4	51, 55
RAC400SS	117	RLB20090 316SS	118	SL7	35	ST 5	51, 55
RAC50HD	32	RLB25045	21	SL8	35	ST 6	51, 55
RAC50SS	117	RLB25090	21	SL9	35	ST 7	51, 55
						ST 8	51, 55
						ST 9	51, 55

Catalog Number	Page	Catalog Number	Page	Catalog Number	Page	Catalog Number	Page
ST100PVC	102	STTB 3	53	T65 MT	42	TP16007	171
ST125PVC	102	STTB 4	53	T65 MTC	42	TP16008	171
ST150PVC	102	STTB 5	53	T68SS	111	TP16012	171
ST200PVC	102	STTB 6	53	T75	42	TP16022	171
ST250PVC	102	STTB 7	53	T75 CGN	42	TP16023	171
ST300PVC	102	STTB 8	53	T75M	46	TP16099	170
ST400PVC	102	STTB 9	53	T75M CG	46	TP161	143
ST50PVC	102	STTBA 1	53	T75NM	109	TP16107	171
ST75PVC	102	STTBA 2	53	T85	42	TP16108	171
STA 1	51	STTBA 3	53	T85 CGN	42	TP16110	171
STA 10	51	STTBA 4	53	T95	42	TP16111	171
STA 11	51	STTBA 5	53	T95 CGN	42	TP16112	171
STA 12	51	STTBA 6	53	TB100M	47	TP16113	171
STA 2	51	STTBA 7	53	TB100M CG	46	TP16122	171
STA 3	51	STTBA 8	53	TB125M	47	TP16123	171
STA 4	51	STTTB 1	53	TB125M CG	46	TP162	143
STA 5	51	STTTB 2	53	TB15	42	TP16200	170
STA 6	51	STTTB 3	53	TB15 ICG	42	TP16201	170
STA 7	51	STTTB 4	53	TB150M	47	TP163	143
STA 8	51	STTTB 5	53	TB150M CG	46	TP16307	170
STA 9	51	STTTB 6	53	TB200M	47	TP16308	170
STAC 1	53	STTTBA 1	53	TB200M CG	46	TP16310	170
STAC 1CD	54	STTTBA 2	53	TB25	42	TP16311	170
STAC 1ST	54	STTTBA 3	53	TB25 ICG	42	TP16317	170
STAC 2	53	STTTBA 4	53	TB28SS	111	TP16318	170
STAC 3	53	STTTBA 5	53	TB35	42	TP164	143
STAG 1	52	STTTBA 6	53	TB35 ICG	42	TP16511	162, 171
STAG 10	52	SWCM1	50	TB38SS	111	TP168	143
STAG 11	52	SWCS1	50	TB45	42	TP1690	166
STAG 12	52	T100M	46	TB50M	47	TP170	143
STAG 2	52	T100M CG	46	TB50M CG	46	TP171	143
STAG 3	52	T100NM	109	TB55	42	TP172	143
STAG 4	52	T105	42	TB58SS	111	TP174	143
STAG 5	52	T105 CGN	42	TB65	42	TP177	144
STAG 6	52	T125M	46	TB68SS	111	TP178	144
STAG 7	52	T125M CG	46	TB75M	47	TP179	144
STAG 8	52	T125NM	109	TB75M CG	46	TP180	144
STAG 9	52	T15	42	TCC1	19	TP1800	166
STAGN 1	53	T15 CGN	42	TCC10	19	TP1802	166
STAGN 2	53	T15 ICG	42	TCC12	19	TP1832	166
STAGN 3	53	T15 MT	42	TCC14	19	TP184	144
STAGN 4	53	T15 MTC	42	TCC2	19	TP185	144
STAGN 5	53	T150M	46	TCC3	19	TP188	145
STAGN 6	53	T150M CG	46	TCC4	19	TP190	145
STC 1	53	T150NM	109	TCC5	19	TP1900	169
STC 2	53	T18SS	111	TCC6	19	TP1930	169
STC 3	53	T200M	46	TCC7	19	TP196	145
STC 4	53	T200M CG	46	TCC8	19	TP2000	166
STC 5	53	T200NM	109	TCC9	19	TP2002	166
STC 6	53	T25	42	TP100	141	TP2020	166
STG 1	52	T25 CGN	42	TP1000	168	TP2030	166
STG 10	52	T25 ICG	42	TP1009	169	TP214	145
STG 11	52	T25 MT	42	TP101	141	TP216	145
STG 12	52	T25 MTC	42	TP1010	169	TP217	145
STG 2	52	T250M	46	TP1013	169	TP218	145
STG 3	52	T250NM	109	TP1014	169	TP220	145
STG 4	52	T28SS	111	TP1020	169	TP222	145
STG 5	52	T300M	46	TP1023	169	TP224	145
STG 6	52	T300NM	109	TP1024	169	TP2300	166
STG 7	52	T35	42	TP103	141	TP2302	166
STG 8	52	T35 CGN	42	TP104	141	TP2332	166
STG 9	52	T35 ICG	42	TP1040	172	TP236	147
STGK 1	52	T35 MT	42	TP1045	172	TP238	147
STGK 2	52	T35 MTC	42	TP106	141	TP239	147
STGK 3	52	T350M	46	TP114	141	TP240	147
STGK 4	52	T350NM	109	TP115	143	TP242	147
STGK 5	52	T38SS	111	TP116	142	TP243	147
STGK 6	52	T400M	46	TP118	142	TP244	148
STGN 1	52	T400NM	109	TP120	142	TP246	148
STGN 2	52	T45	42	TP123	142	TP248	148
STGN 3	52	T45 CGN	42	TP124	142	TP249	148
STGN 4	52	T45 MT	42	TP126	142	TP250	148
STGN 5	52	T45 MTC	42	TP130	142	TP252	148
STGN 6	52	T50M	46	TP1300	162, 172	TP254	148
STM 1	54	T50M CG	46	TP131	142	TP256	154
STM 2	54	T50NM	109	TP132	142	TP258	154
STM 3	54	T55	42	TP134	143	TP259	154
STM 4	54	T55 CGN	42	TP137	143	TP260	154
STM 5	54	T55 MT	42	TP138	143	TP261	161
STM 6	54	T55 MTC	42	TP158	143	TP264	154
STTB 1	53	T58SS	111	TP1600	166	TP266	153
STTB 10	53	T65	42	TP16002	171	TP267	153
STTB 2	53	T65 CGN	42	TP16003	171	TP269	153

Catalog Number	Page	Catalog Number	Page	Catalog Number	Page	Catalog Number	Page
TP270	153	TP3240DPF	175	TP3740DPF	175	TP474	130
TP272	153	TP3240S C203WV	180	TP3740S C203W3WV	180	TP475	130
TP273	154	TP3240S C20DV	179	TP3740S C20DDV	179	TP476	130
TP274	154	TP3240S C20SPV	180	TP3740S C20SPSPV	180	TP477	130
TP275	161	TP3240S H20DV	179	TP3740S H20DDV	179	TP478	130
TP276	154	TP3240S H20GV	179	TP3740S H20GGV	179	TP479	130
TP278	154	TP3240S I203WV	180	TP3740S I203W3WV	180	TP480	130
TP280	154	TP3240S I20DV	179	TP3740S I20DDV	179	TP482	130
TP282	154	TP3240S I20SPV	180	TP3740S I20SPSPV	180	TP483	130
TP284	154	TP3240S S20GV	179	TP3740S S20GGV	179	TP484	130
TP286	154	TP32414PF	174	TP37414PF	174	TP486	130
TP288	156	TP32431PF	175	TP37431PF	175	TP487	130
TP288PF	156	TP32434PF	174	TP37434PF	174	TP488	130
TP290	156	TP32454PF	175	TP37454PF	175	TP489	130
TP290PF	156	TP326	158	TP377	157	TP490	130
TP292	156	TP328	158	TP379	161	TP494	130
TP292PF	156	TP329	158	TP391	129	TP496	130
TP292RED	156	TP330	158	TP395	129	TP498	130
TP294	156	TP331	158	TP403	127	TP499	130
TP298	155	TP332	158	TP403PF	127	TP500	130
TP300	155	TP333	158	TP403RED	127	TP501	130
TP30000	133	TP334	158	TP403SSB	127	TP502	130
TP301	161	TP335	158	TP404	125	TP503	132
TP302	155	TP336	158	TP404PF	125	TP504	132
TP304	155	TP338	156	TP404RED	125	TP506	132
TP30403PF	174	TP338PF	156	TP404SSB	125	TP507	132
TP30404PF	174	TP339	156	TP405	125	TP508	132
TP3040DPF	175	TP3490	167	TP408	124	TP509	132
TP30414PF	174	TP35000	133	TP410	125	TP510	132
TP30431PF	175	TP35403PF	174	TP412	125	TP511	132
TP30434PF	174	TP35404PF	174	TP414	125	TP512	132
TP30454PF	175	TP3540DPF	175	TP414RED	125	TP513	132
TP306	155	TP35414PF	174	TP418	125	TP514	132
TP308	155	TP35431PF	175	TP422	129	TP515	132
TP310	155	TP35434PF	174	TP423	125	TP516	132
TP31000	133	TP35454PF	175	TP423RED	125	TP517	132
TP312	155	TP356	157	TP424	129	TP518	132
TP314	155	TP3600	167	TP425	125	TP519	132
TP31403PF	174	TP36000	133	TP426	129	TP520	134
TP31404PF	174	TP3602	167	TP428	129	TP521	136
TP3140D C203WV	180	TP3630	167	TP428RED	129	TP521PF	136
TP3140D C20DV	179	TP3632	167	TP431	128	TP522	134
TP3140D C20SPV	180	TP3635	167	TP431PF	128	TP523	135
TP3140D H20DV	179	TP36403PF	174	TP431SSB	128	TP523PF	135
TP3140D H20GV	179	TP36404PF	174	TP432	127	TP524	134
TP3140D I203WV	180	TP3640D C203W3WV	180	TP432VMS	127	TP525	136
TP3140D I20DV	179	TP3640D C20DDV	179	TP434	127	TP526	134
TP3140D I20SPV	180	TP3640D C20SPSPV	180	TP434RED	127	TP528	134
TP3140D S20GV	179	TP3640D H20DDV	179	TP436	127	TP529	138
TP3140DPF	175	TP3640D H20GGV	179	TP437	127	TP530	134
TP3140S C203WV	180	TP3640D I203W3WV	180	TP438	127	TP531	138
TP3140S C20DV	179	TP3640D I20DDV	179	TP438PF	127	TP532	134
TP3140S C20SPV	180	TP3640D I20SPSPV	180	TP440	128	TP534	134
TP3140S H20DV	179	TP3640D S20GGV	179	TP443	129	TP536	134
TP3140S H20GV	179	TP3640DPF	175	TP444	126	TP538	134
TP3140S I203WV	180	TP3640S C203W3WV	180	TP444SSB	126	TP540	134
TP3140S I20DV	179	TP3640S C20DDV	179	TP445	126	TP541	138
TP3140S I20SPV	180	TP3640S C20SPSPV	180	TP446	126	TP542	134
TP3140S S20GV	179	TP3640S H20DDV	179	TP449	126	TP543	138
TP31414PF	174	TP3640S H20GGV	179	TP450	128	TP548	135
TP31431PF	175	TP3640S I203W3WV	180	TP450SSB	128	TP549	135
TP31434PF	174	TP3640S I20DDV	179	TP451	127	TP550	137
TP31436PF	174	TP3640S I20SPSPV	180	TP451PF	127	TP554	136
TP31454PF	175	TP3640S S20GGV	179	TP451RED	127	TP556	136
TP315	161	TP36414PF	174	TP452	128	TP556PF	136
TP316	156	TP36431PF	175	TP454	126	TP556RED	136
TP317	156	TP36434PF	174	TP454PF	126	TP557	136
TP318	156	TP36454PF	175	TP454SSB	126	TP558	136
TP320	156	TP367	157	TP456	126	TP560	136
TP32000	133	TP367PF	157	TP456PF	126	TP562	136
TP322	158	TP37000	133	TP459	126	TP563	136
TP323	158	TP372	157	TP4600	167	TP564	137
TP32403PF	174	TP37403PF	174	TP4602	167	TP564RED	137
TP32404PF	174	TP37404PF	174	TP461	126	TP568	138
TP3240D C203WV	180	TP3740D C203W3WV	180	TP4630	167	TP568RED	138
TP3240D C20DV	179	TP3740D C20DDV	179	TP4632	167	TP569	138
TP3240D C20SPV	180	TP3740D C20SPSPV	180	TP4635	167	TP570	138
TP3240D H20DV	179	TP3740D H20DDV	179	TP465	129	TP571	138
TP3240D H20GV	179	TP3740D H20GGV	179	TP467	125	TP572	138
TP3240D I203WV	180	TP3740D I203W3WV	180	TP469	125	TP573	138
TP3240D I20DV	179	TP3740D I20DDV	179	TP472	130	TP574	138
TP3240D I20SPV	180	TP3740D I20SPSPV	180	TP472RED	130	TP575	138
TP3240D S20GV	179	TP3740D S20GGV	179	TP473	130	TP576	138

Catalog Number	Page	Catalog Number	Page	Catalog Number	Page	Catalog Number	Page
TP578	.138	TP683	.151	TP7214PVC	.106	TP7471	.207
TP579	.138	TP684	.151	TP7218	.197	TP7472	.207
TP580	.138	TP685	.151	TP7218PVC15	.107	TP7474	.207
TP582	.138	TP686	.151	TP7218PVC20	.107	TP7475	.207
TP583	.138	TP687	.151	TP7218PVC30	.107	TP7476	.207
TP584	.138	TP690	.151	TP7218PVC50	.107	TP7477	.207
TP586	.138	TP691	.151	TP722	.139	TP7478	.206
TP587	.138	TP692	.151	TP7220	.198	TP7479	.206
TP588	.140	TP693	.151	TP7224	.198	TP7488	.199
TP589	.138	TP694	.151	TP7224PVC	.107	TP7488W	.199
TP590	.138	TP695	.151	TP7228	.198	TP7489	.199
TP591	.140	TP701	.163	TP7228PVC	.107	TP7489W	.199
TP592	.140	TP7010	.193	TP7229PVC	.107	TP7491	.199
TP593	.138	TP7011	.193	TP7230PVC	.106	TP7491W	.199
TP594	.140	TP7012	.193	TP7232	.197	TP7496	.206
TP596	.140	TP7018	.193	TP7233	.197	TP7497	.206
TP598	.140	TP7026	.193	TP7236	.197	TP7498	.206
TP600	.140	TP7034	.193	TP7237	.197	TP7499	.206
TP602	.140	TP704	.163	TP7238	.197	TP7600	.205
TP604	.140	TP7042	.193	TP724	.139	TP7601	.205
TP605	.140	TP7050	.193	TP7240	.197	TP7610	.205
TP606	.140	TP7058	.193	TP7240PVC	.107	TP7611	.205
TP608	.140	TP706	.163	TP7241	.197	TP7620	.205
TP610	.140	TP7066	.193	TP7242	.197	TP7621	.205
TP6100	.167	TP7074	.193	TP7244	.198	TP7630	.205
TP6102	.167	TP7078	.193	TP7248	.198	TP7640	.205
TP612	.140	TP708	.164	TP7252	.198	TP7650	.205
TP613	.140	TP7082	.193	TP726	.139	TP7660	.206
TP6132	.167	TP7086	.194	TP7260	.198	TP7670	.206
TP6135	.167	TP7087	.194	TP7268	.198	TP7680	.206
TP614	.140	TP7088	.194	TP7268PVC	.106	TP7800	.205, 207
TP616	.140	TP709	.164	TP7272	.198	TP7801	.205
TP618	.140	TP7090	.194	TP7276	.198	TP7805	.205
TP6180	.167	TP7094	.194	TP728	.139	TP7810	.205, 207
TP620	.159	TP7098	.194	TP7280	.198	TP7811	.205
TP622	.159	TP710	.133, 163	TP7280PVC	.106	TP7815	.205
TP623	.159	TP7102	.194	TP7288PVC	.107	TP7820	.205, 207
TP624	.159	TP7106	.194	TP7292	.200	TP7825	.205
TP628	.159	TP711	.163	TP7293	.200	TP7825	.205
TP629	.149	TP7110	.194	TP7294	.200	TP7830	.206, 207
TP630	.149	TP7114	.194	TP7295	.200	TP7835	.206
TP631	.149	TP7118	.194	TP7296	.200	TP7840	.206, 207
TP632	.144	TP7120	.195	TP7297	.200	TP7860	.205
TP633	.144	TP7122	.194	TP7298	.200	TP7870	.206
TP634	.159	TP7123	.195	TP730	.139	TP7925	.208
TP635	.159	TP7126	.194	TP7300	.200	TP7927	.208
TP636	.159	TP7130	.194	TP7301	.200	TP7928	.208
TP637	.144	TP7134	.194	TP7302	.200	TP7940	.197
TP638	.144	TP7137	.194	TP7308	.200	TP7942	.197
TP639	.159	TP7138	.194	TP7309	.200	TP7944	.197
TP640	.149	TP7142	.194	TP7310	.200	TP7948	.197
TP641	.149	TP7143	.194	TP7312	.200	TP802	.150
TP642	.159	TP7144	.194	TP7313	.200	TP803	.150
TP643	.160	TP7146	.196	TP7314	.200	TP804	.150
TP644	.159	TP7147	.196	TP7316	.200	TP805	.150
TP647	.140	TP7148	.196	TP7317	.200	TP806	.150
TP648	.160	TP7149	.196	TP7318	.200	TP820	.151
TP649	.160	TP7150	.196	TP732	.139	TP821	.151
TP650	.160	TP7151	.196	TP7320	.200	TP830	.125
TP651	.163	TP7152	.196	TP7321	.200	TP831	.127
TP652	.160	TP7158	.200	TP7322	.200	TP832	.136
TP653	.150	TP7159	.200	TP7330	.201	TP833	.129
TP654	.152	TP7160	.200	TP7331	.201	TP834	.154
TP655	.150	TP7162	.201	TP7332	.201	TP835	.136
TP656	.152	TP7163	.201	TP734	.139	TP836	.136
TP657	.150	TP7164	.201	TP736	.139	TP837	.137
TP659	.164	TP7165	.201	TP738	.139	TP838	.156
TP660	.146	TP7166	.201	TP740	.139	TP839	.125
TP661	.150	TP7170	.201	TP741	.139	TP842	.136
TP662	.146	TP7173	.195	TP7440	.206	TP850	.130
TP664	.146	TP7174	.195	TP7445	.206	TP851	.138
TP667	.150	TP7176	.201	TP7446	.206	TP852	.138
TP668	.146	TP7178	.201	TP7447	.206	TP853	.158
TP670	.146	TP7186	.201	TP7450	.206	TP854	.130
TP671	.152	TP7188	.201	TP7451	.206	TP860	.134
TP672	.147	TP7199	.197	TP7460	.207	TP861	.134
TP674	.147	TP720	.139	TP7462	.207	TP862	.134
TP675	.152	TP7202	.197	TP7463	.207	TP863	.134
TP676	.147	TP7206	.197	TP7464	.207	TP870	.149
TP677	.147	TP7207	.197	TP7466	.207	TP871	.149
TP678	.147	TP7208	.197	TP7468	.207	TP872	.149
TP680	.147	TP7209	.197	TP7469	.207	TP873	.149
TP682	.151	TP7214	.197	TP7470	.207	TP874	.149

Catalog Number	Page	Catalog Number	Page	Catalog Number	Page	Catalog Number	Page
TP876	.149	WCB100604	.213	WJB241810	.211	WTC75U	.90
TP877	.149	WCB100804	.213	WJB241812	.211	X100M	.47
TP900	.163	WCB100806	.213	WJB241818	.211	X100M CG	.47
TP901	.163	WCB101006	.213	WJB242412	.211	X125M	.47
TP902	.163	WCB120604	.213	WJB242418	.211	X125M CG	.47
TPFSS	.168	WCB120606	.213	WJB242424	.211	X15	.42
TPRFH12	.158, 204	WCB120806	.213	WJB302412	.211	X15 ICG	.42
TPSFH12	.129, 204	WCB120808	.213	WJB302418	.211	X150M	.47
UBM100HD	.33	WCB121204	.214	WJB362418	.211	X150M CG	.47
UBM100SS	.115	WCB121206	.214	WJB362424	.211	X200M	.47
UBM125HD	.33	WCB121208	.214	WJBF040404	.210	X200M CG	.47
UBM125SS	.115	WCB160606	.214	WJBF060404	.210	X25	.42
UBM150HD	.33	WCB161208	.214	WJBF060604	.210	X25 ICG	.42
UBM150SS	.115	WCB181206	.214	WJBF060606	.210	X35	.42
UBM200HD	.33	WCB181208	.214	WJBF080604	.210	X35 ICG	.42
UBM200SS	.115	WCB181210	.214	WJBF080606	.210	X45	.42
UBM250HD	.33	WCB181806	.214	WJBF080804	.210	X50M	.47
UBM250SS	.115	WCB181812	.214	WJBF080806	.210	X50M CG	.47
UBM300HD	.33	WCB241212	.214	WJBF080808	.210	X55	.42
UBM300SS	.115	WCB242408	.214	WJBF100806	.210	X65	.42
UBM350HD	.33	WEB040403	.214	WJBF100808	.210	X75M	.47
UBM350SS	.115	WEB040404	.214	WJBF101006	.210	X75M CG	.47
UBM400HD	.33	WEB060604	.214	WJBF101008	.210	XD010	.215
UBM400SS	.115	WEB060606	.214	WJBF120606	.210	XD012	.215
UBM50HD	.33	WEB080804	.214	WJBF120806	.210	XD014	.215
UBM50SS	.115	WEB080806	.214	WJBF120808	.210	XD3	.215
UBM75HD	.33	WEB121206	.214	WJBF120810	.210	XD4	.215
UBM75SS	.115	WEB160606	.214	WJBF121206	.210	XD5	.215
WAB040402	.212	WEB160806	.214	WJBF121208	.210	XD6	.215
WAB040403	.212	WEB180808	.214	WJBF121212	.210	XD7	.215
WAB040404	.212	WEB240606	.214	WJBF121218	.210	XD8	.215
WAB050503	.212	WEB240808	.214	WJBF140806	.210	XD9	.215
WAB050504	.212	WEB241010	.214	WJBF141410	.210	XJ128	.216
WAB060403	.212	WEB241210	.214	WJBF161206	.210	XJ148	.216
WAB060404	.212	WEB241212	.214	WJBF161208	.210	XJG104	.216
WAB060603	.212	WEB241812	.214	WJBF161606	.210	XJG104 EMT	.217
WAB060604	.212	WEB361212	.214	WJBF180806	.210	XJG108	.216
WAB060606	.212	WEB361812	.214	WJBF180808	.210	XJG14	.216
WAB080403	.212	WEB362412	.214	WJBF181006	.210	XJG14 EMT	.217
WAB080604	.212	WEB363612	.214	WJBF181206	.210	XJG18	.216
WAB080606	.212	WJB040403	.211	WJBF181208	.210	XJG24	.216
WAB080804	.212	WJB040404	.211	WJBF181210	.210	XJG24 EMT	.217
WAB080806	.212	WJB060404	.211	WJBF181212	.210	XJG28	.216
WAB080808	.212	WJB060604	.211	WJBF181218	.210	XJG34	.216
WAB090604	.212	WJB060606	.211	WJBF181806	.210	XJG34 EMT	.217
WAB100604	.212	WJB080604	.211	WJBF181808	.210	XJG38	.216
WAB100804	.212	WJB080606	.211	WJBF181812	.210	XJG44	.216
WAB100806	.212	WJB080804	.211	WJBF181818	.210	XJG44 EMT	.217
WAB101006	.212	WJB080806	.211	WJBF241208	.210	XJG48	.216
WAB120604	.212	WJB080808	.211	WJBF241212	.210	XJG54	.216
WAB120606	.212	WJB100806	.211	WJBF241808	.210	XJG54 EMT	.217
WAB120806	.212	WJB100808	.211	WJBF241810	.210	XJG58	.216
WAB120808	.212	WJB101006	.211	WJBF241812	.210	XJG64	.216
WAB121204	.212	WJB101008	.211	WJBF241818	.210	XJG64 EMT	.217
WAB121206	.212	WJB120606	.211	WJBF242412	.210	XJG68	.216
WAB121208	.212	WJB120806	.211	WJBF242418	.210	XJG74	.216
WAB160606	.212	WJB120808	.211	WJBF242424	.210	XJG74 EMT	.217
WAB161208	.212	WJB120810	.211	WJBF302412	.210	XJG78	.216
WAB181206	.212	WJB121206	.211	WJBF302418	.210	XJG84	.216
WAB181208	.212	WJB121208	.211	WJBF362418	.210	XJG84 EMT	.217
WAB181210	.212	WJB121212	.211	WJBF362424	.210	XJG88	.216
WAB181806	.212	WJB121218	.211	WMG100	.64	XJG94	.216
WAB181812	.212	WJB140806	.211	WMG125	.64	XJG94 EMT	.217
WAB241212	.212	WJB141410	.211	WMG150	.64	XJG98	.216
WAB242408	.212	WJB161206	.211	WMG200	.64	XJGD104	.218
WCB040402	.213	WJB161208	.211	WMG38	.64	XJGD34	.218
WCB040403	.213	WJB161606	.211	WMG50	.64	XJGD44	.218
WCB040404	.213	WJB180806	.211	WMG75	.64	XJGD54	.218
WCB050503	.213	WJB180808	.211	WTC1004	.90	XJGD64	.218
WCB050504	.213	WJB181006	.211	WTC1006	.90	XJGD74	.218
WCB060403	.213	WJB181206	.211	WTC1008	.90	XJGD84	.218
WCB060404	.213	WJB181208	.211	WTC1251	.90	XJGD94	.218
WCB060603	.213	WJB181210	.211	WTC1252	.90		
WCB060604	.213	WJB181212	.211	WTC1253	.90		
WCB060606	.213	WJB181218	.211	WTC1501	.90		
WCB080403	.213	WJB181806	.211	WTC1502	.90		
WCB080604	.213	WJB181808	.211	WTC2001	.90		
WCB080606	.213	WJB181812	.211	WTC2002	.90		
WCB080804	.213	WJB181818	.211	WTC2003	.90		
WCB080806	.213	WJB241208	.211	WTC2004	.90		
WCB080808	.213	WJB241212	.211	WTC2004A	.90		
WCB090604	.213	WJB241808	.211	WTC50U	.90		

For more information:

If further assistance is required, please contact an authorized Cooper Crouse-Hinds Distributor, Sales Office, or Customer Service Department.

Cooper Crouse-Hinds (Global HQ)

Wolf & Seventh North Streets
Syracuse, NY 13221
(866) 764-5454
FAX: (315) 477-5179
crouse.customerctr@cooperindustries.com

Cooper Crouse-Hinds Pauluhn

1616 N Main St
Pearland, TX 77581
(281) 485-4311
FAX: (281) 485-4398
crouse.pauluhn@cooperindustries.com

Cooper Crouse-Hinds GmbH

Neuer Weg-Nord 49
Eberbach, Germany D-69412
49 (0) 6271 806-500
FAX: 49 (0) 6271 806-476
sales.cch.de@cooperindustries.com

**Cooper Crouse-Hinds
MTL Instruments**

Great Marlings, Butterfield
Luton UK LU2 8DL
+44 (0)1582 723633
FAX: +44 (0)1582 422283
enquiry@mtl-inst.com

**Cooper Crouse-Hinds
Airport Lighting**

1200 Kennedy Road
Windsor, CT 06095
(860) 683-4354
FAX: (860) 683-4354
chalptechsupport@cooperindustries.com

Cooper Crouse-Hinds Regional Offices

Canada:

800-265-0502
FAX: (800) 263-9504
FAX Orders only: (866) 653-0645

Canada (Pauluhn):

888-675-5483
crouse.pauluhn@cooperindustries.com

Mexico/Latin America/Caribbean:

52-555-804-4000
FAX: 52-555-804-4020
mxmercadotecnia@cooperindustries.com

www.crouse-hinds.com

Cooper Crouse-Hinds is a registered trademark
of Cooper Industries, Inc.
©2010 Cooper Industries, Inc.

UK:

+44 247-630-89 30
FAX: +44 247-630-10 27
sales@ceag-crouse-hinds.co.uk

Saudi Arabia:

966 3 812 2236
FAX: 966 3 812 1291

India:

91-124-4683888
FAX: 91-124-4683899
cchindia@cooperindustries.com

Brazil:

+55 15 3238 3970
FAX: +55 15 3238 3976
vendabrasil@cooperindustries.com

Colombia:

+ (57.1) 670 0315
FAX: + (57.1) 670 0376
ventascic@cooperindustries.com

China:

86-21-2899-3600
FAX: 86-21-2899-4055
CCHsales@cooperindustries.com

Middle East (Dubai):

971 4 4272500
FAX: 971 4 4298521

Korea:

82 2 538 3425
FAX: 82 2 538 3505
CCHK-sales@cooperindustries.com

Singapore:

65-6297-4849
FAX: 65-6297-4819
chsi-sales@cooperindustries.com

Australia:

61-2-8787-2777
FAX: 61-2-9609-2342
CEAsales@cooperindustries.com

Your Authorized Cooper Crouse-Hinds Distributor is:

Cooper Industries, Ltd.

600 Travis, Ste. 5800
Houston, TX 77002-1001
P: 713-209-8400
www.cooperindustries.com