

In This Section...

Kindorf®

Kindorf® Modular Metal Framing and Support System

Modular Metal Framing — Overview	C-2—C-7
Channels.....	C-8—C-13
Fittings and Strut Nuts	C-14—C-15
Channel Fittings	C-16—C-23
Bantam Channels.....	C-24—C-25
Conduit, Cable and Pipe Supports	C-26—C-35
Concrete Inserts.....	C-36—C-37
Beam Clamps and Hanger Rod Supports.....	C-38—C-49
Support Brackets	C-50—C-51
Surface Raceway and Lighting Support Systems.....	C-52—C-67
Hardware and Threaded Components	C-68—C-74
Cable and Mounting Systems.....	C-75—C-79
Stainless Steel Channels.....	C-80
Aluminum Channels.....	C-81
Steel PVC Coated Channels.....	C-82—C-83
Metallic Engineering Data and Specifications	C-84—C-93
Non-Metallic Channels and Accessories.....	C-94—C-97
Right Angle Slotted Angle	C-98—C-103

Kindorf® Modular Metal Framing and Support System

Thomas & Betts

Corporate Office
Tel: 901.252.8000
800.816.7809
Fax: 901.252.1354

Customer Service
Tel: 800.816.7809
Fax: 800.816.7810

Technical Services
Tel: 888.862.3289
Fax: 901.252.1321

Tool Services
Tel: 800.284.8665

Thomas & Betts

www.tnb.com

C-1

Kindorf®

Modular Metal Framing — Overview

Kindorf® Modular Metal Framing and Support System

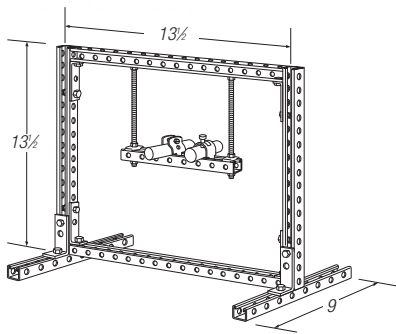
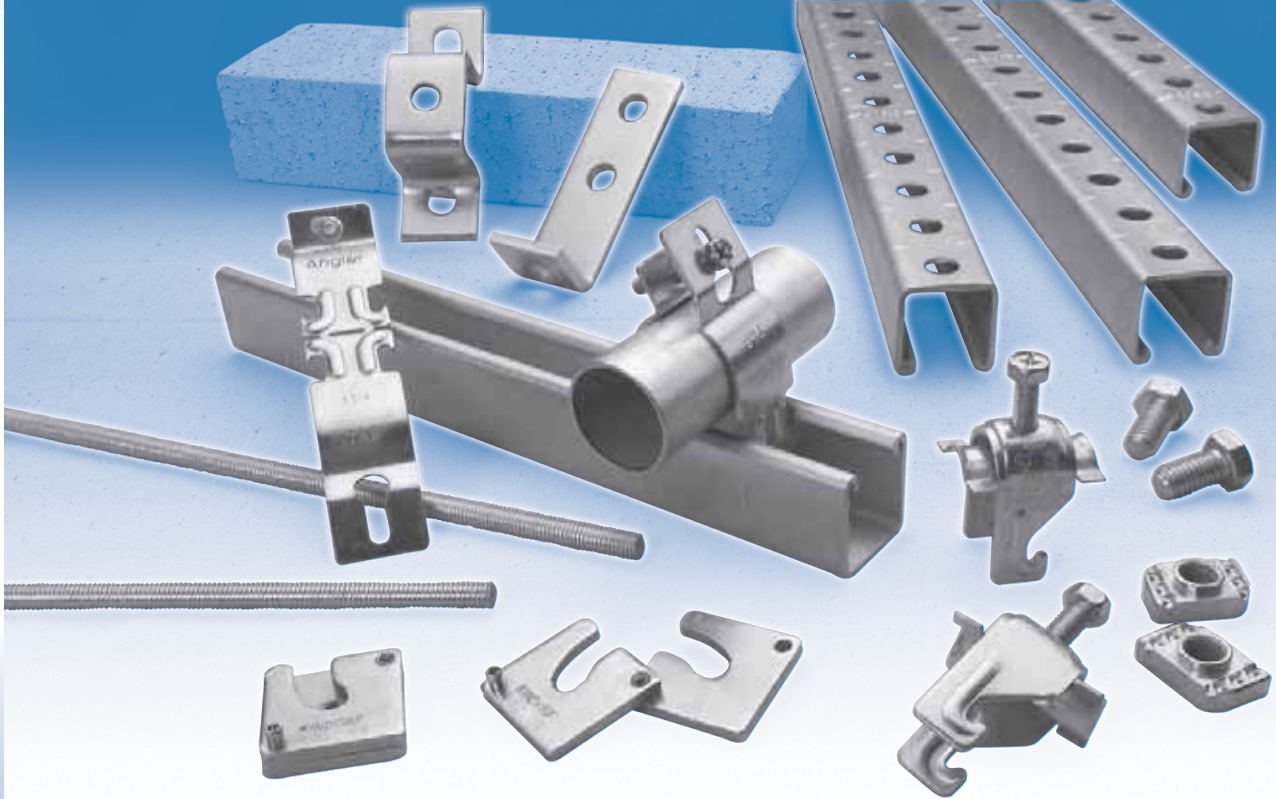

1 1/2" wide x 1 1/2" deep
7/8" continuous open slot
10 ft. and 20 ft. lengths

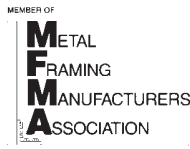

Kindorf® Channel

The Kindorf® Channel System is designed so that the maximum number of support and framing applications can be constructed with a minimum amount of labor and pieces.

Uniqueness in Design

The 1 1/2" dimension in the channel, hole spacing and fittings means all parts fit together, no matter where they're used, or at what angle. This modular dimension provides maximum flexibility in field applications, and results in saving inventory and labor dollars. The Kindorf® channel exclusive Galv-Krom® finish provides superior corrosion protection for all threaded components, channel and fittings. Through a two-part process, the coating is applied on all finished parts after fabrication — there is no exposed surface where corrosion can start.

Strength

Even though the Kindorf® channel is slightly smaller in dimensions, it supports the same weight as 1 1/2" channel.

Compatibility with 1 1/2" Strut

The Kindorf® System is designed so that most accessories are compatible with 1 1/2" strut. Conduit and pipe straps will work equally well with 1 1/2" and 1 3/4" strut. In addition, 98% of 1 1/2" accessories are interchangeable with Kindorf® channel. Angle fittings can adapt easily to the open side of any 1 1/2" strut and the unique parallelogram nuts provide secure attachment to both types of strut.

Full Line of Support Products

The Kindorf® channel system's many advantages are extended into a broad product offering including beam clamps, concrete inserts, lighting supports, cable cleats and a variety of threaded components. This system is available in the largest selection of finishes and materials, including green coated, aluminum, stainless steel and non-metallic. This, combined with a nationwide network of distributors and service centers, makes the Kindorf® system a single source for supported metal-framing needs.

Thomas & Betts

www.tnb.com

Corporate Office
Tel: 901.252.8000
800.816.7809
Fax: 901.252.1354

Customer Service
Tel: 800.816.7809
Fax: 800.816.7810

Technical Services
Tel: 888.862.3289
Fax: 901.252.1321

Tool Services
Tel: 800.284.8665

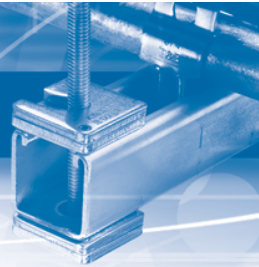

Why Kindorf® 1½" Channel Saves You Labor Dollars

Kindorf® Channel's 1½" is Much More than a Cross-Section Dimension

The 1½" with Kindorf® channel is truly a modular dimension. The channel height, width and prepunched hole spacings are all 1½". The angle fittings and the bolt holes in the angle fittings are all 1½" dimensions. Scribe marks are located at 1½" intervals to mark the midpoint between holes and every 6" on the side for easy measurement.

Jobsite adaptability and structural integrity are the key factors in making strut channel an economical solution to metal framing needs. Kindorf® channel, with its 1½" modular dimensions, enables the installer to do more work with fewer pieces and less labor dollars.

Here's What the Modular Dimension Can Do for You

Using a 1½" channel with hole spacings on 1½" centers requires numerous fittings and, in many cases, limits the joint fastening to the open side of the channel. Field drilling and welding, plus the need for extra fittings, become the rule rather than the exception. With constant 1½" dimensions throughout the system, many structural joints can be made with a minimum of fittings. Consider the following:

1. The Entire Section Can be Used.

You are not limited to using only the open-slot side because holes line up on channel and fittings. Using the scribe marks ensures the fittings will work and a straight cut is made.

2. Considerable Field Drilling and Welding Eliminated.

The holes are already there and they are usable. Back-to-back, side-to-back, side-to-side — all combinations that can be made using B-995 Kindorf® channel.

3. Field Cutting and Layout Made Simple.

8 scribe marks = 1 ft. Simply count the marks and cut. Position of holes ensures balanced support for trapezes on every piece, thus keeping waste to an absolute minimum.

4. Modular Fittings Fasten to Bolt Side or Slot Side — Unique Stud Nut.

Kindorf® framing fittings are engineered for versatile use — to meet the greatest number of framing combinations with maximum rigidity and security. Fittings may be fastened to the channel on either the bolt-hole side or the slot side.

The matching 1½" dimensions of channel bolt holes and fitting bolt holes provide a fast alignment and quick bolting. Fastening on the slot side provides infinite placement of the nut to match bolting requirements. Either way results in simple "building block" erection and permits multiple application of fittings. With the B-911SN Stud Nut, blind fastening of angles and fixtures is eliminated.

Cuts come where they should:

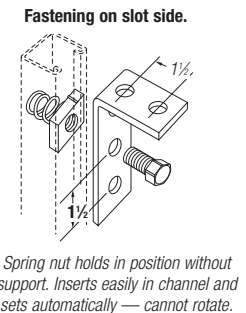
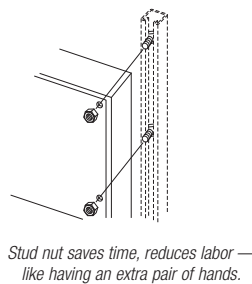
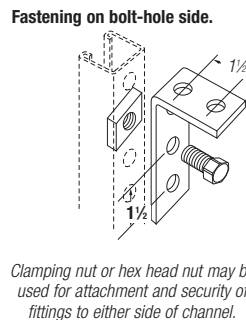
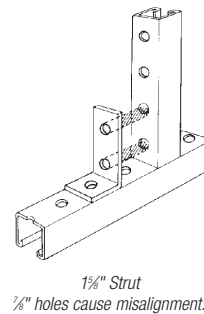
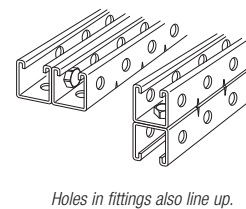
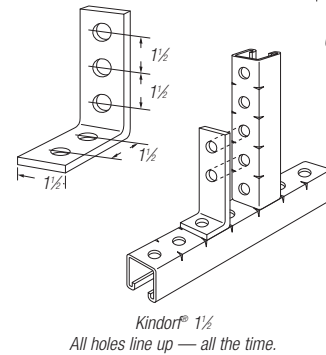
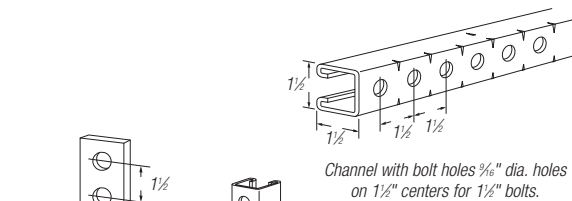
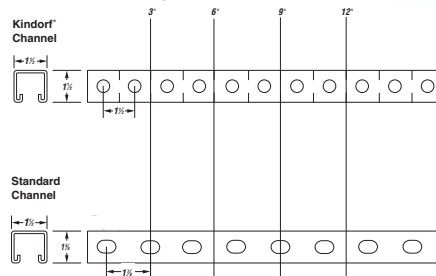

Corporate Office
Tel: 901.252.8000
800.816.7809
Fax: 901.252.1354

Customer Service
Tel: 800.816.7809
Fax: 800.816.7810

Technical Services
Tel: 888.862.3289
Fax: 901.252.1321

Tool Services
Tel: 800.284.8665

Thomas & Betts

www.tnb.com

Kindorf®

Modular Metal Framing — Overview

Let the Modular 1½" Dimension Work for You by Saving Labor and Inventory Dollars!

Why Kindorf® 1½" Channel Saves You Inventory Dollars

Fewer Pieces Do More Work.

By making equal use of the back of the channel, the sides of the channel (B-995 see **page C-13**) and the open slot, your options are increased. Combine this with three simple fittings that are 1½" wide and have 1½" hole layout, and you have the simplest and most versatile channel system on the market today.

By stocking a single-channel system and only three angle fittings, a multitude of jobs can be done.

With fewer pieces doing more work, ordering efficiency is increased and investment dollars are decreased.

Any way you look at it — Kindorf® strut can save you money.

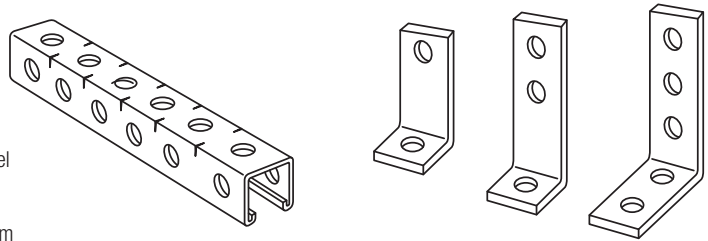

By simply stocking B-995 prepunched channel and three angle fittings, a great number of joints can be made.

One Kindorf® B-915 Two-Hole Connector Will Do:

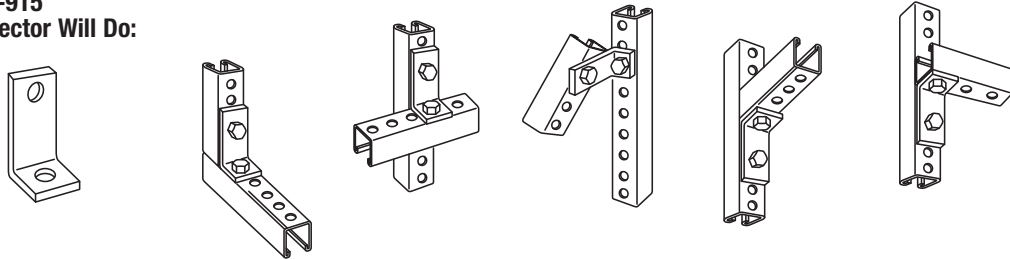

One Kindorf® B-916 Three-Hole Connector Will Do:

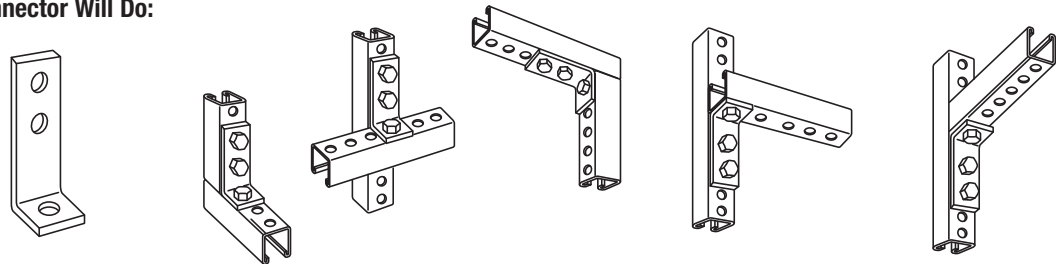

One Kindorf® B-917 Five-Hole Connector Will Do:

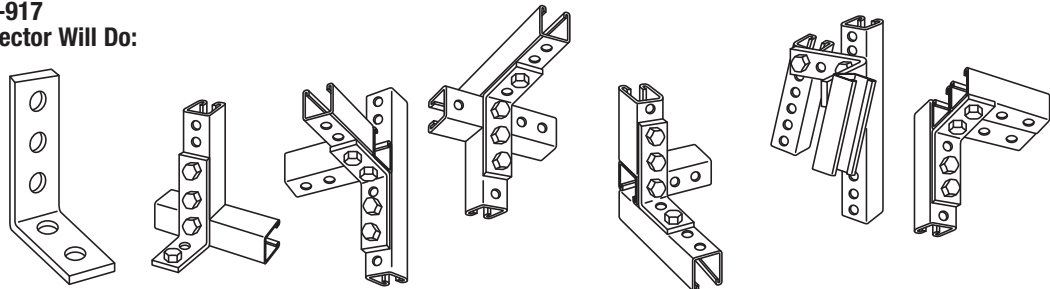

Thomas & Betts

www.tnb.com

Corporate Office
Tel: 901.252.8000
800.816.7809
Fax: 901.252.1354

Customer Service
Tel: 800.816.7809
Fax: 800.816.7810

Technical Services
Tel: 888.862.3289
Fax: 901.252.1321

Tool Services
Tel: 800.284.8665

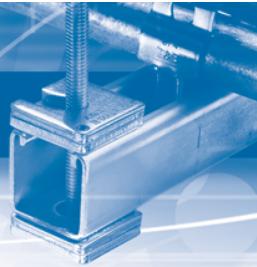

Galv-Krom® Electro-Galvanized Finish

Hexavalent Galv-Krom® Is OSHA Safe.



Over the past several months, there have been many questions about hexavalent chromium in the metal framing industry. Many of these questions relate to the changes made by OSHA. In 2006, the Occupational Safety and Health Administration (OSHA) published a revised standard which includes changes related to occupational exposure to hexavalent chromium (Cr VI). The revised standard was promulgated on February 28, 2006 with the compliance provisions taking effect on November 27, 2006 for most businesses. Cr VI can be found in many metal framing products, such as the hexavalent version of Galv-Krom® finish for Kindorf® channel.

- **Occupational Exposure Limit** — The changes related to Cr VI address the occupational exposure limit. Previously, this level was 52 micrograms per cubic meter (g/m^3) of air. This limit has now been reduced to $5 \text{ g}/\text{m}^3$ of air. Additionally, an “action level” has also been established at $2.5 \text{ g}/\text{m}^3$ of air. If exposure to Cr VI exceeds these levels, comprehensive exposure-control efforts must be implemented to protect workers.
- **OSHA Testing for Galv-Krom® Finish** — Thomas & Betts conducted documented third-party testing for the Cr VI occupational exposure of a typical worker when fabricating Galv-Krom® products. A certified industrial hygienist conducted the testing. The testing was done over one full work day following the OSHA protocol, with air sampling being performed to produce an 8-hour time-weighted average exposure for the affected worker. The TWA result was .00001 micrograms of Cr VI per cubic meter of air (g/m^3). This level is significantly below the $2.5 \text{ g}/\text{m}^3$ in the OSHA standard.
- **Hexavalent Galv-Krom® Finish Is OSHA Safe** — Based on this testing, activities such as normal handling, cutting, grinding and welding of Galv-Krom® products are within the OSHA requirements related to occupational exposure to hexavalent chromium.
- **Certified Industrial Hygienist Report Available** — The test report certified by an independent industrial hygienist on this occupational exposure testing is available to Thomas & Betts customers who require such documentation. This testing was conducted to the OSHA ID-215 ion chromatography method for analytical air sampling and meets the latest OSHA requirements. The findings are reported by a Certified Industrial Hygienist (CIH) and are recognized by OSHA as suitable for questions regarding occupational exposure to hexavalent chromium. For more details on this report, contact Thomas & Betts Technical Services at 888.862.3289.



New Trivalent Galv-Krom® Finish Is RoHS Compliant



In 2007, Thomas & Betts introduced the new and improved trivalent Galv-Krom® finish. Galv-Krom® finish is a combination of .5 mils electro-plated zinc and a gold trivalent chromium finish.

- **Gold Trivalent Chromium Finish** — The new Galv-Krom® finish features a trivalent chromium formulation that provides all the features and protection of hexavalent chromium (CR VI) without the use of this chemical. hexavalent chromium is a substance that is restricted by some standards such as the European Union directive on the restriction of the use of certain hazardous substances in electrical and electronic equipment (RoHS).
- **RoHS Compliant** — One great feature for the new Trivalent Chromium formulation is RoHS compliance. Because hexavalent chromium is a substance that is restricted by RoHS, moving away from a hexavalent formulation to the new trivalent formulation will make the performance of Galv-Krom® coating available to customers affected by RoHS and other standards like RoHS around the world.
- **Trivalent Galv-Krom® Finish Is OSHA Safe** — As mentioned previously, the hexavalent formulation of the Galv-Krom® finish was safe with regard to the revised 2006 OSHA standard. This new trivalent formulation of the Galv-Krom® finish does not contain any hexavalent chromium and therefore does not fall under the scope of the OSHA standard. As a result, the new Trivalent Galv-Krom® finish, just like the Hexavalent Galv-Krom® finish, is OSHA compliant.
- **ASTM B633 Specification** — The improved Galv-Krom® finish is applied in compliance with ASTM B633 coating, the same standard as used previously. This standard outlines electro-deposited coatings of zinc on steel.

Corporate Office
Tel: 901.252.8000
800.816.7809
Fax: 901.252.1354

Customer Service
Tel: 800.816.7809
Fax: 800.816.7810

Technical Services
Tel: 888.862.3289
Fax: 901.252.1321

Tool Services
Tel: 800.284.8665

Thomas & Betts

www.tnb.com

Kindorf®

Modular Metal Framing — Overview

Galv-Krom® Electro-Galvanized Finish (continued)

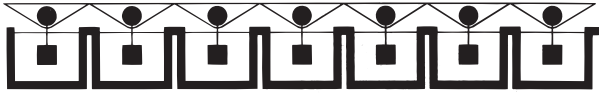

Soak	Degreasing Chemical	Electro Cleaner	Rinse	Sulfuric Acid Bath	Rinse	Zinc Tank	Rinse
Solution removes bulk of oil and grease buildup.	Metal is negatively charged to remove minute surface particles.	Live, clear water rinse.	Prepares the metal by etching the surface for the zinc application.	Live, clear water rinse.	Electrically applies the zinc metal coating.	Chemically treated rinse water.	



Chromate Rinse	Chromate Prep	Chromate Dip	Rinse	Dryer
Live, clear water rinse.	Polishing agent to prepare part for chromate.	A gold trivalent chromium conversion coat is applied to the zinc.	Live, clear water rinse.	Forced hot air is circulated around the strut until dry.

Kindorf® Galv-Krom® Finish Outperforms the Competition



The new and improved Galv-Krom® finish provides many benefits. First, it provides continued safety within OSHA guidelines. Second, the trivalent formulation provides RoHS compliance. But most important of all, the new Kindorf® Galv-Krom® finish provides a level of performance unmatched by the competition.

- **Superior Corrosion Protection** — One hallmark of the Galv-Krom® finish is the superior corrosion protection it provides. In the ASTM B117 salt spray test, the new Galv-Krom® finish provided improved protection to the previous Hexavalent formulation, and substantially more protection than painted finishes or G-90 Pre-Galvanized (see chart at right). This outstanding corrosion protection means more versatile installations and more service life for Galv-Krom® finished products
- **Strong Abrasion Resistance** — The Galv-Krom® finish won't chip or peel like a green-painted strut product. It stands up to rough handling

- **Clean Finish** — For pre-galvanized finishes, the zinc finish is applied before the strut is manufactured. That means all the oil and grime collected while the steel is formed into strut remains on the strut for the customer. Because Galv-Krom® finish is applied after fabrication, the oils and grime collected during the manufacturing process are thoroughly cleaned off during plating. This creates a finished product that leaves no residue on your hands when handling
- **Paintable Surface** — The new Galv-Krom® finish uses nano technology to provide a nonporous and non-crystalline surface. Not only does this feature provide enhanced corrosion protection, but also provides an excellent bond for the paint of your choice
- **No More White Rust** — With pre-galvanized strut, a common quality headache is the formation of white rust on the zinc finish. With Galv-Krom® finish, the trivalent chromium finish is applied over the zinc, to seal in the zinc beneath and stop the formation of white rust
- **Great Electrical Conductivity** — Unlike paint or enamel, the Galv-Krom® surface offers a minimum of electrical resistance so that electrical applications are easily grounded when grounding is needed

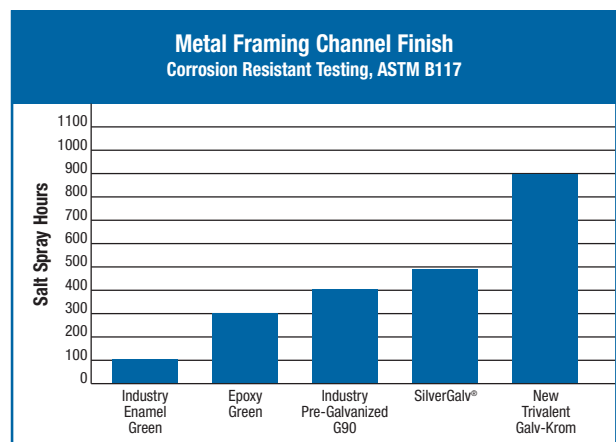

Thomas & Betts

www.tnb.com

Corporate Office
Tel: 901.252.8000
800.816.7809
Fax: 901.252.1354

Customer Service
Tel: 800.816.7809
Fax: 800.816.7810

Technical Services
Tel: 888.862.3289
Fax: 901.252.1321

Tool Services
Tel: 800.284.8665

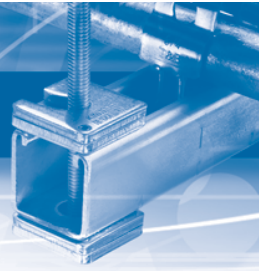

Finishes

1. Galv-Krom®

Commonly referred to as “gold,” the Galv-Krom® finish is a combination of .5 mils electro-plated zinc and a gold trivalent chromium finish, offering superior rust protection and excellent electrical conductivity.

2. SilverGalv® (Suffix EG)

Often referred to as “zinc plated” or “electroplated zinc,” the SilverGalv® finish applies .5 mils of zinc and a clear conversion coat. Electro-galvanizing is available for channel as well as small fittings, hardware and threaded products.

3. Pre-galvanized Steel (Suffix PG)

In addition to the standard Galv-Krom® finish, all Kindorf® channels are available in pre-galvanized steel. This material is identical to the standard steel except for its ASTM G-90 zinc coating. This coating is applied at the steel mill prior to the channel fabrication.

4. Green Coated (Suffix GR)

Green urethane powder resins are applied electrostatically to the steel after fabrication. Once the material is completely covered with the powdered-form urethane, it proceeds through a 400° baking process for ten minutes, creating a chemical bond. This results in a minimum of 1.5 mil thickness of urethane coating providing excellent resistance to chipping or peeling.

5. Hot-Dipped Galvanized (Suffix HD)

The material is zinc coated after fabrication providing total product protection on all surfaces. The fabricated channel or fitting is suspended and then dipped into tanks of hot zinc for a prolonged period, creating a coherent bond. The result is superior corrosion resistance as compared to pre-galvanized material. Hot-dipped galvanizing is not recommended for threaded products, considering the zinc coating thickness will often disrupt the threads.

Kindorf® hot-dipped galvanized channel is in conformance with ASTM Specifications A-123 (formerly A-386) and A-153.

Kindorf® channels maintain a minimum 1.5 ounces of zinc per square foot of steel or 2.5 mils (ASTM A-123, Thickness Grade 65). This finish is also referred to as “Hot-dipped galvanized after fabrication.”

6. PVC Coated (Prefix P)

A polyvinyl chloride (PVC) plastic coating is fused to the channel, fitting or accessory after fabrication by immersing the part in fluidized PVC tanks. The fused-melt mixed powder PVC coating thickness is 15 mils (.015”) plus or minus five mils. PVC material is a thermoplastic and will soften in high temperatures. An inherent weakness with PVC coatings occurs when field alterations are applied, such as cutting or drilling. These acts disrupt the sealed PVC product and warrant field touch-up. Thomas & Betts cannot be held responsible for field-altered PVC coated products.

Materials

1. Standard Steel

The standard Kindorf® Channel is made from high-quality ASTM A570 Grade 40 carbon steel sheet. These sections are cold formed into a unique and modular profile by an efficient roll forming process. Additionally, the process “cold works” the steel is to give it greater mechanical properties.

2. Extruded Aluminum (Suffix AL)

For more corrosive environments, T&B also offers extruded aluminum channel sections. These section are nearly identical to their steel counterparts. Aluminum channel is made from 6063 Aluminum and heat treated to a T-6 specification.

3. Non-Metallic (Suffix N)

Kindorf® channels are also available in fiberglass-reinforced polyester and vinyl ester. These products are pultruded into shapes similar to steel channels. They offer a high degree of corrosion protection and are very lightweight.

4. Stainless Steel (Suffix SS)

For the most corrosive environments, T&B offers Type 304 Stainless Steel channel sections and accessories. Type 316 stainless available upon request. Contact your local sales rep. These products are identical to their carbon steel counterparts except for a much greater corrosion resistance.

Warning

Load tables, charts and design criteria provided in this catalog are intended as guides only. Selection of proper product, installation intervals, erection and placement are the responsibility of the user.

Kindorf® products are intended to be used for the support and bracing of fixtures, cable, pipe and conduit. Improper use or installation may result in injury to persons or damage to property.

Material and finish specifications are subject to change without notice.

Kindorf®

Channels

Channels

Kindorf® channel is a rugged, heavy-gage structural-quality steel channel preformed in a "U" shape with a continuous open slot the entire length. The turned-in edges serve as retaining points for the nuts and bolts assembly of fittings to the channel. The shape of the channel permits infinite adjustability of the clamping nut simply by gliding it along the channel to the desired position. Spring-tensioned nuts are generally used for positioning overhead or in vertical channel installations. A stud nut (with spring) is provided for easy mounting of cabinets and equipment.

Channel Nuts are specially shaped as parallelograms with biting edges so that when tightened with normal pressure on the bolt, the nut clamps the sides of the channel together in a secure connection, which reinforces the rigidity of the channel itself. The nut rests on the "lips" of the channel slot.

Steel Channels

- Galv-Krom® finish
- 10 ft. and 20 ft. lengths

Solid Base

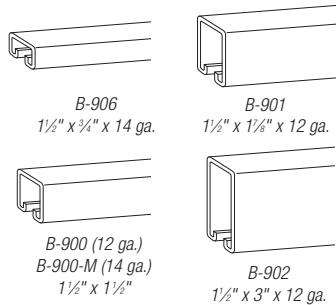

Half-Slot Base

- 1/16" x 7/8" slots on 1 1/2" centers 3/4" from end

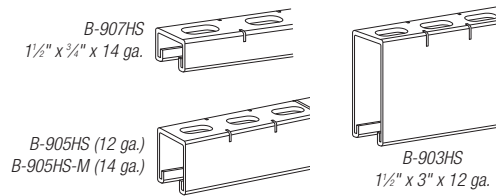

Bolt Hole Base

- 1/16" diameter bolt holes on 1 1/2" centers 3/4" from end

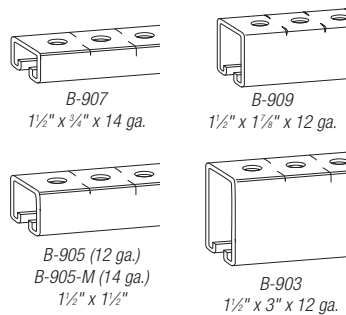

Bolt Hole Base

- Bolt holes on 3 sides, 1/16" diameter on 1 1/2" centers 3/4" from end

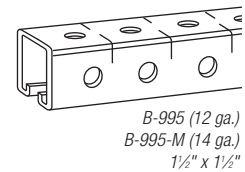

T-Slot Base

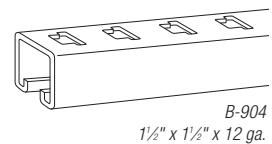

Kindorf® Channels — Welded Combinations

All Kindorf® channels are available in a variety of combinations — some are shown below.

How To Order

Add the suffix designation of the desired combination to the regular channel catalog number. (Example: Two B-900 channels back to back are ordered as B-900-2A.)

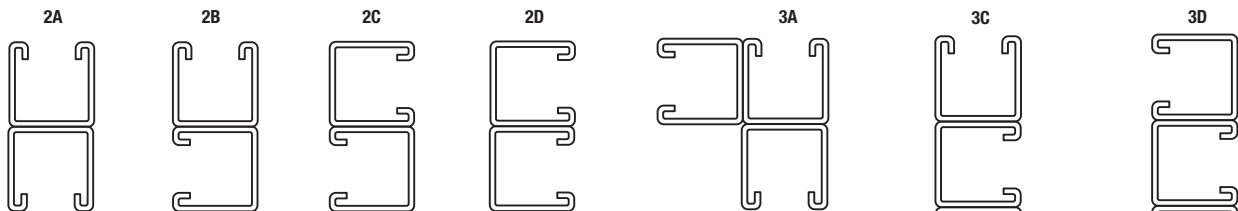

10- and 20-ft. lengths — steel

Special lengths may be ordered.

Thomas & Betts

www.tnb.com

Corporate Office
Tel: 901.252.8000
800.816.7809
Fax: 901.252.1354

Customer Service
Tel: 800.816.7809
Fax: 800.816.7810

Technical Services
Tel: 888.862.3289
Fax: 901.252.1321

Tool Services
Tel: 800.284.8665

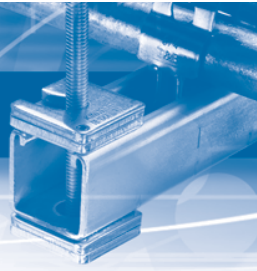

Channels (continued)

B-900 Channel — 1½" x 1½"

Connection by means of continuous slot.

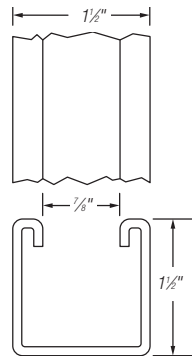

Properties of Section

CAT. NO.	SECTIONAL AREA			MATERIAL THICKNESS	LBS/FT.
	I	S	R		
B-900	0.345			0.104	1.206
B-900-M	0.217			0.074	0.74
X-X AXIS			Y-Y AXIS		
I	S	R	I	S	R
0.101	0.123	0.535	0.129	0.175	0.603
0.018	0.041	0.272	0.077	0.105	0.559

CAT. NO.	DESCRIPTION	MATERIAL
B 900 10	Galv-Krom®	12 ga.
B-900-20	Galv-Krom®	12 ga.
B-900-M-10	Galv-Krom®	14 ga.
B-900-M-20	Galv-Krom®	14 ga.
B-900-10-EG	SilverGalv®	12 ga.
B-900-20-EG	SilverGalv®	12 ga.
B-900-M-10-EG	SilverGalv®	14 ga.
B-900-M-20-EG	SilverGalv®	14 ga.

Use H-113-B bolts and B-910-1/2 or B-911-1/2 steel nuts for mounting fittings.

B-900, 162#/C ft. B-900-M, 107#/C ft.

CAT. NO.	DESCRIPTION	JOINER	END CAPS
B-900	12 ga. Galv-Krom®	—	—
B-900-M	14 ga. Galv-Krom®	—	—
B-900-10GR	Green powder coated	—	—
B-900-20GR	Green powder coated	G978	—
B-900-10PG	Pre-galvanized	G978A	G967
B-900-20PG	Pre-galvanized	G1503S	—
B-900-10HD	Hot-dipped galvanized	—	—
B-900-20HD	Hot-dipped galvanized	—	—

Use H-113-B bolts and B-910-1/2 or B-911-1/2 steel nuts for mounting fittings.

B-900, 162#/C ft. B-900-M, 107#/C ft.

B-901 Channel — 1½" x 1⅞"

For heavier load requirements.
Connection by means of continuous slot.

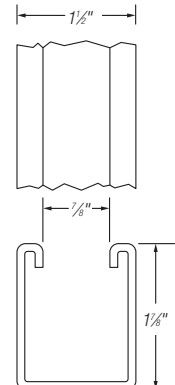

Properties of Section

CAT. NO.	SECTIONAL AREA			MATERIAL THICKNESS	LBS/FT.
	I	S	R		
B-901	0.595			0.104	2.028
X-X AXIS			Y-Y AXIS		
I	S	R	I	S	R
0.263	0.251	0.665	0.238	0.309	0.632

CAT. NO.	DESCRIPTION	MATERIAL
B-901-10	Galv-Krom®	12 ga.
B-901-20	Galv-Krom®	12 ga.
B-901-10-EG	SilverGalv®	12 ga.
B-901-20-EG	SilverGalv®	12 ga.

Use H-113-B bolts and B-910-1/2 or B-911-1/2 steel nuts for mounting fittings. 196#/C ft.

CAT. NO.	DESCRIPTION	JOINER	END CAPS
B-901	12 ga. Galv-Krom®	G978C	G-966
B-901HD	Hot-dipped galvanized	—	—

Use H-113-B bolts and B-910-1/2 or B-911-1/2 steel nuts for mounting fittings. 196#/C ft.

Kindorf®

Channels

Channels (continued)

B-902 Channel — 1½" x 3"

Connection by means of continuous slot.

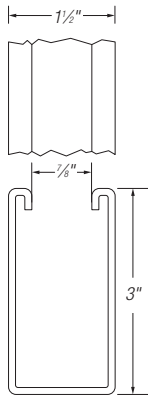

Properties of Section

CAT. NO.	SECTIONAL AREA	MATERIAL THICKNESS	LBS/FT.
B-902	0.837	0.104	2.825

X-X AXIS			Y-Y AXIS		
I	S	R	I	S	R
0.909	0.552	1.042	0.363	0.471	0.658



CAT. NO.	DESCRIPTION	MATERIAL
B 902 10	Galv-Krom®	12 ga.
B-902-20	Galv-Krom®	12 ga.
B-902-10-EG	SilverGalv®	12 ga.
B-902-20-EG	SilverGalv®	12 ga.

Use H-113-B bolts and B-910-1/2 steel nuts for mounting fittings.

285#/C ft.



CAT. NO.	DESCRIPTION	JOINER	END CAP
B-902-10	12 ga. Galv-Krom®	—	—
B-902-20	12 ga. Galv-Krom®	G978-D	G957
B-902-10HD	Hot-dipped galvanized	G-3003S	—
B-902-20HD	Hot-dipped galvanized	—	—

Use H-113-B bolts and B-910-1/2 steel nuts for mounting fittings.

285#/C ft.

B-903 Channel — 1½" x 3"

Connection by means of continuous slot or 9/16" holes on 1½" centers.

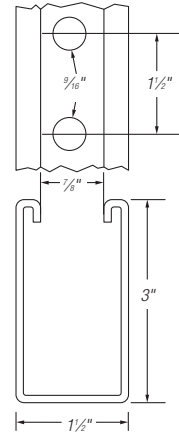
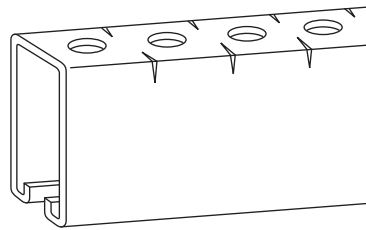

CAT. NO.	DESCRIPTION	MATERIAL
B-903-10	Galv-Krom®	12 ga.
B-903-20	Galv-Krom®	12 ga.
B-903-10-EG	SilverGalv®	12 ga.
B-903-20-EG	SilverGalv®	12 ga.

Use H-113-B bolts and B-910-1/2 steel nuts for mounting fittings.

277#/C ft.

CAT. NO.	DESCRIPTION	JOINER	END CAP
B-903	12 ga. Galv-Krom®	G978-D	—
B-903HD	Hot-Dipped Galvanized	G3003S	—

Use H-113-B bolts and B-910-1/2 steel nuts for mounting fittings.

277#/C ft.

B-903H Channel — 1½" x 3"

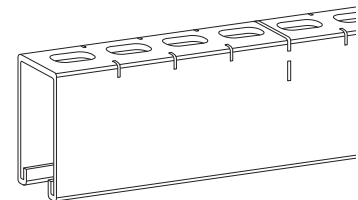
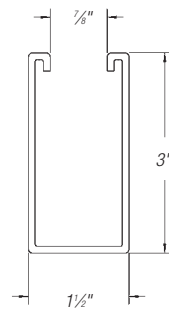

CAT. NO.	DESCRIPTION	MATERIAL
B 903HS 10	Galv-Krom®	12 ga.
B-903HS-20	Galv-Krom®	12 ga.
B-903HS-10-EG	SilverGalv®	12 ga.
B-903HS-20-EG	SilverGalv®	12 ga.

Use H-113-B bolts and B-910-1/2 steel nuts for mounting fittings.

277#/C ft.

Thomas & Betts

www.tnb.com

Corporate Office
Tel: 901.252.8000
800.816.7809
Fax: 901.252.1354

Customer Service
Tel: 800.816.7809
Fax: 800.816.7810

Technical Services
Tel: 888.862.3289
Fax: 901.252.1321

Tool Services
Tel: 800.284.8665

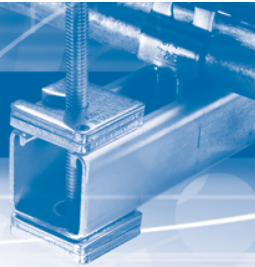

Channels (continued)

B-904 Channel — 1½" x 1½"

Connection by means of continuous slot or T-slots on 1½" centers in base side of channel.

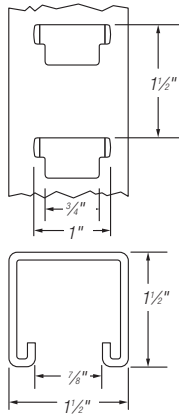
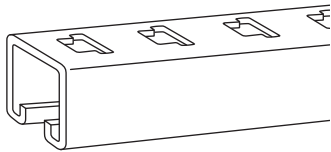

CAT. NO.	DESCRIPTION
B-904 10	12 ga. Galv-Krom®
B-904HD	Hot-Dipped Galvanized

For attachment to continuous slot use H-113-B bolts and B-910-1/2 steel nuts.

For attachment to T-slots use F-739 brackets 155#/C ft.

B-905HS Channel — 1½" x 1½"

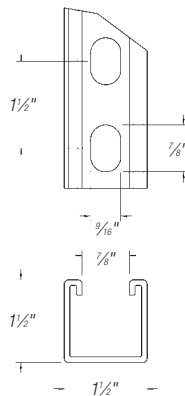
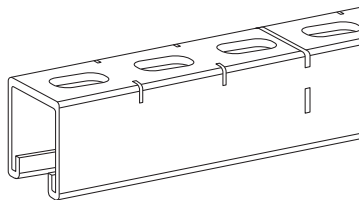

CAT. NO.	DESCRIPTION	MATERIAL
B 905HS 10	Galv-Krom®	12 ga.
B-905HS-20	Galv-Krom®	12 ga.
B-905HS-M-10	Galv-Krom®	14 ga.
B-905HS-M-20	Galv-Krom®	14 ga.
B-905HS-10-EG	SilverGalv®	12 ga.
B-905HS-20-EG	SilverGalv®	12 ga.
B-905HS-M-10-EG	SilverGalv®	14 ga.
B-905HS-M-20-EG	SilverGalv®	14 ga.

Use H-113-B bolts and B-910-1/2 or B-911-1/2 steel nuts for mounting fittings.

Scribe marks designate midpoint between holes for accurate field cutting.

B-905, 158#/C ft. B-905-M, 102#/C ft.

B-905 Channel — 1½" x 1½"

Connections by means of continuous slot or 9/16" holes on 1½" centers that match holes in B-900 series fittings.

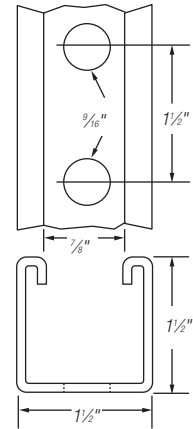
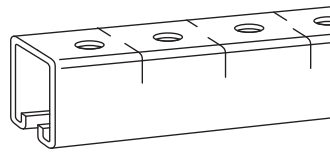

CAT. NO.	DESCRIPTION	MATERIAL
B 905 10	Galv-Krom®	12 ga.
B-905-20	Galv-Krom®	12 ga.
B-905-M-10	Galv-Krom®	14 ga.
B-905-M-20	Galv-Krom®	14 ga.
B-905-10-EG	SilverGalv®	12 ga.
B-905-20-EG	SilverGalv®	12 ga.
B-905-M-10-EG	SilverGalv®	14 ga.
B-905-M-20-EG	SilverGalv®	14 ga.

Use H-113-B bolts and B-910-1/2 or B-911-1/2 steel nuts for mounting fittings.

Scribe marks designate midpoint between holes for accurate field cutting.

B-905, 158#/C ft. B-905-M, 102#/C ft.

CAT. NO.	DESCRIPTION	JOINER	END CAP
B-905	12 ga. Galv-Krom®	—	—
B-905-M	14 ga. Galv-Krom®	—	—
B-905-10GR	Green Coated	—	—
B-905-20GR	Green Coated	—	—
B-905-10PG	Pre-Galvanized	—	—
B-905-20PG	Pre-Galvanized	—	—
B-905-10HD	Hot-Dipped Galvanized	—	—
B-905-20HD	Hot-Dipped Galvanized	—	—

Use H-113-B bolts and B-910-1/2 or B-911-1/2 steel nuts for mounting fittings.

Scribe marks designate midpoint between holes for accurate field cutting.

B-905, 158#/C ft. B-905-M, 102#/C ft.

Kindorf®

Channels

Channels (continued)

B-906 Channel — 1½" x ¾"

Connection by means of continuous slot.

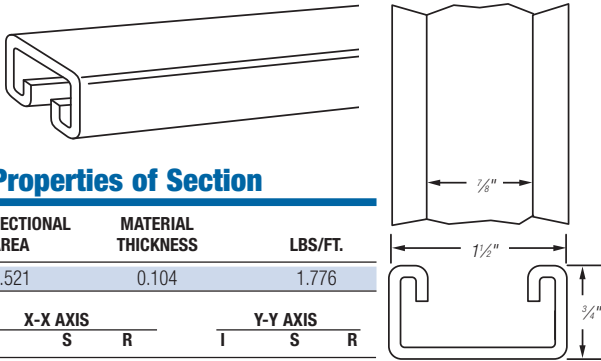

Properties of Section

SECTIONAL AREA	MATERIAL THICKNESS	LBS/FT.
0.521	0.104	1.776

X-X AXIS			Y-Y AXIS		
I	S	R	I	S	R
0.155	0.179	0.545	0.2	0.259	0.619



CAT. NO.	DESCRIPTION	MATERIAL
B 906 10	Galv-Krom®	14 ga.
B-906-20	Galv-Krom®	14 ga.
B-906-10-EG	SilverGalv®	14 ga.
B-906-20-EG	SilverGalv®	14 ga.

Use H-113-A bolts and B-910-1/2 or B-912-1/2 steel nuts for mounting fittings.
Steel 75#/C ft.

B-907HS Channel — 1½" x ¾"

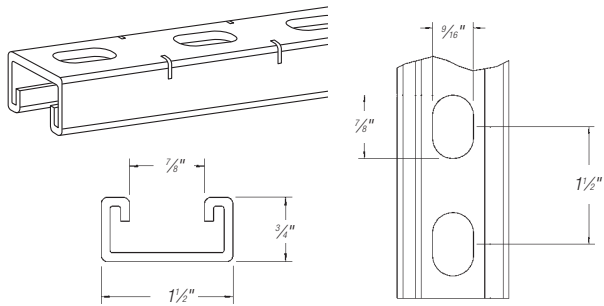

CAT. NO.	DESCRIPTION	MATERIAL
B 907HS 10	Galv-Krom®	14 ga.
B-907HS-20	Galv-Krom®	14 ga.
B-907HS-10-EG	SilverGalv®	14 ga.
B-907HS-20-EG	SilverGalv®	14 ga.

Use H-113-A bolts and B-910-1/2 or B-912-1/2 steel nuts for mounting fittings.
Holes on B-900 series fittings match channel holes.
Scribe marks on steel channel designate midpoint between holes for accurate field cutting.
Steel 71#/C. ft.

B-907 Channel — 1½" x ¾"

Connection by means of continuous slot or 9/16" holes on 1/2" centers.

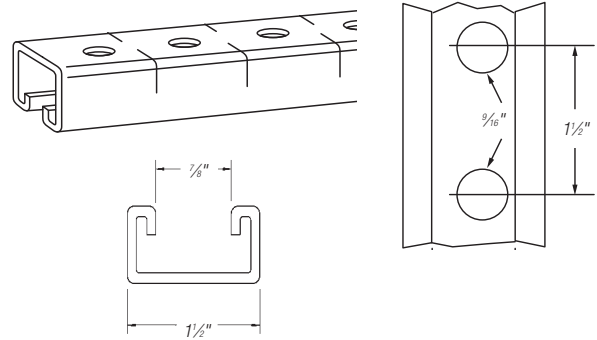

CAT. NO.	DESCRIPTION	MATERIAL
B-907-10	Galv-Krom®	14 ga.
B-907-20	Galv-Krom®	14 ga.
B-907-10-EG	SilverGalv®	14 ga.
B-907-20-EG	SilverGalv®	14 ga.

Use H-113-A bolts and B-910-1/2 or B-912-1/2 steel nuts for mounting fittings.

Holes on B-900 series fittings match channel holes.

Scribe marks on steel channel designate midpoint between holes for accurate field cutting.
Steel 71#/C. ft.



CAT. NO.	DESCRIPTION	JOINER
B-907	14 ga. Galv-Krom	B948
B-907-10GR	Green Coated	B948
B-907-20GR	Green Coated	B948
B-907-10PG	Pre-Galvanized	B948
B-907-20PG	Pre-Galvanized	B948
B-907-10HD	Hot-Dipped Galvanized	B948
B-907-20HD	Hot-Dipped Galvanized	B948

Use H-113-A bolts and B-910-1/2 or B-912-1/2 steel nuts for mounting fittings.

Holes on B-900 series fittings match channel holes.

Scribe marks on steel channel designate midpoint between holes for accurate field cutting.
Steel 71#/C. ft.

Thomas & Betts

www.tnb.com

Corporate Office
Tel: 901.252.8000
800.816.7809
Fax: 901.252.1354

Customer Service
Tel: 800.816.7809
Fax: 800.816.7810

Technical Services
Tel: 888.862.3289
Fax: 901.252.1321

Tool Services
Tel: 800.284.8665

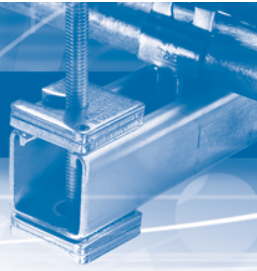

Channels (continued)

B-909 Channel — 1½" x 1⅞"

For heavier load requirements. Connection by means of continuous slot or ⅜" holes on 1½" centers.

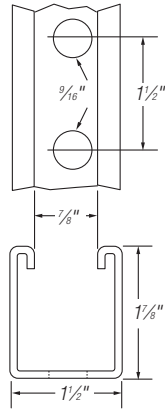
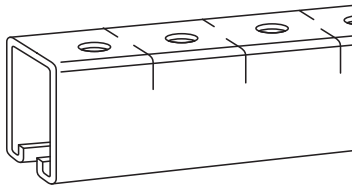

CAT. NO.	DESCRIPTION	MATERIAL
B 909 10	Galv-Krom®	12 ga.
B-909-20	Galv-Krom®	12 ga.
B-909-10-EG	SilverGalv®	12 ga.
B-909-20-EG	SilverGalv®	12 ga.

Use H-113-B bolts and B-910-1/2 or B-911-1/2 steel nuts for mounting fittings.
118#/C. ft.

CAT. NO.	DESCRIPTION	JOINER
B-909	12 ga. Galv-Krom	G978-C
B-909HD	Hot-Dipped Galvanized	G978-C

Use H-113-B bolts and B-910-1/2 or B-911-1/2 steel nuts for mounting fittings.
118#/C. ft.

B-995 Channel — 1½" x 1½"

Connection by means of continuous slot or ⅜" holes on 1½" centers on three sides which match holes in B-900 series fittings.

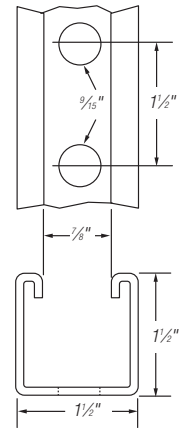
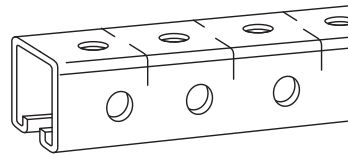

CAT. NO.	DESCRIPTION	MATERIAL
B 995 10	Galv-Krom®	12 ga.
B-995-20	Galv-Krom®	12 ga.
B-995-M-10	Galv-Krom®	14 ga.
B-995-M-20	Galv-Krom®	14 ga.
B-995-10-EG	SilverGalv®	12 ga.
B-995-20-EG	SilverGalv®	12 ga.
B-995-M-10-EG	SilverGalv®	14 ga.
B-995-M-20-EG	SilverGalv®	14 ga.

Use H-113-B bolts and B-910-1/2 or B-911-1/2 steel nuts for mounting fittings.
150#/C. ft. Scribe marks designate midpoint between holes for accurate field cutting.
Standard 10 ft. lengths

Kindorf®

Fittings and Strut Nuts

Channel Nuts

Kindorf® Channel Nuts are manufactured from mild steel and are case hardened.

Design Data

Kindorf® self-aligning channel nuts are designed to provide resistance to pull out and resistance to side slip in excess of the full strength of the channels with which they are used. The extreme resistance to side slip results from the unique design of the alternate teeth, spaced and designed to develop a wedging action that increases with pressure or load.



Load Ratings of Steel Channel and Insert Nuts

(B-910-1/2 or B-911-1/2) when used in slot of 12 ga. Kindorf® channel and tightened to a torque of 50 ft. Pounds are as follows:

Withdrawal resistance to pull out safe-load rating = 1,600 lbs.
Slip resistance safe-load rating = 400 lbs.

(B-910-1/2 or B-912-1/2) when used in slot of 14 ga. Kindorf channel and tightened to a torque of 50 ft. Pounds are as follows:

Withdrawal resistance to pull out safe-load rating = 1,300 lbs. Slip resistance safe-load rating = 400 lbs.

Load ratings are based on safety factor of 3.

BC-910 Universal Cone Nut

Eliminates the inventory and installation hassles of conventional spring nuts. Fits all 1½" channel, regardless of depth, with a simple twist of your thumb. Pliable nylon cone secures the nut in place through the entire range of construction site temperatures.

Screw Threads

THREAD SIZE	B	J	C	D
Threads per inch	20	18	16	13
Design Torque (ft.-lbs.)	6	11	19	50

All threaded products are American Standard thread, free fit class 2.

Galv-Krom® hardware finish is standard for all Superstrut products. This is a multi-process finish of electro-plated zinc, followed by gold-colored zinc dichromate to give excellent corrosion resistance and a superior paint base.

Standard Finish – Galv-Krom®, unless otherwise stated.

Trapnut® Strut Fastener



H 122 3/8
Trapnut® Strut
Fastener Galv-Krom®



H 122 3/8 EG
Trapnut® Strut
Fastener SilverGalv®

CAT. NO.	DESCRIPTION	SIZE (IN.)	DESIGN LOAD LBS.	STD. CTN.
H 122 1/4	¼" Galv-Krom®	¼	150	50
H 122 3/8	¾" Galv-Krom®	¾	590	50
H 122 1/2	½" Galv-Krom®	½	1,080	50
H 122 1/4 EG	¼" SilverGalv®	¼	150	50
H 122 3/8 EG	¾" SilverGalv®	¾	590	50
H 122 1/2 EG	½" SilverGalv®	½	1,080	50
H 122 1/4 SS6	¼" Type 316 Stainless Steel	¼	150	50
H 122 3/8 SS6	¾" Type 316 Stainless Steel	¾	590	50
H 122 1/2 SS6	½" Type 316 Stainless Steel	½	1,080	50

Channel Nuts — Standard Finish: Galv-Krom®

B-910 Series

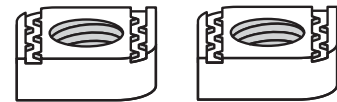

For use with all Kindorf® channels

CAT. NO.	SIZE (IN.)	THICKNESS (IN.)	WT. LBS./C
B 910 1/4	¼-20	⅜	7.5
B-910-5/16	⅝-18	⅜	7.3
B-910-3/8	¾-16	⅜	9.15
B-910-1/2	½-13	⅜	9.9

Load Ratings for B-910 Strut Nuts

CHANNEL NUT SIZES (IN.)	SLIP TEST RATING	PULL TEST RATING
¼	300	500
⅝	750	1000
½	1,200	2000

If connections will be subjected to dynamic or seismic loading conditions, contact the factory for design assistance.

- All ratings have safety factor of 3 applied.
- Load ratings are for Static Applications.

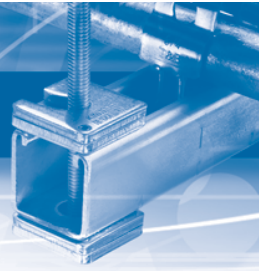

B-911 Series

Self-holding clamping nut with spring attached.
For use with 1/2" deep channels.

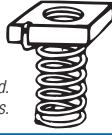

CAT. NO.	SIZE (IN.)	THICKNESS (IN.)	WT. LBS./C
B 911 1/4	1/4-20	3/16	8
B-911-5/16	5/16-18	3/16	8.25
B-911-3/8	3/8-16	3/16	10
B-911-D-3/8*	3/8-16	3/16	12
B-911-1/2	1/2-13	3/8	10
B-911-D-1/2*	1/2-13	3/8	13

* For clamping nuts with spring for 3" deep channels add suffix D to catalog number.

B-911-SN Series

Stud nut self-holding clamping nut with spring attached.

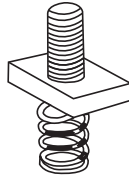

CAT. NO.	SIZE (IN.)	THICKNESS (IN.)	WT. LBS./C
B 911 3/8 SN1†	3/8-16	3/16	12.5
B-911-3/8-SN2†	3/8-16	3/16	13.0
B-911-1/2-SN1†	1/2-13	3/8	16.0
B-911-1/2-SN2†	1/2-13	3/8	17.0

†B-911-3/8-SN1, Stud: 3/8 Dia., 1" Long and B-911-3/8-SN2, Stud: 3/8 Dia., 1 1/4" Long.

Accepts Kindorf® Nuts H-114C (hex), H-116-C (square).

B-911-1/2-SN1, Stud: 1/2 Dia., 1" Long. and B-911-1/2-SN2, Stud: 1/2 Dia., 1 1/4" Long.

Accepts Kindorf® Nuts H-114D (hex), H-116-D (square).

B-912 Series

Self-holding clamping nut with spring attached.
For use with 3/4" deep channels.

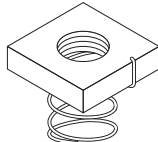

CAT. NO.	SIZE (IN.)	THICKNESS (IN.)	WT. LBS./C
B 912 1/4	1/4-20	3/16	8.0
B-912-5/16	5/16-18	3/16	7.5
B-912-3/8	3/8-16	3/16	9.5
B-912-1/2	1/2-13	3/8	9.8

Standard finish: Galv-Krom®

BC-910 Series

- Universal nylon cone nut
- Sizes: 1/4", 3/8" & 1/2"
For all 1 5/8" & 1 1/2" channels.
May be used with ALL strut depths

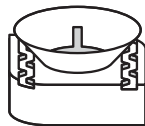

CAT. NO.	SIZE (IN.)	FINISH
BC910 1/4	1/4-20	Galv-Krom®
BC910 3/8	3/8-16	Galv-Krom®
BC910 1/2	1/2-13	Galv-Krom®

B-914 Series

Square nuts for use with channel
and spot-type concrete inserts.

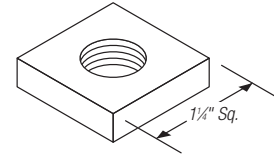

CAT. NO.	SIZE (IN.)	THICKNESS (IN.)	WT. LBS./C
B 914 1/4	1/4-20	3/16	10.50
B-914-3/8	3/8-16	3/16	13.25
B-914-1/2	1/2-13	3/8	14.00
B-914-5/8	5/8-11	3/8	14.00
B-914-3/4	3/4-10	3/8	12.00
B-914-7/8	7/8-9	3/8	10.50
B-914-3/8P	3/8-18**	3/8	12.00
B-914-1/2P	1/2-14**	3/8	11.00

** Standard Pipe Threads.
Standard finish: Galv-Krom®.

Located Square Washers

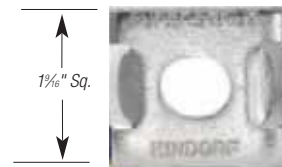

CAT. NO.	BOLT SIZE (IN.)	STD. CTN.
AB-241L-1/4	1/4	100
AB-241L-5/16	5/16	100
AB-241L-3/8	3/8	100
AB-241L-1/2	1/2	100
AB-241L-5/8	5/8	100

GoldGalv® is standard finish.

Add "EG" suffix for SilverGalv®.

Square Washers

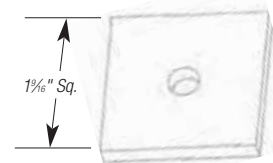

CAT. NO.	BOLT SIZE (IN.)	STD. CTN.
AB-241-1/4	1/4	100
AB-241-5/16	5/16	100
AB-241-3/8	3/8	100
AB-241-1/2	1/2	100
AB-241-5/8	5/8	50

GoldGalv® is standard finish.

Add "EG" suffix for SilverGalv®.

Kindorf®

Channel Fittings

Kindorf® Modular Metal Framing and Support System

B-915 Two-Hole Angle Connector

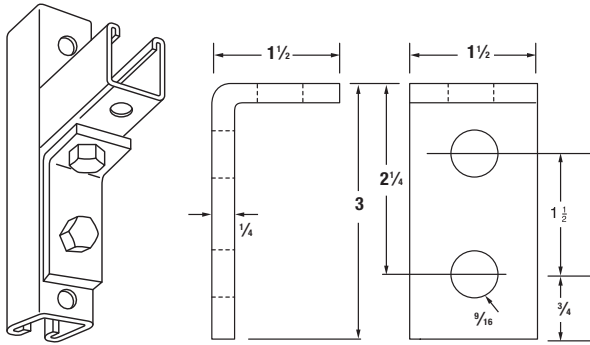

Can also be used as side-beam connector to suspend 1/2" hanger rod.

CAT. NO.	FINISH
B 915	Galv-Krom®
B-915EG	Electro-Galvanized
B-915HD	Hot-Dipped Galvanized

1/4" steel, 39#/C.

B-917 Five-Hole Angle Connector

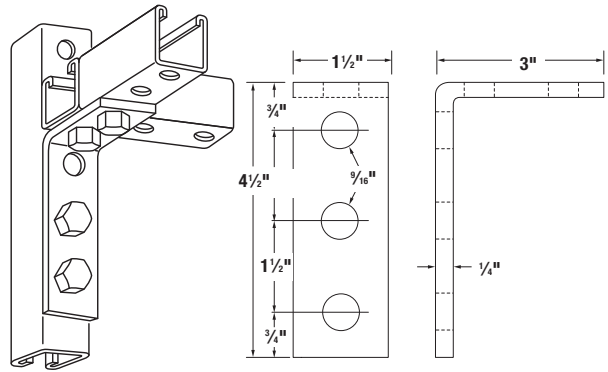

CAT. NO.	FINISH
B 917	Galv-Krom®
B-917EG	Electro-Galvanized
B-917HD	Hot-Dipped Galvanized

1/4" steel, 68#/C.

B-916 Three-Hole Angle Connector

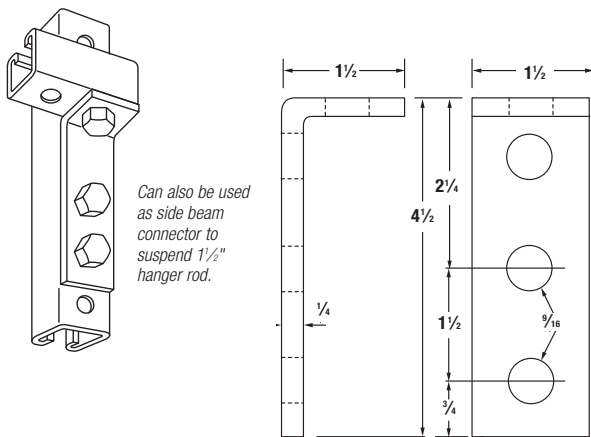

Can also be used as side beam connector to suspend 1 1/2" hanger rod.

CAT. NO.	FINISH
B 916	Galv-Krom®
B-916HD	Hot-dipped galvanized

1/4" steel, 46#/C.

B-918 Left-Hand Gusset Connector

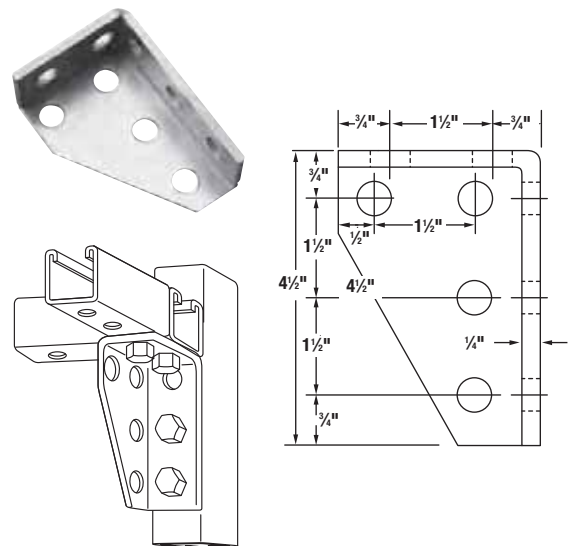

CAT. NO.	FINISH
B 918	Galv-Krom®
B-918EG	Electro-Galvanized

12 Ga. and 1/4" steel, 102#/C.

Thomas & Betts

www.tnb.com

Corporate Office
Tel: 901.252.8000
800.816.7809
Fax: 901.252.1354

Customer Service
Tel: 800.816.7809
Fax: 800.816.7810

Technical Services
Tel: 888.862.3289
Fax: 901.252.1321

Tool Services
Tel: 800.284.8665

Kindorf®

Channel Fittings

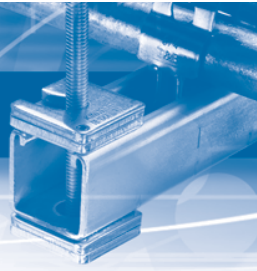

B-919 Right-Hand Gusset Connector

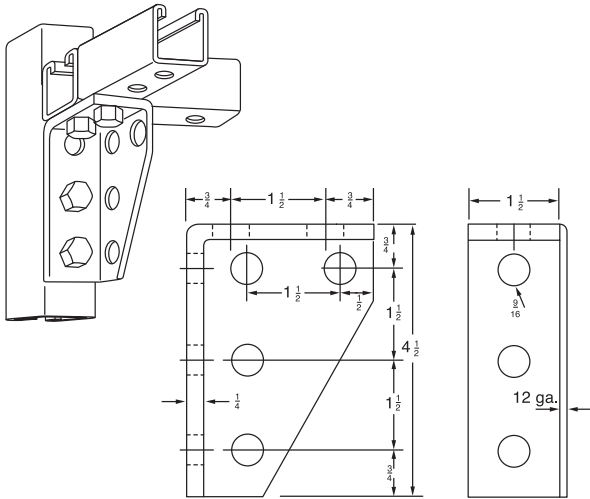

CAT. NO.	FINISH
B 919	Galv-Krom®
B-919EG	Electro-Galvanized

12 ga. and 1/4" steel. 102#/C.

B-920 End Connector

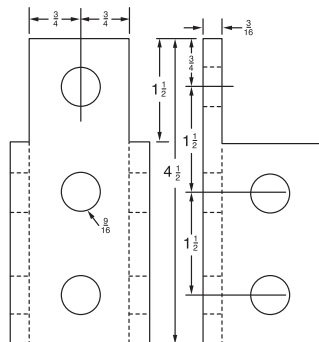
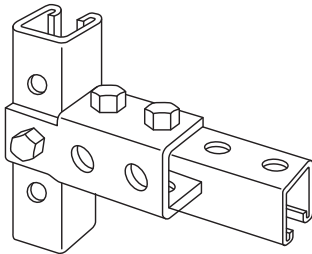

CAT. NO.	FINISH
B 920	Galv-Krom®

3/16" steel. 80#/C.

B-921 Two-Side Corner Connector

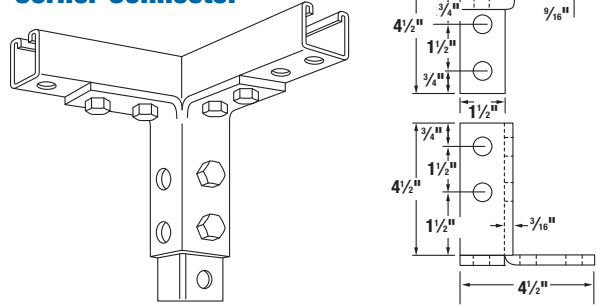

CAT. NO.	FINISH
B 921	Galv-Krom®

3/16" steel. 101#/C.

B-922 Opposite-Side Angle Connector

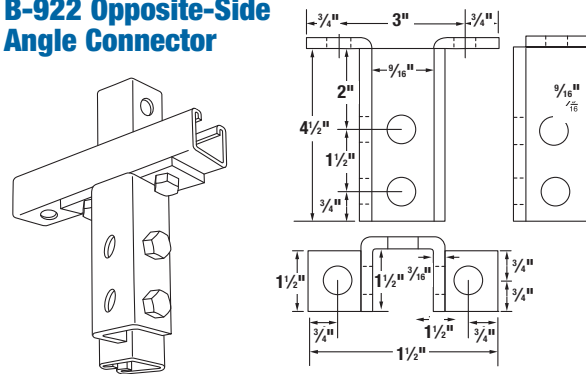

CAT. NO.	FINISH
B 922	Galv-Krom®

3/16" steel. 124#/C.

B-923 Three-Side Angle Connector

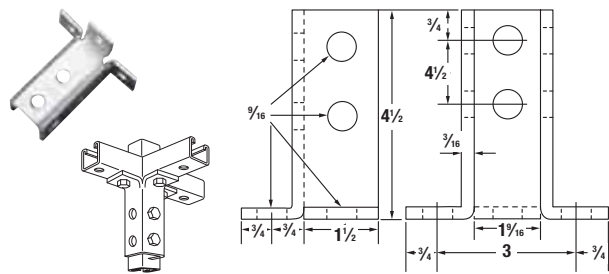

CAT. NO.	FINISH
B 923	Galv-Krom®

3/16" steel. 137#/C.

Kindorf® Modular Metal Framing and Support System

Corporate Office
Tel: 901.252.8000
800.816.7809
Fax: 901.252.1354

Customer Service
Tel: 800.816.7809
Fax: 800.816.7810

Technical Services
Tel: 888.862.3289
Fax: 901.252.1321

Tool Services
Tel: 800.284.8665

Thomas & Betts

www.tnb.com

Kindorf®

Channel Fittings

Kindorf® Modular Metal Framing and Support System

B-924 Post Base Connector

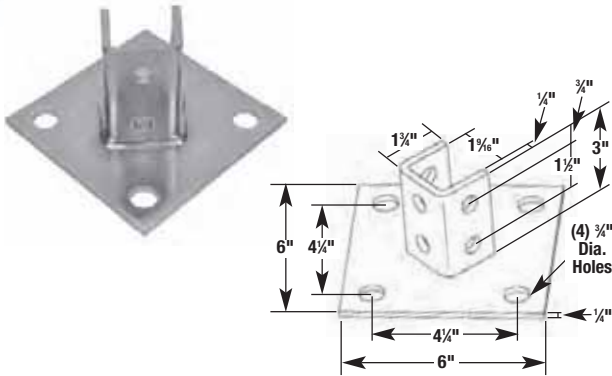

CAT. NO.	FINISH
B 924	Galv-Krom®
B-924-EG	SilverGalv®

1/4" steel 250#/C.
For use with 1 1/2" x 1 1/2" channels.

B-924FL Post Base Connector

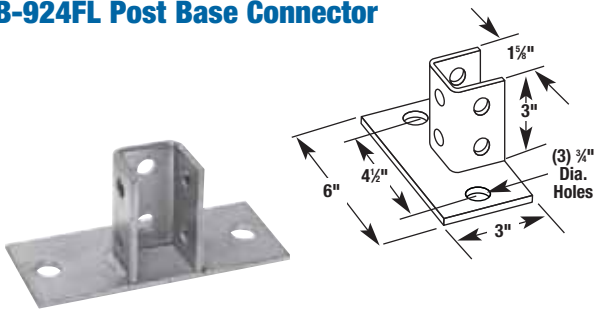

CAT. NO.	FINISH
B 924FL	Galv-Krom®
B-924-FLEG	SilverGalv®

B-924SQ Post Base Connector

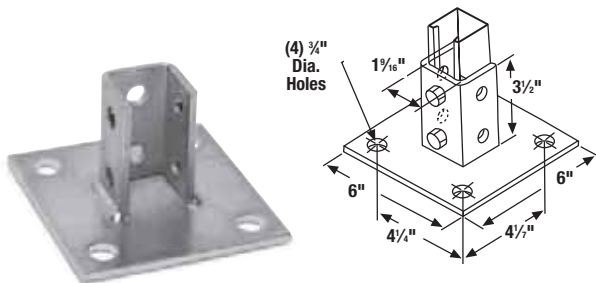

CAT. NO.	FINISH
B 924SQ	Galv-Krom®
B-924SQEG	SilverGalv®

B-925 Post Base Connector

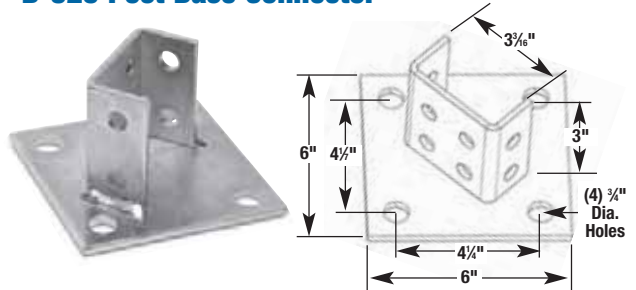

CAT. NO.	FINISH
B-925	Galv-Krom®
B-925-EG	SilverGalv®

B-925FL Post Base Connector

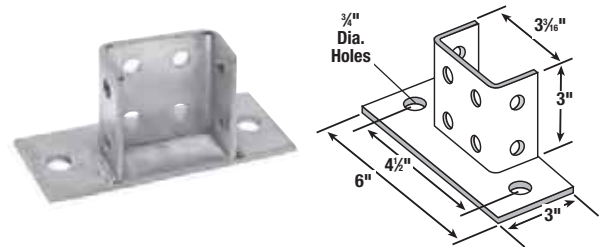

CAT. NO.	FINISH
B-925FL	Galv-Krom®
B-925FLEG	SilverGalv®

B-925SQ Post Base Connector

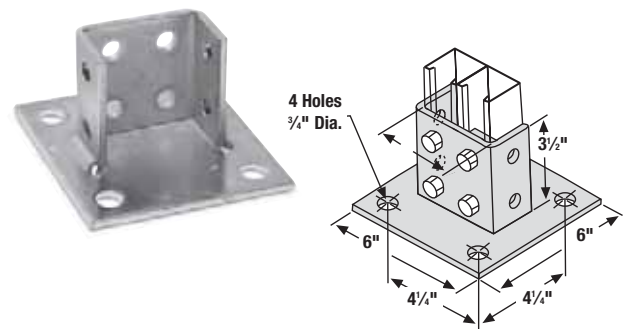

CAT. NO.	FINISH
B-925SQ	Galv-Krom®
B-925SQEG	SilverGalv®

Thomas & Betts

www.tnb.com

Corporate Office
Tel: 901.252.8000
800.816.7809
Fax: 901.252.1354

Customer Service
Tel: 800.816.7809
Fax: 800.816.7810

Technical Services
Tel: 888.862.3289
Fax: 901.252.1321

Tool Services
Tel: 800.284.8665

Kindorf®

Channel Fittings

B-933 Five-Hole Joint Connector

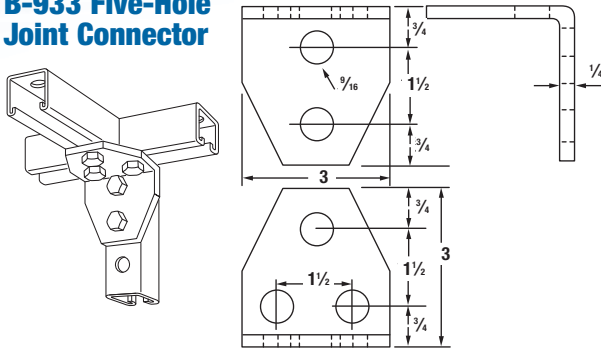

CAT. NO.	FINISH
B 933	Galv-Krom®

1/4" steel, 96#/C.

B-934 Outside Corner Connector

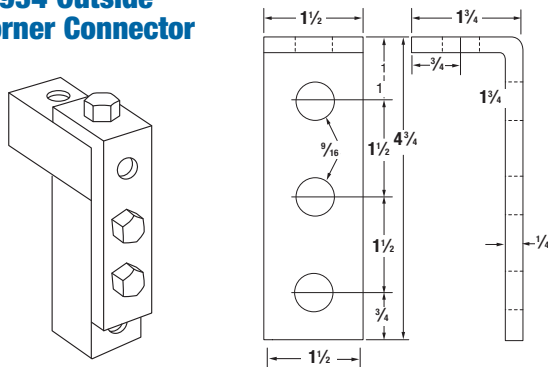

CAT. NO.	FINISH
B 934	Galv-Krom®

1/4" steel, 57#/C.

B-935 Three-Hole Plate Connector

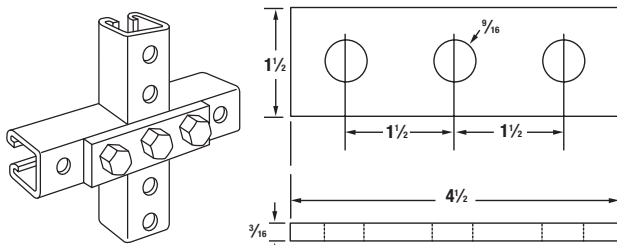

CAT. NO.	FINISH
B 935	Galv-Krom®
B-935-GR	Green Coated
B-935-EG	Electro-Galvanized

3/16" steel, 32#/C.

B-936 Angle Plate Connector

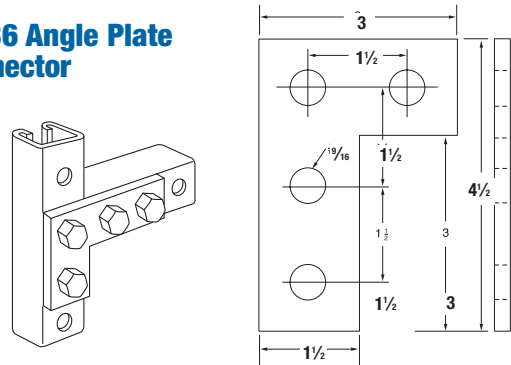

CAT. NO.	FINISH
B 936	Galv-Krom®
B-936GR	Green Coated
B-936EG	Electro-Galvanized

3/16" steel, 42#/C.

B-937 T-Plate Connector

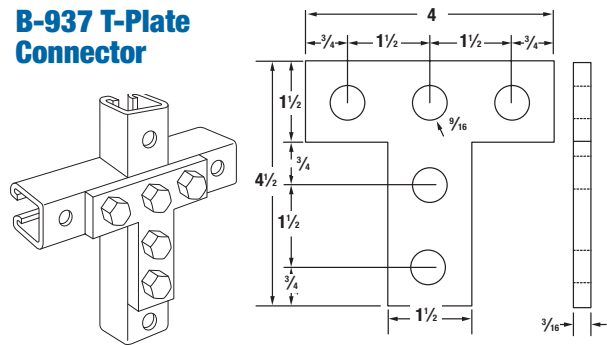

CAT. NO.	FINISH
B 937	Galv-Krom®

3/16" steel, 53#/C.

B-938 Open Angle Connector

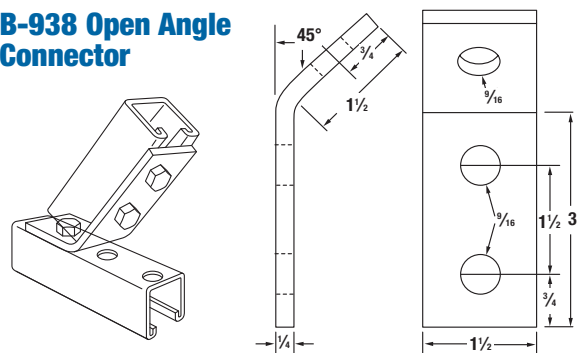

CAT. NO.	FINISH
B 938	Galv-Krom®

1/4" steel, 42#/C.

Kindorf®

Channel Fittings

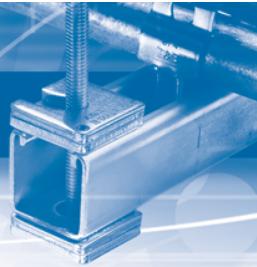

B-939 Closed Angle Connector

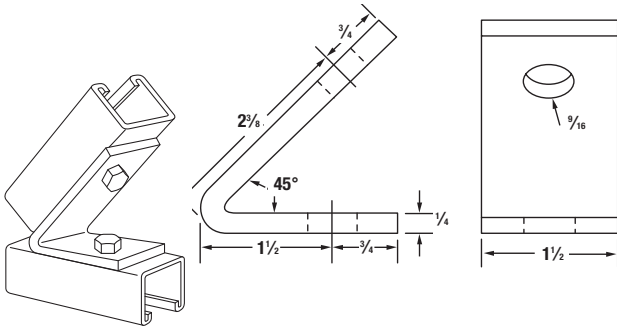

CAT. NO.	FINISH
B 939	Galv-Krom®

1/4" steel, 50#/C.

B-942 Swivel Plate

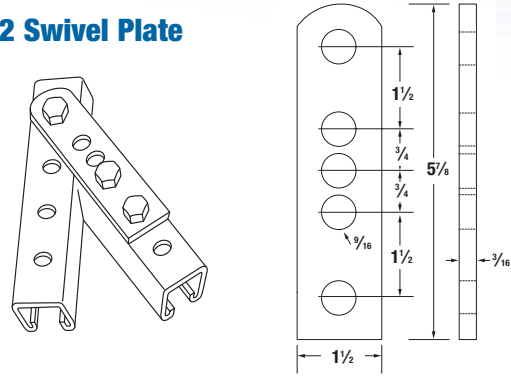

CAT. NO.	FINISH
B 942	Galv-Krom®

3/16" steel, 40#/C.

B-940 Corner Braces

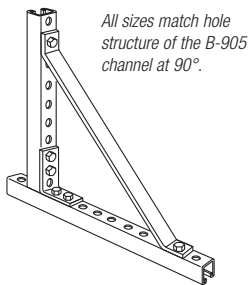

All sizes match hole structure of the B-905 channel at 90°.

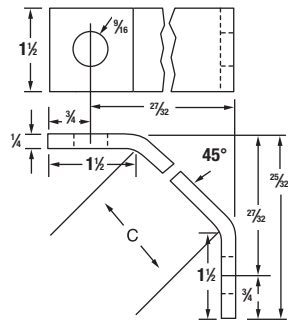

CAT. NO.	DIMENSIONS (IN.)			WT. IN LBS./C
	A	B	C	
B 940 1	7 1/2	6 3/4	8 1/8	115
B-940-2	13 1/2	12 3/4	16 1/8	212
B-940-3	19 1/2	18 3/4	25 1/8	305

1/4" steel, Galv-Krom®.

B-943 Brace Connectors

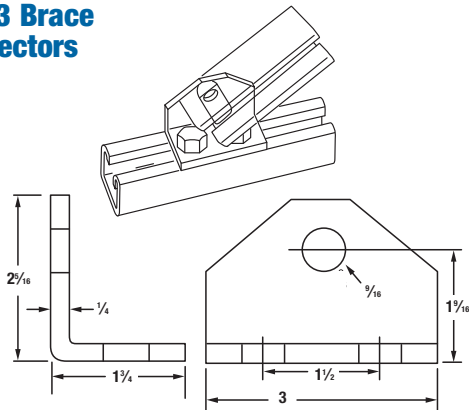

CAT. NO.	FINISH
B 943	Galv-Krom®

1/4" steel, 66#/C.

B-941 Joiner for B-905 Channel

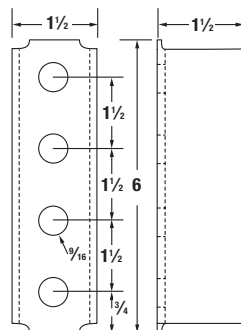
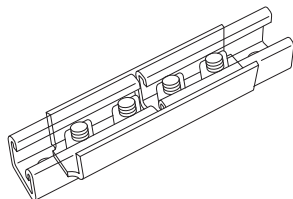

CAT. NO.	FINISH
B 941	Galv-Krom®

Order four B-910-1/2 nuts and four H-113-A cap screws separately.

12 ga. steel 80#/C.

B-944 Double Brace Connector

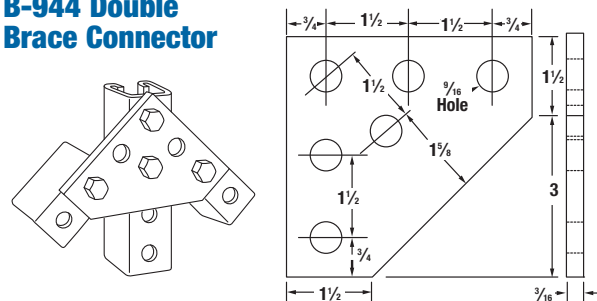

CAT. NO.	FINISH
B 944	Galv-Krom®

3/16" steel, 75#/C.

Kindorf® Modular Metal Framing and Support System

Corporate Office
Tel: 901.252.8000
800.816.7809
Fax: 901.252.1354

Customer Service
Tel: 800.816.7809
Fax: 800.816.7810

Technical Services
Tel: 888.862.3289
Fax: 901.252.1321

Tool Services
Tel: 800.284.8665

Thomas & Betts

www.tnb.com

Kindorf®

Channel Fittings

B-945 Rod Connector

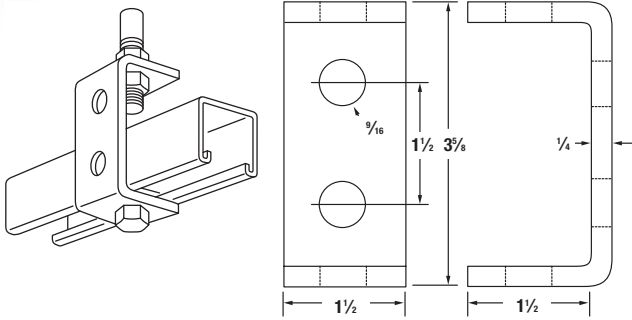

CAT. NO.	FINISH
B 945	Galv-Krom®

1/4" steel. 61#/C.

B-946 Z-Support

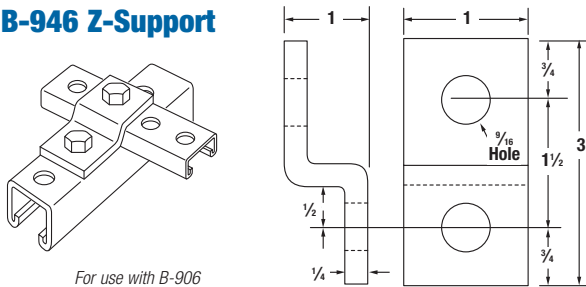

For use with B-906 or B-907 channel only.

CAT. NO.	FINISH
B 946	Galv-Krom®

1/4" steel. 34#/C.

B-947 Cross-Plate Connector

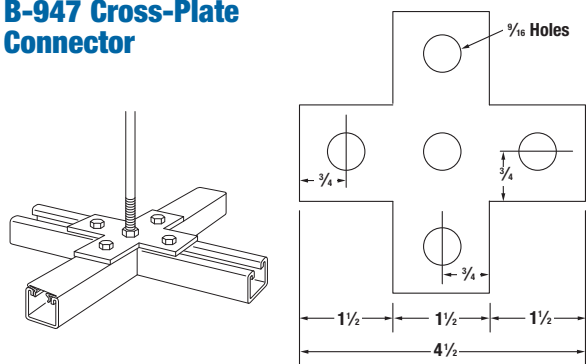

CAT. NO.	FINISH
B 947	Galv-Krom®

1/4" steel. 55#/C.

B-948 Joiner for B-907 Channel

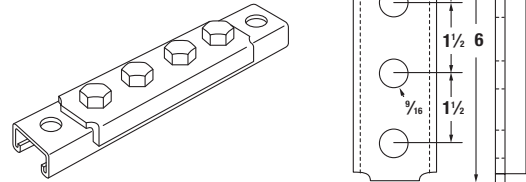

CAT. NO.	FINISH
B 948	Galv-Krom®

Order four B-910-1/2 nuts and four H-113-A cap screws separately.
12 ga. steel. 51#/C.

B-951 Wing Connector

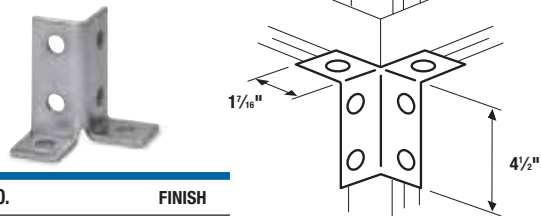

CAT. NO.	FINISH
B-951	Galv-Krom®

B-952 Wing Connector

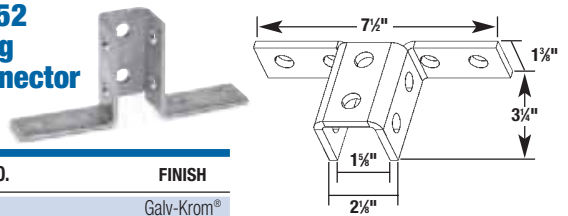

CAT. NO.	FINISH
B-952	Galv-Krom®

B-953 Wing Connector

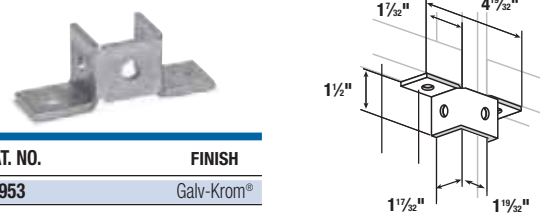

CAT. NO.	FINISH
B-953	Galv-Krom®

B-954 Wing Connector

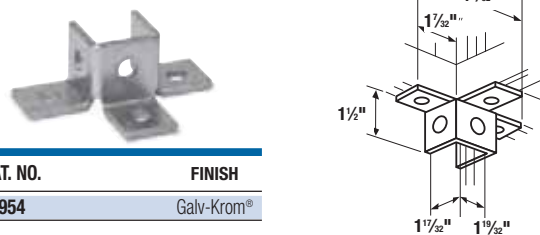

CAT. NO.	FINISH
B-954	Galv-Krom®

Kindorf®

Channel Fittings

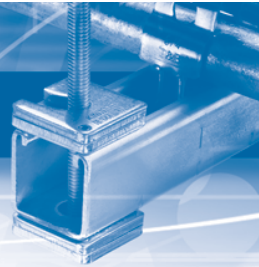

Kindorf® Modular Metal Framing and Support System

B-957 Wing Connector

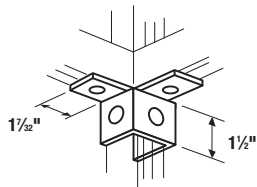

CAT. NO.	FINISH
B 957	Galv-Krom®

B-958L Wing Connector

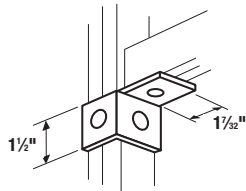

CAT. NO.	FINISH
B 958L	Galv-Krom®

B-958R Wing Connector

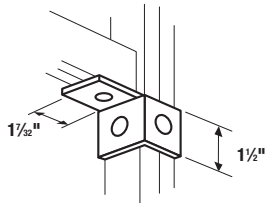

CAT. NO.	FINISH
B 958R	Galv-Krom®

B-960 Plate Connector

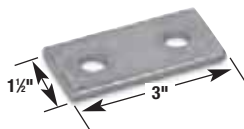

CAT. NO.	FINISH
B 960	Galv-Krom®

B-961 Plate Connector

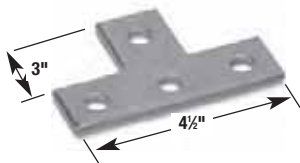

CAT. NO.	FINISH
B 961	Galv-Krom®

B-962 Plate Connector

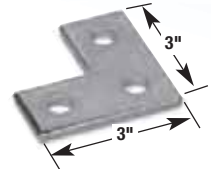

CAT. NO.	FINISH
B-962	Galv-Krom®

B-964 Plate Connector

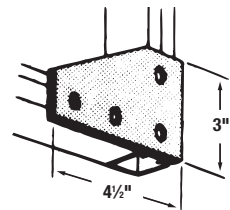

CAT. NO.	FINISH
B-964	Galv-Krom®

B-965 Plate Connector

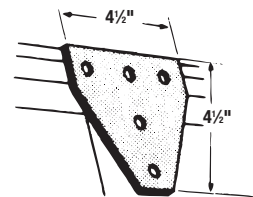

CAT. NO.	FINISH
B-965	Galv-Krom®

B-966 Plate Connector

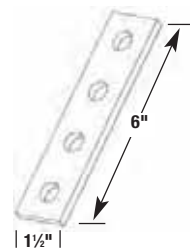

CAT. NO.	FINISH
B-966	Galv-Krom®

B-967 Plate Connector

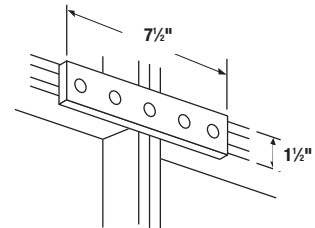

CAT. NO.	FINISH
B-967	Galv-Krom®

Corporate Office
Tel: 901.252.8000
800.816.7809
Fax: 901.252.1354

Customer Service
Tel: 800.816.7809
Fax: 800.816.7810

Technical Services
Tel: 888.862.3289
Fax: 901.252.1321

Tool Services
Tel: 800.284.8665

Thomas & Betts

www.tnb.com

Kindorf®

Bantam Channels

For the support of light- and medium-weight equipment in electrical and mechanical applications.

Bantam Channels

Bantam Channels simplify the support of overhead fixtures, conduits, pipes and boxes in suspended ceiling installations where they can be supported on runs of lathers channel or directly from bar joists or ceiling beams. Ribbed channels may also be mounted on concrete forms and used as low-cost continuous-slot concrete inserts.

Installed slot down the open slot accommodates and enables easy positioning of accessory fittings or 1/4" hanger rod to support light- or medium-weight equipment.

The use of Kindorf® Channel Bars provides a ready made system of bars and accessories designed to eliminate costly and time-consuming on-the-job improvising.

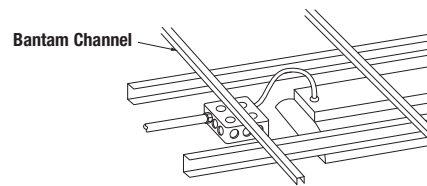
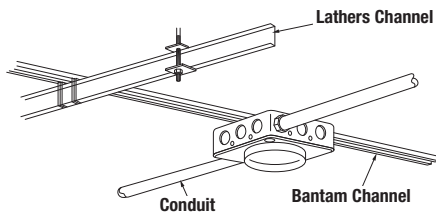

Box mounted on Bantam Channel to feed fixtures.

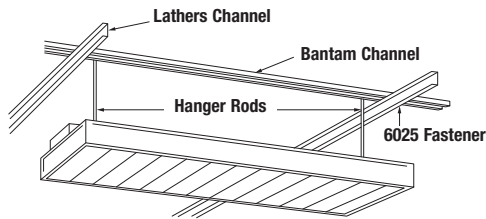

Suspended Fixture

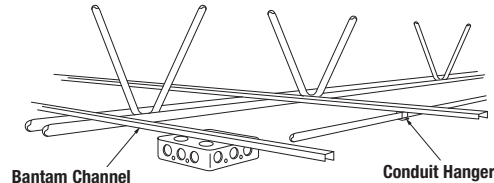

Typical mounting on bar joists

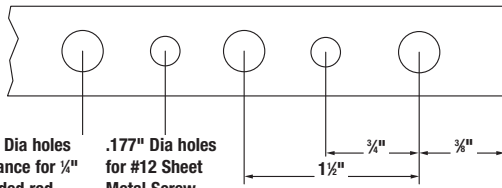
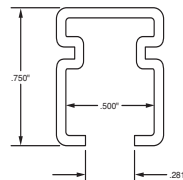
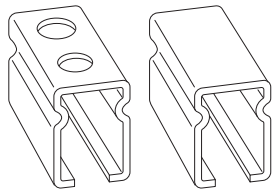

Ribbed Channels (extra strength)

CAT. NO.	DESCRIPTION	WT. LBS./C FT.
6029 H	16 gauge (.060") Ribbed Channel with Holes	30
6029	16 gauge (.060") Ribbed Channel	45

Channels are produced in 10-ft. lengths. Pre-galvanized steel.

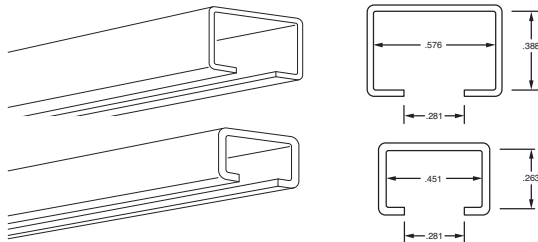

Lightweight Channels

CAT. NO.	DESCRIPTION	WT. LBS./C FT.
6013	20 gauge (.034") Lightweight Channel	17
6014	18 gauge (.044") Lightweight Channel	16

Channels are produced in 10-ft. lengths. Pre-galvanized steel.

Thomas & Betts

www.tnb.com

Corporate Office
Tel: 901.252.8000
800.816.7809
Fax: 901.252.1354

Customer Service
Tel: 800.816.7809
Fax: 800.816.7810

Technical Services
Tel: 888.862.3289
Fax: 901.252.1321

Tool Services
Tel: 800.284.8665

Kindorf®

Bantam Channels

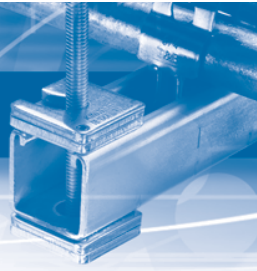

Kindorf® Modular Metal Framing and Support System

Low-Cost Techniques for Bantam Channel. Fast, Easy Hanging With Standard Fittings

**Groove Holds Nut Squarely —
Nut Won't Rotate.**

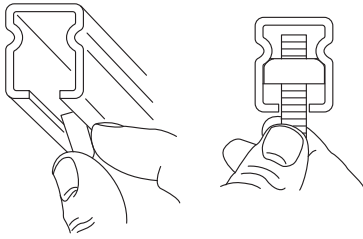

Cat. No. H-116-A-1/4
square nut tips in anywhere.

T-Bar Clip

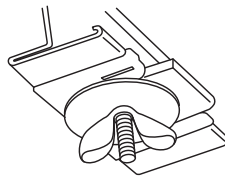

Cat. No. 6075
Mounts electrical fixtures to exposed
grid acoustical ceilings. Fits 1/8" or 1" bar face.
Load Rating: 100 lbs. Safety factor of 4.
Furnished complete with cupped washer and wing nut.

**Bantam Channel for
Low-Cost, Continuous-Slot
Concrete Inserts.**

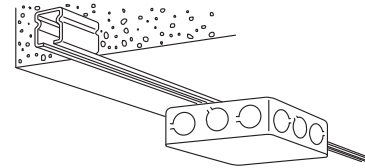

Cat. No. 6029
Maximum recommended loads 200 lbs.

**Insert Rod Full Height of Channel
for Rigidity.**

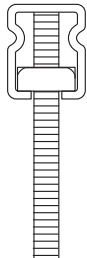

Cat. No. H-193-1/4
hanger rod.

**Fastener and Carrier,
(Complete Assembly) 6#/C**

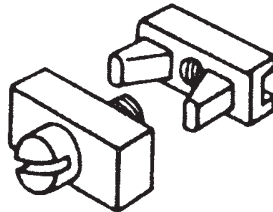

Cat. No. 6016

Beam Flange Clip

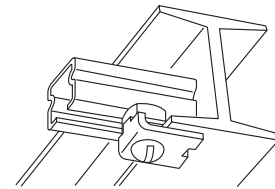

Cat. No. 6024
Secures channel to I-beams, angle iron or bar joists
with flanges not exceeding 1/4" thickness.

Channel Carrier 2#/C

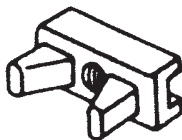

Cat. No. 6017

Hung Ceiling Carrying Channel

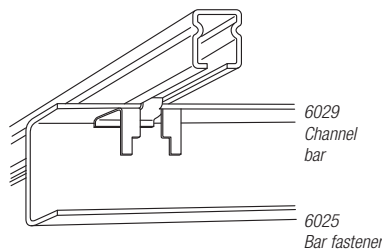

Cat. No. 6025
Secures channel to lathers channel
or other ceiling-carrying channels.

**Fixture Stud and Carrier,
(Complete Assembly) 7#/C**

Cat. No. 6026

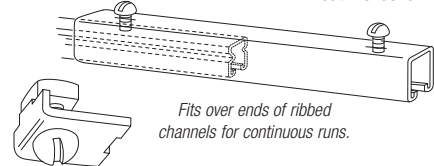

Fits over ends of ribbed
channels for continuous runs.

Cat. No. 6015



C-18 N.P.S.

Corporate Office
Tel: 901.252.8000
800.816.7809
Fax: 901.252.1354

Customer Service
Tel: 800.816.7809
Fax: 800.816.7810

Technical Services
Tel: 888.862.3289
Fax: 901.252.1321

Tool Services
Tel: 800.284.8665

Thomas & Betts

www.tnb.com

Kindorf®

Conduit, Cable and Pipe Supports

C105 and C106 Series Pipe Straps

Kindorf® Pipe Straps are designed to be twist inserted anywhere along the slot side of the channel. Pipes can be placed as closely as pipe couplings permit.

Single or multiple runs of pipe and cable are secured easily and economically by Kindorf® supports. In the racking of multiple runs of pipe, for example, C-105 Straps are quickly twist inserted into a channel slot and the pipe is installed by the tightening of a single screw. There are no holes to drill and position adjustment is made simple by sliding the strap along the channel slot. Runs of pipe or conduit can be spaced with complete freedom, as close as conduit couplings permit.

For single runs, the C-149 Pipe Hanger saves installation time by allowing the conduit or pipe to be laid in place after the hanger is mounted. The versatile C-149 can be suspended from hanger rod or bolted directly to the wall, and pipe insulation, when needed, can be installed without removing the pipe from the hanger.

These are but two examples of how Kindorf® products deliver lower installed costs. Whether it be a problem of tight spacing, adjustment or alignment of adequate spacing between hangers, there's a Kindorf® support to solve it.

Kindorf® pipe and cable supports are engineered to provide safe and secure installations. The majority of Kindorf® supports are protected by the exclusive Galv-Krom® finish, including threaded components.

There's a wide range of Kindorf® pipe and cable supports to meet almost every job condition, installed either in combination with channel or individually secured to the structure surface.

Some unique features of the straps include:

- Bolt head is combination slot and hexhead for flexibility of attachment
- Square nut is captivated on the shoulder for easy one-handed tightening
- Straps are interchangeable with 1 5/8" strut for broader application
- Straps are shipped assembled so counting and sorting are easier
- Pipe or conduit sizes are shown on the strap for easy identification

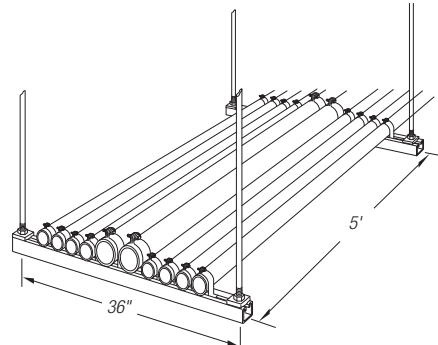

Trapeze application supporting multiple conduit runs.



C-247 Beam clamp supports pipe.

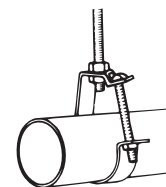

Pipe supported by C-149 lay-in hanger.

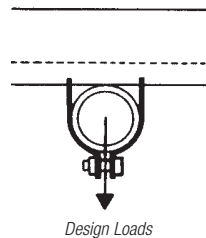

Design Loads

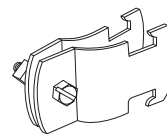
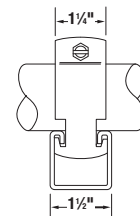

All Kindorf® Straps are pre-assembled for easy handling and sorting.

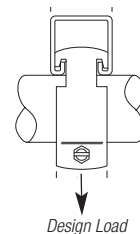

Design Load

Conduit Strap Size Chart — Old Kindorf Strut

EMT TRADE SIZE (IN.)	STRAP
1/2	700-3/8STR
3/4	700-3/4-STR
1	700-1
1 1/4	700-1-1/4-STR
1 1/2	700-1-1/2-STR
2	700-2-STR

RIGID CONDUIT SIZE (IN.)	STRAP
1/2	702-1/2
3/4	702-3/4
1	702-1
1 1/4	702-1-1/4
1 1/2	702-1-1/2
2	702-2-STR

Thomas & Betts

www.tnb.com

Corporate Office
Tel: 901.252.8000
800.816.7809
Fax: 901.252.1354

Customer Service
Tel: 800.816.7809
Fax: 800.816.7810

Technical Services
Tel: 888.862.3289
Fax: 901.252.1321

Tool Services
Tel: 800.284.8665

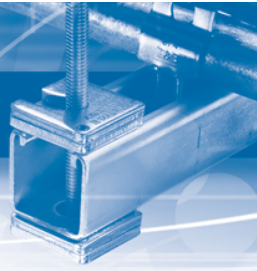

Angler® Pipe and Conduit Clamp

For EMT, IMC, Rigid and Standard Pipe.



Universal Series



CAT. NO.	SIZE (IN.)	STRAP THICKNESS	DESIGN LOAD (LBS.)	INSTALL TORQUE (IN. LBS.)	STD. CTN.
Galv-Krom® Finish					
C 109 1/2	½	14 ga.	400	40	100
C 109 3/4	¾	14 ga.	500	40	100
C 109 1	1	14 ga.	500	40	100
C 109 1 1/4	1¼	14 ga.	500	40	100
C 109 1 1/2	1½	12 ga.	800	60	50
C 109 2	2	12 ga.	800	60	50
C 109 2 1/2	2½	12 ga.	800	60	50
C 109 3	3	12 ga.	800	60	50
C 109 3 1/2	3½	11 ga.	1,200	60	25
C 109 4	4	11 ga.	1,200	60	25

SilverGalv® Finish

C 109 1/2 EG	½	14 ga.	400	40	100
C 109 3/4 EG	¾	14 ga.	500	40	100
C 109 1 EG	1	14 ga.	500	40	100
C 109 1 1/4 EG	1¼	14 ga.	500	40	100
C 109 1 1/2 EG	1½	12 ga.	800	60	50
C 109 2 EG	2	12 ga.	800	60	50
C 109 2 1/2 EG	2½	12 ga.	800	60	50
C 109 3 EG	3	12 ga.	800	60	50
C 109 3 1/2 EG	3½	11 ga.	1,200	60	25
C 109 4 EG	4	11 ga.	1,200	60	25

Available in SilverGalv® Finish by adding "EG" suffix to catalog number.

Rigid Series



CAT. NO.	SIZE (IN.)	STRAP THICKNESS	DESIGN LOAD (LBS.)	INSTALL TORQUE (IN. LBS.)	STD. CTN.
Galv-Krom® Finish					
C 109R 1/2	½	14 ga.	600	40	100
C 109R 3/4	¾	14 ga.	600	40	100
C 109R 1	1	14 ga.	600	40	100
C 109R 1 1/4	1¼	14 ga.	600	40	100
C 109R 1 1/2	1½	12 ga.	800	60	50
C 109R 2	2	12 ga.	800	60	50
C 109R 2 1/2	2½	12 ga.	800	60	50
C 109R 3	3	12 ga.	800	60	50
C 109R 3 1/2	3½	11 ga.	1,200	60	25
C 109R 4	4	11 ga.	1,200	60	25

SilverGalv® Finish

C 109R 1/2 EG	½	14 ga.	600	40	100
C 109R 3/4 EG	¾	14 ga.	600	40	100
C 109R 1 EG	1	14 ga.	600	40	100
C 109R 1 1/4 EG	1¼	14 ga.	600	40	100
C 109R 1 1/2 EG	1½	12 ga.	800	60	50
C 109R 2 EG	2	12 ga.	800	60	50
C 109R 2 1/2 EG	2½	12 ga.	800	60	50
C 109R 3 EG	3	12 ga.	800	60	50
C 109R 3 1/2 EG	3½	11 ga.	1,200	60	25
C 109R 4 EG	4	11 ga.	1,200	60	25

Hex head size ⅝" for ½" to 1¼" sizes, ⅞" for 1½" to 4" sizes.

Material: Stamped Steel.

Pipe sizes 2½" to 4" utilize the same clamps for the Rigid Series and the Universal Series.

Available in SilverGalv® Finish by adding "EG" suffix to catalog number.

C-200 Universal Pipe Straps

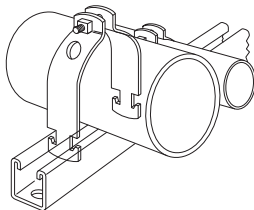

CAT. NO.	EMT, IMC, RIGID PIPE SIZE (IN.)	PIPE O.D. RANGE (IN.)	STRAP THICKNESS	WT. LBS./C
C-200-1/2	½	.706–.804	14 ga.	12
C-200-3/4	¾	.922–1.060	14 ga.	13
C-200-1	1	1.163–1.315	14 ga.	14
C-200-1-1/4	1¼	1.508–1.660	14 ga.	16
C-200-1-1/2	1½	1.738–1.900	12 ga.	27
C-200-2	2	2.196–2.375	12 ga.	31

Design load equal to C-105 straps.

Corporate Office
Tel: 901.252.8000
800.816.7809
Fax: 901.252.1354

Customer Service
Tel: 800.816.7809
Fax: 800.816.7810

Technical Services
Tel: 888.862.3289
Fax: 901.252.1321

Tool Services
Tel: 800.284.8665

Thomas & Betts

www.tnb.com

Kindorf®

Conduit, Cable and Pipe Supports

Kindorf® Modular Metal Framing and Support System

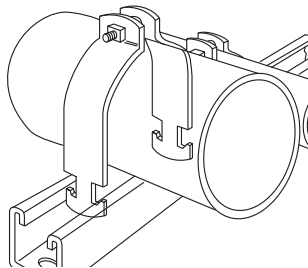
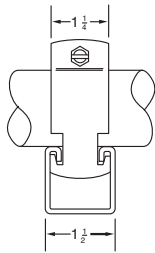
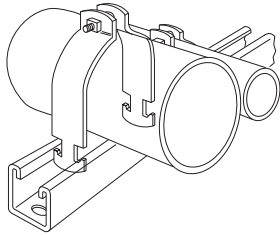

Interchangeable strap fits both 1 1/2" and 1 3/4".

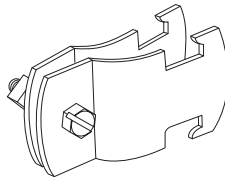

All Kindorf® Straps are preassembled for easy handling and sorting.

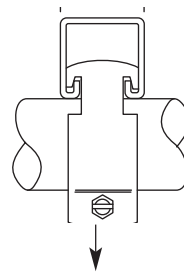

Design Load

C-105 and C-106 Pipe Straps

Kindorf® Pipe Straps are designed to be twist inserted anywhere along the slot side of the channel. Pipes can be placed as closely as pipe couplings permit.

Some unique features of the straps include:

- Bolt head is combination slot and hex head for flexibility of attachment
- Square nut is captivated on the shoulder for easy one-handed tightening

- Straps are interchangeable with 1 1/2" strut for broader application
- Straps are shipped assembled so counting and sorting are easier
- Pipe or conduit sizes are shown on the strap for easy identification

Kindorf® Straps for Rigid Conduit, IMC and Pipe



STEEL STRAPS — GALV-KROM® FINISH

CAT. NO.	RIGID CONDUIT OR PIPE SIZE (IN.)	O.D. SIZE (IN.)	STEEL STRAP THICKNESS	DESIGN LOAD (LBS.)	WT. LBS./C
C-105-3/8	3/8	0.675	14 ga.	750	12
C-105-1/2	1/2	0.840	14 ga.	750	13
C-105-3/4	3/4	1.050	14 ga.	750	15
C-105-1	1	1.315	14 ga.	750	17
C-105-1-1/4	1 1/4	1.660	14 ga.	800	19
C-105-1-1/2	1 1/2	1.900	12 ga.	800	28
C-105-2	2	2.375	12 ga.	800	31
C-105-2-1/2	2 1/2	2.875	12 ga.	1000	36
C-105-3	3	3.500	12 ga.	1650	42
C-105-3-1/2	3 1/2	4.000	11 ga.	1650	56
C-105-4	4	4.500	11 ga.	1650	64
C-105-4-1/2	4 1/2	5.000	11 ga.	1650	72
C-105-5	5	5.563	11 ga.	1650	76
C-105-6	6	6.625	11 ga.	1650	89
C-105-8	8	8.625	11 ga.	1650	114
C-105-10	10	10.750	10 ga.	1650	160
C-105-12	12	12.750	10 ga.	1650	165

Thomas & Betts

www.tnb.com

Corporate Office
Tel: 901.252.8000
800.816.7809
Fax: 901.252.1354

Customer Service
Tel: 800.816.7809
Fax: 800.816.7810

Technical Services
Tel: 888.862.3289
Fax: 901.252.1321

Tool Services
Tel: 800.284.8665

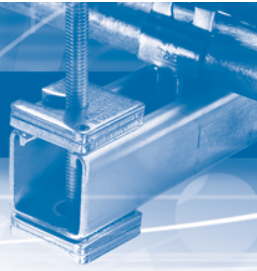

Kindorf® Straps for EMT

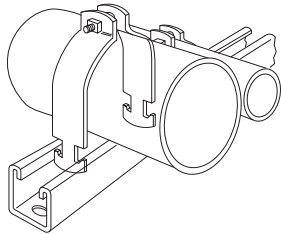

STEEL — GALV-KROM® FINISH					
CAT. NO.	EMT SIZE (IN.)	O.D. SIZE (IN.)	STEEL STRAP THICKNESS	DESIGN LOAD (LBS.)	WT. LBS./C
C-106-3/8	3/8	0.577	14 ga.	750	13
C-106-1/2	1/2	0.706	14 ga.	750	14
C-106-3/4	3/4	0.922	14 ga.	750	13
C-106-1	1	1.163	14 ga.	750	16
C-106-1-1/4	1 1/4	1.510	14 ga.	750	19
C-106-1-1/2	1 1/2	1.740	12 ga.	800	20
C-106-2	2	2.197	12 ga.	800	22

Kindorf® Straps for O.D. Tubing

CAT. NO.	TUBING O.D. (IN.)	STEEL STRAP THICKNESS	DESIGN LOAD (LBS.)	CAT. NO.	TUBING O.D. (IN.)	STEEL STRAP THICKNESS	DESIGN LOAD (LBS.)
<i>Galv-Krom® Finish</i>				<i>Galv-Krom® Finish</i>			
701-1/4	1/4	14 ga.	750	701-4	4	11 ga.	1,650
701-3/8	3/8	14 ga.	750	701-4-1/8	4 1/8	11 ga.	1,650
701-1/2-STR	1/2	14 ga.	750	701-4-1/4	4 1/4	11 ga.	1,650
701-5/8	5/8	14 ga.	750	701-4-3/8	4 3/8	11 ga.	1,650
701-3/4	3/4	14 ga.	750	701-4-1/2	4 1/2	11 ga.	1,650
701-7/8	7/8	14 ga.	750	701-4-5/8	4 5/8	11 ga.	1,650
701-1-STR	1	14 ga.	750	701-4-3/4	4 3/4	11 ga.	1,650
701-1-1/8	1 1/8	14 ga.	1,000	701-4-7/8	4 7/8	11 ga.	1,650
701-1-1/4	1 1/4	14 ga.	1,000	701-5	5	11 ga.	1,650
701-1-3/8	1 3/8	14 ga.	1,000	701-5-1/8	5 1/8	11 ga.	1,650
701-1-1/2	1 1/2	14 ga.	1,000	701-5-1/4	5 1/4	11 ga.	1,650
701-1-5/8	1 5/8	14 ga.	1,000	701-5-3/8	5 3/8	11 ga.	1,650
701-1-3/4	1 3/4	12 ga.	1,000	701-5-1/2	5 1/2	11 ga.	1,650
701-1-7/8	1 7/8	12 ga.	1,000	701-5-5/8	5 5/8	10 ga.	1,650
701-2	2	12 ga.	1,000	701-5-3/4	5 3/4	10 ga.	1,650
701-2-1/8	2 1/8	12 ga.	1,300	701-5-7/8	5 7/8	10 ga.	1,650
701-2-1/4	2 1/4	12 ga.	1,300	701-6	6	10 ga.	1,650
701-2-3/8	2 3/8	12 ga.	1,300	701-6-1/8	6 1/8	10 ga.	1,650
701-2-1/2	2 1/2	12 ga.	1,300	701-6-1/4	6 1/4	10 ga.	1,650
701-2-5/8	2 5/8	12 ga.	1,300	701-6-3/8	6 3/8	10 ga.	1,650
701-2-3/4	2 3/4	12 ga.	1,300	701-6-1/2	6 1/2	10 ga.	1,650
701-2-7/8	2 7/8	12 ga.	1,300	701-6-5/8	6 5/8	10 ga.	1,650
701-3	3	12 ga.	1,300	701-6-3/4	6 3/4	10 ga.	1,650
701-3-1/8	3 1/8	12 ga.	1,300	701-6-7/8	6 7/8	10 ga.	1,650
701-3-1/4	3 1/4	12 ga.	1,300	701-8	8	10 ga.	1,650
701-3-3/8	3 3/8	12 ga.	1,300				
701-3-1/2	3 1/2	12 ga.	1,300				
701-3-5/8	3 5/8	11 ga.	1,650				
701-3-3/4	3 3/4	11 ga.	1,650				
701-3-7/8	3 7/8	11 ga.	1,650				

Kindorf® Modular Metal Framing and Support System

C-708-U Short Strap for Channel or Wall Mounting

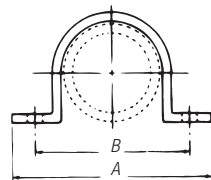
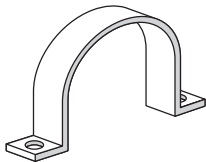

CAT. NO.	PIPE SIZE (IN.)	DIMENSIONS (IN.)		HOLE SIZE (IN.)	STOCK SIZE (IN.)	DESIGN LOAD (LBS.)
		A	B			
C708U 1/2	1/2	2 5/8	2	5/32	1/8 x 1 1/2	650
C-708-U-3/4	3/4	3 1/8	2 1/8	5/32	1/8 x 1 1/2	650
C-708-U-1	1	3 3/8	2 1/2	5/32	1/8 x 1 1/2	650
C-708-U-1-1/4	1 1/4	3 11/8	2 3/8	5/32	1/8 x 1 1/2	650
C-708-U-1-1/2	1 1/2	3 5/8	3 1/8	5/32	1/8 x 1 1/2	650
C-708-U-2	2	5 1/4	4 1/8	7/16	1/4 x 1 1/2	650
C-708-U-2-1/2	2 1/2	6 1/8	4 3/8	7/16	1/4 x 1 1/2	1,000
C-708-U-3	3	6 3/8	5 1/8	7/16	1/4 x 1 1/2	1,000
C-708-U-3-1/2	3 1/2	7 1/8	5 3/8	7/16	1/4 x 1 1/2	1,000
C-708-U-4	4	7 3/8	6 1/8	7/16	1/4 x 1 1/2	1,200
C-708-U-5	5	8 1/8	7 1/4	7/16	1/4 x 1 1/2	1,200
C-708-U-6	6	9 1/8	8 1/8	7/16	1/4 x 1 1/2	1,200

Corporate Office
Tel: 901.252.8000
800.816.7809
Fax: 901.252.1354

Customer Service
Tel: 800.816.7809
Fax: 800.816.7810

Technical Services
Tel: 888.862.3289
Fax: 901.252.1321

Tool Services
Tel: 800.284.8665

Thomas & Betts

www.tnb.com

Kindorf®

Conduit, Cable and Pipe Supports

EZ-Strap

- Fits EMT, IMC and rigid conduit
- Size range ½" thru 2"
- Can be used on 1½" or 1⅝" channel
- Saves inventory dollars
- Corrosion-resistant Galv-Krom® finish
- One-piece construction means no assembly required
- Installs directly over conduit for easy installation
- 50% reduction of installation time
- No twisting required to install
- Slotted hex head screw

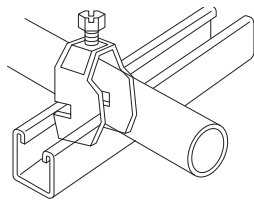

C-108 Universal Pipe Strap

CAT. NO. & SIZE	DIMENSIONS (IN.)			THICKNESS STEEL	O.D. SIZE	WT. LBS./C
	EMT	IMC	Rigid			
C-108-1/2	½ EMT	½ IMC	½ Rigid	16 ga.	⅞	8
C-108-¾	¾ EMT	¾ IMC	¾ Rigid	16 ga.	1⅜	10
C-108-1	1 EMT	1 IMC	1 Rigid	16 ga.	1⅞	10
C-108-1-¼	1¼ EMT	1¼ IMC	1¼ Rigid	14 ga.	1⅞	15
C-108-1-½	1½ EMT	1½ IMC	1½ Rigid	14 ga.	1⅞	16
C-108-2	2 EMT	2 IMC	2 Rigid	14 ga.	2⅜	19

C-144 Two-Hole Pipe Straps

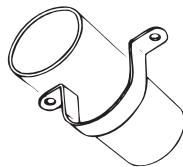
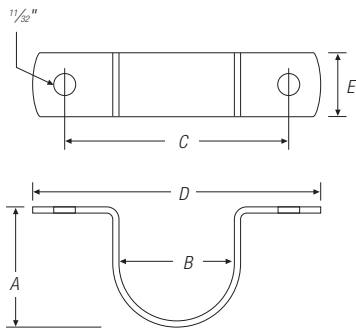

Holds pipe tight against mounting surface.

CAT. NO.	DIMENSIONS (IN.)				WOOD SCREW SIZE REQ'D.	THICKNESS STEEL	WT. LBS./C
	A & B	C	D	E			
C-144-1/2	.840	2	3	¾	No. 12 x 1	⅛	10
C-144-¾	1.050	2¼	3¼	¾	No. 12 x 1	⅛	11
C-144-1	1.315	2½	3½	¾	No. 12 x 1	⅛	13
C-144-1-¼	1.660	3¼	4¼	1	No. 12 x 1	⅛	20
C-144-1-½	1.900	3½	4½	1	No. 12 x 1	⅛	23
C-144-2	2.375	4¼	5¼	1	No. 16 x 1½	⅛	30
C-144-2-½	2.875	5	6	1	No. 16 x 1½	⅛	35
C-144-3	3.500	5¾	6¾	1	No. 16 x 2	⅛	42
C-144-3-½	4.000	6½	7½	1	No. 16 x 2½	⅜	69
C-144-4	4.500	7	8	1	No. 16 x 3	⅜	78

Standard finish Galv-Krom®.

Framing Channel Clamp

Ty-Rap® Cable Clamp

When fastening wire bundles, cables or hoses to framing channels, you can cut costs considerably by using the TY-RAP® Cable Clamp. It is made of smooth, weather-resistant nylon and designed to protect cable insulation and hoses from wear or damage as can occur with metal clamps. The clamp may be used for both indoor or outdoor applications. It installs in the framing channel with a simple push and twist. It requires no screws, nuts or tools. The clamp fits all 1½" and 1⅝" channels regardless of channel depth.



- Installs with a push and twist
- Designed for indoor or outdoor use
- Smooth design protects cable insulation
- Takes range of cable diameters



CAT. NO.	CHANNEL SIZE	MAXIMUM TIE WIDTH ACCOM.	UNIT QUAN.	STD. CTN.
TC5363X	1.5 & 1.625	.301	50	250

Mounting bases for heavy-duty applications are made from high-impact weather-resistant nylon.

Kindorf®

Conduit, Cable and Pipe Supports

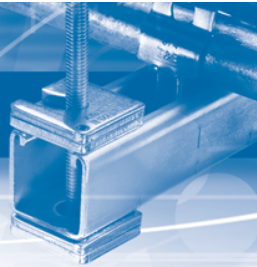

The new specification standard for heavy-duty industrial applications.

NEW!

King Cobra® Cable and Pipe Clamp with GoldGalv® Finish

- Superior design load capabilities for industrial applications: 350 lbs. for ½" to 2½" trade sizes; 450 lbs. for 3" to 4" trade sizes
- Durable one-piece heavy-duty steel construction — designed specifically for use in industrial applications
- Embosses on shoulder and hooks increase loading capability and durability, preventing deformation of clamps
- Rugged stirrup provides increased strength for heavier loads, minimizing deflection
- Wider saddle design with anti-rotation tabs distributes load evenly over a larger surface area, preventing jacket damage
- Increased corrosion protection* — GoldGalv® (yellow zinc dichromate) finish stands up to harsh industrial applications
- Parallel hook design keeps conduit and cable square with strut
- Heavy-duty ⅝" hex bolt
- One clamp size works on equal trade sizes for both EMT and rigid conduit, simplifying clamp specification



* Compared to conventional electrogalvanization.

King Cobra®

CAT. NO.	FOR EMT AND RIGID CONDUIT TRADE SIZE (IN.)	CABLE O.D. RANGE (IN.)	STATIC LOAD LIMIT (LB) SAFETY FACTOR = 4	STD. CTN.
GoldGalv® Finish				
KGPC050	½	0.650–0.890	350	100
KGPC075	¾	0.860–1.110	350	100
KGPC100	1	1.100–1.400	350	100
KGPC125	1¼	1.400–1.725	350	50
KGPC150	1½	1.690–1.980	350	50
KGPC200	2	1.980–2.576	350	50
KGPC250	2½	2.576–3.060	350	25
KGPC300	3	3.060–3.626	450	25
KGPC350	3½	3.626–4.126	450	25
KGPC400	4	4.126–4.626	450	25

Standard Finish — GoldGalv®, unless otherwise stated.

Cobra® One-Piece Cable and Pipe Clamp

Takes a bite out of your installation time!

- One-piece heavy-duty construction ready to install right out of the box, no need to break apart and reassemble, no screws or bolts to drop
- Installs quickly and securely using one hand
- Universal bolt head accepts a range of tools
- Eliminates the guesswork from clamp selection — one catalog number attaches equal trade sizes of EMT and rigid conduit
- Parallel hook design keeps conduits and cable square with strut
- Reconfigure wiring without complete disassembly. Remove cables easily without disturbing neighboring clamps



Cobra®

CAT. NO.	FOR EMT AND RIGID CONDUIT TRADE SIZE (IN.)	CABLE O.D. RANGE (IN.)	STATIC LOAD LIMIT (LB) SAFETY FACTOR = 4	STD. CTN.
Electro-Galvanized Steel				
CPC025	½	0.312–0.600	200	100
CPC050	¾	0.650–0.890	200	100
CPC075	¾	0.860–1.110	200	100
CPC100	1	1.100–1.400	200	100
CPC125	1¼	1.400–1.725	200	50
CPC150	1½	1.690–1.980	200	50
CPC200	2	1.980–2.576	200	50
CPC250	2½	2.576–3.060	350	25
CPC300	3	3.060–3.626	350	25
CPC350	3½	3.626–4.126	350	25
CPC400	4	4.126–4.626	350	25

Standard Finish — GoldGalv®, unless otherwise stated.

Stainless Steel: add suffix SS or 556.

Modular Metal Framing and Support System

Corporate Office
Tel: 901.252.8000
800.816.7809
Fax: 901.252.1354

Customer Service
Tel: 800.816.7809
Fax: 800.816.7810

Technical Services
Tel: 888.862.3289
Fax: 901.252.1321

Tool Services
Tel: 800.284.8665

Thomas & Betts

www.tnb.com

Kindorf®

Conduit, Cable and Pipe Supports

C-711 Lay-in-Pipe Hanger (J-Hanger)

Saves installation time by allowing the conduit or pipe to be laid in place after the hanger is mounted. Fastening of side bolt can be delayed until most convenient for job conditions. Insulation can be installed without removing pipe from hanger. The C-149 hanger can be suspended from hanger rod or can be bolted directly to a wall. When used with hanger rod, assembly requires two H-114 hex nuts.

Vertical adjustment of at least 1½" after pipe is laid in place. The lower nut adjusts pipe lines to the proper pitch and the top nut, when locked into position, prevents loosening due to vibration. The square nut on the side bolt is kept from loosening by the arrangement of hole and up-turned lip.

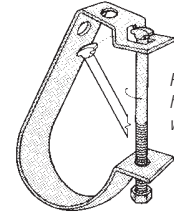

Rest pipe in body of hanger. Fasten side bolt when convenient.

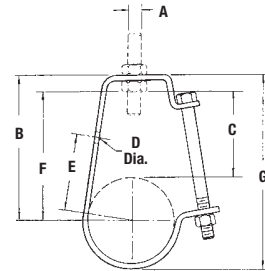
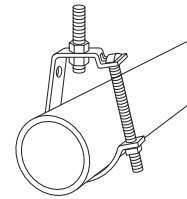

CAT. NO.	PIPE SIZE (IN.)	A ROD SIZE (IN.)	DIMENSIONS (IN.)						BOLT SIZE (IN.)	STOCK SIZE	MAX. REC. LOADS LBS.
			B	C	D	E	F	G			
C-711-1/2	½	¾	2 5/8	1¾	7/16	1½	1 15/16	3 3/32	¼	12 ga. x ¾	400
C-711-3/4	¾	¾	2 ½	1¾	7/16	1 11/16	2 ½	3 ½	¼	12 ga. x ¾	400
C-711-1	1	¾	2 11/16	1 15/16	7/16	1 3/16	2 11/16	3 11/16	¼	12 ga. x ¾	400
C-711-1-1/4	1¼	¾	3¼	2	7/16	2 1/16	2 ½	4 ½	¼	12 ga. x ¾	400
C-711-1-1/2	1½	¾	3 5/8	2 1/8	7/16	2 1/8	2 ½	4 ¾	¼	12 ga. x ¾	400
C-711-2	2	¾	3 11/16	2 ½	7/16	2 5/8	3 1/8	5	¼	12 ga. x ¾	400
C-711-2-1/2	2½	½	7 1/8	2 1/8	5/16	3 3/8	3 ¾	6	¾	12 ga. x 1¼	500
C-711-3	3	½	4 13/16	2 1/8	5/16	3 ½	4 1/8	6 3/32	¾	12 ga. x 1¼	500
C-711-3-1/2	3½	½	5 ½	2 5/8	5/16	3 ¾	4 ¾	7 1/16	¾	¾ x 1¼	500
C-711-4	4	¾	6 ¾	3 1/8	5/16	4 ¾	5 1/8	8 1/8	¾	¾ x 1¼	550
C-711-5	5	¾	6 ¾	3¼	5/16	5 1/8	5 ¾	9 3/32	¾	¾ x 1¼	550
C-711-6	6*	¾	7¾	3 1/8	5/16	5 13/16	6 ¾	11¼	¾	¾ x 1¼	600
C-711-8	8*	¾	9 1/8	3 1/8	5/16	6 11/16	8	13 1/16	¾	¾ x 1¼	760

* Hangers 6" and over have hole instead of slot.

C-710 Clevis Hanger

CAT. NO.	PIPE SIZE (IN.)	SIZE OF STEEL (IN.)		DIMENSIONS (IN.)						MAX. REC. LOADS LBS.
		UPPER	LOWER	A	B	C	D	E	F	
C710 1/2	½	½ x 1	½ x 1	¾	1 1/16	2 ½	2 ½	7/8	7/16	610
C-710-3/4	¾	½ x 1	½ x 1	¾	1 ½	2 1/8	2 ½	1	½	610
C-710-1	1	½ x 1	½ x 1	¾	2 ½	2 13/16	2 ½	1¼	¾	610
C-710-1-1/4	1¼	½ x 1	½ x 1	¾	2 1/8	3 1/8	2 ½	1 ¾	¾	610
C710-1-1/2	1½	½ x 1	½ x 1	¾	3	4	2 ½	2 1/8	1 1/8	610
C-710-2	2	½ x 1	½ x 1	¾	3 1/8	4 ¾	2 ½	2 1/8	1 ½	610
C-710-2-1/2	2½	¾ x 1¼	¾ x 1¼	½	4 1/8	6 ½	3	3 1/8	2	1,130
C-710-3	3	¾ x 1¼	¾ x 1¼	½	4 ¾	6 5/8	3	3 ¾	1¼	1,130
C-710-3-1/2	3½	¾ x 1¼	¾ x 1¼	½	4 1/8	6 1/8	3	4 1/8	1¼	1,130
C-710-4	4	¾ x 1¼	¾ x 1¼	5/8	5 1/8	7 1/8	3 ½	4 ½	1 15/16	1,130
C-710-5	5	¾ x 1¼	¾ x 1¼	5/8	6 1/8	9	3 ½	5 1/8	1¼	1,430
C-710-6	6	¾ x 1½	¾ x 1½	¾	6 1/8	10 ¾	4	5 1/8	1 ½	1,430
C-710-7	7	¾ x 1 ¾	¾ x 1 ¾	¾	8 ½	12 ¼	4 ¾	6 ½	2 ¼	1,940
C-710-8	8	¾ x 1 ¾	¾ x 1 ¾	¾	8 1/8	12 ¾	4 ¾	7	2 ½	1,940
C-710-10	10	¾ x 1 ¾	¾ x 1 ¾	7/8	9 ¾	15 ¼	4 ½	8 ¾	2 ¼	1,940
C-710-12	12	¾ x 2	¾ x 2	¾	11 1/8	17 1/8	4 ¾	9 ¾	2 ¾	3,600
C-710-14	14	½ x 2 ½	½ x 2 ½	1	12 1/8	19 1/8	5 ¼	10 13/16	2 15/16	3,800
C-710-16	16	½ x 2 ½	½ x 2 ½	1	15	23	6	12 1/8	2 ¾	4,200
C-710-18	18	½ x 2 ½	½ x 2 ½	1 1/8	15 ¼	24 ¼	6 ½	13 1/8	3 ¾	4,600
C-710-20	20	5/8 x 3	5/8 x 3	1¼	16 ¾	26 ¾	7	13 15/16	4	4,800
C-710-24	24	¾ x 3	¾ x 3	1¼	19	31	7 1/2	17 1/2	4 ¾	4,800
C-710-30	30	¾ x 3	¾ x 3	1¼	24 ¾	39 ¾	8 ¾	21 ¾	5	6,000

Order by Cat. No., finish and pipe size.

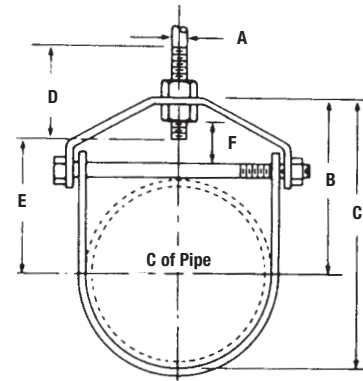

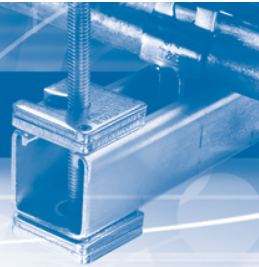

C-720 Riser Clamps

Firmly grips vertically mounted pipe or conduit and distributes the load over a larger area.

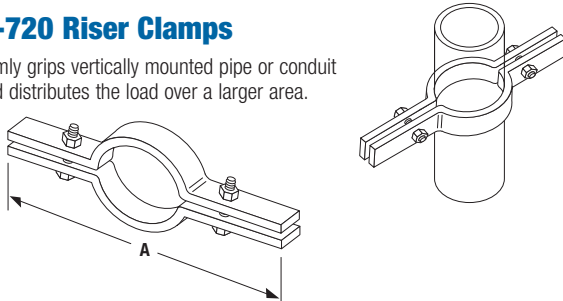

CAT. NO.	PIPE SIZE (IN.)	A (IN.)	SIZE STOCK (IN.)	SIZE BOLT (IN.)	MAX. REC. LOAD LBS.
C720 1/2	1/2	9 1/8	3/16 x 1	3/8 x 1 1/2	220
C-720-3/4	3/4	9 1/4	3/16 x 1	3/8 x 1 1/2	220
C-720-1	1	9 3/8	3/16 x 1	3/8 x 1 1/2	220
C-720-1-1/4	1 1/4	9 3/4	1/4 x 1	3/8 x 1 1/2	250
C-720-1-1/2	1 1/2	10	1/4 x 1	3/8 x 1 1/2	250
C-720-2	2	10 1/2	1/4 x 1	3/8 x 1 1/2	300
C-720-2-1/2	2 1/2	11 1/8	1/4 x 1	3/8 x 1 1/2	400
C-720-3	3	11 1/4	1/4 x 1	3/8 x 1 1/2	500
C-720-3-1/2	3 1/2	13	1/4 x 1	1/2 x 1 1/2	600
C-720-4	4	13 1/2	1/4 x 1	1/2 x 1 1/2	750
C-720-5	5	14	1/4 x 1 1/2	1/2 x 1 3/4	1,500
C-720-6	6	15 1/8	1/4 x 1 1/2	1/2 x 1 3/4	1,600
C-720-8	8	19	3/8 x 1 1/2	3/8 x 2 1/2	2,500

C-247, C-248 & C-249 Steel Conduit Clamps

A versatile clamp for attaching conduit to any type of beam, channel, angle or column. Designed to hold the conduit snug against the support with conduit either parallel or at right angle to it. The case-hardened set screw bites into the structural member for maximum security. 1/8" steel.

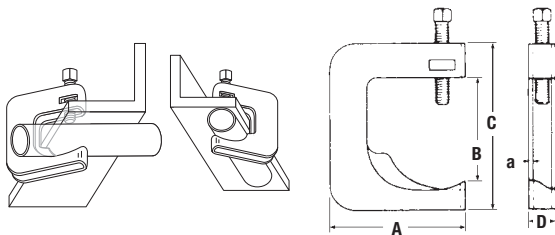

CONDUIT SIZE	MAXIMUM BEAM FLANGE THICKNESS (IN.)		
	C-247	C-248	C-249
1/2	3/8	1	—
3/4	7/16	3/4	1 1/2
1	—	1/2	1 1/4
1 1/4	—	1	—
1 1/2	—	—	5/8
Dim A	2 1/4	2 5/8	3 1/4
Dim B	1 3/8	1 1/4	2 1/2
Dim C	2 3/4	3	4
Dim D	3/8	3/8	3/8
Per Carton	100	50	50
Wt. in lbs./C	33	36	59

Galv-Krom® Finish.

C-708 Messenger Cable Support

Designed for use as intermediate supports for 3/8" messenger cable. Grips cable when 3/16" screw is tightened. Provides easy vertical adjustment. Design load 1,000 lbs. Safety factor of 3.

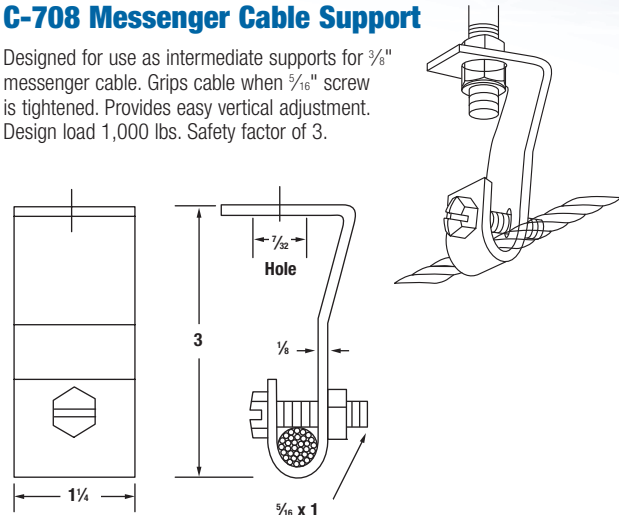

CAT. NO.	DESCRIPTION
C-708	3/8" Steel, 27#/C

Galv-Krom® finish.

C-750 Maple Cable Clamp

Maple blocks, impregnated with paraffin. 3/8" bolts with special nuts facilitate installation on B-900 channel.

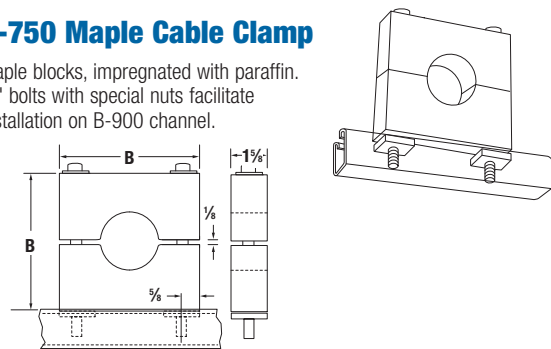

CAT. NO. & SIZE	O.D. OF CABLE (IN.)	DIMENSIONS (IN.)		WT. IN. LBS./C
		A	B	
C-750-1	0-0.99	4	3 3/8	90
C750 2	1.0-1.49	4 1/2	4 3/8	100
C-750-3	1.5-1.99	5	4 7/8	120
C-750-4	2-2.49	5 1/2	5 3/8	140
C-750-5	2.5-2.99	6	5 7/8	160
C750 6	3-3.49	7	6 3/8	200
C-750-7	3.5-3.99	8	7 3/8	240
C-750-8	4-4.49	—	—	—
C-750-9	4.5-5.00	—	—	—

Size refers to overall dimensions of Maple Cable Clamp only.

Hole will be bored to fit O.D. of cable.

Orders MUST specify exact O.D. of cable.

Special order.

Corporate Office
Tel: 901.252.8000
800.816.7809
Fax: 901.252.1354

Customer Service
Tel: 800.816.7809
Fax: 800.816.7810

Technical Services
Tel: 888.862.3289
Fax: 901.252.1321

Tool Services
Tel: 800.284.8665

Thomas & Betts

www.tnb.com

Kindorf®

Conduit, Cable and Pipe Supports

Lightweight, non-breakable and inexpensive! Kindorf® TPE Cable Insulator Clamps

Offer a less expensive, lighter weight and non-breakable alternative to porcelain for cable support, and they won't rot like maple clamps. The one-piece thermoplastic elastomer (TPE) insulator is flame-retardant, UV-resistant and chemical-resistant. A tapered flange isolates and protects cable. Available sizes accommodate cables from 3/8" to 4 1/2" O.D. and fit all Kindorf® channels as well as all 1 1/2" channel systems.



CAT. NO.	HOLE DIA. (IN.)	CLAMP SIZE (IN.)	DIM. A (IN.)	DIM. B&R (IN.)	TOTAL HEIGHT (IN.)
C755 1ATP	3/8	1 1/8	1.12	.56	1.82
C-755-1B-TP	1/2	1 1/8	1.12	.56	1.82
C-755-1C-TP	3/4	1 1/8	1.12	.56	1.82
C-755-2 TP	3/4	1 1/2	1.62	.81	2.34
C-755-2A-TP	7/8	1 1/2	1.62	.81	2.34
C-755-2B-TP	1	1 1/2	1.62	.81	2.34
C-755-2C-TP	1 1/8	1 1/2	1.62	.81	2.34
C-755-3 TP	1 1/4	2 1/8	2.12	1.06	2.86
C-755-3A-TP	1 1/2	2 1/8	2.12	1.06	2.86
C-755-3B-TP	1 3/4	2 1/8	2.12	1.06	2.86
C-755-3C-TP	2	2 1/8	2.12	1.06	2.86
C-755-4 TP	2 1/4	2 3/4	2.62	1.31	3.5
C-755-4A-TP	2 1/2	2 3/4	2.62	1.31	3.5
C-755-4B-TP	2 3/4	2 3/4	2.62	1.31	3.5
C-755-4C-TP	3	2 3/4	2.62	1.31	3.5
C-755-5 TP	3 1/4	3 1/4	3.12	1.56	4.05
C-755-5A-TP	3 1/2	3 1/4	3.12	1.56	4.05
C-755-5B-TP	3 3/4	3 1/4	3.12	1.56	4.05
C-755-5C-TP	4	3 1/4	3.12	1.56	4.05
C-755-6 TP	4 1/4	3 3/4	3.62	1.81	4.75
C-755-6A-TP	4 1/2	3 3/4	3.62	1.81	4.75
C-755-6B-TP	4 3/4	3 3/4	3.62	1.81	4.75
C-755-6C-TP	5	3 3/4	3.62	1.81	4.75
C-755-7 TP	5 1/4	4 1/4	4.12	2.06	5.125
C-755-7A-TP	5 1/2	4 1/4	4.12	2.06	5.125
C-755-7B-TP	5 3/4	4 1/4	4.12	2.06	5.125
C-755-7C-TP	6	4 1/4	4.12	2.06	5.125
C-755-8 TP	6 1/4	4 3/4	4.62	2.31	5.54
C-755-8A-TP	6 1/2	4 3/4	4.62	2.31	5.54
C-755-8B-TP	6 3/4	4 3/4	4.62	2.31	5.54
C-755-8C-TP	7	4 3/4	4.62	2.31	5.54
C-755-8D-TP	7 1/4	5	5	2.5	5.92
C-755-8E-TP	7 1/2	5	5	2.5	5.92
C-755-8F-TP	7 3/4	5	5	2.5	5.92

- Tapered flange isolates and protects cable
- Flame retardant
- UV resistant
- Exceptional chemical resistance
- Ideal for commercial and industrial applications
- Thermoplastic elastomer (TPE) insulator
- Electro-galvanized finish steel clamp with Everdur nut and bolt
- Dielectric strength of 640V per mil
- Sizes to hold cables 3/8" to 4 1/2" O.D.
- Fits all channel sizes
- UL Listed

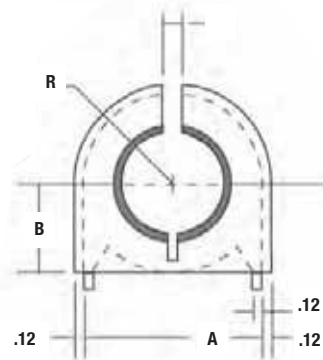

Kindorf® Modular Metal Framing and Support System

Thomas & Betts

www.tnb.com

Corporate Office
Tel: 901.252.8000
800.816.7809
Fax: 901.252.1354

Customer Service
Tel: 800.816.7809
Fax: 800.816.7810

Technical Services
Tel: 888.862.3289
Fax: 901.252.1321

Tool Services
Tel: 800.284.8665

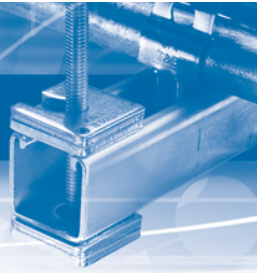

C-755 Porcelain Insulator Clamp

Dry-process white-glaze porcelain insulators assembled in pairs to accept cables from 3/8" through 4 1/2" O.D. C-105 clamp with bronze slotted hex head screw and nut furnished. Fits all Kindorf® channels.

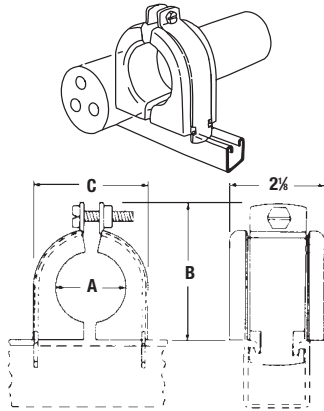

CAT. NO.	DIMENSIONS (IN.)			STRAP C-105 (IN.)	WT. IN LBS./C
	A	B	C		
C-755-1A	3/8	2 1/16	1 9/16	1	50
C-755-1B	1/2	2 1/16	1 9/16	1	50
C-755-1C	5/8	2 1/16	1 9/16	1	50
C-755-2	3/4	2 21/32	2 3/32	1 1/2	91
C-755-2A	7/8	2 27/32	2 7/32	1 1/2	90
C-755-2B	1	2 27/32	2 7/32	1/2	85
C-755-2C	1 1/8	2 27/32	2 7/32	1 1/2	82
C-755-3	1 1/4	3 3/8	2 3/8	2	114
C-755-3A	1 3/8	3 3/8	2 3/8	2	110
C-755-3B	1 1/2	3 3/8	2 3/8	2	105
C-755-3C	1 5/8	3 3/8	2 3/8	2	102
C-755-4	1 3/4	4 1/4	3 3/4	3	220
C-755-4A	1 7/8	4 1/4	3 3/4	3	214
C-755-4B	2	4 1/4	3 3/4	3	205
C-755-4C	2 1/8	4 1/4	3 3/4	3	200
C-755-5	2 1/4	4 3/4	4 1/4	3 1/2	260
C-755-5A	2 3/8	4 3/4	4 1/4	3 1/2	250
C-755-5B	2 1/2	4 3/4	4 1/4	3 1/2	243
C-755-5C	2 5/8	4 3/4	4 1/4	3 1/2	240
C-755-6	2 3/4	5 1/4	4 3/4	4	250
C-755-6A	2 7/8	5 1/4	4 3/4	4	240
C-755-6B	3	5 1/4	4 3/4	4	230
C-755-6C	3 1/8	5 1/4	4 3/4	4	220
C-755-7	3 1/4	6 1/16	5 13/16	5	340
C-755-7A	3 3/8	6 1/16	5 13/16	5	330
C-755-7B	3 1/2	6 1/16	5 13/16	5	318
C-755-7C	3 5/8	6 1/16	5 13/16	5	387
C-755-8	3 3/4	7 3/8	6 3/8	6	565
C-755-8A	3 7/8	7 3/8	6 3/8	6	550
C-755-8B	4	7 3/8	6 3/8	6	535
C-755-8C	4 1/8	7 3/8	6 3/8	6	520
C-755-8D	4 1/4	7 3/8	6 3/8	6	490
C-755-8E	4 3/8	7 3/8	6 3/8	6	475
C-755-8F	4 1/2	7 3/8	6 3/8	6	460

* Also available in thermoplastic, order as C775-TP.

C-756-1 Porcelain Saddle, C-756-2 Porcelain Saddle

- White-glaze dry-process porcelain cable rack insulator
- Fits all sizes of B-900 series channel including B-906

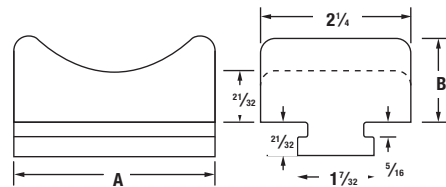
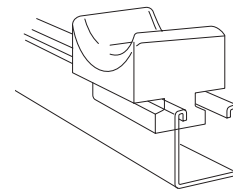

CAT. NO.	DIMENSIONS (IN.)	
	A	B
C-756-1	3	1 3/16
C-756-2	4	1 7/32

C-756-1 is for cables up to 3" O.D. Weight 72 lbs/C.

C-756-2 for cables up to 5" O.D. Weight 102 lbs/C.

Corporate Office
Tel: 901.252.8000
800.816.7809
Fax: 901.252.1354

Customer Service
Tel: 800.816.7809
Fax: 800.816.7810

Technical Services
Tel: 888.862.3289
Fax: 901.252.1321

Tool Services
Tel: 800.284.8665

Thomas & Betts

www.tnb.com

Kindorf®

Concrete Inserts

Buildings designed with concrete inserts as an integral part of the ceiling or wall construction realize many economies, both in initial construction and when updating of the mechanical and electrical system is required. The initial economies of construction stem from the ease with which pipe, air conditioning, lighting and other fixtures can be attached to ceilings or walls.

Inserted by casting into the structure, Kindorf® continuous-slot channels will accept all the assembly parts and fittings of the Kindorf® system. This provides virtually limitless structural arrangements — present and future.

Hanger attachments are made by the standard Kindorf® procedure of simply inserting a standard channel nut which can be pre-started on the hanger rod or bolt. Placement or adjustment of attachments can be made in infinite increments at any time along the length of the concrete insert. Future flexibility means economies in terms of future changes in equipment or its placement.

Initial Installation of Continuous-Slot Channel Inserts Offers:

- An immediate savings in time and labor by eliminating the need for precise calculation and measurement, both in layout planning and actual installation of attachment devices
- Additional savings in time and labor because changes or additions can be made readily to the existing channel at any time; the need for costly drilling in concrete and other costly procedures can be eliminated

Companion to the channel inserts is the spot-type insert for use where a single hanger is required at a specific location.

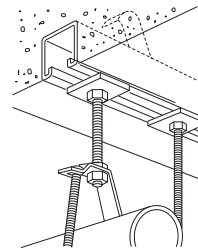

Pipe section hangs from D-990 concrete insert.

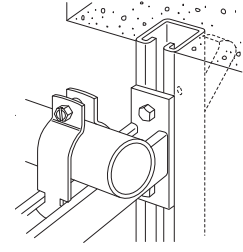

D-990 concrete insert supports conduit installation.

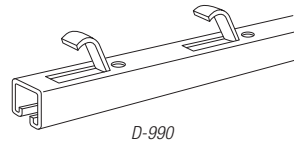

D-990

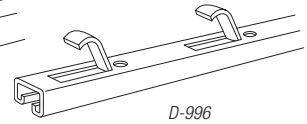

D-996

CAT. NO.	TYPE ANCHOR	CROSS-SECTION	LOAD RATING LBS. PER FT.*
D-990	Punched	1½ x 1½ x 12 ga.	2,000
D-996	Punched	1½ x ¾ x 14 ga.	1,500

* Safety factor of 3. Based on uniformly distributed load.

* Standard lengths 10 and 20 feet.

* Special lengths available on request.

D-255 Concrete Inserts

An insert with a knockout saves covering the slot or covering the opening. Load rating at 1,300 lbs. with a safety factor of three. Accommodates hanger rod sizes from ¼" through 7/8" by means of a B-914 insert nut. ¼" steel. 52 lbs./C.

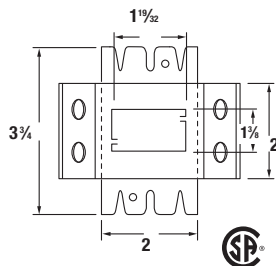
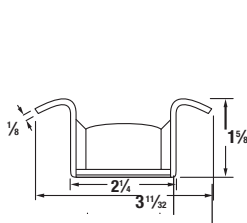
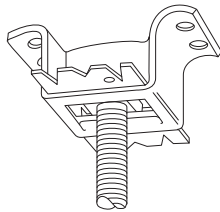

CAT. NO.	DESCRIPTION
D-255	For ¼" through 7/8" Hanger Rod — ¼"-½" Pipe

Standard finish: Galv-Krom®.

D-256-2 and D-256-5 Concrete Insert

This unique product reduces the "spot" concrete insert to its simplest possible components with all the adjustability of the most expensive. Its features include: two sizes — 2" and 5" adjustability, takes standard insert nuts, uses hanger rod sizes ¼" through ¾" and has a load rating up to 1,000 lbs. and a safety factor of 3 (hanger rod permitting).

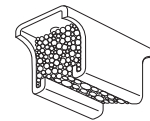
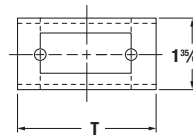

D-256-2

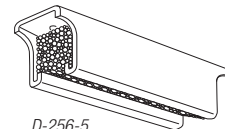
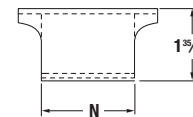

D-256-5



CAT. NO.	N (IN.)	T (IN.)	WT. IN LBS./C
D-256-2	2	3	34
D-256-5	5	6	76

Standard finish: Galv-Krom®.

Thomas & Betts

www.tnb.com

Corporate Office
Tel: 901.252.8000
800.816.7809
Fax: 901.252.1354

Customer Service
Tel: 800.816.7809
Fax: 800.816.7810

Technical Services
Tel: 888.862.3289
Fax: 901.252.1321

Tool Services
Tel: 800.284.8665

Kindorf®

Concrete Inserts

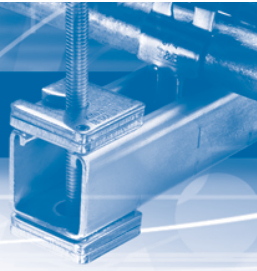

Kindorf® Modular Metal Framing and Support System

D-990 Continuous-Slot Concrete Insert

Insert is made of B-900 channel (12-ga.) with anchors punched out of insert on 6" centers. Polystyrene filled.

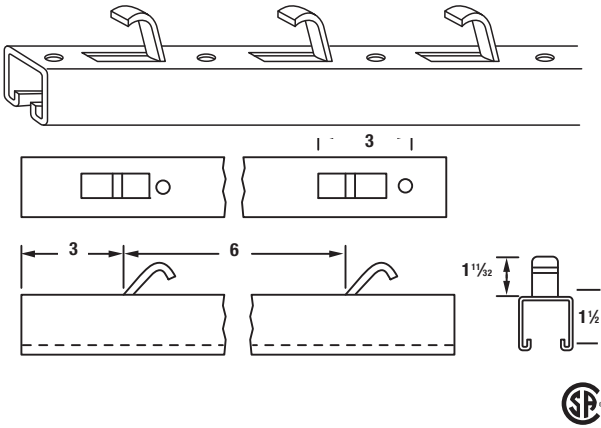

CAT. NO.	DESCRIPTION
D-990	Continuous Slot and Concrete Insert

Use B-910 or B-914 steel nuts for assembly. Load rating 2,000 lbs. per foot with a safety factor of three. Available in 10- and 20-foot lengths.

Galv-Krom® finish.

D-996 Continuous-Slot Concrete Insert

Insert is made of B-900 channel (14-ga.) with anchors punched out of insert on 6" centers. Polystyrene filled.

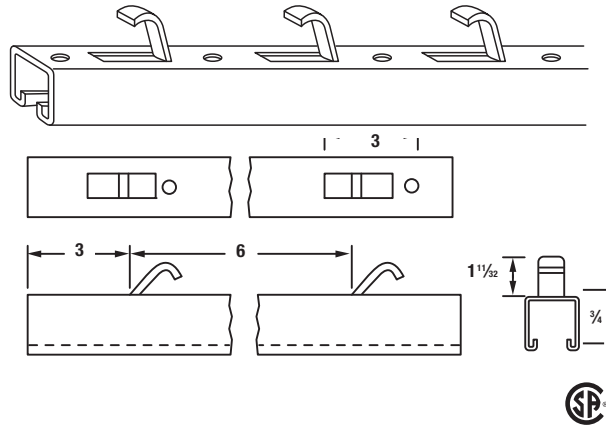

CAT. NO.	DESCRIPTION
D-996	Continuous Slot and Concrete Insert

Use B-910 or B-914 steel nuts for assembly. Load rating 1,500 lbs. per foot with a safety factor of three. Available in 10- and 20-foot lengths.

Galv-Krom® finish.

D-982 Anchor End Cap

For capping the ends of D-990 continuous-slot concrete inserts. It may be used on the job to make up inserts of less than 1-foot lengths of B-900 channel.

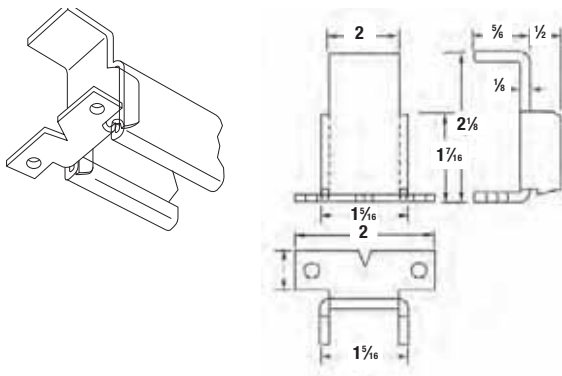

CAT. NO.	DESCRIPTION
D-982	Anchor End Cap

Load rating of such an insert less than 1-foot long is 1,000 lbs. with a safety factor of three. 1/8" steel. 19 lbs./C.

Galv-Krom® finish.

D-988 Anchor End Cap

For capping the ends of D-996 continuous-slot concrete inserts. May be used on the job to make up inserts of less than 1-foot lengths of B-906 channel.

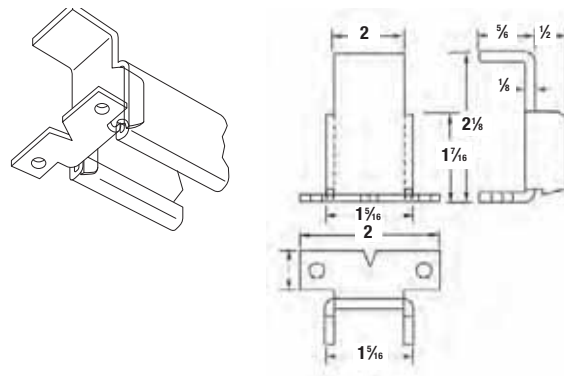

CAT. NO.	DESCRIPTION
D-988	Anchor End Cap

Load rating of each insert less than 1-foot long is 600 lbs. with a safety factor of three. 1/8" steel. 13 lbs./C.

Galv-Krom® finish.

Corporate Office
Tel: 901.252.8000
800.816.7809
Fax: 901.252.1354

Customer Service
Tel: 800.816.7809
Fax: 800.816.7810

Technical Services
Tel: 888.862.3289
Fax: 901.252.1321

Tool Services
Tel: 800.284.8665

Thomas & Betts

www.tnb.com



Kindorf®

Beam Clamps and Hanger Rod Supports

Kindorf® Modular Metal Framing and Support System



Attach to I-Beam by Hand, then Lock and Load in One Step! Heavy-Duty Beam Clamp

You can't get much easier than the new Kindorf® Heavy-Duty Beam Clamp. Simply clamp it to the I-beam flange by hand, and it will remain firmly fixed while you install the threaded rod. When tightened, the threaded rod locks the tongue of the clamp against the I-beam for a fast installation and a superior hold.

New Way vs. Old Way

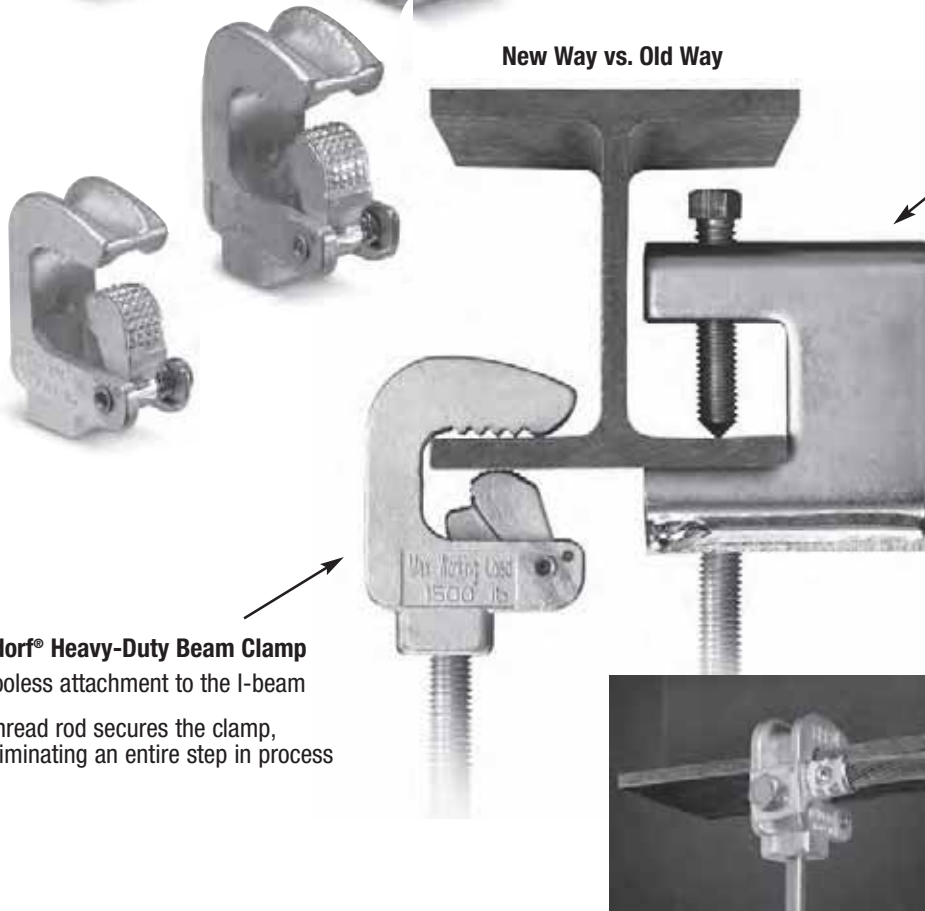

Standard Heavy-Duty Beam Clamp

- The clamp must be held in place while tightening the set screw
- The set screw is difficult to access within the I-beam web

Kindorf® Heavy-Duty Beam Clamp

- Toolless attachment to the I-beam
- Thread rod secures the clamp, eliminating an entire step in process

Kindorf® Heavy-Duty Beam Clamps can also be used for electrical grounding connections.

CAT. NO.	DESCRIPTION	LOAD RATING (LBS.)	ROD SIZE	STD. CTN.
FBC1	Heavy-Duty Beam Clamp, 600 lbs.	600	3/8-16	24
FBC2	Heavy-Duty Beam Clamp, 800 lbs.	800	3/8-16	24
FBC3	Heavy-Duty Beam Clamp, 1,000 lbs.	1,000	3/8-16	24
FBC4	Heavy-Duty Beam Clamp, 1,500 lbs.	1,500	1/2-13	24

Thomas & Betts

www.tnb.com

Corporate Office
Tel: 901.252.8000
800.816.7809
Fax: 901.252.1354

Customer Service
Tel: 800.816.7809
Fax: 800.816.7810

Technical Services
Tel: 888.862.3289
Fax: 901.252.1321

Tool Services
Tel: 800.284.8665

Kindorf®

Beam Clamps and Hanger Rod Supports

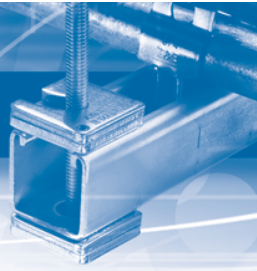

From the Simple Job to the Complex Job with Special Needs, the Kindorf® Line of Beam Clamps Can Fit the Bill.

Kindorf® devices for hanging the load can deliver lower installation costs. Hanger rod and conduit pipe supports are attached to ceilings or to other structural members such as beams, columns or purlins, without drilling, welding or fastening by means of power-actuated tools. A full selection of beam clamps and hanger rod supports are offered to meet a wide variety of needs.

The flexibility of the Kindorf® Series of clamps affords a range of applications, from simple attachment of channel to the suspending of supports from sloping, as well as horizontal, beams.

Where high vibrations are expected, additional support can be attained by gripping the beam on both sides.

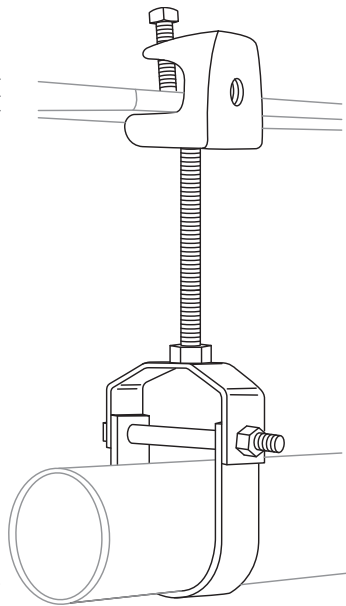

500 Series Beam Clamp
supports pipe with C-710 clevis hanger.

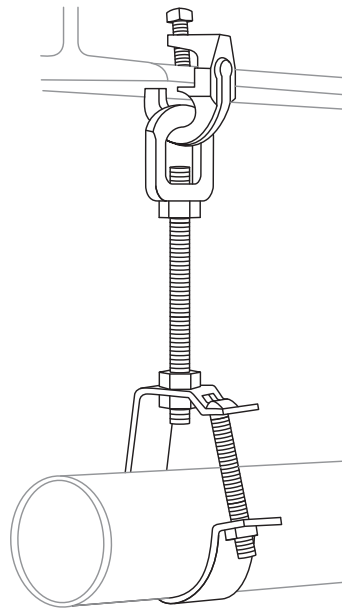

H-550 Swivel Beam Clamp
supports pipe with C-711 hanger.

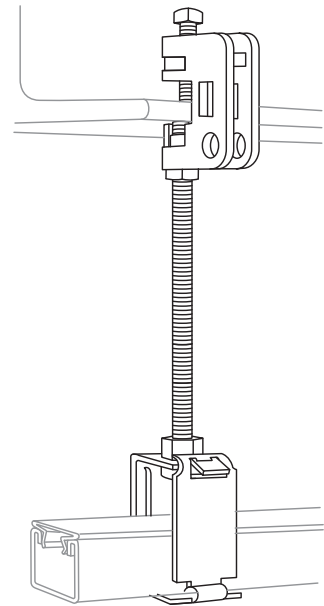

E-231 Beam Clamp
supports channel raceway
with G-1012 lay-in-hanger.

Modular Metal Framing and Support System

Corporate Office
Tel: 901.252.8000
800.816.7809
Fax: 901.252.1354

Customer Service
Tel: 800.816.7809
Fax: 800.816.7810

Technical Services
Tel: 888.862.3289
Fax: 901.252.1321

Tool Services
Tel: 800.284.8665

Thomas & Betts

www.tnb.com

C-39

Kindorf®

Beam Clamps and Hanger Rod Supports

E-761 Channel to Beam Clamp

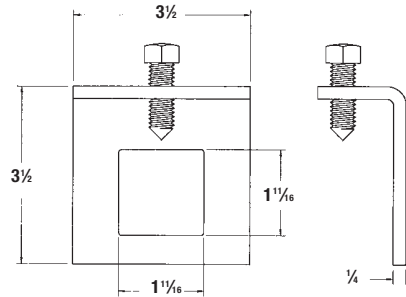
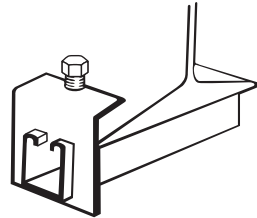

CAT. NO.	DESIGN LOAD LBS./EA.	CHANNEL SERIES	WT. LBS./C
E-761	800	B-900, B-905, B-995	108

1/2" x 1 1/2" set screw included.

Galv-Krom® finish.

E-763 Channel to Beam Clamp

- Secures all sizes of Kindorf® channel to beams where flange edge does not exceed .8" thickness

CAT. NO.	DESIGN LOAD (LBS.)	WT. LBS./C
E-763	500	25

Load rating each clamp 800 lbs. with a safety factor of 3/4" steel.

Assembly requires one H-113-E bolt and one B-910-1/2 steel nut per clamp — order separately.

Galv-Krom® finish.

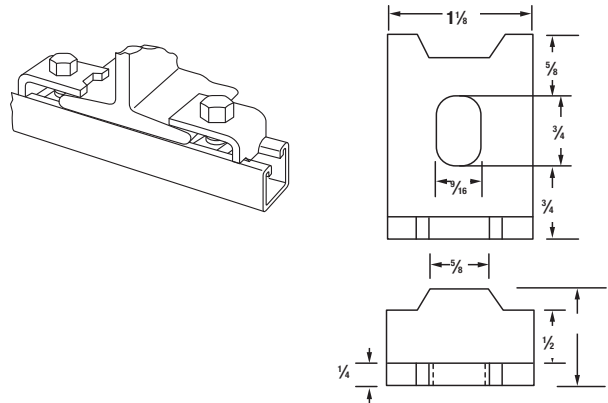

E-767 Channel Support

- Supports any size Kindorf® channel. Clamps to I-beam where flange edge does not exceed .8" thickness

CAT. NO.	LOAD RATING (LBS.)	WT. LBS./C
E-767	800	44

Load rating is 800 lbs. with a safety factor of 3/4" steel.

Galv-Krom® finish.

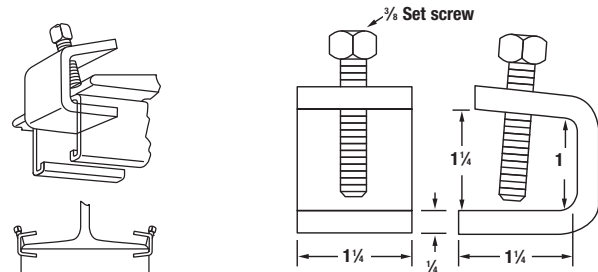

Kindorf® Modular Metal Framing and Support System

Thomas & Betts

www.tnb.com

Corporate Office
Tel: 901.252.8000
800.816.7809
Fax: 901.252.1354

Customer Service
Tel: 800.816.7809
Fax: 800.816.7810

Technical Services
Tel: 888.862.3289
Fax: 901.252.1321

Tool Services
Tel: 800.284.8665

Beam Clamps and Hanger Rod Supports

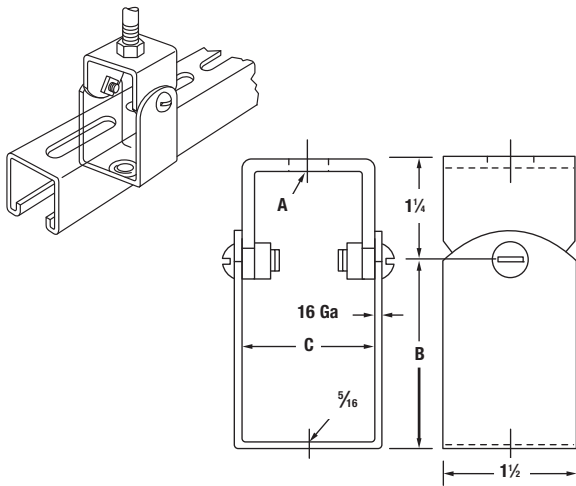
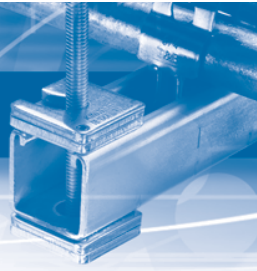

G-962 and G-962-D Channel Hangers

- G-962 fits around 1½" or 1⅞" deep channel, G-962-D series hangers for 3" deep channel

CAT. NO.	WT. LBS./C	HANGER SIZE (IN.)	DIM. A (IN.)
G-962-D-1	47	¼ and ⅜ rod	13/32
G-962-D-2	47	½ rod and ¼ pipe	9/16
G-962-D-3	47	¾ pipe and ⅝ rod	11/16
G-962-D-4**	47	1" pipe	7/8

** Load rating of 700 lbs. with a safety factor of three.

"B" dimension for G-962: 2¼"; for G-962-D: 4". UL Listed for raceway. "C" dimension for G-962, 1⅞"; for G-962-D, 3⅞".

Galv-Krom® finish.

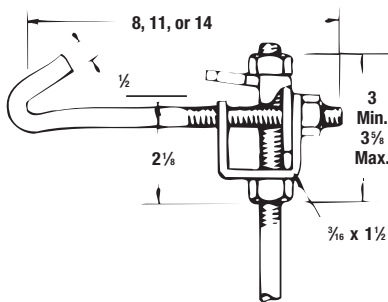
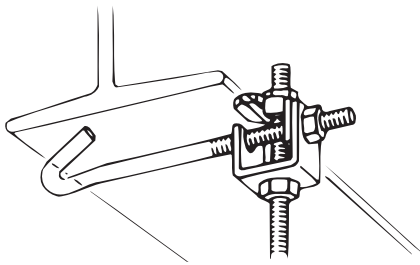

E-160 Adjustable Beam Clamp (½" Rod)

- Clamps to I-beams where edge of beam flange does not exceed .8" thickness. Hook rod is furnished in three lengths to fit beam flanges up to 6, 9 or 12" widths



CAT. NO. FOR ½" HANGER RODS	FOR BEAM FLANGE WIDTH (IN.)	WT. LBS./C
E-160-1/2-6	2½ to 6	115
E-160-1/2-9	5½ to 9	125
E-160-1/2-12	8½ to 12	154

Load rating 800 lbs. with a safety factor of three.

Assembly requires hanger rod of the proper length and size plus two H-114-D nuts.

⅜" steel, ½" hook rod.

Galv-Krom® finish.

Corporate Office
Tel: 901.252.8000
800.816.7809
Fax: 901.252.1354

Customer Service
Tel: 800.816.7809
Fax: 800.816.7810

Technical Services
Tel: 888.862.3289
Fax: 901.252.1321

Tool Services
Tel: 800.284.8665

Thomas & Betts

www.tnb.com

Kindorf®

Beam Clamps and Hanger Rod Supports

U577 Adjustable Swinging Hanger Flange (3/8" or 1/2" Rod)

- Flange has 13/32" holes for connection to ceiling



CAT. NO.	WT. LBS./C
U577	100

Assembly requires 3/8" or 1/2" hanger rod of proper length plus two H-114-C or H-114-D nuts. 3/16" steel.

Flange has 13/32" diameter holes for connection to ceiling.

Galv-Krom® finish.

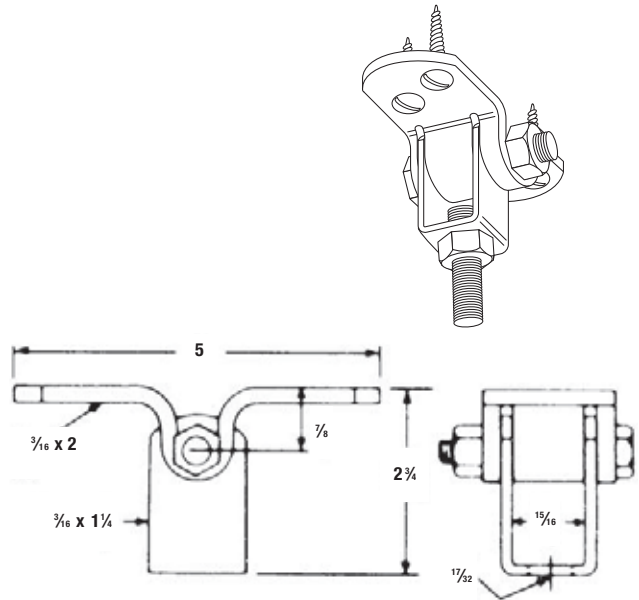

E-177 Adjustable Channel Clamp (1/2" Rod)

- Adjustable to fit all structural channels up to a maximum flange width of 3 1/4", and all structural angles with leg up to 3" long and not more than 3/8" thick



CAT. NO.	WT. LBS./C
E-177	183

Load rating is 800 lbs. with a safety factor of three.

Assembly requires 1/2" hanger rod of the proper length plus two H-114-D nuts.

3/8" steel.

Galv-Krom® finish.

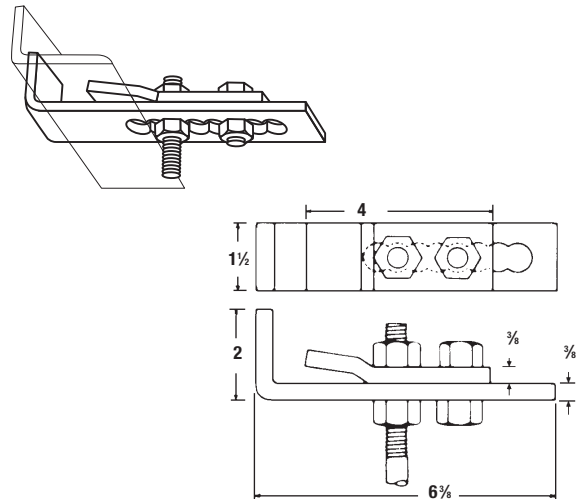

Beam Clamps and Hanger Rod Supports

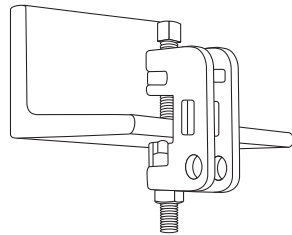
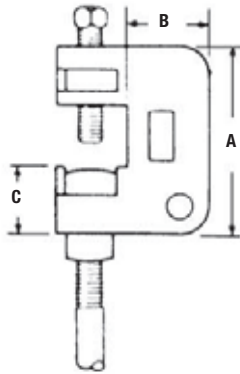
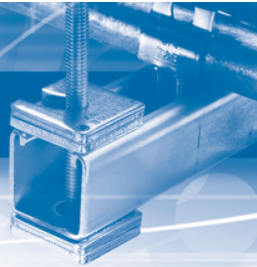

E-231 Structural Steel Clamp ($\frac{3}{8}$ " or $\frac{1}{2}$ " Rod)

- Clamps to I-beams, channels, angles and column. Two sizes are available, one for $\frac{3}{8}$ " and the other for $\frac{1}{2}$ " hanger rod. Each takes flanges up to .8"



CAT. NO.	DIMENSIONS (IN.)			WT. LBS./C
	A	B	C	
E-231-3/8*	2½	1	¾	31
E-231-1/2**	3	1 ½ ₃₂	1 ¼ ₁₆	53

Assembly requires two H-116-C ($\frac{3}{8}$ ") or two H-116-D ($\frac{1}{2}$ ") square nuts to attach hanger rod. $\frac{1}{8}$ " steel.

* Load rating of 500 lbs. with a safety factor of three.

** Load rating of 800 lbs. with a safety factor of three.

Galv-Krom® finish.

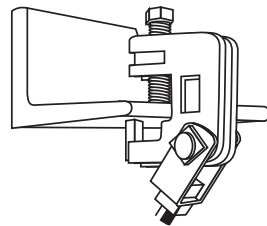
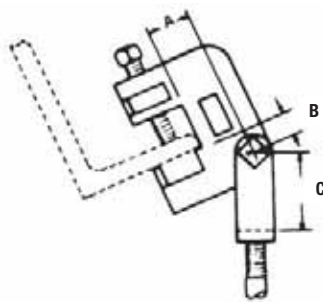

E-231 clamp with swing connector affords a convenient method of attaching to angled beams.

E-232 Clamp with Swing Connector ($\frac{3}{8}$ " or $\frac{1}{2}$ " Rod)



CAT. NO.	DIAMETER FOR ROD (IN.)	DIMENSIONS (IN.)			WT. LBS./C
		A	B	C	
E-232-3/8*	¾	¾ ₁₆	¾ ₁₆	1	48
E-232-1/2**	½	¾	¾ ₆₄	1 ½	76

* Load rating of 400 lbs. with a safety factor of three.

** Load rating of 550 lbs. with a safety factor of three.

Galv-Krom® finish.

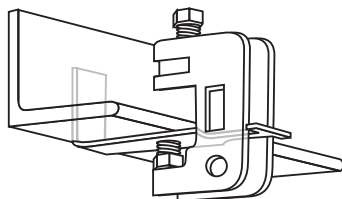

For use with E-231 and E-232 clamps when hanger rod is not in straight through position.

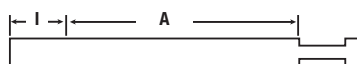

E-233 Anchor Clip

- Anchor clips should be used when clamps are subject to excessive vibration. To obtain the correct size clips add 1" to the flange width. If length required is not standard, order next largest standard length



CAT. NO.	ROD SIZE (IN.)	MAX. BEAM WIDTH (IN.) "A"	FOR USE WITH	WT. LBS./C
E-233-3/8-6	¾	6	E-231-3/8 or	20
E-233-3/8-10	¾	10	E-232-3/8	33
E-233-1/2-6	½	6	E-231-1/2 or	26
E-233-1/2-10	½	10	E-232-1/2	37

Galv-Krom® finish.

Kindorf®

Beam Clamps and Hanger Rod Supports

U-568 Beam Clamps

CAT. NO.	BEAM FLANGE WIDTH (IN.)	DIMENSION A (IN.)	STD. CTN.
U-568-6	6	9	25
U-568-8	12	15	25

16 ga. material.

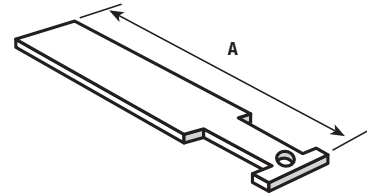

E-760 Channel to Beam Clamp

CAT. NO.	FOR STRUCTOR CHANNEL	DIMENSION A (IN.)	WT. LBS./C
E-760-2*	B-900, B-905, B-906, B-907	3 1/4	76
E-760-2SS	Stainless Steel		
E-760-3	B-901, B-900-2A, B-902, B-903	4 3/4	88

* Load rating of 2,200 lbs. with a safety factor of three.

1/4" steel, 3/8 inch U-bolt.

Standard finish: Galv-Krom®.

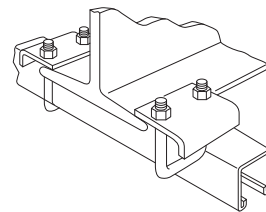

Hardened points bite into beam flange. Fits all I-beams where edge of beam flange does not exceed .8 inch thickness.

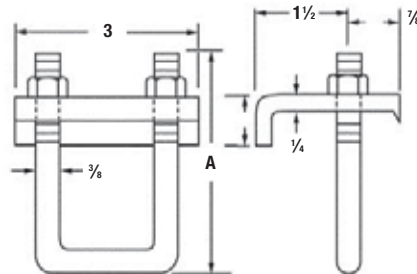

E-235 Heavy-Duty Beam Clamp

CAT. NO.	DIMENSIONS (IN.)			WT. LBS./C	DESIGN LOAD LBS.
	A	B	C		
E-235-3/8-HD	3/8	1/8	3/8 x 2 3/4	109	1,300
E-235-1/2-HD	1/2	1/4	1/2 x 2 3/4	201	3,150

Finish: Hot-dipped galvanized.

Set screw C included

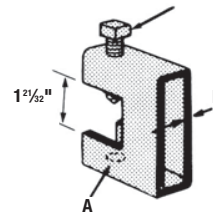

Tapped Hole Size

Beam Clamps and Hanger Rod Supports

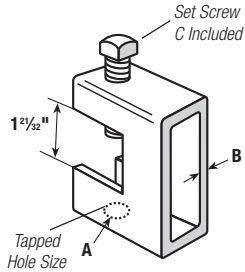
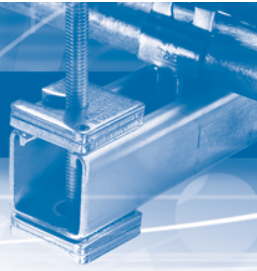

U-564 Heavy-Duty Beam Clamp

CAT. NO.	DIMENSIONS (IN.)			DESIGN LOAD LBS.	STD. CTN.
	A	B	C		
U-564-3/8	3/8	1/4	3/8 x 2 3/4	1,300	25
U-564-1/2	1/2	1/4	1/2 x 2 3/4	3,150	15

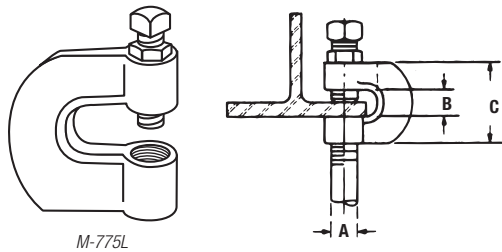

M-775L Clamp with Lock Nut

CAT. NO.	ROD SIZE A (IN.)	B (IN.)	C (IN.)	DESIGN LOAD LBS.	STD. CTN.
M-775L-5/8	5/8	3/4	2	440	50
M-775L-3/4	3/4	3/4	2	500	50

Standard Finishes - GoldGalv® brand or Black (B) Malleable Iron.

EG=Electro-Galv

B=Black

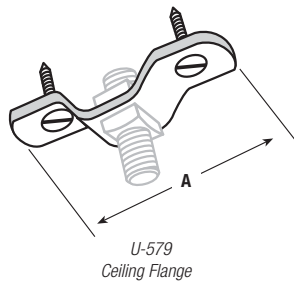

U-579 Beam Clamp for Hanging Rod

CAT. NO.	A (IN.)	STD. CTN.
U579-3/8	3 1/2	25
U-579-1/2	4 1/4	25

Nuts and wood screws not included.

Mounting holes 1 3/32".

Finishes - GoldGalv® brand Malleable Iron.

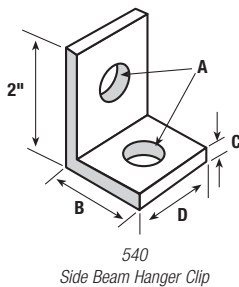

540 Beam Clamp for Hanging Rod

CAT. NO.	DIMENSIONS (IN.)				STD. CTN.
	A	B	C	D	
540 3/8	1/8	1 7/8	1/4	7/8	25
540-5/8	1 1/16	2 1/2	3/8	2	25

Finishes - GoldGalv® brand or Black (B).

Kindorf®

Beam Clamps and Hanger Rod Supports

S5413/8 Swing Connector (3/8" Rod)

Used to secure a 3/8" hanger rod to the side or bottom of beam or ceiling.

CAT. NO.	WT. LBS./C
S54138	28

Assembly requires two (3/4") square nuts. Also screw or bolt for fastening to beam or ceiling.
1/2" steel.

Load rating of 700 lbs. with a safety factor of three.

Galv-Krom® finish.

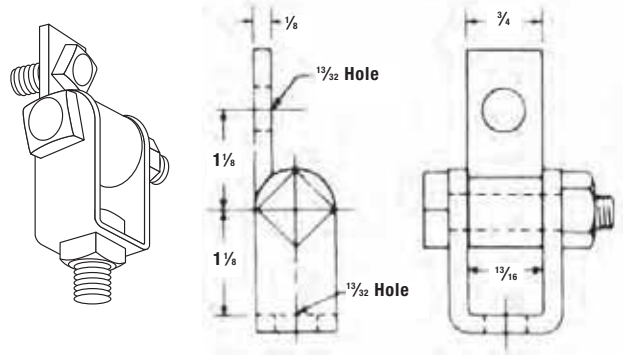

U501 Channel to Beam Clamp

Hardened points bite into beam flange. Fits all I-beams where edge of beam flange does not exceed .8" thickness.

CAT. NO.	FOR STRUCTOR CHANNEL	DIMENSION A (IN.)	WT. LBS./C
U501	B-900, B-905, B-906, B-907	3 1/4	76
U501SS	Stainless Steel	3 1/4	76
U502	B-901, B-900-2A, B-902, B-903	4 3/4	88
U502SS	Stainless Steel	4 3/4	88

* Load rating of 2,200 lbs. with a safety factor of three.

1/4" steel, 3/8-inch U-bolt.

Standard finish: Galv-Krom®.

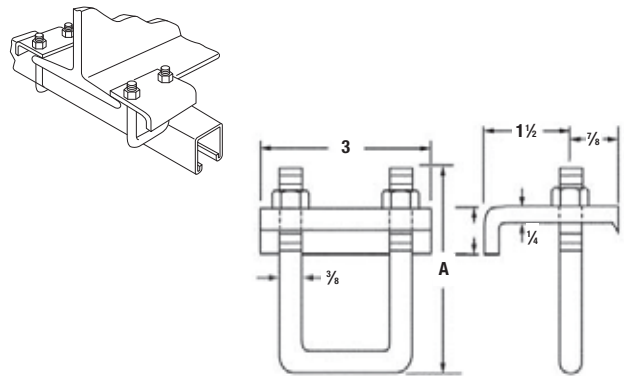

A597 Channel to Beam Clamp

CAT. NO.	DESIGN LOAD LBS./EA.	CHANNEL SERIES	WT. LBS./C
A597	800	B-900, B-905, B-995	108

1/2" x 1 1/2" set screw included.

Galv-Krom® finish.

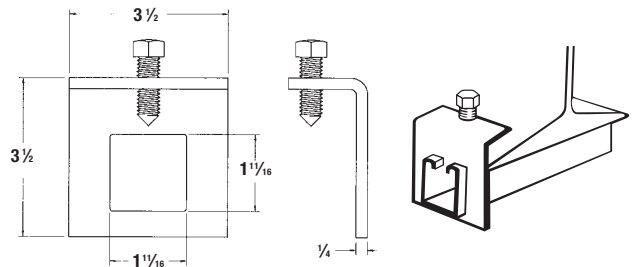

Beam Clamps and Hanger Rod Supports

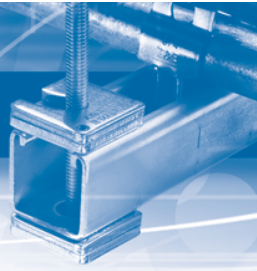

512-U Channel to Beam Clamp

Secures all sizes of Kindorf® channel to beams where flange edge does not exceed .8" thickness.

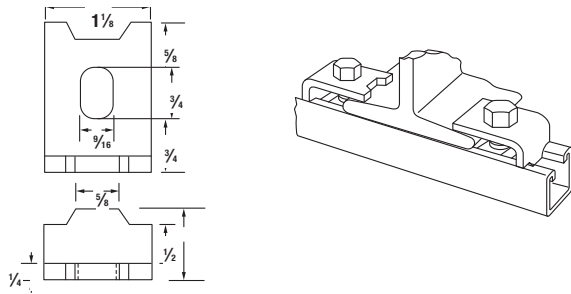

CAT. NO.	DESIGN LOAD (LBS.)	WT. LBS./C
512-U	500	25

Load rating each clamp 800 lbs. with a safety factor of 3 1/4" steel.

Assembly requires one H-113-E bolt and one B-910-1/2 steel nut per clamp — order separately.

Galv-Krom® finish.

E-764 Channel Clip

Complete with set screw for clipping a length of channel slot-side down and across the runner bars of a dropped ceiling installation.

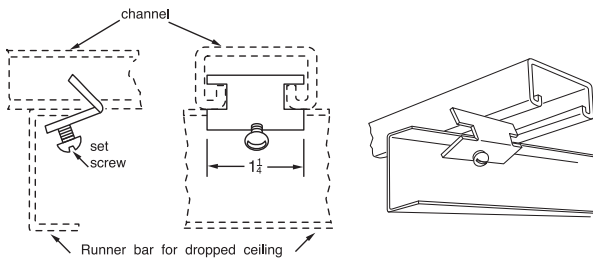

CAT. NO.	WT. LBS./C
E-764	4

At least two required per each such application.

Galv-Krom® finish.

E-765 Center Beam Clamp

Clamps 1 1/2" x 1 1/2" Kindorf® channel to beams where beam flange does not exceed 3/4" thickness and 4" to 6 3/4" wide.

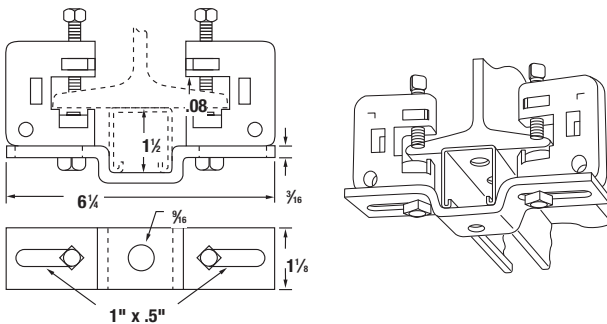

CAT. NO.	LOAD RATING (LBS.)	WT. LBS./C
E-765	800	112

Load rating is 800 lbs. with a safety factor of 3.

Furnished assembled.

1/8" steel clamps, 3/16" steel strap.

Galv-Krom® finish.

Kindorf®

Beam Clamps and Hanger Rod Supports

U514 Channel Support

Supports any size Kindorf® channel. Clamps to I-beam where flange edge does not exceed .8" thickness.

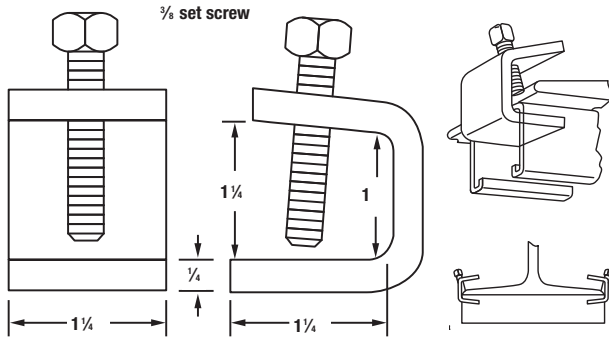

CAT. NO.	LOAD RATING (LBS.)	WT. LBS./C
U514	800	44

Load rating is 800 lbs. with a safety factor of 3 1/4" steel.
Galv-Krom® finish.

E-768 Column Mount Support

For use with 1 1/2" x 1 1/2" channel. Provides a rigid support between 'H' beam flanges for mounting pipe, conduit, outlet boxes and panel boards.

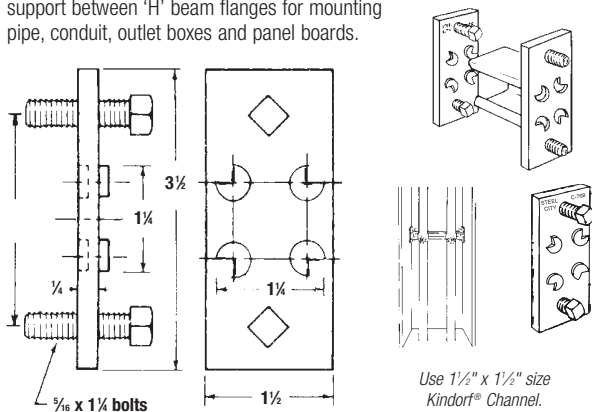

CAT. NO.	LOAD RATING (LBS.)	WT. LBS./C
E-768	800	50

Two E-768's required for installation.
Use C-105, C-106 or C-107 straps for mounting 1/2" to 8" pipe on channel section.
Load rating of 800# — safety factor of three.
Galv-Krom® finish.

E-781 Single-Beam Clamp

For use in attaching channel on top of beam flange with slot side down. Members are shipped assembled for easy installation.

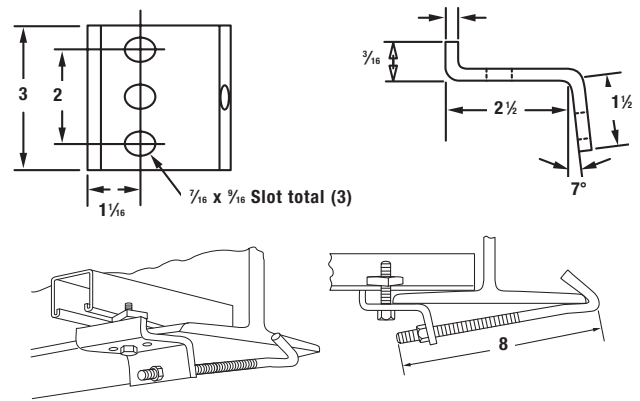

CAT. NO.	WT. LBS./C
E-781	133

Galv-Krom® finish.

E-782 Double-Beam Clamp

For use in attaching channel on both sides of a beam flange with slot side down. Members are shipped assembled for easy installation.

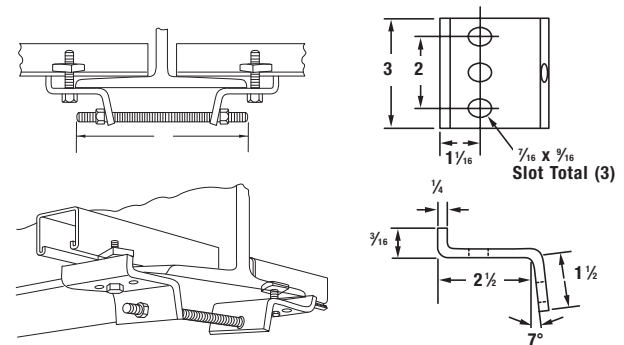

CAT. NO.	WT. LBS./C
E-782	235

Galv-Krom® finish.

Thomas & Betts

www.tnb.com

Corporate Office
Tel: 901.252.8000
800.816.7809
Fax: 901.252.1354

Customer Service
Tel: 800.816.7809
Fax: 800.816.7810

Technical Services
Tel: 888.862.3289
Fax: 901.252.1321

Tool Services
Tel: 800.284.8665

Kindorf®

Beam Clamps and Hanger Rod Supports

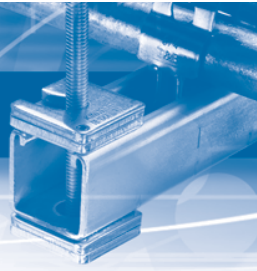

U-504 Single Beam Clamp

For use in attaching channel on top of beam flange with slot side down. Members are shipped assembled for easy installation.

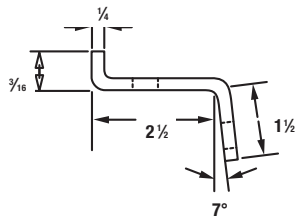
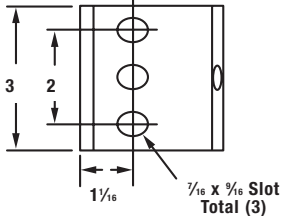
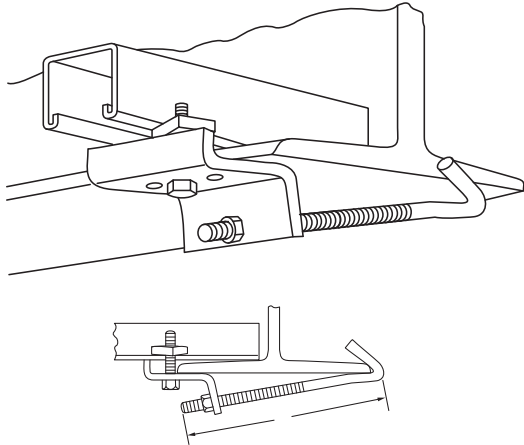

CAT. NO.

U504

WT.
LBS./C

133

Galv-Krom® finish.

U-505 Double Beam Clamp

For use in attaching channel on both sides of a beam flange with slot side down. Members are shipped assembled for easy installation.

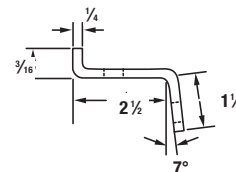
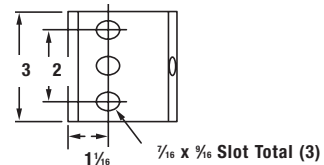
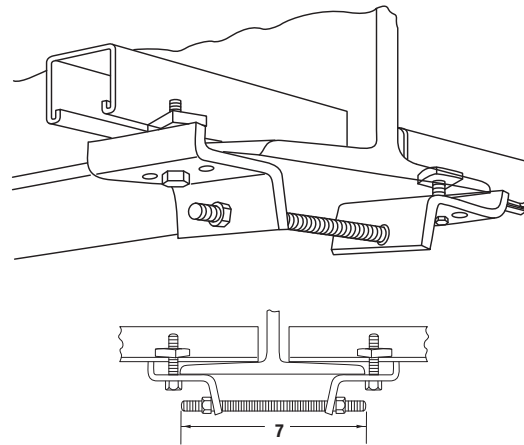

CAT. NO.

U505

WT.
LBS./C

235

Galv-Krom® finish.

Kindorf® Modular Metal Framing and Support System

Corporate Office
Tel: 901.252.8000
800.816.7809
Fax: 901.252.1354

Customer Service
Tel: 800.816.7809
Fax: 800.816.7810

Technical Services
Tel: 888.862.3289
Fax: 901.252.1321

Tool Services
Tel: 800.284.8665

Thomas & Betts

www.tnb.com

C-49

Kindorf®

Support Brackets

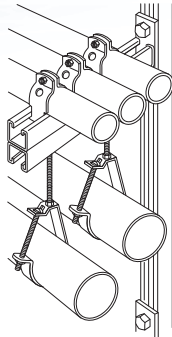

F-721 Wall bracket hangs and supports pipe runs.

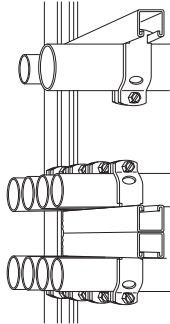

Conduit installations supported above and below by F-721 wall bracket.

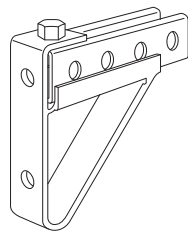
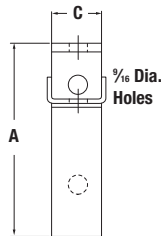
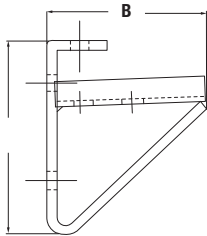

Kindorf® wall brackets provide a ready-made shelving arrangement that can be attached quickly to the supporting channels.

Utilizing the built-in advantages of the Kindorf® Channel, the support bracket members allow a great deal of flexibility in meeting the structural framing needs.

Axle supports and a variety of wall brackets all adapt to the standard Kindorf® channel and allow additional flexibility in the support of cables, conduit, pipe and other equipment.

The application of axle supports and bracket members can be made on either the continuous slot of the channel or the pre-punched hole side. Utilizing the 1/2" hole spacing, greater adaptability is attained with a minimum of fittings.

F-715 Wall Bracket

Mounts on Kindorf® channel or directly to wall. F-715 bracket supports 1/2" or 1/8" channels. Brackets allow for a variety of support channel lengths. The continuous tray on brackets prevent lateral movement of supported channels. Support channels can be fastened from top, bottom or both.

CAT. NO.	DIMENSIONS (IN.)			WT. LBS./C.
	A	B	C	
F-715	5 7/32	4 5/8	1 1/2	163

Galv-Krom® finish.

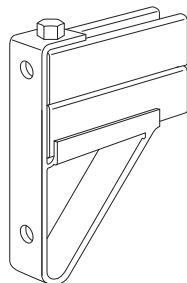
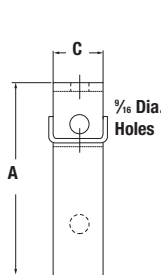
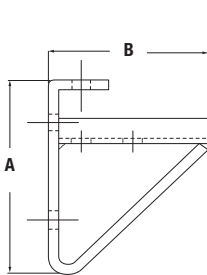

F-716-3 Wall Bracket

Mounts on Kindorf® channel or directly to wall. F-716-3 bracket supports 3" deep or back-to-back channels. Brackets allow for a variety of support channel lengths. The continuous tray on brackets prevent lateral movement of supported channels. Support channels can be fastened from top, bottom or both.

CAT. NO.	DIMENSIONS (IN.)			WT. LBS./C.
	A	B	C	
F-716-3	7 11/32	4 5/8	1 1/2	179

Galv-Krom® finish.

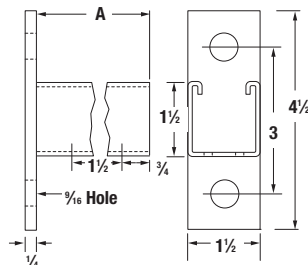
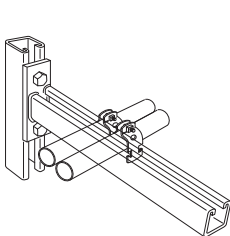

F-720 Wall Bracket

Mounts on Kindorf® channel, concrete inserts or directly to wall.

Continuous-slot accepts C-105, C-106 and C-107 series pipe straps.

Bracket is 12-gauge steel, 1 1/2" x 1 1/2" channel welded to a 1/4" back plate.

May be attached to either the continuous slot side or pre-punched holes in back or side of Kindorf® channel.

CAT. NO.	DIM. A (IN.)	END LOAD RATING LBS.*		WT. LBS./C
		Top	Bottom	
F720 6**	6	600	600	132
F-720-9**	9	450	450	155
F-720-12**	12	300	300	200
F-720-18	18	200	200	275
F-720-24**	24	150	150	350

* Safety factor of 3.

** This product available in green & hot-dipped galvanized.

Standard finish: Galv-Krom®.

Kindorf®

Support Brackets

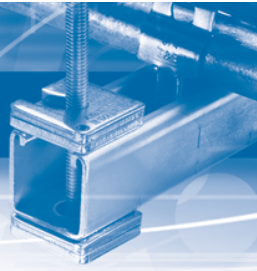

F-721 Wall Bracket

Double channel to provide continuous slot for both top and bottom mounting. 12-ga. steel, 1/4-inch back plate. May be attached to either the continuous slot side or pre-punched holes in back or side of Kindorf® channel.

CAT. NO.	DIM. A (IN.)	END LOAD RATING LBS.*	WT. LBS./C
F721 18	18	300	568
F-721-24	24	225	736
F-721-30	30	180	904
F-721-36	36	150	1072

* Safety factor of 3.

Standard finish: Galv-Krom®.

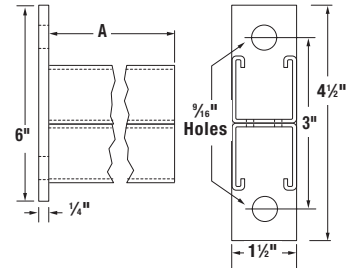
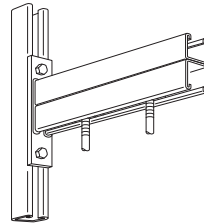

F-735 and F-736 Axle Supports

For use on storage racks constructed on Kindorf® channel. Supports reels of electrical cables, wire rope, chain and other materials. Left-hand axle support illustrated. F-736 identical except right hand. May be attached to either the continuous slot side or pre-punched holes in back or side of Kindorf® channel.

CAT. NO.	DESCRIPTION	WT. LBS./C
F-735	Left Hand	165
F-736	Right Hand	165

Assembly requires two B-910-1/2 steel nuts and two H-113-B bolts.

Accepts up to 1 1/4" steel bar or pipe for axle.

Galv-Krom® finish.

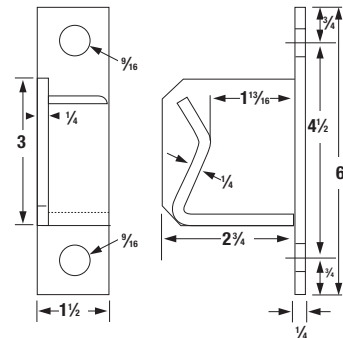
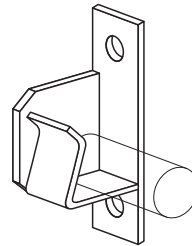

F-737 Double Axle Support

Typical Kindorf® Space-Saver reel rack. Kindorf® reel racks are easy to build, exceptionally strong and economical. Racks adjust easily to accommodate a variety of reel sizes. No special tools needed.

CAT. NO.	WT. LBS./C
F-737	335

Assembly requires four B-910-1/2 steel nuts and four H-113-B bolts.

To be used with F-735 and F-736. 1/4" steel.

Galv-Krom® finish.

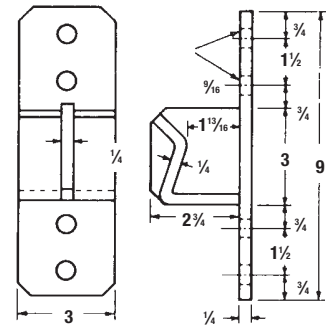
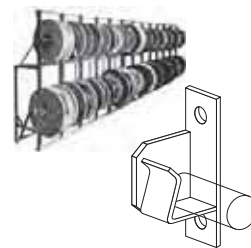

To be used as center support for tandem reel assembly.

F-739 Telephone Cable Hook

Cantilever-type cable hooks fit into 'T' slot on B-904 channel for rigid, non-slip support. Fast mounting, no hardware to tighten.

CAT. NO.	DIMENSION A (IN.)	WT. LBS./C
F-739-4-1/2	4 1/2	81
F-739-7-1/2	7 1/2	122
F-739-10-1/2	10 1/2	162
F-739-13-1/2	13 1/2	198
F-739-18	18	278

Has 5/16" diameter holes on 1 1/2" centers to allow for easy tie banding of cables.

Galv-Krom® 12-ga. steel.

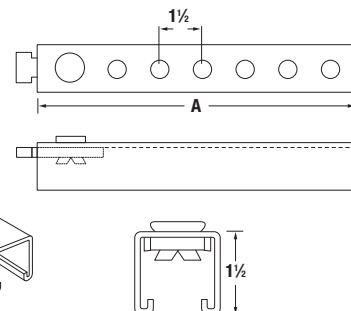
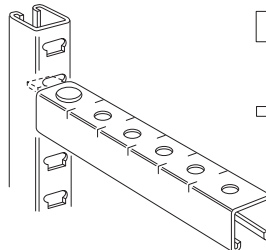

Kindorf® Modular Metal Framing and Support System

Corporate Office
Tel: 901.252.8000
800.816.7809
Fax: 901.252.1354

Customer Service
Tel: 800.816.7809
Fax: 800.816.7810

Technical Services
Tel: 888.862.3289
Fax: 901.252.1321

Tool Services
Tel: 800.284.8665

Thomas & Betts

www.tnb.com

C-51

Kindorf®

Surface Raceway and Lighting Support Systems

For Mounting or Suspending High-Intensity Lighting Fixtures in High-Bay Installations.

Surface Raceway and Lighting Support Systems

The Kindorf® Lighting Support System consists of high-quality construction materials that afford definite installation advantages to those most concerned with lighting installations. When used as a surface metal raceway, it is UL Listed and complies with National Electrical Code® Article 352.

To the Owner

A flexible installation requiring fewer attachments to the building structure with built-in provisions for easy maintenance and future modifications when lighting fixtures must be added, deleted or relocated. Kindorf® channel and fittings form a strong, economical and attractive support and wiring system for fixtures and other equipment.

To the Architect and Engineer

A system of construction least demanding on general design conditions and readily adaptable to all spacing of pillars, purlins and other structural components. Supply will not delay a job because Kindorf® channel is stocked at many locations throughout the country. The Kindorf® System saves planning time because it is designed for fast and easy installation by the contractor with little or no detailing.

To the Contractor

The Kindorf® System consists of time-saving materials that will simultaneously provide for the electrical feed and the mechanical support of lighting and other equipment. Kindorf® affords a means of making fewer attachments to the structure at wider spacing. It insures true and rigid alignment and lends itself to systematic preassembly methods which economize on labor. No special tools for installation and no painting is required. Kindorf® speeds all jobs because a complete line of fittings assures easy solution of many installation problems as they arise in the field.

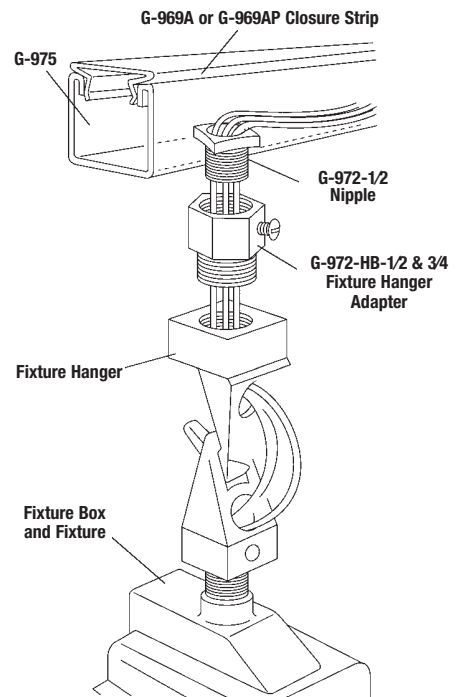

Other Mechanical Details.

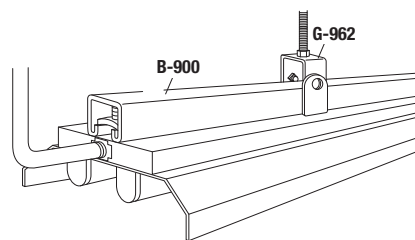

Channel raceway system supports and feeds fluorescent lighting fixtures.

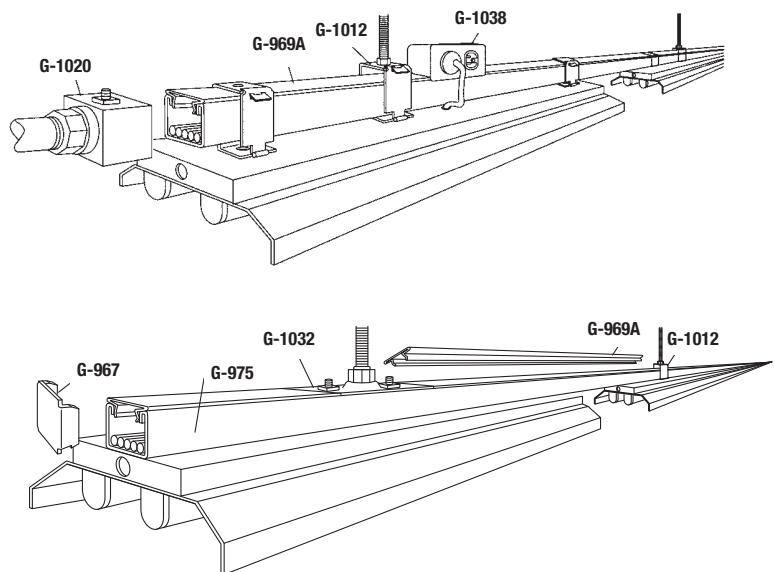

Surface Raceway and Lighting Support Systems

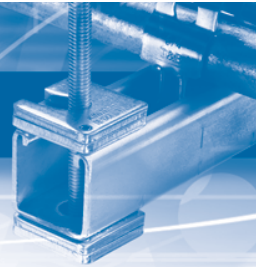

Surface Raceway Channel Systems

- Knock-out type by means of 1/2" channel knockouts on 6" centers

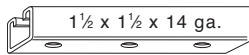

G-975-M

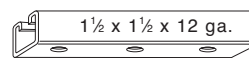

G-975

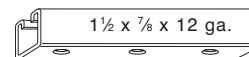

G-965

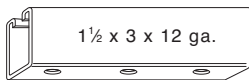

G-955

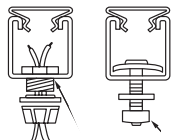

G-972-1/2 G-974-1-1/4

Nipple
Lock nut
and bushing

- Plug-in type by means of sliding fixture hanger

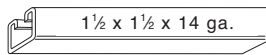

B-900-M

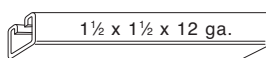

B-900

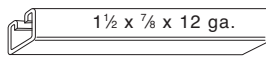

B-901

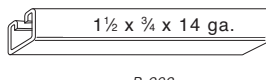

B-906

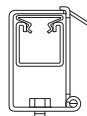

G-1012

Hanger with H-115-A bolt
and square nut plus
G-1016 and H-118-C washers

Channel Support Lighting Systems

- Shoulder-bolt type by means of special shoulder bolt 1 3/32" x 3" slots on 4" centers

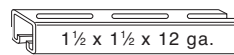

G-953

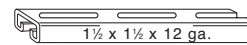

G-956

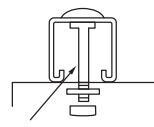

G-973-2-1/4

- Spring-nut type by means of spring-nut and bolt combination

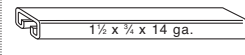

B-906

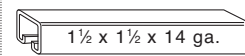

B-900-M

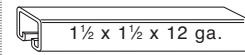

B-900

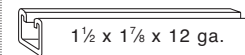

B-901

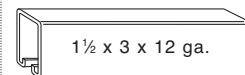

B-902

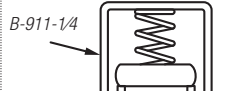

B-911-1/4

H-111-B

Electrical Conductors "Lay-in" the Channel

Kindorf® Surface Raceway channels provide a central wiring distribution system with conductor capacity that exceeds requirements of any lighting layout and with "power to spare" for other uses. Channel adapts to any interval of structural support — may be dropped to any level where it becomes a rigid platform for fixture attachment. Lighting fixtures may be spaced and fastened anywhere along the channel system with "plug-in" or direct-feed electrical connection.

Branch lighting circuit conductors are completely enclosed in channel from panel to fixture, eliminating the ordinary "clutter" of external conductors and protecting the wires from physical damage.

Listed by Underwriters Laboratories, Inc.

Kindorf® channels, installed slot-side down, are designed to provide fixture support only. A range of accessory fittings permit fixture attachment to the channel safely and securely in an approved manner. Channels with solid base or with slots are generally used for simple channel support systems.

Channel support systems combine economy of investment with maximum strength and rigidity. The continuous-slot channel provides complete flexibility of lighting layout with fixture spacing continuous or intermittent. Fixtures may be added or relocated to meet changing requirements without disturbing the basic support system. The rigid channels maintain fixture alignment and adapt to any interval of structural support.

Corporate Office
Tel: 901.252.8000
800.816.7809
Fax: 901.252.1354

Customer Service
Tel: 800.816.7809
Fax: 800.816.7810

Technical Services
Tel: 888.862.3289
Fax: 901.252.1321

Tool Services
Tel: 800.284.8665

Thomas & Betts

www.tnb.com

Kindorf®

Surface Raceway and Lighting Support Systems

Kindorf® Modular Metal Framing and Support System

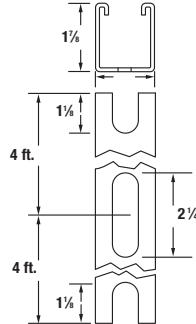
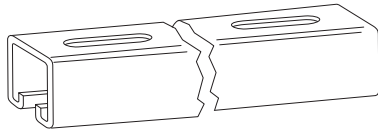

G-950 Fixture Hanging Channel

CAT. NO.	DESCRIPTION	JOINER
G-950	1 1/2" x 1 1/8" x 12 ga.	G-978C

1/16" x 2 1/4" slots on 4 foot centers.
20 ft. lengths only 194#/C ft.
Standard finish: Galv-Krom®.

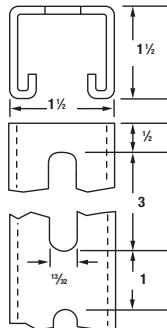
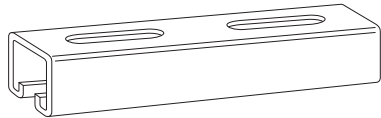

G-953 Fixture Hanging Channel

CAT. NO.	DESCRIPTION	JOINER
G-953	1 1/2" x 1 1/2" x 12 ga.	G-958

Fixtures attached to channel of G-973-2-1/4 shoulder bolts. 154#/C ft.
1 1/2" x 3" slots on 4" centers.
Standard finish: Galv-Krom®.

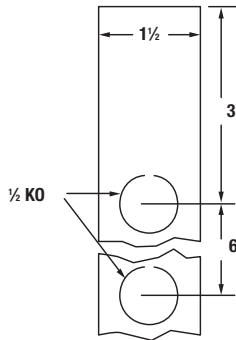
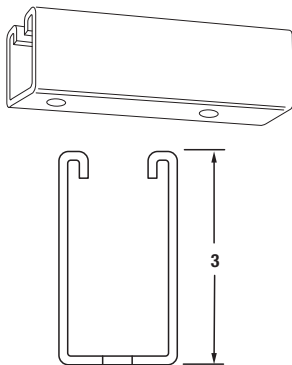

G-955 Fixture Hanging Channel

To be used in place of G-975 channel when heavy fixtures are used or supports are on wider spacing.

CAT. NO.	DESCRIPTION	JOINER	END CAP
G-955	1 1/2" x 3" x 12 ga.	G-978-D	G-957 G-959

270#/C ft. UL Listed for raceway.
1/2" KOs on 6" centers.
Standard finish: Galv-Krom®.

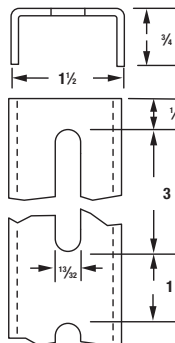
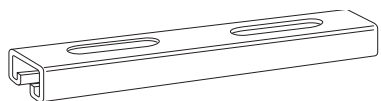

G-956 Fixture Hanging Channel

Similar to G-953 channel except lighter gauge and only 3/4" deep.

CAT. NO.	DESCRIPTION	JOINER
G-956	1 1/2" x 3/4" x 14 ga.	G-960

Fixtures attached to channel by means of G-973-1-1/2 shoulder bolts or G-973-2-1/4 fixture bolts. 80#/C ft.
1 1/2" x 3" slots on 4" centers.
Standard finish: Galv-Krom®.

Thomas & Betts

www.tnb.com

Corporate Office
Tel: 901.252.8000
800.816.7809
Fax: 901.252.1354

Customer Service
Tel: 800.816.7809
Fax: 800.816.7810

Technical Services
Tel: 888.862.3289
Fax: 901.252.1321

Tool Services
Tel: 800.284.8665

Surface Raceway and Lighting Support Systems

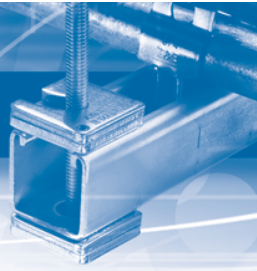

G-957 End Cap

Blank end cap for use with G-955 and B-902 channel.



CAT. NO.	WT. LBS./C
G 957	14

14 ga. steel.

UL Listed for raceway.

Galv-Krom® finish.

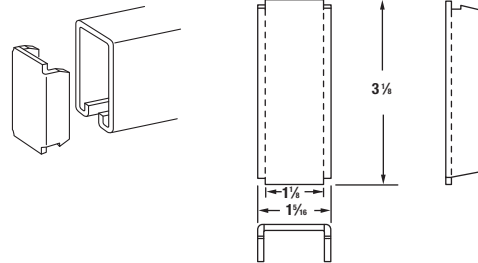

G-958 Channel Joiner

For 1 1/2" deep-slotted channel G-953.

CAT. NO.	WT. LBS./C
G 958	92

Four 3/8" x 3/4" bolts and nuts are furnished with the joiner.

14 ga. steel.

Galv-Krom® finish.

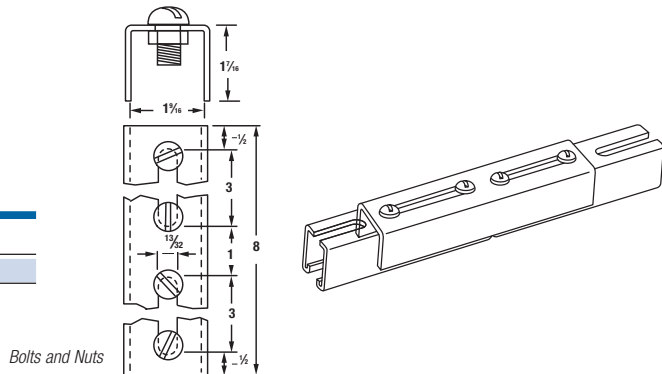

G-959 End Cap

For use with G-955 and B-902 channel.

CAT. NO.	DESCRIPTION	WT. LBS./C
G 959	With two 1/2" Knockouts	31

12 ga. steel.

UL Listed for raceway.

Galv-Krom® finish.

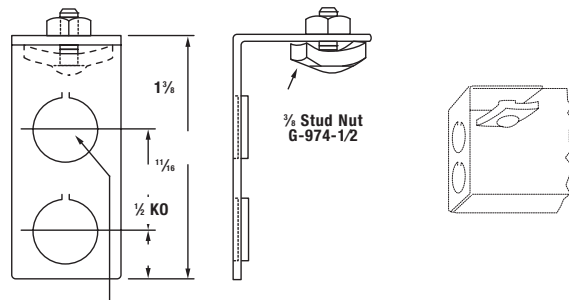

G-960 Channel Joiner

For 3/4" deep-slotted channel G-956.

CAT. NO.	WT. LBS./C
G 960	70

Four 3/8" x 3/4" bolts and nuts are furnished with the joiner.

14 ga. steel.

Galv-Krom® finish.

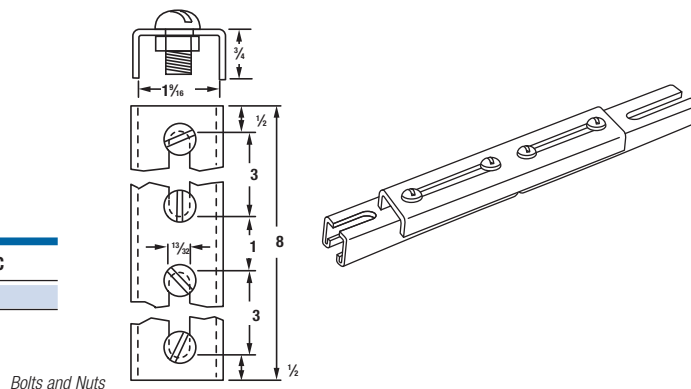

Corporate Office
Tel: 901.252.8000
800.816.7809
Fax: 901.252.1354

Customer Service
Tel: 800.816.7809
Fax: 800.816.7810

Technical Services
Tel: 888.862.3289
Fax: 901.252.1321

Tool Services
Tel: 800.284.8665

Thomas & Betts

www.tnb.com

Kindorf®

Surface Raceway and Lighting Support Systems

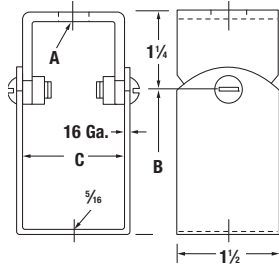
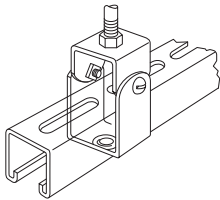

G-962 and G-962-D Channel Hangers

G-962 fits around 1 1/2" or 1 5/8" deep channel. G-962-D series hangers for 3" deep channel.

CAT. NO.	WT. LBS./C	CAT. NO.	WT. LBS./C	HANGER SIZE (IN.)	DIM. A (IN.)
G-962-1	40	G-962-D-1	47	1/4 and 3/8 rod	1 1/2
G-962-2	42	G-962-D-2	47	1/2 rod and 1/4 pipe	9/16
G-962-3	39	G-962-D-3	47	3/8 pipe and 3/8 rod	1 1/16
G-962-4*	47	G-962-D-4**	47	1/2 pipe	7/8

* Load rating of 600 lbs. with a safety factor of three.

** Load rating of 700 lbs. with a safety factor of three.

"B" dimension for G-962: 2 1/2"; for G-962-D: 4".

UL Listed for raceway.

"C" dimension for G-962, 1 3/4"; for G-962-D, 3 3/4".

Galv-Krom® finish.

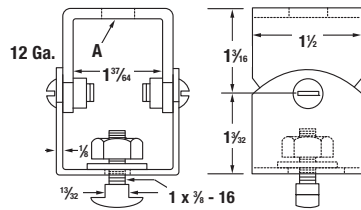
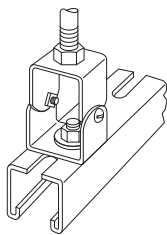

G-963 Channel Hanger

For use with G-953 or G-956 channel. Does not interfere with fluorescent fixtures.

CAT. NO.	HANGER SIZE (IN.)	DIM. A (IN.)
G-963-1	1/4 and 3/8 rod	1 3/32
G-963-2	1/2 rod and 1/4 pipe	9/16

Load rating of 900 lbs. with a safety factor of three.

48#/C.

Galv-Krom® finish.

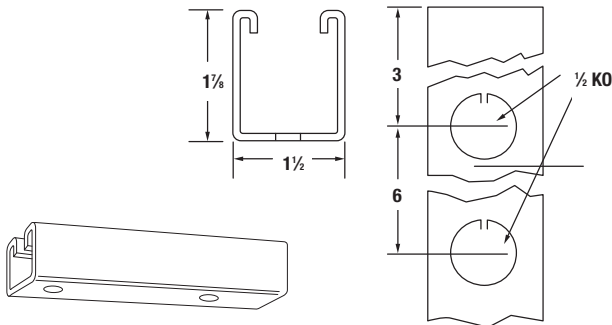

G-965 Fixture Hanging Channel

Provides a combination fixture support and surface raceway.



CAT. NO.	DESCRIPTION	JOINER	END CAP
1 1/2" x 1 7/8"			
G-965	12 ga., 190#/C ft.	G-978-C	6959

UL Listed for raceway.

1/2" knockouts on 6" centers.

Standard finish: Galv-Krom®.

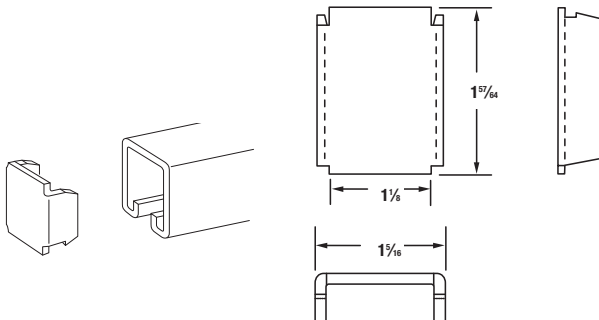

G-966 Blank End Cap

For 1 1/4" deep channel.



CAT. NO.	WT. LBS./C
G-966	8

UL Listed for raceway.

Galv-Krom® finish.

Thomas & Betts

www.tnb.com

Corporate Office
Tel: 901.252.8000
800.816.7809
Fax: 901.252.1354

Customer Service
Tel: 800.816.7809
Fax: 800.816.7810

Technical Services
Tel: 888.862.3289
Fax: 901.252.1321

Tool Services
Tel: 800.284.8665

Surface Raceway and Lighting Support Systems

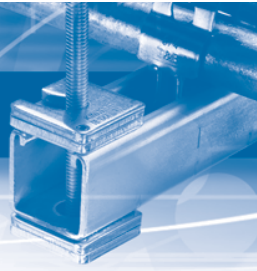

Kindorf® Modular Metal Framing and Support System

G-967 Blank End Cap

- For use with 1½" deep channel

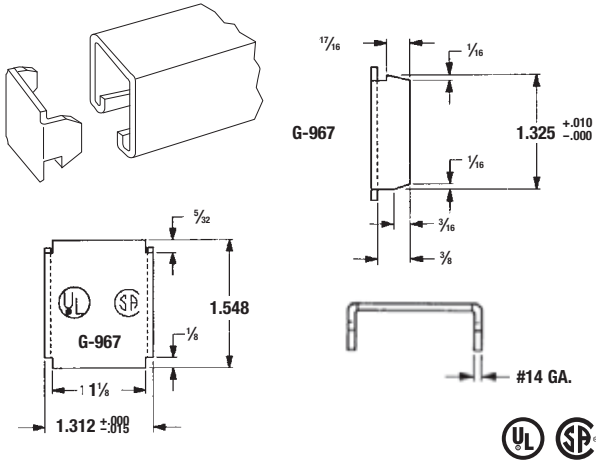

CAT. NO.	WT. LBS./C
G 967	6

UL Listed for raceway.
Galv-Krom® finish.

G-968 Blank End Cap

- For ¾" deep channel

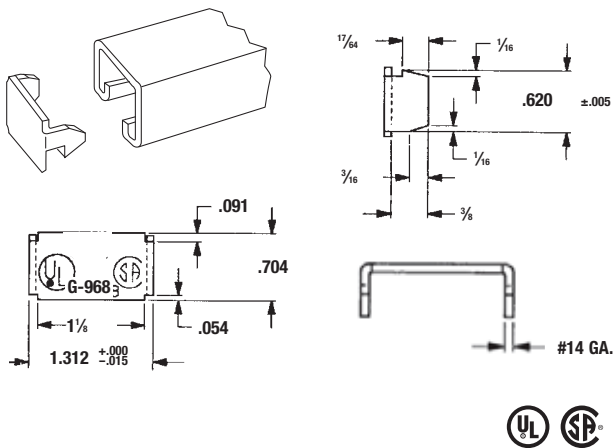

CAT. NO.	WT. LBS./C
G 968	3

UL Listed for raceway.
Galv-Krom® finish.

G-969A Closure Strip for Kindorf® Channel

- For use with all channel series to complete enclosure

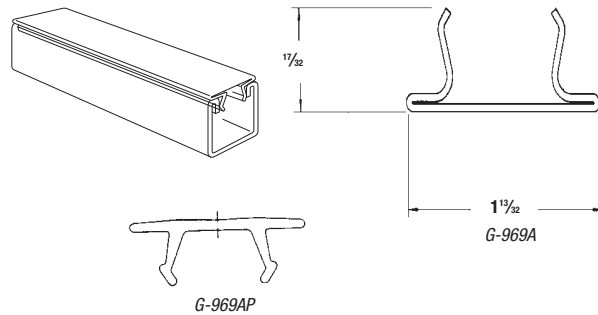

CAT. NO.	DESCRIPTION
G 969A	Steel Closure Strip — Galv-Krom® finish
G-969AP	Plastic Closure Strip — Gold

19 ga. steel, 35#/C.

UL Listed for raceway.

G-972 Nipple Malleable Iron

The ½" size can nipple fixtures through channel knockouts. All sizes can be fastened to the open slot of all Kindorf® channels. Locknut supplied with nipple.

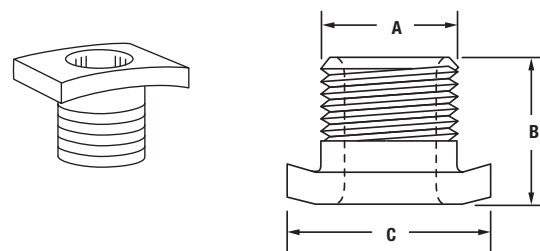

CAT. NO.	DIMENSIONS (IN.)			WT. IN LBS./C
	A	B	C	
G 972 1/2	½ pipe size	¾	1¼	7
G-972-3/4	¾ pipe size	¾	1¼	11
G 972 L 1/2	½ pipe size	2	1¼	9

The extra length of the G-972-L-1/2 permits its use as a spacing nipple when locked into knockout or continuous slot.

Load rating 750#, with a safety factor of 3.

Galv-Krom® finish.

Corporate Office
Tel: 901.252.8000
800.816.7809
Fax: 901.252.1354

Customer Service
Tel: 800.816.7809
Fax: 800.816.7810

Technical Services
Tel: 888.862.3289
Fax: 901.252.1321

Tool Services
Tel: 800.284.8665

Thomas & Betts

www.tnb.com

Kindorf®

Surface Raceway and Lighting Support Systems

Kindorf® Modular Metal Framing and Support System

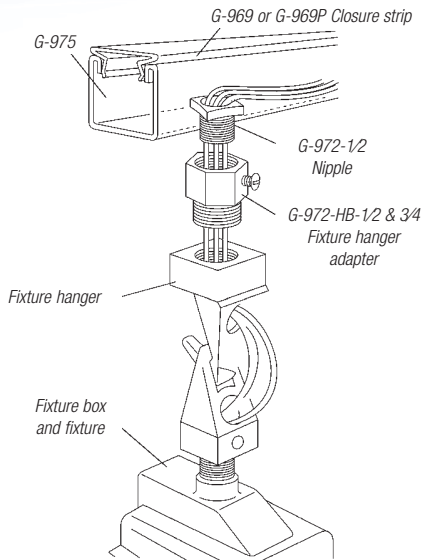

G-972-HB-1/2 Steel Fixture Hanger Adapter

The Fixture Hanger Adapter extends the flexibility of the Kindorf® System by easily adapting the 3/4" hanger size of high-intensity fixtures to channel mounting.

The hanger adapter securely mounts the fixture hanger or box to the channel through the 1/2" KO in the base. No special tools are needed for installation of fittings and fixtures.

Kindorf® channel, with 1/2" KOs every 6", hangs and feeds the fixtures — thus simplifying installation.

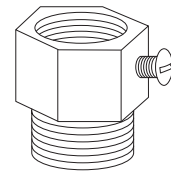

CAT. NO.	DESCRIPTION	WT. LBS./C
G 972 HB 1/2	Galv-Krom® finish	17

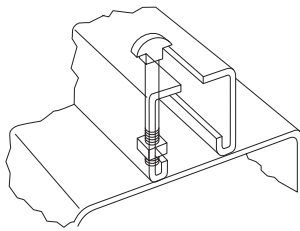

G-973 Shoulder Type Fixture Bolt and Nut

For use in fastening fixtures to slotted channels. Permits the preassembly of hardware to the fixture. The head of the G-973 is simply inserted into the channel slot and twisted 90° to seat. The fixture is secured tightly when the nut is run home.

CAT. NO.	USED WITH CHANNEL	SIZE (IN.)	WT. LBS./C
G 973 1 1/2	G-956	1/2 x 1 1/2	7
G 973 2 1/4	G-953	3/8 x 2 1/4	10

Galv-Krom® finish.

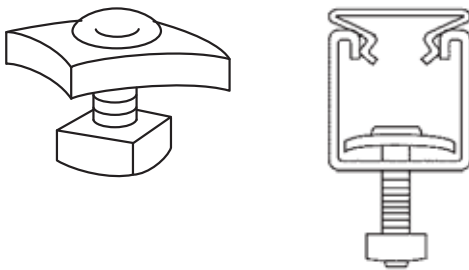

G-974 Fastener

Will fasten fluorescent fixtures to G-975 through knockouts or to the open slot of all Kindorf® channels when installed slot down.

CAT. NO.	SIZE (IN.)	WT. LBS./C
G-974-1/2	1/4 x 1/2	8
G-974-3/4	1/4 x 3/4	8 1/2
G-974-1	1/4 x 1	9
G 974 1 1/4	1/4 x 1 1/4	10
G-974-1-1/2	1/4 x 1 1/2	11

Galv-Krom® finish.

Thomas & Betts

www.tnb.com

Corporate Office
Tel: 901.252.8000
800.816.7809
Fax: 901.252.1354

Customer Service
Tel: 800.816.7809
Fax: 800.816.7810

Technical Services
Tel: 888.862.3289
Fax: 901.252.1321

Tool Services
Tel: 800.284.8665

Surface Raceway and Lighting Support Systems

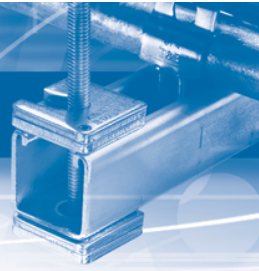

G-975 Fixture Hanging Channel

Designed to provide a combination fixture support and surface raceway. Fixture attaches to KOs by G-972-1/2 nipple for wiring, or a G-974 stud nut where wiring is not required.



CAT. NO.	DESCRIPTION	JOINER	END CAP
1½" x 1½"			
G 975 10	12 ga.	G978A	G967
G 975 20	12 ga.	G978A	G967
G 975 M 10	14 ga.	G1503-S	G979
G 975 M 20	14 ga.	G1503-S	G979

G-975: 160#/C ft. G-975-M: 107#/C ft. UL Listed for raceway.

½" knockouts on 6" centers.

Standard finish: Galv-Krom®.

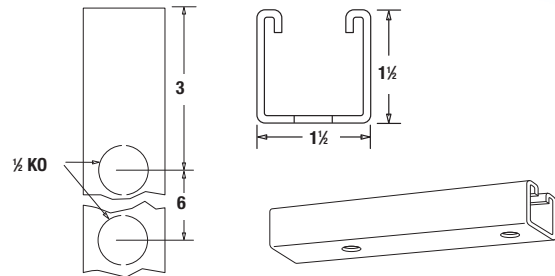

G-976 Connector

Accepts either ½" or ¾" conduit to feed control channel when used as a combination raceway and lighting fixture support. Includes two stud nuts. Malleable iron.



CAT. NO.	DESCRIPTION	WT. LBS./C
G 976	Galv-Krom® finish	54

Load rating 1,000# with a safety factor of 3.

UL Listed for raceway.

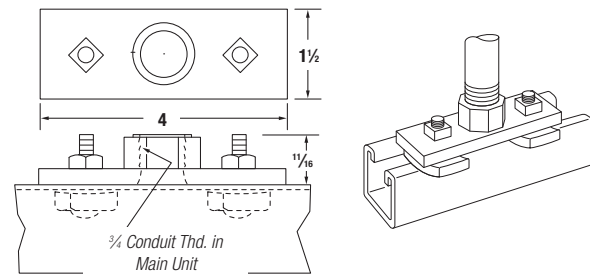

G-977 Swing Connector (Channel Feed Hanger)

Provides a 15° swing in either direction to the channel run. Accepts ½" or ¾" conduit, or may be adapted for use with ¾" fixture stem when specified.



CAT. NO.	DESCRIPTION	WT. LBS./C
G 977	Galv-Krom® finish	130

Includes two stud nuts.

Malleable iron.

UL Listed for raceway.

Load rating of 1,300 lbs. with a safety factor of three.

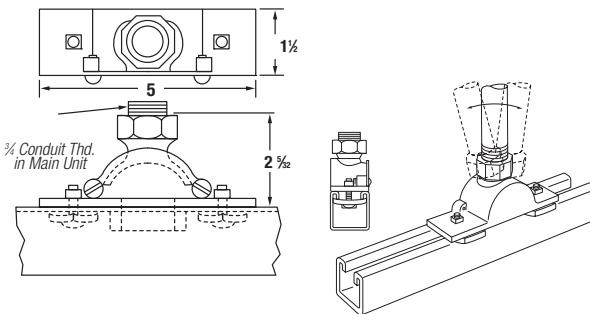

G-978 Joiners

To splice lengths of raceway channel. Installed by tightening nuts on ¼" studs which are permanently attached to a smooth inner plate.



CAT. NO.	TYPE OF CHANNEL APPLICABLE	DIM. A (IN.)	WT. LBS./C
G 978	Use with G-975, G-975-M and B-900, B-900-M	1½	107
G-978-L	Use with B-906	¾	87
G-978-D	Use with G-955 and B-902	3	137
G-978-C	Use with B-901, G-950 and G-965	1"	122

Nuts included. 14 ga. steel.

UL Listed for raceway.

Galv-Krom® finish.

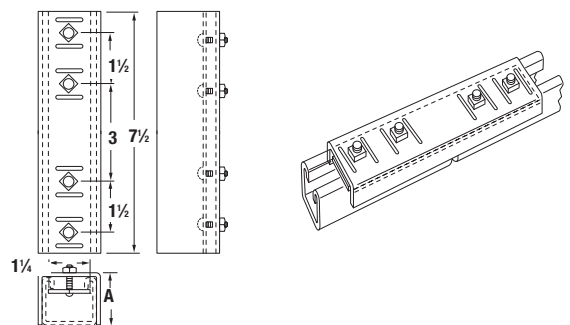

Corporate Office
Tel: 901.252.8000
800.816.7809
Fax: 901.252.1354

Customer Service
Tel: 800.816.7809
Fax: 800.816.7810

Technical Services
Tel: 888.862.3289
Fax: 901.252.1321

Tool Services
Tel: 800.284.8665

Thomas & Betts

www.tnb.com

Kindorf®

Surface Raceway and Lighting Support Systems

Kindorf® Modular Metal Framing and Support System

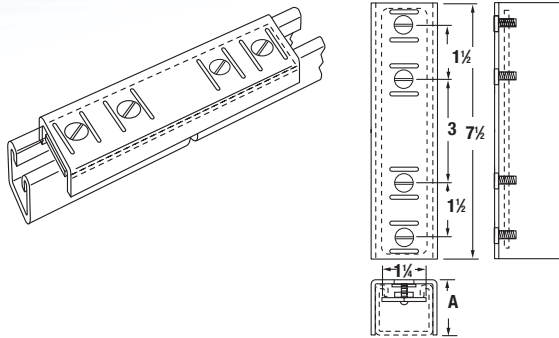

G-978-A Joiners

For installations where fixtures are mounted flush to slot-down channels. Fastening is accomplished by tightening flat head machine screws.



CAT. NO.	TYPE OF CHANNEL APPLICABLE	DIM. A (IN.)	WT. LBS./C
G 978A	Use with G-975, G-975-M and B-900, B-900-M	1 1/2	103
G-978-AL	Use with B-906	3/4	83

14 ga. steel.

Galv-Krom® finish.

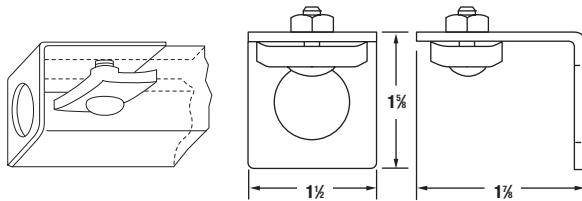

G-979 End Cap

Use with G-975 or B-900 channel to provide conduit entrance.



CAT. NO.	DESCRIPTION	WT. LBS./C
G 979 1/2	For 3/8" Hole, 1/2" Conduit	25
G-979-3/4	For 1/2" Hole, 3/4" Conduit	25

Furnished with stud nut.

12 ga. steel.

UL Listed for raceway.

Galv-Krom® finish.

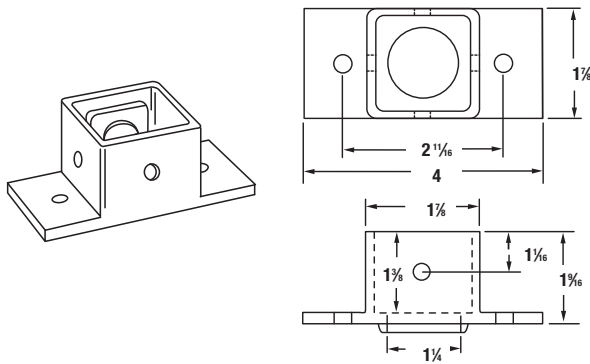

G-1007 Panel Adapter

Mounts 1 1/2" x 1 1/2" raceway channel to panel board.



CAT. NO.	WT. LBS./C
G 1007	36

Complete with stud nuts.

UL Listed for raceway.

Galv-Krom® finish.

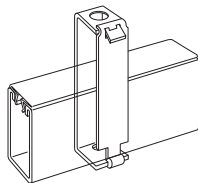

Hinged channel hanger for raceway channel.

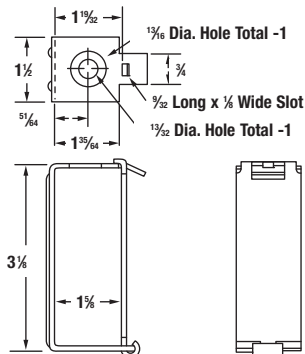

G-1012 "Lay-In" Channel Hanger



CAT. NO.	DESCRIPTION	WT. LBS./C
G 1012	Galv-Krom® Finish	33

14 ga. steel.

UL Listed for raceway.

Load rating of 500 lbs. with a safety factor of three.

Thomas & Betts

www.tnb.com

Corporate Office
Tel: 901.252.8000
800.816.7809
Fax: 901.252.1354

Customer Service
Tel: 800.816.7809
Fax: 800.816.7810

Technical Services
Tel: 888.862.3289
Fax: 901.252.1321

Tool Services
Tel: 800.284.8665

Surface Raceway and Lighting Support Systems

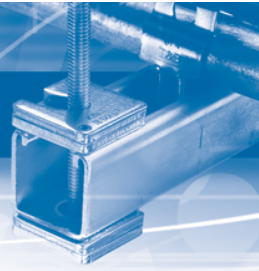

Kindorf® Modular Metal Framing and Support System

G-1012-D "Lay-In" Channel Hanger

Hinged channel hanger for 3" deep raceway channel.

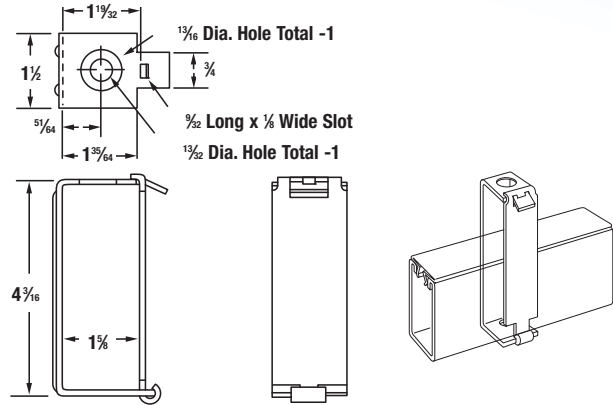

CAT. NO.	DESCRIPTION	WT. LBS./C
G 1012 D	Galv-Krom® Finish	40

14 ga. steel.

UL Listed for raceway.

Load rating of 450 lbs. with a safety factor of three.

G-1013 Hex Swivel Nuts

Two required for each G-1012 channel hanger to provide swivel action.

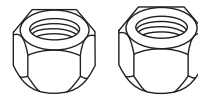

CAT. NO.	DESCRIPTION	WT. LBS./C
G 1013 3/8	For 3/8" Hanger Rod	7
G-1013-1/2	For 1/2" Hanger Rod	7

G-1016 Rubber Washer

Washers are 1" diameter, 1/4" thick with 5/16" hole. Use with G-1012 fixture hanger as cushion between fixture and hanger.



CAT. NO.	WT. LBS./C
G 1016	1

G-1017 Mercury Vapor Hanger

To support high- or low-bay mercury vapor or heavy incandescent fixtures from raceway channels. Permits plug-in connections with G-1038 raceway outlets.

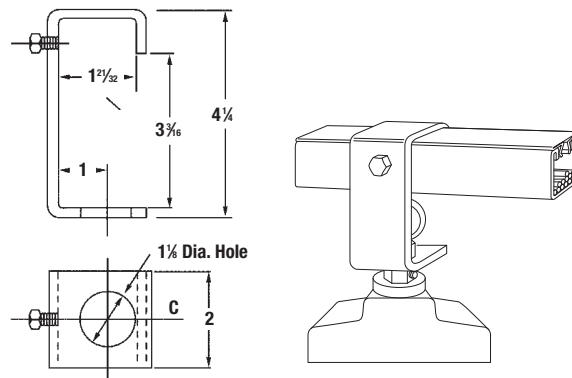

CAT. NO.	USED WITH CHANNEL	DEPTH SIZE (IN.)	WT. LBS./C
G 1017	B-900, B-901 G-975, G-965	4 1/4	76

Galv-Krom® finish.

Corporate Office
Tel: 901.252.8000
800.816.7809
Fax: 901.252.1354

Customer Service
Tel: 800.816.7809
Fax: 800.816.7810

Technical Services
Tel: 888.862.3289
Fax: 901.252.1321

Tool Services
Tel: 800.284.8665

Thomas & Betts

www.tnb.com

Kindorf®

Surface Raceway and Lighting Support Systems

Kindorf® Modular Metal Framing and Support System

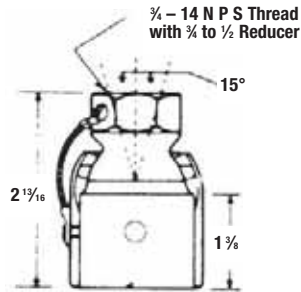
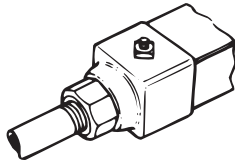

G-1020 End Swivel Joint

Mounts to 1 1/2" x 1 1/2" raceway channel. Threaded for 3/4" conduit or fitting. Swivel action adapter for 1/2" conduit furnished.



CAT. NO.	DESCRIPTION	WT. LBS./C
G 1020	Galv-Krom® Finish	40

UL Listed for raceway.

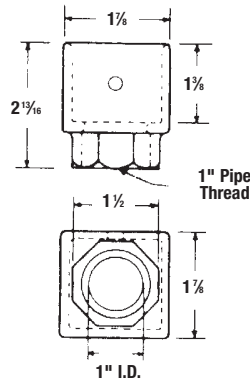
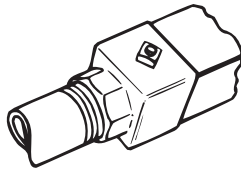

G-1021 Threaded End Fitting

Mounts to 1 1/2" x 1 1/2" raceway channel. Threaded for 1" conduit or fitting. No swivel action.



CAT. NO.	DESCRIPTION	WT. LBS./C
G 1021	Galv-Krom® Finish	32

UL Listed for raceway.

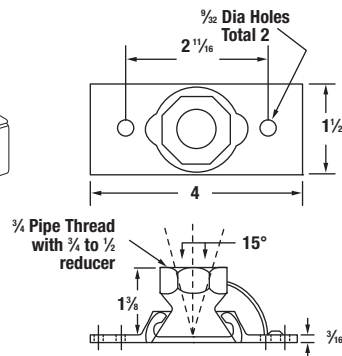
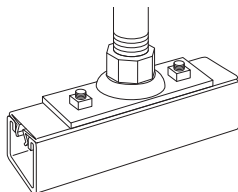

G-1032 Channel Swivel Joint

Provides a 15° swivel action (to offset possible movement) for connection of 1/2" or 3/4" conduit to raceway channels. May be accepted for use with 3/8" fixture stem when specified. Order two G-974 3/4" fasteners for channel mounting.



CAT. NO.	DESCRIPTION	WT. LBS./C
G 1032	Galv-Krom® Finish	25

Load rating 500# with a safety factor of 3.

UL Listed for raceway.

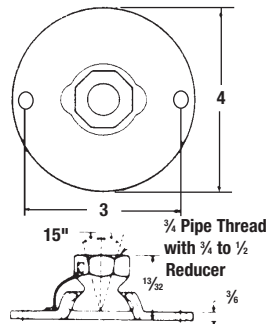
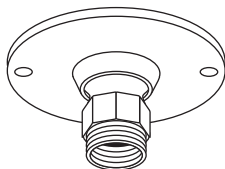

G-1033 4" Diameter Swivel Cover

Cover for G-2000 through G-2004 junction boxes. Use with 3/4" or 1/2" conduit. Swivel action.



CAT. NO.	DESCRIPTION	WT. LBS./C
G 1033	Galv-Krom® Finish	35

Load rating 400 lbs. with a safety factor of three. UL Listed for raceway.

Thomas & Betts

www.tnb.com

Corporate Office
Tel: 901.252.8000
800.816.7809
Fax: 901.252.1354

Customer Service
Tel: 800.816.7809
Fax: 800.816.7810

Technical Services
Tel: 888.862.3289
Fax: 901.252.1321

Tool Services
Tel: 800.284.8665

Surface Raceway and Lighting Support Systems

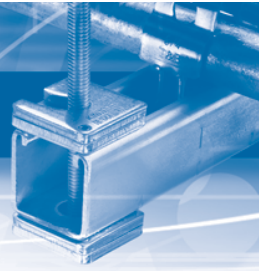

Raceway Outlets

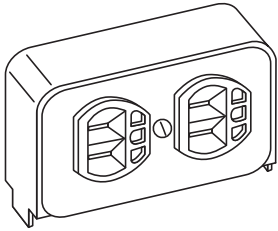

Complete unit including housing, standard duplex 3-wire, 15-amp. 125-volt NEMA ground receptacle and cover plate.

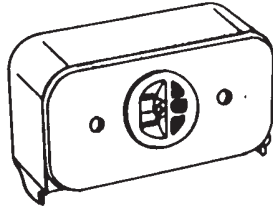

Complete unit including housing, standard single 3-wire, 15-amp. 125-volt NEMA ground receptacle and cover plate.

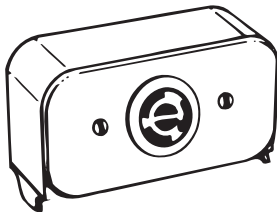

Complete unit including housing, duplex, 3-wire, 15-amp. 277-volt-twistlock receptacle and cover plate.

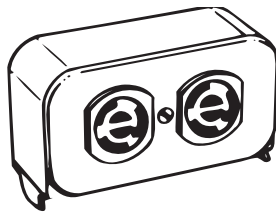

Complete unit including housing, single, 3-wire, 15-amp. 277-volt-twistlock receptacle and cover plate.



CAT. NO.	DESCRIPTION	WT. LBS./C
G 1038	Gold Finish	55
G 1038 A	Gold Finish	50
G-1038-D	Gold Finish	60
G 1038 E	Gold Finish	50

UL Listed for raceway.

G-1038-B Housing Only

CAT. NO.	DESCRIPTION	WT. LBS./C
G 1038 B	Gold Finish	25

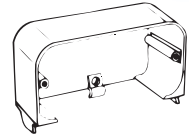

G-1038-C Duplex Cover Plate

CAT. NO.	DESCRIPTION	WT. LBS./C
G 1038 C	Gold Finish	12

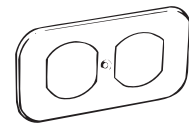

G-1038-CA Single Cover Plate

CAT. NO.	DESCRIPTION	WT. LBS./C
G 1038 CA	Gold Finish	14

Size of opening: 1.391 diameter

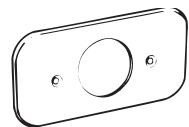

G-1038-CX Blank Cover Plate

CAT. NO.	DESCRIPTION	WT. LBS./C
G 1038 CX	Gold Finish	15

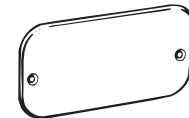

G-1060 Nylon Bushing

CAT. NO.	WT. LBS./C
G-1060	2

Strain relief bushing to protect lead from fluorescent fixture.



Kindorf®

Surface Raceway and Lighting Support Systems

Channel Joiners for Lay-In Wiring

The direction-change joiner fittings for Kindorf® Channels expand to three, the number of channel depths available for complete raceway wiring systems.

Joiner fittings are made for 1½", 1⅝" and 3" depths of 1½" wide channels. These three systems provide raceway conductor fill capacities for any lighting layout and with erected strength to spare for lighting fixture support.

The joiner fitting rests inside the channel without obstructing the channel, or the lay-in of electrical conductors. No time-consuming "fishing" of conductors at the elbows, tee and crosses.

Installation is fast. Simply insert the fitting into the end of the channel and turn the captive set-screw. This "jack-screws" the fitting sidewalls beneath the channel lips for snug, strong joints. Standard Kindorf® Channel Closure Strip is used for a completely enclosed raceway.

Listed by Underwriters Laboratories, Inc.

G-1500, G-1870 and G-3000 Series Direction Change Joiner Assemblies

Direction change joiners for 1½", 1⅝" and 3" deep raceway channels complete with screws and washers. Joiners fit into end of channel. When screws are tightened, joiner is forced up against channel lips for secure installation. Conductors can be laid in, no pulling required. No need for junction boxes. Available in X, T, L and S configurations. Support required within 12" of each joiner.

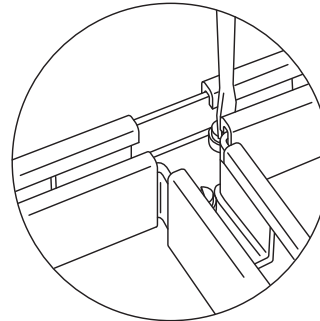

Channel should be supported a minimum of 12" from joiner.

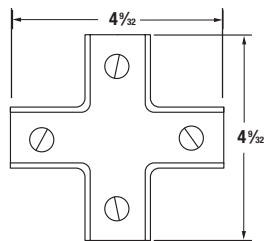
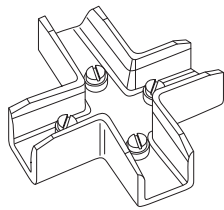
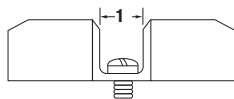
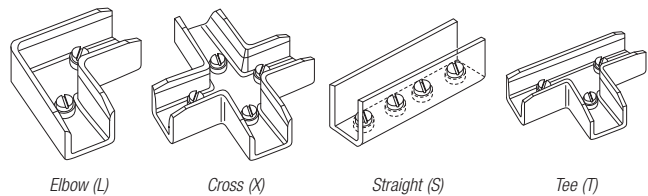

X-Style — G-1500X, G-1870X and G-3000X



CAT. NO.	FOR USE WITH CHANNEL NO.	WT. LBS./C
Cast Aluminum		
G 1500 X	B-900 & G-975	44
G-1870X	B-901 & G-965	51
G-3000X	B-902 & G-955	79

Galv-Krom® finish.

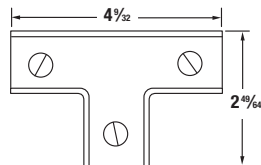
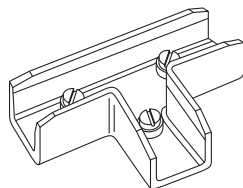
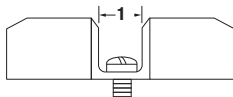

T-Style — G-1501T, G-1871T and G-3001T



CAT. NO.	FOR USE WITH CHANNEL NO.	WT. LBS./C
Cast Aluminum		
G 1501 T	B-900 & G-975	34
G-1871T	B-901 & G-965	45
G-3001T	B-902 & G-955	66

Galv-Krom® finish.

Thomas & Betts

www.tnb.com

Corporate Office
Tel: 901.252.8000
800.816.7809
Fax: 901.252.1354

Customer Service
Tel: 800.816.7809
Fax: 800.816.7810

Technical Services
Tel: 888.862.3289
Fax: 901.252.1321

Tool Services
Tel: 800.284.8665

Surface Raceway and Lighting Support Systems

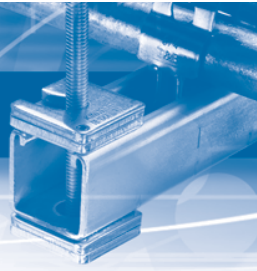

Kindorf® Raceway System Fittings for 1½" x 1½" Channel Systems

The Kindorf® Channel system serves both as a raceway for electrical conductors and a support system for the electrical outlets or tap-offs.

Kindorf® is a complete wiring and support system with fittings and accessories for the design and installation of your electrical system.

A full line of direction change junction boxes are provided for use with the Kindorf® raceway system. These are made up of a standard Steel City® octagon box, box cover and attachment fittings. Assemblies as shown are available complete, or members can be purchased separately to make up a junction.

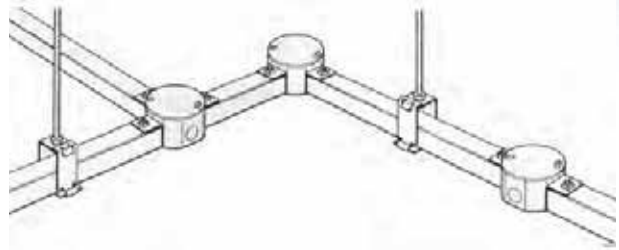

Junction Boxes for 1½" x 1½" Raceway Channels — Galv-Krom® Finish

When purchased as an assembly, the octagon box and cover are Galv-Krom® finish to match the channel and end cap and all parts are factory fabricated.

ITEM	QUANTITY
<i>The assembly consists of the following components:</i>	
Octagon Box	1
Box Cover	1
Locknuts	1, 2, 3, or 4 (as required)
Nipples	1, 2, 3, or 4 (as required)
End Caps	1, 2, 3, or 4 (as required)

L-Style — G-1502L, G-1872L and G-3002L



CAT. NO.	FOR USE WITH CHANNEL NO.	WT. LBS./C
<i>Cast Aluminum</i>		
G 1502 L	B-900 & G-975	25
G-1872L	B-901 & G-965	32
G-3002L	B-902 & G-955	51

Galv-Krom® finish.

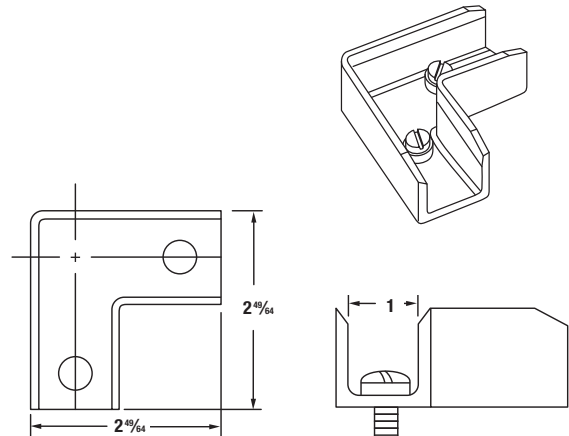

S-Style — G-1503S, G-1873S and G-3003S



CAT. NO.	FOR USE WITH CHANNEL NO.	WT. LBS./C
<i>Steel</i>		
G 1503 S	B-900 & G-975	21
G-1873S	B-901 & G-965	25
G-3003S	B-902 & G-955	36

Galv-Krom® finish.

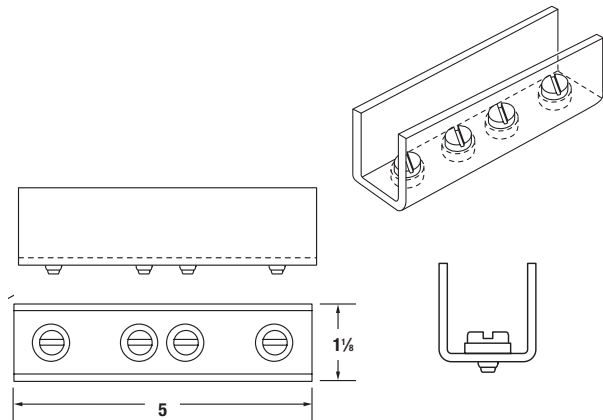

Corporate Office
Tel: 901.252.8000
800.816.7809
Fax: 901.252.1354

Customer Service
Tel: 800.816.7809
Fax: 800.816.7810

Technical Services
Tel: 888.862.3289
Fax: 901.252.1321

Tool Services
Tel: 800.284.8665

Thomas & Betts

www.tnb.com

Kindorf®

Surface Raceway and Lighting Support Systems

Raceway Junction Boxes

Kindorf® Raceway System Fittings
for 1½" x 1½" Channel Systems.



G 2000
Type "E" 100 lbs./C



G 2001
Type "C" 121 lbs./C



G 2002
Type "L" 90°



G 2003
Type "T" 140 lbs./C



G 2004
Type "X" 150 lbs./C



G-2001
Junction Box with No.
5402-LR outlet box cover
and field mounted duplex
receptacle.



G-1007
36 lbs./C

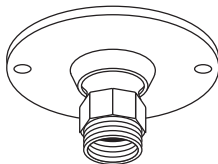

G-1033
For ½" or ¾" conduit feed
from outlet box 35 lbs./C

G-2000 Junction Box

Complete with cover, locknuts, nipples and end caps. Type "E" dead-end junction box for raceway channel. Accepts standard devices and covers for 4" octagon outlet boxes.

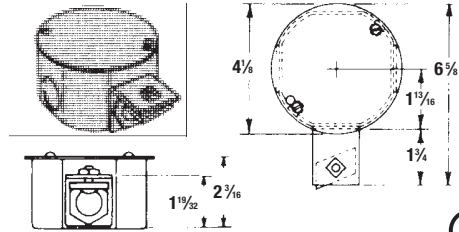

CAT. NO.	DESCRIPTION	WT. LBS./C
G 2000	Galv-Krom® Finish	123

G-2001 Junction Box

Complete with cover, locknuts, nipples and end caps. Type "C" straight-through junction box for two raceway channels. Accepts standard devices and covers for 4" octagon outlet boxes.

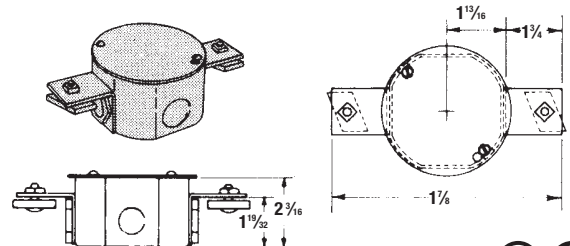

CAT. NO.	DESCRIPTION	WT. LBS./C
G 2001	Galv-Krom® Finish	147

G-2002 Junction Box

Complete with cover, locknuts, nipples and end caps. Type "L" 90° junction box for two raceway channels. Accepts standard devices and covers for 4" octagon outlet boxes.

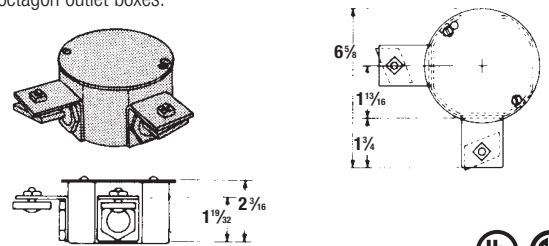

CAT. NO.	DESCRIPTION	WT. LBS./C
G 2002	Galv-Krom® Finish	120

Kindorf® Modular Metal Framing and Support System

Thomas & Betts

www.tnb.com

Corporate Office
Tel: 901.252.8000
800.816.7809
Fax: 901.252.1354

Customer Service
Tel: 800.816.7809
Fax: 800.816.7810

Technical Services
Tel: 888.862.3289
Fax: 901.252.1321

Tool Services
Tel: 800.284.8665

Surface Raceway and Lighting Support Systems

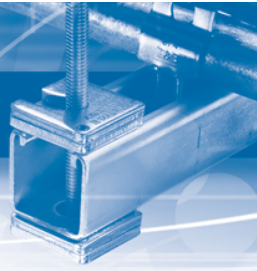

G-2003 Junction Box

Complete with cover, locknuts, nipples and end caps. Type "T" junction box for three raceway channels. Accepts standard devices and covers for 4" octagon outlet boxes.

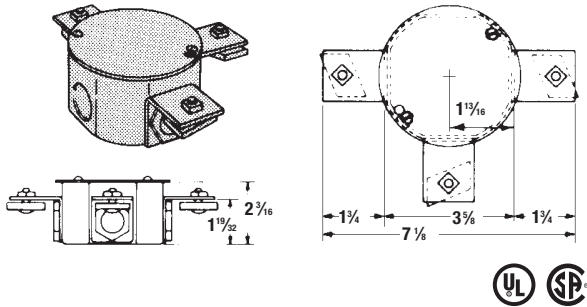

CAT. NO.	DESCRIPTION	WT. LBS./C
G 2003	Galv-Krom® Finish	140

G-2004 Junction Box

Complete with cover, locknuts, nipples and end caps. Type "X" junction box for four raceway channels. Accepts standard devices and covers for 4" octagon outlet boxes.

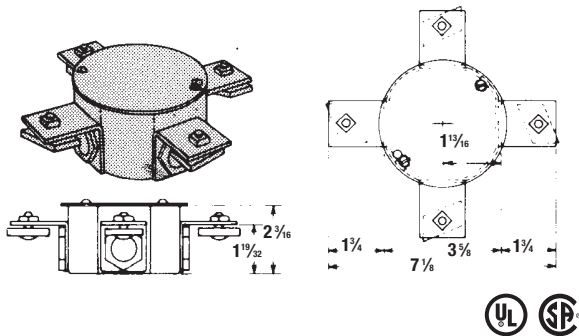

CAT. NO.	DESCRIPTION	WT. LBS./C
G 2004	Galv-Krom® Finish	150

G-2005 Junction Box

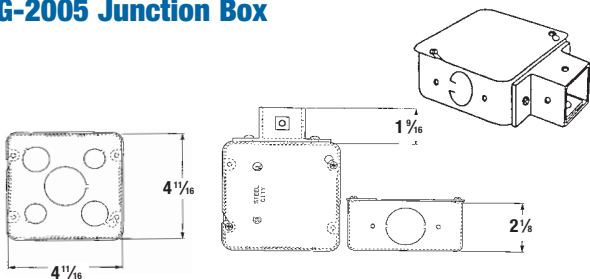

CAT. NO.	DESCRIPTION	WT. LBS./C
G2005	Galv-Krom® Finish	189

G-2006 Junction Box

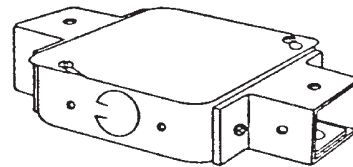

CAT. NO.	DESCRIPTION	WT. LBS./C
G2006	Galv-Krom® Finish	225

G-2007 Junction Box

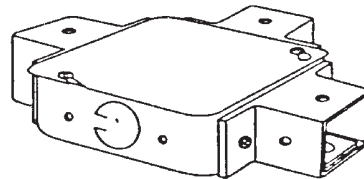

CAT. NO.	DESCRIPTION	WT. LBS./C
G2007	Galv-Krom® Finish	261

G-2008 Junction Box

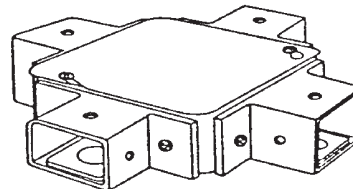

CAT. NO.	DESCRIPTION	WT. LBS./C
G2008	Galv-Krom® Finish	290

Corporate Office
Tel: 901.252.8000
800.816.7809
Fax: 901.252.1354

Customer Service
Tel: 800.816.7809
Fax: 800.816.7810

Technical Services
Tel: 888.862.3289
Fax: 901.252.1321

Tool Services
Tel: 800.284.8665

Thomas & Betts

www.tnb.com

Kindorf®

Hardware and Threaded Components

Fast Installation and Low Maintenance

"Threads" are an integral part of erector systems because nearly everything hangs by or is secured by threaded fasteners. Kindorf® threaded hardware includes continuous rolled-thread hanger rod, and special and standard screws and nuts designed with the necessary holding power to serve the requirements of framing and hanging installations.

It is vital that each thread be fully protected against rust and corrosion because they are usually exposed to corrosive atmospheres. Kindorf® threaded hardware and accessories are completely protected by the same Galv-Krom® finish that protects Kindorf® channel and fittings. Kindorf® extra-quality threads are always:

- Free-running — clean, uniform
- Corrosion resistant — no paint required
- Burr-free — smooth finish

Trouble-free threaded hardware is an investment in fast installation and low maintenance. Free-running threads are a time saving asset on every job — saving fingers and tempers, and eliminating delays that result when threads must be specially treated before use. Threaded rod is packed in tubes to prevent damage during shipment. Kindorf® threaded hardware is produced from high-tensile strength carbon steel with Unified National Coarse (U.N.C.) threads. Galv-Krom® finish is standard.

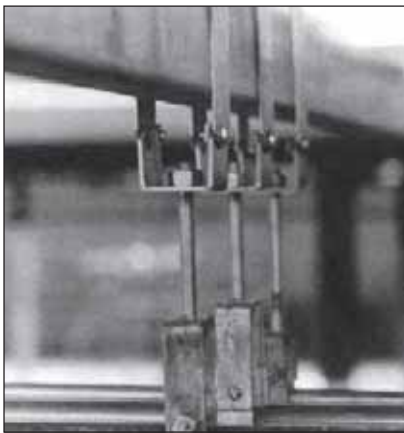

H-193 Hanger Rod supports conduit from G-962-D hanger. ASTM Class 2.

H104 Hanger Rod, Continuous Thread — Galv-Krom®



CAT. NO.	SIZE	WT./LBS. PER 100 PCS.
H104 1/4X6		73
H104 1/4X10	1/4"-20	124
H104 1/4X12		148
H104 3/8X6		172
H104 3/8X10	3/8"-16	293
H104 3/8X12		348
H104 1/2X6		313
H104 1/2X10	1/2"-13	530
H104 1/2X12		648
H104 5/8X6		510
H104 5/8X10	5/8"-11	850
H104 5/8X12		1,020

Suffix indicates rod size and length.

R-Series Continuous Thread Rod — Electro-Galvanized

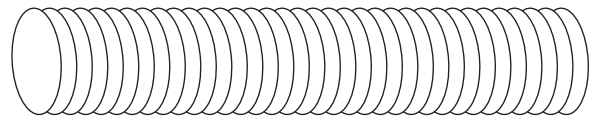

- 6-, 10- and 12-foot lengths continuous thread

CAT. NO.	SIZE	WT./LBS. PER 100 PCS.
R628-6 FT.	1/4"-20	74
R1028-10 FT.		120
R638-6 FT.	3/8"-16	174
R1038-10 FT.		290
R648-6 FT.	1/2"-13	324
R1048-10 FT.		530

Suffix indicates rod size and length.

NATIONAL COARSE THREAD

SIZE (IN.)	THREADS PER INCH	LBS./100 FT.	DESIGN LOAD LBS.
1/4	20	12.5	150
3/8	16	29.0	610
1/2	13	53.5	1,130
3/4	11	85.0	1,810
7/8	10	123.0	2,710
1	9	130.0	3,770
1 1/8	8	214.0	4,960

Grade ASTM A-510.

Thomas & Betts

www.tnb.com

Corporate Office
Tel: 901.252.8000
800.816.7809
Fax: 901.252.1354

Customer Service
Tel: 800.816.7809
Fax: 800.816.7810

Technical Services
Tel: 888.862.3289
Fax: 901.252.1321

Tool Services
Tel: 800.284.8665

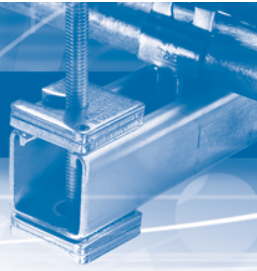

H115 U-Bolts



"U" bolt to support, anchor or guide pipe lines. Sizes through 4" are furnished with one hex nut per leg in Galv-Krom®. H-286 sizes 5" and above are furnished with two hex nuts per leg in black.

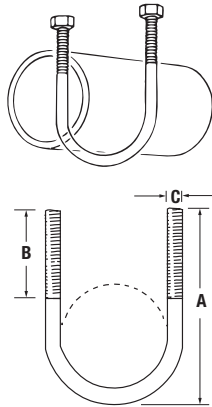

CAT. NO. AND PIPE SIZE	REC. MAX. LOAD (LBS.)	DIMENSIONS (IN.)			WT. IN LBS./C
		A	B	C	
H115 1/2	1,500	2 3/4	1 1/4	5/8	13
H115 3/4	2,000	3 1/8	1 1/2	5/8	15
H115 1	2,500	3 3/8	1 3/4	5/8	16
H115 1 1/4	2,500	3 1/2	1 3/4	5/8	17
H115 1 1/2	2,500	3 3/4	1 3/4	5/8	18
H115 2	3,300	4 1/8	2 1/8	3/4	32
H115 2 1/2	4,000	5 1/8	2 1/8	3/4	34
H115 3	4,000	5 1/2	2	3/4	38
H115 3 1/2	4,000	6 3/8	2	3/4	40
H115 4	4,000	6 1/2	2 1/4	3/4	46
H115 5	4,000	8 3/2	2 1/4	1/2	128
H115 6	4,000	9 3/4	2 3/8	5/8	239
H115 8	4,000	11 3/4	2 3/8	5/8	283

Complies with Fed. Spec. WW-H-171E and MSS SP-69 Type 24.

M117 Swivel Eye

- H-272 swivel eye has 3/8" or 1/2" tapped hole for hanger rod applications

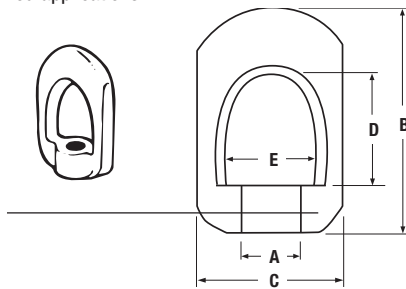

CAT. NO.	DIMENSIONS (IN.)					LOAD RATING (LBS.)	WT. LBS./C
	A	B	C	D	E		
M117 3/8B	3/8-16	2 3/4	1 1/2	1 1/8	3/8	2,000	19
M117 1/2B	1/2-13	2 3/4	1 1/2	1 1/8	3/8	2,000	19

Safety factor of three.

H119 Steel Rod Coupling

For coupling lengths of H-193 hanger rod. Right-hand threaded. Threads tapered to lock rods in place.

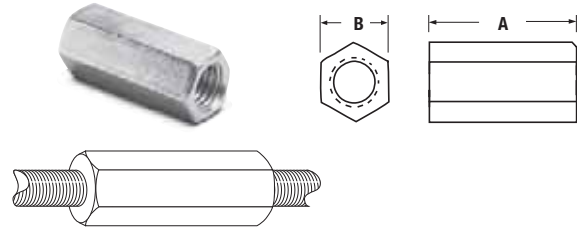

CAT. NO.	THREADS	DIMENSIONS (IN.)		LOAD RATING (LBS.)	WT. LBS./C
		A	B		
H119 1/4	1/4-20	1/8	3/8	240	2
H119 3/8	3/8-16	1 1/2	1/2	610	4
H119 1/2	1/2-13	1 1/4	5/8	1,130	5
H119 5/8	5/8-11	1 1/8	13/16	1,810	10

Galv-Krom® finish.

E120, E130 Eyelet with 1/2" or 3/8" Stud

For bolting to a supporting member to furnish suspension for rope, chain or cable.

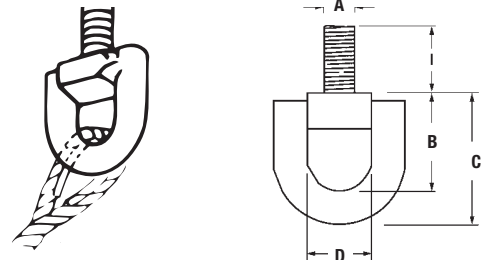

CAT. NO.	DIMENSIONS (IN.)				LOAD RATING (LBS.)	WT. LBS./C
	A	B	C	D		
E120 3/8	3/8-16	1 1/8	1 1/4	1/2	1,000	23
E130 1/2	1/2-13	1 1/2	2	3/4	1,800	28

Safety factor of three.

Galv-Krom® finish.

H-120 Saddle-Type Washer

- For rigid attachment of rod to channel
- For use with either 3/8" or 1/2" hanger rod



CAT. NO.	WT. LBS./C
H-120	7

Standard finish: Galv-Krom® unless otherwise specified.

Kindorf®

Hardware and Threaded Components

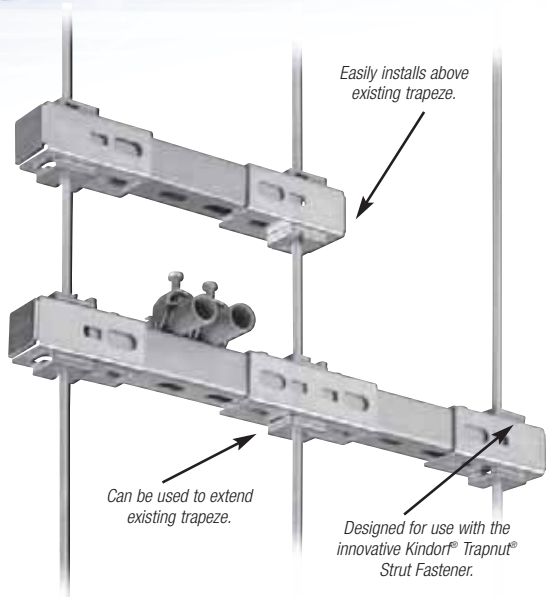

Can be used to extend existing trapeze.

Easily installs above existing trapeze.

Designed for use with the innovative Kindorf® Trapnut® Strut Fastener.

View window provides strut length safety zone for rough cuts versus precision cuts.

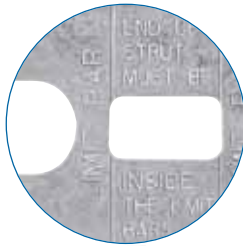

Unique safety slot maintains bracket position on threaded rod and prevents disengagement of the trapeze system.



Handle Retro-Fit Trapeze Applications with Ease!

Trap-Eze™ Connector

The innovative Kindorf® Trap-Eze™ Connector changes a time-consuming retro-fit trapeze application into a streamlined process. Using a Kindorf® Trapnut® Strut Fastener, the new Trap-Eze™ Connector can be easily installed above or to the side of an existing assembly, eliminating the need to disassemble and reassemble the trapeze. It is designed for use with shorter strut lengths that can vary in length by as much as an inch, so the strut can be rough cut versus labor-intense precision cuts.

- Easily installs above or to the side of an existing assembly, eliminating the need to disassemble and reassemble the trapeze
- Connectors can be reused upon disassembly of a trapeze
- Designed for either 3/8" and 1/2" threaded rod
- Designed for use with the innovative Kindorf® Trapnut® Strut Fastener, which can take up to 43% less time than standard nuts and washers on retro-fit trapeze applications
- View window provides safety zone for strut length

CAT. NO.	DESCRIPTION	STD. CTN.
For 1 1/2" Strut		
B998	Trap-Eze™ End Connector Gold-Galv	20
B999	Trap-Eze™ Mid Connector Gold-Galv	10
B998EG	Trap-Eze™ End Connector EG	20
B999EG	Trap-Eze™ Mid Connector EG	10

Trapnut® Strut Fastener



H 122 3/8
Trapnut® Strut
Fastener Galv-Krom®



H 122 3/8 EG
Trapnut® Strut
Fastener SilverGalv®

CAT. NO.	DESCRIPTION	SIZE (IN.)	DESIGN LOAD LBS.	STD. CTN.
H 122 1/4	1/4" Galv-Krom®	1/4	150	50
H 122 3/8	3/8" Galv-Krom®	3/8	590	50
H 122 1/2	1/2" Galv-Krom®	1/2	1,080	50
H 122 1/4 EG	1/4" SilverGalv®	1/4	150	50
H 122 3/8 EG	3/8" SilverGalv®	3/8	590	50
H 122 1/2 EG	1/2" SilverGalv®	1/2	1,080	50
H 122 1/4 SS6	1/4" Type 316 Stainless Steel	1/4	150	50
H 122 3/8 SS6	3/8" Type 316 Stainless Steel	3/8	590	50
H 122 1/2 SS6	1/2" Type 316 Stainless Steel	1/2	1,080	50

Thomas & Betts

www.tnb.com

Corporate Office
Tel: 901.252.8000
800.816.7809
Fax: 901.252.1354

Customer Service
Tel: 800.816.7809
Fax: 800.816.7810

Technical Services
Tel: 888.862.3289
Fax: 901.252.1321

Tool Services
Tel: 800.284.8665

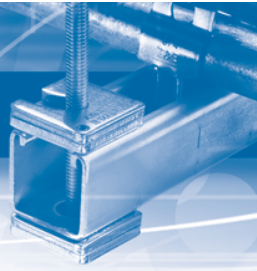

E122 Swivel Joint

Permits hanger rod to swing freely in any direction.

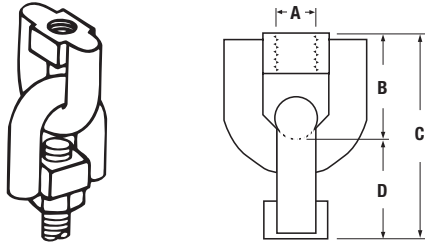

CAT. NO.	DIMENSIONS (IN.)			LOAD RATING	WT. LBS./C
	A	B	C		
E122 3/8	3/8-16	1 1/8	2 3/4	1,000	28
E122 1/2	1/2-13	1 1/2	3	1,800	48

Safety factor of three.

Galv-Krom® finish.

E131 Swivel Joint with Stud

Same as H-260 but with a 3/8" or 1/2" stud on one end.

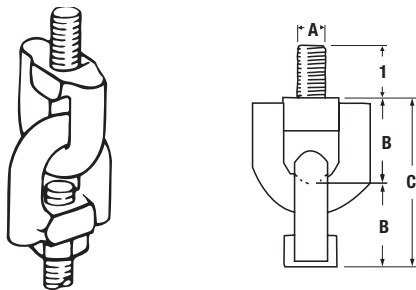

CAT. NO.	DIMENSIONS (IN.)			LOAD RATING	WT. LBS./C
	A	B	C		
E131 3/8	3/8-16	1 1/8	2 3/4	1,000	25
E131 1/2	1/2-13	1 1/2	3	1,800	52

Safety factor of three.

Galv-Krom® finish.

H-134-S Spacer Assembly

Used for attaching fixture to channel with a uniform 1" clearance between fixture and supporting channel. Assembly includes a 1" spacer, a 3/8"-18 x 1 1/2" bolt and jam nut, all galvanized.



CAT. NO.	WT. LBS./C
H-134-S	21

Approved for G.S.A. installations.

E142 Hex Head Cap Screw — Less Nut



CAT. NO.	SIZES (IN.)	WT. LBS./C
E142 1/2 15/16	1/2-13 x 3/4	7.0
E142 1/2 15/16	1/2-13 x 1	9.0
E142 1/2 15/16	1/2-13 x 1	9.0
E142 1/2 1 1/4	1/2-13 x 1 1/4	9.0
E142 1/2 1 1/2	1/2-13 x 1 1/2	10.0
E142 1/2 2	1/2-13 x 1 3/4	13.0
E142 1/2 2	1/2-13 x 2	14.0
E142 1/2 2 1/4	1/2-13 x 2 1/4	16.0
E142 1/2 2 1/2	1/2-13 x 2 1/2	16.0
E142 1/2 3	1/2-13 x 3	20.0
E142 1/2 4	1/2-13 x 4	25.0
E142 3/8 3/4	3/8-16 x 3/4	3.0
E142 3/8 1	3/8-16 x 1	4.0
E142 3/8 1 1/4	3/8-13 x 1 1/4	4.0
E142 3/8 1 1/2	3/8-16 x 1 1/2	5.0
E142 3/8 2 1/4	3/8-16 x 1 3/4	6.0
E142 3/8 2 1/4	3/8-16 x 2 1/4	7.0
E142 3/8 2 1/4	3/8-16 x 2 1/4	7.0
E142 1/4 1	1/4 x 3/4	1.0
E142 1/4 1	1/4 x 1	1.0
E142 1/4 1 1/4	1/4 x 1 1/4	1.5
E142 1/4 1 1/2	1/4 x 1 1/2	2.0

Standard finish: Galv-Krom® unless otherwise specified.

Kindorf®

Hardware and Threaded Components

E145 Hex Nut



CAT. NO.	SIZES (IN.)	WT. LBS./C
E145 1/4	1/4-20	1.2
E145 5/16	5/16-18	2.0
E145 3/8	3/8-16	3.2
E145 1/2	1/2-13	5.0
E145 3/8	5/8-11	9.0

Standard finish: Galv-Krom® unless otherwise specified.

E146 Square Nut



CAT. NO.	SIZES (IN.)	WT. LBS./C
E146 1/4	1/4-20	1.00
E146 5/16	5/16-18	2.40
E146 3/8	3/8-16	2.37
E146 1/2	1/2-13	6.00
E146 5/8	5/8-11	11.00

Standard finish: Galv-Krom® unless otherwise specified.

54, E149 Round Head Machine Screw — Less Nut



CAT. NO.	SIZES (IN.)	WT. LBS./C
54 571P	1/4-20 x 1/2	1.00
54-572-P	1/4-20 x 3/4	1.25
54-574	1/4-20 x 1 1/4	1.76
54-576	1/4-20 x 2	2.54
E149 3/8 1 1/4	3/8-16 x 3/4	3.45

Standard finish: Galv-Krom® unless otherwise specified.

E147 Flat Steel Washer



CAT. NO.	SIZES (IN.)	WT. LBS./C
E147 1/4	1/4	.67
E147 5/16	5/16	1.20
E147 3/8	3/8	2.00
E147 1/2	1/2	3.85
E147 5/8	5/8	7.70
E147 3/4	3/4	9.00

Standard finish: Galv-Krom® unless otherwise specified.

E148 Lock Washer



CAT. NO.	SIZES (IN.)	WT. LBS./C
E148 1/4	1/4	.259
E148 5/16	5/16	.550
E148 3/8	3/8	.630
E148 1/2	1/2	1.436
E148 5/8	5/8	2.587
E148 3/4	3/4	4.293

Standard finish: Galv-Krom® unless otherwise specified.

AB241 Square Washer

CAT. NO.	DIMENSIONS (IN.)		WT. LBS./C
	SIZE	THICKNESS	
AB241 1/4	1/4	1/8	8.10
AB241 5/16	5/16	1/8	8.00
AB241 3/8	3/8	3/16	11.50
AB241 1/2	1/2	1/4	14.36
AB241 5/8	5/8	1/4	13.50
AB241 3/4	3/4	1/4	12.50
AB241 7/8	7/8	1/4	13.00

Standard finish: Galv-Krom® unless otherwise specified.



← 1 1/2 →



Located Square Washers

CAT. NO.	BOLT SIZE (IN.)	STD. CTN.
AB-241L-1/4	1/4	100
AB-241L-5/16	5/16	100
AB-241L-3/8	3/8	100
AB-241L-1/2	1/2	100
AB-241L-5/8	5/8	100

GoldGalv® is standard finish.

Add "EG" suffix for SilverGalv®.



← 1 1/2 →



H-550 Swivel Beam Clamp

One-piece malleable-iron casting. Attaches to beam flanges up to 3/4" thickness.

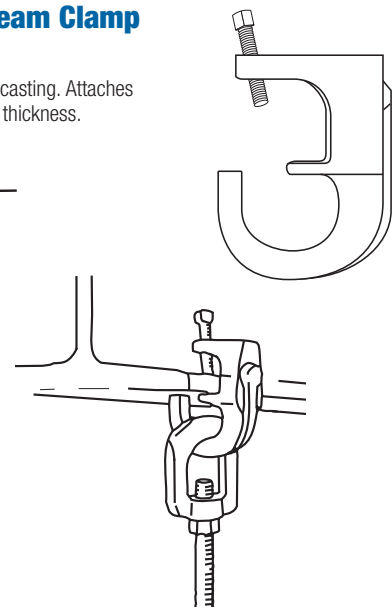
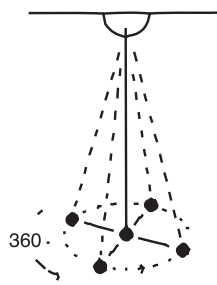

CAT. NO.	DESCRIPTION
H-550	Max. load rating 500 lbs. with a safety factor of 3.33#C.

Galv-Krom® finish.

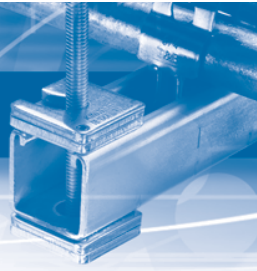

Fast, Precise Installation Method.

Kindorf® J-800 System

Designed originally to eliminate costly and time-consuming methods of installing cables aboard ships, the Kindorf® J-800 series of straps, hangers and brackets has found ever-widening applications by mechanical and electrical contractors in general construction. The J-800 system has proven to be a work-saver when used to install tubing or cable. Tubing and cable of various construction and fabrication can be racked efficiently with built-in provisions for making additions or changes at a later date. They can be secured in all combinations and sequences of sizes. A variety of hangers and brackets secures multiple runs as well as single branch take-offs.

Installation of J-800 straps on Kindorf® supports is simple, requiring only a screwdriver or small wrench. Each run is gripped individually on a hanger and all runs are secured by tightening a single locking device. Loosening the locking device permits fast access to the runs, making it easy to add, remove or adjust them at any time.

J-800 installations have withstood the severe conditions of service at sea for many years. In countless installations, they have proven their ability to withstand the effects of salt air, moisture, shock and vibration.

J-800 racking is well known for its fast, yet precise, installation method. A proven method that results in labor economy and neat, workman-like installation.

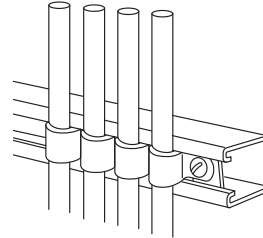

Copper Tubing

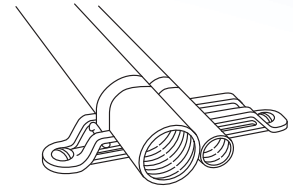

Shipboard Cables

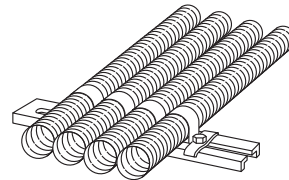

Flexible Tubing

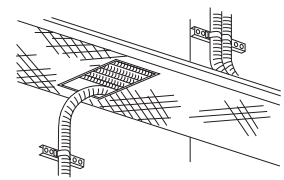

Armored Cable
(Take-off from Cable Tray)

Installation Steps

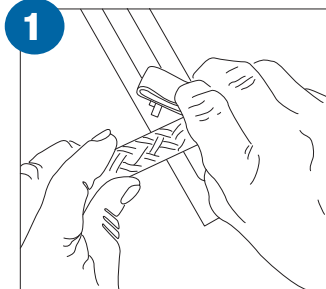

Insert pin of strap in slot of hanger.

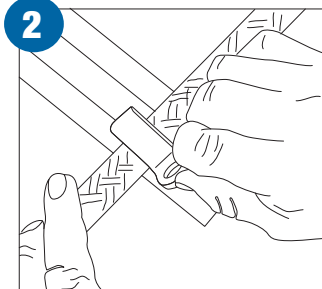

Close Kindorf® cable strap down over cable.

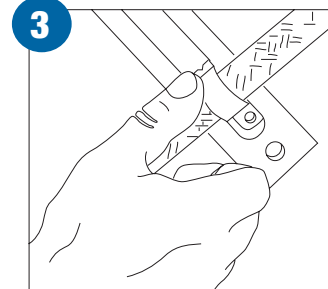

Push strap and cable to end of hanger slot so tongue of strap hooks below slot.

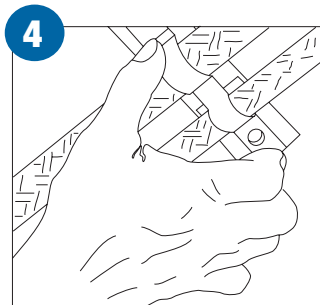

Apply second cable strap, hooking strap tongue under pin of first strap.

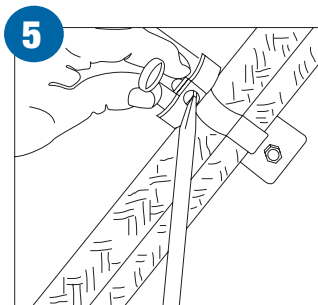

Apply locking device and tighten screw moderately.

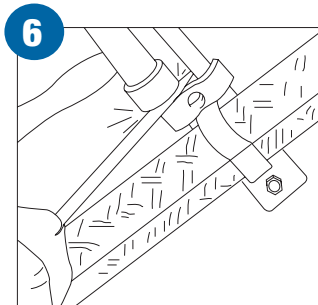

Drive locking device tight against cable strap. Tighten locking device screw.

Corporate Office
Tel: 901.252.8000
800.816.7809
Fax: 901.252.1354

Customer Service
Tel: 800.816.7809
Fax: 800.816.7810

Technical Services
Tel: 888.862.3289
Fax: 901.252.1321

Tool Services
Tel: 800.284.8665

Thomas & Betts

www.tnb.com

Kindorf®

Hardware and Threaded Components

J-800 Interlocking Straps

One J-800 strap of the proper diameter is used to secure each run. All straps have a 1/4" pin. In multiple runs the pin is simply twist inserted into the supporting Kindorf® hanger, bracket or channel slot then the strap is closed over the cable or tube to lock the strap tongue under the pin of the adjacent strap.

The same procedure is used for single runs, except the strap tongue is secured directly to the hanger. When all multiple runs have been assembled, they are secured by a single locking device.

J-800 straps can be installed along the continuous slot of any Kindorf® channel. This increases their versatility and extends their possible applications.

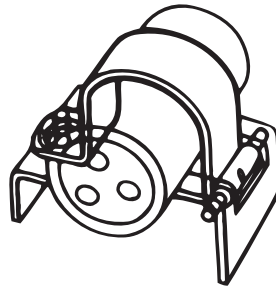

Straps are steel and have Galv-Krom® finish.

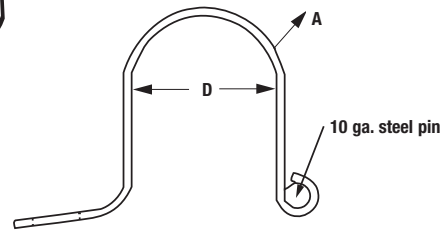
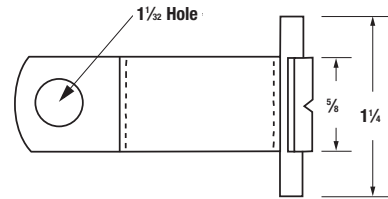

J-800 Interlocking Straps

CAT. NO. & SIZE	STRAP SIZE	A GAUGE	DIMENSIONS (IN.) D MAX.	WT. LBS./C	USE IN NEW KINDORF® CHANNEL	USE IN OLD KINDORF® CHANNEL	USE IN J SERIES MOUNTINGS
J 800 8	8	18	.2500	2.50	—	0.250	0.250
J-800-10	10	18	.3124	2.60	—	0.313	0.313
J-800-12	12	18	.3750	2.75	0.250	0.375	0.375
J-800-14	14	18	.4375	2.90	0.313	0.438	0.438
J-800-16	16	18	.5000	2.75	0.375	0.500	0.500
J-800-18	18	18	.5625	2.90	0.438	0.563	0.563
J-800-20	20	18	.6250	3.35	0.500	0.625	0.625
J-800-22	22	18	.6875	3.50	0.563	0.688	0.688
J-800-24	24	18	.7500	3.65	0.625	0.750	0.750
J-800-26	26	18	.8125	3.80	0.688	0.813	0.813
J-800-28	28	18	.8750	3.95	0.750	0.875	0.875
J-800-30	30	18	.9375	4.10	0.813	0.938	0.938
J-800-32	32	18	1.0000	4.25	0.875	1.000	1.000
J-800-34	34	18	1.0625	4.40	0.938	1.063	1.063
J-800-36	36	18	1.1250	4.55	1.000	1.125	1.125
J-800-38	38	18	1.1875	4.70	1.063	1.188	1.188
J-800-40	40	18	1.2500	4.85	1.125	1.250	1.250
J-800-42	42	18	1.3125	5.00	1.188	1.313	1.313
J-800-44	44	18	1.3750	5.15	1.250	1.375	1.375
J-800-46	46	18	1.4375	5.30	1.313	1.438	1.438
J-800-48	48	18	1.5000	5.45	1.375	1.500	1.500
J-800-50	50	16	1.5625	6.38	1.438	1.563	1.563
J-800-52	52	16	1.6250	6.55	1.500	1.625	1.625
J-800-54	54	16	1.6875	6.73	1.563	1.688	1.688
J-800-56	56	16	1.7500	6.90	1.625	1.750	1.750
J-800-58	58	16	1.8125	7.08	1.688	1.813	1.813
J-800-60	60	16	1.8750	7.25	1.750	1.875	1.875
J-800-62	62	16	1.9375	7.43	1.813	1.938	1.938
J-800-64	64	16	2.0000	7.6	1.875	2.000	2.000
J-800-68	68	16	2.1250	7.95	1.938	2.063	2.063
J-800-72	72	16	2.2500	8.30	2.000	2.250	2.250
J-800-76	76	16	2.3750	8.65	2.125	2.375	2.375
J-800-80	80	16	2.5000	9.00	2.250	2.500	2.500
J-800-84	84	16	2.6250	9.35	2.375	2.625	2.625

Separate strap sizes rack 1/4" through 2 3/4" dia. rounds in 1/16" increments.

Kindorf® Modular Metal Framing and Support System

Thomas & Betts

www.tnb.com

Corporate Office
Tel: 901.252.8000
800.816.7809
Fax: 901.252.1354

Customer Service
Tel: 800.816.7809
Fax: 800.816.7810

Technical Services
Tel: 888.862.3289
Fax: 901.252.1321

Tool Services
Tel: 800.284.8665

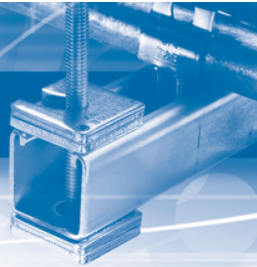

J-850 Locking Device

Secures single or multiple interlocked assemblies on bar hangers, mounting brackets and continuous slot channel. For installations not subject to severe shock.

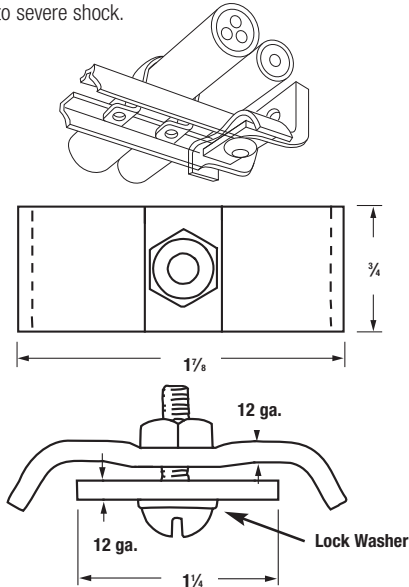

CAT. NO.	DESCRIPTION
J 850	Steel, Galv-Krom® Finish, 11 lbs./C.

Includes 1/4" screw, nut and lock washer.

J-851 Locking Device

Secures single or multiple interlocked assemblies on bar hangers, mounting brackets and continuous slot channels. Similar to J-850 except stud replaces screw for easier assembly.

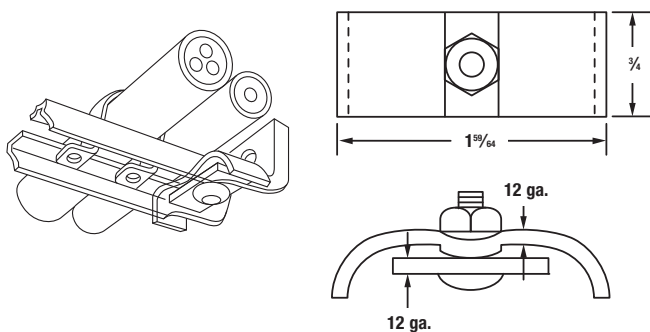

CAT. NO.	DESCRIPTION
J 851	Steel, Galv-Krom® Finish, 11 lbs./C.

Includes 1/4" screw, nut and lock washer.

J-852 Locking Device

Secures single or multiple interlocked assemblies on bar hangers, mounting brackets and continuous slot channels. Designed for use with B-900 Kindorf channels.

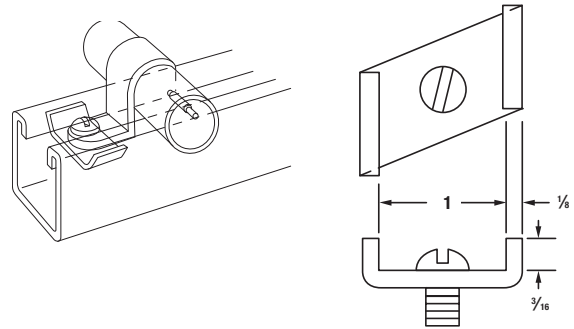

CAT. NO.	DESCRIPTION
J 852	Steel, Galv-Krom® Finish, 11 lbs./C.

J-855 Locking Device — Heavy-Duty

For use with channel-type hangers in installations subject to extreme shock.

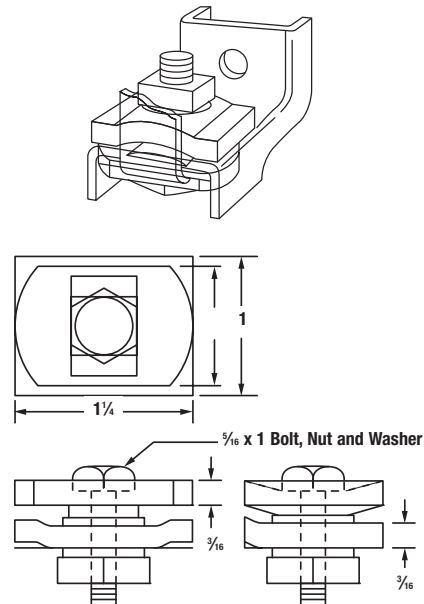

CAT. NO.	DESCRIPTION
J 855	Steel, Galv-Krom® Finish, 11 lbs./C.

Includes 3/16" bolt, nut and washer.

Kindorf®

Cable and Mounting Systems

J-860 Mounting Brackets

U-style channel, 12-ga. steel, with Galv-Krom® finish, 3/8" turned edge. Three sizes.

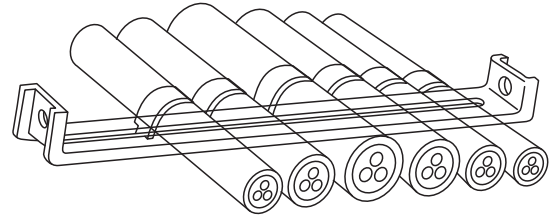
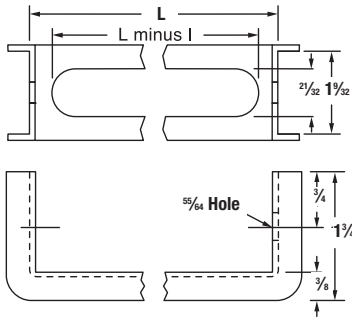

CAT. NO.	DIMENSIONS L (IN.)	WT. LBS./C
J 860 6	6	42
J-860-9	9	48
J-860-12	12	59

J-861 Mounting Brackets

U-style channel, 12-ga. steel, with Galv-Krom® finish, 3/8" turned edge. Six sizes.

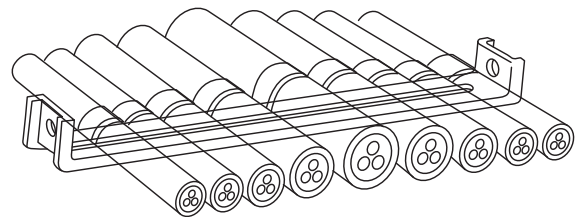
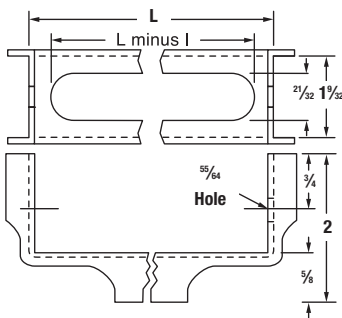

CAT. NO.	DIMENSIONS L (IN.)	WT. LBS./C
J 861 10	10	64
J-861-12	12	73
J-861-14	14	86
J-861-15	15	89
J-861-16	16	96
J-861-18	18	100

J-863 Mounting Brackets

Straight, heavy-duty channel. 12-ga. steel, with Galv-Krom® finish. Five sizes.

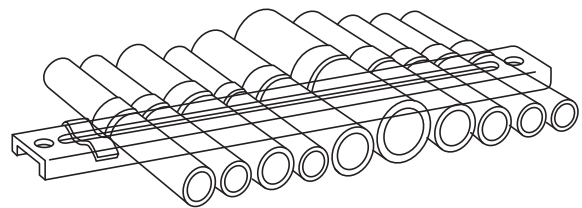
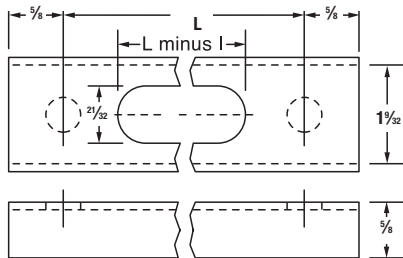

CAT. NO.	DIMENSIONS L (IN.)	WT. LBS./C
J 863 6	6	42
J-863-9	9	57
J-863-12	12	73
J-863-15	15	85
J-863-18	18	106

Kindorf® Modular Metal Framing and Support System

Kindorf®

Cable and Mounting Systems

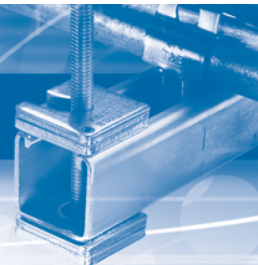

Kindorf® Modular Metal Framing and Support System

J-865 Bar Hanger

Supports one cable or tube up to 1/16" O.D. Only one stud or screw necessary for mounting.

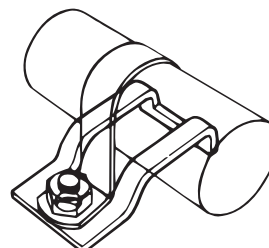
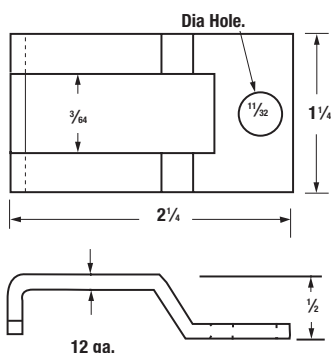

CAT. NO.	DESCRIPTION
J 865	Steel, Galv-Krom® Finish, 6.7 lbs./C.

J-866 Bar Hanger

Supports one large or two small cables or tubes up to a total of 1/16" O.D.

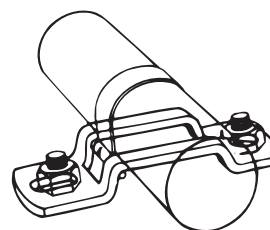
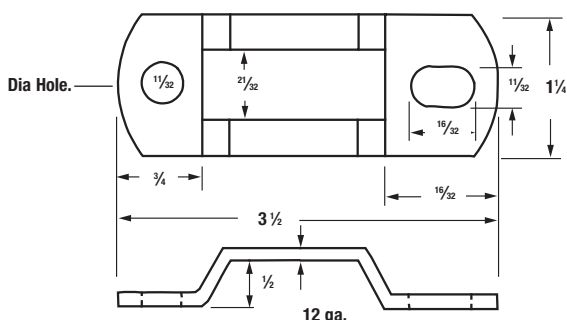

CAT. NO.	DESCRIPTION
J 866	Steel, Galv-Krom® Finish, 9 lbs./C.

J-867 Bar Hanger

- Cable or tube assembly locks in place with one short 1/4" screw and nut
- Use two studs, welding pads or bolts to mount

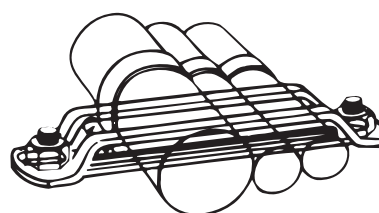
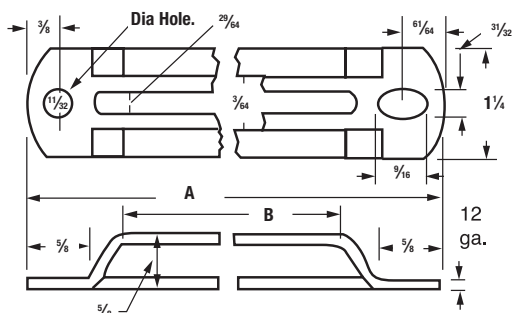

CAT. NO.	DIMENSIONS (IN.)		WT. LBS./C
	A	B	
J 867 1	5 1/8	2 7/8	15
J-867-2	7 1/8	4 1/8	20
J-867-3	9 1/8	6 1/8	27

Steel, Galv-Krom® finish.

Corporate Office
Tel: 901.252.8000
800.816.7809
Fax: 901.252.1354

Customer Service
Tel: 800.816.7809
Fax: 800.816.7810

Technical Services
Tel: 888.862.3289
Fax: 901.252.1321

Tool Services
Tel: 800.284.8665

Thomas & Betts

www.tnb.com

Kindorf®

Cable and Mounting Systems

J-868 Bar Hanger

Supports one cable or tube up to 1/16" O.D. Strap fastens to hanger by short machine screw and nut.

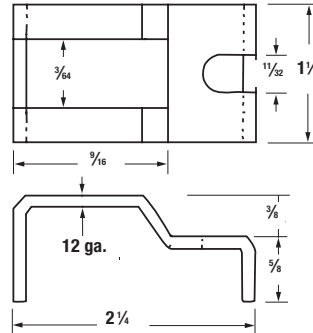
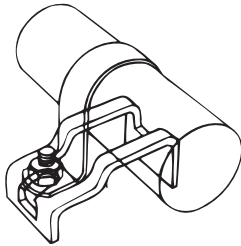

CAT. NO.	DESCRIPTION
J 868	Steel, Galv-Krom® Finish, 8.3 lbs./C.

Use one stud or weld to mount.

J-869 Bar Hanger

- Supports one large or two small cables or tubes up to a total of 1/16" O.D.
- Both ends of hanger have nut-engaging slot

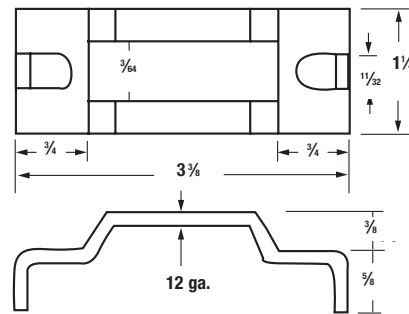
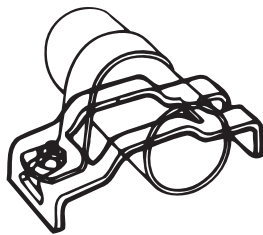

CAT. NO.	DESCRIPTION
J 869	Steel, Galv-Krom® Finish, 11.2 lbs./C.

J-870 Bar Hanger

- Supports cable or tube assembly, locked in place with one short 1/4" screw and nut
- Mount by welding

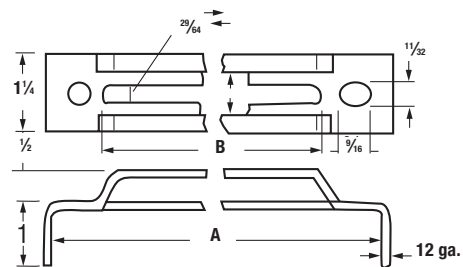
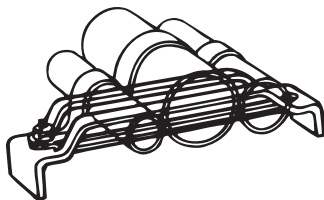

CAT. NO. & SIZE	DIMENSIONS (IN.)		WT. LBS./C
	A	B	
J 870 1	5 1/8	3 7/16	22.5
J-870-2	7 1/8	5 7/16	28.0
J-870-3	9 1/8	7 7/16	33.3

Steel, Galv-Krom® finish.

Kindorf®

Stainless Steel Channels

B-900 Channel — Stainless Steel — 1 1/2" x 1 1/2"

- Connection by means of continuous slot



CAT. NO.	DESCRIPTION
B-900-10SS	Type 304
B-900-10316-SS	Type 316

Use H-113-B bolts and B-910-1/2 or B-911-1/2 stainless steel nuts for mounting fittings.

Available 20 Ft. lengths.

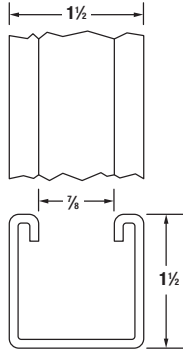

B-905 Channel — Stainless Steel — 1 1/2" x 1 1/2"

- 3/16" holes on 1 1/2" centers punched in channel base. Connection also by means of continuous slot

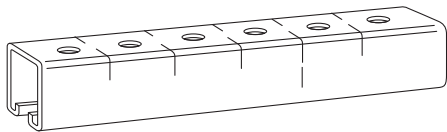

CAT. NO.	DESCRIPTION
B-905-10SS	Type 304
B-905-10-316SS	Type 316

Use H-113-B bolts and B-910-1/2 or B-911-1/2 stainless steel nuts for mounting fittings.

Scribe marks designate mid-point between holes for accurate field cutting.

Available 20 Ft. lengths.

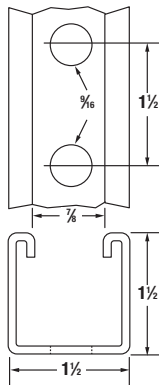

B-907 Channel — Stainless Steel

- Connection by means of continuous slot or 3/16" holes on 1 1/2" centers

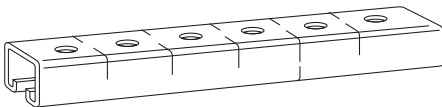

CAT. NO.	DESCRIPTION
B-907-10SS	Type 304
B-907-10316SS	Type 316

Available 20 Ft. lengths.

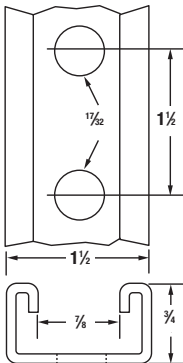

B-911 Channel — Stainless Steel

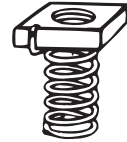

CAT. NO.	SIZE (IN.)	THICKNESS (IN.)	LBS./C
B-911-3/8-SS†	3/8-16	3/16	12.5
B-911-1/2-SS†	1/2-13	3/16	16.0

†Self-holding clamping nut with spring attached. For use with 1/2" deep channels.

Pipe Supports — Stainless Steel



C-105

Kindorf Straps for Rigid Conduit and Pipe — Type 304

CAT. NO.	RIGID CONDUIT OR PIPE SIZE (IN.)	CAT. NO.	RIGID CONDUIT OR PIPE SIZE (IN.)
C-105-1/2SS	1/2	C-105-2SS	2
C-105-3/4SS	3/4	C-105-2-1/2SS	2 1/2
C-105-1SS	1	C-105-3SS	3
C-105-1-1/4SS	1 1/4	C-105-3-1/2SS	3 1/2
C-105-1-1/2SS	1 1/2	C-105-4SS	4



Cobra®

CAT. NO.	FOR EMT AND RIGID CONDUIT TRADE SIZE (IN.)	CABLE O.D. RANGE (IN.)	STATIC LOAD LIMIT (LB) SAFETY FACTOR = 4	STD. CTN.
----------	--	------------------------	--	-----------

Electro-Galvanized Steel

CPC025SS6	1/4	0.312-0.600	200	100
CPC050SS6	1/2	0.650-0.890	200	100
CPC075SS6	3/4	0.860-1.110	200	100
CPC100SS6	1	1.100-1.400	200	100
CPC125SS6	1 1/4	1.400-1.725	200	50
CPC150SS6	1 1/2	1.690-1.980	200	50
CPC200SS6	2	1.980-2.576	200	50
CPC250SS6	2 1/2	2.576-3.060	350	25
CPC300SS6	3	3.060-3.626	350	25
CPC350SS6	3 1/2	3.626-4.126	350	25
CPC400SS6	4	4.126-4.626	350	25

Standard Finish — GoldGalv®, unless otherwise stated.

Stainless Steel: add suffix SS or 556.

Thomas & Betts

www.tnb.com

Corporate Office
Tel: 901.252.8000
800.816.7809
Fax: 901.252.1354

Customer Service
Tel: 800.816.7809
Fax: 800.816.7810

Technical Services
Tel: 888.862.3289
Fax: 901.252.1321

Tool Services
Tel: 800.284.8665

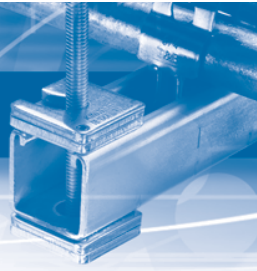

B-900-AL Channel

- Connection by means of continuous slot



Aluminum (Extruded 6063-T6)

CAT. NO.	DESCRIPTION
B-900-AL	1½" x 1½" x .1046; 58 lbs./C. ft.

Use H-113-B bolts and B-910-1/2, B-911--1/2 or B-911-1/2-TL steel nuts for mounting fittings.
10 ft. lengths only.

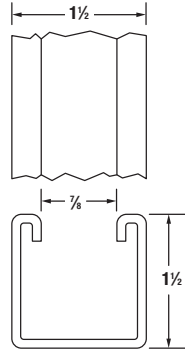

B-905-AL Channel

- ⅝" holes on 1½" centers punched in channel base. Connection also by means of continuous slot

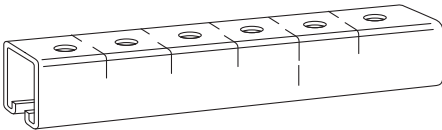

Aluminum (Extruded 6063-T6)

CAT. NO.	DESCRIPTION
B-905-AL	1½" x 1½" x .1046; 56 lbs./C. ft.

Use H-113-B bolts and B-910-1/2 or B-911-1/2 steel nuts for mounting fittings.
10 ft. lengths only.

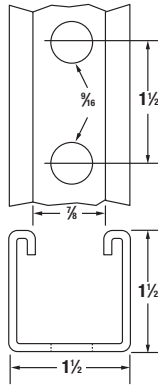

B-907-AL Channel

- Connection by means of continuous slot or ⅝" holes on 1½" centers

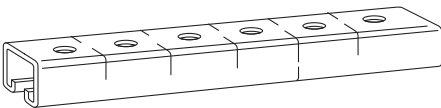

Aluminum (Extruded 6063-T6)

CAT. NO.	DESCRIPTION
B-907-AL	1½" x ¾" x .1046; .37 lbs./C. ft.

Use H-113-A bolts and B-910-1/2 or B-912-1/2 steel nuts for mounting fittings.

Holes on B-900 series fittings match channel holes.

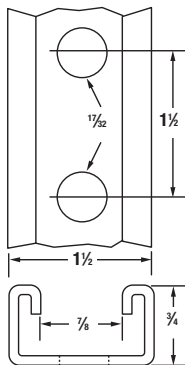

Pipe Supports — Aluminum

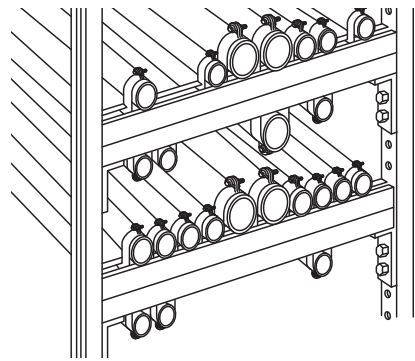
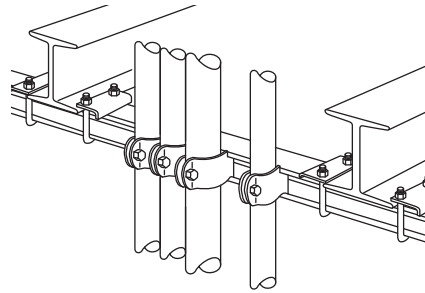

Steel beam mounting application. Aluminum straps with stainless steel hardware. Frame assembly carries multiple conduit runs.

Kindorf Straps for Rigid Conduit and Pipe — Aluminum

CAT. NO.	RIGID CONDUIT OR PIPE SIZE (IN.)	ALUMINUM STRAP MATERIAL THICKNESS	WT. LBS./C
C-105AL-1/2	½	14	7
C-105AL-3/4	¾	14	8
C-105AL-1	1	14	9
C-105AL-1-1/4	1¼	14	10
C-105AL-1-1/2	1½	12	12
C-105AL-2	2	12	14
C-105AL-2-1/2	2½	12	16
C-105AL-3	3	12	18
C-105AL-3-1/2	3½	⅝"	22
C-105AL-4	4	⅝"	24

Kindorf®

Steel PVC Coated Channels

PVC Coated Steel Channel and Fittings for Highly Corrosive Atmospheres

The complete and lasting corrosion protection of conduit with polyvinyl chloride coating is now extended to the supporting system. No longer will installers be faced with the problem of installing PVC coated conduit or other corrosion-resistant material only to have the support system require constant maintenance or replacement.

PVC coated Kindorf® channel and fittings complement other corrosion-resistant services installed in chemical plants, foundries, meat packing plants, oil refineries, paper mills, sewage treatment plants and other locations.

PVC Plastic-Coated Kindorf® Channel Support System for Installations in Severely Corrosive Atmospheres

PVC Coating

The coating is a polyvinyl chloride (PVC) plastic coating that is permanently fused to the Kindorf® Galv-Krom® galvanized steel channels, fittings and accessories. The fused-melt mixed powder (PVC) coating is 15 mils (.015") ±5 mils thickness.

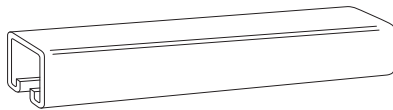

PB-900-10

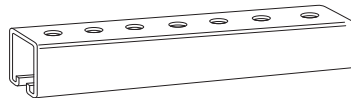

PB-905-10

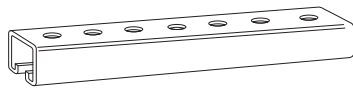

PB-907-10



PBH-193

The physical properties of the PVC coating material are as follows:

Hardness	90+ Shore A Durometer
Dielectric Strength (volts/mil @ 60 cycles)	1100
Flammability	Self-extinguishing
Tensile strength	2000 p.s.i.
Percent elongation	180%
Aging	14,000 hours Atlas Weatherometer

The material is a thermoplastic and will soften in high temperatures. Service life will be decreased if the normal operating temperature of the support system is in excess of 225°F.

The service life expectancy is 20 years in normal weathering, with no indication of hardening, softening or other physical change.

The Kindorf® plastic-coated support system has excellent resistance to the corrosive atmospheres created in modern processing industries which materially reduce the life of standard products and cause high maintenance costs. The fused-on coating of PVC plastic to a pre-galvanized steel effectively bars corrosive action by eliminating "undercreep" or "corrosion travel". There is practically no maintenance. No special tools are required for installation of the Kindorf® PVC system.

The Kindorf® PVC coated support system, combining the strength of steel and the corrosion resistance of plastic, is designed for mechanical support of plastic and plastic-coated conduits and pipes. Kindorf® PVC meets the requirements for corrosion resistance in those environments generally found in chemical processing plants, oil refineries, steel mills, foundries, meat packing and other food processing plants, fertilizer plants, textile and paper processing industries.

PVC Coated Steel Channel

CAT. NO.	DESCRIPTION	WT. LBS./C
PB-900-10	1½" x 1½" x 12 ga. Solid Base	168
PB-905-10	1½" x 1½" x 12 ga. ¾" Holes on 1½" Centers	160
PB-907-10	1½" x ¾" x 14 ga. ¾" Holes on 1½" Centers	82

Standard 10 ft. lengths.

PVC Coated Steel Hanger Rod

CAT. NO. & SIZE	DESCRIPTION	WT. LBS./C
PBH-193-3/8-6	¾" x 6'	174
PBH-193-3/8-10	¾" x 10'	290
PBH-193-1/2-6	½" x 6'	324
PBH-193-1/2-10	½" x 10'	540

Thomas & Betts

www.tnb.com

Corporate Office
Tel: 901.252.8000
800.816.7809
Fax: 901.252.1354

Customer Service
Tel: 800.816.7809
Fax: 800.816.7810

Technical Services
Tel: 888.862.3289
Fax: 901.252.1321

Tool Services
Tel: 800.284.8665

Kindorf®

Steel PVC Coated Channels

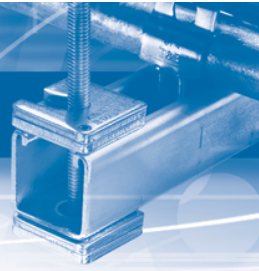

PVC Coated Steel Conduit Straps

CAT. NO. & SIZE	DESCRIPTION (IN.)	WT. LBS./C
PBC-105-3/4	3/4	16
PBC-105-1	1	18
PBC-105-1-1/4	1 1/4	20
PBC-105-1-1/2	1 1/2	29
PBC-105-2	2	33

CAT. NO. & SIZE	DESCRIPTION (IN.)	WT. LBS./C
PBC-105-2-1/2	2 1/2	38
PBC-105-3	3	45
PBC-105-3-1/2	3 1/2	58
PBC-105-4	4	64

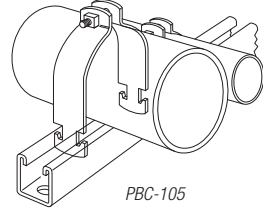

PBC-105

PVC Coated Hardware

CAT. NO. & SIZE	DESCRIPTION	WT. LBS./C
PB-910-3/8	3/8-16 Steel Nut	9
PB-910-1/2	1/2-13 Steel Nut	10
PBH-119C-3/8	1 1/2" Square Washer with 3/16" Hole	12
PBH-119D-1/2	1 1/2" Square Washer with 7/32" Hole	14
PBH-120	Saddle Washer for 3/8" or 1/2" Rod	7

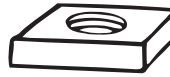

PB-910

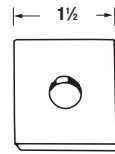

PBH-119



PBH-120

PVC Coated Beam Clamps

CAT. NO. & SIZE	DESCRIPTION	WT. LBS./C
PB-502	2"-7/8" Jaw Tapped 3/8-16	95
PB-508	2 1/2"-2" Jaw Tapped 1/2-13	182
PBE-760-2	For Use with PB-900, PB-905, PB-906 or PB-907	80
PBE-763	For Use with all Channels	25

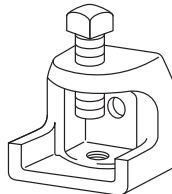

PB-500 Series

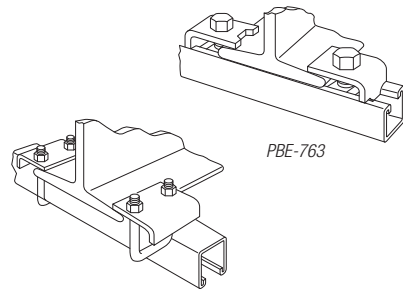

PBE-760

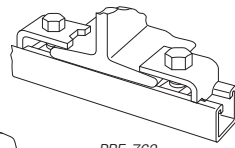

PBE-763

PVC Coated Framing Fittings

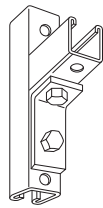

PB-915

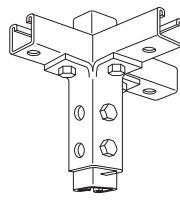

PB-923

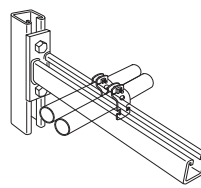

PBF-720

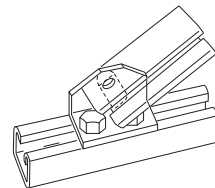

PB-943

CAT. NO. & SIZE	DESCRIPTION	WT. LBS./C
PB-915	2-Hole Angle Connector	40
PB-923	3-Side Angle Connector	137
PB-927	U Support	53
PB-943	Double-Brace Connector	66
PBF-720-18	Single-Channel Wall Bracket — 18"	275
PBF-721-18	Double-Channel Wall Bracket — 18"	568

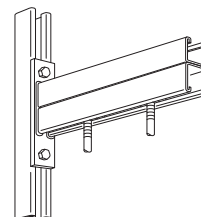

PBF-721

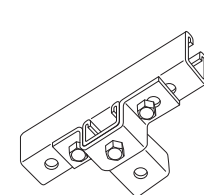

PB-927

Modular Metal Framing and Support System

Corporate Office
Tel: 901.252.8000
800.816.7809
Fax: 901.252.1354

Customer Service
Tel: 800.816.7809
Fax: 800.816.7810

Technical Services
Tel: 888.862.3289
Fax: 901.252.1321

Tool Services
Tel: 800.284.8665

Thomas & Betts

www.tnb.com

Channel Load Data

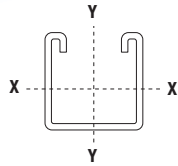

B-900
1½" x 1½" x 12 ga. steel
B-900-M
1½" x 1½" x 14 ga. steel
B-900-AL
1½" x 1½" x .1046 aluminum

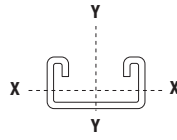

B-906
1½" x ¾" x 14 ga. steel

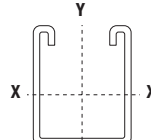

B-901
1¼" x 1½" x 12 ga. steel

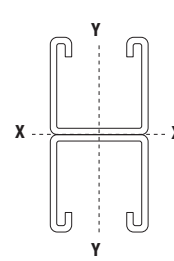

B-900-2A
1½" x 3" x 12 ga. steel

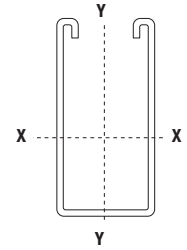

B-902
1½" x 3" x 12 ga. steel

CHANNEL	AREA	LBS./FT.	X-X AXIS			Y-Y AXIS		
			I	S	R	I	S	R
Steel Section Properties								
Material Properties f=30,000 E=30,000,000								
B-906	0.217	0.740	0.018	0.041	0.272	0.077	0.105	0.559
B-900	0.521	1.776	0.155	0.179	0.545	0.200	0.259	0.619
B-900-M	0.354	1.206	0.101	0.123	0.535	0.129	0.175	0.603
B-901	0.595	2.028	0.263	0.251	0.665	0.238	0.309	0.632
B-902	0.837	2.852	0.909	0.552	1.042	0.363	0.471	0.658

SPAN	CHANNEL	SIMPLE BEAM UNIFORMLY DISTRIBUTED LOAD				SIMPLE BEAM CONCENTRATED CENTER LOAD				
		MAX LOAD	DEFLECTION	¼ SPAN LOAD	DESIGN LOAD	MAX LOAD	DEFLECTION	¼ SPAN LOAD	DESIGN LOAD	COL. LOAD FOR K=1
12"	B-906	820	0.034	1,200	820	410	0.027	750	410	7,337
	B-900	3,580	0.017	10,333	3,580	1,790	0.014	6,458	1,790	7,628
	B-900-M	2,460	0.018	6,733	2,460	1,230	0.015	4,208	1,230	7,625
	B-901	5,020	0.014	17,533	5,020	2,510	0.011	10,958	2,510	7,660
	B-902	11,040	0.009	60,600	11,040	5,520	0.007	37,875	5,520	7,699
18"	B-906	547	0.077	533	533	273	0.062	333	273	6,852
	B-900	2,387	0.039	4,593	2,387	1,193	0.031	2,870	1,193	7,507
	B-900-M	1,640	0.041	2,993	1,640	820	0.033	1,870	820	7,499
	B-901	3,347	0.032	7,793	3,347	1,673	0.026	4,870	1,673	7,579
	B-902	7,360	0.020	26,933	7,360	3,680	0.016	16,833	3,680	7,665
24"	B-906	410	0.137	300	300	205	0.109	188	188	6,172
	B-900	1,790	0.069	2,583	1,790	895	0.055	1,615	895	7,338
	B-900-M	1,230	0.073	1,683	1,230	615	0.058	1,052	615	7,324
	B-901	2,510	0.057	4,383	2,510	1,255	0.046	2,740	1,255	7,465
	B-902	5,520	0.036	15,150	5,520	2,760	0.029	9,469	2,760	7,619
30"	B-906	328	0.214	192	192	164	0.171	120	120	5,299
	B-900	1,432	0.108	1,653	1,432	716	0.067	1,033	716	7,121
	B-900-M	984	0.114	1,077	984	492	0.091	673	492	7,098
	B-901	2,008	0.089	2,805	2,008	1,004	0.072	1,753	1,004	7,319
	B-902	4,416	0.057	9,696	4,416	2,208	0.046	6,060	2,208	7,560
36"	B-906	273	0.308	133	133	137	0.246	83	83	4,231
	B-900	1,193	0.156	1,148	1,148	597	0.125	718	597	6,855
	B-900-M	820	0.164	748	748	410	0.132	468	410	6,822
	B-901	1,673	0.129	1,948	1,673	837	0.103	1,218	837	7,140
	B-902	3,680	0.082	6,733	3,680	1,840	0.066	4,208	1,840	7,487

For channel with holes in bottom, multiply load by 0.95.

For channel with holes in bottom and sides, multiply load by 0.90.

For extruded aluminum channel, multiply load by .33.

Column loads calculated in accordance with ANSI Light Gauge Cold-Formed Steel Design Manual, Section 3.6.

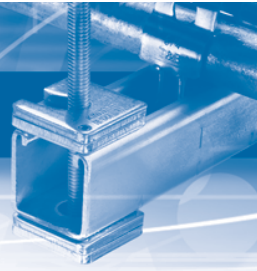

Channel Load Data (continued)

SPAN	CHANNEL	SIMPLE BEAM UNIFORMLY DISTRIBUTED LOAD				SIMPLE BEAM CONCENTRATED CENTER LOAD				COL. LOAD FOR K=1
		MAX LOAD	DEFLECTION	$\frac{1}{800}$ SPAN LOAD	DESIGN LOAD	MAX LOAD	DEFLECTION	$\frac{1}{800}$ SPAN LOAD	DESIGN LOAD	
42"	B-906	234	0.419	98	98	117	0.335	61	61	3,125
	B-900	1,023	0.212	844	844	511	0.170	527	511	6,541
	B-900-M	703	0.224	550	550	351	0.179	344	344	6,496
	B-901	1,434	0.175	1,431	1,431	717	0.140	895	717	6,929
	B-902	3,154	0.112	4,947	3,154	1,577	0.089	3,092	1,577	7,401
48"	B-906	205	0.547	75	75	103	0.437	47	47	2,392
	B-900	895	0.277	646	646	448	0.222	404	404	6,178
	B-900-M	615	0.292	421	421	308	0.234	263	263	6,120
	B-901	1,255	0.229	1,096	1,096	628	0.183	685	628	6,686
	B-902	2,760	0.146	3,788	2,760	1,380	0.117	2,367	1,380	7,302
54"	B-906	182	0.692	59	59	91	0.554	37	37	1,890
	B-900	796	0.351	510	510	398	0.281	319	319	5,767
	B-900-M	547	0.370	333	333	273	0.296	208	208	5,693
	B-901	1,116	0.290	866	866	558	0.232	541	541	6,410
	B-902	2,453	0.184	2,993	2,453	1,227	0.148	1,870	1,227	7,189
60"	B-906	164	0.854	48	48	82	0.683	30	30	1,531
	B-900	716	0.433	413	413	358	0.346	258	258	5,308
	B-900-M	492	0.457	269	269	246	0.365	168	168	5,216
	B-901	1,004	0.358	701	701	502	0.286	438	438	6,101
	B-902	2,208	0.228	2,424	2,208	1,104	0.182	1,515	1,104	7,064
72"	B-906	137	1.230	33	33	68	0.984	21	21	1,063
	B-900	597	0.624	287	287	298	0.499	179	179	4,244
	B-900-M	410	0.658	187	187	205	0.526	117	117	4,113
	B-901	837	0.515	487	487	418	0.412	304	304	5,387
	B-902	1,840	0.328	1,683	1,683	920	0.262	1,052	920	6,773
84"	B-906	117	1.674	24	24	59	1.339	15	15	781
	B-900	511	0.849	211	211	256	0.679	132	132	3,136
	B-900-M	351	0.895	137	137	176	0.716	86	86	3,022
	B-901	717	0.701	358	358	359	0.561	224	224	4,543
	B-902	1,577	0.446	1,237	1,237	789	0.357	773	773	6,429
96"	B-906	103	2.187	19	19	51	1.749	12	12	598
	B-900	448	1.109	161	161	224	0.887	101	101	2,401
	B-900-M	308	1.169	105	105	154	0.935	66	66	2,314
	B-901	628	0.916	274	274	314	0.733	171	171	3,575
	B-902	1,380	0.583	947	947	690	0.466	592	592	6,032
108"	B-906	91	2.768	15	15	46	2.214	9	9	473
	B-900	398	1.403	128	128	199	1.123	80	80	1,897
	B-900-M	273	1.480	83	83	137	1.184	52	52	1,828
	B-901	558	1.160	216	216	279	0.928	135	135	2,825
	B-902	1,227	0.738	748	748	613	0.590	468	468	5,582
120"	B-906	82	3.417	12	12	41	2.733	8	8	383
	B-900	358	1.732	103	103	179	1.386	65	65	1,537
	B-900-M	246	1.827	67	67	123	1.461	42	42	1,481
	B-901	502	1.432	175	175	251	1.145	110	110	2,288
	B-902	1,104	0.911	606	606	552	0.729	379	379	5,080

For channel with holes in bottom, multiply load by 0.95.

For channel with holes in bottom and sides, multiply load by 0.90.

For extruded aluminum channel, multiply load by .33.

Column loads calculated in accordance with ANSI Light Gauge Cold-Formed Steel Design Manual, Section 3.6.

Beam Formula

For calculating deflection and maximum safe load
(Beams of uniform cross section)

- I** = Moment of inertia, in position of load, in inches 4.
- S** = Section modulus – in position of load I/n, in inches 3.
- f** = Bending stress in extreme fiber, in pounds per square inch.
- E** = Modulus of elasticity, in pounds per square inch.
- L** = Length of section, in inches.
- W** = Superimposed loads supported by beam, in pounds.
- W Max.** = Maximum safe load at point given, in pounds.
- M** = Maximum bending moment, in inch pounds.
- D, D1** = Deflections at points given, in inches.
- D Max.** = Maximum deflection at point given, in inches.

Steel and Aluminum

Modulus of Elasticity (E)

- Steel — 29,500,000 pounds per square inch
- Aluminum — 10,000,000 pounds per square inch

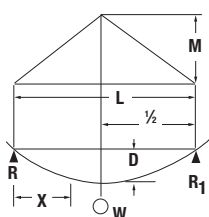

Beam supported at ends
Concentrated load at center
 $W \text{ max.} = 4fS/L$
 $D \text{ max.} = WL^3/48EI$

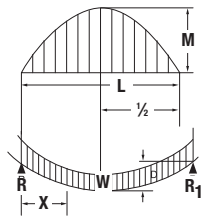

Beam supported at ends
Uniformly distributed load
 $W \text{ max.} = 8fS/L$
 $D \text{ max.} = 5WL^3/384EI$

Maximum Fiber Stress (f)

- Steel — 30,000 pounds per square inch
- Aluminum — 10,000 pounds per square inch

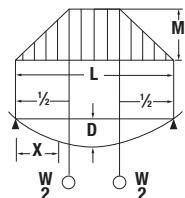

Beam supported at ends
Two symmetrical concentrated loads
 $W \text{ max.} = 2fS/a$
 $D \text{ max.} = Wa/12EI (\frac{1}{2}L^2 - a^2)$

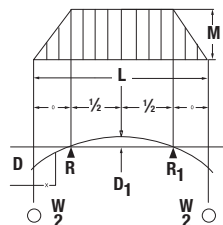

Beam continuous over two supports
Two exterior symmetrical loads
 $W \text{ max.} = 2fS/a$
 D , distance $a = Wa(3aL - 4a^2)/12EI$
 $D1$, distance $L/2 - a = Wa(2-2a)^2/16EI$

Conclusion

Referring to the load span tables on **pages C-84–C-85** for B-905 channel, a 36-inch span has a uniformly distributed load rating of 1,133 lbs., which is greater than the 390 lb. load calculated above, and is therefore satisfactory.

On longer spans or spans with greater loads, use B-901, B-900-2A or B-905-2A channel or provide an intermediate support

Note on Conduit Support

The 1987 edition of the National Electrical Code® states the rigid metal conduit, intermediate metal conduit, and electrical metallic tubing shall be supported at least every 10 feet. See Article 346, Section 346-12 for exceptions for rigid-metal conduit.

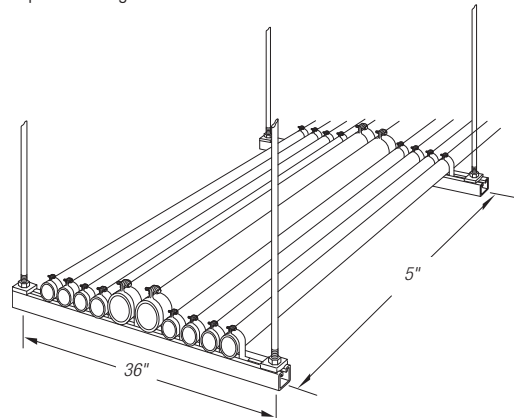

Problem

Design trapeze to support 8–2" rigid steel conduits and 2–3" rigid steel conduits on a No. B-905 channel span with hangers spaced five (5) feet apart.

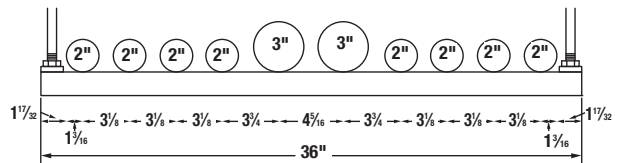

Weight per Hanger Equals

2" rigid steel conduit with heaviest conductor combination = 6.625 lbs. per foot.

3" rigid steel conduit with heaviest conductor combination = 13.415 lbs. per foot.

$$\begin{aligned}
 8 \times 6.625 \times 5 &= 265 \text{ lbs.} = \text{weight of 2" conduits per hanger} \\
 2 \times 13.415 \times 5 &= 134 \text{ lbs.} = \text{weight of 3" conduits per hanger} \\
 \text{Total} &= 399 \text{ lbs.} = \text{weight of conduits per hanger}
 \end{aligned}$$

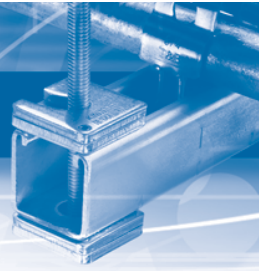

Conduit Spacings

Spacings in inches between centers of conduits.

The light face figures are the minimum dimensions to provide clearance between locknuts.
The more liberal spacings printed in bold face type should be used whenever possible.

SIZE (IN.)	½	¾	1	1¼	1½	2	2½	3	3½	4	4½	5	6
½	1⅞	—	—	—	—	—	—	—	—	—	—	—	—
	1¾	—	—	—	—	—	—	—	—	—	—	—	—
¾	1⅞	1⅞	—	—	—	—	—	—	—	—	—	—	—
	1½	1¾	—	—	—	—	—	—	—	—	—	—	—
1	1½	1½	1¾	—	—	—	—	—	—	—	—	—	—
	1¼	1½	2	—	—	—	—	—	—	—	—	—	—
1¼	1¾	1¾	2	2¼	—	—	—	—	—	—	—	—	—
	2	2½	2¾	2½	—	—	—	—	—	—	—	—	—
1½	1⅞	2⅞	2⅞	2⅞	2⅞	—	—	—	—	—	—	—	—
	2½	2¼	2½	2½	2½	—	—	—	—	—	—	—	—
2	2⅞	2⅞	2½	2¾	2⅞	3⅞	—	—	—	—	—	—	—
	2½	2½	2¾	3	3⅞	3⅞	—	—	—	—	—	—	—
2½	2⅞	2⅞	2¾	3	3⅞	3⅞	3⅞	—	—	—	—	—	—
	2½	2½	3	3¼	3½	3½	4	—	—	—	—	—	—
3	2⅞	2⅞	3⅞	3⅞	3⅞	3¼	4	4⅞	—	—	—	—	—
	3	3½	3¾	3¾	3¾	4	4¼	4¼	—	—	—	—	—
3½	3⅞	3¼	3¾	3¾	3¼	4⅞	4⅞	4⅞	4⅞	—	—	—	—
	3¾	3½	3¾	3¾	4	4¼	4¼	4¼	5	5½	—	—	—
4	3⅞	3⅞	3⅞	3⅞	4⅞	4⅞	4⅞	4⅞	4⅞	5¼	5¼	—	—
	3¾	3¾	4	4¼	4¼	4¼	4¼	5	5½	5½	6	—	—
4½	3¾	3¾	4	4¼	4¼	4¼	4¼	4¼	5¼	5¼	5¼	6¼	—
	4	4¼	4¼	4½	4½	4½	5	5¼	5¼	6	6¼	6½	—
5	4¼	4¼	4¼	4¼	4¼	5	5	5¼	5¼	5¼	6¼	6¼	7¼
	4¼	4¼	4¼	4¼	5	5½	5½	6	6¼	6¼	7	7¼	—
6	4¼	4¼	5	5¼	5¼	5¼	5¼	6¼	6¼	6¼	7¼	7¼	8¼
	5	5½	5¼	5½	5½	6	6¼	6¼	7	7¼	7¼	8	8¼

Modular Metal Framing and Support System

Corporate Office
Tel: 901.252.8000
800.816.7809
Fax: 901.252.1354

Customer Service
Tel: 800.816.7809
Fax: 800.816.7810

Technical Services
Tel: 888.862.3289
Fax: 901.252.1321

Tool Services
Tel: 800.284.8665

Thomas & Betts

www.tnb.com

Pipe Data

RIGID CONDUIT – ALUMINUM AND STEEL

TRADE SIZE (IN.)	NOMINAL OUTSIDE DIAMETER (IN. PER UL-6)		OUTSIDE DIAMETER OF COUPLING (IN. PER UL-6)		WEIGHT OF CONDUIT (LBS. PER FT.)		MAX. WEIGHT OF CONDUIT AND CONDUCTOR (LBS. PER FOOT) NOT LEAD COVERED	
	STEEL	ALUM.	STEEL	ALUM.	STEEL	ALUM.	STEEL	ALUM.
	½	0.840	0.840	1.010	1.078	0.790	0.274	1.040
¾	1.050	1.050	1.250	1.328	1.050	0.364	1.760	1.074
1	1.315	1.315	1.525	1.563	1.530	0.530	2.695	1.695
1¼	1.660	1.660	1.869	1.953	2.010	0.696	3.975	2.661
1½	1.900	1.900	2.155	2.219	2.490	0.822	5.000	3.332
2	2.375	2.375	2.650	2.750	3.320	1.157	6.625	4.462
2½	2.875	2.875	3.250	3.281	5.270	1.825	9.460	6.015
3	3.500	3.500	3.870	3.812	6.830	2.389	13.415	8.974
3½	4.000	4.000	4.500	4.438	8.310	2.877	16.690	11.257
4	4.500	4.500	4.875	5.000	9.720	3.400	20.410	14.090
5	5.563	5.563	6.000	6.219	13.140	4.654	29.350	20.864
6	6.625	6.625	7.200	7.313	17.450	6.120	41.910	30.580

THINWALL CONDUIT (EMT) PER UL-797

TRADE SIZE (IN.)	INTERMEDIATE METAL CONDUIT (IMC)			THINWALL CONDUIT (EMT) PER UL-797			
	NOMINAL OUTSIDE DIAMETER (IN. PER UL)	OUTSIDE DIAMETER OF COUPLING (IN. PER UL)	WEIGHT OF CONDUIT (LBS. PER FOOT)	MAX. WEIGHT OF CONDUIT AND CONDUCTOR (LBS. PER FT.)	NOMINAL OUTSIDE DIAMETER (IN.)	WEIGHT OF EMT (LBS. PER FT.)	MAX. WEIGHT OF EMT AND CONDUCTOR (LBS. PER FT.)
½	0.815	1.010	.6	0.850	0.706	0.285	0.538
¾	1.029	1.250	.8	1.530	0.922	0.435	1.160
1	1.290	1.525	1.1	2.325	1.163	0.640	1.825
1¼	1.638	1.869	1.5	3.465	1.510	0.950	2.950
1½	1.883	2.155	1.8	4.330	1.740	1.100	3.674
2	2.360	2.650	2.4	5.725	2.197	1.400	4.436
2½	2.857	3.250	4.2	8.470	2.875	2.050	6.400
3	3.476	3.870	5.2	11.845	3.500	2.500	9.262
3½	3.971	4.500	6.1	14.500	4.000	3.400	12.100
4	4.466	4.875	6.8	17.510	4.500	3.700	15.355

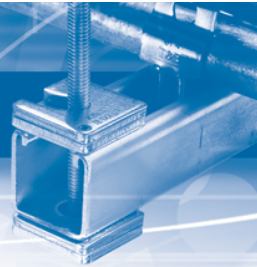

Column Loading-Structure Channel Maximum Load in Pounds — Column Loading

COLUMN HEIGHT (FT.)	TYPE OF CHANNEL	MAX. COLUMN LOADING (LBS.)	NUMBER OF TIERS OR BRACES PER COLUMN					
			1	2	3	4	5	
1	B-900	8,625	2,590					
	B-900-2A	17,400	4,450					
	B-906	4,170	1,280					
	B-906-2A	8,570	2,160					
2	B-900	7,900	2,520	2,000				
	B-900-2A	16,500	4,400	3,650				
	B-906	3,450	1,200	980				
	B-906-2A	7,840	2,100	1,720				
3	B-900	6,960	2,420	1,960	1,780			
	B-900-2A	15,000	4,300	3,520	2,960			
	B-906	2,250	1,015	950	795			
	B-906-2A	6,680	2,020	1,700	1,435			
4	B-900	5,970	2,280	1,910	1,640	1,360		
	B-900-2A	13,095	4,100	3,480	2,930	2,520		
	B-906	1,270	755	895	775	670		
	B-906-2A	4,980	1,830	1,660	1,420	1,230		
5	B-900	5,055	2,140	1,850	1,560	1,340	1,180	
	B-900-2A	11,490	3,950	3,420	2,900	2,500	2,210	
	B-906			830	745	650	575	
	B-906-2A	3,340	1,550	1,610	1,400	1,215	1,075	

COLUMN HEIGHT (FT.)	TYPE OF CHANNEL	MAX. COLUMN LOADING (LBS.)	NUMBER OF TIERS OR BRACES PER COLUMN										
			1	2	3	4	5	6	7	8	9	10	
6	B-900	4,275	1,990	1,790	1,540	1,325	1,150	1,035					
	B-900-2A	9,990	3,750	3,340	2,870	2,480	2,190	1,960					
	B-906			700	710	635	565	505					
	B-906-2A	2,170	1,240	1,550	1,370	1,205	1,065	955					
7	B-900	3,645	1,840	1,720	1,490	1,310	1,140	1,025	925				
	B-900-2A	8,715	3,550	3,240	2,820	2,470	2,170	1,945	1,760				
	B-906			520	635	610	550	495	450				
	B-906-2A			1,450	1,330	1,180	1,050	945	860				
8	B-900	3,045	1,670	1,650	1,460	1,290	1,130	1,015	920	835			
	B-900-2A	7,395	3,180	3,140	2,780	2,450	2,160	1,930	1,750	1,600			
	B-906			470	605	590	535	490	445	410			
	B-906-2A			1,330	1,290	1,160	1,040	935	850	780			
9	B-900	2,580	1,520	1,570	1,430	1,260	1,120	1,000	905	825	760		
	B-900-2A	6,190	3,030	3,040	2,730	2,420	2,140	1,920	1,745	1,595	1,465		
	B-906			130	535	555	525	485	435	400	370		
	B-906-2A			1,200	1,250	1,150	1,020	930	840	775	715		
10	B-900	2,100	1,340	1,500	1,380	1,230	1,110	990	900	820	755	700	
	B-900-2A	5,580	2,900	2,940	2,665	2,380	2,135	1,910	1,730	1,580	1,460	1,350	
	B-906			470	520	500	465	430	395	365	340		
	B-906-2A			1,160	1,190	1,120	1,010	915	835	770	710	660	

This table recognizes eccentricity on the column caused by usual connections.

Modular Metal Framing and Support System

Corporate Office
Tel: 901.252.8000
800.816.7809
Fax: 901.252.1354

Customer Service
Tel: 800.816.7809
Fax: 800.816.7810

Technical Services
Tel: 888.862.3289
Fax: 901.252.1321

Tool Services
Tel: 800.284.8665

Thomas & Betts

www.tnb.com

Kindorf®

Metallic Engineering Data and Specifications

Kindorf® Modular Metal Framing and Support System

Examples for Using the Continuous Run Load Chart for Channel

Example Number 1

A total load of 500 lbs. is to be supported in an evenly distributed manner over a distance of 28 feet with the maximum deflection being not greater than $\frac{1}{240}$ of the span between the supports.

Which Kindorf® channel should be used and how many supports are needed? On the chart, find the point of intersection for a total load of 500 lbs. and a total run of 28 feet.

Pick the next graph line vertically above this point. This B-900 or G-975 with 4 supports (4B) evenly spaced. By reading horizontally to the left from this point, it can be seen that up to 565 lbs. can be supported on B-900, (G-975) under these conditions and still maintain a deflection of $\frac{1}{240}$ of the span.

Example Number 2

Four foot fixtures weighing 30 lbs. each are to be attached to a channel suspended from a ceiling in a continuous 20-foot run and maintain a deflection of less than $\frac{1}{240}$ of the span between the supports.

Which Kindorf channel should be used and how many supports are needed?

$$\text{Number of fixtures} = \frac{20 \text{ ft.}}{4 \text{ ft./fixture}} = 5 \text{ fixtures}$$

$$\text{Total Load} = 5 \text{ fixtures} \times \frac{30 \text{ lbs.}}{\text{fixture}} = 150 \text{ lbs.}$$

On the chart, find the point of intersection for a total load of 150 lbs. and a total run of 20 feet.

Pick the next graph line vertically above this point. This is B-900-M (G-975-M) with 3 supports (3A) – one support on each end and one in the center of the run.

Example Number 3

A 20-foot run of B-901 or G-965 is supported by 3 hangers, one on each end and one in the center. How much evenly distributed weight can this system support and maintain a maximum deflection of $\frac{1}{240}$ of the span between the supports?

On the chart, find the point of the intersection for a total run of 20 feet and the graph line for B-901 (G-965) with 3 supports (3C).

From this point, read horizontally to the left to find the total uniform load of 690 lbs. on the vertical scale.

Selection of Hanger Rods

USE H-193-3/8 OR 'R' SERIES HANGER ROD FOR	IF THE TOTAL UNIFORM LOAD IS:	USE H-193-1/2 OR 'R' SERIES HANGER ROD FOR	IF THE TOTAL UNIFORM LOAD IS BETWEEN
2 supports	1220 lbs. or less	2 supports	1220 lbs. and 2260 lbs.
3 supports	975 lbs. or less	3 supports	975 lbs. and 1810 lbs.
4 supports	1665 lbs. or less	4 supports	1665 lbs. and 3080 lbs.

Load Distribution on Hanger Rods

2 Supports

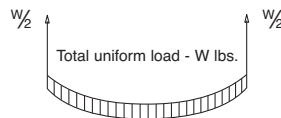

Example – If the total uniformly distributed load W is 1,000 lbs., each hanger must be capable of supporting half of the load or 500 lbs. Therefore, H-193-3/8 or c 'R' series hanger rod would be sufficient to support this load.

3 Supports

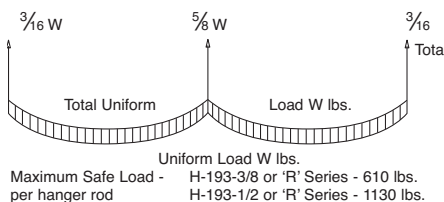

Example – If the total uniformly distributed load W is 1,000 lbs., the load is distributed to each support in the following manner: 187d lbs. to each end support and 625 lbs. to the center support. In this case, the maximum load to be supported is 625 lbs., which exceeds the recommended safe load of 610 lbs. for H-193-3/8 hanger rod., therefore H-193-1/2, or d 'R' series supports should be used.

4 Supports

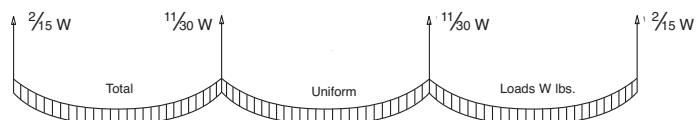

Example – If the total uniformly distributed load W is 1,000 lbs., the load is distributed to each support in the following manner: 133 lbs. to each end support and 367 lbs. to each inner support. Therefore, H-193-3/8, or c 'R' series hanger rod would be sufficient to support this load.

Thomas & Betts

www.tnb.com

Corporate Office
Tel: 901.252.8000
800.816.7809
Fax: 901.252.1354

Customer Service
Tel: 800.816.7809
Fax: 800.816.7810

Technical Services
Tel: 888.862.3289
Fax: 901.252.1321

Tool Services
Tel: 800.284.8665

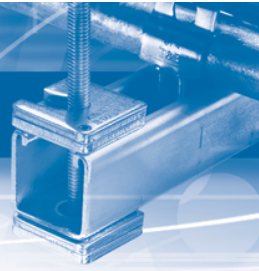

Kindorf® Channel Bars — Load Deflection Charts

Concentrated Center Loads

CAT. NO.	BEAM SPAN (IN.)	LOAD AT 25,000 PSI STRESS (LBS.)	DEFLECTION AT 25,000 PSI STRESS (IN.)	LOAD AT MAX. DEFLECTION OF 1/40 SPAN (LBS.)
6013		55	.038	55
6014	12	34	.048	34
6029		180	.023	180
6029-H		175	.024	175
6013		27	.153	18
6014	24	17	.192	9
6029		89	.093	89
6029-H		87	.095	87
6013		18	.345	8
6014	36	11	.433	4
6029		59	.208	42
6029-H		57	.213	40
6013		13	.615	4
6014	48	8	.773	2
6029		43	.367	23
6029-H		42	.375	22
6013		11	.963	2
6014	60	6	1.216	1
6029		34	.550	14
6029-H		33	.581	13

Loads for lengths greater than 60" spans are available on request.

Uniformly Distributed Loads

CAT. NO.	BEAM SPAN (IN.)	LOAD AT 25,000 PSI STRESS (LBS.)	DEFLECTION AT 25,000 PSI STRESS (LBS.)	LOAD AT MAX. DEFLECTION OF 1/40 SPAN (LBS.)
6013		110	.049	110
6014	12	68	.060	57
6029		361	.029	361
6029-H		350	.030	350
6013		55	.194	28
6014	24	34	.238	14
6029		180	.117	154
6029-H		174	.119	146
6013		36	.437	12
6014	36	22	.536	6
6029		119	.263	67
6029-H		115	.268	64
6013		27	.776	6
6014	48	16	.953	3
6029		88	.467	37
6029-H		86	.477	35
6013		21	1.213	4
6014	60	13	1.490	1
6029		70	.729	22
6029-H		68	.746	21

Loads are rounded off to the nearest pound in all cases.

To Select Proper Channel

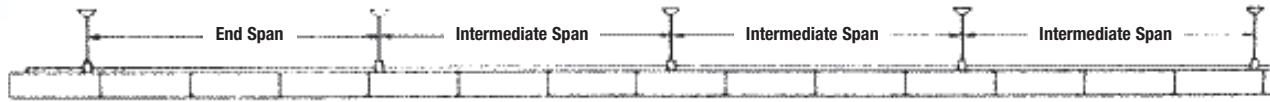

Figure 1 — Long Continuous Run

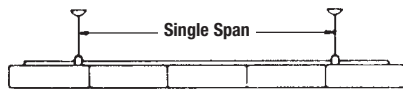

Figure 2 — Single Span

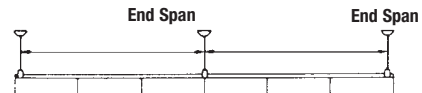

Figure 3 — Double Span

The hanger spacing is often determined by the type of building construction. The deflection then will determine the proper channel since this deflection should not exceed $\frac{1}{240}$ of the span.

To estimate the deflection at the center of an intermediate span in long continuous runs (Figure 1), multiply the weight of a single fixture times

the applicable deflection constant (from table). This deflection also applies to the end span in Figure 1 and the single span in Figure 2 if the dimension "C" is between $\frac{1}{4}$ and $\frac{1}{3}$ of the length of the span. If a cantilever does not exist as in the double span (Figure 3), the deflection of end spans (Figure 3) will be doubled.

Deflection Constants for Continuous Run, 4-Foot Fixtures*

SPAN FEET	B-906 G-956	B-900-M G-975-M	G-953	B-900 G-975	B-901 G-950, G-965	B-900-2A	B-902 G-955
6	.004	.000	.000	.000	.000	.000	.000
8	.009	.002	.001	.000	.000	.000	.000
10	—	.005	.004	.003	.001	.000	.000
12	—	.010	.007	.006	.004	.001	.001
14	—	—	—	.012	.007	.002	.002
16	—	—	—	.020	.011	.004	.004
18	—	—	—	—	.018	.007	.006
20	—	—	—	—	—	.010	.009

* For 8-foot fixtures reduce the deflection constant by 50%. This table is for normal weight fixtures — the constant ".000" infers negligible deflection.

A long, continuous run of 30# 4-foot fixtures on G-975 channel is supported on 12' centers. The deflection at the center of an intermediate span will be the deflection constant (.006) times the fixture weight (30#) or 0.18 inches.

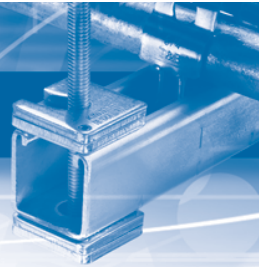

Suggested Kindorf® Specifications

I. For purposes of designating type and quality for work in this section, drawings and specifications are based upon products of standard Kindorf® product drawings. Whenever substitute products are to be considered, supporting technical literature, samples, drawings, and certified performance data must be submitted in order to make a valid comparison of products involved.

II. Materials

Steel channel sections shall be rolled from AISI 1008 commercial grade steel and be in conformance with ASTM A569-72.

Aluminum channel sections shall be extruded from 6063-T6 aluminum alloy and be in conformance with ASTM-B221-80.

III. Construction

A. Channel and Accessories for Support Systems.

The cross sectional width dimension of the channel shall be a minimum of 1½". The depth will be as required to satisfy the load requirements. Channel with 1½" depth or greater shall be rolled from Manufacturing Std. 12 gauge steel. Channel smaller than 1½" may be Manufacturing Std. 14 gauge.

Attachment holes, when required, shall be factory punched on hole centers equal to the channel cross sectional width dimension and shall be a maximum of ⅝" in diameter.

Channel attachment nuts shall be designed to prelocate in the channel and provide a bearing surface on the turned down lips while making positive contact with the side walls of the channel.

Straps for the support of conduit shall be designed such that the attachment nut is captivated on the shoulder of the strap when tightened, and the attachment bolt will allow tightening by either a slot-head screwdriver or wrench.

All nuts, bolts, straps, threaded rod and edges of punched holes shall be protected with the same finish as the channel as described in the FINISH section of this specification.

B. Channel and Accessories for Surface Raceway Systems.

Fluorescent fixtures, as designated on the drawings and according to the fixture schedule, shall be supported and supplied through a combination raceway and support system.

The cross sectional width dimension of the channel shall be a minimum of 1½". The depth will be as required to satisfy the load and wire carrying requirements.

The supporting channel shall have ½" diameter knockouts on 6" centers to accommodate ½" conduit fittings, and be listed by Underwriters' Laboratories Inc. as complying with Std. UL-5 for use as surface raceway and support for electric discharge type lighting fixture. The channel must also provide for ground continuity.

The combination raceway and support system shall be complete with channel joiners, end caps, closure strips, hangers, wiring entrance and all necessary fittings for electrical and mechanical connections.

When splicing or joining raceway channel at 90 degree angles, the joiners shall be designed such that they are concealed and fastened to the inside surface of the channel. Joiners shall be listed by Underwriters' Laboratories Inc. and allow wires to be directly laid in place.

All channel and fittings, including threaded components, shall be protected against corrosion as outlined in the finish section of this specification.

Installation of the system shall be in accordance with the National Electrical Code®, NFPA 70 and ANSI C1.

IV. Galv-Krom® Zinc Dichromate Finish

The finish on steel components shall consist of a combination of .0005 inch electrogalvanizing on steel in accordance with ASTM B633-78 Type LS coating and a gold zinc dichromate barrier formed on the zinc. This coating shall be applied after factory fabrication of the material.

When tested in accordance with ASTM B117-73 procedure, there shall be no sign of red rust after 1,000 hours of testing. Certified test results to support this must be submitted upon request.

Kindorf®

Non-Metallic Channels and Accessories

Channels

Kindorf® strut is a complete corrosion-proof system, with a comprehensive selection of channels and accessories. Cost-efficient, extremely durable, easy to use, and made of the strongest non-metallic materials available.

Kindorf®: Demanding products for demanding environments.

- Can't rust under the worst of conditions
- Cost effective
- Maintenance free
- Easy to use, cut and drill
- Ideal for a wide variety of applications
- Unsurpassed reliability

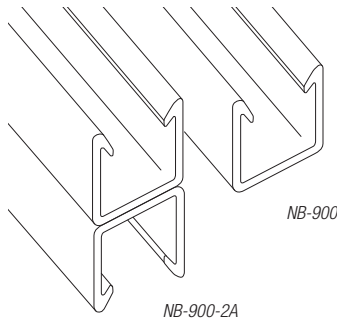

CAT. NO.	DESCRIPTION	MATERIAL	COLOR	LBS. WT./100 FT.
NB 900 10 P	1½" x 1½" x 10' Single Channel	Polyester	Gray	55
NB-900-10-V	1½" x 1½" x 10' Single Channel	Vinylester	Beige	55
NB-900-2A-10-P	3" x 1½" x 10' Back-to-Back Channel	Polyester	Gray	110
NB-900-2A-10-V	3" x 1½" x 10' Back-to-Back Channel	Vinylester	Beige	110

Channel Closure Strip

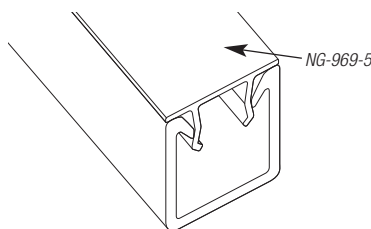

CAT. NO.	DESCRIPTION	MATERIAL	COLOR	LBS. WT./100 FT.
NG-969-5	Standard Length 5'	Rigid PVC	Dark gray	20

Channel Simple Beam Loading Table

CAT. NO.	MAX UNIFORM BEAM LOAD		1/360 SPAN		MAX COLUMN LOAD LBS.
	LBS.	DEF (IN.)	LBS.	DEF (IN.)	
12 inches					
NB 900 10 P	1,430	0.066	723	0.033	3439
NB-900-10-V	1,430	0.066	723	0.033	3439
NB-900-2A-10-P	4231	0.036	3940	0.033	7007
NB-900-2A-10-V	4231	0.036	3940	0.033	7007
18 inches					
NB 900 10 P	953	0.148	321	0.050	3136
NB-900-10-V	953	0.148	321	0.050	3136
NB-900-2A-10-P	2,821	0.081	1751	0.050	6501
NB-900-2A-10-V	2,821	0.081	1751	0.050	6501
24 inches					
NB 900 10 P	715	0.264	180	0.067	2778
NB-900-10-V	715	0.264	180	0.067	2778
NB-900-2A-10-P	2,115	0.143	985	0.067	5909
NB-900-2A-10-V	2,115	0.143	985	0.067	5909
30 inches					
NB 900 10 P	572	0.412	115	0.083	2369
NB-900-10-V	572	0.412	115	0.083	2369
NB-900-2A-10-P	1,692	0.224	630	0.083	5236
NB-900-2A-10-V	1,692	0.224	630	0.083	5236
36 inches					
NB 900 10 P	476	0.593	80	0.100	1,906
NB-900-10-V	476	0.593	80	0.100	1,906
NB-900-2A-10-P	1,410	0.322	437	0.100	4,482
NB-900-2A-10-V	1,410	0.322	437	0.100	4,482
48 inches					
NB 900 10 P	357	1.055	45	0.133	1,091
NB-900-10-V	357	1.055	45	0.133	1,091
NB-900-2A-10-P	1,057	0.573	246	0.133	2,809
NB-900-2A-10-V	1,057	0.573	246	0.133	2,809
60 inches					
NB 900 10 P	286	1.648	28	0.167	698
NB-900-10-V	286	1.648	28	0.167	698
NB-900-2A-10-P	846	0.895	157	0.167	1,798
NB-900-2A-10-V	846	0.895	157	0.167	1,798
72 inches					
NB 900 10 P	238	2.373	20	0.200	485
NB-900-10-V	238	2.373	20	0.200	485
NB-900-2A-10-P	705	1.289	109	0.200	1,248
NB-900-2A-10-V	705	1.289	109	0.200	1,248

Deflection in excess of 3.00 inches; midspan support is recommended.

Table lists the total allowable load for various simple spans based on a minimum safety factor of 3:1.

All beams should be supported in a manner to prevent rotation at supports. **For beams longer than 72 inches, contact manufacturer's engineering department.** Recommend sealing ends of channel with sealant after cutting.

Thomas & Betts

www.tnb.com

Corporate Office
Tel: 901.252.8000
800.816.7809
Fax: 901.252.1354

Customer Service
Tel: 800.816.7809
Fax: 800.816.7810

Technical Services
Tel: 888.862.3289
Fax: 901.252.1321

Tool Services
Tel: 800.284.8665

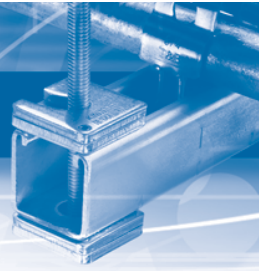

Pipe Clamps

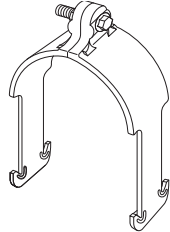

CAT. NO.	CONDUIT/PIPE STYLE				RECOMMENDED		WT. LBS./100
	NOMINAL IN.	PVC SCH. 80	RIGID	PVC COATED METAL (TYP)	TORQUE IN LBS.	DESIGN LOAD*	
NC-105-1/2	1/2	.840	.840	.920	5	100	4
NC-105-3/4	3/4	1.050	1.050	1.130	5	100	4
NC-105-1	1	1.315	1.315	1.395	5	200	4.8
NC-105-1 1/4	—	—	—	—	—	—	—
NC-105-1 1/2	1 1/2	1.900	1.900	1.980	5	200	6.4
NC-105-2	2	2.375	2.375	2.455	5	200	8
NC-105-3	3	3.500	3.500	3.580	20	300	10
NC-105-4	4	4.500	4.500	4.580	20	300	10
NC-105-6	6	6.625	6.625	6.705	20	300	16.3

* Design load is based on pullout values with a 3:1 factor of safety.

Material: Polyurethane.

Color: Gray.

Clevis Hangers

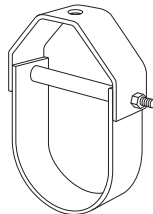

CAT. NO.	NOMINAL DIAMETER	(A) MAX PIPE OD	(B) DIMENSION HEIGHT	(C) HANGER ROD SIZE	MAXIMUM LOAD	WT. LBS./100
NC-149-1	1	1 1/2	2 3/4	1/2	60	20.8
NC-149-1 1/2	1 1/2	2	3 1/2	1/2	60	24
NC-149-2	2	2 3/4	4 3/4	1/2	90	38
NC-149-2 1/2	2 1/2	3 1/4	5 1/2	1/2	120	40
NC-149-3	3	3 3/8	7	3/8	160	62.5
NC-149-4	4	5 1/8	8 1/2	3/8	250	88
NC-149-6	6	7 1/8	10 3/8	3/8	400	170
NC-149-8	8	9 1/4	14	3/8	450	250
NC-149-10	10	11 3/8	18	3/8	500	400
NC-149-12	12	13 1/2	21 1/2	3/8	600	550
NC-149-14	14	15 3/4	24 1/2	3/8	700	700
NC-149-16	16	18	27 3/8	3/8	800	1,150
NC-149-19	19	21	34 1/4	3/8	900	1,700

Design loads given are in pounds at 70°F with a 3:1 factor of safety.

Insulate hangers from pipe at higher temperatures

Material: Polyester

Color: Yellow and Gray

Fittings

- Polyester and Vinylester Kindorf® fittings are suited for use with all 1 1/2" and 1 3/4" channels
- Kindorf® fittings are manufactured from 3/16" flat material
- Consult the Chemical Compatibility Chart to ensure material will withstand the specific chemical environment
- All holes in Kindorf® fittings are 1/32" in diameter

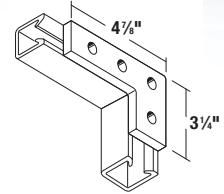

NB-936-P
NB-936-V

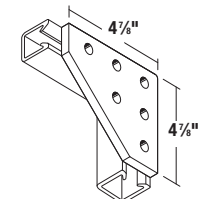

NB-944

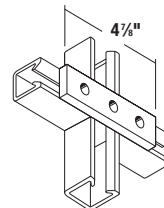

NB-935-P
NB-935-V

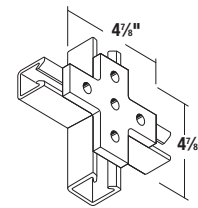

NB-947

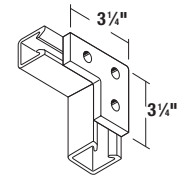

NB-931

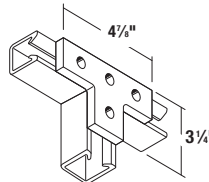

NB-937-P
NB-937-V

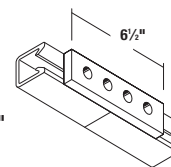

NB-949-P
NB-949-V

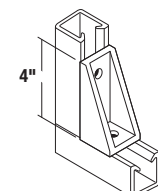

NB-918

CAT. NO.	MATERIAL	COLOR	WT LBS./100
NB-935-P	Polyester	Gray	13
NB-935-V	Vinylester	Beige	13
NB-931	Polyurethane	Gray	14
NB-947	Polyurethane	Gray	24
NB-949-P	Polyester	Gray	22
NB-936-P	Polyester	Gray	28
NB-936-V	Vinylester	Beige	28
NB-937-P	Polyester	Gray	20
NB-924	Polyurethane	Gray	56
NB-944	Polyurethane	Gray	34
NB-925	Polyurethane	Gray	70
NB-918	Polyurethane	Gray	4.6

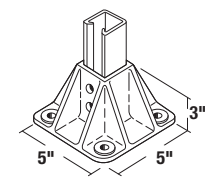

NB-924

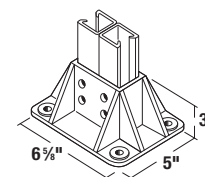

NB-925

Kindorf®

Non-Metallic Channels and Accessories

Channel Nuts

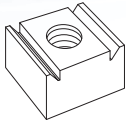

CAT. NO.	THREAD SIZE (IN.)	MAXIMUM LOAD/LBS.	MAXIMUM TORQUE/LBS.	WT. LBS./100
NB-910-3/8	3/8	450	35	1.8
NB-910-3/8 HD	3/8	1,370	100	2.6
NB-910-1/2	1/2	450	40	1.8
NB-910-1/2 HD	1/2	1,500	130	5.2

3:1 Factor of Safety.

Material: Glass fiber reinforced polyurethane.

Color: Gray.

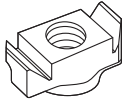

Hex Nuts

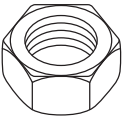

CAT. NO.	SIZE (IN.)	MAXIMUM LOAD/LBS.	MAXIMUM TORQUE/LBS.	WT. LBS./100
NH-114C	3/8	465	50	.33
NH-114-D	1/2	830	125	.8

3:1 Factor of Safety.

Material: Glass fiber reinforced polyurethane.

Color: Gray.

Square Nuts

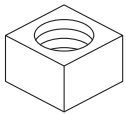

CAT. NO.	SIZE (IN.)	THREAD SHEAR/LBS.	MAX. TORQUE/LBS.	WT. LBS./100
NH-116C	3/8	1,300	125	1.8
NH-116-D	1/2	1,600	200	2.8
NH-116-E	3/4	1,600	200	5.6

3:1 Factor of Safety.

Material: Vinylester.

Color: Gray.

Hex Head Bolts

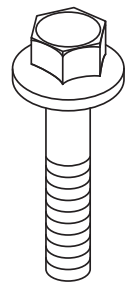

CAT. NO.	SIZE (IN.)	MAXIMUM LOAD/LBS.	MAXIMUM TORQUE/LBS.	WT. LBS./100
NH-113-P	3/8 x 1 1/4	360	30	1.4
NH-113-U	3/8 x 2 1/2	360	30	2
NH-113C*	1/2 x 1 1/4	600	90	1.4
NH-113-H*	1/2 x 2 1/2	600	90	2

3:1 Factor of Safety.

Material: Glass fiber reinforced polyurethane.

Color: Gray.

* With molded washer.

Channel Reinforcement Spacer

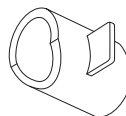

CAT. NO.	HOLE SIZE (IN.)	WT. LBS./100
NB-950	3/8-1/2	1.6

Material: Polyurethane

Color: Gray

Channel Washers

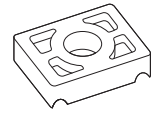

CAT. NO.	SIZE (IN.)	WT. LBS./100
NH-119-C	3/8	4
NH-119-D	1/2	3.6
NH-119-E	5/8	3.6

Material: Glass fiber reinforced polyurethane.

Color: Gray.

Flat Washers

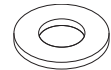

CAT. NO.	SIZE (IN.)	WT. LBS./100
NH-117-C	3/8	.6
NH-117-D	1/2	.6
NH-117-E	5/8	.8

Material: Rigid PVC.

Color: Gray.

Threaded Rod



CAT. NO.	SIZE	THREAD SHEAR/LBS.	MAXIMUM TORQUE/LBS.	WT. LBS./100
NH-193-3/8-4	3/8" x 4'	300	30	7.0
NH-193-1/2-4	1/2" x 4'	510	80	12
NH-193-5/8-4	5/8" x 4'	1,600	200	18

3:1 Factor of Safety.

Material: Vinylester.

Color: Gray.

Rod Couplers

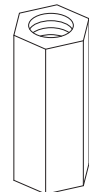

CAT. NO.	SIZE (IN.)	MAXIMUM LOAD/LBS.	WT. LBS./100
NH-195-3/8	3/8	880	6.4
NH-195-1/2	1/2	1,000	6.4
NH-195-5/8	5/8	1,700	13.2

3:1 Factor of Safety.

Material: Glass fiber reinforced polyurethane.

Color: Gray.

Channel to Beam Clamp Assembly

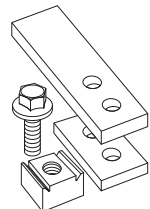

CAT. NO.	STD. WT. (LBS.)	MAXIMUM LOAD/LBS.
NE-763-3/8	110	200
NE-763-1/2	120	200

Kit consists of:

DESCRIPTION	STD. CTN.	MATERIAL	COLOR
Channel Nuts	4	Polyurethane	Gray
Clips (set)	2	Vinylester	Beige
Bolts	4	Polyurethane	Gray

Non-Metallic Channels and Accessories

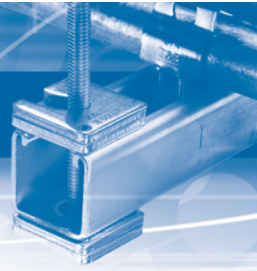

Kindorf® Brush-On Fiberglass End Sealant

When fabricating Type "P" or "V" Series materials, Kindorf® Fiberglass End Sealant should be used. After cutting or drilling the channel, interior glass fibers may fray and lose strength due to exposure to the environment. Kindorf® sealant protects the exposed glass fibers and prevents deterioration. Kindorf® sealant exceeds Vinylester (V) material in corrosion resistance.



CAT. NO.	DESCRIPTION	SIZE	WT. LBS./100
NH-600	Brush-on sealant	1 qt.	220

Kindorf® Spray-On Fiberglass End Sealant

Kindorf® Spray-On Fiberglass End Sealant provides a quick and easy corrosion-resistant coating when applied to fiberglass channel and accessories. Kindorf® Spray-On Fiberglass End Sealant is a rubberized spray which is supplied in a 12 oz. pressurized can.



CAT. NO.	DESCRIPTION	SIZE	WT. LBS./100
NH-601	Spray-on sealant	12 oz.	100

Chemical Resistance

CHEMICAL	POLYESTER		VINYLESTER		RIGID PVC		POLYURETHANE	
	70°F	160°F	70°F	160°F	70°F	160°F	70°F	160°F
Acetic Acid, <50%	•	•	•	•	†	†	•	—
Acetone, <10%	†	†	†	†	—	—	—	—
Aluminum Hydroxide	•	•	•	•	—	—	—	—
Ammonium Hydroxide, <20%	†	†	•	150°	•	•	•	—
Ammonium Nitrate	•	•	•	•	—	—	—	—
Ammonium Phosphate	•	•	•	•	—	—	—	—
Benzene	•	•	†	†	—	—	—	—
Benzoic Acid	•	•	•	•	•	•	•	—
Bromine, Wet Gas	†	†	•	100°	•	†	—	—
Butylene Glycol	•	•	•	•	—	—	—	—
Butyric Acid, <50%	•	•	•	•	—	—	—	—
Chlorine, Dry Gas	•	•	•	•	—	—	—	—
Chlorine, Wet Gas	†	†	•	•	—	—	—	—
Chlorine, Liquid	†	†	†	†	—	—	—	—
Chlorine, Water	•	•	•	•	•	•	•	—
Chromic Acid, <5%	†	†	•	•	—	—	—	—
Copper Chloride	•	•	•	•	•	•	•	—
Copper Cyanide	•	•	•	•	•	•	•	—
Copper Nitrate	•	•	•	•	—	—	—	—
Copper Sulfate	•	•	•	•	•	•	•	—
Esters, Fatty Acids	•	•	•	•	—	—	—	—
Ferric Chloride	•	•	•	•	•	•	•	—
Ferrous Chloride	•	•	•	•	—	—	—	—
Fluoboric Acid	•	120°	•	•	•	•	•	—
Fluosilicic Acid, <32%	†	†	•	100°	—	—	—	—
Formic Acid, <50%	†	†	•	100°	†	†	•	—

- Recommended for use
- ° Recommended up to temperature indicated
- † Not recommended for use
- No information available at this time

NOTE: The guidelines presented in this table assume the typical application of Kindorf® products where exposure is limited to fumes, vapors, and occasional splashes from chemicals. This information is intended as a guideline and does not guarantee product performance for the applications listed. In special situations where chemical resistance is critical, the factory should be consulted. Some applications may require a screening test of samples in the chemical environment of interest. The user is advised to determine suitability of the product for its particular use. Class I fire rated per ASTM E-84 and are UL-94 V-0.

CHEMICAL	POLYESTER		VINYLESTER		RIGID PVC		POLYURETHANE	
	70°F	160°F	70°F	160°F	70°F	160°F	70°F	160°F
Gasoline, Aviation	•	†	•	•	—	—	—	—
Hydrochloric Acid, <37%	•	†	•	•	•	•	•	—
Hydrofluoric Acid, <20%	†	†	•	100°	•	†	—	—
Hydrogen Chloride, Wet Gas	•	†	•	•	—	—	—	—
Hydrogen Sulfide, Wet Gas	•	†	•	•	•	•	—	—
Lactic Acid	•	†	•	•	•	•	•	—
Nickel Sulfate, low pH	†	†	•	•	—	—	—	—
Nickel Sulfate, high pH	†	†	•	•	—	—	—	—
Nitric Acid, <35%	†	†	•	120°	•	•	•	—
Perchloric Acid, <10%	†	†	•	150°	—	—	—	—
Phosphoric Acid	•	•	•	•	•	•	•	—
Potassium Chloride	•	•	•	•	•	•	•	—
Potassium Nitrate	•	•	•	•	—	—	—	—
Potassium Persulfate	†	†	•	•	—	—	—	—
Sodium Hydroxide, <50%	†	†	•	180°	•	•	•	—
Sodium Hypochlorite, <15%	†	†	•	150°	•	•	•	—
Sodium Nitrate	•	•	•	•	—	—	—	—
Sodium Sulfate	•	†	•	•	—	—	—	—
Sodium Sulfide	†	†	•	•	•	•	•	—
Sulfuric Acid, <70%	†	†	•	•	•	•	•	—
Sulfuric Acid >70%	†	†	•	102°	†	†	—	—
Trisodium Phosphate	†	†	•	•	•	•	•	—
Urea	•	†	•	150°	—	—	—	—
Vegetable Oils	•	•	•	•	—	—	—	—
Vinegar	•	•	•	•	—	—	—	—
White Liquor	—	—	•	•	•	•	•	—

- Type operating ranges for:
- Polyester -30° F–150° F
 - Vinylester -35° F–200° F
 - Polyurethane -40° F–130° F
 - Nylon -20° F–150° F

Corporate Office
Tel: 901.252.8000
800.816.7809
Fax: 901.252.1354

Customer Service
Tel: 800.816.7809
Fax: 800.816.7810

Technical Services
Tel: 888.862.3289
Fax: 901.252.1321

Tool Services
Tel: 800.284.8665

Thomas & Betts

www.tnb.com

Kindorf®

Right Angle Slotted Angle

With Right Angle, you get Flexibility — Simplicity — Economy!

Create the support framing you need.

Right Angle is manufactured from commercial-quality steel in three different sizes. The small sizes are 14-ga. steel, the larger size is 12-ga. steel. With this offering, an endless variety of metal framing requirements can be met, from lightweight supporting needs to larger shelving for inventory storage.

One of the legs on all sizes is 1 1/8" wide, while the other is either 1 1/8", 2 3/8" or 3 1/8" long. Depending on the frame requirements, a single size can be utilized throughout, or the sizes can be interchanged to get the most efficient usage from the material.

This book will serve as a guide to plan and build your structure.

Installation time is reduced — inventory space is minimal.

Scribe marks are placed every 3/4" which saves planning, layout and cutting time and assures accuracy. The exclusive slot and hole pattern, repeated every 3", is scientifically designed for ease of assembly and rigidity. No welding is necessary, no holes to drill. A 3/16" wrench is the only tool required for assembly. The proper nuts and bolts are included with the material to ensure fast and easy erection.

Right Angle Metal Framing is packaged in 10' and 12' lengths to minimize cut offs and ensure maximum use of material.

120' (10 x 12' lengths) of Right Angle takes up the same amount of space as one 2 x 4. A standard package includes five pieces to a bundle, therefore handling and storage space are significantly reduced.

The importance of cutting Right Angle easily, quickly and accurately is the key to time saving assembly. The Steel City® Portable Cutter provides these advantages and make layout and erection of any structure a "light-work" job.

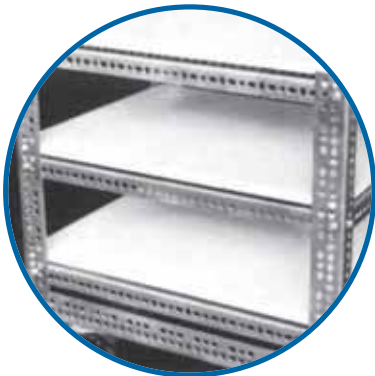
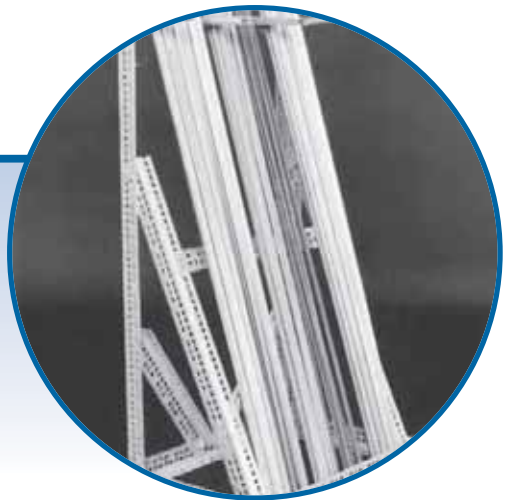

Kindorf® Right Angle comes standard with our Galv-Krom® Finish, which ensures a long-lasting, durable installation.

The Galv-Krom® finish is a two-part finishing process that protects the entire system, including all nuts and bolts. The first part of the finish is electro-galvanized zinc that covers the bare steel. The second part is a gold zinc dichromate that is applied over the zinc base.

Three aspects of the Galv-Krom® process are worthy of note:

1. Zinc Coating — In the first part of the Galv-Krom® process, a .5 mil coating of zinc is placed on the bare steel. This assures the sacrificial quality of any galvanizing and becomes a working finish. The zinc literally sacrifices itself over bare steel and protects cut edges or scratches which may occur during construction.

Galv-Krom® is in compliance with ASTM B633-78 Type II coating.

2. Electrogalvanizing — Because the zinc is applied through a temperature-controlled electrolytic process, a cohesive bond with the steel is assured. This prohibits chipping or peeling. It also distributes the zinc evenly so all components — including threads — can be equally protected.

3. Trivalent Gold Chromate Barrier — The second part of the Galv-Krom® finish is a gold zinc dichromate that is applied over the zinc base. This second layer of plating forms a non-porous barrier which protects the underlying zinc and adds additional resistance to corrosion. In addition, the gold zinc dichromate covering provides an excellent base if the surface is to be painted.

Thomas & Betts

www.tnb.com

Corporate Office
Tel: 901.252.8000
800.816.7809
Fax: 901.252.1354

Customer Service
Tel: 800.816.7809
Fax: 800.816.7810

Technical Services
Tel: 888.862.3289
Fax: 901.252.1321

Tool Services
Tel: 800.284.8665

Kindorf®

Right Angle Slotted Angle

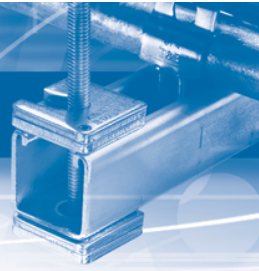

Type RA-160 Slotted Angle

- 1½" x 1½" x .080" (14 gauge)
- Designed for light-duty applications where extra strength is not a requirement
- Ideal material for light racking and shelving
- Packaged in five 10-ft. or 12-ft. lengths complete with thirty-six ¾" x ¾" long hex head bolts and nuts
- Standard package 10' lengths: 39 lbs., 12' lengths: 48 lbs.

CAT. NO.	LENGTH	FT. PER PKG.	WT. PER 100 FT.
RA-160-10	10 ft.	50	75 lbs.
RA-160-12	12 ft.	60	75 lbs.

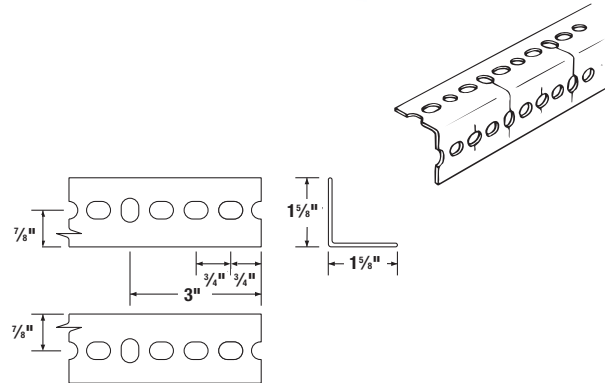

Type RA-225 — For Heavy-Duty

- 2½" x 1½" x .080" (14 gauge)
- Wide range versatility for nearly every type of framing
- Well suited for electrical applications
- Slot-and-hole pattern provides ready-made anchoring points for panel-board framing and fixtures of all kinds
- Packaged in five 10-ft. or 12-ft. lengths complete with thirty-six ¾" x ¾" long hex head bolts and nuts
- Standard package 10' lengths: 48 lbs., 12' lengths: 56 lbs.

CAT. NO.	LENGTH	FT. PER PKG.	WT. PER 100 FT.
RA-225-10	10 ft.	50	93 lbs.
RA-225-12	12 ft.	60	93 lbs.

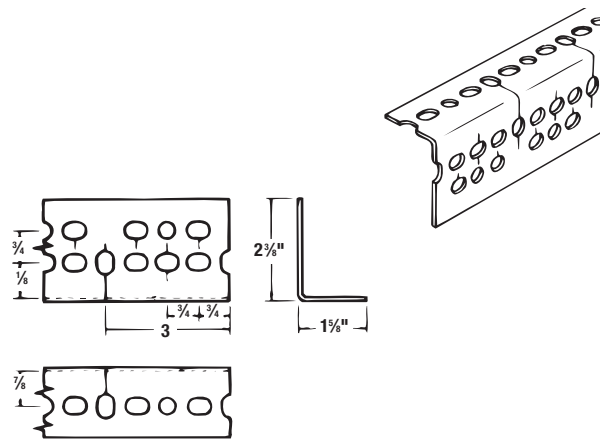

Type RA-300 — For Extra Heavy-Duty

- 3½" x 1½" x .104" (12 gauge)
- Used where heavy loads are involved
- Racks and shelving for heavy material and large structures such as ramps and balconies are typical uses
- Packaged in five 10-ft. or 12-ft. lengths complete with thirty-six ¾" x ¾" long hex head bolts and nuts
- Standard package 10' lengths: 72 lbs., 12' lengths: 84 lbs.

CAT. NO.	LENGTH	FT. PER PKG.	WT. PER 100 FT.
RA 300 10	10 ft.	50	135 lbs.
RA-300-12	12 ft.	60	135 lbs.

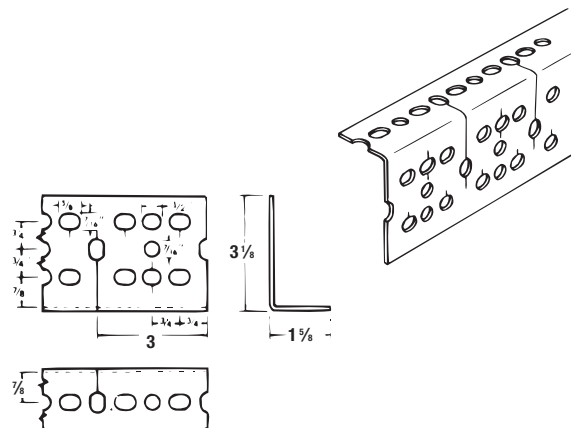

Kindorf® Modular Metal Framing and Support System

Corporate Office
Tel: 901.252.8000
800.816.7809
Fax: 901.252.1354

Customer Service
Tel: 800.816.7809
Fax: 800.816.7810

Technical Services
Tel: 888.862.3289
Fax: 901.252.1321

Tool Services
Tel: 800.284.8665

Thomas & Betts

www.tnb.com

Kindorf®

Right Angle Slotted Angle

Nuts Serrated — For Self-Locking

- 100 sets per package
- No. RA-BN-5/8, 3/8"–16 x 5/8" long for RA-160 and RA-225
- No. RA-BN-3/4, 3/8"–16 x 3/4" long for RA-300
- A 9/16" wrench is only tool needed for assembly

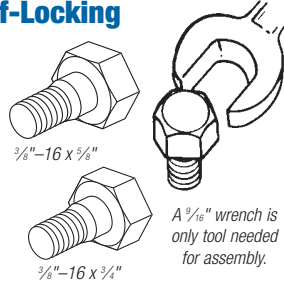

CAT. NO.	STD. CTN.	WEIGHT PER 100 SETS
RA BN 5/8	100	4 lbs., 3/8"–16 x 5/8"
RA BN 3/4	100	5 lbs., 3/8"–16 x 3/4"

Gusset Plate

- Three hole connector for extra rigid angle assembly
- For use with all three types of right angle
- Galvanized steel

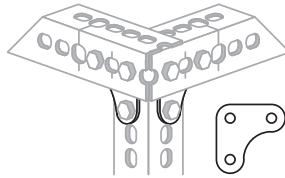

For proper assembly, insert plate between the angle flanges for 3-bolt connection.

CAT. NO.	STD. CTN.	WEIGHT PER 100 SETS
RA GP	25	10

Portable Cutter

- Designed for use with all three types of slotted angle
- Cuts with single stroke of handle
- Produces clean, burr-free cuts



CAT. NO.	STD. CTN.	WEIGHT EACH
RA C	1	17

Rigid and Swivel Casters

- Hard rubber composition
- 3 1/2" diameter with load rating of 225 lbs. per wheel
- Plate has 1/2" diameter holes for mounting on all three types of slotted angle

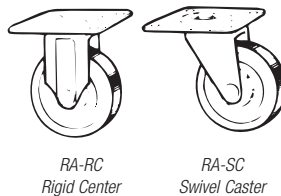

CAT. NO.	STD. CTN.	WEIGHT EACH
RA RC	2	2
RA SC	2	3

Helpful Hints to Maximize Right Angle Erection.

Slot and Hole Pattern

The Right Angle hole pattern is simple and flexible. It is repeated every 3" along the entire length of the Right Angle. An extended line marks the 3" increments, (vertical slots), while shorter lines mark every 3/4" increment. With this hole pattern, nesting, triangulation, cross beams and many additional combinations are possible.

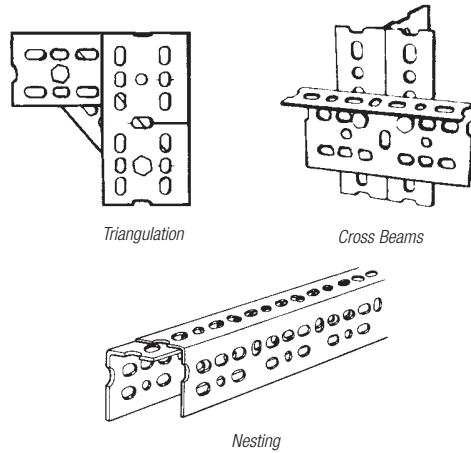

Cleat Sections

Cut Off Cleats are small sections of Right Angle used to reinforce joints or used as feet to support vertical columns. These feet prevent damage to floor surfaces or can be used to bolt a structure to the floor.

Additional joints can be made using cut off cleats. Simply butt the cleat against a column and behind a right side beam, as shown in the illustration.

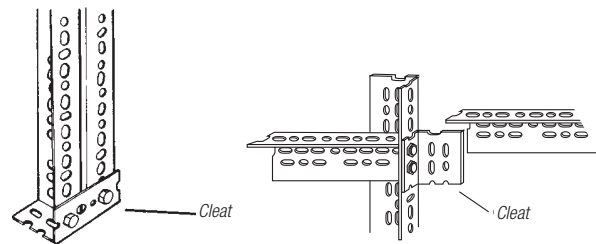

Kindorf®

Right Angle Slotted Angle

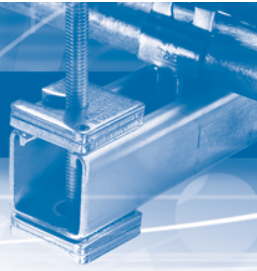

When a beam rests on a ledge of other material (such as a wall) the long flange should extend upward. Right Angle beams are at their strongest when assembled with long flange downward. Vertical columns may be in either direction. Place short flange of vertical column in front for shelving to permit wider opening for handling material.

Variety of Combinations to Meet Needs

Greater strength is obtained by joining sections of Right Angle in various combinations for beams and columns. See the load charts on **page C-99** for the combination that best suits your need.

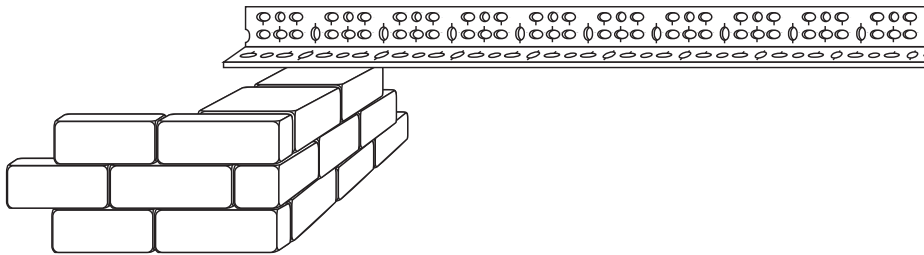
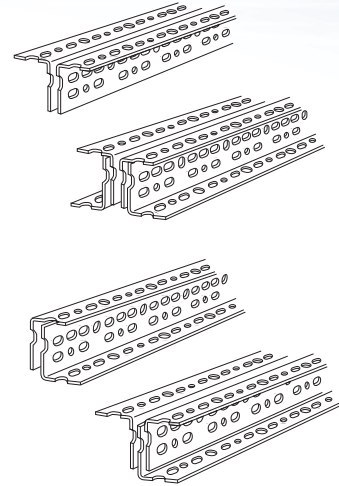

Kindorf® Modular Metal Framing and Support System

Procedure for Laying Out Structure.

Measure the Space

Right Angle structures may be built to the size of the space available. Measure the space and make a sketch of the area.

Sketch the Planned Structure

Sketch the structure you plan to build listing all vital dimensions. Include length, width and height of all sections so that load limits can be calculated safely.

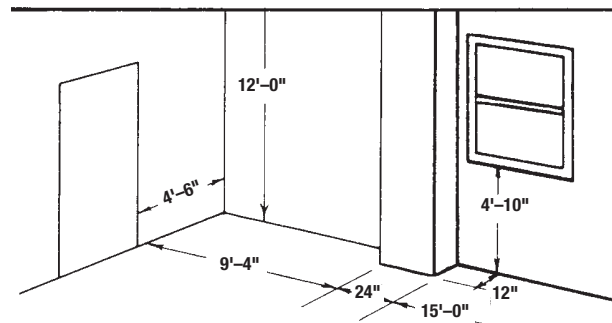
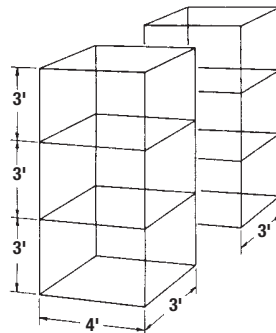

Plan Flange Direction

Right Angle beams are at their strongest position with the long flange downward. Vertical uprights may be in either direction for equal strength. Be sure to measure the material to be shelved to allow space for handling. Your sketch will also be used as a cutting and assembly plan.

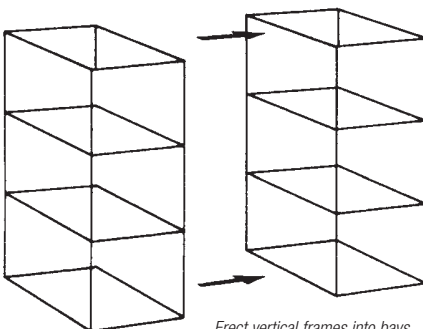
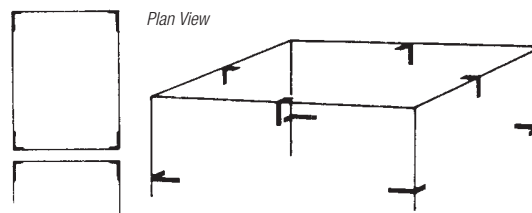

Erect vertical frames into bays.
Bolt bays together.

Assembling the Structure

Follow your plan for cutting sections and for layout. Assemble the structure as a series of frames, or bays and bolt together as units. Use as many bolts as possible and turn nuts up finger-tight. Square-up and level the entire structure. Proceed to tighten bolts with wrench, starting with corners to assure permanent squareness. Use diagonal bracing, if necessary. Add shelves. Your Right Angle structure is ready for a useful lifetime.

Corporate Office
Tel: 901.252.8000
800.816.7809
Fax: 901.252.1354

Customer Service
Tel: 800.816.7809
Fax: 800.816.7810

Technical Services
Tel: 888.862.3289
Fax: 901.252.1321

Tool Services
Tel: 800.284.8665

Thomas & Betts

www.tnb.com

C-101

Kindorf®

Right Angle Slotted Angle

Figure Load Limits

Figure the load your structure must bear on each level or shelf. This is necessary to determine the sections required to carry the load safely.

The load tables will enable you to determine the Right Angle gauge and section combination needed.

Load Limit Example for Evenly Distributed Loads

Using the sketch shown and the load tables, calculate the weight supportable by a structure with two or more shelves. A 6-ft. high single shelf structure AB will support a load of 5,200 lbs. using RA-225 Right Angle (4 single uprights x 1,100 lbs. each) from table.

When an additional shelf is framed at C, columns become the same as two 3-ft. uprights, AC and CB, and the total safe load is 10,200 lbs. on columns CB (4 x 2,550 lbs.). This load can be divided between the shelves in any convenient way, so long as the total load on columns CB does not exceed 10,200 lbs. If shelf loads are unequal, the heavier load should go on the lower shelf to avoid top-heavy instability.

Use the same method of calculating for three or more shelves with the load tables as reference.

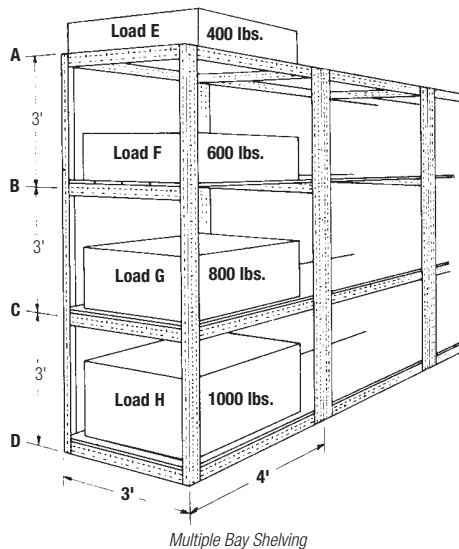
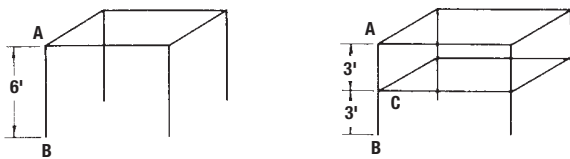

How to Determine Weight to Be Supported

Multiple-bay shelving is typical of many Right Angle weight-bearing structures. Load tables are your guide to the weights supportable by RA-160, RA-225 and RA-300. Strengths are increased where needed by combining sections for beams or columns, and by adding braces.

Example for Checking Load Safety

This structure is erected as 3 separate bays and bolted together, using RA-225.

Beam Load Bearing

Load E = 400 lbs. evenly distributed on two 4' beams. Refer to beam load tables for RA-225: Two 4' beams will support 1,090 lbs. — safe load.

Load F = 600 lbs. on solid shelf evenly distributes weight to two 3' beams. Refer to beam load tables: Two 3' beams will support 1,560 lbs. — safe load.

Load G = 800 lbs. on shelf supported by two 3' beams and two 4' beams. Add the 4 sections: 3 + 3 + 4 + 4 = 14 ft. Divide total load G by 14, i.e., 800 ÷ 14 = 57 lbs. per ft.

Compute wt. on longest beam — two 4' sections, or 8 ft. Multiply 8' x 57 lbs. per ft. load = 456 lbs. supported by the two 4' beam. Refer to load tables: Two 4' beams support 1,090 lbs. — safe load. Since the 3' beams are stronger, they are also safe for the load. Load H, any load on shelf supported by beams at floor level — considered safe.

The example illustrates methods of figuring loads on three different types of shelf construction. It is not a typical bay.

It should be remembered that a safe beam load does not assure a safe structure — column load safety must also be computed.

Column Load Bearing

Four columns support load equally. Column section AB = b load E, or 100 lbs.

Column section BC = b load F, or 150 lbs., PLUS b load E, 100 lbs. or 250 lbs.

Column section CD = b load G, or 200 lbs. PLUS 150 lbs., b load F, PLUS 100 lbs., b load E, for a total load on section CD of 450 lbs. Load H is at floor level, does not count.

Assuming a 9' high structure, the 9' column is supported at 3' intervals by ties for shelving, the 3' column section data is used. Refer to column load tables: 3 column (vertical) supports 2,550 lbs. — safe for the load.

Figures are for a free-standing, unbraced structure. Common uprights in two or more bay structures carry a double load.

See **page C-99** for load tables.

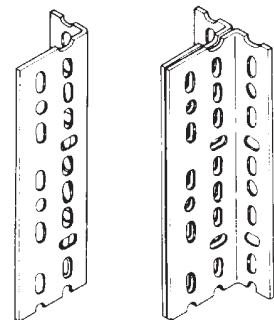

Single Section

T-Section

Thomas & Betts

www.tnb.com

Corporate Office
Tel: 901.252.8000
800.816.7809
Fax: 901.252.1354

Customer Service
Tel: 800.816.7809
Fax: 800.816.7810

Technical Services
Tel: 888.862.3289
Fax: 901.252.1321

Tool Services
Tel: 800.284.8665

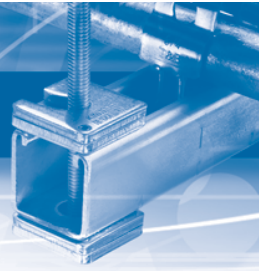

Column Loads

RA 160 — 14 ga. x 1 5/8" x 1 5/8"

	T-SECTION	SINGLE SECTION
3'	3,880	1,500
4'	3,500	1,200
5'	3,000	950
6'	2,500	750



Single Section

RA 300 — 12 ga. x 3 1/8" x 1 5/8"

	T-SECTION	SINGLE SECTION
3'	8,000	3,500
4'	7,100	2,900
5'	6,300	2,400
6'	5,550	1,800
7'	4,750	1,300
8'	4,000	1,000
9'	3,200	—
10'	2,400	—

NOTE: Values shown are static loads (lbs.) applied vertically to an unbraced column. Min. safety factor 2.1. To increase load capacity columns can be reinforced with side braces cut to size.

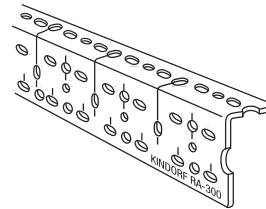

Broad Channels

RA 225 — 14 ga. x 2 3/8" x 1 5/8"

	T-SECTION	SINGLE SECTION
3'	5,550	2,550
4'	5,050	1,900
5'	4,400	1,550
6'	3,850	1,300
7'	3,400	970
8'	3,000	—
9'	2,650	—
10'	2,300	—

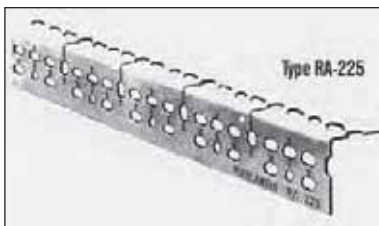

Narrow Channel

Beam Loads

	BROAD CHANNEL	NARROW CHANNEL	SINGLE SECTION
3'	2,550	1,490	770
4'	1,780	1,040	530
5'	1,330	770	400
6'	1,030	600	310
7'	820	470	240
8'	590	380	—
9'	420	310	—
10'	310	230	—
3'	4,110	3,050	1,560
4'	2,870	2,130	1,090
5'	2,140	1,580	810
6'	1,660	1,230	630
7'	1,330	980	500
8'	1,080	790	410
9'	890	650	330
10'	720	540	280
3'	7,570	6,300	3,220
4'	5,290	4,400	2,250
5'	3,950	3,280	1,680
6'	3,060	2,540	1,300
7'	2,440	2,020	1,040
8'	1,990	1,650	840
9'	1,650	1,360	690
10'	1,380	1,140	580

NOTE: Values shown are for a pair of beams supporting an evenly distributed load (lbs.). For a concentrated load these values should be halved. Min. safety factor 1.4. Multiple angle beams should be bolted every 6 in. with bolts staggered in alternate rows. To increase load capacity tie angles can be cut to size and bolted between beams.

Handle Retro-Fit Trapeze Applications with Ease!

Kindorf® Trap-Eze™ Connector



Easily installs
above existing
trapeze.

Can be used to
extend existing
trapeze.

Designed for use
with the innovative
Kindorf® Trapnut®
Strut Fastener.

The innovative Kindorf® Trap-Eze™ Connector changes a time-consuming retro-fit trapeze application into a streamlined process. Using a Kindorf® Trapnut® Strut Fastener, the new Trap-Eze™ Connector can be easily installed above or to the side of an existing assembly, eliminating the need to disassemble and reassemble the trapeze. It is designed for use with shorter strut lengths that can vary in length by as much as an inch, so the strut can be rough cut versus labor-intensive precision cut.



Unique safety slot maintains bracket position on threaded rod and prevents disengagement of the trapeze system.

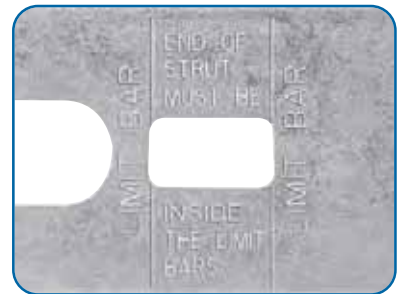

View window provides strut length safety zone for rough cuts versus precision cuts.

**See page C-70 for
more information**