



Table of Contents

The Thomas & Betts method of installing compression connectors on power cables is designed to provide a high degree of reliability in electrical wiring. This method allows electrical workers to make installations with little effort and at a considerable savings in time. The benefit, of course, is a high quality connection at a low installed cost.

- Introduction B2–B9
- Compression Connectors for Copper Conductors..... B10–B48
- Copper H-Tap Connectors for Copper Conductors B49–B50
- Copper H-Tap Connectors for Conductors B51
- Interlocking Insulating Covers for Compression Taps..... B52
- Wire Joints for Copper Conductor B53
- Cast Copper Bus Taps for Copper Conductor..... B54
- Motor Pigtail Connectors..... B55–B58
- KUBE Connectors B59
- Flag and Tee Connectors B60
- Connectors for Aluminum/Copper Code Conductors B61–B64
- Transformer Lug Kits for Aluminum Code Conductors..... B65
- Pin Connectors for Aluminum/Copper Code Conductors B66–B67
- Insulating Covers for H-Type Compression Taps B68–B69
- Parallel Splices..... B70
- Heavy-Duty Battery/Connectors and Tools B71–B75
- Accessories and Miscellaneous Hardware..... B76–B79





Introduction

The Thomas & Betts Method is Better.

The Thomas & Betts method of installing compression connectors on power cables is designed to provide a high degree of reliability in electrical wiring. This method allows electrical workers to make installations with little effort and at a considerable savings in time. The benefit, of course, is a high quality connection at a low installed cost.

Just Four Easy Steps to a Perfect Connection!

Step 1

Strip the insulation carefully to avoid nicking or cutting conductors (wire brush if required).

Strip the insulation to the proper length so that conductors can be fully inserted into the connector barrel.

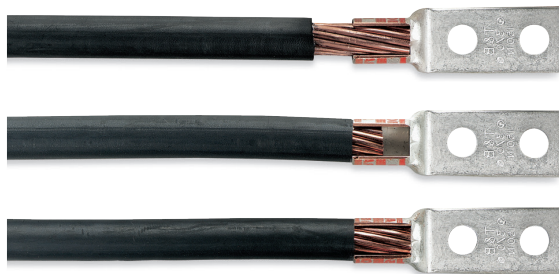

Strip Length Too Long

Strip Length Too Short

Strip Length Just Right

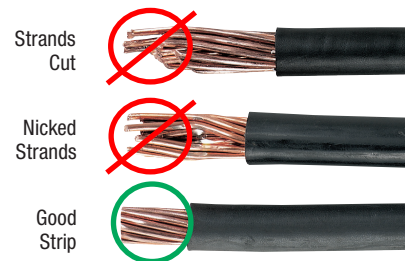

Strands Cut

Nicked Strands

Good Strip



Step 2

Determine the proper Color-Keyed® Connector for the cable size being used. Connectors are marked to show cable size.

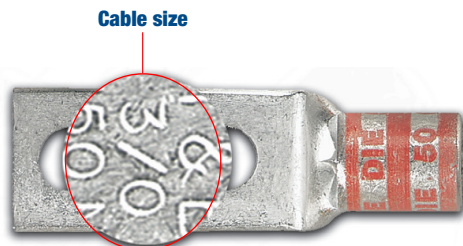

- Connectors marked with just cable size or Cu should be used on copper conductors only.
- Connectors marked "AL9" with the cable size should be used on aluminum conductors only.
- Connectors marked "AL9CU" with the cable size may be used on aluminum or copper conductors.

Note: Aluminum lugs with a "9" indicate 90°C rating.

Introduction

Step 3

Select the proper installing die and appropriate tool.

Color-Keyed® Connectors have coloured bands or coloured dots that correspond to colour markings on the dies.

Connectors and dies also have a die code number marked or stamped on them. Dies have a code number engraved in the crimp surface.



Colour Codes



Die Code Marking

Coloured Bands



Die Code Engraving

Coloured Stripe

Step 4

Locate tool with correct die in proper position on connector and activate tool.

When making multiple crimps, make the first crimp nearest the tongue and work towards the barrel end.

When properly crimped, the die code number will be embossed on the connector for easy inspection to determine if correct die and connector combination were used.

Die location for compression

Copper
Die to be positioned
BETWEEN bands



Aluminum
Die to be positioned
ON bands



Tongue

Barrel

1st crimp
2nd crimp

Coloured bands



Die code embossed

Color-Keyed® Connectors are banded by coloured stripes or engraving to indicate location of die on connector for compression.

Thomas & Betts uses “full-width” and “half-width” dies dependent on connector size and tool used. “Half-width” dies are marked with the letter “H” after the die code number.

Refer to the instruction sheet supplied with the connectors for information regarding strip length, die selection and number of compressions.



Introduction

Precision Dies form a Solid Homogeneous Mass

The T&B method utilizing compression tools with matching dies forms the connector and conductor into a solid, homogeneous mass to provide an optimum electrical bond between connector and conductor.

Thomas & Betts method dies are designed to produce a circumferential, hex- or diamond-shaped compression rather than a simple indent. Precision dies are an integral part of the Thomas & Betts method. The precision hardened steel dies exert tremendous, controlled pressure on the connector and conductor. The dies compress the connector around the cable, converting the round strands to hexagonal or diamond shapes and forming the strands and connector into a solid mass. Each die is designed so that all conductors receive the same amount of compression force.

The circumferential compression creates a large area of high-pressure contact between cable and connector which, in turn assures high-conductivity, low resistance and high pullout values which exceed CSA and UL requirements. These features result in a permanent, low-installed cost connection. You can install it and forget it.

Thomas & Betts' System Tells You Where to Place the Installing Die

Color-Keyed® connectors not only identify the correct installing die to be used for positive compressions, but also indicate the proper placement of the die on the connector. This is done by the bands of colour on the connector which match the colour on the dies. Compression is made between or on these colour bands. The colour name is also spelled on the connector as an added means of identification.



Before compression, a typical cross section of cable and connector consists of about 75% metal and 25% air.

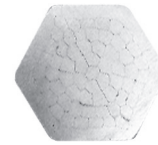

After air compression by the T&B Method, the cross section looks like this, 100% metal with virtually no air spaces.

Thomas & Betts Dies Offer Inspection Capability

Dies that are used in Thomas & Betts hand and hydraulic tools contain the "die code" numbers which are engraved on the compression surface of the die. Under compression, this number becomes embossed on the completed connection for inspection purposes.

The inspector compares the die code number embossed on the connector with the die table to ensure that the proper connector was compressed with the correct die for that particular size conductor.

Copper
Die to be positioned
BETWEEN bands



Aluminum
Die to be positioned
ON bands



Color-Keyed® Connectors are banded by coloured stripes or engraving to indicate location of die on connector for compression.



Introduction

Quality Tooling with the Shure Stake® Mechanism

T&B manual tools with the exclusive Shure Stake® mechanism take the guesswork out of making compression connections. The Shure Stake® mechanism provides a full cycle compression stroke every time. Once the stroke has started, the tool will not release the connector until the proper amount of force has been applied. This is your assurance of a fully compressed connection. T&B compression tools develop uniform, controlled pressure to each connector within their size range. Thomas & Betts offers electric and battery-powered hydraulic pumps with a Shure Stake® feature that guarantees a full cycle compression.



Battpac® LT Pump

The newest battery-powered hydraulic pump, rated for 10,000 psi. Portable power for all T&B hydraulic heads, using just one Ni-MH 24 V rechargeable battery.



TBM62PCR-LI

Designed for one-handed control ram advancement and retraction. Capacity up to Cu #8-600 kcmil • Al #8-400 kcmil.



TBM6S

Hard-operated crimping tool, features Shure Stake® mechanism to insure a completed crimp. For connectors up to 500 kcmil Cu, 350 kcmil Al.

Thomas & Betts Method Components Meet Industry Standards

Depending on the application, all Thomas & Betts copper connectors meet UL standard for code stranded and 24 gauge flex, CSA standard requirements for power and UL and CSA standards requirements for direct buried grounding.

T&B method connectors are available in a range of sizes and styles to accommodate copper and larger aluminum cable. They may be compressed on cable with either manual or hydraulic tools. They are offered with standard length or long barrels, with one bolt or two bolt holes, or in two-way styles, for splicing applications. Two-way connectors are compact, providing high pullout values with low resistance.

Color-Keyed® two-hole lugs are ideal for bus bar applications that require two bolts to prevent lug rotation.

The T&B Method is the most efficient, highest quality connection that has been engineered and delivers the best electrical performance and highest reliability. T&B compression connectors eliminate risk of problems relating to loose connections when installed properly.

High Grade Materials Incorporated in Thomas & Betts Method

Low-installed cost connections of superior quality can be achieved only through the use of high grade components. That is an important part of the T&B method – quality products you can depend on.

Copper Color-Keyed® connectors are made of high-conductivity wrought copper and electro-tin plated to prevent corrosion and to improve conductivity. Thomas & Betts Color-Keyed® connectors offer the thickest tin-plating in the industry. Other copper connectors for heavy duty use and grid grounding applications are made of high-conductivity cast copper, bright finished.

High-conductivity cast aluminum connectors are available for heavy-duty application.



Introduction

Color-Keyed® Special Lugs for Special Problems — Angled, Shaped and Flared the Way You Need Them

Thomas & Betts can solve your difficult wire bending and terminating problems in confined power distribution panels, switchgear and motor control enclosures.

We have the design and production capability to deliver exactly the type lug you need, shaped the way you need.

- Straight, 45° and 90° angle
- Stacking or non-stacking
- Narrow-tongue or standard
- Tin, silver and nickel plating available

Thomas & Betts offers an extensive line of copper Color-Keyed® lugs for #8 AWG through 1000 kcmil flex and code cables. The lug tongues are modified in several different configurations to meet your exact needs: 45° and 90° bend angles, narrow-tongues to fit into circuit breakers, offset tongues to stack two cables and special stud hole drilling. These special configurations let you:

1. Run cable directly to the bus bar with no bending
2. Terminate into very narrow spaces
3. Utilize minimal bus bar space

The specially designed lugs help you “clean up” your cabling in crowded enclosures. The pictures show some examples of how and where the lugs can be used.

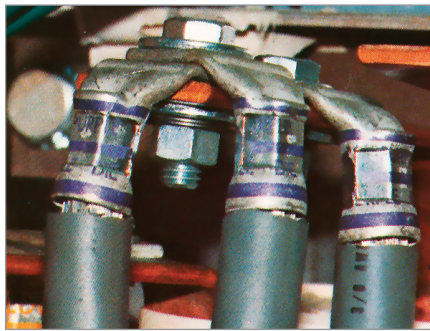

Customized Color-Keyed® Connectors for Copper Cables

- Standard and special tongue angles, stacking and non-stacking, bolt holes sizes and centers, protective platings.
- Specially modified one and two hole copper Color-Keyed® compression lugs, Series 54100, 54200, 54850BE and 54930BE for flex and code copper stranded cables. Material: high-conductivity wrought copper.
- Minimum order quantity: Standard package quantity by cable size. Consult your Regional Sales Office for price and delivery. All customized lugs are made to order and cannot be cancelled.



Introduction

Order Form (to be scanned or photocopied)

Catalogue No. _____ Qty. _____

Design Controls and Requirements

All "MADE-UP" catalogue numbers start with a standard or basic catalogue number and are followed by the customer-required extra features: Tongue shape, bolt hole size, distance between bolt holes, stacking, plating and inspection hole (peep hole). A code letter or a number has been assigned to each extra feature. See CODE CABLE TABLE below.

Notes: 1) Lack of any of the extra features on the "MADE-UP" catalogue number means that the standard Cat. No. features are prevalent.
 2) If either bolt hole size or distance between bolt holes needs to be changed from standard Cat. No., both code numbers will appear on the "MADE-UP" Cat. No. (see example below).

Cat. No. 54212UB0416BSP

54212	UB	04	16	B
2 hole 4/0 Cu lug basic cat. no.	90° bend	1/4 in. bolt hole	1 in. hole spacing	bottom stack

Code Cable Table

Tongue Shape		Bolt Holes Size .020		Code	Bolt Hole Centers		Stacking		Finish (Plating)		Inspection Hole (Long Barrel)		Inspection Hole (Short Barrel)	
Type	Code				Center to Center (in.)	Code	Type	Code	Type 1	Code	I.D.	Code	I.D.	Code
45°	UF	#8	0.173	02	1/2	08	Top	T**	Silver	SP	Peep Hole	PH	Blind End	BE
90°	UB	#10	0.204	03	5/8	10	Bottom	B	Lead	LP				
Blank	BT	1/4	0.281	04	3/4	12			Nickel	NP	150°			
(No Bolt Hole)		5/16	0.344	05	7/8	14			Plain Finish	PF				
		3/8	0.406	06	1	16			No Marking	NM				
		1/2	0.531	08	1-1/8	18								
		5/8	0.656	10	1-1/4	20								
		3/4	0.812	12	1-3/8	22								
		1/8	0.937	14	1-1/2	24								
		1	1.062	16	1-5/8	26								
					1-3/4	28								
					*1-7/8	30								
					*2	32								

* These bolt centers are not available for bolt holes larger than 13/16 in.

** Not required for 45° & 90° Top Stacking.

Cable	Code	<input type="checkbox"/>
	Weld	<input type="checkbox"/>
<input type="checkbox"/> #8	<input type="checkbox"/> #6	<input type="checkbox"/> #4
<input type="checkbox"/> #2	<input type="checkbox"/> #1	<input type="checkbox"/> 1/0
<input type="checkbox"/> 2/0	<input type="checkbox"/> 3/0	<input type="checkbox"/> 4/0
<input type="checkbox"/> 250 kcmil & up (Code cable Only)		

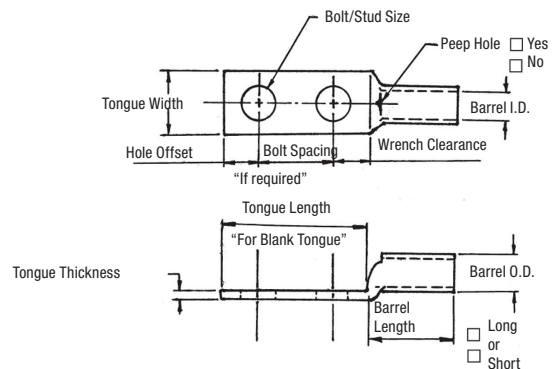

Introduction

Tongue Specifications — See Chart “A” for Dimensions

Stud Sizes		
<input type="checkbox"/> #8	<input type="checkbox"/> #10	<input type="checkbox"/> 1/4 in.
<input type="checkbox"/> 5/16 in.	<input type="checkbox"/> 3/8 in.	<input type="checkbox"/> 1/2 in.
<input type="checkbox"/> 5/8 in.	<input type="checkbox"/> 3/4 in.	<input type="checkbox"/> 7/8 in.
<input type="checkbox"/> 1 in.		

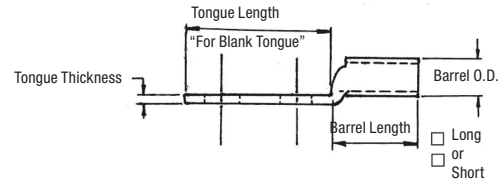
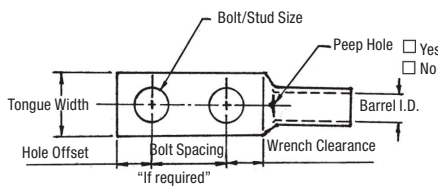

Chart A

Nominal Bolt Hole	Hole Offset	Min. Wrench Clearance	Tongue Width Cable Size									
			#8 Code #8 Weld	#6 Code #6 Weld	#4 Code	#2 Code #4 Weld	#1 Code #2 Weld	1/0 Code #1 Weld	2/0 Code 1/0 Weld	3/0 Code 2/0 Weld	4/0 Code 3/0 Weld	250 Code
#8	0.173	0.200	0.406	0.437	0.562	0.593	0.672	0.750	0.825	0.937	1.030	1.125
#10	0.204	0.218	0.469	0.500								
1/4	0.281	0.250	0.562	0.562	0.594	0.750	0.750					
5/16	0.344	0.375										
3/8	0.406	0.375										
1/2	0.531	0.500										
5/8	0.656	0.812										
3/4	0.812	0.750										
*7/8	0.937	0.875										
*1	1.062	0.937										

* These bolt holes are available in one hole lug only. Dimensions are in inches.

Chart B

Cable Size	Tongue Thickness	Straight Lug Barrel Length		Barrel		Dim. "X" Stacked Lugs			Dim. "Y"		Dim. "H"	
		Short	Long	O.D.	I.D.	Straight	45°	90°	Short	Long	Short	Long
#8	0.080	0.635	0.935	0.260	0.180	0.158	0.478	0.394	0.595	0.808	0.779	1.079
#6	0.081	0.675	0.975	0.296	0.215	0.134	0.544	0.432	0.587	0.799	0.767	10.67
#4	0.099	0.685	0.985	0.365	0.266	0.175	0.622	0.502	0.637	0.849	0.838	1.138
#2	0.108	0.815	1.115	0.410	0.302	0.216	0.649	0.535	0.711	0.923	0.958	1.258
#1	0.106	0.825	1.275	0.467	0.361	0.212	0.731	0.592	0.710	1.028	0.956	1.406
1/0	0.125	0.975	1.325	0.520	0.396	0.250	0.789	0.646	0.794	1.042	1.075	1.425
2/0	0.125	0.965	1.315	0.571	0.446	0.250	0.859	0.696	0.829	1.077	1.125	1.475
3/0	0.125	1.085	1.435	0.632	0.507	0.250	0.946	0.757	0.900	1.148	1.225	1.575
4/0	0.137	1.255	1.705	0.701	0.564	0.274	1.031	0.826	1.015	1.333	1.387	1.837
250	0.137	1.375	1.925	0.766	0.629	0.274	1.123	0.891	1.085	1.474	1.487	2.037
300	0.153	1.900	2.675	0.850	0.660	0.459	1.226	0.975	1.180	1.726	1.924	2.679
350	0.177	2.090	2.896	0.926	0.720	0.531	1.333	1.103	1.267	1.830	2.096	2.896
400	0.173	2.460	2.980	0.960	0.757	0.519	1.370	1.085	1.551	1.913	2.484	2.984
500	0.218	2.670	3.610	1.100	0.852	0.654	1.514	1.225	1.629	2.266	2.669	3.619
600	0.244	2.900	3.490	1.200	0.926	0.732	1.630	1.325	1.762	2.147	2.897	3.497
700	0.228	2.784	-	1.255	0.997	0.684	1.662	1.375	1.780	-	3.011	-
750	0.270	3.050	3.925	1.330	1.030	0.810	1.745	1.455	1.827	2.434	3.050	3.925
800	0.266	3.213	-	1.375	1.079	0.800	1.728	1.625	1.952	2.787	3.213	4.554
900	0.313	3.450	4.550	1.500	1.145	0.940	1.900	1.650	2.065	-	1.387	-
1,000	0.297	3.356	4.500	1.550	1.203	0.890	2.070	1.675	2.031	2.787	1.487	4.506

Stacking lugs are available for one bolt only. Consult your Regional Sales Office for details. Straight: 700 kcmil & up; 45°: 400 kcmil & up; 90°: 500 kcmil & up. Dimensions are in inches.

Introduction

Tongue Specifications — See Chart “A” for Dimensions

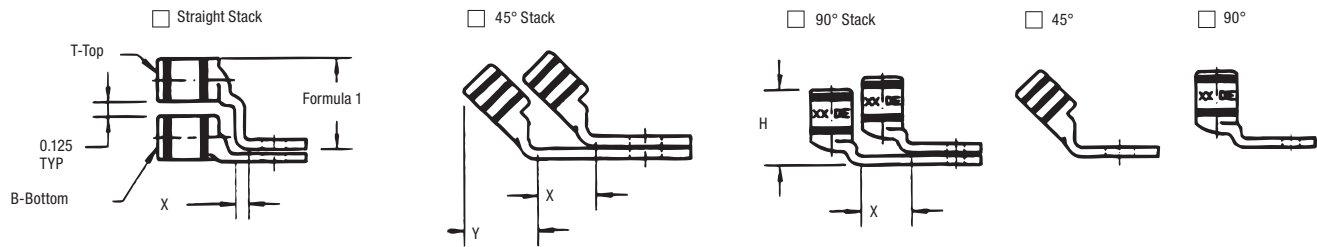

Formula 1 = (0.125 + 2 (OD) + 0.037 – Tongue Thickness)

Chart C

Bolt Hole Size	Tongue Width 0.030 / Code Cable Size										
	300 kcmil 4/0 Weld	350 kcmil	400 kcmil	500 kcmil 400 Weld	600 kcmil 500 Weld	1325/24	700 kcmil	750 kcmil	800 kcmil	900 kcmil	1000 kcmil
#8	-	-	-	-	-	-	-	-	-	-	-
#10	-	-	-	-	-	-	-	-	-	-	-
1/4	1.250	1.355	1.410	1.605	1.745	1.805	1.840	1.935	2.010	2.180	2.265
5/16											
3/8											
1/2											
5/8											
3/4	-	-	-	-	-	-	-	-	-	-	
*7/8	-	-	-	-	-	-	-	-	-	-	-
*1	-	-	-	-	-	-	-	-	-	-	-

* These bolt holes are available in one hole lug only. Dimensions are in inches.



Compression Connectors for Copper Conductors

One-Hole Lugs — Standard Barrel Certified to 600 V and Recommended up to 35 kV[‡]

Material: High-Conductivity Wrought Copper

Finish: Electro-Tin Plated

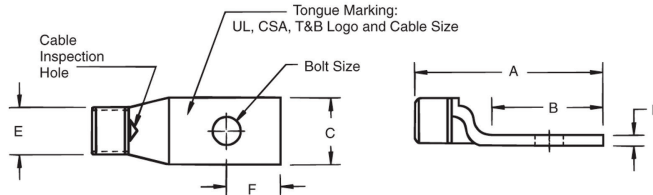

Cat. No.	Wire Size		Bolt Size	Dimensions in. (mm)						Die Code	Colour Code
	Code Cable	Flex Cable Classes G, H, I, K, M		A	B	C	D	E	F		
54101	#14-10 AWG	-	1/4	1.23 (31.2)	0.56 (14.2)	0.50 (12.7)	0.05 (1.3)	0.20 (5.1)	0.25 (6.4)	ERG2002	Yellow
256-30695-1351			#8	1.36 (34.5)	0.68 (17.3)	0.36 (9.1)	0.05 (1.3)	0.20 (5.1)	0.25 (6.4)		
256-30695-1352			1/4	1.36 (34.5)	0.68 (17.3)	0.41 (10.4)	0.05 (1.3)	0.20 (5.1)	0.25 (6.4)		
256-30695-263			1/4	1.69 (43.0)	0.81 (20.6)	0.50 (12.7)	0.07 (1.8)	0.20 (5.1)	0.25 (6.4)		
54104	#8 AWG	#8 Str., 23 Navy #8 Weld 37/24 0.180	#10	1.16 (29.5)	0.50 (12.7)	0.39 (9.9)	0.08 (2.0)	0.25 (6.4)	0.22 (5.6)	21	Red
54130			1/4	1.20 (30.5)	0.61 (15.5)	0.45 (11.4)	0.07 (1.8)	0.25 (6.4)	0.25 (6.4)		
54131			5/16	1.33 (33.8)	0.64 (16.3)	0.56 (14.2)	0.05 (1.3)	0.25 (6.4)	0.28 (7.1)		
54132			3/8	1.33 (33.8)	0.64 (16.3)	0.56 (14.2)	0.05 (1.3)	0.25 (6.4)	0.28 (7.1)		
256-30695-424			1/2	1.75 (44.5)	1.31 (33.3)	1.00 (25.4)	0.13 (3.3)	0.25 (6.4)	0.50 (12.7)		
256-30695-1361	#6 AWG	#6 Str., #30 Navy #6 Weld 61/24 133/0.014, 0.227	#12	1.23 (31.2)	0.53 (13.5)	0.44 (11.2)	0.07 (1.8)	0.31 (7.8)	0.22 (5.6)	24	Blue
54134			#10	1.23 (31.2)	0.53 (13.5)	0.44 (11.2)	0.07 (1.8)	0.31 (7.8)	0.22 (5.6)		
54105			1/4	1.23 (31.2)	0.53 (13.5)	0.44 (11.2)	0.07 (1.8)	0.31 (7.8)	0.22 (5.6)		
54135			5/16	1.41 (35.8)	0.67 (17.0)	0.60 (15.2)	0.07 (1.8)	0.31 (7.8)	0.31 (7.9)		
54136			3/8	1.41 (35.8)	0.67 (17.0)	0.60 (15.2)	0.07 (1.8)	0.31 (7.8)	0.31 (7.9)		
256-30695-282			3/8	1.41 (35.8)	0.75 (19.1)	0.56 (14.2)	0.06 (1.5)	0.31 (7.8)	0.31 (7.9)		
256-30695-422	1/2	1.75 (44.5)	1.31 (33.3)	1.00 (25.4)	0.13 (3.3)	0.31 (7.8)	0.50 (12.7)				
256-30695-1362	#4 AWG	# 5 Str., 40-50 Navy 91/24 133/0.0177, 49/0.029 0.265	#12	1.38 (35.1)	0.60 (15.2)	0.55 (14.0)	0.09 (2.3)	0.37 (9.4)	0.25 (6.4)	29	Grey
54138			#10	1.38 (35.1)	0.60 (15.2)	0.55 (14.0)	0.09 (2.3)	0.37 (9.4)	0.25 (6.4)		
54106			1/4	1.38 (35.1)	0.60 (15.2)	0.55 (14.0)	0.09 (2.3)	0.37 (9.4)	0.25 (6.4)		
54139			5/16	1.42 (36.1)	0.66 (16.8)	0.61 (15.5)	0.07 (1.8)	0.37 (9.4)	0.31 (7.9)		
54140			3/8	1.42 (36.1)	0.66 (16.8)	0.61 (15.5)	0.07 (1.8)	0.37 (9.4)	0.31 (7.9)		
256-30695-233			3/8	1.56 (37.0)	0.75 (19.1)	0.59 (15.0)	0.06 (1.5)	0.37 (9.4)	0.31 (7.9)		
256-30695-264	1/2	2.20 (56.0)	1.40 (35.6)	1.00 (25.4)	0.06 (1.5)	0.37 (9.4)	0.50 (12.7)				
54107	#2 AWG	#3 Str., #60 Navy 125/24 #4 Weld 0.300	1/4	1.50 (38.1)	0.65 (16.5)	0.59 (15.0)	0.11 (2.8)	0.41 (10.4)	0.25 (6.4)	33	Brown
54142-TB			5/16	1.73 (43.9)	0.88 (22.4)	0.59 (15.0)	0.11 (2.8)	0.41 (10.4)	0.38 (9.7)		
54143-TB			3/8	1.65 (41.9)	0.80 (20.3)	0.59 (15.0)	0.11 (2.8)	0.41 (10.4)	0.38 (9.7)		
54145-TB			1/2	1.92 (48.8)	1.08 (27.4)	0.75 (19.1)	0.08 (2.0)	0.41 (10.4)	0.50 (12.7)		
54108	#1 AWG	#2 Str., 75 Navy, #2 Weld 150/24 175/24 133/0.0223, 0.360	1/4	1.50 (38.1)	0.65 (16.5)	0.68 (17.3)	0.11 (2.8)	0.47 (11.9)	0.25 (6.4)	37	Green
54147			5/16	1.73 (43.9)	0.93 (23.6)	0.68 (17.3)	0.11 (2.8)	0.47 (11.9)	0.38 (9.7)		
54148			3/8	1.78 (45.2)	0.98 (24.9)	0.68 (17.3)	0.11 (2.8)	0.47 (11.9)	0.38 (9.7)		
54150			1/2	2.10 (53.3)	1.25 (31.8)	0.76 (19.3)	0.11 (2.8)	0.47 (11.9)	0.50 (12.7)		
54152-TB	1/0 AWG	1 AWG, #100 Navy #1 Weld 225/24 133/0.0254, 0.389 min.	1/4	1.60 (40.6)	0.65 (16.5)	0.75 (19.1)	0.13 (3.3)	0.52 (13.2)	0.25 (6.4)	42	Pink
54153-TB			5/16	1.83 (46.5)	0.88 (22.4)	0.75 (19.1)	0.13 (3.3)	0.52 (13.2)	0.38 (9.7)		
54109			3/8	1.88 (47.8)	0.93 (23.6)	0.75 (19.1)	0.13 (3.3)	0.52 (13.2)	0.38 (9.7)		
54155-TB			1/2	2.20 (55.9)	1.25 (31.8)	0.75 (19.1)	0.13 (3.3)	0.52 (13.2)	0.50 (12.7)		
256-30695-1383	2/0 AWG	1/0 AWG, 125 Navy 1/0 Weld 275/24 427/0.0155, 438 min. 133/0.0282	5/8	2.54 (64.5)	1.50 (38.1)	0.88 (22.4)	0.13 (3.3)	0.52 (13.2)	0.63 (16.0)	45	Black
54157			1/4	1.65 (41.9)	0.65 (16.5)	0.83 (21.1)	0.13 (3.3)	0.57 (14.5)	0.25 (6.4)		
54158			5/16	1.88 (47.8)	0.88 (22.4)	0.83 (21.1)	0.13 (3.3)	0.57 (14.5)	0.38 (9.7)		
54110			3/8	1.93 (49.0)	0.93 (23.6)	0.83 (21.1)	0.13 (3.3)	0.57 (14.5)	0.38 (9.7)		
54160			1/2	2.25 (57.2)	1.25 (31.6)	0.83 (21.1)	0.13 (3.3)	0.57 (14.5)	0.50 (12.7)		
256-30695-131	5/8	2.56 (65.0)	1.50 (38.1)	0.83 (21.1)	0.13 (3.3)	0.57 (14.5)	0.63 (16.0)				

‡ For installations from 16 kV up to 35 kV, consult shielded cable manufacturers for stress relief and insulation requirements. Call your Regional Sales Office for sizes not listed.

Tooling: pp. E4–E62

Die Selector Chart: pp. E35–E50

Compression Connectors for Copper Conductors

One-Hole Lugs — Standard Barrel Certified to 600 V and Recommended up to 35 kV[‡] (cont'd)

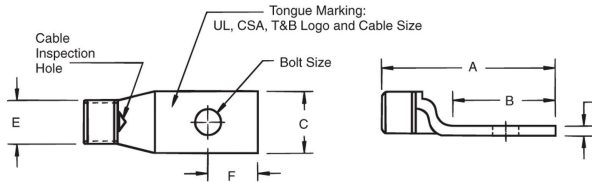

Material: High-Conductivity Wrought Copper

Finish: Electro-Tin Plated



Cat. No.	Wire Size		Bolt Size	Dimensions in. (mm)						Die Code	Colour Code
	Code Cable	Flex Cable Classes G, H, I, K, M		A	B	C	D	E	F		
54162-TB	3/0 AWG	2/0 AWG, 150 Navy 2/0 Weld 325/24 133/0.0316, 259/0.0227 427/0.0177, 0.500	1/4	1.75 (44.5)	0.65 (16.5)	0.92 (23.4)	0.13 (3.3)	0.63 (16.0)	0.25 (6.4)	50	Orange
54163-TB			5/16	1.98 (50.3)	0.88 (22.4)	0.92 (23.4)	0.13 (3.3)	0.63 (16.0)	0.38 (9.7)		
54111			3/8	2.03 (51.6)	0.93 (23.6)	0.92 (23.4)	0.13 (3.3)	0.63 (16.0)	0.38 (9.7)		
54165-TB			1/2	2.35 (59.7)	1.25 (31.8)	0.92 (23.4)	0.13 (3.3)	0.63 (16.0)	0.50 (12.7)		
54167	4/0 AWG	3/0 AWG, 200 Navy 3/0 Weld 450/24 703/0.0154, 0.560	1/4	1.90 (48.3)	0.65 (16.5)	1.03 (26.2)	0.14 (3.6)	0.70 (17.8)	0.25 (6.4)	54	Purple
54168			5/16	2.13 (54.1)	0.87 (22.1)	1.03 (26.2)	0.14 (3.6)	0.70 (17.8)	0.38 (9.7)		
54112			3/8	2.18 (55.4)	0.93 (23.6)	1.03 (26.2)	0.14 (3.6)	0.70 (17.8)	0.38 (9.7)		
54170			1/2	2.50 (63.5)	1.25 (31.8)	1.03 (26.2)	0.14 (3.6)	0.70 (17.8)	0.50 (12.7)		
256-30695-1174	-	4/0 Weld 550/24 130/0.0399 259/0.0286 66	3/4	2.86 (72.6)	1.56 (39.6)	1.03 (26.2)	0.14 (3.6)	0.70 (17.8)	0.75 (19.1)	62	Yellow
58161			1/4	2.23 (56.6)	0.78 (19.8)	1.25 (31.8)	0.15 (3.8)	0.79 (20.1)	0.38 (9.7)		
58162			5/16	2.33 (59.2)	0.88 (22.4)	1.25 (31.8)	0.15 (3.8)	0.79 (20.1)	0.38 (9.7)		
58163			3/8	2.38 (60.5)	0.93 (23.6)	1.25 (31.8)	0.15 (3.8)	0.79 (20.1)	0.38 (9.7)		
58165	-	259/0.0286 66	1/2	2.76 (70.1)	1.25 (31.8)	1.25 (31.8)	0.15 (3.8)	0.79 (20.1)	0.50 (12.7)	62	Yellow
58166			5/8	3.03 (77.0)	1.58 (40.1)	1.25 (31.8)	0.15 (3.8)	0.79 (20.1)	0.83 (21.1)		
54172-TB			1/4	2.00 (50.8)	0.65 (16.5)	1.13 (28.7)	0.14 (3.6)	0.77 (19.6)	0.50 (12.7)		
54173			5/16	2.23 (56.6)	0.88 (22.4)	1.13 (28.7)	0.14 (3.6)	0.77 (19.6)	0.38 (9.7)		
54174	250 kcmil	4/0 250 Navy 0.629	3/8	2.28 (57.9)	0.93 (23.6)	1.13 (28.7)	0.14 (3.6)	0.77 (19.6)	0.38 (9.7)	62	Yellow
54113			1/2	2.60 (66.0)	1.25 (31.8)	1.13 (28.7)	0.14 (3.6)	0.77 (19.6)	0.50 (12.7)		
58168	-	250 Weld 650/24 = 262 kcmil 259/0.0311, 703/0.0189	1/2	2.70 (68.6)	1.25 (31.8)	1.25 (31.8)	0.15 (3.8)	0.85 (21.6)	0.50 (12.7)	66	White
54178	300 kcmil	250 kcmil 300 Navy 0.660	5/16	2.33 (59.2)	0.88 (22.4)	1.25 (31.8)	0.15 (3.8)	0.85 (21.6)	0.38 (9.7)		
54179			3/8	2.43 (61.7)	0.93 (23.6)	1.25 (31.8)	0.15 (3.8)	0.85 (21.6)	0.38 (9.7)		
54114			1/2	2.70 (68.6)	1.25 (31.8)	1.25 (31.8)	0.15 (3.8)	0.85 (21.6)	0.50 (12.7)		
54181			5/8	3.03 (77.0)	1.58 (40.1)	1.25 (31.8)	0.15 (3.8)	0.85 (21.6)	0.75 (19.1)		
58171	-	300 Weld, 259/0.034 427/0.0265, 889/0.0183 775/24 = 313 kcmil 0.719	1/2	2.85 (72.4)	1.25 (31.8)	1.36 (34.5)	0.18 (4.6)	0.93 (23.6)	0.50 (12.7)	71	Red
256-30695-112	350 kcmil	350 Navy 0.719	3/8	2.90 (73.7)	1.25 (31.8)	1.36 (34.5)	0.18 (4.6)	0.93 (23.6)	0.50 (12.7)		
54115			1/2	2.85 (72.4)	1.25 (31.8)	1.36 (34.5)	0.18 (4.6)	0.93 (23.6)	0.50 (12.7)		
54183			5/8	3.21 (81.5)	1.28 (32.5)	1.36 (34.5)	0.18 (4.6)	0.93 (23.6)	0.75 (19.1)		
58174	-	350 Weld, 259/0.0368 427/0.0285 889/0.0201	1/2	3.35 (85.1)	1.25 (31.8)	1.61 (40.9)	0.22 (5.6)	1.09 (27.7)	0.50 (12.7)	76	Blue
54116	400 kcmil	300 kcmil 400 Navy, 0.757	1/2	3.20 (81.3)	1.25 (31.8)	1.41 (35.8)	0.17 (4.3)	0.96 (24.4)	0.50 (12.7)		
54185			5/8	3.53 (89.7)	1.58 (40.1)	1.41 (35.8)	0.17 (4.3)	0.96 (24.4)	0.75 (19.1)		

‡ For installations from 16 kV up to 35 kV, consult shielded cable manufacturers for stress relief and insulation requirements. Call your Regional Sales Office for sizes not listed.

Tooling: pp. E4–E62

Die Selector Chart: pp. E35–E50



Compression Connectors for Copper Conductors

One-Hole Lugs — Standard Barrel Certified to 600 V and Recommended up to 35 kV \ddagger (cont'd)

Material: High-Conductivity Wrought Copper

Finish: Electro-Tin Plated

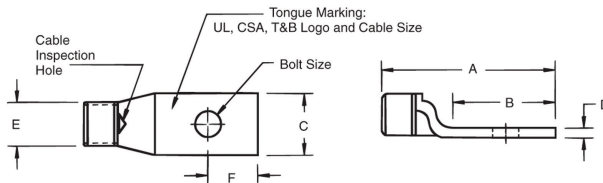

Cat. No.	Wire Size		Bolt Size	Dimensions in. (mm)						Die Code	Colour Code
	Code Cable	Flex Cable Classes G, H, I, K, M		A	B	C	D	E	F		
58177	-	400 Weld 925/24 = 373 kcmil 259/0.0393 or 427/0.0306, 0.799	1/2	3.31 (84.1)	1.25 (31.8)	1.61 (40.9)	0.22 (5.6)	1.04 (26.4)	0.50 (12.7)	80	-
256-30695-1403			3/8	3.31 (84.1)	1.31 (33.3)	1.61 (40.9)	0.22 (5.6)	1.04 (26.4)	0.63 (16.0)		
256-30695-339	500 kcmil	925/24 500 Navy 0.850	3/8	3.10 (78.7)	1.00 (25.4)	1.61 (40.9)	0.22 (5.6)	1.10 (28.0)	0.38 (9.7)	87	Brown
54118			1/2	3.30 (83.8)	1.25 (31.8)	1.61 (40.9)	0.22 (5.6)	1.10 (27.9)	0.50 (12.7)		
54187			5/8	3.63 (92.2)	1.58 (40.1)	1.61 (40.9)	0.22 (5.6)	1.10 (27.9)	0.63 (16.0)		
58180	-	1100/24 = 444 kcmil 500 Weld, 259/0.0417 427/0.0325, 703/0.0253	5/8	3.79 (96.3)	1.58 (40.1)	1.75 (44.5)	0.24 (6.1)	1.20 (30.5)	0.63 (16.0)	94	Green
256-30695-1370	600 kcmil	0.956	1/2	3.65 (92.7)	1.44 (36.6)	1.75 (44.5)	0.24 (6.1)	1.20 (30.5)	0.48 (12.2)		
54120			5/8	3.79 (96.3)	1.58 (40.1)	1.75 (44.5)	0.24 (6.1)	1.20 (30.5)	0.63 (16.0)		
54122-TB	700 kcmil	-	5/8	3.68 (93.5)	1.58 (40.1)	1.84 (46.7)	0.23 (5.8)	1.26 (32.0)	0.63 (16.0)	99	Pink
256-30695-1404	-	1325/24 = 500/535 kcmil 427/0.0342, 0.968	3/8	3.29 (83.6)	1.29 (32.8)	1.81 (46.0)	0.28 (7.1)	1.25 (31.8)	0.66 (16.8)		
256-30695-1405			1/2	3.29 (83.6)	1.29 (32.8)	1.81 (46.0)	0.28 (7.1)	1.25 (31.8)	0.66 (16.8)		
256-30695-840			1/2	4.00 (101.6)	1.69 (42.9)	1.81 (46.0)	0.28 (7.1)	1.25 (31.8)	0.48 (12.2)		
58182			5/8	3.83 (97.3)	1.58 (40.1)	1.81 (46.0)	0.28 (7.1)	1.25 (31.8)	0.63 (16.0)		
256-30695-193			1/2	4.00 (101.6)	1.69 (42.9)	1.94 (49.3)	0.27 (6.9)	1.33 (33.8)	0.48 (12.2)		
54123-TB	750 kcmil	1.060	5/8	3.87 (98.3)	1.58 (40.1)	1.94 (49.3)	0.27 (6.9)	1.33 (33.8)	0.63 (16.0)	106	Black
58184	-	1600/24 = 646 kcmil	5/8	3.80 (96.5)	1.58 (40.1)	1.94 (49.3)	0.27 (6.9)	1.33 (33.8)	0.63 (16.0)	107	Orange
54124-TB	800 kcmil	800 Navy, 1.109	5/8	4.04 (102.6)	1.58 (40.1)	2.01 (51.1)	0.27 (6.9)	1.38 (35.1)	0.63 (16.0)		
256-30695-843	900 kcmil	1925/24 = 750/777 kcmil 1.187	1/2	4.31 (109.5)	1.81 (46.0)	2.17 (55.1)	0.31 (7.9)	1.50 (38.1)	0.88 (22.4)	115	Yellow
54126			5/8	4.15 (105.4)	1.58 (40.1)	2.17 (55.1)	0.31 (7.9)	1.50 (38.1)	0.63 (16.0)		
54128	1000 kcmil	1000 Navy, 1.253	5/8	4.09 (103.9)	1.58 (40.1)	2.27 (57.7)	0.30 (7.6)	1.55 (39.4)	0.63 (16.0)	125	-

‡ For installations from 16 kV up to 35 kV, consult shielded cable manufacturers for stress relief and insulation requirements. Call your Regional Sales Office for sizes not listed.

Tooling: pp. E4–E62

Die Selector Chart: pp. E35–E50

Compression Connectors for Copper Conductors

One-Hole Lugs — 45° Standard Barrel Certified to 600 V and Recommended up to 35 kV‡

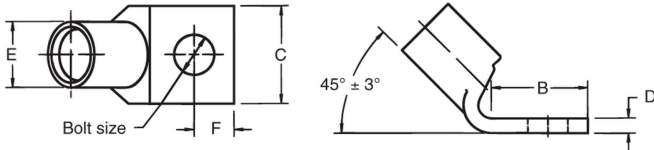

Material: High-Conductivity Wrought Copper

Finish: Electro-Tin Plated



Cat. No.	Wire Size		Bolt Size	Dimensions in. (mm)					Die Code	Colour Code
	Code Cable	Flex Cable Classes G, H, I, K, M		B	C	D	E	F		
54104UF	#8 AWG	#8 Str., 23 Navy #8 weld 37/24 0.180	#10	0.50 (12.7)	0.39 (9.9)	0.08 (2.0)	0.25 (6.4)	0.22 (5.6)	21	Red
54130UF			1/4	0.61 (15.5)	0.45 (11.4)	0.07 (1.8)	0.25 (6.4)	0.25 (6.4)		
54131UF			5/16	0.64 (16.3)	0.56 (14.2)	0.05 (1.3)	0.25 (6.4)	0.28 (7.1)		
54132UF			3/8	0.64 (16.3)	0.56 (14.2)	0.05 (1.3)	0.25 (6.4)	0.28 (7.1)		
54134UF	#6 AWG	#6 Str., 30 Navy #6 Weld 61/24 133/0.014 0.227	#10	0.53 (13.5)	0.44 (11.2)	0.07 (1.8)	0.31 (7.9)	0.22 (5.6)	24	Blue
54105UF			1/4	0.53 (13.5)	0.44 (11.2)	0.07 (1.8)	0.31 (7.9)	0.22 (5.6)		
54135UF			5/16	0.67 (17.0)	0.60 (15.2)	0.07 (1.8)	0.31 (7.9)	0.31 (7.8)		
54136UF			3/8	0.67 (17.0)	0.60 (15.2)	0.07 (1.8)	0.31 (7.9)	0.31 (7.8)		
54138UF	#4 AWG	#5 Str., 40-50 Navy 91/24 133/0.0177 49/0.029 0.265	#10	0.60 (15.2)	0.55 (14.0)	0.09 (2.3)	0.37 (9.4)	0.25 (6.4)	29	Grey
54106UF			1/4	0.60 (15.2)	0.55 (14.0)	0.09 (2.3)	0.37 (9.4)	0.25 (6.4)		
54139UF			5/16	0.66 (16.8)	0.61 (15.5)	0.07 (1.8)	0.37 (9.4)	0.31 (7.8)		
54140UF			3/8	0.66 (16.8)	0.61 (15.5)	0.07 (1.8)	0.37 (9.4)	0.31 (7.8)		
256-30695-264UF			1/2	1.40 (35.6)	1.00 (25.4)	0.06 (1.5)	0.37 (9.4)	0.50 (12.7)		
54107UF	#2 AWG	#3 Str. 60 Navy 125/24 #4 Weld 0.300	1/4	0.65 (16.5)	0.59 (15.0)	0.11 (2.8)	0.41 (10.4)	0.25 (6.4)	33	Brown
54142UF			5/16	0.88 (22.4)	0.59 (15.0)	0.11 (2.8)	0.41 (10.4)	0.38 (9.7)		
54143UF			3/8	0.80 (20.3)	0.59 (15.0)	0.11 (2.8)	0.41 (10.4)	0.38 (9.7)		
54145UF			1/2	1.08 (27.4)	0.75 (19.1)	0.08 (2.0)	0.41 (10.4)	0.50 (12.7)		
54108UF	#1 AWG	#2 AWG, 75 Navy, #2 Weld 150/24 175/24 133/0.0223 0.360	1/4	0.65 (16.5)	0.68 (17.3)	0.11 (2.8)	0.47 (11.9)	0.25 (6.4)	37	Green
54147UF			5/16	0.93 (23.6)	0.68 (17.3)	0.11 (2.8)	0.47 (11.9)	0.38 (9.7)		
54148UF			3/8	0.98 (24.9)	0.68 (17.3)	0.11 (2.8)	0.47 (11.9)	0.38 (9.7)		
54150UF			1/2	1.25 (31.8)	0.76 (19.3)	0.11 (2.8)	0.47 (11.9)	0.50 (12.7)		
54152UF	1/0 AWG	#1 AWG 100 Navy, #1 Weld 225/24 133/0.0254 0.389	1/4	0.65 (16.5)	0.75 (19.1)	0.13 (3.3)	0.52 (13.2)	0.25 (6.4)	42	Pink
54153UF			5/16	0.88 (22.4)	0.75 (19.1)	0.13 (3.3)	0.52 (13.2)	0.38 (9.7)		
54109UF			3/8	0.93 (23.6)	0.75 (19.1)	0.13 (3.3)	0.52 (13.2)	0.38 (9.7)		
54155UF			1/2	1.25 (31.8)	0.75 (19.1)	0.13 (3.3)	0.52 (13.2)	0.50 (12.7)		
54157UF	2/0 AWG	1/0 AWG, 125 Navy 1/0 Weld 275/24 427/0.0155, 133/0.0282	1/4	0.65 (16.5)	0.83 (21.1)	0.13 (3.3)	0.57 (14.5)	0.25 (6.4)	45	Black
54158UF			5/16	0.88 (22.4)	0.83 (21.1)	0.13 (3.3)	0.57 (14.5)	0.38 (9.7)		
54110UF			3/8	0.93 (23.6)	0.83 (21.1)	0.13 (3.3)	0.57 (14.5)	0.38 (9.7)		
54160UF			1/2	1.25 (31.8)	0.83 (21.1)	0.13 (3.3)	0.57 (14.5)	0.50 (12.7)		
54162UF	3/0 AWG	2/0 AWG, 150 Navy 2/0 Weld, 325/24 133/0.0316, 259/0.0227 427/0.0177	1/4	0.65 (16.5)	0.92 (23.4)	0.13 (3.3)	0.63 (16.0)	0.25 (6.4)	50	Orange
54163UF			5/16	0.88 (22.4)	0.92 (23.4)	0.13 (3.3)	0.63 (16.0)	0.38 (9.7)		
54111UF			3/8	0.93 (23.6)	0.92 (23.4)	0.13 (3.3)	0.63 (16.0)	0.38 (9.7)		
54165UF			1/2	1.25 (31.8)	0.92 (23.4)	0.13 (3.3)	0.63 (16.0)	0.50 (12.7)		
58147UF*	-	375/24	1/4	0.78 (19.8)	1.03 (26.2)	0.16 (4.1)	0.70 (17.8)	0.34 (8.6)	54	Purple
58148UF*			5/16	0.78 (19.8)	1.03 (26.2)	0.16 (4.1)	0.70 (17.8)	0.34 (8.6)		
58149UF*			3/8	0.81 (20.6)	1.03 (26.2)	0.16 (4.1)	0.70 (17.8)	0.38 (9.7)		
58151UF*			1/2	1.06 (26.9)	1.03 (26.2)	0.16 (4.1)	0.70 (17.8)	0.50 (12.7)		
54167UF	4/0 AWG	3/0 AWG 200 Navy, 3/0 Weld 450/24 703/0.0154	1/4	0.65 (16.5)	1.03 (26.2)	0.14 (3.6)	0.70 (17.8)	0.25 (6.4)	54	Purple
54168UF			5/16	0.87 (22.1)	1.03 (26.2)	0.14 (3.6)	0.70 (17.8)	0.38 (9.7)		
54112UF			3/8	0.93 (23.6)	1.03 (26.2)	0.14 (3.6)	0.70 (17.8)	0.38 (9.7)		
54170UF			1/2	1.25 (31.8)	1.03 (26.2)	0.14 (3.6)	0.70 (17.8)	0.50 (12.7)		
58161UF	-	4/0 AWG, 4/0 Weld 550/24 133/0.0399 259/0.0286 637/0.0183	1/4	0.78 (19.8)	1.25 (31.8)	0.15 (3.8)	0.79 (20.1)	0.38 (9.7)	62	Yellow
58162UF			5/16	0.88 (22.4)	1.25 (31.8)	0.15 (3.8)	0.79 (20.1)	0.38 (9.7)		
58163UF			3/8	0.93 (23.6)	1.25 (31.8)	0.15 (3.8)	0.79 (20.1)	0.38 (9.7)		
58165UF			1/2	1.25 (31.8)	1.25 (31.8)	0.15 (3.8)	0.79 (20.1)	0.50 (12.7)		
58166UF			5/8	1.58 (40.1)	1.25 (31.8)	0.15 (3.8)	0.79 (20.1)	0.63 (16.0)		

* Not CSA approved.
Call your Regional Sales Office for sizes not listed.
Tooling: pp. E4-E62
Die Selector Chart: pp. E35-E50

‡ For installations from 16 kV up to 35 kV, consult shielded cable manufacturers for stress relief and insulation requirements.



Compression Connectors for Copper Conductors

One-Hole Lugs — 45° Standard Barrel Certified to 600 V and Recommended up to 35 kV¥ (cont'd)

Material: High-Conductivity Wrought Copper

Finish: Electro-Tin Plated

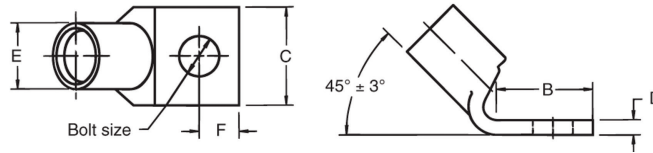

Cat. No.	Wire Size		Bolt Size	Dimensions in. (mm)					Die Code	Colour Code
	Code Cable	Flex Cable Classes G, H, I, K, M		B	C	D	E	F		
54172UF	250 kcmil	4/0 AWG 250 Navy 550/24	1/4	0.65 (16.5)	1.13 (28.7)	0.14 (3.6)	0.77 (19.6)	0.25 (6.4)	62	Yellow
54173UF			5/16	0.88 (22.4)	1.13 (28.7)	0.14 (3.6)	0.77 (19.6)	0.38 (9.7)		
54174UF			3/8	0.93 (23.6)	1.13 (28.7)	0.14 (3.6)	0.77 (19.6)	0.38 (9.7)		
54113UF			1/2	1.25 (31.8)	1.13 (28.7)	0.14 (3.6)	0.77 (19.6)	0.50 (12.7)		
58168UF	—	250 Weld 650/24 259/0.0311, 703/0.0189	1/2	1.25 (31.8)	1.25 (31.8)	0.15 (3.8)	0.85 (21.6)	0.50 (12.7)	66	White
54178UF	300 kcmil	250 kcmil 300 Navy 650/24	5/16	0.88 (22.4)	1.25 (31.8)	0.15 (3.8)	0.85 (21.6)	0.38 (9.7)		
54179UF			3/8	0.93 (23.6)	1.25 (31.8)	0.15 (3.8)	0.85 (21.6)	0.38 (9.7)		
54114UF			1/2	1.25 (31.8)	1.25 (31.8)	0.15 (3.8)	0.85 (21.6)	0.50 (12.7)		
54181UF			5/8	1.58 (40.1)	1.25 (31.8)	0.15 (3.8)	0.85 (21.6)	0.63 (16.0)		
58171UF	—	300 kcmil, 300 Weld 259/0.034, 427/0.0265 889/0.0183 775/24 = 313 kcmil	1/2	1.25 (31.8)	1.36 (34.5)	0.18 (4.6)	0.93 (23.6)	0.50 (12.7)	71	Red
256-30695-112UF	350 kcmil	650/24 350 Navy 262 kcmil	3/8	1.25 (31.8)	1.36 (34.5)	0.18 (4.6)	0.93 (23.6)	0.50 (12.7)		
54115UF			1/2	1.25 (31.8)	1.36 (34.5)	0.18 (4.6)	0.93 (23.6)	0.50 (12.7)		
54183UF			5/8	1.58 (40.1)	1.36 (34.5)	0.18 (4.6)	0.93 (23.6)	0.63 (16.0)		
58174UF	—	350 Weld 259/0.0368, 427/0.0285 703/0.0224, 889/0.0201	1/2	1.25 (31.8)	1.61 (40.9)	0.22 (5.6)	1.09 (27.7)	0.50 (12.7)	76	Blue
54116UF	400 kcmil	300 kcmil 400 Navy 775/24, 313 kcmil	1/2	1.25 (31.8)	1.41 (35.8)	0.17 (4.3)	0.96 (24.4)	0.50 (12.7)		
54185UF			5/8	1.58 (40.1)	1.41 (35.8)	0.17 (4.3)	0.96 (24.4)	0.63 (16.0)		
256-30695-1403UF	—	350 kcmil, 400 Weld	3/8	1.31 (28.7)	1.61 (40.9)	0.22 (5.6)	1.04 (26.4)	0.63 (16.0)		
58177UF	—	925/24 = 373 kcmil	1/2	1.25 (31.8)	1.61 (40.9)	0.22 (5.6)	1.04 (26.4)	0.50 (12.7)		
54118UF	500 kcmil	925/24 500 Navy 400 kcmil	1/2	1.25 (31.8)	1.61 (40.9)	0.22 (5.6)	1.10 (27.9)	0.50 (12.7)	87	Brown
58187UF			5/8	1.58 (40.1)	1.61 (40.9)	0.22 (5.6)	1.10 (27.9)	0.63 (16.0)		
58180UF	—	1100/24 = 444 kcmil 500 Weld, 259/0.0417 427/0.0325, 703/0.0253	5/8	1.58 (40.1)	1.75 (44.5)	0.24 (6.1)	1.20 (30.5)	0.50 (12.7)	94	Green
58120UF	600 kcmil	1110/24 = 444 kcmil	5/8	1.58 (40.1)	1.75 (44.5)	0.24 (6.1)	1.20 (30.5)	0.50 (12.7)		
54122UF	700 kcmil	1325/24 = 500 kcmil	5/8	1.58 (40.1)	1.84 (46.7)	0.23 (5.8)	1.26 (32.0)	0.50 (12.7)	99	Pink
256-30695-840UF	—	1325/24 = 535 kcmil	1/2	1.69 (42.9)	1.81 (46.0)	0.28 (7.1)	1.25 (31.8)	0.81 (20.6)		
58182UF	—	427/0.0342	5/8	1.58 (40.1)	1.81 (46.0)	0.28 (7.1)	1.25 (31.8)	0.63 (16.0)		
54123UF	750 kcmil	1325/24 = 535 kcmil	5/8	1.58 (40.1)	1.94 (49.3)	0.27 (6.9)	1.33 (33.8)	0.63 (16.0)	106	Black
58184UF	—	1600/24 = 646 kcmil	5/8	1.58 (40.1)	1.94 (49.3)	0.27 (6.9)	1.33 (33.8)	0.63 (16.0)		
54124UF	800 kcmil	800 Navy	5/8	1.58 (40.1)	2.01 (51.1)	0.27 (6.9)	1.38 (35.1)	0.63 (16.0)	107	Orange
54126UF	900 kcmil	1925/24 = 777 kcmil	5/8	1.58 (40.1)	2.17 (55.1)	0.31 (7.9)	1.50 (38.1)	0.63 (16.0)	115	Yellow
54128UF	1000 kcmil	1000 Navy	5/8	1.58 (40.1)	2.27 (57.7)	0.30 (7.6)	1.55 (39.4)	0.63 (16.0)	125	—

¥ For installations from 16 kV up to 35 kV, consult shielded cable manufacturers for stress relief and insulation requirements. Call your Regional Sales Office for sizes not listed.

Tooling: pp. E4–E62

Die Selector Chart: pp. E35–E50

Compression Connectors for Copper Conductors

One-Hole Lugs — 90° Standard Barrel Certified to 600 V and Recommended up to 35 kV \ddot{V}

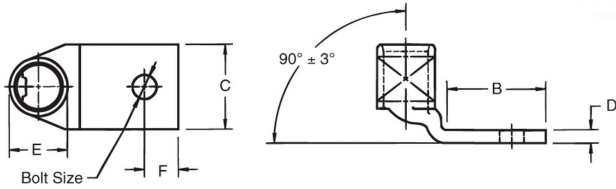
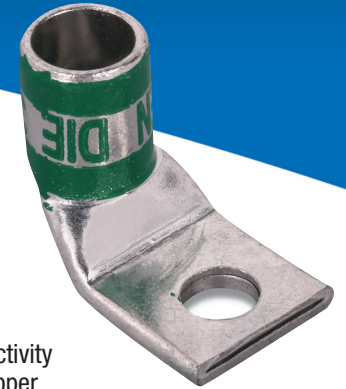

Material: High-Conductivity Wrought Copper

Finish: Electro-Tin Plated



Cat. No.	Wire Size		Bolt Size	Dimensions in. (mm)						Die Code	Colour Code
	Code Cable	Flex Cable Classes G, H, I, K, M		B	C	D	E	F			
54104UB	#8 AWG	#8 Str. 23 Navy #8 Weld 37/24 0.180	#10	0.50 (12.7)	0.39 (9.9)	0.08 (2.0)	0.25 (6.4)	0.22 (5.6)	21	Red	
54130UB			1/4	0.61 (15.5)	0.45 (11.4)	0.07 (1.8)	0.25 (6.4)	0.25 (6.4)			
54131UB			5/16	0.64 (16.3)	0.56 (14.2)	0.05 (1.3)	0.25 (6.4)	0.28 (7.1)			
54132UB			3/8	0.64 (16.3)	0.56 (14.2)	0.05 (1.3)	0.25 (6.4)	0.28 (7.1)			
54134UB	#6 AWG	#6 AWG, 30 Navy #6 Weld 61/24 133/0.014 0.227	#10	0.53 (13.5)	0.44 (11.2)	0.07 (1.8)	0.31 (7.9)	0.22 (5.6)	24	Blue	
54105UB			1/4	0.53 (13.5)	0.44 (11.2)	0.07 (1.8)	0.31 (7.9)	0.22 (5.6)			
54135UB			5/16	0.67 (17.0)	0.60 (15.2)	0.07 (1.8)	0.31 (7.9)	0.31 (7.8)			
54136UB			3/8	0.67 (17.0)	0.60 (15.2)	0.07 (1.8)	0.31 (7.9)	0.31 (7.8)			
54138UB	#4 AWG	#5 AWG, 40/50 Navy 91/24 133/0.0177 49/0.029 0.265	#10	0.60 (15.2)	0.55 (14.0)	0.09 (2.3)	0.37 (9.4)	0.25 (6.4)	29	Grey	
54106UB			1/4	0.60 (15.2)	0.55 (14.0)	0.09 (2.3)	0.37 (9.4)	0.25 (6.4)			
54139UB			5/16	0.66 (16.8)	0.61 (15.5)	0.07 (1.8)	0.37 (9.4)	0.31 (7.8)			
54140UB			3/8	0.66 (16.8)	0.61 (15.5)	0.07 (1.8)	0.37 (9.4)	0.31 (7.8)			
256-30695-264UB			1/2	1.40 (35.6)	1.00 (25.4)	0.06 (1.5)	0.37 (9.4)	0.50 (12.7)			
54107UB	#2 AWG	#3 AWG 60 Navy 125/24 #4 Weld 0.300	1/4	0.65 (16.5)	0.59 (15.0)	0.11 (2.8)	0.41 (10.4)	0.25 (6.4)	33	Brown	
54142UB			5/16	0.88 (22.4)	0.59 (15.0)	0.11 (2.8)	0.41 (10.4)	0.38 (9.7)			
54143UB			3/8	0.80 (20.3)	0.59 (15.0)	0.11 (2.8)	0.41 (10.4)	0.38 (9.7)			
54145UB			1/2	1.08 (27.4)	0.75 (19.1)	0.08 (2.0)	0.41 (10.4)	0.50 (12.7)			
54108UB	#1 AWG	#2 AWG, 75 Navy, #2 Weld 150/24 175/24 133/0.0223 0.360	1/4	0.65 (16.5)	0.68 (17.3)	0.11 (2.8)	0.47 (11.9)	0.25 (6.4)	37	Green	
54147UB			5/16	0.93 (23.6)	0.68 (17.3)	0.11 (2.8)	0.47 (11.9)	0.38 (9.7)			
54148UB			3/8	0.98 (24.9)	0.68 (17.3)	0.11 (2.8)	0.47 (11.9)	0.38 (9.7)			
54150UB			1/2	1.25 (31.8)	0.76 (19.3)	0.11 (2.8)	0.47 (11.9)	0.50 (12.7)			
54152UB	1/0 AWG	#1 AWG 100 Navy, #1 Weld 225/24 133/0.0254 0.389	1/4	0.65 (16.5)	0.75 (19.1)	0.13 (3.3)	0.52 (13.2)	0.25 (6.4)	42	Pink	
54153UB			5/16	0.88 (22.4)	0.75 (19.1)	0.13 (3.3)	0.52 (13.2)	0.38 (9.7)			
54109UB			3/8	0.93 (23.6)	0.75 (19.1)	0.13 (3.3)	0.52 (13.2)	0.38 (9.7)			
54155UB			1/2	1.25 (31.8)	0.75 (19.1)	0.13 (3.3)	0.52 (13.2)	0.50 (12.7)			
54157UB	2/0 AWG	1/0 AWG, 125 Navy 1/0 Weld 275/24 427/0.0155, 133/0.0282	1/4	0.65 (16.5)	0.83 (21.1)	0.13 (3.3)	0.57 (14.5)	0.25 (6.4)	45	Black	
54158UB			5/16	0.88 (22.4)	0.83 (21.1)	0.13 (3.3)	0.57 (14.5)	0.38 (9.7)			
54110UB			3/8	0.93 (23.6)	0.83 (21.1)	0.13 (3.3)	0.57 (14.5)	0.38 (9.7)			
54160UB			1/2	1.25 (31.8)	0.83 (21.1)	0.13 (3.3)	0.57 (14.5)	0.50 (12.7)			
54162UB	3/0 AWG	2/0 AWG, 150 Navy, 2/0 Weld 325/24 133/0.0316, 259/0.0227 427/0.0177	1/4	0.65 (16.5)	0.92 (23.4)	0.13 (3.3)	0.63 (16.0)	0.25 (6.4)	50	Orange	
54163UB			5/16	0.88 (22.4)	0.92 (23.4)	0.13 (3.3)	0.63 (16.0)	0.38 (9.7)			
54111UB			3/8	0.93 (23.6)	0.92 (23.4)	0.13 (3.3)	0.63 (16.0)	0.38 (9.7)			
54165UB			1/2	1.25 (31.8)	0.92 (23.4)	0.13 (3.3)	0.63 (16.0)	0.50 (12.7)			
54167UB	-	3/0 AWG, 200 Navy, 3/0 Weld 450/24 703/0.0154	1/4	0.65 (16.5)	1.03 (26.2)	0.14 (3.6)	0.70 (17.8)	0.34 (8.6)	54	Purple	
54168UB			5/16	0.87 (22.1)	1.03 (26.2)	0.14 (3.6)	0.70 (17.8)	0.34 (8.6)			
54112UB			3/8	0.93 (23.6)	1.03 (26.2)	0.14 (3.6)	0.70 (17.8)	0.38 (9.7)			
54170UB			1/2	1.25 (31.8)	1.03 (26.2)	0.14 (3.6)	0.70 (17.8)	0.50 (12.7)			
58161UB	4/0 AWG	3/0 AWG, 4/0 Weld 550/24 133/0.0399 259/0.0286 637/0.0183	1/4	0.78 (19.8)	1.25 (31.8)	0.15 (3.8)	0.79 (20.1)	0.38 (9.7)	62	Yellow	
58162UB			5/16	0.88 (22.4)	1.25 (31.8)	0.15 (3.8)	0.79 (20.1)	0.38 (9.7)			
58163UB			3/8	0.93 (23.6)	1.25 (31.8)	0.15 (3.8)	0.79 (20.1)	0.38 (9.7)			
58165UB			1/2	1.25 (31.8)	1.25 (31.8)	0.15 (3.8)	0.79 (20.1)	0.50 (12.7)			
58166UB			5/8	1.58 (40.1)	1.25 (31.8)	0.15 (3.8)	0.79 (20.1)	0.63 (16.0)			

¥ For installations from 16 kV up to 35 kV, consult shielded cable manufacturers for stress relief and insulation requirements. Call your Regional Sales Office for sizes not listed.

Tooling: pp. E4–E62

Die Selector Chart: pp. E35–E50



Compression Connectors for Copper Conductors

One-Hole Lugs — 90° Standard Barrel Certified to 600 V and Recommended up to 35 kV¥ (cont'd)

Material: High-Conductivity Wrought Copper

Finish: Electro-Tin Plated

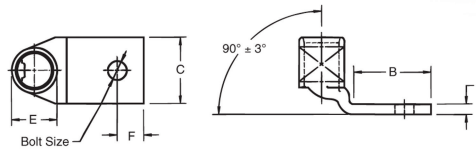

Cat. No.	Code Cable	Wire Size Flex Cable Classes G, H, I, K, M	Bolt Size	Dimensions in. (mm)					Die Code	Colour Code
				B	C	D	E	F		
54172UB	250 kcmil	4/0 AWG 250 Navy 550/24	1/4	0.65 (16.5)	1.13 (28.7)	0.14 (3.6)	0.77 (19.6)	0.25 (6.4)	62	Yellow
54173UB			5/16	0.88 (22.4)	1.13 (28.7)	0.14 (3.6)	0.77 (19.6)	0.38 (9.7)		
54174UB			3/8	0.93 (23.6)	1.13 (28.7)	0.14 (3.6)	0.77 (19.6)	0.38 (9.7)		
54113UB			1/2	1.25 (31.8)	1.13 (28.7)	0.14 (3.6)	0.77 (19.6)	0.50 (12.7)		
58168UB	—	250 Weld 650/24 = 262 kcmil 259/0.0311, 703/0.0189	1/2	1.25 (31.8)	1.25 (31.8)	0.15 (3.8)	0.85 (21.6)	0.50 (12.7)	66	White
54178UB	300 kcmil	250 kcmil 300 Navy 650/24	5/16	0.88 (22.4)	1.25 (31.8)	0.15 (3.8)	0.85 (21.6)	0.38 (9.7)		
54179UB			3/8	0.93 (23.6)	1.25 (31.8)	0.15 (3.8)	0.85 (21.6)	0.38 (9.7)		
54114UB			1/2	1.25 (31.8)	1.25 (31.8)	0.15 (3.8)	0.85 (21.6)	0.50 (12.7)		
54181UB			5/8	1.58 (40.1)	1.25 (31.8)	0.15 (3.8)	0.85 (21.6)	0.63 (16.0)		
58171UB	—	300 Weld, 259/0.034 427/0.0265, 889/0.0183 775/24 = 313 kcmil	1/2	1.25 (31.8)	1.36 (34.5)	0.18 (4.6)	0.93 (23.6)	0.50 (12.7)	71	Red
256-30695-112UB	350 kcmil	650/24, 350 Navy 262 kcmil	3/8	1.25 (31.8)	1.36 (34.5)	0.18 (4.6)	0.93 (23.6)	0.50 (12.7)		
54115UB			1/2	1.25 (31.8)	1.36 (34.5)	0.18 (4.6)	0.93 (23.6)	0.50 (12.7)		
54183UB	—	350 Weld 259/0.0368, 427/0.0285 703/0.0224, 889/0.0201	1/2	1.25 (31.8)	1.61 (40.9)	0.22 (5.6)	1.09 (27.7)	0.50 (12.7)	76	Blue
58174UB	400 kcmil	300 kcmil 400 Navy 775/24, 313 kcmil	5/8	1.58 (40.1)	1.41 (35.8)	0.17 (4.3)	0.96 (24.4)	0.63 (16.0)		
54116UB			1/2	1.25 (31.8)	1.41 (35.8)	0.17 (4.3)	0.96 (24.4)	0.63 (16.0)		
256-30695-1403UB	—	400 Weld 925/24 = 373 kcmil 259/0.0393, 427/0.0306	3/8	1.31 (33.3)	1.61 (40.9)	0.22 (5.6)	1.04 (26.4)	0.63 (16.0)	80	—
58177UB	500 kcmil	400 kcmil 500 Navy 925/24	1/2	1.25 (31.8)	1.61 (40.9)	0.22 (5.6)	1.04 (26.4)	0.50 (12.7)		
54118UB			1/2	1.25 (31.8)	1.61 (40.9)	0.22 (5.6)	1.10 (27.9)	0.50 (12.7)		
54187UB	—	1100/24 = 444 kcmil 500 Weld, 259/0.0417 427/0.0325, 703/0.0253	5/8	1.58 (40.1)	1.75 (44.5)	0.24 (6.1)	1.20 (30.5)	0.50 (12.7)	94	Green
58180UB	600 kcmil	1100/24 = 444 kcmil	5/8	1.58 (40.1)	1.75 (44.5)	0.24 (6.1)	1.20 (30.5)	0.50 (12.7)		
54120UB	700 kcmil	1325/24, 535 kcmil 500 AWG, 550/535	5/8	1.58 (40.1)	1.84 (46.7)	0.23 (5.8)	1.26 (32.0)	0.50 (12.7)	99	Pink
54122UB	—	1325/24 = 535 kcmil 427/0.0342	1/2	1.69 (42.9)	1.81 (46.0)	0.28 (7.1)	1.25 (31.8)	0.63 (16.0)		
256-30695-840UB			5/8	1.58 (40.1)	1.81 (46.0)	0.28 (7.1)	1.25 (31.8)	0.63 (16.0)		
58182UB	750 kcmil	—	5/8	1.58 (40.1)	1.94 (49.3)	0.27 (6.9)	1.33 (33.8)	0.63 (16.0)	106	Black
54123UB	—	1600/24 = 646 kcmil	5/8	1.58 (40.1)	1.94 (49.3)	0.27 (6.9)	1.33 (33.8)	0.63 (16.0)		
58184UB	800 kcmil	800 Navy	5/8	1.58 (40.1)	2.01 (51.1)	0.27 (6.9)	1.38 (35.1)	0.63 (16.0)	107	Orange
54124UB	900 kcmil	1925/24 = 777 kcmil	5/8	1.58 (40.1)	2.17 (55.1)	0.31 (7.9)	1.50 (38.1)	0.63 (16.0)	115	Yellow
54126UB	1000 kcmil	1000 Navy	5/8	1.58 (40.1)	2.27 (57.7)	0.30 (7.6)	1.55 (39.4)	0.63 (16.0)	125	—

¥ For installations from 16 kV up to 35 kV, consult shielded cable manufacturers for stress relief and insulation requirements. Call your Regional Sales Office for sizes not listed.
Tooling: pp. E4–E62
Die Selector Chart: pp. E35–E50

Compression Connectors for Copper Conductors

Two-Hole Lugs — Standard Barrel Certified to 600 V and Recommended up to 35 kV[¥]

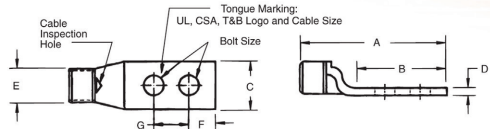

Material: High-Conductivity Wrought Copper

Finish: Electro-Tin Plated



Cat. No.	Code Cable	Wire Size Flex Cable Classes G, H, I, K, M	Bolt Size	Dimensions in. (mm)						Die Code	Colour Code	
				A	B	C	D	E	F			G
54201	#14-10 AWG	—	1/4	1.86 (47.2)	1.19 (30.2)	0.50 (12.7)	0.05 (1.3)	0.20 (5.1)	0.25 (6.4)	0.63 (16.0)	ERG2002	Yellow
256-30695-1302			3/8	2.48 (63.0)	1.81 (46.0)	0.56 (14.2)	0.04 (1.0)	0.22 (5.6)	0.38 (9.7)	1.00 (25.4)		
54204	#8 AWG	#8 AWG, 23 Navy #8 Weld 37/24	#10	1.88 (47.8)	1.18 (30.0)	0.42 (10.7)	0.08 (2.0)	0.26 (6.6)	0.25 (6.4)	0.63 (16.0)	21	Red
256-31426-33*			#10	1.88 (47.8)	1.18 (30.0)	0.41 (10.4)	0.06 (1.5)	0.26 (6.6)	0.23 (5.8)	0.75 (19.0)		
256-31426-33PH			#10	1.88 (47.8)	1.18 (30.0)	0.41 (10.4)	0.06 (1.5)	0.26 (6.6)	0.23 (5.8)	0.75 (19.0)		
542040410			1/4	2.01 (51.1)	1.31 (33.3)	0.42 (10.7)	0.08 (2.0)	0.26 (6.6)	0.25 (6.4)	0.63 (16.0)		
542040416			1/4	2.38 (60.5)	1.68 (42.7)	0.42 (10.7)	0.08 (2.0)	0.26 (6.6)	0.25 (6.4)	1.00 (25.4)		
256-30695-1094			1/4	2.50 (63.5)	1.81 (46.0)	0.56 (14.22)	0.05 (1.3)	0.26 (6.6)	0.25 (6.4)	0.75 (19.0)		
256-30695-251	#6 AWG	#6 AWG, 30 Navy #6 Weld 61/24 133/0.014	3/8	2.50 (63.5)	1.81 (46.0)	0.56 (14.22)	0.05 (1.3)	0.26 (6.6)	0.38 (9.7)	1.00 (25.4)	24	Blue
256-30695-1070			#12	1.81 (46.0)	1.19 (30.2)	0.44 (11.2)	0.11 (2.8)	0.30 (7.6)	0.25 (6.4)	0.50 - 0.63 (12.7 - 16.0)		
256-30695-1153			#10	1.98 (50.3)	1.28 (32.5)	0.44 (11.2)	0.08 (2.0)	0.30 (7.6)	0.25 (6.4)	0.50 (12.7)		
256-30695-1183			#10	1.98 (50.3)	1.19 (30.2)	0.44 (11.2)	0.08 (2.0)	0.30 (7.6)	0.22 (5.6)	0.63 - 0.75 (16.0 - 19.0)		
54205			1/4	1.98 (50.3)	1.28 (32.5)	0.44 (11.2)	0.08 (2.0)	0.30 (7.6)	0.25 (6.4)	0.63 (16.0)		
256-30695-1095			1/4	2.13 (54.1)	1.31 (33.3)	0.43 (10.9)	0.08 (2.0)	0.30 (7.6)	0.25 (6.4)	0.75 (19.0)		
256-30695-252			1/4	2.38 (60.5)	1.63 (41.4)	0.43 (10.9)	0.08 (2.0)	0.30 (7.6)	0.25 (6.4)	1.00 (25.4)		
256-30695-372			1/4	2.13 (54.1)	1.43 (36.3)	0.43 (10.9)	0.08 (2.0)	0.30 (7.6)	0.25 (6.4)	0.75 (19.0)		
256-30695-913			1/4	2.38 (60.5)	1.75 (44.5)	0.43 (10.9)	0.08 (2.0)	0.30 (7.6)	0.25 (6.4)	1.00 (25.4)		
256-30695-253			3/8	2.58 (65.3)	1.81 (45.9)	0.55 (14.0)	0.08 (2.0)	0.30 (7.6)	0.38 (9.7)	1.00 (25.4)		
54206	#4 AWG	#5 AWG 40-50 Navy 91/24 133/0.0177 49/0.029	1/4	2.03 (51.6)	1.28 (32.5)	0.52 (13.2)	0.10 (2.5)	0.37 (9.4)	0.25 (6.4)	0.63 (16.0)	29	Grey
256-30695-1184			5/16	2.31 (58.7)	1.63 (41.4)	0.52 (13.2)	0.10 (2.5)	0.37 (9.4)	0.31 (7.9)	1.00 (25.4)		
256-30695-255			3/8	2.56 (65.0)	1.81 (45.9)	0.59 (15.0)	0.09 (2.3)	0.37 (9.4)	0.38 (9.7)	1.00 (25.4)		
54207	#2 AWG	#3 AWG 60 Navy 125/24, #4 Weld	1/4	2.13 (54.1)	1.28 (32.5)	0.59 (15.0)	0.11 (2.8)	0.41 (10.4)	0.25 (6.4)	0.63 (16.0)	33	Brown
256-30695-1355			1/4	2.15 (54.6)	1.31 (33.3)	0.59 (15.0)	0.13 (3.3)	0.41 (10.4)	0.25 (6.4)	0.75 (19.0)		
256-30695-1185			1/4	2.38 (60.5)	1.53 (38.9)	0.59 (15.0)	0.11 (2.8)	0.41 (10.4)	0.25 (6.4)	1.00 (25.4)		
256-30695-257			3/8	2.67 (67.8)	1.81 (45.9)	0.60 (15.2)	0.10 (2.5)	0.41 (10.4)	0.38 (9.7)	1.00 (25.4)		
256-30695-1049			1/2	3.75 (95.3)	2.88 (73.2)	0.75 (19.1)	0.09 (2.3)	0.41 (10.4)	0.31 (7.9)	1.75 (44.5)		
54208	#1 AWG	#2 AWG, 75 Navy 150/24 175/24 133/0.0223	1/4	2.13 (54.1)	1.28 (32.5)	0.68 (17.3)	0.11 (2.8)	0.47 (11.9)	0.25 (6.4)	0.63 (16.0)	37	Green
256-30695-1233			5/16	2.69 (68.3)	1.62 (41.2)	0.69 (17.5)	0.13 (3.3)	0.47 (11.9)	0.34 (8.6)	1.00 (25.4)		
256-30695-1236			3/8	2.75 (69.9)	1.81 (45.9)	0.68 (17.3)	0.11 (2.8)	0.47 (11.9)	0.38 (9.7)	1.00 (25.4)		
256-30695-329	1/0 AWG	#1 AWG 100 Navy, #1 Weld 225/24 133/0.0254	1/4	2.75 (69.9)	1.81 (45.9)	0.75 (19.1)	0.14 (3.6)	0.52 (13.2)	0.38 (9.7)	0.75 (19.4)	42	Pink
54255			5/16	2.56 (65.0)	1.56 (39.6)	0.75 (19.1)	0.14 (3.6)	0.52 (13.2)	0.38 (9.7)	0.88 (22.4)		
256-30695-1234			5/16	2.75 (69.9)	1.78 (45.2)	0.75 (19.1)	0.14 (3.6)	0.52 (13.2)	0.33 (8.4)	1.00 (25.4)		
54209			3/8	2.88 (73.2)	1.93 (49.0)	0.75 (19.1)	0.13 (3.3)	0.52 (13.2)	0.38 (9.7)	1.00 (25.4)		
256-30695-1265			3/8	3.50 (89.0)	2.57 (65.3)	0.75 (19.1)	0.14 (3.6)	0.52 (13.2)	0.38 (9.7)	1.75 (44.5)		
256-30695-886	2/0 AWG	1/0 AWG, 125 Navy 1/0 Weld 275/24 133/0.0282	1/2	3.78 (96.0)	2.83 (71.2)	0.75 (19.1)	0.13 (3.3)	0.52 (13.2)	0.5 (12.7)	1.75 (44.5)	45	Black
256-30695-1175			1/4	2.45 (6.2)	1.44 (36.6)	0.83 (21.1)	0.14 (3.6)	0.57 (14.5)	0.25 (6.4)	0.75 (19.0)		
54261			5/16	2.70 (68.6)	1.63 (41.4)	0.83 (21.1)	0.14 (3.6)	0.57 (14.5)	0.33 (8.4)	0.88 (22.4)		
256-30695-832			5/16	2.88 (73.2)	1.81 (45.9)	0.81 (20.6)	0.14 (3.6)	0.57 (14.5)	0.38 (9.7)	1.00 (25.4)		
54210			3/8	2.93 (74.4)	1.93 (49.0)	0.83 (21.1)	0.13 (3.3)	0.57 (14.5)	0.38 (9.7)	1.00 (25.4)		
54260	3/0 AWG	150 Navy, 2/0 Weld 2/0 AWG 325/24 133/0.0316 259/0.0227 427/0.0177	1/2	3.83 (97.3)	2.81 (71.4)	0.83 (21.1)	0.14 (3.6)	0.57 (14.5)	0.38 (9.7)	1.75 (44.5)	50	Orange
54266			5/16	2.88 (73.2)	1.75 (44.5)	0.94 (23.9)	0.14 (3.6)	0.63 (16.0)	0.33 (8.4)	1.00 (25.4)		
54211			3/8	2.94 (74.7)	1.81 (46.0)	0.94 (23.9)	0.14 (3.6)	0.63 (16.0)	0.38 (9.7)	1.00 (25.4)		
54265			1/2	3.94 (100.1)	2.81 (71.4)	0.94 (23.9)	0.14 (3.6)	0.63 (16.0)	0.50 (12.7)	1.75 (44.5)		

* Blind End
 ¥ For installations from 16 kV up to 35 kV, consult shielded cable manufacturers for stress relief and insulation requirements. Call your Regional Sales Office for sizes not listed.
 Tooling: pp. E4-E62
 Die Selector Chart: pp. E35-E50



Compression Connectors for Copper Conductors

Two-Hole Lugs — Standard Barrel Certified to 600 V and Recommended up to 35 kV $\frac{1}{2}$ (cont'd)

Material: High-Conductivity Wrought Copper

Finish: Electro-Tin Plated

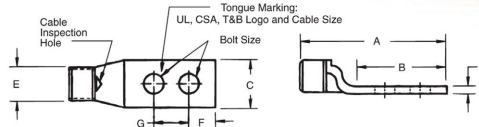

Cat. No.	Wire Size		Bolt Size	Dimensions in. (mm)							Die Code	Colour Code
	Code Cable	Flex Cable Classes G, H, I, K, M		A	B	C	D	E	F	G		
54212	4/0 AWG	3/0 AWG, 200 Navy 3/0 Weld 450/24 = 182 kcmil 703/0.0154	3/8	3.18 (80.8)	1.93 (49.0)	1.03 (26.2)	0.14 (3.6)	0.70 (17.8)	0.38 (9.7)	1.00 (25.4)	54	Purple
54270			1/2	4.25 (108.0)	3.00 (76.2)	1.03 (26.2)	0.14 (3.6)	0.70 (17.8)	0.50 (12.7)	1.75 (44.5)		
256-30695-1247			1/4	3.06 (77.7)	1.44 (36.6)	1.03 (26.2)	0.16 (4.1)	0.70 (17.8)	0.38 (9.7)	0.63 (16.0)		
256-30695-331			1/4	3.06 (77.7)	1.81 (46.0)	1.03 (26.2)	0.14 (3.6)	0.70 (17.8)	0.38 (9.7)	0.75 (19.1)		
256-30695-1261			5/16	3.18 (80.8)	1.93 (49.0)	1.03 (26.2)	0.14 (3.6)	0.70 (17.8)	0.38 (9.7)	1.00 (25.4)		
54213	250 kcmil	4/0 AWG 250 Navy	3/8	3.28 (83.3)	1.93 (49.0)	1.13 (28.7)	0.14 (3.6)	0.77 (19.6)	0.38 (9.7)	1.00 (25.4)	62	Yellow
54275			1/2	4.19 (106.4)	2.81 (71.4)	1.13 (28.7)	0.18 (4.6)	0.77 (19.6)	0.50 (12.7)	1.75 (44.5)		
256-30695-345	-	4/0 AWG, 4/0 Weld 550/24 = 222 kcmil 133/0.0399 259/0.0286 637/0.018	3/8	3.25 (82.6)	1.69 (42.9)	1.25 (31.8)	0.15 (3.8)	0.79 (20.1)	0.38 (9.7)	0.88 (22.4)	66	White
256-30695-835			3/8	4.25 (108.0)	2.80 (71.1)	1.25 (31.8)	0.15 (3.8)	0.79 (20.1)	0.38 (9.7)	1.00 (25.4)		
256-30695-452			3/8	3.13 (79.5)	1.88 (47.8)	1.25 (31.8)	0.16 (4.1)	0.79 (20.1)	0.38 (9.7)	0.88 (22.4)		
58265			1/2	3.94 (100.1)	2.81 (71.4)	0.94 (23.9)	0.14 (3.6)	0.79 (20.1)	0.50 (12.7)	1.75 (44.5)		
54214	300 kcmil	250 AWG 300 Navy 650/24 = 262 kcmil	3/8	3.45 (87.6)	1.93 (49.0)	1.25 (31.8)	0.15 (3.8)	0.85 (21.6)	0.38 (9.7)	1.00 (25.4)	71	Red
54280			1/2	4.45 (113.0)	3.00 (76.2)	1.25 (31.8)	0.15 (3.8)	0.85 (21.6)	0.50 (12.7)	1.75 (44.5)		
256-30695-332	350 kcmil	350 Navy	1/4	3.40 (86.4)	1.81 (46.0)	1.36 (34.5)	0.18 (4.6)	0.93 (23.6)	0.38 (9.7)	0.75 (19.1)	76	Blue
256-30695-1240			5/16	4.18 (106.2)	2.63 (66.8)	1.36 (34.5)	0.18 (4.6)	0.93 (23.6)	0.38 (9.7)	1.75 (44.5)		
54215			3/8	3.51 (89.2)	1.93 (49.0)	1.36 (34.5)	0.18 (4.6)	0.93 (23.6)	0.38 (9.7)	1.00 (25.4)		
54282	1/2	4.60 (116.8)	3.00 (76.2)	1.36 (34.5)	0.18 (4.6)	0.93 (23.6)	0.50 (12.7)	1.75 (44.5)				
54216	400 kcmil	300 kcmil 313 kcmil 775/24	3/8	3.93 (99.8)	1.93 (49.0)	1.41 (35.8)	0.17 (4.3)	0.96 (24.4)	0.38 (9.7)	1.00 (25.4)	80	-
54283			3/8	3.88 (98.6)	1.93 (49.0)	1.41 (35.8)	0.17 (4.3)	0.96 (24.4)	0.38 (9.7)	1.06 (26.9)		
256-30695-439	-	400 Weld 925/24 = 373 kcmil 259/0.0393 427/0.0306	3/8	4.35 (110.5)	2.25 (57.2)	1.61 (40.9)	0.22 (5.6)	1.04 (26.4)	0.50 (12.7)	1.00 (25.4)	87	Brown
58277			1/2	5.06 (128.5)	3.00 (76.2)	1.61 (40.9)	0.22 (5.6)	1.04 (26.4)	0.50 (12.7)	1.75 (44.5)		
256-30695-839			3/8	4.09 (103.9)	2.06 (52.3)	1.61 (40.9)	0.22 (5.6)	1.04 (26.4)	0.50 (12.7)	1.00 (25.4)		
54218	500 kcmil	400 kcmil 500 Navy	3/8	3.96 (100.6)	1.93 (49.0)	1.61 (40.9)	0.22 (5.6)	1.10 (27.9)	0.38 (9.7)	1.00 (25.4)	94	Green
54286			1/2	5.07 (128.8)	3.00 (76.2)	1.61 (40.9)	0.22 (5.6)	1.10 (27.9)	0.50 (12.7)	1.75 (44.5)		
256-30695-188	1/2	4.06 (103.1)	2.31 (58.7)	1.63 (41.4)	0.22 (5.6)	1.10 (27.9)	0.50 (12.7)	1.25 (31.8)				
54220	600 kcmil	-	3/8	4.13 (104.9)	1.93 (49.0)	1.75 (44.5)	0.24 (6.1)	1.20 (30.5)	0.38 (9.7)	1.00 (25.4)	99	Pink
54289			1/2	5.23 (132.8)	3.00 (76.2)	1.75 (44.5)	0.24 (6.1)	1.20 (30.5)	0.50 (12.7)	1.75 (44.5)		
256-30695-1406	700 kcmil	550/535 1325/24 500 AWG	3/8	4.05 (102.9)	2.11 (53.6)	1.78 (45.2)	0.24 (6.1)	1.25 (31.8)	0.50 (12.7)	1.00 (25.4)	106	Black
256-30695-842			3/8	4.30 (109.2)	2.06 (52.3)	1.80 (45.7)	0.28 (7.1)	1.25 (31.8)	0.50 (12.7)	1.00 (25.4)		
256-30695-898			3/8	4.30 (109.2)	2.06 (52.3)	1.80 (45.7)	0.28 (7.1)	1.25 (31.8)	0.50 (12.7)	1.00 (25.4)		
54291			1/2	5.18 (131.6)	3.00 (76.2)	1.84 (46.7)	0.23 (5.8)	1.25 (31.8)	0.50 (12.7)	1.75 (44.5)		
58281	1/2	5.23 (132.8)	3.00 (76.2)	1.80 (45.7)	0.28 (7.1)	1.25 (31.8)	0.50 (12.7)	1.75 (44.5)				
256-30695-237	750 kcmil	-	3/8	5.10 (129.5)	2.80 (71.1)	1.94 (49.3)	0.27 (6.9)	1.33 (33.8)	0.38 (9.7)	1.00 (25.4)	107	Orange
54223			1/2	5.32 (135.1)	3.00 (76.2)	1.94 (49.3)	0.27 (6.9)	1.33 (33.8)	0.50 (12.7)	1.75 (44.5)		
256-30695-1376	800 kcmil	-	3/8	4.78 (121.4)	2.28 (57.9)	2.01 (51.1)	0.27 (6.9)	1.38 (35.1)	0.44 (11.2)	1.13 (28.7)	115	Yellow
54224			1/2	5.50 (139.7)	3.00 (76.2)	2.01 (51.1)	0.27 (6.9)	1.38 (35.1)	0.50 (12.7)	1.75 (44.5)		
256-30695-694	900 kcmil	1925/24 = 777 kcmil	3/8	4.65 (118.1)	2.06 (52.3)	2.18 (55.4)	0.31 (7.9)	1.50 (38.1)	0.50 (12.7)	1.00 (25.4)	125	-
54226			1/2	5.59 (142.0)	3.00 (76.2)	2.18 (55.4)	0.31 (7.9)	1.50 (38.1)	0.50 (12.7)	1.75 (44.5)		
256-30695-846			3/8	4.60 (116.8)	2.06 (52.3)	2.12 (53.9)	0.31 (7.9)	1.50 (38.1)	0.50 (12.7)	1.00 (25.4)		
256-30695-844			5/8	5.00 (127.0)	2.63 (66.8)	2.18 (55.4)	0.31 (7.9)	1.50 (38.1)	0.56 (14.2)	1.50 (38.1)		
54228	1000 kcmil	1000 Navy	1/2	5.45 (138.4)	3.00 (76.2)	2.27 (57.7)	0.30 (7.6)	1.55 (39.4)	0.50 (12.7)	1.75 (44.5)		

¥ For installations from 16 kV up to 35 kV, consult shielded cable manufacturers for stress relief and insulation requirements. Call your Regional Sales Office for sizes not listed.

Tooling: pp. E4–E62

Die Selector Chart: pp. E35–E50

Compression Connectors for Copper Conductors

Two-Hole Lugs — 45° Standard Barrel Certified to 600 V and Recommended up to 35 kV \ddagger

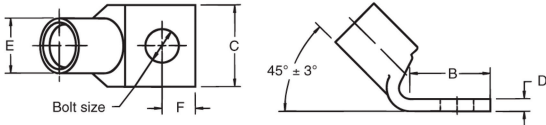

Material: High-Conductivity Wrought Copper

Finish: Electro-Tin Plated



Cat. No.	Wire Size		Bolt Size	Dimensions in. (mm)						Die Code	Colour Code
	Code Cable	Flex Cable Classes G, H, I, K, M		B	C	D	E	F	G		
256-31426-9	#14 – 10 AWG	—	#10	1.22 (31.0)	0.37 (9.4)	0.05 (1.3)	0.20 (5.1)	0.25 (6.4)	0.63 (16.0)	—	—
54204UF	#8 AWG	#8 AWG, 23 Navy #8 Weld 37/24	#10	1.18 (30.0)	0.42 (10.7)	0.08 (2.0)	0.26 (6.6)	0.25 (6.4)	0.63 (16.0)	21	Red
256-30695-1183UF	#6 AWG	#6 AWG, 30 Navy #6 Weld 61/24 133/0.014	#10	1.19 (30.2)	0.44 (11.2)	0.08 (2.0)	0.30 (7.6)	0.22 (5.6)	0.63 – 0.75 (16.0) – (19.1)	24	Blue
54205UF			1/4	1.28 (32.5)	0.44 (11.2)	0.08 (2.0)	0.30 (7.6)	0.25 (6.4)	0.63 (16.0)		
54205UF0416			1/4	1.56 (39.6)	0.43 (10.9)	0.08 (2.0)	0.30 (7.6)	0.25 (6.4)	1.00 (25.4)		
54206UF	#4 AWG	#5 AWG 40-50 Navy 91/24 133/0.0177 49/0.029	1/4	1.28 (32.5)	0.52 (13.2)	0.10 (2.5)	0.37 (9.4)	0.25 (6.4)	0.63 (16.0)	29	Grey
54207UF	#2 AWG	#3 AWG 60 Navy, #4 Weld 125/24	1/4	1.28 (32.5)	0.59 (15.0)	0.11 (2.8)	0.41 (10.4)	0.25 (6.4)	0.63 (16.0)	33	Brown
256-30695-257UF			3/8	1.81 (46.0)	0.60 (15.2)	0.11 (2.8)	0.41 (10.4)	0.38 (9.7)	1.00 (25.4)		
54208UF	#1 AWG	#2 AWG, 75 Navy 150/24 175/24 133/0.0223	1/4	1.28 (32.5)	0.68 (17.3)	0.11 (2.8)	0.47 (11.9)	0.25 (6.4)	0.63 (16.0)	37	Green
54209UF	1/0 AWG	#1 AWG 100 Navy, #1 Weld 225/24 133/0.0254	3/8	1.93 (49.0)	0.75 (19.1)	0.13 (3.3)	0.52 (13.2)	0.38 (9.7)	1.00 (25.4)	42	Pink
54209UF0412			1/4	1.55 (39.4)	0.75 (19.1)	0.13 (3.3)	0.52 (13.2)	0.25 (6.4)	0.75 (19.1)		
54261UF	2/0 AWG	1/0 AWG, 125 Navy 1/0 Weld 275/24 133/0.0282	5/16	1.63 (41.4)	0.83 (21.1)	0.14 (3.6)	0.57 (14.5)	0.33 (8.4)	0.88 (22.4)	45	Black
54210UF			3/8	1.93 (49.0)	0.83 (21.1)	0.13 (3.3)	0.57 (14.5)	0.38 (9.7)	1.00 (25.4)		
54260UF			1/2	2.81 (71.4)	0.83 (21.1)	0.14 (3.6)	0.57 (14.5)	0.38 (9.7)	1.75 (44.5)		
54266UF	3/0 AWG	2/0 AWG, 150 Navy 2/0 Weld 325/24 133/0.0316 259/0.0227 427/0.0177	5/16	1.75 (44.5)	0.94 (23.9)	0.14 (3.6)	0.63 (16.0)	0.33 (8.4)	1.00 (25.4)	50	Orange
54211UF			3/8	1.81 (46.0)	0.94 (23.9)	0.14 (3.6)	0.63 (16.0)	0.38 (9.7)	1.00 (25.4)		
54265UF			1/2	2.81 (71.4)	0.94 (23.9)	0.14 (3.6)	0.63 (16.0)	0.25 (6.4)	1.75 (44.5)		
54212UF	4/0 AWG	200 Navy, 3/0 AWG 3/0 Weld 450/24 703/0.0154	3/8	1.93 (49.0)	1.03 (26.2)	0.14 (3.6)	0.70 (17.8)	0.38 (9.7)	1.00 (25.4)	54	Purple
54270UF			1/2	3.00 (76.2)	1.03 (26.2)	0.14 (3.6)	0.70 (17.8)	0.25 (6.4)	1.75 (44.5)		
54213UF	250 kcmil	4/0 AWG 250 Navy 550/24	3/8	1.93 (49.0)	1.13 (28.7)	0.14 (3.6)	0.77 (19.6)	0.38 (9.7)	1.00 (25.4)	62	Yellow
54275UF			1/2	2.81 (71.4)	1.13 (28.7)	0.18 (4.6)	0.77 (19.6)	0.25 (6.4)	1.75 (44.5)		
256-30695-399UF	—	4/0 Weld 550/24 133/0.0399 259/0.0286 637/0.018	3/8	2.80 (71.1)	1.25 (31.2)	0.15 (3.8)	0.79 (20.1)	0.38 (9.7)	1.00 (25.4)	62	Yellow
58265UF			1/2	2.81 (71.4)	0.94 (23.9)	0.14 (3.6)	0.79 (20.1)	0.25 (6.4)	1.75 (44.5)		

\ddagger For installations from 16 kV up to 35 kV, consult shielded cable manufacturers for stress relief and insulation requirements. Call your Regional Sales Office for sizes not listed.

Tooling: pp. E4–E62

Die Selector Chart: pp. E35–E50



Compression Connectors for Copper Conductors

Two-Hole Lugs — 45° Standard Barrel Certified to 600 V and Recommended up to 35 kV¥ (cont'd)

Material: High-Conductivity Wrought Copper

Finish: Electro-Tin Plated

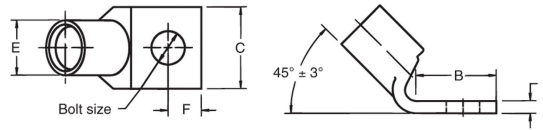

Cat. No.	Wire Size		Bolt Size	Dimensions in. (mm)						Die Code	Colour Code
	Code Cable	Flex Cable Classes G, H, I, K, M		B	C	D	E	F	G		
54214UF	300 kcmil	250 AWG	3/8	1.93 (49.0)	1.25 (31.8)	0.15 (3.8)	0.85 (21.6)	0.38 (9.7)	1.00 (25.4)	66	White
54280UF		300 Navy 650/24 = 262 kcmil	1/2	3.00 (76.2)	1.25 (31.8)	0.15 (3.8)	0.85 (21.6)	0.50 (12.7)	1.75 (44.5)		
54215UF	350 kcmil	350 Navy	3/8	1.93 (49.0)	1.36 (34.5)	0.18 (4.6)	0.93 (23.6)	0.38 (9.7)	1.00 (25.4)	71	Red
54282UF		650/24 = 262 kcmil	1/2	3.00 (76.2)	1.36 (34.5)	0.18 (4.6)	0.93 (23.6)	0.50 (12.7)	1.75 (44.5)		
54216UF	400 kcmil	300 kcmil	3/8	1.93 (49.0)	1.41 (35.8)	0.17 (4.3)	0.96 (24.4)	0.38 (9.7)	1.06 (26.9)	76	Blue
54283UF		713 kcmil 775/24	3/8	1.93 (49.0)	1.41 (35.8)	0.17 (4.3)	0.96 (24.4)	0.38 (9.7)	1.75 (44.5)		
54277UF	—	400 Weld 925/24 = 373 kcmil 259/0.0393 427/0.0306	1/2	3.00 (76.2)	1.61 (40.9)	0.22 (5.6)	1.04 (26.4)	0.50 (12.7)	1.00 (25.4)	80	—
54218UF	500 kcmil	400 kcmil	3/8	1.93 (49.0)	1.61 (40.9)	0.22 (5.6)	1.10 (27.9)	0.38 (9.7)	1.75 (44.5)	87	Brown
54286UF		500 Navy 925/24 = 373 kcmil	1/2	3.00 (76.2)	1.61 (40.9)	0.22 (5.6)	1.10 (27.9)	0.50 (12.7)	1.00 (25.4)		
54220UF	600 kcmil	1100/24 = 444 kcmil	3/8	1.93 (49.0)	1.75 (44.5)	0.24 (6.1)	1.20 (30.5)	0.38 (9.7)	1.75 (44.5)	94	Green
54289UF			1/2	3.00 (76.2)	1.75 (44.5)	0.24 (6.1)	1.20 (30.5)	0.50 (12.7)	1.75 (44.5)		
54291UF	700 kcmil	500 AWG 1325/24 = 535 kcmil	1/2	3.00 (76.2)	1.84 (46.7)	0.23 (5.8)	1.25 (31.8)	0.50 (12.7)	1.75 (44.5)	99	Pink
54281UF			1/2	3.00 (76.2)	1.84 (46.7)	0.28 (7.1)	1.25 (31.8)	0.50 (12.7)	1.75 (44.5)		
256-30695-237UF	750 kcmil	—	3/8	2.80 (71.1)	1.94 (49.3)	0.27 (6.9)	1.33 (33.8)	0.38 (9.7)	1.00 (25.4)	106	Black
54223UF		—	1/2	3.00 (76.2)	1.94 (49.3)	0.27 (6.9)	1.33 (33.8)	0.50 (12.7)	1.75 (44.5)		
54224UF	800 kcmil	—	1/2	3.00 (76.2)	2.01 (51.1)	0.27 (6.9)	1.38 (35.1)	0.50 (12.7)	1.75 (44.5)		
54226UF	900 kcmil	1925/24 = 777 kcmil	1/2	3.00 (76.2)	2.18 (55.4)	0.31 (7.9)	1.50 (38.1)	0.50 (12.7)	1.75 (44.5)	115	Yellow
54228UF	1000 kcmil	1000 Navy	1/2	3.00 (76.2)	2.27 (57.7)	0.30 (7.6)	1.55 (39.4)	0.50 (12.7)	1.75 (44.5)	125	—

¥ For installations from 16 kV up to 35 kV, consult shielded cable manufacturers for stress relief and insulation requirements. Call your Regional Sales Office for sizes not listed.

Tooling: pp. E4–E62

Die Selector Chart: pp. E35–E50

Compression Connectors for Copper Conductors

Two-Hole Lugs — 90° Standard Barrel Certified to 600 V and Recommended up to 35 kV \ddot{V}

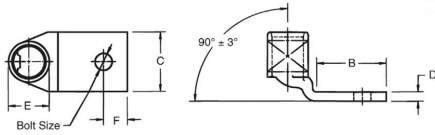
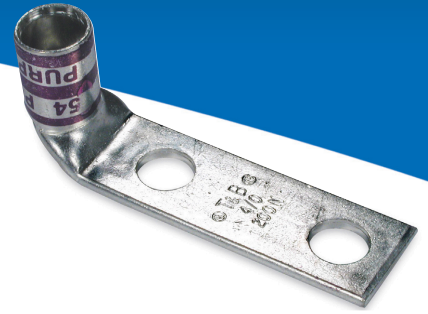

Material: High-Conductivity Wrought Copper

Finish: Electro-Tin Plated



Cat. No.	Wire Size		Bolt Size	Dimensions in. (mm)						Die Code	Colour Code
	Code Cable	Flex Cable Classes G, H, I, K, M		B	C	D	E	F	G		
256-31426-141	#14 – 10 AWG	—	#10	1.25 (31.2)	0.37 (9.4)	0.07 (1.8)	0.20 (5.1)	0.22 (5.6)	0.63 (16.0)	ERG2002	Yellow
256-31426-6SPH		—	#10	1.30 (33.0)	0.37 (9.4)	0.07 (1.8)	0.20 (5.1)	0.22 (5.6)	0.63 – 0.75 (16.0) – (19.1)		
256-31426-6		—	#10	1.30 (33.0)	0.37 (9.4)	0.07 (1.8)	0.20 (5.1)	0.22 (5.6)	0.63 (16.0)		
256-31426-6S		—	#10	1.30 (33.0)	0.37 (9.4)	0.07 (1.8)	0.20 (5.1)	0.22 (5.6)	0.63 – 0.75 (16.0) – (19.1)		
256-30695-1409	#8 AWG	#8 AWG, 23 Navy #8 Weld 37/24	#10	1.19 (30.2)	0.41 (10.4)	0.06 (1.5)	0.26 (6.6)	0.23 (5.8)	0.63 – 0.75 (16.0) – (19.1)	21	Red
54204UB			#10	1.25 (31.8)	0.42 (10.7)	0.08 (2.0)	0.26 (6.6)	0.25 (6.4)	0.63 (16.0)		
256-31426-33UB*			#10	1.19 (30.2)	0.41 (10.4)	0.06 (1.5)	0.26 (6.6)	0.23 (5.8)	0.63 (16.0)		
256-31426-33UBPH			#10	1.19 (30.2)	0.41 (10.4)	0.06 (1.5)	0.26 (6.6)	0.23 (5.8)	0.63 – 0.75 (16.0) – (19.1)		
256-30695-1411	#6 AWG	#6 AWG, 30 Navy #6 Weld 133/0.014 61/24	#10	1.19 (30.2)	0.44 (11.2)	0.08 (2.0)	0.30 (7.6)	0.23 (5.8)	0.63 – 0.75 (16.0) – (19.1)	24	Blue
256-30695-1183B			#10	1.19 (30.2)	0.44 (11.2)	0.08 (2.0)	0.30 (7.6)	0.23 (5.8)	0.63 – 0.75 (16.0) – (19.1)		
256-30695-1356			#10	1.19 (30.2)	0.43 (10.1)	0.08 (2.0)	0.30 (7.6)	0.23 (5.8)	0.63 (16.0)		
54205UB			1/4	1.28 (32.5)	0.44 (11.2)	0.08 (2.0)	0.30 (7.6)	0.25 (6.4)	0.63 (16.0)		
256-30695-252UB	1/4	1.56 (39.6)	0.43 (10.1)	0.08 (2.0)	0.30 (7.6)	0.25 (6.4)	1.00 (25.4)				
54206UB	#4 AWG	#5 AWG 40-50 Navy 91/24 133/0.0177 49/0.029	1/4	1.28 (32.5)	0.52 (13.2)	0.10 (2.5)	0.37 (9.4)	0.25 (6.4)	0.63 (16.0)	29	Grey
54207UB	#2 AWG	#3 AWG 60 Navy, #4 Weld 125/24	1/4	1.28 (32.5)	0.59 (15.0)	0.11 (2.8)	0.41 (10.4)	0.25 (6.4)	0.63 (16.0)	33	Brown
54208UB	#1 AWG	#2 AWG, 75 Navy 150/24 133/0.0223	1/4	1.28 (32.5)	0.68 (17.3)	0.11 (2.8)	0.47 (11.9)	0.25 (6.4)	0.63 (16.0)	37	Green
54209UB	1/0 AWG	1 AWG 100 Navy, #1 Weld 225/24 133/0.0254	3/8	1.93 (49.0)	0.75 (19.1)	0.13 (3.3)	0.52 (13.2)	0.38 (9.7)	1.00 (25.4)	42	Pink
54209UB0412			1/4	1.55 (39.4)	0.75 (19.1)	0.13 (3.3)	0.52 (13.2)	0.25 (6.4)	0.75 (19.1)		
54261UB	2/0 AWG	1/0 AWG, 125 Navy 1/0 Weld 275/24 133/0.0282	5/16	1.63 (41.4)	0.83 (21.1)	0.14 (3.6)	0.57 (14.5)	0.34 (8.6)	0.88 (22.4)	45	Black
54210UB			3/8	1.93 (49.0)	0.83 (21.1)	0.13 (3.3)	0.57 (14.5)	0.38 (9.7)	1.00 (25.4)		
54260UB			1/2	2.81 (71.4)	0.83 (21.1)	0.14 (3.6)	0.57 (14.5)	0.38 (9.7)	1.75 (44.5)		
54266UB	3/0 AWG	2/0 AWG, 150 Navy 2/0 Weld 325/24 133/0.0316 259/0.0227 427/0.0177	5/16	1.75 (44.5)	0.94 (23.9)	0.14 (3.6)	0.63 (16.0)	0.34 (8.6)	1.00 (25.4)	50	Orange
54211UB			3/8	1.81 (46.0)	0.94 (23.9)	0.14 (3.6)	0.63 (16.0)	0.38 (9.7)	1.00 (25.4)		
54265UB			1/2	2.81 (71.4)	0.94 (23.9)	0.14 (3.6)	0.63 (16.0)	0.38 (9.7)	1.75 (44.5)		
54212UB	4/0 AWG	3/0 AWG, 200 Navy 3/0 Weld 450/24 703/0.0154	3/8	1.93 (49.0)	1.03 (26.2)	0.14 (3.6)	0.70 (17.8)	0.38 (9.7)	1.00 (25.4)	54	Purple
54270UB			1/2	3.00 (76.2)	1.03 (26.2)	0.14 (3.6)	0.70 (17.8)	0.50 (12.7)	1.75 (44.5)		
54213UB	250 kcmil	4/0 AWG 250 Navy 550/24	3/8	1.93 (49.0)	1.13 (28.7)	0.14 (3.6)	0.77 (19.6)	0.38 (9.7)	1.00 (25.4)	62	Yellow
54275UB			1/2	2.81 (71.4)	1.13 (28.7)	0.18 (4.6)	0.77 (19.6)	0.50 (12.7)	1.75 (44.5)		
256-30595-399UB	—	4/0 AWG, 4/0 Weld 550/24 133/0.0399	3/8	2.80 (71.1)	1.25 (31.8)	0.15 (3.8)	0.79 (20.1)	0.38 (9.7)	1.00 (25.4)		
58265UB	—	259/0.0286 637/0.018	1/2	2.81 (71.4)	0.94 (23.9)	0.14 (3.6)	0.79 (20.1)	0.50 (12.7)	1.75 (44.5)		

* Blind End

† For installations from 16 kV up to 35 kV, consult shielded cable manufacturers for stress relief and insulation requirements. Call your Regional Sales Office for sizes not listed.

Tooling: pp. E4–E62

Die Selector Chart: pp. E35–E50

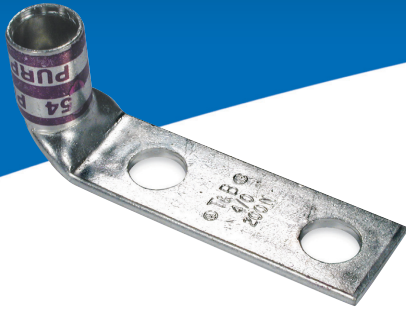

Compression Connectors for Copper Conductors

Two-Hole Lugs — 90° Standard Barrel Certified to 600 V and Recommended up to 35 kV¥ (cont'd)

Material: High-Conductivity Wrought Copper

Finish: Electro-Tin Plated

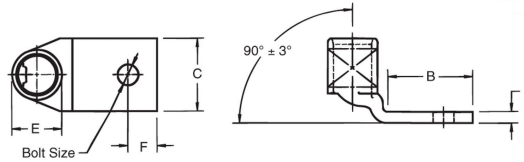

Cat. No.	Wire Size		Bolt Size	Dimensions in. (mm)						Die Code	Colour Code	
	Code Cable	Flex Cable Classes G, H, I, K, M		B	C	D	E	F	G			
54214UB	300 kcmil	250 AWG	3/8	1.93 (49.0)	1.25 (31.8)	0.15 (3.8)	0.85 (21.6)	0.38 (9.7)	1.00 (25.4)	66	White	
54280UB		300 Navy	1/2	3.00 (76.2)	1.25 (31.8)	0.15 (3.8)	0.85 (21.6)	0.50 (12.7)	1.75 (44.5)			
54215UB	350 kcmil	350 Navy	3/8	1.93 (49.0)	1.36 (34.5)	0.18 (4.6)	0.93 (23.6)	0.38 (9.7)	1.00 (25.4)	71	Red	
54282UB		650/24 = 262 kcmil	1/2	3.00 (76.2)	1.36 (34.5)	0.18 (4.6)	0.93 (23.6)	0.50 (12.7)	1.75 (44.5)			
54216UB	400 kcmil	300/313 kcmil	3/8	1.93 (49.0)	1.41 (35.8)	0.17 (4.3)	0.96 (24.4)	0.38 (9.7)	1.06 (26.9)	76	Blue	
54283UB		775/24	3/8	1.93 (49.0)	1.41 (35.8)	0.17 (4.3)	0.96 (24.4)	0.38 (9.7)	1.75 (44.5)			
54277UB	—	400 Weld, 925/24	1/2	3.00 (76.2)	1.61 (40.9)	0.22 (5.6)	1.04 (26.4)	0.50 (12.7)	1.00 (25.4)	80	—	
54218UB	500 kcmil	400 kcmil	3/8	1.93 (49.0)	1.61 (40.9)	0.22 (5.6)	1.10 (27.9)	0.38 (9.7)	1.75 (44.5)	87	Brown	
54286UB			500 Navy	1/2	3.00 (76.2)	1.61 (40.9)	0.22 (5.6)	1.10 (27.9)	0.50 (12.7)			1.75 (44.5)
256-30695-1221B			925/24 = 373 kcmil	3/8	—	1.61 (40.9)	0.22 (5.6)	1.10 (27.9)	0.38 (9.7)			1.00 (25.4)
54220UB	600 kcmil	1100/24, 444 kcmil	3/8	1.93 (49.0)	1.75 (44.5)	0.24 (6.1)	1.20 (30.5)	0.38 (9.7)	1.75 (44.5)	94	Green	
54289UB			1/2	3.00 (76.2)	1.75 (44.5)	0.24 (6.1)	1.20 (30.5)	0.50 (12.7)	1.75 (44.5)			
54291UB	700 kcmil	1325/24, 535 kcmil	1/2	3.00 (76.2)	1.84 (46.7)	0.23 (5.8)	1.25 (31.8)	0.50 (12.7)	1.75 (44.5)	99	Pink	
54281UB			1/2	3.00 (76.2)	1.84 (46.7)	0.28 (7.1)	1.25 (31.8)	0.50 (12.7)	1.75 (44.5)			
54223UB	750 kcmil	—	1/2	3.00 (76.2)	1.94 (49.3)	0.27 (6.9)	1.33 (33.8)	0.50 (12.7)	1.75 (44.5)	106	Black	
54224UB	800 kcmil		1/2	3.00 (76.2)	2.01 (51.1)	0.27 (6.9)	1.38 (35.1)	0.50 (12.7)	1.75 (44.5)			
54226UB	900 kcmil		1925/24, 777 kcmil	1/2	3.00 (76.2)	2.18 (55.4)	0.31 (7.9)	1.50 (38.1)	0.50 (12.7)			1.75 (44.5)
54228UB	1000 kcmil	1000 Navy	1/2	3.00 (76.2)	2.27 (57.7)	0.30 (7.6)	1.55 (39.4)	0.50 (12.7)	1.75 (44.5)	125	—	

¥ For installations from 16 kV up to 35 kV, consult shielded cable manufacturers for stress relief and insulation requirements. Call your Regional Sales Office for sizes not listed.

Tooling: pp. E4–E62

Die Selector Chart: pp. E35–E50

Compression Connectors for Copper Conductors

One-Hole Lugs — Long Barrel Certified to 600 V and Recommended up to 35 kV \ddot{V}

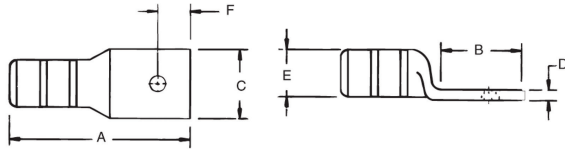

*Peep Holes Available!
Add suffix -PH*

Material: High-Conductivity Wrought Copper

Finish: Electro-Tin Plated



Cat. No.	Wire Size		Bolt Size	Dimensions in. (mm)						Die Code	Colour Code
	Code Cable	Flex Cable Classes G, H, I, K, M		A	B	C	D	E	F		
54901BE	#14-10 AWG	—	1/4	1.23 (31.2)	0.56 (14.2)	0.50 (12.7)	0.05 (1.3)	0.20 (5.1)	0.25 (6.4)	ERG2002	—
54929BE	#8 AWG	#8 AWG 37/24	#10	1.65 (41.9)	0.65 (16.5)	0.42 (10.7)	0.08 (2.0)	0.26 (6.6)	0.25 (6.4)	21	Red
54930BE			1/4	1.65 (41.9)	0.65 (16.5)	0.42 (10.7)	0.08 (2.0)	0.26 (6.6)	0.25 (6.4)		
54904BE	#6 AWG	#6 AWG 61/24	#10	1.65 (41.9)	0.65 (16.5)	0.44 (11.2)	0.08 (2.0)	0.30 (7.6)	0.25 (6.4)	24	Blue
54905BE			1/4	1.65 (41.9)	0.65 (16.5)	0.44 (11.2)	0.08 (2.0)	0.30 (7.6)	0.25 (6.4)		
54908BE	#4 AWG	#5 AWG 91/24	#10	1.70 (43.2)	0.65 (16.5)	0.52 (13.2)	0.10 (2.5)	0.37 (9.4)	0.25 (6.4)	29	Grey
54906BE			1/4	1.70 (43.2)	0.65 (16.5)	0.52 (13.2)	0.10 (2.5)	0.37 (9.4)	0.25 (6.4)		
54933BE	#2-3 AWG	#3 AWG 125/24	#10	1.88 (47.8)	0.65 (16.5)	0.59 (15.0)	0.11 (2.8)	0.41 (10.4)	0.25 (6.4)	33	Brown
54942BE			5/16	2.03 (51.6)	0.88 (22.4)	0.59 (15.0)	0.11 (2.8)	0.41 (10.4)	0.38 (9.7)		
54945BE	#1 AWG	#2 AWG 150/24	#10	1.95 (49.5)	0.65 (16.5)	0.68 (17.3)	0.11 (2.8)	0.47 (11.9)	0.25 (6.4)	37	Green
54947BE			5/16	2.18 (55.4)	0.88 (22.4)	0.68 (17.3)	0.11 (2.8)	0.47 (11.9)	0.38 (9.7)		
54946BE	1/0 AWG	#1 AWG 225/24	#10	1.95 (49.5)	0.65 (16.5)	0.75 (19.1)	0.13 (3.3)	0.52 (13.2)	0.25 (6.4)	42	Pink
54949BE			5/16	2.18 (55.4)	0.88 (22.4)	0.75 (19.1)	0.13 (3.3)	0.52 (13.2)	0.38 (9.7)		
54909BE			3/8	2.23 (56.6)	0.93 (23.6)	0.75 (19.1)	0.13 (3.3)	0.52 (13.2)	0.38 (9.7)		
54950BE			1/2	2.55 (64.8)	1.25 (31.8)	0.75 (19.1)	0.13 (3.3)	0.52 (13.2)	0.50 (12.7)		
54910BE	2/0 AWG	1/0 AWG 275/24	3/8	2.28 (57.9)	1.25 (31.8)	0.83 (21.1)	0.13 (3.3)	0.57 (14.5)	0.38 (9.7)	45	Black
54951BE			1/2	2.60 (66.4)	1.25 (31.8)	0.83 (21.1)	0.13 (3.3)	0.57 (14.5)	0.50 (12.7)		
54965BE	3/0 AWG	2/0 AWG 325/24	1/2	2.70 (68.6)	1.25 (31.8)	0.92 (23.4)	0.13 (3.3)	0.63 (16.0)	0.50 (12.7)	50	Orange
256-30695-1252	4/0 AWG	3/0 AWG, 3/0 Weld 450/24	1/4	2.35 (59.7)	0.65 (16.5)	1.03 (33.0)	0.14 (3.6)	0.70 (17.8)	0.75 (19.1)	54	Purple
256-30695-1253			3/8	2.95 (74.9)	1.25 (31.8)	1.03 (33.0)	0.14 (3.6)	0.70 (17.8)	0.38 (9.7)		
54970BE			1/2	2.95 (74.9)	1.25 (31.8)	1.03 (33.0)	0.14 (3.6)	0.77 (19.6)	0.50 (12.7)		
54913BE	250 kcmil	4/0 AWG, 4/0 Weld 550/24	1/2	3.15 (80.1)	1.25 (31.8)	1.13 (28.7)	0.14 (3.6)	0.85 (21.6)	0.50 (12.7)	62	Yellow
54914BE	300 kcmil	250 kcmil 650/24 = 262 kcmil	1/2	3.50 (88.9)	1.25 (31.8)	1.25 (31.8)	0.15 (3.8)	0.93 (23.6)	0.50 (12.7)	66	White
54915BE	350 kcmil	775/24 = 300/313 kcmil	1/2	3.68 (93.5)	1.58 (40.1)	1.36 (34.5)	0.18 (4.6)	0.96 (24.4)	0.50 (12.7)	71	Red
54916BE	400 kcmil		5/8	3.75 (95.3)	1.25 (31.8)	1.41 (35.8)	0.17 (4.3)	0.96 (24.4)	0.50 (12.7)	76	Blue
54917BE			1/2	4.03 (102.4)	1.58 (40.1)	1.41 (35.8)	0.17 (4.3)	1.10 (27.9)	0.63 (16.0)		
54918BE	500 kcmil		400 kcmil 925/24 = 373 kcmil	1/2	4.25 (108.0)	1.25 (31.8)	1.61 (40.9)	0.22 (5.6)	1.10 (27.9)	0.50 (12.7)	87
54919BE		5/8		4.57 (116.8)	1.58 (40.1)	1.61 (40.9)	0.22 (5.6)	1.20 (30.5)	0.63 (16.0)		
54921BE	600 kcmil	1100/24 = 444 kcmil	1/2	4.10 (104.1)	1.25 (31.8)	1.75 (44.5)	0.24 (6.1)	1.20 (30.5)	0.50 (12.7)	94	Green
54920BE			5/8	4.39 (111.6)	1.58 (40.1)	1.75 (44.5)	0.24 (6.1)	1.20 (30.5)	0.63 (16.0)		
54979BE	—	1325/24 = 535 kcmil	1/2	4.40 (111.8)	1.25 (31.8)	1.80 (45.7)	0.24 (6.1)	1.25 (31.8)	0.50 (12.7)	99	Pink
54922BE	750 kcmil	1325/24 = 535 kcmil	1/2	4.40 (111.8)	1.25 (31.8)	1.94 (49.3)	0.27 (6.9)	1.33 (33.8)	0.50 (12.7)	106	Black
54923BE	—	1325/24 = 535 kcmil	5/8	4.72 (119.9)	1.58 (40.1)	1.94 (49.3)	0.27 (6.9)	1.33 (33.8)	0.63 (16.0)		
58984BE	—	1600/24 = 646 kcmil	5/8	4.73 (120.1)	1.58 (40.1)	1.94 (49.3)	0.27 (6.9)	1.33 (33.8)	0.63 (16.0)		
58926BE	900 kcmil	1925/24 = 777 kcmil	5/8	5.23 (132.8)	1.58 (40.1)	2.17 (55.1)	0.31 (7.9)	1.50 (38.1)	0.63 (16.0)	115	Yellow
54928BE	1000 kcmil	—	5/8	5.24 (134.0)	1.58 (40.1)	2.27 (57.7)	0.30 (7.6)	1.55 (39.4)	0.63 (16.0)	125	—
256-30695-918			7/8	5.42 (137.7)	1.82 (46.2)	2.38 (60.5)	0.30 (7.6)	1.55 (39.4)	0.88 (22.4)		

¥ For installations from 16 kV up to 35 kV, consult shielded cable manufacturers for stress relief and insulation requirements. Call your Regional Sales Office for sizes not listed.

Tooling: pp. E4–E62

Die Selector Chart: pp. E35–E50



Peep Holes Available!
Add suffix -PH

Compression Connectors for Copper Conductors

One-Hole Lugs — 45° Long Barrel Certified to 600 V and Recommended up to 35 kV \ddagger

Material: High-Conductivity Wrought Copper

Finish: Electro-Tin Plated

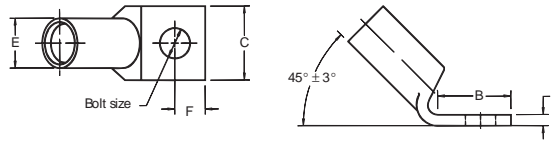

Cat. No.	Wire Size		Bolt Size	Dimensions in. (mm)					Die Code	Colour Code
	Code Cable	Flex Cable Classes G, H, I, K, M		B	C	D	E	F		
54929BEUF	#8 AWG	—	#1/0	0.65 (16.5)	0.42 (10.7)	0.08 (2.0)	0.26 (6.6)	0.25 (6.4)	21	Red
54930BEUF	#8 AWG	37/24	1/4	0.65 (16.5)	0.42 (10.7)	0.08 (2.0)	0.26 (6.6)	0.25 (6.4)		
54904BEUF	#6 AWG	61/24, #6 AWG	#1/0	0.65 (16.5)	0.44 (11.2)	0.08 (2.0)	0.30 (7.6)	0.25 (6.4)		
54905BEUF	—	—	1/4	0.65 (16.5)	0.44 (11.2)	0.08 (2.0)	0.30 (7.6)	0.25 (6.4)	24	Blue
54908BEUF	—	—	#1/0	0.65 (16.5)	0.52 (13.2)	0.10 (2.5)	0.37 (9.4)	0.25 (6.4)		
54906BEUF	#4 AWG	#5 AWG, 91/24	1/4	0.65 (16.5)	0.52 (13.2)	0.10 (2.5)	0.37 (9.4)	0.25 (6.4)	29	Grey
54933BEUF	#2-3 AWG	125/24	#1/0	0.65 (16.5)	0.59 (15.0)	0.11 (2.8)	0.41 (10.4)	0.25 (6.4)		
54942BEUF	#3 AWG	—	5/16	0.88 (22.4)	0.59 (15.0)	0.11 (2.8)	0.41 (10.4)	0.88 (22.4)	33	Brown
54945BEUF	—	—	#1/0	0.65 (16.5)	0.68 (17.3)	0.11 (2.8)	0.47 (11.9)	0.25 (6.4)		
54947BEUF	#1 AWG	#2 AWG, 150/24 – 175/24	5/16	0.88 (22.4)	0.68 (17.3)	0.11 (2.8)	0.47 (11.9)	0.38 (9.7)	37	Green
54946BEUF	—	—	#1/0	0.65 (16.5)	0.75 (19.1)	0.13 (3.3)	0.52 (13.2)	0.25 (6.4)		
54949BEUF	1/0 AWG	#1 AWG 225/24	5/16	0.88 (22.4)	0.75 (19.1)	0.13 (3.3)	0.52 (13.2)	0.38 (9.7)	42	Pink
54909BEUF			3/8	0.93 (23.6)	0.75 (19.1)	0.13 (3.3)	0.52 (13.2)	0.38 (9.7)		
54950BEUF			1/2	1.25 (31.8)	0.75 (19.1)	0.13 (3.3)	0.52 (13.2)	0.50 (12.7)		
54910BEUF	2/0 AWG	1/0 AWG, 275/24 111 kcmil	3/8	0.93 (23.6)	0.83 (21.1)	0.13 (3.3)	0.57 (14.5)	0.38 (9.7)	45	Black
54951BEUF			1/2	1.25 (31.8)	0.83 (21.1)	0.13 (3.3)	0.57 (14.5)	0.50 (12.7)		
54965BEUF	3/0 AWG	325/24 – 2/0 AWG	1/2	1.25 (31.8)	0.92 (23.4)	0.13 (3.3)	0.63 (16.0)	0.50 (12.7)	50	Orange
54970BEUF04	4/0 AWG	450/24 3/0 Weld	1/4	1.00 (25.4)	1.03 (26.1)	0.14 (3.6)	0.70 (17.8)	0.25 (6.4)	54	Purple
54970BEUF06			3/8	1.13 (23.6)	1.03 (26.1)	0.14 (3.6)	0.70 (17.8)	0.38 (9.7)		
54970BEUF			1/2	1.25 (31.8)	1.03 (26.1)	0.14 (3.6)	0.70 (17.8)	0.50 (12.7)		
54913BEUF	250 kcmil	550/24 – 4/0 AWG 4/0 Weld	1/2	1.25 (31.8)	1.13 (28.7)	0.14 (3.6)	0.77 (19.6)	0.50 (12.7)	62	Yellow
54914BEUF	300 kcmil	250 kcmil 650/24 = 262 kcmil	1/2	1.25 (31.8)	1.25 (31.8)	0.15 (3.8)	0.85 (21.6)	0.50 (12.7)	66	White
54915BEUF	350 kcmil	650/24, 262 kcmil	1/2	1.25 (31.8)	1.36 (34.8)	0.18 (4.6)	0.93 (23.6)	0.50 (12.7)	71	Red
54916BEUF	400 kcmil	775/24, 313 kcmil	1/2	1.25 (31.8)	1.41 (35.8)	0.17 (4.3)	0.96 (24.4)	0.50 (12.7)	76	Blue
54917BEUF			5/8	1.58 (40.1)	1.41 (35.8)	0.17 (4.3)	0.96 (24.4)	0.63 (16.0)		
54918BEUF			1/2	1.25 (31.8)	1.61 (40.9)	0.22 (5.6)	1.10 (27.9)	0.50 (12.7)		
54919BEUF	500 kcmil	925/24, 373 kcmil, 400 kcmil	5/8	1.58 (40.1)	1.61 (40.9)	0.22 (5.6)	1.10 (27.9)	0.63 (16.0)	87	Brown
54921BEUF	600 kcmil	1100/24, 444 kcmil	1/2	1.25 (31.8)	1.75 (44.5)	0.24 (6.1)	1.20 (30.5)	0.50 (12.7)	94	Green
54920BEUF			5/8	1.58 (40.1)	1.75 (44.5)	0.24 (6.1)	1.20 (30.5)	0.63 (16.0)		
54922BEUF			1/2	1.25 (31.8)	1.94 (49.3)	0.27 (6.9)	1.33 (33.8)	0.50 (12.7)		
54923BEUF	750 kcmil	1325/24, 500/535 kcmil	5/8	1.58 (40.1)	1.94 (49.3)	0.27 (6.9)	1.33 (33.8)	0.63 (16.0)	106	Black
58984BEUF	—	1600/24, 646 kcmil	5/8	1.58 (40.1)	1.94 (49.3)	0.27 (6.9)	1.33 (33.8)	0.63 (16.0)	115	Yellow
58926BEUF	900 kcmil	1925/24, 777 kcmil	5/8	1.58 (40.1)	2.17 (55.1)	0.31 (7.9)	1.50 (38.1)	0.63 (16.0)		
54928BEUF	1000 kcmil	—	5/8	1.58 (40.1)	2.27 (57.7)	0.30 (7.6)	1.55 (39.4)	0.63 (16.0)	125	—
54928BEUF12			7/8	1.83 (46.5)	2.37 (60.2)	0.30 (7.6)	1.55 (39.4)	0.88 (22.4)		

\ddagger For installations from 16 kV up to 35 kV, consult shielded cable manufacturers for stress relief and insulation requirements. Call your Regional Sales Office for sizes not listed.
Tooling: pp. E4–E62
Die Selector Chart: pp. E35–E50

Compression Connectors for Copper Conductors

One-Hole Lugs — 90° Long Barrel Certified to 600 V and Recommended up to 35 kV \ddot{Y}

*Peep Holes Available!
Add suffix -PH*

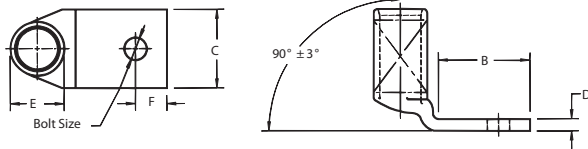

Material: High-Conductivity Wrought Copper

Finish: Electro-Tin Plated

Cat. No.	Wire Size		Bolt Size	Dimensions in. (mm)					Die Code	Colour Code
	Code Cable	Flex Cable Classes G, H, I, K, M		B	C	D	E	F		
54929BEUB	#8 AWG	37/24	#10	0.65 (16.5)	0.42 (10.7)	0.08 (2.0)	0.26 (6.6)	0.25 (6.4)	21	Red
54930BEUB			1/4	0.65 (16.5)	0.42 (10.7)	0.08 (2.0)	0.26 (6.6)	0.25 (6.4)		
54904BEUB	#6 AWG	#6 AWG, 61/24	#10	0.65 (16.5)	0.44 (11.2)	0.08 (2.0)	0.30 (7.6)	0.25 (6.4)	24	Blue
54905BEUB			1/4	0.65 (16.5)	0.44 (11.2)	0.08 (2.0)	0.30 (7.6)	0.25 (6.4)		
54908BEUB	#4 AWG	#5 AWG, 91/24	#10	0.65 (16.5)	0.52 (13.2)	0.10 (2.5)	0.37 (9.4)	0.25 (6.4)	29	Grey
54806BEUB			1/4	0.65 (16.5)	0.52 (13.2)	0.10 (2.5)	0.37 (9.4)	0.25 (6.4)		
54933BEUB	#2-3 AWG	125/24	#10	0.65 (16.5)	0.59 (15.0)	0.11 (2.8)	0.41 (10.4)	0.25 (6.4)	33	Brown
54942BEUB			5/16	0.88 (22.4)	0.59 (15.0)	0.11 (2.8)	0.41 (10.4)	0.38 (9.7)		
54945BEUB	#1 AWG	#2 AWG, 150/24 – 175/24	#10	0.65 (16.5)	0.68 (17.3)	0.11 (2.8)	0.47 (11.9)	0.25 (6.4)	37	Green
54947BEUB			5/16	0.88 (22.4)	0.68 (17.3)	0.11 (2.8)	0.47 (11.9)	0.38 (9.7)		
54946BEUB	1/0 AWG	#1 AWG 225/24	#10	0.65 (16.5)	0.75 (19.1)	0.13 (3.3)	0.52 (13.2)	0.25 (6.4)	42	Pink
54949BEUB			5/16	0.88 (22.4)	0.75 (19.1)	0.13 (3.3)	0.52 (13.2)	0.38 (9.7)		
54909BEUB			3/8	0.93 (23.6)	0.75 (19.1)	0.13 (3.3)	0.52 (13.2)	0.38 (9.7)		
54950BEUB			1/2	1.25 (31.8)	0.75 (19.1)	0.13 (3.3)	0.52 (13.2)	0.50 (12.7)		
54910BEUB	2/0 AWG	1/0 AWG, 275/24	3/8	0.93 (23.6)	0.83 (21.1)	0.13 (3.3)	0.57 (14.5)	0.38 (9.7)	45	Black
54951BEUB			1/2	1.25 (31.8)	0.83 (21.1)	0.13 (3.3)	0.57 (14.5)	0.50 (12.7)		
54965BEUB	3/0 AWG	2/0 AWG – 325/24	1/2	1.25 (31.8)	0.92 (23.4)	0.13 (3.3)	0.63 (16.0)	0.50 (12.7)	50	Orange
54970BEUB04	4/0 AWG	3/0 AWG, 450/24 3/0 Weld	1/4	1.00 (25.4)	1.03 (26.2)	0.14 (3.6)	0.70 (17.8)	0.25 (6.4)	54	Purple
54970BEUB06			3/8	1.13 (28.7)	1.03 (26.2)	0.14 (3.6)	0.70 (17.8)	0.38 (9.7)		
54970BEUB			1/2	1.25 (31.8)	1.03 (26.2)	0.14 (3.6)	0.70 (17.8)	0.50 (12.7)		
54913BEUB	250 kcmil	550/24 – 4/0 AWG, 4/0 Weld	1/2	1.25 (31.8)	1.13 (28.7)	0.14 (3.6)	0.77 (19.6)	0.50 (12.7)	62	Yellow
54914BEUB	300 kcmil	250 kcmil, 650/24 = 262 kcmil	1/2	1.25 (31.8)	1.25 (31.8)	0.15 (3.8)	0.85 (21.6)	0.50 (12.7)	66	White
54915BEUB	350 kcmil	650/24, 262 kcmil	1/2	1.25 (31.8)	1.36 (34.5)	0.18 (4.6)	0.93 (23.6)	0.50 (12.7)	71	Red
54916BEUB	400 kcmil	775/24, 300/313 kcmil	1/2	1.58 (40.1)	1.41 (35.8)	0.17 (4.3)	0.96 (24.4)	0.50 (12.7)	76	Blue
54917BEUB			5/8	1.25 (31.8)	1.41 (35.8)	0.17 (4.3)	0.96 (24.4)	0.63 (16.0)		
54918BEUB	500 kcmil	925/24, 350/373 kcmil 400 kcmil	1/2	1.58 (40.1)	1.61 (40.9)	0.22 (5.6)	1.10 (27.9)	0.50 (12.7)	87	Brown
54919BEUB			5/8	1.25 (31.8)	1.61 (40.9)	0.22 (5.6)	1.10 (27.9)	0.63 (16.0)		
54921BEUB	600 kcmil	1100/24, 444 kcmil	1/2	1.58 (40.1)	1.75 (44.5)	0.24 (6.1)	1.20 (30.5)	0.50 (12.7)	94	Green
54920BEUB			5/8	1.25 (31.8)	1.75 (44.5)	0.24 (6.1)	1.20 (30.5)	0.63 (16.0)		
54922BEUB	750 kcmil	1325/24, 500/535 kcmil	1/2	1.25 (31.8)	1.94 (49.3)	0.27 (6.9)	1.33 (33.8)	0.50 (12.7)	106	Black
54923BEUB			5/8	1.58 (40.1)	1.94 (49.3)	0.27 (6.9)	1.33 (33.8)	0.63 (16.0)		
58984BEUB	–	1600/24, 646 kcmil	5/8	1.58 (40.1)	1.94 (49.3)	0.27 (6.9)	1.33 (33.8)	0.63 (16.0)		
58926BEUB	900 kcmil	1925/24, 777 kcmil	5/8	1.58 (40.1)	2.17 (55.1)	0.31 (7.9)	1.50 (38.1)	0.63 (16.0)	115	Yellow
54928BEUB	1000 kcmil	–	5/8	1.58 (40.1)	2.27 (57.7)	0.30 (7.6)	1.55 (39.4)	0.63 (16.0)	125	–
54928BEUB12			7/8	1.58 (46.5)	2.37 (60.2)	0.30 (7.6)	1.55 (39.4)	0.88 (22.4)		

¥ For installations from 16 kV up to 35 kV, consult shielded cable manufacturers for stress relief and insulation requirements. Call your Regional Sales Office for sizes not listed.

Tooling: pp. E4–E62

Die Selector Chart: pp. E35–E50

Peep Holes Available!
Add suffix -PH



Compression Connectors for Copper Conductors

Two-Hole Lugs — Long Barrel Certified to 600 V and Recommended up to 35 kV \ddagger

Material: High-Conductivity Wrought Copper

Finish: Electro-Tin Plated

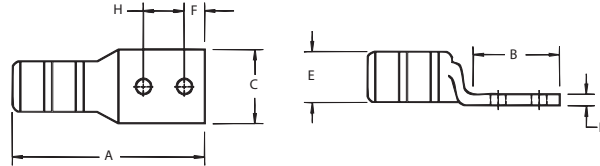

Cat. No.	Wire Size		Bolt Size	Dimensions in. (mm)							Die Code	Colour Code
	Code Cable	Flex Cable Classes G, H, I, K, M		A	B	C	D	E	F	H		
54801BE	#14-10 AWG	-	1/4	1.86 (47.2)	1.19 (30.2)	0.50 (12.7)	0.05 (1.3)	0.20 (5.1)	0.25 (6.4)	0.63 (16.0)	ERG4002	Yellow
256-31426-3			#10	2.00 (50.8)	1.25 (31.2)	0.37 (9.4)	0.07 (1.8)	0.20 (5.1)	0.25 (6.4)	0.63 (16.0)		
256-31426-3SPH			#10	2.00 (50.8)	1.25 (31.2)	0.37 (9.4)	0.07 (1.8)	0.20 (5.1)	0.22 (5.6)	0.63 - 0.75 (16.0) - (19.1)		
256-30695-1298			1/4	1.89 (48.0)	1.22 (31.0)	0.50 (12.7)	0.05 (1.3)	0.20 (5.1)	0.25 (6.4)	0.63 (16.0)		
256-30695-1730			1/4	1.98 (50.3)	1.31 (33.3)	0.50 (12.7)	0.05 (1.3)	0.20 (5.1)	0.25 (6.4)	0.63 - 0.75 (16.0) - (19.1)		
54850BE	#8 AWG	#8 AWG, #8 Weld 37/24	1/4	2.19 (55.6)	1.89 (48.0)	0.42 (10.7)	0.07 (1.78)	0.26 (6.6)	0.25 (6.4)	0.63 (16.0)	21	Red
54851BE			1/4	2.31 (58.7)	1.29 (32.8)	0.47 (11.9)	0.06 (1.52)	0.26 (6.6)	0.25 (6.4)	0.75 (19.1)		
256-30695-1157			3/8	3.00 (76.2)	2.10 (53.3)	0.56 (14.2)	0.06 (1.52)	0.26 (6.6)	0.38 (9.7)	1.00 (25.4)		
54852BE	#6 AWG	#6 AWG, 61/24, #6 Weld	1/4	2.28 (57.9)	1.28 (32.5)	0.44 (11.1)	0.08 (2.03)	0.30 (7.6)	0.25 (6.4)	0.63 (16.0)	24	Blue
256-30695-1014			1/4	2.63 (66.8)	1.63 (41.4)	0.43 (10.9)	0.08 (2.03)	0.30 (7.6)	0.25 (6.4)	1.00 (25.4)		
256-30695-1225			1/4	2.43 (61.7)	1.43 (36.3)	0.43 (10.9)	0.08 (2.03)	0.30 (7.6)	0.25 (6.4)	0.75 (19.1)		
256-30695-1158			3/8	2.93 (74.4)	1.93 (49.0)	0.59 (14.9)	0.06 (1.52)	0.30 (7.6)	0.38 (9.7)	1.00 (25.4)		
256-30695-868	#4 AWG	91/24, #5 AWG, #4 Weld	1/2	4.18 (106.2)	3.00 (76.2)	0.88 (22.4)	0.11 (2.8)	0.30 (7.6)	0.50 (12.7)	1.75 (44.5)	29	Grey
54854BE			1/4	2.31 (58.7)	1.19 (30.2)	0.52 (13.1)	0.10 (2.5)	0.37 (9.4)	0.25 (6.4)	0.63 (16.0)		
256-30695-1246			1/4	2.31 (54.1)	1.31 (33.3)	0.56 (14.2)	0.09 (2.3)	0.37 (9.4)	0.25 (6.4)	0.75 (19.1)		
256-30695-1015			1/4	2.88 (73.2)	1.88 (47.8)	0.58 (14.7)	0.09 (2.3)	0.37 (9.4)	0.38 (9.7)	1.00 (25.4)		
256-30695-1337			5/16	2.75 (69.9)	1.75 (44.5)	0.56 (14.2)	0.10 (2.5)	0.37 (9.4)	0.34 (8.4)	1.00 (25.4)		
256-30695-1159	#2-3 AWG	#3 AWG, 125/24	3/8	3.13 (79.5)	1.98 (50.3)	0.59 (14.9)	0.09 (2.3)	0.37 (9.4)	0.38 (9.7)	1.00 (25.4)	33	Brown
256-30695-733			1/2	4.18 (106.2)	3.00 (76.2)	0.88 (22.4)	0.09 (2.3)	0.37 (9.4)	0.50 (12.7)	1.75 (44.5)		
256-30695-1016*			1/4	3.06 (77.7)	1.88 (47.8)	0.67 (17.0)	0.09 (2.3)	0.41 (10.4)	0.38 (9.7)	1.00 (25.4)		
54855BE	#1 AWG	#2 AWG 150/24 175/24 #2 Weld	1/4	2.43 (61.7)	1.28 (32.5)	0.59 (14.9)	0.11 (2.8)	0.41 (10.4)	0.50 (12.7)	0.63 (16.0)	37	Green
256-30695-1300			1/4	2.63 (66.8)	1.35 (34.3)	0.68 (17.3)	0.11 (2.8)	0.41 (10.4)	0.25 (6.4)	0.75 (19.1)		
54856BE			5/16	2.78 (70.6)	1.63 (41.4)	0.59 (14.9)	0.11 (2.8)	0.41 (10.4)	0.38 (9.7)	0.75 (19.1)		
54810BE			3/8	3.80 (96.5)	2.57 (65.3)	0.59 (14.9)	0.11 (2.8)	0.41 (10.4)	0.38 (9.7)	1.75 (44.5)		
256-30695-1160			3/8	3.08 (78.2)	1.94 (49.3)	0.59 (14.9)	0.11 (2.8)	0.41 (10.4)	0.38 (9.7)	1.00 (25.4)		
256-30695-869	1/0 AWG	#1 AWG, 225/24	1/2	4.02 (102.1)	2.88 (73.2)	0.25 (6.4)	0.75 (19.1)	0.41 (10.4)	0.63 (16.0)	1.75 (44.5)	42	Pink
54811BE			1/2	4.28 (108.7)	3.00 (76.2)	0.88 (22.4)	0.11 (2.8)	0.41 (10.4)	0.50 (12.7)	1.75 (44.5)		
54809BE			1/4	2.88 (73.2)	1.19 (30.2)	0.67 (17.0)	0.11 (2.8)	0.47 (11.9)	0.25 (6.4)	0.63 (16.0)		
54812BE			1/4	2.75 (69.9)	1.40 (35.6)	0.67 (17.0)	0.11 (2.8)	0.47 (11.9)	0.25 (6.4)	0.75 (19.1)		
54858BE	1/0 AWG	#1 AWG, 225/24	5/16	2.94 (75.4)	1.63 (41.4)	0.67 (17.0)	0.11 (2.8)	0.47 (11.9)	0.38 (9.7)	0.88 (22.4)	42	Pink
256-30695-1161			3/8	3.30 (83.8)	1.98 (50.3)	0.67 (17.0)	0.11 (2.8)	0.47 (11.9)	0.38 (9.7)	1.00 (25.4)		
54857BE			1/2	4.43 (112.5)	3.00 (76.2)	0.88 (22.4)	0.11 (2.8)	0.47 (11.9)	0.50 (12.7)	1.75 (44.5)		
256-30695-1018			1/4	3.63 (92.2)	1.88 (47.8)	0.75 (19.0)	0.13 (3.3)	0.52 (13.2)	0.38 (9.7)	1.00 (25.4)		
256-30695-1018P			1/4	3.63 (92.2)	1.88 (47.8)	0.75 (19.0)	0.13 (3.3)	0.52 (13.2)	0.38 (9.7)	1.00 (25.4)		
54859BE			1/4	2.63 (66.8)	1.19 (30.2)	0.75 (19.0)	0.13 (3.3)	0.52 (13.2)	0.25 (6.4)	0.63 (16.0)		
54813BE			1/4	2.71 (68.8)	1.38 (35.1)	0.75 (19.0)	0.13 (3.3)	0.52 (13.2)	0.25 (6.4)	0.75 (19.1)		
54860BE			5/16	2.97 (75.4)	1.63 (41.4)	0.75 (19.0)	0.13 (3.3)	0.52 (13.2)	0.50 (12.7)	0.88 (22.4)		
256-30695-1162P	3/8	3.25 (82.3)	1.98 (50.3)	0.75 (19.0)	0.13 (3.3)	0.52 (13.2)	0.38 (9.7)	1.00 (25.4)				
256-30695-1162	3/8	3.23 (82.0)	1.93 (49.0)	0.75 (19.0)	0.13 (3.3)	0.52 (13.2)	0.38 (9.7)	1.00 (25.4)				
256-30695-593	1/2	4.33 (110.0)	3.00 (76.2)	0.75 (19.0)	0.13 (3.3)	0.52 (13.2)	0.63 (16.0)	1.75 (44.5)				

\ddagger For installations from 16 kV up to 35 kV, consult shielded cable manufacturers for stress relief and insulation requirements. Call your Regional Sales Office for sizes not listed.

* CSA not applicable

Tooling: pp. E4-E62

Die Selector Chart: pp. E35-E50

Peep Holes Available!
Add suffix -PH



Compression Connectors for Copper Conductors

Two-Hole Lugs — Long Barrel Certified to 600 V and Recommended up to 35 kV ∇ (cont'd)

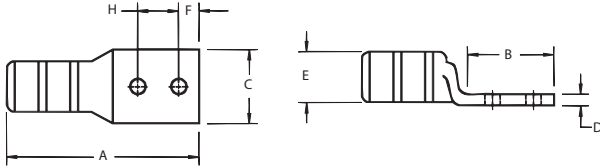

Material: High-Conductivity Wrought Copper

Finish: Electro-Tin Plated



Cat. No.	Wire Size		Bolt Size	Dimensions in. (mm)							Die Code	Colour Code
	Code Cable	Flex Cable Classes G, H, I, K, M		A	B	C	D	E	F	H		
54814BE	2/0 AWG	1/0 AWG, 1/0 Weld 275/24	1/4	2.62 (66.5)	1.25 (31.8)	0.83 (21.1)	0.13 (3.3)	0.57 (14.5)	0.25 (6.4)	0.63 (16.0)	45	Black
256-30695-1299			1/4	2.69 (68.3)	1.31 (33.3)	0.81 (20.6)	0.13 (3.3)	0.57 (14.5)	0.25 (6.4)	0.75 (19.1)		
256-30695-1116			3/8	3.19 (81.0)	1.81 (46.0)	0.83 (21.1)	0.13 (3.3)	0.57 (14.5)	0.38 (9.7)	1.00 (25.4)		
256-30695-1116P			3/8	3.19 (81.0)	1.81 (46.0)	0.83 (21.1)	0.13 (3.3)	0.57 (14.5)	0.38 (9.7)	1.00 (25.4)		
54862BE			1/2	4.20 (106.7)	2.81 (71.4)	0.83 (21.1)	0.13 (3.3)	0.57 (14.5)	0.50 (12.7)	1.75 (44.5)		
54815BE	3/0 AWG	2/0 AWG, 2/0 Weld 325/24	1/4	2.89 (73.4)	1.45 (36.8)	0.92 (23.4)	0.13 (3.3)	0.63 (16.0)	0.25 (6.4)	0.75 (19.1)	50	Orange
54816BE			3/8	3.25 (82.6)	1.63 (41.4)	0.92 (23.4)	0.13 (3.3)	0.63 (16.0)	0.38 (9.7)	1.00 (25.4)		
54864BE			1/2	4.48 (113.8)	3.00 (76.2)	0.94 (23.9)	0.13 (3.3)	0.63 (16.0)	0.50 (12.7)	1.75 (44.5)		
54817BE	4/0 AWG	3/0 AWG, 3/0 Weld 450/24	1/4	3.15 (80.0)	1.38 (35.1)	1.03 (33.0)	0.14 (3.6)	0.70 (17.8)	0.25 (6.4)	0.75 (19.1)	54	Purple
54818BE			3/8	4.38 (111.3)	2.63 (66.8)	1.03 (33.0)	0.14 (3.6)	0.70 (17.8)	0.38 (9.7)	1.75 (44.5)		
256-30695-1117			3/8	3.35 (85.1)	1.81 (46.0)	1.03 (33.0)	0.14 (3.6)	0.70 (17.8)	0.38 (9.7)	1.00 (25.4)		
256-30695-1117P			3/8	3.50 (88.9)	1.88 (47.8)	1.03 (33.0)	0.14 (3.6)	0.70 (17.8)	0.38 (9.7)	1.00 (25.4)		
54866BE			1/2	4.70 (119.4)	3.00 (76.2)	1.03 (33.0)	0.14 (3.6)	0.70 (17.8)	0.50 (12.7)	1.75 (44.5)		
256-30695-1245	250 kcmil	4/0 AWG, 4/0 Weld 550/24	3/8	3.83 (97.3)	1.93 (49.0)	1.13 (28.7)	0.14 (3.6)	0.77 (19.6)	0.38 (9.7)	1.00 (25.4)	62	Yellow
256-30695-1245P			3/8	3.83 (97.3)	1.93 (49.0)	1.13 (28.7)	0.14 (3.6)	0.77 (19.6)	0.38 (9.7)	1.00 (25.4)		
54868BE			1/2	4.92 (125.0)	3.00 (76.2)	1.13 (28.7)	0.14 (3.6)	0.77 (19.6)	0.50 (12.7)	1.75 (44.5)		
54819BE	300 kcmil	250 kcmil 650/24 = 262 kcmil	3/8	5.04 (137.2)	2.80 (71.1)	1.25 (31.8)	0.15 (3.8)	0.85 (21.6)	0.38 (9.7)	1.00 (25.4)	66	White
54870BE			1/2	5.23 (132.8)	3.00 (76.2)	1.25 (31.8)	0.15 (3.8)	0.85 (21.6)	0.50 (12.7)	1.75 (44.5)		
54820BE	350 kcmil	-	1/4	4.29 (109.0)	1.93 (49.0)	1.36 (34.5)	0.18 (4.6)	0.93 (23.6)	0.25 (6.4)	1.75 (44.5)	71	Red
256-30695-1118			3/8	4.33 (110.0)	1.93 (49.0)	1.36 (34.5)	0.18 (4.6)	0.93 (23.6)	0.38 (9.7)	1.00 (25.4)		
256-30695-1118P			3/8	4.33 (110.0)	1.93 (49.0)	1.36 (34.5)	0.18 (4.6)	0.93 (23.6)	0.38 (9.7)	1.00 (25.4)		
54872BE			1/2	5.40 (137.2)	3.00 (76.2)	1.36 (34.5)	0.18 (4.6)	0.93 (23.6)	0.50 (12.7)	1.75 (44.5)		
54822BE	400 kcmil	300 kcmil 775/24, 313 kcmil	1/4	4.38 (111.3)	1.93 (49.0)	1.41 (35.8)	0.17 (4.3)	0.96 (24.4)	0.25 (6.4)	0.75 (19.1)	76	Blue
54821BE			3/8	4.43 (112.5)	1.93 (49.0)	1.41 (35.8)	0.17 (4.3)	0.96 (24.4)	0.38 (9.7)	1.00 (25.4)		
54874BE			1/2	5.51 (140.0)	3.00 (76.2)	1.41 (35.8)	0.17 (4.3)	0.96 (24.4)	0.50 (12.7)	1.75 (44.5)		
54823BE	500 kcmil	400 kcmil 925/24 350/373 kcmil	1/4	4.93 (125.2)	1.94 (49.3)	1.61 (40.9)	0.22 (5.6)	1.10 (27.9)	0.25 (6.4)	0.75 (19.1)	87	Brown
256-30695-1119			3/8	5.00 (127.0)	1.93 (49.0)	1.61 (40.9)	0.22 (5.6)	1.10 (27.9)	0.38 (9.7)	1.00 (25.4)		
256-30695-1119P			3/8	5.00 (127.0)	1.93 (49.0)	1.61 (40.9)	0.22 (5.6)	1.10 (27.9)	0.38 (9.7)	1.00 (25.4)		
54876BE			1/2	6.00 (152.4)	3.00 (76.2)	1.61 (40.9)	0.22 (5.6)	1.10 (27.9)	0.50 (12.7)	1.75 (44.5)		
54824BE	600 kcmil	1100/24, 444 kcmil	3/8	5.70 (144.8)	2.80 (71.1)	1.75 (44.5)	0.24 (6.1)	1.20 (30.5)	0.38 (9.7)	1.00 (25.4)	94	Green
54878BE			1/2	5.83 (148.1)	3.00 (76.2)	1.75 (44.5)	0.24 (6.1)	1.20 (30.5)	0.50 (12.7)	1.75 (44.5)		
54879BE	700 kcmil	1325/24, 535 kcmil	1/2	5.83 (148.1)	3.00 (76.2)	1.80 (45.7)	0.24 (6.1)	1.25 (31.8)	0.50 (12.7)	1.75 (44.5)	99	Pink
256-30695-1222			3/8	5.25 (133.4)	2.06 (52.3)	1.94 (49.3)	0.27 (6.7)	1.33 (33.8)	0.50 (12.7)	1.00 (25.4)		
256-30695-1222P	750 kcmil	1325/24, 535 kcmil	3/8	5.25 (133.4)	2.06 (52.3)	1.94 (49.3)	0.27 (6.7)	1.33 (33.8)	0.50 (12.7)	1.00 (25.4)	106	Black
54880BE			1/2	6.20 (157.5)	3.00 (76.2)	1.94 (49.3)	0.27 (6.9)	1.33 (33.8)	0.50 (12.7)	1.75 (44.5)		
58884BE			1/2	6.16 (156.5)	3.00 (76.2)	1.94 (49.3)	0.27 (6.9)	1.33 (33.8)	0.50 (12.7)	1.75 (44.5)		
58826BE	900 kcmil	1925/24, 777 kcmil	1/2	6.74 (171.2)	3.00 (76.2)	2.18 (55.4)	0.31 (7.9)	1.50 (38.1)	0.50 (12.7)	1.75 (44.5)	115	Yellow
54826BE			3/8	6.49 (164.8)	2.80 (71.1)	2.27 (57.7)	0.30 (7.6)	1.55 (39.4)	0.38 (9.7)	1.00 (25.4)		
54882BE	1000 kcmil	-	1/2	6.66 (169.2)	3.00 (76.2)	2.27 (57.7)	0.30 (7.6)	1.55 (39.4)	0.38 (9.7)	1.75 (44.5)	125	-
54888BE			1/2	7.88 (200.2)	3.00 (76.2)	2.42 (61.5)	0.35 (8.9)	1.67 (42.4)	0.63 (16.0)	1.75 (44.5)		

† For installations from 16 kV up to 35 kV, consult shielded cable manufacturers for stress relief and insulation requirements. Call your Regional Sales Office for sizes not listed.

Tooling: pp. E4-E62

Die Selector Chart: pp. E35-E50

Peep Holes Available!
Add suffix -PH

Compression Connectors for Copper Conductors

Two-Hole Lugs — 45° Long Barrel Certified to 600 V and Recommended up to 35 kV \ddagger

Material: High-Conductivity Wrought Copper

Finish: Electro-Tin Plated

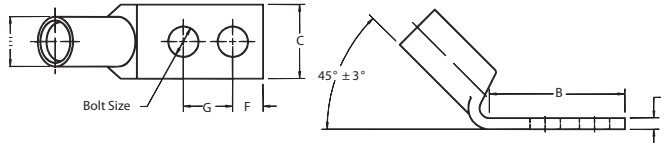

Cat. No.	Wire Size		Bolt Size	Dimensions in. (mm)						Die Code	Colour Code
	Code Cable	Flex Cable Classes G, H, I, K, M		B	C	D	E	F	G		
256-31426-3SPHUF	#14 – 10 AWG	-	#10	1.25 (31.75)	0.37 (9.4)	0.07 (1.8)	0.20 (5.1)	0.22 (5.6)	0.50 – 0.63 (12.7 – 16.0)	ERG2002	Yellow
256-30695-1298UF			1/4	1.22 (31.0)	0.50 (12.7)	0.05 (1.3)	0.20 (5.1)	0.25 (6.4)	0.63 (16.0)		
54850BEUF	#8 AWG	#8 AWG 37/24 #8 Weld	1/4	1.89 (48.0)	0.42 (10.7)	0.07 (17.8)	0.26 (6.6)	0.25 (6.4)	0.63 (16.0)	21	Red
54851BEUF			1/4	1.29 (32.8)	0.47 (11.9)	0.06 (15.2)	0.26 (6.6)	0.25 (6.4)	0.75 (19.1)		
54851BEUF0612			3/8	1.42 (36.1)	0.47 (11.9)	0.06 (15.2)	0.26 (6.6)	0.38 (9.7)	0.75 (19.1)		
54852BEUF	#6 AWG	#6 AWG 61/24 #6 Weld	1/4	1.28 (32.5)	0.44 (11.2)	0.08 (20.3)	0.30 (7.6)	0.25 (6.4)	0.63 (16.0)	24	Blue
54852BEUF0416			1/4	1.63 (41.4)	0.43 (10.9)	0.08 (20.3)	0.30 (7.6)	0.25 (6.4)	1.00 (25.4)		
54852BEUF0412			1/4	1.43 (36.3)	0.43 (10.9)	0.08 (20.3)	0.30 (7.6)	0.25 (6.4)	0.75 (19.1)		
54852BEUF0616			3/8	1.93 (49.0)	0.59 (15.0)	0.06 (15.2)	0.30 (7.6)	0.38 (9.7)	1.00 (25.4)		
54852BEUF0828	#4 AWG	#5 AWG 91/24 #4 Weld	1/2	3.00 (76.2)	0.88 (22.4)	0.11 (2.8)	0.30 (7.6)	0.50 (12.7)	1.75 (44.5)	29	Grey
54854BEUF			1/4	1.19 (30.2)	0.52 (13.2)	0.10 (2.5)	0.37 (9.4)	0.25 (6.4)	0.63 (16.0)		
54854BEUF0412	#4 AWG	#5 AWG 91/24 #4 Weld	1/4	1.31 (33.3)	0.56 (14.2)	0.09 (2.3)	0.37 (9.4)	0.25 (6.4)	0.75 (19.1)	29	Grey
54854BEUF0416			1/4	1.88 (47.8)	0.58 (14.7)	0.09 (2.3)	0.37 (9.4)	0.38 (9.7)	1.00 (25.4)		
54854BEUF0516			5/16	1.75 (44.5)	0.56 (14.2)	0.10 (2.5)	0.37 (9.4)	0.63 (16.0)	1.00 (25.4)		
54854BEUF0616			3/8	1.98 (50.3)	0.59 (15.0)	0.09 (2.3)	0.37 (9.4)	0.38 (9.7)	1.00 (25.4)		
54854BEUF0828			1/2	3.00 (76.2)	0.88 (22.4)	0.09 (2.3)	0.37 (9.4)	0.50 (12.7)	1.75 (44.5)		
54855BEUF0416	#2-3 AWG	#3 AWG 125/24	1/4	1.88 (47.8)	0.67 (17.0)	0.09 (2.3)	0.41 (10.4)	0.38 (9.7)	1.00 (25.4)	33	Brown
54855BEUF			1/4	1.28 (32.5)	0.59 (15.0)	0.11 (2.8)	0.41 (10.4)	0.25 (6.4)	0.63 (16.0)		
54855BEUF0412			1/4	1.35 (34.3)	0.68 (17.3)	0.11 (2.8)	0.41 (10.4)	0.25 (6.4)	0.75 (19.1)		
54856BEUF			5/16	1.63 (41.4)	0.59 (15.0)	0.11 (2.8)	0.41 (10.4)	0.38 (9.7)	0.75 (19.1)		
54810BEUF			3/8	2.57 (65.3)	0.59 (15.0)	0.11 (2.8)	0.41 (10.4)	0.38 (9.7)	1.75 (44.5)		
54810BEUF0616	#1 AWG	#2 AWG 150/24 175/24 #2 Weld	3/8	1.94 (49.3)	0.59 (15.0)	0.11 (2.8)	0.41 (10.4)	0.38 (9.7)	1.00 (25.4)	37	Green
54811BEUF			1/2	3.00 (76.2)	0.88 (22.4)	0.11 (2.8)	0.41 (10.4)	0.50 (12.7)	1.75 (44.5)		
54809BEUF			1/4	1.19 (30.2)	0.67 (17.0)	0.11 (2.8)	0.47 (11.9)	0.25 (6.4)	0.63 (16.0)		
54812BEUF			1/4	1.40 (35.6)	0.67 (17.0)	0.11 (2.8)	0.47 (11.9)	0.25 (6.4)	0.75 (19.1)		
54858BEUF			5/16	1.63 (41.4)	0.67 (17.0)	0.11 (2.8)	0.47 (11.9)	0.63 (16.0)	0.88 (22.4)		
54857BEUF0616	1/0 AWG	1 AWG 225/24	3/8	1.98 (50.3)	0.67 (17.0)	0.11 (2.8)	0.47 (11.9)	0.38 (9.7)	1.00 (25.4)	42	Pink
54857BEUF			1/2	3.00 (76.2)	0.88 (22.4)	0.11 (2.8)	0.47 (11.9)	0.50 (12.7)	1.75 (44.5)		
54859BEUF0416			1/4	1.88 (47.8)	0.75 (19.1)	0.13 (3.3)	0.52 (13.2)	0.38 (9.7)	1.00 (25.4)		
54859BEUF0416PH			1/4	1.88 (47.8)	0.75 (19.1)	0.13 (3.3)	0.52 (13.2)	0.38 (9.7)	1.00 (25.4)		
54859BEUF			1/4	1.19 (30.2)	0.75 (19.1)	0.13 (3.3)	0.52 (13.2)	0.25 (6.4)	0.38 (9.7)		
54813BEUF	2/0 AWG	1/0 AWG 275/24 1/0 Weld	1/4	1.38 (35.1)	0.75 (19.1)	0.13 (3.3)	0.52 (13.2)	0.25 (6.4)	0.75 (19.1)	45	Black
54860BEUF			5/16	1.63 (41.4)	0.75 (19.1)	0.13 (3.3)	0.52 (13.2)	0.38 (9.7)	0.88 (22.4)		
54860BEUF0616			3/8	1.98 (50.3)	0.75 (19.1)	0.13 (3.3)	0.52 (13.2)	0.38 (9.7)	1.00 (25.4)		
54860BEUF0616PH			3/8	1.93 (49.0)	0.75 (19.1)	0.13 (3.3)	0.52 (13.2)	0.38 (9.7)	1.00 (25.4)		
54860BEUF0828			1/2	3.00 (76.0)	0.75 (19.1)	0.13 (3.3)	0.52 (13.2)	0.63 (16.0)	1.75 (44.5)		
54814BEUF	2/0 AWG	1/0 AWG 275/24 1/0 Weld	1/4	1.25 (31.8)	0.83 (21.1)	0.13 (3.3)	0.57 (14.5)	0.25 (6.4)	0.63 (16.0)	45	Black
54814BEUF0412			1/4	1.31 (33.3)	0.81 (20.6)	0.13 (3.3)	0.57 (14.5)	0.25 (6.4)	0.75 (19.1)		
54862BEUF0616			3/8	1.81 (46.0)	0.83 (21.1)	0.13 (3.3)	0.57 (14.5)	0.38 (9.7)	1.00 (25.4)		
54862BEUF0616PH			3/8	1.81 (46.0)	0.83 (21.1)	0.13 (3.3)	0.57 (14.5)	0.38 (9.7)	1.00 (25.4)		
54862BEUF			1/2	2.81 (71.4)	0.83 (21.1)	0.13 (3.3)	0.57 (14.5)	0.50 (12.7)	1.75 (44.5)		

\ddagger For installations from 16 kV up to 35 kV, consult shielded cable manufacturers for stress relief and insulation requirements. Call your Regional Sales Office for sizes not listed.
Tooling: pp. E4–E62
Die Selector Chart: pp. E35–E50

Peep Holes Available!
Add suffix -PH

Compression Connectors for Copper Conductors

Two-Hole Lugs — 45° Long Barrel Certified to 600 V and Recommended up to 35 kV¥ (cont'd)

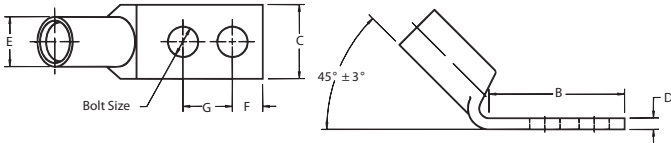

Material: High-Conductivity Wrought Copper

Finish: Electro-Tin Plated



Cat. No.	Wire Size		Bolt Size	Dimensions in. (mm)						Die Code	Colour Code
	Code Cable	Flex Cable Classes G, H, I, K, M		B	C	D	E	F	G		
54815BEUF	3/0 AWG	2/0 AWG 325/24 2/0 Weld	1/4	1.45 (36.8)	0.92 (23.4)	0.13 (3.3)	0.63 (16.0)	0.25 (6.4)	0.75 (19.1)	50	Orange
54816BEUF			3/8	0.63 (16.0)	0.92 (23.4)	0.13 (3.3)	0.63 (16.0)	0.38 (9.7)	1.00 (25.4)		
54864BEUF			1/2	3.00 (76.2)	0.94 (23.9)	0.13 (3.3)	0.63 (16.0)	0.50 (12.7)	1.75 (44.5)		
54817BEUF	4/0 AWG	3/0 AWG 450/24 3/0 Weld	1/4	1.38 (35.1)	1.03 (33.0)	0.14 (3.6)	0.70 (17.8)	0.25 (6.4)	0.75 (19.1)	54	Purple
54818BEUF			3/8	2.63 (66.8)	1.03 (33.0)	0.14 (3.6)	0.70 (17.8)	0.38 (9.7)	1.75 (44.5)		
54818BEUF0616			3/8	1.81 (46.0)	1.03 (33.0)	0.14 (3.6)	0.70 (17.8)	0.38 (9.7)	1.00 (25.4)		
54818BEUF0616PH			3/8	1.88 (47.8)	1.03 (33.0)	0.14 (3.6)	0.70 (17.8)	0.38 (9.7)	1.00 (25.4)		
54866BEUF	250 kcmil	4/0 AWG 550/24 4/0 Weld	1/2	3.00 (76.2)	1.03 (33.0)	0.14 (3.6)	0.70 (17.8)	0.50 (12.7)	1.75 (44.5)	62	Yellow
54868BEUF0616			3/8	1.93 (49.0)	1.13 (28.7)	0.14 (3.6)	0.77 (19.6)	0.38 (9.7)	1.00 (25.4)		
54868BEUF0616PH			5/8	1.93 (49.0)	1.13 (28.7)	0.14 (3.6)	0.77 (19.6)	0.38 (9.7)	1.00 (25.4)		
54868BEUF	300 kcmil	250 kcmil 650/24 = 262 kcmil	1/2	3.00 (76.2)	1.13 (28.7)	0.14 (3.6)	0.77 (19.6)	0.50 (12.7)	1.75 (44.5)	66	White
54819BEUF			3/8	2.80 (71.1)	1.25 (31.8)	0.15 (3.8)	0.85 (21.6)	0.38 (9.7)	1.00 (25.4)		
54870BEUF	350 kcmil	650/24 262 kcmil	1/4	1.93 (49.0)	1.36 (34.5)	0.18 (4.6)	0.93 (23.6)	0.25 (6.4)	0.75 (19.1)	71	Red
54872BEUF0616			3/8	1.93 (49.0)	1.36 (34.5)	0.18 (4.6)	0.93 (23.6)	0.38 (9.7)	1.00 (25.4)		
54872BEUF0616PH			3/8	1.93 (49.0)	1.36 (34.5)	0.18 (4.6)	0.93 (23.6)	0.38 (9.7)	1.00 (25.4)		
54872BEUF			1/2	3.00 (76.2)	1.36 (34.5)	0.18 (4.6)	0.93 (23.6)	0.50 (12.7)	1.75 (44.5)		
54822BEUF	400 kcmil	775/24 313 kcmil	1/4	1.93 (49.0)	1.41 (35.8)	0.17 (4.3)	0.96 (24.4)	0.25 (6.4)	0.75 (19.1)	76	Blue
54821BEUF			3/8	1.93 (49.0)	1.41 (35.8)	0.17 (4.3)	0.96 (24.4)	0.38 (9.7)	1.00 (25.4)		
54874BEUF			1/2	3.00 (76.2)	1.41 (35.8)	0.17 (4.3)	0.96 (24.4)	0.50 (12.7)	1.75 (44.5)		
54823BEUF	500 kcmil	400 kcmil 925/24 350/373 kcmil	1/4	1.93 (49.0)	1.61 (40.9)	0.22 (5.6)	1.10 (27.9)	0.25 (6.4)	0.75 (19.1)	87	Brown
54876BEUF0616			3/8	1.93 (49.0)	1.61 (40.9)	0.22 (5.6)	1.10 (27.9)	0.38 (9.7)	1.00 (25.4)		
54876BEUF0616PH			3/8	1.93 (49.0)	1.61 (40.9)	0.22 (5.6)	1.10 (27.9)	0.38 (9.7)	1.00 (25.4)		
54876BEUF			1/2	3.00 (76.2)	1.61 (40.9)	0.22 (5.6)	1.10 (27.9)	0.50 (12.7)	1.75 (44.5)		
54824BEUF	600 kcmil	1100/24 444 kcmil	3/8	2.80 (71.1)	1.75 (44.5)	0.24 (6.1)	1.20 (27.9)	0.38 (9.7)	1.00 (25.4)	94	Green
54878BEUF			1/2	3.00 (76.2)	1.75 (44.5)	0.24 (6.1)	1.20 (27.9)	0.50 (12.7)	1.75 (44.5)		
54880BEUF0616	750 kcmil	1325/24 535 kcmil	3/8	2.06 (52.3)	1.94 (49.3)	0.27 (6.9)	1.33 (33.8)	0.50 (12.7)	1.00 (25.4)	106	Black
54880BEUF0616PH			3/8	2.06 (52.3)	1.94 (49.3)	0.27 (6.9)	1.33 (33.8)	0.50 (12.7)	1.00 (25.4)		
54880BEUF			1/2	3.00 (76.2)	1.94 (49.3)	0.27 (6.9)	1.33 (33.8)	0.50 (12.7)	1.75 (44.5)		
58884BEUF	—	1600/24, 646 kcmil	1/2	3.00 (76.2)	1.94 (49.3)	0.27 (6.9)	1.33 (33.8)	0.50 (12.7)	1.75 (44.5)		
58826BEUF	900 kcmil	1925/24 750/777 kcmil	1/2	3.00 (76.2)	2.18 (55.4)	0.31 (7.9)	1.50 (38.1)	0.50 (12.7)	1.75 (44.5)	115	Yellow
54826BEUF	1000 kcmil	—	3/8	2.80 (71.1)	2.27 (57.7)	0.30 (7.6)	1.55 (39.4)	0.38 (9.7)	1.00 (25.4)	125	—
54882BEUF			1/2	3.00 (76.2)	2.27 (57.7)	0.30 (7.6)	1.55 (39.4)	0.50 (12.7)	1.75 (44.5)		

¥ For installations from 16 kV up to 35 kV, consult shielded cable manufacturers for stress relief and insulation requirements. Call your Regional Sales Office for sizes not listed.
Tooling: pp. E4–E62
Die Selector Chart: pp. E35–E50

Peep Holes Available!
Add suffix -PH



Compression Connectors for Copper Conductors

Two-Hole Lugs — 90° Long Barrel Certified to 600 V and Recommended up to 35 kV \ddot{V}

Material: High-Conductivity Wrought Copper

Finish: Electro-Tin Plated

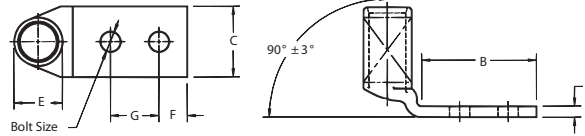

Cat. No.	Wire Size		Bolt Size	Dimensions in. (mm)						Die Code	Colour Code
	Code Cable	Flex Cable Classes G, H, I, K, M		B	C	D	E	F	G		
54850BEUB	#8 AWG	#8 AWG 37/24 #8 Weld	1/4	1.89 (48.0)	0.42 (10.7)	0.07 (1.8)	0.26 (6.6)	0.21 (5.3)	0.63–0.75 (16.0–19.1)	21	Red
54851BEUB			1/4	0.29 (32.8)	0.47 (11.9)	0.06 (1.5)	0.26 (6.6)	0.25 (6.4)	0.75 (19.1)		
54851BEUB0616			3/8	2.10 (53.3)	0.56 (14.2)	0.06 (1.5)	0.26 (6.6)	0.38 (9.7)	1.00 (25.4)		
54852BEUB	#6 AWG	#6 AWG 61/24 #6 Weld	1/4	1.28 (32.5)	0.44 (11.2)	0.08 (2.0)	0.30 (7.6)	0.25 (6.4)	0.63 (16.0)	24	Blue
54852BEUB0412			1/4	1.43 (36.3)	0.43 (10.9)	0.08 (2.0)	0.30 (7.6)	0.25 (6.4)	0.75 (19.1)		
54852BEUB0616			3/8	1.93 (49.0)	0.59 (15.0)	0.06 (1.5)	0.30 (7.6)	0.38 (9.7)	1.00 (25.4)		
54852BEUB0828	1/2	3.00 (76.2)	0.88 (22.4)	0.11 (2.8)	0.30 (7.6)	0.50 (12.7)	1.75 (44.5)				
54854BEUB	#4 AWG	#5 AWG 91/24 #4 Weld	1/4	1.19 (30.2)	0.52 (13.2)	0.10 (2.5)	0.37 (9.4)	0.25 (6.4)	0.63 (16.0)	29	Grey
54854BEUB0412			1/4	1.31 (33.3)	0.56 (14.2)	0.09 (2.3)	0.37 (9.4)	0.25 (6.4)	0.75 (19.1)		
54854BEUB0416			1/4	1.88 (47.8)	0.58 (14.7)	0.09 (2.3)	0.37 (9.4)	0.38 (9.7)	1.00 (25.4)		
54854BEUB0516			5/16	1.75 (44.5)	0.56 (14.2)	0.10 (2.5)	0.37 (9.4)	0.38 (9.7)	1.00 (25.4)		
54854BEUB0616			3/8	1.98 (50.3)	0.59 (15.0)	0.09 (2.3)	0.37 (9.4)	0.38 (9.7)	1.00 (25.4)		
54854BEUB0828			1/2	3.00 (76.2)	0.88 (22.4)	0.09 (2.3)	0.37 (9.4)	0.50 (12.7)	1.75 (44.5)		
54858BEUB0416	#2-3 AWG	#3 AWG 125/24	1/4	1.88 (47.8)	0.67 (17.0)	0.09 (2.3)	0.41 (10.4)	0.38 (9.7)	1.00 (25.4)	33	Brown
54855BEUB			1/4	1.28 (32.5)	0.59 (15.0)	0.11 (2.8)	0.41 (10.4)	0.25 (6.4)	0.63 (16.0)		
54855BEUB0412			1/4	1.35 (34.3)	0.68 (17.3)	0.11 (2.8)	0.41 (10.4)	0.25 (6.4)	0.75 (19.1)		
54856BEUB			5/16	1.63 (41.4)	0.59 (15.0)	0.11 (2.8)	0.41 (10.4)	0.38 (9.7)	0.75 (19.1)		
54810BEUB			3/8	2.57 (65.3)	0.59 (15.0)	0.11 (2.8)	0.41 (10.4)	0.38 (9.7)	1.75 (44.5)		
54810BEUB0616			3/8	1.94 (49.3)	0.59 (15.0)	0.11 (2.8)	0.41 (10.4)	0.38 (9.7)	1.00 (25.4)		
54811BEUB	#1 AWG	#2 AWG 150/24 175/24 #2 Weld	1/2	3.00 (76.2)	0.88 (22.4)	0.11 (2.8)	0.41 (10.4)	0.50 (12.7)	0.75 (19.1)	37	Green
54809BEUB			1/4	1.19 (30.2)	0.67 (17.0)	0.11 (2.8)	0.47 (11.9)	0.25 (6.4)	0.63 (16.0)		
54812BEUB			1/4	1.40 (35.6)	0.67 (17.0)	0.11 (2.8)	0.47 (11.9)	0.25 (6.4)	0.75 (19.1)		
54858BEUB			5/16	1.63 (41.4)	0.67 (17.0)	0.11 (2.8)	0.47 (11.9)	0.38 (9.7)	0.88 (22.4)		
54857BEUB0616			3/8	1.98 (50.3)	0.67 (17.0)	0.11 (2.8)	0.47 (11.9)	0.38 (9.7)	1.00 (25.4)		
54857BEUB			1/2	3.00 (76.2)	0.88 (22.4)	0.11 (2.8)	0.47 (11.9)	0.50 (12.7)	1.75 (44.5)		
54859BEUB0416	1/0 AWG	1 AWG 225/24	1/4	1.88 (47.8)	0.75 (19.1)	0.13 (3.3)	0.52 (13.2)	0.38 (9.7)	1.00 (25.4)	42	Pink
54859BEUB0416PH			1/4	1.88 (47.8)	0.75 (19.1)	0.13 (3.3)	0.52 (13.2)	0.38 (9.7)	1.00 (25.4)		
54859BEUB			1/4	1.19 (30.2)	0.75 (19.1)	0.13 (3.3)	0.52 (13.2)	0.25 (6.4)	0.63 (16.0)		
54813BEUB			1/4	1.38 (35.1)	0.75 (19.1)	0.13 (3.3)	0.52 (13.2)	0.25 (6.4)	0.75 (19.1)		
54860BEUB			5/16	1.63 (41.4)	0.75 (19.1)	0.13 (3.3)	0.52 (13.2)	0.38 (9.7)	0.88 (22.4)		
54860BEUB0616			3/8	1.98 (50.3)	0.75 (19.1)	0.13 (3.3)	0.52 (13.2)	0.38 (9.7)	1.00 (25.4)		
54860BEUB0828	1/2	3.00 (76.2)	0.75 (19.1)	0.13 (3.3)	0.52 (13.2)	0.38 (9.7)	1.75 (44.5)				
54814BEUB	2/0 AWG	1/0 AWG 275/24 1/0 Weld	1/4	1.25 (31.8)	0.83 (21.1)	0.13 (3.3)	0.57 (14.5)	0.25 (6.4)	0.63 (16.0)	45	Black
54814BEUB0412			1/4	1.31 (33.3)	0.81 (20.6)	0.13 (3.3)	0.57 (14.5)	0.25 (6.4)	0.75 (19.1)		
54862BEUB0616			3/8	1.81 (46.0)	0.83 (21.1)	0.13 (3.3)	0.57 (14.5)	0.38 (9.7)	1.00 (25.4)		
54862BEUB0616PH			3/8	1.81 (46.0)	0.83 (21.1)	0.13 (3.3)	0.57 (14.5)	0.38 (9.7)	1.00 (25.4)		
54862BEUB			1/2	2.81 (71.4)	0.83 (21.1)	0.13 (3.3)	0.57 (14.5)	0.50 (12.7)	0.75 (19.1)		

¥ For installations from 16 kV up to 35 kV, consult shielded cable manufacturers for stress relief and insulation requirements. Call your Regional Sales Office for sizes not listed.

Tooling: pp. E4–E62

Die Selector Chart: pp. E35–E50

Compression Connectors for Copper Conductors

Two-Hole Lugs — 90° Long Barrel Certified to 600 V and Recommended up to 35 kV \ddagger (cont'd)

*Peep Holes Available!
Add suffix -PH*



Material: High-Conductivity Wrought Copper

Finish: Electro-Tin Plated

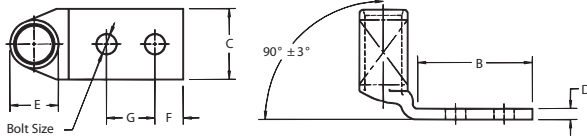

Cat. No.	Wire Size		Bolt Size	Dimensions in. (mm)						Die Code	Colour Code
	Code Cable	Flex Cable Classes G, H, I, K, M		B	C	D	E	F	G		
54815BEUB	3/0 AWG	2/0 AWG 325/24 2/0 Weld	1/4	1.45 (36.8)	0.92 (23.4)	0.13 (3.3)	0.63 (16.0)	0.25 (6.4)	0.75 (19.1)	50	Orange
54816BEUB			3/8	0.63 (41.4)	0.92 (23.4)	0.13 (3.3)	0.63 (16.0)	0.38 (9.7)	1.00 (25.4)		
54864BEUB			1/2	3.00 (76.2)	0.94 (23.9)	0.13 (3.3)	0.63 (16.0)	0.50 (12.7)	1.75 (44.5)		
54817BEUB	4/0 AWG	3/0 AWG 450/24 3/0 Weld	1/4	1.38 (35.1)	1.03 (33.0)	0.14 (3.6)	0.70 (17.8)	0.25 (6.4)	0.75 (19.1)	54	Purple
54818BEUB			3/8	2.63 (66.8)	1.03 (33.0)	0.14 (3.6)	0.70 (17.8)	0.38 (9.7)	1.75 (44.5)		
54818BEUB0616			3/8	1.81 (46.0)	1.03 (33.0)	0.14 (3.6)	0.70 (17.8)	0.38 (9.7)	1.00 (25.4)		
54818BEUB0616PH			3/8	1.88 (47.8)	1.03 (33.0)	0.14 (3.6)	0.70 (17.8)	0.38 (9.7)	1.00 (25.4)		
54866BEUB	250 kcmil	4/0 AWG 550/24 4/0 Weld	1/2	3.00 (76.2)	1.03 (33.0)	0.14 (3.6)	0.70 (17.8)	0.50 (12.7)	1.75 (44.5)	62	Yellow
54868BEUB0616			3/8	1.93 (49.0)	1.13 (28.7)	0.14 (3.6)	0.77 (19.6)	0.38 (9.7)	1.00 (25.4)		
54868BEUB0616PH			3/8	1.93 (49.0)	1.13 (28.7)	0.14 (3.6)	0.77 (19.6)	0.38 (9.7)	1.00 (25.4)		
54868BEUB	300 kcmil	250 kcmil 650/24 = 262 kcmil	1/2	3.00 (76.2)	1.13 (28.7)	0.14 (3.6)	0.77 (19.6)	0.50 (12.7)	1.75 (44.5)	66	White
54819BEUB			3/8	2.80 (71.1)	1.25 (31.8)	0.15 (3.8)	0.85 (21.6)	0.38 (9.7)	1.00 (25.4)		
54870BEUB	350 kcmil	650/24 262 kcmil	1/4	1.93 (49.0)	1.36 (34.5)	0.18 (4.6)	0.93 (23.6)	0.25 (6.4)	0.75 (19.1)	71	Red
54820BEUB			3/8	1.93 (49.0)	1.36 (34.5)	0.18 (4.6)	0.93 (23.6)	0.38 (9.7)	1.00 (25.4)		
54872BEUB0616			3/8	1.93 (49.0)	1.36 (34.5)	0.18 (4.6)	0.93 (23.6)	0.38 (9.7)	1.00 (25.4)		
54872BEUB0616PH			3/8	1.93 (49.0)	1.36 (34.5)	0.18 (4.6)	0.93 (23.6)	0.38 (9.7)	1.00 (25.4)		
54872BEUB	400 kcmil	775/24 313 kcmil	1/2	3.00 (76.2)	1.36 (34.5)	0.18 (4.6)	0.93 (23.6)	0.50 (12.7)	1.75 (44.5)	76	Blue
54822BEUB			1/4	1.93 (49.0)	1.41 (35.8)	0.17 (4.3)	0.96 (24.4)	0.25 (6.4)	0.75 (19.1)		
54821BEUB			3/8	1.93 (49.0)	1.41 (35.8)	0.17 (4.3)	0.96 (24.4)	0.38 (9.7)	1.00 (25.4)		
54874BEUB	500 kcmil	400 kcmil 925/24 350/373 kcmil	1/2	3.00 (76.2)	1.41 (35.8)	0.17 (4.3)	0.96 (24.4)	0.50 (12.7)	1.75 (44.5)	87	Brown
54823BEUB			1/4	1.94 (49.3)	1.61 (40.9)	0.22 (5.6)	1.10 (27.9)	0.25 (6.4)	0.75 (19.1)		
54823BEUB0616			3/8	1.93 (49.0)	1.61 (40.9)	0.22 (5.6)	1.10 (27.9)	0.38 (9.7)	1.00 (25.4)		
54876BEUB0616PH			3/8	1.93 (49.0)	1.61 (40.9)	0.22 (5.6)	1.10 (27.9)	0.38 (9.7)	1.00 (25.4)		
54876BEUB	600 kcmil	1110/24, 444 kcmil	1/2	3.00 (76.2)	1.61 (40.9)	0.22 (5.6)	1.10 (27.9)	0.50 (12.7)	1.75 (44.5)	94	Green
54824BEUB			3/8	2.80 (71.1)	1.75 (44.5)	0.24 (6.1)	1.20 (30.5)	0.38 (9.7)	1.00 (25.4)		
54878BEUB			1/2	3.00 (76.2)	1.75 (44.5)	0.24 (6.1)	1.20 (30.5)	0.50 (12.7)	1.75 (44.5)		
54880BEUB0616	750 kcmil	1325/24 535 kcmil	3/8	2.06 (52.3)	1.94 (6.9)	0.27 (6.9)	1.33 (33.8)	0.50 (12.7)	1.00 (25.4)	106	Black
54880BEUB0616PH			3/8	2.06 (52.3)	1.94 (6.9)	0.27 (6.9)	1.33 (33.8)	0.50 (12.7)	1.00 (25.4)		
54880BEUB			1/2	3.00 (76.2)	1.94 (6.9)	0.27 (6.9)	1.33 (33.8)	0.50 (12.7)	1.75 (44.5)		
58884BEUB	—	1600/24, 646 kcmil	1/2	3.00 (76.2)	1.94 (6.9)	0.27 (6.9)	1.33 (33.8)	0.50 (12.7)	1.75 (44.5)		
58826BEUB	900 kcmil	1925/24 750/777 kcmil	1/2	3.00 (76.2)	2.18 (7.9)	0.31 (7.9)	1.50 (38.1)	0.50 (12.7)	1.75 (44.5)	115	Yellow
54826BEUB	1000 kcmil	—	3/8	2.80 (71.1)	2.27 (7.6)	0.30 (7.6)	1.55 (39.4)	0.38 (9.7)	1.00 (25.4)	125	—
54882BEUB			1/2	3.00 (76.2)	2.27 (7.6)	0.30 (7.6)	1.55 (39.4)	0.50 (12.7)	1.75 (44.5)		

\ddagger For installations from 16 kV up to 35 kV, consult shielded cable manufacturers for stress relief and insulation requirements. Call your Regional Sales Office for sizes not listed.

Tooling: pp. E4–E62

Die Selector Chart: pp. E35–E50



Compression Connectors for Copper Conductors

Narrow-Tongue Lugs

Ideal for Confined-Space Terminations!

To meet increasing demand for smaller components in today's panels and switchgear, Thomas & Betts has expanded its line of Color-Keyed® Narrow-Tongue Lugs to include two-hole and angled lugs. These improved lugs have been precision engineered for consistency in width the entire length of the connector, from barrel to tongue, ensuring a reliable fit in confined-space applications.

Technical specifications

- Certified Rating: 600 V
- Recommended Rating: Up to 35 kV \ddagger
- Material: 99% pure high-conductivity seamless wrought copper
- Finish: Electro-Tin Plated
- Standards: UL Listed, CSA Certified and RoHS compliant

- Narrow-width tongue and barrel, engineered for dimensional consistency the entire length of the lug
- Perfect for connections in limited-space applications
- High-conductivity copper construction
- Electrolytically tin-plated finish resists corrosion
- T&B Color-Keyed® marking system makes connections and verification easy
- Double-chamfered barrel eases insertion of wire

Ideal for use in:

- Panels
- Switchgear
- Molded-case circuit breakers
- Motor starters
- Other limited-space OEM applications



NOW AVAILABLE IN:

- One-hole
- Two-hole
- Straight
- 45° Angled
- 90° Angled

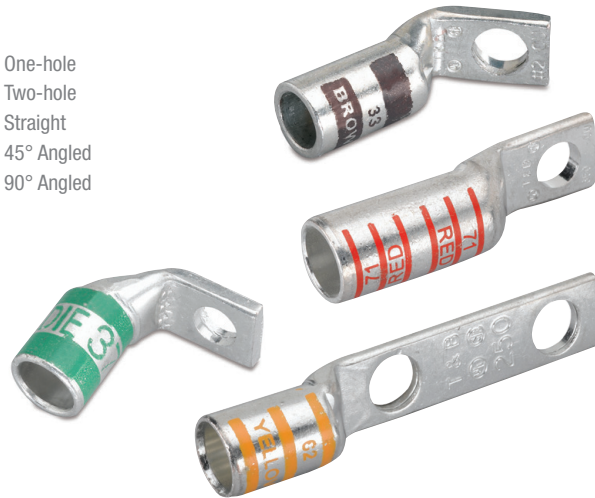

\ddagger For installations from 16 kV up to 35 kV, consult shielded cable manufacturers for stress relief and insulation requirements.

Compression Connectors for Copper Conductors

Narrow-Tongue Copper Lugs

One-Hole, Standard Barrel Certified to 600 V and Recommended up to 35 kV¥

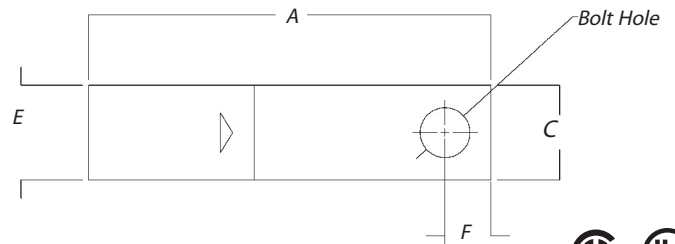
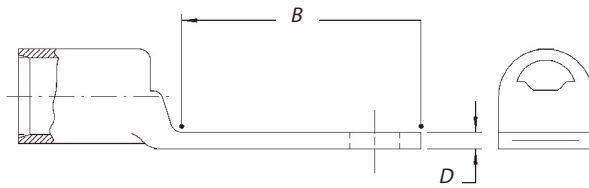

Cat. No.	Wire Size		Bolt Size	Dimensions in. (mm)						Die Code	Colour Code
	Code Cable	Flex Cable Classes G, H, I, K, M		A	B	C	D	E	F		
54138NT	#4 AWG	#5 AWG – 91/24	#10	1.31 (33.3)	0.56 (14.2)	0.37 (9.4)	0.10 (2.5)	0.37 (9.4)	0.25 (6.4)	29	Grey
54107NT	#2-3 AWG	#3 AWG – 125/24	1/4	1.50 (38.1)	0.65 (16.5)	0.41 (10.4)	0.07 (1.8)	0.41 (10.4)	0.25 (6.4)	33	Brown
54108NT	#1 AWG	#2 AWG, 150, 175/24	1/4	1.50 (38.1)	0.65 (16.5)	0.47 (11.9)	0.11 (2.8)	0.47 (11.9)	0.25 (6.4)	37	Green
54152NT	1/0 AWG	#1 AWG – 225/24	1/4	1.60 (40.6)	0.65 (16.5)	0.52 (13.2)	0.13 (3.3)	0.52 (13.2)	0.25 (6.4)	42	Pink
54157NT	2/0 AWG	1/0 AWG – 275/24	1/4	1.60 (40.6)	0.65 (16.5)	0.57 (14.5)	0.13 (3.3)	0.57 (14.5)	0.25 (6.4)	45	Black
54162NT	3/0 AWG	2/0 AWG – 325/24	1/4	1.68 (42.7)	0.65 (16.5)	0.63 (16.0)	0.13 (3.3)	0.63 (16.0)	0.25 (6.4)	50	Orange
54167NT	4/0 AWG	3/0 AWG – 450/24	1/4	1.90 (48.3)	0.65 (16.5)	0.70 (17.8)	0.14 (3.6)	0.70 (17.8)	0.25 (6.4)	54	Purple
54172NT	250 kcmil	4/0 AWG – 550/24	1/4	2.00 (50.8)	0.65 (16.5)	0.77 (19.6)	0.14 (3.6)	0.77 (19.6)	0.25 (6.4)	62	Yellow
54178NT04	300 kcmil	650/24	1/4	2.33 (59.2)	0.88 (22.4)	0.85 (21.6)	0.15 (3.8)	0.85 (21.6)	0.25 (6.4)	66	White
54115NT	350 kcmil	650/24	1/2	2.75 (69.9)	1.25 (31.8)	0.93 (23.6)	0.18 (4.6)	0.93 (23.6)	0.50 (12.7)	71H	Red
54115NT06		650/24	3/8	2.50 (63.5)	1.00 (25.4)	0.93 (23.6)	0.18 (4.6)	0.93 (23.6)	0.38 (9.6)		
54118NT	500 kcmil	925/24	1/2	3.25 (82.6)	1.25 (31.8)	1.10 (27.9)	0.22 (5.6)	1.10 (27.9)	0.50 (12.7)	87	Brown
54123NT08	750 kcmil	1325/24	1/2	3.48 (88.4)	1.25 (31.8)	1.33 (33.8)	0.27 (6.9)	1.33 (33.8)	0.50 (12.7)	106H	Black
54123NT		1325/24	5/8	3.80 (96.5)	1.58 (40.1)	1.33 (33.8)	0.27 (6.9)	1.33 (33.8)	0.63 (16.0)		

¥ For installations from 16 kV up to 35 kV, consult shielded cable manufacturers for stress relief and insulation requirements.

Cat. No.	Type	Cat. No. Example:
54108NT ____ *		54108NTUB is a 90° angled one-hole narrow-tongue lug for #1 AWG.
	____ = To order 45° and 90° Angle Lugs	
	UF = 45°	
	UB = 90°	
Other options include silver plating (add SP to catalogue number), blind end (add BE to catalogue number) and peep holes (add PH to catalogue number).		



Compression Connectors for Copper Conductors

Narrow-Tongue Copper Lugs
Two-Hole, Standard Barrel Certified to 600 V
and Recommended up to 35 kV‡

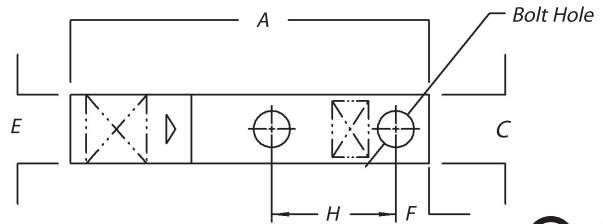
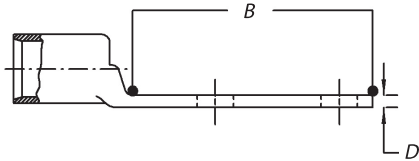

Cat. No.	Wire Size		Bolt Size	Dimensions in. (mm)							Die Code	Colour Code
	Code Cable	Flex Cable Classes G, H, I, K, M		A	B	C	D	E	F	H		
54206NT0310	#4 AWG	# 5 AWG – 91/24	#10	1.88 (47.8)	1.13 (28.7)	0.37 (9.4)	0.10 (2.5)	0.37 (9.4)	0.25 (6.4)	0.63 (16.0)	29	Grey
54207NT	#2-3 AWG	#3 AWG – 125/24	1/4	2.04 (61.0)	1.19 (30.2)	0.41 (10.4)	0.11 (2.8)	0.41 (10.4)	0.25 (6.4)	0.63 (16.0)	33	Brown
54207NT0412			1/4	2.16 (54.9)	1.31 (33.3)	0.41 (10.4)	0.11 (2.8)	0.41 (10.4)	0.25 (6.4)	0.75 (19.1)		
54207NT0416			1/4	2.41 (61.2)	1.56 (39.6)	0.41 (10.4)	0.11 (2.8)	0.41 (10.4)	0.25 (6.4)	1.00 (25.4)		
54208NT	#1 AWG	#2 AWG – 150, 175/24	1/4	2.40 (61.0)	1.19 (30.2)	0.47 (11.9)	0.11 (2.8)	0.47 (11.9)	0.25 (6.4)	0.63 (16.0)	37	Green
54208NT0516			5/16	2.63 (66.8)	1.78 (45.2)	0.47 (11.9)	0.11 (2.8)	0.47 (11.9)	0.38 (9.7)	1.00 (25.4)		
54255NT	1/0 AWG	#1 AWG – 225/24	5/16	2.61 (66.3)	1.66 (42.2)	0.52 (13.2)	0.14 (3.6)	0.52 (13.2)	0.38 (9.7)	0.88 (22.4)	42	Pink
54261NT	2/0 AWG	1/0 AWG – 275/24	5/16	2.66 (67.6)	1.66 (42.2)	0.57 (14.5)	0.14 (3.6)	0.52 (13.2)	0.38 (9.7)	0.88 (22.4)	45	Black
54210NT			3/8	2.82 (71.6)	1.82 (46.2)	0.57 (14.5)	0.14 (3.6)	0.52 (13.2)	0.38 (9.7)	1.00 (25.4)		
54266NT	3/0 AWG	2/0 AWG – 325/24	5/16	2.88 (73.2)	1.78 (45.2)	0.63 (16.0)	0.13 (3.3)	0.63 (16.0)	0.38 (9.7)	1.00 (25.4)	50	Orange
54211NT			3/8	2.92 (74.2)	1.82 (46.2)	0.63 (16.0)	0.13 (3.3)	0.63 (16.0)	0.38 (9.7)	1.00 (25.4)		
54212NT	4/0 AWG	3/0 AWG – 450/24	3/8	3.07 (94.0)	1.82 (46.2)	0.70 (17.8)	0.14 (3.6)	0.70 (17.8)	0.38 (9.7)	1.00 (25.4)	54	Purple
54213NT	250 kcmil	4/0 AWG – 550/24	3/8	3.17 (80.5)	1.82 (46.2)	0.77 (19.6)	0.14 (3.6)	0.77 (19.6)	0.38 (9.7)	1.00 (25.4)	62	Yellow
54275NT			1/2	4.16 (105.7)	2.81 (71.4)	0.77 (19.6)	0.14 (3.6)	0.77 (19.6)	0.50 (12.7)	1.75 (44.5)		
54282NT	350 kcmil	650/24	1/2	4.36 (110.7)	2.81 (71.4)	0.93 (23.6)	0.18 (4.6)	0.93 (23.6)	0.50 (12.7)	1.75 (44.5)	71H	Red
54218NT	500 kcmil	925/24	3/8	4.57 (116.1)	2.57 (65.3)	1.10 (27.9)	0.22 (5.6)	1.10 (27.9)	0.38 (9.7)	1.75 (44.5)	87	Brown
54286NT			1/2	4.81 (122.2)	2.81 (71.4)	1.10 (27.9)	0.22 (5.6)	1.10 (27.9)	0.50 (12.7)	1.75 (44.5)		
54878BENTPH	600 kcmil	1100/24	1/2	5.83 (148.1)	3.00 (76.2)	1.20 (30.5)	0.24 (6.1)	1.20 (30.5)	0.50 (12.7)	1.75 (44.5)	94	Green
54223NT0628	750 kcmil	1325/24	3/8	4.79 (121.7)	2.57 (65.3)	1.33 (33.8)	0.27 (6.9)	1.33 (33.8)	0.38 (9.7)	1.75 (44.5)	106H	Black
54223NT			1/2	5.04 (137.2)	2.81 (71.4)	1.33 (33.8)	0.27 (6.9)	1.33 (33.8)	0.50 (12.7)	1.75 (44.5)		
58884BENTPH	–	1600/24	1/2	6.16 (156.5)	3.00 (76.2)	1.33 (33.8)	0.24 (6.1)	1.20 (30.5)	0.50 (12.7)	1.75 (44.5)		

Catalogue numbers 54878BENTPH and 58884BENTPH include peep holes.
 ‡ For installations from 16 kV up to 35 kV, consult shielded cable manufacturers for stress relief and insulation requirements.

Cat. No.	Type	Cat. No. Example:
54212NT ____ *	____ = To order 45° and 90° Angle Lugs UF = 45° UB = 90°	54212NTUB is a 45° angled one-hole narrow-tongue lug for #1 AWG.
Other options include silver plating (add SP to catalogue number), blind end (add BE to catalogue number) and peep holes (add PH to catalogue number).		

Compression Connectors for Copper Conductors

Copper One-Hole Lugs — Certified to 600 V and Recommended up to 15 kV

These Color-Keyed® Connectors are recommended for up to 15 kV applications. Installed with standard T&B 14 and 15-Tons compression tools with special rounding dies, the compression forms the connector and conductor into a solid mass to provide an optimum electrical bond between connector and conductor. The rounding die-overlapped compressions provide a smooth round surface. This combined with the tapered barrel ends, addresses the control for potentially damaging electrical stresses of high voltages.

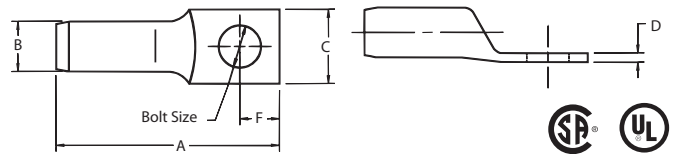

Cat. No.	Cable Size**		Dimensions in. (mm)						Installing Tools 14 and 15 Tons*		
	Code Cable	Stud Size (in.)	A	B	C	D	E	F	Die Set Cat. No.	Strip Length (in.)	Colour Code
54440	#4 AWG	3/8	2.08 (71.1)	0.81 (20.6)	0.58 (14.7)	0.08 (2.0)	0.38 (9.7)	0.50 (12.7)	15CA29R	1-7/16	Grey
54443	#2 AWG		2.25 (57.2)	0.81 (20.6)	0.66 (16.8)	0.09 (2.3)	0.38 (9.7)	0.50 (12.7)	15CA33R	1-7/16	Brown
54448	#1 AWG		2.36 (59.9)	0.81 (20.6)	0.69 (17.5)	0.10 (2.5)	0.38 (9.7)	0.50 (12.7)	15CA37R	1-18/32	Green
54409	1/0 AWG		2.38 (60.5)	0.81 (20.6)	0.75 (19.1)	0.12 (3.0)	0.38 (9.7)	0.50 (12.7)	15CA42R	1-5/8	Pink
54460	2/0 AWG	1/2	2.73 (69.3)	1.06 (40.6)	0.83 (21.1)	0.12 (3.0)	0.50 (12.7)	0.50 (12.7)	15CA45R	1-5/8	Black
54465	3/0 AWG		2.81 (71.4)	1.06 (40.6)	0.94 (23.9)	0.12 (3.0)	0.50 (12.7)	0.50 (12.7)	15CA49R	1-3/4	Orange
54470	4/0 AWG		2.78 (70.6)	1.06 (40.6)	1.00 (25.4)	0.13 (3.3)	0.50 (12.7)	0.50 (12.7)	15CA54R	1-13/16	Purple
54413	250 kcmil		3.19 (81.0)	1.06 (40.6)	1.07 (43.2)	0.14 (3.6)	0.50 (12.7)	0.50 (12.7)	15CA60R	2-1/32	Ruby

**Cable size: Concentric (code) and compact strandings
 *Cat. No. TB15500 Die Adaptor required for TBM151
 Tooling: pp. E4–E62
 Die Selector Chart: pp. E35–E50

Copper Two-Hole Lugs — Certified to 600 V and Recommended up to 15 kV Applications

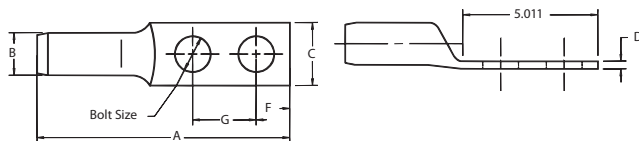

Cat. No.	Cable Size**		Dimensions in. (mm)							Installing Tools 14 and 15 Tons*		
	Code Cable	Stud Size (in.)	A	B	C	D	E	F	G	Die Set Cat. No.	Strip Length (in.)	Colour Code
54475	1/0 AWG	3/8	3.56 (90.4)	0.53 (13.5)	0.77 (19.6)	0.12 (3.0)	0.38 (9.7)	0.38 (9.7)	1.00 (25.4)	15CA42R	1-5/8	Pink
54476	2/0 AWG		4.67 (118.6)	0.56 (14.2)	0.83 (21.1)	0.12 (3.0)	0.50 (12.7)	0.50 (12.7)	1.75 (44.5)	15CA45R	1-5/8	Black
54478	3/0 AWG		4.75 (120.7)	0.63 (16.0)	0.94 (23.9)	0.12 (3.0)	0.50 (12.7)	0.50 (12.7)	1.75 (44.5)	15CA49R	1-3/4	Orange
54479	4/0 AWG		4.64 (117.9)	0.69 (17.3)	1.00 (25.4)	0.13 (3.3)	0.50 (12.7)	0.50 (12.7)	1.75 (44.5)	15CA54R	1-13/16	Purple
54480	250 kcmil	1/2	5.17 (131.3)	0.75 (19.1)	1.08 (45.7)	0.14 (3.6)	0.50 (12.7)	0.50 (12.7)	1.75 (44.5)	15CA60R	2-1/32	Ruby
54481	300 kcmil		5.16 (131.1)	0.81 (20.6)	1.19 (30.2)	0.16 (4.1)	0.50 (12.7)	0.50 (12.7)	1.75 (44.5)	15CA66R	23/32	White
54482	350 kcmil		5.35 (135.9)	0.88 (22.1)	1.29 (32.8)	0.19 (4.8)	0.50 (12.7)	0.50 (12.7)	1.75 (44.5)	15CA71R	2-13/32	Red
54483	400 kcmil		5.35 (135.9)	0.92 (23.4)	1.36 (34.5)	0.18 (4.6)	0.50 (12.7)	0.50 (12.7)	1.75 (44.5)	15CA76R	2-13/32	Blue
54484	500 kcmil		5.60 (142.2)	1.06 (40.6)	1.54 (39.1)	0.23 (5.8)	0.50 (12.7)	0.50 (12.7)	1.75 (44.5)	15CA87R	2-13/32	Brown
54485***	600 kcmil	5.83 (148.1)	1.17 (29.7)	1.70 (43.2)	0.24 (6.1)	0.50 (12.7)	0.50 (12.7)	1.75 (44.5)	15CA84R	2-1/16	Green	
54487***	750 kcmil	1/21	6.13 (155.7)	1.11 (27.9)	1.89 (48.0)	0.27 (6.9)	0.50 (12.7)	0.50 (12.7)	1.75 (44.5)	15CA106R	2-3/4	Black
54490	1000 kcmil	1/2	6.60 (167.6)	1.50 (38.1)	2.18 (55.4)	0.31 (7.9)	0.50 (12.7)	0.50 (12.7)	1.75 (44.5)	15C125R*	2-29/32	-

• No adaptor required – TBM151 only.
 ** Cable Size: Concentric (code) and compact strandings.
 14-Tons Tool UL Listing limited to 1/0 AWG and 500 kcmil cable sizes.
 *** 15-Tons Tool only for 500 kcmil and over.

* Cat. No. TB15500 Die Adaptor required for TBM151.
 Tooling: pp. E4–E62
 Die Selector Chart: pp. E35–E50



Compression Connectors for Copper Conductors

Bell-Ended Lugs — Standard Barrel Certified to 600 V and Recommended up to 35 kV¥

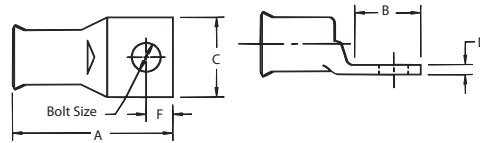

Cat. No.	Wire Size*			Classes					Bolt Size (in.)	Dimensions in. (mm)					Die Code	Colour Code
	Cable Code	Navy	Flex	G	H	I	K	M		A	B	C	D	F		
54104BS	8	23	37/24	8	8	—	8	8	#10	1.06 (40.6)	0.46 (11.7)	0.40 (10.2)	0.07 (1.8)	0.21 (5.3)	21	Red
54105BS	6	30	61/24	5	5	5	5	5	1/4	1.18 (30.0)	0.56 (14.2)	0.43 (10.9)	0.10 (2.5)	0.25 (6.4)	24	Blue
54106BS	4	40-50	91/24	5	5	5	5	5	1/4	1.28 (32.5)	0.56 (14.2)	0.56 (14.2)	0.10 (2.5)	0.25 (6.4)	29	Grey
54139BS	3 and 4	40-50	91/24	4	4	4	4	4	5/16	1.43 (36.3)	0.78 (19.8)	0.59 (19.8)	0.07 (1.8)	0.34 (8.6)		
54142BS	2	60	125/24	3	3	3	3	3	5/16	1.53 (38.9)	0.71 (18.0)	0.65 (16.5)	0.07 (1.8)	0.34 (8.6)	33	Brown
54147BS	1	75	150, 175/24	2	2	2	2	2	5/16	1.91 (48.5)	0.71 (18.0)	0.67 (17.0)	0.12 (3.0)	0.38 (9.7)	37	Green
54153BS	1/0	100	225/24	1	1	1	1	1	5/16	1.63 (41.4)	0.71 (18.0)	0.75 (19.1)	0.14 (3.6)	0.38 (9.7)	42	Pink
54110BS	2/0	125	275/24	1/0	1/0	1/0	1/0	1/0	3/8	1.88 (47.8)	0.81 (20.6)	0.81 (20.6)	0.14 (3.6)	0.38 (9.7)	45	Black
54165BS	3/0	150	325/24	2/0	2/0	2/0	2/0	2/0	1/2	2.21 (56.1)	1.06 (40.6)	0.93 (23.6)	0.14 (3.6)	0.50 (12.7)	50	Orange
54170BS	4/0	200	450/24	3/0	3/0	3/0	3/0	3/0	1/2	2.31 (58.7)	1.06 (40.6)	1.03 (33.0)	0.15 (3.8)	0.50 (12.7)	54	Purple
58165BS	250	—	550/24	4/0	4/0	4/0	4/0	4/0	1/2	2.46 (62.5)	1.12 (28.4)	1.25 (31.8)	0.18 (4.6)	0.50 (12.7)	62	Yellow
54114BS	300	300	650/24	250	250	250	250	—	1/2	2.46 (62.5)	1.12 (28.4)	1.25 (31.8)	0.18 (4.6)	0.50 (12.7)	66	White
5411440BS		300	650/24	250	250	250	250	—	1/2	2.38 (60.5)	1.12 (28.4)	1.25 (31.8)	0.18 (4.6)	0.50 (12.7)		
54115260BS		350	650/24	—	—	250	250	250	1/2	2.63 (66.8)	1.18 (30.0)	1.38 (35.1)	0.20 (5.1)	0.56 (14.2)		
54185BS	400	400	775/24	300	300	300	300	300	5/8	3.43 (87.1)	1.68 (42.7)	1.40 (35.6)	0.21 (5.3)	0.81 (20.6)	76	Blue
58177BS	500	—	925/24	400	400	400	400	400	5/8	3.00 (76.2)	1.31 (33.3)	1.63 (41.4)	0.25 (6.4)	0.81 (20.6)	80	—
58180BS	600	—	1100/24	—	—	450	450	450	5/8	3.63 (92.2)	1.68 (42.7)	1.78 (45.2)	0.26 (6.6)	0.81 (20.6)	94	Green
54122BS	700	—	1325/24	500	500	500	500	500	5/8	3.63 (92.2)	1.68 (42.7)	1.78 (45.2)	0.28 (7.1)	0.81 (20.6)	99	Pink
54123BS	750	—	—	600	—	—	—	550	5/8	3.63 (92.2)	1.68 (42.7)	1.93 (49.0)	0.31 (7.9)	0.81 (20.6)	106	Black
54124BS	800	800	—	—	—	—	600	—	5/8	3.81 (96.8)	1.68 (42.7)	2.00 (50.8)	0.31 (7.9)	0.63 (16.0)	107	Orange
54126BS	900	—	1925/24	—	—	750	—	—	5/8	4.12 (104.6)	1.81 (46.0)	2.18 (55.4)	0.37 (9.4)	0.88 (22.4)	115	Yellow

¥ For installations from 16 kV up to 35 kV, consult shielded cable manufacturers for stress relief and insulation requirements.

* Stranding will differ per class.

Tooling: pp. E4–E62

Die Selector Chart: pp. E35–E50

Compression Connectors for Copper Conductors

Bell-Ended Lugs — Long Barrel Certified to 600 V and Recommended up to 35 kV[‡]

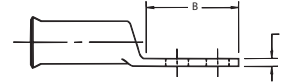
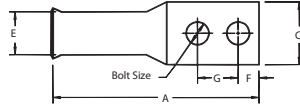

Cat. No.	Wire Size*			Classes					Bolt Size (in.)	Dimensions in. (mm)							Die Code	Colour Code
	Code Cable	Navy	Flex	G	H	I	K	M		A	B	C	D	E	F	G		
54850BEBS	8	23	8	8	8	-	8	-	1/4	2.19 (55.6)	1.88 (47.8)	0.42 (10.7)	0.07 (1.8)	0.26 (6.6)	0.25 (6.4)	0.63 (16.0)	21	Red
54851BEBS									1/4	2.31 (58.7)	1.59 (32.8)	0.47 (11.9)	0.06 (1.5)	0.26 (6.6)	0.25 (6.4)	0.75 (19.1)		
54851BE0616BS									3/8	3.00 (76.2)	2.10 (53.3)	0.56 (14.2)	0.06 (1.5)	0.26 (6.6)	0.38 (9.7)	1.00 (25.4)		
54852BE0616BS	6	30	6	5	5	5	5	-	3/8	2.93 (74.4)	1.93 (49.0)	0.59 (15.0)	0.06 (1.5)	0.30 (7.6)	0.38 (9.7)	1.00 (25.4)	24	Blue
54852BEBS									1/4	2.28 (57.9)	1.28 (32.5)	0.44 (11.2)	0.08 (2.0)	0.30 (7.6)	0.25 (6.4)	0.63 (16.0)		
54852BE0412BS									1/4	2.43 (61.7)	1.43 (36.3)	0.43 (10.9)	0.07 (1.8)	0.30 (7.6)	0.25 (6.4)	0.75 (19.1)		
54854BEBS	4-3	40-50	5	5	5	5	5	-	1/4	2.31 (58.7)	1.19 (30.2)	0.52 (13.2)	0.10 (2.5)	0.37 (9.4)	0.25 (6.4)	0.63 (16.0)	29	Grey
54854BE0412BS									1/4	2.31 (58.7)	1.31 (33.3)	0.56 (14.2)	0.09 (2.3)	0.37 (9.4)	0.25 (6.4)	0.75 (19.1)		
54854BE0616BS									3/8	3.13 (79.5)	1.98 (50.3)	0.59 (15.0)	0.09 (2.3)	0.37 (9.4)	0.38 (9.7)	1.00 (25.4)		
54855BE0412BS	2	60	3	3	3	3	3	3	1/4	2.63 (66.8)	1.35 (34.3)	0.68 (17.3)	0.11 (2.8)	0.41 (10.4)	0.25 (6.4)	0.75 (19.1)	33	Brown
54855BEBS									1/4	2.43 (61.7)	1.28 (32.5)	0.59 (15.0)	0.11 (2.8)	0.41 (10.4)	0.25 (6.4)	0.63 (16.0)		
54856BEBS									3/16	2.78 (70.6)	1.63 (41.4)	0.59 (15.0)	0.11 (2.8)	0.41 (10.4)	0.38 (9.7)	0.75 (19.1)		
54810BE0616BS	1	75	2	2	2	2	2	2	3/8	3.08 (96.5)	1.94 (49.3)	0.59 (15.0)	0.11 (2.8)	0.41 (10.4)	0.38 (9.7)	1.00 (25.4)	37	Green
54811BEBS									1/2	4.28 (108.7)	3.00 (76.2)	0.88 (22.4)	0.09 (2.3)	0.41 (10.4)	0.50 (12.7)	1.75 (44.5)		
54809BEBS									1/4	2.88 (73.2)	1.19 (30.2)	0.67 (17.0)	0.11 (2.8)	0.47 (11.9)	0.25 (6.4)	0.63 (16.0)		
54812BEBS	1/0	100	1	1	1	1	1	1	1/4	2.75 (69.9)	1.40 (35.6)	0.67 (17.0)	0.11 (2.8)	0.47 (11.9)	0.25 (6.4)	0.75 (19.1)	42	Pink
54813BEBS									5/16	2.97 (75.4)	1.63 (41.4)	0.67 (17.0)	0.11 (2.8)	0.47 (11.9)	0.38 (9.7)	0.88 (22.4)		
54857BEBS									1/2	4.43 (112.5)	3.00 (76.2)	0.88 (22.4)	0.10 (2.5)	0.47 (11.9)	0.50 (12.7)	1.75 (44.5)		
54859BEBS	2/0	125	1/0	1/0	1/0	1/0	1/0	1/0	1/4	2.63 (66.8)	1.19 (30.2)	0.75 (19.1)	0.13 (3.3)	0.52 (13.2)	0.25 (6.4)	0.63 (16.0)	45	Black
54814BEBS									1/4	2.71 (68.8)	1.38 (35.1)	0.75 (19.1)	0.13 (3.3)	0.52 (13.2)	0.25 (6.4)	0.75 (19.1)		
54860BEBS									5/16	2.97 (75.4)	1.63 (41.4)	0.75 (19.1)	0.13 (3.3)	0.52 (13.2)	0.38 (9.7)	0.88 (22.4)		
54860BE0616BS	3/0	150	2/0	2/0	2/0	2/0	2/0	2/0	3/8	3.23 (82.0)	1.93 (49.0)	0.75 (19.1)	0.13 (3.3)	0.52 (13.2)	0.38 (9.7)	1.00 (25.4)	50	Orange
54814BEBS									1/4	2.62 (66.5)	1.25 (31.8)	0.83 (21.1)	0.13 (3.3)	0.57 (14.5)	0.25 (6.4)	0.63 (16.0)		
54814BE0412BS									1/4	2.69 (68.3)	1.31 (33.3)	0.81 (20.6)	0.13 (3.3)	0.57 (14.5)	0.25 (6.4)	0.75 (19.1)		
54862BE0616BS	4/0	200	3/0	3/0	3/0	3/0	3/0	3/0	3/8	3.19 (81.0)	1.81 (46.0)	0.83 (21.1)	0.13 (3.3)	0.57 (14.5)	0.38 (9.7)	1.00 (25.4)	54	Purple
54862BEBS									1/2	2.20 (55.9)	2.81 (71.4)	0.83 (21.1)	0.13 (3.3)	0.57 (14.5)	0.50 (12.7)	1.75 (44.5)		
54815BEBS									1/4	2.89 (73.4)	1.45 (36.8)	0.92 (23.4)	0.13 (3.3)	0.63 (16.0)	0.25 (6.4)	0.75 (19.1)		
54816BEBS	4/0	200	3/0	3/0	3/0	3/0	3/0	3/0	3/8	3.25 (82.6)	1.63 (41.4)	0.92 (23.4)	0.13 (3.3)	0.63 (16.0)	0.38 (9.7)	1.00 (25.4)	54	Purple
54864BEBS									1/2	4.45 (113.0)	3.00 (76.2)	0.92 (23.4)	0.13 (3.3)	0.63 (16.0)	0.50 (12.7)	1.75 (44.5)		
54817BEBS									1/4	3.15 (80.0)	1.38 (35.1)	1.03 (26.2)	0.14 (3.6)	0.70 (17.8)	0.50 (12.7)	0.75 (19.1)		
54818BE0616BS	250	-	4/0	4/0	4/0	4/0	4/0	4/0	3/8	3.35 (85.1)	1.81 (46.0)	1.03 (26.2)	0.14 (3.6)	0.70 (17.8)	0.25 (6.4)	1.00 (25.4)	62	Yellow
54818BEBS									1/2	4.70 (119.4)	3.00 (76.2)	1.03 (26.2)	0.14 (3.6)	0.70 (17.8)	0.50 (12.7)	1.75 (44.5)		
54866BEBS									1/4	4.38 (111.3)	2.63 (66.8)	1.03 (26.2)	0.14 (3.6)	0.70 (17.8)	0.38 (9.7)	1.75 (44.5)		
54868BE0616BS	300	300	262 kcmil	250 kcmil	250	250	250	-	3/8	3.83 (97.3)	1.93 (49.0)	1.13 (28.7)	0.14 (3.6)	0.77 (19.6)	0.50 (12.7)	1.00 (25.4)	66	White
54868BEBS									1/2	4.92 (125.0)	3.00 (76.2)	1.13 (28.7)	0.14 (3.6)	0.77 (19.6)	0.50 (12.7)	1.75 (44.5)		
54819BEBS									1/4	5.04 (137.2)	2.80 (71.1)	1.25 (31.8)	0.15 (3.8)	0.85 (21.6)	0.50 (12.7)	1.00 (25.4)		
54820BEBS	400	400	313 kcmil	300 kcmil	300	300	300	-	1/2	5.23 (132.8)	3.00 (76.2)	1.25 (31.8)	0.15 (3.8)	0.85 (21.6)	0.50 (12.7)	1.00 (25.4)	76	Blue
54822BEBS									1/4	4.38 (111.3)	1.93 (49.0)	1.41 (35.8)	0.17 (4.3)	0.96 (24.4)	0.63 (16.0)	0.75 (19.1)		
54821BEBS									3/8	4.43 (112.5)	1.93 (49.0)	1.41 (35.8)	0.17 (4.3)	0.96 (24.4)	0.63 (16.0)	1.00 (25.4)		
54874BEBS	500	-	373 kcmil	400 kcmil	400	400	400	-	1/2	5.51 (140.0)	3.00 (76.2)	1.41 (35.8)	0.17 (4.3)	0.96 (24.4)	0.63 (16.0)	1.75 (44.5)	87	Brown
54823BEBS									1/4	4.93 (125.2)	1.94 (49.3)	1.61 (40.9)	0.22 (5.6)	1.10 (27.9)	0.50 (12.7)	0.75 (19.1)		
54876BE0616BS									3/8	5.00 (127.0)	1.93 (49.0)	1.61 (40.9)	0.22 (5.6)	1.10 (27.9)	0.50 (12.7)	1.00 (25.4)		
54876BEBS	-	-	444 kcmil	-	-	450	450	-	1/2	6.00 (152.4)	3.00 (76.2)	1.61 (40.9)	0.22 (5.6)	1.10 (27.9)	0.50 (12.7)	1.75 (44.5)	94	Green
54824BEBS									3/8	5.70 (144.8)	2.80 (71.1)	1.75 (44.5)	0.24 (6.1)	1.20 (30.5)	0.63 (16.0)	1.00 (25.4)		
54878BEBS									1/2	5.83 (148.1)	3.00 (76.2)	1.75 (44.5)	0.24 (6.1)	1.20 (30.5)	0.63 (16.0)	1.75 (44.5)		
54879BEBS	700	-	535 Kcmil	500 kcmil	500	500	500	-	1/2	6.00 (152.4)	3.00 (76.2)	2.81 (71.4)	0.28 (7.1)	1.25 (31.8)	0.50 (12.7)	1.75 (44.5)	99	Pink
54880BEBS									1/2	6.20 (157.5)	3.00 (76.2)	1.94 (49.3)	0.27 (6.9)	1.33 (33.8)	0.63 (16.0)	1.75 (44.5)		
58848BEBS									1/2	6.16 (156.4)	3.00 (76.2)	1.94 (49.3)	0.27 (6.9)	1.33 (33.8)	0.50 (12.7)	1.75 (44.5)		
58826BEBS	900	-	777 kcmil	-	-	750	-	-	3/8	6.49 (164.8)	2.80 (71.1)	2.27 (57.7)	0.30 (7.6)	1.50 (38.1)	0.63 (16.0)	1.00 (25.4)	115	Yellow

‡ For installations from 16 kV up to 35 kV, consult shielded cable manufacturers for stress relief and insulation requirements.
 * Stranding will differ per class.
 Tooling: pp. E4-E62
 Die Selector Chart: pp. E35-E50



Compression Connectors for Copper Conductors

Two-Barrel Lugs — Certified to 600 V and Recommended up to 35 kV‡

Material: High-Conductivity Wrought Copper

Finish: Electro-Tin Plated

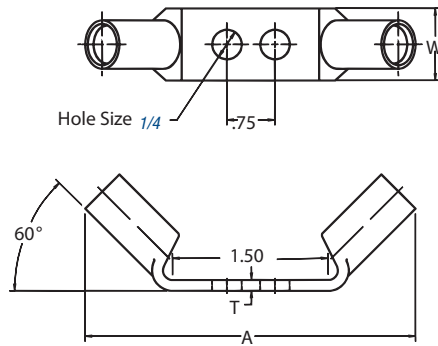

Figure 1

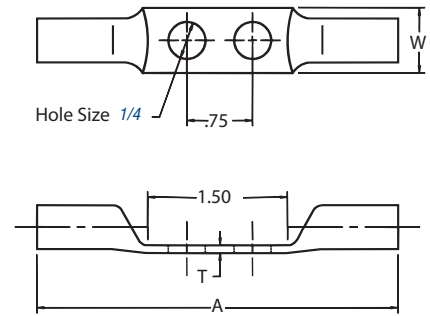

Figure 2



Cat. No.	Wire Size		Hole Size (in.)	Figure No.	Dimensions in. (mm)			Die Code	Colour Code
	Code Cable	Flex			A	W	T		
256-30695-828	6	61/24	1/4	1	2.94 (74.7)	0.44 (11.2)	0.06 (1.5)	24	Blue
256-30695-1227				2	3.38 (85.9)				

‡ For installations from 16 kV up to 35 kV, consult shielded cable manufacturers for stress relief and insulation requirements.

Tooling: pp. E4–E62

Die Selector Chart: pp. E35–E50

Compression Connectors for Copper Conductors

Cast Copper One-Hole Lugs Heavy-Duty
Certified to 600 V and Recommended up to 35 kV‡

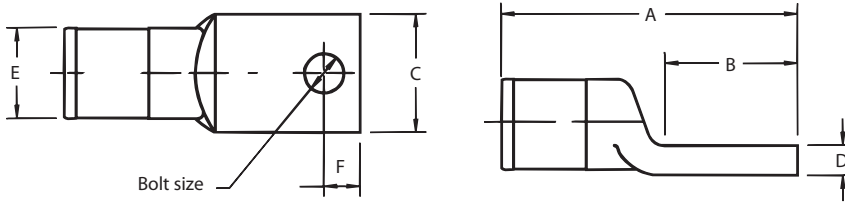

Material: High-Conductivity Wrought Copper
Finish: Electro-Tin Plated



Cat. No.	Code Cable Size	Dimensions in. (mm)					Bolt Size (in.)	Die Code
		A	B	C	D	F		
53104	8	1.43 (36.3)	0.75 (19.1)	0.50 (12.7)	0.12 (3.0)	0.28 (7.1)	1/4	29
53105	6	1.43 (36.3)	0.75 (19.1)	0.50 (12.7)	0.12 (3.0)	0.28 (7.1)		
53106	4	1.43 (36.3)	0.75 (19.1)	0.50 (12.7)	0.12 (3.0)	0.28 (7.1)		
53107	2	2.00 (50.8)	1.00 (25.4)	0.75 (19.1)	0.25 (6.4)	0.43 (10.9)		
53108	1	2.00 (50.8)	1.00 (25.4)	0.75 (19.1)	0.25 (6.4)	0.43 (10.9)	3/8	45
53109	1/0	2.00 (50.8)	1.00 (25.4)	0.75 (19.1)	0.25 (6.4)	0.43 (10.9)		
53161*	325/24	2.18 (55.4)	0.75 (19.1)	0.81 (20.6)	0.21 (5.3)	0.43 (10.9)		
53110	2/0	2.63 (66.8)	1.25 (31.8)	1.00 (25.4)	0.28 (7.1)	0.53 (13.5)	3/8	66
53111	3/0	2.63 (66.8)	1.25 (31.8)	1.00 (25.4)	0.28 (7.1)	0.53 (13.5)		
53112	4/0	2.63 (66.8)	1.25 (31.8)	1.00 (25.4)	0.28 (7.1)	0.53 (13.5)		
53165*	650/24	3.06 (91.4)	1.38 (35.1)	1.18 (30.0)	0.31 (7.9)	0.75 (19.1)	1/2	76
53113	250 kcmil	3.06 (91.4)	1.50 (38.1)	1.18 (30.0)	0.31 (7.9)	0.75 (19.1)		
53114	300 kcmil	3.06 (91.4)	1.50 (38.1)	1.18 (30.0)	0.31 (7.9)	0.75 (19.1)		
53115	350 kcmil	3.81 (96.8)	2.00 (50.8)	1.38 (35.1)	0.38 (9.7)	0.81 (20.6)		
53116	400 kcmil	3.81 (96.8)	2.00 (50.8)	1.38 (35.1)	0.38 (9.7)	0.81 (20.6)		
53118	500 kcmil	3.81 (96.8)	2.00 (50.8)	1.38 (35.1)	0.38 (9.7)	0.81 (20.6)		
53168*	1100/24	3.81 (96.8)	1.63 (41.4)	1.63 (41.4)	0.40 (10.2)	0.88 (22.4)		
53169*	1325/24	3.81 (96.8)	1.63 (41.4)	1.63 (41.4)	0.40 (10.2)	0.88 (22.4)		
53123	750 kcmil	4.18 (106.2)	2.12 (53.8)	1.63 (41.4)	0.43 (10.9)	1.00 (25.4)		
53173*	2750/24	5.06 (142.2)	1.88 (47.8)	2.12 (53.8)	0.56 (14.2)	1.18 (30.0)		

‡ For installations from 16 kV up to 35 kV, consult shielded cable manufacturers for stress relief and insulation requirements.

Applicable tools: 12, 14, 15 and 40-Tons (see tool section E4–E62).

* Not UL Listed and CSA non applicable.

Die Selector Chart: pp. E35–E50



Compression Connectors for Copper Conductors

Cast Copper Two-Hole Lugs for Code Copper Cable — Certified to 600 V and Recommended up to 35 kV‡

Material: High-Conductivity Wrought Copper

Finish: Electro-Tin Plated

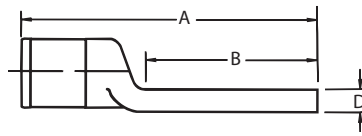
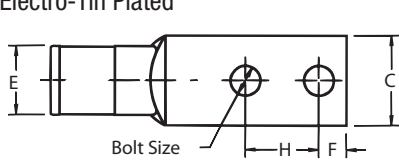

Figure 1

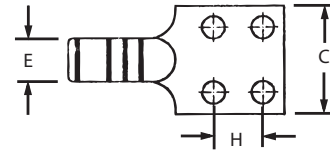

Figure 2



Cat. No.	Code Cable Size	Bolt Size (in.)	Dimensions in. (mm)							Die Code	No. of Crimps		
			A	B	C	D	E	F	H		12-Tons	15-Tons	40-Tons
256-30695-1055	#14-10	1/4	2.00 (50.8)	1.31 (33.3)	0.50 (12.7)	0.12 (3.0)	0.38 (9.7)	0.25 (6.4)	0.63-0.75 (16.0-19.1)	29	1		
53204	#8		2.00 (50.8)	1.31 (33.3)	0.50 (12.7)	0.09 (2.3)	0.38 (9.7)	0.25 (6.4)	0.63 (16.0)				
53205	#4		2.00 (50.8)	1.31 (33.3)	0.50 (12.7)	0.12 (3.0)	0.38 (9.7)	0.25 (6.4)	0.63 (16.0)				
53206	#2		3.00 (76.2)	2.00 (50.8)	0.75 (19.1)	0.12 (3.0)	0.59 (15.0)	0.50 (12.7)	0.75 (19.1)				
53207	#1	3/8	3.00 (76.2)	2.00 (50.8)	0.75 (19.1)	0.25 (6.4)	0.59 (15.0)	0.50 (12.7)	1.00 (25.4)	45			
53208	1/0		3.00 (76.2)	2.00 (50.8)	0.75 (19.1)	0.25 (6.4)	0.59 (15.0)	0.50 (12.7)	1.00 (25.4)				
53209	2/0		4.31 (109.5)	3.00 (76.2)	0.75 (19.1)	0.18 (4.6)	0.84 (21.3)	0.63 (16.0)	1.75 (44.5)				
53210	3/0		4.31 (109.5)	3.00 (76.2)	1.00 (25.4)	0.28 (7.1)	0.84 (21.3)	0.63 (16.0)	1.75 (44.5)				
53211	4/0	1/2	4.31 (109.5)	3.00 (76.2)	1.00 (25.4)	0.28 (7.1)	0.84 (21.3)	0.63 (16.0)	1.75 (44.5)	66			
53212	250 kcmil		4.56 (115.8)	3.00 (76.2)	1.18 (30.0)	0.18 (4.6)	0.93 (23.6)	0.63 (16.0)	1.75 (44.5)				
53213	300 kcmil		4.56 (115.8)	3.00 (76.2)	1.18 (30.0)	0.31 (7.9)	0.93 (23.6)	0.63 (16.0)	1.75 (44.5)				
53214	350 kcmil		5.31 (134.9)	3.50 (88.9)	1.38 (35.1)	0.25 (6.4)	1.21 (30.7)	0.63 (16.0)	1.75 (44.5)				
53215	400 kcmil	2	5.31 (134.9)	3.50 (88.9)	1.38 (35.1)	0.38 (9.7)	1.21 (30.7)	0.63 (16.0)	1.75 (44.5)	99			
53216	500 kcmil		5.31 (134.9)	3.50 (88.9)	1.38 (35.1)	0.38 (9.7)	1.21 (30.7)	0.63 (16.0)	1.75 (44.5)				
53218	600 kcmil		5.31 (134.9)	3.50 (88.9)	1.63 (41.4)	0.53 (13.5)	1.35 (34.3)	0.63 (16.0)	1.75 (44.5)				
53220M	700 kcmil		5.31 (134.9)	3.50 (88.9)	1.63 (41.4)	0.03 (0.8) ±	1.35 (34.3)	0.63 (16.0)	1.75 (44.5)				
53222M	750 kcmil	150 or 150H	5.31 (134.9)	3.50 (88.9)	1.63 (41.4)	0.03 (0.8) ±	1.35 (34.3)	0.63 (16.0)	1.75 (44.5)	112			
53223M	1325/24		5.50 (139.7)	3.50 (88.9)	1.63 (41.4)	0.40 (10.2)	1.35 (34.3)	0.63 (16.0)	1.75 (44.5)				
53269•	800 kcmil		6.00 (152.4)	3.50 (88.9)	1.88 (47.8)	0.31 (7.9)	1.56 (39.6)	0.63 (16.0)	1.75 (44.5)				
53224	900 kcmil		6.00 (152.4)	3.50 (88.9)	1.88 (47.8)	0.46 (11.7)	1.56 (39.6)	0.63 (16.0)	1.75 (44.5)				
53226	1000 kcmil	150	6.00 (152.4)	3.50 (88.9)	1.88 (47.8)	0.46 (11.7)	1.56 (39.6)	0.63 (16.0)	1.75 (44.5)	130			
53228	1100 kcmil 2750/24		6.19 (157.2)	3.50 (88.9)	2.12 (53.8)	0.56 (14.2)	1.90 (28.3)	0.63 (16.0)	1.75 (44.5)				
53273•	1500 kcmil		6.25 (158.8)	3.50 (88.9)	2.25 (57.2)	0.50 (12.7)	1.90 (28.3)	0.63 (16.0)	1.75 (44.5)				
53233	1750 kcmil		7.31 (185.7)	3.12 (79.2)	2.00 (50.8)	0.50 (12.7)	1.88 (47.8)	0.63 (16.0)	1.75 (44.5)				
53233L	1250 kcmil	9/16	7.31 (185.7)	3.12 (79.2)	3.00 (76.2)	0.50 (12.7)	1.88 (47.8)	0.63 (16.0)	1.75 (44.5)	150	1		1
53432L•*			7.31 (185.7)	3.12 (79.2)	3.00 (76.2)	0.50 (12.7)	1.88 (47.8)	0.63 (16.0)	1.75 (44.5)				
251-30485-1275	1750 kcmil	-	6.19 (157.2)	3.50 (88.9)	2.12 (53.8)	0.56 (14.2)	1.90 (48.3)	0.63 (16.0)	1.75 (44.5)	-	-	-	2 (fig. 2)
251-30485-1211	2000 kcmil 169/110	1/2	6.38 (162.1)	3.12 (79.2)	3.00 (76.2)	0.50 (12.7)	2.18 (55.4)	-	-	175			2 (fig. 1)
251-30485-1212			6.38 (162.1)	3.12 (79.2)	2.25 (57.2)	0.50 (12.7)	2.18 (55.4)	-	-				
53239	178/0.104 2000 kcmil 169/0.110	1/2	6.19 (157.2)	3.50 (88.9)	2.75 (69.9)	0.50 (12.7)	2.18 (55.4)	0.63 (16.0)	0.63 (16.0)	175			
53239L	7.31 (185.7)		3.12 (79.2)	2.25 (57.2)	0.50 (12.7)	2.46 (62.5)	0.63 (16.0)	0.63 (16.0)					
53439L•*	7.31 (185.7)		3.12 (79.2)	3.00 (76.2)	0.50 (12.7)	2.18 (55.4)	0.63 (16.0)	0.63 (16.0)					

‡ For installations from 16 kV up to 35 kV, consult shielded cable manufacturers for stress relief and insulation requirements.

* Heavy-Duty copper lugs for flexible strand cables 600 V not UL or CSA Listed.

• CSA not applicable. Die Selector Chart: pp. E35-E50

Compression Connectors for Copper Conductors

T&B Method — Traction Motor Disconnect Lugs for Diesel-Electric Locomotives

Material: Cast Copper

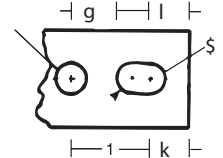
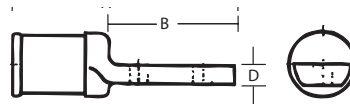
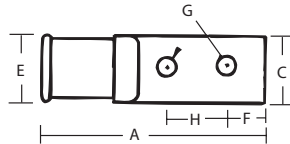

Cat. No.	Cable Size	Dimensions in. (mm)				Approx. Dia. E in. (mm)	Bolt Size in. (mm)			Die Code
		A	B	C	D		F	G	H	
MD37	37/24	2.44 (62.0)	1.75 (44.5)	0.59 (15.0)	0.16 (4.1)	0.38 (9.7)	0.38 (9.7)	0.31 (7.9)	0.88 (24.4)	26
MDD61	61/24	2.44 (62.0)	1.75 (44.5)	0.59 (15.0)	0.16 (4.1)	0.38 (9.7)	0.38 (9.7)	0.31 (7.9)	0.88 (24.4)	
MD 105	105/24	2.63 (66.8)	1.75 (44.5)	0.59 (15.0)	0.16 (4.1)	0.44 (11.2)	0.38 (9.7)	0.31 (7.9)	0.88 (24.4)	33
MD 105	91/24	2.63 (66.8)	1.75 (44.5)	0.59 (15.0)	0.16 (4.1)	0.44 (11.2)	0.38 (9.7)	0.31 (7.9)	0.88 (24.4)	
MD 125	125/24	2.63 (66.8)	1.75 (44.5)	0.59 (15.0)	0.20 (5.2)	0.44 (11.2)	0.38 (9.7)	0.31 (7.9)	0.88 (24.4)	45
MD 150	150/24	2.06 (52.3)	1.88 (47.8)	0.59 (15.0)	0.20 (5.2)	0.63 (16.0)	0.44 (11.2)	0.31 (7.9)	0.88 (24.4)	
MD 175	175/24	2.06 (52.3)	1.88 (47.8)	0.59 (15.0)	0.20 (5.2)	0.63 (16.0)	0.44 (11.2)	0.31 (7.9)	0.88 (24.4)	60
MD 225	225/24	3.00 (76.2)	1.88 (47.8)	0.69 (17.5)	0.20 (5.2)	0.72 (18.3)	0.44 (11.2)	0.31 (7.9)	0.88 (24.4)	
MD 275	275/24	3.00 (76.2)	1.88 (47.8)	0.69 (17.5)	0.20 (5.2)	0.72 (18.3)	0.44 (11.2)	0.31 (7.9)	0.88 (24.4)	76
MD 325	325/24	3.00 (76.2)	1.88 (47.8)	0.69 (17.5)	0.20 (5.2)	0.72 (18.3)	0.44 (11.2)	0.31 (7.9)	0.88 (24.4)	
MD 375	375/24	3.13 (79.5)	2.00 (50.8)	0.78 (19.8)	0.20 (5.2)	0.72 (18.3)	0.44 (11.2)	0.31 (7.9)	0.88 (24.4)	87
MD 450	450/24	3.13 (79.5)	2.00 (50.8)	0.78 (19.8)	0.20 (5.2)	0.72 (18.3)	0.44 (11.2)	0.31 (7.9)	0.88 (24.4)	
MD 550	550/24	3.19 (81.0)	1.88 (47.8)	0.94 (23.9)	0.20 (5.2)	1.00 (25.4)	0.44 (11.2)	0.31 (7.9)	0.88 (24.4)	107
MD 650	650/24	3.19 (81.0)	1.88 (47.8)	0.94 (23.9)	0.20 (5.2)	1.00 (25.4)	0.44 (11.2)	0.31 (7.9)	0.88 (24.4)	
MD 775	775/24	3.19 (81.0)	1.88 (47.8)	0.94 (23.9)	0.38 (9.5)	1.00 (25.4)	0.44 (11.2)	0.38 (9.7)	1.00 (25.4)	115
MD 925	925/24	3.75 (95.3)	2.06 (52.3)	1.13 (28.7)	0.38 (9.5)	1.16 (29.5)	0.44 (11.2)	0.38 (9.7)	1.00 (25.4)	
MD 1100	1100/24	3.75 (95.3)	2.06 (52.3)	1.34 (34.0)	0.38 (9.5)	1.38 (35.1)	0.44 (11.2)	0.38 (9.7)	1.00 (25.4)	130
MD 1325	1325/24	3.78 (96.0)	2.09 (53.3)	1.16 (29.5)	0.38 (9.5)	1.75 (44.5)	0.44 (11.2)	0.38 (9.7)	1.00 (25.4)	
MD 1600	1600/24	3.75 (95.3)	2.06 (52.3)	1.34 (34.0)	0.38 (9.5)	1.38 (35.1)	0.44 (11.2)	0.38 (9.7)	1.00 (25.4)	130
MD 1925*	1925/24	4.06 (103.1)	2.09 (53.3)	1.34 (34.0)	0.38 (9.5)	1.50 (38.1)	0.44 (11.2)	0.38 (9.7)	1.00 (25.4)	
MD 2300	2300/24	4.38 (111.3)	2.13 (54.1)	1.59 (40.4)	0.38 (9.5)	1.66 (42.2)	0.44 (11.2)	0.38 (9.7)	1.00 (25.4)	

Note: Some parts may not be current on the system. Consult your Regional Sales Office for informations.

Tooling: All hydraulic tools 12 tons and up.

For use mechanically splice traction motor wires. MES Flex (B) and DLLU.

* Supplied with Elongated Bolt Hole.

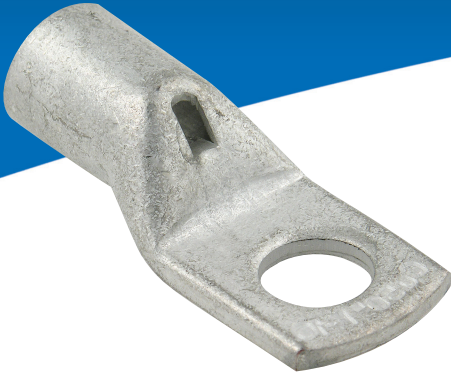

Compression Connectors for Copper Conductors

One-Hole Metric Lugs

Color-Keyed® metric lugs are manufactured from electrolytic copper tube. The dimensions of the tube are designed to obtain the most efficient electrical conductivity and mechanical strength, resisting vibration and pullout.

Color-Keyed® metric lugs are annealed to guarantee optimum ductility, which is a necessity for compression connectors having to withstand severe deformation arising when compressed or bending of the tongue that may happen during installation.

Connectors have to perform adequately with vibration loads, and annealing is necessary to avoid material failure between the barrel and the tongue.

The presence of an inspection hole facilitates full insertion of the conductor, and the barrel length is designed to allow easy and accurate positioning of the dies during the crimping operation.

Lugs are electrolytically tin-plated to eliminate oxidation of the copper material. Color-Keyed® metric lugs complement our connector family and meet a growing need for customer's connector requirements. Details of the appropriate crimping tools and dies are included. Our Thomas & Betts Sales Representative group is always available to provide any technical advice required. Please contact them if sizes are needed additional to those shown in this catalogue.

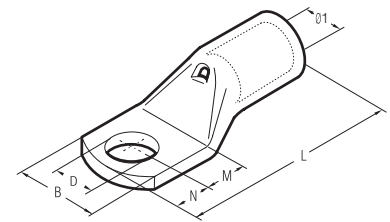

Cat. No.	Cond. Size mm ²		Stud (mm)	Dimensions (mm)						Std. Pkg.	6-Tons TBM62PCR-LI (Crimps)	14-Tons TBM14CR-LI (Crimps)	26-Tons TBM26MCC (Crimps)
	Low Stranded	Flexible		Ø1	B	M	N	L	D				
MCC6M4*	4 ÷ 6		4	3.6	8.0	5.0	4.0	21.5	4.3	100	MCD6-6 (1)	-	
MCC6M5*			5	3.6	9.0	6.5	6.0	25.0	5.3				
MCC6M6*			6	3.6	11.0	7.0	6.0	25.5	6.4				
MCC10M4	10		4	4.6	10.0	5.0	4.0	22.5	4.3		MCD10-6 (1)	MCD10-14 (1)	
MCC10M5			5	4.6	10.0	6.5	6.0	26.0	5.3				
MCC10M6			6	4.6	11.0	7.0	6.0	26.5	6.4				
MCC10M8			8	4.6	15.0	9.0	8.0	30.5	8.4				
MCC10M10			10	4.6	18.0	11.0	10.0	34.5	10.5				
MCC16M4	16		4	5.8	11.5	5.0	4.0	25.5	4.3		MCD16-6 (1)	MCD16-14 (1)	
MCC16M5			5	5.8	11.5	6.5	6.0	29.0	5.3				
MCC16M6			6	5.8	11.5	7.0	6.0	29.5	6.4				
MCC16M8			8	5.8	15.0	9.0	8.0	33.5	8.4				
MCC16M10			10	5.8	18.0	11.0	10.0	37.5	10.5				
MCC25M5	25		5	7.0	14.0	6.5	6.0	31.5	5.3	MCD25-6 (1)	MCD25-14 (1)		
MCC25M6			6	7.0	14.0	7.0	6.0	32.0	6.4				
MCC25M10			10	7.0	18.0	11.0	10.0	40.0	10.5				
MCC35M5	35	25 35	5	8.9	17.0	6.5	6.0	34.0	5.3	MCD35-6 (1)	MCD35-14 (1)		
MCC35M6			6	8.9	17.0	7.0	6.0	34.5	6.4				
MCC35M8			8	8.9	17.0	9.0	8.0	38.5	8.4				
MCC35M10			10	8.9	19.0	11.0	10.0	42.5	10.5				
MCC35M12			12	8.9	21.0	14.0	12.0	47.5	13.2				
MCC50M8	50	35 50	8	10.0	19.0	19.0	8.0	42.5	8.4	MCD50-6 (1)	MCD50-14 (1)		
MCC50M10			10	10.0	20.0	11.0	10.0	46.5	10.5				
MCC50M12			12	10.0	21.0	14.0	12.0	51.5	13.2				
MCC70M6	70	50 70	6	11.3	21.0	8.0	7.0	44.0	6.4	MCD70-6 (1)	MCD70-14 (1)		
MCC70M8			8	11.3	21.0	9.0	8.0	46.0	8.4				
MCC70M10			10	11.3	21.0	11.0	10.0	50.0	10.5				
MCC70M12			12	11.3	22.0	14.0	12.0	55.0	13.2				
MCC70M16			16	11.3	26.0	18.0	16.0	63.0	17.0				
MCC95M8	95	70 95	8	13.5	25.0	9.0	8.0	52.5	8.4	MCD95-6 (1)	MCD95-14 (1)		
MCC95M10			10	13.5	25.0	11.0	10.0	56.5	10.5				
MCC95M12			12	13.5	25.0	14.0	12.0	61.5	13.2				

* UL not applicable.

Compression Connectors for Copper Conductors

One-Hole Metric Lugs (cont'd)

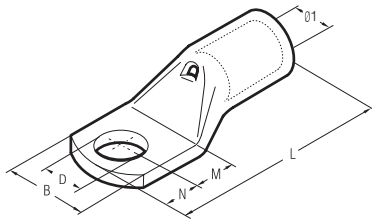

Cat. No.	Cond. Size mm ²		Stud (mm)	Dimensions (mm)						Std. Pkg.	6-Tons TBM62PCR-LI (Crimps)	14-Tons TBM14CR-LI (Crimps)	26-Tons TBM26MCC (Crimps)
	Low Stranded	Flexible		Ø1	B	M	N	L	D				
MCC120M6*	120	95 120	8	—	—	—	—	—	6.4	25	MCD120-6 (1)	MCD120-14 (1)	
MCC120M8			8	15.2	28.5	9.0	8.0	54.0	8.4	25			
MCC120M10			10	15.2	28.5	11.0	10.0	58.0	10.5	25			
MCC120M12			12	15.2	28.5	14.0	12.0	63.0	13.2	25			
MCC120M16			16	15.2	28.5	18.0	16.0	71.0	17.0	25			
MCC150M10	150	120 150	10	15.2	28.5	18.0	16.0	71.0	17.0	25	MCD150-6 (3)	MCD150-14 (1)	
MCC150M12			12	16.7	31.5	16.0	14.0	75.0	13.2	25			
MCC150M16			16	16.7	31.5	19.0	17.0	81.0	17.0	25			
MCC185M10	185	150 185	10	19.2	35.5	13.0	11.0	76.0	10.5	25	MCD185-6 (3)	MCD185-14 (1)	—
MCC185M12			12	19.2	35.5	16.0	14.0	82.0	13.2	25			
MCC185M16			16	19.2	35.5	19.0	17.0	88.0	17.0	15			
MCC240M10	240	185 240	10	21.1	39.0	13.0	11.0	82.0	10.5	15	MCD240-6 (3)	MCD240-14 (2)	
MCC240M12			12	21.1	39.0	16.0	14.0	88.0	13.2	15			
MCC240M16			16	21.1	39.0	19.0	17.0	94.0	17.0	15			
MCC300M10	300	240	10	23.7	44.0	13.0	11.0	96.0	10.5	10		MCD300-14 (3)	
MCC300M12			12	23.7	44.0	16.0	14.0	99.0	13.2	10			
MCC300M16			16	23.7	44.0	19.0	19.0	10.0	17.0	10			
MCC400M10*	400	300	10	27.0	51.0	22.0	19.0	113.0	13.2	5		MCD400-14 (3)	MCD400-26 (2)
MCC400M12			12	27.0	51.0	22.0	19.0	113.0	13.2	5			
MCC400M16			16	27.0	51.0	22.0	19.0	113.0	17.0	5			
MCC500M10*	500	400	10	—	—	—	—	—	13.2	5	—		MCD500-26 (2)
MCC500M12*			12	—	—	—	—	—	17.0	5			
MCC500M16			16	30.3	56.5	22.0	19.0	117.0	17.0	5			
MCC630M16	630	500	16	33.4	61.6	22.0	19.0	128.0	17.0	6		—	MCD630-26 (2)
MCC630M20			20	33.4	61.6	24.0	23.0	134.0	21.0	6			
MCC800M16	800	630	16	38.0	72.0	24.0	19.0	141.0	17.0	3		—	—
MCC800M20			20	38.0	72.0	24.0	23.0	145.0	21.0	3			
MCC1000M16	1000	800	16	44.0	80.0	24.0	19.0	158.0	17.0	2		—	—
MCC1000M20			20	44.0	80.0	24.0	23.0	162.0	21.0	2			

* UL not applicable.

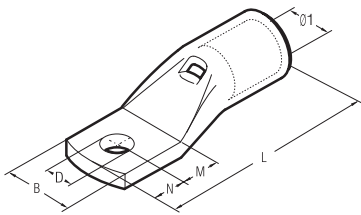

Compression Connectors for Copper Conductors

Narrow-Tongue Metric Lugs

Color-Keyed® narrow-tongue metric lugs feature a contained tongue width.

Our lugs have been specifically developed for applications with L.V. circuit breakers with reduced space requirements. The tongue width allows a quicker and easier installation.

Color-Keyed® narrow-tongue metric lugs are manufactured from electrolytic copper tube.

The specific design of the barrel and dimensions create the best combination of mechanical strength and electrical conductivity.

Color-Keyed® narrow-tongue metric lugs are annealed to guarantee optimum ductility and are electrolytically tin-plated to avoid oxidation.

The barrel is provided with an internal chamfer for easy insertion of the conductor. The length allows easy positioning of the dies for proper crimping.



Cat. No.	Cond. Size Flexible (mm ²)	Stud (mm)	Dimensions (mm)						Std. Pkg.	6-Tons TBM62PCR-LI (Crimps)	14-Tons TBM14CR-LI (Crimps)
			Ø1	B	M	N	L	D			
MCCNT10M5	10	5	4.6	9.0	6.5	6.0	26.0	5.3	100	MCD10-6 (1)	MCD10-14 (1)
MCCNT16M5	16	5	5.8	9.0	6.5	6.0	29.0	5.3	100	MCD16-6 (1)	MCD16-14 (1)
MCCNT25M5	25	5	7.0	9.0	6.5	6.0	31.5	5.3	100	MCD25-6 (1)	MCD25-14 (1)
MCCNT35M6	35	6	8.9	11.5	8.0	7.0	36.5	6.4	100	MCD35-6 (2)	MCD35-14 (1)
MCCNT50M6	50	6	10.0	11.5	8.0	7.0	40.5	6.4	50	MCD50-6 (1)	MCD50-14 (1)
MCCNT70M6	70	6	11.3	11.5	8.0	7.0	44.0	6.4	50	MCD70-6 (2)	MCD70-14 (1)
MCCNT95M8	95	8	13.5	15.5	9.0	8.0	52.5	8.0	25	MCD95-6 (1)	MCD95-14 (1)
MCCNT120M8	120	8	15.2	19.0	14.0	9.0	60.0	8.4	25	MCD120-6 (2)	MCD120-14 (1)
MCCNT120M10		10	15.2	19.0	14.0	9.0	60.0	10.5	25	MCD120-6 (2)	MCD120-14 (1)
MCCNT150M8	150	8	16.7	19.0	18.0	9.0	70.0	8.4	25	MCD150-6 (3)	MCD150-14 (1)
MCCNT150M10		10	16.7	19.0	18.0	9.0	70.0	10.5	25	MCD150-6 (3)	MCD150-14 (1)
MCCNT185M10	185	10	19.2	24.5	18.0	9.0	77.0	10.5	25	MCD185-6 (3)	MCD185-14 (1)
MCCNT240M10	240	10	21.1	31.0	13.0	9.0	80.0	10.5	15	MCD240-6 (3)	MCD240-14 (1)
MCCNT240M12		12	21.1	31.0	16.0	12.0	86.0	13.2	15	MCD240-6 (3)	MCD240-14 (1)
MCCNT240M16		16	21.1	31.0	19.0	17.0	94.0	17.0	15	MCD240-6 (3)	MCD240-14 (1)
MCCNT300M12	300	12	23.7	31.0	16.0	12.0	95.0	13.2	10	-	MCD300-14 (3)

Compression Connectors for Copper Conductors

Two-Way Metric Splice Connectors

Color-Keyed® metric splice connectors are designed for joining low voltage conductors.

Made of electrolytic copper tube having similar dimensions to the Color-Keyed® metric lugs, these connectors are also annealed and electrolytically tin-plated.

They feature an internal chamfer at both ends. For easy insertion of the conductor, a center stop is provided to ensure correct positioning.

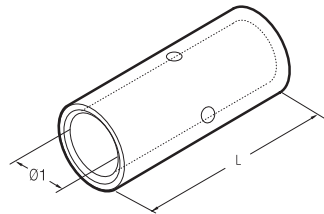
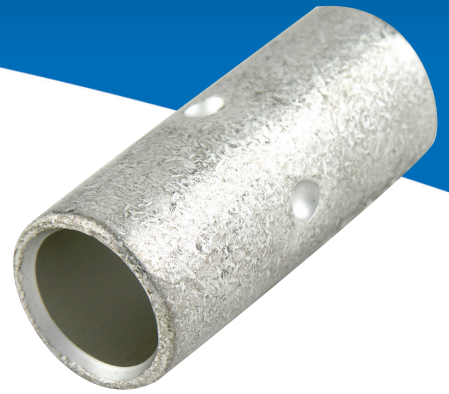

Cat. No.	Cond. Size (mm ²)		Dimensions (mm)		Std. Pkg.	6-Tons TBM62PCR-LI (Crimps)	14-Tons TBM14CR-LI (Crimps)	26-Tons TBM26MCC (Crimps)
	Low Stranded	Flexible	Ø1	L				
MCST1	0.25 ÷ 1.5	0.25 ÷ 1.5	1.8	15	100	-	-	
MCST2	1.5 ÷ 2.5	1.5 ÷ 2.5	2.4	15	100			
MCST6	4 ÷ 6	4 ÷ 6	3.6	22	100	MCD6-6 (1 + 1)		
MCST10	10	10	4.6	25	100	MCD10-6 (1 + 1)	MCD10-14 (1 + 1)	
MCST16	16	16	5.8	27	100	MCD16-6 (1 + 1)	MCD16-14 (1 + 1)	
MCST25	25	25	7.0	29	100	MCD25-6 (1 + 1)	MCD25-14 (1 + 1)	
MCST35	35	25 ÷ 35	8.9	33	100	MCD35-6 (1 + 1)	MCD35-14 (1 + 1)	
MCST50	50	35 ÷ 50	10.0	37	50	MCD50-6 (2 + 2)	MCD50-14 (1 + 1)	
MCST70	70	50 ÷ 70	11.3	39	50	MCD70-6 (2 + 2)	MCD70-14 (1 + 1)	
MCST95	95	70 ÷ 95	13.5	43	25	MCD95-6 (2 + 2)	MCD95-14 (1 + 1)	
MCST120	120	95 ÷ 120	15.2	47	25	MCD120-6 (2 + 2)	MCD120-14 (1 + 1)	
MCST150	150	120 ÷ 150	16.7	58	25	MCD150-6 (3 + 3)	MCD150-14 (1 + 1)	
MCST185	185	150 ÷ 85	19.2	64	25	MCD185-6 (3 + 3)	MCD185-14 (1 + 1)	
MCST240	240	185 ÷ 240	21.1	75	15	MCD240-6 (3 + 3)	MCD240-14 (2 + 2)	
MCST300	300	240	23.7	90	10		MCD300-14 (3 + 3)	
MCST400	400	300	27.0	94	5		MCD400-14 (3 + 3)	MCD400-26 (2 + 2)
MCST500	500	400	30.3	98	6			MCD500-26 (2 + 2)
MCST630	600 ÷ 630	500	33.4	105	6			MCD630-26 (2 + 2)
MCST800	800	600	38.0	112	3			
MCST1000	1000	800	44.0	120	3			



Compression Connectors for Copper Conductors

Two-Way Splice Connectors — Standard Barrel Certified to 600 V and Recommended up to 35 kV‡

Material: High-Conductivity Wrought Copper

Finish: Electro-Tin Plated

Two-way connectors provide high-pullout values, are easy to insulate and provide a low-resistance connection of high quality and low installed cost.

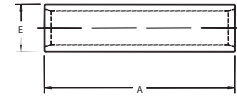

Cat. No.	Code Cable	Wire Size Flex Cable Classes G, H, I, K, M*	Dimensions in. (mm)		Die Set Cat. No.	Colour Code
			A	E		
54504	#8 AWG	#8 AWG, 37/24, #8 Weld	1.00 (25.4)	0.27 (6.9)	21	Red
54505	#6 AWG	#6 AWG, 61/24, #6 Weld, 133/0.014	1.00 (25.4)	0.30 (7.6)	24	Blue
54506	#4 AWG	#4 AWG, 91/24, 133/0.0177, 49/0.029	1.00 (25.4)	0.37 (9.4)	29	Grey
54507	#2 AWG	125/24, #4 Weld	1.25 (31.8)	0.41 (10.4)	33	Brown
54508	#1 AWG	#2 AWG, 150/24, 175/24, #2 Weld, 133/0.0223	1.50 (38.1)	0.47 (11.9)	37	Green
54509	1/0 AWG	225/24, #1 Weld, 133/0.0254	1.63 (41.4)	0.52 (13.2)	42	Pink
54510	2/0 AWG	1/0 AWG, 275/24, 1/0 Weld, 427/0.0155, 133/0.0282	1.75 (44.5)	0.57 (14.5)	45	Black
54511	3/0 AWG	2/0 AWG, 325/24, 2/0 Weld, 133/0.0316, 259/0.0227, 427/0.0177	1.75 (44.5)	0.63 (16.0)	50	Orange
53962	—	375/24, 179 kcmil, 133/0.0355, 259/0.0255, 427/0.0199	1.81 (46.0)	0.70 (17.8)		
54512	4/0 AWG	3/0 AWG, 450/24, 3/0 Weld, 703/0.0154	1.88 (47.8)	0.70 (17.8)	54	Purple
54513	250 kcmil	4/0 AWG, 550/24, 4/0 Weld, 133/0.0399, 259/0.0286, 637/0.0183	2.25 (57.2)	0.77 (19.6)	62	Yellow
53964	—	4/0 AWG, 550/24, 4/0 Weld, 133/0.0399, 259/0.0286, 637/0.0183	2.13 (54.1)	0.79 (20.1)		
54514	300 kcmil	—	2.13 (54.1)	0.83 (21.1)	66	White
54515	350 kcmil		2.25 (57.2)	0.90 (22.9)	71	Red
54516	400 kcmil	300 kcmil, 775/24 (313 kcmil)	2.75 (69.9)	0.93 (23.6)	76	Blue
53968	—		3.00 (76.2)	1.13 (28.7)	87	Brown
54518	500 kcmil	2.75 (69.9)	1.11 (28.2)			
54520	600 kcmil	—	3.00 (76.2)	1.18 (30.0)	94	Green
54522-TB	700 kcmil		3.25 (82.6)	1.23 (31.2)	99	Pink
53969	—	1325/24 = 500/535 kcmil, 427/0.0342	3.00 (76.2)	1.24 (31.5)		
54523-TB	750 kcmil	—	3.00 (76.2)	1.30 (33.0)	106	Black
54528	1000 kcmil		3.63 (92.2)	1.50 (38.1)	125	—
54530	1250 kcmil	4.13 (104.9)	1.67 (42.4)	140		

‡ For installations from 16 kV up to 35 kV, consult shielded cable manufacturers for stress relief and insulation requirements.

*Consult your Regional Sales Office for complete list of flex cable class sizes M.

Tooling: pp. E4–E62

Die Selector Chart: pp. E35–E50

Two-Way Splice Connectors — Long Barrel Certified to 600 V and Recommended up to 35 kV‡

Material: High-Conductivity Wrought Copper

Finish: Electro-Tin Plated

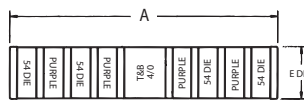

Cat. No.	Code Cable	Wire Size Flex Cable Classes G, H, I, K, M	Dimensions in. (mm)		Die Code	Colour Code
			A	E		
54804	#8 AWG	#8, 37/24 = 14.9 kcmil	1.75 (44.5)	0.27 (6.9)	21	Red
54805	#6 AWG	#6, 61/24 = 24.6 kcmil	1.75 (44.5)	0.31 (7.9)	24	Blue
54806	#4 AWG	#4, 91/24 = 36.7 kcmil	1.75 (44.5)	0.39 (9.9)	29	Grey
54807	#2 AWG	125/24 = 50.4 kcmil	1.88 (47.8)	0.43 (11.0)	33	Brown
54808	#1 AWG	#2, 150/24 = 60.5 kcmil 175/24 = 70.6 kcmil	2.00 (50.8)	0.49 (12.4)	37	Green
54809	1/0 AWG	225/24 = 90.8 kcmil	2.00 (50.8)	0.54 (13.7)	42	Pink
54810	2/0 AWG	1/0, 275/24 = 111 kcmil	2.13 (54.1)	0.59 (15.0)	45	Black
54811	3/0 AWG	2/0, 325/24 = 131 kcmil	2.25 (57.2)	0.65 (16.5)	50	Orange
54812	4/0 AWG	450/24 = 182 kcmil	2.75 (69.9)	0.72 (18.3)	54	Purple
54813	250 kcmil	4/0, 550/24 = 222 kcmil	3.38 (85.9)	0.79 (20.1)	62	Yellow

‡ For installations from 16 kV up to 35 kV, consult shielded cable manufacturers for stress relief and insulation requirements.

Cat. No.	Code Cable	Wire Size Flex Cable Classes G, H, I, K, M	Dimensions in. (mm)		Die Code	Colour Code
			A	E		
54814	300 kcmil	250, 650/24 = 262 kcmil	3.50 (88.9)	0.87 (22.1)	66	White
54815	350 kcmil	—	3.75 (95.3)	0.95 (24.1)	71	Red
54816	400 kcmil	775/24 = 313 kcmil	3.75 (95.3)	0.98 (24.9)	76	Blue
54818	500 kcmil	350, 925/24 = 373 kcmil	4.75 (120.6)	1.11 (28.2)	87	Brown
54820	600 kcmil	1100/24 = 444 kcmil	4.25 (108.0)	1.21 (30.7)	94	Green
54823	750 kcmil	500, 1325/24 = 535 kcmil	4.75 (120.6)	1.34 (34.0)	106	Black
58524	—	1600/24 = 646 kcmil	5.00 (127.0)	1.39 (35.3)	106	
58526*	900 kcmil	750, 1925/24 = 777 kcmil	5.50 (139.7)	1.51 (38.4)	115	Yellow
54828	1000 kcmil	—	5.63 (143.0)	1.56 (39.6)	125	—
54833	1500 kcmil		5.63 (143.0)	1.56 (39.6)	125	
54839	2000 kcmil		7.06 (179.3)	2.13 (54.1)	—	

Tooling: pp. E4–E62

Die Selector Chart: pp. E35–E50

Compression Connectors for Copper Conductors

Copper Two-Way Splice — Certified to 600 V and Recommended up to 15 kV

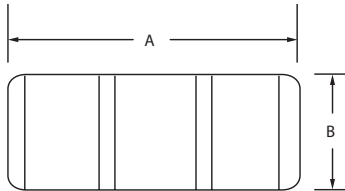

Cat. No.	Cable Size**	Dimensions in. (mm)		Installing Tools 14 and 15-Tons*		
		A	B	Die Set Cat. No.	Strip Length (in.)	Colour Code
54006-TB	#4 AWG	2.00 (50.8)	0.37 (9.4)	15CA29R	1-1/2	Grey
54007-TB	#2 AWG	2.13 (54.1)	0.41 (10.4)	15CA33R	1-5/8	Brown
54008-TB	#1 AWG	2.25 (57.2)	0.47 (11.9)	15CA37R	1-5/8	Green
54009-TB	1/0 AWG	2.38 (60.5)	0.52 (13.2)	15CA42R	1-3/4	Pink
54010	2/0 AWG	2.38 (60.5)	0.57 (14.5)	15CA45R	1-3/4	Black
54011	3/0 AWG	2.63 (66.8)	0.63 (16.0)	15CA49R	1-13/16	Orange
54012-TB	4/0 AWG	2.69 (68.3)	0.69 (17.5)	15CA54R	1-13/16	Purple
54013	250 kcmil	3.19 (81.0)	0.74 (18.8)	15CA60R	2-1/8	Ruby
54015	350 kcmil	4.13 (104.9)	0.89 (22.6)	15CA71R	2-5/8	Red
54018	500 kcmil	4.13 (104.9)	1.06 (40.6)	15CA87R	2-5/8	Brown
54023	750 kcmil	4.75 (120.7)	1.30 (33.0)	15CA106R	2-7/8	Black

*Cat. No. 15505-TB Die Adaptor required for TBM151.
 ** Cable Size: Concentric and Compact strandings.

Tooling: pp. E4–E62
 Die Selector Chart: pp. E35–E50

Cast-Copper Two-Way Splice Connectors – Heavy-Duty Certified to 600 V and Recommended up to 35 kV‡

Material: High-Conductivity Wrought Copper

Finish: Electro-Tin Plated



Cat. No.	Cable Size	Die Code
53504	8 AWG	29
53505	6 AWG	
53506	4 AWG	
53507	2 AWG	45
53508	1 AWG	
53509	1/0 AWG	
53510	2/0 AWG	66
53511	3/0 AWG	
53512	4/0 AWG	
53513	250 kcmil	76
53515	350 kcmil	
53518	500 kcmil	
53523	750 kcmil	112

‡ For installations from 16 kV up to 35 kV, consult shielded cable manufacturers for stress relief and insulation requirements.
 Use hydraulic tools with hex dies 13642M, 13400 and 21940.
 Tooling: pp. E4–E62
 Die Selector Chart: pp. E35–E50



Constant O.D. enables faster, easier installation than contoured design

Thomas & Betts takes the splicing of different-sized conductors to a new level of economy and efficiency with Color-Keyed® Cast-Copper Reducing Splices. In addition to a lower cost, the key benefit to these splices is in their constant outer diameter.

Unlike screw-machined, externally contoured splices, Cast-Copper Reducing Splices require no change of tool or die between crimping each end. Just slide each wire easily into the chamfered barrel and use the same Color-Keyed® tool and die to crimp both ends. The consistent O.D. also makes these splices faster and easier to insulate with clear heat-shrink wrap than a contoured splice. Sand-cast construction ensures high-tensile strength for heavy-duty applications and tin-plated copper material provides high-conductivity and superior corrosion-resistance.

- Ideal for telecom (inside office/outside plant), commercial, industrial MRO, and any other certified to 600 V and recommended up to 35 kV applications requiring splicing of different-sized conductors.
- Tin-plated, sand-cast copper construction provides superior tensile strength, high-conductivity and excellent corrosion-resistance.
- Easier to install and insulate than screw-machined, contour-designed reducing splices.
- Constant O.D. saves time on installation by eliminating the need for crimp-tool/die change.
- Fast and simple to insulate with clear or coloured heat-shrink wrap.
- Chamfered barrel facilitates easy wire insertion.
- Compact, low-profile design takes up minimal space in cable tray or wire run.
- Simple installation with Color-Keyed® crimp tools (12, 14 and 15-Tons).

Compression Connectors for Copper Conductors

Cast-Copper Reducing Splices



Cat. No.	Cond. 1 Size	Cond. 2 Size	Length in. (mm)	Dia. in. (mm)	Die Code	Colour Code
251-30485-19	4/0 Str.	2 Str.	2.25 (57.2)	0.81 (20.6)	66	White
251-30485-91	500 kcmil Str.	300 kcmil Str.	3.31 (84.1)	0.81 (20.6)	99	Pink
251-30485-229	2/0 Str.	250 kcmil Str.	2.38 (60.5)	0.93 (23.6)	76	Blue
251-30485-247	2 Str.	8 Str.	0.56 (14.2)	0.59 (15.0)	45	Black
251-30485-294	4 Str.	2/0 Str.	2.25 (57.2)	0.84 (21.3)	66	White
251-30485-295	4/0 Str.	4 Str.	2.25 (57.2)	0.81 (20.6)	66	White
251-30485-331	4/0 Str.	350 kcmil Str.	3.31 (84.1)	0.53 (13.5)	99	Pink
251-30485-445	4/0 Str.	2/0 Str.	2.25 (57.2)	0.81 (20.6)	66	White
251-30485-495	1/0 Str.	2 Str.	1.56 (39.6)	0.59 (15.0)	45	Black
251-30485-610	6 Str.	8 Str.	1.21 (30.7)	0.38 (9.7)	29	Grey
251-30485-611	4 Str.	8 Str.	1.21 (30.7)	0.38 (9.7)	29	Grey
251-30485-612	4 Str.	6 Str.	1.21 (30.7)	0.38 (9.7)	29	Grey
251-30485-613	2 Str.	6 Str.	1.56 (39.6)	0.59 (15.0)	45	Black
251-30485-640	4/0 Str.	1/0 Str.	2.25 (57.2)	0.81 (20.6)	66	White
251-30485-653	2 Str.	250 kcmil Str.	2.38 (60.5)	0.93 (23.6)	76	Blue
251-30485-739	1/0 Str.	250 kcmil Str.	2.38 (60.5)	0.93 (23.6)	76	Blue
251-30485-882	400 kcmil Str.	350 kcmil Str.	3.31 (84.1)	0.53 (13.5)	99	Pink
251-30485-950	1/0 Str.	6 Str.	1.56 (39.6)	0.59 (15.0)	45	Black
251-30485-951	6 Str.	2/0 Str.	2.25 (57.2)	0.84 (21.3)	66	White
251-30485-1027	1/0 Str.	4 Str.	1.56 (39.6)	0.59 (15.0)	45	Black
251-30485-1029	1/0 Str.	#12 Str.	1.56 (39.6)	0.57 (14.5)	45	Black
251-30485-1030	10 Str.	4 Str.	1.21 (30.7)	0.38 (9.7)	29	Grey
251-30485-1031	12 Str.	4 Str.	1.21 (30.7)	0.38 (9.7)	29	Grey
251-30485-1032	#6 Str.	#10 Str.	1.21 (30.7)	0.38 (9.7)	29	Grey
251-30485-1033	12 Str.	6 Str.	1.21 (30.7)	0.38 (9.7)	29	Grey
251-30485-1034	14 Str.	8 Str.	1.21 (30.7)	0.38 (9.7)	29	Grey
251-30485-1035	1 Str.	1/0 Str.	1.56 (39.6)	0.59 (15.0)	45	Black
251-30485-1044	10 Str.	8 Str.	1.21 (30.7)	0.38 (9.7)	29	Grey
251-30485-1045	12 Str.	8 Str.	1.21 (30.7)	0.38 (9.7)	29	Grey
251-30485-1085	10 Str.	1/0 Str.	1.56 (39.6)	0.59 (15.0)	45	Black
251-30485-1086	10 Str.	2/0 Str.	2.25 (57.2)	0.84 (21.3)	66	White
251-30485-1087	4 Str.	250 kcmil Str.	2.38 (60.5)	0.93 (23.6)	76	Blue
251-30485-1088	400 kcmil Str.	250 kcmil Str.	3.31 (84.1)	0.53 (13.5)	99	Pink
251-30485-1089	14 Str.	8 Sol.	1.21 (30.7)	0.38 (9.7)	29	Grey
251-30485-1090	12 Str.	8 Sol.	1.21 (30.7)	0.38 (9.7)	29	Grey
251-30485-1091	10 Str.	8 Sol.	1.21 (30.7)	0.38 (9.7)	29	Grey
251-30485-1092	12 Str.	6 Sol.	1.21 (30.7)	0.38 (9.7)	29	Grey
251-30485-1093	8 Str.	6 Sol.	1.21 (30.7)	0.38 (9.7)	29	Grey
251-30485-1094	4 Str.	6 Sol.	1.21 (30.7)	0.38 (9.7)	29	Grey
251-30485-1095	2 Str.	6 Sol.	1.56 (39.6)	0.59 (15.0)	45	Black
251-30485-1096	12 Str.	4 Sol.	1.21 (30.7)	0.38 (9.7)	29	Grey
251-30485-1097	10 Str.	4 Sol.	1.21 (30.7)	0.38 (9.7)	29	Grey
251-30485-1098	8 Str.	4 Sol.	1.21 (30.7)	0.38 (9.7)	29	Grey
251-30485-1099	6 Str.	4 Sol.	1.21 (30.7)	0.38 (9.7)	29	Grey
251-30485-1100	1/0 Str.	4 Sol.	1.56 (39.6)	0.59 (15.0)	45	Black
251-30485-1130	Cast Copper*	12-4 Str.	1.28 (32.5)	0.38 (9.7)	29	Black
251-30485-1245	1/0 Flex	#4 Flex	2.25 (57.2)	0.81 (20.6)	66	White
251-30485-1246	#4 Flex	#8 Flex	1.56 (39.6)	0.57 (14.5)	45	Black

For installations from 16 kV up to 35 kV, consult shielded cable manufacturers for stress relief and insulation requirements.
* Cast Copper – Field Modifiable Special.

Copper H-Tap Connectors for Copper Conductors

Copper H-Taps – Certified to 600 V

Material: High-Conductivity Extruded Copper

Finish: Electro-Tin Plated

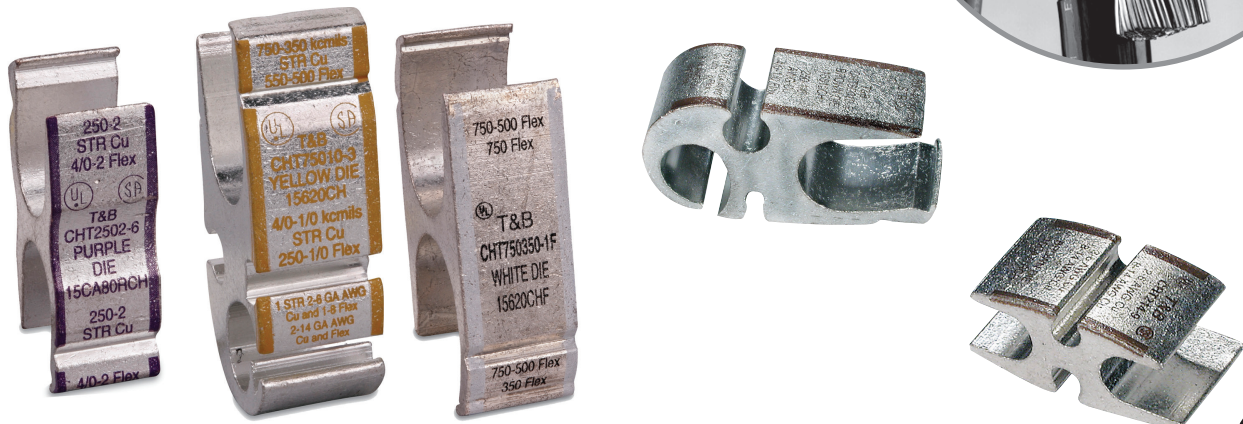
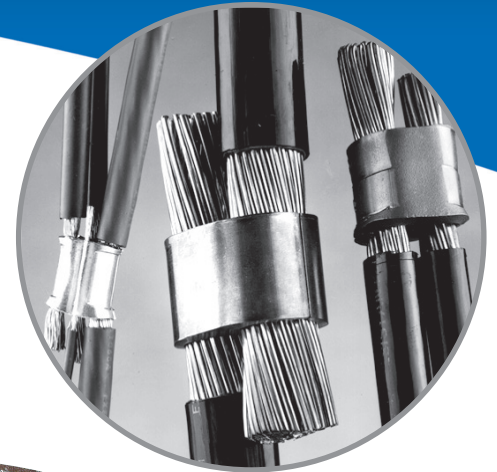

Cat. No.	Fig. No.	Colour Code	Dimensions in. (mm)				Crimping Information								
			Main	Branch 1	Branch 2	Branch 3	Hydraulic Head	Installing Die	# of Crimps	Colour Code	Die Code	Strip Length (in.)	Insulating Covers		
CHT750350-1F	1	White	(750-500) (750) Flex Only	(750-500) (350) Flex Only	-	-	TBM15I	15620CHF	1	White	F	1-1/8	HTC500		
CHT750350-2	2	Yellow	750-500 (550-500)	750-500 (550-500)	-	-				15620CH	Yellow	Z		1-3/8	
CHT75010-3	9	Yellow	-	4/0-1/0 (250-1/0)	1 Str. 2-6 AWG (1-8)	2-14 (2-14)				-	-	-		-	-
CHT50040-4	2	Brown	500-250 (350-4/0)	500-4/0 (350-4/0)	-	-				15612CH	2	Brown		N	1-1/8
CHT50010-5	3	Brown	500-4/0 (350-4/0)	250-1/0 (4/0-1/0)	1 Str. 2-6 AWG (1-8)	8-14 (8-14)	-	-	-	-	-	-			
CHT2502-6	2	Purple	250-2 (4/0-2)	250-2 (4/0-2)	-	-	•TBM15I TBM14M	15CA80RCH	1	Purple	80R	13/16	HTC40		
CHT25014-7	4			2-6 Str./Sol. (2-8)	-	-						1-1/8			
CHT250214-8	5			8-14 (8-14)	-	-						-			
CHT214-9	6	Brown	2-6 Str./Sol. (2-8)	2-6 Str./Sol. (2-8)	8-14 (8-14)	-	•TBM15I TBM14M 13100A	15CA71RCH	3	Brown	71R	7/8	-		
CHT814-10	7	Green	8-14 (8-14)	8-14 (8-14)	-	8-14 (8-14)		15CA37RCH	1	Green	37R	1/2	HTC2C		
CHT75040-11	8	Yellow	750 Str. (750-500)	350-4/0 Str. Cu and Flex	-	-	TBM15I	15620CH	1	Yellow	Z	1-1/8	HTC500		

• Requires adaptor Cat. No. 15500-TB when used with hydraulic head TBM15I.
Material: Copper per AS™ designation B-124-55 Alloy 12.
Tooling: pp. E4-E62
Die Selector Chart: pp. E35-E50

Copper H-Tap Connectors for Copper Conductors

Copper H-Taps – Certified to 600 V (cont'd)

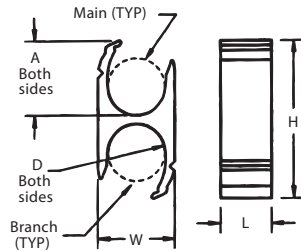

Figure 1

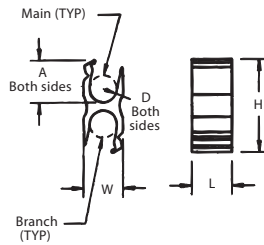

Figure 2

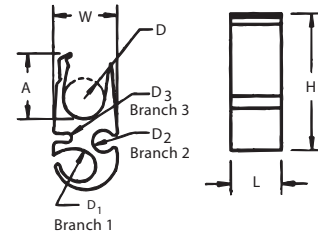

Figure 3

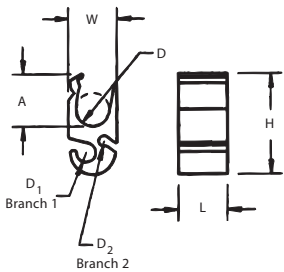

Figure 4

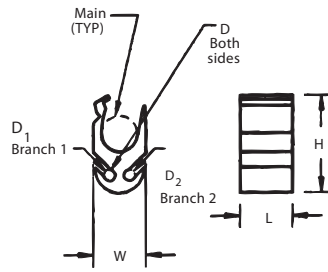

Figure 5

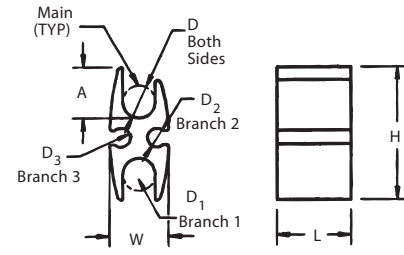

Figure 6

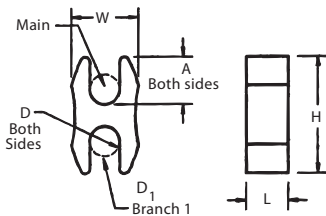

Figure 7

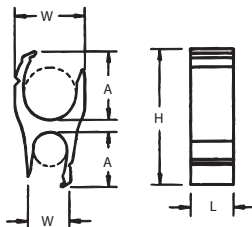

Figure 8

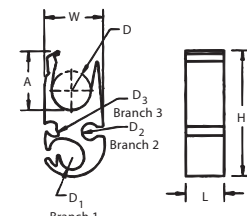

Figure 9



Cat. No.	Fig. No.	Dimensions in. (mm)								Strip Length (in.)	Insulating Covers
		H	W	L	A	D	D1	D2	D3		
CHT750350-1F	1	3.46 (87.9)	1.66 (42.1)	1.10 (27.9)	1.73 (43.9)	1.23 (31.2)	-	-	-	1-1/8	HTC1000
CHT750350-2	2	3.24 (82.3)	1.50 (38.1)	1.25 (31.8)	1.62 (41.1)	1.02 (30.5)	-	-	-	1-3/8	
CHT75010-3	9	3.13 (79.5)	1.50 (38.1)	1.00 (25.4)	1.54 (39.1)	1.00 (25.4)	0.40 (10.2)	0.35 (8.9)	0.41 (10.4)	1-1/8	HTC500
CHT75040-11	8	3.19 (81.0)	(1) 1.65 (41.9)	1.00 (25.4) (2) 1.05 (26.7)	(1) 1.61 (40.9)	(1) 1.24 (31.5) (2) 1.29 (32.8)	(2) 0.80 (20.3)	-	-		
CHT50040-4	2	2.64 (67.1)	1.18 (30.0)	1.00 (25.4)	1.32 (33.5)	0.80 (20.3)	-	-	-	13/16	HTC40
CHT50010-5	3	2.28 (57.9)	1.30 (33.0)	1.00 (25.4)	1.20 (30.5)	0.80 (20.3)	0.67 (17.0)	0.19 (4.8)	0.43 (10.9)		
CHT2502-6	2	1.99 (50.9)	0.90 (22.9)	0.66 (16.8)	1.00 (25.4)	0.62 (15.7)	-	-	-	1-1/8	HTC40
CHT25014-7	4	1.63 (41.4)	0.90 (22.9)	0.90 (22.9)	0.96 (24.4)	0.52 (13.2)	0.35 (8.9)	0.19 (4.8)	-		
CHT250214-8	5	1.63 (41.4)	0.90 (22.9)	0.90 (22.9)	0.96 (24.4)	0.62 (15.7)	0.19 (4.8)	0.19 (4.8)	-	7/8	HTC2S
CHT214-9	6	1.35 (34.3)	0.60 (15.2)	0.75 (19.1)	0.50 (12.7)	0.33 (8.4)	0.19 (4.8)	0.19 (4.8)	-		
CHT814-10	7	0.62 (15.7)	0.60 (15.2)	0.37 (9.4)	0.25 (6.4)	0.16 (4.1)	-	-	-	1/2	

Copper H-Tap Connectors for Conductors

Copper H-Taps – Certified to 600 V 90°C Applications

- H-type compression taps
- For aluminum-to-aluminum, aluminum-to-copper and copper-to-copper stranded-conductor applications
- Concentric and compact code strandings

Exclusive FILLERLOK tab design.

Material: High-Conductivity Wrought Aluminum



Cat. No.	Combinations			Length (in.)	Die Code Cat. No.				Colour Code			
	Main	Branch	Side Tap		TBM6-TBM6S TBM6ORS 13474 upper 13477 lower	Hydraulic TBM14M 13100A	TBM12 12-TON HEAD	TBM15I 15-TON HEAD				
63105†	2-6	8-14	-	3/4	13470	15530	TBM12D-4	15530*	Orange			
63110	4-6	4-6		1-1/2					13471	15502	TBM12D-H	15001A*
63118	2/0-2	8-14		3/4	15502*	15502	15612	Blue				
63125	2/0-2	1/0-6		1-1/2				15612				
63140	4/0-2/0	2-10		8-14	3	-	-		15620	Black		
63148•	4/0-2/0	3/0-1	2-6	2-3/4	-			-		-	-	
63160	500-4/0	4/0-2	-	3		-	-		-			-
63169	750-4/0	750-4/0	-	6	-			-		-	-	
63170	1000-500	1000-1/0	-	3		-	-		-			-
63180	750-350	350-1/0	1-6									

* Use with adaptor Cat.No.15500-TB.

† 63105 also installed by TBM5/TBM5S with 13455 die or TBM8/TBM8S with 13462 die.

• 63148 = #1 CU or AL - wire bent double (hairpin).

For Smart™ Tools Installation

63110,63118,63125: Use TBM8-750HG

63140,63148:Use TBM8-750BH

Tooling: pp. E4-E62

Die Selector Chart: pp. E35-E50



Interlocking Insulating Covers for Compression Taps

Soft Shell H-Tap/C-Tap Covers

Better covers for taps!

Thomas & Betts offers an improved design for one-piece covers of H-Tap and C-Tap connectors. The new design is more size-efficient and includes an easy latch mechanism. The new covers also contain flash barriers to help protect against electrical flashovers. The covers are molded from high-impact polypropylene (UL 94V-1) and are certified to 600 V applications at 105°C UL listed.

Features

- Size-efficient design**
 Won't take up as much room in the enclosure or vault, easier to store and carry to the job site.
- Easy Latch Mechanism**
 Quick but sturdy cover latch for optimum insulation.
- Flash Barriers**
 Provides protection from electrical flashovers.
- 105°C Rating**
 Offers maximum performance and higher than many competitor's temperature ratings.
- High-Impact Polypropylene**
 Constructed from rugged materials for long-lasting protection.

Smaller size requires less space in enclosure.
 High-impact polypropylene for rugged, dependable use.



Clear, polycarbonate
 (UL 94V-0) version available.

Also available in clear, impact-resistant and flame-retardant polycarbonate (UL 94V-0). The clear version includes an internal pocket for a visible identification label without opening the cover. Consult your Regional Sales Office for shipping and availability. See HTC2CLRFR in table.

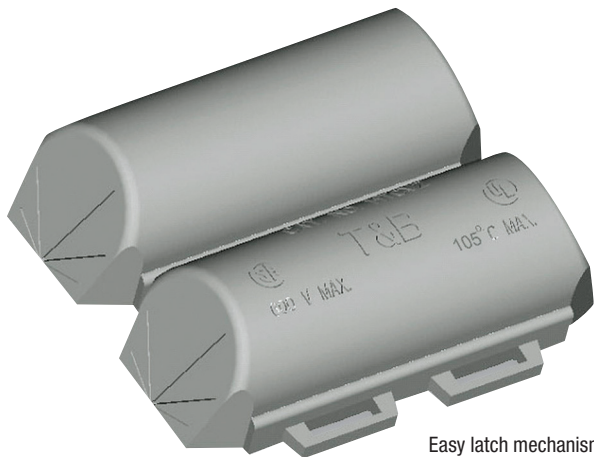

Easy latch mechanism

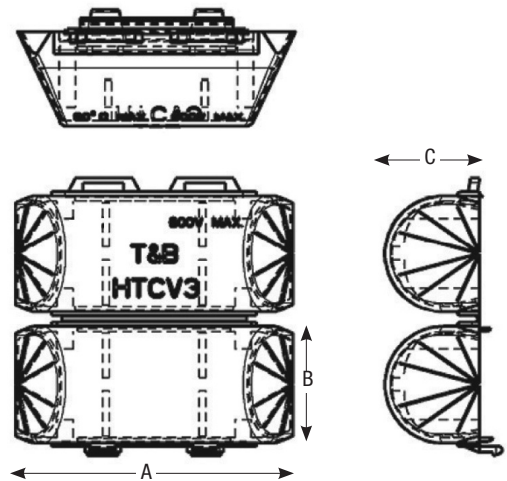

Cat. No.	For H-Taps	For C-Taps	Dimensions in.			Std. Pkg.
			A	B	C	
HTCV1	CHT814-10	54705, 54710, 54715	1-3/4	7/8	9/16	5
HTCV2	CHT214-9, CHT250214-8, CHT25014-7, CHT2502-6	54770, 54775, 54780	3-3/8	1-1/8	1	
HTCV3	CHT50010-5, CHT50040-4	54740, 54745, 54750, 54755, 54760, 54765	3-27/32	1-5/8	1-5/16	
HTCV4	CHT75010-3, CHT750350-2, CHT750350-1F, CHT75040-11	-	5-5/8	2	1-11/16	
HTCV2CLRFR	CHT214-9, CHT250214-8, CHT25014-7, CHT2502-6	-	3-3/8	1-3/8	1	

Wire Joints for Copper Conductors

Compression Wire Joints for Copper Conductors

All-around compression ensures high conductivity, low resistance and high pull-out values exceeding CSA requirements

Features

- Deal for pigtailing, tapping multiple conductors or 2-way splicing
- Form a permanent installation in minimal space
- Easily insulated
- Offer lowest installed cost
- Made of high-conductivity copper and electro-tin plated
- Colour-coded dies for positive matching and compression

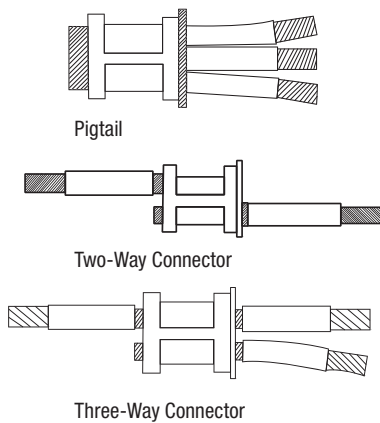

AWG Size	Circular Mil Area
#14	4,107
#12	6,530
#10	10,380
#8	16,510
#6	26,250
#4	41,740
#2	66,370
#1	83,690
1/0	105,500
2/0	133,100
3/0	167,800
4/0	211,600

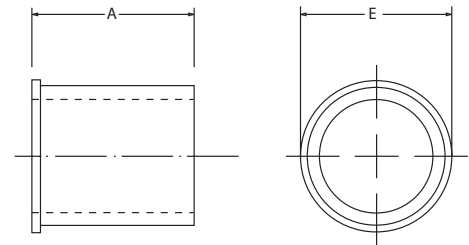

Cat. No.	Conductor Range				Dimensions in. (mm)		Colour Code	Installing Hand Tools				
	Circular Mil Area		Cable Combination		A	E		TBM25S/21E TBM45S Die Cat. No.	TBM8/8S Die Cat. No.	TBM5/5S Die Cat. No.	TBM6 and TBM6S	
	Min.	Max.	Min.	Max.							Upper	Lower
54610	19,590	27,290	3 #12 Sol. or Str.	2 #10 w/1 #12 Sol. or Str.	0.407 (10.3)	0.370 (9.4)	Blue	Included	-	-	13475	13477
54615	31,140	43,400	3 #10 Sol. or Str.	4 #10 Sol. or Str.	0.407 (10.3)	0.430 (10.9)	Grey		13461	13454	13472	13476
54620	49,530	65,560	3 #8 Sol. or Str.	1 #4 w/2 #10 Sol. or Str.	0.417 (10.6)	0.475 (12.1)	Brown	-	-	-	13474	-
54625-TB	66,040	87,130	4 #8 Sol. or Str.	1 #2 str w/2 #12 Sol. or Str.	0.479 (12.2)	0.545 (13.8)	Green	-	-	-	-	-
54630	83,480	99,990	2 #4 Sol. or Str.	2 #4 w/1 #10 Sol. or Str.	0.479 (12.2)	0.585 (14.9)	Pink	-	13462	13455	13475	13477
54635	99,060	124,220	6 #8 Str.	2 #4 w/2 #8 Sol. or Str.	0.762 (19.4)	0.620 (15.7)	Black	-	-	-	13474	-
54640	125,220	166,120	3 #4 Sol. or Str.	3 #4 w/2 #10 Sol. or Str.	0.762 (19.4)	0.695 (17.7)	Orange	-	-	-	-	-
54645-TB	166,960	193,630	4 #4 Sol. or Str.	2 #1 w/2 #10 Sol. or Str.	0.824 (20.9)	0.770 (19.6)	Purple	-	13463	13456	13475	-
54650	189,190	244,020	3 #2 Str.	2 #1/0 w/2 #8 Str.	0.887 (22.5)	0.830 (21.1)	Yellow	-	13463	13456	13473	13476

Hand tools only.
Tooling: pp. E4-E62
Die Selector Chart: pp. E35-E50

Cast Copper Bus Taps for Copper Conductors

Heavy-Duty Bus Bar Taps – Certified to 600 V and Recommended up to 35 kV¥ Applications

Clamps onto bus bar – No drilling required

Features

- For bus bars up to 1/4 in. thick, 3-6 in. wide and code copper cable
- Take up less than 1-1/4 in. of bus bar space
- Convex shape of connector tongue exerts great contact pressure on bus bar
- Install with hydraulic tools and hex crimp dies

Material: High-Conductivity Cast Copper Alloy

Finish: Electro-Tin Plated

Contact

Material: Beryllium Copper

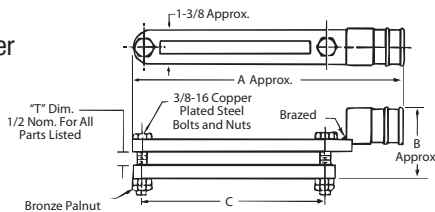
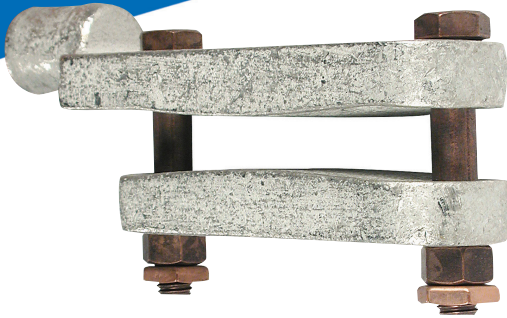

Figure 1

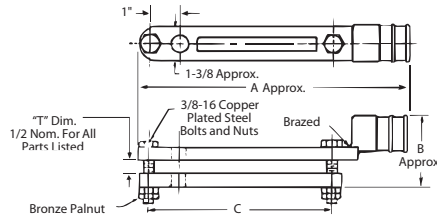

Figure 2

Cat. No.	Wire Size		Fig. No.	Busbar Width	Dimensions in. (mm)			Die Code
	Code Cable	Flex			A	B	C	
251-31446-1	1/0	225/24	1	3	6.12 (155.4)	2.28 (57.9)	3.50 (88.9)	66H
251-31446-7				4	7.12 (180.8)	2.28 (57.9)	4.50 (114.3)	
251-31446-13				5 or 6	9.12 (231.6)	2.28 (57.9)	6.38 (162.1)	
251-31446-8	2/0	1/0, 275/24	1	4	7.12 (180.8)	2.28 (57.9)	4.50 (114.3)	
251-31446-14				2	9.12 (231.6)	2.28 (57.9)	6.38 (162.1)	
251-31446-23	4/0	450/24	1	3	6.12 (155.4)	2.28 (57.9)	3.50 (88.9)	
251-31446-22				4	7.12 (180.8)	2.28 (57.9)	4.50 (114.3)	
251-31446-19				6	9.12 (231.6)	2.28 (57.9)	6.44 (163.6)	
251-31446-29	250 kcmil	4/0, 550/24	1	3	5.68 (144.3)	2.28 (57.9)	3.38 (85.9)	
251-31446-30				4	7.12 (180.8)	2.28 (57.9)	4.50 (114.3)	
251-31446-31				5 or 6	9.12 (231.6)	2.28 (57.9)	6.38 (162.1)	
251-31446-3	350 kcmil	-	1	3	6.63 (168.4)	2.56 (65.0)	3.50 (88.9)	
251-31446-9				4	7.63 (193.8)	2.56 (65.0)	4.50 (114.3)	
251-31446-15				2	9.63 (244.6)	2.56 (65.0)	6.38 (162.1)	
251-31446-4	500 kcmil	350, 925/24	1	3	6.63 (168.4)	2.56 (65.0)	3.50 (88.9)	
251-31446-10				4	7.63 (193.8)	2.56 (65.0)	4.50 (114.3)	
251-31446-16				2	9.63 (244.6)	2.56 (65.0)	6.38 (162.1)	
251-31446-17	600 kcmil	-	1	5 or 6	9.75 (247.7)	2.75 (69.9)	6.38 (162.1)	
251-31446-21	700 kcmil				6	9.75 (247.7)	2.75 (69.9)	6.44 (163.6)
251-31446-6	750 kcmil	500, 1325/24	1	5 or 6	3	6.75 (171.5)	2.75 (69.9)	3.50 (88.9)
251-31446-12					4	7.75 (196.6)	2.75 (69.9)	4.50 (114.3)
251-31446-18					2	9.75 (247.7)	2.75 (69.9)	6.38 (162.1)
251-31446-36	-	750, 1925/24	2	5 or 6	9.75 (247.7)	2.75 (69.9)	6.44 (163.6)	112H

Styles shown have cable tap on one portion of clamp assembly. Clamp assemblies with cable taps on both portions (top and bottom identical) are also available. These assemblies are identified by adding suffix "AD" to catalogue numbers shown (example: 251-31446-1AD).

Only one hydraulic tools with hex crimp dies TBM12.

¥ For installations from 16 kV up to 35 kV, consult shielded cable manufacturers for stress relief and insulation requirements.

Tooling: pp. E4-E62

Die Selector Chart: pp. E35-E50

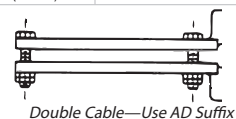



Material: High-Conductivity
Finish: Electro-Tin Plated
Insulator: Thermoplastic Elastomer
Contact Material: Beryllium Copper

Motor Pigtail Connectors

One Line to One Load (two wires) (cont'd)

Quick, easy installation!

- 1 Choose appropriate Color-Keyed® disconnect for conductor size to be terminated. Note colour of bands on disconnect barrel.
- 2 Select proper installing die by matching colour code to disconnect barrel colour bands.
- 3 Install die in T&B tool, insert stripped wire into barrel of disconnect and compress between colour bands. Repeat for mating half.
- 4 Snap the two halves together and slip on insulator over mated connection. Secure insulator with Ty-Rap® cable ties provided with the insulators.

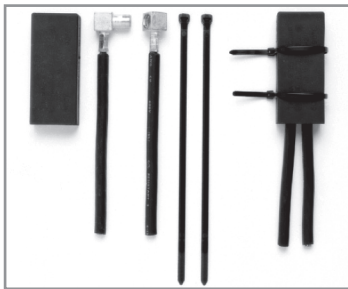

600 V Version



5 kV Version



Cat. No. Certified to 600 V		WT112M WT111M WT2000 ERG4002 ERG4005	TBM45S	Installing Tools					
				TBM6, TBM6S		TBM5 TBM5S	TBM8 TBM8S	Hydraulic Tools	
				Upper Die	Lower Die	Die Set	Die Set	Die Code	Colour Code
Female Disconnect	Male Disconnect								
MD1614F-0	MD1614M-0	X	-	-	-	-	-	-	-
MD1614F-1	MD1614M-1								
MD1210F-1	MD1210M-1								
MD1210F-2	MD1210M-2								
MD8F-1	MD8M-1	-	-	-	-	-	-	-	-
MD8F-2	MD8M-2								
MD6F-1	MD6M-1								
MD6F-2	MD6M-2								
MD4F-2	MD4M-2								
MD2F-2	MD2M-2								
MD2F-3	MD2M-3	-	-	-	-	-	-	-	-
MD1F-2	MD1M-2								
MD1F-3	MD1M-3								
MD10F-3	MD10M-3								
MD20F-3	MD20M-3								
MD30F-3	MD30M-3								
MD40F-3	MD40M-3								

Specifications:
 Wire Range: No. 16 to 4/0 AWG.
 Rating: 600 V, 90°C.

Tooling: pp. E4-E62
 Die Selector Chart: pp. E35-E50

Motor Pigtail Connectors

One Line to Two Load (three wires)

- KON-TOUR™ louvered contact bands
- Colour-coded to match installing dies

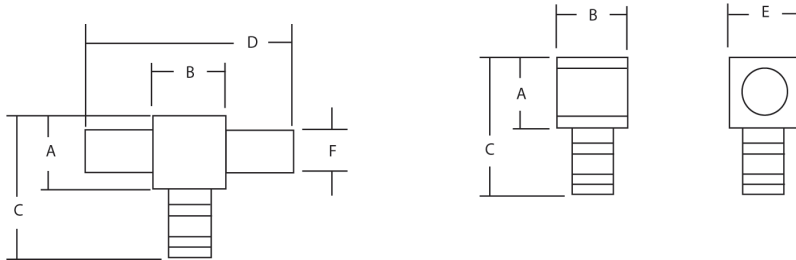

Material: High-Conductivity Wrought Copper

Finish: Electro-Tin Plated

Contact Material: Beryllium Copper



Cat. No. Certified to 600 V		Wire Size	Body Size	Colour Code	Boot Insulation	Dimensions in. (mm)						Strip Length (in.)
Female Disconnect	Male Disconnect					A	B	C	D	E	F	
MD1614F-0	M2D1614M-0	16-14 AWG	0	Blue	MDBOOT-1	0.25 (6.4)	0.25 (6.4)	0.63 (16.0)	0.52 (13.2)	0.25 (6.4)	0.13 (3.3)	3/8
MD1614F-1	M2D1614M-1		1	Yellow		0.38 (9.7)	0.38 (9.7)	0.78 (19.8)	0.75 (19.1)	0.38 (9.7)	0.25 (6.4)	
MD1210F-1	M2D1210M-1	12-10 AWG	1	Yellow	MDBOOT-2	0.38 (9.7)	0.35 (8.9)	0.78 (19.8)	0.75 (19.1)	0.38 (9.7)	0.25 (6.4)	
MD1210F-2	M2D1210M-2		2	Red		0.50 (12.7)	0.50 (12.7)	0.90 (22.9)	1.00 (25.4)	0.50 (12.7)	0.37 (9.4)	
MD8F-1	M2D8M-1	8 AWG	1	Red	MDBOOT-1	0.38 (9.7)	0.38 (9.7)	0.82 (20.8)	0.75 (19.1)	0.38 (9.7)	0.25 (6.4)	7/16
MD8F-2	M2D8M-2		2	Blue		0.50 (12.7)	0.50 (12.7)	0.95 (24.1)	1.00 (25.4)	0.50 (12.7)	0.37 (9.4)	
MD6F-1	M2D6M-1	6 AWG	1	Blue	MDBOOT-1	0.38 (9.7)	0.38 (9.7)	0.88 (22.4)	0.75 (19.1)	0.38 (9.7)	0.25 (6.4)	1/2
MD6F-2	M2D6M-2		2	Grey		0.50 (12.7)	0.50 (12.7)	1.02 (25.9)	1.00 (25.4)	0.50 (12.7)	0.37 (9.4)	
MD4F-2	M2D4M-2	4 AWG	2	Grey	MDBOOT-2	0.50 (12.7)	0.50 (12.7)	1.03 (26.2)	1.00 (25.4)	0.50 (12.7)	0.37 (9.4)	17/32
MD2F-2	M2D2M-2	2 AWG	2	Brown	MDBOOT-3	0.50 (12.7)	0.50 (12.7)	1.09 (27.7)	1.00 (25.4)	0.50 (12.7)	0.37 (9.4)	
MD2F-3	M2D2M-3		3	Green		0.88 (22.4)	0.88 (22.4)	1.46 (37.1)	1.75 (44.5)	0.88 (22.4)	0.50 (12.7)	
MD1F-2	M2D1M-2	1 AWG	2	Green	MDBOOT-2	0.50 (12.7)	0.50 (12.7)	1.23 (31.2)	1.00 (25.4)	0.50 (12.7)	0.37 (9.4)	9/16
MD1F-3	M2D1M-3		3	Pink		0.88 (22.4)	0.88 (22.4)	1.56 (39.6)	1.75 (44.5)	0.88 (22.4)	0.50 (12.7)	
MD10F-3	M2D10M-3	1/0 AWG	3	Pink	MDBOOT-3	0.88 (22.4)	0.88 (22.4)	1.56 (39.6)	1.75 (44.5)	0.88 (22.4)	0.50 (12.7)	5/8
MD20F-3	M2D20M-3	2/0 AWG	3	Black		0.88 (22.4)	0.88 (22.4)	1.59 (40.4)	1.75 (44.5)	0.88 (22.4)	0.50 (12.7)	
MD30F-3	M2D30M-3	3/0 AWG	3	Orange		0.88 (22.4)	0.88 (22.4)	1.71 (43.4)	1.75 (44.5)	0.88 (22.4)	0.50 (12.7)	
MD40F-3	M2D40M-3	4/0 AWG	3	Purple		0.88 (22.4)	0.88 (22.4)	1.81 (46.0)	1.75 (44.5)	0.88 (22.4)	0.50 (12.7)	

Operating Range: 600 V max., 1000 V max. in signs and fixtures.

Listing: UL Listed and CSA Certified for 12/8 AWG solid copper conductors and stranded copper conductors in the sizes shown.

Selection: Always use the same body size when selecting male and female disconnects.

For example: to connect a 2 AWG male to an #8 AWG female, select cat. no. M2DM-2 and MD8F-2. Both have body size 2.

Insulation: Use insulating boots matching the disconnect body size as indicated in the chart.

To protect the connection from moisture and dirt, use sealing compound cat. no. MDBOOT-SEAL.

Tooling: pp. E4-E62

Die Selector Chart: pp. E35-E50



Motor Pigtail Connectors

5 kV Motor Pigtail Connectors Supplied with Boot, Pin, Silicon Gel (Two Female Connectors Required) *

Cat. No.	Wire Range AWG	Female Disconnect Cat. No.	Colour Code	Dimensions in. (mm)			Body Size
				L	W	H	
5KVB00T-2L (connection pin for two female connectors included)	#8	MD8F-2	Red	4.50 (114.3)	2.25 (57.2)	1.44 (36.6)	2
	#6	MD6F-2	Blue				
	#4	MD4F-2	Grey				
	#2	MD2F-2	Brown				
	#1	MD1F-2	Green				
5KVB00T-3L (connection pin for two female connectors included)	#2	MD2F-3	Brown	4.50 (114.3)	2.25 (57.2)	1.44 (36.6)	3
	#1	MD1F-3	Green				
	1/0	MD10F-3	Pink				
	2/0	MD20F-3	Black				
	3/0	MD30F-3	Orange				
	4/0	MD40F-3	Purple				

CSA and UL non applicable.
* Male pin supplied will fit all ranges and combinations of wire sizes per body size.

Sealing for motor-disconnect boots

Sealant



Technical Specifications

- Description: Polybutene Compound
- Application Temperature: 4°C to 38°C (40°F to 100°F)
- Service Temperature: -40°C to 82°C (-40°F to 180°F)
- Dimensions: Width 1 in., Thickness 1/8 in., Length (std. roll) 10 ft, wrapped on release liner
- Environmental Resistance: Resists normal aging process
- Chemical Resistance: Resists acids, bases and alcohols
- Dielectric Strength: 200 V/mil minimum
- Volume Resistivity: 1013 ohms/cm
- Flame Retardancy: Passed VO Vertical Flame Test

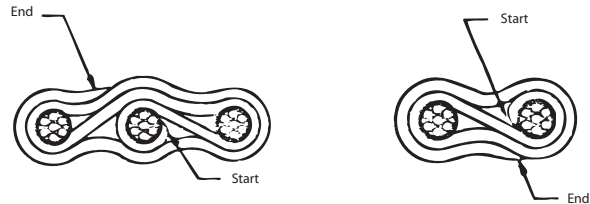

Sealant should be used with T&B motor-disconnect boots: MDBOOT-0, MDBOOT-1, MDBOOT-2 and MDBOOT-3.

The cable should be clean and free of grease and other foreign substances. Apply two layers around each cable at the same distance from the connector. Slide the assembly into boot, apply Ty-Rap® cable ties and work sealant around wires at end of boot to eliminate voids.

Cat. No.	Description
MDBOOT-SEAL	Sealant

For watertight applications, consult your Regional Sales Office for informations.

Silicone Lubricant for High Voltage Electrical Work



Cat. No.	Size	Std. Pkg.
2015	5 grams	100 envelopes
SL5	5 oz./142 grams	12 tubes

KUBE™ Connectors

Flag and Tee Connectors

A cost-saving breakthrough in 90° and T-connections

Finally there's a fast, easy and affordable way to make those 90° and T electrical connections whenever and wherever you need them. Color-Keyed® Flags and Tees are designed — and CSA/UL approved — to be used with standard Color-Keyed® lugs and splices from #8 through 4/0 AWG in field-assembled configurations. Now you don't need to use high-cost flexible conductor for connections requiring 90° bending radius or expensive brazed or welded connectors for T connections! Insulated with custom-fit, halogen-free polypropylene for safety and performance, Color-Keyed® Flags and Tees are available in bulk quantities for OEM applications and in a convenient kit for field use.



- Offers lowest installed cost for the application
- Versatile, modular design enables thousands of field-constructible connection possibilities, including multi-circuit configurations
- CSA Certified and UL Listed for field installation
- Insulated for fast, safe termination and installation
- Used with standard Color-Keyed® lugs and splices
- Colour coded for easy selection of correct crimping die and easy Certification of proper crimp
- Constructed from high-conductivity, low-resistance 99.9% pure wrought copper for optimum electrical performance
- Tin-plated for corrosion resistance and excellent contact

Technical Specifications

- Connector: Tin-plated copper
- Insulation: Halogen-free polypropylene
- Standards: CSA Certified and UL Listed

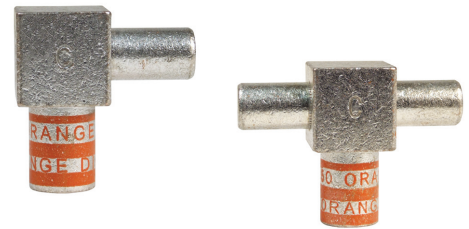

Cat. No.	Wire Size (AWG)	Insulator	Std. Pkg. Qty.
Flags			
FLAG1614	#16-14	F-INSUL-0	20
FLAG1210	#12-10		
FLAG8	#8	F-INSUL-1	10
FLAG6	#6		
FLAG4	#4	F-INSUL-2	6
FLAG2	#2		
FLAG1	#1		
FLAG10	1/0	F-INSUL-3	3
FLAG20	2/0		
FLAG30	3/0		
FLAG40	4/0		

Cat. No.	Wire Size (AWG)	Insulator	Std. Pkg. Qty.
Tees			
TEE1614	#16-14		20
TEE1210	#12-10		
TEE8	#8		10
TEE6	#6		
TEE4	#4	-	6
TEE2	#2		
TEE1	#1		
TEE10	1/0		3
TEE20	2/0		
TEE30	3/0		
TEE40	4/0		

Flag and Tee connectors

Make on-site custom electrical connections in:

- 90° lugs (lugs can rotate 360°)
- 90° splices
- T-lugs
- T-splices
- Countless connection possibilities using any straight or angled lug from 15° to 90° (lugs can rotate 360° for easy positioning)



Cat. No.	Wire Size (AWG)	Std. Pkg. Qty.
Flag Insulators		
F-INSUL-0	For #16-10 AWG	20/200
F-INSUL-1	For #8, #6 AWG	10/100
F-INSUL-2	For #4, #2, #1 AWG	6/60
F-INSUL-3	For 1/0, 2/0, 3/0, 4/0 AWG	3/30

Flag & Tee Kit Contents:

- Steel carrying case
- TBM45S crimp tool
- 25 each #8, #6 and #4 AWG flag bodies
- 25 each #8, #6 and #4 AWG one-hole lugs
- 10 each #2, #1, 1/0, 2/0, 3/0 and 4/0 AWG flag bodies
- 10 each #2, #1, 1/0, 2/0, 3/0 and 4/0 AWG one-hole lugs
- 50 size 1 flag insulators
- 45 size 2 flag insulators
- 40 size 3 flag insulators
- 10 each #8 and #6 AWG tee bodies
- 20 each #8 and #6 AWG two-way splices
- 6 each #4, #2 and #1 AWG tee bodies
- 12 each #4, #2 and #1 AWG two-way splices
- 3 each 1/0, 2/0, 3/0 and 4/0 AWG tee bodies
- 6 each 1/0, 2/0, 3/0 and 4/0 AWG two-way splices



Cat. No.	Description	Std. Pkg. Qty.
Flag and Tee Kit		
FLAGTEEKIT	Flag and Tee Kit	1

Connectors for Aluminum/Copper Code Conductors

One-Hole Lugs



Cat. No.	Cable Size Al-Cu	Bolt Size (in.)	Dimensions in. (mm)						Die Code	Colour Code
			A	B	C	D	E	F		
60096	#10	#10	1.09 (27.7)	0.56 (14.2)	0.41 (10.4)	0.06 (1.5)	0.27 (6.9)	0.22 (5.6)	21	Red
60097		1/4	1.31 (33.3)	0.72 (18.3)	0.43 (10.9)	0.07 (1.8)	0.27 (6.9)	0.34 (8.6)		
60099		3/8	1.53 (38.9)	0.93 (23.6)	0.58 (14.7)	0.06 (1.5)	0.27 (6.9)	0.44 (11.2)		
60101-TB	#8	#10	1.22 (31.0)	0.56 (14.2)	0.41 (10.4)	0.09 (2.3)	0.28 (7.1)	0.22 (5.6)	24	Blue
60102-TB		1/4	1.38 (35.1)	0.71 (18.0)	0.44 (11.2)	0.09 (2.3)	0.28 (7.1)	0.34 (8.6)		
60103-TB		5/16	1.56 (39.6)	0.91 (23.1)	0.60 (15.2)	0.06 (1.5)	0.28 (7.1)	0.44 (11.2)		
60104-TB	#6	3/8	1.60 (40.6)	0.93 (23.6)	0.60 (15.2)	0.06 (1.5)	0.28 (7.1)	0.44 (11.2)	29	Grey
60106-TB		#10	1.52 (38.6)	0.59 (15.0)	0.47 (11.9)	0.13 (3.3)	0.35 (8.9)	0.22 (5.6)		
60107-TB		1/4	1.67 (42.4)	0.75 (19.1)	0.47 (11.9)	0.13 (3.3)	0.35 (8.9)	0.34 (8.6)		
60108-TB	#4	5/16	1.83 (46.5)	0.91 (23.1)	0.63 (16.0)	0.09 (2.3)	0.35 (8.9)	0.44 (11.2)	37	Green
60109-TB		3/8	1.86 (47.2)	0.93 (23.6)	0.63 (16.0)	0.09 (2.3)	0.35 (8.9)	0.44 (11.2)		
60112-TB		1/4	1.81 (46.0)	0.75 (19.1)	0.64 (16.3)	0.19 (4.8)	0.46 (11.7)	0.34 (8.6)		
60113-TB	#2	5/16	2.00 (50.8)	0.91 (23.1)	0.64 (16.3)	0.19 (4.8)	0.46 (11.7)	0.44 (11.2)	42	Pink
60114-TB		3/8	2.03 (51.6)	0.93 (23.6)	0.64 (16.3)	0.19 (4.8)	0.46 (11.7)	0.44 (11.2)		
60116-TB		1/4	1.91 (48.5)	0.75 (19.1)	0.72 (18.3)	0.19 (4.8)	0.51 (13.0)	0.34 (8.6)		
60117-TB	#1	5/16	2.06 (52.3)	0.91 (23.1)	0.72 (18.3)	0.19 (4.8)	0.51 (13.0)	0.44 (11.2)	45	Gold
60118-TB		3/8	2.09 (53.1)	0.93 (23.6)	0.72 (18.3)	0.19 (4.8)	0.51 (13.0)	0.44 (11.2)		
60120		1/2	2.25 (57.2)	1.41 (35.8)	0.88 (22.4)	0.19 (4.8)	0.51 (13.0)	0.69 (17.5)		
60122	1/0	1/4	2.30 (58.4)	0.81 (20.6)	0.75 (19.1)	0.19 (4.8)	0.56 (14.2)	0.34 (8.6)	50	Tan
60123		5/16	2.39 (60.7)	0.91 (23.1)	0.75 (19.1)	0.19 (4.8)	0.56 (14.2)	0.44 (11.2)		
60124		3/8	2.42 (61.5)	0.93 (23.6)	0.75 (19.1)	0.19 (4.8)	0.56 (14.2)	0.44 (11.2)		
60126	2/0	1/2	2.89 (73.4)	1.41 (35.8)	0.88 (22.4)	0.16 (4.1)	0.56 (14.2)	0.69 (17.5)	54	Olive
60128		1/4	2.36 (59.9)	0.81 (20.6)	0.88 (22.4)	0.19 (4.8)	0.62 (15.7)	0.34 (8.6)		
60129		5/16	2.51 (63.8)	0.97 (24.6)	0.88 (22.4)	0.19 (4.8)	0.62 (15.7)	0.44 (11.2)		
60130	3/0	3/8	2.51 (63.8)	0.97 (24.6)	0.88 (22.4)	0.19 (4.8)	0.62 (15.7)	0.44 (11.2)	60	Ruby
60132		1/2	2.95 (74.9)	1.41 (35.8)	0.94 (23.9)	0.19 (4.8)	0.62 (15.7)	0.69 (17.5)		
60134		1/4	2.48 (63.0)	0.87 (22.1)	0.97 (24.6)	0.22 (5.6)	0.70 (17.8)	0.34 (8.6)		
60135	4/0	5/16	2.64 (67.1)	1.03 (26.2)	0.97 (24.6)	0.22 (5.6)	0.70 (17.8)	0.44 (11.2)	66	White
60136		3/8	2.64 (67.1)	1.03 (26.2)	0.97 (24.6)	0.22 (5.6)	0.70 (17.8)	0.44 (11.2)		
60138		1/2	3.10 (78.7)	1.41 (35.8)	1.03 (26.2)	0.22 (5.6)	0.70 (17.8)	0.69 (17.5)		
60140	250 kcmil	1/4	2.58 (65.5)	0.87 (22.1)	1.06 (26.9)	0.22 (5.6)	0.77 (19.6)	0.34 (8.6)	71	Red
60141		5/16	2.83 (71.9)	1.09 (27.7)	1.06 (26.9)	0.22 (5.6)	0.77 (19.6)	0.44 (11.2)		
60142		3/8	2.83 (71.9)	1.09 (27.7)	1.06 (26.9)	0.22 (5.6)	0.77 (19.6)	0.44 (11.2)		
60144	300 kcmil	1/2	3.15 (80.0)	1.41 (35.8)	1.06 (26.9)	0.22 (5.6)	0.77 (19.6)	0.69 (17.5)	76	Blue
60147		5/16	3.53 (89.7)	0.88 (22.4)	1.21 (30.7)	0.25 (6.4)	0.86 (21.8)	0.38 (9.7)		
60148		3/8	3.59 (91.2)	0.93 (23.6)	1.21 (30.7)	0.25 (6.4)	0.86 (21.8)	0.38 (9.7)		
60150	350 kcmil	1/2	3.90 (99.1)	1.25 (31.8)	1.21 (30.7)	0.25 (6.4)	0.86 (21.8)	0.50 (12.7)	87	Brown
60151		5/8	4.65 (118.1)	2.00 (50.8)	1.21 (30.7)	0.25 (6.4)	0.86 (21.8)	0.75 (19.0)		
60154		3/8	3.73 (94.7)	0.93 (23.6)	1.29 (32.8)	0.27 (6.9)	0.92 (23.4)	0.38 (9.7)		
60156	400 kcmil	1/2	4.05 (102.9)	1.25 (31.8)	1.29 (32.8)	0.27 (6.9)	0.92 (23.4)	0.50 (12.7)	94	Green
60157		5/8	4.80 (121.9)	2.00 (50.8)	1.29 (32.8)	0.27 (6.9)	0.92 (23.4)	0.75 (19.0)		
60159		5/16	3.75 (95.3)	0.88 (22.4)	1.39 (35.3)	0.28 (7.1)	0.99 (25.1)	0.38 (9.7)		
60160	500 kcmil	3/8	3.80 (96.5)	0.93 (23.6)	1.39 (35.3)	0.28 (7.1)	0.99 (25.1)	0.38 (9.7)	99	Pink
60162		1/2	4.13 (104.9)	1.25 (31.8)	1.39 (35.3)	0.28 (7.1)	0.99 (25.1)	0.50 (12.7)		
60165		5/8	4.83 (122.7)	1.25 (31.8)	1.53 (38.9)	0.33 (8.4)	1.09 (27.7)	0.50 (12.7)		
60166	600 kcmil	5/8	5.58 (141.7)	2.00 (50.8)	1.53 (38.9)	0.33 (8.4)	1.09 (27.7)	0.75 (19.0)	106	Black
60168		1/2	4.95 (125.7)	1.25 (31.8)	1.65 (41.9)	0.38 (9.7)	1.18 (30.0)	0.50 (12.7)		
60171		1/2	4.95 (125.7)	1.25 (31.8)	1.79 (45.5)	0.38 (9.7)	1.28 (32.5)	0.50 (12.7)		
60172	700 kcmil	5/8	5.70 (144.8)	2.00 (50.8)	1.79 (45.5)	0.38 (9.7)	1.28 (32.5)	0.75 (19.0)	112	Purple
60174		5/8	5.83 (148.1)	2.00 (50.8)	1.92 (48.8)	0.37 (9.4)	1.36 (34.5)	0.75 (19.0)		
60176		5/8	5.95 (151.1)	2.00 (50.8)	2.04 (51.8)	0.38 (9.7)	1.44 (36.6)	0.75 (19.0)		
60178	750 kcmil	5/8	6.03 (153.2)	2.00 (50.8)	2.13 (54.1)	0.40 (10.2)	1.50 (38.1)	0.75 (19.0)	115	Yellow
60184		5/8	6.78 (172.2)	2.00 (50.8)	2.50 (63.5)	0.50 (12.7)	1.77 (45.0)	0.75 (19.0)		

Material: High-Conductivity Wrought Aluminum

Finish: Electro-Tin Plated

Designed and approved for use with both aluminum and copper conductors

- For 90°C certified to 600 V and recommended up to 35 kV ¥ applications
- Easily matched to the correct Color-Keyed® installing die for positive compressions
- Hardened steel dies compress connector around cable, changing round strands to polygonal shapes and cold flowing strands and connector into a solid, homogenous mass
- Long compression areas ensure complete contact
- Multiple compressions prevent creep of aluminum conductors
- Filled with high-temperature oxide-inhibitor compound
- Electro-tin plated prevents electrolytic corrosion of copper to ensure lowest contact resistance

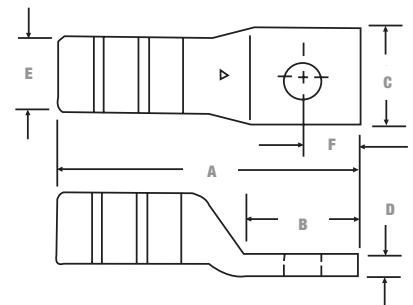

¥ For installations from 16 kV up to 35 kV, consult shielded cable manufacturers for stress relief and insulation requirements.

Tooling: pp. E4-E62

Die Selector Chart: pp. E35-E50



Connectors for Aluminum/Copper Code Conductors

Two-Hole Lugs



Material: High-Conductivity Wrought Aluminum

Finish: Electro-Tin Plated

Designed and approved for use with both aluminum and copper conductors

- For 90°C certified to 600 V and recommended up to 35 kV ¥ applications
- For aluminum and copper concentric conductors and compact code aluminum strandings
- Filled with oxide-inhibitor compound

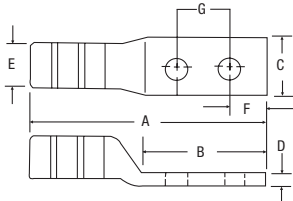

Cat. No.	Cable Size	Bolt Size (in.)	Dimensions in. (mm)							Die Code	Colour Code
			A	B	C	D	E	F	G		
60230	1/0 AWG	3/8	3.50 (88.9)	1.90 (48.3)	0.88 (22.4)	0.19 (4.8)	0.62 (15.7)	0.38 (9.7)	1.00 (25.4)	50	Tan
60236	2/0 AWG	3/8	3.50 (88.9)	1.90 (48.3)	0.97 (24.6)	0.22 (5.6)	0.70 (17.8)	0.38 (9.7)	1.00 (25.4)	54	Olive
60238		1/2	5.03 (127.8)	3.41 (86.6)	0.97 (24.6)	0.22 (5.6)	0.70 (17.8)	0.75 (19.1)	1.75 (44.5)		
60242	3/0 AWG	3/8	3.66 (93.0)	1.18 (30.0)	1.06 (27.0)	0.22 (5.6)	0.77 (19.6)	0.38 (9.7)	1.00 (25.4)	60	Ruby
60244		1/2	5.16 (131.1)	3.41 (86.6)	0.06 (1.5)	0.22 (5.6)	0.77 (19.6)	0.75 (19.1)	1.75 (44.5)		
60248	4/0 AWG	3/8	4.58 (116.3)	1.18 (30.0)	1.21 (30.7)	0.25 (6.4)	0.86 (21.8)	0.38 (9.7)	1.00 (25.4)	66	White
60250		1/2	5.65 (143.5)	3.41 (86.6)	1.21 (30.7)	0.25 (6.4)	0.86 (21.8)	0.50 (12.7)	1.75 (44.5)		
60254	250 kcmil	3/8	4.73 (120.1)	1.93 (49.0)	1.29 (32.8)	0.27 (6.9)	0.92 (23.4)	0.38 (9.7)	1.00 (25.4)	71	Red
60256		1/2	5.80 (147.3)	3.00 (76.2)	1.29 (32.8)	0.27 (6.9)	0.92 (23.4)	0.50 (12.7)	1.75 (44.5)		
60260	300 kcmil	3/8	4.80 (121.9)	1.93 (49.0)	1.39 (35.3)	0.28 (7.1)	0.99 (25.1)	0.38 (9.7)	1.00 (25.4)	76	Blue
60262		1/2	5.88 (149.4)	3.00 (76.2)	1.39 (35.3)	0.28 (7.1)	0.99 (25.1)	0.50 (12.7)	1.75 (44.5)		
60265	350 kcmil	3/8	5.50 (139.7)	1.93 (49.0)	1.53 (38.9)	0.33 (8.4)	1.09 (27.7)	0.38 (9.7)	1.00 (25.4)	87	Brown
60267		1/2	6.58 (167.1)	3.00 (76.2)	1.53 (38.9)	0.33 (8.4)	1.09 (27.7)	0.50 (12.7)	1.75 (44.5)		
60268	400 kcmil	3/8	5.63 (143.0)	1.93 (49.0)	1.65 (41.9)	0.38 (9.7)	1.18 (30.0)	0.38 (9.7)	1.00 (25.4)	94	Green
60269		1/2	6.70 (170.2)	3.00 (76.2)	1.65 (41.9)	0.38 (9.7)	1.18 (30.0)	0.50 (12.7)	1.75 (44.5)		
60271	500 kcmil	3/8	5.63 (143.0)	1.93 (49.0)	1.79 (45.5)	0.38 (9.7)	1.28 (32.5)	0.38 (9.7)	1.00 (25.4)	99	Pink
60273		1/2	6.70 (170.2)	3.00 (76.2)	1.79 (45.5)	0.38 (9.7)	1.28 (32.5)	0.50 (12.7)	1.75 (44.5)		
60274	600 kcmil	3/8	5.75 (143.1)	1.93 (49.0)	1.92 (48.8)	0.37 (9.4)	1.36 (34.5)	0.38 (9.7)	1.00 (25.4)	106	Black
60275		1/2	6.83 (173.5)	3.00 (76.2)	1.92 (48.8)	0.37 (9.4)	1.36 (34.5)	0.50 (12.7)	1.75 (44.5)		
60276	700 kcmil	3/8	5.88 (149.4)	1.93 (49.0)	2.04 (51.8)	0.38 (9.7)	1.44 (36.6)	0.38 (9.7)	1.00 (25.4)	112	Purple
60277		1/2	6.95 (176.5)	3.00 (76.2)	2.04 (51.8)	0.38 (9.7)	1.44 (36.6)	0.50 (12.7)	1.75 (44.5)		
60278	750 kcmil	1/2	7.15 (181.6)	3.00 (76.2)	2.13 (54.1)	0.40 (10.2)	1.50 (38.1)	0.50 (12.7)	1.75 (44.5)	115	Yellow
60284	1000 kcmil	1/2	7.78 (197.6)	3.00 (76.2)	2.50 (63.5)	0.50 (12.7)	1.77 (45.0)	0.50 (12.7)	1.75 (44.5)	140	—

Bolt holes 3/8 in. on 1 in. centers, 1/2 in. on 1-3/4 in. centers.

¥ For installations from 16 kV up to 35 kV, consult shielded cable manufacturers for stress relief and insulation requirements.

Tooling: pp. E4–E62

Die Selector Chart: pp. E35–E50

Range-Taking Narrow-Tongue Single-Barrel Lugs

- For 90°C certified to 600 V and recommended up to 35 kV ¥ applications
- 1-1/2 in. wide tongues
- Bolt holes on 1-3/4 in. centers
- Wire barrel factory-filled with oxide-inhibitor compound

Material: Aluminum

Finish: Tin-Plated



Cat. No.	Al-Cu Cable Size	Bolt Size (in.)	No. of compression		Dimensions in. (mm)				Hex Die No.	Colour Code
			TBM12M	13642, TBM15	A	B	C	D		
60273N	350–500 kcmil	1/2	4	4	6.88 (174.8)	3.13 (79.5)	1.28 (32.5)	0.41 (10.4)	99H	Pink
60278N	500–750 kcmil		—		7.13 (181.1)	3.69 (93.7)	1.50 (38.1)	0.50 (12.7)	115H	Yellow

¥ For installations from 16 kV up to 35 kV, consult shielded cable manufacturers for stress relief and insulation requirements.

Tooling: pp. E4–E62

Die Selector Chart: pp. E35–E50

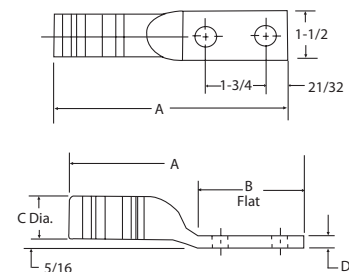

Connectors for Aluminum/Copper Code Conductors

Two-Way Splice Connectors



Cat. No.	Cable Size	Dimensions in. (mm)		Die Code	Colour Code
		A	E		
60500-TB	10 Str.	1.00 (25.4)	0.27 (6.9)	21	Red
60501-TB	8 Str.	1.19 (30.2)	0.28 (7.1)	24	Blue
60507-TB	6 Str.	1.63 (41.4)	0.35 (8.9)	29	Grey
60512	4 Str.	1.81 (46.0)	0.46 (11.7)	37	Green
60516	2 Str./3 Str.	1.81 (46.0)	0.51 (13.0)	42	Pink
60522-TB	1 Str.	2.38 (60.5)	0.56 (14.2)	45	Gold
60530-TB	1/0	2.38 (60.5)	0.62 (15.7)	50	Tan
60536	2/0	2.50 (63.5)	0.70 (17.8)	54	Olive
60542	3/0	2.81 (71.4)	0.77 (19.6)	60	Ruby
60548	4/0	3.66 (93.0)	0.86 (21.8)	66	White
60554	250 kcmil	3.91 (99.3)	0.92 (23.4)	71	Red
60560	300 kcmil	3.97 (100.8)	0.99 (25.1)	76	Blue
60565	350 kcmil	4.97 (126.2)	1.09 (27.7)	87	Brown
60568	400 kcmil	4.97 (126.2)	1.18 (30.0)	94	Green
60571	500 kcmil	4.97 (126.2)	1.28 (32.5)	99	Pink
60574	600 kcmil	5.22 (132.6)	1.36 (34.5)	106	Black
60576	700 kcmil	5.44 (138.2)	1.44 (36.6)	112	Purple
60578	750 kcmil	5.69 (144.5)	1.50 (38.1)	115	Yellow
60584	1000 kcmil	6.69 (169.9)	1.77 (45.0)	140	-

For aluminum-to-copper or aluminum-to-aluminum splicing

- Connectors are pre-filled with oxide-inhibitor
- For 90°C certified to 600 V and recommended up to 35 kV ¥ applications
- For aluminum and copper concentric conductors and compact code aluminum strandings
- Permit aluminum conductors to be spliced to copper or aluminum conductors

Material: High-Conductivity Wrought Aluminum

Finish: Electro-Tin Plated

¥ For installations from 16 kV up to 35 kV, consult shielded cable manufacturers for stress relief and insulation requirements.
Tooling: pp. E4–E62
Die Selector Chart: pp. E35–E50

Aluminum Reducing Connectors

Splice aluminum conductors to copper conductors of equal ampacities



Cat. No.	Cable Size		Dimensions in. (mm)		Die Code	Colour Code
	Al	Cu	A	E		
60905-TB	8	10	0.81 (20.6)	0.28 (7.1)	24	Blue
60910	6	8	1.63 (41.4)	0.34 (8.6)	29	Grey
60915	4	6	1.81 (46.0)	0.44 (11.2)	37	Green
60925	1	3	2.38 (60.5)	0.53 (13.5)	45	Gold
60930	1/0	2	2.38 (60.5)	0.63 (16.0)	50	Tan
60935	2/0	1	2.50 (63.5)	0.69 (17.5)	54	Olive
60940	3/0	1/0	2.81 (71.4)	0.75 (19.1)	60	Ruby
60945	4/0	2/0	3.75 (95.3)	0.88 (22.4)	66H	White
60950	250 kcmil	3/0	4.00 (101.6)	0.94 (23.9)	71H	Red
60955	300 kcmil	4/0	4.06 (103.4)	1.00 (25.4)	76H	Blue
60960	350 kcmil	4/0	5.06 (128.5)	0.09 (2.3)	87H	Brown
60965	400 kcmil	250 kcmil	5.06 (128.5)	1.22 (31.0)	94H	Green
60970	500 kcmil	350 kcmil	5.06 (128.5)	1.31 (33.3)	99H	Pink
60975	600 kcmil	400 kcmil	5.31 (134.9)	1.34 (34.0)	106H	Black
60980	700 kcmil	500 kcmil	5.56 (141.2)	1.44 (36.6)	112H	Purple
60985	750 kcmil	500 kcmil	5.81 (147.6)	1.50 (38.1)	115H	Yellow

¥ For installations from 16 kV up to 35 kV, consult shielded cable manufacturers for stress relief and insulation requirements.
Die Selector Chart: pp. E35–E50



Material: High-Conductivity Wrought Aluminum

Finish: Electro-Tin Plated

Installing Tools:

- TBM5(S) #10 AWG – 4/0 AWG
- TBM6(S) #10 AWG – 350 kcmil
- TBM8(S) #10 AWG – 350 kcmil

- For 90°C, certified to 600 V and recommended up to 35 kV ¥ applications
- Filled with high-temperature oxide-inhibitor compound
- Designed for the right combination of equivalent sizes (example: 4/0 aluminum to 2/0 copper)
- Selection table gives aluminum/copper equivalents to all sizes

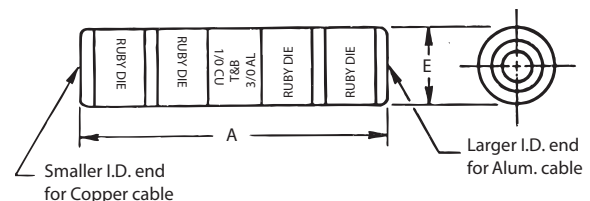

Connectors for Aluminum/Copper Code Conductors

One-Hole Aluminum Compact-Size Equipment Lugs



Much smaller than standard aluminum lugs for the same cable size

- For 90°C, certified 600 V applications
- For use with aluminum cables only
- Can be directly substituted for equipment mechanical lugs in most applications
- Only 7 dies handle all 14 lug sizes
- Factory-filled with joint compound
- Electro-Tin Plated
- Supplied with Neoprene insulating covers

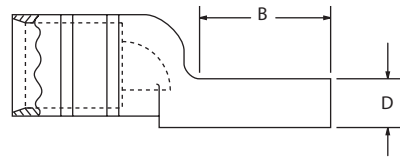
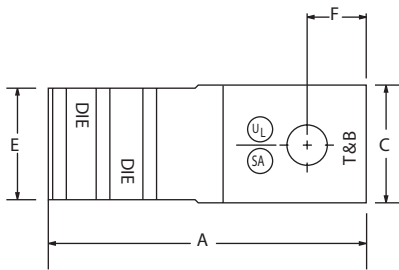

Cat. No.	Aluminum Cable Size	Aluminum Range-Taking*	Bolt Hole (in.)	Dimensions in. (mm)						
				A	B	C	D	E	F	
61102	#8	-	1/4	1.33 (33.8)	0.54 (13.7)	0.50 (12.7)	0.14 (3.6)	0.37 (9.4)	0.25 (6.4)	
61107	#6			1.33 (33.8)	0.54 (13.7)	0.50 (12.7)	0.14 (3.6)	0.37 (9.4)	0.25 (6.4)	
61112	#4			1.33 (33.8)	0.54 (13.7)	0.50 (12.7)	0.14 (3.6)	0.37 (9.4)	0.25 (6.4)	
61116	#2			1.75 (44.5)	0.68 (17.3)	0.55 (14.0)	0.20 (5.1)	0.48 (12.2)	0.25 (6.4)	
61122	#1	#8-1/0	3/8	1.75 (44.5)	0.68 (17.3)	0.55 (14.0)	0.20 (5.1)	0.48 (12.2)	0.25 (6.4)	
61130	1/0			2.00 (50.8)	0.83 (21.1)	0.64 (16.3)	0.20 (5.1)	0.57 (14.5)	0.38 (9.7)	
61136	2/0			#1-2/0	2.00 (50.8)	0.83 (21.1)	0.64 (16.3)	0.20 (5.1)	0.57 (14.5)	0.38 (9.7)
61142	3/0			-	2.50 (63.5)	1.08 (27.4)	0.78 (19.8)	0.23 (5.8)	0.70 (17.8)	0.38 (9.7)
61148	4/0	2/0-4/0	1/2	2.50 (63.5)	1.08 (27.4)	0.78 (19.8)	0.23 (5.8)	0.70 (17.8)	0.38 (9.7)	
61156	250 kcmil	-		2.50 (63.5)	1.23 (31.2)	0.98 (24.9)	0.25 (6.4)	0.85 (21.6)	0.50 (12.7)	
61162	300 kcmil	#4-300		2.50 (63.5)	1.23 (31.2)	0.98 (24.9)	0.25 (6.4)	0.85 (21.6)	0.50 (12.7)	
61165	350 kcmil	250-350		3.25 (82.6)	1.23 (31.2)	1.20 (30.5)	0.41 (10.4)	1.04 (26.4)	0.56 (14.2)	
61171	500 kcmil	2/0-500	5/8	3.25 (82.6)	1.23 (31.2)	1.20 (30.5)	0.41 (10.4)	1.04 (26.4)	0.56 (14.2)	
61178	750 kcmil	500-750		3.75 (95.3)	1.54 (39.1)	1.49 (37.8)	0.41 (10.4)	1.33 (33.8)	0.81 (20.6)	

*For range-taking capability, use TBM8-750/TBM8-750M-1 Smart™ Tools.

Tooling: pp. E4–E62

Die Selector Chart: pp. E35–E50

Transformer Lug Kits for Aluminum Code Conductors

Transformer Lug Kits

Everything you need to connect to a transformer in one convenient kit!

- For 90°C, certified 600 V applications
- For use with aluminum cables only
- Include all necessary range-taking compression or mechanical type lugs and bolting hardware to connect to designated transformers
- Lugs pre-filled



Transformer		Terminal Lugs			Kit Contents						Std. Pkg.
KVA Size	KIT Cat. No.	Al Cable Range*		Qty.	Nuts	Qty.	Bolts	Qty.	Washers	Qty.	
Compression Lugs											
15 – 37-1/2 1Ø	611CL-SK1	#8-1/0 Al	Color-Keyed® Compression Equipment Lugs	8		8	1/4-20 x 1 in.	8	Flat 1/4 in. Spring 1/4 in.	8	1
15 – 45 3Ø		#4-300 kcmil		4		–	–				
50 – 75 1Ø	611CL-SK2	#4-300 kcmil Al		12	1/4-20	16	1/4-20 x 1 in.	3	Flat 3/8 in. Spring 3/8 in.	16	
75 – 112-1/2 3Ø				3		3	1/4-20 x 2 in.			3	
100 – 167 1Ø	611CL-SK3	#2/0-500MM Al		22	3/8-16	16	3/8-16 x 2 in.	16	Flat 3/8 in. Spring 3/8 in.	16	
150 – 300 3Ø				3		3	1/4-20 x 1 in.			3	
100 – 167 1Ø	611CL-SK3-500	#4-300 kcmil Al		22	3/8-16	16	3/8-16 x 2 in.	16	Flat 1/4 in. Spring 1/4 in.	16	
150 – 300 3Ø		#2/0-500 kcmil Al		3		3				3	
150 – 300 3Ø	611CL-SK4	#500-750 kcmil Al	29		18				16		
500 3Ø		18	18		18						
Mechanical Lugs											
15 – 37-1/2 1Ø	622ML-SK1	#14-2	Mechanical Lugs	8		8	1/4-20 x 3/4 in.	8	Flat 1/4 in. Spring 1/4 in.	8	1
15 – 45 3Ø		4		–		–					
50 – 75 1Ø	622ML-SK2	#6-250		12	1/4-20	16	1/4-20 x 1/4 in.	3	Flat 3/8 in. Spring 3/8 in.	16	
75 – 112-1/2 3Ø				3		3	1/4-20 x 1-3/4 in.			3	
100 – 167 1Ø	622ML-SK3	350-800		22	3/8-16	16	3/8-16 x 2 in.	16	Flat 1/4 in. Spring 1/4 in.	16	
150 – 300 3Ø				29		18				18	
500 3Ø	622ML-SK4			18		18				18	
				18		18					

*To ensure proper range-taking compression on Color-Keyed® equipment lugs, use Smart™ Tools (Cat. Nos. TBM8-750/TBM8-750M-1).

Tooling: pp. E4–E62

Die Selector Chart: pp. E35–E50



Pin Connectors for Aluminum/Copper Code Conductors

Bi-Pin® Bi-Metal Pin Connectors

Converts an aluminum cable into a two-sizes-smaller copper pigtail

- For 90°C, certified 600 V applications
- Upgrade connection by eliminating cold flow and oxidation of aluminum
- Reduces oversized aluminum cable
- Enables termination of aluminum cable into a copper-only lug
- Barrel pre-filled with joint compound

Material: Copper Wire/Aluminum Body

Finish: Electro-Tin Plated

Insulation: Neoprene (600 V dielectric rating)



Cat. No. Insulating Covers	Cat. No. Heat Shrink Covers	Aluminum Cable Size	Copper Wire Size	Body Length after installing (in.)	Die Code No.	Colour Code
61905A	61905AT	8 AWG	10 AWG	1.88	24	Blue
61910A	61910AT	6 AWG	8 AWG	1.88		
61915A	61915AT	4 AWG	6 AWG	1.56	45	Gold
61920A	61920AT	2 AWG	4 AWG	1.56		
61925A	61925AT	1 AWG	3 AWG	1.63	50	Orange
61930A	61930AT	1/0 AWG	2 AWG	1.63		
61935	61935T	2/0 AWG	1 AWG	1.94	60	Ruby
61940	61940T	3/0 AWG	1/0 AWG	2.13		
61945	61945T	4/0 AWG	2/0 AWG	2.13	66	White
61950	61950T	250 kcmil	3/0 AWG	2.19		
61955	61955T	300 kcmil	4/0 AWG	2.50	71H	Red
61960	61960T	350 kcmil	250 kcmil	2.50		
61963	61963T	400 kcmil	250 kcmil	3.75	87H	Brown
61965	61965T	500 kcmil	350 kcmil	3.75		
61970	61970T	600 kcmil	400 kcmil	3.75	107H	Orange
61975	61975T	700-750 kcmil	500 kcmil	3.75		

Hand Tools – Smart™ Tools.
 Tooling: pp. E4–E62
 Die Selector Chart: pp. E35–E50

Pin Connectors for Aluminum/Copper Code Conductors

Bi-Pin® Bi-Metal Pin Connectors

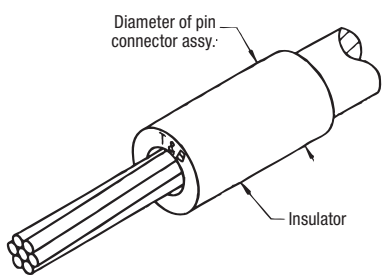
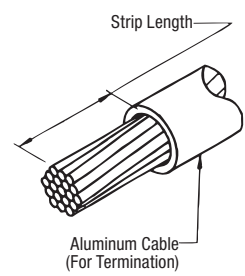
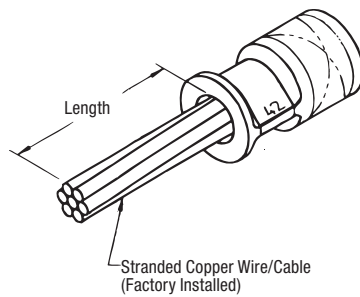
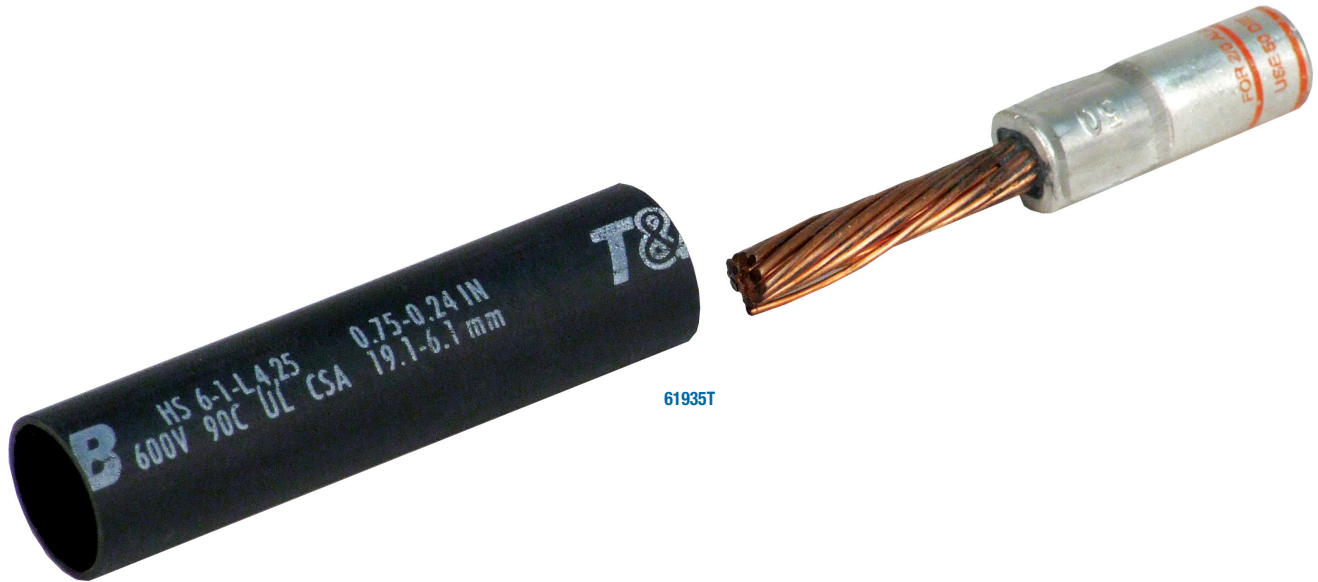

Connector Installed with Insulator

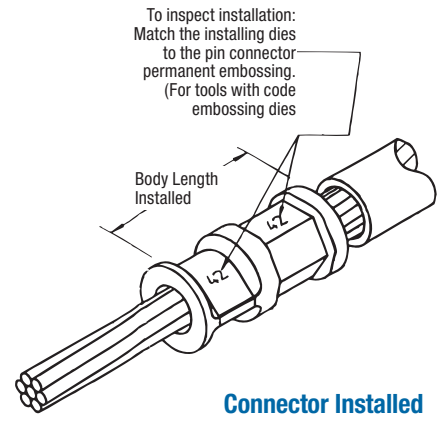

Connector Installed

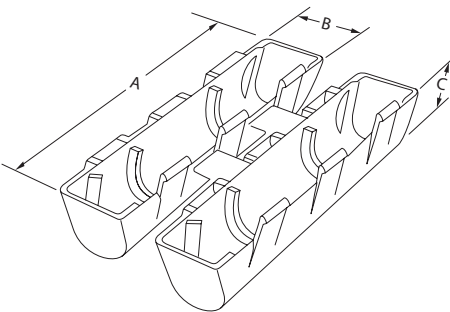
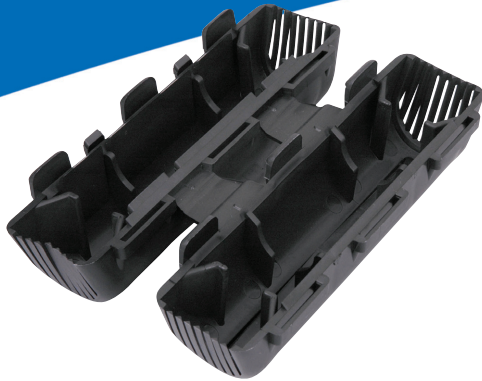

(C) Height – typical both halves

Insulating Covers for H-Type Compression Taps

Interlocking Insulating Soft Covers

Quick and easy insulation for H-type compression taps

- Ideal for pigtail, 2-way splicing or tapping to an unbroken continuous main
- Insulation covers are not reusable

Technical Specifications

- Material: Flame-Retardant, High-Impact Polypropylene
- Colour: Black
- Voltage Rating: 600 V max.
- Temperature: 90°C



Cat. No.	Wire Range		Al H-Taps	Use to Insulate	Dimensions in. (mm)			"A" Dim.	"B" Dim.
	Max.	Min.			A	B	C		
HT20C	2/0	6	63110/63115 63125/63120	-	4.50 (114.3)	1.25 (31.8)	1.12 (28.4)	-	-
HT40C	4/0		63140 63148		5.60 (142.2)	1.40 (35.6)	1.18 (30.0)		
HT600C	500 kcmil	2	63160	63169	6.81 (173.0)	2.12 (53.8)	1.60 (40.6)		
HT1000C	1000 kcmil to 500 kcmil	250 kcmil to 1/0 AWG	63180	-	-	-	-	[184.15MM] 7.250	2.330 +0.060
HT1000C-L		250 kcmil to 250 kcmil	63170		[263.40MM] 10.374				

Insulating Covers for H-Type Compression Taps

Insulating Hard Covers

- For indoor use in splice boxes and trays
- Easy to use – simply place H-Tap in cover and snap cover closed
- Consult your Regional Sales Office for available flame-retardant version
- Hard shell outer covers guard inner seal, keep out dust
- Installs quickly and easily without special tools – simply snaps together
- Eliminate time-consuming taping
- Provide high-quality, neat, uniform installations
- Range-taking design reduces inventory

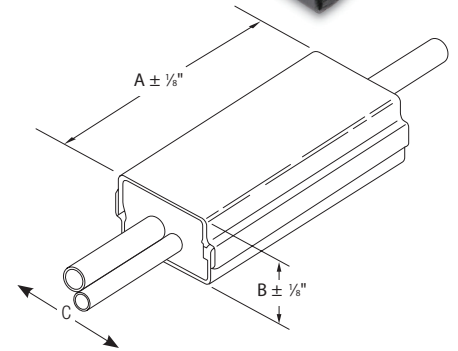

Cat. No.	Dimensions in. (mm)		
	A (Length)	B (Thick)	C (Width)
HTC2S	2.00 (50.8)	1.12 (28.4)	1.43 (36.3)
HTC2	3.50 (88.9)	1.12 (28.4)	1.43 (36.3)
HTC40	4.25 (108.0)	1.56 (39.6)	2.00 (50.8)
HTC40L2	5.75 (146.1)	1.56 (39.6)	2.00 (50.8)
HTC500	6.00 (152.4)	1.75 (44.5)	2.75 (69.9)
HTC1000	7.00 (177.8)	2.38 (60.5)	3.88 (98.6)
HTC1000L	10.00 (25.4)	2.38 (60.5)	3.88 (98.6)

Interlocking insulating covers for "H" type compression taps. For use in splice boxes, indoors or in tray indoors. Place the H-Tap in the cover and snap the cover closed. Consult your Regional Sales Office for flame-retardant version.

Technical Data: HTC2 and HTC2S use insulation wrap instead of end cushions for inner seal. Connector Cat. Nos. 54755 through 54790 and 63148 through 63180 require hydraulic crimping tools. Refer to instruction sheet.

Materials:
Outer Hard Shell Covers – High Impact Black Thermoplastic (Noryl), flammability Class, UL 94V-1.
Inner seal – Black neoprene sponge soft closed cell, oxygen index 28% UL 94 HBF.

Temperature Rating – 90°C maximum.

Certified Voltage Rating – 600 V maximum.

NOTE: Insulation covers are not reusable.

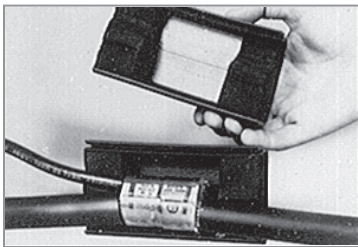

These insulating covers provide hard shell insulated protection for "H" type compression taps and splices and because there is no taping required, you get uniform quality and appearance each time.

The exclusive locking design provides the range-taking capability. Only five H-Tap insulating catalogue cover numbers accommodate the range of 6 AWG – 1000 kcmil in the main and 12 AWG – 500 kcmil in the branch.

For H-Tap Applications

Cat. No.	Al H-Taps	Cu H-Taps
HTC2	63105	–
HTC2S	–	CHT814-10
HTC40	63110	CHT214-9
	63118	CHT250214-8
	63125	CHT2514-7
	63140	CHT2502-6
	63148	CHT50010-5/CHT50040-4
HTC500	63160	CHT75010-3/CHT750350-2
HTC1000L	63170	–
HTC1000	63180/63169	CHT750350-1F

For C-Tap Applications

Cat. No.	C-Taps	Colour Code
HTC40	54720	Brown
	54725	Green
	54730	Pink
	54755	Blue
	54760	Brown
HTC40L2	54735	Black
	54740	Orange
	54745	Purple
	54750	Yellow
	54765	Pink
HTC500	54770	Black
	54775	Yellow
	54780	White
	54785	–
HTC1000	54790	–



Parallel Splices

Ideal for Use in Transformer and Motor/Turbine Windings!

Color-Keyed® Parallel Splices offer conductor-splicing solutions for hundreds of OEM, utility and communications applications. They're especially well suited for use in the manufacturing, repair and servicing of windings for transformers, motors, generators and turbines. Rely on them for excellent reliability, long-term performance and a CSA certified connection at a low-installed cost.

- Accommodate multiple wire sizes from 22 AWG to 500 kcmil for application flexibility
- Simple extruded-tube design for ease of use
- Chamfered barrel ends eliminate high-voltage corona and partial discharge failures
- Easy to install with standard compression crimp tools
- 99.9% pure copper for low resistance and high conductivity – tin-plated for corrosion resistance
- Certified for 600 V

Tools

Cat. No.	Tools
540008	WT-115A, TBM8-750MI, TBM8-780BSCR
540006	TBM8-780M-I, TBM*-750BSCR, ERG2008 (6 AWG die)
540700	TBM8-750M-1, TBM*-750BSCR
540800 – 540900	TBM15I with die 15600X and 15615X
541000	TBM15I with die 15600X and 15604X



Cat. No.	Min. Wire Range (AWG)	Max. Wire Range (AWG)	Cir. Mil Range*	Length (in.)	O.D. (in.)	I.D. (in.)	Std. Pkg.
540008	#10 & #14	(2) #10	13,000–20,800	0.375	0.260	0.180	5000
540006	(2) #10 & #14	(2) #10 & (3) #14	20,800–33,100	0.500	0.365	0.266	
540004	(2) #8 & #14	(2) #6	33,100–52,600	0.531	0.410	0.302	2500
540002	(3) #8 & #14	(2) #4	52,600–83,700	0.640	0.521	0.396	
540010	(6) #8	(2) #4 & (1) #6	83,700–119,500	0.750	0.571	0.446	1000
540020	(3) #4	#1 & #2	119,500–150,500	0.750	0.632	0.507	
540030	(4) #4	(2) #1 & (2) #10	150,500–190,000	0.750	0.701	0.564	500
540040	(3) #2	1/0 & (3) #4	190,000–231,100	0.770	0.766	0.629	
540250	3/0 & (4) #8	3/0 & (8) #8	231,100–300,000	1.063	0.926	0.749	250
540300	2/0 & (4) #4	300 & (3) #6	300,000–380,000	1.125	1.100	0.882	100
540400	250 & (5) #6	4/0 & (4) #2	380,000–478,000	1.250	1.200	0.956	
540500	400 & (3) #6	250 & (13) #6	478,000–600,000	1.438	1.330	1.060	50
540600	(2) 2/0 & (2) 3/0	(2) 4/0 & (2) 2/0	601,800–689,400	1.500	1.500	1.187	60
540700	350, 4/0 & 1/0	(3) 4/0 & (1) 1/0	667,100–740,300	1.531	1.550	1.253	
540800	(7) 1/0	250, (2) 3/0 & (2) 2/0	738,500–851,800	1.562	1.650	1.353	
540900	500 & 350	(2) 350 & (1) 250	850,000–950,000	1.625	1.750	1.453	30
541000	(2) 350 & (1) 250	(2) 500 & (1) 3/0	950,000–1,167,800	1.625	1.875	1.578	

* The total combined cross-sectional area of all wires must be within the circular mil range for the splice.

Heavy-Duty Battery Connectors and Tools

Tin-Plated Straight Battery Connectors



Cat. No.	BULK Cat. No.	SAE Cable Size	Description	I.D.	O.D.	Pkg. Qty.	Bulk Pkg. Qty.	Colour Code
BAC4SUBT	BAC4SUBT-C	4 Gauge	Straight Universal	0.261	0.430	5	100	Grey
BAC2SUBT	BAC2SUBT-C	2 Gauge		0.340	0.550			Green
BAC1SUBT	BAC1SIBT-C	1 Gauge		0.340	0.550			Pink
BAC10SUBT	BAC10SUBT-C	1/0 Gauge		0.455	0.625			Black
BAC20SUBT	BAC20SUBT-C	2/0 Gauge		0.502	0.676			Orange
BAC30SUBT	BAC30SUBT-C	3/0 Gauge		0.530	0.730			Purple
BAC40SUBT	BAC40SUBT-C	4/0 Gauge	0.600	0.844	Yellow			
BAC4SPBT	BAC4SPBT-C	4 Gauge	Straight Positive	0.261	0.430			Grey
BAC4SNBT	BAC4SNBT-C		Straight Negative	0.261	0.430			Grey
BAC2SPBT	BAC2SPBT-C	2 Gauge	Straight Positive	0.340	0.550			Green
BAC2SNBT	BAC2SNBT-C		Straight Negative	0.340	0.550	Green		
BAC1SPBT	BAC1SPBT-C	1 Gauge	Straight Positive	0.340	0.550	Pink		
BAC1SNBT	BAC1SNBT-C		Straight Negative	0.340	0.550	Pink		
BAC10SPBT	BAC10SPBT-C	1/0 Gauge	Straight Positive	0.455	0.625	Black		
BAC10SNBT	BAC10SNBT-C		Straight Negative	0.455	0.625	Black		
BAC20SPBT	BAC20SPBT-C	2/0 Gauge	Straight Positive	0.502	0.676	Orange		
BAC20SNBT	BAC20SNBT-C		Straight Negative	0.502	0.676	Orange		
BAC30SPBT	BAC30SPBT-C	3/0 Gauge	Straight Positive	0.530	0.730	Purple		
BAC30SNBT	BAC30SNBT-C		Straight Negative	0.530	0.730	Purple		
BAC40SPBT	BAC40SPBT-C	4/0 Gauge	Straight Positive	0.600	0.844	Yellow		
BAC40SNBT	BAC40SNBT-C		Straight Negative	0.600	0.844	Yellow		

Material: High-Conductivity Copper

Finish: Electro-Tin Plated

Installing

Tools: TBM5-SV, TBM5V, TBM8250S

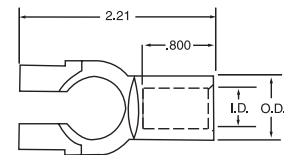
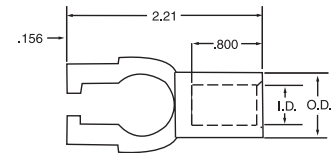

Material: High-Conductivity Copper

Finish: Electro-Tin Plated

Installing

Tools: TBM5-SV, TBM5V

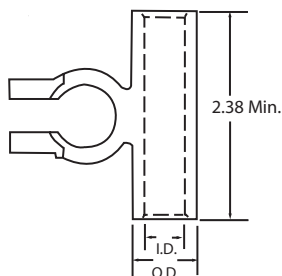

Tin-Plated Flag Battery Connectors

Cat. No.	BULK Cat. No.	SAE Cable Size	Description	I.D.	O.D.	Pkg. Qty.	Bulk Pkg. Qty.	Colour Code
BAC10FU	BAC10FNBL	1/0 Gauge	Flag Universal	0.455	0.625	5	100	Black
BAC20FU	BAC20FNBL	2/0 Gauge		0.502	0.676			Orange
BAC30FU	BAC30FNBL	3/0 Gauge		0.530	0.730			Purple
BAC40FU	BAC40FNBL	4/0 Gauge		0.600	0.844			Yellow
BAC10FPBT	BAC10FPBT-C	1/0 Gauge	Flag Positive	0.455	0.625			Black
BAC10FNBT	BAC10FNBT-C	2/0 Gauge	Flag Negative	0.455	0.625			Black
BAC20FPBT	BAC20FPBT-C		Flag Positive	0.502	0.676			Orange
BAC20FNBT	BAC20FNBT-C	3/0 Gauge	Flag Negative	0.502	0.676			Orange
BAC30FPBT	BAC30FPBT-C		Flag Positive	0.530	0.730			Purple
BAC30FNBT	BAC30FNBT-C	4/0 Gauge	Flag Negative	0.530	0.730			Purple
BAC40FPBT	BAC40FPBT-C		Flag Positive	0.600	0.844	Yellow		
BAC40FNBT	BAC40FNBT-C	Flag Negative	0.600	0.844	Yellow			

Heavy-Duty Battery Connectors and Tools

Tin-Plated Elbow Battery Connectors

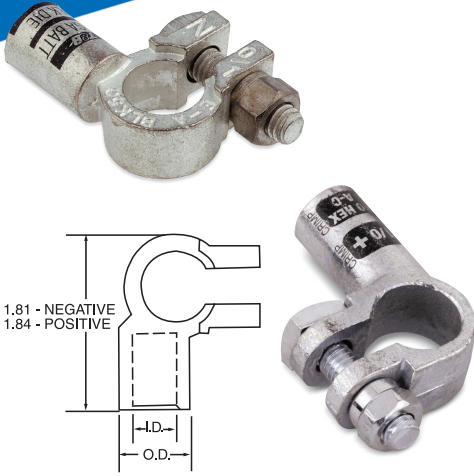

Material: High-Conductivity Copper

Finish: Electro-Tin Plated

Installing

Tools: TBM5-SV, TBM5V

Cat. No.	BULK Cat. No.	SAE Cable Size	Description	I.D.	O.D.	Pkg. Qty.	Bulk Pkg. Qty.	Colour Code
BAC10ERNBT	BAC10ERNBT-C	1/0 Gauge	Right Elbow-Negative	0.455	0.625	5	100	Black
BAC10ERPBT	BAC10ERPBT-C		Right Elbow-Positive	0.455	0.625			Orange
BAC20ERNBT	BAC20ERNBT-C	2/0 Gauge	Right Elbow-Negative	0.502	0.676			Purple
BAC20ERPBT	BAC20ERPBT-C		Right Elbow-Positive	0.502	0.676			Yellow
BAC30ERNBT	BAC30ERNBT-C	3/0 Gauge	Right Elbow-Negative	0.530	0.730			Black
BAC30ERPBT	BAC30ERPBT-C		Right Elbow-Positive	0.530	0.730			Orange
BAC40ERNBT	BAC40ERNBT-C	4/0 Gauge	Right Elbow-Negative	0.600	0.844			Purple
BAC40ERPBT	BAC40ERPBT-C		Right Elbow-Positive	0.600	0.844			Yellow
BAC10ELNBT	BAC10ELNBT-C	1/0 Gauge	Left Elbow-Negative	0.455	0.625			Black
BAC10ELPBT	BAC10ELPBT-C		Left Elbow-Positive	0.455	0.625			Orange
BAC20ELNBT	BAC20ELNBT-C	2/0 Gauge	Left Elbow-Negative	0.502	0.676			Purple
BAC20ELPBT	BAC20ELPBT-C		Left Elbow-Positive	0.502	0.676			Yellow
BAC30ELNBT	BAC30ELNBT-C	3/0 Gauge	Left Elbow-Negative	0.530	0.730			Black
BAC30ELPBT	BAC30ELPBT-C		Left Elbow-Positive	0.530	0.730			Orange
BAC40ELNBT	BAC40ELNBT-C	4/0 Gauge	Left Elbow-Negative	0.600	0.844			Purple
BAC40ELPBT	BAC40ELPBT-C		Left Elbow-Positive	0.600	0.844			Yellow

Stackable Battery Connectors — Lead-Plated



Material: High-Conductivity Copper

Finish: Lead-Plated

Installing

Tools: TBM5-SV or TBM5V

Cat. No.	BULK Cat. No.	SAE Cable Size	A ±.040	M ±.020	W ±.020	C ±.020	E ±.010	Stud Size	Pkg. Qty.	Bulk Pkg. Qty.	Colour Code
BAC438	273-31853-1	4 Gauge	1.46 (37.0)	1.14 (29.0)	0.62 (15.6)	0.75 (19.1)	0.37 (9.3)	3/8	10	100	Grey
BAC238	273-31853-2	2 Gauge	1.78 (45.1)	1.40 (35.6)	0.68 (17.1)	0.85 (21.6)	0.47 (11.9)				Green
BAC138	273-31853-3	1 Gauge	1.88 (47.6)	1.50 (38.1)	0.75 (44.5)	0.95 (24.1)	0.52 (13.2)				Pink
BAC1038	273-31853-4	1/0 Gauge	1.93 (48.9)	1.55 (39.4)	0.83 (21.0)	1.00 (25.4)	0.57 (14.5)				Black
BAC2038	273-31853-5	2/0 Gauge	2.11 (53.6)	1.65 (41.8)	0.93 (23.6)	1.10 (27.9)	0.63 (16.1)				Orange
BAC3038	273-31853-6	3/0 Gauge	2.03 (51.4)	1.65 (41.9)	1.03 (26.0)	1.10 (27.9)	0.70 (17.8)				Purple
BAC4038	273-31853-7	4/0 Gauge	2.23 (57.8)	1.90 (48.3)	1.03 (26.0)	1.35 (34.3)	0.77 (19.5)				Yellow

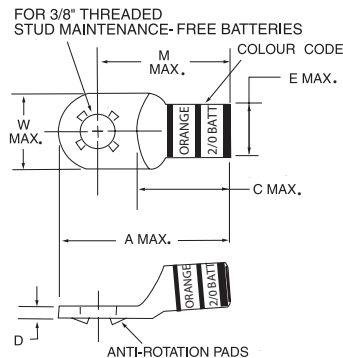

Heavy-Duty Battery Connectors and Tools

Starter Lugs — Tin-Plated



Cat. No.	BULK Cat. No.	SAE Cable Size	Stud Size (in.)	A ±04	B ±02	C ±02	D ±02	Pkg. Qty.	Bulk Pkg. Qty.	Colour Code	
BAL414	273-31852-1	4 Gauge	1/4	140	52	40	115	10	100	Grey	
BAL4516	273-31852-2		5/16	145	61	363	114			Green	
BAL438	273-31852-3		3/8	145	61	6	114			Pink	
BAL2516	—	2 Gauge	5/16	159	69	40	1258		—	Green	
BAL238	273-31852-4		3/8	178	67	55	140		100	Green	
BAL212	273-31852-5		1/2	177	76	54	140		—	Pink	
BAL1516	—	1 Gauge	5/16	183	76	49	150		—	—	Pink
BAL138	273-31852-6		3/8	185	75	55	150		100	Pink	
BAL112	273-31852-7		1/2	220	75	75	170		—	—	Black
BAL10516	—	1/0 Gauge	5/16	192	83	50	150		—	—	Black
BAL1038	273-31852-8		3/8	193	83	55	155		100	Black	
BAL1012	273-31852-9		1/2	197	88	53	153		—	—	Orange
BAL20516	—	2/0 Gauge	5/16	206	93	50	160		—	—	Orange
BAL2038	273-31852-10		3/8	211	93	55	165		100	Orange	
BAL2012	273-31852-11		1/2	211	93	55	165		—	—	Purple
BAL30516	—	3/0 Gauge	5/16	216	103	55	165	—	—	Purple	
BAL3038	273-31852-12		3/8	203	103	55	165	100	Purple		
BAL3012	273-31852-13		1/2	235	103	75	185	—	—	Yellow	
BAL40516	—	4/0 Gauge	5/16	240	113	59	184	—	—	Yellow	
BAL4038	273-31852-14		3/8	228	112	55	190	100	Yellow		
BAL4012	273-31852-15		1/2	260	112	75	210	—	—	Yellow	

Material: High-Conductivity Copper

Finish: Electro-Tin Plated

Installing

Tools: TBM5-SV or TBM5V

Splices (Two-Way Connectors)



Material: High-Conductivity Copper

Finish: Electro-Tin Plated

Installing

Tools: TBM5-SV or TBM5V

Cat. No.	BULK Cat. No.	SAE Cable Size	Pkg. Qty.	Bulk Pkg. Qty.	Colour Code
BAS4	273-31852-16	4 Gauge	10	100	Grey
BAS2	273-31852-17	2 Gauge			Green
BAS1	273-31852-18	1 Gauge			Pink
BAS10	273-31852-19	1/0 Gauge			Black
BAS20	273-31852-20	2/0 Gauge			Orange
BAS30	273-31852-21	3/0 Gauge			Purple
BAS40	273-31852-22	4/0 Gauge			Yellow

“Y” Splices



Material: High-Conductivity Copper

Finish: Electro-Tin Plated

Installing

Tools: TBM5-SV or TBM5V

Installing

Covers: AC5X3

Cat. No.	Strip Cable Size	SAE Cable Size	Length (in.)	Colour Code
BASY20	2/0-(2)2	2/0 Gauge	3/4	Orange
BASY3	3/0-(2)1	3/0 Gauge		Purple
BASY40	4/0-(2)1/0	4/0 Gauge		Yellow



Heavy-Duty Battery Connectors and Tools

Battery/Starter Cables

Abrasion-resistant and engineered for optimum performance at both high and low temperatures

- Fine flexible copper rope stranding PVC jacket conforms to SAE J1127 specifications
- Layer of paper separates insulation from copper, providing easy stripping with no stranding damage
- Temperature-rated for 80°C
- Flexibility ideal for tight spaces and cold environments
- Color-Keyed® markings for fast and accurate identification
- Marked in 1-ft. increments for easy measurement
- Available in red or black jacket colour

Material: High-Conductivity Copper

Finish: Electro-Tin Plated

Installing

Tools: TBM5-SV or TBM5V

Cat. No.	Strip Cable Size	Cable Length	Cable Colour
BC4-100	4 Gauge	100 ft. Coil	Black
BC2-100	2 Gauge		
BC1-100	1 Gauge		
BC10-100	1/0 Gauge		
BC20-100	2/0 Gauge		
BC30-100	3/0 Gauge		
BC40-100	4/0 Gauge		
BC4-1000	4 Gauge	1000 ft. Coil	Red
BC2-500	2 Gauge	500 ft. Coil	
BC1-500	1 Gauge		
BC10-500	1/0 Gauge		
BC20-500	2/0 Gauge		
BC30-500	3/0 Gauge		
BC40-500	4/0 Gauge		
BC4-1000R	4 Gauge		
BC2-500R	2 Gauge	500 ft. Coil	
BC1-500R	1 Gauge		
BC10-500R	1/0 Gauge		
BC20-500R	2/0 Gauge		
BC30-500R	3/0 Gauge		
BC40-500R	4/0 Gauge		

Cat. No.	Strip Cable Size	Cable Length	Cable Colour
BC4-25	4 Gauge	25 ft. Coil	Black
BC2-25	2 Gauge		
BC1-25	1 Gauge		
BC10-25	1/0 Gauge		
BC20-25	2/0 Gauge		
BC30-25	3/0 Gauge		
BC40-25	4/0 Gauge		
BC4-25R	4 Gauge		
BC2-25R	2 Gauge		
BC1-25R	1 Gauge		
BC10-25R	1/0 Gauge		
BC20-25R	2/0 Gauge		
BC30-25R	3/0 Gauge		
BC40-25R	4/0 Gauge		

Heavy-Duty Battery Cable

Specially designed for demanding industrial and OEM requirements

- 105°C Temperature-rated and UL recognized
- Heavier PVC jacket conforms to SAE J1127 specifications
- Color-Keyed® markings for fast and accurate identification
- Marked in 1-ft. increments for easy measurement
- Layer of paper separates insulation from copper for easy stripping with no strand damage
- 600 V rated available in bulk only
- Application-specific – To order, contact your Regional Sales offices



Heavy-Duty Battery Connectors and Tools

BCT840, BCT840S



TBM5-SV, TBM5V



Contact Tool Service for replacement blades.



Crimping Tools

Cat. No.	Description
BCT840 BCT840S	<ul style="list-style-type: none"> Adjustable die crimping tools for Color-Keyed® cast and tubular connectors The single die is an integral part of the tool; no dies to lose or misplace Available with Shure Stake® mechanism to insure a complete crimp every time (BCT840S) Crimp casting and tubular connectors ranging from #4 AWG to 4/0 AWG.
TBM5V	<ul style="list-style-type: none"> Heavy-Duty crimping tool including dies for #8 AWG–4/0 battery connectors, lugs and splices
TBM5-SV	<ul style="list-style-type: none"> Available with Shure Stake® mechanism to insure a complete crimp every time (TBM5S)

Cable Cutter

Cat. No.	Description
364RF	<ul style="list-style-type: none"> Cuts cable up to 500 kcmil Fiberglass handles and carbon steel blades For copper and aluminum cable only

Cable Stripper

Cat. No.	Description
BCS8-40	<ul style="list-style-type: none"> Cable stripper for cable #8 AWG–4/0 battery cable Replacement blade provided in the handle



Accessories and Miscellaneous Hardware

Kopr-Shield® Joint Compound

Copper colloidal surface treatment protects, lubricates and enhances conductivity of all electrical connections

- Unique, homogenized blend of pure, polished colloidal copper, rust and corrosion inhibitors
- Simultaneously protects, lubricates and enhances conductivity of mating surfaces
- Extremely adhesive compound flows smoothly into uneven contours and voids, ensuring easy application and complete, positive protection and lubrication
- Won't settle-out, thin, thicken, harden or dry out under the most severe environmental conditions
- Excellent temperature characteristics— can be brushed on at -45.5°C (-50°F) to 121°C (250°F) (other compounds either turn solid or run like water at these extremes) and remains intact at short terms even at 980°C (1,800°F)

Good connections are one of the most important aspects of electrical work. Mechanics know how much downtime is caused when fluids or oils leak into the raceway system or when they have to look for a weak link in a ground system caused by a high-resistance connection. Mechanics also know how much time is spent keeping contacts, switches, lugs and other connectors clean or replacing parts because of “green scourage” buildup. Thomas & Betts has the solution to improve connections made in thousands of electrical and raceway installations made each day by electricians everywhere. Kopr-Shield® Compound may be used to advantage in all electrical installations. When the environment is hostile to electrical and mechanical connections, Kopr-Shield® Compound is a must!

Use Kopr-Shield® Compound for battery lugs and cables to:

- Prevent “green scourage” corrosion
- Reduce resistance
- Ease terminal installation and removal

Use Kopr-Shield® Compound for raceways to:

- Lubricate for ease of assembly and disassembly
- Improve grounding continuity (exceeds code requirements)

Use Kopr-Shield® Compound for fuse clips to:

- Eliminate hot spots for even heat distribution
- Prevent oxidation by preventing carbon path formation
- Lubricate for easy installation and removal of fuses

Use Kopr-Shield® Compound for wiping contacts, drum switches and slip rings to:

- Prevent galling, burning, pitting and discoloration
- Suppress arching and dissipation of coronas
- Lubricate for ease of operation

Cat. No.	Description	Std. Pkg.	Weight lb. / C
201-31879	1-1/2 oz. Container with Brush	96	11.46
201-31879-1	4 oz. Container with Brush	24	38.54
CP8-TB	8 oz. Container with Brush	12	64.58
CP16	16 oz. Container with Brush	12	120.83
CP128	1 Gallon Can	4	952.00

ALUMA-SHIELD® Aluminum Joint Compound



Cat. No.	Contents
21059	Squeeze Bottle, Pt.
AP8	8 oz. Brush Cap Can
M53	5 Gallon Can

Accessories and Miscellaneous Hardware

Belleville Compression Washers

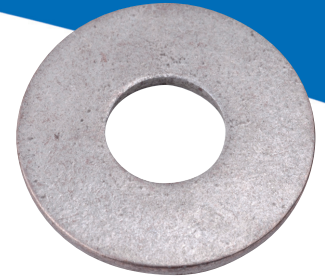

Cat. No.	Bolt Size (in.)	Dimensions in. (mm)			
		Flat Washer		Belleville Washer	
		O.D.	Thickness	O.D.	Thickness
Belleville Compression Washers Plus Flat Washer					
60800B	1/4	0.75 (19.1)	0.07 (1.8)	0.69 (17.5)	0.06 (1.5)
60801B	5/16	0.88 (22.1)	0.07 (1.8)	0.81 (20.6)	0.07 (1.8)
60802B	3/8	1.00 (25.4)	0.08 (2.0)	0.94 (23.9)	0.08 (2.0)
60803B	1/2	1.25 (31.8)	0.11 (2.8)	0.81 (20.6)	0.10
Belleville Compression Washers ONLY					
60800-TB	1/4	-	-	0.69 (17.5)	0.06 (1.5)
60801-TB	5/16	-	-	0.81 (20.6)	0.07 (1.8)
60802-TB	3/8	-	-	0.94 (23.9)	0.08 (2.0)
60803-TB	1/2	-	-	0.81 (20.6)	0.10 (2.5)
60804-TB	5/8	-	-	1.50 (38.1)	0.11 (2.8)

Note: Ordering quantity must be in unit quantities and multiples thereof. The Belleville washer should be installed with a larger flat washer to spread the high stresses of the compression washer edges over a large area of the lug and/or bus bar.

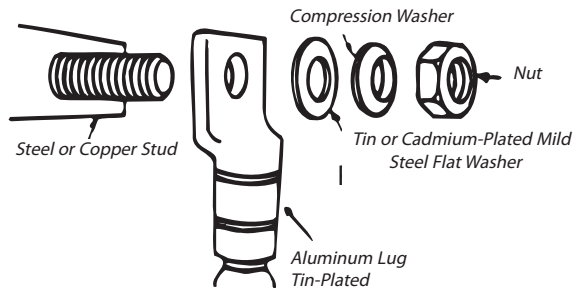

- Essential when bolting aluminum lugs and connectors to bus bars with steel or brass hardware
- Maintain constant pressure in heavy-duty, high-temperature applications
- Available with or without flat washer

When bolting aluminum lugs and connectors to bus bars with steel or brass hardware, the recommended practice to ensure a tight connection is to use a Belleville spring washer on top of a flat washer under the bolt head or nut. For heavy-duty service where the heat rise is expected to exceed 30°C above ambient, this procedure maintains constant pressure as the connector metals expand and contract with temperature changes.

Dragon Tooth® Transition Washers

Quick, dependable and versatile!

- Connect copper-to-aluminum, copper-to-copper or aluminum-to-aluminum component
- Toothed surface penetrates aluminum and copper oxides
- Lower installed cost – no need to grind aluminum surfaces, apply compounds or use spring-type washers



Cat. No.	Size (in.)	Bolt Torque in lb.
DTW14	1/4	50–80
DTW516	5/16	125–160
DTW38	3/8	160–240
DTW12	1/2	390–540
DTW58	5/8	540–730

Accessories and Miscellaneous Hardware

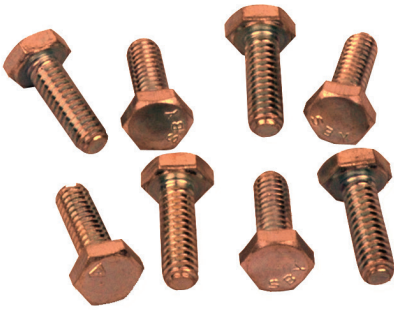

Cat. No. Diameter and Threads per inch				Length (in.)
1/4 in.-20	5/16 in.-18	3/8 in.-16	1/2 in.-13	
Type BB — Silicon Bronze Hex Head Bolts				
25100BB-C	31100BB-C	37100BB-C	50100BB-C	1
	31125BB-C	37125BB-C	50125BB-C	1-1/4
	31150BB-C	37150BB-C	50150BB-C	1-1/2
	31175BB-C	37175BB-C	50175BB-C	1-3/4
	32100BB-C	37200BB-C	50200BB-C	2
25225BB-C	31225BB-C	37225BB-C	50225BB-C	2-1/4
	31250BB-C	37250BB-C	50250BB-C	2-1/2
	31275BB-C	37275BB-C	50275BB-C	2-3/4
	31300BB-C	37300BB-C	50300BB-C	3
	-	37325BB-C	50325BB-C	3-1/4
	-	37350BB-C	50350BB-C	3-1/2
Type HN — Silicon Bronze Hex Nuts				
14010HN-C	31010HN-C	37010HN-C	50010HN-C	-

Cat. No.	Bolt Size (in.)	O.D. (in.)	I.D. (in.)	Thickness (in.)	Height (in.)
Type SW — Silicon Bronze Split Lock Washers					
14030SW-C	1/4				
31030SW-C	5/16				
37030SW-C	3/8				
50030SW-C	1/2				
Type FW — Silicon Bronze Flat Washers					
14040FW-C	1/4	1/4	11/16	0.260	0.040
31040FW-C	5/16	5/16	7/8	0.336	0.064
37040FW-C	3/8	3/8	1	0.395	0.064
50040FW-C	1/2	1/2	1-1/4	0.562	0.091
Type BW — Belleville Compression Washer 304 Series Stainless Steel					
50050BW-C	1/2	1-1/8	17/32	0.062	1/8

Accessories and Miscellaneous Hardware

Sealants and Lubricants

Type CT — CONTAX™ Oxide Inhibiting Compound

- Seals electrical connections from oxygen and moisture
- Non-water soluble, non-petroleum based polymer grease
- Nontoxic, will not irritate the skin
- Service temperature to 238°C (460°F) can be applied in -18°C (0°F) weather



Cat. No.	Description
CTA	1/2 oz. Package
CTB	4 oz. Plastic Bottle
CTB8	8 oz. Plastic Bottle
CTQ	Quart Can
CTG	Gallon Can

Type DX — Duct Seal

- Seals around junction boxes, flashings, service mast entries, service cable entries and countless other applications
- Easy to use, forms around irregular surfaces and configurations
- Highly resistant to cracking, drying and shrinking
- Cuts and trims easily
- Can be painted immediately after application
- Grey colour
- No unpleasant odor
- -6.7°C to 100°C (20°F to 212°F) workable temperature range
- -40°C to 121°C (-40°F to 250°F) service temperature range
- Contains no asbestos



Cat. No.	Description
DX-1	1 lb. Slug
DX-5	5-1 lb. Slugs
DX-5S	5 lb. Slug

Silicone Lubricant for High Voltage Electrical Work



Cat. No.	Description	Pkg. Qty.
2012	2 grams	250 tubes
2015	5 grams	100 tubes
SL5	5 oz./142 grams	12 tubes

Type WW — Wire Bristle Brush

- Removes oxides from conductor surfaces
- Easy-grip handle with guard to prevent rubber-glove puncture
- Replaceable long-life brushes can be rotated
- Handle and guard coated with durable, nonconductive plastic for safety



Cat. No.	Description	Pkg. Qty.
WWB1	Complete Brush with Handle	1
WRB1	Brush Replacement	

