

Raychem RayClic Connection System

INSTALLATION INSTRUCTIONS

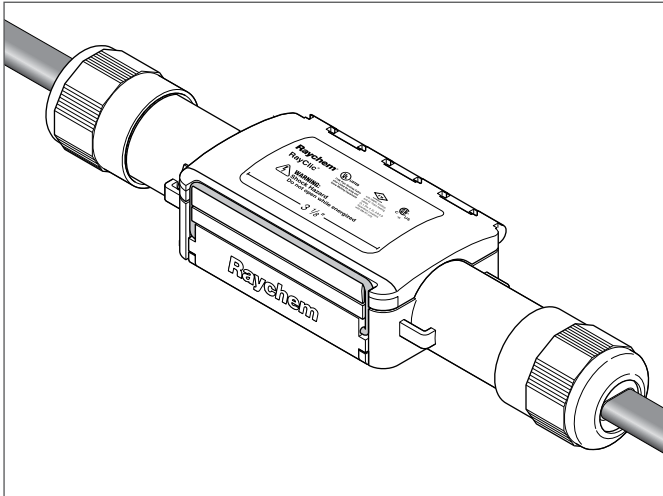

DESCRIPTION

RayClic-S Splice Kit

RayClic-T Tee and End Seal Kit

RayClic-X Cross and End Seal Kit

These kits are for use with Raychem IceStop, XL-Trace and HWAT heating cables. The connection is designed to be strapped to the pipe, or wall mounted. These installation instructions should be used in conjunction with the IceStop, XL-Trace, and HWAT System Installation and Operation Manuals. For technical support, contact your Pentair Thermal Management representative or call Pentair Thermal Management (800) 545-6258.

TOOLS REQUIRED

- TORX® T20 screw driver
- Utility knife
- Wire cutters

OPTIONAL ACCESSORIES (NOT INCLUDED IN THIS KIT)

- RayClic-SB-02 Wall mounting bracket
- RayClic-SB-04 Pipe mounting bracket

APPROVALS



718K Pipe Heating Cable
877Z De-Icing and Snow Melting
Not UL Listed with XL-Trace heating cable
for buried piping.



For HWAT, IceStop, and XL-Trace only
Hazardous Locations: For IceStop (GM-XT) only
Class I, Div. 2, Groups A,B,C,D

WARNING:

This component is an electrical device that must be installed correctly to ensure proper operation and to prevent shock or fire. Read these important warnings and carefully follow all the installation instructions.

- To minimize the danger of fire from sustained electrical arcing if the heating cable is damaged or improperly installed, and to comply with the requirements of Pentair Thermal Management,

agency certifications, and national electrical codes, ground-fault equipment protection must be used. Arcing may not be stopped by conventional circuit breakers.

- Bus wires will short if they contact each other. Keep bus wires separated.
- Keep components and heating cable ends dry before and during installation.

- The black heating cable core is conductive and can short. It must be properly insulated and kept dry.
- Component approvals and performance are based on the use of Pentair Thermal Management-specified parts only. Do not use substitute parts or vinyl electrical tape.
- Leave these instructions with end user for reference and future use.

KIT CONTENTS

RAYCLIC-S SPLICE KIT

Item	Qty	Description
A	1	Splice
B	2	Plastic cable ties
C	2	Clips
D	3	Labels (1 splice, 2 warning)
E	1	Cable lubricant

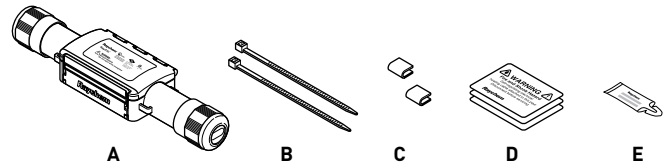

RAYCLIC-T TEE KIT

Item	Qty	Description
A	1	Tee
B	2	Plastic cable ties
C	3	Clips
D	1	End seal
E	3	Labels (1 splice, 2 warning)
F	1	Cable lubricant

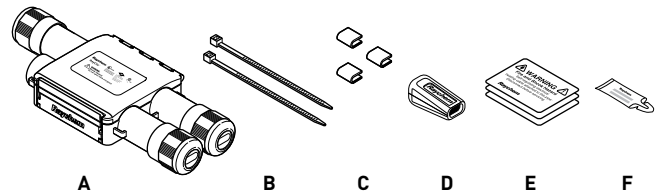

RAYCLIC-X CROSS KIT

Item	Qty	Description
A	1	Cross
B	2	Plastic cable ties
C	4	Clips
D	2	End seals
E	3	Labels (1 splice, 2 warning)
F	1	Cable lubricant

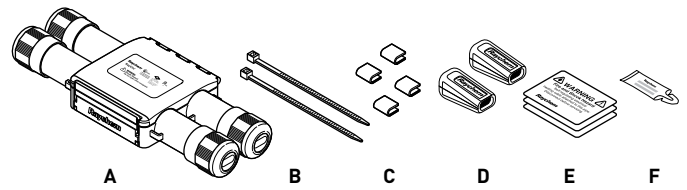

If you experience difficulty during installation, refer to the "Troubleshooting Guide" on page 8.

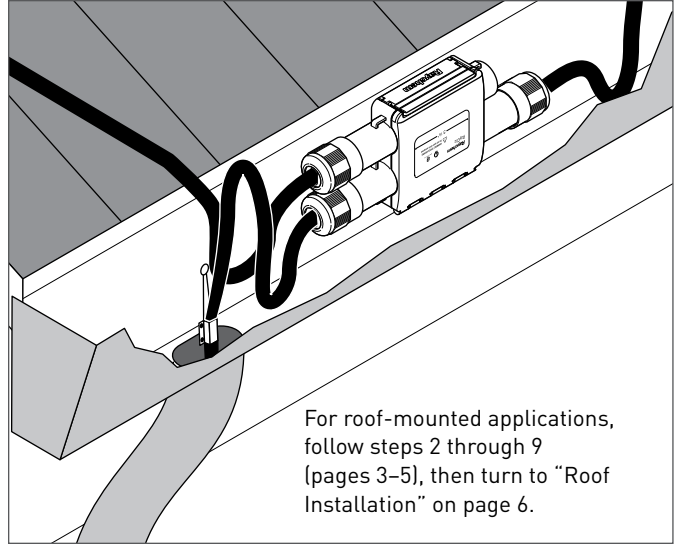
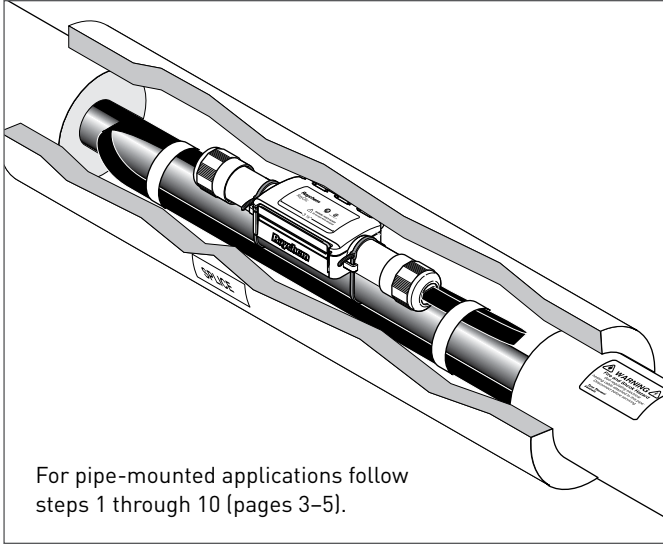

Splice, Tee, and Cross Installation

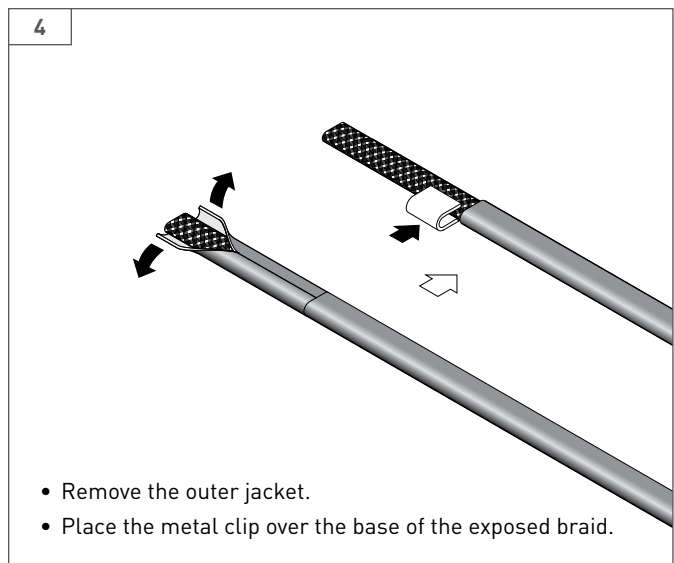
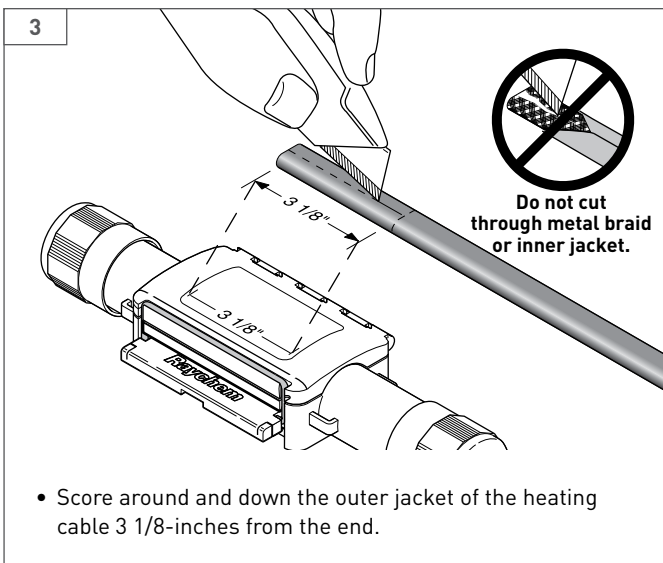
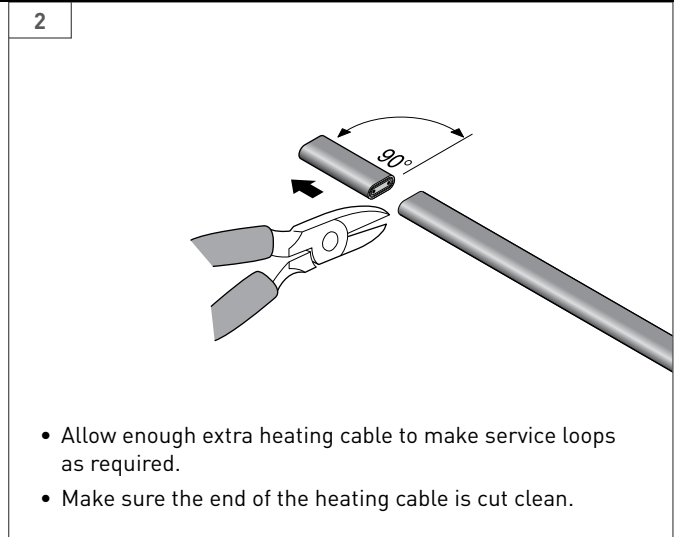
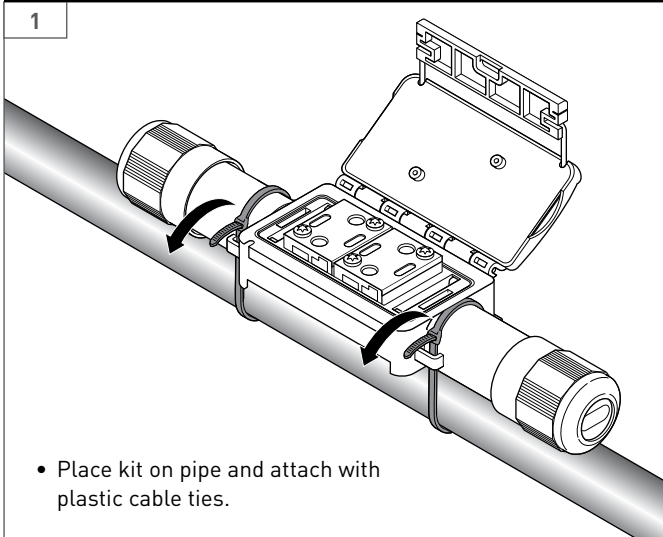

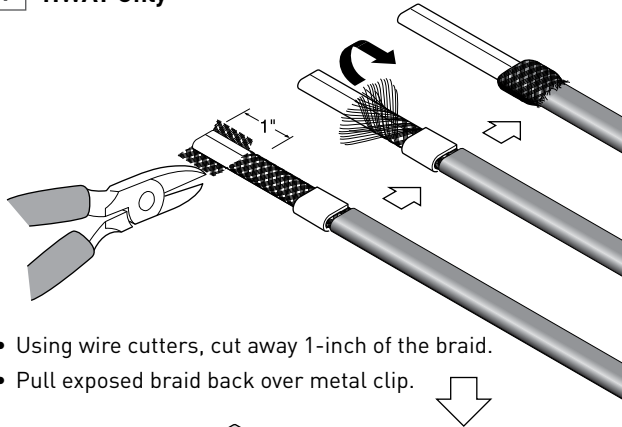
HWAT**5A HWAT Only**

- Using wire cutters, cut away 1-inch of the braid.
- Pull exposed braid back over metal clip.

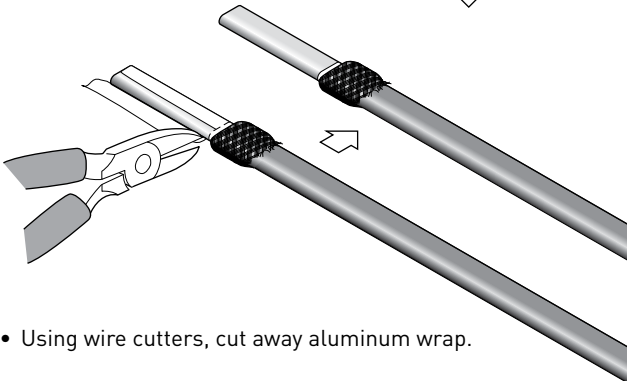

- Using wire cutters, cut away aluminum wrap.

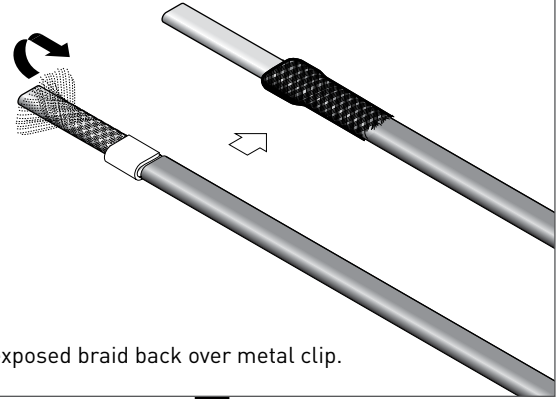
IceStop and XL-Trace**5B IceStop and XL-Trace Only**

- Pull exposed braid back over metal clip.

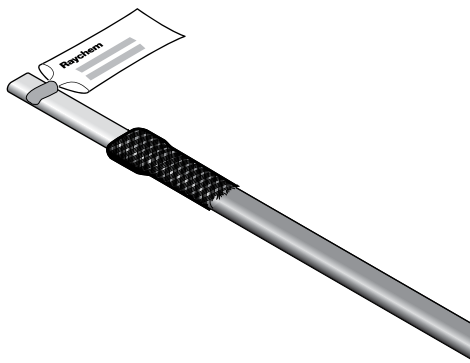
6

- Apply a small amount of lubricant to the jacket surface near the end of the cable.
- Avoid using large amounts of lubricant on the exposed end of the cable.

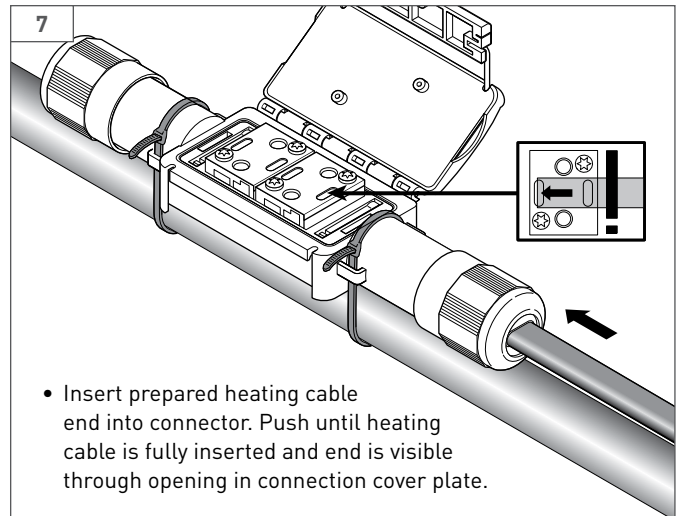
7

- Insert prepared heating cable end into connector. Push until heating cable is fully inserted and end is visible through opening in connection cover plate.

Note: Heating cable cannot be removed. The connection and end seal are designed to be installed only once; the heating cable cannot be removed once installed.

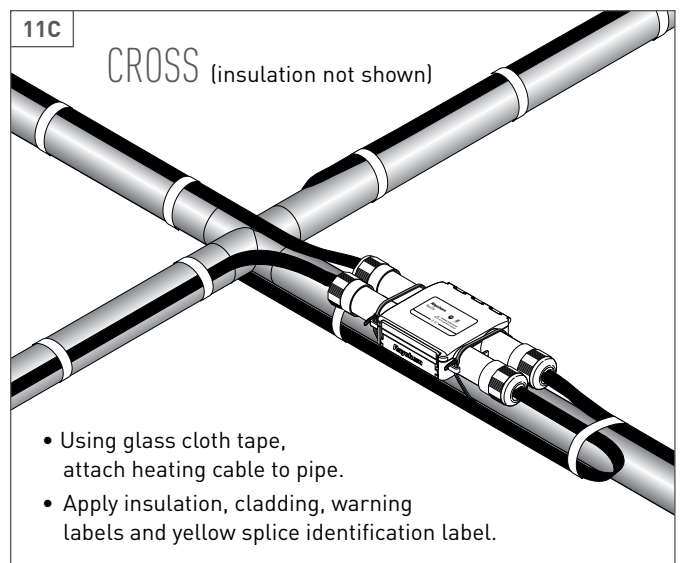
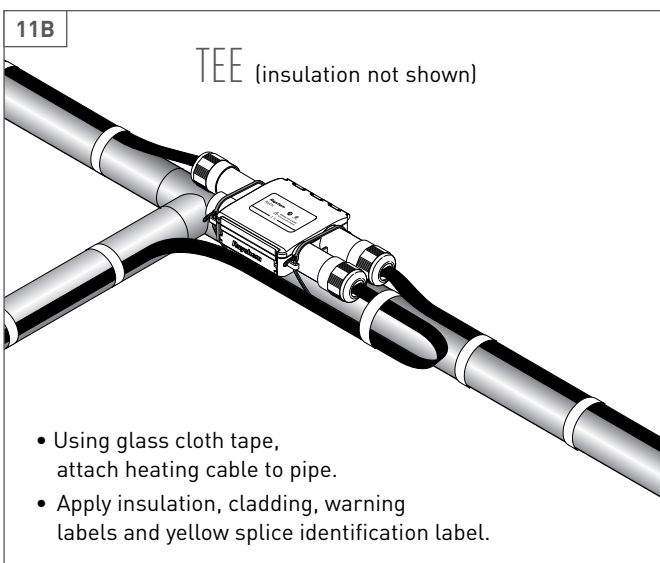
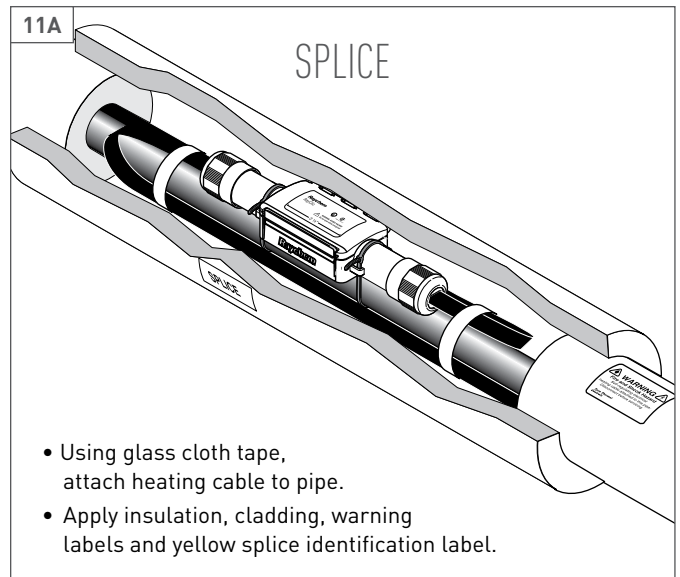
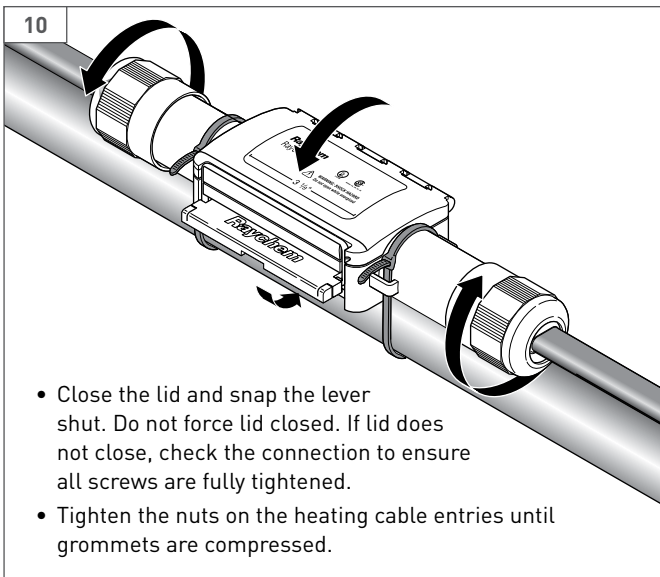
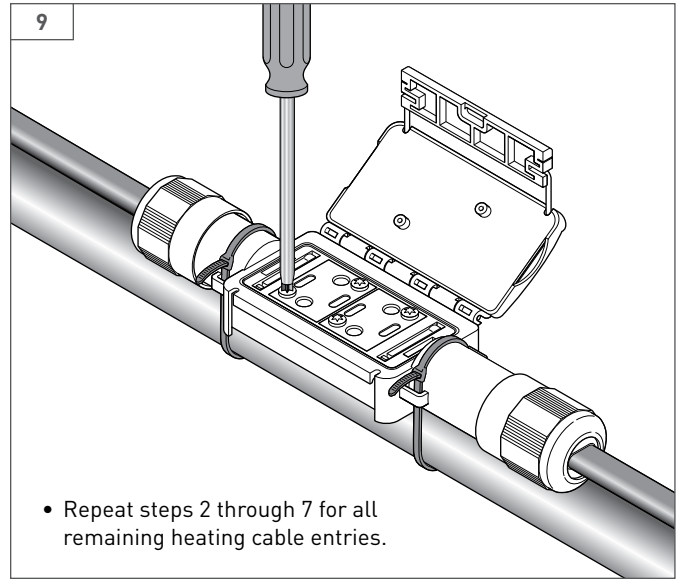
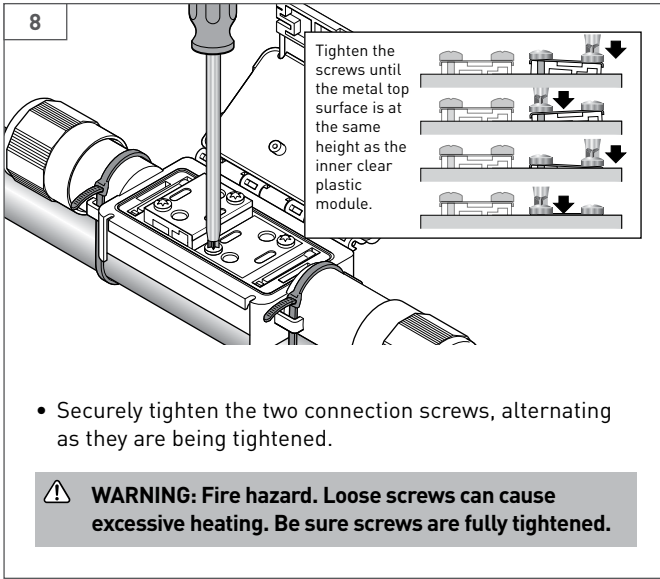

Roof Installation

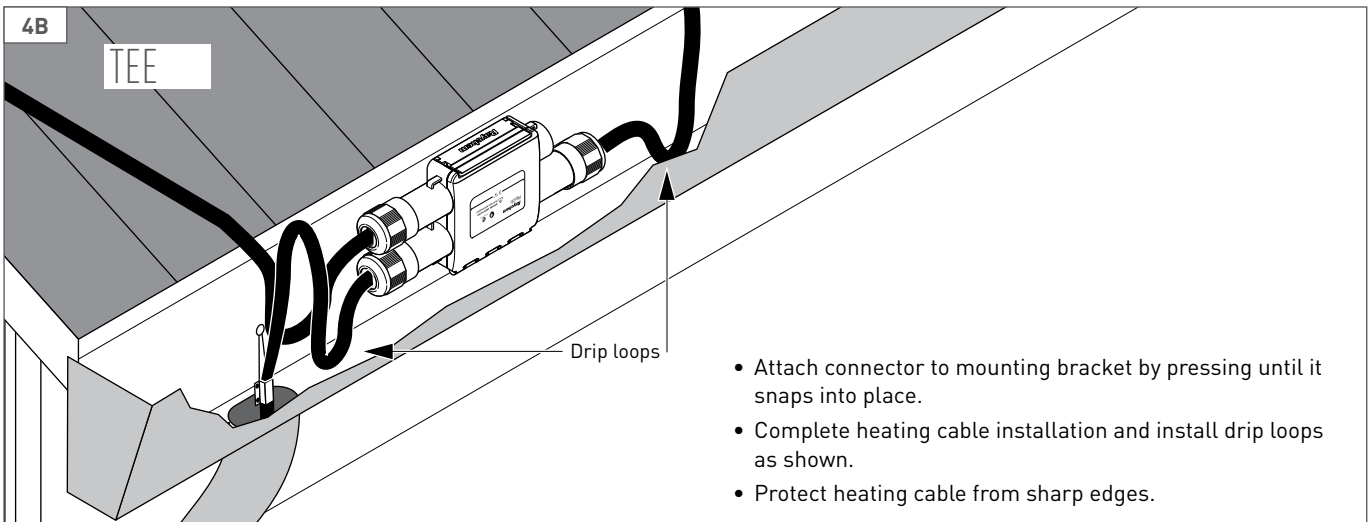
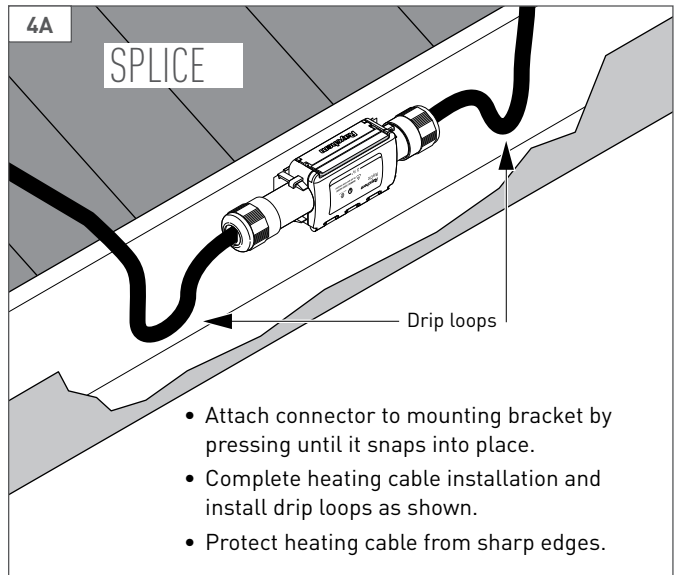
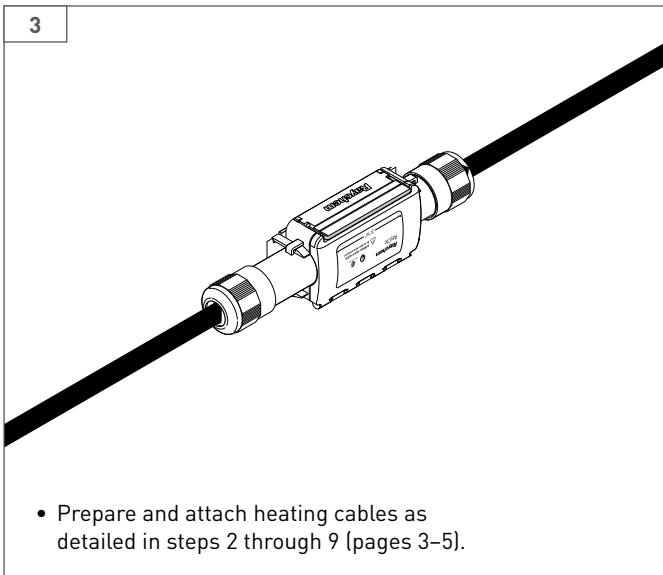
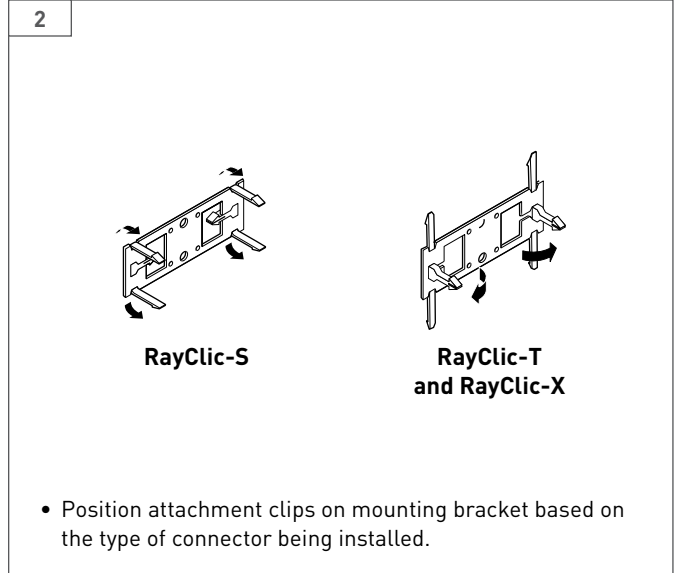
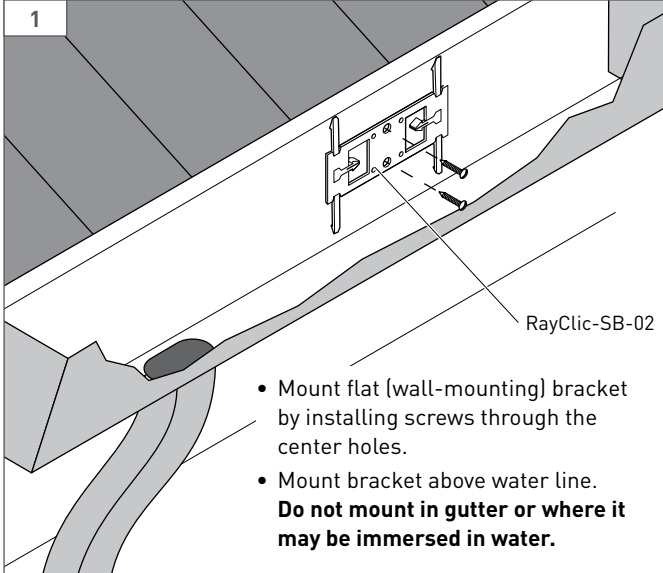

End Seal Installation

1

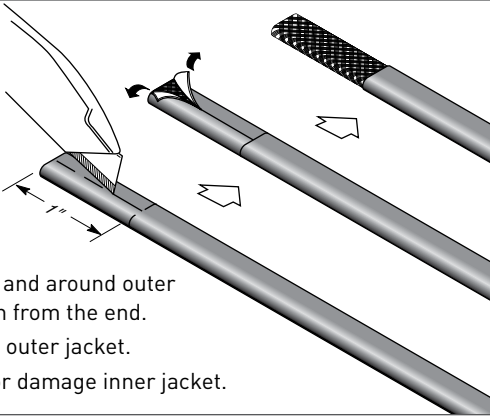

- Score down and around outer jacket 1 inch from the end.
- Remove the outer jacket.
- Do not cut or damage inner jacket.

2

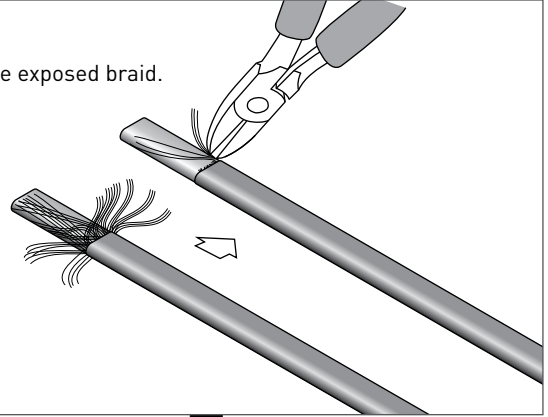

- Remove exposed braid.

HWAT

IceStop, XL-Trace, and RaySol

2A

- Using wire cutters, cut away aluminum wrap close to braid and outer jacket.

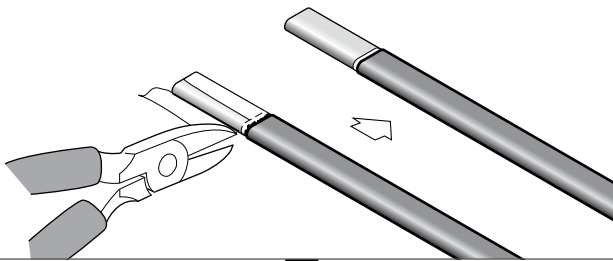

3

- Push end seal completely onto heating cable.

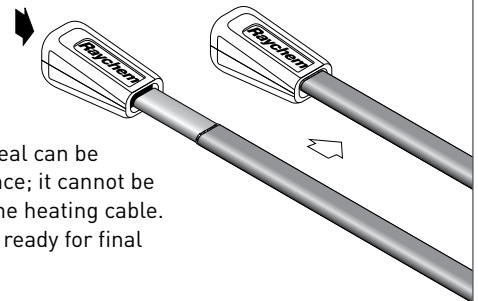

Note: The end seal can be installed only once; it cannot be removed from the heating cable. Do not use until ready for final installation.

Troubleshooting Guide

Problem	Solution
Braid clips are missing.	The braid clips are attached to the cardboard packing insert under the lid. The braid clips must be used to ensure a ground connection. If clips are missing or lost, call Pentair Thermal Management at (800) 545-6258.
Mounting bracket is missing.	A mounting bracket is not included in the splice, tee and cross kits. One can be ordered using one of the catalog numbers listed under "Optional Accessories" on the front page of these instructions when you place your order.
Connector does not snap onto bracket.	The bracket has two sets of attachment clips. Fold up the four outer clips for the splice kit. Fold up only the center clips for the tee and cross kits.
Heating cable type not mentioned.	RayClic connection kits are approved for use only with Raychem HWAT, XL-Trace, and IceStop heating cables. Do not use with other heating cables.
Braid clip does not fit.	Be sure the clip is installed on the metal braid, not on the outer jacket.
Heating cable does not have aluminum wrap.	Only HWAT heating cables have the aluminum wrap under the braid. Skip the aluminum wrap removal step for XL-Trace and IceStop heating cables.
Heating cable cannot be inserted into connector.	Check for the following: <ul style="list-style-type: none">• Apply cable lubricant to the heating cable primary (white) jacket.• Outer jacket strip length is 3 1/8-inches.• Braid clip is installed on top of the metal braid, not on the outer jacket.• Braid is pulled back over braid clip.• For HWAT, 1-inch of braid is removed.• Sealing nut is loose (but not removed).• Connection screws are loose.
Lid does not close.	Be sure all screws are fully tightened before closing the lid.
Heating cable cannot be inserted into end seal.	The outer jacket must be removed from the heating cable before the end seal is installed (see the "End Seal Installation" instructions on page 7). Make sure 1-inch of the outer jacket, braid, and aluminum wrap (HWAT only) are removed.
Heating cable cannot be removed.	The connection and end seal are designed to be installed only once; the heating cable cannot be removed once installed. Additional RayClic-E end seals can be ordered from Pentair Thermal Management.

Heating Cable Circuit Testing

The RayClic-T now includes test ports in the blank module. Voltage can be measured at these points to confirm continuity or power to the installed heating cable circuit. For detail heating cable operation refer to the appropriate installation and operating manual.

Instructions:

1. Open the RayClic Cover.
2. Set multimeter to AC voltage function.
3. Insert multimeter test probes into the two test ports.

⚠ WARNING: To avoid shock do not cross the test probes or touch them to the metal pressure plate when measuring voltage.

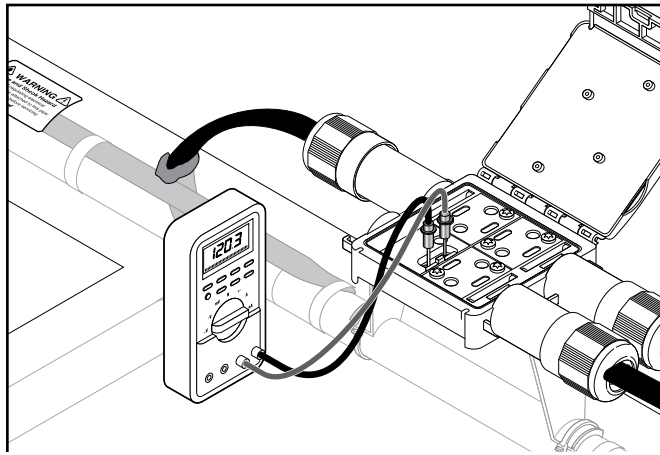
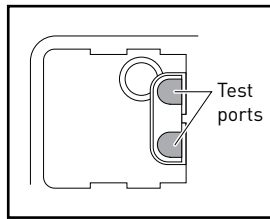



WWW.THERMAL.PENTAIR.COM

NORTH AMERICA

Tel: +1.800.545.6258
Fax: +1.800.527.5703
Tel: +1.650.216.1526
Fax: +1.650.474.7711
thermal.info@pentair.com

EUROPE, MIDDLE EAST, AFRICA

Tel: +32.16.213.511
Fax: +32.16.213.603
thermal.info@pentair.com

ASIA PACIFIC

Tel: +86.21.2412.1688
Fax: +86.21.5426.2917
cn.thermal.info@pentair.com

LATIN AMERICA

Tel: +55.11.2588.1400
Fax: +55.11.2588.1410
thermal.info@pentair.com

Pentair, HWAT, IceStop, RayClic, and XL-Trace are owned by Pentair or its global affiliates. All other trademarks are the property of their respective owners. Pentair reserves the right to change specifications without prior notice.