



GENERAC® STANDBY GENERATORS

130 kW

Liquid-Cooled Engine Generator Sets

Standby Power Rating

Model QT130 (Bisque) - 130 kW 60Hz

INCLUDES:

- Generac Naturally Aspirated Gaseous Fueled 6.8L Engine
- Two Line LCD Tri-lingual Digital Nexus™ Controller
- Sound Attenuated Enclosure
- Isochronous Electronic Governor
- Closed Coolant Recovery System
- Smart Battery Charger
- UV/Ozone Resistant Hoses
- ±1% Voltage Regulation
- Natural Gas or LP Operation
- 2 Year Limited Warranty
- UL 2200 Listed



Meets 2010 EPA Emission Regulations

Meets CA/MA emissions requirement with optional catalyst

FEATURES

- **INNOVATIVE DESIGN & PROTOTYPE TESTING** are key components of GENERAC'S success in "IMPROVING POWER BY DESIGN." But it doesn't stop there. Total commitment to component testing, reliability testing, environmental testing, destruction and life testing, plus testing to applicable CSA, NEMA, EGSA, and other standards, allows you to choose GENERAC POWER SYSTEMS with the confidence that these systems will provide superior performance.
- **TEST CRITERIA:**
 - ✓ **PROTOTYPE TESTED**
 - ✓ **SYSTEM TORSIONAL TESTED**
 - ✓ **NEMA MG1-22 EVALUATION**
 - ✓ **MOTOR STARTING ABILITY**
- **SOLID-STATE, FREQUENCY COMPENSATED VOLTAGE REGULATION.** This state-of-the-art power maximizing regulation system is standard on all Generac models. It provides optimized FAST RESPONSE to changing load conditions and MAXIMUM MOTOR STARTING CAPABILITY by electronically torque-matching the surge loads to the engine. An unequalled ±1% voltage regulation.
- **SINGLE SOURCE SERVICE RESPONSE** from Generac's extensive dealer network provides parts and service know-how for the entire unit, from the engine to the smallest electronic component.
- **GENERAC TRANSFER SWITCHES.** Long life and reliability are synonymous with GENERAC POWER SYSTEMS. One reason for this confidence is that the GENERAC product line includes its own transfer systems and controls for total system compatibility.



GENERATOR SPECIFICATIONS

TYPE	Synchronous
ROTOR INSULATION	Class F or H (see Data Label)
STATOR INSULATION	Class H
TELEPHONE INTERFERENCE FACTOR (TIF)	< 50
ALTERNATOR OUTPUT LEADS 3-PHASE/1-PHASE	6/4 wire
BEARINGS	Sealed Ball
COUPLING	Gear Drive
LOAD CAPACITY (STANDBY RATING)	130 kW
EXCITATION SYSTEM	Brushless

VOLTAGE REGULATION

TYPE	Full Digital
SENSING	Three Phase
REGULATION	± 1%

GENERATOR FEATURES

<p>Revolving field heavy duty generator Directly connected to the engine Operating temperature rise 120 °C above a 40 °C ambient Insulation is Class H rated at 130 °C rise All models are fully prototyped tested</p>
--

ENCLOSURE FEATURES

Aluminum all weather protective enclosure options available	Ensures protection against mother nature. Electrostatically applied textured epoxy paint for added durability.
Enclosed critical grade muffler	Quiet, critical grade muffler is mounted inside the unit.
Small, compact, attractive	Makes for easy installation of an eye appealing unit.
SAE	Sound attenuated enclosure ensures quiet operation.

ENGINE SPECIFICATIONS

MAKE	Generac
MODEL	V-type
CYLINDERS	10
DISPLACEMENT	6.8 Liter
BORE	3.55
STROKE	4.17
COMPRESSION RATIO	9:1
INTAKE AIR SYSTEM	Naturally Aspirated
LIFTER TYPE	Hydraulic

GOVERNOR SPECIFICATIONS

TYPE	Electronic
FREQUENCY REGULATION	Isochronous
STEADY STATE REGULATION	± 0.25%

ENGINE LUBRICATION SYSTEM

OIL PUMP	Gear
OIL FILTER	Full flow spin-on cartridge
CRANKCASE CAPACITY	5 Quarts

ENGINE COOLING SYSTEM

TYPE	Closed
WATER PUMP	Belt driven
FAN SPEED	1950
FAN DIAMETER	26 inches
FAN MODE	Puller

FUEL SYSTEM

FUEL TYPE	Natural gas, propane vapor
CARBURETOR	Down Draft
SECONDARY FUEL REGULATOR	Standard
FUEL SHUT OFF SOLENOID	Standard
OPERATING FUEL PRESSURE	11" - 14" H ₂ O

ELECTRICAL SYSTEM

BATTERY CHARGE ALTERNATOR	12V 30 Amp
SMART BATTERY CHARGER	12V, 2 Amp
RECOMMENDED BATTERY	Group 24F, 12V, 525CCA
SYSTEM VOLTAGE	12 Volts

OPERATING DATA					
KW RATING (LP/NG)	130				
ENGINE SIZE	6.8 Liter V-10				
GENERATOR OUTPUT VOLTAGE/KW - 60Hz	LP	AMP	NG	AMP	CB Size
120/240V, 1-phase, 1.0 pf	130	542	117	488	600
120/208V, 3-phase, 0.8 pf	130	451	122	423	500
120/240V, 3-phase, 0.8 pf	130	391	122	367	450
277/480V, 3-phase, 0.8 pf	130	195	122	183	225
GENERATOR LOCKED ROTOR KVA AVAILABLE @ VOLTAGE DIP OF 35%					
Single phase or 208-240 3-phase	270				
480V 3-phase	320				
ENGINE FUEL CONSUMPTION (Natural Gas) (Propane)	Natural Gas		Propane		
	(ft ³ /hr.)		(gal/hr.)	(ft ³ /hr.)	
Exercise cycle	135		1.4	54.5	
25% of rated load	482		5.3	193	
50% of rated load	927		10.3	373	
75% of rated load	1292		14.3	520	
100% of rated load	1786		19.8	719	
For Btu content, multiply ft ³ /hr x 2520 (LP) or ft ³ /hr x 1000 (NG)					
ENGINE COOLING					
Air flow (inlet air including alternator and combustion air)	ft ³ /min.	6,450			
System coolant capacity	US gal.	4.5			
Heat rejection to coolant	BTU/hr.	496,000			
Max. operating air temp. on radiator	°C (°F)	60 (150)			
Max. ambient temperature	°C (°F)	50 (140)			
COMBUSTION AIR REQUIREMENTS					
Flow at rated power 60 Hz	cfm	336			
SOUND EMISSIONS IN DBA					
Exercising at 7 meters	65				
Normal operation at 7 meters	75				
EXHAUST					
Exhaust flow at rated output 60 Hz	cfm	1,119			
Exhaust temp. at muffler outlet	°C (°F)	521 (970)			
ENGINE PARAMETERS					
Rated synchronous RPM	60 Hz	2970			
POWER ADJUSTMENT FOR AMBIENT CONDITIONS					
Temperature Deration	3% for every 10 °C above - °C			25	
	1.65% for every 10 °F above - °F			77	
Altitude Deration	1% for every 100 m above - m			183	
	3% for every 1000 ft. above - ft.			600	

RATING: All three phases units are rated at 0.8 power factor. All single phase units are rated at 1.0 power factor. STANDBY RATING: Standby ratings apply to installations served by a reliable utility source. The standby rating is applicable to varying loads for the duration of a power outage. There is no overload capability for this rating. Ratings are in accordance with ISO-3046-1. Design and specifications are subject to change without notice.

kW rating is based on LPG Fuel and may derate with natural gas.

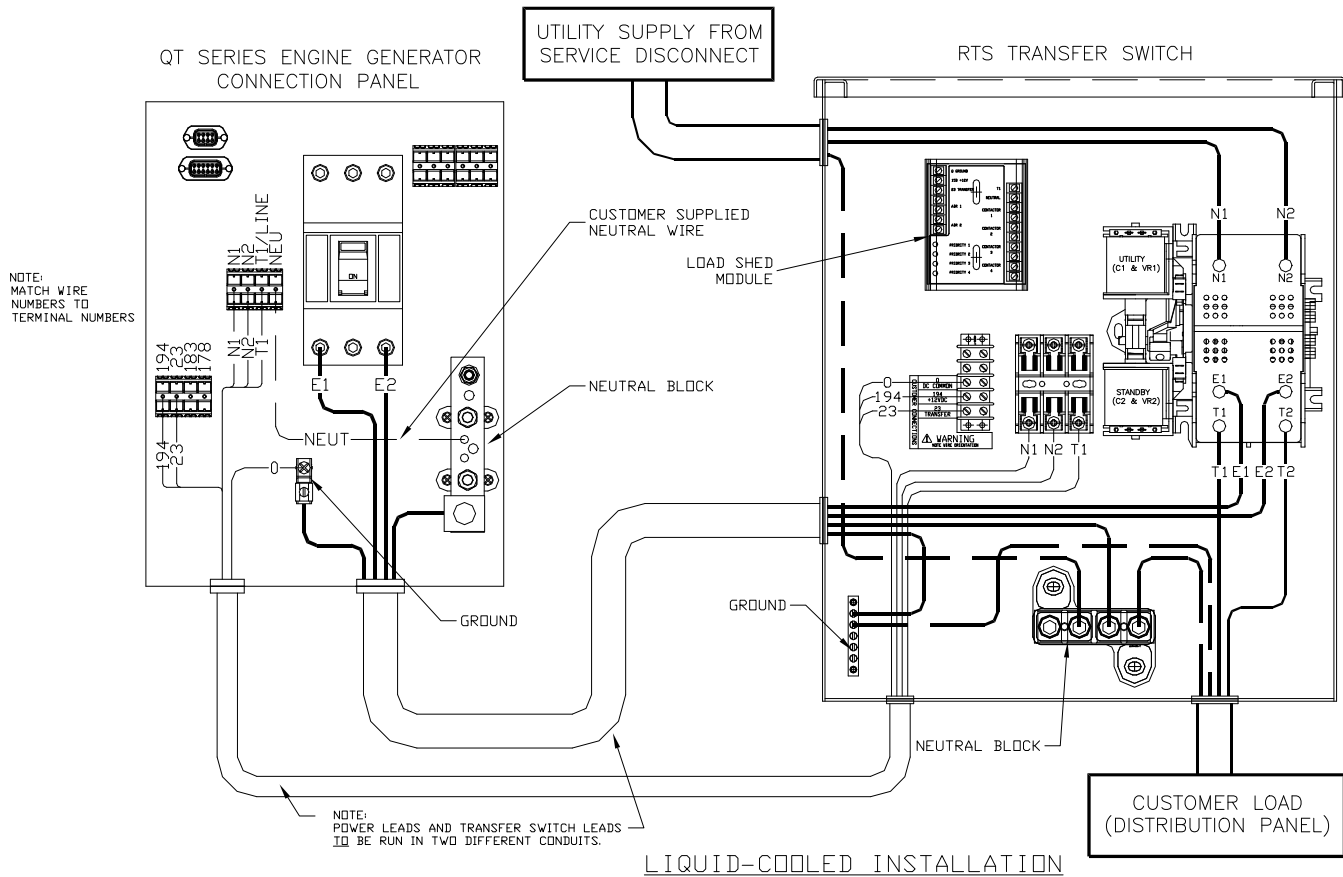

CIRCUIT BREAKER WIRE AND CONDUIT SIZE

KW	VOLTS	CB AMPS	LUG SIZE
130	240 1 Ø	600	(3) 2/0 to 400 mcm
130	240 3 Ø	450	(3) 2/0 to 400 mcm
130	208 3 Ø	500	(3) 2/0 to 400 mcm
130	480 3 Ø	225	(1) 600 mcm or (2) 1/0 to 250 mcm

NEXUS™ CONTROL FEATURES

2-Line Plain Text LCD Display	Simple user interface for ease of operation.
Mode Switch	Automatic Start on Utility failure. 7 day exerciser.
-Auto	Stops unit. Power is removed. Control and charger still operate.
-Off	Start with starter control, unit stays on. If utility fails, transfer to load takes place.
-Manual/Test (start)	Standard
Programmable start delay between 10-30 seconds	Cyclic cranking: 16 sec. on, 7 rest (90 sec. maximum duration).
Engine Start Sequence	5 seconds
Engine Warm-up	1 minute
Engine Cool-Down	Starter cannot re-engage until 5 sec. after engine has stopped.
Starter Lock-out	Standard
Smart Battery Charger	Standard
Automatic Voltage Regulation with Over and Under Voltage Protection	Standard
Automatic Low Oil Pressure Shutdown	Standard
Overspeed Shutdown	Standard, 72Hz
High Temperature Shutdown	Standard
Overcrank Protection	Standard
Safety Fused	Standard
Failure to Transfer Protection	Standard
Low Battery Protection	Standard
50 Event Run Log	Standard
Future Set Capable Exerciser	Standard
Incorrect Wiring Protection	Standard
Internal Fault Protection	Standard
Common External Fault Capability	Standard
Governor Failure Protection	Standard

*Single and three phase connections may vary, refer to the owner's manual for specific connection information.

WEIGHT DATA			
ENGINE/KW	ENCLOSURE MATERIAL	WEIGHT (GROSS/NET)	LIFTING POINTS (NUMBER/SPACING AND CENTER TO CENTER)
6.8L 150KW	ALUMINUM	1148 (E231)	79 (1175) 1287 (E206)
6.8L 130KW	ALUMINUM	1284 (E295)	79 (1175) 1304 (E274)
6.8L 150KW	ALUMINUM	1130 (E282)	79 (1175) 1210 (E267)

- NOTES:**
- 1) MINIMUM RECOMMENDED CONCRETE PAD SIZE: 1240X 48.8" WIDE X 3230 (127.2') LONG. REFERENCE INSTALLATION GUIDE SPECIFIED WITH UNIT FOR CONCRETE PAD GUIDELINES.
 - 2) ALLOW SUFFICIENT ROOM ON ALL SIDES OF THE GENERATOR FOR MAINTENANCE AND SERVICING. THIS UNIT MUST BE INSTALLED IN ACCORDANCE WITH CURRENT APPLICABLE NFPA 37 AND NFPA 70 STANDARDS AS WELL AS ANY OTHER FEDERAL, STATE AND LOCAL CODES FOR MINIMUM DISTANCES FROM OTHER STRUCTURES.
 - 3) CIRCUIT BREAKER INFORMATION:
SEE SPECIFICATION SHEET WITHIN OWNERS MANUAL.
 - 4) INSIDE STUB-UP AREA FOR AC LOAD LEAD CONDUIT CONNECTION, NEUTRAL CONNECTION, BATTERY CHARGER 120 VOLT AC (5 AMP MAX.) CONNECTION, AND ACCESS TO TRANSFER SWITCH CONTROL WIRES. REMOVE FRONT COVER FOR ACCESS.
 - 4A) FIELD CUT HOLE IS ONLY REQUIRED FOR MOUNTING OF GENERATOR ON AN EXISTING PAD.
 - 5) REFERENCE OWNERS MANUAL FOR LIFTING WARNINGS.
 - 6) REMOVE EITHER LEFT OR RIGHT HAND SIDE PANEL TO ACCESS EXHAUST MUFFLERS AND FAN BELT.

SERVICE ITEM ACCESSIBILITY CHART

SERVICE ITEM	150KW 6.8L	130KW 6.8L	150KW 6.8L
OIL FILL CAP	THRU RIGHT FRONT DOOR	THRU LEFT FRONT DOOR	THRU LEFT FRONT DOOR
OIL DIPP STICK	THRU LEFT FRONT DOOR	THRU LEFT FRONT DOOR	THRU LEFT FRONT DOOR
OIL FILLER	THRU LEFT FRONT DOOR	THRU LEFT FRONT DOOR	THRU LEFT FRONT DOOR
RADIATOR DRAIN HOSE	THRU LEFT FRONT DOOR	THRU LEFT FRONT DOOR	THRU LEFT FRONT DOOR
AIR CLEANER ELEMENT	EITHER FRONT DOORS	EITHER FRONT DOORS	EITHER FRONT DOORS
SPARK PLUGS	BOTH FRONT DOORS	BOTH FRONT DOORS	BOTH FRONT DOORS
FAN BELT	SEE NOTE 6	SEE NOTE 6	SEE NOTE 6
BATTERY	THRU RIGHT REAR DOOR	THRU RIGHT REAR DOOR	THRU RIGHT REAR DOOR
*GEARBOX FILL & DRAIN	THRU RIGHT REAR DOOR	THRU RIGHT REAR DOOR	THRU RIGHT REAR DOOR

*NOTE: EXCLUDING 6.8L 150KW UNITS
REFER TO OWNERS MANUAL FOR PERIODIC REPLACEMENT PART LISTINGS

135 (53") DIA. MOUNTING HOLE (4) PLACES LOCATED IN BOTTOM OF GENERATOR MOUNTING FRAME

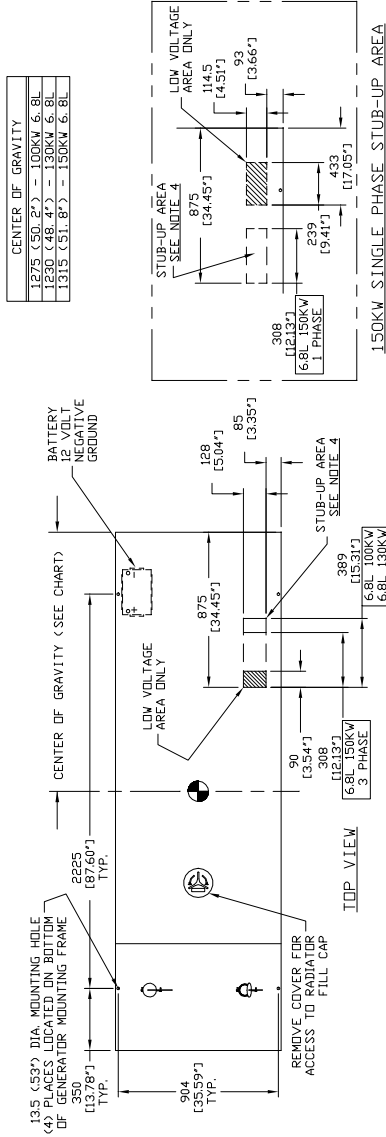

EXHAUST MUFFLERS AND FAN BELT INCLUDED WITHIN SEE NOTE 6

VISE ACTION LATCH, ONE PER DOOR, TWO LIFT-OFF DOORS PER SIDE OF GENERATOR

CONTROL PANEL BATTERY CHARGER IS ENCLOSED WITHIN

1133 (44.61") DOOR TYP.

1933 (76.84")

152.5 (6.0") MIN.

LIFTING PROVISION (4) PLACES, SEE NOTE 5 AND CENTER OF GRAVITY DIMENSIONS

FIELD CUT FOR OUTSIDE CONDUIT CONNECTION ONLY, SEE NOTE 4A

1220 (48.03")

STUB-UP AREA (48.03")

NATURAL GAS LINE CONNECTION 1-1/4" NPT FEMALE COUPLING LOCATED ON (LH) SIDE

LEFT SIDE VIEW

51 (2.01")

152.5 (6.0") MIN.

CIRCUIT BREAKER (SEE NOTE 3)

FRONT COVER (SEE NOTE 4)

685 (26.97") DOOR TYP.

2925 (115.16")

REAR VIEW

935 (36.81")

AIR INLET LOUVERS, REAR AND SIDES.

CONCRETE MOUNTING PAD (SEE NOTE 1)

FRONT VIEW

1571.4 (61.87")

152.5 (6.0") MIN.

152.5 (6.0") MIN.

152.5 (6.0") MIN.

RECOMMENDED MASONRY ANCHOR BOLTS

Model #	Product	Description
5633	Cold Weather Kit	If the temperature regularly falls below 32° F, install a cold weather kit to maintain optimal battery temperature. Kit consists of battery warmer with thermostat built into the wrap.
5620	Extreme Cold Weather Kit	Recommended where the temperature regularly falls below 32° F for extended periods of time. For liquid-cooled units only.
5651	Base Plug Kit	Add base plugs to the base of the generator to keep out debris.
5703	Paint Kit	Bisque Kit
5660	Scheduled Maintenance Kit	The Liquid-Cooled Scheduled Maintenance Kits offer all the hardware necessary to perform a complete maintenance on Generac liquid-cooled generators.
5928	Nexus Wireless Remote	Completely wireless and battery powered, Generac's Nexus wireless remote monitor provides you with instant status information without ever leaving the house.
5951	Advanced Nexus Wireless Remote	Remotely control generator functions with the advanced model's LCD display. In addition to remote testing of the generator, set the exercise cycle and maintenance interval reminders.
5937	DLM Load Control Module (50 Amps)	DLM Modules are used in conjunction with the Nexus Smart Switch to increase its load management capabilities. It gives the Nexus Smart Switch additional load management flexibility not found in any other transfer switch.