

SC228 HANGER ROD STIFFENER

- For $\frac{3}{8}$ " thru $\frac{5}{8}$ " ATR
- Strut ordered separately
- Standard finish: ZN
- Wt./C 21 Lbs. (9.5 kg)

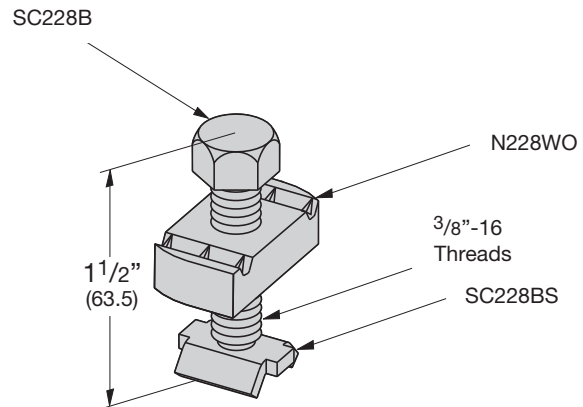
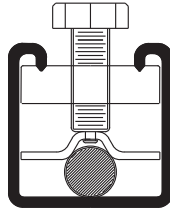

Fig. 98 ROD STIFFENER

- For $\frac{3}{8}$ " thru $\frac{7}{8}$ " ATR
- Use with 12 ga. strut only, ordered separately
- Secures channel to hanger rod for vertical seismic bracing
- Standard finish: ZN
- Wt./C 11 Lbs. (5.0 kg)

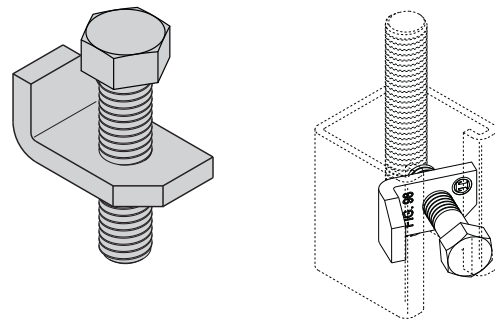
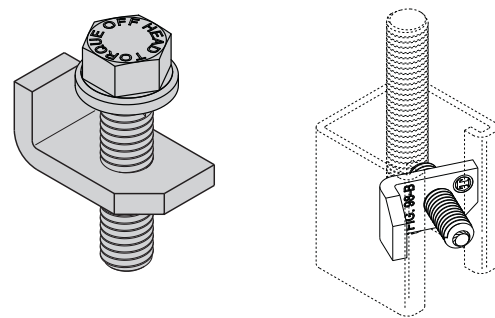

Fig. 98B ROD STIFFENER w/BREAK-OFF BOLT HEAD

- For $\frac{3}{8}$ " thru $\frac{7}{8}$ " ATR
- Use with 12 ga. strut only, ordered separately
- Secures channel to hanger rod for vertical seismic bracing
- Uses a snap-off bolt head
- Standard finish: ZN
- Wt./C 13 Lbs. (5.9 kg)



SC-UB HANGER ROD STIFFENER

- For $\frac{3}{4}$ " thru $\frac{7}{8}$ " ATR
- Strut ordered separately
- Includes: (1) B3188-1 $\frac{1}{2}$ WO U-Bolt
- (2) $\frac{3}{8}$ "-16 Hex Nuts
- (1) 2-Hole Plate
- Standard finish: ZN
- Wt./C 50 Lbs. (22.7 kg)

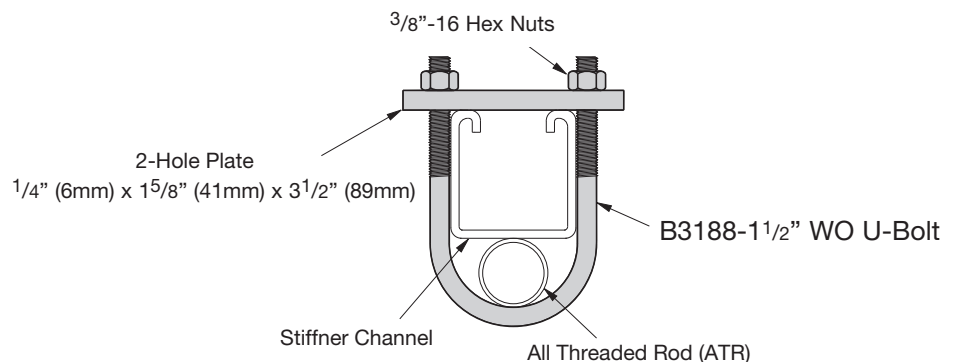

Reference page 44 for general fitting and standard finish specifications.