



Mini Inverter Series

Interruptible Unit Equipment



The **Mini Inverter** is a UL Listed stand-alone pure sine wave (250W and up) output inverter designed to provide power to designated emergency lighting fixtures. In a power loss situation, it will supply power from the onboard battery supply.

The **Mini Inverter** works in conjunction with incandescent, LED, and fluorescent fixture types and will automatically run switched, normally-on, or normally-off designated emergency fixtures.

The **Mini Inverter** is ideal for applications requiring an emergency source for lighting arrangements that utilize multiple lamp and fixture types and is available in surface mount and comes with a three year warranty and seven-year pro-rata battery warranty.

Standard Features

- Lamps operated: Incandescent, LED, fluorescent lamps and ballast combinations, including dimming ballasts (consult factory if 0-10V or DALI dimming)
- Components: High-efficiency pure sine wave inverter (250W and up), temperature-compensated charger, 12V oversized Valve Regulated Lead-Acid (VRLA) battery
- Construction: 14-Gauge (400W & 720W) or 18-Gauge (125W & 250W) housing
- Emergency lighting supplied from one convenient source
- Input/Output voltage 120V 60 Hz or 277V 60 Hz
- Replacable output fuse protection
- Line voltage allows for remote mounting of emergency fixtures at distances up to 1000 feet
- Low Voltage Battery Disconnect
- Unit comes standard with electronic lockout and brownout circuits
- Meets or exceeds all National Electrical Code and Life Safety Code Emergency Lighting Requirements UL924 Listed
- Cabinet in factory white semi-gloss powder-coat paint finish
- May accept load to its full capacity when load feature power factor 0.8 leading to 0.8 lagging for 125 & 720W model
- Standard auto-diagnostic, non-audible, Nexus® system interface optional with an improved minimum lost load detection of 10%
- Standard lighting control override for 0-10V dimming systems

Replacement Battery

EMIU-125	860.0024-E
EMIU-250	2X 860.0024-E
EMIU-400	2X 860.0043-E
EMIU-720	2X 860.0096-E

Suggested Specification

Emergency lighting shall be provided by inverter unit equipment designed to operate designated incandescent, fluorescent and LED fixtures on emergency power at their full nominal lumen rating during the full 90 minutes emergency discharge cycle. System output will be rated at _____ watts for 90 minutes and provide fused output connections to the load. The system's voltage rating shall be _____ VAC input/output. The inverter unit shall allow for connected emergency fixture(s) to be normally-on, normally-off, switched or triac dimmable ballasts without affecting lamp operation during a power failure. Upon utility power loss, the inverter unit shall deliver 100% of its rated output to the emergency fixtures regardless of the local switch or dimmer position, and will provide power to emergency fixtures at distances of up to 1000 feet. The housing shall be manufactured using 14-Gauge (400W & 720W) or 18-Gauge (125W & 250W) steel with a white baked-on powder coat paint finish. The unit's electronics shall include a self-contained inverter section with a fully automatic, thermal-compensating variable-rate battery charger, AC lockout feature, low voltage battery disconnect, DC overload, short circuit and brownout protection as standard. The unit shall utilize a sealed Lead-Acid battery with a 10-year design life. The inverter system shall be UL 924 Listed and labeled. The unit shall be covered under a 3-year warranty on the electronics and battery and a 7-year pro-rata warranty on the battery.

Specifications

TRANSFER TIME: less than 1 second
VOLTAGE REGULATION ON EMERGENCY: +/- 3%
FREQUENCY REGULATION ON EMERGENCY: 60 Hz +/- 1%
LOAD POWER FACTOR RANGE: <ul style="list-style-type: none"> • 250W model: 0.9 leading to 0.9 lagging • 125, 400 & 720W models: 0.8 leading to 0.8 lagging
OPERATING TEMPERATURE: 68° TO 86°F (20° TO 30°C)

Warranty

All **Emergi-Lite®** inverter products receive 100% quality inspection before shipment to insure proper and satisfactory operation. When operated under normal conditions, **Emergi-Lite®** inverter products will provide years of dependable service. The unit is covered by a complete 3-year warranty against defects in material or workmanship, and a 7-year pro-rata battery warranty.

The inverter unit shall be Emergi-Lite® model: _____

Wiring Diagram

125W

NOTE: THE EMERGENCY LIGHT AND INDICATORS WILL NOT TURN ON AT THIS TIME.

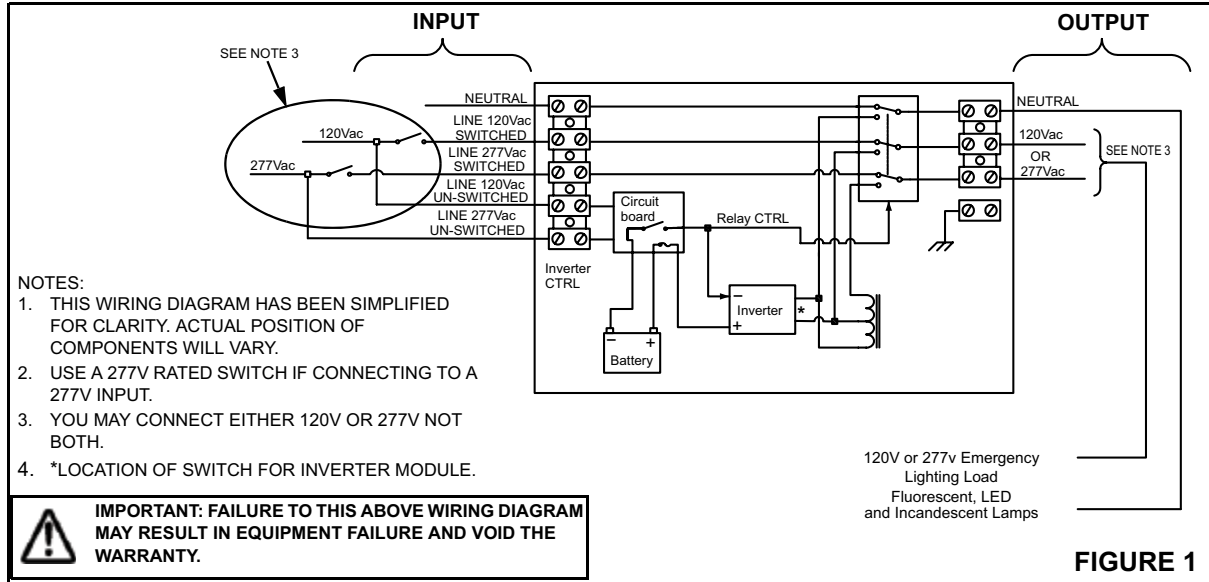

720W

NOTE: THE EMERGENCY LIGHT AND INDICATORS WILL NOT TURN ON AT THIS TIME.

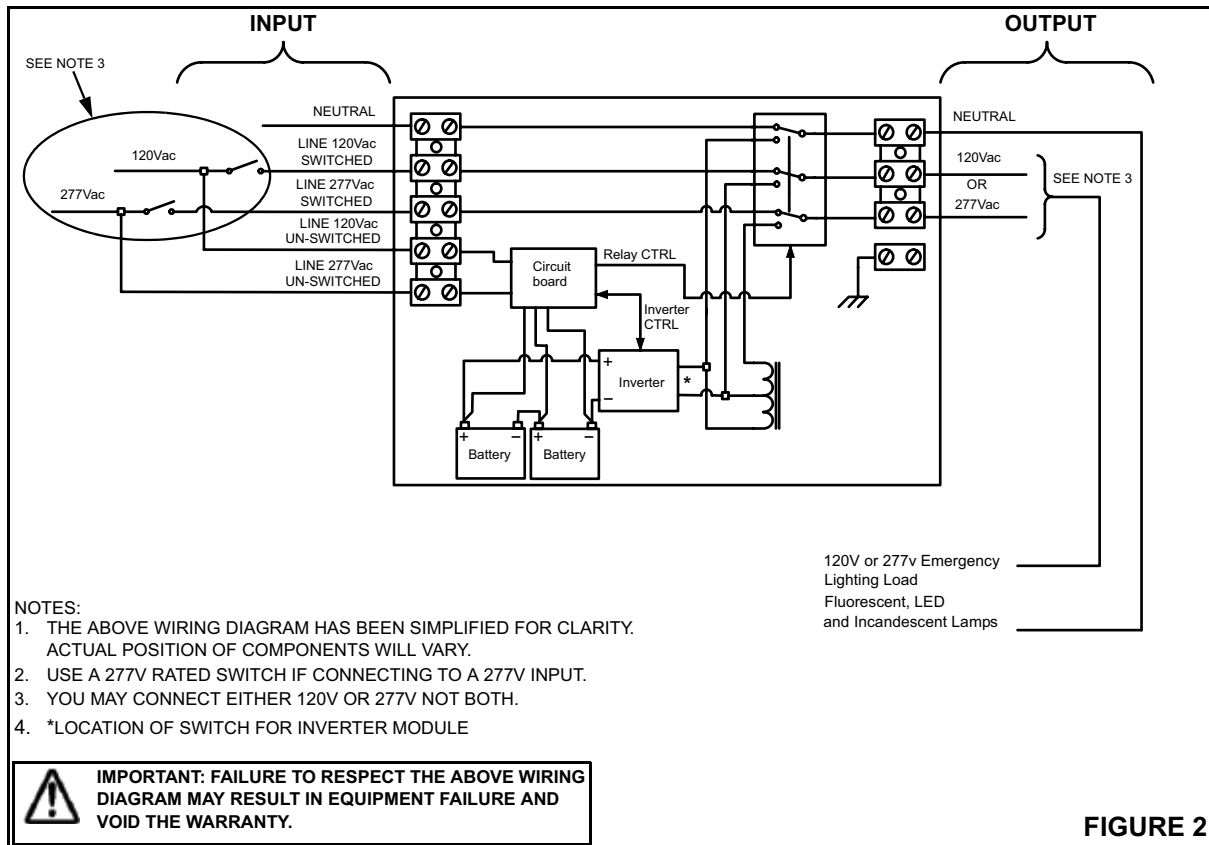



Electrical Characteristics & Dimensions

POWER RATING	SINE WAVE	INSTALLATION	CABINET DIMENSIONS			NO. OF BATTERY	TOTAL WEIGHT	WEIGHT W/O BATTERY
			W"	H"	D"		120V & 277V	120V & 277V
125W	Modified	T-Bar	24"	6.5"	8"	1	50 lbs	22 lbs
125W	Modified	Wall	16.5"	12.2"	7.3"	1	50 lbs	22 lbs
250W	Pure	Wall	27"	12.2"	7.3"	2	100 lbs	45 lbs
400W	Pure	Wall	24"	10.5"	20"	2	150 lbs	65 lbs
720W	Pure	Wall	24"	14.5"	20"	2	220 lbs	95 lbs

Power Consumption And Unit Rating

MODEL NUMBER	AC SPECS	EMERGENCY POWER AVAILABLE FOR LOAD				
		90 MIN	2H	3H	4H	
EMIU-125	120/277VAC	1.15 / 0.70 Amps	125W	83W	62W	47W
EMIU-250		2.75 / 1.20 Amps	250W	167W	125W	94W
EMIU-400		4.60 / 2.00 Amps	400W	300W	200W	150W
EMIU-720		9.60 / 4.00 Amps	720W	614W	473W	340W

How to Order

SERIES	CAPACITY	VOLTAGE	DIAGNOSTIC FEATURE	OPTIONS
EMIU	-125= 125W -250= 250W -400= 400W -720= 720W	BLANK = 120/120VAC or 277/277VAC	- Blank = Advanced-Diagnostic, non-audible - AD = Advanced-Diagnostic, audible - NEX = Nexus® wired - NEXRF = Nexus® wireless	- D1 = Time Delay (5 minutes) - D2 = Time Delay (10 minutes) - D3 = Time Delay (15 minutes) - SAC = Service Alarm Contact* - T = Recessed T-Bar mounting (125W unit only)

* Service alarm contact (SAC) shall provide a 24V signal, the charger board will indicate a fault by choosing a contact. Not available with 720 capacity

Example: **EMIU-720**