

PHILIPS

Floodlights

General purpose flood



Project: _____
 Location: _____
 Cat.No: _____
 Type: _____
 Qty: _____
 Notes: _____

The Philips LED Floodlights offer energy saving LED technology for long life and reduced maintenance. Versatile and stylish with five different sizes to choose from provides application flexibility for ground mount, wall mount, or pole mount installations. Ideal for sign lighting, building facades, security lighting, and general purpose floodlighting applications.

Ordering guide

example: PFL150-NW-G1-T-FL-8-BZ

Luminaire	LED Color	Generation	Mounting	Distribution	Voltage	Finish
<input type="text"/>	NW	G1	<input type="text"/>	FL	8	BZ
PFL20 LED Floodlight 20W PFL40 LED Floodlight 40W PFL80 LED Floodlight 80W PFL150 LED Floodlight 150WP PFL300 LED Floodlight 300W	NW Neutral White 4000K, 80CRI	G1 Generation 1	K¹ Knuckle Mount ½" NPS male T² Trunion Mount	FL Flood	8 120-277VAC	BZ Bronze

1. K Knuckle Mount only available with PFL20 and PFL40.
2. T Trunion Mount only available with PFL80, PFL150 and PFL300.

LED Wattage and Lumen Values

Neutral White Ordering Codes	Total LEDs	LED Current (mA)	Color Temp. (K)	Average System Wattage ¹	Lumen Output ^{1,2}	Efficacy (LPW)
PFL20-NW-G1-K-FL-8-BZ	32	500	4000	20	2122	109
PFL40-NW-G1-K-FL-8-BZ	64	1100	4000	39	4433	113
PFL80-NW-G1-T-FL-8-BZ	128	2450	4000	79	8856	113
PFL150-NW-G1-T-FL-8-BZ	248	4200	4000	146	16,325	112
PFL300-NW-G1-T-FL-8-BZ	544	2100	4000	301	34,025	113

1. Wattage and lumen output may vary by +/- 8% due to LED manufacturer forward volt specification and ambient temperature. Wattage shown is average for 120V through 277V input. Actual wattage may vary by an additional +/- 10% due to actual input voltage.
2. Lumen values based on photometric tests performed in compliance with IESNA LM-79.

NOTE: Contact outdoorlighting.applications@philips.com for additional photometric tests or information.

Lighttogo



General purpose flood LED

PFL20/40/80/150/300

Dimensions

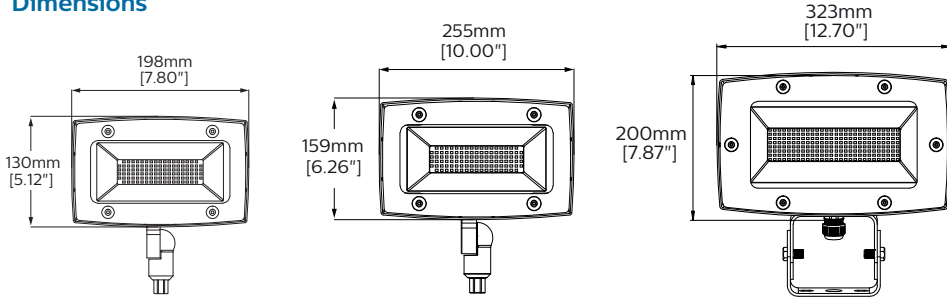

PFL20 Front

PFL40 Front

PFL80 Front

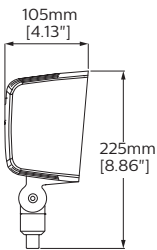

PFL20 Side

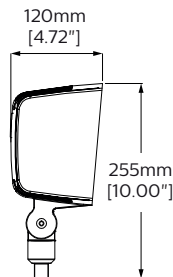

PFL40 Side

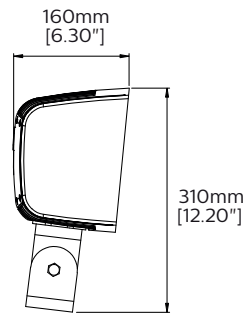

PFL80 Side

Accessory (ordered separately, field installed)

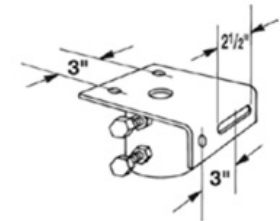

USF10BRZ

Mounting adapter for trunion, fits 2-3/8" O.D. tenon, bronze finish.

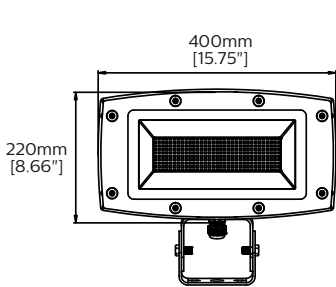

PFL150 Front

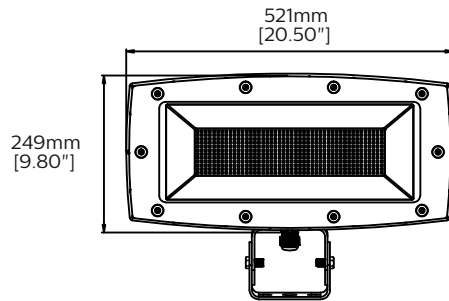

PFL300 Front

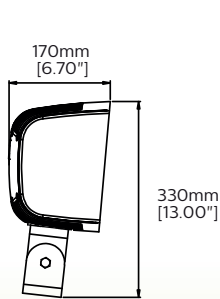

PFL150 Side

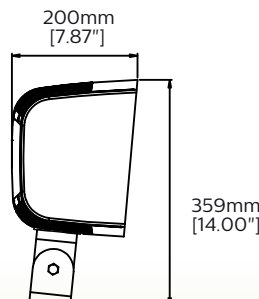

PFL300 Side

EPA and Weight

Product	Effective Projected Area (EPA-ft ²)			Weight
	0° Aim	45° Aim	90° Aim	
PFL20	0.238	0.271	0.316	4.6lbs (2.09kg)
PFL40	0.351	0.415	0.500	6.6lbs (2.99kg)
PFL80	0.595	0.680	0.798	15lbs (6.8kg)
PFL150	0.784	0.915	1.089	20lbs (9.1kg)
PFL300	1.199	1.369	1.604	33lbs (14.9kg)

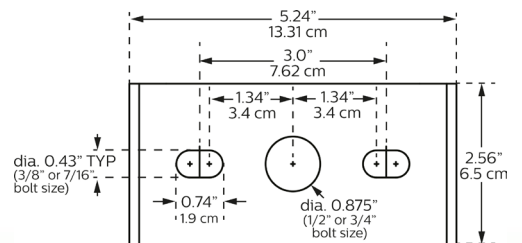

Trunion Mount Bolt Pattern

General purpose flood LED

PFL20/40/80/150/300

Specifications

Housing and Heat Sink

Single piece lower copper die cast aluminum alloy for resistance to corrosion. Housing also acts as a heat sink, designed to ensure high efficacy and superior cooling by natural convection. Air flow pattern always close to LEDs and driver optimizing their efficiency and life. Product does not use any cooling device with moving parts (only passive cooling).

Mounting

Knuckle (K, see Ordering guide): Integral die cast Aluminum adjustable knuckle (K) with 1/2" NPS male threads, made of a lower copper alloy for resistance to corrosion, with locking teeth and bolt to lock in aiming angle. Ships fully assembled, ready to install. Six inch (6" or 152mm) leads exit out of Knuckle for connection by others.

Trunnion (T, see Ordering guide): Integral structural steel adjustable trunnion (T) for direct surface mounting, painted for resistance to corrosion, with bolt to lock in aiming angle. Ships fully assembled, ready to install. Six foot (6' or 1.83m) watertight STW 16 gauge cord exits out of Housing for connection by others, IP66 liquid tight connector to seal cord exit point.

Lens

Heat and impact resistant tempered glass lens with one piece silicone gasket surrounding the entire perimeter of the LED light engine and electronics compartment providing an IP66 seal. Lens secured with screws and recessed sleeve washers outside of gasket perimeter. Lens includes silk screen to help reduce glare and for aesthetic purposes.

Light Engine

Composed of 3 main components: LED Module / Optical System / Driver. Electrical components are RoHS compliant. LEDs tested by ISO 17025-2005 accredited lab in accordance with IESNA LM-80 guidelines extrapolations in accordance with IESNA TM-21. Metal core substrate ensures greater heat transfer and longer lifespan.

Predicted Lumen Depreciation Data

Ambient Temperature °C	System Current	L ₇₀ per TM21 ^{1,2}	Lumen Maintenance @ 42,000hrs
25°C	4200 mA	>42,000	85%

- L₇₀ is the predicted time when LED performance depreciates to 70% of initial lumen output.
- Calculated per IESNA TM 21-11. Published L₇₀ hours limited to 6 times actual LED test hours.

LED Module

Composed of mid-power performance white LEDs. Color temperature as per ANSI/NEMA bin Neutral White, 4000 Kelvin nominal (3985 +/- 275K or 3710K to 4260K), CRI 80 Min.

Optical System

Flood distribution, optimized for target lumens and a superior lighting uniformity. Photometric performance shall be tested per LM-79 (IESNA) certifying its photometric performance and published in accordance with LM-63.

Driver

High power factor of 90% min. Electronic driver, operating range 50/60 Hz, Class 1 or Class 2.

Other Integrated Features

Surge Protection: Each luminaire is provided as standard with surge protector (Philips designed SP1 or SP1HV) tested in accordance with ANSI/IEEE C62.45 per ANSI/IEEE C62.41.2 Scenario I Category C High Exposure 10kV/10kA waveforms for Line Ground, Line Neutral and Neutral Ground.

Wiring

Insulated internal wiring located inside the housing, silicone seals all places where wiring passes through openings including sealed going into the knuckle or exiting the luminaire for trunnion mount. Due to the inrush current that occurs with electronic drivers, recommend using a time delay or slow blow fuse to avoid unnecessary and unwanted fuse blowing that can occur with fast acting fuses.

Hardware

All exposed screws shall be stainless steel and/or corrosion resistant and captive. All seals and sealing devices are made and/or lined with EPDM and/or silicone and/or rubber.

Finish

Fade and abrasion resistant, electrostatically applied, thermally cured, triglycidal isocyanurate (TGIC) polyester powdercoat textured bronze finish.

LED Products Manufacturing Standard

The electronic components sensitive to electrostatic discharge (ESD) such as light emitting diodes (LEDs) are assembled in compliance with EC61340-5-1 and ANSI/ESD S20.20 standards so as to eliminate ESD events that could decrease the useful life of the product.

Vibration Resistance

Knuckle mounts meet the ANSI C136.31 Luminaire vibration specifications for normal applications (1.5G).

Certifications and Compliance

cULus Listed for Canada and USA. DesignLights Consortium qualified. Entire luminaire is rated for operation in ambient temperature of -30°C (-22°F) up to +40°C (+104°F).

IP66 Rating

Entire luminaire including light engine and driver/electrical compartment IP66 rated in all aiming positions including upward aiming floodlighting applications.

Limited Warranty

5-year limited warranty. See philips.com/warranties for details and restrictions. Visit our eCatalog or contact your local sales representative for more information.

