

# cope® Cat-Tray™ Wire Mesh Cable Tray System

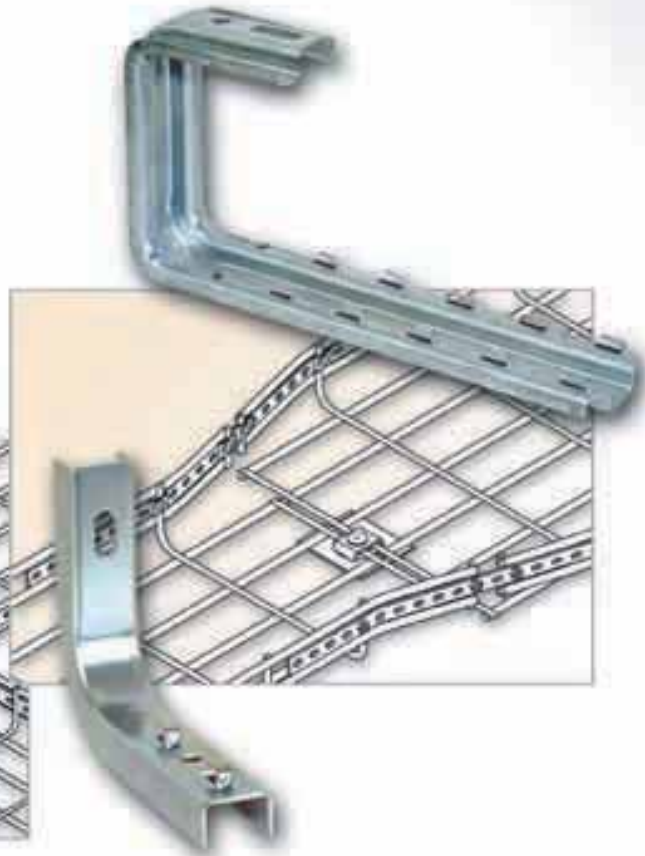



Product Description.....	3
Assembly .....	4 - 5
Straight Lengths .....	6 - 8
Connectors.....	9 - 11
Supports.....	12 - 16
Pendants .....	17
Brackets.....	18 - 20
Accessories .....	21 - 23
Radius Bends.....	25 - 26
Tees, Crosses .....	27
Reducers, Offsets & Risers.....	28
Sample Specification .....	29
Grounding Hardware.....	30
Hardware .....	31-33
Index .....	34



## Product Description

Cat-Tray™ is a welded wire mesh cable management system produced from high mechanical strength steel wires. Cat-Tray is produced by first welding a net, forming the channel, and then finishing after fabrication. The 2" x 4" mesh permits continuous airflow to help prevent heat buildup. This unique open design also prevents the buildup of dust, contaminants and bacterial proliferation.

Cat-Tray is produced in standard 10' lengths and is supplied in three channel depths: 1", 2" and 4".

Cat-Tray is offered in nine different widths:

2" (50 mm), 4" (100mm),  
6" (150mm), 8" (200mm),  
12" (300mm), 16" (400mm),  
18" (450mm), 20" (500mm), and  
24" (550mm).

**Special sizes are available to meet your unique requirements.**

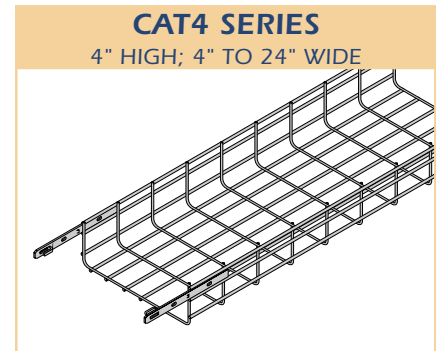
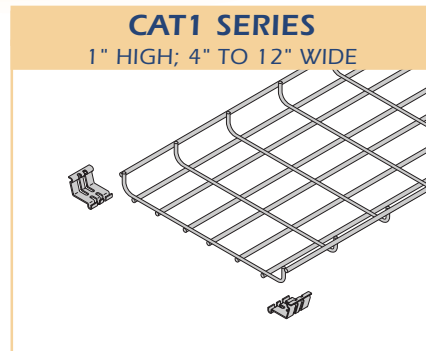

### STANDARD FINISH

**EG — Electro-plated Zinc Galvanizing** (ASTM B633 Type 1, SC3 ▪ Thickness: .000472" (12um))

Electrodeposited zinc coating is suitable for most indoor applications and may be used outdoors in mild environments only.

### SPECIAL ORDER FINISHES

**HG — Hot Dip Galvanizing** (ASTM A123 GRD.55 ▪ Thickness: .0002165" (55um))

Provided by immersing the product in a molten zinc bath. This treatment is most suitable for outdoor applications or situations where increased corrosion resistance is desired.

**SS — 304 Type Stainless Steel**

**S1 — 316 Type Stainless Steel**

Corrosive resistant stainless steel with no additional surface treatment. This material option provides the most corrosion resistant option available. Stainless steel is used primarily in marine environments or food processing facilities.

**ZD — Dichromate** (ASTM B633 Type II, SC3 ▪ Thickness: .000472" (12um))

An electro-galvanized zinc plate is applied to the steel base metal. Yellow dichromate is applied over the zinc and results in a gold appearance which acts as a nonporous barrier sealant.

**Other**— PVC and powder coating available.

### HOW TO ORDER

Part numbers shown in the catalog are for the standard electro-galvanized finish. For special order finishes, add the finish code as a suffix.

**EXAMPLE:** CAT2-12SL-120 is electro-galvanized  
CAT2-12SL-120-SS is stainless steel



## Self-Splicing Straight Lengths

Cope's exclusive Kwik-Latch splicing system makes connecting Cat-Tray fast and simple. The Kwik-Latch, or self splicing bars which come pre-installed on most Cat-Tray systems, eliminates the need for a typical nut and bolt type connection. For proper grounding of Cat-Tray please refer to page 30.

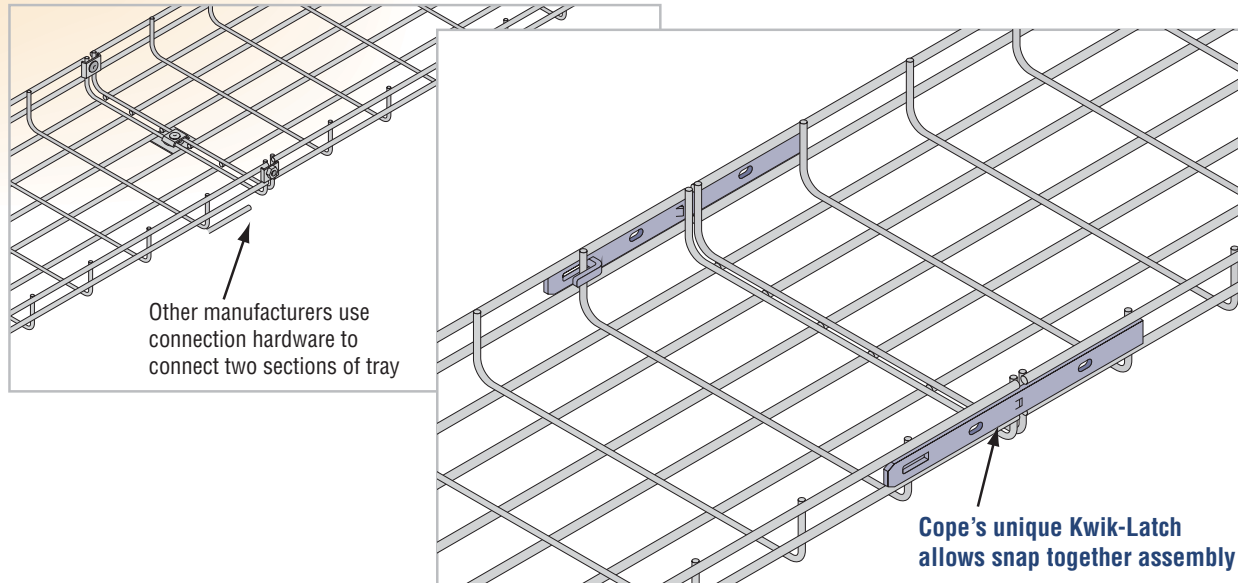

## Kwik-Latch Assembly

### CAT2 & CAT4 ASSEMBLY

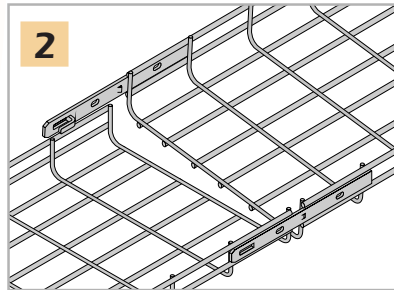
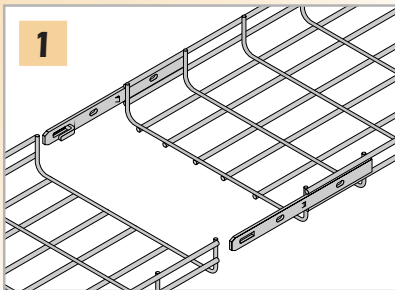

**STEP 1** Align the trays as shown.

**STEP 2** While raising the rear edge of the male connection, slide the tray forward, but do not engage the locking clip.

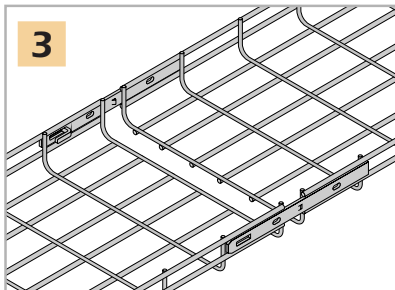

**STEP 3** Push the rear locking clip over the back edge of the tray.

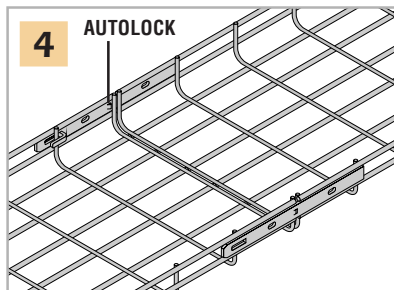

**STEP 4** Slide the tray forward to engage both front and rear locking clips.

# Assembly

## ACCESSORY ASSEMBLY

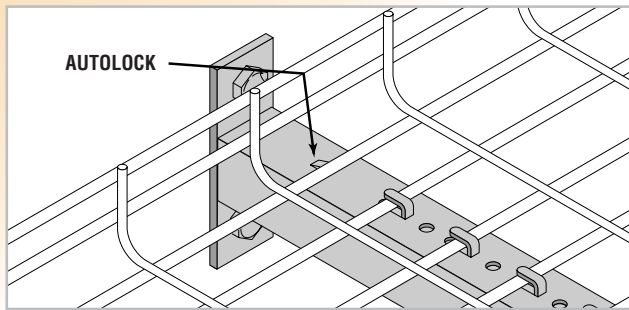

Many of the Cope wire basket accessories feature the unique Autolock. Just slide the tray under the tabs and then push down to engage the autolock. No tools, bending, or attachments are required for a secure connection.

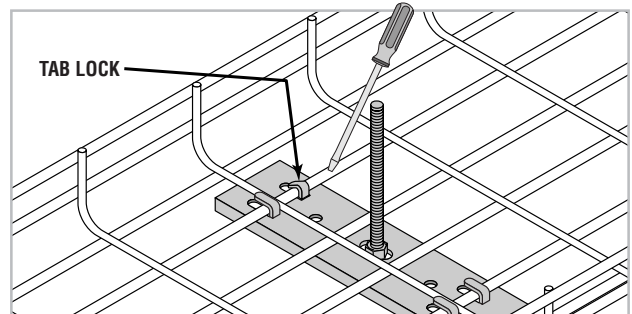

For accessories which use the tab lock, the tray is secured by using a screw driver to gently bend one of the tabs down over the tray.

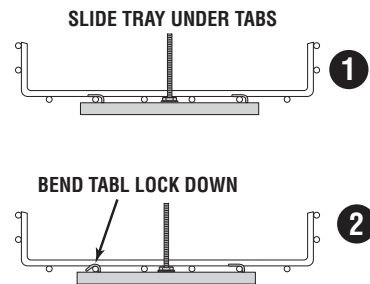
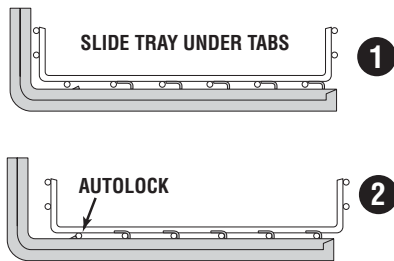

## CAT1 ASSEMBLY

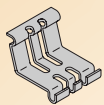

**Locking Clip  
CAT1-AUTO**

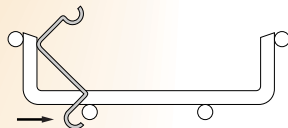

**STEP 1** Snap the clip onto the bottom rods of the two trays to be connected.

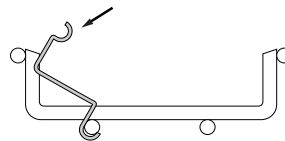

**STEP 2** Rotate and snap the clip onto the top rod of the trays to be connected.

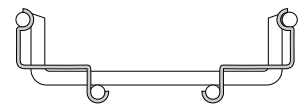

**STEP 3** Install a second locking clip on the opposite side.

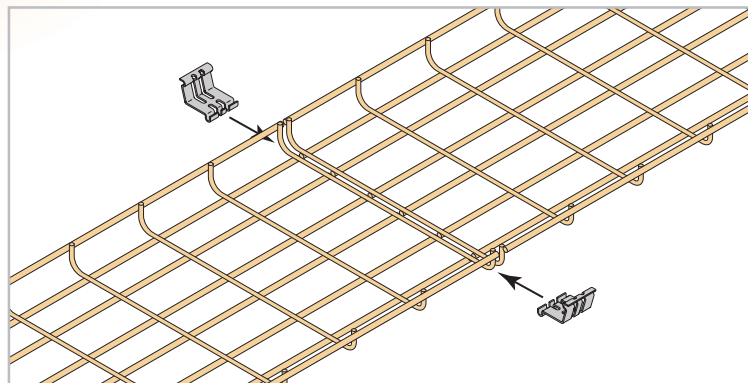





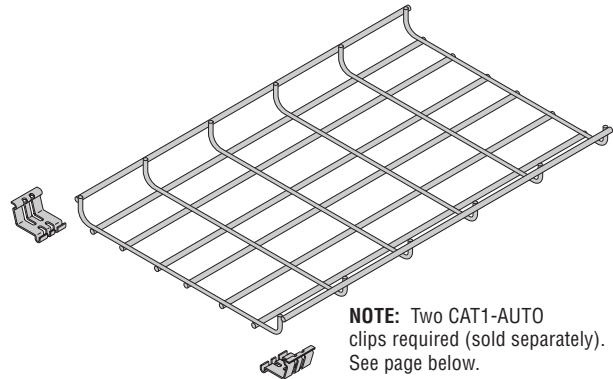
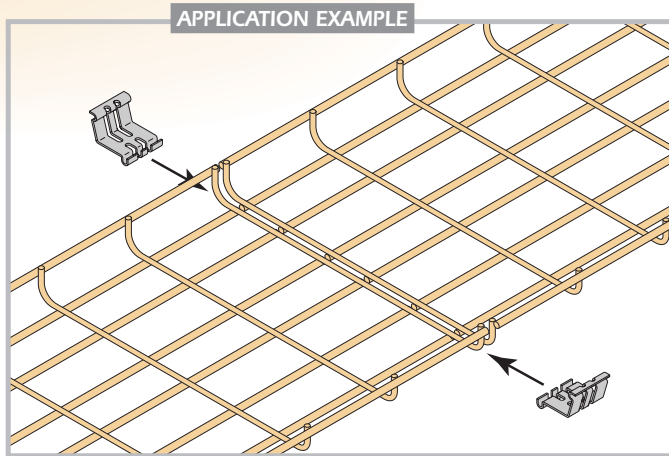

## Single Rod Reinforced Tray (1" Depth)

### CAT1-(W)SL-120

- Single rod reinforced tray is 1" high
- Standard length of tray is 10'
- Standard finish is electro-galvanized (EG)
- Use CAT1-AUTO for splicing



PART DESCRIPTION	Width Nom. in. (mm)	Dimensions Wire Dia (in.)	Wt. (piece)	Loading (lb/ft) – at Deflection Limited to L/300			
				5' Span	6' Span	8' Span	9' Span
 CAT1-04SL-120	4" (100mm)	0.177	5.3	20.3	10.1	3.6	2.0
 CAT1-06SL-120	6" (150mm)	0.177	6.6	20.3	10.1	3.6	2.0
 CAT1-08SL-120	8" (200mm)	0.177	7.9	20.3	10.1	3.6	2.0
*  CAT1-12SL-120	12" (300mm)	0.197	10.6	20.3	10.1	3.6	2.0



### CAT1-AUTO

Weight: .06 lb/each

- Standard finish is pregalvanized (PG)
- Sold separately (not in pairs)

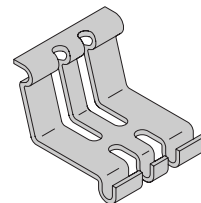

**NOTE:** CAT1-AUTO clips are designed exclusively for use with the CAT1 series of tray as shown in example above.

# Double Rod Reinforced Tray (2" Depth)

## CAT2-(W)SL-120

- Double rod reinforced tray is 2" high
- Standard length of tray is 10'
- Standard finish is electro-galvanized (EG)
- No hardware is necessary to connect straight sections
- For continuous grounding use CAT-GC (See page 30.)

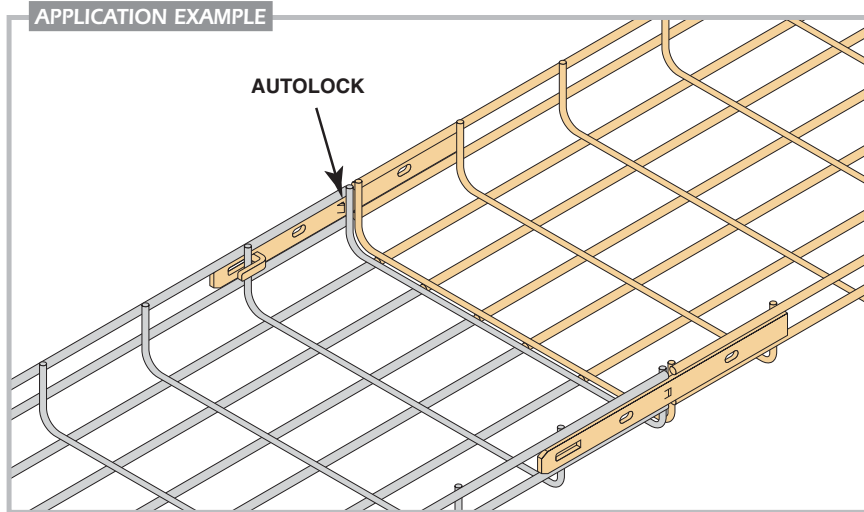
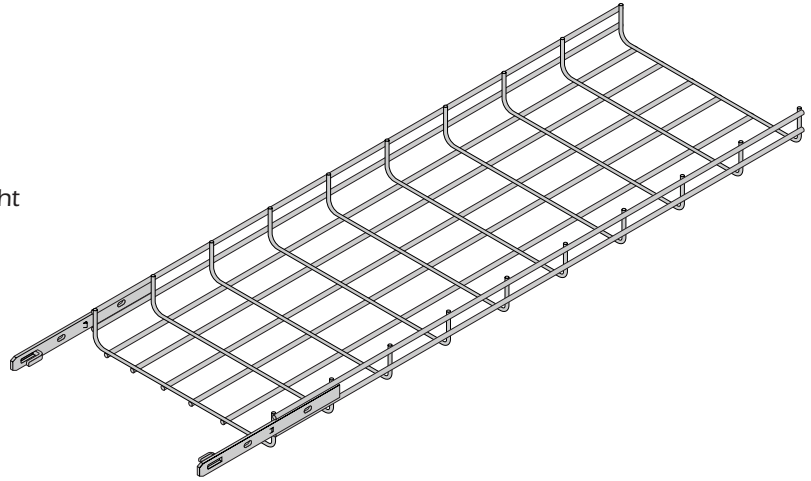

PART DESCRIPTION	Width Nom. in. (mm)	Dimensions Wire Dia (in.)	Wt. (piece)	Loading (lb/ft) – at Deflection Limited to L/300			
				5' Span	6' Span	8' Span	9' Span
CAT2-02SL-120	2" (50mm)	0.177	5.4	40.5	23.7	10.1	5.4
CAT2-04SL-120	4" (100mm)	0.177	9.0	40.5	23.7	10.1	5.4
CAT2-06SL-120	6" (150mm)	0.177	9.9	40.5	23.7	10.1	5.4
*  CAT2-08SL-120	8" (200mm)	0.177	11.2	40.5	23.7	10.1	5.4
*  CAT2-12SL-120	12" (300mm)	0.197	15.9	40.5	23.7	10.1	5.4
*  CAT2-16SL-120	16" (400mm)	0.236	23.8	60.8	50.7	33.8	27.0
*  CAT2-18SL-120	18" (450mm)	0.236	28.1	60.8	50.7	33.8	27.0
*  CAT2-20SL-120	20" (500mm)	0.236	32.4	60.8	50.7	33.8	27.0
*  CAT2-24SL-120	24" (600mm)	0.236	41.0	60.8	50.7	33.8	27.0

Denotes Popular Sizes





## Triple Rod Reinforced Tray (4" Depth)





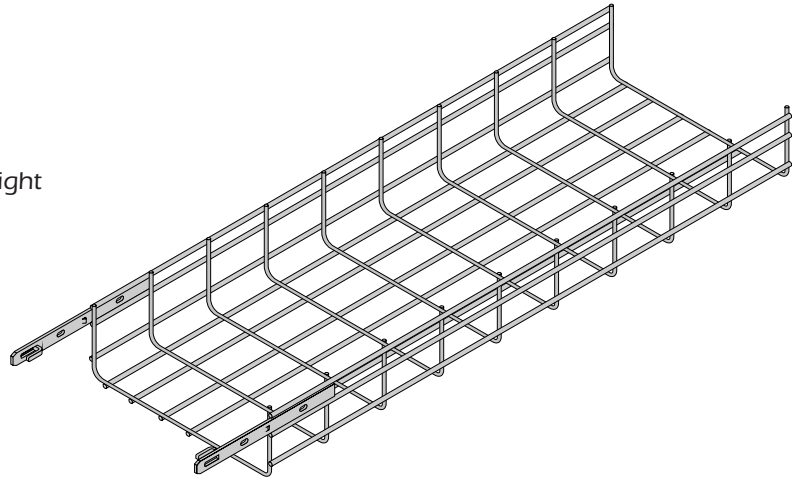

### CAT4-(W)SL-120

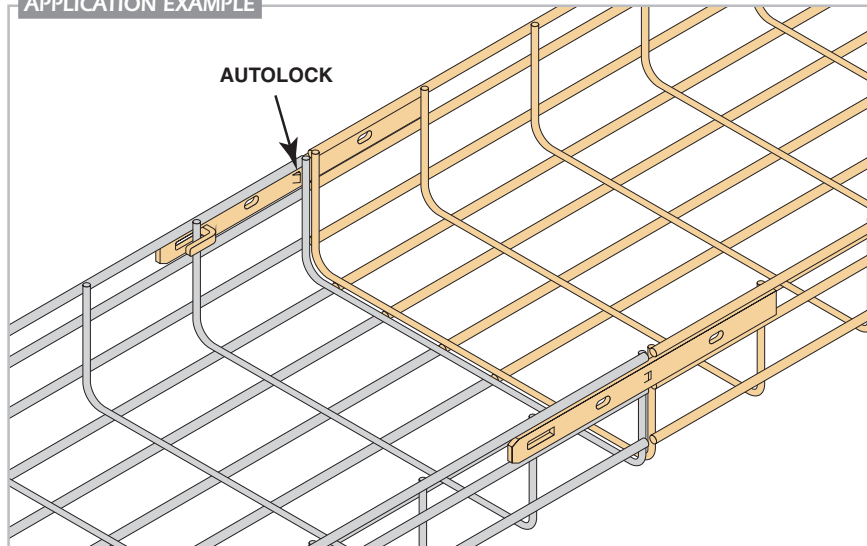
- Triple rod reinforced tray is 4" high
- Standard length of tray is 10'
- Standard finish is electro-galvanized (EG)
- No hardware is necessary to connect straight sections
- For continuous grounding use CAT-GC (See page 30.)



#### APPLICATION EXAMPLE



PART DESCRIPTION	Width Nom. in. (mm)	Dimensions Wire Dia (in.)	Wt. (piece)	Loading (lb/ft) – at Deflection Limited to L/300			
				5' Span	6' Span	8' Span	9' Span
*  CAT4-04SL-120	4" (100mm)	0.177	11.2	40.5	33.8	21.6	13.5
*  CAT4-08SL-120	8" (200mm)	0.197	15.9	40.5	33.8	21.6	13.5
*  CAT4-12SL-120	12" (300mm)	0.236	23.8	64.2	54.1	46.0	37.2
*  CAT4-16SL-120	16" (400mm)	0.236	32.4	64.2	54.1	46.0	37.2
*  CAT4-18SL-120	18" (450mm)	0.236	36.7	64.2	54.1	46.0	37.2
*  CAT4-20SL-120	20" (500mm)	0.236	41.0	64.2	54.1	46.0	37.2
*  CAT4-24SL-120	24" (600mm)	0.232	50.0	64.2	54.1	46.0	37.2

\*Item is



Denotes Popular Sizes



## Standard Bar Connector

### SPLICE

Weight: .29/each

- Splice bar connector is  $\frac{3}{4}$  x 9" long
- Standard finish is electro-galvanized (EG)
- Connect using CH3 (sold separately)
- Bend 90° for use as an angle connector

#### NOTES:

1. Always place nut on outside of tray
2. For use with CAT2 and CAT4 tray only
3. This connector is only needed for cases when integrated self-splice sections cannot be used (for example, pre-fabricated fittings)

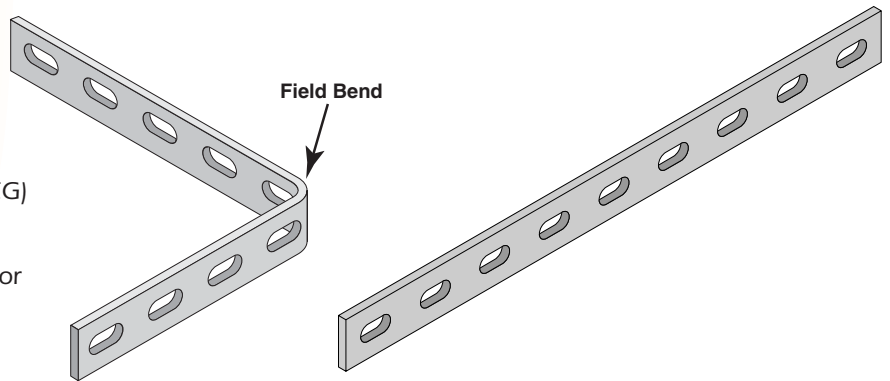

#### APPLICATION EXAMPLE

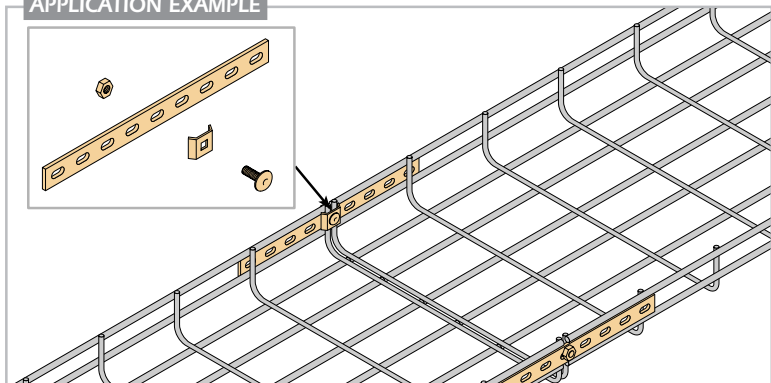

## Bend & Intersection Bars

### T-BAR

Weight: 1.43/each

- T-Bar connector is  $\frac{3}{4}$  x 44" long
- Connect using CH3 (sold separately)
- Bend 90° for use as an angle connector

### T-BAR-22

Weight: .715/each

- T-Bar connector is  $\frac{3}{4}$  x 22" long
- Connect using CH3 (sold separately)

#### NOTES:

1. Always place nut on outside of tray
2. For use with CAT2 and CAT4 tray only
3. Used for tees which require a heavier support
4. These bars are normally cut to appropriate length

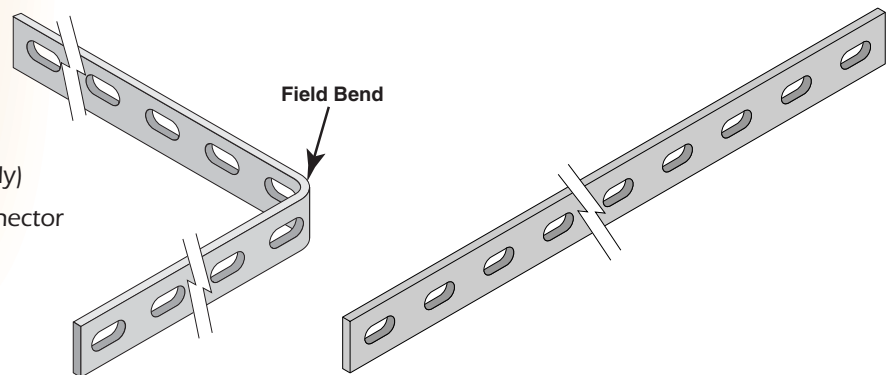

#### APPLICATION EXAMPLE

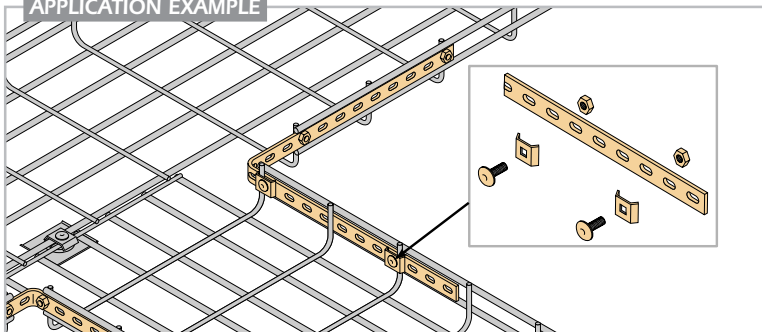

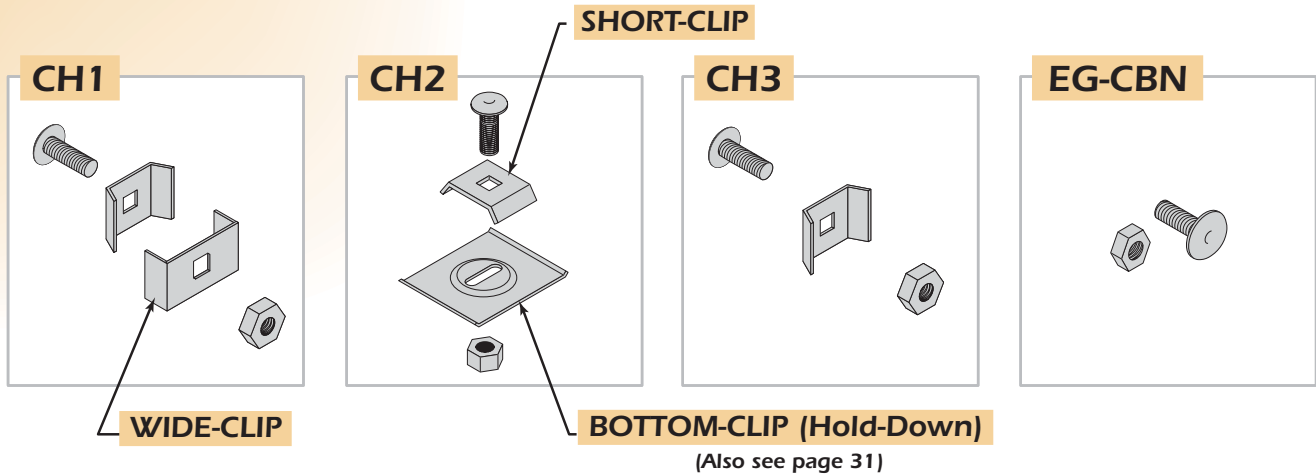

PART KIT	WEIGHT	NO. / PKG
CH1	.70	10
CH2	1.16	10
CH3	.44	10
EG-CBN	.20	10

SINGLE PART	WEIGHT	NO. / PKG
Short-Clip	.20	10
Wide-Clip	.31	10
Bottom-Clip	.92	10

## Connector Kits

### CH1

- Standard bar connector is 1<sup>3</sup>/<sub>16</sub> x 1<sup>1</sup>/<sub>16</sub>"
- Standard finish is electro-galvanized (EG)
- Sold in packs of 10

**NOTE:** Always place nut on outside of tray

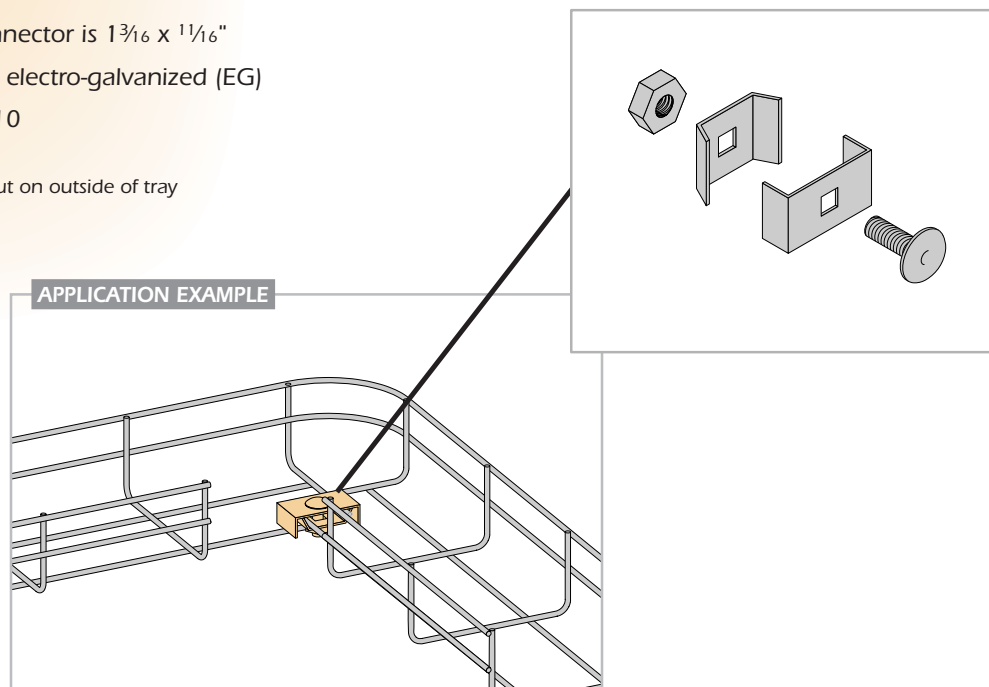

## Connector Kits

### CH2

- Bottom connector is 2 x 2<sup>3</sup>/<sub>8</sub>"
- Standard finish is electro-galvanized (EG)
- Sold in packs of 10

**NOTE:**

Always place nut on outside of tray

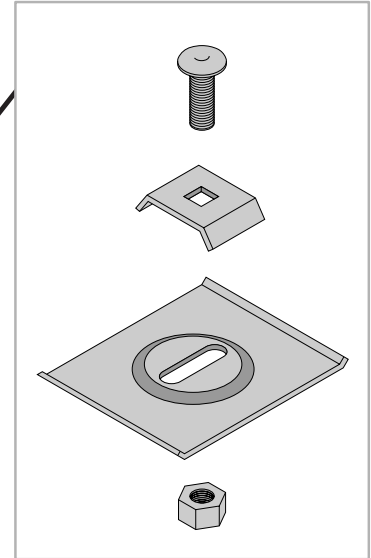
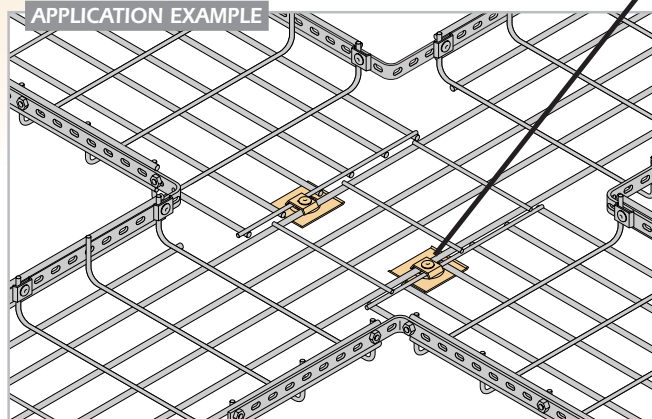

### CH3

- Universal connector is 1<sup>1</sup>/<sub>16</sub> x 1<sup>5</sup>/<sub>16</sub>"
- Standard finish is electro-galvanized (EG)
- Sold in packs of 10

**NOTE:** Always place nut on outside of tray

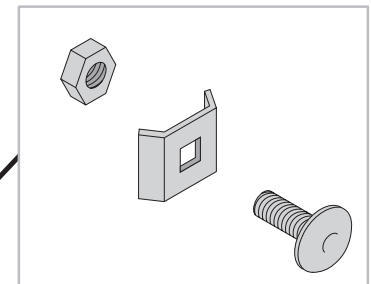
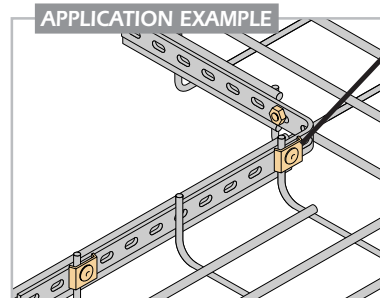

### EG-CBN

- 1/4-20 x 3/4" Carriage bolt
- 1/4-20 Hex head nut
- Standard finish is electro-galvanized (EG)
- Sold in packs of 10 each

**NOTE:** Always place nut on outside of tray

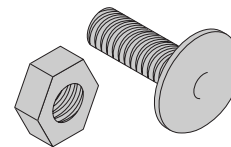



## U Support Bracket

### CAT-USB-120

Weight: 6.83 lb/each

- U support bracket  $1\frac{5}{16} \times 1\frac{5}{16}$ " channel
- Standard finish is pregalvanized (PG)
- Support is 10' long, customer cuts to size as needed
- Cut lengths 6" wider than tray width for trapeze  
Cut lengths 1" shorter than tray width for single rod support
- Unique grip system requires only a push of a screwdriver to fasten the tray to the supports

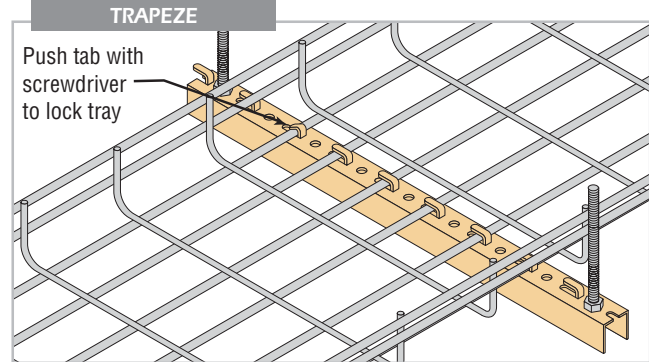
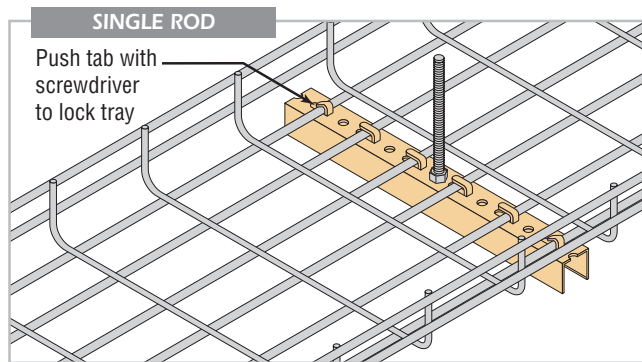
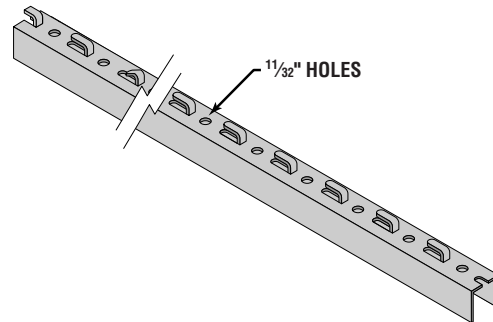

## Support Bracket

### MEDIUM SUPPORT BRACKET – CAT-MSB-120

### HEAVY SUPPORT BRACKET – CAT-HSB-120

- Heavy support bracket is  $1\frac{5}{8} \times 1\frac{5}{8}$ " strut, Medium support bracket is  $1\frac{5}{8} \times 1\frac{3}{16}$ " strut
- Standard finish is pregalvanized (PG)
- Support is 10' long, customer cuts to size as needed
- Cut lengths 6" wider than tray width for trapeze  
Cut lengths 1" shorter than tray width for single rod support
- Unique grip system requires only a push of a screwdriver to fasten the tray to the supports

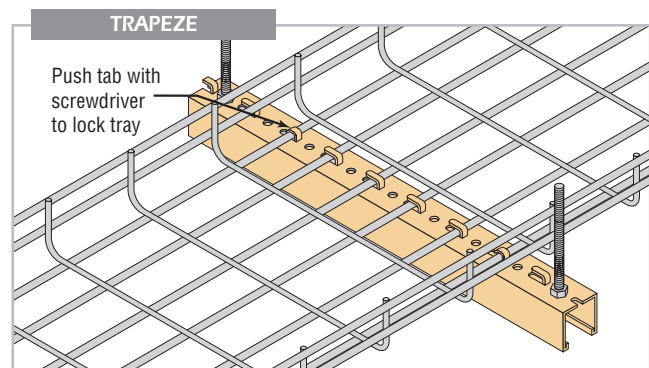
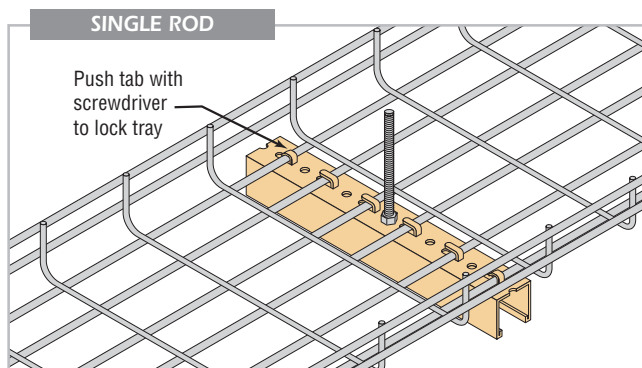
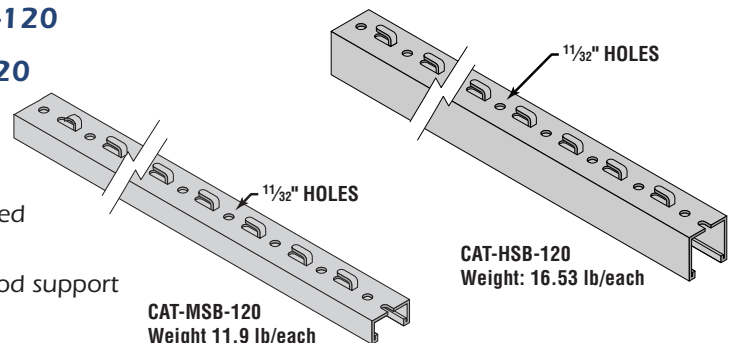

# Drop Rod Clip

## CAT-SIDE-HC

Weight: .13 lb/each

- Standard finish pregalvanized (PG)
- .08" Bracket thickness
- For all widths of tray

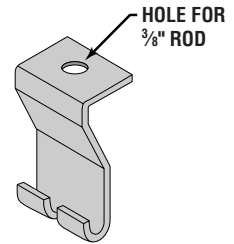
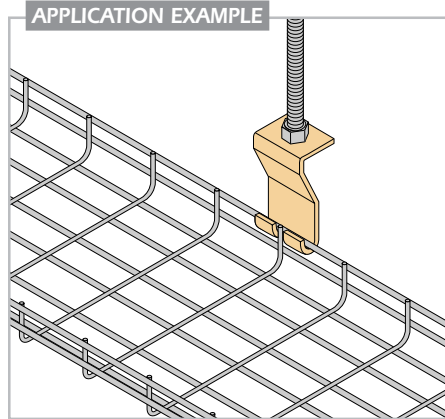

## CAT-1x6-HC

Weight: .12 lb/each

- Standard finish pregalvanized (PG)
- .08" Bracket thickness
- For all 4"w & 6"w tray

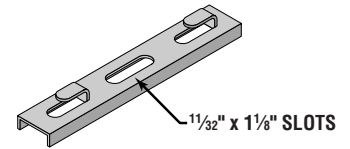
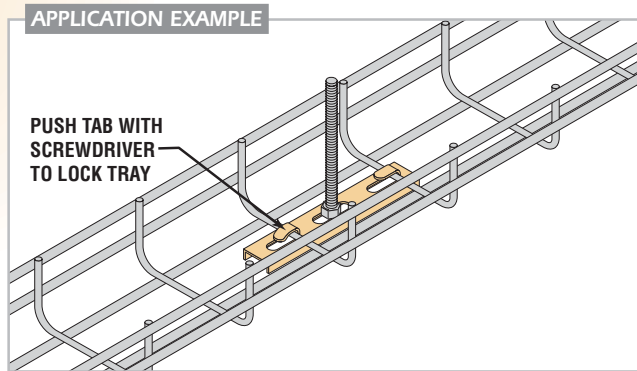

## CAT-2x8-HC

Weight: .40 lb/each

- Standard finish pregalvanized (PG)
- .08" Bracket thickness
- For all 8"w & 12"w tray

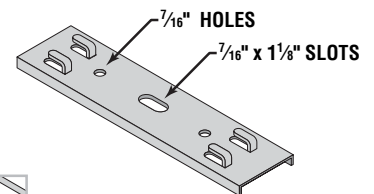
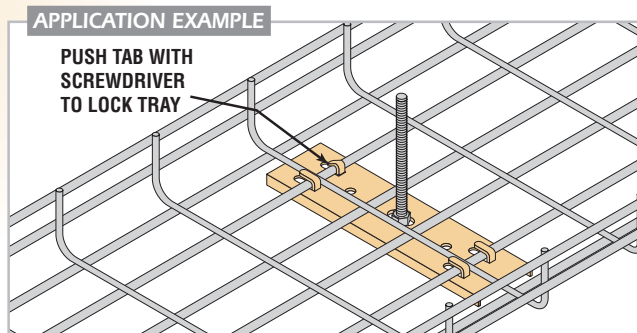



## Ceiling Clip

### CAT-CCA-(W)

- For attaching tray to ceiling
- Standard finish pregalvanized (PG)
- Easy mounting of the cable tray using grips and autolock

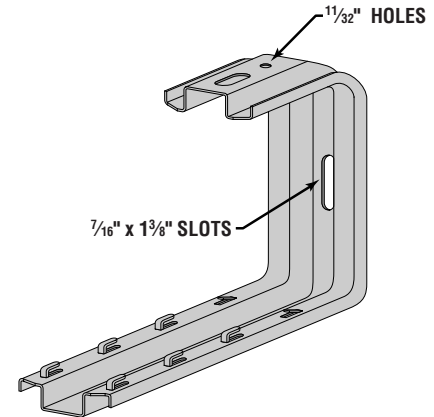
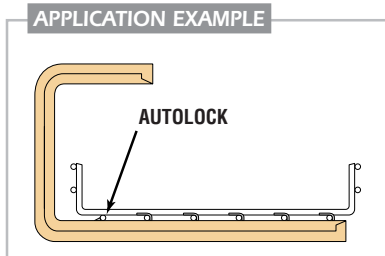

Part No.	Tray Size (In.)	Height (In.)	Length (In.)	Wt (Lbs)	Load (Lbs)
CAT-CCA-04	4	7	6	1.3	270
CAT-CCA-06	6	7	8	1.5	225
CAT-CCA-08	8	7	10	1.7	202
CAT-CCA-12	12	7	14	2.0	180
CAT-CCA-16	16	7	18	2.3	90

## Wall Clip

### CAT-CPA-(W)

- For attaching tray to wall
- Standard finish pregalvanized (PG)
- Easy mounting of the cable tray using grips and autolock

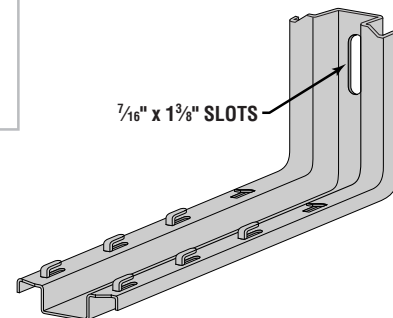
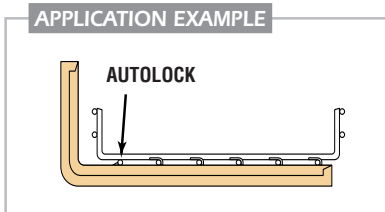

Part No.	Tray Size (In.)	Height (In.)	Length (In.)	Wt (Lbs)	Load (Lbs)
CAT-CPA-06	6	5	8	1.0	337
CAT-CPA-08	8	5	10	1.1	225
CAT-CPA-12	12	5	14	1.5	202
CAT-CPA-16	16	5	18	1.8	90

## Pendant

### CAT-PPA-(L)

- Standard finish is pregalvanized (PG)
- For attaching tray to ceiling. Used with wall clip CAT-CPA-(W)

Part No.	Height (In.)	Length (In.)	Wt (Lbs)
CAT-PPA-06	6	5	0.7
CAT-PPA-10	10	5	1.1
CAT-PPA-14	14	5	1.3
CAT-PPA-18	18	5	1.7
CAT-PPA-22	22	5	2.0
CAT-PPA-26	26	5	2.3

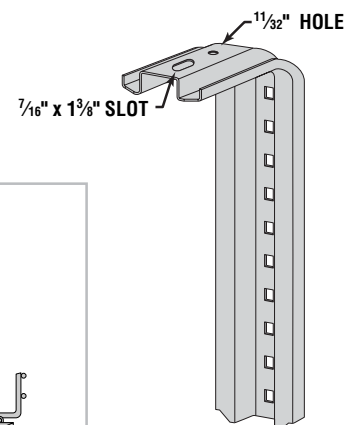
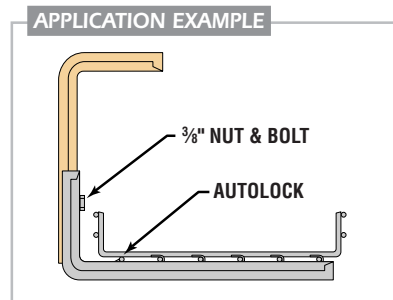

# ZED

## CAT-ZBAR-120

Weight: 11.24 lb/each

- ZED floor or wall mounted support is 1/2 x 3 1/2
- Standard finish pregalvanized (PG)
- Support is 10' long, customer cuts to size as needed
- Unique grip system requires only a push of a screwdriver to fasten the tray to the supports

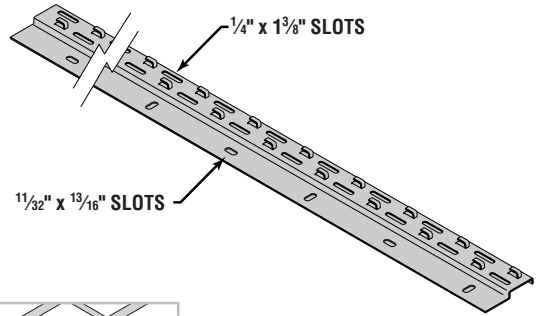

### APPLICATION EXAMPLE

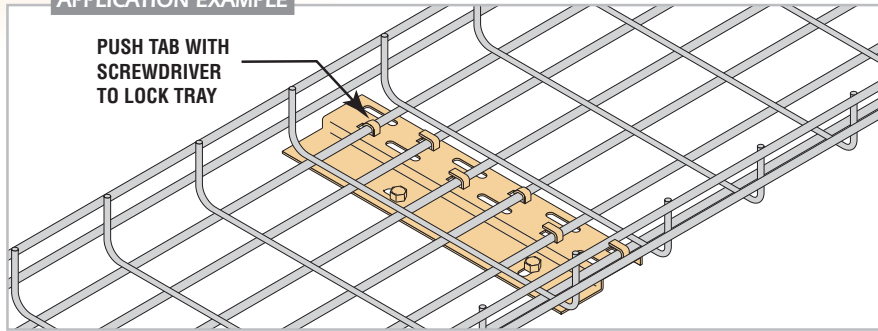

# Cantilver

## MEDIUM CAT-MWSB-(W) & HEAVY CAT-HWSB-(W)

- Standard finish is hot-dipped galvanized (HG)
- Cantilever arm support 1 5/8 x 1 5/8" or 1 5/8 x 13/16" strut
- Unique Auto-Lock system requires no hardware to fasten the tray to the supports
- Use Strut Profile to support other items below the support bracket using strut hardware

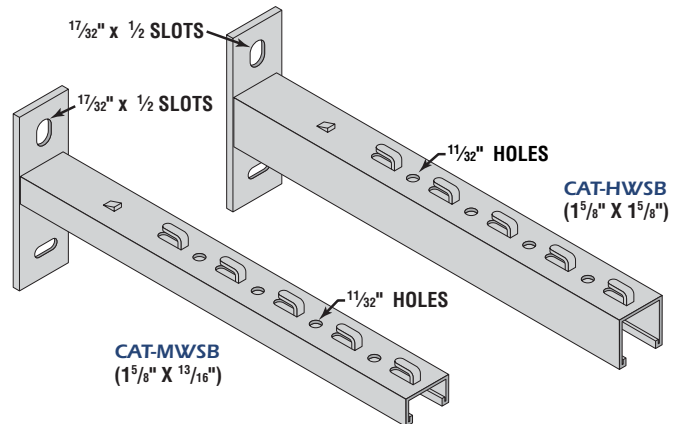

### APPLICATION EXAMPLE

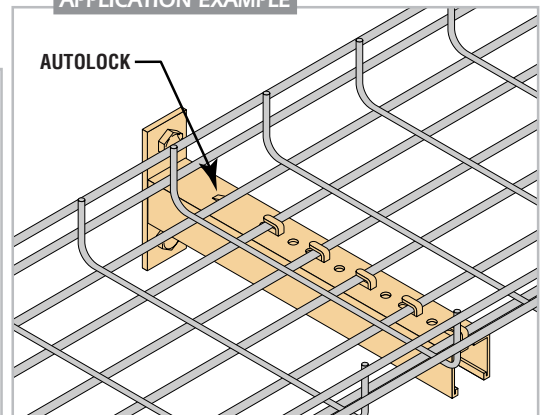

Part No.	Channel Size	Tray Size (In.)	Length (In.)	Wt (Lbs)	Load (Lbs)
CAT-MWSB-06	1 5/8" x 13/16"	6	8	1.3	270
CAT-MWSB-08	1 5/8" x 13/16"	8	10	1.5	225
CAT-MWSB-12	1 5/8" x 13/16"	12	14	1.9	157
CAT-HWSB-08	1 5/8" x 1 5/8"	8	10	1.9	562
CAT-HWSB-12	1 5/8" x 1 5/8"	12	14	2.5	450
CAT-HWSB-18	1 5/8" x 1 5/8"	18	18	3.0	337
CAT-HWSB-20	1 5/8" x 1 5/8"	20	22	3.6	292
CAT-HWSB-24	1 5/8" x 1 5/8"	24	26	4.1	247



## Hangers

### CAT-HGR-2

- Standard finish is pregalvanized (PG)
- Ceiling or center hung with threaded rod

**NOTE:** For use with CAT2-02 only

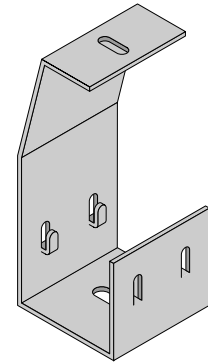
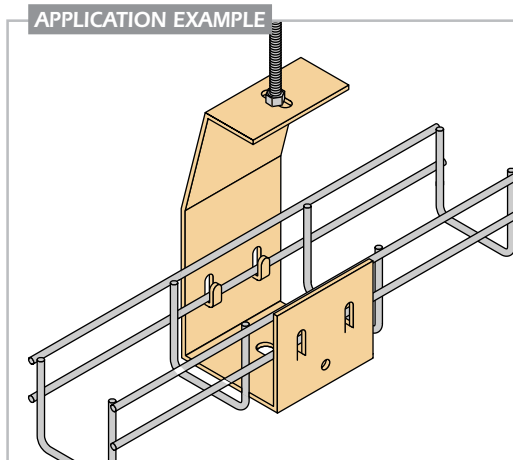

### CAT-HGR-4

- Standard finish is pregalvanized (PG)
- Ceiling or center hung with threaded rod

**NOTE:** For use with CAT2-04 or CAT4-04 only

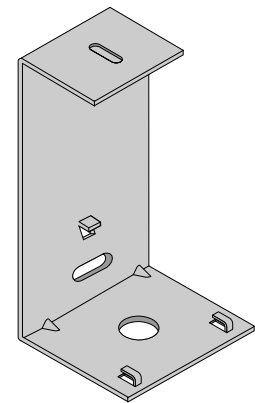
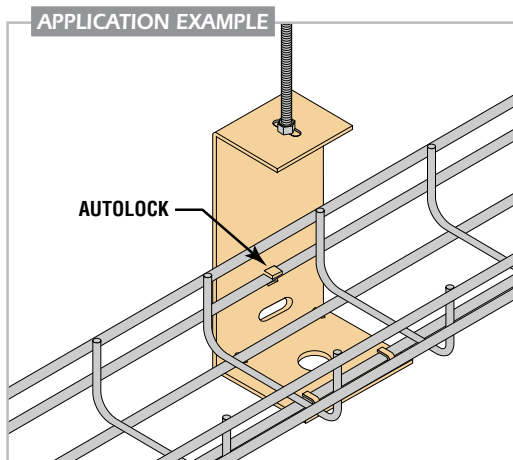

## Wall Bracket

### CAT-WC-2

- Standard finish is pregalvanized (PG)

**NOTE:** For use with CAT2-02 only

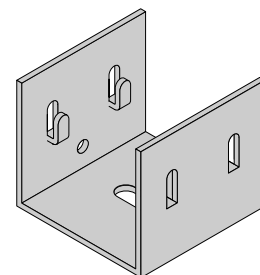
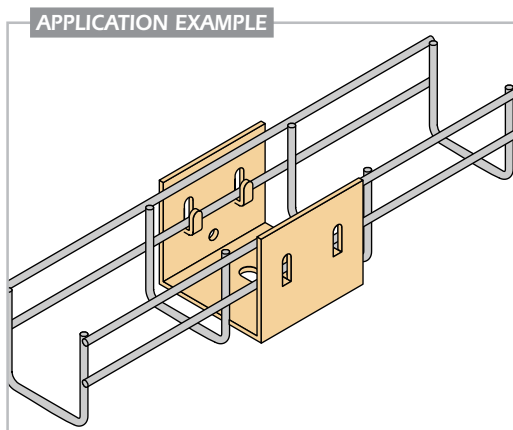



## Single Channel Pendants

### PS 651-(L)

- Standard finish is electro-galvanized (EG)

Part	Length	Uniform Load*	Weight
PS-651-06	6"	1,200	1.85
PS-651-12	12"	600	2.93
PS-651-18	18"	400	4.01
PS-651-24	24"	300	5.09

\*Mounted on 12 Ga. Channel

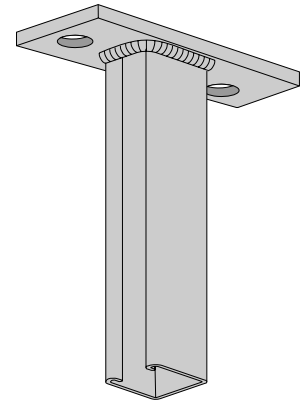
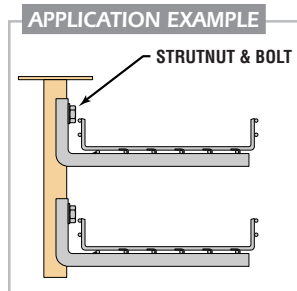

## Back-to-Back Channel Pendant

### PS 809-(L)

- Standard finish is electro-galvanized (EG)

Part	Length	Uniform Load*	Weight
PS809-12	12"	2,000	5.02
PS809-18	18"	1,300	6.92
PS809-24	24"	1,000	8.82
PS809-30	30"	800	10.72
PS809-36	36"	650	12.62

\*Mounted on 12 Ga. Channel

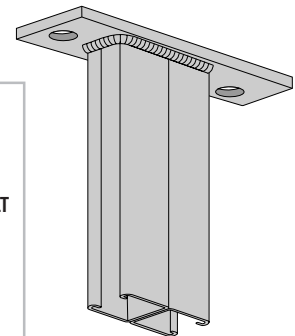
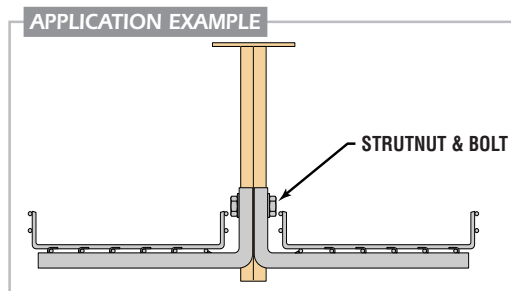

## Hanging Bracket

### CAT-CB-USB

Weight: .8 lb/each

- Standard finish is pregalvanized (PG)
- For Use with CAT-USB-120 Style Support Bracket Channel

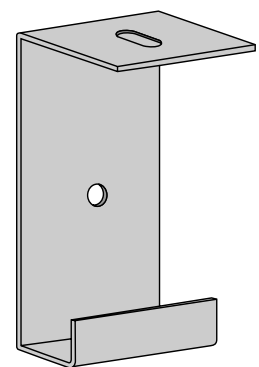
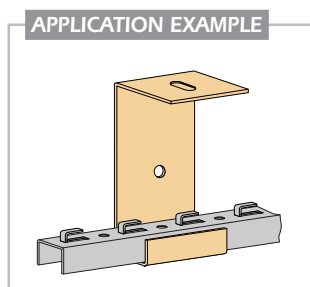
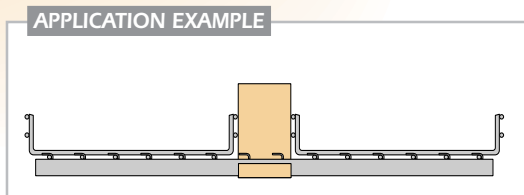



## Hanging Bracket

### CAT-AB-USB

Weight: .53 lb/each

- Standard finish is pregalvanized (PG)
- For use with CAT-USB-120 Support Bracket Channel

APPLICATION EXAMPLE

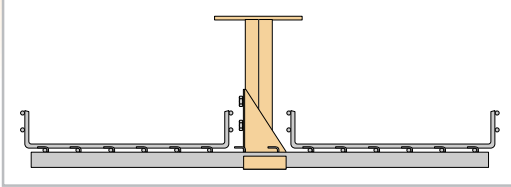

APPLICATION EXAMPLE

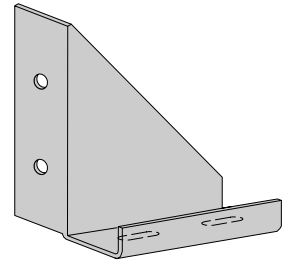
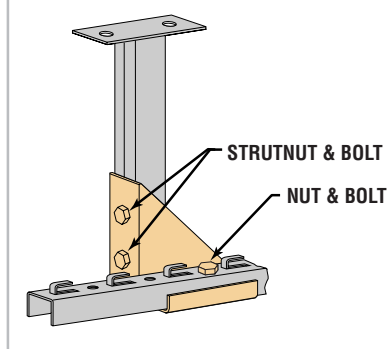

### CAT-AB-HSB

Weight: .62 lb/each

- Standard finish is hot-dipped galvanized (HG)
- For Use with:  
CAT-MSB-10 Medium Support Bracket Strut  
CAT-HSB-10 Heavy Support Bracket Strut

APPLICATION EXAMPLE

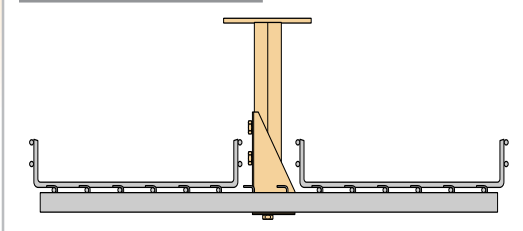

APPLICATION EXAMPLE

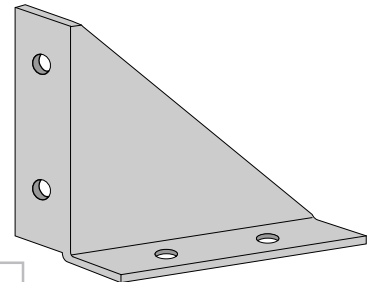
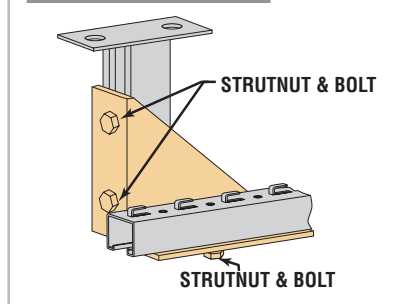

### CAT-CB-MSB

Weight: 1.46 lb/each

- Standard finish is pregalvanized (PG)
- For Use with:  
CAT-MSB-10 Medium Support Bracket Strut

APPLICATION EXAMPLE

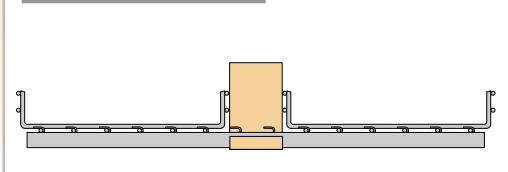

APPLICATION EXAMPLE

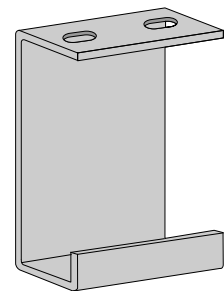
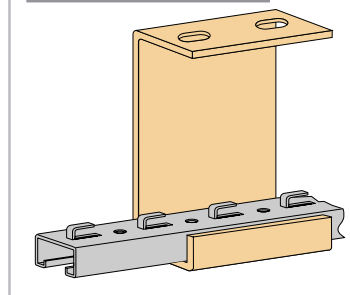

# Hanging Bracket

## CAT-CB-HSB

Weight: 2.98 lb/each

- Available in pregalvanized (PG) or hot-dipped galvanized (HG)
- For Use with:  
CAT-MSB-10 Medium Support Bracket Strut  
CAT-HSB-10 Heavy Support Bracket Strut

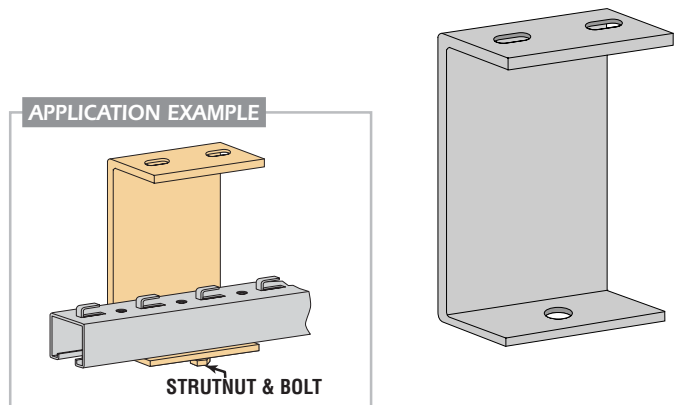
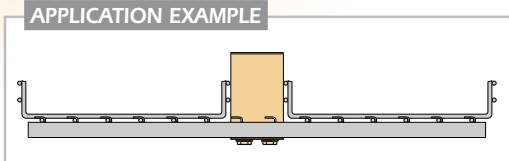

# Bracket

## CAT-CMA-(W)

- Standard finish is pregalvanized (PG)
- Mounted on cantilever arms or channels
- Easy mounting of the bracket using grips and autolock
- Designed for use with new/existing 1 5/8" strut framing

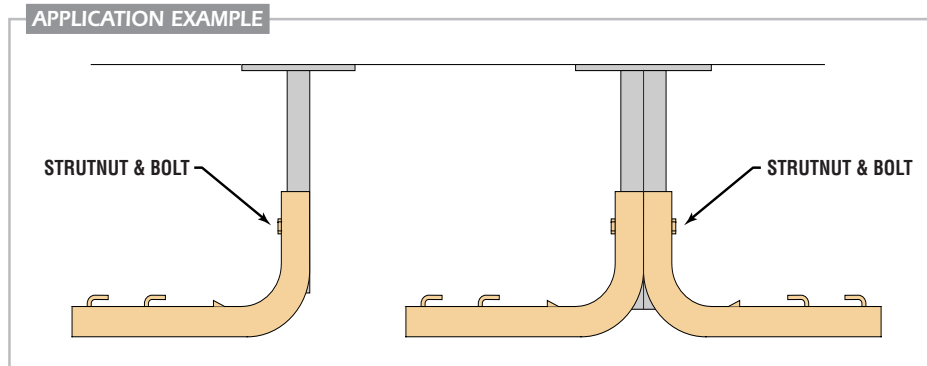
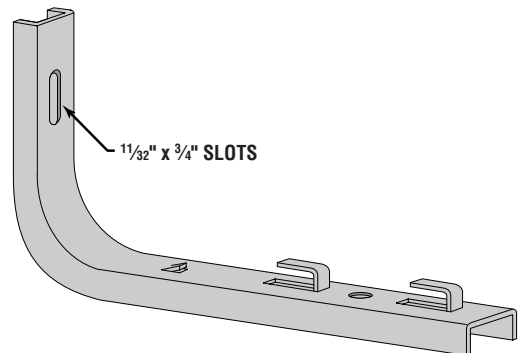

Part No.	Height	Tray Size (In.)	Length (In.)	Wt (Lbs)	Load (Lbs)
CAT-CMA-04	4.7	4	5	0.8	360
CAT-CMA-06	4.7	6	7	1.0	270
CAT-CMA-08	4.7	8	9	1.1	180
CAT-CMA-12	4.7	12	13	1.5	135



## Pedestal Brackets

### CAT-PED-06

### CAT-PED-12

- Channel use on pedestal for raised floor
- Attach to pedestal using U-Bolt & nuts (included)

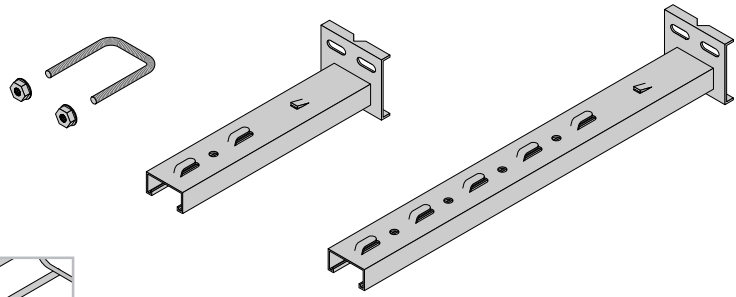

APPLICATION EXAMPLE

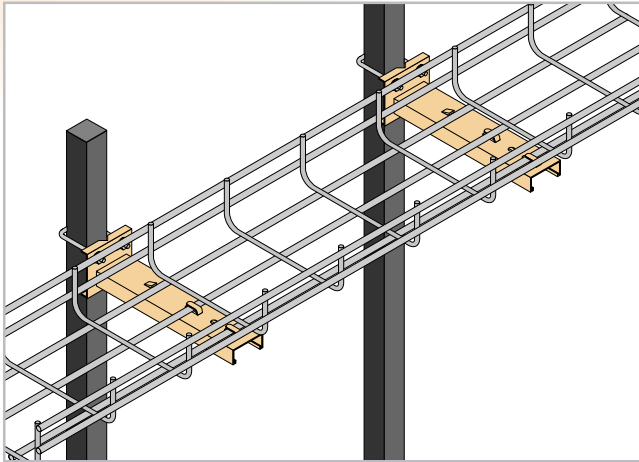

APPLICATION EXAMPLE

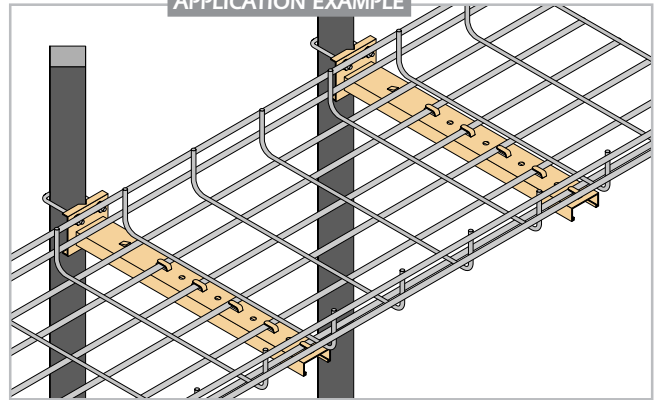

### CAT-PED-KIT

- Channel use on pedestal for raised floor
- Attach to pedestal using U-Bolt & nuts (included)

APPLICATION EXAMPLE

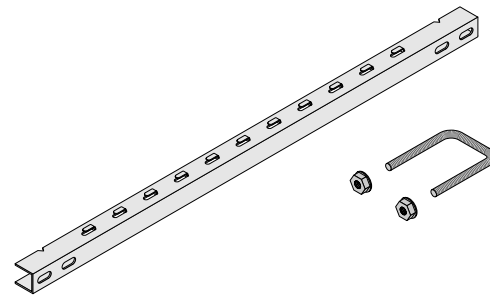
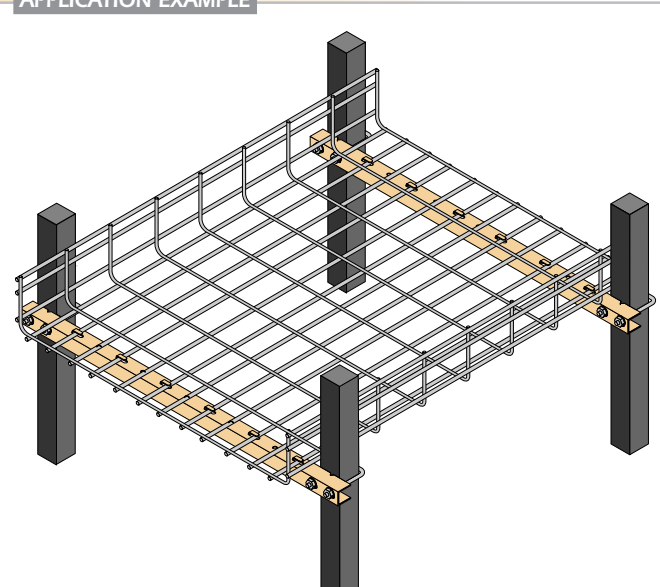

APPLICATION EXAMPLE

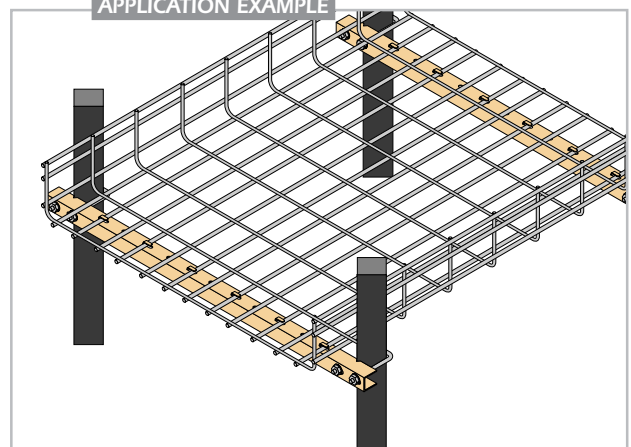

## Cover

### CAT-CVR-(W)

- Standard finish is pregalvanized (PG)
- Length is 10' or 120"

PART	WEIGHT (lb)
CAT-CVR-02	5.29
CAT-CVR-04	7.93
CAT-CVR-06	10.58
CAT-CVR-08	13.22
CAT-CVR-12	18.52
CAT-CVR-16	35.71
CAT-CVR-18	39.68
CAT-CVR-20	43.65
CAT-CVR-24	51.53

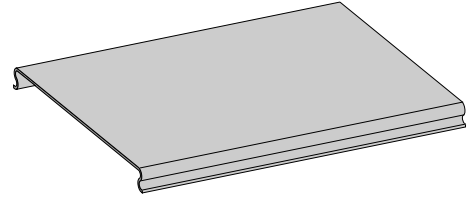

#### APPLICATION EXAMPLE

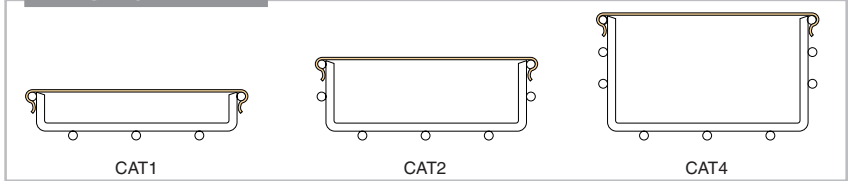

## Tray Divider

### CAT1-01SB-120

### CAT2-01SB-120

### CAT4-01SB-120

- Standard finish is pregalvanized (PG)
- Locks into tray with auto-lock tabs (no hardware required)
- Cut "V" notches into bottom flange to make barriers for flat fittings

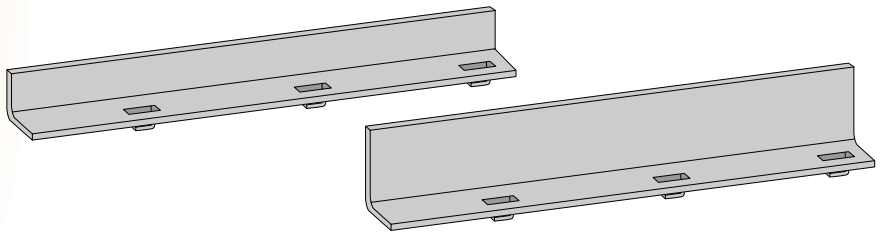

#### APPLICATION EXAMPLE

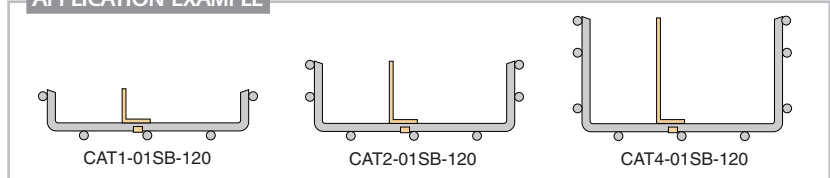

## Drop Out ■ CAT-(W)DO

### CAT-(W)DO

- Standard finish is pregalvanized (PG)
- Cat-Uni-Do can be used in any 2" x 4" mesh opening or as a "side-out"

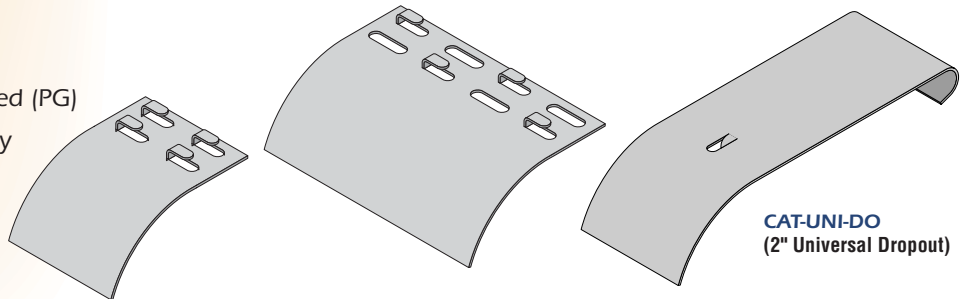

CAT-UNI-DO  
(2" Universal Dropout)

#### APPLICATION EXAMPLE

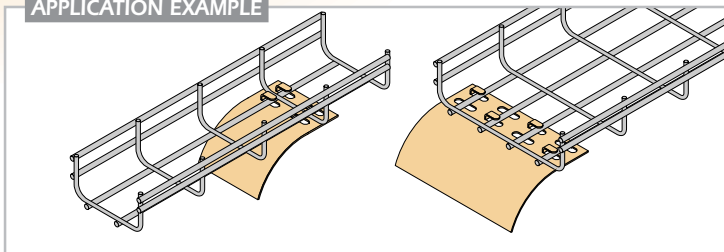

#### APPLICATION EXAMPLE

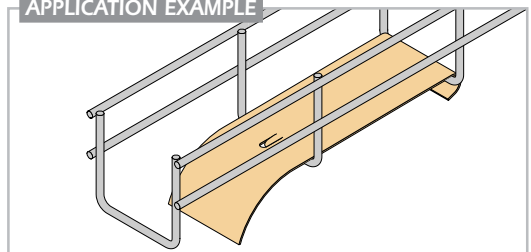



## Blind End

### CAT(H)-(W)BE

- Standard finish is pregalvanized (PG)
- Standard use per blind end is:  
(2 pc) CH3 (sold separately)

**NOTES:**

- Always place nut on outside of tray
- For use with CAT2 and CAT4 tray only

SHORT-CLIP

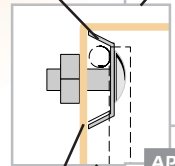

BLIND END

APPLICATION EXAMPLE

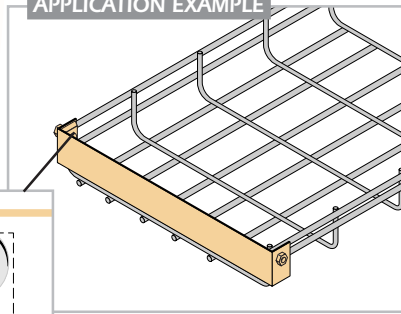

APPLICATION EXAMPLE

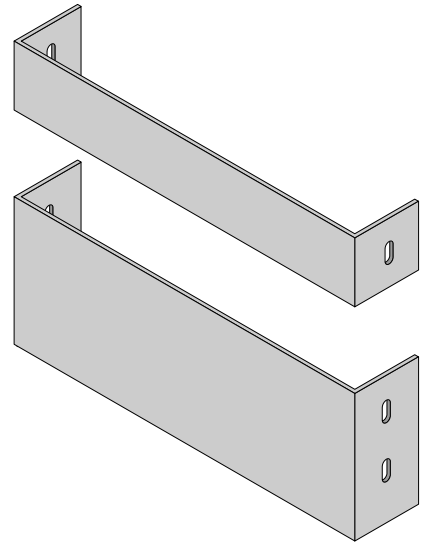
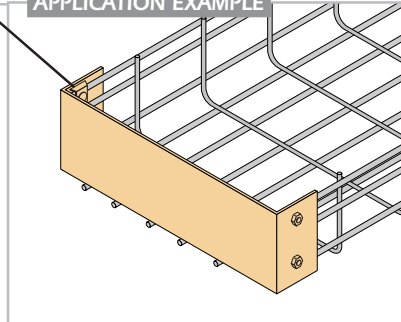

PART	WEIGHT (lb)
CAT2-04BE	.18
CAT2-06BE	.22
CAT2-08BE	.28
CAT2-12BE	.40
CAT2-16BE	.50
CAT2-18BE	.57
CAT2-20BE	.64
CAT2-24BE	.70

PART	WEIGHT (lb)
CAT4-04BE	.52
CAT4-08BE	.64
CAT4-12BE	.76
CAT4-16BE	.96
CAT4-18BE	1.08
CAT4-20BE	1.20

## Box Connector

### CAT(H)-(W)CB

- Standard finish is pregalvanized (PG)
- Standard use per box connector is:  
(2 pc) CH3  
(5 pc) EG-CBN  
(both sold separately)

**NOTES:**

- Always place nut on outside of tray
- For use with CAT2 and CAT4 tray only

APPLICATION EXAMPLE

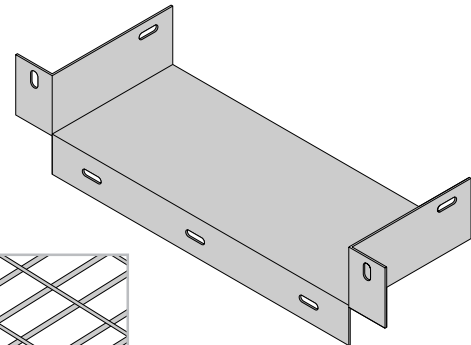
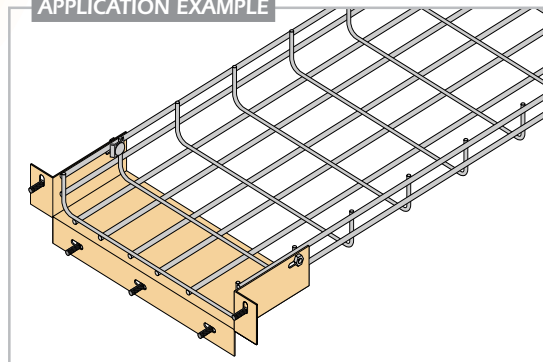

## Lighting Bracket

### CAT-HLT

- Standard finish is pregalvanized (PG)

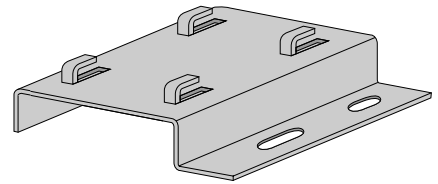
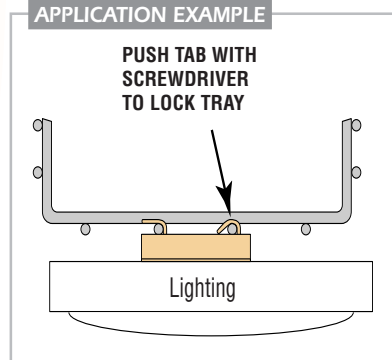

## Electrical Box Bracket

### CAT-EBC

- Standard finish is pregalvanized (PG)

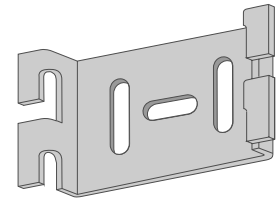
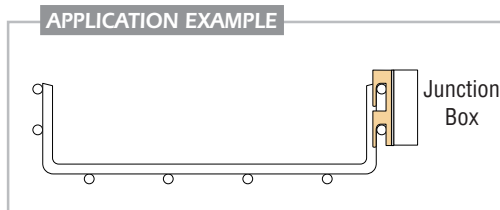

## Wall Sleeve

### CAT(H)-(W)WS

- Standard finish is pregalvanized (PG)
- Standard use per wall sleeve is:  
(4 pc) CH3 (5 pc) 6112-0  
(4 pc) 5003-1 (4 pc) 5009-1  
(8 pc) EM -CC  
(all sold separately)

#### NOTES:

- Always place nut on outside of tray
- For use with CAT2 and CAT4 tray only

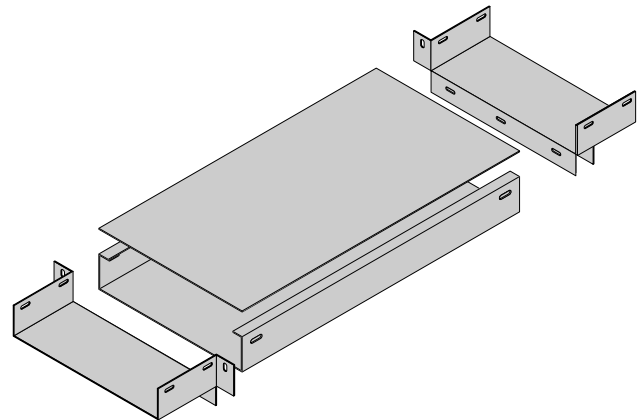
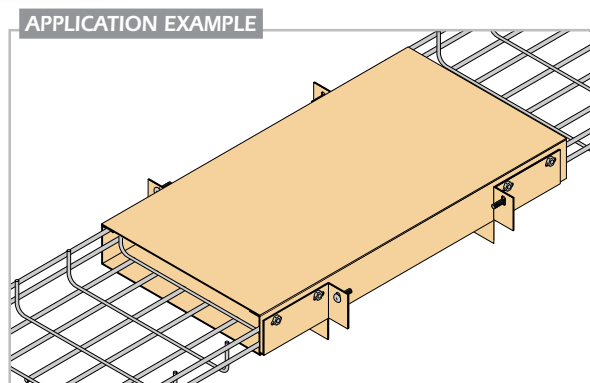



Fittings are typically fabricated on the job, however prefabricated fittings are available upon request, please contact factory.

To determine the fitting hardware required to create a set of fittings, please consult our online calculator (Choose Cat-Tray from the Products menu on the front page of "tycoelectrical.com").

## TEE AND CROSS

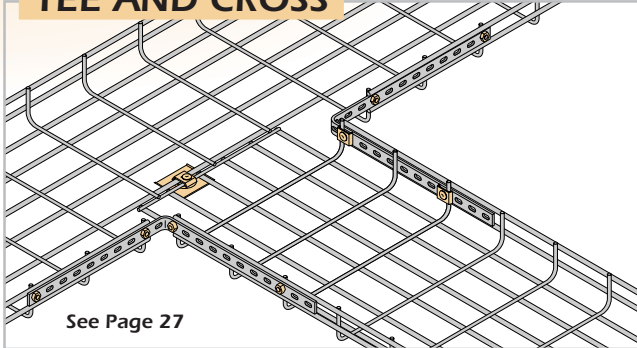

## 90° SHORT RADIUS BEND

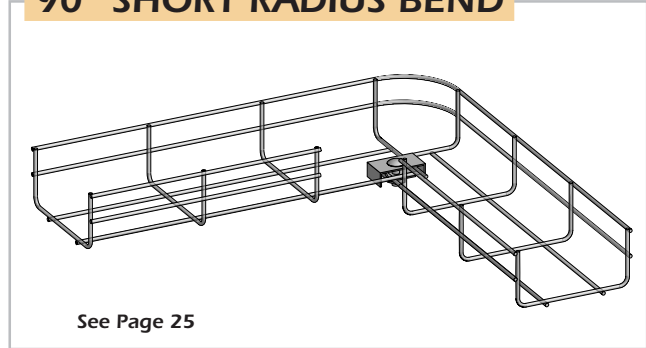

## 90° LONG RADIUS BEND

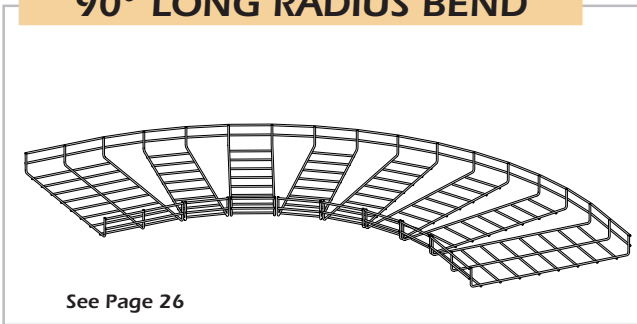

## RISERS

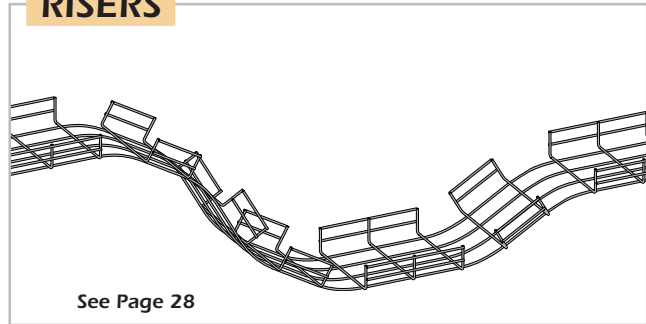

## Cutting Tool ■ CAT-CUT

Fittings can be formed easily on-site by cutting the bottom and side wires. Cut the tray bars on an angle as shown in the illustration.

NOTE: When cutting, keep the remaining sharp edge away from the inside of the tray.

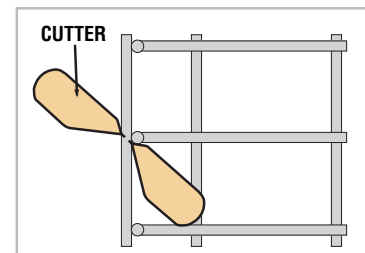
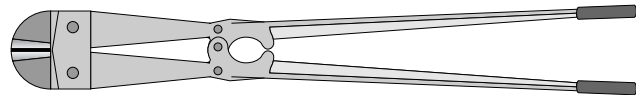



## 90° Bends - Short Radius

To form 90° bends in the tray, cut the wires shown in the color shaded area of the drawing which corresponds to the width of the tray used.

### 1 CUT THE BOTTOM AND SIDE WIRES

Bends can be formed easily on-site by cutting the bottom and side wires. The shaded areas indicated should be cut and removed. Then, simply bend Cat-Tray cable tray to form a 90° angle and you are ready to install. Make sure you use the appropriate hardware.

### 2 ASSEMBLE USING APPROPRIATE HARDWARE

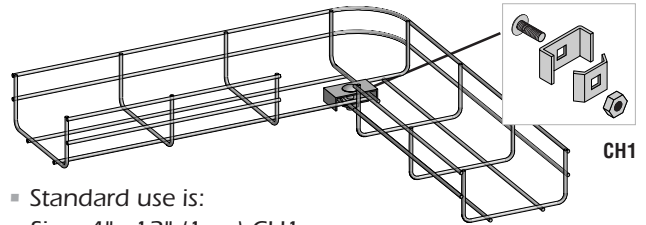

- Standard use is:  
 Sizes 4" - 12" (1 pc) CH1  
 Sizes 16" - 24" (2 pc) CH1

**NOTE:** Always place nut on outside of tray)

1

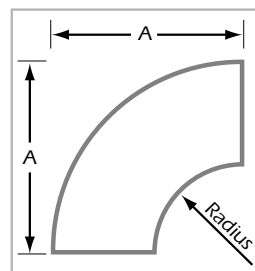
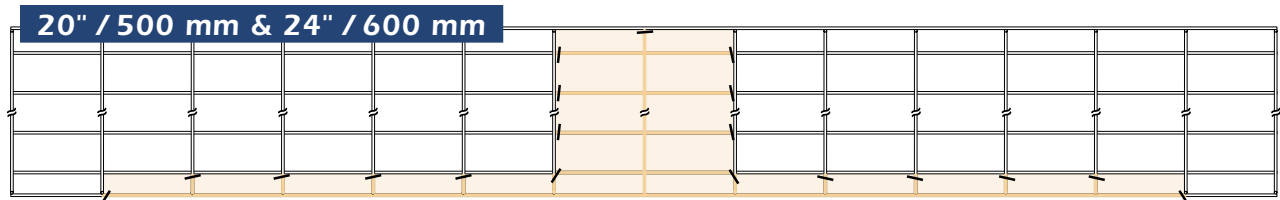
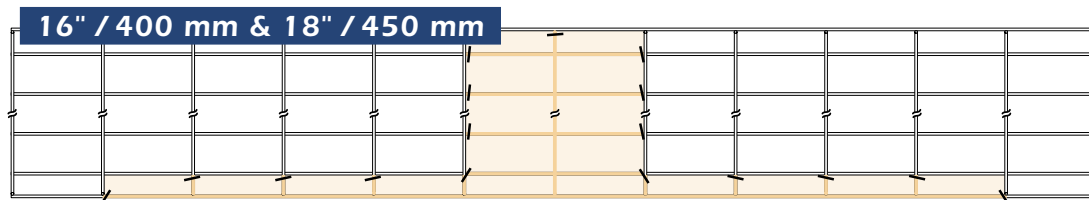
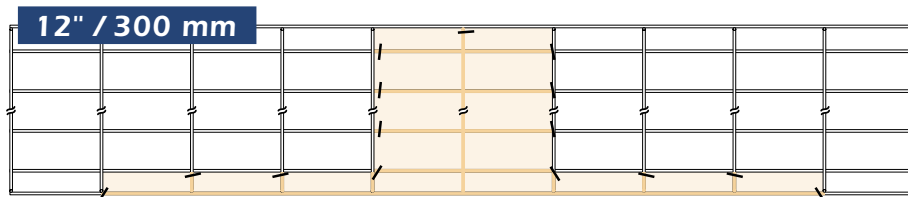
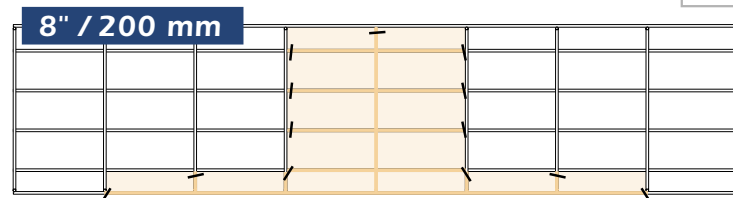
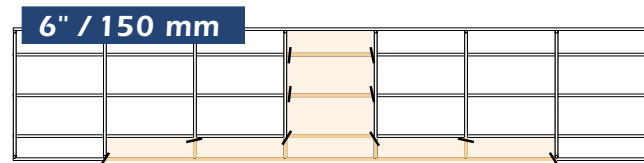
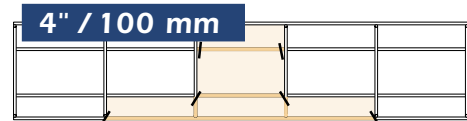

#### Internal Radius and size of the small radius bends

Tray Width (in.)	Radius (in.)	"A" (in.)
4"	6"	15"
6"	5"	17"
8"	5"	17"
12"	5"	21"
16"	5"	25"
18"	5"	25"
20"	5"	29"
24"	5"	29"



## 90° Bends - Long Radius

### 1 CUT THE BOTTOM AND SIDE WIRES

To form 90° bends in the tray, cut out the number of sections shown below based on the width of the tray used

### 2 ASSEMBLE USING APPROPRIATE HARDWARE

- Standard hardware is shown with each bend size.

#### ADVANTAGES:

- Use as bonding jumper
- Vertical support of standing sections
- Adjustable radius allowances

**NOTE:** Always place nut on outside of tray

#### CAT2-04SL-120, CAT2-06SL-120, CAT2-08SL-120

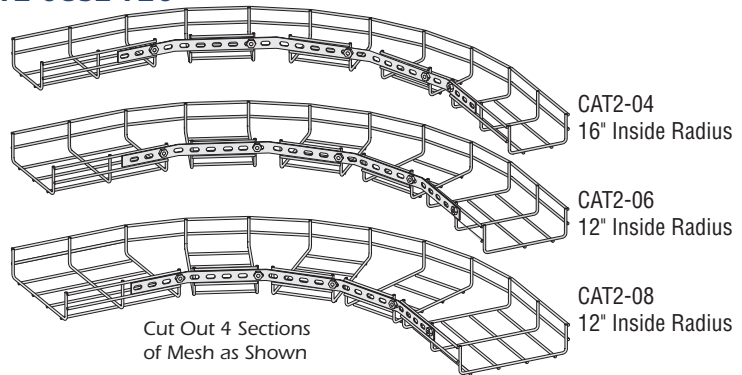
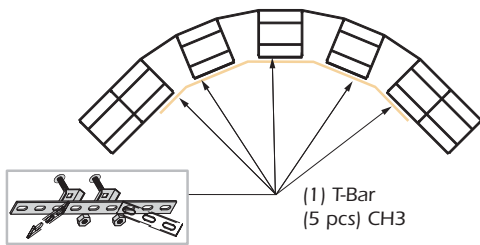

#### CAT2-12SL-120

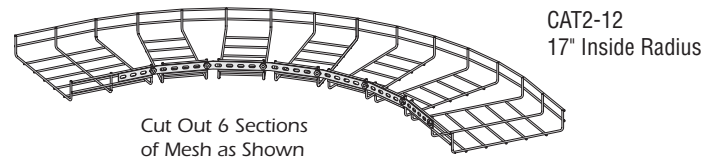
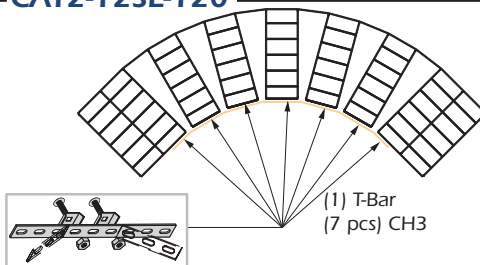

#### CAT2-16SL-120, CAT2-18SL-120

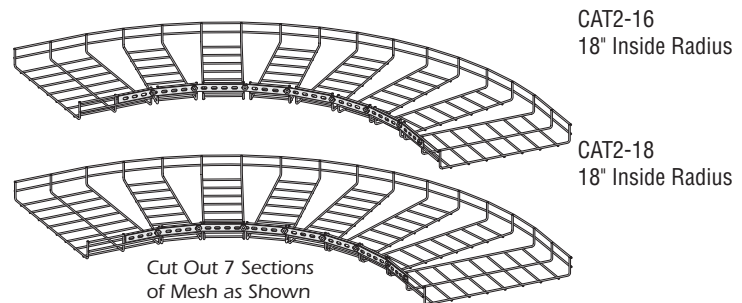
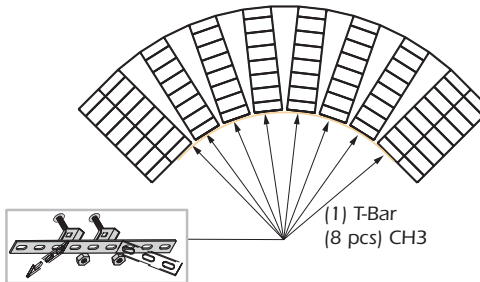

#### CAT2-20SL-120, CAT2-24SL-120

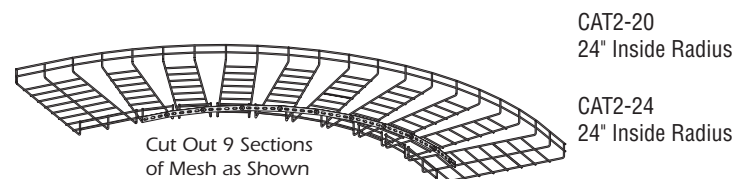
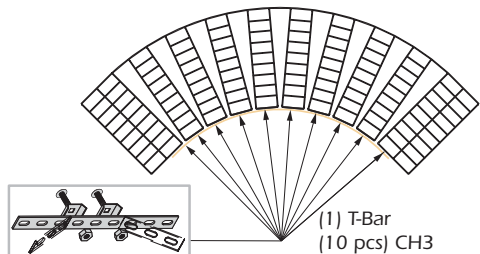

## Standard Tee

- Standard use per tee is:  
(2 pc) T-Bar-22 or (1 pc) T-Bar cut in half  
(8 pc) CH3  
(1 pc) CH2

**NOTE:** Always place nut on outside of tray

To form a tee, cut the wires marked in yellow.

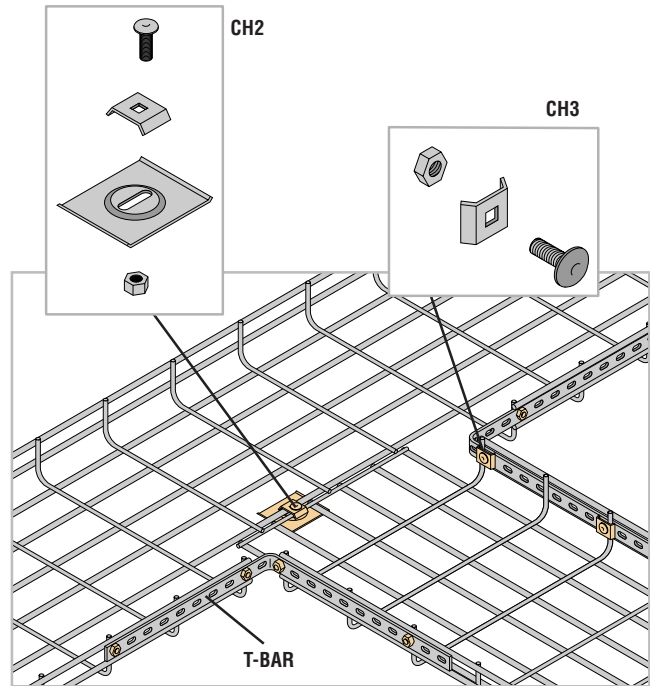
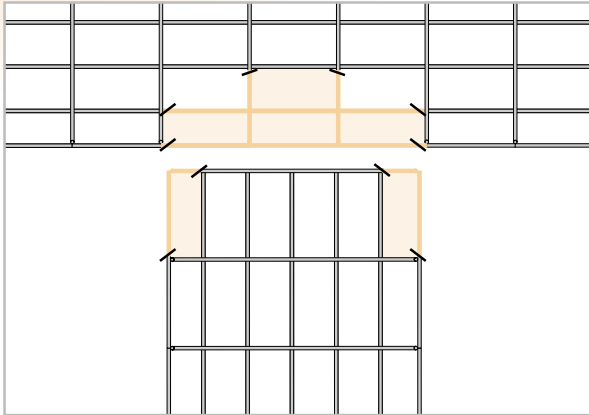

## Cross

- Standard use per cross is:  
(4 pc) T-Bar-22 or (2 pc) T-Bar cut in half  
(16 pc) CH3  
(2 pc) CH2

**NOTE:** Always place nut on outside of tray

To form a cross, cut the wires marked in yellow.

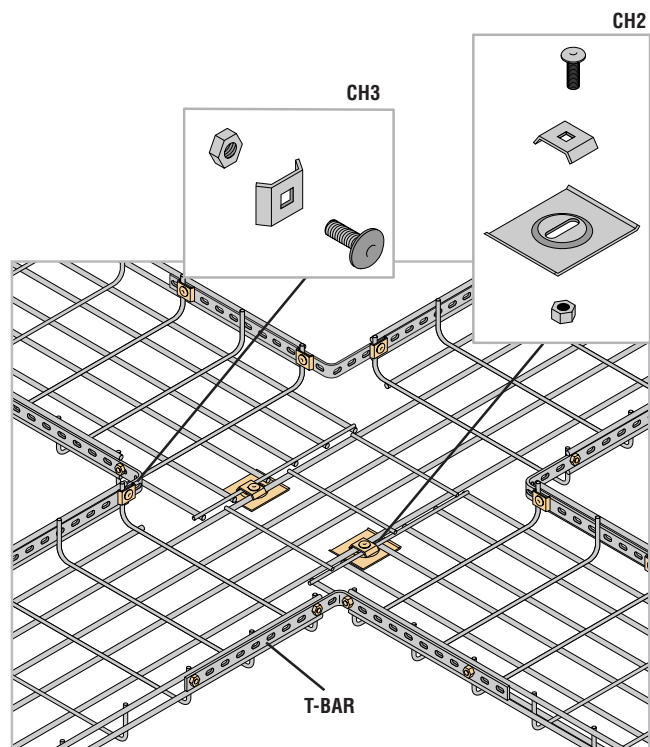
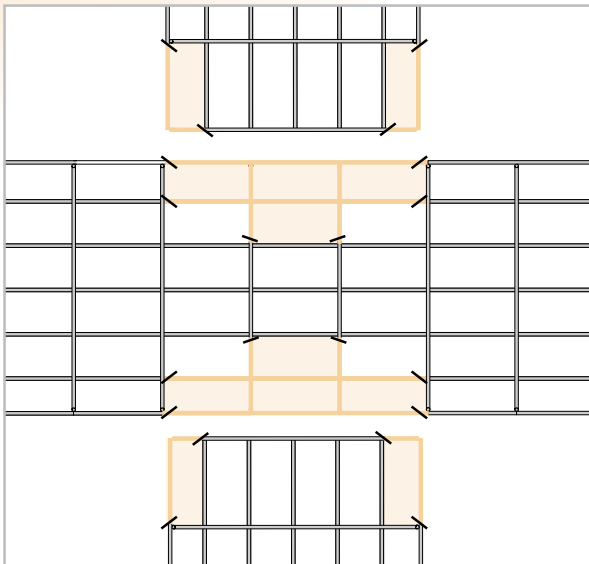



## Reducer & Offset

### REDUCER

- Standard use per reducer is:  
 (2 pc) T-bar  
 (8 pc) CH3  
 (1 pc) CH2

**NOTE:** Always place nut on outside of tray

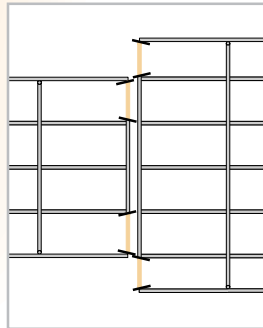

### OFFSET

- Standard use per offset is:  
 (2 pc) T-Bar  
 (8 pc) CH3  
 (1 pc) CH2

**NOTE:** Always place nut on outside of tray

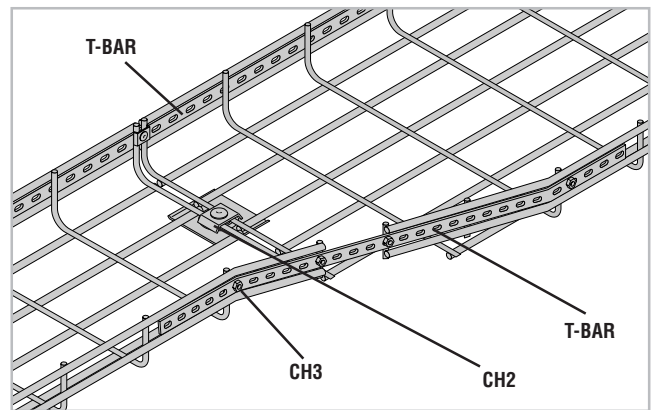
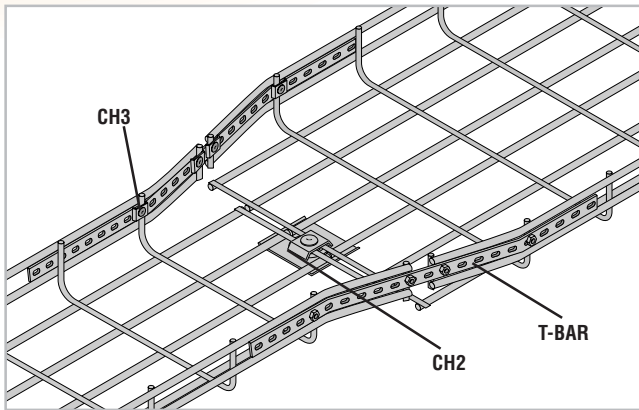
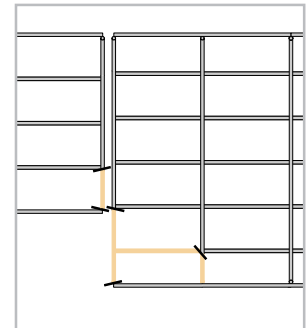

## Riser

Cut out 4 side sections of mesh for a soft 90° bend.

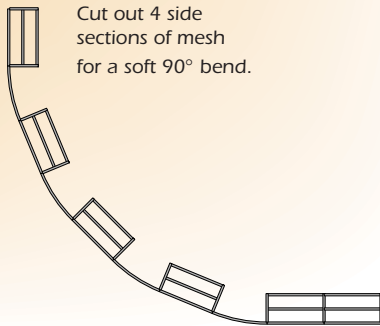

Cut out 3 side sections of mesh for a 90° bend.

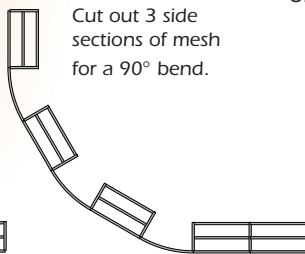

Cut out 2 side sections of mesh for a 90° bend.

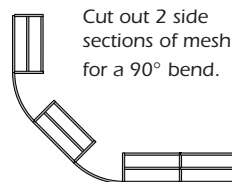

Cut out 1 side section of mesh for a hard 90° bend.

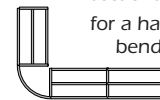

Risers and drops can be created to avoid different obstacles in the job path. Simply cut out the required number of side mesh sections and bend a vertical riser or drop to fit the application.

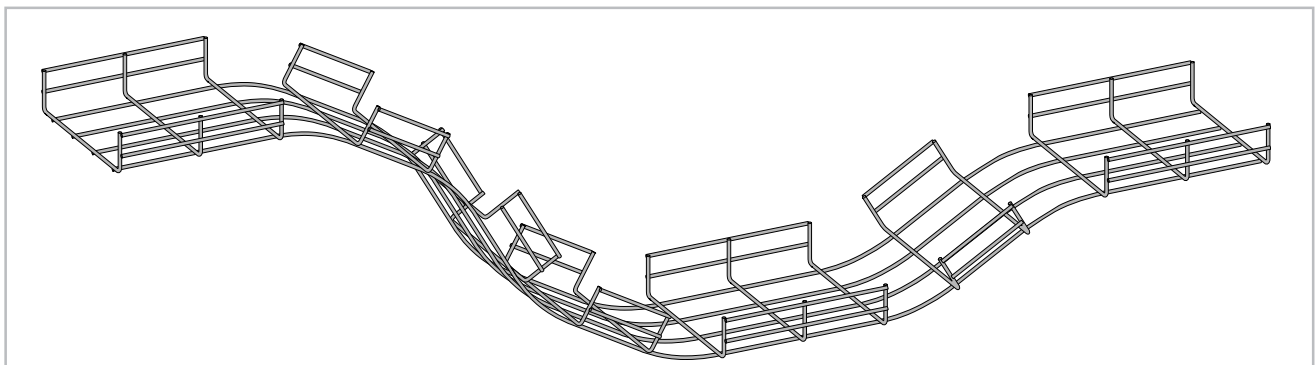



## 1.0 ACCEPTABLE MANUFACTURES'

Provide "Cat-Tray" Wire Basket type of cable management system as manufactured by T. J. Cope, Inc. or engineered approved equal. All cable trays shall be installed in a neat uniform fashion. Installing contractor shall field modify tray system to accommodate the exact routing requirements.

## 2.0 MATERIAL/FINISHES

Wire basket tray to be fabricated from high strength steel wires.

### 2.1 ACCEPTABLE FINISHES;

#### 2.1.A STANDARD FINISH

**EG** – Electro-Galvanized Steel in accordance with ASTM 633 Type I SC3.

#### 2.1.B SPECIAL FINISHES

**HD** – Hot dipped Galvanized Steel in accordance with ASTM 123.

**ZD** – Electro- Galvaned Steel with a Yellow Dichromate applied over the Standard EG finish per ASTM633 type II, SC3.

**EP** – Epoxy Coated Steel.

**SS** – AISI 304L stainless or AISI 316L stainless steel.

## 3.0 - STRAIGHT SECTIONS

Straight sections shall be manufactured from high strength steel wires forming 2" X 4" openings and shall conform to the following dimensions

### 3.1 LENGTH

Straight sections shall be supplied in 10' lengths

### 3.2 WIDTH

Widths shall be 2", 4", 6", 8", 12", 16", 18", 20", or 24" as called out on drawings.

## 3.3 - LOAD DEPTHS

The load depths shall include 1", 2", 4" & 6" as required.

## 4.0 SPLICES

All straight sections shall be supplied with pre-installed, auto-locking, splices plates, where possible, as per T. J. Copes' "Cat-Tray". Trays design shall allow for a snap together type connection and shall require no nut and bolt assembly.

## 5.0 FITTINGS

All fittings shall be fabricated in the field as required, per manufacturer's recommendations. Radius of the fittings shall be based on the "minimum bending" radius of the cables being installed.

## 6.0 ACCESSORIES

Accessories such as blind ends, dropouts, and barriers, etc... shall be installed as specified on drawings.

## 7.0 SUPPORTS

Supports shall include, but are not limited to, center type, trapeze type, wall supports, and floor supports.

### 7.1 AUTO LOCKING

All supports shall be supplied with an Auto locking feature, requiring no special tools for attachment of the trays.

### 7.2 FINISH

All supports, including threaded rod and associated hardware shall be electro-galvanized coated to ASTM B633 SC1, or ASTM B633 SC3.



## UL CLASSIFIED SYSTEMS

The T. J. Cope, Cat-Tray Systems which meet the UL Classification are referenced on pages 6, 7, & 8.

**NOTES:** Cope recommends use of a separate ground wire for equipment grounding.

Any non-conductive coating to Cat-Tray must be removed by the contractor/end-user to maintain electrical continuity.

**Straight sections** - The grounding of two straight sections requires the use of  
(2) CAT-GC's and (2) EG-CBN's.

These items consist of grounding clips and the appropriate hardware, for connecting to the trays. One clip should be placed on both sides of the tray, attached at the self-splicing bar.

**Fittings** - Grounding of fittings requires special attention. Typically fittings are fabricated in the field by cutting straight sections, thus altering the cross sectional area of the tray. A bonding jumper, and or a T-Bar Splice, along with the appropriate hardware must be used on either side of the fitting to ensure electrical continuity.

### Straights

- 2 pcs of CAT-GC
- 2 pcs of EG-CBN

#### EG-CBN

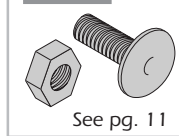

See pg. 11

#### APPLICATION EXAMPLE

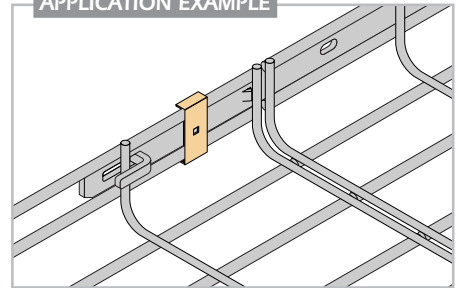

### Fittings

- T-Bar and
- CH3s

#### APPLICATION EXAMPLE

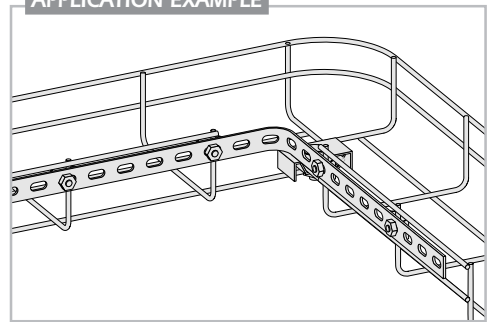

## CAT-GC GROUNDING CLIP

- Standard finish is pregalvanized (PG)
- Sold in packs of 10
- Connection to splice bars requires a nut and bolt assembly (EG-CBN) purchased separately
- Use on both sides of tray

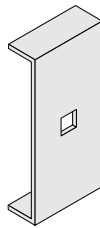

**NOTE:** Always place nut on outside of tray

CAT-GC's must be utilized if the tray is to be utilized as an equipment ground conductor.

## GROUNDING CLAMP/SPLIT BOLT

- Split bolts are utilized for the attachment of a separate ground wire.
- Use with #6 AWG Ground Conductor

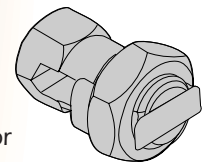

**NOTE:** Always place nut on outside of tray

#### APPLICATION EXAMPLE

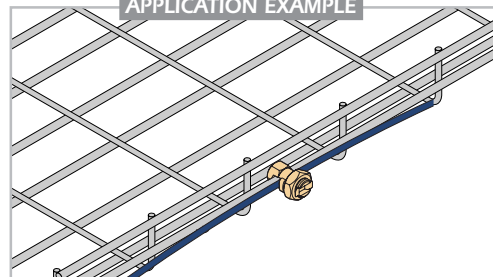

# Hardware

## BOTTOM-CLIP

- Bottom-clip used as a hold-down clip

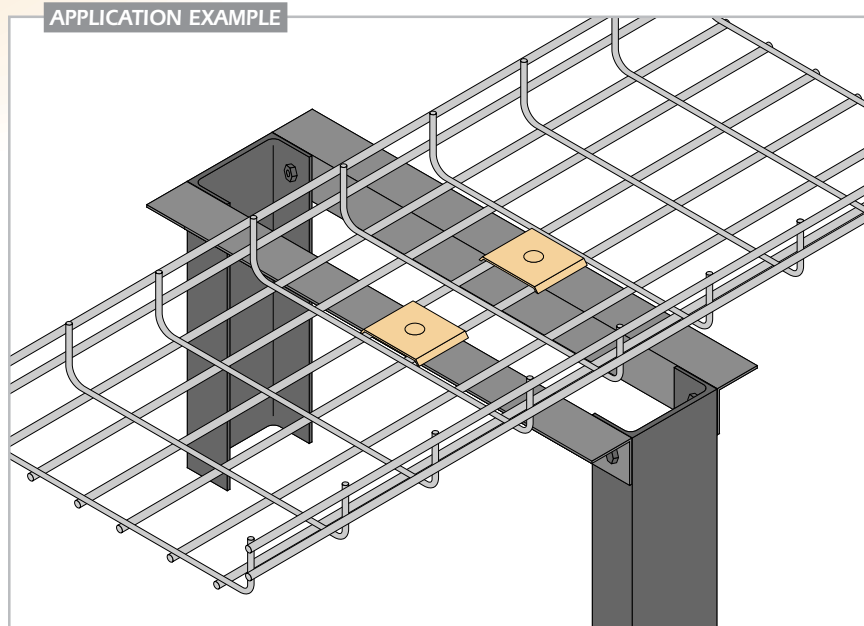
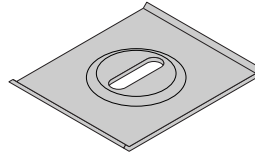

Drill hole in aluminum angle of relay rack.

Use bottom-clip to hold Cat-Tray to relay rack using 1/4"-20 round head machine screw and bolt and washer.

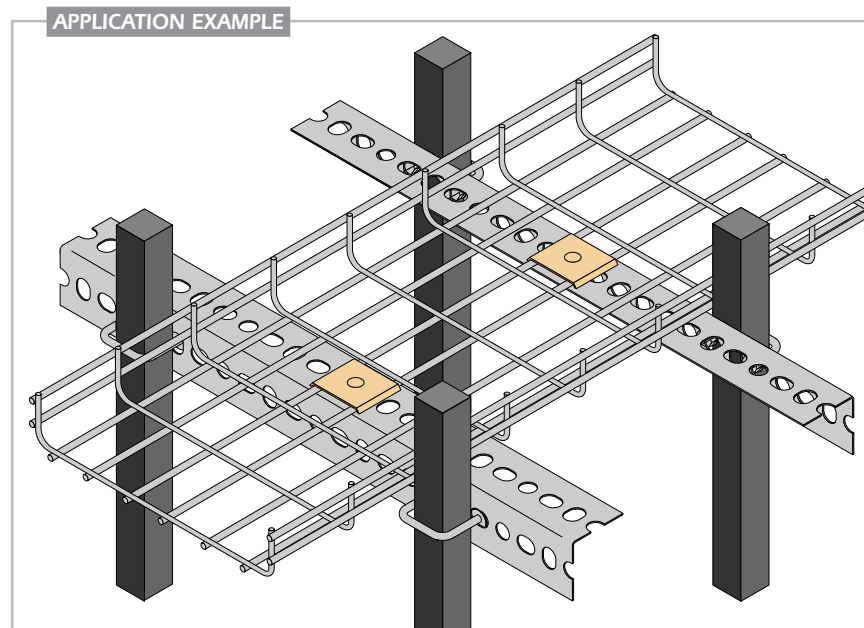



### HEX HEAD CAP SCREWS

- Standard finish is electro-galvanized (EG)

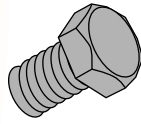

Part No.	Description
5100-0	1/4"-20 x 1" Long
5112-0	1/4"-20 x 1 1/2" Long
5058-1	3/8"-16 x 5/8" Long
5100-1	3/8"-16 x 1" Long
5112-1	3/8"-16 x 1 1/2" Long
5200-1	3/8"-16 x 2" Long

### ROUND HEAD MACHINE SCREWS

- Standard finish is electro-galvanized (EG)

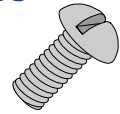

Part No.	Description
6100-0	1/4"-20 x 1" Long
6112-0	1/4"-20 x 1 1/2" Long
6058-1	3/8"-16 x 5/8" Long
6100-1	3/8"-16 x 1" Long
6112-1	3/8"-16 x 1 1/2" Long
6200-1	3/8"-16 x 2" Long

### HEX NUTS

- Standard finish is electro-galvanized (EG)

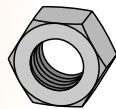

Part No.	Description
5001-0	1/4"-20
5001-1	3/8"-16
5001-2	1/2"-13

### SQUARE NUTS

- Standard finish is electro-galvanized (EG)

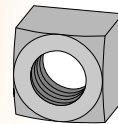

Part No.	Description
5002-0	1/4" - 20
5002-1	3/8" - 16
5002-2	1/2" - 13

### FLAT WASHERS

- Standard finish is electro-galvanized (EG)



Part No.	Description
5006-0	1/4"
5006-1	3/8"
5006-2	1/2"

### LOCK WASHERS

- Standard finish is electro-galvanized (EG)

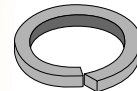

Part No.	Description
5007-0	1/4"
5007-1	3/8"
5007-2	1/2"



# Hardware

## STRUT NUTS

- Standard finish is electro-galvanized (EG)

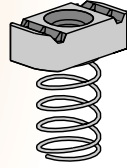

Part No.	Description
PSRS-1/4	1/4" - 20
PSRS-3/8	3/8" - 16
PSRS-1/2	1/2" - 13

## SQUARE STRUT WASHERS

- Standard finish is electro-galvanized (EG)

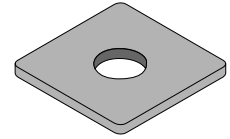

Part No.	Description
0620	1/4" hole
0621	3/8" hole
0622	1/2" hole

## TRAY CLIPS (See Page 10 for Connector Kits)

- Standard finish is electro-galvanized (EG)

SINGLE PART	WEIGHT	NO./ PKG
Short-Clip	.20	10
Wide-Clip	.31	10
Bottom-Clip	.92	10

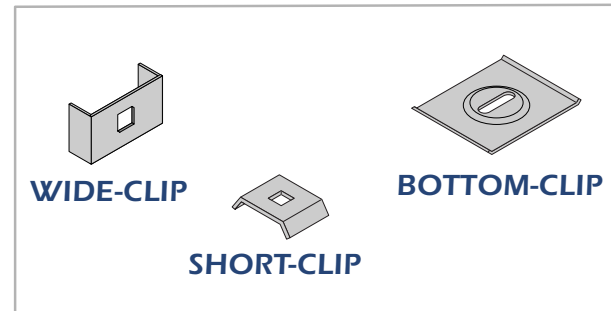

## THREADED ROD

- Standard finish is electro-galvanized (EG)

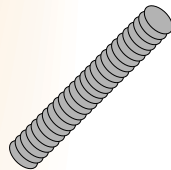

Part No.	Description
8193-0-10	1/4" - 20
8193-1-10	3/8" - 16
8193-2-10	1/2" - 13



90° Long Radius Bends . . . . .	26	CAT-CB-MSB . . . . .	18	CAT-SIDE-HC . . . . .	13
90° Short Radius Bends . . . . .	25	CAT-CB-USB . . . . .	17	CAT-UNI-DO . . . . .	21
Accessory Assembly . . . . .	5	CAT-CCA-04 . . . . .	14	CAT-USB-120 . . . . .	12
Advantages of Cope . . . . .	4	CAT-CCA-06 . . . . .	14	CAT-WC-2 . . . . .	16
Bottom-Clip (Hold-Down) . . . . .	10,31	CAT-CCA-08 . . . . .	14	CAT-WS . . . . .	23
<hr/>					
CAT1 Assembly . . . . .	5	CAT-CCA-12 . . . . .	14	CAT-ZBAR-120 . . . . .	15
CAT1-01SB-120 . . . . .	21	CAT-CCA-16 . . . . .	14	CH1 . . . . .	10
CAT1-04SL-120-EG . . . . .	6	CAT-CMA-04 . . . . .	19	CH2 . . . . .	10,11,31
CAT1-06SL-120-EG . . . . .	6	CAT-CMA-06 . . . . .	19	CH3 . . . . .	10,11
CAT1-08SL-120-EG . . . . .	6	CAT-CMA-08 . . . . .	19	Cross . . . . .	27
<hr/>					
CAT1-12SL-120-EG . . . . .	6	CAT-CMA-12 . . . . .	19	EG-CBN . . . . .	10,11
CAT1-AUTO . . . . .	6	CAT-CPA-06 . . . . .	14	Flat Washers . . . . .	32
CAT-1x6-HC . . . . .	13	CAT-CPA-08 . . . . .	14	Grounding . . . . .	30
CAT2 Assembly . . . . .	4	CAT-CPA-12 . . . . .	14	Hardware . . . . .	31-33
CAT2-01SB-120 . . . . .	21	CAT-CPA-16 . . . . .	14	Hex Head Cap Screws . . . . .	32
<hr/>					
CAT2-02SL-120 . . . . .	7	CAT-CUT . . . . .	24	Hex Nuts . . . . .	32
CAT2-04SL-120 . . . . .	7	CAT-CVR . . . . .	21	How to Order . . . . .	3
CAT2-06SL-120 . . . . .	7	CAT-EBC . . . . .	23	Lock Washers . . . . .	32
CAT2-08SL-120 . . . . .	7	CAT-GC . . . . .	30	Offset . . . . .	28
CAT2-12SL-120 . . . . .	7	CAT-HGR-2 . . . . .	16	Product Description . . . . .	3
<hr/>					
CAT2-16SL-120 . . . . .	7	CAT-HGR-4 . . . . .	16	PS651 . . . . .	17
CAT2-18SL-120 . . . . .	7	CAT-HLT . . . . .	23	PS809 . . . . .	17
CAT2-20SL-120 . . . . .	7	CAT-HSB-120 . . . . .	12	PSRS (Strut Nut) . . . . .	33
CAT2-24SL-120 . . . . .	7	CAT-HWSB-08 . . . . .	15	Reducer . . . . .	28
CAT-2-DO . . . . .	21	CAT-HWSB-12 . . . . .	15	Riser . . . . .	28
<hr/>					
CAT-2x8-HC . . . . .	13	CAT-HWSB-18 . . . . .	15	Round Head Machine Screws . . . . .	32
CAT4 Assembly . . . . .	4	CAT-HWSB-20 . . . . .	15	Sample Specification . . . . .	29
CAT4-01SB-120 . . . . .	21	CAT-HWSB-24 . . . . .	15	Short-Clip . . . . .	33
CAT4-04SL-120 . . . . .	8	CAT-MSB-120 . . . . .	12	Special Order Finishes . . . . .	3
CAT4-08SL-120 . . . . .	8	CAT-MWSB-06 . . . . .	15	Splice . . . . .	9
<hr/>					
CAT4-12SL-120 . . . . .	8	CAT-MWSB-08 . . . . .	15	Split Bolt/Grounding Clamp . . . . .	30
CAT4-16SL-120 . . . . .	8	CAT-MWSB-12 . . . . .	15	Square Nuts . . . . .	32
CAT4-18SL-120 . . . . .	8	CAT-Ped-06 . . . . .	20	Square Strut Washers . . . . .	32
CAT4-20SL-120 . . . . .	8	CAT-Ped-12 . . . . .	20	Standard Finish . . . . .	3
CAT4-24SL-120 . . . . .	8	CAT-Ped-KIT . . . . .	20	Standard Tee . . . . .	27
<hr/>					
CAT-4-DO . . . . .	21	CAT-PPA-06 . . . . .	14	Strut Nuts (PSRS) . . . . .	33
CAT-AB-HSB . . . . .	18	CAT-PPA-10 . . . . .	14	T-Bar . . . . .	9
CAT-AB-USB . . . . .	18	CAT-PPA-14 . . . . .	14	T-Bar-22 . . . . .	9
CAT-BE . . . . .	22	CAT-PPA-18 . . . . .	14	Threaded Rod . . . . .	33
CAT-CB . . . . .	22	CAT-PPA-22 . . . . .	14	Tray Clips . . . . .	33
CAT-CB-HSB . . . . .	19	CAT-PPA-26 . . . . .	14	Wide-Clip . . . . .	33

## Other Tyco Electrical and Metal Products

### CONDUIT

#### Steel

- Rigid, EMT, IMC
- Kwik-Couple® IMC/GRC
- Kwik-Fit™ EMT
- Fire Alarm™ EMT
- Blue EMT

#### Aluminum

- Rigid, EMT
- Rigid and EMT Elbows and Couplings

#### PVC

- Schedule-40
- Schedule-80
- PVC Fittings
- EB/DB Duct



### POWER-STRUT® FRAMING SYSTEMS

- Pre-Galvanized Channel
- Power-Gold™ Channel
- Hot-Dip Galv Channel
- Aluminum Channel
- Stainless Steel Channel

- Fiberglass Channel
- Power-Green® Channel
- Strut Fittings
- Threaded Rod
- Junior Strut

- Junior Strut Fittings
- Fiberglass Fittings
- Concrete Inserts



### COPE® CABLE TRAY SYSTEMS

- Aluminum Ladder Tray
- Aluminum Trof
- Fiberglass Tray
- Steel Trof

- Steel Ladder Tray
- CAT-Tray™ Wire Basket
- Centipede® Center-Hung Tray
- Cope Channel



### AFC CABLE SYSTEMS®

#### AC & MC Cable

- AC-90® & AC-Lite® Aluminum Armored Cable
- MC TUFF® Lightweight Steel (MC)
- Home Run Cable®
- Super Neutral Cable

- HCF-90® Steel & HCF-Lite® Aluminum Sheath
- Healthcare Facilities Cable
- Fire Alarm/Control Cable™
- Parking Deck/Lot Cable

- MC TUFF®-IG MC Cable with Isolated Ground
- MOF® Metal Clad Optical Fiber Cable

#### Conduit Fittings

- EMT Steel Compression and Set-Screw
- Liquid-Tight Metallic and Non-Metallic Fittings

#### Flexible Conduit

- LIQUID-TUFF™ Liquid-Tight Flexible Conduit
- Full and Reduced Wall Flexible Conduit

#### ACS/Uni-Fab Specialty Products

- Lighting, Power & Appliance Whips
- ACS/Uni-Fab Wiring Systems
- Temp-Lites®



# cope® Cat -Tray™ Wire Mesh Cable Tray

16100 S. Lathrop Ave. • Harvey, Illinois 60426 (708) 339-1610 • (800) 688-4857 • Fax (215) 961-2580

[www.atcelectrical.com](http://www.atcelectrical.com)

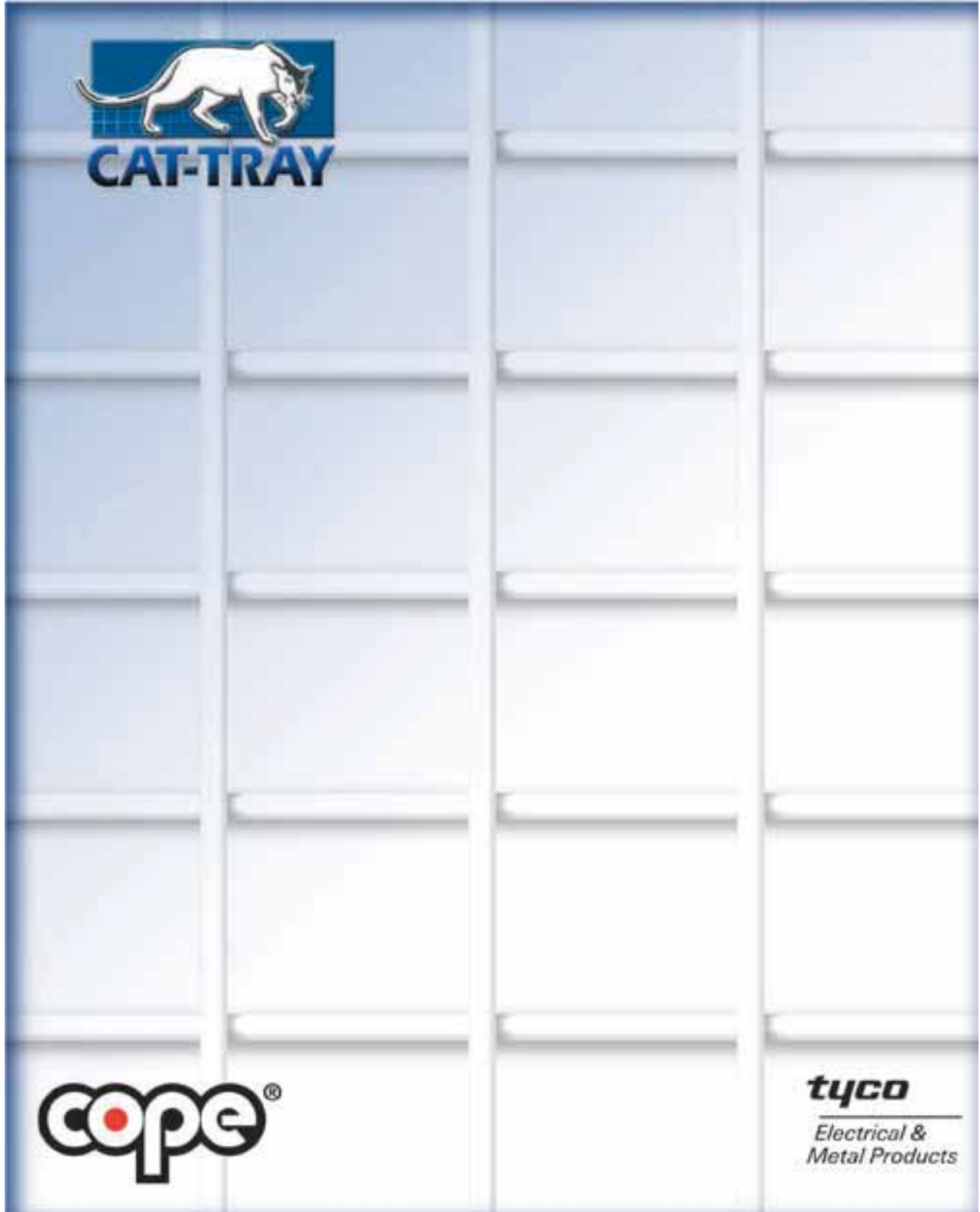

Cope® Cable Tray · AFC Cable Systems® · Allied Tube & Conduit · Power-Strut® Metal & Fiberglass Framing

Allied and Tyco are trademarks or registered trademarks of Tyco and/or its affiliates in the United States and in other countries.  
All other brand names, product names, or trademarks belong to their respective holders.