

# S9/S12 SERIES

VANDAL RESISTANT FIXTURES

Cat.#	
Job	Type



**APPLICATIONS**

- Ceiling/canopy lighting. Safety and security illumination for parking garage, entrance canopies, stairwells, building eaves

**SPECIFICATIONS**

- Die cast aluminum housing with 1/2" conduit hubs
- Vandal resistant prismatic polycarbonate refractor
- Bronze powder paint finish on H.I.D. units
- Medium base or compact fluorescent lamps included
- Typical mounting height ranges from 8 to 15 feet

**LISTINGS**

- **S9/S12 Series**  
Listed to UL1598 for use in wet locations for wall or ceiling mount  
Center pin torx screws are standard

**CERTIFICATIONS/LISTINGS**



	A	B	C	D	E
<b>S9 H.I.D.</b>	7.09" 180 mm	8.858" 225 mm	8.858" 225 mm	4.1" 104 mm	8.5" 216 mm
<b>S12 H.I.D.</b>	8.858" 225 mm	12.362" 314 mm	12.362" 314 mm	5.3" 135 mm	11.8" 300 mm

**PRODUCT IMAGE(S)**

**S9 H.I.D.**



**S12 H.I.D.**



**DIMENSIONS**

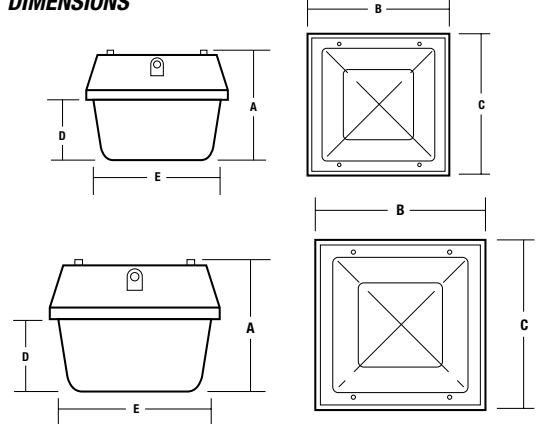

**ORDERING INFORMATION**

Catalog Number <sup>1</sup>	Description	Voltage	Finish	Weight lbs. (kg)
<b>Wet Location - Ceiling / Wall Mount Compact S9 – 9 inch Square</b>				
<b>S9-70H</b>	70w PSMH	120, 208, 240, 277	Bronze	10 (4.5)
<b>Mid-Size S12 – 12 inch Square</b>				
<b>S12-100H</b>	100w PSMH	120, 208, 240, 277	Bronze	15 (6.8)
<b>S12-150P</b>	150w PSMH	120, 208, 240, 277	Bronze	16 (7.3)

<sup>1</sup> Lamp included

**REPLACEMENT PARTS**

Catalog Number	Description
<b>SM009-LENS</b>	Refractor only for S9 units
<b>SM012-LENS</b>	Refractor only for S12 units



For CFL unit with battery backup for Egress applications, see Dual-Lite page 945

