



*Hoffman*<sup>®</sup>

CONTRACTOR

# SPECIFIER'S GUIDE

DESIGN WITH CONFIDENCE<sup>™</sup>

EQUIPMENT PROTECTION

CONTRACTOR

VOLUME 7

## ADVANCING A HERITAGE OF LEADERSHIP

Pentair Equipment Protection is a global leader in safeguarding industrial controls, electrical components, and communications hardware. Its premier brand, Hoffman®, provides a comprehensive range of standard, modified and custom engineered solutions. For more information, visit [www.hoffmanonline.com](http://www.hoffmanonline.com)



Hoffman is a leading designer and manufacturer of systems to safely and reliably protect the electronic controls and mission critical electrical systems in industrial, data communications, commercial construction and government applications. Our product catalog features the wide array of enclosures, accessories and thermal management products.

We have developed significant vertical market expertise to help us understand and develop industry solutions to address your particular circumstances. Our extensive network of North American distributors and our global sales channel can help you obtain the products you need.

In addition to our broad line of standard enclosures, Hoffman has the expertise to deliver modified standard enclosures quickly and reliably as well as complicated co-developed and custom solutions.

Hoffman maintains a high standard of quality and operates under a global ISO 9000 certificate. We design and test our products in our in-house UL laboratory to ensure they meet stringent quality standards. Hoffman products comply with UL, NEMA, CSA and other international standards.



MCLEAN® IS NOW HOFFMAN COOLING

Hoffman Cooling helps create optimal conditions for the reliable operation of electronic and electrical components in manufacturing controls, telecom equipment, data networks, and other vital systems. From standard fan assemblies to air conditioners, to heat exchangers, to integrated cooling enclosures for a variety of applications, Hoffman assures maximum productivity and uptime while protecting the life cycles of controls and equipment. Flawless operation is the expectation of OEMs, engineers, and end-users alike. That's why choosing the most qualified cooling technology provider reaches far beyond the implications of product performance to include service and support benchmarks.

As a premier global provider with decades of experience in cooling industrial automation and electrical components, Hoffman remains unrivaled with an industry-leading portfolio of proven products, pre- and post-sale support, and comprehensive engineering and testing services.

For more information about Hoffman Cooling products visit [hoffmanonline.com](http://hoffmanonline.com).

### About Pentair Ltd.

Pentair ([www.pentair.com](http://www.pentair.com)) delivers industry-leading products, services and solutions for its customers in diverse needs in water and other fluids, thermal management and equipment protection. With 2012 pro forma revenues of approximately \$8 billion, Pentair employs more than 30,000 people worldwide.



## Working Harder for the Contractor

Now more than ever, Hoffman® Enclosures have the right products for today's contractor. Not only do we continue to add new products and additional sizes of our most popular boxes and cabinets, our broad distribution network assures you of convenient, fast product delivery.

We have what you need for every application – junction boxes, weatherproof outdoor enclosures, basic panel enclosures and wireway.



We deliver what you expect – innovative products, competitive pricing, easy ordering and the industry's largest and most-experienced sales and applications staff.

Use this catalog as a reference to our complete range of commercial contractor products.



# TABLE OF CONTENTS

## TYPE 1

### SCREW-COVER TYPE 1 PULL BOXES AND ACCESSORIES

Screw-Cover, Type 1	4
Flush Covers	8
Flush-Mount Door Frames	9
Type 1 Locking Window Pull Box Accessory	10
Type 1 Pull Box Perforated Panel	11

### HINGED-COVER TYPE 1 BOXES, ENCLOSURES AND ACCESSORIES

Hinged-Cover with Recessed Handle, Type 1	12
T1FLO™ Vented Enclosure with Fan, Type 1	14
Hinged-Cover, Type 1	16
Small, Type 1	18
Medium, Type 1	20
Large, Type 1	22
Locking Integrated Perforated Panel Enclosure, Type 1	24
Locking Utility Cabinets, Type 1	26

## TYPE 3

### SCREW-COVER TYPE 3 ENCLOSURES

Screw-Cover, Gasketed, Type 3	30
-------------------------------	----

## TYPE 3R

### SCREW-COVER TYPE 3R BOXES AND ENCLOSURES

Horizontal-Mount, Type 3R	32
Screw-Cover, Type 3R	34
Screw-Cover Galvanized, Type 3R	38

### HINGE-COVER TYPE 3R ENCLOSURES

Hinge-Cover, Small, Type 3R	40
Hinge-Cover, Medium, Type 3R	42

### HINGE-COVER LIFT-OFF TYPE 3R ENCLOSURES AND ACCESSORIES

Hinge-Cover Lift-Off, Type 3R	44
Panel Mounting Kit	45
Mounting Bracket Kit	45

### PAD-MOUNT TYPE 3R ENCLOSURES AND ACCESSORIES

WEATHERPRO™ Outdoor Pad Mount, Type 3R	46
19-in. Hinged Wall-Mount Panel	49
19-in. Fixed Wall-Mount Rack	50
Insect Screens	50
Fan Shroud Kits	51

### WEATHERFLO™ TYPE 3R VENTED ENCLOSURES

WEATHERFLO™ with Fan, Type 3R	52
Technical Information	54
Solar Consideration	54
Critical Parameters (upper temperature limits)	55
Critical Parameters (lower temperature limits)	55

### WEATHERFLO™ HD

WEATHERFLO™ HD Enclosures	56
Tops	57
Bases	58
Panel	58
Rear Covers	58
CFM Performance Chart	59
Product Selection Matrix	59
Gland Plate	59
Joining Kit	59
Impeller	59

## TELEPHONE CABINETS

### TELEPHONE CABINETS AND ACCESSORIES

Telephone Cabinet, Type 1	62
Replacement Tumbler Lock	63
T3-Box Telephone Cabinet, Type 3R	64
Locking T Handle	65

## CURRENT TRANSFORMER CABINETS AND TERMINAL BOXES

### CURRENT TRANSFORMER CABINETS

Current Transformer, Screw Cover, Type 3R	68
Current Transformer, Hinged Cover, Type 3R	70
CT Mounting Base	72
Current Transformer Cabinets, 400-800 Amp, Type 3R	74
3-Phase 400-1200 Amp with Mechanical Lugs, Type 3R	76
Current Transformer, Type 3R, Overview	78
Screw Cover with Steel Foot Mount Panel	78
Lift-Off Cover with Wood Panel	78
Hinged Screw Cover with Steel Panel	78
Hinged Double-Door with Three-Point Latch and Wood Panel	79
400- and 800-Amp Bar-Type Mount with Line/Load Lugs	79
Vented Double Door	79

### TYPE 3R TERMINAL BOX AND ACCESSORIES

Terminal Box, Type 3R	80
Interchangeable Bolt-on Hub	81
Lug Assembly	81

## ELECTRICAL UTILITY

### SECTIONALIZING

Utility Junction (UJ) Cabinets	82
--------------------------------	----

## CANADIAN CABINETS AND SPLITTERS

### CANADIAN CABINETS

Metering, Type 1	88
------------------	----

### CANADIAN SPLITTERS

Splitter Trough, Type 1	90
Splitter Box, Type 1	92
Splitter Block Assemblies Overview	93
Splitter Box Block Assemblies	93
Splitter Trough Block Assemblies	94
Ground Splitter (Ground Bar)	94

## LAY-IN WIREWAY

### LAY-IN NEMA TYPE 1 GALVANIZED WIREWAY

Lay-In Galvanized Wireway, NEMA Type 1	98
Straight Section	100
Galvanized 90-Degree Flush Tee	101
Galvanized Sweep Tee	101
Galvanized Cross Fitting	102
Galvanized 90-Degree Sweep Elbow	102
Galvanized 90-Degree Elbow-Tee-Cross	102
Galvanized 90-Degree Elbow	102
Galvanized 90-Degree Elbow—Outside Opening	103
Galvanized 90-Degree Elbow—Inside Opening	103
Galvanized 45-Degree Elbow	103
Galvanized Telescope Fitting	104
Galvanized Panel Adapter	104
Galvanized Closure Plate, With and Without Knockouts	104
Reducer	105
Galvanized Support Hanger	105
Drop and Bracket Hangers	105
Galvanized Universal U-Connector	105



### LAY-IN NEMA TYPE 1 PAINTED FLAT-COVER WIREWAY

Lay-In Painted Flat-Cover Wireway, NEMA Type 1	106
Straight Section	107
90-Degree Flush Tee	109
Sweep Tee	109
Cross Fitting	109
90-Degree Sweep Elbow	109
90-Degree Elbow-Tee-Cross	110
90-Degree Elbow	110
90-Degree Elbow—Outside Opening	110
90-Degree Elbow—Inside Opening	110
45-Degree Elbow	111
Telescope Fitting	111
Open Adapter	111
Panel Adapter	111
Closure Plate	112
Drop and Bracket Hangers	112
Support Hanger	112
Universal U-Connector	113
Barrier Kit, Bolt-On	113
Reducer	113

### LAY-IN NEMA TYPE 1 HINGED-COVER WIREWAY

Lay-In Hinged-Cover Wireway, NEMA Type 1	114
Straight Section	115
90-Degree Flush Tee	117
Sweep Tee	117
Cross Fitting	117
90-Degree Sweep Elbow	117
90-Degree Elbow-Tee-Cross	118
90-Degree Elbow	118
90-Degree Elbow—Outside Opening	118
90-Degree Elbow—Inside Opening	118
45-Degree Elbow	119
Telescope Fitting	119
Open Adapter	119
Panel Adapter	119
Closure Plate	120
Reducer	120
Drop and Bracket Hangers	120
Support Hanger	120
Universal U-Connector	121
Barrier Kit, Bolt-On	121

### LAY-IN NEMA TYPE 3R WIREWAY

Lay-In Wireway, NEMA Type 3R	122
Straight Section	123
90-Degree Flush Tee	123
30-Degree Sweep Elbow	123
90-Degree Elbow-Tee-Cross	124
90-Degree Elbow	124
Panel Adapter	124
Closure Plate	124
Reducer	124
Drop and Bracket Hanger	125
Wall Hanger	125
U-Connector	125

### LAY-IN NEMA TYPE 12 WIREWAY

Lay-In Wireway, NEMA Type 12	126
Straight Section	129
Cut-Off Fitting, Lay-In	130
Cut-Off Fitting, Non-Lay-In	130

Telescope Fitting, Lay-In	130
Cross Fitting	130
90-Degree Elbows	131
90-Degree Elbow—Outside Top Opening	131
45-Degree Elbows	132
Tee Fitting—Top Opening	132
Tee Fitting—Outside Top Opening	133
Junction Box	133
Closure Plate	133
Reducer	134
Nipple	134
Drop Hanger	134
Bracket Hanger	135
Box Connector	135
Transposition Sections	136
Barrier Kit, Bolt-On	136
Barrier Kits, Bracket-Mounted	137
90-Degree Angle Sealing Plate	137
Quick-Release Flat Sealing Plate	137

### FEED-THROUGH WIREWAY

#### FEED-THROUGH NEMA TYPE 12 WIREWAY

Feed-Through Wireway, NEMA Type 12	140
Straight Section	142
Flexible Fitting	143
Telescope Fitting	143
Cut-Off Fitting	143
Cross	143
22.50-Degree Elbow	144
45-Degree Elbow	144
90-Degree Elbow	144
Tee	144
Closure Plate	145
Reducer Bushings	145
Nipple	145
Swivel Nipples	146
Hangers	146
Box Connector	146
Barrier Kits	147
Gasket and Screws	147

#### STAINLESS STEEL FEED-THROUGH NEMA TYPE 4X WIREWAY

Stainless Steel Feed-Through Wireway, NEMA Type 4X	148
Straight Section	149
Flexible Fitting	149
Telescope Fitting	149
45-Degree Elbow	149
90-Degree Elbow	150
Tee	150
Closure Plate	150
Reducer Bushings	150
Nipple	151
Swivel Nipple	151
Drop Hanger	151
Bracket Hanger	151
Box Connector	151
Gasket and Screws	151

#### FIBERGLASS FEED-THROUGH TYPE 12 AND 3R WIREWAY

Fiberglass Feed-Through Wireway, NEMA Type 12 and 3R	152
Straight Section	153
Straight Tube Section	153
Cross Fitting	153

Flexible Fitting	153
45-Degree Elbow	154
90-Degree Elbow	154
Cut-Off Fitting	154
Tee Fitting	154
Closure Plate	154
Wireway Hanger	155
Box Connector	155

## WIRING TROUGHS

### WIRING TROUGHS

Wiring Trough, NEMA Type 1	158
Wiring Trough, NEMA Type 3R	160
EconoTrough, NEMA Type 3R	162
Padlock Hasp Kit	163
Hinged Cover Wiring Trough, NEMA Type 12	164
Screw Cover Wiring Trough, NEMA Type 12	166
Fiberglass Wiring Trough, NEMA Type 12 and 3R	168

## STAINLESS STEEL CABLE TRAY

### CLEAN TRAY™ STAINLESS STEEL CABLE TRAY

CLEAN TRAY™ Stainless Steel Cable Tray, Type 1	172
Straight Section	173
Divider Straight Section	173
Telescopic Straight Section	173
Divider, Telescopic Straight Section	174
90-Degree Elbows	174
90-Degree Elbows—Perforated without Tabs	175
90-Degree Elbows—Front Cover Sloped Inward without Tabs	175
90-Degree Elbows—Front Cover Sloped Outward with Tabs	175
90-Degree Elbows—Front Cover Sloped Outward without Tabs	176
90-Degree Elbows—Inside Cover Sloped	176
90-Degree Elbows—Outside Cover Sloped	176
45-Degree Elbows	177
45-Degree Elbows—Front Cover Sloped Outward	178
45-Degree Elbows—Inside Cover Sloped	178
45-Degree Elbows—Outside Cover Sloped	178
Variable-Angle Elbow Fitting	179
90-Degree Tee	179
90-Degree Tee—Front Cover Sloped Outward	180
90-Degree Tee—Inside Cover Sloped	180
90-Degree Tee—Outside Cover Sloped	180
Cross	181
Divider 90-Degree Tee	181
Divider 90-Degree Elbow	182
Divider 45-Degree Elbow	182
U-Connector	182
Closure Plate	183
Enclosure Adapter	183
Reducer	184
Cable Exit Cover	184
Straight Section Splice	185
Divider Straight Section Splice	185
Transition Cover	186
Side Coupling	186
Fastener Package	186
Hanger Bracket	187
L-Bracket	187
Wall Bracket	187
Latch Hardware Kits	187

## CABLE PATHWAY / BONDING AND GROUNDING

### CABLE PATHWAY AND ACCESSORIES

Ladder Rack System	190
Ladder Rack Straight Sections (cULus Classified)	191
Ladder Rack Curved Sections (cULus Classified)	191
90-Degree Horizontal E-Bend Section (cULus Classified)	191
Butt-Splice Kit (cULus Classified)	191
Adjustable Butt-Splice Kit (cULus Classified)	191
Junction Splice Kit (cULus Classified)	192
Adjustable Junction Splice Kit (cULus Classified)	192
Retaining Post Kit	192
L-Bracket Kit	192
Radius Drop Kit	192
Stringer Radius Drop Kit	192
Ceiling Support Kit	193
Foot Kit	193
Rack-to-Runway Mounting Plate Kit	193
Vertical Wall Bracket	193
Triangle Support Bracket Kit	194
Modular Triangle Support Bracket Kit	194
Wall Angle Support	194
Corner Support Bracket Kit	194
End Cap Kit	195
Runway Termination Kit	195
Movable Cross Member	195
Rack-to-Wall Kit	195
Runway Elevation Kit	195
Runway Overhead 12-in. Stack Kit	196
Runway Center Support Kit	196
Spool Divider Kit	196
Insulated Ground Jumper Kit	196
J-Bolt Kit	197
CABLERACK™	197

### QUICK TRAY PRO™

Straight Section	198
Splice Kit	200
Splice Washer	200
Splice Bars	200
Trapeze Hanging Clip	201
C-Bracket	201
Center Hangers	201
L-Brackets	202
Reinforced Wall Bracket	202
Divider Strip	203
Side-Action Bolt Cutter	203
Vertical Down	203
Wall-Termination Bracket	204
Polymer Insert	204

### BONDING AND GROUNDING ACCESSORIES

Bonding and Grounding Overview	206
Lay-In Lug	207
Compression Lugs	207
Heavy-Duty C-Taps	207
Telecommunications Ground Bar Kits	208
Vertical Ground Bar Kits	208
Horizontal Ground Bar Kits	208
Insulated Ground Jumper Kit	209
Rack Jumper Kit	209

## STANDARDS

### STANDARDS ORGANIZATION SUMMARY AND DIRECTORY

Standards Organization Summary and Directory Overview	212
---	-----

### INDUSTRY STANDARDS FOR NON-HAZARDOUS APPLICATIONS

Comparison of Specific Non-Hazardous Applications in Outdoor Locations	213
Comparison of Specific Non-Hazardous Applications in Indoor Locations	213
Enclosure Type Rating versus IP Rating	213
Glossary Terms Specifying Non-Hazardous Environmental Conditions	214

### NEMA, UL AND CSA RATINGS

NEMA, UL and CSA Ratings	215
--------------------------	-----

### IEC AND CE CLASSIFICATIONS

IP Rating Descriptions	216
CE	216

### SHORT CIRCUIT CURRENT RATING

Short Circuit Current Rating for Enclosures	217
---	-----

## WIREWAY FILL AND DISCONNECT WIRE BEND SPACE

### WIREWAY FILL

Wireway Fill Tables	218
---------------------	-----

## INDEX

Bulletin Number Index	222
Catalog Number Index	223
Product Index	237



*Hoffman*<sup>®</sup>

# CHAPTER 1 TYPE 1 BOXES AND ENCLOSURES

## OVERVIEW

Pentair offers a wide range of indoor Type 1 Boxes that are used for power distribution, merging conductors, and splicing and housing control assemblies. They come in a wide variety of sizes and styles, with or without knockouts, and with a painted or galvanized finish.

Our Type 1 enclosures with optional solid or perforated panels are ideal for building control assemblies or as control enclosures in clean industrial environments. The perforated panels provide fast and easy component mounting because pre-drilling is not required.



### T1FLO™ VENTED ENCLOSURE WITH FAN, TYPE 1

These enclosures have a thermostatically controlled forced-air ventilation system for the removal of heat. Ideal for control systems in HVAC or industrial environments that have a combination of heat-sensitive electronics with high heat producing components such as (VFD) drives, inverters, PLCs and non-hardened processors.





## CHAPTER CONTENTS

### SCREW-COVER TYPE 1 PULL BOXES AND ACCESSORIES

Screw-Cover, Type 1 .....	4
Flush Covers .....	8
Flush-Mount Door Frames .....	9
Type 1 Locking Window Pull Box Accessory .....	10
Type 1 Pull Box Perforated Panel .....	11

### HINGED-COVER TYPE 1 BOXES, ENCLOSURES AND ACCESSORIES

Hinged-Cover with Recessed Handle, Type 1 .....	12
TIFLO™ Vented Enclosure with Fan, Type 1 .....	14
Hinged-Cover, Type 1 .....	16
Small, Type 1 .....	18
Medium, Type 1 .....	20
Large, Type 1 .....	22
Locking Integrated Perforated Panel Enclosure, Type 1 ..	24
Locking Utility Cabinets, Type 1 .....	26



### TYPE 1 LOCKING WINDOW PULL BOX ACCESSORY



Flush- or surface-mount accessory fits Screw Cover, Type 1, boxes to prevent public access to lighting switches and controls. Includes a removable aluminum dead-front mounting surface for component cutouts and four torx-head screws for securing to enclosure.



SCREW-COVER, TYPE 1



INDUSTRY STANDARDS

UL 50, 50E Listed; Type 1; File No. E27525  
 cUL Listed per CSA C22.2 No 40; Type 1; File No. E27525

NEMA/EEMAC Type 1  
 IEC 60529, IP30

APPLICATION

Use this enclosure in commercial and general industrial applications that require a junction or pull box. For flush installations, order flush covers and door frames separately.

FEATURES

- Unique keyhole screw slots in the cover
- Available with or without knockouts. Various sizes of easy-to-remove concentric knockouts on all four sides of standard boxes with knockouts.
- Optional flush-mounted door frame available
- Optional flush covers
- Flat, removable covers fastened with plated steel screws
- Provision for grounding
- Mounting holes on back of box

SPECIFICATIONS

- 16, 14 or 12 gauge steel or plated steel

FINISH

ANSI 61 gray polyester powder paint finish inside and out. Unless otherwise specified, all custom pull boxes are finished with ANSI 61 gray polyester powder paint.

ACCESSORIES

- Flush Covers
- Flush-Mount Door Frames
- Grounding Device
- Type 1 Locking Window Pull Box Accessory
- Touch-Up Paint

BULLETIN: A90P1

Standard Product Screw-Cover Type 1 Pull Boxes with Knockouts

Catalog Number	AxBxC in.	AxBxC mm	Style	Number of Cover Screws	Knockout Pattern Along "A" Sides	Knockout Pattern Along "B" Sides
ASE4X4X3	4.00 x 4.00 x 3.00	102 x 102 x 76	Painted	2	B-C	B-C
ASG4X4X3	4.00 x 4.00 x 3.00	102 x 102 x 76	Galvanized	2	B-C	B-C
ASE6X6X3	6.00 x 6.00 x 3.00	152 x 152 x 76	Painted	2	B-C-D	B-C-D
ASG6X6X3	6.00 x 6.00 x 3.00	152 x 152 x 76	Galvanized	2	B-C-D	B-C-D
ASE8X6X3	8.00 x 6.00 x 3.00	203 x 152 x 76	Painted	2	F-G-H-I	B-C-D
ASG8X6X3	8.00 x 6.00 x 3.00	203 x 152 x 76	Galvanized	2	F-G-H-I	B-C-D
ASE16X14X3	16.00 x 14.00 x 3.00	406 x 356 x 76	Painted	4	B-C-D-E-F-G-H	B-C-D-E-F-G-H
ASG16X14X3	18.00 x 14.00 x 3.00	457 x 356 x 76	Painted	4	A-B-C-D-E-F-G-H-I	B-C-D-E-F-G-H
ASE4X4X4	4.00 x 4.00 x 4.00	102 x 102 x 102	Painted	2	B-C	B-C
ASG4X4X4	4.00 x 4.00 x 4.00	102 x 102 x 102	Galvanized	2	B-C	B-C
ASE6X4X4	6.00 x 4.00 x 4.00	152 x 102 x 102	Painted	2	B-C-D	B-C
ASG6X4X4	6.00 x 4.00 x 4.00	152 x 102 x 102	Galvanized	2	B-C-D	B-C
ASE6X6X4	6.00 x 6.00 x 4.00	152 x 152 x 102	Painted	2	B-C-D	B-C-D
ASG6X6X4	6.00 x 6.00 x 4.00	152 x 152 x 102	Galvanized	2	B-C-D	B-C-D
ASE8X6X4	8.00 x 6.00 x 4.00	203 x 152 x 102	Painted	2	F-G-H-I	B-C-D
ASG8X6X4	8.00 x 6.00 x 4.00	203 x 152 x 102	Galvanized	2	F-G-H-I	B-C-D
ASE8X8X4	8.00 x 8.00 x 4.00	203 x 203 x 102	Painted	4	F-G-H-I	F-G-H-I
ASG8X8X4	8.00 x 8.00 x 4.00	203 x 203 x 102	Galvanized	4	F-G-H-I	F-G-H-I
ASE10X8X4	10.00 x 8.00 x 4.00	254 x 203 x 102	Painted	4	F-G-H-I	F-G-H-I
ASG10X8X4	10.00 x 8.00 x 4.00	254 x 203 x 102	Galvanized	4	F-G-H-I	F-G-H-I
ASE10X10X4	10.00 x 10.00 x 4.00	254 x 254 x 102	Painted	4	F-G-H-I	C-D-E-F-G
ASG10X10X4	10.00 x 10.00 x 4.00	254 x 254 x 102	Galvanized	4	F-G-H-I	C-D-E-F-G
ASE12X8X4	12.00 x 8.00 x 4.00	305 x 203 x 102	Painted	4	C-D-E-F-G	F-G-H-I
ASG12X8X4	12.00 x 8.00 x 4.00	305 x 203 x 102	Galvanized	4	C-D-E-F-G	F-G-H-I
ASE12X10X4	12.00 x 10.00 x 4.00	305 x 254 x 102	Painted	4	C-D-E-F-G	C-D-E-F-G
ASG12X10X4	12.00 x 10.00 x 4.00	305 x 254 x 102	Galvanized	4	C-D-E-F-G	C-D-E-F-G
ASE12X12X4	12.00 x 12.00 x 4.00	305 x 305 x 102	Painted	4	C-D-E-F-G	C-D-E-F-G
ASG12X12X4	12.00 x 12.00 x 4.00	305 x 305 x 102	Galvanized	4	C-D-E-F-G	C-D-E-F-G
ASE16X12X4	16.00 x 12.00 x 4.00	406 x 305 x 102	Painted	4	B-C-D-E-F-G-H	C-D-E-F-G
ASG16X12X4	16.00 x 12.00 x 4.00	406 x 305 x 102	Galvanized	4	B-C-D-E-F-G-H	C-D-E-F-G
ASE18X12X4	18.00 x 12.00 x 4.00	457 x 305 x 102	Painted	4	A-B-C-D-E-F-G-H-I	C-D-E-F-G
ASG18X12X4	18.00 x 12.00 x 4.00	457 x 305 x 102	Galvanized	4	A-B-C-D-E-F-G-H-I	C-D-E-F-G
ASE18X18X4	18.00 x 18.00 x 4.00	457 x 457 x 102	Painted	4	A-B-C-D-E-F-G-H-I	A-B-C-D-E-F-G-H-I
ASG18X18X4	18.00 x 18.00 x 4.00	457 x 457 x 102	Galvanized	4	A-B-C-D-E-F-G-H-I	A-B-C-D-E-F-G-H-I
ASE24X12X4	24.00 x 12.00 x 4.00	610 x 305 x 102	Painted	4	A-B-C-D-E-F-G-H-I	C-D-E-F-G
ASG24X12X4	24.00 x 12.00 x 4.00	610 x 305 x 102	Galvanized	4	A-B-C-D-E-F-G-H-I	C-D-E-F-G
ASE24X24X4	24.00 x 24.00 x 4.00	610 x 610 x 102	Painted	4	A-B-C-D-E-F-G-H-I	A-B-C-D-E-F-G-H-I
ASG24X24X4	24.00 x 24.00 x 4.00	610 x 610 x 102	Galvanized	4	A-B-C-D-E-F-G-H-I	A-B-C-D-E-F-G-H-I
ASE30X24X4	30.00 x 24.00 x 4.00	762 x 610 x 102	Painted	6	A-B-C-D-E-F-G-H-I	A-B-C-D-E-F-G-H-I



Catalog Number	AxBxC in.	AxBxC mm	Style	Number of Cover Screws	Knockout Pattern Along "A" Sides	Knockout Pattern Along "B" Sides
ASE6X6X6	6.00 x 6.00 x 6.00	152 x 152 x 152	Painted	2	B-C-D	B-C-D
ASG6X6X6	6.00 x 6.00 x 6.00	152 x 152 x 152	Galvanized	2	B-C-D	B-C-D
ASE8X6X6	8.00 x 6.00 x 6.00	203 x 152 x 152	Painted	4	F-G-H-I	B-C-D
ASE8X8X6	8.00 x 8.00 x 6.00	203 x 203 x 152	Painted	4	F-G-H-I	F-G-H-I
ASG8X8X6	8.00 x 8.00 x 6.00	203 x 203 x 152	Galvanized	4	F-G-H-I	F-G-H-I
ASE10X8X6	10.00 x 8.00 x 6.00	254 x 203 x 152	Painted	4	F-G-H-I	F-G-H-I
ASG10X8X6	10.00 x 8.00 x 6.00	254 x 203 x 152	Galvanized	4	F-G-H-I	F-G-H-I
ASE10X10X6	10.00 x 10.00 x 6.00	254 x 254 x 152	Painted	4	F-G-H-I	C-D-E-F-G
ASG10X10X6	10.00 x 10.00 x 6.00	254 x 254 x 152	Galvanized	4	F-G-H-I	C-D-E-F-G
ASE12X10X6	12.00 x 10.00 x 6.00	305 x 254 x 152	Painted	4	C-D-E-F-G	C-D-E-F-G
ASG12X10X6	12.00 x 10.00 x 6.00	305 x 254 x 152	Galvanized	4	C-D-E-F-G	C-D-E-F-G
ASE12X12X6	12.00 x 12.00 x 6.00	305 x 305 x 152	Painted	4	C-D-E-F-G	C-D-E-F-G
ASG12X12X6	12.00 x 12.00 x 6.00	305 x 305 x 152	Galvanized	4	C-D-E-F-G	C-D-E-F-G
ASE16X12X6	16.00 x 12.00 x 6.00	406 x 305 x 152	Painted	4	B-C-D-E-F-G-H	C-D-E-F-G
ASG16X12X6	16.00 x 12.00 x 6.00	406 x 305 x 152	Galvanized	4	B-C-D-E-F-G-H	C-D-E-F-G
ASE16X16X6	16.00 x 16.00 x 6.00	406 x 406 x 152	Painted	4	B-C-D-E-F-G-H	B-C-D-E-F-G-H
ASG16X16X6	16.00 x 16.00 x 6.00	406 x 406 x 152	Galvanized	4	B-C-D-E-F-G-H	B-C-D-E-F-G-H
ASE18X12X6	18.00 x 12.00 x 6.00	457 x 305 x 152	Painted	4	A-B-C-D-E-F-G-H-I	C-D-E-F-G
ASG18X12X6	18.00 x 12.00 x 6.00	457 x 305 x 152	Galvanized	4	A-B-C-D-E-F-G-H-I	C-D-E-F-G
ASE18X18X6	18.00 x 18.00 x 6.00	457 x 457 x 152	Painted	4	A-B-C-D-E-F-G-H-I	A-B-C-D-E-F-G-H-I
ASG18X18X6	18.00 x 18.00 x 6.00	457 x 457 x 152	Galvanized	4	A-B-C-D-E-F-G-H-I	A-B-C-D-E-F-G-H-I
ASE24X18X6	24.00 x 18.00 x 6.00	610 x 457 x 152	Painted	4	A-B-C-D-E-F-G-H-I	A-B-C-D-E-F-G-H-I
ASG24X18X6	24.00 x 18.00 x 6.00	610 x 457 x 152	Galvanized	4	A-B-C-D-E-F-G-H-I	A-B-C-D-E-F-G-H-I
ASE24X24X6	24.00 x 24.00 x 6.00	610 x 610 x 152	Painted	4	A-B-C-D-E-F-G-H-I	A-B-C-D-E-F-G-H-I
ASG24X24X6	24.00 x 24.00 x 6.00	610 x 610 x 152	Galvanized	4	A-B-C-D-E-F-G-H-I	A-B-C-D-E-F-G-H-I
ASE30X24X6	30.00 x 24.00 x 6.00	762 x 610 x 152	Painted	6	A-B-C-D-E-F-G-H-I	A-B-C-D-E-F-G-H-I
ASG30X24X6	30.00 x 24.00 x 6.00	762 x 610 x 152	Galvanized	6	A-B-C-D-E-F-G-H-I	A-B-C-D-E-F-G-H-I
ASE36X24X6	36.00 x 24.00 x 6.00	914 x 610 x 152	Painted	6	A-B-C-D-E-F-G-H-I	A-B-C-D-E-F-G-H-I
ASE8X8X8	8.00 x 8.00 x 8.00	203 x 203 x 203	Painted	4	F-G-H-I	F-G-H-I
ASE12X12X8	12.00 x 12.00 x 8.00	305 x 305 x 203	Painted	4	C-D-E-F-G	C-D-E-F-G
ASG12X12X8	12.00 x 12.00 x 8.00	305 x 305 x 203	Galvanized	4	C-D-E-F-G	C-D-E-F-G
ASE16X12X8	16.00 x 12.00 x 8.00	406 x 305 x 203	Painted	4	B-C-D-E-F-G-H	C-D-E-F-G
ASG16X12X8	16.00 x 12.00 x 8.00	406 x 305 x 203	Galvanized	4	B-C-D-E-F-G-H	C-D-E-F-G
ASE18X12X8	18.00 x 12.00 x 8.00	457 x 305 x 203	Painted	4	A-B-C-D-E-F-G-H-I	C-D-E-F-G
ASG18X12X8	18.00 x 12.00 x 8.00	457 x 305 x 203	Galvanized	4	A-B-C-D-E-F-G-H-I	C-D-E-F-G
ASE24X12X8	24.00 x 12.00 x 8.00	610 x 305 x 203	Painted	4	A-B-C-D-E-F-G-H-I	C-D-E-F-G
ASG24X12X8	24.00 x 12.00 x 8.00	610 x 305 x 203	Galvanized	4	A-B-C-D-E-F-G-H-I	C-D-E-F-G
ASE24X18X8	24.00 x 18.00 x 8.00	610 x 457 x 203	Painted	4	A-B-C-D-E-F-G-H-I	A-B-C-D-E-F-G-H-I
ASG24X18X8	24.00 x 18.00 x 8.00	610 x 457 x 203	Galvanized	4	A-B-C-D-E-F-G-H-I	A-B-C-D-E-F-G-H-I
ASE36X24X8	36.00 x 24.00 x 8.00	914 x 610 x 203	Painted	6	A-B-C-D-E-F-G-H-I	A-B-C-D-E-F-G-H-I
ASE18X12X10	18.00 x 12.00 x 10.00	457 x 305 x 254	Painted	4	A-B-C-D-E-F-G-H-I	C-D-E-F-G
ASE18X18X10	18.00 x 18.00 x 10.00	457 x 457 x 254	Painted	4	A-B-C-D-E-F-G-H-I	A-B-C-D-E-F-G-H-I
ASE24X18X10	24.00 x 18.00 x 10.00	610 x 457 x 254	Painted	4	A-B-C-D-E-F-G-H-I	A-B-C-D-E-F-G-H-I
ASE24X24X10	24.00 x 24.00 x 10.00	610 x 610 x 254	Painted	4	A-B-C-D-E-F-G-H-I	A-B-C-D-E-F-G-H-I
ASE36X24X10	36.00 x 24.00 x 10.00	914 x 610 x 254	Painted	6	A-B-C-D-E-F-G-H-I	A-B-C-D-E-F-G-H-I
ASE24X12X12	24.00 x 12.00 x 12.00	610 x 305 x 305	Painted	4	A-B-C-D-E-F-G-H-I	C-D-E-F-G
ASE18X18X12	18.00 x 18.00 x 12.00	457 x 457 x 305	Painted	4	A-B-C-D-E-F-G-H-I	A-B-C-D-E-F-G-H-I
ASE24X18X12	24.00 x 18.00 x 12.00	610 x 457 x 305	Painted	4	A-B-C-D-E-F-G-H-I	A-B-C-D-E-F-G-H-I
ASE24X24X12	24.00 x 24.00 x 12.00	610 x 610 x 305	Painted	4	A-B-C-D-E-F-G-H-I	A-B-C-D-E-F-G-H-I
ASE30X24X12	30.00 x 24.00 x 12.00	762 x 610 x 305	Painted	6	A-B-C-D-E-F-G-H-I	A-B-C-D-E-F-G-H-I
ASE36X24X12	36.00 x 24.00 x 12.00	914 x 610 x 305	Painted	6	A-B-C-D-E-F-G-H-I	A-B-C-D-E-F-G-H-I

Standard Product **Screw-Cover Type 1 Pull Boxes without Knockouts**

Catalog Number	AxBxC in.	AxBxC mm	Style	Number of Cover Screws
ASE4X4X3NK	4.00 x 4.00 x 3.00	102 x 102 x 76	Painted	2
ASG4X4X3NK	4.00 x 4.00 x 3.00	102 x 102 x 76	Galvanized	2
ASE6X6X3NK	6.00 x 6.00 x 3.00	152 x 152 x 76	Painted	2
ASG6X6X3NK	6.00 x 6.00 x 3.00	152 x 152 x 76	Galvanized	2
ASE8X6X3NK	8.00 x 6.00 x 3.00	203 x 152 x 76	Painted	2
ASG8X6X3NK	8.00 x 6.00 x 3.00	203 x 152 x 76	Galvanized	2
ASE16X14X3NK	16.00 x 14.00 x 3.00	406 x 356 x 76	Painted	4
ASE20X14X3NK	20.00 x 14.00 x 3.00	508 x 356 x 76	Painted	4
ASE4X4X4NK	4.00 x 4.00 x 4.00	102 x 102 x 102	Painted	2
ASG4X4X4NK	4.00 x 4.00 x 4.00	102 x 102 x 102	Galvanized	2
ASE6X6X4NK	6.00 x 6.00 x 4.00	152 x 152 x 102	Painted	2
ASG6X6X4NK	6.00 x 6.00 x 4.00	152 x 152 x 102	Galvanized	2
ASE8X6X4NK	8.00 x 6.00 x 4.00	203 x 152 x 102	Painted	2
ASG8X6X4NK	8.00 x 6.00 x 4.00	203 x 152 x 102	Galvanized	2
ASE8X8X4NK	8.00 x 8.00 x 4.00	203 x 203 x 102	Painted	2
ASG8X8X4NK	8.00 x 8.00 x 4.00	203 x 203 x 102	Galvanized	2
ASE10X6X4NK	10.00 x 6.00 x 4.00	254 x 152 x 102	Painted	4
ASG10X6X4NK	10.00 x 6.00 x 4.00	254 x 152 x 102	Galvanized	4
ASE10X8X4NK	10.00 x 8.00 x 4.00	254 x 203 x 102	Painted	4
ASG10X8X4NK	10.00 x 8.00 x 4.00	254 x 203 x 102	Galvanized	4
ASE10X10X4NK	10.00 x 10.00 x 4.00	254 x 254 x 102	Painted	4
ASG10X10X4NK	10.00 x 10.00 x 4.00	254 x 254 x 102	Galvanized	4
ASE12X6X4NK	12.00 x 6.00 x 4.00	305 x 152 x 102	Painted	4
ASG12X6X4NK	12.00 x 6.00 x 4.00	305 x 152 x 102	Galvanized	4

Catalog Number	AxBxC in.	AxBxC mm	Style	Number of Cover Screws
ASE12X8X4NK	12.00 x 8.00 x 4.00	305 x 203 x 102	Painted	4
ASG12X8X4NK	12.00 x 8.00 x 4.00	305 x 203 x 102	Galvanized	4
ASE12X10X4NK	12.00 x 10.00 x 4.00	305 x 254 x 102	Painted	4
ASG12X10X4NK	12.00 x 10.00 x 4.00	305 x 254 x 102	Galvanized	4
ASE12X12X4NK	12.00 x 12.00 x 4.00	305 x 305 x 102	Painted	4
ASG12X12X4NK	12.00 x 12.00 x 4.00	305 x 305 x 102	Galvanized	4
ASE15X15X4NK	15.00 x 15.00 x 4.00	381 x 381 x 102	Painted	4
ASG15X15X4NK	15.00 x 15.00 x 4.00	381 x 381 x 102	Galvanized	4
ASE16X12X4NK	16.00 x 12.00 x 4.00	406 x 305 x 102	Painted	4
ASG16X12X4NK	16.00 x 12.00 x 4.00	406 x 305 x 102	Galvanized	4
ASE18X12X4NK	18.00 x 12.00 x 4.00	457 x 305 x 102	Painted	4
ASG18X12X4NK	18.00 x 12.00 x 4.00	457 x 305 x 102	Galvanized	4
ASE18X15X4NK	18.00 x 15.00 x 4.00	457 x 381 x 102	Painted	4
ASG18X15X4NK	18.00 x 15.00 x 4.00	457 x 381 x 102	Galvanized	4
ASE18X18X4NK	18.00 x 18.00 x 4.00	457 x 457 x 102	Painted	4
ASG18X18X4NK	18.00 x 18.00 x 4.00	457 x 457 x 102	Galvanized	4
ASE24X12X4NK	24.00 x 12.00 x 4.00	610 x 305 x 102	Painted	4
ASG24X12X4NK	24.00 x 12.00 x 4.00	610 x 305 x 102	Galvanized	4
ASE24X18X4NK	24.00 x 18.00 x 4.00	610 x 457 x 102	Painted	4
ASG24X18X4NK	24.00 x 18.00 x 4.00	610 x 457 x 102	Galvanized	4
ASE24X24X4NK	24.00 x 24.00 x 4.00	610 x 610 x 102	Painted	4
ASG24X24X4NK	24.00 x 24.00 x 4.00	610 x 610 x 102	Galvanized	4
ASE30X24X4NK	30.00 x 24.00 x 4.00	762 x 610 x 102	Painted	6
ASG30X24X4NK	30.00 x 24.00 x 4.00	762 x 610 x 102	Galvanized	6
ASE30X30X4NK	30.00 x 30.00 x 4.00	762 x 762 x 102	Painted	8
ASG30X30X4NK	30.00 x 30.00 x 4.00	762 x 762 x 102	Galvanized	8
ASE6X6X6NK	6.00 x 6.00 x 6.00	152 x 152 x 152	Painted	2
ASG6X6X6NK	6.00 x 6.00 x 6.00	152 x 152 x 152	Galvanized	2
ASE8X6X6NK	8.00 x 6.00 x 6.00	203 x 152 x 152	Painted	2
ASG8X6X6NK	8.00 x 6.00 x 6.00	203 x 152 x 152	Galvanized	2
ASE8X8X6NK	8.00 x 8.00 x 6.00	203 x 203 x 152	Painted	4
ASG8X8X6NK	8.00 x 8.00 x 6.00	203 x 203 x 152	Galvanized	4
ASE10X8X6NK	10.00 x 8.00 x 6.00	254 x 203 x 152	Painted	4
ASG10X8X6NK	10.00 x 8.00 x 6.00	254 x 203 x 152	Galvanized	4
ASE10X10X6NK	10.00 x 10.00 x 6.00	254 x 254 x 152	Painted	4
ASG10X10X6NK	10.00 x 10.00 x 6.00	254 x 254 x 152	Galvanized	4
ASE12X6X6NK	12.00 x 6.00 x 6.00	305 x 152 x 152	Painted	4
ASG12X6X6NK	12.00 x 6.00 x 6.00	305 x 152 x 152	Galvanized	4
ASE12X8X6NK	12.00 x 8.00 x 6.00	305 x 203 x 152	Painted	4
ASG12X8X6NK	12.00 x 8.00 x 6.00	305 x 203 x 152	Galvanized	4
ASE12X10X6NK	12.00 x 10.00 x 6.00	305 x 254 x 152	Painted	4
ASG12X10X6NK	12.00 x 10.00 x 6.00	305 x 254 x 152	Galvanized	4
ASE12X12X6NK	12.00 x 12.00 x 6.00	305 x 305 x 152	Painted	4
ASG12X12X6NK	12.00 x 12.00 x 6.00	305 x 305 x 152	Galvanized	4
ASE16X12X6NK	16.00 x 12.00 x 6.00	406 x 305 x 152	Painted	4
ASG16X12X6NK	16.00 x 12.00 x 6.00	406 x 305 x 152	Galvanized	4
ASE16X16X6NK	16.00 x 16.00 x 6.00	406 x 406 x 152	Painted	4
ASG16X16X6NK	16.00 x 16.00 x 6.00	406 x 406 x 152	Galvanized	4
ASE18X12X6NK	18.00 x 12.00 x 6.00	457 x 305 x 152	Painted	4
ASG18X12X6NK	18.00 x 12.00 x 6.00	457 x 305 x 152	Galvanized	4
ASE18X18X6NK	18.00 x 18.00 x 6.00	457 x 457 x 152	Painted	4
ASG18X18X6NK	18.00 x 18.00 x 6.00	457 x 457 x 152	Galvanized	4
ASE24X12X6NK	24.00 x 12.00 x 6.00	610 x 305 x 152	Painted	4
ASG24X12X6NK	24.00 x 12.00 x 6.00	610 x 305 x 152	Galvanized	4
ASE24X18X6NK	24.00 x 18.00 x 6.00	610 x 457 x 152	Painted	4
ASG24X18X6NK	24.00 x 18.00 x 6.00	610 x 457 x 152	Galvanized	4
ASE24X20X6NK	24.00 x 20.00 x 6.00	610 x 508 x 152	Painted	4
ASG24X20X6NK	24.00 x 20.00 x 6.00	610 x 508 x 152	Galvanized	4
ASE24X24X6NK	24.00 x 24.00 x 6.00	610 x 610 x 152	Painted	4
ASG24X24X6NK	24.00 x 24.00 x 6.00	610 x 610 x 152	Galvanized	4
ASE30X24X6NK	30.00 x 24.00 x 6.00	762 x 610 x 152	Painted	6
ASG30X24X6NK	30.00 x 24.00 x 6.00	762 x 610 x 152	Galvanized	6
ASE30X30X6NK	30.00 x 30.00 x 6.00	762 x 762 x 152	Painted	8
ASG30X30X6NK	30.00 x 30.00 x 6.00	762 x 762 x 152	Galvanized	8
ASE36X24X6NK	36.00 x 24.00 x 6.00	914 x 610 x 152	Painted	6
ASG36X24X6NK	36.00 x 24.00 x 6.00	914 x 610 x 152	Galvanized	6
ASE36X30X6NK	36.00 x 30.00 x 6.00	914 x 762 x 152	Painted	8
ASG36X30X6NK	36.00 x 30.00 x 6.00	914 x 762 x 152	Galvanized	8
ASE36X36X6NK	36.00 x 36.00 x 6.00	914 x 914 x 152	Painted	8
ASG36X36X6NK	36.00 x 36.00 x 6.00	914 x 914 x 152	Galvanized	8
ASE8X8X8NK	8.00 x 8.00 x 8.00	203 x 203 x 203	Painted	4
ASG8X8X8NK	8.00 x 8.00 x 8.00	203 x 203 x 203	Galvanized	4
ASE10X10X8NK	10.00 x 10.00 x 8.00	254 x 254 x 203	Painted	4
ASG10X10X8NK	10.00 x 10.00 x 8.00	254 x 254 x 203	Galvanized	4
ASE12X10X8NK	12.00 x 10.00 x 8.00	305 x 254 x 203	Painted	4
ASG12X10X8NK	12.00 x 10.00 x 8.00	305 x 254 x 203	Galvanized	4
ASE12X12X8NK	12.00 x 12.00 x 8.00	305 x 305 x 203	Painted	4
ASG12X12X8NK	12.00 x 12.00 x 8.00	305 x 305 x 203	Galvanized	4
ASE16X12X8NK	16.00 x 12.00 x 8.00	406 x 305 x 203	Painted	4
ASG16X12X8NK	16.00 x 12.00 x 8.00	406 x 305 x 203	Galvanized	4
ASE18X12X8NK	18.00 x 12.00 x 8.00	457 x 305 x 203	Painted	4
ASG18X12X8NK	18.00 x 12.00 x 8.00	457 x 305 x 203	Galvanized	4
ASE18X18X8NK	18.00 x 18.00 x 8.00	457 x 457 x 203	Painted	4
ASG18X18X8NK	18.00 x 18.00 x 8.00	457 x 457 x 203	Galvanized	4
ASE24X12X8NK	24.00 x 12.00 x 8.00	610 x 305 x 203	Painted	4
ASG24X12X8NK	24.00 x 12.00 x 8.00	610 x 305 x 203	Galvanized	4



Catalog Number	AxBxC in.	AxBxC mm	Style	Number of Cover Screws
ASE24X18X8NK	24.00 x 18.00 x 8.00	610 x 457 x 203	Painted	4
ASG24X18X8NK	24.00 x 18.00 x 8.00	610 x 457 x 203	Galvanized	4
ASE24X20X8NK	24.00 x 20.00 x 8.00	610 x 508 x 203	Painted	4
ASG24X20X8NK	24.00 x 20.00 x 8.00	610 x 508 x 203	Galvanized	4
ASE24X24X8NK	24.00 x 24.00 x 8.00	610 x 610 x 203	Painted	4
ASG24X24X8NK	24.00 x 24.00 x 8.00	610 x 610 x 203	Galvanized	4
ASE30X24X8NK	30.00 x 24.00 x 8.00	762 x 610 x 203	Painted	6
ASG30X24X8NK	30.00 x 24.00 x 8.00	762 x 610 x 203	Galvanized	6
ASE30X30X8NK	30.00 x 30.00 x 8.00	762 x 762 x 203	Painted	8
ASG30X30X8NK	30.00 x 30.00 x 8.00	762 x 762 x 203	Galvanized	8
ASE36X24X8NK	36.00 x 24.00 x 8.00	914 x 610 x 203	Painted	6
ASG36X24X8NK	36.00 x 24.00 x 8.00	914 x 610 x 203	Galvanized	6
ASE36X36X8NK	36.00 x 36.00 x 8.00	914 x 914 x 203	Painted	8
ASG36X36X8NK	36.00 x 36.00 x 8.00	914 x 914 x 203	Galvanized	8
ASE12X12X10NK	12.00 x 12.00 x 10.00	305 x 305 x 254	Painted	4
ASG12X12X10NK	12.00 x 12.00 x 10.00	305 x 305 x 254	Galvanized	4
ASE18X12X10NK	18.00 x 12.00 x 10.00	457 x 305 x 254	Painted	4
ASG18X12X10NK	18.00 x 12.00 x 10.00	457 x 305 x 254	Galvanized	4
ASE18X18X10NK	18.00 x 18.00 x 10.00	457 x 457 x 254	Painted	4
ASG18X18X10NK	18.00 x 18.00 x 10.00	457 x 457 x 254	Galvanized	4
ASE24X12X10NK	24.00 x 12.00 x 10.00	610 x 305 x 254	Painted	4
ASG24X12X10NK	24.00 x 12.00 x 10.00	610 x 305 x 254	Galvanized	4
ASE24X24X10NK	24.00 x 24.00 x 10.00	610 x 610 x 254	Painted	4
ASG24X24X10NK	24.00 x 24.00 x 10.00	610 x 610 x 254	Galvanized	4
ASE30X24X10NK	30.00 x 24.00 x 10.00	762 x 610 x 254	Painted	6
ASG30X24X10NK	30.00 x 24.00 x 10.00	762 x 610 x 254	Galvanized	6
ASE30X30X10NK	30.00 x 30.00 x 10.00	762 x 762 x 254	Painted	8
ASG30X30X10NK	30.00 x 30.00 x 10.00	762 x 762 x 254	Galvanized	8
ASE36X24X10NK	36.00 x 24.00 x 10.00	914 x 610 x 254	Painted	6
ASG36X24X10NK	36.00 x 24.00 x 10.00	914 x 610 x 254	Galvanized	6
ASE36X36X10NK	36.00 x 36.00 x 10.00	914 x 914 x 254	Painted	8
ASG36X36X10NK	36.00 x 36.00 x 10.00	914 x 914 x 254	Galvanized	8
ASE12X12X12NK	12.00 x 12.00 x 12.00	305 x 305 x 305	Painted	4
ASG12X12X12NK	12.00 x 12.00 x 12.00	305 x 305 x 305	Galvanized	4
ASE24X12X12NK	24.00 x 12.00 x 12.00	610 x 305 x 305	Painted	4
ASG24X12X12NK	24.00 x 12.00 x 12.00	610 x 305 x 305	Galvanized	4
ASE18X18X12NK	18.00 x 18.00 x 12.00	457 x 457 x 305	Painted	4
ASG18X18X12NK	18.00 x 18.00 x 12.00	457 x 457 x 305	Galvanized	4
ASE24X18X12NK	24.00 x 18.00 x 12.00	610 x 457 x 305	Painted	4
ASG24X18X12NK	24.00 x 18.00 x 12.00	610 x 457 x 305	Galvanized	4
ASE24X24X12NK	24.00 x 24.00 x 12.00	610 x 610 x 305	Painted	4
ASG24X24X12NK	24.00 x 24.00 x 12.00	610 x 610 x 305	Galvanized	4
ASE30X24X12NK	30.00 x 24.00 x 12.00	762 x 610 x 305	Painted	6
ASG30X24X12NK	30.00 x 24.00 x 12.00	762 x 610 x 305	Galvanized	6
ASE30X30X12NK	30.00 x 30.00 x 12.00	762 x 762 x 305	Painted	8
ASG30X30X12NK	30.00 x 30.00 x 12.00	762 x 762 x 305	Galvanized	8
ASE36X24X12NK	36.00 x 24.00 x 12.00	914 x 610 x 305	Painted	6
ASG36X24X12NK	36.00 x 24.00 x 12.00	914 x 610 x 305	Galvanized	6
ASE36X36X12NK	36.00 x 36.00 x 12.00	914 x 914 x 305	Painted	8
ASG36X36X12NK	36.00 x 36.00 x 12.00	914 x 914 x 305	Galvanized	8
ASE48X48X12NK	48.00 x 48.00 x 12.00	1219 x 1219 x 305	Painted	12
ASG48X48X12NK	48.00 x 48.00 x 12.00	1219 x 1219 x 305	Galvanized	12
ASE30X30X16NK	30.00 x 30.00 x 16.00	762 x 762 x 406	Painted	8
ASG30X30X16NK	30.00 x 30.00 x 16.00	762 x 762 x 406	Galvanized	8
ASE48X48X16NK	48.00 x 48.00 x 16.00	1219 x 1219 x 406	Painted	12
ASG48X48X16NK	48.00 x 48.00 x 16.00	1219 x 1219 x 406	Galvanized	12

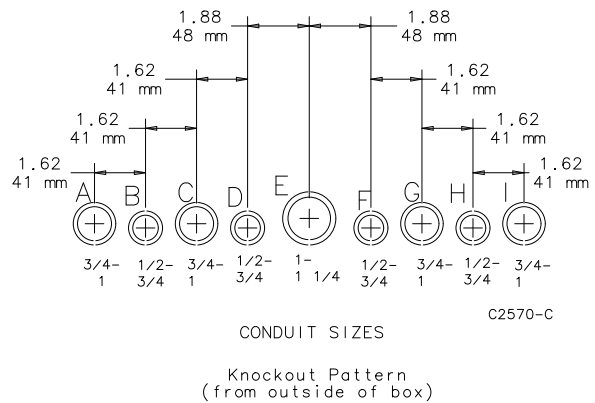
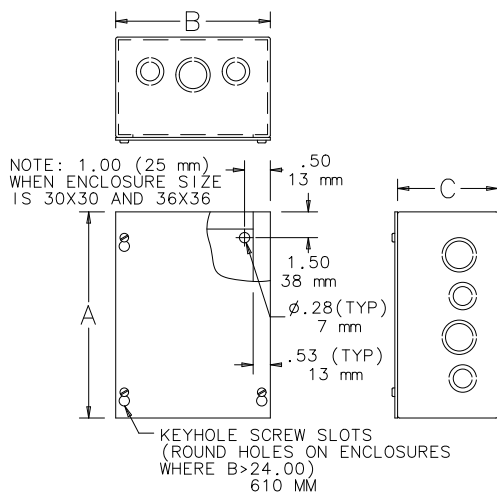

**FLUSH COVERS**

Designed to mount on enclosure for flush installations. Cover is 16 or 14 gauge steel finished with ANSI 61 gray polyester powder paint.

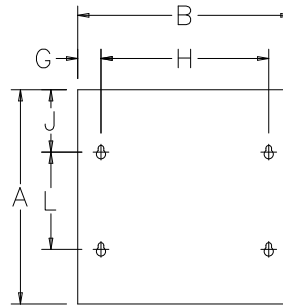
**BULLETIN: A90P1**

87948556

**Standard Product**

Catalog Number	AxB in./mm	Fits Box Size A x B in./mm	G in./mm	H in./mm	J in./mm	L in./mm	Cover Gauge
AFE6X6	7.50 x 7.50	6.00 x 6.00	1.03	5.44	3.75	—	16
	191 x 191	152 x 152	26	138	95	—	
AFE8X6	9.50 x 7.50	8.00 x 6.00	1.03	5.44	4.75	—	16
	241 x 191	203 x 152	26	138	121	—	
AFE8X8	8.00 x 8.00	8.00 x 8.00	1.03	7.44	2.77	4.31	16
	203 x 203	203 x 203	26	189	70	109	
AFE10X8	11.50 x 9.50	10.00 x 8.00	1.03	7.44	2.77	6.31	16
	292 x 241	254 x 203	26	189	70	160	
AFE10X10	11.50 x 11.50	10.00 x 10.00	1.03	9.44	2.77	6.31	16
	292 x 292	254 x 254	26	240	70	160	
AFE12X8	12.00 x 8.00	12.00 x 8.00	1.03	7.44	2.77	8.31	16
	305 x 203	305 x 203	26	189	70	211	
AFE12X12	13.50 x 13.50	12.00 x 12.00	1.03	11.44	2.77	8.31	16
	343 x 343	305 x 305	26	291	70	211	
AFE18X12	19.50 x 13.50	18.00 x 12.00	1.03	11.44	2.77	14.31	16
	495 x 343	457 x 305	26	291	70	363	
AFE18X18	18.00 x 18.00	18.00 x 18.00	1.03	17.44	2.77	14.31	16
	457 x 457	457 x 457	26	443	70	363	
AFE24X18	25.50 x 19.50	24.00 x 18.00	1.05	17.41	2.77	20.31	14
	648 x 495	610 x 457	27	442	70	516	
AFE24X24	24.00 x 24.00	24.00 x 24.00	1.05	23.41	2.77	20.31	14
	610 x 610	610 x 610	27	595	70	516	



**FLUSH-MOUNT DOOR FRAMES**



Use in Screw-Cover Pull Box telephone cabinet installations or in communication wiring and signal systems. Also as a junction or pull box and switch enclosure.

- Continuous hinge
- Rugged black composite slide latch
- Optional tamper-resistant lock kit includes cylinder lock, tamper-resistant screws and special driver bit.
- Lock Kit: ACLFDF
- 14 gauge steel door frame has ANSI 61 gray polyester powder paint finish

**BULLETIN: A90P1**

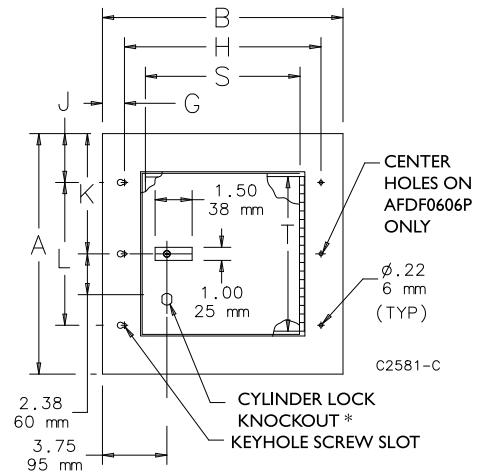

\* Not available on AFDF0606P

**Standard Product**

Catalog Number	AxB in./mm	Frame Size A x B in./mm	Door Size T in./mm	Door Size S in./mm	Fits Box Size A x B in./mm	G in./mm	H in./mm	J in./mm	K in./mm	L in./mm
AFDF0606P	0.00	8.00 x 8.00 203 x 203	3.00 76	3.00 76	6.00 x 6.00 152 x 152	1.28 32	5.44 138	N/A N/A	4.00 102	N/A N/A
AFDF1212P	12.00 x 12.00 305 x 305	14.00 x 14.00 356 x 356	9.00 229	9.00 229	12.00 x 12.00 305 x 305	1.28 32	11.44 291	2.84 72	7.00 178	8.31 211
AFDF1812P	18.00 x 12.00 457 x 305	20.00 x 14.00 508 x 356	15.00 381	9.00 229	18.00 x 12.00 457 x 305	1.28 32	11.44 291	2.84 72	10.00 254	14.31 364
AFDF1818P	18.00 x 18.00 457 x 457	20.00 x 20.00 508 x 508	15.00 381	15.00 381	18.00 x 18.00 457 x 457	1.28 32	17.44 443	2.84 72	10.00 254	14.31 364
AFDF2418P	24.00 x 18.00 610 x 457	26.00 x 20.00 660 x 508	21.00 533	15.00 381	24.00 x 18.00 610 x 457	1.28 32	17.44 443	2.84 72	13.00 330	20.31 516
AFDF2424P	24.00 x 24.00 610 x 610	26.00 x 26.00 660 x 660	21.00 533	21.00 533	24.00 x 24.00 610 x 610	1.30 33	23.41 595	2.84 72	13.00 330	20.31 516
AFDF3024P	30.00 x 24.00 762 x 610	32.00 x 26.00 813 x 660	27.00 686	21.00 533	30.00 x 24.00 762 x 610	1.30 33	23.41 595	2.84 72	16.00 406	26.31 668

**TYPE 1 LOCKING WINDOW PULL BOX ACCESSORY**

Flush- or surface-mount accessory fits Screw Cover, Type 1, boxes to prevent public access to lighting switches and controls. Includes a removable aluminum dead-front mounting surface for component cutouts and four torx-head screws for securing to enclosure.

BULLETIN: A90P1



Standard Product

Catalog Number	AxB in./mm	Dead Front Panel Size D x E in./mm	Mounting Holes G x H in./mm	Window Size M x N in./mm	Fits Pull Box
ALDF88W	9.00 x 9.00 229 x 293	6.00 x 6.14 152 x 99	4.31 x 7.44 109 x 189	6.25 x 3.88 164 x 156	ASE8X8X4
ALDF1212W	13.00 x 13.00 330 x 330	10.00 x 10.14 254 x 200	8.31 x 11.44 211 x 291	10.25 x 7.88 265 x 258	ASE12X12X4

A x B = Frame Size

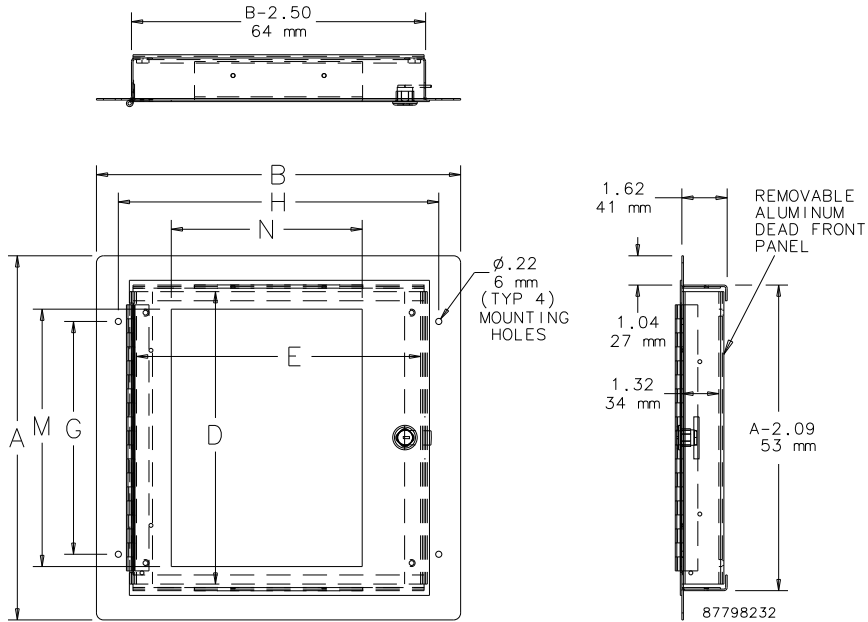

TYPE 1 PULL BOX PERFORATED PANEL

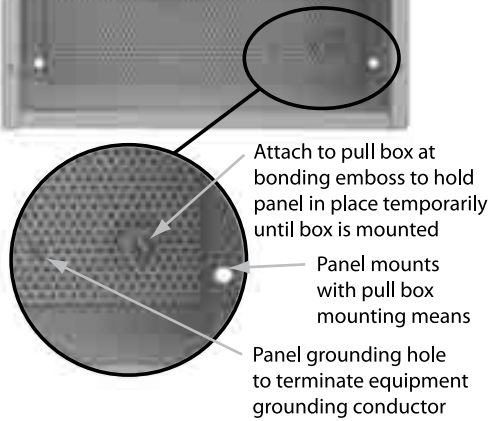
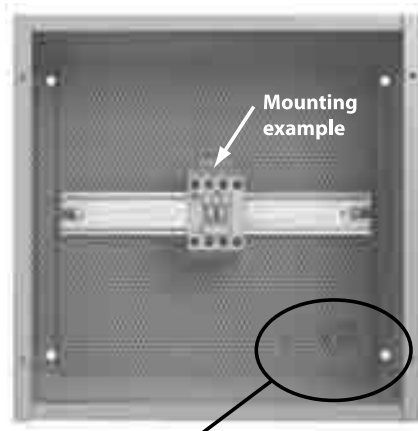
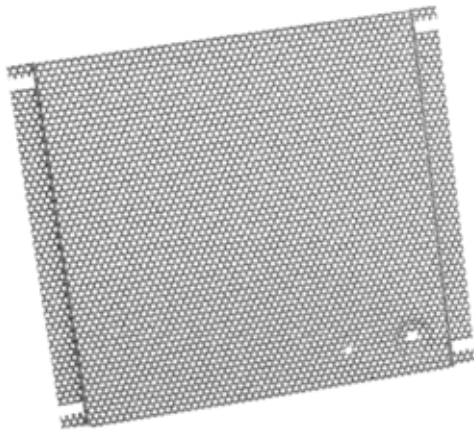

Panel is formed to provide 7/16-in. space off back of pull box for component mounting screw clearance and includes a grounding hole to terminate equipment grounding conductors. Ideal for mounting components that require infrequent access such as control transformers, terminals and contactors.

BULLETIN: PNLP

Standard Product

Catalog Number	Panel Gauge	Panel Size D x E (in.)	Panel Size D x E (mm)	Fits Pull Box
PB66PP	16	4.40 x 5.50	112 x 140	ASE6X6X
PB88PP	16	6.40 x 7.50	163 x 191	ASE8X8X
PB1212PP	16	10.40 x 11.50	264 x 292	ASE12X12X
PB1818PP	16	16.40 x 17.50	417 x 445	ASE18X18X
PB2424PP	16	22.40 x 23.50	569 x 597	ASE24X24X

PB1818PP and PB2424PP are flanged on all four sides.

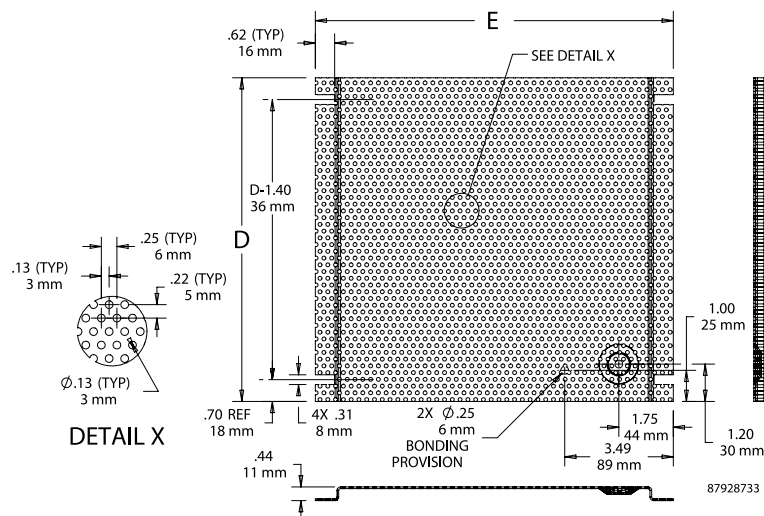

**HINGED-COVER WITH RECESSED HANDLE, TYPE 1**



1

**APPLICATION**

These enclosures have an easy-to-open recessed T-handle and meet basic functionality requirements for housing controls and instrumentation.

**FEATURES**

- Removable doors have butt hinges
- Mounting holes on back of enclosure
- Recessed T-handle latch is flush with door
- Flush cover and offset body

**SPECIFICATIONS**

- 16 or 14 gauge steel

**FINISH**

ANSI 61 gray polyester powder paint inside and out

**ACCESSORIES**

See also Accessories.  
 Electric Heater  
 Grounding Device  
 Lock Kit for Clamp Cover Junction Boxes  
 19-in. and 23-in. Rack Angles  
 Steel and Stainless Steel Window Kits

**MODIFICATION AND CUSTOMIZATION**

Hoffman excels at modifying and customizing products to your specifications. Contact your local Hoffman sales office or distributor for complete information.

**BULLETIN: A1M**

**INDUSTRY STANDARDS**

UL 50, 50E Listed; Type 1; File No. E27567  
 cUL Listed per CSA C22.2 No. 40; Type 1; File No. E27567

NEMA/EEMAC Type 1  
 CSA, File No. 42184: Type 1  
 IEC 60529, IP30

Standard Product

Catalog Number	AxBxC in./mm	Gauge	Panel	Panel Size D x E in./mm	Panel Gauge	Number of Studs	Mounting G x H in./mm	J in./mm	Q in./mm	P in./mm	F in./mm	K in./mm
A16N126LP	16.00 x 12.00 x 6.62 406 x 305 x 168	16	A16N12MP	13.00 x 10.50 330 x 267	14	4	13.88 x 7.00 353 x 178	2.50 64	1.06 27	0.31 8	6.00 152	1.50 38
A20N126LP	20.00 x 12.00 x 6.62 508 x 305 x 168	16	A20N12MP	17.00 x 10.50 432 x 267	14	4	17.88 x 7.00 454 x 178	2.50 64	1.06 27	0.31 8	6.00 152	1.50 38
A16N166LP	16.00 x 16.00 x 6.62 406 x 406 x 168	16	A16N16MP	13.00 x 14.50 330 x 368	14	4	13.88 x 11.00 353 x 279	2.50 64	1.06 27	0.31 8	6.00 152	1.50 38
A16N206LP	16.00 x 20.00 x 6.62 406 x 508 x 168	16	A16N20MP	13.00 x 18.50 330 x 470	14	4	13.88 x 15.00 353 x 381	2.50 64	1.06 27	0.31 8	6.00 152	1.50 38
A20N166LP	20.00 x 16.00 x 6.62 508 x 406 x 168	16	A20N16MP	17.00 x 14.50 432 x 368	14	4	17.88 x 11.00 454 x 279	2.50 64	1.06 27	0.31 8	6.00 152	1.50 38
A20N206LP	20.00 x 20.00 x 6.62 508 x 508 x 168	16	A20N20MP	17.00 x 18.50 432 x 470	14	4	17.88 x 15.00 454 x 381	2.50 64	1.06 27	0.31 8	6.00 152	1.50 38
A24N166LP	24.00 x 16.00 x 6.62 610 x 406 x 168	16	A24N16MP	21.00 x 14.50 533 x 368	14	4	21.88 x 11.00 556 x 279	2.50 64	1.06 27	0.31 8	6.00 152	1.50 38
A24N206LP	24.00 x 20.00 x 6.62 610 x 508 x 168	16	A24N20MP	21.00 x 18.50 533 x 470	14	4	21.88 x 15.00 556 x 381	2.50 64	1.06 27	0.31 8	6.00 152	1.50 38
A24N246LP	24.00 x 24.00 x 6.62 610 x 610 x 168	14	A24N24MP	21.00 x 22.50 533 x 572	12	4	21.88 x 19.00 556 x 483	2.50 64	1.06 27	0.31 8	6.00 152	1.50 38
A30N206LP	30.00 x 20.00 x 6.62 762 x 508 x 168	14	A30N20MP	26.00 x 18.50 660 x 470	12	6	27.50 x 12.75 699 x 324	3.62 92	1.25 32	0.44 11	6.00 152	2.00 51
A30N246LP	30.00 x 24.00 x 6.62 762 x 610 x 168	14	A30N24MP	26.00 x 22.50 660 x 572	12	6	27.50 x 16.75 699 x 425	3.62 92	1.25 32	0.44 11	6.00 152	2.00 51
A36N246LP	36.00 x 24.00 x 6.62 914 x 610 x 168	14	A36N24MP	32.00 x 22.50 813 x 572	12	6	33.50 x 16.75 851 x 425	3.62 92	1.25 32	0.44 11	6.00 152	2.00 51
A36N306LP	36.00 x 30.00 x 6.62 914 x 762 x 168	14	A36N30MP	32.00 x 28.50 813 x 724	12	8	33.50 x 22.75 851 x 578	3.62 92	1.25 32	0.44 11	6.00 152	2.00 51
A16N128LP	16.00 x 12.00 x 8.62 406 x 305 x 219	16	A16N12MP	13.00 x 10.50 330 x 267	14	4	13.88 x 7.00 353 x 178	2.50 64	1.06 27	0.31 8	8.00 203	1.50 38
A20N168LP	20.00 x 16.00 x 8.62 508 x 406 x 219	16	A20N16MP	17.00 x 14.50 432 x 368	14	4	17.88 x 11.00 454 x 279	2.50 64	1.06 27	0.31 8	8.00 203	1.50 38
A24N168LP	24.00 x 16.00 x 8.62 610 x 406 x 219	16	A24N16MP	21.00 x 14.50 533 x 368	14	4	21.88 x 11.00 556 x 279	2.50 64	1.06 27	0.31 8	8.00 203	1.50 38
A20N208LP	20.00 x 20.00 x 8.62 508 x 508 x 219	16	A20N20MP	17.00 x 18.50 432 x 470	14	4	17.88 x 15.00 454 x 381	2.50 64	1.06 27	0.31 8	8.00 203	1.50 38
A24N208LP	24.00 x 20.00 x 8.62 610 x 508 x 219	16	A24N20MP	21.00 x 18.50 533 x 470	14	4	21.88 x 15.00 556 x 381	2.50 64	1.06 27	0.31 8	8.00 203	1.50 38
A24N248LP	24.00 x 24.00 x 8.63 610 x 610 x 219	14	A24N24MP	21.00 x 22.50 533 x 572	12	4	21.88 x 19.00 556 x 483	2.50 64	1.06 27	0.31 8	8.00 203	1.50 38
A30N208LP	30.00 x 20.00 x 8.62 762 x 508 x 219	14	A30N20MP	26.00 x 18.50 660 x 470	12	6	27.50 x 12.75 699 x 324	3.62 92	1.25 32	0.44 11	8.00 203	2.00 51



Catalog Number	AxBxC in./mm	Gauge	Panel	Panel Size D x E in./mm	Panel Gauge	Number of Studs	Mounting G x H in./mm	J in./mm	Q in./mm	P in./mm	F in./mm	K in./mm
A30N248LP	30.00 x 24.00 x 8.62 762 x 610 x 219	14	A30N24MP	26.00 x 22.50 660 x 572	12	6	27.50 x 16.75 699 x 425	3.62 92	1.25 32	0.44 11	8.00 203	2.00 51
A30N308LP	30.00 x 30.00 x 8.62 762 x 762 x 219	14	A30N30MP	26.00 x 28.50 660 x 724	12	8	27.50 x 22.75 699 x 578	3.62 92	1.25 32	0.44 11	8.00 203	2.00 51
A36N248LP	36.00 x 24.00 x 8.62 914 x 610 x 219	14	A36N24MP	32.00 x 22.50 813 x 572	12	6	33.50 x 16.75 851 x 425	3.62 92	1.25 32	0.44 11	8.00 203	2.00 51
A36N308LP	36.00 x 30.00 x 8.62 914 x 762 x 219	14	A36N30MP	32.00 x 28.50 813 x 724	12	8	33.50 x 22.75 851 x 578	3.62 92	1.25 32	0.44 11	8.00 203	2.00 51
A24N2010LP	24.00 x 20.00 x 10.62 610 x 508 x 270	16	A24N20MP	21.00 x 18.50 533 x 470	14	4	21.88 x 15.00 556 x 381	2.50 64	1.06 27	0.31 8	10.00 254	1.50 38
A24N2412LP	24.00 x 24.00 x 12.63 610 x 610 x 321	14	A24N24MP	21.00 x 22.50 533 x 572	12	4	21.88 x 19.00 556 x 483	2.50 64	1.06 27	0.31 8	12.00 305	1.50 38
A30N2412LP	30.00 x 24.00 x 12.62 762 x 610 x 321	14	A30N24MP	26.00 x 22.50 660 x 724	12	6	27.50 x 16.75 699 x 425	3.62 92	1.25 32	0.44 11	12.00 305	2.00 51
A36N3012LP	36.00 x 30.00 x 12.62 914 x 762 x 321	14	A36N30MP	32.00 x 28.50 813 x 724	12	8	33.50 x 22.75 851 x 578	3.62 92	1.25 32	0.44 11	12.00 305	2.00 51

Purchase panels separately.

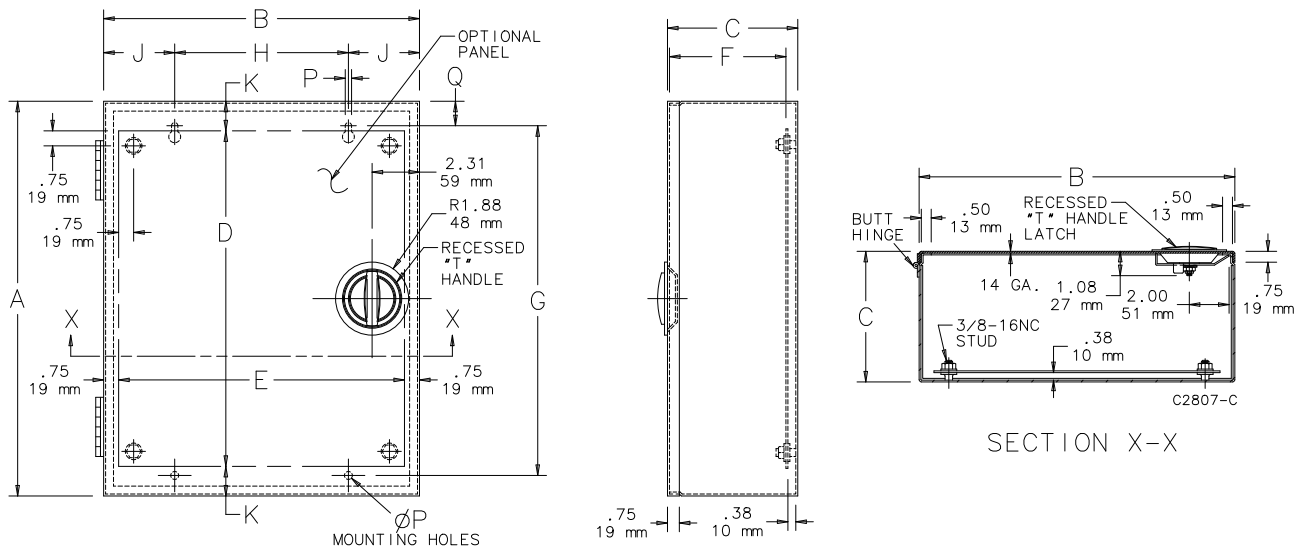



**T1FLO™ VENTED ENCLOSURE WITH FAN, TYPE 1**



**INDUSTRY STANDARDS**

UL 508A Listed; Type 1; File No. E61997  
 cUL Listed per CSA C22.2 No. 94; Type 1; File No. E61997

NEMA/EEMAC Type 1  
 IEC 60529, IP20

**APPLICATION**

These enclosures have a thermostatically controlled forced-air ventilation system for the removal of heat. Ideal for control systems in HVAC or industrial environments that have a combination of heat-sensitive electronics with high heat producing components such as (VFD) drives, inverters, PLCs and non-hardened processors.

**FEATURES**

- Active cooling ventilation system with factory installed, thermostatically controlled fan (115 VAC) and filter
- Terminal block power connection for fan
- Washable expanded metal filter
- Lift-off hinged door
- Slotted quarter-turn latch
- Collar studs for mounting optional panel
- Grounding provision on door and body
- Mounting holes on back of enclosure
- Accepts optional mounting foot kit
- Door gasket

**SPECIFICATIONS**

- 14 gauge steel

**FINISH**

ANSI 61 gray polyester powder paint finish inside and out over pretreated surfaces. Optional solid panels are white; optional perforated panels are gray.

**ACCESSORIES**

- See also Accessories.*
- Electric Heater
  - Electrical Interlocks
  - Grounding Device
  - Locking T Handle
  - Mounting Bracket Kits
  - Panels for Type 3R, 4, 4X, 12 and 13 Enclosures
  - Rack Mounting Angles - U Style (Type RA)
  - Compact Cooling Fans
  - Touch-Up Paint
  - Steel and Stainless Steel Window Kits

**NOTES**

**Required Airflow**

The following equation is used to calculate the airflow required in a forced-air system to remove heat and maintain enclosure temperature a given amount above the ambient temperature.

$$CFM = W_T \times 3.16 / T_{int} - T_{amb}$$

Where:

CFM = Required airflow (ft.<sup>3</sup> / min.)

W<sub>T</sub> = Total heat dissipated in enclosure (watts)

T<sub>amb</sub> = Ambient or external Temperature (degrees F)

T<sub>int</sub> = Desired internal Temperature (degrees F)

**BULLETIN: A1DR**

Standard Product

Catalog Number	AxBxC in./mm	System CFM	Suggested HP	Solid Panel	Perforated Panel	Panel Size D x E in./mm	Panel Gauge	G in./mm	H in./mm	Fan Size in./mm
T1F80LP	28.00 x 24.00 x 12.75 711 x 610 x 324	80	3	A24P24	A24P24PP	21.00 x 21.00 533 x 533	12	26.50 673	21.00 533	4
T1F130LP	34.00 x 24.00 x 12.75 864 x 610 x 324	130	Up to 20	A30P24	A30P24PP	27.00 x 21.00 686 x 533	12	32.50 826	21.00 533	4 (2x)
T1F200LP	40.00 x 24.00 x 12.75 1016 x 610 x 324	200	40	A36P24	A36P24PP	33.00 x 21.00 838 x 533	12	38.50 978	21.00 533	6
T1F350LP	54.00 x 30.00 x 12.75 1372 x 762 x 324	350	Up to 75	A48P30	N/A	45.00 x 27.00 1143 x 686	12	52.50 1334	27.00 686	6 (2x)

Sample Values

Catalog Number	Airflow (CFM)	Max. Internal Heat Load (W) 5 F Temp. Rise	Max. Internal Heat Load (W) 10 F Temp. Rise	Max. Internal Heat Load (W) 20 F Temp. Rise	Max. Internal Heat Load (W) 30 F Temp. Rise
T1F80LP	80	127	253	506	759
T1F130LP	130	206	411	823	1234
T1F200LP	200	316	633	1266	1899
T1F350LP	350	554	1108	2215	3323

Sample Values in a VFD Drive Application

Catalog Number (with enough air flow)	Drive HP	Heat from Drive (W)	Total Heat <sup>a</sup> (W)	Airflow (CFM) to Maintain 15 F Temp. Rise
T1F80LP	10	246	307	65
T1F130LP	20	492	615	129
T1F200LP	30	738	922	194
T1F350LP	50	1229	1536	324

<sup>a</sup>Total heat load factors 25 percent greater than VFD for passive components

**Assumptions:** Specific values and physical sizes must be verified.  
Typical motor efficiency is 91 percent; typical drive efficiency is 97 percent.

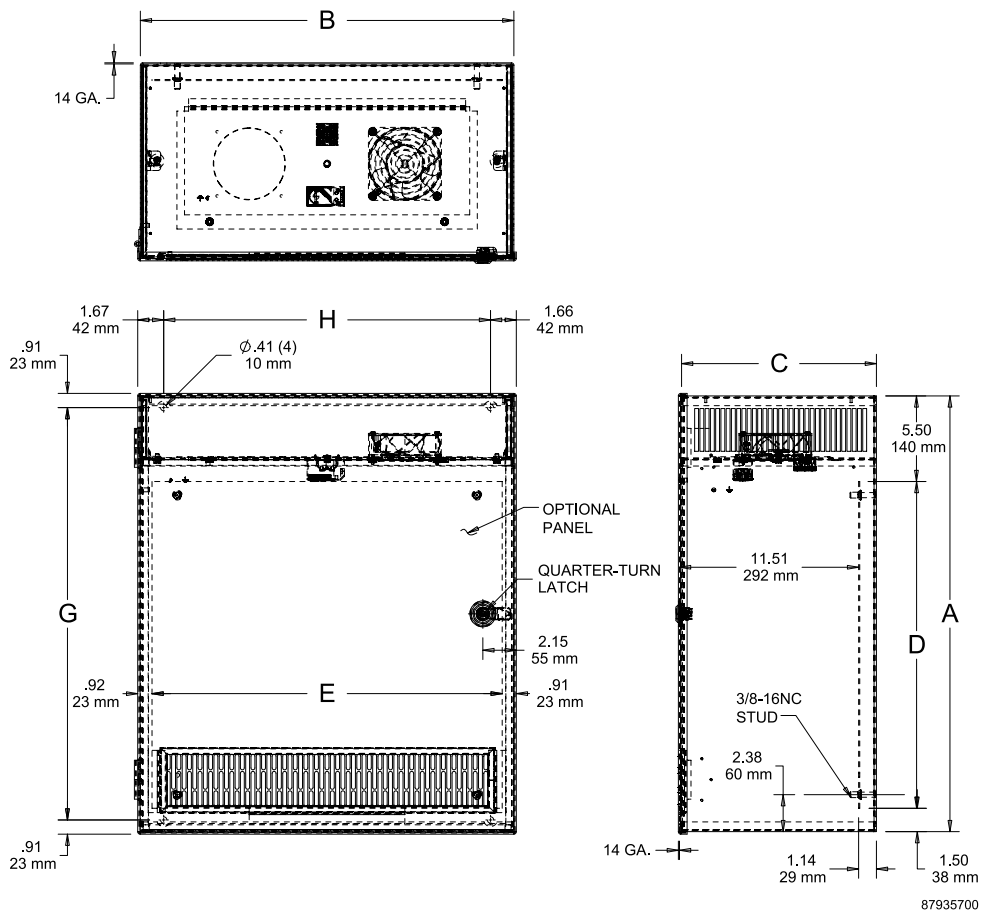

**HINGED-COVER, TYPE 1**

1

**INDUSTRY STANDARDS**

 UL 50, 50E Listed; Type 1; File No. E27567  
 cUL Listed per CSA C22.2 No 40; Type 1; File No. E27567

 NEMA/EEMAC Type 1  
 CSA, File 42184: Type 1  
 IEC 60529, IP30

**APPLICATION**

These boxes feature a recessed, slotted flush latch for security as well as knockouts on all four sides, making them suitable for a wide variety of applications.

**FEATURES**

- Various sizes of easily removable concentric knockouts on all four sides
- Butt hinges
- Mounting holes on back of box
- Provision for grounding

**SPECIFICATIONS**

- 16 or 14 gauge steel

**FINISH**

ANSI 61 gray polyester powder paint finish inside and out over pretreated surfaces. Unless otherwise specified, all custom cutout boxes are finished with ANSI 61 gray polyester paint.

**ACCESSORIES**

 See *Accessories*.  
 T-Handle Latch and Keyed Cylinder Lock Kits  
 Grounding Device  
 Touch-Up Paint

**BULLETIN: A90HC**
**Standard Product**

Catalog Number	AxBxC in.	AxBxC mm	Knockout Pattern along "A" Sides	Knockout Pattern along "B" Sides
AHE6X4X4	6.00 x 4.00 x 4.00	152 x 102 x 102	B-C-D	B-C
AHE6X6X4	6.00 x 6.00 x 4.00	152 x 152 x 102	B-C-D	B-C-D
AHE8X6X4	8.00 x 6.00 x 4.00	203 x 152 x 102	F-G-H-I	B-C-D
AHE8X8X4	8.00 x 8.00 x 4.00	203 x 203 x 102	F-G-H-I	F-G-H-I
AHE10X8X4	10.00 x 8.00 x 4.00	254 x 203 x 102	F-G-H-I	F-G-H-I
AHE10X10X4	10.00 x 10.00 x 4.00	254 x 254 x 102	F-G-H-I	C-D-E-F-G
AHE12X8X4	12.00 x 8.00 x 4.00	305 x 203 x 102	C-D-E-F-G	F-G-H-I
AHE12X10X4	12.00 x 10.00 x 4.00	305 x 254 x 102	C-D-E-F-G	C-D-E-F-G
AHE12X12X4	12.00 x 12.00 x 4.00	305 x 305 x 102	C-D-E-F-G	C-D-E-F-G
AHE16X12X4	16.00 x 12.00 x 4.00	406 x 305 x 102	B-C-D-E-F-G-H	C-D-E-F-G
AHE18X12X4	18.00 x 12.00 x 4.00	457 x 305 x 102	A-B-C-D-E-F-G-H-I	C-D-E-F-G
AHE6X6X6	6.00 x 6.00 x 6.00	152 x 152 x 152	B-C-D	B-C-D
AHE8X8X6	8.00 x 8.00 x 6.00	203 x 203 x 152	F-G-H-I	F-G-H-I
AHE10X8X6	10.00 x 8.00 x 6.00	254 x 203 x 152	F-G-H-I	F-G-H-I
AHE10X10X6	10.00 x 10.00 x 6.00	254 x 254 x 152	F-G-H-I	C-D-E-F-G
AHE12X10X6	12.00 x 10.00 x 6.00	305 x 254 x 152	C-D-E-F-G	C-D-E-F-G
AHE12X12X6	12.00 x 12.00 x 6.00	305 x 305 x 152	C-D-E-F-G	C-D-E-F-G
AHE16X12X6	16.00 x 12.00 x 6.00	406 x 305 x 152	B-C-D-E-F-G-H	C-D-E-F-G
AHE16X16X6	16.00 x 16.00 x 6.00	406 x 406 x 152	B-C-D-E-F-G-H	B-C-D-E-F-G-H
AHE18X12X6	18.00 x 12.00 x 6.00	457 x 305 x 152	A-B-C-D-E-F-G-H-I	C-D-E-F-G
AHE18X18X6	18.00 x 18.00 x 6.00	457 x 457 x 152	A-B-C-D-E-F-G-H-I	A-B-C-D-E-F-G-H-I
AHE24X18X6	24.00 x 18.00 x 6.00	610 x 457 x 152	A-B-C-D-E-F-G-H-I	A-B-C-D-E-F-G-H-I
AHE24X24X6	24.00 x 24.00 x 6.00	610 x 610 x 152	A-B-C-D-E-F-G-H-I	A-B-C-D-E-F-G-H-I
AHE30X24X6	30.00 x 24.00 x 6.00	762 x 610 x 152	A-B-C-D-E-F-G-H-I	A-B-C-D-E-F-G-H-I
AHE36X24X6	36.00 x 24.00 x 6.00	914 x 610 x 152	A-B-C-D-E-F-G-H-I	A-B-C-D-E-F-G-H-I
AHE36X24X8	36.00 x 24.00 x 8.00	914 x 610 x 203	A-B-C-D-E-F-G-H-I	A-B-C-D-E-F-G-H-I

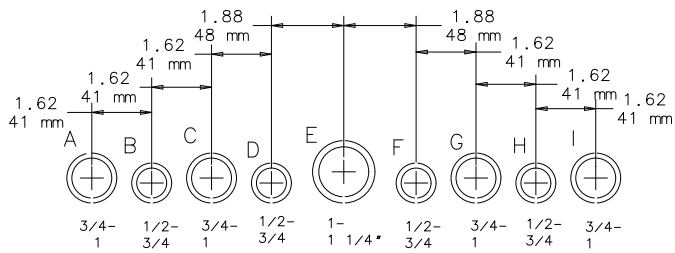
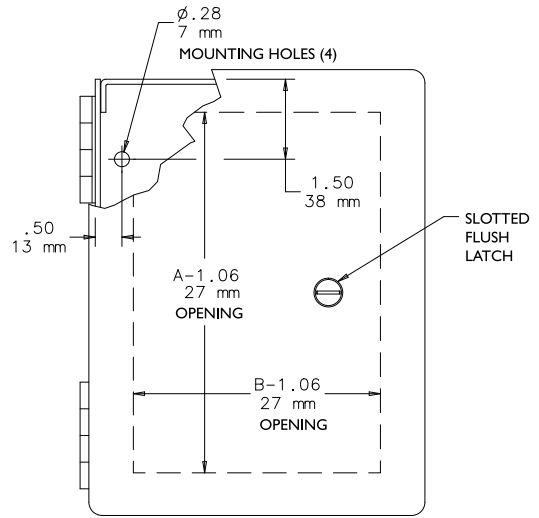
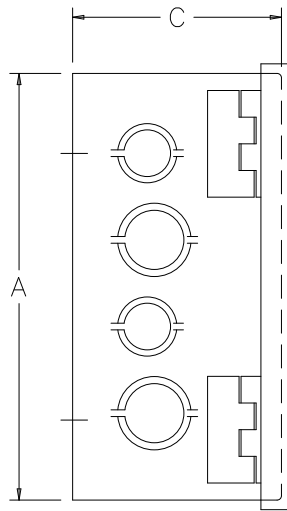

CONDUIT SIZES  
**Knockout Pattern**  
 (from outside of box)

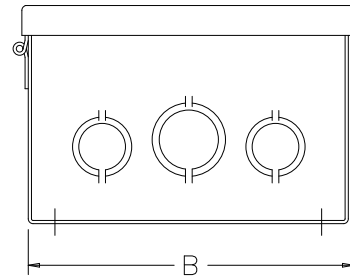

C2571-C

NOTE: Refer to table for applicable knockout pattern.



**SMALL, TYPE 1**

**INDUSTRY STANDARDS**

UL 50, 50E Listed; Type 1; File No. E27567  
 cUL Listed per CSA C22.2 No 40; Type 1; File No. E27567

NEMA/EEMAC Type 1  
 CSA, File 42184: Type 1  
 IEC 60529, IP30

**Standard Product**

Catalog Number	AxBxC in./mm	Panel	Perforated Panel	Panel Size D x E in./mm
A6N64	6.00 x 6.00 x 4.00 152 x 152 x 102	A6N6P	A6N6PP	4.25 x 4.25 108 x 108
A8N64	8.00 x 6.00 x 4.00 203 x 152 x 102	A8N6P	A8N6PP	6.25 x 4.25 159 x 108
A8N84	8.00 x 8.00 x 4.00 203 x 203 x 102	A8N8P	A8N8PP	6.25 x 6.25 159 x 159
A10N84	10.00 x 8.00 x 4.00 254 x 203 x 102	A10N8P	A10N8PP	8.25 x 6.25 210 x 159
A10N104	10.00 x 10.00 x 4.00 254 x 254 x 102	A10N10P	A10N10PP	8.25 x 8.25 210 x 210
A12N104	12.00 x 10.00 x 4.00 305 x 254 x 102	A12N10P	A12N10PP	10.25 x 8.25 260 x 210
A12N124	12.00 x 12.00 x 4.00 305 x 305 x 102	A12N12P	A12N12PP	10.25 x 10.25 260 x 260
A14N124	14.00 x 12.00 x 4.00 356 x 305 x 102	A14N12P	A14N12PP	12.25 x 10.25 311 x 260
A8N66	8.00 x 6.00 x 6.00 203 x 152 x 152	A8N6P	A8N6PP	6.25 x 4.25 159 x 108
A8N86	8.00 x 8.00 x 6.00 203 x 203 x 152	A8N8P	A8N8PP	6.25 x 6.25 159 x 159
A10N86	10.00 x 8.00 x 6.00 254 x 203 x 152	A10N8P	A10N8PP	8.25 x 6.25 210 x 159
A10N106	10.00 x 10.00 x 6.00 254 x 254 x 152	A10N10P	A10N10PP	8.25 x 8.25 210 x 210
A12N106	12.00 x 10.00 x 6.00 305 x 254 x 152	A12N10P	A12N10PP	10.25 x 8.25 260 x 210
A12N126	12.00 x 12.00 x 6.00 305 x 305 x 152	A12N12P	A12N12PP	10.25 x 10.25 260 x 260
A14N126	14.00 x 12.00 x 6.00 356 x 305 x 152	A14N12P	A14N12PP	12.25 x 10.25 311 x 260
A16N126	16.00 x 12.00 x 6.00 406 x 305 x 152	A16N12P	A16N12PP	14.25 x 10.25 362 x 260
A20N126	20.00 x 12.00 x 6.00 508 x 305 x 152	A20N12P	A20N12PP	18.25 x 10.25 464 x 260
A12N128	12.00 x 12.00 x 8.00 305 x 305 x 203	A12N12P	A12N12PP	10.25 x 10.25 260 x 260
A14N128	14.00 x 12.00 x 8.00 356 x 305 x 203	A14N12P	A14N12PP	12.25 x 10.25 311 x 260

Purchase panels separately.

**APPLICATION**

These enclosures have a size range of 6 x 6 x 4-in. to 14 x 12 x 8-in. and meet basic functionality requirements for applications that do not require oil- or dust-tight enclosures.

**FEATURES**

- Flush slotted latch operated with a screwdriver; optional latches available
- Weldnuts provided for mounting optional panels
- Butt hinges
- Mounting holes on back of enclosure

**SPECIFICATIONS**

- 16 gauge steel

**FINISH**

ANSI 61 gray polyester powder paint finish inside and out over pretreated surfaces. Optional solid panels are white and optional perforated panels are gray.

**ACCESSORIES**

See also *Accessories*.

T-Handle Latch and Keyed Cylinder Lock Kits

Grounding Device

Panels for Type 1 Enclosures and Small Type 3R Enclosures

T-Handle Latch and Keyed Cylinder Lock Kits

Touch-Up Paint

Steel and Stainless Steel Window Kits

**BULLETIN: A1SM**



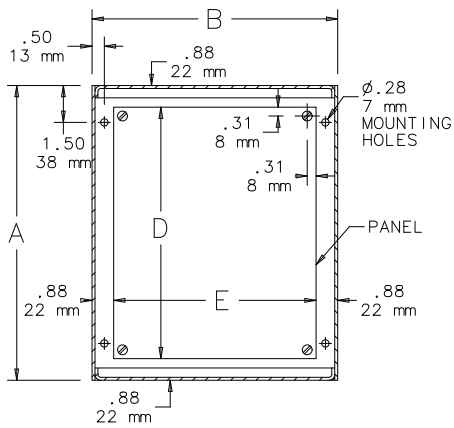
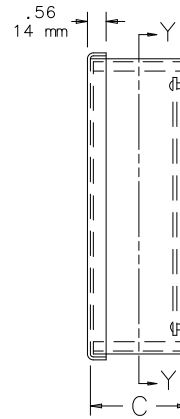
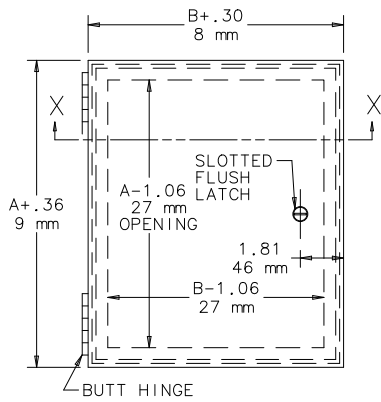

NOTE: 1. Panels are 14 gauge steel.  
2. Panel screws have #10-32 threads.

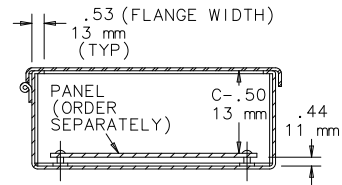

SECTION X-X

SECTION Y-Y

Optional Latches

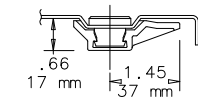
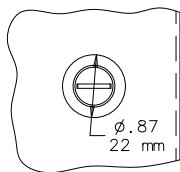

Standard Slotted Flush Latch

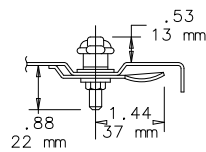
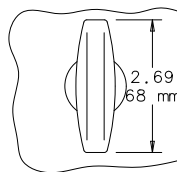

\*T\* Handle Latch Kit AL7A

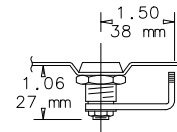
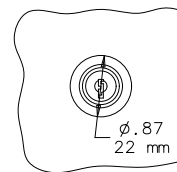

Cylinder Lock Kit AL12AR C2572-C



MEDIUM, TYPE 1



INDUSTRY STANDARDS

UL 50, 50E Listed; Type 1; File No. E27567  
 cUL Listed per CSA C22.2 No 40; Type 1; File No. E27567

NEMA/EEMAC Type 1  
 CSA, File 42184: Type 1  
 IEC 60529, IP30

Standard Product

Catalog Number	AxBxC in./mm	Panel	Perforated Panel	Panel Size D x E in./mm	Panel Gauge	G in./mm	H in./mm	J in./mm	Q in./mm	P in./mm	F in./mm	K in./mm
A16N12ALP	16.00 x 12.00 x 6.62 406 x 305 x 168	A16N12MP	A16N12MPP	13.00 x 10.50 330 x 267	14	13.88 353	7.00 178	2.50 64	1.06 27	0.31 8	6.00 152	1.50 38
A16N16ALP	16.00 x 16.00 x 6.62 406 x 406 x 168	A16N16MP	A16N16MPP	13.00 x 14.50 330 x 368	14	13.88 353	11.00 279	2.50 64	1.06 27	0.31 8	6.00 152	1.50 38
A16N20ALP	16.00 x 20.00 x 6.62 406 x 508 x 168	A16N20MP	A16N20MPP	13.00 x 18.50 330 x 470	14	13.88 353	15.00 381	2.50 64	1.06 27	0.31 8	6.00 152	1.50 38
A20N16ALP	20.00 x 16.00 x 6.62 508 x 406 x 168	A20N16MP	A20N16MPP	17.00 x 14.50 432 x 368	14	17.88 454	11.00 279	2.50 64	1.06 27	0.31 8	6.00 152	1.50 38
A20N20ALP	20.00 x 20.00 x 6.62 508 x 508 x 168	A20N20MP	A20N20MPP	17.00 x 18.50 432 x 470	14	17.88 454	15.00 381	2.50 64	1.06 27	0.31 8	6.00 152	1.50 38
A24N16ALP	24.00 x 16.00 x 6.62 610 x 406 x 168	A24N16MP	A24N16MPP	21.00 x 14.50 533 x 368	14	21.88 556	11.00 279	2.50 64	1.06 27	0.31 8	6.00 152	1.50 38
A24N20ALP	24.00 x 20.00 x 6.62 610 x 508 x 168	A24N20MP	A24N20MPP	21.00 x 18.50 533 x 470	14	21.88 556	15.00 381	2.50 64	1.06 27	0.31 8	6.00 152	1.50 38
A24N24ALP	24.00 x 24.00 x 6.62 610 x 610 x 168	A24N24MP	A24N24MPP <sup>a</sup>	21.00 x 22.50 533 x 572	12	21.88 556	19.00 483	2.50 64	1.06 27	0.31 8	6.00 152	1.50 38
A30N24ALP	30.00 x 24.00 x 6.62 762 x 610 x 168	A30N24MP	A30N24MPP <sup>a</sup>	26.00 x 22.50 660 x 572	12	27.50 699	16.75 425	3.62 92	1.25 32	0.44 11	6.00 152	2.00 51
A36N24ALP	36.00 x 24.00 x 6.62 914 x 610 x 168	A36N24MP	A36N24MPP <sup>a</sup>	32.00 x 22.50 813 x 572	12	33.50 851	16.75 425	3.62 92	1.25 32	0.44 11	6.00 152	2.00 51
A36N30ALP	36.00 x 30.00 x 6.62 914 x 762 x 168	A36N30MP	A36N30MPP <sup>a</sup>	32.00 x 28.50 813 x 724	12	33.50 851	22.75 578	3.62 92	1.25 32	0.44 11	6.00 152	2.00 51
A16N12BLP	16.00 x 12.00 x 8.62 406 x 305 x 219	A16N12MP	A16N12MPP	13.00 x 10.50 330 x 267	14	13.88 353	7.00 178	2.50 64	1.06 27	0.31 8	8.00 203	1.50 38
A20N12BLP	20.00 x 12.00 x 8.62 508 x 305 x 219	A20N12MP	A20N12MPP	17.00 x 10.50 432 x 267	14	17.88 454	7.00 178	2.50 64	1.06 27	0.31 8	8.00 203	1.50 38
A20N16BLP	20.00 x 16.00 x 8.62 508 x 406 x 219	A20N16MP	A20N16MPP	17.00 x 14.50 432 x 368	14	17.88 454	11.00 279	2.50 64	1.06 27	0.31 8	8.00 203	1.50 38
A20N20BLP	20.00 x 20.00 x 8.62 508 x 508 x 219	A20N20MP	A20N20MPP	17.00 x 18.50 432 x 470	14	17.88 454	15.00 381	2.50 64	1.06 27	0.31 8	8.00 203	1.50 38
A24N20BLP	24.00 x 20.00 x 8.62 610 x 508 x 219	A24N20MP	A24N20MPP	21.00 x 18.50 533 x 470	14	21.88 556	15.00 381	2.50 64	1.06 27	0.31 8	8.00 203	1.50 38
A24N24BLP	24.00 x 24.00 x 8.62 610 x 610 x 219	A24N24MP	A24N24MPP <sup>a</sup>	21.00 x 22.50 533 x 572	12	21.88 556	19.00 483	2.50 64	1.06 27	0.31 8	8.00 203	1.50 38

APPLICATION

These enclosures have a size range of 16 x 12 x 6-in. to 36 x 30 x 12-in. and meet basic functionality requirements for applications that do not require oil- or dust-tight enclosures.

FEATURES

- Doors have butt hinges
- Collar studs provided for mounting optional panel
- Slotted flush latches; optional latches available
- Mounting holes on back of enclosure

SPECIFICATIONS

- 14 or 12 gauge steel

FINISH

ANSI 61 gray polyester powder paint finish inside and out over pretreated surfaces. Optional solid panels are white and optional perforated panels are gray.

ACCESSORIES

- See also Accessories.
- T-Handle Latch and Keyed Cylinder Lock Kits
  - Electric Heater
  - Electrical Interlocks
  - Grounding Device
  - Panels for Medium Type 1 Enclosures
  - Rack Mounting Angles - U Style (Type RA)
  - T-Handle Latch and Keyed Cylinder Lock Kits
  - Touch-Up Paint
  - Steel and Stainless Steel Window Kits

BULLETIN: A1M



Panel Size	Panel Size		Panel	Perforated Panel	D x E	Panel	G	H	J	Q	P	F	K
Catalog Number	AxBxC in./mm				in./mm	Gauge	in./mm	in./mm	in./mm	in./mm	in./mm	in./mm	in./mm
A30N20BLP	30.00 x 20.00 x 8.62 762 x 508 x 219	A30N20MP	A30N20MPP <sup>a</sup>	26.00 x 18.50 660 x 470	12	27.50 699	15.00 381	2.50 64	1.25 32	0.44 11	8.00 203	2.00 51	
A30N24BLP	30.00 x 24.00 x 8.62 762 x 610 x 219	A30N24MP	A30N24MPP <sup>a</sup>	26.00 x 22.50 660 x 572	12	27.50 699	16.75 425	3.62 92	1.25 32	0.44 11	8.00 203	2.00 51	
A30N30BLP	30.00 x 30.00 x 8.62 762 x 762 x 219	A30N30MP	A30N30MPP <sup>a</sup>	26.00 x 28.50 660 x 724	12	27.50 699	22.75 578	3.62 92	1.25 32	0.44 11	8.00 203	2.00 51	
A36N24BLP	36.00 x 24.00 x 8.62 914 x 610 x 219	A36N24MP	A36N24MPP <sup>a</sup>	32.00 x 22.50 813 x 572	12	33.50 851	16.75 425	3.62 92	1.25 32	0.44 11	8.00 203	2.00 51	
A36N30BLP	36.00 x 30.00 x 8.62 914 x 762 x 219	A36N30MP	A36N30MPP <sup>a</sup>	32.00 x 28.50 813 x 724	12	33.50 851	22.75 578	3.62 92	1.25 32	0.44 11	8.00 203	2.00 51	
A18N18CLP	18.00 x 18.00 x 10.62 441 x 441 x 270	A18N18MP	A18N18MPP	15.00 x 16.50 381 x 419	14	15.88 403	13.00 330	2.50 64	1.06 27	0.31 8	10.00 254	1.50 38	
A24N20CLP	24.00 x 20.00 x 10.62 610 x 508 x 270	A24N20MP	A24N20MPP	21.00 x 18.50 533 x 470	14	21.88 556	15.00 381	2.50 64	1.06 27	0.31 8	10.00 254	1.50 38	
A30N24CLP	30.00 x 24.00 x 10.62 762 x 610 x 270	A30N24MP	A30N24MPP <sup>a</sup>	21.00 x 22.50 533 x 572	12	27.50 699	16.75 425	3.62 92	1.25 32	0.44 11	10.00 254	2.00 51	
A24N24DLP	24.00 x 24.00 x 12.62 610 x 610 x 321	A24N24MP	A24N24MPP <sup>a</sup>	21.00 x 22.50 533 x 572	12	21.88 556	19.00 483	2.50 64	1.06 27	0.31 8	12.00 305	1.50 38	
A30N24DLP	30.00 x 24.00 x 12.62 762 x 610 x 321	A30N24MP	A30N24MPP <sup>a</sup>	26.00 x 22.50 660 x 724	12	27.50 699	16.75 425	3.62 92	1.25 32	0.44 11	12.00 305	2.00 51	
A36N30DLP	36.00 x 30.00 x 12.62 914 x 762 x 321	A36N30MP	A36N30MPP <sup>a</sup>	32.00 x 28.50 813 x 724	12	33.50 851	22.75 578	3.62 92	1.25 32	0.44 11	12.00 305	2.00 51	

Purchase panels separately.

<sup>a</sup>Flanged on all four sides

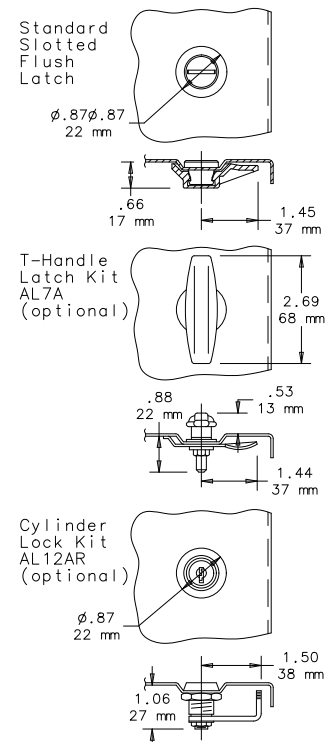
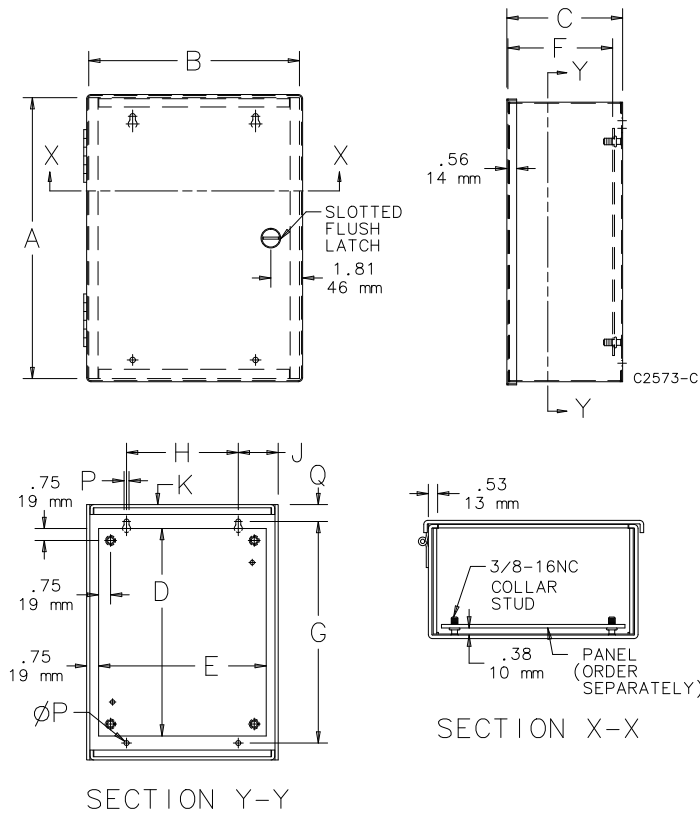

LARGE, TYPE 1



**APPLICATION**

These enclosures have a size range of 42 x 30 x 9-in. to 48 x 36 x 17-in. and meet basic functionality requirements for applications that do not require oil- or dust-tight enclosures.

**FEATURES**

- Continuous hinge on door
- Slotted flush latch; optional latches available
- Collar studs provided for mounting optional panels
- Mounting holes on back of enclosure; optional mounting bracket kit is available (AMFLN1)

**SPECIFICATIONS**

- 14 gauge steel

**FINISH**

ANSI 61 gray polyester powder paint finish inside and out over pretreated surfaces. Optional panels are white.

**ACCESSORIES**

- See also Accessories.
- T-Handle Latch and Keyed Cylinder Lock Kit
- Electric Heater
- Electrical Interlocks
- Grounding Device
- Panels for Medium Type 1 Enclosures
- Junction Box and Wall-Mount Enclosure Swing Out Panel Kit
- Terminal Block Kit Assembly for Junction Boxes Overview
- Touch-Up Paint
- Steel and Stainless Steel Window Kits

**BULLETIN: A1L**

**INDUSTRY STANDARDS**

UL 50, 50E Listed; Type 1; File No. E27567  
 cUL Listed per CSA C22.2 No 40; Type 1; File No. E27567

NEMA/EEMAC Type 1  
 CSA, File 42184: Type 1  
 IEC 60529, IP30

Standard Product

Catalog Number	AxBxC in./mm	Panel	Panel Size D x E in./mm	Mounting Bracket Kit
A42N3009	42.00 x 30.00 x 9.25 1067 x 762 x 235	A42P30	39.00 x 27.00 991 x 686	AMFLN1
A42N3609	42.00 x 36.00 x 9.25 1067 x 914 x 235	A42P36	39.00 x 33.00 991 x 838	AMFLN1
A48N3609	48.00 x 36.00 x 9.25 1219 x 914 x 235	A48P36	45.00 x 33.00 1143 x 838	AMFLN1
A48N3611	48.00 x 36.00 x 11.25 1219 x 914 x 286	A48P36	45.00 x 33.00 1143 x 838	AMFLN1
A42N3013	42.00 x 30.00 x 13.25 1067 x 762 x 337	A42P30	39.00 x 27.00 991 x 686	AMFLN1
A42N3613	42.00 x 36.00 x 13.25 1067 x 914 x 337	A42P36	39.00 x 33.00 991 x 838	AMFLN1
A48N3613	48.00 x 36.00 x 13.25 1219 x 914 x 337	A48P36	45.00 x 33.00 1143 x 838	AMFLN1
A48N3617	48.00 x 36.00 x 17.00 1219 x 914 x 432	A48P36	45.00 x 33.00 1143 x 838	AMFLN1

Purchase panels separately. Optional aluminum panels are available for most sizes.  
 Mounting Bracket Kit must be ordered separately.

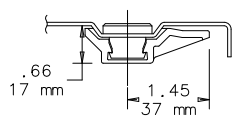
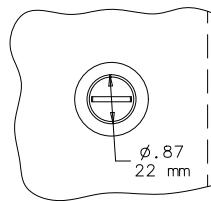
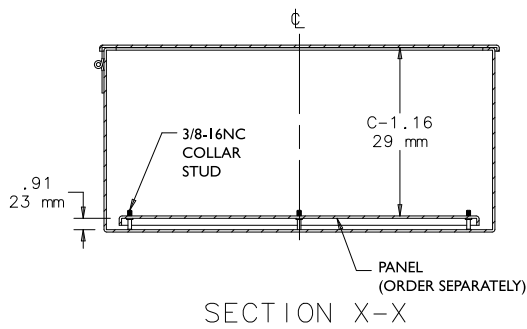
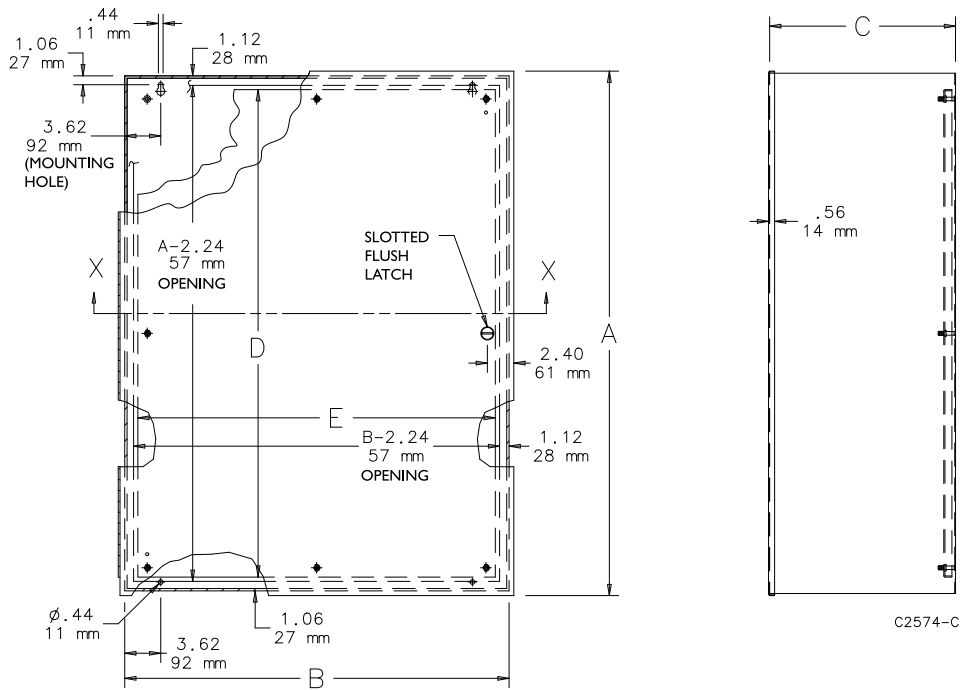

Standard Slotted  
Flush Latch

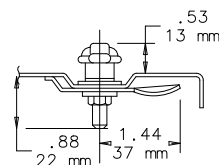
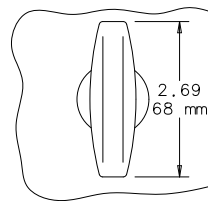

"T" Handle Latch Kit  
AL7A (optional)

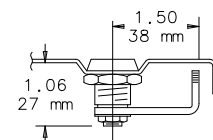
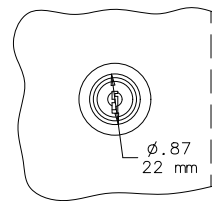

Cylinder Lock Kit  
AL12AR (optional)



**LOCKING INTEGRATED PERFORATED PANEL ENCLOSURE, TYPE 1**



*Example of Integrated Panel; wiring devices not included.*

**INDUSTRY STANDARDS**

UL 50, 50E Listed; Type 1; File No. E27567  
 cUL Listed per CSA C22.2 No 40; Type 1; File No. E27567

NEMA/EEMAC Type 1  
 IEC 60529, IP30

**APPLICATION**

The perforated panel that ships inside these enclosures accepts self-tapping screws and eliminates the need to measure, mark and drill when mounting components, which results in labor and time savings.

**FEATURES**

- Door has key lock quarter-turn latch; two keys included
- Select models have concentric knockouts on four sides

**SPECIFICATIONS**

- 14 and 16 gauge steel
- Includes removable 16 gauge gray perforated panel

**FINISH**

ANSI 61 gray polyester powder paint finish inside and out over pretreated surfaces.

**ACCESSORIES**

Touch-Up Paint

**BULLETIN: A1PP**

Standard Product

Catalog Number	AxBxC in./mm	Panel Size D x E in./mm	Mounting Holes G x H in./mm	Knockout Pattern A-Sides	Knockout Pattern B-Sides
A12126T1PP	12.00 x 12.00 x 6.00 305 x 305 x 152	10.25 x 10.25 260 x 260	9.00 x 11.00 229 x 279	C-D-E-F-G	C-D-E-F-G
A16126T1PP	16.00 x 12.00 x 6.00 406 x 305 x 152	14.25 x 10.25 362 x 260	13.00 x 11.00 330 x 279	B-C-D-E-F-G-H	C-D-E-F-G
A2016AT1PP	20.00 x 16.00 x 6.62 508 x 406 x 168	17.00 x 14.50 432 x 368	17.88 x 11.00 454 x 279	A-B-C-D-E-F-G-H-I	B-C-D-E-F-G-H
A2420AT1PP	24.00 x 20.00 x 6.62 610 x 508 x 168	21.00 x 18.50 533 x 470	21.88 x 15.00 556 x 381	A-B-C-D-E-F-G-H-I	A-B-C-D-E-F-G-H-I
A3624AT1PP	36.00 x 24.00 x 6.62 914 x 610 x 168	32.00 x 22.50 813 x 572	33.50 x 16.75 851 x 425	—	—
A3630AT1PP	36.00 x 30.00 x 6.62 914 x 762 x 168	32.00 x 31.50 813 x 800	33.50 x 22.75 851 x 578	—	—

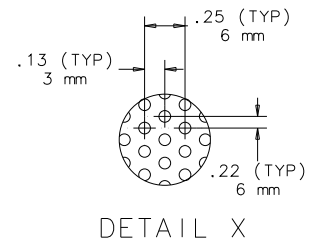
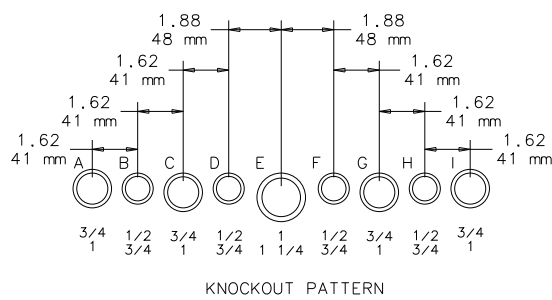
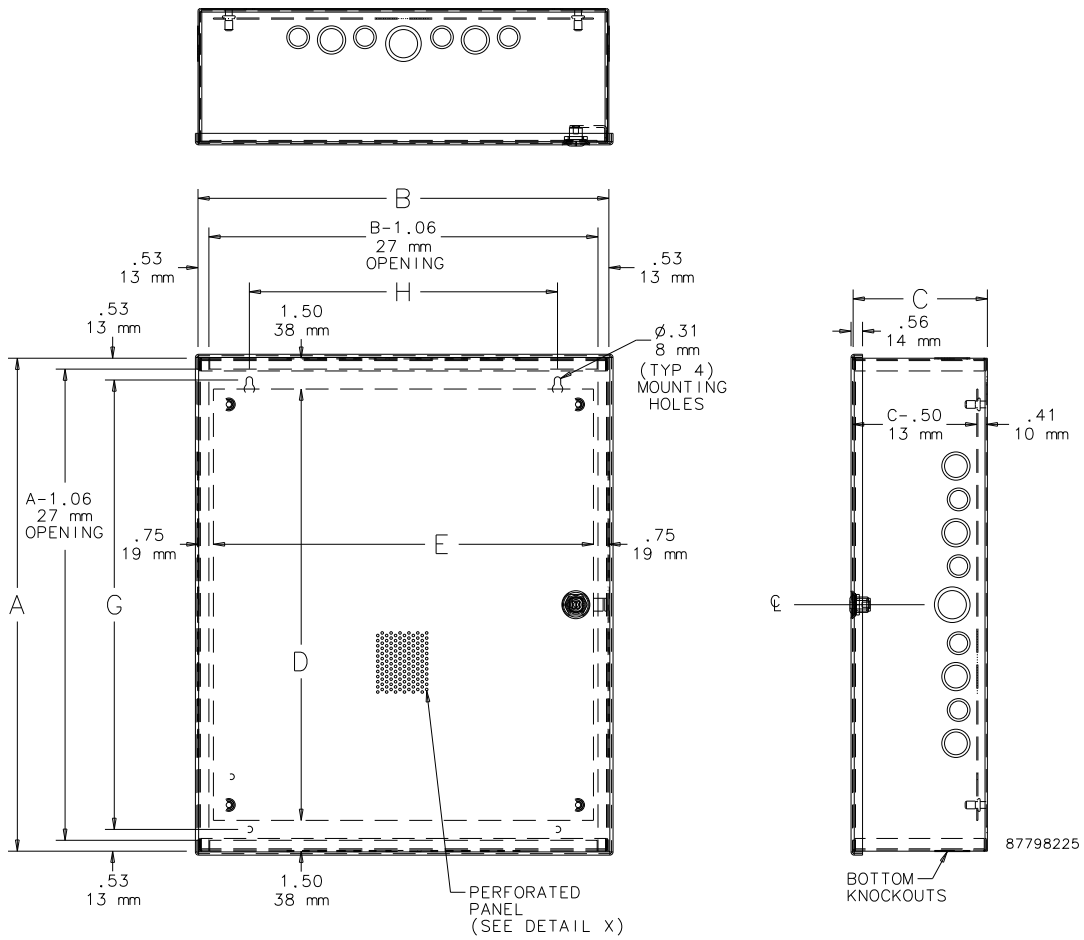

**LOCKING UTILITY CABINETS, TYPE 1**



**INDUSTRY STANDARDS**

UL 50, 50E Listed; Type 1; File Number E27567  
cUL Listed per CSA C22.2 No 40; Type 1; File Number E27567

NEMA/EEMAC Type 1  
IEC 60529, IP30

**APPLICATION**

Key hook and shelf models of this cabinet protect fuses and other components and can be equipped with a combination lock for applications that require security.

**SHELF MODELS** A242412UC, A302412UC, A362412UC, A363012UC  
Shelf cabinets provide a level of security for storage of equipment, fuses, and other components. Two shelves included with shelf models are easily adjusted without tools by placing tabs in slots located on enclosure sides.

**KEY HOOK MODELS** A24244UC, A12122UC  
Use as key cabinets or a hanging locker to organize items that require a level of security. Key hook models have integral hooks assembled in door and back of enclosure.

**FEATURES**

- Four mounting keyholes in back of enclosure
- Removable door with reversible hinge; door can hinge from either left or right side and can be changed without tools
- Door has quarter-turn key lock; two keys included
- Combination lock is available as an accessory and is interchangeable with standard cutout and latch cam
- Retractable spring hinge
- No gasketing

**SPECIFICATIONS**

- 16 or 14 gauge steel

**FINISH**

ANSI 61 gray polyester powder paint finish inside an out

**ACCESSORIES**

See also *Accessories*.  
Double-Sided Solid Aluminum Shelf  
Touch-Up Paint

**BULLETIN:** A1UC, DWS12

Standard Product

Catalog Number	AxBxC in./mm	Description	Mounting Holes G in./mm	Mounting Holes H in./mm	Maximum No. Shelf Locations/Hooks
A242412UC	24.00 x 24.00 x 12.00 610 x 610 x 305	Shelf Model	16.00 406	18.00 457	3 Shelves
A302412UC	30.00 x 24.00 x 12.00 762 x 610 x 305	Shelf Model	22.00 558	18.00 457	4 Shelves
A363012UC	36.00 x 30.00 x 12.00 914 x 762 x 305	Shelf Model	28.00 711	24.00 610	5 Shelves
A12122UC	12.00 x 12.00 x 2.00 305 x 305 x 51	Hook Model	7.00 178	7.25 184	52 Hooks

**Accessories**

Catalog Number	AxBxC in./mm	Description
A30S12UC	30.00 x 12.00 762 x 305	Shelf
PTLCMB3B	0.00	Combination Lock



Shelf Model

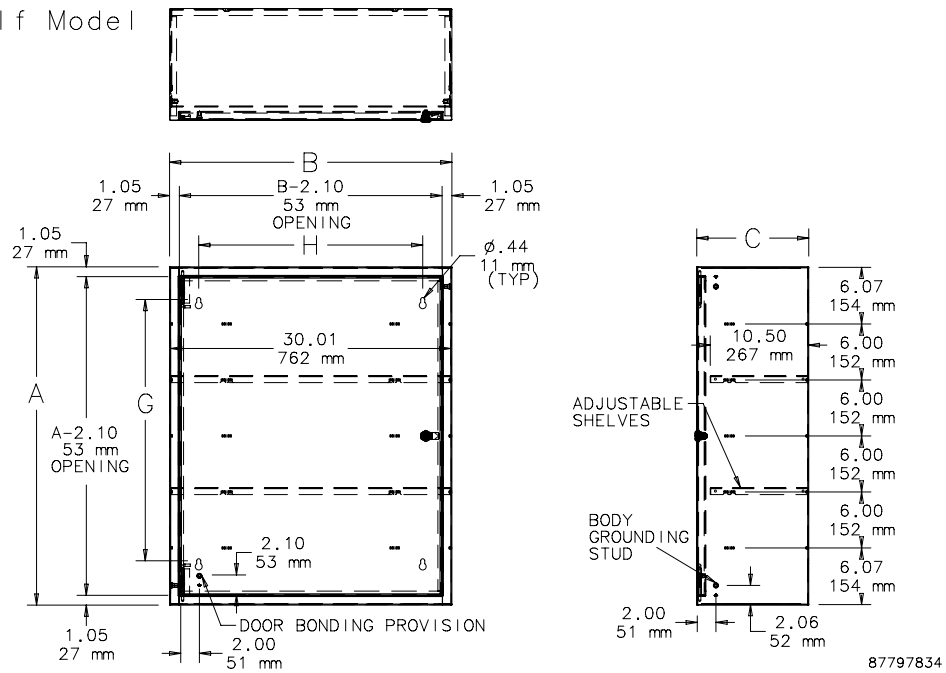

Key Cabinet

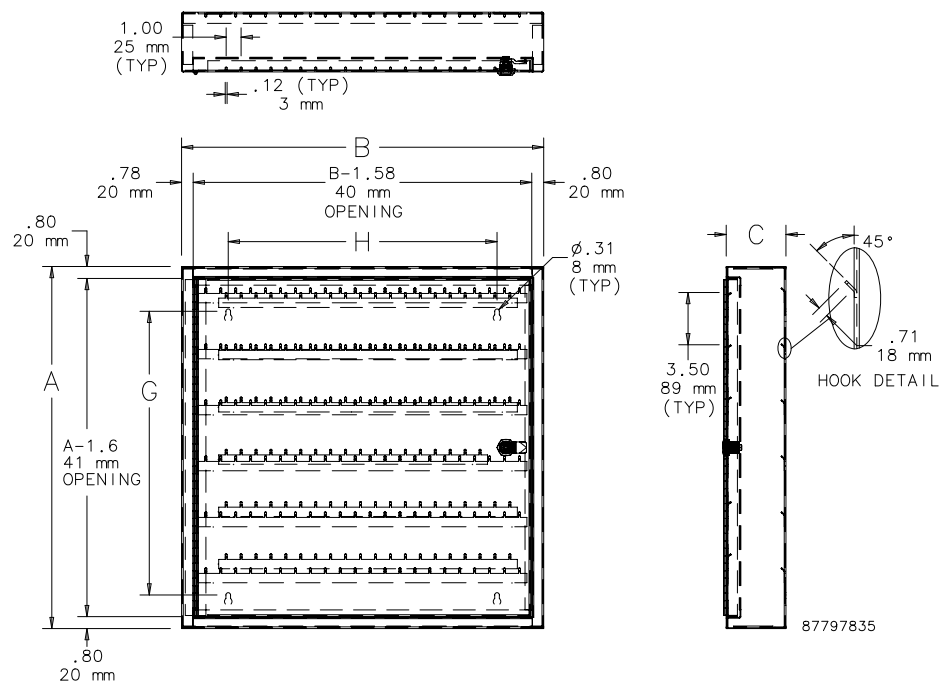

*Hoffman*<sup>®</sup>

# CHAPTER 2 TYPE 3 AND 3R BOXES AND ENCLOSURES

## OVERVIEW

Pentair Type 3R outdoor enclosures protect wiring and electrical equipment from rain, sleet and snow. They have a superior corrosion-resistant finish that exceeds NEMA, CSA and UL requirements.

Many sizes of the hinged enclosures can be used with the optional labor-saving, perforated panels which provide fast and easy component mounting because pre-drilling is not required.



## WEATHERFLO™ HD ENCLOSURES

WeatherFlo™ HD Enclosures are designed to protect and cool 100-500 HP variable frequency drives. These enclosures provide an integrated cooling solution for your VFD application needs.

## SCREW-COVER, GASKETED, TYPE 3

Use this enclosure as a wiring, junction, pull or terminal box in applications subject to windblown dust and/or rain.





## CHAPTER CONTENTS

### SCREW-COVER TYPE 3 ENCLOSURES

Screw-Cover, Gasketed, Type 3 ..... 30

### SCREW-COVER TYPE 3R BOXES AND ENCLOSURES

Horizontal-Mount, Type 3R ..... 32

Screw-Cover, Type 3R ..... 34

Screw-Cover Galvanized, Type 3R ..... 38

### HINGE-COVER TYPE 3R ENCLOSURES

Hinge-Cover, Small, Type 3R ..... 40

Hinge-Cover, Medium, Type 3R ..... 42

### HINGE-COVER LIFT-OFF TYPE 3R ENCLOSURES AND ACCESSORIES

Hinge-Cover Lift-Off, Type 3R ..... 44

Panel Mounting Kit ..... 45

Mounting Bracket Kit ..... 45

### PAD-MOUNT TYPE 3R ENCLOSURES AND ACCESSORIES

WEATHERPRO™ Outdoor Pad Mount, Type 3R ..... 46

19-in. Hinged Wall-Mount Panel ..... 49

19-in. Fixed Wall-Mount Rack ..... 50

Insect Screens ..... 50

Fan Shroud Kits ..... 51

### WEATHERFLO™ TYPE 3R VENTED ENCLOSURES

WEATHERFLO™ with Fan, Type 3R ..... 52

Technical Information ..... 54

Solar Consideration ..... 54

Critical Parameters (upper temperature limits) ..... 55

Critical Parameters (lower temperature limits) ..... 55

### WEATHERFLO™ HD

WEATHERFLO™ HD Enclosures ..... 56

Tops ..... 57

Bases ..... 58

Panel ..... 58

Rear Covers ..... 58

CFM Performance Chart ..... 59

Product Selection Matrix ..... 59

Gland Plate ..... 59

Joining Kit ..... 59

Impeller ..... 59

### WEATHERFLO™ WITH FAN, TYPE 3R

WeatherFlo™ Enclosures feature a forced-air ventilation system for cooling drives or other high-heat producing equipment in outdoor applications.



**SCREW-COVER, GASKETED, TYPE 3**

2

**INDUSTRY STANDARDS**

UL 508A Listed; Type 3, 12; File No. E61997  
cUL Listed per CSA C22.2 No 94; Type 3, 12; File No. E61997

NEMA/EEMAC Type 3 and 12 (except for mounting provisions)  
CSA, File 42184: Type 4 and 12  
IEC 60529, IP66

**APPLICATION**

Use this enclosure as a wiring, junction, pull or terminal box in applications subject to windblown dust and/or rain.

**FEATURES**

- Captivated stainless steel cover screws thread into sealed wells
- Oil-resistant gasket and adhesive
- Seams continuously welded and ground smooth
- No holes or knockouts
- Grounding stud on inside back of box

**SPECIFICATIONS**

- 14 or 12 gauge G-90 grade galvanized steel bodies
- 12 or 10 gauge G-90 grade galvanized steel covers

**FINISH**

Cover is unpainted. Body external welds have zinc-rich ANSI 61 powder.

**ACCESSORIES**

*See also Accessories.*  
Industrial Corrosion Inhibitors  
Electric Heater  
Grounding Device  
Mounting Bracket Kit

**BULLETIN: A90GS**

Standard Product

Catalog Number	AxBxC in.	AxBxC mm	Body Gauge	Cover Gauge	Number of Cover Screws
A664GSC	6.00 x 6.00 x 4.00	152 x 152 x 102	14	12	4
A864GSC	8.00 x 6.00 x 4.00	203 x 152 x 102	14	12	4
A884GSC	8.00 x 8.00 x 4.00	203 x 203 x 102	14	12	4
A1084GSC	10.00 x 8.00 x 4.00	254 x 203 x 102	14	12	6
A10104GSC	10.00 x 10.00 x 4.00	254 x 254 x 102	14	12	8
A12124GSC	12.00 x 12.00 x 4.00	305 x 305 x 102	14	12	8
A666GSC	6.00 x 6.00 x 6.00	152 x 152 x 152	14	12	4
A886GSC	8.00 x 8.00 x 6.00	203 x 203 x 152	14	12	4
A10106GSC	10.00 x 10.00 x 6.00	254 x 254 x 152	14	12	8
A12106GSC	12.00 x 10.00 x 6.00	305 x 254 x 152	14	12	8
A12126GSC	12.00 x 12.00 x 6.00	305 x 305 x 152	14	12	8
A16126GSC	16.00 x 12.00 x 6.00	406 x 305 x 152	14	12	8
A16166GSC	16.00 x 16.00 x 6.00	406 x 406 x 152	14	10	8
A18186GSC	18.00 x 18.00 x 6.00	457 x 457 x 152	14	10	8
A20166GSC	20.00 x 16.00 x 6.00	508 x 406 x 152	14	10	8
A24246GSC	24.00 x 24.00 x 6.00	610 x 610 x 152	14	10	12
A888GSC	8.00 x 8.00 x 8.00	203 x 203 x 203	14	12	4
A10108GSC	10.00 x 10.00 x 8.00	254 x 254 x 203	14	12	8
A12128GSC	12.00 x 12.00 x 8.00	305 x 305 x 203	14	12	8
A16168GSC	16.00 x 16.00 x 8.00	406 x 406 x 203	14	10	8
A20208GSC	20.00 x 20.00 x 8.00	508 x 508 x 203	14	10	8
A24208GSC	24.00 x 20.00 x 8.00	610 x 508 x 203	14	10	10
A24248GSC	24.00 x 24.00 x 8.00	610 x 610 x 203	14	10	12
A30248GSC	30.00 x 24.00 x 8.00	762 x 610 x 203	14	10	12
A242410GSC	24.00 x 24.00 x 10.00	610 x 610 x 254	14	10	12
A121212GSC	12.00 x 12.00 x 12.00	305 x 305 x 305	14	12	8
A161612GSC	16.00 x 16.00 x 12.00	406 x 406 x 305	14	10	8
A202012GSC	20.00 x 20.00 x 12.00	508 x 508 x 305	14	10	8
A242412GSC	24.00 x 24.00 x 12.00	610 x 610 x 305	14	10	12
A303012GSC	30.00 x 30.00 x 12.00	762 x 762 x 305	12	10	12
A363612GSC	36.00 x 36.00 x 12.00	914 x 914 x 305	12	10	16

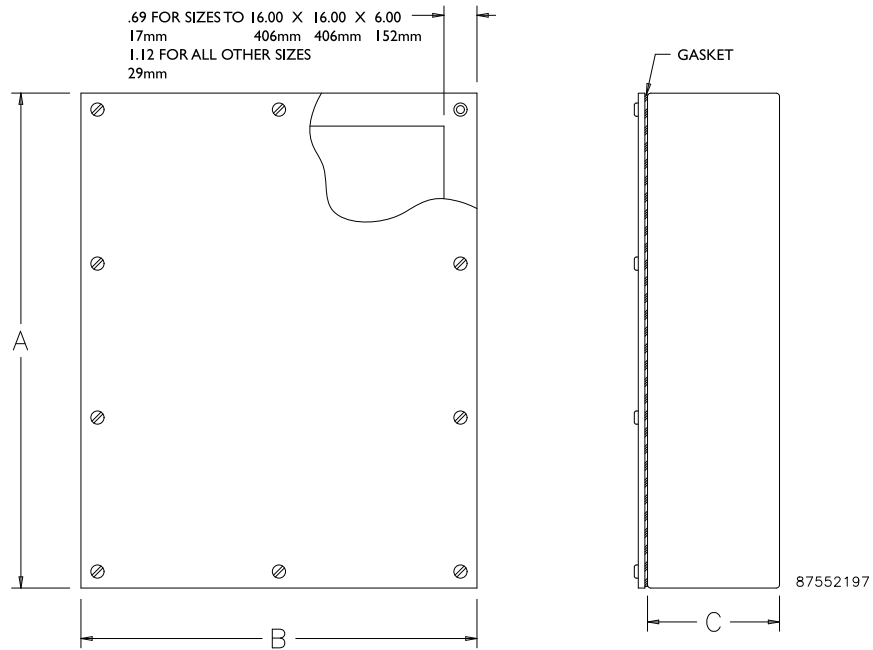

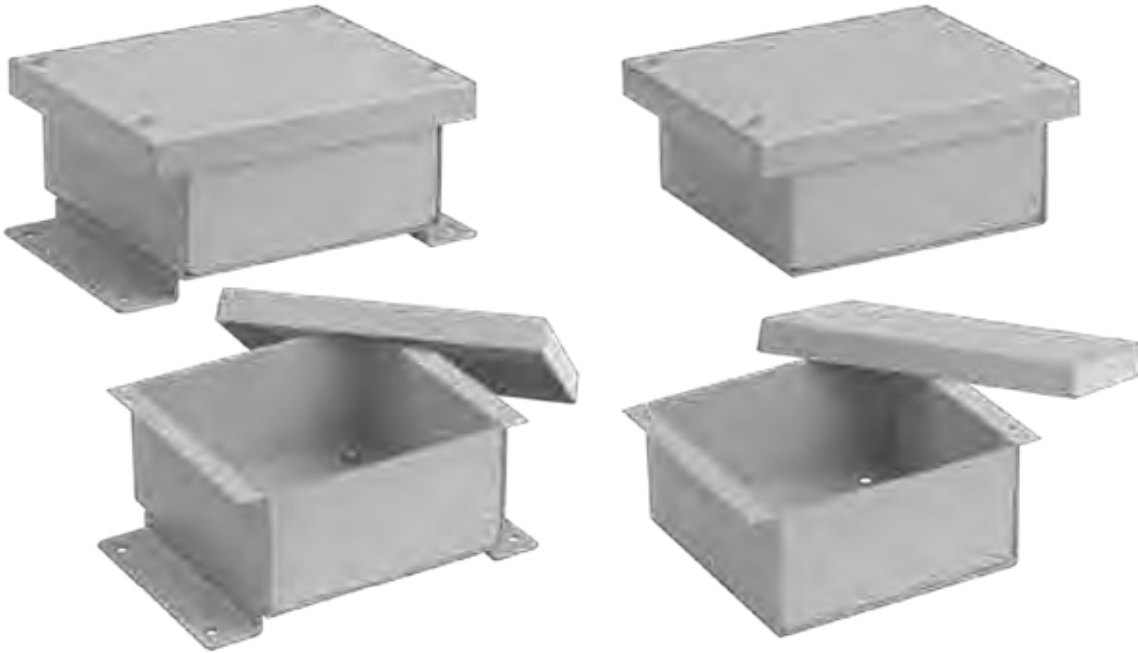
**HORIZONTAL-MOUNT, TYPE 3R**

2

**INDUSTRY STANDARDS**

Maintains Type 3R rating when mounted horizontally. Maintains Type 1 rating when mounted vertically.

UL 50, 50E Listed; Type 3R; File No. E27525  
 cUL Listed per CSA C22.2 No 94; Type 3R; File No. E27525

NEMA/EEMAC Type 3R  
 IEC 60529, IP32

**APPLICATION**

Use this enclosure as a wiring, junction or pull box for outside horizontal mounting applications such as rooftops or pads. Vertical structure for mounting is not required.

**FEATURES**

- The screw cover is the drip shield providing 3/4-in. overhang on each side for outdoor protection
- No gasketing
- Screw locations on cover are embossed
- Enclosure body flange is formed outward
- Mounting holes on back for direct mounting through the back to strut or mounting surface; vertical structure for mounting not required
- Optional mounting brackets (included) provide a 1-in. clearance off surface for protection against pooling water

**SPECIFICATIONS**

- 16 or 12 gauge galvanized steel

**FINISH**

ANSI 61 gray polyester powder paint finish inside and out over pretreated surfaces.

**ACCESSORIES**

Touch-Up Paint

**BULLETIN: A90RH**

Standard Product

Catalog Number	AxBxC in./mm	G in./mm	H in./mm	L in./mm	W in./mm
A8R84HM	8.00 x 8.00 x 4.00 203 x 203 x 102	5.50 140	5.50 140	9.83 250	8.83 213
A10R104HM	10.00 x 10.00 x 4.00 254 x 254 x 102	5.50 140	7.50 191	11.83 300	10.38 264
A12R126HM	12.00 x 12.00 x 6.00 305 x 305 x 152	5.50 140	9.50 241	13.83 351	12.38 314
A24R206HM	24.00 x 20.00 x 6.00 610 x 508 x 152	21.50 546	17.50 445	25.83 656	20.38 518

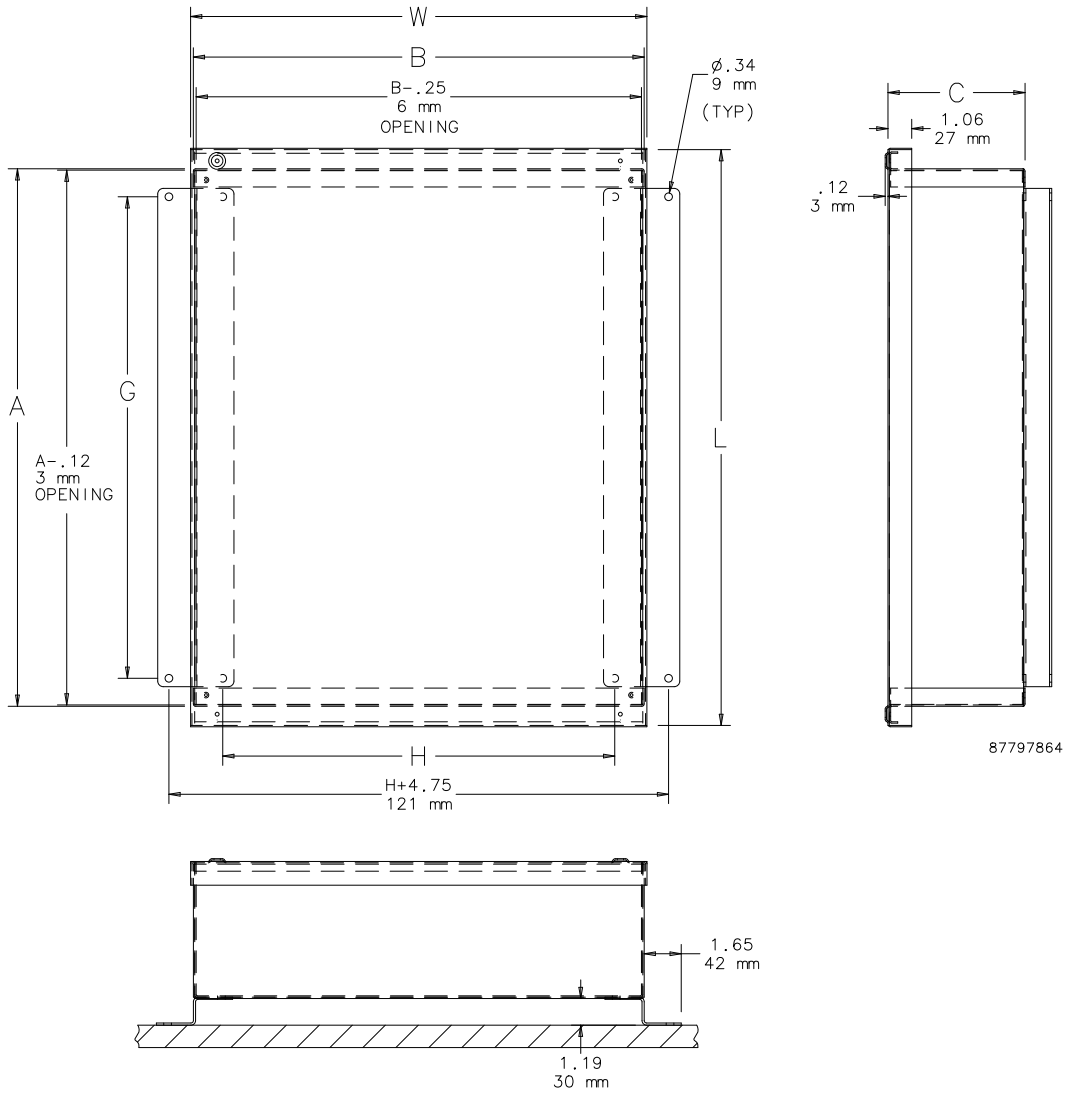

**SCREW-COVER, TYPE 3R**

2

**INDUSTRY STANDARDS**

 UL 50, 50E Listed; Type 3R; File No. E27525  
 cUL Listed per CSA C22.2 No 94; Type 3R; File No. E27525

 NEMA/EEMAC Type 3R  
 IEC 60529, IP32

**APPLICATION**

Use this enclosure with or without knockouts in outdoor applications as a wiring or junction box.

**FEATURES**

- Drip shield top and seam-free sides, front and back
- Slip-on removable cover fastened with plated steel screws along bottom edge
- Handles on larger sizes (see table)
- Embossed mounting holes on back of enclosure
- Knockouts in bottom of 16 and 14 gauge enclosures
- Provision for padlocking
- No gasketing

**SPECIFICATIONS**

- 16, 14 or 12 gauge galvanized steel

**FINISH**

ANSI 61 gray polyester powder paint finish inside and out over pretreated surfaces.

**ACCESSORIES**

See also *Accessories*.  
 Industrial Corrosion Inhibitors  
 Electric Heater  
 Grounding Device  
 Mounting Bracket Kit  
 Touch-Up Paint

**BULLETIN: A90S3**
**Standard Product**

Catalog Number	AxBxC in./mm	Body Style	D in./mm	Mounting H in./mm	Mounting J in./mm	Knockout Pattern
A4R44	4.00 x 4.00 x 4.00 102 x 102 x 102	A	—	1.88 48	2.00 51	B-C
A6R44	6.00 x 4.00 x 4.00 152 x 102 x 102	A	—	1.88 48	1.06 27	B-C
A12R44	12.00 x 4.00 x 4.00 305 x 102 x 102	A	—	1.88 48	1.06 27	B-C
A6R64	6.00 x 6.00 x 4.00 152 x 152 x 102	A	—	2.25 57	1.06 27	B-C-D
A8R64	8.00 x 6.00 x 4.00 203 x 152 x 102	A	—	2.25 57	1.06 27	B-C-D
A8R84	8.00 x 8.00 x 4.00 203 x 203 x 102	A	—	2.25 57	1.06 27	F-G-H-I
A10R84	10.00 x 8.00 x 4.00 254 x 203 x 102	A	—	2.25 57	1.06 27	F-G-H-I
A12R84	12.00 x 8.00 x 4.00 305 x 203 x 102	A	—	2.25 57	1.06 27	F-G-H-I
A10R104	10.00 x 10.00 x 4.00 254 x 254 x 102	A	—	2.25 57	1.06 27	C-D-E-F-G
A12R104	12.00 x 10.00 x 4.00 305 x 254 x 102	A	—	2.25 57	1.06 27	C-D-E-F-G
A12R124	12.00 x 12.00 x 4.00 305 x 305 x 102	A	—	2.25 57	1.06 27	C-D-E-F-G
A18R124	18.00 x 12.00 x 4.00 457 x 305 x 102	A	—	2.25 57	1.06 27	C-D-E-F-G
A18R184	18.00 x 18.00 x 4.00 457 x 457 x 102	B	—	13.00 330	1.12 28	A-B-C-D-E-F-G-H-I
A6R66	6.00 x 6.00 x 6.00 152 x 152 x 152	A	—	2.25 57	1.06 27	B-C-D
A8R86	8.00 x 8.00 x 6.00 203 x 203 x 152	A	—	2.25 57	1.06 27	F-G-H-I
A10R86	10.00 x 8.00 x 6.00 254 x 203 x 152	A	—	2.25 57	1.06 27	F-G-H-I
A10R106	10.00 x 10.00 x 6.00 254 x 254 x 152	A	—	2.25 57	1.06 27	C-D-E-F-G



Catalog Number	AxBxC in./mm	Body Style	D in./mm	Mounting H in./mm	Mounting J in./mm	Knockout Pattern
A12R86	18.00 x 8.00 x 6.00 457 x 203 x 152	A	—	2.25 57	1.06 27	F-G-H-I
A12R106	12.00 x 10.00 x 6.00 305 x 254 x 152	A	—	2.25 57	1.06 27	C-D-E-F-G
A12R126	12.00 x 12.00 x 6.00 305 x 305 x 152	A	—	2.25 57	1.06 27	C-D-E-F-G
A15R126	15.00 x 12.00 x 6.00 381 x 305 x 152	A	—	2.25 57	1.06 27	C-D-E-F-G
A16R126	16.00 x 12.00 x 6.00 406 x 305 x 152	A	—	2.25 57	1.06 27	C-D-E-F-G
A18R126	18.00 x 12.00 x 6.00 457 x 305 x 152	A	—	2.25 57	1.06 27	C-D-E-F-G
A18R186	18.00 x 18.00 x 6.00 457 x 457 x 152	B	—	13.00 330	1.12 28	A-B-C-D-E-F-G-H-I
A24R126	24.00 x 12.00 x 6.00 610 x 305 x 152	B	—	13.00 330	1.12 28	C-D-E-F-G
A24R186	24.00 x 18.00 x 6.00 610 x 457 x 152	B	—	13.00 330	1.12 28	A-B-C-D-E-F-G-H-I
A24R246	24.00 x 24.00 x 6.00 610 x 610 x 152	B	—	13.00 330	1.12 28	A-B-C-D-E-F-G-H-I
A8R88	8.00 x 8.00 x 8.00 203 x 203 x 203	A	—	2.25 57	1.06 27	F-G-H-I
A12R128	12.00 x 12.00 x 8.00 305 x 305 x 203	A	—	2.25 57	1.06 27	C-D-E-F-G
A15R128	15.00 x 12.00 x 8.00 381 x 305 x 203	A	—	2.25 57	1.06 27	C-D-E-F-G
A18R128	18.00 x 12.00 x 8.00 457 x 305 x 203	A	—	2.25 57	1.12 28	C-D-E-F-G
A24R168	24.00 x 16.00 x 8.00 610 x 406 x 203	B	—	13.00 330	1.12 28	C-D-E-F-G
A18R188	18.00 x 18.00 x 8.00 457 x 457 x 203	B	—	13.00 330	1.12 28	A-B-C-D-E-F-G-H-I
A24R188	24.00 x 18.00 x 8.00 610 x 457 x 203	B	—	13.00 330	1.12 28	A-B-C-D-E-F-G-H-I
A24R208	24.00 x 20.00 x 8.00 610 x 508 x 203	B	—	13.00 330	1.12 28	A-B-C-D-E-F-G-H-I
A24R248	24.00 x 24.00 x 8.00 610 x 610 x 203	C	12.19 310	13.00 330	1.12 28	A-B-C-D-E-F-G-H-I
A30R248	30.00 x 24.00 x 8.00 762 x 610 x 203	C	15.19 386	13.00 330	1.12 28	A-B-C-D-E-F-G-H-I
A48R368	48.00 x 36.00 x 8.00 1219 x 914 x 203	C	24.19 614	33.00 838	1.50 38	A-B-C-D-E-F-G-H-I
A18R1810	18.00 x 18.00 x 10.00 457 x 457 x 254	B	—	13.00 330	1.12 28	A-B-C-D-E-F-G-H-I
A24R1810	24.00 x 18.00 x 10.00 610 x 457 x 254	B	—	13.00 330	1.12 28	A-B-C-D-E-F-G-H-I
A24R2410	24.00 x 24.00 x 10.00 610 x 610 x 254	C	12.19 310	13.00 330	1.12 28	A-B-C-D-E-F-G-H-I
A30R2410	30.00 x 24.00 x 10.00 762 x 610 x 254	C	15.19 386	13.00 330	1.50 38	A-B-C-D-E-F-G-H-I
A24R2412	24.00 x 24.00 x 12.00 610 x 610 x 305	C	12.19 310	13.00 330	1.12 28	A-B-C-D-E-F-G-H-I
A30R3012	30.00 x 30.00 x 12.00 762 x 762 x 305	C	15.19 386	27.00 686	1.50 38	A-B-C-D-E-F-G-H-I
A36R3012	36.00 x 30.00 x 12.00 914 x 762 x 305	C	18.19 462	27.00 686	1.50 38	A-B-C-D-E-F-G-H-I
A36R3612	36.00 x 36.00 x 12.00 914 x 914 x 305	C	18.19 462	33.00 838	1.50 38	A-B-C-D-E-F-G-H-I
A30R3016	30.00 x 30.00 x 16.00 762 x 762 x 406	C	15.19 386	27.00 686	1.50 38	A-B-C-D-E-F-G-H-I
A48R3616	48.00 x 36.00 x 16.00 1219 x 914 x 406	C	24.19 614	33.00 838	1.50 38	A-B-C-D-E-F-G-H-I
A4R44NK	4.00 x 4.00 x 4.00 102 x 102 x 102	A	—	1.88 48	2.00 51	—
A6R64NK	6.00 x 6.00 x 4.00 152 x 152 x 102	A	—	2.25 57	1.06 27	—
A8R64NK	8.00 x 6.00 x 4.00 203 x 152 x 102	A	—	2.25 57	1.06 27	—
A8R84NK	8.00 x 8.00 x 4.00 203 x 203 x 102	A	—	2.25 57	1.06 27	—
A10R84NK	10.00 x 8.00 x 4.00 254 x 203 x 102	A	—	2.25 57	1.06 27	—
A12R84NK	12.00 x 8.00 x 4.00 305 x 203 x 102	A	—	2.25 57	1.06 27	—
A10R104NK	10.00 x 10.00 x 4.00 254 x 254 x 102	A	—	2.25 57	1.06 27	—
A12R104NK	12.00 x 10.00 x 4.00 305 x 254 x 102	A	—	2.25 57	1.06 27	—



Catalog Number	AxBxC in./mm	Body Style	D in./mm	Mounting H in./mm	Mounting J in./mm	Knockout Pattern
A12R124NK	12.00 x 12.00 x 4.00 305 x 305 x 102	A	— —	2.25 57	1.06 27	—
A18R184NK	18.00 x 18.00 x 4.00 457 x 457 x 102	B	— —	13.00 330	1.12 28	—
A6R66NK	6.00 x 6.00 x 6.00 152 x 152 x 152	A	— —	2.25 57	1.06 27	—
A18R66NK	18.00 x 6.00 x 6.00 457 x 152 x 152	A	— —	2.25 57	1.06 27	—
A8R86NK	8.00 x 8.00 x 6.00 203 x 203 x 152	A	— —	2.25 57	1.06 27	—
A10R86NK	10.00 x 8.00 x 6.00 254 x 203 x 152	A	— —	2.25 57	1.06 27	—
A10R106NK	10.00 x 10.00 x 6.00 254 x 254 x 152	A	— —	2.25 57	1.06 27	—
A12R106NK	12.00 x 10.00 x 6.00 305 x 254 x 152	A	— —	2.25 57	1.06 27	—
A12R126NK	12.00 x 12.00 x 6.00 305 x 305 x 152	A	— —	2.25 57	1.06 27	—
A15R126NK	15.00 x 12.00 x 6.00 381 x 305 x 152	A	— —	2.25 57	1.06 27	—
A16R126NK	16.00 x 12.00 x 6.00 406 x 305 x 152	A	— —	2.25 57	1.06 27	—
A18R126NK	18.00 x 12.00 x 6.00 457 x 305 x 152	A	— —	2.25 57	1.06 27	—
A18R186NK	18.00 x 18.00 x 6.00 457 x 457 x 152	B	— —	13.00 330	1.12 28	—
A24R186NK	24.00 x 18.00 x 6.00 610 x 457 x 152	B	— —	13.00 330	1.12 28	—
A24R246NK	24.00 x 24.00 x 6.00 610 x 610 x 152	B	— —	13.00 330	1.12 28	—
A8R88NK	8.00 x 8.00 x 8.00 203 x 203 x 203	A	— —	2.25 1.06	1.06 27	—
A24R88NK	24.00 x 8.00 x 8.00 610 x 203 x 203	A	— —	2.25 1.06	1.06 27	—
A12R128NK	12.00 x 12.00 x 8.00 305 x 305 x 203	A	— —	2.25 57	1.06 27	—
A15R128NK	15.00 x 12.00 x 8.00 381 x 305 x 203	A	— —	2.25 57	1.06 27	—
A18R128NK	18.00 x 12.00 x 8.00 457 x 305 x 203	A	— —	2.25 57	1.12 28	—
A18R188NK	18.00 x 18.00 x 8.00 457 x 457 x 203	B	— —	13.00 330	1.12 28	—
A24R188NK	24.00 x 18.00 x 8.00 610 x 457 x 203	B	— —	13.00 330	1.12 28	—
A24R208NK	24.00 x 20.00 x 8.00 610 x 508 x 203	B	— —	13.00 330	1.12 28	—
A24R248NK	24.00 x 24.00 x 8.00 610 x 610 x 203	C	12.19 310	13.00 330	1.12 28	—
A30R248NK	30.00 x 24.00 x 8.00 762 x 610 x 203	C	15.19 386	13.00 330	1.12 28	—
A48R368NK	48.00 x 36.00 x 8.00 1219 x 914 x 203	C	24.19 614	33.00 838	1.50 38	—
A24R2410NK	24.00 x 24.00 x 10.00 610 x 610 x 254	C	12.19 310	13.00 330	1.12 28	—
A24R2412NK	24.00 x 24.00 x 12.00 610 x 610 x 305	C	12.19 310	13.00 330	1.12 28	—
A30R3012NK	30.00 x 30.00 x 12.00 762 x 762 x 305	C	15.19 386	27.00 686	1.50 38	—
A36R3012NK	36.00 x 30.00 x 12.00 914 x 762 x 305	C	18.19 462	27.00 686	1.50 38	—
A36R3612NK	36.00 x 36.00 x 12.00 914 x 914 x 305	C	18.19 462	33.00 838	1.50 38	—
A30R3016NK	30.00 x 30.00 x 16.00 762 x 762 x 406	C	15.19 386	27.00 686	1.50 38	—
A48R3616NK	48.00 x 36.00 x 16.00 1219 x 915 x 406	C	24.19 614	33.00 838	1.50 38	—

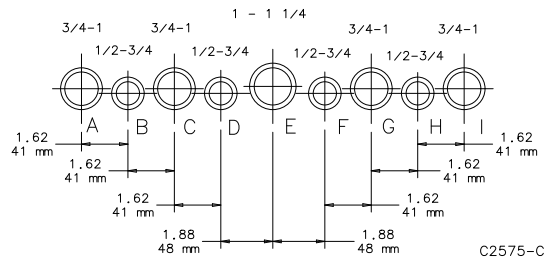
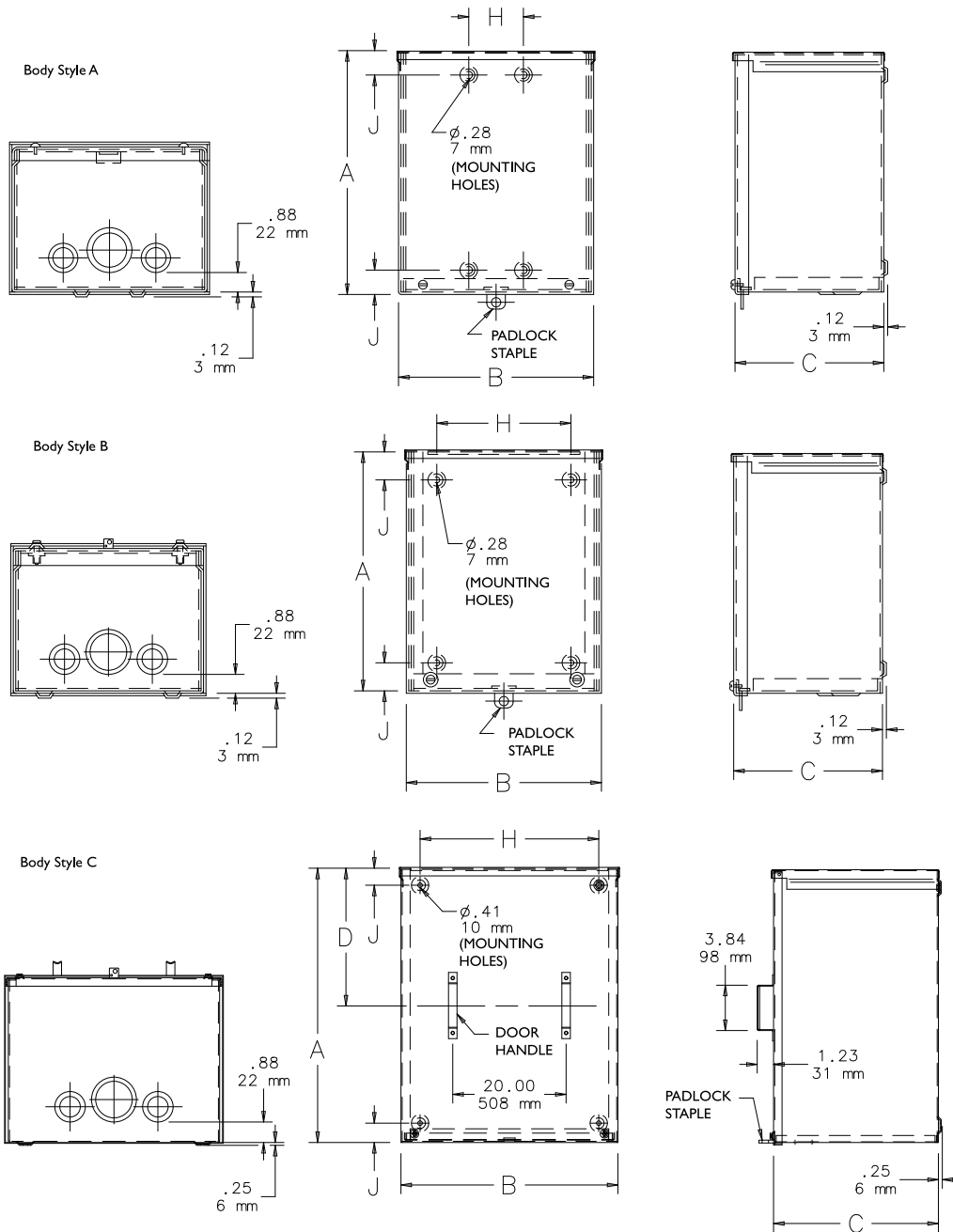

**SCREW-COVER GALVANIZED, TYPE 3R**

2

**INDUSTRY STANDARDS**

 UL50, 50E Listed; Type 3R; File No. E27525  
 cUL Listed per CSA C22.2 No 94; Type 3R; File No. E27525

 NEMA/EEMAC Type 3R  
 IEC 60529, IP32

**Standard Product**

Catalog Number	AxBxC in./mm	Body Style	D in./mm	Mounting H in./mm	Mounting J in./mm	Knockout Pattern
A4R44GV	4.00 x 4.00 x 4.00	A	—	1.88	2.00	B-C
	102 x 102 x 120		—	48	51	
A6R64GV	6.00 x 6.00 x 4.00	A	—	1.8	1.06	B-C-D
	152 x 152 x 102		—	48	27	
A8R84GV	8.00 x 8.00 x 4.00	A	—	2.25	1.06	B-C-D
	203 x 203 x 102		—	57	27	
A10R104GV	10.00 x 10.00 x 4.00	A	—	2.25	1.06	C-D-E-F-G
	254 x 254 x 102		—	57	27	
A12R124GV	12.00 x 12.00 x 4.00	A	—	2.25	1.06	C-D-E-F-G
	305 x 305 x 102		—	57	27	
A6R66GV	6.00 x 6.00 x 6.00	A	—	2.25	1.06	B-C-D
	152 x 152 x 152		—	57	27	
A8R86GV	8.00 x 8.00 x 6.00	A	—	2.25	1.06	F-G-H-I
	203 x 203 x 152		—	57	27	
A10R106GV	10.00 x 10.00 x 6.00	A	—	2.25	1.06	C-D-E-F-G
	254 x 254 x 152		—	27	27	
A12R126GV	12.00 x 12.00 x 6.00	A	—	2.25	1.06	C-D-E-F-G
	305 x 305 x 152		—	27	27	
A18R186GV	18.00 x 18.00 x 6.00	B	—	13.00	1.12	A-B-C-D-E-F-G-H-I
	457 x 457 x 152		—	330	28	
A8R88GV	8.00 x 8.00 x 8.00	A	—	2.25	1.06	F-G-H-I
	203 x 203 x 203		—	57	27	
A8R88GVNKC	8.00 x 8.00 x 8.00	A	—	2.25	1.06	—
	203 x 203 x 203		—	57	27	
A10R108GVNKC	10.00 x 10.00 x 8.00	A	—	2.25	1.06	—
	254 x 254 x 203		—	57	27	
A12R128GV	12.00 x 12.00 x 8.00	A	—	2.25	1.06	C-D-E-F-G
	305 x 305 x 203		—	57	27	
A24R248GV	24.00 x 24.00 x 8.00	C	12.19	13.00	1.12	A-B-C-D-E-F-G-H-I
	610 x 610 x 203		310	330	28	
A24R2410GV	24.00 x 24.00 x 10.00	C	12.19	13.00	1.12	A-B-C-D-E-F-G-H-I
	610 x 610 x 254		310	330	28	

**APPLICATION**

Use this enclosure as a wiring or junction box to protect controls in outdoor applications requiring galvanized steel.

**FEATURES**

- Drip-shield top and seam-free sides, front and back
- Slip-on removable cover fastened with plated steel screws along bottom edge
- Door handles on larger sides (body style C; see table)
- Embossed mounting holes on back of enclosure
- See table for knockout pattern
- Provision for padlocking
- No gasketing

**SPECIFICATIONS**

- 16 or 14 gauge galvanized steel

**FINISH**

Unpainted galvanized steel

**ACCESSORIES**

 See also *Accessories*.

Industrial Corrosion Inhibitors

Electric Heater

Grounding Device

Mounting Bracket Kit

**BULLETIN: A90G3**

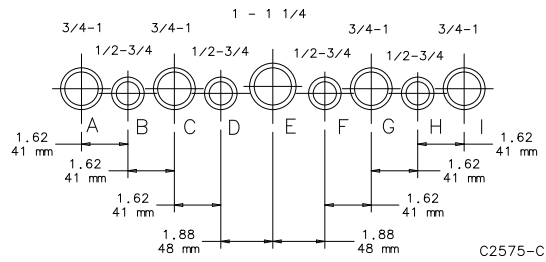
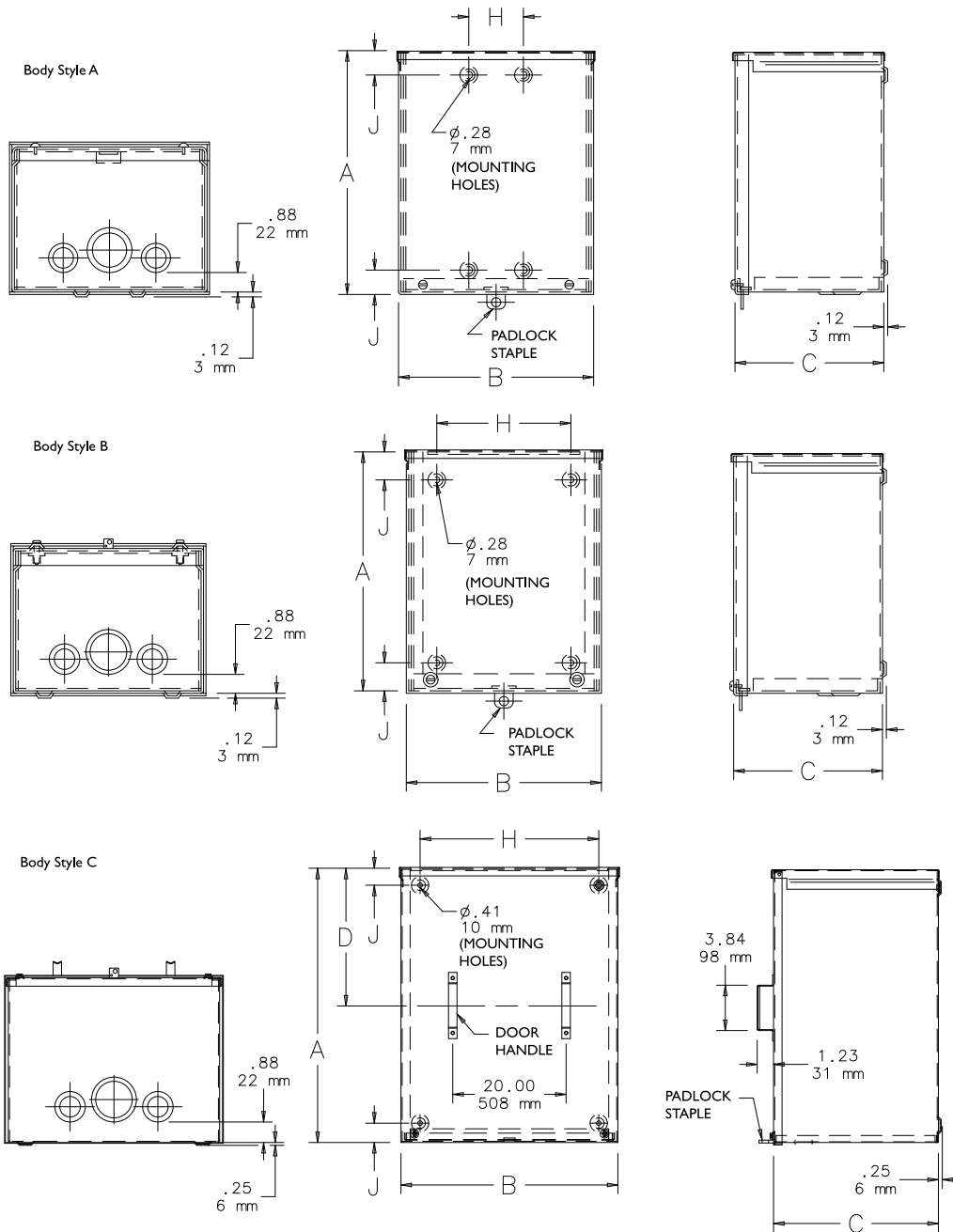

**HINGE-COVER, SMALL, TYPE 3R**



2

**INDUSTRY STANDARDS**

UL 50, 50E Listed; Type 3R; File No. E27567  
 cUL Listed per CSA C22.2 No 94; Type 3R File No. E27567

NEMA/EEMAC Type 3R  
 IEC 60529, IP32

**APPLICATION**

These enclosures have a size range of 6 x 4 x 4-in. to 12 x 12 x 10-in. and meet basic functionality requirements for applications that require protection from rain, sleet, snow or dripping water.

**FEATURES**

- Drip-shield top and seam-free sides, front and back
- Plated steel hinge has stainless steel pin
- Weldnuts provided for mounting optional panels
- Provisions for padlocking on zinc-plated draw-pull catch
- Knockouts on bottom of enclosure
- No gasketing

**SPECIFICATIONS**

- 16 gauge galvanized steel

**FINISH**

ANSI 61 gray polyester powder paint finish inside and out over galvanized steel. Optional solid panels are white and optional perforated panels are gray.

**ACCESSORIES**

See also *Accessories*.  
 Industrial Corrosion Inhibitors  
 Grounding Device  
 Panels for Type 1 Enclosures and Small Type 3R Enclosures  
 Touch-Up Paint

**BULLETIN: A3SM**

Standard Product

Catalog Number	AxBxC in./mm	Panel	Perforated Panel	Panel Size D x E in./mm	Mounting G in./mm	Overall L x W in./mm	Knockout Pattern
A6R44HCR	6.00 x 4.00 x 4.00 152 x 102 x 102	A6N4P	A6N4PP	4.25 x 2.25 108 x 57	7.00 178	8.00 x 4.81 203 x 122	B-C-D
A6R64HCR	6.00 x 6.00 x 4.00 152 x 152 x 102	A6N6P	A6N6PP	4.25 x 4.25 108 x 108	7.00 178	8.00 x 6.81 203 x 173	B-C-D
A8R64HCR	8.00 x 6.00 x 4.00 203 x 152 x 102	A8N6P	A8N6PP	6.25 x 4.25 159 x 108	9.00 229	10.00 x 6.81 254 x 173	B-C-D
A8R86HCR	8.00 x 8.00 x 6.00 203 x 203 x 152	A8N8P	A8N8PP	6.25 x 6.25 159 x 159	9.00 229	10.00 x 8.81 254 x 224	F-G-H-I
A10R86HCR	10.00 x 8.00 x 6.00 254 x 203 x 152	A10N8P	A10N8PP	8.25 x 6.25 210 x 159	11.0 279	12.00 x 8.81 305 x 224	F-G-H-I
A12R106HCR	12.00 x 10.00 x 6.00 305 x 254 x 152	A12N10P	A12N10PP	10.25 x 8.25 260 x 210	13.0 330	14.00 x 10.81 356 x 275	C-D-E-F-G
A12R126HCR	12.00 x 12.00 x 6.00 305 x 305 x 152	A12N12P	A12N12PP	10.25 x 10.25 260 x 260	13.0 330	14.00 x 12.81 356 x 325	C-D-E-F-G
A12R1210HCR	12.00 x 12.00 x 10.00 305 x 305 x 254	A12N12P	A12N12PP	10.25 x 10.25 260 x 260	13.00 330	14.00 x 12.81 356 x 325	C-D-E-F-G

Purchase panels separately.

Purchase perforated panels separately.

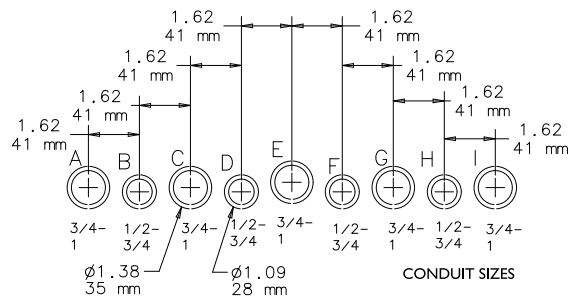
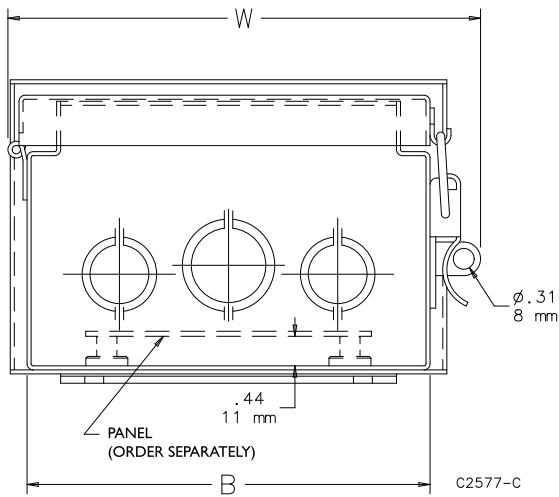
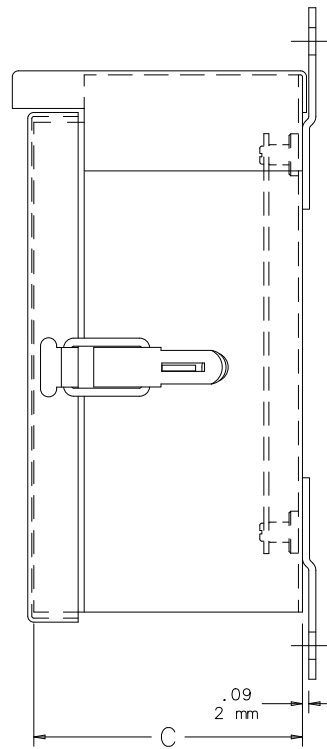
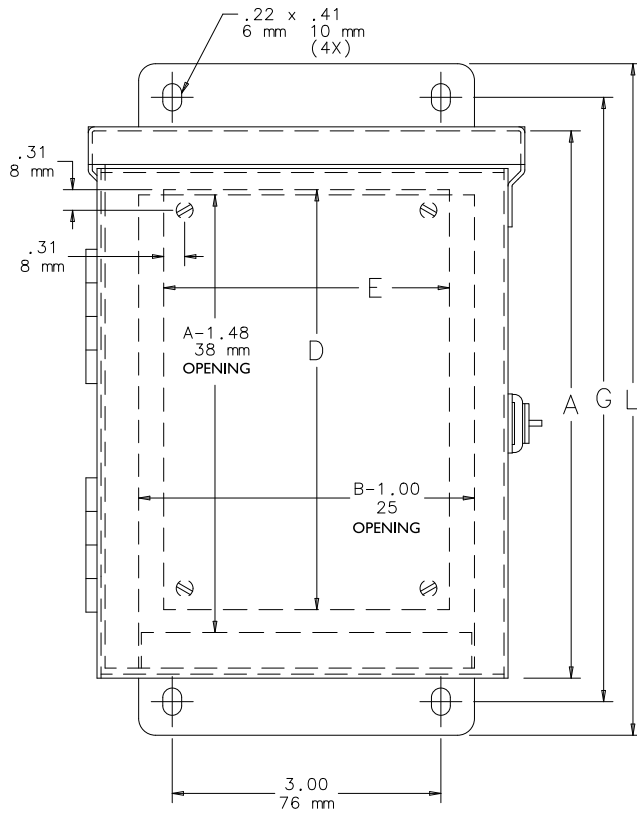

**Knockout Pattern**  
(from outside of box)

NOTE: Refer to table for applicable knockout pattern.



HINGE-COVER, MEDIUM, TYPE 3R



**APPLICATION**

These enclosures have a size range of 16 x 12 x 6-in. to 48 x 36 x 16-in. and meet basic functionality requirements for applications that require protection from rain, sleet, snow or dripping water.

**FEATURES**

- Drip shield top and seam-free sides, front, and back protect from rain, snow, or sleet
- 16 gauge plated steel continuous hinge has stainless steel pin
- Cover fastened securely with captive plated steel screws
- Collar studs provided for mounting optional panels
- Hasp and staple provided for padlocking
- No gasketing or knockouts

**SPECIFICATIONS**

- 16 or 14 gauge galvanized steel

**FINISH**

ANSI 61 gray polyester powder paint finish inside and out over galvanized steel. Optional solid panels are white.

**ACCESSORIES**

See also *Accessories*.

- Industrial Corrosion Inhibitors
- Electric Heater
- Grounding Device
- Panel Support Kit
- Panels for Type 3R, 4, 4X, 12 and 13 Enclosures
- Rack Mounting Angles - U Style (Type RA)
- Terminal Block Kit Assembly for Junction Boxes Overview
- Touch-Up Paint
- Steel and Stainless Steel Window Kits

**BULLETIN: A3M**

**INDUSTRY STANDARDS**

UL 50, 50E Listed; Type 3R; File No. E27567  
 cUL Listed per CSA C22.2 No 94; Type 3R File No. E27567

NEMA/EEMAC Type 3R  
 IEC 60529, IP32

Standard Product

Catalog Number	AxBxC in.	AxBxC mm	Panel	Perforated Panel	Panel Size D x E (in.)	Panel Size D x E (mm)	Mounting G x H (in.)	Mounting G x H (mm)	Overall L (in.)	Overall L (mm)
A16R126HCR	16.00 x 12.00 x 6.00	406 x 305 x 152	A16P12	A16P12PP	13.00 x 9.00	330 x 229	17.00 x 3.00	432 x 76	18.00	457
A16R166HCR	16.00 x 16.00 x 6.00	406 x 406 x 152	A16P16	A16P16PP	13.00 x 13.00	330 x 330	17.00 x 13.00	432 x 330	18.00	457
A18R186HCR	18.00 x 18.00 x 6.00	457 x 457 x 152	A18P18	A18P18PP	15.00 x 15.00	381 x 381	19.00 x 13.00	483 x 330	20.00	508
A20R166HCR	20.00 x 16.00 x 6.00	508 x 406 x 152	A20P16	A20P16PP	17.00 x 13.00	432 x 330	21.00 x 13.00	533 x 330	22.00	559
A20R208HCR	20.00 x 20.00 x 8.00	508 x 508 x 203	A20P20	A20P20PP	17.00 x 17.00	432 x 432	21.00 x 13.00	533 x 330	22.00	559
A24R208HCR	24.00 x 20.00 x 8.00	610 x 508 x 203	A24P20	A24P20PP	21.00 x 17.00	533 x 432	25.00 x 13.00	635 x 330	26.00	660
A24R248HCR	24.00 x 24.00 x 8.00	610 x 610 x 203	A24P24	A24P24PP	21.00 x 21.00	533 x 533	25.00 x 13.00	635 x 330	26.00	660
A30R248HCR	30.00 x 24.00 x 8.00	762 x 610 x 203	A30P24	A30P24PP	27.00 x 21.00	686 x 533	31.00 x 13.00	787 x 330	32.00	813
A18R1810HCR	18.00 x 18.00 x 10.00	457 x 457 x 254	A18P18	A18P18PP	15.00 x 15.00	381 x 381	19.00 x 13.00	483 x 330	20.00	508
A30R308HCR	30.00 x 30.00 x 8.00	762 x 762 x 203	A30P30	A30P30PP	27.00 x 27.00	686 x 686	31.00 x 27.00	787 x 686	32.00	813
A24R2410HCR	24.00 x 24.00 x 10.00	610 x 610 x 254	A24P24	A24P24PP	21.00 x 21.00	533 x 533	25.00 x 13.00	635 x 330	26.00	660
A30R2410HCR	30.00 x 24.00 x 10.00	762 x 610 x 254	A30P24	A30P24PP	27.00 x 21.00	686 x 533	31.00 x 13.00	787 x 330	32.00	813
A36R3610HCR	36.00 x 36.00 x 10.00	914 x 914 x 254	A36P36	A36P36PP	33.00 x 33.00	838 x 838	37.00 x 30.00	940 x 762	38.00	965
A30R3012HCR	30.00 x 30.00 x 12.00	762 x 762 x 305	A30P30	A30P30PP	27.00 x 27.00	686 x 686	31.00 x 27.00	787 x 686	32.00	813
A36R2412HCR	36.00 x 24.00 x 12.00	914 x 610 x 305	A36P24	A36P24PP	33.00 x 21.00	838 x 533	37.00 x 13.00	940 x 330	38.00	965
A36R3012HCR	36.00 x 30.00 x 12.00	914 x 762 x 305	A36P30	A36P30PP	33.00 x 27.00	838 x 686	37.00 x 27.00	940 x 686	38.00	965
A42R3012HCR	42.00 x 30.00 x 12.00	1067 x 914 x 305	A42P30	—	39.00 x 27.00	991 x 686	43.00 x 27.00	1092 x 686	44.00	1118
A36R3612HCR	36.00 x 36.00 x 12.00	914 x 914 x 305	A36P36	A36P36PP	33.00 x 33.00	838 x 838	37.00 x 27.00	940 x 686	38.00	965
A42R3612HCR	42.00 x 36.00 x 12.00	1067 x 914 x 305	A42P36	—	39.00 x 33.00	991 x 838	43.00 x 27.00	1092 x 686	44.00	1118
A48R3612HCR	48.00 x 36.00 x 12.00	1219 x 914 x 305	A48P36	—	45.00 x 33.00	1143 x 838	49.00 x 27.00	1245 x 686	50.00	1270
A60R3612HCR	60.00 x 36.00 x 12.00	1524 x 914 x 305	A60P36	—	57.00 x 33.00	1448 x 838	61.00 x 27.00	1549 x 686	62.00	1575
A30R3016HCR	30.00 x 30.00 x 16.00	762 x 762 x 406	A30P30	A30P30PP	27.00 x 27.00	686 x 686	31.00 x 27.00	787 x 686	32.00	813
A48R3616HCR	48.00 x 36.00 x 16.00	1219 x 914 x 406	A48P36	—	45.00 x 33.00	1143 x 838	49.00 x 27.00	1245 x 686	50.00	1270

Purchase panels separately. Optional aluminum panels are available for most sizes.

Purchase perforated panels separately.

Flanged on all four sides.



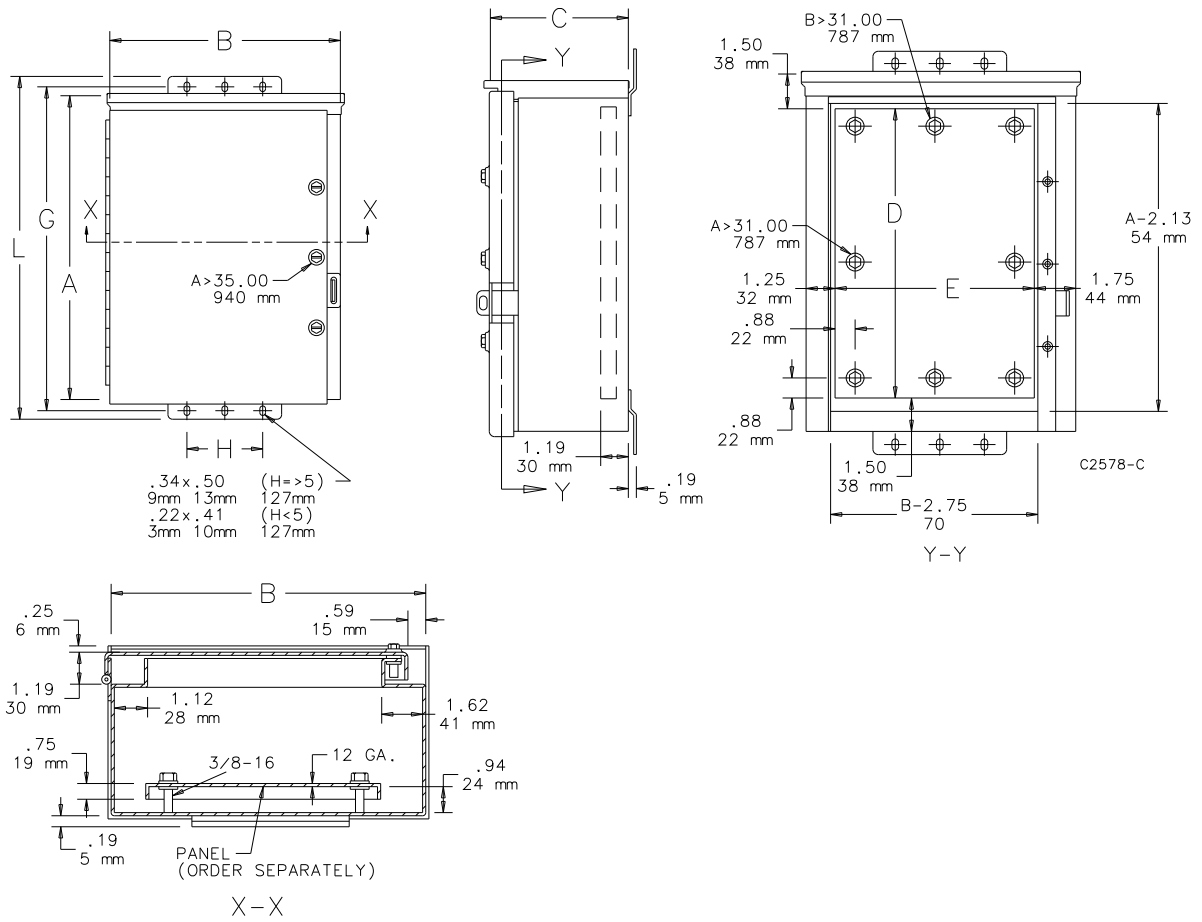

**HINGE-COVER LIFT-OFF, TYPE 3R**

**APPLICATION**

Featuring a removable cover for easy mounting and access, these enclosures protect components in applications subject to rain, sleet, snow or dripping water.

**FEATURES**

- Drip-shield top and seam-free sides, front and back
- Galvanized steel lift-off hinges with stainless steel pins
- Provisions for padlocking on each draw pull catch
- Embossed mounting holes on back of enclosure
- Gasketing along top of door
- No knockouts

**SPECIFICATIONS**

- 16 or 14 gauge galvanized steel
- 16 gauge cover fastened securely with draw pull catch

**FINISH**

ANSI 61 gray polyester powder paint finish inside and out over galvanized steel. Optional panels are white.

**ACCESSORIES**

See also *Accessories*.

Industrial Corrosion Inhibitors

Electric Heater

Grounding Device

Mounting Bracket Kit

Panel Mounting Kit

Panel Support Kit

Panels for Type 3R, 4, 4X, 12 and 13 Enclosures

Junction Box and Wall-Mount Enclosure Swing Out Panel Kit

Terminal Block Kit Assembly for Junction Boxes Overview

Touch-Up Paint

Steel and Stainless Steel Window Kits

**BULLETIN: A3LO**

**INDUSTRY STANDARDS**

UL 50, 50E Listed; Type 3R; File No. E27567  
 cUL Listed per CSA C22.2 No 94; Type 3R File No. E27567

NEMA/EEMAC Type 3R  
 CSA, File 42184: Type 3R  
 IEC 60529, IP32

## Standard Product

Catalog Number	AxBxC in./mm	Body Gauge	Panel <sup>a</sup>	Panel Size D x E in./mm	Mounting G in./mm	Overall L x W in./mm	Panel Mounting Kit <sup>b</sup>	Mounting Bracket Kit <sup>b</sup>	Bracket Gauge	Overall Width of Bracket in./mm	Hole Spacing For Bracket in./mm
A8R64HCL0	8.00 x 6.00 x 4.00 203 x 152 x 102	16	A6P6	4.88 x 4.88 124 x 124	9.12 232	10.12 x 7.25 257 x 184	APMK3RL016	AMFK3RL016	14	5.00 127	4.00 102
A8R86HCL0	8.00 x 8.00 x 6.00 203 x 203 x 152	16	A8P6	6.75 x 4.88 171 x 124	9.12 232	10.12 x 9.25 257 x 235	APMK3RL016	AMFK3RL016	14	5.00 127	4.00 102
A10R86HCL0	10.00 x 8.00 x 6.00 254 x 203 x 152	16	A8P8	6.75 x 6.88 171 x 175	11.12 282	12.12 x 9.25 308 x 235	APMK3RL016	APMK3RL016	14	5.00 127	4.00 102
A12R106HCL0	12.00 x 10.00 x 6.00 305 x 254 x 152	16	A10P10	8.75 x 8.88 222 x 226	13.12 333	14.12 x 11.25 359 x 286	APMK3RL016	AMFK3RL016	14	5.00 127	4.00 102
A12R126HCL0	12.00 x 12.00 x 6.00 305 x 305 x 152	16	A12P10	10.75 x 8.88 273 x 226	13.12 333	14.12 x 13.25 359 x 337	APMK3RL016	AMFK3RL016	14	5.00 127	4.00 102
A16R126HCL0	16.00 x 12.00 x 6.00 406 x 305 x 152	16	A14P12	12.75 x 10.88 324 x 276	17.12 435	18.12 x 13.25 460 x 337	APMK3RL016	AMFK3RL016	14	5.00 127	4.00 102
A16R166HCL0	16.00 x 16.00 x 6.00 406 x 406 x 152	16	A16P16	13.00 x 13.00 330 x 330	17.31 440	18.31 x 17.25 465 x 438	APMK3RL014	AMFK3RL014	12	14.00 356	13.00 330
A20R166HCL0	20.00 x 16.00 x 6.00 508 x 406 x 152	16	A20P16	17.00 x 13.00 432 x 330	21.31 541	22.31 x 17.25 567 x 438	APMK3RL014	AMFK3RL014	12	14.00 356	13.00 330
A20R208HCL0	20.00 x 20.00 x 8.00 508 x 508 x 203	14	A20P20	17.00 x 17.00 432 x 432	21.31 541	22.31 x 21.25 567 x 540	APMK3RL014	AMFK3RL014	12	14.00 356	13.00 330
A24R208HCL0	24.00 x 20.00 x 8.00 610 x 508 x 203	14	A24P20	21.00 x 17.00 533 x 432	25.31 643	26.31 x 21.25 668 x 540	APMK3RL014	AMFK3RL014	12	14.00 356	13.00 330
A24R248HCL0	24.00 x 24.00 x 8.00 610 x 610 x 203	14	A24P24	21.00 x 21.00 533 x 533	25.31 643	26.31 x 25.25 668 x 641	APMK3RL014	AMFK3RL014	12	14.00 356	13.00 330
A30R248HCL0	30.00 x 24.00 x 8.00 762 x 610 x 203	14	A30P24	27.00 x 21.00 686 x 533	31.31 795	32.31 x 25.25 821 x 641	APMK3RL014	AMFK3RL014	12	14.00 356	13.00 330

<sup>a</sup> Purchase panels separately.

<sup>b</sup> Panel Mounting Kit and Mounting Bracket Kit must be ordered separately. (A Panel Mounting Kit must be ordered to install panel.)

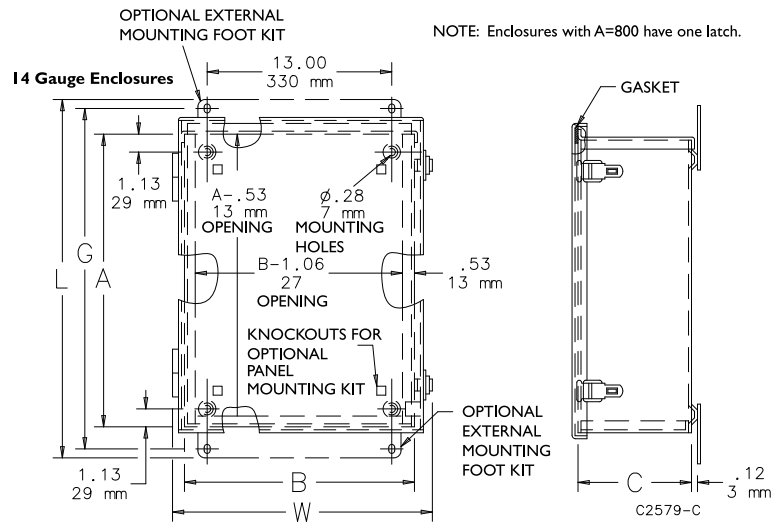
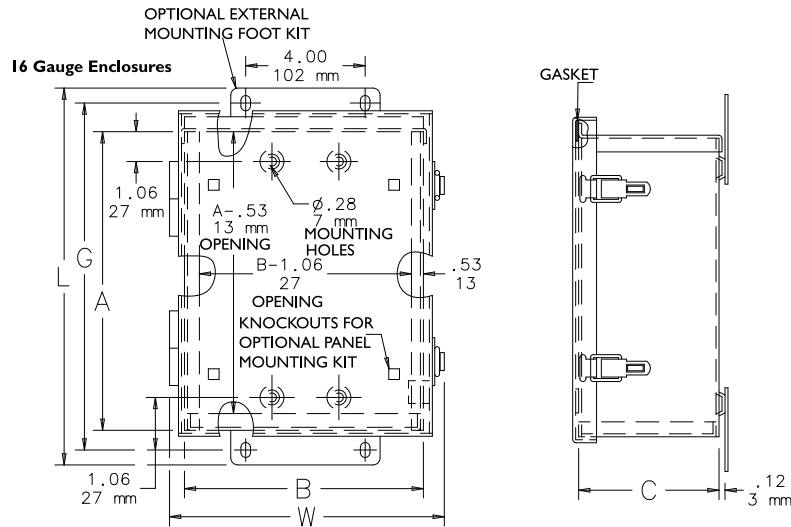

**PANEL MOUNTING KIT**

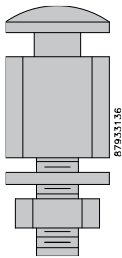

A panel mounting kit (order separately) is required in order to install a panel.

**BULLETIN: A3LO**

Catalog Number	Description
APMK3RL014	Required to install panel
APMK3RL016	Required to install panel

**MOUNTING BRACKET KIT**

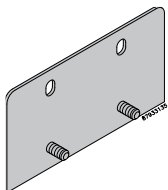

Optional external mounting bracket kit available for installing enclosure (order separately).

**BULLETIN: A3LO**

Catalog Number	Foot Gauge	Overall Bracket Width in./mm	Hole Spacing for Bracket in./mm
AMFK3RL014	12	14.00 356	13.00 330
AMFK3RL016	14	5.00 127	4.00 102



**WEATHERPRO™ OUTDOOR PAD MOUNT, TYPE 3R**

2

**INDUSTRY STANDARDS**

UL 508A Listed; Type 3R; File No. E61997 cUL/CSA C22.2 No. 94 Listed; Type 3R; File No. E61997
---

NEMA/EEMAC Type 3R  
IEC 60529, IP32

**APPLICATION**

WEATHERPRO™ Outdoor Pad Mount Enclosures protect controls, drives, power distribution components or contactors in outdoor commercial or industrial power distribution and control applications. The overlapping two-door models with no center post allow full-width access to enclosure interior.

**FEATURES**

- 3-point latching system with heavy duty handle
- Padlock provision in handle
- Open bottom with pre-punched mounting hole flange
- Drip edge overhang on top
- Louvered overhang with a closure plate
- Studs included for mounting optional panels on threaded bolts
- Welded body construction
- Sturdy 7 gauge lifting tabs
- Overlapping doors with no center post on two-door models
- Bonding provision on each door
- Bolted hinges on doors

**SPECIFICATIONS**

- 14 gauge galvanized steel

**FINISH**

RAL 7035 light-gray polyester powder paint inside and outside. Optional panels are white.

**ACCESSORIES**

*See also Accessories.*

- Fan Shroud Kits
- 19-in. Fixed Wall-Mount Rack
- 19-in. Hinged Wall-Mount Panel
- Insect Screens

**MODIFICATION AND CUSTOMIZATION**

Hoffman excels at modifying and customizing products to your specifications. Contact your local Hoffman sales office or distributor for complete information.

**BULLETIN: A3PM**

Standard Product **WEATHERPRO Outdoor Pad-Mount Type 3R Single Door Enclosures**

Catalog Number	AxBxC in./mm	Panel	Panel Size D x E in./mm	Mounting Dimensions F x G in./mm
A60R2518FSLP	60.00 x 25.00 x 18.00 1524 x 635 x 457	A49P21N	49.16 x 21.50 1249 x 546	4.90 x 7.40 124 x 188
A60R2524FSLP	60.00 x 25.00 x 24.00 1524 x 635 x 610	A49P21N	49.16 x 21.50 1249 x 546	7.90 x 7.40 201 x 188
A72R2518FSLP	72.00 x 25.00 x 18.00 1829 x 635 x 457	A61P21N	61.16 x 21.50 1553 x 546	4.90 x 7.40 124 x 188
A60R3618FSLP	60.00 x 36.00 x 18.00 1524 x 914 x 457	A49P32N	49.16 x 32.00 1249 x 813	4.90 x 12.90 124 x 328
A72R3618FSLP	72.00 x 36.00 x 18.00 1829 x 914 x 457	A61P32N	61.16 x 32.00 1553 x 813	4.90 x 12.90 124 x 328
A72R3624FSLP	72.00 x 36.00 x 24.00 1829 x 914 x 610	A61P32N	61.16 x 32.00 1553 x 813	7.90 x 12.90 201 x 328

Purchase panels separately.

Single Door Enclosures

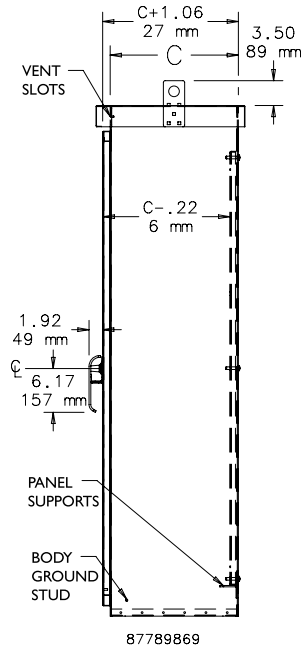
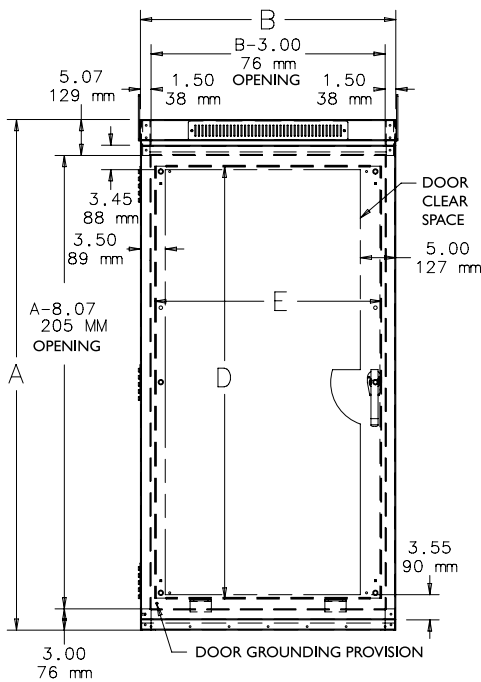
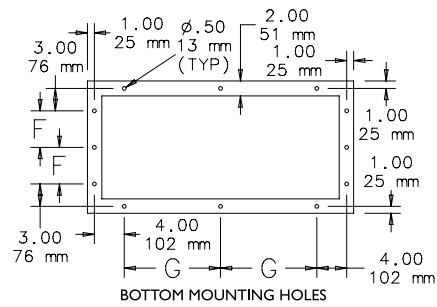
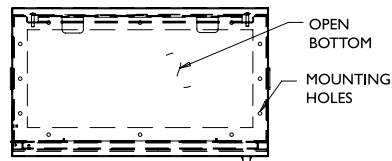

Standard Product WEATHERPRO Outdoor Pad-Mount Type 3R Two-Door Enclosures

Catalog Number	AxBxC in./mm	Panel	Panel Size D x E in./mm	Mounting Dimensions F x G in./mm
A60R5218FSLP	60.00 x 52.00 x 18.00 1524 x 1321 x 457	A49P48N	49.16 x 48.00 1249 x 1219	4.90 x 20.90 124 x 531
A60R5224FSLP	60.00 x 52.00 x 24.00 1524 x 1321 x 610	A49P48N	49.16 x 48.00 1249 x 1219	7.90 x 20.90 201 x 531
A60R7224FSLP	60.00 x 72.00 x 24.00 1524 x 1829 x 610	A49P68N	49.16 x 68.00 1249 x 1727	7.90 x 30.90 201 x 785
A72R7218FSLP	72.00 x 72.00 x 18.00 1829 x 1829 x 457	A61P68N	61.16 x 68.00 1553 x 1727	4.90 x 30.90 124 x 785
A72R7224FSLP	72.00 x 72.00 x 24.00 1829 x 18290 x 610	A61P68N	61.16 x 68.00 1553 x 1727	7.90 x 30.90 201 x 785

Purchase panels separately.

Two-Door Enclosures

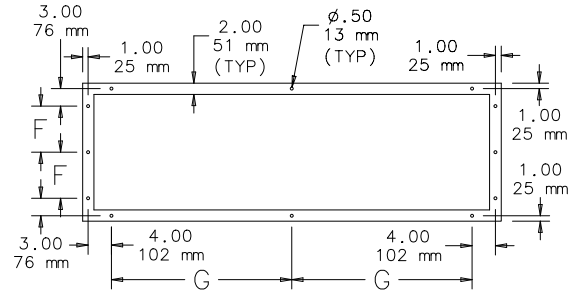
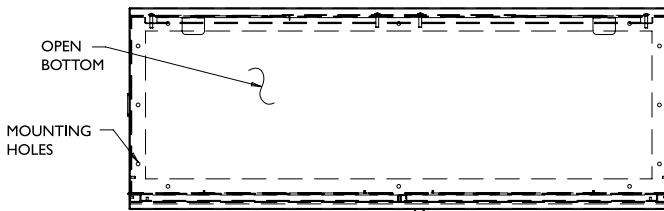

BOTTOM MOUNTING HOLES

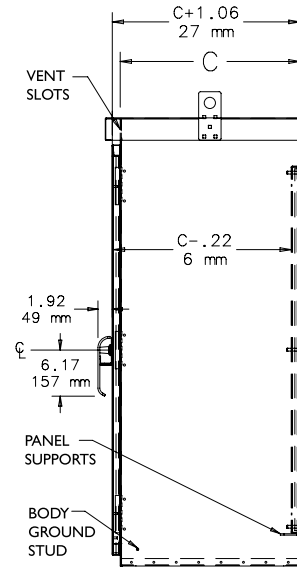
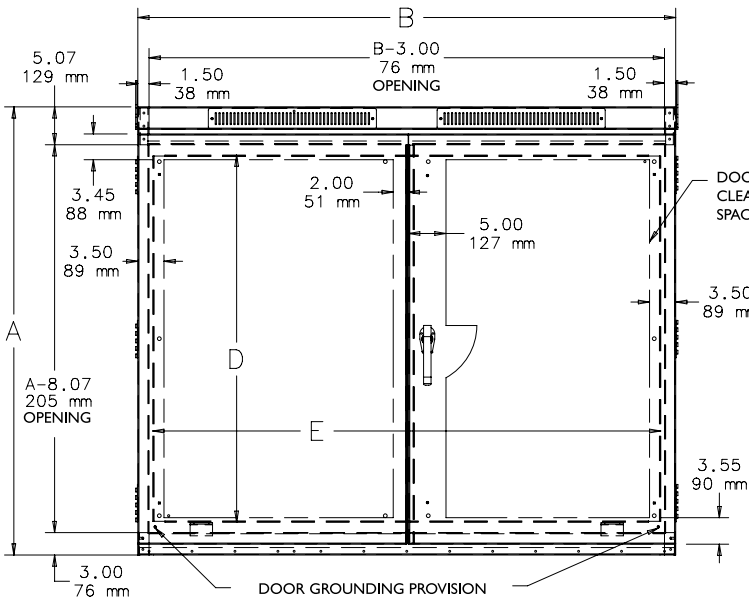

87789871



**19-IN. HINGED WALL-MOUNT PANEL**



**INDUSTRY STANDARDS**

UL 1863 Listed; File No. E230874  
 cUL Listed per CSA C22.2 No. 182.4; File No. E230874

EIA 310-D

**APPLICATION**

The 19-in. Hinged Panel provides a solution for smaller network equipment, punch-downs and patch panels in areas where floor space is at a premium. Easy access facilitates component installation and future expansion without disturbing existing equipment or cabling. Can be mounted with hinges on left or right side.

**FEATURES**

- Open design offers unrestricted airflow
- Large cable exit holes on back surface
- Keyhole mounting slots on 16-in. centers accommodate up to 3/8-in. dia. mounting fasteners (not supplied)
- Heavy duty hinges are welded to frame
- Hinge provided for every two rack unit spacing
- One rack unit model has half-size hinge
- Provides access to rear of equipment
- 12-24 rack mounting screws (package of 20) included with assembly
- Wall mounting hardware not included

**SPECIFICATIONS**

- Made of 12 gauge steel
- EIA universal 5/8, 5/8, 1/2 in. spaced 12-24 tapped holes. EIA spacing provides 1.75 in. per rack unit.

**FINISH**

Finish is RAL 9005 black low-gloss polyester powder paint

**BULLETIN: DOFRW**

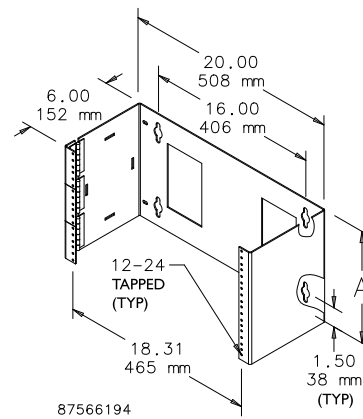

Standard Product

Catalog Number	A (in.)	A (mm)	Load Rating (lb.)	Load Rating (kg)	Rack Units
E19HPM1U	1.75	44	25	11.3	1
E19HPM2U	3.50	89	50	22.7	2
E19HPM4U	8.00	203	100	45.4	4
E19HPM6U	10.50	267	150	68.0	6
E19HPM8U	14.00	356	200	90.7	8



19-IN. FIXED WALL-MOUNT RACK



Economical solution for banks of small networking equipment. Integral VELCRO® cable tiedown slots facilitate cable routing. Made of 16 gauge steel, finished with RAL 9005 low gloss black polyester powder paint. Shipped in four easy-to-assemble sections.

VELCRO is a trademark of Velcro Industries B.V.

BULLETIN: DOFRW

INSECT SCREENS



Catalog Number	A (in.)	A (mm)	Load Rating (lb.)	Load Rating (kg)	Rack Units
E19FWM12U20	23.00	584	150	68.0	12
E19FWM20U20	37.00	940	150	68.0	20
E19FWM25U20	45.75	1162	150	68.0	25
E19FWM32U20	58.00	1473	150	68.0	32

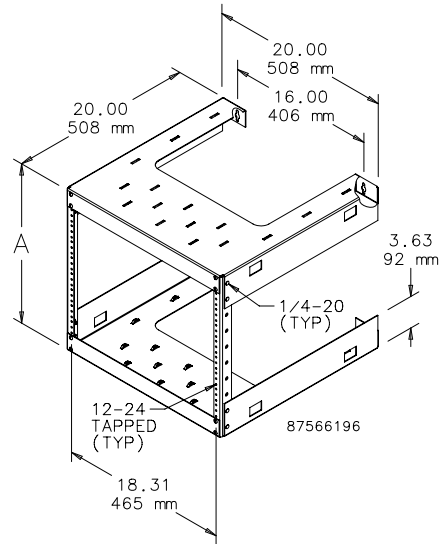

Fastens over ventilation slot with two screws provided. Requires one for single-door enclosure and two for two-door enclosure. Purchase insect screens separately.

BULLETIN: A3PM

Catalog Number	Description	Requires
A3PMIS	Insect Screen	One for one-door enclosure and two for two-door enclosure

FAN SHROUD KITS

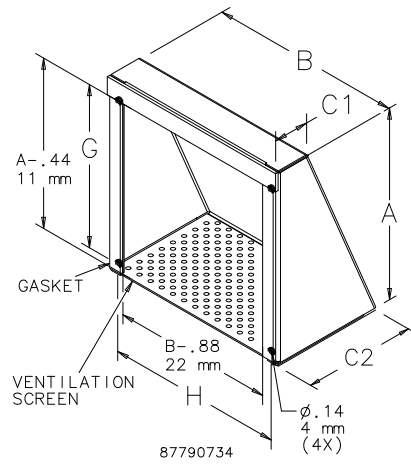
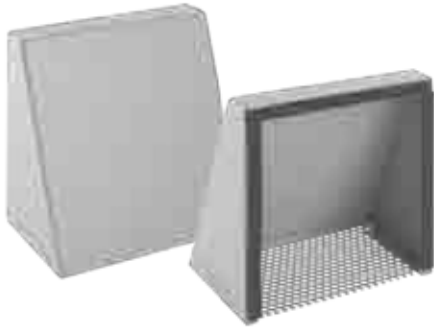

Fan shroud kits are available for outdoor enclosure applications requiring Type 3R ventilation protection from falling rain, sleet and snow.

BULLETIN: D85

Catalog Number	Material	Height x Width (in.)	Height x Width (mm)
T4S3R	Steel	6.00 x 6.00	152 x 152
T6S3R	Steel	8.00 x 8.00	203 x 203
T10S3R	Steel	12.00 x 12.00	305 x 305
T4S3RSS	Stainless Steel	6.00 x 6.00	152 x 152
T6S3RSS	Stainless Steel	8.00 x 8.00	203 x 203
T10S3RSS	Stainless Steel	12.00 x 12.00	305 x 305



## WEATHERFLO™ WITH FAN, TYPE 3R



Fan with Finger Guard

### INDUSTRY STANDARDS

UL 508A Listed; Type 3R; File Number E61997  
cUL Listed per CSA C22.2 No 94; Type 3R; File Number E61997

NEMA/EEMAC Type 3R  
IEC 60529, IP32

### APPLICATION

WEATHERFLO™ Enclosures feature a forced-air ventilation system for cooling drives or other high-heat producing equipment in outdoor applications.

### FEATURES

- White polyester powder finish with low solar absorption
- Integrated solar shield top and intake cover
- Gasket and filter
- Adjustable thermostat (70-140 F)
- Active cooling ventilation system with factory-installed fan and filter (115 VAC)
- Terminal power connection for fan
- Easily accessible and washable metal filter
- Top front hood exhaust and door
- Lift-off hinged door
- Quarter-turn latch
- External mounting brackets
- Collar studs provided to mount the optional panel
- Grounding provision on door and body
- Gasketed door

### SPECIFICATIONS

- 16 and 14 gauge galvanized steel
- Largest two sizes constructed of aluminum

### FINISH

RAL 9003 white polyester powder texturized finish inside and out.

### ACCESSORIES

*See also Accessories.*  
Compact Cooling Fans  
Electric Heater  
Panels for Type 3R, 4, 4X, 12 and 13 Enclosures  
Junction Box and Wall-Mount Enclosure Swing Out Panel Kit

### BULLETIN: A3RD

Standard Product

Catalog Number	AxBxC in./mm	Drive Horsepower (hp)	Panel	Panel Size D x E in./mm	Mounting Holes G x H in./mm	I in./mm
WF3LP	29.00 x 24.00 x 12.00	3	A24P24	21.00 x 21.00	29.94 x 13.00	5.59
	737 x 610 x 305			533 x 533	760 x 330	142
WF10LP	35.00 x 24.00 x 12.00	10	A30P24	27.00 x 21.00	35.94 x 13.00	5.81
	889 x 610 x 305			686 x 533	913 x 330	148
WF25LP	41.00 x 24.00 x 12.00	25	A36P24	33.00 x 21.00	41.94 x 13.00	5.81
	1041 x 610 x 305			838 x 533	1065 x 330	148
WF40LP	47.00 x 24.00 x 14.00	40	A42P24	39.00 x 21.00	47.94 x 13.00	5.81
	1194 x 610 x 356			991 x 533	1218 x 330	148
WF75LP	56.00 x 36.00 x 16.00	75	A48P36	45.00 x 33.00	55.94 x 27.00	7.43
	1422 x 914 x 406			1143 x 838	1421 x 686	189
WF100LP	67.00 x 36.00 x 16.00	100	A60P36	57.00 x 33.00	67.94 x 27.00	7.43
	1702 x 914 x 406			1448 x 838	1726 x 686	189

Purchase panels separately.

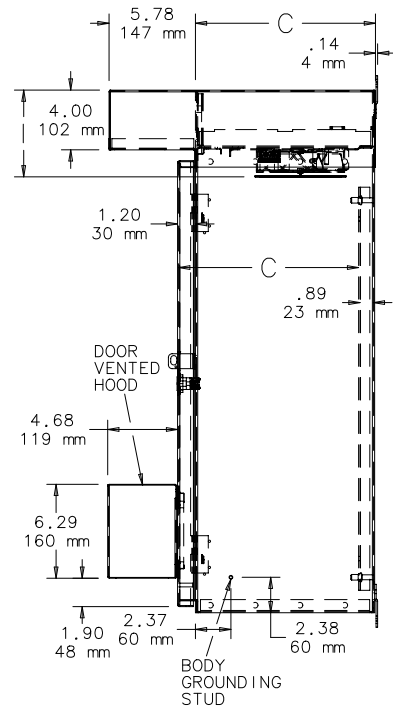
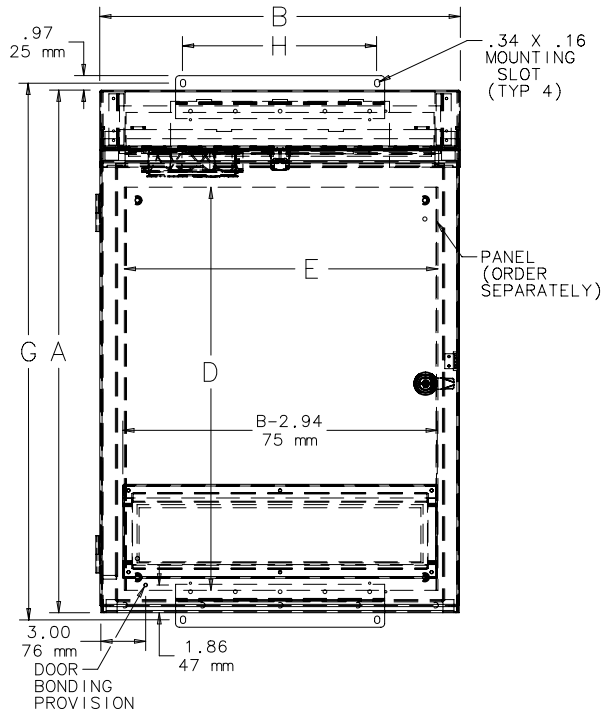
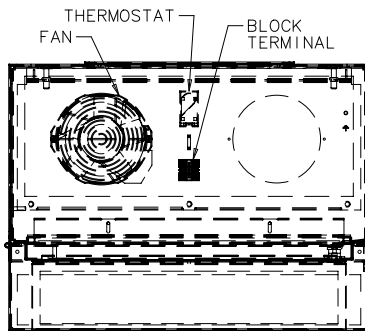

87798234



### TECHNICAL INFORMATION

This information is for guidance only; user is responsible for load values to evaluate the system.

Catalog Number	Drive Horsepower (hp)	Fan	Fan Size in./mm	Fan VAC	Fan Amps (50/60 Hz)	System CFM	Replacement Filter
WF3LP	3	A4AXFN	4	115	.26/.21	75	WFF1
WF10LP	10	A6AXFN	6	115	.45/.36	160	WFF1
WF25LP	25	A6AXFN	6	115	.45/.36	160	WFF1
WF40LP	40	A6AXFN	6 (2x)	115	.90/.72	200	WFF1
WF75LP	75	A10EFN	10	115	.58/.70	400	WFF2
WF100LP	100	A10EFN	10 (2x)	115	1.16/1.40	500	WFF2

### SOLAR CONSIDERATION

The WEATHERFLO® Enclosure’s glossy white finish and solar shield top shroud minimize the heat load caused by the sun. If the allowable temperature rise is greater than 5 F, the solar load can be neglected because the transmitted load of the illuminated sides would be equal to the energy dissipated on the sides not exposed to the sun.

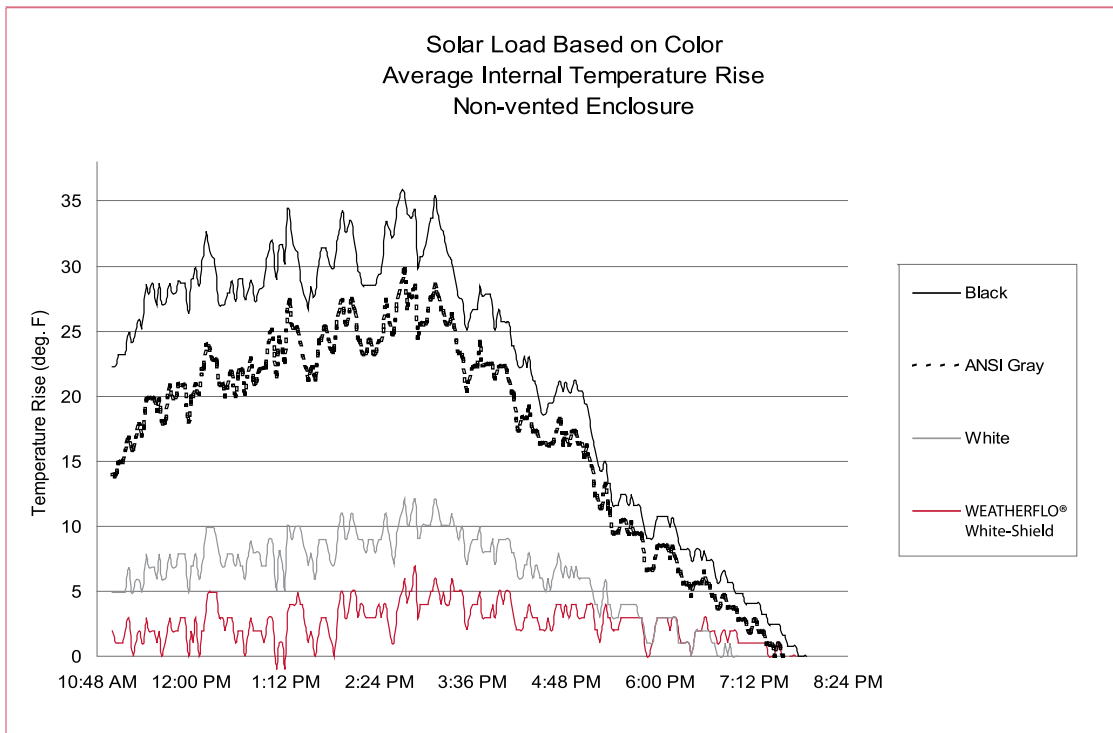

## CRITICAL PARAMETERS (UPPER TEMPERATURE LIMITS)

### Enclosure Heat Load Calculations

**Drive heat:**

$$W_D = [(HP \times 745.7 \text{ Watts/HP}) / E_M] \times (1 - E_D) \quad [\text{Watts}]$$

**Total heat:**

Estimate an additional 25%<sup>a</sup> for wire connections and other components.

$$W_T = W_D \times 1.25^a \quad [\text{Watts}]$$

**Required airflow:**

$$CFM = (W_T \times 3.16) / (T_{int} - T_{amb}) \quad [\text{ft.}^3 / \text{min.}]$$

<sup>a</sup>This is an estimated factor. Further investigation is necessary to obtain actual total heat dissipated in enclosure.

Variables

Variable Descriptions	Variables	Typical Values
Maximum ambient temperature	T <sub>amb</sub>	104 F
Maximum internal temperature	T <sub>int</sub>	122 F
Typical temperature rise	(T <sub>int</sub> - T <sub>amb</sub> )	15 F
Full-load drive power	HP	—
Motor efficiency <sup>b</sup>	E <sub>M</sub>	.80-.96
Drive efficiency <sup>b</sup>	E <sub>D</sub>	.96-.98
Drive heat loss	W <sub>D</sub>	—
Total heat loss	W <sub>T</sub>	—
Required airflow	CFM	—

<sup>b</sup>Use full-load efficiency. Motor and drive efficiency will vary based on HP and voltage.

Sample Values

Drive HorsePower (hp)	Typical Full Load Rating - Motor Efficiency	Typical Full Load Rating - Drive Efficiency	Drive Heat Loss W <sub>D</sub> (W)	Additional Heat Loss <sup>a</sup> (W)	Total Heat Loss W <sub>T</sub> (W)	Airflow when T <sub>int</sub> - T <sub>amb</sub> = 15 F (CFM)
3	.86	.97	78	20	98	21
10	.90	.97	249	62	311	65
25	.91	.97	615	154	768	162
40	.92	.98	648	162	811	171
75	.93	.98	1203	301	1503	317
100	.94	.98	1587	397	1983	418

<sup>a</sup>Additional Heat Loss - This is an estimated factor. Further investigation is necessary to obtain actual total heat dissipated in enclosure.

## CRITICAL PARAMETERS (LOWER TEMPERATURE LIMITS)



Determine the ambient operating temperature range of the drive. A typical operating range is from 14 to 122 F (-10 to 50 C). For outdoor assemblies in northern climates, the lower operating temperature may be below the lower temperature limit. To ensure that cold starts are not below the low limit temperature, the addition of a heater is recommended.

Hoffman has 100-, 200-, 400-, and 800-W heaters available with adjustable thermostats from 0-100 F. For additional information, see the Thermal Management chapter.

WEATHERFLO Catalog Number	Recommended Heater (115 VAC)	Recommended Heater (230 VAC)	Heater Size (W)	Estimated Temperature Rise Above Ambient (°F)
WF3LP	DAH2001A	DAH2002A	200	55
WF10LP	DAH2001A	DAH2002A	200	46
WF25LP	DAH2001A	DAH2002A	200	40
WF40LP	DAH2001A	DAH2002A	200	33
WF75LP	DAH4001A	DAH4002A	400	41
WF100LP	DAH4001A	DAH4002A	400	37



**WEATHERFLO™ HD ENCLOSURES**

2

**APPLICATION**

WEATHERFLO™ HD Enclosures are designed to protect and cool 100-500 HP variable frequency drives. These enclosures provide an integrated cooling solution for your VFD application needs.

**FEATURES**

- Optional impeller packages provide 840 actual CFM per impeller
- Easy-to-install back panel with flexible installation methods
- Painted white polyester powder finish with low solar absorption
- Selectable bases and tops, designed to meet your specific needs
- Gangable; enclosures can be joined to one another
- Easy-to-change filter (not included)

**SPECIFICATIONS**

- Frames, bases and gland plates constructed of .125-in. aluminum
- Tops and fan housing constructed of .080-in. aluminum
- Sides and standard rear cover constructed of .100-in. aluminum
- Gasketed door, top and base
- Panels and heavy-duty rear cover constructed of 12 gauge mild steel
- Three-point latches operated by patented padlocking handle
- Grounding provisions on door and body

**FINISH**

RAL 9003 white polyester powder paint finish inside and outside, including panels, tops, covers and bases.

**ACCESSORIES**

INTERSAFE™ Data Interface Ports, Type 4/4X/12  
 PANELITE™ Enclosure Lights Overview  
 Thermoplastic Data Pocket  
 H2OMIT™ Thermoelectric Dehumidifier  
 Stainless Steel Window Kits

**ORDERING**

For your specific needs please identify and order each individual component.

1. Select frame
2. Select top, dependent on cooling solution
3. Select base, dependent on cooling solution
4. Select panel
5. Select rear cover, HD rear cover designed for applications when the drive is mounted on rear cover instead of the panel
6. Select number of Impellers (if needed), room for two impellers per door

*Please see Product Selection Matrix on page 4.*

**MODIFICATION AND CUSTOMIZATION**

Hoffman excels at modifying and customizing products to your specifications. Modification options for WEATHERFLO HD include: size changes, custom paint, and holes and cut-outs. Contact your local Hoffman sales office or distributor for complete information.

**BULLETIN: A3RHD**

**INDUSTRY STANDARDS**

UL 508A Listed; Type 3R; File Number E61997  
 cUL Listed per CSA C22.2 No 94; Type 3R; File Number E61997

NEMA/EEMAC Type 3R  
 IEC 60529, IP22



Standard Product **One- and Two-Door Frames**

Catalog Number	AxBxC in./mm	Description
WFHD3E723630	74.14 x 36.00 x 30.00 1883 x 914 x 762	One-Door Frame
WFHD3E726830	74.14 x 68.56 x 30.00 1883 x 1741 x 762	Two-Door Frame

Includes frame, door(s), two sides and four lifting eyes.

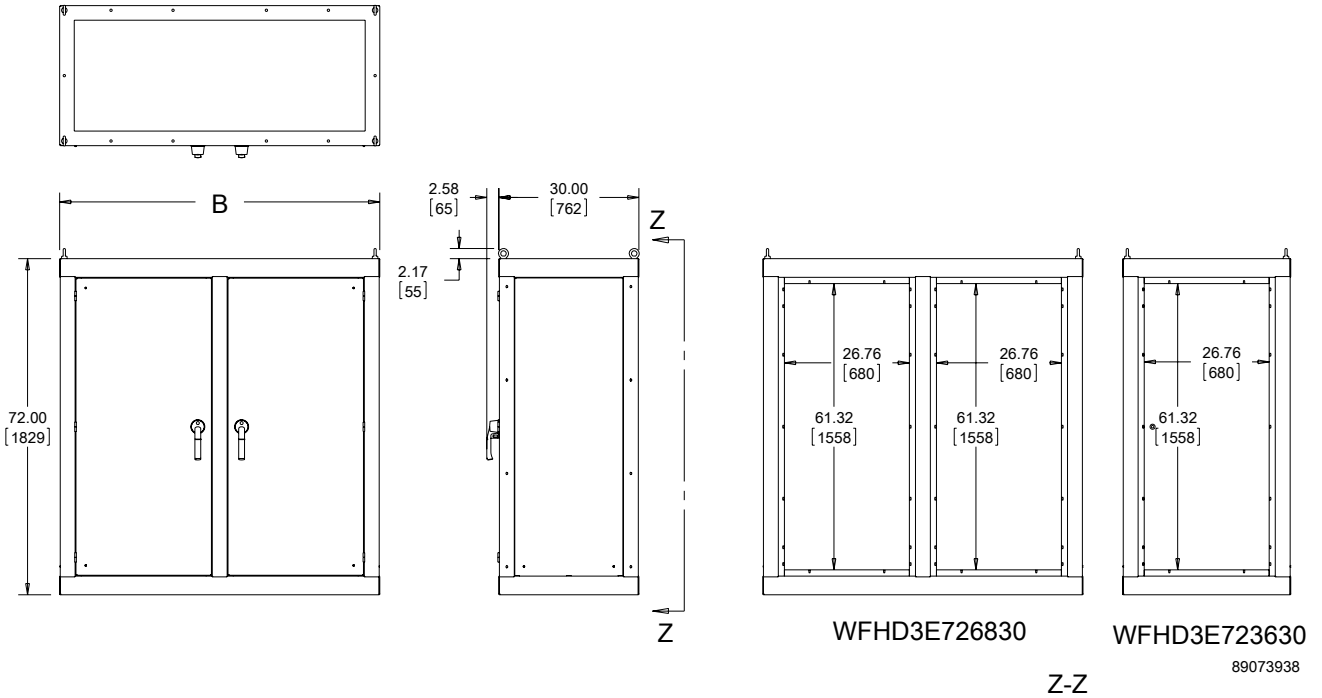

**TOPS**

Pagoda tops are designed to be used with Hoffman's Impeller packages. Pagoda tops include aluminum dampers and a stainless steel mesh to prevent the ingress of debris. Solid tops are designed to be used with a closed-loop cooling solution.

**BULLETIN: A3RHD**

Catalog Number	AxBxC in./mm	Description
WFHD3PT3630	15.53 x 36.00 x 33.42 394 x 914 x 849	Pagoda Top, One-Door
WFHD3ST3630	5.50 x 36.26 x 33.42 140 x 921 x 849	Solid Top, One-Door
WFHD3PT6830	15.53 x 68.89 x 33.42 394 x 1750 x 849	Pagoda Top, Two-Door
WFHD3ST6830	5.50 x 68.89 x 33.42 140 x 1750 x 849	Solid Top, Two-Door

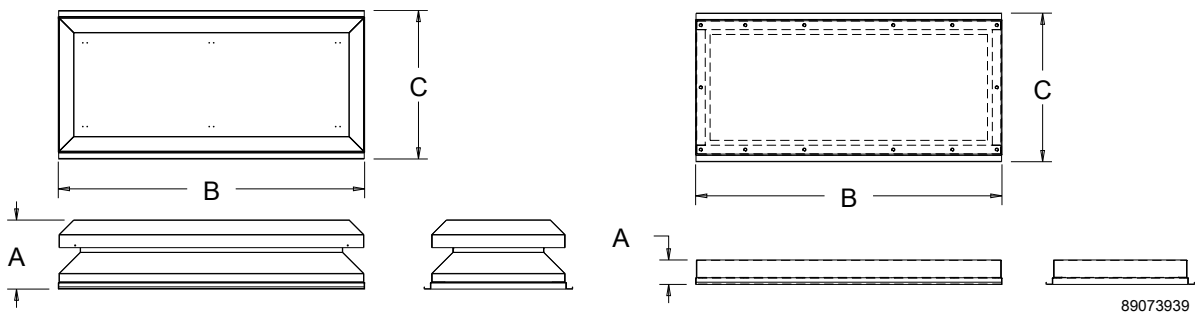

## BASES

Vented bases are designed to be used with Hoffman's Impeller packages and include a stainless steel mesh to prevent the ingress of debris. The vented bases have a provision to easily install a standard furnace filter. If vented bases are used, a maximum airflow furnace filter is recommended. Filters are not provided. Solid bases are designed to be used with a closed-loop cooling solution.

### BULLETIN: A3RHD

Catalog Number	AxBxC in./mm	Description	Gland Plate Openings
WFHD3B3630	24.00 x 36.00 x 30.00 610 x 914 x 762	Solid Base, One-Door	2
WFHD3VB3630	24.00 x 36.00 x 30.00 610 x 914 x 762	Vented Base, One-Door	2
WFHD3B6830	24.00 x 68.56 x 30.00 610 x 1741 x 762	Solid Base, Two-Door	4
WFHD3VB6830	24.00 x 68.56 x 30.00 610 x 1741 x 762	Vented Base, Two-Door	4

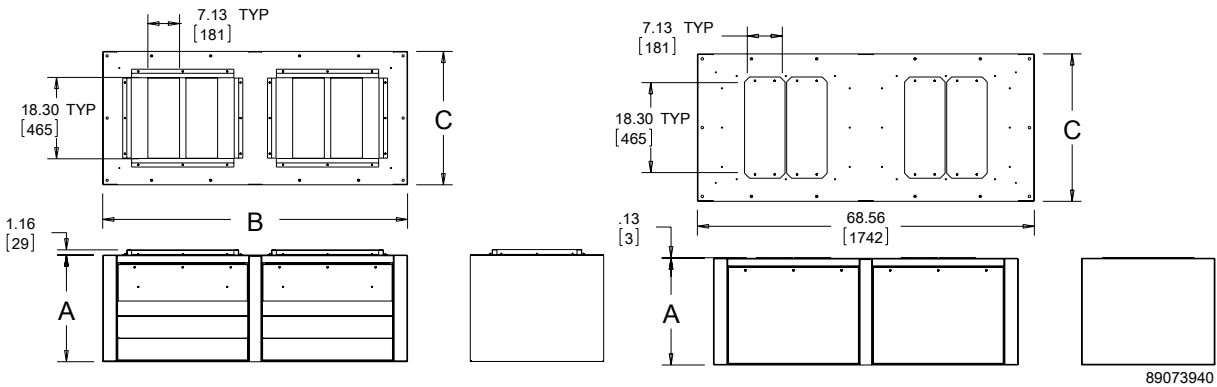

## PANEL

The panel size and openings are the same regardless of frame size. Select a panel for each door.

### BULLETIN: A3RHD

Catalog Number	AxBxC in./mm	Description
WFHDP7236	63.77 x 28.93 x 1.12 1620 x 735 x 28	Panel

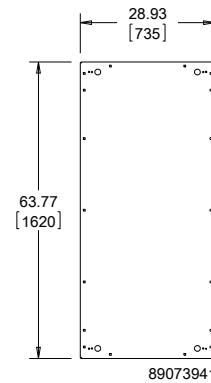

## REAR COVERS

The heavy-duty rear cover is designed for those applications when the drive is mounted directly to the rear cover of the enclosure instead of to the panel. Select a rear cover for each door.

### BULLETIN: A3RHD

Catalog Number	AxBxC in./mm	Description	Material
WFHD3RC7236	63.69 x 29.25 x 1.29 1618 x 743 x 33	Aluminum Rear Cover	.100-in. Aluminum
WFHD3RCH7236	63.69 x 29.25 x 1.29 1618 x 743 x 33	Heavy-Duty Rear Cover	12 Ga. Mild Steel

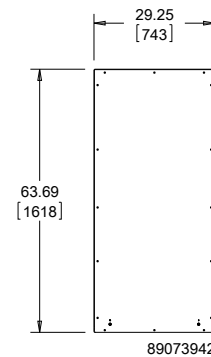

### GLAND PLATE

The gland plate is intended for use in combination with the vented base to cover unused impeller locations.

BULLETIN: A3RHD

Catalog Number	AxB in./mm	Description
WFHD3GP	20.60 x 8.24 523 x 209	Gland Plate

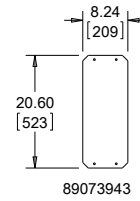

### JOINING KIT

The joining kit will work on either one- or two-door models. The kit includes hardware and instructions. Enclosures should be joined/ganged at the application site, as the kit is not designed to be used while the enclosures are in transit.

Catalog Number	Description
WFHDJK	Joining Kit

### IMPELLER

Each Impeller package includes one high-performance, 115 VAC 60 Hz, shielded impeller and an aluminum housing. Each vented base has a provision for two impellers per door. Please see performance chart below.

Catalog Number	Description	Impeller Qty.
WFHDFP	Impeller Package	1

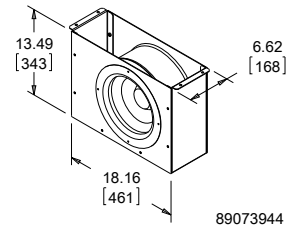

### CFM PERFORMANCE CHART

NO. OF IMPELLERS	CFM	MAX HEAT DISSIPATION (IN WATTS) AT:			
		10° Delta T	20° Delta T	30° Delta T	40° Delta T
1	840	2,654	5,309	7,963	10,618
2	1680	5,309	10,618	15,926	21,235
3	2520	7,963	15,926	23,890	31,853
4	3360	10,618	21,235	31,853	42,470

Calculated using the following equation: Watts = .316 x CFM x ΔT

### PRODUCT SELECTION MATRIX

	One-Door Enclosure	Two-Door Enclosure
Frame	WFHD3E723630	WFHD3E726830
Solid Top	WFHD3ST3630	WFHD3ST6830
Pagoda Top	WFHD3PT3630	WFHD3PT6830
Solid Base	WFHD3B3630	WFHD3B6830
Vented Base	WFHD3VB3630	WFHD3VB6830
Panel	WFHDP7236	WFHDP7236
Rear Cover	WFHD3RC7236	WFHD3RC7236
Heavy-Duty Rear Cover	WFHD3RCH7236	WFHD3RCH7236
Gland Plate	WFHD3GP	WFHD3GP
Impeller	WFHDFP	WFHDFP

Two-Door enclosures require two rear covers and two panels.



*Hoffman*<sup>®</sup>

# CHAPTER 3 TELEPHONE CABINETS

## OVERVIEW

Pentair Type 1 and Type 3R telephone termination cabinets provide indoor and outdoor solutions for telecommunication and data connections and distribution.

Pentair Telephone Cabinets are suitable for mounting and protecting:

- telecommunications circuits
- cross-connect terminal block assemblies
- maintenance terminal modules
- cable-splice enclosures
- network interface devices
- wire-guide assemblies



## TELEPHONE CABINET, TYPE 1

Telephone Cabinets house telephone and communication cable terminations as well as electrical controls and instruments in indoor applications.



## CHAPTER CONTENTS

### TELEPHONE CABINETS AND ACCESSORIES

Telephone Cabinet, Type 1 .....	.62
Replacement Tumbler Lock .....	.63
T3-Box Telephone Cabinet, Type 3R .....	.64
Locking T Handle .....	.65

### T3-BOX TELEPHONE CABINET, TYPE 3R

Use T3-Box Telephone Cabinets to mount and protect telephone terminations, telecommunications circuit accessories, cross-connect terminal block assemblies, maintenance terminal modules, cable-splice enclosures, network interface devices, wire-guide assemblies and telephone protectors in outdoor applications.



**TELEPHONE CABINET, TYPE 1**

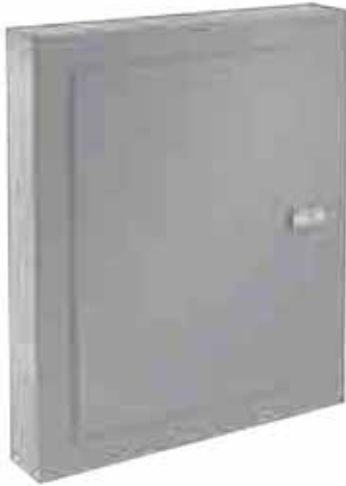

**FEATURES**

- Continuous hinge
- Tumbler lock with key
- Flush or surface mounting
- 3/4-in.-thick plywood mounting panel included

**SPECIFICATIONS**

- 16, 14 or 12 gauge galvanized steel body, mild steel door

**FINISH**

- ANSI 61 gray polyester powder paint on front only

**ACCESSORIES**

See also *Accessories*.  
Replacement Tumbler Lock

**BULLETIN: T90**

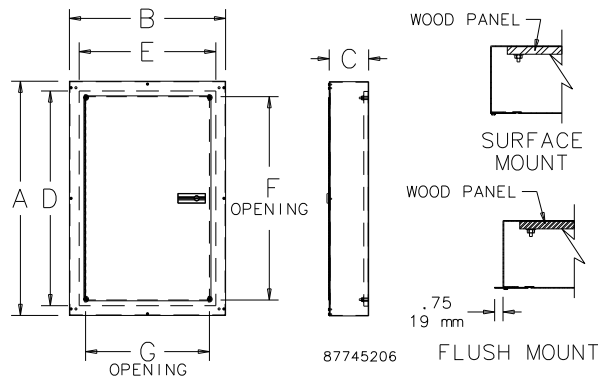

**INDUSTRY STANDARDS**

UL 50, 50E Listed; Type 1; File No. E27567  
cUL Listed per CSA C22.2 No 40; Type 1; File No. E27567

NEMA/EEMAC Type 1  
IEC 60529, IP30

**APPLICATION**

Telephone Cabinets house telephone and communication cable terminations as well as electrical controls and instruments in indoor applications.

3

Standard Product

Catalog Number	AxBxC in./mm	Mount	Panel Size D x E in./mm	Nominal Door Size F in./mm	Nominal Door Size G in./mm
ATC10104S	10.00 x 10.00 x 4.00 254 x 254 x 102	Surface	7.00 x 7.00 178 x 178	6.80 173	6.75 171
ATC10104F	10.00 x 10.00 x 4.00 254 x 254 x 102	Flush	7.00 x 7.00 178 x 178	6.80 173	6.75 171
ATC12124S	12.00 x 12.00 x 4.00 305 x 305 x 102	Surface	9.00 x 9.00 229 x 229	8.30 211	8.25 210
ATC12124F	12.00 x 12.00 x 4.00 305 x 305 x 102	Flush	9.00 x 9.00 229 x 229	8.30 211	8.25 210
ATC18124S	18.00 x 12.00 x 4.00 455 x 305 x 102	Surface	15.00 x 9.00 381 x 229	14.30 363	8.25 210
ATC18124F	18.00 x 12.00 x 4.00 455 x 305 x 102	Flush	15.00 x 9.00 381 x 229	14.30 363	8.25 210
ATC18184S	18.00 x 18.00 x 4.00 455 x 455 x 102	Surface	15.00 x 15.00 381 x 381	14.30 363	14.25 362
ATC18184F	18.00 x 18.00 x 4.00 455 x 455 x 102	Flush	15.00 x 15.00 381 x 381	14.30 363	14.25 362
ATC24184S	24.00 x 18.00 x 4.00 610 x 455 x 102	Surface	21.00 x 15.00 533 x 381	20.30 516	14.25 362
ATC24184F	24.00 x 18.00 x 4.00 610 x 455 x 102	Flush	21.00 x 15.00 533 x 381	20.30 516	14.25 362
ATC24244S	24.00 x 24.00 x 4.00 610 x 610 x 102	Surface	21.00 x 21.00 533 x 533	19.30 490	19.14 486
ATC24244F	24.00 x 24.00 x 4.00 610 x 610 x 102	Flush	21.00 x 21.00 533 x 533	19.30 490	19.14 486
ATC30244S	30.00 x 24.00 x 4.00 762 x 610 x 102	Surface	27.00 x 21.00 686 x 533	25.30 643	19.14 486
ATC30244F	30.00 x 24.00 x 4.00 762 x 610 x 102	Flush	27.00 x 21.00 686 x 533	25.30 643	19.14 486
ATC30304S	30.00 x 30.00 x 4.00 762 x 762 x 102	Surface	27.00 x 27.00 686 x 686	25.30 643	25.14 639
ATC36244S	36.00 x 24.00 x 4.00 914 x 610 x 102	Surface	33.00 x 21.00 838 x 533	31.30 795	19.14 486
ATC36244F	36.00 x 24.00 x 4.00 914 x 610 x 102	Flush	33.00 x 21.00 838 x 533	31.30 795	19.14 486

Catalog Number	AxBxC in./mm	Mount	Panel Size D x E in./mm	Nominal Door Size F in./mm	Nominal Door Size G in./mm
ATC36304S	36.00 x 30.00 x 4.00 914 x 762 x 102	Surface	33.00 x 27.00 838 x 686	31.30 795	25.14 639
ATC36364S	36.00 x 36.00 x 4.00 914 x 914 x 102	Surface	33.00 x 33.00 838 x 838	31.30 795	31.14 791
ATC36364F	36.00 x 36.00 x 4.00 914 x 914 x 102	Flush	33.00 x 33.00 838 x 838	31.30 795	31.14 791
ATC12126S	12.00 x 12.00 x 6.00 305 x 305 x 152	Surface	9.00 x 9.00 229 x 229	8.30 211	8.25 210
ATC12126F	12.00 x 12.00 x 6.00 305 x 305 x 152	Flush	9.00 x 9.00 229 x 229	8.30 211	8.25 210
ATC18126S	18.00 x 12.00 x 6.00 455 x 305 x 152	Surface	15.00 x 9.00 381 x 229	14.30 363	8.25 210
ATC18126F	18.00 x 12.00 x 6.00 455 x 305 x 152	Flush	15.00 x 9.00 381 x 229	14.30 363	8.25 210
ATC18186S	18.00 x 18.00 x 6.00 455 x 455 x 152	Surface	15.00 x 15.00 381 x 381	14.30 363	14.25 362
ATC18186F	18.00 x 18.00 x 6.00 455 x 455 x 152	Flush	15.00 x 15.00 381 x 381	14.30 363	14.25 362
ATC24186S	24.00 x 18.00 x 6.00 610 x 455 x 152	Surface	21.00 x 15.00 533 x 381	20.30 516	14.25 362
ATC24186F	24.00 x 18.00 x 6.00 610 x 455 x 152	Flush	21.00 x 15.00 533 x 381	20.30 516	14.25 362
ATC24246S	24.00 x 24.00 x 6.00 610 x 610 x 152	Surface	21.00 x 21.00 533 x 533	19.30 490	19.14 486
ATC24246F	24.00 x 24.00 x 6.00 610 x 610 x 152	Flush	21.00 x 21.00 533 x 533	19.30 490	19.14 486
ATC30246S	30.00 x 24.00 x 6.00 762 x 610 x 152	Surface	27.00 x 21.00 686 x 533	25.30 643	19.14 486
ATC30306S	30.00 x 30.00 x 6.00 762 x 762 x 152	Surface	27.00 x 27.00 686 x 686	25.30 643	25.14 639
ATC30306F	30.00 x 30.00 x 6.00 762 x 762 x 152	Flush	27.00 x 27.00 686 x 686	25.30 643	25.14 639
ATC36246S	36.00 x 24.00 x 6.00 914 x 610 x 152	Surface	33.00 x 21.00 838 x 533	31.30 795	19.14 486
ATC36246F	36.00 x 24.00 x 6.00 914 x 610 x 152	Flush	33.00 x 21.00 838 x 533	31.30 795	19.14 486
ATC36306S	36.00 x 30.00 x 6.00 914 x 762 x 152	Surface	33.00 x 27.00 838 x 686	31.30 795	25.14 639
ATC36306F	36.00 x 30.00 x 6.00 914 x 762 x 152	Flush	33.00 x 27.00 838 x 686	31.30 795	25.14 639
ATC36366S	36.00 x 36.00 x 6.00 914 x 914 x 152	Surface	33.00 x 33.00 838 x 838	31.30 795	31.14 791
ATC36366F	36.00 x 36.00 x 6.00 914 x 914 x 152	Flush	33.00 x 33.00 838 x 838	31.30 795	31.14 791
ATC36308S	36.00 x 30.00 x 8.00 914 x 762 x 203	Surface	33.00 x 27.00 838 x 686	31.30 795	25.14 639
ATC36308F	36.00 x 30.00 x 8.00 914 x 762 x 203	Flush	33.00 x 27.00 838 x 686	31.30 795	25.14 639



**REPLACEMENT TUMBLER LOCK**

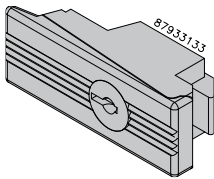

Tumbler lock including key available for replacement of door latch (order separately).

**BULLETIN: T90**

Catalog Number	Description
ATCL	Keyed Tumbler Lock



**T3-BOX TELEPHONE CABINET, TYPE 3R**



**INDUSTRY STANDARDS**

UL 50, 50E Listed; Type 3R; File No. E27567  
 UL 497 / 1863 Listed; File No. E230874  
 cUL Listed per CSA C22.2 No 94; Type 3R; File No. E27567

NEMA Type 3R  
 IEC 60529 IP32

**APPLICATION**

Use T-3 Box Telephone Cabinets to mount and protect telephone terminations, telecommunications circuit accessories, cross-connect terminal block assemblies, maintenance terminal modules, cable-splice enclosures, network interface devices, wire-guide assemblies and telephone protectors in outdoor applications.

**FEATURES**

- Lift-off hinges
- 4-position grounding bar #14-2/0
- Tamper-resistant quarter-turn latch
- 7-mm square drive; use key accessory CLKSM7 or 5/16 12-point socket
- Padlock hasp
- Standard knockouts

**SPECIFICATIONS**

- 16 or 14 gauge galvanized steel
- 3/4-in.-thick plywood panel

**FINISH**

ANSI 61 gray polyester powder paint inside and outside.

**ACCESSORIES**

*See also Accessories.*  
 Locking T Handle  
 Large Enclosure Door Stop Kit  
 Lock Inserts  
 Touch-Up Paint

**BULLETIN: T90R3**

3

Standard Product

Catalog Number	AxBxC in./mm	Door	F in./mm	Panel Size D x E in./mm	Conduit Pattern
ATC12R145	12.00 x 14.00 x 5.00 305 x 356 x 127	Single	4.00 102	9.00 x 11.00 229 x 279	G-H-I
ATC36R366	36.00 x 36.00 x 6.00 914 x 914 x 152	Single	13.50 343	33.00 x 33.00 838 x 838	C-D-E-F-G-H-I-J-K-L-M
ATC26R248	26.00 x 24.00 x 8.00 660 x 610 x 203	Single	7.50 191	23.00 x 21.00 584 x 533	E-F-G-H-I-J-K
ATC36R248	36.00 x 24.00 x 8.00 914 x 610 x 203	Single	7.50 191	33.00 x 21.00 838 x 533	E-F-G-H-I-J-K
ATC36R308	36.00 x 30.00 x 8.00 914 x 762 x 203	Single	10.50 267	33.00 x 27.00 838 x 686	D-E-F-G-H-I-J-K-L
ATC36R369	36.00 x 36.00 x 9.00 914 x 914 x 229	Single	13.50 343	33.00 x 33.00 838 x 838	C-D-E-F-G-H-I-J-K-L-M
ATC42R369	42.00 x 36.00 x 9.00 1067 x 914 x 229	Double	13.50 343	39.00 x 33.00 911 x 838	C-D-E-F-G-H-I-J-K-L-M
ATC48R369	48.00 x 36.00 x 9.00 1219 x 914 x 229	Double	13.50 343	45.00 x 33.00 1143 x 838	C-D-E-F-G-H-I-J-K-L-M
ATC48R489	48.00 x 48.00 x 9.00 1219 x 1219 x 229	Double	19.50 495	45.00 x 45.00 1143 x 1143	A-B-C-D-E-F-G-H-I-J-K-L-M-O
ATC36R3612	36.00 x 36.00 x 12.00 914 x 914 x 305	Single	13.50 343	33.00 x 33.00 838 x 838	C-D-E-F-G-H-I-J-K-L-M



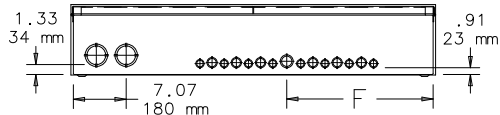
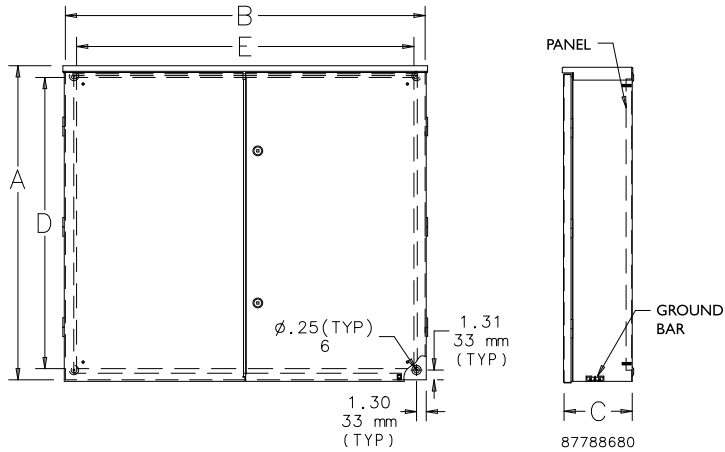
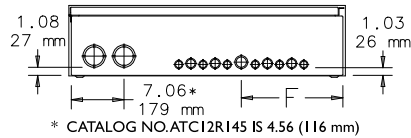
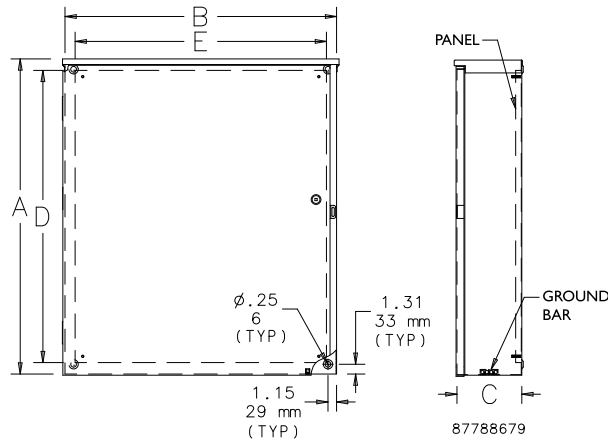
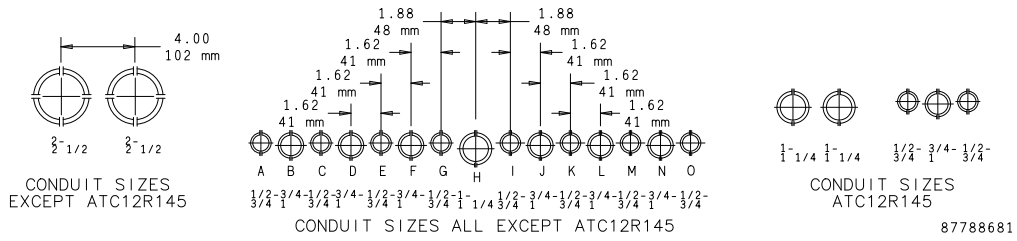

**LOCKING T HANDLE**

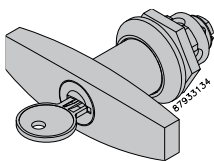

Optional locking T-Handle available for replacement of the quarter-turn latch (order separately).

**BULLETIN: T90R3**

Catalog Number	Description
ALTC3R	Available for replacement of the quarter-turn latch



*Hoffman*<sup>®</sup>

# CHAPTER 4 CURRENT TRANSFORMER AND UTILITY CABINETS AND TERMINAL BOXES

## OVERVIEW

Pentair has a wide range of Type 3R corrosion-resistant current transformer cabinet solutions with hinged or removable screw covers. Current transformer mounting options include window-style, bar-type and foot mounting. All feature a drip-shield top and seam-free sides to keep dripping water away from the sensitive electrical components inside.

Pentair Type 3R terminal boxes are used to split power feeders into branch services.

Primary sectionalizing enclosures provide above-ground facilities for sectionalizing, tapping or terminating underground distribution systems.

### CURRENT TRANSFORMER, SCREW COVER, TYPE 3R

Current Transformer Cabinets provide outdoor protection and security for instrument current transformers, which are frequently required for transformer-rated watt-hour metering.

Cabinets can also be used as junction or service boxes and house meter, transformer, relay or terminal assemblies.





## CHAPTER CONTENTS

### CURRENT TRANSFORMER CABINETS

Current Transformer, Screw Cover, Type 3R .....	68
Current Transformer, Hinged Cover, Type 3R .....	70
CT Mounting Base .....	72
Current Transformer Cabinets, 400-800 Amp, Type 3R .....	74
3-Phase 400-1200 Amp with Mechanical Lugs, Type 3R .....	76
Current Transformer, Type 3R, Overview .....	78
Screw Cover with Steel Foot Mount Panel .....	78
Lift-Off Cover with Wood Panel .....	78
Hinged Screw Cover with Steel Panel .....	78
Hinged Double-Door with Three-Point Latch and Wood Panel .....	79
400- and 800-Amp Bar-Type Mount with Line/Load Lugs .....	79
Vented Double Door .....	79

### TYPE 3R TERMINAL BOX AND ACCESSORIES

Terminal Box, Type 3R .....	80
Interchangeable Bolt-on Hub .....	81
Lug Assembly .....	81

### SECTIONALIZING

Utility Junction (UJ) Cabinets .....	82
--------------------------------------	----

### TERMINAL BOX, TYPE 3R

These Terminal Boxes are wire-splice boxes for outdoor commercial and industrial applications that have a



feeder tap to branch circuits. Boxes are available in three- or four-wire configurations in sizes up to 400 Amp.



**CURRENT TRANSFORMER, SCREW COVER, TYPE 3R**



**INDUSTRY STANDARDS**

UL 50, 50E Listed; Type 3R; File No. E27525  
 cUL Listed per CSA C22.2 No 94; Type 3R; File No. E27525

NEMA Type 3R  
 IEC 60529, IP32

**APPLICATION**

Current Transformer Cabinets provide outdoor protection and security for instrument current transformers, which are frequently required for transformer-rated watt-hour metering. Cabinets can also be used as junction or service boxes and house meter, transformer, relay or terminal assemblies.

**FEATURES**

- Dripshield top and seam-free sides, front and back
- Slip-on removable cover fastened with captivated plated steel screws along bottom edge
- Mounting studs on enclosure body
- Mounting holes on back of enclosure
- Door handles provided
- Provisions for padlocking
- No gasketing or knockouts
- Ground lug

**SPECIFICATIONS**

- 16, 14 or 12 gauge plated steel

**FINISH**

ANSI 61 gray polyester powder paint finish inside and out over plated surfaces.

**ACCESSORIES**

*See also Accessories.*  
 Industrial Corrosion Inhibitors  
 Grounding Device  
 Touch-Up Paint

**BULLETIN: A90CT**



Standard Product

Catalog Number	AxBxC in./mm	D in./mm	E in./mm	F in./mm	G in./mm	H in./mm
A242411CT	24.00 x 24.00 x 11.00 610 x 610 x 279	12.19 310	9.00 229	8.00 203	8.00 203	— —
A303011CT	30.00 x 30.00 x 11.00 762 x 762 x 279	15.19 386	12.00 305	7.00 178	8.00 203	8.00 203
A363011CT	36.00 x 30.00 x 11.00 914 x 762 x 279	18.19 462	15.00 381	7.00 178	8.00 203	8.00 203
A363611CT	36.00 x 36.00 x 11.00 914 x 914 x 279	18.19 462	15.00 381	10.00 254	8.00 203	8.00 203
A483611CT	48.00 x 36.00 x 11.00 1219 x 914 x 279	24.19 614	21.00 533	10.00 254	8.00 203	8.00 203

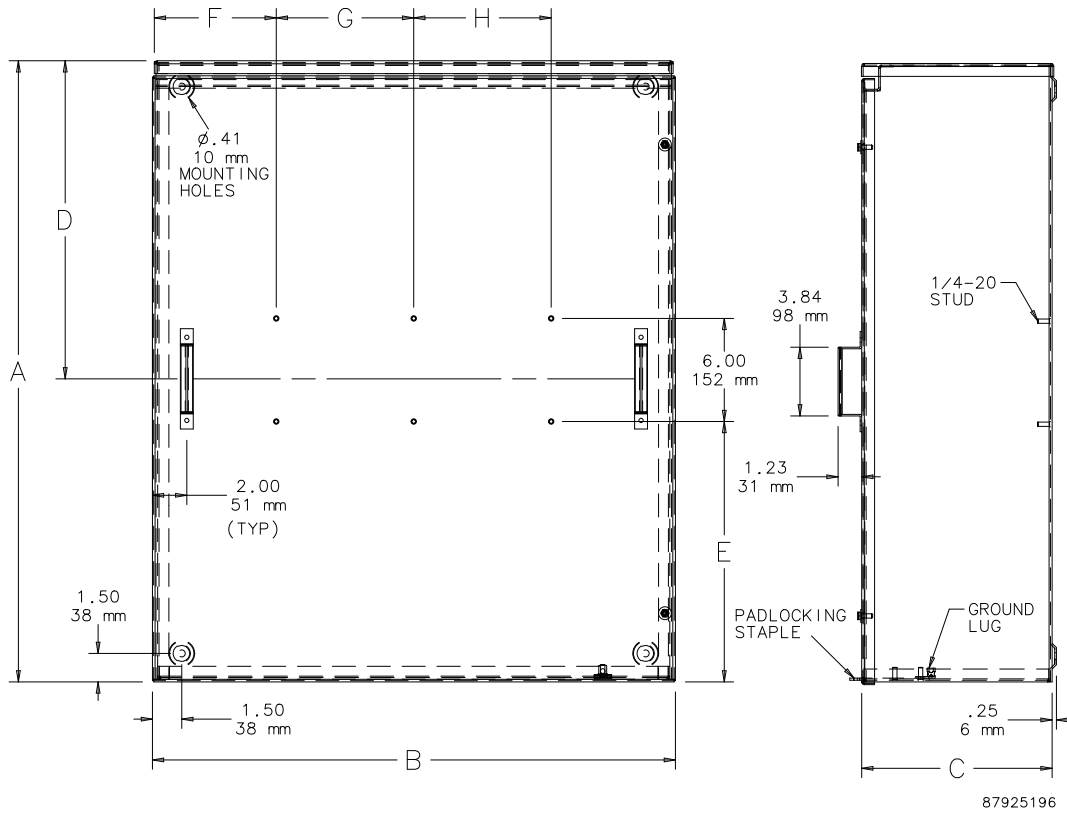



**CURRENT TRANSFORMER, HINGED COVER, TYPE 3R**



*Double Door (A484814HCT only)*

**INDUSTRY STANDARDS**

UL 50, 50E Listed; Type 3R; File No. E27525  
 cUL Listed per CSA C22.2 No 94; Type 3R; File No. E27525

NEMA Type 3R  
 IEC 60529, IP32

**APPLICATION**

Current Transformer Cabinets provide outdoor protection and security for instrument current transformers, which are frequently required for transformer-rated watt-hour metering. Cabinets can also be used as junction or service boxes and house meter, transformer, relay or terminal assemblies.

**FEATURES**

- Dripshield top and seam-free sides, front and back
- Mounting holes on back of enclosure
- Mounting studs are provided on the enclosure body
- Cover is removable in the open position
- Door handles provided
- Provisions for padlocking
- No gasketing or knockouts
- Ground lug
- Mounting provisions for optional door stop

**SPECIFICATIONS**

- 14 or 12 gauge galvanized steel

**FINISH**

ANSI 61 gray polyester powder paint finish inside and out over galvanized surfaces.

**ACCESSORIES**

*See also Accessories.*  
 Industrial Corrosion Inhibitors  
 Grounding Device  
 Touch-Up Paint  
 Large Enclosure Door Stop Kit

**BULLETIN: A90CT**

Standard Product

Catalog Number	AxBxC in./mm	Gauge	D in./mm	E in./mm	F in./mm	G in./mm	H in./mm
A362011HCT	36.00 x 20.00 x 11.00 914 x 508 x 279	14	18.75 476	15.00 381	6.67 169	8.00 203	—
A302411HCT	30.00 x 24.00 x 11.00 762 x 610 x 279	14	15.75 400	12.00 305	8.00 203	8.00 203	—
A482411HCT	48.00 x 24.00 x 11.00 1219 x 610 x 279	14	24.75 629	21.00 533	8.00 203	8.00 203	—
A363011HCT	36.00 x 30.00 x 11.00 914 x 762 x 279	12	18.75 476	15.00 381	7.00 178	8.00 203	8.00 203
A483011HCT	48.00 x 30.00 x 11.00 1219 x 762 x 279	12	24.75 629	21.00 533	7.00 178	8.00 203	8.00 203
A363611HCT	36.00 x 36.00 x 11.00 914 x 914 x 279	12	18.75 476	15.00 381	10.00 254	8.00 203	8.00 203
A483611HCT	48.00 x 36.00 x 11.00 1219 x 914 x 279	12	24.75 629	21.00 533	10.00 254	8.00 203	8.00 203
A484814HCT	48.00 x 48.00 x 14.00 1219 x 1219 x 356	12	—	21.00 533	16.00 406	8.00 203	8.00 203

A484814HCT is a double-door cabinet.

Single-Door Cabinet

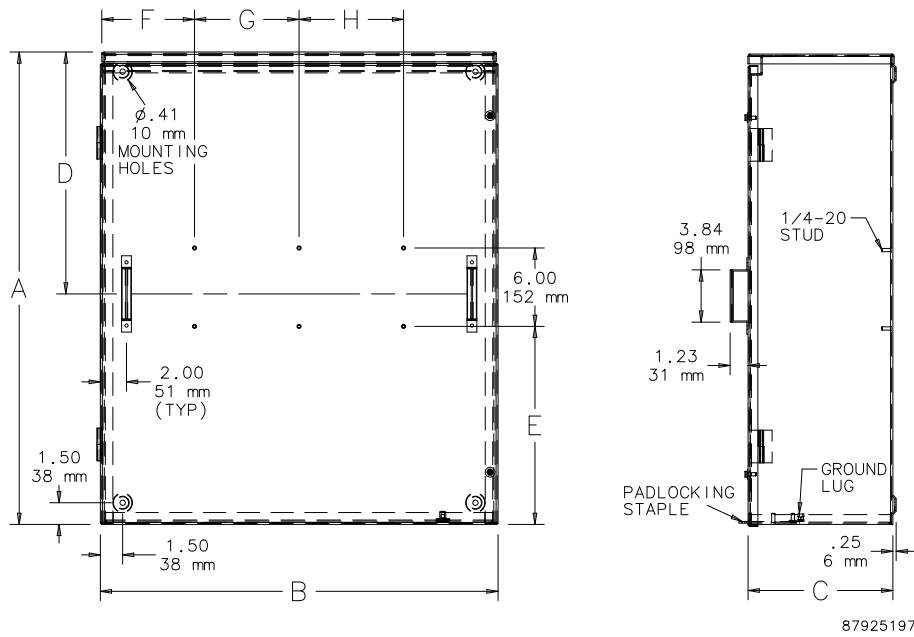

Double-Door Cabinet (A484814HCT only)

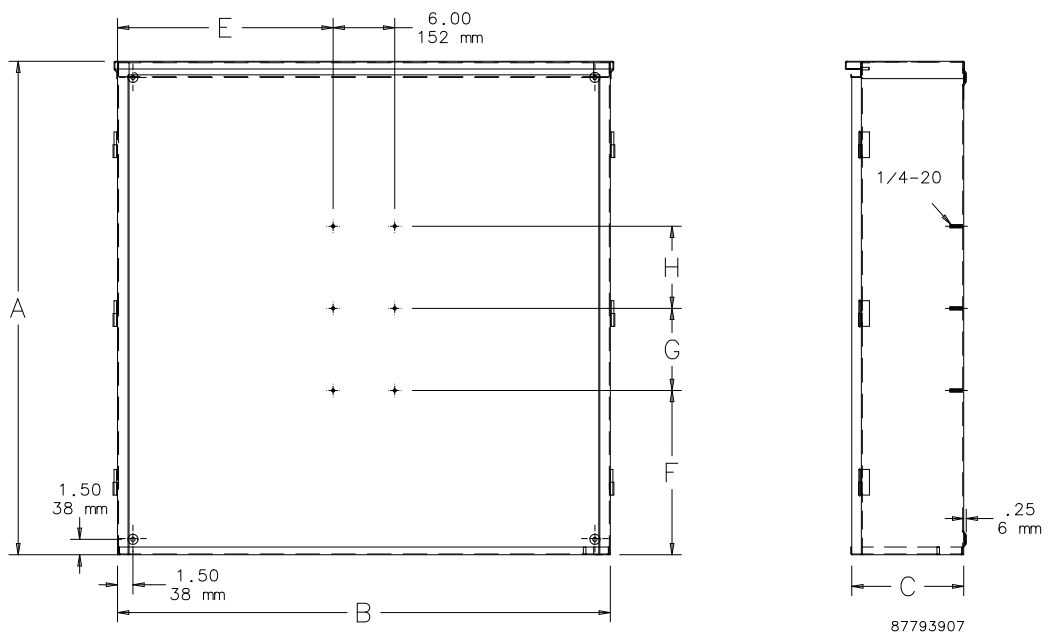

**CT MOUNTING BASE**

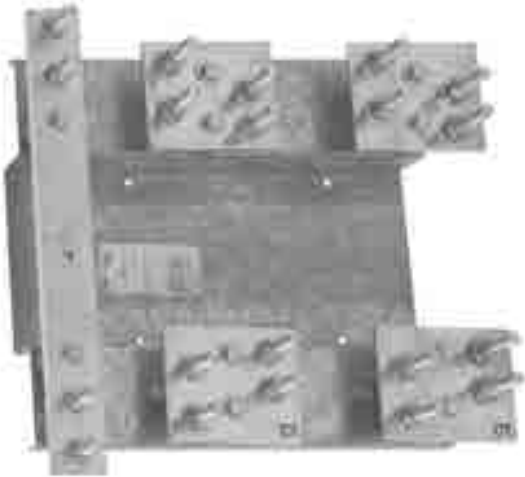

CTMB8001

**INDUSTRY STANDARDS**

UL 414 Listed; File E240312

**APPLICATION**

Available in three variations of conductor connection styles to match your application: 1/2-in. studs on 1-3/4-in. centers, a model with mechanical lugs and a model with lugs on one side and studs on the other to accommodate the preference difference between line and load connections. Pre-punched mounting base holes align with the studs in a CT enclosure.

**FEATURES**

- Spacing for bar-type current transformer that conforms to ANSI 12.11
- Conductor provisions: either mechanical lugs or 1/2-in. bolt on 1-3/4-in. centers with nut, spring and flat washer
- Neutral bar with 10-32 tap screw

**SPECIFICATIONS**

- 12-gauge galvanized formed base has electrically isolated mount/termination platform

**FINISH**

Galvanized (mounting plate only)

BULLETIN: A90CM

Standard Product **CT Mounting Base**

Catalog Number	A.I.C. Rating	Ampacity	Voltage Max. VAC	Service Type	No. of CT Provisions	Connection
CTMB8001	50,000	400-800	600	1Ø3W	2	Studs
CTMB8003	50,000	400-800	600	3Ø4W	3	Studs
CTMB4001L	50,000	400	600	1Ø3W	2	Lugs <sup>a</sup>
CTMB8003L	50,000	800	600	3Ø4W	3	Lugs <sup>a</sup>
CTMB4001LS	50,000	400	600	1Ø3W	2	Lugs and Studs <sup>a</sup>

<sup>a</sup>Wire range per phase: (3) 750MCM to 1/0 or (6) 250MCM to 1/0

**Wire Bend Space**

Catalog Number	CTMB8001, CTMB4001LS (in.)	CTMB8001, CTMB4001LS (mm)	CTMB8003 (in.)	CTMB8003 (mm)	CTMB4001L (in.)	CTMB4001L (mm)	CTMB8003L (in.)	CTMB8003L (mm)
A303011CT	6.75	171	6.75	171	7.25	184	7.25	184
A363011CT	9.75	248	9.75	248	10.25	260	10.25	260
A363611CT	9.75	248	9.75	248	10.25	260	10.25	260
A483611CT	15.75	400	15.75	400	16.25	413	10.25	260
A302411HCT	6.75	171	n/a	n/a	7.25	184	n/a	n/a
A482411HCT	15.75	400	n/a	n/a	16.25	413	n/a	n/a
A363011HCT	9.75	248	9.24	235	10.25	260	10.25	260
A483011HCT	15.75	400	15.75	400	16.25	413	16.25	413
A363611HCT	9.75	248	9.75	248	10.25	260	10.25	260
A483611HCT	15.75	400	15.75	400	16.25	413	16.25	413

Consult UL414 for minimum space requirements based on the wire size and the number of wires per terminal.



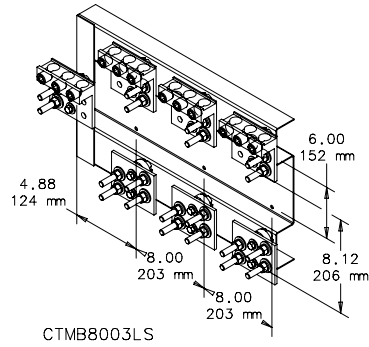
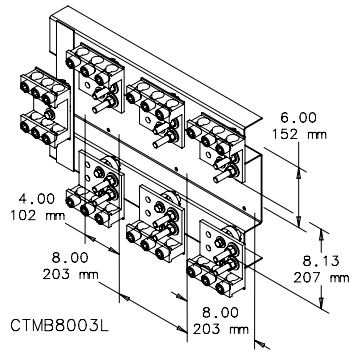
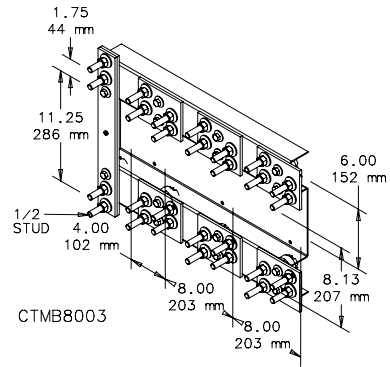
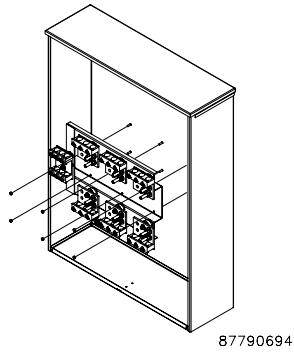

**CURRENT TRANSFORMER CABINETS, 400-800 AMP, TYPE 3R**



**INDUSTRY STANDARDS**

UL 414 Listed; Type 3R; File No. E240312  
 UL 50, 50E Listed; Type 3R; File No. E27525  
 cUL Listed per CSA C22.2 No 94; Type 3R; File No. E27525

NEMA Type 3R  
 IEC 60529, IP32

**APPLICATION**

These Current Transformer Cabinets (for Window-Type Current Transformers) provide Type 3R protection and a factory-installed wiring buss for 400-800 Amp, 600 VAC current transformers. The assembly has a 50 k AIC rating.

**FEATURES**

- Overlapping double-door model with 3-point latch and lift-off hinges
- Door stop provision included
- Includes padlock provisions in handle
- Mild steel hinges
- Use with window-type current transformer
- Drip-shield top and seam-free sides, front and back
- Three removable copper buss bars

- Buss bar cross section 3.00 in. x .25 in. (76 mm x 6 mm)
- Neutral bar
- Aluminum mechanical lugs dual rated (Cu/Al), two conductor
- Maximum conductor size 600 kcmil
- Insulating bar mounting bracket 12 gauge painted steel
- Mounting holes on back of enclosure
- No gasketing or knockouts
- Ground stud provided

**SPECIFICATIONS**

14 gauge galvanized steel

**FINISH**

ANSI 61 gray polyester powder paint

**ELECTRICAL SPECIFICATIONS**

400-800 Amp, 50 k AIC, 600 VAC

**ACCESSORIES**

See also *Accessories*.  
 Touch-Up Paint

**BULLETIN: A90CT**

Standard Product

Catalog Number	AxBxC in.	AxBxC mm	Style
A800HCT1R	36.00 x 36.00 x 11.00	914 x 914 x 305	Hinged double-door

**Buss Assembly**

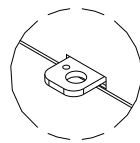
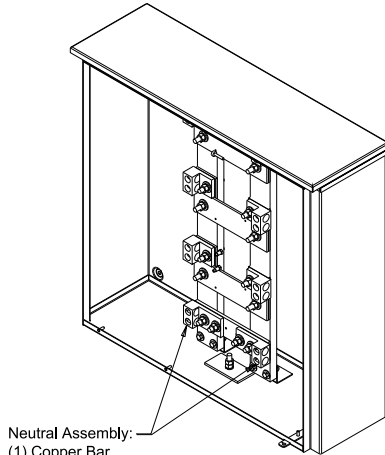

**Padlocking Staple**

Neutral Assembly:-  
 (1) Copper Bar  
 (2) Aluminum Mechanical Lugs,  
 Dual Rated, 2 Conductor (600 KCMIL)  
 1/2" Hardware

87938979

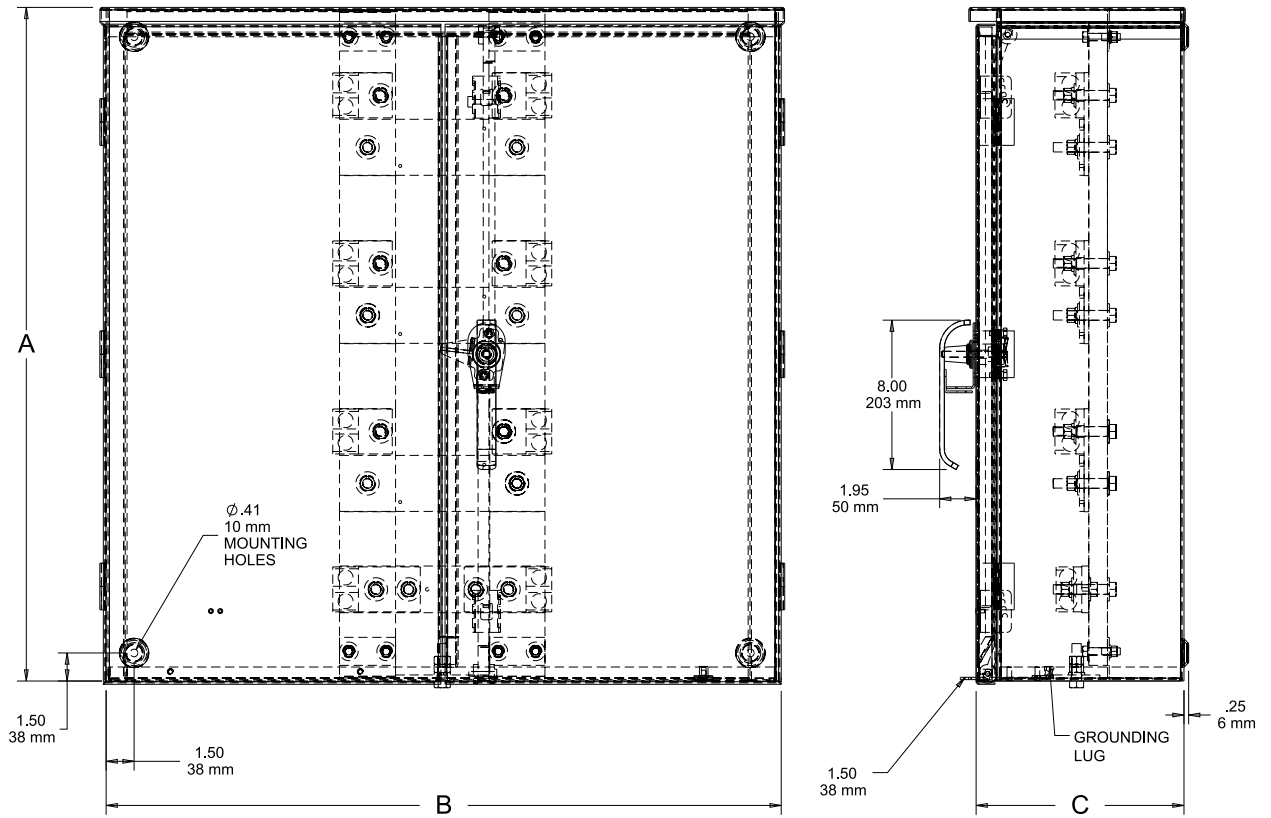

87938807



**3-PHASE 400-1200 AMP WITH MECHANICAL LUGS, TYPE 3R**

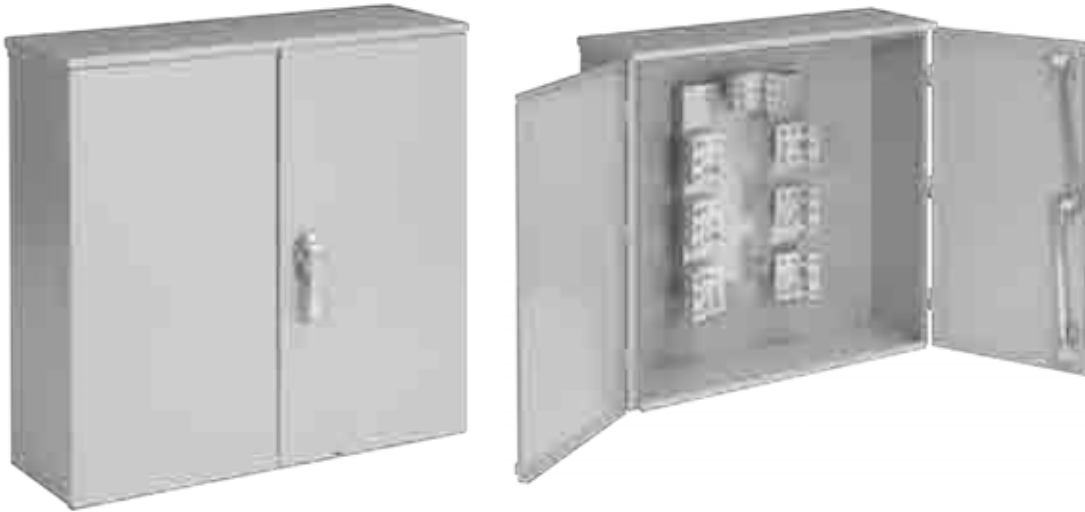

**INDUSTRY STANDARDS**

UL 414 Listed; Type 3R; File No. E240312  
 UL 50, 50E Listed; Type 3R; File No. E27525  
 cUL Listed per CSA C22.2 No 94; Type 3R; File No. E27525

NEMA Type 3R  
 IEC 60529, IP 32

**APPLICATION**

Used in indoor or outdoor applications, these cabinets provide an assembly solution for three-phase service from 400-1200 amp line load terminations for each phase and neutral. Hardware to mount a bar-style current transformer is included.

**FEATURES**

- Double door with 3-point latch includes padlock feature
- Lift-off hinges for removable doors
- Mechanical lugs provided for three-phase line-load connections plus neutral
- Ground lug
- Catalog no. A1200NECT includes panel-mounting provisions for voltage transformer (VT)
- Embossed mounting holes
- No gasketing or knockouts

**SPECIFICATIONS**

- Enclosure body and cover constructed of galvanized steel

**FINISH**

ANSI 61 gray polyester powder paint finish inside and out.

**ACCESSORIES**

See also *Accessories*.  
 Touch-Up Paint

**BULLETIN: ARCT**



Standard Product

Catalog Number	AxBxC in./mm	Service	Mechanical Lug Capacity
A800NECT	36.00 x 36.00 x 12.00 914 x 914 x 305	208Y/120-400 and 800 Amp	Each Phase (3) 750MCM-1/0
A1200NECT	48.00 x 48.00 x 12.00 1219 x 1219 x 305	208Y/120-480Y/277-800 and 1200 Amp	Each Phase (6) 750MCM-1/0

A800NECT

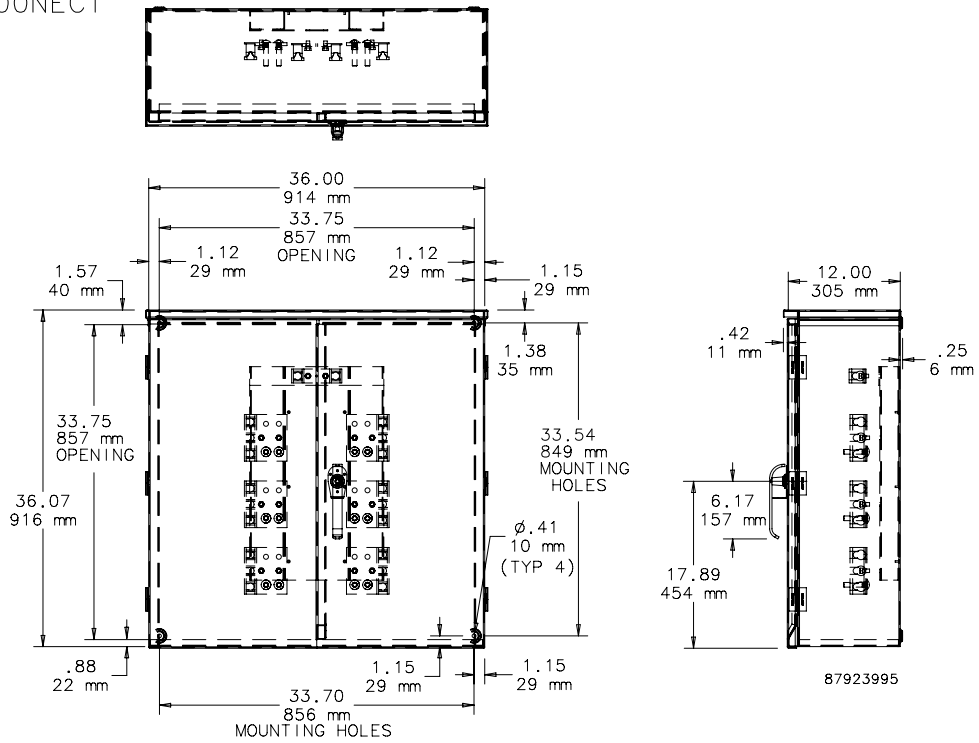

A1200NECT

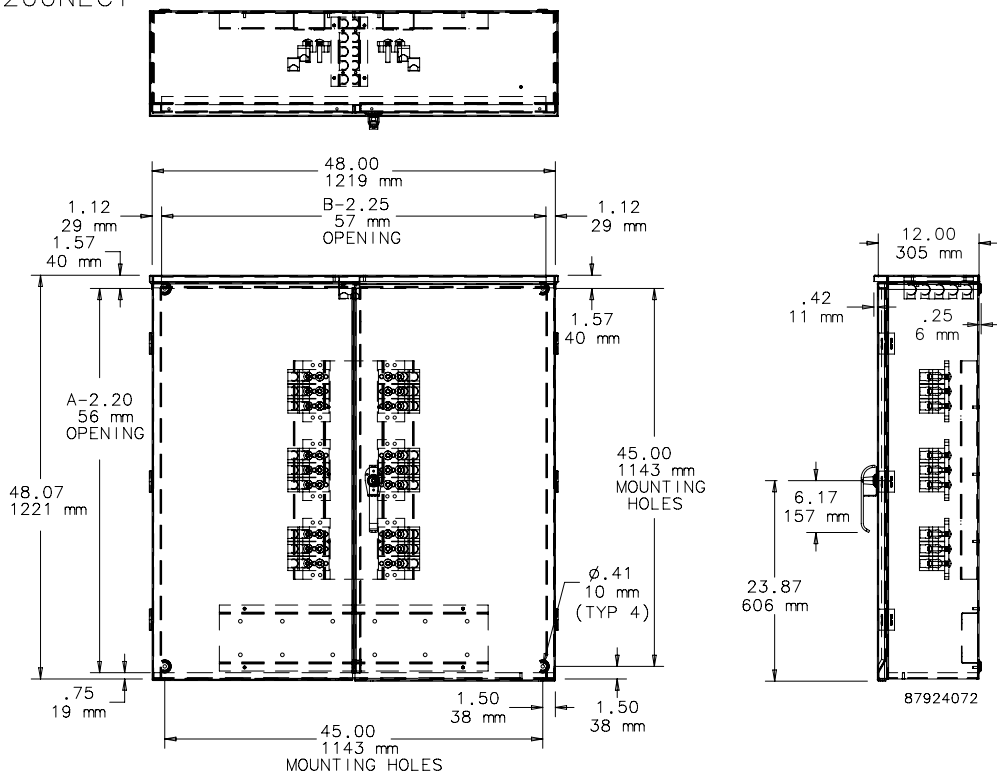

**CURRENT TRANSFORMER, TYPE 3R, OVERVIEW**



**INDUSTRY STANDARDS**

UL 50, 50E Listed; Type 3R; File No. E27525, E27567  
 cUL Listed per CSA C22.2 No 94; File No. E27525, E27567

NEMA Type 3R  
 IEC 60529, IP32  
*Models with termination lugs also have UL414, File No. E240312*

**APPLICATION**

These cabinets are available in a variety of sizes, models and instrument current transformer mounting methods to fit a wide range of applications.

**FEATURES**

- Drip-shield top and seam-free sides, front and back
- Welded-in collar studs supply provisions for mounting panel
- Provision for padlocking
- Ground lug on body
- Mounting holes on back of enclosure
- No gasketing or knockouts

**SPECIFICATIONS**

- 14 gauge galvanized steel enclosure body and cover
- Enclosure bottom of 16 gauge galvanized steel

**FINISH**

ANSI 61 gray polyester power paint inside and out over pretreated surfaces.

**SCREW COVER WITH STEEL FOOT MOUNT PANEL**



**FEATURES**

- Cover with handles and captivated screws
- 12 gauge plated mounting panel
- Panel studs allow for either vertical or horizontal panel mounting

**BULLETIN: A90CT**

Catalog Number	AxBxC in./mm	CT Panel D x E in./mm
A303012CTCJ	30.00 x 30.00 x 12.00 762 x 762 x 305	29.00 x 7.25 737 x 184
A363614CTCJ	36.07 x 36.00 x 14.00 916 x 914 x 356	35.00 x 7.25 889 x 184
A424214CTCJ	42.00 x 42.00 x 14.00 1067 x 1067 x 356	41.00 x 7.25 1041 x 184
A484814CTCJ	46.81 x 48.00 x 14.00 1189 x 1219 x 356	45.73 x 7.25 1162 x 184

**LIFT-OFF COVER WITH WOOD PANEL**



**FEATURES**

- Includes 3/4-in. plywood panel
- Screw cover with two padlock or sealing locations

**BULLETIN: A90CT**

Catalog Number	AxBxC in./mm	CT Panel D x E in./mm
A243212CTDP	24.32 x 32.50 x 13.00 618 x 826 x 330	21.00 x 21.00 533 x 533

**HINGED SCREW COVER WITH STEEL PANEL**



**FEATURES**

- Includes steel panel
- Center sealing locations

**BULLETIN: A90CT**

Catalog Number	AxBxC in./mm	CT Panel D x E in./mm
A243210CTC	24.00 x 32.00 x 10.00 610 x 813 x 254	21.00 x 29.25 533 x 743
A304410CTC	30.00 x 44.00 x 10.00 762 x 1118 x 254	27.00 x 41.25 686 x 1048

**HINGED DOUBLE-DOOR WITH THREE-POINT LATCH AND WOOD PANEL**



**FEATURES**

- Includes 3/4-in. plywood panel
- Three-point latch with seal or padlock

**BULLETIN: A90CT**

Catalog Number	AxBxC in./mm	CT Panel D x E in./mm
A404014CTDP	40.07 x 40.00 x 14.00 1018 x 1016 x 356	33.00 x 27.00 838 x 686

**400- AND 800-AMP BAR-TYPE MOUNT WITH LINE/LOAD LUGS**



**FEATURES**

- Lift-off hinges
- Doorstop
- Line and load lugs
- Staple for seal or padlock
- Quarter-turn latch

**BULLETIN: A90CT**

Catalog Number	AxBxC in./mm	Phase	Wire Range per Phase
A400HCTB	36.07 x 30.00 x 11.00 916 x 762 x 279	3Ø	(1) 1/0-750MCM or (2) 1/0-250MCM
A800HCTB	48.07 x 30.00 x 11.00 1221 x 762 x 279	3Ø	(3) 1/0-750MCM or (6) 1/0-250MCM

**VENTED DOUBLE DOOR**



**FEATURES**

- Double door with 3-point latch that includes padlock feature
- Lift-off hinges for removable doors
- Ventilating louvers with insect barrier
- Welded 1.625 x 1.625 in. mounting channel

**BULLETIN: A90CT**

Catalog Number	AxBxC in./mm	Construction
A203012BGECT	20.00 x 30.00 x 12.00 508 x 762 x 305	Galvanized; spot-welded
A364214BGECT	36.00 x 42.00 x 14.00 914 x 1067 x 356	Aluminum; riveted
A423614BGECT	42.00 x 36.00 x 14.00 1067 x 914 x 356	Aluminum; riveted



**TERMINAL BOX, TYPE 3R**

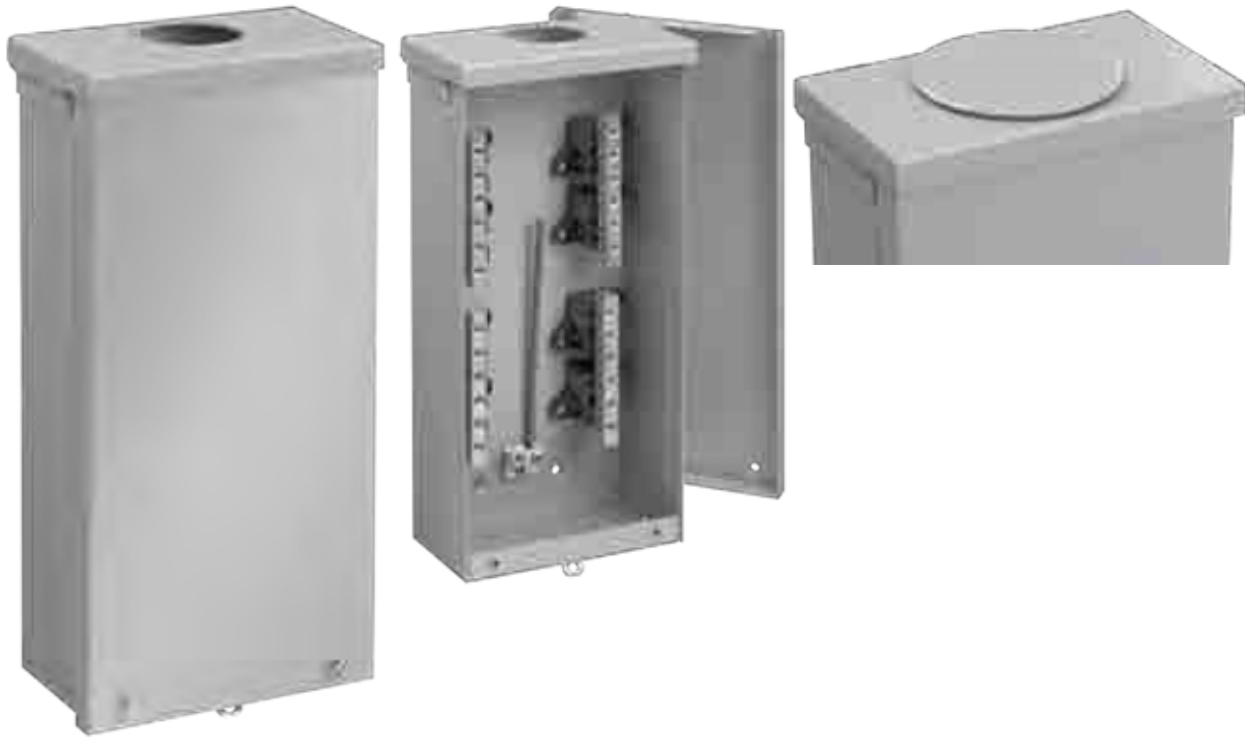

**INDUSTRY STANDARDS**

UL 1773 Listed; Type 3R; File No. E256098  
 UL 50, 50E Listed; Type 3R; File No. E27525  
 cUL Listed per CSA C22.2 No 94; Type 3R; File No. E27525

NEMA/EEMAC Type 3R  
 IEC 60529, IP32

**APPLICATION**

These Terminal Boxes are wire-splice boxes for outdoor commercial and industrial applications that have a feeder tap to branch circuits. Boxes are available in three- or four-wire configurations in sizes up to 400 A.

**FEATURES**

- Drip-shield top and seam-free sides, front and back
- Removable cover
- Distribution lugs installed (see table for sizes)
- Hub opening at top with cover

- Provisions for padlocking or seal
- Knockouts on bottom of enclosure
- Grounding provisions

**SPECIFICATIONS**

- 16 gauge galvanized steel

**FINISH**

ANSI 61 gray polyester powder paint finish inside and out over galvanized steel.

**ACCESSORIES**

See also *Accessories*.  
 Touch-Up Paint  
 Interchangeable Bolt-on Hub  
 Lug Assembly

**BULLETIN: S90B3**

Standard Product

Catalog Number	AxBxC in./mm	Volts	Phase	Amps	Number of Bars	Wire Range	G in./mm	H in./mm
TB3R101	18.00 x 8.00 x 4.50 457 x 203 x 114	120/240	1Ø	100	3	(6) #14-2/0	15.00 381	3.88 99
TB3R103	18.00 x 10.75 x 4.50 457 x 273 x 114	600	3Ø	100	4	(6) #14-2/0	15.00 381	3.88 99
TB3R103240	18.00 x 8.00 x 114.00 457 x 203 x 5	120/240	3Ø	100	4	(6) #14-2/0	15.00 381	3.88 99
TB3R201	23.00 x 12.00 x 4.50 584 x 305 x 114	120/240	1Ø	200	3	(6) #6-350MCM	20.00 508	5.50 140
TB3R203	23.00 x 12.00 x 4.50 584 x 305 x 114	600	3Ø	200	4	(6) #6-350MCM	20.00 508	5.50 140
TB3R203240	23.00 x 12.00 x 114.00 584 x 305 x 5	120/240	3Ø	200	4	(6) #6-350MCM	20.00 508	5.50 140
TB3R401	27.00 x 16.00 x 5.00 686 x 406 x 127	120/240	1Ø	400	3	(6) #4-600MCM	24.00 610	8.75 222
TB3R403	27.00 x 16.00 x 5.00 686 x 406 x 127	600	3Ø	400	4	(6) #4-600MCM	24.00 610	8.75 222

TB3R401 is UL and cUL for copper conductor only



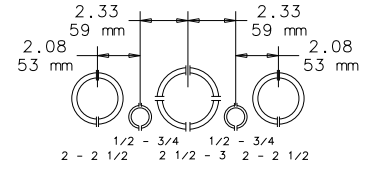
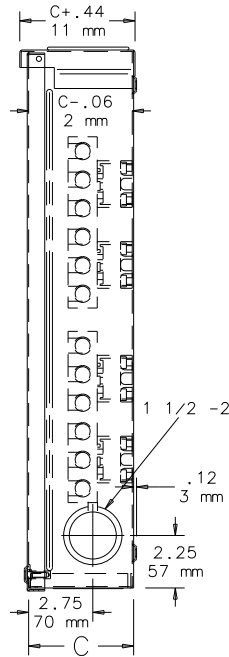
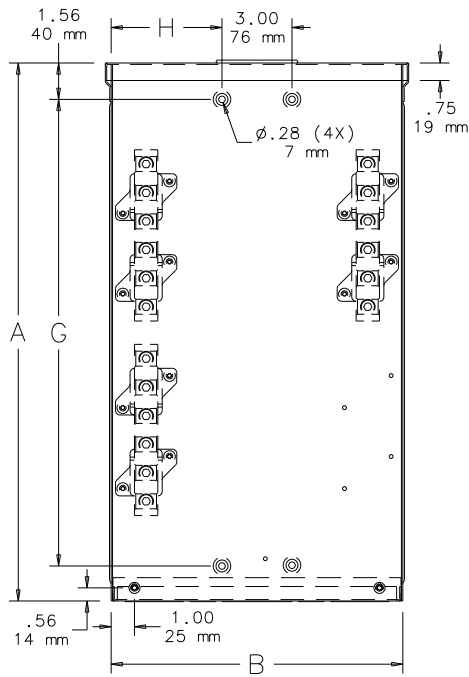

TB3R201, TB3R203, TB3R401, TB3R403

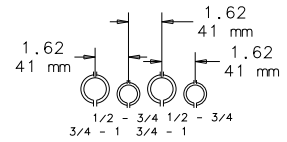

TB3R101, TB3R103

CONDUIT SIZES

Knockout Pattern  
(from outside of box)

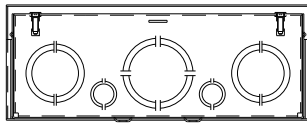

87790363

INTERCHANGEABLE BOLT-ON HUB



BULLETIN: S90B3

Catalog Number	Fits Conduit Size (in.)	Fits Conduit Size (mm)
TBHUB10	1.00	25
TBHUB12	1.25	32
TBHUB15	1.50	38
TBHUB20	2.00	51
TBHUB25	2.50	64

LUG ASSEMBLY



BULLETIN: S90B3

Catalog Number	Wire Range
TBL100	(6) #14-2/0
TBL200	(6) #6-350 MCM
TBL400	(6) #4-600 MCM

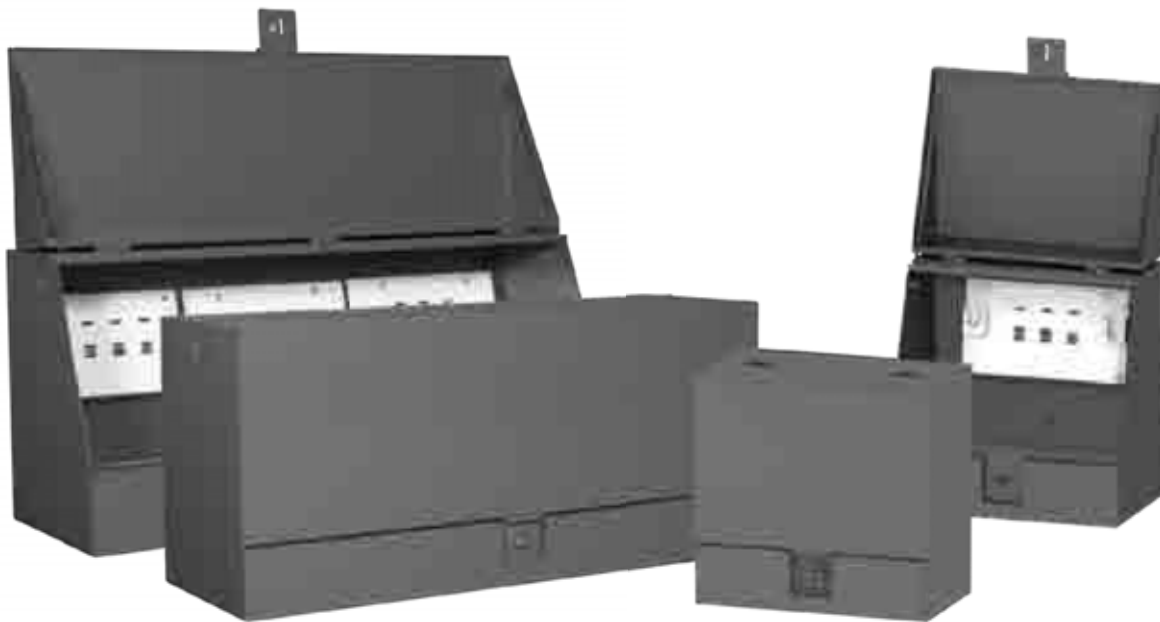

## UTILITY JUNCTION (UJ) CABINETS

**INDUSTRY STANDARDS**

ANSI C57.12.28 Pad-Mounted Equipment Enclosure Integrity  
RUS Approved

**APPLICATION**

Enclosures provide sectionalizing and tap-point functionality for underground distribution systems. Available in a wide variety of single- and three-phase models, these enclosures are rated 15 and 25 KV at 200 or 600 amperes and will accept two-, three- and four-way junctions from all manufacturers.

**FEATURES**

- Recessed stainless steel penta-head bolt with padlock security system standard on all models
- 5/8-11 threaded lifting provisions
- Wind stop standard on all models (two stops provided if B dimension is greater than or equal to 42-in.)
- Ground nut for each phase
- Full range of modifications available on request

**SPECIFICATIONS**

- Welded 12 gauge steel or .125 aluminum construction (stainless steel available as a modification)
- When ordering UJ cabinets, customer may specify multiple mounting panel options, including mild steel, galvanized and stainless steel (panels must be purchased separately)

**FINISH**

- Munsell Green 7GY3.29/1.5 polyester powder paint finish inside and out over pretreated surfaces
- Mounting panels have white polyester powder paint over pretreated surfaces

**BULLETIN: UJ**

4

**Standard Product Enclosures**

Catalog Number	AxBxC in.	AxBxC mm	Material	Recommended Panel Qty.	Recommended Panel Style
UJ303018M2	30.00 x 30.00 x 18.00	762 x 762 x 457	Steel	1	B or D
UJ303019M2	30.00 x 30.00 x 19.00	762 x 762 x 483	Steel	1	B or D
UJ303023M2	30.00 x 30.00 x 23.00	762 x 762 x 584	Steel	1	B or D
UJ303024M2	30.00 x 30.00 x 24.00	762 x 762 x 610	Steel	1	B or D
UJ304824M2	30.00 x 48.00 x 24.00	762 x 1219 x 610	Steel	2	B or D
UJ306018M2	30.00 x 30.00 x 18.00	762 x 762 x 457	Steel	3	A or C
UJ306424M2	30.00 x 64.00 x 24.00	762 x 1626 x 610	Steel	1, 2	A or C, B or D
UJ306623M2	30.00 x 66.00 x 23.00	762 x 1676 x 584	Steel	1, 2	A or C, B or D
UJ306724M2	30.00 x 67.00 x 24.00	762 x 1702 x 610	Steel	3	B or D
UJ307424M2	30.00 x 74.00 x 24.00	762 x 1880 x 610	Steel	3	B or D
UJ307622M2	30.00 x 76.00 x 22.00	762 x 1930 x 559	Steel	3	B or D
UJ482618M2	48.00 x 26.00 x 18.00	1219 x 660 x 457	Steel	1	B or D
UJ303018A	30.00 x 30.00 x 18.00	762 x 762 x 457	Aluminum	1	B or D
UJ306018A	30.00 x 60.00 x 18.00	762 x 1524 x 457	Aluminum	3	A or C
UJ306723A	30.00 x 67.00 x 23.00	762 x 1702 x 584	Aluminum	3	B or D

Single-Phase Enclosure

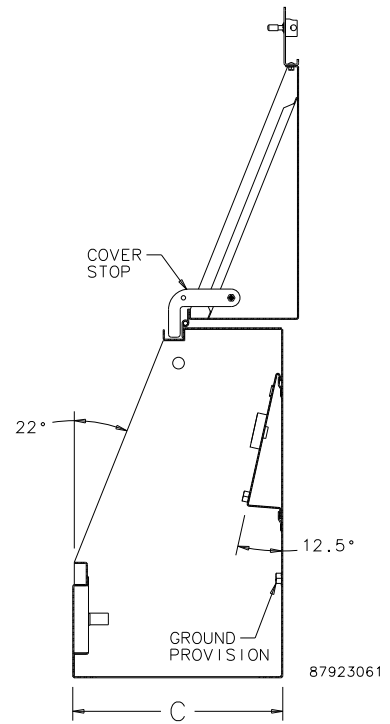
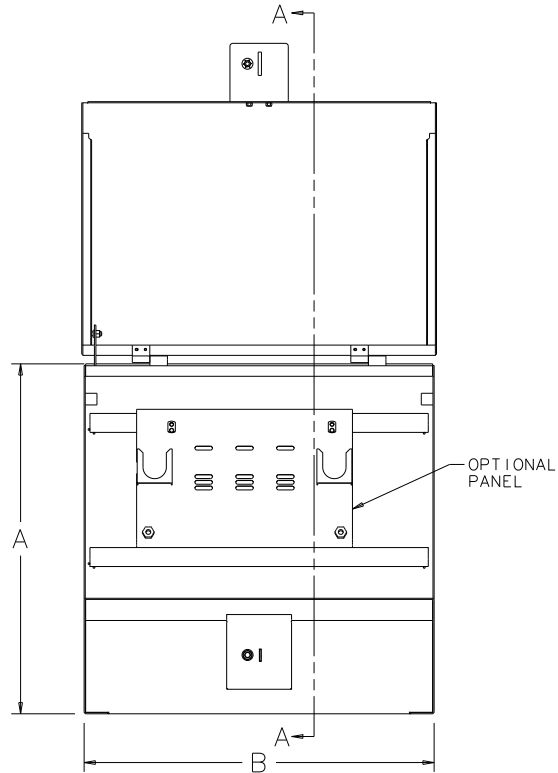

SECTION A-A

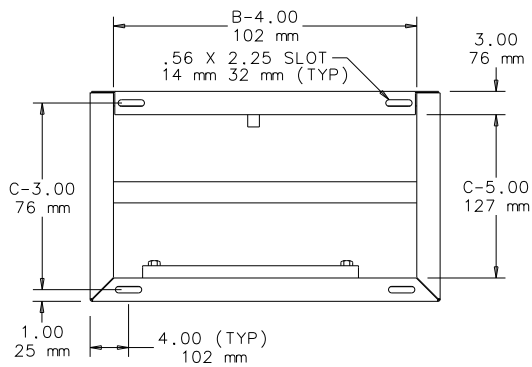

Three-Phase Enclosure

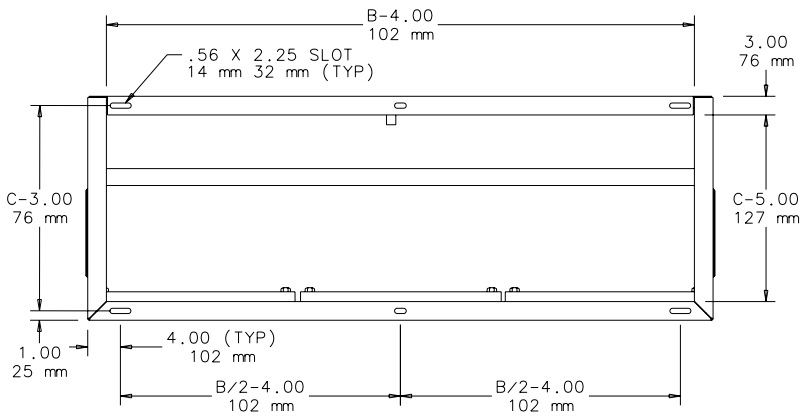
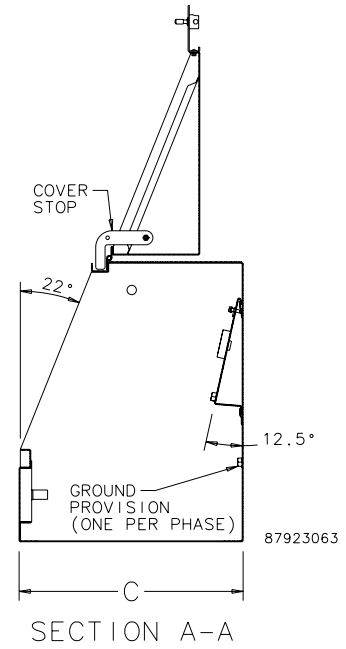
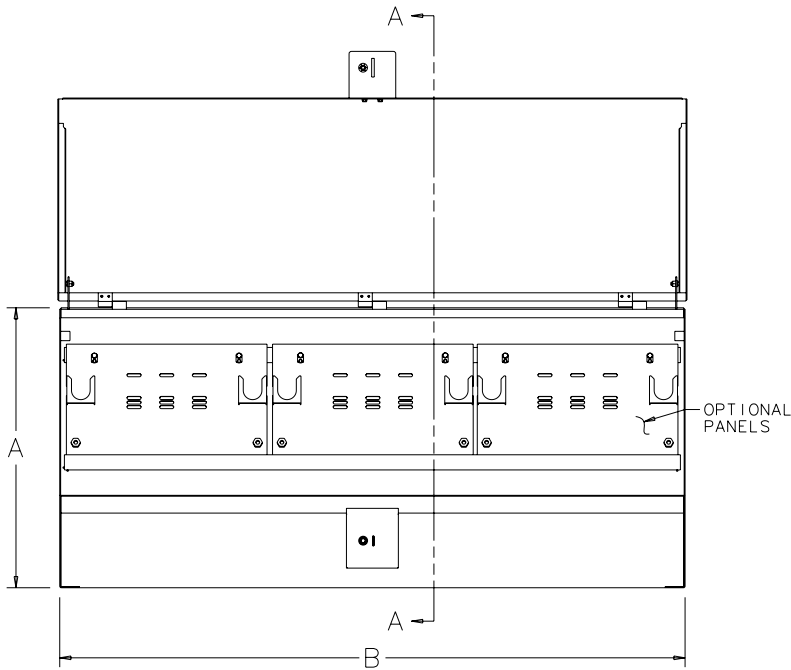

Standard Panels

Catalog Number	AxBxC in.	AxBxC mm	Panel Material	Style	No. of Parking Stands
UJP1M	11.66 x 18.50	296 x 470	Mild Steel	A	1
UJP2M	11.66 x 21.50	296 x 546	Mild Steel	B	2
UJP1MOFF	11.66 x 18.50	296 x 470	Mild Steel	C	1
UJP2MOFF	11.66 x 21.50	296 x 546	Mild Steel	D	2
UJP1G	11.66 x 18.50	296 x 470	Galvanneal	A	1
UJP2G	11.66 x 21.50	296 x 546	Galvanneal	B	2
UJP1GOFF	11.66 x 18.50	296 x 470	Galvanneal	C	1
UJP2GOFF	11.66 x 21.50	296 x 546	Galvanneal	D	2
UJP1SS	11.66 x 18.50	296 x 470	Stainless Steel	A	1
UJP2SS	11.66 x 21.50	296 x 546	Stainless Steel	B	2
UJP1SSOFF	11.66 x 18.50	296 x 470	Stainless Steel	C	1
UJP2SSOFF	11.66 x 21.50	296 x 546	Stainless Steel	D	2

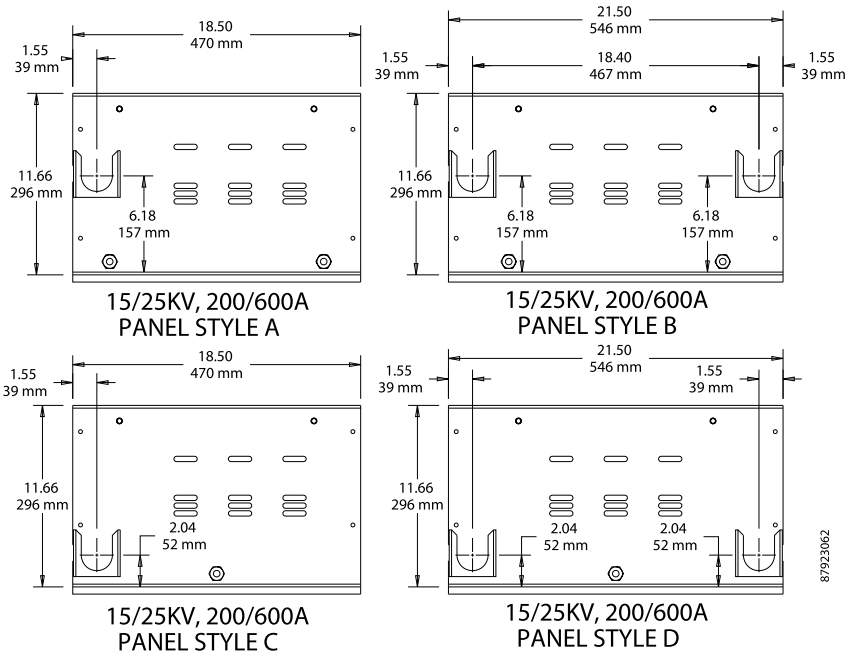

*Hoffman*<sup>®</sup>

# CHAPTER 5 CANADIAN CABINETS AND SPLITTERS

## OVERVIEW

Pentair Canadian cabinets and splitters have been tested and approved by CSA. The Type 1 standard metering cabinets include gland plates, panels, and hinged doors with spring latches and hasps. The HQ model meter cabinets are designed for use in the Hydro-Québec service area and include pre-punched panels.

Use Pentair splitter products to split power feeders into smaller branch services. Type 1 splitter troughs and boxes have hinged covers, integral 3- or 4-wire feed configurations and standard knockout patterns. Splitter lugs are integral to the trough and available in 85 through 600 Amp versions.

Type 1 splitter boxes have hinged covers, integral 3- or 4-wire feed configurations and standard knockouts. Splitter lugs are integral to the boxes and available in 85 through 400 Amp versions.

### SPLITTER TROUGH, TYPE 1

With pre-installed terminal blocks for three- and four-wire power distribution systems, this trough splits feeder circuit conductors into multiple branch circuit conductors.

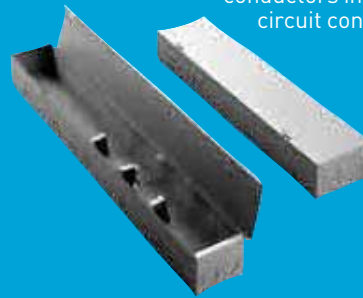



# CHAPTER CONTENTS

**CANADIAN CABINETS**  
Metering, Type 1 ..... 88

**CANADIAN SPLITTERS**  
Splitter Trough, Type 1 ..... 90  
Splitter Box, Type 1 ..... 92  
Splitter Block Assemblies Overview ..... 93  
Splitter Box Block Assemblies ..... 93  
Splitter Trough Block Assemblies ..... 94  
Ground Splitter (Ground Bar) ..... 94

## SPLITTER BOX, TYPE 1

This box splits feeder circuit conductors into multiple branch circuit conductors and comes with pre-installed terminal blocks for three- and four-wire power distribution systems.



**METERING, TYPE 1**

**INDUSTRY STANDARDS**

CSA File Number 42184: Type 1  
 NEMA/EEMAC Type 1  
 IEC 60529, IP30

**APPLICATION**

This enclosure houses metering transformers and instrument assemblies in indoor applications. HQ models meet Hydro-Québec requirements. It includes one pre-punched accessory, one potential transformer and one current transformer panel, and a four-lug splitter block.

**FEATURES**

- Gland plates on top of two-door enclosure for meter connection
- Hinged door with pull latch and provision for padlocking
- Mounting holes in back

**SPECIFICATIONS**

- 14 or 16 gauge steel

**FINISH**

ANSI 61 gray polyester powder paint finish inside and out

**ACCESSORIES**

See also *Accessories*.  
 Touch-Up Paint

**BULLETIN: M1**
**Standard Product Metering Cabinets**

Catalog Number	AxBxC in.	AxBxC mm	Panel Dimensions D x E (in.)	Panel Dimension D x E (mm)	Door
AMC271310R	27.00 x 13.00 x 10.00	686 x 330 x 254	22.75 x 8.75	578 x 222	Single
AMC302010R	30.00 x 20.00 x 10.00	762 x 508 x 254	25.75 x 15.75	654 x 400	Single
AMC303010R	30.00 x 30.00 x 10.00	762 x 762 x 254	25.75 x 25.75	654 x 654	Double
AMC363612R	36.00 x 36.00 x 12.00	914 x 914 x 305	31.75 x 31.75	806 x 806	Double
AMC484812R	48.00 x 48.00 x 12.00	1219 x 1219 x 305	43.75 x 43.75	1111 x 1111	Double

**Standard Product UG-Series Cabinets**

Catalog Number	AxBxC in.	AxBxC mm	Door
AMC202010UG	20.00 x 20.00 x 10.00	508 x 508 x 254	Single
AMC303010UG	30.00 x 30.00 x 10.00	762 x 762 x 254	Double
AMC363612UG	36.00 x 36.00 x 12.00	914 x 914 x 305	Double
AMC484812UG	48.00 x 48.00 x 12.00	1219 x 1219 x 305	Double

Panels included.

**Standard Product Metering Cabinets Meeting Hydro-Québec Requirements**

Catalog Number	AxBxC in.	AxBxC mm	Door
AMC303010HQ	30.00 x 30.00 x 10.00	762 x 762 x 254	Double
AMC363612HQ	36.00 x 36.00 x 12.00	914 x 914 x 305	Double
AMC484812HQ	48.00 x 48.00 x 12.00	1219 x 1219 x 305	Double

**Panels Included with Hydro-Québec Cutouts**

Catalog Number	AxBxC in.	AxBxC mm	Panel with Cutouts for	D (in.)	D (mm)	E (in.)	E (mm)
A32N34HQ	0.00		Current Transformer	12.76	324	13.39	340
A62N17HQ	0.00		Accessory	24.69	627	7.01	178
A65N38HQ	0.00		Main and Potential Transformer	25.59	650	15.00	381



**Single-Door Enclosures**

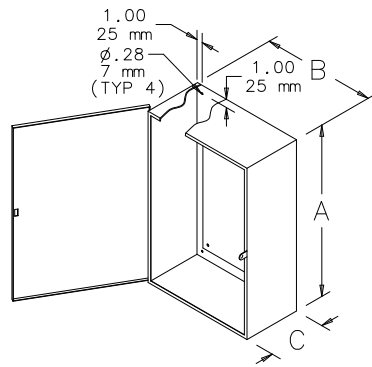

**Two-Door Enclosures**

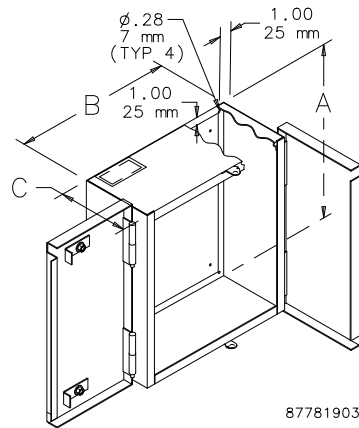

87781903

**PANELS**

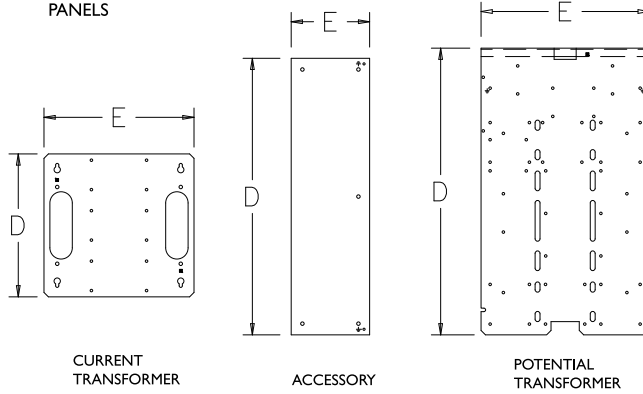

87781904



## SPLITTER TROUGH, TYPE 1



### INDUSTRY STANDARDS

CSA C22.2 No. 76, File No. 42184: Type 1  
 NEMA/EEMAC Type 1  
 IEC 60529, IP30

### APPLICATION

With pre-installed terminal blocks for three- and four-wire power distribution systems, this trough splits feeder circuit conductors into multiple branch circuit conductors.

### FEATURES

- Various size knockouts on each side
- Hinged covers
- Mounting holes in back
- Includes single-point ground lug
- Ground Splitter (ground bar) accessory available

### SPECIFICATIONS

- 16 or 14 gauge steel

### Knockout Size and Spacing

Amps Rating	Qty.	End Knockout Size	Spacing (in.)	Spacing (mm)	Side Knockout Size and Position	Spacing (in.)	Spacing (mm)
85	2	1-3/4 - 2	2.75	70	Alternating 1/2 - 3/4 and 1 - 1-3/4	4.50	114
125	2	1-3/4 - 2	2.75	70	Alternating 1/2 - 3/4 and 1 - 1-3/4	4.50	114
225	2	2-1/2 - 3	4.06	103	Alternating 1/2 - 3/4 and 1 - 1-3/4	4.50	114
400	2	3 - 3-1/2	4.91	125	Alternating 1/2 - 3/4 and 1 - 1-3/4	4.50	114
600	2	3 - 3-1/2	4.91	125	Alternating 1/2 - 3/4 and 1 - 1-3/4	4.50	114

### FINISH

ANSI 61 gray polyester powder paint finish inside and out

### ACCESSORIES

See also *Accessories*.  
 Ground Bar Kit  
 Splitter Block Assemblies  
 Touch-Up Paint

BULLETIN: S90T

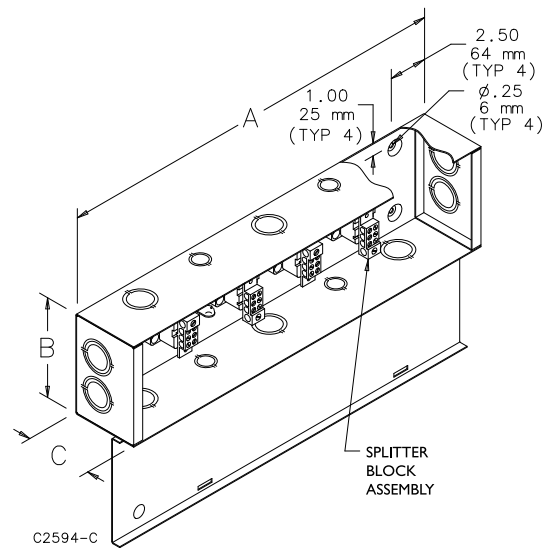

Standard Product **Type 1 Splitter Trough**

Catalog Number	in.	mm	Number of Wires	Main Lugs Amps CU	Main Lugs Wire Size Range	Main Lugs Qty.	Branch Lugs Amps CU	Branch Lugs Wire Size Range	Branch Lugs Qty.
AST283R	24.00 x 6.00 x 4.50	610 x 152 x 114	3	85	14-1	1	55	14-6	6
AST284R	24.00 x 6.00 x 4.50	610 x 152 x 114	4	85	14-1	1	55	14-6	6
AST383R	36.00 x 6.00 x 4.50	914 x 152 x 114	3	85	14-1	1	55	14-6	6
AST384R	36.00 x 6.00 x 4.50	914 x 152 x 114	4	85	14-1	1	55	14-6	6
AST483R	48.00 x 6.00 x 4.50	1219 x 152 x 114	3	85	14-1	1	55	14-6	6
AST484R	48.00 x 6.00 x 4.50	1219 x 152 x 114	4	85	14-1	1	55	14-6	6
AST123R	24.00 x 6.00 x 4.50	610 x 152 x 114	3	125	14-1/0	1	110	14-2	6
AST124R	24.00 x 6.00 x 4.50	610 x 152 x 114	4	125	14-1/0	1	110	14-2	6
AST3123R	36.00 x 6.00 x 4.50	914 x 152 x 114	3	125	14-1/0	1	110	14-2	6
AST3124R	36.00 x 6.00 x 4.50	914 x 152 x 114	4	125	14-1/0	1	110	14-2	6
AST4123R	48.00 x 6.00 x 4.50	1219 x 152 x 114	3	125	14-1/0	1	110	14-2	6
AST4124R	48.00 x 6.00 x 4.50	1219 x 152 x 114	4	125	14-1/0	1	110	14-2	6
AST3223R	36.00 x 8.25 x 4.50	914 x 210 x 114	3	225	6-300MCM	1	150	14-2/0	6
AST3224R	36.00 x 8.25 x 4.50	914 x 210 x 114	4	225	6-300MCM	1	150	14-2/0	6
AST4223R	48.00 x 8.25 x 4.50	1219 x 210 x 114	3	225	6-300MCM	1	150	14-2/0	6
AST4224R	48.00 x 8.25 x 4.50	1219 x 210 x 114	4	225	6-300MCM	1	150	14-2/0	6
AST5223R	60.00 x 8.25 x 4.50	1524 x 210 x 114	3	225	6-300MCM	1	150	14-2/0	6
AST5224R	60.00 x 8.25 x 4.50	1524 x 210 x 114	4	225	6-300MCM	1	150	14-2/0	6
AST6223R	72.00 x 8.25 x 4.50	1829 x 210 x 114	3	225	6-300MCM	1	150	14-2/0	6
AST6224R	72.00 x 8.25 x 4.50	1829 x 210 x 114	4	225	6-300MCM	1	150	14-2/0	6
AST3403R	36.00 x 10.00 x 6.00	914 x 254 x 152	3	400	1/0-250MCM: 4-600MCM	2:1	175	6-4/0 AND 14-3/0 <sup>a</sup>	4 and 2 <sup>a</sup>
AST4403R	48.00 x 10.00 x 6.00	1219 x 254 x 152	3	400	1/0-250MCM: 4-600MCM	2:1	175	6-4/0 AND 14-3/0 <sup>a</sup>	4 and 2 <sup>a</sup>
AST4404R	48.00 x 10.00 x 6.00	1219 x 254 x 152	4	400	1/0-250MCM: 4-600MCM	2:1	175	6-4/0 AND 14-3/0 <sup>a</sup>	4 and 2 <sup>a</sup>
AST5403R	60.00 x 10.00 x 6.00	1524 x 254 x 152	3	400	1/0-250MCM: 4-600MCM	2:1	175	6-4/0 AND 14-3/0 <sup>a</sup>	4 and 2 <sup>a</sup>
AST5404R	60.00 x 10.00 x 6.00	1524 x 254 x 152	4	400	1/0-250MCM: 4-600MCM	2:1	175	6-4/0 AND 14-3/0 <sup>a</sup>	4 and 2 <sup>a</sup>
AST6403R	72.00 x 10.00 x 6.00	1829 x 254 x 152	3	400	1/0-250MCM: 4-600MCM	2:1	175	6-4/0 AND 14-3/0 <sup>a</sup>	4 and 2 <sup>a</sup>
AST6404R	72.00 x 10.00 x 6.00	1829 x 254 x 152	4	400	1/0-250MCM: 4-600MCM	2:1	175	6-4/0 AND 14-3/0 <sup>a</sup>	4 and 2 <sup>a</sup>
AST4603R	48.00 x 11.00 x 6.50	1219 x 279 x 165	3	600	1/0-250MCM: 4-600MCM	4:2	175	6-4/0 AND 14-3/0 <sup>a</sup>	4 and 2 <sup>a</sup>
AST4604R	48.00 x 11.00 x 6.50	1219 x 279 x 165	4	600	1/0-250MCM: 4-600MCM	4:2	175	6-4/0 AND 14-3/0 <sup>a</sup>	4 and 2 <sup>a</sup>
AST5603R	60.00 x 11.00 x 6.50	1524 x 279 x 165	3	600	1/0-250MCM: 4-600MCM	4:2	175	6-4/0 AND 14-3/0 <sup>a</sup>	4 and 2 <sup>a</sup>
AST5604R	60.00 x 11.00 x 6.50	1524 x 279 x 165	4	600	1/0-250MCM: 4-600MCM	4:2	175	6-4/0 AND 14-3/0 <sup>a</sup>	4 and 2 <sup>a</sup>
AST6603R	72.00 x 11.00 x 6.50	1829 x 279 x 165	3	600	1/0-250MCM: 4-600MCM	4:2	175	6-4/0 AND 14-3/0 <sup>a</sup>	4 and 2 <sup>a</sup>
AST6604R	72.00 x 11.00 x 6.50	1829 x 279 x 165	4	600	1/0-250MCM: 4-600MCM	4:2	175	6-4/0 AND 14-3/0 <sup>a</sup>	4 and 2 <sup>a</sup>

<sup>a</sup>Six total branch lugs: (4) 6-4/0 and (2) 14-3/0



**SPLITTER BOX, TYPE 1**

**INDUSTRY STANDARDS**

CSA C22.2 No. 76, File No. 42184: Type 1  
 NEMA/EEMAC Type 1  
 IEC 60529, IP30

**APPLICATION**

This box splits feeder circuit conductors into multiple branch circuit conductors and comes with pre-installed terminal blocks for three- and four-wire power distribution systems.

**FEATURES**

- Various numbers and sizes of combination knockouts are provided on all four sides: see Knockout Size and Spacing Table
- Hinged covers
- Mounting holes in back
- Includes single point ground lug
- Ground Splitter (ground bar) accessory available

**SPECIFICATIONS**

- 16 or 14 gauge steel

**FINISH**

ANSI 61 gray polyester powder paint finish inside and out

**ACCESSORIES**

See also *Accessories*.  
 Splitter Block Assemblies  
 Touch-Up Paint

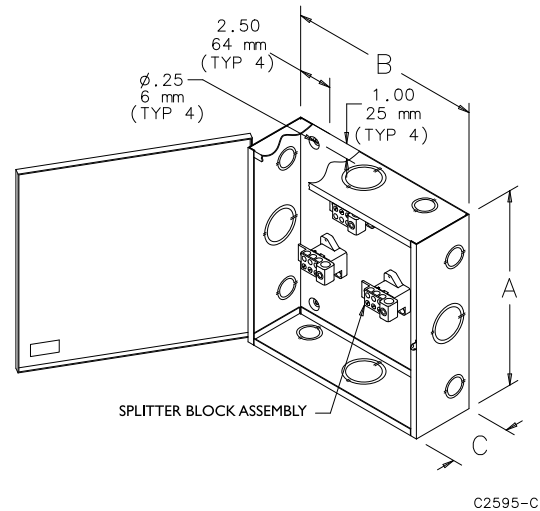
**BULLETIN: S90B**

C2595-C

**Standard Product Type 1 Splitter Box, 600 volt**

Catalog Number	AxBxC in.	AxBxC mm	Number of Wires	Main Lugs Amps CU	Main Lugs Wire Size Range	Main Lugs Qty.	Branch Lugs Amps CU	Branch Lugs Wire Size Range	Branch Lugs Qty.
ASB83R	12.00 x 12.00 x 4.00	305 x 305 x 102	3	85	14-1	1	55	14-6	3
ASB84R	12.00 x 12.00 x 4.00	305 x 305 x 102	4	85	14-1	1	55	14-6	3
ASB123R	12.00 x 12.00 x 4.00	305 x 305 x 102	3	125	14-2/0	1	110	14-2/0	3
ASB124R	12.00 x 12.00 x 4.00	305 x 305 x 102	4	125	14-2/0	1	110	14-2/0	3
ASB223R	16.00 x 16.00 x 5.00	406 x 406 x 127	3	225	6-300MCM	1	175	14-2/0	3
ASB224R	16.00 x 16.00 x 5.00	406 x 406 x 127	4	225	6-300MCM	1	175	14-2/0	3
ASB403R	22.00 x 22.00 x 6.00	559 x 559 x 152	3	400	4-600MCM	2	285	4-600MCM	2
ASB404R	22.00 x 22.00 x 6.00	559 x 559 x 152	4	400	4-600MCM	2	285	4-600MCM	2

**Knockout Size and Spacing from Outside Enclosure**

Amps Rating	Qty.	Knockout Size	Spacing (in.)	Spacing (mm)
85	21	1-3/4 - 2	2.00	51
		2 - 2-1/2	4.00	102
125	21	1-3/4 - 2	2.00	51
		2 - 2-1/2	4.00	102
225	21	1-3/4 - 2	2.00	51
		2-1/2 - 3	6.00	152
400	21	2 - 2-1/2	2.00	51
		3 - 3-1/2	6.00	152

Knockouts viewed from outside enclosure. Pattern and sizes same on all four sides.

**SPLITTER BLOCK ASSEMBLIES OVERVIEW**



**INDUSTRY STANDARDS**

CSA Certified

**APPLICATION**

Splitter Block Assemblies tap feeder branch circuits in splitter boxes and troughs. Each 600-volt block includes a main lug and branch lugs, together with copper/aluminum (CU/AL) connectors secured to insulators.

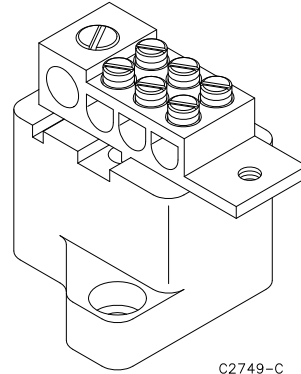

C2749-C

**SPLITTER BOX BLOCK ASSEMBLIES**



BULLETIN: S90Y

Catalog Number	Main Amps	Main Lug Qty.	Main Lug Wire Size Range	Branch Amps	Branch Lug Qty.	Branch Lug Wire Size Range
ASBB85	85	1	14-1	40	3	14-6
ASBB125	125	1	14-2/0	85	3	14-2/0
ASBB225	225	1	6-300MCM	125	3	14-2/0
ASBB400R	400	2	4-600MCM	225	2	4-600MCM

**SPLITTER TROUGH BLOCK ASSEMBLIES**

BULLETIN: S90Y



Catalog Number	Main Amps	Main Lug Qty.	Main Lug Wire Size Range	Branch Amps	Branch Lug Qty.	Branch Lug Wire Size Range
ASTB85	85	1	14-1	40	6	14-6
ASTB125	125	1	14-1/0	85	6	14-2
ASTB225	225	1	6-300MCM	125	6	14-2/0
ASTB400	400	1:2	4-600MCM:1/0-250	125	4 + 2 <sup>A</sup>	6-4/0 and 14-3/0 <sup>A</sup>
ASTB600	600	2:4	4-600MCM:1/0-250	125	4 + 2 <sup>A</sup>	6-4/0 and 14-3/0 <sup>A</sup>

<sup>A</sup> Six total branch lugs: (4) 6-4/0 and (2) 14-3/0

**GROUND SPLITTER (GROUND BAR)**

BULLETIN: S90Y

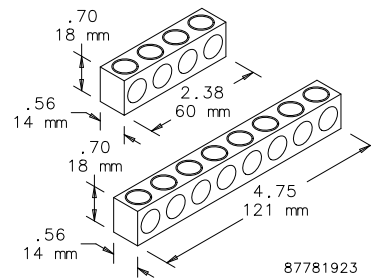

Catalog Number	Depth in./mm	Lug Qty.	Wire Size Range	Application
ASG4	2.38 60	4	14-2/0	Splitter Box or Splitter Trough
ASG8	4.75 121	8	14-2/0	Splitter Trough

## Notes



*Hoffman*<sup>®</sup>

# CHAPTER 6 LAY-IN WIREWAY

## OVERVIEW

Pentair lay-in wireways are used in commercial and industrial environments to provide fast, flexible methods of distributing power and controlling wiring.

The Type 1 lay-in wireway products are available in three styles and in six cross-sections, from 2.5 x 2.5 in. through 12 x 12 in. in several incremental lengths up to 10 ft.

Type 3R wireway products feature Pentair patented labor-saving tab-and-slot connections for securely attaching adjoining pieces to exclude rain, sleet, snow or dripping water. The Type 3R wireways also have a unique, removable hinged cover with quick-release clamps.

## LAY-IN PAINTED FLAT-COVER WIREWAY, NEMA TYPE 1

This painted wireway features an open design on one side so wires and cables can be laid in safely along the entire run without pulling, a practice that can damage insulation. A variety of lengths and fittings provide design flexibility.







## CHAPTER CONTENTS

### LAY-IN NEMA TYPE 1 GALVANIZED WIREWAY

Lay-In Galvanized Wireway, NEMA Type 1	98
Straight Section	100
Galvanized 90-Degree Flush Tee	101
Galvanized Sweep Tee	101
Galvanized Cross Fitting	102
Galvanized 90-Degree Sweep Elbow	102
Galvanized 90-Degree Elbow-Tee-Cross	102
Galvanized 90-Degree Elbow	102
Galvanized 90-Degree Elbow—Outside Opening	103
Galvanized 90-Degree Elbow—Inside Opening	103
Galvanized 45-Degree Elbow	103
Galvanized Telescope Fitting	104
Galvanized Panel Adapter	104
Galvanized Closure Plate, With and Without Knockouts	104
Reducer	105
Galvanized Support Hanger	105
Drop and Bracket Hangers	105
Galvanized Universal U-Connector	105

### LAY-IN NEMA TYPE 1 PAINTED FLAT-COVER WIREWAY

Lay-In Painted Flat-Cover Wireway, NEMA Type 1	106
Straight Section	107
90-Degree Flush Tee	109
Sweep Tee	109
Cross Fitting	109
90-Degree Sweep Elbow	109
90-Degree Elbow-Tee-Cross	110
90-Degree Elbow	110
90-Degree Elbow—Outside Opening	110
90-Degree Elbow—Inside Opening	110
45-Degree Elbow	111
Telescope Fitting	111
Open Adapter	111
Panel Adapter	111
Closure Plate	112
Drop and Bracket Hangers	112
Support Hanger	112
Universal U-Connector	113
Barrier Kit, Bolt-On	113
Reducer	113

### LAY-IN NEMA TYPE 1 HINGED-COVER WIREWAY

Lay-In Hinged-Cover Wireway, NEMA Type 1	114
Straight Section	115
90-Degree Flush Tee	117
Sweep Tee	117
Cross Fitting	117
90-Degree Sweep Elbow	117
90-Degree Elbow-Tee-Cross	118
90-Degree Elbow	118
90-Degree Elbow—Outside Opening	118
90-Degree Elbow—Inside Opening	118
45-Degree Elbow	119
Telescope Fitting	119
Open Adapter	119
Panel Adapter	119
Closure Plate	120
Reducer	120
Drop and Bracket Hangers	120
Support Hanger	120
Universal U-Connector	121
Barrier Kit, Bolt-On	121

### LAY-IN NEMA TYPE 3R WIREWAY

Lay-In Wireway, NEMA Type 3R	122
Straight Section	123
90-Degree Flush Tee	123
30-Degree Sweep Elbow	123
90-Degree Elbow-Tee-Cross	124
90-Degree Elbow	124
Panel Adapter	124
Closure Plate	124
Reducer	124
Drop and Bracket Hanger	125
Wall Hanger	125
U-Connector	125

### LAY-IN NEMA TYPE 12 WIREWAY

Lay-In Wireway, NEMA Type 12	126
Straight Section	129
Cut-Off Fitting, Lay-In	130
Cut-Off Fitting, Non-Lay-In	130
Telescope Fitting, Lay-In	130
Cross Fitting	130
90-Degree Elbows	131
90-Degree Elbow—Outside Top Opening	131
45-Degree Elbows	132
Tee Fitting—Top Opening	132
Tee Fitting—Outside Top Opening	133
Junction Box	133
Closure Plate	133
Reducer	134
Nipple	134
Drop Hanger	134
Bracket Hanger	135
Box Connector	135
Transposition Sections	136
Barrier Kit, Bolt-On	136
Barrier Kits, Bracket-Mounted	137
90-Degree Angle Sealing Plate	137
Quick-Release Flat Sealing Plate	137

### LAY-IN WIREWAY, NEMA TYPE 3R

This moisture-proof wireway features a quick-release latch cover for convenient access and an opening on one side so wires and cables can be laid in along the entire run without pulling.



LAY-IN GALVANIZED WIREWAY, NEMA TYPE 1



45° Elbow (bottom) and Telescope Fitting (top)

**INDUSTRY STANDARDS**

UL 870 Listed; File No. E27524  
 cUL Listed per CSA C22.2 No. 26; File No. E27524

NEMA/EEMAC: Type 1  
 IEC 60529, IP30

**APPLICATION**

This galvanized wireway features an open design on one side so wires and cables can be laid in safely along the entire run without pulling. A variety of lengths and fittings accommodate design requirements.

**FEATURES**

- Flat cover design
- Open top assembly
- Available with or without knockouts
- Keyhole screw slots on flat covers
- Knockouts on wireway sides

**SPECIFICATIONS**

- 16 or 14 gauge galvanized steel covers and bodies

**FINISH**

Unpainted galvanized steel

This drawing illustrates how most of the Hoffman NEMA Type 1 lay-in wireway sections and fittings could be used in an actual wireway run. The covers have been omitted to present the lay-in feature more clearly. Many different sections and fittings can be combined in any configuration desired.

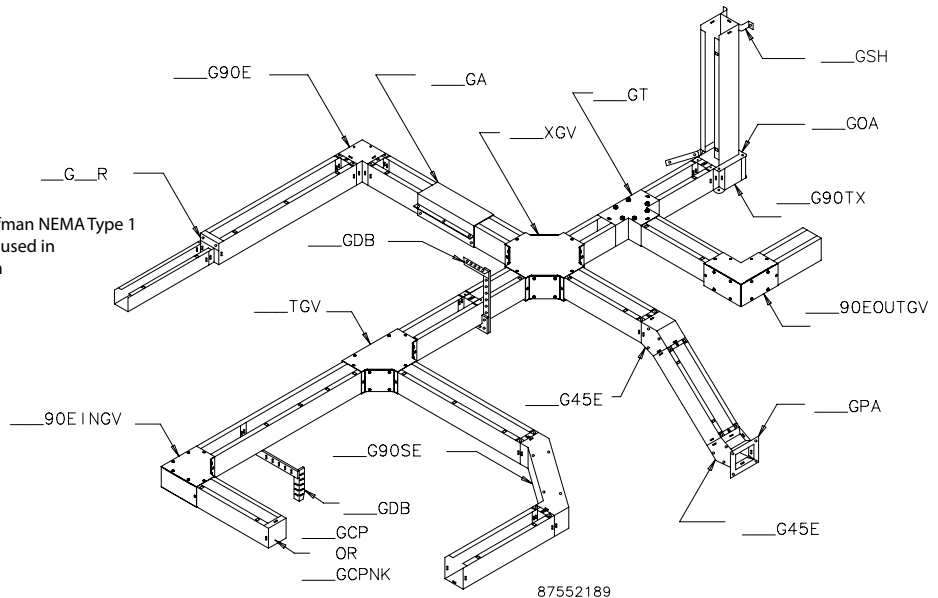

Standard Product Selection Matrix

Description	2.50 x 2.50 in. (64 x 64 mm)	4.00 x 4.00 in. (102 x 102 mm)	6.00 x 6.00 in. (152 x 152 mm)	8.00 x 8.00 in. (203 x 203 mm)	10.00 x 10.00 in. (254 x 254 mm)	12.00 x 12.00 in. (305 x 305 mm)
12.00-in. (305-mm) Straight Section with knockouts	—	F44T112GVWK	F66T112GVWK	F88T112GVWK	—	—
12.00-in. (305-mm) Straight Section without knockouts	F22T112GV	F44T112GV	F66T112GV	F88T112GV	F1010T112GV	F1212T112GV
18.00-in. (455-mm) Straight Section without knockouts	—	F44T118GV	F66T118GV	F88T118GV	—	—
24.00-in. (610-mm) Straight Section with knockouts	F22T124GVWK	F44T124GVWK	F66T124GVWK	F88T124GVWK	—	—
24.00-in. (610-mm) Straight Section without knockouts	F22T124GV	F44T124GV	F66T124GV	F88T124GV	F1010T124GV	F1212T124GV
24.00-in. (610-mm) Straight Section without knockouts	F22T136GVWK	F44T136GVWK	F66T136GVWK	F88T136GVWK	—	—
36.00-in. (914-mm) Straight Section without knockouts	F22T136GV	F44T136GV	F66T136GV	F88T136GV	F1010T136GV	F1212T136GV
48.00-in. (1219-mm) Straight Section with knockouts	—	F44T148GVWK	F66T148GVWK	F88T148GVWK	—	—
48.00-in. (1219-mm) Straight Section without knockouts	F22T148GV	F44T148GV	F66T148GV	F88T148GV	F1010T148GV	F1212T148GV
60.00-in. (1524-mm) Straight Section with knockouts	F22T160GVWK	F44T160GVWK	F66T160GVWK	F88T160GVWK	—	—
60.00-in. (1524-mm) Straight Section without knockouts	F22T160GV	F44T160GV	F66T160GV	F88T160GV	F1010T160GV	F1212T160GV
72.00-in. (1829-mm) Straight Section with knockouts	—	F44T172GVWK	F66T172GVWK	F88T172GVWK	—	—
72.00-in. (1829-mm) Straight Section without knockouts	—	F44T172GV	F66T172GV	F88T172GV	F1010T172GV	—
120.00-in. (3048-mm) Straight Section with knockouts	F22T1120GVWK	F44T1120GVWK	F66T1120GVWK	F88T1120GVWK	—	—
120.00-in. (3048-mm) Straight Section without knockouts	F22T1120GV	F44T1120GV	F66T1120GV	F88T1120GV	F1010T1120GV	F1212T1120GV
90° Flush Tee	F22GTGV	F44GTGV	F66GTGV	F88GTGV	F1010GTGV	F1212GTGV
Sweep Tee	F22TGV	F44TGV	F66TGV	F88TGV	F1010TGV	F1212TGV
Cross Fitting	F22XGV	F44XGV	F66XGV	F88XGV	F1010XGV	F1212XGV
90° Sweep Elbow	F2290SEGV	F4490SEGV	F6690SEGV	F8890SEGV	F101090SEGV	F121290SEGV
90° Elbow Tee-Cross	F2290TXGV	F4490TXGV	F6690TXGV	F8890TXGV	F101090TXGV	F121290TXGV
90° Elbow	F2290EGV	F4490EGV	F6690EGV	F8890EGV	F101090EGV	F121290EGV
90° Elbow Outside Opening	F2290INGV	F4490INGV	F6690INGV	F8890INGV	F101090INGV	F121290INGV
90° Elbow Outside Opening	F2290EOUTGV	F4490EOUTGV	F6690EOUTGV	F8890EOUTGV	F101090EOUTGV	F121290EOUTGV
45° Elbow	F2245EGV	F4445EGV	F6645EGV	F8845EGV	F101045EGV	F121245EGV
Telescope Fitting <sup>3</sup>	F22GAGV	F44GAGV	F66GAGV	F88GAGV	F1010GAGV	F1212GAGV
Panel Adapter	F22GPAGV	F44GPAGV	F66GPAGV	F88GPAGV	F1010GPAGV	F1212GPAGV
Closure Plate with knockouts	F22GCPGV	F44GCPGV	F66GCPGV	F88GCPGV	—	F1212GCPGV
Closure Plate without knockouts	F22GCPNKGV	F44GCPNKGV	F66GCPNKGV	F88GCPNKGV	F1010GCPNKGV	F1212GCPNKGV
Reducer	—	F44G22R	F66G44R	F88G66R	F1010G88R	F1212G1010R
Drop and Bracket Hanger	F22GDB	F44GDB	F66GDB	F88GDB	F1010GDB	F1212GDB
Support Hanger	F22GSHGV	F44GSHGV	F66GSHGV	F88GSHGV	F1010GSHGV	F1212GSHGV
Universal U-Connector	F22GUCGV	F44GUCGV	F66GUCGV	F88GUCGV	F1010GUCGV	F1212GUCGV

<sup>3</sup>Not UL/cUL listed.



**STRAIGHT SECTION**

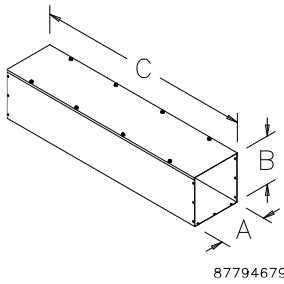

87794679

Available in lengths from 12.00 in. (305 mm) to 120.00 in. (3048 mm), with or without knockouts.

BULLETIN: F40, F40G

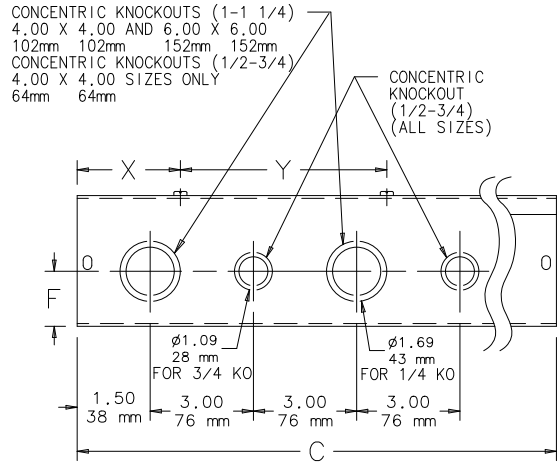

87794743

PATTERN REPEATS EVERY 12.00 305 mm

**Straight Sections**

Catalog Number	AxBxC in.	AxBxC mm	Number of Knockouts, .50 in.-.75 in.	Number of Knockouts, 1.00 in.-1.25 in.	F (in.)	F (mm)	X (in.)	X (mm)	Y (in.)	Y (mm)
F22T112GV	2.50 x 2.50 x 12.00	64 x 64 x 305	—	—	—	—	—	—	—	—
F22T124GVWK	2.50 x 2.50 x 24.00	64 x 64 x 610	16	—	1.06	27	6.00	152	12.00	305
F22T124GV	2.50 x 2.50 x 24.00	64 x 64 x 610	—	—	—	—	—	—	—	—
F22T136GVWK	2.50 x 2.50 x 36.00	64 x 64 x 914	24	—	1.06	27	6.00	152	12.00	305
F22T136GV	2.50 x 2.50 x 36.00	64 x 64 x 914	—	—	—	—	—	—	—	—
F22T148GV	2.50 x 2.50 x 48.00	64 x 64 x 1219	—	—	—	—	—	—	—	—
F22T160GVWK	2.50 x 2.50 x 60.00	64 x 64 x 1524	40	—	1.06	27	6.00	152	12.00	305
F22T160GV	2.50 x 2.50 x 60.00	64 x 64 x 1524	—	—	—	—	—	—	—	—
F22T1120GVWK	2.50 x 2.50 x 120.00	64 x 64 x 3048	80	—	1.06	27	6.00	152	12.00	305
F22T1120GV	2.50 x 2.50 x 120.00	64 x 64 x 3048	—	—	—	—	—	—	—	—
F44T112GVWK	4.00 x 4.00 x 12.00	102 x 102 x 305	4	4	1.62	41	3.00	76	6.00	152
F44T112GV	4.00 x 4.00 x 12.00	102 x 102 x 305	—	—	—	—	—	—	—	—
F44T118GV	4.00 x 4.00 x 18.00	102 x 102 x 457	—	—	—	—	—	—	—	—
F44T124GVWK	4.00 x 4.00 x 24.00	102 x 102 x 610	8	8	1.62	41	6.00	152	12.00	305
F44T124GV	4.00 x 4.00 x 24.00	102 x 102 x 610	—	—	—	—	—	—	—	—
F44T136GVWK	4.00 x 4.00 x 36.00	102 x 102 x 914	12	12	1.62	41	6.00	152	12.00	305
F44T136GV	4.00 x 4.00 x 36.00	102 x 102 x 914	—	—	—	—	—	—	—	—
F44T148GVWK	4.00 x 4.00 x 48.00	102 x 102 x 1219	16	16	1.62	41	6.00	152	12.00	305
F44T148GV	4.00 x 4.00 x 48.00	102 x 102 x 1219	—	—	—	—	—	—	—	—
F44T160GVWK	4.00 x 4.00 x 60.00	102 x 102 x 1524	20	20	1.62	41	6.00	152	12.00	305
F44T160GV	4.00 x 4.00 x 60.00	102 x 102 x 1524	—	—	—	—	—	—	—	—
F44T172GVWK	4.00 x 4.00 x 72.00	102 x 102 x 1829	24	24	1.62	41	6.00	152	12.00	305
F44T172GV	4.00 x 4.00 x 72.00	102 x 102 x 1829	—	—	—	—	—	—	—	—
F44T1120GVWK	4.00 x 4.00 x 120.00	102 x 102 x 3048	40	40	1.62	41	6.00	152	12.00	305
F44T1120GV	4.00 x 4.00 x 120.00	102 x 102 x 3048	—	—	—	—	—	—	—	—
F66T112GVWK	6.00 x 6.00 x 12.00	152 x 152 x 305	4	4	1.62	41	6.00	152	12.00	305
F66T112GV	6.00 x 6.00 x 12.00	152 x 152 x 305	—	—	—	—	—	—	—	—
F66T118GV	6.00 x 6.00 x 18.00	152 x 152 x 455	—	—	—	—	—	—	—	—
F66T124GVWK	6.00 x 6.00 x 24.00	152 x 152 x 610	8	8	1.62	41	6.00	152	12.00	305
F66T124GV	6.00 x 6.00 x 24.00	152 x 152 x 610	—	—	—	—	—	—	—	—
F66T136GVWK	6.00 x 6.00 x 36.00	152 x 152 x 914	12	12	1.62	41	6.00	152	12.00	305
F66T136GV	6.00 x 6.00 x 36.00	152 x 152 x 914	—	—	—	—	—	—	—	—
F66T148GVWK	6.00 x 6.00 x 48.00	152 x 152 x 1219	16	16	1.62	41	6.00	152	12.00	305
F66T148GV	6.00 x 6.00 x 48.00	152 x 152 x 1219	—	—	—	—	—	—	—	—
F66T160GVWK	6.00 x 6.00 x 60.00	152 x 152 x 1524	20	20	1.62	41	6.00	152	12.00	305
F66T160GV	6.00 x 6.00 x 60.00	152 x 152 x 1524	—	—	—	—	—	—	—	—
F66T172GVWK	6.00 x 6.00 x 72.00	152 x 152 x 1829	24	24	1.62	41	6.00	152	12.00	305
F66T172GV	6.00 x 6.00 x 72.00	152 x 152 x 1829	—	—	—	—	—	—	—	—
F66T1120GVWK	6.00 x 6.00 x 120.00	152 x 152 x 3048	40	40	1.62	41	6.00	152	12.00	305
F66T1120GV	6.00 x 6.00 x 120.00	152 x 152 x 3048	—	—	—	—	—	—	—	—
F88T112GVWK	8.00 x 8.00 x 12.00	203 x 203 x 305	4	4	1.62	41	3.00	76	6.00	152
F88T112GV	8.00 x 8.00 x 12.00	203 x 203 x 305	—	—	—	—	—	—	—	—
F88T118GV	8.00 x 8.00 x 18.00	203 x 203 x 455	—	—	—	—	—	—	—	—
F88T124GVWK	8.00 x 8.00 x 24.00	203 x 203 x 610	8	8	1.62	41	6.00	152	12.00	305
F88T124GV	8.00 x 8.00 x 24.00	203 x 203 x 610	—	—	—	—	—	—	—	—
F88T136GVWK	8.00 x 8.00 x 36.00	203 x 203 x 914	12	12	1.62	41	6.00	152	12.00	305
F88T136GV	8.00 x 8.00 x 36.00	203 x 203 x 914	—	—	—	—	—	—	—	—

Catalog Number	AxBxC in.	AxBxC mm	Number of Knockouts, .50 in.-.75 in.	Number of Knockouts, 1.00 in.-1.25 in.	F (in.)	F (mm)	X (in.)	X (mm)	Y (in.)	Y (mm)
F88T148GVWK	8.00 x 8.00 x 48.00	203 x 203 x 1219	16	16	1.62	41	6.00	152	12.00	305
F88T148GV	8.00 x 8.00 x 48.00	203 x 203 x 1219	—	—	—	—	—	—	—	—
F88T160GVWK	8.00 x 8.00 x 60.00	203 x 203 x 1524	20	20	1.62	41	6.00	152	12.00	305
F88T160GV	8.00 x 8.00 x 60.00	203 x 203 x 1524	—	—	—	—	—	—	—	—
F88T172GVWK	8.00 x 8.00 x 72.00	203 x 203 x 1829	24	24	1.62	41	6.00	152	12.00	305
F88T172GV	8.00 x 8.00 x 72.00	203 x 203 x 1829	—	—	—	—	—	—	—	—
F88T1120GVWK	8.00 x 8.00 x 120.00	203 x 203 x 3048	40	40	1.62	41	6.00	152	12.00	305
F88T1120GV	8.00 x 8.00 x 120.00	203 x 203 x 3048	—	—	—	—	—	—	—	—
F1010T112GV	10.00 x 10.00 x 12.00	254 x 254 x 305	—	—	—	—	—	—	—	—
F1010T124GV	10.00 x 10.00 x 24.00	254 x 254 x 610	—	—	—	—	—	—	—	—
F1010T136GV	10.00 x 10.00 x 36.00	254 x 254 x 914	—	—	—	—	—	—	—	—
F1010T148GV	10.00 x 10.00 x 48.00	254 x 254 x 1219	—	—	—	—	—	—	—	—
F1010T160GV	10.00 x 10.00 x 60.00	254 x 254 x 1524	—	—	—	—	—	—	—	—
F1010T172GV	10.00 x 10.00 x 72.00	254 x 254 x 1829	—	—	—	—	—	—	—	—
F1010T1120GV	10.00 x 10.00 x 120.00	254 x 254 x 3048	—	—	—	—	—	—	—	—
F1212T112GV	12.00 x 12.00 x 12.00	305 x 305 x 305	—	—	—	—	—	—	—	—
F1212T124GV	12.00 x 12.00 x 24.00	305 x 305 x 610	—	—	—	—	—	—	—	—
F1212T136GV	12.00 x 12.00 x 36.00	305 x 305 x 914	—	—	—	—	—	—	—	—
F1212T148GV	12.00 x 12.00 x 48.00	305 x 305 x 1219	—	—	—	—	—	—	—	—
F1212T160GV	12.00 x 12.00 x 60.00	305 x 305 x 1524	—	—	—	—	—	—	—	—
F1212T1120GV	12.00 x 12.00 x 120.00	305 x 305 x 3048	—	—	—	—	—	—	—	—

### GALVANIZED 90-DEGREE FLUSH TEE

For flush mounting against a vertical or horizontal surface.

BULLETIN: F40GF

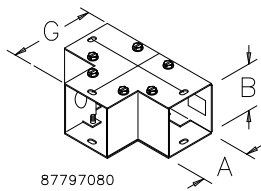

Catalog Number	AxB in./mm	G in./mm
F22GTGV	2.50 x 2.50 64 x 64	4.50 114
F44GTGV	4.00 x 4.00 102 x 102	6.00 152
F66GTGV	6.00 x 6.00 152 x 152	8.00 203
F88GTGV	8.00 x 8.00 203 x 203	10.00 254
F1010GTGV	10.00 x 10.00 254 x 254	12.00 305
F1212GTGV	12.00 x 12.00 305 x 305	14.00 356

### GALVANIZED SWEEP TEE

For large radius turns. Mounts against vertical or horizontal surfaces. Top and inside covers removable.

BULLETIN: F40GF

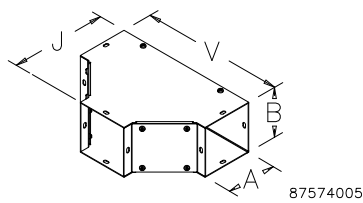

Catalog Number	AxB in./mm	J in./mm	V in./mm
F22TGV	2.50 x 2.50 64 x 64	6.50 165	10.35 263
F44TGV	4.00 x 4.00 102 x 102	8.00 203	11.85 301
F66TGV	6.00 x 6.00 152 x 152	10.00 254	13.85 352
F88TGV	8.00 x 8.00 203 x 203	12.00 305	15.84 402
F1010TGV	10.00 x 10.00 254 x 254	14.00 356	17.84 453
F1212TGV	12.00 x 12.00 305 x 305	16.00 406	19.84 504



### GALVANIZED CROSS FITTING

For routing cables in four directions. Top, bottom and side covers removable.

BULLETIN: F40GF

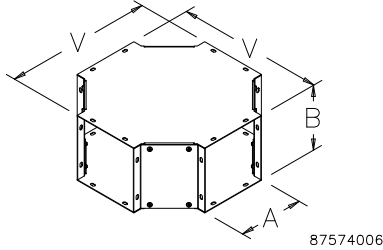

Catalog Number	AxB in./mm	V in./mm
F22XGV	2.50 x 2.50 64 x 64	10.35 263
F44XGV	4.00 x 4.00 102 x 102	11.85 301
F66XGV	6.00 x 6.00 152 x 152	13.85 352
F88XGV	8.00 x 8.00 203 x 203	15.84 402
F1010XGV	10.00 x 10.00 254 x 254	17.84 453
F1212XGV	12.00 x 12.00 305 x 305	19.84 504

### GALVANIZED 90-DEGREE SWEEP ELBOW

90-Degree Sweep Elbow for large-radius turns.

BULLETIN: F40GF

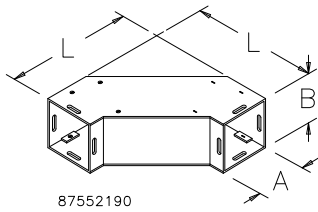

Catalog Number	AxB in./mm	L in./mm
F2290SEGV	2.50 x 2.50 64 x 64	7.91 201
F4490SEGV	4.00 x 4.00 102 x 102	9.41 239
F6690SEGV	6.00 x 6.00 152 x 152	11.34 288
F8890SEGV	8.00 x 8.00 203 x 203	13.44 341
F101090SEGV	10.00 x 10.00 254 x 254	15.62 395
F121290SEGV	12.00 x 12.00 305 x 305	17.44 443

### GALVANIZED 90-DEGREE ELBOW-TEE-CROSS

Forms left or right 90-degree turns. Can be used as a tee or cross. Use with open adapter for cable entrance in top and bottom. Includes two closure plates.

BULLETIN: F40GF

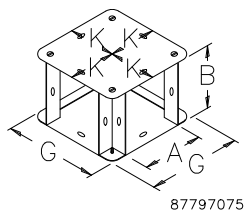

Catalog Number	AxB in./mm	G in./mm	K in./mm
F2290TXGV	2.50 x 2.50 64 x 64	4.50 114	2.25 57
F4490TXGV	4.00 x 4.00 102 x 102	6.00 152	3.00 76
F6690TXGV	6.00 x 6.00 152 x 152	8.00 203	4.00 102
F8890TXGV	8.00 x 8.00 203 x 203	10.00 254	5.00 127
F101090TXGV	10.00 x 10.00 254 x 254	12.00 305	6.00 152
F121290TXGV	12.00 x 12.00 305 x 305	14.00 356	7.00 178

### GALVANIZED 90-DEGREE ELBOW

Any side can be removed, retaining lay-in feature regardless of how the elbow is oriented. Sides are held together with screws.

BULLETIN: F40GF

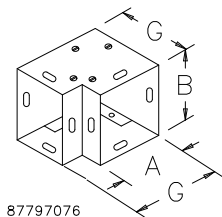

Catalog Number	AxB in./mm	G in./mm
F2290EGV	2.50 x 2.50 64 x 64	4.50 114
F4490EGV	4.00 x 4.00 102 x 102	6.00 152
F6690EGV	6.00 x 6.00 152 x 152	8.00 203
F8890EGV	8.00 x 8.00 203 x 203	10.00 254
F101090EGV	10.00 x 10.00 254 x 254	12.00 305
F121290EGV	12.00 x 12.00 305 x 305	14.00 356

### GALVANIZED 90-DEGREE ELBOW—OUTSIDE OPENING

For continuous run with 90-degree turns. Top, bottom and outside covers removable.

BULLETIN: F40GF

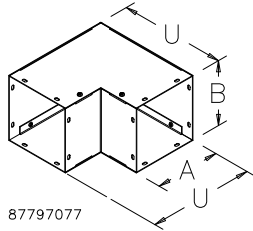

Catalog Number	AxB in./mm	U in./mm
F2290EOUTGV	2.50 x 2.50 64 x 64	6.50 165
F4490EOUTGV	4.00 x 4.00 102 x 102	8.00 203
F6690EOUTGV	6.00 x 6.00 152 x 152	10.00 254
F8890EOUTGV	8.00 x 8.00 203 x 203	12.00 305
F101090EOUTGV	10.00 x 10.00 254 x 254	14.00 356
F121290EOUTGV	12.00 x 12.00 305 x 305	16.00 406

### GALVANIZED 90-DEGREE ELBOW—INSIDE OPENING

For continuous run with 90-degree turns. Top and inside covers removable.

BULLETIN: F40GF

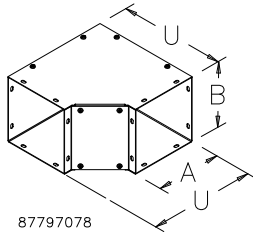

Catalog Number	AxB in./mm	U in./mm
F2290EINGV	2.50 x 2.50 64 x 64	6.50 165
F4490EINGV	4.00 x 4.00 102 x 102	8.00 203
F6690EINGV	6.00 x 6.00 152 x 152	10.00 254
F8890EINGV	8.00 x 8.00 203 x 203	12.00 305
F101090EINGV	10.00 x 10.00 254 x 254	14.00 356
F121290EINGV	12.00 x 12.00 305 x 305	16.00 406

### GALVANIZED 45-DEGREE ELBOW

Any side can be removed, retaining lay-in feature regardless of how the elbow is oriented. Sides are held together with screws.

BULLETIN: F40GF

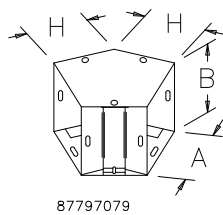

Catalog Number	AxB in./mm	H in./mm
F2245EGV	2.50 x 2.50 64 x 64	2.75 70
F4445EGV	4.00 x 4.00 102 x 102	3.38 86
F6645EGV	6.00 x 6.00 152 x 152	4.25 108
F8845EGV	8.00 x 8.00 203 x 203	5.06 129
F101045EGV	10.00 x 10.00 254 x 254	6.00 152
F121245EGV	12.00 x 12.00 305 x 305	6.75 171



### GALVANIZED TELESCOPE FITTING

Length easily adjusts to approximately 12.00 in. (305 mm). No cutting or welding required.

BULLETIN: F40GF

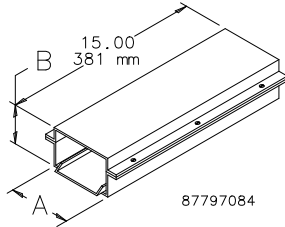

### GALVANIZED PANEL ADAPTER

A flanged fitting which allows the wireway to be securely connected to an enclosure.

BULLETIN: F40GF

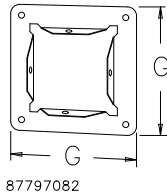

### GALVANIZED CLOSURE PLATE, WITH AND WITHOUT KNOCKOUTS

Closes the end of a wireway section or run.

BULLETIN: F40GF

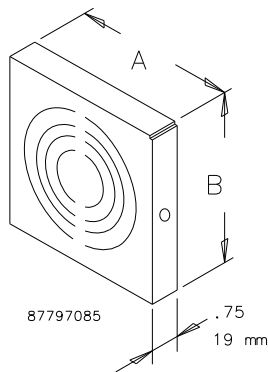

Catalog Number	AxB in./mm
F22GAGV	2.50 x 2.50 64 x 64
F44GAGV	4.00 x 4.00 102 x 102
F66GAGV	6.00 x 6.00 152 x 152
F88GAGV	8.00 x 8.00 203 x 203
F1010GAGV	10.00 x 10.00 254 x 254
F1212GAGV	12.00 x 12.00 305 x 305

Not UL/cUL listed.

Catalog Number	G (in.)	G (mm)
F22GPAGV	4.50	114
F44GPAGV	6.00	152
F66GPAGV	8.00	203
F88GPAGV	10.00	254
F1010GPAGV	12.00	305
F1212GPAGV	14.00	356

Catalog Number	AxB in./mm	Knockouts
F22GCPGV	2.00 x 2.00 64 x 64	With knockouts
F22GCPNKGV	2.00 x 2.00 64 x 64	Without knockouts
F44GCPGV	4.00 x 4.00 102 x 102	With knockouts
F44GCPNKGV	4.00 x 4.00 102 x 102	Without knockouts
F66GCPGV	6.00 x 6.00 152 x 152	With knockouts
F66GCPNKGV	6.00 x 6.00 152 x 152	Without knockouts
F88GCPGV	8.00 x 8.00 203 x 203	With knockouts
F88GCPNKGV	8.00 x 8.00 203 x 203	Without knockouts
F1010GCPNKGV	10.00 x 10.00 254 x 254	Without knockouts
F1212GCPGV	12.00 x 12.00 305 x 305	With knockouts
F1212GCPNKGV	12.00 x 12.00 305 x 305	Without knockouts



### REDUCER

Reduces wireway to a smaller size.

BULLETTIN: F40PF

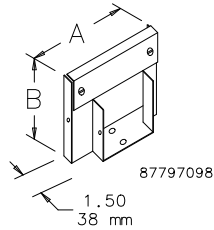

Catalog Number	AxB in./mm
F44G22R	4.00 x 4.00 102 x 102
F66G44R	6.00 x 6.00 152 x 152
F88G66R	8.00 x 8.00 203 x 203
F1010G88R	10.00 x 10.00 254 x 254
F1212G88R	12.00 x 12.00 305 x 305
F1212G1010R	12.00 x 12.00 305 x 305

### GALVANIZED SUPPORT HANGER

For floor or wall installations.

BULLETTIN: F40GF

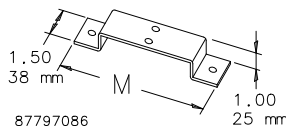

Catalog Number	M (in.)	M (mm)
F22GSHGV	4.62	117
F44GSHGV	6.12	155
F66GSHGV	8.12	206
F88GSHGV	10.12	257
F1010GSHGV	12.12	308
F1212GSHGV	14.12	359

### DROP AND BRACKET HANGERS

Drop and bracket hangers support a wireway run.

BULLETTIN: F40PF

Catalog Number	N max. (in.)	N max. (mm)	P (in.)	P (mm)	R (in.)	R (mm)	S (in.)	S (mm)	T (in.)	T (mm)
F22GDB	8.50	216	4.50	114	3.38	86	7.25	184	3.75	95
F44GDB	10.50	267	6.00	152	4.12	105	9.25	235	4.50	114
F66GDB	15.00	381	7.12	181	5.12	130	13.75	349	5.50	140
F88GDB	21.00	533	10.81	275	7.00	178	13.75	349	7.75	197
F1010GDB	22.00	559	13.81	335	8.38	213	13.75	349	10.25	260
F1212GDB	23.00	584	15.56	395	9.78	248	13.75	349	12.50	318

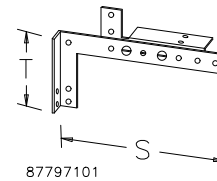
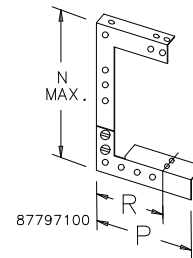

### GALVANIZED UNIVERSAL U-CONNECTOR

Joins wireway sections and fittings. Top swings aside to retain the lay-in feature. One U-connector required at each wireway joint except telescope fittings, panel adapters, open adapters, closure plates or reducers.

BULLETTIN: F40GF

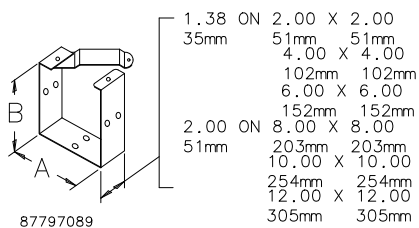

Catalog Number	AxB in./mm
F22GUCGV	2.50 x 2.50 64 x 64
F44GUCGV	4.00 x 4.00 102 x 102
F66GUCGV	6.00 x 6.00 152 x 152
F88GUCGV	8.00 x 8.00 203 x 203
F1010GUCGV	10.00 x 10.00 254 x 254
F1212GUCGV	12.00 x 12.00 305 x 305



LAY-IN PAINTED FLAT-COVER WIREWAY, NEMA TYPE 1



**APPLICATION**

This painted wireway features an open design on one side so wires and cables can be laid in safely along the entire run without pulling, a practice that can damage insulation. A variety of lengths and fittings provide design flexibility.

**FEATURES**

- Flat cover design
- Open top assembly
- Available with or without knockouts
- Keyhole screw slots on flat covers

**SPECIFICATIONS**

- 16 and 14 gauge pre-painted steel covers and bodies

**FINISH**

ANSI 61 gray polyester powder paint finish inside and out.

**INDUSTRY STANDARDS**

UL 870 Listed; File No. E27524  
 cUL Listed per CSA C22.2 No. 26; File No. E27524

NEMA/EEMAC Type 1  
 IEC 60529

This drawing illustrates how most of the Hoffman NEMA Type I lay-in wireway sections and fittings could be used in an actual wireway run. The covers have been omitted to present the lay-in feature more clearly. Many different sections and fittings can be combined in any configuration desired.

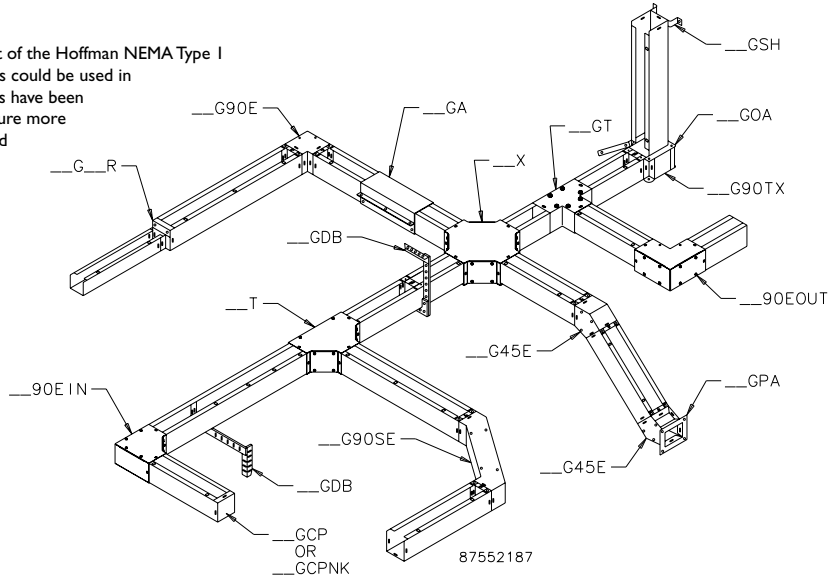

Standard Product Selection Matrix

Description	2.50 x 2.50 in. (64 x 64 mm)	3.00 x 3.00 in. (76 x 76 mm)	4.00 x 4.00 in. (102 x 102 mm)	6.00 x 6.00 in. (152 x 152 mm)	8.00 x 8.00 in. (203 x 203 mm)	10.00 x 10.00 in. (254 x 254 mm)	12.00 x 12.00 in. (305 x 305 mm)
12.00-in. (305-mm) Straight Section with knockouts	F22T112GVPWK	—	F44T112GVPWK	F66T112GVPWK	F88T112GVPWK	—	F1212T112GVPWK
12.00-in. (305-mm) Straight Section without knockouts	F22T112GVP	—	F44T112GVP	F66T112GVP	F88T112GVP	F1010T112GVP	F1212T112GVP
18.00-in. (455-mm) Straight Section without knockouts	—	—	F44T118GVP	F66T118GVP	F88T118GVP	—	—
24.00-in. (610-mm) Straight Section with knockouts	F22T124GVPWK	—	F44T124GVPWK	F66T124GVPWK	F88T124GVPWK	—	F1212T124GVPWK
24.00-in. (610-mm) Straight Section without knockouts	F22T124GVP	—	F44T124GVP	F66T124GVP	F88T124GVP	F1010T124GVP	F1212T124GVP
36.00-in. (914-mm) Straight Section with knockouts	F22T136GVPWK	—	F44T136GVPWK	F66T136GVPWK	F88T136GVPWK	—	F1212T136GVPWK
36.00-in. (914-mm) Straight Section without knockouts	F22T136GVP	—	F44T136GVP	F66T136GVP	F88T136GVP	F1010T136GVP	F1212T136GVP
48.00-in. (1219-mm) Straight Section with knockouts	F22T148GVPWK	—	F44T148GVPWK	F66T148GVPWK	F88T148GVPWK	—	F1212T148GVPWK
48.00-in. (1219-mm) Straight Section without knockouts	F22T148GVP	—	F44T148GVP	F66T148GVP	F88T148GVP	F1010T148GVP	F1212T148GVP
60.00-in. (1524-mm) Straight Section with knockouts	F22T160GVPWK	—	F44T160GVPWK	F66T160GVPWK	F88T160GVPWK	—	F1212T160GVPWK
60.00-in. (1524-mm) Straight Section without knockouts	F22T160GVP	F33T160GVP	F44T160GVP	F66T160GVP	F88T160GVP	F1010T160GVP	F1212T160GVP
72.00-in. (1829-mm) Straight Section with knockouts	—	—	F44T172GVPWK	F66T172GVPWK	—	—	—
72.00-in. (1829-mm) Straight Section without knockouts	—	—	F44T172GVP	F66T172GVP	F88T172GVP	F1010T172GVP	—
120.00-in. (3048-mm) Straight Section with knockouts	F22T1120GVPWK	—	F44T1120GVPWK	F66T1120GVPWK	F88T1120GVP	—	—
120.00-in. (3048-mm) Straight Section without knockouts	F22T1120GVP	F33T1120GVP	F44T1120GVP	F66T1120GVP	F88T1120GVP	F1010T1120GVP	F1212T1120GVP
90° Flush Tee	F22GT	F33GT	F44GT	F66GT	F88GT	F1010GT	F1212GT
Sweep Tee	F22T	—	F44T	F66T	F88T	F1010T	F1212T
Cross Fitting	F22X	—	F44X	F66X	F88X	F1010X	F1212X
90° Sweep Elbow	F22G90SE	—	F44G90SE	F66G90SE	F88G90SE	F1010G90SE	F1212G90SE
90° Elbow-Tee-Cross	F22G90TX	F33G90TX	F44G90TX	F66G90TX	F88G90TX	F1010G90TX	F1212G90TX
90° Elbow	F22G90E	F33G90E	F44G90E	F66G90E	F88G90E	F1010G90E	F1212G90E
90° Elbow Outside Opening	F2290EOUT	—	F4490EOUT	F6690EOUT	F8890EOUT	F101090EOUT	F121290EOUT
90° Elbow Inside Opening	F2290EIN	—	F4490EIN	F6690EIN	F8890EIN	F101090EIN	F121290EIN
45° Elbow	F22G45E	F33G45E	F44G45E	F66G45E	F88G45E	F1010G45E	F1212G45E
Telescope Fitting <sup>a</sup>	F22GA	—	F44GA	F66GA	F88GA	F1010GA	F1212GA
Open Adapter	F22GOA	—	F44GOA	F66GOA	F88GOA	F1010GOA	F1212GOA
Panel Adapter	F22GPA	F33GPA	F44GPA	F66GPA	F88GPA	F1010GPA	F1212GPA
Closure Plate with knockouts	F22GCP	—	F44GCP	F66GCP	F88GCP	F1010GCP	F1212GCP
Closure Plate without knockouts	F22GCPNK	F33GCPNK	F44GCPNK	F66GCPNK	F88GCPNK	F1010GCPNK	F1212GCPNK
Reducer	—	F33G22R	F44G22R	F66G44R	F88G66R	F1010G88R	F1212G88R
Drop and Bracket Hanger	F22GDB	—	F44GDB	F66GDB	F88GDB	F1010GDB	F1212GDB
Support Hanger	F22GSH	—	F44GSH	F66GSH	F88GSH	F1010GSH	F1212GSH
Universal U-Connector	F22GUC	F33GUC	F44GUC	F66GUC	F88GUC	F1010GUC	F1212GUC
Barrier Kit, bolt-on Each barrier 60.00 in. (1524 mm)	—	F33BK60	F44BK60	F66BK60	F88BK60	—	—

<sup>a</sup>Not UL/cUL listed.

STRAIGHT SECTION

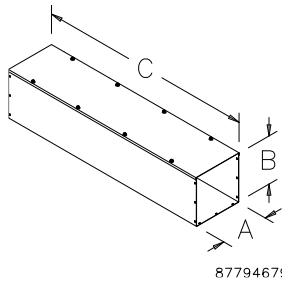

Protects electrical wiring in applications where dust, dirt, oil and water are not serious problems. All sections and fittings are completely open on one side so wires and cables can be laid in along wireway run. No pulling through of wires or cables prevents damage to insulation that often occurs in a pull-through wiring system. Flat cover design allows for mounting flush with walls or ceilings. Keyhole screw slots on flat covers provide easy access.

BULLETIN: F40FC, F40G

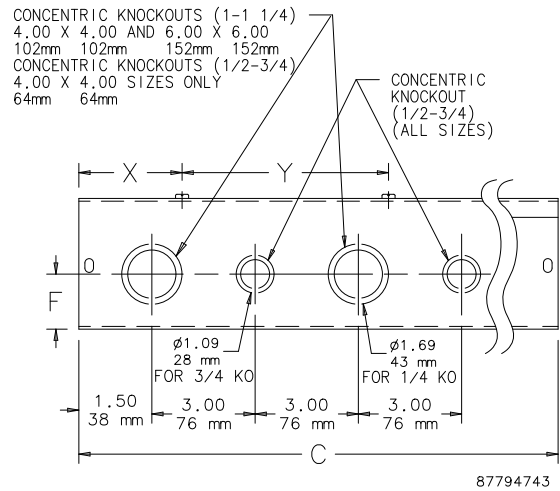

PATTERN REPEATS EVERY 12.00 305 mm

## Straight Sections

Catalog Number	AxBxC in.	AxBxC mm	Number of Knockouts, .50 in.-.75 in.	Number of Knockouts, 1.00 in.-1.25 in.	F (in.)	F (mm)	X (in.)	X (mm)	Y (in.)	Y (mm)
F22T112GVPWK	2.50 x 2.50 x 12.00	64 x 64 x 305	8	—	1.06	27	3.00	76	6.00	152
F22T112GVP	2.50 x 2.50 x 12.00	64 x 64 x 305	—	—	—	—	—	—	—	—
F22T124GVPWK	2.50 x 2.50 x 24.00	64 x 64 x 610	16	—	1.06	27	6.00	152	12.00	305
F22T124GVP	2.50 x 2.50 x 24.00	64 x 64 x 610	—	—	—	—	—	—	—	—
F22T136GVPWK	2.50 x 2.50 x 36.00	64 x 64 x 610	24	—	1.06	27	6.00	152	12.00	305
F22T136GVP	2.50 x 2.50 x 36.00	64 x 64 x 914	—	—	—	—	—	—	—	—
F22T148GVPWK	2.50 x 2.50 x 48.00	64 x 64 x 1219	32	—	1.06	27	6.00	152	12.00	305
F22T148GVP	2.50 x 2.50 x 48.00	64 x 64 x 1219	—	—	—	—	—	—	—	—
F22T160GVPWK	2.50 x 2.50 x 60.00	64 x 64 x 1524	40	—	1.06	27	6.00	152	12.00	305
F22T160GVP	2.50 x 2.50 x 60.00	64 x 64 x 1524	—	—	—	—	—	—	—	—
F22T1120GVPWK	2.50 x 2.50 x 120.00	64 x 64 x 3048	80	—	1.06	27	6.00	152	12.00	305
F22T1120GVP	2.50 x 2.50 x 120.00	64 x 64 x 3048	—	—	—	—	—	—	—	—
F33T160GVP	3.00 x 3.00 x 60.00	76 x 76 x 1524	—	—	—	—	—	—	—	—
F33T1120GVP	3.00 x 3.00 x 120.00	76 x 76 x 3048	—	—	—	—	—	—	—	—
F44T112GVPWK	4.00 x 4.00 x 12.00	102 x 102 x 305	4	4	1.62	41	3.00	76	6.00	152
F44T112GVP	4.00 x 4.00 x 12.00	102 x 102 x 305	—	—	—	—	—	—	—	—
F44T118GVP	4.00 x 4.00 x 18.00	102 x 102 x 455	—	—	—	—	—	—	—	—
F44T124GVPWK	4.00 x 4.00 x 24.00	102 x 102 x 610	8	8	1.62	41	6.00	152	12.00	305
F44T124GVP	4.00 x 4.00 x 24.00	102 x 102 x 610	—	—	—	—	—	—	—	—
F44T136GVPWK	4.00 x 4.00 x 36.00	102 x 102 x 914	12	12	1.62	41	6.00	152	12.00	305
F44T136GVP	4.00 x 4.00 x 36.00	102 x 102 x 914	—	—	—	—	—	—	—	—
F44T148GVPWK	4.00 x 4.00 x 48.00	102 x 102 x 1219	16	16	1.62	41	6.00	152	12.00	305
F44T148GVP	4.00 x 4.00 x 48.00	102 x 102 x 1219	—	—	—	—	—	—	—	—
F44T160GVPWK	4.00 x 4.00 x 60.00	102 x 102 x 1524	20	20	1.62	41	6.00	152	12.00	305
F44T160GVP	4.00 x 4.00 x 60.00	102 x 102 x 1524	—	—	—	—	—	—	—	—
F44T172GVPWK	4.00 x 4.00 x 72.00	102 x 102 x 1829	24	24	1.62	41	6.00	152	12.00	305
F44T172GVP	4.00 x 4.00 x 72.00	102 x 102 x 1829	—	—	—	—	—	—	—	—
F44T1120GVPWK	4.00 x 4.00 x 120.00	102 x 102 x 3048	40	40	1.62	41	6.00	152	12.00	305
F44T1120GVP	4.00 x 4.00 x 120.00	102 x 102 x 3048	—	—	—	—	—	—	—	—
F66T112GVPWK	6.00 x 6.00 x 12.00	152 x 152 x 305	4	4	1.62	41	6.00	152	12.00	305
F66T112GVP	6.00 x 6.00 x 12.00	152 x 152 x 305	—	—	—	—	—	—	—	—
F66T118GVP	6.00 x 6.00 x 18.00	152 x 152 x 455	—	—	—	—	—	—	—	—
F66T124GVPWK	6.00 x 6.00 x 24.00	152 x 152 x 610	8	8	1.62	41	6.00	152	12.00	305
F66T124GVP	6.00 x 6.00 x 24.00	152 x 152 x 610	—	—	—	—	—	—	—	—
F66T136GVPWK	6.00 x 6.00 x 36.00	152 x 152 x 914	12	12	1.62	41	6.00	152	12.00	305
F66T136GVP	6.00 x 6.00 x 36.00	152 x 152 x 914	—	—	—	—	—	—	—	—
F66T148GVPWK	6.00 x 6.00 x 48.00	152 x 152 x 1219	16	16	1.62	41	6.00	152	12.00	305
F66T148GVP	6.00 x 6.00 x 48.00	152 x 152 x 1219	—	—	—	—	—	—	—	—
F66T160GVPWK	6.00 x 6.00 x 60.00	152 x 152 x 1524	20	20	1.62	41	6.00	152	12.00	305
F66T160GVP	6.00 x 6.00 x 60.00	152 x 152 x 1524	—	—	—	—	—	—	—	—
F66T172GVPWK	6.00 x 6.00 x 72.00	152 x 152 x 1829	24	24	1.62	41	6.00	152	12.00	305
F66T172GVP	6.00 x 6.00 x 72.00	152 x 152 x 1829	—	—	—	—	—	—	—	—
F66T1120GVPWK	6.00 x 6.00 x 120.00	152 x 152 x 3048	40	40	1.62	41	6.00	152	12.00	305
F66T1120GVP	6.00 x 6.00 x 120.00	152 x 152 x 3048	—	—	—	—	—	—	—	—
F88T112GVPWK	8.00 x 8.00 x 12.00	203 x 203 x 305	4	4	1.62	41	3.00	76	6.00	152
F88T112GVP	8.00 x 8.00 x 12.00	203 x 203 x 305	—	—	—	—	—	—	—	—
F88T118GVP	8.00 x 8.00 x 18.00	203 x 203 x 455	—	—	—	—	—	—	—	—
F88T124GVPWK	8.00 x 8.00 x 24.00	203 x 203 x 610	8	8	1.62	41	6.00	152	12.00	305
F88T124GVP	8.00 x 8.00 x 24.00	203 x 203 x 610	—	—	—	—	—	—	—	—
F88T136GVPWK	8.00 x 8.00 x 36.00	203 x 203 x 914	12	12	1.62	41	6.00	152	12.00	305
F88T136GVP	8.00 x 8.00 x 36.00	203 x 203 x 914	—	—	—	—	—	—	—	—
F88T148GVPWK	8.00 x 8.00 x 48.00	203 x 203 x 1219	16	16	1.62	41	6.00	152	12.00	305
F88T148GVP	8.00 x 8.00 x 48.00	203 x 203 x 1219	—	—	—	—	—	—	—	—
F88T160GVPWK	8.00 x 8.00 x 60.00	203 x 203 x 1524	20	20	1.62	41	6.00	152	12.00	305
F88T160GVP	8.00 x 8.00 x 60.00	203 x 203 x 1524	—	—	—	—	—	—	—	—
F88T172GVP	8.00 x 8.00 x 72.00	203 x 203 x 1829	—	—	—	—	—	—	—	—
F88T1120GVP	8.00 x 8.00 x 120.00	203 x 203 x 3048	—	—	—	—	—	—	—	—
F1010T112GVP	10.00 x 10.00 x 12.00	254 x 254 x 305	—	—	—	—	—	—	—	—
F1010T124GVP	10.00 x 10.00 x 24.00	254 x 254 x 610	—	—	—	—	—	—	—	—
F1010T136GVP	10.00 x 10.00 x 36.00	254 x 254 x 914	—	—	—	—	—	—	—	—
F1010T148GVP	10.00 x 10.00 x 48.00	254 x 254 x 1219	—	—	—	—	—	—	—	—
F1010T160GVP	10.00 x 10.00 x 60.00	254 x 254 x 1524	—	—	—	—	—	—	—	—
F1010T172GVP	10.00 x 10.00 x 72.00	254 x 254 x 1829	—	—	—	—	—	—	—	—
F1010T1120GVP	10.00 x 10.00 x 120.00	254 x 254 x 3048	—	—	—	—	—	—	—	—
F1212T112GVPWK	12.00 x 12.00 x 12.00	305 x 305 x 305	4	4	1.62	41	3.00	76	6.00	152
F1212T112GVP	12.00 x 12.00 x 12.00	305 x 305 x 305	—	—	—	—	—	—	—	—
F1212T124GVPWK	12.00 x 12.00 x 24.00	305 x 305 x 610	8	8	1.62	41	6.00	152	12.00	305
F1212T124GVP	12.00 x 12.00 x 24.00	305 x 305 x 610	—	—	—	—	—	—	—	—
F1212T136GVPWK	12.00 x 12.00 x 36.00	305 x 305 x 914	12	12	1.62	41	6.00	152	12.00	305
F1212T136GVP	12.00 x 12.00 x 36.00	305 x 305 x 914	—	—	—	—	—	—	—	—
F1212T148GVPWK	12.00 x 12.00 x 48.00	305 x 305 x 1219	16	16	1.62	41	6.00	152	12.00	305
F1212T148GVP	12.00 x 12.00 x 48.00	305 x 305 x 1219	—	—	—	—	—	—	—	—
F1212T160GVPWK	12.00 x 12.00 x 60.00	305 x 305 x 1524	20	20	1.62	41	6.00	152	12.00	305
F1212T160GVP	12.00 x 12.00 x 60.00	305 x 305 x 1524	—	—	—	—	—	—	—	—
F1212T1120GVP	12.00 x 12.00 x 120.00	305 x 305 x 3048	—	—	—	—	—	—	—	—

### 90-DEGREE FLUSH TEE

For flush mounting against a vertical or horizontal surface.

BULLETIN: F40PF

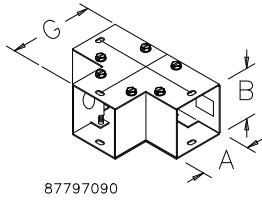

Catalog Number	AxB in./mm	G in./mm
F22GT	2.50 x 2.50 64 x 64	4.50 114
F33GT	3.00 x 3.00 76 x 76	5.00 127
F44GT	4.00 x 4.00 102 x 102	6.00 152
F66GT	6.00 x 6.00 152 x 152	8.00 203
F88GT	8.00 x 8.00 203 x 203	10.00 254
F1010GT	10.00 x 10.00 254 x 254	12.00 305
F1212GT	12.00 x 12.00 305 x 305	14.00 356

### SWEEP TEE

For large radius turns. Mounts against vertical or horizontal surfaces. Top and inside covers removable.

BULLETIN: F40PF

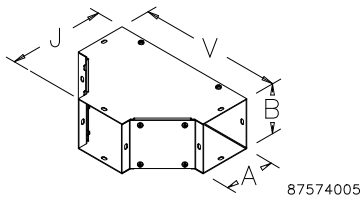

Catalog Number	AxB in./mm	J in./mm	V in./mm
F22T	2.50 x 2.50 64 x 64	6.50 165	10.35 263
F44T	4.00 x 4.00 102 x 102	8.00 203	11.85 301
F66T	6.00 x 6.00 152 x 152	10.00 254	13.85 352
F88T	8.00 x 8.00 203 x 203	12.00 305	15.84 402
F1010T	10.00 x 10.00 254 x 254	14.00 356	17.84 453
F1212T	12.00 x 12.00 305 x 305	16.00 406	19.84 504

### CROSS FITTING

For routing cables in four directions. Top, bottom and side covers removable.

BULLETIN: F40PF

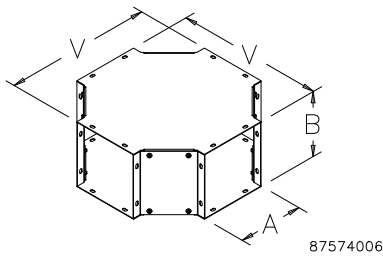

Catalog Number	AxB in./mm	V in./mm
F22X	2.50 x 2.50 64 x 64	10.35 263
F44X	4.00 x 4.00 102 x 102	11.85 301
F66X	6.00 x 6.00 152 x 152	13.85 352
F88X	8.00 x 8.00 203 x 203	15.84 402
F1010X	10.00 x 10.00 254 x 254	17.84 453
F1212X	12.00 x 12.00 305 x 305	19.84 504

### 90-DEGREE SWEEP ELBOW

For large radius turns.

BULLETIN: F40PF

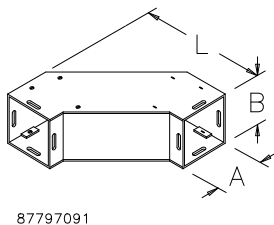

Catalog Number	AxB in./mm	L in./mm
F22G90SE	2.50 x 2.50 64 x 64	7.91 201
F44G90SE	4.00 x 4.00 102 x 102	9.41 239
F66G90SE	6.00 x 6.00 152 x 152	11.34 288
F88G90SE	8.00 x 8.00 203 x 203	13.44 341
F1010G90SE	10.00 x 10.00 254 x 254	15.62 395
F1212G90SE	12.00 x 12.00 305 x 305	17.44 443



### 90-DEGREE ELBOW-TEE-CROSS

Forms left or right 90-degree turns. Can be used as a tee or cross. Use with open adapter for cable entrance in top and bottom. Includes two closure plates.

BULLETIN: F40PF

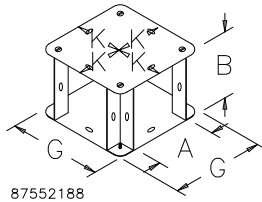

### 90-DEGREE ELBOW

Any side can be removed, retaining lay-in feature regardless of how the elbow is oriented. Sides are held together with screws.

BULLETIN: F40PF

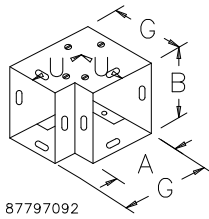

### 90-DEGREE ELBOW—OUTSIDE OPENING

For continuous run with 90-degree turns. Top, bottom and outside covers removable.

BULLETIN: F40PF

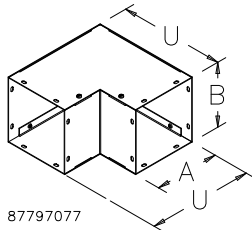

### 90-DEGREE ELBOW—INSIDE OPENING

For continuous run with 90-degree turns. Top and inside covers removable.

BULLETIN: F40PF

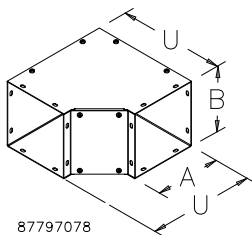

Catalog Number	AxB in./mm	G in./mm	K in./mm
F22G90TX	2.50 x 2.50 64 x 64	4.50 114	2.25 57
F33G90TX	3.00 x 3.00 76 x 76	5.00 127	2.50 64
F44G90TX	4.00 x 4.00 102 x 102	6.00 152	3.00 76
F66G90TX	6.00 x 6.00 152 x 152	8.00 203	4.00 102
F88G90TX	8.00 x 8.00 203 x 203	10.00 254	5.00 127
F1010G90TX	10.00 x 10.00 254 x 254	12.00 305	6.00 152
F1212G90TX	12.00 x 12.00 305 x 305	14.00 356	7.00 178

Catalog Number	AxB in./mm	G in./mm
F22G90E	2.50 x 2.50 64 x 64	4.50 114
F33G90E	3.00 x 3.00 76 x 76	5.00 127
F44G90E	4.00 x 4.00 102 x 102	6.00 152
F66G90E	6.00 x 6.00 152 x 152	8.00 203
F88G90E	8.00 x 8.00 203 x 203	10.00 254
F1010G90E	10.00 x 10.00 254 x 254	12.00 305
F1212G90E	12.00 x 12.00 305 x 305	14.00 356

Catalog Number	AxB in./mm	U in./mm
F2290EOUT	2.50 x 2.50 64 x 64	6.50 165
F4490EOUT	4.00 x 4.00 102 x 102	8.00 203
F6690EOUT	6.00 x 6.00 152 x 152	10.00 254
F8890EOUT	8.00 x 8.00 203 x 203	12.00 305
F101090EOUT	10.00 x 10.00 254 x 254	14.00 356
F121290EOUT	12.00 x 12.00 305 x 305	16.00 406

Catalog Number	AxB in./mm	U in./mm
F2290EIN	2.50 x 2.50 64 x 64	6.50 165
F4490EIN	4.00 x 4.00 102 x 102	8.00 203
F6690EIN	6.00 x 6.00 152 x 152	10.00 254
F8890EIN	8.00 x 8.00 203 x 203	12.00 305
F101090EIN	10.00 x 10.00 254 x 254	14.00 356
F121290EIN	12.00 x 12.00 305 x 305	16.00 406

### 45-DEGREE ELBOW

For continuous run with 45-degree turns. Top and inside covers removable.

BULLETIN: F40PF

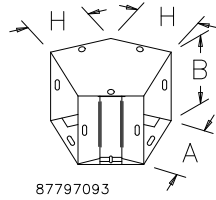

Catalog Number	AxB in./mm	H in./mm
F22G45E	2.50 x 2.50 64 x 64	2.75 70
F33G45E	3.00 x 3.00 76 x 76	2.99 76
F44G45E	4.00 x 4.00 102 x 102	3.38 86
F66G45E	6.00 x 6.00 152 x 152	4.25 108
F88G45E	8.00 x 8.00 203 x 203	5.06 129
F1010G45E	10.00 x 10.00 254 x 254	6.00 152
F1212G45E	12.00 x 12.00 305 x 305	6.75 171

### TELESCOPE FITTING

Length easily adjusts to approximately 12.00 in. (305 mm). No cutting or welding required.

BULLETIN: F40PF

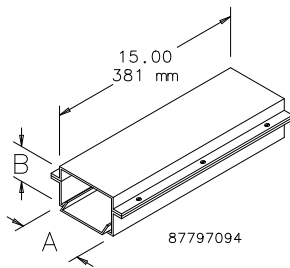

Catalog Number	AxB in./mm
F22GA	2.50 x 2.50 64 x 64
F44GA	4.00 x 4.00 102 x 102
F66GA	6.00 x 6.00 152 x 152
F88GA	8.00 x 8.00 203 x 203
F1010GA	10.00 x 10.00 254 x 254
F1212GA	12.00 x 12.00 305 x 305

These items not UL/cUL listed.

### OPEN ADAPTER

Used with the 90-Degree Elbow-Tee-Cross fitting to permit a run directly up or down.

BULLETIN: F40PF

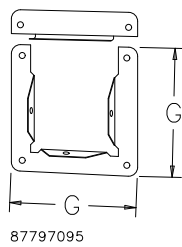

Catalog Number	G (in.)	G (mm)
F22G0A	4.50	114
F44G0A	6.00	152
F66G0A	8.00	203
F88G0A	10.00	254
F1010G0A	12.00	305
F1212G0A	14.00	356

### PANEL ADAPTER

A flanged fitting which allows the wireway to be securely connected to an enclosure.

BULLETIN: F40PF

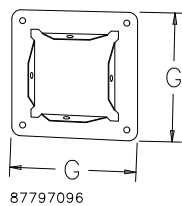

Catalog Number	G (in.)	G (mm)
F22GPA	4.50	114
F33GPA	5.00	127
F44GPA	6.00	152
F66GPA	8.00	203
F88GPA	10.00	254
F1010GPA	12.00	305
F1212GPA	14.00	356



### CLOSURE PLATE

Closes the end of a wireway section or run.

BULLETTIN: F40PF

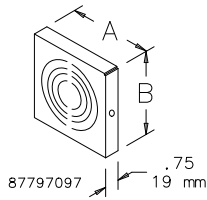

Catalog Number	AxB in.	AxB mm	Knockouts
F22GCP	2.50 x 2.50	64 x 64	With knockouts
F22GCPNK	2.50 x 2.50	64 x 64	Without knockouts
F44GCP	4.00 x 4.00	102 x 102	With knockouts
F33GCPNK	3.00 x 3.00	76 x 76	Without knockouts
F44GCPNK	4.00 x 4.00	102 x 102	Without knockouts
F66GCP	6.00 x 6.00	152 x 152	With knockouts
F66GCPNK	6.00 x 6.00	152 x 152	Without knockouts
F88GCP	8.00 x 8.00	203 x 203	With knockouts
F88GCPNK	8.00 x 8.00	203 x 203	Without knockouts
F1010GCP	10.00 x 10.00	254 x 254	With knockouts
F1010GCPNK	10.00 x 10.00	254 x 254	Without knockouts
F1212GCP	12.00 x 12.00	305 x 305	With knockouts
F1212GCPNK	12.00 x 12.00	305 x 305	Without knockouts

### DROP AND BRACKET HANGERS

Drop and bracket hangers support a wireway run.

BULLETTIN: F40PF

Catalog Number	N max. (in.)	N max. (mm)	P (in.)	P (mm)	R (in.)	R (mm)	S (in.)	S (mm)	T (in.)	T (mm)
F22GDB	8.50	216	4.50	114	3.38	86	7.25	184	3.75	95
F44GDB	10.50	267	6.00	152	4.12	105	9.25	235	4.50	114
F66GDB	15.00	381	7.12	181	5.12	130	13.75	349	5.50	140
F88GDB	21.00	533	10.81	275	7.00	178	13.75	349	7.75	197
F1010GDB	22.00	559	13.81	335	8.38	213	13.75	349	10.25	260
F1212GDB	23.00	584	15.56	395	9.78	248	13.75	349	12.50	318

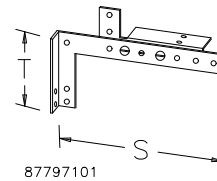
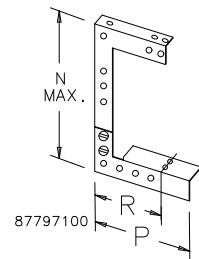

### SUPPORT HANGER

For floor or wall installations.

BULLETTIN: F40PF

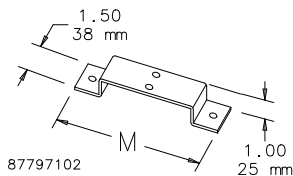

Catalog Number	M in./mm
F22GSH	4.62 117
F44GSH	6.12 155
F66GSH	8.12 206
F88GSH	10.12 257
F1010GSH	12.12 308
F1212GSH	14.12 359



### UNIVERSAL U-CONNECTOR

Joins wireway sections and fittings. Top swings aside to retain the lay-in feature. One U-connector required at each wireway joint except telescope fittings, panel adapters, open adapters, closure plates or reducers.

BULLETIN: F40PF

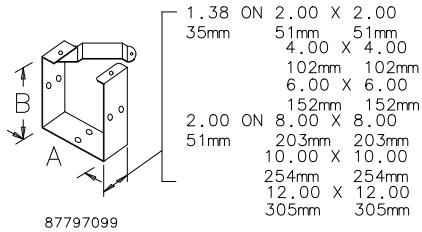

Catalog Number	AxB in./mm
F22GUC	2.50 x 2.50 64 x 64
F33GUC	3.00 x 3.00 76 x 76
F44GUC	4.00 x 4.00 102 x 102
F66GUC	6.00 x 6.00 152 x 152
F88GUC	8.00 x 8.00 203 x 203
F1010GUC	10.00 x 10.00 254 x 254
F1212GUC	12.00 x 12.00 305 x 305

### BARRIER KIT, BOLT-ON

Divides wireway into two or more compartments. Barriers are fastened to wireway sections with screws. Sealing washers are included.

BULLETIN: F20

Catalog Number	W in./mm
F33BK60	2.00 51
F44BK60	3.00 76
F66BK60	4.50 114
F88BK60	6.00 152

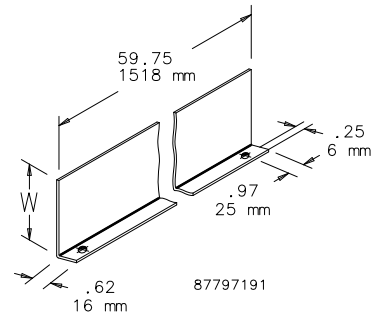

### REDUCER

Reduces wireway to a smaller size.

BULLETIN: F10, F40PF

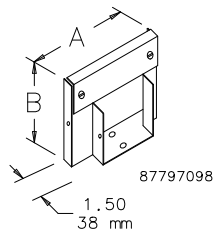

Catalog Number	AxB in./mm
F33G22R	3.00 x 3.00 76 x 76
F44G22R	4.00 x 4.00 102 x 102
F44G33R	4.00 x 4.00 101 x 101
F66G44R	6.00 x 6.00 152 x 152
F88G66R	8.00 x 8.00 203 x 203
F1010G88R	10.00 x 10.00 254 x 254
F1212G88R	12.00 x 12.00 305 x 305
F1212G1010R	12.00 x 12.00 305 x 305



### LAY-IN HINGED-COVER WIREWAY, NEMA TYPE 1



#### INDUSTRY STANDARDS

UL 870 Listed; File No. E27524  
 cUL Listed per CSA C22.2 No. 26; File No. E27524

NEMA/EEMAC Type 1  
 IEC 60529, IP30

#### APPLICATION

This wireway provides convenient cable installation and maintenance with its top hinged cover and an opening on one side so wires and cables can be laid in along the entire run without pulling. A variety of lengths and fittings provide increased design flexibility.

#### FEATURES

- Open top assembly
- Removable hinged cover latches with captive screws
- 12.00 x 12.00-in. models available in hinged or non-hinged styles
- Available with or without knockouts on wireway sides
- Covers include captivated plated screw fasteners

#### SPECIFICATIONS

- 16 gauge or 14 gauge steel covers and bodies

#### FINISH

ANSI 61 gray polyester powder paint finish inside and out over pretreated surfaces.

#### ACCESSORIES

See *Accessories* chapter.  
 Touch-Up Paint (ATPPY61)

This drawing illustrates how most of the Hoffman NEMA Type I lay-in wireway sections and fittings could be used in an actual wireway run. The covers have been omitted to present the lay-in feature more clearly. Many different sections and fittings can be combined in any configuration desired.

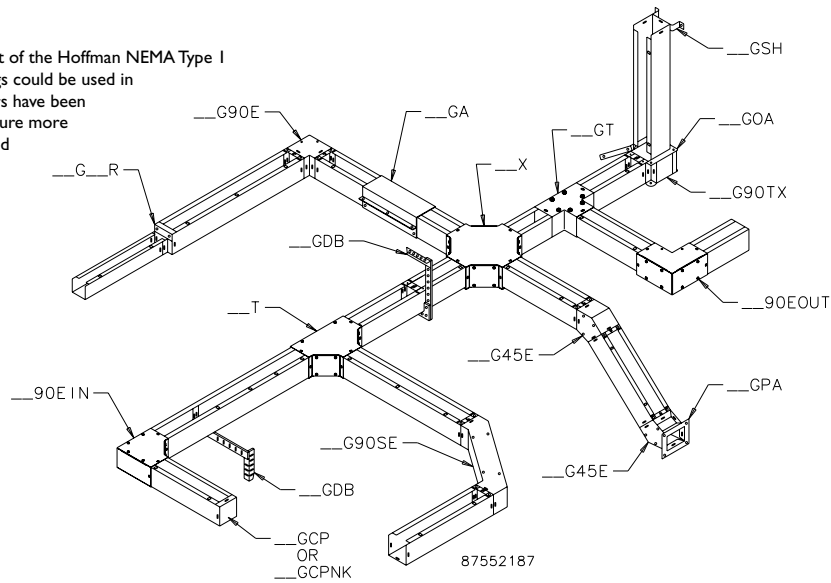

Standard Product Selection Matrix

Description	2.50 x 2.50 in. (64 x 64 mm) 16 Gauge	4.00 x 4.00 in. (102 x 102 mm) 16 Gauge	6.00 x 6.00 in. (152 x 152 mm) 16 Gauge	8.00 x 8.00 in. (203 x 203 mm) 14 Gauge	10.00 x 10.00 in. (254 x 254 mm) 14 Gauge	Not Hinged 12.00 x 12.00 in. (305 x 305 mm) 14 Gauge	Hinged 12.00 x 12.00 in. (305 x 305 mm) 14 Gauge
12.00-in. (305-mm) Straight Section with knockouts	F22G12WK	F44G12WK	F66G12WK	—	—	—	—
12.00-in. (305-mm) Straight Section without knockouts	F22G12	F44G12	F66G12	F66G12	F1010G12	F1212G12	F1212G12H
18.00-in. (455-mm) Straight Section without knockouts	—	F44G18	F66G18	F88G18	—	—	—
24.00-in. (610-mm) Straight Section with knockouts	F22G24WK	F44G24WK	F66G24WK	—	—	—	—
24.00-in. (610-mm) Straight Section without knockouts	F22G24	F44G24	F66G24	F88G24	F1010G24	F1212G24	F1212G24H
36.00-in. (914-mm) Straight Section with knockouts	F22G36WK	F44G36WK	F66G36WK	—	—	—	—
36.00-in. (914-mm) Straight Section without knockouts	F22G36	F44G36	F66G36	F88G36	F1010G36	F1212G36	F1212G36H
48.00-in. (1219-mm) Straight Section with knockouts	F22G48WK	F44G48WK	F66G48WK	—	—	—	—
48.00-in. (1219-mm) Straight Section without knockouts	F22G48	F44G48	F66G48	F88G48	F1010G48	F1212G48	F1212G48H
60.00-in. (1524-mm) Straight Section with knockouts	F22G60WK	F44G60WK	F66G60WK	—	—	—	—
60.00-in. (1524-mm) Straight Section without knockouts	F22G60	F44G60	F66G60	F88G60	F1010G60	F1212G60	F1212G60H
72.00-in. (1829-mm) Straight Section with knockouts	—	F44G72WK	F66G72WK	—	—	—	—
72.00-in. (1829-mm) Straight Section without knockouts	—	F44G72	F66G72	F88G72	F1010G72	F1212G72	F1212G72H
96.00-in. (2438-mm) Straight Section without knockouts	—	F44G96	F66G96	F88G96	F1010G96	F1212G96	—
120.00-in. (3048-mm) Straight Section with knockouts	F22G120WK	F44G120WK	F66G120WK	—	—	—	—
120.00-in. (3048-mm) Straight Section without knockouts	F22G120	F44G120	F66G120	F66G120	F1010G120	F1212G120	F1212G120H
90° Flush Tee	F22GT	F44GT	F66GT	F88GT	F1010GT	F1212GT	F1212GT
Sweep Tee	F22T	F44T	F66T	F88T	F1010T	F1212T	F1212T
Cross Fitting	F22X	F44X	F66X	F88X	F1010X	F1212X	F1212X
90° Sweep Elbow	F22G90SE	F44G90SE	F66G90SE	F88G90SE	F1010G90SE	F1212G90SE	F1212G90SE
90° Elbow-Tee-Cross	F22G90TX	F44G90TX	F66G90TX	F88G90TX	F1010G90TX	F1212G90TX	F1212G90TX
90° Elbow	F22G90E	F44G90E	F66G90E	F88G90E	F1010G90E	F1212G90E	F1212G90E
90° Elbow Outside Opening	F2290EOUT	F4490EOUT	F6690EOUT	F8890EOUT	F101090EOUT	F121290EOUT	F121290EOUT
90° Elbow Inside Opening	F2290EIN	F4490EIN	F6690EIN	F8890EIN	F101090EIN	F121290EIN	F121290EIN
45° Elbow	F22G45E	F44G45E	F66G45E	F88G45E	F1010G45E	F1212G45E	F1212G45E
Telescope Fitting <sup>a</sup>	F22GA	F44GA	F66GA	F88GA	F1010GA	F1212GA	F1212GA
Open Adapter	F22GOA	F44GOA	F66GOA	F88GOA	F1010GOA	F1212GOA	F1212GOA
Panel Adapter	F22GPA	F44GPA	F66GPA	F88GPA	F1010GPA	F1212GPA	F1212GPA
Closure Plate without knockouts	F22GCPNK	F44GCPNK	F66GCPNK	F88GCPNK	F1010GCPNK	F1212GCPNK	F1212GCPNK
Closure Plate with knockouts	F22GCP	F44GCP	F66GCP	F88GCP	F1010GCP	F1212GCP	F1212GCP
Reducer	—	F44G22R	F66G44R	F88G66R	F1010G88R	F1212G108R	F1212G108R
Drop and Bracket Hanger	F22GDB	F44GDB	F66GDB	F88GDB	F1010GDB	F1212GDB	F1212GDB
Support Hanger	F22GSH	F44GSH	F66GSH	F88GSH	F1010GSH	F1212GSH	F1212GSH
Universal U-Connector	F22GUC	F44GUC	F66GUC	F88GUC	F1010GUC	F1212GUC	F1212GUC
Barrier Kit, bolt-on h barrier 60.00 in. (1524 mm)	—	F44BK60	F66BK60	F88BK60	—	—	—

<sup>a</sup>Not UL/cUL listed.

STRAIGHT SECTION

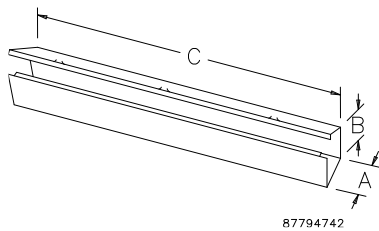

87794742

Available in lengths from 12.00 in. (305 mm), with or without knockouts.

BULLETIN: F40, F40PF

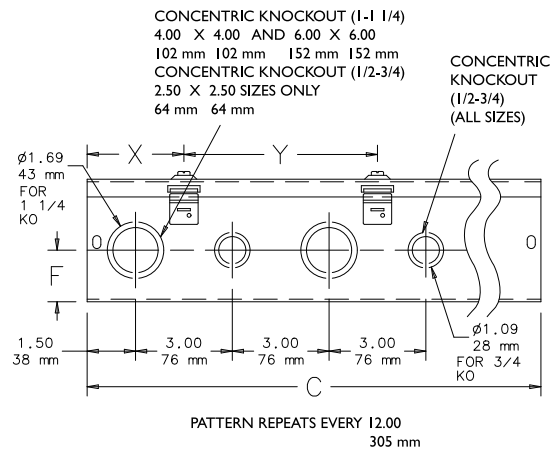

Patented hidden hinge permits usual plated steel screw cover arrangement to be converted to hinge cover system on all sizes except 12.00 in x 12.00 in. (305mm x 305mm).

**Straight Sections**

Catalog Number	AxBxC in.	AxBxC mm	Number of Knockouts, 5.0 in. - 7.5 in.	Number of Knockouts, 1.00 in. - 1.25 in.	F (in.)	F (mm)	X (in.)	X (mm)	Y (in.)	Y (mm)
F22G12WK	2.50 x 2.50 x 12.00	64 x 64 x 305	8	—	1.06	27	3.00	76	6.00	152
F22G12	2.50 x 2.50 x 12.00	64 x 64 x 305	—	—	—	—	—	—	—	—
F22G24WK	2.50 x 2.50 x 24.00	64 x 64 x 610	16	—	1.06	27	6.00	152	12.00	305
F22G24	2.50 x 2.50 x 24.00	64 x 64 x 610	—	—	—	—	—	—	—	—
F22G36WK	2.50 x 2.50 x 36.00	64 x 64 x 914	24	—	1.06	27	6.00	152	12.00	305
F22G36	2.50 x 2.50 x 36.00	64 x 64 x 914	—	—	—	—	—	—	—	—
F22G48WK	2.50 x 2.50 x 48.00	64 x 64 x 1219	32	—	1.06	27	6.00	152	12.00	305
F22G48	2.50 x 2.50 x 48.00	64 x 64 x 1219	—	—	—	—	—	—	—	—
F22G60WK	2.50 x 2.50 x 60.00	64 x 64 x 1524	40	—	1.06	27	6.00	152	12.00	305
F22G60	2.50 x 2.50 x 60.00	64 x 64 x 1524	—	—	—	—	—	—	—	—
F22G120WK	2.50 x 2.50 x 120.00	64 x 64 x 3048	80	—	1.06	27	6.00	152	12.00	305
F22G120	2.50 x 2.50 x 120.00	64 x 64 x 3048	—	—	—	—	—	—	—	—
F44G12WK	4.00 x 4.00 x 12.00	102 x 102 x 305	4	4	1.62	41	3.00	76	6.00	152
F44G12	4.00 x 4.00 x 12.00	102 x 102 x 305	—	—	—	—	—	—	—	—
F44G18	4.00 x 4.00 x 18.00	102 x 102 x 455	—	—	—	—	—	—	—	—
F44G24WK	4.00 x 4.00 x 24.00	102 x 102 x 610	8	8	1.62	41	6.00	152	12.00	305
F44G24	4.00 x 4.00 x 24.00	102 x 102 x 610	—	—	—	—	—	—	—	—
F44G36WK	4.00 x 4.00 x 36.00	102 x 102 x 914	12	12	1.62	41	6.00	152	12.00	305
F44G36	4.00 x 4.00 x 36.00	102 x 102 x 914	—	—	—	—	—	—	—	—
F44G48WK	4.00 x 4.00 x 48.00	102 x 102 x 1219	16	16	1.62	41	6.00	152	12.00	305
F44G48	4.00 x 4.00 x 48.00	102 x 102 x 1219	—	—	—	—	—	—	—	—
F44G60WK	4.00 x 4.00 x 60.00	102 x 102 x 1524	20	20	1.62	41	6.00	152	12.00	305
F44G60	4.00 x 4.00 x 60.00	102 x 102 x 1524	—	—	—	—	—	—	—	—
F44G72WK	4.00 x 4.00 x 72.00	102 x 102 x 1829	24	24	1.62	41	6.00	152	12.00	305
F44G72	4.00 x 4.00 x 72.00	102 x 102 x 1829	—	—	—	—	—	—	—	—
F44G96	4.00 x 4.00 x 96.00	102 x 102 x 2438	—	—	—	—	—	—	—	—
F44G120WK	4.00 x 4.00 x 120.00	102 x 102 x 3048	40	40	1.62	41	6.00	152	12.00	305
F44G120	4.00 x 4.00 x 120.00	102 x 102 x 3048	—	—	—	—	—	—	—	—
F66G12WK	6.00 x 6.00 x 12.00	152 x 152 x 305	4	4	1.62	41	3.00	76	6.00	152
F66G12	6.00 x 6.00 x 12.00	152 x 152 x 305	—	—	—	—	—	—	—	—
F66G18	6.00 x 6.00 x 18.00	152 x 152 x 455	—	—	—	—	—	—	—	—
F66G24WK	6.00 x 6.00 x 24.00	152 x 152 x 610	8	8	1.62	41	6.00	152	12.00	305
F66G24	6.00 x 6.00 x 24.00	152 x 152 x 610	—	—	—	—	—	—	—	—
F66G36WK	6.00 x 6.00 x 36.00	152 x 152 x 914	12	12	1.62	41	6.00	152	12.00	305
F66G36	6.00 x 6.00 x 36.00	152 x 152 x 914	—	—	—	—	—	—	—	—
F66G48WK	6.00 x 6.00 x 48.00	152 x 152 x 1219	16	16	1.62	41	6.00	152	12.00	305
F66G48	6.00 x 6.00 x 48.00	152 x 152 x 1219	—	—	—	—	—	—	—	—
F66G60WK	6.00 x 6.00 x 60.00	152 x 152 x 1524	20	20	1.62	41	6.00	152	12.00	305
F66G60	6.00 x 6.00 x 60.00	152 x 152 x 1524	—	—	—	—	—	—	—	—
F66G72WK	6.00 x 6.00 x 72.00	152 x 152 x 1829	24	24	1.62	41	6.00	152	12.00	305
F66G72	6.00 x 6.00 x 72.00	152 x 152 x 1829	—	—	—	—	—	—	—	—
F66G96	6.00 x 6.00 x 96.00	152 x 152 x 2438	—	—	—	—	—	—	—	—
F66G120WK	6.00 x 6.00 x 120.00	152 x 152 x 3048	40	40	1.62	41	6.00	152	12.00	305
F66G120	6.00 x 6.00 x 120.00	152 x 152 x 3048	—	—	—	—	—	—	—	—
F88G12	8.00 x 8.00 x 12.00	203 x 203 x 305	—	—	—	—	—	—	—	—
F88G18	8.00 x 8.00 x 18.00	203 x 203 x 455	—	—	—	—	—	—	—	—
F88G24	8.00 x 8.00 x 24.00	203 x 203 x 610	—	—	—	—	—	—	—	—
F88G36	8.00 x 8.00 x 36.00	203 x 203 x 914	—	—	—	—	—	—	—	—
F88G48	8.00 x 8.00 x 48.00	203 x 203 x 1219	—	—	—	—	—	—	—	—
F88G60	8.00 x 8.00 x 60.00	203 x 203 x 1524	—	—	—	—	—	—	—	—
F88G72	8.00 x 8.00 x 72.00	203 x 203 x 1829	—	—	—	—	—	—	—	—
F88G96	8.00 x 8.00 x 96.00	203 x 203 x 2438	—	—	—	—	—	—	—	—
F88G120	8.00 x 8.00 x 120.00	203 x 203 x 3048	—	—	—	—	—	—	—	—
F1010G12	10.00 x 10.00 x 12.00	254 x 254 x 305	—	—	—	—	—	—	—	—
F1010G24	10.00 x 10.00 x 24.00	254 x 254 x 610	—	—	—	—	—	—	—	—
F1010G36	10.00 x 10.00 x 36.00	254 x 254 x 914	—	—	—	—	—	—	—	—
F1010G48	10.00 x 10.00 x 48.00	254 x 254 x 1219	—	—	—	—	—	—	—	—
F1010G60	10.00 x 10.00 x 60.00	254 x 254 x 1524	—	—	—	—	—	—	—	—
F1010G72	10.00 x 10.00 x 72.00	254 x 254 x 1829	—	—	—	—	—	—	—	—
F1010G96	10.00 x 10.00 x 96.00	254 x 254 x 2438	—	—	—	—	—	—	—	—
F1010G120	10.00 x 10.00 x 120.00	254 x 254 x 3048	—	—	—	—	—	—	—	—
F1212G12	12.00 x 12.00 x 12.00	305 x 305 x 305	—	—	—	—	—	—	—	—
F1212G12H	12.00 x 12.00 x 12.00	305 x 305 x 305	—	—	—	—	—	—	—	—
F1212G24	12.00 x 12.00 x 24.00	305 x 305 x 610	—	—	—	—	—	—	—	—
F1212G24H	12.00 x 12.00 x 24.00	305 x 305 x 610	—	—	—	—	—	—	—	—
F1212G36	12.00 x 12.00 x 36.00	305 x 305 x 914	—	—	—	—	—	—	—	—
F1212G36H	12.00 x 12.00 x 36.00	305 x 305 x 914	—	—	—	—	—	—	—	—
F1212G48	12.00 x 12.00 x 48.00	305 x 305 x 1219	—	—	—	—	—	—	—	—
F1212G48H	12.00 x 12.00 x 48.00	305 x 305 x 1219	—	—	—	—	—	—	—	—
F1212G60	12.00 x 12.00 x 60.00	305 x 305 x 1524	—	—	—	—	—	—	—	—
F1212G60H	12.00 x 12.00 x 60.00	305 x 305 x 1524	—	—	—	—	—	—	—	—
F1212G72	12.00 x 12.00 x 72.00	305 x 305 x 1829	—	—	—	—	—	—	—	—
F1212G72H	12.00 x 12.00 x 72.00	305 x 305 x 1829	—	—	—	—	—	—	—	—
F1212G96	12.00 x 12.00 x 96.00	305 x 305 x 2438	—	—	—	—	—	—	—	—
F1212G120	12.00 x 12.00 x 120.00	305 x 305 x 3048	—	—	—	—	—	—	—	—
F1212G120H	12.00 x 12.00 x 120.00	305 x 305 x 3048	—	—	—	—	—	—	—	—

F1212GXX catalog numbers without "H" are not hinged. F1212GXXH catalog numbers are hinged.

### 90-DEGREE FLUSH TEE

For flush mounting against a vertical or horizontal surface.

BULLETIN: F40PF

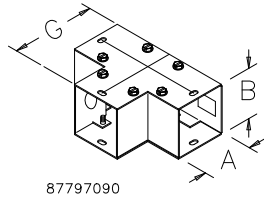

87797090

Catalog Number	AxB in./mm	G in./mm
F22GT	2.50 x 2.50 64 x 64	4.50 114
F33GT	3.00 x 3.00 76 x 76	5.00 127
F44GT	4.00 x 4.00 102 x 102	6.00 152
F66GT	6.00 x 6.00 152 x 152	8.00 203
F88GT	8.00 x 8.00 203 x 203	10.00 254
F1010GT	10.00 x 10.00 254 x 254	12.00 305
F1212GT	12.00 x 12.00 305 x 305	14.00 356

### SWEEP TEE

For large radius turns. Mounts against vertical or horizontal surfaces. Top and inside covers removable.

BULLETIN: F40PF

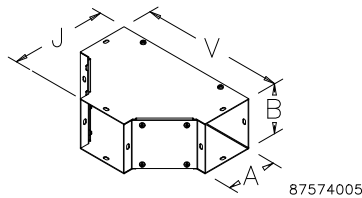

87574005

Catalog Number	AxB in./mm	J in./mm	V in./mm
F22T	2.50 x 2.50 64 x 64	6.50 165	10.35 263
F44T	4.00 x 4.00 102 x 102	8.00 203	11.85 301
F66T	6.00 x 6.00 152 x 152	10.00 254	13.85 352
F88T	8.00 x 8.00 203 x 203	12.00 305	15.84 402
F1010T	10.00 x 10.00 254 x 254	14.00 356	17.84 453
F1212T	12.00 x 12.00 305 x 305	16.00 406	19.84 504

### CROSS FITTING

For routing cables in four directions. Top, bottom and side covers removable.

BULLETIN: F40PF

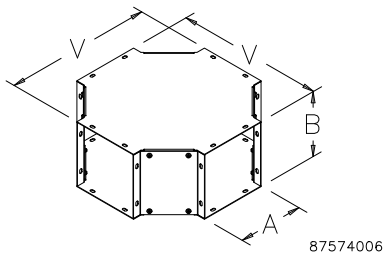

87574006

Catalog Number	AxB in./mm	V in./mm
F22X	2.50 x 2.50 64 x 64	10.35 263
F44X	4.00 x 4.00 102 x 102	11.85 301
F66X	6.00 x 6.00 152 x 152	13.85 352
F88X	8.00 x 8.00 203 x 203	15.84 402
F1010X	10.00 x 10.00 254 x 254	17.84 453
F1212X	12.00 x 12.00 305 x 305	19.84 504

### 90-DEGREE SWEEP ELBOW

For large radius turns.

BULLETIN: F40PF

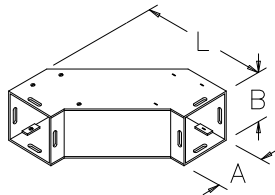

87797091

Catalog Number	AxB in./mm	L in./mm
F22G90SE	2.50 x 2.50 64 x 64	7.91 201
F44G90SE	4.00 x 4.00 102 x 102	9.41 239
F66G90SE	6.00 x 6.00 152 x 152	11.34 288
F88G90SE	8.00 x 8.00 203 x 203	13.44 341
F1010G90SE	10.00 x 10.00 254 x 254	15.62 395
F1212G90SE	12.00 x 12.00 305 x 305	17.44 443



### 90-DEGREE ELBOW-TEE-CROSS

Forms left or right 90-degree turns. Can be used as a tee or cross. Use with open adapter for cable entrance in top and bottom. Includes two closure plates.

BULLETIN: F40PF

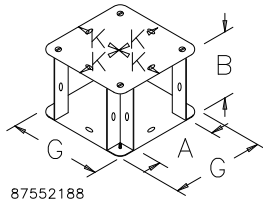

### 90-DEGREE ELBOW

Any side can be removed, retaining lay-in feature regardless of how the elbow is oriented. Sides are held together with screws.

BULLETIN: F40PF

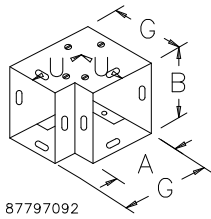

### 90-DEGREE ELBOW—OUTSIDE OPENING

For continuous run with 90-degree turns. Top, bottom and outside covers removable.

BULLETIN: F40PF

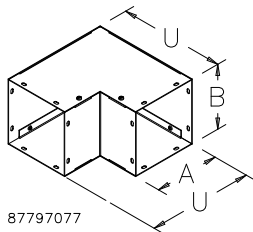

### 90-DEGREE ELBOW—INSIDE OPENING

For continuous run with 90-degree turns. Top and inside covers removable.

BULLETIN: F40PF

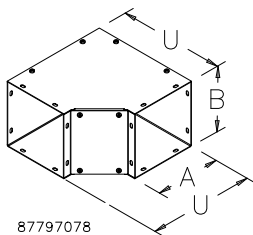

Catalog Number	AxB in./mm	G in./mm	K in./mm
F22G90TX	2.50 x 2.50 64 x 64	4.50 114	2.25 57
F33G90TX	3.00 x 3.00 76 x 76	5.00 127	2.50 64
F44G90TX	4.00 x 4.00 102 x 102	6.00 152	3.00 76
F66G90TX	6.00 x 6.00 152 x 152	8.00 203	4.00 102
F88G90TX	8.00 x 8.00 203 x 203	10.00 254	5.00 127
F1010G90TX	10.00 x 10.00 254 x 254	12.00 305	6.00 152
F1212G90TX	12.00 x 12.00 305 x 305	14.00 356	7.00 178

Catalog Number	AxB in./mm	G in./mm
F22G90E	2.50 x 2.50 64 x 64	4.50 114
F33G90E	3.00 x 3.00 76 x 76	5.00 127
F44G90E	4.00 x 4.00 102 x 102	6.00 152
F66G90E	6.00 x 6.00 152 x 152	8.00 203
F88G90E	8.00 x 8.00 203 x 203	10.00 254
F1010G90E	10.00 x 10.00 254 x 254	12.00 305
F1212G90E	12.00 x 12.00 305 x 305	14.00 356

Catalog Number	AxB in./mm	U in./mm
F2290EOUT	2.50 x 2.50 64 x 64	6.50 165
F4490EOUT	4.00 x 4.00 102 x 102	8.00 203
F6690EOUT	6.00 x 6.00 152 x 152	10.00 254
F8890EOUT	8.00 x 8.00 203 x 203	12.00 305
F101090EOUT	10.00 x 10.00 254 x 254	14.00 356
F121290EOUT	12.00 x 12.00 305 x 305	16.00 406

Catalog Number	AxB in./mm	U in./mm
F2290EIN	2.50 x 2.50 64 x 64	6.50 165
F4490EIN	4.00 x 4.00 102 x 102	8.00 203
F6690EIN	6.00 x 6.00 152 x 152	10.00 254
F8890EIN	8.00 x 8.00 203 x 203	12.00 305
F101090EIN	10.00 x 10.00 254 x 254	14.00 356
F121290EIN	12.00 x 12.00 305 x 305	16.00 406

### 45-DEGREE ELBOW

For continuous run with 45-degree turns. Top and inside covers removable.

BULLETIN: F40PF

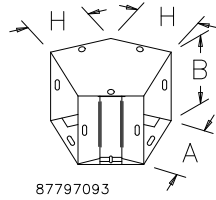

Catalog Number	AxB in./mm	H in./mm
F22G45E	2.50 x 2.50 64 x 64	2.75 70
F33G45E	3.00 x 3.00 76 x 76	2.99 76
F44G45E	4.00 x 4.00 102 x 102	3.38 86
F66G45E	6.00 x 6.00 152 x 152	4.25 108
F88G45E	8.00 x 8.00 203 x 203	5.06 129
F1010G45E	10.00 x 10.00 254 x 254	6.00 152
F1212G45E	12.00 x 12.00 305 x 305	6.75 171

### TELESCOPE FITTING

Length easily adjusts to approximately 12.00 in. (305 mm). No cutting or welding required.

BULLETIN: F40PF

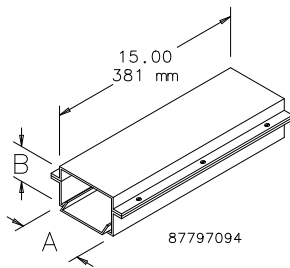

Catalog Number	AxB in./mm
F22GA	2.50 x 2.50 64 x 64
F44GA	4.00 x 4.00 102 x 102
F66GA	6.00 x 6.00 152 x 152
F88GA	8.00 x 8.00 203 x 203
F1010GA	10.00 x 10.00 254 x 254
F1212GA	12.00 x 12.00 305 x 305

These items not UL/cUL listed.

### OPEN ADAPTER

Used with the 90-Degree Elbow-Tee-Cross fitting to permit a run directly up or down.

BULLETIN: F40PF

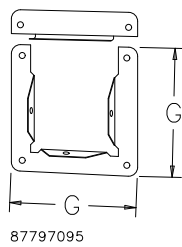

Catalog Number	G (in.)	G (mm)
F22G0A	4.50	114
F44G0A	6.00	152
F66G0A	8.00	203
F88G0A	10.00	254
F1010G0A	12.00	305
F1212G0A	14.00	356

### PANEL ADAPTER

A flanged fitting which allows the wireway to be securely connected to an enclosure.

BULLETIN: F40PF

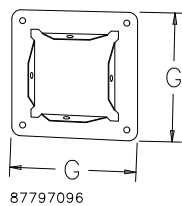

Catalog Number	G (in.)	G (mm)
F22GPA	4.50	114
F33GPA	5.00	127
F44GPA	6.00	152
F66GPA	8.00	203
F88GPA	10.00	254
F1010GPA	12.00	305
F1212GPA	14.00	356



### CLOSURE PLATE

Closes the end of a wireway section or run.

BULLETTIN: F40PF

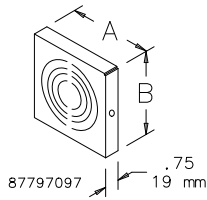

### REDUCER

Reduces wireway to a smaller size.

BULLETTIN: F10, F40PF

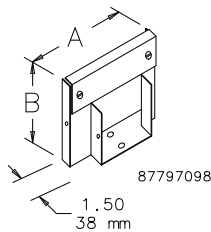

### DROP AND BRACKET HANGERS

Drop and bracket hangers support a wireway run.

BULLETTIN: F40PF

Catalog Number	N max. (in.)	N max. (mm)	P (in.)	P (mm)	R (in.)	R (mm)	S (in.)	S (mm)	T (in.)	T (mm)
F22GDB	8.50	216	4.50	114	3.38	86	7.25	184	3.75	95
F44GDB	10.50	267	6.00	152	4.12	105	9.25	235	4.50	114
F66GDB	15.00	381	7.12	181	5.12	130	13.75	349	5.50	140
F88GDB	21.00	533	10.81	275	7.00	178	13.75	349	7.75	197
F1010GDB	22.00	559	13.81	335	8.38	213	13.75	349	10.25	260
F1212GDB	23.00	584	15.56	395	9.78	248	13.75	349	12.50	318

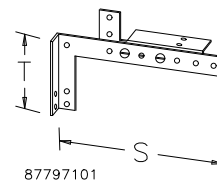
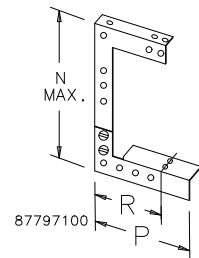

### SUPPORT HANGER

For floor or wall installations.

BULLETTIN: F40PF

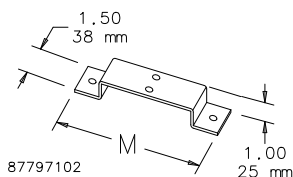

Catalog Number	AxB in.	AxB mm	Knockouts
F22GCP	2.50 x 2.50	64 x 64	With knockouts
F22GCPNK	2.50 x 2.50	64 x 64	Without knockouts
F44GCP	4.00 x 4.00	102 x 102	With knockouts
F33GCPNK	3.00 x 3.00	76 x 76	Without knockouts
F44GCPNK	4.00 x 4.00	102 x 102	Without knockouts
F66GCP	6.00 x 6.00	152 x 152	With knockouts
F66GCPNK	6.00 x 6.00	152 x 152	Without knockouts
F88GCP	8.00 x 8.00	203 x 203	With knockouts
F88GCPNK	8.00 x 8.00	203 x 203	Without knockouts
F1010GCP	10.00 x 10.00	254 x 254	With knockouts
F1010GCPNK	10.00 x 10.00	254 x 254	Without knockouts
F1212GCP	12.00 x 12.00	305 x 305	With knockouts
F1212GCPNK	12.00 x 12.00	305 x 305	Without knockouts

Catalog Number	AxB in./mm
F33G22R	3.00 x 3.00 76 x 76
F44G22R	4.00 x 4.00 102 x 102
F44G33R	4.00 x 4.00 101 x 101
F66G44R	6.00 x 6.00 152 x 152
F88G66R	8.00 x 8.00 203 x 203
F1010G88R	10.00 x 10.00 254 x 254
F1212G88R	12.00 x 12.00 305 x 305
F1212G1010R	12.00 x 12.00 305 x 305

Catalog Number	M in./mm
F22GSH	4.62 117
F44GSH	6.12 155
F66GSH	8.12 206
F88GSH	10.12 257
F1010GSH	12.12 308
F1212GSH	14.12 359



### UNIVERSAL U-CONNECTOR

Joins wireway sections and fittings. Top swings aside to retain the lay-in feature. One U-connector required at each wireway joint except telescope fittings, panel adapters, open adapters, closure plates or reducers.

BULLETIN: F40PF

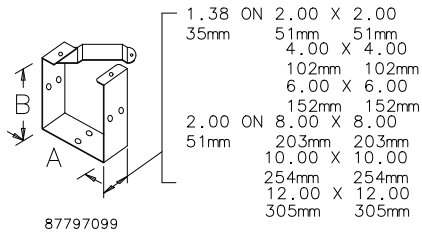

Catalog Number	AxB in./mm
F22GUC	2.50 x 2.50 64 x 64
F33GUC	3.00 x 3.00 76 x 76
F44GUC	4.00 x 4.00 102 x 102
F66GUC	6.00 x 6.00 152 x 152
F88GUC	8.00 x 8.00 203 x 203
F1010GUC	10.00 x 10.00 254 x 254
F1212GUC	12.00 x 12.00 305 x 305

### BARRIER KIT, BOLT-ON

Divides wireway into two or more compartments. Barriers are fastened to wireway sections with screws. Sealing washers are included.

BULLETIN: F20

Catalog Number	W in./mm
F33BK60	2.00 51
F44BK60	3.00 76
F66BK60	4.50 114
F88BK60	6.00 152

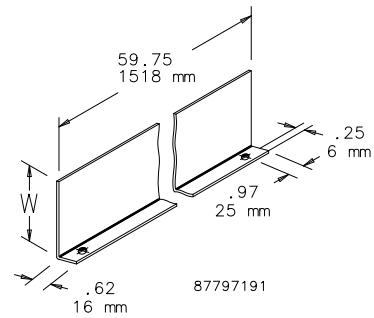

**LAY-IN WIREWAY, NEMA TYPE 3R**



**APPLICATION**

This moisture-proof wireway features a quick-release latch cover for convenient access and an opening on one side so wires and cables can be laid in along the entire run without pulling.

**FEATURES**

- Open top assembly
- Self-connecting system
- Removable covers with quick-release latches

**SPECIFICATIONS**

- 16 or 14 gauge galvanized steel

**FINISH**

ANSI 61 gray polyester powder paint finish inside and out over pretreated surfaces.

**INDUSTRY STANDARDS**

UL 870 Listed; File No. E27524; Raintight

NEMA/EEMAC Type 3R  
 CSA File No. 42184, Type 3R  
 IEC 60529, IP32

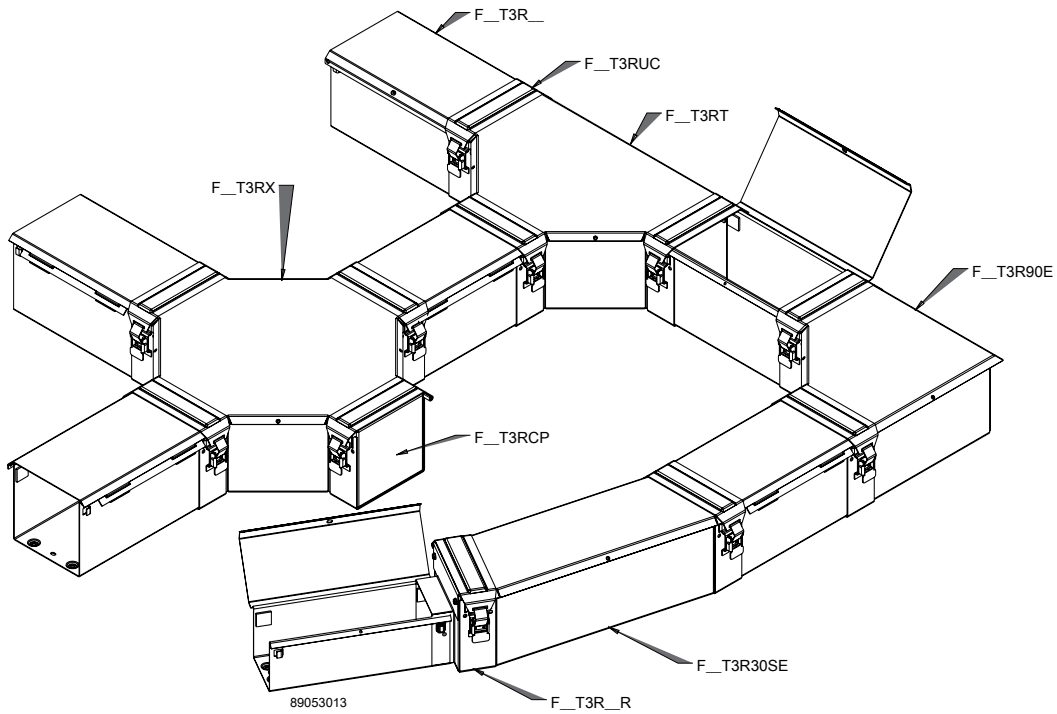

Standard Product Selection Matrix

Description	4.00 x 4.00 in. (102 x 102 mm)	6.00 x 6.00 in. (152 x 152 mm)	8.00 x 8.00 in. (203 x 203 mm)
12.00-in. (305-mm) Straight Section <sup>a</sup>	F44T3R12	F66T3R12	F88T3R12
60.00-in. (1524-mm) Straight Section <sup>a</sup>	F44T3R60	F66T3R60	F88T3R60
120.00-in. (3048-mm) Straight Section <sup>a</sup>	F44T3R120	F66T3R120	F88T3R120
90° Flush Tee	F44T3RT	F66T3RT	F88T3RT
30° Sweep Elbow	F44T3R30SE	F66T3R30SE	F88T3R30SE
90° Elbow-Tee-Cross	F44T3RTX	F66T3RTX	F88T3RTX
90° Elbow	F44T3R90E	F66T3R90E	F88T3R90E
Panel Adapter	F44T3RPA	F66T3RPA	F88T3RPA
Closure Plate	F44T3RCP	F66T3RCP	F88T3RCP
Reducer	—	F66T3R44R	F88T3R66R
Drop and Bracket Hanger	F44T3RDH	F66T3RDH	F88T3RDH
Wall Hanger	F44T3RWH	F66T3RWH	F88T3RWH
Universal U-Connector	F44T3RUC	F66T3RUC	F88T3RUC

STRAIGHT SECTION

Available in lengths from 12 in. (305 mm) to 120 in. (3038 mm).

BULLETIN: F30G

Catalog Number	AxBx C in.	AxBx C mm
F44T3R12	4.00 x 4.00 x 12.00	102 x 102 x 305
F44T3R60	4.00 x 4.00 x 60.00	102 x 102 x 1524
F44T3R120	4.00 x 4.00 x 120.00	102 x 102 x 3048
F66T3R12	4.00 x 4.00 x 12.00	102 x 102 x 305
F66T3R60	4.00 x 4.00 x 60.00	102 x 102 x 1524
F66T3R120	4.00 x 4.00 x 120.00	102 x 102 x 3048
F88T3R12	4.00 x 4.00 x 12.00	102 x 102 x 305
F88T3R60	8.00 x 8.00 x 60.00	203 x 203 x 1524
F88T3R120	4.00 x 4.00 x 120.00	102 x 102 x 3048

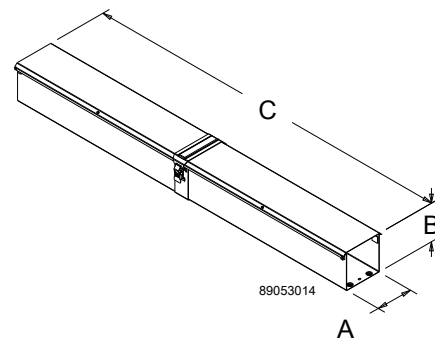

90-DEGREE FLUSH TEE

Use whenever flush mounting against a vertical surface is required.

BULLETIN: F30G

Catalog Number	AxB in./mm	O in./mm
F44T3RT	4.00 x 4.00	16.00
	102 x 102	406
F66T3RT	6.00 x 6.00	18.00
	152 x 152	457
F88T3RT	8.00 x 8.00	20.00
	203 x 203	508

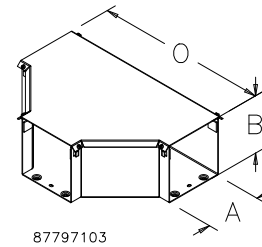

30-DEGREE SWEEP ELBOW

When a large radius is needed, use this sweep elbow.

BULLETIN: F30G

Catalog Number	AxB in./mm	N in./mm	U in./mm
F44T3R30SE	4.00 x 4.00	13.00	1.25
	102 x 102	330	31
F66T3R30SE	6.00 x 6.00	13.00	1.25
	152 x 152	330	31
F88T3R30SE	8.00 x 8.00	13.00	1.25
	203 x 203	330	31

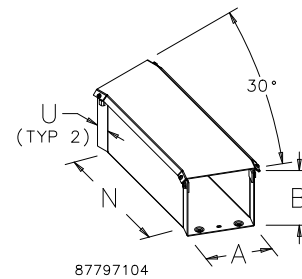

### 90-DEGREE ELBOW-TEE-CROSS

Use when there are four branches. It can be used as a 90-degree elbow or a 90-degree flush tee by adding Closure Plates.

BULLETIN: F30G

Catalog Number	AxB in./mm	G in./mm
F44T3RTX	4.00 x 4.00 102 x 102	16.00 406
F66T3RTX	6.00 x 6.00 152 x 152	18.00 457
F88T3RTX	8.00 x 8.00 203 x 203	20.00 508

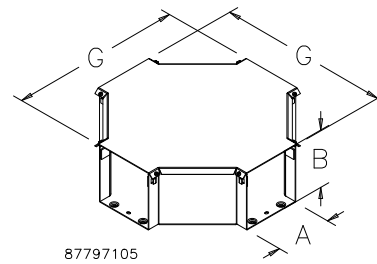

### 90-DEGREE ELBOW

Used whenever a right-angle installation is needed.

BULLETIN: F30G

Catalog Number	AxB in./mm	Q in./mm
F44T3R90E	4.00 x 4.00 102 x 102	10.00 254
F66T3R90E	6.00 x 6.00 152 x 152	12.00 305
F88T3R90E	8.00 x 8.00 203 x 203	14.00 356

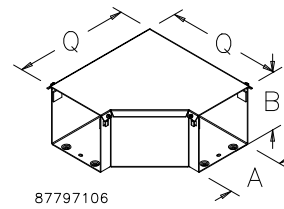

### PANEL ADAPTER

Allows the wireway to be securely connected to an enclosure.

BULLETIN: F30G

Catalog Number	AxB in./mm
F44T3RPA	4.00 x 4.00 102 x 102
F66T3RPA	6.00 x 6.00 152 x 152
F88T3RPA	8.00 x 8.00 203 x 203

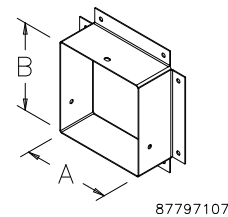

### CLOSURE PLATE

Closes the end of a wireway section or run. A U-connector must be used in combination with a closure plate to close the end of a wireway section or run.

BULLETIN: F30G

Catalog Number	AxB in./mm
F44T3RCP	4.00 x 4.00 102 x 102
F66T3RCP	6.00 x 6.00 152 x 152
F88T3RCP	8.00 x 8.00 203 x 203

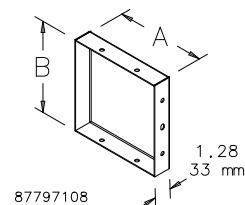

### REDUCER

Used to reduce to a smaller wireway size.

BULLETIN: F30G

Catalog Number	AxB in./mm
F66T3R44R	6.00 x 6.00 152 x 152
F88T3R66R	8.00 x 8.00 203 x 203

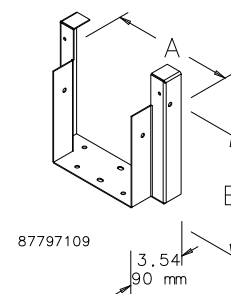

### DROP AND BRACKET HANGER

Used to support a wireway run.

BULLETIN: F30G

Catalog Number	S in./mm	T in./mm
F44T3RDH	9.50 241	4.50 114
F66T3RDH	14.00 356	5.50 140
F88T3RDH	14.00 356	8.00 203

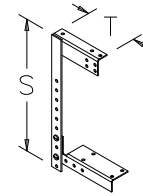

87797111

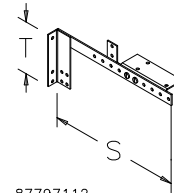

87797112

### WALL HANGER

Used to support a wireway run.

BULLETIN: F30G

Catalog Number	V in./mm	W in./mm
F44T3RWH	5.00 127	5.00 127
F66T3RWH	7.00 178	7.00 178
F88T3RWH	9.00 229	9.00 229

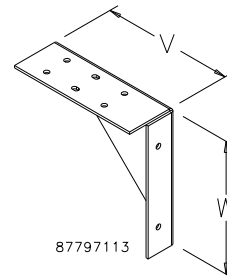

87797113

### U-CONNECTOR

Used to rigidly join fittings to straight sections.

BULLETIN: F30G

Catalog Number	AxB in./mm
F44T3RUC	4.00 x 4.00 102 x 102
F66T3RUC	6.00 x 6.00 152 x 152
F88T3RUC	8.00 x 8.00 203 x 203

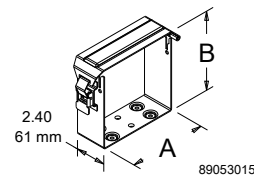

89053015

## LAY-IN WIREWAY, NEMA TYPE 12



*Clockwise from top: Tee, Flange Gasket, Quick-Release Sealing Plate, Barriers, Barrier Bracket, 90° Elbow*

### INDUSTRY STANDARDS

UL 870 Listed; File No. E27524

NEMA/EEMAC Type 12  
 JIC standards EGP-1-1967 and EMP-1-1967  
 CSA, File No. 42184, Type 1  
 IEC 60529, IP54

### APPLICATION

Used primarily in industrial applications to protect wiring against exposure to oil and other contaminants, this gasketed wireway features quick-release latches for easy access and an opening on one side so wires and cables can be laid in along the entire run without pulling. Available in multiple sizes, this wireway's finish color and texture can be customized to meet application requirements.

### FEATURES

- Seams continuously welded and ground smooth
- No holes or knockouts
- Smooth, rounded edges on all sections and fittings
- Butt hinges and strong latches
- Quick-release cover latches
- Oil-resistant gasket and adhesive
- Gasketed quick-release sealing plate

### SPECIFICATIONS

- 14 gauge steel covers and bodies
- 10 gauge steel end flanges

### FINISH

- ANSI 61 gray polyester powder finish inside and out over pretreated surfaces
- Box connector is gray ANSI 61
- LSGQR sealing plate and quick-release latches are plated

### ACCESSORIES

Touch-Up Paint (ATPPY61)

The drawing below illustrates how most of the Hoffman lay-in wireway sections and fittings could be used in an actual wireway run. The covers have been omitted to present the lay-in feature more clearly. Many different sections and fittings can be combined in any configuration desired.

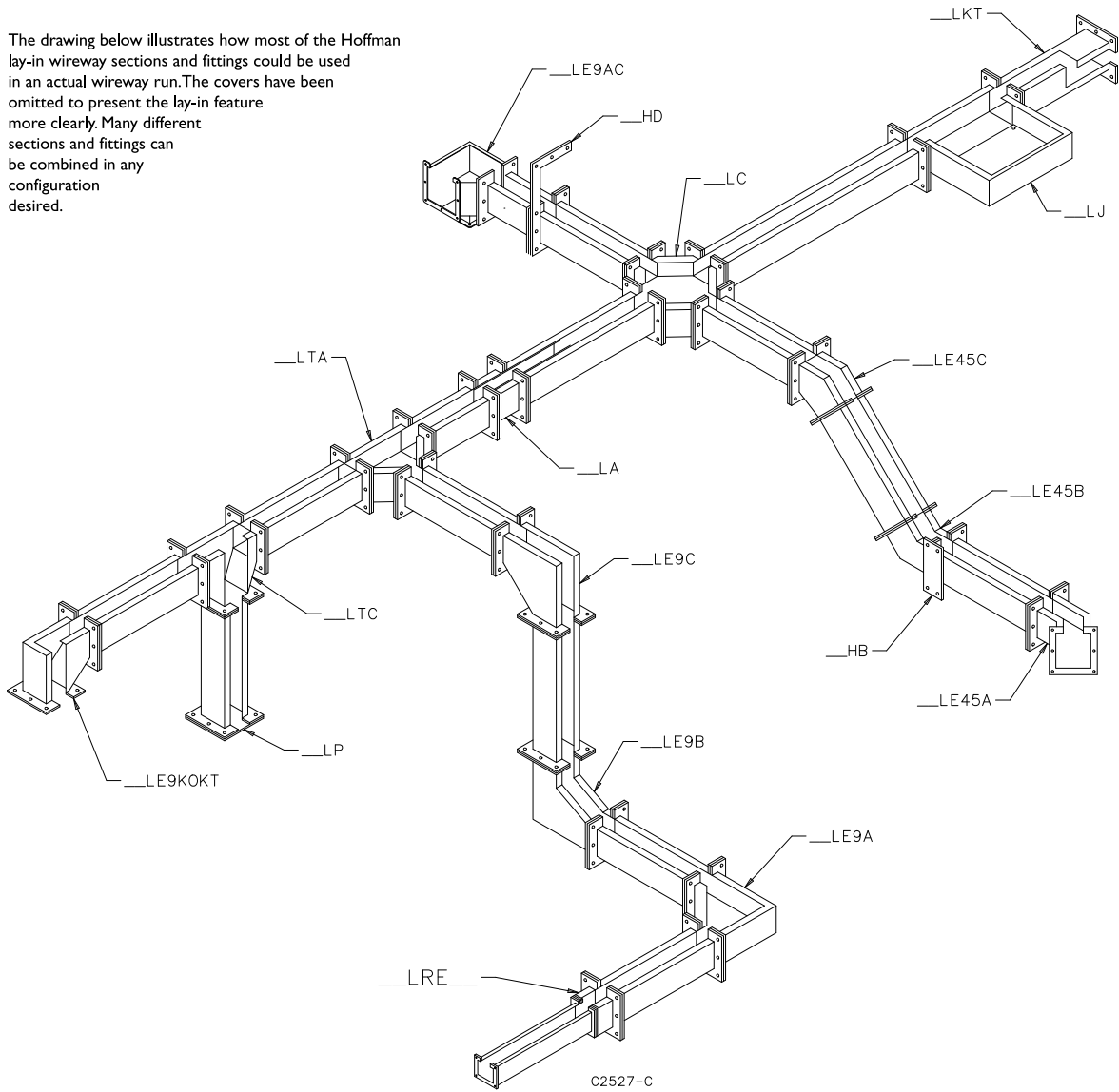

## Standard Product Selection Matrix

Description	Sealing Plates <sup>a</sup> Type	Sealing Plates <sup>a</sup> Qty.	2.50 x 2.50 in. (64 x 64 mm)	4.00 x 4.00 in. (102 x 102 mm)	6.00 x 6.00 in. (152 x 152 mm)	8.00 x 8.00 in. (203 x 203 mm)	12.00 x 6.00 in. (305 x 152 mm)
6.00-in. (152-mm) Straight Section	Flat	1	F22L06 <sup>c,d</sup>	F44L06 <sup>c,d</sup>	F66L06 <sup>c,d</sup>	F88L06 <sup>c,d</sup>	F126L06 <sup>c,d</sup>
12.00-in. (305-mm) Straight Section	Flat	1	F22L12 <sup>c,d</sup>	F44L12 <sup>c,d</sup>	F66L12 <sup>c,d</sup>	F88L12 <sup>c,d</sup>	F126L12 <sup>c,d</sup>
24.00-in. (610-mm) Straight Section	Flat	1	F22L24 <sup>c,d</sup>	F44L24 <sup>c,d</sup>	F66L24 <sup>c,d</sup>	F88L24 <sup>c,d</sup>	F126L24 <sup>c,d</sup>
36.00-in. (914-mm) Straight Section	Flat	1	F22L36 <sup>c,d</sup>	F44L36 <sup>c,d</sup>	F66L36 <sup>c,d</sup>	F88L36 <sup>c,d</sup>	F126L36 <sup>c,d</sup>
48.00-in. (1219-mm) Straight Section	Flat	1	F22L48 <sup>c,d</sup>	F44L48 <sup>c,d</sup>	F66L48 <sup>c,d</sup>	F88L48 <sup>c,d</sup>	F126L48 <sup>c,d</sup>
60.00-in. (1524-mm) Straight Section	Flat	1	F22L60 <sup>c,d</sup>	F44L60 <sup>c,d</sup>	F66L60 <sup>c,d</sup>	F88L60 <sup>c,d</sup>	F126L60 <sup>c,d</sup>
120.00-in. (3048-mm) Straight Section	Flat	1	F22L120 <sup>c,d</sup>	F44L120 <sup>c,d</sup>	F66L120 <sup>c,d</sup>	F88L120 <sup>c,d</sup>	F126L120 <sup>c,d</sup>
Cutoff Fitting, Lay-In	Flat	1	F22LXL	F44LXL	F66LXL	F88LXL	F126LXL
Cutoff Fitting, Not Lay-In	90° Angle	1	F22LX	F44LX	F66LX	F88LX	F126LX
Telescope Fitting, Lay-In	Special	1	F22LA	F44LA	F66LA	F88LA	F126LA
Cross Fitting	Flat	3	F22LC <sup>c,d</sup>	F44LC <sup>c,d</sup>	F66LC <sup>c,d</sup>	F88LC <sup>c,d</sup>	F126LC <sup>c,d</sup>
90° Elbow, top opening	Flat	1	F22LE9A <sup>c,d</sup>	F44LE9A <sup>c,d</sup>	F66LE9A <sup>c,d</sup>	F88LE9A <sup>c,d</sup>	F126LE9A <sup>c,d</sup>
90° Elbow, inside opening	Flat	1	F22LE9B <sup>c,d</sup>	F44LE9B <sup>c,d</sup>	F66LE9B <sup>c,d</sup>	F88LE9B <sup>c,d</sup>	F126LE9B <sup>c,d</sup>
90° Elbow, outside opening	Flat	1	F22LE9C <sup>c,d</sup>	F44LE9C <sup>c,d</sup>	F66LE9C <sup>c,d</sup>	F88LE9C <sup>c,d</sup>	F126LE9C <sup>c,d</sup>
90° Elbow, outside top opening	Flat	2	—	F44LE9AC <sup>c,d</sup>	F66LE9AC <sup>c,d</sup>	F88LE9AC <sup>c,d</sup>	—
45° Elbow, top opening	Flat	1	F22LE45A <sup>c,d</sup>	F44LE45A <sup>c,d</sup>	F66LE45A <sup>c,d</sup>	F88LE45A <sup>c,d</sup>	F126LE45A <sup>c,d</sup>
45° Elbow, inside opening	Flat	1	F22LE45B <sup>c,d</sup>	F44LE45B <sup>c,d</sup>	F66LE45B <sup>c,d</sup>	F88LE45B <sup>c,d</sup>	—
45° Elbow, outside opening	Flat	1	F22LE45C <sup>c,d</sup>	F44LE45C <sup>c,d</sup>	F66LE45C <sup>c,d</sup>	F88LE45C <sup>c,d</sup>	—
Tee Fitting, top opening	Flat	2	F22LTA <sup>c,d</sup>	F44LTA <sup>c,d</sup>	F66LTA <sup>c,d</sup>	F88LTA <sup>c,d</sup>	F126LTA <sup>c,d</sup>
Tee Fitting, outside top opening	Flat	2	F22LTC <sup>c,d</sup>	F44LTC <sup>c,d</sup>	F66LTC <sup>c,d</sup>	F88LTC <sup>c,d</sup>	—
Junction Box	Flat	1	F22LJ <sup>c,d</sup>	F44LJ <sup>c,d</sup>	F66LJ <sup>c,d</sup>	F88LJ <sup>c,d</sup>	—
Closure Plate	90°	1	F22LP	F44LP	F66LP	F88LP	—
Box Connector	90°	1	F22LB	F44LB	F66LB	F88LB	—
Reducer 4.00 x 4.00 to 2.50 x 2.50 (102 x 102) to (64 x 64)	None	0	—	F44LRE2	—	—	—
Reducer 6.00 x 6.00 to 4.00 x 4.00 (152 x 152) to (102 x 102)	None	0	—	—	F66LRE44 <sup>c,d</sup>	—	—
Reducer 8.00 x 8.00 to 6.00 x 6.00 (203 x 203) to (152 x 152)	None	0	—	—	—	F88LRE66 <sup>d</sup>	—
Reducer 12.00 x 6.00 to 6.00 x 6.00 (305 x 152) to (152 x 152)	None	0	—	—	—	—	F126LRE66 <sup>c,d</sup>
Reducer 12.00 x 6.00 to 4.00 x 4.00 (305 x 152) to (102 x 102)	None	0	—	—	—	—	F126LRE44 <sup>c,d</sup>
1.00-in. (25-mm) Nipple	Special	1	F22LN1 <sup>c,d</sup>	F44LN1 <sup>c,d</sup>	F66LN1 <sup>c,d</sup>	—	—
2.00-in. (51-mm) Nipple	Special	1	F22LN2 <sup>c,d</sup>	F44LN2 <sup>c,d</sup>	F66LN2 <sup>c,d</sup>	—	—
3.00-in. (76-mm) Nipple	Special	1	F22LN3 <sup>c,d</sup>	F44LN3 <sup>c,d</sup>	F66LN3 <sup>c,d</sup>	—	—
Drop Hanger	None	0	F22HD	F44HD	F66HD	F88HD	—
Bracket Hanger	None	0	F22HB	F44HB	F66HB	F88HB	—
Clockwise Transposition Section	Flat	1	F22LKT <sup>c,d</sup>	F44LKT <sup>c,d</sup>	F66LKT <sup>c,d</sup>	—	—
Counterclockwise Transposition Section	Flat	1	F22LKOKT <sup>c,d</sup>	F44LKOKT <sup>c,d</sup>	F66LKOKT <sup>c,d</sup>	—	—
90° Elbow, Clockwise Transposition	Flat	1	F22LE9KT <sup>c,d</sup>	F44LE9KT <sup>c,d</sup>	F66LE9KT <sup>c,d</sup>	F88LE9KT <sup>c,d</sup>	—
90° Elbow, Counterclockwise Transposition	Flat	1	F22LE9KOKT <sup>c,d</sup>	F44LE9KOKT <sup>c,d</sup>	F66LE9KOKT <sup>c,d</sup>	F88LE9KOKT <sup>c,d</sup>	—
Barrier Kit, bolt-on Each barrier 60.00 in. (1524 mm)	None	0	—	F44BK60	F66BK60	F88BK60	F66BK60
Barrier, bracket-mounted <sup>a</sup> Each barrier 60.00 in. (1524 mm) <sup>b</sup>	—	1 pkg. (5 pcs.)	—	F44B360	F66B560	—	—
Barrier Brackets, 2 compartment <sup>b</sup>	—	1 pkg. (5 pcs.)	—	F44B2C	F66B2C	—	—
Barrier Brackets, 3 compartment <sup>b</sup>	—	1 pkg. (5 pcs.)	—	F44B3C	F66B3C	—	—
Flat Sealing Plate <sup>a</sup>	—	—	F22LSGQR	F44LSGQR	F66LSGQR	F88LSGQR	F126LSGQR
90° Angle Sealing Plate <sup>a</sup>	—	—	F22LSAG	F44LSAG	F66LSAG	F88LSAG	F126LSAG

<sup>a</sup> Each sealing plate also includes one gasket and one set of screws to join sections.

<sup>b</sup> Package consists of five barriers or five brackets. Each barrier is 60-in. long.

<sup>c</sup> Certified by Canadian Standards Association.

<sup>d</sup> UL 870



**STRAIGHT SECTION**

Available in lengths from 6.00 in. (152 mm) to 120.00 in. (3048 mm).  
 BULLETIN: F10

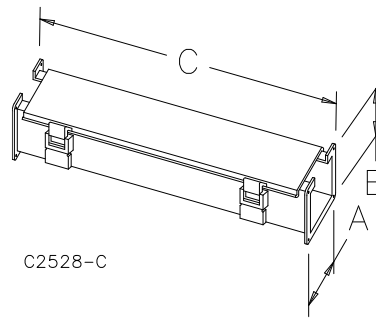

**Straight Sections**

Catalog Number	AxBxC in.	AxBxC mm	Sealing Plates, Type <sup>a</sup>	Sealing Plates, Qty. <sup>a</sup>	D (in.)	D (mm)	E (in.)	E (mm)
F22L06	2.50 x 2.50 x 6.00	64 x 64 x 152	Flat	1	3.88	99	3.88	99
F22L12	2.50 x 2.50 x 12.00	64 x 64 x 305	Flat	1	3.88	99	3.88	99
F22L24	2.50 x 2.50 x 24.00	64 x 64 x 610	Flat	1	3.88	99	3.88	99
F22L36	2.50 x 2.50 x 36.00	64 x 64 x 914	Flat	1	3.88	99	3.88	99
F22L48	2.50 x 2.50 x 48.00	64 x 64 x 1219	Flat	1	3.88	99	3.88	99
F22L60	2.50 x 2.50 x 60.00	64 x 64 x 1524	Flat	1	3.88	99	3.88	99
F22L120	2.50 x 2.50 x 120.00	64 x 64 x 3048	Flat	1	3.88	99	3.88	99
F44L06	4.00 x 4.00 x 6.00	102 x 102 x 152	Flat	1	5.38	137	5.38	137
F44L12	4.00 x 4.00 x 12.00	102 x 102 x 305	Flat	1	5.38	137	5.38	137
F44L24	4.00 x 4.00 x 24.00	102 x 102 x 610	Flat	1	5.38	137	5.38	137
F44L36	4.00 x 4.00 x 36.00	102 x 102 x 914	Flat	1	5.38	137	5.38	137
F44L48	4.00 x 4.00 x 48.00	102 x 102 x 1219	Flat	1	5.38	137	5.38	137
F44L60	4.00 x 4.00 x 60.00	102 x 102 x 1524	Flat	1	5.38	137	5.38	137
F44L120	4.00 x 4.00 x 120.00	102 x 102 x 3048	Flat	1	5.38	137	5.38	137
F66L06	6.00 x 6.00 x 6.00	152 x 152 x 152	Flat	1	7.62	194	7.62	194
F66L12	6.00 x 6.00 x 12.00	152 x 152 x 305	Flat	1	7.62	194	7.62	194
F66L24	6.00 x 6.00 x 24.00	152 x 152 x 610	Flat	1	7.62	194	7.62	194
F66L36	6.00 x 6.00 x 36.00	152 x 152 x 914	Flat	1	7.62	194	7.62	194
F66L48	6.00 x 6.00 x 48.00	152 x 152 x 1219	Flat	1	7.62	194	7.62	194
F66L60	6.00 x 6.00 x 60.00	152 x 152 x 1524	Flat	1	7.62	194	7.62	194
F66L120	6.00 x 6.00 x 120.00	152 x 152 x 3048	Flat	1	7.62	194	7.62	194
F88L06	8.00 x 8.00 x 6.00	203 x 203 x 152	Flat	1	9.62	244	9.62	244
F88L12	8.00 x 8.00 x 12.00	203 x 203 x 305	Flat	1	9.62	244	9.62	244
F88L24	8.00 x 8.00 x 24.00	203 x 203 x 610	Flat	1	9.62	244	9.62	244
F88L36	8.00 x 8.00 x 36.00	203 x 203 x 914	Flat	1	9.62	244	9.62	244
F88L48	8.00 x 8.00 x 48.00	203 x 203 x 1219	Flat	1	9.62	244	9.62	244
F88L60	8.00 x 8.00 x 60.00	203 x 203 x 1524	Flat	1	9.62	244	9.62	244
F88L120	8.00 x 8.00 x 120.00	203 x 203 x 3048	Flat	1	9.62	244	9.62	244
F126L06	12.00 x 6.00 x 6.00	305 x 152 x 152	Flat	1	13.62	346	7.62	194
F126L12	12.00 x 6.00 x 12.00	305 x 152 x 305	Flat	1	13.62	346	7.62	194
F126L24	12.00 x 6.00 x 24.00	305 x 152 x 610	Flat	1	13.62	346	7.62	194
F126L36	12.00 x 6.00 x 36.00	305 x 152 x 914	Flat	1	13.62	346	7.62	194
F126L48	12.00 x 6.00 x 48.00	305 x 152 x 1219	Flat	1	13.62	346	7.62	194
F126L60	12.00 x 6.00 x 60.00	305 x 152 x 1524	Flat	1	13.62	346	7.62	194
F126L120	12.00 x 6.00 x 120.00	305 x 152 x 3048	Flat	1	13.62	346	7.62	194

<sup>a</sup>Each sealing plate also includes one gasket and one set of screws to join sections.  
 Certified by Canadian Standards Association.

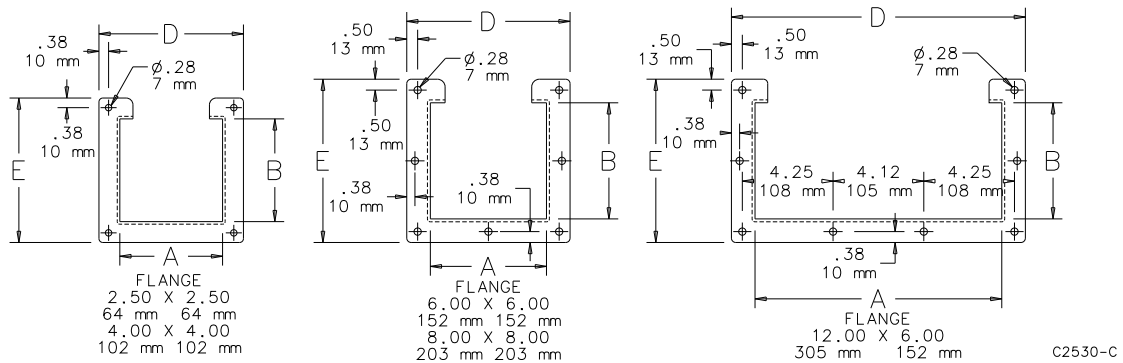

### CUT-OFF FITTING, LAY-IN

For lengths of 9.00 in. (229 mm) to 15.00 in. (381 mm) only. Body comes in two pieces. Shorten body and cover to the desired length and weld together.

BULLETIN: F10

Catalog Number	AxB in.	AxB mm	Sealing Plates, Type <sup>a</sup>	Sealing Plates, Qty. <sup>a</sup>
F22LXL	2.50 x 2.50	64 x 64	Flat	1
F44LXL	4.00 x 4.00	102 x 102	Flat	1
F66LXL	6.00 x 6.00	152 x 152	Flat	1
F88LXL	8.00 x 8.00	203 x 203	Flat	1
F126LXL	12.00 x 6.00	305 x 152	Flat	1

<sup>a</sup>Each sealing plate also includes one gasket and one set of screws to join sections.

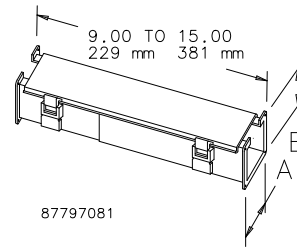

### CUT-OFF FITTING, NON-LAY-IN

For lengths up to 12.00 in. (305 mm). Shorten body to desired length and weld on flange. This is not a "lay-in" fitting but often is used when entering an enclosure.

BULLETIN: F10

Catalog Number	AxB in.	AxB mm	Sealing Plates, Type <sup>a</sup>	Sealing Plates, Qty. <sup>a</sup>
F22LX	2.50 x 2.50	64 x 64	90° Angle	1
F44LX	4.00 x 4.00	102 x 102	90° Angle	1
F66LX	6.00 x 6.00	152 x 152	90° Angle	1
F88LX	8.00 x 8.00	203 x 203	90° Angle	1
F126LX	12.00 x 6.00	305 x 152	90° Angle	1

<sup>a</sup>Each sealing plate also includes one gasket and one set of screws to join sections.

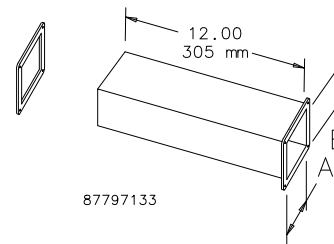

### TELESCOPE FITTING, LAY-IN

Length is easily adjustable from 1.00 in. (25 mm) to 7.00 in. (178 mm). No cutting or welding required.

BULLETIN: F10

Catalog Number	AxB in.	AxB mm	Sealing Plates, Type <sup>a</sup>	Sealing Plates, Qty. <sup>a</sup>
F22LA	2.50 x 2.50	64 x 64	Special	1
F44LA	4.00 x 4.00	102 x 102	Special	1
F66LA	6.00 x 6.00	152 x 152	Special	1
F88LA	8.00 x 8.00	203 x 203	Special	1
F126LA	12.00 x 6.00	305 x 152	Special	1

<sup>a</sup>Each sealing plate also includes one gasket and one set of screws to join sections

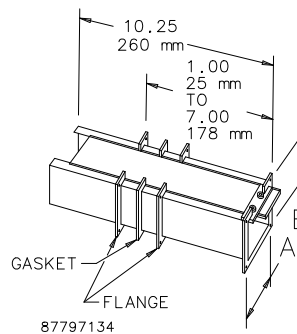

### CROSS FITTING

Used when there are four branches, all open along the same side.

BULLETIN: F10

Catalog Number	AxB in./mm	Sealing Plates, Type <sup>a</sup>	Sealing Plates, Qty. <sup>a</sup>	G in./mm	K in./mm
F22LC	2.50 x 2.50	Flat	3	8.50	4.25
	64 x 64			216	108
F44LC	4.00 x 4.00	Flat	3	10.00	5.00
	102 x 102			254	127
F66LC	6.00 x 6.00	Flat	3	12.00	6.00
	152 x 152			305	152
F88LC	8.00 x 8.00	Flat	3	14.00	7.00
	203 x 203			356	178
F126LC	12.00 x 6.00	Flat	3	18.00	9.00
	305 x 152			457	229

<sup>a</sup>Each sealing plate also includes one gasket and one set of screws to join sections.

Certified by Canadian Standards Association

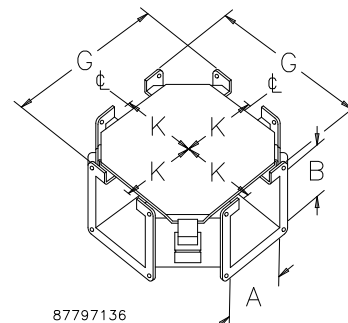

### 90-DEGREE ELBOWS

Because sections of lay-in wireway can be mounted with covers oriented in any direction, three different 90-degree elbows are available. Proper selection allows the user to maintain the same access and thereby preserve the lay-in feature for right-angle installations.

**BULLETIN: F10**

**Top Opening**

Catalog Number	AxB in./mm	Sealing Plates, Type <sup>a</sup>	Sealing Plates, Qty. <sup>a</sup>	K in./mm
F22LE9A	2.50 x 2.50 64 x 64	Flat	1	4.25 108
F44LE9A	4.00 x 4.00 102 x 102	Flat	1	5.00 127
F66LE9A	6.00 x 6.00 152 x 152	Flat	1	6.00 152
F88LE9A	8.00 x 8.00 203 x 203	Flat	1	7.00 178
F126LE9A	12.00 x 6.00 305 x 152	Flat	1	9.00 229

<sup>a</sup>Each sealing plate also includes one gasket and one set of screws to join sections.  
Certified by Canadian Standards Association.

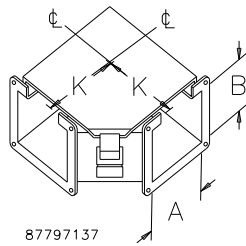

### Inside Opening

Catalog Number	AxB in./mm	Sealing Plates, Type <sup>a</sup>	Sealing Plates, Qty. <sup>a</sup>	H in./mm
F22LE9B	2.50 x 2.50 64 x 64	Flat	1	4.25 108
F44LE9B	4.00 x 4.00 102 x 102	Flat	1	5.00 127
F66LE9B	6.00 x 6.00 152 x 152	Flat	1	6.00 152
F88LE9B	8.00 x 8.00 203 x 203	Flat	1	7.00 178
F126LE9B	12.00 x 6.00 305 x 152	Flat	1	6.00 152

<sup>a</sup>Each sealing plate also includes one gasket and one set of screws to join sections.  
Certified by Canadian Standards Association.

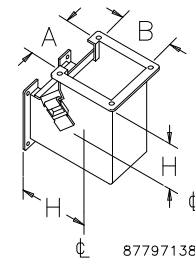

### Outside Opening

Catalog Number	AxB in./mm	Sealing Plates, Type <sup>a</sup>	Sealing Plates, Qty. <sup>a</sup>	H in./mm
F22LE9C	2.50 x 2.50 64 x 64	Flat	1	4.25 108
F44LE9C	4.00 x 4.00 102 x 102	Flat	1	5.00 127
F66LE9C	6.00 x 6.00 152 x 152	Flat	1	6.00 152
F88LE9C	8.00 x 8.00 203 x 203	Flat	1	7.00 178
F126LE9C	12.00 x 6.00 305 x 152	Flat	1	6.00 152

<sup>a</sup>Each sealing plate also includes one gasket and one set of screws to join sections.  
Certified by Canadian Standards Association.

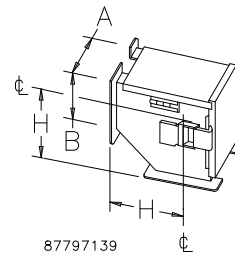

### 90-DEGREE ELBOW—OUTSIDE TOP OPENING

This elbow fitting allows a vertical drop to equipment below at a 90-degree corner while maintaining the top opening lay-in feature.

**BULLETIN: F10**

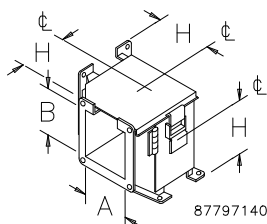

Catalog Number	AxB in./mm	Sealing Plates, Type <sup>a</sup>	Sealing Plates, Qty. <sup>a</sup>	H in./mm
F44LE9AC	4.00 x 4.00 102 x 102	Flat	2	5.00 127
F66LE9AC	6.00 x 6.00 152 x 152	Flat	2	6.00 152
F88LE9AC	8.00 x 8.00 203 x 203	Flat	2	7.00 178

<sup>a</sup>Each sealing plate also includes one gasket and one set of screws to join sections.



## 45-DEGREE ELBOWS

Because sections of lay-in wireway can be mounted with covers oriented in any direction, three different 45-degree elbows are available. Proper selection allows the user to maintain the same access and thereby preserve the lay-in feature for right-angle installations.

### BULLETIN: F10

#### Top Opening

Catalog Number	AxB in./mm	Sealing Plates, Type <sup>a</sup>	Sealing Plates, Qty. <sup>a</sup>	J in./mm
F22LE45A	2.50 x 2.50 64 x 64	Flat	1	2.00 51
F44LE45A	4.00 x 4.00 102 x 102	Flat	1	2.44 62
F66LE45A	6.00 x 6.00 152 x 152	Flat	1	3.00 76
F88LE45A	8.00 x 8.00 203 x 203	Flat	1	3.75 95
F126LE45A	12.00 x 6.00 305 x 152	Flat	1	4.75 121

<sup>a</sup>Each sealing plate also includes one gasket and one set of screws to join sections.  
Certified by Canadian Standards Association

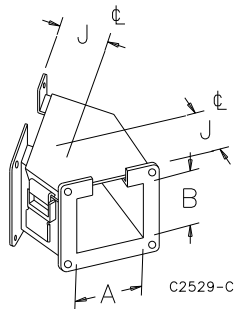

#### Inside Opening

Catalog Number	AxB in./mm	Sealing Plates, Type <sup>a</sup>	Sealing Plates, Qty. <sup>a</sup>	J in./mm
F22LE45B	2.50 x 2.50 64 x 64	Flat	1	2.00 51
F44LE45B	4.00 x 4.00 102 x 102	Flat	1	2.44 62
F66LE45B	6.00 x 6.00 152 x 152	Flat	1	3.00 76
F88LE45B	8.00 x 8.00 203 x 203	Flat	1	3.75 95

<sup>a</sup>Each sealing plate also includes one gasket and one set of screws to join sections.  
Certified by Canadian Standards Association.

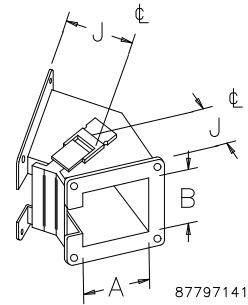

#### Outside Opening

Catalog Number	AxB in./mm	Sealing Plates, Type <sup>a</sup>	Sealing Plates, Qty. <sup>a</sup>	J in./mm
F22LE45C	2.50 x 2.50 64 x 64	Flat	1	2.00 51
F44LE45C	4.00 x 4.00 102 x 102	Flat	1	2.44 62
F66LE45C	6.00 x 6.00 152 x 152	Flat	1	3.00 76
F88LE45C	8.00 x 8.00 203 x 203	Flat	1	3.75 95

<sup>a</sup>Each sealing plate also includes one gasket and one set of screws to join sections.  
Certified by Canadian Standards Association

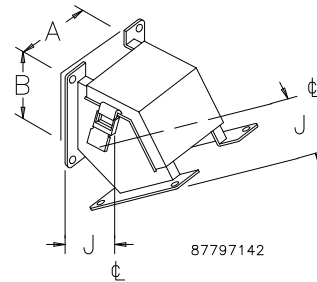

## TEE FITTING—TOP OPENING

This fitting is used when the covers of all three branches of the wireway run are open along the same side.

### BULLETIN: F10

Catalog Number	AxB in./mm	Sealing Plates, Type <sup>a</sup>	Sealing Plates, Qty. <sup>a</sup>	G in./mm	K in./mm
F22LTA	2.50 x 2.50 64 x 64	Flat	2	8.50 216	4.25 108
F44LTA	4.00 x 4.00 102 x 102	Flat	2	10.00 254	5.00 127
F66LTA	6.00 x 6.00 152 x 152	Flat	2	12.00 305	6.00 152
F88LTA	8.00 x 8.00 203 x 203	Flat	2	14.00 356	7.00 178
F126LTA	12.00 x 6.00 305 x 152	Flat	2	18.00 457	9.00 229

<sup>a</sup>Each sealing plate also includes one gasket and one set of screws to join sections.  
Certified by Canadian Standards Association.

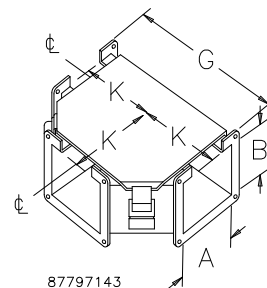

### TEE FITTING—OUTSIDE TOP OPENING

This fitting is used when the covers of two branches are on the same side and the third is on a different side.

BULLETIN: F10

Catalog Number	AxB in./mm	Sealing Plates, Type <sup>a</sup>	Sealing Plates, Qty. <sup>a</sup>	G in./mm	K in./mm
F22LTC	2.50 x 2.50 64 x 64	Flat	2	8.50 216	4.25 108
F44LTC	4.00 x 4.00 102 x 102	Flat	2	10.00 254	5.00 127
F66LTC	6.00 x 6.00 152 x 152	Flat	2	12.00 305	6.00 152
F88LTC	8.00 x 8.00 203 x 203	Flat	2	14.00 356	7.00 178

<sup>a</sup>Each sealing plate also includes one gasket and one set of screws to join sections.  
Certified by Canadian Standards Association.

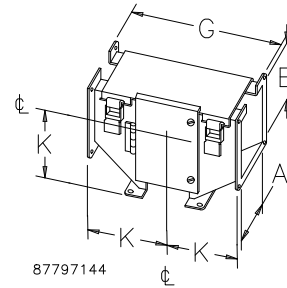

### JUNCTION BOX

The junction box has a removable panel on which terminal blocks and other components may be mounted.

BULLETIN: F10

Catalog Number	AxB in./mm	Sealing Plates, Type	Sealing Plates, Qty. <sup>a</sup>	M in./mm	N in./mm	Removable Panel Size in./mm
F22LJ	2.50 x 2.50 64 x 64	Flat	1	12.00 305	10.25 260	8.75 x 6.88 222 x 175
F44LJ	4.00 x 4.00 102 x 102	Flat	1	14.00 356	13.88 353	10.75 x 8.88 273 x 225
F66LJ	6.00 x 6.00 152 x 152	Flat	1	16.00 406	17.88 454	12.75 x 10.88 324 x 276
F88LJ	8.00 x 8.00 203 x 203	Flat	1	18.00 457	21.88 556	14.75 x 12.88 375 x 327

<sup>a</sup>Each sealing plate also includes one gasket and one set of screws to join sections.  
Certified by Canadian Standards Association.

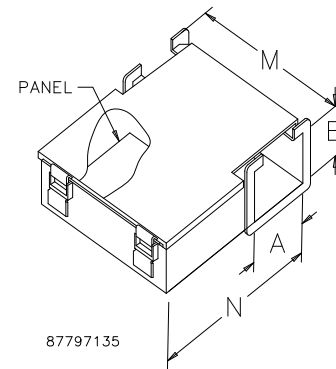

### CLOSURE PLATE

Used to seal the end of a wireway section or run.

BULLETIN: F10

Catalog Number	Sealing Plates, Type <sup>a</sup>	Sealing Plates, Qty. <sup>a</sup>	D in./mm	E in./mm
F22LP	90°	1	3.88 99	3.88 99
F44LP	90°	1	5.38 137	5.38 137
F66LP	90°	1	7.62 194	7.62 194
F88LP	90°	1	9.62 244	9.62 244
F126LP	90°	1	13.62 346	7.62 194

<sup>a</sup>Each sealing plate also includes one gasket and one set of screws to join sections.

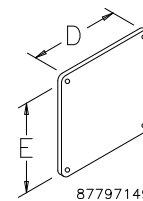

### REDUCER

This fitting permits the lay-in feature to be retained when reducing to a smaller wireway size.

BULLETIN: F10

Catalog Number	Sealing Plates, Type	Sealing Plates, Qty.	From A x B in./mm	To A x B in./mm
F44LREZ2	None	0	4.00 x 4.00 102 x 102	2.50 x 2.50 64 x 64
F66LRE44	None	0	6.00 x 6.00 152 x 152	4.00 x 4.00 102 x 102
F80LRE66	None	0	8.00 x 8.00 203 x 203	6.00 x 6.00 152 x 152
F126LRE66	None	0	12.00 x 6.00 305 x 152	6.00 x 6.00 152 x 152
F126LRE44	None	0	12.00 x 6.00 305 x 152	4.00 x 4.00 102 x 102

Certified by Canadian Standards Association.

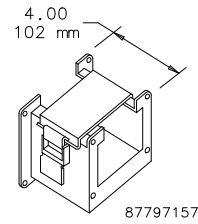

87797157

### NIPPLE

Available in lengths of 1.00 in. (25 mm), 2.00 in. (51 mm) and 3.00 in. (76 mm).

BULLETIN: F10

Catalog Number	AxBxC in./mm	Sealing Plates, Type <sup>a</sup>	Sealing Plates, Qty. <sup>a</sup>
F22LN1	2.50 x 2.50 x 1.00 64 x 64 x 25	Special	1
F22LN2	2.50 x 2.50 x 2.00 64 x 64 x 51	Special	1
F22LN3	2.50 x 2.50 x 3.00 64 x 64 x 76	Special	1
F44LN1	4.00 x 4.00 x 1.00 102 x 102 x 25	Special	1
F44LN2	4.00 x 4.00 x 2.00 102 x 102 x 51	Special	1
F44LN3	4.00 x 4.00 x 3.00 102 x 102 x 76	Special	1
F66LN1	6.00 x 6.00 x 1.00 152 x 152 x 25	Special	1
F66LN2	6.00 x 6.00 x 2.00 152 x 152 x 51	Special	1
F66LN3	6.00 x 6.00 x 3.00 152 x 152 x 76	Special	1

<sup>a</sup>Each sealing plate also includes one gasket and one set of screws to join sections.

Certified by Canadian Standards Association.

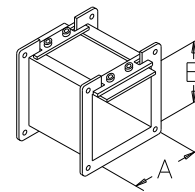

87797145

### DROP HANGER

Hangers are used to support a wireway run. The drop hanger is normally attached to an overhead beam or ceiling.

BULLETIN: F20

Catalog Number	Sealing Plates, Type <sup>a</sup>	Sealing Plates, Qty. <sup>a</sup>	S in./mm	T in./mm
F22HD	None	0	9.25 235	4.50 114
F44HD	None	0	11.75 298	6.00 152
F66HD	None	0	15.25 387	8.12 206
F88HD	None	0	20.56 522	12.12 308

<sup>a</sup>Each sealing plate also includes one gasket and one set of screws to join sections.

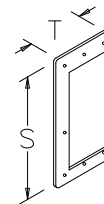

87797146

**BRACKET HANGER**

Hangers are used to support a wireway run. The bracket hanger can be used for wall, floor or ceiling installations.

**BULLETIN: F20**

Catalog Number	P in./mm	R in./mm	U in./mm
F22HB	4.62 117	3.62 92	4.38 111
F44HB	6.12 155	3.62 92	5.88 149
F66HB	8.25 210	3.62 92	7.88 200
F88HB	10.25 260	3.62 92	11.25 286

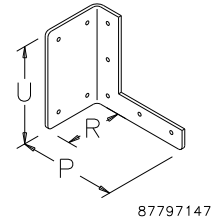
**BOX CONNECTOR**

When wireway enters an enclosure, a box connector should be used on the inside of the enclosure to ensure a tight seal.

**BULLETIN: F10**

Catalog Number	Sealing Plates, Type <sup>a</sup>	Sealing Plates, Qty. <sup>a</sup>	D in./mm	E in./mm
F22LB	90°	1	3.88 99	3.88 99
F44LB	90°	1	5.38 137	5.38 137
F66LB	90°	1	7.62 194	7.62 194
F88LB	90°	1	9.62 244	9.62 244
F126LB	90°	1	13.62 346	7.62 194

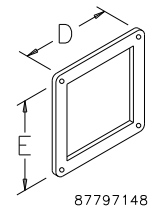

<sup>a</sup>Each sealing plate also includes one gasket and one set of screws to join sections.

### TRANSPOSITION SECTIONS

These fittings are used when it is necessary to rotate the open side of the wireway run by 90 degrees and still retain the lay-in feature.

BULLETIN: F10

#### Clockwise

Catalog Number	AxB in./mm	Sealing Plates, Type <sup>a</sup>	Sealing Plates, Qty. <sup>a</sup>
F22LKT	2.50 x 2.50 64 x 64	Flat	1
F44LKT	4.00 x 4.00 102 x 102	Flat	1
F66LKT	6.00 x 6.00 152 x 152	Flat	1

<sup>a</sup>Each sealing plate also includes one gasket and one set of screws to join sections.

Certified by Canadian Standards Association.

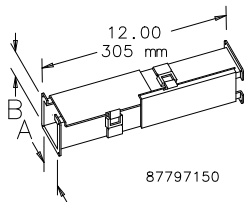

#### Counterclockwise

Catalog Number	AxB in./mm	Sealing Plates, Type <sup>a</sup>	Sealing Plates, Qty. <sup>a</sup>
F22LKOKT	2.50 x 2.50 64 x 64	Flat	1
F44LKOKT	4.00 x 4.00 102 x 102	Flat	1
F66LKOKT	6.00 x 6.00 152 x 152	Flat	1

<sup>a</sup>Each sealing plate also includes one gasket and one set of screws to join sections.

Certified by Canadian Standards Association.

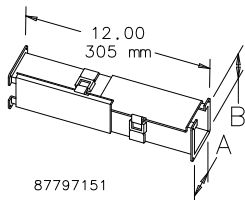

### 90-Degree Elbow—Clockwise

Catalog Number	AxB in./mm	Sealing Plates, Type <sup>a</sup>	Sealing Plates, Qty. <sup>a</sup>	H in./mm
F22LE9KT	2.50 x 2.50 64 x 64	Flat	1	2.45 108
F44LE9KT	4.00 x 4.00 102 x 102	Flat	1	5.00 127
F66LE9KT	6.00 x 6.00 152 x 152	Flat	1	6.00 452
F88LE9KT	8.00 x 8.00 203 x 203	Flat	1	7.00 178

<sup>a</sup>Each sealing plate also includes one gasket and one set of screws to join sections.

Certified by Canadian Standards Association.

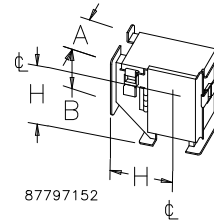

### 90-Degree Elbow—Counterclockwise

Catalog Number	AxB in./mm	Sealing Plates, Type <sup>a</sup>	Sealing Plates, Qty. <sup>a</sup>	H in./mm
F22LE9KOKT	2.50 x 2.50 64 x 64	Flat	1	4.25 108
F44LE9KOKT	4.00 x 4.00 102 x 102	Flat	1	5.00 127
F66LE9KOKT	6.00 x 6.00 152 x 152	Flat	1	6.00 152
F88LE9KOKT	8.00 x 8.00 203 x 203	Flat	1	7.00 178

<sup>a</sup>Each sealing plate also includes one gasket and one set of screws to join sections.

Certified by Canadian Standards Association.

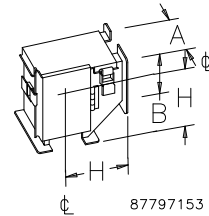

### BARRIER KIT, BOLT-ON

Divides wireway into two or more compartments. Barriers are fastened to wireway sections with screws. Sealing washers are included.

BULLETIN: F20

Catalog Number	W in./mm
F33BK60	2.00 51
F44BK60	3.00 76
F66BK60	4.50 114
F88BK60	6.00 152

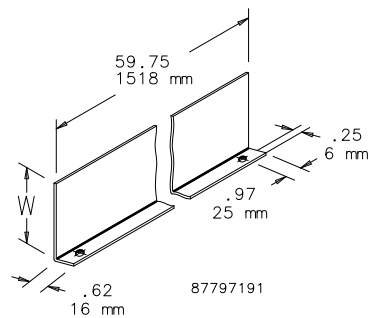



### BARRIER KITS, BRACKET-MOUNTED

Spring steel brackets hold barriers in place by friction fit inside wireway. Order barrier and bracket separately. Recommended spacing in increments of 3 ft. (.9 m).

BULLETTIN: F10

#### Two or Three Compartment

Catalog Number	AxB in.	AxB mm	Sealing Plates (qty.) <sup>a</sup>	W (in.)	W (mm)
F44B360	4.00 x 4.00	102 x 102	1 pkg. <sup>a</sup> (5 pcs.)	3.00	76
F66B560	6.00 x 6.00	152 x 152	1 pkg. <sup>a</sup> (5 pcs.)	4.50	114

<sup>a</sup>Package consists of five barriers or five brackets. Each barrier is 60 inches long.

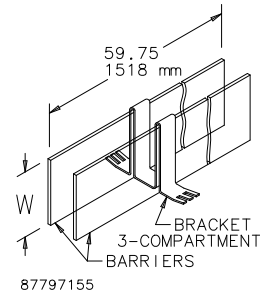
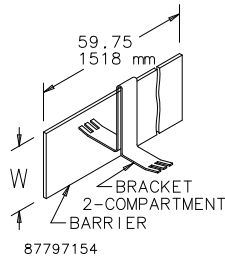

#### Two Compartment

Catalog Number	AxB in.	AxB mm	Sealing Plates (qty.) <sup>a</sup>	W (in.)	W (mm)
F44BB2C	4.00 x 4.00	102 x 102	1 pkg.	3.00	76
F66BB2C	0.00		1 pkg.	4.50	114

<sup>a</sup>Package consists of five barriers or five brackets. Each barrier is 60 inches long.

#### Three Compartment

Catalog Number	in.	mm	Sealing Plates (qty.) <sup>a</sup>	W (in.)	W (mm)
F44BB3C	4.00 x 4.00	102 x 102	1 pkg.	3.00	76
F66BB3C	6.00 x 6.00	152 x 152	1 pkg.	4.50	114

<sup>a</sup>Package consists of five barriers or five brackets. Each barrier is 60 inches long.

### 90-DEGREE ANGLE SEALING PLATE

When joining a lay-in section or fitting to a closure plate, a box connector, a non-lay-in cut-off fitting or any similar non-lay-in section or fitting, a F\_\_\_\_LSAG 90-degree angle sealing plate is required at each junction. Hoffman furnishes this plate with fittings. Additional 90-degree angle sealing plates may be required in some cases. Plate includes a flange gasket and flange screws, not shown in drawing.

BULLETTIN: F10

Catalog Number	AxB in./mm
F22LSAG	2.50 x 2.50 64 x 64
F44LSAG	4.00 x 4.00 102 x 102
F66LSAG	6.00 x 6.00 152 x 152
F88LSAG	8.00 x 8.00 203 x 203
F126LSAG	12.00 x 6.00 305 x 152

Each sealing plate also includes one gasket and one set of screws to join sections.

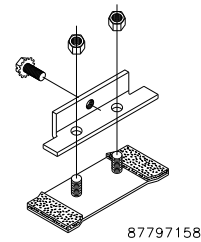

### QUICK-RELEASE FLAT SEALING PLATE

This exclusive Hoffman-designed hinged sealing plate permits quick and easy access to the wireway interior without using a tool.

BULLETTIN: F10

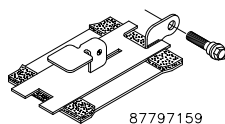

Catalog Number	AxB in./mm
F22LSGQR	2.50 x 2.50 64 x 64
F44LSGQR	4.00 x 4.00 102 x 102
F66LSGQR	6.00 x 6.00 152 x 152
F88LSGQR	8.00 x 8.00 203 x 203
F126LSGQR	12.00 x 6.00 305 x 152

Each sealing plate also includes one gasket and one set of screws to join sections.





Hoffman®

# CHAPTER 7 FEED-THROUGH WIREWAY

## OVERVIEW

Pentair feed-through wireways are used in commercial and industrial environments to provide fast, flexible methods of distributing power and controlling wiring.

The NEMA Type 12 mild steel wireway is available in four sizes to protect wiring from dust, dirt, oil and water.

The stainless steel NEMA Type 4X wireway is available in two sizes to protect wiring in wet or corrosive applications.

The fiberglass NEMA Type 12 and 3R wireway is available in two sizes to protect wiring where harmful chemicals may be present.

### FEED-THROUGH WIREWAY, NEMA TYPE 12

With a variety of fittings and brackets, this traditional-design wireway is suitable for a broad range of industrial applications.



### STAINLESS STEEL FEED-THROUGH WIREWAY, NEMA TYPE 4X

Stainless steel wireway protects wiring in applications that are regularly hosed down, very wet or highly corrosive. A complete selection of sections and fittings is available in multiple sizes for customization and design flexibility.



### FIBERGLASS FEED-THROUGH WIREWAY, NEMA TYPE 12 AND 3R

This temperature- and chemically-resistant fiberglass wireway protects wires and cables in corrosive or dirty indoor or outdoor applications.



## CHAPTER CONTENTS

### FEED-THROUGH NEMA TYPE 12 WIREWAY

Feed-Through Wireway, NEMA Type 12	140
Straight Section	142
Flexible Fitting	143
Telescope Fitting	143
Cut-Off Fitting	143
Cross	143
22.50-Degree Elbow	144
45-Degree Elbow	144
90-Degree Elbow	144
Tee	144
Closure Plate	145
Reducer Bushings	145
Nipple	145
Swivel Nipples	146
Hangers	146
Box Connector	146
Barrier Kits	147
Gasket and Screws	147

### STAINLESS STEEL FEED-THROUGH NEMA TYPE 4X WIREWAY

Stainless Steel Feed-Through Wireway, NEMA Type 4X	148
Straight Section	149
Flexible Fitting	149
Telescope Fitting	149
45-Degree Elbow	149
90-Degree Elbow	150
Tee	150
Closure Plate	150
Reducer Bushings	150
Nipple	151
Swivel Nipple	151
Drop Hanger	151
Bracket Hanger	151
Box Connector	151
Gasket and Screws	151

### FIBERGLASS FEED-THROUGH TYPE 12 AND 3R WIREWAY

Fiberglass Feed-Through Wireway, NEMA Type 12 and 3R	152
Straight Section	153
Straight Tube Section	153
Cross Fitting	153
Flexible Fitting	153
45-Degree Elbow	154
90-Degree Elbow	154
Cut-Off Fitting	154
Tee Fitting	154
Closure Plate	154
Wireway Hanger	155
Box Connector	155



**FEED-THROUGH WIREWAY, NEMA TYPE 12**

7

**INDUSTRY STANDARDS**

UL 870; File No. E27524

 NEMA/EEMAC Type 12  
 JIC standards EGP-1-1967 and EMP-1-1967  
 CSA, File No. 42184, Type 1  
 IEC 60529, IP54

**APPLICATION**

With a variety of fittings and brackets, this traditional-design wireway is suitable for a broad range of industrial applications.

**FEATURES**

- Seams continuously welded and ground smooth
- No holes or knockouts
- Smooth, rounded edges on all sections and fittings
- Heavy butt hinges and external screw clamps
- Oil-resistant gasket and adhesive

**SPECIFICATIONS**

- 14 gauge steel covers and bodies
- 10 gauge steel end flanges

**FINISH**

ANSI 61 gray polyester powder finish inside and out over pretreated surfaces. Box connector is gray ANSI 61. Clamps and screws are plated.

**ACCESSORIES**

Touch-Up Paint (ATPPY61)

This drawing illustrates how most of the Hoffman feed-through wireway sections and fittings could be used in an actual wireway run. The covers have been omitted to show the installation more clearly. Many different sections and fittings can be combined in any configuration desired.

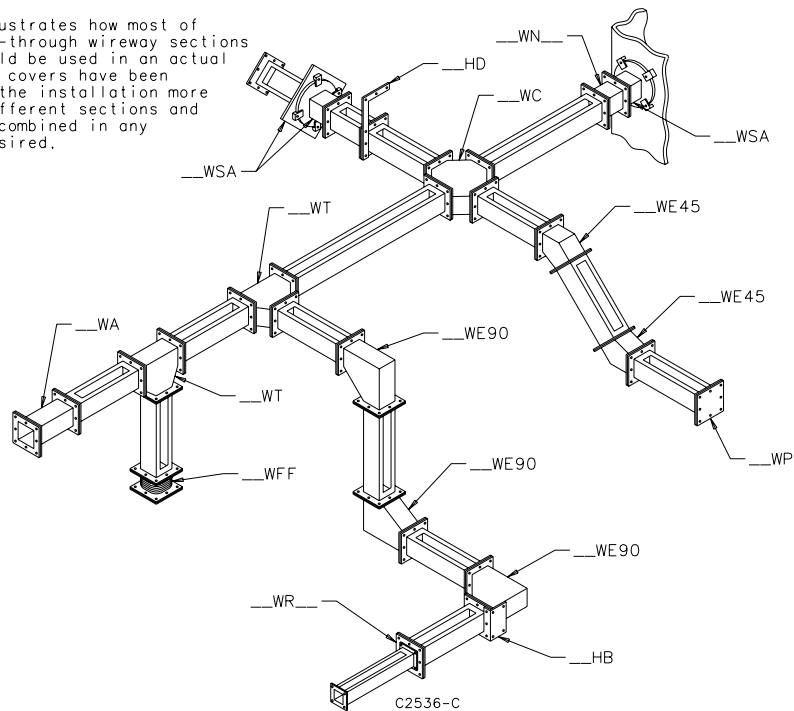

Standard Product Selection Matrix

Description	2.50 x 2.50 in. (64 x 64 mm)	4.00 x 4.00 in. (102 x 102 mm)	6.00 x 6.00 in. (152 x 152 mm)	8.00 x 8.00 in. (203 x 203 mm)
12.00-in. (305-mm) Straight Section	F22W12 <sup>c,d</sup>	F44W12 <sup>c,d</sup>	F66W12 <sup>c,d</sup>	F88W12 <sup>c,d</sup>
24.00-in. (610-mm) Straight Section	F22W24 <sup>c,d</sup>	F44W24 <sup>c,d</sup>	F66W24 <sup>c,d</sup>	F88W24 <sup>c,d</sup>
36.00-in. (914-mm) Straight Section	F22W36 <sup>c,d</sup>	F44W36 <sup>c,d</sup>	F66W36 <sup>c,d</sup>	F88W36 <sup>c,d</sup>
48.00-in. (1219-mm) Straight Section	F22W48 <sup>c,d</sup>	F44W48 <sup>c,d</sup>	F66W48 <sup>c,d</sup>	F88W48 <sup>c,d</sup>
60.00-in. (1524-mm) Straight Section	F22W60 <sup>c,d</sup>	F44W60 <sup>c,d</sup>	F66W60 <sup>c,d</sup>	F88W60 <sup>c,d</sup>
120.00-in. (3048-mm) Straight Section	F22W120 <sup>c,d</sup>	F44W120 <sup>c,d</sup>	F66W120 <sup>c,d</sup>	F88W120 <sup>c,d</sup>
90° Elbow	F22WE90 <sup>c,d</sup>	F44WE90 <sup>c,d</sup>	F66WE90 <sup>c,d</sup>	F88WE90 <sup>c,d</sup>
45° Elbow	F22WE45 <sup>c,d</sup>	F44WE45 <sup>c,d</sup>	F66WE45 <sup>c,d</sup>	F88WE45 <sup>c,d</sup>
22.50° Elbow	F22WE225 <sup>c,d</sup>	F44WE225 <sup>c,d</sup>	F66WE225 <sup>c,d</sup>	F88WE225 <sup>c,d</sup>
Cross	F22WC <sup>c,d</sup>	F44WC <sup>c,d</sup>	F66WC <sup>c,d</sup>	F88WC <sup>c,d</sup>
Closure Plate	F22WP <sup>c</sup>	F44WP <sup>c</sup>	F66WP <sup>c</sup>	F88WP <sup>c</sup>
Tee	F22WT <sup>c,d</sup>	F44WT <sup>c,d</sup>	F66WT <sup>c,d</sup>	F88WT <sup>c,d</sup>
Telescope Fitting	F22WA	F44WA	F66WA	F88WA
Cutoff Fitting	F22WX	F44WX	F66WX	F88WX
Swivel Nipple (Box Entry)	F22WSA <sup>c,d</sup>	F44WSA <sup>c,d</sup>	F66WSA <sup>c,d</sup>	F88WSA <sup>c,d</sup>
Swivel Nipple (Regular)	F22WSC <sup>c,d</sup>	F44WSC <sup>c,d</sup>	F66WSC <sup>c,d</sup>	F88WSC <sup>c,d</sup>
1.00-in. (25-mm) Nipple	F22WN1 <sup>c,d</sup>	F44WN1 <sup>c,d</sup>	F66WN1 <sup>c,d</sup>	F88WN1 <sup>c,d</sup>
2.00-in. (51-mm) Nipple	F22WN2 <sup>c,d</sup>	F44WN2 <sup>c,d</sup>	F66WN2 <sup>c,d</sup>	F88WN2 <sup>c,d</sup>
3.00-in. (76-mm) Nipple	F22WN3 <sup>c,d</sup>	F44WN3 <sup>c,d</sup>	F66WN3 <sup>c,d</sup>	F88WN3 <sup>c,d</sup>
6.00-in. (152-mm) Nipple	F22WN6 <sup>c,d</sup>	F44WN6 <sup>c,d</sup>	F66WN6 <sup>c,d</sup>	F88WN6 <sup>c,d</sup>
Box Connector	F22WB	F44WB	F66WB	F88WB
Flexible Fitting	F22WFF	F44WFF	F66WFF	F88WFF
Reducer Bushings: 4.00-in. (102-mm) to 2.50-in. (64-mm) Center Hole	—	F44WR22 <sup>c,d</sup>	—	—
Reducer Bushings: 4.00-in. (102-mm) to 2.50-in. (64-mm) Edge Hole	—	F44WRE22 <sup>c,d</sup>	—	—
Reducer Bushings: 6.00-in. (152-mm) to 4.00-in. (102-mm) Center Hole	—	—	F66WR44 <sup>c,d</sup>	—
Reducer Bushings: 6.00-in. (152-mm) to 4.00-in. (102-mm) Edge Hole	—	—	F66WRE44 <sup>c,d</sup>	—
Reducer Bushings: 8.00-in. (203-mm) to 6.00-in. (152-mm) Center Hole	—	—	—	F88WR66 <sup>c,d</sup>
8.00-in. (203-mm) to 6.00-in. (152-mm) Edge Hole	—	—	—	F88WRE66 <sup>c,d</sup>
Reducer Bushings: 8.00-in. (203-mm) to 4.00-in. (102-mm) Center Hole	—	—	—	F88WR44 <sup>c,d</sup>
Reducer Bushings: 8.00-in. (203-mm) to 4.00-in. (102-mm) Edge Hole	—	—	—	F88WRE44 <sup>c,d</sup>
Drop Hanger	F22HD	F44HD	F66HD	F88HD
Bracket Hanger	F22HB	F44HB	F66HB	F88HB
Barrier Kit, bolton barrier 60.00 in. (1524 mm)	—	F44BK60	F66BK60	F88BK60
Barrier, bracketmounted Each barrier 60.00 in. (1524 mm) <sup>a</sup>	—	F44B360	F66B560	—
Barrier Brackets, 2 compartment <sup>a</sup>	—	F44BB2C	F66BB2C	—
Barrier Brackets, 3 compartment <sup>a</sup>	—	F44BB3C	F66BB3C	—
Gasket and Screws <sup>b</sup>	F22WG	F44WG	F66WG	F88WG

<sup>a</sup> Package consists of five barriers or five barrier brackets. Each barrier is 60-in. long.

<sup>b</sup> Standard packages of wireway contain one gasket and one set of screws to join sections, except “Cross” fittings which contain three of each, “Tee” fittings which contain two of each and Telescope” fittings which contain none. Additional gasket and screw sets may be ordered by catalog number.

<sup>c</sup> Certified by Canadian Standards Association.

<sup>d</sup> UL 870

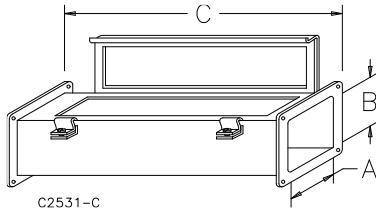

**STRAIGHT SECTION**

Available in lengths from 12.00 in. (305 mm) to 120.00 in. (3048 mm).  
**BULLETIN: F20**

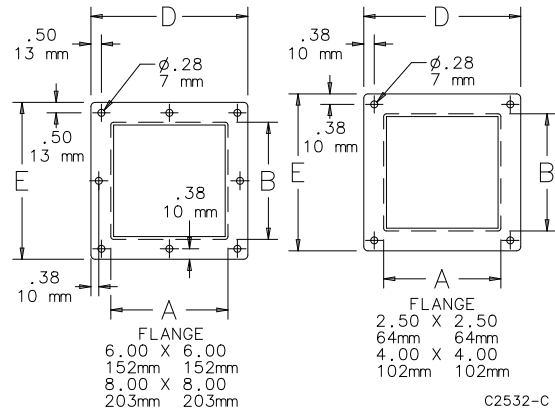
**Straight Section**

Catalog Number	AxBxC in.	AxBxC mm	D (in.)	D (mm)	E (in.)	E (mm)
F22W12	2.50 x 2.50 x 12.00	64 x 64 x 305	3.88	99	3.88	99
F22W24	2.50 x 2.50 x 24.00	64 x 64 x 610	3.88	99	3.88	99
F22W36	2.50 x 2.50 x 36.00	64 x 64 x 914	3.88	99	3.88	99
F22W48	2.50 x 2.50 x 48.00	64 x 64 x 1219	3.88	99	3.88	99
F22W60	2.50 x 2.50 x 60.00	64 x 64 x 1524	3.88	99	3.88	99
F22W120	2.50 x 2.50 x 120.00	64 x 64 x 3048	3.88	99	3.88	99
F44W12	4.00 x 4.00 x 12.00	102 x 102 x 305	5.38	137	5.38	137
F44W24	4.00 x 4.00 x 24.00	102 x 102 x 610	5.38	137	5.38	137
F44W36	4.00 x 4.00 x 36.00	102 x 102 x 914	5.38	137	5.38	137
F44W48	4.00 x 4.00 x 48.00	102 x 102 x 1219	5.38	137	5.38	137
F44W60	4.00 x 4.00 x 60.00	102 x 102 x 1524	5.38	137	5.38	137
F44W120	4.00 x 4.00 x 120.00	102 x 102 x 3048	5.38	137	5.38	137
F66W12	6.00 x 6.00 x 12.00	152 x 152 x 305	7.62	194	7.62	194
F66W24	6.00 x 6.00 x 24.00	152 x 152 x 610	7.62	194	7.62	194
F66W36	6.00 x 6.00 x 36.00	152 x 152 x 914	7.62	194	7.62	194
F66W48	6.00 x 6.00 x 48.00	152 x 152 x 1219	7.62	194	7.62	194
F66W60	6.00 x 6.00 x 60.00	152 x 152 x 1524	7.62	194	7.62	194
F66W120	6.00 x 6.00 x 120.00	152 x 152 x 3048	7.62	194	7.62	194
F88W12	8.00 x 8.00 x 12.00	203 x 203 x 305	9.62	244	9.62	244
F88W24	8.00 x 8.00 x 24.00	203 x 203 x 610	9.62	244	9.62	244
F88W36	8.00 x 8.00 x 36.00	203 x 203 x 914	9.62	244	9.62	244
F88W48	8.00 x 8.00 x 48.00	203 x 203 x 1219	9.62	244	9.62	244
F88W60	8.00 x 8.00 x 60.00	203 x 203 x 1524	9.62	244	9.62	244
F88W120	8.00 x 8.00 x 120.00	203 x 203 x 3048	9.62	244	9.62	244

All dimensions are to outside surfaces. Allow .12 in. (3 mm) additional for gasket at joints.

Certified by Canadian Standards Association.



### FLEXIBLE FITTING

Isolates a wireway run from shock and vibration. Compensates for misalignment. Used where an odd angle is required (but not to exceed 90 degrees). Permits movement of a machine or control station connected to a wireway run. Hypalon bellow with steel flanges.

**BULLETIN: F20**

Catalog Number	AxB in./mm
F22WFF	2.50 x 2.50 64 x 64
F44WFF	4.00 x 4.00 102 x 102
F66WFF	6.00 x 6.00 152 x 152
F88WFF	8.00 x 8.00 203 x 203

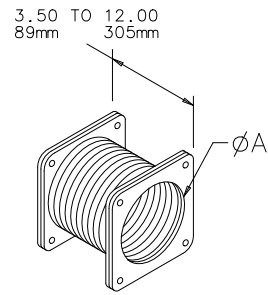

87797188

### TELESCOPE FITTING

Length is easily adjustable from 1.50 in. (38 mm) to 13.50 in. (343 mm). No cutting or welding required.

**BULLETIN: F20**

Catalog Number	AxB in./mm
F22WA	2.50 x 2.50 64 x 64
F44WA	4.00 x 4.00 102 x 102
F66WA	6.00 x 6.00 152 x 152
F88WA	8.00 x 8.00 203 x 203

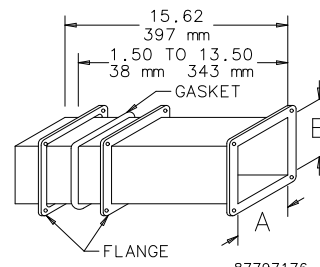

87797176

All dimensions are to outside surfaces. Allow .12 in. (3 mm) additional for gasket at joints.

### CUT-OFF FITTING

For lengths up to 12.00 in. (305 mm). Shorten body to desired length and weld on flange.

**BULLETIN: F20**

Catalog Number	AxB in./mm
F22WX	2.50 x 2.50 64 x 64
F44WX	4.00 x 4.00 102 x 102
F66WX	6.00 x 6.00 152 x 152
F88WX	8.00 x 8.00 203 x 203

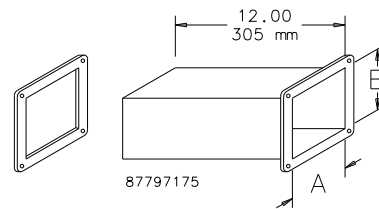

87797175

All dimensions are to outside surfaces. Allow .12 in. (3 mm) additional for gasket at joints.

### CROSS

**BULLETIN: F20**

Catalog Number	AxB in./mm	G in./mm	K in./mm
F22WC	2.50 x 2.50 64 x 64	8.50 216	4.25 108
F44WC	4.00 x 4.00 102 x 102	10.00 254	5.00 127
F66WC	6.00 x 6.00 152 x 152	12.00 305	6.00 152
F88WC	8.00 x 8.00 203 x 203	14.00 356	7.00 178

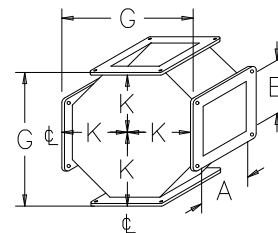

87797183

All dimensions are to outside surfaces. Allow .12 in. (3 mm) additional for gasket at joints. Dimension K are from intersection of center lines.

Certified by Canadian Standards Association.



### 22.50-DEGREE ELBOW

**BULLETIN: F20**

Catalog Number	AxB in./mm	H in./mm
F22WE225	2.50 x 2.50 64 x 64	2.50 64
F44WE225	4.00 x 4.00 102 x 102	3.25 83
F66WE225	6.00 x 6.00 152 x 152	4.25 108
F88WE225	8.00 x 8.00 203 x 203	5.25 133

All dimensions are to outside surfaces. Allow .12 in. (3 mm) additional for gasket at joints.  
 Certified by Canadian Standards Association.

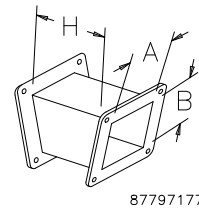

87797177

### 45-DEGREE ELBOW

**BULLETIN: F20**

Catalog Number	AxB in./mm	H in./mm	J in./mm
F22WE45	2.50 x 2.50 64 x 64	2.50 64	2.00 51
F44WE45	4.00 x 4.00 102 x 102	3.25 83	2.44 62
F66WE45	6.00 x 6.00 152 x 152	4.25 108	3.00 76
F88WE45	8.00 x 8.00 203 x 203	5.25 133	3.62 92

All dimensions are to outside surfaces. Allow .12 in. (3 mm) additional for gasket at joints. Dimension J is from intersection of center lines.  
 Certified by Canadian Standards Association.

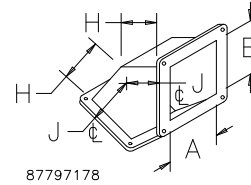

87797178

### 90-DEGREE ELBOW

**BULLETIN: F20**

Catalog Number	AxB in./mm	F in./mm	K in./mm
F22WE90	2.50 x 2.50 64 x 64	5.50 140	4.25 108
F44WE90	4.00 x 4.00 102 x 102	7.00 178	5.00 127
F66WE90	6.00 x 6.00 152 x 152	9.00 229	6.00 152
F88WE90	8.00 x 8.00 203 x 203	11.00 279	7.00 178

All dimensions are to outside surfaces. Allow .12 in. (3 mm) additional for gasket at joints. Dimension K is from intersection of center lines.  
 Certified by Canadian Standards Association.

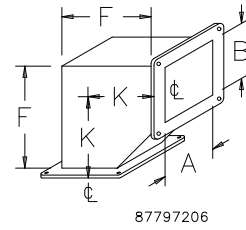

87797206

### TEE

**BULLETIN: F20**

Catalog Number	AxB in./mm	F in./mm	G in./mm	K in./mm
F22WT	2.50 x 2.50 64 x 64	5.50 140	8.50 216	4.25 108
F44WT	4.00 x 4.00 102 x 102	7.00 178	10.00 254	5.00 127
F66WT	6.00 x 6.00 152 x 152	9.00 229	12.00 305	6.00 152
F88WT	8.00 x 8.00 203 x 203	11.00 279	14.00 356	7.00 178

All dimensions are to outside surfaces. Allow .12 in. (3 mm) additional for gasket at joints. Dimension K is from intersection of center lines.  
 Certified by Canadian Standards Association.

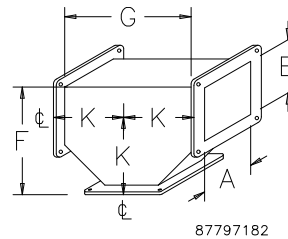

87797182



## CLOSURE PLATE

Used to seal the end on a wireway section or run.

BULLETIN: F20

Catalog Number	AxB in./mm	D in./mm	E in./mm
F22WP	2.50 x 2.50 64 x 64	3.88 99	3.88 99
F44WP	0.00	5.38 137	5.38 137
F66WP	0.00	7.62 194	7.62 194
F88WP	8.00 x 8.00 203 x 203	9.62 244	9.62 244

All dimensions are to outside surfaces. Allow .12 in. (3 mm) additional for gasket at joints.

Certified by Canadian Standards Association.

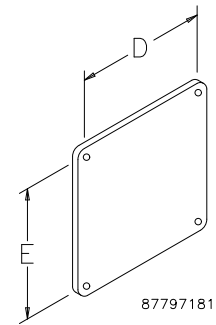

## REDUCER BUSHINGS

Used to reduce to a smaller wireway size. The center hole bushing centers the two wireway sizes relative to each other while the edge hole bushing keeps the top surfaces even.

BULLETIN: F20

### Center Hole

Catalog Number	AxB in.	AxB mm	D (in.)	D (mm)	E (in.)	E (mm)
F44WR22	2.00 x 2.00	51 x 51	5.38	137	5.38	137
F66WR44	4.00 x 4.00	102 x 102	7.62	194	7.62	194
F88WR44	4.00 x 4.00	102 x 102	9.62	244	9.62	244
F88WR66	6.00 x 6.00	152 x 152	9.62	244	9.62	244

All dimensions are to outside surfaces. Allow .12 in. (3 mm) additional for gasket at joints.

Certified by Canadian Standards Association.

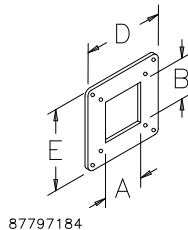

### Edge Hole

Catalog Number	AxB in.	AxB mm	D (in.)	D (mm)	E (in.)	E (mm)
F44WRE22	2.00 x 2.00	51 x 51	5.38	137	5.38	137
F66WRE44	4.00 x 4.00	102 x 102	7.62	194	7.62	194
F88WRE44	4.00 x 4.00	102 x 102	9.62	244	9.62	244
F88WRE66	6.00 x 6.00	152 x 152	9.62	244	9.62	244

All dimensions are to outside surfaces. Allow .12 in. (3 mm) additional for gasket at joints.

Certified by Canadian Standards Association.

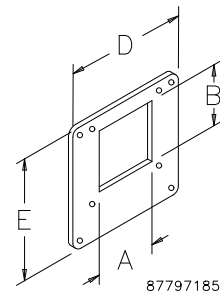

## NIPPLE

BULLETIN: F20

Catalog Number	AxBxC in.	AxBxC mm
F22WN1	2.50 x 2.50 x 1.00	64 x 64 x 25
F22WN2	2.50 x 2.50 x 2.00	64 x 64 x 51
F22WN3	2.50 x 2.50 x 3.00	64 x 64 x 76
F22WN6	2.50 x 2.50 x 6.00	64 x 64 x 152
F44WN1	4.00 x 4.00 x 1.00	102 x 102 x 25
F44WN2	4.00 x 4.00 x 2.00	102 x 102 x 51
F44WN3	4.00 x 4.00 x 3.00	102 x 102 x 76
F44WN6	4.00 x 4.00 x 6.00	102 x 102 x 152
F66WN1	6.00 x 6.00 x 1.00	152 x 152 x 25
F66WN2	6.00 x 6.00 x 2.00	152 x 152 x 51
F66WN3	6.00 x 6.00 x 3.00	152 x 152 x 76
F66WN6	6.00 x 6.00 x 6.00	152 x 152 x 152
F88WN1	8.00 x 8.00 x 1.00	203 x 203 x 25
F88WN2	8.00 x 8.00 x 2.00	203 x 203 x 51
F88WN3	8.00 x 8.00 x 3.00	203 x 203 x 76
F88WN6	8.00 x 8.00 x 6.00	203 x 203 x 152

Certified by Canadian Standards Association.

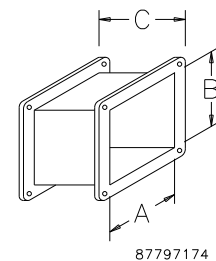

### SWIVEL NIPPLES

Allows wireway run to be adjusted to any angle. Regular type is used between adjacent wireway sections or fittings while the box entry type is used when entering an enclosure.

**BULLETIN: F20**

#### Regular

Catalog Number	AxB in.	AxB mm
F22WSC	2.50 x 2.50	64 x 64
F44WSC	4.00 x 4.00	102 x 102
F66WSC	6.00 x 6.00	152 x 152
F88WSC	8.00 x 8.00	203 x 203

All dimensions are to outside surfaces. Allow .12 in. (3 mm) additional for gasket at joints.

Certified by Canadian Standards Association.

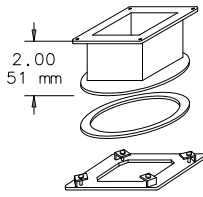

87797186

### HANGERS

Hangers are used to support a wireway run. The drop hanger is normally attached to an overhead beam or ceiling while the bracket hanger can be used for wall, floor or ceiling installations.

**BULLETIN: F20**

#### Drop Hanger

Catalog Number	AxB in.	AxB mm	S (in.)	S (mm)	T (in.)	T (mm)
F22HD	2.50 x 2.50	64 x 64	9.25	235	4.50	114
F44HD	0.00		11.75	298	6.00	152
F66HD	6.00 x 6.00	152 x 152	15.25	387	8.12	206
F88HD	8.00 x 8.00	203 x 203	20.56	522	12.12	308

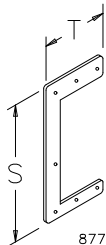

87797192

### BOX CONNECTOR

When wireway enters an enclosure, a box connector should be used on the inside of the enclosure to ensure a tight and stable seal.

**BULLETIN: F20**

Catalog Number	AxB in./mm	D in./mm	E in./mm
F22WB	0.00	3.88 99	3.88 99
F44WB	4.00 x 4.00 102 x 102	5.38 137	5.38 137
F66WB	0.00	7.62 194	7.62 194
F88WB	8.00 x 8.00 203 x 203	9.62 244	9.62 244

All dimensions are to outside surfaces. Allow .12 in. (3 mm) additional for gasket at joints.

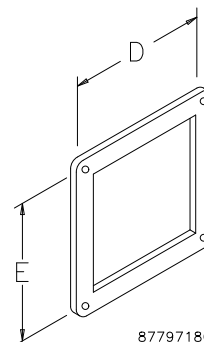

87797180

### Box Entry

Catalog Number	AxB in.	AxB mm
F22WSA	2.50 x 2.50	64 x 64
F44WSA	4.00 x 4.00	102 x 102
F66WSA	6.00 x 6.00	152 x 152
F88WSA	8.00 x 8.00	203 x 203

All dimensions are to outside surfaces. Allow .12 in. (3 mm) additional for gasket at joints.

Certified by Canadian Standards Association.

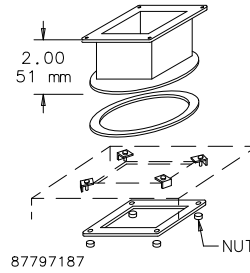

87797187

### Bracket Hanger

Catalog Number	AxB in.	AxB mm	P (in.)	P (mm)	R (in.)	R (mm)	U (in.)	U (mm)
F22HB	2.50 x 2.50	64 x 64	4.62	117	3.62	92	4.38	111
F44HB	0.00		6.12	155	3.62	92	5.88	149
F66HB	0.00		8.25	210	3.62	92	7.88	200
F88HB	0.00		10.25	260	3.62	92	11.25	286

All dimensions are to outside surfaces. Allow .12 in. (3 mm) additional for gasket at joints.

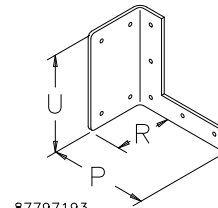

87797193

**BARRIER KITS**

Divides wireway into two or three compartments. Plated spring steel brackets hold barriers in place by friction fit inside wireway. Order barrier and bracket separately. Recommended spacing increments of 3 ft.

W = 3.00 in. (76 mm) for 4.00 x 4.00 in. (102 x 102 mm)  
 W = 4.50 in. (114 mm) for 6.00 x 6.00 in. (152 x 152 mm)

BULLETIN: F10, F20

**Bracket Mounted**

Catalog Number	AxB in.	AxB mm	W (in.)	W (mm)
F44B360	4.00 x 4.00	102 x 102	3.00	76
F66B560	6.00 x 6.00	152 x 152	4.50	114

All dimensions are to outside surfaces. Allow .12 in. (3 mm) additional for gasket at joints.  
 Package consists of five barriers or five barrier brackets. Each barrier is 60 in. long.

**2 Compartment**

Catalog Number	AxB in.	AxB mm	W (in.)	W (mm)
F44BB2C	4.00 x 4.00	102 x 102	3.00	76
F66BB2C	6.00 x 6.00	152 x 152	4.50	114

All dimensions are to outside surfaces. Allow .12 in. (3 mm) additional for gasket at joints.  
 Package consists of five barriers or five barrier brackets. Each barrier is 60 in. long.

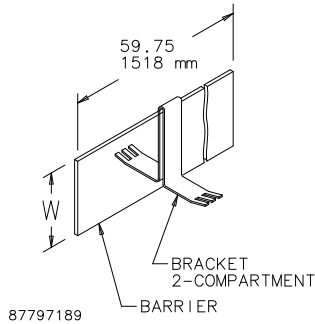

**3 Compartment**

Catalog Number	in.	mm	W (in.)	W (mm)
F44BB3C	4.00 x 4.00	102 x 102	3.00	76
F66BB3C	6.00 x 6.00	152 x 152	4.50	114

All dimensions are to outside surfaces. Allow .12 in. (3 mm) additional for gasket at joints.  
 Package consists of five barriers or five barrier brackets. Each barrier is 60 in. long.

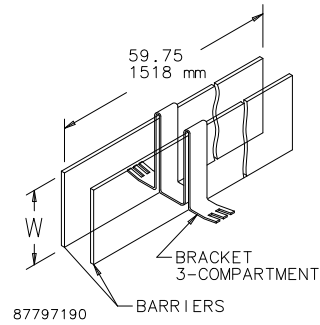

**Bolt-On**

Catalog Number	AxB in.	AxB mm	W (in.)	W (mm)
F44BK60	4.00 x 4.00	102 x 102	3.00	76
F66BK60	6.00 x 6.00	152 x 152	4.50	114
F88BK60	8.00 x 8.00	203 x 203	6.00	152

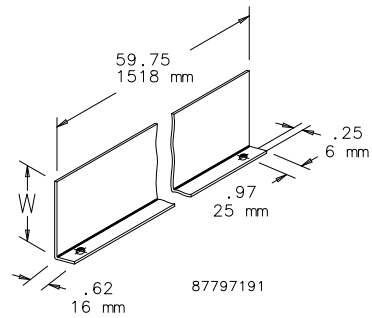

**GASKET AND SCREWS**

Standard packages of wireway contain one gasket and one set of screws to join sections, except Cross fittings which contain three of each, Tee fittings which contain two of each and Telescope fittings which contain none. Additional gasket and screw sets may be ordered by catalog number.

BULLETIN: F20

Catalog Number	AxB in./mm
F22WG	2.50 x 2.50 64 x 64
F44WG	4.00 x 4.00 102 x 102
F66WG	6.00 x 6.00 152 x 152
F88WG	8.00 x 8.00 203 x 203



**STAINLESS STEEL FEED-THROUGH WIREWAY, NEMA TYPE 4X**

**FEATURES**

- Seams continuously welded and ground smooth
- No holes or knockouts
- Smooth, rounded edges on all sections and fittings
- Butt hinges and external screw clamps
- Oil-resistant gasket and adhesive

**SPECIFICATIONS**

- 16 gauge Type 304 stainless steel covers and bodies
- 10 gauge stainless steel flanges

**FINISH**

No. 2B finish.

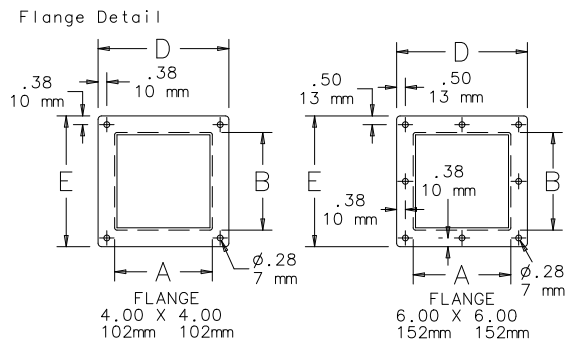
**INDUSTRY STANDARDS**

UL 870 Listed; File No. E27524

 NEMA Type 4, 4X, 12  
 CSA, File No. 42184, Type 1  
 IEC 60529, IP66

**APPLICATION**

Stainless steel wireway protects wiring in applications that are regularly hosed down, very wet or highly corrosive. A complete selection of sections and fittings is available in multiple sizes for customization and design flexibility.

**Standard Product Selection Matrix**

Description	4.00 x 4.00 in. (102 x 102 mm)	6.00 x 6.00 in. (152 x 152 mm)
12.00-in. (305-mm) Straight Section	F44W12SS <sup>b,c</sup>	F66W12SS <sup>b,c</sup>
24.00-in. (610-mm) Straight Section	F44W24SS <sup>b,c</sup>	F66W24SS <sup>b,c</sup>
36.00-in. (914-mm) Straight Section	F44W36SS <sup>b,c</sup>	F66W36SS <sup>b,c</sup>
48.00-in. (1219-mm) Straight Section	F44W48SS <sup>b,c</sup>	F66W48SS <sup>b,c</sup>
60.00-in. (1524-mm) Straight Section	F44W60SS <sup>b,c</sup>	F66W60SS <sup>b,c</sup>
120.00-in. (3048-mm) Straight Section	F44W120SS <sup>b,c</sup>	F66W120SS <sup>b,c</sup>
Flexible Fitting	F44WFFSS	F66WFFSS
Telescope Fitting	F44WASS	F66WASS
45° Elbow	F44WE45SS <sup>b,c</sup>	F66WE45SS <sup>b,c</sup>
90° Elbow	F44WE90SS <sup>b,c</sup>	F66WE90SS <sup>b,c</sup>
Tee	F44WTSS <sup>b,c</sup>	F66WTSS <sup>b,c</sup>
Closure Plate	F44WPSS	F66WPSS
Reducer Bushings: 6.00-in. (152-mm) to 4.00-in. (102-mm) Center Hole	—	F66WR44SS
Reducer Bushings: 6.00-in. (152-mm) to 4.00-in. (102-mm) Edge Hole	—	F66WRE44SS
6.00-in. (152-mm) Nipple	F44WN6SS <sup>b</sup>	F66WN6SS <sup>b,c</sup>
Swivel Nipple (Regular)	F44WSSCS <sup>b,c</sup>	—
Drop Hanger	F44HDSS	F66HDSS
Bracket Hanger	F44HBSS	F66HBSS
Box Connector	F44WBSS	F66WBSS
Gasket and Screws <sup>a</sup>	F44WGSS	F66WGSS

<sup>a</sup>Standard packages of wireway contain one gasket and one set of screws to join sections, except "Tee" fittings which contain two of each, and "Telescope" fittings which contain none. Additional gasket and screw sets may be ordered by catalog number.

<sup>b</sup>Certified by Canadian Standards Association.

<sup>c</sup>UL 870

### STRAIGHT SECTION

Available in lengths from 12.00 in. (305 mm) to 120.00 in. (3048 mm).

BULLETIN: F22

Catalog Number	AxBxC in.	AxBxC mm
F44W12SS	4.00 x 4.00 x 12.00	102 x 102 x 305
F44W24SS	4.00 x 4.00 x 24.00	102 x 102 x 610
F44W36SS	4.00 x 4.00 x 36.00	102 x 102 x 914
F44W48SS	4.00 x 4.00 x 48.00	102 x 102 x 1219
F44W60SS	4.00 x 4.00 x 60.00	102 x 102 x 1524
F44W120SS	4.00 x 4.00 x 120.00	102 x 102 x 3048
F66W12SS	6.00 x 6.00 x 12.00	152 x 152 x 305
F66W24SS	6.00 x 6.00 x 24.00	152 x 152 x 610
F66W36SS	6.00 x 6.00 x 36.00	152 x 152 x 914
F66W48SS	6.00 x 6.00 x 48.00	152 x 152 x 1219
F66W60SS	6.00 x 6.00 x 60.00	152 x 152 x 1524
F66W120SS	6.00 x 6.00 x 120.00	152 x 152 x 3048

All dimensions are to outside surfaces. Allow .12 in. (3 mm) additional for gasket at joints.

Certified by Canadian Standards Association.

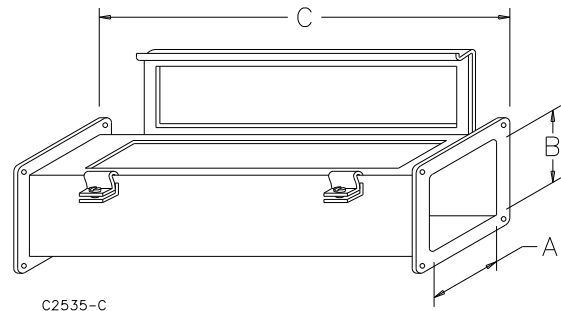

### FLEXIBLE FITTING

Isolates a wireway run from shock and vibration. Compensates for misalignment. Used where an odd angle is required (but not to exceed 90 degrees). Permits movement of a machine or control station connected to a wireway run. Hypalon bellows with steel flanges.

BULLETIN: F22

Catalog Number	AxB in./mm
F44WFFSS	4.00 x 4.00 102 x 102
F66WFFSS	6.00 x 6.00 152 x 152

All dimensions are to outside surfaces. Allow .12 in. (3 mm) additional for gasket at joints.

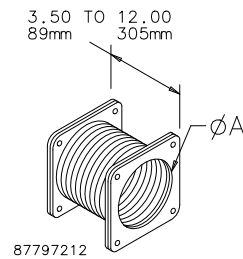

### TELESCOPE FITTING

Length is easily adjustable from 1.50 in. (38 mm) to 13.50 in. (343 mm). No cutting or welding required.

BULLETIN: F22

Catalog Number	AxB in./mm
F44WASS	4.00 x 4.00 102 x 102
F66WASS	6.00 x 6.00 152 x 152

All dimensions are to outside surfaces. Allow .12 in. (3 mm) additional for gasket at joints.

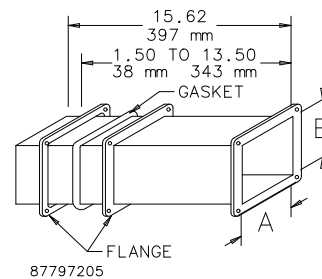

### 45-DEGREE ELBOW

BULLETIN: F22

Catalog Number	AxB in./mm	H in./mm	J in./mm
F44WE45SS	4.00 x 4.00 102 x 102	3.25 83	2.44 62
F66WE45SS	6.00 x 6.00 152 x 152	4.25 108	3.00 76

All dimensions are to outside surfaces. Allow .12 in. (3 mm) additional for gasket at joints. Dimension J is from intersection of center lines.

Certified by Canadian Standards Association.

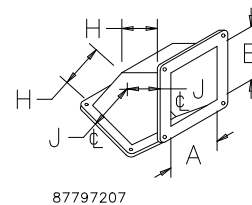

### 90-DEGREE ELBOW

BULLETIN: F22

Catalog Number	AxB in./mm	F in./mm	K in./mm
F44WE90SS	4.00 x 4.00 102 x 102	7.00 178	5.00 127
F66WE90SS	6.00 x 6.00 152 x 152	9.00 229	6.00 152

All dimensions are to outside surfaces. Allow .12 in. (3 mm) additional for gasket at joints. Dimension K is from intersection of center lines.

Certified by Canadian Standards Association.

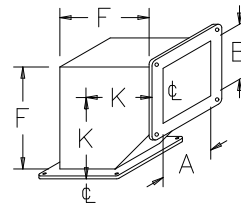

87797206

### TEE

BULLETIN: F22

Catalog Number	AxB in./mm	F in./mm	G in./mm	K in./mm
F44WTSS	4.00 x 4.00 102 x 102	7.00 178	10.00 254	5.00 127
F66WTSS	6.00 x 6.00 152 x 152	9.00 229	12.00 305	6.00 152

All dimensions are to outside surfaces. Allow .12 in. (3 mm) additional for gasket at joints. Dimension K is from intersection of center lines.

Certified by Canadian Standards Association.

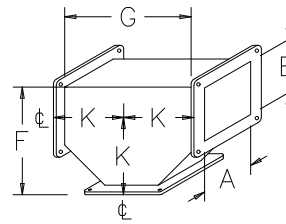

87797208

### CLOSURE PLATE

Used to seal the end of a wireway section or run.

BULLETIN: F22

Catalog Number	AxB in./mm	D in./mm	E in./mm
F44WPSS	4.00 x 4.00 102 x 102	5.38 137	5.38 137
F66WPSS	6.00 x 6.00 152 x 152	7.62 194	7.62 194

Note: All dimensions are to outside surfaces. Allow .12 in. (3mm) additional for gasket at joints.

Certified by Canadian Standards Association.

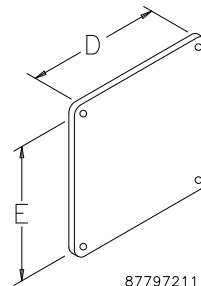

87797211

### REDUCER BUSHINGS

Used to reduce to a smaller wireway size. The center hole bushing centers the two wireway sizes relative to each other while the edge hole bushing keeps the top surfaces even.

BULLETIN: F22

Center Hole

Catalog Number	AxB in./mm	D in./mm	E in./mm
F66WR44SS	4.00 x 4.00 102 x 102	7.62 194	7.62 194

All dimensions are to outside surfaces. Allow .12 in. (3 mm) additional for gasket at joints.

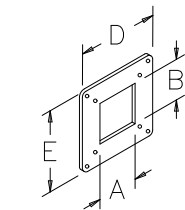

87797213

### Edge Hole

Catalog Number	AxB in./mm	D in./mm	E in./mm
F66WRE44SS	4.00 x 4.00 102 x 102	7.62 194	7.62 194

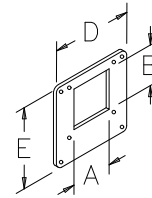

87797214

### NIPPLE

Available in 6.00-in. (152-mm) length.

BULLETIN: F22

Catalog Number	AxBxC in./mm
F44WN6SS	4.00 x 4.00 x 6.00 102 x 102 x 152
F66WN6SS	6.00 x 6.00 x 6.00 152 x 152 x 152

All dimensions are to outside surfaces. Allow .12 in. (3 mm) additional for gasket at joints.

Certified by Canadian Standards Association.

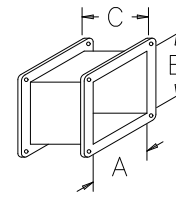

87797204

### SWIVEL NIPPLE

Allows wireway run to be adjusted to any angle. Regular type is used between adjacent wireway sections or fittings.

BULLETIN: F22

Catalog Number	AxB in./mm
F44WSCSS	4.00 x 4.00 102 x 102

All dimensions are to outside surfaces. Allow .12 in. (3 mm) additional for gasket at joints.

Certified by Canadian Standards Association.

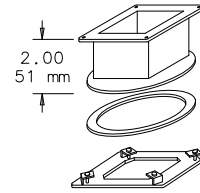

87797209

### DROP HANGER

BULLETIN: F22

Catalog Number	S in./mm	T in./mm
F44HDSS	11.75 298	6.00 152
F66HDSS	15.25 387	8.12 206

All dimensions are to outside surfaces. Allow .12 in. (3 mm) additional for gasket at joints.

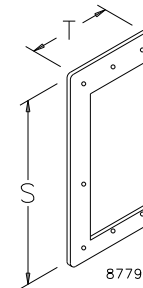

87797215

### BRACKET HANGER

BULLETIN: F22

Catalog Number	AxB in./mm	P in./mm	R in./mm	U in./mm
F44HBSS	0.00	6.12 155	3.62 92	5.88 149
F66HBSS	6.00 x 6.00 152 x 152	8.25 210	3.62 92	7.88 200

All dimensions are to outside surfaces. Allow .12 in. (3 mm) additional for gasket at joints.

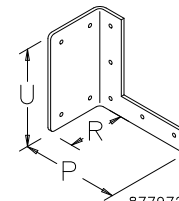

87797216

### BOX CONNECTOR

When wireway enters an enclosure, a box connector should be used on the inside of the enclosure to ensure a tight and stable seal.

BULLETIN: F22

Catalog Number	D in./mm	E in./mm
F44WBSS	5.38 137	5.38 137
F66WBSS	7.62 194	7.62 194

All dimensions are to outside surfaces. Allow .12 in. (3 mm) additional for gasket at joints.

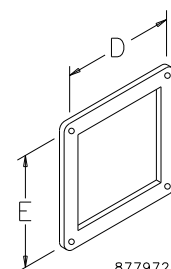

87797210

### GASKET AND SCREWS

Standard packages of wireway contain one gasket and one set of screws to join sections, except Tee fittings which contain two of each and Telescope fittings which contain none. Additional gasket and screw sets may be ordered by catalog number.

BULLETIN: F22

Catalog Number	AxB in./mm
F44WGSS	4.00 x 4.00 102 x 102
F66WGSS	6.00 x 6.00 152 x 152

**FIBERGLASS FEED-THROUGH WIREWAY, NEMA TYPE 12 AND 3R**

**INDUSTRY STANDARDS**

Material Flammability Rating UL 94-5V  
Meets UL cold impact test for temperatures to -35 C

NEMA Type 12, 3R  
IEC 60529, IP55  
Recognized by National Electric Code for indoor and outdoor applications

**APPLICATION**

This temperature- and chemically-resistant fiberglass wireway protects wires and cables in corrosive or dirty indoor or outdoor applications.

**FEATURES**

- Seams are sealed
- No holes or knockouts
- Captivated Monel cover screws
- Oil-resistant cover gasket attached with oil-resistant adhesive
- Stainless steel flange screws
- Solid oil-resistant flange gasket
- Pultruded fiberglass polyester covers and bodies

**FINISH**

Fiberglass wireway is gray inside and out.

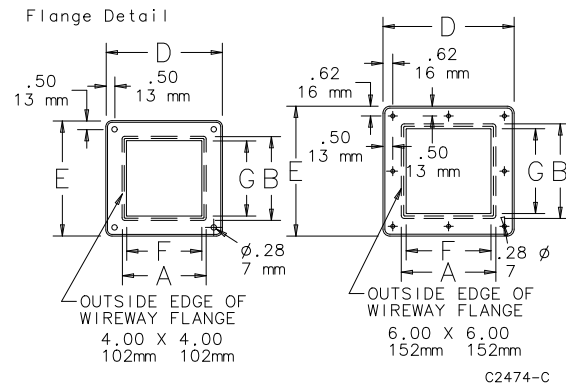
**Standard Product Selection Matrix**

Description	4.00 x 4.00 in. (102 x 102 mm)	6.00 x 6.00 in. (152 x 152 mm)
12.00-in. (305-mm) Straight Section	F44W12FG	F66W12FG
24.00-in. (610-mm) Straight Section	F44W24FG	F66W24FG
36.00-in. (914-mm) Straight Section	F44W36FG	F66W36FG
48.00-in. (1219-mm) Straight Section	F44W48FG	F66W48FG
60.00-in. (1524-mm) Straight Section	F44W60FG	F66W60FG
12.00-in. (305-mm) Straight Tube Section	F44W12STFG	—
24.00-in. (610-mm) Straight Tube Section	F44W24STFG	—
36.00-in. (914-mm) Straight Tube Section	F44W36STFG	—
48.00-in. (1219-mm) Straight Tube Section	F44W48STFG	—
60.00-in. (1524-mm) Straight Tube Section	F44W60STFG	—
120.00-in. (3048-mm) Straight Tube Section	F44W120STFG	—
Cross Fitting	F44WCFG	F66WCFG
Flexible Fitting	F44WFFFG	F66WFFFG
45° Elbow	F44WE45FG	F66WE45FG
90° Elbow	F44WE90FG	F66WE90FG
Cutoff Fitting	F44WXFG	F66WXFG
Tee Fitting	F44WTFG	F66WTFG
Closure Plate	F44WPFG	F66WPFG
Wireway Hanger	F44HBEP	F66HBEP
Box Connector	F44WBFG	F66WBFG



### STRAIGHT SECTION

BULLETIN: F25

Catalog Number	AxBxC in.	AxBxC mm	F (in.)	F (mm)	G (in.)	G (mm)
F44W12FG	4.00 x 4.00 x 12.00	102 x 102 x 305	3.38	86	3.38	86
F44W24FG	4.00 x 4.00 x 24.00	102 x 102 x 610	3.38	86	3.38	86
F44W36FG	4.00 x 4.00 x 36.00	102 x 102 x 914	3.38	86	3.38	86
F44W48FG	4.00 x 4.00 x 48.00	102 x 102 x 1219	3.38	86	3.38	86
F44W60FG	4.00 x 4.00 x 60.00	102 x 102 x 1524	3.38	86	3.38	86
F66W12FG	6.00 x 6.00 x 12.00	152 x 152 x 305	5.38	137	5.38	137
F66W24FG	6.00 x 6.00 x 24.00	152 x 152 x 610	5.38	137	5.38	137
F66W36FG	6.00 x 6.00 x 36.00	152 x 152 x 914	5.38	137	5.38	137
F66W48FG	6.00 x 6.00 x 48.00	152 x 152 x 1219	5.38	137	5.38	137
F66W60FG	6.00 x 6.00 x 60.00	152 x 152 x 1524	5.38	137	5.38	137

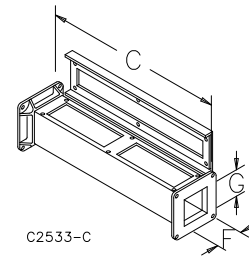

### STRAIGHT TUBE SECTION

BULLETIN: F25

Catalog Number	AxBxC in./mm	F in./mm	G in./mm
F44W12STFG	4.00 x 4.00 x 12.00 102 x 102 x 305	3.38 86	3.38 86
F44W24STFG	4.00 x 4.00 x 24.00 102 x 102 x 610	3.38 86	3.38 86
F44W36STFG	4.00 x 4.00 x 36.00 102 x 102 x 914	3.38 86	3.38 86
F44W48STFG	4.00 x 4.00 x 48.00 102 x 102 x 1219	3.38 86	3.38 86
F44W60STFG	4.00 x 4.00 x 60.00 102 x 102 x 1524	3.38 86	3.38 86
F44W120STFG	4.00 x 4.00 x 120.00 102 x 102 x 3048	3.38 86	3.38 86

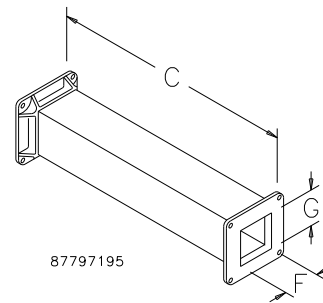

### CROSS FITTING

BULLETIN: F25

Catalog Number	AxB in./mm	F in./mm	G in./mm	K in./mm	L in./mm
F44WCFCG	4.00 x 4.00 102 x 102	3.38 86	3.38 86	6.00 152	12.00 305
F66WCFCG	6.00 x 6.00 152 x 152	5.38 137	5.38 137	6.00 152	12.00 305

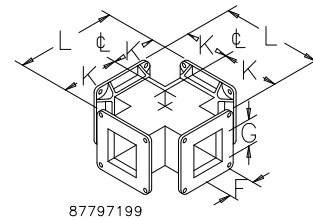

### FLEXIBLE FITTING

Isolates a wireway run from shock and vibration. Compensates for misalignment. Used where an odd angle is required (but not to exceed 90 degrees). Permits movement of a machine or control station connected to a wireway run. Hypalon bellow with stainless steel flanges.

BULLETIN: F25

Catalog Number	AxB in./mm
F44WFFFG	4.00 x 4.00 102 x 102
F66WFFFG	6.00 x 6.00 152 x 152

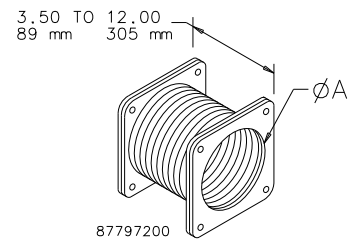

### 45-DEGREE ELBOW

BULLETIN: F25

Catalog Number	AxB in./mm	F in./mm	G in./mm	H in./mm	J in./mm
F44WE45FG	4.00 x 4.00 102 x 102	3.38 86	3.38 86	5.81 148	5.00 127
F66WE45FG	6.00 x 6.00 152 x 152	5.38 137	5.38 137	7.62 194	6.62 168

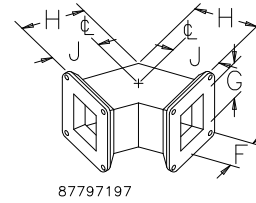

87797197

### 90-DEGREE ELBOW

BULLETIN: F25

Catalog Number	F in./mm	G in./mm	K in./mm
F44WE90FG	3.38 86	3.38 86	6.00 152
F66WE90FG	5.38 137	5.38 137	6.00 152

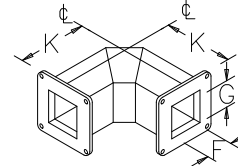

87797196

### CUT-OFF FITTING

For lengths up to 24.00 in. (610 mm). Shorten body to desired length and bond flange to body. Adhesive is furnished.

BULLETIN: F25

Catalog Number	AxB in./mm	F in./mm	G in./mm
F44WXFG	4.00 x 4.00 102 x 102	3.38 86	3.38 86
F66WXFG	6.00 x 6.00 152 x 152	5.38 137	5.38 137

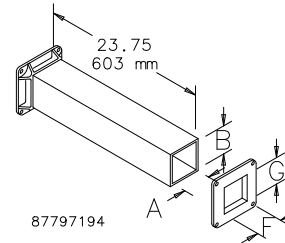

87797194

### TEE FITTING

BULLETIN: F25

Catalog Number	AxB in./mm	F in./mm	G in./mm	K in./mm	L in./mm
F44WTFG	4.00 x 4.00 102 x 102	3.38 86	3.38 86	6.00 152	12.00 305
F66WTFG	6.00 x 6.00 152 x 152	5.38 137	5.38 137	6.00 152	12.00 305

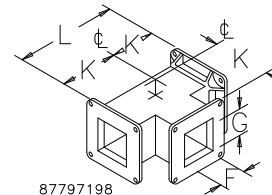

87797198

### CLOSURE PLATE

10 gauge 316 stainless steel, used to seal the end of a wireway section or run. 6.00 x 6.00 in. (152 x 152 mm) can be used for transition to 4.00 x 4.00-in. (102 x 102-mm) size.

BULLETIN: F25

Catalog Number	AxB in.	AxB mm	D (in.)	D (mm)	E (in.)	E (mm)
F44WPPFG	0.00		6.00	152	6.00	152
F66WPPFG	6.00 x 6.00	152 x 152	8.25	210	8.25	210

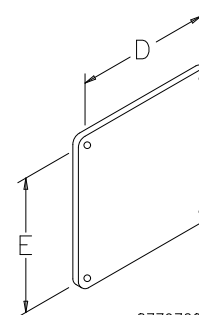

87797202

**WIREWAY HANGER**

10 gauge epoxy-coated steel, used to support wireway from overhead.

BULLETIN: F25

Catalog Number	AxB in./mm	M in./mm
F44HBEP	4.00 x 4.00 102 x 102	9.23 234
F66HBEP	4.00 x 4.00 102 x 102	12.36 314

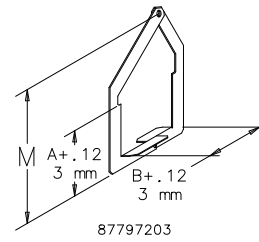

**BOX CONNECTOR**

When wireway enters an enclosure, a box connector should be used on the inside of the enclosure to ensure a tight seal. Made from epoxy-coated 10 gauge steel.

BULLETIN: F25

Catalog Number	D (in.)	D (mm)	E (in.)	E (mm)
F44WBFG	6.00	152	6.00	152
F66WBFG	8.25	210	8.25	210

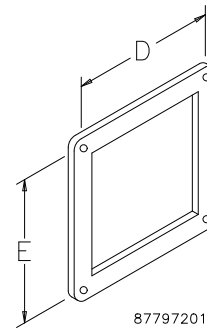

*Hoffman*<sup>®</sup>

# CHAPTER 8 WIRING TROUGH

## OVERVIEW

Pentair offers a wiring trough for every application. Type 1 and 3R rated troughs that are available in a range of sizes.

### WIRING TROUGH, NEMA TYPE 1

Using a unique joining method that mechanically locks components together without fasteners or heat, this wiring trough ships completely assembled to save both time and labor. Designed for indoor use, this trough is available in various lengths.



### ECONOTROUGH, NEMA TYPE 3R

The EconoTrough meets basic functionality requirements for outdoor applications that may be exposed to wet conditions. A Padlock Hasp Kit can be installed for increased security.



## CHAPTER CONTENTS

### WIRING TROUGHS

Wiring Trough, NEMA Type 1 .....	158
Wiring Trough, NEMA Type 3R .....	160
EconoTrough, NEMA Type 3R .....	162
Padlock Hasp Kit .....	163
Hinged Cover Wiring Trough, NEMA Type 12 .....	164
Screw Cover Wiring Trough, NEMA Type 12 .....	166
Fiberglass Wiring Trough, NEMA Type 12 and 3R .....	168



### WIRING TROUGH, NEMA TYPE 3R

Available in a range of sizes, this wiring trough meets basic functionality requirements for applications subjected to moisture.

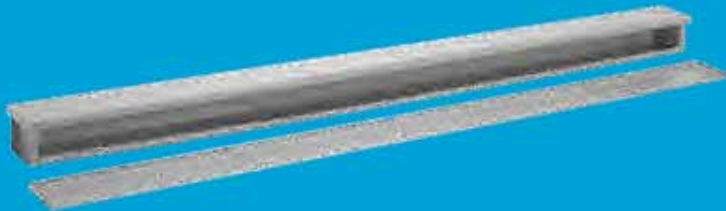

**WIRING TROUGH, NEMA TYPE 1**

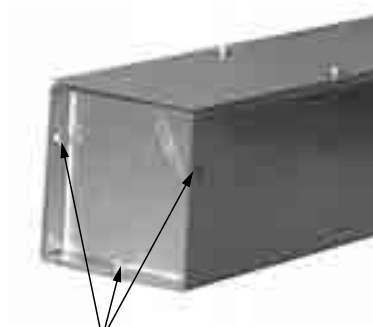

*Joining Locations*

**INDUSTRY STANDARDS**

UL 870 Listed; File No. E27524  
 cUL CSA C22.2 No. 26 Listed; File No. E27524

NEMA/EEMAC: Type 1  
 IEC 60529, IP30

**APPLICATION**

Using a unique joining method that mechanically locks components together without fasteners or heat, this wiring trough ships completely assembled to save both time and labor. Designed for indoor use, this trough is available in various lengths.

**FEATURES**

- Keyhole screw slots in cover
- Shipped completely assembled—no end caps to install
- Mounting holes on the back of the enclosure
- Flat cover fastened with plated steel screws
- No gasketing or knockouts

**SPECIFICATIONS**

- 16 or 14 gauge plated steel

**FINISH**

Unpainted plated steel

BULLETIN: F40T1

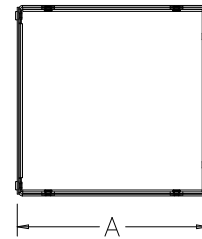
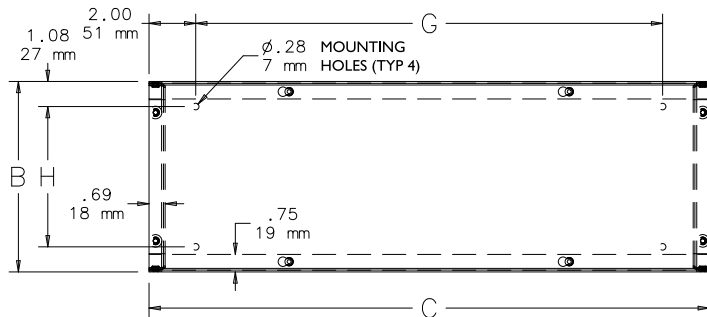

87572058

Standard Product

Catalog Number	AxBxC in./mm	Gauge	Mounting G in./mm	Mounting H in./mm
A4412T1T	4.00 x 4.00 x 12.00 102 x 102 x 305	16	8.00 203	2.00 51
A4424T1T	4.00 x 4.00 x 24.00 102 x 102 x 610	16	20.00 508	2.00 51
A4436T1T	4.00 x 4.00 x 36.00 102 x 102 x 914	16	24.00 610	2.00 51
A4448T1T	4.00 x 4.00 x 48.00 102 x 102 x 1219	16	36.00 914	2.00 51
A4460T1T	4.00 x 4.00 x 60.00 102 x 102 x 1524	16	48.00 1219	2.00 51
A4472T1T	4.00 x 4.00 x 72.00 102 x 102 x 1829	16	60.00 1524	2.00 51
A4496T1T	4.00 x 4.00 x 96.00 102 x 102 x 2438	16	84.00 2134	2.00 51
A6612T1T	6.00 x 6.00 x 12.00 152 x 152 x 305	16	8.00 203	4.00 102
A6624T1T	6.00 x 6.00 x 24.00 152 x 152 x 610	16	20.00 508	4.00 102
A6636T1T	6.00 x 6.00 x 36.00 152 x 152 x 914	16	24.00 610	4.00 102
A6648T1T	6.00 x 6.00 x 48.00 152 x 152 x 1219	16	36.00 914	4.00 102
A6660T1T	6.00 x 6.00 x 60.00 152 x 152 x 1524	16	48.00 1219	4.00 102
A6672T1T	6.00 x 6.00 x 72.00 152 x 152 x 1829	16	60.00 1524	4.00 102
A6696T1T	6.00 x 6.00 x 96.00 152 x 152 x 2438	16	84.00 2134	4.00 102
A8824T1T	8.00 x 8.00 x 24.00 203 x 203 x 610	14	8.00 203	6.01 153
A8836T1T	8.00 x 8.00 x 36.00 203 x 203 x 914	14	20.00 508	6.01 153
A8848T1T	8.00 x 8.00 x 48.00 203 x 203 x 1219	14	36.00 914	6.01 153
A8860T1T	8.00 x 8.00 x 60.00 203 x 203 x 1524	14	48.00 1219	6.01 153
A8872T1T	8.00 x 8.00 x 72.00 203 x 203 x 1829	14	60.00 1524	6.01 153
A8896T1T	8.00 x 8.00 x 96.00 203 x 203 x 2438	14	84.00 2134	6.01 153
A101048T1T	10.00 x 10.00 x 48.00 254 x 254 x 1219	14	36.00 914	8.01 203
A121224T1T	12.00 x 12.00 x 24.00 305 x 305 x 610	14	8.00 203	10.01 254
A121236T1T	12.00 x 12.00 x 36.00 305 x 305 x 914	14	20.00 508	10.01 254
A121248T1T	12.00 x 12.00 x 48.00 305 x 305 x 1219	14	36.00 914	10.01 254
A121260T1T	12.00 x 12.00 x 60.00 305 x 305 x 1524	14	48.00 1219	10.01 254
A121272T1T	12.00 x 12.00 x 72.00 305 x 305 x 1829	14	60.00 1524	10.01 254
A121296T1T	12.00 x 12.00 x 96.00 305 x 305 x 2438	14	84.00 2134	10.01 254
A1212120T1T	12.00 x 12.00 x 120.00 305 x 305 x 3048	14	108.00 2743	10.01 254





WIRING TROUGH, NEMA TYPE 3R



**INDUSTRY STANDARDS**

UL 870 Listed; File No. E27524; Raintight  
 cUL CSA C22.2 No. 26 Listed; File No. E27524; Raintight

NEMA/EEMAC Type 3R  
 IEC 60529, IP32

**APPLICATION**

Available in a range of sizes, this wiring trough meets basic functionality requirements for applications subjected to moisture.

**FEATURES**

- Drip shield top and seam-free sides, front, and back
- Slip-on removable cover
- Embossed mounting holes on back of enclosure
- Provision for padlocking
- No gasketing or knockouts

**SPECIFICATIONS**

- 16 or 14 gauge plated steel

**FINISH**

ANSI 61 gray polyester powder paint finish inside and out over pretreated surfaces.

**ACCESSORIES**

See also *Accessories chapter*.  
 Touch-Up Paint (ATPPY61)

**BULLETIN: F40PT**

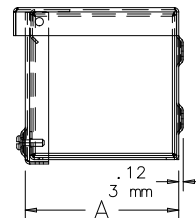
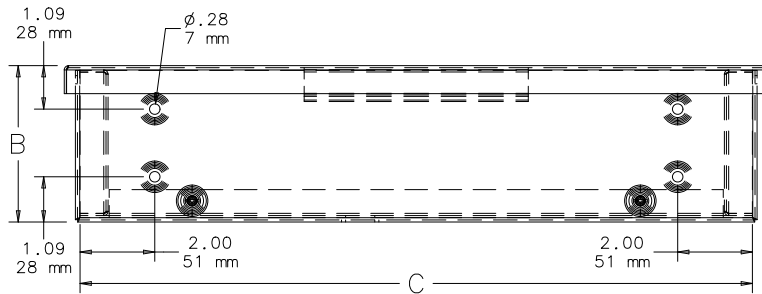

87552191



## Standard Product

Catalog Number	AxBxC in.	AxBxC mm	Gauge
A4412RT	4.00 x 4.00 x 12.00	102 x 102 x 305	16
A4418RT	4.00 x 4.00 x 18.00	102 x 102 x 457	16
A4424RT	4.00 x 4.00 x 24.00	102 x 102 x 610	16
A4436RT	4.00 x 4.00 x 36.00	102 x 102 x 914	16
A4448RT	4.00 x 4.00 x 48.00	102 x 102 x 1219	16
A4460RT	4.00 x 4.00 x 60.00	102 x 102 x 1524	16
A4472RT	4.00 x 4.00 x 72.00	102 x 102 x 1829	16
A6612RT	6.00 x 6.00 x 12.00	152 x 152 x 305	16
A6618RT	6.00 x 6.00 x 18.00	152 x 152 x 457	16
A6624RT	6.00 x 6.00 x 24.00	152 x 152 x 610	16
A6636RT	6.00 x 6.00 x 36.00	152 x 152 x 914	16
A6648RT	6.00 x 6.00 x 48.00	152 x 152 x 1219	16
A6660RT	6.00 x 6.00 x 60.00	152 x 152 x 1524	16
A6672RT	6.00 x 6.00 x 72.00	152 x 152 x 1829	16
A8812RT	8.00 x 8.00 x 12.00	203 x 203 x 305	14
A8824RT	8.00 x 8.00 x 24.00	203 x 203 x 610	14
A8836RT	8.00 x 8.00 x 36.00	203 x 203 x 914	14
A8848RT	8.00 x 8.00 x 48.00	203 x 203 x 1219	14
A8860RT	8.00 x 8.00 x 60.00	203 x 203 x 1524	14
A8872RT	8.00 x 8.00 x 72.00	203 x 203 x 1829	14
A8896RT	8.00 x 8.00 x 96.00	203 x 203 x 2438	14
A88116RT	8.00 x 8.00 x 116.00	203 x 203 x	14
A101024RT	10.00 x 10.00 x 24.00	254 x 254 x 610	14
A101036RT	10.00 x 10.00 x 36.00	254 x 254 x 914	14
A101048RT	10.00 x 10.00 x 48.00	254 x 254 x 1219	14
A101060RT	10.00 x 10.00 x 60.00	254 x 254 x 1524	14
A101072RT	10.00 x 10.00 x 72.00	254 x 254 x 1829	14
A101096RT	10.00 x 10.00 x 96.00	254 x 254 x	14
A1010116RT	10.00 x 10.00 x 116.00	254 x 254 x 2946	14
A121224RT	12.00 x 12.00 x 24.00	305 x 305 x 610	14
A121236RT	12.00 x 12.00 x 36.00	305 x 305 x 914	14
A121248RT	12.00 x 12.00 x 48.00	305 x 305 x 1219	14
A121260RT	12.00 x 12.00 x 60.00	305 x 305 x 1524	14
A121272RT	12.00 x 12.00 x 72.00	305 x 305 x 1829	14
A121284RT	12.00 x 12.00 x 84.00	305 x 305 x 2134	14
A121296RT	12.00 x 12.00 x 96.00	305 x 305 x 2438	14
A1212116RT	12.00 x 12.00 x 116.00	305 x 305 x 2946	14
A141448RT	14.00 x 14.00 x 48.00	356 x 356 x 1219	14
A141472RT	14.00 x 14.00 x 72.00	356 x 356 x 1829	14
A141484RT	14.00 x 14.00 x 84.00	356 x 356 x 2134	14
A141496RT	14.00 x 14.00 x 96.00	356 x 356 x 2438	14
A1414116RT	14.00 x 14.00 x 116.00	356 x 356 x 2946	14

**ECONOTROUGH, NEMA TYPE 3R**



**INDUSTRY STANDARDS**

UL 870 Listed; File No. E27524; Raintight  
 cUL CSA C22.2 No. 26 Listed; File No. E27524; Raintight

NEMA/EEMAC Type 3R  
 IEC 60529, IP 32

**APPLICATION**

The EconoTrough meets basic functionality requirements for outdoor applications that may be exposed to wet conditions. A Padlock Hasp Kit can be installed for increased security.

**FEATURES**

- Drip-shield top covers sides, front and back
- Removable cover
- Embossed mounting holes on back of enclosure
- Provision for utility seal
- No gasketing or knockouts
- Padlock Hasp Kit available

**SPECIFICATIONS**

- 16 or 14 gauge galvanized steel

**FINISH**

Unpainted galvanized steel

**ACCESSORIES**

See also *Accessories*.  
 Padlock Hasp Kit

**BULLETIN: F40GT, F40PT**

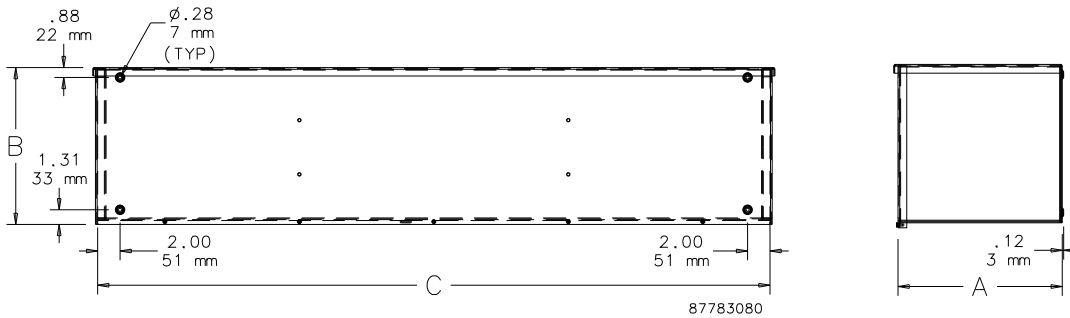

Standard Product

Catalog Number	AxBxC in.	AxBxC mm	Gauge
F4412RTGV	4.00 x 4.00 x 12.00	102 x 102 x 305	16
F4424RTGV	4.00 x 4.00 x 24.00	102 x 102 x 610	16
F4436RTGV	4.00 x 4.00 x 36.00	102 x 102 x 914	16
F4448RTGV	4.00 x 4.00 x 48.00	102 x 102 x 1219	16
F4460RTGV	4.00 x 4.00 x 60.00	102 x 102 x 1524	16
F4472RTGV	4.00 x 4.00 x 72.00	102 x 102 x 1829	16
F6612RTGV	6.00 x 6.00 x 12.00	152 x 152 x 305	16
F6618RTGV	6.00 x 6.00 x 18.00	152 x 152 x 457	16
F6624RTGV	6.00 x 6.00 x 24.00	152 x 152 x 610	16
F6636RTGV	6.00 x 6.00 x 36.00	152 x 152 x 914	16
F6648RTGV	6.00 x 6.00 x 48.00	152 x 152 x 1219	16
F6660RTGV	6.00 x 6.00 x 60.00	152 x 152 x 1524	16
F6672RTGV	6.00 x 6.00 x 72.00	152 x 152 x 1829	16
F8812RTGV	8.00 x 8.00 x 12.00	203 x 203 x 305	14
F8824RTGV	8.00 x 8.00 x 24.00	203 x 203 x 610	14
F8836RTGV	8.00 x 8.00 x 36.00	203 x 203 x 914	14
F8848RTGV	8.00 x 8.00 x 48.00	203 x 203 x 1219	14
F8860RTGV	8.00 x 8.00 x 60.00	203 x 203 x 1524	14
F8872RTGV	8.00 x 8.00 x 72.00	203 x 203 x 1829	14
F8896RTGV	8.00 x 8.00 x 96.00	203 x 203 x 2438	14
F88116RTGV	8.00 x 8.00 x 116.00	203 x 203 x 2946	14
F101024RTGV	10.00 x 10.00 x 24.00	254 x 254 x 610	14
F101036RTGV	10.00 x 10.00 x 36.00	254 x 254 x 914	14
F101048RTGV	10.00 x 10.00 x 72.00	254 x 254 x 1829	14
F101060RTGV	10.00 x 10.00 x 60.00	254 x 254 x 1524	14
F101072RTGV	10.00 x 10.00 x 72.00	254 x 254 x 1829	14
F101096RTGV	10.00 x 10.00 x 96.00	254 x 254 x 2438	14
F1010116RTGV	10.00 x 10.00 x 116.00	254 x 254 x 2946	14
F121224RTGV	12.00 x 12.00 x 24.00	305 x 305 x 610	14
F121236RTGV	12.00 x 12.00 x 36.00	305 x 305 x 914	14
F121248RTGV	12.00 x 12.00 x 48.00	305 x 305 x 1219	14
F121260RTGV	12.00 x 12.00 x 60.00	305 x 305 x 1524	14
F121272RTGV	12.00 x 12.00 x 72.00	305 x 305 x 1829	14
F121284RTGV	12.00 x 12.00 x 84.00	305 x 305 x 2134	14
F121296RTGV	12.00 x 12.00 x 96.00	305 x 305 x 2438	14
F1212116RTGV	12.00 x 12.00 x 116.00	305 x 305 x 2946	14
F141448RTGV	14.00 x 14.00 x 48.00	356 x 356 x 1219	14
F141472RTGV	14.00 x 14.00 x 72.00	356 x 356 x 1829	14
F141496RTGV	14.00 x 14.00 x 96.00	356 x 356 x 2438	14
F1414116RTGV	14.00 x 14.00 x 116.00	356 x 356 x 2946	14



**PADLOCK HASP KIT**



Provides a means to padlock NEMA Type 3R trough. Includes mounting screws.

**BULLETIN: F40GT**

Catalog Number	Description	Kit Qty.
APLK3R	Padlock Hasp	1

**HINGED COVER WIRING TROUGH, NEMA TYPE 12**



**APPLICATION**

This wiring trough meets basic functionality requirements for moist or dirty applications, with the added feature of a hinged, screw clamp cover for easy access.

**FEATURES**

- Ends and seams continuously welded and ground smooth
- No holes or knockouts
- Butt hinges
- External screw clamps
- Screw clamps
- Oil-resistant gasket and adhesive

**SPECIFICATIONS**

- 14 gauge steel covers and bodies

**FINISH**

ANSI 61 gray polyester powder coating inside and out over pretreated surfaces.

**ACCESSORIES**

See also *Accessories*.  
Touch-Up Paint

**BULLETIN: F20HC**

**INDUSTRY STANDARDS**

UL 870 Listed; File No. E27524

NEMA Type 12  
JIC standards EGP-1-1967 and EMP-1-1967  
CSA, File No. 42184, Type 1  
IEC 60529, IP55

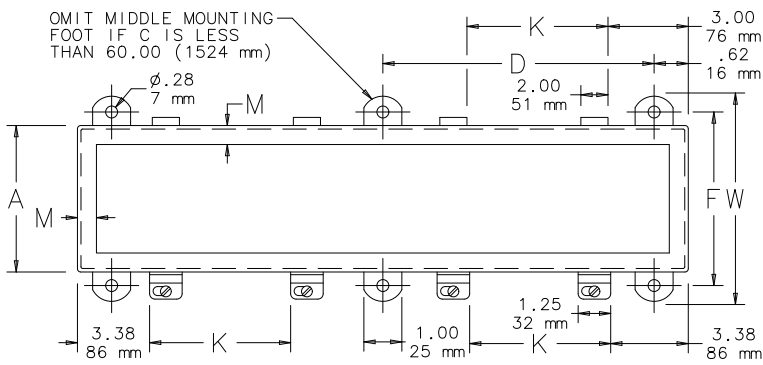

TOP VIEW WITH COVER REMOVED

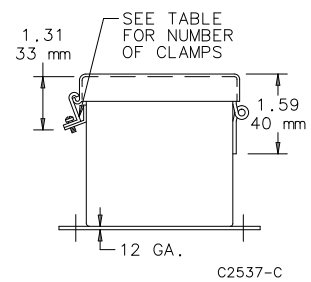
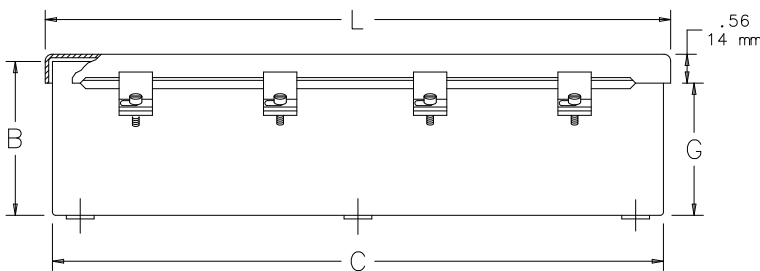

Standard Product

Catalog Number	AxBxC in./mm	Clamps	Mounting Bracket	D in./mm	F in./mm	G in./mm	K in./mm	L in./mm	M in./mm	W in./mm
F22T12HC	2.50 x 2.50 x 12.00 64 x 64 x 305	2	2	—	3.19	2.11	—	12.25	0.41	4.00
F22T18HC	2.50 x 2.50 x 18.00 64 x 64 x 457	2	2	—	3.19	2.11	—	18.25	0.41	4.00
F22T24HC	2.50 x 2.50 x 24.00 64 x 64 x 610	2	2	—	3.19	2.11	—	24.25	0.41	4.00
F22T36HC	2.50 x 2.50 x 36.00 64 x 64 x 914	3	3	—	3.19	2.11	14.00	36.25	0.41	4.00
F22T48HC	2.50 x 2.50 x 48.00 64 x 64 x 1219	3	2	—	3.19	2.11	20.00	48.25	0.41	4.00
F22T60HC	2.50 x 2.50 x 60.00 64 x 64 x 1524	4	3	29.38	3.19	2.11	17.34	60.25	0.41	4.00
F22T72HC	2.50 x 2.50 x 72.00 64 x 64 x 1829	5	3	35.38	3.19	2.11	16.00	72.25	0.41	4.00
F44T12HC	4.00 x 4.00 x 12.00 102 x 102 x 305	2	2	—	4.69	3.59	—	12.25	0.41	5.50
F44T18HC	4.00 x 4.00 x 18.00 102 x 102 x 457	2	2	—	4.69	3.59	—	18.25	0.41	5.50
F44T24HC	4.00 x 4.00 x 24.00 102 x 102 x 610	2	2	—	4.69	3.59	—	24.25	0.41	5.50
F44T30HC	4.00 x 4.00 x 30.00 102 x 102 x 762	3	2	—	4.69	3.59	11.00	30.25	0.41	5.50
F44T36HC	4.00 x 4.00 x 36.00 102 x 102 x 914	3	2	—	4.69	3.59	14.00	36.25	0.41	5.50
F44T48HC	4.00 x 4.00 x 48.00 102 x 102 x 1219	3	2	—	4.69	3.59	20.00	48.25	0.41	5.50
F44T60HC	4.00 x 4.00 x 60.00 102 x 102 x 1524	4	3	29.38	4.69	3.59	17.34	60.25	0.41	5.50
F44T72HC	4.00 x 4.00 x 72.00 102 x 102 x 1829	5	3	35.38	4.69	3.59	16.00	72.25	0.56	5.50
F66T12HC	6.00 x 6.00 x 12.00 152 x 152 x 305	2	2	—	6.69	5.59	—	12.25	0.41	7.50
F66T18HC	6.00 x 6.00 x 18.00 152 x 152 x 457	2	2	—	6.69	5.59	—	18.25	0.41	7.50
F66T24HC	6.00 x 6.00 x 24.00 152 x 152 x 610	2	2	—	6.69	5.59	—	24.25	0.41	7.50
F66T30HC	6.00 x 6.00 x 30.00 152 x 152 x 762	3	2	—	6.69	5.59	11.00	30.25	0.41	7.50
F66T36HC	6.00 x 6.00 x 36.00 152 x 152 x 914	3	2	—	6.69	5.59	14.00	36.25	0.41	7.50
F66T48HC	6.00 x 6.00 x 48.00 152 x 152 x 1219	3	2	—	6.69	5.59	20.00	48.25	0.41	7.50
F66T60HC	6.00 x 6.00 x 60.00 152 x 152 x 1524	4	3	29.38	6.69	5.59	17.34	60.25	0.41	7.50
F66T72HC	6.00 x 6.00 x 72.00 152 x 152 x 1829	5	3	35.38	6.69	5.59	16.00	72.25	0.56	7.50
F88T12HC	8.00 x 8.00 x 12.00 203 x 203 x 305	2	2	—	8.69	7.61	—	12.25	0.75	9.50
F88T24HC	8.00 x 8.00 x 24.00 203 x 203 x 610	2	2	—	8.69	7.61	n/a	24.25	0.75	9.50
F88T36HC	8.00 x 8.00 x 36.00 203 x 203 x 914	3	2	—	8.69	7.61	14.00	36.25	0.75	9.50
F88T48HC	8.00 x 8.00 x 48.00 203 x 203 x 1219	3	2	—	8.69	7.61	20.00	48.25	0.75	9.50
F88T60HC	8.00 x 8.00 x 60.00 203 x 203 x 1524	4	3	29.38	8.69	7.61	17.34	60.25	0.75	9.50
F1212T60HC	12.00 x 12.00 x 60.00 305 x 305 x 1524	4	3	29.38	12.69	11.61	17.34	60.25	0.75	13.50
F1212T24HC	12.00 x 12.00 x 24.00 305 x 305 x 610	2	2	—	12.69	11.61	—	24.25	0.75	13.50
F1212T36HC	12.00 x 12.00 x 36.00 305 x 305 x 914	3	2	—	12.69	11.61	14.00	36.25	0.75	13.50
F1212T48HC	12.00 x 12.00 x 48.00 305 x 305 x 1219	3	2	—	12.69	11.61	20.00	48.25	0.75	13.50



**SCREW COVER WIRING TROUGH, NEMA TYPE 12**

8

**INDUSTRY STANDARDS**

UL 870 Listed; File No. E27524
--------------------------------

NEMA/EEMAC Type 12  
JIC standards EGP-1-1967 and EMP-1-1967  
CSA, File No. 42184: Type 12  
IEC 60529, IP55

**APPLICATION**

This wiring trough meets basic functionality requirements for applications in which frequent access is not needed. Providing protection in moist or dirty environments, the trough can be customized with different finish colors and textures.

**FEATURES**

- Ends and seams continuously welded and ground smooth; no holes or knockouts
- Captivated cover screws thread into sealed wells
- Oil-resistant gasket and adhesive

**SPECIFICATIONS**

- 14 gauge steel covers and bodies
- F2212SC is 16 gauge steel

**FINISH**

ANSI 61 gray polyester powder finish inside and out over pretreated surfaces.

**ACCESSORIES**

See also *Accessories chapter*.  
Touch-Up Paint (ATPPY61)

**MODIFICATION AND CUSTOMIZATION**

Hoffman excels at modifying and customizing products to your specifications. Contact your local Hoffman sales office or distributor for complete information.

**BULLETIN: F20SC**

Standard Product

Catalog Number	AxBxC in./mm	Number of Fasteners	D in./mm	F in./mm	G in./mm	H in./mm	K in./mm	L in./mm	M in./mm	P in./mm	W in./mm
F2212SC	2.50 x 2.50 x 12.00 64 x 64 x 305	4	10.75 273	3.19 81	2.09 53	0.56 14	—	12.22 310	0.69 18	0.41 10	4.00 102
F4412SC	4.00 x 4.00 x 12.00 102 x 102 x 305	4	10.75 273	4.69 119	3.59 91	0.58 15	—	12.25 311	0.69 18	0.69 18	5.50 140
F4418SC	4.00 x 4.00 x 18.00 102 x 102 x 457	6	16.75 425	4.69 119	3.59 91	0.58 15	8.64 219	18.25 464	0.69 18	0.69 18	5.50 140
F4424SC	4.00 x 4.00 x 24.00 102 x 102 x 610	6	22.75 578	4.69 119	3.59 91	0.58 15	11.64 296	24.25 616	0.69 18	0.69 18	5.50 140
F4430SC	4.00 x 4.00 x 30.00 102 x 102 x 762	8	28.75 730	4.69 119	3.59 91	0.58 15	9.77 248	30.25 768	0.69 18	0.69 18	5.50 140

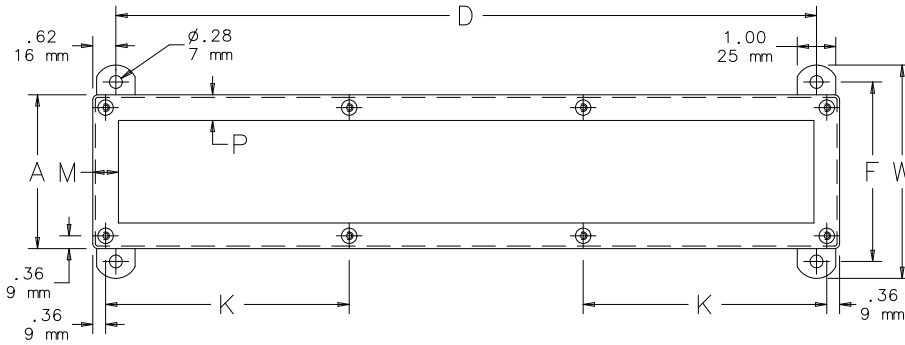

TOP VIEW WITH COVER REMOVED

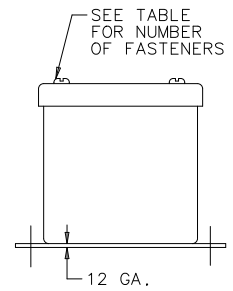
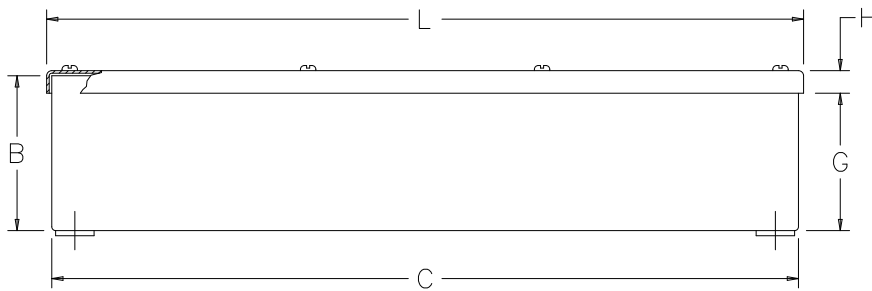

C2538-C



**FIBERGLASS WIRING TROUGH, NEMA TYPE 12 AND 3R**

8

**INDUSTRY STANDARDS**

Flammability Rating UL 94-5V  
Meets UL cold impact test for temperatures to -35 C

NEMA Type 12 and Type 3R  
IEC 60529, IP55  
Recognized by National Electric Code for indoor and outdoor applications

**APPLICATION**

This lightweight, temperature- and chemically-resistant fiberglass trough is designed for use in corrosive or dirty indoor or outdoor applications.

**FEATURES**

- Seams are sealed
- No holes or knockouts
- Captivated Monel cover screws
- Oil-resistant gasket attached with oil-resistant adhesive

**SPECIFICATIONS**

- Pultruded fiberglass polyester bodies and covers

**FINISH**

Fiberglass wireway is gray inside and out.

**BULLETIN: F25**



Standard Product

Catalog Number	AxBxC in./mm	Number of Openings	Number of Cover Screws	D in./mm	E in./mm	F in./mm	G in./mm	H in./mm	J in./mm	K in./mm	W in./mm	X in./mm
F4412FG	4.00 x 4.00 x 12.00 102 x 102 x 305	1	4	10.38 264	3.50 89	5.00 127	3.12 79	4.50 114	3.12 79	6.62 168	6.00 152	4.34 110
F4424FG	4.00 x 4.00 x 24.00 102 x 102 x 610	2	6	22.38 568	3.50 89	5.00 127	3.12 79	4.50 114	3.12 79	8.50 216	6.00 152	4.34 110
F4436FG	4.00 x 4.00 x 36.00 102 x 102 x 914	3	8	34.38 873	3.50 89	5.00 127	3.12 79	4.50 114	3.12 79	8.50 216	6.00 152	4.34 110
F4448FG	4.00 x 4.00 x 47.88 102 x 102 x 1216	4	10	46.38 1178	3.50 89	5.00 127	3.12 79	4.50 114	3.12 79	8.50 216	6.00 152	4.34 110
F4460FG	4.00 x 4.00 x 60.00 102 x 102 x 1524	5	12	58.38 1483	3.50 89	5.00 127	3.12 79	4.50 114	3.12 79	8.50 216	6.00 152	4.34 110
F6612FG	6.00 x 6.00 x 12.00 152 x 152 x 305	1	6	10.38 264	5.50 140	7.00 178	5.12 130	6.50 165	5.12 130	6.62 168	8.00 203	6.34 161
F6624FG	6.00 x 6.00 x 23.88 152 x 152 x 607	2	8	22.38 568	5.50 140	7.00 178	5.12 130	6.50 165	5.12 130	8.50 216	8.00 203	6.34 161
F6636FG	6.00 x 6.00 x 36.00 152 x 152 x 914	3	10	34.38 873	5.50 140	7.00 178	5.12 130	6.50 165	5.12 130	8.50 216	8.00 203	6.34 161
F6648FG	6.00 x 6.00 x 48.00 152 x 152 x 1219	4	12	46.38 1178	5.50 140	7.00 178	5.12 130	6.50 165	5.12 130	8.50 216	8.00 203	6.34 161
F6660FG	6.00 x 6.00 x 60.00 152 x 152 x 1524	5	14	58.38 1483	5.50 140	7.00 178	5.12 130	6.50 165	5.12 130	8.50 216	8.00 203	6.34 161

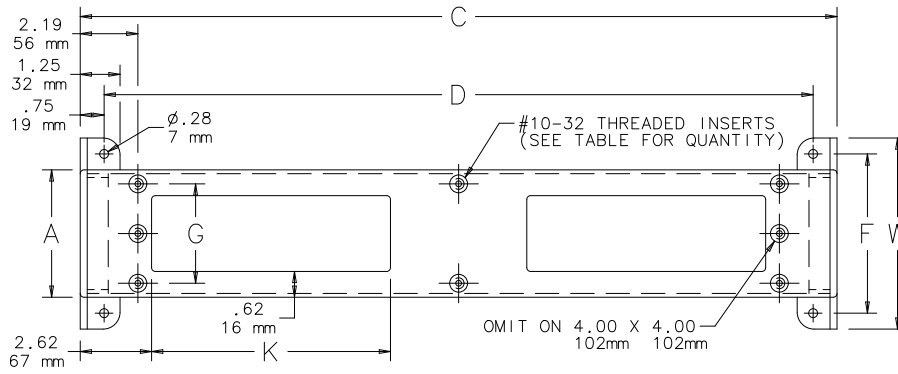

TOP VIEW WITH COVER REMOVED

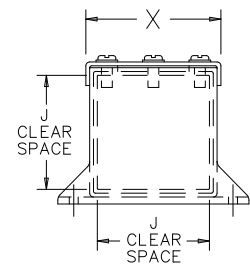
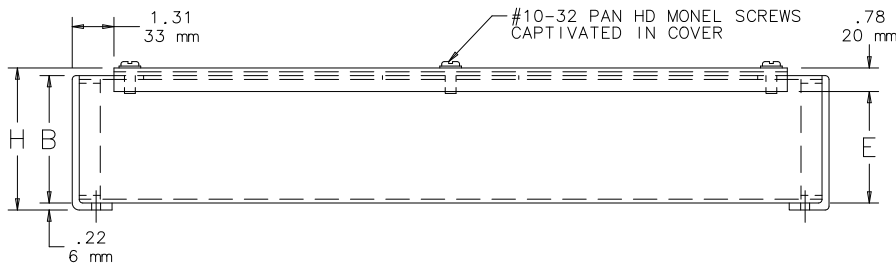

C2539-C





*Hoffman*<sup>®</sup>

# CHAPTER 9 STAINLESS STEEL CABLE TRAY

## OVERVIEW

Pentair CLEAN TRAY™ Stainless Steel Cable Tray protects rated cabling in applications that require frequent washdown. A variety of sloped-top fittings with front, inside or outside cover options allows for highly-customized runs using standard catalog product and supports directional control of washdown effluent.

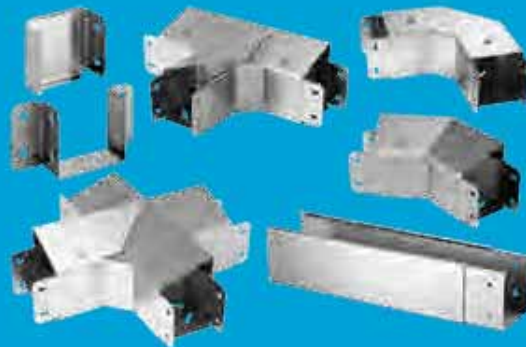

### **CLEAN TRAY™ STAINLESS STEEL CABLE TRAY, TYPE 1**

The CLEAN TRAY™ Stainless Steel Cable Tray is designed to protect rated cabling in applications that require frequent washdown. A variety of sloped-top fittings with front, inside or outside cover options allows for highly-customized runs using standard catalog product and supports directional control of washdown effluent.



## CHAPTER CONTENTS

### CLEAN TRAY™ STAINLESS STEEL CABLE TRAY

CLEAN TRAY™ Stainless Steel Cable Tray, Type 1	172
Straight Section	173
Divider Straight Section	173
Telescopic Straight Section	173
Divider, Telescopic Straight Section	174
90-Degree Elbows	174
90-Degree Elbows—Perforated without Tabs	175
90-Degree Elbows—Front Cover Sloped Inward without Tabs	175
90-Degree Elbows—Front Cover Sloped Outward with Tabs	175
90-Degree Elbows—Front Cover Sloped Outward without Tabs	176
90-Degree Elbows—Inside Cover Sloped	176
90-Degree Elbows—Outside Cover Sloped	176
45-Degree Elbows	177
45-Degree Elbows—Front Cover Sloped Outward	178
45-Degree Elbows—Inside Cover Sloped	178
45-Degree Elbows—Outside Cover Sloped	178
Variable-Angle Elbow Fitting	179
90-Degree Tee	179
90-Degree Tee—Front Cover Sloped Outward	180
90-Degree Tee—Inside Cover Sloped	180
90-Degree Tee—Outside Cover Sloped	180
Cross	181
Divider 90-Degree Tee	181
Divider 90-Degree Elbow	182
Divider 45-Degree Elbow	182
U-Connector	182
Closure Plate	183
Enclosure Adapter	183
Reducer	184
Cable Exit Cover	184
Straight Section Splice	185
Divider Straight Section Splice	185
Transition Cover	186
Side Coupling	186
Fastener Package	186
Hanger Bracket	187
L-Bracket	187
Wall Bracket	187
Latch Hardware Kits	187





**CLEAN TRAY™ STAINLESS STEEL CABLE TRAY, TYPE 1**

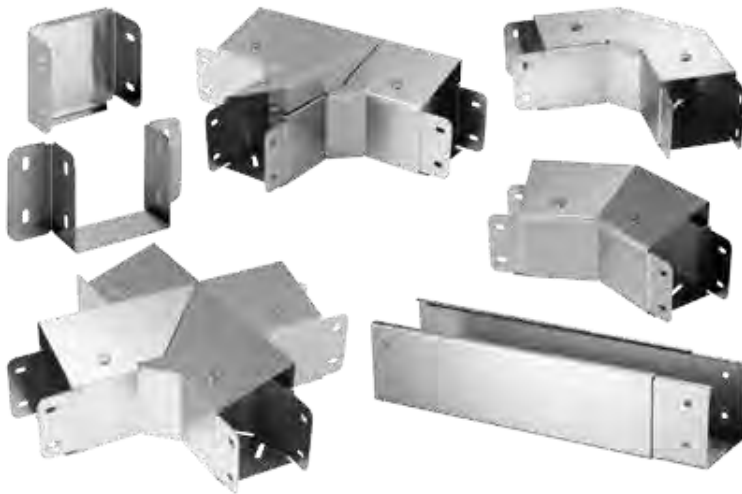

**INDUSTRY STANDARDS**

UL Classified; File No. E263414  
 This product is classified as to its suitability as an equipment grounding conductor only.

NEMA/EEMAC Type 1

**APPLICATION**

The CLEAN TRAY™ Stainless Steel Cable Tray is designed to protect rated cabling in applications that require frequent washdown. A variety of sloped-top fittings with front, inside or outside cover options allows for highly-customized runs using standard catalog product and supports directional control of washdown effluent.

**FEATURES**

- Adjustable dividers
- Tops and sides can completely open
- Flat cover and 20-degree sloped cover models available
- Perforated fittings and straight sections
- Elbows contain three cover options: front, inside and outside
- Connecting hardware is included with each model
- Quarter-turn latches

**SPECIFICATIONS**

- 18 gauge stainless steel

**FINISH**

Smooth brushed finish

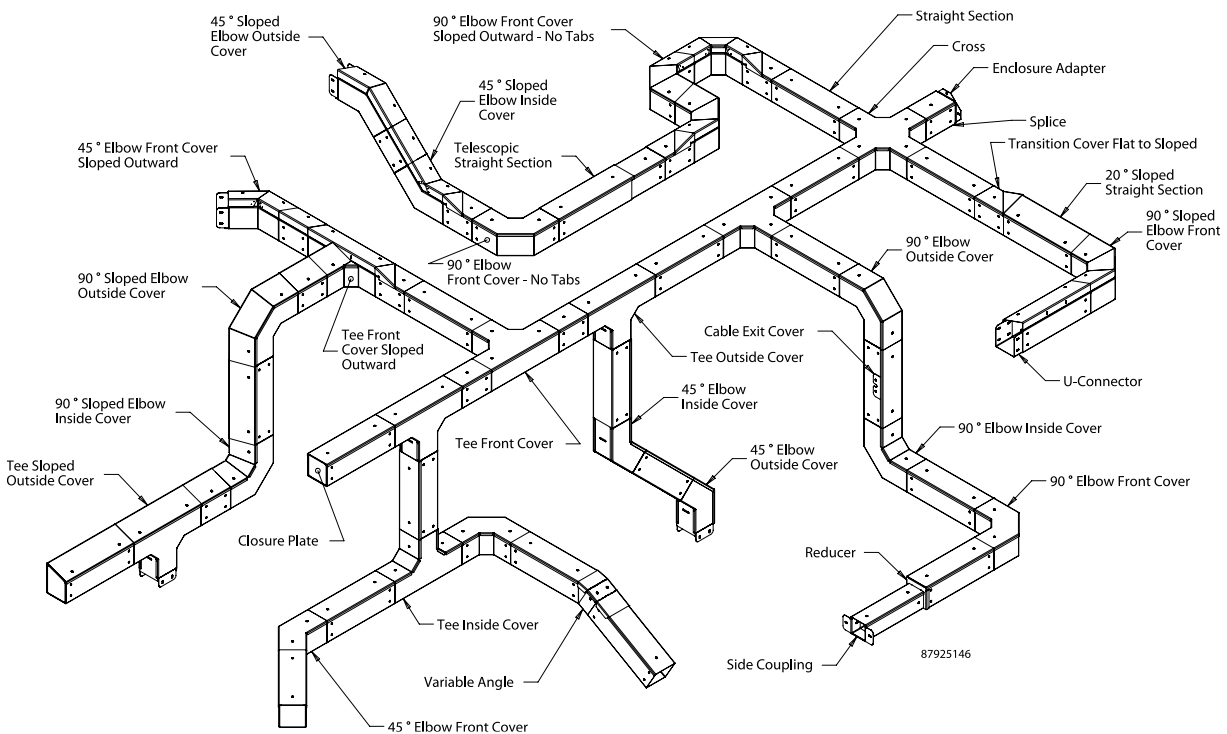

**STRAIGHT SECTION**



Straight sections are available in 10-ft. lengths with or without perforations. Available with a 20-degree sloped cover in some sizes. One U-connector and hardware is supplied with each straight section.

**BULLETIN: F23**

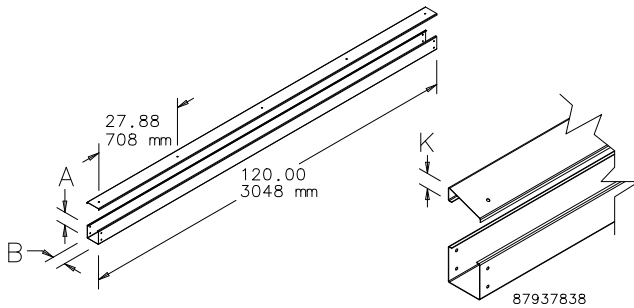

Catalog Number	AxBxC in./mm	Description	K in./mm
CT22120SS	2.00 x 2.00 x 120.00 51 x 51 x 3048	Standard	—
CT33120SS	3.00 x 3.00 x 120.00 76 x 76 x 3048	Standard	—
CT44120SS	4.00 x 4.00 102 x 102	Standard	—
CT46120SS	4.00 x 6.00 x 120.00 102 x 152 x 3048	Standard	—
CT66120SS	6.00 x 6.00 x 120.00 152 x 152 x 3048	Standard	—
CT22P120SS	2.00 x 2.00 51 x 51	Perforated	—
CT33P120SS	3.00 x 3.00 76 x 76	Perforated	—
CT44P120SS	4.00 x 4.00 102 x 102	Perforated	—
CT46P120SS	4.00 x 6.00 102 x 152	Perforated	—
CT66P120SS	6.00 x 6.00 152 x 152	Perforated	—
CTS33120SS	3.00 x 3.00 76 x 76	Sloped Top	1.06 24
CTS44120SS	4.00 x 4.00 102 x 102	Sloped Top	1.42 36
CTS46120SS	4.00 x 6.00 102 x 152	Sloped Top	2.16 55
CTS66120SS	6.00 x 6.00 152 x 152	Sloped Top	2.16 55
CTS33P120SS	3.00 x 3.00 76 x 76	Sloped Top Perforated	1.06 27
CTS44P120SS	4.00 x 4.00 102 x 102	Sloped Top Perforated	1.42 36
CTS46P120SS	4.00 x 6.00 102 x 152	Sloped Top Perforated	2.16 55
CTS66P120SS	6.00 x 6.00 152 x 152	Sloped Top Perforated	2.16 55

**DIVIDER STRAIGHT SECTION**

Used to divide one straight section into two sections.

**BULLETIN: F23**

Catalog Number	AxB in./mm	Fits Cable Tray Size in./mm	L in./mm
CT33DSS	3.00 x 3.00 76 x 76	4.00 x 4.00 102 x 102	2.13 54
CT44DSS	4.00 x 4.00 102 x 102	4.00 x 6.00 102 x 152	3.13 79
CT66DSS	6.00 x 6.00 152 x 152	6.00 x 6.00 152 x 152	5.13 130

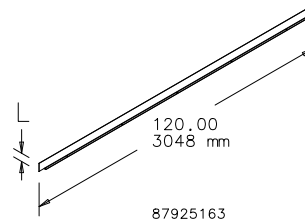

**TELESCOPIC STRAIGHT SECTION**



Adjusts from 18.74 in. to 30.61 in.

**BULLETIN: F23**

Catalog Number	AxB in.	AxB mm
CT22TSS	2.00 x 2.00	51 x 51
CT33TSS	3.00 x 3.00	76 x 76
CT44TSS	4.00 x 4.00	102 x 102
CT46TSS	4.00 x 6.00	102 x 152
CT66TSS	6.00 x 6.00	152 x 152

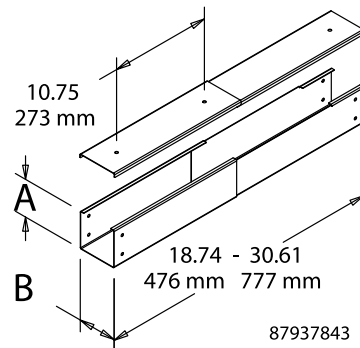

### DIVIDER, TELESCOPIC STRAIGHT SECTION

Must be trimmed to length.

BULLETIN: F23

Catalog Number	AxB in.	AxB mm
CT33TDPSS	3.00 x 3.00	76 x 76
CT44TDPSS	4.00 x 4.00	102 x 102
CT66TDPSS	6.00 x 6.00	152 x 152

### 90-DEGREE ELBOWS



Used wherever a 90-degree transition is required. Models without tabs connect directly to another elbow without using a splice.

BULLETIN: F23

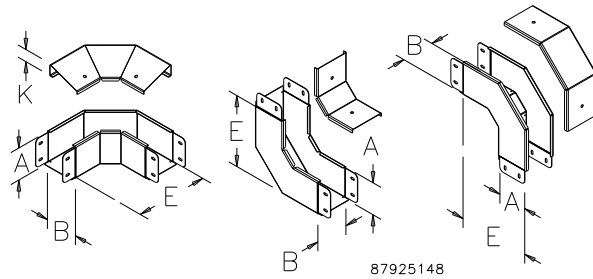

Catalog Number	AxB in.	AxB mm	Description	E (in.)	E (mm)	K (in.)	K (mm)
CT22EFC90SS	2.00 x 2.00	51 x 51	Front Cover	6.00	152	—	—
CT33EFC90SS	3.00 x 3.00	76 x 76	Front Cover	7.00	178	—	—
CT44EFC90SS	4.00 x 4.00	102 x 102	Front Cover	9.00	229	—	—
CT46EFC90SS	4.00 x 6.00	102 x 152	Front Cover	11.00	279	—	—
CT66EFC90SS	6.00 x 6.00	152 x 152	Front Cover	11.00	279	—	—
CT22EFCNT90SS	2.00 x 2.00	51 x 51	Front Cover without Tabs	6.00	152	—	—
CT33EFCNT90SS	3.00 x 3.00	76 x 76	Front Cover without Tabs	7.00	178	—	—
CT44EFCNT90SS	4.00 x 4.00	102 x 102	Front Cover without Tabs	9.00	229	1.42	36
CT46EFCNT90SS	4.00 x 6.00	102 x 152	Front Cover without Tabs	11.00	279	2.16	55
CT66EFCNT90SS	6.00 x 6.00	152 x 152	Front Cover without Tabs	11.00	279	2.16	55
CT22EIC90SS	2.00 x 2.00	51 x 51	Inside Cover	6.00	152	—	—
CT33EIC90SS	3.00 x 3.00	76 x 76	Inside Cover	7.00	178	—	—
CT44EIC90SS	4.00 x 4.00	102 x 102	Inside Cover	9.00	229	—	—
CT46EIC90SS	4.00 x 6.00	102 x 152	Inside Cover	11.00	279	—	—
CT66EIC90SS	6.00 x 6.00	152 x 152	Inside Cover	11.00	279	—	—
CT22EOC90SS	2.00 x 2.00	51 x 51	Outside Cover	6.00	152	—	—
CT33EOC90SS	3.00 x 3.00	76 x 76	Outside Cover	7.00	178	—	—
CT44EOC90SS	4.00 x 4.00	102 x 102	Outside Cover	9.00	229	—	—
CT46EOC90SS	4.00 x 6.00	102 x 152	Outside Cover	11.00	279	—	—
CT66EOC90SS	6.00 x 6.00	152 x 152	Outside Cover	11.00	279	—	—
CT22PEFC90SS	2.00 x 2.00	51 x 51	Front Cover Perforated	6.00	152	—	—
CT33PEFC90SS	3.00 x 3.00	76 x 76	Front Cover Perforated	7.00	178	—	—
CT44PEFC90SS	4.00 x 4.00	102 x 102	Front Cover Perforated	9.00	229	—	—
CT46PEFC90SS	4.00 x 5.00	102 x 127	Front Cover Perforated	11.00	279	—	—
CT66PEFC90SS	6.00 x 5.00	152 x 127	Front Cover Perforated	11.00	279	—	—
CTS33EFC90SS	3.00 x 3.00	76 x 76	Front Cover Sloped Inward	7.00	178	1.06	27
CTS44EFC90SS	4.00 x 4.00	102 x 102	Front Cover Sloped Inward	9.00	229	1.42	36
CTS46EFC90SS	4.00 x 6.00	102 x 152	Front Cover Sloped Inward	11.00	279	2.16	55
CTS66EFC90SS	6.00 x 6.00	152 x 152	Front Cover Sloped Inward	11.00	279	2.16	55
CTS33PEFC90SS	3.00 x 3.00	76 x 76	Front Cover Sloped Inward Perforated	7.00	178	1.06	27
CTS44PEFC90SS	4.00 x 4.00	102 x 102	Front Cover Sloped Inward Perforated	9.00	229	1.42	36
CTS46PEFC90SS	4.00 x 6.00	102 x 152	Front Cover Sloped Inward Perforated	11.00	279	2.16	55
CTS66PEFC90SS	6.00 x 6.00	152 x 152	Front Cover Sloped Inward Perforated	11.00	279	2.16	55

**90-DEGREE ELBOWS—PERFORATED WITHOUT TABS**



Used wherever a 90-degree transition is required.  
BULLETIN: F23

Catalog Number	AxB in.	AxB mm	E (in.)	E (mm)
CT22PEFCNT90SS	2.00 x 2.00	51 x 51	6.00	152
CT33PEFCNT90SS	3.00 x 3.00	76 x 76	7.00	178
CT44PEFCNT90SS	4.00 x 4.00	102 x 102	9.00	229
CT46PEFCNT90SS	4.00 x 6.00	102 x 152	11.00	279
CT66PEFCNT90SS	6.00 x 6.00	152 x 152	11.00	279

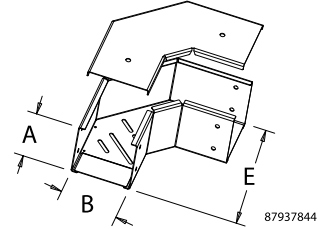

**90-DEGREE ELBOWS—FRONT COVER SLOPED INWARD WITHOUT TABS**



Used wherever a 90-degree transition is required.  
BULLETIN: F23

Catalog Number	AxB in./mm	E in./mm	K in./mm
CTS44EFCNT90SS	4.00 x 4.00	9.00	1.42
	102 x 102	229	36
CTS46EFCNT90SS	4.00 x 6.00	11.00	2.16
	102 x 152	279	55
CTS66EFCNT90SS	6.00 x 6.00	11.00	2.16
	152 x 152	279	55

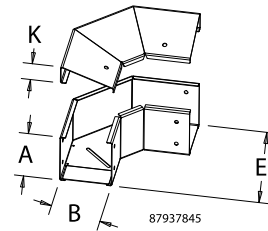

**90-DEGREE ELBOWS—FRONT COVER SLOPED OUTWARD WITH TABS**



Used wherever a 90-degree transition is required.  
BULLETIN: F23

Catalog Number	AxB in./mm	E in./mm	K in./mm
CTS44EFCO90SS	4.00 x 4.00	9.00	1.42
	102 x 102	229	36
CTS46EFCO90SS	4.00 x 6.00	11.00	2.16
	102 x 152	279	55
CTS66EFCO90SS	6.00 x 6.00	11.00	2.16
	152 x 152	279	55

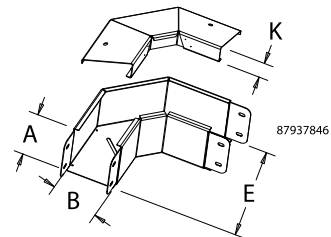

**90-DEGREE ELBOWS—FRONT COVER SLOPED OUTWARD WITHOUT TABS**

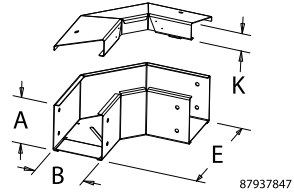

Used wherever a 90-degree transition is required.  
**BULLETIN: F23**

Catalog Number	AxB in./mm	E in./mm	K in./mm
CTS44EFCONT90SS	4.00 x 4.00 102 x 102	9.00 229	1.42 36
CTS46EFCONT90SS	4.00 x 6.00 102 x 152	11.00 279	2.16 55
CTS66EFCONT90SS	6.00 x 6.00 152 x 152	11.00 279	2.16 55

**90-DEGREE ELBOWS—INSIDE COVER SLOPED**

Used wherever a 90-degree transition is required.  
**BULLETIN: F23**

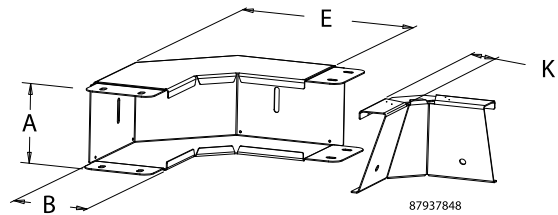
Catalog Number	AxB in./mm	E in./mm	K in./mm
CTS44EIC90SS	4.00 x 4.00 102 x 102	9.00 229	1.42 36
CTS46EIC90SS	4.00 x 6.00 102 x 152	11.00 279	2.16 55
CTS66EIC90SS	6.00 x 6.00 152 x 152	11.00 279	2.16 55

**90-DEGREE ELBOWS—OUTSIDE COVER SLOPED**

Used wherever a 90-degree transition is required.  
**BULLETIN: F23**

Catalog Number	AxB in./mm	E in./mm	K in./mm
CTS44EOC90SS	4.00 x 4.00 102 x 102	9.00 229	1.42 36
CTS46EOC90SS	4.00 x 6.00 102 x 152	11.00 279	2.16 55

Catalog Number	AxB in./mm	E in./mm	K in./mm
CTS66EOC90SS	6.00 x 6.00 152 x 152	11.00 279	2.16 55

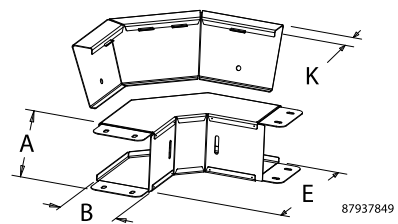



**45-DEGREE ELBOWS**

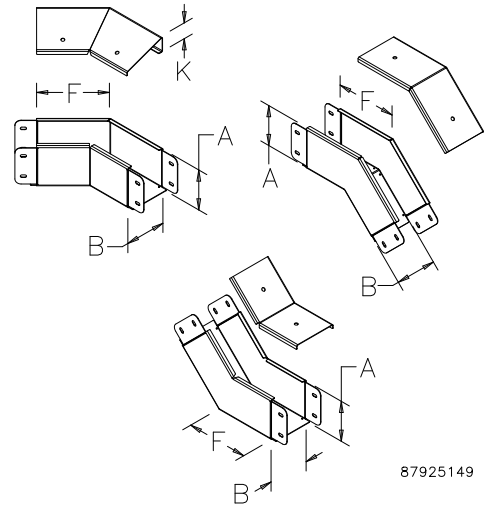
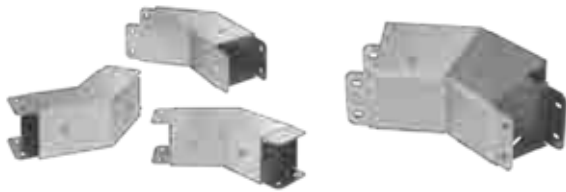

Used wherever a 45-degree transition is required.

BULLETIN: F23

87925149

Catalog Number	AxB in.	AxB mm	Description	F (in.)	F (mm)	K (in.)	K (mm)
CT22EFC45SS	2.00 x 2.00	51 x 51	Front Cover	4.57	116	—	—
CT33EFC45SS	3.00 x 3.00	76 x 76	Front Cover	4.98	127	—	—
CT44EFC45SS	4.00 x 4.00	102 x 102	Front Cover	5.96	151	—	—
CT46EFC45SS	4.00 x 6.00	102 x 152	Front Cover	6.79	173	—	—
CT66EFC45SS	6.00 x 6.00	152 x 152	Front Cover	6.79	173	—	—
CT22EIC45SS	2.00 x 2.00	51 x 51	Inside Cover	4.57	116	—	—
CT33EIC45SS	3.00 x 3.00	76 x 76	Inside Cover	4.98	127	—	—
CT44EIC45SS	4.00 x 4.00	102 x 102	Inside Cover	5.96	151	—	—
CT46EIC45SS	4.00 x 6.00	102 x 152	Inside Cover	6.79	173	—	—
CT66EIC45SS	6.00 x 6.00	152 x 152	Inside Cover	6.79	173	—	—
CT22EOC45SS	2.00 x 2.00	51 x 51	Outside Cover	4.57	116	—	—
CT33EOC45SS	3.00 x 3.00	76 x 76	Outside Cover	4.98	127	—	—
CT44EOC45SS	4.00 x 4.00	102 x 102	Outside Cover	5.96	151	—	—
CT46EOC45SS	4.00 x 6.00	102 x 152	Outside Cover	6.79	173	—	—
CT66EOC45SS	6.00 x 6.00	152 x 152	Outside Cover	6.79	173	—	—
CT22PEFC45SS	2.00 x 2.00	51 x 51	Front Cover Perforated	4/57	116	—	—
CT33PEFC45SS	3.00 x 3.00	76 x 76	Front Cover Perforated	4.98	127	—	—
CT44PEFC45SS	4.00 x 4.00	102 x 102	Front Cover Perforated	5.96	151	—	—
CT46PEFC45SS	4.00 x 6.00	102 x 152	Front Cover Perforated	6.79	173	—	—
CT66PEFC45SS	6.00 x 6.00	152 x 152	Front Cover Perforated	6.79	173	—	—
CTS33EFC45SS	3.00 x 3.00	76 x 76	Front Cover Sloped	4.98	127	1.06	27
CTS44EFC45SS	4.00 x 4.00	102 x 102	Front Cover Sloped	5.96	151	1.42	36
CTS46EFC45SS	4.00 x 6.00	102 x 152	Front Cover Sloped	6.79	173	2.16	55
CTS66EFC45SS	6.00 x 6.00	152 x 152	Front Cover Sloped	6.79	173	2.16	55
CTS33PEFC45SS	3.00 x 3.00	76 x 76	Front Cover Sloped Perforated	4.98	127	1.06	27
CTS44PEFC45SS	4.00 x 4.00	102 x 102	Front Cover Sloped Perforated	5.96	151	1.42	36
CTS46PEFC45SS	4.00 x 6.00	102 x 152	Front Cover Sloped Perforated	6.79	173	2.16	55
CTS66PEFC45SS	6.00 x 6.00	152 x 152	Front Cover Sloped Perforated	6.79	173	2.16	55



**45-DEGREE ELBOWS—FRONT COVER SLOPED OUTWARD**



Used wherever a 45-degree transition is required.  
BULLETIN: F23

Catalog Number	AxB in./mm	F in./mm	K in./mm
CTS44EFC045SS	4.00 x 4.00 102 x 102	5.96 151	1.42 36
CTS46EFC045SS	4.00 x 6.00 102 x 152	6.79 173	2.16 55
CTS66EFC045SS	6.00 x 6.00 152 x 152	6.79 173	2.16 55

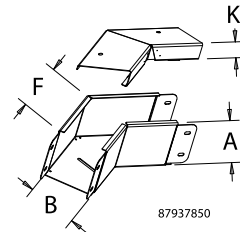

**45-DEGREE ELBOWS—INSIDE COVER SLOPED**



Used wherever a 45-degree transition is required.  
BULLETIN: F23

Catalog Number	AxB in./mm	F in./mm	K in./mm
CTS44EIC45SS	4.00 x 4.00 102 x 102	5.96 151	1.42 36
CTS46EIC45SS	4.00 x 6.00 102 x 152	6.79 173	2.16 55
CTS66EIC45SS	6.00 x 6.00 152 x 152	6.79 173	2.16 55

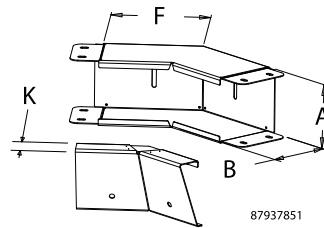

**45-DEGREE ELBOWS—OUTSIDE COVER SLOPED**



Used wherever a 45-degree transition is required.  
BULLETIN: F23

Catalog Number	AxB in./mm	F in./mm	K in./mm
CTS44E0C45SS	4.00 x 4.00 102 x 102	5.96 151	1.42 36
CTS46E0C45SS	4.00 x 6.00 102 x 152	6.79 173	2.16 55
CTS66E0C45SS	6.00 x 6.00 152 x 152	6.79 173	2.16 55

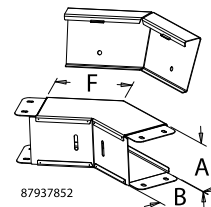

**VARIABLE-ANGLE ELBOW FITTING**



Adjustable from 0 to 90 degrees. Simplifies and saves field integration and installation time.

BULLETIN: F23

Catalog Number	AxB in.	AxB mm
CT22VSS	2.00 x 2.00	51 x 51
CT33VSS	3.00 x 3.00	76 x 76
CT44VSS	4.00 x 4.00	102 x 102
CT46VSS	4.00 x 6.00	102 x 152
CT66VSS	6.00 x 6.00	152 x 152

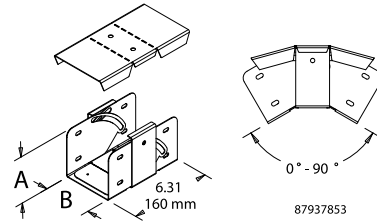

**90-DEGREE TEE**

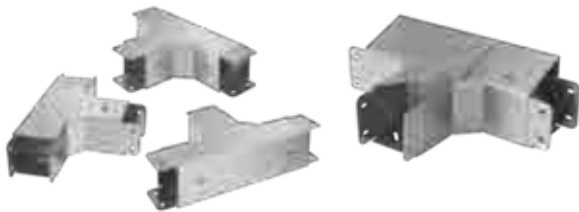

Available with or without perforations in three cover options: front, inside and outside. Used wherever two 90-degree transitions are required. Available with a 20-degree sloped cover in some sizes (Front Cover only).

BULLETIN: F23

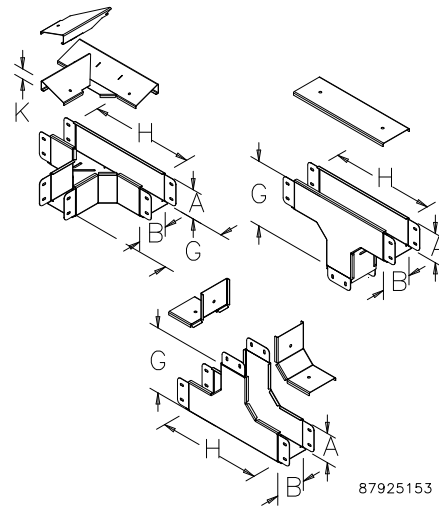

Catalog Number	AxB in.	AxB mm	Description	G (in.)	G (mm)	H (in.)	H (mm)	K (in.)	K (mm)
CT22TFCSS	2.00 x 2.00	51 x 51	Front Cover	3.00	152	10.00	254	—	—
CT33TFCSS	3.00 x 3.00	76 x 76	Front Cover	9.00	229	14.00	356	—	—
CT44TFCSS	4.00 x 4.00	102 x 102	Front Cover	7.00	178	11.00	279	—	—
CT46TFCSS	4.00 x 6.00	102 x 152	Front Cover	11.00	279	16.00	406	—	—
CT66TFCSS	6.00 x 6.00	152 x 152	Front Cover	11.00	279	16.00	406	—	—
CT33TICSS	3.00 x 3.00	76 x 76	Inside Cover	7.00	178	11.00	279	—	—
CT44TICSS	4.00 x 4.00	102 x 102	Inside Cover	9.00	229	14.00	356	—	—
CT46TICSS	4.00 x 6.00	102 x 152	Inside Cover	11.00	279	16.00	406	—	—
CT66TICSS	6.00 x 6.00	152 x 152	Inside Cover	11.00	279	16.00	406	—	—
CT22TOCSS	2.00 x 2.00	51 x 51	Outside Cover	6.00	152	10.00	254	—	—
CT33TOCSS	3.00 x 3.00	76 x 76	Outside Cover	7.00	178	11.00	279	—	—
CT44TOCSS	4.00 x 4.00	102 x 102	Outside Cover	9.00	229	14.00	356	—	—
CT46TOCSS	4.00 x 6.00	102 x 152	Outside Cover	11.00	279	16.00	406	—	—
CT66TOCSS	6.00 x 6.00	152 x 152	Outside Cover	11.00	279	16.00	406	—	—
CT22PTFCSS	2.00 x 2.00	51 x 51	Front Cover Perforated	6.00	152	10.00	254	—	—
CT33PTFCSS	3.00 x 3.00	76 x 76	Front Cover Perforated	7.00	178	11.00	279	—	—
CT44PTFCSS	4.00 x 4.00	102 x 102	Front Cover Perforated	9.00	229	14.00	356	—	—
CT46PTFCSS	4.00 x 6.00	102 x 152	Front Cover Perforated	11.00	279	16.00	406	—	—
CT66PTFCSS	6.00 x 6.00	152 x 152	Front Cover Perforated	11.00	279	16.00	406	—	—
CTS33TFCSS	3.00 x 3.00	76 x 76	Front Cover Sloped	7.00	178	11.00	279	1.06	27
CTS44TFCSS	4.00 x 4.00	102 x 102	Front Cover Sloped	9.00	229	14.00	356	1.42	36
CTS46TFCSS	4.00 x 6.00	102 x 152	Front Cover Sloped	11.00	279	16.00	406	2.16	55
CTS66TFCSS	6.00 x 6.00	152 x 152	Front Cover Sloped	11.00	279	16.00	406	2.16	55
CTS33PTFCSS	3.00 x 3.00	76 x 76	Front Cover Sloped Perforated	7.00	178	11.00	279	1.06	27
CTS44PTFCSS	4.00 x 4.00	102 x 102	Front Cover Sloped Perforated	9.00	229	14.00	356	1.42	36
CTS46PTFCSS	4.00 x 6.00	102 x 152	Front Cover Sloped Perforated	11.00	279	16.00	406	2.16	55
CTS66PTFCSS	6.00 x 6.00	152 x 152	Front Cover Sloped Perforated	11.00	279	16.00	406	2.16	55



**90-DEGREE TEE—FRONT COVER SLOPED OUTWARD**

Used wherever two 90-degree transitions are required.

BULLETIN: F23

Catalog Number	AxB in.	AxB mm	K (in.)	K (mm)
CTS44TFCOSS	4.00 x 4.00	102 x 102	1.42	36
CTS46TFCOSS	4.00 x 6.00	102 x 152	2.16	55
CTS66TFCOSS	6.00 x 6.00	152 x 152	2.16	55

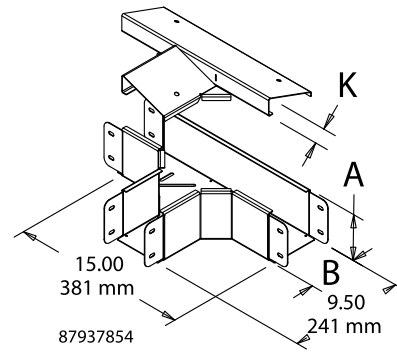
**90-DEGREE TEE—INSIDE COVER SLOPED**

Used wherever two 90-degree transitions are required.

BULLETIN: F23

Catalog Number	AxB in.	AxB mm	K (in.)	K (mm)
CTS44TICSS	4.00 x 4.00	102 x 102	1.42	36
CTS46TICSS	4.00 x 6.00	102 x 152	2.16	55
CTS66TICSS	6.00 x 6.00	152 x 152	2.16	55

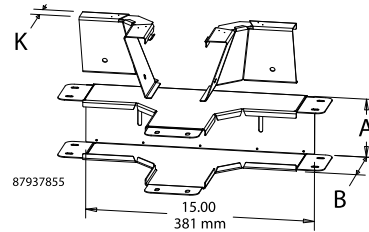
**90-DEGREE TEE—OUTSIDE COVER SLOPED**



Used wherever two 90-degree transitions are required.

BULLETIN: F23

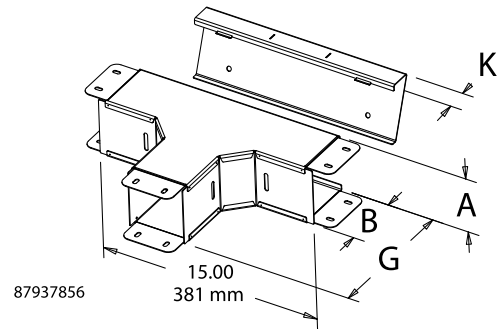
Catalog Number	AxB in.	AxB mm	G (in.)	G (mm)	K (in.)	K (mm)
CTS44TOCSS	4.00 x 4.00	102 x 102	9.00	229	1.42	36
CTS46TOCSS	4.00 x 6.00	102 x 152	11.00	279	2.16	55
CTS66TOCSS	6.00 x 6.00	152 x 152	11.00	279	2.16	55

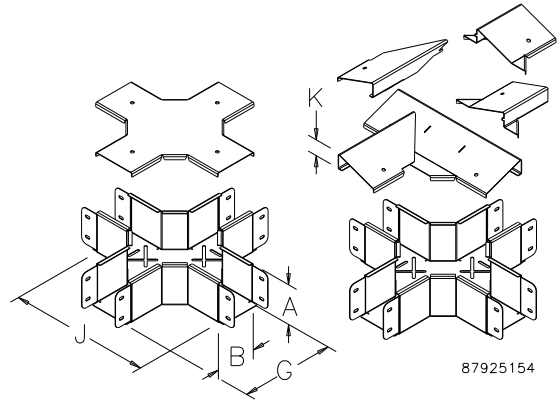
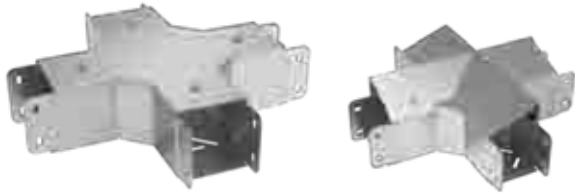

**CROSS**



87925154

Available with or without perforations. Used where there are four branches. Available with 20-degree sloped cover in some sizes. Kit includes both left and right sloped covers to create any configuration.

BULLETIN: F23

Catalog Number	AxB in.	AxB mm	Description	G (in.)	G (mm)	J (in.)	J (mm)	K (in.)	K (mm)
CT22CSS	2.00 x 2.00	51 x 51	Standard	6.00	152	10	254	—	—
CT33CSS	3.00 x 3.00	76 x 76	Standard	7.00	178	11.00	279	—	—
CT44CSS	4.00 x 4.00	102 x 102	Standard	9.00	229	14.00	356	—	—
CT46CSS	4.00 x 6.00	102 x 152	Standard	11.00	279	16.00	406	—	—
CT66CSS	6.00 x 6.00	152 x 152	Standard	11.00	279	16.00	406	—	—
CT22PCSS	2.00 x 2.00	51 x 51	Perforated	6.00	152	10.00	254	—	—
CT33PCSS	3.00 x 3.00	76 x 76	Perforated	7.00	178	11.00	279	—	—
CT44PCSS	4.00 x 4.00	102 x 102	Perforated	9.00	229	14.00	356	—	—
CT46PCSS	4.00 x 6.00	102 x 152	Perforated	11.00	279	16.00	406	—	—
CT66PCSS	6.00 x 6.00	152 x 152	Perforated	11.00	279	16.00	406	—	—
CTS33CSS	3.00 x 3.00	76 x 76	Sloped Top	7.00	178	11.00	279	1.06	27
CTS44CSS	4.00 x 4.00	102 x 102	Sloped Top	9.00	229	14.00	356	1.42	36
CTS46CSS	4.00 x 6.00	102 x 152	Sloped Top	11.00	279	16.00	406	2.16	55
CTS66CSS	6.00 x 6.00	152 x 152	Sloped Top	11.00	279	16.00	406	2.16	55
CTS33PCSS	3.00 x 3.00	76 x 76	Sloped Top Perforated	7.00	178	11.00	279	1.06	27
CTS44PCSS	4.00 x 4.00	102 x 102	Sloped Top Perforated	9.00	229	14.00	356	1.42	36
CTS46PCSS	4.00 x 6.00	102 x 152	Sloped Top Perforated	11.00	279	16.00	406	2.16	55
CTS66PCSS	6.00 x 6.00	152 x 152	Sloped Top Perforated	11.00	279	16.00	406	2.16	55

**DIVIDER 90-DEGREE TEE**



Catalog Number	AxB in.	AxB mm	Fits Cable Tray Size	Description	L (in.)	L (mm)
CT33DTCSS	3.00 x 3.00	76 x 76	3 x 3	Front Cover	2.13	54
CT44DTCSS	4.00 x 4.00	102 x 102	4 x 4	Front Cover	3.13	79
CT46DTCSS	4.00 x 6.00	102 x 152	4 x 6	Front Cover	3.13	79
CT66DTCSS	6.00 x 6.00	152 x 152	6 x 6	Front Cover	5.13	130
CT33DTICSS	3.00 x 3.00	76 x 76	3 x 3	Inside Cover	2.13	54
CT44DTICSS	4.00 x 4.00	102 x 102	4 x 4	Inside Cover	3.13	79
CT66DTICSS	6.00 x 6.00	152 x 152	6 x 6	Inside Cover	5.13	130
CT33DTCSS	3.00 x 3.00	76 x 76	3 x 3	Outside Cover	2.13	54
CT44DTCSS	4.00 x 4.00	102 x 102	4 x 4	Outside Cover	3.13	79
CT66DTCSS	6.00 x 6.00	152 x 152	6 x 6	Outside Cover	5.13	130

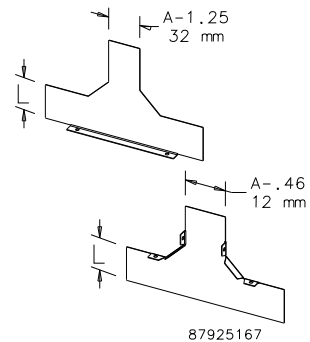

87925167

Used to divide a 90-degree tee into two sections.

BULLETIN: F23



### DIVIDER 90-DEGREE ELBOW



Used to divide a 90-degree elbow into two sections.  
BULLETIN: F23

Catalog Number	AxB in.	AxB mm	Description	Fits Cable Tray Size	L (in.)	L (mm)
CT33DEFC90SS	3.00 x 3.00	76 x 76	Front Cover	3 x 3	2.13	54
CT44DEFC90SS	4.00 x 4.00	102 x 102	Front Cover	4 x 4	3.13	79
CT46DEFC90SS	4.00 x 6.00	102 x 152	Front Cover	4 x 6	3.13	79
CT66DEFC90SS	6.00 x 6.00	152 x 152	Front Cover	6 x 6	5.13	130
CT33DEIC90SS	3.00 x 3.00	76 x 76	Inside Cover	3 x 3	2.13	54
CT44DEIC90SS	4.00 x 4.00	102 x 102	Inside Cover	4 x 4, 4 x 6	3.13	79
CT66DEIC90SS	6.00 x 6.00	152 x 152	Inside Cover	6 x 6	5.13	130
CT33DEOC90SS	3.00 x 3.00	76 x 76	Outside Cover	3 x 3	2.13	54
CT44DEOC90SS	4.00 x 4.00	102 x 102	Outside Cover	4 x 4, 4 x 6	3.13	79
CT66DEOC90SS	6.00 x 6.00	152 x 152	Outside Cover	6 x 6	5.13	130

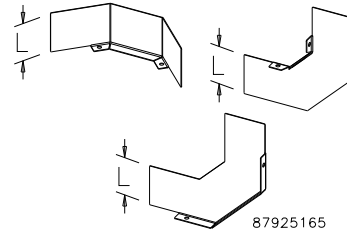

### DIVIDER 45-DEGREE ELBOW



Used to divide a 45-degree elbow into two sections.  
BULLETIN: F23

Catalog Number	AxB in.	AxB mm	Description	Fits Cable Tray Size	L (in.)	L (mm)
CT33DEFC45SS	3.00 x 3.00	76 x 76	Front Cover	3 x 3	2.13	54
CT44DEFC45SS	4.00 x 4.00	102 x 102	Front Cover	4 x 4	3.13	79
CT46DEFC45SS	4.00 x 6.00	102 x 152	Front Cover	4 x 6	3.13	79
CT66DEFC45SS	6.00 x 6.00	152 x 152	Front Cover	6 x 6	5.13	130
CT33DEIC45SS	3.00 x 3.00	76 x 76	Inside Cover	3 x 3	2.13	54
CT44DEIC45SS	4.00 x 4.00	102 x 102	Inside Cover	4 x 4, 4 x 6	3.13	79
CT66DEIC45SS	6.00 x 6.00	152 x 152	Inside Cover	6 x 6	5.13	130
CT33DEOC45SS	3.00 x 3.00	76 x 76	Outside Cover	3 x 3	2.13	54
CT44DEOC45SS	4.00 x 4.00	102 x 102	Outside Cover	4 x 4, 4 x 6	3.13	79
CT66DEOC45SS	6.00 x 6.00	152 x 152	Outside Cover	6 x 6	5.13	130

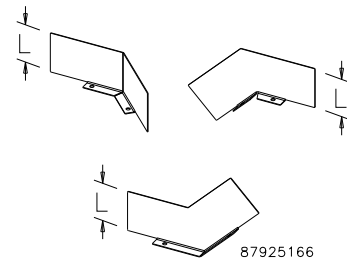

### U-CONNECTOR



Used to connect two straight sections.  
BULLETIN: F23

Catalog Number	AxB in./mm
CT22UCSS	2.00 x 2.00 51 x 51
CT33UCSS	3.00 x 3.00 76 x 76
CT44UCSS	4.00 x 4.00 102 x 102
CT46UCSS	4.00 x 6.00 102 x 152
CT66UCSS	6.00 x 6.00 152 x 152

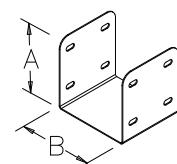

87925155

**CLOSURE PLATE**



Closes the end of a cable tray section or run. Available with 20-degree slope in some sizes (left slope shown).

BULLETIN: F23

Catalog Number	AxB in.	AxB mm	Description	K (in.)	K (mm)
CT22CPSS	2.00 x 2.00	51 x 51	Standard	—	—
CT33CPSS	3.00 x 3.00	76 x 76	Standard	—	—
CT44CPSS	4.00 x 4.00	102 x 102	Standard	—	—
CT46CPSS	4.00 x 6.00	102 x 152	Standard	—	—
CT66CPSS	6.00 x 6.00	152 x 152	Standard	—	—
CTS33CPRSS	3.00 x 3.00	76 x 76	Sloped Right	1.06	27
CTS33CPLSS	3.00 x 3.00	76 x 76	Sloped Left	1.06	27
CTS44CPRSS	4.00 x 4.00	102 x 102	Sloped Right	1.42	36
CTS44CPLSS	4.00 x 4.00	102 x 102	Sloped Left	1.42	36
CTS46CPRSS	4.00 x 6.00	102 x 152	Sloped Right	2.16	55
CTS46CPLSS	4.00 x 6.00	102 x 152	Sloped Left	2.16	55
CTS66CPRSS	6.00 x 6.00	152 x 152	Sloped Right	2.16	55
CTS66CPLSS	6.00 x 6.00	152 x 152	Sloped Left	2.16	55

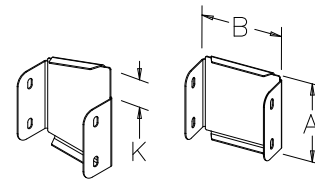

87925156

**ENCLOSURE ADAPTER**



Allows the cable tray to be securely connected to an enclosure.

BULLETIN: F23

Catalog Number	AxB in./mm
CT22AESS	2.00 x 2.00 51 x 51
CT33AESS	3.00 x 3.00 76 x 76
CT44AESS	4.00 x 4.00 102 x 102
CT46AESS	4.00 x 6.00 102 x 152
CT66AESS	6.00 x 6.00 152 x 152

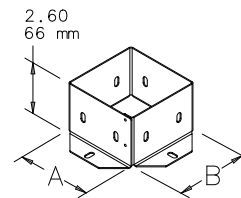

87925157



**REDUCER**

Used to reduce to a smaller size cable tray. Available with 20-degree slope in some sizes (right slope shown).

**BULLETIN: F23**

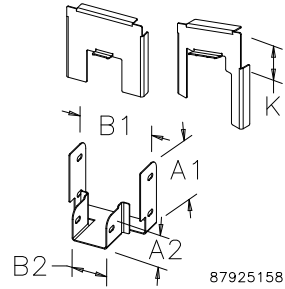

87925158

Catalog Number	AxB in.	AxB mm	Description	A2 (in.)	A2 (mm)	B2 (in.)	B2 (mm)	K (in.)	K (mm)
CT3322RSS	3.00 x 3.00	76 x 76	3 x 3 2 x 2 Standard	2.00	51	2.00	51	—	—
CT4433RSS	4.00 x 4.00	102 x 102	4 x 4 3 x 3 Standard	3.00	76	3.00	76	—	—
CT4422RSS	4.00 x 4.00	102 x 102	4 x 4 2 x 2 Standard	2.00	51	2.00	51	—	—
CT4644RSS	4.00 x 6.00	102 x 152	4 x 6 4 x 4 Standard	4.00	102	4.00	102	—	—
CT4633RSS	4.00 x 6.00	102 x 152	4 x 6 3 x 3 Standard	3.00	76	3.00	76	—	—
CT6622RSS	6.00 x 6.00	152 x 152	6 x 6 2 x 2 Standard	2.00	51	2.00	51	—	—
CT6646RSS	6.00 x 6.00	152 x 152	6 x 6 4 x 6 Standard	4.00	102	6.00	152	—	—
CT6644RSS	6.00 x 6.00	152 x 152	6 x 6 4 x 4 Standard	4.00	102	4.00	102	—	—
CT6633RSS	6.00 x 6.00	152 x 152	6 x 6 3 x 3 Standard	3.00	76	3.00	76	—	—
CTS4433RRSS	4.00 x 4.00	102 x 102	4 x 4 3 x 3 Sloped Right	3.00	76	3.00	76	1.42	36
CTS4433RLSS	4.00 x 4.00	102 x 102	4 x 4 3 x 3 Sloped Left	3.00	76	3.00	76	1.42	36
CTS4644RRSS	4.00 x 6.00	102 x 152	4 x 6 4 x 4 Sloped Right	4.00	102	4.00	102	2.16	55
CTS4644RLSS	4.00 x 6.00	102 x 152	4 x 6 4 x 4 Sloped Left	4.00	102	4.00	102	2.16	55
CTS4633RRSS	4.00 x 6.00	102 x 152	4 x 6 3 x 3 Sloped Right	3.00	76	3.00	76	2.16	55
CTS4633RLSS	4.00 x 6.00	102 x 152	4 x 6 3 x 3 Sloped Left	3.00	76	3.00	76	2.16	55
CTS6646RRSS	6.00 x 6.00	152 x 152	6 x 6 4 x 6 Sloped Right	4.00	102	6.00	152	2.16	55
CTS6646RLSS	6.00 x 6.00	152 x 152	6 x 6 4 x 6 Sloped Left	4.00	102	6.00	152	2.16	55
CTS6644RRSS	6.00 x 6.00	152 x 152	6 x 6 4 x 4 Sloped Right	4.00	102	4.00	102	2.16	55
CTS6644RLSS	6.00 x 6.00	152 x 152	6 x 6 4 x 4 Sloped Left	4.00	102	4.00	102	2.16	55
CTS6633RRSS	6.00 x 6.00	152 x 152	6 x 6 3 x 3 Sloped Right	3.00	76	3.00	76	2.16	55
CTS6633RLSS	6.00 x 6.00	152 x 152	6 x 6 3 x 3 Sloped Left	3.00	76	3.00	76	2.16	55

**CABLE EXIT COVER**

Catalog Number	T in./mm
CT2233CEC	1.50 38
CT4466CEC	3.00 76

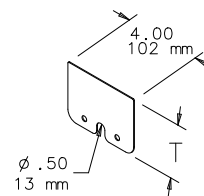

87925159

Covers cables that exit the side of the cable tray. Will cover a keyhole or slot used to pass the cable through.

**BULLETIN: F23**



**STRAIGHT SECTION SPLICE**

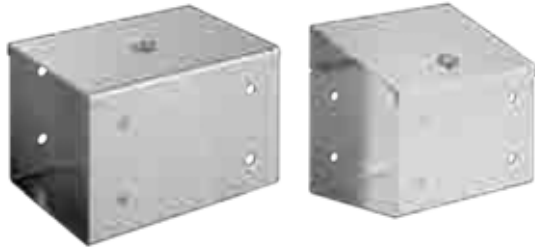

Used to connect two fittings with tabs. Available with 20-degree slope in some sizes.

BULLETIN: F23

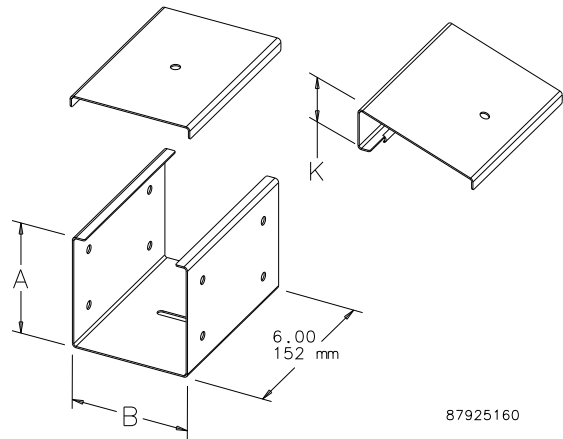

87925160

Catalog Number	AxB in.	AxB mm	Description	K (in.)	K (mm)
CT22SPSS	2.00 x 2.00	51 x 51	Standard	—	—
CT33SPSS	3.00 x 3.00	76 x 76	Standard	—	—
CT44SPSS	4.00 x 4.00	102 x 102	Standard	—	—
CT46SPSS	4.00 x 6.00	102 x 152	Standard	—	—
CT66SPSS	6.00 x 6.00	152 x 152	Standard	—	—
CT22PSPSS	2.00 x 2.00	51 x 51	Perforated	—	—
CT33PSPSS	3.00 x 3.00	76 x 76	Perforated	—	—
CT44PSPSS	4.00 x 4.00	102 x 102	Perforated	—	—
CT46PSPSS	4.00 x 6.00	102 x 152	Perforated	—	—
CT66PSPSS	6.00 x 6.00	152 x 152	Perforated	—	—
CTS33SPSS	3.00 x 3.00	76 x 76	Sloped Top	1.06	27
CTS44SPSS	4.00 x 4.00	102 x 102	Sloped Top	1.42	36
CTS46SPSS	4.00 x 6.00	102 x 152	Sloped Top	2.16	55
CTS66SPSS	6.00 x 6.00	152 x 152	Sloped Top	2.16	55
CTS33PSPSS	3.00 x 3.00	76 x 76	Sloped Top Perforated	1.06	27
CTS44PSPSS	4.00 x 4.00	102 x 102	Sloped Top Perforated	1.42	36
CTS46PSPSS	4.00 x 6.00	102 x 152	Sloped Top Perforated	2.16	55
CTS66PSPSS	6.00 x 6.00	152 x 152	Sloped Top Perforated	2.16	55

**DIVIDER STRAIGHT SECTION SPLICE**



Used to divide a straight section splice into two sections.

BULLETIN: F23

Catalog Number	AxB in./mm	Fits Cable Tray Size	L in./mm
CT33DSPSS	3.00 x 3.00	3 x 3	2.13
	76 x 76		54
CT44DSPSS	4.00 x 4.00	4 x 4, 4 x 6	3.13
	102 x 102		79
CT66DSPSS	6.00 x 6.00	6 x 6	5.13
	152 x 152		130

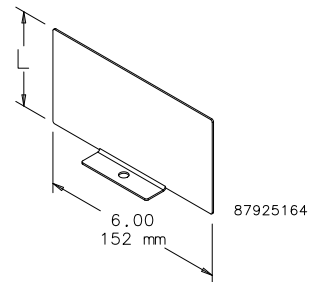

87925164



**TRANSITION COVER**



Transitions from a sloped to standard cable tray. Available with right- and left-hand slope. Will fit the Splice (order separately) or anywhere on a straight section (transition cover sloped to flat left-hand shown in drawing).

BULLETIN: F23

Catalog Number	Description	Fits Cable Tray Size	B in./mm	K in./mm
CTS33TCRSS	Transition Cover Sloped to Flat Right Hand	3 x 3	3.00 76	1.06 27
CTS33TCLSS	Transition Cover Sloped to Flat Left Hand	3 x 3	3.00 76	1.06 27
CTS44TCRSS	Transition Cover Sloped to Flat Right Hand	4 x 4	4.00 102	1.42 36
CTS44TCLSS	Transition Cover Sloped to Flat Left Hand	4 x 4	4.00 102	1.42 36
CTS46TCRSS	Transition Cover Sloped to Flat Right Hand	4 x 6, 6 x 6	6.00 152	2.16 55
CTS46TCLSS	Transition Cover Sloped to Flat Left Hand	4 x 6, 6 x 6	6.00 152	2.16 55

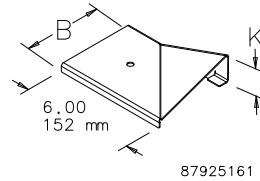

87925161

**SIDE COUPLING**

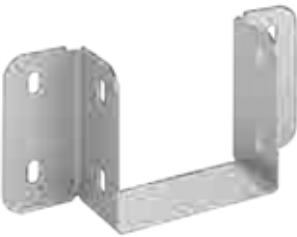

Used to connect straight sections or fittings to the side of a cable tray run. A cutout will be required in the side of the cable tray.

BULLETIN: F23

Catalog Number	AxB in.	AxB mm
CT22SCSS	2.00 x 2.00	51 x 51
CT33SCSS	3.00 x 3.00	76 x 76
CT44SCSS	4.00 x 4.00	102 x 102
CT46SCSS	4.00 x 6.00	102 x 152
CT66SCSS	6.00 x 6.00	152 x 152

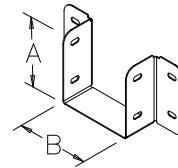

87925162

**FASTENER PACKAGE**

1/4-20 stainless steel fasteners used to connect cable tray components.

BULLETIN: F23

Catalog Number	Screws	Nuts
CT1420SS	100	100

### HANGER BRACKET

Used to support a cable tray run.

BULLETIN: F23

Catalog Number	AxB in./mm	M in./mm	Pkg. Qty.
CT22HB	2.00 x 2.00 51 x 51	3.58 91	20
CT33HB	3.00 x 3.00 76 x 76	4.58 116	20
CT44HB	4.00 x 4.00 102 x 102	5.58 142	20
CT66HB	6.00 x 6.00 152 x 152	7.58 193	20

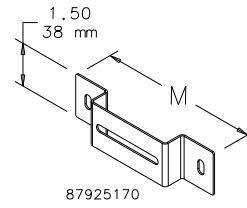

87925170

### L-BRACKET

Used to support a cable tray run. Can be mounted to a vertical UNISTRUT® channel.

UNISTRUT is a registered trademark of Unistrut Corporation.

BULLETIN: F23

Catalog Number	AxB in./mm	N in./mm	P in./mm	Pkg. Qty.
CT22LB	2.00 x 2.00 51 x 51	3.00 76	3.64 92	20
CT33LB	3.00 x 3.00 76 x 76	4.00 102	4.64 118	20
CT44LB	4.00 x 4.00 102 x 102	5.00 127	5.64 143	20
CT66LB	6.00 x 6.00 152 x 152	7.64 194	7.64 194	20

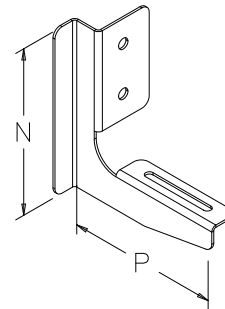

87925169

### WALL BRACKET

Used to support a cable tray run.

BULLETIN: F23

Catalog Number	AxB in./mm	R in./mm	S in./mm	Pkg. Qty.
CT22WB	2.00 x 2.00 51 x 51	1.55 39	2.25 57	20
CT33WB	3.00 x 3.00 76 x 76	2.55 65	3.25 83	20
CT44WB	4.00 x 4.00 102 x 102	3.55 90	4.25 108	20
CT66WB	6.00 x 6.00 152 x 152	5.55 141	6.25 159	20

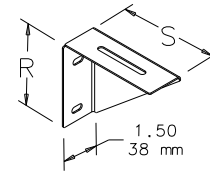

87925168

### LATCH HARDWARE KITS

BULLETIN: F23

Catalog Number	Use on (in.)	Use on (mm)
CTLCHSS	2.00 x 2.00, 4.00 x 6.00, 6.00 x 6.00	51 x 51, 102 x 152, 152 x 152
CTLCH3SS	3.00 x 3.00	76 x 76
CTLCH4SS	4.00 x 4.00	102 x 102
CTSLCHSS	Sloped	—





*Hoffman*<sup>®</sup>

# CHAPTER 10 CABLE RUNWAY SYSTEM/ BONDING AND GROUNDING

## OVERVIEW

Pentair's cable runway system provides a fast, flexible pathway solution for voice and data cabling and is also ideal for power and control cabling. These systems add field flexibility because all lengths are easily cut.

Standard bonding and grounding hardware is also available for telecommunication rooms and data center applications.

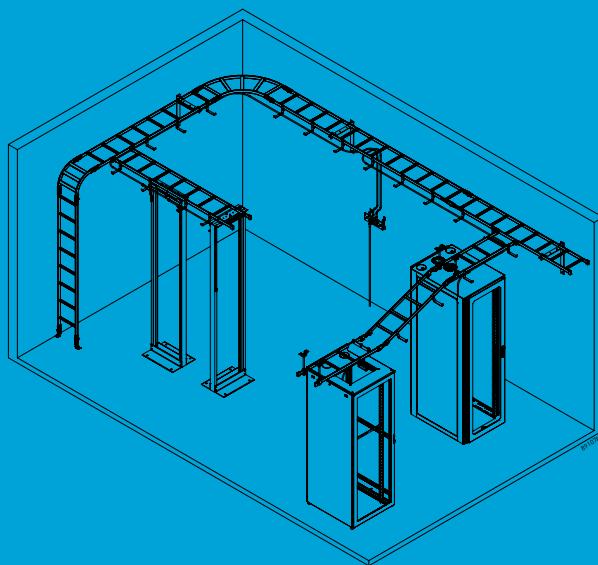

## LADDER RACK SYSTEM/ BONDING AND GROUNDING

The Ladder Rack System conveniently routes cables via a modular pathway through unused space on the floor, wall or ceiling while keeping cables accessible for easy maintenance. A variety of straight and curved sections are highly adaptable and can accommodate virtually any room layout.

These components meet open frame rack and cabinet bonding and grounding requirements for telecommunication room and data center applications.



### QUICK TRAY PRO™

The QUICK TRAY PRO™ cable tray routes cables through unused space while keeping them accessible for easy maintenance. Combine components to configure a system that meets application requirements.



## CHAPTER CONTENTS

### CABLE PATHWAY AND ACCESSORIES

Ladder Rack System	190
Ladder Rack Straight Sections (cULus Classified)	191
Ladder Rack Curved Sections (cULus Classified)	191
90-Degree Horizontal E-Bend Section (cULus Classified)	191
Butt-Splice Kit (cULus Classified)	191
Adjustable Butt-Splice Kit (cULus Classified)	191
Junction Splice Kit (cULus Classified)	192
Adjustable Junction Splice Kit (cULus Classified)	192
Retaining Post Kit	192
L-Bracket Kit	192
Radius Drop Kit	192
Stringer Radius Drop Kit	192
Ceiling Support Kit	193
Foot Kit	193
Rack-to-Runway Mounting Plate Kit	193
Vertical Wall Bracket	193
Triangle Support Bracket Kit	194
Modular Triangle Support Bracket Kit	194
Wall Angle Support	194
Corner Support Bracket Kit	194
End Cap Kit	195
Runway Termination Kit	195
Movable Cross Member	195
Rack-to-Wall Kit	195
Runway Elevation Kit	195
Runway Overhead 12-in. Stack Kit	196
Runway Center Support Kit	196
Spool Divider Kit	196
Insulated Ground Jumper Kit	196
J-Bolt Kit	197
CABLERACK™	197

### QUICK TRAY PRO™

Straight Section	198
Splice Kit	200
Splice Washer	200
Splice Bars	200
Trapeze Hanging Clip	201
C-Bracket	201
Center Hangers	201
L-Brackets	202
Reinforced Wall Bracket	202
Divider Strip	203
Side-Action Bolt Cutter	203
Vertical Down	203
Wall-Termination Bracket	204
Polymer Insert	204

### BONDING AND GROUNDING ACCESSORIES

Bonding and Grounding Overview	206
Lay-In Lug	207
Compression Lugs	207
Heavy-Duty C-Taps	207
Telecommunications Ground Bar Kits	208
Vertical Ground Bar Kits	208
Horizontal Ground Bar Kits	208
Insulated Ground Jumper Kit	209
Rack Jumper Kit	209

## LADDER RACK SYSTEM

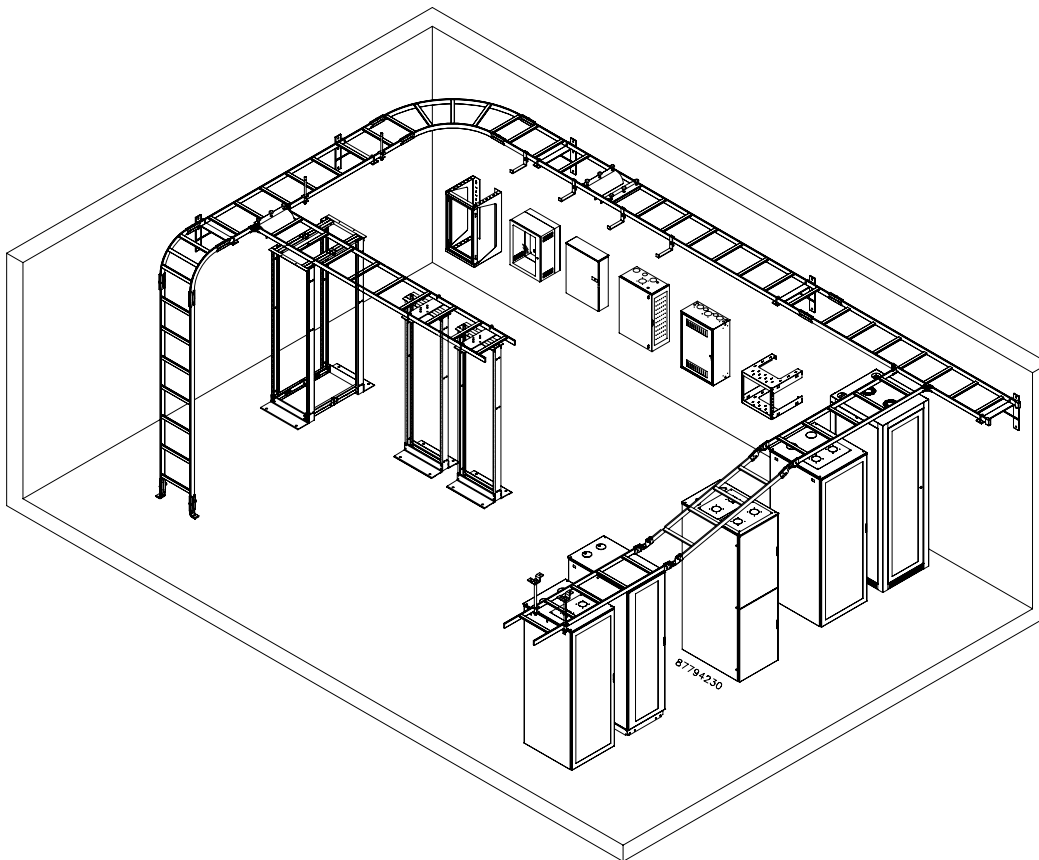

10

### INDUSTRY STANDARDS

#### Painted and Plated Straight Sections:

UL/cULus Classified for Equipment Grounding and Load; File No. E236414

#### Curved Sections and Splice Kits:

UL/cULus Classified for Equipment Grounding; File No. E236414

#### cULus Bonding & Grounding

- Classified as suitable for an equipment ground conductor
  - CSA C22.2 No. 126.1-02 Section 5.2.8 Load Destruction Test
- Two grounding jumper kits required per each splice kit on painted ladder rack sections

#### cULus Load Testing

- Load capacity per 10 support lengths is 369.2 lb.; safety factor of 1.5X
  - CSA C22.2 No. 126.1-02 Section 5.1 Electrical Continuity Test

### APPLICATION

The Ladder Rack System conveniently routes cables via a modular pathway through unused space on the floor, wall or ceiling while keeping cables accessible for easy maintenance. A variety of straight and curved sections are highly adaptable and can accommodate virtually any room layout.

### FEATURES

- Section cross members welded on 9-in. (229-mm) centers
- Accessory adjustable cross members
- Butt-splice kits and junction-splice kits
- Each model is boxed or bagged

### SPECIFICATIONS

- Straight and curved sections made of 1-1/2-in. steel
- Sections available in 6-, 12-, 18- and 24-in. (152-, 305-, 457- and 610-mm) widths
- Steel connecting and mounting hardware

### FINISH

Available in three finishes:

- ANSI 61 gray polyester powder paint
- RAL 9005 black polyester powder paint
- Plated

### ACCESSORIES

Touch-up Paint





### LADDER RACK STRAIGHT SECTIONS (CULUS CLASSIFIED)

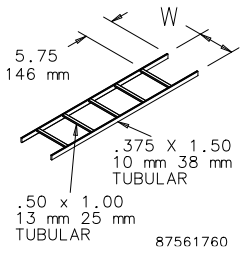

Supports cable on straight runs. Made of 1-1/2 in. x 3/8 in. (38 mm x 8 mm) 16 gauge tubular steel with a painted or plated finish. Nominal installed length is 10 ft. (3.05 m). Each section is 9 ft. 11-1/2 in. (3.03 m) long with cross members welded at 9-in. (229-mm) intervals.

**BULLETIN: DCR**

Catalog Number	AxB in.	AxB mm	Finish	W (in.)	W (mm)
LSS6G	0.00		Gray	6.00	152
LSS6BLK	6.00 x 120.00	152 x 3048	Black	6.00	152
LSS6GZ	0.00		Plated	6.00	152
LSS12G	0.00		Gray	12.00	305
LSS12BLK	0.00		Black	12.00	305
LSS12GZ	0.00		Plated	12.00	305
LSS18G	0.00		Gray	18.00	457
LSS18BLK	0.00		Black	18.00	457
LSS18GZ	18.00 x 120.00	457 x 3048	Plated	18.00	457
LSS24BLK	0.00		Black	24.00	610

### LADDER RACK CURVED SECTIONS (CULUS CLASSIFIED)

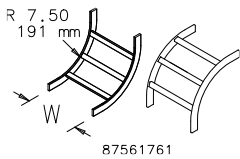

Provide a vertical change in direction. They are made of 1-1/2 in. x 3/8 in. (38 mm x 8 mm) tubular steel with a painted or plated finish. Cross members are welded on the inside (inside bends) or outside (outside bends) of the section. Connect to straight section with butt-splice kits. Designed for category 5e, 6, 6A and fiber optic cable.

**BULLETIN: DCR**

Catalog Number	Finish	Vertical Bend Type	W (in.)	W (mm)
LIB6G	Gray	Inside	6.00	152
LIB6BLK	Black	Inside	6.00	152
LIB6GZ	Plated	Inside	6.00	152
LIB12G	Gray	Inside	12.00	305
LIB12BLK	Black	Inside	12.00	305
LIB12GZ	Plated	Inside	12.00	305
LIB18G	Gray	Inside	18.00	457
LIB18BLK	Black	Inside	18.00	457
LIB18GZ	Plated	Inside	18.00	457
LIB24BLK	Black	Inside	24.00	610
LOB6G	Gray	Outside	6.00	152
LOB6BLK	Black	Outside	6.00	152
LOB6GZ	Plated	Outside	6.00	152
LOB12G	Gray	Outside	12.00	305
LOB12BLK	Black	Outside	12.00	305
LOB12GZ	Plated	Outside	12.00	305
LOB18G	Gray	Outside	18.00	457
LOB18BLK	Black	Outside	18.00	457
LOB18GZ	Plated	Outside	18.00	457
LOB24BLK	Black	Outside	24.00	610

### 90-DEGREE HORIZONTAL E-BEND SECTION (CULUS CLASSIFIED)

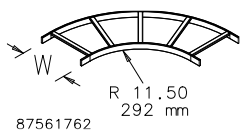

Provide a 90-degree horizontal change in cable runway direction. Made of 1-1/2 in. x 3/8 in. (38 mm x 8 mm) tubular steel with a painted or plated finish. Connect to straight sections with butt-splice kits. Designed for category 5e, 6, 6A and fiber optic cable.

**BULLETIN: DCR**

Catalog Number	Finish	W (in.)	W (mm)
L90HB12G	Gray	12.00	305
L90HB12BLK	Black	12.00	305
L90HB12GZ	Plated	12.00	305
L90HB18G	Gray	18.00	457
L90HB18BLK	Black	18.00	457
L90HB18GZ	Plated	18.00	457
L90HB24BLK	Black	24.00	610

### BUTT-SPLICE KIT (CULUS CLASSIFIED)

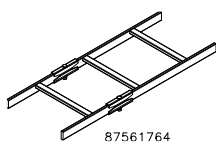

Joins straight ladder rack sections, inside and outside bends, and 90-degree horizontal e-bends. Each kit connects one section to another. Includes mounting hardware.

**BULLETIN: DCR**

Catalog Number	Finish	Kit Qty.
LBSKG	Gray	2
LBSKB	Black	2
LBSK	Plated	2

### ADJUSTABLE BUTT-SPLICE KIT (CULUS CLASSIFIED)

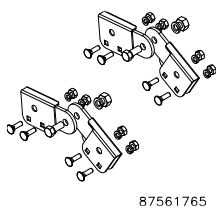

Provides a change in up-and-down direction of the cable runway. It can be adjusted to any angle from 0 to 90 degrees. Made of steel with a painted or plated finish. Each kit connects one ladder rack section to another. Includes mounting hardware.

**BULLETIN: DCR**

Catalog Number	Finish	Kit Qty.
LABSKG	Gray	2
LABSKB	Black	2
LABSK	Plated	2

### JUNCTION SPLICE KIT (CULUS CLASSIFIED)

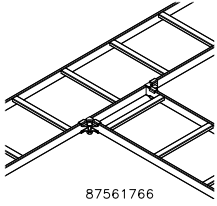

Connects two straight ladder rack sections at a 90-degree angle. Made of steel with a painted or plated finish. Each kit connects one section to another. Includes mounting hardware.

**BULLETIN: DCR**

Catalog Number	Finish	Kit Qty.
LJSKG	Gray	2
LJSKB	Black	2
LJSK	Plated	2

### ADJUSTABLE JUNCTION SPLICE KIT (CULUS CLASSIFIED)

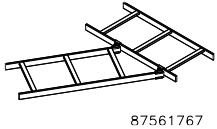

Connects two ladder rack sections at any junction angle. Made of steel with a painted or plated finish. Each kit connects one section to another. Includes mounting hardware.

**BULLETIN: DCR**

Catalog Number	Finish	Kit Qty.
LJASKG	Gray	2
LJASKB	Black	2
LJASK	Plated	2

### RETAINING POST KIT

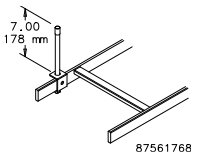

Provides extra ladder rack capacity. Mounts onto rack side stringer. Post is unthreaded 1/2-in. tube. Kit components are plated steel. Includes post cap and mounting hardware.

**BULLETIN: DCR**

Catalog Number	Finish	Kit Qty.
LRP	Plated	1
LRPB	Black	1

### L-BRACKET KIT

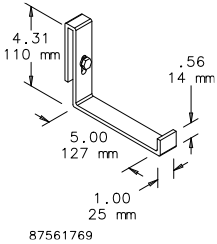

The L-Bracket Kit supports power or other cables that need to be separated from the main cable run. Made of steel with a painted or plated finish. Mounts onto ladder rack stringer. Includes mounting hardware.

**BULLETIN: DCR**

Catalog Number	Finish	Kit Qty.
LLBG	Gray	1
LLBB	Black	1
LLB	Plated	1

### RADIUS DROP KIT

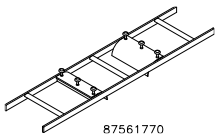

Mounts over ladder rack cross member to provide bending radius when dropping cable. Includes cable spools to separate cable and all mounting hardware. Made of extruded aluminum.

**BULLETIN: DCR**

Catalog Number	Finish	Cable Runway Width (in.)	Cable Runway Width (mm)	Kit Qty.
LRD6G	Gray	6.00	152	1
LRD6BLK	Black	6.00	152	1
LRD6GZ	Aluminum	6.00	152	1
LRD12G	Gray	12.00	305	1
LRD12BLK	Black	12.00	305	1
LRD12GZ	Aluminum	12.00	305	1
LRD18G	Gray	18.00	457	1
LRD18BLK	Black	18.00	457	1
LRD18GZ	Aluminum	18.00	457	1
LRD24BLK	Black	24.00	610	1

### STRINGER RADIUS DROP KIT

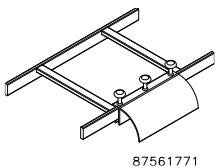

Mounts over ladder rack stringer to provide bending radius when dropping cable. Includes cable spools to separate cable and all mounting hardware. Made of extruded aluminum.

**BULLETIN: DCR**

Catalog Number	Finish	Kit Qty.
LSRDG	Gray	1
LSRDBLK	Black	1
LSRDGZ	Aluminum	1



### CEILING SUPPORT KIT

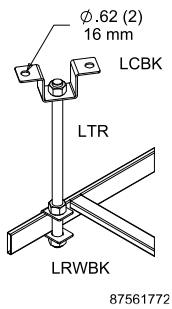

Supports ladder rack from ceiling. Components available separately or as a kit. Six-foot-long, 5/8-in. diameter rod is threaded for easy tension adjustment. Made of plated steel. Requires surface mounting hardware (not included).

**BULLETIN: DCR**

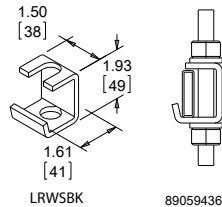

Catalog Number	Finish	Description	Kit Qty.
LCK	Plated	Kit includes one each: - LTR Threaded Rod - 5/8-in. nuts (4) - LRWBK Rack Runway Bracket - LCBK Ceiling Bracket	1
LTR	Plated	5/8-in. x 6-ft. Threaded Rod	1
LRWBK	Plated	Rack Runway Brackets (10) 5/8-in. nuts (20)	1
LRWBKB	Black	Rack Runway Brackets (10) 5/8-in. nuts (20)	1
LCBK	Plated	Ceiling Brackets (10) 5/8-in nuts (20)	1
LCBKB	Black	Ceiling Brackets (10) 5/8-in nuts (20)	1
LRWSBK	Plated	Rack-to-Runway Brackets (10) Slip-On 5/8 in. nuts (2)	1
LRWSBKB	Black	Rack-to-Runway Brackets (10) Slip-On 5/8 in. nuts (2)	1

### FOOT KIT

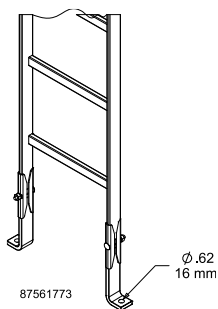

Secures ladder rack to floor, ceiling or wall. Made of steel with a painted or plated finish. One kit secures one ladder rack section. Requires surface mounting hardware (not included).

**BULLETIN: DCR**

Catalog Number	Finish	Kit Qty.
LFKG	Gray	2
LFKB	Black	2
LFK	Plated	2

### RACK-TO-RUNWAY MOUNTING PLATE KIT

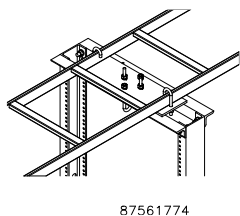

Secures ladder rack to the top of equipment racks. Made of steel with a painted or plated finish. The plate is designed for mounting either parallel or perpendicular to the rack. Includes mounting hardware.

**BULLETIN: DCR**

Catalog Number	Fits Ladder Width	Finish	Kit Qty.
LRRMPG	6, 12	Gray	1
LRRMPBLK	6, 12	Black	1
LRRMPGZ	6, 12	Plated	1
LRRMPG18	12, 18	Gray	1
LRRMPBLK18	12, 18	Black	1
LRRMPGZ18	12, 18	Plated	1
LRRMPBLK24	18, 24	Black	1

### VERTICAL WALL BRACKET

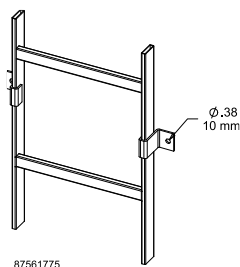

Secures ladder rack section to wall or other flat surface. Made of steel with a painted or plated finish. Requires surface mounting hardware (not included).

**BULLETIN: DCR**

Catalog Number	Finish	Kit Qty.
LWVBG	Gray	2
LWVBB	Black	2
LWVB	Plated	2



### TRIANGLE SUPPORT BRACKET KIT

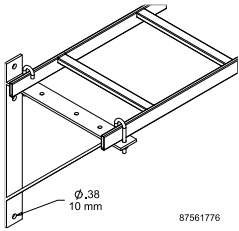

Supports ladder rack from wall. Bracket is made of steel with painted or plated finish. Brackets have predrilled mounting holes for two sizes of ladder rack. Includes one J-Bolt Kit.

**BULLETIN: DCR**

Catalog Number	A in.	A mm	Finish	Fits Cable Runway	Kit Qty.
LTSB12G	0.00		Gray	6, 12	1
LTSB12BLK	0.00		Black	6, 12	1
LTSB12GZ	0.00		Plated	6, 12	1
LTSB18G	0.00		Gray	12, 18	1
LTSB18BLK	0.00		Black	12, 18	1
LTSB18GZ	0.00		Plated	12, 18	1
LTSB24BLK	24.00	610	Black	12, 18, 24	1

### MODULAR TRIANGLE SUPPORT BRACKET KIT

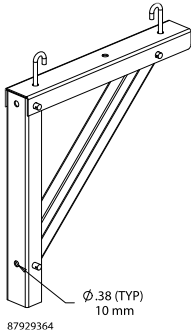

Secures and supports ladder rack to wall. Design features three bracket support arms that easily attach to each other with quick-release pins and fold down to ease assembly. Each model accommodates two ladder rack widths. Kit includes one modular bracket assembly, three quick-release pins and two J-bolts with washers and nuts. Bracket made of painted steel with plated hardware.

**BULLETIN: DCR**

Catalog Number	Finish	Fits Cable Runway	Kit Qty.
LMTSB12B	Black	6, 12	1
LMTSB18B	Black	12, 18	1
LMTSB24B	Black	18, 24	1

### WALL ANGLE SUPPORT

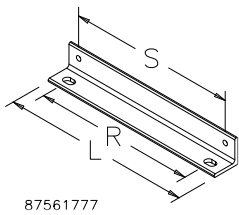

Supports ladder rack from wall or other flat surface. Made of 2-in. x 2-in. 10 gauge steel angle with painted or plated finish. Includes two J-bolts, nuts and screws.

**BULLETIN: DCR**

Catalog Number	Finish	L in./mm	R in./mm	S in./mm	Kit Qty.
LWASK6G	Gray	8.00	6.00	6.38	1
		203	152	162	
LWASK6BLK	Black	8.00	6.00	6.38	1
		203	152	162	
LWASK6GZ	Plated	8.00	6.00	6.38	1
		203	152	162	
LWASK12G	Gray	14.00	12.00	12.38	1
		356	305	314	
LWASK12BLK	Black	14.00	12.00	12.38	1
		356	305	314	
LWASK12GZ	Plated	14.00	12.00	12.38	1
		356	305	314	
LWASK18G	Gray	20.00	18.00	18.38	1
		508	457	467	
LWASK18BLK	Black	20.00	18.00	18.38	1
		508	457	467	
LWASK18GZ	Plated	20.00	18.00	18.38	1
		508	457	467	
LWASK24BLK	Black	26.00	24.00	24.38	1
		660	610	619	

### CORNER SUPPORT BRACKET KIT

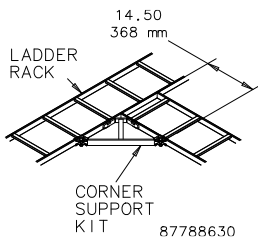

Provides additional support for 90-degree ladder rack junction. Made of steel with a painted or plated finish.

**BULLETIN: DCR**

Catalog Number	Finish	Kit Qty.
LCSKG	Gray	1
LCSKB	Black	1
LCSK	Plated	1

**END CAP KIT**

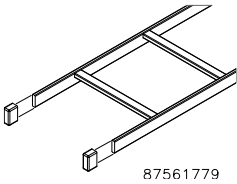

Provides protective covering for ends of ladder rack. Made of black vinyl.

**BULLETIN: DCR**

Catalog Number	Kit Qty.
LEC	2

**RUNWAY TERMINATION KIT**

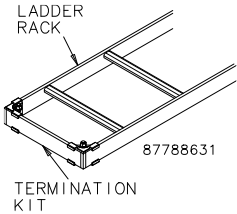

Provides a solid termination when the last section of ladder rack ends away from a wall. Made of steel with a painted or plated finish.

**BULLETIN: DCR**

Catalog Number	Finish	Fits Cable Runway	Kit Qty.
LRTK12G	Gray	12	1
LRTK12B	Black	12	1
LRTK12	Plated	12	1
LRTK18G	Gray	18	1
LRTK18B	Black	18	1
LRTK18	Plated	18	1
LRTK24B	Black	24	1

**MOVABLE CROSS MEMBER**

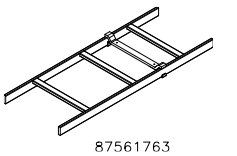

Supports cable at drop locations between welded cross members. Made of steel with a painted or plated finish. For maximum cable protection, use with radius drop kit. Includes hardware for secure mounting to ladder rack stringers.

**BULLETIN: DCR**

Catalog Number	Finish	W (in.)	W (mm)	Kit Qty.
LMCM12G	Gray	12.00	305	1
LMCM12BLK	Black	12.00	305	1
LMCM12GZ	Plated	12.00	305	1
LMCM18G	Gray	18.00	457	1
LMCM18BLK	Black	18.00	457	1
LMCM18GZ	Plated	18.00	457	1
LMCM24BLK	Black	24.00	610	1

**RACK-TO-WALL KIT**

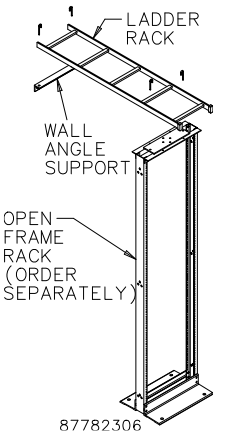

Includes one section of straight ladder rack and everything needed to fasten the ladder section to an open frame rack and to the wall. Ladder is 54-in. (1372-mm) long by 12-in. (305-mm) wide. All parts have a black painted finish. Order open frame rack separately.

**BULLETIN: DOFR2**

Catalog Number	Description
E45RUBKIT	Each Rack-to-Wall Kit includes one: - LSS12BLK [54-in. (1372-mm) long] Ladder Rack* - LWASK12BLK Wall Angle Support with j-bolts - LRRMPBLK Rack-to-Runway Mounting Kit - LEC End Cap Kit

\* Ladder Rack is cULus Classified

**RUNWAY ELEVATION KIT**

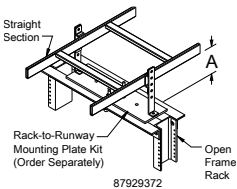

Elevates ladder rack 3 or 6 in. (76 or 152 mm) above rack-to-ladder mounting plate. Use on any width ladder rack. Kit includes two brackets and all mounting hardware. Made of heavy plated steel.

**BULLETIN: DCR**

Catalog Number	A (in.)	A (mm)	Finish	Kit Qty.
LEK3	3.00	76	Plated	1
LEK3B	3.00	76	Black	1
LEK6	6.00	152	Plated	1
LEK6B	6.00	152	Black	1
LEK12	12.00	305	Plated	1
LEK12B	12.00	305	Black	1



### RUNWAY OVERHEAD 12-IN. STACK KIT

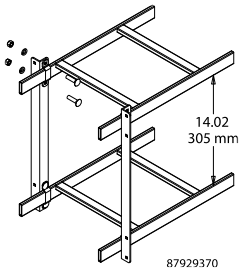

Allows stacking any width of ladder rack runways 12 in. (305 mm) above each other. Each kit contains two complete stacking brackets with all necessary hardware. Use one kit at least every 5 ft. (1.5 m). Brackets and fasteners made of plated steel.

**BULLETIN: DCR**

Catalog Number	Finish	Includes	Kit Qty.
LST12	Plated	2 brackets and hardware	1
LST12B	Black	2 brackets and hardware	1

### RUNWAY CENTER SUPPORT KIT

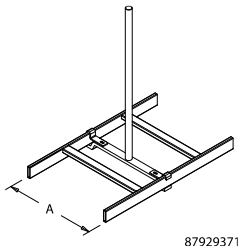

Threaded rod and bracket supports center of ladder rack from ceiling. Kit includes heavy-duty ladder rack cross member, 5/8-in. threaded rod, two J-bolts, protected sleeve and 5/8-in. nut. Use one kit at least every 5 ft. (1.5 m). Made of plated steel.

**BULLETIN: DCR**

Catalog Number	Finish	Fits Cable Runway	Kit Qty.
LCSK6	Plated	6	1
LCSK12	Plated	12	1
LCSK18	Plated	18	1
LCSK24	Plated	24	1

### SPOOL DIVIDER KIT

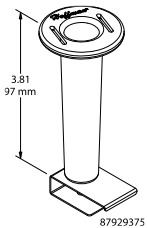

Spools separate cables to improve cable management and to control cable-to-cable distances. Spool and bracket attach to ladder rack cross member and can be located anywhere across the width. Kit includes ten 4-in.-tall spools, brackets and all necessary hardware. Spool made of black plastic and bracket made of plated steel.

**BULLETIN: DCR**

Catalog Number	Finish	Kit Includes
LCRDSK	Black plastic spool; plated steel bracket	10 spools, 10 brackets and mounting hardware

### INSULATED GROUND JUMPER KIT

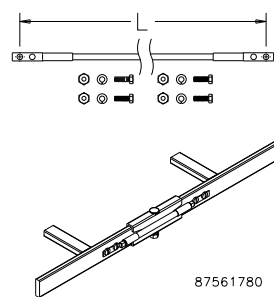

Fastens across splices to provide a secure ground between sections of ladder rack. Made of #6 AWG x 7 strand wire with green THW insulation and two-hole compression lugs mounted on each end. Includes fasteners.

**BULLETIN: DBG**

Catalog Number	Conductor Type	L in./mm
DGJ	#6-7 Stranded	12.00 305

cULus requires 2 kits per splice on all painted ladder sections

**J-BOLT KIT**

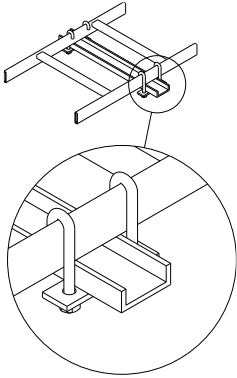

87561778

Connects ladder rack to top of cabinet or to auxiliary support channel. Each kit includes two J-bolts and makes one support connection. Kit components are plated steel. Includes mounting hardware.

- Each kit contains:
- (2) J-Bolts, 5/16 in.
  - (2) Nuts, 5/16 in.
  - (2) Washers, 5/16 in.
  - (2) Lock Washers, 5/16 in.
  - (1) Plate

**BULLETIN: DCR**

Catalog Number	J (in.)	J (mm)	Finish
LJBK	3.5	89	Plated
LJBK5	5.00	127	Plated
LJBK6	6.00	152	Plated
LJBK7	7.00	178	Plated

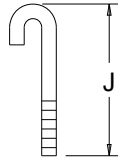

89059437

**CABLERACK™**



CABLERACK™ is used for ladder or basket tray mounting and securing 19-inch rack equipment for Data centers, Telecommunication rooms and other locations. The fixed, open frame rack allows suspending 19-inch rack equipment from Ladder Rack or Basket Tray. The rack has universal tapped holes per industry standards to accommodate typical applications. These open frame racks are ideal for high-density cabling applications which require above-the-cabinet mounting of equipment, and provide maximum access to cables and equipment. CABLERACK is ideal for Data Center applications, expanding equipment to above-the-cabinet while providing increased equipment and cable densities.

**BULLETIN: DOFRW**

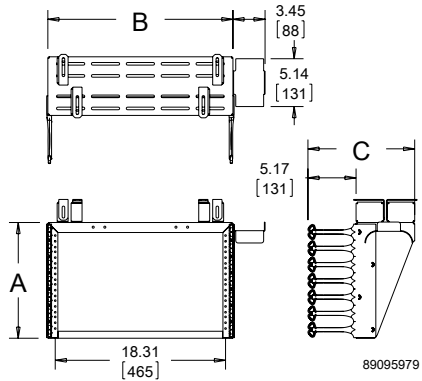

89095979

**Standard Product**

Catalog Number	AxBxC in./mm	Rack Units	Cable Bend Radius Accessory
E19T6U	12.44 x 20.16 x 11.50 316 x 512 x 292	6	ECMBA4

**STRAIGHT SECTION**



**INDUSTRY STANDARDS**

UL Classified for suitability as equipment ground conductor only.

NFPA 70, National Electrical Code, Article 392: Cable Trays; provides UL Classification and labels  
 IEC 61537, Cable Tray Systems and Cable Ladder systems for Cable Management  
 NEMA VE 1, Metal Cable Tray Systems, for materials, sizes and configurations

**APPLICATION**

The QUICK TRAY PRO™ cable tray routes cables through unused space while keeping them accessible for easy maintenance. Combine components to configure a system that meets application requirements.

**SPECIFICATIONS**

- Made of high-strength 5-mm or higher gauge steel wire
- T-weld top wire

**FINISH**

Pre-galvanized steel or black powder-coated finish.

**BULLETIN: DQT**

Standard Product

Catalog Number	AxBxC in./mm	Description	Finish	Load per 6-ft. span lbs./ft.	Cat6 Fill Rate* .19-in. dia. cable	Cat6A Fill Rate* .23-in. dia. cable
QTP2X4	2.00 x 4.00 x 120.00 51 x 102 x 3048	2 x 4-in. Straight Section	Pre-galvanized	43	108	99
QTP2X4BLK	2.00 x 4.00 x 120.00 51 x 102 x 3048	2 x 4-in. Straight Section	Black	43	108	99
QTP2X6	2.00 x 6.00 x 120.00 51 x 152 x 3048	2 x 6-in. Straight Section	Pre-galvanized	50	163	149
QTP2X6BLK	2.00 x 6.00 x 120.00 51 x 152 x 3048	2 x 6-in. Straight Section	Black	50	163	149
QTP2X8	2.00 x 8.00 x 120.00 51 x 203 x 3048	2 x 8-in. Straight Section	Pre-galvanized	52	218	200
QTP2X8BLK	2.00 x 8.00 x 120.00 51 x 203 x 3048	2 x 8-in. Straight Section	Black	52	218	200
QTP2X12	2.00 x 12.00 x 120.00 51 x 305 x 3048	2 x 12-in. Straight Section	Pre-galvanized	58	326	298
QTP2X12BLK	2.00 x 12.00 x 120.00 51 x 305 x 3048	2 x 12-in. Straight Section	Black	58	326	298
QTP2X16	2.00 x 16.00 x 120.00 51 x 406 x 3048	2 x 16-in. Straight Section	Pre-galvanized	70	439	402
QTP2X16BLK	2.00 x 16.00 x 120.00 51 x 406 x 3048	2 x 16-in. Straight Section	Black	70	439	402
QTP2X18	2.00 x 18.00 x 120.00 51 x 457 x 3048	2 x 18-in. Straight Section	Pre-galvanized	70	495	452
QTP2X18BLK	2.00 x 18.00 x 120.00 51 x 457 x 3048	2 x 18-in. Straight Section	Black	70	495	452
QTP2X20	2.00 x 20.00 x 120.00 51 x 508 x 3048	2 x 20-in. Straight Section	Pre-galvanized	73	550	503
QTP2X20BLK	2.00 x 20.00 x 120.00 51 x 508 x 3048	2 x 20-in. Straight Section	Black	73	550	503
QTP2X22	2.00 x 22.00 x 120.00 51 x 559 x 3048	2 x 22-in. Straight Section	Pre-galvanized	73	600	554
QTP2X22BLK	2.00 x 22.00 x 120.00 51 x 559 x 3048	2 x 22-in. Straight Section	Black	73	600	554
QTP2X24	2.00 x 24.00 x 120.00 51 x 610 x 3048	2 x 24-in. Straight Section	Pre-galvanized	75	660	604

Catalog Number	AxBxC in./mm	Description	Finish	Load per 6-ft. span lbs./ft.	Cat6 Fill Rate* .19-in. dia. cable	Cat6A Fill Rate* .23-in. dia. cable
QTP2X24BLK	2.00 x 24.00 x 120.00 51 x 610 x 3048	2 x 24-in. Straight Section	Black	75	660	604
QTP4X4	4.00 x 4.00 x 120.00 102 x 102 x 3048	4 x 4-in. Straight Section	Pre-galvanized	45	205	188
QTP4X4BLK	4.00 x 4.00 x 120.00 102 x 102 x 3048	4 x 4-in. Straight Section	Black	45	205	188
QTP4X6	4.00 x 6.00 x 120.00 102 x 152 x 3048	4 x 6-in. Straight Section	Pre-galvanized	49	310	285
QTP4X6BLK	4.00 x 6.00 x 120.00 102 x 152 x 3048	4 x 6-in. Straight Section	Black	49	310	285
QTP4X8	4.00 x 8.00 x 120.00 102 x 203 x 3048	4 x 8-in. Straight Section	Pre-galvanized	78	416	380
QTP4X8BLK	4.00 x 8.00 x 120.00 102 x 203 x 3048	4 x 8-in. Straight Section	Black	78	416	380
QTP4X12	4.00 x 12.00 x 120.00 102 x 305 x 3048	4 x 12-in. Straight Section	Pre-galvanized	78	621	568
QTP4X12BLK	4.00 x 12.00 x 120.00 102 x 305 x 3048	4 x 12-in. Straight Section	Black	78	621	568
QTP4X16	4.00 x 16.00 x 120.00 102 x 406 x 3048	4 x 16-in. Straight Section	Pre-galvanized	108	837	765
QTP4X16BLK	4.00 x 16.00 x 120.00 102 x 406 x 3048	4 x 16-in. Straight Section	Black	108	837	765
QTP4X18	4.00 x 18.00 x 120.00 102 x 457 x 3048	4 x 18-in. Straight Section	Pre-galvanized	116	942	862
QTP4X18BLK	4.00 x 18.00 x 120.00 102 x 457 x 3048	4 x 18-in. Straight Section	Black	116	942	862
QTP4X20	4.00 x 20.00 x 120.00 102 x 508 x 3048	4 x 20-in. Straight Section	Pre-galvanized	116	1047	958
QTP4X20BLK	4.00 x 20.00 x 120.00 102 x 508 x 3048	4 x 20-in. Straight Section	Black	116	1047	958
QTP4X22	4.00 x 22.00 x 120.00 102 x 559 x 3048	4 x 22-in. Straight Section	Pre-galvanized	116	1152	1054
QTP4X22BLK	4.00 x 22.00 x 120.00 102 x 559 x 3048	4 x 22-in. Straight Section	Black	116	1152	1054
QTP4X24	4.00 x 24.00 x 120.00 102 x 610 x 3048	4 x 24-in. Straight Section	Pre-galvanized	116	1257	1150
QTP4X24BLK	4.00 x 24.00 x 120.00 102 x 610 x 3048	4 x 24-in. Straight Section	Black	116	1257	1150
QTP6X8	6.00 x 8.00 x 120.00 152 x 203 x 3048	6 x 8-in. Straight Section	Pre-galvanized	116	623	570
QTP6X8BLK	6.00 x 8.00 x 120.00 152 x 203 x 3048	6 x 8-in. Straight Section	Black	116	623	570
QTP6X12	6.00 x 12.00 x 120.00 152 x 305 x 3048	6 x 12-in. Straight Section	Pre-galvanized	123	931	852
QTP6X12BLK	6.00 x 12.00 x 120.00 152 x 305 x 3048	6 x 12-in. Straight Section	Black	123	931	852
QTP6X16	6.00 x 16.00 x 120.00 152 x 406 x 3048	6 x 16-in. Straight Section	Pre-galvanized	123	1255	1148
QTP6X16BLK	6.00 x 16.00 x 120.00 152 x 406 x 3048	6 x 16-in. Straight Section	Black	123	1255	1148
QTP6X18	6.00 x 18.00 x 120.00 152 x 457 x 3048	6 x 18-in. Straight Section	Pre-galvanized	127	1413	1292
QTP6X18BLK	6.00 x 18.00 x 120.00 152 x 457 x 3048	6 x 18-in. Straight Section	Black	127	1413	1292
QTP6X20	6.00 x 20.00 x 120.00 152 x 508 x 3048	6 x 20-in. Straight Section	Pre-galvanized	127	1571	1437
QTP6X20BLK	6.00 x 20.00 x 120.00 152 x 508 x 3048	6 x 20-in. Straight Section	Black	127	1571	1437
QTP6X22	6.00 x 22.00 x 120.00 152 x 559 x 3048	6 x 22-in. Straight Section	Pre-galvanized	127	1728	1580
QTP6X22BLK	6.00 x 22.00 x 120.00 152 x 559 x 3048	6 x 22-in. Straight Section	Black	127	1728	1580
QTP6X24	6.00 x 24.00 x 120.00 152 x 610 x 3048	6 x 24-in. Straight Section	Pre-galvanized	150	1886	1726
QTP6X24BLK	6.00 x 24.00 x 120.00 152 x 610 x 3048	6 x 24-in. Straight Section	Black	150	1886	1726

\* Based on 50% fill rate.



### SPLICE KIT



Splice Kits are used for bolting turns, bends and tees; connecting QUICK TRAY PRO™ sections; and fastening splice bars. Kit includes three-piece staked bolt, washer and nut.

BULLETIN: DQT

Catalog Number	AxBxC in./mm	Description	Pkg. Qty.
QTPBNWK	2.00 x 4.00 x 2.00 51 x 102 x 51	Splice Kit (Zinc)	50
QTPBNWKBLK	2.00 x 4.00 x 2.00 51 x 102 x 51	Splice Kit (Black)	50

### SPLICE WASHER



QUICK TRAY PRO Splice Washers are used with QTPBNWK/ QTPBNWKBLK Splice Kits for bolting turns, bends, and tees; connecting tray sections; and fastening splice bars.

BULLETIN: DQT

Catalog Number	AxBxC in./mm	Description	Finish	Pkg. Qty.
QTPSSW3	4.00 x 4.00 x 8.00 102 x 102 x 203	Splice Washer	Pre-galvanized	50
QTPSSW3BLK	4.00 x 4.00 x 8.00 102 x 102 x 203	Splice Washer	Black	50

### SPLICE BARS



QUICK TRAY PRO Splice Bars provide extra support and stability to tray sides when connecting tray sections with splice washers. Universal bars can be cut to fit with bolt cutters and bent for use in tees and elbows. Made of plated steel. Requires QTPSSW3/ QTPSSW3BLK Splice Washers and QTPBNWK/QTPBNWKBLK Splice Kits to fasten to side of tray.

BULLETIN: DQT

Catalog Number	AxBxC in./mm	Description	Pkg. Qty.
QTPUS10	4.00 x 13.00 x 4.00 102 x 330 x 102	Splice Bar, 10 in. Universal (Zinc)	50
QTPUS10BLK	4.00 x 13.00 x 4.00 102 x 330 x 102	Splice Bar, 10 in. Universal (Black)	50
QTP90TKIT	1.00 x 5.00 x 5.00 25 x 127 x 127	Includes: (2) 90° bends; (8) washers, (8) nuts, (8) bolts (Zinc)	1
QTP90TKITBLK	1.00 x 5.00 x 5.00 25 x 127 x 127	Includes: (2) 90° bends; (8) washers, (8) nuts, (8) bolts (Black)	1



### TRAPEZE HANGING CLIP



For trapeze hung QUICK TRAY PRO™ installations. Use with 1/4- or 3/8-in. threaded rod; obtain locally. Poly grommet retains tray in slot-unsnap to detach one side of tray for loading cables. Corrosion-resistant pre-galvanized finish.

**BULLETIN: DQT**

Catalog Number	AxBxC in./mm	Description	Pkg. Qty.
QTPTH	3.00 x 6.00 x 14.00 76 x 152 x 356	Trapeze Hanging Clips, Pre-galvanized	50
QTPTHBLK	3.00 x 6.00 x 14.00 76 x 152 x 356	Trapeze Hanging Clips, Black	50

### C-BRACKET



For QUICK TRAY PRO installations under ceiling or overhangs. Use with tray widths up to 12 in. (305 mm). To secure tray to bracket, use one QTPSSW3/QTPSSW3BLK Splice Washer and one QTPBNWK/QTPBNWKBLK Splice Kit on sizes up to 8 in. (203 mm); use two on 12-in. (305-mm) trays. Can be stacked for multi-level tray installations. Corrosion resistant plated finish.

**BULLETIN: DQT**

Catalog Number	AxBxC in./mm	Description	Finish	Tray Width in./mm
QTPCB4	8.00 x 1.00 x 4.00 203 x 25 x 102	C-Bracket	Pre-galvanized	4 102
QTPCB4BLK	8.00 x 1.00 x 4.00 203 x 25 x 102	C-Bracket	Black	4 102
QTPCB8	8.00 x 1.00 x 8.00 203 x 25 x 203	C-Bracket	Pre-galvanized	8 203
QTPCB8BLK	8.00 x 1.00 x 8.00 203 x 25 x 203	C-Bracket	Black	8 203
QTPCB12	8.00 x 1.00 x 12.00 203 x 25 x 305	C-Bracket	Pre-galvanized	12 305
QTPCB12BLK	8.00 x 1.00 x 12.00 203 x 25 x 305	C-Bracket	Black	12 305

### CENTER HANGERS



Use with up to 1/2-in. threaded rod (obtain locally). Only one rod needed to suspend tray. Snap-on attachment holds QUICK TRAY PRO cable tray secure without nuts and bolts. For use with 4- to 24-in. (102- to 610-mm) tray widths. Can be used for multiple-level installations; 1/2-in. threaded rod recommended. Corrosion-resistant plated finish.

**BULLETIN: DQT**

Catalog Number	AxBxC in./mm	Description	Finish	Tray Width in./mm
QTPCH4	7.50 x 4.00 x 1.00 191 x 102 x 25	Center Hanger	Pre-galvanized	4 102
QTPCH4BLK	7.50 x 4.00 x 1.00 191 x 102 x 25	Center Hanger	Black	4 102
QTPCH12	7.50 x 12.00 x 1.00 191 x 305 x 25	Center Hanger	Pre-galvanized	12 305
QTPCH12BLK	7.50 x 12.00 x 1.00 191 x 305 x 25	Center Hanger	Black	12 305
QTPCH24	7.50 x 24.00 x 1.00 191 x 610 x 25	Center Hanger	Pre-galvanized	24 610
QTPCH24BLK	7.50 x 24.00 x 1.00 191 x 610 x 25	Center Hanger	Black	24 610



**L-BRACKETS**

L-Brackets mount directly to wall for overhead mounting. Corrosion-resistant plated finish. Fasten QUICK TRAY PRO™ to bracket with one QTPSSW3/QTPSSW3BLK Splice Washer and one QTPBNWK/QTPBNWKBLK Splice Kit on sizes up to 8 in. (203 mm); use two on 12-in. (305-mm) trays.

**BULLETIN: DQT**

Catalog Number	AxBxC in./mm	Description	Finish
QTPLB4	6.00 x 1.00 x 4.00 152 x 25 x 102	4-in. L-Bracket	Pre-galvanized
QTPLB4BLK	6.00 x 1.00 x 4.00 152 x 25 x 102	4-in. L-Bracket	Black
QTPLB8	6.00 x 1.00 x 8.00 152 x 25 x 203	8-in. L-Bracket	Pre-galvanized
QTPLB8BLK	6.00 x 1.00 x 8.00 152 x 25 x 203	8-in. L-Bracket	Black
QTPLB12	6.00 x 1.00 x 12.00 152 x 25 x 305	12-in. L-Bracket	Pre-galvanized
QTPLB12BLK	6.00 x 1.00 x 12.00 152 x 25 x 305	12-in. L-Bracket	Black

**REINFORCED WALL BRACKET**

For heavy-duty QUICK TRAY PRO applications. Mounts on 1-5/8-in. wide metal channel. To secure tray to bracket, use one QTPSSW3/QTPSSW3BLK Splice Washer and one QTPBNWK/QTPBNWKBLK Splice Kit on sizes up to 8 in. (203 mm); use two on 12-in. (305-mm) and wider trays. Made of plated steel for corrosion resistance.

**BULLETIN: DQT**

Catalog Number	AxBxC in./mm	Description	Finish	Width in./mm
QTPRWB4	3.00 x 1.00 x 4.00 76 x 25 x 102	Reinforced Wall Bracket	Pre-galvanized	4 102
QTPRWB4BLK	3.00 x 1.00 x 4.00 76 x 25 x 102	Reinforced Wall Bracket	Black	4 102
QTPRWB6	3.00 x 1.00 x 6.00 76 x 25 x 152	Reinforced Wall Bracket	Pre-galvanized	6 152
QTPRWB6BLK	3.00 x 1.00 x 6.00 76 x 25 x 152	Reinforced Wall Bracket	Black	6 152
QTPRWB8	4.00 x 1.00 x 8.00 102 x 25 x 203	Reinforced Wall Bracket	Pre-galvanized	8 203
QTPRWB8BLK	4.00 x 1.00 x 8.00 102 x 25 x 203	Reinforced Wall Bracket	Black	8 203
QTPRWB12	6.00 x 1.00 x 12.00 152 x 25 x 305	Reinforced Wall Bracket	Pre-galvanized	12 305
QTPRWB12BLK	6.00 x 1.00 x 12.00 152 x 25 x 305	Reinforced Wall Bracket	Black	12 305
QTPRWB16	9.00 x 1.00 x 16.00 229 x 25 x 406	Reinforced Wall Bracket	Pre-galvanized	16 406
QTPRWB16BLK	9.00 x 1.00 x 16.00 229 x 25 x 406	Reinforced Wall Bracket	Black	16 406
QTPRWB18	3.00 x 8.00 x 3.00 76 x 203 x 76	Reinforced Wall Bracket	Pre-galvanized	18 457
QTPRWB18BLK	3.00 x 8.00 x 3.00 76 x 203 x 76	Reinforced Wall Bracket	Black	18 457
QTPRWB20	9.00 x 1.00 x 20.00 229 x 25 x 508	Reinforced Wall Bracket	Pre-galvanized	20 508
QTPRWB20BLK	9.00 x 1.00 x 20.00 229 x 25 x 508	Reinforced Wall Bracket	Black	20 508
QTPRWB24	9.00 x 1.00 x 24.00 229 x 25 x 610	Reinforced Wall Bracket	Pre-galvanized	24 610
QTPRWB24BLK	9.00 x 1.00 x 24.00 229 x 25 x 610	Reinforced Wall Bracket	Black	24 610

### DIVIDER STRIP



For wire separation within a single QUICK TRAY PRO™ cable tray. 5-ft. (1.5-m) long strips are available in 2-, 4- and 6-in. (51-, 102- and 152-mm) heights. To secure divider strips to tray, use QTPSSW3/QTPSSW3BLK Splice Washer and QTPBNWK/QTPBNWKBLK Splice Kit for each strip.

**BULLETIN: DQT**

Catalog Number	AxBxC in./mm	Description	Finish	Tray Height in./mm
QTPDS2	2.00 x 1.00 x 60.00 51 x 25 x 1524	Divider Strip	Pre-galvanized	2 51
QTPDS2BLK	2.00 x 1.00 x 60.00 51 x 25 x 1524	Divider Strip	Black	2 51
QTPDS4	4.00 x 1.00 x 60.00 102 x 25 x 1524	Divider Strip	Pre-galvanized	4 102
QTPDS4BLK	4.00 x 1.00 x 60.00 102 x 25 x 1524	Divider Strip	Black	4 102
QTPDS6	6.00 x 1.00 x 60.00 152 x 25 x 1524	Divider Strip	Pre-galvanized	6 152
QTPDS6BLK	6.00 x 1.00 x 60.00 152 x 25 x 1524	Divider Strip	Black	6 152

### SIDE-ACTION BOLT CUTTER



The QUICK TRAY PRO Side-Action Bolt Cutter insures a flush cut and helps create a protective coating for the new cut.

**BULLETIN: DQT**

Catalog Number	AxBxC in./mm	Description
QTPBC	12.00 x 1.00 x 0.50 305 x 25 x 13	Side Action Bolt Cutter

### VERTICAL DOWN

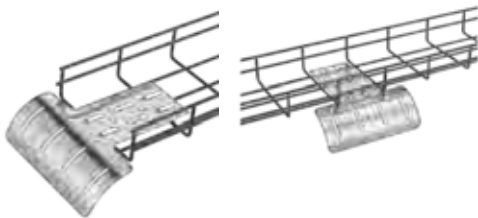

The QUICK TRAY PRO Vertical Down protects cables when exiting and entering tray. Built-in hold down method for side mount. Attached with 1/4 in. hardware for center mount.

**BULLETIN: DQT**

Catalog Number	AxBxC in./mm	Description	Finish
QTPVD	1.00 x 8.00 x 11.00 25 x 203 x 279	Vertical Down	Pre-galvanized
QTPVDBLK	1.00 x 8.00 x 11.00 25 x 203 x 279	Vertical Down	Black



**WALL-TERMINATION BRACKET**

Fastens the end of QUICK TRAY PRO™ cable tray to a wall. Attach to tray with QTPSSW3/QTPSSW3BLK Splice Washers and QTPBNWK/QTPBNWKBLK Splice Kits.

**BULLETIN: DQT**

Catalog Number	AxBxC in./mm	Description	Finish
QTPWTB	3.00 x 12.00 x 3.00 76 x 305 x 76	Wall-Termination Bracket, 12 in. (305 mm)	Pre-galvanized
QTPWTBBLK	3.00 x 12.00 x 3.00 76 x 305 x 76	Wall-Termination Bracket, 12 in. (305 mm)	Black

**POLYMER INSERT**



Polymer inserts provide continuous support for the cables when used as a tray liner. This flame retardant polymer material is prescored at the factory to fit in all standard width QUICK TRAY PRO cable trays.

**BULLETIN: DQT**

Catalog Number	Description	Tray Width in./mm
QTP4INST	4 x 120-in. (102 x 3048-mm) Polymer Insert	4 102
QTP6INST	6 x 120-in. (152 x 3048-mm) Polymer Insert	6 152
QTP8INST	8 x 120-in. (203 x 3048-mm) Polymer Insert	8 203
QTP12INST	12 x 120-in. (305 x 3048-mm) Polymer Insert	12 305
QTP16INST	16 x 120-in. (406 x 3048-mm) Polymer Insert	16 406
QTP18INST	18 x 120-in. (457 x 3048-mm) Polymer Insert	18 457
QTP20INST	20 x 120-in. (508 x 3048-mm) Polymer Insert	20 508
QTP24INST	24 x 120-in. (610 x 3048-mm) Polymer Insert	24 610

## Notes

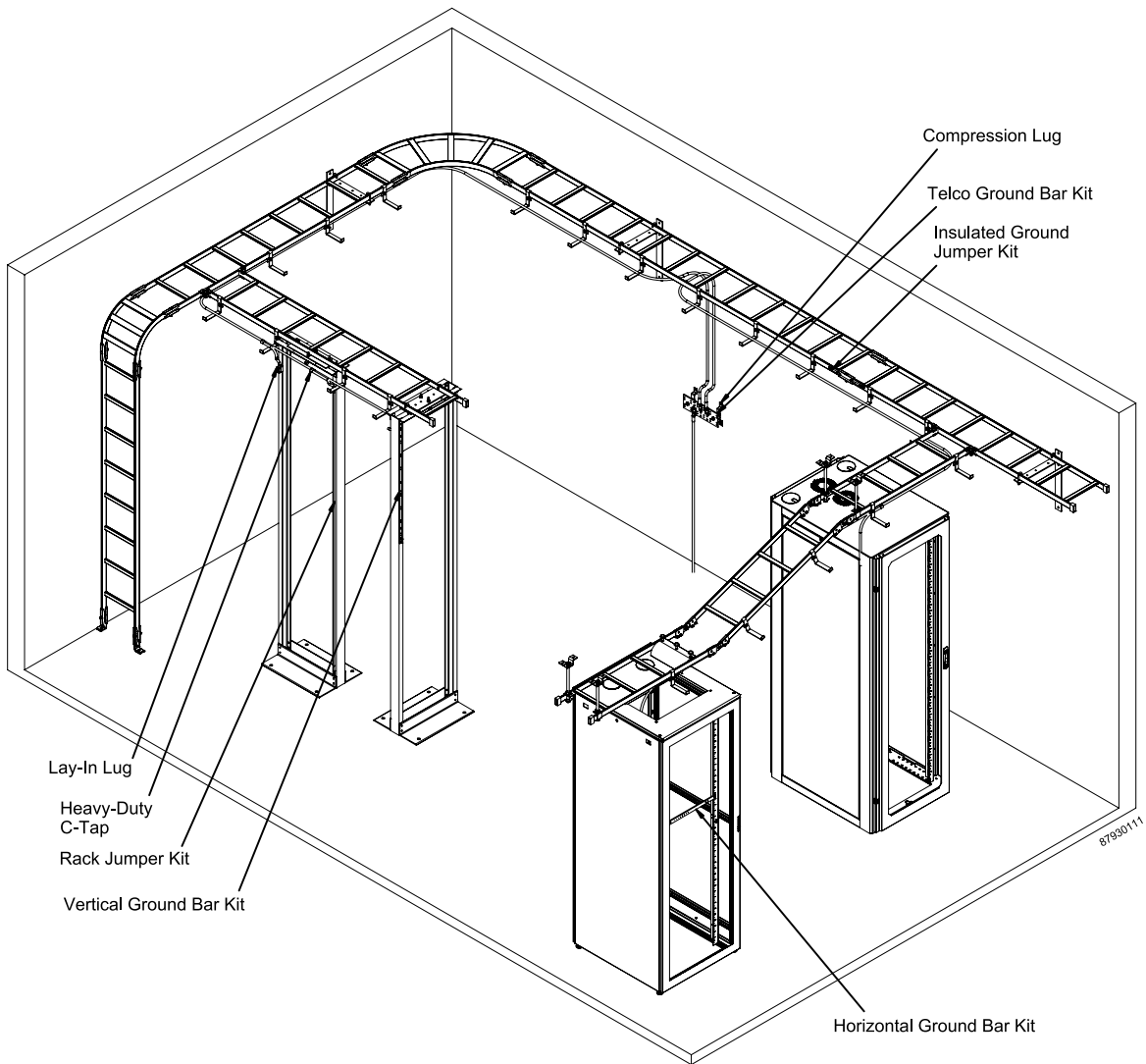
**BONDING AND GROUNDING OVERVIEW**



10

**INDUSTRY STANDARDS**

Ground Bar Kits:

UL 467 Listed  
 cUL Listed per CSA C22.2 No. 41  
 File No. E319377

**APPLICATION**

These components meet open frame rack and cabinet bonding and grounding requirements for telecommunication room and data center applications.

**FEATURES**

- Components specially designed to efficiently facilitate reliable connections
- Enable system to meet equipment manufacturer grounding requirements
- Components fit EIA 310-D-rated open frame racks

**LAY-IN LUG**

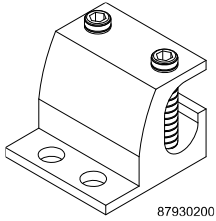

Dual-rated, UL486B listed lay-in lug bonds end of cable securely to rack. Made of electroplated 6061-T6 aluminum. Requires 3/16-in. hex key (not included).

**BULLETIN: DBG**

Catalog Number	For Cable Size Range	Size (in.)	Size (mm)	Pkg. Qty.
DGLG	#14 AWG to 2/0	1.75 x 1.50	44 x 38	10

**COMPRESSION LUGS**

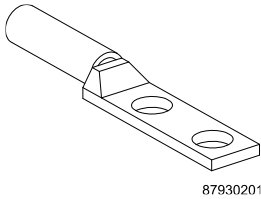

Compression lugs terminate copper or tinned-copper conductors for connection to busbars, cabinets, racks, and cable runway. Color-coded by conductor size. Made of electroplated, tinned copper. Require two screws (not included).

**BULLETIN: DBG**

Catalog Number	Cable Size (#)	On-Center Dimension Between Holes	Required Screw Size	Color Code	Pkg. Qty.
DGCL61	6	.625	1/4	Blue	10
DGCL62	6	1.00	3/8	Blue	10
DGCL21	2	.625	1/4	Brown	10
DGCL22	2	1.00	3/8	Brown	10
DGCL201	2/0	1.00	3/8	Black	10
DGCL402	4/0	1.00	3/8	Purple	10

**HEAVY-DUTY C-TAPS**

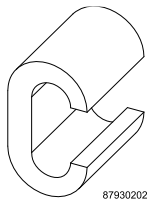

C-Taps splice two stranded or solid connectors together. Made of copper. Require a crimping tool (not included) to correctly tighten C-Taps around connectors.

**BULLETIN: DBG**

Catalog Number	Conductor Run	Conductor Tap	Pkg. Qty.
DGT1	#2 stranded or solid	#4 stranded, #8 solid	10
DGT2	#2 stranded or solid	#2 stranded or solid	10



### TELECOMMUNICATIONS GROUND BAR KITS

Provide a convenient central location for connecting grounds from telecommunications equipment, computers, and other data center equipment. Made of copper. Kits include ground bar with two mounting brackets, an assortment of connectors, and a tube of antioxidant.

**BULLETIN: DBG**

Standard Product

Catalog Number	Bar Size in./mm	No. of 5/16-in. Hole Sets	No. of 7/16-in. Hole Sets
DGTB212	2.00 x 12.00 x .25 51 x 305 x 6	6	3
DGTB216	2.00 x 16.00 x .25 51 x 406 x 6	8	3
DGTB412	4.00 x 12.00 x .25 102 x 305 x 6	12	6
DGTB420	4.00 x 20.00 x .25 102 x 508 x 6	24	6

2-inch Wide Bar

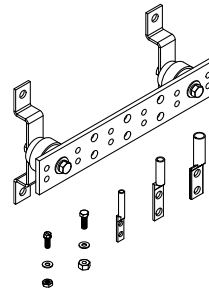

4-inch Wide Bar

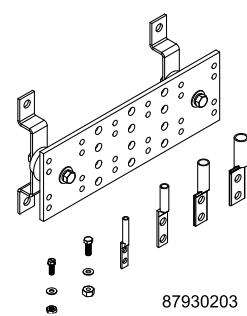

87930203

#### Compression Lugs Included with Ground Bar Kits

Catalog Number	#6 Wire Size (DGCL41)	#2 Wire Size (DGCL22)	#2/0 Wire Size (DGCL201)	#4/0 Wire Size (DGCL402)
DGTB212	6 lugs	3 lugs	1 lug	0
DGTB216	6 lugs	3 lugs	1 lug	0
DGTB412	6 lugs	3 lugs	1 lug	1 lug
DGTB420	6 lugs	3 lugs	1 lug	1 lug

### VERTICAL GROUND BAR KITS

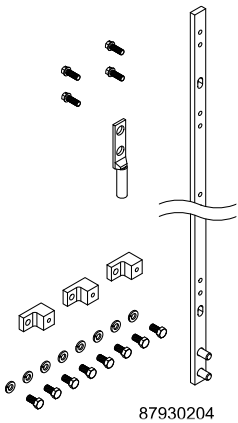

87930204

Mount vertically on rack, providing a convenient place to connect equipment grounds. Made of electrolytic tough-pitch 110 copper alloy. Kits include ground bar with compression lug for #2 wire, connection hardware, and mounting hardware.

**BULLETIN: DBG**

Catalog Number	Bar Size (in.)	Bar Size (mm)
DG36	36.00 x .625 x .25	914 x 16 x 6
DG72	72.00 x .625 x .25	1829 x 16 x 6

### HORIZONTAL GROUND BAR KITS

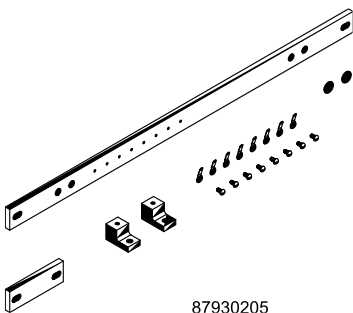

87930205

Mount horizontally on rack, providing a convenient place to connect equipment grounds. Made of electrolytic tough-pitch 110 copper alloy. Kits include ground bar with mounting hardware, eight #6-32 x 14 machine screws, and eight #6 ring terminals.

**BULLETIN: DBG**

Catalog Number	Bar Size (in.)	Bar Size (mm)
DG19	1.00 x 19.25 x .25	25 x 489 x 6
DG23	1.00 x 23.25 x .25	25 x 591 x 6



**INSULATED GROUND JUMPER KIT**

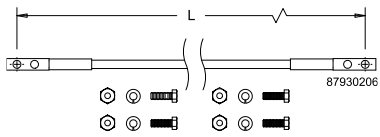

Fastens across splices to provide a secure ground between sections of ladder rack. Made of #6 AWG x 7 strand wire with green THW insulation and two-hole compression lugs mounted on each end. Includes fasteners.

**BULLETIN: DBG**

Catalog Number	Conductor Type	L (in.)	L (mm)
DGJ	#6-7 Stranded	12.00	305

cULus requires 2 kits per splice on all painted ladder sections

**RACK JUMPER KIT**

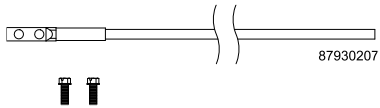

Grounds rack or cabinet to common bonding network under floor or overhead. Made of #6 AWG x 7 strand wire with green THW insulation and two-hole compression lug mounted on one end. Includes fasteners.

**BULLETIN: DBG**

Catalog Number	Conductor Type	Length (ft.)	Length (m)
DGRJ	#6-7 stranded	9	2.7



*Hoffman*<sup>®</sup>

# CHAPTER 11 TECHNICAL INFORMATION





## OVERVIEW

Pentair is active at many levels to ensure your complete satisfaction. Compliance with all relevant standards governing the performance of our products facilitates their international acceptance.

## CHAPTER CONTENTS

### STANDARDS ORGANIZATION SUMMARY AND DIRECTORY

Standards Organization Summary and Directory Overview ..... 212

### INDUSTRY STANDARDS FOR NON-HAZARDOUS APPLICATIONS

Comparison of Specific Non-Hazardous Applications in Outdoor Locations ..... 213

Comparison of Specific Non-Hazardous Applications in Indoor Locations ..... 213

Enclosure Type Rating versus IP Rating ..... 213

Glossary Terms Specifying Non-Hazardous Environmental Conditions ..... 214

### NEMA, UL AND CSA RATINGS

NEMA, UL and CSA Ratings ..... 215

### IEC AND CE CLASSIFICATIONS

IP Rating Descriptions ..... 216

CE ..... 216

### SHORT CIRCUIT CURRENT RATING

Short Circuit Current Rating for Enclosures ..... 217

### WIREWAY FILL

Wireway Fill Tables ..... 218

## STANDARDS ORGANIZATION SUMMARY AND DIRECTORY OVERVIEW

### What's in a Rating?

As a way of standardizing enclosure performance, organizations like NEMA, UL, CSA, IEC and VDE use rating systems to identify an enclosure's ability to resist external environmental influences. Resistance to everything from dripping liquid to hose-down to total submersion is defined by the ratings systems. While these ratings are all intended to provide information to help you make a safer, more-informed product choice, there are differences among them.

### North American Standards Organizations

In North America, NEMA, UL and CSA are the commonly recognized standards organizations. Their ratings are based on similar application descriptions and expected performance. UL and CSA both require enclosure testing by qualified evaluators in their certified labs. They also send site inspectors to make sure a manufacturer adheres to prescribed manufacturing methods and material specifications. NEMA, on the other hand, does not require independent testing and leaves compliance completely up to the manufacturer.

North American enclosure rating systems also include a rating that indicates corrosion resistance. This rating is based on the enclosure's ability to withstand prolonged exposure to salt water spray.

While the corrosion resistance rating is a good indicator that an enclosure can resist corrosion, it does not provide information on how a specific corrosive agent will affect a given enclosure material. It is best to conduct a full analysis of the specific application and environment to determine the best enclosure choice.

### International Standards Organizations

Like NEMA, IEC does not require independent testing and leaves compliance completely up to the manufacturer. Nevertheless, there are differences in how enclosure performance is interpreted. For example, UL and CSA test requirements specify that an enclosure fails the water-tight test if even a single drop of water enters the enclosure. In the IEC standards for each level of ingress protection (IP), a certain amount of water is allowed to enter the enclosure.

IEC 60529 IP ratings do not specify construction requirements or degrees of protection against corrosive atmospheres, risk of explosion or conditions such as moisture or corrosive vapors. NEMA Type ratings, on the other hand, do specify construction and performance requirements for most environmental conditions. For this reason, and because the tests and evaluations for other characteristics are not identical, the IEC enclosure classification designations cannot be exactly equated with NEMA enclosure Type numbers.

## COMPARISON OF SPECIFIC NON-HAZARDOUS APPLICATIONS IN OUTDOOR LOCATIONS

## Enclosure Type Rating

Provides a Degree of Protection Against the Following Environmental Conditions	3	3R <sup>a</sup>	3RX <sup>a</sup>	4	4X	6
Incidental contact with the enclosed equipment	•	•	•	•	•	•
Rain, snow and sleet <sup>b</sup>	•	•	•	•	•	•
Windblown dust	•			•	•	•
Hose-down				•	•	•
Corrosive agents			•		•	
Occasional temporary submersion						•

<sup>a</sup>These enclosures may be ventilated.

<sup>b</sup>External operating mechanisms are not required to be operable when the enclosure is ice covered.

The preceding table is reproduced by permission of the National Electrical Manufacturers Association from NEMA Standards Publication 250 "Enclosures for Electrical Equipment (1000 Volts Maximum)".

## COMPARISON OF SPECIFIC NON-HAZARDOUS APPLICATIONS IN INDOOR LOCATIONS

## Enclosure Type Rating

Provides a Degree of Protection Against the Following Environmental Conditions	1 <sup>a</sup>	4	4X	6	12	12K	13
Incidental contact with the enclosed equipment	•	•	•	•	•	•	•
Falling dirt	•	•	•	•	•	•	•
Falling liquids and light splashing		•	•	•	•	•	•
Dust, lint, fibers and flyings <sup>b</sup>		•	•	•	•	•	•
Hose-down and splashing water		•	•	•			
Oil and coolant seepage					•	•	•
Oil or coolant spraying and splashing							•
Corrosive agents			•				
Occasional temporary submersion				•			

<sup>a</sup>These enclosures may be ventilated. However, Type 1 may not provide protection against small particles of falling dirt when ventilation is provided in the enclosure top. Consult Hoffman for more information.

<sup>b</sup>These fibers and flyings are non-hazardous materials and are not considered Class II type ignitable fibers or combustible flyings. For Class III type ignitable fibers or combustible flyings see the National Electrical Code Section 505.

The preceding table is reproduced by permission of the National Electrical Manufacturers Association from NEMA Standards Publication 250 "Enclosures for Electrical Equipment (1000 Volts Maximum)".

## ENCLOSURE TYPE RATING VERSUS IP RATING

Electrical enclosures are rated by Type (NEMA 250 / UL 50, 50E), and/or IP rating (IEC 60529) based upon the degree of protection provided. Type ratings and IP ratings have only the following in common:

1. A degree of protection for persons from hazardous components inside the enclosure
2. A degree of protection for equipment inside the enclosure from ingress of solid foreign objects, including dust
3. A degree of protection for equipment inside the enclosure from ingress of water

NEMA 250 and UL 50, 50E Type rating documentation defines additional requirements that a Type-rated enclosure must meet. These include:

- Mechanical impact on enclosure walls
  - Gasket aging and oil resistance
  - Corrosion resistance
  - Door and cover latching requirements
  - Sheet metal gauge construction requirements (UL 50 only)
- Electrical enclosures that carry only an IP rating have not been designed or tested to the additional Type-rating requirements. For this reason, and because the tests and evaluations for other characteristics are not identical, the IP ratings cannot be exactly equated with NEMA enclosure Types.
- Electrical enclosures manufactured by Hoffman are tested for and carry both Type and IP ratings.**

## Fluid Statics and Dynamic Comparison of Ingress Water Tests

Test Type	Flow Rate (gal./min.)	Flow Rate (l/min.)	Nozzle Diameter in./mm	Nozzle Area (in. <sup>2</sup> )	Nozzle Velocity (ft./sec.)	Equivalent Head (ft.)	Equivalent Pressure (psi)	Mass Flow (lb./sec.)	Power (hp)	Total Force on Vertical Plate (lb.)
Type 3	45.00	170	1.0000 25.4	0.7854	18.38	5.25	2.274	6.256	0.060	3.5716
Type 4	65.00	246	1.000 25.4	0.7854	26.55	10.85	4.744	9.037	0.180	7.4516
IPX5	3.30	12.5	0.2480 6.3	0.0483	21.93	7.46	3.235	0.459	0.006	0.3126
IPX6	26.42	100	0.4921 12.5	0.1902	44.55	30.82	13.357	3.672	0.206	5.0815

**GLOSSARY TERMS SPECIFYING NON-HAZARDOUS ENVIRONMENTAL CONDITIONS****Corrosion-Resistant**

Constructed to provide a degree of protection against exposure to corrosive agents such as salt spray. Type 3RX and 4X enclosures meet this requirement.

**Damp Locations**

Locations protected from weather and not subject to saturation with water or other liquids but subject to moderate degrees of moisture. Examples of such locations include partially protected locations under canopies, marquees, roofed open porches and like locations, and interior locations subject to moderate degrees of moisture, such as some basements, some barns and some cold-storage warehouses. See the indoor enclosure types and select a type rating that fits the specific application.

**Dust-tight**

Constructed so that circulating or airborne dust will not enter the enclosure under specified test conditions. Type 3, 4, 4X, 12, 12K and 13 enclosures meet this requirement.

**Drip-tight**

Constructed so that falling moisture or dirt does not enter the enclosure under specified test conditions. Type 3, 4, 4X, 12, 12K and 13 enclosures meet this requirement.

**Indoor**

Not to be exposed to weather. Type 1, 12, 12K and 13 enclosures meet this requirement.

**Oil-Resistant**

Constructed so that oil will not interfere with successful operation of equipment. Type 12 and 13 enclosures meet this requirement.

**Oil-tight**

Constructed so that oil will not enter the enclosure under specified test conditions. Type 13 enclosures meet this requirement.

**Outdoor**

Constructed or protected so that exposure to the weather will not interfere with successful operation of equipment. Type 3, 3R, 4, 4X and 6 enclosures meet this requirement. These ratings can also be used indoors.

**Rainproof**

Constructed, protected or treated to prevent beating rain from interfering with the successful operation of the apparatus or result in wetting of live parts and wiring within the enclosure under specified test conditions. Type 3R and 3RX enclosures meet this requirement.

**Rain-tight**

Constructed or protected so that exposure to beating rain will not result in water entering the enclosure under specified test conditions. Type 3, 4, 4X and 6 enclosures meet this requirement.

**Water-tight**

Constructed so that moisture will not enter the enclosure when it is subjected to a stream of water under specified test conditions. Type 4, 4X and 6 enclosures meet this requirement.

**Weatherproof**

Constructed or protected so that exposure to the weather will not interfere with successful operation of the equipment. Rainproof, rain-tight or water-tight equipment can fulfill the requirements for weatherproof where varying weather conditions other than wetness, such as snow, ice, dust or temperature extremes, are not a factor.

**Wet Locations**

Installations underground or in concrete slabs or masonry in direct contact with the earth; in locations subject to saturation with water or other liquids, such as vehicle washing areas; and in unprotected locations exposed to weather. Use weatherproof enclosures with a type rating that fits the specific application.

## NEMA, UL AND CSA RATINGS

## Enclosure Type Descriptions for Non-Hazardous Locations

Type	NEMA	UL	CSA
Indoor Type 1	Enclosures are intended for indoor use primarily to provide a degree of protection against contact with the enclosed equipment or locations where unusual service conditions do not exist.	Indoor use primarily to provide protection against contact with the enclosed equipment and against a limited amount of falling dirt.	General purpose enclosure. Protects against accidental contact with live parts.
Indoor Type 12	Enclosures are intended for indoor use primarily to provide a degree of protection against dust, falling dirt and dripping noncorrosive liquids.	Indoor use to provide a degree of protection against dust, dirt, fiber flyings, dripping water and external condensation of noncorrosive liquids.	Indoor use; provides a degree of protection against circulating dust, lint, fibers and flyings; dripping and light splashing of non-corrosive liquids; not provided with knockouts.
Indoor Type 12K	Enclosures with knockouts are intended for indoor use primarily to provide a degree of protection against dust, falling dirt and dripping noncorrosive liquids.	Indoor use to provide a degree of protection against dust, dirt, fiber flyings, dripping water and external condensation of noncorrosive liquids.	Indoor use; provides a degree of protection against circulating dust, lint, fibers and flyings; dripping and light splashing of noncorrosive liquids; not provided with knockouts.
Indoor Type 13	Enclosures are intended for indoor use primarily to provide a degree of protection against dust, spraying of water, oil and noncorrosive coolant.	Indoor use to provide a degree of protection against lint, dust seepage, external condensation and spraying of water, oil and noncorrosive liquids.	Indoor use; provides a degree of protection against circulating dust, lint, fibers and flyings; seepage and spraying of non-corrosive liquids, including oils and coolants.
Outdoor Type 3	Enclosures are intended for outdoor use primarily to provide a degree of protection against windblown dust, rain and sleet; undamaged by the formation of ice on the enclosure.	Outdoor use to provide a degree of protection against windblown dust and windblown rain; undamaged by the formation of ice on the enclosure.	Indoor or outdoor use; provides a degree of protection against rain, snow and windblown dust; undamaged by the external formation of ice on the enclosure.
Outdoor Type 3R	Enclosures are intended for outdoor use primarily to provide a degree of protection against falling rain and sleet; undamaged by the formation of ice on the enclosure.	Outdoor use to provide a degree of protection against falling rain; undamaged by the formation of ice on the enclosure.	Indoor or outdoor use; provides a degree of protection against rain and snow; undamaged by the external formation of ice on the enclosure.
Outdoor Type 3RX	Enclosures are intended for outdoor use primarily to provide a degree of protection against corrosion, falling rain and sleet; undamaged by the formation of ice on the enclosure.	Not specifically defined.	Not specifically defined.
Outdoor Type 4	Enclosures are intended for indoor or outdoor use primarily to provide a degree of protection against windblown dust and rain, splashing water and hose directed water; undamaged by the formation of ice on the enclosure.	Either indoor or outdoor use to provide a degree of protection against falling rain, splashing water and hose-directed water; undamaged by the formation of ice on the enclosure.	Indoor or outdoor use; provides a degree of protection against rain, snow, windblown dust, splashing and hose-directed water; undamaged by the external formation of ice on the enclosure.
Outdoor Type 4X	Enclosures are intended for indoor or outdoor use primarily to provide a degree of protection against corrosion, windblown dust and rain, splashing water and hose-directed water; undamaged by the formation of ice on the enclosure.	Either indoor or outdoor use to provide a degree of protection against falling rain, splashing water and hose-directed water; undamaged by the formation of ice on the enclosure; resists corrosion.	Indoor or outdoor use; provides a degree of protection against rain, snow, windblown dust, splashing and hose-directed water; undamaged by the external formation of ice on the enclosure; resists corrosion.
Outdoor Type 6	Enclosures are intended for use indoors or outdoors where occasional submersion is encountered; limited depth; undamaged by the formation of ice on the enclosure.	Indoor or outdoor use to provide a degree of protection against entry of water during temporary submersion at a limited depth; undamaged by the external formation of ice on the enclosure.	Indoor or outdoor use; provides a degree of protection against the entry of water during temporary submersion at a limited depth. Undamaged by the external formation of ice on the enclosure; resists corrosion.

This material is reproduced with permission from NEMA. The preceding descriptions, however, are not intended to be complete representations of National Electrical Manufacturers Association standards for enclosures nor those of the Electrical and Electronic Manufacturers Association of Canada.

This material is reproduced with permission from Underwriters Laboratories Inc. Enclosures for Electrical Equipment, UL 50, 50E and Industrial Control Panels, UL 508A.

This material is reproduced with permission from the Canadian Standards Association.

Underwriters Laboratories Inc. (UL) shall not be responsible for the use of or reliance upon a UL Standard by anyone. UL shall not incur any obligation or liability for damages, including consequential damages, arising out of or in connection with the use, interpretation of, or reliance upon a UL Standard.

Some enclosures may have multiple ratings. For instance:

- 4, 12—Outdoor use; able to be used indoors with modifications
- 4X, 3RX—Outdoor use; able to be used indoors with modifications
- 4, 9—Can be used in both hazardous and non-hazardous locations

## IP RATING DESCRIPTIONS

### Example Rating

If 1st IP number is...	and the 2nd ip number is...	Then the IP rating is
2 (protection against solid objects)	3 (protection against liquids)	IP23 An enclosure with this designation provides protection against touch with a finger, penetration of solid objects greater than 12mm, and spraying water.

### First Numeral (Solid Objects and Dust)

IP	Protection of Persons	Protection of Equipment
0	No Protection	No Protection
1	Protected against contact with large areas of the body (back of hand)	Protected against objects over 50 mm in diameter
2	Protected against contact with fingers	Protected against solid objects over 12 mm in diameter
3	Protected against tools and wires over 2.5 mm in diameter	Protected against solid objects over 2.5 mm in diameter
4	Protected against tools and wires over 1 mm in diameter	Protected against solid objects over 1 mm in diameter
5	Protected against tools and wires over 1 mm in diameter	Protected against dust (limited ingress, no harmful deposit)
6	Protected against tools and wires over 1 mm in diameter	Totally protected against dust

### Second Numeral (Liquid)

IP	Protection of Equipment
0	No Protection
1	Protected against vertically falling drops of water, e.g. condensation
2	Protected against direct sprays of water up to 15 degrees from vertical
3	Protected against sprays to 60 degrees from vertical
4	Protected against water sprayed from all directions (limited ingress permitted)
5	Protected against low-pressure jets of water from all directions (limited ingress permitted)
6	Protected against strong jets of water
7	Protected against the effects of immersion between 15 cm and 1 m
8	Protected against long periods of immersion under pressure

## CE

For industrial control equipment, the CE Mark is not intended to be applied to empty enclosures because such enclosures are inactive components of a final assembly. The responsibility of ensuring compliance with all applicable EU directives and harmonized standards belongs with the final equipment manufacturer.



### SHORT CIRCUIT CURRENT RATING FOR ENCLOSURES

The short circuit current rating is not required for an empty UL 508A enclosure. The majority of Hoffman's electrical accessories are generally used in the control circuit portion of a UL 508A Industrial Control Panel. Electrical accessories used in a control circuit are not included in determining the overall short circuit current rating of the industrial control panel. UL has not issued a requirement at the time of this publication to mark these accessories with a short circuit current rating.

For electrical accessories that are NOT located in a control circuit, and are not otherwise marked with a short circuit current rating, like Hoffman's power distribution units, then the default rating in Table SB4.1 of UL 508A would apply to the component being evaluated. If the power distribution unit is essentially receptacles or terminals, then the assumed short circuit current value from Table SB4.1 would be selected.

If the accessory contains both a load and controls, the controls would need to be assigned a short circuit current rating. An example of this would be an air conditioner that has a contactor included in the design. In this case, if the contactor is not marked, the SCCR could be assigned from Table SB4.1 in UL508A, or be tested per UL508, or the standard that applies to the component being evaluated, in this case the contactor.

## WIREWAY FILL TABLES

Lay-In and Feed-Through Type 12 and Type 3R (Based on 2008 National Electric Code)

**Wireway Size and Maximum Number of Conductors Allowed**  
 (Areas shown are 20% of the full interior cross sectional area of the wireway)

Conductor Size AWG-MCM	Area of Conductor (sq. in.)	2.50 x 2.50 (1.11 sq. in.)	4.00 x 4.00 (2.98 sq. in.)	6.00 x 6.00 (6.87 sq. in.)	8.00 x 8.00 (12.4 sq. in.)	12.00 x 6.00 (13.7 sq. in.)	Conductor Size AWG-MCM	Area of Conductor (sq. in.)	2.50 x 2.50 (1.11 sq. in.)	4.00 x 4.00 (2.98 sq. in.)	6.00 x 6.00 (6.87 sq. in.)	8.00 x 8.00 (12.4 sq. in.)	12.00 x 6.00 (13.7 sq. in.)
<b>"RFH-2, FFH-2, RH"</b>							12	0.0181	61	164	379	684	757
18	0.0145	76	205	473	854	945	10	0.0243	45	122	282	509	564
16	0.0172	64	173	399	720	797	8	0.0437	25	68	157	283	313
14	0.0209	52	1426	328	592	656	<b>"RHH*, RHW*, RHW-2*, THHW, THW, AF, XF, XFF, THW-2, TW"</b>						
12	0.0260	42	114	264	476	527	14	0.0209	52	142	328	592	656
<b>"RHW-2, RHH, RHW"</b>							12	0.0260	42	114	264	476	527
14	0.0293	37	101	234	422	467	10	0.0333	33	89	206	371	411
12	0.0353	31	84	194	350	388	8	0.0556	19	53	123	222	246
<b>"RHW-2, RHH, RHW, RH"</b>							6	0.0726	15	41	94	170	188
10	0.0437	25	68	157	283	313	4	0.0973	11	30	70	127	140
8	0.0835	13	35	82	148	164	3	0.1134	9	26	60	109	120
6	0.1041	10	28	65	118	131	2	0.1333	8	22	51	92	102
4	0.1333	8	22	51	92	102	1	0.1901	5	15	36	65	72
3	0.1521	7	19	45	81	90	1/0	0.2223	4	13	30	55	61
2	0.1750	6	17	39	70	78	2/0	0.2624	4	11	26	47	52
1	0.2660	4	11	25	46	51	3/0	0.3117	3	9	22	39	43
1/0	0.3039	3	9	22	40	45	4/0	0.3718	2	8	18	33	36
2/0	0.3505	3	8	19	35	39	250	0.4596	2	6	14	26	29
3/0	0.4072	2	7	16	30	33	300	0.5281	2	5	13	23	25
4/0	0.4754	2	6	14	26	28	350	0.5958	1	5	11	20	23
250	0.6291	1	4	10	19	21	400	0.6619	1	4	10	18	20
300	0.7088	1	4	9	17	19	500	0.7901	1	3	8	15	17
350	0.7870	1	3	8	15	17	600	0.9729	1	3	7	12	14
400	0.8626	1	3	7	14	15	700	1.1010	1	2	6	11	12
500	1.0082	1	2	6	12	13	750	1.1652	0	2	5	10	11
600	1.2135	0	2	5	10	11	800	1.2272	0	2	5	10	11
700	1.3561	0	2	5	9	10	900	1.3561	0	2	5	9	10
750	1.4272	0	2	4	8	9	1000	1.4784	0	2	4	8	9
800	1.4957	0	1	4	8	9	1250	1.8602	0	1	3	6	7
900	1.6377	0	1	4	7	8	1500	2.1695	0	1	3	5	6
1000	1.7719	0	1	3	6	7	1750	2.4773	0	1	2	5	5
1250	2.3479	0	1	2	5	5	2000	2.7818	0	1	2	4	4
1500	2.6938	0	1	2	4	5	<b>"TFN, TFFN, THHN, THWN, THWN-2"</b>						
1750	3.0357	0	0	2	4	4	18	0.0055	200	541	1248	2252	2493
2000	3.3719	0	0	2	3	4	16	0.0072	153	413	953	1720	1904
<b>"SF-2, SFF-2"</b>							14	0.0097	113	307	708	1277	1413
18	0.0115	96	259	597	1077	1192	12	0.0133	83	224	516	931	1030
16	0.0139	79	214	494	891	986	10	0.0211	52	141	325	587	649
14	0.0172	64	173	399	720	797	8	0.0366	30	81	187	338	374
<b>"SF-1, SFF-1"</b>							6	0.0507	21	58	135	244	270
18	0.0065	169	458	1056	1905	2109	4	0.0824	13	36	83	150	166
<b>"RFH-1, AF, XF, XFF, AF, TF, TFF, TW"</b>							3	0.0973	11	30	70	127	140
18	0.0080	138	372	858	1548	1713	2	0.1158	9	25	59	106	118
16	0.0109	101	273	630	1136	1257	1	0.1562	7	19	43	79	87
14	0.0139	79	214	494	891	986	1/0	0.1855	5	16	37	66	73

The 2008 National Electric Code limits wireway fill as follows:

1. A wireway shall not contain more than thirty current-carrying conductors except where the ampacity has been adjusted according to Table 310-15(b)(2)(a).
2. The sum of the cross-sectional areas of all conductors shall not exceed 20% of the interior cross-sectional area of the wireway.

NOTE: Section 14 of NFPA 79 allows 50% fill for industrial machine wireway.

Wireway Size and Maximum Number of Conductors Allowed (Areas shown are 20% of the full interior cross sectional area of the wireway)														
Conductor Size AWG-MCM	Area of Conductor (sq. in.)	2.50 x 2.50 (1.11 sq. in.)	4.00 x 4.00 (2.98 sq. in.)	6.00 x 6.00 (6.87 sq. in.)	8.00 x 8.00 (12.4 sq. in.)	12.00 x 6.00 (13.7 sq. in.)		Conductor Size AWG-MCM	Area of Conductor (sq. in.)	2.50 x 2.50 (1.11 sq. in.)	4.00 x 4.00 (2.98 sq. in.)	6.00 x 6.00 (6.87 sq. in.)	8.00 x 8.00 (12.4 sq. in.)	12.00 x 6.00 (13.7 sq. in.)
<b>Continued</b>								2/0	0.2027	5	14	33	61	67
2/0	0.2223	4	13	30	55	61		3/0	0.2463	4	12	27	50	55
3/0	0.2679	4	11	25	46	51		4/0	0.3000	3	9	22	41	45
4/0	0.3237	3	9	21	38	42		<b>"XHHW, ZW, XHHW-2, XHH"</b>						
250	0.3970	2	7	17	31	34		14	0.0139	79	214	494	891	986
300	0.4608	2	6	14	26	29		12	0.0181	61	164	379	684	757
350	0.5242	2	5	13	23	26		10	0.0243	45	122	282	509	564
400	0.5863	1	5	11	21	23		8	0.0437	25	68	157	283	313
500	0.7073	1	4	9	17	19		6	0.0590	18	50	116	209	232
600	0.8676	1	3	7	14	15		4	0.0814	13	36	84	152	168
700	0.9887	1	3	6	12	13		3	0.0962	11	30	71	128	142
750	1.0496	1	2	6	11	13		2	0.1146	9	26	59	108	119
800	1.1085	0	2	6	11	12		1	0.1534	7	19	44	80	89
900	1.2311	0	2	5	10	11		1/0	0.1825	6	16	37	67	75
1000	1.3478	0	2	5	9	10		2/0	0.2190	5	13	31	56	62
<b>"PF, PGFF, PGF, PFF, PTE, PAF, PTFF, PAFF, TFE, FEP, PFA, FEPB, PFAH"</b>								3/0	0.2642	4	11	25	46	51
18	0.0058	190	513	1184	2135	2364		4/0	0.3197	3	9	21	38	42
16	0.0075	147	397	915	1651	1828		250	0.3904	2	7	17	31	35
14	0.0100	110	297	686	1238	1371		300	0.4536	2	6	15	27	30
12	0.0137	80	217	501	904	1000		350	0.5166	2	5	13	23	26
10	0.0191	57	156	359	648	717		400	0.5782	1	5	11	21	23
8	0.0333	33	89	206	371	411		500	0.6984	1	4	9	17	19
6	0.0468	23	63	146	264	292		600	0.8709	1	3	7	14	15
4	0.0670	16	44	102	184	204		700	0.9923	1	3	6	12	13
3	0.0804	13	37	85	154	170		750	1.0532	1	2	6	11	13
2	0.0973	11	30	70	127	140		800	1.1122	0	2	6	11	12
1	0.1399	7	21	49	88	98		900	1.2351	0	2	5	10	11
1/0	0.1676	6	17	40	73	81		1000	1.3519	0	2	5	9	10
2/0	0.2027	5	14	33	61	67		1250	1.7180	0	1	3	7	7
3/0	0.2463	4	12	27	50	55		1500	2.0157	0	1	3	6	6
4/0	0.3000	3	9	22	41	45		1750	2.3127	0	1	2	5	5
<b>"ZF, ZFF, Z"</b>								2000	2.6073	0	1	2	4	5
18	0.0045	245	662	1526	2752	3047		<b>"KF-2, KFF-2"</b>						
16	0.0061	181	488	1125	2030	2247		18	0.0031	356	961	2215	3995	4423
14	0.0083	133	359	827	1492	1652		16	0.0044	251	677	1560	2815	3116
12	0.0117	94	254	587	1058	1171		14	0.0064	172	465	1073	1935	2142
10	0.0191	57	156	359	648	717		12	0.0093	118	320	738	1331	1474
8	0.0302	36	98	227	410	454		10	0.0139	79	214	494	891	986
6	0.0430	25	69	159	288	318		<b>"KF-1, KFF-1"</b>						
4	0.06250	1	4	10	19	21		18	0.0026	424	1146	2641	4764	5273
3	0.0855	12	34	80	144	160		16	0.0037	298	805	1856	3347	3705
2	0.1029	10	28	66	120	133		14	0.0055	200	541	1248	2252	2493
1	0.1269	8	23	54	97	108		12	0.0083	133	359	827	1492	1652
1/0	0.1676	6	17	40	73	81		10	0.0127	86	234	540	975	1079

The 2008 National Electric Code limits wireway fill as follows:

1. A wireway shall not contain more than thirty current-carrying conductors except where the ampacity has been adjusted according to Table 310-15(b)(2)(a).
2. The sum of the cross-sectional areas of all conductors shall not exceed 20% of the interior cross-sectional area of the wireway.

NOTE: Section 14 of NFPA 79 allows 50% fill for industrial machine wireway.



**Lay-In Type 1 (Based on 2008 National Electric Code)**

Wireway Size and Maximum Number of Conductors Allowed (Areas shown are 20% of the full interior cross sectional area of the wireway)															
Conductor Size AWG-MCM	Area of Conductor (sq. in.)	2.50 x 2.50 (1.25 sq. in.)	4.00 x 4.00 (3.20 sq. in.)	6.00 x 6.00 (7.20 sq. in.)	8.00 x 8.00 (12.8 sq. in.)	10.00 x 10.00 (20 sq. in.)	12.00 x 12.00 (28.8 sq. in.)	Conductor Size AWG-MCM	Area of Conductor (sq. in.)	2.50 x 2.50 (1.25 sq. in.)	4.00 x 4.00 (3.20 sq. in.)	6.00 x 6.00 (7.20 sq. in.)	8.00 x 8.00 (12.8 sq. in.)	10.00 x 10.00 (20 sq. in.)	12.00 x 12.00 (28.8 sq. in.)
<b>"RFH-2, FFH-2, RH"</b>								12	0.0181	69	176	397	707	1104	1591
18	0.0145	86	220	496	882	1379	1986	10	0.0243	51	131	296	526	823	1185
16	0.0172	72	186	418	744	1162	1674	8	0.0437	28	73	164	292	457	659
14	0.0209	59	153	344	612	956	1377	<b>"RHH*, RHW*, RHW-2*, THHW, THW, AF, XF, XFF, THW-2, TW"</b>							
12	0.0260	48	123	276	492	769	1107	14	0.0209	59	153	344	612	956	1377
<b>"RHW-2, RHH, RHW"</b>								12	0.0260	48	123	276	492	769	1107
14	0.0293	42	109	245	436	682	982	10	0.0333	37	96	216	384	600	864
12	0.0353	35	90	203	362	566	815	8	0.0556	22	57	129	230	359	517
<b>"RHW-2, RHH, RHW, RH"</b>								6	0.0726	17	44	99	176	275	396
10	0.0437	28	73	164	292	457	659	4	0.0973	12	32	73	131	205	295
8	0.0835	14	38	86	153	239	344	3	0.1134	11	28	63	112	176	253
6	0.1041	12	30	69	122	192	276	2	0.1333	9	24	54	96	150	216
4	0.1333	9	24	54	96	150	216	1	0.1901	6	16	37	67	105	151
3	0.1521	8	21	47	84	131	189	1/0	0.2223	5	14	32	57	89	129
2	0.1750	7	18	41	73	114	164	2/0	0.2624	4	12	27	48	76	109
1	0.2660	4	12	27	48	75	108	3/0	0.3117	4	10	23	41	64	92
1/0	0.3039	4	10	23	42	65	94	4/0	0.3718	3	8	19	34	53	77
2/0	0.3505	3	9	20	36	57	82	250	0.4596	2	6	15	27	43	62
3/0	0.4072	3	7	17	31	49	70	300	0.5281	2	6	13	24	37	54
4/0	0.4754	2	6	15	26	42	60	350	0.5958	2	5	12	21	33	48
250	0.6291	1	5	11	20	31	45	400	0.6619	1	4	10	19	30	43
300	0.7088	1	4	10	18	28	40	500	0.7901	1	4	9	16	25	36
350	0.7870	1	4	9	16	25	36	600	0.9729	1	3	7	13	20	29
400	0.8626	1	3	8	14	23	33	700	1.1010	1	2	6	11	18	26
500	1.0082	1	3	7	12	19	28	750	1.1652	1	2	6	10	17	24
600	1.2135	1	2	5	10	16	23	800	1.2272	1	2	5	10	16	23
700	1.3561	0	2	5	9	14	21	900	1.3561	0	2	5	9	14	21
750	1.4272	0	2	5	8	14	20	1000	1.4784	0	2	4	8	13	19
800	1.4957	0	2	4	8	13	19	1250	1.8602	0	1	3	6	10	15
900	1.6377	0	1	4	7	12	17	1500	2.1695	0	1	3	5	9	13
1000	1.7719	0	1	4	7	11	16	1750	2.4773	0	1	2	5	8	11
1250	2.3479	0	1	3	5	8	12	2000	2.7818	0	1	2	4	7	10
1500	2.6938	0	1	2	4	7	10	<b>"TFN, TFFN, THHN, THWN, THWN-2"</b>							
1750	3.0357	0	1	2	4	6	9	18	0.0055	227	581	1309	2327	3636	5236
2000	3.3719	0	0	2	3	5	8	16	0.0072	173	444	1000	1777	2777	4000
<b>"SF-2, SFF-2"</b>								14	0.0097	128	329	742	1319	2061	2969
18	0.0115	108	278	626	1113	1739	2504	12	0.0133	93	240	541	962	1503	2165
16	0.0139	89	230	517	920	1438	2071	10	0.0211	59	151	341	606	947	1364
14	0.0172	72	186	418	744	1162	1674	8	0.0366	34	87	196	349	546	786
<b>"SF-1, SFF-1"</b>								6	0.0507	24	63	142	252	394	568
18	0.0065	192	492	1107	1969	3076	4430	4	0.0824	15	38	87	155	242	349
<b>"RFH-1, AF, XF, XFF, AF, TF, TFF, TW"</b>								3	0.0973	12	32	73	131	205	295
18	0.0080	156	400	900	1600	2500	3600	2	0.1158	10	27	62	110	172	248
16	0.0109	114	293	660	1174	1834	2642	1	0.1562	8	20	46	81	128	184
14	0.0139	89	230	517	920	1438	2071	1/0	0.1855	6	17	38	69	107	155

The 2008 National Electric Code limits wireway fill as follows:

1. A wireway shall not contain more than thirty current-carrying conductors except where the ampacity has been adjusted according to Table 310-15(b)(2)(a).

2. The sum of the cross-sectional areas of all conductors shall not exceed 20% of the interior cross-sectional area of the wireway.

NOTE: Section 14 of NFPA 79 allows 50% fill for industrial machine wireway.

Wireway Size and Maximum Number of Conductors Allowed (Areas shown are 20% of the full interior cross sectional area of the wireway)															
Conductor Size AWG-MCM	Area of Conductor (sq. in.)	2.50 x 2.50 (1.25 sq. in.)	4.00 x 4.00 (3.20 sq. in.)	6.00 x 6.00 (7.20 sq. in.)	8.00 x 8.00 (12.8 sq. in.)	10.00 x 10.00 (20 sq. in.)	12.00 x 12.00 (28.8 sq. in.)	Conductor Size AWG-MCM	Area of Conductor (sq. in.)	2.50 x 2.50 (1.25 sq. in.)	4.00 x 4.00 (3.20 sq. in.)	6.00 x 6.00 (7.20 sq. in.)	8.00 x 8.00 (12.8 sq. in.)	10.00 x 10.00 (20 sq. in.)	12.00 x 12.00 (28.8 sq. in.)
<b>Continued</b>								2/0	0.2027	6	15	35	63	98	142
2/0	0.2223	5	14	32	57	89	129	3/0	0.2463	5	12	29	51	81	116
3/0	0.2679	4	11	26	47	74	107	4/0	0.3000	4	10	24	42	66	96
4/0	0.3237	3	9	22	39	61	88	<b>"XHHW, ZW, XHHW-2, XHH"</b>							
250	0.3970	3	8	18	32	50	72	14	0.0139	89	230	517	920	1438	2071
300	0.4608	2	6	15	27	43	62	12	0.0181	69	176	397	707	1104	1591
350	0.5242	2	6	13	24	38	54	10	0.0243	51	131	296	526	823	1185
400	0.5863	2	5	12	21	34	49	8	0.0437	28	73	164	292	457	659
500	0.7073	1	4	10	18	28	40	6	0.0590	21	54	122	216	338	488
600	0.8676	1	3	8	14	23	33	4	0.0814	15	39	88	157	245	353
700	0.9887	1	3	7	12	20	29	3	0.0962	12	33	74	133	207	299
750	1.0496	1	3	6	12	19	27	2	0.1146	10	27	62	111	174	251
800	1.1085	1	2	6	11	18	25	1	0.1534	8	20	46	83	130	187
900	1.2311	1	2	5	10	16	23	1/0	0.1825	6	17	39	70	109	157
1000	1.3478	0	2	5	9	14	21	2/0	0.2190	5	14	32	58	91	131
<b>"PF, PGFF, PGF, PFF, PTF, PAF, PTF, PAFF, TFE, FEP, PFA, FEPB, PFAH"</b>								3/0	0.2642	4	12	27	48	75	109
18	0.0058	215	551	1241	2206	3448	4965	4/0	0.3197	3	10	22	40	62	90
16	0.0075	166	426	960	1706	2666	3840	250	0.3904	3	8	18	32	51	73
14	0.0100	125	320	720	1280	2000	2880	300	0.4536	2	7	15	28	44	63
12	0.0137	91	233	525	934	1459	2102	350	0.5166	2	6	13	24	38	55
10	0.0191	65	167	376	670	1047	1507	400	0.5782	2	5	12	22	34	49
8	0.0333	37	96	216	384	600	864	500	0.6984	1	4	10	18	28	41
6	0.0468	26	68	153	273	427	615	600	0.8709	1	3	8	14	22	33
4	0.0670	18	47	107	191	298	429	700	0.9923	1	3	7	12	20	29
3	0.0804	15	39	89	159	248	358	750	1.0532	1	3	6	12	18	27
2	0.0973	12	32	73	131	205	295	800	1.1122	1	2	6	11	17	25
1	0.1399	8	22	51	91	142	205	900	1.2351	1	2	5	10	16	23
1/0	0.1676	7	19	42	76	119	171	1000	1.3519	0	2	5	9	14	21
2/0	0.2027	6	15	35	63	98	142	1250	1.7180	0	1	4	7	11	16
3/0	0.2463	5	12	29	51	81	116	1500	2.0157	0	1	3	6	9	14
4/0	0.3000	4	10	24	42	66	96	1750	2.3127	0	1	3	5	8	12
<b>"ZF, ZFF, Z"</b>								2000	2.6073	0	1	2	4	7	11
18	0.0045	277	711	1600	2844	4444	6400	<b>"KF-2, KFF-2"</b>							
16	0.0061	204	524	1180	2098	3278	4721	18	0.0031	403	1032	2322	4129	6451	9290
14	0.0083	150	385	867	1542	2409	3469	16	0.0044	284	727	1636	2909	4545	6545
12	0.0117	106	273	615	1094	1709	2461	14	0.0064	195	500	1125	2000	3125	4500
10	0.0191	65	167	376	670	1047	1507	12	0.0093	134	344	774	1376	2150	3096
8	0.0302	41	105	238	423	662	953	10	0.0139	89	230	517	920	1438	2071
6	0.0430	29	74	167	297	465	669	<b>"KF-1, KFF-1"</b>							
4	0.06250	2	5	11	20	32	46	18	0.0026	480	1230	2769	4923	7692	11076
3	0.0855	14	37	84	149	233	336	16	0.0037	337	864	1945	3459	5405	7783
2	0.1029	12	31	69	124	194	279	14	0.0055	227	581	1309	2327	3636	5236
1	0.1269	9	25	56	100	157	226	12	0.0083	150	385	867	1542	2409	3469
1/0	0.1676	7	19	42	76	119	171	10	0.0127	98	251	566	1007	1574	2267

The 2008 National Electric Code limits wireway fill as follows:

1. A wireway shall not contain more than thirty current-carrying conductors except where the ampacity has been adjusted according to Table 310-15(b)(2)(a).
2. The sum of the cross-sectional areas of all conductors shall not exceed 20% of the interior cross-sectional area of the wireway.

NOTE: Section 14 of NFPA 79 allows 50% fill for industrial machine wireway.



Bulletin Number	Catalog Page	Bulletin Number	Catalog Page	Bulletin Number	Catalog Page
A1DR	14	A90P1	4, 8, 9, 10	F30G	123, 124, 125
A1L	22	A90RH	32	F40	100, 115
A1M	12, 20	A90S3	34	F40FC	107
A1PP	24	ARCT	76	F40G	100, 107
A1SM	18	D85	51	F40GF	101, 102, 103, 104, 105
A1UC	26	DBG	196, 207, 208, 209	F40GT	162, 163
A3LO	44, 45	DCR	191, 192, 193, 194, 195, 196, 197	F40PF	105, 109, 110, 111, 112, 113, 115, 117, 118, 119, 120, 121
A3M	42	DOFR2	195	F40PT	160, 162
A3PM	46, 50	DOFRW	49, 50, 197	F40T1	158
A3RD	52	DOT	198, 200, 201, 202, 203, 204	M1	88
A3RHD	59	DWS12	26	PNLP	11
A3RHD	56, 57, 58, 59	F10	113, 120, 129, 130, 131, 132, 133, 134, 135, 136, 137, 147	S90B	92
A3SM	40	F20	113, 121, 134, 135, 136, 142, 143, 144, 145, 146, 147	S90B3	80, 81
A90CM	72	F20HC	164	S90T	90
A90CT	68, 70, 74, 78, 79	F20SC	166	S90Y	93, 94
A90G3	38	F22	149, 150, 151	T90	62, 63
A90GS	30	F23	173, 174, 175, 176, 177, 178, 179, 180, 181, 182, 183, 184, 185, 186, 187	T90R3	64, 65
A90HC	16	F25	153, 154, 155, 168	UJ	82

CATALOG NUMBER INDEX



Catalog Number	UPC	Bulletin Number	Catalog Page	Catalog Number	UPC	Bulletin Number	Catalog Page	Catalog Number	UPC	Bulletin Number	Catalog Page
A10N104	34200	A1SM	18	A12R84	38070	A90S3	34	A18N18CLP	48999	A1M	21
A10N106	34390	A1SM	18	A12R84NK	13486	A90S3	35	A18R124	13393	A90S3	34
A10N84	34190	A1SM	18	A12R86	13394	A90S3	35	A18R126	38160	A90S3	35
A10N86	34420	A1SM	18	A12106GSC	56140	A90GS	31	A18R126NK	13504	A90S3	36
A10R104	38060	A90S3	34	A1212116RT	13346	F40PT	161	A18R128	38550	A90S3	35
A10R104GV	16544	A90G3	38	A121212GSC	49139	A90GS	31	A18R128NK	13515	A90S3	36
A10R104HM	15355	A90RH	33	A1212120T1T	11315	F40T1	159	A18R1810	13397	A90S3	35
A10R104NK	13487	A90S3	35	A12122UC	14766	A1UC	26	A18R1810HCR	13406	A3M	42
A10R106	38120	A90S3	34	A121224RT	43049	F40PT	161	A18R184	37970	A90S3	34
A10R106GV	16545	A90G3	38	A121224T1T	11307	F40T1	159	A18R184NK	13492	A90S3	36
A10R106NK	13497	A90S3	36	A121236RT	43059	F40PT	161	A18R186	38340	A90S3	35
A10R108GVNK	16971	A90G3	38	A121236T1T	11308	F40T1	159	A18R186GV	16551	A90G3	38
A10R84	38050	A90S3	34	A12124GSC	49019	A90GS	31	A18R186HCR	13403	A3M	42
A10R84NK	13485	A90S3	35	A121248RT	50199	F40PT	161	A18R186NK	13505	A90S3	36
A10R86	38110	A90S3	34	A121248T1T	11311	F40T1	159	A18R188	38570	A90S3	35
A10R86HCLO	38880	A3LO	44	A12126GSC	56150	A90GS	31	A18R188NK	13516	A90S3	36
A10R86HCR	38740	A3SM	40	A121260RT	43069	F40PT	161	A18R66NK	13494	A90S3	36
A10R86NK	13496	A90S3	36	A12126T1PP	16084	A1PP	24	A18186GSC	49059	A90GS	31
A1010116RT	13343	F40PT	161	A121260T1T	11312	F40T1	159	A20N12BLP	48979	A1M	20
A101024RT	43009	F40PT	161	A121272RT	43079	F40PT	161	A20N126	34670	A1SM	18
A101036RT	43019	F40PT	161	A121272T1T	11313	F40T1	159	A20N126LP	79910	A1M	12
A10104GSC	56130	A90GS	31	A12128GSC	49099	A90GS	31	A20N16ALP	85960	A1M	20
A101048RT	50189	F40PT	161	A121284RT	13344	F40PT	161	A20N16BLP	86050	A1M	20
A101048T1T	11302	F40T1	159	A121296RT	13345	F40PT	161	A20N166LP	79920	A1M	12
A10106GSC	49049	A90GS	31	A121296T1T	11314	F40T1	159	A20N168LP	80920	A1M	12
A101060RT	43029	F40PT	161	A14N124	34230	A1SM	18	A20N20ALP	85970	A1M	20
A101072RT	43039	F40PT	161	A14N126	34260	A1SM	18	A20N20BLP	86060	A1M	20
A10108GSC	49089	A90GS	31	A14N128	34430	A1SM	18	A20N206LP	79930	A1M	12
A101096RT	13342	F40PT	161	A1414116RT	13353	F40PT	161	A20N208LP	80930	A1M	12
A1084GSC	56120	A90GS	31	A141448RT	13347	F40PT	161	A20R166HCLO	38930	A3LO	44
A12N104	34210	A1SM	18	A141472RT	13348	F40PT	161	A20R166HCR	38680	A3M	42
A12N106	34240	A1SM	18	A141484RT	13351	F40PT	161	A20R208HCLO	38940	A3LO	44
A12N124	34220	A1SM	18	A141496RT	13352	F40PT	161	A20R208HCR	38690	A3M	42
A12N126	34250	A1SM	18	A15R126	38320	A90S3	35	A2016AT1PP	16086	A1PP	24
A12N128	34400	A1SM	18	A15R126NK	13502	A90S3	36	A20166GSC	56180	A90GS	31
A1200NECT	14924	ARCT	76	A15R128	50169	A90S3	35	A202012GSC	49159	A90GS	31
A12R104	60710	A90S3	34	A15R128NK	13514	A90S3	36	A20208GSC	56190	A90GS	31
A12R104NK	13488	A90S3	35	A16N12ALP	85930	A1M	20	A203012BGECT	16318	A90CT	79
A12R106	38140	A90S3	35	A16N12BLP	86040	A1M	20	A24N16ALP	85980	A1M	20
A12R106HCLO	38890	A3LO	44	A16N126	34660	A1SM	18	A24N166LP	79940	A1M	12
A12R106HCR	38750	A3SM	40	A16N126LP	79880	A1M	12	A24N168LP	80940	A1M	12
A12R106NK	13498	A90S3	36	A16N128LP	80910	A1M	12	A24N20ALP	85990	A1M	20
A12R1210HCR	13405	A3SM	40	A16N16ALP	85940	A1M	20	A24N20BLP	86070	A1M	20
A12R124	38080	A90S3	34	A16N166LP	79890	A1M	12	A24N20CLP	86130	A1M	21
A12R124GV	16546	A90G3	38	A16N20ALP	85950	A1M	20	A24N2010LP	81960	A1M	13
A12R124NK	13491	A90S3	36	A16N206LP	79900	A1M	12	A24N206LP	79950	A1M	12
A12R126	38150	A90S3	35	A16R126	43400	A90S3	35	A24N208LP	80950	A1M	12
A12R126GV	16547	A90G3	38	A16R126HCLO	38910	A3LO	44	A24N24ALP	86000	A1M	20
A12R126HCLO	38900	A3LO	44	A16R126HCR	38670	A3M	42	A24N24BLP	86080	A1M	20
A12R126HCR	38760	A3SM	40	A16R126NK	13503	A90S3	36	A24N24DLP	86140	A1M	21
A12R126HM	15356	A90RH	33	A16R166HCLO	38920	A3LO	44	A24N2412LP	81970	A1M	13
A12R126NK	13501	A90S3	36	A16R166HCR	38770	A3M	42	A24N246LP	79960	A1M	12
A12R128	37990	A90S3	35	A16126GSC	56160	A90GS	31	A24N248LP	80960	A1M	12
A12R128GV	16548	A90G3	38	A16126T1PP	16085	A1PP	24	A24R126	13395	A90S3	35
A12R128NK	13513	A90S3	36	A161612GSC	49149	A90GS	31	A24R168	13396	A90S3	35
A12R44	49179	A90S3	34	A16166GSC	56170	A90GS	31	A24R1810	13398	A90S3	35
				A16168GSC	49109	A90GS	31	A24R186	38360	A90S3	35



Catalog Number	UPC	Bulletin Number	Catalog Page	Catalog Number	UPC	Bulletin Number	Catalog Page	Catalog Number	UPC	Bulletin Number	Catalog Page
A24R186NK	13506	A90S3	36	A30R308HCR	13404	A3M	42	A4436RT	38220	F40PT	161
A24R188	38580	A90S3	35	A30S12UC	15664	A1UC	26	A4436T1T	11273	F40T1	159
A24R188NK	13517	A90S3	36	A302411HCT	42699	A90CT	70, 72	A4448RT	38230	F40PT	161
A24R206HM	15357	A90RH	33	A302412UC	14762	A1UC	26	A4448T1T	11274	F40T1	159
A24R208	43410	A90S3	35	A30248GSC	56220	A90GS	31	A4460RT	38240	F40PT	161
A24R208HCLO	38950	A3LO	44	A303011CT	47499	A90CT	68, 72	A4460T1T	11275	F40T1	159
A24R208HCR	38700	A3M	42	A303012CTCJ	14516	A90CT	78	A4472RT	13335	F40PT	161
A24R208NK	13518	A90S3	36	A303012GSC	50520	A90GS	31	A4472T1T	11276	F40T1	159
A24R2410	49269	A90S3	35	A304410CTC	13782	A90CT	78	A4496T1T	11278	F40T1	159
A24R2410GV	16552	A90G3	38	A32N34HQ	13932	M1	88	A48N3609	34530	A1L	22
A24R2410HCR	49279	A3M	42	A36N24ALP	86020	A1M	20	A48N3611	34560	A1L	22
A24R2410NK	13524	A90S3	36	A36N24BLP	86110	A1M	21	A48N3613	34760	A1L	22
A24R2412	38620	A90S3	35	A36N246LP	79990	A1M	12	A48N3617	34610	A1L	22
A24R2412NK	13525	A90S3	36	A36N248LP	81940	A1M	13	A48R3612HCR	42750	A3M	42
A24R246	39540	A90S3	35	A36N30ALP	86030	A1M	20	A48R3616	43450	A90S3	35
A24R246NK	13507	A90S3	36	A36N30BLP	86120	A1M	21	A48R3616HCR	43480	A3M	42
A24R248	38980	A90S3	35	A36N30DLP	86160	A1M	21	A48R3616NK	13807	A90S3	36
A24R248GV	16938	A90G3	38	A36N3012LP	81990	A1M	13	A48R368	49259	A90S3	35
A24R248HCLO	38960	A3LO	44	A36N306LP	80900	A1M	12	A48R368NK	13523	A90S3	36
A24R248HCR	38780	A3M	42	A36N308LP	81950	A1M	13	A482411HCT	42709	A90CT	70, 72
A24R248NK	13521	A90S3	36	A36R2412HCR	38800	A3M	42	A483011HCT	42729	A90CT	70, 72
A24R88NK	13512	A90S3	36	A36R3012	42890	A90S3	35	A483611CT	47529	A90CT	68, 72
A2420AT1PP	16087	A1PP	24	A36R3012HCR	42710	A3M	42	A483611HCT	42749	A90CT	70, 72
A24208GSC	56200	A90GS	31	A36R3012NK	13804	A90S3	36	A484814CTCJ	14514	A90CT	78
A242410GSC	49129	A90GS	31	A36R3610HCR	13407	A3M	42	A484814HCT	15306	A90CT	70
A242411CT	47489	A90CT	68	A36R3612	43440	A90S3	35	A6N64	34340	A1SM	18
A242412GSC	49169	A90GS	31	A36R3612HCR	42730	A3M	42	A60R2518FSLP	14412	A3PM	47
A242412UC	14761	A1UC	26	A36R3612NK	13805	A90S3	36	A60R2524FSLP	14413	A3PM	47
A24246GSC	49069	A90GS	31	A362011HCT	42689	A90CT	70	A60R3612HCR	42760	A3M	42
A24248GSC	56210	A90GS	31	A3624AT1PP	16088	A1PP	24	A60R3618FSLP	14415	A3PM	47
A243210CTC	13783	A90CT	78	A3630AT1PP	16091	A1PP	24	A6R44	13392	A90S3	34
A243212CTDP	14802	A90CT	78	A363011CT	47509	A90CT	68, 72	A6R44HCR	13402	A3SM	40
A30N20BLP	48989	A1M	21	A363011HCT	42719	A90CT	70, 72	A60R5218FSLP	14423	A3PM	48
A30N206LP	79970	A1M	12	A363012UC	14764	A1UC	26	A60R5224FSLP	14424	A3PM	48
A30N208LP	80970	A1M	12	A363611CT	47519	A90CT	68, 72	A6R64	38020	A90S3	34
A30N24ALP	86010	A1M	20	A363611HCT	42739	A90CT	70, 72	A6R64GV	16553	A90G3	38
A30N24BLP	86090	A1M	21	A363612GSC	56250	A90GS	31	A6R64HCR	38710	A3SM	40
A30N24CLP	14276	A1M	21	A363614CTCJ	14517	A90CT	78	A6R64NK	13482	A90S3	35
A30N24DLP	86150	A1M	21	A364214BGECT	16321	A90CT	79	A6R66	37980	A90S3	34
A30N2412LP	81980	A1M	13	A400HCTB	14576	A90CT	79	A6R66GV	16934	A90G3	38
A30N246LP	79980	A1M	13	A4R44	37960	A90S3	34	A6R66NK	13493	A90S3	36
A30N248LP	80980	A1M	13	A4R44GV	16933	A90G3	38	A60R7224FSLP	14418	A3PM	48
A30N30BLP	86100	A1M	21	A4R44NK	13478	A90S3	35	A62N17HQ	13931	M1	88
A30N308LP	80990	A1M	13	A404014CTDP	14168	A90CT	79	A65N38HQ	13928	M1	88
A3PMIS	14578	A3PM	50	A42N3009	34510	A1L	22	A6612RT	38260	F40PT	161
A30R2410	13401	A90S3	35	A42N3013	34740	A1L	22	A6612T1T	11281	F40T1	159
A30R2410HCR	49289	A3M	42	A42N3609	34520	A1L	22	A6618RT	13336	F40PT	161
A30R248	38990	A90S3	35	A42N3613	34750	A1L	22	A6624RT	38270	F40PT	161
A30R248HCLO	38970	A3LO	44	A42R3012HCR	42720	A3M	42	A6624T1T	11282	F40T1	159
A30R248HCR	38790	A3M	42	A42R3612HCR	42740	A3M	42	A6636RT	38280	F40PT	161
A30R248NK	13522	A90S3	36	A423614BGECT	16322	A90CT	79	A6636T1T	11283	F40T1	159
A30R3012	43420	A90S3	35	A424214CTCJ	14515	A90CT	78	A664GSC	56090	A90GS	31
A30R3012HCR	42700	A3M	42	A4412RT	38200	F40PT	161	A6648RT	38290	F40PT	161
A30R3012NK	13803	A90S3	36	A4412T1T	11271	F40T1	159	A6648T1T	11284	F40T1	159
A30R3016	38640	A90S3	35	A4418RT	16658	F40PT	161	A666GSC	49029	A90GS	31
A30R3016HCR	42770	A3M	42	A4424RT	38210	F40PT	161	A6660RT	38300	F40PT	161
A30R3016NK	13806	A90S3	36	A4424T1T	11272	F40T1	159	A6660T1T	11285	F40T1	159



Catalog Number	UPC	Bulletin Number	Catalog Page	Catalog Number	UPC	Bulletin Number	Catalog Page	Catalog Number	UPC	Bulletin Number	Catalog Page
A6672RT	38310	F40PT	161	AFE10X10	43700	A90P1	8	ASB123R	13866	S90B	92
A6672T1T	11286	F40T1	159	AFE10X8	43680	A90P1	8	ASB124R	13872	S90B	92
A6696T1T	11288	F40T1	159	AFE12X12	43720	A90P1	8	ASB223R	13867	S90B	92
A72R2518FSLP	14414	A3PM	47	AFE12X8	43690	A90P1	8	ASB224R	13873	S90B	92
A72R3618FSLP	14416	A3PM	47	AFE18X12	43740	A90P1	8	ASB403R	13868	S90B	92
A72R3624FSLP	14417	A3PM	47	AFE18X18	43770	A90P1	8	ASB404R	13874	S90B	92
A72R7218FSLP	14421	A3PM	48	AFE24X18	43780	A90P1	8	ASB83R	13865	S90B	92
A72R7224FSLP	14422	A3PM	48	AFE24X24	43790	A90P1	8	ASB84R	13871	S90B	92
A800HCT1R	18701	A90CT	74	AFE6X6	43640	A90P1	8	ASBB125	49840	S90Y	93
A800HCTB	14575	A90CT	79	AFE8X6	43650	A90P1	8	ASBB225	49850	S90Y	93
A8N64	34170	A1SM	18	AFE8X8	43670	A90P1	8	ASBB400R	13933	S90Y	93
A8N66	14275	A1SM	18	AHE10X10X4	51110	A90HC	16	ASBB85	49830	S90Y	93
A8N84	34180	A1SM	18	AHE10X10X6	51180	A90HC	16	ASE10X10X4	43070	A90P1	4
A8N86	34890	A1SM	18	AHE10X8X4	51090	A90HC	16	ASE10X10X4NK	43360	A90P1	5
A800NECT	14923	ARCT	76	AHE10X8X6	51680	A90HC	16	ASE10X10X6	43200	A90P1	5
A8R64	38030	A90S3	34	AHE12X10X4	51120	A90HC	16	ASE10X10X6NK	43490	A90P1	6
A8R64HCLO	38860	A3LO	44	AHE12X10X6	60700	A90HC	16	ASE10X10X8NK	49579	A90P1	6
A8R64HCR	38720	A3SM	40	AHE12X12X4	51140	A90HC	16	ASE10X6X4NK	49319	A90P1	5
A8R64NK	13483	A90S3	35	AHE12X12X6	51220	A90HC	16	ASE10X8X4	43050	A90P1	4
A8R84	38040	A90S3	34	AHE12X8X4	51100	A90HC	16	ASE10X8X4NK	43340	A90P1	5
A8R84GV	16935	A90G3	38	AHE16X12X4	86530	A90HC	16	ASE10X8X6	43180	A90P1	5
A8R84HM	15354	A90RH	33	AHE16X12X6	85910	A90HC	16	ASE10X8X6NK	43470	A90P1	6
A8R84NK	13484	A90S3	35	AHE16X16X6	85920	A90HC	16	ASE12X10X4	43080	A90P1	4
A8R86	38100	A90S3	34	AHE18X12X4	51160	A90HC	16	ASE12X10X4NK	43370	A90P1	6
A8R86GV	16936	A90G3	38	AHE18X12X6	51240	A90HC	16	ASE12X10X6	43210	A90P1	5
A8R86HCLO	38870	A3LO	44	AHE18X18X6	51280	A90HC	16	ASE12X10X6NK	60650	A90P1	6
A8R86HCR	38730	A3SM	40	AHE24X18X6	51290	A90HC	16	ASE12X10X8NK	49599	A90P1	6
A8R86NK	13495	A90S3	36	AHE24X24X6	51690	A90HC	16	ASE12X12X10NK	49759	A90P1	7
A8R88	49229	A90S3	35	AHE30X24X6	51700	A90HC	16	ASE12X12X12NK	49919	A90P1	7
A8R88GV	16937	A90G3	38	AHE36X24X6	51310	A90HC	16	ASE12X12X4	43090	A90P1	4
A8R88GVNK	16972	A90G3	38	AHE36X24X8	86520	A90HC	16	ASE12X12X4NK	43380	A90P1	6
A8R88NK	13508	A90S3	36	AHE6X4X4	51000	A90HC	16	ASE12X12X6	43220	A90P1	5
A864GSC	56100	A90GS	31	AHE6X6X4	51050	A90HC	16	ASE12X12X6NK	43510	A90P1	6
A88116RT	13341	F40PT	161	AHE6X6X6	51210	A90HC	16	ASE12X12X8	46990	A90P1	5
A8812RT	13337	F40PT	161	AHE8X6X4	51060	A90HC	16	ASE12X12X8NK	47420	A90P1	6
A8824RT	38380	F40PT	161	AHE8X8X4	51080	A90HC	16	ASE12X6X4NK	49339	A90P1	5
A8824T1T	11291	F40T1	159	AHE8X8X6	51170	A90HC	16	ASE12X6X6NK	13386	A90P1	6
A8836RT	38390	F40PT	161	ALDF1212W	16093	A90P1	10	ASE12X8X4	43060	A90P1	4
A8836T1T	11292	F40T1	159	ALDF88W	16092	A90P1	10	ASE12X8X4NK	43350	A90P1	6
A884GSC	56110	A90GS	31	ALTC3R	14681	T90R3	65	ASE12X8X6NK	49459	A90P1	6
A8848RT	38400	F40PT	161	AMC202010UG	16393	M1	88	ASE15X15X4NK	49359	A90P1	6
A8848T1T	11293	F40T1	159	AMC271310R	13785	M1	88	ASE16X12X4	86430	A90P1	4
A886GSC	49039	A90GS	31	AMC302010R	13786	M1	88	ASE16X12X4NK	86300	A90P1	6
A8860RT	38410	F40PT	161	AMC303010HQ	13912	M1	88	ASE16X12X6	86440	A90P1	5
A8860T1T	11294	F40T1	159	AMC303010R	13787	M1	88	ASE16X12X6NK	86460	A90P1	6
A8872RT	42999	F40PT	161	AMC303010UG	16394	M1	88	ASE16X12X8	13358	A90P1	5
A8872T1T	11295	F40T1	159	AMC363612HQ	13913	M1	88	ASE16X12X8NK	49619	A90P1	6
A888GSC	49079	A90GS	31	AMC363612R	13788	M1	88	ASE16X14X3	41679	A90P1	4
A8896RT	13338	F40PT	161	AMC363612UG	16395	M1	88	ASE16X14X3NK	41699	A90P1	5
A8896T1T	11297	F40T1	159	AMC484812HQ	13914	M1	88	ASE16X16X6	86450	A90P1	5
AFDF0606P	43630	A90P1	9	AMC484812R	13791	M1	88	ASE16X16X6NK	86310	A90P1	6
AFDF1212P	42930	A90P1	9	AMC484812UG	16396	M1	88	ASE18X12X10	13367	A90P1	5
AFDF1812P	42940	A90P1	9	AMFK3RL014	38180	A3LO	45	ASE18X12X10NK	49779	A90P1	7
AFDF1818P	42950	A90P1	9	AMFK3RL016	38170	A3LO	45	ASE18X12X4	43110	A90P1	4
AFDF2418P	42960	A90P1	9	APLK3R	14277	F40GT	163	ASE18X12X4NK	86320	A90P1	6
AFDF2424P	42970	A90P1	9	APMK3RL014	38250	A3LO	45	ASE18X12X6	43240	A90P1	5
AFDF3024P	42980	A90P1	9	APMK3RL016	38190	A3LO	45	ASE18X12X6NK	43530	A90P1	6



Catalog Number	UPC	Bulletin Number	Catalog Page	Catalog Number	UPC	Bulletin Number	Catalog Page	Catalog Number	UPC	Bulletin Number	Catalog Page
ASE18X12X8	13361	A90P1	5	ASE36X24X10	13375	A90P1	5	ASG12X12X4NK	42380	A90P1	6
ASE18X12X8NK	49639	A90P1	6	ASE36X24X10NK	49879	A90P1	7	ASG12X12X6	42220	A90P1	5
ASE18X14X3	41719	A90P1	4	ASE36X24X12	13383	A90P1	5	ASG12X12X6NK	42510	A90P1	6
ASE18X15X4NK	49379	A90P1	6	ASE36X24X12NK	50039	A90P1	7	ASG12X12X8	47220	A90P1	5
ASE18X18X10	13371	A90P1	5	ASE36X24X6	86290	A90P1	5	ASG12X12X8NK	48490	A90P1	6
ASE18X18X10NK	49799	A90P1	7	ASE36X24X6NK	86350	A90P1	6	ASG12X6X4NK	49349	A90P1	5
ASE18X18X12	13377	A90P1	5	ASE36X24X8	13366	A90P1	5	ASG12X8X4	42060	A90P1	4
ASE18X18X12NK	49959	A90P1	7	ASE36X24X8NK	43830	A90P1	7	ASG12X8X4NK	42350	A90P1	6
ASE18X18X4	46890	A90P1	4	ASE36X30X6NK	49539	A90P1	6	ASG12X8X6NK	49469	A90P1	6
ASE18X18X4NK	47230	A90P1	6	ASE36X36X10NK	49899	A90P1	7	ASG15X15X4NK	49369	A90P1	6
ASE18X18X6	43270	A90P1	5	ASE36X36X12NK	43860	A90P1	7	ASG16X12X4	86490	A90P1	4
ASE18X18X6NK	43560	A90P1	6	ASE36X36X16NK	50099	A90P1	7	ASG16X12X4NK	86470	A90P1	6
ASE18X18X8NK	86330	A90P1	6	ASE36X36X6NK	47330	A90P1	6	ASG16X12X6	86500	A90P1	5
ASE20X14X3NK	41779	A90P1	5	ASE36X36X8NK	49739	A90P1	7	ASG16X12X6NK	86480	A90P1	6
ASE24X12X10NK	13387	A90P1	7	ASE4X4X3	41559	A90P1	4	ASG16X16X6	86510	A90P1	5
ASE24X12X12	13376	A90P1	5	ASE4X4X3NK	41579	A90P1	5	ASG16X16X6NK	86370	A90P1	6
ASE24X12X12NK	49939	A90P1	7	ASE4X4X4	42990	A90P1	4	ASG18X12X4	42110	A90P1	4
ASE24X12X4	13354	A90P1	4	ASE4X4X4NK	60630	A90P1	5	ASG18X12X4NK	86380	A90P1	6
ASE24X12X4NK	13384	A90P1	6	ASE48X48X12NK	50059	A90P1	7	ASG18X12X6	42240	A90P1	5
ASE24X12X6NK	49479	A90P1	6	ASE48X48X16NK	50119	A90P1	7	ASG18X12X6NK	42530	A90P1	6
ASE24X12X8	13362	A90P1	5	ASE6X4X4	43000	A90P1	4	ASG18X12X8NK	49649	A90P1	6
ASE24X12X8NK	49659	A90P1	6	ASE6X4X4NK	60640	A90P1	5	ASG18X18X10NK	49809	A90P1	7
ASE24X18X10	13372	A90P1	5	ASE6X6X3	41599	A90P1	4	ASG18X18X12NK	49969	A90P1	7
ASE24X18X10NK	49819	A90P1	7	ASE6X6X3NK	41619	A90P1	5	ASG18X18X4	47020	A90P1	4
ASE24X18X12	13378	A90P1	5	ASE6X6X4	43010	A90P1	4	ASG18X18X4NK	47840	A90P1	6
ASE24X18X12NK	49979	A90P1	7	ASE6X6X4NK	43300	A90P1	5	ASG18X18X6	42270	A90P1	5
ASE24X18X4NK	49399	A90P1	6	ASE6X6X6	43140	A90P1	5	ASG18X18X6NK	42560	A90P1	6
ASE24X18X6	43280	A90P1	6	ASE6X6X6NK	43430	A90P1	6	ASG18X18X8NK	86390	A90P1	6
ASE24X18X6NK	43570	A90P1	6	ASE8X6X3	41639	A90P1	4	ASG24X12X12NK	49949	A90P1	7
ASE24X18X8	13363	A90P1	5	ASE8X6X3NK	41659	A90P1	5	ASG24X12X6NK	49489	A90P1	6
ASE24X18X8NK	43800	A90P1	7	ASE8X6X4	43020	A90P1	4	ASG24X12X8NK	49669	A90P1	6
ASE24X20X6NK	49499	A90P1	6	ASE8X6X4NK	43310	A90P1	5	ASG24X18X4NK	49409	A90P1	6
ASE24X20X8NK	49699	A90P1	7	ASE8X6X6	13356	A90P1	5	ASG24X18X6	42280	A90P1	5
ASE24X24X10	13373	A90P1	5	ASE8X6X6NK	49439	A90P1	6	ASG24X18X6NK	42570	A90P1	6
ASE24X24X10NK	49839	A90P1	7	ASE8X8X4	43040	A90P1	4	ASG24X18X8NK	49689	A90P1	7
ASE24X24X12	13381	A90P1	5	ASE8X8X4NK	43330	A90P1	5	ASG24X20X6NK	49509	A90P1	6
ASE24X24X12NK	49999	A90P1	7	ASE8X8X6	43170	A90P1	5	ASG24X20X8NK	49709	A90P1	7
ASE24X24X4	46900	A90P1	4	ASE8X8X6NK	43460	A90P1	6	ASG24X24X10NK	49849	A90P1	7
ASE24X24X4NK	47310	A90P1	6	ASE8X8X8	13357	A90P1	5	ASG24X24X12NK	50009	A90P1	7
ASE24X24X6	43290	A90P1	5	ASE8X8X8NK	49559	A90P1	6	ASG24X24X4	47080	A90P1	4
ASE24X24X6NK	43580	A90P1	6	ASG10X10X4	42070	A90P1	4	ASG24X24X4NK	48390	A90P1	6
ASE24X24X8	13364	A90P1	5	ASG10X10X4NK	42360	A90P1	5	ASG24X24X6	42290	A90P1	5
ASE24X24X8NK	43810	A90P1	7	ASG10X10X6	42200	A90P1	5	ASG24X24X6NK	42580	A90P1	6
ASE30X24X10NK	13388	A90P1	7	ASG10X10X6NK	42490	A90P1	6	ASG24X24X8NK	42590	A90P1	7
ASE30X24X12	13382	A90P1	5	ASG10X10X8NK	49589	A90P1	6	ASG30X24X6	42160	A90P1	5
ASE30X24X12NK	13391	A90P1	7	ASG10X6X4NK	49329	A90P1	5	ASG30X24X6NK	86400	A90P1	6
ASE30X24X4	13355	A90P1	4	ASG10X8X4	42050	A90P1	4	ASG30X24X8NK	49729	A90P1	7
ASE30X24X4NK	49419	A90P1	6	ASG10X8X4NK	42340	A90P1	5	ASG30X30X10NK	49869	A90P1	7
ASE30X24X6	43160	A90P1	5	ASG10X8X6	42180	A90P1	5	ASG30X30X12NK	50029	A90P1	7
ASE30X24X6NK	86340	A90P1	6	ASG10X8X6NK	60680	A90P1	6	ASG30X30X6NK	49529	A90P1	6
ASE30X24X8NK	43820	A90P1	7	ASG12X10X4	42080	A90P1	4	ASG30X30X8NK	42600	A90P1	7
ASE30X30X10NK	49859	A90P1	7	ASG12X10X4NK	42370	A90P1	6	ASG36X24X10NK	49889	A90P1	7
ASE30X30X12NK	50019	A90P1	7	ASG12X10X6	42210	A90P1	5	ASG36X24X12NK	50049	A90P1	7
ASE30X30X16NK	50079	A90P1	7	ASG12X10X6NK	60690	A90P1	6	ASG36X24X6NK	86410	A90P1	6
ASE30X30X4NK	47320	A90P1	6	ASG12X12X10NK	49769	A90P1	7	ASG36X24X8NK	86420	A90P1	7
ASE30X30X6NK	49519	A90P1	6	ASG12X12X12NK	49929	A90P1	7	ASG36X36X10NK	49909	A90P1	7
ASE30X30X8NK	43840	A90P1	7	ASG12X12X4	42090	A90P1	4	ASG36X36X12NK	42610	A90P1	7

Catalog Number	UPC	Bulletin Number	Catalog Page	Catalog Number	UPC	Bulletin Number	Catalog Page	Catalog Number	UPC	Bulletin Number	Catalog Page
ASG36X36X16NK	50109	A90P1	7	AST6224R	13702	S90T	91	ATC36366S	42969	T90	63
ASG36X36X6NK	48480	A90P1	6	AST6403R	13685	S90T	91	ATC42R369	14408	T90R3	64
ASG36X36X8NK	49749	A90P1	7	AST6404R	13705	S90T	91	ATC48R369	14803	T90R3	64
ASG4	13924	S90Y	94	AST6603R	13688	S90T	91	ATC48R489	14411	T90R3	64
ASG4X4X3	41569	A90P1	4	AST6604R	13708	S90T	91	ATCL	13253	T90	63
ASG4X4X3NK	41589	A90P1	5	ASTB125	49790	S90Y	94	CT1420SS	16757	F23	186
ASG4X4X4	41990	A90P1	4	ASTB225	49800	S90Y	94	CT22AESS	15815	F23	183
ASG4X4X4NK	60660	A90P1	5	ASTB400	49810	S90Y	94	CT22CPSS	15808	F23	183
ASG48X48X12NK	50069	A90P1	7	ASTB600	49820	S90Y	94	CT22CSS	15791	F23	181
ASG48X48X16NK	50129	A90P1	7	ASTB85	49780	S90Y	94	CT22EFC45SS	15765	F23	177
ASG6X4X4	42000	A90P1	4	ATC10104F	44419	T90	62	CT22EFC90SS	15734	F23	174
ASG6X4X4NK	60670	A90P1	5	ATC10104S	42759	T90	62	CT22EFCNT90SS	17765	F23	174
ASG6X6X3	41609	A90P1	4	ATC12R145	14403	T90R3	64	CT22EIC45SS	15753	F23	177
ASG6X6X3NK	41629	A90P1	5	ATC12124F	44429	T90	62	CT22EIC90SS	15741	F23	174
ASG6X6X4	42010	A90P1	4	ATC12124S	42769	T90	62	CT22EOC45SS	15758	F23	177
ASG6X6X4NK	42300	A90P1	5	ATC12126F	44549	T90	63	CT22EOC90SS	15746	F23	174
ASG6X6X6	42140	A90P1	5	ATC12126S	42889	T90	63	CT22HB	17153	F23	187
ASG6X6X6NK	42430	A90P1	6	ATC18124F	44439	T90	62	CT22LB	17154	F23	187
ASG8	13925	S90Y	94	ATC18124S	42779	T90	62	CT22P120SS	16097	F23	173
ASG8X6X3	41649	A90P1	4	ATC18126F	44559	T90	63	CT22PCSS	16573	F23	181
ASG8X6X3NK	41669	A90P1	5	ATC18126S	42899	T90	63	CT22PEFC45SS	16561	F23	177
ASG8X6X4	42020	A90P1	4	ATC18184F	44449	T90	62	CT22PEFC90SS	16554	F23	174
ASG8X6X4NK	42310	A90P1	5	ATC18184S	42789	T90	62	CT22PEFCNT90SS	17772	F23	175
ASG8X6X6NK	49449	A90P1	6	ATC18186F	44569	T90	63	CT22PSPSS	16578	F23	185
ASG8X8X4	42040	A90P1	4	ATC18186S	42909	T90	63	CT22PTFCSS	16566	F23	179
ASG8X8X4NK	42330	A90P1	5	ATC24184F	44459	T90	62	CT22SCSS	16111	F23	186
ASG8X8X6	42170	A90P1	5	ATC24184S	42799	T90	62	CT22SPSS	16104	F23	185
ASG8X8X6NK	42460	A90P1	6	ATC24186F	44579	T90	63	CT22TFCSS	15772	F23	179
ASG8X8X8NK	49569	A90P1	6	ATC24186S	42919	T90	63	CT22TOCSS	15784	F23	179
AST2123R	13673	S90T	91	ATC24244F	44469	T90	62	CT22TSS	17824	F23	173
AST2124R	13694	S90T	91	ATC24244S	42809	T90	62	CT22UCSS	15803	F23	182
AST283R	13668	S90T	91	ATC24246F	44589	T90	63	CT22VSS	17831	F23	179
AST284R	13691	S90T	91	ATC24246S	42929	T90	63	CT22WB	17156	F23	187
AST3123R	13674	S90T	91	ATC26R248	14404	T90R3	64	CT22120SS	15727	F23	173
AST3124R	13695	S90T	91	ATC30244F	44479	T90	62	CT2233CEC	16755	F23	184
AST3223R	13676	S90T	91	ATC30244S	42819	T90	62	CT33AESS	15816	F23	183
AST3224R	13697	S90T	91	ATC30246S	46619	T90	63	CT33CPSS	15811	F23	183
AST3403R	13682	S90T	91	ATC30304S	42829	T90	62	CT33CSS	15792	F23	181
AST383R	13671	S90T	91	ATC30306F	44599	T90	63	CT33DEFC45SS	16148	F23	182
AST384R	13692	S90T	91	ATC30306S	42939	T90	63	CT33DEFC90SS	16117	F23	182
AST4123R	13675	S90T	91	ATC36R248	14405	T90R3	64	CT33DEIC45SS	16136	F23	182
AST4124R	13696	S90T	91	ATC36R308	14406	T90R3	64	CT33DEIC90SS	16124	F23	182
AST4223R	13677	S90T	91	ATC36R3612	15361	T90R3	64	CT33DEOC45SS	16143	F23	182
AST4224R	13698	S90T	91	ATC36R366	15358	T90R3	64	CT33DEOC90SS	16131	F23	182
AST4403R	13683	S90T	91	ATC36R369	14407	T90R3	64	CT33DSPSS	15834	F23	185
AST4404R	13703	S90T	91	ATC36244F	44509	T90	62	CT33DSS	15797	F23	173
AST4603R	13686	S90T	91	ATC36244S	42849	T90	62	CT33DTFCSS	16155	F23	181
AST4604R	13706	S90T	91	ATC36246F	44609	T90	63	CT33DTICSS	16162	F23	181
AST483R	13672	S90T	91	ATC36246S	42949	T90	63	CT33DOTCSS	16167	F23	181
AST484R	13693	S90T	91	ATC36304S	42859	T90	63	CT33EFC45SS	15766	F23	177
AST5223R	13678	S90T	91	ATC36306F	44619	T90	63	CT33EFC90SS	15735	F23	174
AST5224R	13701	S90T	91	ATC36306S	42959	T90	63	CT33EFCNT90SS	17766	F23	174
AST5403R	13684	S90T	91	ATC36308F	44649	T90	63	CT33EIC45SS	15754	F23	177
AST5404R	13704	S90T	91	ATC36308S	42989	T90	63	CT33EIC90SS	15742	F23	174
AST5603R	13687	S90T	91	ATC36364F	44529	T90	63	CT33EOC45SS	15761	F23	177
AST5604R	13707	S90T	91	ATC36364S	42869	T90	63	CT33EOC90SS	15747	F23	174
AST6223R	13681	S90T	91	ATC36366F	44629	T90	63	CT33HB	17157	F23	187

Catalog Number	UPC	Bulletin Number	Catalog Page	Catalog Number	UPC	Bulletin Number	Catalog Page	Catalog Number	UPC	Bulletin Number	Catalog Page
CT33LB	17158	F23	187	CT44UCSS	15805	F23	182	CT66EOC45SS	15764	F23	177
CT33P12OSS	16098	F23	173	CT44VSS	17833	F23	179	CT66EOC90SS	15752	F23	174
CT33PCSS	16574	F23	181	CT44WB	17167	F23	187	CT66HB	17162	F23	187
CT33PEFC45SS	16562	F23	177	CT44120SS	15731	F23	173	CT66LB	17163	F23	187
CT33PEFC90SS	16555	F23	174	CT4422RSS	15824	F23	184	CT66P120SS	16103	F23	173
CT33PEFCNT90SS	17773	F23	175	CT4433RSS	15823	F23	184	CT66PCSS	16577	F23	181
CT33PSPSS	16581	F23	185	CT4466CEC	16756	F23	184	CT66PEFC45SS	16565	F23	177
CT33PTFCSS	16567	F23	179	CT46AESS	15818	F23	183	CT66PEFC90SS	16558	F23	174
CT33SCSS	16112	F23	186	CT46CPSS	15813	F23	183	CT66PEFCNT90SS	17776	F23	175
CT33SPSS	16105	F23	185	CT46CSS	15794	F23	181	CT66PSPSS	16584	F23	185
CT33TDSPPSS	18507	F23	174	CT46DEFC45SS	16152	F23	182	CT66PTFCSS	16572	F23	179
CT33TFCSS	15773	F23	179	CT46DEFC90SS	16121	F23	182	CT66SCSS	16115	F23	186
CT33TICSS	15778	F23	179	CT46DTFCSS	16157	F23	181	CT66SPSS	16108	F23	185
CT33TOCSS	15785	F23	179	CT46EFC45SS	15768	F23	177	CT66TDSPPSS	18511	F23	174
CT33TSS	17825	F23	173	CT46EFC90SS	15737	F23	174	CT66TFCSS	15776	F23	179
CT33UCSS	15804	F23	182	CT46EFCNT90SS	17768	F23	174	CT66TICSS	15783	F23	179
CT33VSS	17832	F23	179	CT46EIC45SS	15756	F23	177	CT66TOCSS	15788	F23	179
CT33WB	17161	F23	187	CT46EIC90SS	15744	F23	174	CT66TSS	17828	F23	173
CT33120SS	15728	F23	173	CT46EOC45SS	15763	F23	177	CT66UCSS	15807	F23	182
CT3322RSS	15822	F23	184	CT46EOC90SS	15751	F23	174	CT66VSS	17835	F23	179
CT44AESS	15817	F23	183	CT46P120SS	16102	F23	173	CT66WB	17164	F23	187
CT44CPSS	15812	F23	183	CT46PCSS	16576	F23	181	CT66120SS	15733	F23	173
CT44CSS	15793	F23	181	CT46PEFC45SS	16564	F23	177	CT6622RSS	15827	F23	184
CT44DEFC45SS	16151	F23	182	CT46PEFC90SS	16557	F23	174	CT6633RSS	15832	F23	184
CT44DEFC90SS	16118	F23	182	CT46PEFCNT90SS	17775	F23	175	CT6644RSS	15831	F23	184
CT44EIC45SS	16137	F23	182	CT46PSPSS	16583	F23	185	CT6646RSS	15828	F23	184
CT44EIC90SS	16125	F23	182	CT46PTFCSS	16571	F23	179	CTLCH3SS	17821	F23	187
CT44EOC45SS	16144	F23	182	CT46SCSS	16114	F23	186	CTLCH4SS	17822	F23	187
CT44EOC90SS	16132	F23	182	CT46SPSS	16107	F23	185	CTLCHSS	17818	F23	187
CT44DPSPPSS	15835	F23	185	CT46TFCSS	15775	F23	179	CTMB4001L	15638	A90CM	72
CT44DSS	15798	F23	173	CT46TICSS	15782	F23	179	CTMB4001LS	15641	A90CM	72
CT44DTFCSS	16156	F23	181	CT46TOCSS	15787	F23	179	CTMB8001	14436	A90CM	72
CT44DTICSS	16163	F23	181	CT46TSS	17827	F23	173	CTMB8003	14437	A90CM	72
CT44DTCSS	16168	F23	181	CT46UCSS	15806	F23	182	CTMB8003L	14441	A90CM	72
CT44EFC45SS	15767	F23	177	CT46VSS	17834	F23	179	CTS33CPLSS	17137	F23	183
CT44EFC90SS	15736	F23	174	CT46120SS	15732	F23	173	CTS33CPRSS	16615	F23	183
CT44EFCNT90SS	17767	F23	174	CT4633RSS	15826	F23	184	CTS33CSS	16605	F23	181
CT44EIC45SS	15755	F23	177	CT4644RSS	15825	F23	184	CTS33EFC45SS	16595	F23	177
CT44EIC90SS	15743	F23	174	CT66AESS	15821	F23	183	CTS33EFC90SS	16591	F23	174
CT44EOC45SS	15762	F23	177	CT66CPSS	15814	F23	183	CTS33P120SS	16627	F23	173
CT44EOC90SS	15748	F23	174	CT66CSS	15795	F23	181	CTS33PCSS	16647	F23	181
CT44HB	17165	F23	187	CT66DEFC45SS	16153	F23	182	CTS33PEFC45SS	16637	F23	177
CT44LB	17166	F23	187	CT66DEFC90SS	16122	F23	182	CTS33PEFC90SS	16633	F23	174
CT44P120SS	16101	F23	173	CT66DEIC45SS	16141	F23	182	CTS33PSPSS	16653	F23	185
CT44PCSS	16575	F23	181	CT66DEIC90SS	16127	F23	182	CTS33PTFCSS	16643	F23	179
CT44PEFC45SS	16563	F23	177	CT66DEOC45SS	16146	F23	182	CTS33SPSS	16611	F23	185
CT44PEFC90SS	16556	F23	174	CT66DEOC90SS	16134	F23	182	CTS33TCLSS	17136	F23	186
CT44PEFCNT90SS	17774	F23	175	CT66DPSPPSS	15837	F23	185	CTS33TCRSS	17135	F23	186
CT44PSPSS	16582	F23	185	CT66DSS	15802	F23	173	CTS33TFCSS	16601	F23	179
CT44PTFCSS	16568	F23	179	CT66DTFCSS	16158	F23	181	CTS33120SS	16585	F23	173
CT44SCSS	16113	F23	186	CT66DTICSS	16165	F23	181	CTS44CPLSS	17142	F23	183
CT44SPSS	16106	F23	185	CT66DTCSS	16172	F23	181	CTS44CPRSS	16616	F23	183
CT44TDSPPSS	18508	F23	174	CT66EFC45SS	15771	F23	177	CTS44CSS	16606	F23	181
CT44TFCSS	15774	F23	179	CT66EFC90SS	15738	F23	174	CTS44EFC45SS	16596	F23	177
CT44TICSS	15781	F23	179	CT66EFCNT90SS	17771	F23	174	CTS44EFC90SS	16592	F23	174
CT44TOCSS	15786	F23	179	CT66EIC45SS	15757	F23	177	CTS44EFCNT90SS	17777	F23	175
CT44TSS	17826	F23	173	CT66EIC90SS	15745	F23	174	CTS44EFCO45SS	17785	F23	178

Catalog Number	UPC	Bulletin Number	Catalog Page	Catalog Number	UPC	Bulletin Number	Catalog Page	Catalog Number	UPC	Bulletin Number	Catalog Page
CTS44EFC90SS	17788	F23	175	CTS66EFC90SS	16594	F23	174	E45RUBKIT	13863	DOFR2	195
CTS44EFCNT90SS	17782	F23	176	CTS66EFCNT90SS	17781	F23	175	F1010G12	42790	F40	116
CTS44EIC45SS	17812	F23	178	CTS66EFC045SS	17787	F23	178	F1010G120	44940	F40	116
CTS44EIC90SS	17807	F23	176	CTS66EFC90SS	17792	F23	175	F1010G24	43540	F40	116
CTS44E0C45SS	17801	F23	178	CTS66EFCNT90SS	17784	F23	176	F1010G36	43590	F40	116
CTS44E0C90SS	17796	F23	176	CTS66EIC45SS	17814	F23	178	F1010G45E	45690	F40PF	111, 119
CTS44P120SS	16628	F23	173	CTS66EIC90SS	17811	F23	176	F1010G48	43610	F40	116
CTS44PCSS	16648	F23	181	CTS66E0C45SS	17803	F23	178	F1010G60	43870	F40	116
CTS44PEFC45SS	16638	F23	177	CTS66E0C90SS	17798	F23	176	F1010G72	43890	F40	116
CTS44PEFC90SS	16634	F23	174	CTS66P120SS	16632	F23	173	F1010G88R	46760	F40PF	105, 113, 120
CTS44PSPSS	16654	F23	185	CTS66PCSS	16652	F23	181	F1010G90E	45590	F40PF	110, 118
CTS44PTFCSS	16644	F23	179	CTS66PEFC45SS	16642	F23	177	F1010G90SE	45610	F40PF	109, 117
CTS44SPSS	16612	F23	185	CTS66PEFC90SS	16636	F23	174	F1010G90TX	45190	F40PF	110, 118
CTS44TCLSS	17141	F23	186	CTS66PSPSS	16656	F23	185	F1010G96	13288	F40	116
CTS44TCRSS	17138	F23	186	CTS66PTFCSS	16646	F23	179	F1010GA	46400	F40PF	111, 119
CTS44TFCOSS	17793	F23	180	CTS66SPSS	16614	F23	185	F1010GAGV	46650	F40GF	104
CTS44TFCSS	16602	F23	179	CTS66TFCOSS	17795	F23	180	F1010GCP	46720	F40PF	112, 120
CTS44TICSS	17815	F23	180	CTS66TFCSS	16604	F23	179	F1010GCPNK	46740	F40PF	112, 120
CTS44TOCSS	17804	F23	180	CTS66TICSS	17817	F23	180	F1010GCPNKGV	46750	F40GF	104
CTS44120SS	16586	F23	173	CTS66TOCSS	17806	F23	180	F1010GDB	46770	F40PF	105, 112, 120
CTS4433RLSS	15801	F23	184	CTS66120SS	16588	F23	173	F1010GOA	46370	F40PF	111, 119
CTS4433RRSS	16621	F23	184	CTS6633RLSS	17152	F23	184	F1010GPA	45840	F40PF	111, 119
CTS46CPLSS	17147	F23	183	CTS6633RRSS	16626	F23	184	F1010GPAGV	45990	F40GF	104
CTS46CPRSS	16617	F23	183	CTS6644RLSS	17151	F23	184	F1010GSH	46790	F40PF	112, 120
CTS46CSS	16607	F23	181	CTS6644RRSS	16625	F23	184	F1010GSHGV	46800	F40GF	105
CTS46EFC45SS	16597	F23	177	CTS6646RLSS	17148	F23	184	F1010GT	46820	F40PF	109, 117
CTS46EFC90SS	16593	F23	174	CTS6646RRSS	16624	F23	184	F1010GTGV	46880	F40GF	101
CTS46EFCNT90SS	17778	F23	175	CTS66SLCHSS	17823	F23	187	F1010GUC	46390	F40PF	113, 121
CTS46EFC045SS	17786	F23	178	DG19	17266	DBG	208	F1010GUCGV	57170	F40GF	105
CTS46EFC90SS	17791	F23	175	DG23	17267	DBG	208	F1010T112GV	43320	F40	101
CTS46EFCNT90SS	17783	F23	176	DG36	17268	DBG	208	F1010T1120GV	45040	F40	101
CTS46EIC45SS	17813	F23	178	DG72	17271	DBG	208	F1010T1120GVP	36329	F40FC	108
CTS46EIC90SS	17808	F23	176	DGCL201	17256	DBG	207	F1010T1120GVP	36389	F40FC	108
CTS46E0C45SS	17802	F23	178	DGCL21	17254	DBG	207	F1010T124GV	43550	F40	101
CTS46E0C90SS	17797	F23	176	DGCL22	17255	DBG	207	F1010T124GVP	36339	F40FC	108
CTS46P120SS	16631	F23	173	DGCL402	17257	DBG	207	F1010T	13171	F40PF	109, 117
CTS46PCSS	16651	F23	181	DGCL61	17252	DBG	207	F1010T136GV	43600	F40	101
CTS46PEFC45SS	16641	F23	177	DGCL62	17253	DBG	207	F1010T136GVP	36349	F40FC	108
CTS46PEFC90SS	16635	F23	174	DGJ	17272	DBG	196, 209	F1010T148GV	43620	F40	101
CTS46PSPSS	16655	F23	185	DGLG	17251	DBG	207	F1010T148GVP	36359	F40FC	108
CTS46PTFCSS	16645	F23	179	DGRJ	17273	DBG	209	F1010T160GV	43880	F40	101
CTS46SPSS	16613	F23	185	DGT1	17258	DBG	207	F1010T160GVP	36369	F40FC	108
CTS46TCLSS	17146	F23	186	DGT2	17261	DBG	207	F1010T172GV	44930	F40	101
CTS46TCRSS	17145	F23	186	DGTB212	17262	DBG	208	F1010T172GVP	36379	F40FC	108
CTS46TFCOSS	17794	F23	180	DGTB216	17263	DBG	208	F1010TGV	13177	F40GF	101
CTS46TFCSS	16603	F23	179	DGTB412	17264	DBG	208	F1010X	13185	F40PF	109, 117
CTS46TICSS	17816	F23	180	DGTB420	17265	DBG	208	F1010XGV	13193	F40GF	102
CTS46TOCSS	17805	F23	180	E19FWM12U20	11012	DOFRW	50	F1010116RTGV	13834	F40GT	163
CTS46120SS	16587	F23	173	E19FWM20U20	11013	DOFRW	50	F101024RTGV	13826	F40GT	163
CTS4633RLSS	17144	F23	184	E19FWM25U20	11014	DOFRW	50	F101036RTGV	13827	F40GT	163
CTS4633RRSS	16623	F23	184	E19FWM32U20	11015	DOFRW	50	F101045EGV	45830	F40GF	103
CTS4644RLSS	17143	F23	184	E19HPM1U	11001	DOFRW	49	F101048RTGV	13828	F40GT	163
CTS4644RRSS	16622	F23	184	E19HPM2U	11002	DOFRW	49	F101060RTGV	13831	F40GT	163
CTS66CPLSS	17155	F23	183	E19HPM4U	11003	DOFRW	49	F101072RTGV	13832	F40GT	163
CTS66CPRSS	16618	F23	183	E19HPM6U	11004	DOFRW	49	F101090EGV	45600	F40GF	102
CTS66CSS	16608	F23	181	E19HPM8U	11005	DOFRW	49	F101090EIN	13141	F40PF	110, 118
CTS66EFC45SS	16598	F23	177	E19T6U	26176	DOFRW	197	F101090EINGV	13147	F40GF	103

Catalog Number	UPC	Bulletin Number	Catalog Page	Catalog Number	UPC	Bulletin Number	Catalog Page	Catalog Number	UPC	Bulletin Number	Catalog Page
F101090EOUT	13155	F40PF	110, 118	F1212T160GV	88950	F40G	101	F22G24WK	52860	F40	116
F101090EOUTGV	13163	F40GF	103	F1212T160GVP	36439	F40FC	108	F22G36	52030	F40	116
F101090SEGV	45680	F40GF	102	F1212T160GVPWK	16707	F40FC	108	F22G36WK	52870	F40	116
F101090TXGV	45370	F40GF	102	F1212T24HC	16790	F20HC	165	F22G45E	52080	F40PF	111, 119
F101096RTGV	13833	F40GT	163	F1212T36HC	16800	F20HC	165	F22G48	52040	F40	116
F1212G1010R	41360	F40PF	105, 113, 120	F1212T48HC	16810	F20HC	165	F22G48WK	52880	F40	116
F1212G12	51820	F40	116	F1212T60HC	16820	F20HC	165	F22G60	52050	F40	116
F1212G120	51870	F40	116	F1212TGV	13178	F40GF	101	F22G60WK	52890	F40	116
F1212G12H	16742	F40	116	F1212X	13186	F40PF	109, 117	F22G90E	52510	F40PF	110, 118
F1212G120H	16751	F40	116	F1212XGV	13194	F40GF	102	F22G90SE	52570	F40PF	109, 117
F1212G24	51830	F40	116	F1212116RTGV	13844	F40GT	163	F22G90TX	52070	F40PF	110, 118
F1212G24H	16743	F40	116	F121224RTGV	13835	F40GT	163	F22GA	52540	F40PF	111, 119
F1212G36	51840	F40	116	F121236RTGV	13836	F40GT	163	F22GAGV	88030	F40GF	104
F1212G36H	16744	F40	116	F121245EGV	89000	F40GF	103	F22GCP	52110	F40PF	112, 120
F1212G45E	51910	F40PF	111, 119	F121248RTGV	13837	F40GT	163	F22GCPGV	88070	F40GF	104
F1212G48	51850	F40	116	F121260RTGV	13838	F40GT	163	F22GCPNK	52810	F40PF	112, 120
F1212G48H	16745	F40	116	F121272RTGV	13841	F40GT	163	F22GCPNKG	88080	F40GF	104
F1212G60	51860	F40	116	F121284RTGV	13842	F40GT	163	F22GDB	52120	F40PF	105, 112, 120
F1212G60H	16746	F40	116	F121290EGV	88980	F40GF	102	F22GOA	52140	F40PF	111, 119
F1212G72	13291	F40	116	F121290EIN	13142	F40PF	110, 118	F22GPA	52090	F40PF	111, 119
F1212G72H	16747	F40	116	F121290EINGV	13148	F40GF	103	F22GPAGV	88040	F40GF	104
F1212G88R	52000	F40PF	105, 113, 120	F121290EOUT	13156	F40PF	110, 118	F22GSH	52130	F40PF	112, 120
F1212G90E	51890	F40PF	110, 118	F121290EOUTGV	13164	F40GF	103	F22GSHGV	88100	F40GF	105
F1212G90SE	51900	F40PF	109, 117	F121290SEGV	88990	F40GF	102	F22GT	89150	F40PF	109, 117
F1212G90TX	51880	F40PF	110, 118	F121290TXGV	88970	F40GF	102	F22GTGV	89100	F40GF	101
F1212G96	13292	F40	116	F121296RTGV	13843	F40GT	163	F22GUC	52100	F40PF	113, 121
F1212GA	51920	F40PF	111, 119	F126L06	18720	F10	129	F22GUCGV	88060	F40GF	105
F1212GAGV	89010	F40GF	104	F126L12	18730	F10	129	F22HB	14180	F20	135, 146
F1212GCP	51950	F40PF	112, 120	F126L120	18780	F10	129	F22HD	14170	F20	134, 146
F1212GCPGV	89050	F40GF	104	F126L24	18740	F10	129	F22L06	18010	F10	129
F1212GCPNK	51960	F40PF	112, 120	F126L36	18750	F10	129	F22L12	18020	F10	129
F1212GCPNKG	89060	F40GF	104	F126L48	18760	F10	129	F22L120	18070	F10	129
F1212GDB	51970	F40PF	105, 112, 120	F126L60	18770	F10	129	F22L24	18030	F10	129
F1212GOA	51990	F40PF	111, 119	F126LA	18960	F10	130	F22L36	18040	F10	129
F1212GPA	51930	F40PF	111, 119	F126LB	18880	F10	135	F22L48	18050	F10	129
F1212GPAGV	89020	F40GF	104	F126LC	18860	F10	130	F22L60	18060	F10	129
F1212GSH	51980	F40PF	112, 120	F126LE45A	18840	F10	132	F22LA	18930	F10	130
F1212GSHGV	89090	F40GF	105	F126LE9A	18810	F10	131	F22LB	18210	F10	135
F1212GT	89190	F40PF	109, 117	F126LE9B	18820	F10	131	F22LC	18190	F10	130
F1212GTGV	89140	F40GF	101	F126LE9C	18830	F10	131	F22LE45A	18140	F10	132
F1212GUC	51940	F40PF	113, 121	F126LP	18870	F10	133	F22LE45B	18150	F10	132
F1212GUCGV	89040	F40GF	105	F126LRE44	18890	F10	134	F22LE45C	18160	F10	132
F1212T112GV	88910	F40G	101	F126LRE66	18900	F10	134	F22LE9A	18110	F10	131
F1212T1120GV	88960	F40G	101	F126LSAG	18920	F10	137	F22LE9B	18120	F10	131
F1212T1120GVP	36399	F40FC	108	F126LSGQR	19990	F10	137	F22LE9C	18130	F10	131
F1212T1120GVP	36449	F40FC	108	F126LTA	18850	F10	132	F22LE9KOKT	19760	F10	136
F1212T1120GVPWK	16703	F40FC	108	F126LX	18790	F10	130	F22LE9KT	19750	F10	136
F1212T124GV	88920	F40G	101	F126LXL	18800	F10	130	F22LJ	18100	F10	133
F1212T124GVP	36409	F40FC	108	F1414116RTGV	13851	F40GT	163	F22LKOKT	19780	F10	136
F1212T124GVPWK	16704	F40FC	108	F141448RTGV	13845	F40GT	163	F22LKT	19770	F10	136
F1212T	13172	F40PF	109, 117	F141472RTGV	13846	F40GT	163	F22LN1	19870	F10	134
F1212T136GV	88930	F40G	101	F141496RTGV	13848	F40GT	163	F22LN2	19880	F10	134
F1212T136GVP	36419	F40FC	108	F22G12	52010	F40	116	F22LN3	19890	F10	134
F1212T136GVPWK	16705	F40FC	108	F22G120	52060	F40	116	F22LP	18200	F10	133
F1212T148GV	88940	F40G	101	F22G120WK	52710	F40	116	F22LSAG	18230	F10	137
F1212T148GVP	36429	F40FC	108	F22G12WK	52850	F40	116	F22LSGQR	19960	F10	137
F1212T148GVPWK	16706	F40FC	108	F22G24	52020	F40	116	F22LTA	18170	F10	132

Catalog Number	UPC	Bulletin Number	Catalog Page	Catalog Number	UPC	Bulletin Number	Catalog Page	Catalog Number	UPC	Bulletin Number	Catalog Page
F22LTC	18180	F10	133	F22X	13181	F40PF	109, 117	F44GPAGV	88310	F40GF	104
F22LX	18080	F10	130	F22XGV	13187	F40GF	102	F44GSH	52300	F40PF	112, 120
F22LXL	18090	F10	130	F2212SC	15350	F20SC	167	F44GSHGV	88380	F40GF	105
F22T112GV	87870	F40G	100	F2245EGV	88020	F40GF	103	F44GT	89160	F40PF	109, 117
F22T1120GV	87970	F40G	100	F2290EGV	88000	F40GF	102	F44GTGV	89110	F40GF	101
F22T112GVP	35869	F40FC	108	F2290EIN	13135	F40PF	110, 118	F44GUC	52260	F40PF	113, 121
F22T1120GVP	35969	F40FC	108	F2290EINGV	13143	F40GF	103	F44GUCGV	88330	F40GF	105
F22T1126VVPWK	13293	F40FC	108	F2290EOUT	13151	F40PF	110, 118	F44HB	14390	F20	135, 146
F22T1120GVPWK	13297	F40FC	108	F2290EOUTGV	13157	F40GF	103	F44HBEP	19480	F25	155
F22T1120GVWK	87980	F40G	100	F2290SEGV	88010	F40GF	102	F44HBSS	16000	F22	151
F22T12HC	16500	F20HC	165	F2290TXGV	87990	F40GF	102	F44HD	14380	F20	134, 146
F22T124GV	87890	F40G	100	F33BK60	15626	F20	113, 121, 136	F44HDS	16010	F22	151
F22T124GVP	35889	F40FC	108	F33G22R	16657	F40PF	113, 120	F44L06	18240	F10	129
F22T124GVPWK	13294	F40FC	108	F33G45E	15487	F40PF	111, 119	F44L12	18250	F10	129
F22T124GVWK	87900	F40G	100	F33G90E	15486	F40PF	110, 118	F44L120	18300	F10	129
F22T	13165	F40PF	109, 117	F33G90TX	15488	F40PF	110, 118	F44L24	18260	F10	129
F22T136GV	87910	F40G	100	F33GCPNK	15493	F40PF	112, 120	F44L36	18270	F10	129
F22T136GVP	35909	F40FC	108	F33GPA	15492	F40PF	111, 119	F44L48	18280	F10	129
F22T136GVPWK	13295	F40FC	108	F33GT	15491	F40PF	109, 117	F44L60	18290	F10	129
F22T136GVWK	87920	F40G	100	F33GUC	15494	F40PF	113, 121	F44LA	18940	F10	130
F22T148GV	87930	F40G	100	F33T1120GVP	15485	F40FC	108	F44LB	18440	F10	135
F22T148GVP	35929	F40FC	108	F33T160GVP	15484	F40FC	108	F44LC	18420	F10	130
F22T148GVPWK	13296	F40FC	108	F44B360	20320	F10	137, 147	F44LE45A	18370	F10	132
F22T160GV	87950	F40G	100	F44BB2C	20270	F10	137, 147	F44LE45B	18380	F10	132
F22T160GVP	35949	F40FC	108	F44BB3C	20290	F10	137, 147	F44LE45C	18390	F10	132
F22T160GVPWK	35939	F40FC	108	F44BK60	19570	F20	113, 121, 136, 147	F44LE9A	18340	F10	131
F22T160GVWK	87960	F40G	100	F44G12	52170	F40	116	F44LE9AC	16410	F10	131
F22T18HC	16510	F20HC	165	F44G120	52220	F40	116	F44LE9B	18350	F10	131
F22T24HC	16520	F20HC	165	F44G120WK	52760	F40	116	F44LE9C	18360	F10	131
F22T36HC	16540	F20HC	165	F44G12WK	52900	F40	116	F44LE9KOKT	19800	F10	136
F22T48HC	16550	F20HC	165	F44G18	33759	F40	116	F44LE9KT	19790	F10	136
F22T60HC	16560	F20HC	165	F44G22R	52280	F40PF	105, 113, 120	F44LJ	18330	F10	133
F22T72HC	16570	F20HC	165	F44G24	52180	F40	116	F44LKOKT	19820	F10	136
F22TGV	13173	F40GF	101	F44G24WK	52910	F40	116	F44LKT	19810	F10	136
F22W12	14010	F20	142	F44G33R	15627	F10	113, 120	F44LN1	19900	F10	134
F22W120	14060	F20	142	F44G36	52190	F40	116	F44LN2	19910	F10	134
F22W24	14020	F20	142	F44G36WK	52920	F40	116	F44LN3	19920	F10	134
F22W36	14030	F20	142	F44G45E	52240	F40PF	111, 119	F44LP	18430	F10	133
F22W48	14040	F20	142	F44G48	52200	F40	116	F44LRE22	18450	F10	134
F22W60	14050	F20	142	F44G48WK	52930	F40	116	F44LSAG	18470	F10	137
F22WA	14120	F20	143	F44G60	52210	F40	116	F44LSGQR	19970	F10	137
F22WB	14160	F20	146	F44G60WK	52940	F40	116	F44LTA	18400	F10	132
F22WC	14090	F20	143	F44G72	51730	F40	116	F44LTC	18410	F10	133
F22WE225	15740	F20	144	F44G72WK	51740	F40	116	F44LX	18310	F10	130
F22WE45	14080	F20	144	F44G90E	52520	F40PF	110, 118	F44LXL	18320	F10	130
F22WE90	14070	F20	144	F44G90SE	52580	F40PF	109, 117	F44T112GV	88120	F40G	100
F22WFF	15780	F20	143	F44G90TX	52230	F40PF	110, 118	F44T1120GV	88240	F40G	100
F22WG	14190	F20	147	F44G96	13285	F40PF	116	F44T112GVP	35989	F40FC	108
F22WN1	14810	F20	145	F44GA	52550	F40PF	111, 119	F44T1120GVP	36109	F40FC	108
F22WN2	14820	F20	145	F44GAGV	88300	F40GF	104	F44T1120GVPWK	13298	F40FC	108
F22WN3	14830	F20	145	F44GCP	52270	F40PF	112, 120	F44T1120GVPWK	36099	F40FC	108
F22WN6	14840	F20	145	F44GCPGV	88340	F40GF	104	F44T1120GVWK	88130	F40G	100
F22WP	14100	F20	145	F44GCPNK	52820	F40PF	112, 120	F44T1120GVWK	88250	F40G	100
F22WSA	14140	F20	146	F44GCPNKGV	88350	F40GF	104	F44T118GV	33789	F40G	100
F22WSC	14150	F20	146	F44GDB	52290	F40PF	105, 112, 120	F44T118GVP	35879	F40FC	108
F22WT	14110	F20	144	F44GOA	52310	F40PF	111, 119	F44T12HC	16580	F20HC	165
F22WX	14130	F20	143	F44GPA	52250	F40PF	111, 119	F44T124GV	88140	F40G	100



Catalog Number	UPC	Bulletin Number	Catalog Page	Catalog Number	UPC	Bulletin Number	Catalog Page	Catalog Number	UPC	Bulletin Number	Catalog Page
F44T124GVP	36009	F40FC	108	F44W48SS	15430	F22	149	F4448RTGV	13815	F40GT	163
F44T124GVPWK	13301	F40FC	108	F44W48STFG	19130	F25	153	F4460FG	15710	F25	169
F44T124GVWK	88150	F40G	100	F44W60	14240	F20	142	F4460RTGV	14771	F40PT	163
F44T	13166	F40PF	109, 117	F44W60FG	15860	F25	153	F4472RTGV	13816	F40GT	163
F44T136GV	88160	F40G	100	F44W60SS	15440	F22	149	F4490EGV	88270	F40GF	102
F44T136GVP	36029	F40FC	108	F44W60STFG	19140	F25	153	F4490EIN	13136	F40PF	110, 118
F44T136GVPWK	13302	F40FC	108	F44WA	14310	F20	143	F4490INGV	13144	F40GF	103
F44T136GVWK	88170	F40G	100	F44WASS	15490	F22	149	F4490EOUT	13152	F40PF	110, 118
F44T148GV	88180	F40G	100	F44WB	14350	F20	146	F4490EOUTGV	13158	F40GF	103
F44T148GVP	36049	F40FC	108	F44WBF6G	15930	F25	155	F4490SEGV	88280	F40GF	102
F44T148GVPWK	13303	F40FC	108	F44WBSS	15520	F22	151	F4490TXGV	88260	F40GF	102
F44T148GVWK	88190	F40G	100	F44WC	14280	F20	143	F66B560	20340	F10	137, 147
F44T160GV	88200	F40G	100	F44WCFG	15900	F25	153	F66BB2C	20300	F10	137, 147
F44T160GVP	36069	F40FC	108	F44WE225	15750	F20	144	F66BB3C	20310	F10	137, 147
F44T160GVPWK	36059	F40FC	108	F44WE45	14270	F20	144	F66BK60	19630	F20	113, 121, 136, 147
F44T160GVWK	88210	F40G	100	F44WE45FG	15880	F25	154	F66G12	52340	F40	116
F44T172GV	88220	F40G	100	F44WE45SS	15460	F22	149	F66G120	52390	F40	116
F44T172GVP	36089	F40FC	108	F44WE90	14260	F20	144	F66G120WK	52770	F40	116
F44T172GVPWK	36079	F40FC	108	F44WE90FG	15870	F25	154	F66G12WK	52950	F40	116
F44T172GVWK	88230	F40G	100	F44WE90SS	15450	F22	150	F66G18	33769	F40	116
F44T18HC	16590	F20HC	165	F44WFF	15790	F20	143	F66G24	52350	F40	116
F44T24HC	16600	F20HC	165	F44WFFFG	15910	F25	153	F66G24WK	52960	F40	116
F44T30HC	16610	F20HC	165	F44WFFSS	16020	F22	149	F66G36	52360	F40	116
F44T3R12	43489	F30G	123	F44WG	14400	F20	147	F66G36WK	52970	F40	116
F44T3R120	43529	F30G	123	F44WGSS	15530	F22	151	F66G44R	52450	F40PF	105, 113, 120
F44T3R30SE	43559	F30G	123	F44WN1	14850	F20	145	F66G45E	52410	F40PF	111, 119
F44T3R60	43509	F30G	123	F44WN2	14860	F20	145	F66G48	52370	F40	116
F44T3R90E	43569	F30G	124	F44WN3	14870	F20	145	F66G48WK	52980	F40	116
F44T3RCP	43609	F30G	124	F44WN6	14880	F20	145	F66G60	52380	F40	116
F44T3RDH	43629	F30G	125	F44WN6SS	15510	F22	151	F66G60WK	52990	F40	116
F44T3RPA	43599	F30G	124	F44WP	14290	F20	145	F66G72	51750	F40	116
F44T3RT	43579	F30G	123	F44WPF6G	15920	F25	154	F66G72WK	51760	F40	116
F44T3RTX	43589	F30G	124	F44WPSS	15470	F22	150	F66G90E	52530	F40PF	110, 118
F44T3RUC	43549	F30G	125	F44WR22	14360	F20	145	F66G90SE	52590	F40PF	109, 117
F44T3RWH	43619	F30G	125	F44WRE22	14370	F20	145	F66G90TX	52400	F40PF	110, 118
F44T36HC	16620	F20HC	165	F44WSA	14330	F20	146	F66G96	13286	F40	116
F44T48HC	16630	F20HC	165	F44WSC	14340	F20	146	F66GA	52560	F40PF	111, 119
F44T60HC	16640	F20HC	165	F44WSCSS	15500	F22	151	F66GAGV	88590	F40GF	104
F44T72HC	16650	F20HC	165	F44WT	14300	F20	144	F66GCP	52440	F40PF	112, 120
F44TGV	13174	F40GF	101	F44WTF6G	15890	F25	154	F66GCPGV	88630	F40GF	104
F44W12	14200	F20	142	F44WTSS	15480	F22	150	F66GCPNK	52830	F40PF	112, 120
F44W120	14250	F20	142	F44WX	14320	F20	143	F66GCPNKG	88640	F40GF	104
F44W12FG	15820	F25	153	F44WCFG	15940	F25	154	F66GDB	52460	F40PF	105, 112, 120
F44W12SS	15400	F22	149	F44X	13182	F40PF	109, 117	F66GOA	52480	F40PF	111, 119
F44W120SS	15720	F22	149	F44XGV	13188	F40GF	102	F66GPA	52420	F40PF	111, 119
F44W12STFG	19100	F25	153	F4412FG	15670	F25	169	F66GPAGV	88600	F40GF	104
F44W120STFG	19150	F25	153	F4412RTGV	14767	F40PT	163	F66GSH	52470	F40PF	112, 120
F44W24	14210	F20	142	F4412SC	15360	F20SC	167	F66GSHGV	88670	F40GF	105
F44W24FG	15830	F25	153	F4418SC	15370	F20SC	167	F66GT	89170	F40PF	109, 117
F44W24SS	15410	F22	149	F4424FG	15680	F25	169	F66GTGV	89120	F40GF	101
F44W24STFG	19110	F25	153	F4424RTGV	13814	F40GT	163	F66GUC	52430	F40PF	113, 121
F44W36	14220	F20	142	F4424SC	15380	F20SC	167	F66GUCGV	88620	F40GF	105
F44W36FG	15840	F25	153	F4430SC	15390	F20SC	167	F66HB	14600	F20	135, 146
F44W36SS	15420	F22	149	F4436FG	15690	F25	169	F66HBEP	19490	F25	155
F44W36STFG	19120	F25	153	F4436RTGV	14768	F40PT	163	F66HBSS	16030	F22	151
F44W48	14230	F20	142	F4445EGV	88290	F40GF	103	F66HD	14590	F20	134, 146
F44W48FG	15850	F25	153	F4448FG	15700	F25	169	F66HDSS	16040	F22	151



Catalog Number	UPC	Bulletin Number	Catalog Page	Catalog Number	UPC	Bulletin Number	Catalog Page	Catalog Number	UPC	Bulletin Number	Catalog Page
F66L06	18480	F10	129	F66T160GVP	36209	F40FC	108	F66WE90FG	19020	F25	154
F66L12	18490	F10	129	F66T160GVPWK	36199	F40FC	108	F66WE90SS	15590	F22	150
F66L120	18540	F10	129	F66T160GVWK	88500	F40G	100	F66WFF	15800	F20	143
F66L24	18500	F10	129	F66T172GV	88510	F40G	100	F66WFFFG	19060	F25	153
F66L36	18510	F10	129	F66T172GVP	36229	F40FC	108	F66WFFSS	16050	F22	149
F66L48	18520	F10	129	F66T172GVPWK	36219	F40FC	108	F66WVG	14610	F20	147
F66L60	18530	F10	129	F66T172GVWK	88520	F40G	100	F66WVGSS	15660	F22	151
F66LA	18950	F10	130	F66T18HC	16670	F20HC	165	F66WVN1	14890	F20	145
F66LB	18680	F10	135	F66T24HC	16680	F20HC	165	F66WVN2	14900	F20	145
F66LC	18660	F10	130	F66T30HC	16690	F20HC	165	F66WVN3	14910	F20	145
F66LE45A	18610	F10	132	F66T3R12	43639	F30G	123	F66WVN6	14920	F20	145
F66LE45B	18620	F10	132	F66T3R120	43679	F30G	123	F66WVN6SS	15640	F22	151
F66LE45C	18630	F10	132	F66T3R30SE	43709	F30G	123	F66WVP	14500	F20	145
F66LE9A	18580	F10	131	F66T3R44R	43789	F30G	124	F66WVPFG	19070	F25	154
F66LE9AC	19500	F10	131	F66T3R60	43659	F30G	123	F66WVPSS	15610	F22	150
F66LE9B	18590	F10	131	F66T3R90E	43719	F30G	124	F66WR44	14570	F20	145
F66LE9C	18600	F10	131	F66T3RCP	43759	F30G	124	F66WR44SS	16060	F22	150
F66LE9KOKT	19840	F10	136	F66T3RDH	43779	F30G	125	F66WRE44	14580	F20	145
F66LE9KT	19830	F10	136	F66T3RPA	43749	F30G	124	F66WRE44SS	16070	F22	150
F66LJ	18570	F10	133	F66T3RT	43729	F30G	123	F66WSA	14540	F20	146
F66LKOKT	19860	F10	136	F66T3RTX	43739	F30G	124	F66WSC	14550	F20	146
F66LN1	19930	F10	134	F66T3RUC	43699	F30G	125	F66WT	14510	F20	144
F66LN2	19940	F10	134	F66T3RWH	43769	F30G	125	F66WTFG	19040	F25	154
F66LN3	19950	F10	134	F66T36HC	16700	F20HC	165	F66WTSS	15620	F22	150
F66LP	18670	F10	133	F66T48HC	16710	F20HC	165	F66WX	14530	F20	143
F66LRE44	18690	F10	134	F66T60HC	16720	F20HC	165	F66WXFG	19090	F25	154
F66LSAG	18710	F10	137	F66T72HC	16730	F20HC	165	F66X	13183	F40PF	109, 117
F66LSGQR	19980	F10	137	F66TGV	13175	F40GF	101	F66XGV	13191	F40GF	102
F66LTA	18640	F10	132	F66W12	14410	F20	142	F6612FG	15950	F25	169
F66LTC	18650	F10	133	F66W120	14460	F20	142	F6612RTGV	14772	F40PT	163
F66LX	18550	F10	130	F66W12FG	18970	F25	153	F6618RTGV	14773	F40PT	163
F66LXL	18560	F10	130	F66W12SS	15540	F22	149	F6624FG	15960	F25	169
F66T112GV	88410	F40G	100	F66W120SS	15730	F22	149	F6624RTGV	13817	F40GT	163
F66T1120GV	88530	F40G	100	F66W24	14420	F20	142	F6636FG	15970	F25	169
F66T112GVP	36129	F40FC	108	F66W24FG	18980	F25	153	F6636RTGV	14774	F40PT	163
F66T1120GVP	36249	F40FC	108	F66W24SS	15550	F22	149	F6645EGV	88580	F40GF	103
F66T112GVPWK	13304	F40FC	108	F66W36	14430	F20	142	F6648FG	15980	F25	169
F66T1120GVPWK	36239	F40FC	108	F66W36FG	18990	F25	153	F6648RTGV	13818	F40GT	163
F66T112GVWK	88420	F40G	100	F66W36SS	15560	F22	149	F6660FG	15990	F25	169
F66T1120GVWK	88540	F40G	100	F66W48	14440	F20	142	F6660RTGV	14775	F40PT	163
F66T118GV	33799	F40G	100	F66W48FG	19000	F25	153	F6672RTGV	13821	F40GT	163
F66T118GVP	35899	F40FC	108	F66W48SS	15570	F22	149	F6690EGV	88560	F40GF	102
F66T12HC	16660	F20HC	165	F66W60	14450	F20	142	F6690EIN	13137	F40PF	110, 118
F66T124GV	88430	F40G	100	F66W60FG	19010	F25	153	F6690INGV	13145	F40GF	103
F66T124GVP	36149	F40FC	108	F66W60SS	15580	F22	149	F6690EOUT	13153	F40PF	110, 118
F66T124GVPWK	13305	F40FC	108	F66WA	14520	F20	143	F6690EOUTGV	13161	F40GF	103
F66T124GVWK	88440	F40G	100	F66WASS	15630	F22	149	F6690SEGV	88570	F40GF	102
F66T	13167	F40PF	109, 117	F66WB	14560	F20	146	F6690TXGV	88550	F40GF	102
F66T136GV	88450	F40G	100	F66WBF	19080	F25	155	F88BK60	19680	F20	113, 121, 136, 147
F66T136GVP	36169	F40FC	108	F66WBSS	15650	F22	151	F88G12	52600	F40	116
F66T136GVPWK	13306	F40FC	108	F66WC	14490	F20	143	F88G120	52650	F40	116
F66T136GVWK	88460	F40G	100	F66WCFG	19050	F25	153	F88G18	33779	F40	116
F66T148GV	88470	F40G	100	F66WE225	15760	F20	144	F88G24	52610	F40	116
F66T148GVP	36189	F40FC	108	F66WE45	14480	F20	144	F88G36	52620	F40	116
F66T148GVPWK	13307	F40FC	108	F66WE45FG	19030	F25	154	F88G45E	52670	F40PF	111, 119
F66T148GVWK	88480	F40G	100	F66WE45SS	15600	F22	149	F88G48	52630	F40	116
F66T160GV	88490	F40G	100	F66WE90	14470	F20	144	F88G60	52640	F40	116



Catalog Number	UPC	Bulletin Number	Catalog Page	Catalog Number	UPC	Bulletin Number	Catalog Page	Catalog Number	UPC	Bulletin Number	Catalog Page
F88G66R	52720	F40PF	105, 113, 120	F88T112GVWK	13312	F40G	100	F88WN1	14930	F20	145
F88G72	51770	F40	116	F88T112GVWK	13318	F40G	101	F88WN2	14940	F20	145
F88G90E	52780	F40PF	110, 118	F88T118GV	33809	F40G	100	F88WN3	14950	F20	145
F88G90SE	52800	F40PF	109, 117	F88T118GVP	35919	F40FC	108	F88WN6	14960	F20	145
F88G90TX	52660	F40PF	110, 118	F88T12HC	16740	F20HC	165	F88WP	14710	F20	145
F88G96	13287	F40PF	116	F88T124GV	88710	F40G	100	F88WR44	14780	F20	145
F88GA	52790	F40PF	111, 119	F88T124GVP	36269	F40FC	108	F88WR66	14760	F20	145
F88GAGV	88810	F40GF	104	F88T124GVPWK	16697	F40FC	108	F88WRE44	14790	F20	145
F88GCP	52700	F40PF	112, 120	F88T124GVWK	13313	F40G	100	F88WRE66	14770	F20	145
F88GCPGV	88850	F40GF	104	F88T	13168	F40PF	109, 117	F88WSA	14970	F20	146
F88GCPNK	52840	F40PF	112, 120	F88T136GV	88720	F40G	100	F88WSC	14980	F20	146
F88GCPNKGV	88860	F40GF	104	F88T136GVP	36279	F40FC	108	F88WT	14720	F20	144
F88GDB	52730	F40PF	105, 112, 120	F88T136GVPWK	16698	F40FC	108	F88WX	14740	F20	143
F88GOA	52750	F40PF	111, 119	F88T136GVWK	13314	F40G	100	F88X	13184	F40PF	109, 117
F88GPA	52680	F40PF	111, 119	F88T148GV	88730	F40G	101	F88XGV	13192	F40GF	102
F88GPAGV	88820	F40GF	104	F88T148GVP	36289	F40FC	108	F88116RTGV	13825	F40GT	163
F88GSH	52740	F40PF	112, 120	F88T148GVWK	16701	F40FC	108	F8812RTGV	14776	F40PT	163
F88GSHGV	88890	F40GF	105	F88T148GVWK	13315	F40G	101	F8824RTGV	13822	F40GT	163
F88GT	89180	F40PF	109, 117	F88T160GV	88740	F40G	101	F8836RTGV	14777	F40PT	163
F88GTGV	89130	F40GF	101	F88T160GVP	36299	F40FC	108	F8845EGV	88800	F40GF	103
F88GUC	52690	F40PF	113, 121	F88T160GVPWK	16702	F40FC	108	F8848RTGV	13823	F40GT	163
F88GUCGV	88840	F40GF	105	F88T160GVWK	13316	F40G	101	F8860RTGV	14778	F40PT	163
F88HB	15000	F20	135, 146	F88T172GV	88750	F40G	101	F8872RTGV	13824	F40GT	163
F88HD	14990	F20	134, 146	F88T172GVP	36309	F40FC	108	F8890EGV	88780	F40GF	102
F88L06	19160	F10	129	F88T172GVWK	13317	F40G	101	F8890EIN	13138	F40PF	110, 118
F88L12	19170	F10	129	F88T24HC	16750	F20HC	165	F8890EINGV	13146	F40GF	103
F88L120	19220	F10	129	F88T3R12	43799	F30G	123	F8890EOUT	13154	F40PF	110, 118
F88L24	19180	F10	129	F88T3R120	43839	F30G	123	F8890EOUTGV	13162	F40GF	103
F88L36	19190	F10	129	F88T3R30SE	43869	F30G	123	F8890SEGV	88790	F40GF	102
F88L48	19200	F10	129	F88T3R60	43819	F30G	123	F8890TXGV	88770	F40GF	102
F88L60	19210	F10	129	F88T3R66R	43949	F30G	124	F8896RTGV	14781	F40PT	163
F88LA	19340	F10	130	F88T3R90E	43879	F30G	124	L90HB12BLK	10062	DCR	191
F88LB	19370	F10	135	F88T3RCP	43919	F30G	124	L90HB12G	10058	DCR	191
F88LC	19310	F10	130	F88T3RDH	43939	F30G	125	L90HB12G2	10063	DCR	191
F88LE45A	19260	F10	132	F88T3RPA	43909	F30G	124	L90HB18BLK	10065	DCR	191
F88LE45B	19270	F10	132	F88T3RT	43889	F30G	123	L90HB18G	10064	DCR	191
F88LE45C	19280	F10	132	F88T3RTX	43899	F30G	124	L90HB18G2	10066	DCR	191
F88LE9A	19230	F10	131	F88T3RUC	43859	F30G	125	L90HB24BLK	17338	DCR	191
F88LE9AC	19510	F10	131	F88T3RWH	43929	F30G	125	LBSK	10076	DCR	191
F88LE9B	19240	F10	131	F88T36HC	16760	F20HC	165	LBSKB	14588	DCR	191
F88LE9C	19250	F10	131	F88T48HC	16770	F20HC	165	LBSK6	14591	DCR	191
F88LE9KOKT	19450	F10	136	F88T60HC	16780	F20HC	165	LAJSK	10078	DCR	192
F88LE9KT	19440	F10	136	F88TGV	13176	F40GF	101	LAJSKB	14594	DCR	192
F88LJ	19350	F10	133	F88W12	14620	F20	142	LAJSK6	14595	DCR	192
F88LP	19360	F10	133	F88W120	14670	F20	142	LBSK	10075	DCR	191
F88LE66	19380	F10	134	F88W24	14630	F20	142	LBSKB	14586	DCR	191
F88LSAG	19400	F10	137	F88W36	14640	F20	142	LBSK6	14587	DCR	191
F88LSGQR	19390	F10	137	F88W48	14650	F20	142	LCBK	17358	DCR	193
F88LTA	19290	F10	132	F88W60	14660	F20	142	LCBK6	19928	DCR	193
F88LTC	19300	F10	133	F88WA	14730	F20	143	LCK	10083	DCR	193
F88LX	19330	F10	130	F88WB	14750	F20	146	LCRDSK	17362	DCR	196
F88LXL	19320	F10	130	F88WC	14700	F20	143	LCSK12	17353	DCR	196
F88T112GV	88700	F40G	100	F88WE225	15770	F20	144	LCSK	14612	DCR	194
F88T1120GV	88760	F40G	101	F88WE45	14690	F20	144	LCSK18	17354	DCR	196
F88T112GVP	36259	F40FC	108	F88WE90	14680	F20	144	LCSK24	17355	DCR	196
F88T1120GVP	36319	F40FC	108	F88WFF	15810	F20	143	LCSK6	17352	DCR	196
F88T112GVPWK	16696	F40FC	108	F88WG	14800	F20	147	LCSKB	14613	DCR	194

CATALOG NUMBER INDEX



Catalog Number	UPC	Bulletin Number	Catalog Page	Catalog Number	UPC	Bulletin Number	Catalog Page	Catalog Number	UPC	Bulletin Number	Catalog Page
LCSKG	14614	DCR	194	LRD24BLK	17341	DCR	192	LWASK6BLK	10115	DCR	194
LEC	10085	DCR	195	LRD6BLK	10092	DCR	192	LWASK6G	10114	DCR	194
LEK12	19935	DCR	195	LRD6G	10091	DCR	192	LWASK6GZ	10116	DCR	194
LEK12B	19936	DCR	195	LRD6GZ	10093	DCR	192	PB1212PP	17176	PNLP	11
LEK3	17356	DCR	195	LRP	10086	DCR	192	PB1818PP	17177	PNLP	11
LEK3B	19933	DCR	195	LRPB	19926	DCR	192	PB2424PP	17178	PNLP	11
LEK6	17357	DCR	195	LRMPBLK	10127	DCR	193	PB66PP	17174	PNLP	11
LEK6B	19934	DCR	195	LRMPBLK18	13471	DCR	193	PB88PP	17175	PNLP	11
LFK	10082	DCR	193	LRMPBLK24	17344	DCR	193	PTLCMB3B	15666	DWS12	26
LFKB	14598	DCR	193	LRMPG	10126	DCR	193	QTP12INST	23667	DOT	204
LFKG	14601	DCR	193	LRMPG18	13468	DCR	193	QTP16INST	23668	DOT	204
LIB12BLK	10053	DCR	191	LRMPG18	10128	DCR	193	QTP18INST	23671	DOT	204
LIB12G	10052	DCR	191	LRMPG218	13472	DCR	193	QTP20INST	23672	DOT	204
LIB12GZ	10054	DCR	191	LRTK12	14604	DCR	195	QTP2X12	21341	DOT	198
LIB18BLK	10056	DCR	191	LRTK12B	14605	DCR	195	QTP2X12BLK	21365	DOT	198
LIB18G	10055	DCR	191	LRTK12G	14606	DCR	195	QTP2X16	21342	DOT	198
LIB18GZ	10057	DCR	191	LRTK18	14607	DCR	195	QTP2X16BLK	21374	DOT	198
LIB24BLK	17337	DCR	191	LRTK18B	14608	DCR	195	QTP2X18	21343	DOT	198
LIB6BLK	10047	DCR	191	LRTK18G	14611	DCR	195	QTP2X18BLK	21386	DOT	198
LIB6G	10046	DCR	191	LRTK24B	17347	DCR	195	QTP2X20	21344	DOT	198
LIB6GZ	10048	DCR	191	LRWBK	17343	DCR	193	QTP2X20BLK	21387	DOT	198
LJBK	10081	DCR	197	LRWBKB	19927	DCR	193	QTP2X22	23144	DOT	198
LJBK5	19922	DCR	197	LRWSBK	19931	DCR	193	QTP2X22BLK	23145	DOT	198
LJBK6	19923	DCR	197	LRWSKB	19932	DCR	193	QTP2X24	21346	DOT	198
LJBK7	19924	DCR	197	LSRDBLK	10103	DCR	192	QTP2X24BLK	21388	DOT	199
LJSK	10077	DCR	192	LSRDG	10102	DCR	192	QTP2X4	21336	DOT	198
LJSKB	14592	DCR	192	LSRDGZ	10104	DCR	192	QTP2X4BLK	21335	DOT	198
LJSG	14593	DCR	192	LSS12BLK	10026	DCR	191	QTP2X6	21337	DOT	198
LLB	10087	DCR	192	LSS12G	10025	DCR	191	QTP2X6BLK	21345	DOT	198
LLBB	14596	DCR	192	LSS12GZ	10027	DCR	191	QTP2X8	21338	DOT	198
LLBG	14597	DCR	192	LSS18BLK	10032	DCR	191	QTP2X8BLK	21356	DOT	198
LMCM12BLK	10068	DCR	195	LSS18G	10028	DCR	191	QTP24INST	23673	DOT	204
LMCM12G	10067	DCR	195	LSS18GZ	10033	DCR	191	QTP4INST	23664	DOT	204
LMCM12GZ	10071	DCR	195	LSS24BLK	17335	DCR	191	QTP4X12	21352	DOT	199
LMCM18BLK	10073	DCR	195	LSS6BLK	10023	DCR	191	QTP4X12BLK	21407	DOT	199
LMCM18G	10072	DCR	195	LSS6G	10022	DCR	191	QTP4X16	21353	DOT	199
LMCM18GZ	10074	DCR	195	LSS6GZ	10024	DCR	191	QTP4X16BLK	21408	DOT	199
LMCM24BLK	17348	DCR	195	LST12	17351	DCR	196	QTP4X18	21354	DOT	199
LMTSB12B	17382	DCR	194	LST12B	19937	DCR	196	QTP4X18BLK	21412	DOT	199
LMTSB18B	17383	DCR	194	LTR	17342	DCR	193	QTP4X20	21355	DOT	199
LMTSB24B	17345	DCR	194	LTSB12BLK	10106	DCR	194	QTP4X20BLK	21415	DOT	199
LOB12BLK	10038	DCR	191	LTSB12G	10105	DCR	194	QTP4X22	23813	DOT	199
LOB12G	10037	DCR	191	LTSB12GZ	10107	DCR	194	QTP4X22BLK	21416	DOT	199
LOB12GZ	10042	DCR	191	LTSB18BLK	10112	DCR	194	QTP4X24	21357	DOT	199
LOB18BLK	10044	DCR	191	LTSB18G	10108	DCR	194	QTP4X24BLK	21417	DOT	199
LOB18G	10043	DCR	191	LTSB18GZ	10113	DCR	194	QTP4X4	21347	DOT	199
LOB18GZ	10045	DCR	191	LTSB24BLK	19925	DCR	194	QTP4X4BLK	21391	DOT	199
LOB24BLK	17336	DCR	191	LWVB	10084	DCR	193	QTP4X6	21348	DOT	199
LOB6BLK	10035	DCR	191	LWVB	14602	DCR	193	QTP4X6BLK	21392	DOT	199
LOB6G	10034	DCR	191	LWVBG	14603	DCR	193	QTP4X8	21351	DOT	199
LOB6GZ	10036	DCR	191	LWASK12BLK	10118	DCR	194	QTP4X8BLK	21393	DOT	199
LRD12BLK	10095	DCR	192	LWASK12G	10117	DCR	194	QTP6INST	23665	DOT	204
LRD12G	10094	DCR	192	LWASK12GZ	10122	DCR	194	QTP6X12	21361	DOT	199
LRD12GZ	10096	DCR	192	LWASK18BLK	10124	DCR	194	QTP6X12BLK	21425	DOT	199
LRD18BLK	10098	DCR	192	LWASK18G	10123	DCR	194	QTP6X16	21362	DOT	199
LRD18G	10097	DCR	192	LWASK18GZ	10125	DCR	194	QTP6X16BLK	21426	DOT	199
LRD18GZ	10101	DCR	192	LWASK24BLK	17346	DCR	194	QTP6X18	21363	DOT	199



Catalog Number	UPC	Bulletin Number	Catalog Page	Catalog Number	UPC	Bulletin Number	Catalog Page	Catalog Number	UPC	Bulletin Number	Catalog Page
QTP6X18BLK	23146	DQT	199	QTPH	21414	DQT	201	UJP2M	17942	UJ	85
QTP6X20	21364	DQT	199	QTPHBLK	23172	DQT	201	UJP2MOFF	17944	UJ	85
QTP6X20BLK	23147	DQT	199	QTPUS10	21424	DQT	200	UJP2SS	17952	UJ	85
QTP6X22	23148	DQT	199	QTPUS10BLK	23173	DQT	200	UJP2SSOFF	17954	UJ	85
QTP6X22BLK	23151	DQT	199	QTPVD	21382	DQT	203	WF10LP	15652	A3RD	53
QTP6X24	21366	DQT	199	QTPVDBLK	21428	DQT	203	WF100LP	15684	A3RD	53
QTP6X24BLK	23152	DQT	199	QTPWTB	21427	DQT	204	WF25LP	15653	A3RD	53
QTP6X8	21358	DQT	199	QTPWTBBLK	23174	DQT	204	WF3LP	15651	A3RD	53
QTP6X8BLK	21418	DQT	199	T1F130LP	17371	A1DR	14, 15	WF40LP	15654	A3RD	53
QTP8INST	23666	DQT	204	T1F200LP	17372	A1DR	14, 15	WF75LP	15683	A3RD	53
QTP90TKIT	21367	DQT	200	T1F350LP	17373	A1DR	14, 15	WFHD3B3630	21006	A3RHD	58
QTP90TKITBLK	23153	DQT	200	T1F80LP	17368	A1DR	14, 15	WFHD3B6830	21007	A3RHD	58
QTPBC	21371	DQT	203	T10S3R	13862	D85	51	WFHD3E723630	19916	A3RHD	57
QTPBNWK	21368	DQT	200	T10S3RSS	14077	D85	51	WFHD3E726830	19915	A3RHD	57
QTPBNWKBLK	23154	DQT	200	T4S3R	13858	D85	51	WFHD3GP	21015	A3RHD	59
QTPCB12	21375	DQT	201	T4S3RSS	14075	D85	51	WFHD3PT3630	20986	A3RHD	57
QTPCB12BLK	21372	DQT	201	T6S3R	13861	D85	51	WFHD3PT6830	20991	A3RHD	57
QTPCB4	21376	DQT	201	T6S3RSS	14076	D85	51	WFHD3RC7236	21904	A3RHD	58
QTPCB4BLK	21373	DQT	201	TB3R101	14443	S90B3	80	WFHD3RCH7236	21906	A3RHD	58
QTPCB8	21377	DQT	201	TB3R103	14444	S90B3	80	WFHD3ST3630	20996	A3RHD	57
QTPCB8BLK	23155	DQT	201	TB3R103240	17001	S90B3	80	WFHD3ST6830	21001	A3RHD	57
QTPCH12	21378	DQT	201	TB3R201	14445	S90B3	80	WFHD3VB3630	21013	A3RHD	58
QTPCH12BLK	21383	DQT	201	TB3R203	14446	S90B3	80	WFHD3VB6830	21012	A3RHD	58
QTPCH24	21381	DQT	201	TB3R203240	17002	S90B3	80	WFHDFP	21002	A3RHD	59
QTPCH24BLK	21411	DQT	201	TB3R401	14447	S90B3	80	WFHDJK	21915	A3RHD	59
QTPCH4	23675	DQT	201	TB3R403	14448	S90B3	80	WFHDP7236	21003	A3RHD	58
QTPCH4BLK	23674	DQT	201	TBHUB10	15555	S90B3	81				
QTPDS2	21384	DQT	203	TBHUB12	15556	S90B3	81				
QTPDS2BLK	21431	DQT	203	TBHUB15	15557	S90B3	81				
QTPDS4	21385	DQT	203	TBHUB20	15558	S90B3	81				
QTPDS4BLK	23156	DQT	203	TBHUB25	15561	S90B3	81				
QTPDS6	23142	DQT	203	TBL100	15628	S90B3	81				
QTPDS6BLK	23716	DQT	203	TBL200	15631	S90B3	81				
QTPLB12	21394	DQT	202	TBL400	15632	S90B3	81				
QTPLB12BLK	23157	DQT	202	UJ303018A	17936	UJ	82				
QTPLB4	21395	DQT	202	UJ303018M2	16908	UJ	82				
QTPLB4BLK	23158	DQT	202	UJ303019M2	16911	UJ	82				
QTPLB8	21396	DQT	202	UJ303023M2	16912	UJ	82				
QTPLB8BLK	23161	DQT	202	UJ303024M2	16973	UJ	82				
QTPRWB12	21398	DQT	202	UJ304824M2	16974	UJ	82				
QTPRWB12BLK	23162	DQT	202	UJ306018A	17937	UJ	82				
QTPRWB16	21401	DQT	202	UJ306018M2	16913	UJ	82				
QTPRWB16BLK	23163	DQT	202	UJ306424M2	16914	UJ	82				
QTPRWB18	23143	DQT	202	UJ306623M2	16915	UJ	82				
QTPRWB18BLK	23797	DQT	202	UJ306723A	17938	UJ	82				
QTPRWB20	21402	DQT	202	UJ306724M2	16976	UJ	82				
QTPRWB20BLK	23164	DQT	202	UJ307424M2	16975	UJ	82				
QTPRWB24	21403	DQT	202	UJ307622M2	16916	UJ	82				
QTPRWB24BLK	23165	DQT	202	UJ482618M2	16917	UJ	82				
QTPRWB4	21404	DQT	202	UJP1G	17945	UJ	85				
QTPRWB4BLK	23166	DQT	202	UJP1GOFF	17947	UJ	85				
QTPRWB6	21405	DQT	202	UJP1M	17941	UJ	85				
QTPRWB6BLK	23167	DQT	202	UJP1MOFF	17943	UJ	85				
QTPRWB8	21406	DQT	202	UJP1SS	17951	UJ	85				
QTPRWB8BLK	23168	DQT	202	UJP1SSOFF	17953	UJ	85				
QTPSSW3	21413	DQT	200	UJP2G	17946	UJ	85				
QTPSSW3BLK	23171	DQT	200	UJP2GOFF	17948	UJ	85				

**PRODUCT INDEX**

Product Description	Catalog Page	Product Description	Catalog Page	Product Description	Catalog Page
19-in. Fixed Wall-Mount Rack .....	50	Comparison of Specific Non-Hazardous Applications in Outdoor Locations .....	213	Gland Plate .....	59
19-in. Hinged Wall-Mount Panel .....	49	Compression Lugs .....	207	Glossary Terms Specifying Non-Hazardous Environmental Conditions .....	214
22.50-Degree Elbow .....	144	Corner Support Bracket Kit .....	194	Ground Splitter (Ground Bar) .....	94
30-Degree Sweep Elbow .....	123	Critical Parameters (lower temperature limits) .....	55	Hanger Bracket .....	187
3-Phase 400-1200 Amp with Mechanical Lugs, Type 3R .....	76	Critical Parameters (upper temperature limits) .....	55	Hangers .....	146
400- and 800-Amp Bar-Type Mount with Line/Load Lugs .....	79	Cross .....	143, 181	Heavy-Duty C-Taps .....	207
45-Degree Elbow .....	111, 119, 144, 149, 154	Cross Fitting .....	109, 117, 130, 153	Hinge-Cover Lift-Off, Type 3R .....	44
45-Degree Elbows .....	132	CT Mounting Base .....	72	Hinge-Cover, Medium, Type 3R .....	42
45-Degree Elbows .....	177	Current Transformer Cabinets, 400-800 Amp, Type 3R .....	74	Hinge-Cover, Small, Type 3R .....	40
45-Degree Elbows—Front Cover Sloped Outward .....	178	Current Transformer, Hinged Cover, Type 3R .....	70	Hinged-Cover, Type 1 .....	16
45-Degree Elbows—Inside Cover Sloped .....	178	Current Transformer, Screw Cover, Type 3R .....	66, 68, 188	Hinged Cover Wiring Trough, NEMA Type 12 .....	164
45-Degree Elbows—Outside Cover Sloped .....	178	Current Transformer, Type 3R, Overview .....	78	Hinged-Cover with Recessed Handle, Type 1 .....	12
90-Degree Angle Sealing Plate .....	137	Cut-Off Fitting .....	143, 154	Hinged Double-Door with Three-Point Latch and Wood Panel .....	79
90-Degree Elbow .....	110, 118, 124, 144, 150, 154	Cut-Off Fitting, Lay-In .....	130	Hinged Screw Cover with Steel Panel .....	78
90-Degree Elbow—Inside Opening .....	110, 118	Cut-Off Fitting, Non-Lay-In .....	130	Horizontal Ground Bar Kits .....	208
90-Degree Elbow—Outside Opening .....	110, 118	Divider 45-Degree Elbow .....	182	Horizontal-Mount, Type 3R .....	32
90-Degree Elbow—Outside Top Opening .....	131	Divider 90-Degree Elbow .....	182	Impeller .....	59
90-Degree Elbows .....	131	Divider 90-Degree Tee .....	181	Insect Screens .....	50
90-Degree Elbows .....	174	Divider Straight Section .....	173	Insulated Ground Jumper Kit .....	196, 209
90-Degree Elbows—Front Cover Sloped Inward without Tabs .....	175	Divider Straight Section Splice .....	185	Interchangeable Bolt-on Hub .....	81
90-Degree Elbows—Front Cover Sloped Outward without Tabs .....	176	Divider Strip .....	203	IP Rating Descriptions .....	216
90-Degree Elbows—Front Cover Sloped Outward with Tabs .....	175	Divider, Telescopic Straight Section .....	174	J-Bolt Kit .....	197
90-Degree Elbows—Inside Cover Sloped .....	176	Drop and Bracket Hanger .....	125	Joining Kit .....	59
90-Degree Elbows—Outside Cover Sloped .....	176	Drop and Bracket Hangers .....	105, 112, 120	Junction Box .....	133
90-Degree Elbows—Perforated without Tabs .....	175	Drop Hanger .....	134, 151	Junction Splice Kit (cULus Classified) .....	192
90-Degree Elbow-Tee-Cross .....	110, 118, 124	EconoTrough, NEMA Type 3R .....	156, 162	Ladder Rack Curved Sections (cULus Classified) .....	191
90-Degree Flush Tee .....	109, 117, 123	Enclosure Adapter .....	183	Ladder Rack Straight Sections (cULus Classified) .....	191
90-Degree Horizontal E-Bend Section (cULus Classified) .....	191	Enclosure Type Rating versus IP Rating .....	213	Ladder Rack System .....	190
90-Degree Sweep Elbow .....	109, 117	End Cap Kit .....	195	Large, Type 1 .....	22
90-Degree Tee .....	179	Fan Shroud Kits .....	51	Latch Hardware Kits .....	187
90-Degree Tee—Front Cover Sloped Outward .....	180	Fastener Package .....	186	Lay-In Galvanized Wireway, NEMA Type 1 .....	98
90-Degree Tee—Inside Cover Sloped .....	180	Feed-Through Wireway, NEMA Type 12 .....	138, 140, 156	Lay-In Hinged-Cover Wireway, NEMA Type 1 .....	114
90-Degree Tee—Outside Cover Sloped .....	180	Fiberglass Feed-Through Wireway, NEMA Type 12 and 3R .....	139, 152	Lay-In Lug .....	207
Adjustable Butt-Splice Kit (cULus Classified) .....	191	Fiberglass Wiring Trough, NEMA Type 12 and 3R .....	168	Lay-In Painted Flat-Cover Wireway, NEMA Type 1 .....	96, 106
Adjustable Junction Splice Kit (cULus Classified) .....	192	Flexible Fitting .....	143, 149, 153	Lay-In Wireway, NEMA Type 12 .....	126
Barrier Kit, Bolt-On .....	113, 121, 136	Flush Covers .....	8	Lay-In Wireway, NEMA Type 3R .....	97, 122
Barrier Kits .....	147	Flush-Mount Door Frames .....	9	L-Bracket .....	187
Barrier Kits, Bracket-Mounted .....	137	Foot Kit .....	193	L-Bracket Kit .....	192
Bases .....	58	Galvanized 45-Degree Elbow .....	103	L-Brackets .....	202
Bonding and Grounding Overview .....	206	Galvanized 90-Degree Elbow .....	102	Lift-Off Cover with Wood Panel .....	78
Box Connector .....	135, 146, 151, 155	Galvanized 90-Degree Elbow—Inside Opening .....	103	Locking Integrated Perforated Panel Enclosure, Type 1 .....	24
Bracket Hanger .....	135, 151	Galvanized 90-Degree Elbow—Outside Opening .....	103	Locking T Handle .....	65
Butt-Splice Kit (cULus Classified) .....	191	Galvanized 90-Degree Elbow-Tee-Cross .....	102	Locking Utility Cabinets, Type 1 .....	26
Cable Exit Cover .....	184	Galvanized 90-Degree Flush Tee .....	101	Lug Assembly .....	81
CABLERACK™ .....	197	Galvanized 90-Degree Sweep Elbow .....	102	Medium, Type 1 .....	20
C-Bracket .....	201	Galvanized Closure Plate, With and Without Knockouts .....	104	Metering, Type 1 .....	88
CE .....	216	Galvanized Cross Fitting .....	102	Modular Triangle Support Bracket Kit .....	194
Ceiling Support Kit .....	193	Galvanized Panel Adapter .....	104	Mounting Bracket Kit .....	45
Center Hangers .....	201	Galvanized Support Hanger .....	105	Movable Cross Member .....	195
CFM Performance Chart .....	59	Galvanized Sweep Tee .....	101	NEMA, UL and CSA Ratings .....	215
CLEAN TRAY™ Stainless Steel Cable Tray, Type 1 .....	170, 172	Galvanized Telescope Fitting .....	104	Nipple .....	134, 145, 151
Closure Plate .....	112, 120, 124, 133, 145, 150, 154, 183	Galvanized Universal U-Connector .....	105	Open Adapter .....	111, 119
Comparison of Specific Non-Hazardous Applications in Indoor Locations .....	213	Gasket and Screws .....	147, 151	Padlock Hasp Kit .....	163

Product Description	Catalog Page
Panel	58
Panel Adapter	111, 119, 124
Panel Mounting Kit	45
Polymer Insert	204
Product Selection Matrix	59
Quick-Release Flat Sealing Plate	137
Rack Jumper Kit	209
Rack-to-Runway Mounting Plate Kit	193
Rack-to-Wall Kit	195
Radius Drop Kit	192
Rear Covers	58
Reducer	105, 113, 120, 124, 134, 184
Reducer Bushings	145, 150
Reinforced Wall Bracket	202
Replacement Tumbler Lock	63
Retaining Post Kit	192
Runway Center Support Kit	196
Runway Elevation Kit	195
Runway Overhead 12-in. Stack Kit	196
Runway Termination Kit	195
Screw-Cover Galvanized, Type 3R	38
Screw-Cover, Gasketed, Type 3	30
Screw-Cover, Type 1	4
Screw-Cover, Type 3R	34
Screw Cover Wiring Trough, NEMA Type 12	166
Screw Cover with Steel Foot Mount Panel	78
Short Circuit Current Rating for Enclosures	217
Side-Action Bolt Cutter	203
Side Coupling	186
Small, Type 1	18
Solar Consideration	54
Splice Bars	200
Splice Kit	200
Splice Washer	200
Splitter Block Assemblies Overview	93
Splitter Box Block Assemblies	93
Splitter Box, Type 1	87, 92
Splitter Trough Block Assemblies	94
Splitter Trough, Type 1	86, 90
Spool Divider Kit	196
Stainless Steel Feed-Through Wireway, NEMA Type 4X	148
Standards Organization Summary and Directory Overview	212
Straight Section	100, 198, 107, 115, 123, 142, 149, 129, 153, 173
Straight Section Splice	185
Straight Tube Section	153
Stringer Radius Drop Kit	192
Support Hanger	112, 120
Sweep Tee	109, 117
Swivel Nipple	151
Swivel Nipples	146
T1FLO™ Vented Enclosure with Fan, Type 1	2, 3, 14, 29, 67
T3-Box Telephone Cabinet, Type 3R	61, 64
Technical Information	54
Tee	144, 150

Product Description	Catalog Page
Tee Fitting	154
Tee Fitting—Outside Top Opening	133
Tee Fitting—Top Opening	132
Telecommunications Ground Bar Kits	208
Telephone Cabinet, Type 1	60, 62
Telescope Fitting	111, 119, 143, 149
Telescope Fitting, Lay-In	130
Telescopic Straight Section	173
Terminal Box, Type 3R	67, 80
Tops	57
Transition Cover	186
Transposition Sections	136
Trapeze Hanging Clip	201
Triangle Support Bracket Kit	194
Type 1 Locking Window Pull Box Accessory	3, 10, 29
Type 1 Pull Box Perforated Panel	11
U-Connector	125, 182
Universal U-Connector	113, 121
Utility Junction (UJ) Cabinets	82
Variable-Angle Elbow Fitting	179
Vented Double Door	79
Vertical Down	203
Vertical Ground Bar Kits	208
Vertical Wall Bracket	193
Wall Angle Support	194
Wall Bracket	187
Wall Hanger	125
Wall-Termination Bracket	204
WEATHERFLO™ HD Enclosures	28, 56
WEATHERFLO™ with Fan, Type 3R	52
WEATHERPRO™ Outdoor Pad Mount, Type 3R	46
Wireway Fill Tables	218
Wireway Hanger	155
Wiring Trough, NEMA Type 1	156, 158
Wiring Trough, NEMA Type 3R	157, 160

Product Description	Catalog Page
---------------------	--------------





FOR MORE INFORMATION AND TO CONTACT US, GO TO: [HOFFMANONLINE.COM](http://HOFFMANONLINE.COM)



**EQUIPMENT PROTECTION**

HOFFMAN ENCLOSURES INC.  
2100 HOFFMAN WAY, MINNEAPOLIS, MN 55303

All Pentair trademarks and logos are owned by Pentair. All other brand or product names are trademarks or registered marks of their respective owners. Because we are continuously improving our products and services, Pentair reserves the right to change specifications without prior notice.

Pentair is an equal opportunity employer.  
Printed in the USA. © 2005-2014 Pentair. All Rights Reserved.

CAT-00005 H