

Multiple Metering Products

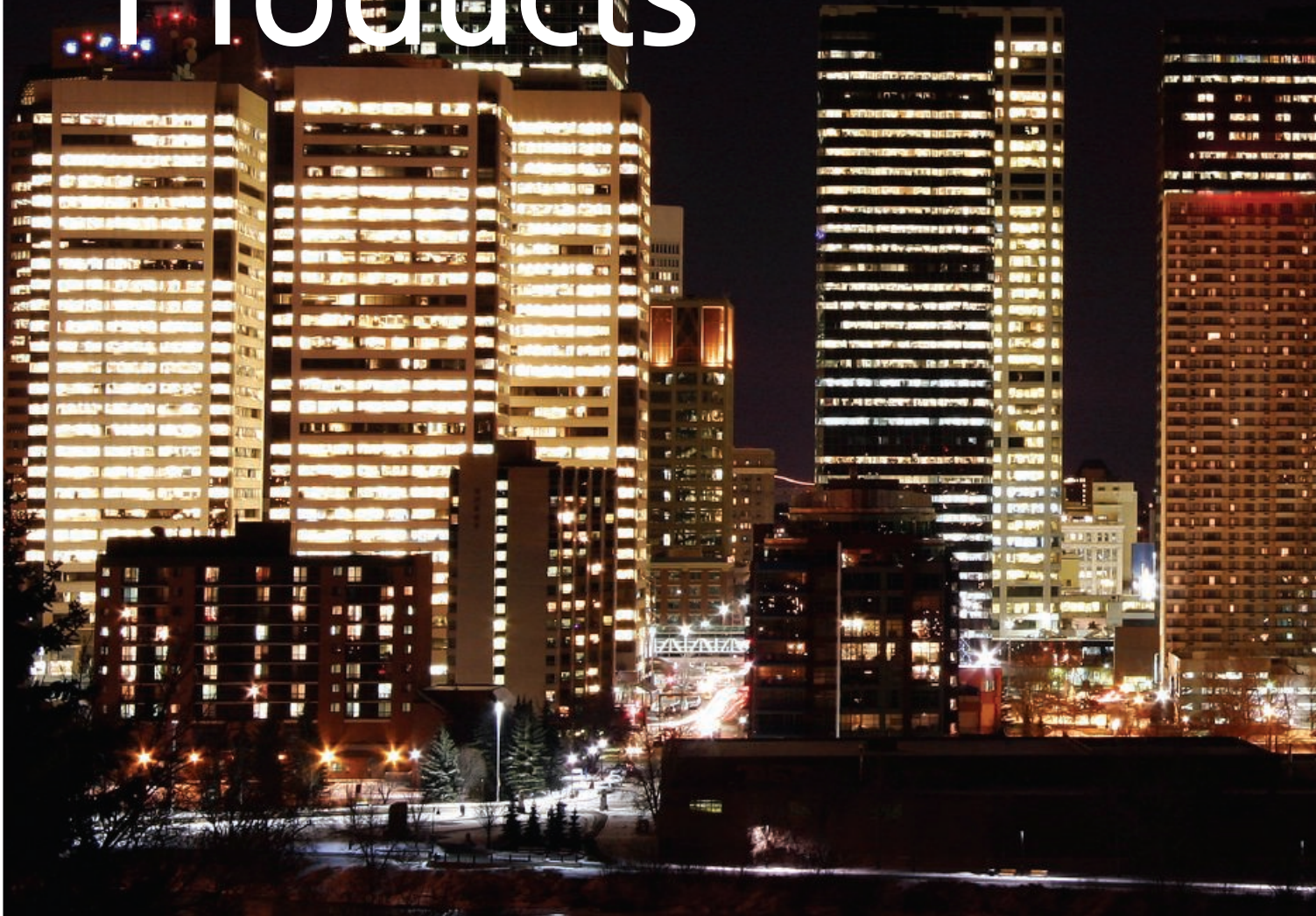

Powering Business Worldwide

Multiple Metering Products

Contents

Description	Page
Multiple Metering Products Overview	1-4
240V Multiple Metering Product	5-14
Main Service Modules	5-6
Main Terminal Box	5
Main Circuit Breaker	5
Main Fusible Switch	6
Residential Application 5 Jaw Design	7-10
Meter Stack Modules	7
Main Tenant Circuit Breakers	8
Feed Through Cable Connection Tap Boxes	8
Accessories	9
Replacement Parts	10
Myers Type Hubs	10
Commercial Application 7 Jaw Design	11-14
Meter Stack Modules	11
Main Tenant Circuit Breakers	12
Feed Through Cable Connection Tap Boxes	12
Accessories	13
Replacement Parts	14
Myers Type Hubs	14
600V Multiple Metering Product	15-20
Main Service Modules	15-16
Main Terminal Box	15
Main Circuit Breaker	15
Main Fusible Switch	16
Commercial Application 7 Jaw Design	17-20
Meter Stack Modules	17
Main Tenant Circuit Breakers	18
Feed Through Cable Connection Tap Boxes	18
Accessories	19
Replacement Parts	20
Myers Type Hubs	20
Classic MCN Design	21-22
Accessories and Replacement Parts	21-22
Main Service Module Dimensions	23-24
Meter Stack Module Dimensions	25
Meter Stack Module Wiring Diagrams	26-35
Catalogue Number Index	36-37



Note:

Eaton multiple metering products are designed to meet CSA requirements for "cold metering".

Main Service Modules



Main Circuit Breaker



Main Fusible Switch



Main Terminal Box

- ◆ Three module types
 - Main terminal box
 - Main circuit breaker
 - Main fusible switch.
- ◆ Mechanically and electrically built to bolt-up with the meter stack modules.
- ◆ 240V and 600V versions.
- ◆ 240V three phase main service modules can couple to both the 5 and 7 jaw 240V meter stack modules
- ◆ Three phase main service modules require three phase bussed meter stack modules for proper application.
- ◆ 240V Main service modules rated higher than 800A must be installed in a centre feed configuration when used with residential meter stack modules. When used with commercial meter stack modules they may be installed in a centre or end feed configuration.
- ◆ Type 3R enclosure (rainproof).
- ◆ All main service modules include both left and right horizontal bus closure plates.^①
- ◆ For service entrance rating or grounding use **GRDKIT**
- ◆ Three phase feed through cable connection tap box available.

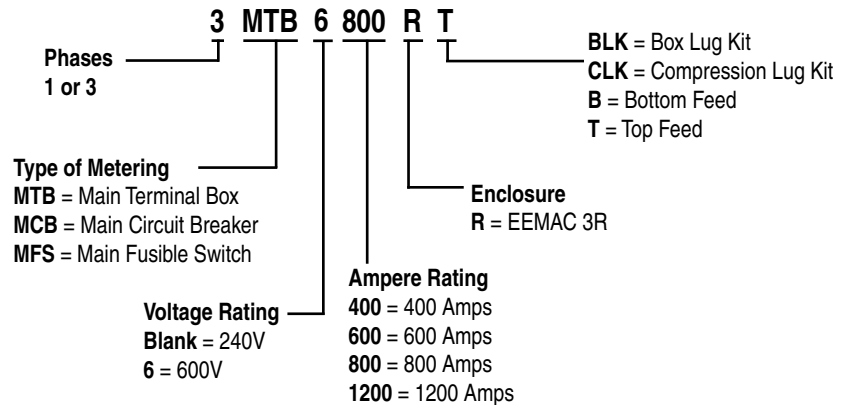

^① Replacement bus closure plates are available for purchase. For a replacement closure plate for the recessed bus side of the main service module order **47-24139A**. For a replacement closure plate for the extended bus side of the main service module order **47-28172-2A**.



Residential Meter Stack Modules

- ◆ Mechanically and electrically built to bolt-up with main service modules.
- ◆ Offered with four horizontal cross bus (for 3Ø incoming voltage systems).
- ◆ All devices include fifth jaw as standard.
- ◆ Type 3R enclosure (rainproof).

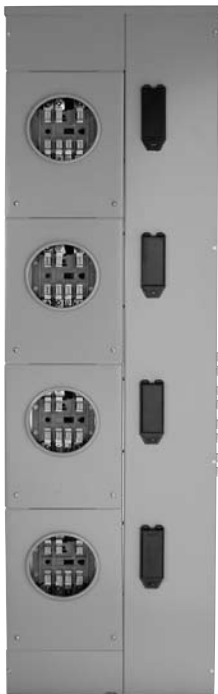
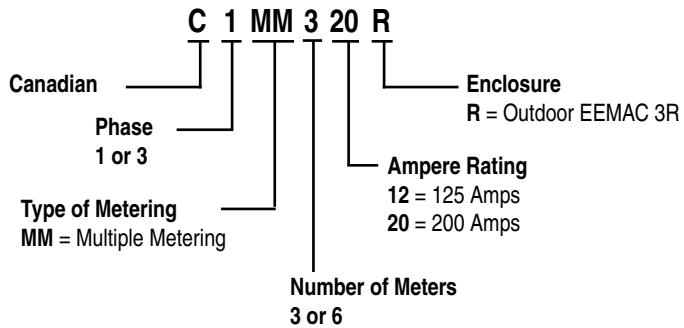

Commercial Meter Stack Modules

- ◆ Mechanically and electrically built to bolt-up with main service modules.
- ◆ All commercial meter stack modules contain four horizontal cross bus.
- ◆ Applications:
 - Strip malls
 - Light commercial multiple metering projects
 - 3Ø in 3Ø out (4 wire /4 wire)
- ◆ Type 3R enclosure (rainproof).

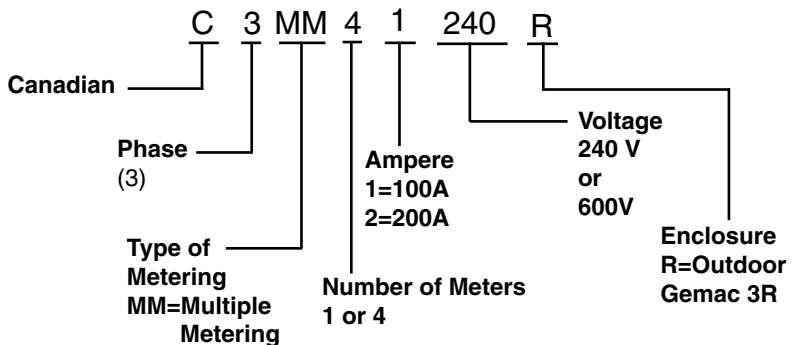

3 Multiple Metering Product Overview

Meter Stack Modules

A. Barrier

Meter socket and tenant main breaker/wireway sections are separated by a solid metal barrier to guard unmetered bus against power theft.

B. Tenant Breaker

Reliable busbar-to-busbar connection. 200 ampere modules accept bolt-on breakers 60-200 amperes for 240V and 70-200 amperes for 600V. 125 ampere modules accept 15-125 ampere plug-on breakers for 240V.

C. Factory Phase Balanced

All meter centres are factory phase balanced for ease and speed of installation.

D. Neutral Assembly

A convenient termination for neutral conductors is in the wireway of each module.

E. Enclosed Horizontal Aluminum Bus

Added safety of a non-removable barrier that protects the installer from direct contact with the bus as it passes through the tenant breaker section.

F. Equipment Ground Bar

Factory installed in side gutter, a standard feature that's movable to the top or bottom gutter.

G. Continuous Ground

A convenient lay-in lug is attached to the back of all cells. No longer do you need to purchase ground bar kits. Just remove knockouts and run your ground cable from cell to cell.

H. Raintight Cap

Shipped on all modules. Enclosure type 3R rainproof.

I. Knockouts

Tangential in top and bottom, concentric in removable backwall plate

J. Superior Finish

Rust inhibiting phosphate primer and grey baked enamel is standard (ANSI 61 grey). All outdoor enclosures are of galvanized steel construction

K. Meter Socket

Our unique meter socket base is installed without any fasteners - reducing chances for hot spots, easily replaceable, and improves connection to vertical bus.

L. Bus Connection

Mains and modules slip together quickly, smoothly with front-accessible captive bolts securing the juncture without removing socket interiors or bus access plate. No additional Bus Links required.

M. Separate Wireway Cover

Separate covers allow easy access to tenant breaker and wireway section, permit work on breakers or in wireway without disturbing meters or meter covers (not shown).

N. Vertical Busbar

One-piece vertical busbar removes most of the standard electrical joints to the meter socket. Eliminating any chance of "hot spots" from multiple connection points.

O. Horizontal Mounting Rail

To speed up and simplify installations, a two piece Mounting Rail is included with each meter stack. Swing away feet located at the top and bottom of structure can be utilized for wall mounting (not shown).

P. Padlock HASP

Included for additional security when required (not shown).

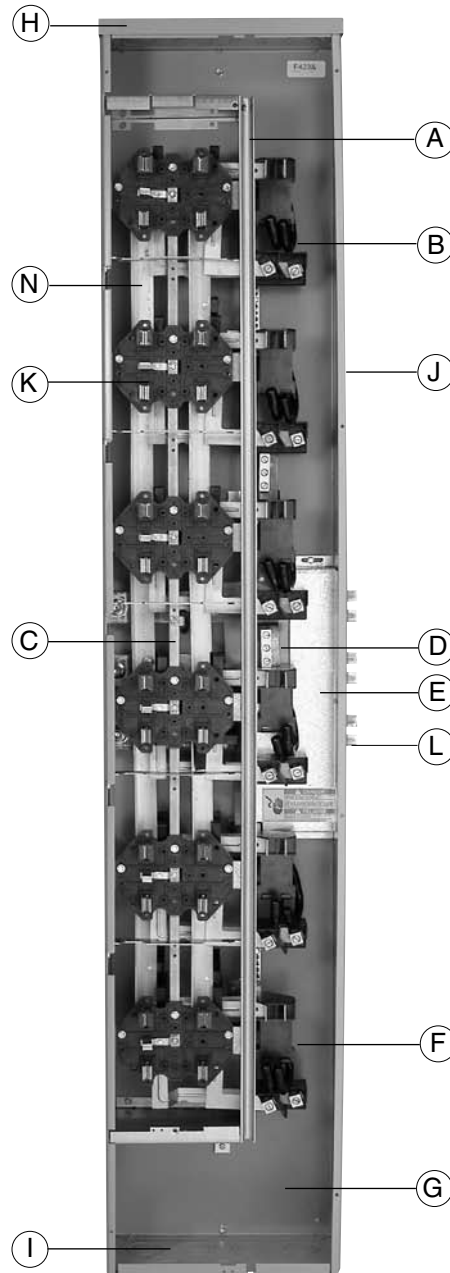

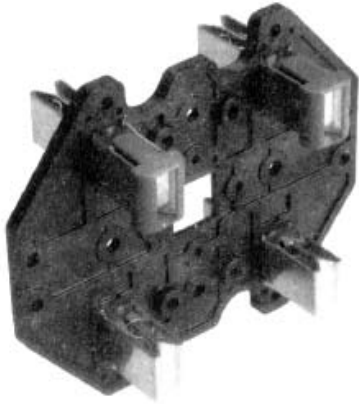

Clip-Tight™ Socket

Eaton meter stack modules incorporate the only socket base in the industry without fasteners. This component utilizes jaws on both sides of a thermoplastic polyester glass fibre reinforced (PBT) base eliminating the need for self tapping screw connections to vertical bus bars.

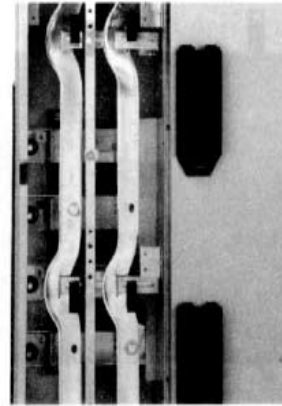

One-Piece Vertical Busbar

The meter stack modules employ a one-piece busbar construction to each socket, as well as one-piece cross bus to each tenant main. Without any busbar joints and Clip-Tight™ meter socket, Eaton residential multiple metering product eliminate any chance for hot spots.

NOTE: Canadian stacks have straight bus not curved

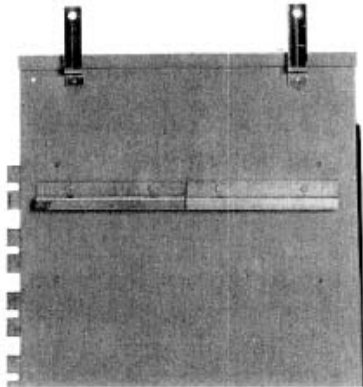

Mounting Features

Standard mounting rail and factory installed swing away feet, speed up and simplify installation. The mounting rail for the stack is affixed to the back of the structure. The wall bracket is a removable rail located at the bottom of the structure.



Main Tenant Breaker Cover

Each tenant circuit breaker is protected by a lockable raintight cover which secures the breaker against unauthorized operation. The tenant breaker cover is a high impact plastic to resist wear, rusting and corrosion.

Main Service Modules

Main Terminal Box

- ◆ Top/bottom feed
- ◆ Phase and neutral lugs included with the following devices.
- ◆ Terminal box CSA listed short circuit rating is the least AIC rating of any installed main tenant breaker – to a maximum of 100 kAIC RMS symmetrical amperes.
- ◆ Enclosure type 3R rainproof. For outdoor applications order Myers type hubs (page 10).
- ◆ Refer to pages 23 and 24 for dimensions.

Ampere Rating	System Voltage		Line Side Lug and Wire Sizes Lugs Included with Terminal Box
	120/240V AC 1Ø, 3-Wire	120/208V AC 3Ø, 4-Wire	
	Catalogue Number	Catalogue Number	
400	Use 3Ø	3MTB400R	(1) #6-600 kcmil or ②③ (2) 1/0-250 kcmil
600	Use 3Ø	3MTB600R	(2) 250-500 kcmil ②③④
800	1MTB800R	3MTB800R	(4) 250-500 kcmil ②③
1200	1MTB1200R ①	3MTB1200R ①	(4) 250-500 kcmil ②③

① When a main service module with a rating greater than 800A is used with residential meter stacks it must be installed in a centre feed configuration. When used with commercial meter stack modules it can be installed in a centre or end feed configuration.

② To obtain (4) 1/0-300 kcmil or (2) 1/0-750 kcmil cables per phase - order catalogue number 3MTB800BLK, one lug kit per cable tap box required.

③ To obtain (6) 1/0-300 kcmil or (3) 750 kcmil cables per phase - order catalogue number 3MTB1200BLK, one lug kit per cable tap box required. Includes phase and neutral lugs.

④ For compression lug landing kit, order 3MTB600CLK. Kit includes lug landings for 3 phases and neutral.

⑤ For compression lug landing kit, order 3MTB1200CLK. Kit includes lug landings for 3 phases and neutral.

⑥ To obtain (1) 750 kcmil cables per phase - order catalogue number 1MPLK2, one lug kit per pole or neutral required.

⑦ To obtain (3) 1/0-250 kcmil cables per phase - order catalogue number 3MTB600BLK, one lug kit per cable tap box required.

Main Circuit Breaker

- ◆ Phase and neutral lugs included with the following devices.
- ◆ Top/Bottom feed.
- ◆ Refer to pages 23 and 24 for dimensions.
- ◆ For shunt trip mains, order the field installable shunt trip kit from the Series C MCCB Product Guide.
- ◆ Main breaker included.
- ◆ Enclosure type 3R use Myers type hubs (page 10), for outdoor use.
- ◆ Can be factory supplied as “Reverse Fed.” Must be specified at time of purchase.

Table 1

Main Ampere Rating	Main Circuit Breaker Type	Feed	AIC	System Voltage		Line Side Lug & Wire Sizes Lugs Included with Main Breaker	
				120/240V AC 1Ø, 3-Wire	120/208V AC 3Ø, 4-Wire		
				Catalogue Number	Catalogue Number		
250	KD	Top/Bottom	65k	1MCB250R	3MCB250R	(2) 3/0-250 kcmil or ⑥ (1) 2/0-500 kcmil	
	HKD	Top/Bottom	100k	1MHCB250R	3MHCB250R		
300	KD	Top/Bottom	65k	1MCB300R	3MCB300R		
	HKD	Top/Bottom	100k	1MHCB300R	3MHCB300R		
350	KD	Top/Bottom	65k	1MCB350R	3MCB350R		
	HKD	Top/Bottom	100k	1MHCB350R	3MHCB350R		
400	KD	Top/Bottom	65k	1MCB400R ⑦⑧	3MCB400R ⑦⑧		
	HKD	Top/Bottom	100k	1MHCB400R ⑦⑧	3MHCB400R ⑦⑧		
500	LD	Top/Bottom	65k	1MCB500R	3MCB500R		(2) 300-500 kcmil ⑥
	HLD	Top/Bottom	100k	1MHCB500R	3MHCB500R		
600	LD	Top/Bottom	65k	1MCB600R ⑨	3MCB600R ⑨		
	HLD	Top/Bottom	100k	1MHCB600R ⑨	3MHCB600R ⑨		
700	MD	Top/Bottom	42k	1MCB700R	3MCB700R	(3) 3/0-400 kcmil ⑥⑦	
	HMD	Top/Bottom	100k	1MHCB700R	3MHCB700R		
800	MD	Top/Bottom	42k	1MCB800R ⑩	3MCB800R ⑩	(4) 4/0-500 kcmil ⑥⑦	
	HMD	Top/Bottom	100k	1MHCB800R ⑩	3MHCB800R ⑩		
900	ND	Top/Bottom	65k	1MCB900R ⑪⑫	3MCB900R ⑪⑫		
	HND	Top/Bottom	100k	1MHCB900R ⑪⑫	3MHCB900R ⑪⑫		
1000	ND	Top/Bottom	65k	1MCB1000R ⑬	3MCB1000R ⑬		
	HND	Top/Bottom	100k	1MHCB1000R ⑬⑭	3MHCB1000R ⑬⑭		
1200	ND	Top/Bottom	65k	1MCB1200R ⑮	3MCB1200R ⑮		
	HND	Top/Bottom	100k	1MHCB1200R ⑮⑯	3MHCB1200R ⑮⑯		

⑥ When a main service module with a rating greater than 800A is used with residential meter stacks it must be installed in a centre feed configuration. When used with commercial meter stack modules it may be installed in a centre or end feed configuration.

⑦ Add CL to end of catalogue number for compression lug pad (includes lug pads for lines and neutral).

NOTE:

⑧ If (3) 500-750 kcmil are needed, order TA1201NB1. Order one kit per pole.

⑨ If additional neutral lugs are needed, order 1MCB1200NLK [(3) 1/0-750 kcmil or (6) 1/0-300 kcmil].

⑩ If (2) 500-750 kcmil are needed, order TA801MA. Order one kit per pole.

⑪ If (1) 500-750 kcmil needed, order 3TA402K (3 pole kit).

Main Service Modules

Main Fusible Switches

- ◆ Fuses not included.
- ◆ Main lugs and neutral included with device.
- ◆ Enclosure type 3R rainproof, order Myers type hubs (page 10) for outdoor use.
- ◆ 100 kAIC rating on switches with Class T fuses installed. If converted to Class H, the AIC rating is 10k and if converted to Class R, or J fusing the AIC rating is 200k.
- ◆ Refer to pages 23 and 24 for dimensions.

Table 2.

Amperage Rating	Feed	System Voltage		Class Fuse Clips Fuses Not Included	Line Side Box Lugs and Wire Sizes Included with Switch
		120/240V AC 1Ø, 3-Wire	120/208V AC 3Ø, 4-Wire		
		Catalogue Number	Catalogue Number		
400 ①	Bottom	1MFS400RB	3MFS400RB	T ①	(2) 1/0-300 kcmil or (1) 750 kcmil ④
	Top	1MFS400RT	3MFS400RT	T ①	(2) 1/0-300 kcmil or (1) 750 kcmil ④
600 ①	Bottom	1MFS600RB	3MFS600RB	T ②	(2) #2-600 kcmil ④⑤⑥
	Top	1MFS600RT	3MFS600RT	T ②	(2) #2-600 kcmil ④⑤⑥
800	Bottom	1MFS800RB	3MFS800RB	T ③	(4) #3/0-750 kcmil ④
	Top	1MFS800RT	3MFS800RT	T ③	(4) #3/0-750 kcmil ④
1200	Bottom	1MFS1200RB ④	3MFS1200RB ④	T ③	(4) #2 to 500 kcmil ④⑦

① If Class H fuse clips are needed, use catalogue number **WCG3HK400**. If Class R fuse clips are needed, order catalogue number **DS56FK** in addition to **WCG3HK400**. In order to go from T to R, the device must first be converted to H. Kits are field installable and each kit will convert 1 pole.

② If Class H fuse clips are needed, use catalogue number **WCG3HK600**. If Class R fuse clips are needed, order catalogue number **DS66FK** in addition to **WCG3HK600**. In order to go from T to R, the device must first be converted to H. Kits are field installable and each kit will convert 1 pole.

③ Class T fuse clips provided are field convertible to Class L by repositioning. No kit is needed.

④ If compression lugs are being used, order **3MFS800CLK**. This compression lug kit includes four pads (3 poles and neutral).

⑤ If compression lugs are being used, order **3MFS800CLKT** Top Feed. This compression lug kit includes four pads (3 poles and neutral).

⑥ For top feed application cables must be looped.

⑦ To obtain (1) 750 kcmil order **1MFS600BLK** one lug kit per pole required.

⑧ To obtain (3) 750 kcmil cable per phase order **1MFS1200LK**, one lug kit per pole required.

⑨ If additional neutral lugs needed order **1MFS1200LKN** (3) 750 kcmil cables per phase.

⑩ Class J Fuse Clip Kit for 400 and 600A use **3MFS600JFK**.

Residential Application 5 Jaw Design

Meter Stack Modules

- ◆ Stacks with 1-phase horizontal bus are rated 240/120V, 1 phase, 3-wire. Stacks with 3-phase horizontal bus are rated 208Y/120V, 3Ø, 4-wire but can be used on 240/120V, 3Ø, 4-wire delta systems.
- ◆ All 3Ø horizontal bus modules have 4-wire, 800A cross bus and all stacks are factory balanced for ease of installation.
- ◆ Short circuit ratings up to 100,000A RMS symmetrical depending upon AIC rating of installed main tenant circuit breakers and main device.
- ◆ Lay-in Lug is attached to back of every cell. Removal of K/O allows ground cable to run from cell to cell.
- ◆ Main tenant feeders can exit top or bottom. Knockouts are available at all exit locations.
- ◆ Type 3R enclosure. If being used in outdoor application and exiting the top, mount Myer type hubs on rainproof cap. See page 10.
- ◆ Provision for 2-pole breaker. Plug-on type for 125A meters and bolt-on type for 200A meters. Circuit breakers not included. See page 8 for selection.
- ◆ Available in three and six meter socket configuration, 5 jaw standard.

Table 3

Amperes Per Meter Socket	Number of Meter Sockets	Bus Ampacity	Enclosure Type	1Ø Horizontal Bus (3 Horizontal Bus Bars - A, B, and Neutral)	3Ø Horizontal Bus (4 Horizontal Bus Bars - A, B, C and Neutral)	Main Tenant Breaker Type (For Specific Catalogue Numbers. Refer to page 9)
				Catalogue Number	Catalogue Number	
125	3	800	Indoor & Outdoor	-	C3MM312R [Ⓢ]	Plug on Type BR, BRH, BRHH
	6	800	Indoor & Outdoor	C1MM612R [Ⓢ]	C3MM612R [Ⓢ]	
200	3	800	Indoor & Outdoor	C1MM320R [Ⓢ]	C3MM320R [Ⓢ]	Bolt-on Type CCV2-X, CHH2-H2X, CHH2-H4X, CHH2-X

Wire Sizes - Neutral and Ground Lugs

- ◆ Each stack includes a neutral and ground bar.
- ◆ If an extra ground bar is needed then order 1MMGBK.

Table 4

Lugs in Meter Socket Modules	Wire Size (Al/Cu)
Branch Neutral - 125A module	#6 - 2/0
Branch Neutral - 200A module	#1/0 - 300kcmil
Equipment Ground Bar - 125A module	#14 - 2
Equipment Ground Bar - 200A module	#14 - 2/0
Optional Ground Bar 1MMGBK	#6 - 2/0

[Ⓢ] Fifth jaw at 9 o'clock position included as standard. Can be field adjusted to the 3, or 6, or 12 o'clock position.

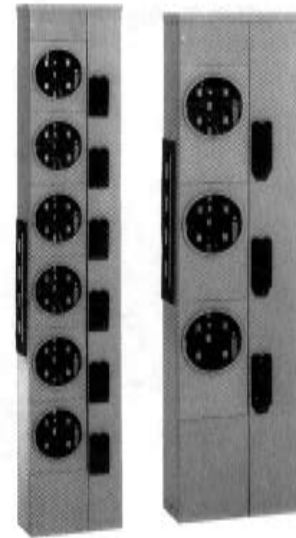

Dimensions Page 25

Residential Application 5 Jaw Design

Main Tenant Circuit Breakers

- ◆ The following breakers are to be used on residential meter stack modules.
- ◆ 120/240V AC - field installed.

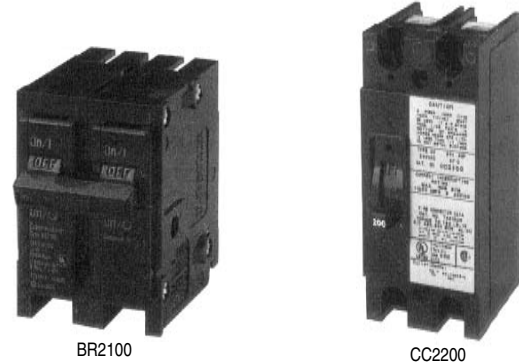

Table 5.

	Description	Number of Poles	Main Tenant Circuit Breaker	10,000 AIC	22,000 AIC	25,000 AIC	42,000 AIC	100,000 AIC
				Catalogue Number	Catalogue Number	Catalogue Number	Catalogue Number	Catalogue Number
125A	Plug-in type circuit breakers used with C1MM and C3MM 125A modular metering stacks	2	60	BR260	BRH260	–	BRHH260	–
		2	70	BR270	BRH270	–	BRHH270	–
		2	80	BR280	BRH280	–	BRHH280	–
		2	90	BR290	BRH290	–	BRHH290	–
		2	100	BR2100	BRH2100	–	BRHH2100	–
		2	110	BR2110	BRH2110	–	BRHH2110	–
		2	125	BR2125	BRH2125	–	BRHH2125	–
200A	Bolt-on [Ⓢ] circuit breakers used with C1MM and C3MM 200A modular metering stacks	2	60	–	–	CHH2060H2X	CHH2060H4X	CHH2060X
		2	70	–	–	CHH2070H2X	CHH2070H4X	CHH2070X
		2	80	–	–	CHH2080H2X	CHH2080H4X	CHH2080X
		2	90	–	–	CHH2090H2X	CHH2090H4X	CHH2090X
		2	100	CCV2100X	–	CHH2100H2X	CHH2100H4X	CHH2100X
		2	125	CCV2125X	–	CHH2125H2X	CHH2125H4X	CHH2125X
		2	150	CCV2150X	–	CHH2150H2X	CHH2150H4X	CHH2150X
		2	175	CCV2175X	–	CHH2175H2X	CHH2175H4X	CHH2175X
		2	200	CCV2200X	–	CHH2200H2X	CHH2200H4X	CHH2200X

NOTE:

Reference to Bolt-on Breakers is not the former BQL frame, it represents a commercial grade Bolt-on Moulded case frame.

Ⓢ Mounting hardware kit for CCV and CHH type (bolt-on) breakers included in 200A meter stack.

ⓧ X suffix on breakers indicates load side lugs included with breaker.

Feed Through Cable Connection Tap Boxes

Table 6.

Amperage Rating (A)	Entry Side	System Voltage 120/208V 3Ø 4W	Dimension (Inches / mm)			Conductors Per Phase CU/AL "IN" & "OUT" Lugs Supplied with Box
		Catalogue Number	H	W	D	
800	Top/Bottom	C3MTB800FT [Ⓢ]	50-3/4 / 1289.05	26-5/8 / 676.28	9 / 228.60	(4) 250 - 500 kcmil "IN" (4) 250 - 500 kcmil "OUT"
1200	Top/Bottom	C3MTB1200FT [Ⓢ] [ⓧ]	50-3/4 / 1289.05	26-5/8 / 676.28	9 / 228.60	(4) 250 - 500 kcmil "IN" (4) 250 - 500 kcmil "OUT"

Ⓢ To obtain (2) 1/0 - 750 kcmil (2 in/2 out) or (4) 1/0 - 300 kcmil (4 in/4 out) cables per phase - order catalogue number **C3MTBFTLUG**.

ⓧ To obtain (3) #2 - 750 kcmil (3 in/3 out) cables per phase - order catalogue number **C3MTB12FTLUG**.

Ⓢ If used with residential meter stack modules the feed through cable connection tap box must be installed in a centre feed configuration. If used with commercial meter stack modules it may be installed in a centre or end feed configuration.

NOTE:

- Feed through tap boxes are required when cables enter and exit at the same end of the meter centre. No KO's are provided.
- Cable connection tap boxes may be used for sub-feeds. Mount on opposite end to main cable entry.

Residential Application 5 Jaw Design

Accessories

Table 7

Description	Application	Catalogue Number
Lexan Blank Cover	Circular cover mounted on devices preventing access to meter socket while meter is not in place. Includes 4 plastic tabs which plug into each jaw.	1MMPCP
	Same as 1MMPCP minus the tabs located in the back to plug into jaws. This device to be used while meter bypassjumpers are in place (1MMBPJ).	1MMACP
Blank Meter Socket Cover	Used for 125 stacks. Kit replaces existing meter cover preventing access to meter socket. Includes hasp for sealing.	1MMBC125B
	Used on 200A stacks. Kit replaces existing meter cover preventing access to meter socket. Includes hasp for sealing.	1MMBC200B
Wall Mounting Rail	Rails are 4 feet (1219.20 mm) in length. Bolted on wall for stacks and mains to be hung.	1MMWB
Indoor Corner Elbow	12-inch (303.8mm) indoor corner elbow, 1200 ampere, 3Ø, 4-wire for use with C1MM and C3MM.	3MMEB12
Meter Jumper	Meter bypass jumpers for 125A and 200A sockets.	1MMBPJ
Meter Jumper and Cover	Combination meter jumper and cover (200 ampere maximum). Used to jumper line and load jaws as well as cover meter socket prevention exposure to current carrying parts.	1MMJCK
Suite Identification Plates	Lamacoid adhesive backed nameplates, white with black, black with white or red with white lettering available. Size 1" x 2 1/2", letter size 3/16", 1/8" suitable for 1, 2, 3 line engraving. Loose nameplates supplied for customer mounting. NOTE: 2 or 3 identical plates may be required as some utilities require marking on the cover, compartment and disconnect, where the disconnecting means is not in the compartment. Actual lettering required must be specified.	
Lug Barrier Kit	Used on bottom fed main fusible switch main service modules.	3MFSBBK
	Used on top fed main fusible switch main service modules.	3MFSTBK

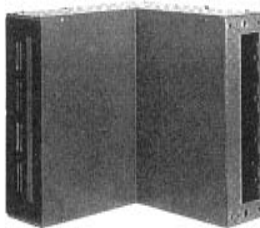

Indoor Corner Elbow



Wall Mounting Rail

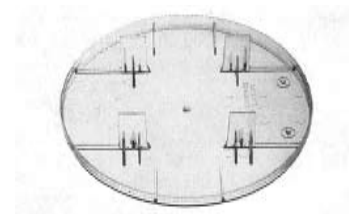

Lexan Blank Cover



Blank Cover Kit

Residential Application 5 Jaw Design

Replacement Parts

Table 8.

Description	Application	Catalogue Number
Ring Cover	Installed on 125A socket for ring security	1MMCP1
	Installed on 200A socket for ring security	1MMCP2
Tenant Breaker Hinged Cover	125A	1MMBC1
	200A	1MMBC2
Meter Socket	125A and 200A	1MMMS
Bus Cover	Protective bus cover for protruding bus side of any module	47-28172-2A
	Protective bus cover for recessed bus side of any module	47-24139A

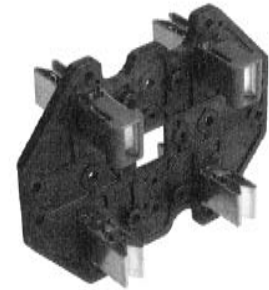

Meter Socket



Ring Cover



Tenant Breaker Hinged Cover



Sealing Ring

Myers Type Hubs

- ◆ For outdoor applications.
- ◆ For use with main terminal, breaker and fusible switch modules.

Table 9.

Conduit Size		Catalogue Number
Inches	mm	
1/2	12.7	DS050MH
3/4	19.0	DS075MH
1	25.4	DS100MH
1-1/4	31.8	DS125MH
1-1/2	38.1	DS150MH
2	50.8	DS200MH
2-1/2	63.5	DS250MH
3	76.2	DS300MH



Myers Type Hub

Typical Ordering Procedure

- ① Select a main service module
 - ◆ Main Terminal Box
 - ◆ Main Breaker
 - ◆ Main Fusible Switch
- ② Select the number of basic meter stacks required based on:
 - ◆ 3 - 125A socket positions maximum with 2 or 3 pole breakers.
 - ◆ 6 - 125A socket position maximum with 2 or 3 pole breakers.
 - ◆ 3 - 200A socket positions with 2 or 3 pole breakers.
- ③ Select the applicable tenant breakers.
- ④ Add a feed through cable connection tap box if required.
- ⑤ Add any elbows if required.
- ⑥ Add ID nameplates, optional lugs, covers, etc.

11 240V Multiple Metering Product

Commerical Application 7 Jaw Design

Meter Stack Modules

- ◆ Meter stacks are available in 125 and 200 ampere 3Ø in 3Ø out (4W/4W), 240V AC maximum.
- ◆ Short circuit ratings up to 100,000A RMA symmetrical depending upon the interrupting rating of the installed main tenant circuit breakers and main device.
- ◆ Lay-in lug is attached to the back of every cell. Removal of knockout allows ground cable to run from cell to cell.
- ◆ Main tenant feeders can exit top or bottom. Knockouts are available at all exit locations.
- ◆ Type 3R enclosure. If being used in an outdoor application and exiting the top then mount a Myers hub on rainproof cap (See page 14).

Table 10

Amperes Per Meter Socket (A)	Number of Meter Sockets	Bus Ampacity (A)	Enclosure Type	3Ø Horizontal Bus (4 Horizontal Bus Bars A,B,C & Neutral)	Main Tenant Breaker Type
125	4	1200	Indoor / Outdoor	C3MM41240R	Bolt-on Type GD (3 Pole)
200	1			C3MM12240R	Bolt-on Type EHD, ED and EDH (3 Pole)
	4			C3MM42240R	

Wire Sizes - Neutral and Ground Lugs

- ◆ Each stack includes a neutral and ground bar.
- ◆ If an extra ground bar is needed then order 1MMGBK.

Table 11

Lugs in Meter Socket Modules	Wire Size (Al/Cu)
Branch Neutral - 125A module	#1/0 - 300MCM
Branch Neutral - 200A module	#1/0 - 300MCM
Equipment Ground Bar - 125A module	#6 - 2/0
Equipment Ground Bar - 200A module	#6 - 2/0
Optional Ground Bar 1MMGBK	#6 - 2/0

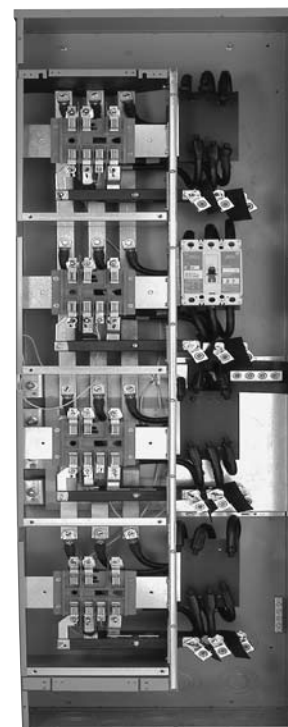

Commercial Application 7 Jaw Design

Main Tenant Circuit Breakers

- ◆ The following breakers are to be used on C3MM 7 jaw modular metering stacks.
- ◆ 120/240V AC - field installed.
- ◆ Use 3 pole tenant breaker (see chart below).



GD Breaker

Table 12.

	Description	Number of Poles	Main Tenant Breaker Am- pere Rating	65,000 AIC	100,000 AIC
				Catalogue Number	Catalogue Number
125A	Bolt-on type ① circuit breakers used with C3MM 125A modular metering stacks	3	60	GD3060	—
		3	70	GD3070	—
		3	100	GD3100	—
200A	Bolt-on ② circuit breakers used with C3MM 200A modular metering stacks	3	100	ED3100	EDH3100
		3	125	ED3125	EDH3125
		3	150	ED3150	EDH3150
		3	175	ED3175	EDH3175
		3	200	ED3200	EDH3200

NOTE:

Reference to Bolt-on Breakers, is not the former BQL frame, it represents a commercial grade Bolt-on moulded case frame.

① Mounting hardware kit for ED type breakers is included in 200A meter stack (MHDF3). GD mounting hardware is included with the breakers.

② 3TA225FD (#4-4/0) lugs for standard 200A applications are included with the meter stack module. If other lugs are required they must be purchased separately.

Feed Through Cable Connection Tap Boxes

Table 13.

Amperage Rating (A)	Entry Side	System Voltage 120/208V 3Ø 4W	Dimension (Inches / mm)			Conductors Per Phase CU/AL "IN" & "OUT" Lugs Supplied with Box
		Catalogue Number	H	W	D	
800	Top/Bottom	C3MTB800FT	50-3/4 / 1289.05	26-5/8 / 676.28	9 / 228.60	(4) 250 - 500 kcmil "IN" (4) 250 - 500 kcmil "OUT"
1200	Top/Bottom	C3MTB1200FT ③	50-3/4 / 1289.05	26-5/8 / 676.28	9 / 228.60	(4) 250 - 500 kcmil "IN" (4) 250 - 500 kcmil "OUT"

③ To obtain (2) 1/0 - 750 kcmil (2 in/2 out) or (4) 1/0 - 300 kcmil (4 in/4 out) cables per phase - order catalogue number C3MTBFTLUG.

④ To obtain (3) #2 - 750 kcmil (3 in/3 out) cables per phase - order catalogue number C3MTB12FTLUG.

⑤ If used with residential meter stack modules the feed through cable connection tap box must be installed in a centre feed configuration. If used with commercial meter stack modules it may be installed in a centre or end feed configuration.

NOTE:

- Feed through tap boxes are required when cables enter and exit at the same end of the meter centre. No KO's are provided.
- Cable connection tap boxes may be used for sub-feeds. Mount on opposite end to main cable entry.

Commerical Application 7 Jaw Design

Accessories

Table 14

Description	Application	Catalogue Number
Lexan Blank Cover	Circular cover mounted on devices preventing access to meter socket while meter is not in place. Includes 4 plastic tabs which plug into each jaw.	1MMPCP
	Same as 1MMPCP minus the tabs located in the back to plug into jaws. This device to be used while meter bypassjumpers are in place (1MMBPJ).	1MMACP
Blank Meter Socket Cover (For bottom position only)	Used for 125 and 200A 7 Jaw stacks. Kit replaces existing meter cover preventing access to meter socket. Includes hasp for seal.	37MMCKCAN
Wall Mounting Rail	Rails are 4 feet (1219.20 mm) in length. Bolted on wall for stacks and mains to be hung.	1MMWB
Indoor Corner Elbow	16-inch (406.4 mm) indoor corner elbow, 1200 ampere, 3-phase, 4-wire for use with 7 Jaw C3MM.	3MMEB16
Meter Jumper	Meter bypass jumpers for 125A and 200A sockets. (order 3 for 7 Jaw application)	1MMBPJ
Meter Jumper and Cover	Combination meter jumper and cover (200 ampere maximum). Used to jumper line and load jaws as well as cover meter socket prevention exposure to current carrying parts.	1MMJCK
F-Frame Terminals (Maximum Breakers Amperes)	100A (#14 - 1/0)	3T100FB
	150A (#4 - 4/0)	3TA150FB
Lug Barrier Kit	Used on bottom fed main fusible switch main service modules.	3MFSBBK
	Used on top fed main fusible switch main service modules.	3MFSTBK

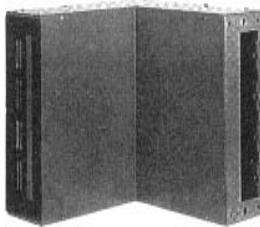

Indoor Corner Elbow



Wall Mounting Rail

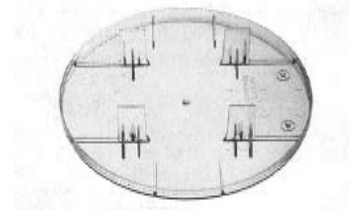

Lexan Blank Cover



Blank Cover Kit

Commercial Application 7 Jaw Design

Replacement Parts

Table 15.

Description	Application	Catalogue Number
Ring Cover	Installed on 125A socket for ring security	37MMSKCAN
Tenant Breaker Hinged Cover	125-200A	1MMBC2
Meter Socket	125A and 200A	99-5115-2
Sealing Ring	Stainless steel screw type (standard)	SR3
Bus Cover	Protective bus cover for protruding bus side of any module	47-28172-2A
	Protective bus cover for recessed bus side of any module	47-24139A

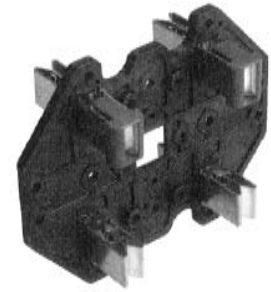

Meter Socket



Ring Cover



Tenant Breaker Hinged Cover



Sealing Ring

Myers Type Hubs

- ◆ For outdoor applications.
- ◆ For use with main terminal, breaker and fusible switch modules.

Table 16.

Conduit Size		Catalogue Number
Inches	mm	
1/2	12.7	DS050MH
3/4	19.0	DS075MH
1	25.4	DS100MH
1-1/4	31.8	DS125MH
1-1/2	38.1	DS150MH
2	50.8	DS200MH
2-1/2	63.5	DS250MH
3	76.2	DS300MH



Myers Type Hub

Typical Ordering Procedure

- ① Select a main service module
 - ◆ Main Terminal Box
 - ◆ Main Breaker
 - ◆ Main Fusible Switch
- ② Select the number of basic meter stacks required based on:
 - ◆ 4 - 125A socket positions maximum with 3 pole breakers.
 - ◆ 1 - 200A socket position with 3 pole breakers.
 - ◆ 4 - 200A socket positions with 3 pole breakers.
- ③ Select the applicable tenant breakers.
- ④ Add a feed through cable connection tap box if required.
- ⑤ Add any elbows if required.
- ⑥ Add ID nameplates, optional lugs, covers, etc.

15 600V Multiple Metering Product

Main Service Modules

Main Terminal Box

- ◆ Indoor or outdoor.
- ◆ Top or bottom feed.
- ◆ Phase and neutral lugs included with the following devices.
- ◆ Terminal box CSA listed short circuit rating is the least AIC rating of any installed main tenant breaker. To a maximum of 100kAIC RMS symmetrical amperes.
- ◆ Enclosure type 3R rainproof, order Myers type hubs (page 20) for outdoor use.
- ◆ Refer to pages 23 and 24 for dimensions.

Table 17.

Amperage Rating	System Voltage 347/600V AC 3Ø, 4-Wire	Line Side Lug and Wire Sizes (Lugs Included with Terminal Box)
	Catalogue Number	
400	3MTB6400R	(1) #6-600 kcmil or ④⑤ (2) 1/0-250 kcmil
600	3MTB6600R	(2) 250-500 kcmil ②④⑤
800	3MTB6800R	(4) 250-500 kcmil ①③
1200	3MTB61200R	(4) 250-500 kcmil ①③

① To obtain (4) 1/0-300 kcmil or (2) 1/0-750 kcmil cables per phase - order catalogue number **3MTB800BLK**, one lug kit per cable tap box required.

② For compression lug landing kit, order **3MTB600CLK**. Kit includes lug landings for 3 phases and neutral.

③ For compression lug landing kit, order **3MTB1200CLK**. Kit includes lug landings for 3 phases and neutral.

④ To obtain (1) 750 kcmil cables per phase - order catalogue number **1MPLK2**, one lug kit per pole or neutral required.

⑤ To obtain (3) 1/0-250 kcmil cables per phase - order catalogue number **3MTB600BLK**, one lug kit per cable tap box required.

Main Circuit Breaker

- ◆ Phase and neutral lugs included with the following devices.
- ◆ Top/Bottom feed.
- ◆ For shunt trip mains, order the field installable shunt trip kit from the Series C MCCB Product Guide.
- ◆ Main breaker included.
- ◆ Enclosure type 3R use Myers type hubs (page 20), for outdoor use.
- ◆ Refer to pages 23 and 24 for dimensions

Table 18

Main Ampere Rating	Main Circuit Breaker Type	Feed	AIC	System Voltage 347/600V AC 3Ø, 4-Wire	Line Side Lug and Wire Sizes Lugs Included with Main Breaker
				Catalogue Number	
400	KD	Top/Bottom	25k	3MCB6400R ④⑤	(2) 3/0 - 250 kcmil or ②(1) 2/0 - 500 kcmil
	HKD	Top/Bottom	35k	3MHC6400R ④⑤	
600	LD	Top/Bottom	25k	3MCB6600R ④	(2) 300 - 500 kcmil ②
	HLD	Top/Bottom	35k	3MHC6600R ④	
800	MD	Top/Bottom	25k	3MCB6800R ④	(3) 3/0 - 400 kcmil ②⑥
	HMD	Top/Bottom	35k	3MHC6800R ④	

④ Add CL to end of catalogue number for compression lug pad (includes lug pads for lines and neutral).

② If additional neutral lugs are needed, order **1MCB1200NLK** [(3) 1/0-750 kcmil or (6) 1/0-300 kcmil].

⑤ If (2) 500-750 kcmil are needed, order **TA801MA**. Order one kit per pole.

⑥ If (1) 500-750 kcmil needed, order **3TA402K** (3 pole kit).

Main Service Modules

Main Fusible Switches

- ◆ Fuses not included.
- ◆ Main lugs and neutral included with the switch.
- ◆ Enclosure type 3R rainproof, order Myers type hubs page 20 for outdoor use.
- ◆ 100kAIC rating on switches with Class T fuses installed.
- ◆ Refer to pages 23 and 24 for dimensions.
- ◆ 347/600V AC 3Ø 4 Wire system voltage

Table 19.

Ampere Rating	Feed	Catalogue Number	Class Fuse Clips	Line Side Box Lugs and Wire Sizes
400	Bottom	3MFS6400RB	T ^⑤	(2) 1/0-300 kcmil or (1) 750 kcmil ^①
	Top	3MFS6400RT	T ^⑤	(2) 1/0-300 kcmil or (1) 750 kcmil ^②
600	Bottom	3MFS6600RB	T ^⑤	(2) #2-600 kcmil ^{①③④}
	Top	3MFS6600RT	T ^⑤	(2) #2-600 kcmil ^{②③④}
800	Bottom	3MFS6800RB	T	(4) #3/0-750 kcmil ^①
	Top	3MFS6800RT	T	(4) #3/0-750 kcmil ^②

① If compression lugs are being used, order **3MFS800CLK**. This compression lug kit includes four pads (3 poles and neutral).

② If compression lugs are being used, order **3MFS800CLKT** Top Feed. This compression lug kit includes four pads (3 poles and neutral).

③ To obtain (1) 750 kcmil order **1MFS600BLK** one lug kit per pole required.

④ If additional neutral lugs needed order **1MFS1200LKN** (3) 750 kcmil cables per phase.

⑤ Class J Fuse Clip Kit for 400 and 600A use 3MFS600JFK.

17 600V Multiple Metering Product

Commerical Application 7 Jaw Design

Meter Stack Modules

- ◆ Stacks with 3-phase horizontal bus are rated 600Y/347V, 3-phase, 4-wire.
- ◆ All three phase horizontal bus modules are 1200A 100% rated. 800A cross bus and all stacks are factory balanced for ease of installation.
- ◆ Short circuit ratings up to 100,000A RMS symmetrical depending upon AIC rating of installed main tenant circuit breakers and main device.
- ◆ Lay-in Lug is attached to back of every cell. Removal of K/O allows ground cable to run from cell to cell.
- ◆ Main tenant feeders can exit top or bottom. Knockouts are available at all exit locations.
- ◆ Type 3R enclosure. If being used in outdoor application and exiting the top, mount Myer type hubs on rainproof cap.
- ◆ Provision for 3-pole breaker. Bolt-on type for 200A meters. Circuit breakers not included.
- ◆ Available in one and four meter socket configuration, 7 jaw standard.

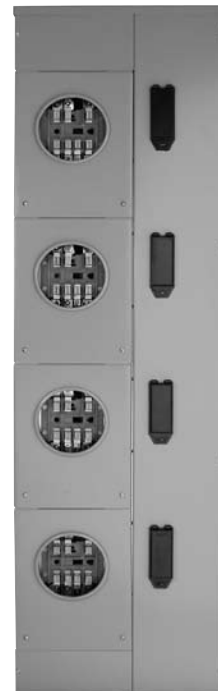

Table 20

Amperes Per Meter Socket	Number of Meter Sockets	Bus Ampacity	Enclosure Type	3-Phase Horizontal Bus (4 Horizontal Bus Bars - A, B, C and Neutral)	Main Tenant Breaker Type. For Specific Catalogue Numbers.
				Catalogue Number	
200	1	1200	Indoor & Outdoor	C3MM12600R	Bolt-on Type FDB - 3 Pole FD - 3 Pole HFD - 3 Pole FDC - 3 Pole
200	4	1200	Indoor & Outdoor	C3MM42600R	Bolt-on Type FDB - 3 Pole FD - 3 Pole HFD - 3 Pole FDC - 3 Pole

Wire Sizes - Neutral and Ground Lugs

- ◆ Each stack includes a neutral and ground bar.
- ◆ If an extra ground bar is needed order **1MMGBK**.

Table 21

Lugs in Meter Socket Modules	Wire Size, Al/Cu
Branch Neutral -125A socket module	#1/0-300MCM
Branch Neutral -200A socket module	#1/0-300MCM
Equipment Ground Bar, 125A socket module	#6-2/0
Equipment Ground Bar, 200A socket module	#6-2/0
Optional Ground Bar (1MMGBK)	#6-2/0

Commercial Application 7 Jaw Design

Main Tenant Circuit Breakers

- ◆ The following breakers are to be used on C3MM modular metering stacks, 600V.
- ◆ 7 Jaw standard meter centre.
- ◆ 120/240V AC - field installed.
- ◆ Use 3 pole tenant breaker (see chart below)



FD Breaker

Table 22.

	Description	Number of Poles	Main Tenant Breaker Ampere Rating	14,000 AIC	18,000 AIC	25,000 AIC	35,000 AIC
				Catalogue Number	Catalogue Number	Catalogue Number	Catalogue Number
200A	Bolt-on ^① breakers used with C3MM 200A modular metering stacks	3	70	FDB3070	FD3070	HFD3070	FDC3070
		3	100	FDB3100	FD3100	HFD3100	FDC3100
		3	125	FDB3125	FD3125	HFD3125	FDC3125
		3	150	FDB3150	FD3150	HFD3150	FDC3150
		3	175	FDB3175	FD3175	HFD3175	FDC3175
		3	200	FDB3200	FD3200	HFD3200	FDC3200

^① Reference to Bolt-on Breakers, is not the former BQL frame, it represents a commercial grade Bolt-on Moulded case frame.

^② Mounting hardware kit for F-Frame type breakers included in 200A meter stack. Kit includes **3TA225FD** (#4 - 4/0) lugs for standard 200A applications. If other lugs are required, they must be purchased separately.

Feed Through Cable Connection Tap Boxes

- ◆ System Voltage 347/600V AC 3Ø, 4W.
- ◆ “IN” and “OUT” Lugs Supplied with the connection tap box.

Table 23.

Ampere Rating	Entry Side	Catalogue Number	Dimensions			Conductors Per Phase (CU/AL)
			H	W	D	
800	Top/Bottom	C3MTB6800FT ^③	46 1/8"	26 1/2"	8 1/2"	(4) 250 - 500 kcmil "IN" (4) 250 - 500 kcmil "OUT"
1200	Top/Bottom	C3MTB61200FT ^④	50 3/4"	26 5/8"	9"	

^③ Contact your local Eaton sales rep for additional lug sizes.

^④ Contact your local Eaton sales rep for additional lug sizes.

NOTE:

- Feed through tap boxes are required when cables enter and exit at the same end of the meter centre. No KO's are provided.
- Cable connection tap boxes may be used for subfeeds.
- Mount on opposite end to main cable entry.

Commerical Application 7 Jaw Design

Accessories

Table 24

Description	Application	Catalogue Number
Lexan Blank Cover	Circular cover mounted on devices preventing access to meter socket while meter is not in place. Includes 4 plastic tabs which plug into each jaw.	1MMPCP
	Same as 1MMPCP minus the tabs located in the back to plug into jaws. This device to be used while meter bypassjumpers are in place (1MMBPJ).	1MMACP
Blank Meter Socket Cover (For bottom position only)	Used for 125 and 200A 7 Jaw stacks. Kit replaces existing meter cover preventing access to meter socket. Includes hasp for seal.	37MMCKCAN
Wall Mounting Rail	Rails are 4 feet (1219.20 mm) in length. Bolted on wall for stacks and mains to be hung.	1MMWB
Indoor Corner Elbow	16-inch (406.4 mm) indoor corner elbow, 1200 ampere, 3-phase, 4-wire for use with 7 Jaw C3MM.	3MMEB616
Meter Jumper	Meter bypass jumpers for 125A and 200A sockets. (order 3 for 7 Jaw application)	1MMBPJ
Meter Jumper and Cover	Combination meter jumper and cover (200 ampere maximum). Used to jumper line and load jaws as well as cover meter socket prevention exposure to current carrying parts.	1MMJCK
F-Frame Terminals (Maximum Breakers Amperes)	100A (#14 - 1/0)	3T100FB
	150A (#4 - 4/0)	3TA150FB
Lug Barrier Kit	Used on bottom fed main fusible switch main service modules.	3MFSBBK
	Used on top fed main fusible switch main service modules.	3MFSTBK

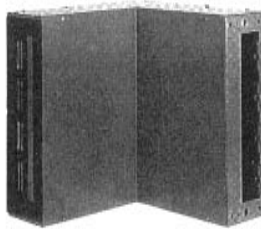

Indoor Corner Elbow



Wall Mounting Rail

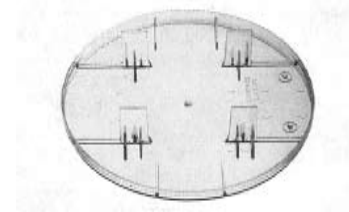

Lexan Blank Cover



Blank Cover Kit

Commercial Application 7 Jaw Design

Replacement Parts

Table 25.

Description	Application	Catalogue Number
Ring Cover	Installed on 125A socket for ring security	37MMSKCAN
Tenant Breaker Hinged Cover	125-200A	1MMBC2
Meter Socket	125A and 200A	99-5115-2
Sealing Ring	Stainless steel screw type (standard)	SR3
Bus Cover	Protective bus cover for protruding bus side of any module	47-28172-2A
	Protective bus cover for recessed bus side of any module	47-24139A

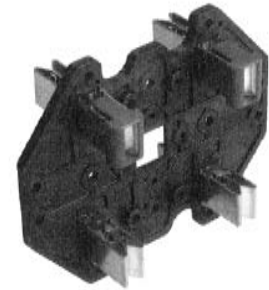

Meter Socket



Ring Cover



Tenant Breaker Hinged Cover



Sealing Ring

Myers Type Hubs

- ◆ For outdoor applications.
- ◆ For use with main terminal, breaker and fusible switch modules.

Table 26.

Conduit Size		Catalogue Number
Inches	mm	
1/2	12.7	DS050MH
3/4	19.0	DS075MH
1	25.4	DS100MH
1-1/4	31.8	DS125MH
1-1/2	38.1	DS150MH
2	50.8	DS200MH
2-1/2	63.5	DS250MH
3	76.2	DS300MH
4	101.6	DS400MH
5	127.0	DS500MH



Myers Type Hub

Typical Ordering Procedure

- ① Select a main service module
 - ◆ Main Terminal Box
 - ◆ Main Breaker
 - ◆ Main Fusible Switch
- ② Select the number of basic meter stacks required based on:
 - ◆ 4 - 200A socket positions with 3 pole breakers.
- ③ Select the applicable tenant breakers.
- ④ Add a feed through cable connection tap box if required.
- ⑤ Add any elbows if required.
- ⑥ Add ID nameplates, optional lugs, covers, etc.

Accessories and Replacement Parts

Transition Cell

- ◆ For 3Ø in 3Ø out applications (4 wire / 4 wire).
- ◆ Used to tie Commander (MCA), Westinghouse (WMCA) and, Cutler-Hammer (MCN) meter centres to the new CMM design.
- ◆ Left side or right side entry available.
- ◆ 800A vertical bus rating.
- ◆ System Voltage 120/208V AC 3Ø, 4W / 4W.
- ◆ Lugs Included with cell.
- ◆ Refer to page 24 for dimensions.



Table 27

Ampere Rating	Entry Side	Catalogue Number	Line Side Box Lugs and Wire Sizes
800	Left	C3M800LTC	(4) 4/0-500 kcmil
800	Right	C3M800RTC	(4) 4/0-500 kcmil

MCN Replacement Main Tenant Circuit Breaker

- ◆ The following breakers are to be used on MCN design meter centres.
- ◆ 120/208 Vac field installed.

Table 29

	Description	Number of Poles	Main Tenant Circuit Breaker Ampere Rating	10,000 AIC	22,000 AIC	65,000 AIC
				Catalogue Number	Catalogue Number	Catalogue Number
100/125A	Bolt-on circuit breaker used with 100A/125A MCN design	3	60	BQL360	HBQL360	-
		3	70	BQL370	HBQL370	-
		3	100	BQL3100	HBQL3100	-
200/225A	Bolt-on circuit breaker used with 200A/225A MCN design	3	60	-	-	-
		3	70	-	-	-
		3	100	-	-	-
		3	125	-	-	ED3125
		3	150	-	-	ED3150
		3	175	-	-	ED3175
		3	200	-	-	ED3200

NOTE:

- For sub services of 100A or less in 200A stacks EHD breakers are available in 3 pole 15 to 100 ampere. (18,000 AIC)

Accessories and Replacement Parts

Accessories

Table 32.

Catalogue Number	Description
JB2	Copper jumper bars, 200A maximum. Used to "jumper" a metering position, when a meter is not to be installed. Use 2 for a 4 jaw application and 3 for a 7 jaw.
MS-BCP-P	Blank cover plate Lexan, clear, blank cover plates. Required when jumper bars are installed in a metering position.
FJ2-6	Fifth jaw kit 6 o'clock position for 200A stacks only.
SR3	Meter socket sealing ring.



Blank Cover Plate



Jumper Bar

Main Service Modules

Figure 1. Main Circuit Breakers, Terminal Boxes

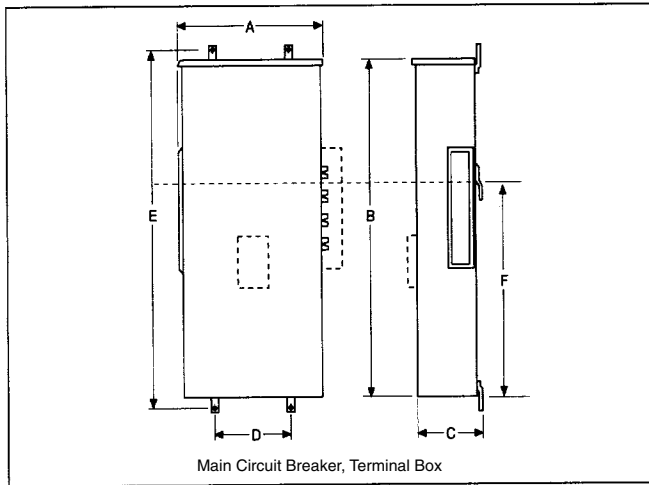

Figure 2. Bottom Feed Fusible Switch

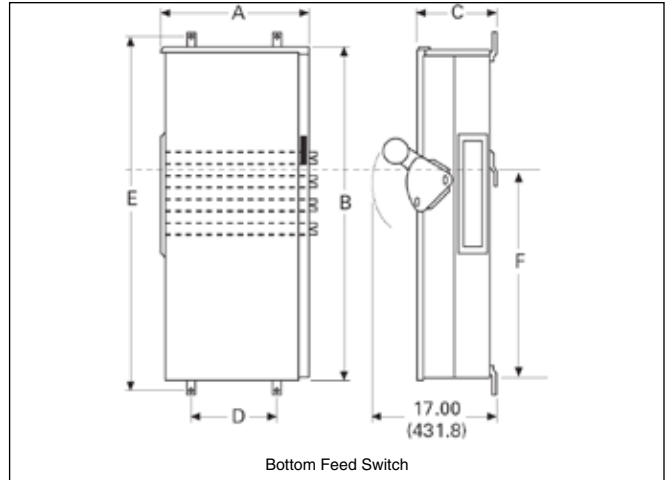
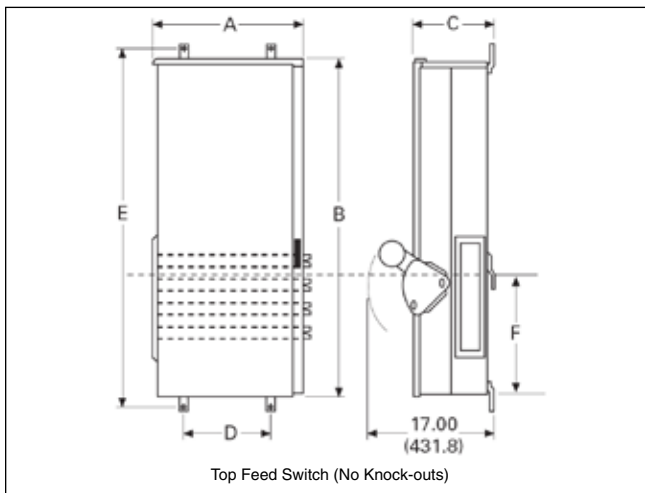

Figure 3. Top Feed Fusible Switch



NOTE:
See page 24 for approximate dimensions.

Main Service Modules

Approximate Dimensions (not to be used for construction purposes)

Table 33.

Main Device	Width		Height		Depth		Mounting				Centre Line of Wall Mounting Bracket		Knock-Out Sizes (KOs in Bottom Endwalls Only)	
	A		B		C		D		E		F		Inches	mm
	Inches	mm	Inches	mm	Inches	mm	Inches	mm	Inches	mm	Inches	mm		
Terminal Box 400 & 600 Ampere	13-1/2	342.50	48-3/4	1238.25	7	177.80	-	-	54	1371.60	30-5/8	777.88	(1) 2-1/2, 3, 3-1/2, 4 & (1) 1/2	(1) 63.50-76.20- 88.90-101.60
Terminal Box 800 & 1200 Ampere	20	508.00	47-5/8	1209.68	11-5/8	295.28	12	304.80	51-1/2	1308.10	30-5/8	777.88	(2) 1/2, 3/4, 1 & (4) 2, 2-1/2, 3, 3-1/2, 4	(2) 12.70-19.05-25.40(4) 50.80-63.50-76.20-88.90-101.60
Main Circuit Breaker with Box Lugs 400-1200 Ampere	20	508.00	47-5/8	1209.68	11-5/8	295.28	12	304.80	51-1/2	1308.10	30-5/8	777.88	(2) 1/2, 3/4, 1 & (4) 2, 2-1/2, 3, 3-1/2, 4	(2) 12.70-19.05-25.40(4) 50.80-63.50-76.20-88.90-101.60
Main Circuit Breaker with Compression Lugs 400-1200 Ampere	20	508.00	47-5/8	1209.68	11-5/8	295.28	12	304.80	51-1/2	1308.10	44	1117.60	(2) 1/2, 3/4, 1 & (4) 2, 2-1/2, 3, 3-1/2, 4	(2) 12.70-19.05-25.40(4) 50.80-63.50-76.20-88.90-101.60
Main Fusible Switch -Bottom Feed 400-800 Ampere	20	508.00	47-5/8	1209.68	11-5/8	295.28	12	304.80	51-1/2	1308.10	30-5/8	777.88	(2) 1/2, 3/4, 1 & (4) 2, 2-1/2, 3, 3-1/2, 4	(2) 12.70-19.05-25.40(4) 50.80-63.50-76.20-88.90-101.60
Main Fusible Switch -Top Feed 400-800 Ampere	20	508.00	47-5/8	1209.68	11-5/8	295.28	12	304.80	51-1/2	1308.10	18-1/8	460.38	(2) 1/2, 3/4, 1 & (4) 2, 2-1/2, 3, 3-1/2, 4	(2) 12.70-19.05-25.40(4) 50.80-63.50-76.20-88.90-101.60
Main Fusible Switch -1200 Ampere ②	33-1/2	850.90	52-3/4	1339.85	11-7/8	301.63	16	406.40	56-1/4	1428.75	30-3/4	781.05	(5) 3-1/2, 4, 5 & (1) 3/4, 1, 1-1/4, 1-1/2	(5) 88.90-101.60-127.00 (1) 19.05-25.40-31.75-38.10
Transition Cell ① -800 Ampere	18.173	474.75	37.938	962.49	9.035	229.22	15.780	400.34	23.000	583.51	N/A		N/A	
Feed Through Cable Connection Tap Boxes	26-5/8	676.28	50-3/4	1289.05	9	228.60	23-5/8	600.08	47-1/8	1196.98	30-5/8	777.88	N/A	

① Note: Transition Cell dimensions refer to both left and right hand applications.
 ② 1200A Main Fusible Switches and Main Circuit Breakers are not available for 600V applications.

Modular Metering Stacks

125A Single and Three Phase

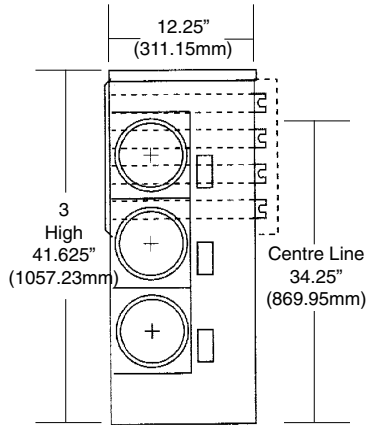

Figure 4. C3MM312R

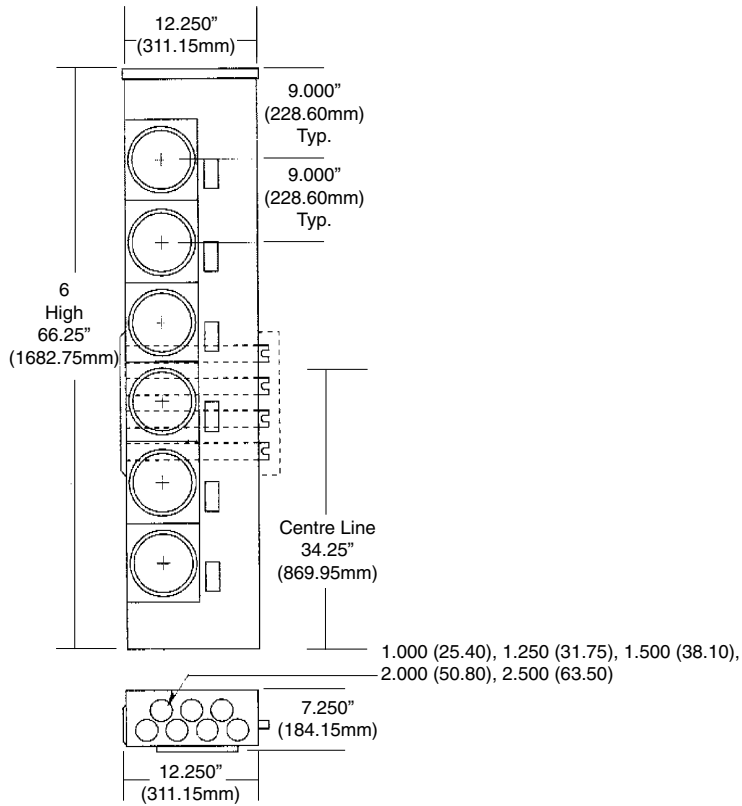

Figure 5. C1MM612R
C3MM612R

200A Single and Three Phase

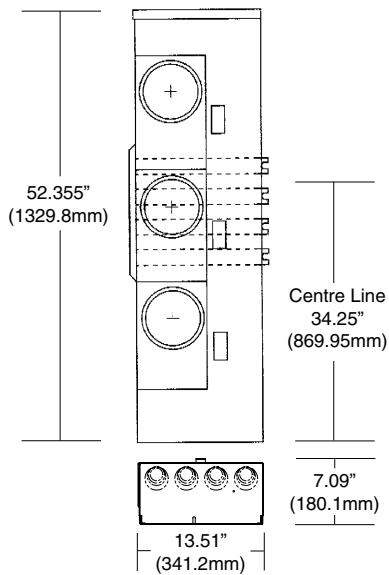

Figure 6. C1MM320R
C3MM320R

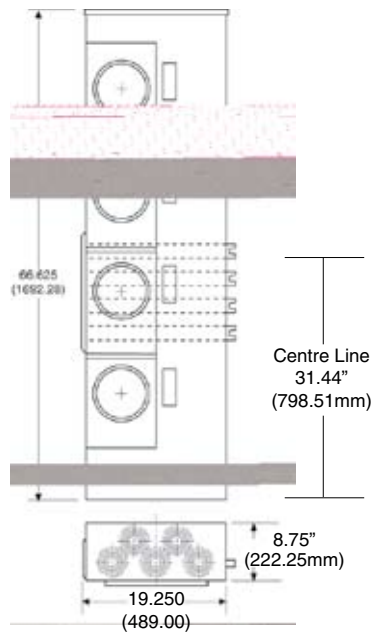

Figure 7. C3MM42240R
C3MM42600R
C3MM41240R

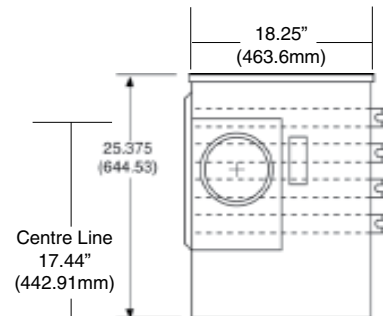















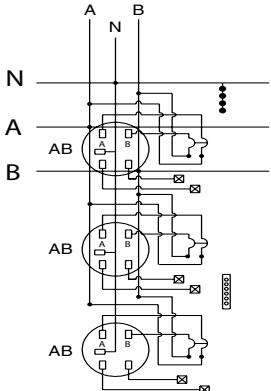



Figure 8. C3MM12240R
C3MM12600R

C1MM Wiring Diagrams / Typical Nameplate Information (240 VAC Maximum)

◆ All C1MM are factory phase balanced.

Figure 9. 1Ø (3W), 125A, 3 Socket, 5 Jaw

		TORQUE WIRE PRESSURE SCREWS AS FOLLOWS: SERRER LES VIS D'USURE À PRESSION COMME SUIV:																		
		WIRE SIZE CALIBRE DES FILS 60° / 75° AL-CU	 LB.-IN. (N-M)	 LB.-IN. (N-M)	 LB.-IN. (N-M)															
CATALOGUE NO. SERIES A / SERIE: A C1MM320R RING TYPE SOCKET 120/240 VAC/VCA EMBASE À ANNEAU 208Y/120 VAC/VCA 1-PHASE, 3W+G	<table border="1"> <tr> <td>#14-10</td> <td>35 (3.96)</td> <td></td> <td>35 (3.96)</td> </tr> <tr> <td>#8</td> <td>40 (4.52)</td> <td></td> <td>40 (4.52)</td> </tr> <tr> <td>#6-4</td> <td>45 (5.08)</td> <td></td> <td>45 (5.08)</td> </tr> <tr> <td>#3-2/0</td> <td>50 (5.65)</td> <td></td> <td>50 (5.65)</td> </tr> </table>				#14-10	35 (3.96)		35 (3.96)	#8	40 (4.52)		40 (4.52)	#6-4	45 (5.08)		45 (5.08)	#3-2/0	50 (5.65)		50 (5.65)
#14-10	35 (3.96)		35 (3.96)																	
#8	40 (4.52)		40 (4.52)																	
#6-4	45 (5.08)		45 (5.08)																	
#3-2/0	50 (5.65)		50 (5.65)																	
TYPE 3R ENCLOSURE -RAINPROOF METER SOCKET RATING - 200 AMPS MAX. HORIZONTAL BUS RATING - 800 AMPS VERTICAL BUS RATING - 480 AMPS ENVELOPPE DE TYPE 3R - À L'ÉPREUVE DE LA PLUIE COURANT NOMINAL DE L'EMBASE DE COMPTEUR - 125 A MAX. COURANT NOMINAL BARRE HORIZONTALE - 800 A COURANT NOMINAL BARRE VERTICALE - 480 A																				
TORQUE HORIZONTAL BUS JOINT BOLTS TO 25 LBS./FT. (300 LBS./IN.)(33.90 N-M) SERRER LES BOULONS DES JOINTS DE BARRE HORIZONTALE À 25 LB-PI (300 LB-PO)(33.90 N-M)																				
FOR USE WITH EATON MAIN SWITCH, MAIN CIRCUIT BREAKER, OR MAIN TERMINAL BOX. POUR UTILISATION AVEC INTERRUPTEUR PRINCIPAL, DISJONCTEUR PRIN-CIPAL OU BOÎTE DE RACCORDEMENT PRINCIPALE DE EATON																				
TORQUE CIRCUIT BREAKER LUGS TO VALUES SPECIFIED ON THE CIRCUIT BREAKER. SERRER LES COSSES DU DISJONCTEUR SELON LES VALEURS SPÉCIFIÉES SUR LE DISJONCTEUR.																				
BREAKER TERMINALS SUITABLE FOR AL-CU WIRE WHEN SO MARKED. REFER TO MARKINGS ON BREAKERS. BORNES DE DISJONCTEUR CONVENANT AUX CONDUCTEURS AL-CU SI IN-DIQUÉ. CONSULTER LES INSCRIPTIONS SUR LE DISJONCTEUR.																				
INSTALLATION AND USE OF THIS EQUIPMENT SHOULD BE IN ACCORDANCE WITH ALL APPLICABLE LOCAL AND NATIONAL CODES AND REGULATIONS. L'INSTALLATION ET L'UTILISATION DE CET ÉQUIPEMENT DOIT SE CONFORMER À TOUS LES CODES ET RÉGLEMENTS LOCAUX ET NATIONAUX APPLICABLES.																				
USE CSA LISTED EATON TYPE CCV OR CHH CIRCUIT BREAKERS, 200 AMPS MAX. UTILISER DES DISJONCTEURS CCV OU CHHNTERRUPTEURS TYPE EATON CSA CERTIFIÉS 200A MAXIMALES.																				
		☒ #14-2/0 AWG (LOAD CIRCUITS); (CIRCUITS DE CHARGE) ○ # 14-3 AWG (EQUIPMENT GROUND) (MALT DE L'ÉQUIPEMENT) ● # 6-2/0 AWG (NEUTRAL); (NEUTRE)																		
		SWITCHING AND METERING CENTRE		 CENTRE D'INTERRUPTION ET DE MESURAGE																
PUB 49200		LR21128		REV. C																

C1MM Wiring Diagrams / Typical Nameplate Information (240 VAC Maximum)

◆ All C1MM are factory phase balanced.





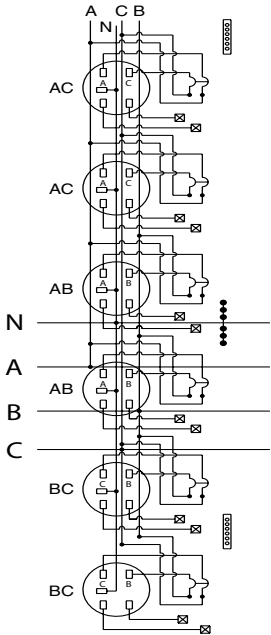

Figure 10. 1Ø (3W), 125A, 6 Socket, 5 Jaw

		TORQUE WIRE PRESSURE SCREWS AS FOLLOWS: SERRER LES VIS D'USURE À PRESSION COMME SUIT:		
CATALOGUE NO. SERIES A / SERIE: A C1MM612R RING TYPE SOCKET 120/240 VAC/VCA EMBASE À ANNEAU 208Y/120 VAC/VCA 1-PHASE, 3W+G	WIRE SIZE CALIBRE DES FILS 60° / 75° AL-CU	○ LB.-IN. (N-M)	● LB.-IN. (N-M)	☒ LB.-IN. (N-M)
		#14-10 #8 #6-4 #3-2/0	35 (3.96) 40 (4.52) 45 (5.08) 50 (5.65)	— — 45 (5.08) 50 (5.65)
TYPE 3R ENCLOSURE -RAINPROOF METER SOCKET RATING - 125 AMPS MAX. HORIZONTAL BUS RATING - 800 AMPS VERTICAL BUS RATING - 600 AMPS ENVELOPPE DE TYPE 3R - À LÉPREUVE DE LA PLUIE COURANT NOMINAL DE L'EMBASE DE COMPTEUR - 125 A MAX. COURANT NOMINAL BARRE HORIZONTALE - 800 A COURANT NOMINAL BARRE VERTICALE - 600 A		<p>☒ #14-2/0 AWG (LOAD CIRCUITS); (CIRCUITS DE CHARGE) ○ # 14-3 AWG (EQUIPMENT GROUND) (MALT DE L'ÉQUIPEMENT) ● # 6-2/0 AWG (NEUTRAL); (NEUTRE)</p>		
TORQUE HORIZONTAL BUS JOINT BOLTS TO 25 LBS./FT. (300 LBS./IN.)(33.90 N-M) SERRER LES BOULONS DES JOINTS DE BARRE HORIZONTALE À 25 LB-PI (300 LB-PO)(33.90 N-M)				
FOR USE WITH EATON MAIN SWITCH, MAIN CIRCUIT BREAKER, OR MAIN TERMINAL BOX. POUR UTILISATION AVEC INTERRUPTEUR PRINCIPAL, DISJONCTEUR PRIN-CIPAL OU BOÎTE DE RACCORDEMENT PRINCIPALE DE EATON				
TORQUE CIRCUIT BREAKER LUGS TO VALUES SPECIFIED ON THE CIRCUIT BREAKER. SERRER LES COSSES DU DISJONCTEUR SELON LES VALEURS SPECIFIÉES SUR LE DISJONCTEUR.				
BREAKER TERMINALS SUITABLE FOR AL-CU WIRE WHEN SO MARKED. REFER TO MARKINGS ON BREAKERS. BORNES DE DISJONCTEUR CONVENANT AUX CONDUCTEURS AL-CU SI IN-DIQUÉ. CONSULTER LES INSCRIPTIONS SUR LE DISJONCTEUR.				
INSTALLATION AND USE OF THIS EQUIPMENT SHOULD BE IN ACCORDANCE WITH ALL APPLICABLE LOCAL AND NATIONAL CODES AND REGULATIONS. L'INSTALLATION ET L'UTILISATION DE CET ÉQUIPEMENT DOIT SE CONFORMER À TOUS LES CODES ET RÉGLEMENTS LOCAUX ET NATIONAUX APPLICABLES.				
USE CSA LISTED EATON TYPE BR, BRH, BRHH, OR DNPL CIRCUIT BREAKERS, 125 AMPS MAX. UTILISER DES DISJONCTEURS BR, BRH, BRHH, OU DNPL INTERRUPTEURS TYPE EATON CSA CERTIFIÉS 125A MAXIMALES.		SWITCHING AND METERING CENTRE CENTRE D'INTERRUPTION ET DE MESURAGE PUB 49199 LR21128 REV.B		

C1MM, C3MM Wiring Diagrams / Typical Nameplate Information (240 VAC Max.)

◆ All C1MM and C3MM are factory phase balanced.

Figure 11. 3Ø (4W), 125A, 6 Socket, 5 Jaw

	TORQUE WIRE PRESSURE SCREWS AS FOLLOWS: SERRER LES VIS D'USURE À PRESSION COMME SUIT:			
	WIRE SIZE CALIBRE DES FILS 60° / 75° AL-CU	 LB.-IN. (N-M)	 LB.-IN. (N-M)	 LB.-IN. (N-M)
CATALOGUE NO. SERIES A / SERIE: A C3MM612R RING TYPE SOCKET EMBASE À ANNEAU 120/240 VAC/VCA 1-PHASE, 3W+G 208Y/120 VAC/VCA 3-PHASE, 4W+G	#14-10	35 (3.96)	—	35 (3.96)
	#8	40 (4.52)	—	40 (4.52)
	#6-4	45 (5.08)	45 (5.08)	45 (5.08)
	#3-2/0	50 (5.65)	50 (5.65)	50 (5.65)
TYPE 3R ENCLOSURE -RAINPROOF METER SOCKET RATING - 125 AMPS MAX. HORIZONTAL BUS RATING - 800 AMPS VERTICAL BUS RATING - 600 AMPS ENVELOPPE DE TYPE 3R - À L'ÉPREUVE DE LA PLUIE COURANT NOMINAL DE L'EMBASE DE COMPTEUR - 125 A MAX. COURANT NOMINAL BARRE HORIZONTALE - 800 A COURANT NOMINAL BARRE VERTICALE - 600 A				
TORQUE HORIZONTAL BUS JOINT BOLTS TO 25 LBS./FT. (300 LBS./IN.)(33.90 N-M) SERRER LES BOULONS DES JOINTS DE BARRE HORIZONTALE À 25 LB-PI (300 LB-PO)(33.90 N-M)				
FOR USE WITH EATON MAIN SWITCH, MAIN CIRCUIT BREAKER, OR MAIN TERMINAL BOX. POUR UTILISATION AVEC INTERRUPTEUR PRINCIPAL, DISJONCTEUR PRIN-CIPAL OU BOÎTE DE RACCORDEMENT PRINCIPALE DE EATON				
TORQUE CIRCUIT BREAKER LUGS TO VALUES SPECIFIED ON THE CIRCUIT BREAKER. SERRER LES COSSES DU DISJONCTEUR SELON LES VALEURS SPÉCIFIÉES SUR LE DISJONCTEUR.				
BREAKER TERMINALS SUITABLE FOR AL-CU WIRE WHEN SO MARKED. REFER TO MARKINGS ON BREAKERS. BORNES DE DISJONCTEUR CONVENANT AUX CONDUCTEURS AL-CU SI IN-DIQUÉ. CONSULTER LES INSCRIPTIONS SUR LE DISJONCTEUR.				
INSTALLATION AND USE OF THIS EQUIPMENT SHOULD BE IN ACCORDANCE WITH ALL APPLICABLE LOCAL AND NATIONAL CODES AND REGULATIONS. L'INSTALLATION ET L'UTILISATION DE CET ÉQUIPEMENT DOIT SE CONFORMER À TOUS LES CODES ET RÉGLEMENTS LOCAUX ET NATIONAUX APPLICABLES.				
USE CSA LISTED EATON TYPE BR, BRH, BRHH, OR DNPL CIRCUIT BREAKERS, 125 AMPS MAX. UTILISER DES DISJONCTEURS BR, BRH, BRHH, OU DNPL INTERRUPTEURS TYPE EATON CSA CERTIFIÉS 125A MAXIMALES.	SWITCHING AND METERING CENTRE  CENTRE D'INTERRUPTION ET DE MESURAGE PUB 26752 LR21128 REV. D			

NOTE

- ① Socket rated at single phase.
- ② Bus rated at three phase

C1MM, C3MM Wiring Diagrams / Typical Nameplate Information (240 VAC Max.)

◆ All C1MM and C3MM are factory phase balanced.

Figure 12. 3Ø (4W), 125A, 3 Socket, 5 Jaw

		TORQUE WIRE PRESSURE SCREWS AS FOLLOWS: SERRER LES VIS D'USURE À PRESSION COMME SUIT:			
CATALOGUE NO. SERIES A / SERIE: A C3MM312R RING TYPE SOCKET EMBASE À ANNEAU 120/240 VAC/VCA 1-PHASE, 3W+G 208Y/120 VAC/VCA 3-PHASE, 4W+G		WIRE SIZE CALIBRE DES FILS 60° / 75° AL-CU	○ LB.-IN. (N-M)	● LB.-IN. (N-M)	☒ LB.-IN. (N-M)
		#14-10 35 (3.96) #8 40 (4.52) #6-4 45 (5.08) #3-2/0 50 (5.65)	——— 45 (5.08)	——— 50 (5.65)	35 (3.96) 40 (4.52) 45 (5.08) 50 (5.65)
TYPE 3R ENCLOSURE - RAINPROOF METER SOCKET RATING - 125 AMPS MAX. HORIZONTAL BUS RATING - 800 AMPS VERTICAL BUS RATING - 300 AMPS ENVELOPPE DE TYPE 3R - À LÉPREUVE DE LA PLUIE COURANT NOMINAL DE L'EMBASE DE COMPTEUR - 125 A MAX. COURANT NOMINAL BARRE HORIZONTALE - 800 A COURANT NOMINAL BARRE VERTICALE - 300 A					
TORQUE HORIZONTAL BUS JOINT BOLTS TO 25 LBS./FT. (300 LBS./IN.)(33.90 N-M) SERRER LES BOULONS DES JOINTS DE BARRE HORIZONTALE À 25 LB-PI (300 LB-PO)(33.90 N-M)					
FOR USE WITH EATON MAIN SWITCH, MAIN CIRCUIT BREAKER, OR MAIN TERMINAL BOX. POUR UTILISATION AVEC INTERRUPTEUR PRINCIPAL, DISJONCTEUR PRIN-CIPAL OU BOÎTE DE RACCORDEMENT PRINCIPALE DE EATON					
TORQUE CIRCUIT BREAKER LUGS TO VALUES SPECIFIED ON THE CIRCUIT BREAKER. SERRER LES COSES DU DISJONCTEUR SELON LES VALEURS SPÉCIFIÉES SUR LE DISJONCTEUR.					
BREAKER TERMINALS SUITABLE FOR AL-CU WIRE WHEN SO MARKED. REFER TO MARKINGS ON BREAKERS. BORNES DE DISJONCTEUR CONVENANT AUX CONDUCTEURS AL-CU SI IN-DIQUÉ. CONSULTER LES INSCRIPTIONS SUR LE DISJONCTEUR.					
INSTALLATION AND USE OF THIS EQUIPMENT SHOULD BE IN ACCORDANCE WITH ALL APPLICABLE LOCAL AND NATIONAL CODES AND REGULATIONS. L'INSTALLATION ET L'UTILISATION DE CET ÉQUIPEMENT DOIT SE CONFORMER À TOUS LES CODES ET RÉGLEMENTS LOCAUX ET NATIONAUX APPLICABLES.					
USE CSA LISTED EATON TYPE BR, BRH, BRHH, OR DNPL CIRCUIT BREAKERS, 125 AMPS MAX. UTILISER DES DISJONCTEURS BR, BRH, BRHH, OU DNPL INTERRUPTEURS TYPE EATON CSA CERTIFIÉS 125A MAXIMALES.		☒ #14-2/0 AWG (LOAD CIRCUITS) (CIRCUITS DE CHARGE) ○ # 14-3 AWG (EQUIPMENT GROUND) (MALT DE L'ÉQUIPEMENT) ● # 6-2/0 AWG (NEUTRAL) (NEUTRE)			
SWITCHING AND METERING CENTRE PUB 26750				CENTRE D'INTERRUPTION ET DE MESURAGE LR21128 REV. D	



NOTE

- ① Socket rated at single phase.
- ② Bus rated at three phase

C1MM, C3MM Wiring Diagrams / Typical Nameplate Information (240 VAC Maximum)

◆ All C1MM & C3MM are factory phase balanced.

Figure 13. 3Ø 4 Wire, 200A, 3 Socket, 5 Jaw

		TORQUE WIRE PRESSURE SCREWS AS FOLLOWS: SERRER LES VIS D'USURE À PRESSION COMME SUIV:			
CATALOGUE NO. SERIES A / SERIE: A C3MM320R RING TYPE SOCKET EMBASE À ANNEAU 120/240 VAC/VCA 1-PHASE, 3W+G 208Y/120 VAC/VCA 3-PHASE, 4W+G	WIRE SIZE CALIBRE DES FILS 60° / 75° AL-CU	○	●	☒	
		LB.-IN. (N-M)	LB.-IN. (N-M)	LB.-IN. (N-M)	
TYPE 3R ENCLOSURE - RAINPROOF METER SOCKET RATING - 200 AMPS MAX. HORIZONTAL BUS RATING - 800 AMPS VERTICAL BUS RATING - 480 AMPS ENVELOPPE DE TYPE 3R - À LÉPREUVE DE LA PLUIE COURANT NOMINAL DE L'EMBASE DE COMPTEUR - 200 A MAX. COURANT NOMINAL BARRE HORIZONTALE - 800 A COURANT NOMINAL BARRE VERTICALE - 480 A	#14-10	35 (3.96)	—	35 (3.96)	
	#8	40 (4.52)	—	40 (4.52)	
	#6-4	45 (5.08)	45 (5.08)	45 (5.08)	
	#3-2/0	50 (5.65)	50 (5.65)	50 (5.65)	
	#1-300 Kcmil	—	200 (22.4)	275 (31.1)	
TORQUE HORIZONTAL BUS JOINT BOLTS TO 25 LBS./FT. (300 LBS./IN.)(33.90 N-M) SERRER LES BOULONS DES JOINTS DE BARRE HORIZONTALE À 25 LB-PI (300 LB-PO)(33.90 N-M)					
FOR USE WITH EATON MAIN SWITCH, MAIN CIRCUIT BREAKER, OR MAIN TERMINAL BOX. POUR UTILISATION AVEC INTERRUPTEUR PRINCIPAL, DISJONCTEUR PRIN-CIPAL OU BOÎTE DE RACCORDEMENT PRINCIPALE DE EATON					
TORQUE CIRCUIT BREAKER LUGS TO VALUES SPECIFIED ON THE CIRCUIT BREAKER. SERRER LES COSSES DU DISJONCTEUR SELON LES VALEURS SPÉCIFIÉES SUR LE DISJONCTEUR.					
BREAKER TERMINALS SUITABLE FOR AL-CU WIRE WHEN SO MARKED. REFER TO MARKINGS ON BREAKERS. BORNES DE DISJONCTEUR CONVENANT AUX CONDUCTEURS AL-CU SI IN-DIQUÉ. CONSULTER LES INSCRIPTIONS SUR LE DISJONCTEUR.					
INSTALLATION AND USE OF THIS EQUIPMENT SHOULD BE IN ACCORDANCE WITH ALL APPLICABLE LOCAL AND NATIONAL CODES AND REGULATIONS. L'INSTALLATION ET L'UTILISATION DE CET ÉQUIPEMENT DOIT SE CONFORMER À TOUS LES CODES ET RÉGLEMENTS LOCAUX ET NATIONAUX APPLICABLES.					
USE CSA LISTED EATON TYPE CCV OR CHH CIRCUIT BREAKERS, 200 AMPS MAX. UTILISER DES DISJONCTEURS CCV OU CHHNTERRUPTEURS TYPE EATON CSA CERTIFIÉS 200A MAXIMALES.		☒ #1-300 MCM (LOAD CIRCUITS) (CIRCUITS DE CHARGE) ○ #14-3 AWG (EQUIPMENT GROUND) (MALT DE L'ÉQUIPEMENT) ● #1/0-300 MCM (NEUTRAL) (NEUTRE)			
		SWITCHING AND METERING CENTRE PUB 26754		 CENTRE D'INTERRUPTION ET DE MESURAGE LR21128 REV. E	

NOTE

① Socket rated at single phase.

② Bus rated at three phase

C3MM Wiring Diagrams / Typical Nameplate Information (240 VAC Maximum)

◆ All C3MM are factory phase balanced.

Figure 14. 3Ø (4W), 125A, 4 Socket, 7 Jaw

		<p>TORQUE WIRE PRESSURE SCREW(S) AS FOLLOWS: SERRER LES VIS À PRESSION SELON LE COUPLE CI-DESSOUS :</p>																													
<p>CATALOG NO. C3MM41240R</p>		<table border="1"> <tr> <th>WIRE SIZE CALIBRE DES CONDUCTEURS 60°/75° AL/CU</th> <th>LB-IN (N-M)</th> <th>LB-IN (N-M)</th> <th></th> </tr> <tr> <td>#14-10</td> <td>35 (3.96)</td> <td>--</td> <td></td> </tr> <tr> <td>#8</td> <td>40 (4.52)</td> <td>--</td> <td></td> </tr> <tr> <td>#6-4</td> <td>45 (5.08)</td> <td>--</td> <td></td> </tr> <tr> <td>#3-2/0</td> <td>50 (5.68)</td> <td>--</td> <td></td> </tr> <tr> <td>#1/0-3/00</td> <td>--</td> <td>200(2260)</td> <td></td> </tr> </table>		WIRE SIZE CALIBRE DES CONDUCTEURS 60°/75° AL/CU	LB-IN (N-M)	LB-IN (N-M)		#14-10	35 (3.96)	--		#8	40 (4.52)	--		#6-4	45 (5.08)	--		#3-2/0	50 (5.68)	--		#1/0-3/00	--	200(2260)					
WIRE SIZE CALIBRE DES CONDUCTEURS 60°/75° AL/CU	LB-IN (N-M)	LB-IN (N-M)																													
#14-10	35 (3.96)	--																													
#8	40 (4.52)	--																													
#6-4	45 (5.08)	--																													
#3-2/0	50 (5.68)	--																													
#1/0-3/00	--	200(2260)																													
<p>HORIZONTAL BUS RATING - 1200 AMPS COURANT NOMINAL BARRES HORIZONTALES - 1200 A</p>		<p>TORQUE HORIZONTAL BUS JOINT TO 25 LB-FT (33.90N-M). TORQUE CIRCUIT BREAKER LUGS TO VALUES SPECIFIED ON THE CIRCUIT BREAKER.</p>																													
<p>METER SOCKET RATING - 100 AMPS MAX. COURANT NOMINAL EMBASE DE COMPTEUR - 100 A MAX.</p>		<p>SERRER LES JOINTS DES BARRES HORIZONTALES À UN COUPLE DE 25 LB-PI (33.90 Nm). SERRER LES COSSES DES DISJONCTEURS SELON LE COUPLE INDIQUÉ SUR LE DISJONCTEUR.</p>																													
<p>100 AMPS CONTINUOUS/100A CONTINUS</p>		<p>BREAKER TERMINALS SUITABLE FOR AL-CU WIRE WHEN SO MARKED. REFER TO MARKINGS ON BREAKERS.</p>																													
<p>BRANCH CIRCUIT BREAKERS - 100 AMP MAX. DISJONCTEURS DE DÉRIVATION - 100 A MAX.</p>		<p>LES BORNES DES DISJONCTEURS CONVIENNENT AUX FILS AL-CU SI IDENTIFIÉES COMME TEL. CONSULTER LES INSCRIPTIONS SUR LES DISJONCTEURS.</p>																													
<p>120/240 VAC/VCA 1 PHASE/1 PHASES</p>		<p>FOR RAINPROOF FITTINGS, REFER TO TABLE BELOW.</p>																													
<p>208/120 VAC/VCA 3 PHASE/3 PHASES</p>		<table border="1"> <thead> <tr> <th>HUB SIZE DIMENSIONS DU MANCHON</th> <th>CAT.NO. N° CAT.</th> <th>HUB SIZE DIMENSIONS DU MANCHON</th> <th>CAT.NO. N° CAT.</th> </tr> </thead> <tbody> <tr> <td>1/2</td> <td>DS050MH</td> <td>2</td> <td>DS200MH</td> </tr> <tr> <td>3/4</td> <td>DS075MH</td> <td>2-1/2</td> <td>DS250MH</td> </tr> <tr> <td>1</td> <td>DS100MH</td> <td>3</td> <td>DS300MH</td> </tr> <tr> <td>1-1/4</td> <td>DS125MH</td> <td>3-1/2</td> <td>DS350MH</td> </tr> <tr> <td>1-1/2</td> <td>DS150MH</td> <td>4</td> <td>DS400MH</td> </tr> <tr> <td></td> <td></td> <td>5</td> <td>DS500MH</td> </tr> </tbody> </table>		HUB SIZE DIMENSIONS DU MANCHON	CAT.NO. N° CAT.	HUB SIZE DIMENSIONS DU MANCHON	CAT.NO. N° CAT.	1/2	DS050MH	2	DS200MH	3/4	DS075MH	2-1/2	DS250MH	1	DS100MH	3	DS300MH	1-1/4	DS125MH	3-1/2	DS350MH	1-1/2	DS150MH	4	DS400MH			5	DS500MH
HUB SIZE DIMENSIONS DU MANCHON	CAT.NO. N° CAT.	HUB SIZE DIMENSIONS DU MANCHON	CAT.NO. N° CAT.																												
1/2	DS050MH	2	DS200MH																												
3/4	DS075MH	2-1/2	DS250MH																												
1	DS100MH	3	DS300MH																												
1-1/4	DS125MH	3-1/2	DS350MH																												
1-1/2	DS150MH	4	DS400MH																												
		5	DS500MH																												
<p>TYPE 3R ENCLOSURE-OUTDOOR ENVELOPPE TYPE 3R - EXTÉRIEUR</p>		<p>FOR USE WITH CUTLER-HAMMER/CHALLENGER MAIN SWITCH, MAIN CIRCUIT BREAKER OR MAIN TERMINAL BOX.</p>																													
<p>USE CUTLER-HAMMER/WESTINGHOUSE TYPE CC, WCC, EHD, CHH OR WCHH, OR CUTLER-HAMMER/CHALLENGER TYPE CB OR HCB CIRCUIT BREAKERS.</p>		<p>DESTINÉ AUX INTERRUPTEURS PRINCIPAUX, AUX DISJONCTEURS PRINCIPAUX OU AUX BOÎTES À BORNES PRINCIPALES CUTLER-HAMMER/CHALLENGER.</p>																													
<p>UTILISER DES DISJONCTEURS CUTLER-HAMMER/WESTINGHOUSE TYPES CC, WCC, EHD, CHH OR WCHH, OU CUTLER-HAMMER/CHALLENGER TYPES CB OU HCB.</p>		<p>INSTALLATION AND USE OF THIS EQUIPMENT SHOULD BE IN ACCORDANCE WITH ALL APPLICABLE LOCAL AND NATIONAL CODES AND REGULATIONS.</p>																													
<p>SUITABLE FOR USE AS SERVICE EQUIPMENT WHEN USED WITH A MAIN TERMINAL BOX.</p>		<p>L'INSTALLATION ET L'UTILISATION DE CET ÉQUIPEMENT DOIVENT SE CONFORMER AUX CODES ET RÉGLEMENTS LOCAUX ET NATIONAUX APPLICABLES.</p>																													
<p>CONVIENT COMME ÉQUIPEMENT DE BRANCHEMENT SI UTILISÉ AVEC UNE BOÎTE À BORNES PRINCIPALE.</p>		<p>○ #14-2/0 AWG (EQUIPMENT GROUND) N° 14-2/0 AWG (MALT DE L'ÉQUIPEMENT) ● #1/0-3/00 AWG (NEUTRAL) N° 1/0-3/00 AWG (NEUTRE)</p>																													
<p>FOR USE WITH CUTLER-HAMMER/CHALLENGER MAIN SWITCH, MAIN CIRCUIT BREAKER OR MAIN TERMINAL BOX.</p>																															
<p>MADE IN CANADA FABRIQUÉ AU CANADA</p>		<p>LR21128 PUB50821 REV.3</p>																													

NOTE

- ① Socket rated at single phase.
- ② Bus rated at three phase

C3MM Wiring Diagrams / Typical Nameplate Information (240 VAC Maximum)

◆ All C3MM are factory phase balanced.

Figure 15. 3Ø 4 Wire, 200A, 1 Socket, 7 Jaw

EATON		<p>TORQUE WIRE PRESSURE SCREW(S) AS FOLLOWS:</p> <p>SERRER LES VIS À PRESSION SELON LE COUPLE CI-DESSOUS :</p>																													
<p>CATALOG NO.</p> <p>C3MM12240R</p>		<table border="1"> <tr> <th>WIRE SIZE CALIBRE DES CONDUCTEURS 60°/75° AL/CU</th> <th>LB-IN (N-M)</th> <th>LB-IN (N-M)</th> <th></th> </tr> <tr> <td>#14-10</td> <td>35 (3.96)</td> <td>--</td> <td></td> </tr> <tr> <td>#8</td> <td>40 (4.52)</td> <td>--</td> <td></td> </tr> <tr> <td>#6-4</td> <td>45 (5.08)</td> <td>--</td> <td></td> </tr> <tr> <td>#3-2/0</td> <td>50 (5.68)</td> <td>--</td> <td></td> </tr> <tr> <td>#1/0-300</td> <td>--</td> <td>200(2260)</td> <td></td> </tr> </table>		WIRE SIZE CALIBRE DES CONDUCTEURS 60°/75° AL/CU	LB-IN (N-M)	LB-IN (N-M)		#14-10	35 (3.96)	--		#8	40 (4.52)	--		#6-4	45 (5.08)	--		#3-2/0	50 (5.68)	--		#1/0-300	--	200(2260)					
WIRE SIZE CALIBRE DES CONDUCTEURS 60°/75° AL/CU	LB-IN (N-M)	LB-IN (N-M)																													
#14-10	35 (3.96)	--																													
#8	40 (4.52)	--																													
#6-4	45 (5.08)	--																													
#3-2/0	50 (5.68)	--																													
#1/0-300	--	200(2260)																													
<p>HORIZONTAL BUS RATING - 1200 AMPS COURANT NOMINAL BARRES HORIZONTALES - 1200 A</p>		<p>TORQUE HORIZONTAL BUS JOINT TO 25 LB-FT (33.90N-M). TORQUE CIRCUIT BREAKER LUGS TO VALUES SPECIFIED ON THE CIRCUIT BREAKER.</p>																													
<p>METER SOCKET RATING - 200 AMPS MAX. COURANT NOMINAL EMBASE DE COMPTEUR - 200 A MAX.</p>		<p>SERRER LES JOINTS DES BARRES HORIZONTALES À UN COUPLE DE 25 LB-PI (33.90 Nm). SERRER LES COSSES DES DISJONCTEURS SELON LE COUPLE INDIQUÉ SUR LE DISJONCTEUR.</p>																													
<p>200 AMPS CONTINUOUS/200A CONTINUS</p>		<p>BREAKER TERMINALS SUITABLE FOR AL-CU WIRE WHEN SO MARKED. REFER TO MARKINGS ON BREAKERS.</p>																													
<p>BRANCH CIRCUIT BREAKERS - 200 AMP MAX. DISJONCTEURS DE DÉRIVATION - 200 A MAX.</p>		<p>LES BORNES DES DISJONCTEURS CONVIENTENT AUX FILS AL-CU SI IDENTIFIÉES COMME TEL. CONSULTER LES INSCRIPTIONS SUR LES DISJONCTEURS.</p>																													
<p>120/240 VAC/VCA 1 PHASE/1 PHASES</p>		<p>FOR RAINPROOF FITTINGS. REFER TO TABLE BELOW.</p>																													
<p>208/120 VAC/VCA 3 PHASE/3 PHASES</p>		<p>POUR LES ACCESSOIRES À L'ÉPREUVE DE LA PLUIE, CONSULTER LE TABLEAU CI-DESSOUS.</p>																													
<p>240/120 VAC/VCA 3 PHASE/3 PHASES</p>		<table border="1"> <tr> <th>HUB SIZE DIMENSIONS DU MANCHON</th> <th>CAT.NO. N° CAT.</th> <th>HUB SIZE DIMENSIONS DU MANCHON</th> <th>CAT.NO. N° CAT.</th> </tr> <tr> <td>1/2</td> <td>DS050MH</td> <td>2</td> <td>DS200MH</td> </tr> <tr> <td>3/4</td> <td>DS075MH</td> <td>2-1/2</td> <td>DS250MH</td> </tr> <tr> <td>1</td> <td>DS100MH</td> <td>3</td> <td>DS300MH</td> </tr> <tr> <td>1-1/4</td> <td>DS125MH</td> <td>3-1/2</td> <td>DS350MH</td> </tr> <tr> <td>1-1/2</td> <td>DS150MH</td> <td>4</td> <td>DS400MH</td> </tr> <tr> <td></td> <td></td> <td>5</td> <td>DS500MH</td> </tr> </table>		HUB SIZE DIMENSIONS DU MANCHON	CAT.NO. N° CAT.	HUB SIZE DIMENSIONS DU MANCHON	CAT.NO. N° CAT.	1/2	DS050MH	2	DS200MH	3/4	DS075MH	2-1/2	DS250MH	1	DS100MH	3	DS300MH	1-1/4	DS125MH	3-1/2	DS350MH	1-1/2	DS150MH	4	DS400MH			5	DS500MH
HUB SIZE DIMENSIONS DU MANCHON	CAT.NO. N° CAT.	HUB SIZE DIMENSIONS DU MANCHON	CAT.NO. N° CAT.																												
1/2	DS050MH	2	DS200MH																												
3/4	DS075MH	2-1/2	DS250MH																												
1	DS100MH	3	DS300MH																												
1-1/4	DS125MH	3-1/2	DS350MH																												
1-1/2	DS150MH	4	DS400MH																												
		5	DS500MH																												
<p>TYPE 3R ENCLOSURE-OUTDOOR ENVELOPPE TYPE 3R - EXTÉRIEUR</p>		<p>INSTALLATION AND USE OF THIS EQUIPMENT SHOULD BE IN ACCORDANCE WITH ALL APPLICABLE LOCAL AND NATIONAL CODES AND REGULATIONS.</p>																													
<p>USE CUTLER-HAMMER/WESTINGHOUSE TYPE CC, WCC, EHD, CHH OR WCHH, OR CUTLER-HAMMER/CHALLENGER TYPE CB OR HCB CIRCUIT BREAKERS.</p>		<p>L'INSTALLATION ET L'UTILISATION DE CET ÉQUIPEMENT DOIVENT SE CONFORMER AUX CODES ET RÉGLEMENTS LOCAUX ET NATIONAUX APPLICABLES.</p>																													
<p>UTILISER DES DISJONCTEURS CUTLER-HAMMER/WESTINGHOUSE TYPES CC, WCC, EHD, CHH OR WCHH, OU CUTLER-HAMMER/CHALLENGER TYPES CB OU HCB.</p>		<p>MADE IN CANADA FABRIQUÉ AU CANADA</p>																													
<p>SUITABLE FOR USE AS SERVICE EQUIPMENT WHEN USED WITH A MAIN TERMINAL BOX.</p>		<p>LR21128 PUB50884 REV.3</p>																													
<p>CONVIENT COMME ÉQUIPEMENT DE BRANCHEMENT SI UTILISÉ AVEC UNE BOÎTE À BORNES PRINCIPALE.</p>																															
<p>FOR USE WITH CUTLER-HAMMER/CHALLENGER MAIN SWITCH, MAIN CIRCUIT BREAKER OR MAIN TERMINAL BOX.</p>		<p>○ #14-2/0 AWG (EQUIPMENT GROUND) N° 14-2/0 AWG (MALT DE L'ÉQUIPEMENT)</p>																													
<p>DESTINÉ AUX INTERRUPTEURS PRINCIPAUX, AUX DISJONCTEURS PRINCIPAUX OU AUX BOÎTES À BORNES PRINCIPALES CUTLER-HAMMER/CHALLENGER.</p>		<p>● #1/0-300 AWG (NEUTRAL) N° 1/0-300 AWG (NEUTRE)</p>																													

NOTE

- ① Socket rated at single phase.
- ② Bus rated at three phase

C3MM Wiring Diagrams / Typical Nameplate Information (240 VAC Maximum)

◆ All C3MM are factory phase balanced.

Figure 16. 3Ø 4 Wire, 200A, 4 Socket, 7 Jaw

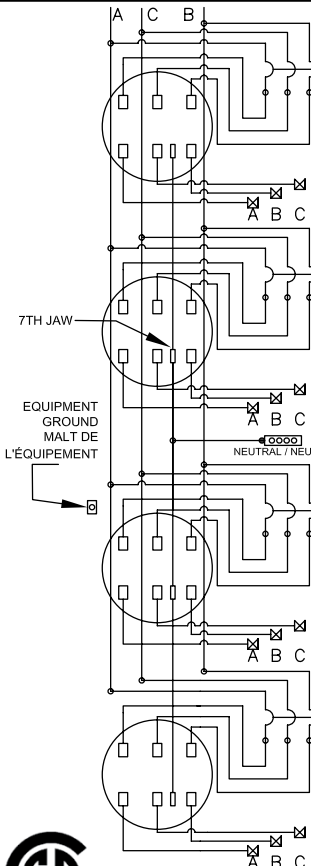
		<p>TORQUE WIRE PRESSURE SCREW(S) AS FOLLOWS:</p> <p>SERRER LES VIS À PRESSION SELON LE COUPLE CI-DESSOUS :</p>																													
<p>CATALOG NO. C3MM42240R</p>		<p>WIRE SIZE CALIBRE DES CONDUCTEURS 60°/75° AL/CU</p> <table border="1"> <tr> <td>○ LB-IN (N-M)</td> <td>● LB-IN (N-M)</td> </tr> <tr> <td>#14-10</td> <td>35 (3.96)</td> </tr> <tr> <td>#8</td> <td>40 (4.52)</td> </tr> <tr> <td>#6-4</td> <td>45 (5.08)</td> </tr> <tr> <td>#3-2/0</td> <td>50 (5.68)</td> </tr> <tr> <td>#1/0-300</td> <td>200(2260)</td> </tr> </table>			○ LB-IN (N-M)	● LB-IN (N-M)	#14-10	35 (3.96)	#8	40 (4.52)	#6-4	45 (5.08)	#3-2/0	50 (5.68)	#1/0-300	200(2260)															
○ LB-IN (N-M)	● LB-IN (N-M)																														
#14-10	35 (3.96)																														
#8	40 (4.52)																														
#6-4	45 (5.08)																														
#3-2/0	50 (5.68)																														
#1/0-300	200(2260)																														
<p>HORIZONTAL BUS RATING - 1200 AMPS COURANT NOMINAL BARRES HORIZONTALES - 1200 A</p>		<p>TORQUE HORIZONTAL BUS JOINT TO 25 LB-FT (33.90N-M). TORQUE CIRCUIT BREAKER LUGS TO VALUES SPECIFIED ON THE CIRCUIT BREAKER.</p>																													
<p>METER SOCKET RATING - 200 AMPS MAX. COURANT NOMINAL EMBASE DE COMPTEUR - 200 A MAX.</p>		<p>SERRER LES JOINTS DES BARRES HORIZONTALES À UN COUPLE DE 25 LB-PI (33.90 Nm). SERRER LES COSSES DES DISJONCTEURS SELON LE COUPLE INDIQUÉ SUR LE DISJONCTEUR.</p>																													
<p>200 AMPS CONTINUOUS/200A CONTINUS</p>		<p>BREAKER TERMINALS SUITABLE FOR AL-CU WIRE WHEN SO MARKED. REFER TO MARKINGS ON BREAKERS.</p>																													
<p>BRANCH CIRCUIT BREAKERS - 200 AMP MAX. DISJONCTEURS DE DÉRIVATION - 200 A MAX.</p>		<p>LES BORNES DES DISJONCTEURS CONVIENNENT AUX FILS AL-CU SI IDENTIFIÉES COMME TEL. CONSULTEZ LES INSCRIPTIONS SUR LES DISJONCTEURS.</p>																													
<p>120/240 VAC/VCA 1 PHASE/1 PHASES</p>		<p>FOR RAINPROOF FITTINGS, REFER TO TABLE BELOW.</p>																													
<p>208/120 VAC/VCA 3 PHASE/3 PHASES</p>		<p>FOR USE WITH CUTLER-HAMMER/WESTINGHOUSE MAIN SWITCH, MAIN CIRCUIT BREAKER OR MAIN TERMINAL BOX.</p>																													
<p>240/120 VAC/VCA 3 PHASE/3 PHASES</p>		<p>DESTINÉ AUX INTERRUPTEURS PRINCIPAUX, AUX DISJONCTEURS PRINCIPAUX OU AUX BOÎTES À BORNES PRINCIPALES CUTLER-HAMMER/CHALLENGER.</p>																													
<p>TYPE 3R ENCLOSURE-OUTDOOR ENVELOPPE TYPE 3R - EXTÉRIEUR</p>		<table border="1"> <tr> <th>HUB SIZE DIMENSIONS DU MANCHON</th> <th>CAT. NO. N° CAT.</th> <th>HUB SIZE DIMENSIONS DU MANCHON</th> <th>CAT. NO. N° CAT.</th> </tr> <tr> <td>1/2</td> <td>DS050MH</td> <td>2</td> <td>DS200MH</td> </tr> <tr> <td>3/4</td> <td>DS075MH</td> <td>2-1/2</td> <td>DS250MH</td> </tr> <tr> <td>1</td> <td>DS100MH</td> <td>3</td> <td>DS300MH</td> </tr> <tr> <td>1-1/4</td> <td>DS125MH</td> <td>3-1/2</td> <td>DS350MH</td> </tr> <tr> <td>1-1/2</td> <td>DS150MH</td> <td>4</td> <td>DS400MH</td> </tr> <tr> <td></td> <td></td> <td>5</td> <td>DS500MH</td> </tr> </table>		HUB SIZE DIMENSIONS DU MANCHON	CAT. NO. N° CAT.	HUB SIZE DIMENSIONS DU MANCHON	CAT. NO. N° CAT.	1/2	DS050MH	2	DS200MH	3/4	DS075MH	2-1/2	DS250MH	1	DS100MH	3	DS300MH	1-1/4	DS125MH	3-1/2	DS350MH	1-1/2	DS150MH	4	DS400MH			5	DS500MH
HUB SIZE DIMENSIONS DU MANCHON	CAT. NO. N° CAT.	HUB SIZE DIMENSIONS DU MANCHON	CAT. NO. N° CAT.																												
1/2	DS050MH	2	DS200MH																												
3/4	DS075MH	2-1/2	DS250MH																												
1	DS100MH	3	DS300MH																												
1-1/4	DS125MH	3-1/2	DS350MH																												
1-1/2	DS150MH	4	DS400MH																												
		5	DS500MH																												
<p>USE CUTLER-HAMMER/WESTINGHOUSE TYPE CC, WCC, EHD, CHH OR WCHH, OR CUTLER-HAMMER/CHALLENGER TYPE CB OR HCB CIRCUIT BREAKERS.</p>		<p>INSTALLATION AND USE OF THIS EQUIPMENT SHOULD BE IN ACCORDANCE WITH ALL APPLICABLE LOCAL AND NATIONAL CODES AND REGULATIONS.</p>																													
<p>UTILISER DES DISJONCTEURS CUTLER-HAMMER/WESTINGHOUSE TYPES CC, WCC, EHD, CHH OR WCHH, OU CUTLER-HAMMER/CHALLENGER TYPES CB OU HCB.</p>		<p>L'INSTALLATION ET L'UTILISATION DE CET ÉQUIPEMENT DOIVENT SE CONFORMER AUX CODES ET RÉGLEMENTS LOCAUX ET NATIONAUX APPLICABLES.</p>																													
<p>SUITABLE FOR USE AS SERVICE EQUIPMENT WHEN USED WITH A MAIN TERMINAL BOX.</p>		<p>○ #14-2/0 AWG (EQUIPMENT GROUND) N° 14-2/0 AWG (MALT DE L'ÉQUIPEMENT)</p> <p>● #1/0-300 AWG (NEUTRAL) N° 1/0-300 AWG (NEUTRE)</p>																													
<p>CONVIENT COMME ÉQUIPEMENT DE BRANCHEMENT SI UTILISÉ AVEC UNE BOÎTE À BORNES PRINCIPALE.</p>		<p>MADE IN CANADA FABRIQUÉ AU CANADA</p>																													
<p>FOR USE WITH CUTLER-HAMMER/CHALLENGER MAIN SWITCH, MAIN CIRCUIT BREAKER OR MAIN TERMINAL BOX.</p>		<p>LR21128 PUB50822 REV.3</p>																													

NOTE

- ① Socket rated at single phase.
- ② Bus rated at three phase

C3MM Wiring Diagrams / Typical Nameplate Information (600 VAC)

◆ All C3MM are factory phase balanced.

Figure 17. 3Ø 4 Wire, 200A, 1 Socket, 7 Jaw

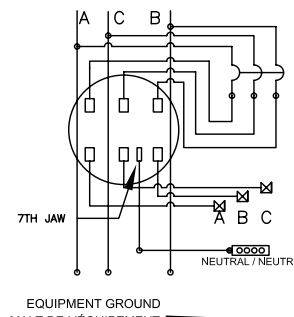
		<p>TORQUE WIRE PRESSURE SCREW(S) AS FOLLOWS:</p> <p>SERRER LES VIS À PRESSION SELON LE COUPLE CI-DESSOUS :</p>																													
<p>CATALOG NO. C3MM12600R</p>		<table border="1"> <tr> <th>WIRE SIZE CALIBRE DES CONDUCTEURS 60°/75° AL/CU</th> <th>LB-IN (N-M)</th> <th>LB-IN (N-M)</th> <th></th> </tr> <tr> <td>#14-10</td> <td>35 (3.96)</td> <td>--</td> <td></td> </tr> <tr> <td>#8</td> <td>40 (4.52)</td> <td>--</td> <td></td> </tr> <tr> <td>#6-4</td> <td>45 (5.08)</td> <td>--</td> <td></td> </tr> <tr> <td>#3-2/0</td> <td>50 (5.68)</td> <td>--</td> <td></td> </tr> <tr> <td>#1/0-300</td> <td>--</td> <td>200(2260)</td> <td></td> </tr> </table>		WIRE SIZE CALIBRE DES CONDUCTEURS 60°/75° AL/CU	LB-IN (N-M)	LB-IN (N-M)		#14-10	35 (3.96)	--		#8	40 (4.52)	--		#6-4	45 (5.08)	--		#3-2/0	50 (5.68)	--		#1/0-300	--	200(2260)					
WIRE SIZE CALIBRE DES CONDUCTEURS 60°/75° AL/CU	LB-IN (N-M)	LB-IN (N-M)																													
#14-10	35 (3.96)	--																													
#8	40 (4.52)	--																													
#6-4	45 (5.08)	--																													
#3-2/0	50 (5.68)	--																													
#1/0-300	--	200(2260)																													
<p>HORIZONTAL BUS RATING - 1200 AMPS COURANT NOMINAL BARRES HORIZONTALES - 1200 A</p>		<p>TORQUE HORIZONTAL BUS JOINT TO 25 LB-FT (33.90N-M). TORQUE CIRCUIT BREAKER LUGS TO VALUES SPECIFIED ON THE CIRCUIT BREAKER.</p>																													
<p>METER SOCKET RATING - 200 AMPS MAX. COURANT NOMINAL EMBASE DE COMPTEUR - 200 A MAX.</p>		<p>SERRER LES JOINTS DES BARRES HORIZONTALES À UN COUPLE DE 25 LB-PI (33,90 Nm). SERRER LES COSSES DES DISJONCTEURS SELON LE COUPLE INDIQUÉ SUR LE DISJONCTEUR.</p>																													
<p>200 AMPS CONTINUOUS/200A CONTINUS</p>		<p>BREAKER TERMINALS SUITABLE FOR AL-CU WIRE WHEN SO MARKED. REFER TO MARKINGS ON BREAKERS.</p>																													
<p>BRANCH CIRCUIT BREAKERS - 200 AMP MAX. DISJONCTEURS DE DÉRIVATION - 200 A MAX.</p>		<p>LES BORNES DES DISJONCTEURS CONVIENNENT AUX FILS AL-CU SI IDENTIFIÉES COMME TEL. CONSULTER LES INSCRIPTIONS SUR LES DISJONCTEURS.</p>																													
<p>347/600 VAC/VCA 1 PHASE/1 PHASES/ 3W</p>		<p>FOR RAINPROOF FITTINGS, REFER TO TABLE BELOW.</p>																													
<p>600 VAC/VCA 3 PHASE/3 PHASES/ 4W</p>		<p>POUR LES ACCESSOIRES À L'ÉPREUVE DE LA PLUIE, CONSULTER LE TABLEAU CI-DESSOUS.</p>																													
<p>TYPE 3R ENCLOSURE-OUTDOOR ENVELOPPE TYPE 3R - EXTÉRIEUR</p>		<table border="1"> <tr> <th>HUB SIZE DIMENSIONS DU MANCHON</th> <th>CAT.NO. N° CAT.</th> <th>HUB SIZE DIMENSIONS DU MANCHON</th> <th>CAT.NO. N° CAT.</th> </tr> <tr> <td>1/2</td> <td>DS050MH</td> <td>2</td> <td>DS200MH</td> </tr> <tr> <td>3/4</td> <td>DS075MH</td> <td>2-1/2</td> <td>DS250MH</td> </tr> <tr> <td>1</td> <td>DS100MH</td> <td>3</td> <td>DS300MH</td> </tr> <tr> <td>1-1/4</td> <td>DS125MH</td> <td>3-1/2</td> <td>DS350MH</td> </tr> <tr> <td>1-1/2</td> <td>DS150MH</td> <td>4</td> <td>DS400MH</td> </tr> <tr> <td></td> <td></td> <td>5</td> <td>DS500MH</td> </tr> </table>		HUB SIZE DIMENSIONS DU MANCHON	CAT.NO. N° CAT.	HUB SIZE DIMENSIONS DU MANCHON	CAT.NO. N° CAT.	1/2	DS050MH	2	DS200MH	3/4	DS075MH	2-1/2	DS250MH	1	DS100MH	3	DS300MH	1-1/4	DS125MH	3-1/2	DS350MH	1-1/2	DS150MH	4	DS400MH			5	DS500MH
HUB SIZE DIMENSIONS DU MANCHON	CAT.NO. N° CAT.	HUB SIZE DIMENSIONS DU MANCHON	CAT.NO. N° CAT.																												
1/2	DS050MH	2	DS200MH																												
3/4	DS075MH	2-1/2	DS250MH																												
1	DS100MH	3	DS300MH																												
1-1/4	DS125MH	3-1/2	DS350MH																												
1-1/2	DS150MH	4	DS400MH																												
		5	DS500MH																												
<p>USE CUTLER-HAMMER/WESTINGHOUSE TYPE CC, WCC, EHD, CHH OR WCHH, OR CUTLER-HAMMER/CHALLENGER TYPE CB OR HCB CIRCUIT BREAKERS.</p>		<p>INSTALLATION AND USE OF THIS EQUIPMENT SHOULD BE IN ACCORDANCE WITH ALL APPLICABLE LOCAL AND NATIONAL CODES AND REGULATIONS.</p>																													
<p>UTILISER DES DISJONCTEURS CUTLER-HAMMER/WESTINGHOUSE TYPES CC, WCC, EHD, CHH OR WCHH, OU CUTLER-HAMMER/CHALLENGER TYPES CB OU HCB.</p>		<p>L'INSTALLATION ET L'UTILISATION DE CET ÉQUIPEMENT DOIVENT SE CONFORMER AUX CODES ET RÉGLEMENTS LOCAUX ET NATIONAUX APPLICABLES.</p>																													
<p>SUITABLE FOR USE AS SERVICE EQUIPMENT WHEN USED WITH A MAIN TERMINAL BOX.</p>		<p>MADE IN CANADA FABRIQUÉ AU CANADA</p>																													
<p>CONVIENT COMME ÉQUIPEMENT DE BRANCHEMENT SI UTILISÉ AVEC UNE BOÎTE À BORNES PRINCIPALE.</p>		<p>LR2128 PUB50885 REV.2</p>																													
<p>FOR USE WITH CUTLER-HAMMER/CHALLENGER MAIN SWITCH, MAIN CIRCUIT BREAKER OR MAIN TERMINAL BOX.</p>																															

NOTE

- ① Socket rated at single phase.
- ② Bus rated at three phase

C3MM Wiring Diagrams / Typical Nameplate Information (600 VAC)

◆ All C3MM are factory phase balanced.

Figure 18. 3Ø 4 Wire, 200A, 4 Socket, 7 Jaw

		<p>TORQUE WIRE PRESSURE SCREW(S) AS FOLLOWS: SERRER LES VIS À PRESSION SELON LE COUPLE CI-DESSOUS :</p>																													
<p>CATALOG NO. C3MM42600R</p>		<p>WIRE SIZE CALIBRE DES CONDUCTEURS 60°/75° AL/CU</p> <table border="1"> <tr> <td></td> <td>LB-IN (N-M)</td> <td>LB-IN (N-M)</td> <td></td> </tr> <tr> <td>#14-10</td> <td>35 (3.96)</td> <td>--</td> <td></td> </tr> <tr> <td>#6</td> <td>40 (4.52)</td> <td>--</td> <td></td> </tr> <tr> <td>#6-4</td> <td>45 (5.08)</td> <td>--</td> <td></td> </tr> <tr> <td>#3-2/0</td> <td>50 (5.68)</td> <td>--</td> <td></td> </tr> <tr> <td>#1/0-300</td> <td>--</td> <td>200(2260)</td> <td></td> </tr> </table>				LB-IN (N-M)	LB-IN (N-M)		#14-10	35 (3.96)	--		#6	40 (4.52)	--		#6-4	45 (5.08)	--		#3-2/0	50 (5.68)	--		#1/0-300	--	200(2260)				
	LB-IN (N-M)	LB-IN (N-M)																													
#14-10	35 (3.96)	--																													
#6	40 (4.52)	--																													
#6-4	45 (5.08)	--																													
#3-2/0	50 (5.68)	--																													
#1/0-300	--	200(2260)																													
<p>HORIZONTAL BUS RATING - 1200 AMPS COURANT NOMINAL BARRES HORIZONTALES - 1200 A</p>		<p>TORQUE HORIZONTAL BUS JOINT TO 25 LB-FT (33.90N-M). TORQUE CIRCUIT BREAKER LUGS TO VALUES SPECIFIED ON THE CIRCUIT BREAKER.</p>																													
<p>METER SOCKET RATING - 200 AMPS MAX. COURANT NOMINAL EMBASE DE COMPTEUR - 200 A MAX.</p>		<p>SERRER LES JOINTS DES BARRES HORIZONTALES À UN COUPLE DE 25 LB-PI (33,90 Nm). SERRER LES COSSES DES DISJONCTEURS SELON LE COUPLE INDIQUÉ SUR LE DISJONCTEUR.</p>																													
<p>200 AMPS CONTINUOUS/200A CONTINUS</p>		<p>BREAKER TERMINALS SUITABLE FOR AL-CU WIRE WHEN SO MARKED. REFER TO MARKINGS ON BREAKERS.</p>																													
<p>BRANCH CIRCUIT BREAKERS - 200 AMP MAX. DISJONCTEURS DE DÉRIVATION - 200 A MAX.</p>		<p>LES BORNES DES DISJONCTEURS CONVIENTENT AUX FILS AL-CU SI IDENTIFIÉES COMME TEL. CONSULTEZ LES INSCRIPTIONS SUR LES DISJONCTEURS.</p>																													
<p>347/600 VAC/VCA 1 PHASE/1 PHASES/ 3W</p>		<p>FOR RAINPROOF FITTINGS, REFER TO TABLE BELOW.</p>																													
<p>600 VAC/VCA 3 PHASE/3 PHASES/ 4W</p>		<p>POUR LES ACCESSOIRES À L'ÉPREUVE DE LA PLUIE, CONSULTEZ LE TABLEAU CI-DESSOUS.</p>																													
<p>TYPE 3R ENCLOSURE-OUTDOOR ENVELOPPE TYPE 3R - EXTÉRIEUR</p>		<table border="1"> <tr> <th>HUB SIZE DIMENSIONS DU MANCHON</th> <th>CAT.NO. N° CAT.</th> <th>HUB SIZE DIMENSIONS DU MANCHON</th> <th>CAT.NO. N° CAT.</th> </tr> <tr> <td>1/2</td> <td>DS050MH</td> <td>2</td> <td>DS200MH</td> </tr> <tr> <td>3/4</td> <td>DS075MH</td> <td>2-1/2</td> <td>DS250MH</td> </tr> <tr> <td>1</td> <td>DS100MH</td> <td>3</td> <td>DS300MH</td> </tr> <tr> <td>1-1/4</td> <td>DS125MH</td> <td>3-1/2</td> <td>DS350MH</td> </tr> <tr> <td>1-1/2</td> <td>DS150MH</td> <td>4</td> <td>DS400MH</td> </tr> <tr> <td></td> <td></td> <td>5</td> <td>DS500MH</td> </tr> </table>		HUB SIZE DIMENSIONS DU MANCHON	CAT.NO. N° CAT.	HUB SIZE DIMENSIONS DU MANCHON	CAT.NO. N° CAT.	1/2	DS050MH	2	DS200MH	3/4	DS075MH	2-1/2	DS250MH	1	DS100MH	3	DS300MH	1-1/4	DS125MH	3-1/2	DS350MH	1-1/2	DS150MH	4	DS400MH			5	DS500MH
HUB SIZE DIMENSIONS DU MANCHON	CAT.NO. N° CAT.	HUB SIZE DIMENSIONS DU MANCHON	CAT.NO. N° CAT.																												
1/2	DS050MH	2	DS200MH																												
3/4	DS075MH	2-1/2	DS250MH																												
1	DS100MH	3	DS300MH																												
1-1/4	DS125MH	3-1/2	DS350MH																												
1-1/2	DS150MH	4	DS400MH																												
		5	DS500MH																												
<p>USE CUTLER-HAMMER/WESTINGHOUSE TYPE CC, WCC, EHD, CHH OR WCHH, OR CUTLER-HAMMER/CHALLENGER TYPE CB OR HCB CIRCUIT BREAKERS.</p>		<p>FOR USE WITH CUTLER-HAMMER/CHALLENGER MAIN SWITCH, MAIN CIRCUIT BREAKER OR MAIN TERMINAL BOX.</p>																													
<p>UTILISER DES DISJONCTEURS CUTLER-HAMMER/WESTINGHOUSE TYPES CC, WCC, EHD, CHH OR WCHH, OU CUTLER-HAMMER/CHALLENGER TYPES CB OU HCB.</p>		<p>DESTINÉ AUX INTERRUPTEURS PRINCIPAUX, AUX DISJONCTEURS PRINCIPAUX OU AUX BOÎTES À BORNES PRINCIPALES CUTLER-HAMMER/CHALLENGER.</p>																													
<p>SUITABLE FOR USE AS SERVICE EQUIPMENT WHEN USED WITH A MAIN TERMINAL BOX.</p>		<p>INSTALLATION AND USE OF THIS EQUIPMENT SHOULD BE IN ACCORDANCE WITH ALL APPLICABLE LOCAL AND NATIONAL CODES AND REGULATIONS.</p>																													
<p>CONVIENT COMME ÉQUIPEMENT DE BRANCHEMENT SI UTILISÉ AVEC UNE BOÎTE À BORNES PRINCIPALE.</p>		<p>L'INSTALLATION ET L'UTILISATION DE CET ÉQUIPEMENT DOIVENT SE CONFORMER AUX CODES ET RÉGLEMENTS LOCAUX ET NATIONAUX APPLICABLES.</p>																													
<p>FOR USE WITH CUTLER-HAMMER/CHALLENGER MAIN SWITCH, MAIN CIRCUIT BREAKER OR MAIN TERMINAL BOX.</p>		<p>○ #14-2/0 AWG (EQUIPMENT GROUND) N° 14-2/0 AWG (MALT DE L'ÉQUIPEMENT) ● #1/0-300 AWG (NEUTRAL) N° 1/0-300 AWG (NEUTRE)</p>																													
<p>FOR USE WITH CUTLER-HAMMER/CHALLENGER MAIN SWITCH, MAIN CIRCUIT BREAKER OR MAIN TERMINAL BOX.</p>																															
<p>DESTINÉ AUX INTERRUPTEURS PRINCIPAUX, AUX DISJONCTEURS PRINCIPAUX OU AUX BOÎTES À BORNES PRINCIPALES CUTLER-HAMMER/CHALLENGER.</p>		<p>MADE IN CANADA FABRIQUÉ AU CANADA</p>																													
<p>INSTALLATION AND USE OF THIS EQUIPMENT SHOULD BE IN ACCORDANCE WITH ALL APPLICABLE LOCAL AND NATIONAL CODES AND REGULATIONS.</p>		<p>LR21128 PUB50823 REV.3</p>																													

NOTE

- ① Socket rated at single phase.
- ② Bus rated at three phase

Index

Symbols

1MCB1000R 5
 1MCB1200NLK 5,15
 1MCB1200R 5
 1MCB250R 5
 1MCB300R 5
 1MCB350R 5
 1MCB400R 5
 1MCB500R 5
 1MCB600R 5
 1MCB700R 5
 1MCB800R 5
 1MCB900R 5
 1MFS1200LK 6
 1MFS1200LKN 6,16
 1MFS1200RB 6
 1MFS400RB 6
 1MFS400RT 6
 1MFS600BLK 6,16
 1MFS600RB 6
 1MFS600RT 6
 1MFS800RB 6
 1MFS800RT 6
 1MHC1000R 5
 1MHC1200R 5
 1MHC250R 5
 1MHC300R 5
 1MHC350R 5
 1MHC400R 5
 1MHC500R 5
 1MHC600R 5
 1MHC700R 5
 1MHC800R 5
 1MHC900R 5
 1MMACP 9,13,19
 1MMBC1 10
 1MMBC125B 9
 1MMBC2 10,14,20
 1MMBC200B 9
 1MMBPJ 9,13,19
 1MMCP1 10
 1MMCP2 10
 1MMGBK 7,11,17
 1MMJCK 9,13,19
 1MMMS 10
 1MMPCP 9,13,19
 1MMWB 9,13,19
 1MPLK2 5,15
 1MTB1200R 5
 1MTB800R 5
 37MMCKCAN 13,19
 37MMSKCAN 14,20
 3MCB1000R 5
 3MCB1200R 5
 3MCB250R 5
 3MCB300R 5
 3MCB350R 5
 3MCB36600R 15
 3MCB400R 5
 3MCB500R 5
 3MCB600R 5
 3MCB6400R 15
 3MCB6800R 15
 3MCB700R 5
 3MCB800R 5
 3MCB900R 5
 3MFS1200RB 6
 3MFS400RB 6
 3MFS400RT 6
 3MFS600JFK 6,16
 3MFS600RB 6
 3MFS600RT 6
 3MFS6400RB 16
 3MFS6400RT 16
 3MFS6600RB 16
 3MFS6600RT 16
 3MFS6800RB 16
 3MFS6800RT 16
 3MFS800CLK 6,16
 3MFS800CLKT 6,16
 3MFS800RB 6
 3MFS800RT 6
 3MFSBBK 9, 13, 19

3MFSTBK 9, 13, 19
 3MHCB1000R 5
 3MHCB1200R 5
 3MHCB250R 5
 3MHCB300R 5
 3MHCB350R 5
 3MHCB400R 5
 3MHCB500R 5
 3MHCB600R 5
 3MHCB6400R 15
 3MHCB6600R 15
 3MHCB6800R 15
 3MHCB700R 5
 3MHCB800R 5
 3MHCB900R 5
 3MMEB616 9,13,19
 3MTB1200BLK 5
 3MTB1200CLK 5,15
 3MTB1200R 5
 3MTB400R 5
 3MTB600BLK 5,15
 3MTB600CLK 5,15
 3MTB600R 5
 3MTB61200R 15
 3MTB6400R 15
 3MTB6600R 15
 3MTB6800R 15
 3MTB800BLK 5,15
 3MTB800R 5
 3T100FB 13,19
 3TA150FB 13,19
 3TA225FD 12,18
 3TA402K 5,15
 47-24139A 10, 14, 20
 47-28172-2A 10, 14, 20
 99-5115-2 14,20

B

BQL3100 21
 BQL360 21
 BQL370 21
 BR2100 8
 BR2110 8
 BR2125 8
 BR260 8
 BR270 8
 BR280 8
 BR290 8
 BRH2100 8
 BRH2110 8
 BRH2125 8
 BRH260 8
 BRH270 8
 BRH280 8
 BRH290 8
 BRHH2100 8
 BRHH2110 8
 BRHH2125 8
 BRHH260 8
 BRHH270 8
 BRHH280 8
 BRHH290 8

C

C1MM320R 7
 C1MM612R 7
 C3M800LTC 21
 C3M800RTC 21
 C3MM12240R 11
 C3MM12600R 17
 C3MM312R 7
 C3MM320R 7
 C3MM41240R 11
 C3MM42240R 11
 C3MM42600R 17
 C3MM612R 7
 C3MTB1200FT 8,12
 C3MTB12FTLUG 8,12
 C3MTB61200FT 18
 C3MTB6800FT 18
 C3MTB800FT 8,12
 C3MTBFTLUG 8,12
 CCV2100X 8
 CCV2125X 8
 CCV2150X 8
 CCV2175X 8
 CCV2200X 8
 CHH2060H2X 8

CHH2060H4X 8
 CHH2060X 8
 CHH2070H2X 8
 CHH2070H4X 8
 CHH2070X 8
 CHH2080H2X 8
 CHH2080H4X 8
 CHH2080X 8
 CHH2090H2X 8
 CHH2090H4X 8
 CHH2090X 8
 CHH2100H2X 8
 CHH2100H4X 8
 CHH2100X 8
 CHH2125H2X 8
 CHH2125H4X 8
 CHH2125X 8
 CHH2150H2X 8
 CHH2150H4X 8
 CHH2150X 8
 CHH2175H2X 8
 CHH2175H4X 8
 CHH2175X 8
 CHH2200H2X 8
 CHH2200H4X 8
 CHH2200X 8

D

DS050MH 10,14,20
 DS075MH 10,14,20
 DS100MH 10,14,20
 DS125MH 10,14,20
 DS150MH 10,14,20
 DS200MH 10,14,20
 DS250MH 10,14,20
 DS300MH 10,14,20
 DS400MH 20
 DS500MH 20
 DS56FK 6
 DS66FK 6

E

ED3100 12
 ED3125 12,21
 ED3150 12,21
 ED3175 12,21
 ED3200 12,21
 EDH3100 12
 EDH3125 12
 EDH3150 12
 EDH3175 12
 EDH3200 12

F

FD3070 18
 FD3100 18
 FD3125 18
 FD3150 18
 FD3175 18
 FD3200 18
 FDB3070 18
 FDB3100 18
 FDB3125 18
 FDB3150 18
 FDB3175 18
 FDB3200 18
 FDC3070 18
 FDC3100 18
 FDC3125 18
 FDC3150 18
 FDC3175 18
 FDC3200 18
 FJ2-6 22

G

GD3060 12
 GD3070 12
 GD3100 12

H

HBQL3100 21
 HBQL360 21
 HFD3125 18
 HFD3150 18

HFD3175	18
HFD3200	18
J		
JB2	22
M		
MHDF3	12
MS-BCP-P	22
S		
SR3	14,20,22
T		
TA1201NB1	5
TA801MA	5,15
W		
WCG3HK400	6
WCG3HK600	6

Notes

Notes

Eaton Corporation is a diversified power management company with 2010 sales of \$13.7 billion. Celebrating its 100th anniversary in 2011, Eaton is a global technology leader in electrical components and systems for power quality, distribution and control; hydraulics components, systems and services for industrial and mobile equipment; aerospace fuel, hydraulics and pneumatic systems for commercial and military use; and truck and automotive drivetrain and powertrain systems for performance, fuel economy and safety. Eaton has approximately 70,000 employees and sells products to customers in more than 150 countries. For more information, visit www.eaton.com