



Strut Systems

Channels, Hardware, Fittings, Mechanical & Electrical Accessories,
Special Materials (Aluminum, Stainless Steel, Fiberglass),
Mini Channel, Concrete Inserts, Slotted Angle, Kwik-Wire™,
Dura-Blok™ Supports, Dura Clean™ Washdown Supports

SS-09

 **COOPER B-Line**



INTRODUCTION

Cooper B-Line, Inc. is a leading manufacturer and fabricator of steel and aluminum products which are used in support of equipment for industrial, commercial, utility, and OEM installations. Cooper B-Line is proud of the exacting standards of research, design, engineering, and manufacturing that go into each and every product that comprise our metal framing product line. Our customers have access to the most complete support systems offered in the industry, including metal framing, cable tray, pipe hangers, slotted angle, and fasteners.

Many of Cooper B-Line's products are listed by the Underwriter's Laboratories, Inc. All Cooper B-Line products are manufactured to meet or exceed MFMA and other industry standards set for their design and manufacture.

The majority of Cooper B-Line products are produced in four modern plants consisting of approximately 900,000 square feet. These facilities are located in Highland, Illinois; Troy, Illinois; Reno, Nevada; and Sherman, Texas. Regional sales and distribution centers are located throughout the United States stocking standard Cooper B-Line products for quick service and delivery.

This catalog is designed to be helpful to engineers and contractors in the application and selection of strut products for construction and maintenance.

If a unique application requires a special product not included in this catalog. Cooper B-Line engineering personnel are ready to furnish design consultation and realistic cost estimates. In addition, sales representatives with engineering know-how are located throughout the United States and abroad for your convenience.



Cooper B-Line, Inc.
509 West Monroe Street
Highland, Illinois 62249-0326
Phone: 800-851-7415
www.cooperbline.com

**DURA-BLOK™
ROOFTOP SUPPORTS**
Pgs. 136-143



DB Series



DB6 Series



DB10 Series



DBE10 Series



DBR10-12



DBM Series



DB_DS Series



DBR Series

**DURA CLEAN™
WASHDOWN SUPPORTS**
Pg. 144-149



U-Bolts



Dura Clean™ Channel



**Dura Clean™
Wall Mount Rails**



Hardware



Threaded Rod



Spacers

New Products

ARMAFIX® CLAMPS & ACCESSORIES Pg. 120

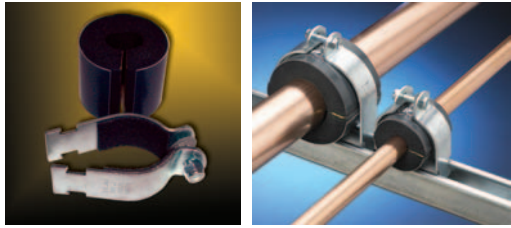

Clamp & Insert Assembly
Includes: Insert, Clamp, and Hardware

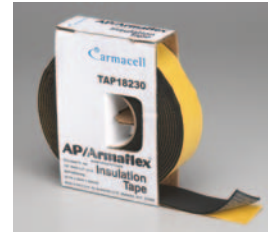

**Armaflex®
Insulation
Tape**



Insert Only
Used with B-Line
Pipe Hangers
(Sold Separately)

KWIKWIRE™ & ACCESSORIES Pg. 57

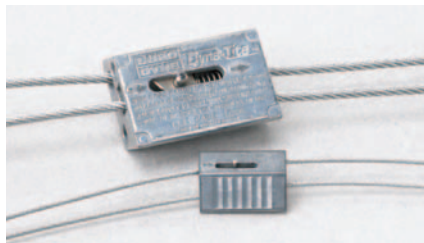

**KwikWire™
Wire Rope**



KwikPak™
(Includes clamps & wire rope)



KwikWire™ Clamps



KwikWire™ Cutter



Air Duct Corner Protector

AHHK-1/4 & AHHK-3/8 AIR HANDLER HANGING KIT Pg. 215

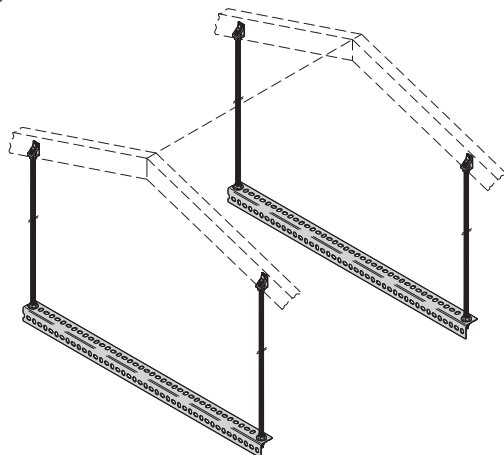

HOT RODS™ Pg. 56



BTS22TH
TELESCOPING CHANNEL
Pg. 38 & 39

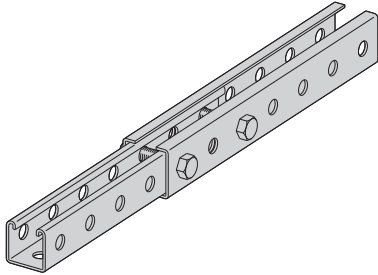

B22SHA
SLOTTED BACK-TO-BACK CHANNEL
Pg. 41

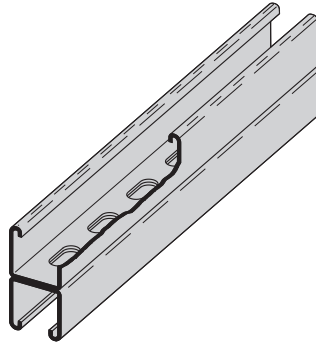

BK_H112
CHANNEL WITH 9/16" HOLES
ON 1 1/2" CENTERS & CUTTING
MARKS ON 1 1/2" CENTERS
Pg. 42

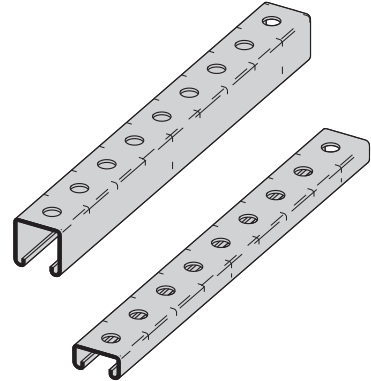

B_S58, B_M, B_H25
CHANNELS
Pg. 42 & 43

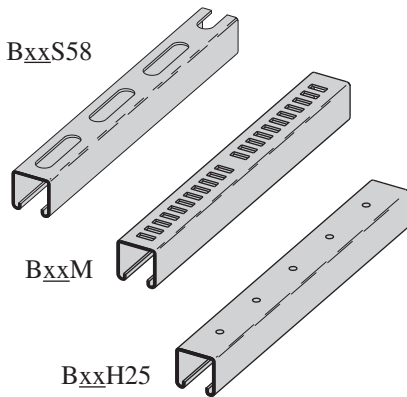

DCN3/8
CONVEYOR NUT
Pg. 52

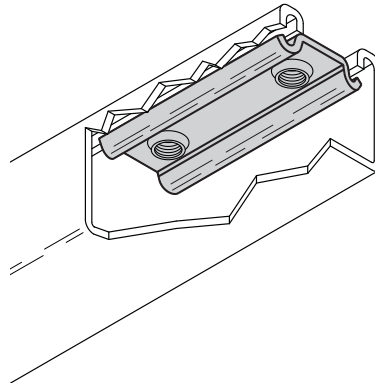

B650
SEISMIC RETROFIT BRACKET
Pg. 70

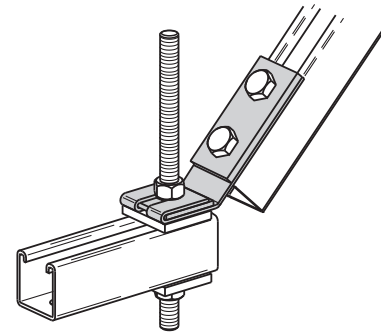

UTILITY POLE BRACKET
Pgs. 90 & 91

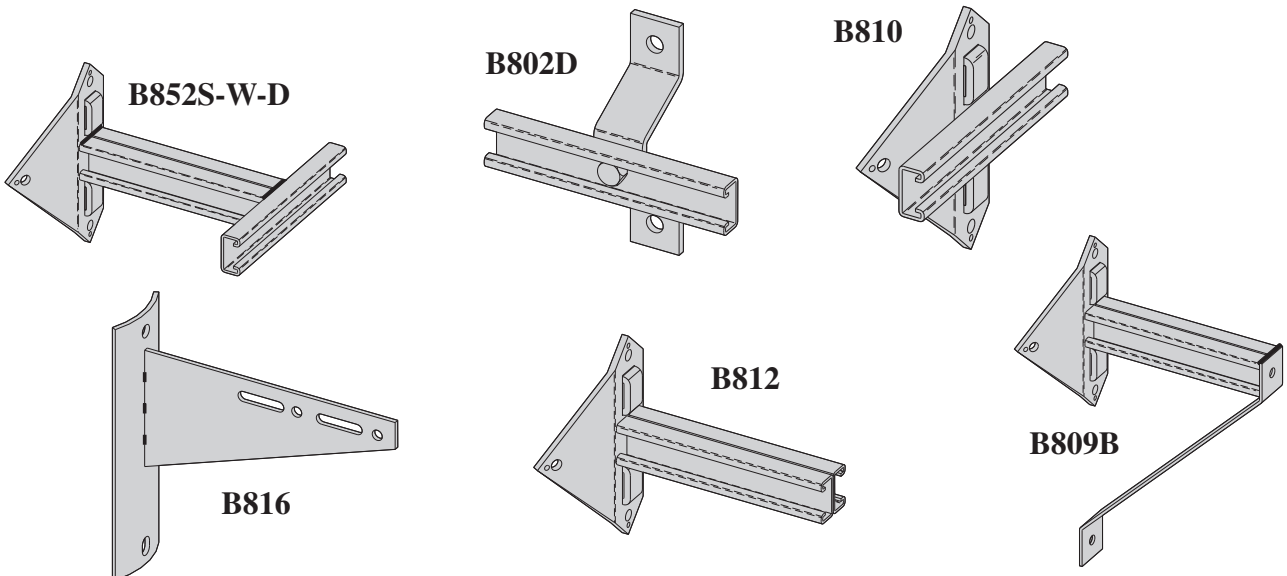

Product Showcase

PLASTIC END CAPS
Pgs. 96 & 97

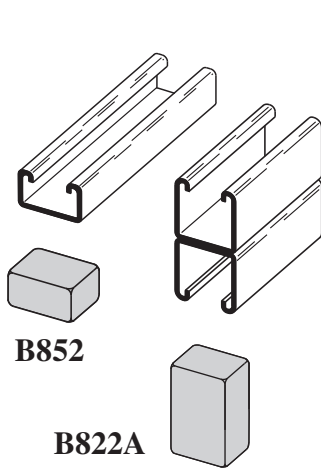

B823 Series

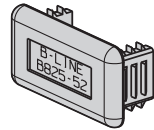
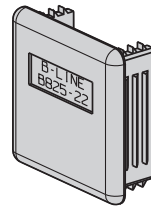
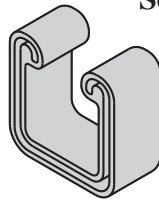

B825 Series

P CLAMPS
O.D. SIZE .250"-2.750"
Pg. 117

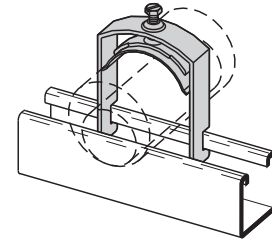

VIBRACLAMP®
O.D. SIZE 1/4"-6 1/8"
PIPE SIZE 1/4"-6"
Pg. 118 & 119

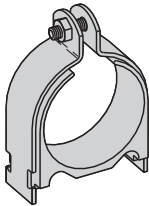

BVS-12 & BVS-120
VIBRA STRIP FOR 1 5/8" WIDE CHANNEL
Pg. 121

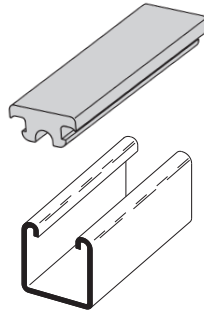

B2417 & B2417-CT
STRUT MOUNTED PIPE GUIDE
Pg. 123

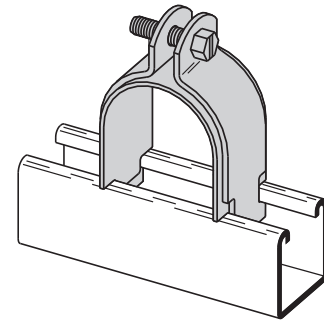

Stainless Steel & Aluminum
Pgs. 164 - 169

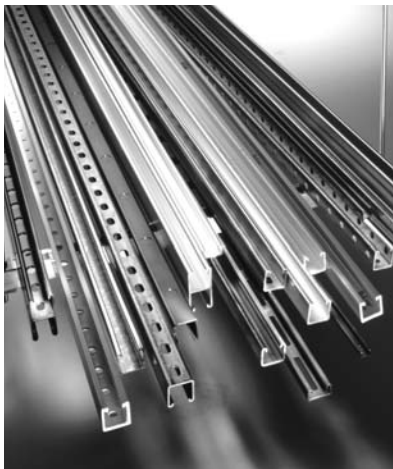







Fiberglass
Pgs. 170 - 187



Slotted Angle
Pgs. 210 - 215



Introduction	2-3		Dura-Blok™ Rooftop Supports	
Technical Data			Info. & Specifications	136
Materials	4		Base Support	137
Finishes	5-6		Base Support - Channel	137-138
Welding	7		Base Support - Pipe/Tubing Riser	138
Corrosion	8-9		Base Support Riser - Channel	139
Design of Strut Systems	10-12		Base Support Riser - Pipe Roller	139
Recommended Specification	13		Base Support - 'H' Stand	140-141
Channel & Combinations			Base Support - Pipe Roller	142
Info. & Specifications	14		Application Photos	143
Selection Chart	15		Dura-Clean™ Washdown Supports	
B11 Channel	16-17		Info. & Specifications	144
B12 Channel	18-19		Channel	145
B22 Channel	20-23		Wall Mount Rails	146
B24 Channel	24-25		U-Bolts & Hardware	147
B26 Channel	26-27		Threaded Rod & Spacers	148
B32 Channel	28-29		Application Photos	149
B42 Channel	30-31		Electrical Accessories	
B52 Channel	32-33		Info. & Specifications	150
B54 Channel	34-35		Selection Chart	151
B56 Channel	36-37		Fluorescent Fixture Hangers	152-154
Telescoping Channel	38-39		Electrical Accessories	155-156
Channel Hole Patterns	40-43		Junction Boxes	157
Channel Hole Punch	43		Strut Joiners	158-159
Channel Nuts & Hardware			Electrical Hardware	160
Info. & Specifications	44		Porcelain Clamps	161-162
Channel Nuts			Maple Clamps	162-163
Selection Charts	45-49		Aluminum & Stainless Steel Materials	
Slip & Pull-out Load Charts	50-51		Info. & Specifications	164
Other Hardware	52-56		Aluminum	165-167
KwikWire™ & Accessories	57		Stainless Steel	168-169
Strut Fittings			Fiberglass Materials	
Info. & Specifications	58		Info. & Specifications	170-171
Flat Plate Fittings	59-61		Channels	172-176
90° Angle Fittings	62-67		Hardware	176-178
Angular Fittings	68-70		Fittings	179-187
Braces	71		Mini Channel & Fittings	
Clevis Fittings	72		Info. & Specifications	188
U-Fittings	73-76		Mini Channels	189-190
Z-Fittings	77-79		Mini Channel Nuts	191
Wing Fittings	80-82		Mini Fittings	191-199
Post Bases	83-84		Econo-Strut & Fittings	200-201
Brackets	85-91		Concrete Inserts	
Miscellaneous Fittings	92-97		Info. & Specifications	202
Beam Clamps & Accessories			Continuous Inserts	203-206
Info. & Specifications	98		Spot Inserts	207
Beam Clamps & Accessories	99-109		Insert Accessories	208
Pipe/Conduit Clamps & Hangers			Anchors	209
Info. & Specifications	110		Slotted Angle	
Pipe Clamps	111-117		Info. & Specifications	210
Vibra Clamps	118-119		Slotted Angle	
Armafix® Clamps & Accessories	120		Sizes	211
Vibra Cushions	121		Loading Charts	212-214
Pipe Clamps	122-126		Slotted Angle Fittings	215
Pipe Hangers	127-128		Reference Data	216-225
Pipe Brackets	129		Index	226-233
Pipe Rollers	130-135			

Introduction

B-Line's metal framing support system is designed with many time-saving features. They are fully adjustable and reusable, with a complete line of channels, fittings and accessories for multi-purpose applications.

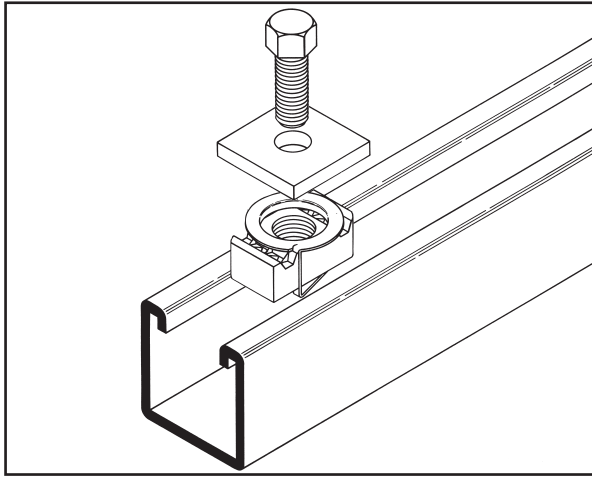

- No Welding
- No Drilling
- Use Your Imagination

B-Line metal framing installs quickly. There is no need for special tools. All you need is a wrench and hacksaw. Channels and parts can be taken apart for reuse as quickly as they were assembled, yet they provide the strength of welded construction. Eliminating welding and drilling produces substantial savings in time and labor.

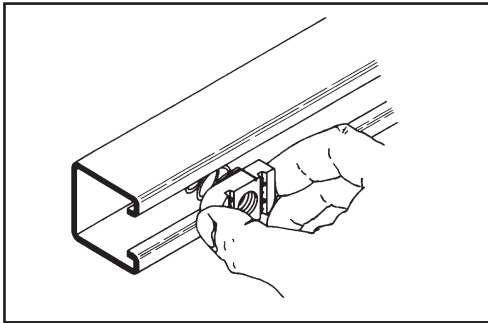

1. Tite-Grip channel nut may be inserted anywhere along continuous slot. Designed for easy insertion and self-alignment.

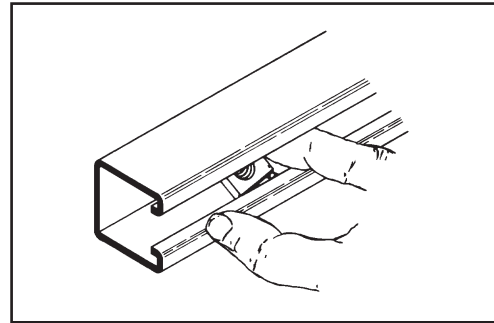

2. A 90 degree turn aligns channel nut grooves with inturred lips of the channel.

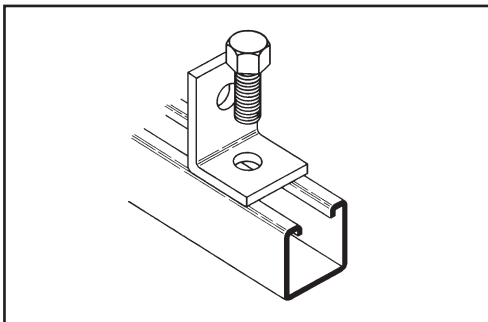

3. Position fitting over channel nut and insert bolt to start any connection.

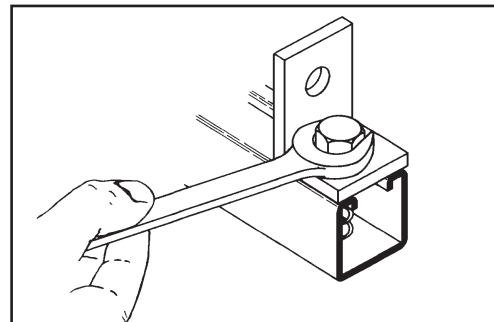

4. With the twist of a wrench, channel nut locks its teeth firmly against inturred lips.

B-Line's Metal Framing system provides an economical solution for electrical, mechanical and industrial supports with an unlimited variety of applications in the construction industry.

Metal Framing Electrical Applications

- Lighting Fixture Supports
- Raceway Systems
- Trapeze Hangers
- Pipe & Conduit Supports
- Cable Tray Supports
- Beam Adjustments

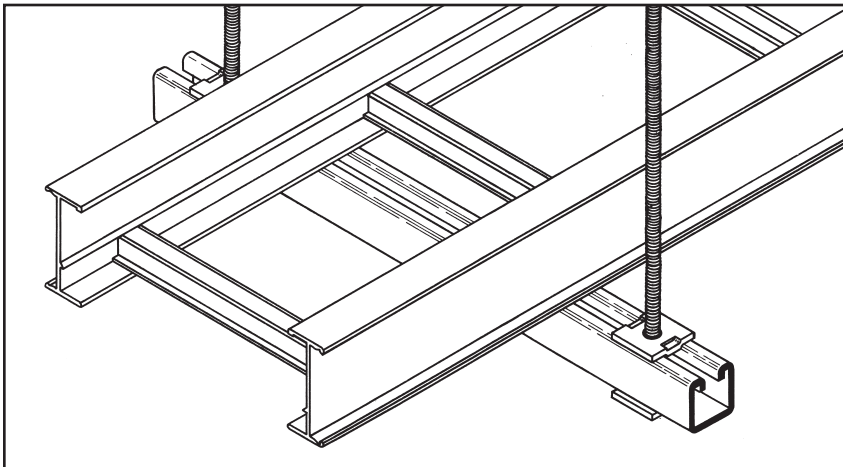
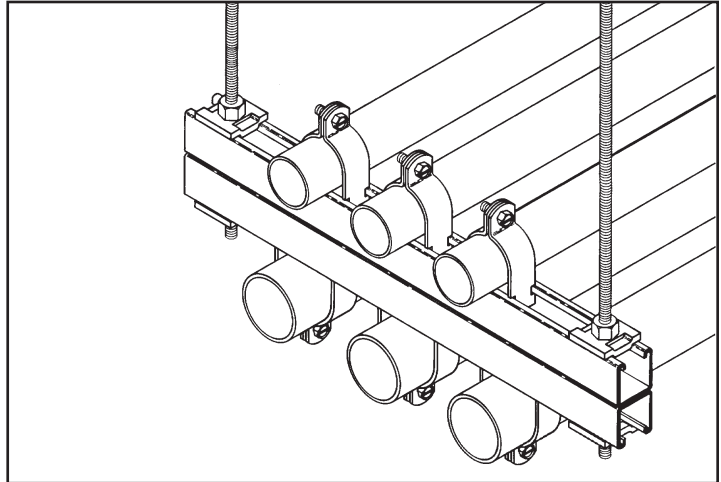

Metal Framing Mechanical Applications

- Piping Racks
- Tunnel Pipe Stanchions
- Concrete Inserts
- Beam Attachments
- Pipe Risers

Metal Framing Industrial Applications

- Racks and Shelving
- Partitions
- Production Line Supports
- Trolley Systems
- Wall Framing

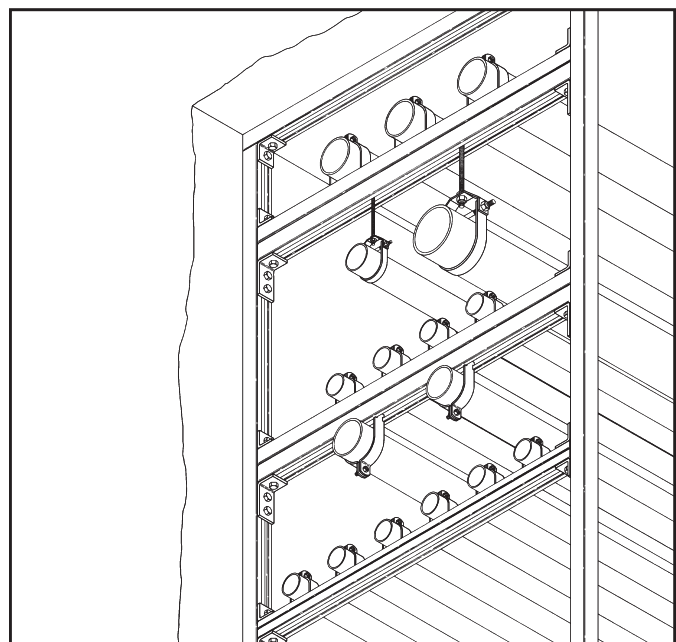

MATERIALS

Carbon Steel

Channels made from high-quality carbon steel are continuously roll formed to precise dimensions. By cold working the steel mechanical properties are increased, allowing lightweight structures to carry the required load. Corrosion resistance of carbon steel varies widely with coating and alloy. See "Finishes" for more detailed information.

Stainless Steel

Stainless steel channel is available in AISI Type 304 or 316 material. Both are non-magnetic and belong to the austenitic stainless steels group, based on alloy content and crystallographic structure. Like carbon steel, stainless steel exhibits increased strength when cold worked by roll-forming.

Several conditions make the use of stainless steel ideal. These include reducing long term maintenance costs, high ambient temperatures, appearance, and stable structural properties such as yield strength, and high creep strength.

Type 304 resists most organic chemicals, dyestuffs and a wide variety of inorganic chemicals at elevated or cryogenic temperatures. Type 316 contains slightly more nickel and adds molybdenum to give it better corrosion resistance in chloride and sulfuric acid environments. More specific information concerning the differences between types 304 and 316 is available from B-Line.

Aluminum

B-Line's standard aluminum channel is extruded from aluminum alloy 6063-T6. Strut fittings are made from aluminum alloy 5052-H32.

The high strength to weight ratio of channel made of aluminum greatly reduces the overall cost of installation through ease of handling and field cutting.

Aluminum owes its excellent corrosion resistance to its ability to form an aluminum oxide film that immediately reforms when scratched or cut. In most outdoor applications, aluminum has excellent resistance to "weathering". The resistance to chemicals, indoor or outdoor, can best be determined by tests conducted by the user with exposure to the specific conditions for which it is intended. The corrosion resistance of aluminum to some commonly known chemicals is shown in the Corrosion Chart. For further information, contact B-Line Systems, Inc. or the Aluminum Association.

Fiberglass

B-Line offers two fire retardant (FR) resins for strut systems, polyester and vinyl ester. Both resins are ideal for corrosive environments or nonconductive applications with moderate strength requirements. Some common types of environments where Vinyl Ester Resins are recommended, that Poly Esters are not, are paper mills, most any metal plating operation and any

condition with concentrated levels of Chlorine, [Cl⁻]. Please consult our fiberglass corrosion resistance charts on pg. 173 for specific chemical recommendation data.

Unlike other base materials depicted in this catalog, fiberglass exhibits unique physical property changes when operating in elevated temperature conditions, that are a fraction of increase compared to steel or aluminum. This being true, B-Line advises against using fiberglass in temperatures greater than 200° F.

Please refer to the "Corrosion Resistance Guide" below for specific applications.

B-Line Fiberglass Strut systems are manufactured from glass fiber-reinforced plastic shapes that meet ASTM E-84, Class 1 Flame Rating and self-extinguishing requirements of ASTM D-635. A surface veil is applied during pultrusion to insure a resin-rich surface and ultraviolet resistance.

While polyester is sufficient for most uses, vinyl ester is suitable for a broader range of environments.

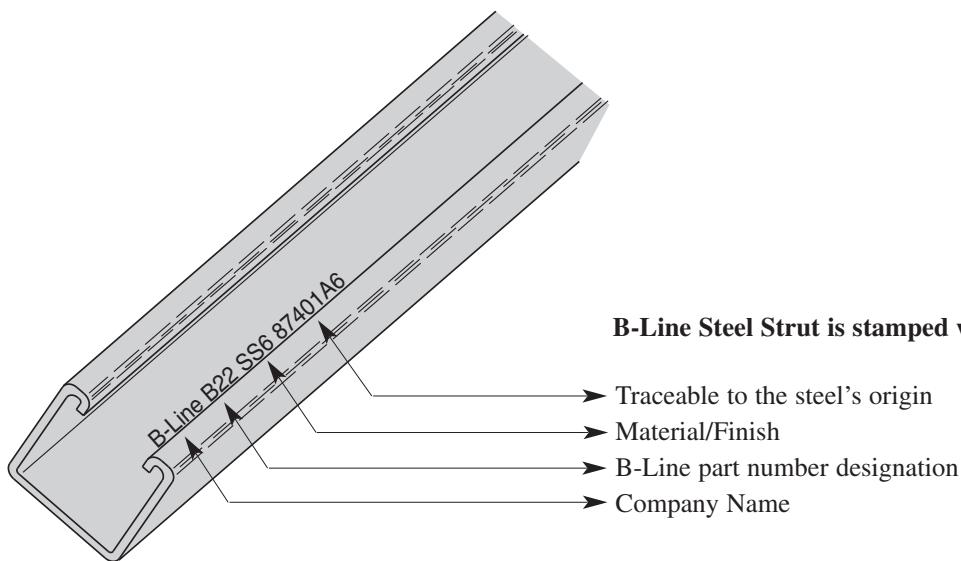

B-Line Steel Strut is stamped with:

FINISHES

Zinc Coatings

Zinc protects steel in two ways. First it protects the steel as a coating and second as a sacrificial anode to repair bare areas such as cut edges, scratches, and gouges. The corrosion protection of zinc is directly related to its thickness and the environment. This means a .2 mil coating will last twice as long as a .1 mil coating in the same environment.

Galvanizing also protects cut and drilled edges.

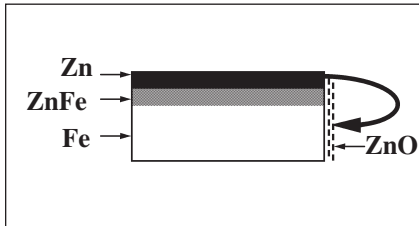

Electrogalvanized Zinc

Electrogalvanized Zinc (also known as zinc plated or electroplated) is the process by which a coating of zinc is deposited on the steel by electrolysis from a bath of zinc salts.

A rating of SC3, B-Line's standard, provides a minimum zinc coating thickness of .5 mils (excluding hardware, which is SC1 = .2 mils).

When exposed to air and moisture, zinc forms a tough, adherent, protective film consisting of a mixture of zinc oxides, hydroxides, and carbonates. This film is in itself a barrier coating which slows subsequent corrosive attack on the zinc. This coating is usually recommended for indoor use in relatively dry areas, as it provides ninety-six hours protection in salt spray testing per ASTM B117.

Chromium/ Zinc

Chromium/ Zinc is a corrosion resistant composition, which was developed to protect fasteners and small bulk items for automotive use. The coating applications have since been extended to larger parts and other markets.

Chromium/Zinc composition is an aqueous coating dispersion containing chromium, proprietary organics, and zinc flake.

This finish provides 500 hours protection in salt spray testing per ASTM B117.

Pre-Galvanized Zinc

(Mill galvanized, hot dip mill galvanized or continuous hot dip galvanized) Pre-galvanized steel is produced by coating coils of sheet steel with zinc by continuously rolling the material through molten zinc at the mills. This is also known as mill galvanized or hot dip mill galvanized. These coils are then slit to size and fabricated by roll forming, shearing, punching, or forming to produce B-Line pre-galvanized strut products.

The G90 specification calls for a coating of .90 ounces of zinc per square foot of steel. This results in a coating of .45 ounces per square foot on each side of the sheet. This is important when comparing this finish to hot dip galvanized after fabrication.

During fabrication, cut edges and welded areas are not normally zinc coated; however, the zinc near the uncoated metal becomes a sacrificial anode to protect the bare areas after a short period of time.

Hot Dip Galvanized After Fabrication (Hot dip galvanized or batch hot dip galvanized)

Hot dip galvanized strut products are fabricated from steel and then completely immersed in a bath of molten zinc. A metallic bond occurs resulting in a zinc coating that completely coats all surfaces, including edges and welds.

Another advantage of this method is coating thickness. Strut products that are hot dip galvanized after fabrication have a minimum thickness of 1.50 ounces per square foot on each side, or a total 3.0 ounces per square foot of steel, according to ASTM A123.

The zinc thickness is controlled by the amount of time each part is immersed in the molten zinc bath as well as the speed at which it is removed. The term "double dipping" refers to parts too large to fit into the galvanizing kettle and, therefore, must be dipped one end at a time. It does not refer to extra coating thickness.

The layer of zinc which bonds to steel provides a dual protection against corrosion. It protects first as an overall barrier coating. If this coating happens to be scratched or gouged, zinc's secondary defense is called upon to protect the steel by galvanic action.

Hot-Dip Galvanized After Fabrication is recommended for prolonged outdoor exposure and will usually protect steel for 20 years or more in most atmospheric environments and in many industrial environments. For best results, a zinc rich paint (available from B-Line) should be applied to field cuts. The zinc rich paint will provide immediate protection for these areas and eliminate the short time period for galvanic action to "heal" the damaged coating.

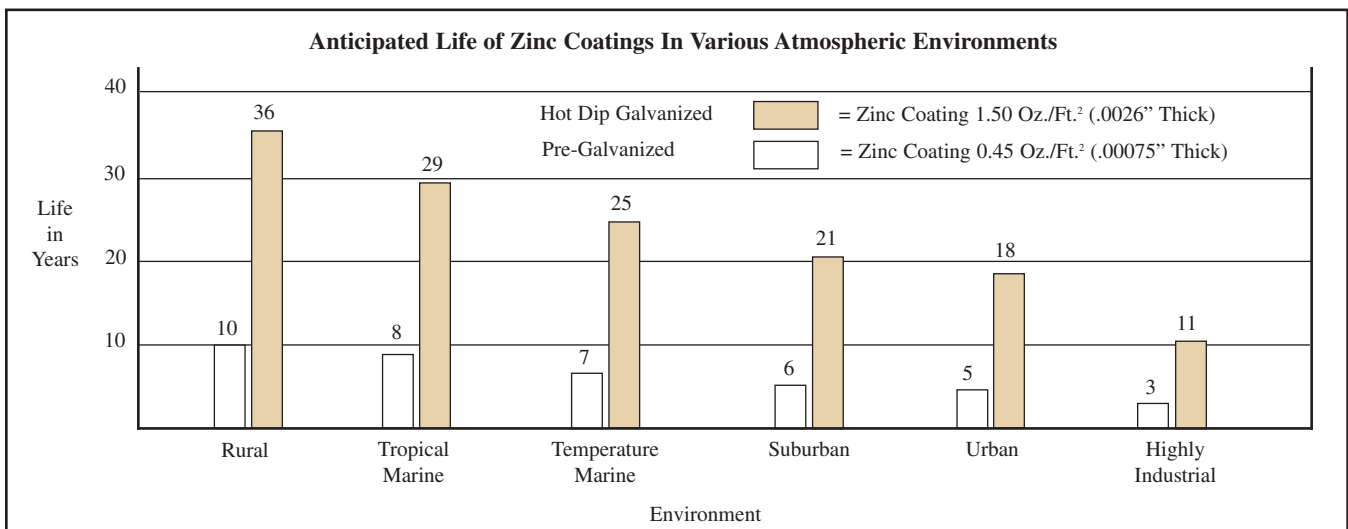

Dura-Green® and Dura-Copper® Epoxy Coatings

Dura-Green and Dura-Copper epoxy coatings are water borne epoxy coatings applied to B-Line products by a precisely controlled cathodic electro-deposition process. This process is accomplished using a conveyor to transport channel and fittings through several cleaning, phosphatizing and application stages prior to being baked (See diagram below).

This custom-designed paint system is used for painting all channels, channel combinations, slotted angle, and fittings.

Samples are selected on a routine basis for Salt Spray (fog) testing to verify the quality of the finish. These tests are performed in accordance with ASTM B117 and evaluated and related according to ASTM D1654 (Tables 1 & 2).

The Dura-Green and Dura-Copper Epoxy coatings have been tested and listed by Underwriters Laboratories in accordance with “Standard for Surface Metal Raceway

and Fittings, UL5” and “Standard for Pipe Hanger Equipment for Fire Protection Service, UL203”.

Due to Dura-Green’s organically based composition, it seats itself into porous surfaces more completely and efficiently than zinc coatings. As these porous caverns are filled along the material profile, the outer finished surface demonstrates an increased smooth uniform plane which produces considerably less off-gasing when tested.

B-Line’s Dura-Green channel meets or exceeds 100 level clean room standards. This was confirmed by testing the channel in accordance with Boeing (PCL) Standards, which are more stringent and complete than ASTM E595-93. Dura-Green was found to be a superior finish, due in part to its proven application process.

PVC Coating

Another of the corrosion resistant coatings offered by B-Line is PVC (polyvinyl

chloride), applied over steel or aluminum channel and fittings. The PVC coating process begins by cleaning the product thoroughly. A bonding coat is applied to the part and then preheated to a temperature above the melting point of the coating powder. The product is then passed through a fluidized bed of vinyl plastic powder where the powder particles melt, adhere and flow out to form a smooth continuous coating. The thickness is controlled by the base metal temperature and the immersion time in the bed. It is then post-heated to complete the fusion of the outer surfaces.

The standard coating thickness of B-Line’s PVC coated products is 15 mils (.380 mm), plus or minus 5 mils (.125 mm). Since the chemistry, not the thickness of vinyl plastic PVC determines longevity, a coating of 10 to 20 mils (.250 to .500 mm) is more than adequate. If the corrosive conditions are such that the plasticizers are leached out, a thicker coating will do little to extend the life of a coated product.

For certain environments, a plastisol dipped PVC coating is available on request.

PVC coating depends totally on the concept of encapsulation attached to the base metal by a bonding agent. If any hole or discontinuity occurs, the corrosive action can undercut the base metal to a point where all that remains is the PVC.

In the event of field cuts or any other damage to the coating, a liquid PVC patch, available from B-Line, must be applied to maintain the integrity of the coating. After the installation is complete, a thorough inspection should be performed to assure the absence of voids, pinholes, or cuts.

SALT SPRAY TEST RESULTS

Type of Finish	Unscribed 5% Failure (1)	Scribed 1/8" (3.2) Creepage from Scribe (1)
B-Line Dura-Green Epoxy	1000 Hours	312 Hours
Mill Galv. (Pre-Galv.) G90	192 Hours	288 Hours
Perma-Green	438 Hours	231 Hours
Zinc Chromate	36 Hours	96 Hours
Industry Green (Range)	10 to 36 Hours	4 to 30 Hours

(1) All salt spray (fog) tests conducted in accordance with ASTM B117 and evaluated and rated according to ASTM D1654 Tables 1 & 2. Tests are performed and certified by an independent testing laboratory.

DURA-GREEN®/DURA-COPPER® EPOXY COATING PROCESS

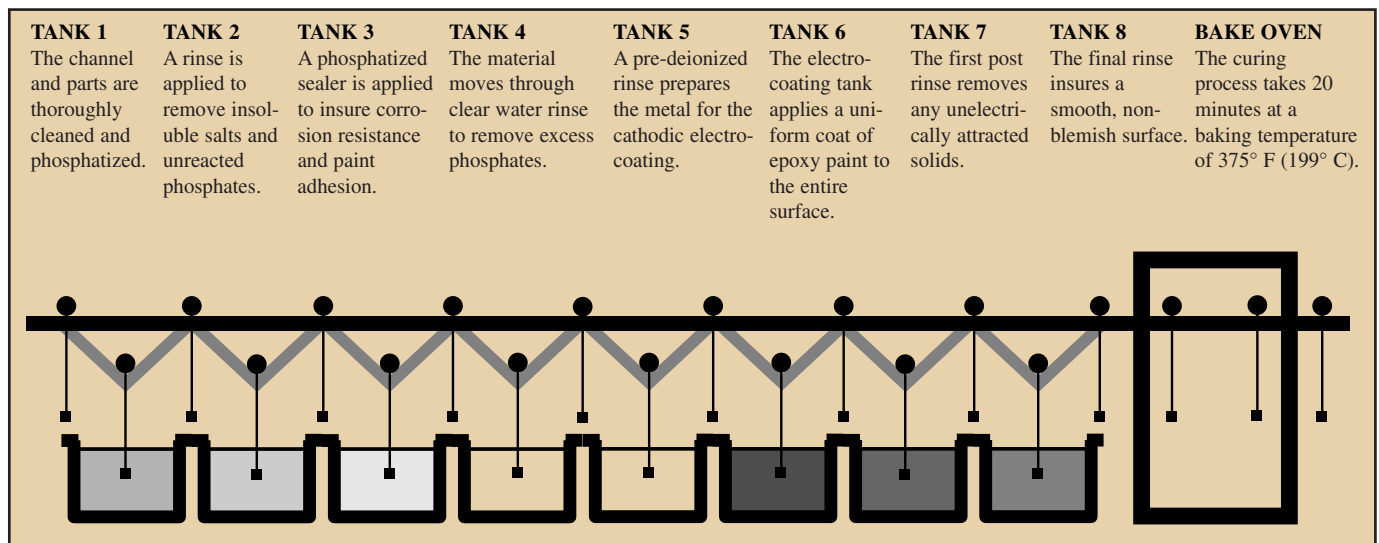

WELDING

The welding procedures used in the fabrication of B-Line steel products are in accordance with American Welding Society Standards. To achieve the highest quality in our manufacturing processes, our welders follow standards set by AWS Code.

Spot Welding

Spot welded back-to-back channel is manufactured using a modern DC powered resistance welder controlled by a microprocessor. This produces a series of spot welds with speed and consistency. Consistency is one of the most important

advantages in specifying B-Line back-to-back channel. Variables such as weld sequence, speed and duration are carefully controlled and monitored by a sophisticated electronic control system. A statistical quality control program, combining destructive and non-destructive testing, is used by B-Line to ensure high quality welds.

MIG Welding

MIG welded, more properly called gas metal arc welded (GMAW) combination channels and fittings, are produced when physical dimensions or certain combinations require a weld process other

than automatic spot welding. The same quality control requirements are imposed on MIG welded and spot-welded products.

Quality Assurance

B-Line System's Quality Assurance Program has been developed and implemented for compliance to 10CFR50 appendix B and NQA-1. B-Line also complies with various industry standards and specifications. B-Line has extensive experience in supplying metal framing components for the nuclear power generating industry and complies with 10 CFR21.

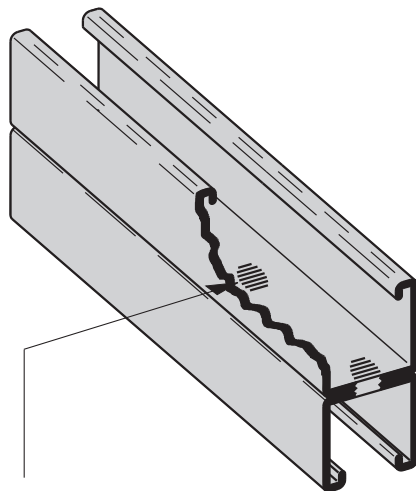

Spot Weld

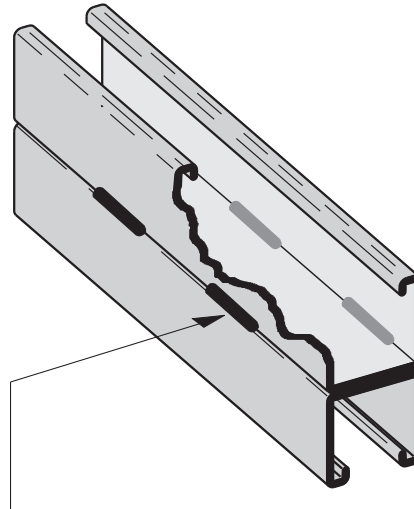

Mig Weld

CORROSION

All metal surfaces are affected by corrosion. Depending on the physical properties of the metal and the environment to which it is exposed, chemical or electromechanical corrosion may occur.

Atmospheric Corrosion

Atmospheric corrosion occurs when metal is exposed to airborne liquids, solids or gases. Some sources of atmospheric corrosion are moisture, salt, dirt and sulphuric acid. This form of corrosion is typically more severe outdoors, especially near marine environments.

Chemical Corrosion

Chemical corrosion takes place when metal comes in direct contact with a corrosive solution. Some factors which affect the severity of chemical corrosion include: chemical concentration level, duration of contact, frequency of washing, and operating temperature.

Storage Corrosion

Wet storage stain (white rust) is caused by the entrapment of moisture between surfaces of closely packed and poorly ventilated material for an extended period. Wet storage stain is usually superficial, having no effect on the properties of the metal.

Light staining normally disappears with weathering. Medium to heavy buildup should be removed in order to allow the formation of normal protective film. Proper handling and storage will help to assure stain-free material. If product arrives wet, it should be unpacked and dried before storage. Dry material should be stored in a well ventilated "low moisture" environment to avoid condensation formation. Outdoor storage is undesirable, and should be avoided whenever possible.

Galvanic Corrosion

Galvanic corrosion occurs when two or more dissimilar metals are in contact in the presence of an electrolyte (ie. moisture). An electrolytic cell is created and the metals form an anode or a cathode depending on their relative position on the Galvanic Series Table. The anodic material will be the one to corrode. Anodic or cathodic characteristics of two dissimilar metals will depend on the type of each material. For example: If zinc and steel are in contact, the zinc acts as the anode and will corrode; the steel acts as the cathode, and will be protected. If steel and copper are in contact, the steel is now the anode and will corrode.

The rate at which galvanic corrosion occurs depends on several factors:

GALVANIC SERIES IN SEA WATER

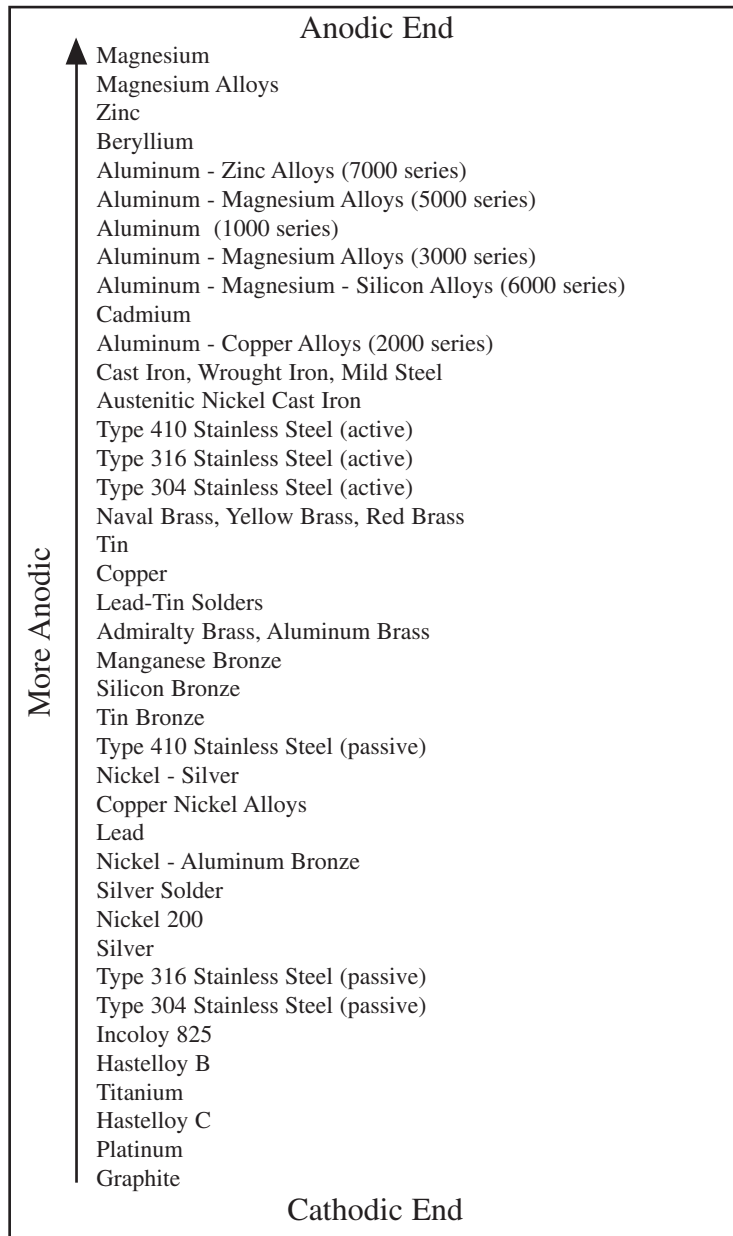

Metals in descending order of activity in the presence of an electrolyte.

1. The relative position on the Galvanic Series Table - the further apart materials are in the Galvanic Series Table, the greater the potential for corrosion of the anodic material.
2. The amount and concentration of electrolyte present - an indoor, dry environment will have little or no galvanic corrosion compared to a wet atmosphere.
3. The relative size of the materials - a small amount of anodic material in contact

with a large cathodic material will result in greater corrosion. Likewise, a large anode in contact with a small cathode will decrease the rate of attack.

Chemical	Aluminum	Dura-Green	PVC	Type 304 Stainless	Type 316 Stainless	Zinc Coated Steel
Acetic Acid 10%	R	NR	R	R	R	NR
Acetic Acid 2%	R	F	R	R	R	NR
Acetone	R	R	NR	R	R	R
Ammonium Hydroxide-Conc.	R	R	R	R	R	-
Ammonium Hydroxide 10%	F	R	R	R	R	-
Ammonium Hydroxide 2%	R	R	R	R	R	-
Benzene	R	R	NR	R	R	-
Bromine Water	NR	R	R	NR	NR	-
Butanol (Butyl Alcohol)	R	R	R	R	R	R
Carbon Disulfide	R	R	NR	R	R	-
Carbon Tetrachloride	F	R	F	R	R	-
Chlorine Water	R	R	R	NR	F	R
Cutting Oil	-	R	-	-	-	-
Diethanolamine	R	R	NR	-	-	NR
Ethanol	R	R	R	R	R	R
Ethyl Acetate	R	R	NR	-	-	R
Ethylene Dichloride	F	R	NR	-	-	R
Formaldehyde 20%	R	R	R	R	R	R
Gasoline	R	R	R	R	R	R
Glycerine	R	R	R	R	R	R
Household Detergent 10%	F	R	R	R	R	-
Hydrochloric Acid 40%	NR	NR	R	NR	NR	NR
Hydrochloric Acid 10%	NR	F	-	NR	NR	NR
Hydrochloric Acid 2%	NR	F	-	NR	NR	NR
Hydrogen Peroxide 30%	R	NR	R	R	R	-
Hydrogen Peroxide 3%	R	R	-	R	R	-
Hydrogen Sulfide (Gas)	R	R	R	F	R	-
JP-4 Jet Fuel	R	R	R	R	R	-
Lactic Acid 85%	F	R	R	NR	-	-
Latex	R	R	-	R	R	NR
Linseed Oil Fatty Acid	R	F	R	R	R	-
Methanol	R	R	R	R	R	R
Methyl Ethyl Ketone	R	R	NR	-	-	R
Methyl Isobutyl Ketone	R	R	NR	-	-	R
Mineral Spirits	R	R	-	-	-	-
Motor Oil-10W	R	R	R	R	R	R
Naphtha, VM&P	R	R	R	R	R	R
Nitric Acid 2%	F	NR	R	R	R	-
Perchloroethylene	R	R	-	-	-	NR
Petroleum Ether	-	R	-	R	R	R
Phenol 10%	R	R	NR	R	R	R
Phosphoric Acid 2%	F	NR	R	R	R	NR
Potassium Hydroxide 50%	NR	R	R	R	R	-
Potassium Hydroxide 10%	NR	R	R	R	R	-
Potassium Hydroxide 2%	NR	R	R	R	R	-
Sodium Chloride 25%	F	R	R	R	R	F
Sodium Hydroxide 50%	NR	R	R	R	R	NR
Sodium Hydroxide 10%	NR	R	R	R	R	F
Sodium Hydroxide 2%	NR	R	R	-	-	-
Sodium Hypochlorite-C1. 10%	F	R	R	-	-	-
Sodium Hypochlorite-C1. 6%	F	R	R	NR	R	-
Sulfuric Acid 2%	F	NR	R	NR	R	NR
Tall Oil Fatty Acid (Syfate 94)	R	R	R	-	-	-
Tannic Acid 50%	F	R	R	R	R	F
Water-Deionized	R	R	R	R	R	F
Water-Sea	F	F	R	R	R	F
Water-Tap	R	R	R	F	F	R
Xyol	R	R	NR	-	-	-

Fiberglass corrosion chart on page 171.

The corrosion data given in this table is for general comparison only.

The presence of contaminants and the effect of temperature in chemical environments can greatly affect the corrosion of any material.

B-Line strongly suggests that field service tests or simulated laboratory tests using actual environmental conditions be conducted in order to determine the proper materials and finishes to be selected.

R=Recommended

F=May be used under some conditions

NR=Not Recommended

-Information not available

DESIGN OF STRUT SYSTEMS

Beams

Beams are usually defined as horizontal members which are subjected to vertical loads such as shelves, platforms or supports for pipes, conduits or cable trays. The following is a brief overview of common beam configurations:

Simple Beam

An example of a simple beam is a length of channel placed across two cylinders. When a load is applied, the channel will support the load because of its stiffness. The cylinders serve to support the channel, but do not interfere with its natural tendency to flex or bend. Simple beam analysis is used almost universally for beam comparisons, even though it is seldom practical in field installations.

A cable tray or conduit trapeze hanger closely resembles a simple beam.

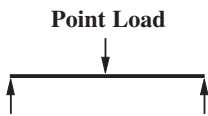

Fixed Beam

This type of fixed support restricts the movement of the ends of the channel when a load is applied. Because of this, the stiffness of the channel at the ends and center is employed to resist the load. The result is a load capability which is greater than that of an identical simple beam.

The fixed beam can be approximated by bolting or welding a length of channel to rigid supports.



Cantilever Beam

Cantilever beams are often viewed as variations of a fixed beam, but they have special characteristics of their own. One end of the channel is firmly attached to a rigid support while the other end remains completely free.

A shelf bracket is an example of a cantilever beam.



Continuous Beam

This beam configuration is commonly used in lighting installations. The continuous beam possesses traits of both the simple and fixed beams. When equal loads are applied to all spans simultaneously, the counter-balancing effect of the loads on both sides of a support restricts the movement of the channel at the support, similar to that of the fixed beam. The end spans behave substantially like simple beams.



Continuous beam installations can typically support 20% more load than a simple beam of the same span with approximately half the deflection.

Therefore, simple beam data should be used for a general comparison only. An example of this configuration is found in a long run of channel when installed across several supports to form a number of spans.

Deflection

Deflection, commonly referred to as "sag", is inherent in applying a load to a beam and cannot be avoided. Any and all beams will deflect when loaded. The amount of deflection will vary depending upon the material and the stiffness or moment of inertia. The deflection equations in this section show that increasing the stiffness can be increased by a variety of methods. Increasing the depth of the channel is the most direct method.

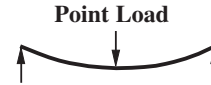

The material used affects deflection in a manner which is significantly different from the way in which it affects load capacity. The deflection under load is inversely proportional to a material property known as the "modulus of elasticity" designated by "E".

The modulus of elasticity is dependent upon the basic composition of the material and is not necessarily related to the material's strength.

Safety Factor

The design loads given for strut beam loads are based on a simple beam condition using allowable stress of 25,000 psi. This allowable stress results in a safety factor of 1.68. This is based upon a virgin steel minimum yield strength of 33,000 psi cold worked during rolling to an average yield stress of 42,000 psi.

Aluminum typically has an elastic modulus which is $\frac{1}{3}$ that of steel even though they may have identical strength. As a result, the deflection of aluminum channel will be three times that of steel channel under equal loading. In areas where structures will be subject to general viewing, deflection can produce a displeasing effect. To the untrained eye, a sagging channel may appear to be a result of poor design or excessive loading. This is not usually the case. Many properly designed channel installations will show a noticeable deflection at their designed loads. In areas where cosmetics are not important, deflection should not be a factor. Designing an entire installation based on minimal deflection could result in an over designed structure. This translates into increased material and installation cost. Where cosmetics are important, it may be necessary to limit the deflection to an aesthetically pleasing amount. This "acceptable deflection" amount is typically given as a fraction of the span. **1/240 span** deflection is typically the limit where the amount of deflection appears negligible. For example, a beam span of 240" would be allowed 1" (240/240) of deflection at the mid point. A 120" span would only be allowed $\frac{1}{2}$ " (120/240) of deflection. The maximum load for the channel must be limited in order to remain under these deflection requirements. The allowable load resulting in 1/240 span deflection is posted in the beam load chart for each channel size.

For even more stringent deflection requirements, an allowable load is listed in the beam load charts which results in **1/360** span deflection. This amount of deflection is sometimes used for beams in finished ceilings that are to be plastered.

Twisting & Lateral Bracing

Loading of strut on long spans can cause torsional stress, resulting in the tendency of the strut to twist or bend laterally. This phenomenon reduces the allowable beam loads as shown in the beam loading charts. It is recommended that long spans be supported in a manner to prevent twisting (fixed ends), and that the channel have adequate lateral bracing. Many typical strut applications provide this support and bracing inherently. Piping, tubing, cable

trays, or conduits mounted to the strut with straps and clamps prevent twisting or lateral movement. If no such lateral support exists, contact the factory for loading recommendations.

Columns

Columns are vertical members which carry loads in compression. One common example of a channel column is the vertical members of a storage rack.

In theory, a column will carry a load equal to its cross sectional area multiplied by the ultimate compressive stress of the material of which the column is made. In reality, there are many factors affecting the load capacity of a column, such as the tendency to buckle or twist laterally (torsional-flexural buckling), the type of connection at the top or bottom, and the eccentricity of the load application, and material imperfections. Several of these failure modes have been considered in the allowable column load tables shown in the "Channel" section of this catalog.

B-Line strongly recommends that the engineer perform a detailed study of the many variable conditions before the selection process begins.

Design Factors to be Considered

The loading capacity of channel depends primarily on the material, its cross-sectional design, and the beam or column loading configuration. It should be noted that if two lengths of channel have identical designs and configurations, the one made of the stronger base material will support a larger load. Therefore, any comparison of channel should begin by determining whether the materials are approximately equal in strength.

The column loading chart for each channel lists the allowable load for each channel in compression. This load varies depending on the support condition or "K-factor".

Several "K-factors" are listed, which correspond to the following support conditions:

- K = .8 pinned top - fixed bottom
- K = .65 fixed top - fixed bottom
- K = 1.0 pinned top - pinned bottom
- K = 1.2 free top - fixed bottom

There are a number of physical properties which are important to the complete design of a channel member; the "section modulus" designated as "Sx" or "Sy", "moment of inertia" designated by "Ix" or "Iy", and the "radius of gyration" which is given as "rx" or "ry".

Every structural material has its own maximum or ultimate stress, which is usually expressed in "pounds per square inch" (pascals). Any load which causes a member to fail is referred to as its "ultimate" load. In order to prevent channel from being accidentally loaded up to or beyond its ultimate load, a safety factor is included into the design. The ultimate load is divided by the safety factor to obtain the "recommended" or "allowable" working load.

When evaluating channel under various beam conditions, it is often more convenient to compare in terms of the ultimate or recommended "bending moment". Simple equations show the stress is directly proportional to the bending moment.

Therefore, comparing bending moments can save time in repeated calculations. The chart containing Formulas on Common Beam Loadings (following page) shows how to calculate the bending moment for various configurations and load conditions. It should be noted that the bending moment is usually not constant, but varies along the length of the span. However, the channel must be designed for a single point, which is the point of maximum bending moment.

For information regarding dynamic or seismic design, contact B-Line's Home Office.

GENERAL INFORMATION

Torque









The torque values given throughout the catalog are to be used as a guide only. The relationship between the applied torque or torque wrench reading and the actual tension created in the bolt may be substantially different. For example, a dry non-lubricated bolt with a heavy plating may rate 50% as efficient as a bolt which is lubricated with a mixture of heavy oil and graphite. Other important factors affecting torque-tension relationships include friction under the bolt head or nut, hole tolerances, and torque wrench tolerances. Accuracy of many commercial torque wrenches may vary as much as plus or minus 25%.

Charts and Tables

Charts and tables in this section are compiled from information published by nationally recognized organizations and are intended for use as a guide only. B-Line recommends that users of this information determine the validity of such information as applied to their own application.

Technical Data

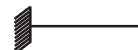
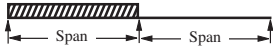
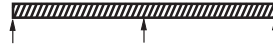
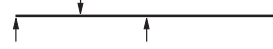
The data shown in the beam load charts for appropriate channels on page(s) 17 thru 39 is for simply supported, single span beams with a uniformly distributed load. For other loading and/or support conditions, use the appropriate factor from the chart below.

LOAD AND SUPPORT CONDITION	Load Factor	Deflection Factor
Simple Beam - Uniform Load 	1.00	1.00
Simple Beam - Concentrated Load at Center 	.50	.80
Simple Beam - Two Equal Concentrated Loads at 1/4 Points 	1.00	1.10
Beam Fixed at Both Ends - Uniform Load 	1.50	.30
Beam Fixed at Both Ends - Concentrated Load at Center 	1.00	.40
Cantilever Beam - Uniform Load 	.25	2.40
Cantilever Beam - Concentrated Load at End 	.12	3.20
Continuous Beam - Two Equal Spans - Uniform Load on One Span 	1.30	.92
Continuous Beam - Two Equal Spans - Concentrated Load on Both Spans 	1.00	.42
Continuous Beam - Two Equal Spans - Concentrated Load at Center of One Span 	.62	.71
Continuous Beam - Two Equal Spans - Concentrated Load at Center of Both Spans 	.67	.48

Technical Data

EXAMPLES:

PROBLEM:

Calculate the maximum allowable load and corresponding deflection of a simply supported B22 beam with a concentrated load at midspan as shown.

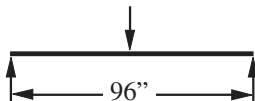

SOLUTION:

From beam load chart for B22 (page 22), maximum allowable Load is A and the corresponding deflection is B.
Multiplying by the appropriate factors shown in the chart above.

$$\text{LOAD} = \underline{A} \times \text{load factor} = \underline{\hspace{2cm}}$$

$$\text{DEFLECTION} = \underline{B} \times \text{deflection factor} = \underline{\hspace{2cm}}$$

PROBLEM:

Calculate the maximum allowable load and corresponding deflection of a cantilever B52 beam with a uniformly distributed load.



SOLUTION:

From beam load chart for B52 (page 33), maximum allowable load is A and the corresponding deflection is B.
Multiplying by the appropriate factors shown in chart above.

$$\text{LOAD} = \underline{A} \times \text{load factor} = \underline{\hspace{2cm}}$$

$$\text{DEFLECTION} = \underline{B} \times \text{deflection factor} = \underline{\hspace{2cm}}$$

RECOMMENDED BOLTED METAL FRAMING SPECIFICATION

Brackets [] indicate alternative specifications which may be substituted by the project engineer.

PART 1 - GENERAL

1.01 WORK INCLUDED

A. Continuous slot, bolted framing channels and all associated fittings and hardware.

B. Trapeze type supports for cable tray, conduit, pipe and other similar systems.

C. Use of bolted metal framing as a surface metal raceway.

1.02 REFERENCES

A. ASTM A108 - Specification for Steel Bars, Carbon, Cold Finished, Structural Quality.

B. ASTM A123 - Specification for Zinc (hot-dip galvanized) Coatings on Products Fabricated from Rolled, Pressed, and Forged Steel Shapes, Plates, Bars and Strips.

C. ASTM A1011, 33,000 PSI min. yield - Specification for Steel, Sheet and Strip, Carbon, Hot-Rolled, Structural Quality.

D. ASTM B633 - Specification for Electrodeposited Coatings of Zinc on Iron and Steel.

E. ASTM A653 33,000 PSI min. yield G90 - Specification for Steel Sheet, Zinc Coated (Galvanized) by the Hot-Dip Process.

F. ASTM A1018 - Standard Specification for Steel, Sheet and Strip, Heavy-Thickness Coils, Carbon, Hot-Rolled, Structural Quality.

G. MFMA - Metal Framing Standards Publication, MFMA-1.

1.03 QUALITY ASSURANCE

A. Manufacturers : Firms regularly engaged in the manufacture of bolted metal framing of the types required, whose products have been in satisfactory use in similar service for not less than 5 years.

B. A material heat code number shall be stamped on all strut and fittings. This is required to maintain traceability of the product to the material test reports to the ASTM standard.

C. For stainless steel items, the part number shall contain a material designator (EXAMPLE: B-Line B22SS6 for type 316 or B22SS4 for type 304), or a separate stamp shall be included to reference the type of material used.

D. MFMA Compliance: comply with the latest revision of MFMA Standard Publication Number MFMA-3, "Metal Framing".

E. NEC Compliance: Comply with the latest revision NFPA 70 - Article 352 "Surface Metal Raceways and Surface Nonmetallic Raceways".

F. UL Compliance: Comply with UL "Standard for Surface Metal Raceway and Fittings".

1.04 SUBMITTALS

A. Submit drawings of strut and accessories including clamps, brackets, hanger rods and fittings.

B. Submit manufacturer's product data on strut channels including, but not limited to, types, materials, finishes, gauge thickness and hole patterns. For each different strut cross section, submit cross sectional properties including Section Modulus (S_x) and Moment of Inertia (I_x).

1.05 DELIVERY, STORAGE AND HANDLING

A. Deliver strut systems and components carefully to avoid breakage, denting, and scoring finishes. Do not install damaged equipment.

B. Store strut systems and components in original cartons and in clean dry space; protect from weather and construction traffic.

PART 2 - PRODUCTS

2.01 ACCEPTABLE MANUFACTURERS

A. Manufacturer: Subject to compliance with these specifications, strut systems to be installed shall be as manufactured by B-Line Systems, Inc. [or engineer approved equal.]

2.02 STRUT CHANNELS AND COMPONENTS

A. General: Strut shall be 1⁵/₈" wide in varying heights and welded combinations as required to meet load capacities and designs indicated on the drawings.

B. Material and Finish: Material and finish specifications for each strut type are as follows:

1. Aluminum: Strut shall be manufactured of extruded aluminum alloy 6063-T6. All fittings and hardware shall be zinc plated according to ASTM B633. For outdoor use, all fittings and hardware shall be stainless steel Type 316 [Type 304] or chromium zinc, ASTM F1136 Gr. 3.

2. Epoxy Painted: Strut shall be made from steel meeting the minimum mechanical properties of ASTM A1011 33,000 PSI min yield, then painted with water born epoxy

applied by a cathodic electro-deposition process. Fittings shall be manufactured from steel meeting the minimum requirements of ASTM A1018 33,000 PSI min. yield. The fittings shall have the same epoxy finish as the strut. Threaded hardware shall be zinc plated in accordance with ASTM B633 Service Class 1 (SC1). Service Class 1 is not an acceptable coating for fittings or components other than threaded hardware.

3. Pre-Galvanized Steel: Strut shall be made from steel meeting the minimum mechanical properties of ASTM A653 33,000 PSI min. yield, mill galvanized coating designation G90. Fittings shall be manufactured from steel meeting the minimum requirements of ASTM A1018 33,000 PSI min. yield and zinc plated in accordance with ASTM B633 service class 3 (SC3). Threaded hardware shall be zinc plated in accordance with ASTM B633 Service Class 1 (SC1). Service Class 1 is not an acceptable coating for fittings or components other than threaded hardware.

4. Hot-Dip Galvanized Steel: Strut shall be made from steel meeting the minimum mechanical properties of ASTM A1011 33,000 PSI min. yield and shall be hot-dip galvanized after fabrication in accordance with ASTM A123. Fittings shall be manufactured from steel meeting the minimum requirements of ASTM A1018 33,000 PSI min. yield, and hot-dip galvanized after fabrication in accordance with ASTM A123. All hardware shall be stainless steel Type 316 [Type 304] or chromium zinc ASTM F1136 Gr. 3. All hot-dip galvanized after fabrication products must be returned to point of manufacture after coating for inspection and removal of all sharp burrs.

5. Stainless Steel: All strut, fittings and hardware shall be made of AISI Type 316 [Type 304] stainless steel as indicated. Channels must be identified as required in previous section 1.03 Quality Assurance.

PART 3 - EXECUTION

3.01 INSTALLATION

A. Install strut as indicated; in accordance with equipment manufacturer's recommendations, and with recognized industry practices.

B. All nuts and bolts shall be tightened to the following values.

Bolt Size	Torque (ft-lbs)
1/4-20	6
5/16-18	11
3/8-16	19
1/2-13	50

Metal Framing Channels

Channel

B-Line's metal framing channel is cold formed on our modern rolling mills from 12 Ga. (2.6mm), 14 Ga. (1.9mm), and 16 Ga. (1.5mm) low carbon steel strips. A continuous slot with inturned lips provides the ability to make attachments at any point.

Lengths

Standard lengths are 10' (3.05m) and 20' (6.09m) with length tolerance of $\pm 1/8"$ (+3.2mm). Custom lengths are available upon request.

Slots

B-Line's slotted series of channels offer full flexibility. A variety of pre-punched slot patterns eliminate the need for precise field measuring for hole locations. Slots offer wide adjustments in the alignment and bolt sizing.

Holes

A variety of pre-punched $9/16"$ (14.3 mm) diameter hole patterns are available in B-Line channels. These hole patterns provide an economical alternative to costly field drilling required for many applications.

Knockouts

When used with series B217-20 Closure Strips, B-Line's knockout channels can be used to provide an economical U.L. listed surface raceway. Channels are furnished with $7/8"$ (22.2 mm) knockouts on 6" (152 mm) centers, allowing for perfect fixture alignment on spans up to 20' (6.09 m).

Materials & Finishes (Unless otherwise noted)

Steel: Plain

12 Ga. (2.6), 14 Ga. (1.9) and 16 Ga. (1.5)

Steel: Pre-galvanized

12 Ga. (2.6), 14 Ga. (1.9) and 16 Ga. (1.5)

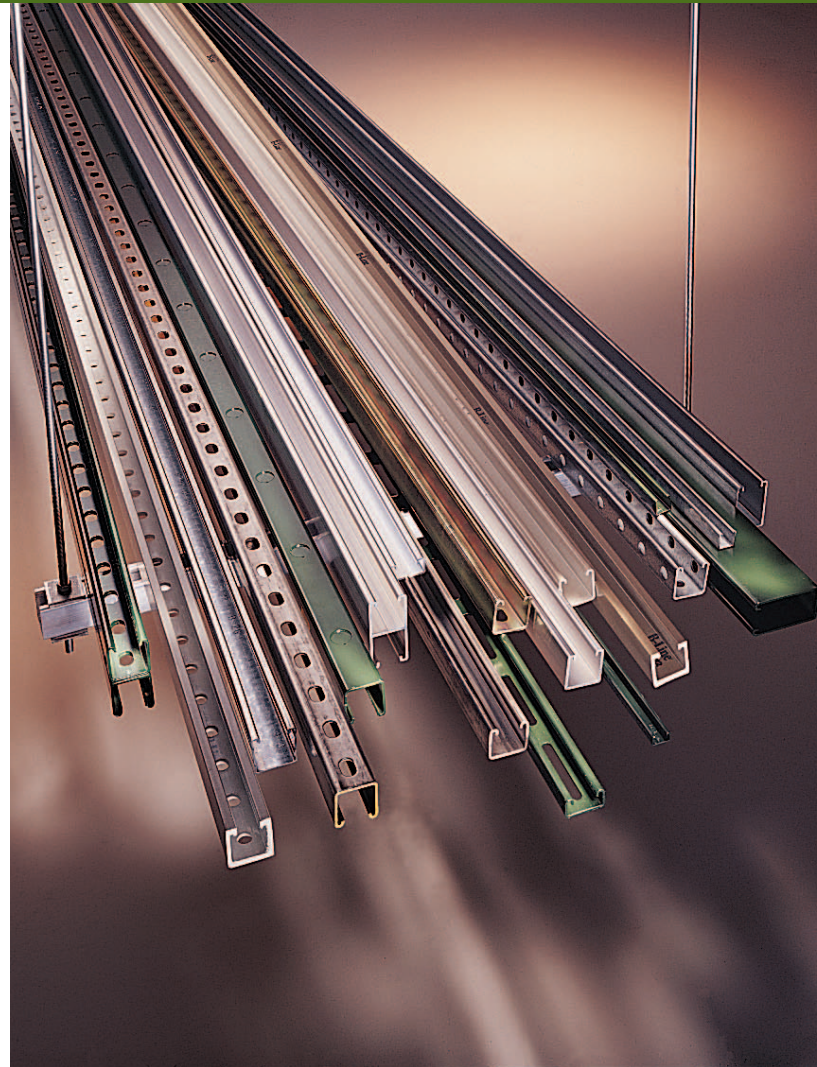

Finish Code	Finish	Specification
PLN	Plain	ASTM A1011, 33,000 PSI min. yield
GRN	Dura-Green	
GALV	Pre-Galvanized	ASTM A653 33,000 PSI min. yield
HDG	Hot-Dipped Galvanized	ASTM A123
YZN	Yellow Zinc Chromate	ASTM B633 SC3 Type II
SS4	Stainless Steel Type 304	ASTM A240
SS6	Stainless Steel Type 316	ASTM A240
AL	Aluminum	Aluminum 6063-T6

Note: A minimum order may apply on special material and finishes.

Design Load

The design loads given for strut beam loads are based on a simple beam condition using an allowable stress of 25,000 psi. This allowable stress results in a safety factor of 1.68. This is based upon virgin steel minimum yield strength of 33,000 psi cold worked during rolling to an average yield stress of 42,000 psi.

Welding

Weld spacing is maintained between 2 $1/2$ inches (63.5 mm) and 4 inches (101.6 mm) on center. Through high quality control testing of welded channels and continuous monitoring of welding equipment, B-Line provides the most consistent combination channels available today.

Metric

Metric dimensions are shown in parentheses. Unless noted, all metric dimensions are in millimeters.

SELECTION CHART

for Channels, Materials and Hole Patterns

Channel Type	Channel Dimensions				Material & Thickness *				Channel Hole Pattern **				
	Height		Width		Steel	Alum.	Stainless Steel		SH 9/16" x 1 1/8" slots on 2" centers	S 13/32" x 3" slots	H17/8 9/16" diameter holes	TH 9/16" diameter on 1 7/8" centers	KO6 7/8" diameter knockouts
							Type 304	Type 316					
				<u>1</u>	<u>2</u>	<u>3</u>	<u>4</u>						
B11	3 1/4"	(82.5)	1 5/8"	(41.3)	12 Ga.	-	-	-	<u>1</u>	<u>1</u>	<u>1</u>	-	<u>1</u>
B12	2 7/16"	(61.9)	1 5/8"	(41.3)	12 Ga.	.105	-	-	<u>1 2</u>	<u>1</u>	<u>1 2</u>	-	<u>1 2</u>
B22	1 5/8"	(41.3)	1 5/8"	(41.3)	12 Ga.	.105	12 Ga.	12 Ga.	<u>1 2 3 4</u>	<u>1 3</u>	<u>1 2 3</u>	<u>1</u>	<u>1 2</u>
B24	1 5/8"	(41.3)	1 5/8"	(41.3)	14 Ga.	.080	14 Ga.	14 Ga.	<u>1 2 3 4</u>	<u>1</u>	<u>1 2 3</u>	-	<u>1 2</u>
B26	1 5/8"	(41.3)	1 5/8"	(41.3)	16 Ga.	-	-	-	<u>1</u>	<u>1</u>	<u>1</u>	-	<u>1</u>
B32	1 3/8"	(34.9)	1 5/8"	(41.3)	12 Ga.	-	12 Ga.	-	<u>1 3</u>	<u>1</u>	<u>1 3</u>	-	<u>1</u>
B42	1"	(25.4)	1 5/8"	(41.3)	12 Ga.	-	12 Ga.	-	<u>1 3</u>	<u>1</u>	<u>1 3</u>	-	<u>1</u>
B52	1 3/16"	(20.6)	1 5/8"	(41.3)	12 Ga.	-	12 Ga.	-	<u>1</u>	<u>1</u>	<u>1</u>	-	<u>1</u>
B54	1 3/16"	(20.6)	1 5/8"	(41.3)	14 Ga.	.080	14 Ga.	14 Ga.	<u>1 2 3 4</u>	<u>1</u>	<u>1 2 3 4</u>	-	<u>1 2</u>
B56	1 3/16"	(20.6)	1 5/8"	(41.3)	16 Ga.	-	-	-	<u>1</u>	<u>1</u>	<u>1</u>	-	<u>1</u>
B62	1 3/16"	(20.6)	1 3/16"	(20.6)	18 Ga.	-	-	-	-	-	-	-	-
B72	1 3/32"	(10.3)	1 3/16"	(20.6)	18 Ga.	-	-	-	-	-	-	-	-
E7016	3/4"	(19.0)	5/8"	(15.9)	16 Ga.	-	-	-	-	-	-	-	-

The selection has been prepared to provide a reference for available channel, materials and hole patterns. Material types available for various hole patterns are defined by numbers 1 thru 4.

Some stainless steel channels with hole patterns are available on special order only.

*Metric equivalent for thicknesses shown in chart.

12 Ga. = 2.6 mm

18 Ga. = 1.2 mm

14 Ga. = 1.9 mm

.105 = 2.6 mm

16 Ga. = 1.5 mm

.080 = 2.0 mm

**1 - Steel

2 - Aluminum

3 - Type 304 Stainless Steel

4 - Type 316 Stainless Steel

Properties may vary due to commercial tolerances of the material.

Channel Part Numbering			
Example:			
B22 SH SS4 120			
Channel Type	Hole Patterns	Material/Finish	Length
B11	SH (pg. 40)	GRN	120
B12	S (pg. 40)	GALV	240
B22 †	H178 (pg. 40)	HDG	
B24 †	TH (pg. 41)	YZN	
B26	K06 (pg. 41)	SS4	
B32	SHA (pg. 41)	SS6	
B42	S58 (pg. 42)	AL	
B52 †	M (pg. 42)		
B54 †	H25 (pg. 43)		
B56	H112 † (pg. 42)		
B62	* Leave blank for no hole pattern		
B72			
E7016			

† BK style channel available in four (4) channel sizes and one (1) hole pattern only. (Example BK22H112)

Reference page 14 for general fitting and standard finish specifications.

B11 Channel, Combinations & Load Data

B11

- Thickness: 12 Gauge (2.6 mm)
- Standard lengths: 10' (3.05 m) & 20' (6.09 m)
- Standard finishes: Plain, Dura-Green, Pre-Galvanized, Hot-Dipped Galvanized, Aluminum
- Weight: 3.05 Lbs./Ft. (4.54 kg/m)

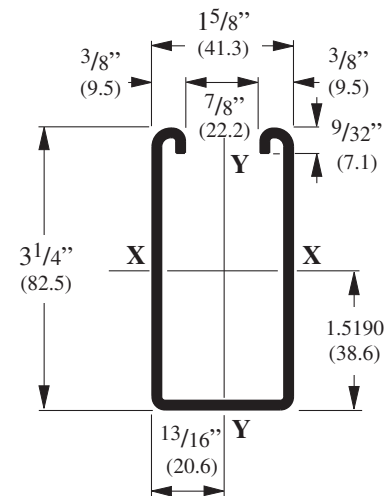
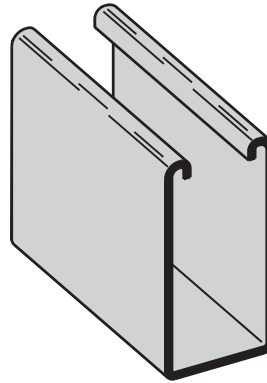

SECTION PROPERTIES

Channel	Weight		Areas of Section		Moment of Inertia (I)		Section Modulus (S)		Radius of Gyration (r)		X - X Axis		Y - Y Axis	
											Moment of Inertia (I)	Section Modulus (S)	Radius of Gyration (r)	
	lbs./ft.	kg/m	sq. in.	cm ²	in. ⁴	cm ⁴	in. ³	cm ³	in.	cm	in. ⁴	cm ⁴	in. ³	cm ³
B11	3.059	(4.55)	.900	(5.81)	1.1203	(46.63)	.6472	(10.61)	1.116	(2.83)	.4357	(18.14)	.5362	(8.79)
B11A	6.119	(9.11)	1.800	(11.61)	6.3931	(266.10)	1.9671	(32.24)	1.885	(4.79)	.8714	(36.27)	1.0725	(17.58)

Calculations of section properties are based on metal thicknesses as determined by the AISI Cold-Formed Steel Design Manual.

BEAM LOADING

Beam Span In.	mm	Channel Style	Uniform Load and Deflection				Uniform Load @ Deflection =			
			Lbs.	N	In.	mm	1/240 Span Lbs.	N	1/360 Span Lbs.	N
24	(609)	B11	5130	(22819)	.029	(.73)	5130	(22819)	5130	(22819)
		B11A	5130*	(22819)	.005	(.13)	5130*	(22819)	5130*	(22819)
36	(914)	B11	3488	(15515)	.065	(1.65)	3488	(15515)	3488	(15515)
		B11A	5130*	(22819)	.017	(.43)	5130*	(22819)	5130*	(22819)
48	(1219)	B11	2616	(11636)	.117	(2.97)	2616	(11636)	2616	(11636)
		B11A	5130*	(22819)	.040	(1.01)	5130*	(22819)	5130*	(22819)
60	(1524)	B11	2093	(9310)	.183	(4.65)	2093	(9310)	1908	(8487)
		B11A	5130*	(22819)	.079	(2.00)	5130*	(22819)	5130*	(22819)
72	(1829)	B11	1744	(7757)	.263	(6.68)	1744	(7757)	1325	(5894)
		B11A	5130*	(22819)	.136	(3.45)	5130*	(22819)	5130*	(22819)
84	(2133)	B11	1495	(6650)	.358	(9.09)	1460	(6494)	974	(4332)
		B11A	4552	(20248)	.191	(4.85)	4552	(20248)	4552	(20248)
96	(2438)	B11	1308	(5818)	.468	(11.89)	1118	(4973)	745	(3314)
		B11A	3983	(17717)	.250	(6.35)	3983	(17717)	3983	(17717)
108	(2743)	B11	1163	(5173)	.592	(15.03)	884	(3932)	589	(2620)
		B11A	3541	(15751)	.317	(8.05)	3541	(15751)	3353	(14915)
120	(3048)	B11	1046	(4653)	.731	(18.57)	716	(3185)	477	(2122)
		B11A	3187	(14176)	.391	(9.93)	3187	(14176)	2716	(12081)
144	(3657)	B11	872	(3879)	1.053	(26.74)	497	(2211)	331	(1472)
		B11A	2656	(11814)	.563	(14.30)	2656	(11814)	1886	(8389)
168	(4267)	B11	747	(3323)	1.433	(36.40)	365	(1623)	243	(1081)
		B11A	2276	(10124)	.766	(19.45)	2078	(9243)	1386	(6165)
192	(4877)	B11	654	(2909)	1.871	(47.52)	280	(1245)	186	(827)
		B11A	1992	(8861)	1.001	(25.42)	1591	(7077)	1061	(4719)
216	(5486)	B11	581	(2584)	2.368	(60.15)	221	(983)	147	(654)
		B11A	1770	(7873)	1.267	(32.18)	1257	(5591)	838	(3727)
240	(6096)	B11	523	(2326)	2.924	(74.27)	179	(796)	119	(529)
		B11A	1593	(7086)	1.564	(39.72)	1018	(4528)	679	(3020)

Based on simple beam condition using an allowable design stress of 25,000 psi (172 MPa) in accordance with MFMA, with adequate lateral bracing (see page 11 for further explanation). Actual yield point of cold rolled steel is 42,000 psi. To determine concentrated load capacity at mid span, multiply uniform load by 0.5 and corresponding deflection by 0.8. *Failure determined by weld shear.

Reference page 14 for general fitting and standard finish specifications.

B11 Beam & Column Loading Data

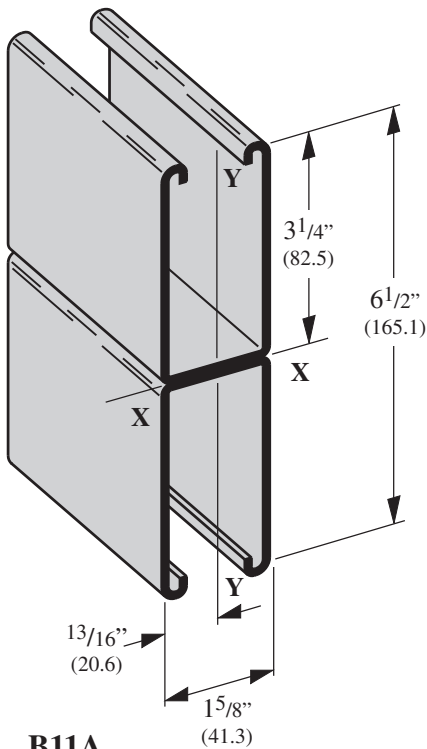

B11A
Wt. 6.10 Lbs./Ft. (9.08 kg/m)

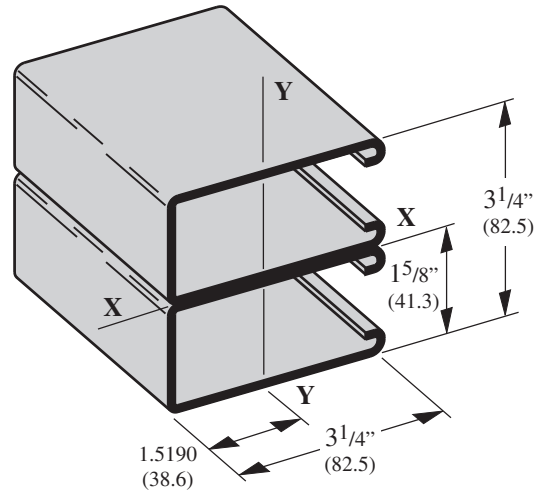

B11B
Wt. 6.10 Lbs./Ft. (9.08 kg/m)

COLUMN LOADING

Unbraced Height In. mm		Channel Style	Max. Column Loading K = .80				Max. Column Loading (Loaded @ C.G.)					
			Loaded @ C.G.		Loaded @ Slot Face		K = .65		K = 1.0		K = 1.2	
			Lbs.	N	Lbs.	N	Lbs.	N	Lbs.	N	Lbs.	N
24	(609)	B11	8190	(36431)	4477	(19914)	8446	(37569)	7783	(34620)	7311	(32521)
		B11A	17701	(78738)	8267	(36773)	17778	(79080)	17572	(78164)	17416	(77470)
36	(914)	B11	7311	(32521)	4183	(18607)	7838	(34865)	6503	(28927)	5612	(24963)
		B11A	17416	(77470)	8189	(36426)	17590	(78244)	17127	(76184)	16774	(74614)
48	(1219)	B11	6214	(27641)	3783	(16827)	7053	(31373)	4988	(22188)	3816	(16974)
		B11A	17016	(75691)	8079	(35937)	17327	(77074)	16503	(73409)	15876	(70620)
60	(1524)	B11	4988	(22188)	3279	(14586)	6140	(27312)	3595	(15991)	2790	(12410)
		B11A	16503	(73409)	7727	(34371)	16988	(75566)	15701	(69841)	14721	(65478)
72	(1829)	B11	3816	(16974)	2444	(10871)	5146	(22890)	2790	(12410)	2213	(9844)
		B11A	15876	(70620)	6160	(27401)	16574	(73724)	14721	(65482)	13310	(59206)
84	(2133)	B11	3063	(13625)	1897	(8438)	4133	(18384)	2291	(10191)	1846	(8211)
		B11A	15135	(67324)	4961	(22067)	16084	(71545)	13563	(60331)	11642	(51786)
96	(2438)	B11	2564	(11405)	1532	(6814)	3398	(15115)	1953	(8687)	1591	(7077)
		B11A	14279	(63516)	4045	(7993)	15520	(69036)	12226	(54384)	9717	(43223)
108	(2743)	B11	2213	(9844)	1273	(5662)	2886	(12837)	1708	(7597)	1401	(6232)
		B11A	13310	(59206)	3337	(14844)	14880	(66189)	10712	(47649)	7725	(34362)
120	(3048)	B11	1953	(8687)	1081	(4808)	2514	(11183)	1522	(6770)	1251**	(5565)
		B11A	12226	(54384)	2784	(12384)	14164	(63004)	9019	(40118)	6257**	(27832)
144	(3657)	B11	1591	(7077)	816	(3630)	2011	(8945)	1251**	(5565)	1026**	(4564)
		B11A	9717	(43223)	1990	(8852)	12508	(55638)	6257**	(27832)	4345**	(19327)
168	(4267)	B11	1347	(5992)	642	(2856)	1687	(7504)	1058**	(4706)	859**	(3821)
		B11A	7183	(31951)	1464	(6512)	10550	(46929)	4597**	(20448)	3192**	(14199)
192	(4877)	B11	1167**	(5191)	519	(2308)	1459	(6490)	910**	(4048)	-	-
		B11A	5499**	(24461)	1121	(4986)	8330	(37053)	3520**	(15658)	-	-
216	(5486)	B11	1026**	(4564)	429	(1908)	1285**	(5716)	-	-	-	-
		B11A	4345**	(19327)	885	(3936)	6582**	(29278)	-	-	-	-
240	(6096)	B11	910**	(4048)	360	(1601)	1148**	(5106)	-	-	-	-
		B11A	3520**	(15658)	717	(3189)	5331**	(23713)	-	-	-	-

**Where the slenderness ratio $\frac{KL}{r}$ exceeds 200, and K = end fixity factor, L = actual length and r = radius of gyration.

Reference page 14 for general fitting and standard finish specifications.

B12 Channel & Combinations

B12

- Thickness: 12 Gauge (2.6 mm)
- Standard lengths: 10' (3.05 m) & 20' (6.09 m)
- Standard finishes: Plain, Dura-Green, Pre-Galvanized, Hot-Dipped Galvanized, Aluminum
- Weight: 2.47 Lbs./Ft. (3.67 kg/m)

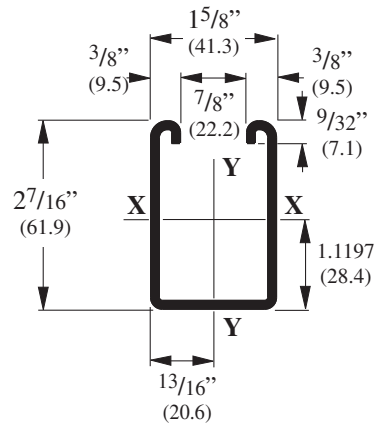
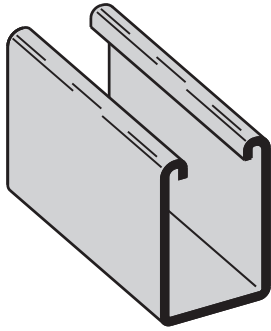

SECTION PROPERTIES

Channel	Weight lbs./ft. kg/m	Areas of Section		Moment of Inertia (I)		Section Modulus (S)		Radius of Gyration (r)		Moment of Inertia (I)		Section Modulus (S)		Radius of Gyration (r)	
		sq. in.	cm ²	in. ⁴	cm ⁴	in. ³	cm ³	in.	cm	in. ⁴	cm ⁴	in. ³	cm ³	in.	cm
B12	2.484 (3.70)	.731 (4.71)		.5349 (22.26)		.4061 (6.65)		.856 (2.17)		.3377 (14.06)		.4156 (6.81)		.680 (1.73)	
B12A	4.969 (7.40)	1.462 (9.43)		2.9036 (120.86)		1.1915 (19.52)		1.409 (3.58)		.6756 (28.12)		.8315 (13.63)		.680 (1.73)	

Calculations of section properties are based on metal thicknesses as determined by the AISI Cold-Formed Steel Design Manual.

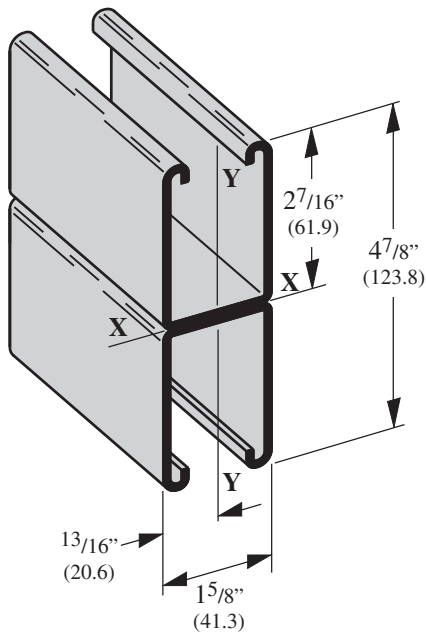

B12A
Wt. 4.94 Lbs./Ft. (7.35 kg/m)

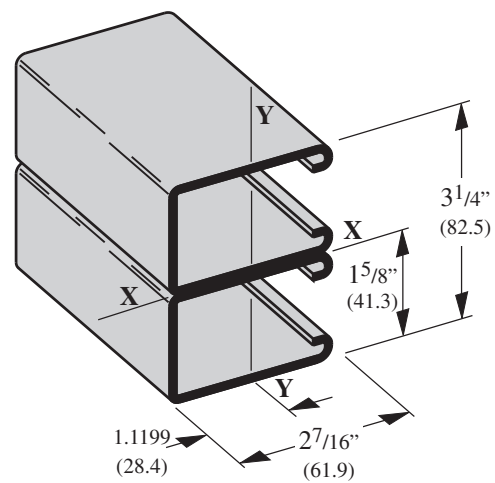

B12B
Wt. 4.94 Lbs./Ft. (7.35 kg/m)

Reference page 14 for general fitting and standard finish specifications.

B12 Beam & Column Loading Data

BEAM LOADING

Beam Span In. mm		Channel Style	Uniform Load and Deflection				Uniform Load @ Deflection =			
			Lbs. N		In. mm		1/240 Span		1/360 Span	
			Lbs.	N	In.	mm	Lbs.	N	Lbs.	N
12	(305)	B12	3880	(17259)	.009	(.23)	3880	(17259)	3880	(17259)
		B12A	3880*	(17259)	.001	(.02)	3880*	(17259)	3880*	(17259)
24	(609)	B12	3273	(14559)	.038	(.96)	3273	(14559)	3273	(14559)
		B12A	3880*	(17259)	.008	(.20)	3880*	(17259)	3880*	(17259)
36	(914)	B12	2182	(9706)	.086	(2.18)	2182	(9706)	2182	(9706)
		B12A	3880*	(17259)	.028	(.71)	3880*	(17259)	3880*	(17259)
48	(1219)	B12	1636	(7277)	.153	(3.88)	1636	(7277)	1421	(6321)
		B12A	3880*	(17259)	.067	(1.70)	3880*	(17259)	3880*	(17259)
60	(1524)	B12	1309	(5823)	.240	(6.09)	1309	(5823)	909	(4043)
		B12A	3847*	(17112)	.130	(3.30)	3847*	(17112)	3847*	(17112)
72	(1829)	B12	1091	(4853)	.345	(8.76)	947	(4212)	632	(2811)
		B12A	3206	(14261)	.188	(4.77)	3206	(14261)	3206	(14261)
84	(2133)	B12	935	(4159)	.470	(11.94)	696	(3096)	464	(2064)
		B12A	2748	(12224)	.255	(6.48)	2748	(12224)	2509	(11160)
96	(2438)	B12	818	(3638)	.614	(15.59)	533	(2371)	355	(1579)
		B12A	2404	(10693)	.334	(8.48)	2404	(10693)	1921	(8545)
108	(2743)	B12	727	(3234)	.777	(19.73)	421	(1873)	281	(1250)
		B12A	2137	(9506)	.422	(10.72)	2137	(9506)	1518	(6752)
120	(3048)	B12	655	(2913)	.959	(24.36)	341	(1517)	227	(1010)
		B12A	1924	(8558)	.521	(13.23)	1844	(8202)	1229	(5467)

Based on simple beam condition using an allowable design stress of 25,000 psi (172 MPa) in accordance with MFMA, with adequate lateral bracing (see page 11 for further explanation). Actual yield point of cold rolled steel is 42,000 psi. To determine concentrated load capacity at mid span, multiply uniform load by 0.5 and corresponding deflection by 0.8. *Failure determined by weld shear.

COLUMN LOADING

Unbraced Height In. mm		Channel Style	Max. Column Loading K = .80				Max. Column Loading (Loaded @ C.G.)					
			Loaded @ C.G.		Loaded @ Slot Face		K = .65		K = 1.0		K = 1.2	
			Lbs.	N	Lbs.	N	Lbs.	N	Lbs.	N	Lbs.	N
12	(305)	B12	10140	(45105)	4752	(21138)	10247	(45581)	9965	(44326)	9756	(43397)
		B12A	20820	(92612)	8023	(35688)	20854	(92763)	20763	(92358)	20694	(92051)
24	(609)	B12	9244	(41119)	4514	(20079)	9639	(42876)	8629	(38384)	7933	(35288)
		B12A	20519	(91273)	7956	(35390)	20655	(91878)	20293	(90268)	20017	(89040)
36	(914)	B12	7933	(35288)	4137	(18402)	8711	(35748)	6786	(30185)	5572	(24785)
		B12A	20017	(89040)	7844	(34892)	20324	(90405)	19509	(86780)	18889	(84022)
48	(1219)	B12	6386	(28406)	3638	(16182)	7562	(33637)	4785	(21285)	3717	(16534)
		B12A	19315	(85917)	7688	(34198)	19861	(88346)	18412	(81900)	17309	(76994)
60	(1524)	B12	4785	(21285)	2963	(13180)	6285	(27957)	3523	(15671)	2806	(12482)
		B12A	18412	(81900)	6941	(30875)	19265	(85695)	17002	(75628)	15278	(67960)
72	(1829)	B12	3717	(16534)	2197	(9773)	4964	(22081)	2806	(12482)	2271	(10102)
		B12A	17309	(76994)	5334	(23727)	18536	(82452)	15278	(67960)	12795	(56915)
84	(2133)	B12	3052	(13576)	1717	(7637)	3994	(17766)	2345	(10431)	1913	(8509)
		B12A	16005	(71194)	4176	(18576)	17675	(78622)	13240	(58894)	9884	(43966)
96	(2438)	B12	2600	(11565)	1391	(6187)	3350	(14901)	2019	(8981)	1650	(7339)
		B12A	14500	(64499)	3328	(14803)	16682	(74205)	10889	(48436)	7567	(33659)
108	(2743)	B12	2271	(10102)	1155	(5137)	2893	(12869)	1773	(7886)	1446	(6432)
		B12A	12795	(56915)	2692	(11974)	15556	(69196)	8610	(38299)	5979	(26596)
120	(3048)	B12	2019	(8981)	977	(4346)	2553	(11356)	1577	(7015)	1279**	(5689)
		B12A	10889	(48436)	2202	(9795)	14298	(63600)	6974	(31022)	4843**	(21543)

**Where the slenderness ratio $\frac{KL}{r}$ exceeds 200, and K = end fixity factor, L = actual length and r = radius of gyration.

Reference page 14 for general fitting and standard finish specifications.

B22 Channel

B22

- Thickness: 12 Gauge (2.6 mm)
- Standard lengths: 10' (3.05 m) & 20' (6.09 m)
- Standard finishes: Plain, Dura-Green, Pre-Galvanized, Hot-Dipped Galvanized, Stainless Steel Type 304 or 316, Aluminum
- Weight: 1.90 Lbs./Ft. (2.83 kg/m)

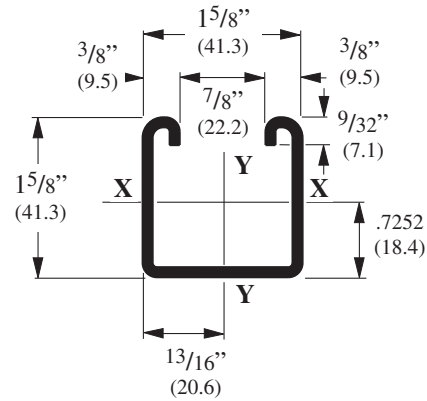
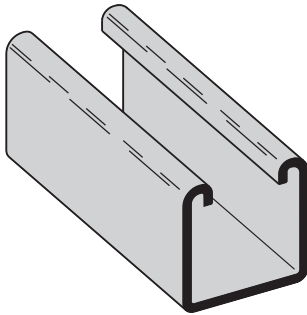

SECTION PROPERTIES

Channel	Weight		Areas of Section		Moment of Inertia (I)		Section Modulus (S)		Radius of Gyration (r)		Moment of Inertia (I)		Section Modulus (S)		Radius of Gyration (r)	
	lbs./ft.	kg/m	sq. in.	cm ²	in. ⁴	cm ⁴	in. ³	cm ³	in.	cm	in. ⁴	cm ⁴	in. ³	cm ³	in.	cm
B22	1.910	(2.84)	.562	(3.62)	.1912	(7.96)	.2125	(3.48)	.583	(1.48)	.2399	(9.99)	.2953	(4.84)	.653	(1.66)
B22A	3.820	(5.69)	1.124	(7.25)	.9732	(40.51)	.5989	(9.81)	.931	(2.36)	.4798	(19.97)	.5905	(9.68)	.653	(1.66)
B22X	6.649	(9.89)	1.956	(12.62)	4.1484	(172.67)	1.7019	(27.89)	1.456	(3.70)	1.1023	(45.88)	1.2027	(19.71)	.751	(1.91)

Calculations of section properties are based on metal thicknesses as determined by the AISI Cold-Formed Steel Design Manual.

Channel & Combinations

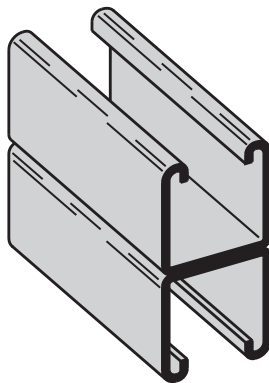

B22A

Wt. 3.80 Lbs./Ft. (5.65 kg/m)

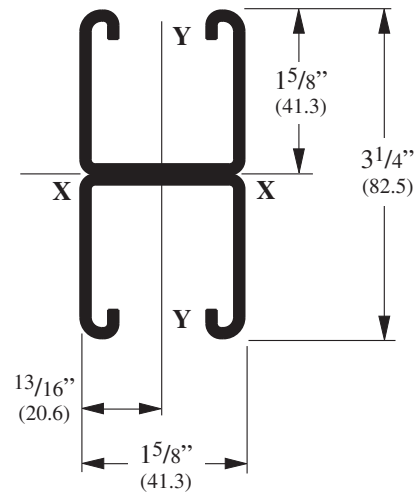

Reference page 14 for general fitting and standard finish specifications.

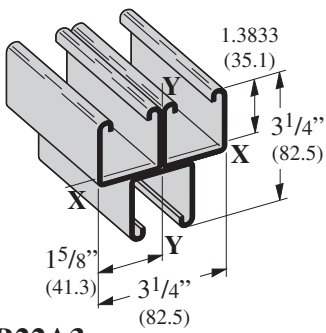

B22A3
Wt. 5.70 Lbs./Ft. (8.48 kg/m)

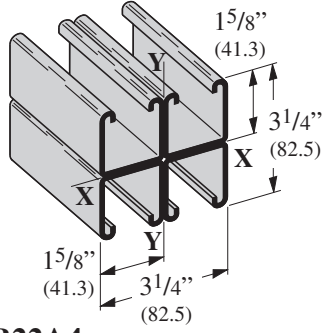

B22A4
Wt. 7.60 Lbs./Ft. (11.31 kg/m)

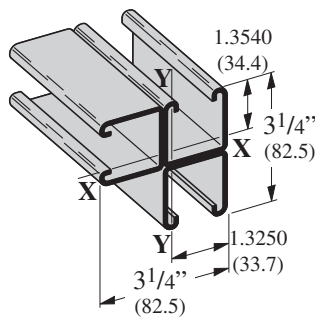

B22AD3
Wt. 5.70 Lbs./Ft. (8.48 kg/m)

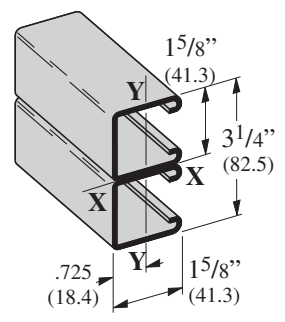

B22B
Wt. 3.80 Lbs./Ft. (5.65 kg/m)

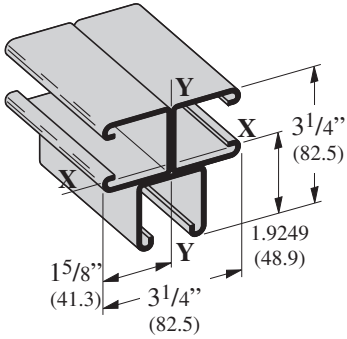

B22B3
Wt. 5.70 Lbs./Ft. (8.48 kg/m)

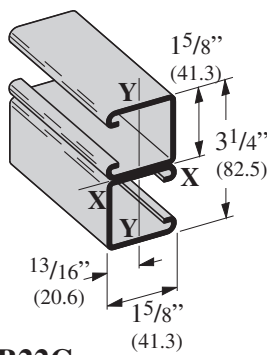

B22C
Wt. 3.80 Lbs./Ft. (5.65 kg/m)

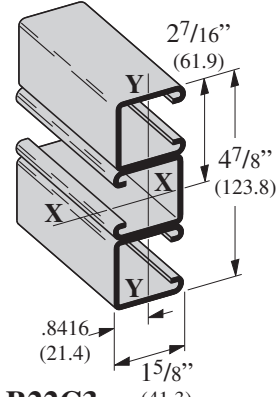

B22C3
Wt. 5.70 Lbs./Ft. (8.48 kg/m)

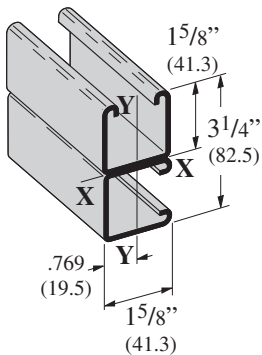

B22D
Wt. 3.80 Lbs./Ft. (5.65 kg/m)

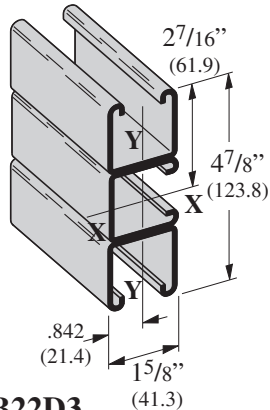

B22D3
Wt. 5.70 Lbs./Ft. (8.48 kg/m)

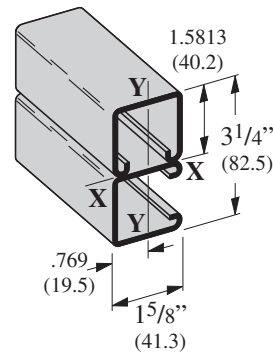

B22E
Wt. 3.80 Lbs./Ft. (5.65 kg/m)

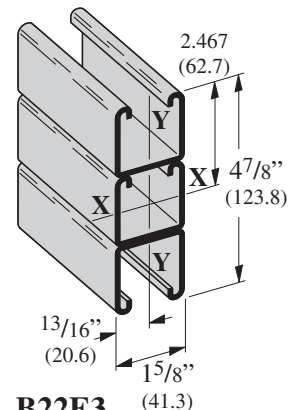

B22E3
Wt. 5.70 Lbs./Ft. (8.48 kg/m)

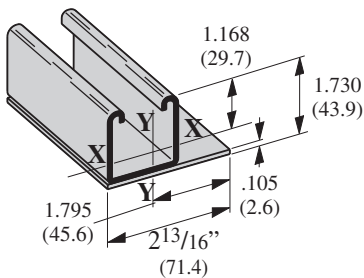

B22LPL
Wt. 2.90 Lbs./Ft. (4.31 kg/m)

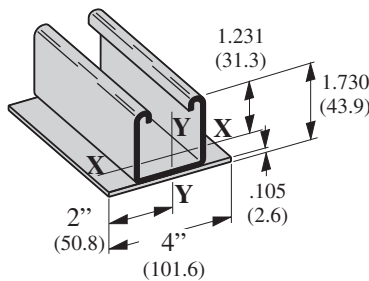

B22PL
Wt. 3.35 Lbs./Ft. (4.98 kg/m)

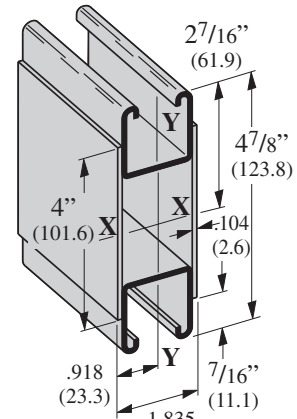

B22X
Wt. 6.70 Lbs./Ft. (9.97 kg/m)

Reference page 14 for general fitting and standard finish specifications.

B22 Beam Loading Data

Beam Span In. mm		Channel Style	Uniform Load and Deflection				Uniform Load @ Deflection = 1/240 Span 1/360 Span			
			Lbs.	N	In.	mm	Lbs.	N	Lbs.	N
12	(305)	B22	2610	(11610)	.014	(.35)	2610	(11610)	2610	(11610)
		B22A	2610*	(11610)	.002	(.05)	2610*	(11610)	2610*	(11610)
		B22X	5790*	(25755)	.001	(.02)	5790*	(25755)	5790*	(25755)
18	(457)	B22	2269	(10093)	.031	(.79)	2269	(10093)	2269	(10093)
		B22A	2610*	(11610)	.007	(.18)	2610*	(11610)	2610*	(11610)
		B22X	5790*	(25755)	.003	(.07)	5790*	(25755)	5790*	(25755)
24	(609)	B22	1702	(7571)	.056	(1.42)	1702	(7571)	1702	(7571)
		B22A	2610*	(11610)	.017	(.43)	2610*	(11610)	2610*	(11610)
		B22X	5790*	(25755)	.008	(.20)	5790*	(25755)	5790*	(25755)
30	(762)	B22	1361	(6054)	.087	(2.21)	1361	(6054)	1294	(5756)
		B22A	2610*	(11610)	.033	(.84)	2610*	(11610)	2610*	(11610)
		B22X	5790*	(25755)	.017	(.73)	5790*	(25755)	5790*	(25755)
36	(914)	B22	1135	(5049)	.126	(3.20)	1135	(5049)	899	(3999)
		B22A	2610*	(11610)	.057	(1.45)	2610*	(11610)	2610*	(11610)
		B22X	5790*	(25755)	.029	(.73)	5790*	(25755)	5790*	(25755)
42	(1067)	B22	972	(4323)	.172	(4.37)	972	(4323)	660	(2936)
		B22A	2610*	(11610)	.091	(2.31)	2610*	(11610)	2610*	(11610)
		B22X	5790*	(25755)	.046	(1.17)	5790*	(25755)	5790*	(25755)
48	(1219)	B22	851	(3785)	.224	(5.69)	758	(3372)	505	(2246)
		B22A	2405	(10698)	.125	(3.17)	2405	(10698)	2405	(10698)
		B22X	5790*	(25755)	.068	(1.73)	5790*	(25755)	5790*	(25755)
54	(1371)	B22	756	(3363)	.284	(7.21)	599	(2664)	399	(1775)
		B22A	2138	(9510)	.158	(4.01)	2138	(9510)	2024	(9003)
		B22X	5790*	(25755)	.097	(2.46)	5790*	(25755)	5790*	(25755)
60	(1524)	B22	681	(3029)	.351	(8.91)	485	(2157)	323	(1437)
		B22A	1924	(8558)	.195	(4.95)	1924	(8558)	1640	(7295)
		B22X	5645	(25110)	.130	(3.30)	5645	(25110)	5645	(25110)
66	(1676)	B22	619	(2753)	.424	(10.77)	401	(1784)	267	(1187)
		B22A	1749	(7780)	.236	(5.99)	1749	(7780)	1355	(6027)
		B22X	5132	(22828)	.158	(4.01)	5132	(22828)	5132	(22828)
72	(1829)	B22	567	(2522)	.505	(12.83)	337	(1499)	225	(1001)
		B22A	1603	(7130)	.281	(7.14)	1603	(7130)	1139	(5066)
		B22X	4704	(20924)	.188	(4.77)	4704	(20924)	4704	(20924)
78	(1981)	B22	524	(2331)	.593	(15.06)	287	(1276)	191	(849)
		B22A	1480	(6583)	.330	(8.38)	1455	(6472)	970	(4315)
		B22X	4342	(19314)	.220	(5.59)	4342	(19314)	4270	(18994)
84	(2133)	B22	486	(2162)	.687	(17.45)	248	(1103)	165	(734)
		B22A	1374	(6112)	.383	(9.73)	1255	(5582)	837	(3723)
		B22X	4032	(17935)	.255	(6.48)	4032	(17935)	3682	(16378)
90	(2286)	B22	454	(2019)	.789	(20.04)	216	(961)	144	(640)
		B22A	1283	(5707)	.440	(11.17)	1093	(4862)	729	(3243)
		B22X	3763	(16738)	.293	(7.44)	3763	(16738)	3207	(14265)
96	(2438)	B22	425	(1890)	.898	(22.81)	190	(845)	126	(560)
		B22A	1202	(5347)	.500	(12.70)	961	(4275)	640	(2847)
		B22X	3528	(15693)	.334	(8.48)	3528	(15693)	2819	(12539)
102	(2591)	B22	400	(1779)	1.013	(25.73)	168	(747)	112	(498)
		B22A	1132	(5035)	.565	(14.35)	851	(3785)	567	(2522)
		B22X	3320	(14768)	.377	(9.57)	3320	(14768)	2497	(11107)
108	(2743)	B22	378	(1681)	1.136	(28.85)	150	(667)	100	(445)
		B22A	1069	(4755)	.633	(16.08)	759	(3376)	506	(2251)
		B22X	3136	(13949)	.422	(10.72)	3136	(13949)	2227	(9906)
114	(2895)	B22	358	(1592)	1.266	(32.15)	134	(596)	90	(400)
		B22A	1013	(4506)	.706	(17.93)	681	(3029)	454	(2019)
		B22X	2971	(13215)	.471	(11.96)	2971	(13215)	1999	(8892)
120	(3048)	B22	340	(1512)	1.403	(35.63)	121	(538)	81	(360)
		B22A	962	(4279)	.782	(19.86)	615	(2735)	410	(1824)
		B22X	2822	(12553)	.521	(13.23)	2706	(12037)	1804	(8024)

Based on simple beam condition using an allowable design stress of 25,000 psi (172 MPa) in accordance with MFMA, with adequate lateral bracing (see page 11 for further explanation). Actual yield point of cold rolled steel is 42,000 psi. To determine concentrated load capacity at mid span, multiply uniform load by 0.5 and corresponding deflection by 0.8. *Failure determined by weld shear.

Reference page 14 for general fitting and standard finish specifications.

B22 Column Loading Data

Unbraced Height		Channel Style	Max. Column Loading K = .80				Max. Column Loading (Loaded @ C.G.)					
			Loaded @ C.G.		Loaded @ Slot Face		K = .65		K = 1.0		K = 1.2	
			Lbs.	N	Lbs.	N	Lbs.	N	Lbs.	N	Lbs.	N
In.	mm											
12	(305)	B22	10454	(46502)	4276	(19120)	10598	(47142)	10222	(45470)	9950	(44260)
		B22A	21625	(96193)	7002	(31146)	21677	(96424)	21539	(95810)	21433	(95339)
		B22X	46948	(208835)	18975	(84405)	47061	(209338)	46761	(208003)	46531	(206980)
18	(457)	B22	9950	(44260)	4153	(18473)	10253	(45607)	9481	(42173)	8955	(39834)
		B22A	21433	(95339)	6959	(30955)	21551	(95863)	21239	(94476)	21001	(93417)
		B22X	46531	(206980)	18859	(83899)	46787	(208119)	46110	(205107)	45593	(202808)
24	(609)	B22	9311	(41417)	3993	(17762)	9801	(43597)	8582	(38174)	7801	(34700)
		B22A	21164	(94142)	6898	(30684)	21373	(95072)	20819	(92607)	20397	(90730)
		B22X	45947	(204382)	18693	(84440)	46401	(206402)	45198	(201051)	44282	(196976)
30	(762)	B22	8582	(38174)	3802	(16912)	9268	(41226)	7601	(33811)	6595	(29336)
		B22A	20819	(92607)	6821	(30341)	21145	(94057)	20279	(90205)	19619	(87269)
		B22X	45198	(201051)	18485	(82225)	45906	(204200)	44026	(195837)	42593	(189463)
36	(914)	B22	7801	(34700)	3589	(15964)	8676	(38593)	6595	(28336)	5392	(23985)
		B22A	20397	(90730)	6728	(29927)	20866	(92816)	19619	(87269)	18669	(83044)
		B22X	44282	(196976)	18233	(81104)	45300	(201504)	42593	(189463)	40530	(180286)
42	(1067)	B22	6998	(31128)	3360	(14946)	8048	(35799)	5595	(24888)	4444	(19768)
		B22A	19898	(88511)	6620	(29447)	20537	(91353)	18840	(83804)	17546	(78048)
		B22X	43198	(192154)	17940	(79801)	44586	(198328)	40901	(181937)	38092	(169441)
48	(1219)	B22	6193	(27548)	3118	(13869)	7401	(32921)	4718	(20987)	3791	(16863)
		B22A	19322	(85948)	6496	(28895)	20157	(89663)	17940	(79801)	16251	(72288)
		B22X	41948	(186594)	17604	(78306)	43761	(194568)	38948	(173254)	35281	(156938)
54	(1371)	B22	5392	(23985)	2864	(12740)	6746	(30008)	4090	(18193)	3310	(14723)
		B22A	18669	(83044)	6263	(27859)	19276	(87745)	16920	(75264)	14782	(65753)
		B22X	40530	(180286)	16973	(75499)	42825	(190495)	36733	(163396)	32092	(142752)
60	(1524)	B22	4718	(20987)	2631	(11703)	6093	(27103)	3616	(16085)	2936	(13060)
		B22A	17940	(79801)	5340	(23753)	19244	(85601)	15781	(70197)	13141	(58454)
		B22X	38948	(173249)	14471	(64370)	41779	(185842)	34260	(152396)	28529	(126903)
66	(1676)	B22	4202	(18691)	2434	(10827)	5441	(24203)	3242	(14421)	2634	(11716)
		B22A	17134	(76216)	4587	(20404)	18712	(83235)	14521	(64592)	11328	(50389)
		B22X	37198	(165465)	12431	(55296)	40624	(180704)	31525	(140230)	24593	(109395)
72	(1829)	B22	3791	(16863)	2264	(10071)	4869	(21658)	2936	(13060)	2381	(10591)
		B22A	16251	(72288)	3968	(17650)	18129	(80642)	13141	(58454)	9524	(42365)
		B22X	35281	(156938)	10753	(47832)	39358	(175073)	28529	(126903)	20676	(91971)
78	(1981)	B22	3456	(15373)	2116	(9412)	4412	(19625)	2680	(11921)	2166	(9635)
		B22A	15291	(68018)	3456	(15373)	17496	(77826)	11642	(51786)	8115	(36097)
		B22X	33197	(147667)	9366	(41662)	37984	(168961)	25275	(112429)	17617	(78364)
84	(2133)	B22	3176	(14127)	1984	(8825)	4037	(17957)	2461	(10947)	1980	(8807)
		B22A	14255	(63409)	3028	(13469)	16812	(74783)	10076	(44820)	6998	(31128)
		B22X	30947	(137659)	8206	(36502)	36499	(162355)	21875	(97305)	15192	(67577)
90	(2286)	B22	2936	(13060)	1867	(8305)	3724	(16565)	2270	(10097)	1816	(8078)
		B22A	13141	(58454)	2667	(11863)	16077	(71514)	8778	(39046)	6096	(27116)
		B22X	28529	(126903)	7227	(32147)	34903	(155256)	19057	(84770)	13234	(58868)
96	(2438)	B22	2728	(16583)	1761	(7833)	3456	(15373)	2101	(9346)	1671	(7433)
		B22A	11951	(53160)	2359	(10493)	15291	(68018)	7715	(34318)	5357	(23829)
		B22X	25945	(115409)	6393	(28437)	33197	(147667)	16749	(74503)	11630	(51733)
102	(2591)	B22	2545	(11321)	1664	(7402)	3225	(14345)	1951	(8678)	1542**	(6343)
		B22A	10678	(47498)	2093	(9310)	14455	(64299)	6834	(30399)	4746	(21111)
		B22X	23182	(103118)	5672	(25230)	31382	(139594)	14836	(65994)	10303	(45830)
108	(2743)	B22	2381	(10591)	1575	(7006)	3022	(13442)	1816	(8078)	1426**	(68599)
		B22A	9524	(42365)	1867	(8305)	13568	(60353)	6096	(27116)	4233	(18829)
		B22X	20676	(91971)	5059	(22503)	29456	(131027)	13234	(58868)	9190	(40879)
114	(2895)	B22	2234	(9937)	1494	(6645)	2842	(12642)	1694	(7535)	1322**	(5880)
		B22A	8548	(38023)	1675	(7451)	12630	(56181)	5471	(24336)	3799**	(16899)
		B22X	18558	(82550)	4539	(20190)	27420	(121970)	11877	(52831)	8247	(36684)
120	(3048)	B22	2101	(9346)	1418	(6307)	2680	(11921)	1583**	(7041)	1228**	(5462)
		B22A	7715	(34318)	1512	(6726)	11642	(51786)	4937	(21961)	3429**	(15253)
		B22X	16749	(74503)	4097	(18224)	25275	(112429)	10718	(47676)	7444	(33112)

**Where the slenderness ratio $\frac{KL}{r}$ exceeds 200, and K = end fixity factor, L = actual length and r = radius of gyration.

Reference page 14 for general fitting and standard finish specifications.

B24 Channel & Combinations

B24

- Thickness: 14 Gauge (1.9 mm)
- Standard lengths: 10' (3.05 m) & 20' (6.09 m)
- Standard finishes: Plain, Dura-Green, Pre-Galvanized, Hot-Dipped Galvanized, Stainless Steel Type 304 or 316, Aluminum
- Weight: 1.40 Lbs./Ft. (2.08 kg/m)

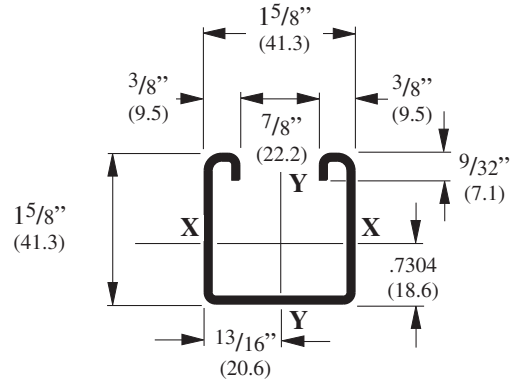
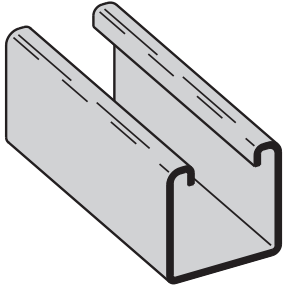

SECTION PROPERTIES

Channel	Weight		Areas of Section		X - X Axis					Y - Y Axis						
					Moment of Inertia (I)		Section Modulus (S)		Radius of Gyration (r)		Moment of Inertia (I)		Section Modulus (S)		Radius of Gyration (r)	
	lbs./ft.	kg/m	sq. in.	cm ²	in. ⁴	cm ⁴	in. ³	cm ³	in.	cm	in. ⁴	cm ⁴	in. ³	cm ³	in.	cm
B24	1.442	(2.15)	.424	(2.74)	.1494	(6.22)	.1670	(2.74)	.594	(1.51)	.1857	(7.73)	.2286	(3.75)	.662	(1.68)
B24A	2.884	(4.29)	.848	(5.47)	.7514	(31.28)	.4624	(7.58)	.941	(2.39)	.3713	(15.45)	.4570	(7.49)	.662	(1.68)

Calculations of section properties are based on metal thicknesses as determined by the AISI Cold-Formed Steel Design Manual.

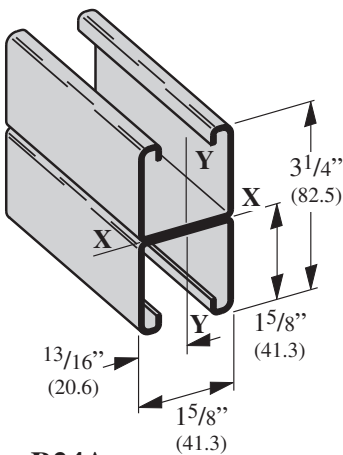

B24A
Wt. 2.80 Lbs./Ft. (4.16 kg/m)

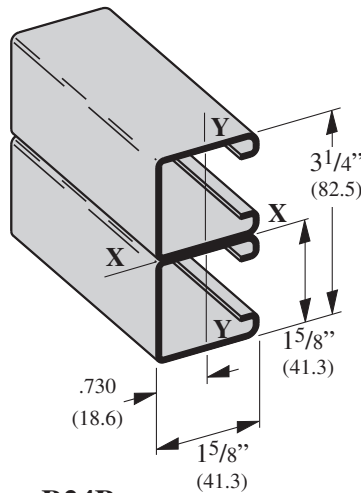

B24B
Wt. 2.80 Lbs./Ft. (4.16 kg/m)

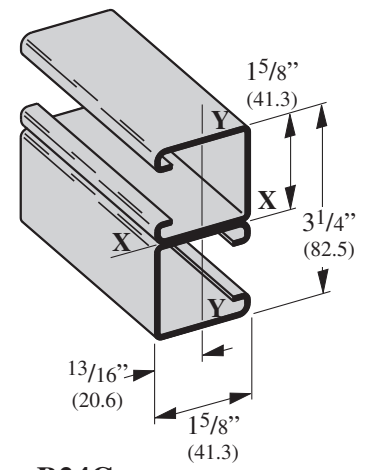

B24C
Wt. 2.80 Lbs./Ft. (4.16 kg/m)

Reference page 14 for general fitting and standard finish specifications.

B24 Beam & Column Loading Data

BEAM LOADING

Beam Span In. mm		Channel Style	Uniform Load and Deflection				Uniform Load @ Deflection =			
			Lbs.		N		1/240 Span		1/360 Span	
In.	mm		Lbs.	N	In.	mm	Lbs.	N	Lbs.	N
12	(305)	B24	1750	(7784)	.014	(.35)	1750	(7784)	1750	(7784)
		B24A	1750*	(7784)	.002	(.05)	1750*	(7784)	1750*	(7784)
24	(609)	B24	1379	(6134)	.057	(1.45)	1379	(6134)	1379	(6134)
		B24A	1750*	(7784)	.014	(.35)	1750*	(7784)	1750*	(7784)
36	(914)	B24	919	(4088)	.128	(3.25)	919	(4088)	720	(3203)
		B24A	1750*	(7784)	.048	(1.22)	1750*	(7784)	1750*	(7784)
48	(1219)	B24	689	(3065)	.227	(5.76)	607	(2700)	405	(1801)
		B24A	1750*	(7784)	.115	(2.92)	1750*	(7784)	1750*	(7784)
60	(1524)	B24	551	(2451)	.355	(9.02)	389	(1730)	259	(1152)
		B24A	1518	(6752)	.195	(4.95)	1518	(6752)	1294	(5756)
72	(1829)	B24	460	(2046)	.511	(12.98)	270	(1201)	180	(800)
		B24A	1265	(5627)	.281	(7.14)	1265	(5627)	898	(3994)
84	(2133)	B24	394	(1752)	.695	(17.65)	198	(881)	132	(587)
		B24A	1084	(4822)	.383	(9.73)	990	(4404)	660	(2936)
96	(2438)	B24	345	(1534)	.908	(23.06)	152	(676)	101	(449)
		B24A	949	(4221)	.500	(12.70)	758	(3372)	505	(2246)
108	(2743)	B24	306	(1361)	1.149	(29.18)	120	(534)	80	(356)
		B24A	843	(3750)	.633	(16.08)	599	(2664)	399	(1775)
120	(3048)	B24	276	(1228)	1.419	(36.04)	97	(431)	65	(289)
		B24A	759	(3376)	.782	(19.86)	485	(2157)	323	(1437)

Based on simple beam condition using an allowable design stress of 25,000 psi (172 MPa) in accordance with MFMA, with adequate lateral bracing (see page 11 for further explanation). Actual yield point of cold rolled steel is 42,000 psi. To determine concentrated load capacity at mid span, multiply uniform load by 0.5 and corresponding deflection by 0.8. *Failure determined by weld shear.

COLUMN LOADING

Unbraced Height In. mm		Channel Style	Max. Column Loading K = .80				Max. Column Loading (Loaded @ C.G.)					
			Loaded @ C.G.		Loaded @ Slot Face		K = .65		K = 1.0		K = 1.2	
In.	mm		Lbs.	N	Lbs.	N	Lbs.	N	Lbs.	N	Lbs.	N
12	(305)	B24	6441	(28651)	3077	(13687)	6509	(28953)	6330	(28157)	6198	(27570)
		B24A	13212	(58770)	4988	(22188)	13237	(58881)	13171	(58587)	13121	(58365)
24	(609)	B24	5874	(26129)	2896	(12882)	6124	(27241)	5483	(24389)	5038	(22410)
		B24A	12993	(57796)	4924	(21903)	13092	(58236)	12828	(57062)	12627	(56167)
36	(914)	B24	5038	(22410)	2619	(11650)	5535	(24621)	4302	(19136)	3516	(15640)
		B24A	12627	(56167)	4819	(21436)	12851	(57164)	12256	(54517)	11804	(52507)
48	(1219)	B24	4043	(17984)	2272	(10106)	4800	(21351)	3008	(13380)	2324	(10337)
		B24A	12115	(53890)	4675	(20795)	12512	(55656)	11456	(50959)	10651	(47378)
60	(1524)	B24	3008	(13380)	1873	(8331)	3978	(17695)	2200	(9786)	1740	(7740)
		B24A	11456	(50959)	4020	(17882)	12078	(53725)	10427	(46381)	9169	(40786)
72	(1829)	B24	2324	(10337)	1562	(6948)	3123	(13892)	1740	(7740)	1397	(6214)
		B24A	10651	(47378)	3048	(13558)	11546	(51359)	9169	(40786)	7358	(32730)
84	(2133)	B24	1898	(8443)	1340	(5960)	2502	(11129)	1444	(6423)	1168	(5195)
		B24A	9700	(43148)	2362	(10506)	10918	(48565)	7683	(34175)	5464	(24305)
96	(2438)	B24	1608	(7153)	1175	(5226)	2089	(9292)	1236	(5498)	1000	(4448)
		B24A	8602	(38263)	1866	(8300)	10194	(45345)	6024	(26796)	4184	(18611)
108	(2743)	B24	1397	(6214)	1046	(4653)	1796	(7989)	1078	(4795)	870**	(3870)
		B24A	7358	(32730)	1498	(6663)	9373	(41693)	4760	(21173)	3306	(14706)
120	(3048)	B24	1236	(5498)	942	(4190)	1578	(7019)	953**	(4239)	764**	(3398)
		B24A	6024	(26796)	1216	(5409)	8455	(37610)	3856	(17152)	2677**	(11908)

**Where the slenderness ratio $\frac{KL}{r}$ exceeds 200, and K = end fixity factor, L = actual length and r = radius of gyration.

Reference page 14 for general fitting and standard finish specifications.

B26 Channel & Combinations

B26

- Thickness: 16 Gauge (1.5 mm)
- Standard lengths: 10' (3.05 m) & 20' (6.09 m)
- Standard finishes: Plain, Dura-Green, Pre-Galvanized
- Weight: 1.12 Lbs./Ft. (1.66 kg/m)

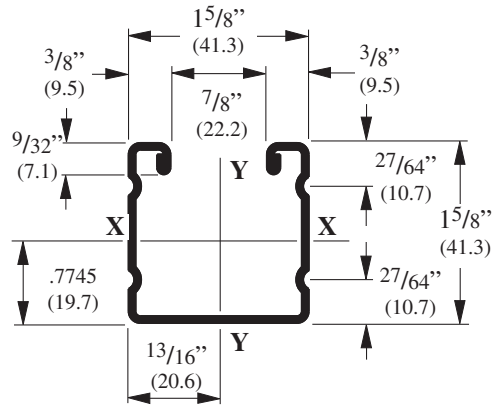
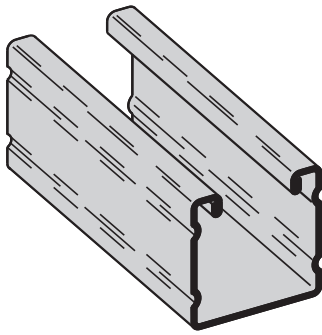

SECTION PROPERTIES

Channel	Weight lbs./ft. kg/m	Areas of Section		Moment of Inertia (I)		Section Modulus (S)		Radius of Gyration (r)		Moment of Inertia (I)		Section Modulus (S)		Radius of Gyration (r)	
		sq. in.	cm ²	in. ⁴	cm ⁴	in. ³	cm ³	in.	cm	in. ⁴	cm ⁴	in. ³	cm ³	in.	cm
B26	1.234 (1.84)	.363 (2.34)		.1337 (5.57)		.1581 (2.59)		.607 (1.54)		.1564 (6.51)		.1925 (3.15)		.656 (1.67)	
B26A	2.467 (3.67)	.726 (4.68)		.7086 (29.49)		.4361 (7.15)		.988 (2.51)		.3128 (13.02)		.3850 (6.31)		.656 (1.67)	

Calculations of section properties are based on metal thicknesses as determined by the AISI Cold-Formed Steel Design Manual.

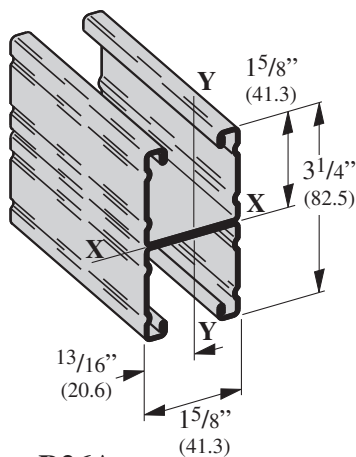

B26A

Wt. 2.24 Lbs./Ft. (3.33 kg/m)

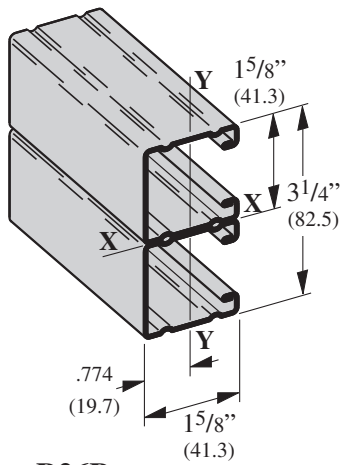

B26B

Wt. 2.24 Lbs./Ft. (3.33 kg/m)

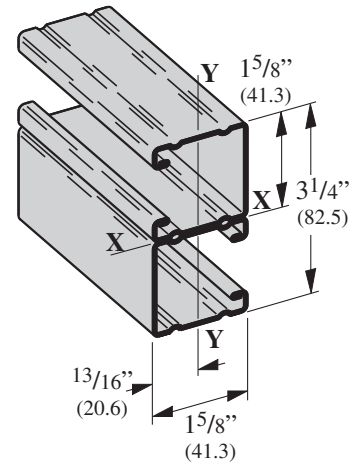

B26C

Wt. 2.24 Lbs./Ft. (3.33 kg/m)

Reference page 14 for general fitting and standard finish specifications.

B26 Beam & Column Loading Data

BEAM LOADING

Beam Span In. mm		Channel Style	Uniform Load and Deflection				Uniform Load @ Deflection =			
			Lbs. N		In. mm		1/240 Span		1/360 Span	
			Lbs.	N	In.	mm	Lbs.	N	Lbs.	N
12	(305)	B26	1220	(5427)	.014	(.35)	1220	(5427)	1220	(5427)
		B26A	1220*	(5427)	.001	(.02)	1220*	(5427)	1220*	(5427)
24	(609)	B26	1163	(5173)	.057	(1.45)	1163	(5173)	1163	(5173)
		B26A	1220*	(5427)	.012	(.30)	1220*	(5427)	1220*	(5427)
36	(914)	B26	775	(3447)	.128	(3.25)	775	(3447)	603	(2682)
		B26A	1220*	(5427)	.040	(1.01)	1220*	(5427)	1220*	(5427)
48	(1219)	B26	581	(2584)	.228	(5.79)	509	(2264)	339	(1508)
		B26A	1220*	(5427)	.096	(2.44)	1220*	(5427)	1220*	(5427)
60	(1524)	B26	465	(2068)	.357	(9.07)	326	(1450)	217	(965)
		B26A	1220*	(5427)	.188	(4.77)	1220*	(5427)	1076	(4786)
72	(1829)	B26	388	(1726)	.514	(13.05)	226	(1450)	151	(965)
		B26A	1052	(4679)	.281	(7.14)	1052	(4679)	747	(3323)
84	(2133)	B26	332	(1477)	.699	(17.75)	166	(738)	111	(494)
		B26A	902	(4012)	.383	(9.73)	824	(3665)	549	(2442)
96	(2438)	B26	291	(1294)	.913	(23.19)	127	(565)	85	(378)
		B26A	789	(3509)	.500	(12.70)	631	(2807)	420	(1868)
108	(2743)	B26	258	(1147)	1.156	(29.36)	101	(449)	67	(298)
		B26A	702	(3122)	.633	(16.08)	498	(2215)	332	(1477)
120	(3048)	B26	233	(1036)	1.427	(36.24)	81	(360)	54	(240)
		B26A	631	(2807)	.782	(19.86)	404	(1797)	269	(1196)

Based on simple beam condition using an allowable design stress of 25,000 psi (172 MPa) in accordance with MFMA, with adequate lateral bracing (see page 11 for further explanation). Actual yield point of cold rolled steel is 42,000 psi. To determine concentrated load capacity at mid span, multiply uniform load by 0.5 and corresponding deflection by 0.8. *Failure determined by weld shear.

COLUMN LOADING

Unbraced Height In. mm		Channel Style	Max. Column Loading K = .80				Max. Column Loading (Loaded @ C.G.)					
			Loaded @ C.G.		Loaded @ Slot Face		K = .65		K = 1.0		K = 1.2	
			Lbs.	N	Lbs.	N	Lbs.	N	Lbs.	N	Lbs.	N
12	(305)	B26	4002	(17802)	2216	(9857)	4032	(17935)	3952	(17579)	3891	(17308)
		B26A	8151	(36257)	3630	(16147)	8163	(36311)	8133	(36177)	8109	(36070)
24	(609)	B26	3740	(16636)	2109	(9381)	3857	(17157)	3554	(15809)	3336	(14838)
		B26A	8051	(35812)	3591	(15973)	8096	(36013)	7975	(35474)	7883	(35065)
36	(914)	B26	3336	(14839)	1941	(8634)	3579	(15920)	2962	(13175)	2546	(11325)
		B26A	7883	(35065)	3528	(15693)	7986	(35523)	7713	(34309)	7505	(33384)
48	(1219)	B26	2828	(12579)	1725	(7613)	3217	(14310)	2251	(10013)	1705	(7584)
		B26A	7648	(34020)	3441	(15306)	7831	(34834)	7346	(32676)	6977	(31035)
60	(1524)	B26	2251	(10013)	1469	(6534)	2793	(12424)	1603	(7130)	1233	(5484)
		B26A	7346	(32676)	3066	(13638)	7631	(33944)	6874	(30577)	6298	(28015)
72	(1829)	B26	1705	(7584)	1203	(5351)	2326	(10346)	1233	(5484)	967	(4301)
		B26A	6977	(31035)	2385	(10609)	7388	(32863)	6298	(28015)	5467	(24318)
84	(2133)	B26	1358	(6040)	1011	(4497)	1851	(8233)	1003	(4461)	797	(3545)
		B26A	6541	(29096)	1884	(8380)	7100	(31582)	5616	(24981)	4486	(19955)
96	(2438)	B26	1129	(5022)	871	(3874)	1513	(6730)	847	(3767)	680	(3025)
		B26A	6038	(26858)	1512	(6726)	6767	(30101)	4830	(21485)	3463	(15404)
108	(2743)	B26	967	(4301)	766	(3407)	1277	(5680)	734	(3265)	592**	(2633)
		B26A	5467	(24318)	1231	(5476)	6391	(28428)	3940	(17526)	2736	(12170)
120	(3048)	B26	847	(3767)	684	(3042)	1105	(4915)	648	(2882)	523**	(2326)
		B26A	4830	(21485)	1015	(4515)	5970	(26556)	3192	(14199)	2216**	(9857)

**Where the slenderness ratio $\frac{KL}{r}$ exceeds 200, and K = end fixity factor, L = actual length and r = radius of gyration.

Reference page 14 for general fitting and standard finish specifications.

B32 Channel & Combinations

B32

- Thickness: 12 Gauge (2.6 mm)
- Standard lengths: 10' (3.05 m) & 20' (6.09 m)
- Standard finishes: Plain, Dura-Green, Pre-Galvanized, Hot-Dipped Galvanized, Stainless Steel Type 304
- Weight: 1.70 Lbs./Ft. (2.53 kg/m)

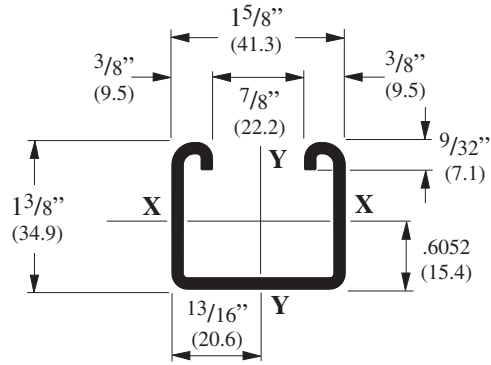
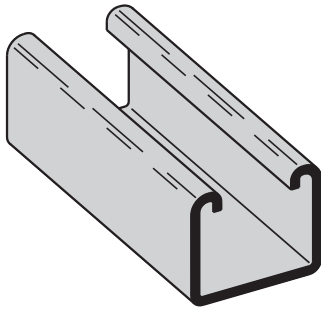

SECTION PROPERTIES

Channel	Weight lbs./ft. kg/m	Areas of Section		Moment of Inertia (I)		Section Modulus (S)		Radius of Gyration (r)		Moment of Inertia (I)		Section Modulus (S)		Radius of Gyration (r)	
		sq. in.	cm ²	in. ⁴	cm ⁴	in. ³	cm ³	in.	cm	in. ⁴	cm ⁴	in. ³	cm ³	in.	cm
B32	1.733 (2.58)	.510 (3.29)		.1252 (5.21)		.1626 (2.67)		.496 (1.26)		.2098 (8.73)		.2582 (4.23)		.642 (1.63)	
B32A	3.467 (5.16)	1.020 (6.58)		.6238 (25.96)		.4537 (7.43)		.782 (1.99)		.4195 (17.46)		.5163 (8.46)		.642 (1.63)	

Calculations of section properties are based on metal thicknesses as determined by the AISI Cold-Formed Steel Design Manual.

Channel & Combinations

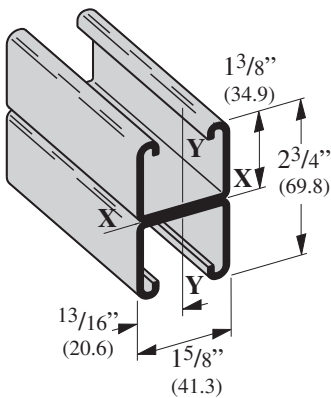

B32A
Wt. 3.40 Lbs./Ft. (5.06 kg/m)

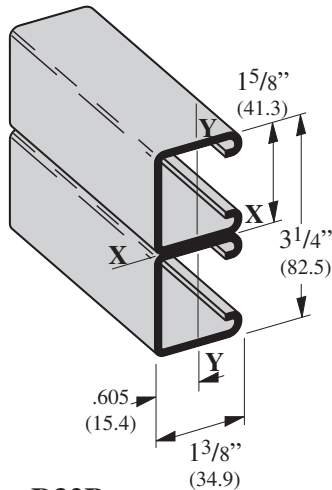

B32B
Wt. 3.40 Lbs./Ft. (5.06 kg/m)

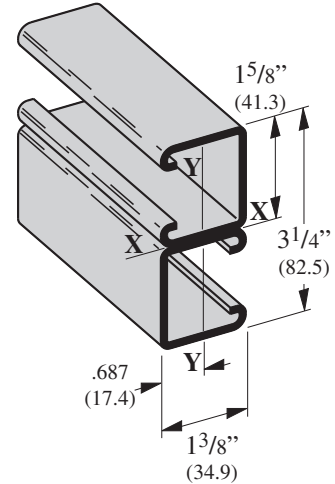

B32C
Wt. 3.40 Lbs./Ft. (5.06 kg/m)

Reference page 14 for general fitting and standard finish specifications.

B32 Beam & Column Loading Data

BEAM LOADING

Beam Span In. mm		Channel Style	Uniform Load and Deflection				Uniform Load @ Deflection =			
			Lbs.		N		1/240 Span		1/360 Span	
In.	mm		Lbs.	N	In.	mm	Lbs.	N	Lbs.	N
12	(305)	B32 B32A	2210	(9830)	.016	(.40)	2210	(9830)	2210	(9830)
			2210*	(9830)	.003	(.07)	2210*	(9830)	2210*	(9830)
24	(609)	B32 B32A	1299	(5778)	.065	(1.65)	1299	(5778)	1299	(5778)
			2210*	(9830)	.022	(.56)	2210*	(9830)	2210*	(9830)
36	(914)	B32 B32A	866	(3852)	.147	(3.73)	866	(3852)	587	(2611)
			2210*	(9830)	.076	(1.93)	2210*	(9830)	2210*	(9830)
48	(1219)	B32 B32A	649	(2887)	.262	(6.65)	495	(2202)	330	(1468)
			1817	(8082)	.148	(3.76)	1817	(8082)	1638	(7286)
60	(1524)	B32 B32A	520	(2313)	.410	(10.41)	317	(1410)	211	(938)
			1454	(6468)	.231	(5.87)	1454	(6468)	1048	(4662)
72	(1829)	B32 B32A	433	(1926)	.590	(14.98)	220	(978)	147	(654)
			1211	(5387)	.333	(8.46)	1092	(4857)	728	(3238)
84	(2133)	B32 B32A	371	(1650)	.803	(20.39)	162	(720)	108	(480)
			1038	(4617)	.453	(11.50)	802	(3567)	535	(2380)
96	(2438)	B32 B32A	325	(1445)	1.049	(26.64)	124	(551)	83	(369)
			909	(4043)	.591	(15.01)	614	(2731)	410	(1824)
108	(2743)	B32 B32A	289	(1285)	1.327	(33.70)	98	(436)	65	(289)
			808	(3594)	.749	(19.02)	485	(2157)	324	(1441)
120	(3048)	B32 B32A	260	(1156)	1.639	(41.63)	79	(351)	53	(236)
			727	(3234)	.924	(23.47)	393	(1748)	262	(1165)

Based on simple beam condition using an allowable design stress of 25,000 psi (172 MPa) in accordance with MFMA, with adequate lateral bracing (see page 11 for further explanation). Actual yield point of cold rolled steel is 42,000 psi. To determine concentrated load capacity at mid span, multiply uniform load by 0.5 and corresponding deflection by 0.8. *Failure determined by weld shear.

COLUMN LOADING

Unbraced Height In. mm		Channel Style	Max. Column Loading K = .80				Max. Column Loading (Loaded @ C.G.)					
			Loaded @ C.G.		Loaded @ Slot Face		K = .65		K = 1.0		K = 1.2	
In.	mm		Lbs.	N	Lbs.	N	Lbs.	N	Lbs.	N	Lbs.	N
12	(305)	B32 B32A	10278	(45719)	4036	(17953)	10432	(46404)	10035	(44638)	9753	(43383)
			21320	(94836)	6557	(29167)	21378	(95094)	21224	(94409)	21106	(93884)
24	(609)	B32 B32A	9104	(40496)	3732	(16601)	9600	(42702)	8387	(37307)	7640	(33984)
			20806	(92550)	6431	(28606)	21039	(93586)	20421	(90837)	19950	(88742)
36	(914)	B32 B32A	7640	(33984)	3323	(14781)	8479	(37716)	6520	(29002)	5425	(24131)
			19950	(88742)	6228	(27703)	20474	(91073)	19083	(84885)	18023	(80170)
48	(1219)	B32 B32A	6151	(27361)	2877	(12797)	7265	(32316)	4778	(21253)	3870	(17214)
			18751	(83408)	5954	(26485)	19682	(87550)	17210	(76554)	15326	(68173)
60	(1524)	B32 B32A	4778	(21253)	2435	(10831)	6060	(26956)	3693	(16427)	2994	(13318)
			17210	(76554)	4692	(20871)	18665	(83026)	14801	(65838)	11858	(52747)
72	(1829)	B32 B32A	3870	(17214)	2089	(9292)	4923	(21898)	2994	(13318)	2403	(10689)
			15326	(68173)	3448	(15337)	17421	(77492)	11858	(52747)	8316	(36991)
84	(2133)	B32 B32A	3243	(14425)	1817	(8082)	4114	(18300)	2489	(11071)	1807**	(8038)
			13100	(58272)	2609	(11605)	15951	(70953)	8798	(39135)	6110	(27178)
96	(2438)	B32 B32A	2774	(12339)	1594	(7090)	3531	(15706)	1993	(8865)	1384**	(6156)
			10525	(46817)	2014	(8959)	14256	(63414)	6736	(29963)	4678	(20809)
108	(2743)	B32 B32A	2403	(10689)	1407	(6258)	3083	(13714)	1574**	(7001)	1093**	(4862)
			8316	(36991)	1592	(7081)	12334	(54864)	5322	(23673)	3696**	(16440)
120	(3048)	B32 B32A	1993	(8865)	1221	(5431)	2723	(12112)	1275**	(5671)	886**	(3941)
			6736	(29963)	1289	(5734)	10203	(45385)	4311	(19176)	2994**	(13318)

**Where the slenderness ratio $\frac{KL}{r}$ exceeds 200, and K = end fixity factor, L = actual length and r = radius of gyration.

Reference page 14 for general fitting and standard finish specifications.

B42 Channel & Combinations

B42

- Thickness: 12 Gauge (2.6 mm)
- Standard lengths: 10' (3.05 m) & 20' (6.09 m)
- Standard finishes: Plain, Dura-Green, Pre-Galvanized, Hot-Dipped Galvanized, Stainless Steel Type 304
- Weight: 1.44 Lbs./Ft. (2.14 kg/m)

Note: Also available in 14 gauge (1.9mm) material as B44

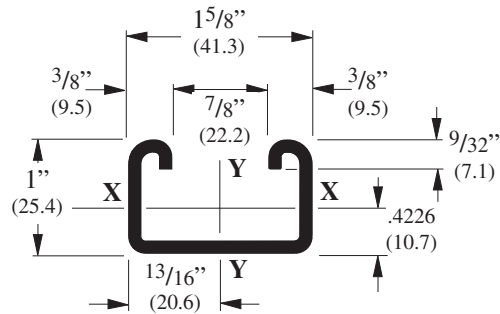
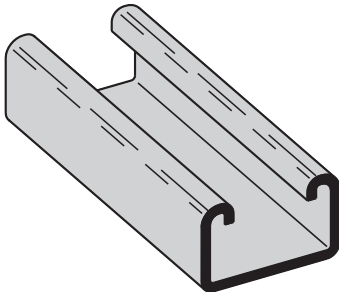

SECTION PROPERTIES

Channel	Weight		Areas of Section		Moment of Inertia (I)		Section Modulus (S)		X - X Axis		Moment of Inertia (I)		Y - Y Axis		Radius of Gyration (r)	
									Radius of Gyration (r)				Section Modulus (S)			
	lbs./ft.	kg/m	sq. in.	cm ²	in. ⁴	cm ⁴	in. ³	cm ³	in.	cm	in. ⁴	cm ⁴	in. ³	cm ³	in.	cm
B42	1.468	(2.18)	.432	(2.79)	.0554	(2.31)	.0968	(1.59)	.358	(.91)	.1645	(6.85)	.2025	(3.32)	.617	(1.57)
B42A	2.936	(4.37)	.864	(5.57)	.2689	(11.19)	.2689	(4.41)	.558	(1.42)	.3292	(13.70)	.4052	(6.64)	.617	(1.57)

Calculations of section properties are based on metal thicknesses as determined by the AISI Cold-Formed Steel Design Manual.

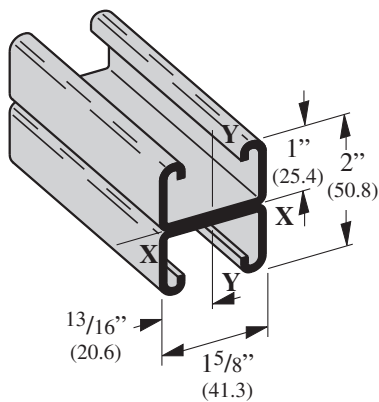

B42A

Wt. 2.88 Lbs./Ft. (4.28 kg/m)

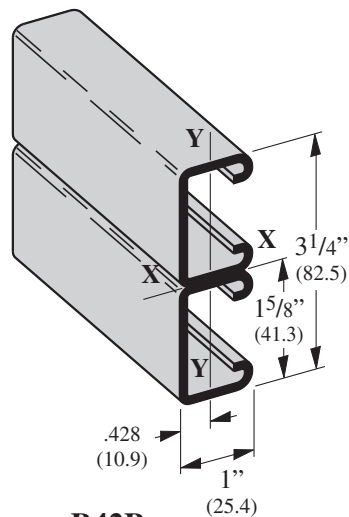

B42B

Wt. 2.88 Lbs./Ft. (4.28 kg/m)

Reference page 14 for general fitting and standard finish specifications.

B42 Beam & Column Loading Data

BEAM LOADING

Beam Span In. mm		Channel Style	Uniform Load and Deflection				Uniform Load @ Deflection =			
			Lbs. N		In. mm		1/240 Span		1/360 Span	
			Lbs.	N	In.	mm	Lbs.	N	Lbs.	N
12	(305)	B42	1538	(6841)	.022	(.56)	1538	(6841)	1538	(6841)
		B42A	1590*	(7072)	.005	(.13)	1590*	(7072)	1590*	(7072)
24	(609)	B42	769	(3420)	.088	(2.23)	769	(3420)	582	(2589)
		B42A	1590*	(7072)	.038	(.96)	1590*	(7072)	1590*	(7072)
36	(914)	B42	513	(2282)	.198	(5.03)	388	(1726)	259	(1152)
		B42A	1428	(6352)	.114	(2.89)	1428	(6352)	1248	(5551)
48	(1219)	B42	384	(1708)	.352	(8.94)	218	(970)	145	(645)
		B42A	1071	(4764)	.203	(5.15)	1053	(4684)	702	(3122)
60	(1524)	B42	308	(1370)	.550	(13.97)	140	(623)	93	(413)
		B42A	857	(3812)	.318	(8.08)	674	(2998)	449	(1997)
72	(1829)	B42	256	(1139)	.792	(20.11)	97	(431)	65	(289)
		B42A	714	(3176)	.457	(11.61)	468	(2082)	312	(1388)
84	(2133)	B42	220	(978)	1.079	(27.40)	71	(316)	48	(213)
		B42A	612	(2722)	.623	(15.82)	344	(1530)	229	(1018)
96	(2438)	B42	192	(854)	1.409	(35.79)	55	(244)	36	(160)
		B42A	535	(2380)	.813	(20.65)	263	(1170)	176	(783)
108	(2743)	B42	171	(760)	1.783	(45.29)	43	(191)	29	(129)
		B42A	476	(2117)	1.029	(26.13)	208	(925)	139	(618)
120	(3048)	B42	154	(685)	2.202	(55.93)	35	(155)	23	(102)
		B42A	428	(1904)	1.271	(32.28)	168	(747)	112	(498)

Based on simple beam condition using an allowable design stress of 25,000 psi (172 MPa) in accordance with MFMA, with adequate lateral bracing (see page 11 for further explanation). Actual yield point of cold rolled steel is 42,000 psi. To determine concentrated load capacity at mid span, multiply uniform load by 0.5 and corresponding deflection by 0.8. *Failure determined by weld shear.

COLUMN LOADING

Unbraced Height In. mm		Channel Style	Max. Column Loading K = .80				Max. Column Loading (Loaded @ C.G.)					
			Loaded @ C.G.		Loaded @ Slot Face		K = .65		K = 1.0		K = 1.2	
			Lbs.	N	Lbs.	N	Lbs.	N	Lbs.	N	Lbs.	N
12	(305)	B42	9138	(40648)	3493	(15537)	9283	(41293)	8916	(39660)	8670	(38566)
		B42A	21094	(93831)	5834	(25951)	21304	(94765)	20793	(92492)	20469	(91050)
24	(609)	B42	8137	(36195)	3145	(13989)	8540	(37988)	7589	(33757)	7050	(31360)
		B42A	19757	(87883)	5585	(24843)	20299	(90294)	18964	(84356)	18094	(80486)
36	(914)	B42	7050	(31360)	2722	(12108)	7657	(34060)	5925	(26356)	4335	(19283)
		B42A	18094	(80486)	5237	(23295)	19067	(84814)	16654	(74080)	15057	(66977)
48	(1219)	B42	5405	(24042)	2227	(9906)	6786	(30185)	3512	(15622)	2439	(10849)
		B42A	16139	(71790)	4818	(21431)	17632	(78431)	13906	(61857)	11387	(50652)
60	(1524)	B42	3512	(15622)	1718	(7642)	5272	(23451)	2247	(9995)	1561**	(6943)
		B42A	13906	(61857)	4352	(19358)	16008	(71207)	10710	(47640)	7531	(33499)
72	(1829)	B42	2439	(10849)	1351	(6009)	3694	(16432)	1561**	(6943)	1084**	(4822)
		B42A	11387	(50652)	3856	(17152)	14200	(64165)	7531	(33499)	5230	(23264)
84	(2133)	B42	1792	(7971)	1087	(4835)	2714	(12072)	1147**	(5102)	796**	(3541)
		B42A	8645	(38455)	3332	(14821)	12206	(54295)	5533	(24612)	3842	(17090)
96	(2438)	B42	1372**	(6103)	891	(3963)	2078	(9243)	878**	(3905)	-	-
		B42A	6619	(29443)	2873	(12780)	10012	(44535)	4236	(18842)	2942**	(13086)
108	(2743)	B42	1084**	(4822)	743	(3305)	1642	(7304)	-	-	-	-
		B42A	5230	(23264)	2495	(11098)	7922	(35239)	3347	(14888)	2324**	(10337)
120	(3048)	B42	878**	(3905)	628	(2793)	1330**	(5916)	-	-	-	-
		B42A	4236	(18842)	2182	(9706)	6417	(28544)	2711**	(12059)	1883**	(8376)

**Where the slenderness ratio $\frac{KL}{r}$ exceeds 200, and K = end fixity factor, L = actual length and r = radius of gyration.

Reference page 14 for general fitting and standard finish specifications.

B52 Channel & Combinations

B52

- Thickness: 12 Gauge (2.6 mm)
- Standard lengths: 10' (3.05 m) & 20' (6.09 m)
- Standard finishes: Plain, Dura-Green, Pre-Galvanized, Hot-Dipped Galvanized
- Weight: 1.27 Lbs./Ft. (1.89 kg/m)

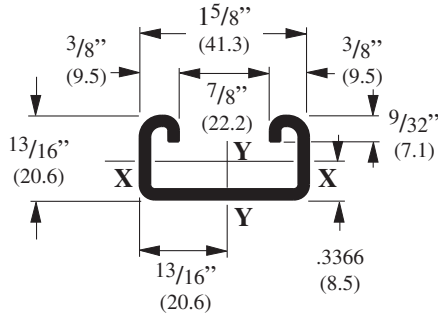
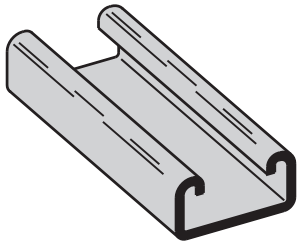

SECTION PROPERTIES

Channel	Weight lbs./ft. kg/m	Areas of Section sq. in. cm ²		X - X Axis						Y - Y Axis					
				Moment of Inertia (I) in. ⁴ cm ⁴		Section Modulus (S) in. ³ cm ³		Radius of Gyration (r) in. cm		Moment of Inertia (I) in. ⁴ cm ⁴		Section Modulus (S) in. ³ cm ³		Radius of Gyration (r) in. cm	
B52	1.313 (1.95)	.386 (2.49)	.386 (2.49)	.0320 (1.33)	.0320 (1.33)	.0673 (1.10)	.0673 (1.10)	.288 (.73)	.288 (.73)	.1404 (5.84)	.1404 (5.84)	.1728 (2.83)	.1728 (2.83)	.603 (1.53)	.603 (1.53)
B52A	2.627 (3.91)	.773 (4.99)	.773 (4.99)	.1517 (6.31)	.1517 (6.31)	.1868 (3.06)	.1868 (3.06)	.443 (1.13)	.443 (1.13)	.2809 (11.69)	.2809 (11.69)	.3457 (5.67)	.3457 (5.67)	.603 (1.53)	.603 (1.53)

Calculations of section properties are based on metal thicknesses as determined by the AISI Cold-Formed Steel Design Manual.

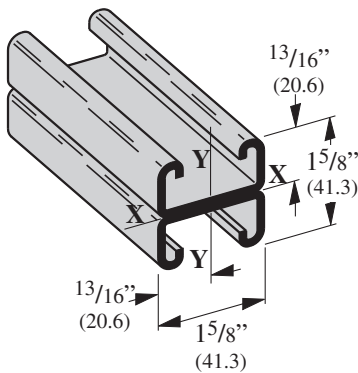

B52A

Wt. 2.54 Lbs./Ft. (3.78 kg/m)

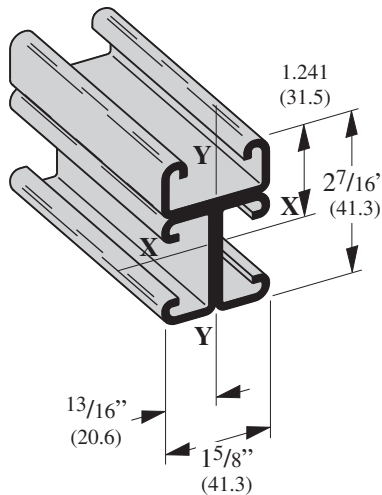

B52B3

Wt. 3.81 Lbs./Ft. (5.67 kg/m)

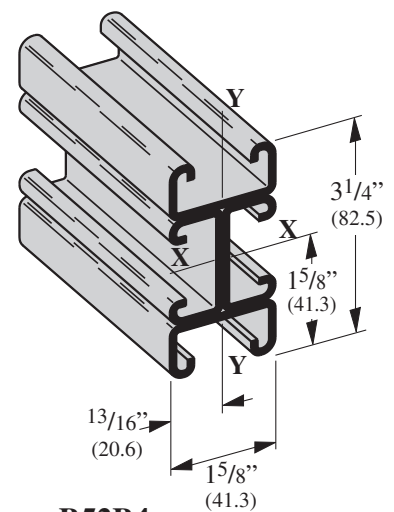

B52B4

Wt. 5.08 Lbs./Ft. (7.56 kg/m)

Reference page 14 for general fitting and standard finish specifications.

B52 Beam & Column Loading Data

BEAM LOADING

Beam Span		Channel Style	Uniform Load and Deflection				Uniform Load @ Deflection =			
In.	mm		Lbs.	N	In.	mm	1/240 Span		1/360 Span	
						Lbs.	N	Lbs.	N	
12	(305)	B52 B52A	1079 1270*	(4799) (5649)	.026 .006	(.66) (.15)	1079 1270*	(4799) (5649)	1079 1270*	(4799) (5649)
24	(609)	B52 B52A	539 1270*	(2397) (5649)	.106 .052	(2.69) (1.32)	506 1270*	(2251) (5649)	337 1270*	(1499) (5649)
36	(914)	B52 B52A	360 1013	(1601) (4506)	.240 .141	(6.09) (3.58)	225 1013	(1001) (4506)	150 719	(667) (3198)
48	(1219)	B52 B52A	270 759	(1201) (3376)	.427 .250	(10.84) (6.35)	126 607	(560) (2700)	84 404	(373) (1797)
60	(1524)	B52 B52A	216 608	(961) (2704)	.667 .391	(16.94) (9.93)	81 388	(360) (1726)	54 259	(240) (1152)
72	(1829)	B52 B52A	180 506	(800) (2251)	.960 .563	(24.38) (14.30)	56 270	(249) (1201)	37 180	(164) (800)
84	(2133)	B52 B52A	154 434	(685) (1930)	1.307 .766	(33.20) (19.45)	41 198	(182) (881)	28 132	(124) (587)
96	(2438)	B52 B52A	135 380	(600) (1690)	1.707 1.001	(43.36) (25.42)	32 152	(142) (676)	21 101	(93) (449)
108	(2743)	B52 B52A	120 338	(534) (1503)	2.160 1.267	(54.86) (32.18)	25 120	(111) (534)	17 80	(75) (356)
120	(3048)	B52 B52A	108 304	(480) (1352)	2.667 1.564	(67.74) (39.72)	20 97	(89) (431)	13 65	(58) (289)

Based on simple beam condition using an allowable design stress of 25,000 psi (172 MPa) in accordance with MFMA, with adequate lateral bracing (see page 11 for further explanation). Actual yield point of cold rolled steel is 42,000 psi. To determine concentrated load capacity at mid span, multiply uniform load by 0.5 and corresponding deflection by 0.8. *Failure determined by weld shear.

COLUMN LOADING

Unbraced Height		Channel Style	Max. Column Loading K = .80				Max. Column Loading (Loaded @ C.G.)					
In.	mm		Loaded @ C.G.		Loaded @ Slot Face		K = .65		K = 1.0		K = 1.2	
		Lbs.	N	Lbs.	N	Lbs.	N	Lbs.	N	Lbs.	N	
12	(305)	B52 B52A	8407 19160	(37396) (85228)	3162 5290	(14065) (23531)	8543 19425	(38001) (86407)	8205 18777	(36497) (83524)	7989 18363	(35537) (81682)
24	(609)	B52 B52A	7519 17444	(33446) (77595)	2755 4955	(12255) (22041)	7879 18144	(35047) (80708)	6521 16412	(29007) (73004)	5397 15275	(24007) (67946)
36	(914)	B52 B52A	5397 15275	(24007) (67946)	2152 4496	(9572) (19999)	6653 16547	(29594) (73605)	3616 13376	(16085) (59499)	2511 11243	(11169) (50011)
48	(1219)	B52 B52A	3178 12692	(14136) (56457)	1560 3963	(6939) (17628)	4785 14667	(21285) (65242)	2034 9683	(9047) (43072)	1412** 6780	(6281) (30159)
60	(1524)	B52 B52A	2034 9683	(9047) (43072)	1159 3383	(5155) (15048)	3081 12516	(13705) (55674)	1302** 6248	(5791) (27792)	904** 4339	(4021) (19301)
72	(1829)	B52 B52A	1412** 6780	(6281) (30159)	891 2799	(3963) (12450)	2139 10084	(9515) (44856)	904** 4339	(4021) (19301)	- 3013	- (13402)
84	(2133)	B52 B52A	1038** 4981	(4617) (22156)	704 2337	(3131) (10395)	1572 7545	(6992) (33562)	664** 3188	(2953) (14181)	- 2214**	- (9848)
96	(2438)	B52 B52A	794** 3814	(3532) (16965)	570 1973	(2535) (8776)	1203** 5777	(5351) (25697)	- 2441**	- (10858)	- 1695**	- (7540)
108	(2743)	B52 B52A	- 3013	- (13402)	470 1684	(2090) (7491)	951** 4564	(4230) (20301)	- 1928**	- (8576)	- 1339**	- (5956)
120	(3048)	B52 B52A	- 2441**	- (10858)	394 1452	(1752) (6459)	770** 3697	(3425) (16445)	- 1562**	- (6948)	- -	- -

**Where the slenderness ratio $\frac{KL}{r}$ exceeds 200, and K = end fixity factor, L = actual length and r = radius of gyration.

Reference page 14 for general fitting and standard finish specifications.

B54 Channel & Combinations

B54

- Thickness: 14 Gauge (1.9 mm)
- Standard lengths: 10' (3.05 m) & 20' (6.09 m)
- Standard finishes: Plain, Dura-Green, Pre-Galvanized, Hot-Dipped Galvanized, Stainless Steel Type 304 or 316, Aluminum
- Weight: .97 Lbs./Ft. (1.44 kg/m)

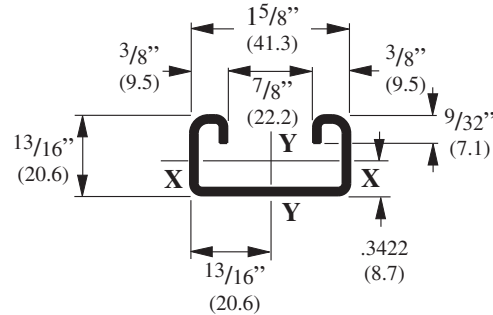
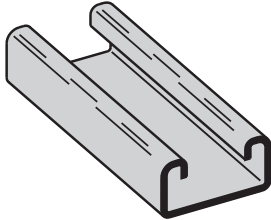

SECTION PROPERTIES

Channel	Weight lbs./ft. kg/m		Areas of Section sq. in. cm ²		Moment of Inertia (I) in. ⁴ cm ⁴		X - X Axis		Y - Y Axis		Moment of Inertia (I)		Section Modulus (S)		Radius of Gyration (r)	
							in. ³	cm ³	in. ⁴	cm ⁴	in. ³	cm ³	in.	cm	in. ³	cm ³
B54	1.016	(1.51)	.299	(1.93)	.0263	(1.09)	.0560	(.92)	.297	(.75)	.1106	(4.60)	.1361	(2.23)	.608	(1.55)
B54A	2.032	(3.02)	.598	(3.86)	.1226	(5.10)	.1510	(2.47)	.453	(1.15)	.2212	(9.12)	.2722	(4.46)	.608	(1.55)

Calculations of section properties are based on metal thicknesses as determined by the AISI Cold-Formed Steel Design Manual.

Channel & Combinations

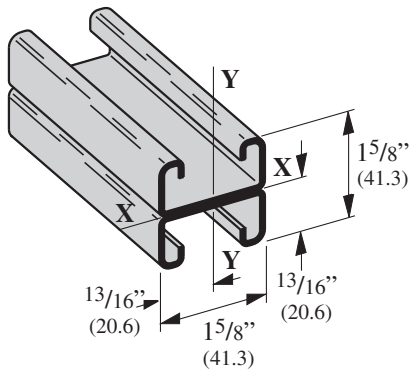

B54A

Wt. 1.94 Lbs./Ft. (2.89 kg/m)

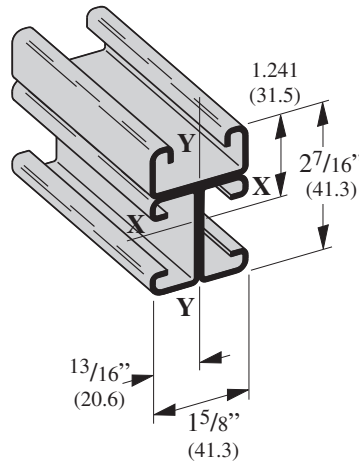

B54B3

Wt. 2.91 Lbs./Ft. (4.33 kg/m)

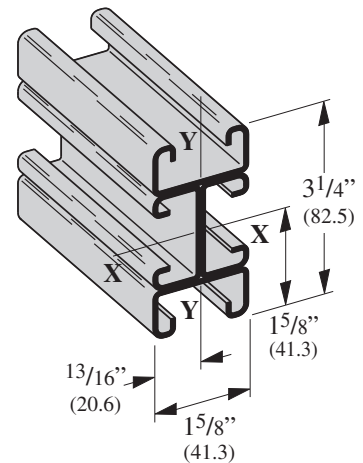

B54B4

Wt. 3.88 Lbs./Ft. (5.77 kg/m)

Reference page 14 for general fitting and standard finish specifications.

B54 Beam & Column Loading Data

BEAM LOADING

Beam Span In. mm		Channel Style	Uniform Load and Deflection				Uniform Load @ Deflection =			
			Lbs. N		In. mm		1/240 Span		1/360 Span	
			Lbs.	N	In.	mm	Lbs.	N	Lbs.	N
12	(305)	B54	870	(3870)	.027	(.68)	870	(3870)	870	(3870)
		B54A	870*	(3870)	.005	(.13)	870*	(3870)	870*	(3870)
24	(609)	B54	465	(2068)	.108	(2.74)	430	(1913)	287	(1276)
		B54A	870*	(3870)	.043	(1.09)	870*	(3870)	870*	(3870)
36	(914)	B54	310	(1379)	.243	(6.17)	191	(849)	127	(565)
		B54A	832	(3701)	.141	(3.58)	832	(3701)	591	(2629)
48	(1219)	B54	233	(1036)	.432	(10.97)	108	(480)	72	(320)
		B54A	624	(2775)	.250	(6.35)	499	(2219)	332	(1477)
60	(1524)	B54	186	(827)	.676	(17.17)	69	(307)	46	(204)
		B54A	499	(2219)	.391	(9.93)	319	(1419)	213	(947)
72	(1829)	B54	155	(689)	.973	(24.71)	48	(213)	32	(142)
		B54A	416	(1850)	.563	(14.30)	222	(987)	148	(658)
84	(2133)	B54	133	(591)	1.324	(33.63)	35	(155)	23	(102)
		B54A	357	(1588)	.766	(19.45)	163	(725)	109	(485)
96	(2438)	B54	116	(516)	1.730	(43.94)	27	(120)	18	(80)
		B54A	312	(1388)	1.001	(25.42)	125	(556)	83	(369)
108	(2743)	B54	103	(458)	2.189	(55.60)	21	(93)	14	(62)
		B54A	277	(1232)	1.267	(32.18)	98	(436)	66	(293)
120	(3048)	B54	93	(413)	2.703	(68.65)	17	(75)	11	(49)
		B54A	250	(1112)	1.564	(39.72)	80	(356)	53	(236)

Based on simple beam condition using an allowable design stress of 25,000 psi (172 MPa) in accordance with MFMA, with adequate lateral bracing (see page 11 for further explanation). Actual yield point of cold rolled steel is 42,000 psi. To determine concentrated load capacity at mid span, multiply uniform load by 0.5 and corresponding deflection by 0.8. *Failure determined by weld shear.

COLUMN LOADING

Unbraced Height In. mm		Channel Style	Max. Column Loading K = .80				Max. Column Loading (Loaded @ C.G.)					
			Loaded@ C.G.		Loaded@ Slot Face		K = .65		K = 1.0		K = 1.2	
			Lbs.	N	Lbs.	N	Lbs.	N	Lbs.	N	Lbs.	N
12	(305)	B54	6186	(27516)	2586	(11503)	6284	(27952)	6032	(26831)	5857	(26053)
		B54A	12763	(56772)	4060	(18060)	12835	(57093)	12645	(56248)	12501	(55607)
24	(609)	B54	5464	(24305)	2254	(10026)	5763	(25635)	4968	(22099)	4300	(19127)
		B54A	12135	(53979)	3857	(17157)	12420	(55247)	11663	(51879)	11087	(49317)
36	(914)	B54	4300	(19127)	1816	(8078)	5043	(22432)	3076	(13683)	2136	(9501)
		B54A	11087	(49317)	3549	(15787)	11728	(52169)	10026	(44598)	8729	(38828)
48	(1219)	B54	2703	(12023)	1341	(5965)	3920	(17437)	1730	(7695)	1201	(5342)
		B54A	9620	(42792)	3169	(14096)	10759	(47858)	7734	(34402)	5571	(24781)
60	(1524)	B54	1730	(7695)	995	(4426)	2621	(11659)	1107**	(4924)	769**	(3420)
		B54A	7734	(34402)	2745	(12210)	9514	(42320)	5134	(22837)	3566	(15862)
72	(1829)	B54	1201	(5342)	763	(3394)	1820	(8096)	769**	(3420)	534**	(2375)
		B54A	5571	(24781)	2291	(10191)	7992	(35550)	3566	(15862)	2476	(11014)
84	(2133)	B54	883**	(3928)	603	(2682)	1337	(5947)	565**	(2513)	-	-
		B54A	4093	(18206)	1913	(8509)	6200	(27579)	2620	(11654)	1819**	(8091)
96	(2438)	B54	676**	(3007)	487	(2166)	1024**	(4555)	-	-	-	-
		B54A	3134	(13941)	1616	(7188)	4747	(21116)	2006**	(8923)	1393**	(6196)
108	(2743)	B54	534**	(2375)	401	(1784)	809**	(3598)	-	-	-	-
		B54A	2476	(11014)	1380	(6138)	3751	(16685)	1585**	(7050)	1100**	(4893)
120	(3048)	B54	-	-	336	(1494)	655**	(2913)	-	-	-	-
		B54A	2006**	(8923)	1190	(5293)	3038	(13513)	1284**	(5711)	-	-

**Where the slenderness ratio $\frac{KL}{r}$ exceeds 200, and K = end fixity factor, L = actual length and r = radius of gyration.

Reference page 14 for general fitting and standard finish specifications.

B56 Channel & Combinations

B56

- Thickness: 16 Gauge (1.5 mm)
- Standard lengths: 10' (3.05 m) & 20' (6.09 m)
- Standard finishes: Plain, Dura-Green, Pre-Galvanized, Hot-Dipped Galvanized
- Weight: .85 Lbs./Ft. (1.26 kg/m)

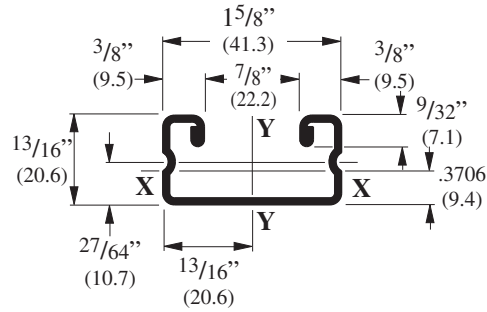
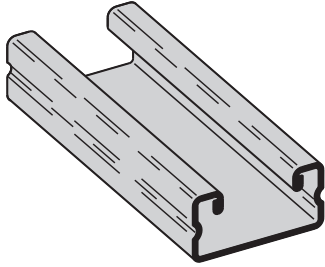

SECTION PROPERTIES

Channel	Weight lbs./ft. kg/m	Areas of Section		Moment of Inertia (I)		Section Modulus (S)		Radius of Gyration (r)		Moment of Inertia (I)		Section Modulus (S)		Radius of Gyration (r)	
		sq. in.	cm ²	in. ⁴	cm ⁴	in. ³	cm ³	in.	cm	in. ⁴	cm ⁴	in. ³	cm ³	in.	cm
B56	.894 (1.33)	.263 (1.70)		.0241 (1.00)		.0546 (.89)		.303 (.77)		.0966 (4.02)		.1189 (1.95)		.606 (1.54)	
B56A	1.789 (2.66)	.526 (3.39)		.1205 (5.02)		.1484 (2.43)		.479 (1.22)		.1931 (8.04)		.2377 (3.89)		.606 (1.54)	

Calculations of section properties are based on metal thicknesses as determined by the AISI Cold-Formed Steel Design Manual.

Channel & Combinations

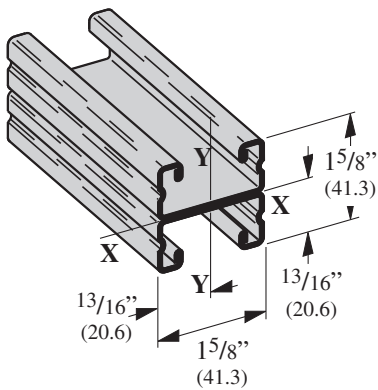

B56A

Wt. 1.70 Lbs./Ft. (2.53 kg/m)

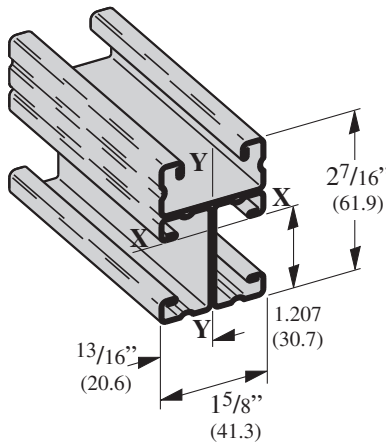

B56B3

Wt. 2.55 Lbs./Ft. (3.79 kg/m)

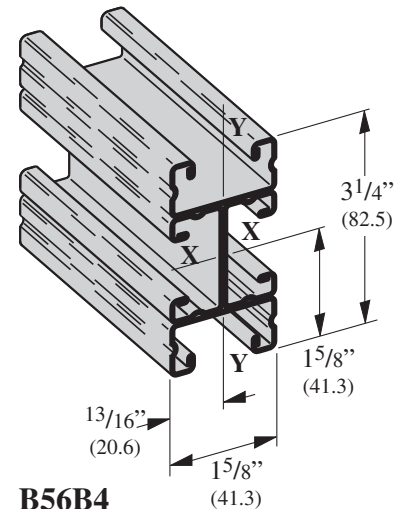

B56B4

Wt. 3.40 Lbs./Ft. (5.06 kg/m)

Reference page 14 for general fitting and standard finish specifications.

B56 Beam & Column Loading Data

BEAM LOADING

Beam Span In. mm		Channel Style	Uniform Load and Deflection				Uniform Load @ Deflection =			
			Lbs.		N		1/240 Span		1/360 Span	
In.	mm		Lbs.	N	In.	mm	Lbs.	N	Lbs.	N
12	(305)	B56	610	(2713)	.027	(.68)	610	(2713)	610	(2713)
		B56A	610*	(2713)	.004	(.10)	610*	(2713)	610*	(2713)
24	(609)	B56	405	(1801)	.109	(2.77)	372	(1655)	248	(1103)
		B56A	610*	(2713)	.035	(.89)	610*	(2713)	610*	(2713)
36	(914)	B56	270	(1201)	.245	(6.22)	165	(734)	110	(489)
		B56A	610*	(2713)	.121	(3.07)	610*	(2713)	502	(2233)
48	(1219)	B56	202	(898)	.435	(11.05)	93	(413)	62	(276)
		B56A	530	(2357)	.250	(6.35)	423	(1881)	282	(1699)
60	(1524)	B56	162	(720)	.680	(17.27)	59	(262)	40	(178)
		B56A	424	(1886)	.391	(9.93)	271	(1205)	181	(805)
72	(1829)	B56	135	(600)	.980	(24.89)	41	(182)	28	(124)
		B56A	353	(1570)	.563	(14.30)	188	(836)	125	(556)
84	(2133)	B56	116	(516)	1.334	(33.88)	30	(133)	20	(89)
		B56A	303	(1348)	.766	(19.45)	138	(614)	92	(409)
96	(2438)	B56	101	(449)	1.742	(44.24)	23	(102)	15	(67)
		B56A	265	(1179)	1.001	(25.42)	106	(471)	71	(316)
108	(2743)	B56	90	(400)	2.205	(56.01)	18	(80)	12	(53)
		B56A	236	(1050)	1.267	(32.18)	84	(373)	56	(249)
120	(3048)	B56	81	(360)	2.722	(69.14)	15	(67)	10	(44)
		B56A	212	(943)	1.564	(39.72)	68	(302)	45	(200)

Based on simple beam condition using an allowable design stress of 25,000 psi (172 MPa) in accordance with MFMA, with adequate lateral bracing (see page 11 for further explanation). Actual yield point of cold rolled steel is 42,000 psi. To determine concentrated load capacity at mid span, multiply uniform load by 0.5 and corresponding deflection by 0.8. *Failure determined by weld shear.

COLUMN LOADING

Unbraced Height In. mm		Channel Style	Max. Column Loading K = .80				Max. Column Loading (Loaded @ C.G.)					
			Loaded @ C.G.		Loaded @ Slot Face		K = .65		K = 1.0		K = 1.2	
In.	mm		Lbs.	N	Lbs.	N	Lbs.	N	Lbs.	N	Lbs.	N
12	(305)	B56	4968	(22099)	2182	(9706)	5044	(22437)	4845	(21551)	4702	(20915)
		B56A	10237	(45536)	3365	(14968)	10291	(45776)	10148	(45140)	10039	(44655)
24	(609)	B56	4367	(19425)	1903	(8465)	4624	(20568)	3985	(17726)	3572	(15889)
		B56A	9762	(43423)	3202	(14243)	9977	(44380)	9405	(41835)	8969	(39896)
36	(914)	B56	3572	(15889)	1557	(6926)	4034	(17944)	2658	(11823)	1845	(8207)
		B56A	8969	(39896)	2955	(13144)	9454	(42053)	8167	(36328)	7186	(31965)
48	(1219)	B56	2335	(10386)	1164	(5178)	3290	(14634)	1495	(6650)	1038	(4617)
		B56A	7860	(34963)	2649	(11783)	8722	(38797)	6434	(28620)	4731	(21044)
60	(1524)	B56	1495	(6650)	862	(3834)	2264	(10071)	957	(4257)	664**	(2953)
		B56A	6434	(28620)	2307	(10262)	7780	(34607)	4360	(19394)	3028	(13469)
72	(1829)	B56	1038	(4617)	661	(2940)	1572	(6992)	664**	(2953)	461**	(2050)
		B56A	4731	(21044)	1937	(8616)	6629	(29487)	3028	(13469)	2103	(9354)
84	(2133)	B56	763**	(3394)	522	(2322)	1155	(5137)	488**	(2171)	-	-
		B56A	3476	(15462)	1619	(7201)	5269	(23437)	2224	(9893)	1545**	(6872)
96	(2438)	B56	584**	(2598)	422	(1877)	884**	(3932)	-	-	-	-
		B56A	2661	(11837)	1368	(6085)	4031	(17931)	1703**	(7575)	1183**	(5262)
108	(2743)	B56	461**	(2050)	348	(1548)	699**	(3109)	-	-	-	-
		B56A	2103	(9354)	1169	(5200)	3185	(14167)	1346**	(5987)	934**	(4154)
120	(3048)	B56	-	-	291	(1294)	566**	(2417)	-	-	-	-
		B56A	1703**	(7575)	1008	(4484)	2580	(11476)	1090**	(4848)	-	-

**Where the slenderness ratio $\frac{KL}{r}$ exceeds 200, and K = end fixity factor, L = actual length and r = radius of gyration.

Reference page 14 for general fitting and standard finish specifications.

Telescoping Channel

BTS22TH

- Can be secured at any point of system
- Order BTS22TH & B22TH separately
- Thickness: 12 Gauge (1.5 mm)
- Standard lengths: 10' (3.05 m)
- Standard finishes: Dura-Green, Yellow Zinc Dichromate, Hot-Dipped Galvanized

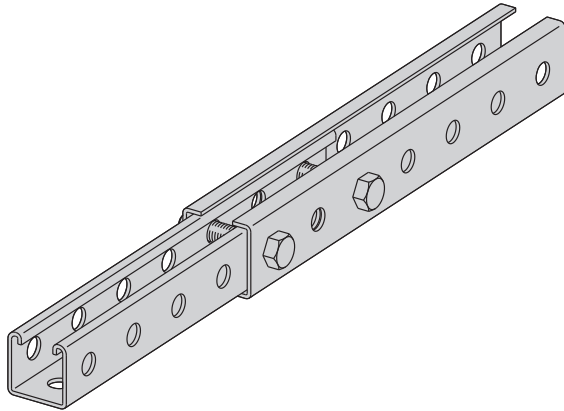

Slip Load Data

Resistance to slip*
700 lbs.

1/4" thick 2-hole fitting with (2) 1/2" bolts & channel nuts.
Typical of many standard fittings.

Resistance to slip*
3600 lbs.

1/2" bolt & nut

*With a safety factor of 3

BTS22TH TELESCOPING STRUT

Fits over all 1⁵/₈" x 1⁵/₈" channels ⁹/₁₆" holes on 1⁷/₈" centers 12 gauge material thickness

Section Properties			X-X Axis				Y-Y Axis			
Channel	Weight lbs./ft.	Area In ²	C _x In	I _x In ⁴	S _x In ³	r _x In	C _y In	I _y In ⁴	S _y In ³	r _y In
BTS22TH	1.934	0.4578	1.0009	0.2525	0.2523	0.7426	0.9375	0.2757	0.2941	0.7761

Section properties are based on nominal metal thickness, and overall dimensions.

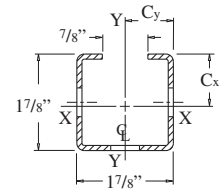

B22TH THREE HOLE STRUT

⁹/₁₆" holes on 1⁷/₈" centers 12 gauge material thickness

Section Properties			X-X Axis				Y-Y Axis			
Channel	Weight lbs./ft.	Area In ²	C _x In	I _x In ⁴	S _x In ³	r _x In	C _y In	I _y In ⁴	S _y In ³	r _y In
B22TH	1.760	0.3863	0.8245	0.1596	0.1936	0.6400	0.8125	0.1719	0.2116	0.6642

Section properties are based on nominal metal thickness, and overall dimensions.

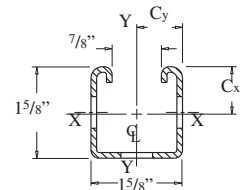

COMBINATION OF BTS22TH & B22TH

Section Properties			X-X Axis				Y-Y Axis			
Channel Combination	Weight lbs./ft.	Area In ²	C _x In	I _x In ⁴	S _x In ³	r _x In	C _y In	I _y In ⁴	S _y In ³	r _y In
BTS22TH/B22TH	3.597	0.8474	0.9773	0.4126	0.4222	0.6978	0.9375	0.4476	0.4774	0.7268

Section properties are based on nominal metal thickness, and overall dimensions.

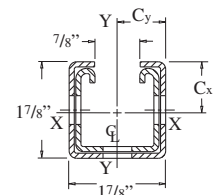

Reference page 14 for general fitting and standard finish specifications.

BEAM LOADING DATA

B22TH

Beam Span in	Beam Load Data x-x Axis		
	Allowable Load lbs*	Resulting Deflection in	Allowable Load @ Deflection= 1/240 Span
12	2225	0.015	3225
24	1610	0.061	1610
36	1071	0.136	1071
48	800	0.243	658
60	637	0.379	417
72	528	0.546	286
84	449	0.743	206
96	390	0.970	153
108	344	1.228	116
120	306	1.516	90

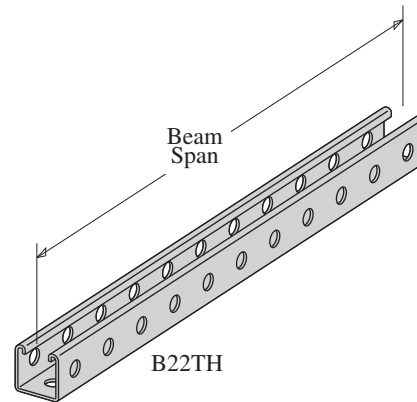

BTS22TH

Beam Span in	Beam Load Data x-x Axis		
	Allowable Load lbs*	Resulting Deflection in	Allowable Load @ Deflection= 1/240 Span
12	4203	0.012	4203
24	2099	0.050	2099
36	1396	0.112	1396
48	1044	0.200	1044
60	831	0.312	664
72	689	0.450	456
84	587	0.612	330
96	510	0.799	248
108	450	1.012	190
120	401	1.249	149

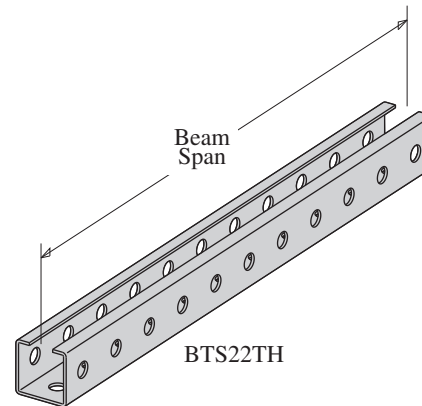

BTS22TH & B22TH TELESCOPING MEMBERS OF EQUAL LENGTH

Beam Span in	Beam Load Data x-x Axis		
	Allowable Load lbs*	Resulting Deflection in	Allowable Load @ Deflection= 1/240 Span
12	7033	0.013	7033
24	3511	0.051	3511
36	2335	0.115	2335
48	1745	0.205	1705
60	1389	0.320	1082
72	1151	0.460	742
84	980	0.627	536
96	851	0.819	401
108	749	1.036	307
120	668	1.279	239

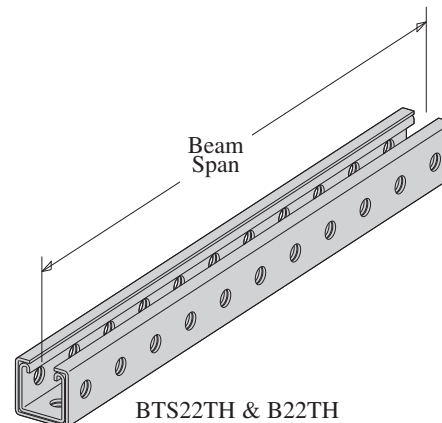

*Based on simple beam condition using an allowable design stress of 25,000 psi (172 MPa) with adequate lateral bracing (see page 11 for further explanation). To determine concentrated load capacity at mid span, multiply uniform load by 0.5 and corresponding deflection by 0.8.

Reference page 14 for general fitting and standard finish specifications.

Channel Hole Patterns

B11SH THRU B56SH SH TYPE CHANNEL

•For beam loads use 90% of Channel Loading Chart

Part No.	Thickness		Height H		Weight	
	Ga.	(mm)	In.	mm	Lbs./Ft.	kg/m
B11SH	12 Ga.	(2.6)	3 ¹ / ₄ "	(82.5)	2.97	(4.42)
B12SH	12 Ga.	(2.6)	27/16"	(61.9)	2.39	(3.55)
B22SH	12 Ga.	(2.6)	1 ⁵ / ₈ "	(41.3)	1.82	(2.71)
B24SH	14 Ga.	(1.9)	1 ⁵ / ₈ "	(41.3)	1.34	(1.99)
B26SH	16 Ga.	(1.5)	1 ⁵ / ₈ "	(41.3)	1.07	(1.59)
B32SH	12 Ga.	(2.6)	1 ³ / ₈ "	(34.9)	1.62	(2.41)
B42SH	12 Ga.	(2.6)	1"	(25.4)	1.36	(2.02)
B52SH	12 Ga.	(2.6)	1 ³ / ₁₆ "	(20.6)	1.19	(1.77)
B54SH	14 Ga.	(1.9)	1 ³ / ₁₆ "	(20.6)	.91	(1.35)
B56SH	16 Ga.	(1.5)	1 ³ / ₁₆ "	(20.6)	.80	(1.19)

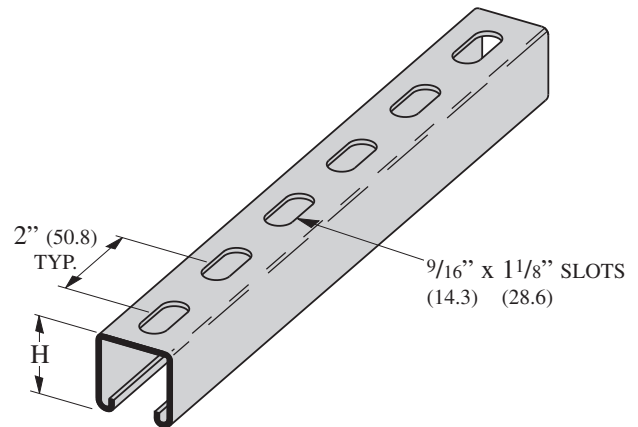

B11S THRU B56S S TYPE CHANNEL

•For beam loads use 90% of Channel Loading Chart

Part No.	Thickness		Height H		Weight	
	Ga.	(mm)	In.	mm	Lbs./Ft.	kg/m
B11S	12 Ga.	(2.6)	3 ¹ / ₄ "	(82.5)	2.94	(4.37)
B12S	12 Ga.	(2.6)	27/16"	(61.9)	2.36	(3.51)
B22S	12 Ga.	(2.6)	1 ⁵ / ₈ "	(41.3)	1.79	(2.66)
B24S	14 Ga.	(1.9)	1 ⁵ / ₈ "	(41.3)	1.32	(1.96)
B26S	16 Ga.	(1.5)	1 ⁵ / ₈ "	(41.3)	1.06	(1.58)
B32S	12 Ga.	(2.6)	1 ³ / ₈ "	(34.9)	1.59	(2.36)
B42S	12 Ga.	(2.6)	1"	(25.4)	1.33	(1.98)
B52S	12 Ga.	(2.6)	1 ³ / ₁₆ "	(20.6)	1.16	(1.72)
B54S	14 Ga.	(1.9)	1 ³ / ₁₆ "	(20.6)	.89	(1.32)
B56S	16 Ga.	(1.5)	1 ³ / ₁₆ "	(20.6)	.79	(1.17)

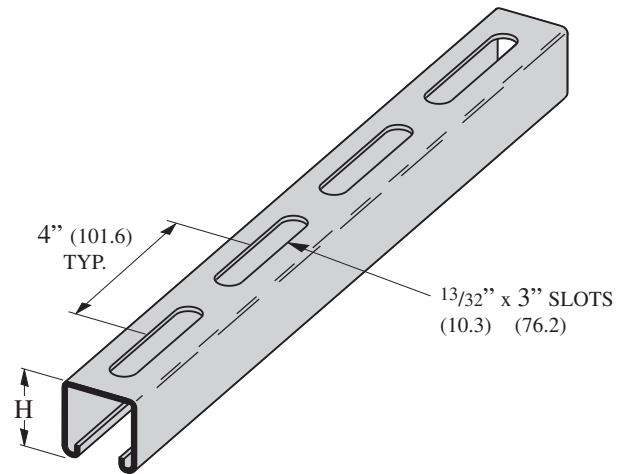

B11H17/8 THRU B56H17/8 H17/8 TYPE CHANNEL

•For beam loads use 90% of Channel Loading Chart

Part No.	Thickness		Height H		Weight	
	Ga.	(mm)	In.	mm	Lbs./Ft.	kg/m
B11H17/8	12 Ga.	(2.6)	3 ¹ / ₄ "	(82.5)	3.00	(4.46)
B12H17/8	12 Ga.	(2.6)	27/16"	(61.9)	2.42	(3.60)
B22H17/8	12 Ga.	(2.6)	1 ⁵ / ₈ "	(41.3)	1.85	(2.75)
B24H17/8	14 Ga.	(1.9)	1 ⁵ / ₈ "	(41.3)	1.36	(2.02)
B26H17/8	16 Ga.	(1.5)	1 ⁵ / ₈ "	(41.3)	1.09	(1.62)
B32H17/8	12 Ga.	(2.6)	1 ³ / ₈ "	(34.9)	1.65	(2.45)
B42H17/8	12 Ga.	(2.6)	1"	(25.4)	1.39	(2.07)
B52H17/8	12 Ga.	(2.6)	1 ³ / ₁₆ "	(20.6)	1.22	(1.81)
B54H17/8	14 Ga.	(1.9)	1 ³ / ₁₆ "	(20.6)	.93	(1.38)
B56H17/8	16 Ga.	(1.5)	1 ³ / ₁₆ "	(20.6)	.82	(1.22)

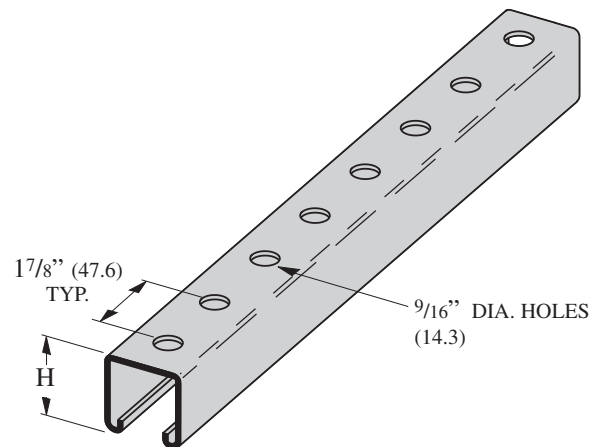

Reference page 14 for general fitting and standard finish specifications.

B22TH (TH TYPE CHANNEL)

•For beam loads use 90% of Channel Loading Chart

Part No.	Thickness		Height H		Weight	
	In.	mm	In.	mm	Lbs./Ft.	kg/m
B22TH	12 Ga.	(2.6)	1 ⁵ / ₈ "	(41.3)	1.76	(2.62)

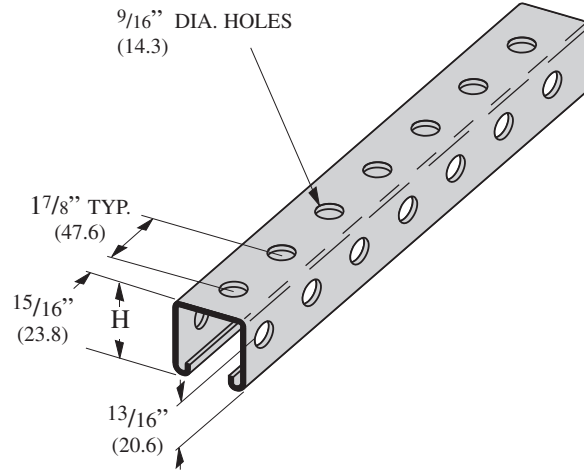

B11KO6 THRU B56KO6 (KO6 TYPE KNOCKOUT CHANNEL)

•For beam loads use 90% of Channel Loading Chart

Part No.	Thickness		Height H		Weight	
	In.	mm	In.	mm	Lbs./Ft.	kg/m
B11KO6	12 Ga.	(2.6)	3 ¹ / ₄ "	(82.5)	3.05	(4.54)
B12KO6	12 Ga.	(2.6)	2 ⁷ / ₁₆ "	(61.9)	2.47	(3.67)
B22KO6	12 Ga.	(2.6)	1 ⁵ / ₈ "	(41.3)	1.90	(2.83)
B24KO6	14 Ga.	(1.9)	1 ⁵ / ₈ "	(41.3)	1.40	(2.08)
B26KO6	16 Ga.	(1.5)	1 ⁵ / ₈ "	(41.3)	1.12	(1.66)
B32KO6	12 Ga.	(2.6)	1 ³ / ₈ "	(34.9)	1.70	(2.53)
B42KO6	12 Ga.	(2.6)	1"	(25.4)	1.44	(2.14)
B52KO6	12 Ga.	(2.6)	1 ³ / ₁₆ "	(20.6)	1.27	(1.89)
B54KO6	14 Ga.	(1.9)	1 ³ / ₁₆ "	(20.6)	.97	(1.44)
B56KO6	16 Ga.	(1.5)	1 ³ / ₁₆ "	(20.6)	.85	(1.26)

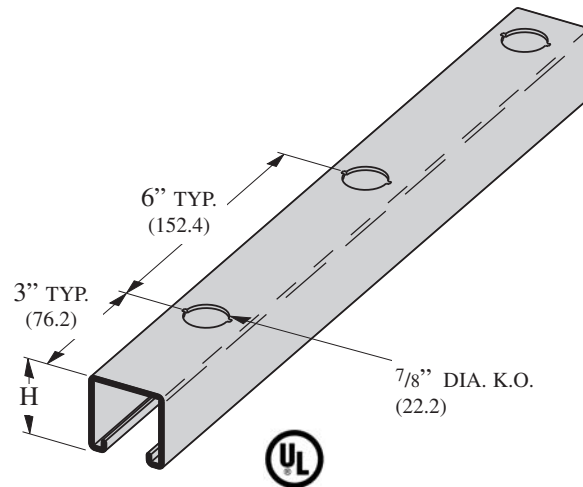

B22SHA (BACK TO BACK SH TYPE CHANNEL)

•For beam loads use 90% of Channel Loading Chart

Part No.	Thickness		Height H		Weight	
	In.	mm	In.	mm	Lbs./Ft.	kg/m
B22SHA	12 Ga.	(2.6)	3 ¹ / ₄ "	(82.5)	3.64	(5.42)

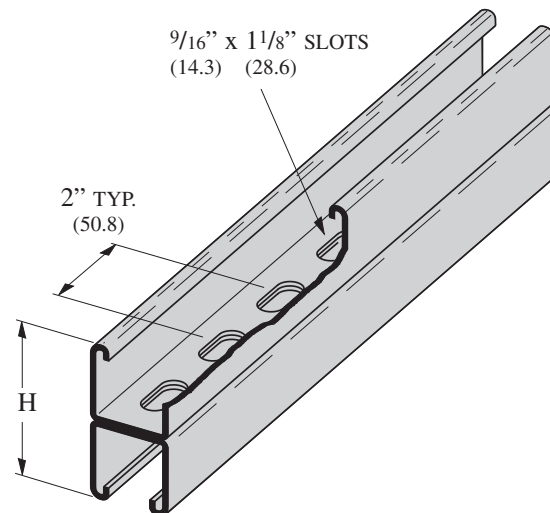

Reference page 14 for general fitting and standard finish specifications.

Channel Hole Patterns

BK22H112 THRU BK54H112 H11/2 TYPE CHANNEL

- For beam loads use 90% of Channel Loading Chart
- Standard Finish: Yellow Zinc Chromate (YZN) Other finishes available.

Part No.	Thickness		Height H		Weight	
	In.	mm	In.	mm	Lbs./Ft.	kg/m
BK22H112	12 Ga.	(2.6)	1 ⁵ / ₈ "	(41.3)	1.85	(2.75)
BK24H112	14 Ga.	(1.9)	1 ⁵ / ₈ "	(41.3)	1.36	(2.02)
BK52H112	12 Ga.	(2.6)	1 ³ / ₁₆ "	(20.6)	1.22	(1.81)
BK54H112	14 Ga.	(1.9)	1 ³ / ₁₆ "	(20.6)	.93	(1.38)

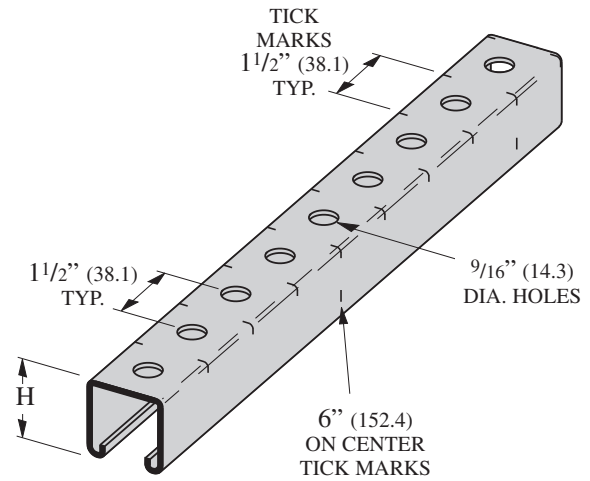

B11S58 THRU B56S58 S58 TYPE CHANNEL

- For beam loads use 90% of Channel Loading Chart

Part No.	Thickness		Height H		Weight	
	In.	mm	In.	mm	Lbs./Ft.	kg/m
B11S58	12 Ga.	(2.6)	3 ¹ / ₄ "	(82.5)	2.94	(4.37)
B12S58	12 Ga.	(2.6)	2 ⁷ / ₁₆ "	(61.9)	2.36	(3.51)
B22S58	12 Ga.	(2.6)	1 ⁵ / ₈ "	(41.3)	1.79	(2.66)
B24S58	14 Ga.	(1.9)	1 ⁵ / ₈ "	(41.3)	1.32	(1.96)
B26S58	16 Ga.	(1.5)	1 ⁵ / ₈ "	(41.3)	1.06	(1.58)
B32S58	12 Ga.	(2.6)	1 ³ / ₈ "	(34.9)	1.59	(2.36)
B42S58	12 Ga.	(2.6)	1"	(25.4)	1.33	(1.98)
B52S58	12 Ga.	(2.6)	1 ³ / ₁₆ "	(20.6)	1.16	(1.72)
B54S58	14 Ga.	(1.9)	1 ³ / ₁₆ "	(20.6)	.89	(1.32)
B56S58	16 Ga.	(1.5)	1 ³ / ₁₆ "	(20.6)	.79	(1.17)

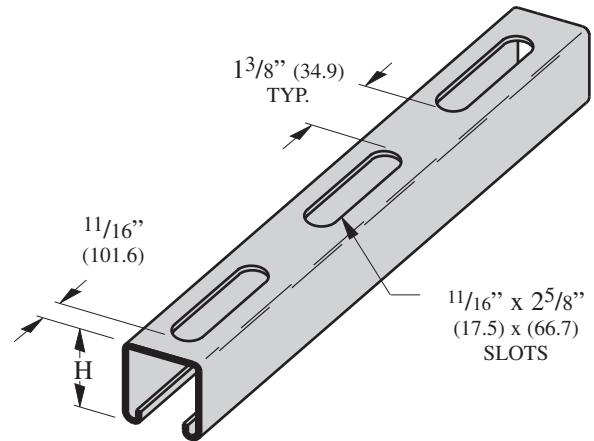

B22M THRU B54M M (MARINE RUNG) TYPE CHANNEL

- For beam loads use 90% of Channel Loading Chart

Part No.	Thickness		Height H		Weight	
	In.	mm	In.	mm	Lbs./Ft.	kg/m
B22M	12 Ga.	(2.6)	1 ⁵ / ₈ "	(41.3)	1.79	(2.66)
B24M	14 Ga.	(1.9)	1 ⁵ / ₈ "	(41.3)	1.32	(1.96)
B32M	12 Ga.	(2.6)	1 ³ / ₈ "	(34.9)	1.59	(2.36)
B42M	12 Ga.	(2.6)	1"	(25.4)	1.33	(1.98)
B44M	14 Ga.	(1.9)	1"	(25.4)	0.98	(1.46)
B52M	12 Ga.	(2.6)	1 ³ / ₁₆ "	(20.6)	1.16	(1.72)
B54M	14 Ga.	(1.9)	1 ³ / ₁₆ "	(20.6)	.89	(1.32)

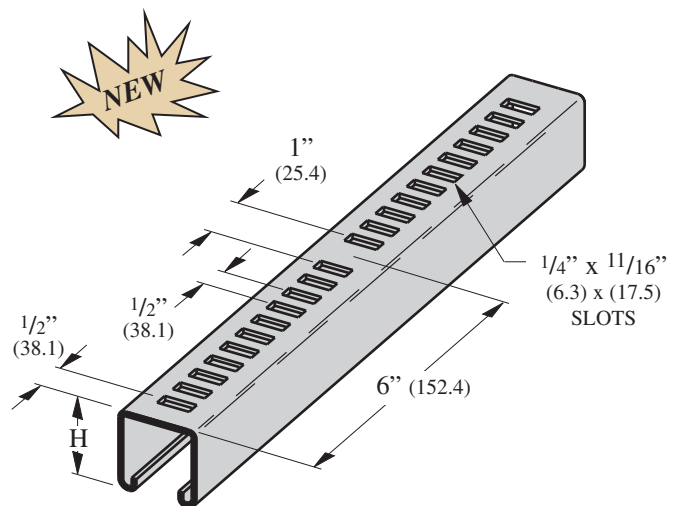

Reference page 14 for general fitting and standard finish specifications.

B22H25 THRU B56H25 H25 TYPE CHANNEL

•For beam loads use 90% of Channel Loading Chart

Part No.	Thickness		Height H		Weight	
			In.	mm	Lbs./Ft.	kg/m
B22H25	12 Ga.	(2.6)	1 ⁵ / ₈ "	(41.3)	1.85	(2.75)
B24H25	14 Ga.	(1.9)	1 ⁵ / ₈ "	(41.3)	1.36	(2.02)
B26H25	16 Ga.	(1.5)	1 ⁵ / ₈ "	(41.3)	1.09	(1.62)
B32H25	12 Ga.	(2.6)	1 ³ / ₈ "	(34.9)	1.65	(2.45)
B42H25	12 Ga.	(2.6)	1"	(25.4)	1.39	(2.07)
B52H25	12 Ga.	(2.6)	1 ³ / ₁₆ "	(20.6)	1.22	(1.81)
B54H25	14 Ga.	(1.9)	1 ³ / ₁₆ "	(20.6)	.93	(1.38)
B56H25	16 Ga.	(1.5)	1 ³ / ₁₆ "	(20.6)	.82	(1.22)

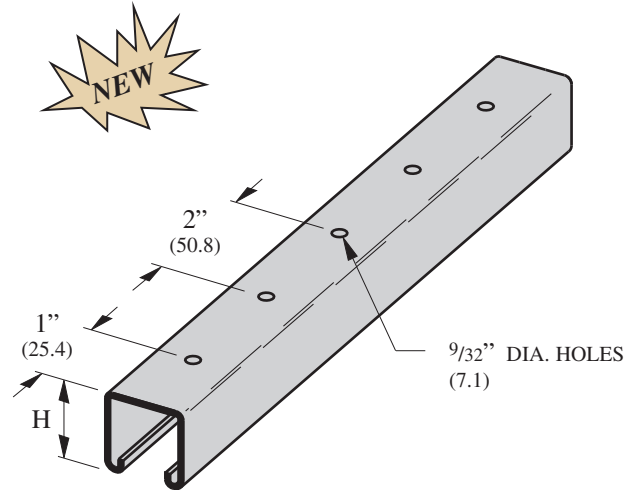

B96HP CHANNEL PUNCH

- Field-punch holes exactly where you want them in any type channel...Quick and easy!
- Any size holes...anywhere you need them...with on-the-job convenience!
- Channel punch will work on any standard single channels that have solid backs.
- Do not use this punch on combination, stainless steel, or KO6 channels.

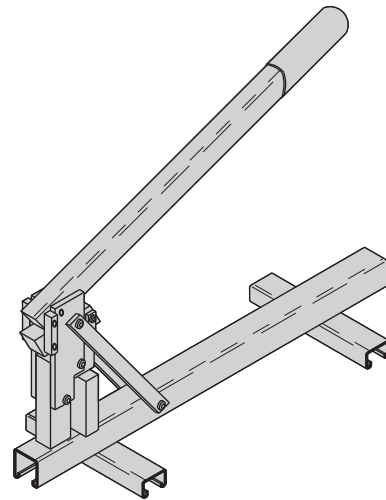

Die Blocks Only

Part No.	Hole Size		Bolt Size		Weight Each	
					Lbs.	kg
B96HP-0.562D	⁹ / ₁₆ "	(14.3)	¹ / ₂ "	(12.7)	.50	(.2)
B96HP-0.438D	⁷ / ₁₆ "	(11.1)	³ / ₈ "	(9.5)	.50	(.2)
B96HP-0.281D	⁹ / ₃₂ "	(7.1)	¹ / ₄ "	(6.3)	.50	(.2)

Punch & Die Block Assembly

Part No.	Hole Size		Bolt Size		Weight Each	
					Lbs.	kg
B96HP-0.562	⁹ / ₁₆ "	(14.3)	¹ / ₂ "	(12.7)	24.5	(11.1)
B96HP-0.438	⁷ / ₁₆ "	(11.1)	³ / ₈ "	(9.5)	24.5	(11.1)
B96HP-0.281	⁹ / ₃₂ "	(7.1)	¹ / ₄ "	(6.3)	24.5	(11.1)



Reference page 14 for general fitting and standard finish specifications.

Channel Nuts & Hardware

Channel Nuts

B-Line's channel nut is one of the main components of our metal framing system. It is designed to provide essential gripping power and ease during installation. Channel nuts are press formed, machined and hardened from steel which meets the requirements of ASTM A108 or ASTM A36 for our larger sizes.

Bolts, Screws, and Nuts

All bolts, screws and nuts meet the physical and chemical requirements of ASTM A307, SAE J429 or ASTM A563, and have unified inch screw threads (coarse, UNC). ISO metric threads are also available on special request.

Recommended Torque

Bolt Size	1/4"-20	5/16"-18	3/8"-16	1/2"-13
Foot/Lbs.	6	11	19	50
Nm	8	15	26	68

Bolt Size	M6x1	M8 x1.25	M10 x 1.5	M12x1.75
NM	12	17	36	62
Foot/Lbs.	9	13	27	46

Materials & Finishes*

Finish Code	Finish	Specification
PLN	Plain	ASTM A108/A307 Gr. A, ASTM A563, SAE J429
ZN	Electro-Plated Zinc	ASTM B633 SC1 Type III
CZ	Chromium Zinc	ASTM F1136 Gr. 3
HDG	Hot-Dipped Galvanized	ASTM A153
SS4	Stainless Steel Type 304	ASTM F593
SS6	Stainless Steel Type 316	MPIF 35/ASTM A593
AL	Aluminum	ASTM F468 S4

*Unless otherwise noted.

Note: Channel nuts are not available in HDG or Aluminum

Metric

Metric dimensions are shown in parentheses. Unless noted, all metric dimensions are in millimeters.



STANDARD CHANNEL NUTS

Numbering Example: **N 7 25 (*) WO**

Nut Type	Channel Type	Thread Size	Stud Length	Suffix
N = Standard Nut	7 = Tall Channels	21 = #8-32	* = Specify Length of stud below for Stud Nut or Twirl Stud Nuts	WO = Without Spring
TN = Twirl Nut	B11	22 = #10-24	$\frac{3}{4}$ = $\frac{3}{4}$ "	** = Twirl Nuts or nuts with springs have blank suffix
SN = Stud Nut	B12	27 = #10-32	1 = 1"	
STN = Stud Twirl Nut	2 = Medium Channels	24 = $\frac{1}{4}$ -20	$1\frac{1}{4}$ = $1\frac{1}{4}$ "	
NW = Combo Nut Washer	B22	23 = $\frac{5}{16}$ -18	$1\frac{1}{2}$ = $1\frac{1}{2}$ "	
	B24	28 = $\frac{3}{8}$ -16		
	B26	26 = $\frac{7}{16}$ -14		
	B32	25 = $\frac{1}{2}$ -13		
	5 = Short Channels	55 = $\frac{5}{8}$ -11		
	B42	75 = $\frac{5}{8}$ -11		
	B52	78 = $\frac{7}{8}$ -9		
	B54			
	B56			

METRIC CHANNEL NUTS

Numbering Example: **BMS 6 M**

Nut Type	Metric Thread Size	Suffix
BMS = Spring Nut	3 = M3.5	S = Short Spring
BMS-D = Spring Nut ($\frac{1}{2}$ " thick)	4 = M4	M = Medium Spring
BMT = Twirl Nut	5 = M5	L = Long Spring
BMT-D = Twirl Nut ($\frac{1}{2}$ " thick)	6 = M6	* = Twirl Nuts and nuts without springs have blank suffix
BMM = Spring Nut (Mini channel)	8 = M8	
	10 = M10	
	12 = M12	

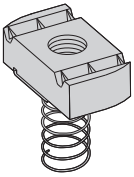

SPRING NUT

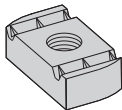

NUT WITHOUT SPRING

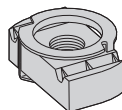

TWIRL-NUT®

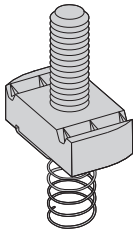

STUD NUT WITH SPRING

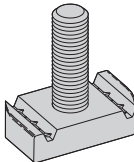

STUD NUT WITHOUT SPRING

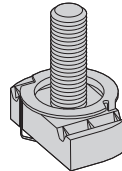

TWIRL STUD NUT

Reference page 44 for general fitting and standard finish specifications.

Channel Nuts

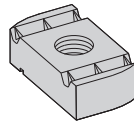

Note: See page 50 for resistance to slip & page 51 for pull-out strength.

NUT WITHOUT SPRING

Part No.	Thread Size	Fits Channel Sizes	Nut Thickness		Wt./C	
					Lbs.	kg
N221WO	#8-32	All sizes except B62 & B72	1/4"	(6.3)	7.0	(3.17)
N227WO	#10-32	All sizes except B62 & B72	1/4"	(6.3)	7.0	(3.17)
N222WO	#10-24	All sizes except B62 & B72	1/4"	(6.3)	7.0	(3.17)
N224WO	1/4-20	All sizes except B62 & B72	1/4"	(6.3)	6.7	(3.04)
N223WO	5/16-18	All sizes except B62 & B72	1/4"	(6.3)	6.7	(3.04)
N228WO	3/8-16	All sizes except B62 & B72	3/8"	(9.5)	9.3	(4.22)
N226WO	7/16-14	All sizes except B62 & B72	3/8"	(9.5)	8.8	(3.99)
N225WO	1/2-13	B11, B12, B22, B24, B26, B32	1/2"	(12.7)	11.6	(5.26)
N525WO	1/2-13	B42, B52, B54, B56	3/8"	(9.5)	8.8	(3.99)
N255WO	5/8-11	B11, B12, B22, B24, B26, B32	1/2"	(12.7)	16.4	(7.44)
N555WO	5/8-11	B42, B52, B54, B56	3/8"	(9.5)	10.2	(4.62)
N275WO	3/4-10	B11, B12, B22, B24, B26, B32	1/2"	(12.7)	14.5	(6.58)
N575WO	3/4-10	B42, B52, B54, B56	3/8"	(9.5)	8.8	(3.99)
N278WO	7/8-9	B11, B12, B22, B24, B26, B32	1/2"	(12.7)	12.5	(5.67)
Metric Threads						
BMS-6	M6 x 1	All sizes except B62 & B72	1/4"	(6.3)	6.9	(3.13)
BMS-8	M8 x 1.25	All sizes except B62 & B72	1/4"	(6.3)	6.7	(3.04)
BMS-10	M10 x 1.5	All sizes except B62 & B72	3/8"	(9.5)	9.6	(4.35)
BMS-12	M12 x 1.75	All sizes except B62 & B72	3/8"	(9.5)	9.2	(4.17)
BMS-D-12	M12 x 1.75	B11, B12, B22, B24, B26, B32	1/2"	(12.7)	12.2	(5.53)

Note: For mini channel nut information see page 191.

Reference page 44 for general fitting and standard finish specifications.

Note: See page 50 for resistance to slip & page 51 for pull-out strength.

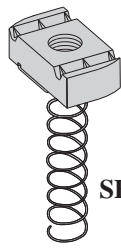

**700
SERIES**

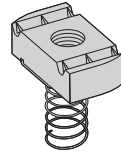

**200
SERIES**

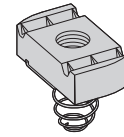

**500
SERIES**

SPRING NUT

Part No.	Thread Size	Fits Channel Sizes	Nut Thickness		Wt./C	
					Lbs.	kg
N721	#8-32	B11 & B12	1/4"	(6.3)	7.0	(3.17)
N221	#8-32	B22, B24, B26, B32	1/4"	(6.3)	7.0	(3.17)
N521	#8-32	B42, B52, B54, B56	1/4"	(6.3)	7.0	(3.17)
N727	#10-32	B11 & B12	1/4"	(6.3)	7.0	(3.17)
N227	#10-32	B22, B24, B26, B32	1/4"	(6.3)	7.0	(3.17)
N527	#10-32	B42, B52, B54, B56	1/4"	(6.3)	7.0	(3.17)
N722	#10-24	B11 & B12	1/4"	(6.3)	7.0	(3.17)
N222	#10-24	B22, B24, B26, B32	1/4"	(6.3)	7.0	(3.17)
N522	#10-24	B42, B52, B54, B56	1/4"	(6.3)	7.0	(3.17)
N724	1/4-20	B11 & B12	1/4"	(6.3)	6.7	(3.04)
N224	1/4-20	B22, B24, B26, B32	1/4"	(6.3)	6.7	(3.04)
N524	1/4-20	B42, B52, B54, B56	1/4"	(6.3)	6.7	(3.04)
N723	5/16-18	B11 & B12	1/4"	(6.3)	6.7	(3.04)
N223	5/16-18	B22, B24, B26, B32	1/4"	(6.3)	6.7	(3.04)
N523	5/16-18	B42, B52, B54, B56	1/4"	(6.3)	6.7	(3.04)
N728	3/8-16	B11 & B12	3/8"	(9.5)	9.3	(4.22)
N228	3/8-16	B22, B24, B26, B32	3/8"	(9.5)	9.3	(4.22)
N528	3/8-16	B42, B52, B54, B56	3/8"	(9.5)	9.3	(4.22)
N726	7/16-14	B11 & B12	3/8"	(9.5)	8.8	(3.99)
N226	7/16-14	B22, B24, B26, B32	3/8"	(9.5)	8.8	(3.99)
N526	7/16-14	B42, B52, B54, B56	3/8"	(9.5)	8.8	(3.99)
N725	1/2-13	B11 & B12	1/2"	(12.7)	11.6	(5.26)
N225	1/2-13	B22, B24, B26, B32	1/2"	(12.7)	11.6	(5.26)
N525	1/2-13	B42, B52, B54, B56	3/8"	(9.5)	8.8	(3.99)
N755	5/8-11	B11 & B12	1/2"	(12.7)	16.4	(7.44)
N255	5/8-11	B22, B24, B26, B32	1/2"	(12.7)	16.4	(7.44)
N555	5/8-11	B42, B52, B54, B56	3/8"	(9.5)	10.2	(4.62)
N775	3/4-10	B11 & B12	1/2"	(12.7)	14.5	(6.58)
N275	3/4-10	B22, B24, B26, B32	1/2"	(12.7)	14.5	(6.58)
N575	3/4-10	B42, B52, B54, B56	3/8"	(9.5)	8.8	(3.99)
N778	7/8-9	B11 & B12	1/2"	(12.7)	12.5	(5.67)
N278	7/8-9	B22, B24, B26, B32	1/2"	(12.7)	12.5	(5.67)
Metric Threads						
BMS-6L	M6 x 1	B11 & B12	1/4"	(6.3)	6.9	(3.13)
BMS-6M	M6 x 1	B22, B24, B26, B32	1/4"	(6.3)	6.9	(3.13)
BMS-6S	M6 x 1	B42, B52, B54, B56	1/4"	(6.3)	6.9	(3.13)
BMS-8L	M8 x 1.25	B11 & B12	1/4"	(6.3)	6.7	(3.04)
BMS-8M	M8 x 1.25	B22, B24, B26, B32	1/4"	(6.3)	6.7	(3.04)
BMS-8S	M8 x 1.25	B42, B52, B54, B56	1/4"	(6.3)	6.7	(3.04)
BMS-10L	M10 x 1.5	B11 & B12	3/8"	(9.5)	9.6	(4.35)
BMS-10M	M10 x 1.5	B22, B24, B26, B32	3/8"	(9.5)	9.6	(4.35)
BMS-10S	M10 x 1.5	B42, B52, B54, B56	3/8"	(9.5)	9.6	(4.35)
BMS-12M	M12 x 1.75	B22, B24, B26, B32	3/8"	(9.5)	9.2	(4.17)
BMS-12S	M12 x 1.75	B42, B52, B54, B56	3/8"	(9.5)	9.2	(4.17)
BMS-D-12L	M12 x 1.75	B11 & B12	1/2"	(12.7)	12.2	(5.53)
BMS-D-12M	M12 x 1.75	B22, B24, B26, B32	1/2"	(12.7)	12.2	(5.53)

Note: For mini channel nut information see page 191.

Reference page 44 for general fitting and standard finish specifications.

Channel Nuts

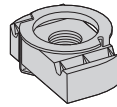

Note: See page 50 for resistance to slip & page 51 for pull-out strength.

TWIRL-NUT® Patented

Part No.	Thread Size	Fits Channel Sizes	Nut Thickness		Wt./C		
					Lbs.	kg	
TN221	#8-32	All sizes except B62 & B72	1/4"	(6.3)	7.0	(3.17)	
TN227	#10-32	All sizes except B62 & B72	1/4"	(6.3)	7.0	(3.17)	
TN222	#10-24	All sizes except B62 & B72	1/4"	(6.3)	7.0	(3.17)	
TN224	1/4-20	All sizes except B62 & B72	1/4"	(6.3)	6.7	(3.04)	
TN223	5/16-18	All sizes except B62 & B72	1/4"	(6.3)	6.7	(3.04)	
TN228	3/8-16	All sizes except B62 & B72	3/8"	(9.5)	9.3	(4.22)	
TN226	7/16-14	All sizes except B62 & B72	3/8"	(9.5)	8.8	(3.99)	
TN225	1/2-13	B11, B12, B22, B24, B26, B32	1/2"	(12.7)	11.6	(5.26)	
TN525	1/2-13	B42, B52, B54, B56	3/8"	(9.5)	8.8	(3.99)	
TN255	5/8-11	B11, B12, B22, B24, B26, B32	1/2"	(12.7)	11.0	(4.99)	
Metric Threads	BMT-6	M6 x 1	All sizes except B62 & B72	1/4"	(6.3)	6.9	(3.13)
	BMT-8	M8 x 1.25	All sizes except B62 & B72	1/4"	(6.3)	6.7	(3.04)
	BMT-10	M10 x 1.5	All sizes except B62 & B72	3/8"	(9.5)	9.6	(4.35)
	BMT-12	M12 x 1.75	All sizes except B62 & B72	3/8"	(9.5)	9.2	(4.17)
	BMT-D-12	M12 x 1.75	B11, B12, B22, B24, B26, B32	1/2"	(12.7)	12.2	(5.53)

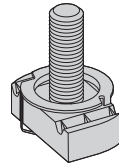

Note: See page 50 for resistance to slip & page 51 for pull-out strength.

STUD TWIRL NUT

Part No.	Thread Size	Fits Channel Sizes	Nut Thickness		Ave. Wt./C	
					Lbs.	kg
STN224-*	1/4-20	All sizes except B62 & B72	1/4"	(6.3)	8.1	(3.66)
STN228-*	3/8-16	All sizes except B62 & B72	3/8"	(9.5)	12.9	(5.85)
STN225-*	1/2-13	B11, B12, B22, B24, B26, B32	1/2"	(12.7)	18.2	(8.23)
STN525-*	1/2-13	B42, B52, B54, B56	3/8"	(9.5)	15.4	(6.96)

*Note: Add stud length in inches (3/4, 1, 1 1/4, 1 1/2)

Reference page 44 for general fitting and standard finish specifications.

Note: See page 50 for resistance to slip & page 51 for pull-out strength.

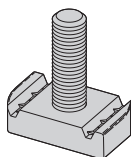

STUD NUT WITHOUT SPRING

Part No.	Thread Size	Fits Channel Sizes	Nut Thickness		Ave. Wt./C	
					Lbs.	kg
SN224-*WO	1/4-20	All sizes except B62 & B72	1/4"	(6.3)	8.1	(3.66)
SN228-*WO	3/8-16	All sizes except B62 & B72	3/8"	(9.5)	12.9	(5.85)
SN225-*WO	1/2-13	B11, B12, B22, B24, B26, B32	1/2"	(12.7)	18.2	(8.23)
SN525-*WO	1/2-13	B42, B52, B54, B56	3/8"	(9.5)	15.4	(6.96)

*Note: Add stud length in inches (3/4, 1, 1 1/4, 1 1/2)

Note: See page 50 for resistance to slip & page 51 for pull-out strength.

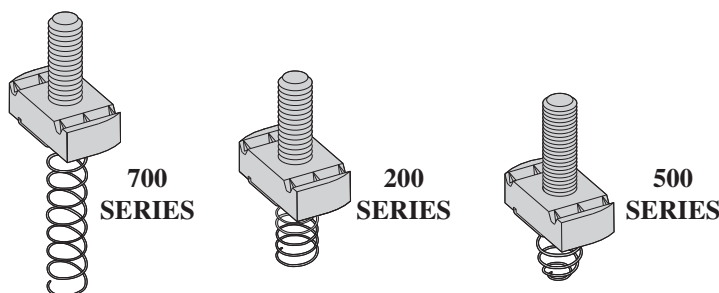

STUD NUT WITH SPRING

Part No.	Thread Size	Fits Channel Sizes	Nut Thickness		Ave. Wt./C	
					Lbs.	kg
SN724-*	1/4-20	B11 & B12	1/4"	(6.3)	8.1	(3.66)
SN224-*	1/4-20	B22, B24, B26, B32	1/4"	(6.3)	8.1	(3.66)
SN524-*	1/4-20	B42, B52, B54, B56	1/4"	(6.3)	8.1	(3.66)
SN728-*	3/8-16	B11 & B12	3/8"	(9.5)	12.9	(5.85)
SN228-*	3/8-16	B22, B24, B26, B32	3/8"	(9.5)	12.9	(5.85)
SN528-*	3/8-16	B42, B52, B54, B56	3/8"	(9.5)	12.9	(5.85)
SN725-*	1/2-13	B11 & B12	1/2"	(12.7)	18.2	(8.23)
SN225-*	1/2-13	B22, B24, B26, B32	1/2"	(12.7)	18.2	(8.23)
SN525-*	1/2-13	B42, B52, B54, B56	3/8"	(9.5)	15.4	(6.96)

*Note: Add stud length in inches (3/4, 1, 1 1/4, 1 1/2)

- Finish: Electrodeposited zinc ASTM B633 SC1
- Available in 316 stainless steel - add SS6 to part number

Note: See page 50 for resistance to slip & page 51 for pull-out strength.



Patent Number
7,604,444

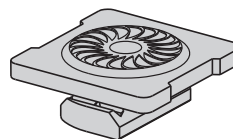

COMBO NUT WASHER

Part No.	Thread Size	Fits Channel Sizes	Nut Thickness		Ave. Wt./C	
					Lbs.	kg
NW524	1/4-20	All Channel Sizes	1/4"	(6.3)	11.9	(5.40)
NW528	3/8-16	All Channel Sizes	3/8"	(9.5)	13.8	(6.26)
NW525	1/2-13	All Channel Sizes	3/8"	(9.5)	13.1	(5.94)

Reference page 44 for general fitting and standard finish specifications.

Channel Nuts

RESISTANCE TO SLIP

•With Safety Factor of 3

Thread Size	Nut Part Numbers	Resistance to Slip					
		12 ga. Channel		14 ga. Channel		16 ga. Channel	
		Lbs.	N	Lbs.	N	Lbs.	N
#8-32	N221, N221WO, N521, N721, TN221	50	220	50	220	50	220
#10-24	N222, N222WO, N522, N722, TN222	100	440	100	440	100	440
#10-32	N227, N227WO, N527, N727, TN227	100	440	100	440	100	440
1/4"-20	NW524*, N224, N224WO, N524, N724, TN224, STN224, SN224WO, SN224, SN524, SN724	300	1330	300	1330	300	1330
5/16"-18	N223, N223WO, N523, N723, TN223	450	2000	450	2000	450	2000
3/8"-16	NW528*, N228, N228WO, N528, N728, TN228, STN228, SN228WO, SN228, SN528, SN728	800	3560	600	2670	600	2670
7/16"-14	N226, N226WO, N526, N726, TN226	1000	4450	800	3560	800	3560
1/2"-13	N225, N225WO, N725, TN225, STN225, SN225WO, SN225, SN725	1500	6670	1000	4450	1000	4450
	NW525*, N525, N525WO, TN525, STN525, SN525WO, SN525	1500	6670	1000	4450	1000	4450
5/8"-11	N255, N255WO, N755, TN255	1500	6670	1000	4450	1000	4450
	N555, N555WO	1500	6670	1000	4450	1000	4450
3/4"-10	N275, N275WO, N775	1500	6670	1000	4450	1000	4450
	N575, N575WO	1500	6670	1000	4450	1000	4450
7/8"-9	N278, N278WO, N778	1500	6670	1000	4450	1000	4450
M6 x 1	BMS-6, BMS-6L, BMS-6M, BMS-6S, BMT-6	300	1330	300	1330	300	1330
M8 x 1.25	BMS-8, BMS-8L, BMS-8M, BMS-8S, BMT-8	450	2000	450	2000	450	2000
M10 x 1.50	BMS-10, BMS-10L, BMS-10M, BMS-10S, BMT-20	800	3560	600	2760	600	2760
M12 x 1.75	BMS-D-12, BMS-D-12L, BMS-D-12M, BMT-D-12	1500	6670	1000	4450	1000	4450
	BMS-12, BMS-12M, BMS-12S, BMT-12	1500	6670	1000	4450	1000	4450

* Combo Nut Washer (see page 49)

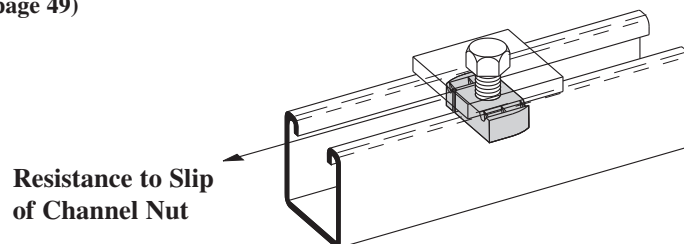

Note: For mini channel nut information see page 191.

Reference page 44 for general fitting and standard finish specifications.

PULL-OUT STRENGTH

•With Safety Factor of 3

•Maximum pullout strength for B11 & B12 channels is limited to 1500 lbs. (6670 N).

Thread Size	Nut Part Numbers	Pull-Out Strength					
		12 ga. Channel		14 ga. Channel		16 ga. Channel	
		Lbs.	N	Lbs.	N	Lbs.	N
#8-32	N221, N221WO, N521, N721, TN221	200	890	200	890	200	890
#10-24	N222, N222WO, N522, N722, TN222	250	1110	250	1110	250	1110
#10-32	N227, N227WO, N527, N727, TN227	250	1110	250	1110	250	1110
1/4"-20	NW524*, N224, N224WO, N524, N724, TN224, STN224, SN224WO, SN224, SN524, SN724	450	2000	450	2000	450	2000
5/16"-18	N223, N223WO, N523, N723, TN223	750	3330	750	3330	750	3330
3/8"-16	NW528*, N228, N228WO, N528, N728, TN228, STN228, SN228WO, SN228, SN528, SN728	1100	4890	1000	4450	1000	4450
7/16"-14	N226, N226WO, N526, N726, TN226	1500	6670	1200	5340	1000	4450
1/2"-13	N225, N225WO, N725, TN225, STN225, SN225WO, SN225, SN725	2000	8900	1400	6230	1000	4450
	NW525*, N525, N525WO, TN525, STN525, SN525WO, SN525	1500	6670	1400	6230	1000	4450
5/8"-11	N255, N255WO, N755, TN255	2000	8900	1400	6230	1000	4450
	N555, N555WO	1500	6670	1400	6230	1000	4450
3/4"-10	N275, N275WO, N775	2000	8900	1400	6230	1000	4450
	N575, N575WO	1500	6670	1400	6230	1000	4450
7/8"-9	N278, N278WO, N778	1500	6670	1400	6230	1000	4450
M6 x 1	BMS-6, BMS-6L, BMS-6M, BMS-6S, BMT-6	450	2000	450	2000	450	2000
M8 x 1.25	BMS-8, BMS-8L, BMS-8M, BMS-8S, BMT-8	750	3330	750	3330	750	3330
M10 x 1.50	BMS-10, BMS-10L, BMS-10M, BMS-10S, BMT-20	1100	4890	1000	4450	1000	4450
M12 x 1.75	BMS-D-12, BMS-D-12L, BMS-D-12M, BMT-D-12	2000	8900	1400	6230	1000	4450
	BMS-12, BMS-12M, BMS-12S, BMT-12	1500	6670	1400	6230	1000	4450

Channel Nuts & Hardware
Metric Threads

* Combo Nut Washer (see page 49)

Note: For mini channel nut information see page 191.

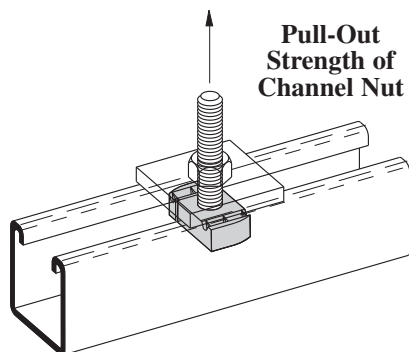

Reference page 44 for general fitting and standard finish specifications.

DCN 3/8 DOUBLE CONVEYOR NUT

- Recommended torque - 19 ft./Lbs.
- Allowable slip loading - 700 Lbs.(3.11kN)
- Safety Factor of 3
- Material: ASTM 1011SS Gr. 33
- Finish: Electrodeposited zinc ASTM B633 SC1
- Strut ordered separately

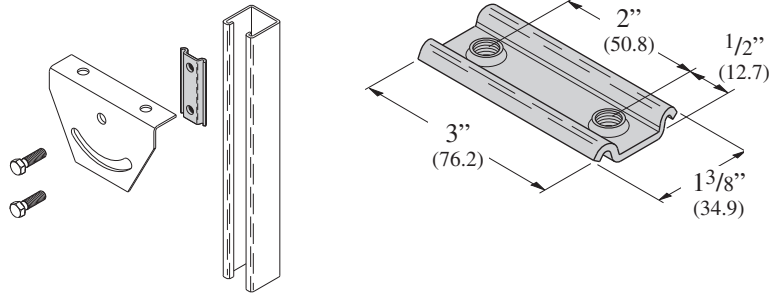

B501 SERIES U-BOLT

- Designed for use with Rigid Conduit or Iron Pipe
- Dimension "C" is dependent on the type of pipe or conduit supported and is a reference only

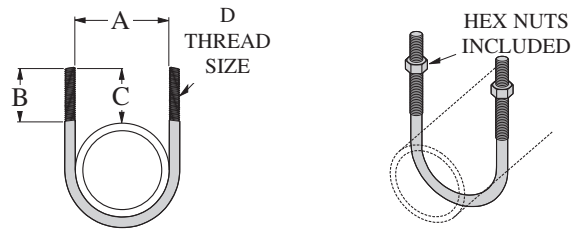

Part No.	A		B		C		D	Design Load		Wt./C	
	Lbs.	mm	Lbs.	mm	Lbs.	mm		Lbs.	kN	Lbs.	kg
B501-1/2	15/16"	(23.8)	1 3/4"	(44.4)	1 1/2"	(38.1)	5/16"-18	600	(2.67)	12	(5.4)
B501-3/4	1 1/8"	(28.6)	1 3/4"	(44.4)	1 5/8"	(41.3)	5/16"-18	600	(2.67)	13	(5.9)
B501-1	1 3/8"	(29.9)	1 7/8"	(47.6)	1 5/8"	(41.3)	5/16"-18	900	(4.00)	14	(6.3)
B501-1 1/4	1 23/32"	(43.6)	1 3/4"	(44.4)	1 15/32"	(37.3)	5/16"-18	900	(4.00)	15	(6.8)
B501-1 1/2	2"	(50.8)	1 3/4"	(44.4)	1 7/16"	(36.5)	5/16"-18	900	(4.00)	16	(7.2)
B501-2	2 7/16"	(61.9)	2 1/16"	(52.4)	1 7/8"	(47.6)	3/8"-16	1200	(5.34)	27	(12.2)
B501-2 1/2	2 15/16"	(74.6)	2 1/16"	(52.4)	1 13/16"	(46.0)	3/8"-16	1200	(5.34)	32	(14.5)
B501-3	3 9/16"	(90.5)	2"	(50.8)	1 3/4"	(44.4)	3/8"-16	1800	(8.00)	36	(16.3)
B501-3 1/2	4 3/32"	(94.6)	2"	(50.8)	1 23/32"	(43.6)	3/8"-16	1800	(8.00)	38	(17.2)
B501-4	4 19/32"	(116.7)	2 1/4"	(57.1)	1 21/32"	(50.0)	3/8"-16	1800	(8.00)	42	(19.0)
B501-5	5 21/32"	(143.6)	2 1/4"	(57.1)	2"	(50.8)	1/2"-13	2400	(10.70)	92	(41.7)
B501-6	6 3/4"	(171.4)	2 5/8"	(66.7)	2 3/8"	(60.3)	5/8"-11	2400	(10.70)	176	(79.8)
B501-8	8 3/4"	(222.2)	2 5/8"	(66.7)	2 3/8"	(60.3)	5/8"-11	2400	(10.70)	191	(86.6)

B500 SERIES SQUARE U-BOLT

- Includes:
 - 1 pc. U-Bolt only
 - 2 pcs. 3/8"-16 Hex Nuts
- Additional sizes available
- Standard finish: ZN, SS4

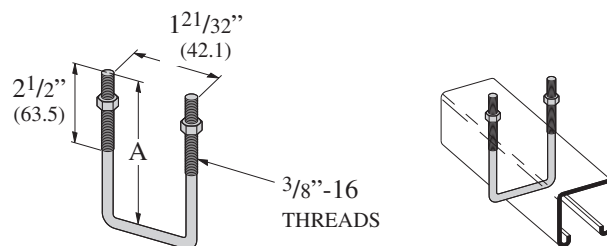

Part No.	A		Channel Size	Wt./C	
	Lbs.	mm		Lbs.	kg
B500-3-3/8	3 3/8"	(85.7)	1 5/8" x 1 5/8"	25	(11.3)
B500-5	5"	(127.0)	3 1/4" x 1 5/8"	33	(14.9)

Reference page 44 for general fitting and standard finish specifications.

HHCS HEX HEAD CAP SCREWS

•Standard finish: Zinc-Plated, Stainless Steel

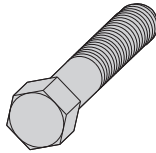

Part No.	Wt./C	
	Lbs.	kg
1/4" x 1/2" HHCS	1.3	(.59)
1/4" x 3/4" HHCS	1.4	(.63)
1/4" x 1" HHCS	1.7	(.77)
1/4" x 1 1/4" HHCS	2.1	(.95)
1/4" x 1 1/2" HHCS	2.4	(1.09)
5/16" x 1" HHCS	2.8	(1.27)
5/16" x 1 1/4" HHCS	3.2	(1.45)
5/16" x 1 1/2" HHCS	3.8	(1.72)
3/8" x 3/4" HHCS	3.4	(1.54)
3/8" x 1" HHCS	4.1	(1.86)
3/8" x 1 1/4" HHCS	4.7	(2.13)
3/8" x 1 1/2" HHCS	5.2	(2.36)
3/8" x 1 3/4" HHCS	5.9	(2.67)
3/8" x 2" HHCS	7.0	(3.17)
3/8" x 2 1/4" HHCS	7.8	(3.54)
3/8" x 2 1/2" HHCS	8.5	(3.85)
1/2" x 7/8" HHCS	8.0	(3.63)
1/2" x 1" HHCS	8.4	(3.81)
1/2" x 1 1/4" HHCS	9.2	(4.17)
1/2" x 1 1/2" HHCS	10.1	(4.58)
1/2" x 1 3/4" HHCS	12.0	(5.44)
1/2" x 2" HHCS	13.2	(5.99)
1/2" x 2 1/2" HHCS	16.0	(7.26)

SRHMS SLOTTED ROUND HEAD MACHINE SCREWS

•Standard finish: Zinc-Plated

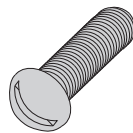

Part No.	Wt./C	
	Lbs.	kg
1/4" x 1/2" SRHMS	.9	(.41)
1/4" x 3/4" SRHMS	1.2	(.54)
1/4" x 1" SRHMS	1.5	(.68)
1/4" x 1 1/4" SRHMS	1.7	(.77)
1/4" x 1 1/2" SRHMS	1.9	(.86)
5/16" x 1" SRHMS	2.5	(1.13)
5/16" x 1 1/4" SRHMS	2.9	(1.31)
5/16" x 1 1/2" SRHMS	3.3	(1.49)
3/8" x 1" SRHMS	4.0	(1.81)
3/8" x 1 1/4" SRHMS	4.5	(2.04)
3/8" x 1 1/2" SRHMS	5.1	(2.31)
3/8" x 2" SRHMS	6.3	(2.86)
3/8" x 2 1/4" SRHMS	7.1	(3.22)
3/8" x 2 1/2" SRHMS	7.7	(3.49)

SFHMS SLOTTED FLAT HEAD MACHINE SCREWS

•Standard finish: Zinc-Plated

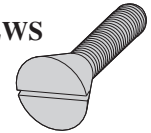

Part No.	Wt./C	
	Lbs.	kg
1/4" x 1/2" SFHMS	1.1	(.50)
1/4" x 5/8" SFHMS	1.2	(.54)
1/4" x 3/4" SFHMS	1.4	(.63)
5/16" x 1" SFHMS	2.8	(1.27)
3/8" x 1 1/2" SFHMS	5.6	(2.54)
3/8" x 2" SFHMS	6.7	(3.04)
3/8" x 2 1/4" SFHMS	7.3	(3.31)
3/8" x 2 1/2" SFHMS	7.9	(3.58)
1/2" x 1" SFHMS	5.9	(2.67)
1/2" x 1 1/4" SFHMS	7.0	(3.17)
1/2" x 1 1/2" SFHMS	8.3	(3.76)
1/2" x 2 1/2" SFHMS	13.8	(6.26)

SHHMS SLOTTED (COMBINATION RECESS) HEX HEAD MACHINE SCREWS

•Standard finish: Zinc-Plated, Stainless Steel

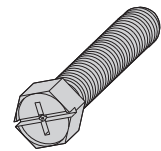

Part No.	Wt./C	
	Lbs.	kg
1/4" x 3/4" SHHMS	1.2	(.54)
1/4" x 1" SHHMS	1.5	(.68)
1/4" x 1 1/4" SHHMS	1.8	(.80)
1/4" x 1 1/2" SHHMS	2.0	(.91)
5/16" x 1" SHHMS	2.6	(1.18)
5/16" x 1 1/4" SHHMS	3.1	(1.40)
5/16" x 1 1/2" SHHMS	3.4	(1.54)
3/8" x 1 1/4" SHHMS	4.6	(2.08)
3/8" x 1 1/2" SHHMS	5.3	(2.40)

CNPSS SQUARE HEAD CONE POINT SET SCREWS

•Standard finish: ZN

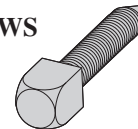

Part No.	Wt./C	
	Lbs.	kg
3/8" x 1 1/2" CNPSS	4.7	(2.13)
3/8" x 2" CNPSS	6.0	(2.72)
1/2" x 1 1/2" CNPSS	9.2	(4.17)
1/2" x 2" CNPSS	11.4	(5.17)
1/2" x 2 1/2" CNPSS	13.7	(6.21)
5/8" x 2" CNPSS	19.0	(8.62)
5/8" x 2 1/2" CNPSS	22.6	(10.25)

Reference page 44 for general fitting and standard finish specifications.

B446A SWIVEL HANGER (FEMALE ONLY)

- Design Load: (3/8)-610 Lbs. (2.71 kN)
(1/2)-1130 Lbs. (5.02 kN)
- Safety Factor of 3
- Standard finish: ZN

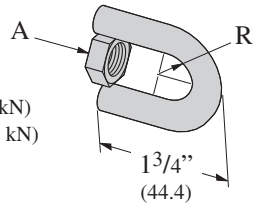

Part No.	A	R	Wt./C	
			Lbs.	kg
B446A-3/8	3/8"-16 HN	9/32" (7.1)	13	(5.9)
B446A-1/2	1/2"-13 HN	3/8" (9.5)	15	(6.8)

B446B SWIVEL HANGER (MALE ONLY)

- Design Load: (3/8)-610 Lbs. (2.71 kN)
(1/2)-1130 Lbs. (5.02 kN)
- Safety Factor of 3
- Standard finish: ZN

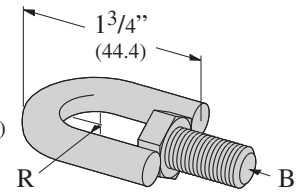

Part No.	B	R	Wt./C	
			Lbs.	kg
B446B-3/8	3/8"-16 HHCS	9/32" (7.1)	16	(7.2)
B446B-1/2	1/2"-13 HHCS	3/8" (9.5)	20	(9.1)

B446C SWIVEL HANGER (FEMALE-FEMALE)

- Design Load:
(3/8)-610 Lbs. (2.71 kN)
(1/2)-1130 Lbs. (5.02 kN)
- Safety Factor of 3
- Standard finish: ZN

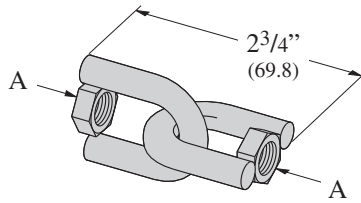

Part No.	A	Wt./C	
		Lbs.	kg
B446C-3/8	3/8"-16 HN	26	(11.8)
B446C-1/2	1/2"-13 HN	31	(14.0)

B446 SWIVEL HANGER (FEMALE-MALE)

- Design Load:
(3/8)-610 Lbs. (2.71 kN)
(1/2)-1130 Lbs. (5.02 kN)
- Safety Factor of 3
- Standard finish: ZN

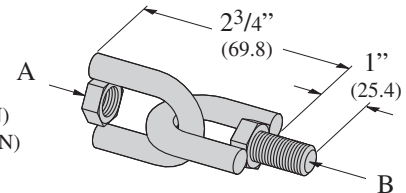

Part No.	A	B	Wt./C	
			Lbs.	kg
B446-3/8	3/8"-16 HN	3/8"-16 HHCS	28	(12.7)
B446-1/2	1/2"-13 HN	1/2"-13 HHCS	36	(16.3)

B617 SHOULDER BOLT

- Standard finish: ZN
- Wt./C 6 Lbs. (2.7 kg)

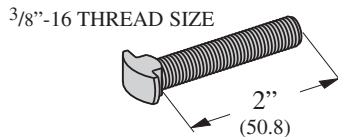

HN HEX NUTS

- Standard finish: Zinc-Plated, Stainless Steel



Part No.	Wt./C	
	Lbs.	kg
1/4" HN	.7	(.32)
5/16" HN	1.0	(.45)
3/8" HN	1.5	(.68)
1/2" HN	3.6	(1.63)
5/8" HN	7.2	(3.26)
3/4" HN	11.1	(5.03)
7/8" HN	17.9	(8.12)
1" HN	27.2	(12.34)

MSQN MACHINE SQUARE NUT

- For use with B755 Beam Clamp
- Standard finish: Zinc-Plated

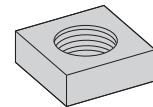

Part No.	Wt./C	
	Lbs.	kg
MSQN 1/4"	.6	(.27)
MSQN 5/16"	1.2	(.54)
MSQN 3/8"	1.8	(.81)

SQN SQUARE NUTS

- Standard finish: Zinc-Plated

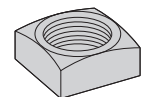

Part No.	Wt./C	
	Lbs.	kg
1/2" SQN	5.7	(2.58)
5/8" SQN	10.1	(4.58)

Reference page 44 for general fitting and standard finish specifications.

SLN SLIP-ON LOCK NUT

- Material: ASTM A307 Gr. A.
- Safety Factor of 3
- Standard finish: Zinc-Plated

Part No.	Size	B		C		Recommended Load		Wt./C	
		in.	mm	in.	mm	Lbs.	kN	Lbs.	kg
SLN $\frac{1}{2}$	$\frac{1}{2}$ "-13	$\frac{1}{8}$ "	(28.6)	$\frac{5}{8}$ "	(15.9)	1330	(5.91)	6.0	(2.72)
SLN $\frac{5}{8}$	$\frac{5}{8}$ "-11	$\frac{1}{4}$ "	(33.3)	$\frac{5}{8}$ "	(15.9)	1650	(7.34)	7.0	(3.17)

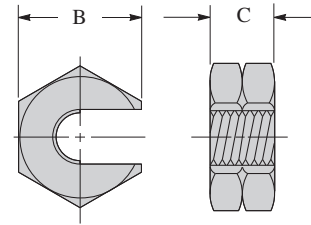

FW FLAT WASHERS

- Standard finish: Zinc-Plated, Stainless Steel

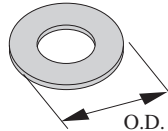

Part No.	O.D. Outside Dia.		Wt./C	
	in.	mm	Lbs.	kg
$\frac{1}{4}$ " FW	$\frac{47}{64}$ "	(18.7)	.7	(.32)
$\frac{5}{16}$ " FW	$\frac{7}{8}$ "	(22.2)	1.4	(.63)
$\frac{3}{8}$ " FW	1"	(25.4)	1.7	(.77)
$\frac{1}{2}$ " FW	$1\frac{3}{8}$ "	(34.9)	3.9	(1.77)
$\frac{5}{8}$ " FW	$1\frac{15}{32}$ "	(37.3)	6.4	(2.90)
$\frac{3}{4}$ " FW	2"	(50.8)	10.9	(4.94)
$\frac{7}{8}$ " FW	$2\frac{1}{4}$ "	(57.1)	13.4	(6.08)
1" FW	$2\frac{1}{2}$ "	(63.5)	18.8	(8.53)

FFW FLAT FENDER WASHERS

- Standard finish: Zinc-Plated

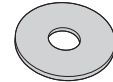

Part No.	Wt./C	
	Lbs.	kg
$\frac{1}{4}$ " x $\frac{1}{4}$ " FFW	2.2	(1.00)
$\frac{1}{4}$ " x $\frac{1}{2}$ " FFW	3.1	(1.40)
$\frac{3}{8}$ " x $\frac{1}{4}$ " FFW	2.0	(.91)
$\frac{3}{8}$ " x $\frac{1}{2}$ " FFW	3.0	(1.36)
$\frac{1}{2}$ " x 2" FFW	5.4	(2.45)

LW LOCK WASHERS

- Standard finish: Zinc-Plated, Stainless Steel

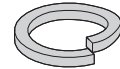

Part No.	Wt./C	
	Lbs.	kg
$\frac{1}{4}$ " LW	.3	(.13)
$\frac{5}{16}$ " LW	.4	(.18)
$\frac{3}{8}$ " LW	.6	(.27)
$\frac{1}{2}$ " LW	1.3	(.59)
$\frac{5}{8}$ " LW	2.4	(1.09)
$\frac{3}{4}$ " LW	3.8	(1.72)
$\frac{7}{8}$ " LW	5.9	(2.67)
1" LW	8.8	(3.99)

SC228 HANGER ROD STIFFENER

- For $\frac{3}{8}$ " thru $\frac{5}{8}$ " ATR
- Strut ordered separately
- Standard finish: ZN

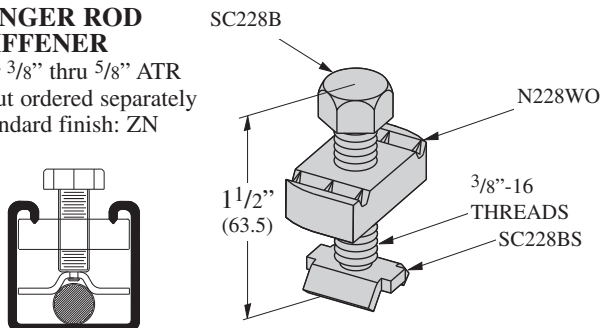

SC-UB HANGER ROD STIFFENER

- For $\frac{3}{4}$ " thru $\frac{7}{8}$ " ATR
- Strut ordered separately
- Includes: (1) B3188- $1\frac{1}{2}$ WO U-Bolt
(2) $\frac{3}{8}$ "-16 Hex Nuts
(1) 2-Hole Plate
- Standard finish: ZN

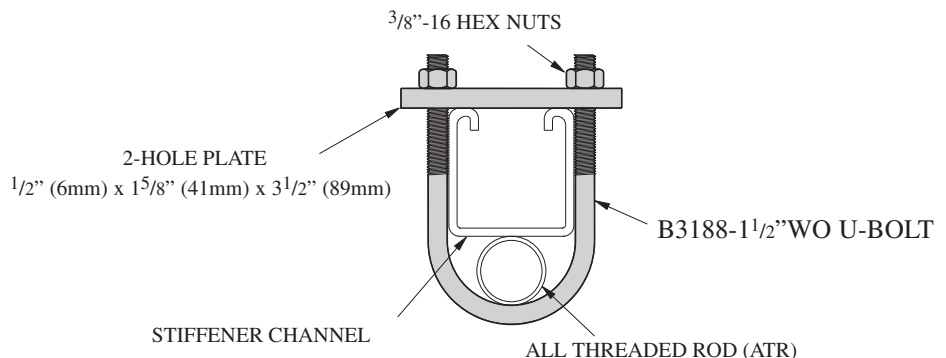

Reference page 44 for general fitting and standard finish specifications.

ATR

ALL THREADED ROD

- Available in 36" (91.4 cm), 72" (182.9 cm), 120" (304.8 cm), 144" (365.7 cm) lengths
- Safety Factor of 5 on recommended load
- Standard finish: Zinc-Plated, Stainless Steel Type 304

Part No. & Size	Threads Per Inch	Recommended Load		Wt./C Ft. (3048.0 cm)	
		Lbs.	kN	Lbs.	kg
ATR 1/4"	20	240	(1.07)	12	(5.44)
ATR 5/16"	18	400	(1.78)	19	(8.62)
ATR 3/8"	16	730	(3.24)	29	(13.15)
ATR 1/2"	13	1350	(6.00)	53	(24.04)
ATR 5/8"	11	2160	(9.60)	89	(40.37)
ATR 3/4"	10	3230	(14.37)	123	(55.79)
ATR 7/8"	9	4480	(19.93)	170	(77.11)
ATR 1"	8	5900	(26.24)	225	(102.06)

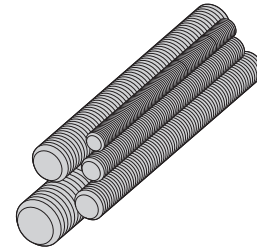

B655 ROD COUPLING B656 REDUCER ROD COUPLING

- Load rating for each coupler meets All Threaded Rod value
- Standard finish: Zinc-Plated, Stainless Steel Type 304

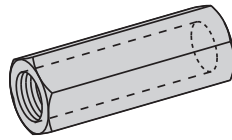

Part No.	Size	Recommended Load		Length		Wt./C	
		Lbs.	kN	Lbs.	kg	Lbs.	kg
B655-1/4	1/4"-20	240	(1.07)	7/8"	(22.2)	1.9	(.86)
B655-5/16	5/16"-18	380	(1.69)	7/8"	(22.2)	1.8	(.81)
B655-3/8	3/8"-16	730	(3.24)	1 1/8"	(28.6)	3.6	(1.63)
B655-1/2	1/2"-13	1350	(6.00)	1 3/4"	(44.4)	11.3	(5.12)
B655-5/8	5/8"-11	1810	(8.05)	2 1/8"	(54.0)	17.6	(7.98)
B655-3/4	3/4"-10	2710	(12.05)	2 1/4"	(57.1)	28.1	(12.74)
B655-7/8	7/8"-9	3770	(16.77)	2 1/2"	(63.5)	57.2	(25.94)
B655-1	1"-8	4960	(22.06)	2 3/4"	(69.8)	73.7	(33.43)

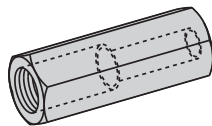

Part No.	Size	Recommended Load		Length		Wt./C	
		Lbs.	kN	Lbs.	kg	Lbs.	kg
B656-3/8 x 1/4	3/8"-16 & 1/4"-20	240	(1.07)	1"	(25.4)	3.7	(1.68)
B656-1/2 x 3/8	1/2"-13 & 3/8"-16	610	(2.71)	1 1/4"	(31.7)	6.6	(2.99)
B656-5/8 x 1/2	5/8"-11 & 1/2"-13	1130	(5.02)	1 1/4"	(31.7)	11.6	(5.26)
B656-3/4 x 5/8	3/4"-10 & 5/8"-11	1810	(8.05)	1 1/2"	(38.1)	20.6	(9.34)
B656-7/8 x 3/4	7/8"-9 & 3/4"-10	2710	(12.05)	1 3/4"	(44.4)	39.4	(17.87)

BHR SERIES HOT RODS FOR TRAPEZE HANGERS

- 12" length of threaded rod completely assembled with rod coupling, locking hex nuts, square washer, and channel nut.
- Standard finish: Zinc-Plated

Part No.	Rod Size	Recommended Load		Wt./C	
		Lbs.	kN	Lbs.	kg
BHR1225ZN	1/4"-20	240	(1.07)	41	(18.6)
BHR1238ZN	3/8"-16	730	(3.24)	63	(28.6)
BHR1250ZN	1/2"-13	1350	(6.00)	98	(44.4)
BHR1262ZN	5/8"-11	1500	(6.67)	148	(67.1)

Note: Based on use with 12 ga. channel.

(BHR1225, BHR1238, and BHR1250 use combo nut washers instead of square washers and channel nuts)



Reference page 44 for general fitting and standard finish specifications.

KWIKWIRE™ HANGING SYSTEM

KWIKPAK™ WIRE ROPE & CLAMPS IN HANDY CARRYING CARTON

- Dispenser Box - Easy Jobsite Handling.
- 1 Kit per box

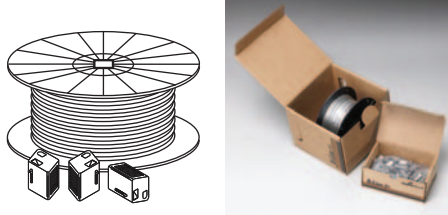

Part No.	Kit Includes	Wt./Kit	
		Lbs.	kg
BKP10063	BKC100 (100 pcs.) 1/16"Ø Wire Rope (500 ft.)	9.1	(4.1)
BKP10094	BKC100 (100 pcs.) 3/32"Ø Wire Rope (500 ft.)	18.1	(8.2)
BKP15094	BKC150 (100 pcs.) 3/32"Ø Wire Rope (500 ft.)	--	(--)
BKP15125	BKC150 (100 pcs.) 1/8"Ø Wire Rope (500 ft.)	--	(--)
BKP20125	BKC200 (50 pcs.) 1/8"Ø Wire Rope (500 ft.)	31.0	(14.1)
BKP20188	BKC200 (50 pcs.) 3/16"Ø Wire Rope (250 ft.)	33.0	(15.0)

CLAMPS

- For use with Wire Rope

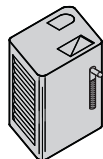

Part No.	For Use With Wire Rope Diameters	Qty. Per Box	Wt./Box	
			Lbs.	kg
BKC100	1/16" & 3/32"	100	4.1	(1.8)
BKC150	3/32" & 1/8"	100	--	(--)
BKC200	1/8" & 3/16"	50	15.0	(6.8)

KwikWire™ Clamp Working Loads**

Clamp Part No.	Wire Rope Dia.	Lbs. Safety Factor 5
BKL100	1/16"	0-75
BKL100	3/32"	25-150
BKL150	3/32"	25-150
BKL150	1/8"	25-250
BKL200	1/8"	25-250
BKL200	3/16"	50-640

**Working loads shown are for hanging vertically. For suspending at 15°, 30°, 45° or 60° angles from vertical use the following percentage of the working loads from the chart:
15° = 96%, 30° = 86%,
45° = 70%, 60° = 50%

For additional information on KwikWire™ products see the KwikWire brochure on the website at www.cooperblineline.com

WIRE ROPE

- Uncoated Galvanized Wire
- 1 Spool per box

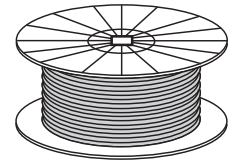

Part No.	Diameter	Working Load		Spool Qty.		Wt./Spool	
		Lbs.	kg	Ft.	M	Lbs.	kg
BKW063 (1)	1/16"	96	(43.5)	500	(152.4)	5.0	(2.3)
BKW094 (1)	3/32"	184	(83.4)	500	(152.4)	14.0	(6.3)
BKW125 (1)	1/8"	340	(154.2)	500	(152.4)	16.0	(7.2)
BKW188 (2)	3/16"	840	(381.0)	250	(76.2)	18.0	(8.2)

(1) Wire rope construction Type 7 x 7 (2) Wire rope construction Type 7 x 19

AIR DUCT CORNER POTECTORS BKCP

- Material: Plastic
- 100 per box
- Weight per 100 pcs. 1.0 Lbs. (0.45 kg)

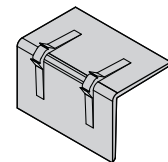

WIRE ROPE CUTTER BKCC

- Never use cutter on energized circuits, wire, or cable.
- 1 per box
- Weight per each 1.0 Lbs. (0.45 kg)

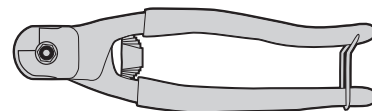

KwikWire™ System Recommendations:

- Do not exceed the safe working load of the products shown in their charts
- KwikWire™ Clamp load ratings are guaranteed only when used in combination with B-Line/Cooper supplied wire rope
- Do not use for overhead lifting or hoisting
- Do not use if cable or components are visibly distorted or worn, remove damaged cable end prior to inserting in KwikWire™ Clamp
- Do not paint cable near working area of KwikWire Clamp connector
- Do not apply lubricant
- Keep product clean and free of dirt
- Do not use on coated wire rope
- Do not use in chlorinated or caustic atmospheres
- For use in dry locations
- Cooper's BKCC tool is recommended for cutting wire rope to prevent fraying

Reference page 44 for general fitting and standard finish specifications.

Fittings

This section offers a full selection of fittings and accessories to complete B-Line's metal framing system. Fittings are made from hot rolled, pickled and oiled plate or strip steel in accordance with ASTM A1018 33,000 PSI min. yield, unless noted.

Dimensions

The following dimensions apply to all fittings except as noted:

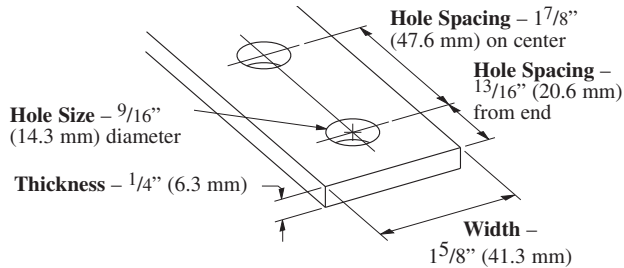

Materials & Finishes (Unless otherwise noted)

Finish Code	Finish	Specification
PLN	Plain	ASTM A1018 33,000 PSI min. yield
ZN	Electro-Plated Zinc	ASTM B633 SC3 Type III
GRN	Dura-Green	
HDG	Hot-Dipped Galvanized	ASTM A123
SS4	Stainless Steel Type 304	ASTM A240
SS6	Stainless Steel Type 316	ASTM A240
AL	Aluminum	ASTM B209

Note: A minimum order may apply on special material and finishes.

Load Data

The load data published includes safety factor of 2.5 when used with 12 ga. (2.6) channel (safety factor = ratio of ultimate load to the design load).

Use 1/2" by 7/8" hex head cap screws and 1/2" (N225 or TN225) channel nuts for the rated results.

Recommended Bolt Torque

Bolt Size	1/4"-20	5/16"-18	3/8"-16	1/2"-13
Foot/Lbs.	6	11	19	50
Nm	8	15	26	68

See chart on page 98 for setscrew torque.

Hardware

Nuts and bolts are not included with the fittings and must be ordered separately, unless noted.

Metric

Metric dimensions are shown in parentheses. Unless noted, all metric dimensions are in millimeters.



B200-B202-2

•Standard finishes: ZN, GRN, HDG, SS4, SS6, AL

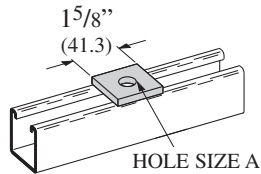

SQUARE WASHER

Part No.	A	(A)	Bolt Size	Wt./C	
				Lbs.	kg
B200	3/8"	(9.5)	5/16" (7.9)	18	(8.1)
B201	7/16"	(11.1)	3/8" (9.5)	18	(8.1)
B202	9/16"	(14.2)	1/2" (12.7)	17	(7.7)
B202-1	11/16"	(17.4)	5/8" (15.9)	16	(7.2)
B202-2	13/16"	(20.6)	3/4" (19.0)	15	(6.8)

B200D-B202-2D

•Standard finishes: ZN, GRN, HDG, SS4, SS6, AL

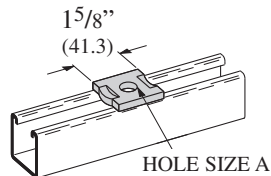

NO TWIST SQUARE WASHER

Part No.	A	(A)	Bolt Size	Wt./C	
				Lbs.	kg
B200D	3/8"	(9.5)	5/16" (7.9)	18	(8.1)
B201D	7/16"	(11.1)	3/8" (9.5)	18	(8.1)
B202D	9/16"	(14.2)	1/2" (12.7)	17	(7.7)
B202-1D	11/16"	(17.4)	5/8" (15.9)	16	(7.2)
B202-2D	13/16"	(20.6)	3/4" (19.0)	15	(6.8)

B129

TWO HOLE SPLICE PLATE

•Standard finishes: ZN, GRN
•Wt./C 37 Lbs. (16.8 kg)

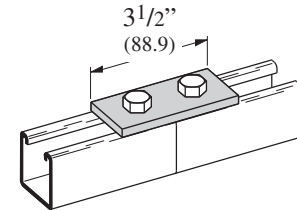

B340

TWO HOLE SPLICE PLATE

•Standard finishes: ZN, GRN
•Wt./C 34 Lbs. (15.4 kg)

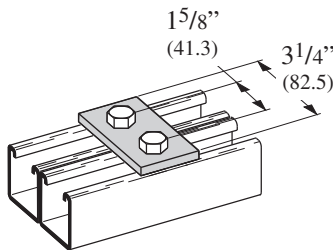

B528

TWO HOLE SPLICE PLATE

•Standard finishes: ZN, GRN
•Wt./C 50 Lbs. (22.7 kg)

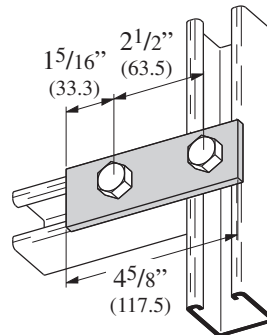

B141

THREE HOLE SPLICE PLATE

•Standard finishes: ZN, GRN
•Wt./C 55 Lbs. (24.9 kg)

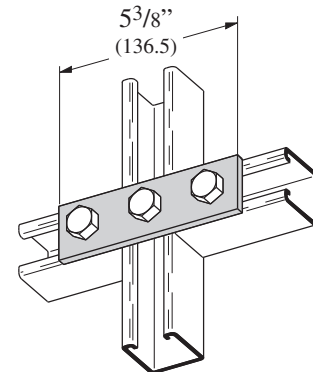

B557

THREE HOLE SPLICE PLATE

•Standard finishes: ZN, GRN
•Wt./C 50 Lbs. (22.7 kg)

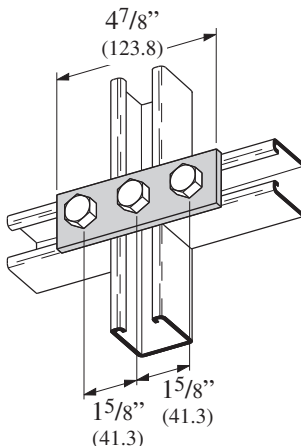

B341

FOUR HOLE SPLICE PLATE

•Standard finishes: ZN, GRN, HDG
•Wt./C 76 Lbs. (34.5 kg)

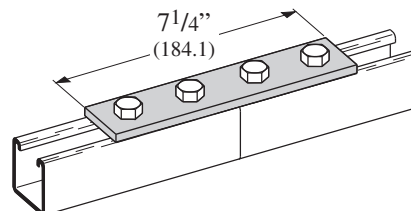

B342

FIVE HOLE SPLICE PLATE

•Standard finishes: ZN, GRN
•Wt./C 96 Lbs. (43.5 kg)

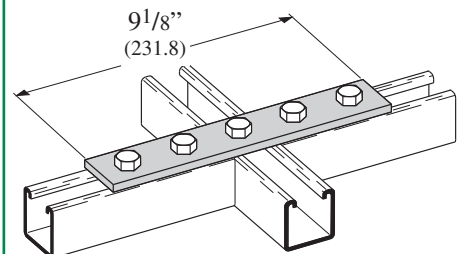

Reference page 58 for general fitting and standard finish specifications.

Flat Plate Fittings

B138 TWO HOLE SWIVEL PLATE

- Standard finishes: ZN, GRN
- Wt./C 48 Lbs. (21.8 kg)

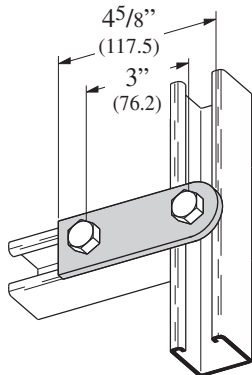

B139 THREE HOLE SWIVEL PLATE

- Standard finishes: ZN, GRN
- Wt./C 69 Lbs. (31.3 kg)

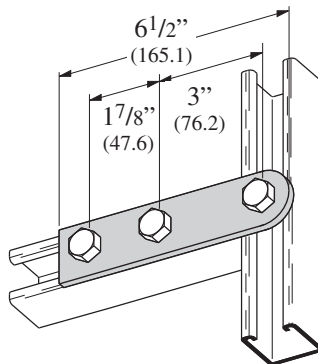

B504 FOUR HOLE SPLICE PLATE

- Standard finishes: ZN, GRN
- Wt./C 73 Lbs. (33.1 kg)

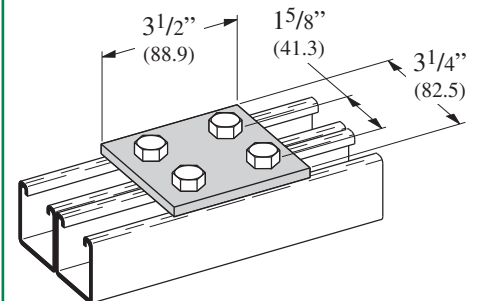

B140 THREE HOLE CORNER PLATE

- Standard finishes: ZN, GRN, HDG, SS4
- Wt./C 56 Lbs. (25.4 kg)

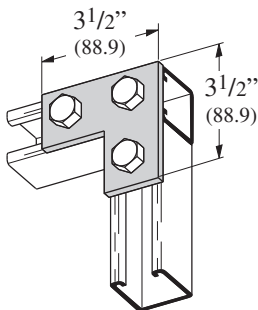

B143 FOUR HOLE CORNER PLATE

- Standard finishes: ZN, GRN, HDG, SS4
- Wt./C 75 Lbs. (34.0 kg)

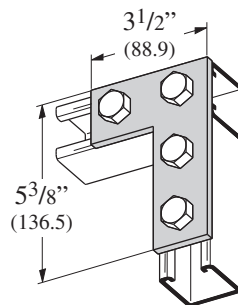

B133 FOUR HOLE TEE PLATE

- Standard finishes: ZN, GRN, HDG, SS4, AL
- Wt./C 75 Lbs. (34.0 kg)

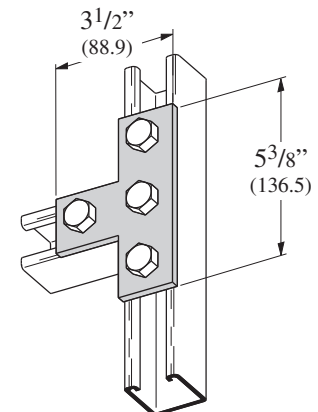

B132 FIVE HOLE CROSS PLATE

- Standard finishes: ZN, GRN, HDG
- Wt./C 100 Lbs. (45.3 kg)

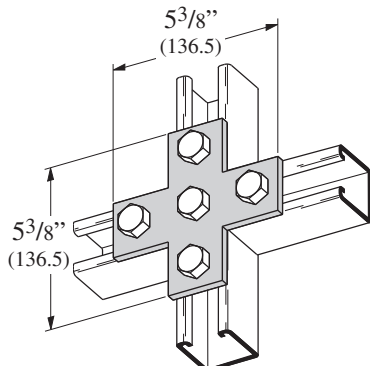

B135 THREE HOLE CORNER GUSSET PLATE

- Standard finishes: ZN, GRN
- Wt./C 70 Lbs. (31.7 kg)

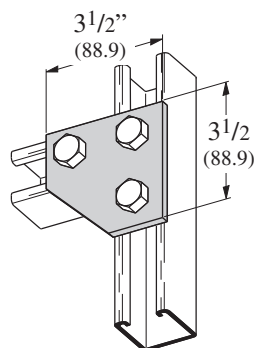

B142 FOUR HOLE CORNER GUSSET PLATE

- Standard finishes: ZN, GRN, HDG
- Wt./C 102 Lbs. (46.2 kg)

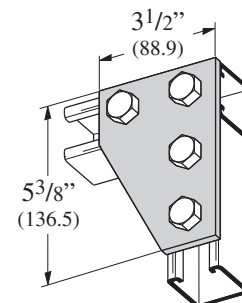

Reference page 58 for general fitting and standard finish specifications.

B137
FOUR HOLE CORNER
GUSSET PLATE

- Standard finishes: ZN, GRN
- Wt./C 273 Lbs. (123.8 kg)

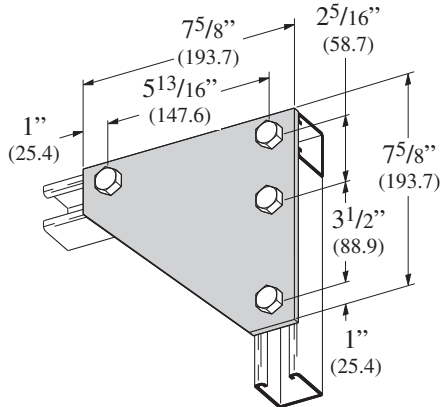

B556
FIVE HOLE CORNER
GUSSET PLATE

- Standard finishes: ZN, GRN
- Wt./C 145 Lbs. (65.8 kg)

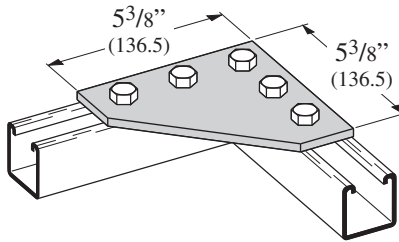

B337
THREE HOLE TEE
GUSSET PLATE

- Standard finishes: ZN, GRN
- Wt./C 70 Lbs. (31.7 kg)

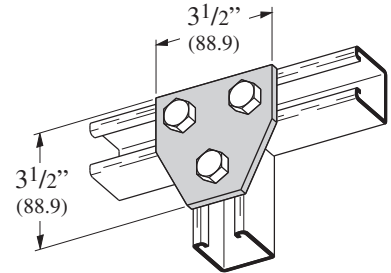

B432
FOUR HOLE TEE
GUSSET PLATE

- Standard finishes: ZN, GRN
- Wt./C 100 Lbs. (45.3 kg)

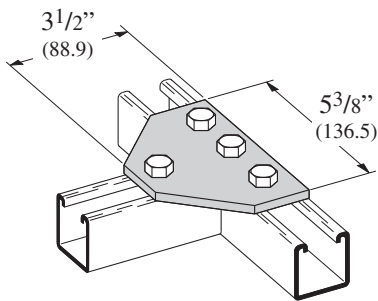

B136
FOUR HOLE TEE
GUSSET PLATE

- Standard finishes: ZN, GRN, HDG
- Wt./C 100 Lbs. (45.3 kg)

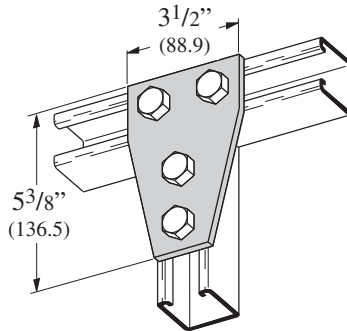

B532
FIVE HOLE TEE
GUSSET PLATE

- Standard finishes: ZN, GRN
- Wt./C 143 Lbs. (64.8 kg)

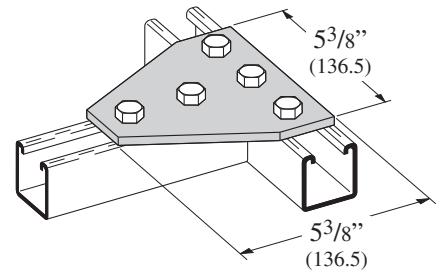

B339
SIX HOLE TEE
GUSSET PLATE

- Standard finishes: ZN, GRN
- Wt./C 149 Lbs. (67.6 kg)

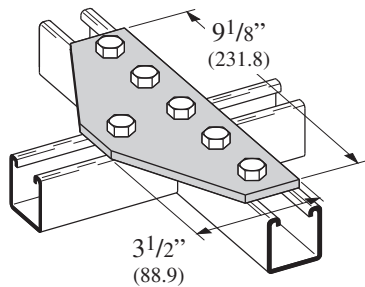

B568
SIX HOLE CROSS
GUSSET PLATE

- Standard finishes: ZN, GRN
- Wt./C 166 Lbs. (75.3 kg)

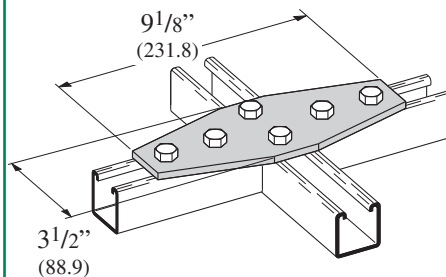

B334
SEVEN HOLE CROSS
GUSSET PLATE

- Standard finishes: ZN, GRN
- Wt./C 232 Lbs. (105.2 kg)

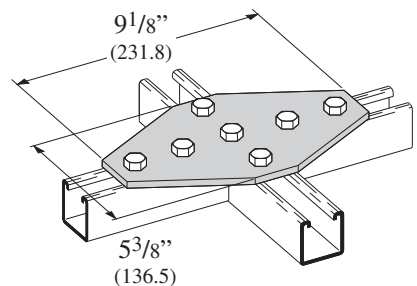

Reference page 58 for general fitting and standard finish specifications.

90° Angle Fittings

B420-378 ONE HOLE CORNER ANGLE

- Standard finishes: ZN, GRN
- Wt./C 60 Lbs. (27.2 kg)

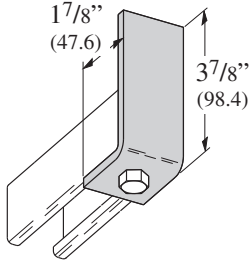

B420-578 ONE HOLE CORNER ANGLE

- Standard finishes: ZN, GRN
- Wt./C 85 Lbs. (38.5 kg)

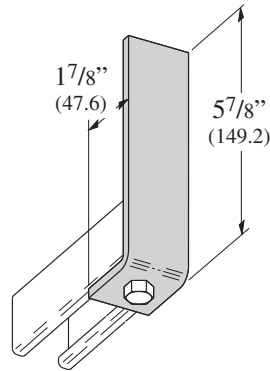

B420-778 ONE HOLE CORNER ANGLE

- Standard finishes: ZN, GRN
- Wt./C 107 Lbs. (48.5 kg)

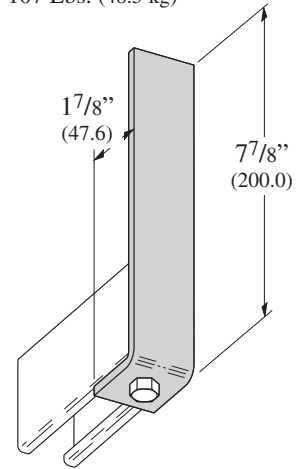

B420-978 ONE HOLE CORNER ANGLE

- Standard finishes: ZN, GRN
- Wt./C 129 Lbs. (58.5 kg)

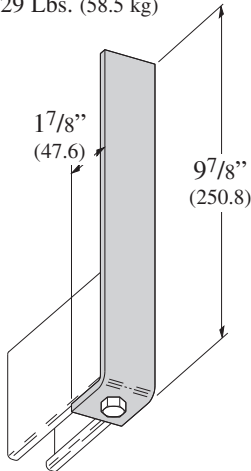

B101 TWO HOLE CORNER ANGLE

- Standard finishes: ZN, GRN, HDG, SS4, AL
- Wt./C 37 Lbs. (16.8 kg)

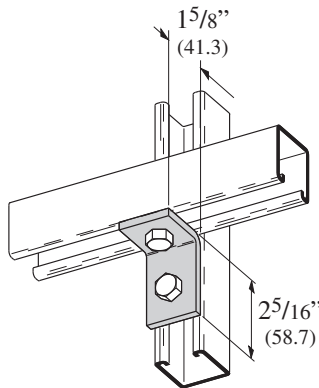

B230 TWO HOLE CORNER ANGLE

- Standard finishes: ZN, GRN, HDG, SS4, AL
- Wt./C 37 Lbs. (16.8 kg)

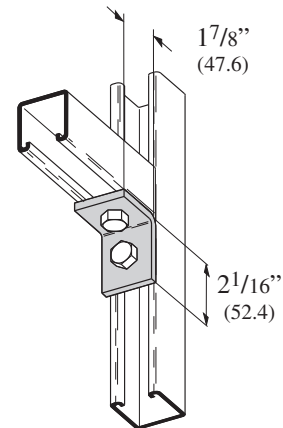

B231 TWO HOLE "NO-TWIST" CORNER ANGLE

- Standard finishes: ZN, GRN, HDG
- Wt./C 41 Lbs. (18.6 kg)

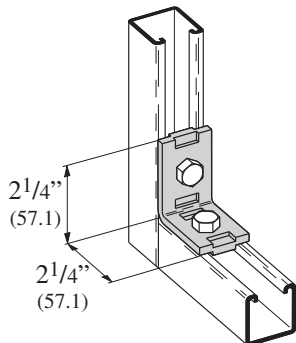

B359 TWO HOLE CORNER ANGLE

- Standard finishes: ZN, GRN
- Wt./C 48 Lbs. (21.8 kg)

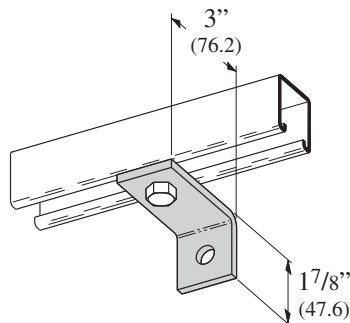

B360 TWO HOLE CORNER ANGLE

- Standard finishes: ZN, GRN
- Wt./C 53 Lbs. (24.0 kg)

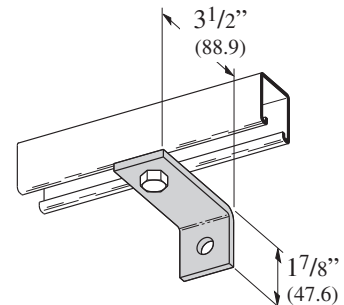

Reference page 58 for general fitting and standard finish specifications.

B361
TWO HOLE CORNER ANGLE

- Standard finishes: ZN, GRN
- Wt./C 60 Lbs. (27.2 kg)

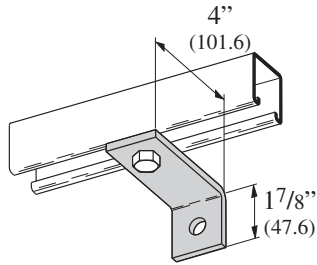

B102
THREE HOLE CORNER ANGLE

- Standard finishes: ZN, GRN, HDG, SS4
- Wt./C 56 Lbs. (25.4 kg)

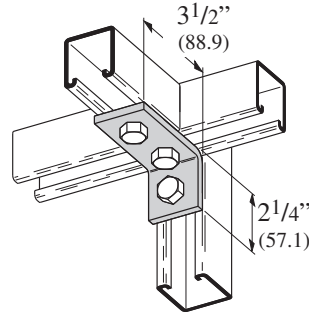

B103
THREE HOLE CORNER ANGLE

- Standard finishes: ZN, GRN, HDG, SS4
- Wt./C 56 Lbs. (25.4 kg)

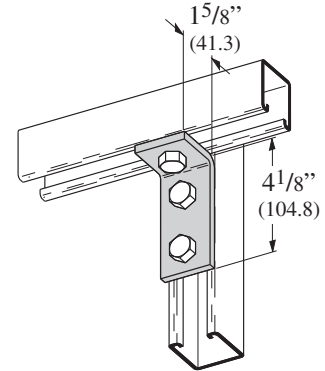

B232
THREE HOLE CORNER ANGLE

- Standard finishes: ZN, GRN, HDG, SS4
- Wt./C 56 Lbs. (25.4 kg)

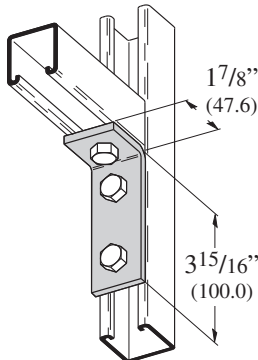

B374
THREE HOLE CORNER ANGLE

- Standard finishes: ZN, GRN, HDG
- Wt./C 56 Lbs. (25.4 kg)

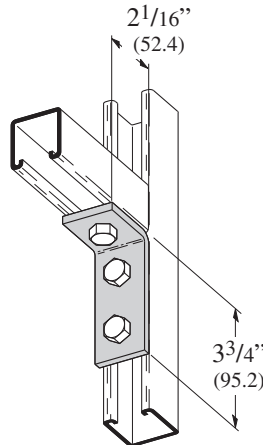

B529
THREE HOLE CORNER ANGLE

- Standard finishes: ZN, GRN
- Wt./C 78 Lbs. (35.4 kg)

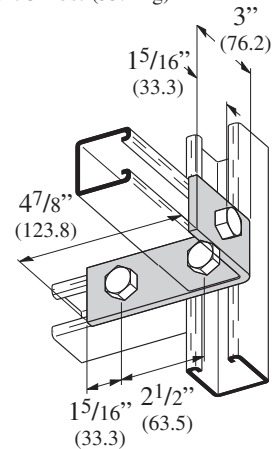

B104
FOUR HOLE CORNER ANGLE

- Standard finishes: ZN, GRN, HDG, SS4, SS6, AL
- Wt./C 78 Lbs. (35.4 kg)

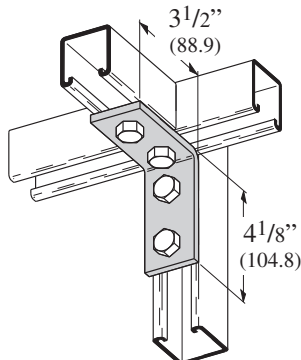

B115
FOUR HOLE CORNER ANGLE

- Standard finishes: ZN, GRN, HDG, SS4, AL
- Wt./C 76 Lbs. (34.5 kg)

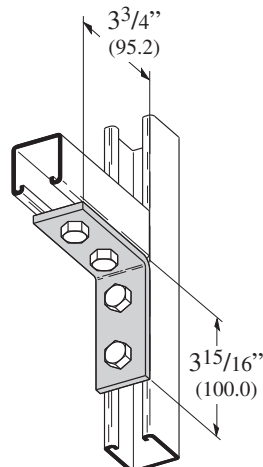

B558
FOUR HOLE CORNER ANGLE

- Standard finishes: ZN, GRN
- Wt./C 73 Lbs. (33.1 kg)

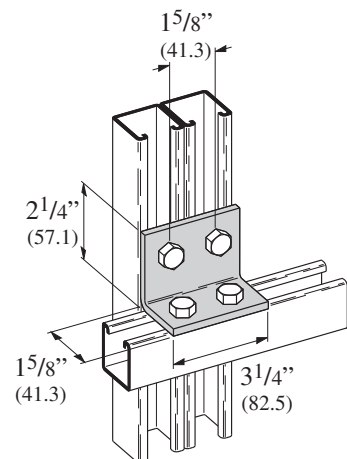

Reference page 58 for general fitting and standard finish specifications.

90° Angle Fittings

B235R THREE HOLE (RIGHT HAND) OFFSET BENT ANGLE

- 1⁵/₈" (41.3) from center to center of the holes that are shown with bolt heads
- Standard finishes: ZN, GRN
- Wt./C 53 Lbs. (24.0 kg)

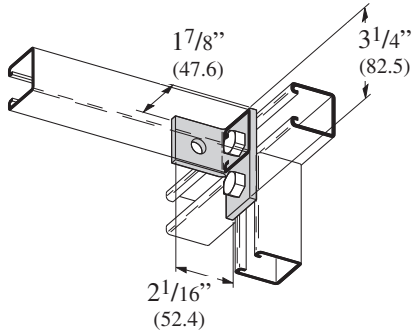

B235L THREE HOLE (LEFT HAND) OFFSET BENT ANGLE

- 1⁵/₈" (41.3) from center to center of the holes that are shown with bolt heads
- Standard finishes: ZN, GRN
- Wt./C 53 Lbs. (24.0 kg)

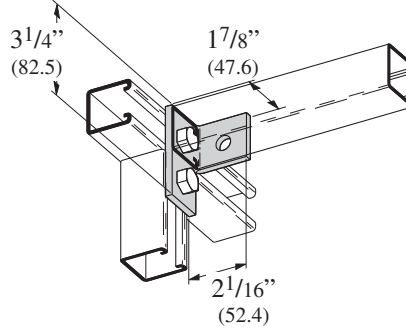

B236R THREE HOLE (RIGHT HAND) OFFSET BENT ANGLE

- Standard finishes: ZN, GRN
- Wt./C 65 Lbs. (29.5 kg)

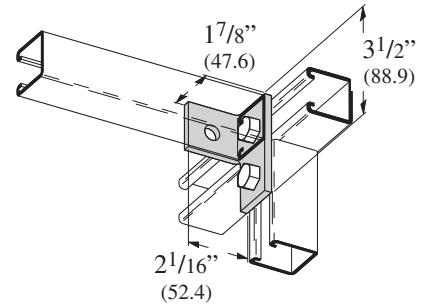

B236L THREE HOLE (LEFT HAND) OFFSET BENT ANGLE

- Standard finishes: ZN, GRN
- Wt./C 65 Lbs. (29.5 kg)

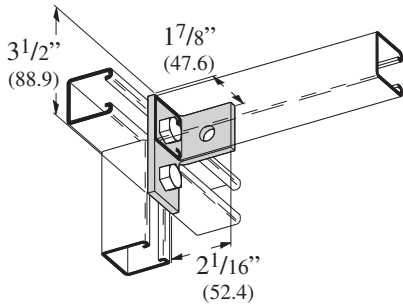

B237 THREE HOLE OFFSET BENT TEE

- Standard finishes: ZN, GRN
- Wt./C 71 Lbs. (32.2 kg)

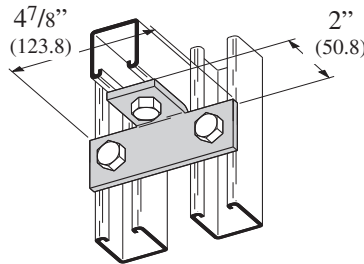

B357 FOUR HOLE OFFSET BENT TEE

- Standard finishes: ZN, GRN
- Wt./C 77 Lbs. (34.9 kg)

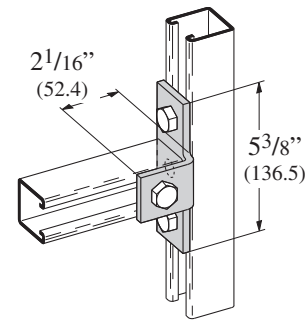

B238R FOUR HOLE (RIGHT HAND) OFFSET BENT TEE

- Standard finishes: ZN, GRN
- Wt./C 76 Lbs. (34.5 kg)

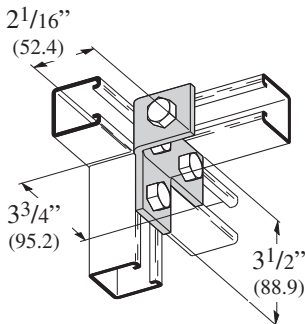

B238L FOUR HOLE (LEFT HAND) OFFSET BENT TEE

- Standard finishes: ZN, GRN
- Wt./C 76 Lbs. (34.5 kg)

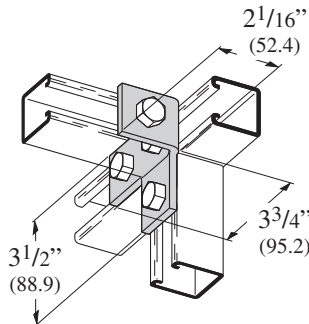

B239 FIVE HOLE OFFSET BENT TEE

- Standard finishes: ZN, GRN
- Wt./C 96 Lbs. (43.5 kg)

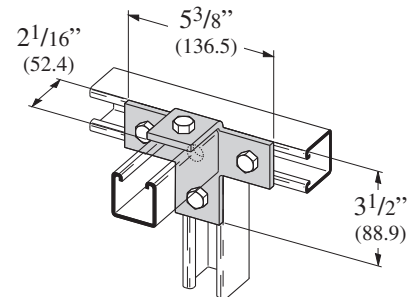

B844
UNIVERSAL SHELF BRACKET
 •Standard finishes: ZN, GRN, HDG, SS4
 •Wt./C 132 Lbs. (59.9 kg)

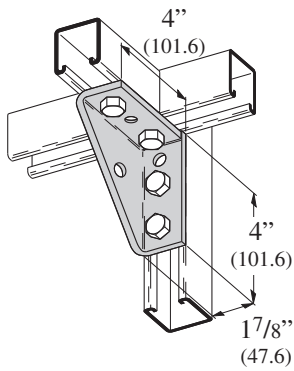

B844W
UNIVERSAL SHELF BRACKET- WELDED
 •Standard finishes: ZN, GRN
 •Wt./C 134 Lbs. (60.8 kg)

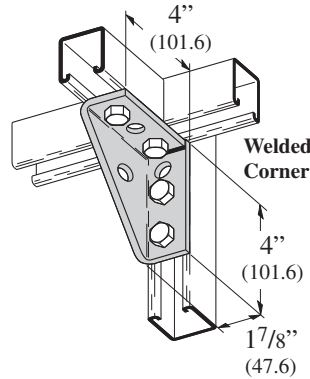

B888W
UNIVERSAL SHELF BRACKET- WELDED
 •Standard finishes: ZN, GRN
 •Wt./C 197 Lbs. (89.4 kg)

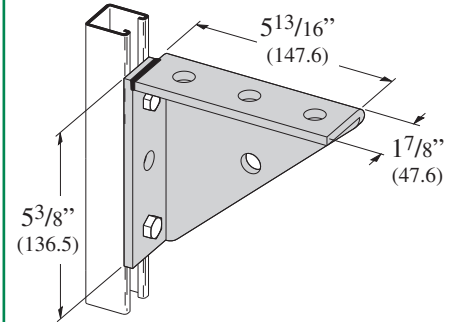

B234R
FOUR HOLE (RIGHT HAND) CORNER GUSSET
 •Standard finishes: ZN, GRN, HDG
 •Wt./C 100 Lbs. (45.3 kg)

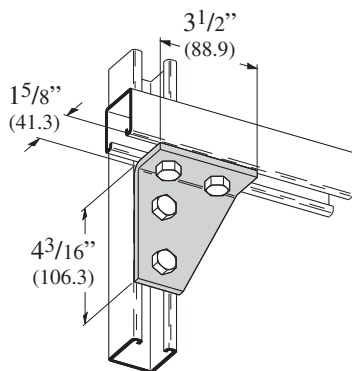

B234L
FOUR HOLE (LEFT HAND) CORNER GUSSET
 •Standard finishes: ZN, GRN, HDG
 •Wt./C 100 Lbs. (45.3 kg)

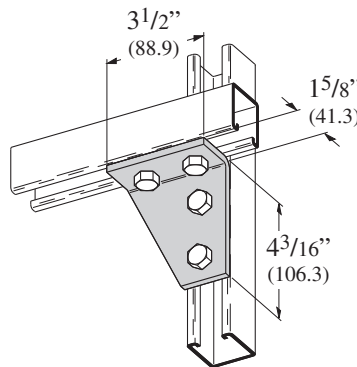

B134R
FOUR HOLE (RIGHT HAND) CORNER GUSSET
 •Standard finishes: ZN, GRN
 •Wt./C 100 Lbs. (45.3 kg)

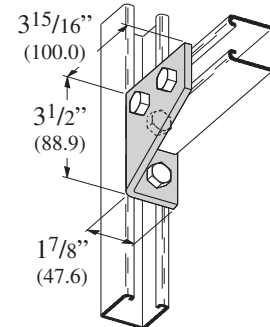

B134L
FOUR HOLE (LEFT HAND) CORNER GUSSET
 •Standard finishes: ZN, GRN
 •Wt./C 100 Lbs. (45.3 kg)

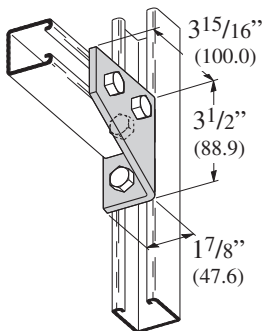

B125
THREE HOLE GUSSETTED SHELF ANGLE
 •Standard finishes: ZN, GRN
 •Wt./C 67 Lbs. (30.4 kg)

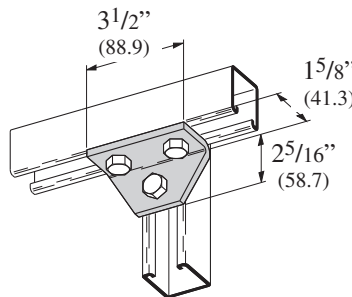

B118
FOUR HOLE GUSSETTED SHELF ANGLE
 •Standard finishes: ZN, GRN, HDG
 •Wt./C 102 Lbs. (46.2 kg)

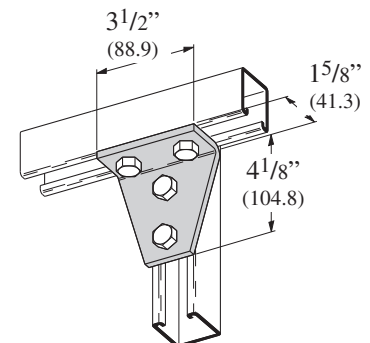

Reference page 58 for general fitting and standard finish specifications.

90° Angle Fittings

B485 FOUR HOLE GUSSETED SHELF ANGLE

- Standard finishes: ZN, GRN
- Wt./C 148 Lbs. (67.1 kg)

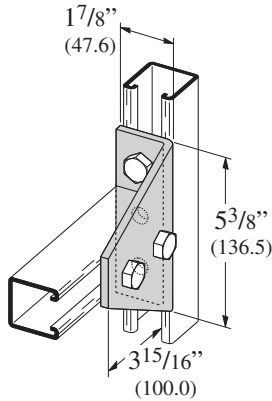

B533 FIVE HOLE GUSSETED SHELF ANGLE

- Standard finishes: ZN, GRN
- Wt./C 141 Lbs. (63.9 kg)

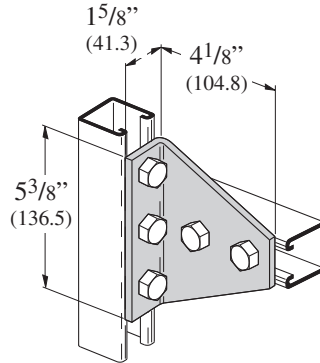

B126 FOUR HOLE GUSSETED THREE WAY SHELF ANGLE

- Standard finishes: ZN, GRN
- Wt./C 101 Lbs. (45.8 kg)

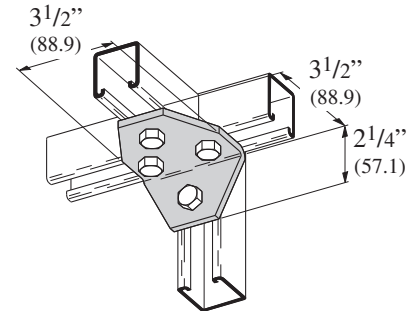

B127 FIVE HOLE GUSSETED THREE WAY SHELF ANGLE

- Standard finishes: ZN, GRN
- Wt./C 135 Lbs. (61.2 kg)

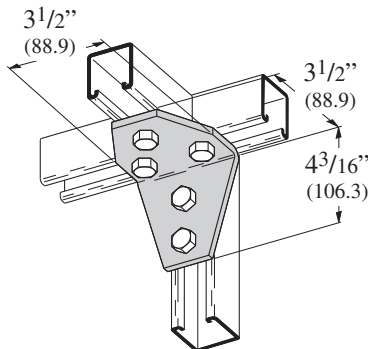

B503R SIX HOLE (RIGHT HAND) GUSSETED CORNER CONNECTION

- Standard finishes: ZN, GRN
- Wt./C 229 Lbs. (103.9 kg)

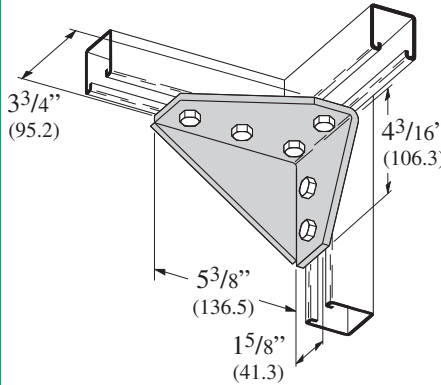

B503L SIX HOLE (LEFT HAND) GUSSETED CORNER CONNECTION

- Standard finishes: ZN, GRN
- Wt./C 229 Lbs. (103.9 kg)

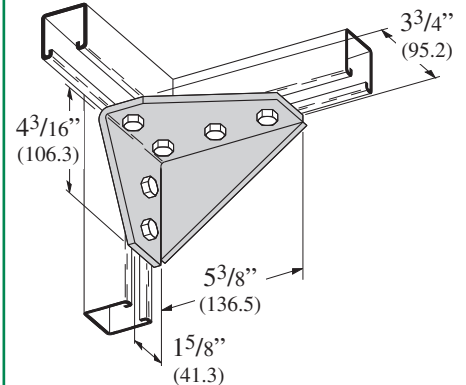

B663 SEVEN HOLE GUSSETED CORNER CONNECTION

- Standard finishes: ZN, GRN
- Wt./C 289 Lbs. (131.1 kg)

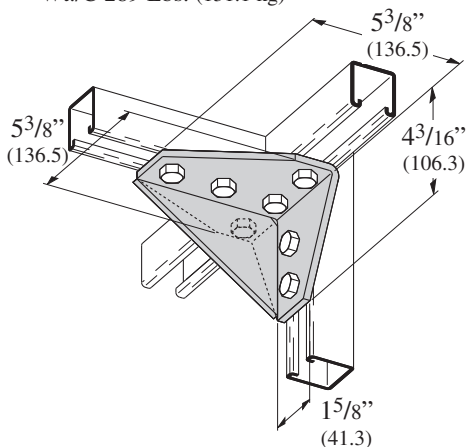

B371 TWO HOLE ADJUSTABLE CORNER ANGLE

- Standard finishes: ZN, GRN
- Wt./C 41 Lbs. (18.6 kg)

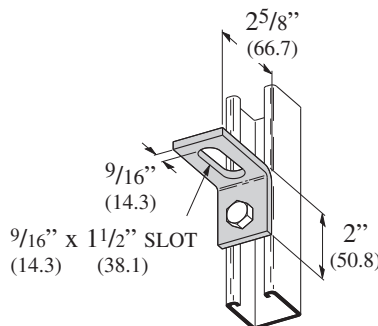

B372 TWO HOLE ADJUSTABLE CORNER ANGLE

- Standard finishes: ZN, GRN
- Wt./C 38 Lbs. (17.2 kg)

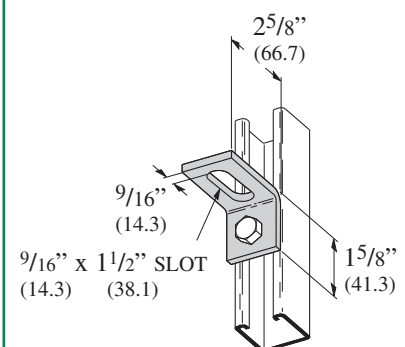

Reference page 58 for general fitting and standard finish specifications.

B496 TWO HOLE ADJUSTABLE CORNER ANGLE

- Standard finishes: ZN, GRN
- Wt./C 85 Lbs. (38.5 kg)

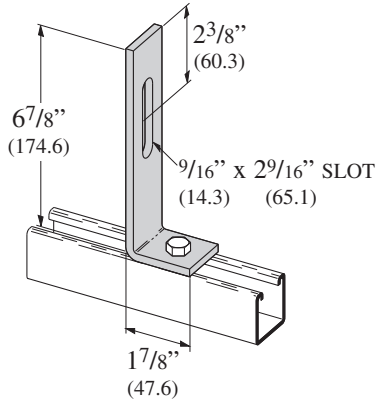

B496-1 TWO HOLE ADJUSTABLE CORNER ANGLE

- Standard finishes: ZN, GRN, HDG
- Wt./C 58 Lbs. (26.3 kg)

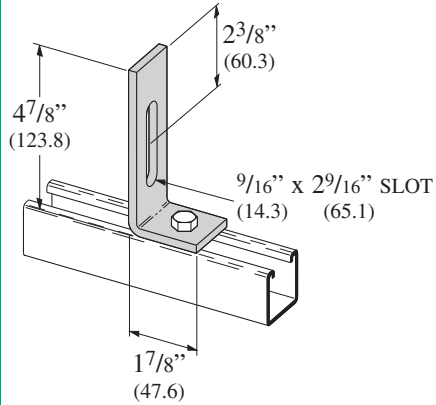

B371-2 THREE HOLE ADJUSTABLE CORNER ANGLE

- Standard finishes: ZN, GRN
- Wt./C 61 Lbs. (27.6 kg)

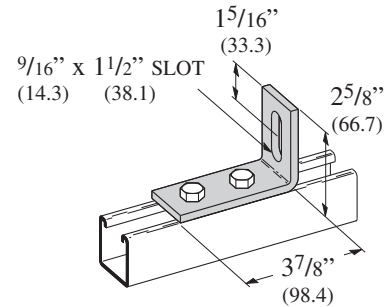

B104SH THREE HOLE ADJUSTABLE CORNER ANGLE

- Standard finishes: ZN, GRN
- Wt./C 68 Lbs. (30.8 kg)

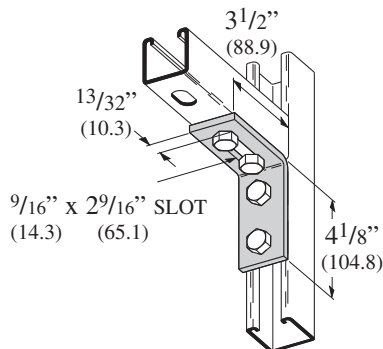

B461 TWO HOLE ADJUSTABLE CORNER ANGLE

- Standard finishes: ZN, GRN
- Wt./C 87 Lbs. (39.4 kg)

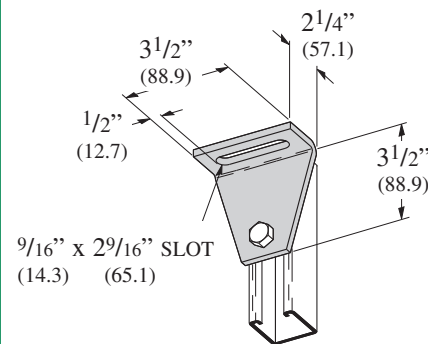

B112 FOUR HOLE ADJUSTABLE CORNER ANGLE

- Standard finishes: ZN, GRN
- Wt./C 180 Lbs. (81.6 kg)

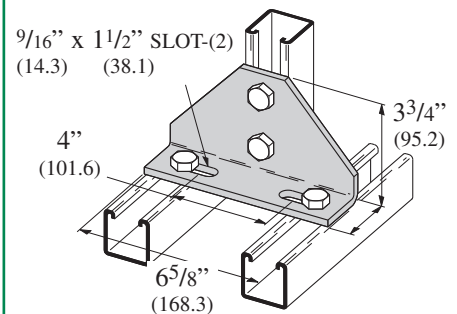

B113 FOUR HOLE ADJUSTABLE CORNER ANGLE

- Standard finishes: ZN, GRN
- Wt./C 256 Lbs. (116.1 kg)

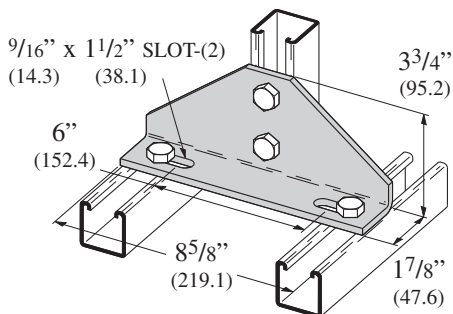

B109S TWO HOLE TAPPED CORNER ANGLE

- Standard finishes: ZN, GRN
- Wt./C 33 Lbs. (14.9 kg)

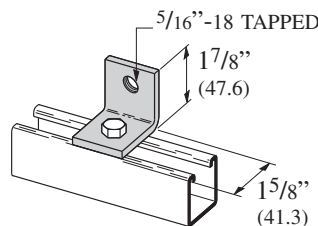

B521 TWO HOLE BUS DUCT ANGLE

- Standard finishes: ZN, GRN
- Wt./C 37 Lbs. (16.8 kg)

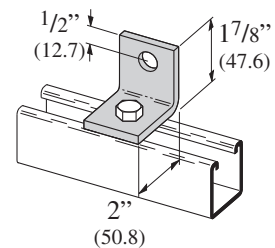

Reference page 58 for general fitting and standard finish specifications.

Angular Fittings

B147-B152 TWO HOLE OPEN ANGLE

•Standard finishes: ZN, GRN

Part No.	A	Wt./C	
		Lbs.	kg
B147	82½°	63	(28.6)
B148	75°		
B149	67½°		
B150	60°		
B151	52½°		
B152	37½°		

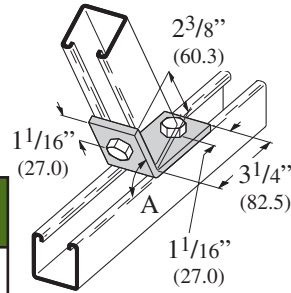

B243-B253 FOUR HOLE OPEN ANGLE

•Standard finishes: ZN, GRN

Part No.	A	Wt./C	
		Lbs.	kg
B243	7½°	77	(34.9)
B244	15°		
B245	22½°		
B246	30°		
B247	37½°		
B248	45°		
B249	52½°		
B250	60°		
B251	67½°		
B252	75°		
B253	82½°		

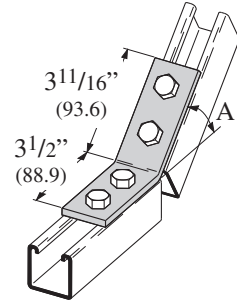

B162-B165 TWO HOLE OPEN ANGLE

•Standard finishes: ZN, GRN

Part No.	A	Wt./C	
		Lbs.	kg
B162	30°	59	(26.7)
B163	22½°		
B164	15°		
B165	7½°		

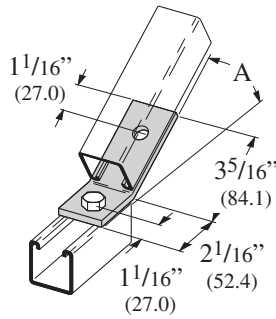

B322-B332 TWO HOLE OPEN SHORT ANGLE

•Standard finishes: ZN, GRN

Part No.	A	Wt./C	
		Lbs.	kg
B322	7½°	35	(15.9)
B323	15°		
B324	22½°		
B325	30°		
B326	37½°		
B327	45°		
B328	52½°		
B329	60°		
B330	67½°		
B331	75°		
B332	82½°		

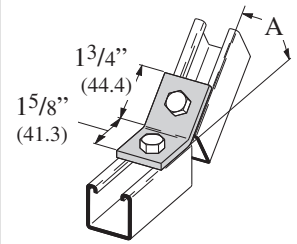

B154 TWO HOLE OPEN ANGLE

•Standard finishes: ZN, GRN, SS4
•Wt./C 58 Lbs. (26.3 kg)

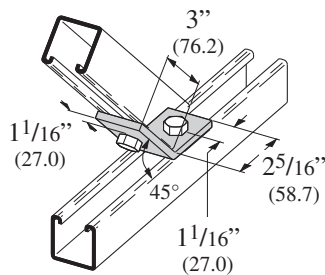

B522 THREE HOLE 95° OPEN ANGLE FITTING

•Standard finishes: ZN, GRN
•Wt./C 54 Lbs. (24.5 kg)

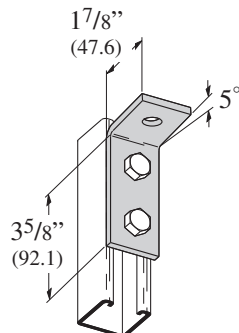

B488 TWO HOLE LEG CONNECTION

•Standard finishes: ZN, GRN
•Wt./C 100 Lbs. (45.3 kg)

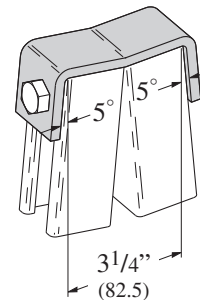

B156 - B161 TWO HOLE CLOSED ANGLE

•Standard finishes: ZN, GRN

Part No.	A	Wt./C	
		Lbs.	kg
B156	82 $\frac{1}{2}$ °	56	(25.4)
B157	75°		
B158	67 $\frac{1}{2}$ °		
B159	60°		
B160	52 $\frac{1}{2}$ °		
B161	37 $\frac{1}{2}$ °		

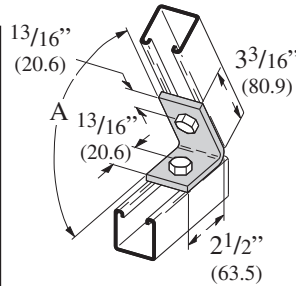

B155 TWO HOLE CLOSED ANGLE

•Standard finishes: ZN, GRN, HDG, SS4
•Wt./C 63 Lbs. (28.6 kg)

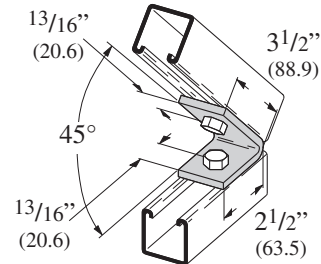

B363 - B369 FOUR HOLE ADJUSTABLE HINGE

•Standard finishes: ZN, GRN

Part No.	A	Wt./C	
		Lbs.	kg
B363	82 $\frac{1}{2}$ °	95	(43.1)
B364	75°		
B365	67 $\frac{1}{2}$ °		
B366	60°		
B367	52 $\frac{1}{2}$ °		
B368	45°		
B369	37 $\frac{1}{2}$ °		

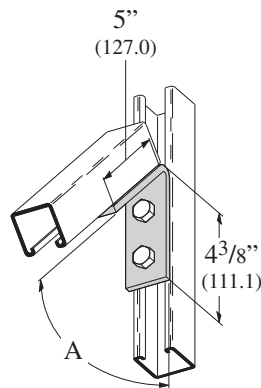

B335 FOUR HOLE ADJUSTABLE HINGE

•Standard finishes: ZN, GRN
•Wt./C 110 Lbs. (49.9 kg)

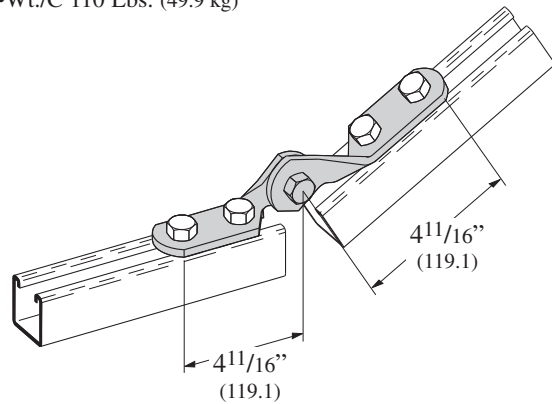

B335-1 TWO HOLE ADJUSTABLE HINGE

•Standard finishes: ZN, GRN
•Wt./C 78 Lbs. (35.4 kg)

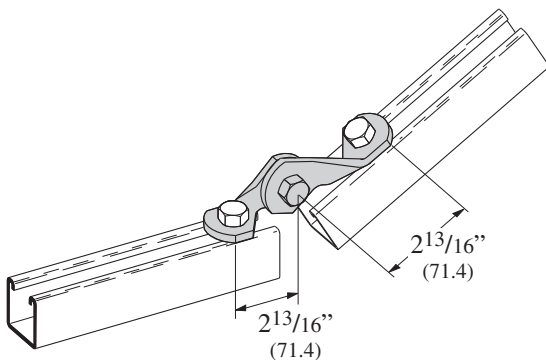

B335-2 SERIES THREE HOLE ADJUSTABLE HINGE

•OSHPD approved for Seismic Zone 4
•Standard finishes: ZN, GRN

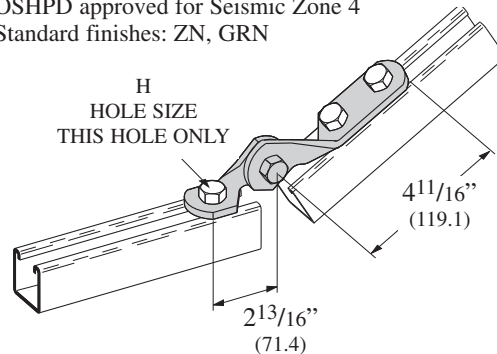

Part No. & Size	Hole Size H		Wt./C	
	Lbs.	kg	Lbs.	kg
B335-2-3/8	7/16"	(11.1)	96	(43.2)
B335-2-1/2	9/16"	(14.3)	94	(42.3)
B335-2-5/8	11/16"	(17.4)	92	(41.4)
B335-2-3/4	13/16"	(20.6)	90	(40.5)

Reference page 58 for general fitting and standard finish specifications.

Angular Fittings

B634 SINGLE CHANNEL ADJUSTABLE BRACE

- Standard finishes: ZN, GRN
- Wt./C 306 Lbs. (138.8 kg)

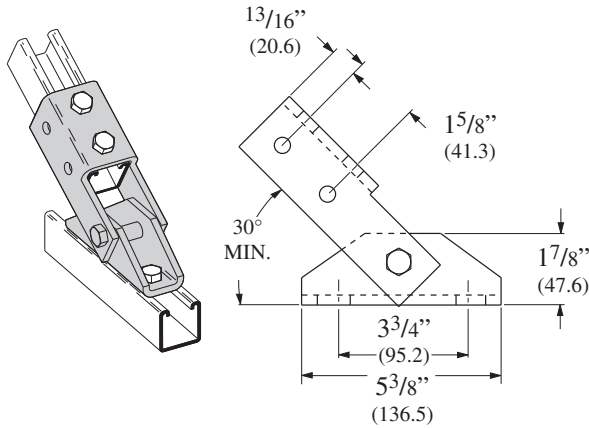

B635 DOUBLE CHANNEL ADJUSTABLE BRACE

- Standard finishes: ZN, GRN
- Wt./C 518 Lbs. (234.9 kg)

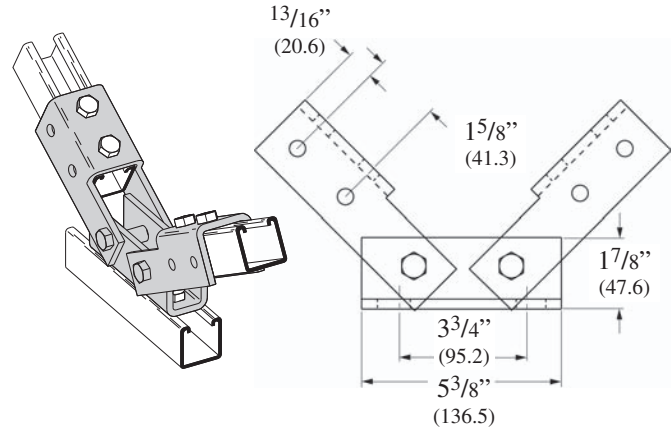

B650 SERIES SEISMIC RETROFIT BRACKET

- OSHPD approved for Seismic Zone 4.
- Available for 3/8", 1/2", 5/8", and 3/4" threaded rods.
- Allows installer to easily brace existing trapeze supports.
- Includes: Bracket, B129 plate, & key. Hardware sold separately.
- Standard finish: ZN, GRN

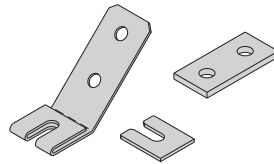

Part No. & Size	For Rod Size	TL		LL		Wt./C	
		Lbs.	kN	Lbs.	kN	Lbs.	kg
B650-3/8	3/8"	1100	(4.89)	1100	(4.89)	92	(41.4)
B650-1/2	1/2"	1500	(6.67)	1500	(6.67)	97	(43.6)
B650-5/8	5/8"	1500	(6.67)	1500	(6.67)	95	(42.7)
B650-3/4	3/4"	1500	(6.67)	1500	(6.67)	107	(48.5)

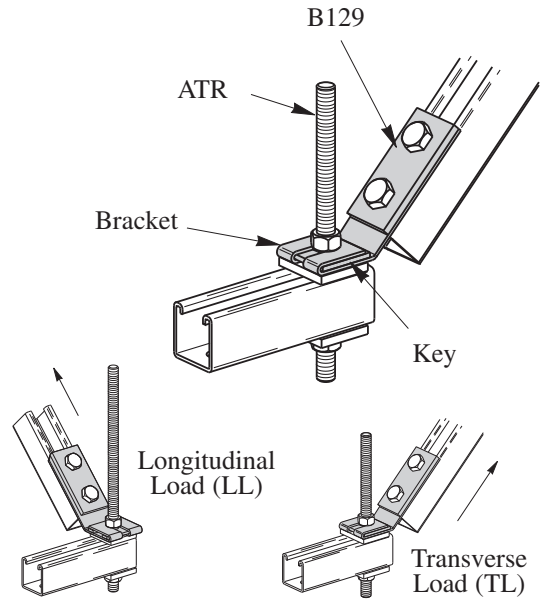

B633 ADJUSTABLE SEISMIC HINGE FITTING

- B633-1/2 thru B633-7/8 - OSHPD approved for Seismic Zone 4.
- Use 1/2" Bolt & Channel Nut on two hole side of Connector Fitting (Torque to 50 ft.-lbs.)
- Allows for swivel in two planes.
- Standard finish: ZN

Part No. & Size	A		B		Hole Size H		Wt./C	
	Lbs.	kg	Lbs.	kg	Lbs.	kg	Lbs.	kg
B633-1/2	3 1/2"	(82.5)	1 5/8"	(41.3)	9/16"	(14.3)	92	(41.4)
B633-5/8	3 1/2"	(82.5)	1 5/8"	(41.3)	1 1/16"	(17.4)	97	(43.6)
B633-3/4	3 1/2"	(82.5)	1 5/8"	(41.3)	1 3/16"	(20.6)	95	(42.7)
B633-7/8	3 9/16"	(90.5)	2"	(50.8)	1 5/16"	(23.8)	107	(48.5)
B633-1	3 9/16"	(90.5)	2"	(50.8)	1 1/16"	(27.0)	120	(54.0)
B633-1 1/8	3 9/16"	(90.5)	2"	(50.8)	1 3/16"	(30.2)	104	(47.2)
B633-1 1/4	3 7/8"	(98.4)	2 1/4"	(57.1)	1 5/16"	(33.3)	114	(51.7)

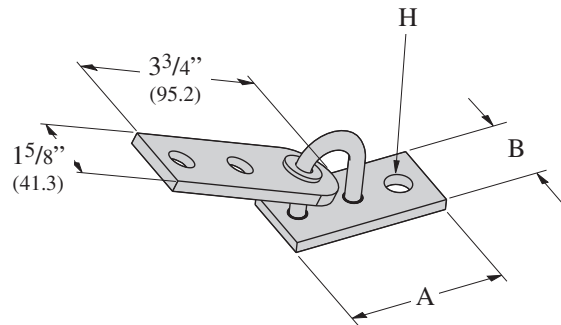

Reference page 58 for general fitting and standard finish specifications.

B261 TWO HOLE 45° KNEE BRACE

- Standard finishes: ZN, GRN
- Design load determined by testing using a B335 hinged corner connection.
- Load ratings are for brace members only. Do not exceed allowable beam or column loads for strut channels.
- Safety Factor of 3

Part No.	A	(A)	B	(B)	Design Load		Wt./C	
					Lbs.	kN	Lbs.	kg
B261-8	8"	(203.2)	7 ³ / ₈ "	(187.3)	1500	(6.67)	119	(54.0)
B261-12	12"	(304.8)	10 ¹ / ₈ "	(257.2)	1020	(4.54)	165	(74.8)
B261-16	16 ⁵ / ₈ "	(422.3)	13 ³ / ₈ "	(339.7)	530	(2.36)	218	(98.9)
B261-18	18"	(457.2)	14 ⁷ / ₁₆ "	(366.7)	450	(2.00)	234	(106.1)
B261-24	24"	(609.6)	18 ¹ / ₁₆ "	(474.7)	250	(1.11)	303	(137.4)
B261-36	36"	(914.4)	27 ³ / ₁₆ "	(690.6)	110	(.49)	441	(200.0)

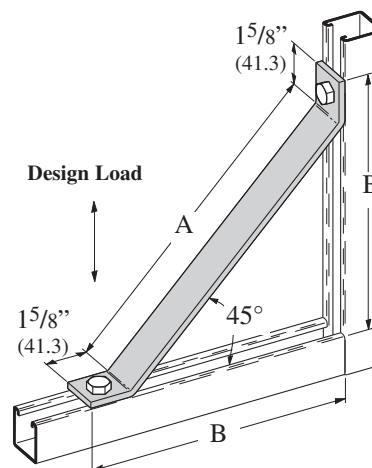

B631 TWO HOLE 45° TUBING KNEE BRACE

- 1" (25.4) Square steel tubing
- Material: ASTM A513
- Standard finishes: ZN, GRN
- Design load determined by testing using a B335 hinged corner connection.
- Load ratings are for brace members only. Do not exceed allowable beam or column loads for strut channels.
- Safety Factor of 3

Part No.	A	(A)	Design Load		Wt./C	
			Lbs.	kN	Lbs.	kg
B631-18	18"	(457.2)	1500	(6.67)	145	(65.8)
B631-24	24"	(609.6)	1500	(6.67)	186	(84.4)
B631-30	30"	(762.0)	1500	(6.67)	225	(102.0)
B631-36	36"	(914.4)	1500	(6.67)	266	(120.6)
B631-42	42"	(1066.8)	1230	(5.47)	307	(139.2)
B631-48	48"	(1219.2)	940	(4.18)	348	(157.8)
B631-54	54"	(1371.6)	740	(3.29)	389	(176.4)
B631-60	60"	(1524.0)	600	(2.67)	430	(195.0)
B631-72	72"	(1828.8)	420	(1.87)	508	(230.4)
B631-84	84"	(2133.6)	310	(1.38)	589	(267.2)
B631-96	96"	(2438.4)	240	(1.07)	669	(303.5)

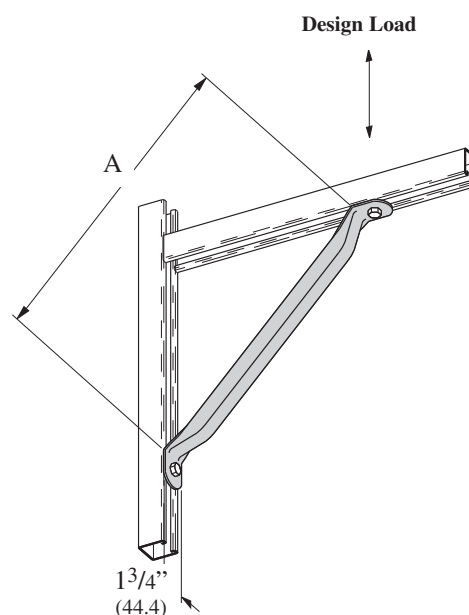

B632 TWO HOLE STRAIGHT TUBING BRACE

- 1" (25.4) Square steel tubing
- Material: ASTM A513
- Standard finishes: ZN, GRN

Part No.	A	(A)	Wt./C	
			Lbs.	kg
B632-18	18"	(457.2)	133	(60.3)
B632-24	24"	(609.6)	174	(78.9)
B632-30	30"	(762.0)	215	(97.5)
B632-36	36"	(914.4)	256	(116.1)
B632-42	42"	(1066.8)	295	(133.8)
B632-48	48"	(1219.2)	335	(151.9)
B632-54	54"	(1371.6)	380	(172.3)
B632-60	60"	(1524.0)	420	(190.5)
B632-72	72"	(1828.8)	500	(226.8)
B632-84	84"	(2133.6)	585	(265.3)
B632-96	96"	(2438.4)	670	(303.9)

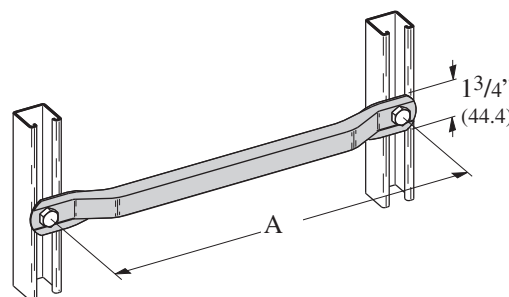

Reference page 58 for general fitting and standard finish specifications.

Clevis Fittings

B169 TWO HOLE SPLICE CLEVIS FOR B52

- Standard finishes: ZN, GRN
- Wt./C 84 Lbs. (38.1 kg)

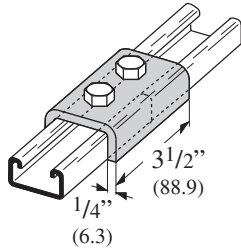

B168 THREE HOLE SPLICE CLEVIS FOR B52

- Standard finishes: ZN, GRN
- Wt./C 126 Lbs. (57.1 kg)

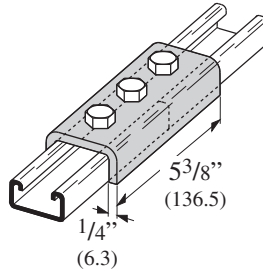

B167 FOUR HOLE SPLICE CLEVIS FOR B52

- Standard finishes: ZN, GRN
- Wt./C 178 Lbs. (80.7 kg)

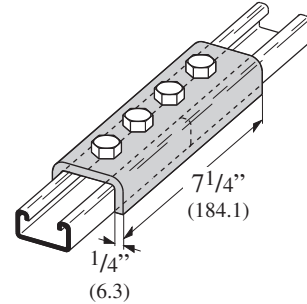

B170 TWO HOLE SPLICE CLEVIS FOR B22 OR B52A

- Standard finishes: ZN, GRN
- Wt./C 123 Lbs. (55.8 kg)

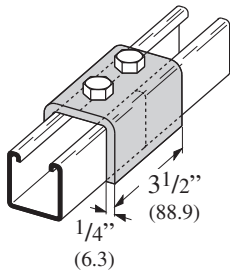

B171 THREE HOLE SPLICE CLEVIS FOR B22 OR B52A

- Standard finishes: ZN, GRN
- Wt./C 195 Lbs. (88.4 kg)

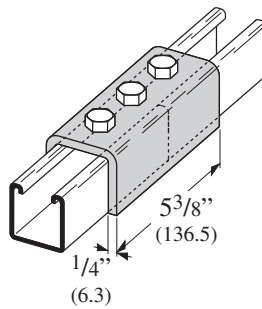

B172 FOUR HOLE SPLICE CLEVIS FOR B22 OR B52A

- Standard finishes: ZN, GRN
- Wt./C 266 Lbs. (120.6 kg)

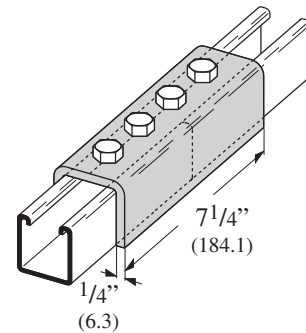

B172-12 FOUR HOLE SPLICE CLEVIS FOR B12

- Standard finishes: ZN, GRN
- Wt./C 326 Lbs. (147.8 kg)

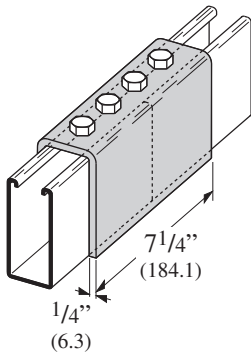

B172-22A FOUR HOLE SPLICE CLEVIS FOR B11 OR B22A

- Standard finishes: ZN, GRN
- Wt./C 406 Lbs. (184.1 kg)

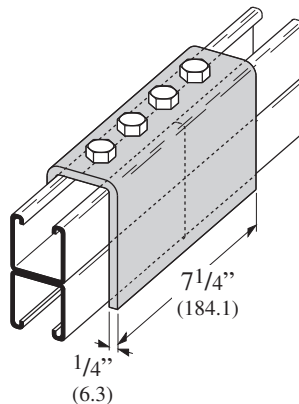

B450 U-WASHER

- Material: ASTM A1011 HSLAS Gr. 50
- Standard finishes: ZN, GRN

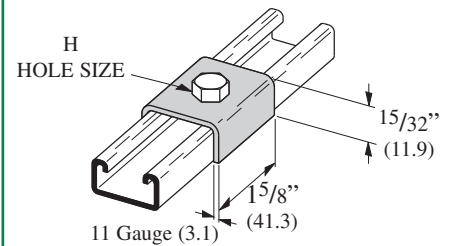

Part No. & Size	Hole Size H	Wt./C Lbs. kg
B450-1/4	5/16" (7.9)	14 (6.3)
B450-3/8	7/16" (11.1)	14 (6.3)
B450-1/2	9/16" (14.3)	13 (5.8)
B450-5/8	11/16" (17.4)	13 (5.8)
B450-3/4	13/16" (20.6)	13 (5.8)

Reference page 58 for general fitting and standard finish specifications.

B527
THREE HOLE OFFSET PLATE CONNECTION

- Standard finishes: ZN, GRN
- Wt./C 54 Lbs. (24.5 kg)

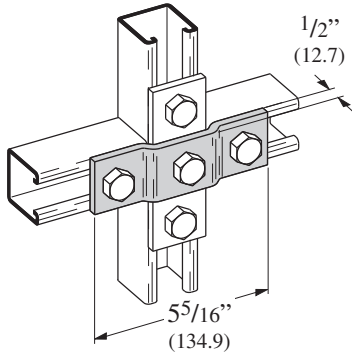

B116-52
THREE HOLE U-SUPPORT

- Standard finishes: ZN, GRN
- Wt./C 70 Lbs. (31.7 kg)

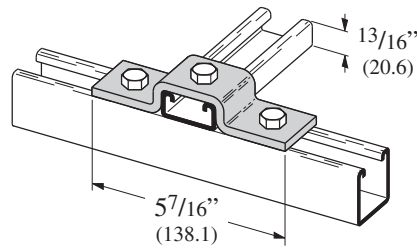

B116-42
THREE HOLE U-SUPPORT

- Standard finishes: ZN, GRN
- Wt./C 75 Lbs. (34.0 kg)

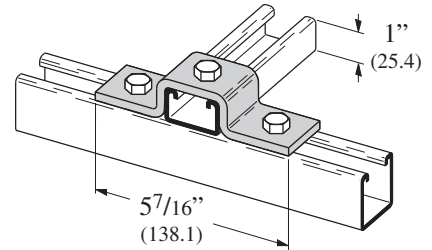

B116-32
THREE HOLE U-SUPPORT

- Standard finishes: ZN, GRN
- Wt./C 84 Lbs. (38.1 kg)

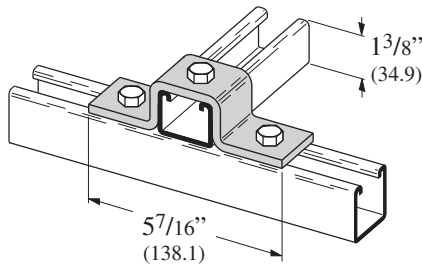

B116-32A
THREE HOLE U-SUPPORT

- Standard finishes: ZN, GRN
- Wt./C 116 Lbs. (52.6 kg)

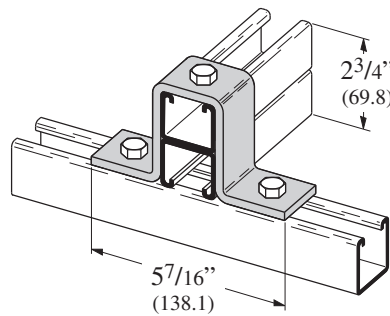

B116-12
THREE HOLE U-SUPPORT

- Standard finishes: ZN, GRN
- Wt./C 108 Lbs. (49.0 kg)

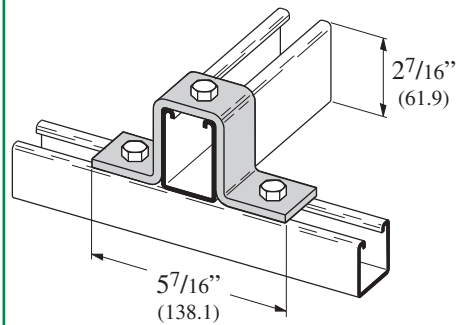

B107
FIVE HOLE U-SUPPORT

- Standard finishes: ZN, GRN, HDG
- Wt./C 85 Lbs. (38.5 kg)

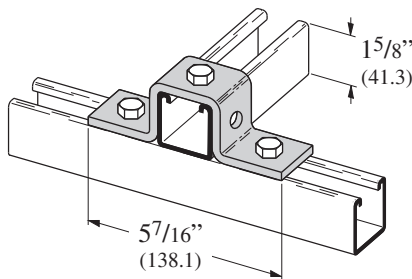

B107-22A
THREE HOLE U-SUPPORT

- Standard finishes: ZN, GRN
- Wt./C 126 Lbs. (57.1 kg)

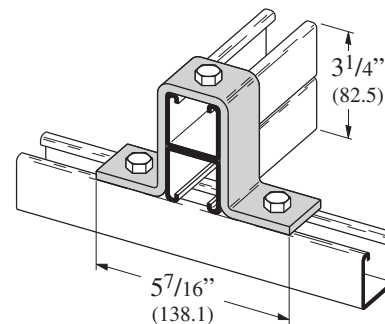

B588
THREE HOLE U-SUPPORT

- Standard finishes: ZN, GRN
- Wt./C 157 Lbs. (71.2 kg)

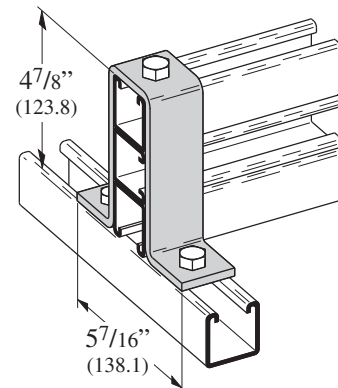

Reference page 58 for general fitting and standard finish specifications.

'U' Fittings

B412 THREE HOLE OFFSET U-SUPPORT

- Standard finishes: ZN, GRN
- Wt./C 89 Lbs. (40.3 kg)

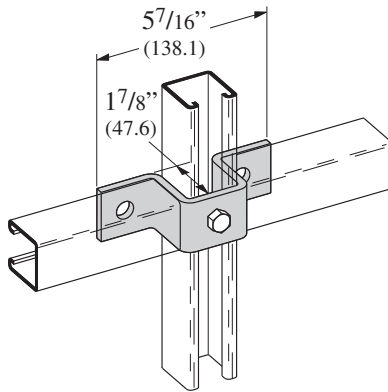

B107S FIVE HOLE U-SUPPORT

- Material: 7 Gauge (4.5)
ASTM A1011 33,000 PSI min. yield
- Standard finishes: ZN, GRN
- Wt./C 51 Lbs. (23.1 kg)

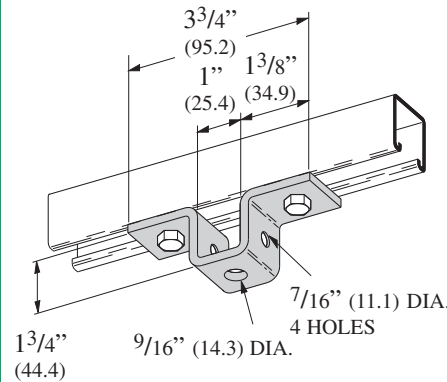

B596 THREE HOLE SWIVEL CLEVIS

- Standard finishes: ZN, GRN
- Wt./C 53 Lbs. (24.0 kg)

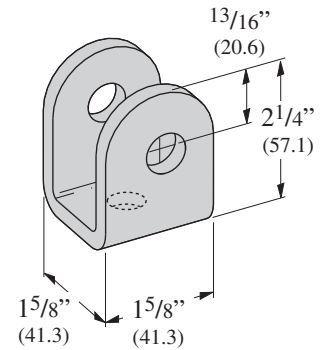

B578 THREE HOLE LIGHT-WEIGHT U-SUPPORT

- Material: 10 Gauge (3.4)
ASTM A1011 HSLAS Gr. 50
- Standard finishes: ZN, GRN
- Wt./C 18 Lbs. (8.1 kg)

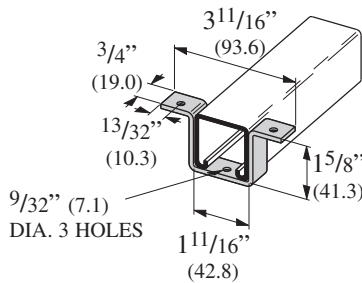

B594 FIVE HOLE U-SUPPORT

- Standard finishes: ZN, GRN
- Wt./C 106 Lbs. (48.1 kg)

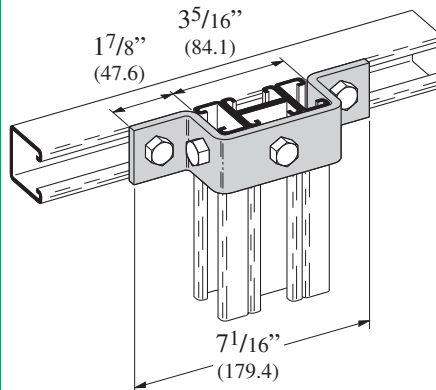

B266 SIX HOLE U-SUPPORT

- Standard finishes: ZN, GRN
- Wt./C 105 Lbs. (47.6 kg)

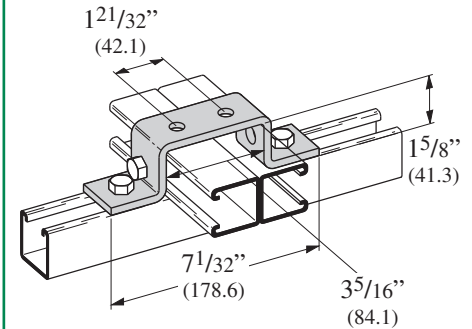

B425 SIX HOLE U-SUPPORT

- Standard finishes: ZN, GRN
- Wt./C 167 Lbs. (75.7 kg)

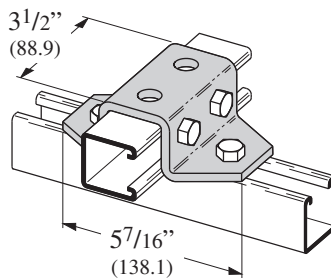

B581 EIGHT HOLE U-SUPPORT

- Standard finishes: ZN, GRN
- Wt./C 201 Lbs. (91.2 kg)

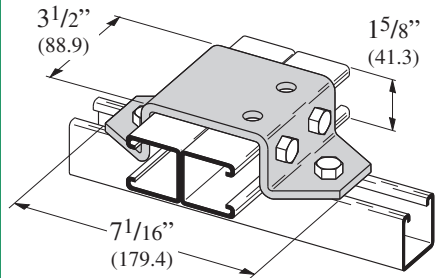

B519 EIGHT HOLE U-SUPPORT

- Standard finishes: ZN, GRN
- Wt./C 266 Lbs. (102.5 kg)

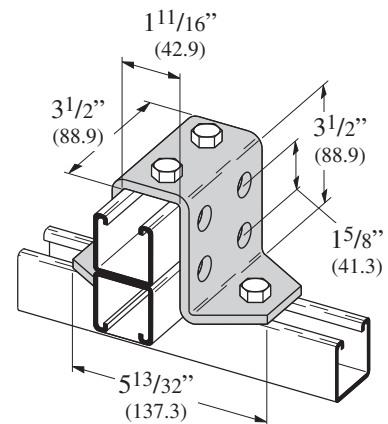

Reference page 58 for general fitting and standard finish specifications.

B333 SLOTTED THREE HOLE U-SUPPORT FOR B22

•Standard finishes: ZN, GRN

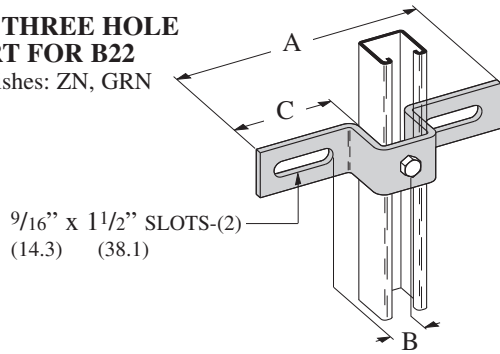

Part No.	A		B		C		Wt./C	
	A	(A)	B	(B)	C	(C)	Lbs.	kg
B333-1	7 1/2"	(190.5)	1 5/16"	(33.3)	2 7/8"	(73.0)	103	(46.7)
B333-2	8 1/2"	(215.9)	1 15/16"	(49.2)	3 3/8"	(85.7)	115	(52.1)
B333-3	10 3/8"	(263.5)	2 7/8"	(73.0)	4 5/16"	(109.5)	135	(61.2)

B451 SLOTTED THREE HOLE U-SUPPORT WITH GUSSET FOR B22

•Consists of B333-1, 2, or 3 with gusset plate welded on back.

•Material: ASTM A1011 HSLAS Gr. 50

•Standard finishes: ZN, GRN

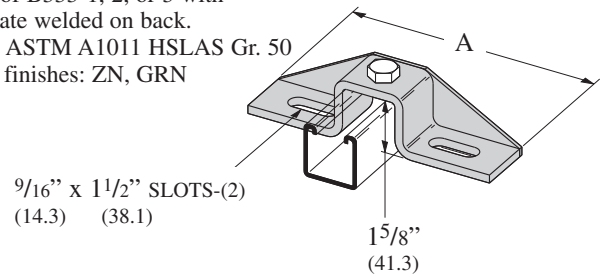

Part No.	A		Wt./C	
	A	(A)	Lbs.	kg
B451-1	7 1/2"	(190.5)	137	(62.1)
B451-2	8 1/2"	(215.9)	156	(70.7)
B451-3	10 3/8"	(263.5)	172	(78.0)

B408 TWO HOLE BUS DUCT CLEVIS

•Standard finishes: ZN, GRN

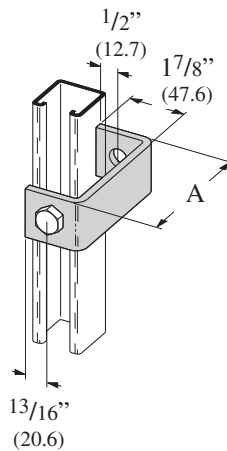

Part No.	A		Wt./C	
	A	(A)	Lbs.	kg
B408-1	2 13/32"	(61.1)	58	(26.3)
B408-2	3 25/32"	(96.0)	76	(34.5)
B408-3	4 3/4"	(762.0)	88	(39.9)

B358 TWO HOLE CLEVIS

•Standard finishes: ZN, GRN

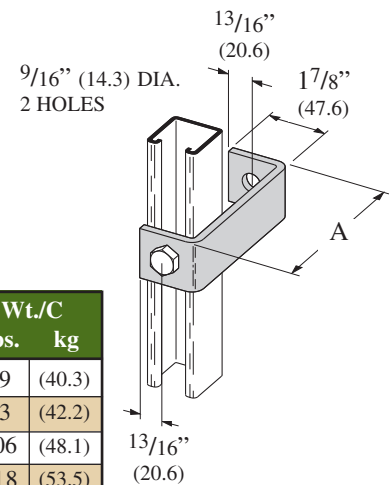

Part No.	A		Wt./C	
	A	(A)	Lbs.	kg
B358-4	4"	(101.6)	89	(40.3)
B358-5	5"	(127.0)	93	(42.2)
B358-6	6"	(152.4)	106	(48.1)
B358-7	7"	(177.8)	118	(53.5)
B358-8	8"	(203.2)	132	(59.9)

B173 FOUR HOLE CLEVIS

•Standard finishes: ZN, GRN

•Wt./C 71 Lbs. (32.2 kg)

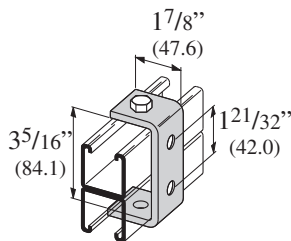

B595 THREE HOLE CLEVIS

•Standard finishes: ZN, GRN

•Wt./C 75 Lbs. (34.0 kg)

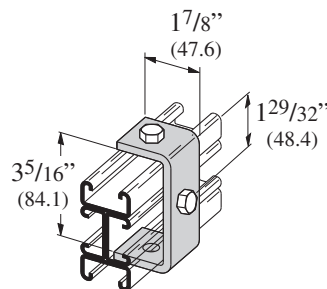

B405 THREE HOLE SUSPENSION CLEVIS

•Standard finishes: ZN, GRN

•Wt./C 75 Lbs. (34.0 kg)

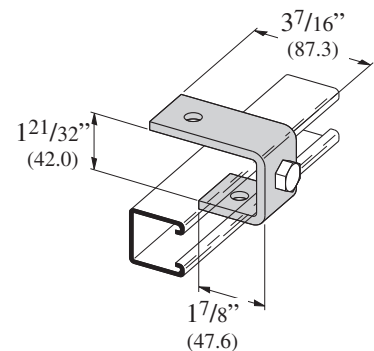

Reference page 58 for general fitting and standard finish specifications.

'U' Fittings

B398-1

THREE HOLE CUP SUPPORT

- Standard finishes: ZN, GRN
- Wt./C 73 Lbs. (33.1 kg)

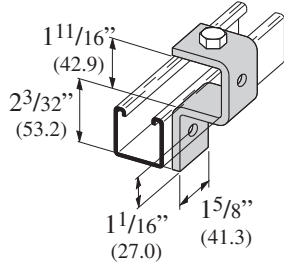

B415

TWO HOLE BUS DUCT CONNECTION

- Standard finishes: ZN, GRN
- Wt./C 56 Lbs. (25.4 kg)

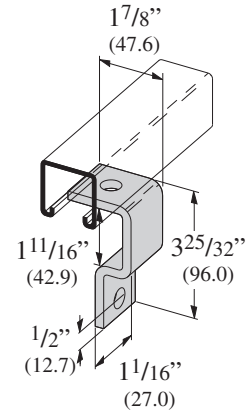

B400

THREE STUD RING CONNECTION

- 1/2"-13 stud protrudes 1" (25.4mm)
- Standard finishes: ZN
- Wt./C 85 Lbs. (38.5 kg)

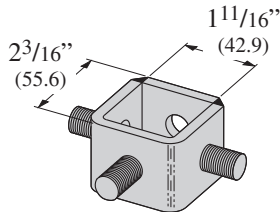

B400-1

ONE STUD RING CONNECTION

- 1/2"-13 stud protrudes 1" (25.4mm)
- Standard finishes: ZN
- Wt./C 53 Lbs. (24.0 kg)

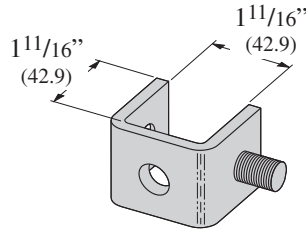

B400-2

ONE STUD RING CONNECTION

- 1/2"-13 stud protrudes 1" (25.4mm)
- Standard finishes: ZN
- Wt./C 40 Lbs. (18.1 kg)

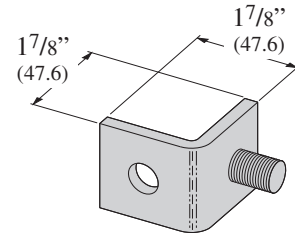

B400-3

TWO STUD RING CONNECTION

- 1/2"-13 stud protrudes 1" (25.4mm)
- Standard finishes: ZN
- Wt./C 59 Lbs. (26.7 kg)

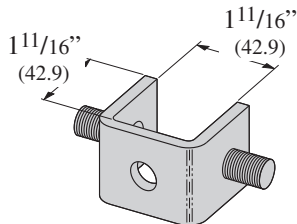

B400-4

TWO STUD RING CONNECTION

- 1/2"-13 stud protrudes 1" (25.4mm)
- Standard finishes: ZN
- Wt./C 59 Lbs. (26.7 kg)

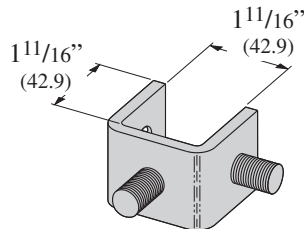

B536

TAPPED U-SUPPORT

- Standard finishes: ZN
- Wt./C 87 Lbs. (39.4 kg)

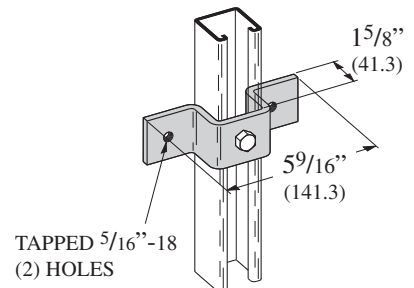

B526
TWO HOLE
OFFSET Z-SUPPORT

- Standard finishes: ZN, GRN
- Wt./C 38 Lbs. (17.2 kg)

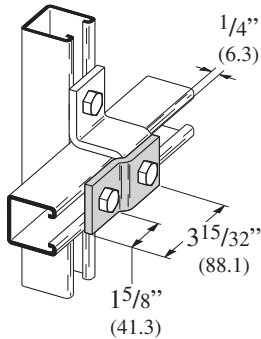

B106-52
TWO HOLE
Z-SUPPORT FOR B52

- Standard finishes: ZN, GRN
- Wt./C 40 Lbs. (18.1 kg)

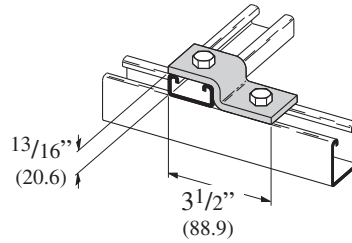

B106-42
TWO HOLE
Z-SUPPORT FOR B42

- Standard finishes: ZN, GRN
- Wt./C 44 Lbs. (20.0 kg)

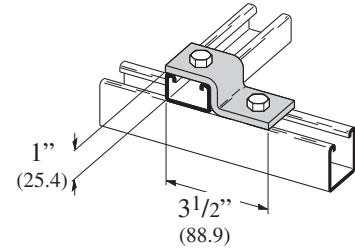

B106-32
TWO HOLE
Z-SUPPORT FOR B32

- Standard finishes: ZN, GRN
- Wt./C 51 Lbs. (23.1 kg)

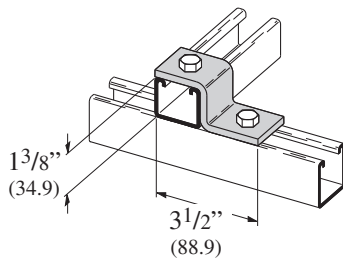

B106-12
TWO HOLE
Z-SUPPORT FOR B12

- Standard finishes: ZN, GRN
- Wt./C 63 Lbs. (28.6 kg)

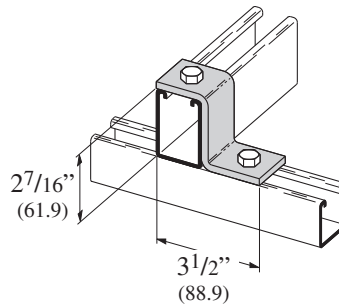

B105
THREE HOLE
Z-SUPPORT FOR B22

- Standard finishes: ZN, GRN, HDG
- Wt./C 51 Lbs. (23.1 kg)

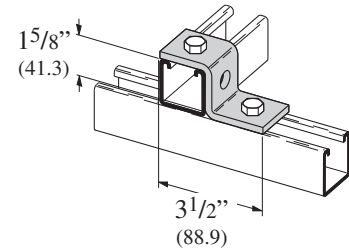

B110
THREE HOLE
Z-SUPPORT FOR B11

- Standard finishes: ZN, GRN
- Wt./C 70 Lbs. (31.7 kg)

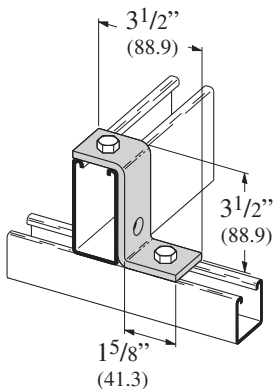

B586
TWO HOLE
Z-SUPPORT

- Standard finishes: ZN, GRN
- Wt./C 90 Lbs. (40.8 kg)

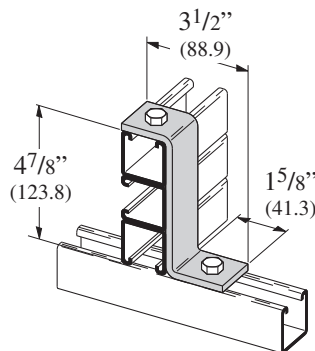

B108
TWO HOLE
OFFSET Z-SUPPORT

- Standard finishes: ZN, GRN
- Wt./C 55 Lbs. (24.9 kg)

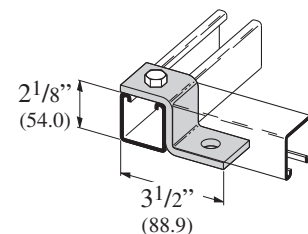

Reference page 58 for general fitting and standard finish specifications.

'Z' Fittings

B387 TWO HOLE Z-BUS DUCT CONNECTION

•Standard finishes: ZN, GRN

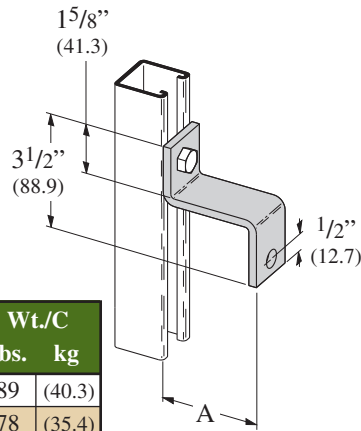

Part No.	A	(A)	Wt./C	
			Lbs.	kg
B387	4 ³ / ₄ "	(120.6)	89	(40.3)
B387-1	3 ²⁵ / ₃₂ "	(96.0)	78	(35.4)
B387-2	2 ¹³ / ₃₂ "	(61.1)	62	(28.1)

B407 TWO HOLE Z-SUPPORT

•Standard finishes: ZN, GRN

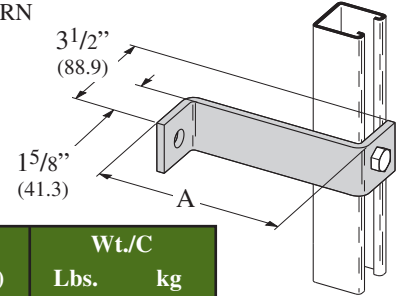

Part No.	A	(A)	Wt./C	
			Lbs.	kg
B407-4	4"	(101.6)	77	(34.9)
B407-5	5"	(127.0)	95	(43.1)
B407-6	6"	(152.4)	98	(44.4)
B407-7	7"	(177.8)	105	(47.6)
B407-8	8"	(203.2)	120	(54.4)
B407-9 ⁵ / ₈ "	9 ⁵ / ₈ "	(244.5)	138	(62.6)

B534 TAPPED Z-SUPPORT

•Standard finishes: ZN
•Wt./C 51 Lbs. (23.1 kg)

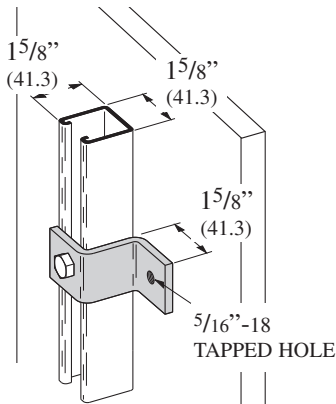

B535 TAPPED Z-SUPPORT

•Standard finishes: ZN
•Wt./C 50 Lbs. (22.7 kg)

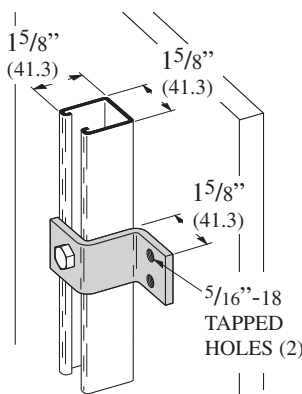

B111 THREE HOLE SHEATH CORNER CONNECTION

•Standard finishes: ZN, GRN
•Wt./C 68 Lbs. (30.8 kg)

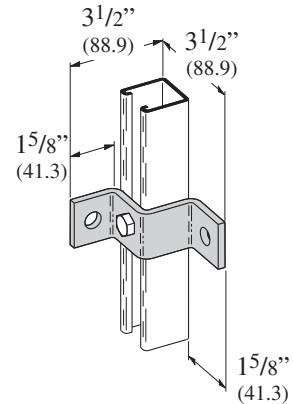

B538 TAPPED CORNER CONNECTION

•Standard finishes: ZN
•Wt./C 71 Lbs. (32.2 kg)

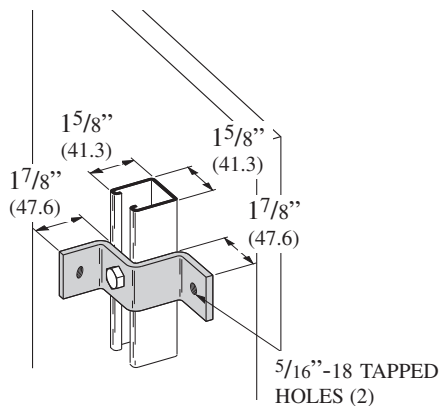

B539 TAPPED CORNER CONNECTION

•Standard finishes: ZN
•Wt./C 68 Lbs. (30.8 kg)

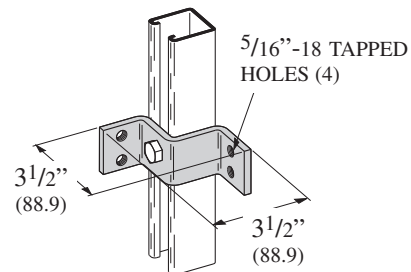

Reference page 58 for general fitting and standard finish specifications.

B410-52 CHANNEL HANGER BRACKET FOR B52

- Material: 11 Gauge (3.0)
ASTM A1011 HSLAS Gr. 50
- Standard finishes: ZN, GRN
- Wt./C 6.7 Lbs. (3.0 kg)

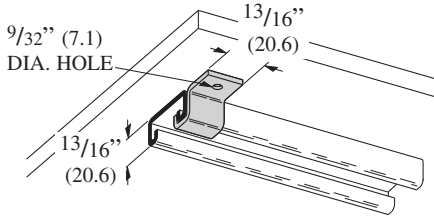

B410-32 CHANNEL HANGER BRACKET FOR B32

- Material: 11 Gauge (3.0)
ASTM A1011 HSLAS Gr. 50
- Standard finishes: ZN, GRN
- Wt./C 8.3 Lbs. (3.7 kg)

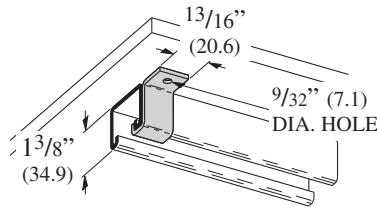

B410-22 CHANNEL HANGER BRACKET FOR B22

- Material: 11 Gauge (3.0)
ASTM A1011 HSLAS Gr. 50
- Standard finishes: ZN, GRN
- Wt./C 9 Lbs. (4.1 kg)

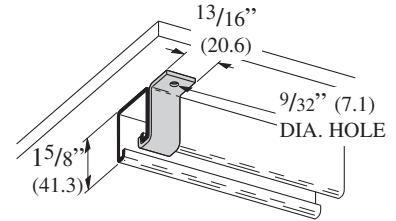

B410-12 CHANNEL HANGER BRACKET FOR B12

- Material: 11 Gauge (3.0)
ASTM A1011 HSLAS Gr. 50
- Standard finishes: ZN, GRN
- Wt./C 11.2 Lbs. (5.1 kg)

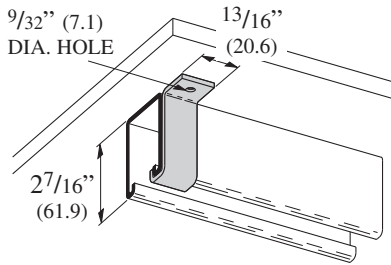

B410-11 CHANNEL HANGER BRACKET FOR B11

- Material: 11 Gauge (3.0)
ASTM A1011 HSLAS Gr. 50
- Standard finishes: ZN, GRN
- Wt./C 13.4 Lbs. (6.1 kg)

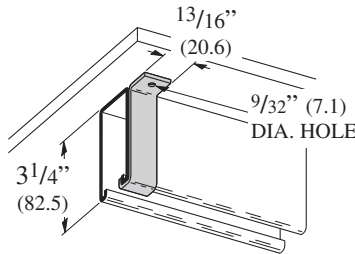

B580 FIVE HOLE GUSSETED Z-SUPPORT

- Standard finishes: ZN, GRN
- Wt./C 100 Lbs. (45.3 kg)

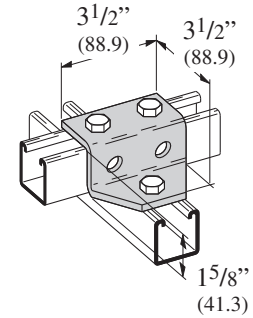

B515 ADJUSTABLE OFFSET GUSSETED Z-SUPPORT

- Standard finishes: ZN, GRN
- Wt./C 93 Lbs. (42.2 kg)

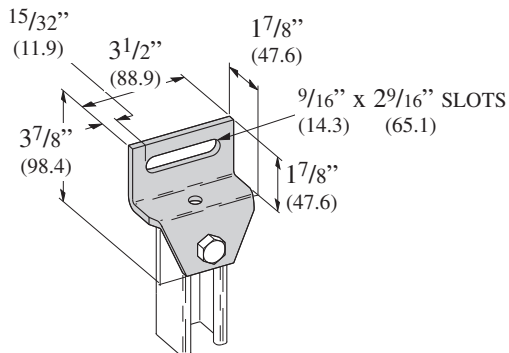

B428 EIGHT HOLE GUSSETED CORNER CONNECTION

- Standard finishes: ZN, GRN
- Wt./C 203 Lbs. (92.1 kg)

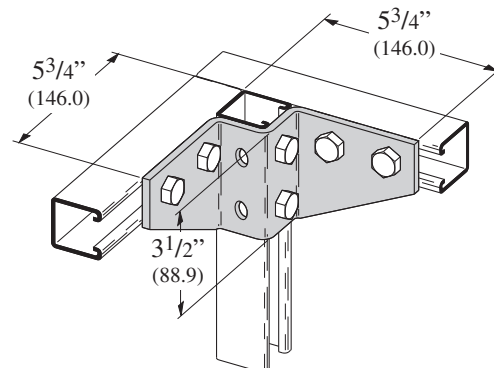

Reference page 58 for general fitting and standard finish specifications.

Wing Fittings

B267R THREE HOLE SINGLE CORNER CONNECTION (RIGHT HAND)

- Standard finishes: ZN, GRN
- Wt./C 54 Lbs. (24.5 kg)

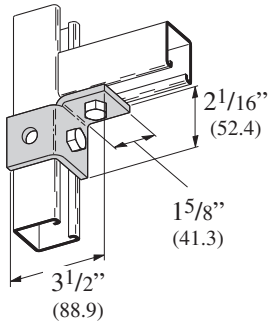

B267L THREE HOLE SINGLE CORNER CONNECTION (LEFT HAND)

- Standard finishes: ZN, GRN
- Wt./C 54 Lbs. (24.5 kg)

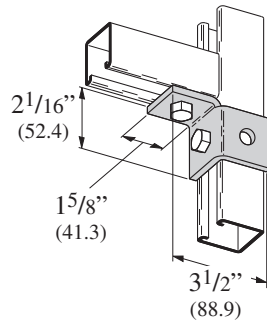

B270R FOUR HOLE SINGLE CORNER CONNECTION (RIGHT HAND)

- Standard finishes: ZN, GRN
- Wt./C 77 Lbs. (34.9 kg)

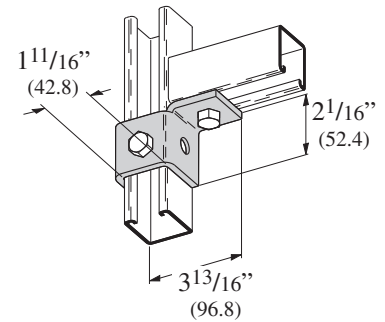

B270L FOUR HOLE SINGLE CORNER CONNECTION (LEFT HAND)

- Standard finishes: ZN, GRN
- Wt./C 77 Lbs. (34.9 kg)

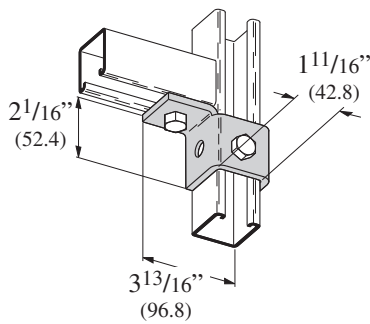

B268R FIVE HOLE SINGLE CORNER CONNECTION (RIGHT HAND)

- Standard finishes: ZN, GRN
- Wt./C 100 Lbs. (45.3 kg)

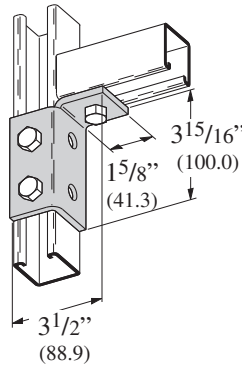

B268L FIVE HOLE SINGLE CORNER CONNECTION (LEFT HAND)

- Standard finishes: ZN, GRN
- Wt./C 100 Lbs. (45.3 kg)

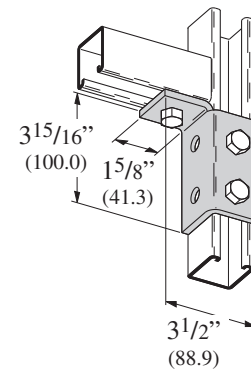

B269R SIX HOLE SINGLE CORNER CONNECTION (RIGHT HAND)

- Standard finishes: ZN, GRN
- Wt./C 120 Lbs. (54.4 kg)

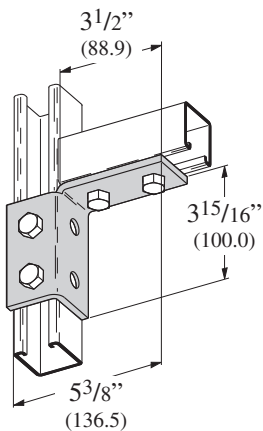

B269L SIX HOLE SINGLE CORNER CONNECTION (LEFT HAND)

- Standard finishes: ZN, GRN
- Wt./C 120 Lbs. (54.4 kg)

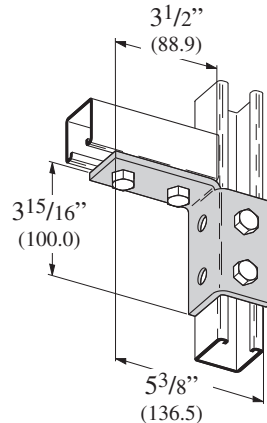

B119 FOUR HOLE DOUBLE CORNER CONNECTION

- Standard finishes: ZN, GRN
- Wt./C 71 Lbs. (32.2 kg)

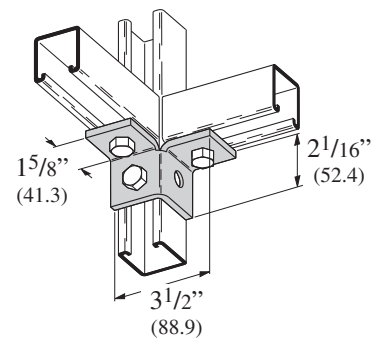

B120
SIX HOLE DOUBLE
CORNER CONNECTION

- Standard finishes: ZN, GRN
- Wt./C 110 Lbs. (49.9 kg)

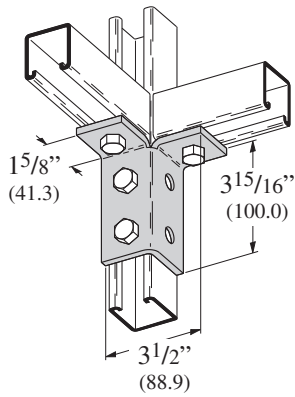

B121
EIGHT HOLE DOUBLE
CORNER CONNECTION

- Standard finishes: ZN, GRN
- Wt./C 152 Lbs. (68.9 kg)

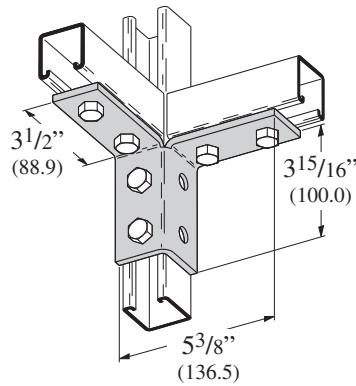

B271
FIVE HOLE DOUBLE
WING CONNECTION

- Standard finishes: ZN, GRN
- Wt./C 95 Lbs. (43.1 kg)

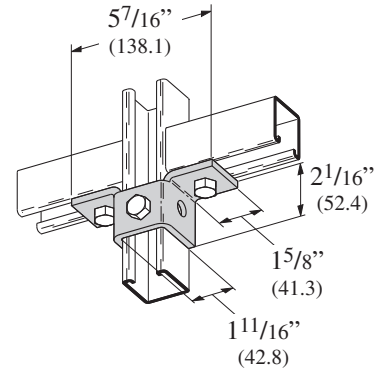

B272
EIGHT HOLE DOUBLE
WING CONNECTION

- Standard finishes: ZN, GRN
- Wt./C 156 Lbs. (70.7 kg)

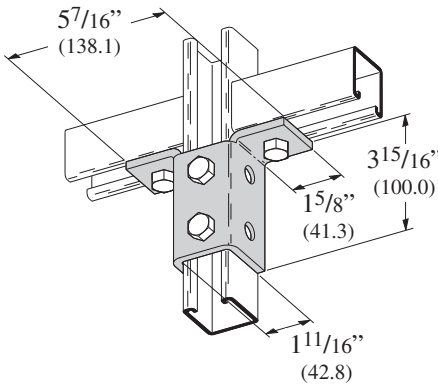

B273
TEN HOLE DOUBLE
WING CONNECTION

- Standard finishes: ZN, GRN
- Wt./C 185 Lbs. (83.9 kg)

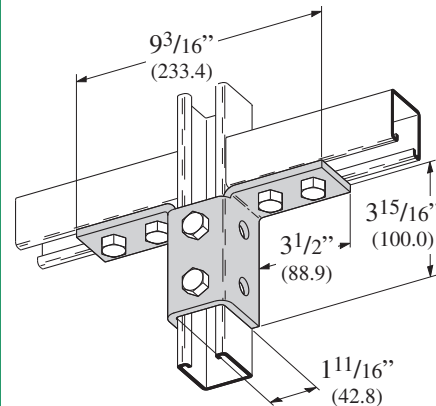

B122
SIX HOLE TRIPLE
WING CONNECTION

- Standard finishes: ZN, GRN
- Wt./C 110 Lbs. (49.9 kg)

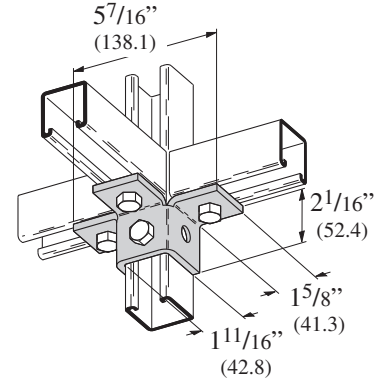

B123
TWELVE HOLE TRIPLE
WING CONNECTION

- Standard finishes: ZN, GRN
- Wt./C 234 Lbs. (106.1 kg)

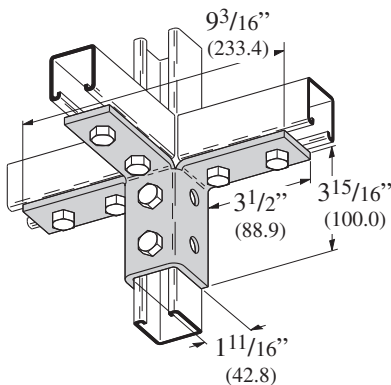

B124
NINE HOLE TRIPLE
WING CONNECTION

- Standard finishes: ZN, GRN
- Wt./C 177 Lbs. (80.3 kg)

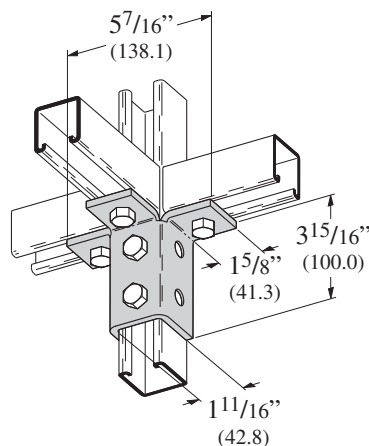

B276
FOURTEEN HOLE DOUBLE CORNER
GUSSETED CONNECTION

- Standard finishes: ZN, GRN
- Wt./C 196 Lbs. (88.9 kg)

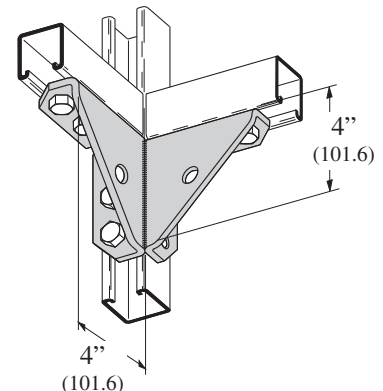

Reference page 58 for general fitting and standard finish specifications.

Wing Fittings

B274R EIGHT HOLE SINGLE CORNER GUSSETED CONNECTION (RIGHT HAND)

- Standard finishes: ZN, GRN
- Wt./C 176 Lbs. (79.8 kg)

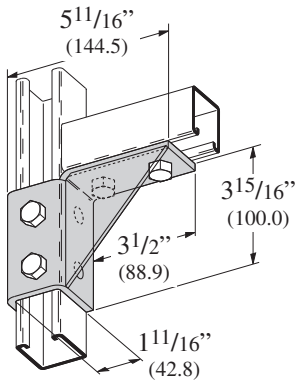

B274L EIGHT HOLE SINGLE CORNER GUSSETED CONNECTION (LEFT HAND)

- Standard finishes: ZN, GRN
- Wt./C 176 Lbs. (79.8 kg)

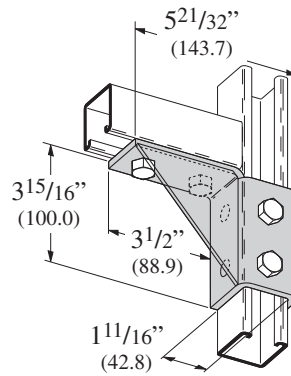

B495 TEN HOLE DOUBLE WING GUSSETED CONNECTION

- Standard finishes: ZN, GRN
- Wt./C 240 Lbs. (108.8 kg)

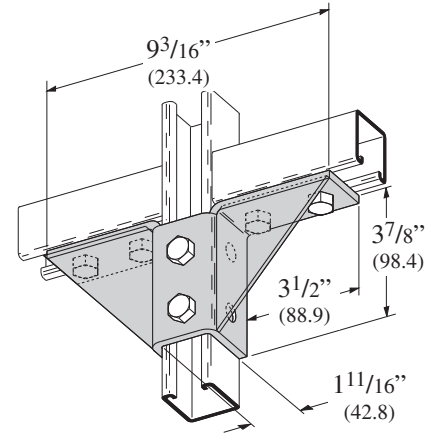

B277 TWELVE HOLE TRIPLE WING GUSSETED CONNECTION

- Standard finishes: ZN, GRN
- Wt./C 285 Lbs. (129.3 kg)

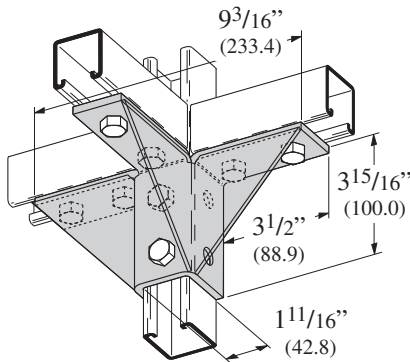

B362 EIGHT HOLE DOUBLE CORNER GUSSETED CONNECTION

- Standard finishes: ZN, GRN
- Wt./C 226 Lbs. (102.5 kg)

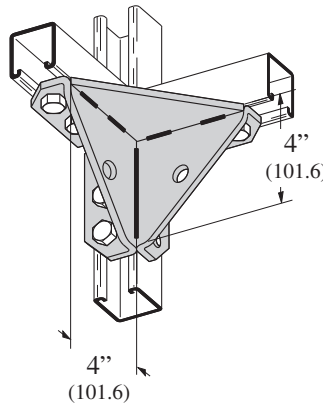

B571 EIGHT HOLE WING CONNECTION

- Standard finishes: ZN, GRN
- Wt./C 201 Lbs. (91.2 kg)

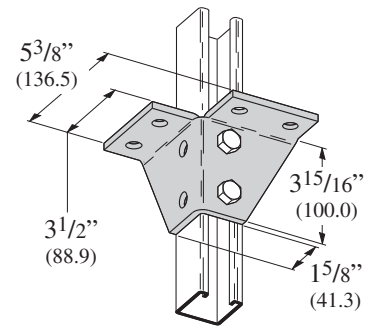

B346L EIGHT HOLE DOUBLE CORNER GUSSETED CONNECTION (LEFT HAND)

- Standard finishes: ZN, GRN
- Wt./C 242 Lbs. (109.8 kg)

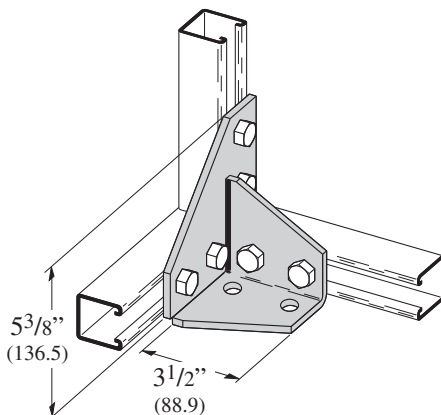

B346R EIGHT HOLE DOUBLE CORNER GUSSETED CONNECTION (RIGHT HAND)

- Standard finishes: ZN, GRN
- Wt./C 242 Lbs. (109.8 kg)

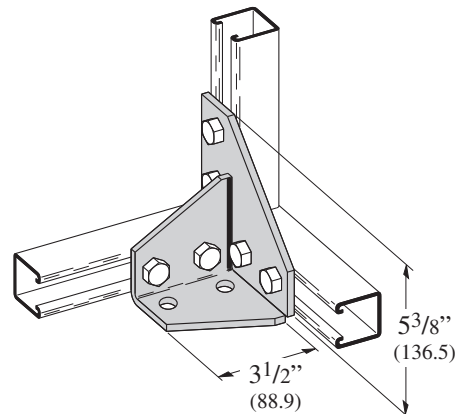

Reference page 58 for general fitting and standard finish specifications.

B279 POST BASE FOR B22

- Standard finishes: ZN, GRN
- Wt./C 314 Lbs. (142.4 kg)

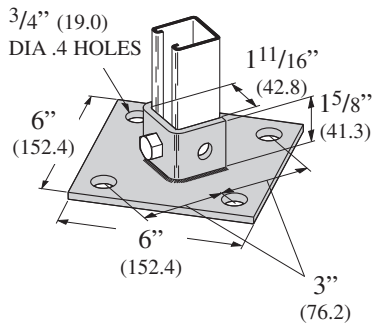

B279SQ POST BASE FOR B22

- Standard finishes: ZN, GRN
- Wt./C 314 Lbs. (142.4 kg)

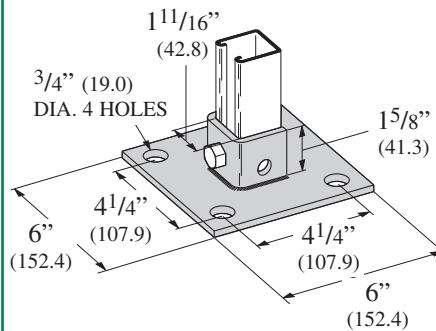

B279FL POST BASE FOR B22

- Standard finishes: ZN, GRN
- Wt./C 230 Lbs. (104.3 kg)

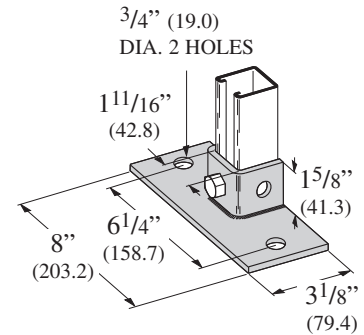

B280 POST BASE FOR B22

- Standard finishes: ZN, GRN, HDG, SS4, AL
- Wt./C 392 Lbs. (177.8 kg)

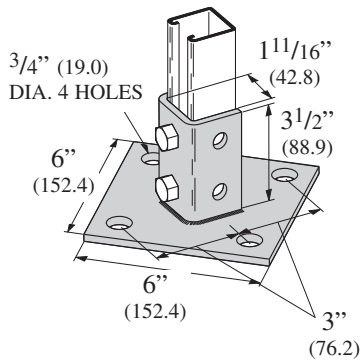

B280SQ POST BASE FOR B22

- Standard finishes: ZN, GRN, HDG, SS4, AL
- Wt./C 392 Lbs. (177.8 kg)

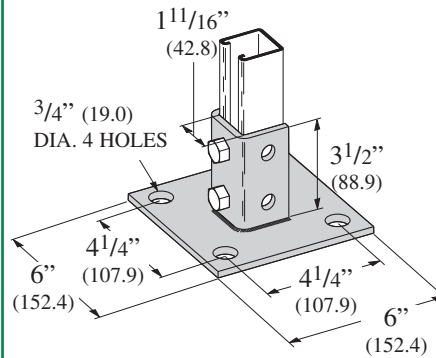

B280FL POST BASE FOR B22

- Standard finishes: ZN, GRN, HDG, SS4
- Wt./C 312 Lbs. (141.5 kg)

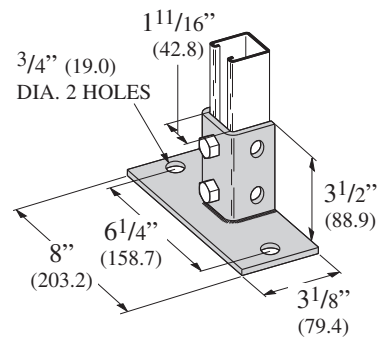

B281A POST BASE FOR B22A, B,C, ETC.

- Standard finishes: ZN, GRN
- Wt./C 330 Lbs. (149.7 kg)

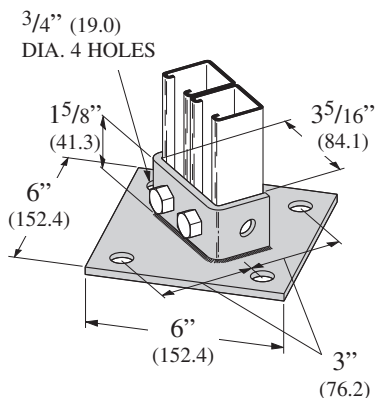

B281ASQ POST BASE FOR B22A, B, C, ETC.

- Standard finishes: ZN, GRN
- Wt./C 330 Lbs. (149.7 kg)

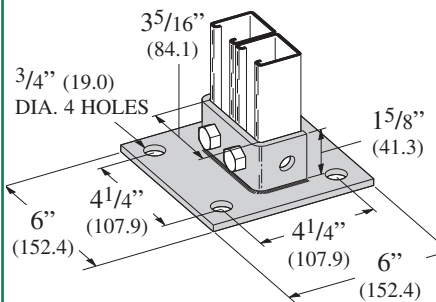

B281AFL POST BASE FOR B22A, B, C, ETC.

- Standard finishes: ZN, GRN
- Wt./C 250 Lbs. (113.4 kg)

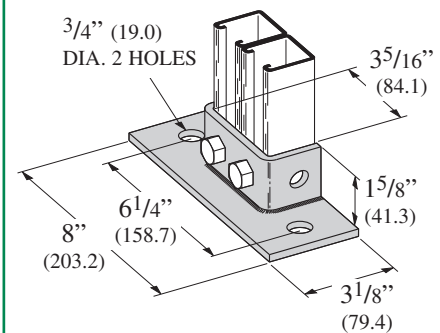

Reference page 58 for general fitting and standard finish specifications.

Post Bases

B281 POST BASE FOR B22A, B, C, ETC.

- Standard finishes: ZN, GRN, HDG
- Wt./C 400 Lbs. (181.4 kg)

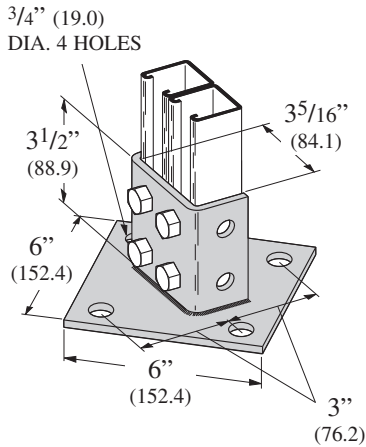

B281SQ POST BASE FOR B22A, B, C, ETC.

- Standard finishes: ZN, GRN, HDG, SS4
- Wt./C 400 Lbs. (181.4 kg)

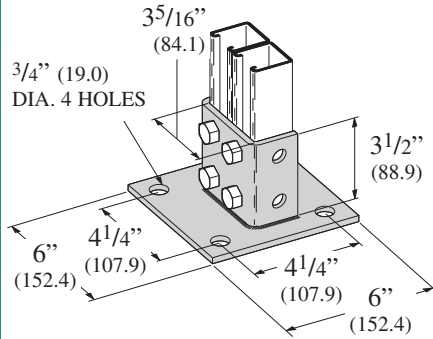

B281FL POST BASE FOR B22A, B, C, ETC.

- Standard finishes: ZN, GRN
- Wt./C 320 Lbs. (145.1 kg)

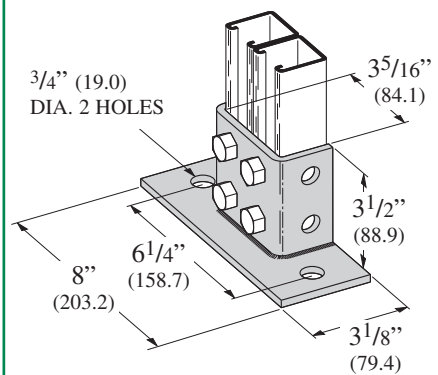

B281M POST BASE FOR B22-2PL

- Standard finishes: ZN, GRN
- Wt./C 470 Lbs. (213.2 kg)

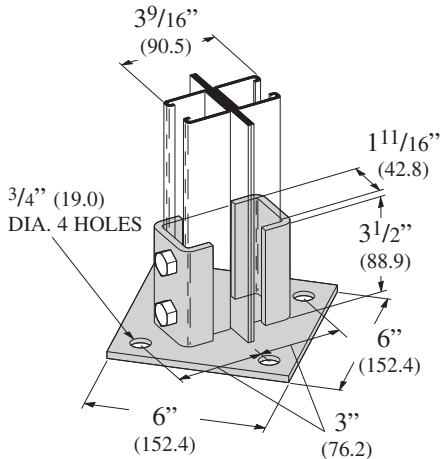

B281MSQ POST BASE FOR B22-2PL

- Standard finishes: ZN, GRN
- Wt./C 470 Lbs. (213.2 kg)

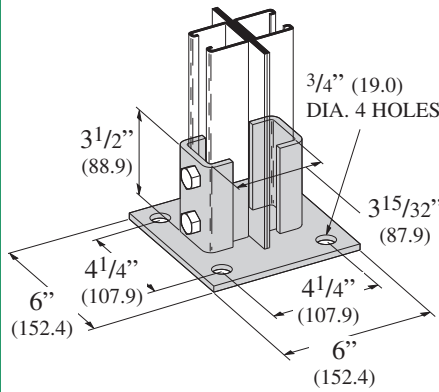

B570 POST BASE FOR FOUR CHANNEL COMBINATIONS

- Standard finishes: ZN, GRN
- Wt./C 397 Lbs. (180.1 kg)

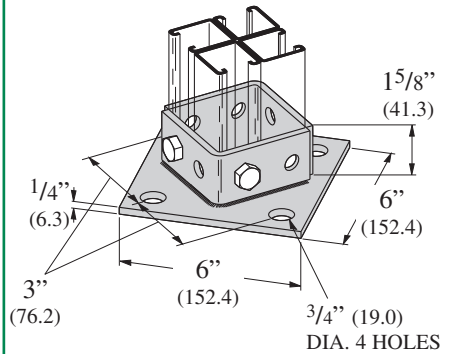

B570A POST BASE FOR FOUR CHANNEL COMBINATIONS

- Standard finishes: ZN, GRN
- Wt./C 550 Lbs. (249.5 kg)

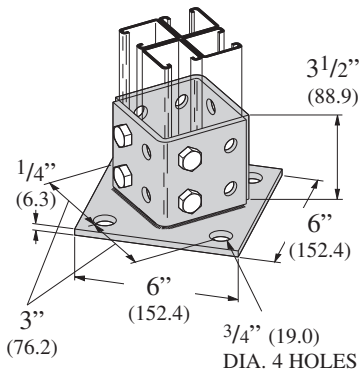

B278 POST BASE FOR B22

- Standard finishes: ZN, GRN
- Wt./C 288 Lbs. (130.6 kg)

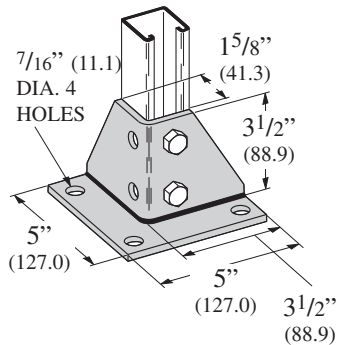

B585 POST BASE FOR B22A

- Standard finishes: ZN, GRN
- Wt./C 97 Lbs. (44.0 kg)

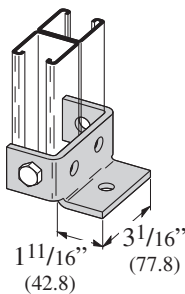

B300 POST BASE

- Material: Malleable Iron
- Standard finishes: ZN, GRN
- Wt./C 259 Lbs. (117.5 kg)

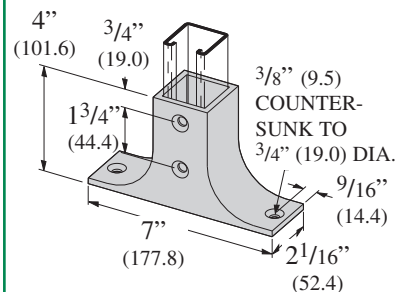

Reference page 58 for general fitting and standard finish specifications.

B187 BRACKET

- Uniform Loading 1450 Lbs. (6.45 kN)
- Safety Factor of 2.5
- Hole Spacing on Bracket Top 5⁵/₁₆" (150.8) Center to Center
- Standard finishes: ZN, GRN
- Wt./C 193 Lbs. (87.5 kg)

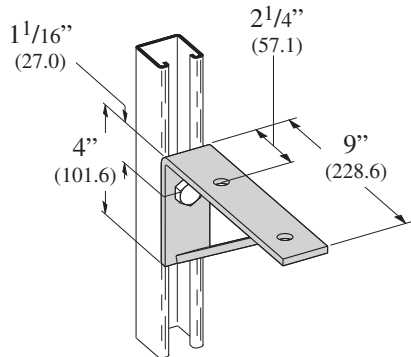

B188 BRACKET

- Uniform Loading 1080 Lbs. (4.80 kN)
- Safety Factor of 2.5
- Hole Spacing on Bracket Top 8¹⁵/₁₆" (227.0) Center to Center
- Standard finishes: ZN, GRN
- Wt./C 241 Lbs. (109.3 kg)

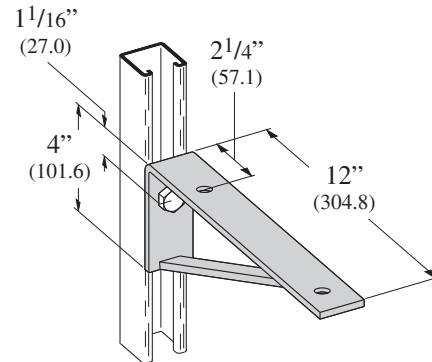

B189 BRACKET

- Uniform Loading 870 Lbs. (3.87 kN)
- Safety Factor of 2.5
- Hole Spacing on Bracket Top 11¹⁵/₁₆" (303.2) Center to Center
- Standard finishes: ZN, GRN
- Wt./C 308 Lbs. (139.7 kg)

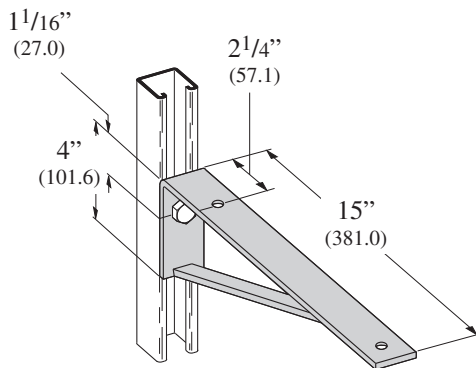

B541 BRACKET

- Uniform Loading 1240 Lbs. (5.51 kN)
- Safety Factor of 2.5
- Hole Spacing on Bracket Top 7⁷/₁₆" (188.9) Center to Center
- Standard finishes: ZN, GRN
- Wt./C 201 Lbs. (91.2 kg)

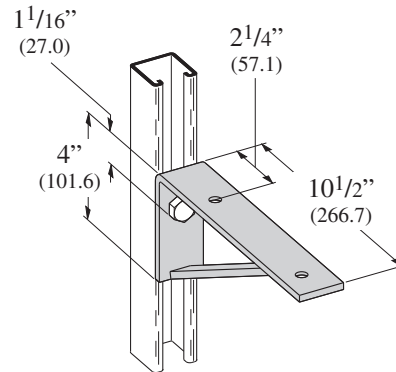

B190 12" (304.8) BRACKET

- Uniform Loading 900 Lbs. (4.00 kN)
- Safety Factor of 2.5
- Standard finishes: ZN, GRN
- Wt./C 260 Lbs. (117.9 kg)

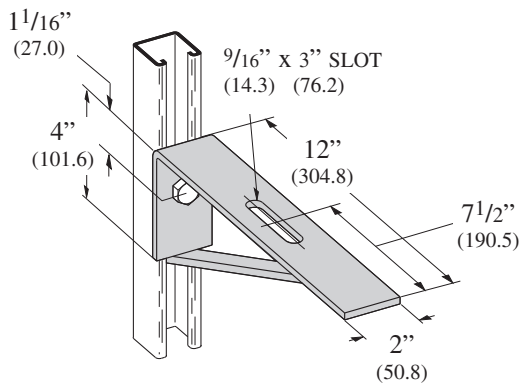

B191-18 18" (457.2) BRACKET

- Uniform Loading 600 Lbs. (2.67 kN)
- Safety Factor of 2.5
- Standard finishes: ZN, GRN
- Wt./C 377 Lbs. (171.0 kg)

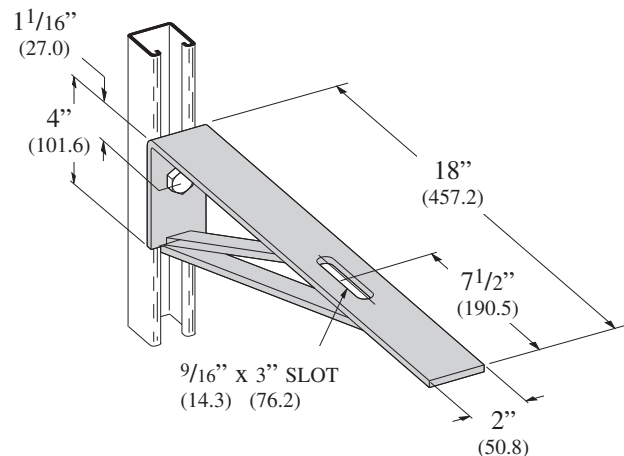

Reference page 58 for general fitting and standard finish specifications.

Brackets

B191-24 24" (609.6) BRACKET

- Uniform Loading 450 Lbs. (2.00 kN)
- Safety Factor of 2.5
- Standard finishes: ZN, GRN
- Wt./C 377 Lbs. (171.0 kg)

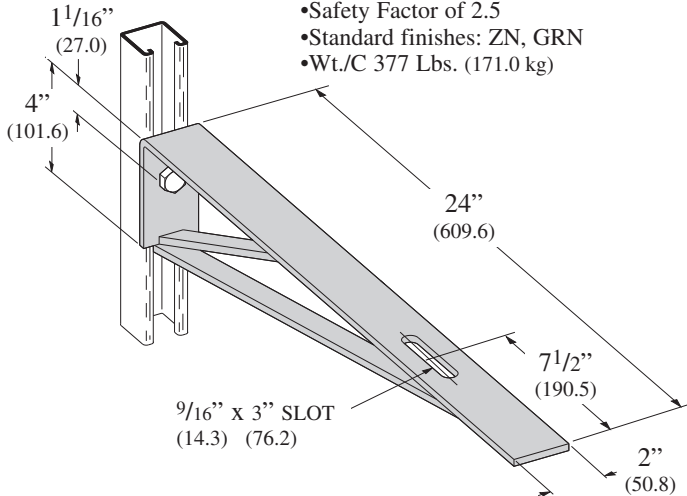

B192 24" (609.6) BRACKET

- Uniform Loading 820 Lbs. (3.65 kN)
- Safety Factor of 2.5
- Standard finishes: ZN, GRN
- Wt./C 576 Lbs. (261.3 kg)

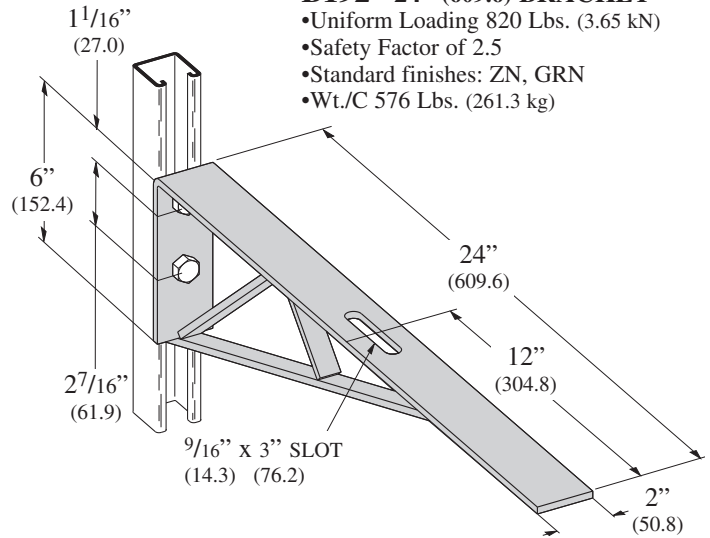

B290 16 1/2" (419.1) BRACKET

- Uniform Loading 1200 Lbs. (5.34 kN)
- Safety Factor of 2.5
- Standard finishes: ZN, GRN
- Wt./C 405 Lbs. (183.7 kg)

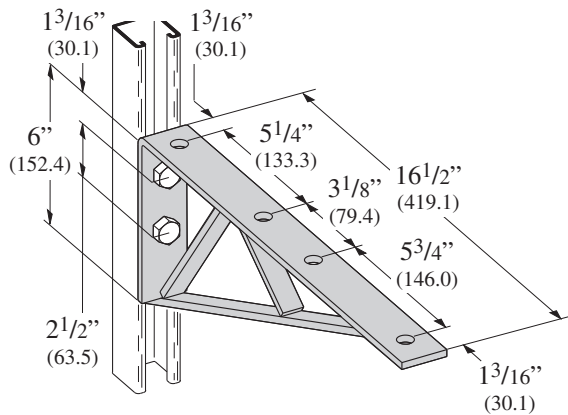

B289-12 12 1/2" (317.5) BRACKET

- Uniform Loading 1040 Lbs. (4.63 kN)
- Safety Factor of 2.5
- Standard finishes: ZN, GRN
- Wt./C 285 Lbs. (129.3 kg)

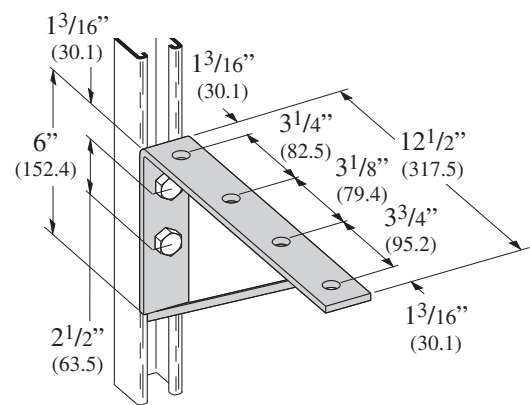

B289-14 14 1/2" (368.3) BRACKET

- Uniform Loading 900 Lbs. (4.00 kN)
- Safety Factor of 2.5
- Standard finishes: ZN, GRN
- Wt./C 295 Lbs. (133.8 kg)

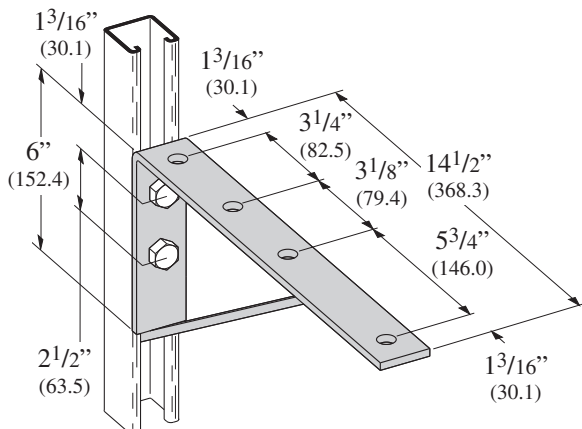

B291 18 1/2" (469.9) BRACKET

- Uniform Loading 1070 Lbs. (4.76 kN)
- Safety Factor of 2.5
- Standard finishes: ZN, GRN
- Wt./C 468 Lbs. (212.3 kg)

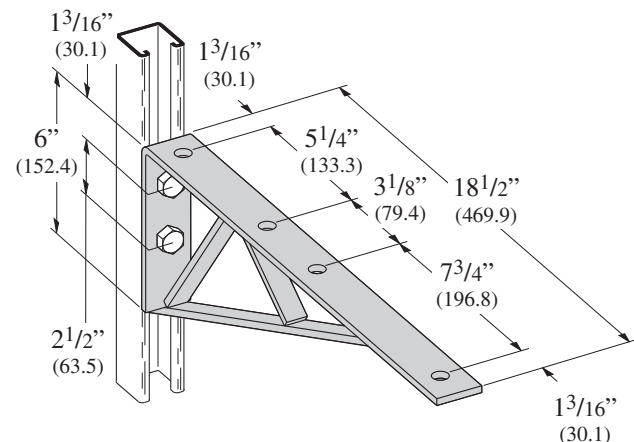

Reference page 58 for general fitting and standard finish specifications.

B292 20¹/₂" (520.7) BRACKET

- Uniform Loading 600 Lbs. (2.67 kN)
- Safety Factor of 2.5
- Standard finishes: ZN, GRN, HDG, SS4
- Wt./C 490 Lbs. (222.2 kg)

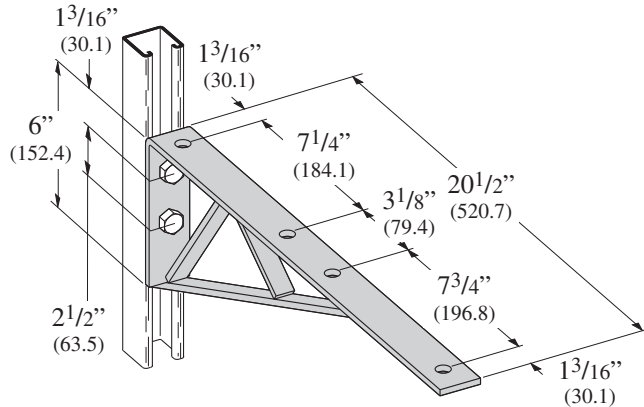

B297 DOUBLE CHANNEL BRACKET

- Safety Factor of 2.5
- Standard finishes: ZN, GRN, HDG

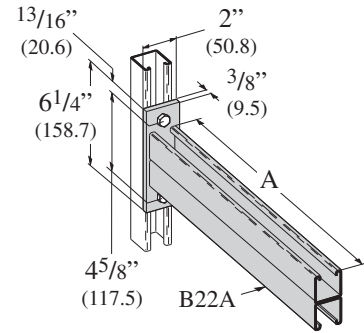

Part No.	A	Uniform Load		Wt./C	
		Lbs.	kN	Lbs.	kg
B297-12	12" (304.8)	1660	(7.37)	485	(220.0)
B297-18	18" (457.2)	1100	(4.88)	668	(303.0)
B297-24	24" (609.6)	835	(3.71)	857	(388.7)
B297-30	30" (762.0)	665	(2.95)	1040	(471.7)
B297-36	36" (914.4)	550	(2.44)	1240	(562.4)
B297-42	42" (1066.8)	465	(2.06)	1440	(653.2)

B409 SINGLE CHANNEL BRACKET

- Safety Factor of 2.5
- Standard finishes: ZN, GRN, SS4

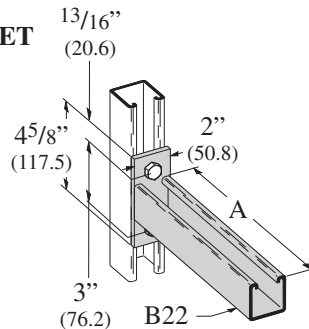

Part No.	A	Uniform Load		Wt./C	
		Lbs.	kN	Lbs.	kg
B409-6	6" (152.4)	1920	(8.54)	152	(68.9)
B409-9	9" (228.6)	1280	(5.69)	195	(88.4)
B409-12	12" (304.8)	960	(4.27)	232	(105.2)
B409-14	14" (355.6)	800	(3.56)	274	(124.3)
B409-16	16" (406.4)	730	(3.25)	314	(142.4)
B409-18	18" (457.2)	640	(2.84)	347	(157.4)
B409-24	24" (609.6)	480	(2.13)	450	(204.1)

B494 BRACED SINGLE BRACKET

- Safety Factor of 2.5
- Standard finishes: ZN, GRN

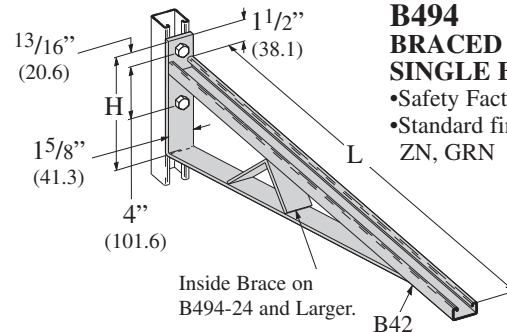

Part No.	L	H	Uniform Load		Wt./C	
			Lbs.	kN	Lbs.	kg
B494-12	12" (304.8)	8 ³ / ₄ " (222.2)	1580	(7.02)	364	(165.1)
B494-18	18" (475.2)	8 ³ / ₄ " (222.2)	1000	(4.45)	479	(217.3)
B494-24	24" (609.6)	8 ³ / ₄ " (222.2)	996	(4.43)	716	(324.8)
B494-30	30" (762.0)	11 ¹ / ₄ " (285.7)	924	(4.11)	927	(420.5)
B494-36	36" (914.4)	11 ¹ / ₄ " (285.7)	864	(3.84)	1095	(496.7)
B494-42	42" (1066.8)	16" (406.4)	580	(2.58)	1400	(635.0)
B494-48	48" (1219.2)	16" (406.4)	500	(2.22)	1510	(684.9)

B174SH-B186SH L&R SLOTTED BRACKET

- Safety Factor of 2.5
- Specify L for left or R for right bracing
- Material: ASTM A1011 33,000 PSI min. yield
- Standard finishes: ZN, GRN

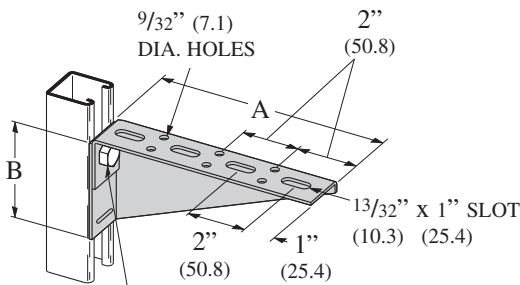

MOUNTING HOLE
7/16" (11.1) DIA.

Right bracket shown, left bracket
gussett on opposite side.

Part No.	A	B	Uniform Load		Wt./C	
			Lbs.	kN	Lbs.	kg
B174SH	24" (609.6)	6 ⁷ / ₁₆ " (163.5)	225	(1.00)	370	(167.8)
B175SH	26" (660.4)	6 ¹⁵ / ₁₆ " (176.2)	225	(1.00)	425	(192.8)
B176SH	28" (711.2)	7 ⁷ / ₁₆ " (188.9)	225	(1.00)	480	(217.7)
B177SH	30" (762.0)	7 ¹⁵ / ₁₆ " (201.6)	225	(1.00)	520	(235.9)
B178SH	12" (304.8)	3 ⁷ / ₁₆ " (87.3)	350	(1.55)	143	(64.8)
B179SH	14" (355.6)	3 ¹⁵ / ₁₆ " (100.0)	350	(1.55)	162	(73.5)
B180SH	16" (406.4)	4 ⁷ / ₁₆ " (112.7)	250	(1.11)	204	(92.5)
B181SH	18" (457.2)	4 ¹⁵ / ₁₆ " (125.4)	250	(1.11)	232	(105.2)
B182SH	20" (508.0)	5 ⁷ / ₁₆ " (138.1)	250	(1.11)	275	(124.7)
B183SH	22" (558.8)	5 ¹⁵ / ₁₆ " (150.8)	250	(1.11)	317	(143.8)
B184SH	6" (152.4)	1 ¹⁵ / ₁₆ " (49.2)	225	(1.00)	58	(26.3)
B185SH	8" (203.2)	2 ⁷ / ₁₆ " (61.9)	225	(1.00)	82	(37.2)
B186SH	10" (254.0)	2 ¹⁵ / ₁₆ " (74.6)	325	(1.44)	103	(46.7)

Reference page 58 for general fitting and standard finish specifications.

Brackets

B196 CHANNEL CLEVIS BRACKET

- Safety Factor of 2.5
- Standard finishes: ZN, GRN

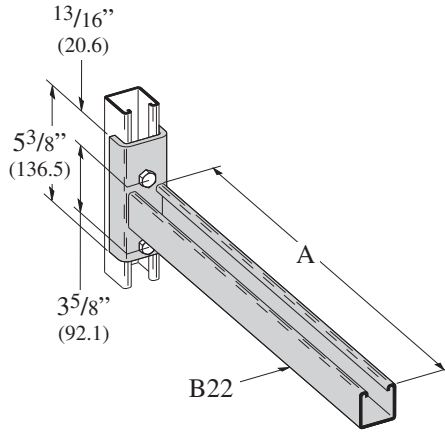

Part No.	A	(A)	Uniform Load		Wt./C	
			Lbs.	kN	Lbs.	kg
B196-18	18"	(457.2)	600	(2.67)	430	(195.0)
B196-24	24"	(609.6)	450	(2.00)	510	(231.3)

B198A CHANNEL CLEVIS BRACKET

- Safety Factor of 2.5
- Standard finishes: ZN, GRN

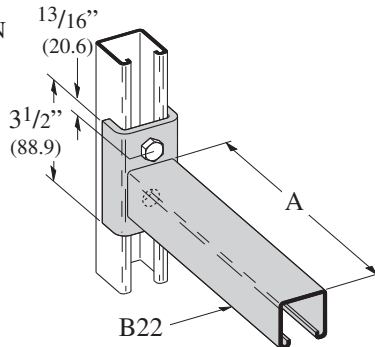

Part No.	A	(A)	Uniform Load		Wt./C	
			Lbs.	kN	Lbs.	kg
B198A-6	6"	(152.4)	1600	(7.12)	185	(83.9)
B198A-12	12"	(304.8)	800	(3.56)	284	(128.8)

B293A CHANNEL BRACKET

- Safety Factor of 2.5
- Standard finishes: ZN, GRN

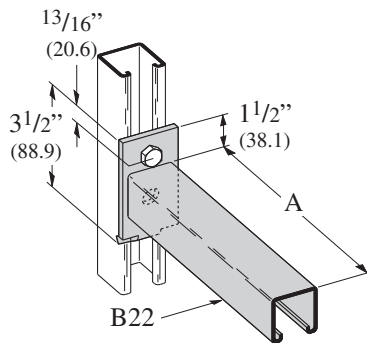

Part No.	A	(A)	Uniform Load		Wt./C	
			Lbs.	kN	Lbs.	kg
B293A-6	6"	(152.4)	1200	(5.34)	144	(65.3)
B293A-12	12"	(304.8)	600	(2.67)	252	(114.3)
B293A-18	18"	(457.2)	400	(1.78)	340	(154.2)
B293A-24	24"	(609.6)	300	(1.33)	412	(186.9)

B198 CHANNEL CLEVIS BRACKET

- Safety Factor of 2.5
- Standard finishes: ZN, GRN

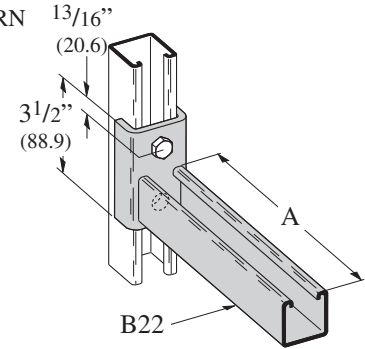

Part No.	A	(A)	Uniform Load		Wt./C	
			Lbs.	kN	Lbs.	kg
B198-6	6"	(152.4)	1600	(7.12)	185	(83.9)
B198-12	12"	(304.8)	800	(3.56)	284	(128.8)

B293 CHANNEL BRACKET

- Safety Factor of 2.5
- Standard finishes: ZN, GRN

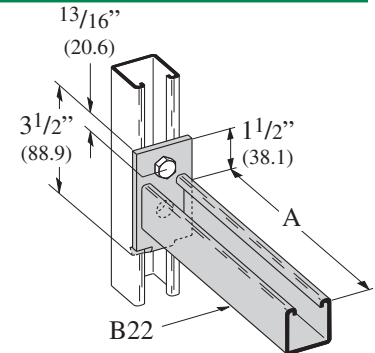

Part No.	A	(A)	Uniform Load		Wt./C	
			Lbs.	kN	Lbs.	kg
B293-6	6"	(152.4)	1200	(5.34)	144	(65.3)
B293-12	12"	(304.8)	600	(2.67)	252	(114.3)
B293-18	18"	(457.2)	400	(1.78)	340	(154.2)
B293-24	24"	(609.6)	300	(1.33)	412	(186.9)

B194 BRACKET FOR B22 & B24

- Safety Factor of 2.5
- 6300 In.-Lbs (712 N•m) applies to fitting only, not to strength of strut arm
- Refer to page 217 for strut loading data
- Standard finishes: ZN, GRN
- Wt./C 210 Lbs. (95.2 kg)

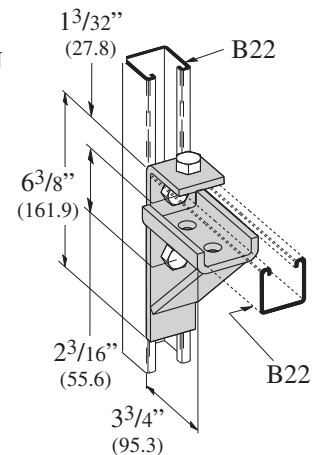

Reference page 58 for general fitting and standard finish specifications.

B370 BRACKET FOR B22A & B11

- Safety Factor of 2.5
- 13000 In.-Lbs (1469 N•m) applies to fitting only, not to strength of strut arm
- Refer to page 217 for strut loading data
- Standard finishes: ZN, GRN
- Wt./C 266 Lbs. (120.6 kg)

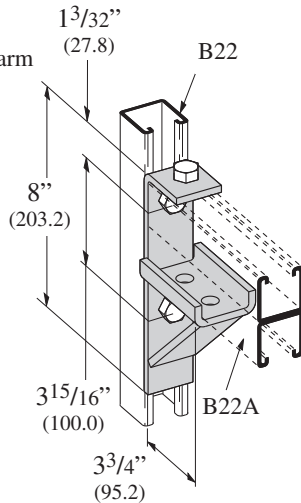

B195 BRACKET FOR B42

- Safety Factor of 2.5
- 2500 In.-Lbs (282 N•m) applies to fitting only, not to strength of strut arm
- Refer to page 217 for strut loading data
- Standard finishes: ZN, GRN
- Wt./C 174 Lbs. (78.9 kg)

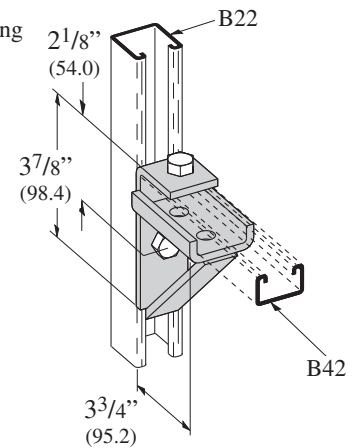

B440 BRACKET FOR B52 & B54

- Safety Factor of 2.5
- 2000 In.-Lbs (226 N•m) applies to fitting only, not to strength of strut arm
- Refer to page 217 for strut loading data
- Standard finishes: ZN, GRN
- Wt./C 177 Lbs. (80.3 kg)

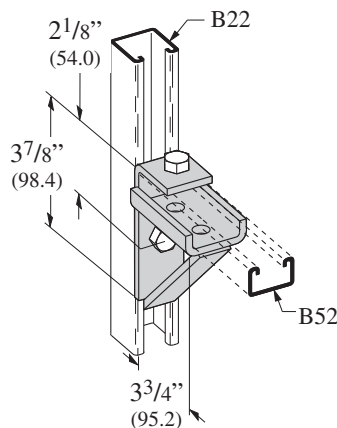

B449-4, 8 & 12 CABLE SADDLE BRACKET

- Safety Factor of 2.5
- Material: 11 Gauge (3.0) ASTM A1011 HSLAS Gr. 50
- Standard finishes: ZN, GRN

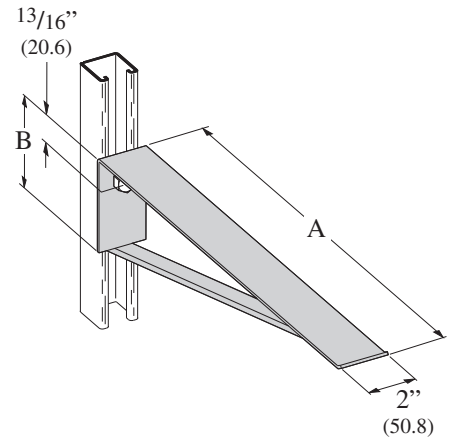

Part No.	A		B		Uniform Load		Wt./C	
	in.	mm	in.	mm	Lbs.	kN	Lbs.	kg
B449-4	4 1/2"	(114.3)	2 3/8"	(60.3)	2400	(10.67)	74	(33.5)
B449-8	8 1/2"	(215.9)	2 3/8"	(60.3)	1270	(5.65)	124	(56.2)
B449-12	12 1/2"	(317.5)	4"	(101.6)	860	(3.82)	184	(83.4)

B449-18 18" (457.2) CABLE SADDLE BRACKET

- Safety Factor of 2.5
- Uniform Load 960 Lbs. (4.17 kN)
- Material: 11 Gauge (3.0) ASTM A1011 HSLAS Gr. 50
- Standard finishes: ZN, GRN
- Wt./C 312 Lbs. (141.5 kg)

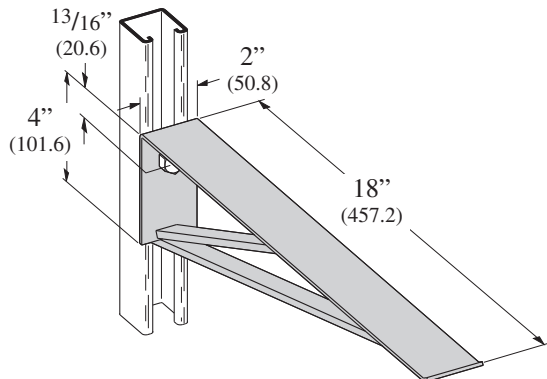

B293PL BRACKET PLATE ONLY

- Standard finishes: ZN, GRN
- Wt./C 46 Lbs. (20.8 kg)

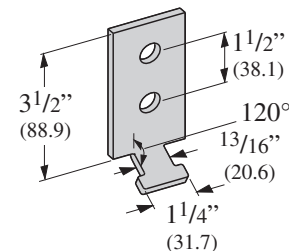

Reference page 58 for general fitting and standard finish specifications.

Brackets

B816

•Standard finishes: ZN, HDG

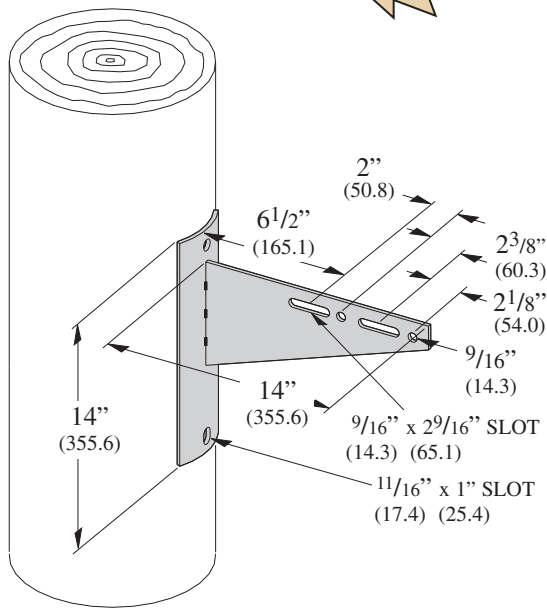

B852S-W-D

•Specify W = 8, 12, 16
 •Specify D = 6, 8, 10, 12, 16, 18, 24
 • $1\frac{3}{16}$ " (20.6mm) x 1" (25.4mm) banding slots for steel band
 •Standard finishes: ZN, HDG

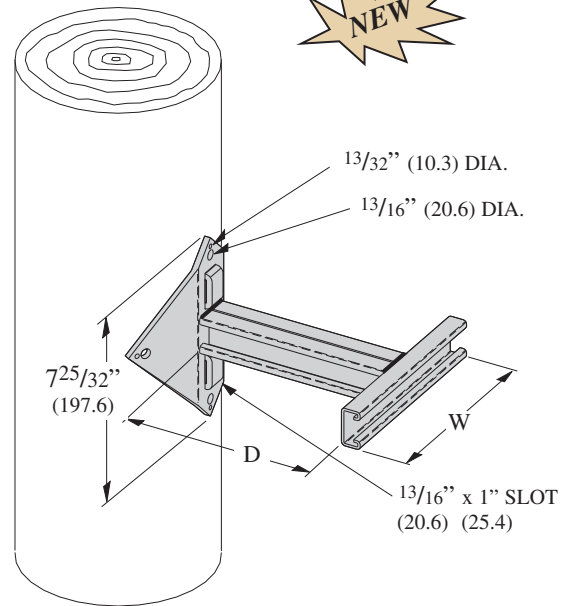

B802D-W

•Specify W = 8, 12, 16
 •Standard finishes: ZN, HDG

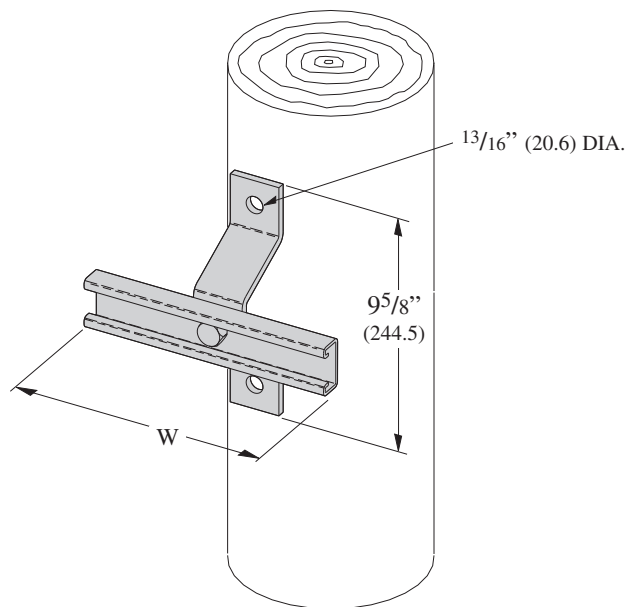

B810-W

•Specify W = 8, 12, 16
 • $1\frac{3}{16}$ " (20.6mm) x 1" (25.6mm) banding slots for steel band
 •Standard finishes: ZN, HDG

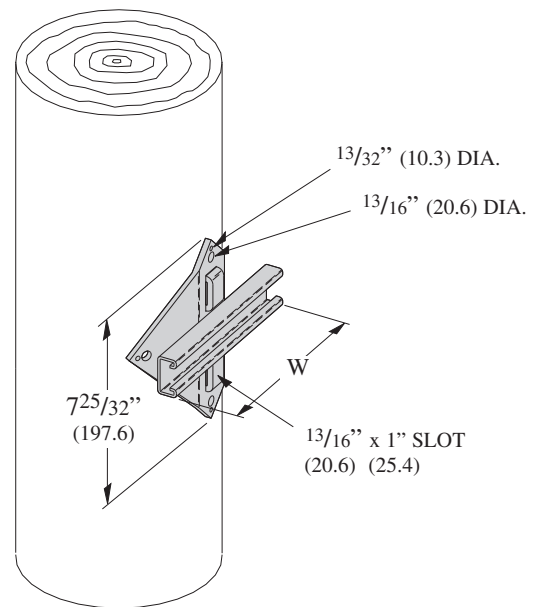

Reference page 58 for general fitting and standard finish specifications.

B811-W

- Can be attached directly to B809 & B812
- Specify W = 8, 12, 16
- Standard finishes: ZN, HDG

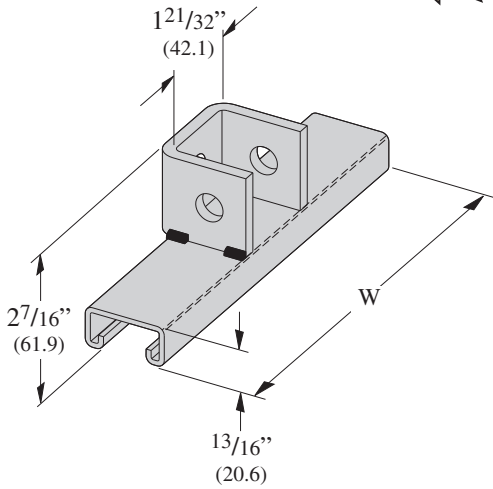

B812-*

- Specify D = 6, 8, 10, 12, 16, 18, 24
- 13/16" (20.6mm) x 1" (25.4mm) banding slots for steel band
- Standard finishes: ZN, HDG

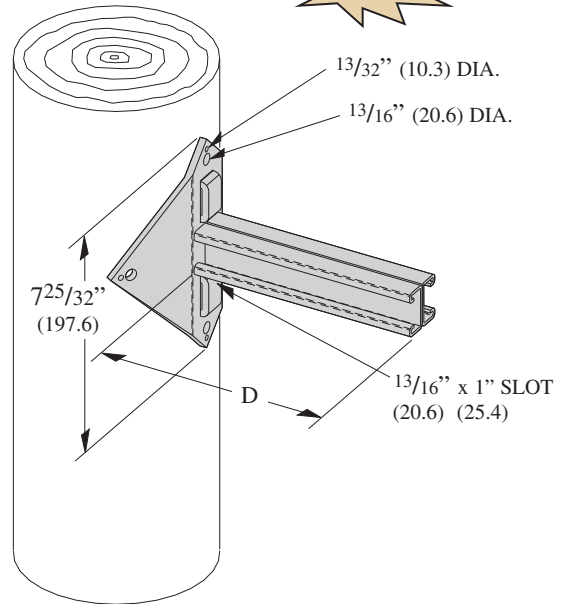

B809B-*

- Specify D = 6, 8, 10, 12, 16, 18, 24
- 13/16" (20.6mm) x 1" (25.4mm) banding slots for steel band
- Standard finishes: ZN, HDG

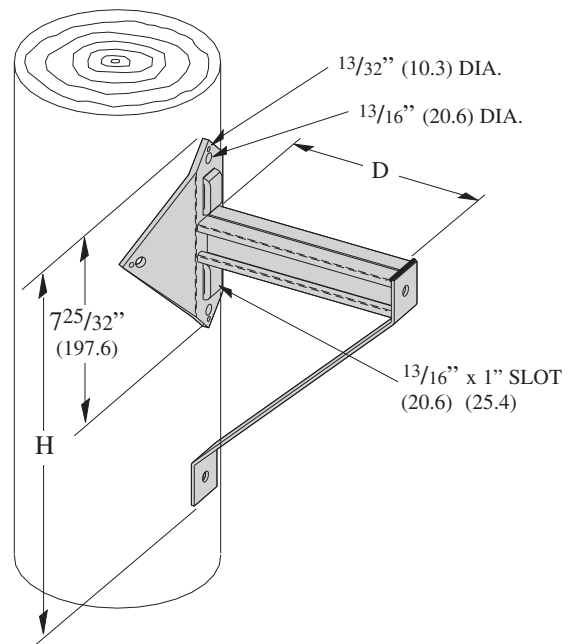

Part No.	D		H	
	In.	mm	In.	mm
B809B-6	6"	(152.4)	12 ³ / ₄ "	(323.9)
B809B-8	8"	(203.2)	14 ³ / ₄ "	(374.7)
B809B-10	10"	(254.0)	16 ³ / ₄ "	(425.5)
B809B-12	12"	(304.8)	18 ³ / ₄ "	(476.2)
B809B-16	16"	(406.4)	22 ³ / ₄ "	(577.8)
B809B-18	18"	(457.2)	24 ³ / ₄ "	(628.6)
B809B-24	24"	(609.6)	27 ³ / ₄ "	(704.8)

Reference page 58 for general fitting and standard finish specifications.

Miscellaneous Fittings

B214 R&L REEL RACK SUPPORT FOR 1 1/4" (32) PIPE

- Standard finishes: ZN, GRN
- Wt./C 200 Lbs. (90.7 kg)

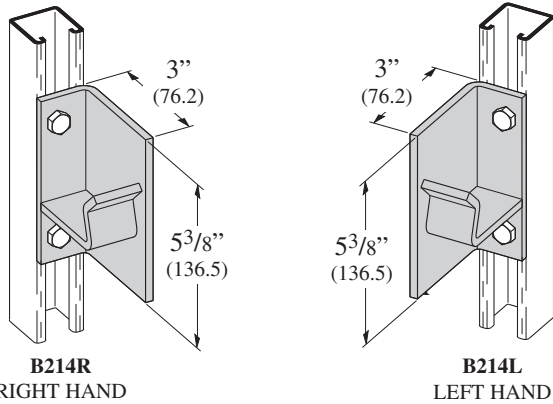

B514 R&L REEL RACK SUPPORT FOR 2" (50) PIPE

- Standard finishes: ZN, GRN
- Wt./C 246 Lbs. (111.6 kg)

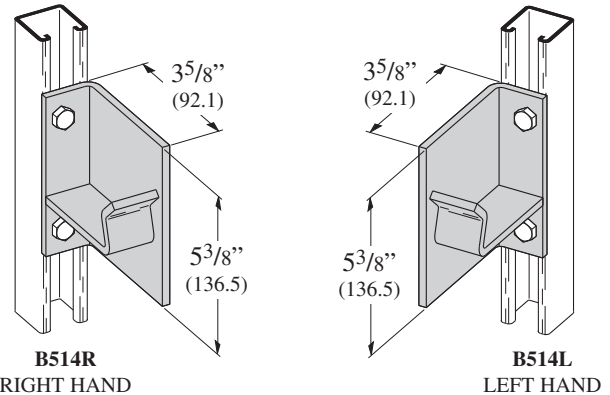

B475 DOUBLE REEL RACK SUPPORT ON SINGLE CHANNEL FOR 1 1/4" (32) PIPE

- Standard finishes: ZN, GRN
- Wt./C 326 Lbs. (147.9 kg)

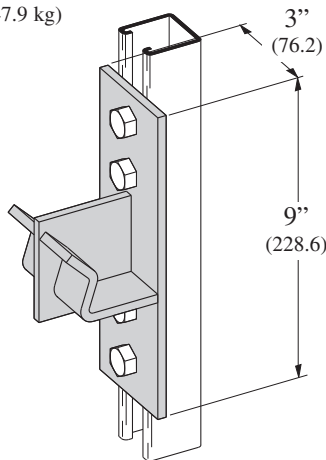

B473 DOUBLE REEL RACK SUPPORT ON SINGLE CHANNEL FOR 2" (50) PIPE

- Standard finishes: ZN, GRN
- Wt./C 351 Lbs. (159.2 kg)

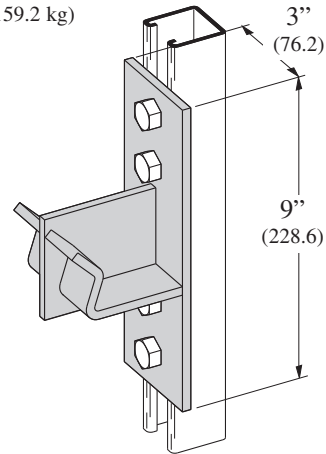

B474 DOUBLE REEL RACK CHANNEL FOR 1 1/4" (32) PIPE

- Standard finishes: ZN, GRN
- Wt./C 257 Lbs. (116.6 kg)

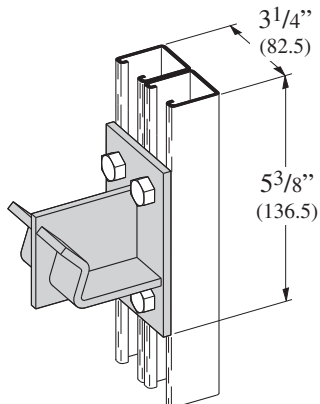

B472 DOUBLE REEL RACK SUPPORT ON DOUBLE CHANNEL FOR 2" (50) PIPE

- Standard finishes: ZN, GRN
- Wt./C 299 Lbs. (135.6 kg)

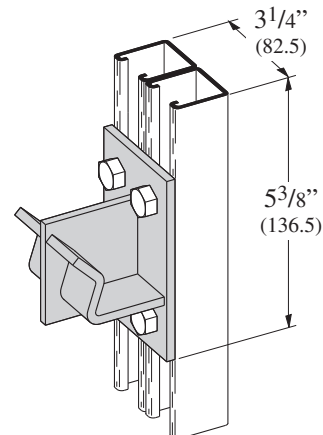

Reference page 58 for general fitting and standard finish specifications.

B664

DOUBLE PIPE SUPPORT FOR 1 1/4" (32) PIPE

- Standard finishes: ZN, GRN
- Wt./C 154 Lbs. (69.8 kg)

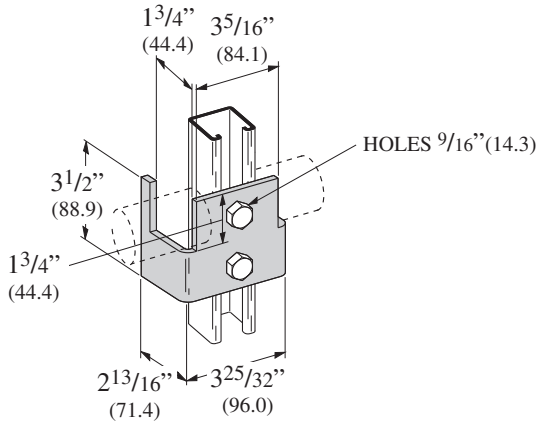

B438

PIPE SUPPORT BRACKET

- Standard finishes: ZN, GRN
- Material: ASTM A36
- Wt./C 132 Lbs. (59.9 kg)

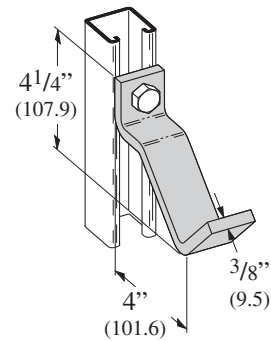

B439

PIPE SUPPORT BRACKET

- Standard finishes: ZN, GRN
- Wt./C 88 Lbs. (39.9 kg)

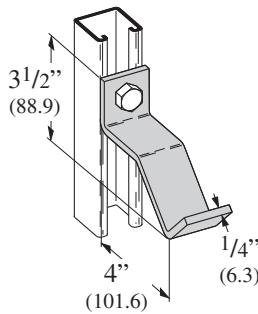

B411 SERIES LADDER RUNGS

- Standard finishes: ZN, GRN

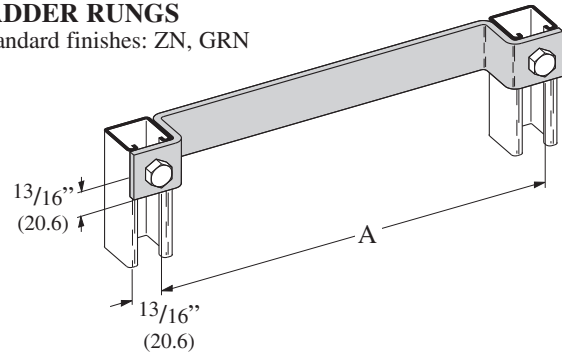

Part No.	A	(A)	Wt./C	
			Lbs.	kg
B411-12	12"	(304.8)	176	(79.8)
B411-15	15"	(381.0)	202	(91.6)
B411-18	18"	(457.2)	234	(106.1)

B381-B385

WALL LADDER BRACKETS

- Standard finishes: ZN, GRN

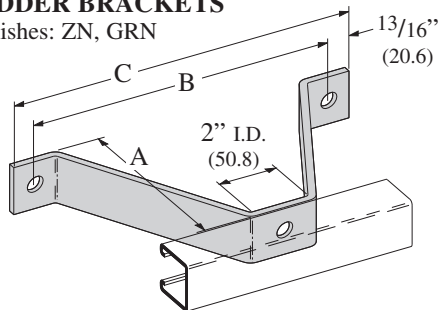

Part No.	A		B		C		Wt./C	
	A	(A)	B	(B)	C	(C)	Lbs.	kg
B381	2 3/8"	(60.3)	6"	(152.4)	7 5/8"	(193.7)	110	(49.9)
B382	4 3/8"	(111.1)	8"	(203.2)	9 5/8"	(244.5)	164	(74.4)
B383	6 3/8"	(161.9)	10"	(254.0)	11 5/8"	(295.3)	200	(90.7)
B384	6 3/8"	(212.7)	12"	(304.8)	13 5/8"	(346.1)	253	(114.7)
B385	6 3/8"	(263.5)	14"	(355.6)	15 5/8"	(396.9)	318	(144.2)

B587-1/2, 3/4 & 1 PIPE COUPLING FITTING

- Safety Factor of 2.5
- Standard finishes: ZN, GRN

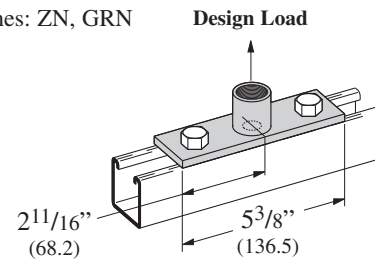

Part No.	For Pipe Size	Wt./C	Design Load			
			Lbs.	kN		
B587-1/2	1/2"	(15)	77	(34.9)	1000	(4.45)
B587-3/4	3/4"	(20)	84	(38.1)	1400	(6.23)
B587-1	1"	(25)	105	(47.6)	1900	(8.45)

Reference page 58 for general fitting and standard finish specifications.

Miscellaneous Fittings

B349 TROLLEY BEAM SUPPORT

- Design Load 1200 Lbs. (5.34 kN)
- Safety Factor of 2.5
- Use $\frac{3}{8}$ " x 3" bolts in side hole to clamp strut together (not included)
- Standard finishes: ZN, GRN
- Wt./C 107 Lbs. (48.5 kg)

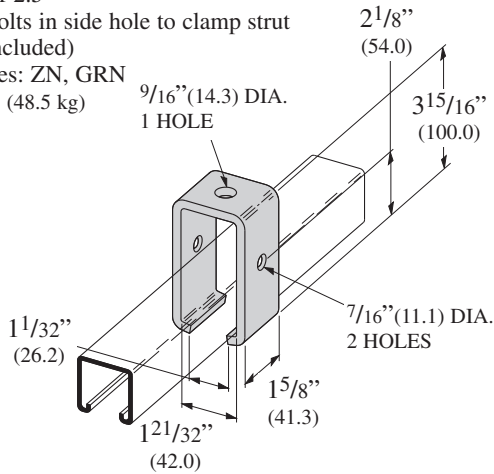

B350 TROLLEY BEAM JOINT SUPPORT

- Design Load 1200 Lbs. (5.34 kN)
- Use $\frac{3}{8}$ " x 3" bolts in side hole to clamp strut together (not included)
- Standard finishes: ZN, GRN
- Wt./C 233 Lbs. (105.7 kg)

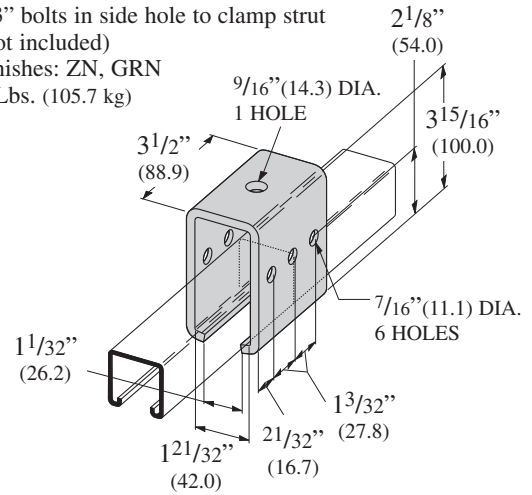

B614 COLUMN SUPPORT FOR B22

- Quick installation (one bolt to tighten)
- Design Load 800 Lbs. (3.56 kN) Slip with Safety Factor of 3
- Use with B22 and B24 Channel
- Sold in pairs
- Standard finish: ZN
- Wt./C 50 Lbs. (22.6 kg)

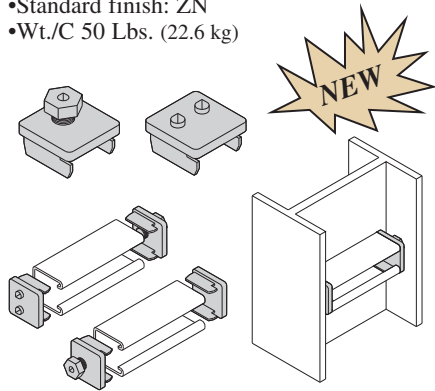

B613 COLUMN SUPPORT FOR B22

- Design Load 800 Lbs. (3.56 kN) Slip with Safety Factor of 3
- Use with B22 and B24 Channel
- Setscrews to be torqued to 19 ft./Lbs
- Sold in pairs
- Standard finishes: ZN, GRN, HDG
- Wt./C 100 Lbs. (45.3 kg)

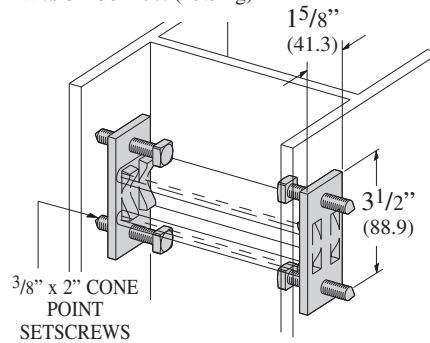

B613A COLUMN SUPPORT FOR B52

- Design Load 800 Lbs. (3.56 kN) Slip with Safety Factor of 3
- Use with B52 and B54 Channel
- Setscrews to be torqued to 19 ft./Lbs
- Sold in pairs
- Standard finishes: ZN, GRN, HDG
- Wt./C 100 Lbs. (45.3 kg)

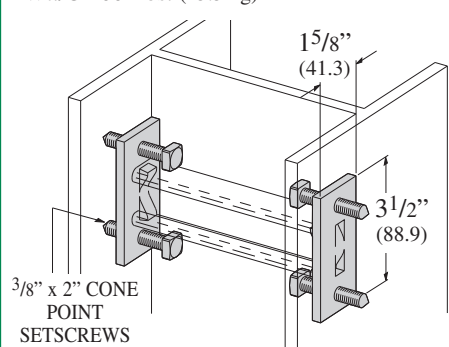

B560 45° STAIR SUPPORT

- Standard finishes: ZN, GRN
- Wt./C 220 Lbs. (99.8 kg)

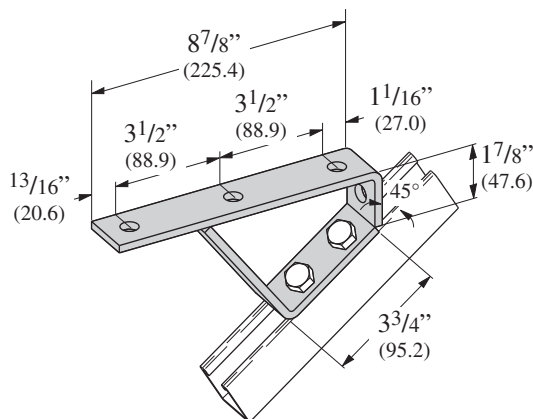

B562 37-1/2° STAIR SUPPORT

- Standard finishes: ZN, GRN
- Wt./C 206 Lbs. (93.4 kg)

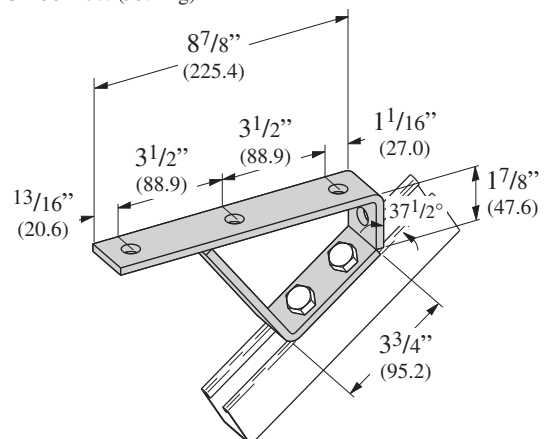

Reference page 58 for general fitting and standard finish specifications.

B376 FOUR BEARING TROLLEY ASSEMBLY

- Safety Factor of 2.5
- Stainless steel ball bearings
- Not for continuous cycling applications
- Standard finishes: ZN
- Wt./C 110 Lbs. (49.9 kg)

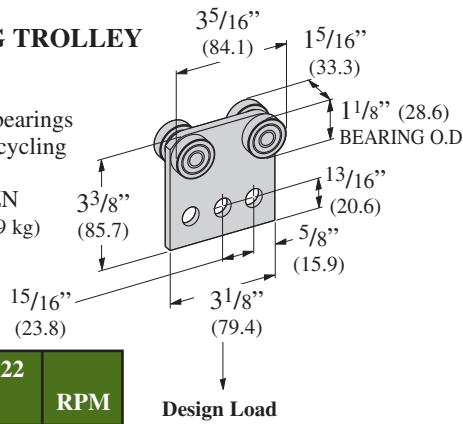

Design Load in B22		
Lbs.	kN	RPM
300	(1.33)	@ 600
450	(2.00)	@ 300
600	(2.67)	@ 100

B377 TWO BEARING TROLLEY ASSEMBLY

- Safety Factor of 2.5
- Stainless steel ball bearings
- Not for continuous cycling applications
- Standard finishes: ZN
- Wt./C 48 Lbs. (21.8 kg)

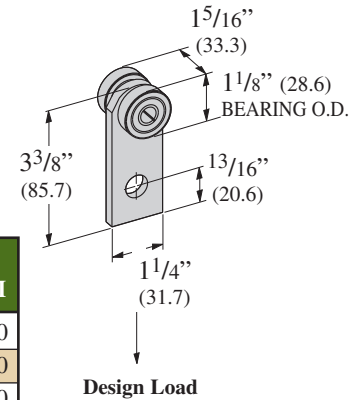

Design Load in B22		
Lbs.	kN	RPM
150	(.67)	@ 600
225	(1.00)	@ 300
437	(1.94)	@ 100

B477 TWO BEARING LIGHT DUTY TROLLEY ASSEMBLY

- Design Load 50 Lbs. (.22 kN)
- Safety Factor of 2.5
- Stainless steel ball bearings
- Not for continuous cycling applications
- Material: 12 Gauge (2.6) ASTM A1011 33,000 PSI min. yield
- Standard finishes: ZN
- Wt./C 30 Lbs. (13.6 kg)

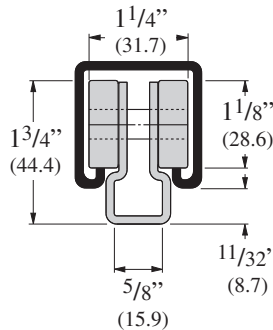

B478 FOUR BEARING LIGHT DUTY TROLLEY ASSEMBLY

- Design Load 100 Lbs. (.44 kN)
- Safety Factor of 2.5
- Stainless steel ball bearings
- Not for continuous cycling applications
- Material: 12 Gauge (2.6) ASTM A1011 33,000 PSI min. yield
- Standard finishes: ZN
- Wt./C 68 Lbs. (30.8 kg)

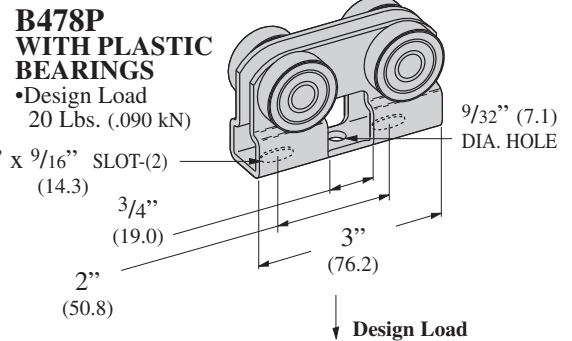

B477P WITH PLASTIC BEARINGS

- Design Load 10 Lbs. (.045 kN)

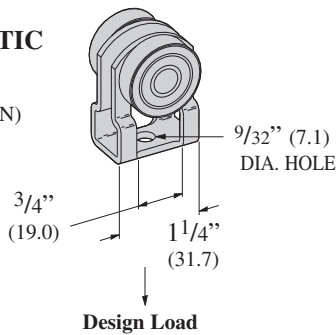

B478P WITH PLASTIC BEARINGS

- Design Load 20 Lbs. (.090 kN)

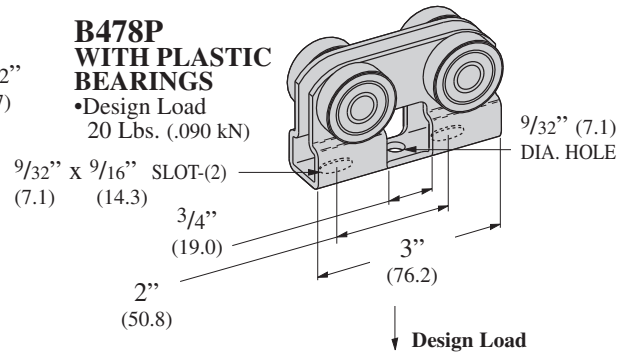

B477H TWO BEARING LIGHT DUTY TROLLEY ASSEMBLY WITH EYE HOOK

- Design Load 50 Lbs. (.22 kN)
- Safety Factor of 2.5
- Stainless steel ball bearings
- Not for continuous cycling applications
- Material: 12 Gauge (2.6) ASTM A1011 33,000 PSI min. yield
- Standard finishes: ZN
- Wt./C 36 Lbs. (16.3 kg)

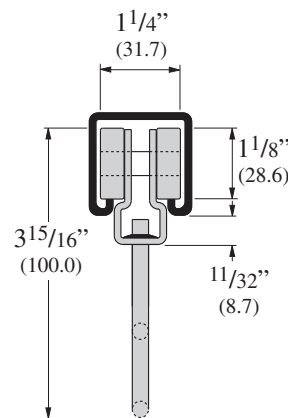

B478H FOUR BEARING LIGHT DUTY TROLLEY ASSEMBLY WITH EYE HOOK

- Design Load 100 Lbs. (.44 kN)
- Safety Factor of 2.5
- Stainless steel ball bearings
- Not for continuous cycling applications
- Material: 12 Gauge (2.6) ASTM A1011 33,000 PSI min. yield
- Standard finishes: ZN
- Wt./C 72 Lbs. (32.6 kg)

B478HP WITH PLASTIC BEARINGS

- Design Load 20 Lbs. (.090 kN)

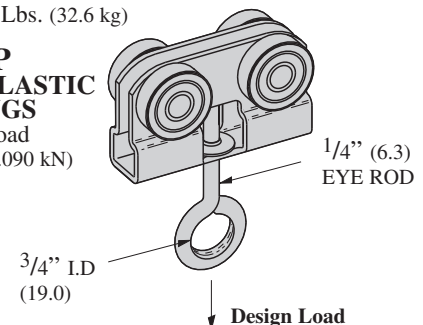
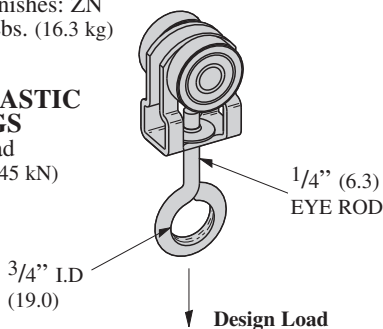

Reference page 58 for general fitting and standard finish specifications.

Miscellaneous Fittings

B203-B206 & B220-B223 CHANNEL END CAPS TYPE X

- Material: ASTM A1011 CS Type B
- Standard finishes: ZN, GRN, HDG, SS4, AL

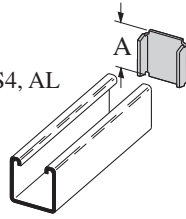

Part No.	Use With	A	(A)	Wt./C	
				Lbs.	kg
B203	B42	1.015	(25.8)	6	(2.7)
B204	B54	.827	(21.0)	5	(2.2)
B205	B22	1.640	(41.6)	10	(4.5)
B206	B32	1.390	(35.3)	8	(3.6)
B220	B52	.827	(21.0)	4	(1.8)
B221	B12	2.452	(62.3)	15	(6.8)
B222	B11	3.265	(82.9)	20	(9.1)
B223	B24	1.640	(41.6)	10	(4.5)

B283-B286 CHANNEL END CAPS

- Material: ASTM A1011 33,000 PSI min. yield
- Standard finishes: ZN, GRN

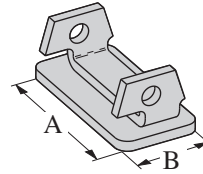

Part No.	Use With	A	(A)	B	(B)	Wt./C	
						Lbs.	kg
B283	B52	1 ¹⁹ / ₃₂ "	(40.5)	2 ⁵ / ₃₂ "	(19.8)	6	(2.7)
B284	B54 & B56	1 ¹⁹ / ₃₂ "	(40.5)	2 ⁵ / ₃₂ "	(19.8)	6	(2.7)
B285	B22	1 ¹⁹ / ₃₂ "	(40.5)	1 ¹⁹ / ₃₂ "	(40.5)	13	(5.9)
B286	B24 & B26	1 ¹⁹ / ₃₂ "	(40.5)	1 ¹⁹ / ₃₂ "	(40.5)	14	(6.3)

B287 & B288 CHANNEL END CAPS

- Material: ASTM A1011 33,000 PSI min. yield
- Standard finishes: ZN, GRN

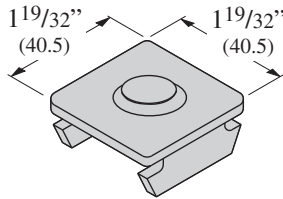

Part No.	Use With	Wt./C	
		Lbs.	kg
B287	B22	13	(5.9)
B288	B24	14	(6.3)

B3322, B3332, B3342, B3352 ANCHOR END CAPS TYPE Y

- Material: ASTM A1011 33,000 PSI min. yield
- Standard finishes: ZN

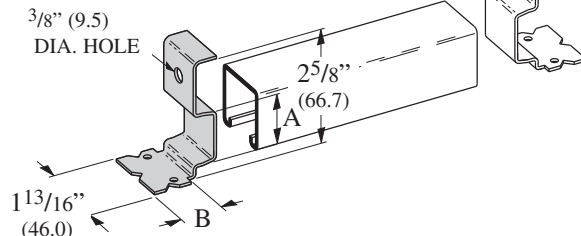

Part No.	Use With	A	(A)	B	(B)	Wt./C	
						Lbs.	kg
B3322	B22I	1.270	(32.2)	1 ³ / ₁₆ "	(30.2)	15	(6.8)
B3332	B32I	1.000	(25.4)	1 ³ / ₁₆ "	(30.2)	15	(6.8)
B3342	B42I	.645	(16.4)	1 ¹ / ₄ "	(31.8)	15	(6.8)
B3352	B52I	.460	(11.7)	1 ⁵ / ₁₆ "	(33.3)	15	(6.8)

B822 PLASTIC END CAP FOR B22 & B24

- Material: Soft White PVC
- Wt./C 3 Lbs. (1.3 kg)
- Available in colors: White (W), Yellow (Y), Black (BLK), Gray (GRY), Green (GRN)

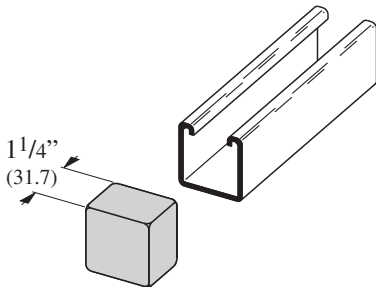

B822A PLASTIC END CAP FOR B22A & B11

- Material: Soft White PVC
- Wt./C 5 Lbs. (2.2 kg)
- Available in colors: White (W), Yellow (Y), Black (BLK), Gray (GRY), Green (GRN)

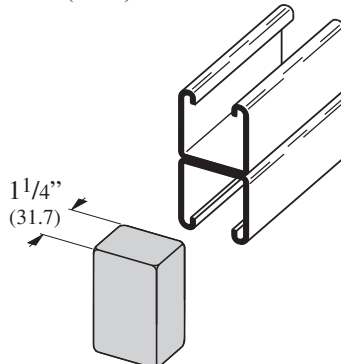

B852 PLASTIC END CAP FOR B52

- Material: Soft White PVC
- Wt./C 2.5 Lbs. (1.1 kg)
- Available in colors: White (W), Yellow (Y), Black (BLK), Gray (GRY), Green (GRN)

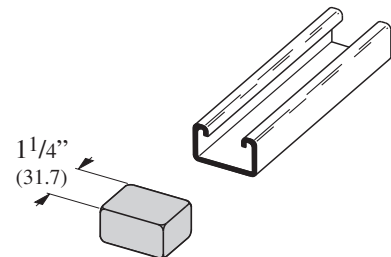

Reference page 58 for general fitting and standard finish specifications.

B823 PROFILE END CAPS

- Material: PVC
- Available in colors: White (W), Yellow (Y), Black (BLK), Gray (GRY), Green (GRN)



Approx. 3/4" deep
(19.0)

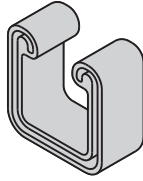

Part No.	Fits Channel Sizes	Wt./C	
		Lbs.	kg
B823-22A	B22A, B24A, B26A	6.9	(3.1)
B823-22	B22, B24, B26	4.1	(1.8)
B823-42	B42	3.8	(1.7)
B823-52	B52, B54, B56	3.5	(1.6)

B825 PLASTIC END CAPS

- Material: Polyurethane
- Available in colors: Gray (GRY), Green (GRN)

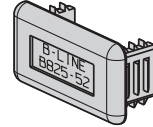
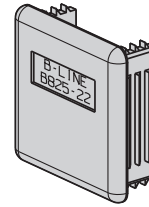

Part No.	Fits Channel Sizes	Wt./C	
		Lbs.	kg
B825-22	B22 & B24	2.0	(0.9)
B825-52	B52 & B54	1.0	(0.4)

Reference page 58 for general fitting and standard finish specifications.

Beam Clamps

B-Line's beam attachments and pipe supports offered in this section are designed to provide supports without drilling or welding. A complete selection of beam clamps, pipe clamps, rollers, supports and accessories are designed for use with B-Line channels and offer many installation advantages.

Materials & Finishes (Unless otherwise noted)

Pipe clamps, pipe hangers, beam clamps, brackets, and rollers are made from low carbon steel strips, plates or rod unless noted.

Finish Code	Finish	Specification
PLN	Plain	ASTM A1018 Gr. 33 ASTM A1011 SS Grade 33
ZN	Electro-Plated Zinc	ASTM B633 SC3 Type III
GRN	Dura-Green	
-	Malleable Iron	ASTM A47 Gr. 32510
HDG	Hot-Dipped Galvanized	ASTM A123
CZ	Chromium Zinc	ASTM F1136
SS4	Stainless Steel Type 304	ASTM A240
SS6	Stainless Steel Type 316	ASTM A240
AL	Aluminum	ASTM B209

Note: A minimum order may apply on special material and finishes.

Load Data

The load data published includes a safety factor of 5.0 unless noted (safety factor = ratio of ultimate load to the design load).

Recommended Torque For Setscrews (unless noted)

Setscrew Size	1/4"-20	3/8"-16	1/2"-13
Foot/Lbs.	4	5	11
Nm	5	7	15

Setscrew Size	5/8"-11	3/4"-10
Foot/Lbs.	21	34
Nm	28	46

See chart on page 58 for bolt torque.

Metric

Metric dimensions are shown in parentheses. Unless noted, all metric dimensions are in millimeters.



B351L STEEL C-CLAMP WITH LOCKNUT

- Safety Factor of 5
- Setscrew and locknut included
- When Retaining Strap is required, order B3362, B3363 or B3365 separately
- Standard finishes: ZN, SS4, PLN

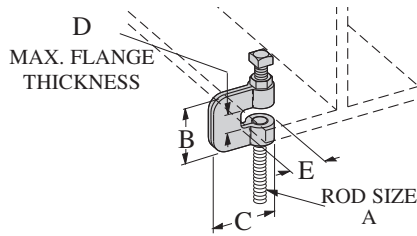

*
3/8 THRU 3/4
SIZES ONLY

Part Number With Locknut	Rod Size A	B		C		D		E		Design Load		Wt./C	
		Lbs.	kg	Lbs.	kg	Lbs.	kg	Lbs.	kg	Lbs.	kg	Lbs.	kg
B351L-3/8 *	3/8"-16	2 3/8"	(60.3)	2 3/8"	(60.3)	3/4"	(19.0)	1 3/8"	(34.9)	230	(1.03)	41	(18.6)
B351L-1/2 *	1/2"-13	2 3/8"	(60.3)	2 3/8"	(60.3)	3/4"	(19.0)	1 3/8"	(34.9)	380	(1.71)	41	(18.6)
B351L-5/8 *	5/8"-11	2 3/8"	(60.3)	2 1/4"	(57.1)	3/4"	(19.0)	1 3/8"	(34.9)	550	(2.47)	60	(27.2)
B351L-3/4 *	3/4"-10	2 3/8"	(60.3)	3 1/4"	(82.5)	3/4"	(19.0)	1 3/8"	(34.9)	630	(2.83)	71	(32.2)
B351L-7/8	7/8"-9	3"	(76.2)	3 1/4"	(82.5)	1"	(25.4)	1 7/8"	(47.6)	1200	(5.34)	184	(83.4)

B3036L C-CLAMP WITH LOCKNUT

- Safety Factor of 5
- When Retaining Strap is required, order B3363 or B3364 separately
- Setscrew and locknut included
- Material: Malleable iron
- Standard finishes: ZN, PLN



3/4" (19.0)
MAX.
FLANGE
THICKNESS

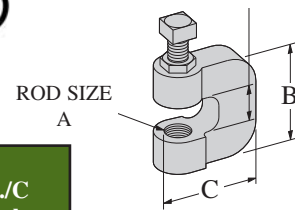

Part Number With Locknut	Rod Size A	B		C		Design Load		Wt./C	
		Lbs.	kg	Lbs.	kg	Lbs.	kg	Lbs.	kg
B3036L-3/8	3/8"-16	1 3/4"	(44.4)	1 3/4"	(44.4)	400	(1.78)	29	(13.1)
B3036L-1/2	1/2"-13	1 3/4"	(44.4)	1 3/4"	(44.4)	400	(1.78)	28	(12.7)
B3036L-5/8	5/8"-11	2"	(50.8)	1 7/8"	(47.6)	450	(2.00)	55	(24.9)
B3036L-3/4	3/4"-10	2"	(50.8)	2"	(50.8)	500	(2.22)	72	(32.6)

B3362 THRU B3365 RETAINING STRAP

- *When ordering specify L (Length) as a suffix to the part number
- Material: 14 Gauge (1.9)
- Standard finishes: GALV, SS4

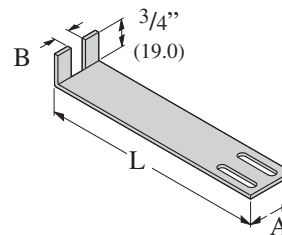

Part No.	Wt./C for Length L of				A	B	For Use With
	6" (152.4) Lbs. kg	8" (203.2) Lbs. kg	10" (254.0) Lbs. kg	12" (304.8) Lbs. kg			
B3362*	17 (7.7)	24 (10.9)	31 (14.0)	38 (17.2)	1 1/4" (31.7)	7/16" (11.1)	B351-3/8 & 1/2
B3363*	16 (7.2)	23 (10.4)	30 (13.6)	37 (16.8)	1 1/4" (31.7)	5/8" (15.9)	B351-5/8 & 3/4 B3036-3/8 & 1/2
B3364*	16 (7.2)	23 (10.4)	30 (13.6)	37 (16.8)	1 1/4" (31.7)	11/16" (17.4)	B3036-5/8 & 3/4
B3365*	21 (9.5)	29 (13.1)	37 (16.8)	46 (20.8)	1 1/2" (38.1)	3/4" (19.0)	B351-7/8

*See note above.

B3037 Z-PURLIN C-CLAMP

- Design Load 500 Lbs. (2.22 kN)
- Safety Factor of 5
- Designed for attaching a 3/8"-16 hanger rod to the bottom flange of a Z-purlin
- Setscrew and locknut included
- Material: Malleable iron
- Standard finishes: ZN, PLN

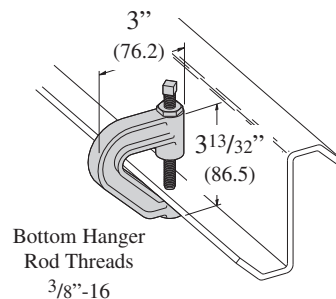

Reference page 98 for general fitting and standard finish specifications.

Beam Clamps

B3033 REVERSIBLE WIDE JAW WEDGE C-CLAMP (MALLEABLE IRON)

- Safety Factor of 5
- Setscrew and locknut included
- Material: Malleable iron
- Standard finishes: ZN, PLN

THROAT OPENINGS

- 1 1/4" (31.7) FOR
3/8 & 1/2 SIZES
- 1 5/16" (33.3) FOR
5/8 & 3/4 SIZES

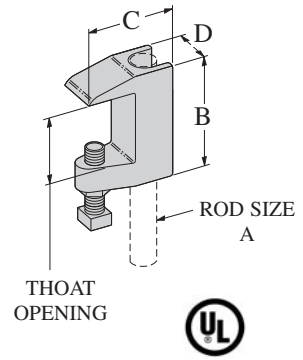

Part No.	Rod Size A	B	C	D	Design Load Lbs. kN	Wt./C Lbs. kg	UL Max. Pipe Size
B3033-3/8	3/8"-16	2 1/4" (57.1)	2" (50.8)	1 1/8" (28.6)	500 (2.22)	46 (20.8)	4" (100)
B3033-1/2	1/2"-13	2 5/16" (58.7)	2 3/16" (55.5)	1 1/4" (31.7)	810 (3.60)	64 (29.0)	8" (200)
B3033-5/8	5/8"-11	2 5/8" (66.7)	2 1/2" (63.5)	1 3/8" (34.9)	1000 (4.48)	116 (52.6)	8" (200)
B3033-3/4	3/4"-10	2 11/16" (68.3)	2 1/2" (63.5)	1 7/16" (36.5)	1400 (6.22)	140 (63.5)	10" (250)

B3034 WEDGE C-CLAMP

- Safety Factor of 5
- 3/4" (19.0) Max. Flange Thickness
- Setscrew and locknut included
- Material: Malleable iron
- Standard finishes: ZN, PLN

NOTE:
3/8" & 1/2" SIZES
ARE REVERSIBLE
STYLE

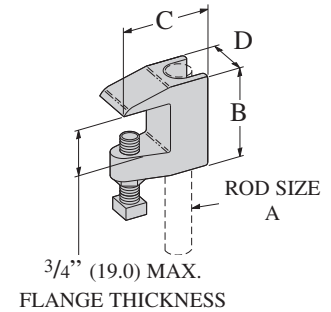

*
3/8 & 1/2
SIZES ONLY



Part No.	Rod Size A	B	C	D	Design Load Lbs. kN	Wt./C Lbs. kg	UL Max. Pipe Size
B3034-3/8*	3/8"-16	1 5/8" (41.3)	2" (50.8)	7/8" (22.2)	560 (2.49)	54 (24.5)	4" (100)
B3034-1/2*	1/2"-13	1 13/16" (46.0)	2 3/16" (55.5)	1 3/16" (30.2)	810 (3.60)	51 (23.1)	8" (200)
B3034-5/8	5/8"-11	1 3/4" (44.5)	2 1/8" (54.0)	1 1/8" (28.6)	1000 (4.48)	70 (31.7)	-- --
B3034-3/4	3/4"-10	2" (50.8)	2 1/4" (57.2)	1 1/8" (28.6)	1500 (6.67)	98 (44.4)	-- --

B3367 RETAINING STRAP

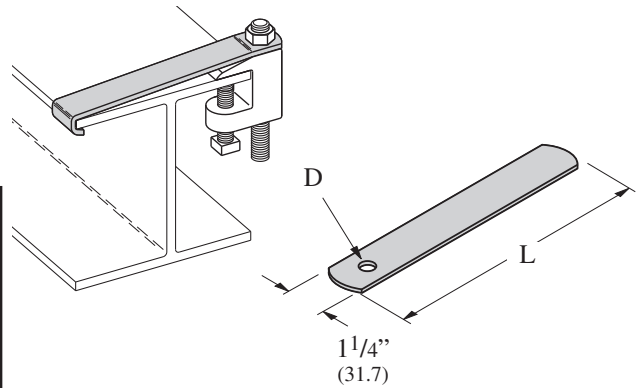
- Available in 'L' lengths of 6" (152.4), 8" (203.2), 9" (228.6), 10" (254.0), 12" (304.8), 14" (355.6), 16" (406.4), 18" (457.2)
- Material: Steel
- Standard finishes: GALV



Part No.	Hole Dia. D	For Use With	Wt./C** Lbs. kg
B3367-3/8-L	7/16" (30.1)	B3033-3/8 & B3034-3/8	23.9 (10.8)
B3367-1/2-L	9/16" (30.1)	B3033-1/2 & B3034-1/2	23.6 (10.7)
B3367-5/8-L	1 1/16" (50.8)	B3033-5/8	23.2 (10.5)
B3367-3/4-L	1 3/16" (63.5)	B3033-3/4	22.7 (10.3)

** Wt./C based on 6" (152.4) length. For each additional inch in strap length add 4.2 Lbs (1.9 kg) to Wt./C.

B444 SERIES ROD SUPPORT

- Safety Factor of 5
- Max. Flange Thickness
3/4" (19.0) for 1/4 & 5/16 sizes
1" (25.4) for 3/8 & 1/2 sizes
- Setscrew included
- Material: Malleable iron
- Standard finish: ZN
Available in HDG with CZ Hardware

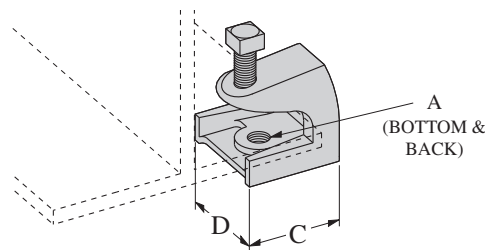

Part No.	Thread Size A	Set Screw	C	D	Design Load Lbs. kN	Wt./C Lbs. kg
B444-1/4	1/4"-20	1/4"-20	1 3/8" (34.9)	1 3/16" (30.1)	150 (.66)	24 (10.9)
B444-5/16	5/16"-18	1/4"-20	1 3/8" (34.9)	1 3/16" (30.1)	150 (.66)	23 (10.4)
B444-3/8	3/8"-16	1/2"-13	1 7/8" (47.6)	2" (50.8)	350 (7.12)	65 (29.5)
B444-1/2	1/2"-13	5/8"-11	2 3/8" (60.3)	2 1/2" (63.5)	1000 (4.45)	132 (59.9)

BC442 LIGHT DUTY BEAM CLAMP

- Design Load 75 Lbs. (.33 kN)
- Safety Factor of 5
- 1 1/16" (17.5) Max. Flange Thickness
- Setscrew included
- Holes tapped 1/4"-20 (Bottom & Back)
- Material: 13 Gauge (2.3)
- Standard finish: ZN
- Wt./C 13 Lbs. (3.9 kg)

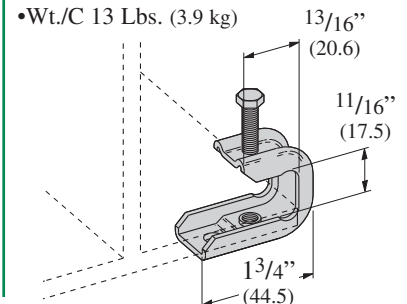

Reference page 98 for general fitting and standard finish specifications.

B210 BEAM CLAMP

- Design Load 800 Lbs. (3.56 kN)
- Safety Factor of 5
- 5/8" (15.9) Max. Flange Thickness
- 1/2"-13 Setscrew included
- Standard finish: ZN
- Wt./C 100 Lbs. (45.3 kg)

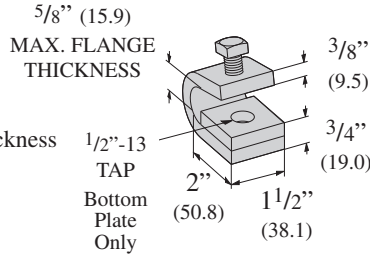

B210A BEAM CLAMP

- Design Load 300 Lbs. (1.33 kN)
- Safety Factor of 5
- 3/4" (19.0) Max. Flange Thickness
- 3/8"-16 Setscrew included
- Standard finish: ZN
- Wt./C 60 Lbs. (27.2 kg)

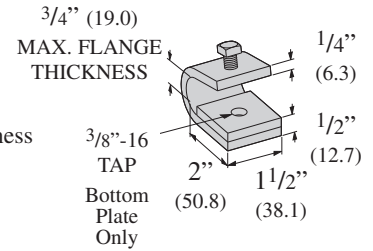

B303 THRU B309 BEAM CLAMPS

- Safety Factor of 5
- Max. Flange Thickness 1/16" (1.6) thru 7/8" (22.2)
- Setscrew included
- When Retaining Strap is required, order B312 separately
- Recommended Setscrew Torque: 3/8"-16 150 in-lbs. (16.9 N•m)
1/2"-13 350 in-lbs. (39.5 N•m)
- Standard finishes: ZN, HDG

Part No.	Rod Size A	Set Screw	C	T	Design Load		Wt./C	
					Lbs.	kN	Lbs.	kg
B303	1/4"-20	3/8"-16	2 5/16" (58.7)	11 Ga. (3.0)	400	(1.78)	72	(32.6)
B304	5/16"-18	3/8"-16	2 5/16" (58.7)	11 Ga. (3.0)	600	(2.67)	72	(32.6)
B305	3/8"-16	3/8"-16	2 5/16" (58.7)	11 Ga. (3.0)	600	(2.67)	72	(32.6)
B306	3/8"-16	1/2"-13	2 7/16" (61.9)	7 Ga. (4.5)	1100	(4.89)	97	(44.0)
B307	1/2"-13	1/2"-13	2 7/16" (61.9)	7 Ga. (4.5)	1100	(4.89)	97	(44.0)
B308	1/2"-13	1/2"-13	2 9/16" (65.1)	1/4" (6.3)	1500	(6.67)	133	(60.3)
B309	5/8"-11	1/2"-13	2 9/16" (65.1)	1/4" (6.3)	1500	(6.67)	133	(60.3)

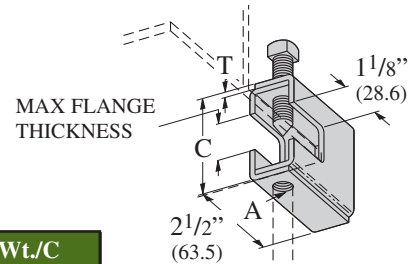

B321 SERIES BEAM CLAMPS

- Safety Factor of 5
- 1 1/16" (42.8) Max. Flange Thickness
- Setscrew included
- When Retaining Strap is required, order B312 separately
- Recommended Setscrew Torque: 1/2"-13 350 in-lbs. (39.5 N•m)
5/8"-11 700 in-lbs. (79.0 N•m)
- Minimum flange thickness: B321-1 thru B321-3 1/4" (6.3)
B321-4 and B321-5 3/8" (9.5)
- Standard finishes: ZN, HDG

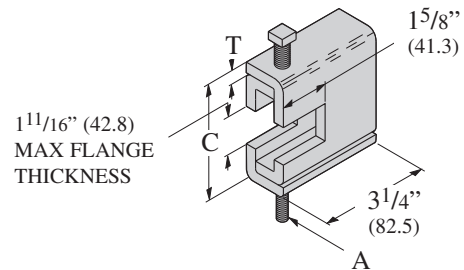

Part No.	Rod Size A	Setscrew	C	T	Design Load		Wt./C	
					Lbs.	kN	Lbs.	kg
B321-1	3/8"-16	1/2"-13	3 9/16" (92.1)	1/4" (6.3)	1300	(5.78)	187	(84.8)
B321-2	1/2"-13	1/2"-13	3 9/16" (92.1)	1/4" (6.3)	1400	(6.23)	186	(84.3)
B321-3	5/8"-11	1/2"-13	3 9/16" (92.1)	1/4" (6.3)	1600	(7.12)	185	(83.9)
B321-4	5/8"-11	5/8"-11	3 23/32" (94.4)	5/16" (7.9)	1800	(8.00)	239	(108.4)
B321-5	3/4"-10	5/8"-11	3 23/32" (94.4)	5/16" (7.9)	2000	(8.89)	238	(107.9)

B312 SERIES RETAINING STRAP FOR USE WITH B303 THRU B309 AND B321 SERIES

- 3/4" (19.0) Max. Flange Thickness
- For thicker beams, step up one flange width size
- Material: 14 Gauge (1.9)
- Standard finishes: GALV, HDG

Part No.	For Flange Width		A	Wt./C	
				Lbs.	kg
B312-6	6"	(152.4)	9"	(228.6)	22 (10.0)
B312-9	9"	(228.6)	12"	(304.8)	30 (13.6)
B312-12	12"	(304.8)	15"	(381.0)	40 (18.1)
B312-15	15"	(381.0)	18"	(457.2)	49 (22.2)

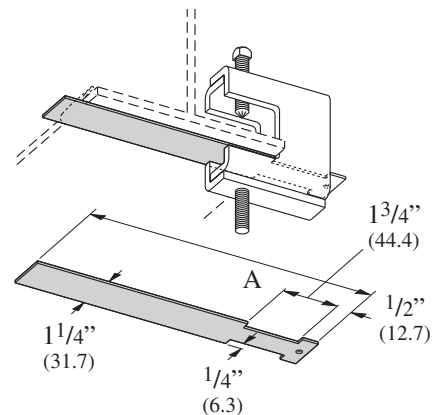

Reference page 98 for general fitting and standard finish specifications.

Beam Clamps

B751 BEAM CLAMP

- Safety Factor of 5
- 3/4" (19.0) Max. Flange Thickness
- Setscrew and Locknut included
- Maximum ATR Size 1/2"
- Use B753 Swivel Nut (not included)
- Material: 12 Gauge (2.6)
- Standard finish: ZN, HDG
- Wt./C 42 Lbs. (19.0 kg)

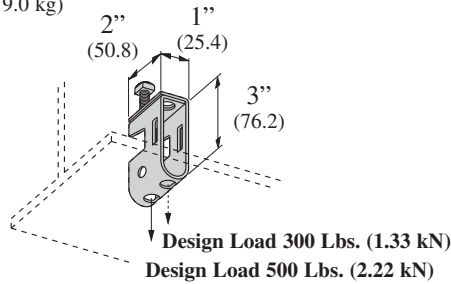

B752 BEAM CLAMP SWIVEL

- Design Load 500 Lbs. (2.22 kN)
- Safety Factor of 5
- Material: 12 Gauge (2.6)
- Use B753 Swivel Nut (not included)
- Includes:
1 pc. B752 Swivel Body
1 pc. 5/16"-18 x 1 3/4" HHCS
1 pc. 5/16"-18 Hex Nut
- Standard finish: ZN
- Wt./C 30 Lbs. (13.6 kg)

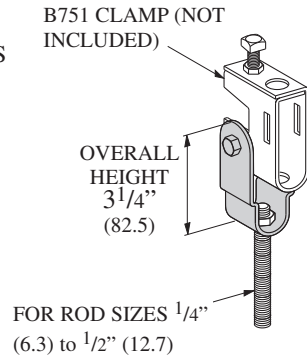

B751-J_-3/8 BEAM CLAMP ASSEMBLY

- Includes:
1 pc. B751 Beam Clamp
1 pc. B701 Type J-Hook only
1 pc. SA203-158 Clip
1 pc. 3/8"-16 Hex Nut
- 1/4" (6.3) Diameter J-Hook available upon request
Part Number changes to B751-J_-1/4 and a 1/4-20 Machine Square Nut (MSQN) is used
- Use B753 Swivel Nut (not included)
- Standard finishes: ZN

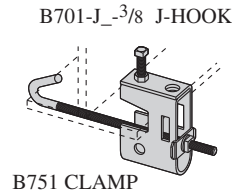

Part No.	For Flange Width		Wt./C	
			Lbs.	kg
B751-J4-3/8	3"-6"	(76.2-152.4)	70	(31.7)
B751-J6-3/8	5"-9"	(127.0-228.6)	78	(35.4)
B751-J9-3/8	8"-12"	(203.2-304.8)	83	(37.6)
B751-J12-3/8	11"-15"	(279.4-381.0)	88	(39.9)

B753 SWIVEL NUT

- Provides a full swivel of 15° in any direction
- Specify rod size
- Standard finish: ZN

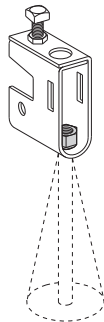

Part No.	For Rod Size	Wt./C	
		Lbs.	kg
B753-3/8	3/8"-16	4.0	(1.8)
B753-1/2	1/2"-13	3.4	(1.5)

B701 SERIES J-HOOK

- 1/4" (6.3) Diameter J-Hook available upon request
Part Number changes to B751-J_-1/4 and a 1/4-20 Machine Square Nut (MSQN) is used
- Standard finish: ZN

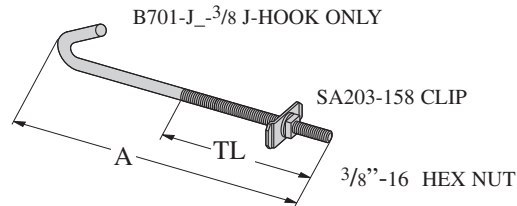

Part No.	A	Thread Length TL		Wt./C	
		Lbs.	kg	Lbs.	kg
B701-J4-3/8	8 3/4"	(222.2)	5 1/2"	(139.7)	26 (11.8)
B701-J6-3/8	11 3/4"	(298.4)	6 1/2"	(165.1)	34 (15.4)
B701-J9-3/8	14 3/4"	(374.6)	6 1/2"	(165.1)	41 (18.6)
B701-J12-3/8	17 3/4"	(450.8)	6 1/2"	(165.1)	48 (21.8)

Reference page 98 for general fitting and standard finish specifications.

B755 3/8" BEAM CLAMP

- Safety Factor of 5
- 5/8" (15.9) Max. Flange Thickness
- For 3/8"-16 Hanger Rod only.
- Material: 12 Gauge (2.6)
- Includes:
 - 1 pc. B755 Beam Clamp
 - 1 pc. 3/8" x 2" Square Head Set Screw
 - 2 pcs. 3/8" Square Nut
- Standard finish: ZN
- Wt./C 30 Lbs. (13.6 kg)

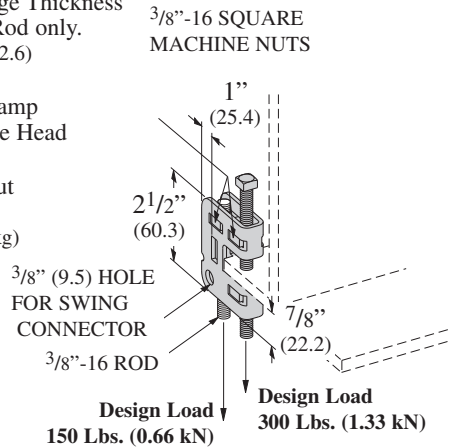

B756-3/8 SWING CONNECTOR

- Design Load 150 Lbs. (0.66 kN)
- Safety Factor of 5
- Material: 12 Gauge (2.6)
- Includes:
 - 1 pc. B756-3/8 Swing Connector Body
 - 1 pc. 5/16"-18 x 1 1/4" SHHMS
 - 1 pc. 5/16"-18 Square Nut
- Use B753 Swivel Nut (not included)
- Standard finish: ZN
- Wt./C 15 Lbs. (6.8 kg)

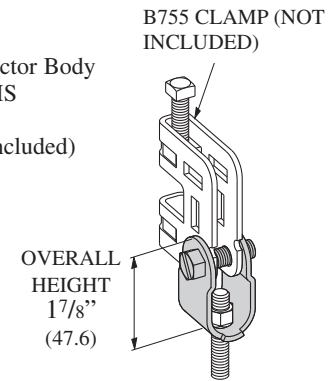

B755-3/8-J BEAM CLAMP ASSEMBLY

- Includes:
 - 1 pc. B755-3/8 Beam Clamp
 - 1 pc. B705 Type J-Hook only
 - 1 pc. B705 Clip
 - 1 pc. 1/4"-20 Square Nut
- Standard finish: ZN

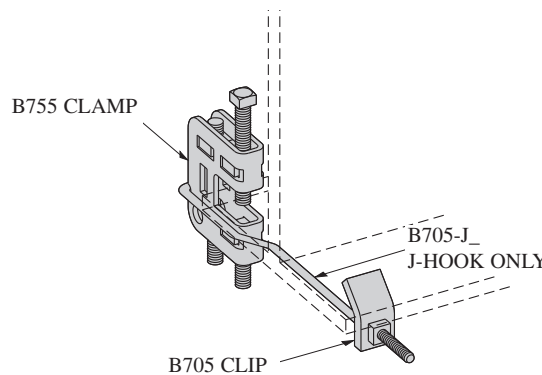

Part No.	For Flange Width		Wt./C	
			Lbs.	kg
B755-3/8-J4	4"-6"	(101.6-152.4)	47	(21.3)
B755-3/8-J6	6"-10"	(152.4-254.0)	51	(23.1)
B755-3/8-J10	10"-12"	(254.0-304.8)	53	(24.0)
B755-3/8-J12	12"-14"	(304.8-355.6)	55	(24.9)

B702 CLEAT

- To eliminate the swiveling of the rod when required, use the B702 Cleat and a locking nut. This can be used with the B751 Beam Clamp, B752 Swivel or B756 Swing Connector.
- Material: 12 Gauge (2.6)
- Standard finish: ZN
- Wt./C 6 Lbs. (2.7 kg)

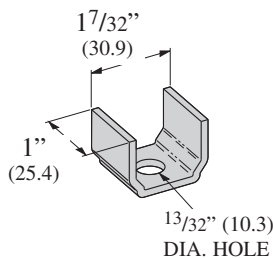

B705 SERIES J-HOOK

- Use with B755-3/8
- Standard finish: ZN

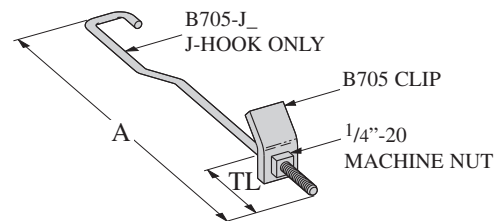

Part No.	A	Thread Length TL		Wt./C		
		Lbs.	kg	Lbs.	kg	
B705-J4	7 3/8"	(187.3)	3"	(76.2)	17	(7.7)
B705-J6	11 3/8"	(288.9)	4 1/2"	(114.3)	21	(9.5)
B705-J10	13 3/8"	(339.7)	4 1/2"	(114.3)	23	(10.4)
B705-J12	15 3/8"	(390.5)	4 1/2"	(114.3)	25	(11.3)

Reference page 98 for general fitting and standard finish specifications.

Beam Clamps

B750 SERIES BEAM CLAMP

- Safety Factor of 5
- Design Load 500 Lbs. (2.22 kN)
- Recommended Torque:
J-Hook Nut 125 in-lbs. (14.1 N•m)
- Maximum Flange Thickness $\frac{5}{8}$ " (15.9)
- Standard finish: ZN

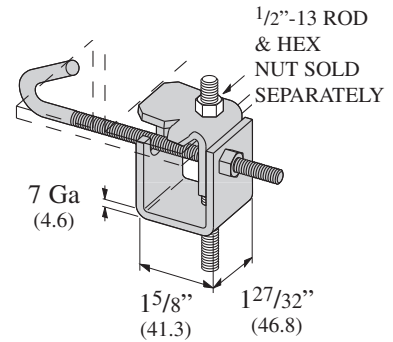

Part No.	For Flange Width		Wt./C	
			Lbs.	kg
B750-J4	3"-6"	(76.2-152.4)	109	(49.4)
B750-J6	5"-9"	(127.0-228.6)	124	(56.2)
B750-J9	8"-12"	(203.2-304.8)	135	(61.2)
B750-J12	11"-15"	(279.4-381.0)	147	(66.7)

B700 SERIES J-HOOK

- Includes:
1 pc. J-Bolt
1 pc. Hex Nut
- Maximum Flange Thickness $\frac{5}{8}$ " (15.9)
- Standard finish: ZN

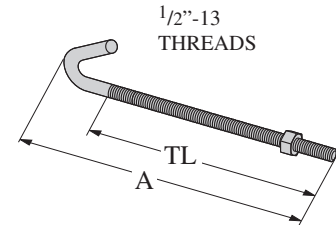

Part No.	A		Thread Length TL		Wt./C	
	Lbs.	kg	Lbs.	kg	Lbs.	kg
B700-J4	8 $\frac{1}{2}$ "	(215.9)	6 $\frac{3}{4}$ "	(171.4)	44	(19.9)
B700-J6	11 $\frac{1}{2}$ "	(292.1)	9 $\frac{3}{4}$ "	(247.6)	53	(24.0)
B700-J9	14 $\frac{1}{2}$ "	(368.3)	12 $\frac{3}{4}$ "	(323.8)	63	(28.6)
B700-J12	17 $\frac{1}{2}$ "	(444.5)	15 $\frac{3}{4}$ "	(400.0)	78	(35.4)

B500 SERIES SQUARE U-BOLT

- Includes:
1 pc. U-Bolt only
2 pcs. $\frac{3}{8}$ "-16 Hex Nuts
- Additional sizes available
- Standard finish: ZN, SS4

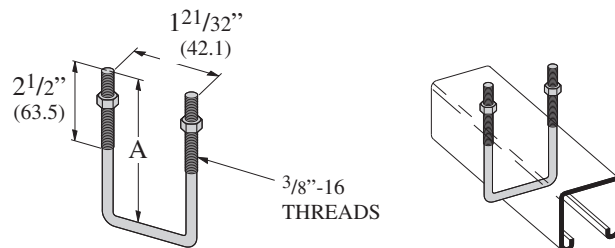

Part No.	A		Channel Size	Wt./C	
	Lbs.	kg		Lbs.	kg
B500-3-3/8	3 $\frac{3}{8}$ "	(85.7)	1 $\frac{5}{8}$ " x 1 $\frac{5}{8}$ "	25	(11.3)
B500-5	5"	(127.0)	3 $\frac{1}{4}$ " x 1 $\frac{5}{8}$ "	33	(14.9)

Reference page 98 for general fitting and standard finish specifications.

B441-22 BEAM CLAMP

- Design Load 1200 Lbs. (5.34 kN) when used in pairs
- Safety Factor of 5
- $3/4''$ (19.0) Max. Flange Thickness
- For use with $13/16''$ (20.6) to $15/8''$ (41.3) high channel
- Recommended Torque: 150 in-lbs. (16.9 N•m)
- Sold in pieces
- Other flange thickness variations are available, contact B-Line Engineering for sizes
- Standard finishes: ZN, HDG, SS4
- Wt./C 87 Lbs. (39.4 kg)

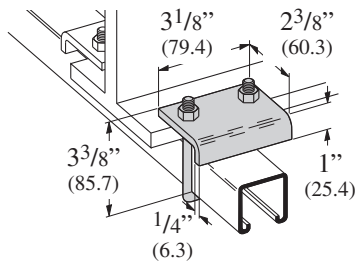

B441-22A BEAM CLAMP

- Design Load 1200 Lbs. (5.34 kN) when used in pairs
- Safety Factor of 5
- $3/4''$ (19.0) Max. Flange Thickness
- For use with $15/8''$ (41.3) to $31/4''$ (82.5) high channel
- Recommended Torque: 150 in-lbs. (16.9 N•m)
- Sold in pieces
- Other flange thickness variations are available, contact B-Line Engineering for sizes
- Standard finishes: ZN, HDG, SS4
- Wt./C 93 Lbs. (42.2 kg)

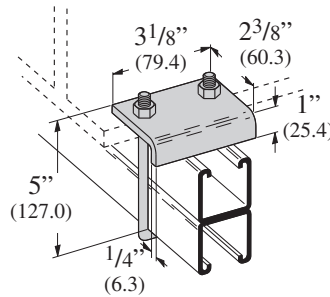

B314 BEAM CLAMP

- Design Load 900 Lbs. (4.00 kN) when used in pairs
- Safety Factor of 5
- $5/8''$ (15.9) Max. Flange Thickness
- For use with channel $15/8''$ (41.3) in height
- Setscrew included
- Sold in pieces.
- Standard finishes: ZN, GRN, HDG, SS4
- Wt./C 105 Lbs. (47.6 kg)

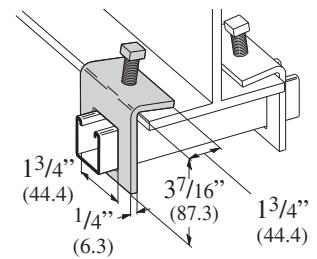

B441Z-22 BEAM CLAMP

- Design Load 1200 Lbs. (5.34 kN) when used in series
- Safety Factor of 5
- Sold in pieces
- For use with $13/16''$ (20.6) to $15/8''$ (41.3) high channel
- Recommended Torque: 150 in-lbs. (16.9 N•m)
- Standard finishes: ZN
- Wt./C 95 Lbs. (43.1 kg)

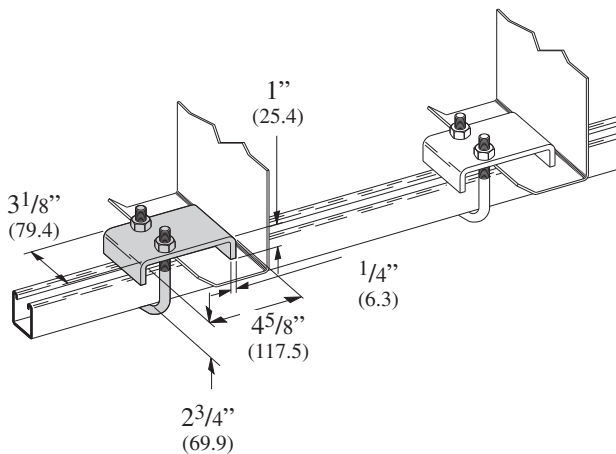

B441Z-22A BEAM CLAMP

- Design Load 1200 Lbs. (5.34 kN) when used in series
- Safety Factor of 5
- Sold in pieces
- For use with $15/8''$ (41.3) to $31/4''$ (82.5) high channel
- Recommended Torque: 150 in-lbs. (16.9 N•m)
- Standard finishes: ZN
- Wt./C 101 Lbs. (45.8 kg)

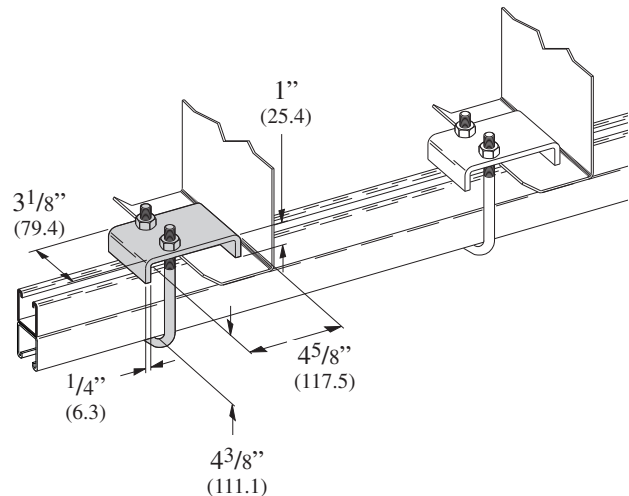

Reference page 98 for general fitting and standard finish specifications.

Beam Clamps

B211 ZEE BEAM CLAMP

- Design Load 600 Lbs. (2.67 kN) when used in pairs
- Safety Factor of 5
- 1" (25.4) Max. Flange Thickness
- 1/2"-13 Setscrew included
- Sold in pieces
- Order 1/2"-13 HHCS and Channel Nut separately
- Standard finishes: ZN, HDG
- Wt./C 66 Lbs. (29.9 kg)

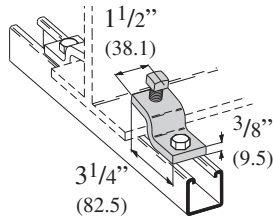

B213 I-BEAM CLAMP

- Design Load 900 Lbs. (4.00 kN) when used in pairs
- Safety Factor of 5
- 7/8" (22.2) Max. Flange Thickness
- 1/2"-13 Setscrew included
- Sold in pieces
- Order 1/2"-13 x 2 1/4" HHCS and Channel Nut separately
- Material: Malleable iron
- Standard finishes: ZN, GRN
- Wt./C 95 Lbs. (43.1 kg)

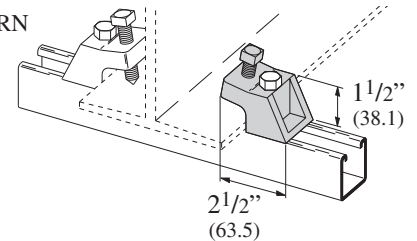

B355 BEAM CLAMP

- Design Load 1200 Lbs. (5.34 kN) when used in pairs
- Safety Factor of 5
- 5/8" (15.9) Max. Flange Thickness
- Sold in pieces
- Order 1/2"-13 x 1 1/2" HHCS and Channel Nut separately
- Standard finishes: ZN, GRN, HDG, SS4
- Wt./C 30 Lbs. (13.6 kg)

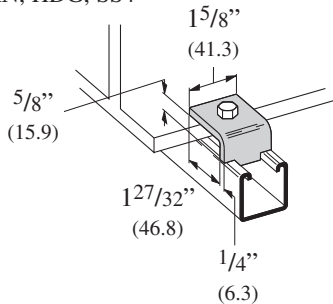

B212-1/4 I-BEAM CLAMP

- Design Load 600 Lbs. (2.67 kN) when used in pairs
- Safety Factor of 5
- 7/8" (22.2) Max. Flange Thickness
- 3/8"-16 Setscrew included
- Sold in pieces
- Standard finish: ZN
- Wt./C 41 Lbs. (18.6 kg)

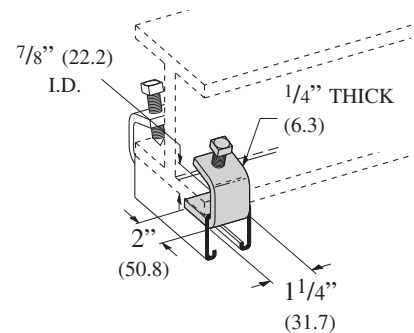

B212-3/8 I-BEAM CLAMP

- Design Load 1000 Lbs. (4.45 kN) when used in pairs
- Safety Factor of 5
- 1 1/8" (28.6) Max. Flange Thickness
- 1/2"-13 Setscrew included
- Sold in pieces
- Standard finishes: ZN, HDG
- Wt./C 62 Lbs. (28.1 kg)

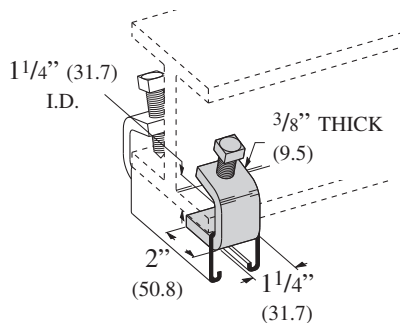

B435 BEAM CLAMP

- Design Load 900 Lbs. (4.00 kN) when used in pairs
- Safety Factor of 5
- 2 1/8" (54.0) Max. Flange Thickness
- 1/2"-13 x 2" Setscrew included
- Sold in pieces
- Standard finish: ZN
- Wt./C 82 Lbs. (37.2 kg)

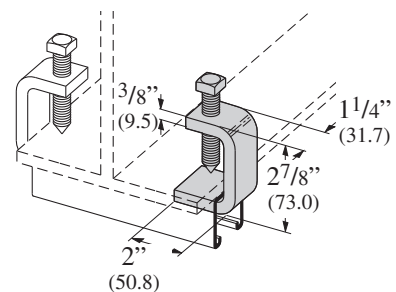

Reference page 98 for general fitting and standard finish specifications.

B427 BEAM CLAMP

- Design Load 1100 Lbs. (4.89 kN) when used in pairs
- Safety Factor of 5
- 2 1/2" (63.5) Max. Flange Thickness without channel
- 1/2"-13 x 1 1/2" Setscrew included
- Sold in pieces
- Standard finish: ZN
- Wt./C 92 Lbs. (41.7 kg)

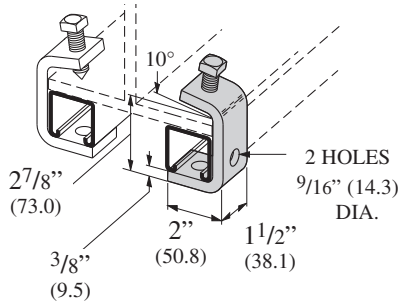

B405 SUSPENSION MEMBER

- Standard finishes: ZN, GRN
- Wt./C 75 Lbs. (34.0 kg)

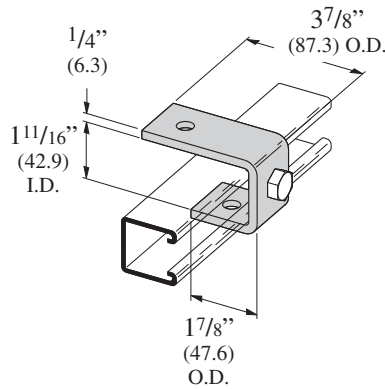

B405A SUSPENSION MEMBER WITH BEAM CLAMP

- 7/8" (22.2) Max. Flange Thickness
- Includes:
 - 1 pc. B405 Suspension Member
 - 1 pc. B213 I-Beam Clamp
 - 1 pc. 1/2"-13 x 2 1/2" HHCS
 - 1 pc. 1/2"-13 Hex Nut
- Material: Malleable iron
- Standard finishes: ZN, GRN
- Wt./C 183 Lbs. (83.0 kg)

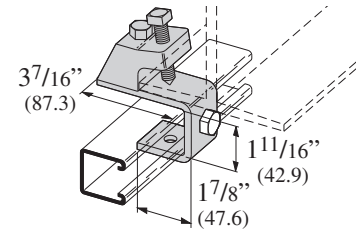

B318 THRU B320 BEAM CLAMP ASSEMBLY

- Safety Factor of 5
- 7/8" (22.2) Max. Flange Thickness
- Includes:
 - 1 pc. B333 Slotted U-Support
 - 2 pcs. B213 I-Beam Clamp
 - 2 pcs. 1/2"-13 x 2 1/2" HHCS
 - 2 pcs. 1/2"-13 Hex Nuts
- Material: Malleable iron
- Standard finishes: ZN, GRN

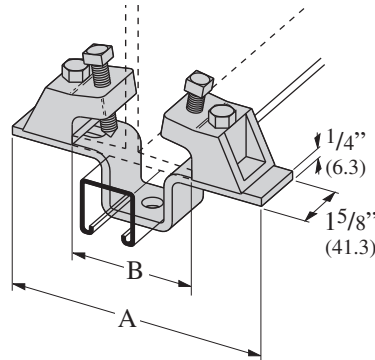

Part No.	A		For Flange Width B		Design Load		Wt./C	
	Lbs.	mm	Lbs.	mm	Lbs.	kN	Lbs.	kg
B318	7 1/4"	(184.1)	2 3/8"-4 1/2"	(60.3-114.3)	1200	(5.34)	325	(147.4)
B319	8 1/2"	(215.9)	3 3/4"-5 3/4"	(95.2-146.0)	800	(3.56)	340	(154.2)
B320	10 3/8"	(263.5)	5 5/8"-7 5/8"	(142.9-193.7)	560	(2.49)	357	(161.9)

B602A THRU B602C BEAM CLAMP WITH GUSSET ASSEMBLY

- Safety Factor of 5
- 7/8" (22.2) Max. Flange Thickness
- Includes:
 - 1 pc. B451 Slotted Three Hole U Support with Gusset
 - 2 pcs. B213 I-Beam Clamp
 - 2 pcs. 1/2"-13 x 2 1/2" HHCS
 - 2 pcs. 1/2"-13 Hex Nuts
- Material: Malleable iron
- Standard finishes: ZN, GRN

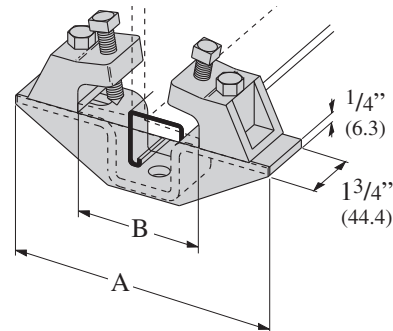

Part No.	A		For Flange Width B		Design Load		Wt./C	
	Lbs.	mm	Lbs.	mm	Lbs.	kN	Lbs.	kg
B602A	7 1/4"	(184.1)	2 3/8"-4 1/2"	(60.3-114.3)	1200	(5.34)	365	(165.1)
B602B	8 1/2"	(215.9)	3 3/4"-5 3/4"	(95.2-146.0)	1200	(5.34)	383	(173.7)
B602C	10 3/8"	(263.5)	5 5/8"-7 5/8"	(142.9-193.7)	1200	(5.34)	408	(185.0)

Reference page 98 for general fitting and standard finish specifications.

Beam Clamps

B760-22 SERIES BEAM CLAMP

- 1" (25.4) Max. Flange Thickness
- For use with 1³/₁₆" (20.6) to 1⁵/₈" (41.3) high channel
- Recommended Torques:
U-Bolt Nuts 150 in-lbs. (16.9 N•m)
J-Hook Nut 60 in-lbs. (6.8 N•m)
- Includes:
1 pc. B760 Plate
1 pc. B701 Type J-Hook only
1 pc. B500-3³/₈" U-Bolt only
3 pcs. 3/8"-16 Hex Nuts
- Standard finish: ZN

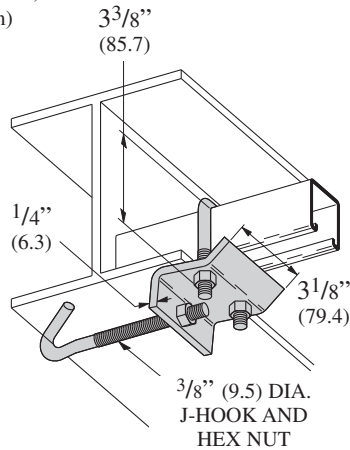

Part No.	For Flange Width		Wt./C	
			Lbs.	kg
B760-22-J4	4"-5 ⁷ / ₈ "	(101.6-149.2)	122	(55.3)
B760-22-J6	6"-8 ⁷ / ₈ "	(152.4-225.4)	129	(58.5)
B760-22-J9	9"-11 ⁷ / ₈ "	(228.6-301.6)	135	(61.2)
B760-22-J12	12"-14 ⁷ / ₈ "	(304.8-377.8)	141	(63.9)

B760-22A SERIES BEAM CLAMP

- 1" (25.4) Max. Flange Thickness
- For use with 1⁵/₈" (41.3) to 3¹/₄" (82.5) high channel
- Recommended Torques:
U-Bolt Nuts 150 in-lbs. (16.9 N•m)
J-Hook Nut 60 in-lbs. (6.8 N•m)
- Includes:
1 pc. B760 Plate
1 pc. B701 Type J-Hook only
1 pc. B500-5" U-Bolt only
3 pcs. 3/8"-16 Hex Nuts
- Standard finish: ZN

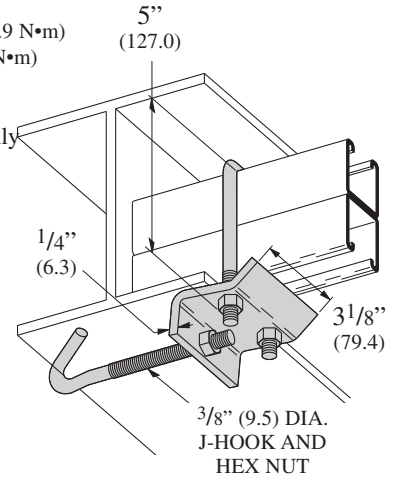

Part No.	For Flange Width		Wt./C	
			Lbs.	kg
B760-22A-J4	4"-5 ⁷ / ₈ "	(101.6-149.2)	129	(58.5)
B760-22A-J6	6"-8 ⁷ / ₈ "	(152.4-225.4)	136	(61.7)
B760-22A-J9	9"-11 ⁷ / ₈ "	(228.6-301.6)	142	(64.4)
B760-22A-J12	12"-14 ⁷ / ₈ "	(304.8-377.8)	148	(67.1)

B761-22 SERIES BEAM CLAMP

- 1" (25.4) Max. Flange Thickness
- For use with 1³/₁₆" (20.6) to 1⁵/₈" (41.3) high channel
- Recommended Torques:
U-Bolt Nuts 150 in-lbs. (16.9 N•m)
ATR Nuts 60 in-lbs. (6.8 N•m)
- Includes:
2 pcs. B700 Plates
2 pcs. B500-3³/₈" U-Bolts only
1 pc. 3/8"-16 ATR (Length)
6 pcs. 3/8"-16 Hex Nuts
- Standard finish: ZN

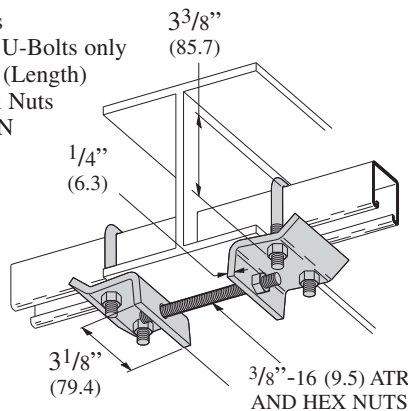

Part No.	For Flange Width	ATR Length	Wt./C			
			Lbs.	kg		
B761-22-4	4"-5 ⁷ / ₈ "	(101.6-149.2)	4"	(101.6)	202	(91.6)
B761-22-6	6"-8 ⁷ / ₈ "	(152.4-225.4)	6"	(152.4)	206	(93.4)
B761-22-9	9"-11 ⁷ / ₈ "	(228.6-301.6)	9"	(228.6)	214	(97.0)
B761-22-12	12"-14 ⁷ / ₈ "	(304.8-377.8)	12"	(304.8)	221	(100.2)

B761-22A SERIES BEAM CLAMP

- 1" (25.4) Max. Flange Thickness
- For use with 1⁵/₈" (41.3) to 3¹/₄" (82.5) high channel
- Recommended Torques:
U-Bolt Nuts 150 in-lbs. (16.9 N•m)
ATR Nuts 60 in-lbs. (6.8 N•m)
- Includes:
2 pcs. B700 Plates
2 pcs. B500-5" U-Bolts only
1 pc. 3/8"-16 ATR (Length)
6 pcs. 3/8"-16 Hex Nuts
- Standard finish: ZN

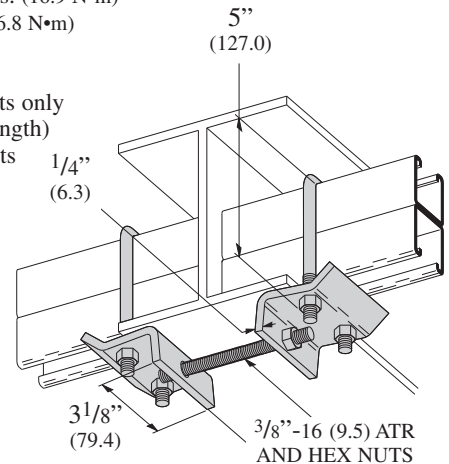

Part No.	For Flange Width	ATR Length	Wt./C			
			Lbs.	kg		
B761-22A-4	4"-5 ⁷ / ₈ "	(101.6-149.2)	4"	(101.6)	216	(98.0)
B761-22A-6	6"-8 ⁷ / ₈ "	(152.4-225.4)	6"	(152.4)	220	(99.8)
B761-22A-9	9"-11 ⁷ / ₈ "	(228.6-301.6)	9"	(228.6)	228	(103.4)
B761-22A-12	12"-14 ⁷ / ₈ "	(304.8-377.8)	12"	(304.8)	235	(106.6)

Reference page 98 for general fitting and standard finish specifications.

B614 COLUMN SUPPORT FOR B22

- Quick installation (one bolt to tighten)
- Design Load 800 Lbs. (3.56 kN) Slip with Safety Factor of 3
- Use with B22 and B24 Channel
- Sold in pairs
- Standard finish: ZN
- Wt./C 50 Lbs. (22.6 kg)

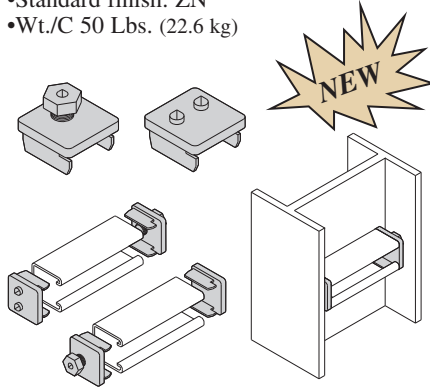

B613 COLUMN SUPPORT FOR B22

- Design Load 800 Lbs. (3.56 kN) Slip with Safety Factor of 3
- Use with B22 and B24 Channel
- Setscrews to be torqued to 19 ft./Lbs
- Sold in pairs
- Standard finishes: ZN, GRN, HDG
- Wt./C 100 Lbs. (45.3 kg)

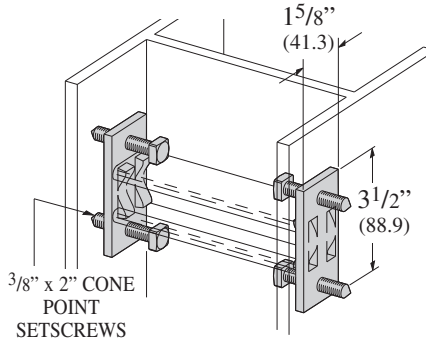

B613A COLUMN SUPPORT FOR B52

- Design Load 800 Lbs. (3.56 kN) Slip with Safety Factor of 3
- Use with B52 and B54 Channel
- Setscrews to be torqued to 19 ft./Lbs
- Sold in pairs
- Standard finishes: ZN, GRN, HDG
- Wt./C 100 Lbs. (45.3 kg)

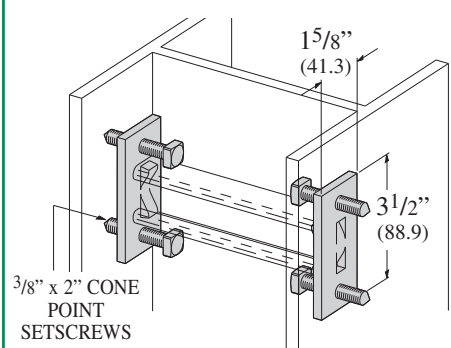

B422 SERIES RIGHT ANGLE CLAMP

- Safety Factor of 5
- Material: 7 Gauge (4.5)
- Standard finishes: ZN, SS4

Part No.	Conduit Size		A		Design Load Vertical Pull		Wt./C	
	in	(mm)	in	(mm)	Lbs.	kg	Lbs.	kg
B422-1/2	1/2"	(15)	2 ³ / ₈ "	(60.3)	250	(1.11)	38	(17.2)
B422-3/4	3/4"	(20)	2 ³ / ₈ "	(60.3)	300	(1.33)	39	(17.7)
B422-1	1"	(25)	2 ⁷ / ₈ "	(73.0)	400	(1.78)	48	(21.8)
B422-1 ¹ / ₄	1 ¹ / ₄ "	(32)	2 ⁷ / ₈ "	(73.0)	400	(1.78)	50	(22.7)
B422-1 ¹ / ₂	1 ¹ / ₂ "	(40)	3 ¹ / ₄ "	(82.5)	500	(2.22)	59	(26.7)
B422-2	2"	(50)	3 ¹¹ / ₁₆ "	(93.7)	600	(2.67)	75	(34.0)
B422-2 ¹ / ₂	2 ¹ / ₂ "	(65)	4 ¹ / ₄ "	(107.9)	700	(3.11)	98	(44.4)
B422-3	3"	(80)	4 ⁷ / ₈ "	(123.8)	800	(3.56)	111	(50.3)
B422-3 ¹ / ₂	3 ¹ / ₂ "	(90)	5 ⁷ / ₁₆ "	(138.1)	900	(4.00)	123	(55.8)
B422-4	4"	(100)	6"	(152.4)	1000	(4.45)	135	(61.2)

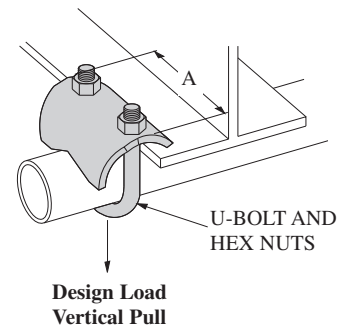

B107S U-SUPPORT

- Material: 7 Gauge (4.5)
- Standard finishes: ZN, GRN
- Wt./C 51 Lbs. (23.1 kg)

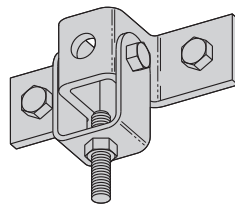
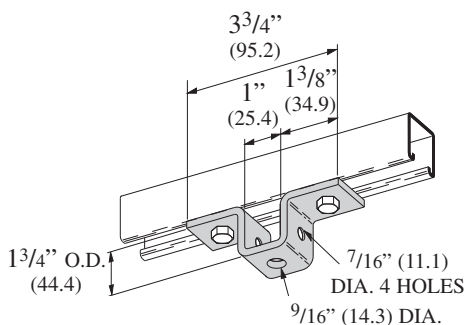

- Illustration shows B107S and B593 used together
- Design Load 900 Lbs., strength of assembly only
- Verify anchorage

B593 CLEVIS SWIVEL

- Includes:
 - 1 pc. 3/8"-16 x 2" HHCS
 - 1 pc. 3/8"-16 Hex Nut
- Material: 11 Gauge (3.0)
- Standard finishes: ZN, GRN
- Wt./C 31 Lbs. (14.0 kg)

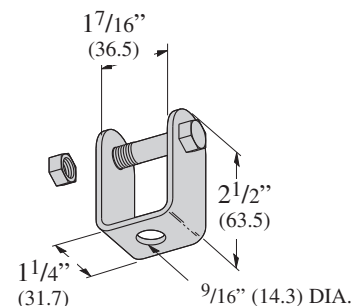

Reference page 98 for general fitting and standard finish specifications.

Pipe/Conduit Clamps & Hangers

B-Line's beam attachments and pipe supports offered in this section are designed to provide supports without drilling or welding. A complete selection of beam clamps, pipe clamps, rollers, supports and accessories are designed for use with B-Line channels and offer many installation advantages.

Materials & Finishes*

Pipe clamps, pipe hangers, beam clamps, brackets, and rollers are made from low carbon steel strips, plates or rod unless noted.

Finish Code	Finish	Specification
PLN	Plain	ASTM A1011 33,000 PSI min. yield
ZN	Electro-Plated Zinc	ASTM B633 SC3 Type III
GRN	Dura-Green	
DCU	Dura-Copper	
HDG	Hot-Dipped Galvanized	ASTM A123
YZN	Yellow Zinc Chromate	ASTM B633 SC3 Type II
SS4	Stainless Steel Type 304	ASTM A240
SS6	Stainless Steel Type 316	ASTM A240
AL	Aluminum	ASTM B209

*Unless otherwise noted.

Load Data

The load data published includes a safety factor of 5.0 unless noted (safety factor = ratio of ultimate load to the design load).

Recommended Torque For Setscrews (unless noted)

Setscrew Size	1/4"-20	3/8"-16	1/2"-13
Foot/Lbs.	4	5	11
Nm	5	7	15

Setscrew Size	5/8"-11	3/4"-10
Foot/Lbs.	21	34
Nm	28	46

*See chart on page 58 for bolt torque.

Metric

Metric dimensions are shown in parentheses. Unless noted, all metric dimensions are in millimeters.



B2207 THRU B2213 MULTI-GRIP PIPE CLAMPS FOR THINWALL (EMT), I.M.C., RIGID CONDUIT OR PIPE

- Safety Factor of 5
- Add PA to suffix for pre-assembled pipe clamps
- Includes Combination Recess Hex Head Machine Screw and Square Nut
- Material: ASTM A1011 33,000 PSI min. yield
- Standard finish: ZN

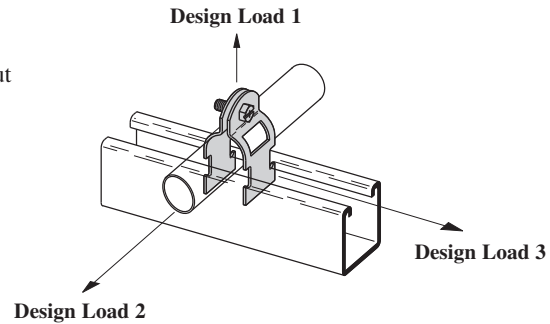

Part No.	Nominal Size		Material Thickness		O.D. Size Range		Alternate For Clamp No.'s	Design Load 1		Design Load 2		Design Load 3		Wt./C	
								Lbs.	kN	Lbs.	kg	Lbs.	kg	Lbs.	kg
B2207	3/8"	(10)	16 Ga.	(1.5)	.557-.706	(14.2-17.9)	B2000, B2007, B2026	400	(1.78)	50	(.22)	50	(.22)	9	(4.1)
B2208	1/2"	(15)	16 Ga.	(1.5)	.701-.875	(17.8-22.2)	B2001, B2008, B2027, B2028	400	(1.78)	50	(.22)	50	(.22)	11	(5.0)
B2209	3/4"	(20)	14 Ga.	(1.9)	.917-1.081	(23.2-27.4)	B2002, B2009, B2029	400	(1.78)	50	(.22)	50	(.22)	12	(5.4)
B2210	1"	(25)	14 Ga.	(1.9)	1.125-1.375	(28.6-34.9)	B2003, B2010, B2030, B2031, B2032	400	(1.78)	50	(.22)	50	(.22)	13	(5.9)
B2211	1 1/4"	(32)	14 Ga.	(1.9)	1.500-1.691	(38.1-42.9)	B2004, B2011, B2033, B2034	400	(1.78)	50	(.22)	50	(.22)	15	(6.8)
B2212	1 1/2"	(40)	12 Ga.	(2.6)	1.735-1.931	(44.0-49.0)	B2005, B2012, B2035, B2036	600	(2.67)	75	(.33)	75	(.33)	23	(10.4)
B2213	2"	(50)	12 Ga.	(2.6)	2.192-2.400	(55.7-60.9)	B2006, B2013 B2039	600	(2.67)	75	(.33)	75	(.33)	26	(11.8)

Pipe/Conduit Clamps & Hangers

BPC-8 THRU BPC-64 BREAK-APART CONDUIT CLAMP

- Design Load 200 Lbs. (.896 kN)
- Includes Combination Recess Hex Head Machine Screw
- Material: ASTM A1011 33,000 PSI min. yield
- Standard finish: ZN

Part No.	A		Wt./C	
	Rigid or EMT Conduit Size		Lbs.	kg
BPC-8	1/2"	(21.3)	11.2	(5.1)
BPC-12	3/4"	(26.7)	12.7	(5.8)
BPC-16	1"	(33.4)	14.5	(6.6)
BPC-20	1 1/4"	(42.2)	16.5	(7.5)
BPC-24	1 1/2"	(48.3)	18.5	(8.4)
BPC-32	2"	(60.3)	21.5	(9.8)
BPC-40	2 1/2"	(73.0)	21.5	(9.8)
BPC-48	3"	(88.9)	22.0	(10.0)
BPC-56	3 1/2"	(101.6)	23.0	(10.4)
BPC-64	4"	(114.3)	27.5	(12.5)

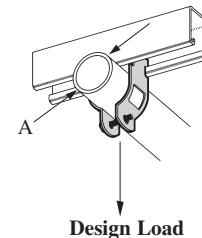

Reference page 110 for general fitting and standard finish specifications.

Pipe Clamps

B2000 SERIES PIPE AND CONDUIT CLAMPS

- Safety Factor of 5
- Add PA to suffix for pre-assembled pipe clamps
- Includes Combination Recess Hex Head Machine Screw and Square Nut
- Material: 16 Ga. (1.5), 14 Ga. (1.9), 12 Ga. (2.6) ASTM A1011 33,000 PSI min. yield and 11 Ga. (3.0) ASTM A1011HSLA Gr. 50
- Standard finishes: ZN, HDG, SS4, SS6, AL

Note: For EMT sizes 2 1/2" and larger use rigid conduit sizes.

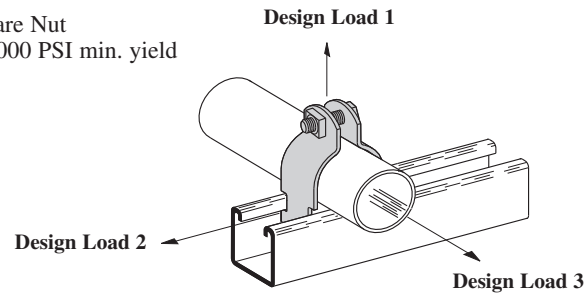

THINWALL CONDUIT (EMT) CLAMPS

Part No.	Conduit Size		Material Thickness		Design Load 1		Design Load 2		Design Load 3		Wt./C	
	Lbs.	kN	Lbs.	kg	Lbs.	kg	Lbs.	kg	Lbs.	kg		
B2000	3/8"	(10)	16 Ga.	(1.5)	400	(1.78)	50	(.22)	50	(.22)	10	(4.5)
B2001	1/2"	(15)	16 Ga.	(1.5)	400	(1.78)	50	(.22)	50	(.22)	10	(4.5)
B2002	3/4"	(20)	16 Ga.	(1.9)	400	(1.78)	50	(.22)	50	(.22)	11	(5.0)
B2003	1"	(25)	14 Ga.	(1.9)	600	(2.67)	75	(.33)	75	(.33)	16	(7.2)
B2004	1 1/4"	(32)	14 Ga.	(1.9)	600	(2.67)	75	(.33)	75	(.33)	19	(8.6)
B2005	1 1/2"	(40)	12 Ga.	(2.6)	800	(3.56)	125	(.56)	125	(.56)	28	(12.7)
B2006	2"	(50)	12 Ga.	(2.6)	800	(3.56)	125	(.56)	125	(.56)	33	(14.9)

RIGID CONDUIT OR PIPE CLAMPS

Part No.	Conduit Size		Material Thickness		Design Load 1		Design Load 2		Design Load 3		Wt./C	
	Lbs.	kN	Lbs.	kg	Lbs.	kg	Lbs.	kg	Lbs.	kg		
B2001	3/8"	(10)	16 Ga.	(1.5)	400	(1.78)	50	(.22)	50	(.22)	10	(4.5)
B2008	1/2"	(15)	16 Ga.	(1.5)	400	(1.78)	50	(.22)	50	(.22)	11	(5.0)
B2009	3/4"	(20)	14 Ga.	(1.9)	600	(2.67)	75	(.33)	75	(.33)	15	(6.8)
B2010	1"	(25)	14 Ga.	(1.9)	600	(2.67)	75	(.33)	75	(.33)	16	(7.2)
B2011	1 1/4"	(32)	14 Ga.	(1.9)	600	(2.67)	75	(.33)	75	(.33)	20	(9.1)
B2012	1 1/2"	(40)	12 Ga.	(2.6)	800	(3.56)	125	(.56)	125	(.56)	30	(13.6)
B2013	2"	(50)	12 Ga.	(2.6)	800	(3.56)	125	(.56)	125	(.56)	34	(15.4)
B2014	2 1/2"	(65)	12 Ga.	(2.6)	800	(3.56)	125	(.56)	125	(.56)	38	(17.2)
B2015	3"	(80)	12 Ga.	(2.6)	800	(3.56)	125	(.56)	125	(.56)	44	(19.9)
B2016	3 1/2"	(90)	11 Ga.	(3.0)	1000	(4.45)	200	(.89)	150	(.67)	61	(27.6)
B2017	4"	(100)	11 Ga.	(3.0)	1000	(4.45)	200	(.89)	150	(.67)	66	(29.9)
B2018	4 1/2"	(115)	11 Ga.	(3.0)	1000	(4.45)	200	(.89)	150	(.67)	70	(31.7)
B2019	5"	(125)	11 Ga.	(3.0)	1000	(4.45)	200	(.89)	150	(.67)	77	(34.9)
B2020	6"	(150)	11 Ga.	(3.0)	1000	(4.45)	200	(.89)	150	(.67)	100	(45.3)
B2021	7"	(175)	11 Ga.	(3.0)	1000	(4.45)	250	(1.11)	200	(.89)	115	(52.1)
B2022	8"	(200)	11 Ga.	(3.0)	1000	(4.45)	250	(1.11)	200	(.89)	128	(58.0)
B2130	10"	(254)	11 Ga.	(3.0)	1000	(4.45)	250	(1.11)	200	(.89)	160	(72.6)
B2132	12"	(305)	11 Ga.	(3.0)	1000	(4.45)	250	(1.11)	200	(.89)	185	(83.9)

Reference page 110 for general fitting and standard finish specifications.

B2000 SERIES

PVC CLAMPS

- Safety Factor of 5
- Add PA to suffix for pre-assembled pipe clamps
- Includes Combination Recess Hex Head Machine Screw and Square Nut
- Material: 16 Ga. (1.5), 14 Ga. (1.9), 12 Ga. (2.6) ASTM A1011 33,000 PSI min. yield and 11 Ga. (3.0) ASTM A1011HSLA Gr. 50
- Standard finishes: PVC

CLAMP SIZING CHART FOR PVC COATED RIGID CONDUIT AND CLAMPS

Nominal Conduit Size		Conduit Coating			
		.020 (.51mm)		.040 (1.01mm)	
		Clamp Coating		Clamp Coating	
		0	.020 (.51mm)	0	.020 (.51mm)
1/2"	(15)	B2008	B2002	B2002	B2029
3/4"	(20)	B2030	B2030	B2030	B2004
1"	(25)	B2032	B2032	B2032	B2004
1 1/4"	(32)	B2005	B2005	B2005	B2005
1 1/2"	(40)	B2012	B2037	B2037	B2037
2"	(50)	B2013	B2041	B2041	B2041
2 1/2"	(65)	B2014	B2045	B2045	B2045
3"	(80)	B2015	B2050	B2050	B2050
3 1/2"	(90)	B2016	B2054	B2054	B2054
4"	(100)	B2017	B2058	B2058	B2058
5"	(125)	B2019	B2066	B2066	B2066
6"	(150)	B2020	B2115	B2115	B2115

*See B2000 O.D. pipe and conduit clamp chart on pgs. 112-113 for corresponding clamp load data.

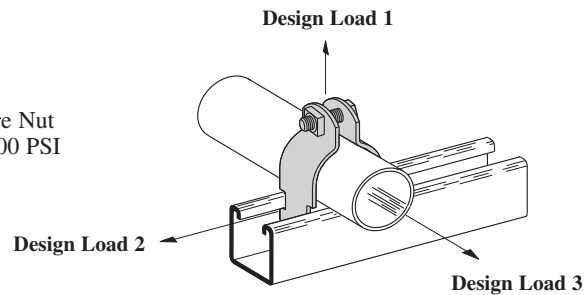

CLAMP SIZING CHART FOR PVC COATED THINWALL (EMT) CONDUIT AND CLAMPS

Nominal Conduit Size		Conduit Coating			
		.020 (.51mm)		.040 (1.01mm)	
		Clamp Coating		Clamp Coating	
		0	.020 (.51mm)	0	.020 (.51mm)
3/8"	(10)	B2026	B2026	B2026	B2001
1/2"	(15)	B2027	B2027	B2027	B2008
3/4"	(20)	B2029	B2029	B2029	B2009
1"	(25)	B2003	B2031	B2031	B2031
1 1/4"	(32)	B2004	B2011	B2011	B2011
1 1/2"	(40)	B2005	B2005	B2005	B2036
2"	(50)	B2039	B2039	B2039	B2013

*See B2000 O.D. pipe and conduit clamp chart on pgs. 112-113 for corresponding clamp load data.

Pipe/Conduit Clamps & Hangers

B2000 SERIES

COPPER TUBING CLAMPS

- Safety Factor of 5
- Add PA to suffix for pre-assembled pipe clamps
- Includes Combination Recess Hex Head Machine Screw and Square Nut
- Material: 16 Ga. (1.5), 14 Ga. (1.9), 12 Ga. (2.6) ASTM A1011 33,000 PSI min. yield and 11 Ga. (3.0) ASTM A1011HSLA Gr. 50
- Standard finish: Exclusive Dura-Copper® Finish (DCU)

COPPER TUBING CLAMPS

Part No.	Tubing Size	O.D. Size In. (mm)	Material Thickness	Design Load 1		Design Load 2		Design Load 3		Wt./C	
				Lbs.	kN	Lbs.	kg	Lbs.	kg	Lbs.	kg
B2024DCU	1/4"	.375 (9.5)	16 Ga. (1.5)	400	(1.78)	50	(.22)	50	(.22)	8	(3.6)
B2025DCU	3/8"	.500 (12.7)	16 Ga. (1.5)	400	(1.78)	50	(.22)	50	(.22)	9	(4.1)
B2026DCU	1/2"	.625 (15.9)	16 Ga. (1.5)	400	(1.78)	50	(.22)	50	(.22)	10	(4.5)
B2027DCU	5/8"	.750 (19.0)	16 Ga. (1.5)	400	(1.78)	50	(.22)	50	(.22)	10	(4.5)
B2008DCU	3/4"	.875 (22.2)	16 Ga. (1.5)	400	(1.78)	50	(.22)	50	(.22)	11	(5.0)
B2030DCU	1"	1.125 (28.6)	14 Ga. (1.9)	600	(2.67)	75	(.33)	75	(.33)	15	(6.8)
B2032DCU	1 1/4"	1.375 (34.9)	14 Ga. (1.9)	600	(2.67)	75	(.33)	75	(.33)	17	(7.7)
B2011DCU	1 1/2"	1.625 (41.3)	14 Ga. (1.9)	600	(2.67)	75	(.33)	75	(.33)	19	(8.6)
B2038DCU	2	2.125 (54.0)	12 Ga. (2.6)	800	(3.56)	125	(.56)	125	(.56)	32	(14.5)
B2042DCU	2 1/2"	2.625 (66.7)	12 Ga. (2.6)	800	(3.56)	125	(.56)	125	(.56)	35	(15.9)
B2046DCU	3	3.125 (79.4)	12 Ga. (2.6)	800	(3.56)	125	(.56)	125	(.56)	39	(17.7)
B2050DCU	3 1/2"	3.625 (92.1)	11 Ga. (3.0)	1000	(4.45)	200	(.89)	150	(.67)	54	(24.5)
B2054DCU	4	4.125 (104.8)	11 Ga. (3.0)	1000	(4.45)	200	(.89)	150	(.67)	61	(27.6)
B2062DCU	5	5.125 (130.2)	11 Ga. (3.0)	1000	(4.45)	200	(.89)	150	(.67)	70	(31.7)
B2110DCU	6	6.125 (155.6)	11 Ga. (3.0)	1000	(4.45)	250	(1.11)	200	(.89)	94	(42.6)
B2126DCU	8	8.125 (206.4)	11 Ga. (3.0)	1000	(4.45)	250	(1.11)	200	(.89)	123	(55.8)

Reference page 110 for general fitting and standard finish specifications.

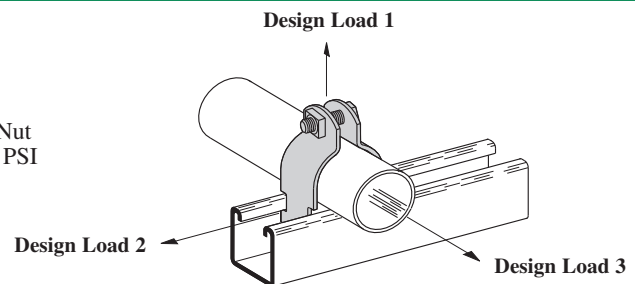

Pipe Clamps

B2000 SERIES O.D. PIPE AND CONDUIT CLAMPS

- Safety Factor of 5
- Add PA to suffix for pre-assembled pipe clamps
- Other sizes available upon request
- Includes Combination Recess Hex Head Machine Screw and Square Nut.
- Material: 16 Ga. (1.5), 14 Ga. (1.9), 12 Ga. (2.6)
ASTM A1011 33,000 PSI min. yield and 11 Ga. (3.0)
ASTM A1011HSLA Gr. 50
- Standard finishes: ZN, HDG, SS4

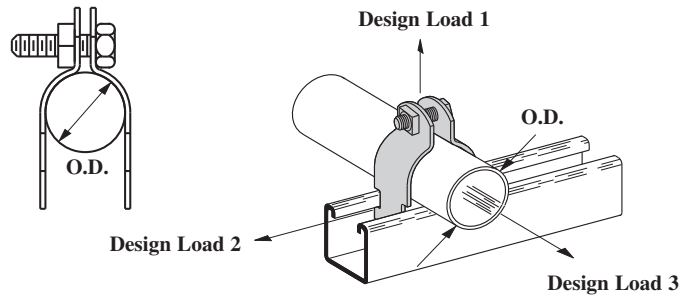

O.D. CLAMPS

Part No.	O.D. Size (in.)		Hardware Size	Material Gauge Thickness		Design Load 1		Design Load 2		Design Load 3		Wt./C	
						Lbs.	kN	Lbs.	kN	Lbs.	kN	Lbs.	kg
B2023	1/4"	(6.3)	1/4"-20	16	(1.5)	120	(.54)	30	(.13)	30	(.13)	8	(3.6)
B2024	3/8"	(9.5)	1/4"-20	16	(1.5)	300	(1.33)	40	(.18)	40	(.18)	8	(3.6)
B2025	1/2"	(12.7)	1/4"-20	16	(1.5)	400	(1.78)	50	(.22)	50	(.22)	9	(4.1)
B2026	5/8"	(15.9)	1/4"-20	16	(1.5)	400	(1.78)	50	(.22)	50	(.22)	10	(4.5)
B2027	3/4"	(19.0)	1/4"-20	16	(1.5)	400	(1.78)	50	(.22)	50	(.22)	10	(4.5)
B2028	7/8"	(22.2)	1/4"-20	16	(1.5)	400	(1.78)	50	(.22)	50	(.22)	11	(5.0)
B2029	1"	(25.4)	1/4"-20	14	(1.9)	500	(2.22)	75	(.33)	75	(.33)	15	(6.8)
B2030	1 1/8"	(28.6)	1/4"-20	14	(1.9)	600	(2.67)	75	(.33)	75	(.33)	15	(6.8)
B2031	1 1/4"	(31.7)	1/4"-20	14	(1.9)	600	(2.67)	75	(.33)	75	(.33)	16	(7.3)
B2032	1 3/8"	(34.9)	1/4"-20	14	(1.9)	600	(2.67)	75	(.33)	75	(.33)	17	(7.7)
B2004	1 1/2"	(38.1)	1/4"-20	14	(1.9)	600	(2.67)	75	(.33)	75	(.33)	18	(8.2)
B2011	1 5/8"	(41.3)	1/4"-20	14	(1.9)	600	(2.67)	75	(.33)	75	(.33)	19	(8.6)
B2005	1 3/4"	(44.4)	5/16"-18	12	(2.6)	800	(3.56)	125	(.56)	125	(.56)	29	(13.1)
B2036	1 7/8"	(47.6)	5/16"-18	12	(2.6)	800	(3.56)	125	(.56)	125	(.56)	30	(13.6)
B2037	2	(50.8)	5/16"-18	12	(2.6)	800	(3.56)	125	(.56)	125	(.56)	30	(13.6)
B2038	2 1/8"	(54.0)	5/16"-18	12	(2.6)	800	(3.56)	125	(.56)	125	(.56)	32	(14.5)
B2039	2 1/4"	(57.1)	5/16"-18	12	(2.6)	800	(3.56)	125	(.56)	125	(.56)	32	(14.5)
B2013	2 3/8"	(60.3)	5/16"-18	12	(2.6)	800	(3.56)	125	(.56)	125	(.56)	34	(15.4)
B2041	2 1/2"	(63.5)	5/16"-18	12	(2.6)	800	(3.56)	125	(.56)	125	(.56)	35	(15.9)
B2042	2 5/8"	(66.7)	5/16"-18	12	(2.6)	800	(3.56)	125	(.56)	125	(.56)	35	(15.9)
B2043	2 3/4"	(69.8)	5/16"-18	12	(2.6)	800	(3.56)	125	(.56)	125	(.56)	38	(17.2)
B2014	2 7/8"	(73.0)	5/16"-18	12	(2.6)	800	(3.56)	125	(.56)	125	(.56)	38	(17.2)
B2045	3	(76.2)	5/16"-18	12	(2.6)	800	(3.56)	125	(.56)	125	(.56)	38	(17.2)
B2046	3 1/8"	(79.4)	5/16"-18	12	(2.6)	800	(3.56)	125	(.56)	125	(.56)	39	(17.7)
B2047	3 1/4"	(82.5)	5/16"-18	12	(2.6)	800	(3.56)	125	(.56)	125	(.56)	41	(18.6)
B2048	3 3/8"	(85.7)	5/16"-18	12	(2.6)	800	(3.56)	125	(.56)	125	(.56)	43	(19.5)
B2015	3 1/2"	(88.9)	5/16"-18	12	(2.6)	800	(3.56)	125	(.56)	125	(.56)	44	(20.0)
B2050	3 5/8"	(92.1)	5/16"-18	11	(3.0)	1000	(4.45)	200	(.89)	150	(.67)	54	(24.5)
B2051	3 3/4"	(95.2)	5/16"-18	11	(3.0)	1000	(4.45)	200	(.89)	150	(.67)	57	(25.8)
B2052	3 7/8"	(98.4)	5/16"-18	11	(3.0)	1000	(4.45)	200	(.89)	150	(.67)	55	(25.0)
B2016	4	(101.6)	5/16"-18	11	(3.0)	1000	(4.45)	200	(.89)	150	(.67)	57	(25.8)
B2054	4 1/8"	(104.8)	5/16"-18	11	(3.0)	1000	(4.45)	200	(.89)	150	(.67)	61	(27.7)
B2055	4 1/4"	(107.9)	5/16"-18	11	(3.0)	1000	(4.45)	200	(.89)	150	(.67)	62	(28.1)
B2056	4 3/8"	(111.1)	5/16"-18	11	(3.0)	1000	(4.45)	200	(.89)	150	(.67)	64	(29.0)
B2017	4 1/2"	(114.3)	5/16"-18	11	(3.0)	1000	(4.45)	200	(.89)	150	(.67)	66	(29.9)
B2058	4 5/8"	(117.5)	5/16"-18	11	(3.0)	1000	(4.45)	200	(.89)	150	(.67)	66	(29.9)

Reference page 110 for general fitting and standard finish specifications.

B2000 SERIES O.D. PIPE AND CONDUIT CLAMPS

- Safety Factor of 5
- Add PA to suffix for pre-assembled pipe clamps
- Other sizes available upon request
- Includes Combination Recess Hex Head Machine Screw and Square Nut.
- Material: 16 Ga. (1.5), 14 Ga. (1.9), 12 Ga. (2.6) ASTM A1011 33,000 PSI min. yield and 11 Ga. (3.0) ASTM A1011HSLA Gr. 50
- Standard finishes: ZN, HDG, SS4

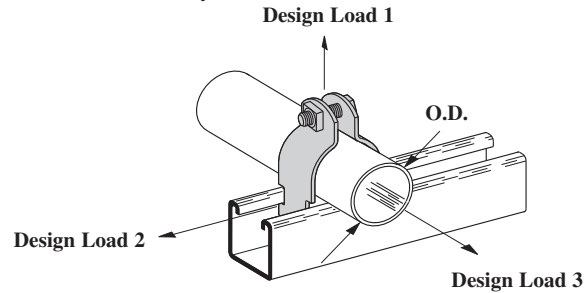

O.D. CLAMPS

Part No.	O.D. Size (in.)		Hardware Size	Material Gauge Thickness		Design Load 1		Design Load 2		Design Load 3		Wt./C	
						Lbs.	kN	Lbs.	kN	Lbs.	kN	Lbs.	kg
B2059	4 ³ / ₄ "	(120.6)	5/16"-18	11	(3.0)	1000	(4.45)	200	(.89)	150	(.67)	68	(30.8)
B2060	4 ⁷ / ₈ "	(123.8)	5/16"-18	11	(3.0)	1000	(4.45)	200	(.89)	150	(.67)	69	(31.3)
B2018	5	(127.0)	5/16"-18	11	(3.0)	1000	(4.45)	200	(.89)	150	(.67)	70	(31.8)
B2062	5 ¹ / ₈ "	(130.2)	5/16"-18	11	(3.0)	1000	(4.45)	200	(.89)	150	(.67)	70	(31.8)
B2063	5 ¹ / ₄ "	(133.3)	5/16"-18	11	(3.0)	1000	(4.45)	200	(.89)	150	(.67)	70	(31.8)
B2064	5 ³ / ₈ "	(136.5)	5/16"-18	11	(3.0)	1000	(4.45)	200	(.89)	150	(.67)	77	(34.9)
B2019	5 ¹ / ₂ "	(139.7)	5/16"-18	11	(3.0)	1000	(4.45)	200	(.89)	150	(.67)	78	(35.4)
B2066	5 ⁵ / ₈ "	(142.9)	5/16"-18	11	(3.0)	1000	(4.45)	200	(.89)	150	(.67)	83	(37.6)
B2067	5 ³ / ₄ "	(146.0)	5/16"-18	11	(3.0)	1000	(4.45)	200	(.89)	150	(.67)	84	(38.1)
B2068	5 ⁷ / ₈ "	(149.2)	5/16"-18	11	(3.0)	1000	(4.45)	200	(.89)	150	(.67)	85	(38.6)
B2069	6"	(152.4)	5/16"-18	11	(3.0)	1000	(4.45)	200	(.89)	150	(.67)	87	(39.5)
B2110	6 ¹ / ₈ "	(155.6)	3/8"-16	11	(3.0)	1000	(4.45)	250	(1.11)	200	(.89)	94	(42.6)
B2111	6 ¹ / ₄ "	(158.7)	3/8"-16	11	(3.0)	1000	(4.45)	250	(1.11)	200	(.89)	96	(43.5)
B2112	6 ³ / ₈ "	(161.9)	3/8"-16	11	(3.0)	1000	(4.45)	250	(1.11)	200	(.89)	98	(44.4)
B2113	6 ¹ / ₂ "	(165.1)	3/8"-16	11	(3.0)	1000	(4.45)	250	(1.11)	200	(.89)	99	(44.9)
B2020	6 ⁵ / ₈ "	(168.3)	3/8"-16	11	(3.0)	1000	(4.45)	250	(1.11)	200	(.89)	100	(45.4)
B2115	6 ³ / ₄ "	(171.4)	3/8"-16	11	(3.0)	1000	(4.45)	250	(1.11)	200	(.89)	102	(46.3)
B2116	6 ⁷ / ₈ "	(174.6)	3/8"-16	11	(3.0)	1000	(4.45)	250	(1.11)	200	(.89)	104	(47.2)
B2117	7"	(177.8)	3/8"-16	11	(3.0)	1000	(4.45)	250	(1.11)	200	(.89)	106	(48.1)
B2118	7 ¹ / ₈ "	(181.0)	3/8"-16	11	(3.0)	1000	(4.45)	250	(1.11)	200	(.89)	108	(49.0)
B2119	7 ¹ / ₄ "	(184.1)	3/8"-16	11	(3.0)	1000	(4.45)	250	(1.11)	200	(.89)	110	(49.9)
B2120	7 ³ / ₈ "	(187.3)	3/8"-16	11	(3.0)	1000	(4.45)	250	(1.11)	200	(.89)	112	(50.8)
B2121	7 ¹ / ₂ "	(190.5)	3/8"-16	11	(3.0)	1000	(4.45)	250	(1.11)	200	(.89)	114	(51.7)
B2021	7 ⁵ / ₈ "	(193.7)	3/8"-16	11	(3.0)	1000	(4.45)	250	(1.11)	200	(.89)	115	(52.2)
B2123	7 ³ / ₄ "	(196.8)	3/8"-16	11	(3.0)	1000	(4.45)	250	(1.11)	200	(.89)	117	(53.1)
B2124	7 ⁷ / ₈ "	(200.0)	3/8"-16	11	(3.0)	1000	(4.45)	250	(1.11)	200	(.89)	119	(54.0)
B2125	8"	(203.2)	3/8"-16	11	(3.0)	1000	(4.45)	250	(1.11)	200	(.89)	121	(54.9)
B2126	8 ¹ / ₈ "	(206.4)	3/8"-16	11	(3.0)	1000	(4.45)	250	(1.11)	200	(.89)	123	(55.8)
B2127	8 ¹ / ₄ "	(209.5)	3/8"-16	11	(3.0)	1000	(4.45)	250	(1.11)	200	(.89)	125	(56.7)
B2128	8 ³ / ₈ "	(212.7)	3/8"-16	11	(3.0)	1000	(4.45)	250	(1.11)	200	(.89)	126	(57.2)
B2129	8 ¹ / ₂ "	(215.9)	3/8"-16	11	(3.0)	1000	(4.45)	250	(1.11)	200	(.89)	128	(58.1)
B2022	8 ⁵ / ₈ "	(219.1)	3/8"-16	11	(3.0)	1000	(4.45)	250	(1.11)	200	(.89)	128	(58.1)
B2130	10 ³ / ₄ "	(273.0)	3/8"-16	11	(3.0)	1000	(4.45)	250	(1.11)	200	(.89)	160	(72.6)
B2132	12 ³ / ₄ "	(323.8)	3/8"-16	11	(3.0)	1000	(4.45)	250	(1.11)	200	(.89)	185	(83.9)

Reference page 110 for general fitting and standard finish specifications.

Pipe Clamps

B1508 THRU B1564S CONDUIT/STRUT CLAMPS

- Safety Factor of 3
- Clamps without saddles are not recommended for flexible conduit or cable
- All Sizes Include:
1/4"-20 Slotted Hex Head Machine Screw
- Standard finish: ZN

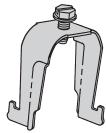
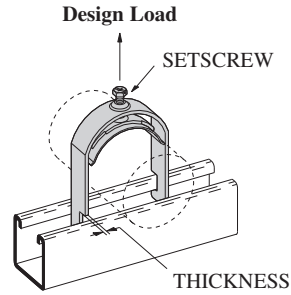

B1508 THRU B1520

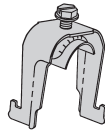

B1508S THRU B1524S

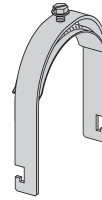

B1532S THRU B1564S

Part No.	Use With				Thickness	Design Load		Wt./C	
	EMT	Rigid Conduit		Lbs.		kN	Lbs.	kg	
B1508	1/2"	(15)	–	–	16 Ga. (1.5)	200	(.89)	7.4	(3.4)
B1512	3/4"	(20)	1/2"	(15)	16 Ga. (1.5)	200	(.89)	8.0	(3.6)
B1516	1"	(25)	3/4"	(20)	14 Ga. (1.9)	300	(1.33)	11.0	(5.0)
B1520	1 1/4"	(32)	1"	(25)	14 Ga. (1.9)	300	(1.33)	12.5	(5.7)
B1508S	1/2"	(15)	–	–	16 Ga. (1.5)	200	(.89)	8.6	(3.9)
B1512S	3/4"	(20)	1/2"	(15)	16 Ga. (1.5)	200	(.89)	9.2	(4.2)
B1516S	1"	(25)	3/4"	(20)	14 Ga. (1.9)	300	(1.33)	12.7	(5.8)
B1520S	1 1/4"	(32)	1"	(25)	14 Ga. (1.9)	300	(1.33)	14.6	(6.6)
B1524S	1 1/2"	(40)	1 1/4"	(32)	12 Ga. (2.6)	400	(1.78)	20.5	(9.3)
B1532S	2"	(50)	1 1/2"	(40)	12 Ga. (2.6)	400	(1.78)	21.5	(9.8)
B1534S	–	–	2"	(50)	12 Ga. (2.6)	400	(1.78)	22.7	(10.3)
B1540S	2 1/2"	(65)	2 1/2"	(65)	12 Ga. (2.6)	400	(1.78)	26.0	(11.9)
B1548S	3"	(80)	3"	(80)	12 Ga. (2.6)	400	(1.78)	30.2	(13.7)
B1556S	3 1/2"	(90)	3 1/2"	(90)	12 Ga. (2.6)	400	(1.78)	33.3	(15.1)
B1564S	4"	(100)	4"	(100)	12 Ga. (2.6)	400	(1.78)	36.6	(16.6)

Reference page 110 for general fitting and standard finish specifications.

B2601 THRU B2610 TWIST EAR® PIPE CLAMP

- One piece break apart, screw retainer, thread impressions
- Tighter alignment, no need to leave additional space between clamps in order to access nut and bolt
- Easier access bolt can be tightened directly from front
- Available in 1/2", 3/4", 1" rigid and EMT Conduit
- Recommended Torque 30 in. - lbs.
- Safety Factor of 3
- Standard finish: ZN

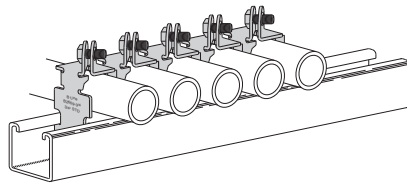

Allows for multiple clamps to be used in succession, with easier access than other pipe clamps.

Design Load

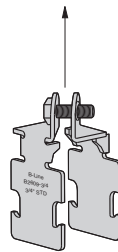

Break-apart - break in the middle, bolt the ends together.

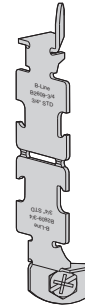

No loose pieces. One piece break apart with screw retainer and thread impressions.

Part No.	Use With				Thickness	Design Load		Wt./C	
	EMT		Rigid Conduit			Lbs.	kN	Lbs.	kg
B2601	1/2"	(17.9)	-	-	16 Ga.	300	(1.34)	8.2	(3.7)
B2602	3/4"	(23.4)	-	-	14 Ga.	500	(2.24)	13.5	(6.1)
B2603	1"	(29.5)	-	-	14 Ga.	500	(2.24)	15.6	(7.1)
B2608	-	-	1/2"	(21.3)	16 Ga.	300	(1.34)	8.2	(3.7)
B2609	-	-	3/4"	(26.7)	14 Ga.	500	(2.24)	13.5	(6.1)
B2610	-	-	1"	(33.4)	14 Ga.	500	(2.24)	15.6	(7.1)

BP081SS THRU BP475SS P CLAMPS

- Minimizes induction heating
- Material: Stainless Steel Type 304

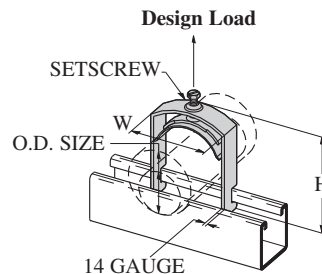

Part No.	O.D. Size		Height H		Width W		Design Load		Wt./C.	
	In.	mm	In.	mm	In.	mm	Lbs.	kN	Lbs.	kg
BP081SS	.250-.840	(6.4-21.3)	1.86	(47.2)	0.87	(22.1)	300	(1.33)	9.0	(4.1)
BP110SS	.810-1.100	(20.6-28.0)	2.18	(55.4)	1.19	(30.2)	300	(1.33)	12.0	(5.4)
BP135SS	.850-1.350	(21.6-34.8)	2.25	(57.2)	1.38	(35.1)	300	(1.33)	14.0	(6.3)
BP175SS	1.250-1.750	(31.8-44.4)	2.78	(70.6)	1.78	(45.2)	300	(1.33)	21.0	(9.5)
BP205SS	1.550-2.050	(39.4-52.1)	3.00	(76.2)	2.28	(57.9)	300	(1.33)	30.0	(13.6)
BP250SS	2.00-2.50	(50.8-63.5)	3.43	(87.1)	2.83	(71.9)	300	(1.33)	35.0	(15.9)
BP300SS	2.55-3.00	(64.7-76.2)	3.87	(97.8)	3.15	(80.0)	300	(1.33)	39.0	(17.7)
BP325SS	2.75-3.25	(69.9-82.8)	4.06	(103.1)	3.28	(83.3)	300	(1.33)	41.0	(18.6)
BP375SS	3.25-3.75	(82.6-95.3)	4.60	(116.8)	3.83	(97.3)	300	(1.33)	47.0	(21.3)
BP425SS	3.75-4.25	(95.3-108.0)	5.13	(130.3)	4.50	(114.3)	300	(1.33)	54.0	(24.4)
BP475SS	4.25-4.75	(108.0-120.7)	5.70	(144.8)	4.85	(123.2)	300	(1.33)	58.0	(26.3)

Reference page 110 for general fitting and standard finish specifications.

VibraClamp® Pipe Clamps

BVT SERIES VIBRACLAMPS-COPPER & O.D.

- Safety Factor of 3
- Accesses tubing sizes 1/8" (3) to 6" (150)
- Allows easy one tool installation
- Endures both high (+300°F) and low (-40°F) temperatures
- Dampens vibration and noise
- Eliminates galvanic metal to metal contact
- Resists most industrial oils and solvents
- Reduces thermal loss and gain
- Secures tubing firmly to channel (strut)
- Dielectric strength of 400 volts/mil
- Includes cushion, clamp, screw and nut
- Standard finishes: YZN, SS4

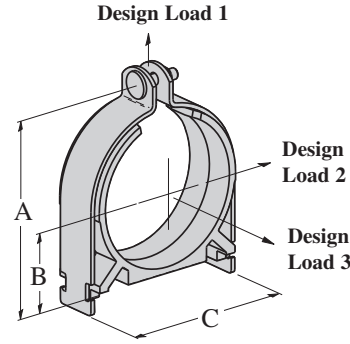

Pipe/Conduit Clamps & Hangers

Catalog Number	Tubing O.D. Size		Copper Tubing Size		Dimensions						Wt./C	
					A	B		C		Lbs.	kg	
BVT025	1/4"	(6.3)	1/8"	(3)	1.22	(30.9)	0.19	(4.8)	0.49	(12.4)	11	(5.0)
BVT037	3/8"	(9.5)	1/4"	(6)	1.36	(34.5)	0.25	(6.3)	0.61	(15.5)	12	(5.4)
BVT050	1/2"	(12.7)	3/8"	(10)	1.49	(37.8)	0.31	(7.8)	0.74	(18.8)	14	(6.3)
BVT062	5/8"	(15.9)	1/2"	(15)	1.62	(41.1)	0.38	(9.6)	0.86	(21.8)	15	(6.8)
BVT075	3/4"	(19.0)	5/8"	(17)	1.87	(47.4)	0.50	(12.7)	1.15	(29.2)	19	(8.6)
BVT087	7/8"	(22.2)	3/4"	(20)	2.00	(50.8)	0.56	(14.2)	1.27	(32.2)	21	(9.5)
BVT100	1"	(25.4)	-	-	2.25	(57.1)	0.69	(17.5)	1.52	(38.6)	22	(10.0)
BVT112	1 1/8"	(28.6)	1"	(25)	2.25	(57.1)	0.69	(17.5)	1.52	(38.6)	26	(11.8)
BVT125	1 1/4"	(31.7)	-	-	2.51	(63.7)	0.81	(20.6)	1.78	(45.2)	36	(16.3)
BVT137	1 3/8"	(34.9)	1 1/4"	(32)	2.51	(63.7)	0.81	(20.6)	1.78	(45.2)	38	(17.2)
BVT150	1 1/2"	(38.1)	-	-	2.74	(69.6)	0.88	(22.4)	1.96	(49.8)	35	(15.9)
BVT162	1 5/8"	(41.3)	1 1/2"	(40)	3.00	(76.2)	1.00	(25.4)	2.20	(55.9)	40	(18.1)
BVT175	1 3/4"	(44.4)	-	-	3.13	(79.5)	1.06	(26.9)	2.33	(59.1)	44	(19.9)
BVT187	1 7/8"	(47.6)	-	-	3.28	(83.3)	1.13	(28.7)	2.46	(62.5)	40	(18.1)
BVT200	2"	(50.8)	-	-	3.52	(89.4)	1.25	(31.7)	2.70	(68.6)	55	(25.0)
BVT212	2 1/8"	(54.0)	2"	(50)	3.52	(89.4)	1.25	(31.7)	2.70	(68.6)	55	(25.0)
BVT225	2 1/4"	(57.1)	-	-	3.64	(92.4)	1.31	(33.2)	2.83	(71.8)	54	(24.5)
BVT250	2 1/2"	(63.5)	-	-	3.91	(99.3)	1.43	(36.3)	3.11	(79.0)	56	(25.4)
BVT262	2 5/8"	(66.6)	2 1/2"	(65)	4.02	(102.1)	1.50	(38.1)	3.20	(81.3)	55	(25.0)
BVT300	3"	(76.2)	-	-	4.42	(112.2)	1.68	(42.6)	3.61	(91.6)	67	(30.4)
BVT312	3 1/8"	(79.4)	3"	(80)	4.53	(115.0)	1.75	(44.4)	3.70	(93.9)	64	(29.0)
BVT362	3 5/8"	(92.1)	3 1/2"	(90)	5.05	(128.2)	2.00	(50.8)	4.23	(107.4)	76	(34.5)
BVT412	4 1/8"	(104.8)	4"	(100)	5.55	(140.9)	2.25	(57.1)	4.73	(120.1)	93	(42.2)
BVT612	6 1/8"	(155.5)	6"	(150)	7.62	(193.5)	3.25	(82.5)	6.74	(171.1)	136	(61.6)

Catalog Number	Design Load 1		Design Load 2		Design Load 3	
	Lbs.	kN	Lbs.	kN	Lbs.	kN
BVT025	400	(1.78)	50	(0.22)	50	(0.22)
BVT037	400	(1.78)	50	(0.22)	50	(0.22)
BVT050	400	(1.78)	50	(0.22)	50	(0.22)
BVT062	400	(1.78)	50	(0.22)	50	(0.22)
BVT075	600	(2.67)	75	(0.33)	75	(0.33)
BVT087	600	(2.67)	75	(0.33)	75	(0.33)
BVT100	600	(2.67)	75	(0.33)	75	(0.33)
BVT112	600	(2.67)	75	(0.33)	75	(0.33)
BVT125	600	(2.67)	75	(0.33)	75	(0.33)
BVT137	600	(2.67)	75	(0.33)	75	(0.33)
BVT150	600	(2.67)	75	(0.33)	75	(0.33)
BVT162	800	(3.56)	125	(0.56)	125	(0.56)
BVT175	800	(3.56)	125	(0.56)	125	(0.56)
BVT187	800	(3.56)	125	(0.56)	125	(0.56)
BVT200	800	(3.56)	125	(0.56)	125	(0.56)
BVT212	800	(3.56)	125	(0.56)	125	(0.56)
BVT225	800	(3.56)	125	(0.56)	125	(0.56)
BVT250	800	(3.56)	125	(0.56)	125	(0.56)
BVT262	800	(3.56)	125	(0.56)	125	(0.56)
BVT300	800	(3.56)	125	(0.56)	125	(0.56)
BVT312	800	(3.56)	125	(0.56)	125	(0.56)
BVT362	1000	(4.45)	200	(0.89)	150	(0.67)
BVT412	1000	(4.45)	200	(0.89)	150	(0.67)
BVT612	1000	(4.45)	200	(0.89)	150	(0.67)

Reference page 110 for general fitting and standard finish specifications.

BVP SERIES VIBRACLAMPS-IRON PIPE & RIGID CONDUIT

- Safety Factor of 3
- Accesses pipe sizes 1/4" (6) to 6" (150)
- Allows easy one tool installation
- Endures both high (+300°F) and low (-40°F) temperatures
- Dampens vibration and noise
- Eliminates galvanic metal to metal contact
- Resists most industrial oils and solvents
- Reduces thermal loss and gain
- Secures pipe firmly to channel (strut)
- Dielectric strength of 400 volts/mil
- Includes cushion, clamp, screw and nut
- Standard finishes: YZN, SS4

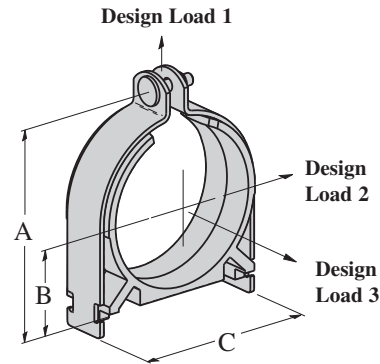

Catalog Number	Nominal Pipe Size		Steel O.D. Size		Dimensions						Wt./C	
					A		B		C		Lbs.	kg
BVP025	1/4"	(6.3)	0.540	(13.7)	1.61	(39.9)	0.37	(9.4)	0.87	(22.1)	15	(6.8)
BVP037	3/8"	(9.5)	0.675	(17.1)	1.86	(47.2)	0.50	(12.7)	1.15	(29.2)	18	(8.2)
BVP050	1/2"	(12.7)	0.875	(22.2)	1.99	(50.5)	0.56	(14.2)	1.27	(32.3)	20	(9.1)
BVP075	3/4"	(19.0)	1.050	(26.7)	2.25	(57.1)	0.69	(17.5)	1.52	(38.6)	21	(9.5)
BVP100	1"	(25.4)	1.312	(33.3)	2.51	(63.8)	0.81	(20.6)	1.77	(45.0)	20	(9.1)
BVP125	1 1/4"	(31.7)	1.660	(42.2)	3.00	(76.2)	1.00	(25.4)	2.21	(56.1)	36	(16.3)
BVP150	1 1/2"	(38.1)	1.900	(48.3)	3.21	(83.1)	1.12	(28.4)	2.41	(62.3)	40	(18.1)
BVP200	2"	(50.8)	2.375	(60.3)	3.77	(95.8)	1.37	(34.8)	2.96	(75.2)	45	(20.4)
BVP250	2 1/2"	(63.5)	2.875	(73.0)	4.28	(108.7)	1.62	(41.1)	3.46	(87.9)	54	(24.5)
BVP300	3"	(76.2)	3.500	(88.9)	5.05	(128.3)	2.00	(50.8)	4.24	(107.7)	81	(36.7)
BVP350	3 1/2"	(88.9)	4.000	(101.6)	5.55	(140.9)	2.25	(57.1)	4.74	(120.3)	87	(39.4)
BVP400	4"	(101.6)	4.500	(114.3)	6.05	(153.7)	2.50	(63.5)	5.24	(133.1)	109	(49.4)
BVP500	5"	(127.0)	5.563	(141.3)	6.84	(173.7)	3.00	(76.2)	6.24	(158.4)	136	(61.6)
BVP600	6"	(152.4)	6.625	(168.3)	8.24	(209.3)	3.56	(90.4)	7.36	(186.9)	163	(73.8)

Catalog Number	Design Load 1		Design Load 2		Design Load 3	
	Lbs.	kN	Lbs.	kN	Lbs.	kN
BVP025	400	(1.78)	50	(0.22)	50	(0.22)
BVP037	600	(2.67)	75	(0.33)	75	(0.33)
BVP050	600	(2.67)	75	(0.33)	75	(0.33)
BVP075	600	(2.67)	75	(0.33)	75	(0.33)
BVP100	600	(2.67)	75	(0.33)	75	(0.33)
BVP125	800	(3.56)	125	(0.56)	125	(0.56)
BVP150	800	(3.56)	125	(0.56)	125	(0.56)
BVP200	800	(3.56)	125	(0.56)	125	(0.56)
BVP250	800	(3.56)	125	(0.56)	125	(0.56)
BVP300	1000	(4.45)	200	(0.89)	150	(0.67)
BVP350	1000	(4.45)	200	(0.89)	150	(0.67)
BVP400	1000	(4.45)	200	(0.89)	150	(0.67)
BVP500	1000	(4.45)	200	(0.89)	150	(0.67)
BVP600	1000	(4.45)	200	(0.89)	150	(0.67)

Reference page 110 for general fitting and standard finish specifications.

Armafix Clamps & Accessories

IPH SERIES

INSERTS - INSERTS WITH CLAMPS

- Engineered load-bearing inserts prevents insulation compression
- Innovative insulated pipe support
- Desirable “Foam-to-Foam” Bond
- Slip Data: 45 lbs. (0.20 kN) max
- Recommended Clamp Torque: 12-15 in-lbs. (1.3-1.7 Nm)
- Service Temperature Range
-58°F (-50°C) to +220°F (+105°C)



Insert Only



Assembly
Insert & Clamp



Pipe/Conduit Clamps & Hangers

3/4" Wall Insulation Thickness

Assembly Part No.	Insert Only Part No.	Pipe/Copper/OD Size	Hanger Size*
IPH03834	IPH03834WO	3/8" O.D.	2"
IPH01234	IPH01234WO	1/2" O.D.	2"
IPH05834	IPH05834WO	5/8" O.D.	2"
IPH03434	IPH03434WO	3/4" O.D.	2"
IPH07834	IPH07834WO	7/8" O.D.	2 1/2"
IPH11834	IPH11834WO	3/4" IPS & 1 1/8" O.D.	2 1/2"
IPH13834	IPH13834WO	1 3/8" O.D.	3"
IPH15834	IPH15834WO	1 5/8" O.D.	3 1/2"
IPH11034	IPH11034WO	1 1/2" IPS & 1 7/8" O.D.	3 1/2"
IPH21834	IPH21834WO	2 1/8" O.D.	4"
IPH25834	IPH25834WO	2 5/8" O.D.	5"
IPH31834	IPH31834WO	3 1/8" O.D.	5"
IPH35834	IPH35834WO	3 5/8" O.D.	6"
IPH41834	IPH41834WO	4 1/8" O.D.	6"
IPH40034	IPH40034WO	4" IPS	6"
IPH50034	IPH50034WO	5" IPS	8"
IPH60034	IPH60034WO	6" IPS	10"
IPH80034	IPH80034WO	8" IPS	12"

* Recommended pipe hanger size for insulation thickness shown.
(Order hanger separately)

IPH18230

ARMACELL® INSULATION TAPE

- 30 ft. (9.14 M) roll



Reference page 110 for general fitting and standard finish specifications.

1/2" Wall Insulation Thickness

Assembly Part No.	Insert Only Part No.	Pipe/Copper/OD Size	Hanger Size*
IPH03812	IPH03812WO	3/8" O.D.	1 1/4"
IPH01212	IPH01212WO	1/2" O.D.	1 1/4"
IPH05812	IPH05812WO	5/8" O.D.	1 1/2"
IPH03412	IPH03412WO	3/4" O.D.	1 1/2"
IPH07812	IPH07812WO	7/8" O.D.	2"
IPH11812	IPH11812WO	3/4" IPS & 1 1/8" O.D.	2"
IPH13812	IPH13812WO	1 3/8" O.D.	2 1/2"
IPH15812	IPH15812WO	1 5/8" O.D.	2 1/2"
IPH11012	IPH11012WO	1 1/2" IPS & 1 7/8" O.D.	3"
IPH21812	IPH21812WO	2 1/8" O.D.	3"
IPH25812	IPH25812WO	2 5/8" O.D.	3 1/2"
IPH31812	IPH31812WO	3 1/8" O.D.	4"
IPH35812	IPH35812WO	3 5/8" O.D.	5"
IPH41812	IPH41812WO	4 1/8" O.D.	6"
IPH40012	IPH40012WO	4" IPS	6"
IPH50012	IPH50012WO	5" IPS	8"
IPH60012	IPH60012WO	6" IPS	8"

* Recommended pipe hanger size for insulation thickness shown.
(Order hanger separately)

1" Wall Insulation Thickness

Assembly Part No.	Insert Only Part No.	Pipe/Copper/OD Size	Hanger Size*
IPH05810	IPH05810WO	5/8" O.D.	2 1/2"
IPH03410	IPH03410WO	3/4" O.D.	2 1/2"
IPH07810	IPH07810WO	7/8" O.D.	3"
IPH11810	IPH11810WO	3/4" IPS & 1 1/8" O.D.	3"
IPH13810	IPH13810WO	1 3/8" O.D.	3 1/2"
IPH15810	IPH15810WO	1 5/8" O.D.	3 1/2"
IPH11010	IPH11010WO	1 1/2" IPS & 1 7/8" O.D.	4"
IPH21810	IPH21810WO	2 1/8" O.D.	4"
IPH25810	IPH25810WO	2 5/8" O.D.	5"
IPH31810	IPH31810WO	3 1/8" O.D.	5"
IPH35810	IPH35810WO	3 5/8" O.D.	6"
IPH41810	IPH41810WO	4 1/8" O.D.	6"
IPH40010	IPH40010WO	4" IPS	8"
IPH50010	IPH50010WO	5" IPS	8"
IPH60010	IPH60010WO	6" IPS	10"
IPH80010	IPH80010WO	8" IPS	12"

* Recommended pipe hanger size for insulation thickness shown.
(Order hanger separately)

B1999 VIBRA CUSHION®

- Packaged 20 Ft. (6.09 m) per carton
- Ideal Isolation Material
- Inhibits Galvanic Corrosion
- Dampens Sound and Vibrations
- Service Temperature Range
-75°F (-60°C) to +375°F (+199°C)
- Wt./Carton 3.8 Lbs. (1.7 kg)

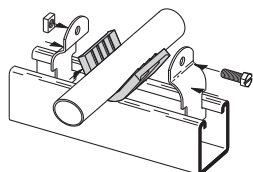

FEATURES

Vibra Cushion® is designed for use with refrigeration lines, HVAC, copper tubing, glass pipe and hydraulic lines. It provides an energy-absorption barrier between the lines and the mounting material and remains flexible thru its entire service range of -75°F (-60°C) to +375°F (+199°C).

This elastomer allows for expansion and contraction within the mounting system and prevents galvanic reaction between dissimilar metals.

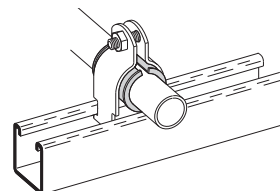

FOR RIGID CONDUIT OR IRON PIPE

Nominal Size		Length of Vibra-Cushion		Use Clamp No.
3/8"	(10)	2 1/8"	(54.0)	B2002
1/2"	(15)	2 5/8"	(66.7)	B2009
3/4"	(20)	3 1/4"	(82.5)	B2031
1"	(25)	4 1/8"	(104.8)	B2004
1 1/4"	(32)	5 3/16"	(131.8)	B2012
1 1/2"	(40)	5 15/16"	(150.8)	B2038
2"	(50)	7 1/2"	(190.5)	B2042
2 1/2"	(65)	9"	(228.6)	B2046
3"	(80)	11"	(279.4)	B2051
3 1/2"	(90)	12 1/2"	(317.5)	B2055
4"	(100)	14 1/2"	(368.3)	B2059
5"	(125)	17 7/16"	(442.9)	B2067
6"	(150)	20 3/4"	(527.0)	B2116

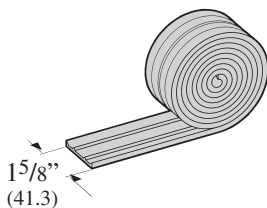

FOR THINWALL (EMT) CONDUIT

Nominal Size		Length of Vibra-Cushion		Use Clamp No.
3/8"	(10)	1 13/16"	(46.0)	B2027
1/2"	(15)	2 13/16"	(58.7)	B2002
3/4"	(20)	2 7/8"	(73.0)	B2003
1"	(25)	3 5/8"	(92.1)	B2032
1 1/4"	(32)	4 3/8"	(120.6)	B2036
1 1/2"	(40)	5 7/16"	(138.1)	B2012
2"	(50)	6 7/8"	(174.6)	B2013

FOR COPPER TUBING TYPE L & K

Nominal Size		Length of Vibra-Cushion		Use Clamp No.
1/4"	(6)	1 3/16"	(30.2)	B2026
3/8"	(10)	1 9/16"	(39.7)	B2027
1/2"	(15)	1 7/8"	(47.6)	B2028
5/8"	(17)	2 5/16"	(58.7)	B2029
3/4"	(20)	2 3/4"	(69.8)	B2030
1"	(25)	3 1/2"	(88.9)	B2032
1 1/4"	(32)	4 5/16"	(109.5)	B2011
1 1/2"	(40)	5 1/8"	(130.2)	B2036
2"	(50)	6 11/16"	(169.9)	B2013
2 1/2"	(65)	8 1/4"	(209.5)	B2014
3"	(80)	9 13/16"	(249.2)	B2048
3 1/2"	(90)	11 3/8"	(288.9)	B2052
4"	(100)	12 15/16"	(328.6)	B2056
5"	(125)	16 1/8"	(409.6)	B2064
6"	(150)	19 1/4"	(488.9)	B2112
8"	(200)	25 1/2"	(647.7)	B2128

ISO PIPE

- Non-adhesive rubber tape
- Fuses to itself
- Water resistant
- Ideal Isolation Material
- Prevents galvanic reaction caused by dissimilar metal contact
- Temperature Range
-140°F (-60°C) to +395°F (+200°C)

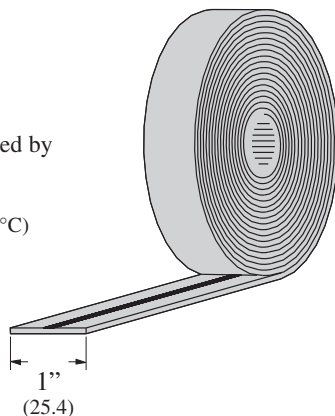

Part No.	Thickness		Ft./Roll	
	In.	mm	Ft.	m
ISO	.020	(0.5)	36	(11)

BVS Type - Vibra Strip™ for 1 5/8" (41.3) wide B-Line channel

- Fits securely in 1 5/8" wide channel
- Temperature range: -20°F to 212°F
- Ideal Isolation & Vibration Dampening Qualities
- 45 durometer hardness
- Material: Neoprene

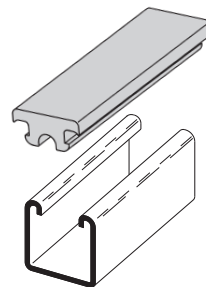

Part No.	Max. Load		Length	Std. Pkg.	Wt. Each	
	Lbs.	kg/25.4 mm			Lbs.	kg
BVS-12	40	(18.1)	12" (304.8)	25	.46	(.21)
BVS-120	40	(18.1)	120" (3048.0)	25	.46	(.21)

Reference page 110 for general fitting and standard finish specifications.

Pipe Clamps

B2400 SERIES STANDARD PIPE STRAP

- Safety Factor of 5
- B2400-3/4 thru B2400-8 are UL listed
- Order hardware separately
- Other sizes available upon request
- Material: Sizes - 1/2" - 1 1/2", ASTM A1011 33,000 PSI min. yield;
2" - 10", ASTM A1018 33,000 PSI min. yield;
12" ASTM A1011 CS Type B;
14"-Larger, ASTM A36
- Standard finish: ZN
- Ductile Iron Sizes Available
- Meets requirements of MSS SP-58 & SP-69 Type 26

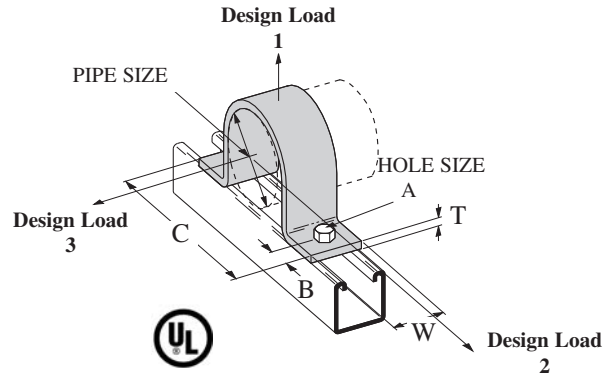

Part No.	Pipe Size		A		B		C		T		W	
B2400-1/2	1/2"	(15)	5/16"	(7.9)	7/16"	(11.1)	2 ¹³ / ₁₆ "	(71.4)	10 Ga.	(3.4)	1 ⁵ / ₈ "	(41.3)
B2400-3/4	3/4"	(20)	5/16"	(7.9)	7/16"	(11.1)	3"	(76.2)	10 Ga.	(3.4)	1 ⁵ / ₈ "	(41.3)
B2400-1	1"	(25)	5/16"	(7.9)	7/16"	(11.1)	3 ¹⁷ / ₃₂ "	(89.7)	10 Ga.	(3.4)	1 ⁵ / ₈ "	(41.3)
B2400-1 1/4	1 1/4"	(32)	5/16"	(7.9)	7/16"	(11.1)	3 ³ / ₄ "	(95.2)	10 Ga.	(3.4)	1 ⁵ / ₈ "	(41.3)
B2400-1 1/2	1 1/2"	(40)	5/16"	(7.9)	7/16"	(11.1)	4 ¹ / ₁₆ "	(103.2)	10 Ga.	(3.4)	1 ⁵ / ₈ "	(41.3)
B2400-2	2"	(50)	7/16"	(11.1)	1 ¹ / ₁₆ "	(17.4)	5 ²¹ / ₃₂ "	(143.6)	1/4"	(6.3)	1 ⁵ / ₈ "	(41.3)
B2400-2 1/2	2 1/2"	(65)	7/16"	(11.1)	1 ¹ / ₁₆ "	(17.4)	6 ⁵ / ₃₂ "	(156.3)	1/4"	(6.3)	1 ⁵ / ₈ "	(41.3)
B2400-3	3"	(80)	7/16"	(11.1)	1 ¹ / ₁₆ "	(17.4)	6 ²⁵ / ₃₂ "	(172.2)	1/4"	(6.3)	1 ⁵ / ₈ "	(41.3)
B2400-3 1/2	3 1/2"	(90)	7/16"	(11.1)	1 ¹ / ₁₆ "	(17.4)	7 ⁹ / ₃₂ "	(184.9)	1/4"	(6.3)	1 ⁵ / ₈ "	(41.3)
B2400-4	4"	(100)	9/16"	(14.3)	1 ¹ / ₁₆ "	(17.4)	7 ²⁵ / ₃₂ "	(197.6)	1/4"	(6.3)	1 ⁵ / ₈ "	(41.3)
B2400-5	5"	(125)	9/16"	(14.3)	1 ¹ / ₁₆ "	(17.4)	8 ⁷ / ₈ "	(225.4)	1/4"	(6.3)	1 ⁵ / ₈ "	(41.3)
B2400-6	6"	(150)	9/16"	(14.3)	1 ¹ / ₁₆ "	(17.4)	9 ¹⁵ / ₁₆ "	(252.4)	1/4"	(6.3)	1 ⁵ / ₈ "	(41.3)
B2400-8	8"	(200)	9/16"	(14.3)	1 ¹ / ₁₆ "	(17.4)	11 ³¹ / ₃₂ "	(304.0)	1/4"	(6.3)	1 ⁵ / ₈ "	(41.3)
B2400-10	10"	(250)	9/16"	(14.3)	1 ¹ / ₁₆ "	(17.4)	14"	(355.6)	1/4"	(6.3)	1 ⁵ / ₈ "	(41.3)
B2400-12	12"	(300)	9/16"	(14.3)	1 ¹ / ₁₆ "	(17.4)	16"	(406.4)	1/4"	(6.3)	1 ⁵ / ₈ "	(41.3)
B2400-14	14"	(350)	1 ⁵ / ₁₆ "	(23.8)	1 1/2"	(38.1)	20 ³ / ₄ "	(527.0)	3/8"	(9.5)	1 ³ / ₄ "	(44.4)
B2400-16	16"	(400)	1 ⁵ / ₁₆ "	(23.8)	1 1/2"	(38.1)	22 ³ / ₄ "	(577.8)	3/8"	(9.5)	1 ³ / ₄ "	(44.4)
B2400-18	18"	(460)	1 ⁵ / ₁₆ "	(23.8)	1 3/4"	(44.4)	27"	(685.8)	1/2"	(12.7)	1 ³ / ₄ "	(44.4)
B2400-20	20"	(510)	1 ⁵ / ₁₆ "	(23.8)	1 3/4"	(44.4)	29"	(736.6)	1/2"	(12.7)	1 ³ / ₄ "	(44.4)
B2400-24	24"	(610)	1 ⁵ / ₁₆ "	(23.8)	1 3/4"	(44.4)	33"	(838.2)	1/2"	(12.7)	1 ³ / ₄ "	(44.4)

Part No.	Design Load 1		Design Load 2		Design Load 3		Wt./C	
	Lbs.	kN	Lbs.	kN	Lbs.	kN	Lbs.	kg
B2400-1/2	600	(2.67)	150	(.67)	105	(.47)	23	(10.4)
B2400-3/4	600	(2.67)	150	(.67)	105	(.47)	26	(11.8)
B2400-1	600	(2.67)	150	(.67)	120	(.53)	31	(14.0)
B2400-1 1/4	600	(2.67)	150	(.67)	120	(.53)	36	(16.3)
B2400-1 1/2	600	(2.67)	150	(.67)	120	(.53)	39	(17.7)
B2400-2	1200	(5.34)	480	(2.14)	180	(.80)	93	(42.2)
B2400-2 1/2	1200	(5.34)	480	(2.14)	180	(.80)	106	(48.1)
B2400-3	1200	(5.34)	480	(2.14)	300	(1.33)	132	(59.9)
B2400-3 1/2	1200	(5.34)	480	(2.14)	300	(1.33)	151	(68.5)
B2400-4	1500	(6.67)	600	(2.67)	450	(2.00)	160	(72.6)
B2400-5	1500	(6.67)	600	(2.67)	450	(2.00)	192	(87.1)
B2400-6	1500	(6.67)	600	(2.67)	450	(2.00)	219	(99.3)
B2400-8	2000	(8.90)	800	(3.56)	600	(2.67)	297	(134.7)
B2400-10	2000	(8.90)	800	(3.56)	600	(2.67)	465	(210.9)
B2400-12	2000	(8.90)	800	(3.56)	600	(2.67)	560	(254.0)
B2400-14	2000	(8.90)	800	(3.56)	600	(2.67)	761	(345.2)
B2400-16	2000	(8.90)	800	(3.56)	600	(2.67)	861	(390.5)
B2400-18	2000	(8.90)	800	(3.56)	600	(2.67)	1297	(588.3)
B2400-20	2000	(8.90)	800	(3.56)	600	(2.67)	1426	(646.8)
B2400-24	2000	(8.90)	800	(3.56)	600	(2.67)	1682	(762.9)

Reference page 110 for general fitting and standard finish specifications.

B437 SERIES TWO PIECE PIPE STRAP

- Clamp halves can turn allowing pipe to be fastened to channel at any direction
- Order hardware separately
- Standard finish: ZN

Part No.	Pipe Size		A		T		Wt./C	
							Lbs.	kg
B437-1/2	1/2"	(15)	5/16"	(7.9)	10 Ga.	(3.4)	22	(10.0)
B437-3/4	3/4"	(20)	5/16"	(7.9)	10 Ga.	(3.4)	26	(11.8)
B437-1	1"	(25)	5/16"	(7.9)	10 Ga.	(3.4)	30	(13.6)
B437-1 1/4	1 1/4"	(32)	5/16"	(7.9)	10 Ga.	(3.4)	35	(15.9)
B437-1 1/2	1 1/2"	(40)	5/16"	(7.9)	10 Ga.	(3.4)	38	(17.2)
B437-2	2"	(50)	7/16"	(11.1)	1/4"	(6.3)	91	(41.3)
B437-2 1/2	2 1/2"	(65)	7/16"	(11.1)	1/4"	(6.3)	104	(47.2)
B437-3	3"	(80)	7/16"	(11.1)	1/4"	(6.3)	130	(58.9)
B437-3 1/2	3 1/2"	(90)	7/16"	(11.1)	1/4"	(6.3)	149	(67.6)
B437-4	4"	(100)	9/16"	(11.1)	1/4"	(6.3)	158	(71.6)
B437-5	5"	(125)	9/16"	(11.1)	1/4"	(6.3)	190	(86.2)
B437-6	6"	(150)	9/16"	(11.1)	1/4"	(6.3)	217	(98.4)
B437-8	8"	(200)	9/16"	(11.1)	1/4"	(6.3)	295	(133.8)

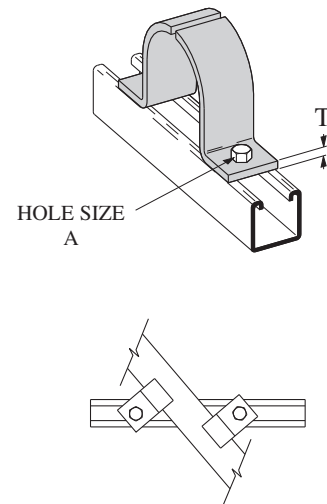

B2417 STRUT MOUNTED PIPE GUIDE

- Copper tubing sizes available - B2417CT Series
- Standard finish: ZN

Part No.	Pipe Size		Minimum Radial Clearance		Includes Clamp No.	Wt./C	
						Lbs.	kg
B2417-1/2	1/2"	(15)	1/16"	(1.6)	B2009	22	(10.0)
B2417-3/4	3/4"	(20)	1/16"	(1.6)	B2010	25	(11.3)
B2417-1	1"	(25)	3/32"	(2.3)	B2034	30	(13.6)
B2417-1 1/4	1 1/4"	(32)	3/32"	(2.3)	B2037	47	(21.8)
B2417-1 1/2	1 1/2"	(40)	3/32"	(2.3)	B2039	51	(23.1)
B2417-2	2"	(50)	1/8"	(3.2)	B2043	62	(28.1)
B2417-2 1/2	2 1/2"	(65)	1/8"	(3.2)	B2047	69	(31.3)
B2417-3	3"	(80)	5/32"	(3.9)	B2016	108	(49.0)
B2417-3 1/2	3 1/2"	(90)	5/32"	(3.9)	B2017	118	(53.5)
B2417-4	4"	(100)	5/32"	(3.9)	B2018	128	(58.0)

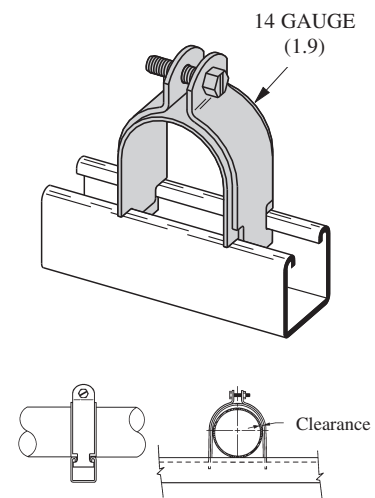

B2070 THRU B2080 PARALLEL PIPE CLAMP

- Safety Factor of 2
- Designed to support pipe or rigid conduit
- Includes:
 - 1 pr. Pipe Clamps
 - 1 pc. Stand Off Plate
 - 1 pc. Slotted Hex Head Machine Screws
 - 1 pc. Square Nut
- Standard finish: ZN

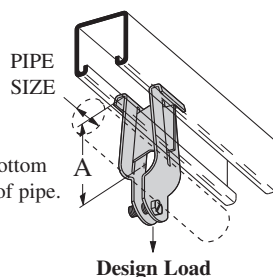

A dimension, from bottom of channel to center of pipe.

Part No.	Pipe Size		A		Material Thickness		Design Load		Wt./C	
							Lbs.	kN	Lbs.	kg
B2070	3/8"	(10)	1 11/16"	(42.9)	16 Ga.	(1.5)	300	(1.33)	24	(10.9)
B2071	1/2"	(15)	1 3/4"	(44.4)	16 Ga.	(1.5)	300	(1.33)	26	(11.8)
B2072	3/4"	(20)	1 7/8"	(47.6)	14 Ga.	(1.9)	300	(1.33)	30	(13.6)
B2073	1"	(25)	2"	(50.8)	14 Ga.	(1.9)	400	(1.78)	33	(14.9)
B2074	1 1/4"	(32)	2 3/16"	(55.6)	14 Ga.	(1.9)	400	(1.78)	36	(16.3)
B2075	1 1/2"	(40)	2 5/16"	(58.7)	12 Ga.	(2.6)	500	(2.22)	50	(22.7)
B2076	2"	(50)	2 9/16"	(65.1)	12 Ga.	(2.6)	500	(2.22)	55	(24.9)
B2077	2 1/2"	(65)	2 7/8"	(73.0)	12 Ga.	(2.6)	500	(2.22)	60	(27.2)
B2078	3"	(80)	3 3/16"	(80.9)	12 Ga.	(2.6)	500	(2.22)	66	(29.9)
B2079	3 1/2"	(90)	3 7/16"	(87.3)	11 Ga.	(3.0)	500	(2.22)	85	(38.5)
B2080	4"	(100)	3 5/8"	(92.1)	11 Ga.	(3.0)	500	(2.22)	95	(43.1)

Reference page 110 for general fitting and standard finish specifications.

Pipe Clamps

B670 SERIES PARALLEL PIPE CLAMP

- Designed to support pipe or rigid conduit parallel to the edge of a beam or angle iron
- Hardware included
- Material: Malleable Iron
- Standard finish: HDG

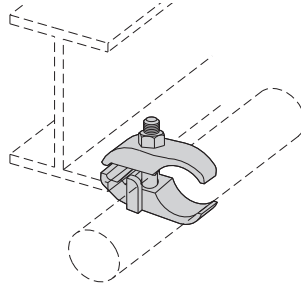

Part Number	Pipe or Conduit Size		Wt./C	
	Size	Qty	Lbs.	kg
B670-3/8	3/8"	(10)	32	(14.5)
B670-1/2	1/2"	(15)	58	(26.3)
B670-3/4	3/4"	(20)	64	(29.0)
B670-1	1"	(25)	70	(31.7)
B670-1 1/4	1 1/4"	(32)	77	(34.9)
B670-1 1/2	1 1/2"	(40)	93	(42.2)
B670-2	2"	(50)	105	(47.6)
B670-2 1/2	2 1/2"	(65)	143	(64.8)
B670-3	3"	(80)	164	(74.4)
B670-3 1/2	3 1/2"	(90)	190	(86.2)
B670-4	4"	(100)	205	(93.0)

B671 SERIES EDGE PIPE CLAMP

- Designed to support pipe or rigid conduit perpendicular to the edge of a beam or angle iron
- Hardware included
- Material: Malleable Iron
- Standard finish: HDG

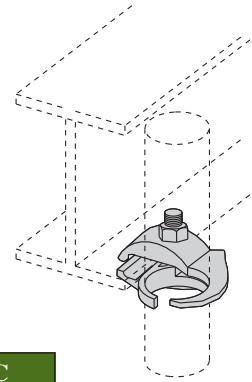

Part Number	Pipe or Conduit Size		Wt./C	
	Size	Qty	Lbs.	kg
B671-1/2	1/2"	(15)	67	(30.4)
B671-3/4	3/4"	(20)	71	(32.2)
B671-1	1"	(25)	85	(38.5)
B671-1 1/4	1 1/4"	(32)	91	(41.3)
B671-1 1/2	1 1/2"	(40)	115	(52.1)
B671-2	2"	(50)	135	(61.2)
B671-2 1/2	2 1/2"	(65)	183	(83.0)
B671-3	3"	(80)	230	(104.3)

B422 SERIES RIGHT ANGLE CLAMP

- Safety Factor of 5
- Material: 7 Gauge (4.5)
- Standard finishes: ZN, SS4

Part No.	Conduit Size		A	Design Load Vertical Pull		Wt./C		
	Size	Qty		Lbs.	kg	Lbs.	kg	
B422-1/2	1/2"	(15)	2 3/8"	(60.3)	250	(1.11)	38	(17.2)
B422-3/4	3/4"	(20)	2 3/8"	(60.3)	300	(1.33)	39	(17.7)
B422-1	1"	(25)	2 7/8"	(73.0)	400	(1.78)	48	(21.8)
B422-1 1/4	1 1/4"	(32)	2 7/8"	(73.0)	400	(1.78)	50	(22.7)
B422-1 1/2	1 1/2"	(40)	3 1/4"	(82.5)	500	(2.22)	59	(26.7)
B422-2	2"	(50)	3 11/16"	(93.7)	600	(2.67)	75	(34.0)
B422-2 1/2	2 1/2"	(65)	4 1/4"	(107.9)	700	(3.11)	98	(44.4)
B422-3	3"	(80)	4 7/8"	(123.8)	800	(3.56)	111	(50.3)
B422-3 1/2	3 1/2"	(90)	5 7/16"	(138.1)	900	(4.00)	123	(55.8)
B422-4	4"	(100)	6"	(152.4)	1000	(4.45)	135	(61.2)

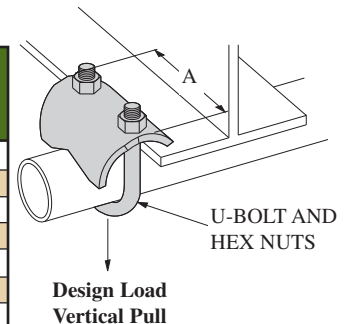

B3367S RETAINING STRAP

- Available in 'L' lengths of 6" (152.4), 8" (203.2), 9" (228.6), 10" (254.0), 12" (304.8), 14" (355.6), 16" (406.4), 18" (457.2)
- Material: Steel
- Standard finishes: ZN, PLN

Part No.	Hole Dia. D	For Use With	Wt./C**	
			Lbs.	kg
B3367S-1-L	7/16"	B422-1/2 & 3/4	33.4	(5.8)
B3367S-2-L	9/16"	B422-1, 1 1/4 & 1 1/2	12.8	(15.1)

** Wt./C based on 6" (152.4) length. For each additional inch in strap length add the following to the Wt./C.
 For B3367S-1 add 5.7 Lbs (2.6 kg)
 For B3367S-2 add 2.2 Lbs (1.0 kg)

Note: Use B3367-3/8 retaining strap (page 100) for B422-2 thru 4

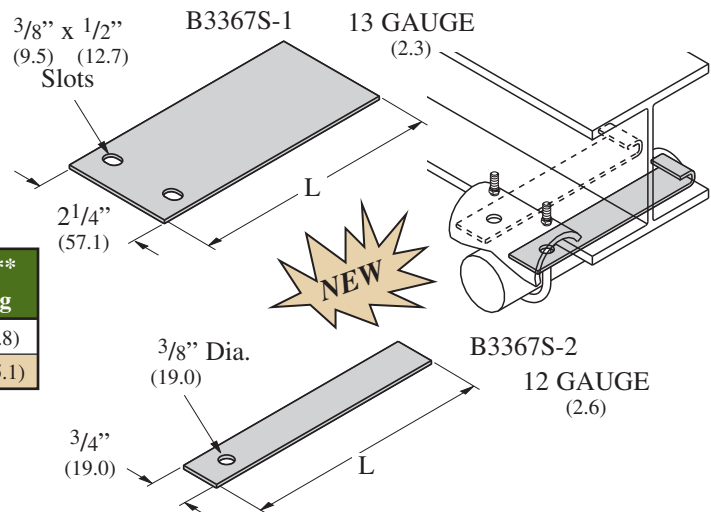

Reference page 110 for general fitting and standard finish specifications.

B2301 SERIES ONE HOLE EMT STRAP

•Standard finish: ZN

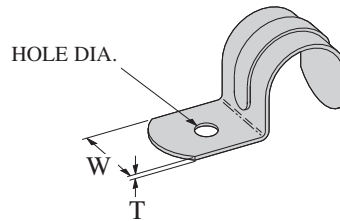

Part No.	Conduit Size		T		W		Hole Dia.		Wt./C	
									Lbs.	kg
B2301-1/2	1/2"	(15)	.050	(1.3)	3/4"	(19.0)	9/32"	(7.1)	2.4	(1.1)
B2301-3/4	3/4"	(20)	.050	(1.3)	7/8"	(22.2)	9/32"	(7.1)	4.2	(1.9)
B2301-1	1"	(25)	.050	(1.3)	1"	(25.4)	9/32"	(7.1)	8.3	(3.7)
B2301-1 1/4	1 1/4"	(32)	.065	(1.6)	1 1/4"	(31.7)	9/32"	(7.1)	11.0	(5.0)
B2301-1 1/2	1 1/2"	(40)	.090	(2.3)	1"	(25.4)	11/32"	(8.7)	14.8	(6.7)
B2301-2	2"	(50)	.090	(2.3)	1 1/4"	(31.7)	13/32"	(10.3)	21.6	(9.8)

B2302 SERIES ONE HOLE RIGID CONDUIT/PIPE STRAP

•Standard finish: ZN

Part No.	Conduit/Pipe Size		T		W		Hole Dia.		Wt./C	
									Lbs.	kg
B2302-1/4	1/4"	(6)	.045	(1.1)	5/8"	(15.9)	13/64"	(5.1)	1.4	(.6)
B2302-3/8	3/8"	(10)	.050	(1.3)	3/4"	(19.0)	9/32"	(7.1)	2.4	(1.1)
B2302-1/2	1/2"	(15)	.050	(1.3)	7/8"	(22.2)	9/32"	(7.1)	3.3	(1.5)
B2302-3/4	3/4"	(20)	.050	(1.3)	7/8"	(22.2)	9/32"	(7.1)	3.8	(1.7)
B2302-1	1"	(25)	.065	(1.6)	1"	(25.4)	9/32"	(7.1)	7.2	(3.2)
B2302-1 1/4	1 1/4"	(32)	.065	(1.6)	1 1/4"	(31.7)	21/64"	(8.3)	11.0	(5.0)
B2302-1 1/2	1 1/2"	(40)	11 Ga.	(3.0)	1"	(25.4)	.380	(9.6)	19.2	(8.7)
B2302-2	2"	(50)	11 Ga.	(3.0)	1 1/4"	(31.7)	.389	(9.9)	28.8	(13.0)
B2302-2 1/2	2 1/2"	(65)	7 Ga.	(4.5)	1 1/4"	(31.7)	.665	(16.9)	55.2	(25.0)
B2302-3	3"	(80)	7 Ga.	(4.5)	1 1/4"	(31.7)	.650	(16.5)	68.0	(30.8)
B2302-3 1/2	3 1/2"	(90)	1/4"	(6.3)	1 1/4"	(31.7)	.622	(15.8)	96.0	(43.5)
B2302-4	4"	(100)	1/4"	(6.3)	1 1/4"	(31.7)	.630	(16.0)	108.0	(49.0)

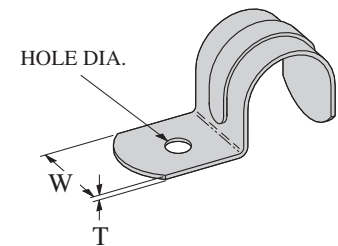

B2084 THRU B2091 ONE HOLE O.D. TUBING CLAMP

•Material: 14 Gauge (1.9) ASTM A1011 33,000 PSI min. yield

•Standard finish: ZN

Part No.	O.D. Size		A		Wt./C	
					Lbs.	kg
B2084	1/4"	(6.3)	7/8"	(22.2)	4.0	(1.8)
B2085	5/16"	(7.9)	29/32"	(23.0)	4.2	(1.9)
B2086	3/8"	(9.5)	31/32"	(24.6)	5.2	(2.3)
B2087	1/2"	(12.7)	1 1/16"	(25.9)	5.8	(2.6)
B2088	5/8"	(15.9)	1 3/32"	(27.8)	7.1	(3.2)
B2089	3/4"	(19.0)	1 5/32"	(29.1)	7.7	(3.5)
B2090	7/8"	(22.2)	1 7/32"	(30.7)	8.7	(3.9)
B2091	1"	(25.4)	1 9/32"	(32.2)	10.0	(4.5)

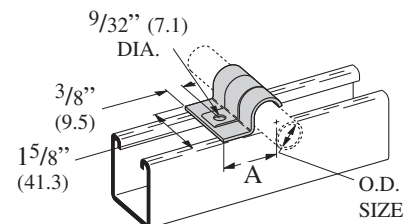

Reference page 110 for general fitting and standard finish specifications.

Pipe Clamps

BL1400 SERIES CONDUIT HANGER

- Safety Factor of 3
- Unless noted all sizes fit both rigid (R) and thinwall (EMT) conduit
- Hardware included
- Standard finishes: ZN, SS4

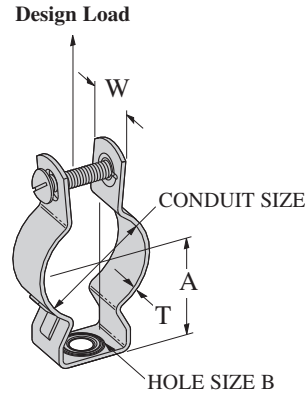

Part No	Conduit Size		A		B		T		W		Design Load		Wt./C	
											Lbs.	kN	Lbs.	kg
BL1400	1/2"	(15)	29/32"	(23.0)	9/32"	(7.1)	16 Ga.	(1.5)	3/4"	(19.0)	590	(2.62)	6	(2.7)
BL1410	3/4"	(20)	31/32"	(24.6)	9/32"	(7.1)	16 Ga.	(1.5)	3/4"	(19.0)	590	(2.62)	7	(3.2)
BL1420	1"	(25)	1 1/4"	(31.7)	9/32"	(7.1)	16 Ga.	(1.5)	3/4"	(19.0)	590	(2.62)	8	(3.6)
BL1425	1 1/4" EMT	(32)	1 1/4"	(31.7)	9/32"	(7.1)	18 Ga.	(1.2)	7/8"	(22.2)	590	(2.62)	10	(4.5)
BL1430	1 1/4" R, 1 1/2" EMT	(32)	1 13/32"	(35.7)	9/32"	(8.7)	18 Ga.	(1.2)	7/8"	(22.2)	590	(2.62)	10	(4.5)
BL1440	1 1/2" R	(40)	1 5/8"	(41.3)	11/32"	(8.7)	16 Ga.	(1.5)	1"	(25.4)	755	(3.36)	17	(7.7)
BL1450	2"	(50)	2 1/16"	(47.6)	11/32"	(8.7)	16 Ga.	(1.5)	1 1/4"	(31.7)	755	(3.36)	25	(11.3)
BL1460	2 1/2"	(65)	2 1/16"	(52.4)	11/32"	(8.7)	16 Ga.	(1.5)	1 1/4"	(31.7)	755	(3.36)	26	(11.8)
BL1470	3"	(80)	2 1/2"	(63.5)	11/32"	(8.7)	16 Ga.	(1.5)	1 1/4"	(31.7)	820	(3.65)	33	(14.9)
BL1480	3 1/2"	(90)	2 3/4"	(69.8)	11/32"	(8.7)	16 Ga.	(1.5)	1 1/4"	(31.7)	850	(3.78)	36	(16.3)
BL1490	4"	(100)	3 1/2"	(88.9)	11/32"	(8.7)	16 Ga.	(1.5)	1 1/4"	(31.7)	1410	(6.27)	40	(18.1)

B3373 SERIES RISER CLAMP

- Safety Factor of 4
- B3373-3/4 thru B3373-8 are UL listed
- Includes Hex Head Cap Screws and Hex Nuts
- Standard finishes: ZN, PLN

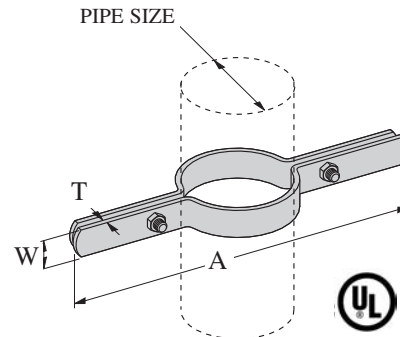

Part No.	Pipe Size		A		T		W		Design Load		Wt./C	
									Lbs.	kN	Lbs.	kg
B3373-1/2	1/2"	(15)	9"	(228.6)	3/16"	(4.7)	1"	(25.4)	255	(1.13)	103	(46.3)
B3373-3/4	3/4"	(20)	9 1/4"	(234.9)	3/16"	(4.7)	1"	(25.4)	255	(1.13)	106	(47.7)
B3373-1	1"	(25)	9 9/16"	(242.9)	3/16"	(4.7)	1"	(25.4)	255	(1.13)	111	(49.9)
B3373-1 1/4	1 1/4"	(32)	10"	(254.0)	3/16"	(4.7)	1"	(25.4)	255	(1.13)	114	(51.3)
B3373-1 1/2	1 1/2"	(32)	10 1/4"	(260.3)	3/16"	(4.7)	1"	(25.4)	255	(1.13)	120	(54.0)
B3373-2	2"	(40)	10 3/4"	(273.0)	1/4"	(6.3)	1"	(25.4)	255	(1.13)	167	(75.1)
B3373-2 1/2	2 1/2"	(50)	11 1/4"	(285.7)	1/4"	(6.3)	1"	(25.4)	390	(1.73)	177	(79.6)
B3373-3	3"	(65)	11 15/16"	(303.2)	1/4"	(6.3)	1"	(25.4)	530	(2.36)	191	(85.9)
B3373-3 1/2	3 1/2"	(80)	12 3/8"	(314.3)	1/4"	(6.3)	1"	(25.4)	670	(2.98)	216	(97.2)
B3373-4	4"	(90)	12 7/8"	(327.0)	1/4"	(6.3)	1"	(25.4)	810	(3.60)	227	(102.1)
B3373-5	5"	(100)	14"	(355.6)	1/4"	(6.3)	1 1/2"	(38.1)	1160	(5.16)	471	(213.6)
B3373-6	6"	(100)	15 3/16"	(385.8)	1/4"	(6.3)	1 1/2"	(38.1)	1570	(6.98)	518	(234.9)
B3373-8	8"	(100)	17 3/4"	(450.8)	3/8"	(9.5)	1 1/2"	(38.1)	2500	(11.12)	950	(430.9)

Reference page 110 for general fitting and standard finish specifications.

B3690 SERIES ADJUSTABLE J HANGER

- Safety Factor of 5
- Material:
 - 12 Ga. (2.6) ASTM A1011 33,000 PSI min. yield
 - 11 Ga. (3.0) ASTM A1011 HSLA Gr. 50 Class 1
 - 7 Ga. (4.5) ASTM A1011 33,000 PSI min. yield and 1/4" (6.3) ASTM A1018 33,000 PSI min. yield
- Standard finish: ZN

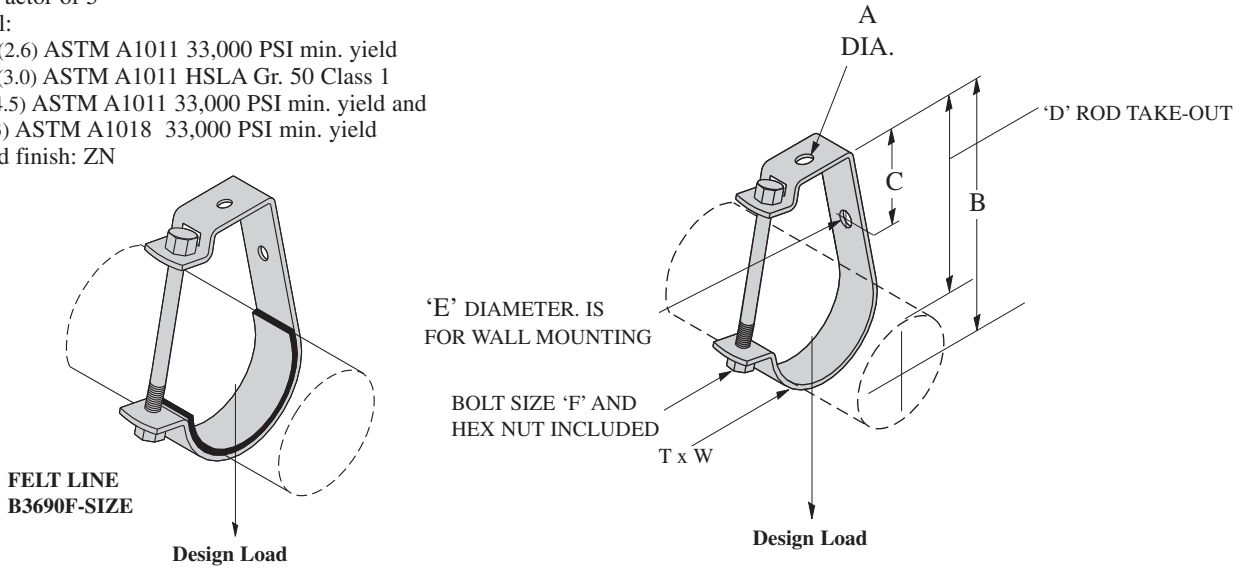

Part No.	Pipe or Conduit Size		A		B		C		D		E		F
	IN	MM	IN	MM	IN	MM	IN	MM	IN	MM	IN	MM	IN
B3690-1/2	1/2"	(15)	13/32"	(10.3)	23/32"	(53.2)	1"	(25.4)	1 11/16"	(42.5)	13/32"	(10.3)	1/4"-20 x 2 1/4"
B3690-3/4	3/4"	(20)	13/32"	(10.3)	2 11/32"	(59.5)	1"	(25.4)	1 13/16"	(46.2)	13/32"	(10.3)	1/4"-20 x 2 1/2"
B3690-1	1"	(25)	13/32"	(10.3)	2 19/32"	(65.9)	1"	(25.4)	1 15/16"	(49.2)	13/32"	(10.3)	1/4"-20 x 2 3/4"
B3690-1 1/4	1 1/4"	(32)	13/32"	(10.3)	2 13/16"	(71.4)	1"	(25.4)	2"	(50.4)	13/32"	(10.3)	1/4"-20 x 3"
B3690-1 1/2	1 1/2"	(40)	13/32"	(10.3)	3 1/16"	(77.8)	1"	(25.4)	2 1/8"	(53.7)	13/32"	(10.3)	1/4"-20 x 3 1/4"
B3690-2	2"	(50)	13/32"	(10.3)	3 1/2"	(88.9)	1"	(25.4)	2 5/16"	(58.7)	13/32"	(10.3)	1/4"-20 x 3 1/2"
B3690-2 1/2	2 1/2"	(65)	9/16"	(14.3)	4 7/16"	(112.7)	1"	(25.4)	3"	(76.2)	9/16"	(14.3)	3/8"-16 x 4 1/2"
B3690-3	3"	(80)	9/16"	(14.3)	4 7/8"	(123.8)	1"	(25.4)	3 1/8"	(79.4)	9/16"	(14.3)	3/8"-16 x 5"
B3690-3 1/2	3 1/2"	(90)	9/16"	(14.3)	5 3/16"	(131.8)	1"	(25.4)	3 3/16"	(81.0)	9/16"	(14.3)	3/8"-16 x 5 1/2"
B3690-4	4"	(100)	11/16"	(17.5)	6 1/8"	(155.6)	1 1/4"	(31.8)	3 7/8"	(98.4)	9/16"	(14.3)	3/8"-16 x 6 1/2"
B3690-5	5"	(125)	11/16"	(17.5)	6 3/4"	(171.4)	1 1/2"	(38.1)	4"	(100.8)	9/16"	(14.3)	3/8"-16 x 7 1/2"
B3690-6	6"	(150)	13/16"	(20.6)	7 3/4"	(196.8)	1 3/16"	(30.2)	4 7/16"	(112.7)	9/16"	(14.3)	3/8"-16 x 8 1/2"
B3690-8	8"	(200)	13/16"	(20.6)	9 1/4"	(235.0)	1"	(25.4)	4 15/16"	(125.4)	9/16"	(14.3)	3/8"-16 x 10 1/2"

Part No.	T	W	Design Load		Wt./C	
			Lbs.	kN	Lbs.	kg
B3690-1/2	12 Ga. (2.6)	3/4" (19.0)	400	(1.78)	20	(9.1)
B3690-3/4	12 Ga. (2.6)	3/4" (19.0)	400	(1.78)	23	(10.4)
B3690-1	12 Ga. (2.6)	3/4" (19.0)	400	(1.78)	24	(10.9)
B3690-1 1/4	12 Ga. (2.6)	3/4" (19.0)	400	(1.78)	27	(12.2)
B3690-1 1/2	12 Ga. (2.6)	3/4" (19.0)	400	(1.78)	29	(13.1)
B3690-2	12 Ga. (2.6)	3/4" (19.0)	400	(1.78)	32	(14.5)
B3690-2 1/2	11 Ga. (3.0)	1 1/4" (31.7)	800	(3.56)	71	(32.2)
B3690-3	11 Ga. (3.0)	1 1/4" (31.7)	800	(3.56)	77	(34.9)
B3690-3 1/2	11 Ga. (3.0)	1 1/4" (31.7)	800	(3.56)	84	(38.1)
B3690-4	7 Ga. (4.5)	1 1/4" (31.7)	800	(3.56)	139	(63.0)
B3690-5	7 Ga. (4.5)	1 1/4" (31.7)	800	(3.56)	166	(75.3)
B3690-6	1/4" (6.3)	1 1/4" (31.7)	1000	(4.45)	226	(102.5)
B3690-8	1/4" (6.3)	1 1/2" (38.1)	1200	(5.34)	332	(150.6)

Reference page 110 for general fitting and standard finish specifications.

Pipe Hangers

B386 SERIES SUSPENSION ROD PIPE STRAP

- Safety Factor of 3
- Includes Hex Head Cap Screws and Hex Nuts
- Standard finishes: ZN, GRN

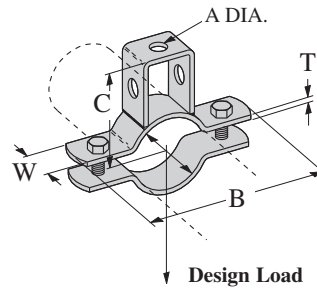

Part No.	Pipe Size	A	B	C	T	W	Design Load Lbs. kN	Wt./C Lbs. kg
B386-3/4	3/4" (20)	7/16" (11.1)	3 ⁵ / ₁₆ " (84.1)	2 ³ / ₁₆ " (55.6)	1/8" (3.2)	1" (25.4)	730 (3.25)	46 (20.8)
B386-1	1" (25)	7/16" (11.1)	3 ³ / ₄ " (95.2)	2 ⁵ / ₁₆ " (58.7)	1/8" (3.2)	1" (25.4)	730 (3.25)	51 (23.1)
B386-1 ¹ / ₄	1 ¹ / ₄ " (32)	7/16" (11.1)	4" (101.6)	2 ¹⁷ / ₃₂ " (64.3)	1/8" (3.2)	1" (25.4)	730 (3.25)	52 (23.6)
B386-1 ¹ / ₂	1 ¹ / ₂ " (40)	7/16" (11.1)	4 ⁵ / ₁₆ " (109.5)	2 ¹¹ / ₁₆ " (68.3)	1/8" (3.2)	1" (25.4)	730 (3.25)	54 (24.5)
B386-2	2" (50)	7/16" (11.1)	5 ¹ / ₂ " (139.7)	3 ⁵ / ₁₆ " (84.1)	1/4" (6.3)	1" (25.4)	730 (3.25)	134 (60.8)
B386-2 ¹ / ₂	2 ¹ / ₂ " (65)	9/16" (14.3)	6 ³ / ₈ " (161.9)	3 ¹ / ₂ " (88.9)	1/4" (6.3)	1" (25.4)	1350 (6.00)	157 (71.2)
B386-3	3" (80)	9/16" (14.3)	7" (177.8)	3 ⁷ / ₈ " (98.4)	1/4" (6.3)	1" (25.4)	1350 (6.00)	168 (76.2)
B386-3 ¹ / ₂	3 ¹ / ₂ " (90)	9/16" (14.3)	7 ⁹ / ₁₆ " (192.1)	4 ¹ / ₈ " (104.8)	1/4" (6.3)	1" (25.4)	1350 (6.00)	197 (89.3)
B386-4	4" (100)	9/16" (14.3)	8 ⁵ / ₈ " (219.1)	4 ³ / ₈ " (111.1)	1/4" (6.3)	1 ¹ / ₄ " (31.7)	1350 (6.00)	270 (122.4)
B386-5	5" (125)	1 ¹ / ₁₆ " (17.4)	9 ³ / ₄ " (247.6)	5 ³ / ₁₆ " (131.8)	1/4" (6.3)	1 ¹ / ₄ " (31.7)	2160 (9.61)	308 (139.7)
B386-6	6" (150)	1 ¹ / ₁₆ " (17.4)	11 ⁵ / ₈ " (295.3)	6 ¹ / ₁₆ " (154.0)	3/8" (9.5)	1 ¹ / ₂ " (38.1)	2160 (9.61)	609 (276.4)
B386-8	8" (200)	1 ³ / ₁₆ " (20.6)	13 ⁷ / ₈ " (352.4)	7 ¹ / ₈ " (181.0)	3/8" (9.5)	1 ¹ / ₂ " (38.1)	3230 (14.37)	713 (323.4)

B394 SERIES PIPE STRAP

- Safety Factor of 3
- Includes:
 - 1 Pair Pipe Clamps with Hex Head Cap Screws and Hex Nuts
 - 1 Hanger Strap
- Standard finishes: ZN

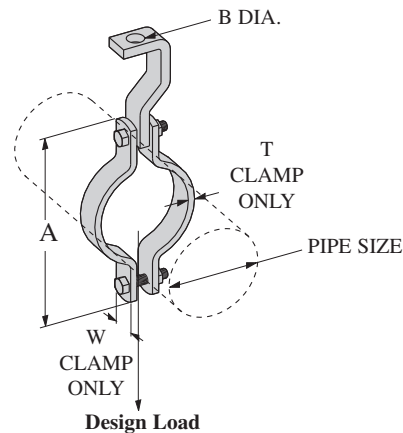

Part No.	Pipe Size	A	B	T	W	Design Load Lbs. kN	Wt./C Lbs. kg
B394-3/4	3/4" (20)	3 ⁵ / ₁₆ " (84.1)	7/16" (11.1)	1/8" (3.2)	1" (25.4)	500 (2.22)	71 (32.2)
B394-1	1" (25)	3 ³ / ₄ " (95.2)	7/16" (11.1)	1/8" (3.2)	1" (25.4)	500 (2.22)	76 (34.5)
B394-1 ¹ / ₄	1 ¹ / ₄ " (32)	4" (101.6)	7/16" (11.1)	1/8" (3.2)	1" (25.4)	500 (2.22)	77 (34.9)
B394-1 ¹ / ₂	1 ¹ / ₂ " (40)	4 ⁵ / ₁₆ " (109.5)	7/16" (11.1)	1/8" (3.2)	1" (25.4)	800 (3.56)	79 (35.8)
B394-2	2" (50)	5 ¹ / ₂ " (139.7)	7/16" (11.1)	1/4" (6.3)	1" (25.4)	1040 (4.62)	166 (75.3)
B394-2 ¹ / ₂	2 ¹ / ₂ " (65)	6 ³ / ₈ " (161.9)	9/16" (14.3)	1/4" (6.3)	1" (25.4)	1040 (4.62)	179 (81.2)
B394-3	3" (80)	7" (177.8)	9/16" (14.3)	1/4" (6.3)	1" (25.4)	1040 (4.62)	190 (86.2)
B394-3 ¹ / ₂	3 ¹ / ₂ " (90)	7 ⁹ / ₁₆ " (192.1)	9/16" (14.3)	1/4" (6.3)	1" (25.4)	1040 (4.62)	203 (92.1)
B394-4	4" (100)	8 ⁵ / ₈ " (219.1)	1 ¹ / ₁₆ " (17.4)	1/4" (6.3)	1 ¹ / ₄ " (31.7)	1040 (4.62)	320 (145.1)
B394-5	5" (125)	9 ³ / ₄ " (247.6)	1 ¹ / ₁₆ " (17.4)	1/4" (6.3)	1 ¹ / ₄ " (31.7)	1040 (4.62)	353 (160.1)
B394-6	6" (150)	11 ⁵ / ₈ " (295.3)	1 ³ / ₁₆ " (20.6)	3/8" (9.5)	1 ¹ / ₂ " (38.1)	1615 (7.18)	637 (288.9)
B394-8	8" (200)	13 ⁷ / ₈ " (352.4)	1 ³ / ₁₆ " (20.6)	3/8" (9.5)	1 ¹ / ₂ " (38.1)	1615 (7.18)	837 (379.6)

Reference page 110 for general fitting and standard finish specifications.

B591 SERIES PIPE BRACKET SADDLE AND CLAMP

- Safety Factor of 3
- Inside brace not required on B591-2 and B591-2½
- Includes:
 - 1 pc. Saddle bottom
 - 1 pc. Saddle top (clamp)
 - 2 pcs. Hex Head Cap Screws
 - 2 pcs. Hex Nuts
- Standard finish: ZN

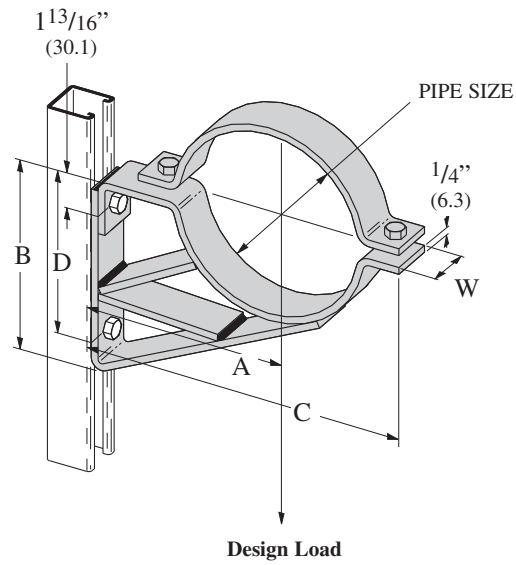

Part No.	Pipe Size		A		B		C		D		W		Design Load		Wt./C	
	in	(mm)	in	(mm)	in	(mm)	in	(mm)	in	(mm)	in	(mm)	Lbs.	kN	Lbs.	kg
B591-2	2"	(50)	4½"	(114.3)	4½"	(114.3)	7¾"	(182.6)	3¼"	(77.8)	1⅝"	(41.3)	1235	(5.53)	290	(131.5)
B591-2½	2½"	(65)	5"	(127.0)	5"	(127.0)	7⅝"	(201.6)	3⅞"	(90.5)	1⅝"	(41.3)	1180	(5.29)	330	(149.7)
B591-3	3"	(80)	5½"	(139.7)	5¾"	(146.0)	8¾"	(222.2)	3⅓"	(96.8)	1⅝"	(41.3)	1125	(5.04)	439	(199.1)
B591-3½	3½"	(90)	6"	(152.4)	6¾"	(171.4)	9½"	(241.3)	4⅞"	(115.9)	1⅝"	(41.3)	1070	(4.79)	490	(222.2)
B591-4	4"	(100)	6½"	(165.1)	6¾"	(171.4)	10¼"	(260.3)	6¼"	(128.6)	1⅝"	(41.3)	1015	(4.55)	545	(247.2)
B591-5	5"	(125)	7½"	(190.5)	8"	(203.2)	12⅞"	(308.0)	6¼"	(154.0)	1⅝"	(41.3)	960	(4.30)	666	(302.1)
B591-6	6"	(150)	8"	(203.2)	8¾"	(222.2)	13⅓"	(335.0)	6⅓"	(173.0)	1⅝"	(41.3)	905	(4.05)	724	(328.4)
B591-8	8"	(200)	9"	(228.6)	10½"	(266.7)	15⅞"	(395.3)	8⅞"	(217.5)	2"	(50.8)	850	(3.81)	1087	(493.0)

Reference page 110 for general fitting and standard finish specifications.

Pipe Block

B356

PIPE BLOCK-2" (50) TO 8" (200) PIPE

- Required hardware not included:
 - 1 pc. $\frac{3}{8}$ "-16 x 1" Hex Head Cap Screw
 - 1 pc. $\frac{3}{8}$ "-16 Channel Nut
- Material: $\frac{1}{4}$ " (6.3) thick $1\frac{5}{8}$ " (41.3) wide
- ASTM A1018 33,000 PSI min. yield
- Standard finish: ZN
- Wt./C 42 Lbs. (19.0 kg) Per Pair

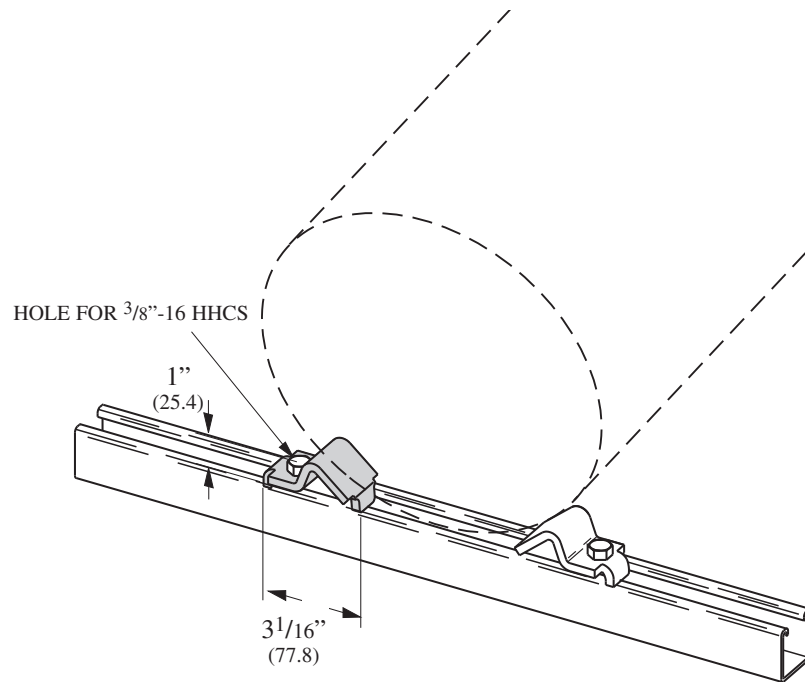

B218

PIPE ROLLERS-1/2" (15) TO 8" (200) PIPE

- Design Load 500 Lbs. (2.22 kN)
- Safety Factor of 5
- When used with B3160 thru B3165 Saddles
(See Pipe Hanger Catalog)
- Malleable Iron Rollers
- Sold in pairs
- Required hardware not included:
2 pcs. 1/2"-13 x 1 1/4" Hex Head Cap Screws
2 pcs. 1/2"-13 Channel Nuts
- Standard finish: ZN
- Wt./C 256 Lbs. (116.1 kg) Per Pair

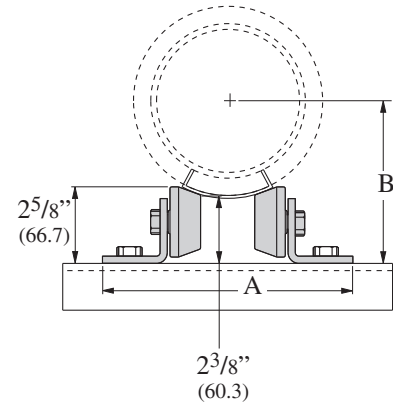
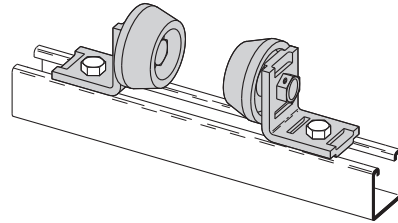

REFERENCE CHART - A DIMENSION

Pipe Size	Insulation Thickness													
	0" (0.0)		1" (25.4)		1 1/2" (38.1)		2" (50.8)		2 1/2" (63.5)		3" (76.2)		4" (101.6)	
1/2" (15)	7 1/4" (184.1)	-	-	-	-	-	-	-	-	-	-	-	-	-
3/4" (20)	7 1/4" (184.1)	7 1/4" (184.1)	7 5/8" (193.7)	8" (203.2)	-	-	-	-	-	-	-	-	-	-
1" (25)	7 1/4" (184.1)	7 1/4" (184.1)	7 5/8" (193.7)	8 1/4" (209.5)	-	-	-	-	-	-	-	-	-	-
1 1/4" (32)	7 1/4" (184.1)	7 1/4" (184.1)	8" (203.2)	8 1/4" (209.5)	-	-	-	-	-	-	-	-	-	-
1 1/2" (40)	7 1/4" (184.1)	7 5/8" (193.7)	8" (203.2)	8 1/2" (215.9)	9" (228.6)	-	-	-	-	-	-	-	-	-
2" (50)	7 1/4" (184.1)	7 5/8" (193.7)	8 1/2" (215.9)	8 1/2" (215.9)	9" (228.6)	-	-	-	-	-	-	-	-	-
2 1/2" (65)	7 1/4" (184.1)	8" (203.2)	8 1/2" (215.9)	9" (228.6)	10" (254.0)	-	-	-	-	-	-	-	-	-
3" (80)	7 1/4" (184.1)	8 1/2" (215.9)	9" (228.6)	9" (228.6)	10" (254.0)	10" (254.0)	-	-	-	-	-	-	-	-
3 1/2" (90)	7 1/4" (184.1)	8 1/2" (215.9)	9" (228.6)	10" (254.0)	10" (254.0)	10" (254.0)	10" (254.0)	-	-	-	-	-	-	-
4" (100)	7 5/8" (193.7)	9" (228.6)	9" (228.6)	10" (254.0)	10" (254.0)	10" (254.0)	10" (254.0)	11" (279.4)	-	-	-	-	-	-
5" (125)	8 1/2" (215.9)	9" (228.6)	10" (254.0)	10" (254.0)	10" (254.0)	11" (279.4)	11" (279.4)	11" (279.4)	11" (279.4)	11" (279.4)	12" (304.8)	-	-	-
6" (150)	9" (228.6)	10" (254.0)	10" (254.0)	11" (279.4)	11" (279.4)	11" (279.4)	11" (279.4)	11" (279.4)	11" (279.4)	11" (279.4)	12" (304.8)	-	-	-
8" (200)	10" (254.0)	11" (279.4)	11" (279.4)	11" (279.4)	11" (279.4)	12" (304.8)	-	-	-	-	-	-	-	-

REFERENCE CHART - B DIMENSION

Pipe Size	Insulation Thickness													
	0" (0.0)		1" (25.4)		1 1/2" (38.1)		2" (50.8)		2 1/2" (63.5)		3" (76.2)		4" (101.6)	
1/2" (15)	2 1/16" (68.3)	-	-	-	-	-	-	-	-	-	-	-	-	-
3/4" (20)	2 13/16" (71.4)	3 7/8" (98.4)	4 3/8" (111.1)	4 7/8" (123.8)	-	-	-	-	-	-	-	-	-	-
1" (25)	2 15/16" (74.6)	4 3/16" (106.4)	4 11/16" (119.1)	5 1/16" (128.6)	-	-	-	-	-	-	-	-	-	-
1 1/4" (32)	3 1/8" (79.4)	4 3/16" (106.4)	4 5/8" (117.5)	5 1/8" (130.2)	-	-	-	-	-	-	-	-	-	-
1 1/2" (40)	3 1/4" (82.5)	4 3/8" (111.1)	4 7/8" (123.8)	5 5/16" (134.9)	5 3/4" (146.0)	-	-	-	-	-	-	-	-	-
2" (50)	3 9/16" (90.5)	4 11/16" (119.1)	5 1/16" (128.6)	5 5/8" (142.9)	6 1/16" (154.0)	-	-	-	-	-	-	-	-	-
2 1/2" (65)	3 13/16" (96.8)	4 7/8" (123.8)	5 5/16" (134.9)	6" (152.4)	6 3/8" (161.9)	-	-	-	-	-	-	-	-	-
3" (80)	4 1/8" (104.8)	5 1/16" (128.6)	5 9/16" (141.3)	6 1/8" (155.6)	6 7/16" (163.5)	7" (177.8)	-	-	-	-	-	-	-	-
3 1/2" (90)	4 3/8" (111.1)	5 5/16" (134.9)	5 13/16" (147.6)	6 1/4" (158.7)	6 11/16" (169.9)	7 1/4" (184.1)	-	-	-	-	-	-	-	-
4" (100)	4 5/8" (117.5)	5 9/16" (141.3)	6 1/16" (154.0)	6 7/16" (163.5)	6 15/16" (176.2)	7 3/8" (187.3)	-	-	-	-	-	-	-	-
5" (125)	5" (127.0)	6 1/16" (154.0)	6 7/16" (163.5)	7" (177.8)	7 3/8" (187.3)	7 7/8" (200.0)	8 13/16" (223.8)	-	-	-	-	-	-	-
6" (150)	5 1/2" (139.7)	6 7/16" (163.5)	6 15/16" (176.2)	7 3/8" (187.3)	7 15/16" (201.6)	8 1/2" (215.9)	9 1/2" (241.3)	-	-	-	-	-	-	-
8" (200)	6 15/16" (160.3)	7 3/8" (187.3)	7 15/16" (201.6)	8 7/16" (214.3)	8 15/16" (227.0)	-	-	-	-	-	-	-	-	-

Reference page 110 for general fitting and standard finish specifications.

Pipe Rollers

B219

PIPE ROLLER SERIES - 3/4" (20) TO 12" (300) PIPE

- Design Load 750 Lbs. (3.33 kN)
- Safety Factor of 5
- Requires field assembly
- When used with B3160 thru B3165 Saddles
(See Pipe Hanger Catalog)
- Malleable Iron Rollers
- Sold in pairs
- Required hardware not included:
2 pcs. 1/2"-13 x 1 1/4" Hex Head Cap Screws
2 pcs. 1/2"-13 Channel Nuts
- Reference sizing chart on page 133
- Standard finish: ZN

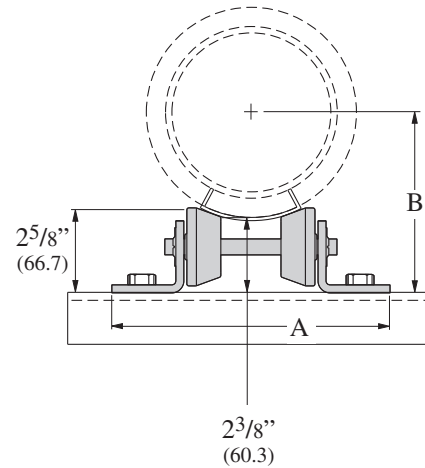
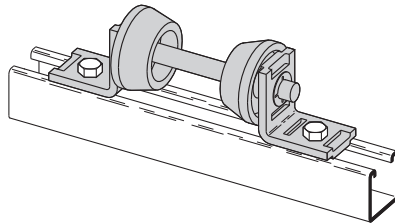

REFERENCE CHART - A DIMENSION

Part No.	A		Wt./C PR	
	Lbs.	kg	Lbs.	kg
B219	7 1/4"	(184.1)	253	(114.7)
B219-1	8"	(203.2)	258	(117.0)
B219-2	9"	(228.6)	263	(119.3)
B219-3	10"	(254.0)	269	(122.0)
B219-4	10 7/8"	(276.2)	274	(124.8)
B219-5	11 5/8"	(295.3)	279	(126.5)

REFERENCE CHART - B DIMENSION

Pipe Size	Insulation Thickness													
	0" (0.0)		1" (25.4)		1 1/2" (38.1)		2" (50.8)		2 1/2" (63.5)		3" (76.2)		4" (101.6)	
1/2" (15)	2 11/16"	(68.3)	-	-	-	-	-	-	-	-	-	-	-	-
3/4" (20)	2 13/16"	(71.4)	3 7/8"	(98.4)	4 1/2"	(114.3)	4 7/8"	(123.8)	-	-	-	-	-	-
1" (25)	2 15/16"	(74.6)	4 3/16"	(106.4)	4 5/8"	(117.5)	5 1/16"	(128.6)	-	-	-	-	-	-
1 1/4" (32)	3 1/8"	(79.4)	4 3/16"	(106.4)	4 5/8"	(117.5)	5 1/8"	(130.2)	-	-	-	-	-	-
1 1/2" (40)	3 1/4"	(82.5)	4 7/16"	(112.7)	4 7/8"	(123.8)	5 1/4"	(133.3)	5 3/4"	(146.0)	-	-	-	-
2" (50)	3 9/16"	(90.5)	4 5/8"	(117.5)	5 3/16"	(131.8)	5 1/2"	(139.7)	6 1/16"	(154.0)	-	-	-	-
2 1/2" (65)	3 3/4"	(95.2)	4 7/8"	(123.8)	5 1/4"	(133.3)	6"	(152.4)	6 3/8"	(161.9)	-	-	-	-
3" (80)	4 1/8"	(104.8)	5 1/8"	(130.2)	5 9/16"	(141.3)	6 1/16"	(154.0)	6 7/16"	(163.5)	6 15/16"	(176.2)	-	-
3 1/2" (90)	4 1/4"	(107.9)	5 1/4"	(133.3)	5 13/16"	(147.6)	6 1/4"	(158.7)	6 11/16"	(169.9)	7 1/16"	(179.4)	-	-
4" (100)	4 9/16"	(115.9)	5 1/2"	(139.7)	6 1/16"	(154.0)	6 7/16"	(163.5)	6 15/16"	(176.2)	7 3/8"	(187.3)	-	-
5" (125)	5 1/16"	(128.6)	6 1/16"	(154.0)	6 7/16"	(163.5)	7"	(177.8)	7 3/8"	(187.3)	7 7/8"	(200.0)	8 15/16"	(227.0)
6" (150)	5 7/16"	(138.1)	6 7/16"	(163.5)	6 15/16"	(176.2)	7 3/8"	(187.3)	7 7/8"	(200.0)	8 15/16"	(211.1)	9 9/16"	(242.9)
8" (200)	6 3/8"	(161.9)	7 7/16"	(188.9)	7 15/16"	(201.6)	8 3/8"	(212.7)	9"	(228.6)	-	-	-	-
10" (250)	7 5/16"	(185.7)	8 3/16"	(208.0)	-	-	-	-	-	-	-	-	-	-
12" (300)	8 1/4"	(209.5)	-	-	-	-	-	-	-	-	-	-	-	-

Reference B219 sizing chart on page 133

Reference page 110 for general fitting and standard finish specifications.

B219 SIZING CHART

Pipe Size		Insulation Thickness						
		0" (0.0)	1" (25.4)	1½" (38.1)	2" (50.8)	2½" (63.5)	3" (76.2)	4" (101.6)
½"	(15)	B219	–	–	–	–	–	–
¾"	(20)	B219	B219	B219	B219-1	–	–	–
1"	(25)	B219	B219	B219-1	B219-1	–	–	–
1¼"	(32)	B219	B219	B219-1	B219-1	–	–	–
1½"	(40)	B219	B219	B219-1	B219-2	B219-2	–	–
2"	(50)	B219	B219-1	B219-1	B219-2	B219-2	–	–
2½"	(65)	B219	B219-1	B219-2	B219-2	B219-3	–	–
3"	(80)	B219	B219-1	B219-2	B219-2	B219-3	B219-3	–
3½"	(90)	B219-1	B219-2	B219-2	B219-3	B219-3	B219-4	–
4"	(100)	B219-1	B219-2	B219-2	B219-3	B219-3	B219-4	–
5"	(125)	B219-1	B219-2	B219-3	B219-3	B219-4	B219-4	B219-5
6"	(150)	B219-2	B219-3	B219-3	B219-4	B219-4	B219-5	B219-5
8"	(200)	B219-3	B219-4	B219-4	B219-5	B219-5	–	–
10"	(250)	B219-4	B219-5	–	–	–	–	–
12"	(300)	B219-5	–	–	–	–	–	–

Reference page 110 for general fitting and standard finish specifications.

Pipe Rollers

B379

PIPE ROLLERS-6" (150) TO 18" (450) PIPE

- Design Load 1500 Lbs. (6.67 kN)
- Safety Factor of 5
- Requires field assembly
- When used with B3160 thru B3165 Saddles
(See Pipe Hanger Catalog)
- Malleable Iron Rollers
- Sold in pairs
- Required hardware not included:
2 pcs. 1/2"-13 x 1 1/4" Hex Head Cap Screws
2 pcs. 1/2"-13 Channel Nuts
- Standard finish: ZN
- Wt./C 889 Lbs. (403.2 kg)

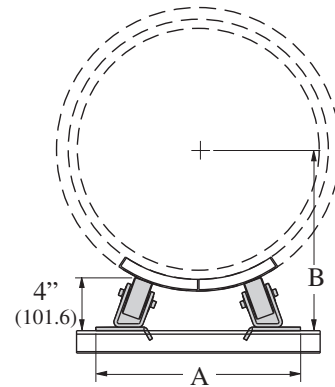
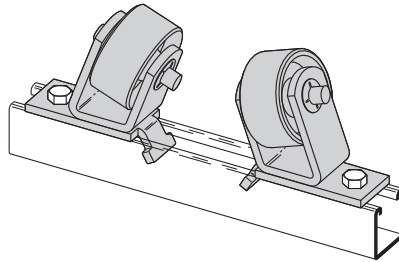

REFERENCE CHART - A DIMENSION

Pipe Size	Insulation Thickness													
	0" (0.0)		1" (25.4)		1 1/2" (38.1)		2" (50.8)		2 1/2" (63.5)		3" (76.2)		4" (101.6)	
6" (150)	9 9/16"	(242.9)	10 3/16"	(258.8)	10 5/8"	(269.9)	11"	(279.4)	11 3/8"	(288.9)	11 3/4"	(298.4)	12 1/2"	(317.5)
8" (200)	10 1/4"	(260.3)	11 1/16"	(281.0)	11 3/8"	(288.9)	11 3/4"	(298.4)	12 3/16"	(309.6)	12 1/2"	(317.5)	13 1/4"	(336.5)
10" (250)	11"	(279.4)	11 3/4"	(298.4)	12 1/8"	(308.0)	12 1/2"	(317.5)	12 13/16"	(325.4)	13 1/8"	(333.4)	13 7/8"	(352.4)
12" (300)	11 11/16"	(296.9)	12 9/16"	(319.1)	12 7/8"	(327.0)	13 1/4"	(336.5)	13 9/16"	(344.5)	13 7/8"	(352.4)	14 5/8"	(371.5)
14" (350)	12 1/16"	(306.4)	12 7/8"	(327.0)	13 3/16"	(335.0)	13 9/16"	(344.5)	13 7/8"	(352.4)	14 1/4"	(361.9)	14 7/8"	(377.8)
16" (400)	12 3/4"	(323.8)	13 1/2"	(342.9)	13 7/8"	(352.4)	14 13/16"	(360.4)	14 1/2"	(368.3)	14 7/8"	(377.8)	15 1/2"	(393.7)
18" (450)	13 1/2"	(342.9)	14 1/4"	(361.9)	14 5/8"	(371.5)	15"	(381.0)	15 5/16"	(388.9)	15 5/8"	(396.9)	16 5/16"	(414.3)

REFERENCE CHART - B DIMENSION

Pipe Size	Insulation Thickness													
	0" (0.0)		1" (25.4)		1 1/2" (38.1)		2" (50.8)		2 1/2" (63.5)		3" (76.2)		4" (101.6)	
6" (150)	6 7/8"	(174.6)	7 7/8"	(200.0)	8 3/8"	(212.7)	8 7/8"	(225.4)	9 3/8"	(238.1)	9 7/8"	(250.8)	10 15/16"	(277.8)
8" (200)	7 13/16"	(198.4)	8 7/8"	(225.4)	9 3/8"	(238.1)	9 7/8"	(250.8)	10 7/16"	(265.1)	10 15/16"	(277.8)	11 7/8"	(301.6)
10" (250)	8 13/16"	(223.8)	9 7/8"	(250.8)	10 7/16"	(265.1)	10 15/16"	(277.8)	11 3/8"	(288.9)	11 7/8"	(301.6)	12 13/16"	(325.4)
12" (300)	9 3/4"	(247.6)	10 15/16"	(277.8)	11 3/8"	(288.9)	11 7/8"	(301.6)	12 5/16"	(312.7)	12 13/16"	(325.4)	13 3/4"	(349.2)
14" (350)	10 5/16"	(261.9)	11 3/8"	(288.9)	11 7/8"	(301.6)	12 5/16"	(312.7)	12 13/16"	(325.4)	13 1/4"	(336.5)	14 1/4"	(361.9)
16" (400)	11 5/16"	(287.3)	12 5/16"	(312.7)	12 13/16"	(325.4)	13 1/4"	(336.5)	13 3/4"	(349.2)	14 1/4"	(361.9)	15 1/8"	(384.2)
18" (450)	12 1/4"	(311.1)	13 1/4"	(336.5)	13 3/4"	(349.2)	14 3/16"	(360.4)	14 11/16"	(373.1)	15 1/8"	(384.2)	16 1/16"	(408.0)

Reference page 110 for general fitting and standard finish specifications.

B479

PIPE ROLLERS-16" (400) TO 30" (750) PIPE

- Design Load 2000 Lbs. (8.89 kN)
- Safety Factor of 5
- Requires field assembly
- When used with B3160 thru B3165 Saddles
(See Pipe Hanger Catalog)
- Malleable Iron Rollers
- Sold in pieces
- Required hardware not included:
4 pcs. 1/2"-13 x 1 1/4" Hex Head Cap Screws
4 pcs. 1/2"-13 Channel Nuts
- Standard finish: ZN
- Wt./C 889 Lbs. (403.2 kg)

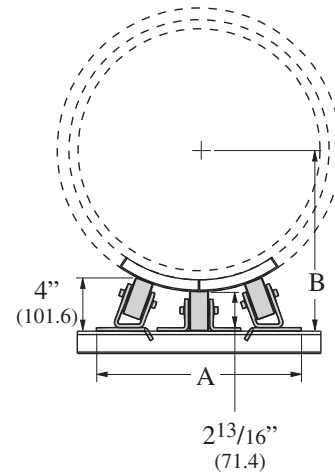
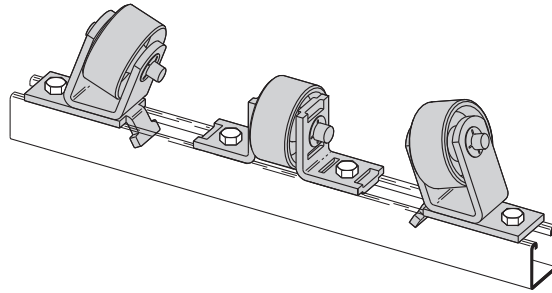

Pipe/Conduit Clamps & Hangers

REFERENCE CHART - A DIMENSION

Pipe Size	Insulation Thickness													
	0" (0.0)		1" (25.4)		1 1/2" (38.1)		2" (50.8)		2 1/2" (63.5)		3" (76.2)		4" (101.6)	
16" (400)	15 3/16"	(385.8)	15 5/8"	(396.9)	15 7/8"	(403.2)	16"	(406.4)	16 1/4"	(412.7)	16 1/2"	(419.1)	17"	(431.8)
18" (450)	15 1/2"	(393.7)	16"	(406.4)	16 3/16"	(411.2)	16 3/8"	(415.9)	16 9/16"	(420.7)	16 3/4"	(425.4)	17 3/16"	(436.6)
20" (500)	16"	(406.4)	16 3/8"	(415.9)	16 9/16"	(420.7)	16 7/8"	(428.6)	16 15/16"	(430.2)	17 3/16"	(436.6)	17 1/2"	(444.5)
24" (600)	16 13/16"	(427.0)	17 5/16"	(439.7)	17 1/2"	(444.5)	17 1/2"	(444.5)	17 11/16"	(449.3)	17 7/8"	(454.0)	18 1/8"	(460.4)
30" (750)	17 13/16"	(452.4)	18 1/4"	(463.5)	18 3/8"	(466.7)	18 9/16"	(471.5)	18 7/8"	(476.2)	18 7/8"	(479.4)	19 1/4"	(488.9)

REFERENCE CHART - B DIMENSION

Pipe Size	Insulation Thickness													
	0" (0.0)		1" (25.4)		1 1/2" (38.1)		2" (50.8)		2 1/2" (63.5)		3" (76.2)		4" (101.6)	
16" (400)	10 13/16"	(274.6)	11 15/16"	(303.2)	12 3/8"	(314.3)	12 15/16"	(328.6)	13 3/8"	(339.7)	13 15/16"	(354.0)	14 15/16"	(379.4)
18" (450)	11 7/8"	(301.6)	12 15/16"	(328.6)	13 7/16"	(341.3)	13 15/16"	(354.0)	14 7/16"	(366.7)	14 15/16"	(379.4)	15 15/16"	(404.8)
20" (500)	12 3/16"	(325.4)	13 15/16"	(354.0)	14 7/16"	(366.7)	14 7/8"	(377.8)	15 7/16"	(392.1)	15 7/8"	(403.2)	16 15/16"	(430.2)
24" (600)	14 13/16"	(376.2)	15 7/8"	(403.2)	16 3/8"	(415.9)	16 7/8"	(428.6)	17 3/8"	(441.3)	17 7/8"	(454.0)	18 7/8"	(479.4)
30" (750)	17 13/16"	(452.4)	18 7/8"	(479.4)	19 3/8"	(492.1)	19 7/8"	(504.8)	20 3/8"	(517.5)	20 5/16"	(531.8)	21 15/16"	(557.2)

Reference page 110 for general fitting and standard finish specifications.

Dura-Blok™ Rooftop Supports

Cooper B-Line's new line of Dura-Blok™ products gives you a versatile and long-term solution for all your roof top support needs. Designed with flexibility in mind, Dura-Bloks are ideal for such roof top support applications as pipe, HVAC, duct, conduit, cable tray, and roof walkways.

Manufactured to provide years of service in harsh, roof top environments, Dura-Bloks are made from 100% recycled rubber, require no supplemental rubber pads, and will not float or blow away. 1" gaps between blocks allow water to flow freely around longer assemblies. For added strength, the Dura-Blok support channel is through bolted on all sizes. For added visibility, a reflective strip is incorporated on both sides of each Dura-Blok.

Beyond product durability, Dura-Bloks help to dampen vibration, are not sharp or abrasive and require no roof penetration to maximize existing roof life - and roof structural and environmental integrity.

Recommended Torque (In channels)

See page 44 Channel Nuts & Hardware section

Materials & Finishes

See appropriate fitting's pages

Metric

Metric dimensions are shown in parentheses.
Unless noted, all metric dimensions are in millimeters.





SUPPORT BASES ONLY

- Base only - see chart for height, width and length.
- 100% recycled rubber, UV resistant.
- Load Rating** 500 lbs. (2.22kN) (Uniform Load)*
- Dura-Blok™ channel support is designed as an economical support for piping systems, cable tray, HVAC equipment and many other applications. The Dura-Blok is UV resistant and suitable for any type of roofing material or other flat surfaces. Material effectively accepts screw fasteners for securing accessories.

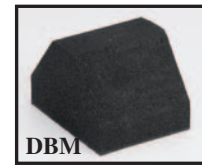

Part No.	Height x Width x Length		Wt./Each	
	In.	(mm)	Lbs.	(kg)
DBM	4" x 6" x 4.8"	(101.6 x 152.4 x 121.9)	2.35	(1.07)
DBP	4" x 6" x 9.6"	(101.6 x 152.4 x 243.8)	4.48	(2.03)

DB SERIES SUPPORT BASE WITH B44 CHANNEL

- Base with 14 ga. (1.9mm) galvanized channel 1" high (25.4mm) - see chart for height, width and length.
- 100% recycled rubber, UV resistant.
- Load Rating - Ultimate Uniform Load (See Chart Below)*
- Dura-Blok™ DB-Series channel support is designed for superior support of piping systems, cable tray, HVAC equipment, walkway systems and many other applications. The Dura-Blok is UV resistant and suitable for installation on any type of roofing material or other flat surfaces. (For pipe straps/clamps, rollers and roller supports that can be used with these Dura-Blok supports, see page 142)
- For sloped roofs use B634 adjustable hinge fittings (see Strut Systems catalog).

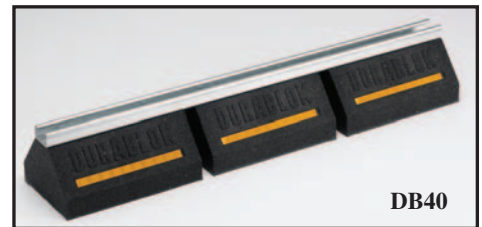

Part No.	Height x Width x Length		Wt./Each		Load Rating	
	In.	(mm)	Lbs.	(kg)	Lbs.	(kN)
DB5	5" x 6" x 4.8"	(127.0 x 152.4 x 121.9)	2.75	(125)	500	(2.22)
DB10	5" x 6" x 9.6"	(127.0 x 152.4 x 243.8)	5.28	(2.39)	500	(2.22)
DB20	5" x 6" x 20.2"	(127.0 x 152.4 x 513.1)	10.63	(4.82)	1000	(4.45)
DB30	5" x 6" x 30.8"	(127.0 x 152.4 x 782.3)	15.99	(7.25)	1500	(6.67)
DB40	5" x 6" x 41.4"	(127.0 x 152.4 x 1051.5)	21.34	(9.68)	2000	(8.89)
DB48	5" x 6" x 52.0"	(127.0 x 152.4 x 1320.8)	26.70	(12.40)	2500	(11.12)

DB6 SERIES SUPPORT BASE WITH B12 CHANNEL

- Base with 12 ga. (2.6mm) galvanized channel 2⁷/₁₆" high (61.9mm) - see chart for height, width and length.
- 100% recycled rubber, UV resistant.
- Load Rating - Ultimate Uniform Load (See Chart Below)*
- Dura-Blok™ DB-Series channel support is designed for superior support of piping systems, cable tray, HVAC equipment, walkway systems and many other applications. The Dura-Blok is UV resistant and suitable for installation on any type of roofing material or other flat surfaces. (For pipe straps/clamps, rollers and roller supports that can be used with these Dura-Blok supports, see page 142)
- For sloped roofs use B634 adjustable hinge fittings (see Strut Systems catalog).

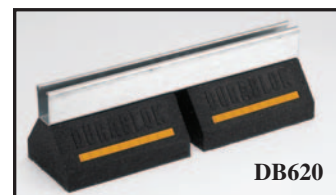

Part No.	Height x Width x Length		Wt./Each		Load Rating	
	In.	(mm)	Lbs.	(kg)	Lbs.	(kN)
DB610	6 ⁷ / ₁₆ " x 6" x 9.6"	(163.5 x 152.4 x 243.8)	6.36	(2.88)	500	(2.22)
DB620	6 ⁷ / ₁₆ " x 6" x 20.2"	(163.5 x 152.4 x 513.1)	12.90	(5.85)	1000	(4.45)
DB630	6 ⁷ / ₁₆ " x 6" x 30.8"	(163.5 x 152.4 x 782.3)	19.45	(8.82)	1500	(6.67)
DB640	6 ⁷ / ₁₆ " x 6" x 41.4"	(163.5 x 152.4 x 1051.5)	26.00	(11.79)	2000	(8.89)
DB648	6 ⁷ / ₁₆ " x 6" x 52.0"	(163.5 x 152.4 x 1320.8)	32.55	(14.76)	2500	(11.12)

* **General Note:** Consult roofing manufacturer or engineer for roof load capacity. The weakest point may be the insulation board beneath the rubber membrane.

Reference page 136 for general fitting and standard finish specifications.

Dura-Blok™ Rooftop Supports



DB10 SERIES SUPPORT BASES WITH B22 CHANNEL

- Two (2) bases bridged with 12 ga. (2.6mm) galvanized channel 1⁵/₈" high (41.3mm) - see chart for height, width and length.
- 100% recycled rubber, UV resistant.
- Load Rating: 1000 lbs. (4.45kN) (Uniform Load)*
- Dura-Blok™ DB10-Series channel support is designed for superior support of piping systems, cable tray, HVAC equipment, walkway systems and many other applications. The Dura-Blok is UV resistant and suitable for installation on any type of roofing material or other flat surfaces. (For pipe straps/clamps, rollers and roller supports that can be used with these Dura-Blok supports, see page 142)

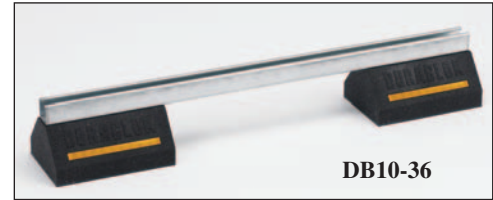

Part No.	Height x Width x Length In.	(mm)	Wt./Each Lbs. (kg)	
DB10-28	5 ⁵ / ₈ " x 6" x 28"	(142.9 x 152.4 x 711.2)	13.16	(5.97)
DB10-36	5 ⁵ / ₈ " x 6" x 36"	(142.9 x 152.4 x 914.4)	14.36	(6.51)
DB10-42	5 ⁵ / ₈ " x 6" x 42"	(142.9 x 152.4 x 1066.8)	15.52	(7.04)
DB10-50	5 ⁵ / ₈ " x 6" x 50"	(142.9 x 152.4 x 1270.0)	16.45	(7.46)
DB10-60	5 ⁵ / ₈ " x 6" x 60"	(142.9 x 152.4 x 1524.0)	17.94	(8.14)

DBM SERIES SUPPORT BASE WITH RISER ROD & CLAMP

- Base with 3/8"-16 threaded rod and B3198H clamp - see chart for height, width and length
- 100% recycled rubber, UV resistant.
- Load Rating* 50 lbs. (0.22kN) (Ultimate Load)*
- Dura-Blok™ DBM-Series pipe/tubing support is designed for support of single piping systems where elevation adjustment is needed. The Dura-Blok is UV resistant and suitable for installation on any type of roofing material or other flat surfaces.



Part No.	Clamp Part No.†	Block -Height x Width x Length In.	(mm)	Height** Min.-Max. In.	(mm)	Wt./Each Lbs. (kg)	
DBM-1/2CT	B3198HCT-1/2	4" x 6" x 4.8"	(101.6 x 152.4 x 121.9)	9.69"-11.19"	(246.1-284.2)	2.75	(1.25)
DBM-3/4CT	B3198HCT-3/4	4" x 6" x 4.8"	(101.6 x 152.4 x 121.9)	9.84"-11.34"	(249.9-2288.0)	2.76	(1.25)
DBM-1CT	B3198HCT-1	4" x 6" x 4.8"	(101.6 x 152.4 x 121.9)	9.95"-11.45"	(252.7-290.8)	2.84	(1.29)
DBM-11/4CT	B3198HCT-11/4	4" x 6" x 4.8"	(101.6 x 152.4 x 121.9)	10.13"-11.63"	(257.3-295.4)	2.95	(1.34)
DBM-11/2CT	B3198HCT-11/2	4" x 6" x 4.8"	(101.6 x 152.4 x 121.9)	10.28"-11.78"	(261.1-299.2)	2.96	(1.34)
DBM-2CT	B3198HCT-2	4" x 6" x 4.8"	(101.6 x 152.4 x 121.9)	10.53"-12.03"	(267.4-305.5)	3.03	(1.37)
DBM-1/2	B3198H-1/2	4" x 6" x 4.8"	(101.6 x 152.4 x 121.9)	9.86"-11.36"	(250.4-288.5)	2.78	(1.26)
DBM-3/4	B3198H-3/4	4" x 6" x 4.8"	(101.6 x 152.4 x 121.9)	10.06"-11.56"	(255.5-293.6)	2.84	(1.29)
DBM-1	B3198H-1	4" x 6" x 4.8"	(101.6 x 152.4 x 121.9)	10.14"-11.64"	(257.5-295.6)	2.86	(1.30)
DBM-11/4	B3198H-11/4	4" x 6" x 4.8"	(101.6 x 152.4 x 121.9)	10.25"-11.75"	(260.3-298.4)	2.93	(1.33)
DBM-11/2	B3198H-11/2	4" x 6" x 4.8"	(101.6 x 152.4 x 121.9)	10.42"-11.92"	(264.6-302.7)	2.99	(1.36)
DBM-2	B3198H-2	4" x 6" x 4.8"	(101.6 x 152.4 x 121.9)	10.66"-12.16"	(270.7-308.8)	3.10	(1.41)

† See Pipe Hanger Catalog for dimensions and specifications. ** From bottom of rubber block to center of pipe/tubing.

* **General Note:** Consult roofing manufacturer or engineer for roof load capacity. The weakest point may be the insulation board beneath the rubber membrane.

Reference page 136 for general fitting and standard finish specifications.



DBE SERIES SUPPORT BASE WITH ROD RISERS & CHANNEL

- Base with (2) 1/2" electro zinc all threaded rod risers - Top channel is 1" (25.4mm) tall. see chart for adjustable height x wide x length.
- 100% recycled rubber, UV resistant.
- Load Rating** 200 lbs. (0.89kN) (To increase load capacity use load distribution plate CLDP10)
- Dura-Blok™ DBE-Series channel support is designed as a superior support of piping systems, cable tray, HVAC equipment and many other applications where elevation adjustment is critical. The Dura-Blok is UV resistant and suitable for installation on any type of roofing material or other flat surfaces. (For pipe straps/clamps, rollers and roller supports that can be used with these Dura-Blok supports, see page 142)



Part No.	Adjustable Height x Width x Length In. (mm)		Wt./Each Lbs. (kg)	
DBE10-8	5 1/2-8" x 6" x 9.6"	(139.7-152.4 x 152.4 x 243.8)	5.68	(2.58)
DBE10-12	5 1/2-12" x 6" x 9.6"	(139.7-304.8 x 152.4 x 243.8)	5.72	(2.59)
DBE10-16	5 1/2-16" x 6" x 9.6"	(139.7-406.4 x 152.4 x 243.8)	5.76	(2.61)

DBR SERIES SUPPORT BASE WITH ROD RISERS & PIPE ROLL

- Base with (2) 1/2" electro zinc all threaded rod risers and a B3114-3 1/2 pipe roll with sockets - base is 4" (101.6mm) high x 6" (152.4mm) wide x 9.6" (243.8mm) long. Overall height is 12" (304.8mm) from bottom of base to contact point on roller.
- Pipe roll & sockets for up to 3 1/2" (90) pipe sizes.
- 100% recycled rubber, UV resistant.
- Load Rating** 200 lbs. (0.89kN) (To increase load capacity use load distribution plate CLDP10)
- Dura-Blok™ DBR-Series support is designed to support pipe up to 3 1/2" (90) nominal size where difference in elevation is required and longitudinal movement is expected. The Dura-Blok is UV resistant and approved for installation on any type of roofing material or other flat surfaces.



Part No.	Adjustable Height x Width x Length In. (mm)		Wt./Each Lbs. (kg)	
DBR10-12	up to 12" x 6" x 9.6"	(up to 304.8 x 152.4 x 243.8)	8.20	(3.72)

CLDP10 LOAD DISTRIBUTION PLATE

- 11 ga. (3.0mm) steel plate with slots.
- Dimensions: 1 5/8" (41.3mm) wide x 9 1/2" (241.3mm) long.
- Dura-Blok™ CLDP10 load bearing stabilizer plate increases load ratings for DBE Series and DBR Series by allowing the load from the threaded rods to be distributed over the length of the base instead of the point load where the rods attach to the base.



Part No.	Thickness x Width x Length In. (mm)		Wt./Each Lbs. (kg)	
CLDP10	11 Ga. x 1 5/8" x 9 1/2"	(3.0 x 41.3 x 241.3)	0.53	(0.24)



Loosen hex nuts and slide plate under the flat washers

Retighten the hex nuts with plate in place



* **General Note:** Consult roofing manufacturer or engineer for roof load capacity. The weakest point may be the insulation board beneath the rubber membrane.

Reference page 136 for general fitting and standard finish specifications.

Dura-Blok™ Rooftop Supports



DB_DS SERIES SUPPORT BASES WITH B22SH VERTICAL & HORIZONTAL CHANNEL MEMBERS

- Product is shipped unassembled.

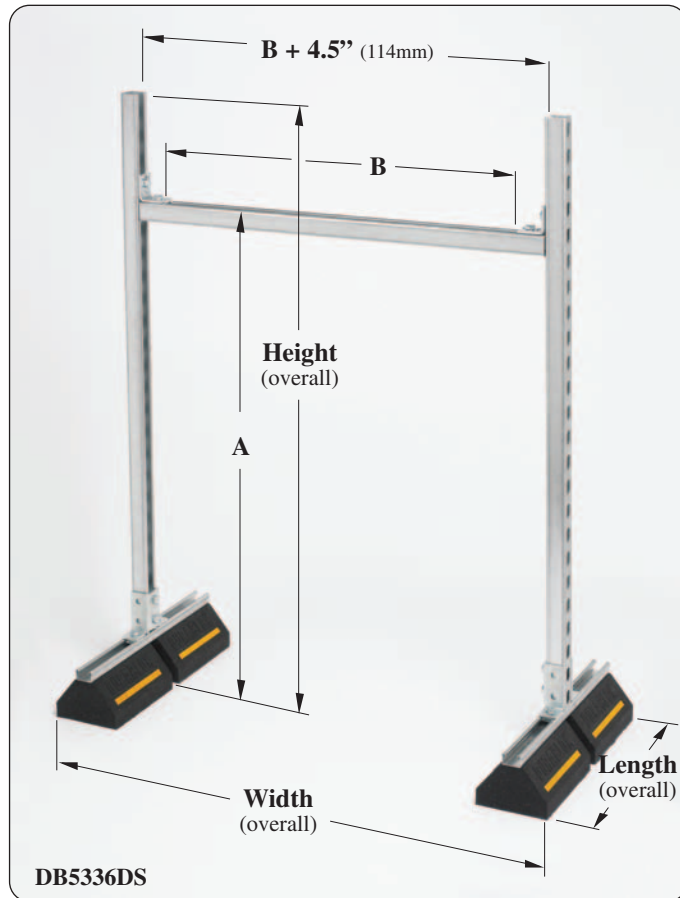

Features

- Two (2) DB20 bases with 14 ga. (1.9mm) galvanized channel 1" high (25.4mm) - Bases are 5" (127.0mm) high x 6" (152.4mm) wide x 20.2" (513.1mm) long.
- Vertical & Horizontal Riser Channels (SH Style) - 1⁵/₈" (41.3mm) x 1⁵/₈" (41.3mm) x 12 ga. (2.6mm) Fittings & Hardware - Electro-Plated Steel
- 100% recycled rubber, UV resistant.
- Ultimate Load Rating: 1000 lbs. (4.45kN) (Uniform Load)*
- Dura-Blok™ DB_DS-Series channel support with risers is designed for superior support of piping systems, cable tray, HVAC equipment, walkway systems and many other applications. The Dura-Blok is UV resistant and suitable for installation on any type of roofing material or other flat surfaces. (For pipe straps/clamps, rollers and roller supports that can be used with these Dura-Blok supports, see page 142)

* **General Note:** Consult roofing manufacturer or engineer for roof load capacity. The weakest point may be the insulation board beneath the rubber membrane.

Reference page 136 for general fitting and standard finish specifications.

Dura-Blok™ Rooftop Supports

DB_DS SERIES cont.

Part No.	A Min. to Max.		B	
	In.	(mm)	In.	(mm)
DB2318DS	10.56" to 20.75"	(268 to 527)	13 ¹ / ₂ "	(343)
DB2918DS	10.56" to 26.75"	(268 to 679)	13 ¹ / ₂ "	(343)
DB4118DS	10.56" to 38.75"	(268 to 984)	13 ¹ / ₂ "	(343)
DB5318DS	10.56" to 50.75"	(268 to 1289)	13 ¹ / ₂ "	(343)
DB2324DS	10.56" to 20.75"	(268 to 527)	19 ¹ / ₂ "	(495)
DB2924DS	10.56" to 26.75"	(268 to 679)	19 ¹ / ₂ "	(495)
DB4124DS	10.56" to 38.75"	(268 to 984)	19 ¹ / ₂ "	(495)
DB5324DS	10.56" to 50.75"	(268 to 1289)	19 ¹ / ₂ "	(495)
DB2336DS	10.56" to 20.75"	(268 to 527)	31 ¹ / ₂ "	(800)
DB2936DS	10.56" to 26.75"	(268 to 679)	31 ¹ / ₂ "	(800)
DB4136DS	10.56" to 38.75"	(268 to 984)	31 ¹ / ₂ "	(800)
DB5336DS	10.56" to 50.75"	(268 to 1289)	31 ¹ / ₂ "	(800)
DB2348DS	10.56" to 20.75"	(268 to 527)	43 ¹ / ₂ "	(1105)
DB2948DS	10.56" to 26.75"	(268 to 679)	43 ¹ / ₂ "	(1105)
DB4148DS	10.56" to 38.75"	(268 to 984)	43 ¹ / ₂ "	(1105)
DB5348DS	10.56" to 50.75"	(268 to 1289)	43 ¹ / ₂ "	(1105)

Part No.	Height (overall)		Width (overall)		Length (overall)		Wt./Each	
	In.	(mm)	In.	(mm)	In.	(mm)	lbs.	(kg)
DB2318DS	23"	(584)	25 ⁵ / ₈ "	(651)	20.2"	(513)	33.31	(15.11)
DB2918DS	29"	(736)	25 ⁵ / ₈ "	(651)	20.2"	(513)	35.00	(15.88)
DB4118DS	41"	(1041)	25 ⁵ / ₈ "	(651)	20.2"	(513)	38.40	(17.42)
DB5318DS	53"	(1346)	25 ⁵ / ₈ "	(651)	20.2"	(513)	41.80	(18.96)
DB2324DS	23"	(584)	31 ⁵ / ₈ "	(803)	20.2"	(513)	34.15	(15.49)
DB2924DS	29"	(736)	31 ⁵ / ₈ "	(803)	20.2"	(513)	35.84	(16.26)
DB4124DS	41"	(1041)	31 ⁵ / ₈ "	(803)	20.2"	(513)	39.25	(17.80)
DB5324DS	53"	(1346)	31 ⁵ / ₈ "	(803)	20.2"	(513)	42.65	(19.34)
DB2336DS	23"	(584)	43 ⁵ / ₈ "	(1108)	20.2"	(513)	35.84	(16.26)
DB2936DS	29"	(736)	43 ⁵ / ₈ "	(1108)	20.2"	(513)	37.56	(17.03)
DB4136DS	41"	(1041)	43 ⁵ / ₈ "	(1108)	20.2"	(513)	40.95	(18.57)
DB5336DS	53"	(1346)	43 ⁵ / ₈ "	(1108)	20.2"	(513)	44.34	(20.11)
DB2348DS	23"	(584)	55 ⁵ / ₈ "	(1415)	20.2"	(513)	37.55	(17.03)
DB2948DS	29"	(736)	55 ⁵ / ₈ "	(1415)	20.2"	(513)	39.25	(17.80)
DB4148DS	41"	(1041)	55 ⁵ / ₈ "	(1415)	20.2"	(513)	42.65	(19.34)
DB5348DS	53"	(1346)	55 ⁵ / ₈ "	(1415)	20.2"	(513)	46.03	(20.88)

A = Adjustable height from bottom of Dura-Blok to top of horizontal channel.

B = Space between fittings that support horizontal channel.

Height (overall) = Distance from bottom of Dura-Blok to top of upright channel.

Width (overall) = Distance from outside-to-outside of Dura-Blok supports.

Length (overall) = Distance from end-to-end of Dura-Blok supports.

Reference page 136 for general fitting and standard finish specifications.

Dura-Blok™ Rooftop Supports



DBR SERIES SUPPORT BASES WITH B42 CHANNEL & PIPE ROLLER

- Base with 14 ga. (1.9mm) galvanized channel 1" high (25.4mm) tall - see chart for height, width and length.
- 100% recycled rubber, UV resistant.
- Load Rating: (See Chart Below)*
- Dura-Blok™ DBR-Series support is designed to support pipe where longitudinal movement is expected. The Dura-Blok is UV resistant and approved for installation on any type of roofing material or other flat surfaces.

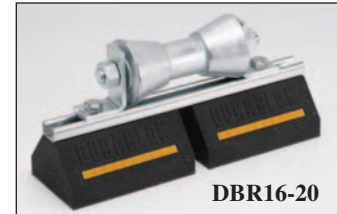

Part No.	Roller Part No.†	Block & Channel -Height x Width x Length In.	(mm)	Height** In.	(mm)	Wt./Each Lbs.	(kg)	Load Rating Lbs.	(kN)
DBR2-3¹/₂	B3126-2 to 3 ¹ / ₂	5" x 6" x 4.8"	(127.0 x 152.4 x 121.9)	7.09"	(180)	5.28	(2.39)	500	(2.22)
DBR4-6	B3126-4 to 6	5" x 6" x 4.8"	(127.0 x 152.4 x 121.9)	7.09"	(180)	10.63	(4.82)	500	(2.22)
DBR8-10	B3126-8-10	5" x 6" x 4.8"	(127.0 x 152.4 x 121.9)	8.34"	(212)	15.99	(7.25)	1000	(4.45)
DBR12-14	B3126-12-14	5" x 6" x 4.8"	(127.0 x 152.4 x 121.9)	9.38"	(238)	21.34	(9.68)	1000	(4.45)
DBR16-20	B3126-16-20	5" x 6" x 4.8"	(127.0 x 152.4 x 121.9)	9.78"	(248)	26.70	(12.11)	1000	(4.45)

† See Pipe Hanger Catalog for dimensions and specifications. ** From bottom of rubber block to bottom of pipe/tubing.

Compatible Components Available to make Dura-Blok bases more versatile (See Strut Systems Catalog for other products)

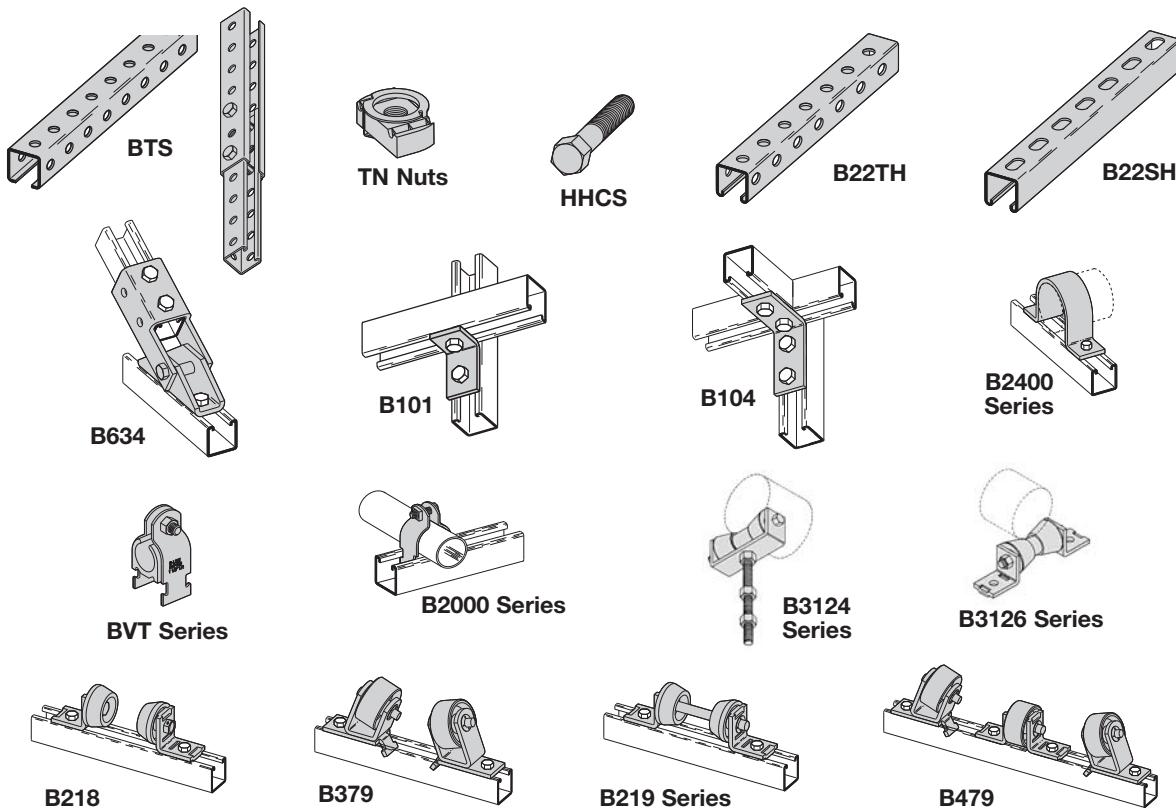

Above rollers can be mounted on C-Series and CB-Series units 19" (482mm) or longer.

Reference page 136 for general fitting and standard finish specifications.

Dura-Blok™ Rooftop Supports

ROOFTOP APPLICATIONS



Dura-Blok™ Supports

Dura Clean™ Washdown Support System

Cooper B-Line's new line of Dura-Clean™ electrical and mechanical support products are specifically designed for the critical and rigorous wash-down requirements of the Food & Beverage and Pharmaceutical industries.

Manufactured from high quality stainless steel with all angles minimized to prevent water pooling and collection, Dura-Clean™ strut and hanger components are designed with the durability and flexibility needed for applications where pipe, conduit and enclosures are subjected to regular, high pressure, high moisture wash-down environments.

Dura-Clean™ products can be installed in trapeze configurations for hanging piping, conduit or virtually any type of roof supported racking system - or wall-mount configurations for vertical or horizontal pipe support runs and enclosure support.

The new Dura-Clean™ Washdown Support System products from Cooper B-Line.

- Highest quality.
- Lasting durability.
- Immediate availability.

Recommended Torque

Bolt Size	3/8"-16	1/2"-13
Foot/Lbs.	19	50
Nm	26	68

Materials

Finish Code	Finish	Specification
SS4	Stainless Steel Type 304	ASTM A240
SS6	Stainless Steel Type 316	ASTM A240



Metric

Metric dimensions are shown in parentheses. Unless noted, all metric dimensions are in millimeters.



DURA CLEAN™ CHANNEL

- Thickness: 12 Gauge (2.6mm)
- Standard Lengths: 12" (.30m), 24" (.61m), 48" (1.22m), 120" (3.06m)
- Standard Finish: #4 Polished 304 Stainless Steel w/cellophane cover (other materials available upon request)
- Weight: 1.68 lbs/ft (2.50kg/m)
- 1⁵/₈" (41mm) x 1⁵/₈" (41mm) profile with 1³/₃₂" (10mm) x 3" (76mm) slot on 4" (101mm) centers
- Straight leg design does not harbor water or dust, eliminating areas known to harbor bacteria
- Profile allows product to be used with standard strut accessories

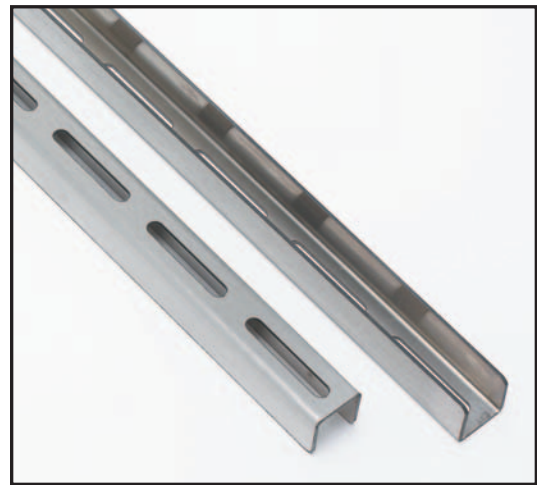

Part No.	Length	
	In.	(mm)
DC22S-12	12"	(305)
DC22S-24	24"	(610)
DC22S-48	48"	(1219)
DC22S-120	120"	(3048)

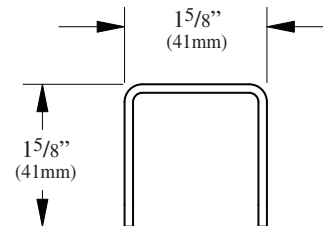

Section Properties				X - X Axis						Y - Y Axis						
Channel	Weight		Areas of Section		Moment of Inertia (I)		Section Modulus (S)		Radius of Gyration (R)		Moment of Inertia (I)		Section Modulus (S)		Radius of Gyration (R)	
	lbs./ft.	kg/m	in. ²	cm ²	in. ⁴	cm ⁴	in. ³	cm ³	in.	cm	in. ⁴	cm ⁴	in. ³	cm ³	in.	cm
DC22S	1.68	0.7628	0.4829	3.1155	0.1328	5.5276	0.1283	2.1025	0.5244	1.332	0.2178	9.0655	0.2681	4.3934	0.6717	1.7061

Channel	Beam Span		Uniform Load		Deflection		Uniform Load @ Deflection =			
	in.	mm	lbs.	N	in.	mm	1/240 Span		1/360 Span	
							lbs.	N	lbs.	N
DC22S	12	305	2500	562	0.0146	0.37	2500	562	2500	562
DC22S	18	457	1667	375	0.0329	0.83	1667	375	1667	375
DC22S	24	610	1250	281	0.0584	1.48	1250	281	1250	281
DC22S	30	762	1000	225	0.0913	2.32	1000	225	913	205
DC22S	36	914	833	187	0.1314	3.34	833	187	634	143
DC22S	42	1067	714	161	0.1788	4.54	699	157	466	105
DC22S	48	1219	625	141	0.2337	5.94	535	120	357	80
DC22S	54	1372	556	125	0.2960	7.52	423	95	282	63
DC22S	60	1524	500	112	0.3651	9.27	342	77	228	51

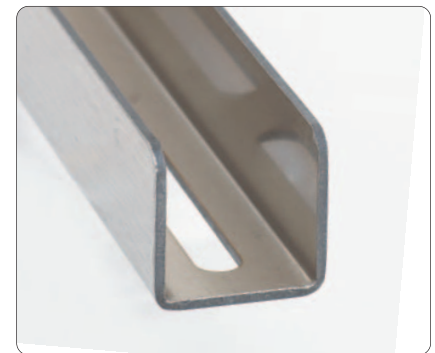

Dura Clean™

Reference page 144 for general fitting and standard finish specifications.

Dura Clean™ Wall Rails



DURA CLEAN™ WALL MOUNT RAILS

- Thickness: 12 Gauge (2.6mm)
- Standard Lengths: 12" (.30m), 24" (.61m), 48" (1.22m), 120" (3.06m)
- Standard Finish: #4 Polished 304 Stainless Steel w/cellophane cover (other materials available upon request)
- Weight: 1.90 lbs/ft (2.83kg/m)
- Z-Profile with ¹³/₃₂" (10mm) x 3" (76mm) slot on 4" (101mm) centers
- DCSP spacers are used to offset profile 1" (25.4mm) from mounting surface to eliminate any area that may harbor bacteria



Part No.	Length	
	In.	(mm)
DCWM-12	12"	(305)
DCWM-24	24"	(610)
DCWM-48	48"	(1219)
DCWM-120	120"	(3048)

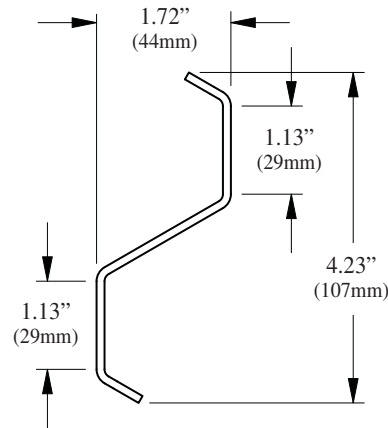

Section Properties				X - X Axis						Y - Y Axis						
Channel	Weight		Areas of Section		Moment of Inertia (I)		Section Modulus (S)		Radius of Gyration (R)		Moment of Inertia (I)		Section Modulus (S)		Radius of Gyration (R)	
	lbs./ft.	kg/m	in. ²	cm ²	in. ⁴	cm ⁴	in. ³	cm ³	in.	cm	in. ⁴	cm ⁴	in. ³	cm ³	in.	cm
DCWM	1.8999	0.8618	0.5456	3.5200	0.7305	30.406	0.3564	5.8403	1.1571	2.939	0.2345	9.7606	0.2646	4.336	0.6556	1.6652

Channel	Beam Span		Uniform Load		Deflection	
	in.	mm	lbs.	N	in.	mm
DCWM	12	305	1350	303	0.0014	0.04
DCWM	18	457	900	202	0.0032	0.08
DCWM	24	610	675	152	0.0057	0.15
DCWM	30	762	540	121	0.0090	0.23
DCWM	36	914	450	101	0.0129	0.33
DCWM	42	1067	386	87	0.0176	0.45
DCWM	48	1219	338	76	0.0230	0.58
DCWM	54	1372	300	67	0.0290	0.74
DCWM	60	1524	270	61	0.0358	0.91



Reference page 144 for general fitting and standard finish specifications.

Dura Clean™



U-BOLTS

- Material: Stream cleaned 304 Stainless Steel
- Includes serrated flange hex nuts and flat washers
- Designed for use with rigid/emt conduit, OD tubing and copper, schedule 40/80 and Ocal pipe sizes

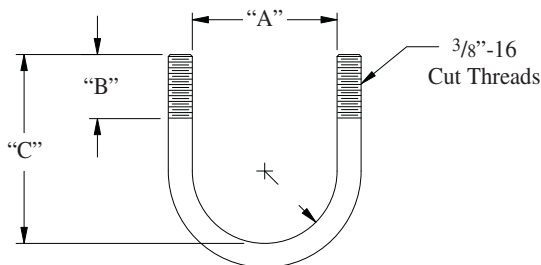

Part Number	Pipe - Conduit - Tubing Sizes						"A"		"B"		"C"		Design Load		Wt./C	
	OD Tubing	Sch. 40/80 Pipe	Rigid Conduit	EMT Conduit	Copper Pipe	Ocal Pipe	in.	mm	in.	mm	in.	mm	lbs.	kN	lbs.	kg
DC-1	1/2", 3/4"	-	-	1/2"	1/2"	-	0.81	20.6	0.88	22.2	1.50	38.1	600	2.67	27.0	12.2
DC-2	-	1/2"	1/2"	3/4"	3/4"	1/2"	0.98	25.0	0.88	22.2	1.67	42.5	600	2.67	28.4	12.9
DC-3	1"	3/4"	3/4"	1"	1"	3/4"	1.23	31.1	1.00	25.4	1.91	48.6	600	2.67	30.4	13.8
DC-4	1 1/4"	1"	1"	-	1 1/4"	1"	1.46	37.0	1.00	25.4	2.15	54.5	900	4.00	32.3	14.6
DC-5	1 1/2"	1 1/4"	1 1/4"	1 1/4"	1 1/2"	-	1.72	43.7	1.00	25.4	2.41	61.2	900	4.00	33.3	15.1
DC-6	-	1 1/2"	1 1/2"	1 1/2"	-	1 1/4"	1.96	49.8	1.00	25.4	2.65	67.3	900	4.00	36.4	16.5
DC-7	2"	-	-	2"	2"	1 1/2"	2.26	57.4	1.00	25.4	2.95	74.9	1200	5.34	38.9	17.6
DC-8	2 1/2"	2"	2"	-	2 1/2"	2"	2.69	68.2	1.00	25.4	3.38	85.7	1200	5.34	42.4	19.2
DC-9	3"	2 1/2"	2 1/2"	2 1/2"	3"	2 1/2"	3.19	80.9	1.00	25.4	3.88	98.4	1200	5.34	46.5	21.1
DC-10	3 1/2"	3"	3"	3"	3 1/2"	3"	3.69	93.6	1.00	25.4	4.38	111.1	1800	8.00	53.0	24.0
DC-11	4"	3 1/2"	3 1/2"	3 1/2"	4"	3 1/2"	4.25	108.0	1.00	25.4	4.88	123.8	1800	8.00	54.9	24.9
DC-12	-	4"	4"	4"	-	4"	4.71	119.5	1.00	25.4	5.33	135.4	1800	8.00	58.6	26.6

HARDWARE

- Material: 316 Stainless Steel
- Flat washer for 3/8" threaded rod
- Serrated hex nut for 3/8"-16 threaded rod
- Weight/C: Flat Washers 1.7 Lbs. (0.77kg)
Serrated Hex Nuts 3.0 Lbs. (1.36kg)

Part Number	Description
3/8FWSS6	3/8" Flat Washer
SFHN3/8SS6	3/8"-16 Serrated Hex Nut



Reference page 144 for general fitting and standard finish specifications.



TREADED ROD

- Material: Steam cleaned 304 Stainless Steel
- Standard Lengths: 36" (.92m) & 72" (1.83m)
(other length available upon request)
- 3/8"-16 cut threads standard
- Cut threads allow the customer to cut rods to length and then field cut threads where required

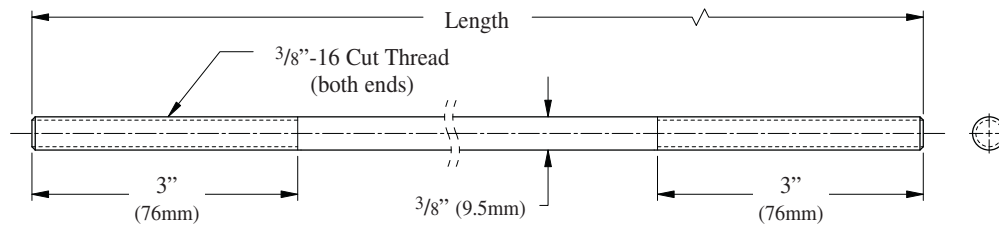

Channel	Length		Threads Per Inch	Recommended Load		Wt./100 pcs	
	in.	mm		lbs.	N	lbs.	kg
DCR38-36	36"	914	16	730	324	186.2	84.4
DCR38-72	72"	1829	16	730	324	372.4	168.9

SPACERS

- Material: 304 Stainless Steel
- Spacers are used to provide 1" (25mm) of separation from wall to channel, eliminating any area that may harbor bacteria.
- Weight/C: 16.9 Lbs. (7.6kg)

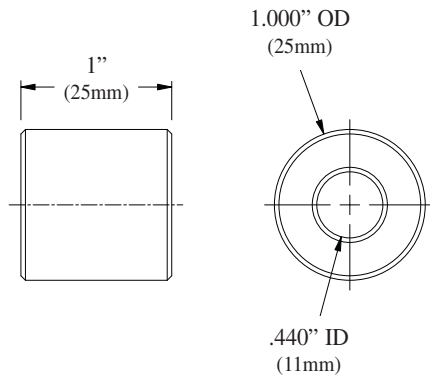

Part Number	Description
DCSP SS4	Stand-off Spacer

Reference page 144 for general fitting and standard finish specifications.

Other Stainless Steel Products

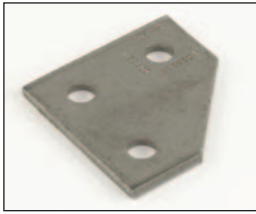

B135
Flat Corner Plate



B102
3-Hole Corner Angle



B104
4-Hole Corner Angle



B154
2-Hole 45° Open Angle



B155
2-Hole 'U' Support

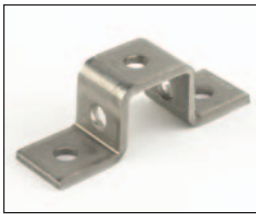

B107
5-Hole 45° Closed Angle



B172
4-Hole Splice Clevis

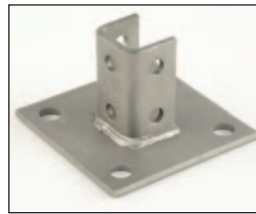

B280SQ
Post Base

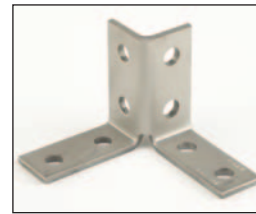

B121
8-Hole Double Corner Connection

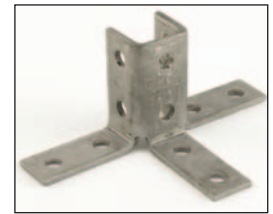

B123
12-Hole Triple Wing Connection

Consult Customer Service for other products that can be made in Stainless Steel material



Electrical Accessories

A complete system of top quality, time saving products, designed for surface metal raceways, lighting and cable supports. Innovative designs offer many installation advantages. B-Line's surface raceways are U.L. listed and meet the requirements of the National Electrical Code, Article 352.

Surface Raceways

B-Line's channel provides structural support in addition to a raceway system.

For U.L. wire fill see chart on page 218-219.

Cable Supports

A full range of clamps and saddles are offered in porcelain, thermoplastic elastomer and maple. B-Line's maple clamps, Insulclamp® cable clamps and porcelain saddles are furnished complete with steel clamps (electro-plated) and Everdur hardware where required.

Materials & Finishes*

Steel products are made from low carbon steel strips or plates. Porcelain saddles and clamps are made by dry process and white glazed (porcelain dielectric strength is 50 volts per mil). Maple clamps are made from kiln-dried maple wood, paraffin impregnated.

Finish Code	Finish	Specification
PLN	Plain	ASTM A1011 33,000 PSI min. yield
ZN	Electro-Plated Zinc	ASTM B633 SC3 Type III
GRN	Dura-Green	
GALV	Pre-Galvanized	ASTM B653
YZN	Yellow Zinc Chromate	ASTM B633 SC3 Type II

*Unless otherwise noted.

Design Load

Design load data published includes a Safety Factor of 3.0 (Safety Factor = Ratio of ultimate load to the design load).

U.L. listed raceway channels:

B11, B11KO6	B32, B32KO6
B12, B12KO6	B42, B42KO6
B22, B22KO6	B52, B52KO6
B24, B24KO6	B54, B54KO6
B26, B26KO6	B56, B56KO6

U.L. File No. E29637

In all cases, the snap-in closure strip is required to complete raceway enclosure.

Metric

Metric dimensions are shown in parentheses. Unless noted, all metric dimensions are in millimeters.



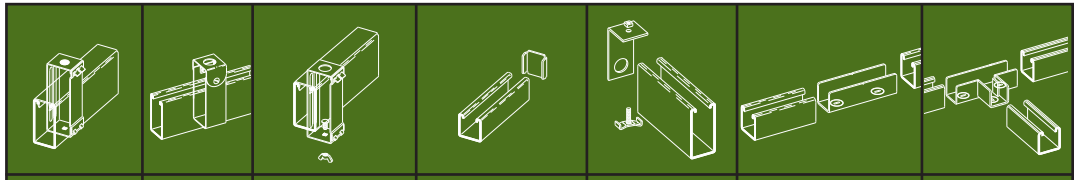
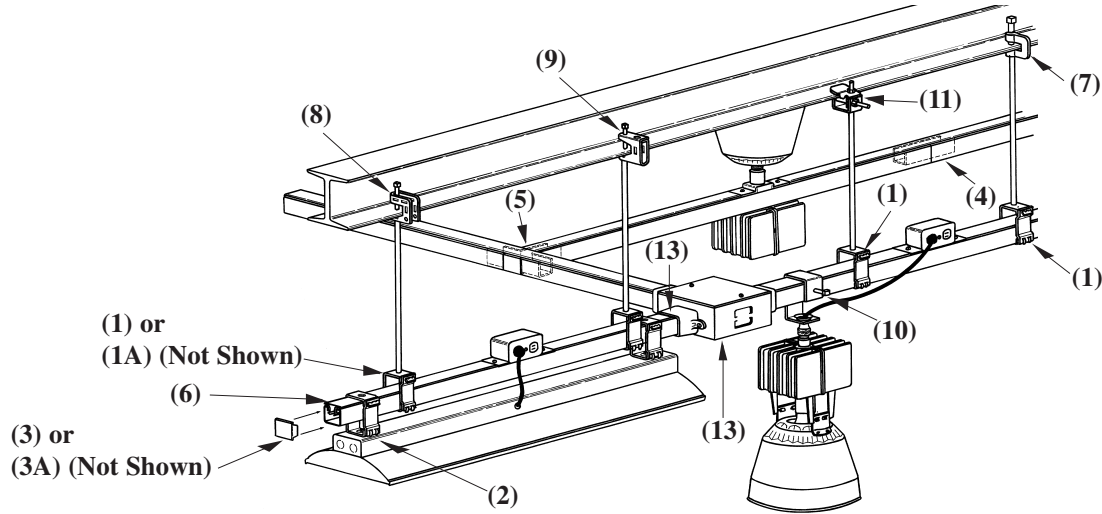

SELECTION CHART

Channel Number	Depth		Channel Hanger	Channel Hanger	Fixture Hanger	End Cap	Connection End Cap	Internal Straight Splice	Internal Tee Splice
B22A	3 ¹ / ₄ "	(82.5)	B616-22A*	B241S*	B616S-22A*	B205 or B285	B392-22** B285	B766-22 (2)	B768-22 (2)
B11	3 ¹ / ₄ "	(82.5)	B616-22A*	B241S*	B616S-22A*	B222	B392-11**	B766-11	B768-11
B12	2 ⁷ / ₁₆ "	(61.9)	B616-22A*	B241S*	B616S-22A*	B221	B392-12**	B766-12	B768-12
B22 B24	1 ⁵ / ₈ "	(41.3)	B616*	B216S*	B616S* B616TG*	B205 or B285 B223 or B286	B392-22**	B766-22	B768-22
B26	1 ⁵ / ₈ "	(41.3)	B616*	—	—	—	B392-22**	—	—
B32	1 ³ / ₈ "	(34.9)	B616*	B216S*	B616S* B616TG*	B206	B392-32**	B766-32	B768-32
B42	1"	(25.4)	B616*	B215S*	B616S* B616TG*	B203	—	B766-42	B768-42
B52 B54	1 ³ / ₁₆ "	(20.6)	B616*	B215S*	B616S* B616TG*	B220 or B283 B204 or B284	—	B766-52	B768-52
B56	1 ³ / ₁₆ "	(20.6)	B616*	B215S*	B616S* B616TG*	—	—	B766-56	—

*Specify Hanger Rod or Conduit Size.

**Specify Conduit Size

OTHER ITEMS SHOWN ON ILLUSTRATION

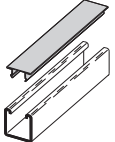
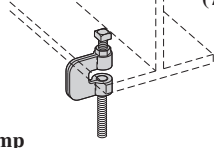
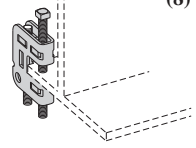
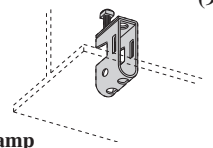
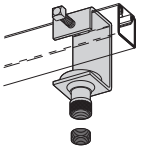
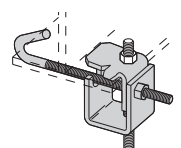
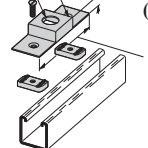
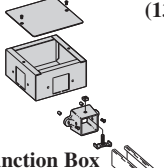
B217-20  Snap-in Closure Strip	(6)	B351L  Beam Clamp	(7)	B755  Beam Clamp	(8)	B751  Beam Clamp	(9)
B465  H.I.D. Fixture Hanger	(10)	B750  Beam Clamp	(11)	B447 B447A  Conduit Connection Plate	(12)	B719  B718 Series Junction Box	(13)

Reference page 150 for general fitting and standard finish specifications. U.L. Wire Fill Chart on pages 218 - 219.

Fluorescent Fixture Hangers

B616-9/16 CHANNEL HANGER

- Design Load 250 Lbs. (1.11 kN)
- Safety Factor of 3
- Maximum design load 50 Lbs. (.22 kN) when used as a fixture support
- Includes:
2 pcs. 3/8" Flat Washers for use with 3/8" ATR
- Material: 16 Gauge (1.5)
- Standard finish: ZN
- Wt./C 25 Lbs. (11.3 kg)

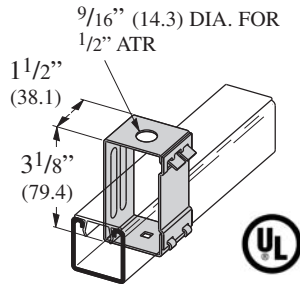

B616-7/8 CHANNEL HANGER

- Design Load 250 Lbs. (1.11 kN)
- Safety Factor of 3
- Maximum design load 50 Lbs. (.22 kN) when used as a fixture support
- Material: 16 Gauge (1.5)
- Standard finish: ZN
- Wt./C 25 Lbs. (11.3 kg)

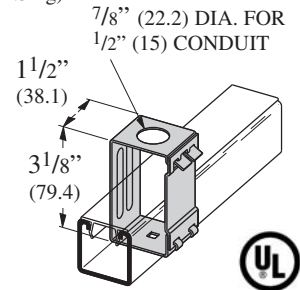

B616S-9/16 FLUORESCENT FIXTURE HANGER WITH STUD

- Design Load 150 Lbs. (.67 kN)
- Safety Factor of 3
- Maximum design load 50 Lbs. (.22 kN) when used as a fixture support
- Allows more than 1/2" (12.7) space between channel and fixture
- Includes:
2 pcs. 3/8" Flat Washers for use with 3/8" ATR
- Material: 16 Gauge (1.5)
- Standard finish: ZN
- Wt./C 30 Lbs. (13.6 kg)

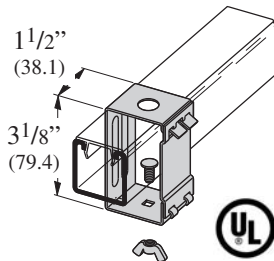

B616S-7/8 FLUORESCENT FIXTURE HANGER WITH STUD

- Design Load 150 Lbs. (.67 kN)
- Safety Factor of 3
- Maximum design load 50 Lbs. (.22 kN) when used as a fixture support
- Allows more than 1/2" (12.7) space between channel and fixture
- Standard finish: ZN
- Wt./C 30 Lbs. (13.6 kg)

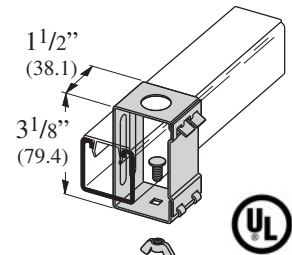

B616-22A-9/16 CHANNEL HANGER

- Design Load 250 Lbs. (1.11 kN)
- Safety Factor of 3
- Maximum design load 50 Lbs. (.22 kN) when used as a fixture support
- Includes:
2 pcs. 3/8" Flat Washers for use with 3/8" ATR
- Material: 14 Gauge (1.9)
- Standard finish: ZN
- Wt./C 44 Lbs. (19.9 kg)

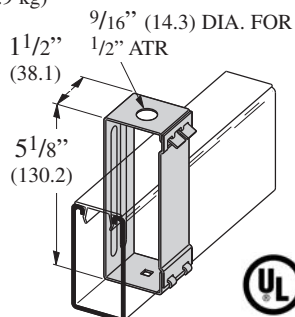

B616-22A-7/8 CHANNEL HANGER

- Design Load 250 Lbs. (1.11 kN)
- Safety Factor of 3
- Maximum design load 50 Lbs. (.22 kN) when used as a fixture support
- Material: 14 Gauge (1.9)
- Standard finish: ZN
- Wt./C 44 Lbs. (19.9 kg)

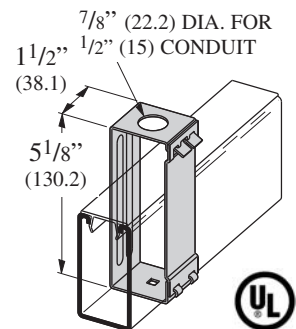

B616S-22A-9/16 FLUORESCENT FIXTURE HANGER WITH STUD

- Design Load 150 Lbs. (.67 kN)
- Safety Factor of 3
- Maximum design load 50 Lbs. (.22 kN) when used as a fixture support
- Includes:
2 pcs. 3/8" Flat Washers for use with 3/8" ATR
- Allows more than 1/2" (12.7) space between channel and fixture
- Material: 14 Gauge (1.9)
- Standard finish: ZN
- Wt./C 49 Lbs. (22.2 kg)

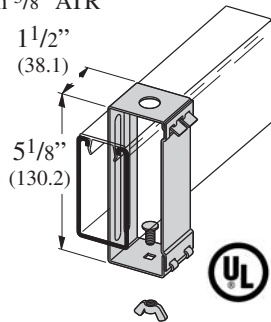

B616S-22A-7/8 FLUORESCENT FIXTURE HANGER WITH STUD

- Design Load 150 Lbs. (.67 kN)
- Safety Factor of 3
- Maximum design load 50 Lbs. (.22 kN) when used as a fixture support
- Allows more than 1/2" (12.7) space between channel and fixture
- Material: 14 Gauge (1.9)
- Standard finish: ZN
- Wt./C 49 Lbs. (22.2 kg)

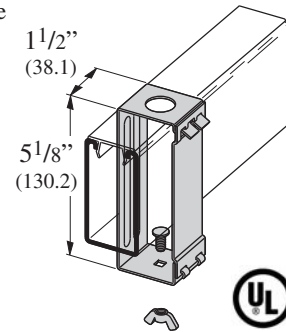

B616TG-9/16 FLUORESCENT FIXTURE HANGER FOR 1/2" (15) KNOCKOUT

- Design Load 150 Lbs. (.67 kN)
- Safety Factor of 3
- Maximum design load 50 Lbs. (.22 kN) when used as a fixture support
- Includes:
2 pcs. 3/8" Flat Washers for use with 3/8" ATR
- Design Load 150 Lbs. (.67 kN)
- Allows more than 1/2" (12.7) space between channel and fixture
- Material: 16 Gauge (1.5)
- Standard finish: ZN
- Wt./C 32 Lbs. (14.5 kg)

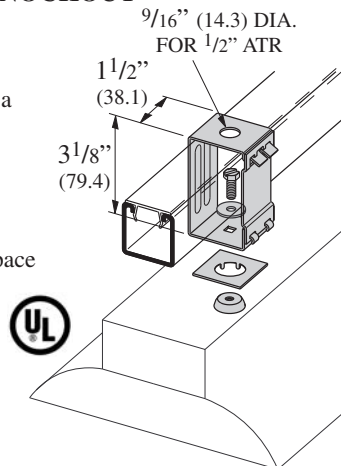

B215S CHANNEL HANGER

- Can be used with 3/8" & 1/2" threaded rod or 3/8" & 1/2" conduit
- Design Load 250 Lbs. (1.11 kN)
- Safety Factor of 3
- For use with B42, B52, B54 & B56 Channels
- Hardware included:
One (1) 3/8" x 1 1/2" FFW for use with 3/8"-16 ATR
One (1) 1/2" FW for use with 1/2"-13 ATR
One (1) 5/8" FW for use with 3/8" conduit
- Material: 16 Gauge (1.5)
- Standard finish: ZN
- Wt./C 31 Lbs. (14.0 kg)

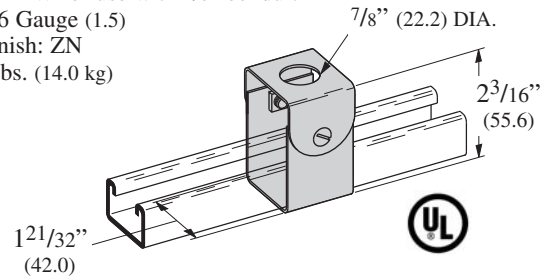

B216S CHANNEL HANGER

- Can be used with 3/8" & 1/2" threaded rod or 3/8" & 1/2" conduit
- Design Load 250 Lbs. (1.11 kN)
- Safety Factor of 3
- For use with B22, B24, B26 & B32 Channels
- Hardware included:
One (1) 3/8" x 1 1/2" FFW for use with 3/8"-16 ATR
One (1) 1/2" FW for use with 1/2"-13 ATR
One (1) 5/8" FW for use with 3/8" conduit
- Material: 16 Gauge (1.5)
- Standard finish: ZN
- Wt./C 38 Lbs. (17.2 kg)

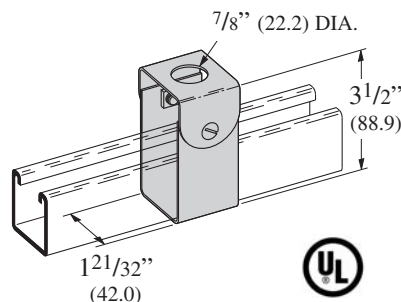

B241S CHANNEL HANGER

- Can be used with 3/8" & 1/2" threaded rod or 3/8" & 1/2" conduit
- Design Load 250 Lbs. (1.11 kN)
- Safety Factor of 3
- For use with B11 & B12 Channels.
- Hardware included:
One (1) 3/8" x 1 1/2" FFW for use with 3/8"-16 ATR
One (1) 1/2" FW for use with 1/2"-13 ATR
One (1) 5/8" FW for use with 3/8" conduit
- Material: 16 Gauge (1.5)
- Standard finish: ZN
- Wt./C 47 Lbs. (21.3 kg)

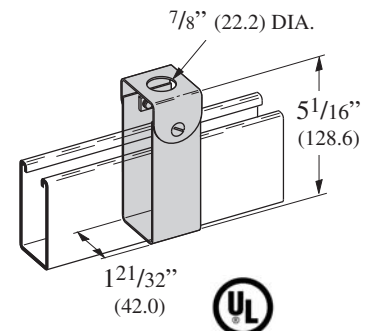

Reference page 150 for general fitting and standard finish specifications. U.L. Wire Fill Chart on pages 218 - 219.

Fluorescent Fixture Hangers

B390S 360° SWIVEL CHANNEL CONNECTOR

- Design Load 250 Lbs. (1.11 kN)
- Safety Factor of 3
- Maximum design load 50 Lbs. (.22 kN) when used as a fixture support
- Swings 15° in 360° plane
- Includes:
2 pcs. SN224-3/4"WO Stud Nut
2 pcs. 1/4"-20 Square Nut
1 pc. 3/4" (20) to 1/2" (15) Conduit Reducer
- Standard finish: ZN
- Wt./C 71 Lbs. (32.2 kg)

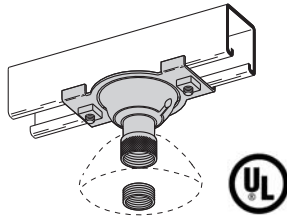

B390BX 360° SWIVEL BOX CONNECTOR

- Design Load 250 Lbs. (1.11 kN) for Connector Fitting only
- Safety Factor of 3
- Design Load 50 Lbs. (.22 kN) when used as illustrated or for use as a fixture support
- Swings 15° in 360° plane
- Includes:
1 pc. 3/4" (20) to 1/2" (15) Conduit Reducer
- Fits on 4" box
- Standard finish: ZN
- Wt./C 55 Lbs. (24.9 kg)

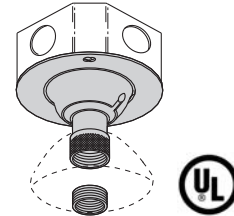

B465 H.I.D. FIXTURE HANGER

- Design Load 250 Lbs. (1.11 kN)
- Safety Factor of 3
- Swings 15° in 360° plane
- Includes:
1 pc. 3/4" (20) to 1/2" (15) Conduit Reducer
- Standard finish: ZN
- Wt./C 95 Lbs. (43.1 kg)

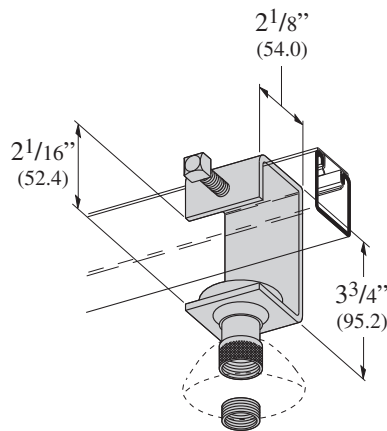

B436 FLUORESCENT FIXTURE NUT

- Standard finish: ZN
- Wt./C 2 Lbs. (.9 kg)

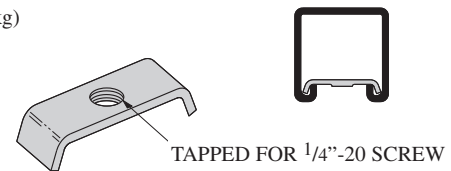

B436S FLUORESCENT FIXTURE STUD NUT

- Bolt size: 1/4" x 1 1/4"
- Standard finish: ZN
- Wt./C 4 Lbs. (1.8 kg)
- Design Load 250 Lbs. (1.11 kN)
- Safety Factor of 3

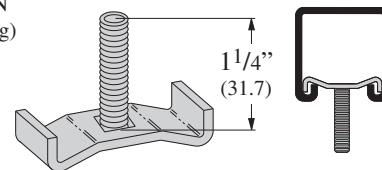

B460 FLUORESCENT FIXTURE HANGER

- Hanger is shipped flat and requires field bending as shown
- Allows more than 1/2" (12.7) space between channel and fixture
- Material: 18 Gauge (1.2)
- Standard finish: ZN

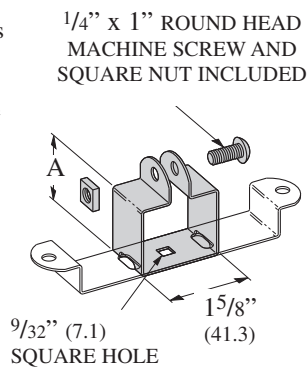

B464 FLUORESCENT FIXTURE HANGER

- Hanger is shipped flat and requires field bending as shown
- Allows more than 1/8" (3.2) space between channel and fixture
- Material: 18 Gauge (1.2)
- Standard finish: ZN

1/4" x 1" ROUND HEAD MACHINE SCREW AND SQUARE NUT INCLUDED

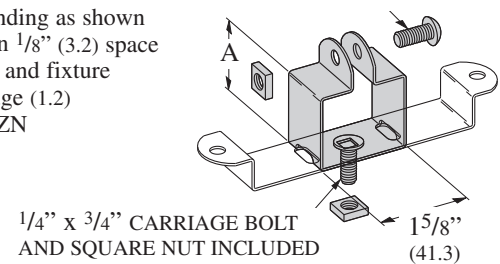

Part No.	For Channel Size	A	Wt./C	
			Lbs.	kg
B460-22	B22, B24, B26, B32	2 1/8" (57.5)	17	(7.7)
B460-12	B12	2 15/16" (79.5)	20	(9.1)
B460-11	B11	3 3/4" (101.6)	23	(10.4)

Part No.	For Channel Size	A	Wt./C	
			Lbs.	kg
B464-32	B32	1 1/2" (40.6)	17	(7.7)
B464-22	B22, B24, B26	1 3/4" (47.4)	18	(8.1)
B464-12	B12	2 9/16" (66.0)	21	(9.5)
B464-11	B11	3 3/8" (91.4)	24	(10.9)

Reference page 150 for general fitting and standard finish specifications. U.L. Wire Fill Chart on pages 218 - 219.

B217-20 SNAP CLOSURE STRIP FOR ALL 1⁵/₈" (41.3) WIDE CHANNELS

- Refer to Raceway Fill Chart Pg. 214-215
- Material: 20 Gauge (.9)
- Standard finishes: GRN, GALV, YZN
- Standard length: 120" (3.05m)
- Wt./CFT 36 Lbs. (16.3 kg)

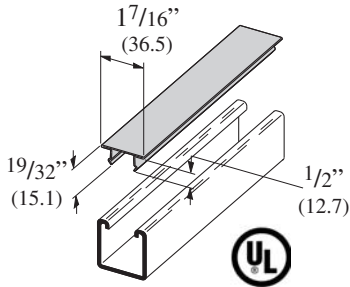

B217P PLASTIC SNAP CLOSURE STRIP FOR ALL 1⁵/₈" (41.3) WIDE CHANNELS

- Refer to Raceway Fill Chart Pg. 214-215
- Standard finishes: Green (GRN) or Gray (GRY) Plastic
- Standard length: 120" (3.05m)
- Wt./CFT 9.2 Lbs. (4.2 kg)

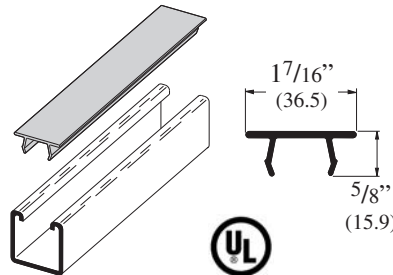

B217-24 SNAP CLOSURE STRIP FOR ALL 1⁵/₈" (41.3) WIDE CHANNELS

- Refer to Raceway Fill Chart Pg. 214-215
- For use with 7 or fewer conductors no larger than #12 AWG
- Material: 24 Gauge (.6)
- Standard finishes: GRN, GALV, YZN
- Standard length: 120" (3.05m)
- Wt./CFT 28 Lbs. (12.7 kg)

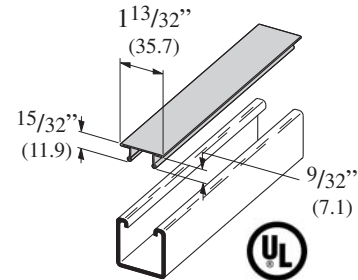

B516 SNAP-IN OUTLET BOX

- Provided with #10-32 tapped hole for grounding strap
- Duplex cover plate included
- Receptacle not furnished
- Requires ground wire installation for use with UL listed channel raceway system
- Standard finish: GALV
- Wt./C 72 Lbs. (32.6 kg)

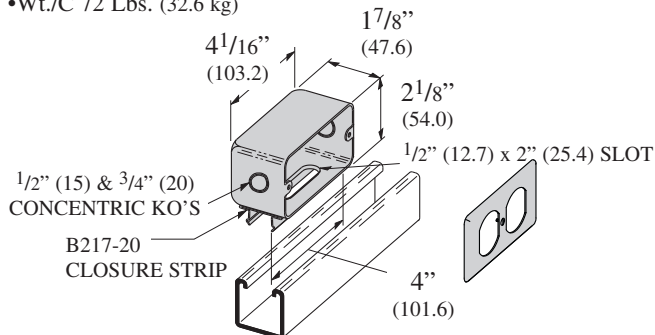

B516S OUTLET BOX

- Duplex cover plate included
- Receptacle not furnished
- Includes:
2 pcs. 1/4"-20 Flat Head Machine Screws
2 pcs. N224WO Channel Nuts
- Standard finish: ZN
- Wt./C 98 Lbs. (44.4 kg)

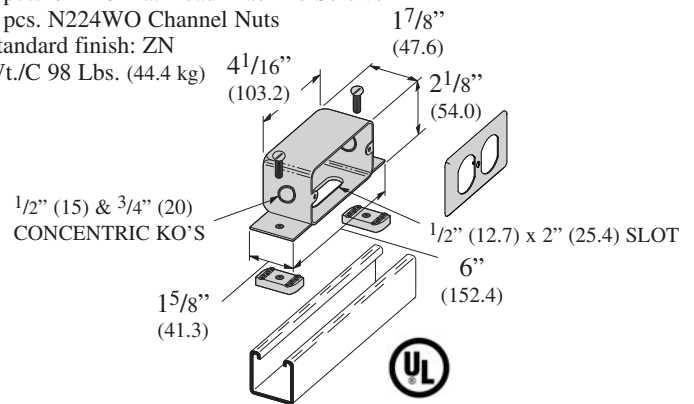

B203 THRU B206 B220 THRU B223 X TYPE END CAPS

- Material: 12 Gauge (2.6)
- Standard finishes: ZN, GRN, HDG, SS4

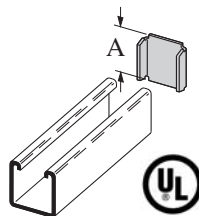

B283 THRU B286 END CAPS

- Material: 12 Gauge (2.6)
- Standard finishes: ZN, GRN

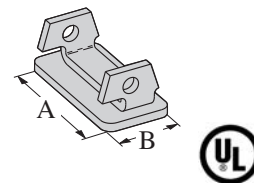

Part No.	Use With	A	Wt./C	
			Lbs.	kg
B203	B42	1.015" (25.8)	6	(2.7)
B204	B54	.827" (21.0)	5	(2.2)
B205	B22	1.640" (41.6)	10	(4.5)
B206	B32	1.390" (35.3)	8	(3.6)
B220	B52	.827" (21.0)	4	(1.8)
B221	B12	2.452" (62.3)	15	(6.8)
B222	B11	3.265" (82.9)	20	(9.1)
B223	B24	1.640" (41.6)	10	(4.5)

Part No.	Use With	A		B	Wt./C	
		Lbs.	kg		Lbs.	kg
B283	B52	1 ¹⁹ / ₃₂ " (40.5)	2 ⁵ / ₃₂ " (19.8)	6	(2.7)	
B284	B54 & B56	1 ¹⁹ / ₃₂ " (40.5)	2 ⁵ / ₃₂ " (19.8)	6	(2.7)	
B285	B22	1 ¹⁹ / ₃₂ " (40.5)	1 ¹⁹ / ₃₂ " (40.5)	13	(5.9)	
B286	B24 & B26	1 ¹⁹ / ₃₂ " (40.5)	1 ¹⁹ / ₃₂ " (40.5)	14	(6.3)	

Reference page 150 for general fitting and standard finish specifications. U.L. Wire Fill Chart on pages 218 - 219.

Electrical Accessories

B447 CONDUIT CONNECTION PLATE FOR 1/2" (15) CONDUIT

- Includes:
2 pcs. 1/4"-20 Flat Head Machine Screws
2 pcs. N224WO Channel Nuts
- Material: 16 Gauge (1.5)
- Standard finish: ZN
- Wt./C 35 Lbs. (15.9 kg)

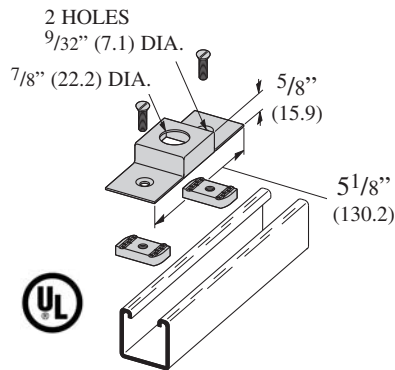

B447A CONDUIT CONNECTION PLATE FOR 3/4" (20) CONDUIT

- Includes:
2 pcs. 1/4"-20 Flat Head Machine Screws
2 pcs. N224WO Channel Nuts
- Material: 16 Gauge (1.5)
- Standard finish: ZN
- Wt./C 35 Lbs. (15.9 kg)

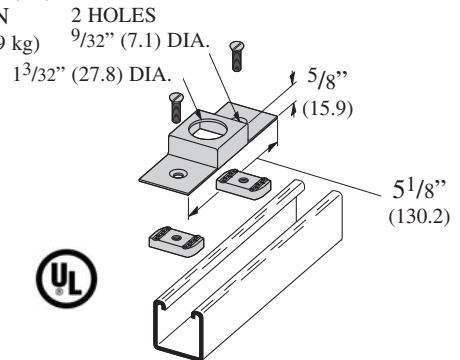

B392-32 SERIES CONNECTION END CAP

- Includes:
1 pc. 1/4"-20 Square Nut
1 pc. B436S Fixture Stud Nut
- Material: 11 Gauge (3.0)
- Standard finish: ZN

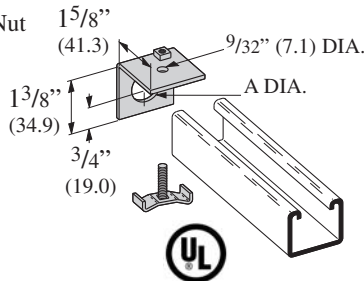

B392-22 SERIES CONNECTION END CAP

- Includes:
1 pc. 1/4"-20 Square Nut
1 pc. B436S Fixture Stud Nut
- Material: 11 Gauge (3.0)
- Standard finish: ZN

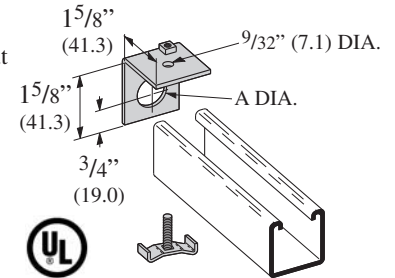

Part No.	A		Conduit Size		Wt./C	
					Lbs.	kg
B392-32-1/2	7/8"	(22.2)	1/2"	(15)	20	(9.1)
B392-32-3/4	1 1/16"	(27.0)	3/4"	(20)	19	(8.6)

Part No.	A		Conduit Size		Wt./C	
					Lbs.	kg
B392-22-1/2	7/8"	(22.2)	1/2"	(15)	21	(9.5)
B392-22-3/4	1 1/16"	(27.0)	3/4"	(20)	20	(9.1)
B392-22-1	1" PIPE THREAD		1"	(25)	17	(7.7)

B392-12 SERIES CONNECTION END CAP

- Includes:
1 pc. 1/4"-20 Square Nut
1 pc. B436S Fixture Stud Nut
- Material: 11 Gauge (3.0)
- Standard finish: ZN

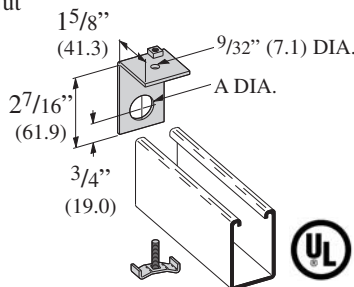

B392-11 SERIES CONNECTION END CAP

- Includes:
1 pc. 1/4"-20 Square Nut
1 pc. B436S Fixture Stud Nut
- Material: 11 Gauge (3.0)
- Standard finish: ZN

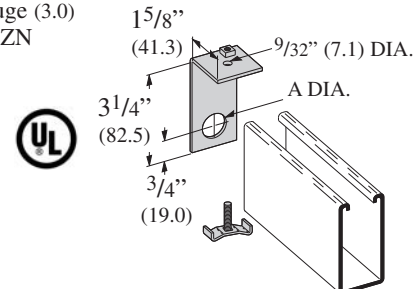

Part No.	A		Conduit Size		Wt./C	
					Lbs.	kg
B392-12-1/2	7/8"	(22.2)	1/2"	(15)	27	(12.2)
B392-12-3/4	1 1/16"	(22.7)	3/4"	(20)	26	(11.8)
B392-12-1	1" PIPE THREAD		1"	(25)	23	(10.4)

Part No.	A		Conduit Size		Wt./C	
					Lbs.	kg
B392-11-1/2	7/8"	(22.2)	1/2"	(15)	36	(16.3)
B392-11-3/4	1 1/16"	(27.0)	3/4"	(20)	33	(14.9)
B392-11-1	1" PIPE THREAD		1"	(25)	32	(14.5)

Reference page 150 for general fitting and standard finish specifications. U.L. Wire Fill Chart on pages 218 - 219.

B718

UNIVERSAL JUNCTION BOX

- Assemble B719 Hubs into B718 square knockouts
- Designed for use with B22, B24 & B26 Channel
- B718 Includes:
 - 1 pc. Junction Box only
 - 1 pc. Cover only
 - 2 pcs. #10-20 Round Head Machine Screws
- Standard finish: ZN
- Wt./C 180 Lbs. (81.6 kg)

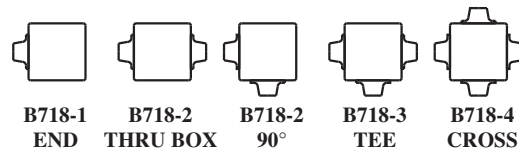

SELECTION GUIDE

Part No.	Includes	Wt./C	
		Lbs.	kg
B718-1	1 B718 & 1 B719	205	(93.0)
B718-2	1 B718 & 2 B719	230	(104.3)
B718-3	1 B718 & 3 B719	255	(115.6)
B718-4	1 B718 & 4 B719	280	(127.0)

Box Dimension:
2 1/2" Deep x 5 1/8" Square

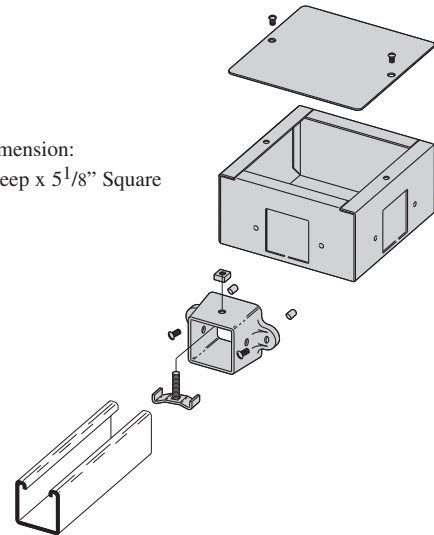

B719AL

UNIVERSAL JUNCTION BOX HUB

- B719AL Includes:
 - 1 pc. B719AL Hub only
 - 1 pc. B436S Fixture Stud Nut
 - 1 pc. 1/4"-20 Square Nut
 - 2 pcs. #10-24 Self Tapping Screws
 - 2 pcs. Rubber Caps
- Material: Aluminum
- Wt./C 25 Lbs. (11.3 kg)

B518-1 THRU B518-4

UNIVERSAL JUNCTION BOX AND HUBS

- Channel Connection Kits as shown in the chart above
- Includes:
 - 1 pc. Junction Box with Screws
 - 1 pc. Box Cover
- Standard finish: ZN

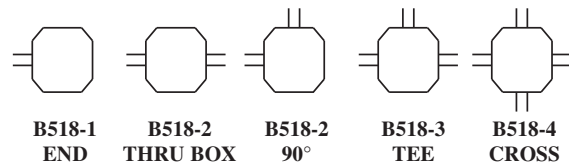

SELECTION GUIDE

Part No.	Channel Connection Kits Included	Wt./C	
		Lbs.	kg
B518-1	1	106	(48.1)
B518-2	2	137	(62.1)
B518-3	3	162	(78.5)
B518-4	4	192	(87.1)

CHANNEL CONNECTION KIT

- For use with B22, B24 & B26 Channels.
- Box Dimension: Standard 4" Octagon Box
- Includes:
 - 1 pc. B392-22-3/4 End Connection (See page 156)
 - 1 pc. 3/4" (20) Insulated Chase Nipple
 - 1 pc. 3/4" (20) Lock Nut
- Standard finish: ZN

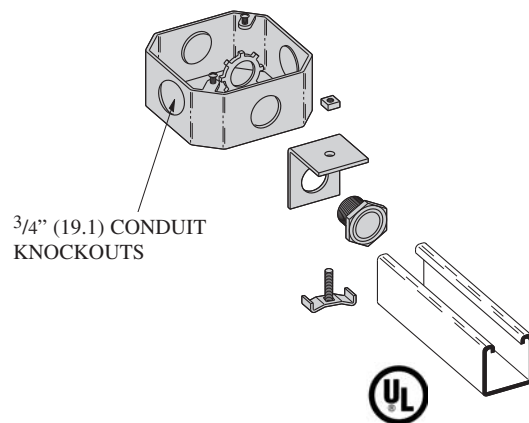

Reference page 150 for general fitting and standard finish specifications. U.L. Wire Fill Chart on pages 218 - 219.

Strut Joiners

B766 SERIES STRAIGHT STRUT JOINER

- Includes: 2 Cam Screws
- Material: 12 Gauge (2.6)
- Standard finish: ZN

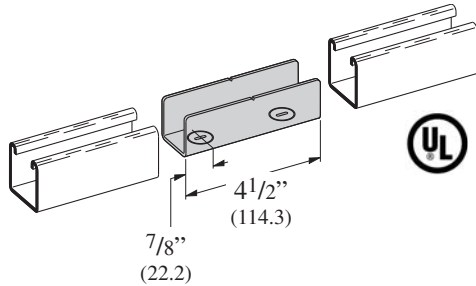

Part No.	For Channel Size	Wt./C	
		Lbs.	kg
B766-11	B11	94	(42.6)
B766-12	B12	72	(32.6)
B766-22 *	B22 & B24	50	(22.7)
B766-26	B26	53	(24.0)
B766-32	B32	44	(19.9)
B766-42	B42	34	(15.4)
B766-52	B52 & B54	28	(12.7)
B766-56	B56	31	(14.0)

B767 SERIES 90° ELBOW STRUT JOINER

- Includes: 2 Cam Screws
- Material: 12 Gauge (2.6)
- Standard finish: ZN

Note: B767-22
(Cast Aluminum Fitting)
does not require miter
cutting of channel as
shown in drawing.

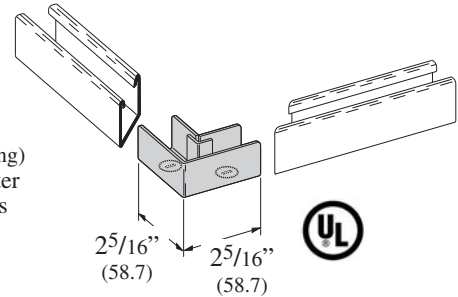

Part No.	For Channel Size	Wt./C	
		Lbs.	kg
B767-11	B11	74	(33.5)
B767-12	B12	56	(25.4)
B767-22 *	B22 & B24	39	(17.7)
B767-26	B26	41	(18.6)
B767-32	B32	34	(15.4)
B767-42	B42	27	(12.2)
B767-52	B52 & B54	23	(10.4)
B767-56	B56	25	(11.3)

B768 SERIES TEE STRUT JOINER

- Includes: 3 Cam Screws
- Patented
- Material: 12 Gauge (2.6)
- Standard finish: ZN

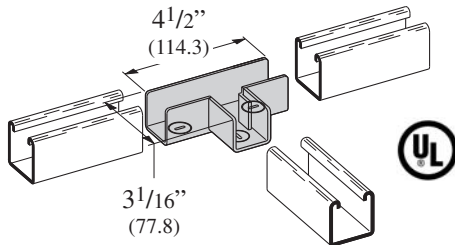

Part No.	For Channel Size	Wt./C	
		Lbs.	kg
B768-11	B11	142	(64.4)
B768-12	B12	112	(50.8)
B768-22 *	B22 & B24	79	(35.8)
B768-26	B26	79	(35.8)
B768-32	B32	72	(32.6)
B768-42	B42	62	(28.1)
B768-52	B52 & B54	57	(25.8)
B768-56	B56	60	(27.2)

* Cast Aluminum parts

B769 SERIES CROSS STRUT JOINER

- Includes: 4 Cam Screws
- Patented
- Material: 12 Gauge (2.6)
- Standard finish: ZN

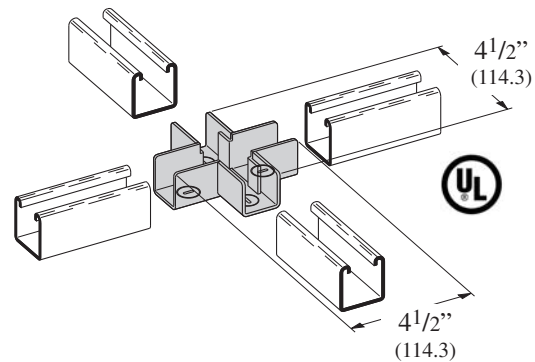

Part No.	For Channel Size	Wt./C	
		Lbs.	kg
B769-11	B11	148	(67.1)
B769-12	B12	120	(54.4)
B769-22 *	B22 & B24	87	(39.4)
B769-26	B26	93	(42.2)
B769-32	B32	78	(35.4)
B769-42	B42	65	(29.5)
B769-52	B52 & B54	58	(26.3)
B769-56	B56	62	(28.1)

Note: Strut joiners are not for structural support. A channel support is recommended within 24" (609 mm) of each joint.

Reference page 150 for general fitting and standard finish specifications. U.L. Wire Fill Chart on pages 218 - 219.

B166 FOUR HOLE SPLICE CLEVIS

- Includes:
1 Splice Clevis
4 pcs. 1/4"-20 Flat Head Machine Screws
4 pcs. N224WO Channel Nuts
- Material: 16 Gauge

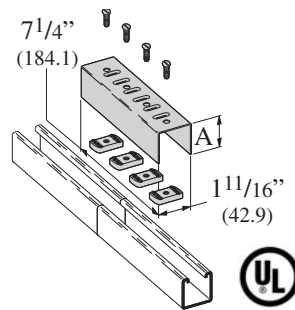

B166-46 FOUR HOLE SPLICE CLEVIS ASSEMBLY

- Requires ground wire for use with UL listed channel raceway system
- Includes:
1 Splice Clevis
1 pc. B466W tapped plate
4 pcs. 1/4"-20 Flat Head Machine Screws
- Material: 16 Gauge (1.5)
- Standard finishes: ZN, GRN

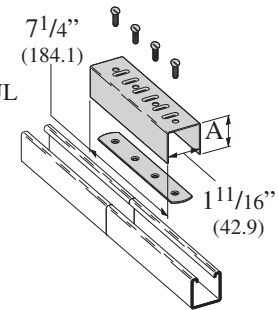

Part No.	A		For Channel Size	Wt./C	
				Lbs.	kg
B166-11	3 1/4"	(82.5)	B11	128	(58.0)
B166-12	2 7/16"	(61.9)	B12	108	(49.0)
B166-22	1 5/8"	(41.3)	B22, B24, B26	91	(40.3)
B166-32	1 3/8"	(34.9)	B32	83	(37.6)
B166-42	1"	(25.4)	B42	75	(34.0)
B166-52	1 3/16"	(20.6)	B52, B54, B56	71	(32.2)

Part No.	A		For Channel Size	Wt./C	
				Lbs.	kg
B166-46-11	3 1/4"	(82.5)	B11	118	(53.5)
B166-46-12	2 7/16"	(61.9)	B12	98	(44.4)
B166-46-22	1 5/8"	(41.3)	B22, B24, B26	79	(35.8)
B166-46-32	1 3/8"	(34.9)	B32	73	(33.1)
B166-46-42	1"	(25.4)	B42	65	(29.5)
B166-46-52	1 3/16"	(20.6)	B52, B54, B56	61	(27.6)

B166CL SPLICE CLEVIS CLIP

- Use to cover gap between strut
- Material: 18 Gauge (1.2)
- Standard finish: ZN
- Wt./C 4 Lbs. (1.8 kg)

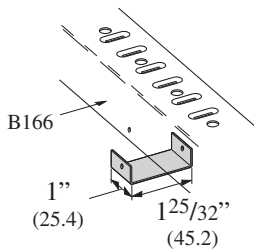

B466W TAPPED SPLICE PLATE

- Includes:
4 pcs. 1/4"-20 Flat Head Machine Screws
- Material: 14 Gauge (1.9)
- Standard finish: ZN
- Wt./C 27 Lbs. (12.2 kg)
- Holes 1 3/16" (20.6) from ends and 1 7/8" (47.6) on centers

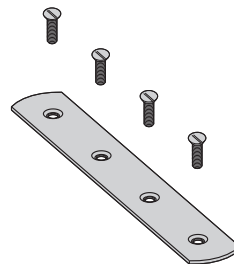

B466S STUD SPLICE PLATE

- Includes:
4 pcs. 1/4"-20 Square Nuts
- Material: 14 Gauge (1.9)
- Standard finish: ZN
- Wt./C 34 Lbs. (15.4 kg)
- Studs 1 3/16" (20.6) from ends and 1 7/8" (47.6) on centers

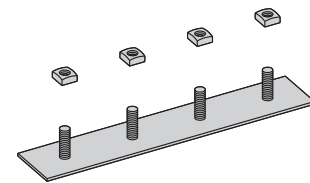

B619 KNOCK-OUT PLATE

- Requires ground wire for use with UL listed channel raceway system
- Includes:
2 pcs. 1/4"-20 Flat Head Machine Screws
2 pcs. N224WO Channel Nuts
- Material: 16 Gauge (1.5)
- 1/2" (15) Conduit Knockouts
- Standard finish: ZN
- Wt./C 40 Lbs. (18.1 kg)

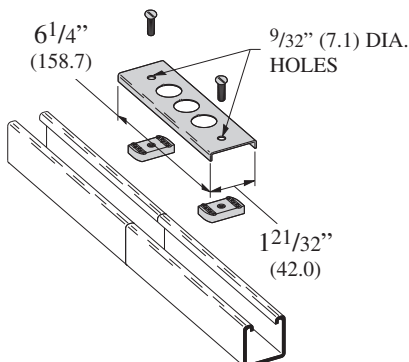

B393-1 WIRING STUD

- Requires ground wire for use with UL listed channel raceway system
- 1/2" (15) pipe threads
- Material: Cast Aluminum
- Wt./C 6 Lbs. (2.7 kg)

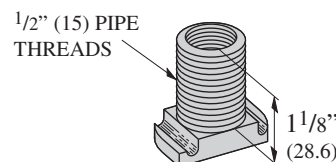

B589 SPACER CLEVIS

- Can be used with B393-1 wiring stud
- Material: 12 Gauge (2.6)
- Standard finish: ZN
- Wt./C 29 Lbs. (13.1 kg)

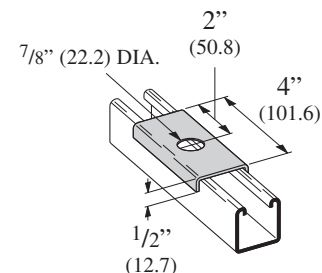

Reference page 150 for general fitting and standard finish specifications. U.L. Wire Fill Chart on pages 218 - 219.

Electrical Hardware

B446 SWIVEL HANGER (FEMALE-MALE)

- Design Load:
(³/₈)-730 Lbs. (3.24 kN)
(¹/₂)-1350 Lbs. (6.00 kN)
- Safety Factor of 3
- Standard finish: ZN

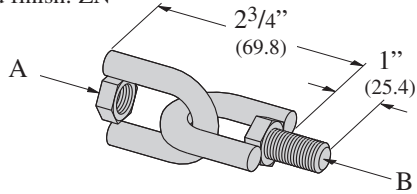

Part No.	A	B	Wt./C	
			Lbs.	kg
B446- ³ / ₈	³ / ₈ "-16 HN	³ / ₈ "-16 HHCS	28	(12.7)
B446- ¹ / ₂	¹ / ₂ "-13 HN	¹ / ₂ "-13 HHCS	36	(16.3)

B446A SWIVEL HANGER (FEMALE ONLY)

- Design Load:
(³/₈)-730 Lbs. (3.24 kN)
(¹/₂)-1350 Lbs. (6.00 kN)
- Safety Factor of 3
- Standard finish: ZN

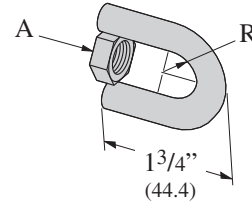

Part No.	A	R	Wt./C	
			Lbs.	kg
B446A- ³ / ₈	³ / ₈ "-16 HN	⁹ / ₃₂ "	(7.1)	13 (5.9)
B446A- ¹ / ₂	¹ / ₂ "-13 HN	³ / ₈ "	(9.5)	15 (6.8)

B446B SWIVEL HANGER (MALE ONLY)

- Design Load:
(³/₈)-730 Lbs. (3.24 kN)
(¹/₂)-1350 Lbs. (6.00 kN)
- Safety Factor of 3
- Standard finish: ZN

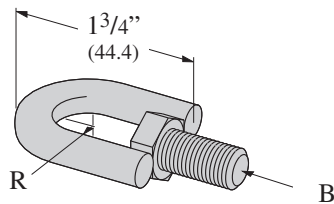

Part No.	B	R	Wt./C	
			Lbs.	kg
B446B- ³ / ₈	³ / ₈ "-16 HHCS	⁹ / ₃₂ "	(7.1)	16 (7.2)
B446B- ¹ / ₂	¹ / ₂ "-13 HHCS	³ / ₈ "	(9.5)	20 (9.1)

B446C SWIVEL HANGER (FEMALE-FEMALE)

- Design Load:
(³/₈)-730 Lbs. (3.24 kN)
(¹/₂)-1350 Lbs. (6.00 kN)
- Safety Factor of 3
- Standard finish: ZN

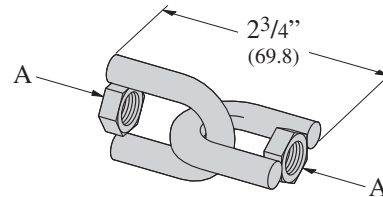

Part No.	A	Wt./C	
		Lbs.	kg
B446C- ³ / ₈	³ / ₈ "-16 HN	26	(11.8)
B446C- ¹ / ₂	¹ / ₂ "-13 HN	31	(14.0)

B590 FIBER WIRE RETAINER

- Installation aid for retaining wires before installing snap closure strip
- Wt./C 1 Lb. (.4 kg)

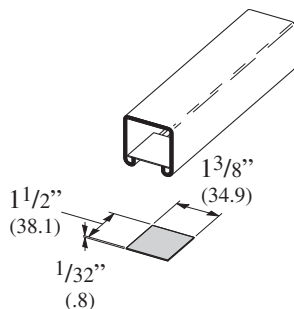

B617 SHOULDER BOLT

- Standard finish: ZN
- Wt./C 6 Lbs. (2.7 kg)

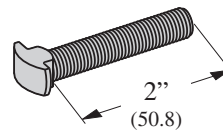

³/₈"-16 THREAD SIZE

B4060 THRU B4093

INSULCLAMP® CABLE CLAMPS (Replaces porcelain clamps)

- Assembly includes:
 - 1 Insulclamp® & 1 pr. zinc plated Pipe Straps with Everdur (Silicon Bronze) Hardware
- The thermoplastic elastomer Insulclamp has a dielectric strength of 640 volts/mil
- The flame retardant one piece design allows for trouble free assembly
- Everdur hardware is non-ferrous and prevents magnetic induction

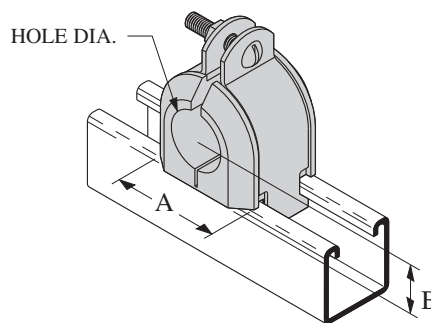

Part No.	Hole Dia.		Wt./C		A		B		Clamp No. (included)
			Lbs.	kg					
B4060	3/8"	(9.5)	25	(11.3)	1.36"	(34.5)	.56"	(14.2)	B2030
B4061	1/2"	(12.7)	25	(11.3)					
B4062	5/8"	(15.9)	25	(11.3)					
B4063	3/4"	(19.0)	37	(16.8)	1.86"	(47.2)	.81"	(20.8)	B2034
B4064	7/8"	(22.2)	37	(16.8)					
B4065	1"	(25.4)	37	(16.8)					
B4066	1 1/8"	(28.6)	37	(16.8)	2.36"	(59.9)	1.06"	(26.9)	B2038
B4067	1 1/4"	(31.7)	58	(26.3)					
B4068	1 3/8"	(34.9)	58	(26.3)					
B4069	1 1/2"	(38.1)	58	(26.3)	2.86"	(72.6)	1.31"	(33.3)	B2042
B4070	1 5/8"	(41.3)	58	(26.3)					
B4071	1 3/4"	(44.4)	76	(34.5)					
B4072	1 7/8"	(47.6)	76	(34.5)	3.36"	(85.3)	1.56"	(39.6)	B2046
B4073	2"	(50.8)	76	(34.5)					
B4074	2 1/8"	(54.0)	76	(34.5)					
B4075	2 1/4"	(57.1)	90	(40.8)	3.86"	(98.0)	1.81"	(46.0)	B2050
B4076	2 3/8"	(60.3)	90	(40.8)					
B4077	2 1/2"	(63.5)	90	(40.8)					
B4078	2 5/8"	(66.7)	90	(40.8)	4.36"	(110.7)	2.06"	(52.3)	B2054
B4079	2 3/4"	(69.8)	109	(49.4)					
B4080	2 7/8"	(73.0)	109	(49.4)					
B4081	3"	(76.2)	109	(49.4)	4.86"	(123.4)	2.31"	(58.7)	B2058
B4082	3 1/8"	(79.4)	109	(49.4)					
B4083	3 1/4"	(82.5)	130	(58.9)					
B4084	3 3/8"	(85.7)	130	(58.9)	5.24"	(133.1)	2.50"	(63.5)	B2018
B4085	3 1/2"	(88.9)	130	(58.9)					
B4086	3 5/8"	(92.1)	130	(58.9)					
B4087	3 3/4"	(95.2)	160	(72.6)	4.86"	(123.4)	2.31"	(58.7)	B2058
B4088	3 7/8"	(98.4)	160	(72.6)					
B4089	4"	(101.6)	160	(72.6)					
B4090	4 1/8"	(104.8)	160	(72.6)	5.24"	(133.1)	2.50"	(63.5)	B2018
B4091	4 1/4"	(107.9)	160	(72.6)					
B4092	4 3/8"	(111.1)	160	(72.6)					
B4093	4 1/2"	(114.3)	160	(72.6)					

Reference page 150 for general fitting and standard finish specifications. U.L. Wire Fill Chart on pages 218 - 219.

Porcelain & Maple Clamps

B4050 & B4051 PORCELAIN CABLE CHANNEL SADDLE

- Electrical porcelain has an dielectric strength of 50 volts/mil

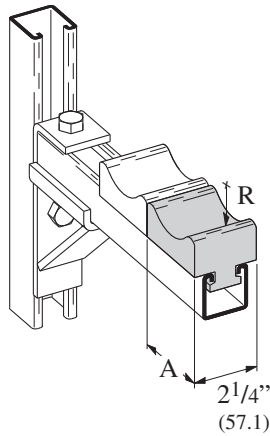

Part No.	A		R		Wt./C	
	Lbs.	kg	Lbs.	kg	Lbs.	kg
B4050	3"	(76.2)	1 3/8"	(34.9)	72	(32.6)
B4051	4"	(101.6)	2 1/8"	(54.0)	100	(45.3)

B4094 & B4095 PORCELAIN CABLE RACK SADDLE

- Electrical porcelain has an dielectric strength of 50 volts/mil
- Designed for use with B449 Brackets

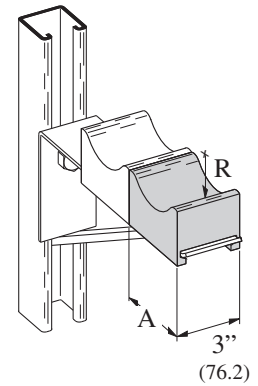

Part No.	A		R		Wt./C	
	Lbs.	kg	Lbs.	kg	Lbs.	kg
B4094	2 7/8"	(73.0)	1 3/8"	(34.9)	67	(30.4)
B4095	3 7/8"	(98.4)	2 1/8"	(54.0)	106	(48.1)

B4035A THRU B4035F 4" (101.6) BUS BAR MAPLE CLAMPS

- Assembly Includes:
 - 1 pr. Maple Clamps (Paraffin Impregnated)
 - 3 pcs. 1/2" Flat Washers
 - 3 pcs. N225WO
 - 3 pcs. SQN-1/2"
 - 3 pcs. ATR-1/2 x L (Length)
- Required number of Separators
- 1/4" (6.3) x 2" (50.8) and 1/4" (6.3) x 6" (152.4) Bus Bar Maple Clamps available

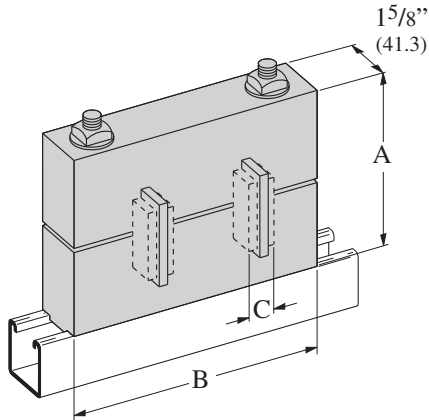

B4037B 1/4" (6.3) x 4" (101.6) BUS BAR SEPARATOR

- Wt./C 9 Lbs. (4.1 kg)

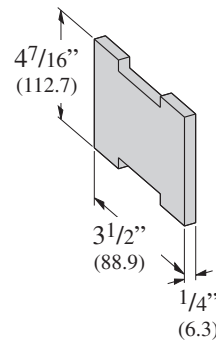

Part No.	A		B		C		No. of Bus Separators	No. of Bars Per Leg	Wt./C	
	Lbs.	kg	Lbs.	kg	Lbs.	kg			Lbs.	kg
B4035A	7 3/8"	(187.3)	8 1/2"	(215.9)	1/4"	(6.3)	—	1	416	(188.7)
B4035B			9 1/2"	(241.3)	3/4"	(19.0)	2	2	447	(202.7)
B4035C			10 1/2"	(266.7)	1 1/4"	(31.7)	4	3	479	(217.3)
B4035D			11 1/2"	(292.1)	1 3/4"	(44.4)	6	4	511	(231.8)
B4035E			12 1/2"	(317.5)	2 1/4"	(57.1)	8	5	542	(245.8)
B4035F			13 1/2"	(342.9)	2 3/4"	(69.8)	10	6	574	(260.3)

Reference page 150 for general fitting and standard finish specifications. U.L. Wire Fill Chart on pages 218 - 219.

B4000 THRU B4007 MAPLE CABLE CLAMPS

- Assembly Includes:
 - 1 pr. Maple Clamps (Paraffin Impregnated)
 - 1 pr. zinc plated Steel Pipe Straps with Everdur Hardware (Silicon Bronze)
- Everdur hardware is non-ferrous and prevents magnetic induction

Note: Maple cable clamps may be replaced with Insulclamps® see page 161 for sizes

Part No.	Specify Hole Dia.		A		B		Clamp No. (included)	Wt./C	
								Lbs.	kg
B4000	0" to 5/8"	(0.0 to 15.9)	1 11/32"	(34.1)	2"	(50.8)	B2010	24	(10.9)
B4001	1/2" to 1"	(12.7 to 25.4)	1 29/32"	(48.4)	2 25/32"	(70.6)	B2012	44	(19.9)
B4002	3/4" to 1 1/2"	(19.0 to 38.1)	2 3/8"	(60.3)	3 9/32"	(83.3)	B2013	58	(26.3)
B4003	1 1/4" to 1 3/4"	(31.7 to 44.4)	2 7/8"	(73.0)	3 3/4"	(95.2)	B2014	66	(29.9)
B4004	1 1/2" to 2 1/4"	(38.1 to 57.1)	3 1/2"	(88.9)	4 3/8"	(111.1)	B2015	86	(39.0)
B4005	2" to 2 1/2"	(50.8 to 63.5)	4"	(101.6)	4 7/8"	(123.8)	B2016	110	(49.9)
B4006	2 1/4" to 3"	(38.1 to 76.2)	4 1/2"	(114.3)	5 3/8"	(136.5)	B2017	125	(56.7)
B4007	3" to 4"	(76.2 to 101.6)	5 9/16"	(141.3)	6 7/16"	(163.5)	B2019	165	(74.8)

SPECIFY HOLE DIA.

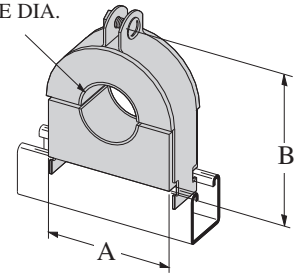

B4008 THRU B4017 SQUARE MAPLE CABLE SADDLE

- Assembly Includes:
 - 1 Maple Saddle (Paraffin Impregnated)
 - 1 pc. 3/8"-16 Flat Head Machine Screw
 - 1 pc. N228 Channel Nut
- Other sizes available

Part No.	Specify Hole Dia.		A		B		Wt./C	
							Lbs.	kg
B4008	0" to 1"	(0.0 to 25.4)	3"	(76.2)	1 3/4"	(44.4)	35	(15.9)
B4009	1" to 1 1/2"	(25.4 to 38.1)	3 1/2"	(88.9)	2"	(50.8)	42	(19.0)
B4010	1 1/2" to 2"	(38.1 to 50.8)	4"	(101.6)	2 1/4"	(57.1)	53	(24.0)
B4011	2" to 2 1/2"	(50.8 to 63.5)	4 1/2"	(114.3)	2 1/2"	(63.5)	62	(28.1)
B4012	2 1/2" to 3"	(63.5 to 76.2)	5"	(127.0)	2 3/4"	(69.8)	76	(34.5)
B4013	3" to 3 1/2"	(76.2 to 88.9)	5 1/2"	(139.7)	3"	(76.2)	85	(38.5)
B4014	3 1/2" to 4"	(88.9 to 101.6)	6"	(152.4)	3 1/4"	(82.5)	95	(43.1)
B4015	4" to 4 1/2"	(101.6 to 114.3)	7"	(177.8)	3 3/4"	(95.2)	105	(47.8)
B4016	4 1/2" to 5"	(114.3 to 127.0)	7 1/2"	(190.5)	4"	(101.6)	115	(52.4)
B4017	5" to 6"	(127.0 to 152.4)	9"	(228.6)	5"	(127.0)	126	(57.1)

SPECIFY HOLE DIA.

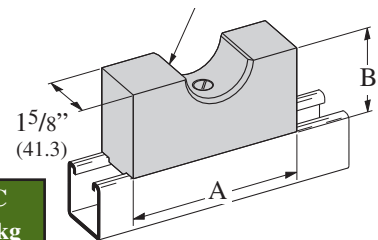

B4033A THRU B4033I MAPLE CABLE CLAMPS

- Assembly Includes:
 - 1 pr. Maple Clamps (Paraffin Impregnated)
 - 2 pcs. 3/8"-16 Stud Bolts
 - 2 pcs. 3/8"-16 Flat Washers
 - 2 pcs. 3/8"-16 Square Nuts
 - 2 pcs. N228 Channel Nuts
- Other sizes available

Part No.	Specify Hole Dia.		A		Wt./C	
					Lbs.	kg
B4033A	0" to 1"	(0.0 to 25.4)	3 1/2"	(88.9)	85	(38.5)
B4033B	1" to 1 1/2"	(25.4 to 38.1)	4"	(101.6)	95	(43.1)
B4033C	1 1/2" to 2"	(38.1 to 50.8)	4 1/2"	(114.3)	118	(53.5)
B4033D	2" to 2 1/2"	(50.8 to 63.5)	5 1/2"	(127.0)	162	(73.5)
B4033E	2 1/2" to 3"	(63.5 to 76.2)	6"	(152.4)	187	(84.8)
B4033F	3" to 3 1/2"	(76.2 to 88.9)	6 1/2"	(165.1)	209	(94.8)
B4033G	3 1/2" to 4"	(88.9 to 101.6)	7"	(177.8)	248	(112.5)
B4033H	4" to 4 1/2"	(101.6 to 114.3)	7 1/2"	(190.5)	270	(122.5)
B4033I	4 1/2" to 5"	(114.3 to 127.0)	8"	(203.2)	298	(135.2)

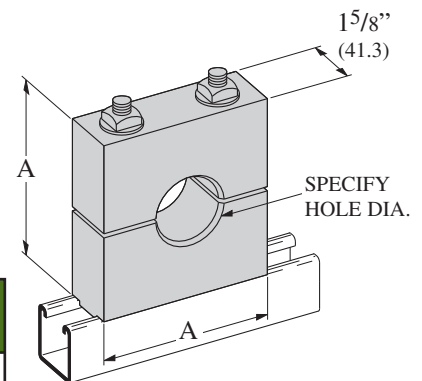

Reference page 150 for general fitting and standard finish specifications. U.L. Wire Fill Chart on pages 218 - 219.

Aluminum & Stainless Steel

Aluminum

Aluminum channels, fittings and accessories offer excellent corrosion resistance and are suitable for many indoor and outdoor applications. Aluminum's high strength to weight ratio greatly reduces overall cost of installation through ease of handling and cutting. B-Line's channels are extruded from aluminum alloy 6063-T6. Closure strips are extruded from aluminum alloy 6063-T5. Fittings and accessories are made from aluminum alloy 5052-H32.

Stainless Steel

Where corrosion problems persist and other material and fittings are ineffective, we recommend use of B-Line's corrosion resistant stainless steel channels and accessories. Channels and fittings are available in two types of stainless steel:

SS4-AISI Type 304

SS6-AISI Type 316

Fittings

Most fittings, as shown in this catalog, can be supplied in aluminum or stainless steel. Consult factory for possible minimum production quantities and set-up charges.

Load Data

Aluminum

Channel's approximate load data can be determined by multiplying load data in the steel channel section of this catalog by a factor of 0.38.

Stainless Steel

Channel load data is the same as the data in the steel channel section of this catalog.

Metric

Metric dimensions are shown in parentheses. Unless noted, all metric dimensions are in millimeters.

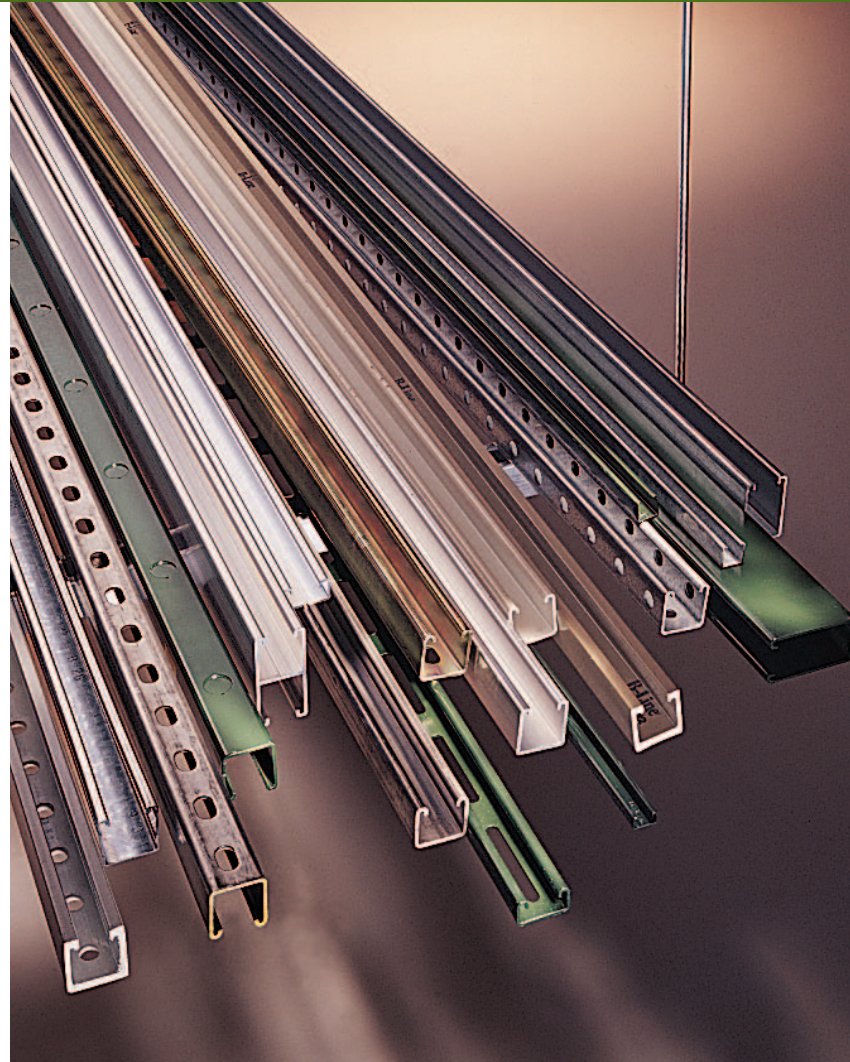

Aluminum Channel & Closure Strips

Alum. & Stainless Steel Materials

B12AL

- Thickness: .105 (2.6 mm)
- Standard Length: 10' (3.05 m) and 20' (6.09 m)
- Material: Aluminum
- Weight: .86 Lbs./Ft. (1.28 kg/m)

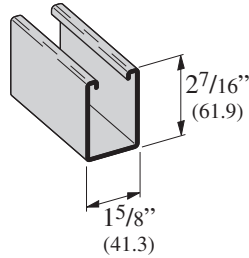

B22AL

- Thickness: .105 (2.6 mm)
- Standard Length: 10' (3.05 m) and 20' (6.09 m)
- Material: Aluminum
- Weight: .66 Lbs./Ft. (0.98 kg/m)

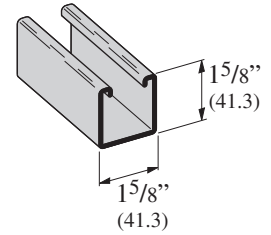

B22AAL

- Thickness: .105 (2.6 mm)
- Standard Length: 10' (3.05 m) and 20' (6.09 m)
- Material: Aluminum
- Weight: 1.18 Lbs./Ft. (1.75 kg/m)

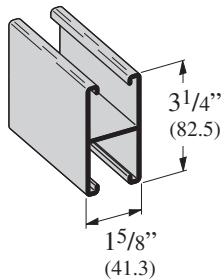

B24AL

- Thickness: .080 (2.0 mm)
- Standard Length: 10' (3.05 m) and 20' (6.09 m)
- Material: Aluminum
- Weight: .52 Lbs./Ft. (0.77 kg/m)

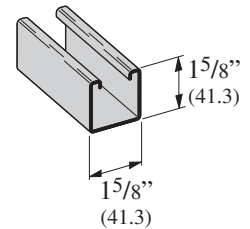

B54AL

- Thickness: .080 (2.0 mm)
- Standard Length: 10' (3.05 m) and 20' (6.09 m)
- Material: Aluminum
- Weight: .37 Lbs./Ft. (0.55 kg/m)

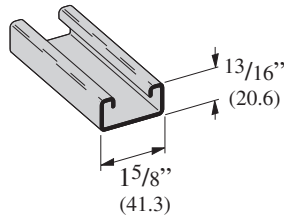

B54AAL

- Thickness: .080 (2.0 mm)
- Standard Length: 10' (3.05 m) and 20' (6.09 m)
- Material: Aluminum
- Weight: .57 Lbs./Ft. (0.84 kg/m)

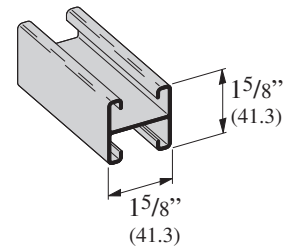

B217AL CLOSURE STRIP

- Standard Length: 10' (304.8 cm)
- Material: Aluminum
- Weight: .15 Lbs./Ft. (0.23 kg/m)

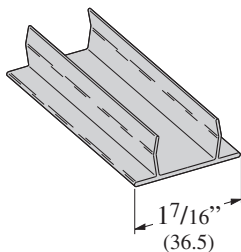

B217P PLASTIC CLOSURE STRIP

- Standard Length: 10' (304.8 cm)
- Material: PVC
- Weight: .09 Lbs./Ft. (0.14 kg/m)

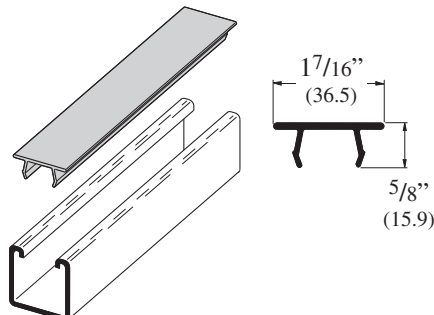

B217FFAL CLOSURE STRIP

- Standard Length: 10' (304.8 cm)
- Material: Aluminum
- Weight: .16 Lbs./Ft. (0.24 kg/m)

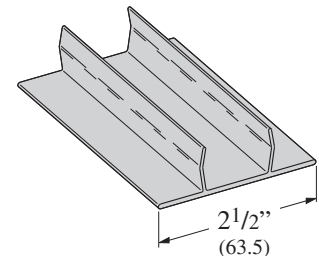

Reference page 164 for general fitting specifications. Other channel combinations available-see steel section for styles.

Aluminum

SH TYPE CHANNEL

•Material: Aluminum

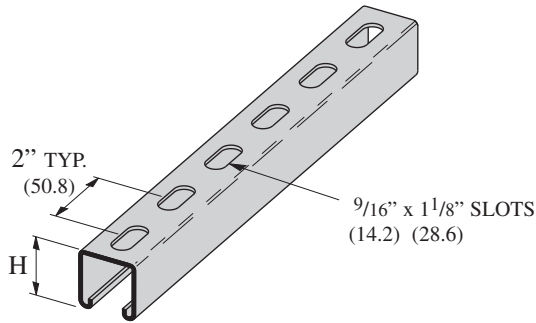

Part No.	Thickness		H	Wt./C		
				Lbs./Ft.	kg/m	
B12SH AL	.105	(2.6)	27/16"	(61.9)	.83	(1.23)
B22SH AL	.105	(2.6)	15/8"	(41.3)	.63	(.93)
B24SH AL	.080	(2.0)	15/8"	(41.3)	.49	(.73)
B54SH AL	.080	(2.0)	13/16"	(20.6)	.34	(.50)

H-17/8 TYPE CHANNEL

•Material: Aluminum

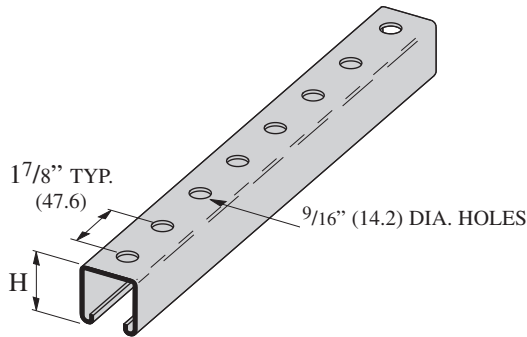

Part No.	Thickness		H	Wt./C		
				Lbs./Ft.	kg/m	
B12H17/8 AL	.105	(2.6)	27/16"	(61.9)	.86	(1.28)
B22H17/8 AL	.105	(2.6)	15/8"	(41.3)	.66	(.98)
B24H17/8 AL	.080	(2.0)	15/8"	(41.3)	.52	(.77)
B54H17/8 AL	.080	(2.0)	13/16"	(20.6)	.37	(.55)

KO6 TYPE KNOCKOUT CHANNEL

•Material: Aluminum

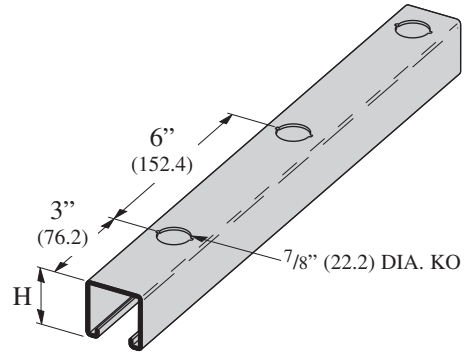

Part No.	Thickness		H	Wt./C		
				Lbs./Ft.	kg/m	
B12KO6 AL	.105	(2.6)	27/16"	(61.9)	.86	(1.28)
B22KO6 AL	.105	(2.6)	15/8"	(41.3)	.66	(.98)
B24KO6 AL	.080	(2.0)	15/8"	(41.3)	.52	(.77)
B54KO6 AL	.080	(2.0)	13/16"	(20.6)	.37	(.55)

B2000 SERIES RIGID CONDUIT CLAMPS

- Safety Factor of 5
- Machine Screw and Square Nut included
- Pipe clamp material 5052-H32

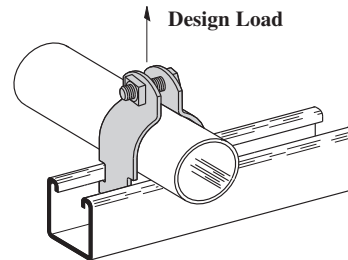

Part No.	Conduit or Pipe Size		Material Thickness		Design Load		Wt./C	
					Lbs.	kN	Lbs.	kg
B2007 AL	3/8"	(10)	.063	(1.6)	180	(.80)	4	(1.8)
B2008 AL	1/2"	(15)	.063	(1.6)	180	(.80)	4	(1.8)
B2009 AL	3/4"	(20)	.080	(2.0)	270	(1.20)	6	(2.7)
B2010 AL	1"	(25)	.080	(2.0)	270	(1.20)	7	(3.2)
B2011 AL	1 1/4"	(32)	.080	(2.0)	270	(1.20)	8	(3.6)
B2012 AL	1 1/2"	(40)	.100	(2.5)	360	(1.60)	11	(5.0)
B2013 AL	2"	(50)	.100	(2.5)	360	(1.60)	12	(5.4)
B2014 AL	2 1/2"	(65)	.100	(2.5)	360	(1.60)	13	(5.9)
B2015 AL	3"	(80)	.100	(2.5)	360	(1.60)	16	(7.2)
B2016 AL	3 1/2"	(90)	.125	(3.2)	450	(2.00)	22	(10.0)
B2017 AL	4"	(100)	.125	(3.2)	450	(2.00)	24	(10.9)
B2018 AL	4 1/2"	(115)	.125	(3.2)	450	(2.00)	26	(11.8)
B2019 AL	5"	(125)	.125	(3.2)	450	(2.00)	27	(12.2)
B2020 AL	6"	(150)	.125	(3.2)	450	(2.00)	33	(14.9)

Reference page 164 for general fitting specifications. Other channel combinations available-see steel section for styles.

ALUMINUM FITTINGS

Most fittings, as shown in this catalog, can be supplied in aluminum. See "Fittings" section of this catalog. Consult factory for possible minimum production quantities and set-up charges.

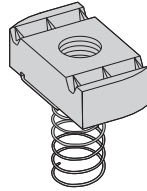

SPRING NUT

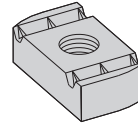

NUT WITHOUT SPRING

NUTS FOR B12 CHANNEL

Part Number		Thread Size	Thickness		Wt./C	
With Spring	Without Spring				Lbs.	kg
N724SS6	N224WOSS6	1/4"-20	1/4"	(6.3)	6.6	(3.0)
N728SS6	N228WOSS6	3/8"-16	3/8"	(9.5)	10.6	(4.8)
N725SS6	N225WOSS6	1/2"-13	3/8"	(9.5)	9.7	(4.4)

NUTS FOR B22, B24 CHANNELS

Part Number		Thread Size	Thickness		Wt./C	
With Spring	Without Spring				Lbs.	kg
N224SS6	N224WOSS6	1/4"-20	1/4"	(6.3)	6.6	(3.0)
N228SS6	N228WOSS6	3/8"-16	3/8"	(9.5)	10.6	(4.8)
N225SS6	N225WOSS6	1/2"-13	3/8"	(9.5)	9.7	(4.4)

NUTS FOR B54 CHANNEL

Part Number		Thread Size	Thickness		Wt./C	
With Spring	Without Spring				Lbs.	kg
N524SS6	N224WOSS6	1/4"-20	1/4"	(6.3)	6.6	(3.0)
N528SS6	N228WOSS6	3/8"-16	3/8"	(9.5)	10.6	(4.8)
N525SS6	N525WOSS6	1/2"-13	3/8"	(9.5)	9.7	(4.4)

B-Line recommends the use of Stainless Steel channel nuts with Aluminum channel. For channel nut pull-out strength and slip resistance, use the channel nut information provided on pg. 50 & 51. A (.70) multiplier is to be applied to obtain the appropriate derated values for aluminum channel.

Reference page 164 for general fitting specifications. Other channel combinations available-see steel section for styles.

B22SS*

- *Substitute 4 for Stainless Steel Type 304 or 6 for Stainless Steel Type 316
- Thickness: 12 Ga. (2.6 mm)
- Standard Length: 10' (3.05 m) and 20' (6.09 m)
- Material: SS4, SS6
- Weight: 1.90 Lbs./Ft. (2.83 kg/m)

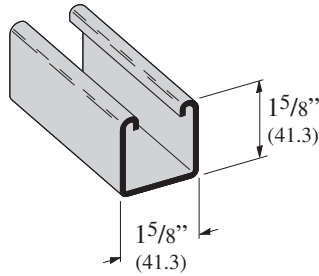

B24SS*

- *Substitute 4 for Stainless Steel Type 304 or 6 for Stainless Steel Type 316
- Thickness: 14 Ga. (1.9 mm)
- Standard Length: 10' (3.05 m) and 20' (6.09 m)
- Material: SS4, SS6
- Weight: 1.40 Lbs./Ft. (2.08 kg/m)

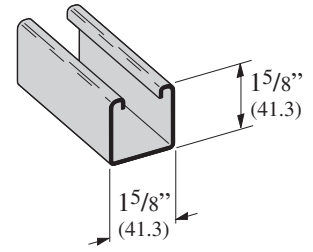

B32SS4

- Thickness: 12 Ga. (2.6 mm)
- Standard Length: 10' (3.05 m) and 20' (6.09 m)
- Material: SS4
- Weight: 1.70 Lbs./Ft. (2.53 kg/m)

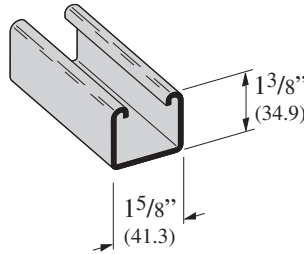

B42SS4

- Thickness: 12 Ga. (2.6 mm)
- Standard Length: 10' (3.05 m) and 20' (6.09 m)
- Material: SS4
- Weight: 1.44 Lbs./Ft. (2.14 kg/m)

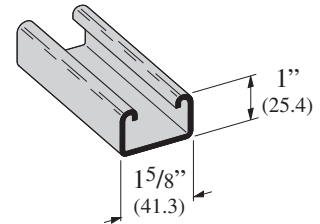

B54SS*

- *Substitute 4 for Stainless Steel Type 304 or 6 for Stainless Steel Type 316
- Thickness: 14 Ga. (1.9 mm)
- Standard Length: 10' (3.05 m) and 20' (6.09 m)
- Material: SS4, SS6
- Weight: .97 Lbs./Ft. (1.44 kg/m)

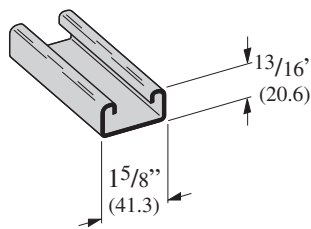

SH TYPE CHANNEL

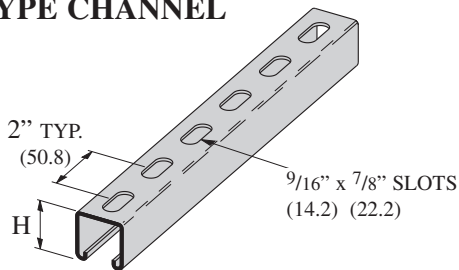

H-17/8 TYPE CHANNEL

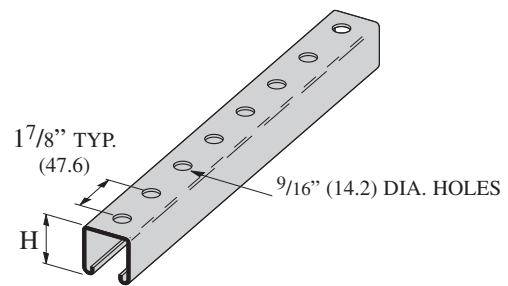

Part No.	Thickness	H	Wt./C Lbs./Ft. kg/m
B22SH SS4	12 Ga. (2.6)	1 5/8" (41.3)	1.82 (2.70)
B22SH SS6	12 Ga. (2.6)	1 5/8" (41.3)	1.82 (2.70)
B24SH SS4	14 Ga. (1.9)	1 5/8" (41.3)	1.34 (1.99)
B24SH SS6	14 Ga. (1.9)	1 5/8" (41.3)	1.34 (1.99)
B32SH SS4	12 Ga. (2.6)	1 3/8" (34.9)	1.62 (2.41)
B42SH SS4	12 Ga. (2.6)	1" (25.4)	1.36 (2.02)
B54SH SS4	14 Ga. (1.9)	1 3/16" (20.6)	.91 (1.35)
B54SH SS6	14 Ga. (1.9)	1 3/16" (20.6)	.91 (1.35)

Part No.	Thickness	H	Wt./C Lbs./Ft. kg/m
B22H17/8 SS4	12 Ga. (2.6)	1 5/8" (41.3)	1.85 (2.75)
B24H17/8 SS4	14 Ga. (1.9)	1 5/8" (41.3)	1.36 (2.02)
B24H17/8 SS6	14 Ga. (1.9)	1 5/8" (41.3)	1.36 (2.02)
B32H17/8 SS4	12 Ga. (2.6)	1 3/8" (34.9)	1.65 (2.45)
B42H17/8 SS4	12 Ga. (2.6)	1" (25.4)	1.39 (2.07)
B54H17/8 SS4	14 Ga. (1.9)	1 3/16" (20.6)	.93 (1.38)
B54H17/8 SS6	14 Ga. (1.9)	1 3/16" (20.6)	.93 (1.38)

Reference page 164 for general fitting specifications. Other channel combinations available-see steel section for styles.

STAINLESS STEEL FITTINGS

Most fittings, as shown in this catalog, can be supplied in Type 304 or Type 316 stainless steel. See "Fittings" section of this catalog. Consult factory for possible minimum production quantities and set-up charges.

B2000 SERIES PIPE AND TUBING CLAMPS

- Safety Factor of 5
- Combination Recess Hex Head Machine Screw and Square Nut included
- Material: Stainless Steel Type 304 & 316

Part No.	Conduit Pipe Size		Material Thickness		Design Load		Wt./C	
					Lbs.	kN	Lbs.	kg
B2007 SS4	3/8"	(10)	16 Ga.	(1.5)	400	(1.78)	10	(4.5)
B2008 SS4	1/2"	(15)	16 Ga.	(1.5)	400	(1.78)	11	(5.0)
B2009 SS4	3/4"	(20)	14 Ga.	(1.9)	600	(2.67)	15	(6.8)
B2010 SS4	1"	(25)	14 Ga.	(1.9)	600	(2.67)	16	(7.2)
B2011 SS4	1 1/4"	(32)	14 Ga.	(1.9)	600	(2.67)	20	(9.1)
B2012 SS4	1 1/2"	(40)	12 Ga.	(2.6)	800	(3.56)	30	(13.6)
B2013 SS4	2"	(50)	12 Ga.	(2.6)	800	(3.56)	34	(15.4)
B2014 SS4	2 1/2"	(65)	12 Ga.	(2.6)	800	(3.56)	38	(17.2)
B2015 SS4	3"	(80)	12 Ga.	(2.6)	800	(3.56)	44	(19.9)
B2016 SS4	3 1/2"	(90)	12 Ga.	(2.6)	1000	(4.45)	51	(23.1)
B2017 SS4	4"	(100)	12 Ga.	(2.6)	1000	(4.45)	55	(24.9)
B2018 SS4	4 1/2"	(115)	12 Ga.	(2.6)	1000	(4.45)	59	(26.7)
B2019 SS4	5"	(125)	12 Ga.	(2.6)	1000	(4.45)	64	(29.0)
B2020 SS4	6"	(150)	12 Ga.	(2.6)	1000	(4.45)	80	(36.3)

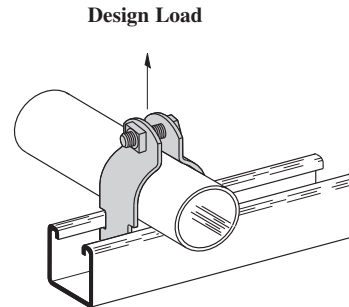

CHANNEL NUTS

•For Channel Nuts pull-out strength and slip resistance, use the data shown in "Channel Nuts & Hardware" section of this catalog.

Note: Reduce slip load by 50% due to hardness of material.

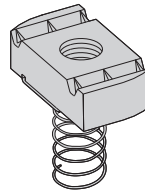

SPRING NUT

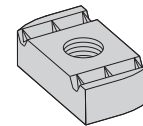

NUT WITHOUT SPRING

NUTS FOR B22, B24, B32 CHANNELS

Part Number		Thread Size	Thickness		Wt./C	
With Spring	Without Spring				Lbs.	kg
N224SS6	N224WOSS6	1/4"-20	1/4"	(6.3)	6.6	(3.0)
N228SS6	N228WOSS6	3/8"-16	3/8"	(9.5)	10.6	(4.8)
N225SS6	N225WOSS6	1/2"-13	3/8"	(9.5)	9.7	(4.4)

NUTS FOR B42, B52, B54 CHANNELS

Part Number		Thread Size	Thickness		Wt./C	
With Spring	Without Spring				Lbs.	kg
N524SS6	N224WOSS6	1/4"-20	1/4"	(6.3)	6.6	(3.0)
N528SS6	N228WOSS6	3/8"-16	3/8"	(9.5)	10.6	(4.8)
N525SS6	N225WOSS6	1/2"-13	3/8"	(9.5)	9.7	(4.4)

Reference page 164 for general fitting specifications. Other channel combinations available-see steel section for styles.

Fiberglass

B-Line offers two fire retardant (FR) resins for strut systems, polyester and vinyl ester. Both resins are ideal for corrosive environments.

While polyester is sufficient for most uses, vinyl ester is suitable for a broader range of environments.

Please refer to the "Corrosion Resistance Guide" for specific applications, page 171.

Materials & Finishes

B-Line Fiberglass Strut systems are manufactured from glass fiber-reinforced plastic shapes that meet ASTM E-84, Class 1 Flame Rating and self-extinguishing requirements of ASTM D-635. A surface veil is applied during pultrusion to insure a resin-rich surface and ultraviolet resistance.

Fittings

The following dimensions apply to all fittings except as noted on the drawings:

Hole Size— $13/32$ " (10.3 mm) Dia.

Hole Spacing— $13/16$ " (20.6 mm) from end and $17/8$ " (47.6 mm) on center.

Width— $15/8$ " (41.3 mm)

Thickness— $1/4$ " (6.3 mm)

Metric

Metric dimensions are shown in parentheses. Unless noted, all metric dimensions are in millimeters.



CHANNEL RESIN INFORMATION

B-Line offers two fire retardant (FR) resins for strut systems, polyester and vinyl ester. Both resins are ideal for corrosive environments.

While polyester is sufficient for most uses, vinyl ester is suitable for a broader range of environments.

Please refer to the "Corrosion Resistance Guide" below for specific applications.

Corrosion Resistance Guide					
Chemicals	70°F (21°C)	160°F (71°C)	Chemicals	70°F (21°C)	160°F (71°C)
Acetic acid 5%	BFP/BFV	BFP/BFV	Methyl alcohol 10%	BFP/BFV	BFV-150° **
Acetic acid 52%	BFP/BFV	BFV-210° **	Naphtha	BFP/BFV	BFP/BFV
Aluminum potassium sulfate 5%	BFP/BFV	BFP/BFV	Nitric acid 5%	BFP/BFV	BFP/BFV
Ammonium hydroxide 10%	BFP/BFV	BFV-150° **	Nitric acid 20%	BFV	BFV-120° **
Ammonium nitrate	BFP/BFV	BFP/BFV	Phosphoric acid 10%	BFP/BFV	BFP/BFV
Benzene sulfonic acid 5%	BFP/BFV	BFP/BFV	Phosphoric acid 30%	BFP/BFV	BFP/BFV
Calcium chloride	BFP/BFV	BFP/BFV	Phosphoric acid 85%	BFP/BFV	BFP/BFV
Carbon tetrachloride	BFV	BFV-100° **	Sodium bicarbonate 10%	BFP/BFV	BFP/BFV
Chlorine dioxide 15%	BFP/BFV	BFV-150° **	Sodium bisulfate	BFP/BFV	BFP/BFV
Chromic acid 5%	BFV	BFV-150° **	Sodium carbonate	BFP/BFV	BFV
Copper sulfate	BFP/BFV	BFP/BFV	Sodium chloride	BFP/BFV	BFP/BFV
Diesel fuel	BFP/BFV	BFV	Sodium hydroxide 1-50%	BFV	BFV-120° **
Ethylene glycol	BFP/BFV	BFP/BFV	Sodium hypochlorite 5%	BFP/BFV	BFV-120° **
Fatty acids 100%	BFP/BFV	BFP/BFV	Sodium nitrate	BFP/BFV	BFP/BFV
Ferrous sulfate	BFP/BFV	BFP/BFV	Sodium silicate	BFP/BFV	BFV-210° **
Fluosilicic acid 0-20%	BFV	BFV	Sodium sulfate	BFP/BFV	BFP/BFV
Gasoline	BFP/BFV	BFV	Sulfuric acid 0-30%	BFP/BFV	BFP/BFV
Hydrochloric acid 1%	BFP/BFV	BFP/BFV	Sulfuric acid 30-50%	BFV	BFV
Hydrochloric acid 15%	BFP/BFV	BFV-180° **	Sulfuric acid 50-70%	BFV	BFV-180° **
Hydrochloric acid 37%	BFP/BFV	BFV-150° **	Trisodium phosphate 25%	BFP/BFV	BFV-210° **
Kerosene	BFP/BFV	BFP/BFV	Trisodium phosphate-All	BFV	BFV-210° **
Magnesium chloride	BFP/BFV	BFP/BFV	Water, Distilled	BFP/BFV	BFP/BFV

BFP - BFP parts recommended BFV - BFV parts recommended ** - Not recommended to exceed this temperature

Information contained in this chart is based on data from raw material suppliers.

Temperatures are not the minimum nor the maximum (except where specifically stated) but represent standard test conditions. The products may be suitable at higher temperatures but individual test data should be required to establish suitability.

The recommendations or suggestions contained in this chart are made without guarantee or representation as to results. We suggest that you evaluate the recommendations and suggestions in your own laboratory or actual field trial prior to use.

Recommended Guideline:

Temperature	Design Load Multiplier
75°F (24°C)	100%
100°F (38°C)	90%
125°F (52°C)	78%
150°F (66°C)	68%
175°F (79°C)	60%
200°F (93°C)	52%

Flame Retardant Properties	BFP	BFV
Flame Resistance (FTMS 406-2023) ign/burn, seconds	75/75	75/75
Intermittent Flame Test (HLT-15), rating	100	100
Flammability Test (ASTM D635) Ignition Burning Time	none 0 sec.	none 0 sec.
Surface Burning Characteristics (ASTM E84), Flame spread index	25	25
UL 94 Flame Class	V-0	V-0

Reference page 170 for general fitting specifications.

Fiberglass

BFP22 THRU BFV22SH

- Channel lengths: 10 Ft. (3.05 m) and 20 Ft. (6.09 m)
- Fiberglass strut meets specification of ASTM D-4385 Levels III and IV.

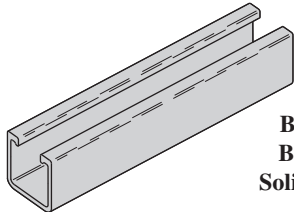

**BFP22
BFV22**
Solid Back

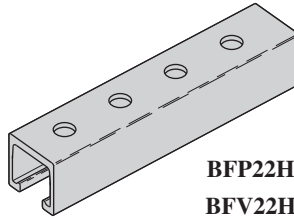

**BFP22H1 7/8
BFV22H1 7/8**
9/16" (14.3) holes
1 7/8" (47.6) on centers

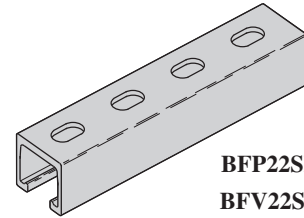

**BFP22SH
BFV22SH**
9/16" (14.3) x 7/8" (22.2) slots
2" (50.8) on centers

Part No.	Material	Description	Color	Weight	
				Lbs./ft.	kg/m
BFP22*	Polyester Resin	Solid Back	Gray	.63	(.94)
BFV22*	Vinyl Ester Resin	Solid Back	Beige	.63	(.94)
BFP22H1 7/8*	Polyester Resin	Holes in Back	Gray	.60	(.89)
BFV22H1 7/8*	Vinyl Ester Resin	Holes in Back	Beige	.60	(.89)
BFP22SH*	Polyester Resin	Slots in Back	Gray	.61	(.91)
BFV22SH*	Vinyl Ester Resin	Slots in Back	Beige	.61	(.91)

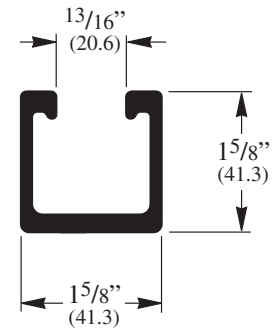

* Insert -10 for 10'-0" (3.05 m) length or -20 for 20'-0" (6.09 m) length

BFP22A BFV22A

- Channel Lengths: 10 Ft. (3.05 m) and 20 Ft. (6.09 m)
- Fiberglass strut meets specification of ASTM D-4385 Levels III and IV.

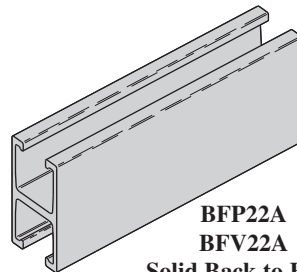

**BFP22A
BFV22A**
Solid Back to Back

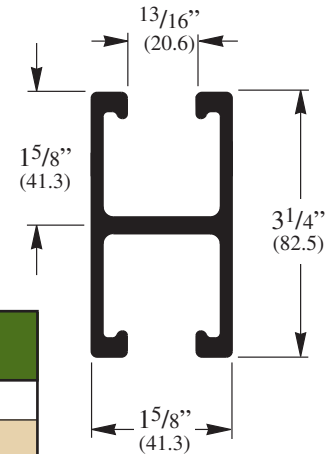

Part No.	Material	Description	Color	Weight	
				Lbs./ft.	kg/m
BFP22A*	Polyester Resin	Back To Back	Gray	1.15	(1.71)
BFV22A*	Vinyl Ester Resin	Back To Back	Beige	1.15	(1.71)

* Insert -10 for 10'-0" (3.05 m) length or -20 for 20'-0" (6.09 m) length

WARNING: Appropriate protective clothing and respiratory protection device should be worn when field cutting or grinding fiberglass.

Published design loads on page 172 are based on usage at 70°F (21°C) and must be reduced for continuous exposure to higher temperatures. Refer to the chart below for high temperature applications.

Field Cutting Sealant Kits

RSK010 Pint Sealing Kit (473 cm³)
includes sealant and brush applicator

- Seals exposed fibers after field cutting. •
- UV resistant •

Temperature	Design Load Multiplier
75°F (24°C)	100%
100°F (38°C)	90%
125°F (52°C)	78%
150°F (66°C)	68%
175°F (79°C)	60%
200°F (93°C)	52%

Reference page 170 for general fitting specifications.

BEAM LOADING DATA FOR GLASS REINFORCED POLYESTER RESIN

Beam Span		Part No.	Maximum Allowable Beam Load		Deflection @ Maximum Allowable Beam Load		Allowable Load @ Deflection =				
			Lbs.	kN	in.	mm	1/240 Span		1/360 Span		
in.	mm							Lbs.	kN	Lbs.	kN
12"	(305)	BFP22	1781	(7.92)	0.064	(1.62)	1392	(6.19)	928	(4.13)	
		BFP22A	2259	(10.05)	0.037	(.94)	2259	(10.05)	2051	(9.12)	
24"	(609)	BFP22	890	(3.96)	0.256	(6.50)	347	(1.54)	231	(1.03)	
		BFP22A	1127	(5.01)	0.147	(3.73)	767	(3.41)	511	(2.27)	
36"	(914)	BFP22	592	(2.63)	0.576	(14.63)	153	(0.68)	101	(0.45)	
		BFP22A	750	(3.33)	0.330	(8.38)	338	(1.50)	224	(0.99)	
48"	(1219)	BFP22	443	(1.97)	1.024	(26.01)	85	(0.38)	55	(0.24)	
		BFP22A	560	(2.49)	0.587	(14.91)	188	(0.83)	123	(0.55)	
60"	(1524)	BFP22	353	(1.57)	1.600	(40.64)	53	(0.23)	34	(0.15)	
		BFP22A	446	(1.98)	0.918	(23.32)	117	(0.52)	76	(0.34)	
72"	(1829)	BFP22	293	(1.30)	2.303	(58.49)	35	(0.15)	22	(0.10)	
		BFP22A	370	(1.64)	1.322	(33.58)	78	(0.34)	50	(0.22)	
96"	(2438)	BFP22	218	(0.97)	4.095	(104.01)	17	(0.07)	9	(0.04)	
		BFP22A	273	(1.21)	2.350	(59.69)	39	(0.17)	23	(0.10)	
120"	(3048)	BFP22	172	(0.76)	6.398	(162.51)	8	(0.03)	3	(0.01)	
		BFP22A	214	(0.95)	3.671	(93.24)	19	(0.08)	9	(0.04)	

BEAM LOADING DATA FOR GLASS REINFORCED VINYL ESTER RESIN

Beam Span		Part No.	Maximum Allowable Beam Load		Deflection @ Maximum Allowable Beam Load		Allowable Load @ Deflection =				
			Lbs.	kN	in.	mm	1/240 Span		1/360 Span		
in.	mm							Lbs.	kN	Lbs.	kN
12"	(305)	BFV22	2220	(9.87)	0.071	(1.80)	1568	(6.97)	1045	(4.65)	
		BFV22A	6442	(28.65)	0.039	(0.99)	6442	(29.65)	5549	(24.68)	
24"	(609)	BFV22	1109	(4.93)	0.283	(7.19)	391	(1.74)	260	(1.15)	
		BFV22A	3219	(14.32)	0.155	(3.94)	2079	(9.25)	1385	(6.16)	
36"	(914)	BFV22	738	(3.28)	0.637	(16.18)	172	(0.76)	114	(0.51)	
		BFV22A	2144	(9.53)	0.348	(8.84)	922	(4.10)	613	(2.72)	
48"	(1219)	BFV22	553	(2.46)	1.133	(28.78)	96	(0.43)	63	(0.28)	
		BFV22A	1606	(7.14)	0.619	(15.72)	516	(2.29)	342	(1.52)	
60"	(1524)	BFV22	441	(1.96)	1.770	(44.96)	60	(0.26)	39	(0.17)	
		BFV22A	1283	(5.70)	0.967	(24.56)	327	(1.45)	216	(0.96)	
72"	(1829)	BFV22	366	(1.63)	2.549	(64.74)	40	(0.18)	25	(0.11)	
		BFV22A	1067	(4.74)	1.393	(35.38)	224	(0.99)	147	(0.65)	
96"	(2438)	BFV22	273	(1.21)	4.531	(115.09)	19	(0.08)	11	(0.05)	
		BFV22A	796	(3.54)	2.477	(62.91)	121	(0.54)	78	(0.34)	
120"	(3048)	BFV22	216	(0.96)	7.079	(179.80)	9	(0.04)	7	(0.02)	
		BFV22A	633	(2.81)	3.870	(98.30)	72	(0.32)	44	(0.19)	

Loading Information

Beam Loads:

The above charts list the total allowable uniform load for various simple spans based on a minimum safety factor of 2. If the load is concentrated at center span, multiply the load from the above charts by 0.5 and the corresponding deflection by 0.8.

All beams should be supported in a manner to prevent rotation at supports. Long, deep beams should be tied between supports to prevent twist.

For channels with holes or slots use 90% of recommended load shown in channel loading chart.

Reference page 170 for general fitting specifications.

Fiberglass

BFP42 THRU BFV42SH

- Channel lengths: 10 Ft. (3.05 m) and 20 Ft. (6.09 m)
- Fiberglass strut meets specification of ASTM D-4385 Levels III and IV.

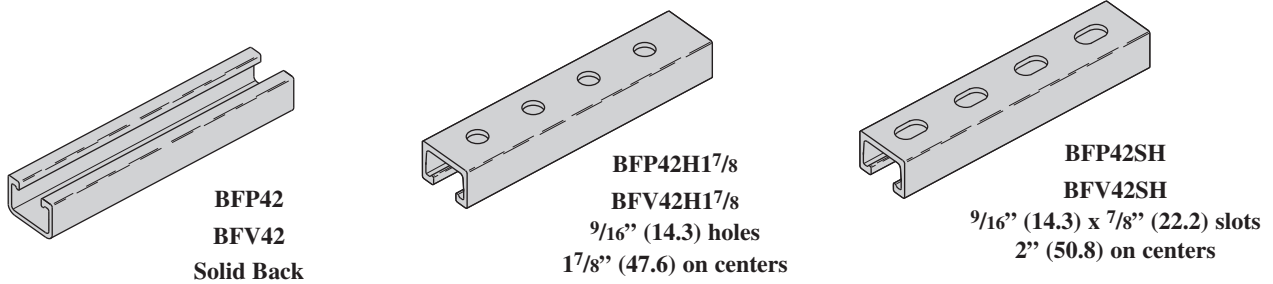

Part No.	Material	Description	Color	Weight	
				Lbs./ft.	kg/m
BFP42*	Polyester Resin	Solid Back	Gray	.48	(.71)
BFV42*	Vinyl Ester Resin	Solid Back	Beige	.48	(.71)
BFP42H1^{7/8}*	Polyester Resin	Holes in Back	Gray	.46	(.68)
BFV42H1^{7/8}*	Vinyl Ester Resin	Holes in Back	Beige	.46	(.68)
BFP42SH*	Polyester Resin	Slots in Back	Gray	.47	(.70)
BFV42SH*	Vinyl Ester Resin	Slots in Back	Beige	.47	(.70)

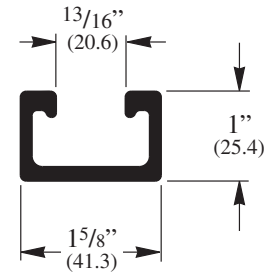

* Insert -10 for 10'-0" (3.05 m) length or -20 for 20'-0" (6.09 m) length

BFP42A BFV42A

- Channel lengths: 10 Ft. (3.05 m) and 20 Ft. (6.09 m)
- Fiberglass strut meets specification of ASTM D-4385 Levels III and IV.

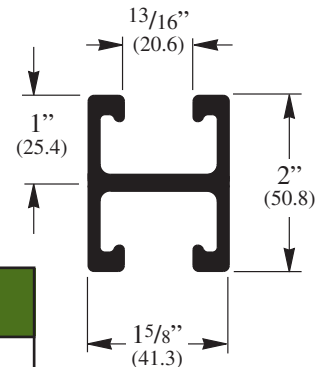
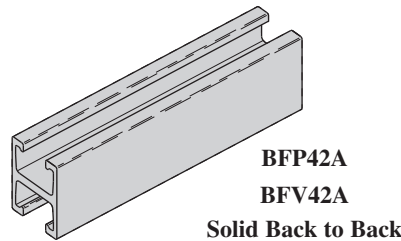

Part No.	Material	Description	Color	Weight	
				Lbs./ft.	kg/m
BFP42A*	Polyester Resin	Back To Back	Gray	.85	(1.26)
BFV42A*	Vinyl Ester Resin	Back To Back	Beige	.85	(1.26)

* Insert -10 for 10'-0" (3.05 m) length or -20 for 20'-0" (6.09 m) length

WARNING: Appropriate protective clothing and respiratory protection device should be worn when field cutting or grinding fiberglass.

Published design loads on page 174 are based on usage at 70°F (21°C) and must be reduced for continuous exposure to higher temperatures. Refer to the chart below for high temperature applications.

Field Cutting Sealant Kits

RSK010 Pint Sealing Kit (473 cm³)
includes sealant and brush applicator

- Seals exposed fibers after field cutting. •
- UV resistant •

Temperature	Design Load Multiplier
75°F (24°C)	100%
100°F (38°C)	90%
125°F (52°C)	78%
150°F (66°C)	68%
175°F (79°C)	60%
200°F (93°C)	52%

Reference page 170 for general fitting specifications.

BEAM LOADING DATA FOR GLASS REINFORCED POLYESTER RESIN

Beam Span		Part No.	Maximum Allowable Beam Load		Deflection @ Maximum Allowable Beam Load		Allowable Load @ Deflection =			
							1/240 Span		1/360 Span	
in.	mm		Lbs.	kN	in.	mm	Lbs.	kN	Lbs.	kN
12"	(305)	BFP42	841	(3.74)	0.104	(2.64)	403	(1.79)	269	(1.19)
		BFP42A	2325	(10.34)	0.060	(1.52)	1948	(8.66)	1299	(5.78)
24"	(609)	BFP42	420	(1.87)	0.417	(10.59)	100	(0.44)	66	(0.29)
		BFP42A	1161	(5.16)	0.239	(6.07)	486	(2.16)	323	(1.43)
36"	(914)	BFP42	279	(1.24)	0.938	(23.82)	43	(0.19)	29	(0.13)
		BFP42A	773	(3.44)	0.537	(13.64)	214	(0.95)	142	(0.63)
48"	(1219)	BFP42	208	(0.92)	1.667	(42.34)	23	(0.10)	15	(0.06)
		BFP42A	578	(2.57)	0.955	(24.26)	119	(0.53)	78	(0.34)
60"	(1524)	BFP42	166	(0.74)	2.604	(66.14)	14	(0.06)	8	(0.03)
		BFP42A	461	(2.05)	1.491	(37.87)	74	(0.33)	48	(0.21)
72"	(1829)	BFP42	137	(0.61)	3.750	(95.25)	8	(0.03)	5	(0.02)
		BFP42A	383	(1.70)	2.148	(54.56)	49	(0.22)	31	(0.14)
96"	(2438)	BFP42	101	(0.45)	6.667	(169.34)	3	(0.01)	–	–
		BFP42A	284	(1.26)	3.818	(96.98)	24	(0.10)	14	(0.04)
120"	(3048)	BFP42	79	(0.35)	10.417	(264.59)	–	–	–	–
		BFP42A	224	(0.99)	5.966	(151.53)	11	(0.05)	5	(0.02)

BEAM LOADING DATA FOR GLASS REINFORCED VINYL ESTER RESIN

Beam Span		Part No.	Maximum Allowable Beam Load		Deflection @ Maximum Allowable Beam Load		Allowable Load @ Deflection =			
							1/240 Span		1/360 Span	
in.	mm		Lbs.	kN	in.	mm	Lbs.	kN	Lbs.	kN
12"	(305)	BFV42	988	(4.39)	0.112	(2.84)	440	(1.96)	293	(1.30)
		BFV42A	2865	(12.74)	0.063	(1.60)	2278	(10.13)	1518	(6.75)
24"	(609)	BFV42	493	(2.19)	0.448	(11.38)	109	(0.48)	73	(0.32)
		BFV42A	1431	(6.36)	0.252	(6.40)	568	(2.52)	378	(1.68)
36"	(914)	BFV42	328	(1.46)	1.009	(25.63)	48	(0.21)	31	(0.14)
		BFV42A	953	(4.24)	0.566	(14.37)	251	(1.11)	166	(0.74)
48"	(1219)	BFV42	245	(1.09)	1.793	(45.54)	26	(0.11)	16	(0.07)
		BFV42A	713	(3.17)	1.006	(25.55)	139	(0.62)	92	(0.41)
60"	(1524)	BFV42	195	(0.87)	2.802	(71.17)	15	(0.06)	9	(0.04)
		BFV42A	569	(2.53)	1.572	(39.93)	87	(0.38)	57	(0.25)
72"	(1829)	BFV42	162	(0.72)	4.035	(102.49)	9	(0.04)	5	(0.02)
		BFV42A	473	(2.10)	2.264	(57.50)	58	(0.26)	37	(0.16)
96"	(2438)	BFV42	120	(0.53)	7.173	(182.19)	3	(0.01)	1	(0.004)
		BFV42A	351	(1.56)	4.025	(102.23)	29	(0.13)	17	(0.07)
120"	(3048)	BFV42	94	(0.42)	11.207	(284.66)	–	–	–	–
		BFV42A	278	(1.23)	6.288	(159.71)	14	(0.06)	7	(0.03)

Loading Information

Beam Loads:

The above charts list the total allowable uniform load for various simple spans based on a minimum safety factor of 2. If the load is concentrated at center span, multiply the load from the above charts by 0.5 and the corresponding deflection by 0.8.

All beams should be supported in a manner to prevent rotation at supports. Long, deep beams should be tied between supports to prevent twist. For channels with holes or slots use 90% of recommended load shown in channel loading chart.

Reference page 170 for general fitting specifications.

Fiberglass

BF*22I CONCRETE INSERTS

- Design Load 300 Lbs (1.47 kN)
- Safety Factor of 3
- Standard lengths: 6" (152), 12" (305), 24" (609), 36" (914), 48" (1219), 60" (1524), 72" (1829), 84" (2133), 96" (2438), 108" (2743) and 120" (3048)
- Available Material:
 - *Insert P for BFP - Polyester Resin channel and tee
 - *Insert V for BFV - Vinyl Ester Resin channel with Polyester Resin tee
- Shipped with removable styrofoam insert

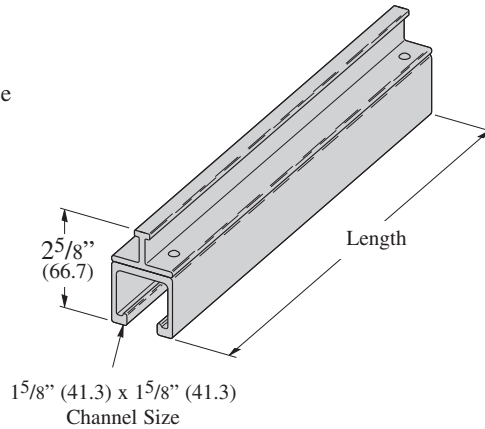

Field Cutting Sealant Kits

RSK010 Pint Sealing Kit (473 cm³)
includes sealant and brush applicator

- Seals exposed fibers after field cutting. •
- UV resistant •

BFV501 SERIES U-BOLTS WITH HEX NUTS

- Design Load Safety Factor of 3
- Load A: Straight down loading
- Load B: Side loading
- Inner surface of U-Bolt is flat to provide additional contact surface area
- Material: Glass Reinforced Polyurethane

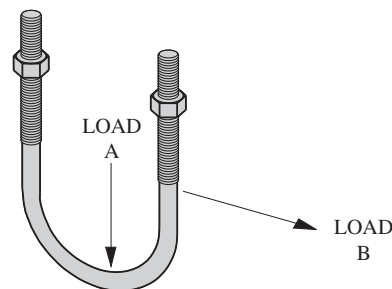

Part No.	Nominal Pipe Size		Thread Size	Design Load A		Design Load B		Maximum Torque		Wt./C	
	in.	mm		Lbs.	kN	Lbs.	kN	in.-Lbs.	N•m	Lbs.	kg
BFV501-1/2	1/2	(15)	3/8"-16	300	(1.33)	150	(.67)	30	(3.4)	3.5	(1.59)
BFV501-3/4	3/4	(20)	3/8"-16	300	(1.33)	150	(.67)	30	(3.4)	3.9	(1.77)
BFV501-1	1	(25)	3/8"-16	300	(1.33)	150	(.67)	30	(3.4)	4.4	(1.99)
BFV501-1 1/4	1 1/4	(32)	3/8"-16	300	(1.33)	150	(.67)	30	(3.4)	4.8	(2.18)
BFV501-1 1/2	1 1/2	(40)	3/8"-16	300	(1.33)	150	(.67)	30	(3.4)	5.2	(2.36)
BFV501-2	2	(50)	1/2"-13	600	(2.67)	200	(.89)	60	(6.8)	7.7	(3.49)
BFV501-2 1/2	2 1/2	(65)	1/2"-13	600	(2.67)	200	(.89)	60	(6.8)	10.2	(4.63)
BFV501-3	3	(80)	1/2"-13	600	(2.67)	200	(.89)	60	(6.8)	12.6	(5.71)
BFV501-3 1/2	3 1/2	(90)	1/2"-13	600	(2.67)	200	(.89)	60	(6.8)	15.1	(6.85)
BFV501-4	4	(100)	1/2"-13	600	(2.67)	200	(.89)	60	(6.8)	17.6	(7.98)

Reference page 170 for general fitting specifications.

CHANNEL NUTS

- Design Load Safety Factor of 3
- Overall Nut Height $5/8''$ (15.9)
- Maximum torque and slip resistance loads shown are when using stainless steel bolts. When using fiberglass hardware use Max. Torque for fiberglass bolts, and multiply slip resistance loads by .14 for $3/8''$ and .60 for $1/2''$ thread size.
- Material: Glass Reinforced Polyurethane
- Spring Material: Zinc Plated Steel

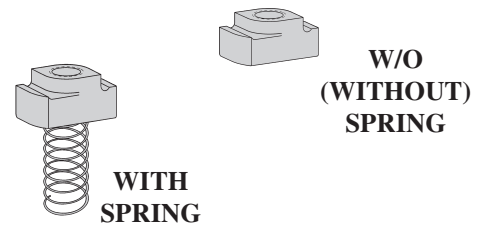

Part No. With Spring	Part No. W/O Spring	Thread Size	Pull-Out		Slip Resistance		Max. Torque		Wt./C	
			Lbs	kN	Lbs.	N	in.-Lbs.	N•m	Lbs.	kg
BFV-224	BFV-224WO	$1/4''$ -20	300	(1.33)	150	(.67)	200	(22.6)	2.4	(1.09)
BFV-223	BFV-223WO	$5/16''$ -18	300	(1.33)	150	(.67)	200	(22.6)	2.5	(1.13)
BFV-228	BFV-228WO	$3/8''$ -16	300	(1.33)	150	(.67)	200	(22.6)	2.3	(1.04)
BFV-225	BFV-225WO	$1/2''$ -13	300	(1.33)	150	(.67)	200	(22.6)	2.1	(0.95)

BFVHHCS HEX HEAD CAP SCREWS

- Design Load Safety Factor of 3
- Material: Glass Reinforced Polyurethane

Part No.	Thread Size	Design Load (in tension)		Max. Torque		Wt./C	
		Lbs.	kN	in.-Lbs.	N•m	Lbs.	kg
BFVHHCS $5/16$ x 1	$5/16''$ -18	190	(.84)	30	(3.4)	.4	(.18)
BFVHHCS $5/16$ x $1 1/4$	$5/16''$ -18	190	(.84)	30	(3.4)	.5	(.23)
BFVHHCS $5/16$ x $1 1/2$	$5/16''$ -18	190	(.84)	30	(3.4)	.6	(.27)
BFVHHCS $5/16$ x 2	$5/16''$ -18	190	(.84)	30	(3.4)	.8	(.36)
BFVHHCS $3/8$ x 1	$3/8''$ -16	300	(1.33)	45	(5.1)	.9	(.41)
BFVHHCS $3/8$ x $1 1/4$	$3/8''$ -16	300	(1.33)	45	(5.1)	1.1	(.50)
BFVHHCS $3/8$ x $1 1/2$	$3/8''$ -16	300	(1.33)	45	(5.1)	1.3	(.59)
BFVHHCS $3/8$ x 2	$3/8''$ -16	300	(1.33)	45	(5.1)	1.3	(.59)
BFVHHCS $3/8$ x $2 1/2$	$3/8''$ -16	300	(1.33)	45	(5.1)	1.5	(.68)
BFVHHCS $1/2$ x 1	$1/2''$ -13	490	(2.18)	110	(12.4)	1.4	(.63)
BFVHHCS $1/2$ x $1 1/4$	$1/2''$ -13	490	(2.18)	110	(12.4)	1.8	(.81)
BFVHHCS $1/2$ x $1 1/2$	$1/2''$ -13	490	(2.18)	110	(12.4)	2.2	(1.00)
BFVHHCS $1/2$ x 2	$1/2''$ -13	490	(2.18)	110	(12.4)	3.0	(1.36)
BFVHHCS $1/2$ x $2 1/2$	$1/2''$ -13	490	(2.18)	110	(12.4)	3.7	(1.68)
BFVHHCS $1/2$ x 3	$1/2''$ -13	490	(2.18)	110	(12.4)	4.5	(2.04)

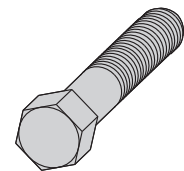

BFVHN HEX NUTS

- $3/4''$ & $1''$ sizes are available. Contact inside sales for details
- Material: Glass Reinforced Polyurethane

Part No.	Thread Size	Nut Thickness		Wt./C	
		in.	mm	Lbs.	kg
BFVHN $5/16$	$5/16''$ -18	$17/64$	(6.7)	.2	(.09)
BFVHN $3/8$	$3/8''$ -16	$21/64$	(8.3)	.3	(.13)
BFVHN $1/2$	$1/2''$ -13	$7/16$	(11.1)	.7	(.32)
BFVHN $5/8$	$5/8''$ -11	$35/64$	(13.9)	1.4	(.63)

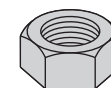

Reference page 170 for general fitting specifications.

Fiberglass

BFVATR ALL THREADED ROD

- Design Load Safety Factor of 3
- Use ATR nuts in place of hex nuts with $3/8$ "-16 and $1/2$ "-13 threaded rod in order to obtain minimum required thread engagement of $17/32$ " (13.5) to obtain design load shown below.
- Material: Glass Reinforced Vinyl Ester

Part No.	Thread Size	Design Load (in tension)		Max. Torque		Wt./Ft.	
		Lbs.	kN	in.-Lbs.	N•m	Lbs.	kg
BFVATR $3/8$ x 48"	$3/8$ "-16	425	(1.89)	45	(5.1)	.08	(.04)
BFVATR $1/2$ x 48"	$1/2$ "-13	750	(3.33)	110	(12.4)	.13	(.06)
BFVATR $5/8$ x 48"	$5/8$ "-11	950	(4.22)	230	(26.0)	.21	(.09)

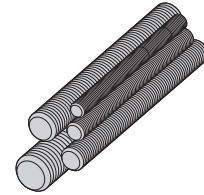

BFVATRH THREADED ROD NUTS

- ATR Nut is required with $3/8$ "-16 and $1/2$ "-13 ATR to provide additional thread engagement which is critical to ATR load carrying capacity.
- Material: Glass Reinforced Polyurethane

Part No.	Thread Size	H		Wt./C	
		in.	mm	Lbs.	kg
BFVATRH $3/8$	$3/8$ "-16	$3/4$	(19)	.8	(.36)
BFVATRH $1/2$	$1/2$ "-13	$7/8$	(22)	1.7	(.77)

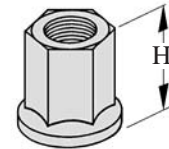

BFVFW FLAT WASHERS

- Material: PVC

Part No.	Hole Size in.	Wt./C	
		Lbs.	kg
BFVFW $3/8$	$3/8$.5	(.22)
BFVFW $1/2$	$1/2$.5	(.22)
BFVFW $5/8$	$5/8$.5	(.22)
BFVFW $3/4$	$3/4$.5	(.22)
BFVFW 1	1	.5	(.22)

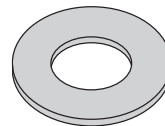

BFV655 SERIES ROD COUPLINGS

- Material: Glass Reinforced Polyurethane

Part No.	Thread Size	Wt./C	
		Lbs.	kg
BFV655- $3/8$	$3/8$ "-16	7.4	(3.35)
BFV655- $1/2$	$1/2$ "-13	11.3	(5.12)
BFV655- $5/8$	$5/8$ "-11	16.7	(7.57)



Reference page 170 for general fitting specifications.

BFV100 thru BFV300 ADJUSTABLE PIPE CLAMPS

- Completely Non-Metallic
- Adjustable to U.S. & Metric Pipe Diameters
- Fits OD Sizes 3/4" (19.0) to 3 1/2" (88.9)
- Easy To Install
- No Special Tools Required
- Design Load Safety Factor of 3
- Material: Glass Reinforced Polyurethane
- Not recommended for vertical installation without additional Stop-Lock Kit. Kit includes one square washer, channel nut and hex head cap screw. Order (Stop-Lock Kit) BFVSL-3/8 for 3/8"-16 hardware or BFVSL-1/2 for 1/2"-13 hardware. Mount kit below clamp when used in vertical strut to prevent clamp slipping.

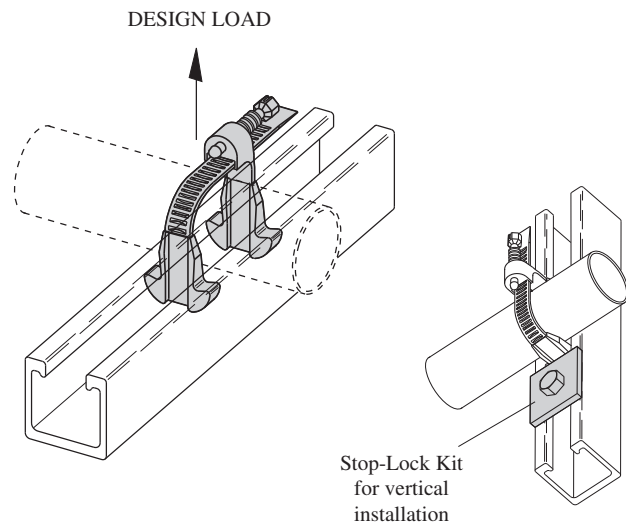

Part No.	Nominal Pipe Sizes		Pipe O.D. Range		Design Load		Max. Torque	
	in.	mm	in.	mm	Lbs.	kN	in.-Lbs.	N•m
BFV100	1/2 - 1 1/2	(15 - 40)	.75 - 1.90	(21.3 - 48.3)	135	(.60)	10	(1.13)
BFV200	1 1/2 - 2	(40 - 51)	1.90 - 2.37	(48.3 - 60.3)	135	(.60)	36	(4.07)
BFV300	2 1/2 - 3	(63 - 76)	2.87 - 3.50	(73.0 - 88.9)	145	(.64)	36	(4.07)

BFV2000 SERIES NON-METALLIC PIPE CLAMPS

- For rigid and PVC conduit.
- Standard hardware includes slotted round head machine screw and square nut in 316 stainless steel
- Design Load Safety Factor of 3
- Material: Glass Reinforced PPO
- Not recommended for vertical installation without additional Stop-Lock Kit. Kit includes one square washer, channel nut and hex head cap screw. Order (Stop-Lock Kit) BFVSL-3/8 for 3/8"-16 hardware or BFVSL-1/2 for 1/2"-13 hardware. Mount kit below clamp when used in vertical strut to prevent clamp slipping.
- If non-metallic hardware is required, add N to the part number. **Example: BFV2008N**

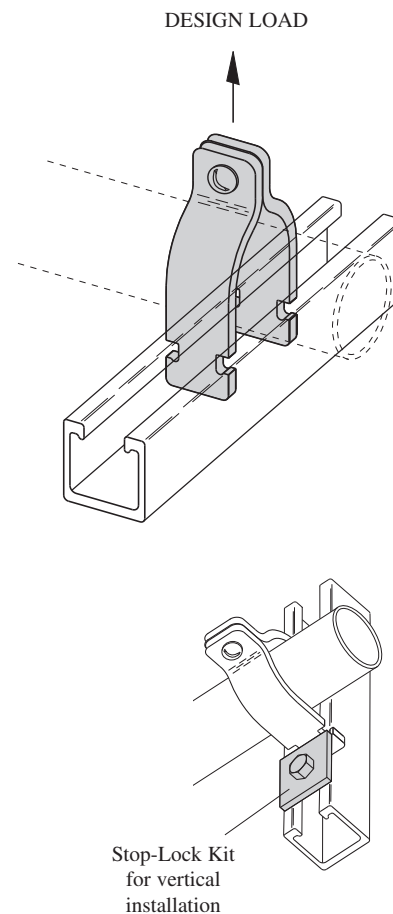

Part No.	Nominal Pipe Size		Design Load		Maximum Torque	
	in.	mm	Lbs.	kN	in.-Lbs.	N•m
BFV2008	1/2	(15)	300	(1.33)	10	(1.13)
BFV2009	3/4	(20)	300	(1.33)	10	(1.13)
BFV2010	1	(25)	300	(1.33)	10	(1.13)
BFV2011	1 1/4	(32)	300	(1.33)	10	(1.13)
BFV2012	1 1/2	(40)	300	(1.33)	10	(1.13)
BFV2013	2	(50)	300	(1.33)	10	(1.13)
BFV2014	2 1/2	(65)	300	(1.33)	10	(1.13)
BFV2015	3	(80)	300	(1.33)	10	(1.13)
BFV2016	3 1/2	(90)	300	(1.33)	10	(1.13)
BFV2017	4	(100)	300	(1.33)	10	(1.13)

Reference page 170 for general fitting specifications.

Fiberglass

BFP2400 SERIES 2-HOLE PIPE CLAMPS

- Design Load Safety Factor of 3
- Material: Glass Reinforced Polyester

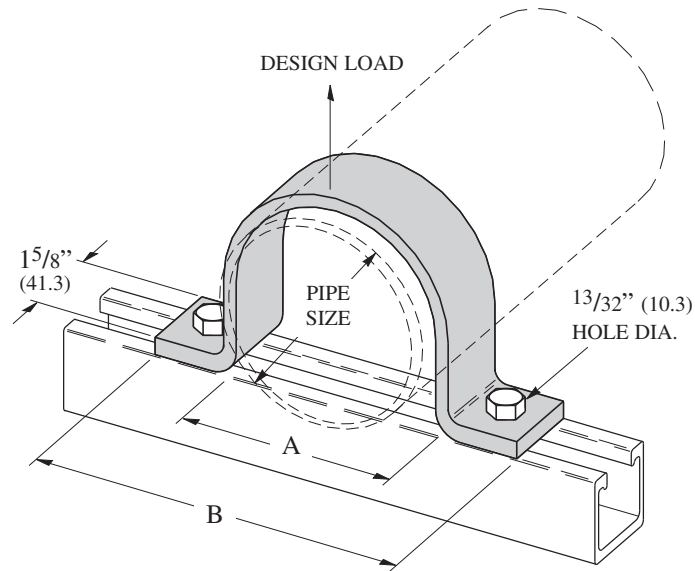

Part No.	Nominal Pipe Size		A		B		Design Load	
	in.	mm	in.	mm	in.	mm	Lbs.	kN
BFP2400-2	2	(50)	2 ³ / ₈	(60)	5 ¹ / ₂	(140)	115	(0.51)
BFP2400-3	3	(80)	3 ¹ / ₂	(89)	6 ³ / ₄	(171)	130	(0.58)
BFP2400-4	4	(100)	4 ¹ / ₂	(114)	7 ³ / ₄	(197)	150	(0.66)
BFP2400-6	6	(150)	6 ⁵ / ₈	(168)	10	(254)	150	(0.66)

BFV751 & BFV751J BEAM CLAMP

- Design Load Safety Factor of 3
- BFV751J (clip included) must be used when installed on tapered flange beams.
- Material: Glass Reinforced Polyurethane
- Setscrew material: Stainless Steel 316 ASTM F593 Group 2, S4

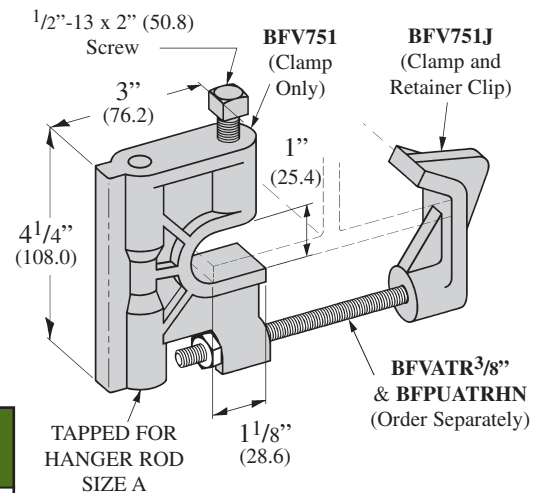

Part No.	For Hanger Rod Size A	Design Load		Torque	
		Lbs.	kN	ft.-Lbs.	N•m
BFV751-3/8	3/8"-16	500	(2.22)	10	(13)
BFV751J-3/8	3/8"-16	500	(2.22)	10	(13)
BFV751-1/2	1/2"-13	500	(2.22)	10	(13)
BFV751J-1/2	1/2"-13	500	(2.22)	10	(13)
BFV751-5/8	5/8"-11	500	(2.22)	10	(13)
BFV751J-5/8	5/8"-11	500	(2.22)	10	(13)

Reference page 170 for general fitting specifications.

BFV755 BEAM CLAMP

- Design Load Safety Factor of 3
- Material: Glass Reinforced Polyurethane
- Setscrew material: Stainless Steel 316
ASTM F593 Group 2, S4

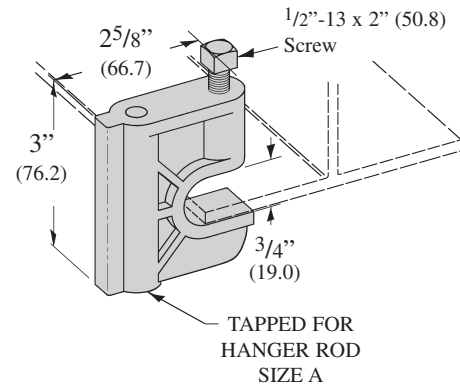

Part No.	For Hanger Rod Size A	Design Load		Torque	
		Lbs.	kN	ft.-Lbs.	N•m
BFV755-3/8	3/8"-16	400	(1.78)	10	(13)
BFV755-1/2	1/2"-13	400	(1.78)	10	(13)

BFV3104 SERIES CLEVIS HANGERS

- Design Load Safety Factor of 3 at 120°F (49°C).
- Insulation may be required at higher temperatures.
- Order hanger rod and nuts separately.
- Material: Glass Reinforced Polyurethane
For BFV3104-1 thru BFV3104-6
- Material: Glass Reinforced Polyester & Vinyl Ester
For BFV3104-8 thru BFV3104-12

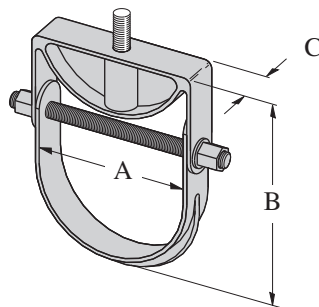

BFV3104-1 thru BFV3104-6

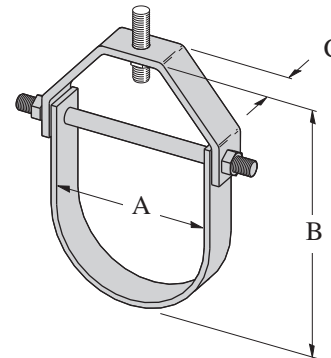

BFV3104-8 thru BFV3104-12

Part No.	Nominal Pipe Size		A		B		C		Hanger Rod Size	Design Load	
	in.	mm	in.	mm	in.	mm	in.	mm		Lbs.	kN
BFV3104-1	1	(50)	1 1/2	(38)	4 1/4	(108)	1 1/4	(32)	1/2"-13	670	(2.98)
BFV3104-1 1/2	1 1/2	(65)	2	(51)	5 1/8	(130)	1 1/4	(32)	1/2"-13	670	(2.98)
BFV3104-2	2	(50)	2 1/2	(63)	6 1/2	(165)	1 1/4	(32)	1/2"-13	730	(3.25)
BFV3104-2 1/2, 3, 4	2 1/2-4	(65-100)	5 1/8	(130)	10	(254)	1 1/2	(38)	1/2"-13	1150	(5.11)
BFV3104-6	6	(150)	6 3/4	(171)	12 5/16	(313)	2	(51)	1/2"-13	1170	(5.20)

Part No.	Nominal Pipe Size		A		B		C		Hanger Rod Size	Design Load	
	in.	mm	in.	mm	in.	mm	in.	mm		Lbs.	kN
BF*3104-8	8	(200)	9 1/4	(235)	16 5/8	(422)	3	(76)	5/8"-11	350	(1.55)
BF*3104-10	10	(250)	11 3/8	(289)	19 7/8	(505)	4	(101)	5/8"-11	450	(2.01)
BF*3104-12	12	(300)	13 1/2	(343)	22 3/8	(568)	5	(127)	5/8"-11	600	(2.69)

*Specify P for polyester or V for Vinyl ester.

Reference page 170 for general fitting specifications.

Fiberglass

BF*409 SERIES BRACKETS 6" (152) TO 24" (609) LONG

- Design Load Safety Factor of 3 based on uniform loading
- MH1 - From Top of Bracket to center of Mounting Hole
- MH2 - From Bottom of Bracket to center of Mounting Hole

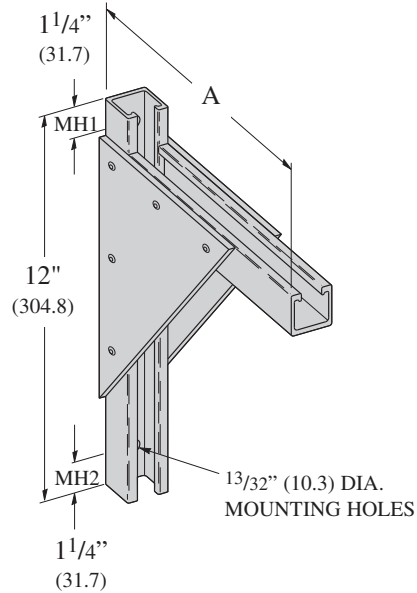

Part No.	A		Design Load	
	in.	mm	Lbs.	kN
BF*409-6	10	(250)	1400	(6.22)
BF*409-9	13	(330)	1000	(4.45)
BF*409-12	16	(406)	800	(3.56)
BF*409-18	22	(559)	675	(3.00)
BF*409-24	28	(711)	450	(2.00)

* Insert P for Glass Reinforced Polyester Resin or V for Glass Reinforced Vinyl Ester Resin

BF*494 SERIES BRACKETS 24" (609) TO 36" (914) LONG

- Design Load Safety Factor of 3 based on uniform loading
- MH1 - From Top of Bracket to center of Mounting Hole
- MH2 - From Bottom of Bracket to center of Mounting Hole
- Material: Glass Reinforced Vinyl Ester or Polyester

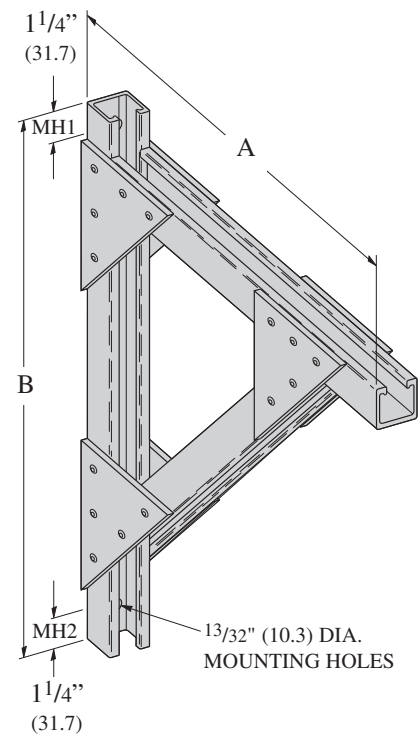

Part No.	A		B		Design Load	
	in.	mm	in.	mm	Lbs.	kN
BF*494-24	28	(711)	23	(584)	750	(3.33)
BF*494-30	34	(863)	26	(660)	750	(3.33)
BF*494-36	40	(1016)	29	(736)	750	(3.33)

* Insert P for Glass Reinforced Polyester Resin or V for Glass Reinforced Vinyl Ester Resin

Reference page 170 for general fitting specifications.

BFV201
SQUARE WASHER FOR 3/8" BOLT

•Material: Injection Molded Glass Reinforced Polyurethane

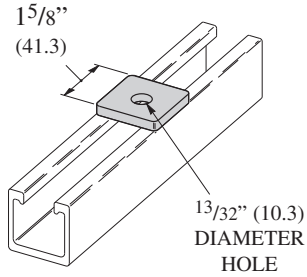

BFV202
SQUARE WASHER FOR 1/2" BOLT

•Material: Injection Molded Glass Reinforced Polyurethane

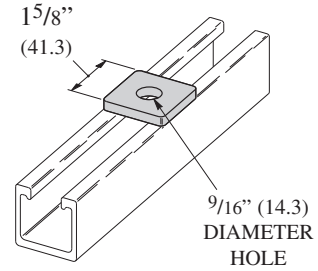

BFV340
TWO HOLE FLAT PLATE

•Material: Injection Molded Glass Reinforced Polyurethane

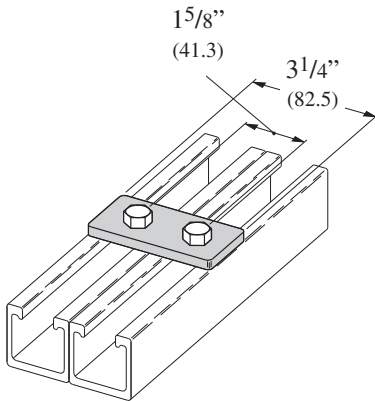

BFV129
TWO HOLE SPLICE PLATE

•Material: Injection Molded Glass Reinforced Polyurethane

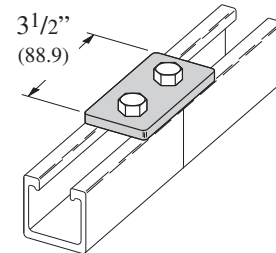

BFV141
THREE HOLE FLAT PLATE

•Material: Injection Molded Glass Reinforced Polyurethane

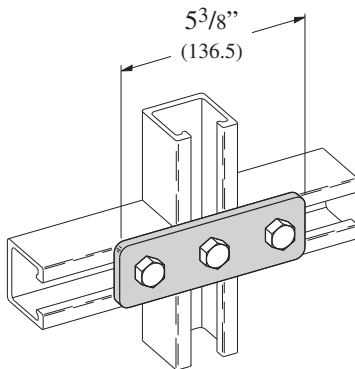

BFV557
THREE HOLE FLAT PLATE

•Material: Injection Molded Glass Reinforced Polyurethane

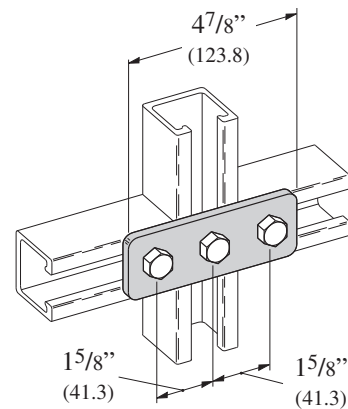

Reference page 170 for general fitting specifications.

BFV341
FOUR HOLE SPLICE PLATE

•Material: Injection Molded Glass Reinforced Polyurethane

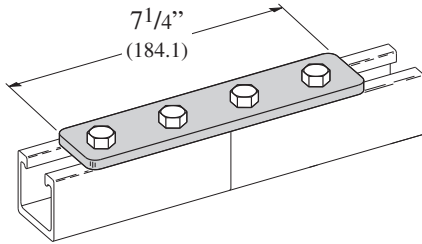

BFV342
FIVE HOLE FLAT PLATE

•Material: Injection Molded Glass Reinforced Polyurethane

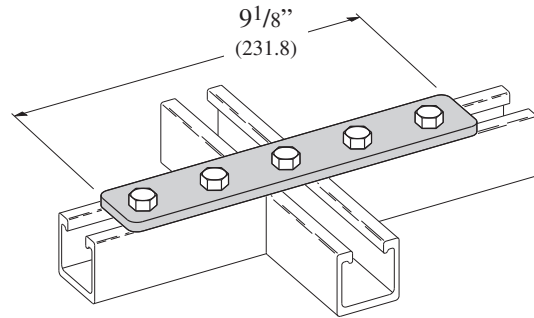

BFV140
THREE HOLE FLAT CORNER PLATE

•Material: Injection Molded Glass Reinforced Polyurethane

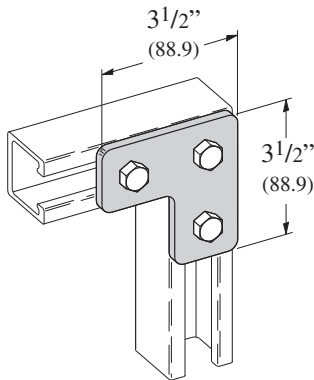

BFV143
FOUR HOLE FLAT CORNER PLATE

•Material: Injection Molded Glass Reinforced Polyurethane

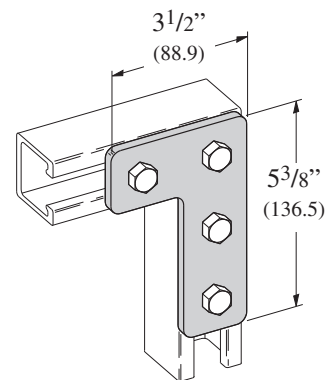

BFV132
FIVE HOLE FLAT CROSS PLATE

•Material: Injection Molded Glass Reinforced Polyurethane

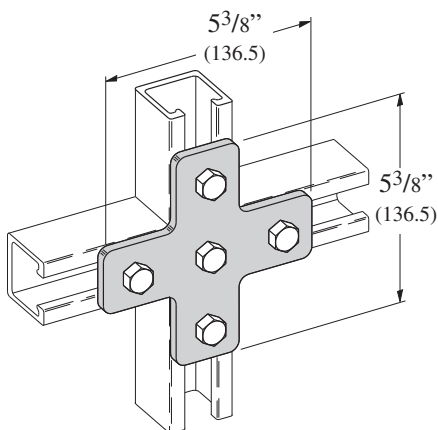

BFV133
FOUR HOLE FLAT TEE PLATE

•Material: Injection Molded Glass Reinforced Polyurethane

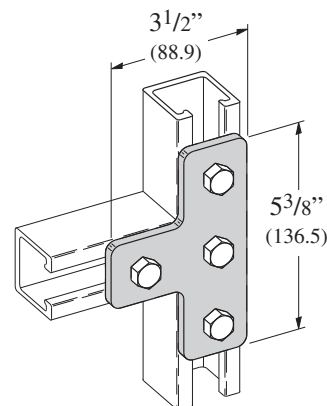

Reference page 170 for general fitting specifications.

BFV135
THREE HOLE FLAT GUSSET CORNER PLATE

•Material: Injection Molding Glass Reinforced Polyurethane

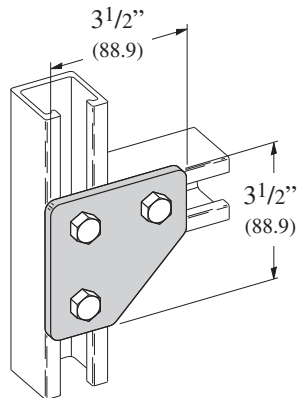

BFV142
FOUR HOLE FLAT GUSSET CORNER PLATE

•Material: Injection Molding Glass Reinforced Polyurethane

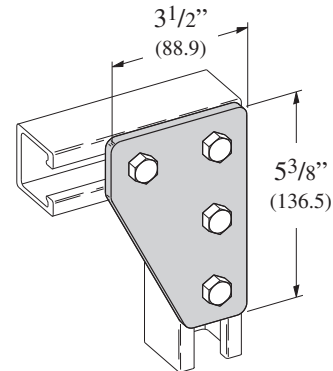

BFV337
THREE HOLE FLAT GUSSET TEE PLATE

•Material: Injection Molding Glass Reinforced Polyurethane

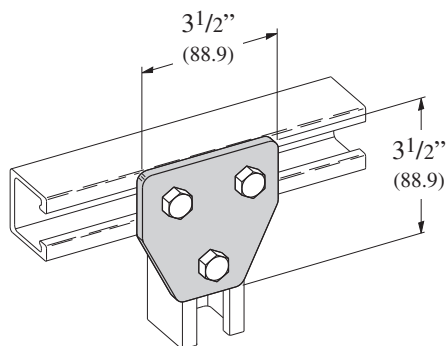

BFV136
FOUR HOLE FLAT GUSSET TEE PLATE

•Material: Injection Molding Glass Reinforced Polyurethane

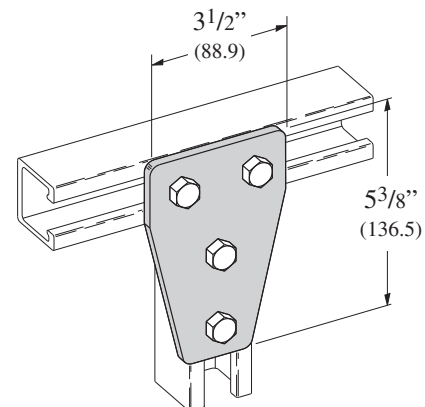

BFV532
FIVE HOLE FLAT GUSSET TEE PLATE

•Material: Injection Molding Glass Reinforced Polyurethane

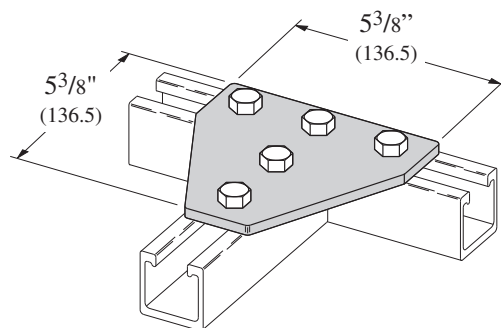

BFV334
SEVEN HOLE FLAT GUSSET CROSS PLATE

•Material: Injection Molding Glass Reinforced Polyurethane

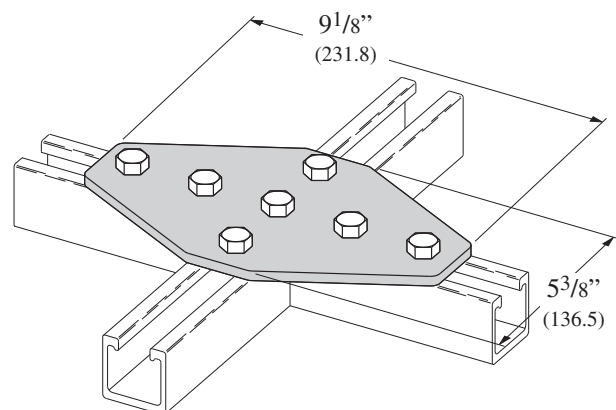

Reference page 170 for general fitting specifications.

BFV101
TWO HOLE 90° CORNER ANGLE

•Material: Injection Molded Glass Reinforced Polyurethane

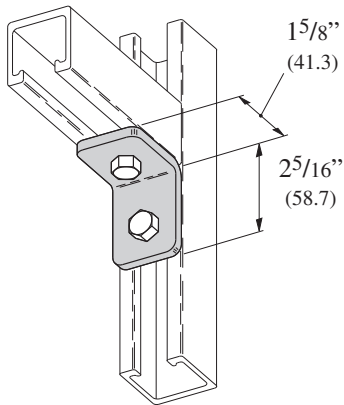

BFV103
THREE HOLE 90° CORNER ANGLE

•Material: Injection Molded Glass Reinforced Polyurethane

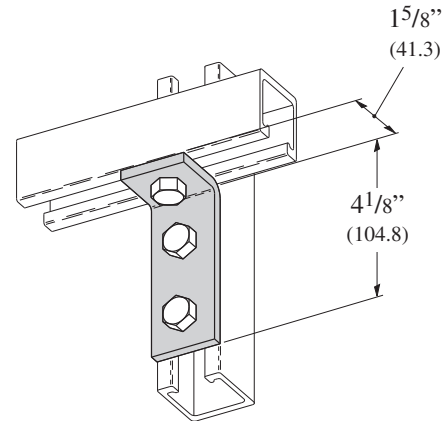

BFV104
FOUR HOLE 90° CORNER ANGLE

•Material: Injection Molded Glass Reinforced Polyurethane

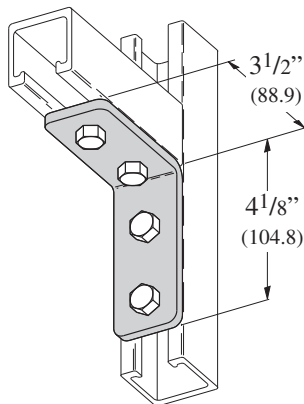

BFV118
FOUR HOLE 90° GUSSETED SHELF ANGLE

•Material: Injection Molded Glass Reinforced Polyurethane

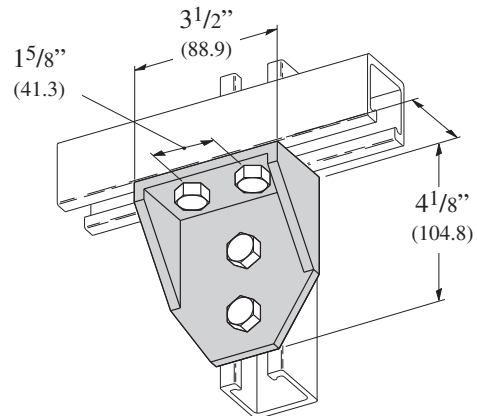

BFV558
FOUR HOLE 90° CORNER ANGLE

•Material: Injection Molded Glass Reinforced Polyurethane

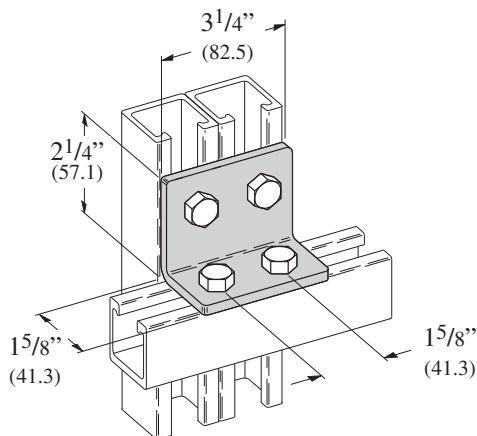

BFV371-2G
THREE HOLE 90° GUSSETED CORNER ANGLE

•Material: Injection Molded Glass Reinforced Polyurethane

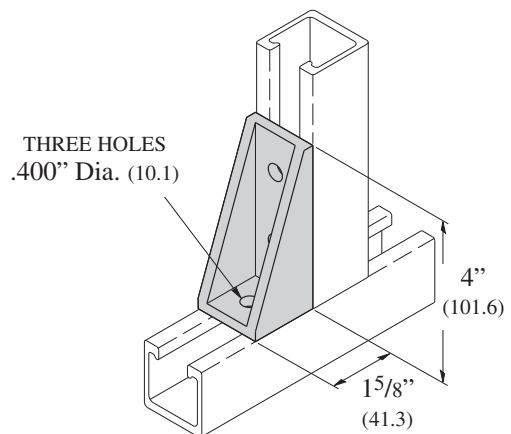

Reference page 170 for general fitting specifications.

BFV280SQ
POST BASE FOR BF*22

•Material: Glass Reinforced Polyurethane

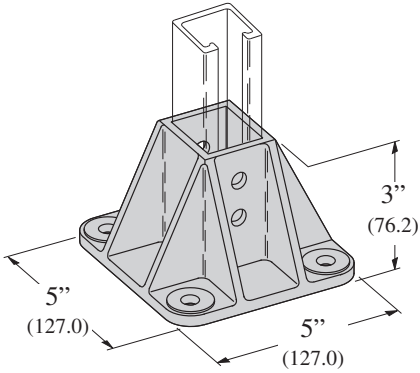

BFV281SQ
POST BASE FOR BF*22A

•Material: Glass Reinforced Polyurethane

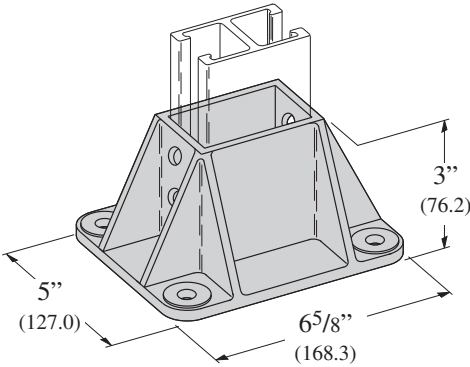

BFV650
CHANNEL SPACER

•Spacer I.D. accommodates 3/8" rod or bolts.
•Material: Polyurethane

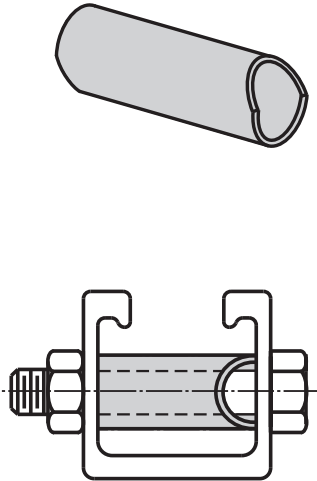

Used when attaching fittings to side walls of channel.
This channel spacer prevents wall compression in heavy load conditions.

B217P
PLASTIC CLOSURE STRIP

•Available in 10 Ft. (3.05 m) lengths.
•Material: PVC

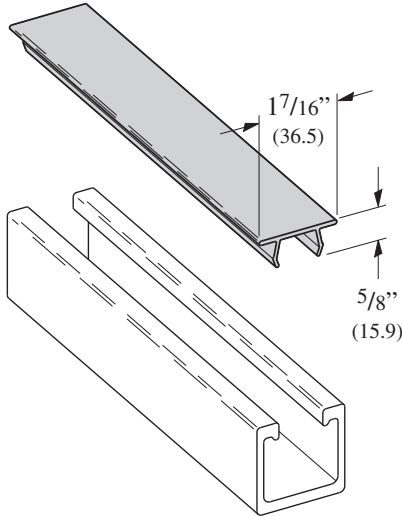

Reference page 170 for general fitting specifications.

Mini Channel & Fittings

B-Line's mini channels and fittings provide for an economical method of supporting light load requirements on a metal framing system.

Channel

Channels are cold formed on our modern rolling mills from 18 Ga. (1.2 mm) low carbon steel strips plain steel (ASTM A1008 33,000 PSI min. yield) and pre-galvanized steel strips, (ASTM A653 33,000 PSI min. yield). A continuous slot with inturned lips provides the ability to make attachments at any point. Channel combinations are made with new state of the art, high-tech welding equipment.

Lengths

Standard lengths are 10' (3.05 m) and 20' (6.09 m) for B62 series, and 10' (3.05 m) for B72 series. Custom lengths are available.

Fittings

Mini fittings are formed from hot rolled pickled and oiled strip or sheet steel (ASTM A1011, HSLAS, Grade 50, Class1). The following dimensions apply to all fittings except as noted on the drawings:

Hole Size— $9/32$ " (7.14 mm) Dia.

Hole Spacing— $13/32$ " (10.3 mm) from end and $11/16$ " (27.0 mm) on center.

Width— $13/16$ " (20.6 mm)

Thickness— $1/8$ " (3.2 mm)

Materials & Finishes*

Finish Code	Finish	Specification
PLN	Plain	ASTM A1011, HSLAS, Grade 50, Class 1
ZN	Electro-Plated Zinc	ASTM B633 SC3 Type II
GRN	Dura-Green	
GALV	Pre-Galvanized	ASTM A653 33,000 PSI min. yield
HDG	Hot-Dipped Galvanized	ASTM A123

*Unless otherwise noted.

Metric

Metric dimensions are shown in parentheses. Unless noted, all metric dimensions are in millimeters.



- Thickness: 18 Ga. (1.2 mm)
- Standard lengths: 10' (3.05 m) & 20' (6.09 m)
- Standard finishes: Plain, Dura-Green, Pre-Galvanized
- Weight: .42 Lbs./Ft. (.62 kg/m)

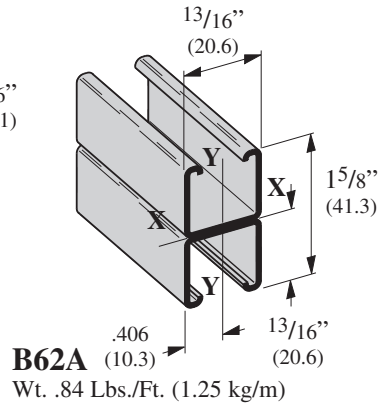
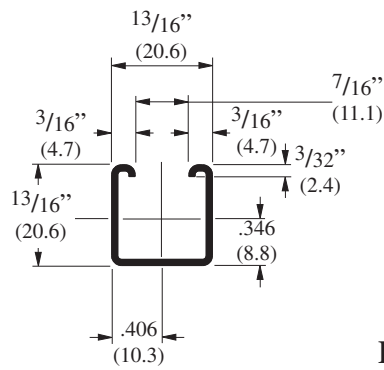
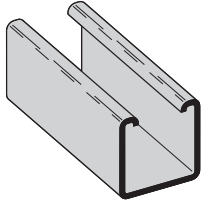

SECTION PROPERTIES

Channel	X - X Axis										Y - Y Axis					
	Weight		Areas of Section		Moment of Inertia (I)		Section Modulus (S)		Radius of Gyration (r)		Moment of Inertia (I)		Section Modulus (S)		Radius of Gyration (r)	
	lbs./ft.	kg/m	sq. in.	cm ²	in. ⁴	cm ⁴	in. ³	cm ³	in.	cm	in. ⁴	cm ⁴	in. ³	cm ³	in.	cm
B62	.420	(.62)	.123	(.80)	.0103	(.43)	.0221	(.36)	.289	(.73)	.0134	(.56)	.0330	(.54)	.330	(.84)
B62A	.839	(1.25)	.247	(1.59)	.0500	(2.08)	.0616	(1.01)	.450	(1.14)	.0269	(1.12)	.0663	(1.09)	.330	(.84)

Calculations of section properties are based on metal thicknesses as determined by the AISI Cold-Formed Steel Design Manual.

BEAM LOADING

Beam Span		Channel Style	Uniform Load and Deflection				Uniform Load @ Deflection =			
In.	mm		Lbs.	N	In.	mm	1/240 Span		1/360 Span	
						Lbs.	N	Lbs.	N	
12	(305)	B62 B62A	364 420*	(1619.1) (1868.2)	.027 .006	(.68) (.15)	364 420*	(1619.1) (1868.2)	364 420*	(1619.1) (1868.2)
24	(609)	B62 B62A	182 420*	(809.6) (1868.2)	.109 .051	(2.77) (1.29)	167 420*	(742.8) (1868.2)	111 420*	(493.7) (1868.2)
36	(914)	B62 B62A	121 341	(538.2) (1516.8)	.245 .141	(6.22) (3.58)	74 341	(329.1) (1516.8)	50 242	(222.4) (1076.4)
48	(1219)	B62 B62A	91 256	(404.8) (1138.7)	.436 .250	(11.07) (6.35)	42 204	(186.8) (907.4)	28 136	(124.5) (604.9)
60	(1524)	B62 B62A	73 205	(324.7) (911.9)	.681 .391	(17.30) (9.93)	27 131	(120.1) (582.7)	18 87	(80.0) (387.0)
72	(1829)	B62 B62A	61 170	(271.3) (756.2)	.981 .563	(24.92) (14.30)	19 91	(84.5) (404.8)	12 61	(53.4) (271.3)

Based on simple beam condition using an allowable design stress of 25,000 psi (172 MPa) in accordance with MFMA, with adequate lateral bracing (see page 11 for further explanation). Actual yield point of cold rolled steel is 42,000 psi. To determine concentrated load capacity at mid span, multiply uniform load by 0.5 and corresponding deflection by 0.8. *Failure determined by weld shear.

COLUMN LOADING

Unbraced Height	Channel Style	Max. Column Loading K = .80				Max. Column Loading (Loaded @ C.G.)					
		Loaded @ C.G.		Loaded @ Slot Face		K = .65		K = 1.0		K = 1.2	
		Lbs.	N	Lbs.	N	Lbs.	N	Lbs.	N	Lbs.	N
12	B62 B62A	2052 4666	(9127.7) (20755.4)	820 1449	(3647) (6445)	2161 4710	(9612.6) (20951.1)	1890 4593	(8407.1) (20430.7)	1715 4503	(7628.7) (20030.3)
24	B62 B62A	1350 4275	(6005.1) (19016.1)	645 1367	(2869) (6081)	1624 4453	(7223.9) (19807.9)	1020 3982	(4537.2) (17712.8)	818 3624	(3638.6) (16120.3)
36	B62 B62A	818 3624	(3638.6) (16120.3)	471 847	(2095) (3767)	1053 4023	(4684.0) (17895.2)	633 2965	(2815.7) (13189.0)	515 2179	(2290.8) (9692.7)
48	B62 B62A	589 2713	(2620.0) (12068.0)	369 504	(1641) (2242)	745 3421	(3313.9) (15217.3)	456 1765	(2028.4) (7851.1)	365** 1225	(1623.6) (5449.1)
60	B62 B62A	456 1765	(2028.4) (7851.1)	300 323	(1334) (1437)	579 2647	(2575.5) (11774.4)	347** 1129	(1543.5) (5022.0)	271** 784**	(1205.4) (3487.4)
72	B62 B62A	365** 1225	(1623.6) (5449.1)	248 224	(1103) (996)	470 1856	(2090.6) (8255.9)	271** 784**	(1205.4) (3487.4)	- 545**	- (2424.3)

**Where the slenderness ratio $\frac{KL}{r}$ exceeds 200, and K = end fixity factor, L = actual length and r = radius of gyration.

Reference page 188 for general fitting specifications.

B72 Channel

- Thickness: 18 Ga. (1.2 mm)
- Standard lengths: 10' (3.05 m)
- Standard finishes: Plain, Dura-Green, Pre-Galvanized
- Weight: .29 Lbs./Ft. (.43 kg/m)

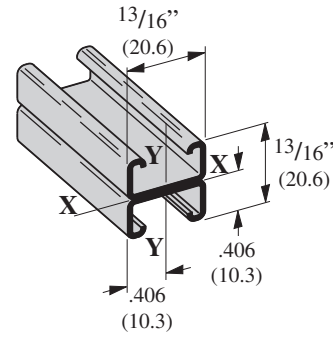
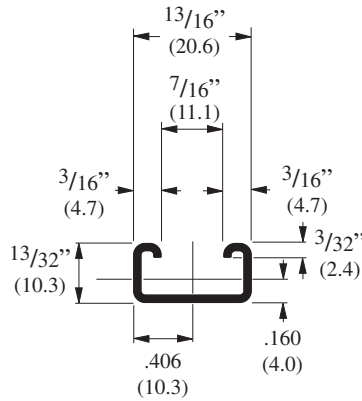
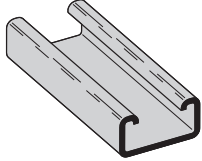

B72A
Wt. .58 Lbs./Ft. (.87 kg/m)

SECTION PROPERTIES		X - X Axis					Y - Y Axis				
		Channel	Weight lbs./ft. kg/m	Areas of Section sq. in. cm ²	Moment of Inertia (I) in. ⁴ cm ⁴	Section Modulus (S) in. ³ cm ³	Radius of Gyration (r) in. cm	Moment of Inertia (I) in. ⁴ cm ⁴	Section Modulus (S) in. ³ cm ³	Radius of Gyration (r) in. cm	
B72	.287 (.43)	.084 (.54)	.0018 (.07)	.0073 (.12)	.146 (.37)	.0077 (.32)	.0190 (.31)	.302 (.77)			
B72A	.574 (.85)	.169 (1.09)	.0078 (.32)	.0192 (.31)	.215 (.55)	.0155 (.65)	.0382 (.63)	.303 (.77)			

Calculations of section properties are based on metal thicknesses as determined by the AISI Cold-Formed Steel Design Manual.

BEAM LOADING

Beam Span		Channel Style	Uniform Load and Deflection				Uniform Load @ Deflection =			
			Lbs.	N	In.	mm	1/240 Span	1/360 Span	Lbs.	N
12	(305)	B72 B72A	116 210*	(516.0) (934.1)	.051 .020	(1.29) (.51)	113 210*	(502.6) (934.1)	75 210*	(324.7) (934.1)
24	(609)	B72 B72A	58 159	(258.0) (707.2)	.206 .125	(5.23) (3.17)	28 127	(124.5) (564.9)	19 85	(84.5) (378.1)
36	(914)	B72 B72A	39 106	(173.5) (471.5)	.465 .281	(11.81) (7.14)	13 57	(57.8) (253.5)	8 38	(35.6) (169.0)
48	(1219)	B72 B72A	29 80	(129.0) (355.8)	.827 .500	(21.00) (12.70)	7 32	(31.1) (142.3)	5 21	(22.2) (93.4)
60	(1524)	B72 B72A	23 64	(102.3) (284.7)	1.292 .782	(32.81) (19.86)	5 20	(22.2) (88.9)	3 14	(13.3) (62.3)

Based on simple beam condition using an allowable design stress of 25,000 psi (172 MPa) in accordance with MFMA, with adequate lateral bracing (see page 11 for further explanation). Actual yield point of cold rolled steel is 42,000 psi. To determine concentrated load capacity at mid span, multiply uniform load by 0.5 and corresponding deflection by 0.8. *Failure determined by weld shear.

COLUMN LOADING

Unbraced Height		Channel Style	Max. Column Loading K = .80				Max. Column Loading (Loaded @ C.G.)					
			Loaded @ C.G.		Loaded @ Slot Face		K = .65		K = 1.0		K = 1.2	
In.	mm	Lbs.	N	Lbs.	N	Lbs.	N	Lbs.	N	Lbs.	N	
12	(305)	B72 B72A	1598 3600	(7108) (16013)	539 986	(2397) (4386)	1712 3700	(7615) (16458)	1410 3433	(6272) (15271)	1181 3229	(5253) (14363)
24	(609)	B72 B72A	701 2710	(3118) (12054)	320 802	(1423) (3567)	1050 3113	(4670) (13847)	450 2043	(2001) (9088)	313** 1421	(1392) (6321)
36	(914)	B72 B72A	313** 1421	(1392) (6321)	188 569	(836) (2531)	473 2135	(2104) (9497)	201** 909	(894) (4043)	— 631**	— (2807)
48	(1219)	B72 B72A	177** 799	(787) (3554)	122 404	(542) (1797)	267** 1211	(1187) (5387)	— 512**	— (2277)	— 355**	— (1579)
60	(1524)	B72 B72A	113** 512**	(502) (2277)	85 298	(378) (1325)	171** 775	(760) (3447)	— 327**	— (1454)	— —	— —

**Where the slenderness ratio $\frac{KL}{r}$ exceeds 200, and K = end fixity factor, L = actual length and r = radius of gyration.

Reference page 188 for general fitting specifications.

NUTS FOR B62, B72 CHANNEL

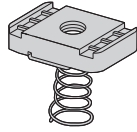

SPRING NUT

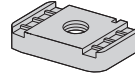

NUT WITHOUT SPRING

Part Number				Thread Size	Thickness		Wt./C	
B62		B72						
With Spring	Without Spring	With Spring	Without Spring				Lbs.	kg
N621	N621WO	N7221	N621WO	#8-32	.150	(3.81)	1.0	(.45)
N622	N622WO	N7222	N622WO	#10-24	.150	(3.81)	1.0	(.45)
N627	N627WO	N7227	N627WO	#10-32	.150	(3.81)	1.0	(.45)
N624	N624WO	N7224	N624WO	1/4-20	.150	(3.81)	1.0	(.45)
BMM-3L	BMM-3	BMM-3S	BMM-3	M3.5 x 0.6	.150	(3.81)	1.0	(.45)
BMM-4L	BMM-4	BMM-4S	BMM-4	M4 x 0.7	.150	(3.81)	1.0	(.45)
BMM-5L	BMM-5	BMM-5S	BMM-5	M5 x 0.8	.150	(3.81)	1.0	(.45)
BMM-6L	BMM-6	BMM-6S	BMM-6	M6 x 1	.150	(3.81)	1.0	(.45)

MINI FITTINGS

B6202 SQUARE WASHER

- Standard finishes: ZN, GRN
- Wt./C 2 Lbs. (.9 kg)

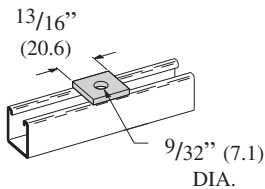

B6129 TWO HOLE SPLICE PLATE

- Standard finishes: ZN, GRN
- Wt./C 5 Lbs. (2.2 kg)

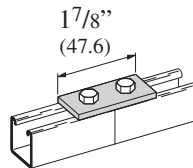

B6340 TWO HOLE SPLICE PLATE

- Standard finishes: ZN, GRN
- Wt./C 5 Lbs. (2.2 kg)

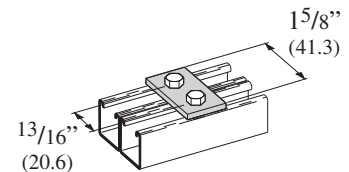

Reference page 188 for general fitting specifications.

Mini Fittings

B6141 THREE HOLE SPLICE PLATE

- Standard finishes: ZN, GRN
- Wt./C 7 Lbs. (3.2 kg)

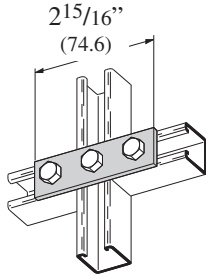

B600-62 THREE HOLE FLAT ADAPTER PLATE

- Standard finishes: ZN, GRN
- Wt./C 19 Lbs. (8.6 kg)

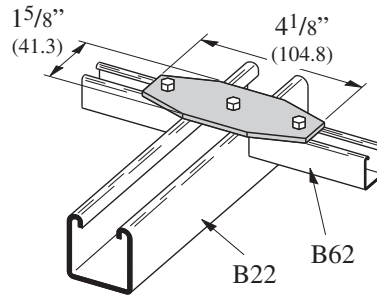

B6557 THREE HOLE SPLICE PLATE

- Standard finishes: ZN, GRN
- Wt./C 7 Lbs. (3.2 kg)

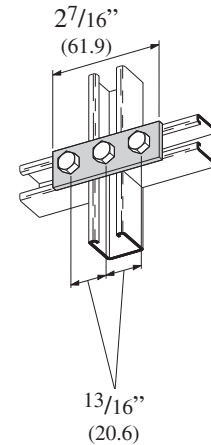

B6341 FOUR HOLE SPLICE PLATE

- Standard finishes: ZN, GRN
- Wt./C 11 Lbs. (5.0 kg)

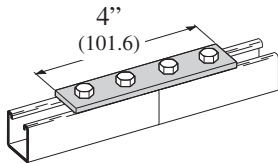

B6138 TWO HOLE SWIVEL PLATE

- Standard finishes: ZN, GRN
- Wt./C 7 Lbs. (3.2 kg)

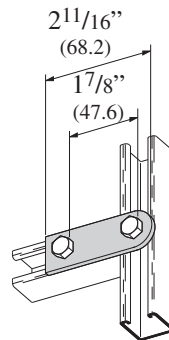

B6139 THREE HOLE SWIVEL PLATE

- Standard finishes: ZN, GRN
- Wt./C 10 Lbs. (4.5 kg)

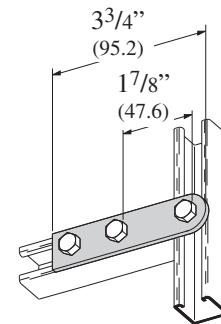

B6504 FOUR HOLE SPLICE PLATE

- Standard finishes: ZN, GRN
- Wt./C 10 Lbs. (4.5 kg)

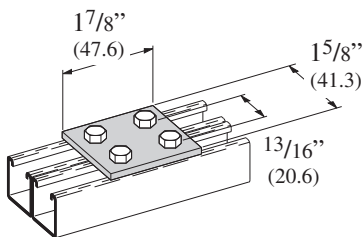

B6140 THREE HOLE CORNER PLATE

- Standard finishes: ZN, GRN
- Wt./C 8 Lbs. (3.6 kg)

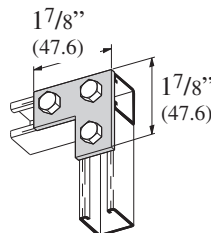

B6143 FOUR HOLE CORNER PLATE

- Standard finishes: ZN, GRN
- Wt./C 11 Lbs. (5.0 kg)

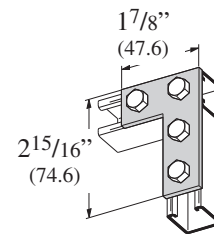

Reference page 188 for general fitting specifications.

B6133
FOUR HOLE TEE PLATE

- Standard finishes: ZN, GRN
- Wt./C 11 Lbs. (5.0 kg)

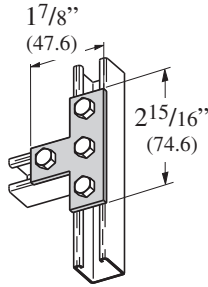

B6132
FIVE HOLE CROSS PLATE

- Standard finishes: ZN, GRN
- Wt./C 13 Lbs. (5.9 kg)

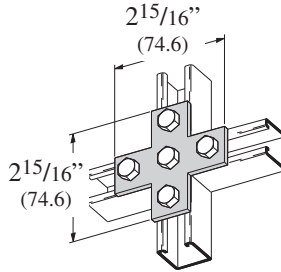

B6135
THREE HOLE CORNER GUSSET PLATE

- Standard finishes: ZN, GRN
- Wt./C 9 Lbs. (4.1 kg)

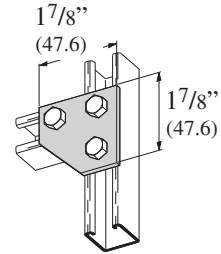

B6142
FOUR HOLE CORNER GUSSET PLATE

- Standard finishes: ZN, GRN
- Wt./C 15 Lbs. (6.8 kg)

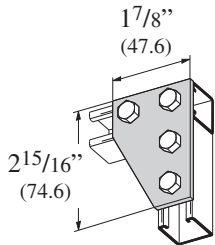

B6337
THREE HOLE TEE GUSSET PLATE

- Standard finishes: ZN, GRN
- Wt./C 10 Lbs. (4.5 kg)

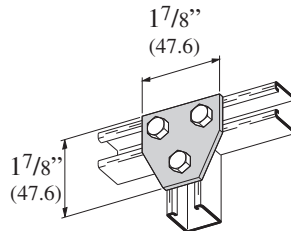

B6136
FOUR HOLE TEE GUSSET PLATE

- Standard finishes: ZN, GRN
- Wt./C 15 Lbs. (6.8 kg)

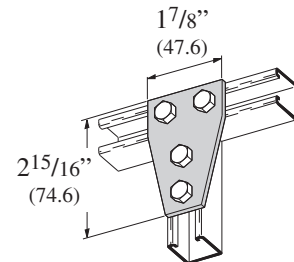

B6532
FIVE HOLE TEE GUSSET PLATE

- Standard finishes: ZN, GRN
- Wt./C 22 Lbs. (10.0 kg)

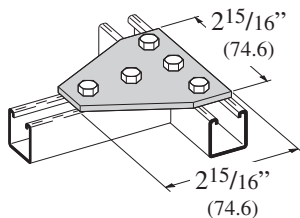

B6101
TWO HOLE CORNER ANGLE

- Standard finishes: ZN, GRN
- Wt./C 5 Lbs. (2.2 kg)

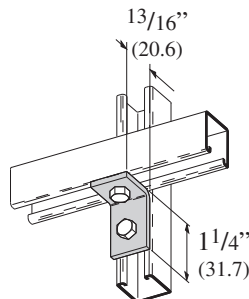

B6230
TWO HOLE CORNER ANGLE

- Standard finishes: ZN, GRN
- Wt./C 5 Lbs. (2.2 kg)

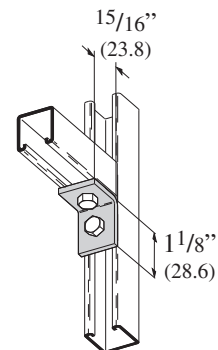

Reference page 188 for general fitting specifications.

Mini Fittings

B6102 THREE HOLE CORNER ANGLE

- Standard finishes: ZN, GRN
- Wt./C 8 Lbs. (3.6 kg)

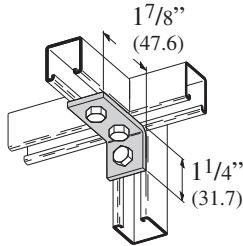

B6103 THREE HOLE CORNER ANGLE

- Standard finishes: ZN, GRN
- Wt./C 8 Lbs. (3.6 kg)

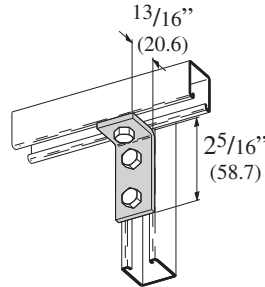

B6232 THREE HOLE CORNER ANGLE

- Standard finishes: ZN, GRN
- Wt./C 7 Lbs. (3.2 kg)

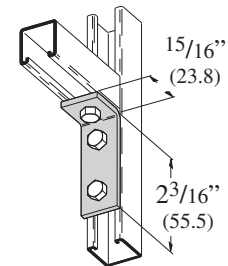

B6374 THREE HOLE CORNER ANGLE

- Standard finishes: ZN, GRN
- Wt./C 7 Lbs. (3.2 kg)

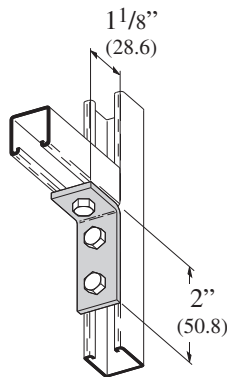

B6104 FOUR HOLE CORNER ANGLE

- Standard finishes: ZN, GRN
- Wt./C 10 Lbs. (4.5 kg)

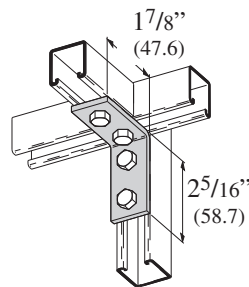

B6558 FOUR HOLE CORNER ANGLE

- Standard finishes: ZN, GRN
- Wt./C 10 Lbs. (4.5 kg)

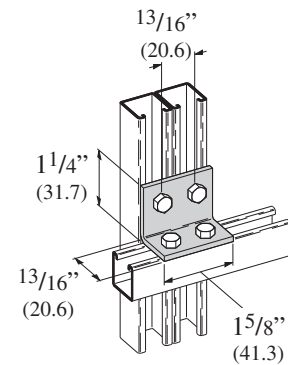

B6357 FOUR HOLE OFFSET BENT TEE

- Standard finishes: ZN, GRN
- Wt./C 11 Lbs. (5.0 kg)

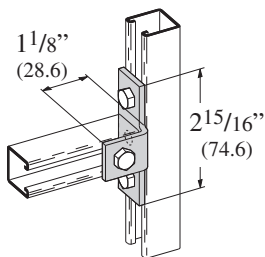

B6239 FIVE HOLE OFFSET BENT TEE

- Standard finishes: ZN, GRN
- Wt./C 14 Lbs. (6.3 kg)

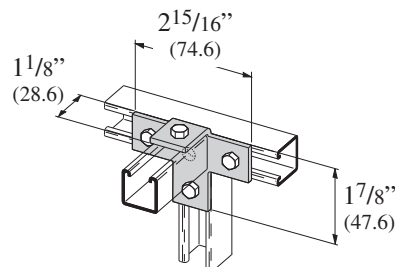

B6144R&L FOUR HOLE SHELF BRACKET

- Standard finishes: ZN, GRN
- Wt./C 19 Lbs. (8.6 kg)

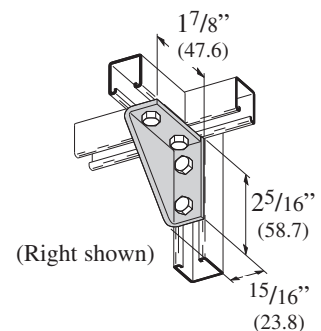

Reference page 188 for general fitting specifications.

B6134R&L FOUR HOLE CORNER GUSSET

- Standard finishes: ZN, GRN
- Wt./C 15 Lbs. (6.8 kg)

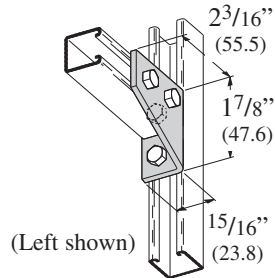

B6234 R&L FOUR HOLE CORNER GUSSET

- Standard finishes: ZN, GRN
- Wt./C 15 Lbs. (6.8 kg)

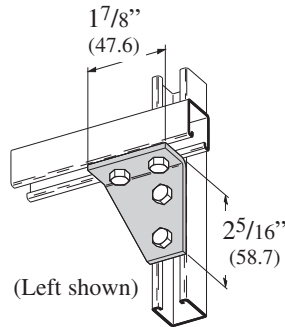

B6118 FOUR HOLE GUSSETED SHELF ANGLE

- Standard finishes: ZN, GRN
- Wt./C 15 Lbs. (6.8 kg)

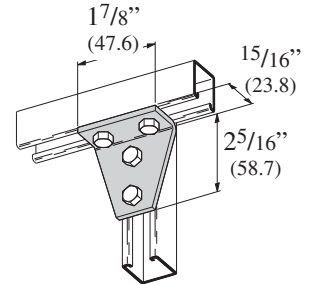

B6533 FIVE HOLE GUSSETED SHELF ANGLE

- Standard finishes: ZN, GRN
- Wt./C 22 Lbs. (10.0 kg)

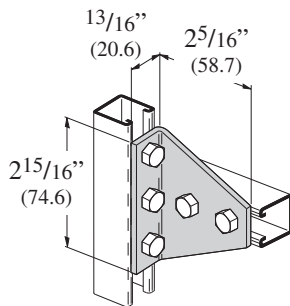

B6126 FOUR HOLE GUSSETED THREE WAY SHELF ANGLE

- Standard finishes: ZN, GRN
- Wt./C 15 Lbs. (6.8 kg)

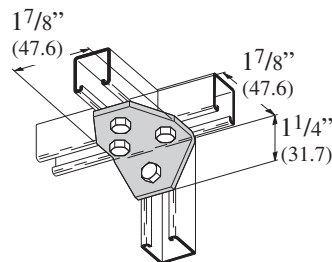

B6127 FIVE HOLE GUSSETED THREE WAY SHELF ANGLE

- Standard finishes: ZN, GRN
- Wt./C 18 Lbs. (8.1 kg)

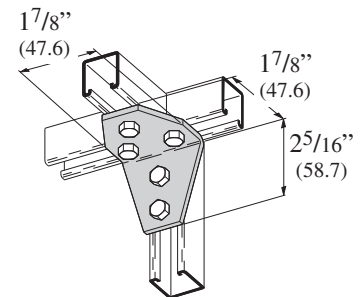

B6112 FOUR HOLE ADJUSTABLE CORNER ANGLE

- Standard finishes: ZN, GRN
- Wt./C 32Lbs. (14.5 kg)

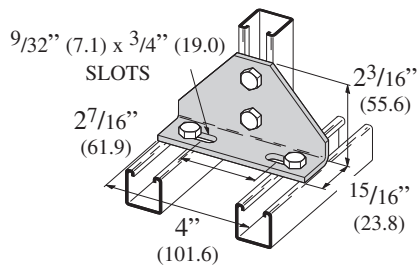

B589-62 TWO HOLE 90° ADAPTER ANGLE

- Standard finishes: ZN, GRN
- Wt./C 11 Lbs. (5.0 kg)

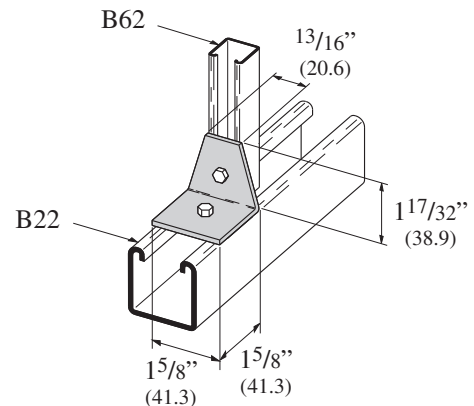

Reference page 188 for general fitting specifications.

Mini Fittings

B6147-B6152 TWO HOLE OPEN ANGLE

•Standard finishes: ZN, GRN

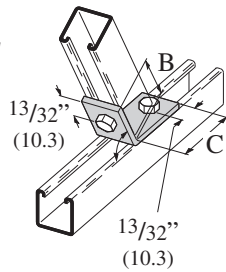

Part No.	A	B		C		Wt./C	
		Lbs.	kg	Lbs.	kg	Lbs.	kg
B6147	82 ¹ / ₂ °	2 ¹ / ₃₂ "	(51.6)	2 ⁷ / ₃₂ "	(21.4)	8.0	(3.6)
B6148	75°	2 ¹ / ₃₂ "	(51.6)	2 ⁷ / ₃₂ "	(21.4)		
B6149	67 ¹ / ₂ °	2"	(50.8)	7 ⁷ / ₈ "	(22.2)		
B6150	60°	1 ³ / ₃₂ "	(50.0)	1 ⁵ / ₁₆ "	(23.8)		
B6151	52 ¹ / ₂ °	1 ⁷ / ₈ "	(47.6)	1 ¹ / ₁₆ "	(27.0)		
B6152	37 ¹ / ₂ °	2"	(50.8)	2 ⁹ / ₃₂ "	(23.0)		

B6154 TWO HOLE OPEN ANGLE

•Standard finishes: ZN, GRN

•Wt./C 8 Lbs. (3.6 kg)

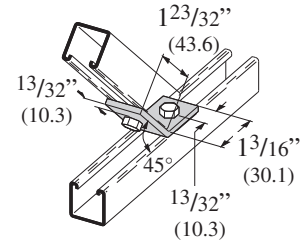

B6162-B6165 TWO HOLE OPEN ANGLE

•Standard finishes: ZN, GRN

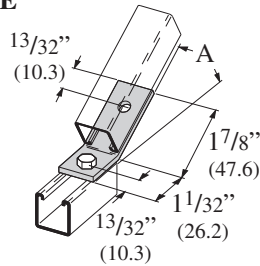

Part No.	A	Wt./C	
		Lbs.	kg
B6162	30°	8.0	(3.6)
B6163	22 ¹ / ₂ °		
B6164	15°		
B6165	7 ¹ / ₂ °		

B6156-B6161 TWO HOLE CLOSED ANGLE

•Standard finishes: ZN, GRN

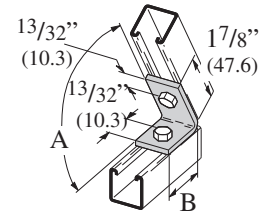

Part No.	A	B	Wt./C		
			Lbs.	kg	
B6156	82 ¹ / ₂ °	1 ⁹ / ₃₂ "	(32.5)	8.0	(3.6)
B6157	75°	1 ⁵ / ₁₆ "	(33.3)		
B6158	67 ¹ / ₂ °	1 ³ / ₈ "	(34.9)		
B6159	60°	1 ¹³ / ₃₂ "	(35.7)		
B6160	52 ¹ / ₂ °	1 ¹⁵ / ₃₂ "	(37.3)		
B6161	37 ¹ / ₂ °	1 ²¹ / ₃₂ "	(42.0)		

B6155 TWO HOLE CLOSED ANGLE

•Standard finishes: ZN, GRN

•Wt./C 8 Lbs. (3.6 kg)

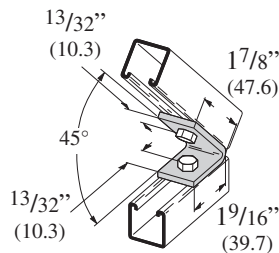

B601-62 TWO HOLE 45° ADAPTER ANGLE

•Standard finishes: ZN, GRN

•Wt./C 14 Lbs. (6.3 kg)

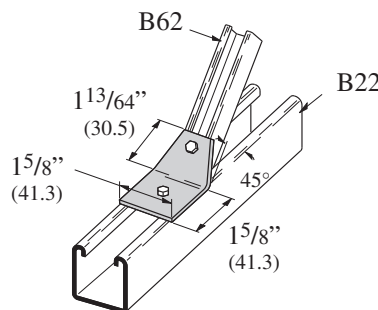

B6169 TWO HOLE SPLICE CLEVIS FOR B72

•Standard finishes: ZN, GRN

•Wt./C 11 Lbs. (5.0 kg)

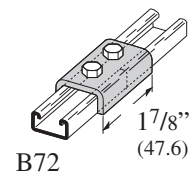

Reference page 188 for general fitting specifications.

B6168
THREE HOLE SPLICE
CLEVIS FOR B72

- Standard finishes: ZN, GRN
- Wt./C 16 Lbs. (7.2 kg)

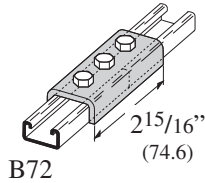

B6167
FOUR HOLE SPLICE
CLEVIS FOR B72

- Standard finishes: ZN, GRN
- Wt./C 24 Lbs. (10.9 kg)

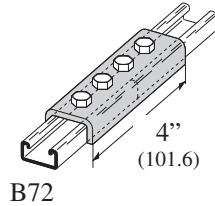

B6170
TWO HOLE SPLICE
CLEVIS FOR B62

- Standard finishes: ZN, GRN
- Wt./C 17 Lbs. (7.7 kg)

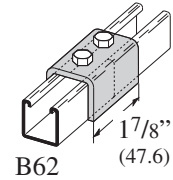

B6171
THREE HOLE SPLICE
CLEVIS FOR B62

- Standard finishes: ZN, GRN
- Wt./C 26 Lbs. (11.8 kg)

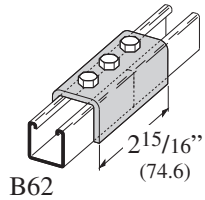

B6172
FOUR HOLE SPLICE
CLEVIS FOR B62

- Standard finishes: ZN, GRN
- Wt./C 36 Lbs. (16.3 kg)

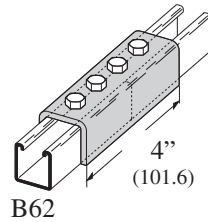

B7116
THREE HOLE U-SUPPORT

- Standard finishes: ZN, GRN
- Wt./C 10 Lbs. (4.5 kg)

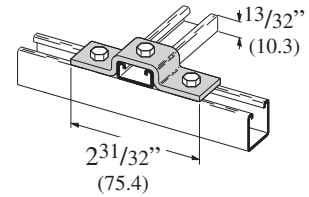

B6107
THREE HOLE U-SUPPORT

- Standard finishes: ZN, GRN
- Wt./C 12 Lbs. (5.4 kg)

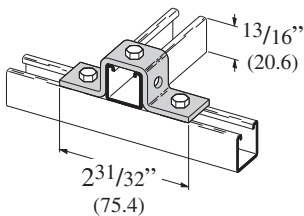

B6107-62A
THREE HOLE U-SUPPORT

- Standard finishes: ZN, GRN
- Wt./C 16 Lbs. (7.2 kg)

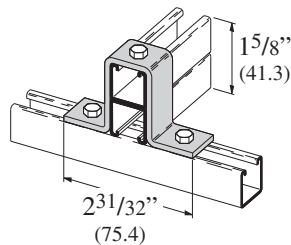

B6594
FIVE HOLE U-SUPPORT

- Standard finishes: ZN, GRN
- Wt./C 13 Lbs. (5.9 kg)

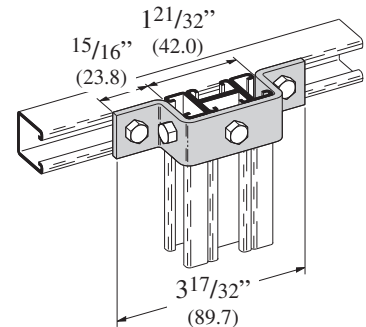

Reference page 188 for general fitting specifications.

Mini Fittings

B6173 FOUR HOLE CLEVIS

- Standard finishes: ZN, GRN
- Wt./C 9 Lbs. (4.1 kg)

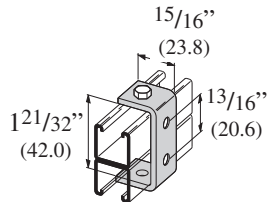

B6526 TWO HOLE OFFSET Z-SUPPORT

- Standard finishes: ZN, GRN
- Wt./C 5 Lbs. (2.2 kg)

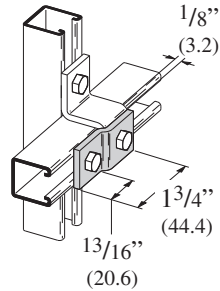

B6105 TWO HOLE Z-SUPPORT FOR B62

- Standard finishes: ZN, GRN
- Wt./C 7 Lbs. (3.2 kg)

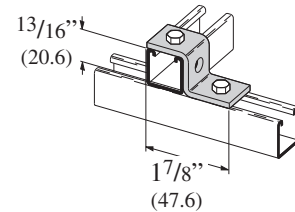

B7105 TWO HOLE Z-SUPPORT FOR B72

- Standard finishes: ZN, GRN
- Wt./C 7 Lbs. (3.2 kg)

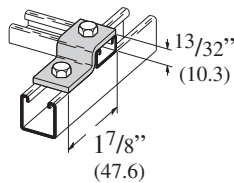

B6110 TWO HOLE Z-SUPPORT FOR B62A

- Standard finishes: ZN, GRN
- Wt./C 9 Lbs. (4.1 kg)

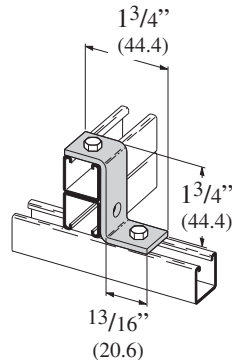

B6108 TWO HOLE OFFSET Z-SUPPORT

- Standard finishes: ZN, GRN
- Wt./C 7 Lbs. (3.2 kg)

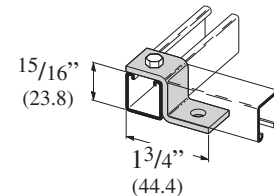

B598-62 TWO HOLE Z-ADAPTER PLATE

- Standard finishes: ZN, GRN
- Wt./C 28 Lbs. (12.7 kg)

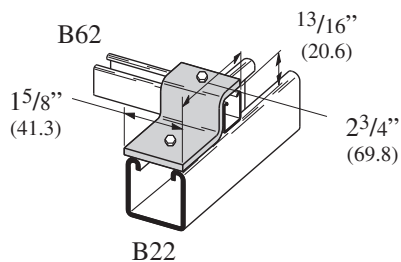

B6571 EIGHT HOLE WING CONNECTION

- Standard finishes: ZN, GRN
- Wt./C 28 Lbs. (12.7 kg)

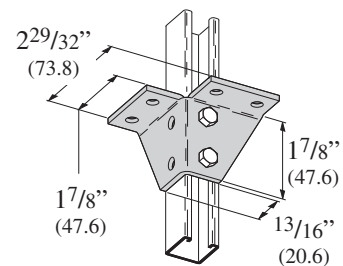

Reference page 188 for general fitting specifications.

B6205 END CAP FOR B62

- Material: ASTM A1008 SS Gr. 33 Type 1
- Standard finishes: ZN, GRN
- Wt./C 3 Lbs. (1.3 kg)

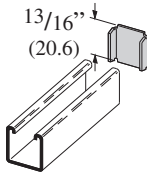

B7205 END CAP FOR B72

- Material: ASTM A1008 SS Gr. 33 Type 1
- Standard finishes: ZN, GRN
- Wt./C 1 Lb. (.4 kg)

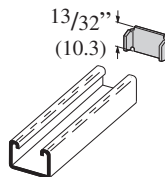

B6211 Z-BEAM CLAMP

- ⁵/₁₆"-18 Setscrew included
- ¹³/₁₆" (20.6) Max. Flange Thickness
- Material: ASTM A36
- Standard finishes: ZN, GRN
- Wt./C 13 Lbs. (5.9 kg)

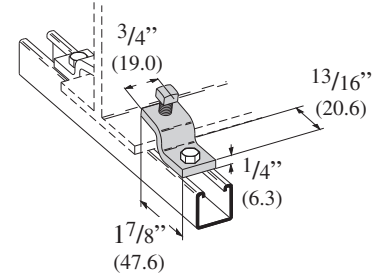

B6409-6, 9 BRACKET

- Safety Factor of 2
- Uniform Design Load 40 Lbs. (.18 kN)
- Standard finishes: ZN, GRN

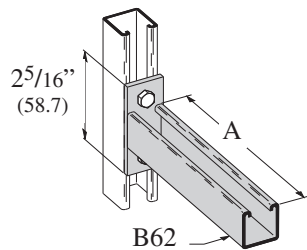

Part No.	A	Wt./C	
		Lbs.	kg
B6409-6	6"	28.0	(12.7)
B6409-9	9"	35.0	(15.8)

B2350-B2355 ONE HOLE DOUBLE TUBING STRAP

- Material: ASTM A1008 SS Gr. 33 Type 1
- Standard finishes: ZN, GRN

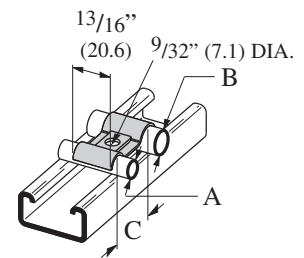

Part No.	O.D. Size A		O.D. Size B		C		Wt./C	
							Lbs.	kg
B2350	1/4"	(6.3)	1/4"	(6.3)	3/4"	(19.0)	1.2	(.5)
B2351	3/8"	(9.5)	3/8"	(9.5)	1"	(25.4)	2.0	(.9)
B2352	1/2"	(12.7)	1/2"	(12.7)	1 1/4"	(31.7)	2.9	(1.3)
B2353	1/4"	(6.3)	3/8"	(9.5)	7/8"	(22.2)	1.6	(.7)
B2354	1/4"	(6.3)	1/2"	(12.7)	1"	(25.4)	2.1	(.9)
B2355	3/8"	(9.5)	1/2"	(12.7)	1 1/8"	(28.6)	2.5	(1.1)

B2308-B2315 ONE HOLE TUBING STRAP

- Material: Sizes ¹/₄" - ¹/₂", ASTM A611 Gr. C
- ⁵/₈" - 1", ASTM A1008 SS Gr. 33 Type 1
- Standard finishes: ZN, GRN

Part No.	O.D. Size A		B		C		Wt./C	
							Lbs.	kg
B2308	1/4"	(6.3)	1 1/32"	(26.2)	.048	(1.2)	1.2	(.5)
B2309	⁵ / ₁₆ "	(7.9)	1 3/32"	(27.8)	.048	(1.2)	1.4	(.6)
B2310	3/8"	(9.5)	1 3/16"	(30.1)	.048	(1.2)	1.6	(.7)
B2311	1/2"	(12.7)	1 21/64"	(33.7)	.048	(1.2)	1.9	(.8)
B2312	⁵ / ₈ "	(15.9)	1 25/64"	(35.3)	.062	(1.6)	2.7	(1.2)
B2313	3/4"	(19.0)	1 39/64"	(40.9)	.075	(1.9)	4.3	(1.9)
B2314	7/8"	(22.2)	1 51/64"	(45.6)	.075	(1.9)	4.9	(2.2)
B2315	1"	(25.4)	2 1/32"	(51.6)	.075	(1.9)	5.2	(2.3)

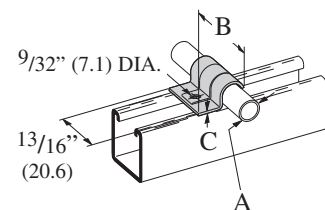

Reference page 188 for general fitting specifications.

E7016

- Light duty support for electrical fixtures, conduits and boxes
- Standard 1/4"-20 square nut slips into the slot for ease of attachment
- Thickness: 16 Ga. (1.5 mm)
- Standard lengths: 120" (3.05 m)
- Standard finish: Pre-Galvanized
- Weight: .45 Lbs./Ft. (.52 kg/m)

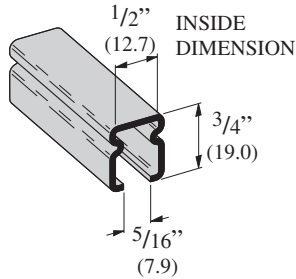

E7016H3/4

- Pre-punched holes provide for installation on 1 1/2" (38.1) centers for 1/4"-20 ATR or for #8 screws or toggle bolts
- Thickness: 16 Ga. (1.5 mm)
- Standard lengths: 120" (3.05 m)
- Standard finish: Pre-Galvanized
- Weight: .44 Lbs./Ft. (.50 kg/m)

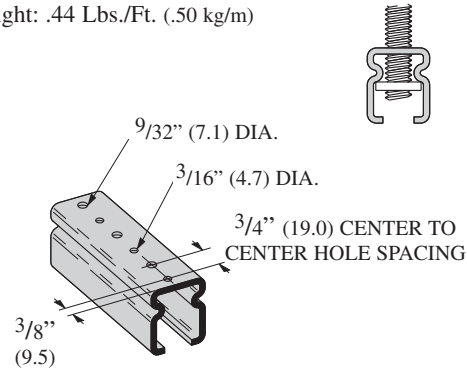

Design Stress = 25,000 PSI (172 MPa)
 Section Modulus (S) = .021 in.³ (.34 cm³)
 Moment of Inertia (I) = .009 in.⁴ (.37 cm⁴)
 Radius of Gyration (r) = .275 in. (.70 cm)

To determine concentrated load capacity at mid span, multiply uniform load by 0.5 and corresponding deflection by 0.8.

LOAD CHART

Beam Span		Uniform Load		Deflection		Uniform Load 1/240 Span		Deflection 1/240 Span	
In.	mm	Lbs.	N	In.	mm	Lbs.	N	In.	mm
12	(305)	347	1543	.030	(.76)	347	1543	.05	(1.27)
24	(609)	173	769	.121	(3.07)	143	636	.10	(2.54)
36	(914)	115	511	.272	(6.91)	63	280	.15	(3.81)
48	(1219)	86	382	.484	(12.29)	35	155	.20	(5.08)
60	(1524)	69	307	.756	(19.20)	23	102	.25	(6.35)

E7166

JOINER PLATE

- Joins Econo-Strut channels together to provide continuous runs
- Includes:
 - 1 pc. Joiner Plate
 - 2 pcs. 1/4"-20 x 1/2" SRHMS
- Wt./C 42 Lbs. (19.0 kg)

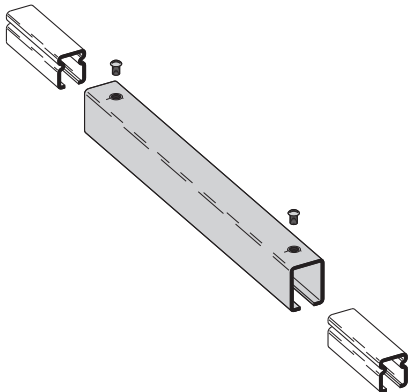

E7212

FASTENER CLIP

- Used to attach Econo-Strut to lathers channel or other light gauge carrying beams
- Wt./C 1 Lb. (.4 kg)

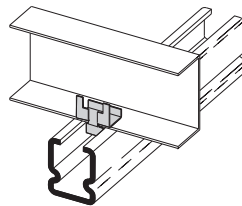

E7355

BEAM CLAMP

- Secures Econo-Strut to bar joists, angle iron, or I-Beams with a maximum flange thickness of 1/4" (6.3)
- Includes:
 - 1 Beam Clamp
 - 1 pc. 1/4"-20 x 1" SHHMS
 - 1 pc. 1/4"-20 Square Nut
- Wt./C 8 Lbs. (3.6 kg)

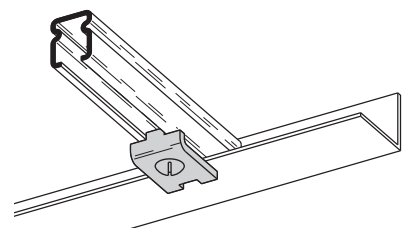

Reference page 188 for general fitting specifications.

Typical Econo-Strut Applications

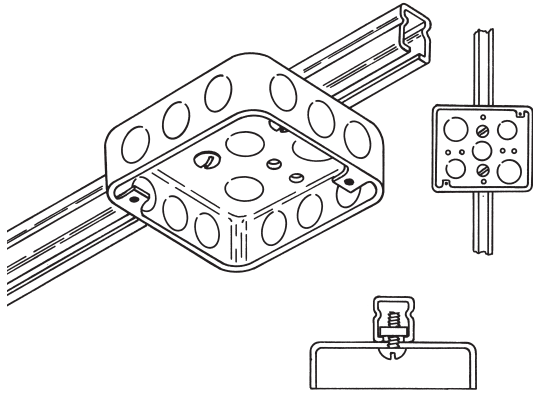

Econo-Strut supports electrical box with screws and square nuts.

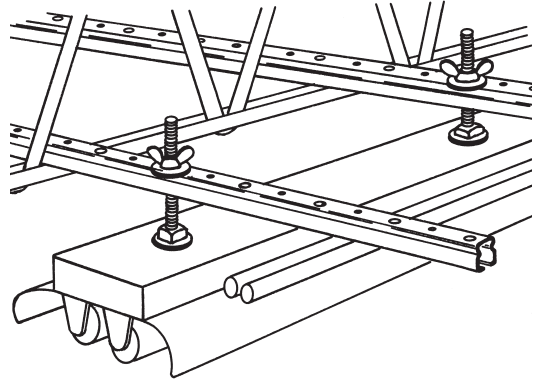

Econo-Strut fixture support secured to the bar joists.

Mini Channel & Fittings

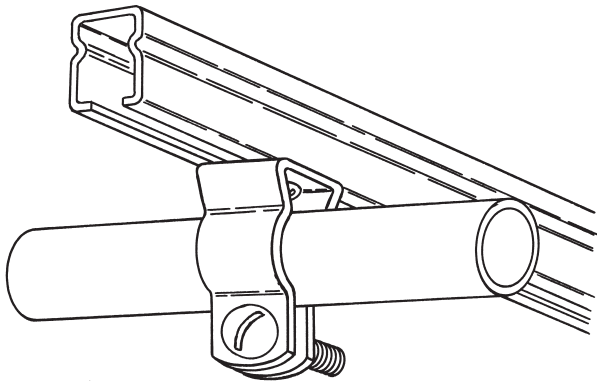

Econo-Strut pipe or conduit support.

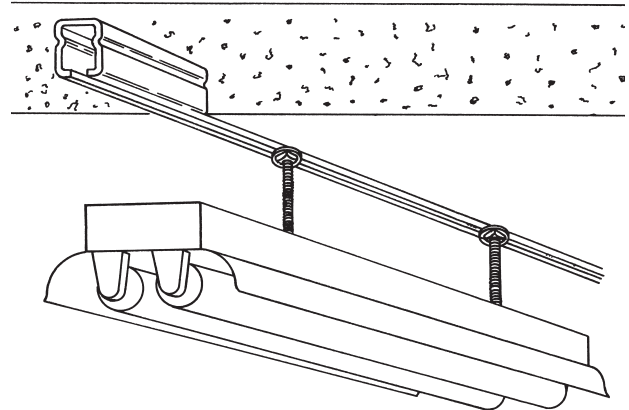

Econo-Strut used as a continuous concrete insert.

Continuous Concrete Inserts

Continuous slot Concrete Inserts are designed to provide a pre-set support system cast in concrete ceilings, walls, and floors to allow flexibility of attachment at any point along the channel. This provides an excellent support system for pipe, conduit, and cable trays.

Continuous Concrete Inserts, manufactured from B-Line's standard channels, have formed anchors spaced on 4 inch (101.6 mm) centers. $\frac{3}{16}$ " (4.8 mm) nail-holes are provided for securing the inserts to the forms.

Available in lengths from 3 inches (7.62 cm) to 240 inches (609.6 cm), Concrete Inserts are shipped complete with end caps and styrofoam filler strips which prevent seepage of concrete into the insert. Styrofoam is easily removed by pulling the convenient pull-tab.

Materials & Finishes*

Finish Code	Finish	Specification
PLN	Plain	ASTM A1011 33,000 PSI min. yield
GRN	Dura-Green	
ZN	Electro-Plated Zinc	ASTM B633 SC1 Type III
GALV	Pre-Galvanized	ASTM A653 33,000 PSI min. yield
HDG	Hot-Dipped Galvanized	ASTM A123
SS4	Stainless Steel Type 304	ASTM A240
SS6	Stainless Steel Type 316	ASTM A240

*Unless otherwise noted.

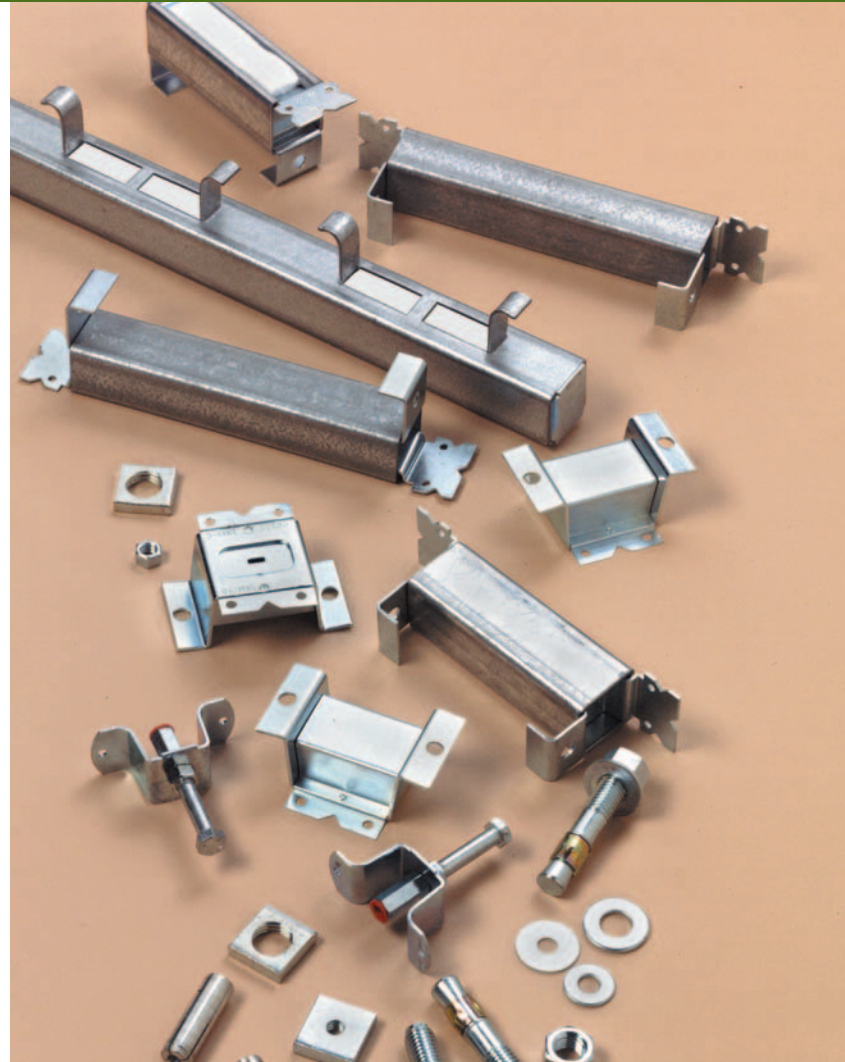

Spot Inserts

B-Line's Spot Inserts provide for economical single attachment points with full flexibility of fastener sizing, but with limited adjustment. These products are made from steel strips in accordance with ASTM A1011, 33,000 PSI min. yield. Standard finish is electro-plated zinc (ASTM B633).

Special Concrete Inserts

Pre-stressed inserts, inserts with studs welded to the back of the channel, and other types of special inserts are available from B-Line.

Test Data

Independent Testing Laboratory test data available upon request.

Metric

Metric dimensions are shown in parentheses. Unless noted, all metric dimensions are in millimeters.

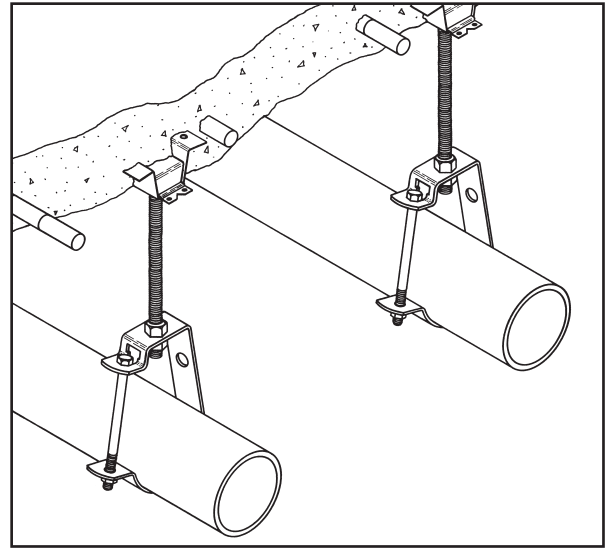
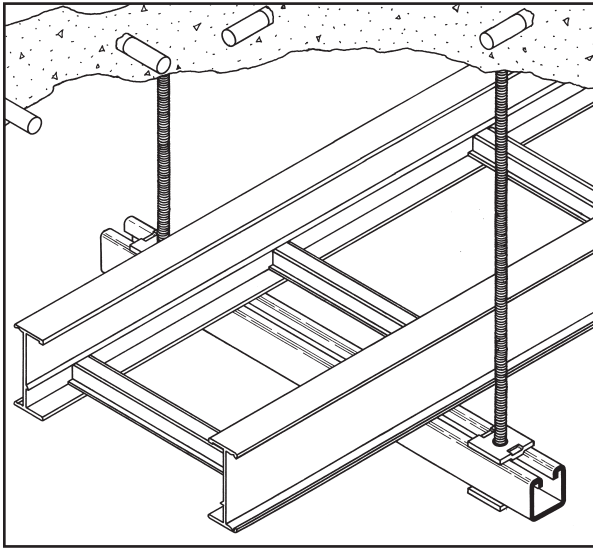

Continuous concrete inserts, installed in the ceiling, can be used to support trapeze hangers, suspended pipe racks, cable trays and single or multiple pipe hangers.

When installed in walls, continuous concrete inserts can be used as a support for tunnel stanchions, equipment braces, brackets and pipe racks.

Use spot inserts for single pipe-support or trapeze type hangers. Spot Inserts offer full flexibility of rod and fastener sizings.

B-Line Channel can be attached to continuous concrete inserts in walls or ceilings. Channel can also be attached to concrete walls and floors with expansion anchors.

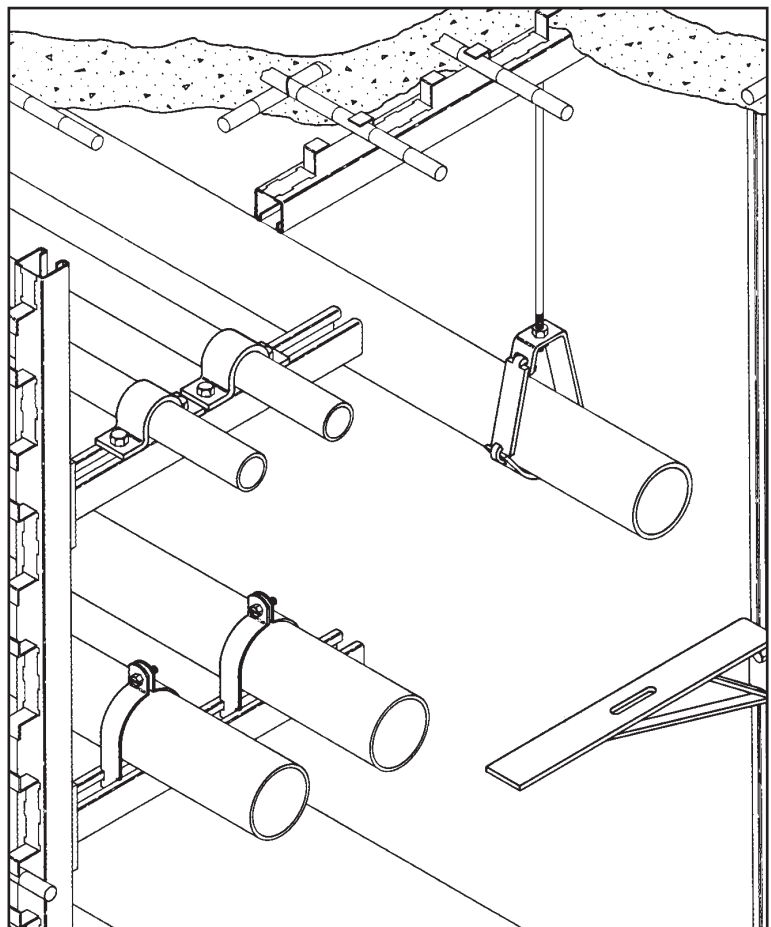

Reference page 202 for general fitting and standard finish specifications.

Continuous Concrete Inserts

B22I CONTINUOUS CONCRETE INSERT

- Design Load for B22-I-12 thru B22-I-240 is 2,000 lbs. (8.89 kN) per foot of concrete insert length with safety factor of 3 in 3000 psi concrete.
- Loads concentrated within the last 2 inches (50.8 mm) of concrete inserts 8" (203.2 mm) and longer should not exceed 1,000 lbs. (4.45kN).
- Concrete insert should be secured to the forms on 16" (406.4 mm) to 24" (609.6 mm) intervals.
- B22-I continuous concrete inserts are made from B22 channel. Use channel nuts designed for use in B22 channel.
- B22-I concrete inserts are supplied with styrofoam fillers. B3322 end caps are furnished with inserts through 8" (203.2 mm) long, and B205 end caps are furnished with inserts 12" (304.8 mm) and longer.
- Material: Plain Steel ASTM A1011 33,000 PSI min. yield or Pre-Galvanized Steel ASTM A653SS 33,000 PSI min. yield.
- Finish: Plain, Dura-Green, Pre-Galv, HDG

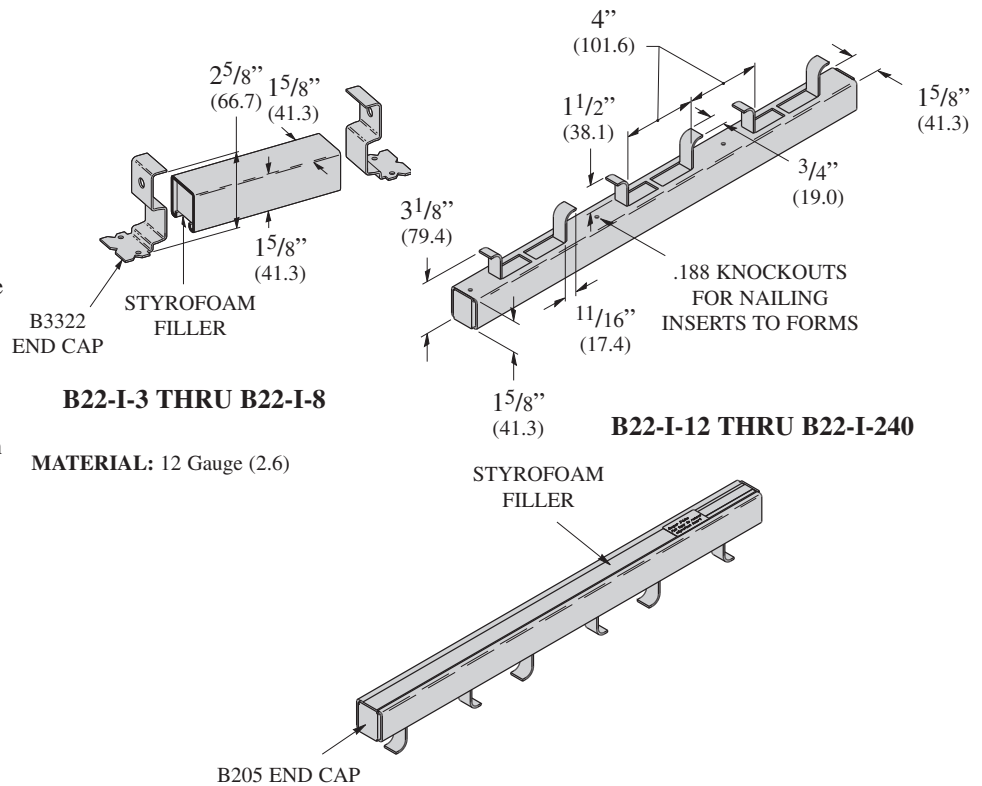

Part No.	Length		Wt./C		Design Load	
	in.	mm	Lbs.	kg	Lbs.	kN
B22-I-3	3"	(76)	72	(32.6)	500	(2.22)
B22-I-4	4"	(101)	88	(39.9)	800	(3.56)
B22-I-6	6"	(152)	120	(54.4)	1000	(4.45)
B22-I-8	8"	(203)	152	(68.9)	1200	(5.34)

Part No.	Length		Wt./C	
	in.	mm	Lbs.	kg
B22-I-12	12"	(305)	224	(101.6)
B22-I-16	16"	(406)	289	(131.1)
B22-I-20	20"	(508)	353	(160.1)
B22-I-24	24"	(609)	420	(190.5)
B22-I-32	32"	(813)	553	(250.8)
B22-I-36	36"	(914)	620	(281.2)
B22-I-40	40"	(1016)	686	(311.1)
B22-I-48	48"	(1219)	820	(371.9)
B22-I-60	60"	(1524)	1018	(461.7)
B22-I-72	72"	(1829)	1218	(552.5)
B22-I-84	84"	(2133)	1417	(642.7)
B22-I-96	96"	(2438)	1616	(733.0)
B22-I-108	108"	(2743)	1816	(823.7)
B22-I-120	120"	(3048)	2016	(914.4)
B22-I-144	144"	(3657)	2416	(1095.9)
B22-I-168	168"	(4267)	2816	(1277.3)
B22-I-192	192"	(4877)	3216	(1458.7)
B22-I-216	216"	(5486)	3616	(1640.2)
B22-I-240	240"	(6096)	4016	(1821.6)

Reference page 202 for general fitting and standard finish specifications.

B32I CONTINUOUS CONCRETE INSERT

- Design Load for B32-I-12 thru B32-I-240 is 2,000 lbs. (8.89 kN) per foot of concrete insert length with safety factor of 3 in 3000 psi concrete.
- Loads concentrated within the last 2 inches (50.8 mm) of concrete inserts 8" (203.2 mm) and longer should not exceed 1,000 lbs. (4.45kN).
- Concrete insert should be secured to the forms on 16" (406.4 mm) to 24" (609.6 mm) intervals.
- B32-I continuous concrete inserts are made from B32 channel. Use channel nuts designed for use in B32 channel.
- B32-I concrete inserts are supplied with styrofoam fillers. B3332 end caps are furnished with inserts through 8" (203.2 mm) long, and B206 end caps are furnished with inserts 12" (304.8 mm) and longer.
- Material: Plain Steel ASTM A1011 33,000 PSI min. yield or Pre-Galvanized Steel ASTM A653SS 33,000 PSI min. yield.
- Finish: Plain, Dura-Green, Pre-Galv, HDG

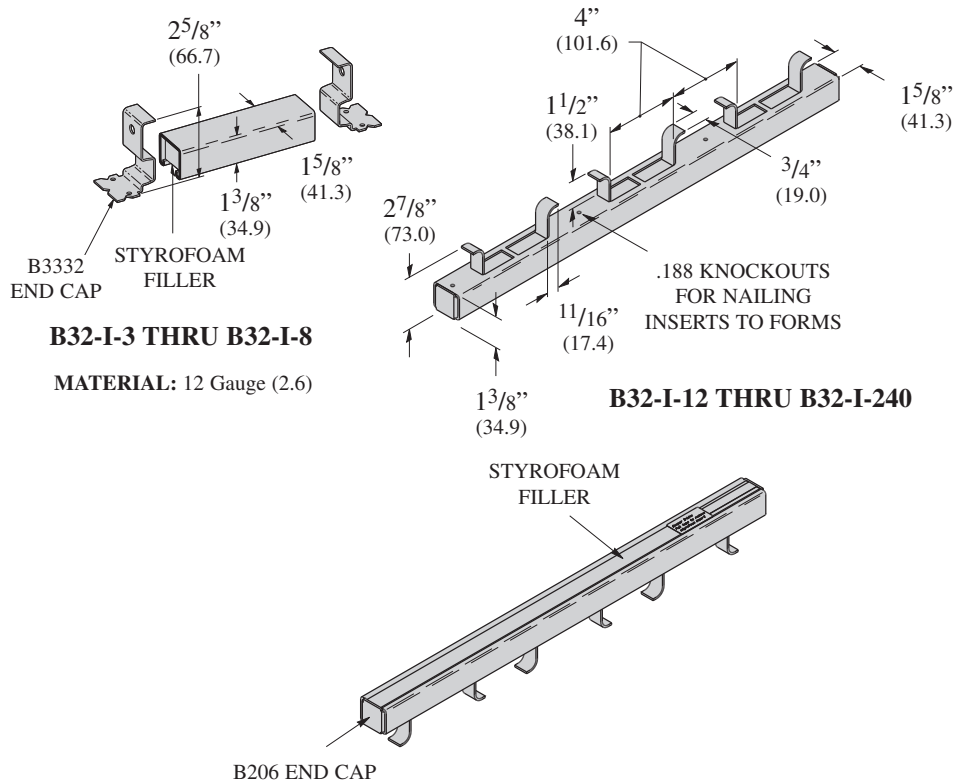

Part No.	Length		Wt./C		Design Load	
	in.	mm	Lbs.	kg	Lbs.	kN
B32-I-3	3"	(76)	65	(29.5)	500	(2.22)
B32-I-4	4"	(101)	80	(36.3)	800	(3.56)
B32-I-6	6"	(152)	108	(49.0)	1000	(4.45)
B32-I-8	8"	(203)	137	(62.1)	1200	(5.34)

Length Part No.	Wt./C		Lbs.	kg
	in.	mm		
B32-I-12	12"	(305)	202	(91.6)
B32-I-16	16"	(406)	262	(118.8)
B32-I-20	20"	(508)	316	(143.3)
B32-I-24	24"	(609)	376	(170.5)
B32-I-32	32"	(813)	496	(225.0)
B32-I-36	36"	(914)	556	(252.2)
B32-I-40	40"	(1016)	616	(279.4)
B32-I-48	48"	(1219)	736	(333.8)
B32-I-60	60"	(1524)	915	(415.0)
B32-I-72	72"	(1829)	1095	(496.7)
B32-I-84	84"	(2133)	1274	(577.9)
B32-I-96	96"	(2438)	1453	(659.0)
B32-I-108	108"	(2743)	1633	(740.7)
B32-I-120	120"	(3048)	1813	(822.3)
B32-I-144	144"	(3657)	2173	(985.6)
B32-I-168	168"	(4267)	2533	(1148.9)
B32-I-192	192"	(4877)	2893	(1312.2)
B32-I-216	216"	(5486)	3253	(1475.5)
B32-I-240	240"	(6096)	3613	(1638.8)

Reference page 202 for general fitting and standard finish specifications.

Continuous Concrete Inserts

B52I CONTINUOUS CONCRETE INSERT

- Design Load for B52-I-12 thru B52-I-240 is 1,500 lbs. (6.67 kN) per foot of concrete insert length with safety factor of 3 in 3000 psi concrete.
- Loads concentrated within the last 2 inches (50.8 mm) of concrete inserts 8" (203.2 mm) and longer should not exceed 750 lbs. (3.33 kN).
- Concrete insert should be secured to the forms on 16" (406.4 mm) to 24" (609.6 mm) intervals.
- B52-I continuous concrete inserts are made from B52 channel. Use channel nuts designed for use in B52 channel.
- B52-I concrete inserts are supplied with styrofoam fillers. B3352 end caps are furnished with inserts through 8" (203.2 mm) long, and B220 end caps are furnished with inserts 12" (304.8 mm) and longer.
- Material: Plain Steel ASTM A1011 33,000 PSI min. yield or Pre-Galvanized Steel ASTM A653SS 33,000 PSI min. yield.
- Finish: Plain, Dura-Green, Pre-Galv, HDG

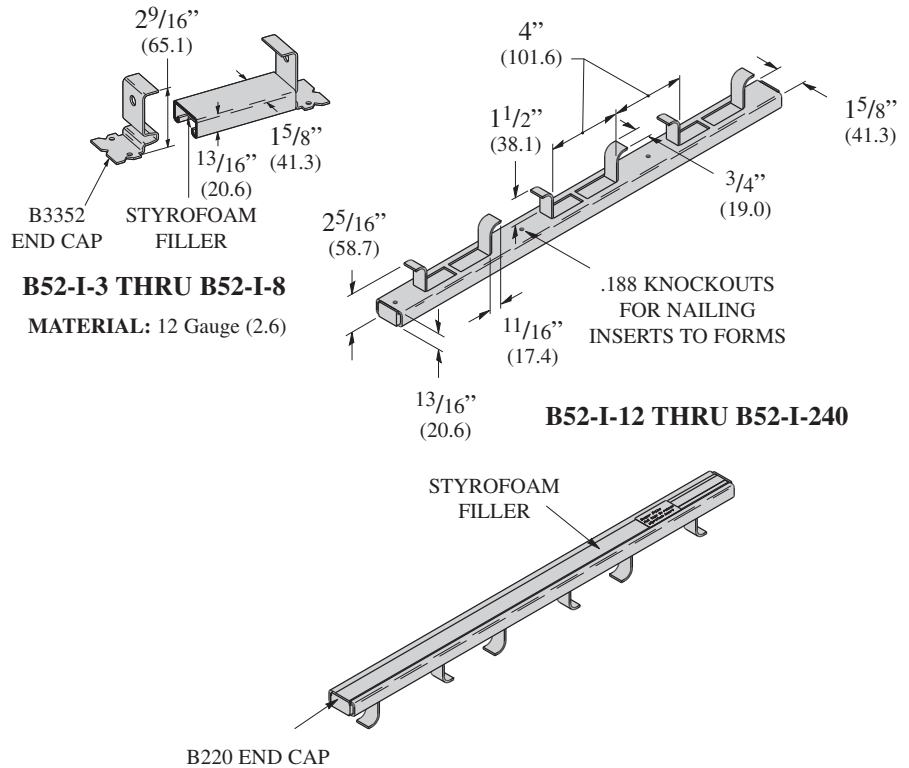

Part No.	Length		Wt./C		Design Load	
	in.	mm	Lbs.	kg	Lbs.	kN
B52-I-3	3"	(76)	53	(24.0)	400	(1.78)
B52-I-4	4"	(101)	63	(28.6)	500	(2.22)
B52-I-6	6"	(152)	85	(38.5)	750	(3.33)
B52-I-8	8"	(203)	106	(48.1)	1000	(4.45)

Part No.	Length		Wt./C	
	in.	mm	Lbs.	kg
B52-I-12	12"	(305)	157	(71.2)
B52-I-16	16"	(406)	202	(91.6)
B52-I-20	20"	(508)	237	(107.5)
B52-I-24	24"	(609)	282	(127.9)
B52-I-32	32"	(813)	373	(169.2)
B52-I-36	36"	(914)	419	(190.0)
B52-I-40	40"	(1016)	464	(210.4)
B52-I-48	48"	(1219)	556	(252.2)
B52-I-60	60"	(1524)	692	(313.9)
B52-I-72	72"	(1829)	829	(376.0)
B52-I-84	84"	(2133)	965	(437.7)
B52-I-96	96"	(2438)	1107	(502.1)
B52-I-108	108"	(2743)	1237	(561.1)
B52-I-120	120"	(3048)	1374	(623.2)
B52-I-144	144"	(3657)	1648	(747.5)
B52-I-168	168"	(4267)	1922	(871.8)
B52-I-192	192"	(4877)	2196	(996.1)
B52-I-216	216"	(5486)	2470	(1120.4)
B52-I-240	240"	(6096)	2744	(1244.6)

Reference page 202 for general fitting and standard finish specifications.

B2500 SPOT INSERT

- Design Load 600 Lbs. (2.67 kN)
- Safety Factor of 5
- Order N2500 Nuts Separately
- Material: Steel ASTM A1011
33,000 PSI min. yield
- Standard finish: ZN
- Wt./C 46 Lbs. (20.8 kg)

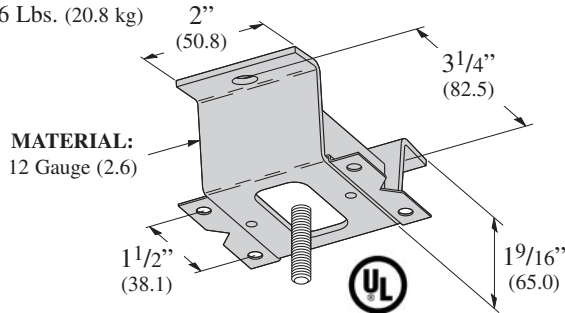

N2500 INSERT SQUARE NUT

- For use in B2500 Spot Insert
- Material: Steel ASTM A36
- Standard finish: ZN

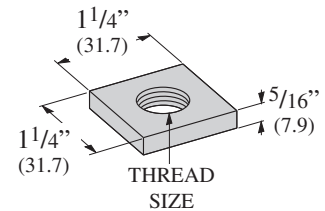

Part No.	Thread Size	Wt./C	
		Lbs.	kg
N2500-1/4	1/4"-20	13	(5.9)
N2500-5/16	5/16"-18	13	(5.9)
N2500-3/8	3/8"-16	12	(5.4)
N2500-1/2	1/2"-13	12	(5.4)
N2500-5/8	5/8"-11	11	(5.0)
N2500-3/4	3/4"-10	10	(4.5)
N2500-7/8	7/8"-9	9	(4.1)

B2503 HEAVY DUTY SPOT INSERT

- Designed for use where heavy loads are required in curtain wall applications
- Design Load is 5000 Lbs. (22.2 kN) with a Safety Factor of 3
- Loading based on two N225 channel nuts spaced 3" (76.2 mm) on center and a minimum of 2" (50.8 mm) from the end of the insert
- Styrofoam end caps prevent concrete seepage into the channel
- 12" (304.8 mm) long insert is anchored into the concrete at a depth of 5 1/2" (139.7 mm)
- Material: 12 Gauge (2.6 mm) thick steel
- Standard finish: ZN
- Wt./C 42 Lbs. (19.0 kg)

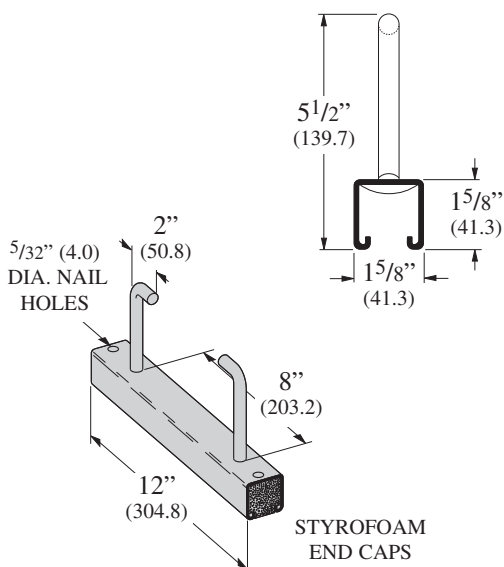

B2505 THRU B2508 SPOT INSERT

- Safety Factor of 5
- To support 10" (250) pipe use B2505 insert with 5/8"-11 Channel Nuts.
- To support up to and including 8" (200) pipes use B2506, B2507 and B2508 inserts with the desired Channel Nuts.
- Standard finish: ZN

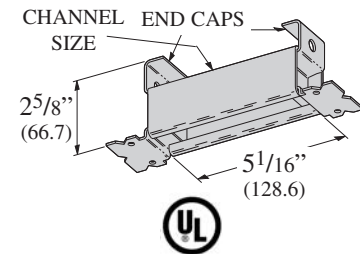

Part No.	Channel Style	End Cap Part No.	Design Load		Maximum Pipe Size	Wt./C	
			Lbs.	kN		Lbs.	kg
B2505	B22	B3322	1200	(5.34)	10" (250)	96	(43.5)
B2506	B32	B3332	1000	(4.45)	8" (200)	88	(39.9)
B2507	B42	B3342	1000	(4.45)	8" (200)	77	(34.9)
B2508	B52	B3352	1000	(4.45)	8" (200)	69	(31.3)

B2501 LIGHT DUTY SPOT INSERT

- Safety Factor of 2
- The concrete attachment problem solver for light duty applications.
- Fast and easy applications.
- No concrete leakage problems.
- One piece unitized construction.
- Color coded cap on thread for rod size identification and to prevent concrete seepage. (1/4"-Yellow, 3/8"-Red, 1/2"-Blue)

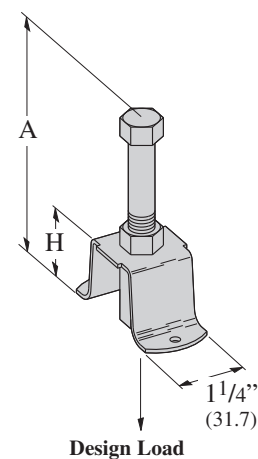

Part No. & Size	Height A		Height H		Design Load		Wt./C	
	Lbs.	kN	Lbs.	kN	Lbs.	kN	Lbs.	kN
B2501-1/4	2 7/16"	(61.9)	7/8"	(22.2)	250	(1.11)	16	(7.2)
B2501-3/8	3 1/16"	(77.8)	1 7/8"	(47.6)	610	(2.71)	22	(9.9)
B2501-1/2	4 1/8"	(104.8)	1 7/8"	(47.6)	880	(3.91)	26	(11.7)

Reference page 202 for general fitting and standard finish specifications.

Insert Accessories

B205, B206, B220 X TYPE END CAPS

- UL listed for raceway use only
- Material: 12 Gauge (2.6)
- Standard finish: ZN

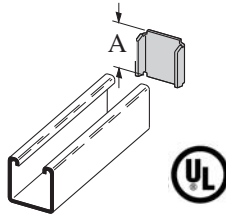

Part No.	Use With	A		Wt./C	
		Lbs.	kg	Lbs.	kg
B205	B22	1 ²¹ / ₃₂ "	(42.0)	10	(4.5)
B206	B32	1 ¹³ / ₃₂ "	(35.7)	8	(3.6)
B220	B52	2 ⁷ / ₃₂ "	(21.4)	4	(1.8)

B3322, B3332, B3342, B3352 Y TYPE END CAPS

- UL listed for raceway use only
- Material: 14 Gauge (1.9)
- Standard finish: ZN

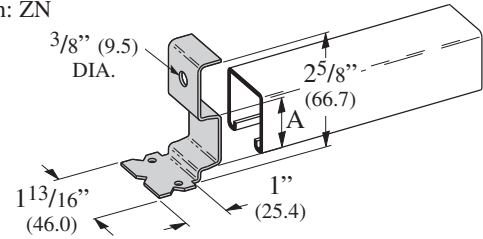

Part No.	Use With	A		Wt./C	
		Lbs.	kg	Lbs.	kg
B3322	B22	1.270	(32.2)	15	(6.8)
B3332	B32	1.000	(25.4)	15	(6.8)
B3342	B42	.645	(16.4)	15	(6.8)
B3352	B52	.460	(11.7)	15	(6.8)

B380 JOINT SPLICE PLATE

- Used at splice points to prevent concrete seepage in long continuous runs of concrete inserts.
- Material: 18 Gauge (1.2)
- Standard finish: GALV

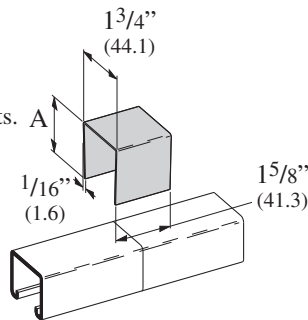

Part No.	Use With	A		Wt./C	
		Lbs.	kg	Lbs.	kg
B380-22	B22	1 ⁵ / ₈ "	(41.3)	11	(5.0)
B380-32	B32	1 ³ / ₈ "	(34.9)	10	(4.5)
B380-42	B42	1"	(25.4)	9	(4.1)
B380-52	B52	1 ³ / ₁₆ "	(20.6)	7	(3.2)

B22IFS-B52IFS STYROFOAM FILLER STRIP

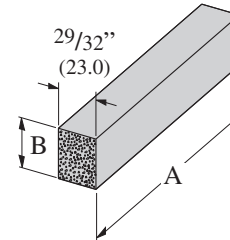

Part No.	A		B	Wt./C	
	Ft.	mm		Lbs.	kg
B22-IFS	4'	(1219)	1 ⁷ / ₃₂ " (309)	10	(4.5)
B32-IFS	4'	(1219)	1" (254)	9	(4.1)
B52-IFS	4'	(1219)	2 ¹ / ₃₂ " (167)	7	(3.2)

PIPE SLEEVE FASTENERS

- Allows for rigid attachment of pipe sleeves to wall and floor forms for concrete pouring.
- Accommodates Schedule 40, Schedule 80, or 5/16" (8) and smaller wall thickness.
- Simply installed with a hammer.



BD40



BE-5-8 & BE-9-12

Part No.	Sleeve Diameter	Wall Thickness
BD40	All Dia.	5/16" & under
BE-5-8	6"	Schedule 80 pipe
BE-9-12	9" - 14"	Schedule 80 pipe

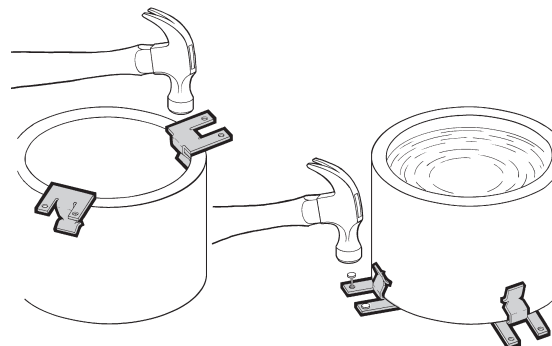

Reference page 202 for general fitting and standard finish specifications.

WEDGE ANCHOR

•Safety Factor of 4

Catalog Number	Thread Size	Overall Length		Max. Mat'l. Thickness to be Anchored		Minimum Embedment Depth		Drill Hole Diameter	
		in.	mm	in.	mm	in.	mm	in.	mm
AWA-37-225	3/8"-16	2 1/4"	(57)	3/8"	(9)	1 1/2"	(38)	3/8"	(10)
AWA-37-275	3/8"-16	2 3/4"	(70)	7/8"	(22)			3/8"	(10)
AWA-37-300	3/8"-16	3"	(76)	1 1/8"	(28)			3/8"	(10)
AWA-37-375	3/8"-16	3 3/4"	(95)	1 7/8"	(47)			3/8"	(10)
AWA-37-500	3/8"-16	5"	(127)	3 1/8"	(79)			3/8"	(10)
AWA-50-275	1/2"-13	2 3/4"	(70)	1/8"	(3)	2 1/4"	(57)	1/2"	(13)
AWA-50-375	1/2"-13	3 3/4"	(95)	1"	(25)			1/2"	(13)
AWA-50-425	1/2"-13	4 1/4"	(108)	1 1/2"	(38)			1/2"	(13)
AWA-50-550	1/2"-13	5 1/2"	(140)	2 3/4"	(70)			1/2"	(13)
AWA-50-700	1/2"-13	7"	(178)	4 1/4"	(108)			1/2"	(13)

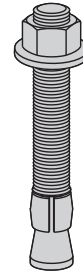

Note: For Information on wedge anchors refer to Cooper B-Line Anchor catalog.

DROP-IN

•Safety Factor of 4

Catalog Number	Thread Size	Length		Thread Depth		Drill/Hole Diameter	
		in.	mm	in.	mm	in.	mm
ADI-25	1/4"-20	1"	(25)	7/16"	(11)	3/8"	(10)
ADI-37	3/8"-16	1 9/16"	(40)	5/8"	(16)	1/2"	(13)
ADI-50	1/2"-13	2"	(51)	13/16"	(21)	5/8"	(16)
ADI-62	5/8"-11	2 1/2"	(64)	13/16"	(30)	7/8"	(22)
ADI-75	3/4"-10	3 1/8"	(79)	13/16"	(30)	1"	(25)

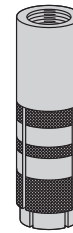

Note: For Information on drop-in anchors refer to Cooper B-Line Anchor catalog.

RAPID ROD™ HANGERS FOR CONCRETE

•Safety Factor of 4

Catalog Number	Size		Drill/Hole Diameter		Rod Size	Allowable Pull-Out Load		Allowable Shear Load	
	in.	mm	in.	mm		Lbs.	kN	Lbs.	kN
ARC-1-RH25	5/16" x 1 1/2"	(8 x 38)	1/4"	(6)	1/4"-20	702	(3.1)	--	--
ARC-1-RH37	5/16" x 1 1/2"	(8 x 38)	1/4"	(6)	3/8"-16	702	(3.1)	--	--
ARC-1-SW37	5/16" x 1 1/2"	(8 x 38)	1/4"	(6)	3/8"-16	--	--	512	(2.3)

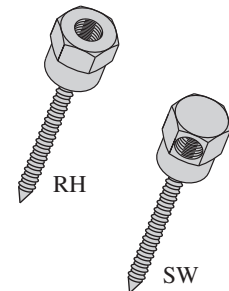

Note: For Information on Rapid Rod hangers refer to Cooper B-Line Anchor catalog.

PLASTIC SCREW ANCHORS

•Safety Factor of 4

Catalog Number	Screw Size	Anchor Length		Drill/Hole Diameter		Allowable Pull Out Load	
		in.	mm	in.	mm	Lbs.	kN
APS-4-87	#4, #6, & #8	7/8"	(22)	3/16"	(5)	50	(0.2)
APS-8-125	#8, #10, & #12	1 1/4"	(32)	1/4"	(6)	100	(0.4)
APS-12-150	#12, #14, & #16	1 1/2"	(38)	5/16"	(8)	150	(0.6)



Note: For Information on plastic screw anchors refer to Cooper B-Line Anchor catalog.

Reference page 202 for general fitting and standard finish specifications.

Slotted Angle

B-Line Slotted Angle is an all-purpose framing system, roll formed from high strength steel strips. It is designed to be used as economical shelving, racks or electrical and mechanical supports. The unique pattern of horizontal and vertical slots permits full flexibility. Three basic sizes are available for light, medium, and heavy duty applications.

Materials & Finishes*

Finish Code	Finish	Specification
PLN	Plain	ASTM A1011 33,000 PSI min. yield
ZN	Electro-Plated Zinc	ASTM B633 SC3
GRN	Dura-Green	
GALV	Pre-Galvanized	ASTM A653 33,000 PSI min. yield

*Unless otherwise noted.

Lengths

Standard lengths are 10' (3.05 m) and 12' (3.66 m). Slotted Angle is shipped in ten piece bundles complete with 75 pieces of $\frac{3}{8}$ " x $\frac{3}{4}$ " (19mm) hex head cap screws and $\frac{3}{8}$ " hex nuts.

Metric

Metric dimensions are shown in parentheses. Unless noted, all metric dimensions are in millimeters.

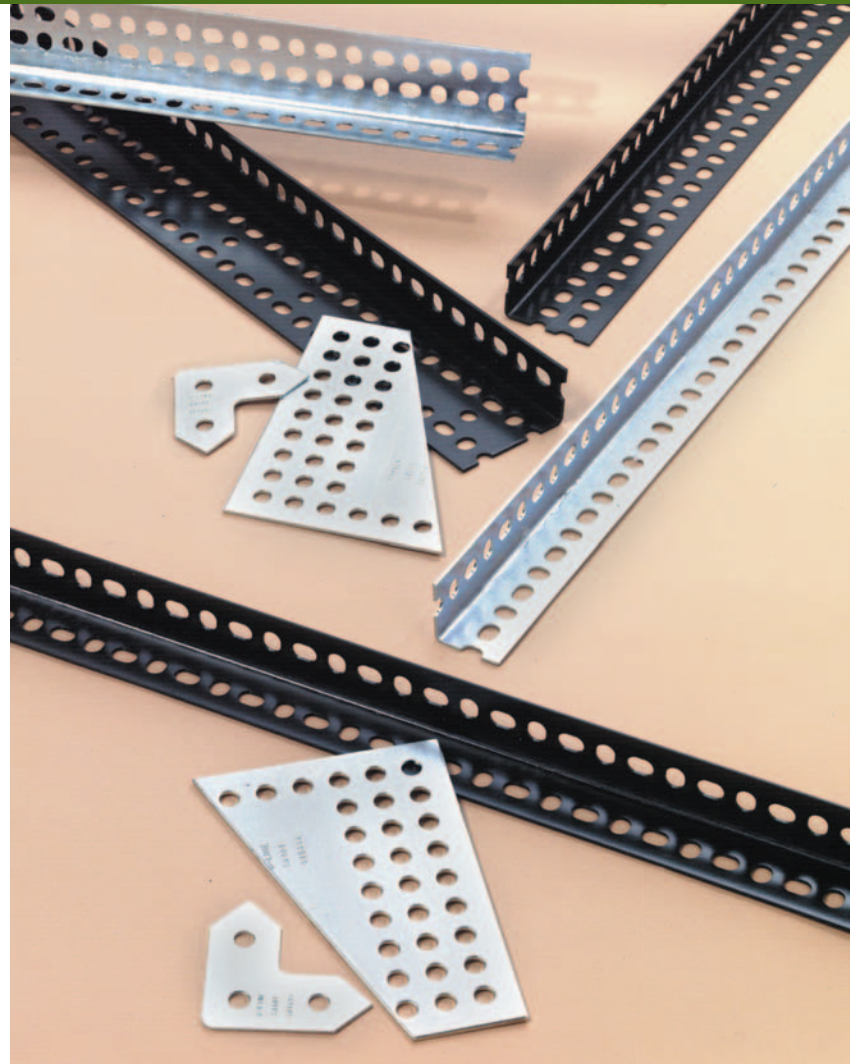

Slotted Angle Sizes

SA158

- 14 Gauge (1.9)
- 1⁵/₈" x 1⁵/₈"
- Standard finishes: ZN, GRN
- Wt./Ft. .66 Lbs. (.98 kg/m)

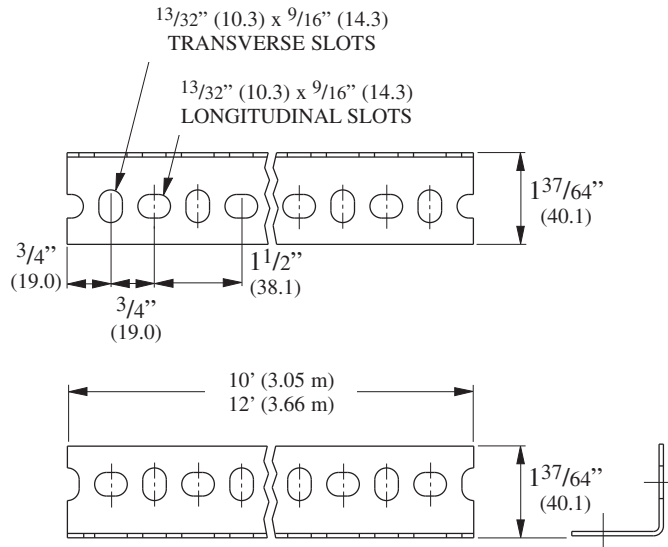
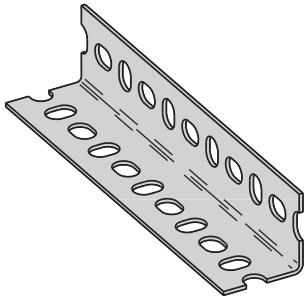

SA276

- 14 Gauge (1.9)
- 1⁵/₈" x 2³/₈"
- Standard finishes: ZN, GRN
- Wt./Ft. .78 Lbs. (1.17 kg/m)

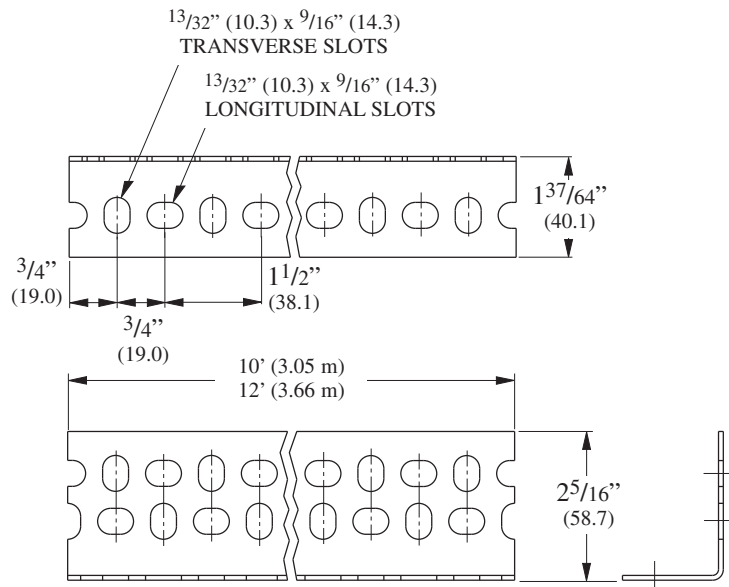
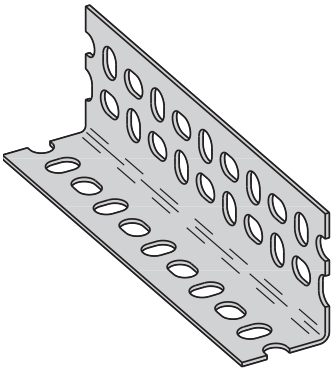

SA318

- 12 Gauge (2.6)
- 1⁵/₈" x 3¹/₈"
- Standard finishes: ZN, GRN
- Wt./Ft. 1.32 Lbs. (1.96 kg/m)

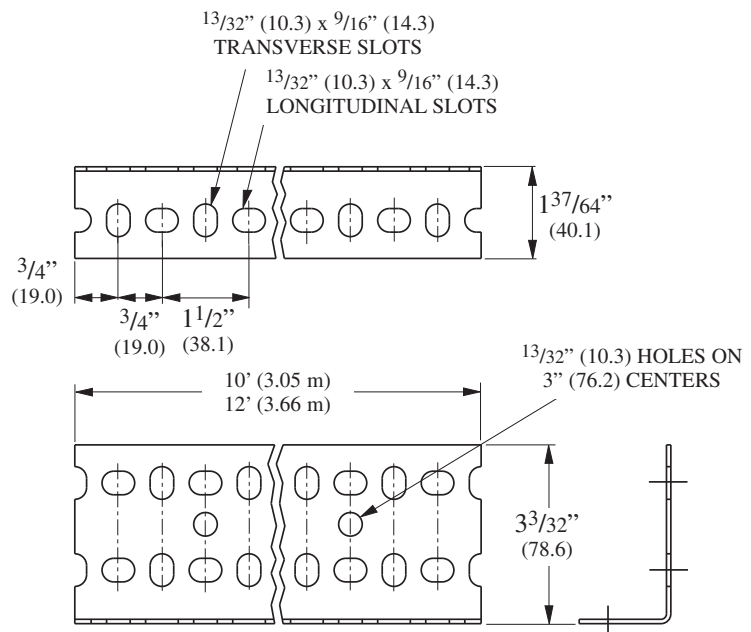
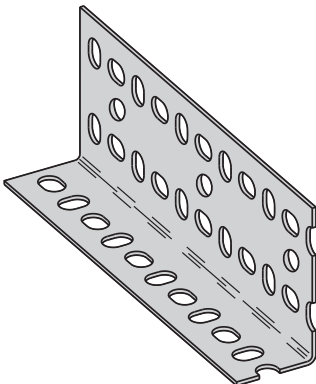

Reference page 210 for general fitting and standard finish specifications.

Slotted Angle Beam Loading & Combinations

BEAM SECTIONS

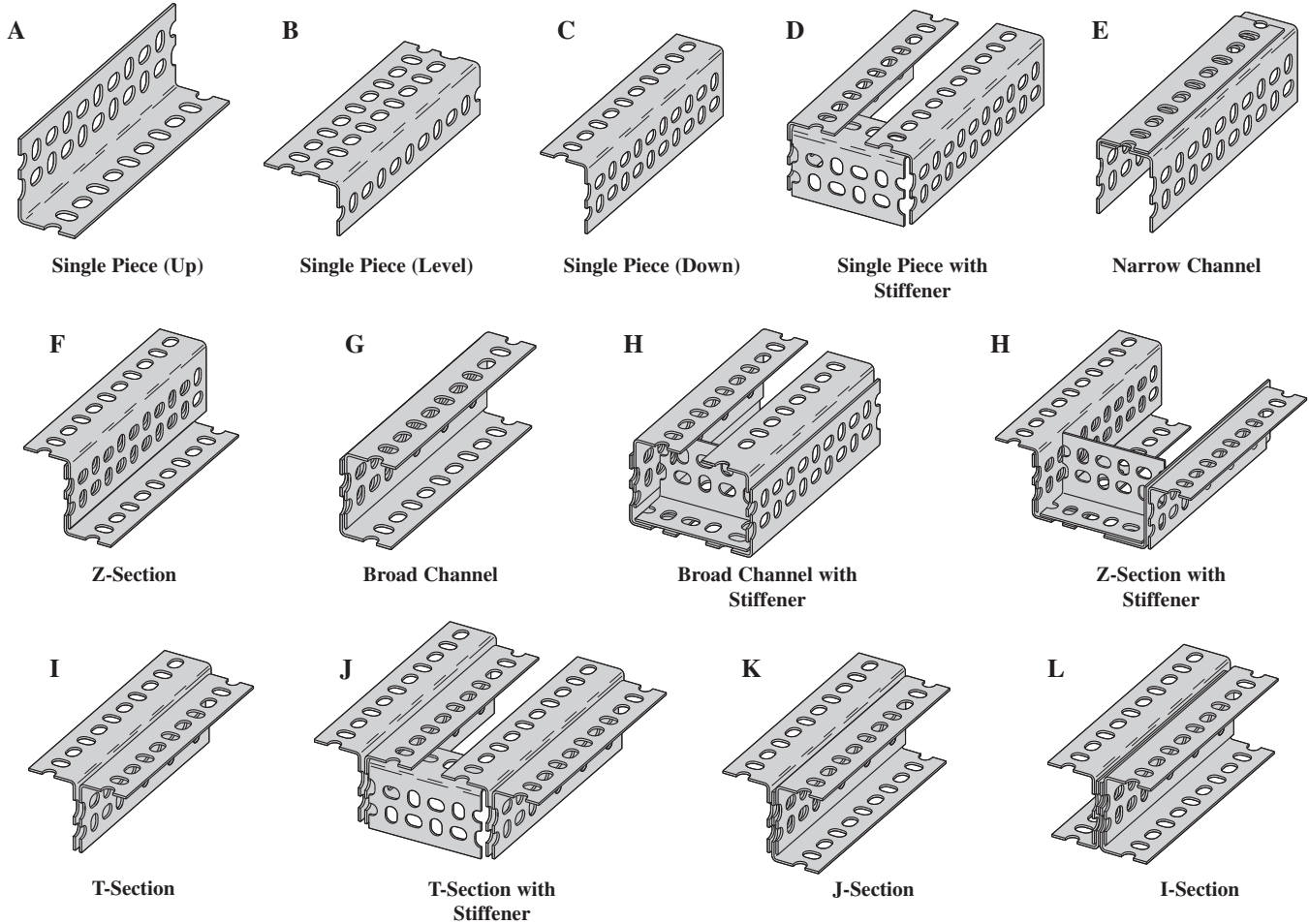

For greater strength required in some applications, Slotted Angle may be fastened together to create combination shapes. A number of these combinations are illustrated above. Refer to the following table for load capacities of these combinations.

Beam Sections illustrated are single sections, except J, N, and P.

BEAM LOADING

SA158-1⁵/₈" (41.3) x 1⁵/₈" (41.3) x 14 Gauge (1.9)

	Beam Span													
	24" (609 mm)		36" (914 mm)		48" (1219 mm)		60" (1524 mm)		72" (1829 mm)		84" (2133 mm)		96" (2438 mm)	
	Lbs.	N	Lbs.	N	Lbs.	N	Lbs.	N	Lbs.	N	Lbs.	N	Lbs.	N
A	825	(3670)	525	(2335)	340	(1512)	230	(1023)	180	(800)	-	-	-	-
B	1100	(4893)	800	(3558)	540	(2402)	370	(1646)	250	(1112)	-	-	-	-
C	1100	(4893)	800	(3558)	540	(2402)	370	(1646)	250	(1112)	-	-	-	-
D	1300	(5782)	900	(4003)	625	(2780)	450	(2001)	330	(1468)	275	(1223)	200	(889)
G	1900	(8451)	1360	(6049)	1050	(4670)	825	(3670)	660	(2936)	530	(2357)	400	(1779)
H	2300	(10231)	1850	(8229)	1450	(6450)	1100	(4893)	950	(4226)	800	(3558)	700	(3114)
I	2200	(9786)	1650	(7339)	1225	(5449)	930	(4137)	700	(3114)	550	(2446)	450	(2001)

Based on simple beam condition with uniform loads on parallel beams. To determine concentrated load capacity at mid-span, multiply uniform load by 0.5.

Reference page 210 for general fitting and standard finish specifications.

Slotted Angle Beam Loading

BEAM LOADING

SA276-1⁵/₈" (41.3) x 2³/₈" (60.3) x 14 Gauge (1.9)

	Beam Span																	
	24" (609 mm)		36" (914 mm)		48" (1219 mm)		60" (1524 mm)		72" (1829 mm)		84" (2133 mm)		96" (2438 mm)		108" (2743 mm)		120" (3048 mm)	
	Lbs.	N	Lbs.	N	Lbs.	N	Lbs.	N	Lbs.	N	Lbs.	N	Lbs.	N	Lbs.	N	Lbs.	N
A	-	-	680	(3025)	450	(2001)	340	(1512)	-	-	-	-	-	-	-	-	-	-
B	-	-	830	(3692)	550	(2446)	360	(1601)	210	(934)	150	(667)	-	-	-	-	-	-
C	-	-	1540	(6850)	1060	(4715)	800	(3558)	610	(2713)	480	(2135)	340	1512	250	(1112)	-	-
D	-	-	1880	(8362)	1280	(5694)	970	(4315)	820	(3647)	650	(2891)	550	(2446)	420	(1868)	340	(1512)
E	-	-	2110	(9386)	1730	(7695)	1460	(5775)	1250	(5560)	1090	(4848)	920	(4092)	820	(3647)	680	(3025)
F	4290	(19083)	2510	(11165)	1790	(7962)	1330	(5916)	980	(4359)	710	(3158)	550	(2446)	420	(1868)	320	(1423)
G	4320	(19216)	3000	(13344)	2140	(9519)	1600	(7117)	1290	(5738)	1040	(4626)	820	(3647)	640	(2847)	490	(2179)
H	-	-	3480	(15480)	2430	(10809)	1890	(8407)	1620	(7206)	1430	(6361)	1270	(5649)	1160	(5160)	1030	(4581)
I	5780	(25711)	3640	(16191)	2820	(12544)	2200	(9786)	1700	(7562)	1350	(6005)	1060	(4715)	850	(3781)	680	(3025)
J	-	-	3660	(16280)	2840	(12633)	2230	(9919)	1720	(7651)	1360	(6049)	1090	(4848)	874	(3888)	700	(3114)
K	-	-	4910	(21841)	3830	(17036)	3000	(13344)	2550	(11343)	2190	(9741)	1880	(8362)	1640	(7295)	1430	(6361)
L	-	-	6360	(28290)	4590	(20417)	3470	(15435)	2910	(12944)	2550	(11343)	2240	(9964)	2010	(8941)	1840	(8185)

Based on simple beam condition with uniform loads on parallel beams. To determine concentrated load capacity at mid-span, multiply uniform load by 0.5.

BEAM LOADING

SA318-1⁵/₈" (41.3) x 3¹/₈" (79.4) x 12 Gauge (2.6)

	Beam Span																	
	24" (609 mm)		36" (914 mm)		48" (1219 mm)		60" (1524 mm)		72" (1829 mm)		84" (2133 mm)		96" (2438 mm)		108" (2743 mm)		120" (3048 mm)	
	Lbs.	N	Lbs.	N	Lbs.	N	Lbs.	N	Lbs.	N	Lbs.	N	Lbs.	N	Lbs.	N	Lbs.	N
A	-	-	1140	(5071)	850	(3781)	690	(3069)	-	-	-	-	-	-	-	-	-	-
B	-	-	1250	(5560)	850	(3781)	600	(2669)	400	(1779)	-	-	-	-	-	-	-	-
C	4800	(21351)	2750	(12232)	1800	(8007)	1280	(5694)	1000	(4448)	790	(3514)	610	(2713)	-	-	-	-
D	-	-	3900	(17348)	2690	(11966)	2050	(9119)	1700	(7562)	1480	(6583)	1280	(5694)	1100	(4893)	960	(4270)
E	-	-	4160	(18504)	3560	(15835)	3130	(13923)	2750	(12232)	2400	(10676)	2170	(9652)	1950	(8674)	1780	(7918)
F	8180	(36386)	5000	(22241)	3650	(16236)	2750	(12232)	2200	(9786)	1750	(7784)	1350	(6005)	1020	(4537)	700	(3114)
G	10600	(47151)	6050	(26912)	4440	(19750)	3330	(14812)	2670	(11877)	2120	(9430)	1660	(7384)	1210	(5382)	1000	(4448)
H	-	-	6100	(27134)	4620	(20551)	3670	(16325)	3110	(13834)	2680	(11921)	2380	(10587)	2100	(9341)	1950	(8674)
I	13700	(60940)	7800	(34696)	5900	(26244)	4600	(20462)	3800	(16903)	3190	(14190)	2630	(11699)	2170	(9652)	1810	(8051)
J	-	-	7900	(35141)	6300	(28024)	5050	(22463)	4070	(18104)	3240	(14412)	2630	(11699)	2170	(9652)	1810	(8051)
K	-	-	10050	(44704)	8000	(35586)	6320	(28113)	5350	(23798)	4650	(20684)	4040	(17971)	3520	(15658)	3120	(13878)
L	-	-	12700	(56492)	9550	(42480)	7540	(33539)	6540	(29091)	5730	(25488)	5030	(22374)	4520	(20106)	4000	(17793)

Based on simple beam condition with uniform loads on parallel beams. To determine concentrated load capacity at mid-span, multiply uniform load by 0.5.

Reference page 210 for general fitting and standard finish specifications.

Slotted Angle Column Loading & Combinations

COLUMN SECTIONS

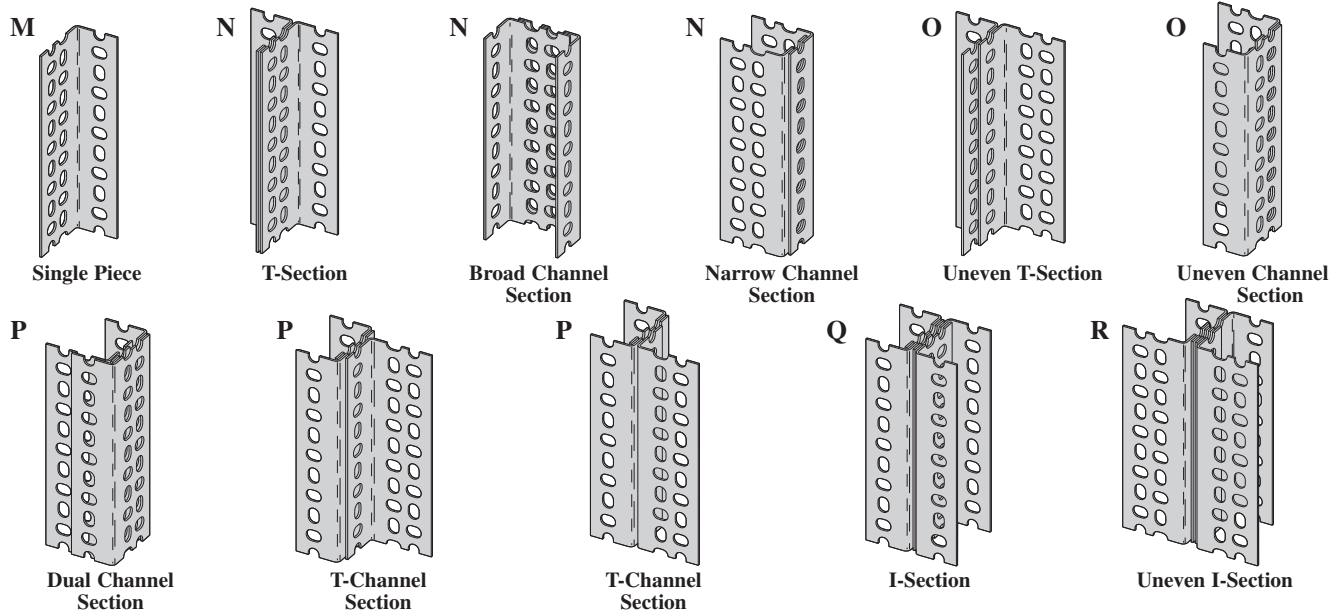

For greater strength required in some applications, Slotted Angle may be fastened together to create combination shapes. A number of these combinations are illustrated above. Refer to the following table for load capacities of these combinations.

COLUMN LOADING - SA158-1⁵/₈" (41.3) x 1⁵/₈" (41.3) x 14 Gauge (1.9)

	Column Height							
	36" (914 mm)		48" (1219 mm)		60" (1524 mm)		72" (1829 mm)	
	Lbs.	N	Lbs.	N	Lbs.	N	Lbs.	N
M	1450	(6450)	1150	(5115)	950	(4226)	750	(3336)
N	3850	(17125)	3500	(15569)	3000	(13344)	2500	(11120)

Column Loads assume no lateral support.

COLUMN LOADING - SA276-1⁵/₈" (41.3) x 2³/₈" (60.3) x 14 Gauge (1.9)

	Column Height															
	36" (914 mm)		48" (1219 mm)		60" (1524 mm)		72" (1829 mm)		84" (2133 mm)		96" (2438 mm)		108" (2743 mm)		120" (3048 mm)	
	Lbs.	N	Lbs.	N	Lbs.	N	Lbs.	N	Lbs.	N	Lbs.	N	Lbs.	N	Lbs.	N
M	2280	(10142)	1970	(8763)	1520	(6761)	1070	(4759)	660	(2936)	-	-	-	-	-	-
N	4760	(21173)	4490	(19972)	3995	(17770)	3140	(13967)	2340	(10409)	1750	(7784)	-	-	-	-
O	4940	(21974)	4680	(20817)	4310	(19172)	3870	(17214)	3665	(16303)	2700	(12010)	2060	(9163)	1610	(7161)
P	7270	(32338)	6920	(30781)	6370	(28335)	5840	(25977)	4930	(21930)	3850	(17125)	2870	(12766)	2060	(9163)
Q	9520	(42347)	8970	(39900)	7990	(35541)	6280	(27935)	4660	(20729)	3500	(15569)	-	-	-	-
R	9865	(43881)	9330	(41502)	8620	(38343)	7715	(34318)	6740	(29981)	5365	(23865)	4115	(18304)	3210	(14279)

Column Loads assume no lateral support.

COLUMN LOADING - SA318-1⁵/₈" (41.3) x 3¹/₈" (79.4) x 12 Gauge (2.6)

	Column Height															
	36" (914 mm)		48" (1219 mm)		60" (1524 mm)		72" (1829 mm)		84" (2133 mm)		96" (2438 mm)		108" (2743 mm)		120" (3048 mm)	
	Lbs.	N	Lbs.	N	Lbs.	N	Lbs.	N	Lbs.	N	Lbs.	N	Lbs.	N	Lbs.	N
M	3470	(15435)	2870	(12766)	1970	(8763)	1280	(5694)	-	-	-	-	-	-	-	-
N	7970	(35452)	7360	(32739)	6570	(29225)	5270	(23442)	3670	(16325)	2580	(11476)	-	-	-	-
O	8770	(39011)	8580	(38166)	8180	(36386)	7690	(34207)	6970	(31004)	6260	(27846)	5460	(24287)	4460	(19839)
P	12560	(55869)	11970	(53245)	11360	(50532)	10480	(46617)	9470	(42124)	8370	(37231)	6880	(30604)	5370	(23887)
Q	15940	(70904)	14750	(65611)	13160	(58538)	10560	(46973)	7370	(32783)	5170	(22997)	-	-	-	-
R	17550	(78066)	17150	(76287)	16360	(72773)	15360	(68324)	13970	(62141)	12570	(55914)	10970	(48797)	8960	(39856)

Column Loads assume no lateral support.

Reference page 202 for general fitting and standard finish specifications.

Slotted Angle Kits & Fittings

AHHK-1/4 & AHHK-3/8 AIR HANDLER HANGING KIT

- Standard finishes: ZN
- Load Capacity Per Kit: 400 Lbs. (181.4 kg)

- ⑧ Hanging rods come in 72" lengths.
Rods can be field cut for proper height requirement.

Item #	Description	Quantity	
		AHHK 1/4	AHHK 3/8
①	Rod Hanger Fitting	4	4
②	Lag Screw	4	4
③	Hex Head Cap Screw	4	4
④	Flat Washer (For HHCS)	4	4
⑤	Hex Nuts (For HHCS)	4	4
⑥	Hex Nuts (For Hanging Rods)	16	16
⑦	Flat Washer (See Note 1)	16	-
⑧	Hanging Rods (72" Long)	4	4
⑨	SA158 (36" Long)	2	2

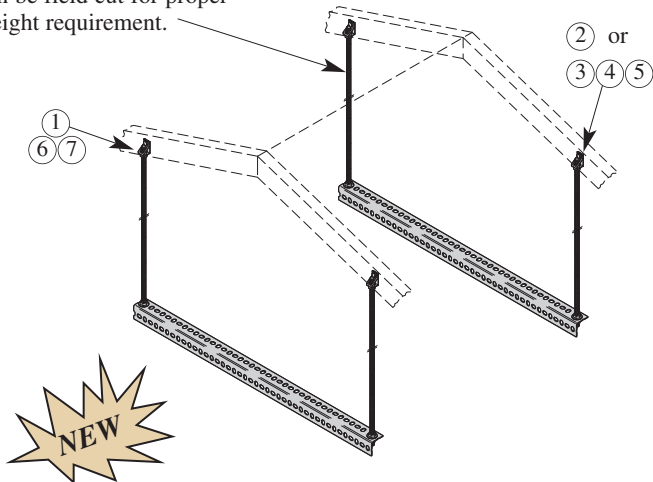

Note 1: Flat washers are required for 1/4"-20 hanging rods only.

SA101 CONNECTION PLATE

- Standard finishes: ZN, GRN
- Wt./C 67 Lbs. (30.4 kg)

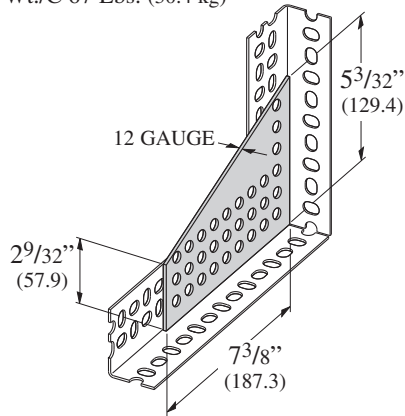

SA102 ANGLE BRACE

- Standard finishes: ZN, GRN
- Wt./C 15 Lbs. (6.8 kg)

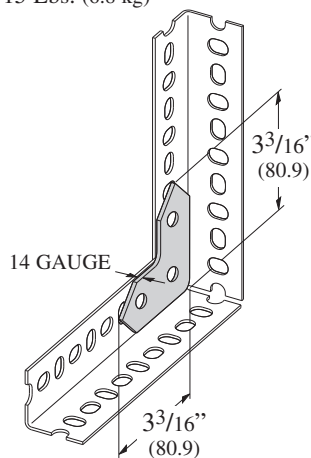

SA154 RIGID CASTER

- Safety Factor of 1.5
- 300 Lbs. (136.1 kg) maximum load capacity
- Caster material: Phenolic
- Standard finishes: ZN, GRN
- Wt./Ea. 2.0 Lbs. (.91 kg)

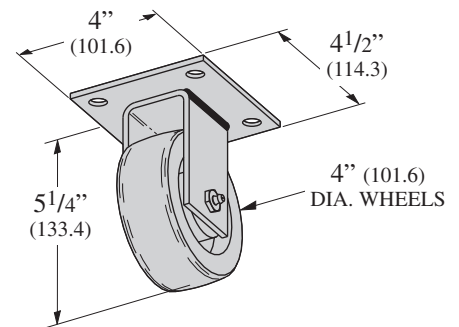

SA155 SWIVEL CASTER

- Safety Factor of 1.5
- 300 Lbs. (136.1 kg) maximum load capacity
- Caster material: Phenolic
- Standard finishes: ZN, GRN
- Wt./Ea. 2.2 Lbs. (1.0 kg)

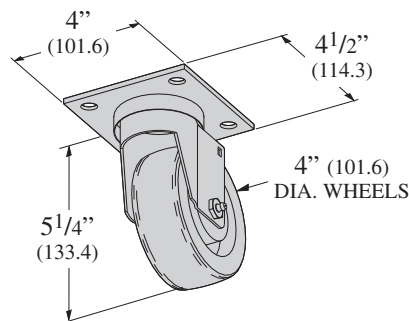

SA110 SLOTTED ANGLE CUTTER

- Standard finishes:
- Wt./Ea. 16 Lbs. (7.26 kg)

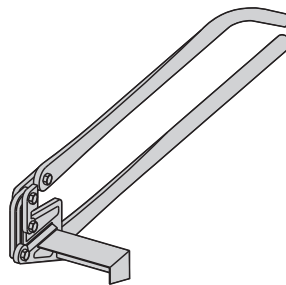

SA131 SLOTTED STRAP

- Hole pattern is identical to the hole pattern in slotted angles
- Standard length: 10' (3.05 m)
- Standard finishes: Pre-Galv. (GALV)
- Material thickness: 14 gauge (1.9)

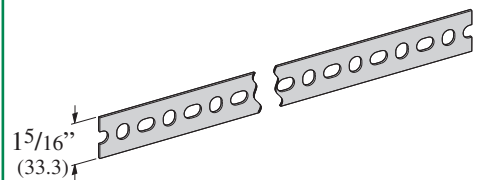

CLEATS: To reinforce load-bearing joints, cleats can be field made by cutting 2 1/4" (57.1) long segments from the widest slotted angle available. Use SA276 for light duty cleats and SA318 for heavy duty cleats.

SPLICE PLATES: To assemble two pieces of slotted angle using a butt joint requires a 6" (152.4) splice plate for reinforcement.

Reference page 210 for general fitting and standard finish specifications.

Reference Data

METRIC CONVERSION CHART

To Convert From	To	Multiply By	To Convert From	To	Multiply By
Angle			Length		
degree	radian (rad)	0.01745329	foot (ft)	meter (m)	0.3048
radian (rad)	degree	57.29578	inch (in)	meter (m)	0.0254
Area			mil	meter (m)	0.0000254
foot ²	square meter (m ²)	0.09290304	inch (in)	micrometer (μm)	25400.00
inch ²	square meter (m ²)	0.00064516	meter (m)	foot (ft)	3.280840
circular mil	square meter (m ²)	0.000000005067075	meter (m)	inch (in)	39.37008
sq. centimeter (cm ²)	square inch (in ²)	0.1550003	meter (m)	mil	39370.08
square meter (m ²)	foot ²	10.76391	micrometer (μm)	inch (in)	0.00003937008
square meter (m ²)	inch ²	1550.003	Volume		
square meter (m ²)	circular mil	1973523000.0	foot ³	cubic meter (m ³)	0.02831685
Temperature			inch ³	cubic meter (m ³)	0.00001638706
degree Fahrenheit	degree Celsius	$t^{\circ C} = (t^{\circ F} - 32) / 1.8$	cubic centimeter (cm ³)	cubic inch (in ³)	0.06102374
degree Celsius	degree Fahrenheit	$t^{\circ F} = 1.8t^{\circ C} + 32$	cubic meter (m ³)	foot ³	35.31466
Force			cubic meter (m ³)	inch ³	61023.76
pounds-force (lbf)	newtons (N)	4.448222	gallon (U.S. liquid)	cubic meter (m ³)	0.003785412
			Section Properties		
			section modulus S (in ³)	S (m ³)	0.00001638706
			moment of inertia I (in ⁴)	I (m ⁴)	0.0000004162314
			modulus of elasticity E (psi)	E (Pa)	6894.757
			section modulus S (m ³)	S (in ³)	61023.74
			moment of inertia I (m ⁴)	I (in ⁴)	2402510.0
			modulus of elasticity E (Pa)	E (psi)	0.0001450377

To Convert From	To	Multiply By
Bending Moment or Torque		
lbf • ft	newton meter (N•m)	1.355818
lbf • in	newton meter (N•m)	0.1129848
N•m	lbf • ft	0.7375621
N•m	lbf • in	8.850748
Mass		
ounce (avoirdupois)	kilogram (kg)	0.02834952
pound (avoirdupois)	kilogram (kg)	0.4535924
ton (short, 2000 lb)	kilogram (kg)	907.1847
ton (long, 2240 lb)	kilogram (kg)	1016.047
kilogram (kg)	ounce (avoirdupois)	35.27396
kilogram (kg)	pound (avoirdupois)	2.204622
kilogram (kg)	ton (short, 2000 lb)	0.001102311
kilogram (kg)	ton (long, 2240 lb)	0.0009842064
Mass Per Unit Length		
lb/ft	kilogram per meter (kg/m)	1.488164
lb/in	kilogram per meter (kg/m)	17.85797
kg/m	lb/ft	0.6719689
kg/m	lb/in	0.5599741
Mass Per Unit Volume		
lb/ft ³	kilogram per cubic meter (kg/m ³)	16.01846
lb/in ³	kilogram per cubic meter (kg/m ³)	27679.9
kg/m ³	lb/ft ³	0.06242797
kg/m ³	lb/in ³	0.0000361273
lbs/ft ³	lbs/in ³	1728.0
Mass Per Unit Area		
lb/ft ²	kilogram per square meter (kg/m ²)	4.882428
kg/m ²	pound per square foot (lb/ft ²)	0.2048161
Pressure or Stress		
lbf/in ² (psi)	pascal (Pa)	6894.757
kip/in ² (ksi)	pascal (Pa)	6894757.0
lbf/in ² (psi)	megapascals (MPa)	0.006894757
pascal (Pa)	pound-force per square inch (psi)	0.0001450377
pascal (Pa)	kip per square inch (ksi)	0.0000001450377
megapascals (MPa)	lbf/in ² (psi)	145.0377

Abbreviations	
Defl.	= Deflection
S.F.	= Safety Factor
Ft.	= Feet
Pre-galv.	= Pre-galvanized Steel
K Factor	= Deflection Divided by load in Lbs./Ft.
o.c.	= On Center
PVC	= Poly Vinyl Chloride
In.	= Inch
psi	= Pounds per Square Inch
wt./c	= Weight pre 100 pieces
Metric Symbols	
m	= meter
cm	= centimeter
mm	= millimeter
μm	= micrometer
kg	= kilogram
N	= newton
kN	= kilonewton
Pa	= pascal
MPa	= megapascal

DESIGN LOAD DATA (For typical channel-fitting connections when USED IN PAIRS).

90° Fittings													
Channel Thickness		Lbs.		kN		Lbs.		kN		Lbs.		kN	
12 ga.	(2.6)	1500	(6.67)	1000	(4.45)	2000	(8.90)	1500	(6.67)	1500	(6.67)	1000	(4.45)
14 ga.	(1.9)	1000	(4.45)	650	(2.89)	1500	(6.67)	1150	(5.12)	1000	(4.45)	650	(2.89)
16 ga.	(1.5)	750	(3.34)	500	(2.22)	900	(4.00)	650	(2.89)	1000	(4.45)	500	(2.22)

Design load data includes a safety factor of 2.5 (safety factor = ratio of ultimate load to design load).

90° Fittings										Flat Fittings			
Channel Thickness		Lbs.		kN		Lbs.		kN		Lbs.		kN	
12 ga.	(2.6)	2500	(11.12)	2000	(8.90)	3000	(13.34)	2500	(11.12)	1000	(4.45)	1000	(4.45)
14 ga.	(1.9)	2000	(8.90)	1650	(7.34)	2000	(8.90)	1650	(7.34)	500	(3.56)	800	(3.56)
16 ga.	(1.5)	1500	(6.67)	1250	(5.56)	1500	(6.67)	1250	(5.56)	600	(2.67)	600	(2.67)

General Notes for Strut-Type Channel Raceway

Guide RIUU - Cooper B-Line, Inc., Highland, IL 62249 December 11, 1998 (C)
 FLUORESCENT AND INCANDESCENT LIGHTING



File No. E29637

Suitable for not more than the number of wires of the sizes and types indicated in the following tables. Intended to enclose circuits operating at potentials not exceeding 600 volts between conductors. In all cases, the B217-20 or B217P snap-in cover is required to complete raceway closure. When using B217-24 snap-in cover, the number of wires is limited to 7 or fewer conductors no larger than #12 AWG.

B-Line's strut-type channel raceways and fittings are manufactured and tested to comply with the UL Standard for Safety for Strut-Type Channel Raceways and Fittings (UL 5B) in accordance with Article 384 of the 2002 National Electrical Code, NFPA 70.

1. Support spans for strut-type channel raceway shall not exceed 10 foot intervals.
2. No conductor larger than that for which the raceway is listed shall be installed in strut-type channel raceways. No wires under 14AWG or over 6AWG are allowed in any of B-Line's strut-type channel raceway. See tables 1, 2 and 3 below for a listing of the approved conductors for B-Line's strut-type channel raceways.
3. The number of conductors permitted in strut-type channel raceway shall not exceed the percentage fill using Table 384-22 and the applicable outside diameter of specific types and sizes of wire given in the tables in chapter 9 of the National Electrical Code. Table 384-22 lists two different percent fill areas depending on the use of internal or external joiners. Use 40% area fill with external joiners and 25% area fill for internal joiners.
4. Items in the electrical section of the B-Line Strut Systems Catalog identified by the UL symbol provide for electrical continuity. Other items require the use of a separate grounding wire.
5. If strut-type channel raceway is connected to another wiring system, the raceway must be field-tapped adjacent to the wire entry point to accept a #10-32 or larger grounding screw. A plated or stainless steel screw may be used. A sheet metal screw is not acceptable. Drill and tap the grounding wire hole before installing wires in raceway or move installed wires out of the way to avoid damage. After drilling and tapping, remove metal chips and burrs before installing screw.

TABLE 1: MAXIMUM NUMBER OF WIRES (Adjusted per NEC Table 384.22 for 40% fill)

Use this table to determine the type and number of conductors for use with B-Line's strut-type channel raceway using external joiners. This table applies for all installations except for the support and supply of electric discharge type lighting fixtures. See table 2 and 3 for further information.

Insulation Type	Wire Size AWG.	B11 B11K06	B12 B12K06	B22 B22K06	B24 B24K06	B26 B26K06	B32 B32K06	B56 B56K06
FEP, FEPB	14	172	127	81	81	81	67	36
	12	126	92	59	59	59	49	26
	10	90	66	42	42	42	35	19
	8	51	38	24	24	24	20	11
	6	24	17	11	12	12	9	5
RH, RHH, RHW	14	52	38	24	26	27	20	12
	12	45	33	21	22	23	17	10
	10	37	27	17	18	19	14	8
	8	20	14	9	10	10	7	4
	6	14	10	6	7	7	5	3
T, TW	14	124	91	58	58	58	48	26
	12	95	70	45	45	45	37	20
	10	69	51	33	33	33	27	14
	8	36	26	17	18	19	14	8
	6	21	15	9	10	11	8	5
THHN, THWN	14	178	131	84	84	84	69	37
	12	130	95	61	61	61	50	27
	10	82	60	38	38	38	32	17
	8	46	34	21	22	22	17	10
	6	33	24	15	16	16	12	7
THW	14	82	61	39	39	39	32	17
	12	66	49	31	31	31	26	14
	10	52	38	24	24	24	20	11
	8	29	21	13	14	15	11	6
	6	21	15	10	10	11	8	5
XHHW	14	124	91	58	58	58	48	26
	12	95	70	45	45	45	37	20
	10	71	52	33	33	33	28	15
	8	37	27	17	19	19	14	8
	6	27	20	13	14	14	10	6

TABLE 2: MAXIMUM NUMBER OF WIRES

Also suitable for the number of wires in table below when installed to support and supply *electric discharge type lighting fixtures* when raceway wiring is suitable for at least 70°C **and** clearance between fixture and raceway is at least 1/8". In all cases, a snap-in cover is required to complete the raceway enclosure.

Wire Size	Raceway Catalog Wires						
	B11 B11K06	B12 B12K06	B22 B22K06	B24 B24K06	B26 B26K06	B32 B32K06	B56 B56K06
Type Insulation: FEP, FEPB, RH, RHH, RHW, RUH, THHN, THWN, THW, XHHW							
14	13	10	10	10	10	10	6
12	13	10	10	10	10	10	6
10	13	10	8	8	8	6	–
8	10	8	6	6	6	4	–
6	8	6	4	4	4	3	–

When using B217-24 snap-in cover, the number of wires is limited to 7 or fewer conductors no larger than #12 AWG.

TABLE 3: MAXIMUM NUMBER OF WIRES









Also suitable for the number of wires in table below when installed to support and supply *electric discharge type lighting fixtures* when raceway wiring is suitable for 75°C, **or** wiring suitable for 60°C **if a minimum clearance between fixture and raceway is at least 1/2"**. In all cases, a snap-in cover is required to complete the raceway enclosure.

Wire Size	Raceway Catalog Wires						
	B11 B11K06	B12 B12K06	B22 B22K06	B24 B24K06	B26 B26K06	B32 B32K06	B56 B56K06
Type Insulation: FEP, FEPB, RH, RHH, RHW, RUH, THHN, THWN, THW, XHHW							
14	10	10	10	10	10	10	4
12	10	10	10	10	10	10	3
10	8	5	5	5	5	5	–
8	6	4	4	4	4	4	–
6	4	4	4	4	4	4	–

When using B217-24 snap-in cover, the number of wires is limited to 7 or fewer conductors no larger than #12 AWG.

Reference Data

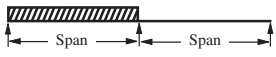
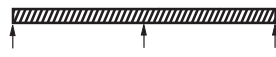
The data shown in the beam load charts for appropriate channels on page(s) 17 thru 39 is for simply supported, single span beams with a uniformly distributed load. For other loading and/or support conditions, use the appropriate factor from the chart below.

LOAD AND SUPPORT CONDITION	Load Factor	Deflection Factor
Simple Beam - Uniform Load 	1.00	1.00
Simple Beam - Concentrated Load at Center 	.50	.80
Simple Beam - Two Equal Concentrated Loads at 1/4 Points 	1.00	1.10
Beam Fixed at Both Ends - Uniform Load 	1.50	.30
Beam Fixed at Both Ends - Concentrated Load at Center 	1.00	.40
Cantilever Beam - Uniform Load 	.25	2.40
Cantilever Beam - Concentrated Load at End 	.12	3.20
Continuous Beam - Two Equal Spans - Uniform Load on One Span 	1.30	.92
Continuous Beam - Two Equal Spans - Concentrated Load on Both Spans 	1.00	.42
Continuous Beam - Two Equal Spans - Concentrated Load at Center of One Span 	.62	.71
Continuous Beam - Two Equal Spans - Concentrated Load at Center of Both Spans 	.67	.48

EXAMPLES:

PROBLEM:

Calculate the maximum allowable load and corresponding deflection of a simply supported B22 beam with a concentrated load at midspan as shown.

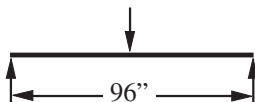

SOLUTION:

From beam load chart for B22 (page 22), maximum allowable load is A and the corresponding deflection is B.
Multiplying by the appropriate factors shown in the chart above.

LOAD = A x load factor = _____
DEFLECTION = B x deflection factor = _____

PROBLEM:

Calculate the maximum allowable load and corresponding deflection of a cantilever B52 beam with a uniformly distributed load.



SOLUTION:

From beam load chart for B52 (page 33), maximum allowable load is A and the corresponding deflection is B.
Multiplying by the appropriate factors shown in chart above.

LOAD = A x load factor = _____
DEFLECTION = B x deflection factor = _____

RIGID STEEL CONDUIT (HEAVY WALL CONDUIT)

Nominal Conduit Size		Outside Diameter		Nominal Inside Diameter		Minimum Weight Per 100 Ft. (30.5m) with Couplings Attached		Weight of Conduit and Conductors Per 100 Ft. (30.5m)*	
In.	mm	In.	mm	In.	mm	Lbs.	kg	Lbs.	kg
3/8"	(10)	0.675	(17.1)	0.493	(12.5)	51.5	(23.4)	65.1	(29.5)
1/2"	(15)	0.840	(21.3)	0.632	(16.0)	79.0	(35.8)	101.1	(45.9)
3/4"	(20)	1.050	(26.7)	0.836	(21.3)	105.0	(47.6)	145.8	(66.1)
1"	(25)	1.315	(33.4)	1.063	(27.0)	153.0	(69.4)	219.3	(99.5)
1 1/4"	(32)	1.660	(42.2)	1.394	(35.4)	201.0	(91.2)	318.3	(144.4)
1 1/2"	(40)	1.900	(48.3)	1.624	(41.3)	249.0	(113.0)	408.8	(185.4)
2"	(50)	2.375	(60.3)	2.083	(52.9)	332.0	(150.6)	593.8	(269.3)
2 1/2"	(65)	2.875	(73.0)	2.489	(63.2)	527.0	(239.1)	901.0	(408.7)
3"	(80)	3.500	(88.9)	3.090	(78.5)	682.6	(309.6)	1259.0	(571.1)
3 1/2"	(90)	4.000	(101.6)	3.570	(90.7)	831.0	(376.9)	1604.0	(727.6)
4"	(100)	4.500	(114.3)	4.050	(102.9)	972.3	(441.0)	1967.0	(892.2)
5"	(125)	5.563	(141.3)	5.073	(128.9)	1313.6	(595.9)	2876.0	(1304.5)
6"	(150)	6.625	(168.3)	6.093	(154.8)	1745.3	(791.7)	4003.0	(1815.7)

Dimensions taken from ANSI C80.1-1977.

*Conduit plus weight of heaviest conductor combination as specified by the National Electrical Code.

INTERMEDIATE METAL CONDUIT (IMC)

Nominal Conduit Size		Outside Diameter		Nominal Inside Diameter		Minimum Weight Per 100 Ft. (30.5m) with Couplings Attached		Weight of Conduit and Conductors Per 100 Ft. (30.5m)*	
In.	mm	In.	mm	In.	mm	Lbs.	kg	Lbs.	kg
1/2"	(15)	0.815	(20.7)	.675	(17.1)	60.0	(27.2)	82.1	(37.2)
3/4"	(20)	1.029	(26.1)	.879	(22.3)	82.0	(37.2)	122.8	(55.7)
1"	(25)	1.290	(32.7)	1.120	(28.4)	116.0	(52.6)	182.3	(82.7)
1 1/4"	(32)	1.638	(41.6)	1.468	(37.3)	150.0	(68.0)	267.3	(121.2)
1 1/2"	(40)	1.883	(47.7)	1.703	(43.3)	182.0	(82.5)	341.8	(155.0)
2"	(50)	2.360	(59.9)	2.170	(55.1)	242.0	(109.7)	503.8	(228.5)
2 1/2"	(65)	2.857	(72.5)	2.597	(66.0)	428.0	(194.1)	775.0	(351.5)
3"	(80)	3.476	(88.3)	3.216	(81.7)	526.0	(238.6)	1069.0	(485.0)
3 1/2"	(90)	3.971	(100.8)	3.711	(94.3)	612.0	(277.6)	1346.0	(610.8)
4"	(100)	4.466	(113.4)	4.206	(106.8)	682.0	(309.4)	1632.0	(740.5)

*Conduit plus weight of heaviest conductor combination as specified by the National Electrical Code.

Rigid and Intermediate Metal Conduit shall be supported at least every 10 feet (3.05 m) and within 3 feet (914 mm) of each outlet box, junction box, cabinet, or fitting, except for straight runs of conduit connected with couplings which may be supported in accordance with NEC Article 345 and 346, provided such supports prevent transmission of stresses to termination where conduit is deflected between supports.

NEC TABLE 346-12

Conduit Size		Maximum Support Span	
In.	mm	Feet	Meters
1/2-3/4	(15-20)	10	(3.05)
1	(25)	12	(3.66)
1 1/4-1 1/2	(32-40)	14	(4.27)
2-2 1/2	(50-65)	16	(4.88)
3-6	(80-150)	20	(6.10)

Reference Data

ELECTRICAL METALLIC TUBING (EMT) — THINWALL CONDUIT

Nominal Conduit Size		Outside Diameter		Inside Diameter		Weight Per 100 Ft. (30.5m)		Weight of Conduit and Conductors Per 100 Ft. (30.5m)*	
In.	mm	In.	mm	In.	mm	Lbs.	kg	Lbs.	kg
3/8"	(10)	0.577	(14.7)	0.493	(12.5)	23.0	(10.4)	36.6	(16.6)
1/2"	(15)	0.706	(17.9)	0.622	(15.8)	28.5	(12.9)	50.6	(23.0)
3/4"	(20)	0.922	(23.4)	0.824	(20.9)	43.5	(19.7)	84.3	(38.2)
1"	(25)	1.163	(29.5)	1.049	(26.6)	64.0	(29.0)	130.3	(59.1)
1 1/4"	(32)	1.510	(38.3)	1.380	(35.1)	95.0	(43.1)	212.3	(96.3)
1 1/2"	(40)	1.740	(44.2)	1.610	(40.9)	110.0	(49.9)	269.8	(122.4)
2"	(50)	2.197	(55.8)	2.067	(52.5)	140.0	(63.5)	401.8	(182.3)
2 1/2"	(65)	2.875	(73.0)	2.731	(69.4)	205.0	(93.0)	579.0	(262.6)
3"	(80)	3.500	(88.9)	3.356	(85.2)	250.0	(113.4)	826.3	(374.8)
3 1/2"	(90)	4.000	(101.6)	3.834	(97.4)	325.0	(147.4)	1098.0	(498.0)
4"	(100)	4.500	(114.3)	4.334	(110.1)	370.0	(167.8)	1364.0	(618.7)

Dimensions taken from ANSI C80.3-1977.

*Conduit plus weight of heaviest conductor combination as specified by the National Electrical Code.

Electrical Metallic tubing shall be supported at least every 10 feet (3.05 m) and within 3 feet (914 mm) of each outlet box, junction box, cabinet or fitting. See NEC Article 348.

RIGID ALUMINUM CONDUIT

Nominal Conduit Size		Outside Diameter		Nominal Inside Diameter		Minimum Weight Per 100 Ft. (30.5m) with Couplings Attached		Weight of Conduit and Conductors Per 100 Ft. (30.5m)*	
In.	mm	In.	mm	In.	mm	Lbs.	kg	Lbs.	kg
1/2"	(15)	0.840	(21.3)	0.632	(16.1)	27.4	(12.4)	49.5	(22.5)
3/4"	(20)	1.050	(26.7)	0.836	(21.2)	36.4	(16.5)	77.2	(35.0)
1"	(25)	1.315	(33.4)	1.063	(27.0)	53.0	(24.0)	119.3	(54.1)
1 1/4"	(32)	1.660	(42.2)	1.394	(35.4)	69.6	(31.6)	186.9	(84.8)
1 1/2"	(40)	1.900	(48.3)	1.624	(41.2)	82.2	(37.3)	242.0	(109.8)
2"	(50)	2.375	(60.3)	2.083	(52.9)	115.7	(52.5)	377.5	(171.2)
2 1/2"	(65)	2.875	(73.0)	2.489	(63.2)	182.5	(82.8)	556.5	(252.4)
3"	(80)	3.500	(88.9)	3.090	(78.5)	238.9	(108.4)	815.2	(369.8)
3 1/2"	(90)	4.000	(101.6)	3.570	(90.7)	287.7	(130.5)	1061.0	(481.3)
4"	(100)	4.500	(114.3)	4.050	(102.9)	340.0	(154.2)	1334.0	(605.1)
5"	(125)	5.563	(141.3)	5.073	(128.9)	465.4	(211.1)	2028.0	(919.9)
6"	(150)	6.625	(168.3)	6.093	(154.8)	612.5	(277.8)	2870.0	(1301.8)

Dimensions taken from ANSI C80.5-1977.

*Conduit plus weight of heaviest conductor combination as specified by the National Electrical Code.

Aluminum Rigid Conduit shall be supported at least every 10 feet (3.05 m) and within 3 feet (914 mm) of each outlet box, junction box, cabinet, or fitting, except for straight runs of conduit connected with couplings which may be supported in accordance with NEC Table 344.30 (B)(2), provided such supports prevent transmission of stresses to termination where conduit is deflected between supports.

NEC TABLE 344.30 (B)(2)

Conduit Size		Maximum Support Span	
In.	mm	Feet	Meters
1/2-3/4	(15-20)	10	(3.05)
1	(25)	12	(3.66)
1 1/4-1 1/2	(32-40)	14	(4.27)
2-2 1/2	(50-65)	16	(4.88)
3-6	(80-150)	20	(6.10)

SCHEDULE 40 PVC PLASTIC PIPE

Nominal Pipe Size		Outside Diameter		Inside Diameter		Weight of Pipe Per 100 Ft. (30.5m)		Weight of Pipe Filled With Water Per 100 Ft. (30.5m)	
In.	mm	In.	mm	In.	mm	Lbs.	kg	Lbs.	kg
1/8"	(3)	.405	(10.3)	.269	(6.8)	4.7	(2.1)	7.2	(3.2)
1/4"	(6)	.540	(13.7)	.364	(9.2)	8.2	(3.7)	12.7	(5.8)
3/8"	(10)	.675	(17.1)	.493	(12.5)	10.9	(4.9)	19.2	(8.7)
1/2"	(15)	.840	(21.3)	.622	(15.8)	16.4	(7.4)	29.6	(13.4)
3/4"	(20)	1.050	(26.7)	.824	(20.9)	21.8	(9.9)	44.9	(20.4)
1"	(25)	1.315	(33.4)	1.049	(26.6)	32.1	(14.6)	69.6	(31.6)
1 1/4"	(32)	1.660	(42.2)	1.380	(35.1)	43.4	(19.7)	108.2	(49.1)
1 1/2"	(40)	1.900	(48.3)	1.610	(40.9)	51.8	(23.5)	140.0	(63.5)
2"	(50)	2.375	(60.3)	2.067	(52.5)	69.5	(31.5)	214.9	(97.5)
2 1/2"	(65)	2.875	(73.0)	2.469	(62.7)	109.6	(49.7)	317.1	(143.8)
3"	(80)	3.500	(88.9)	3.068	(77.9)	143.5	(65.1)	463.9	(210.4)
3 1/2"	(90)	4.000	(101.6)	3.548	(90.1)	175.6	(79.7)	604.1	(274.0)
4"	(100)	4.500	(114.3)	4.026	(102.3)	204.3	(92.7)	756.0	(342.9)
5"	(125)	5.563	(141.3)	5.047	(128.2)	281.7	(127.8)	1148.8	(521.1)
6"	(150)	6.625	(168.3)	6.065	(154.1)	360.9	(163.7)	1613.0	(731.7)
8"	(200)	8.625	(219.1)	7.981	(202.7)	545.3	(247.3)	2713.5	(1230.8)
10"	(250)	10.750	(273.1)	10.020	(254.5)	791.3	(358.9)	4208.9	(1909.1)
12"	(300)	12.750	(323.9)	11.938	(303.2)	1035.2	(469.6)	5886.4	(2670.0)

1 cubic ft. of water weighs 62.41 Lbs.
 1 cubic meter of water weighs 999.972 kg.
 1 gallon (U.S.) weighs 8.335 Lbs.
 1 liter weighs .999 kg.

ALL THREADED ROD (ATR)

Nominal Size (In) and Thread	Root Area		Design Load (SF=5)	
	In. ²	cm ²	Lbs.	kN
1/4-20"	0.027	(0.174)	240	(1.07)
5/16-18"	0.045	(0.290)	400	(1.78)
3/8-16"	0.068	(0.438)	730	(3.24)
1/2-13"	0.126	(0.812)	1350	(6.00)
5/8-11"	0.202	(1.303)	2160	(9.60)
3/4-10"	0.302	(1.948)	3230	(14.37)
7/8-9"	0.419	(2.703)	4480	(19.93)
1-8"	0.551	(3.561)	5900	(26.24)
1 1/8-7"	0.693	(4.471)	7450	(33.14)
1 1/4-7"	0.889	(5.735)	9500	(42.25)
1 1/2-6"	1.293	(8.342)	13800	(61.38)

Dimensions taken from ANSI B1.1-1982 Unified Inch Screw Threads. All threads are UNCR series.

Tabulated loads are based on an allowable tensile stress of 12000 psi (82.7 MPa) reduced by 25% resulting in 9000 psi (62 MPa). From ANSI/MSS SP-58, Table 3.

CLAMP SIZING CHART FOR PVC COATED RIGID CONDUIT AND CLAMPS

Nominal Conduit Size		Conduit Coating			
		.020 (.51mm)		.040 (1.01mm)	
		0	.020 (.51mm)	0	.020 (.51mm)
1/2"	(15)	B2028	B2002	B2002	B2029
3/4"	(20)	B2030	B2030	B2030	B2003
1"	(25)	B2032	B2032	B2032	B2033
1 1/4"	(32)	B2005	B2005	B2005	B2005
1 1/2"	(40)	B2012	B2037	B2037	B2037
2"	(50)	B2013	B2041	B2041	B2041
2 1/2"	(65)	B2014	B2045	B2045	B2045
3"	(80)	B2015	B2050	B2050	B2050
3 1/2"	(90)	B2016	B2054	B2054	B2054
4"	(100)	B2017	B2058	B2058	B2058
5"	(125)	B2019	B2066	B2066	B2066
6"	(150)	B2020	B2115	B2115	B2115

CLAMP SIZING CHART FOR PVC COATED THINWALL (EMT) CONDUIT AND CLAMPS

Nominal Conduit Size		Conduit Coating			
		.020 (.51mm)		.040 (1.01mm)	
		0	.020 (.51mm)	0	.020 (.51mm)
3/8"	(10)	B2026	B2026	B2026	B2007
1/2"	(15)	B2027	B2027	B2027	B2008
3/4"	(20)	B2029	B2029	B2029	B2009
1"	(25)	B2003	B2031	B2031	B2031
1 1/4"	(32)	B2004	B2034	B2034	B2034
1 1/2"	(40)	B2035	B2035	B2035	B2036
2"	(50)	B2039	B2039	B2039	B2013

Reference Data

Reference Data

COPPER TUBING, TYPE L

Nominal Tubing Size		Outside Diameter		Inside Diameter		Weight of Tubing Per 100 Ft. (30.5m)		Weight of Tubing Filled With Water Per 100 Ft. (30.5m)	
In.	mm	In.	mm	In.	mm	Lbs.	kg	Lbs.	kg
1/4"	(6)	.375	(9.5)	.315	(8.0)	12.6	(5.7)	16.0	(7.2)
3/8"	(10)	.500	(12.7)	.430	(10.9)	19.8	(9.0)	26.1	(11.8)
1/2"	(15)	.625	(15.9)	.545	(13.8)	28.5	(12.9)	38.6	(17.5)
5/8"	(17)	.750	(19.1)	.666	(16.9)	36.2	(16.4)	51.3	(23.3)
3/4"	(20)	.875	(22.2)	.785	(19.9)	45.5	(20.6)	66.5	(30.2)
1"	(25)	1.125	(28.6)	1.025	(26.0)	65.5	(29.7)	101.3	(45.9)
1 1/4"	(32)	1.375	(34.9)	1.265	(32.1)	88.4	(40.1)	142.9	(64.8)
1 1/2"	(40)	1.625	(41.3)	1.505	(38.2)	114.0	(51.7)	191.1	(86.7)
2"	(50)	2.125	(54.0)	1.985	(50.4)	175.0	(79.4)	309.1	(140.2)
2 1/2"	(65)	2.625	(66.7)	2.465	(62.6)	248.0	(112.5)	454.8	(206.3)
3"	(80)	3.125	(79.4)	2.945	(74.8)	333.0	(151.0)	628.2	(285.0)
3 1/2"	(90)	3.625	(92.1)	3.425	(87.0)	429.0	(194.6)	828.3	(375.7)
4"	(100)	4.125	(104.8)	3.905	(99.2)	538.0	(244.0)	1057.1	(479.5)
5"	(125)	5.125	(130.2)	4.875	(123.8)	761.0	(345.2)	1570.0	(712.1)
6"	(150)	6.125	(155.6)	5.845	(148.5)	1020.0	(462.7)	2182.9	(990.2)
8"	(200)	8.125	(206.4)	7.725	(196.2)	1930.0	(875.4)	3961.3	(1796.8)
10"	(250)	10.125	(257.2)	9.625	(244.5)	3010.0	(1365.3)	6163.4	(2795.7)
12"	(300)	12.125	(308.0)	11.565	(293.8)	4040.0	(1832.5)	8592.8	(3897.6)

COPPER TUBING, TYPE K

Nominal Tubing Size		Outside Diameter		Inside Diameter		Weight of Tubing Per 100 Ft. (30.5m)		Weight of Tubing Filled With Water Per 100 Ft. (30.5m)	
In.	mm	In.	mm	In.	mm	Lbs.	kg	Lbs.	kg
1/4"	(6)	.375	(9.5)	.305	(7.7)	14.5	(6.6)	17.7	(8.0)
3/8"	(10)	.500	(12.7)	.402	(10.2)	26.9	(12.2)	32.4	(14.7)
1/2"	(15)	.625	(15.9)	.527	(13.4)	34.4	(15.6)	43.9	(19.9)
5/8"	(17)	.750	(19.1)	.652	(16.6)	41.8	(19.0)	56.3	(25.5)
3/4"	(20)	.875	(22.2)	.745	(18.9)	64.1	(29.1)	83.0	(37.6)
1"	(25)	1.125	(28.6)	.995	(25.3)	83.9	(38.1)	117.6	(53.3)
1 1/4"	(32)	1.375	(34.9)	1.245	(31.6)	104.0	(47.2)	156.8	(71.1)
1 1/2"	(40)	1.625	(41.3)	1.481	(37.6)	136.0	(61.7)	210.7	(95.6)
2"	(50)	2.125	(54.0)	1.959	(49.8)	206.0	(93.4)	336.6	(152.7)
2 1/2"	(65)	2.625	(66.7)	2.435	(61.8)	293.0	(132.9)	494.8	(224.5)
3"	(80)	3.125	(79.4)	2.907	(73.8)	400.0	(181.4)	687.7	(311.9)
3 1/2"	(90)	3.625	(92.1)	3.385	(86.0)	512.0	(232.2)	902.0	(409.2)
4"	(100)	4.125	(104.8)	3.857	(98.0)	651.0	(295.3)	1157.4	(525.0)
5"	(125)	5.125	(130.2)	4.805	(122.0)	967.0	(438.6)	1752.9	(795.1)
6"	(150)	6.125	(155.6)	5.741	(145.8)	1390.0	(630.5)	2511.9	(1139.4)
8"	(200)	8.125	(206.4)	7.583	(192.6)	2590.0	(1174.8)	4547.3	(2062.6)
10"	(250)	10.125	(257.2)	9.449	(240.0)	4030.0	(1828.0)	7069.2	(3206.5)
12"	(300)	12.125	(308.0)	11.315	(287.4)	5780.0	(2621.8)	10138.0	(4598.5)

Dimensions taken from ASTM B 88-83.

1 cubic ft. of water weighs 62.41 Lbs.

1 cubic meter of water weighs 999.972 kg.

1 gallon (U.S.) weighs 8.335 Lbs.

1 liter weighs .999 kg.

STANDARD WEIGHT SCHEDULE 40 STEEL PIPE

Nominal Pipe Size		Outside Diameter		Inside Diameter		Nominal Weight Per 100 Ft. (30.5mm) Plain End		Weight of Pipe Filled With Water Per 100 Ft. (30.5mm)	
In.	mm	In.	mm	In.	mm	Lbs.	kg	Lbs.	kg
3/8"	(10)	.675	(17.1)	.493	(12.5)	57.0	(25.9)	65.3	(29.6)
1/2"	(15)	.840	(21.3)	.622	(15.8)	85.0	(38.6)	98.2	(44.5)
3/4"	(20)	1.050	(26.7)	.824	(20.9)	113.0	(51.3)	136.1	(61.7)
1"	(25)	1.315	(33.4)	1.049	(26.6)	168.0	(76.2)	205.5	(93.2)
1 1/4"	(32)	1.660	(42.2)	1.380	(35.1)	227.0	(103.0)	291.8	(132.4)
1 1/2"	(40)	1.900	(48.3)	1.610	(40.9)	272.0	(123.4)	360.2	(163.4)
2"	(50)	2.375	(60.3)	2.067	(52.5)	365.0	(165.6)	510.4	(231.5)
2 1/2"	(65)	2.875	(73.0)	2.469	(62.7)	579.0	(262.6)	786.5	(356.8)
3"	(80)	3.500	(88.9)	3.068	(77.9)	758.0	(343.8)	1078.4	(489.2)
3 1/2"	(90)	4.000	(101.9)	3.548	(90.1)	911.0	(413.2)	1339.5	(607.6)
4"	(100)	4.500	(114.3)	4.026	(102.3)	1079.0	(489.4)	1630.7	(739.7)
5"	(125)	5.563	(141.3)	5.047	(128.2)	1462.0	(663.2)	2329.1	(1056.4)
6"	(150)	6.625	(168.3)	6.065	(154.1)	1897.0	(860.5)	3149.1	(1428.4)
8"	(200)	8.625	(219.1)	7.981	(202.7)	2855.0	(1295.0)	5023.2	(2278.5)
10"	(250)	10.750	(273.1)	10.020	(254.5)	4048.0	(1836.1)	7465.6	(3386.3)
12"	(300)	12.750	(323.9)	12.000	(304.8)	4956.0	(2248.0)	9857.7	(4471.4)
14"	(350)	14.000	(355.6)	13.250	(336.6)	5457.0	(2475.3)	11433.1	(5185.9)
16"	(400)	16.000	(406.4)	15.250	(387.4)	6258.0	(2838.6)	14174.3	(6429.4)
18"	(450)	18.000	(457.2)	17.250	(438.2)	7059.0	(3201.9)	17187.9	(7796.3)
20"	(500)	20.000	(508.0)	19.250	(489.0)	7860.0	(3565.2)	20473.7	(9286.7)
24"	(600)	24.000	(609.6)	23.250	(590.6)	9462.0	(4291.9)	27862.5	(12638.2)

Dimensions taken from ASTM A 53-82.

1 cubic ft. of water weighs 62.41 Lbs.

1 cubic meter of water weighs 999.972 kg.

1 gallon (U.S.) weighs 8.335 Lbs.

1 liter weighs .999 kg.

TRAPEZE HANGERS USING B-LINE STRUT OR ANGLE IRON

Length of Trapeze Bar	NOMINAL PIPE SIZES							
	2 1/2" (65mm) or less	3" (80mm)	3 1/2" (90mm)	4" (100mm)	5" (125mm)	6" (150mm)	8" (200mm)	10" (250mm)
1'-6" (0.46m)	1 1/2" x 1 1/2" x 3/16" B24SH	1 1/2" x 1 1/2" x 3/16" B24SH	1 1/2" x 1 1/2" x 3/16" B24SH	2" x 1 1/2" x 3/16" B22SH	2" x 1 1/2" x 3/16" B22SH	2 1/2" x 1 1/2" x 3/16" B12SH	3" x 2" x 3/16" B11SH	3" x 2" x 1/4" B11SH
2'-0" (0.61m)	1 1/2" x 1 1/2" x 3/16" B24SH	2" x 1 1/2" x 3/16" B22SH	2" x 1 1/2" x 3/16" B22SH	2" x 1 1/2" x 3/16" B22SH	2 1/2" x 1 1/2" x 3/16" B12SH	2 1/2" x 1 1/2" x 3/16" B12SH	3" x 2" x 3/16" B11SH	3" x 2" x 1/4" B11SH
2'-6" (0.76m)	2" x 1 1/2" x 3/16" B22SH	2" x 1 1/2" x 3/16" B22SH	2" x 1 1/2" x 3/16" B22SH	2 1/2" x 1 1/2" x 3/16" B12SH	2 1/2" x 1 1/2" x 3/16" B12SH	3" x 2" x 3/16" B11SH	3" x 2" x 1/4" B11SH	3" x 2" x 1/4" B11SH
3'-0" (0.91m)	2" x 1 1/2" x 3/16" B22SH	2" x 1 1/2" x 3/16" B22SH	2 1/2" x 1 1/2" x 3/16" B12SH	2 1/2" x 1 1/2" x 3/16" B12SH	3" x 2" x 3/16" B11SH	3" x 2" x 3/16" B11SH	3 1/2" x 2 1/2" x 1/4" B12SHA	3 1/2" x 2 1/2" x 5/16" B12SHA
4'-0" (1.22m)	2 1/2" x 1 1/2" x 3/16" B12SH	2 1/2" x 1 1/2" x 3/16" B12SH	2 1/2" x 1 1/2" x 3/16" B12SH	3" x 2" x 3/16" B11SH	3" x 2" x 3/16" B11SH	3" x 2" x 1/4" B11SH	3 1/2" x 2 1/2" x 5/16" B12SHA	4" x 3" x 5/16" B12SHA
5'-0" (1.52m)	2 1/2" x 1 1/2" x 3/16" B12SH	2 1/2" x 1 1/2" x 3/16" B12SH	3" x 2" x 3/16" B11SH	3" x 2" x 3/16" B11SH	3" x 2" x 1/4" B11SH	3 1/2" x 2 1/2" x 5/16" B12SHA	4" x 3" x 5/16" B12SHA	5" x 3 1/2" x 5/16" B11SHA
6'-0" (1.83m)	2 1/2" x 1 1/2" x 3/16" B12SH	3" x 2" x 3/16" B11SH	3" x 2" x 3/16" B11SH	3" x 2" x 1/4" B11SH	3 1/2" x 2 1/2" x 5/16" B12SHA	4" x 3" x 5/16" B12SHA	4" x 3" x 5/16" B12SHA	5" x 3 1/2" x 5/16" B11SHA
7'-0" (2.13m)	3" x 2" x 3/16" B11SH	3" x 2" x 3/16" B11SH	3" x 2" x 1/4" B11SH	3" x 2" x 1/4" B11SH	3 1/2" x 2 1/2" x 5/16" B12SHA	4" x 3" x 5/16" B12SHA	5" x 3 1/2" x 5/16" B11SHA	6" x 4" x 1/4" 2-B12SHA
8'-0" (2.44m)	3" x 2" x 3/16" B11SH	3" x 2" x 1/4" B11SH	3" x 2" x 1/4" B11SH	3 1/2" x 2 1/2" x 5/16" B12SHA	3 1/2" x 2 1/2" x 5/16" B12SHA	4" x 3" x 5/16" B12SHA	5" x 3 1/2" x 5/16" B11SHA	6" x 4" x 1/4" 2-B12SHA
9'-0" (2.74m)	3" x 2" x 3/16" B11SH	3" x 2" x 1/4" B11SH	3 1/2" x 2 1/2" x 5/16" B12SHA	3 1/2" x 2 1/2" x 5/16" B12SHA	3 1/2" x 2 1/2" x 5/16" B12SHA	4" x 3" x 5/16" B12SHA	5" x 3 1/2" x 5/16" B11SHA	6" x 4" x 3/8" 2-B11SHA
10'-0" (3.05m)	3" x 2" x 1/4" B11SH	3" x 2" x 1/4" B11SH	3 1/2" x 2 1/2" x 5/16" B12SHA	3 1/2" x 2 1/2" x 5/16" B12SHA	4" x 3" x 5/16" B12SHA	5" x 3 1/2" x 5/16" B11SHA	6" x 4" x 1/4" 2-B12SHA	6" x 4" x 3/8" 2-B11SHA

REFERENCE: Table 3-14.1.6 standard for the installation of Sprinkler Systems, NFPA No. 13-1985, published by National Fire Protection Association.

Reference Data

ADI Series	209	B22H25	43	B26H25	43	B52S	40
AHHK- ¹ / ₄	215	B22-I Series	204	B26KO6	41	B52S58	42
AHHK- ³ / ₈	215	B22-IFS	208	B26S	40	B52SH	40
APS Series	209	B22KO6	41	B26S58	42	B54	34,35
ARC Series	209	B22KO6AL	166	B26SH	40	B54A	34,35
ATR	56	B22LPL	21	B32	28,29	B54AAL	165
AWA Series	209	B22M	42	B32A	28,29	B54AL	165
B11	16,17	B22PL	21	B32B	28	B54B3	34
B11A	16,17	B22S	40	B32C	28	B54B4	34
B11B	17	B22S58	42	B32H ¹ / ₈	40	B54H ¹ / ₈	40
B11H ¹ / ₈	40	B22SH	40	B32H ¹ / ₈ SS4	168	B54H ¹ / ₈ AL	166
B11KO6	41	B22SHA	41	B32H25	43	B54H ¹ / ₈ SS4	168
B11S	40	B22SHAL	166	B32-I Series	205	B54H ¹ / ₈ SS6	168
B11S58	42	B22SHSS4	168	B32-IFS	208	B54H25	43
B11SH	40	B22SHSS6	168	B32KO6	41	B54KO6	41
B12	18,19	B22SS4	168	B32M	42	B54KO6AL	166
B12A	18,19	B22SS6	168	B32S	40	B54M	42
B12AL	165	B22TH	38,39,41	B32S58	42	B54S	40
B12B	18	B22X	20-23	B32SH	40	B54S58	42
B12H ¹ / ₈	40	B24	24,25	B32SHSS4	168	B54SH	40
B12H ¹ / ₈ AL	166	B24A	24,25	B32SS4	168	B54SHAL	166
B12KO6	41	B24AL	165	B42	30,31	B54SHSS4	168
B12KO6AL	166	B24B	24	B42A	30,31	B54SHSS6	168
B12S	40	B24C	24	B42B	30	B54SS4	168
B12S58	42	B24H ¹ / ₈	40	B42H ¹ / ₈	40	B54SS6	168
B12SH	40	B24H ¹ / ₈ AL	166	B42H ¹ / ₈ SS4	168	B56	36,37
B12SHAL	166	B24H ¹ / ₈ SS4	168	B42H25	43	B56A	36,37
B22	20-23	B24H ¹ / ₈ SS6	168	B42KO6	41	B56B3	36
B22A	20,22,23	B24H25	43	B42M	42	B56B4	36
B22A3	21	B24KO6	41	B42S	40	B56H ¹ / ₈	40
B22A4	21	B24KO6AL	166	B42S58	42	B56H25	43
B22AAL	165	B24M	42	B42SH	40	B56KO6	41
B22AD3	21	B24S	40	B42SHSS4	168	B56S	40
B22AL	165	B24S58	42	B42SS4	168	B56S58	42
B22B	21	B24SH	40	B44M	42	B56SH	40
B22B3	21	B24SHAL	166	B52	32,33	B62	189
B22C	21	B24SHSS4	168	B52A	32,33	B62A	189
B22C3	21	B24SHSS6	168	B52B3	32	B72	190
B22D	21	B24SS4	168	B52B4	32	B72A	190
B22D3	21	B24SS6	168	B52H ¹ / ₈	40	B96HP Series	43
B22E	21	B26	26,27	B52H25	43	B101	62
B22E3	21	B26A	26,27	B52-I Series	206	B102	63
B22H ¹ / ₈	40	B26B	26	B52-IFS	208	B103	63
B22H ¹ / ₈ AL	166	B26C	26	B52KO6	41	B104	63
B22H ¹ / ₈ SS4	168	B26H ¹ / ₈	40	B52M	42	B104SH	67

B105	77	B148	68	B182SHL	87	B214L	92
B106-12	77	B149	68	B182SHR	87	B214R	92
B106-32	77	B150	68	B183SHL	87	B215S	153
B106-42	77	B151	68	B183SHR	87	B216S	153
B106-52	77	B152	68	B184SHL	87	B217-20	155
B107	73	B154	68	B184SHR	87	B217-24	155
B107-22A	73	B155	69	B185SHL	87	B217AL	165
B107S	74,109	B156	69	B185SHR	87	B217FFAL	165
B108	77	B157	69	B186SHL	87	B217P	155,165,187
B109S	67	B158	69	B186SHR	87	B218	131
B110	77	B159	69	B187	85	B219 Series	132,133
B111	78	B160	69	B188	85	B220	96,155,208
B112	67	B161	69	B189	85	B221	96,155
B113	67	B162	68	B190	85	B222	96,155
B115	63	B163	68	B191-18	85	B223	96,155
B116-12	73	B164	68	B191-24	86	B230	62
B116-32	73	B165	68	B192	86	B231	62
B116-32A	73	B166 Series	159	B194	88	B232	63
B116-42	73	B166-46 Series	159	B195	89	B234L	65
B116-52	73	B166CL	159	B196-18	88	B234R	65
B118	65	B167	72	B196-24	88	B235L	64
B119	80	B168	72	B198-6	88	B235R	64
B120	81	B169	72	B198-12	88	B236L	64
B121	81	B170	72	B198A-6	88	B236R	64
B122	81	B171	72	B198A-12	88	B237	64
B123	81	B172	72	B200	59	B238L	64
B124	81	B172-12	72	B200D	59	B238R	64
B125	65	B172-22A	72	B201	59	B239	64
B126	66	B173	75	B201D	59	B241S	153
B127	66	B174SHL	87	B202	59	B243	68
B129	59	B174SHR	87	B202-1	59	B244	68
B132	60	B175SHL	87	B202-1D	59	B245	68
B133	60	B175SHR	87	B202-2	59	B246	68
B134L	65	B176SHL	87	B202-2D	59	B247	68
B134R	65	B176SHR	87	B202D	59	B248	68
B135	60	B177SHL	87	B203	96,155	B249	68
B136	61	B177SHR	87	B204	96,155	B250	68
B137	61	B178SHL	87	B205	96,155,208	B251	68
B138	60	B178SHR	87	B206	96,155,208	B252	68
B139	60	B179SHL	87	B210	101	B253	68
B140	60	B179SHR	87	B210A	101	B261 Series	71
B141	59	B180SHL	87	B211	106	B266	74
B142	60	B180SHR	87	B212- ¹ / ₄	106	B267L	80
B143	60	B181SHL	87	B212- ³ / ₈	106	B267R	80
B147	68	B181SHR	87	B213	106	B268L	80

B268R	80	B305	101	B361	63	B410-12	79
B269L	80	B306	101	B362	82	B410-22	79
B269R	80	B307	101	B363	69	B410-32	79
B270L	80	B308	101	B364	69	B410-52	79
B270R	80	B309	101	B365	69	B411 Series	93
B271	81	B312 Series	101	B366	69	B412	74
B272	81	B314	105	B367	69	B415	76
B273	81	B318	107	B368	69	B420-378	62
B274L	82	B319	107	B369	69	B420-578	62
B274R	82	B320	107	B370	89	B420-778	62
B276	81	B321 Series	101	B371	66	B420-978	62
B277	82	B322	68	B371-2	67	B422 Series	109,124
B278	84	B323	68	B372	66	B425	74
B279	83	B324	68	B374	63	B427	107
B279FL	83	B325	68	B376	95	B428	79
B279SQ	83	B326	68	B377	95	B432	61
B280	83	B327	68	B379	134	B435	106
B280FL	83	B328	68	B380 Series	208	B436	154
B280SQ	83	B329	68	B381	93	B436S	154
B281	84	B330	68	B382	93	B437 Series	123
B281A	83	B331	68	B383	93	B438	93
B281AFL	83	B332	68	B384	93	B439	93
B281ASQ	83	B333-1	75	B385	93	B440	89
B281FL	84	B333-2	75	B386 Series	128	B441-22 Series	105
B281M	84	B333-3	75	B387 Series	78	B441-22A Series	105
B281MSQ	84	B334	61	B390BX	154	B441Z-22	105
B281SQ	84	B335	69	B390S	154	B441Z-22A	105
B283	96,155	B335-1	69	B392-11 Series	156	B444 Series	100
B284	96,155	B335-2 Series	69	B392-12 Series	156	B446 Series	54,160
B285	96,155	B337	61	B392-22 Series	156	B446A Series	54,160
B286	96,155	B339	61	B392-32 Series	156	B446B Series	54,160
B287	96	B340	59	B393-1	159	B446C Series	54,160
B288	96	B341	59	B394 Series	128	B447	156
B289-12	86	B342	59	B398-1	76	B447A	156
B289-14	86	B346L	82	B400	76	B449-4	89
B290	86	B346R	82	B400-1	76	B449-8	89
B291	86	B349	94	B400-2	76	B449-12	89
B292	87	B350	94	B400-3	76	B449-18	89
B293 Series	88	B351L Series	99	B400-4	76	B450 Series	72
B293A Series	88	B355	106	B405	75,107	B451-1	75
B293PL	89	B356	130	B405A	107	B451-2	75
B297 Series	87	B357	64	B407 Series	78	B451-3	75
B300	84	B358 Series	75	B408 Series	75	B460 Series	154
B303	101	B359	62	B409 Series	87	B461	67
B304	101	B360	62	B410-11	79	B464 Series	154

B465	154	B538	78	B633 Series	70	B825-52	97
B466S	159	B539	78	B634	70	B844	65
B466W	159	B541	85	B635	70	B844W	65
B472	92	B556	61	B650 Series	70	B852	96
B473	92	B557	59	B655 Series	56	B852S Series	90
B474	92	B558	63	B656 Series	56	B888W	65
B475	92	B560	94	B663	66	B1508	116
B477	95	B562	94	B664	93	B1508S	116
B477H	95	B568	61	B670 Series	124	B1512	116
B477HP	95	B570	84	B671 Series	124	B1512S	116
B477P	95	B570A	84	B700 Series	104	B1516	116
B478	95	B571	82	B701 Series	102	B1516S	116
B478H	95	B578	74	B702	103	B1520	116
B478HP	95	B580	79	B705 Series	103	B1520S	116
B478P	95	B581	74	B718 Series	157	B1524S	116
B479	135	B585	84	B719AL	157	B1532S	116
B485	66	B586	77	B750 Series	104	B1534S	116
B488	68	B587 Series	93	B751	102	B1540S	116
B494 Series	87	B588	73	B751-J Series	102	B1548S	116
B495	82	B589	159	B752	102	B1556S	116
B496	67	B589-62	195	B753 Series	102	B1564S	116
B496-1	67	B590	160	B755	103	B1999	121
B500 Series	52,104	B591 Series	129	B755- ³ / ₈ -J Series	103	B2000	112
B501 Series	52	B593	109	B756- ³ / ₈	103	B2001	112
B503L	66	B594	74	B760-22 Series	108	B2002	112
B503R	66	B595	75	B760-22A Series	108	B2003	112
B504	60	B596	74	B761-22 Series	108	B2004	112,114
B514L	92	B598-62	198	B761-22A Series	108	B2005	112,114
B514R	92	B600-62	192	B766 Series	158	B2006	112
B515	79	B601-62	196	B767 Series	158	B2007AL	166
B516	155	B602-A	107	B768 Series	158	B2007SS4	169
B516S	155	B602-B	107	B769 Series	158	B2008	112
B518 Series	157	B602-C	107	B802D Series	90	B2008AL	166
B519	74	B613	94,109	B809B Series	91	B2008DCU	113
B521	67	B613A	94,109	B810 Series	90	B2008SS4	169
B522	68	B614	94,109	B811 Series	91	B2009	112
B526	77	B616 Series	152	B812 Series	91	B2009AL	166
B527	73	B616-22A Series	152	B816	90	B2009SS4	169
B528	59	B616S Series	152	B822	96	B2010	112
B529	63	B616S-22A Series	153	B822A	96	B2010AL	166
B532	61	B616TG- ⁹ / ₁₆	153	B823-22	97	B2010SS4	169
B533	66	B617	54,160	B823-22A	97	B2011	112,114
B534	78	B619	159	B823-42	97	B2011AL	166
B535	78	B631 Series	71	B823-52	97	B2011DCU	113
B536	76	B632 Series	71	B825-22	97	B2011SS4	169

B2012	112	B2036	114	B2085	125	B2315	169
B2012AL	166	B2037	114	B2086	125	B2350	169
B2012SS4	169	B2038	114	B2087	125	B2351	169
B2013	112,114	B2038DCU	113	B2088	125	B2352	169
B2013AL	166	B2039	114	B2089	125	B2353	169
B2013SS4	169	B2041	114	B2090	125	B2354	169
B2014	112,114	B2042	114	B2091	125	B2355	169
B2014AL	166	B2042DCU	113	B2110	115	B2400 Series	122
B2014SS4	169	B2043	114	B2110DCU	113	B2417 Series	123
B2015	112,114	B2045	114	B2111	115	B2500	207
B2015AL	166	B2046	114	B2112	115	B2501 Series	207
B2015SS4	169	B2046DCU	113	B2113	115	B2503	207
B2016	112,114	B2047	114	B2115	115	B2505	207
B2016AL	166	B2048	114	B2116	115	B2506	207
B2016SS4	169	B2050	114	B2117	115	B2507	207
B2017	112,114	B2050DCU	113	B2118	115	B2508	207
B2017AL	166	B2051	114	B2119	115	B2601	117
B2017SS4	169	B2052	114	B2120	115	B2602	117
B2018	112,115	B2054	114	B2121	115	B2603	117
B2018AL	166	B2054DCU	113	B2123	115	B2608	117
B2018SS4	169	B2055	114	B2124	115	B2609	117
B2019	112,115	B2056	114	B2125	115	B2610	117
B2019AL	166	B2058	114	B2126	115	B3033 Series	100
B2019SS4	169	B2059	115	B2126DCU	113	B3034 Series	100
B2020	112,115	B2060	115	B2127	115	B3036L Series	99
B2020AL	166	B2062	115	B2128	115	B3037	99
B2020SS4	169	B2062DCU	113	B2129	115	B3322	96,208
B2021	112,115	B2063	115	B2130	112,115	B3332	96,208
B2022	112,115	B2064	115	B2132	112,115	B3342	96,208
B2023	114	B2066	115	B2207	111	B3352	96,208
B2024	114	B2067	115	B2208	111	B3362 Series	99
B2024DCU	113	B2068	115	B2209	111	B3363 Series	99
B2025	114	B2069	115	B2210	111	B3364 Series	99
B2025DCU	113	B2070	123	B2211	111	B3365 Series	99
B2026	114	B2071	123	B2212	111	B3367 Series	100
B2026DCU	113	B2072	123	B2213	111	B3367S-1 Series	124
B2027	114	B2073	123	B2301 Series	125	B3367S-2 Series	124
B2027DCU	113	B2074	123	B2302 Series	125	B3373 Series	126
B2028	114	B2075	123	B2308	199	B3690 Series	127
B2029	114	B2076	123	B2309	199	B3690F Series	127
B2030	114	B2077	123	B2310	199	B4000	163
B2030DCU	113	B2078	123	B2311	199	B4001	163
B2031	114	B2079	123	B2312	199	B4002	163
B2032	114	B2080	123	B2313	169	B4003	163
B2032DCU	113	B2084	125	B2314	169	B4004	163

B4005 163	B4074 161	B6141 192	B6526 198
B4006 163	B4075 161	B6142 193	B6532 193
B4007 163	B4076 161	B6143 192	B6533 195
B4008 163	B4077 161	B6144L 194	B6557 192
B4009 163	B4078 161	B6144R 194	B6558 194
B4010 163	B4079 161	B6147 196	B6571 198
B4011 163	B4080 161	B6148 196	B6594 197
B4012 163	B4081 161	B6149 196	B7105 198
B4013 163	B4082 161	B6150 196	B7116 197
B4014 163	B4083 161	B6151 196	B7205 199
B4015 163	B4084 161	B6152 196	BC442 100
B4016 163	B4085 161	B6154 196	BD40 208
B4017 163	B4086 161	B6155 196	BE-5-8 208
B4033A 163	B4087 161	B6156 196	BE-9-12 208
B4033B 163	B4088 161	B6157 196	BFP22 172,173
B4033C 163	B4089 161	B6158 196	BFP22A 172,173
B4033D 163	B4090 161	B6159 196	BFP22H1 ^{7/8} 172
B4033E 163	B4091 161	B6160 196	BFP22I 176
B4033F 163	B4092 161	B6161 196	BFP22SH 172
B4033G 163	B4093 161	B6162 196	BFP42 174,175
B4033H 163	B4094 162	B6163 196	BFP42A 174,175
B4033I 163	B4095 162	B6164 196	BFP42H1 ^{7/8} 174
B4035A 162	B6101 193	B6165 196	BFP42SH 174
B4035B 162	B6102 194	B6167 197	BFP409 Series 182
B4035C 162	B6103 194	B6168 197	BFP494 Series 182
B4035D 162	B6104 194	B6169 196	BFP2400-2 180
B4035E 162	B6105 198	B6170 197	BFP2400-3 180
B4035F 162	B6107 197	B6171 197	BFP2400-4 180
B4037B 162	B6107-62A 197	B6172 197	BFP2400-6 180
B4050 162	B6108 198	B6173 198	BFP3104-8 181
B4051 162	B6110 198	B6202 191	BFP3104-10 181
B4060 161	B6112 195	B6205 199	BFP3104-12 181
B4061 161	B6118 195	B6211 199	BFV22 172,173
B4062 161	B6126 195	B6230 193	BFV22A 172,173
B4063 161	B6127 195	B6232 194	BFV22H1 ^{7/8} 172
B4064 161	B6129 191	B6234L 195	BFV22I 176
B4065 161	B6132 193	B6234R 195	BFV22SH 172
B4066 161	B6133 193	B6239 194	BFV42 174,175
B4067 161	B6134L 195	B6337 193	BFV42A 174,175
B4068 161	B6134R 195	B6340 191	BFV42H1 ^{7/8} 174
B4069 161	B6135 193	B6341 192	BFV42SH 174
B4070 161	B6136 193	B6357 194	BFV100 179
B4071 161	B6138 192	B6374 194	BFV101 186
B4072 161	B6139 192	B6409 Series 199	BFV103 186
B4073 161	B6140 192	B6504 192	BFV104 186

BFV118	186	BFV755- ³ / ₈	181	BMM-3L	191	BPC Series	111
BFV129	183	BFV2008	179	BMM-3S	191	BTS22TH	38,39
BFV132	184	BFV2009	179	BMM-4	191	BVP Series	119
BFV133	184	BFV2010	179	BMM-4L	191	BVS-12	121
BFV135	185	BFV2011	179	BMM-4S	191	BVS-120	121
BFV136	185	BFV2012	179	BMM-5	191	BVT Series	118
BFV140	184	BFV2013	179	BMM-5L	191	CLDP10	139
BFV141	183	BFV2014	179	BMM-5S	191	CNPSS Series	53
BFV142	185	BFV2015	179	BMM-6	191	DB_DS Series	140-141
BFV143	184	BFV2016	179	BMM-6L	191	DB5	137
BFV200	179	BFV2017	179	BMM-6S	191	DB10	137
BFV201	183	BFV3104 -1 thru 6 ..	181	BMS-6	46	DB10-28	138
BFV202	183	BFV3104-8	181	BMS-6L	47	DB10-36	138
BFV-223	177	BFV3104-10	181	BMS-6M	47	DB10-42	138
BFV-223WO	177	BFV3104-12	181	BMS-6S	47	DB10-50	138
BFV-224	177	BFVATR Series	178	BMS-8	46	DB10-60	138
BFV-224WO	177	BFVATRHN Series ..	178	BMS-8L	47	DB20	137
BFV-225	177	BFVFW Series	178	BMS-8M	47	DB30	137
BFV-225WO	177	BFVHHCS Series	177	BMS-8S	47	DB40	137
BFV-228	177	BFVHN Series	177	BMS-10	46	DB48	137
BFV-228WO	177	BHR1225ZN	56	BMS-10L	47	DB610	137
BFV280SQ	187	BHR1238ZN	56	BMS-10M	47	DB620	137
BFV281SQ	187	BHR1250ZN	56	BMS-10S	47	DB630	137
BFV300	179	BHR1262ZN	56	BMS-12	46	DB640	137
BFV334	185	BK22H112	42	BMS-12M	47	DB648	137
BFV337	185	BK24H112	42	BMS-12S	47	DBE10-8	139
BFV340	183	BK52H112	42	BMS-D-12	46	DBE10-12	139
BFV341	184	BK54H112	42	BMS-D-12L	47	DBE10-16	139
BFV342	184	BKC100	57	BMS-D-12M	47	DBM	137
BFV371-2G	186	BKC150	57	BMT-6	48	DBM-__ Series	138
BFV409 Series	182	BKC200	57	BMT-8	48	DBM-__CT Series ..	138
BFV494 Series	182	BKCC	57	BMT-10	48	DBP	137
BFV501 Series	176	BKCP	57	BMT-12	48	DBR10-12	139
BFV532	185	BKP10063	57	BMT-D-12	48	DBR2-31/2	142
BFV557	183	BKP10094	57	BP081SS	117	DBR4-6	142
BFV558	186	BKP15094	57	BP110SS	117	DBR8-10	142
BFV650	187	BKP15125	57	BP135SS	117	DBR12-14	142
BFV655 Series	178	BKP20125	57	BP175SS	117	DBR16-20	142
BFV751- ¹ / ₂	180	BKP20188	57	BP205SS	117	DC-1	147
BFV751- ³ / ₈	180	BKW063	57	BP250SS	117	DC-2	147
BFV751- ⁵ / ₈	180	BKW094	57	BP300SS	117	DC-3	147
BFV751J- ¹ / ₂	180	BKW125	57	BP325SS	117	DC-4	147
BFV751J- ³ / ₈	180	BKW188	57	BP375SS	117	DC-5	147
BFV751J- ⁵ / ₈	180	BL1400 Series	126	BP425SS	117	DC-6	147
BFV755- ¹ / ₂	181	BMM-3	191	BP475SS	117	DC-7	147

DC-8	147	N226	47	N725SS6	167	SRHMS Series	53
DC-9	147	N226WO	46	N726	47	STN224 Series	48
DC-10	147	N227	47	N727	47	STN225 Series	48
DC-11	147	N227WO	46	N728	47	STN228 Series	48
DC-12	147	N228	47	N728SS6	167	STN525 Series	48
DC22S-12	145	N228SS6	167,169	N755	47	TN221	48
DC22S-24	145	N228WO	46	N775	47	TN222	48
DC22S-48	145	N228WOSS6	167,169	N778	47	TN223	48
DC22S-120	145	N255	47	N2500 Series	207	TN224	48
DCN ³ / ₈	52	N255WO	46	N7221	191	TN225	48
DCR38-36	148	N275	47	N7222	191	TN226	48
DCR38-72	148	N275WO	46	N7224	191	TN227	48
DCSPSS4	148	N278	47	N7227	191	TN228	48
DCWM-12	146	N278WO	46	NW524	49	TN255	48
DCWM-24	146	N521	47	NW525	49	TN525	48
DCWM-48	146	N522	47	NW528	49		
DCWM-120	146	N523	47	SA101	215		
E7016	200	N524	47	SA102	215		
E7016H3/4	200	N524SS6	167,169	SA110	215		
E7166	200	N525	47	SA131	215		
E7212	200	N525SS6	167,169	SA154	215		
E7355	200	N525WO	46	SA155	215		
FFW Series	55	N525WOSS6	167	SA158	211-214		
FW Series	55, 147	N526	47	SA276	211-214		
HHCS Series	53	N527	47	SA318	211-214		
HN Series	54	N528	47	SC228	55		
IPH Series	120	N528SS6	167,169	SC-UB	55		
IPH18230	120	N555	47	SFHMS Series	53		
ISO	121	N555WO	46	SFN38SS6	147		
LW Series	55	N575	47	SHHMS Series	53		
MSQN Series	54	N575WO	46	SLN Series	55		
N221	47	N621	191	SN224 Series	49		
N221WO	46	N621WO	191	SN224WO Series	49		
N222	47	N622	191	SN225 Series	49		
N222WO	46	N622WO	191	SN225WO Series	49		
N223	47	N624	191	SN228 Series	49		
N223WO	46	N624WO	191	SN228WO Series	49		
N224	47	N627	191	SN524 Series	49		
N224SS6	167,169	N627WO	191	SN525 Series	49		
N224WO	46	N721	47	SN525WO Series	49		
N224WOSS6	167,169	N722	47	SN528 Series	49		
N225	47	N723	47	SN724 Series	49		
N225SS6	167,169	N724	47	SN725 Series	49		
N225WO	46	N724SS6	167	SN728 Series	49		
N225WOSS6	167,169	N725	47	SQN Series	54		



Other Cooper B-Line Product Lines

Cable Tray Systems
Electrical Enclosures
Electronic Enclosures
Pipe Hanger & Support Systems
Spring Steel Fasteners
Cable Runway & Relay Racks (CommData)
Meter Mounting & Distribution Equipment
Anchors

Cooper B-Line

509 West Monroe Street
Highland, IL 62249
Phone: 800-851-7415
Fax: 618-654-1917

www.cooperbline.com



SYSTEMS THAT MAKE SENSE

Cooper Industries, Ltd.
600 Travis, Ste. 5800
Houston, TX 77002-1001
Phone: 713-209-8400
www.cooperindustries.com