



Warm Tiles[®]

Electric Floor Warming Guidelines



Choosing the Right System

EASYHEAT[®]
Warming Your World

We Guide You

Discover a better way to plan.



By requesting this Warm Tiles® Professional Room Planner, you have taken the first step in establishing yourself as the leader in your industry. Warm Tiles Electric Floor Warming Systems are a natural add-on sale for tile, stone and engineered wood installations.

Floor Warming will boost your customer satisfaction level while increasing your overall profits. Warm Tiles is a seamless, invisible comfort system that is not seen, heard, smelled or worried about once it is installed. It just makes you feel warm and comfortable.

Our warmth really does make the difference.

Through the Process



Now you can...

begin the real planning. We'll guide you through each phase of the floor warming selection process, helping you make the informed decisions that can save you or your customer time, worry and money.

STEP ONE:

What is electric floor warming? Get the scoop on the fastest growing segment in the floor covering industry. Learn about the two different installation options – cable and mat – and determine which is best for your room application.

STEP TWO:

Determine what floor finish is approved for use, investigate the acceptable substrates for your electric floor warming system to ensure a professional installation.

STEP THREE:

Use the Warm Tiles® Room Layout Paper to complete a preliminary design for your floor warming system. Follow the instructional diagrams providing for measuring and layout of cable and mat installations to save time during the installation phase.

STEP FOUR:

Choose the correct cable or mat kit from the product selection charts for each system. When using a cable kit, we have also provided a Special Cable Coverage Chart. This chart will help determine the exact coverage your kit will cover when the nearest kit square footage size is either too large or too small. You can then preplan your adjustments to the heated coverage areas on your Warm Tiles Room Layout Planner.

STEP FIVE:

We've provided installation cutaways to help you visualize the installation process of both cable and mat systems over varying substrates. Architectural specifications are also included for cracked surfaces and wet applications.

STEP SIX:

Everything you ever needed to know about our Warm Tiles Thermostats, including the "NEW" Relay Kit for two or more kit installations from 16 – 24 Amps in one application.

TABLE OF CONTENTS

Index

Page

How to use this Room Planner	1
What is Electric Floor Warming?	2
Floor Warming Terminology Guide	3
Choosing and Measuring Your Room System	4
Room Layout Diagrams for Cable and Mat	5
Choosing the Right Cable Kit	6
Cable System Product Selection Guide	7
Cable System Specifications	8
Cable System Installation Cutaways	9
Choosing the Right Mat Kit	10
Mat System Product Selection Guide	11
Mat System Specifications	12
Mat System Installation Cutaways	13
Choosing the Right Thermostat	14
Thermostat Specifications	15
Warranty Details	16
Warm Tiles Room Layout Paper	Inside Back Cover

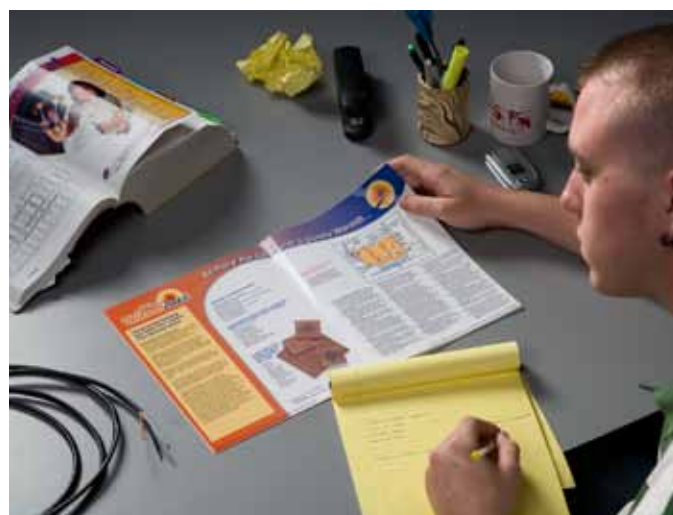



Under 2 Hours

Choosing And Installing Your Warm Tiles® Electric Floor Warming System

Why not enjoy the feel of your floor!

Did you ever notice that if you're feet feel warm, the rest of your body is comfortable? Warm Tiles creates a floor that is comforting, providing an even temperature while hidden under your floor finish.

Warm Tiles comfort costs less than a penny per square foot per day and can operate on ordinary electric current. Warm Tiles radiates this warmth through a network of low profile warming cables, hardware and electrical controls for an economical and long lasting floor warming system.

The system may be installed directly on plywood, concrete or cement backerboard substrates by simply placing the system in the mortar just below the floor finish.

UL Listed and CSA Certified, Warm Tiles provides a clean, energy efficient floor warming system that only draws as much energy as is needed to maintain your predetermined temperature on the floor surface.

The Warm Tiles Systems can be installed by professional electricians, tile installers, general building contractors or skilled Do-it-Yourselfers who have adequate knowledge of flooring and electrical wiring. All installations must be in accordance with all applicable national (CEC and NEC) and local electrical and building codes, regulations and inspection procedures. Electrical inspection may be required during and/or after system installation. Check with your local electrical inspection department before beginning installation. When installing your tile or stone, follow standard tiling procedures of the Tile Council of America for the United States or by the Terrazzo, Tile and Marble Association of Canada.

Advantages of the Warm Tiles System

- Industry Leader for over 40 years
- Providing warmth under tile, stone, laminates and engineered wood* floors
- Easy and quick to install
- Under 2 hours to install an average floor warming system
- Energy and cost efficient
- Only 1¢ per heated square foot per day
- UL and CSA approved
- 15 year Limited Warranty

Recommended for interior use only, the Warm Tiles System can be used over a variety of substrates.

- Exterior Grade Plywood**
- Concrete/masonry
- Cement Mortar Beds
- Existing Ceramic Tile
- Cement Backer Boards†
- Cement Terrazzo
- Properly prepared Vinyl
- Non-soluble cut-back adhesive

A wide variety of final finishes are ideal for use with the Warm Tiles System.

- Ceramic
- Porcelain
- Terrazzo
- Glass mosaics
- Natural Stone
- Agglomerates
- Engineered wood* and laminates



* For use under engineered, floating wood floors only. Not approved for nail down installations.

** Interior use only.

† Consult cement backerboard manufacturer for specific installation recommendations.

to Install an Average System



Warm Tiles Floor Warming Terminology Guide

The following terms may appear frequently throughout your installation. Each is graphically illustrated in this key illustration.

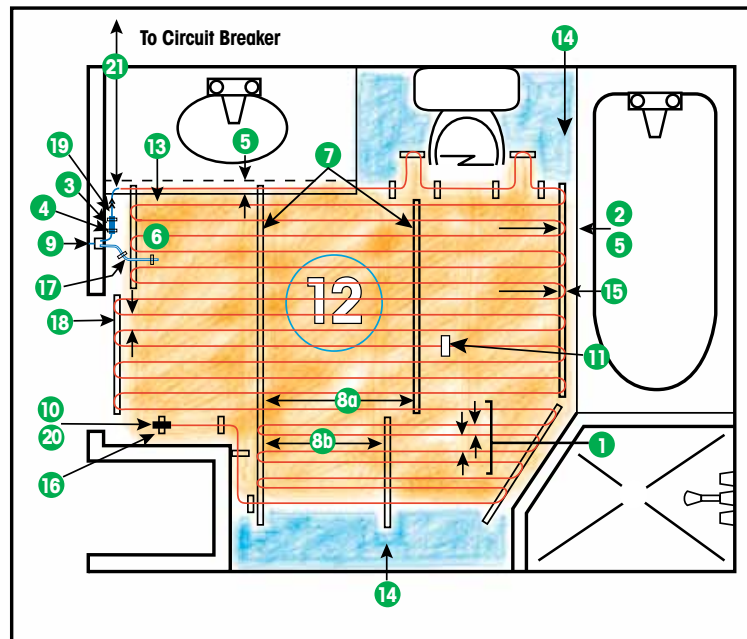

1. **Alternating Heating Cable Spacing** The Heating Cable configuration used for floors above unheated areas and concrete slabs. Cable is laced through the strapping at repeating spacing intervals of 1.5" – 3" – 1.5" – 3" (3.80 cm – 7.6 cm – 3.80 cm – 7.6 cm), etc. using the pre-dimensioned holes of the EasyLock Cable Strapping (see also Standard Heating Cable Spacing).
2. **Border Dimension** Space between the outside perimeter of the Heating Cable and the surrounding room walls; may be set to 1.5" – 6" (3.80 cm – 15.24 cm) as required, to slightly alter the Heated Area and enable a proper fit with the selected DFT Cable.
3. **Cold Lead Splice** Factory connection between the Cold Lead and Heating Cable; can be recessed .25" (25 mm) into the sub-floor, due to its slightly larger diameter.
4. **Cold Lead** Non-heated section of cable that transports current to the Heating Cable section; has a black outer jacket, covering a copper braid and two inner color-coded conductors (black/white for 120V cables or red/black for 240V cables), and is slightly larger in diameter than the Heating Cable section.
5. **Dimension 1.5" (3.80 mm)** Minimum distance permitted between sections of Heating Cable or between Heating Cable and walls, vanity kick plates and fixtures.
6. **Dimension 6" (15.24 mm)** Minimum distance the sensor wire should extend between two adjacent runs of heating cable, measured from the arc of the Return Loop.
7. **"EasyLock" Cable Strapping** Coiled strapping used to harness the Heating Cable to the floor; may be cut to length as needed.
8. **"EasyLock" Cable Strapping Spacing** Distance between parallel rows of the EasyLock Cable Strapping. To prevent contact between adjacent runs of Heating Cable, a minimum separation must be maintained. For Standard Heating Cable Spacing (see 8a in the key) the maximum separation is 36" (91.44 cm). For Alternating Heating Cable Spacing (see 8b in the Key) the maximum separation is 24" (60.96 cm).
9. **Electrical Connection Box (ECB)** Customer-supplied electrical enclosure that houses the heating controller for the heating cable system . Cold Lead is pulled through the wall cavity and into the ECB using the fish cords.
10. **End-of-Run** Location where the Tail Splice is secured to the sub-floor (Step 8). With Warm Tiles DFT Cable there is no need to route the End-of-Run back to the Electrical Connection Box.
11. **"Half of Cable" Marker** Label attached to the Heating Cable at its mid-point, which should appear during installation at the 'Half of Heated Area line drawn on the floor (Step 3). Serves as a useful mid-installation check as to whether or not there will be a cable surplus or shortage at the End-of-Run for cables over 27 ft² (8.23 m) a one quarter and three quarter marker are also used.
12. **Heated Area** Area physically covered by the Heating Cable; typically much smaller than the total room area since it does not include vanities, fixtures and Low Traffic Areas.
13. **Heating Cable** Section of cable that warms the floor; has clear outer covering with visible underlying copper braid.
14. **Low Traffic Areas** Sections of the floor that are seldom walked upon and do not require Heating Cable coverage unless it is necessary to use up surplus cable.
15. **Return Loop** Location where the Heating Cable turns 180° through the EasyLock Cable Strapping, forming a loop that extends .75" (19 mm) [1" (25 mm) max.] beyond the strapping cable slots.
16. **Ribbon Strapping** Plastic strips, 1" (25 mm) wide and 12" (30.48 cm) long; may be cut to length and stapled, to fasten to the Cold Lead Splice and Tail Splice to the floor.
17. **Sensor Wire** If a floor temperature-sensing heating controller will be used, it is necessary to install a sensor wire at the same time as the cable system. The sensor wire relays changes in floor temperature to the heating controller, which maintains the floor temperature at the desired level.
18. **Standard Heating Cable Spacing** The Heating Cable configuration normally used on wood sub-floors located above heated areas. Cable is laced through the EasyLock Cable Strapping at a constant spacing interval of 3" (7.61 cm) between adjacent cable runs (see also Alternating Heating Cable Spacing).
19. **Start-of-Run** Location of the Cold Lead Splice; where the heated section of cable begins.
20. **Tail Splice** Factory connection between the Heating Cable conductors located at the End-of-Run (uncoiled from the spool last).
21. **Power Supply Wiring** The 120V or 240V customer-supplied power cable; terminated in the circuit breaker panel and pulled into the ECB for connection to the heating controller.

Choose the Right System

How do I know which floor warming system to buy?

Warm Tiles® Electric Floor Warming Systems come in two distinct models to suit your application and your budget.

The Warm Tiles Cable System provides unlimited design configurations for even the most difficult shaped room. The Warm Tiles cable allows you to install full floor warming coverage by lacing the cable on the floor wherever you require a heated area. Two different spacing options enable these extremely flexible cables to be installed virtually anywhere. In a typical room above a heated area, simply space the cable 3" (7.61 cm) apart. For a room above an unheated area, on concrete slabs or a high heat loss room such as a solarium, alternate the spacing from 3" (7.61 cm) apart, then 1.5" (3.80 cm) apart, then 3" (7.61 cm) apart and so on. Simply snap the cable into the strapping included in your Cable Installation Kit and follow the Cable installation instructions.

The Warm Tiles "SAM" Mat System provides a quick and easy pre-fabricated installation that saves you time and labor cost. The self-adhesive mesh allows you to place the mat on the substrate and have it stay put while you embed the mat in thin-set or self-leveling underlayment.

How do I know how much floor warming to buy?

There is no need to install floor warming systems under base cabinets or plumbing fixtures, within 2"– 8" (5.08–20.32 cm) of baseboards and 6" (15.24 cm) from the toilet flange.

- Accurately measure the length and width of the walkable heated areas of your room in sections, as shown on the Warm Tiles® room measurement diagrams.
- Add the walkable heated areas together to determine the total square footage of floor warming that will be needed.
- Choose the correct system for your application by square footage from the Warm Tiles Product Selection Charts.

CABLES

MATS

Warm Tiles Cable Kit Room Measurement Diagram

Shaded areas represent installation area of your Cable System.

A is 2'6" x 3' = 7.5 ft² (0.76 m x 0.91 m = 0.69 m²)
B is (2'6" x 2') ÷ 2 = 2.5 ft² [(0.76 m x 0.61 m) ÷ 2 = 0.23 m²]
C is 3' x 5' = 15 ft² (0.91 m x 1.52 m = 1.39 m²)
A + B + C = ft² (m²) total walkable heated area
 7.5 ft² + 2.5 ft² + 15 ft² = **25 ft²**
 (0.69 m² + 0.23 m² + 1.39 m² = **2.31 m²**) total heated area

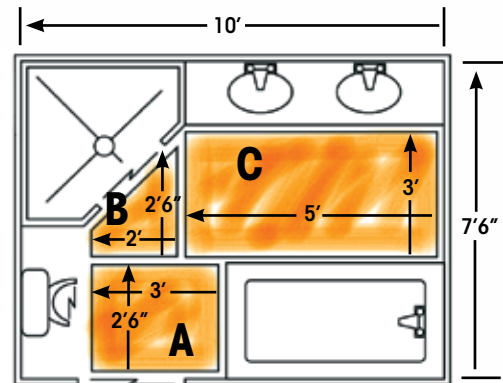

Warm Tiles Mat Kit Room Measurement Diagram

Shaded areas represent installation areas of your Mat System.

A is 1' 8" x 6'6" = 10.86 ft² (0.51 m x 1.98 m = 1.01 m²)
B is 1' 8" x 6'6" = 10.86 ft² (0.51 m x 1.98 m = 1.01 m²)
C is 1' 8" x 6'6" = 10.86 ft² (0.51 m x 1.98 m = 1.01 m²)
D is 1' 8" x 2'6" = 4.18 ft² (0.51 m x 0.76 m = 0.39 m²)
A + B + C + D = ft² (m²) total walkable heated area
 10.86 ft² + 10.86 ft² + 10.86 ft² + 4.18 ft² = **36.78 ft²**
 (1.01 m² + 1.01 m² + 1.01 m² + 0.39 m² = **3.42 m²**) total heated area

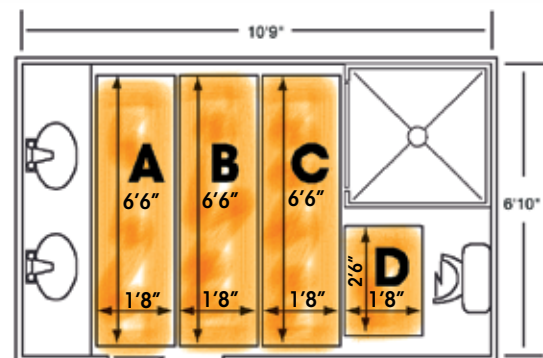

Which System to Use ?



Warm Tiles Cable Kit Room Layout Diagram

Choose the product that most closely matches your heated area square footage from the Product Selection Chart for Warm Tiles Cable Kits.

In this example, you would choose 120V DFT 1022 Cable Kit for Standard Spacing or DFT 1030 for Alternate Spacing.

For additional layouts or help in choosing the right product for your project, contact Technical Services at 800-537-4732 or go to www.warmtiles.com

In this example, you would choose 240V DFT 2118 Cable Kit for Standard Spacing or DFT 2157 for Alternate Spacing.

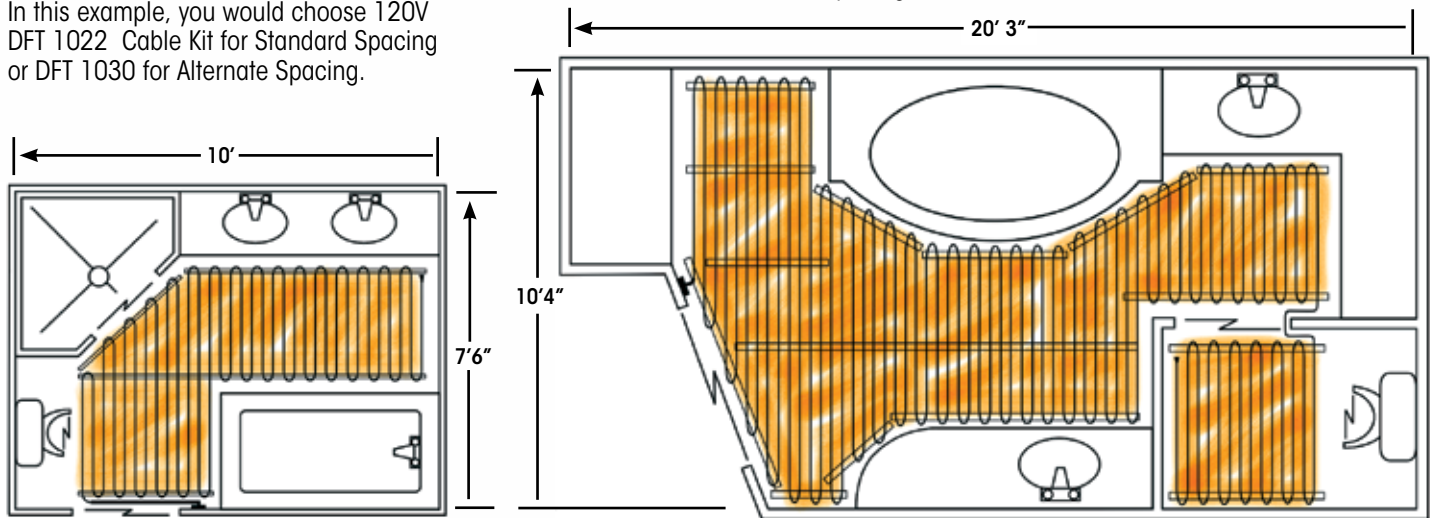

Warm Tiles Mat Kit Room Layout Diagram

Choose the product that most closely matches your heated area square footage from the Product Selection Chart for Warm Tiles Mat Kits.

In this example, you would choose 120V SAM 1033 Mat Kit.

For additional layouts or help in choosing the right product for your project, contact Technical Services at 800-537-4732 or go to www.warmtiles.com.

In this example, you would choose 120V SAM 1087 Mat Kit.

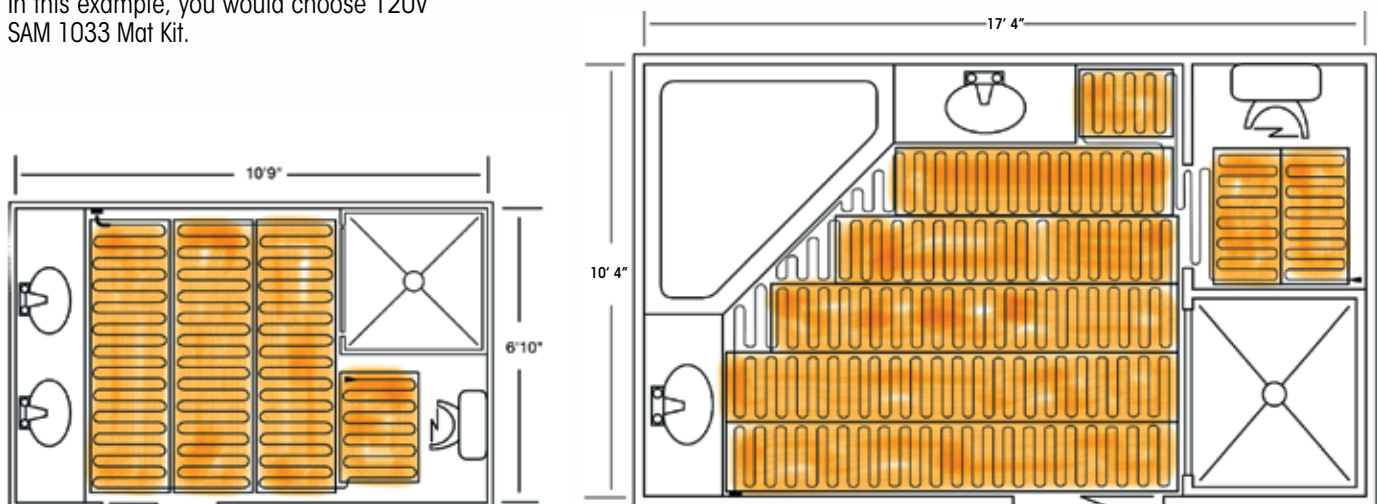



Which Cable Kit

Choose the Right Cable Kit

You've measured your room.

Next, draw your walkable heated area together on the Warm Tiles room layout planner provided.

Now it's time to determine which cable kit is the right one for you!

Choose the correct system for your application by square footage from the Warm Tiles Product Selection Chart for Cable Kits.

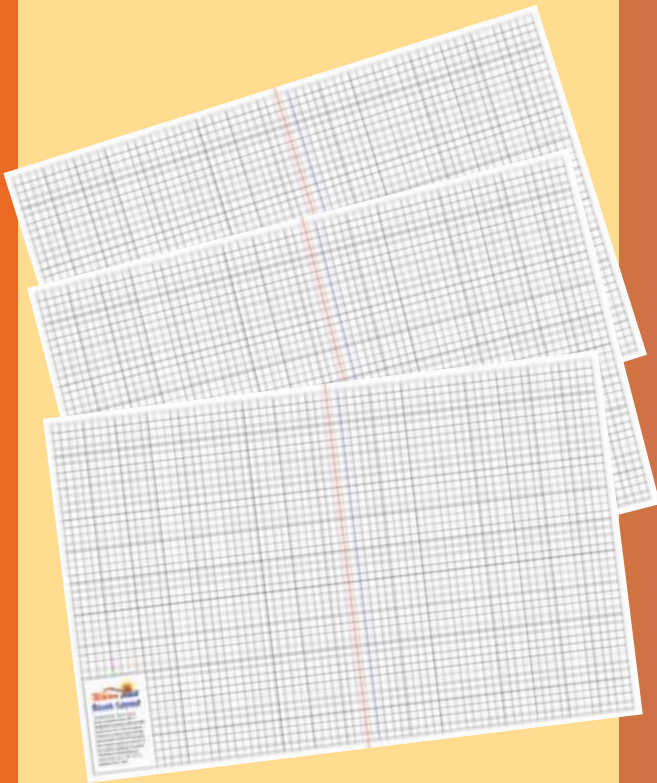

Plan Ahead!

Place the Warm Tiles Room Layout Planner in your copier and make as many copies as you will need! The Planner is provided to you on the inside back cover of this catalog.



is Right for Me?



Product Selection Chart for Cable Kits

Select Floor Warming kit voltage, 120V or 240V, to match your power supply. For areas larger than 70 ft² (6.50 m²), the 240V kits may be more economical. Use Standard 3" (7.61 cm) spacing for rooms above heated areas. Use Alternate 3", 1.5", 3" (7.61 cm, 3.80 cm, 7.61 cm) spacing for rooms above unheated areas, concrete slabs or high heat loss areas. All measurements are per kit.

Warm Tiles 120V Cable Kits

Model No.	Heated Area Standard FT ² (m ²)	Heated Area Alternating FT ² (m ²)	Amps*
DFT 1011 BLUE	9-13 (0.84-1.21)	7-9 (0.65-0.84)	1.1
DFT 1016 RED	14-18 (1.30-1.67)	10-13 (0.93-1.21)	1.6
DFT 1022 GREEN	19-26 (1.77-2.42)	14-19 (1.30-1.77)	2.2
DFT 1030 YELLOW	27-34 (2.51-3.16)	20-26 (1.86-2.42)	3.0
DFT 1039 PURPLE	35-42 (3.25-3.90)	27-33 (2.51-3.07)	4.0
DFT 1048 ORANGE	43-54 (3.99-5.02)	34-39 (3.16-3.62)	5.1
DFT 1059 BROWN	55-65 (5.11-6.04)	40-48 (3.72-4.46)	6.4
DFT 1069 BEIGE	66-72 (6.13-6.69)	49-54 (4.55-5.02)	7.5
DFT 1079 WHITE	73-82 (6.78-7.62)	55-62 (5.11-5.76)	8.5
DFT 1088 PINK	83-92 (7.71-8.55)	63-69 (5.85-6.41)	8.8
DFT 1098 SILVER	93-102 (8.64-9.48)	70-76 (6.50-7.06)	9.6
DFT 1108 BLACK	103-113 (9.57-10.50)	77-85 (7.15-7.90)	10.7

Warm Tiles 240V Cable Kits

Model No.	Heated Area Standard FT ² (m ²)	Heated Area Alternating FT ² (m ²)	Amps*
DFT 2021	18-25 (1.67-2.32)	13-19 (1.21-1.77)	1.1
DFT 2031	26-35 (2.42-3.25)	20-27 (1.86-2.51)	1.6
DFT 2053	48-55 (4.46-5.11)	35-44 (3.25-4.09)	2.6
DFT 2065	60-70 (5.57-6.50)	45-54 (4.18-5.02)	3.3
DFT 2078	71-83 (6.60-7.71)	55-63 (5.11-5.85)	4.0
DFT 2095	90-100 (8.36-9.29)	64-75 (5.95-6.97)	5.1
DFT 2118	110-130 (10.22-12.08)	84-94 (7.80-8.73)	6.3
DFT 2137	131-145 (12.17-13.47)	95-108 (8.83-10.03)	7.5
DFT 2157	146-165 (13.56-15.33)	109-125 (10.13-11.61)	8.4
DFT 2175	166-184 (15.42-17.09)	126-138 (11.71-12.82)	8.8
DFT 2195	185-204 (17.19-18.95)	139-153 (12.91-14.21)	9.6
DFT 2215	205-225 (19.50-20.90)	154-169 (14.31-15.70)	10.7

* **CAUTION:** Kit combinations that exceed 10 Amps should be connected by a qualified electrician.

You must use the Warm Tiles Relay Kit when you are connecting two or more floor warming kits that have a combined total load amperage which exceeds 16 amps.



Warm Tiles Cable System

The Warm Tiles® Floor Warming Kit Includes:

- Warm Tiles Floor Warming Cable • Strapping
- Extra Clips • Multi-lingual Installation Instructions
- User's Guide • Warranty Details

You Will Need:

Warm Tiles Thermostat kit, sold separately in Programmable or Non-Programmable models.





We Make It

Even in warm climates, tile and stone can feel uncomfortably cold.

If the square footage of your heated area does not match a Warm Tiles Cable kit, you will need to adjust your walkable heated areas accordingly.

**If total square footage is higher:
Reduce heated area.**
**If total square footage is lower:
Tighten cable spacing.**

The Actual Coverage Chart provides you the exact square footage that each cable kit will cover. Heating Cables **CANNOT BE CUT** and must be embedded completely in mortar beneath the floor finish. Remember to follow the detailed instructions provided to you in each cable kit when installing your system.

Warm Tiles Cables

Actual Coverage Area

Easy Heat Item No.	Standard 3" Spacing		Alternating 3", 1.5" Spacing	
	ft ²	(m ²)	ft ²	(m ²)
120 VOLT KITS				
DFT 1011	11	(0.98)	8	(0.74)
DFT 1016	16	(1.44)	12	(1.11)
DFT 1022	21	(2.00)	17	(1.58)
DFT 1030	30	(2.81)	23	(2.14)
DFT 1039	39	(3.60)	29	(2.69)
DFT 1048	48	(4.43)	37	(3.44)
DFT 1059	59	(5.46)	44	(4.09)
DFT 1069	69	(6.41)	51	(4.74)
DFT 1079	79	(7.34)	58	(5.39)
DFT 1088	88	(8.18)	64	(5.95)
DFT 1098	98	(9.10)	72	(6.69)
DFT 1108	108	(10.03)	80	(7.43)
240 VOLT KITS				
DFT 2021	21	(1.95)	15	(1.39)
DFT 2031	31	(2.88)	23	(2.13)
DFT 2053	53	(4.93)	38	(3.53)
DFT 2065	65	(6.04)	48	(4.46)
DFT 2078	78	(7.25)	57	(5.30)
DFT 2095	95	(8.83)	70	(6.50)
DFT 2118	118	(10.96)	87	(8.08)
DFT 2137	137	(12.73)	102	(9.48)
DFT 2157	157	(14.59)	116	(10.78)
DFT 2175	176	(16.35)	131	(12.17)
DFT 2195	196	(18.21)	145	(13.47)
DFT 2215	216	(20.07)	160	(14.86)

Warm Tiles® Cable Systems

Specifications:

Applicable Standard

UL(US)1673; UL (CAN/CSA) C22.2 #130.2; NEC Article 424. ASTM C627 Residential, Light Commercial

Physical Properties

Warm Tiles heating cables typically consist of dual alloy conductors insulated with Fluoropolymer. The conductors are enclosed by a PVC rounder that is covered by copper ground braid and covered with a Nylon jacket. The DFT dual conductor cold lead is 10' (3 m) and consists of two separate insulated conductors covered by a copper ground braid and covered with an outer PVC outer jacket.

Working Properties

The Warm Tiles Cables operate on (select 120 or 240) volts. The cables typically have a wattage output of 12 W/ft² (129 W/m²) to 15 W/ft² (172 W/m²) at (select 120 or 240) volts.

Installation Over Double Layer Plywood

When installing Warm Tiles Floor Warming Cable System over a plywood surface, be sure that the substrate is strong enough to support a tile or stone floor finish. Make sure your floor finish is installed according to the Tile Council of America for the United States or by the Terrazzo, Tile and Marble Association of Canada.

Installation Over Cement Backerboard

Install Cement Backerboard per installation instructions provided by manufacturer. Make sure your floor finish is installed according to The Tile Council of America for the United States or Terrazzo, Tile and Marble Association of Canada.

Installation Over Concrete

Rough or uneven concrete surfaces should be made smooth with a Portland cement underlayment to provide a wood float (or better) finish. Dry, dusty concrete slabs or masonry should be dampened and excess water swept off. Installation may be made on a damp surface. New concrete slabs must be plum and true to within .25" (6 mm) in 10' (3 m).

Installation of Thermostat Sensor Wire

Secure the pigtail end of the Warm Tiles Thermostat sensor wire to the second pull cord with electrical tape and pull into the junction box. Create a channel for the sensor wire between cable runs. Fasten the sensor wire to the floor with the supplied clips, making sure you center the sensor bulb between cable runs.

Installation Using Crack Suppression Systems

Your floor warming system must be installed above the crack suppression system to achieve protection from stress cracks from the substrate below. Follow manufacturers installation instructions for the crack suppression system you have purchased.

Installation Using Anti-Fracture Membranes

Your floor warming system must be installed below the anti-fracture membrane. Follow manufacturer's installation instructions for the anti-fracture system you have purchased.

Installation Using Waterproofing Systems

Your floor warming system must be installed underneath the waterproofing system to protect it from water damage. Allow scratch coat to cure. Follow waterproofing manufacturers installation instructions for the system you have purchased.

• TCA Details of Radiant Heat on Wood Subfloor

- TCA RH130-05
- TCA RH135-05
- TCA RH140-05

• TCA Details of Radiant Heat on Concrete

- TCA RH115-05
- TCA RH116-05

Easy to Install ANYWHERE



Tile & Stone Over Double Layer Plywood

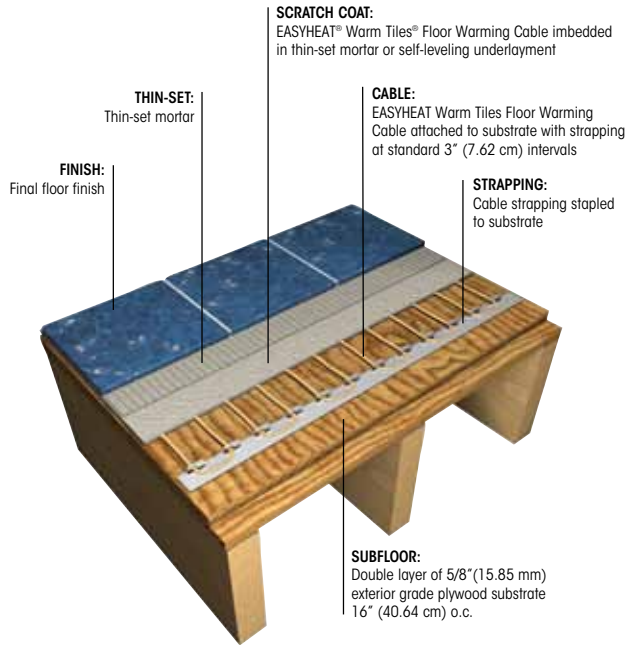

Tile & Stone Over Cement Backerboard

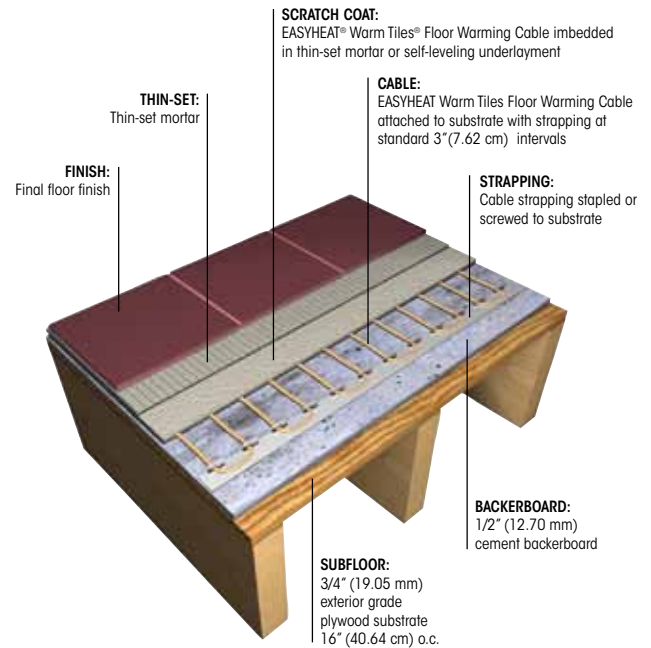

Tile & Stone Over Concrete

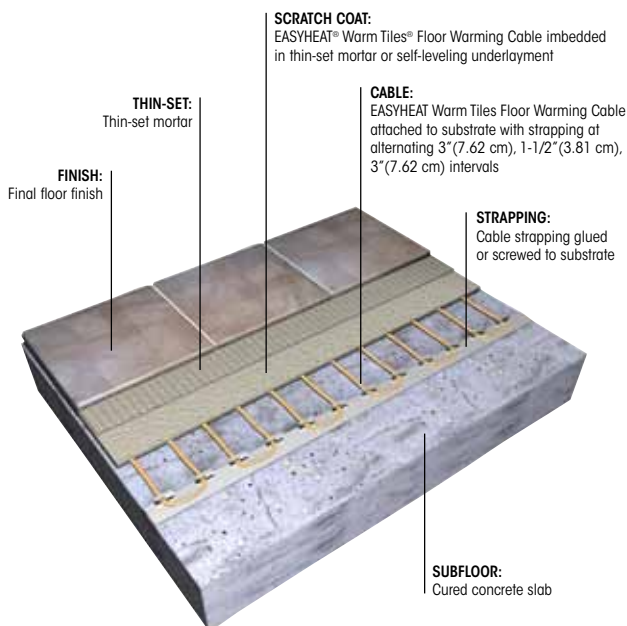

Engineered, Floating Wood Floor Over Plywood

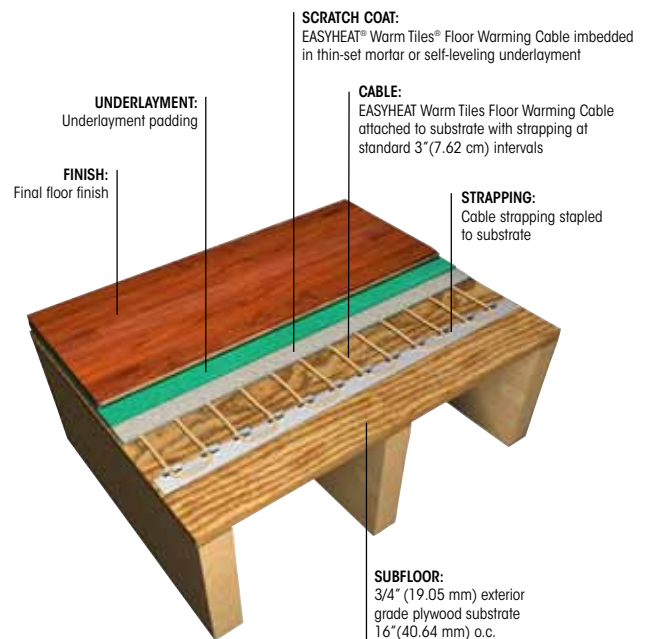



Which Mat Kit

Choose the Right Mat Kit

You've measured your room.

Next, draw your walkable heated area together on the Warm Tiles room layout planner provided.

Now it's time to determine which mat kit is the right one for you!

Choose the correct system for your application by square footage from the Warm Tiles Product Selection Chart for Mat Kits.



Plan Ahead!

Place the Warm Tiles Room Layout Planner in your copier and make as many copies as you will need! The Planner is provided to you on the inside back cover of this catalog.



is Right for Me?



Product Selection Charts for Self-Adhesive Mat Kits

Select Floor Warming kit voltage, 120V or 240V, to match your power supply. For areas larger than about 70 ft² (6.50 m²), the 240V kits may be more economical. All mats are 20" (0.51 m) wide. Multiple Mats may be used to increase heated area ft² (m²) of installation. All measurements are per kit.

Warm Tiles 120 V Mat Kits 

Model No.	Mat Length FT(m)	Heated Area FT ² (m ²)	Amps*
SAM 1010	6.67 (2.03)	12-15 (1.12 - 1.39)	1.3
SAM 1013	8.67 (2.64)	16-19 (1.49 - 1.77)	1.7
SAM 1017	11.33 (3.45)	20-22 (1.86 - 2.04)	2.2
SAM 1020	13.33 (4.06)	23-28 (2.14 - 2.60)	2.5
SAM 1025	16.67 (5.08)	29-36 (2.70 - 3.35)	3.1
SAM 1033	22.00 (6.70)	37-46 (3.44 - 4.28)	4.2
SAM 1042	28.00 (8.53)	47-54 (4.37 - 5.02)	5.3
SAM 1050	33.33 (10.15)	55-66 (5.11 - 6.13)	6.5
SAM 1062	41.33 (12.59)	67-80 (6.23 - 7.44)	8.1
SAM 1075	50.00 (15.24)	81-94 (7.53 - 8.74)	9.7
SAM 1087	58.00 (17.68)	95-106 (8.83 - 9.85)	11.5
SAM 1100	66.67 (20.32)	107-120 (9.95 - 11.15)	13.1

Warm Tiles 240 V Mat Kits 

Model No.	Mat Length FT(m)	Heated Area FT ² (m ²)	Amps*
SAM 2010	6.67 (2.03)	12-15 (1.12 - 1.39)	0.6
SAM 2013	8.67 (2.64)	16-19 (1.49 - 1.77)	0.8
SAM 2017	11.33 (3.45)	20-22 (1.86 - 2.04)	1.1
SAM 2020	13.33 (4.06)	23-28 (2.14 - 2.60)	1.3
SAM 2025	16.67 (5.08)	29-36 (2.70 - 3.35)	1.6
SAM 2033	22.00 (6.70)	37-46 (3.44 - 4.28)	2.1
SAM 2042	28.00 (8.53)	47-54 (4.37 - 5.02)	2.8
SAM 2050	33.33 (10.15)	55-66 (5.11 - 6.13)	3.1
SAM 2062	41.33 (12.59)	67-80 (6.23 - 7.44)	4.1
SAM 2075	50.00 (15.24)	81-94 (7.53 - 8.74)	4.8
SAM 2087	58.00 (17.68)	95-106 (8.83 - 9.85)	5.7
SAM 2100	66.67 (20.32)	107-120 (9.95 - 11.15)	6.5

* **CAUTION:** Kit Combinations that exceed 10 Amps should be connected by a qualified electrician.

You must use the Warm Tiles Relay Kit when you are connecting two or more floor warming kits that have a combined total amperage which exceeds 16 amps.

Custom mats are available for various shaped areas that do not conform to standard mat kits, such as ovals, circles and triangles. For more information on custom mats, contact Technical Services.



Warm Tiles Self-Adhesive Mat System

Floor Warming Mat Kit Includes:

- Warm Tiles® Floor Warming Mat
- User's Guide
- Multi-lingual Installation Instructions
- Warranty Details

You Will Need:

Warm Tiles Thermostat kit, sold separately in Programmable or Non-Programmable models.





We Make It

Warm Tiles® Mat Systems Specifications:

Make the Most of Your Mat

The heating cable of your Warm Tiles Mat Kit is adhered in a serpentine pattern onto lengths of mesh. It is quick and easy to cover large areas. These mats can be angled, turned or completely flipped around in order to cover the space by cutting only the mesh, and moving the remaining sections of mats in a new direction. In doing this, you are creating as much walkable heated area as possible.

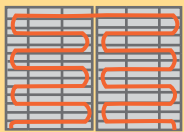

BACK TO BACK TURN

BACK TO BACK: Make a single, straight cut through the entire width of the mesh. Slide the mat around and head the mat back in the opposite direction, keeping the heating cable on top of the mesh, the adhesive side will be on the substrate.

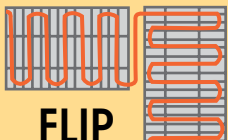

FLIP TURN

FLIP TURN: Make a straight cut on each side of one cable run. Separate the mesh from the cable and rotate the mat so that it continues in a 90 degree direction, keeping the heating cable on top of the mesh, the adhesive side will be on the substrate. Adhere loose cable to the floor with plastic clips provided in your kit.

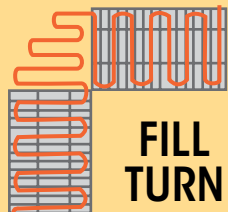

FILL TURN

FILL TURN: Make a straight cut on each side of two cable runs. Separate the mesh from the cable and slide the mat so that it continues in a 90 degree direction but in a different row, keeping the heating cable on top of the mesh, the adhesive side will be on the substrate. Organize the loose cable between the

separated mesh sections into rows. Adhere loose cable to the floor with plastic clips provided in your kit.

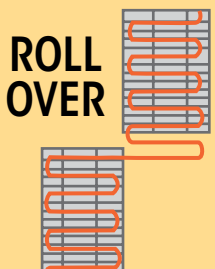

ROLL OVER

ROLL OVER: Make a straight cut on each side of two cable runs. Separate the mesh from the cable and slide the mat so that it continues in the same direction but in a different row, keeping the heating cable on top of the mesh, the adhesive side will be on the substrate. Adhere loose cable to the floor with plastic clips provided in your kit.



Applicable Standard

(CAN/CSA) C22.2 #130.2; NEC Article 424.
ASTM C627 Residential, Light Commercial, Extra Heavy

Physical Properties

Warm Tiles heating cables typically consist of dual alloy conductors insulated with Fluoropolymer. The conductors are enclosed by a PVC rounder that is covered by copper ground braid and covered with a PVC outer jacket. The SAM dual conductor cold lead is 15' (4.57 m) and consists of two separate insulated conductors covered by a copper ground braid and covered with an outer PVC outer jacket. The heating cable shall be bonded to a fiberglass mesh by means of tape bands.

Working Properties

The Warm Tiles Mats shall operate at (select 120 or 240) volts. The mats typically have a wattage output of 15 W/ft² (161 W/m²) at (select 120 or 240) volts.

Installation over Double Layer Plywood

When installing Warm Tiles floor Warming mat system over a plywood surface, be sure that the substrate is strong enough to support a tile or stone floor finish. Make sure your floor finish is installed according to the Tile Council of America for the United States or by the Terrazzo, Tile and Marble Association of Canada.

Installation Over Cement Backerboard

Install Cement Backerboard per installation instructions provided by manufacturer. Make sure your floor finish is installed according to The Tile Council of America for the United States or Terrazzo, Tile and Marble Association of Canada.

Installation Over Concrete

Rough or uneven concrete surfaces should be made smooth with a Portland cement underlayment to provide a wood float (or better) finish. Dry, dusty concrete slabs or masonry should be dampened and excess water swept off. Installation may be made on a damp surface. New concrete slabs must be plum and true to within .25" (6 mm) in 10' (3 m).

Installation of Thermostat Sensor Wire

Secure the pigtail end of the Warm Tiles Thermostat sensor wire to the second pull cord with electrical tape and pull into the junction box. Create a channel for the sensor wire between mat runs. Fasten the sensor wire to the floor with the supplied clips, making sure you center the sensor bulb between mat runs.

Installation Using Crack Suppression Systems

Your floor warming system must be installed above the crack suppression system to achieve protection from stress cracks from the substrate below. Follow manufacturers installation instructions for the crack suppression system you have purchased.

Installation Using Anti-Fracture Membranes

Your floor warming system must be installed below the anti-fracture membrane. Follow manufacturers installation instructions for the anti-fracture system you have purchased.

Installation Using Waterproofing Systems

Your floor warming system must be installed underneath the waterproofing system to protect it from water damage. Allow scratch coat to cure. Follow waterproofing manufacturers installation instructions for the system you have purchased.

• TCA Details of Radiant Heat on Wood Subfloor

- TCA RH1 30-05
- TCA RH1 35-05
- TCA RH1 40-05

• TCA Details of Radiant Heat on Concrete

- TCA RH1 15-05
- TCA RH1 16-05

Easy to Install ANYWHERE



Tile & Stone Over Double Layer Plywood

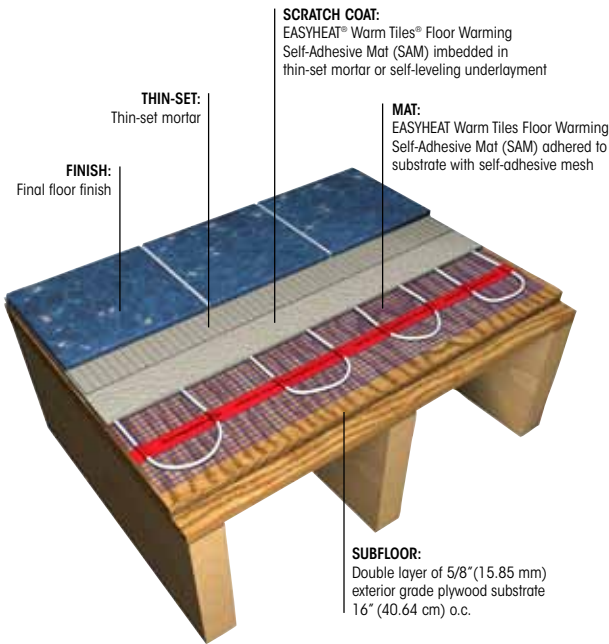

Tile & Stone Over Cement Backerboard

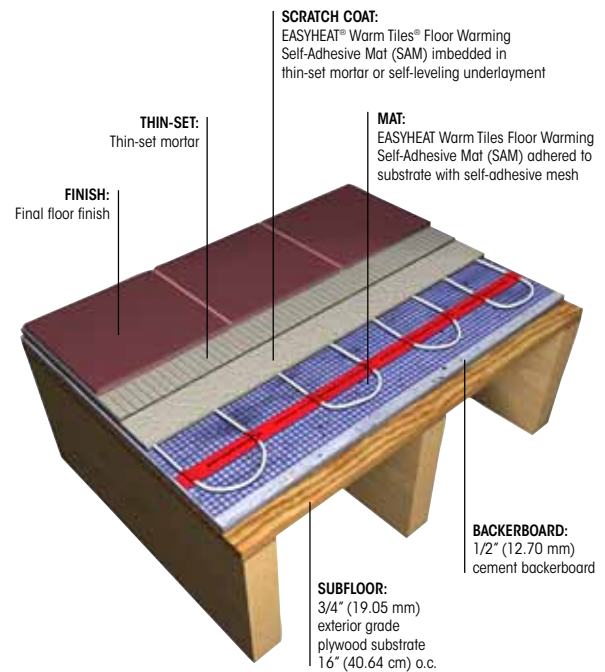

Tile & Stone Over Concrete

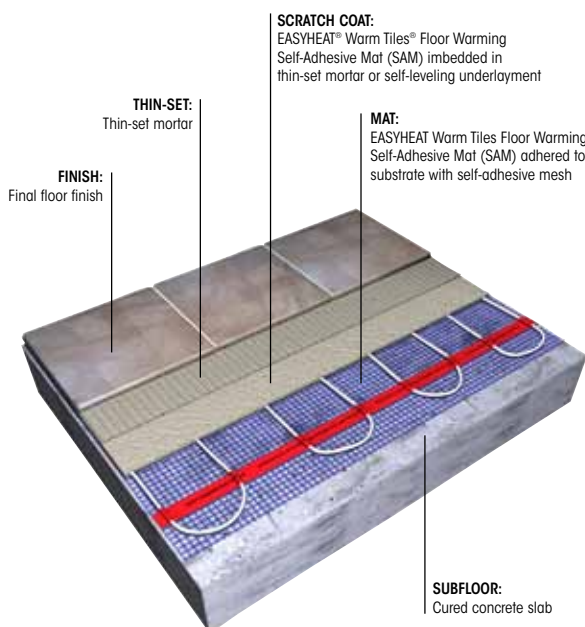

Engineered, Floating Wood Floor Over Plywood

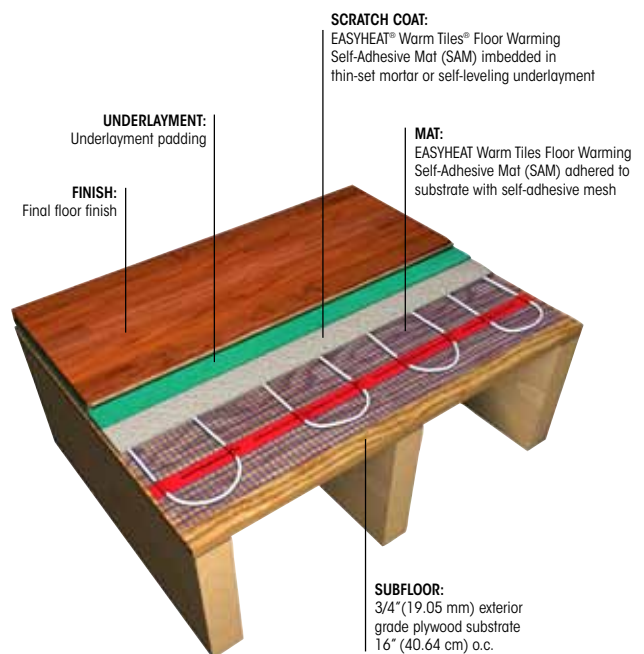



Only 1¢ per

Warm Tiles® Floor Warming Thermostats

Energy and Cost Efficient

Your Warm Tiles Thermostat will regulate only enough electricity to heat your floor to the desired temperature. When the floor reaches your preset temperature, the electricity will cycle off. Since the electricity is generating warmth about one-third of the time, the cost savings are significant. On average, the operating cost is 1¢ per heated square foot per day, regardless of the size of your installation.

Warm Tiles Thermostats provide consistent comfort and control. Our Floor Sensor is embedded in the mortar just below your tiles, which monitors the actual floor temperature to provide you with accurate comfort levels.

Each model features comfort level programming options as well as a simple off-position selector switch. You may also choose the pre-programmed set-back mode to reduce energy usage by over 50%. Optional decorator doors are available for all Warm Tiles Thermostats.

Warm Tiles ET Model Thermostats offer a simple on/off switch along with a temperature adjustment toggle and accept button.

- Manual operation
- LCD Display
- Built-in ground fault protection**
- Optional decorator door
- Installation accessories included

FTS model Thermostats offer comfort-level programming options as well as a simple off-position selector switch.

- Preprogrammed for easy setup
- Manual operation setting
- Programmable 7 day or 5/2 day options
- Built-in ground fault protection**
- Optional decorator door
- Installation accessories included

**Per U.S. National Electrical Code – Installation in a bathroom requires that this device be installed on a circuit protected by a separate Ground Fault Circuit Interrupter (GFCI).

Warm Tiles® Thermostat

Includes:

- 1 Thermostat
- 1 Door without Display Window
- 3 Wire Connectors
- 2 Cable Guards
- 1 Screwdriver
- 2 #6-32 x 1" screws
- 1 Sensor / Wire Assembly - 10' long
- 1 Pull-Cord
- 3 "DO NOT REMOVE" Warning Tags
- 1 Door Label



Model Description	Voltage	Amps*
ET-1 Non-programmable	120V	16
FTS-1 Programmable for 7 or 5/2 days	120V	16
ET-2 Non-programmable	240V	16
FTS-2 Programmable for 7 or 5/2 days	240V	16

* **CAUTION:** Kit combinations that exceed 10 Amps should be connected by a qualified electrician.

LIMITED WARRANTY AND LIABILITY

The manufacturer warrants that if there are any defects in material or workmanship in this thermostat during the first eighteen (18) months after the date of its purchase, the thermostat will be replaced with an equivalent model, not including any labor or other installation costs.

Our obligation to replace the thermostat as described above is conditioned upon (a) the installation of the thermostat conforming to the specifications set forth in the installation instructions and (b) the thermostat not having been damaged by mechanical or electrical activities unrelated to the operation of the mat or cable.

A thermostat replacement as described above shall be your sole and exclusive remedy for a breach of this warranty. This limited warranty does not cover any service costs relating to repair or replacement of any thermostat.

We shall not be liable for any incidental, special or consequential damages as a result of any breach of this warranty or otherwise, whether or not caused by negligence. Some states do not allow the exclusion or limitation of incidental or consequential damages, so the above limitation or exclusion may not apply to you.

The warranty above is exclusive and makes no other warranties with respect to description or quality of the thermostat. No affirmation of fact or promise made by us, by words or action, shall constitute a warranty. If any model or sample was shown to you, the model or sample was used merely to illustrate the general type and quality of the goods and not to represent that the goods would necessarily be of that type or nature. No agent, employee or representative of ours has authority to bind us to any affirmation, representation or warranty concerning the goods sold unless such affirmation, representation or warranty is specifically incorporated by written agreement.

ANY IMPLIED WARRANTY OF MERCHANTABILITY OR FITNESS FOR PARTICULAR PURPOSE THAT MAY ARISE IN CONNECTION WITH THE SALE OF THIS PRODUCT SHALL BE LIMITED IN DURATION TO EIGHTEEN (18) MONTHS FROM THE DATE OF PURCHASE. WE DISCLAIM ALL OTHER IMPLIED WARRANTIES, UNLESS WE ARE PROHIBITED BY LAW FROM DOING SO, IN WHICH CASE ALL SUCH IMPLIED WARRANTIES SHALL EXPIRE AT THE EARLIEST TIME PERMITTED BY APPLICABLE LAW. Some states do not allow limitations on how long an implied warranty lasts, so the above limitation may not apply to you.

This warranty gives you specific legal rights, and you may also have other rights, which vary from state to state or province to province.

To obtain a replacement under this warranty, any inoperative thermostat must be returned, with proof of purchase, to the point of purchase. You are responsible for all costs incurred in removal and re-installation of the thermostat and, if applicable, must pre-pay shipment to point of purchase.

USA: EGS EASYHEAT Inc, 2 Connecticut South Drive, East Granby, CT 06026
Canada: EGS EASYHEAT Ltd, 99 Union Street, Elmira, ON N3B 3L7
ATTENTION: WARRANTY DEPARTMENT

Heated Square Foot per Day



Basic Guidelines for 120 VAC and 240 VAC Floor Warming Kit Combinations Less than 16 Amp Loads

FIG. 1

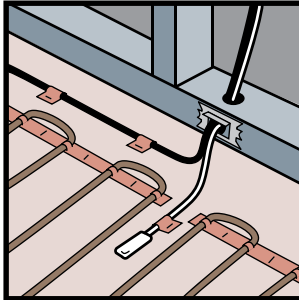

Sensor wire installation tip:
The sensor wire is located between the cable runs to accurately determine the floor temperature, ensuring that your thermostat will run efficiently.

FIG. 2

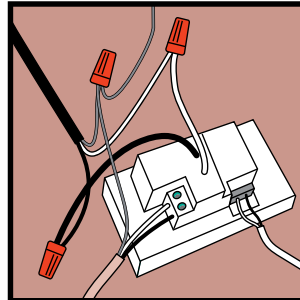

Single floor warming kit installation tip:
The cold lead of your floor warming system will connect directly to the back to the thermostat.

FIG.3

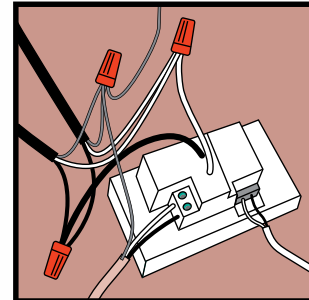

Double floor warming kit installation tip:
When two or more floor warming systems are used in the same room, both cold leads will connect directly to the back of the thermostat.

Warm Tiles Relay Kits for Electric Floor Warming Systems

The Warm Tiles Relay Kit allows you to connect two or more floor warming kits in the same room. First you would connect the first line voltage feed to the thermostat. The load connection pigtails from the thermostat are run to the coil of the relay, which is housed in a separate electrical box. A second line voltage feed is connected to

the input terminals of the relay and the heating cable cold leads are connected to the output terminals. When the thermostat calls for heat, the coil is engaged, connecting the input and output terminals, therefore allowing power to flow to the cables. Remember to follow the detailed instructions provided in each Relay Kit.

Basic Guidelines for 120 VAC floor warming kit combinations from 16 to 24 Amps and require the use of a relay.

RK-1 120 VAC Thermostat RELAY KIT

- Provides large area coverage using only 1 thermostat
- Switches 2 separate multiple 120 VAC floor warming systems, each with a total 24 Amp maximum load.

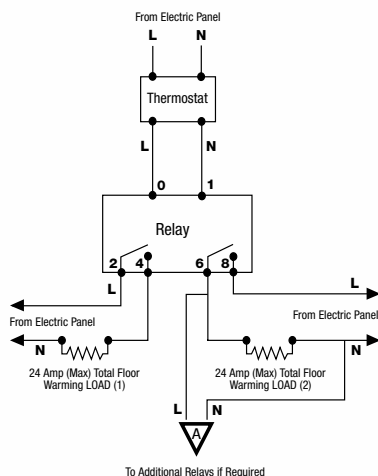

Basic Guidelines for 240 VAC floor warming kit combinations from 16 to 24 Amps and require the use of a relay.

RK-2 240 VAC Thermostat RELAY KIT

- Provides large area coverage using only 1 thermostat
- Switches multiple 240 VAC floor warming systems with a total 24 Amp maximum load.

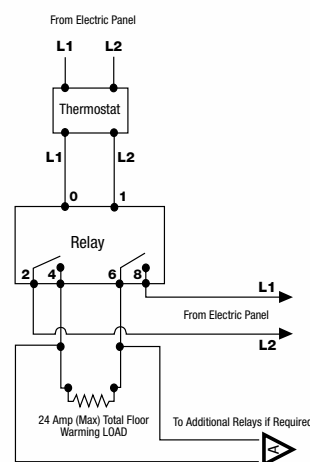



WARM TILES® LIMITED WARRANTY AND LIABILITY

Easy Heat® warrants to the original purchaser only, that if there are any defects in material or workmanship in any Warm Tiles mat or cable during the first fifteen (15) years after the date of its purchase, we will refund the purchase price paid for the mat or cable, not including any labor or other installation costs.

Our obligation to refund the purchase price described above is conditioned upon (a) the installation of the mat or cable conforming to the specifications set forth in our installation instructions and (b) the mat or cable not having been damaged by mechanical or electrical activities unrelated to the operation of the mat or cable.

A refund of your purchase price as described above shall be your sole and exclusive remedy for a breach of this warranty. This limited warranty does not cover any costs relating to the repair or replacement of any mat or cable. Our mats and cables are embedded in a mortar base, and then covered with ceramic tile, marble or equivalent finished flooring material. A failed mat or cable usually cannot be easily repaired. Replacement of a failed mat or cable will require that the finished flooring material under which it is embedded be removed to permit replacement of the mat or cable. **We will not reimburse any costs relating to the repair or replacement of any mat or cable.**

We shall not be liable for any incidental, special or consequential damages as a result of any breach of this warranty or otherwise, whether or not caused by negligence. Some states do not allow the exclusion or limitation of incidental or consequential damages, so the above limitation or exclusion may not apply to you. We make no other express warranty regarding any Warm Tiles mat or cable. No affirmation of fact or promise made by us, by words or action, shall constitute a warranty. If any model or sample was shown to you, the model or sample was used merely to illustrate the general type and quality of the goods and not to represent that the goods would necessarily be of that type or nature. **No agent, employee or representative of ours has authority to bind us to any affirmation, representation or warranty concerning the goods sold unless such affirmation, representation or warranty is specifically incorporated by written agreement.**

ANY IMPLIED WARRANTY OF MERCHANTABILITY OR FITNESS FOR PARTICULAR PURPOSE THAT MAY ARISE IN CONNECTION WITH THE SALE OF THIS PRODUCT SHALL BE LIMITED IN DURATION TO FIFTEEN (15) YEARS FROM THE DATE OF PURCHASE. WE DISCLAIM ALL OTHER IMPLIED WARRANTIES, UNLESS WE ARE PROHIBITED BY LAW FROM DOING SO, IN WHICH CASE ALL SUCH IMPLIED WARRANTIES SHALL EXPIRE AT THE EARLIEST TIME PERMITTED BY APPLICABLE LAW. Some states do not allow limitations on how long an implied warranty lasts, so the above limitation may not apply to you.

This warranty gives you specific legal rights, and you may also have other rights which vary from state to state.

To obtain a refund under this warranty, please send a description of the defect and proof of purchase, postage paid, to Easy Heat at the addresses noted herein.

USA: EGS EASYHEAT Inc.
2 Connecticut South Drive
East Granby, CT 06020

Canada: EGS EASYHEAT Ltd,
99 Union Street
Elmira, ON N3B 3L7

ATTENTION: WARRANTY DEPARTMENT

We Help You Visualize Your Installation



Room Layouts

The Warm Tiles® Room Layout will help you to determine how much cable or mat floor warming to purchase. Place the planner in your copier and make as many copies as you will need. Draw in your cable wiring or mat layouts directly on your copies to help you visualize your installation.

Choose the system that's right for you!

How do I know how much floor warming to buy?

There is no need to install floor warming systems under base cabinets or plumbing fixtures, within 2"– 8" (5.08–20.32 cm) of baseboards and 6" (15.24 cm) from the toilet flange.

- Accurately measure the length and width of the walkable heated areas of your room in sections, as shown on the WarmTiles® room layout diagram.
- Add the walkable heated areas together to determine the total square footage of floor warming that will be needed.
- Choose the correct system for your application by square footage from the WarmTiles Product Selection Chart.

We can help with your Mat Room Layouts

If you need additional help with your mat room layouts or require a custom mat, fill out this questionnaire and fax to 800-523-7636.

Attn: Technical Services

Indicate overall measurements, locations of thermostat, furniture, appliances, doors, vanities, tub, toilet, cabinets, etc.

My room is: Above garage Over unheated area
 Over heated area

My subfloor is: Cement slab Plywood

My floor finish will be:

- Ceramic Porcelain Terrazzo
- Glass mosaics Natural stone Agglomerates
- Floating wood including bamboo and cork
- Engineered wood and laminates*

*not approved for nail down installations

My contact information:

Name: _____
Phone: _____
Fax: _____
Email: _____

Warm Tiles Cable Kit Room Measurement Diagram

Colored shaded areas represent where you would install your Cable System.

A is 2'6" x 3' = 7.5 ft² (0.76 m x 0.91 m = 69 m²)

B is 2'6" x 2' ÷ 2 = 2.5 ft² [(0.76 m x 0.61 m) ÷ 2 = 0.23 m²]

C is 3' x 5' = 15 ft² (0.91 m x 1.52 m = 1.39 m²)

A + B + C = ft² (m²) total walkable heated area

7.5 ft² + 2.5 ft² + 15 ft² = **25 ft²** (0.69 m² + 0.23 m² + 1.39 m² = **2.31 m²**) total heated area

Choose the product that most closely matches your heated area square footage from the Product Selection Chart for Warm Tiles Cable Kits. In this example, you would choose 120V DFT 1022 Cable Kit for Standard Spacing or DFT 1030 for Alternate Spacing. For additional layouts or help in choosing the right product for your project, contact technical services at 800-537-4732 or go to www.warmtiles.com

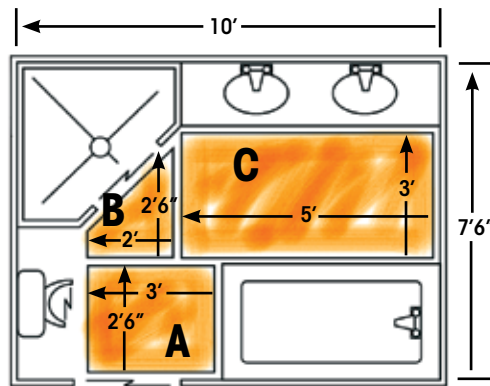

Warm Tiles Mat Kit Room Measurement Diagram

Colored shaded area represents where you would install your Mat System.

A is 1' 8" x 6'6" = 10.86 ft² (0.51 m x 1.98 m = 1.01 m²)

B is 1' 8" x 6'6" = 10.86 ft² (0.51 m x 1.98 m = 1.01 m²)

C is 1' 8" x 6'6" = 10.86 ft² (0.51 m x 1.98 m = 1.01 m²)

D is 1' 8" x 2'6" = 4.18 ft² (0.51 m x 0.76 m = 0.39 m²)

A + B + C + D = ft² (m²) total walkable heated area

10.86 ft² + 10.86 ft² + 10.86 ft² + 4.18 ft² = **36.78 ft²**

(1.01 m² + 1.01 m² + 1.01 m² + 0.39 m²) = **3.42 m²** total heated area

Choose the product that most closely matches your heated area square footage from the Product Selection Chart for Warm Tiles Mat Kits. In this example, you would choose 120V SAM 1033 Mat Kit. For additional layouts or help in choosing the right product for your project, contact technical services at 800-537-4732 or go to www.warmtiles.com

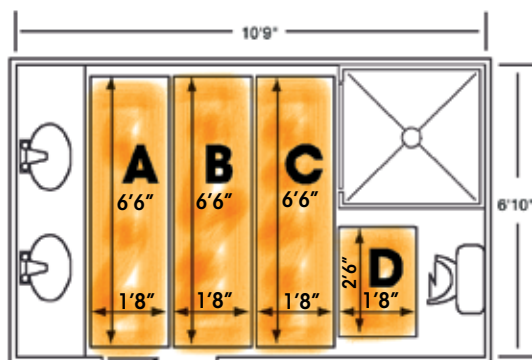



Warm Tiles[®] Room Layout

The grid will help you draw your layout.
Each grid square represents a 3"
(7.62 cm) run.

For Cable Systems: For standard spacing,
draw on the grid squares in either
direction. If you are installing an alternating
run, simply draw the 1-1/2" (3.80 cm) run
in between the grid squares.

For Mat Systems: Your mat is pre-adhered
to the mesh in 3" (7.62 cm) runs and is
20" wide.

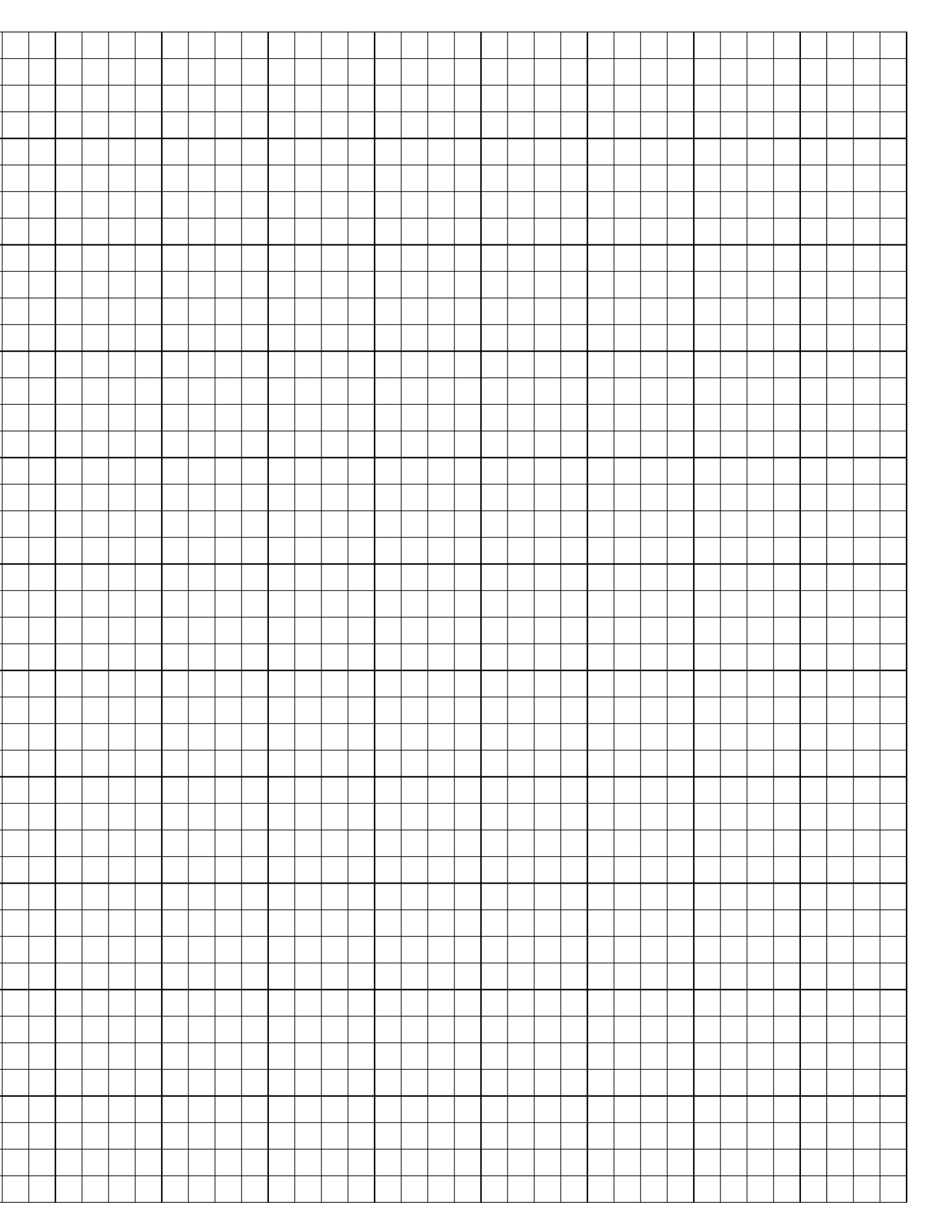



Warm Tiles[®] Room Layout

The grid will help you draw your layout.
Each grid square represents a 3"
(7.62 cm) run.

For Cable Systems: For standard spacing,
draw on the grid squares in either
direction. If you are installing an alternating
run, simply draw the 1-1/2" (3.80 cm) run
in between the grid squares.

For Mat Systems: Your mat is pre-adhered
to the mesh in 3" (7.62 cm) runs and is
20" wide.

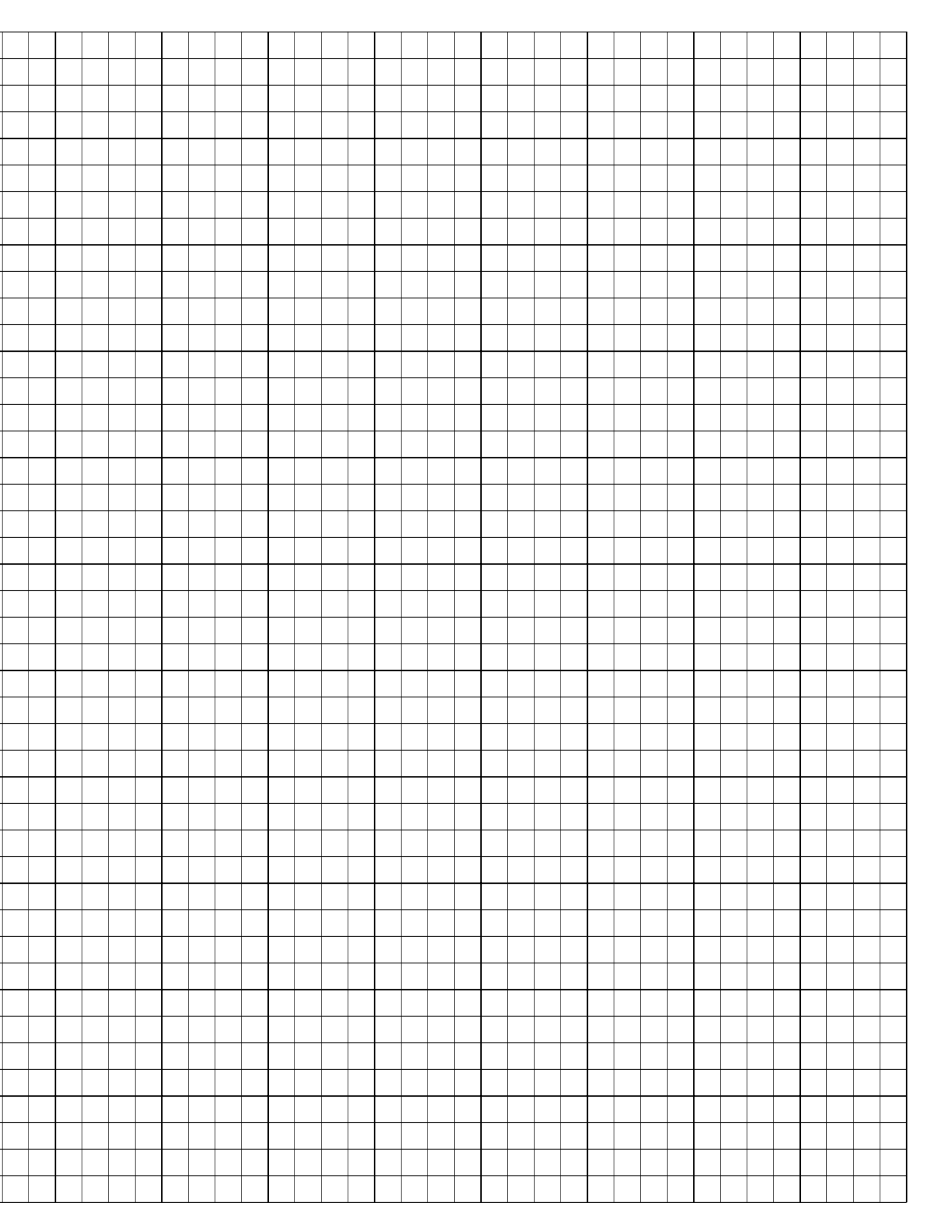

Can You Feel It?



Our warmth makes all the difference.

Worldwide Availability and On-Site Technical Assistance

Our extensive nationwide production facilities and network of local distributors assure the timely availability of the EASYHEAT® Warm Tile® Electric Floor Warming System regardless of where the project is being constructed. Representatives are available to provide specification assistance, job site technical support and post-installation service. EASYHEAT technical resources, such as installation instructional videos and on-line tutorials, are available in three languages, facilitating proper installation techniques.

EASYHEAT specializes in offering the complete system

Including the controls and all of the materials needed to properly install your floor warming system. In addition, EASYHEAT provides roof and gutter de-icing, thermal storage, pipe tracing and snow melting systems. EASYHEAT Sno-Melter® reduces slip hazards and costly snow and ice removal through a network of line voltage cables embedded into the paved surface. Automatic controls which sense moisture and temperature, activate the system during a snowfall without you even having to be there. Sno-Melter is ideal for driveways, sidewalks, plazas, stairs and patios - wherever you want to avoid unnecessary tracking of snow, slush, sand or salt into your home or office.

EASYHEAT®
Warming Your World



For more information call:
US (800)523-7636 • Canada (800) 794-3766

©2010 EASYHEAT Inc. ®EASYHEAT WarmTiles, Sno-Melter, Freeze Free, SR Trace, Deep Heat are Registered Trademarks of EASYHEAT Inc.
40102-003 Rev. 2

