

***Superstrut***<sup>®</sup>

**Metal Framing,  
Channel, Fittings,  
Pipe Straps and  
Beam Clamps**

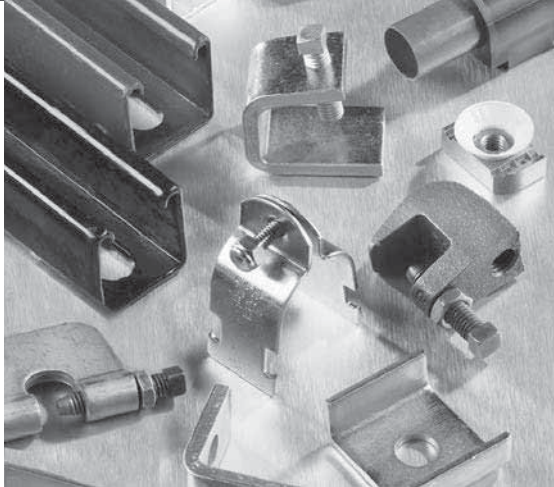

**2008 Edition**



• **ISO 9001 : 2000 REGISTERED MANUFACTURER** •

Thomas & Betts is dedicated to improving its already high quality standards. To date, we have achieved ISO 9001 : 2000 certification for more than 50 plants and distribution centers worldwide and continue to commit resources to the ISO certification program.

**WARRANTY**

Thomas & Betts manufactures its goods and tools in a manner to be free from defects. Should any defect occur in its goods (within two years) or tools (within ninety days), Thomas & Betts, upon prompt notification, will at its option, exchange or repair the goods or tools or refund the purchase price.

**LIMITATIONS AND EXCLUSIONS**

THIS WARRANTY IS IN LIEU OF ALL OTHER REPRESENTATIONS, CONDITIONS AND WARRANTIES, EXPRESSED OR IMPLIED, STATUTORY OR OTHERWISE (INCLUDING STATUTORY IMPLIED CONDITIONS AND WARRANTIES OF MERCHANTABILITY AND FITNESS FOR A PARTICULAR PURPOSE) AND UNDER NO CIRCUMSTANCES SHALL THOMAS & BETTS BE LIABLE FOR ANY INCIDENTAL OR CONSEQUENTIAL DAMAGES OR LOSSES, INCLUDING, WITHOUT LIMITATION, PERSONAL INJURY CAUSED BY IMPROPER USE OR APPLICATION OF ANY THOMAS & BETTS PRODUCT.

---

**TABLE OF CONTENTS**

---

<b>FINISHES AND MATERIALS.....</b>	<b>5</b>
<b>SECTION 1 - CHANNELS AND CONCRETE INSERTS .....</b>	<b>7</b>
Channels .....	8
Welded Combinations .....	10
End Caps and Closure Strips .....	10
Concrete Inserts.....	11
<b>SECTION 2 - THREADED PRODUCTS AND HARDWARE .....</b>	<b>13</b>
Threaded Rod and Accessories .....	14
<b>SECTION 3 - FITTINGS AND BRACKETS .....</b>	<b>19</b>
Flat Fittings.....	20
90° Fittings.....	21
Angular Fittings .....	23
“Z” Shape Fittings .....	23
“U” Shape Fittings .....	24
Wing Fittings .....	25
Brackets .....	26
Post Bases.....	28
Special Application Fittings and Brackets .....	29
<b>SECTION 4 - BEAM CLAMPS .....</b>	<b>31</b>
Beam Clamps for Mounting Channel .....	32
Beam Clamps for Hanging Rod .....	34
Beam Clamps for Mounting Pipe and Conduit.....	37
Beam Fittings.....	38
<b>SECTION 5 - PIPE STRAPS, PIPE CLAMPS AND HANGERS.....</b>	<b>41</b>
Conduit and Cable Clamps.....	42
Pipe Hangers .....	51
Seismic Bracing .....	54
Hanger Accessories.....	55
<b>SECTION 6 - SURFACE RACEWAY AND LIGHTING SYSTEMS .....</b>	<b>57</b>
Fixture Fittings .....	58
Kindorf® Channel Boxes and Receptacles .....	60
Kindorf® Fixture Accessories .....	61
Electrical Applications .....	61
<b>SECTION 7 - RIGHT ANGLE SLOTTED METAL FRAMING .....</b>	<b>65</b>
<b>SECTION 8 - ENGINEERING DATA AND SPECIFICATIONS .....</b>	<b>69</b>
<b>ALPHANUMERIC INDEX .....</b>	<b>86</b>



---

## Finishes and Materials

---

### FINISHES ON STEEL

#### **Bare (Suffix BC)**

#### **Pregalvanized (Suffix PGC)**

A zinc coating is applied by hot-dipping the steel coil at the mill prior to fabrication. Once the material is worked by roll-forming, cutting, or punching, minimal protection is provided for raw edges. This weakness is typical with pre-coated material and affects the channel section around holes, extreme ends, and the edges of the U-shape lips. Superstrut® pregalvanized material is in conformance with ASTM A-525/G-90 specification standards, representing 0.90 oz. of zinc per square foot of steel. This finish is often referred to as “hot-dipped mill galvanized” or “mill galvanized.”

#### **Electrogalvanized (Suffix EGC)**

Often referred to as “zinc plated” or “electroplated zinc,” the steel and 0.5 mils of zinc are bonded by an electrolysis process. Electrogalvanizing is most commonly applied to small fittings, hardware, and threaded products.

#### **GoldGalv® (No Suffix)**

Gold colored zinc dichromate is applied over the zinc, producing a chemically bonded non porous barrier for protection from moisture and air. This extends the protective life of the zinc, and provides an excellent base for paint, if desired. The GoldGalv® hardware finish also provides a low electrical resistance when grounding of the system is required. Superstrut® channel and fittings are plated after fabrication, so there are no unprotected edges from cutting or punching. Where field cutting is necessary or scratches occur due to construction handling, you still have the sacrificial protection of the plated zinc to minimize the corrosion of raw edges and prevent spreading.

#### **Hot-Dipped Galvanized (Suffix HDGC)**

The material is zinc coated after fabrication providing total product protection on all surfaces. The fabricated channel or fitting is suspended and then dipped into tanks of hot zinc for a prolonged period, creating a coherent bond. The result is superior corrosion resistance as compared to pregalvanized material. Hot-dipped galvanizing is not recommended for threaded products, considering the zinc coating thickness will often disrupt the threads. Superstrut® hot-dipped galvanized is in conformance with ASTM Specifications A-123 (formerly A-386) and A-153. Superstrut channels maintain a minimum 1.5 oz. of zinc per square foot of steel or 2.5 mils (ASTM A-123, Thickness Grade 65). This finish is also referred to as “Hot-dipped galvanized after fabrication.”

#### **Epoxy Powder Coated — Green, Gray or White (Suffix GR, GY or WH)**

Epoxy powder resins are applied electrostatically to the steel after fabrication. Once the material is completely covered with the powder-form epoxy, it proceeds through a 400°F (204°C) baking process for ten minutes, creating a chemical bond. This results in a minimum of 1.5 mil thickness of epoxy coating providing excellent resistance to chipping or peeling.

### SPECIAL MATERIALS

#### **Aluminum (Suffix ALC)**

Superstrut® channel is available in aluminum. Fittings in HDG finish or fiberglass material are suggested for fastening products.

#### **Stainless Steel**

Superstrut® **channel** is supplied in Type 304 (SS) and Type 316 (T316L) stainless steel. All fittings and accessories are in 316SS (SS6). Contact your Regional Sales Office for availability.

*Thomas & Betts reserves the right to change material and finish specifications without notice, to improve its products.*



***SECTION 1***  
***CHANNELS AND CONCRETE INSERTS***

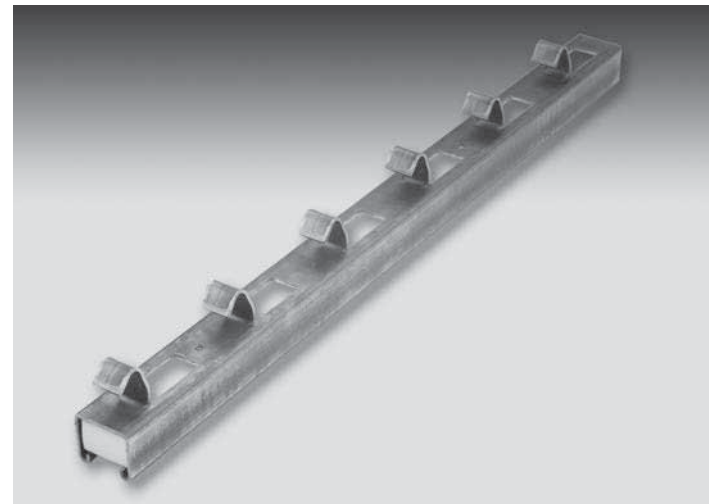
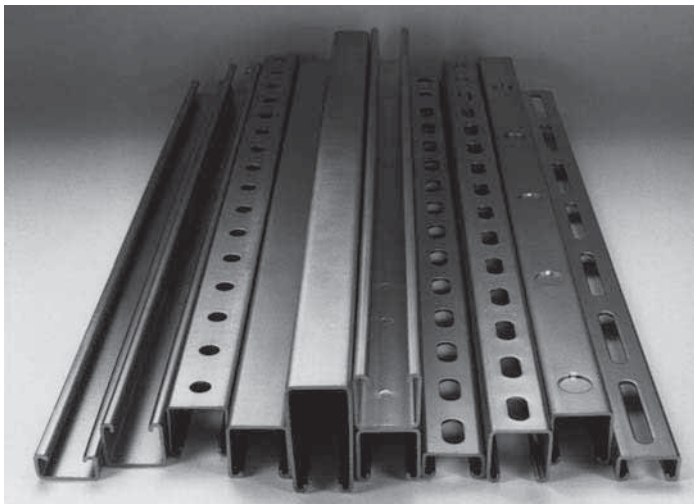

**CHANNEL****Material**

Steel channels are cold-roll formed from strip steel. Aluminum and Fiberglass channels are extruded profiles.

**Material Thickness**

All series 1200 12 gauge material  
 All series 1400 14 gauge material  
 All series 1600 16 gauge ribbed material

**Standard Lengths**

Standard lengths for channel are 10 ft and 20 ft with a tolerance of +1/8". Special lengths can be requested; however, minimum quantities may apply. Channels are sold per foot.

**Warning**

Load tables, charts, and design criteria provided in this catalogue are intended as guides only. Selection of proper product, support spacing, erection, and placement are the responsibility of the user.

When improperly used as tools of erection pipe hanger products have occasionally failed. To avoid an accident, the user is cautioned to use the product only as it was intended.

**CONCRETE INSERT****Material**

Superstrut continuous insert channel is manufactured from 12 gauge hot rolled strip steel in two basic sizes as follows:

**Cat. No. A302**

1-5/8" x 1-5/8" 7/8" slot

**Cat. No. C302**

1-5/8" x 1-3/8" 7/8" slot

**Cat. No. C302**

1-5/8" x 1-3/8" 7/8" slot

**Standard Lengths**

Standard lengths are 10 ft and 20 ft. Product is supplied with foam filler and end caps to prevent concrete from seeping into channel.

**Application**

For casting into concrete walls, floors or ceilings to provide for attachment anywhere along the continuous slot.

**Design Data**

Load ratings as shown have a safety factor of 3 in 3000 lb. hard rock concrete. Where sound concrete does not exist, the load ratings shall not apply.

GoldGalv® hardware finish is standard for all Superstrut Concrete insert products. This is a multi-process finish of electro-plated zinc, followed by gold colored zinc dichromate to give excellent corrosion resistance and a superior paint base.

*For more information on load design, see Section 8 for Engineering Data and Specifications.*

**Channels at Full Scale**

Available in 10 and 20 foot lengths

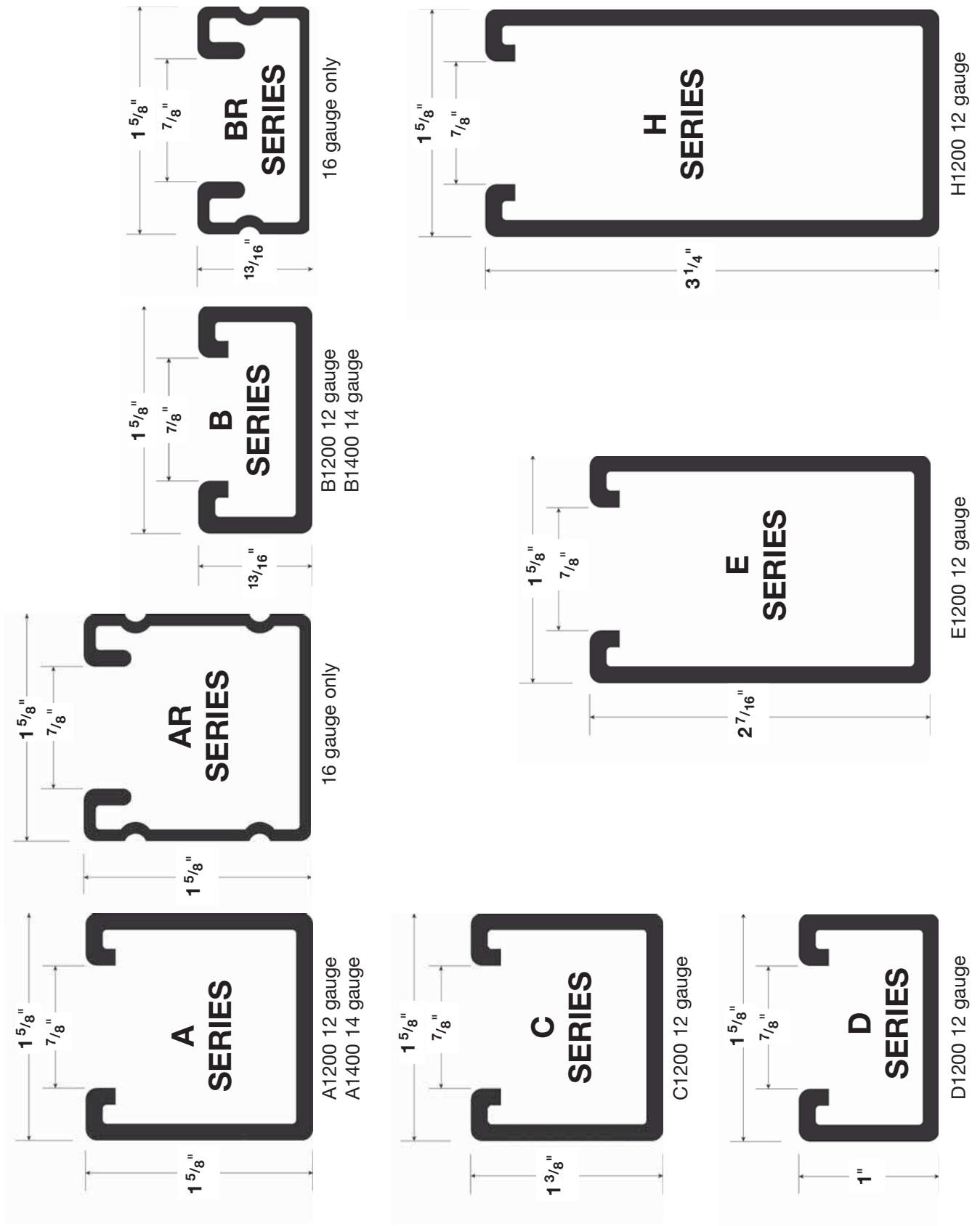



**Channel Selection Chart**

CHANNEL	HOLE CONFIGURATIONS						LENGTH	FINISH ON STEEL						MATÉRIAUX SPÉCIAUX		
	HS	S	SW	P	KO	ft		BC	PG(C)	EG(C)	GoldGalv®	HDG(C)	GR,GY,WH	PV(C)	AL(C)	T316L
<b>Series</b>	<b>HS</b>	<b>S</b>	<b>SW</b>	<b>P</b>	<b>KO</b>	<b>ft</b>	<b>BC</b>	<b>PG(C)</b>	<b>EG(C)</b>	<b>GoldGalv®</b>	<b>HDG(C)</b>	<b>GR,GY,WH</b>	<b>PV(C)</b>	<b>AL(C)</b>	<b>T316L</b>	<b>SS6(C)</b>
A1200						10 or 20										
A1400						10 or 20										
AR1600						10 or 20										
B1200						10 or 20										
B1400						10 or 20										
BR1600						10 or 20										
C1200						10 or 20										
D1200						10 or 20										
E1200						10 or 20										
H1200						10 or 20										

**Legend**

EXAMPLES	HOLE CONFIGURATION	FINISH ON STEEL	SPECIAL MATERIALS
<b>A120010PG</b> Plain channel, 10 ft., pre- galvanized finish	Suffix <b>blank</b> <b>HS</b> <b>S</b> <b>SW</b>	Suffix <b>BC</b> <b>PGC</b> <b>EGC</b> <b>No Suffix</b>	Suffix <b>AL</b> Aluminum <b>SS6 (C)</b> Stainless Steel Type 316 <b>T316L</b> Stainless Steel Type 316L <b>SS (C)</b> Stainless Steel Type 304 *
<b>B1400P10</b> Punched channel, 10 ft., GoldGalv® finish	Plain, no holes Half slot Slotted Slotted wide	Bare Pre-galvanized Electrogalvanized GoldGalv®	
<b>E1200HS20HDG</b> Half slot channel, 20 ft hot dipped galvanized	Punched Knockout	Hot dipped galvanized Epoxy paint in green (GR), grey (GY), or white (WH)	
	Standard offering.	A minimum order quantity may apply.	*Check with your Regional Sales Office

**Hole Configuration**

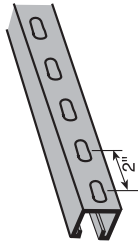
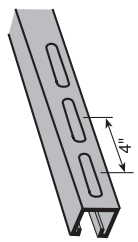
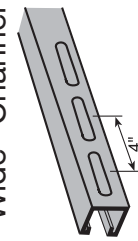
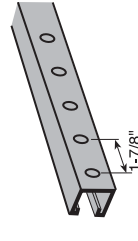
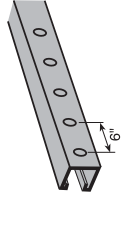
	Half Slot Channel	Slots: 9/16" X 1-1/8"
	Slotted Channel	Slots: 7/16" X 3"
	SW "Slotted Wide" Channel	Slots: 9/16" X 3"
	Punched Channel	Holes: 9/16"
	Channel with Knockouts	KO: 1/2"

## SECTION 1

## Channels and Concrete Inserts

### Welded Combinations

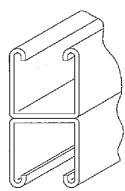

02

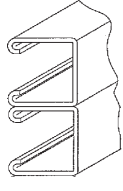

02A

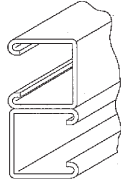

02B

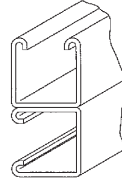

02C

**EXAMPLES**

Two A1200 channels back to back are ordered as A1202. Two A1200 channels back to side are ordered as A1202C.

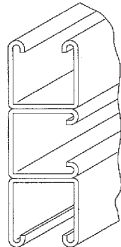

03A

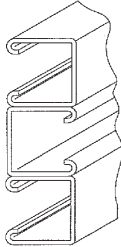

03B

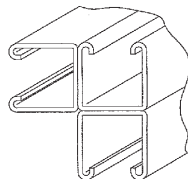

03C

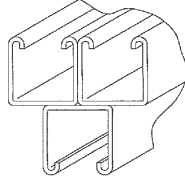

03D

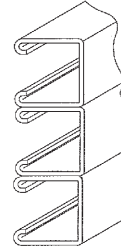

03E

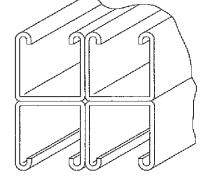

04

Back to back steel channel is riveted at every 4 inches. Aluminum back to back channel are extruded profiles. All other combinations are spot welded at every 4 inches.

### End Caps and Closure Strips

#### A804 End Cap

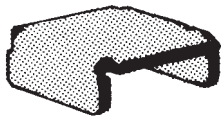

Cat. No.	For Channel	Wt./C lb
A804EG	A1200	10
	A1400 AR1600	10
B804EG	B1400 BR1600	5
C804EG	C1200	8
E804EG	E1200	15
H804	H1200	20

#### Safety End Cap

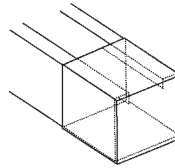

1-5/8" x 1-5/8" White Plastisol.

Cat. No.	For Channel	Wt/C lb
A804NEOPWH	A1200 AR1600	1.75
	A1400	
B804NEOPWH	B1200-BR1600	1.5
H804NEOPWH	H1200	2

#### A2431 End Cap



For A1200 Channel  
Available in GoldGalv® or  
ElectroGalvanized (EG).

Wt./C 16 lb

#### A208

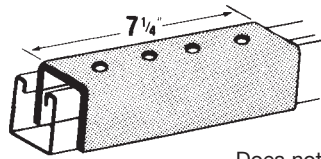

A208HDGC  
A208EG  
A208  
A208SS6C

Does not include  
stud nut or bolts.

For A and AR  
series channel.  
Wt./C 275 lb

#### A213 Inside Joiner

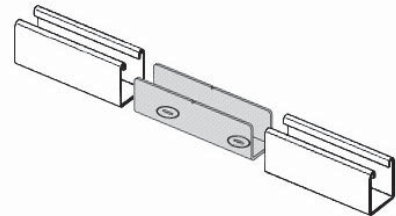

For A1200 Series only.  
Available only in GoldGalv® finish.

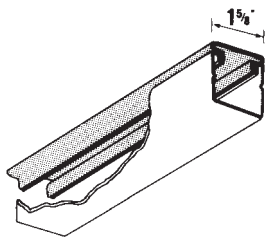

**AB844PGC**  
Pre-Galvanized Closure Strip  
**AB844PCGY**  
Plastic Closure Strip  
Colour: Grey

**AB844PC**  
Plastic Closure Strip  
Colour: Gold

For all channel. Standard lengths 10 ft

**Channels and Concrete Inserts**

**SECTION 1**

**Concrete Inserts**

**Concrete Channel Inserts**

\*Finishes  
HDGC  
GoldGalv®  
PGC

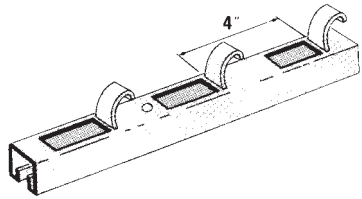

Insert with end caps and foam closure strip installed.

Cat. No.	Length	Gauge	Wt.
<b>A302-10*</b>	10 ft	12	2.19 lb/ft
<b>A302-20*</b>	20 ft	12	2.19 lb/ft
<b>B302-10*</b>	10 ft	12	1.36 lb/ft
<b>B302-20*</b>	20 ft	12	1.36 lb/ft
<b>C302-10*</b>	10 ft	12	1.81 lb/ft

Design Load 2000 lb per foot in hard rock concrete with a safety factor of 3.  
Standard lengths 10 ft and 20 ft.  
Length tolerance: 3/16 in.

**Anchor Caps**

\*Finishes  
EGC  
GoldGalv®

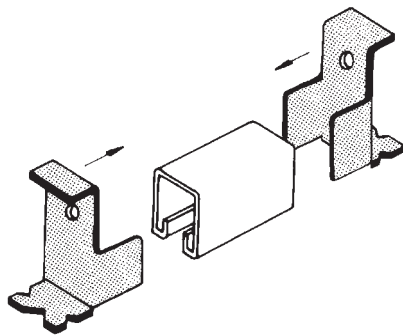

12 gauge, Wt./C: 30 lb/C

A450\* For A Series  
C450\* For C Series

From pieces of A, B, C channel and a pair of anchor caps, short concrete inserts can be fabricated in the field.

**460-10TB**  
**Removable Plastic Closure Strip**

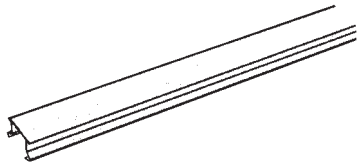

Designed as an added precaution to keep insert free of concrete. Closure strip fits all 1-5/8" wide strip inserts, regardless of depth.

Order per 10 foot, standard length is 10 ft  
Material - Black Plastic

Wt./C 52 lb

**SI400**  
**Spot Insert Kit**

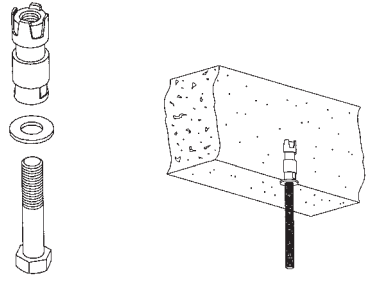

**STD PACK: 10**

Cat. No.	Length ft.	O.D. Insert	Wt./C lb
<b>SI400-3/8</b>	3/8x13x2-3/4	2x5/8	10
<b>SI400-1/2</b>	1/2x13x1-1/4	2-1/2x7/8	35

Other sizes available  
Maximum recommended load:  
SI400-3/8 = 450 lb/204 kg  
SI400-1/2 = 1000 lb/454 kg

**452TB**  
**Spot Insert**

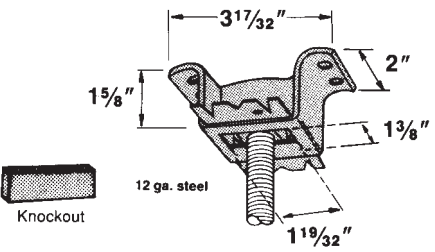

Standard Finish – GoldGalv®

An insert with a knockout saves covering the opening. Accommodates hanger rod sizes from 1/4" through 7/8" by means of an AB102 insert nut, to be ordered separately.

Design load: 1350 lb in 3000 lb. hard rock concrete with a safety factor of 3.

Complies with Specification MSS SP69, Type 18.

Wt./C 52 lb

Wt./C 52 lb

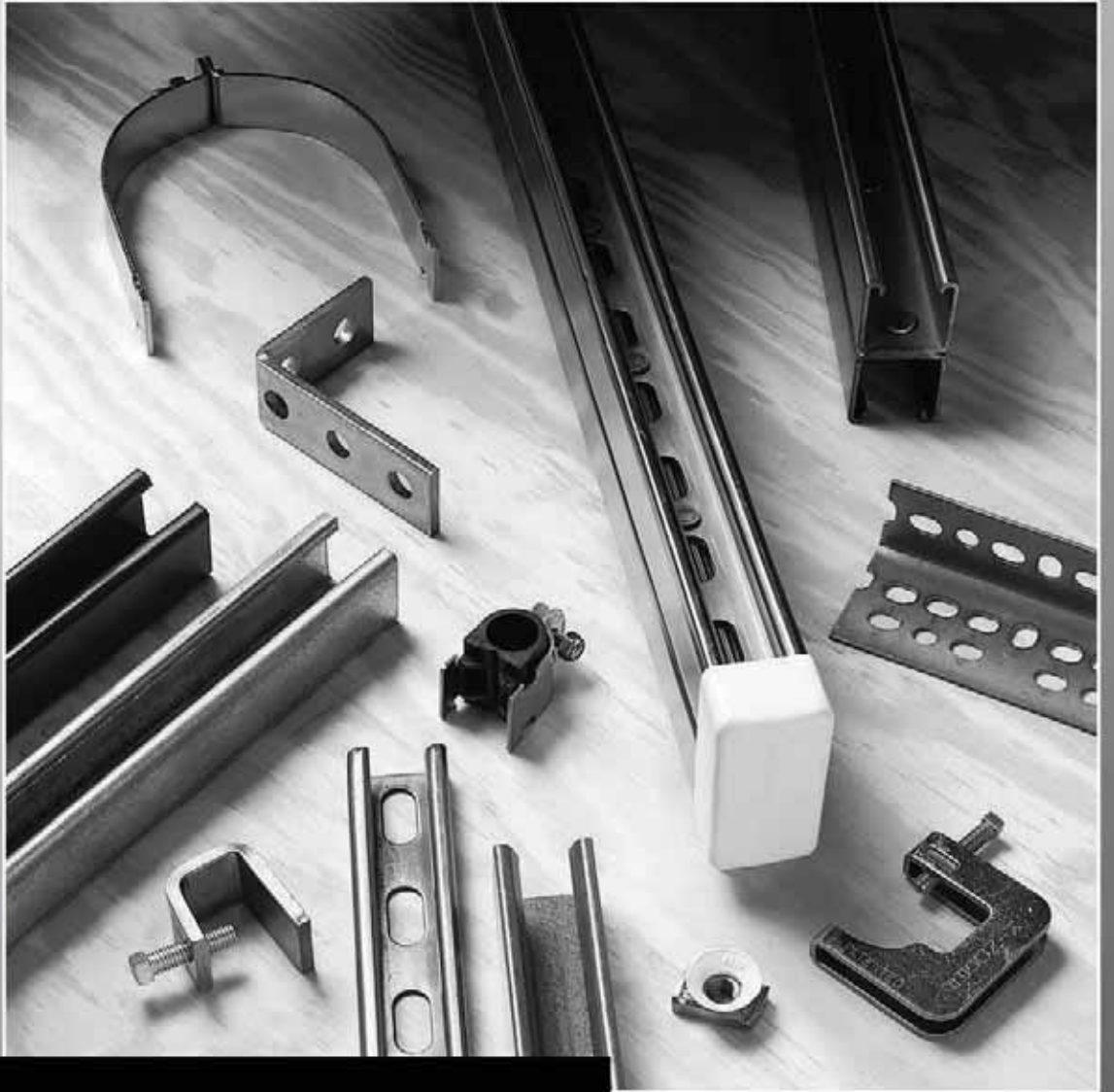

***SECTION 2***  
***THREADED PRODUCTS AND HARDWARE***

***Thomas & Betts***

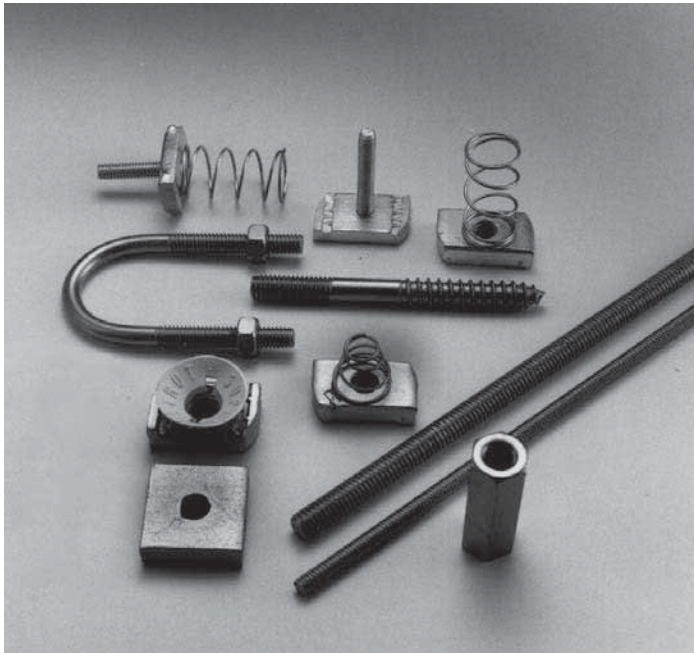

**CHANNEL NUTS**

Superstrut® channel nuts are manufactured from Grade 2 mild steel and are case hardened.

**Design Data**

Superstrut® self aligning channel nuts are designed to provide resistance to pullout and resistance to side slip in excess of the full strength of the channels with which they are used. The extreme resistance to side slip results from the unique design of the alternate teeth, spaced and designed to develop a wedging action that increases with pressure or load.

**Screw Threads**

All threaded products are American Standard thread, free fit class 2.

Thread Size	1/4	5/16	3/8	1/2	5/8	3/4	7/8	1
Threads per inch	20	18	16	13	11	10	9	8
Design Torque (ft-lb)	6	11	19	50	100	125	185	275









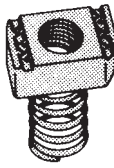
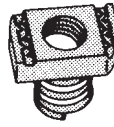
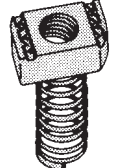

**Finish and special materials**

Standard finish for all hardware is ElectroGalvanized (EGC), GoldGalv®. Stainless Steel Type 316 is also available. Contact your Regional Sales Office for availability and minimum quantities.

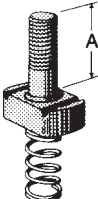
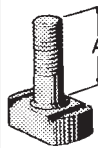
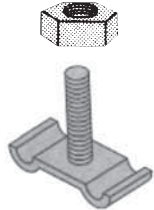
Spring Nut Selector Chart

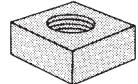
SPRING NUT	CHANNEL SERIES					
	A - AR	B - BR	C	D	E	H
A100-1/4EGC	■		■			
A100-5/16EGC	■		■			
A100-3/8EGC	■		■			
A100-1/2EGC	■		■			
A100-3/4	■		■			
B100-1/4EGC		■		■		
B100-5/16EGC		■		■		
B100-3/8EGC		■		■		
B100-1/2EGC		■		■		
H100-3/8EGC					■	■
H100-1/2EGC					■	■
CM100-1/4	■	■	■	■	■	■
CM100-3/8	■	■	■	■	■	■
CM100-1/2	■		■	■	■	■
CM100-1/2B		■				
UC100-1/4	■	■	■	■	■	■
UC100-3/8	■	■	■	■	■	■
UC100-1/2	■	■	■	■	■	■

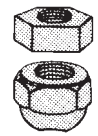

<p><b>A100</b> Regular Spring Nut</p>  <p><b>STD PACK: 100</b></p> <table border="1"> <thead> <tr> <th>Cat. No.</th> <th>Size</th> <th>Wt./C lb</th> </tr> </thead> <tbody> <tr><td>A100-1/4EGC</td><td>1/4</td><td>8</td></tr> <tr><td>A100-5/16EGC</td><td>5/16</td><td>9</td></tr> <tr><td>A100-3/8EGC</td><td>3/8</td><td>10</td></tr> <tr><td>A100-1/2EGC</td><td>1/2</td><td>12</td></tr> <tr><td colspan="3">Nut is square over 1/2" size.</td></tr> <tr><td>A100-5/8EGC</td><td>5/8</td><td>19</td></tr> <tr><td>A100-3/4</td><td>3/4</td><td>19</td></tr> <tr><td>A100-7/8</td><td>7/8</td><td>18</td></tr> </tbody> </table> <p>Available in Stainless Steel 316. For all A and C series channel and inserts.</p>	Cat. No.	Size	Wt./C lb	A100-1/4EGC	1/4	8	A100-5/16EGC	5/16	9	A100-3/8EGC	3/8	10	A100-1/2EGC	1/2	12	Nut is square over 1/2" size.			A100-5/8EGC	5/8	19	A100-3/4	3/4	19	A100-7/8	7/8	18	<p><b>B100</b> Short Spring Nut</p>  <p><b>STD PACK: 100</b></p> <table border="1"> <thead> <tr> <th>Cat. No.</th> <th>Size</th> <th>Wt./C lb</th> </tr> </thead> <tbody> <tr><td>B100-1/4EGC</td><td>1/4</td><td>7</td></tr> <tr><td>B100-5/16EGC</td><td>5/16</td><td>8</td></tr> <tr><td>B100-3/8EGC</td><td>3/8</td><td>9</td></tr> <tr><td>B100-1/2EGC</td><td>1/2</td><td>9</td></tr> </tbody> </table> <p>For all B and D series channel and inserts.</p>	Cat. No.	Size	Wt./C lb	B100-1/4EGC	1/4	7	B100-5/16EGC	5/16	8	B100-3/8EGC	3/8	9	B100-1/2EGC	1/2	9	<p><b>H100</b> Long Spring Nut</p>  <p><b>STD PACK: 100</b></p> <table border="1"> <thead> <tr> <th>Cat. No.</th> <th>Size</th> <th>Wt./C lb</th> </tr> </thead> <tbody> <tr><td>H100-3/8EGC</td><td>3/8</td><td>10</td></tr> <tr><td>H100-1/2EGC</td><td>1/2</td><td>14</td></tr> </tbody> </table> <p>For all E and H series channel and inserts.</p>	Cat. No.	Size	Wt./C lb	H100-3/8EGC	3/8	10	H100-1/2EGC	1/2	14			
Cat. No.	Size	Wt./C lb																																																						
A100-1/4EGC	1/4	8																																																						
A100-5/16EGC	5/16	9																																																						
A100-3/8EGC	3/8	10																																																						
A100-1/2EGC	1/2	12																																																						
Nut is square over 1/2" size.																																																								
A100-5/8EGC	5/8	19																																																						
A100-3/4	3/4	19																																																						
A100-7/8	7/8	18																																																						
Cat. No.	Size	Wt./C lb																																																						
B100-1/4EGC	1/4	7																																																						
B100-5/16EGC	5/16	8																																																						
B100-3/8EGC	3/8	9																																																						
B100-1/2EGC	1/2	9																																																						
Cat. No.	Size	Wt./C lb																																																						
H100-3/8EGC	3/8	10																																																						
H100-1/2EGC	1/2	14																																																						
<p><b>AB100</b> Springless Nut 1/4" thick</p>  <p><b>STD PACK: 100</b></p> <table border="1"> <thead> <tr> <th>Cat. No.</th> <th>Size</th> <th>Wt./C lb</th> </tr> </thead> <tbody> <tr><td>AB100-1/4EGC</td><td>1/4</td><td>7</td></tr> <tr><td>AB100-5/16EGC</td><td>5/16</td><td>8</td></tr> <tr><td>AB100-3/8EGC</td><td>3/8</td><td>9</td></tr> <tr><td>AB100-1/2EG</td><td>1/2</td><td>9</td></tr> <tr><td colspan="3">Nut is square over 1/2" size</td></tr> <tr><td>AB100-5/8EG</td><td>5/8</td><td>10</td></tr> <tr><td>AB100-3/4EG</td><td>3/4</td><td>10</td></tr> </tbody> </table> <p>For use with all channels.</p>	Cat. No.	Size	Wt./C lb	AB100-1/4EGC	1/4	7	AB100-5/16EGC	5/16	8	AB100-3/8EGC	3/8	9	AB100-1/2EG	1/2	9	Nut is square over 1/2" size			AB100-5/8EG	5/8	10	AB100-3/4EG	3/4	10	<p><b>AC100</b> Springless Nut Heavy duty 3/8" thick</p>  <p><b>STD PACK: 100</b></p> <table border="1"> <thead> <tr> <th>Cat. No.</th> <th>Size</th> <th>Wt./C lb</th> </tr> </thead> <tbody> <tr><td>AC100-1/4EGC</td><td>1/4</td><td>7</td></tr> <tr><td>AC100-3/8EGC</td><td>3/8</td><td>9</td></tr> <tr><td>AC100-1/2EGC</td><td>1/2</td><td>11</td></tr> <tr><td colspan="3">Nut is square over 1/2" size</td></tr> <tr><td>AC100-5/8EGC</td><td>5/8</td><td>18</td></tr> <tr><td>AC100-3/4EGC</td><td>3/4</td><td>18</td></tr> </tbody> </table> <p>For all A, C, E and H series channel and inserts.</p>	Cat. No.	Size	Wt./C lb	AC100-1/4EGC	1/4	7	AC100-3/8EGC	3/8	9	AC100-1/2EGC	1/2	11	Nut is square over 1/2" size			AC100-5/8EGC	5/8	18	AC100-3/4EGC	3/4	18	<p><b>813EG</b> Springless Nut Light Duty</p>  <p><b>STD PACK: 100</b></p> <table border="1"> <thead> <tr> <th>Cat. No.</th> <th>Size</th> <th>Wt./C lb</th> </tr> </thead> <tbody> <tr><td>813EG</td><td>1/4</td><td>5</td></tr> </tbody> </table> <p>For use with all channels.</p>	Cat. No.	Size	Wt./C lb	813EG	1/4	5			
Cat. No.	Size	Wt./C lb																																																						
AB100-1/4EGC	1/4	7																																																						
AB100-5/16EGC	5/16	8																																																						
AB100-3/8EGC	3/8	9																																																						
AB100-1/2EG	1/2	9																																																						
Nut is square over 1/2" size																																																								
AB100-5/8EG	5/8	10																																																						
AB100-3/4EG	3/4	10																																																						
Cat. No.	Size	Wt./C lb																																																						
AC100-1/4EGC	1/4	7																																																						
AC100-3/8EGC	3/8	9																																																						
AC100-1/2EGC	1/2	11																																																						
Nut is square over 1/2" size																																																								
AC100-5/8EGC	5/8	18																																																						
AC100-3/4EGC	3/4	18																																																						
Cat. No.	Size	Wt./C lb																																																						
813EG	1/4	5																																																						
<p><b>A182 to A185</b> Regular Spring Stud Nut</p>  <p><b>STD PACK: 100</b></p> <table border="1"> <thead> <tr> <th>Cat. No.</th> <th>Bolt Dia.</th> <th>Length A</th> <th>Wt./C lb</th> </tr> </thead> <tbody> <tr><td>A182-1/4x100EG</td><td>1/4</td><td>1</td><td>10</td></tr> <tr><td>A182-1/4x125EG</td><td>1/4</td><td>1-1/4</td><td>15</td></tr> <tr><td>A184-3/8x100EG</td><td>3/8</td><td>1</td><td>10</td></tr> <tr><td>A184-3/8x125EG</td><td>3/8</td><td>1-1/4</td><td>15</td></tr> <tr><td>A185-1/2x100EG</td><td>1/2</td><td>1</td><td>10</td></tr> <tr><td>A185-1/2x125EG</td><td>1/2</td><td>1-1/4</td><td>15</td></tr> </tbody> </table> <p>For all A and C series channels.</p>	Cat. No.	Bolt Dia.	Length A	Wt./C lb	A182-1/4x100EG	1/4	1	10	A182-1/4x125EG	1/4	1-1/4	15	A184-3/8x100EG	3/8	1	10	A184-3/8x125EG	3/8	1-1/4	15	A185-1/2x100EG	1/2	1	10	A185-1/2x125EG	1/2	1-1/4	15	<p><b>A177 to A180</b> Springless Stud Nut</p>  <p><b>STD PACK: 100</b></p> <table border="1"> <thead> <tr> <th>Cat. No.</th> <th>Bolt Dia.</th> <th>Length A</th> <th>Wt./C lb</th> </tr> </thead> <tbody> <tr><td>A177-1/4x100EG</td><td>1/4</td><td>1</td><td>8</td></tr> <tr><td>A177-1/4x125EG</td><td>1/4</td><td>1-1/4</td><td>10</td></tr> <tr><td>A179-3/8x100EG</td><td>3/8</td><td>1</td><td>13</td></tr> <tr><td>A179-3/8x125EG</td><td>3/8</td><td>1-1/4</td><td>13.5</td></tr> </tbody> </table> <p>For use with all channels.</p>	Cat. No.	Bolt Dia.	Length A	Wt./C lb	A177-1/4x100EG	1/4	1	8	A177-1/4x125EG	1/4	1-1/4	10	A179-3/8x100EG	3/8	1	13	A179-3/8x125EG	3/8	1-1/4	13.5	<p><b>812</b> Stud Nut</p>  <p><b>STD PACK: 100</b></p> <table border="1"> <thead> <tr> <th>Cat. No.</th> <th>For Channel</th> <th>Wt./C lb</th> </tr> </thead> <tbody> <tr><td>812-1EG</td><td>1/4 x 1</td><td>6</td></tr> </tbody> </table> <p>For attaching fixture to channel slot down or to channel slot up knockouts. Specify length. Hex nut included.</p>	Cat. No.	For Channel	Wt./C lb	812-1EG	1/4 x 1	6
Cat. No.	Bolt Dia.	Length A	Wt./C lb																																																					
A182-1/4x100EG	1/4	1	10																																																					
A182-1/4x125EG	1/4	1-1/4	15																																																					
A184-3/8x100EG	3/8	1	10																																																					
A184-3/8x125EG	3/8	1-1/4	15																																																					
A185-1/2x100EG	1/2	1	10																																																					
A185-1/2x125EG	1/2	1-1/4	15																																																					
Cat. No.	Bolt Dia.	Length A	Wt./C lb																																																					
A177-1/4x100EG	1/4	1	8																																																					
A177-1/4x125EG	1/4	1-1/4	10																																																					
A179-3/8x100EG	3/8	1	13																																																					
A179-3/8x125EG	3/8	1-1/4	13.5																																																					
Cat. No.	For Channel	Wt./C lb																																																						
812-1EG	1/4 x 1	6																																																						
<p><b>CM100</b> Nylon Cone Nut</p>  <p><b>STD PACK: 100</b></p> <table border="1"> <thead> <tr> <th>Cat. No.</th> <th>Size</th> <th>Wt./C lb</th> </tr> </thead> <tbody> <tr><td>CM100-1/4</td><td>1/4</td><td>8</td></tr> <tr><td>CM100-3/8</td><td>3/8</td><td>10</td></tr> <tr><td>* CM100-1/2</td><td>1/2</td><td>12</td></tr> <tr><td>** CM100B-1/2</td><td>1/2</td><td>10</td></tr> </tbody> </table> <p>GoldGalv® only For all 1-5/8" channel *Will not fit B Series channel **For B Series channel</p>	Cat. No.	Size	Wt./C lb	CM100-1/4	1/4	8	CM100-3/8	3/8	10	* CM100-1/2	1/2	12	** CM100B-1/2	1/2	10	<p><b>UC100</b> Universal Nylon Cone Nut</p>  <p><b>STD PACK: 100</b></p> <table border="1"> <thead> <tr> <th>Cat. No.</th> <th>Size</th> <th>Wt./C lb</th> </tr> </thead> <tbody> <tr><td>UC100-1/4</td><td>1/4</td><td>8</td></tr> <tr><td>UC100-3/8</td><td>3/8</td><td>10</td></tr> <tr><td>UC100-1/2</td><td>1/2</td><td>12</td></tr> </tbody> </table> <p>GoldGalv® only For all 1-5/8" and 1-1/2" channels May be used with ALL Strut Depths. Can be used for CM100 Series, A100 Series, B100 Series and AB100 Series.</p>	Cat. No.	Size	Wt./C lb	UC100-1/4	1/4	8	UC100-3/8	3/8	10	UC100-1/2	1/2	12	<p><b>AB102</b> Unhardened Square Nut</p>  <p><b>STD PACK: 100</b></p> <table border="1"> <thead> <tr> <th>Cat. No.</th> <th>Size</th> <th>Wt./C lb</th> </tr> </thead> <tbody> <tr><td>AB102-1/4</td><td>1/4</td><td>13</td></tr> <tr><td>AB102-3/8</td><td>3/8</td><td>14</td></tr> <tr><td>AB102-1/2</td><td>1/2</td><td>14</td></tr> <tr><td>AB102-5/8</td><td>5/8</td><td>12</td></tr> <tr><td>AB102-3/4</td><td>3/4</td><td>11</td></tr> <tr><td>AB102-7/8</td><td>7/8</td><td>10</td></tr> </tbody> </table>	Cat. No.	Size	Wt./C lb	AB102-1/4	1/4	13	AB102-3/8	3/8	14	AB102-1/2	1/2	14	AB102-5/8	5/8	12	AB102-3/4	3/4	11	AB102-7/8	7/8	10						
Cat. No.	Size	Wt./C lb																																																						
CM100-1/4	1/4	8																																																						
CM100-3/8	3/8	10																																																						
* CM100-1/2	1/2	12																																																						
** CM100B-1/2	1/2	10																																																						
Cat. No.	Size	Wt./C lb																																																						
UC100-1/4	1/4	8																																																						
UC100-3/8	3/8	10																																																						
UC100-1/2	1/2	12																																																						
Cat. No.	Size	Wt./C lb																																																						
AB102-1/4	1/4	13																																																						
AB102-3/8	3/8	14																																																						
AB102-1/2	1/2	14																																																						
AB102-5/8	5/8	12																																																						
AB102-3/4	3/4	11																																																						
AB102-7/8	7/8	10																																																						
<p><b>E145</b> Standard Hex Nut</p>  <p><b>STD PACK: 100</b></p> <table border="1"> <thead> <tr> <th>Cat. No.</th> <th>Size</th> <th>Wt./C lb</th> </tr> </thead> <tbody> <tr><td>E145-1/4EGC</td><td>1/4</td><td>.72</td></tr> <tr><td>E145-3/8EGC</td><td>3/8</td><td>1.60</td></tr> <tr><td>E145-1/2EGC</td><td>1/2</td><td>2.78</td></tr> <tr><td>E145-5/8EG</td><td>5/8</td><td>6.92</td></tr> <tr><td>E145-3/4EGC</td><td>3/4</td><td>12.70</td></tr> <tr><td>E145-7/8EGC</td><td>7/8</td><td>19.00</td></tr> <tr><td>E145-1EGC</td><td>1</td><td>28.00</td></tr> </tbody> </table>	Cat. No.	Size	Wt./C lb	E145-1/4EGC	1/4	.72	E145-3/8EGC	3/8	1.60	E145-1/2EGC	1/2	2.78	E145-5/8EG	5/8	6.92	E145-3/4EGC	3/4	12.70	E145-7/8EGC	7/8	19.00	E145-1EGC	1	28.00	<p><b>ES145</b> Swivel Nut and Jam Nut Combinations</p>  <p><b>STD PACK: 100</b></p> <table border="1"> <thead> <tr> <th>Cat. No.</th> <th>Size</th> <th>Wt./C lb</th> </tr> </thead> <tbody> <tr><td>ES145-3/8</td><td>3/8</td><td>5.5</td></tr> <tr><td>ES145-1/2</td><td>1/2</td><td>6.0</td></tr> </tbody> </table>	Cat. No.	Size	Wt./C lb	ES145-3/8	3/8	5.5	ES145-1/2	1/2	6.0	<p><b>E146</b> Standard Square Nut</p>  <p><b>STD PACK: 100</b></p> <table border="1"> <thead> <tr> <th>Cat. No.</th> <th>Size</th> <th>Wt./C lb</th> </tr> </thead> <tbody> <tr><td>E146-1/4HDGC</td><td>1/4</td><td>.93</td></tr> <tr><td>E146-5/16HDGC</td><td>5/16</td><td>1.60</td></tr> <tr><td>E146-3/8HDGC</td><td>3/8</td><td>2.65</td></tr> <tr><td>E146-5/8HDGC</td><td>5/8</td><td>10.80</td></tr> </tbody> </table>	Cat. No.	Size	Wt./C lb	E146-1/4HDGC	1/4	.93	E146-5/16HDGC	5/16	1.60	E146-3/8HDGC	3/8	2.65	E146-5/8HDGC	5/8	10.80						
Cat. No.	Size	Wt./C lb																																																						
E145-1/4EGC	1/4	.72																																																						
E145-3/8EGC	3/8	1.60																																																						
E145-1/2EGC	1/2	2.78																																																						
E145-5/8EG	5/8	6.92																																																						
E145-3/4EGC	3/4	12.70																																																						
E145-7/8EGC	7/8	19.00																																																						
E145-1EGC	1	28.00																																																						
Cat. No.	Size	Wt./C lb																																																						
ES145-3/8	3/8	5.5																																																						
ES145-1/2	1/2	6.0																																																						
Cat. No.	Size	Wt./C lb																																																						
E146-1/4HDGC	1/4	.93																																																						
E146-5/16HDGC	5/16	1.60																																																						
E146-3/8HDGC	3/8	2.65																																																						
E146-5/8HDGC	5/8	10.80																																																						



**Threaded Products and Hardware**

**SECTION 2**

**E147**  
Flat Steel Washer

**STD PACK: 100**

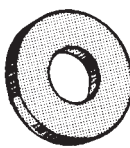

Cat. No.	Size	Wt./C lb
E147-1/4EG	1/4	.67
E147-5/16EG	5/16	1.11
E147-3/8EG	3/8	1.49
E147-1/2EG	1/2	3.85
E147-5/8EG	5/8	7.69
E147-3/4EG	3/4	9.89
E147-7/8EG	7/8	15.40

Available in Stainless Steel.

**EF147**  
Fender Washer

**STD PACK: 100**

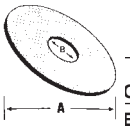

Cat. No.	Size	A	B	Wt./C lb
EF147-1/4EGC	1/4	1-1/4	5/16	3.1
EF147-3/8EGC	3/8	1-1/2	7/16	2.9
	1/2	2	9/16	5.0

Available in Stainless Steel.

**E148**  
Lock Washer

**STD PACK: 100**



Cat. No.	Size	Wt./C lb
E148-1/4EG	1/4	.26
E148-3/8EG	3/8	.50
E148-1/2EG	1/2	1.09
E148-5/8EG	5/8	2.57

Available in Stainless Steel.

**E142**  
Hex Head Cap Screw

**STD PACK: 100**



Cat. No.	Size	Wt./C lb
E142-1/4x100EG	1/4x1	1.74
E142-1/4x150EG	1/4x1-1/2	2.43
E142-3/8x100EG	3/8x1	4.17
E142-3/8x150EG	3/8x1-1/2	5.64
E142-1/2x100EG	1/2x1	8.94
E142-1/2x150EG	1/2x1-1/2	10.00
E142-1/2x200EG	1/2x2	11.19
E142-1/2x225EG	1/2x2-1/4	11.90
E142-1/2x250EG	1/2x2-1/2	12.52
E142-1/2x275EG	1/2x2-3/4	13.22

Available in Stainless Steel.

**E150S**  
Lag Bolt

**STD PACK: 50**



Cat. No.	Drill Size	Size	Wt./C lb
E150S-3/8x1-1/2EG	1/4	3/8x1-1/2	5
E150S-3/8x2EG	1/4	3/8x2	7
E150S-3/8x2-1/2EG	1/4	3/8x2-1/2	8
E150S-3/8x3EG	1/4	3/8x3	9
E150S-1/2x1-1/2EG	11/32	1/2x1-1/2	12
E150S-1/2x2EG	11/32	1/2x2	13
E150S-1/2x2-1/2EG	11/32	1/2x2-1/2	15
E150S-1/2x3EG	11/32	1/2x3	18

**E151**  
Coach Screw Rod



Cat. No.	Rod Size in.	Standard Rod Lengths in.	Wt./C lb
E151-3/8x4EG	3/8	4	9
E151-3/8x6EG	3/8	6	14
E151-3/8x8EG	3/8	8	22
E151-3/8x10EG	3/8	10	29
E151-3/8x12EG	3/8	12	35
E151-1/2x4EG	1/2	4	17
E151-1/2x6EG	1/2	6	22
E151-1/2x8EG	1/2	8	40
E151-1/2x10EG	1/2	10	51

Machine threaded opposite end, carbon steel.

**H104**  
Hanger Rod  
Continuous Threaded

**STD PACK: 3**



- Black available upon request.
- Sold per foot; standard length, 10 ft
- Also available in stainless steel (304 and 316) standard length 6 ft
- National coarse thread

Cat. No.	Thread Size	Wt./lb 100 ft	Design Load lb
H104-1/4x10EGC	1/4	12.5	150
H104-3/8x10EGC	3/8	29	610
H104-1/2x10EGC	1/2	53.5	1130
H104-5/8x10EGC	5/8	85	1810
H104-3/4x10EGC	3/4	123	2710
H104-7/8x10EG	7/8	130	3770
H104-1x10EG	1	214	4960

Available in 12' Stainless Steel.

**H119**  
Rod Couplings

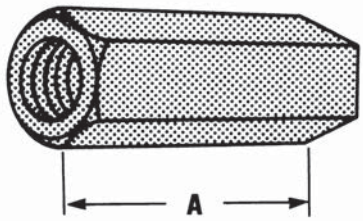

Standard Rod Coupling  
Example: H119-1/2EG

Rod Size	A	Wt./C lb
1/4	7/8	1.90
5/16	7/8	3.75
3/8	1-1/8	3.50
1/2	1-1/4	5.50
5/8	2-1/8	18.00
3/4	2-1/4	28.00
7/8	2-1/2	55.00
1	2-1/4	56.00

Rod Reducer Coupling  
Example: H119-1/4x3/8EG

Rod Size	A	Wt./C lb
1/4 to 3/8	1-1/2	3.50
3/8 to 1/2	1-1/4	6.70
1/2 to 5/8	1-1/4	14.00
5/8 to 3/4	1-1/2	21.00
3/4 to 7/8	1-3/4	40.00

Order by product number, rod size, and finish.  
Available in Stainless Steel.

## SECTION 2

## Threaded Products and Hardware

### H122 Trapnut™ Strut Fastener



**Finishes**  
Electrogalvanized (EG)  
GoldGalv®  
Stainless Steel Type 316 (SS6)

Cat. No.	Size	Design Load lb	Std. Ctn.
H 122 1/4	1/4	150	50
H 122 3/8	3/8	590	50
H 122 1/2	1/2	1080	50
H 122 1/4 EG	1/4	150	50
H 122 3/8 EG	3/8	590	50
H 122 1/2 EG	1/2	1080	50
H 122 1/4 SS6	1/4	150	50
H 122 3/8 SS6	3/8	590	50
H 122 1/2 SS6	1/2	1080	50



### M117 Eye Socket

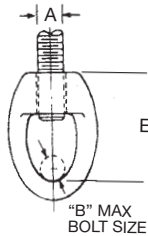
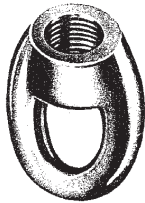

Rod Size A	Pipe Size B	E	Wt./C lb	Design Load, lb
1/4	3/8	1/4	1-11/32	230
3/8	1/2 - 2	1/4	1-11/32	610
1/2	2-1/2 - 3-1/2	1/4	1-17/32	1130
5/8	4 - 5	3/8	1-13/16	1810
3/4	6	1/2	2-5/32	2400
7/8	8	1/2	2-11/32	2800

**Standard Finishes - Bare (B), Electrogalvanized (EG)**  
Malleable iron. For attaching hanger rod to various types of hangers and beam clamps  
Order by product number, rod size, and finish. **Example: M117-1/4B**  
Complies with Specification MSS SP69, Type 16.

### E120 Swivel Joint

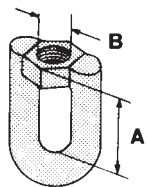

Cat. No.	Size	A	B	Wt./C lb	Design Load lb
E120-3/8	3/8	1-3/8	3/8	15	1000
E120-1/2	1/2	1-1/2	1/2	25	1800

### E120A Weldless Eye Nut

**Standard Finish - Bare (B)**  
Drop Forged Steel  
For use on high temperature piping installations.  
Order by product number and rod size.  
**Example: E120A-3/8B**

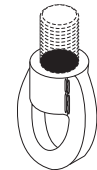

Rod Size T	A	B	C	D	E	F	Wt./C lb	Design Load lb
3/8	7/8	5/8	1-1/4	2	2-1/2	3/8	20	2700
1/2	7/8	5/8	1-1/4	2	2-1/2	3/8	22	2700
5/8	1-3/8	3/4	1-1/2	2-1/2	3	1/2	60	5000
3/4	1-3/8	3/4	1-1/2	2-1/2	3	1/2	56	5000
7/8	1-1/2	1-5/8	1-5/16	3-5/8	4-1/2	3/4	174	10000
1	1-1/2	1-5/8	1-5/16	3-5/8	4-1/2	3/4	168	10000

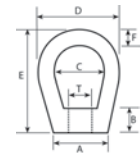

### E122 Swivel Joint

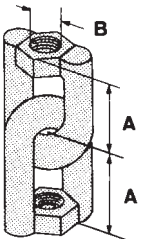

Cat. No.	Size	A	B	Wt./C lb	Design Load lb
E122-3/8	3/8	1-3/8	3/8	28	1000
E122-1/2	1/2	1-1/2	1/2	48	1800

### E130 Swivel Joint

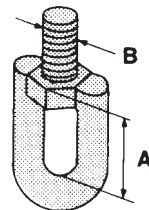

Cat. No.	Size	A	B	Wt./C lb	Design Load lb
E130-3/8	3/8	1-3/8	3/8	23	1000
E130-1/2	1/2	1-1/2	1/2	28	1800

### E131 Swivel Joint

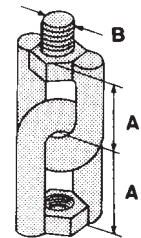

Cat. No.	Size	A	B	Wt./C lb	Design Load lb
E131-3/8	3/8	1-3/8	3/8	25	1000
E131-1/2	1/2	1-1/2	1/2	52	1800

**C781**  
Square Washer

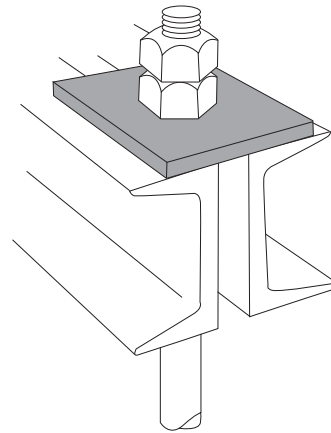

\*Finishes  
B  
HDG  
EG  
SS6

**STD  
PACK:  
50**

Used for beam applications.  
For channel applications use AB241.

Cat. No.	Rod Size	Hole Size	Overall Dimensions	Wt./C lb
C781-3/8*	3/8	7/16	3 x 3 x 3/16	27
C781-1/2*	1/2	9/16	3 x 3 x 3/16	27
C781-5/8*	5/8	11/16	3 x 3 x 1/4	47
C781-3/4*	3/4	13/16	3 x 3 x 1/4	42
C781-7/8*	7/8	15/16	4 x 4 x 3/8	85
C781-1*	1	1-1/8	4 x 4 x 3/8	160

**H115**  
Standard U-Bolt

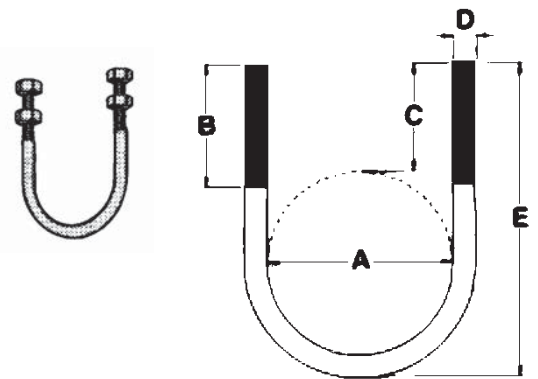

Pipe Size	A	B	C	D	E	Wt./C lb	Design Load lb
1/2	15/16	1-3/4	1-1/2	3/8	2-3/4	13	1500
3/4	1-1/8	1-3/4	1-5/8	3/8	3-1/16	15	2000
1	1-3/8	1-7/8	1-5/8	3/8	3-5/16	16	2500
1-1/4	1-23/32	1-3/4	1-15/32	3/8	3-1/2	17	2500
1-1/2	2	1-3/4	1-7/16	3/8	3-3/4	18	2500
2	2-7/16	2-1/16	1-7/8	3/8	4-11/16	32	3300
2-1/2	2-15/16	2-1/16	1-13/16	3/8	5-1/8	34	4000
3	3-9/16	2	1-3/4	3/8	5-11/16	38	4000
3-1/2	4-3/32	2	1-23/32	3/8	6-3/16	40	4000
4	4-19/32	2-1/4	1-31/32	1/2	6-15/16	46	4000
5	5-5/8	3	2-7/32	1/2	8-5/16	101	4000
6	6-3/4	3-3/4	2-13/16	5/8	10-1/8	197	4000
8	8-3/4	3-3/4	2-13/16	5/8	12-1/8	233	4000
10	10-7/8	4	3	3/4	14-9/16	491	5400
12	12-7/8	4-1/4	3-1/4	7/8	16-15/16	773	7500

For sizes 14 to 36", contact your Regional Sales Office.

**Standard Finishes - Electrogalvanized (EG), GoldGalv®, Stainless Steel or Bare (B)**

**Example: H115-1/2EG**

Sizes through 4" furnished with one hex nut per leg.  
Sizes 5" and above furnished with two hex nuts per leg.  
Order by Cat. No., pipe size, finish.

Complies with Specification MSS SP69, Type 24.

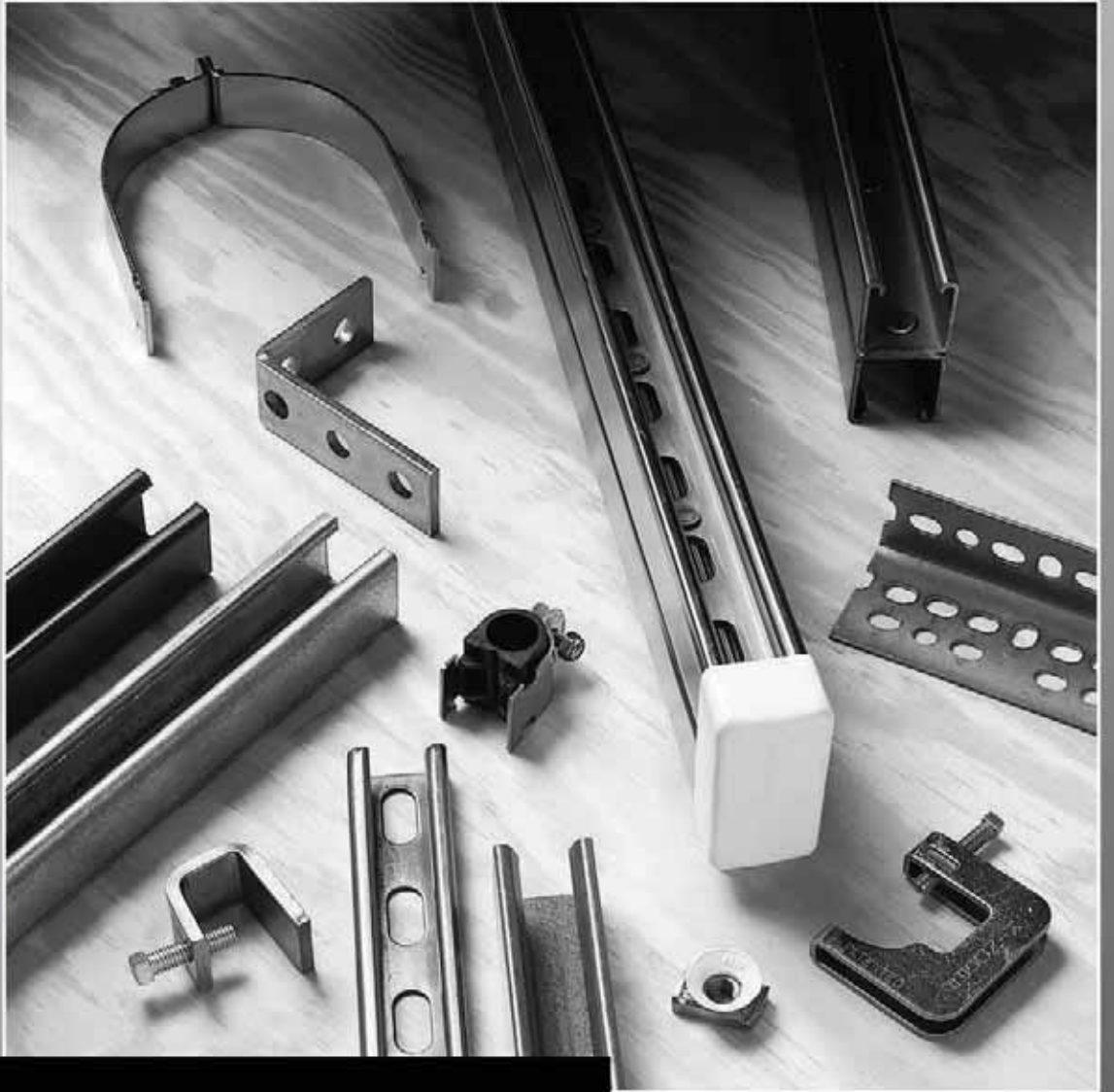

***SECTION 3***  
***FITTINGS AND BRACKETS***

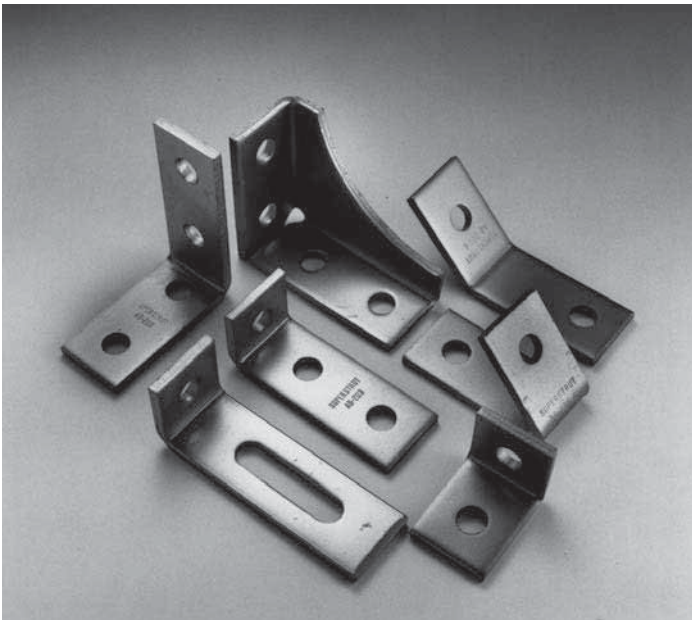

**Material**

Superstrut® fittings and brackets are manufactured from hot rolled carbon steel.

**Dimensions**

The following standard dimensions apply to all fittings except as indicated on the individual drawings.

Hole spacing 13/16" from end of fittings

Hole spacing 1-7/8" centers

Hole size 9/16" diameter

Material 1-5/8" wide

Material 1/4" thick

**Application Instructions**

Parts drawings illustrate a typical use for the fitting, and in many cases other uses for the part are appropriate.

**Design Data**

Load ratings vary depending fittings and brackets are used with 12, 14 or 16 gauge channel. Ratings are shown for each channel material. (See Section 8 Engineering Data and Specifications).

The material is zinc coated after fabrication providing total product protection on all surfaces. The fabricated channel or fitting is suspended and then dipped into tanks of hot zinc for a prolonged period, creating a coherent bond. Other finishes are available. Refer to page 4.

**Nuts and Bolts Required**

Unless otherwise noted, nuts and bolts for use with fittings and brackets should be ordered separately.

The standard bolt for the 9/16" hole is a 1/2" hex head cap screw 1" long. The 1" length may be used with all series channel.

**Design Load**

For more information on design load, see section 8 Engineering Data and Specifications.

**Finishes and Special Materials**

Standard finishes are Hot Dipped Galvanized (HDGC) and GoldGalv® (no suffix). Fittings are also available in ElectroGalvanized (EG) and Stainless Steel 316 (SS6C). Contact your Regional Sales Office for availability and minimum quantities.

**Aluminum channel**

For Aluminum channel, we suggest fittings in HDG(C) or SS6 (C).

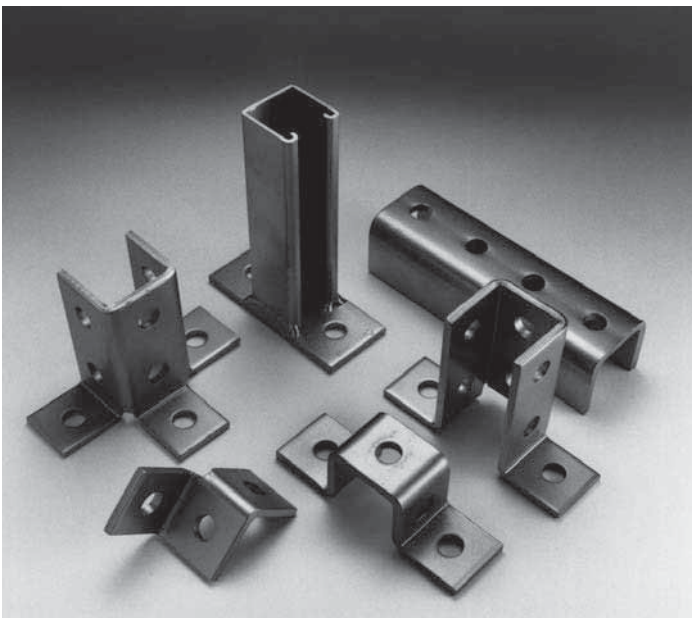

## SECTION 3

## Fittings and Brackets

### Flat Fittings

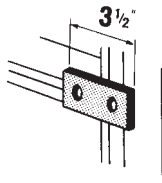
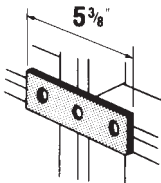
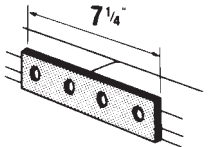
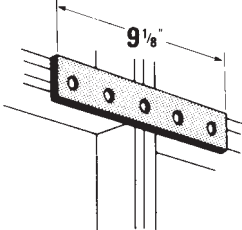
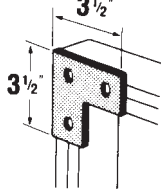
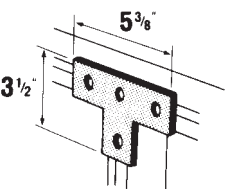
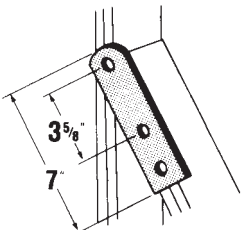
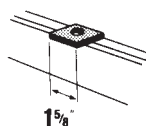
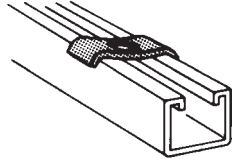
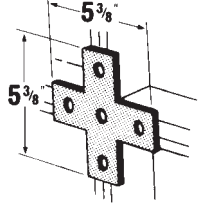
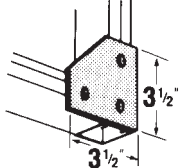
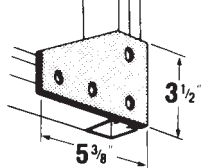
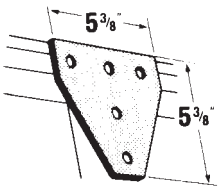
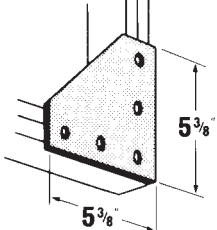
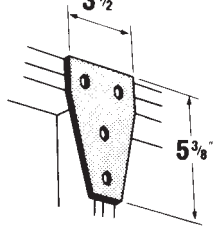
<p><b>AB206</b></p>  <p>AB206HDGC AB206EG AB206 AB206SS6C</p> <p>Wt./C 35 lb</p>	<p><b>AB207</b></p>  <p>AB207HDGC AB207EG AB207 AB207SS6C</p> <p>Wt./C 52 lb</p>	<p><b>X207</b></p>  <p>X207HDG X207EG X207 X207SS6</p> <p>Wt./C 78 lb</p>																					
<p><b>X208</b></p>  <p>X208HDG X208EG X208 X208SS6C</p> <p>Wt./C 88 lb</p>	<p><b>AB219</b></p>  <p>AB219HDGC AB219EG AB219 AB219SS6C</p> <p>Wt./C 53 lb</p>	<p><b>AB220</b></p>  <p>AB220HDGC AB220EG AB220 AB220SS6C</p> <p>Wt./C 78 lb</p>																					
<p><b>AB240</b></p>  <p>AB240HDG AB240EG AB240</p> <p>Wt./C 69 lb</p>	<p><b>AB241</b></p> <p>*Finishes HDGC EG GoldGalv® SS6C</p> <table border="1" data-bbox="534 1060 798 1239"> <thead> <tr> <th>Cat. No.</th> <th>Bolt Size</th> <th>Wt./C lb</th> </tr> </thead> <tbody> <tr> <td>AB241-1/4*</td> <td>1/4</td> <td>18</td> </tr> <tr> <td>AB241-5/16*</td> <td>5/16</td> <td>18</td> </tr> <tr> <td>AB241-3/8*</td> <td>3/8</td> <td>18</td> </tr> <tr> <td>AB241-1/2*</td> <td>1/2</td> <td>17</td> </tr> <tr> <td>AB241-5/8*</td> <td>5/8</td> <td>15</td> </tr> <tr> <td>AB241-3/4*</td> <td>3/4</td> <td>14</td> </tr> </tbody> </table>  <p>1 5/8"</p>	Cat. No.	Bolt Size	Wt./C lb	AB241-1/4*	1/4	18	AB241-5/16*	5/16	18	AB241-3/8*	3/8	18	AB241-1/2*	1/2	17	AB241-5/8*	5/8	15	AB241-3/4*	3/4	14	<p><b>AB242</b></p>  <p>AB242HDGC AB242EG AB242</p> <p>For use with either 3/8" or 1/2" hanger rod.</p> <p>Wt./C 9 lb</p>
Cat. No.	Bolt Size	Wt./C lb																					
AB241-1/4*	1/4	18																					
AB241-5/16*	5/16	18																					
AB241-3/8*	3/8	18																					
AB241-1/2*	1/2	17																					
AB241-5/8*	5/8	15																					
AB241-3/4*	3/4	14																					
<p><b>AB253</b></p>  <p>AB253HDGC AB253EG AB253 AB253SS6C</p> <p>Wt./C 97 lb</p>	<p><b>AB255</b></p>  <p>AB255HDGC AB255EG AB255</p> <p>Wt./C 70 lb</p>	<p><b>AB257</b></p>  <p>AB257HDGC AB257EG AB257</p> <p>Wt./C 105 lb</p>																					
<p><b>AB261</b></p>  <p>AB261HDGC AB261EG AB261</p> <p>Wt./C 148 lb</p>	<p><b>AB263</b></p>  <p>AB263HDGC AB263EG AB263 AB263SS6</p> <p>Wt./C 150 lb</p>	<p><b>AB265</b></p>  <p>AB265HDGC AB265EG AB265</p> <p>Wt./C 105 lb</p>																					



**Fittings and Brackets**

**SECTION 3**

**90° Fittings**

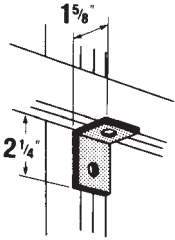
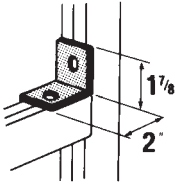
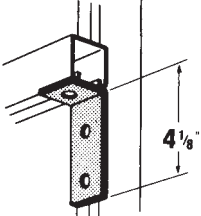
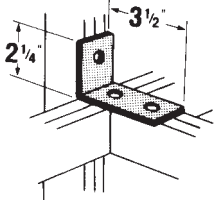
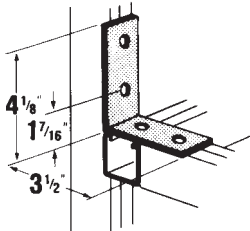
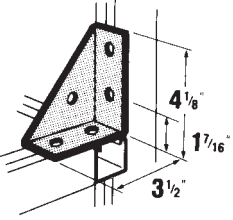
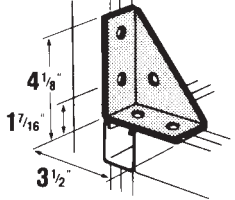
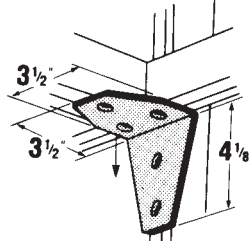
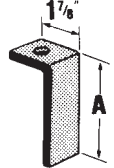
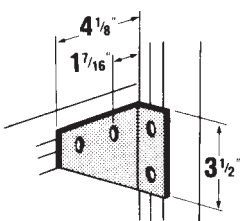
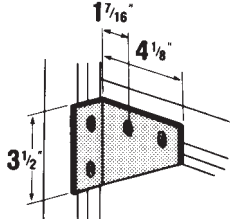
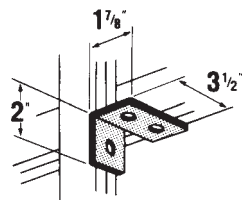
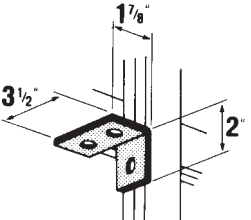
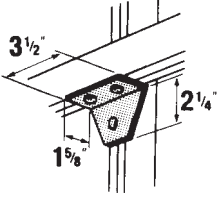
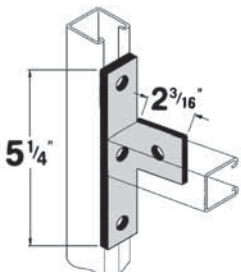
<p><b>AB201</b></p>  <p>AB201HDGC AB201EG AB201 AB201SS6C</p> <p>Wt./C 35 lb</p>	<p><b>AB202</b></p>  <p>AB202HDGC AB202EG AB202 AB202SS6C</p> <p>Wt./C 35 lb</p>	<p><b>AB203</b></p>  <p>AB203HDGC AB203EG AB203 AB203SS6C</p> <p>Wt./C 58 lb</p>															
<p><b>AB204</b></p>  <p>AB204HDGC AB204EG AB204 AB204SS6</p> <p>Wt./C 58 lb</p>	<p><b>AB205</b></p>  <p>AB205HDGC AB205EG AB205 AB205SS6C</p> <p>Wt./C 78 lb</p>	<p><b>AB213</b></p>  <p>AB213HDGC AB213EG AB213</p> <p>Wt./C 125 lb</p>															
<p><b>AB214</b></p>  <p>AB214HDGC AB214EG AB214 AB214SS6</p> <p>Wt./C 125 lb</p>	<p><b>AB216</b></p>  <p>AB216HDGC AB216EG AB216SS6C</p> <p>Wt./C 135 lb</p>	<p><b>AB252</b></p> <p>*Finishes HDGC GoldGalv® EG</p> <table border="1"> <thead> <tr> <th>Cat. No.</th> <th>A</th> <th>Wt./C lb</th> </tr> </thead> <tbody> <tr> <td>AB252-1*</td> <td>3-7/8</td> <td>61</td> </tr> <tr> <td>AB252-2*</td> <td>5-7/8</td> <td>84</td> </tr> <tr> <td>AB252-3*</td> <td>7-7/8</td> <td>107</td> </tr> <tr> <td>AB252-4*</td> <td>9-7/8</td> <td>130</td> </tr> </tbody> </table> 	Cat. No.	A	Wt./C lb	AB252-1*	3-7/8	61	AB252-2*	5-7/8	84	AB252-3*	7-7/8	107	AB252-4*	9-7/8	130
Cat. No.	A	Wt./C lb															
AB252-1*	3-7/8	61															
AB252-2*	5-7/8	84															
AB252-3*	7-7/8	107															
AB252-4*	9-7/8	130															
<p><b>AB254R</b></p>  <p>AB254RHDGC AB254REG AB254R</p> <p>Wt./C 105 lb</p>	<p><b>AB254L</b></p>  <p>AB254LHDGC AB254LEG AB254L</p> <p>Wt./C 105 lb</p>	<p><b>AB260R</b></p>  <p>AB260RHDGC AB260REG AB260R</p> <p>Wt./C 58 lb</p>															
<p><b>AB260L</b></p>  <p>AB260LHDGC AB260LEG AB260L</p> <p>Wt./C 58 lb</p>	<p><b>AB274</b></p>  <p>AB274HDG AB274EG AB274</p> <p>Wt./C 70 lb</p>	<p><b>AB275</b></p>  <p>AB275HDGC AB275EG AB275SS6C</p> <p>Wt./C 77 lb</p>															

**Standard Dimensions**

Hole Spacing 13/16" From End  
Hole Spacing 1-7/8" Centers  
Hole Size 9/16" Diam.  
Material 1-5/8" Width  
Material 1/4" Thick

**Materials**

HDG(C)  
EG(C)  
(No suffix)  
SS6(C)

Hot-Dipped Galvanized  
Electrogalvanized  
GoldGalv®  
Stainless Steel 316

**Thomas & Betts**

**SECTION 3**

**Fittings and Brackets**

**90° Fittings**

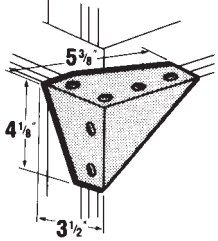
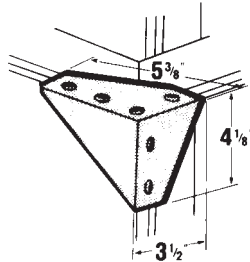
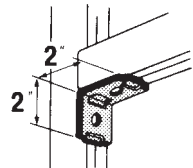
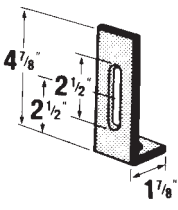
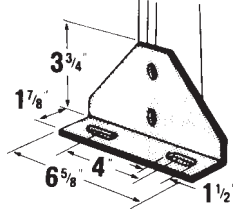
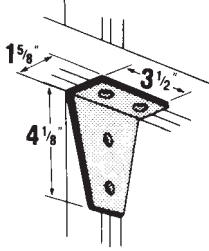
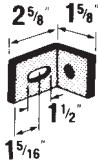
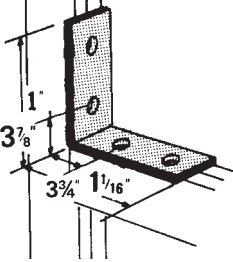
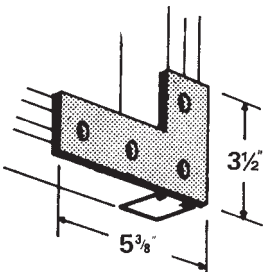
<p><b>AB284R</b></p>  <p>AB284RHDG AB284REG AB284R</p> <p>Wt./C 230 lb</p>	<p><b>AB284L</b></p>  <p>AB284LHDG AB284LEG AB284L</p> <p>Wt./C 230 lb</p>	<p><b>AB299</b></p>  <p>AB299HDG AB299EG AB299</p> <p>Wt./C 40 lb</p>
<p><b>X201</b></p>  <p>X201HDG X201EG X201</p> <p>Wt./C 65 lb</p>	<p><b>X204</b></p>  <p>X204HDG X204EG X204</p> <p>Wt./C 1-90 lb</p>	<p><b>X289</b></p>  <p>X289HDGC X289EG X289</p> <p>Wt./C 105 lb</p>
<p><b>X299</b></p>  <p>X299HDGC X299EG X299</p> <p>Wt./C 38 lb</p>	<p><b>N205</b></p>  <p>N205HDGC N205EG N205 N205SS6C</p> <p>Wt./C 74 lb</p>	<p><b>N219</b></p>  <p>N219HDG N219EG N219 N219SS6</p> <p>Wt./C 71 lb</p>

**Fittings and Brackets**

**SECTION 3**

**Angular Fittings**

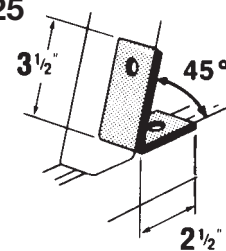
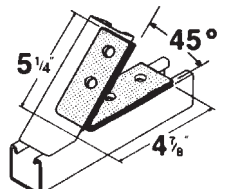
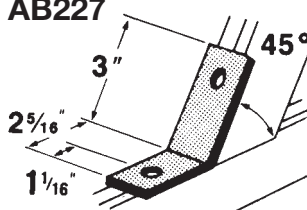
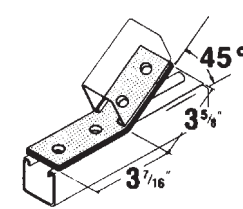
<p><b>AB225</b></p>  <p>Other angles available. Contact Customer Service.</p> <p><b>AB225HDGC</b> <b>AB225EG</b> <b>AB225</b> <b>AB225SS6</b></p> <p>Wt./C 58 lb</p>	<p><b>AB226</b></p>  <p>Other angles available. Contact Customer Service.</p> <p><b>AB226HDGC</b> <b>AB226SS6</b></p> <p>Wt./C 119 lb</p>	<p><b>AB227</b></p>  <p>Other angles available. Contact Customer Service.</p> <p><b>AB227HDGC</b> <b>AB227EG</b> <b>AB227</b> <b>AB227SS6</b></p> <p>Wt./C 58 lb</p>	<p><b>AB228</b></p>  <p>Other angles available. Contact Customer Service.</p> <p><b>AB228HDGC</b> <b>AB228SS6C</b></p> <p>Wt./C 69 lb</p>
---	--	--	--

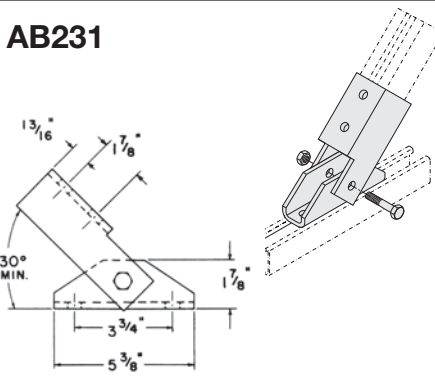
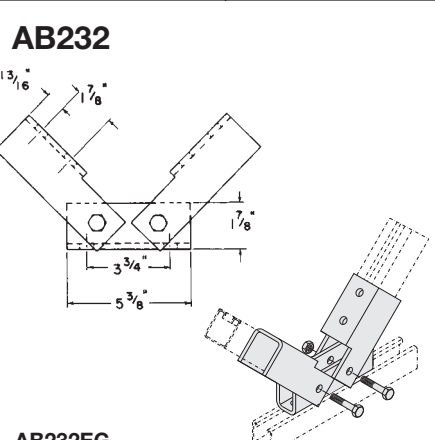
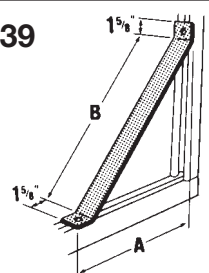
<p><b>AB231</b></p>  <p><b>AB231EG</b></p>	<p><b>AB232</b></p>  <p><b>AB232EG</b></p>	<p><b>AB239</b></p>  <p>*Finishes HDGC GoldGalv® EG</p> <table border="1"> <thead> <tr> <th>Cat. No.</th> <th>A</th> <th>B</th> <th>Wt./C lb</th> </tr> </thead> <tbody> <tr> <td><b>AB239-1*</b></td> <td>7-13/16</td> <td>8-1/2</td> <td>148</td> </tr> <tr> <td><b>AB239-2*</b></td> <td>13-3/4</td> <td>17</td> <td>255</td> </tr> <tr> <td><b>AB239-3*</b></td> <td>19-3/4</td> <td>25-1/2</td> <td>363</td> </tr> </tbody> </table>	Cat. No.	A	B	Wt./C lb	<b>AB239-1*</b>	7-13/16	8-1/2	148	<b>AB239-2*</b>	13-3/4	17	255	<b>AB239-3*</b>	19-3/4	25-1/2	363
Cat. No.	A	B	Wt./C lb															
<b>AB239-1*</b>	7-13/16	8-1/2	148															
<b>AB239-2*</b>	13-3/4	17	255															
<b>AB239-3*</b>	19-3/4	25-1/2	363															

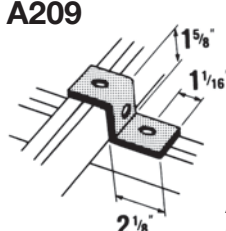
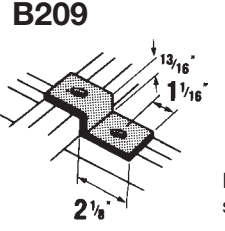
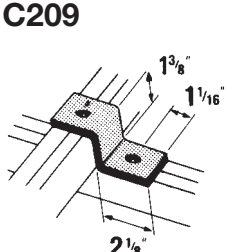
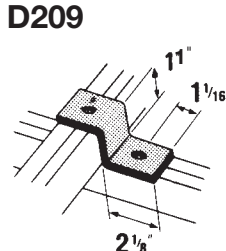
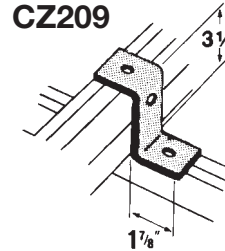
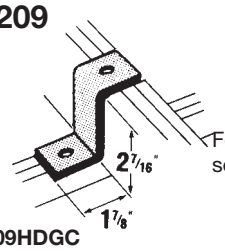
<p><b>"Z" Shape Fittings</b></p>		
<p><b>A209</b></p>  <p>For attaching A and AR series channel.</p> <p><b>A209HDGC</b> <b>A209EG</b> <b>A209</b> <b>A209SS6</b></p> <p>Wt./C 55 lb</p>	<p><b>B209</b></p>  <p>For attaching B and BR series channel.</p> <p><b>B209HDG</b> <b>B209EG</b> <b>B209</b></p> <p>Wt./C 43 lb</p>	<p><b>C209</b></p>  <p>For attaching C series channel.</p> <p><b>C209</b></p> <p>Wt./C 49 lb</p>
<p><b>D209</b></p>  <p>For attaching D series channel.</p> <p><b>D209HDG</b> <b>D209EG</b> <b>D209</b></p> <p>Wt./C 45 lb</p>	<p><b>CZ209</b></p>  <p>For attaching H series and A back to back.</p> <p><b>CZ209EG</b> <b>CZ209</b></p> <p>Wt./C 70 lb</p>	<p><b>EZ209</b></p>  <p>For attaching E series channel.</p> <p><b>EZ209HDGC</b> <b>EZ209EG</b> <b>EZ209</b> <b>EZ209SS6</b></p> <p>Wt./C 70 lb</p>

<b>Standard Dimensions</b>	Hole Spacing Hole Spacing Hole Size Material Material	13/16" From End 1-7/8" Centers 9/16" Diam. 1-5/8" Width 1/4" Thick	<b>Materials</b>	HDG(C) EG(C) (No suffix) SS6(C)	Hot-Dipped Galvanized Electrogalvanized GoldGalv® Stainless Steel 316
----------------------------	---	--	------------------	--	--

**“U” Shape Fittings**

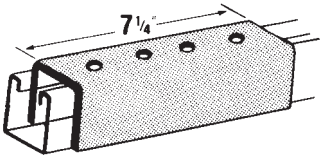
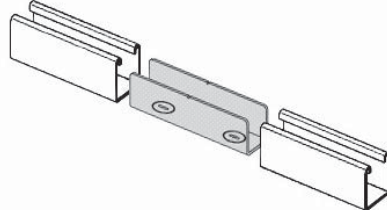
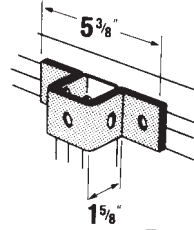
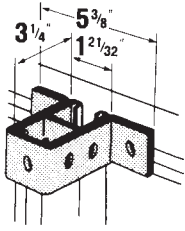
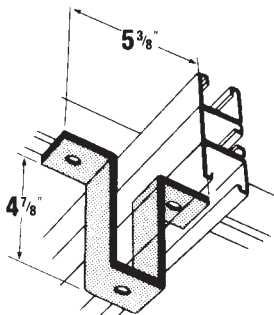
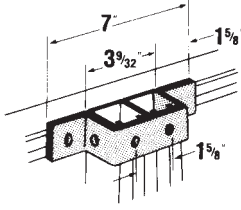
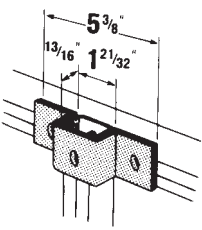
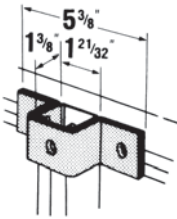
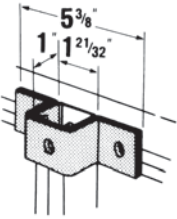
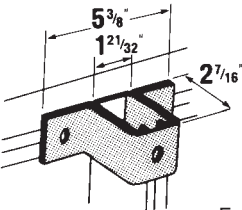
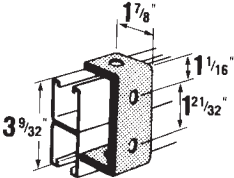
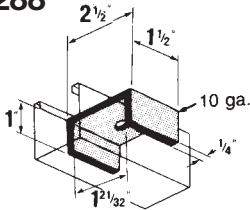
<p><b>A208</b></p>  <p>Does not include stud nut or bolts.</p> <p><b>A208HDGC</b> <b>A208EG</b> <b>A208</b> <b>A208SS6C</b></p> <p>For A and AR series channel. Wt./C 275 lb</p>	<p><b>A213</b> Inside Joiner</p>  <p>For A1200 series Available only in GoldGalv® finish Wt./C 40 lb</p>	<p><b>A210</b></p>  <p>For attaching A and AR series channel. Wt./C 88 lb</p> <p><b>A210HDGC</b> <b>A210EG</b> <b>A210</b> <b>A210SS6C</b></p>												
<p><b>A211</b></p>  <p>For attaching A and AR series double channel, and H series Wt./C 128 lb</p> <p><b>A211HDGC</b> <b>A211EG</b> <b>A211</b></p>	<p><b>AN211</b></p>  <p>Wt./C 181 lb</p> <p><b>AN211HDG</b> <b>AN211EG</b> <b>AN211</b></p>	<p><b>A212</b></p>  <p>Wt./C 113 lb</p> <p><b>A212HDG</b> <b>A212EG</b> <b>A212</b> <b>A212SS6</b></p>												
<p><b>B210</b></p>  <p>For attaching B and BR series. Wt./C 65 lb</p> <p><b>B210HDG</b> <b>B210EG</b> <b>B210</b> <b>B210SS6</b></p>	<p><b>C210</b></p>  <p>For attaching C series channel. Wt./C 77 lb</p> <p><b>C210HDG</b> <b>C210EG</b> <b>C210</b></p>	<p><b>D210</b></p>  <p>For attaching D series channel. Wt./C 71 lb</p> <p><b>D210HDG</b> <b>D210EG</b> <b>D210</b> <b>D210SS6</b></p>												
<p><b>E210</b></p>  <p>For attaching E series channel. Wt./C 112 lb</p> <p><b>E210HDGC</b> <b>E210EG</b> <b>E210</b></p>	<p><b>AB245</b></p>  <p>For attaching A and AR series double channel. Wt./C 70 lb</p> <p><b>AB245HDG</b> <b>AB245EG</b> <b>AB245</b></p>	<p><b>AB288</b></p>  <p>*Finishes HDG GoldGalv® EG</p> <table border="1" data-bbox="1069 1774 1364 1921"> <thead> <tr> <th>Cat. No.</th> <th>Bolt Size</th> <th>Wt./C lb</th> </tr> </thead> <tbody> <tr> <td><b>AB288-3/8*</b></td> <td>3/8</td> <td>37</td> </tr> <tr> <td><b>AB288-1/2*</b></td> <td>1/2</td> <td>37</td> </tr> <tr> <td><b>AB288-5/8*</b></td> <td>5/8</td> <td>37</td> </tr> </tbody> </table>	Cat. No.	Bolt Size	Wt./C lb	<b>AB288-3/8*</b>	3/8	37	<b>AB288-1/2*</b>	1/2	37	<b>AB288-5/8*</b>	5/8	37
Cat. No.	Bolt Size	Wt./C lb												
<b>AB288-3/8*</b>	3/8	37												
<b>AB288-1/2*</b>	1/2	37												
<b>AB288-5/8*</b>	5/8	37												

**Fittings and Brackets**

**SECTION 3**

**Wing Fittings**

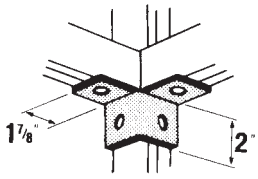
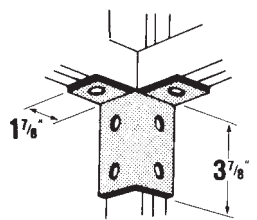
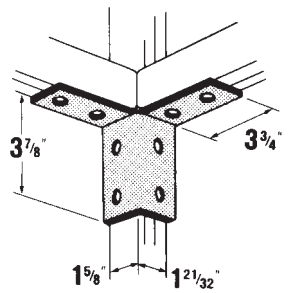
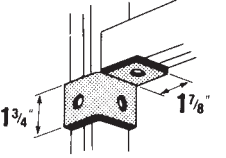
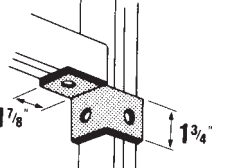
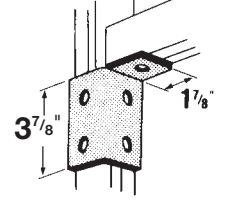
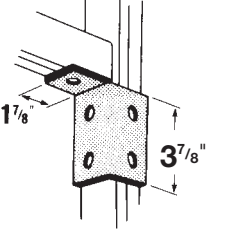
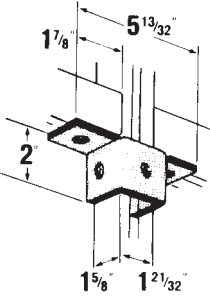
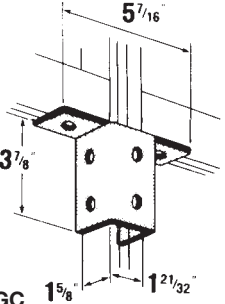
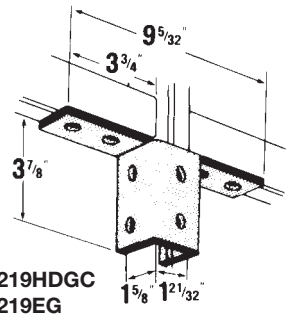
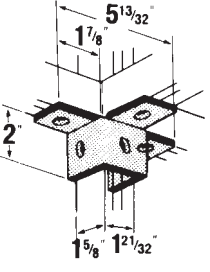
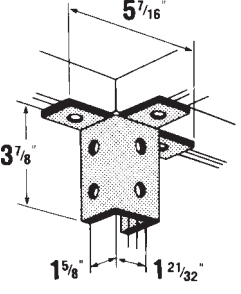
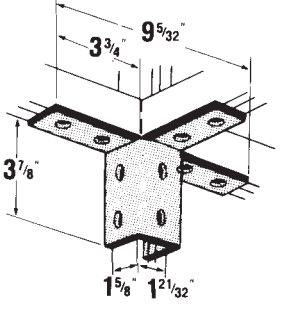
<p><b>AW204</b></p>  <p>AW204HDG AW204EG AW204</p> <p>Wt./C 76 lb</p>	<p><b>AW214</b></p>  <p>AW214HDG AW214EG AW214</p> <p>Wt./C 115 lb</p>	<p><b>A217</b></p>  <p>AW217H A217EG A217</p> <p>Wt./C 155 lb</p>	
<p><b>AW205L</b></p>  <p>AW205LHDG AW205LEG AW205L</p>	<p><b>AW205R</b></p>  <p>AW205RHDG AW205REG AW205R</p> <p>Wt./C 59 lb</p>	<p><b>AW215L</b></p>  <p>AW215LHDG AW215LEG AW215L</p>	<p><b>AW215R</b></p>  <p>AW215RHDG AW215REG AW215R</p> <p>Wt./C 98 lb</p>
<p><b>AW220</b></p>  <p>AW220HI AW220EG AW220</p> <p>Wt./C 90 lb</p>	<p><b>AW224</b></p>  <p>AW224HDGC AW224EG AW224</p> <p>Wt./C 147 lb</p>	<p><b>AW219</b></p>  <p>AW219HDGC AW219EG AW219</p> <p>Wt./C 187 lb</p>	
<p><b>AW226</b></p>  <p>AW226HDG AW226</p> <p>Wt./C 113 lb</p>	<p><b>A218</b></p>  <p>A218HC A218EG A218</p> <p>Wt./C 177 lb</p>	<p><b>AW228</b></p>  <p>AW2 AW2 AW228</p> <p>Wt./C 230 lb</p>	

**Standard Dimensions**  
 Hole Spacing 13/16" From End  
 Hole Spacing 1-7/8" Centers  
 Hole Size 9/16" Diam.  
 Material 1-5/8" Width  
 Material 1/4" Thick

**Materials**

HDG(C)  
EG(C)  
(No suffix)  
SS6(C)

Hot-Dipped Galvanized  
ElectroGalvanized  
GoldGalv®  
Stainless Steel 316

### Brackets

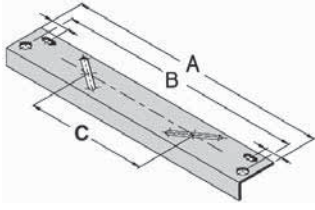
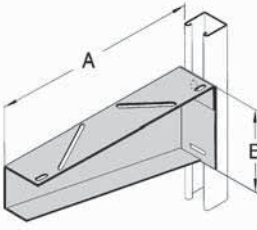
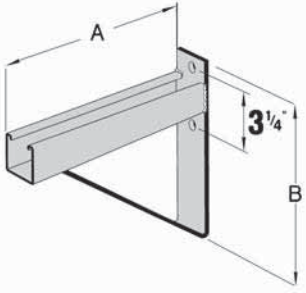
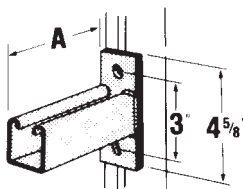
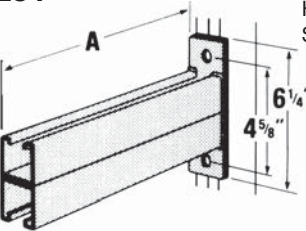
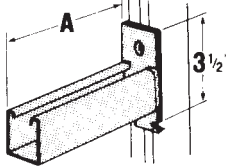
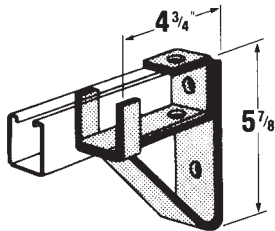
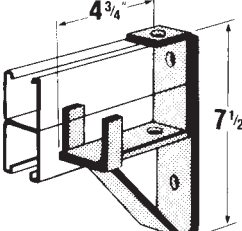
<p><b>S202</b> *Finish HDG</p>  <table border="1"> <thead> <tr> <th>Cat. No.</th> <th>A</th> <th>B</th> <th>C</th> <th>Wt./C lb</th> </tr> </thead> <tbody> <tr><td>S202-6*</td><td>6</td><td>5</td><td>—</td><td>75</td></tr> <tr><td>S202-9*</td><td>9</td><td>8</td><td>2</td><td>100</td></tr> <tr><td>S202-15*</td><td>15</td><td>14</td><td>18</td><td>175</td></tr> <tr><td>S202-21*</td><td>21</td><td>20</td><td>14</td><td>250</td></tr> <tr><td>S202-27*</td><td>27</td><td>26</td><td>20</td><td>325</td></tr> <tr><td>S202-33*</td><td>33</td><td>32</td><td>26</td><td>400</td></tr> </tbody> </table>	Cat. No.	A	B	C	Wt./C lb	S202-6*	6	5	—	75	S202-9*	9	8	2	100	S202-15*	15	14	18	175	S202-21*	21	20	14	250	S202-27*	27	26	20	325	S202-33*	33	32	26	400	<p><b>S203</b> *Finishes HDG</p>  <table border="1"> <thead> <tr> <th>Cat. No.</th> <th>A</th> <th>B</th> <th>Design Load/lb</th> <th>Wt./C lb</th> </tr> </thead> <tbody> <tr><td>S203-8*</td><td>8-1/2</td><td>4-1/16</td><td>1200</td><td>180</td></tr> <tr><td>S203-14*</td><td>14-1/2</td><td>5-3/8</td><td>1200</td><td>325</td></tr> <tr><td>S203-20*</td><td>20-1/2</td><td>6-11/16</td><td>1200</td><td>525</td></tr> <tr><td>S203-26*</td><td>26-1/2</td><td>8</td><td>1200</td><td>675</td></tr> <tr><td>S203-32*</td><td>32-1/2</td><td>8</td><td>1200</td><td>840</td></tr> <tr><td>S203-38*</td><td>38-1/2</td><td>8</td><td>1200</td><td>1050</td></tr> </tbody> </table>	Cat. No.	A	B	Design Load/lb	Wt./C lb	S203-8*	8-1/2	4-1/16	1200	180	S203-14*	14-1/2	5-3/8	1200	325	S203-20*	20-1/2	6-11/16	1200	525	S203-26*	26-1/2	8	1200	675	S203-32*	32-1/2	8	1200	840	S203-38*	38-1/2	8	1200	1050	<p><b>S249</b> *Finishes HDG SS6C</p>  <table border="1"> <thead> <tr> <th>Cat. No.</th> <th>A</th> <th>B</th> <th>Design Load/lb</th> <th>Wt./C lb</th> </tr> </thead> <tbody> <tr><td>S249-8*</td><td>8-1/2</td><td>8</td><td>1500</td><td>320</td></tr> <tr><td>S249-14*</td><td>14-1/2</td><td>9</td><td>1500</td><td>520</td></tr> <tr><td>S249-20*</td><td>20-1/2</td><td>9</td><td>1500</td><td>660</td></tr> <tr><td>S249-26*</td><td>26-1/2</td><td>11-1/2</td><td>1500</td><td>870</td></tr> <tr><td>S249-32*</td><td>32-1/2</td><td>11-1/2</td><td>1500</td><td>1030</td></tr> <tr><td>S249-38*</td><td>38-1/2</td><td>11-1/2</td><td>1500</td><td>1230</td></tr> </tbody> </table>	Cat. No.	A	B	Design Load/lb	Wt./C lb	S249-8*	8-1/2	8	1500	320	S249-14*	14-1/2	9	1500	520	S249-20*	20-1/2	9	1500	660	S249-26*	26-1/2	11-1/2	1500	870	S249-32*	32-1/2	11-1/2	1500	1030	S249-38*	38-1/2	11-1/2	1500	1230											
Cat. No.	A	B	C	Wt./C lb																																																																																																																		
S202-6*	6	5	—	75																																																																																																																		
S202-9*	9	8	2	100																																																																																																																		
S202-15*	15	14	18	175																																																																																																																		
S202-21*	21	20	14	250																																																																																																																		
S202-27*	27	26	20	325																																																																																																																		
S202-33*	33	32	26	400																																																																																																																		
Cat. No.	A	B	Design Load/lb	Wt./C lb																																																																																																																		
S203-8*	8-1/2	4-1/16	1200	180																																																																																																																		
S203-14*	14-1/2	5-3/8	1200	325																																																																																																																		
S203-20*	20-1/2	6-11/16	1200	525																																																																																																																		
S203-26*	26-1/2	8	1200	675																																																																																																																		
S203-32*	32-1/2	8	1200	840																																																																																																																		
S203-38*	38-1/2	8	1200	1050																																																																																																																		
Cat. No.	A	B	Design Load/lb	Wt./C lb																																																																																																																		
S249-8*	8-1/2	8	1500	320																																																																																																																		
S249-14*	14-1/2	9	1500	520																																																																																																																		
S249-20*	20-1/2	9	1500	660																																																																																																																		
S249-26*	26-1/2	11-1/2	1500	870																																																																																																																		
S249-32*	32-1/2	11-1/2	1500	1030																																																																																																																		
S249-38*	38-1/2	11-1/2	1500	1230																																																																																																																		
<p><b>S250</b> *Finishes HDG SS6C</p>  <table border="1"> <thead> <tr> <th>Cat. No.</th> <th>A</th> <th>Design Load lb</th> <th>Wt./C lb</th> </tr> </thead> <tbody> <tr><td>S250-6*</td><td>6</td><td>1500</td><td>150</td></tr> <tr><td>S250-8*</td><td>8-1/2</td><td>1500</td><td>150</td></tr> <tr><td>S250-12*</td><td>12</td><td>800</td><td>250</td></tr> <tr><td>S250-14*</td><td>14-1/2</td><td>800</td><td>250</td></tr> <tr><td>S250-18*</td><td>18</td><td>550</td><td>350</td></tr> <tr><td>S250-20*</td><td>20-1/2</td><td>550</td><td>350</td></tr> <tr><td>S250-24*</td><td>24</td><td>400</td><td>450</td></tr> <tr><td>S250-26*</td><td>26-1/2</td><td>400</td><td>450</td></tr> </tbody> </table> <p>May be installed inverted with no change in load ratings.</p>	Cat. No.	A	Design Load lb	Wt./C lb	S250-6*	6	1500	150	S250-8*	8-1/2	1500	150	S250-12*	12	800	250	S250-14*	14-1/2	800	250	S250-18*	18	550	350	S250-20*	20-1/2	550	350	S250-24*	24	400	450	S250-26*	26-1/2	400	450	<p><b>S251</b> *Finishes HDGC SS6C</p>  <table border="1"> <thead> <tr> <th>Cat. No.</th> <th>A</th> <th>Design Load lb</th> <th>Wt./C lb</th> </tr> </thead> <tbody> <tr><td>S251-12*</td><td>12</td><td>1650</td><td>514</td></tr> <tr><td>S251-14*</td><td>14-1/2</td><td>1650</td><td>514</td></tr> <tr><td>S251-18*</td><td>18</td><td>1050</td><td>714</td></tr> <tr><td>S251-20*</td><td>20-1/2</td><td>1050</td><td>714</td></tr> <tr><td>S251-24*</td><td>24</td><td>800</td><td>914</td></tr> <tr><td>S251-26*</td><td>26-1/2</td><td>800</td><td>914</td></tr> <tr><td>S251-30*</td><td>30</td><td>650</td><td>1114</td></tr> <tr><td>S251-32*</td><td>32-1/2</td><td>650</td><td>1114</td></tr> <tr><td>S251-36*</td><td>36</td><td>500</td><td>1314</td></tr> <tr><td>S251-38*</td><td>38-1/2</td><td>500</td><td>1314</td></tr> </tbody> </table>	Cat. No.	A	Design Load lb	Wt./C lb	S251-12*	12	1650	514	S251-14*	14-1/2	1650	514	S251-18*	18	1050	714	S251-20*	20-1/2	1050	714	S251-24*	24	800	914	S251-26*	26-1/2	800	914	S251-30*	30	650	1114	S251-32*	32-1/2	650	1114	S251-36*	36	500	1314	S251-38*	38-1/2	500	1314	<p><b>S256</b> *Finishes HDGC SS6</p>  <table border="1"> <thead> <tr> <th>Cat. No.</th> <th>A</th> <th>Design Load lb</th> <th>Wt./C lb</th> </tr> </thead> <tbody> <tr><td>S256-6*</td><td>6</td><td>1000</td><td>151</td></tr> <tr><td>S256-8*</td><td>8-1/2</td><td>1000</td><td>151</td></tr> <tr><td>S256-12*</td><td>12</td><td>500</td><td>251</td></tr> <tr><td>S256-14*</td><td>14-1/2</td><td>500</td><td>251</td></tr> <tr><td>S256-18*</td><td>18</td><td>300</td><td>351</td></tr> <tr><td>S256-20*</td><td>20-1/2</td><td>300</td><td>351</td></tr> <tr><td>S256-24*</td><td>24</td><td>250</td><td>451</td></tr> <tr><td>S256-26*</td><td>26-1/2</td><td>250</td><td>451</td></tr> </tbody> </table> <p>When installed in inverted position reduce load rating 40%.</p>	Cat. No.	A	Design Load lb	Wt./C lb	S256-6*	6	1000	151	S256-8*	8-1/2	1000	151	S256-12*	12	500	251	S256-14*	14-1/2	500	251	S256-18*	18	300	351	S256-20*	20-1/2	300	351	S256-24*	24	250	451	S256-26*	26-1/2	250	451
Cat. No.	A	Design Load lb	Wt./C lb																																																																																																																			
S250-6*	6	1500	150																																																																																																																			
S250-8*	8-1/2	1500	150																																																																																																																			
S250-12*	12	800	250																																																																																																																			
S250-14*	14-1/2	800	250																																																																																																																			
S250-18*	18	550	350																																																																																																																			
S250-20*	20-1/2	550	350																																																																																																																			
S250-24*	24	400	450																																																																																																																			
S250-26*	26-1/2	400	450																																																																																																																			
Cat. No.	A	Design Load lb	Wt./C lb																																																																																																																			
S251-12*	12	1650	514																																																																																																																			
S251-14*	14-1/2	1650	514																																																																																																																			
S251-18*	18	1050	714																																																																																																																			
S251-20*	20-1/2	1050	714																																																																																																																			
S251-24*	24	800	914																																																																																																																			
S251-26*	26-1/2	800	914																																																																																																																			
S251-30*	30	650	1114																																																																																																																			
S251-32*	32-1/2	650	1114																																																																																																																			
S251-36*	36	500	1314																																																																																																																			
S251-38*	38-1/2	500	1314																																																																																																																			
Cat. No.	A	Design Load lb	Wt./C lb																																																																																																																			
S256-6*	6	1000	151																																																																																																																			
S256-8*	8-1/2	1000	151																																																																																																																			
S256-12*	12	500	251																																																																																																																			
S256-14*	14-1/2	500	251																																																																																																																			
S256-18*	18	300	351																																																																																																																			
S256-20*	20-1/2	300	351																																																																																																																			
S256-24*	24	250	451																																																																																																																			
S256-26*	26-1/2	250	451																																																																																																																			
<p><b>S247</b></p>  <p><b>Design Moment (channel upright as shown) When Supported By</b></p> <table border="1"> <tbody> <tr> <td>A-1200</td> <td>5250 inch lb</td> </tr> <tr> <td>A-1400</td> <td>3650 inch lb</td> </tr> </tbody> </table> <p>Applies to fitting only, not to the arm.</p> <p>S247HDG S247 S247SS6</p> <p>Wt./C 229 lb</p>		A-1200	5250 inch lb	A-1400	3650 inch lb	<p><b>S248</b></p>  <p><b>Design Moment (channel upright as shown) When Supported By</b></p> <table border="1"> <tbody> <tr> <td>A-1202</td> <td>10800 inch lb</td> </tr> <tr> <td>A-1402</td> <td>7550 inch lb</td> </tr> </tbody> </table> <p>Applies to fitting only, not to the arm.</p> <p>S248HDGC S248</p> <p>Wt./C 272 lb</p>		A-1202	10800 inch lb	A-1402	7550 inch lb																																																																																																											
A-1200	5250 inch lb																																																																																																																					
A-1400	3650 inch lb																																																																																																																					
A-1202	10800 inch lb																																																																																																																					
A-1402	7550 inch lb																																																																																																																					



**Fittings and Brackets**

**SECTION 3**

**Brackets**

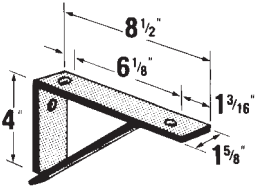
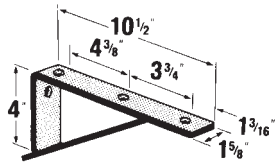
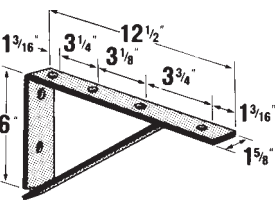
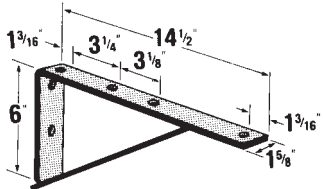
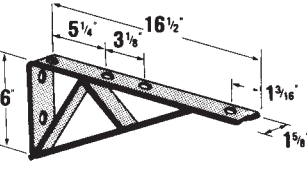
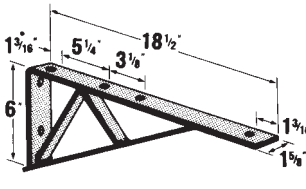
<p><b>S204</b></p>  <table border="1" data-bbox="331 478 576 598"> <thead> <tr> <th colspan="2">Design Uniform Load/lb</th> </tr> </thead> <tbody> <tr> <td>A-1200</td> <td>750</td> </tr> <tr> <td>A-1400</td> <td>500</td> </tr> </tbody> </table> <p><b>S204HDGC</b> <b>S204</b> Wt./C 174 lb</p>	Design Uniform Load/lb		A-1200	750	A-1400	500	<p><b>S205</b></p>  <table border="1" data-bbox="810 478 1054 598"> <thead> <tr> <th colspan="2">Design Uniform Load/lb</th> </tr> </thead> <tbody> <tr> <td>A-1200</td> <td>750</td> </tr> <tr> <td>A-1400</td> <td>500</td> </tr> </tbody> </table> <p><b>S205HDGC</b> <b>S205</b> Wt./C 264 lb</p>	Design Uniform Load/lb		A-1200	750	A-1400	500	<p><b>S217</b></p>  <table border="1" data-bbox="1278 478 1522 598"> <thead> <tr> <th colspan="2">Design Uniform Load/lb</th> </tr> </thead> <tbody> <tr> <td>A-1200</td> <td>750</td> </tr> <tr> <td>A-1400</td> <td>650</td> </tr> </tbody> </table> <p><b>S217HDG</b> <b>S217</b> <b>S217SS6</b> Wt./C 264 lb</p>	Design Uniform Load/lb		A-1200	750	A-1400	650
Design Uniform Load/lb																				
A-1200	750																			
A-1400	500																			
Design Uniform Load/lb																				
A-1200	750																			
A-1400	500																			
Design Uniform Load/lb																				
A-1200	750																			
A-1400	650																			
<p><b>S218</b></p>  <table border="1" data-bbox="341 898 585 1018"> <thead> <tr> <th colspan="2">Design Uniform Load/lb</th> </tr> </thead> <tbody> <tr> <td>A-1200</td> <td>750</td> </tr> <tr> <td>A-1400</td> <td>650</td> </tr> </tbody> </table> <p><b>S218HDG</b> <b>S218</b> Wt./C 295 lb</p>	Design Uniform Load/lb		A-1200	750	A-1400	650	<p><b>S222</b></p>  <table border="1" data-bbox="804 898 1048 1018"> <thead> <tr> <th colspan="2">Design Uniform Load/lb</th> </tr> </thead> <tbody> <tr> <td>A-1200</td> <td>1000</td> </tr> <tr> <td>A-1400</td> <td>750</td> </tr> </tbody> </table> <p><b>S222HDG</b> <b>S222</b> Wt./C 385 lb</p>	Design Uniform Load/lb		A-1200	1000	A-1400	750	<p><b>S226</b></p>  <table border="1" data-bbox="1278 898 1522 1018"> <thead> <tr> <th colspan="2">Design Uniform Load/lb</th> </tr> </thead> <tbody> <tr> <td>A-1200</td> <td>1000</td> </tr> <tr> <td>A-1400</td> <td>750</td> </tr> </tbody> </table> <p><b>S226HDG</b> <b>S226</b> Wt./C 421 lb</p>	Design Uniform Load/lb		A-1200	1000	A-1400	750
Design Uniform Load/lb																				
A-1200	750																			
A-1400	650																			
Design Uniform Load/lb																				
A-1200	1000																			
A-1400	750																			
Design Uniform Load/lb																				
A-1200	1000																			
A-1400	750																			

**SECTION 3**

**Fittings and Brackets**

**Post Bases**

**AP232**

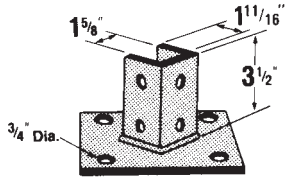

AP232HDGC  
AP232EG  
AP232

Wt./C 384 lb

**AP235**

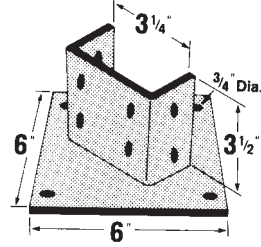

AP235HDGC  
AP235EG  
AP235

Wt./C 400 lb

**AP232SQ**

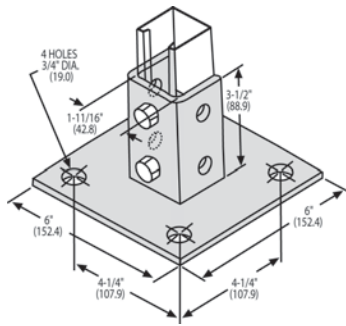

AP232SQHDG  
AP232SQEG  
AP232SQSS6

Wt./C 384 lb

**AP235SQ**

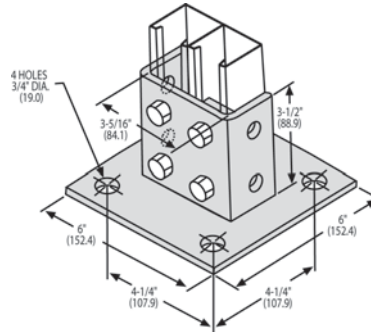

AP235SQHDG  
AP235SQEG  
AP235SQ  
AP235SQSS6

Wt./C 400 lb

**SECTION 3**

**Fittings and Brackets**

**Special Application Fittings and Brackets**

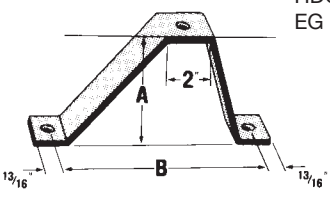
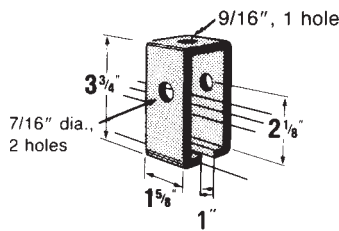
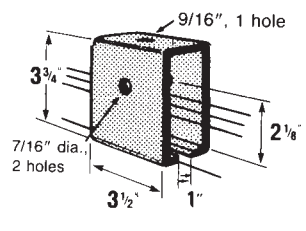
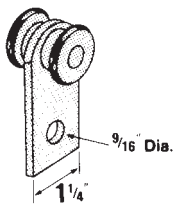
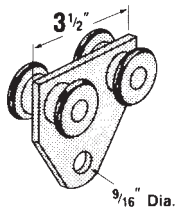
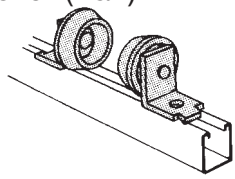
<p><b>AN270</b> <span style="float: right;">*Finishes HDG EG</span></p>  <table border="1" data-bbox="159 609 582 819"> <thead> <tr> <th>Cat. No.</th> <th>A</th> <th>B</th> <th>Wt./C lb</th> </tr> </thead> <tbody> <tr> <td>AN270-1*</td> <td>2-3/8</td> <td>6</td> <td>113</td> </tr> <tr> <td>AN270-2*</td> <td>4-3/8</td> <td>8</td> <td>151</td> </tr> <tr> <td>AN270-3*</td> <td>6-3/8</td> <td>10</td> <td>199</td> </tr> <tr> <td>AN270-4*</td> <td>8-3/8</td> <td>12</td> <td>246</td> </tr> <tr> <td>AN270-*</td> <td>10-3/8</td> <td>14</td> <td>293</td> </tr> </tbody> </table>	Cat. No.	A	B	Wt./C lb	AN270-1*	2-3/8	6	113	AN270-2*	4-3/8	8	151	AN270-3*	6-3/8	10	199	AN270-4*	8-3/8	12	246	AN270-*	10-3/8	14	293	<p><b>TS272</b> Track Support</p>  <p>Requires 3/8" x 2-1/2" bolt and nut (not included). Design load: 1000 lb Wt./C 104 lb</p> <p><b>TS272HDG</b></p>	<p><b>TS273</b> Track Support</p>  <p>For use over channel splice. Requires 3/8" x 2-1/2" bolt and nut (not included). Design load: 2000 lb Wt./C 228 lb</p> <p><b>TS273HDG</b></p>
Cat. No.	A	B	Wt./C lb																							
AN270-1*	2-3/8	6	113																							
AN270-2*	4-3/8	8	151																							
AN270-3*	6-3/8	10	199																							
AN270-4*	8-3/8	12	246																							
AN270-*	10-3/8	14	293																							
<p><b>TR292</b></p>  <p><b>Can be used for series A, E and H channels only.</b> Standard finish is Electrogalvanized Frictionless needle bearings. Design load: 500 lb Safety factor of 5. Wt./C 59 lb</p>	<p><b>TR294</b></p>  <p><b>Can be used for series A, E and H channels only.</b> Standard finish is Electrogalvanized Frictionless needle bearings. Design load: 1000 lb Safety factor of 5. Wt./C 106 lb</p> <p><i>* Do not use with back to back Strut</i></p>	<p><b>C728</b> Pipe Roller (Pair)</p>  <p>Cast aluminum rollers, steel brackets. Designed for standard saddles. Order separately for each pair of rollers: - Two 1/2" x 5/16" hex head cap screws and two 1/2" channel nuts. Space to suit O.D. of pipe and wrapping. Wt./C : 300 lb Design Load: 2350 lb</p>																								

<b>Standard Dimensions</b>	Hole Spacing	13/16" From End	<b>Materials</b>	HDG(C)	Hot-Dipped Galvanized
	Hole Spacing	1-7/8" Centers		EG(C)	Electrogalvanized
	Hole Size	9/16" Diam.		(No suffix)	GoldGalv®
	Material	1/4" Thick		SS6(C)	Stainless Steel 316

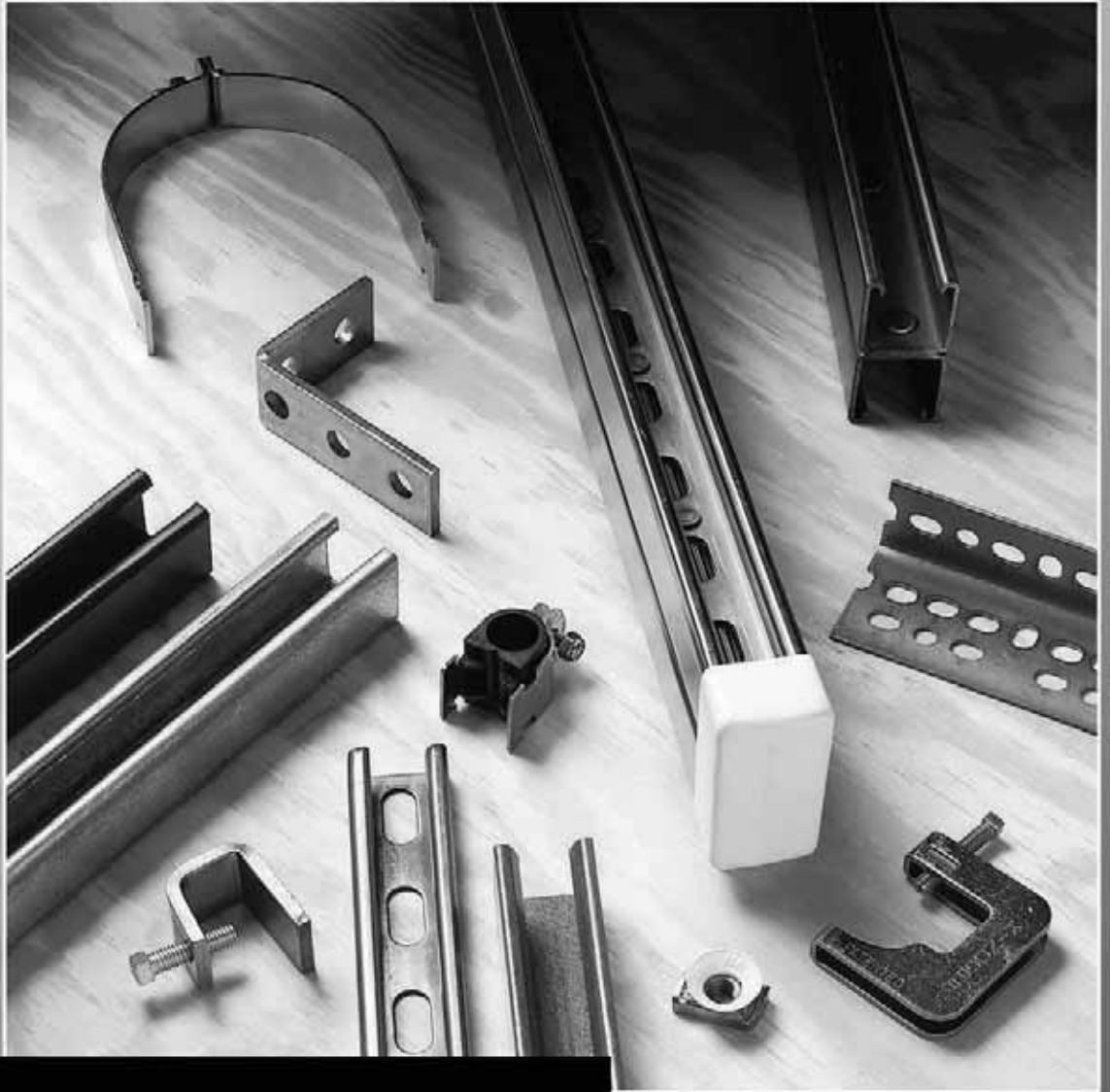

***SECTION 4***  
***BEAM CLAMPS***

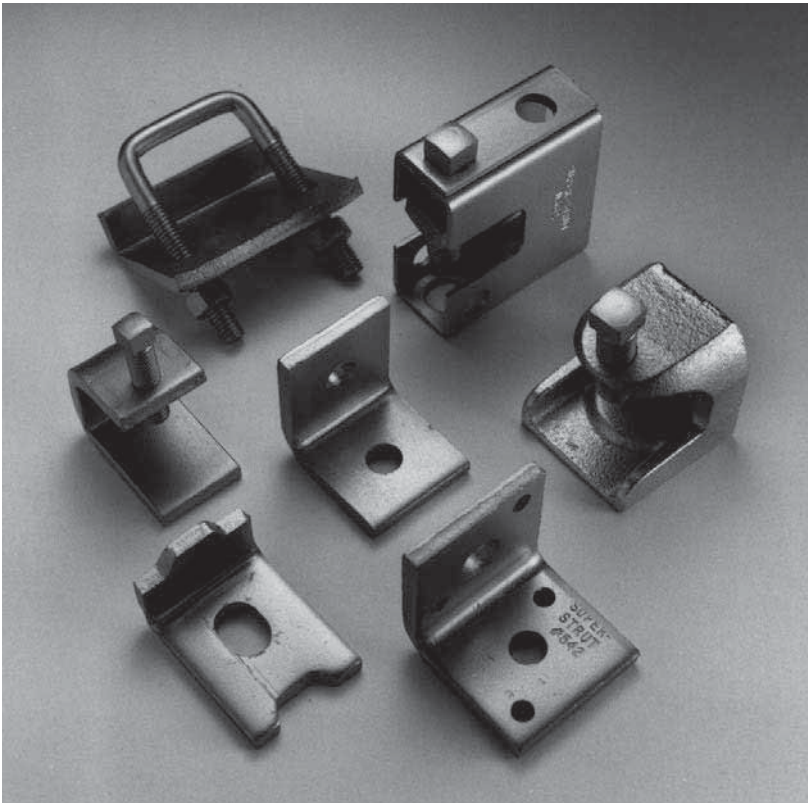
**Material**

Most products are manufactured from hot rolled carbon steel bars or hot rolled strip steel. Pipe rollers are cast iron.

**Design Loads**

Where design loads are indicated, they provide for a safety factor of 3 in conformance with the American Standard Code for Pressure Piping. For more information, see section 8 Engineering Data and Specifications.

**Finishes and Special Materials**

Hot-Dipped Galvanized (HDGC) is standard for all Superstrut® beam clamps. The material is zinc coated after fabrication providing total product protection on all surfaces. The fabricated beam clamps are suspended and then dipped into tanks of hot zinc for a prolonged period, creating a coherent bond.

Selected beam clamps can also be available in GoldGalv® (no suffix) or Stainless Steel Type 316 (SS6C). Contact your Regional Sales Office for availability and minimum quantities.



## SECTION 4

## Beam Clamps

### Beam Clamps for Mounting Channel

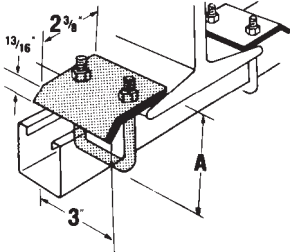
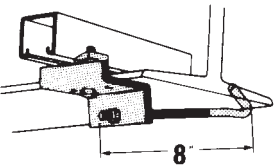
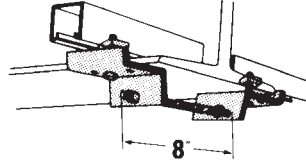
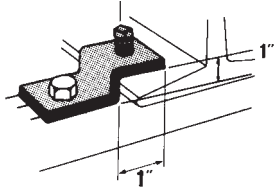
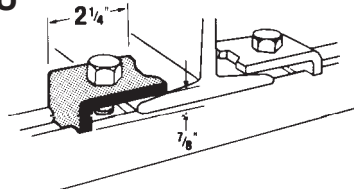
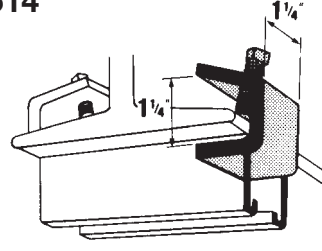
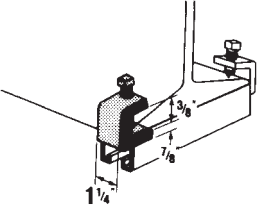
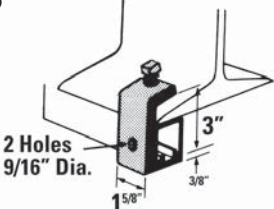
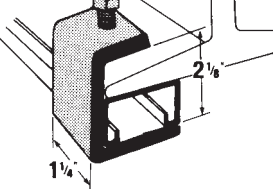
<p><b>U501, U502</b></p> <p>*Finishes HDG EG GoldGalv® SS6C</p>  <p>furnished complete Design Load U501 : 2150 lb U502 : 3000 lb</p> <table border="1"> <thead> <tr> <th>Cat. No.</th> <th>For Channel</th> <th>A</th> <th>Wt./C lb</th> </tr> </thead> <tbody> <tr> <td rowspan="3">U501*</td> <td>A1200 A1400</td> <td>3-3/16</td> <td>90</td> </tr> <tr> <td>B1200 B1400</td> <td></td> <td></td> </tr> <tr> <td>C1200 B1402</td> <td></td> <td></td> </tr> <tr> <td rowspan="2">U502*</td> <td>A1202 A1402</td> <td>4-13/16</td> <td>100</td> </tr> <tr> <td>C1202 H1200</td> <td></td> <td></td> </tr> </tbody> </table>	Cat. No.	For Channel	A	Wt./C lb	U501*	A1200 A1400	3-3/16	90	B1200 B1400			C1200 B1402			U502*	A1202 A1402	4-13/16	100	C1202 H1200			<p><b>U504</b></p>  <p><b>U504HDG</b> <b>U504EG</b> <b>U504</b> <b>U504SS6</b></p> <p>Can be used with all channels.</p> <p>Wt./C 140 lb</p>	<p><b>U505</b></p>  <p><b>U505HDG</b> <b>U505EG</b> <b>U505</b></p> <p>Can be used with all channels.</p> <p>Wt./C 270 lb</p>
Cat. No.	For Channel	A	Wt./C lb																				
U501*	A1200 A1400	3-3/16	90																				
	B1200 B1400																						
	C1200 B1402																						
U502*	A1202 A1402	4-13/16	100																				
	C1202 H1200																						
<p><b>U510</b></p>  <p>1/2" x 1-1/2" set screw included. Order separately one 1/2" x 1-1/2" hex head cap screw and 1/2" channel nut.</p> <table border="1"> <thead> <tr> <th>Design Load lb</th> <th>Channel</th> </tr> </thead> <tbody> <tr> <td>1000</td> <td>A1200</td> </tr> <tr> <td>800</td> <td>A1400</td> </tr> </tbody> </table> <p><b>U510HDGC</b> <b>U510EG</b> <b>U510</b> <b>U510SS6</b></p> <p>Wt./C 75 lb</p>	Design Load lb	Channel	1000	A1200	800	A1400	<p><b>512U</b></p>  <p>Order separately one 1/2" x 1-1/2" hex head cap screw and 1/2" channel nut.</p> <table border="1"> <thead> <tr> <th>Design Load lb</th> <th>Channel</th> </tr> </thead> <tbody> <tr> <td>1000</td> <td>A1200</td> </tr> <tr> <td>800</td> <td>A1400</td> </tr> </tbody> </table> <p><b>512UHDG</b> <b>512UEG</b> <b>512U</b></p> <p>Wt./C 26 lb</p>	Design Load lb	Channel	1000	A1200	800	A1400	<p><b>U514</b></p>  <p>3/8" x 1-1/2" set screw included. Design Load 750 lb/pair</p> <p><b>U514HDGC</b> <b>U514EG</b> <b>U514</b> <b>U514SS6</b></p> <p>Wt./C 40 lb</p>									
Design Load lb	Channel																						
1000	A1200																						
800	A1400																						
Design Load lb	Channel																						
1000	A1200																						
800	A1400																						
<p><b>U514-A</b></p>  <p>1/2" x 1-1/2" set screw included. Design Load 1650 lb/pair</p> <p><b>U514-AHDGC</b> <b>U514-AEG</b> <b>U514-A</b> <b>U514-ASS6</b></p> <p>Wt./C 59 lb</p>	<p><b>U515</b></p>  <p>For all A series channel. 1/2" x 1-1/2" set screw included. Design Load 800 lb</p> <p><b>U515HDGC</b> <b>U515EG</b> <b>U515</b> <b>U515SS6</b></p> <p>Wt./C 95 lb</p>	<p><b>U515-B</b></p>  <p>For all B series channel. 1/2" x 1-1/2" set screw included. Design Load 800 lb</p> <p><b>U515BHDG</b> <b>U515BEG</b> <b>U515B</b> <b>U515BSS6</b></p> <p>Wt./C 91 lb</p>																					

**Beam Clamps**

**SECTION 4**

**Beam Clamps for Mounting Channel**

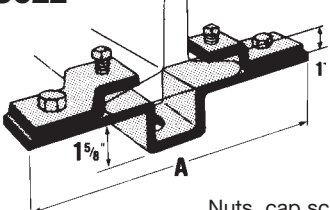
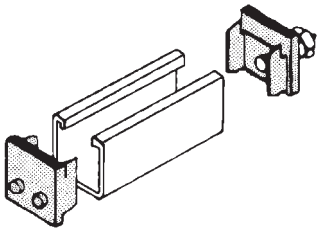
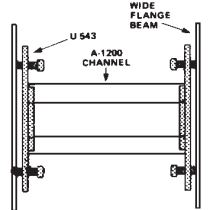
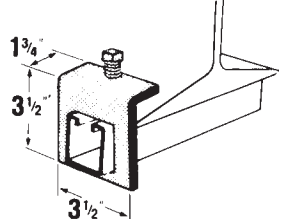
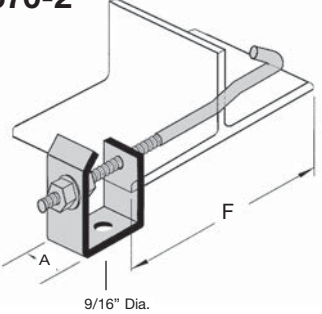
<p><b>U520</b> <b>U521</b> <b>U522</b></p> <p>*Finishes GoldGalv® EG</p>  <p>Nuts, cap screws and set screws included.</p> <table border="1"> <thead> <tr> <th rowspan="2">Cat. No.</th> <th rowspan="2">Flange Width</th> <th rowspan="2">A</th> <th colspan="2">Design</th> </tr> <tr> <th>Wt./C lb</th> <th>Load lb</th> </tr> </thead> <tbody> <tr> <td>U520*</td> <td>2-3/8 - 4-1/2</td> <td>8-3/4</td> <td>328</td> <td>2000</td> </tr> <tr> <td>U521*</td> <td>3-3/4 - 5-3/4</td> <td>10</td> <td>343</td> <td>1300</td> </tr> <tr> <td>U522*</td> <td>5-5/8 - 7-5/8</td> <td>11-7/8</td> <td>353</td> <td>900</td> </tr> </tbody> </table>	Cat. No.	Flange Width	A	Design		Wt./C lb	Load lb	U520*	2-3/8 - 4-1/2	8-3/4	328	2000	U521*	3-3/4 - 5-3/4	10	343	1300	U522*	5-5/8 - 7-5/8	11-7/8	353	900	<p><b>U544</b> Single Adjusting Screw End Cap Set</p>  <p>Should be ordered as one set.</p> <p><b>U544EG</b> Wt./C 39 lb</p>	<p><b>U543</b> Adjusting Screw End Caps</p>  <p>Should be ordered in multiples of two (2).</p> <p><b>U543HDG</b> <b>U543EG</b> <b>U543</b> Wt./C 44 lb</p>					
Cat. No.				Flange Width	A	Design																							
	Wt./C lb	Load lb																											
U520*	2-3/8 - 4-1/2	8-3/4	328	2000																									
U521*	3-3/4 - 5-3/4	10	343	1300																									
U522*	5-5/8 - 7-5/8	11-7/8	353	900																									
<p><b>A597</b></p> <p>*Finishes HDGC SS6</p>  <table border="1"> <thead> <tr> <th rowspan="2">Cat. No.</th> <th rowspan="2">Channel Series</th> <th rowspan="2">Wt./C lb</th> <th colspan="2">Design</th> </tr> <tr> <th>Load lb/ea.</th> </tr> </thead> <tbody> <tr> <td>A597*</td> <td>A</td> <td>108</td> <td>800</td> </tr> </tbody> </table>	Cat. No.	Channel Series	Wt./C lb	Design		Load lb/ea.	A597*	A	108	800	<p><b>U570-1</b> <b>U570-2</b></p> <p>*Finish HDGC</p>  <table border="1"> <thead> <tr> <th rowspan="2">Cat. no.</th> <th rowspan="2">A in.</th> <th rowspan="2">F in.</th> <th colspan="2">Design</th> </tr> <tr> <th>Wt./C lbs</th> <th>Load lbs</th> </tr> </thead> <tbody> <tr> <td>U570-1*</td> <td>1-1/2</td> <td>4 to 9</td> <td>240</td> <td>800</td> </tr> <tr> <td>U570-2*</td> <td>1-1/2</td> <td>7 to 17</td> <td>300</td> <td>800</td> </tr> </tbody> </table>	Cat. no.	A in.	F in.	Design		Wt./C lbs	Load lbs	U570-1*	1-1/2	4 to 9	240	800	U570-2*	1-1/2	7 to 17	300	800	
Cat. No.				Channel Series	Wt./C lb	Design																							
	Load lb/ea.																												
A597*	A	108	800																										
Cat. no.	A in.	F in.	Design																										
			Wt./C lbs	Load lbs																									
U570-1*	1-1/2	4 to 9	240	800																									
U570-2*	1-1/2	7 to 17	300	800																									

**Materials** HDG(C) Hot-Dipped Galvanized  
EG(C) Electrogalvanized  
(No suffix) GoldGalv®  
SS6(C) Stainless Steel 316

## SECTION 4

## Beam Clamps

### Beam Clamps for Hanging Rod

#### U562 Beam Clamp

Optional Use of  
U562HDG Beam Clamp

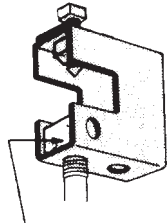

E146 square nut order separately.  
1/2" set screw included.

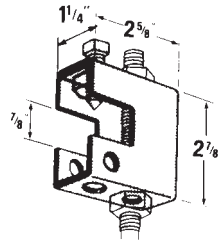

1/2" set screw included.

Rod Size	Wt./C lb	Design Load lb
1/2	80	800

Rod Size	Wt./C lb	Design Load lb
1/2	80	500

For 20° swivel application use ES-145-1/2 nut.

U562HDG  
U562EG  
U562  
U562SS6

#### UM562 Beam Clamp

UM562HDGC  
UM562EG  
UM562  
UM562SS6

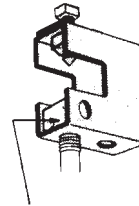

E146 square nut order separately.  
1/2" set screw included.

Rod Size	Wt./C lb	Design Load lb
1/2	100	1200

For 20° swivel application use  
ES-145-1/2 nut.

#### US562 Beam Clamp with Swing Hanger

US562HDG  
US562EG  
US562

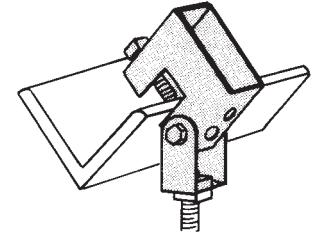

1/2" set screw included.

Rod Size	Wt./C lb	Design Load lb
1/2	113	800

#### U563 Beam Clamp

Optional Use of U563HDG Beam Clamp

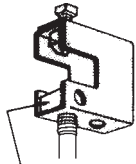

Square nut order separately  
3/8" set screw included.

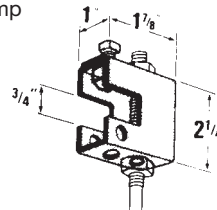

3/8" set screw included.

Rod Size	Wt./C lb	Design Load lb
3/8	33	400

Rod Size	Wt./C lb	Design Load lb
3/8	33	240

U563HDG  
U563EG  
U563

#### US563 Beam Clamp with Swing Hanger

US563HDG  
US563

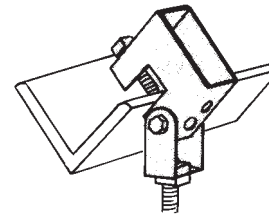

3/8" set screw included.

Rod Size	Wt./C lb	Design Load lb
3/8	50	400

#### U569 Beam Clamp

U569HDG  
U569

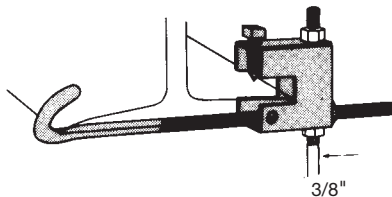

Maximum flange width 5".

Cat. No.	A Size	Wt./C lb	Design Load lb
U569	3/8	150	400

#### A570 Beam Clamp with Safety Rod

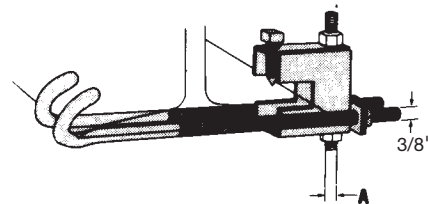

Flange width 4" min. - 8" max.  
For use with 3/8" rod see U-569.

Cat. No.	A Size	Wt./C lb	Design Load lb
A570HDG	1/2	220	500

**Beam Clamps**

**SECTION 4**

**Beam Clamps for Hanging Rod**

**U560**  
Heavy Duty  
Beam Clamp

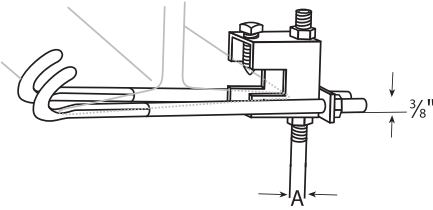

\*Finishes  
GoldGalv®  
EG

Cat. No.	A	B	C	Wt./C lb	Design Load lb
U560-1/4*	1/4	1/8	3/8 x 1-1/2	67	1050
U560-3/8*	3/8	1/8	3/8 x 1-1/2	67	1050
U560-1/2*	1/2	1/4	1/2 x 1-1/2	130	2650
U560-5/8*	5/8	1/4	1/2 x 1-1/2	130	2650

**U564**  
Heavy Duty Beam Clamp

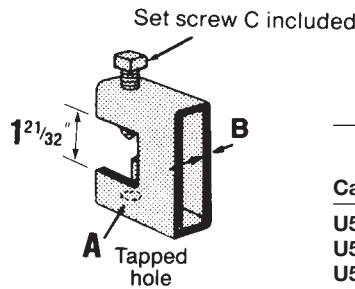

\*Finishes  
GoldGalv®  
EG

Cat. No.	A	B	C	Wt./C lb	Design Load lb
U564-3/8*	3/8	1/8	3/8 x 2-3/4	109	1300
U564-1/2*	1/2	1/4	1/2 x 2-3/4	201	3150
U564-5/8*	5/8	1/4	1/2 x 2-3/4	201	3150

**U568**  
Beam Clamp Safety Strap

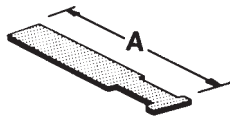

For U563 beam clamp.

Cat. No.	Beam Flange Width	A	Wt./C lb
U568-1EG	6	8	18
U568-2EG	9	11	28

16 gauge material

**U568**  
Beam Clamp Safety Strap

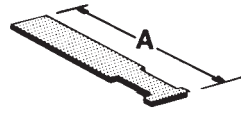

For U562 and UM562 beam clamp.

Cat. No.	Beam Flange Width	A	Wt./C lb
U568-3EG	6	9	25
U568-4EG	9	12	33
U568-5EG	12	15	42

16 gauge material

**U568**  
Beam Clamp Safety Strap

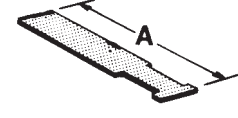

For U560 and U564 beam clamp.

Cat. No.	Beam Flange Width	A	Wt./C lb
U568-6EG	6	9	24
U568-7EG	9	12	31
U568-8EG	12	15	44

16 gauge material

**C775L / M775L**  
Clamp with Lock Nut

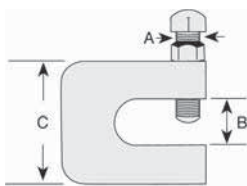

C775L

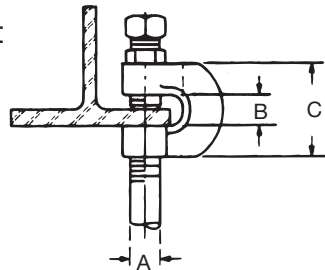

M775L

**Standard Finish - Electrogalvanized (EG)**

Malleable Iron (M775L)  
Carbon Steel (C775L)

Cat. No.	Rod Size	Dimensions in.			Wt./C lb	Design Load lb
		A	B	C		
C775L-3/8EG	3/8	3/8	3/8	3/4	38	400
C775L-1/2EG	1/2	3/8	3/8	3/4	39	500
C775L-5/8EG	5/8	1/2	1/2	3/4	60	550
C775L-3/4EG	3/4	5/8	5/8	3/4	69	600
C775L-7/8EG	7/8	3/4	3/4	1	184	900
M775L-3/8EG	3/8	3/8	3/4	1-3/4	27	400
M775L-1/2EG	1/2	1/2	3/4	1-3/4	35	400
M775L-5/8EG	5/8	5/8	3/4	2	52	440
M775L-3/4EG	3/4	3/4	3/4	2	63	500

Complies to Specification MSS SP69, Type 23.

**Materials**  
HDG(C) Hot-Dipped Galvanized  
EG(C) Electrogalvanized  
(No suffix) GoldGalv®  
SS6(C) Stainless Steel 316

## SECTION 4

## Beam Clamps

### Beam Clamps for Hanging Rod

**500SC, 502, 503SC, 507,  
508, 509, 510, 511**  
Beam Clamp

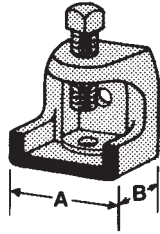

Cat. No.	Tapped Holes	Base Dim. in.		Jaw Opening	Wt./C lb	Design Load lb
		A	B			
500SC	1/4 - 20	1	1-1/4	15/16	18	450
502	3/8 - 16	2	2	1	92	1300
503SC	1/2 - 13	2-5/8	2-1/2	1	164	1300
507	1/2 - 13	2-1/2	2-3/8	1-3/8	165	1700
508	1/2 - 13	2-1/2	2-3/8	2-1/8	184	1700
509	10 - 24	1	1-1/4	15/16	22	375
510	1/4 - 20	27/32	1-1/8	5/8	15	400
511	10 - 24	27/32	1-1/8	5/8	15	400

Standard Finish -  
Electrogalvanized (no suffix)

### 6H Series in combination with 500 series Beam Clamp Conduit and Pipe Hanger

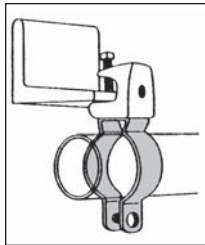

#### Features

- Accommodates 1/2" through 4" EMT or rigid conduit
- Can be used for either vertical or horizontal installation
- 6H-TB Series is threaded so there are less parts to handle or drop
- Installs easily with a screwdriver

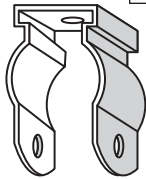

**6H Series**  
without bolt  
Fig. 1



**6H--B Series**  
with bolt and hex nut  
Fig. 2



**6H-T Threaded Series**  
threaded without bolt  
Fig. 3



**6H-TB Threaded Series**  
threaded with bolt  
Fig. 4

Without Bolt		With Bolt		EMT	Rigid Conduit or Pipe	Qty. per Box
Cat. No.	Fig. No.	Cat. No.	Fig. No.			
6H0	1	6H0-B	2	1/2"	3/8"-1/2"	100
6H0-T	3	6H0-TB	4	1/2"	3/8"-1/2"	100
6H1	1	6H1-B	2	3/4"	3/4"	100
6H1-T	3	6H1-TB	4	3/4"	3/4"	100
6H2	1	6H2-B	2	1"	1"	100
		6H2-TB	4	1"	1"	100
6H2 1/2	1	6H2 1/2B	2	1-1/4"	-	100
		6H2 1/2-TB	4	1-1/4"	-	100
6H3-SC	1	6H3-B	2	1-1/2"	1-1/4"	100
		6H3-TB	4	1-1/2"	1-1/4"	100
6H4	1	6H4-B	2	-	1-1/2"	100
		6H4-TB	4	-	1-1/2"	100
6H5	1	6H5-B	2	2"	2"	100
		6H5-TB	4	2"	2"	100
6H6	1	6H6-B	2	2-1/2"	2-1/2"	100
6H7	1	6H7-B	2	3"	3"	100
6H8	1	6H8-B	2	3-1/2"	3-1/2"	100
6H9	1	6H9-B	2	4"	4"	100

Standard Finish - Electrogalvanized (no suffix). Use SS suffix for Stainless Steel.

Load rating: 500 lb with a safety factor of 3. (For weight per 100 see page 46)



**Beam Clamps**

**SECTION 4**

**Beam Clamps for Mounting Pipe and Conduit**

**U571**

**U572**

**Conduit Clamp**

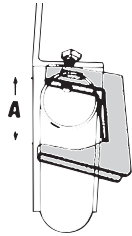

For attaching 1/2" thru 1-1/2" conduit to beam, channel, angle or column. Secures conduit to the support parallel or at right angles to it.

5/16" set screw  
12 gauge material

**Standard Finish - GoldGalv®**

Wt./C 38 lb

Cat. No.	Conduit Size	Max. Flange Thickness	Dim. A	Wt./C lb
<b>U571</b>	1/2	1	1-3/4	36
	3/4	3/4	1-3/4	36
	1	1/2	1-3/4	36
<b>U572</b>	3/4	1-1/2	2-1/2	59
	1	1-1/4	2-1/2	59
	1-1/4	1	2-1/2	59
	1-1/2	5/8	2-1/2	59

**Pipe Supports**

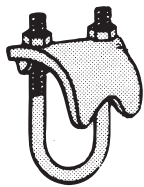

**Type RC and RCS**

- Malleable Iron
- For mounting pipe or conduit at right angles to the beam
- Use SS316 suffix for 316 Stainless Steel
- Use HDG suffix for Hot-Dipped Galvanized

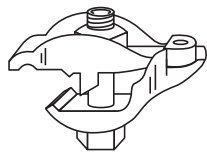

**Type EC**

- Malleable Iron
- For mounting pipe or conduit vertically across the beam
- Use HDG suffix for Hot-Dipped Galvanized
- CSA Certified

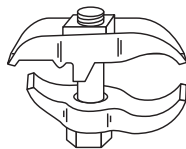

**Type PC**

- Malleable Iron
- For mounting pipe or conduit parallel to the beam
- Use SS316 suffix for 316 Stainless Steel
- Use HDG suffix for Hot-Dipped Galvanized

**Pipe Supports**

Three types of pipe clamps are available to provide right angle, vertical and parallel attachment to a beam. Types RC, EC and PC are malleable iron clamps with an edge that grips the structural member for maximum holding power when tightened.

Type RCS clamps are all steel, providing two bearing surfaces for strong attachment for mounting pipe or conduit at right angles to the beam.

All parts are electrogalvanized (no suffix) including the threads. The clamps are designed for clamping to a wide variety of beam thicknesses and tapers. Can be installed using only a wrench.

Cat No. & Size	Dimensions in inches		Std. Ctn.	Wt./C lb
	O.D. of Conduit or Pipe	Nom. Conduit or Pipe Size		
<b>RCS-3/8</b>	.675	3/8	50	31
<b>RCS-1/2</b>	.840	1/2	50	34
<b>RCS-3/4</b>	1.050	3/4	50	39
<b>RCS-1</b>	1.315	1	50	42
<b>RCS-1-1/4</b>	1.660	1-1/4	50	43
<b>RCS-1-1/2</b>	1.900	1-1/2	50	60
<b>RCS-2</b>	2.375	2	50	72
<b>RC-1/2</b>	.840	1/2	50	36
<b>RC-3/4</b>	1.050	3/4	50	43
<b>RC-1</b>	1.315	1	50	49
<b>RC-1-1/4</b>	1.660	1-1/4	50	51
<b>RC-1-1/2</b>	1.900	1-1/2	50	54
<b>RC-2-SC</b>	2.375	2	50	76
<b>RC-2-1/2</b>	2.875	2-1/2	25	107
<b>RC-3</b>	3.500	3	25	116
<b>RC-3-1/2</b>	4.000	3-1/2	25	134
<b>RC-4-SC</b>	4.500	4	20	158
<b>EC-1/2</b>	.840	1/2	50	69
<b>EC-3/4</b>	1.050	3/4	50	78
<b>EC-1</b>	1.315	1	25	83
<b>EC-1-1/4</b>	1.660	1-1/4	25	108
<b>EC-1-1/2</b>	1.900	1-1/2	25	112
<b>EC-2</b>	2.375	2	25	140
<b>EC-2-1/2</b>	2.875	2-1/2	10	183
<b>EC-3</b>	3.500	3	10	203
<b>PC-3/8</b>	.675	3/8	50	32
<b>PC-1/2</b>	.840	1/2	50	53
<b>PC-3/4</b>	1.050	3/4	50	53
<b>PC-1</b>	1.315	1	50	61
<b>PC-1-1/4</b>	1.660	1-1/4	25	79
<b>PC-1-1/2</b>	1.900	1-1/2	25	56
<b>PC-2</b>	2.375	2	25	116
<b>PC-2-1/2</b>	2.875	2-1/2	25	148
<b>PC-3</b>	3.500	3	10	175
<b>PC-3-1/2</b>	4.00	3-1/2	10	199
<b>PC-4</b>	4.500	4	10	224

### Beam Fittings

#### C781 Square Washer

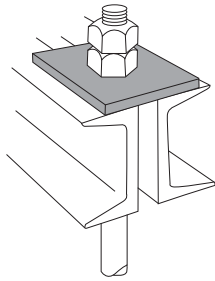

\*Finishes  
B  
HDG  
EG  
SS6

Used for beam applications.  
For channel applications use AB241.

**STD  
PACK:  
50**

Cat. No.	Rod Size	Hole Size	Overall Dimensions	Wt./C lb
C781-3/8*	3/8	7/16	3 x 3 x 3/16	27
C781-1/2*	1/2	9/16	3 x 3 x 3/16	27
C781-5/8*	5/8	11/16	3 x 3 x 1/4	47
C781-3/4*	3/4	13/16	3 x 3 x 1/4	42
C781-7/8*	7/8	15/16	4 x 4 x 3/8	85
C781-1*	1	1-1/8	4 x 4 x 3/8	160

#### M742R Ceiling Flange

\*Finishes  
B  
EG

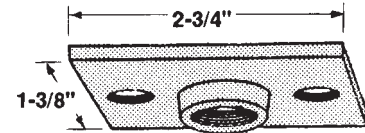

Cat. No.	Rod Size	Wt./C lb
M742R-3/8*	3/8	16
M742R-1/2*	1/2	16

#### 540 Side Beam Hanger Clip

\*Finishes  
B  
EG  
GoldGalv®

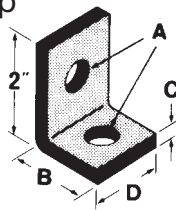

Cat. No.	A	B	C	D	Wt./C lb
540-3/8*	7/16	1-7/8	1/4	7/8	38
540-1/2*	9/16	1-7/8	1/4	1-5/8	36
540-5/8*	11/16	2-1/2	3/8	2	84
540-3/4*	13/16	2-1/2	3/8	2	113

#### 542 Side Beam Hanger Clip

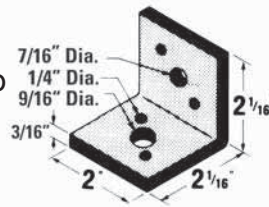

**Standard Finish - GoldGalv®**  
For 3/8" and 1/2" rods.

Cat. No.	Rod Size	Design Load lb	Wt./C lb
542-3/8	3/8	610	35
542-1/2	1/2	1000	38

#### S541 Swing Connector

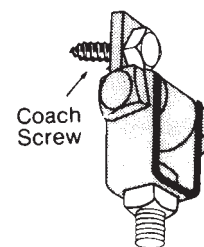

3/8" x 1-3/4" bolt,  
nut and clevis  
included.

**Standard Finish - GoldGalv®**  
For use with wood beam.

Cat. No.	Rod Size	Wt./C lb
S541-3/8	3/8	31

**Beam Clamps**

**SECTION 4**

**Beam Fittings**

**U577**

Clevis and Swing Connector

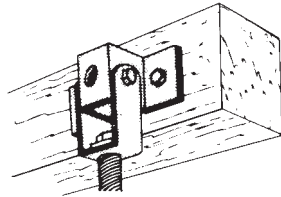

**Standard Finish - GoldGalv®**  
For use with wood beam.

Cat. No.	Rod Size	Wt./C lb
U577-1/2	1/2	69

**U576**

Hanger Clevis

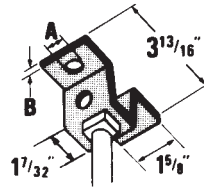

**Standard Finish - GoldGalv®**  
For rods up to 1/2"  
Mounting holes 7/16" diameter.  
For use with wood beam.

Cat. No.	Material		
	Hole A	Thickness B	Wt./C lb
U576-3/8	7/16	3/16	27
U576-1/2	9/16	3/16	27

**U579**

Ceiling Flange

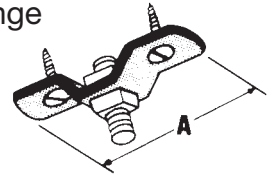

**Standard Finish - GoldGalv®**  
Malleable Iron  
Nuts and wood screws not included.  
Mounting holes 13/32"

Cat. No.	A	Wt./C lb
U579-3/8	3-1/2	30
U579-1/2	4-1/4	50

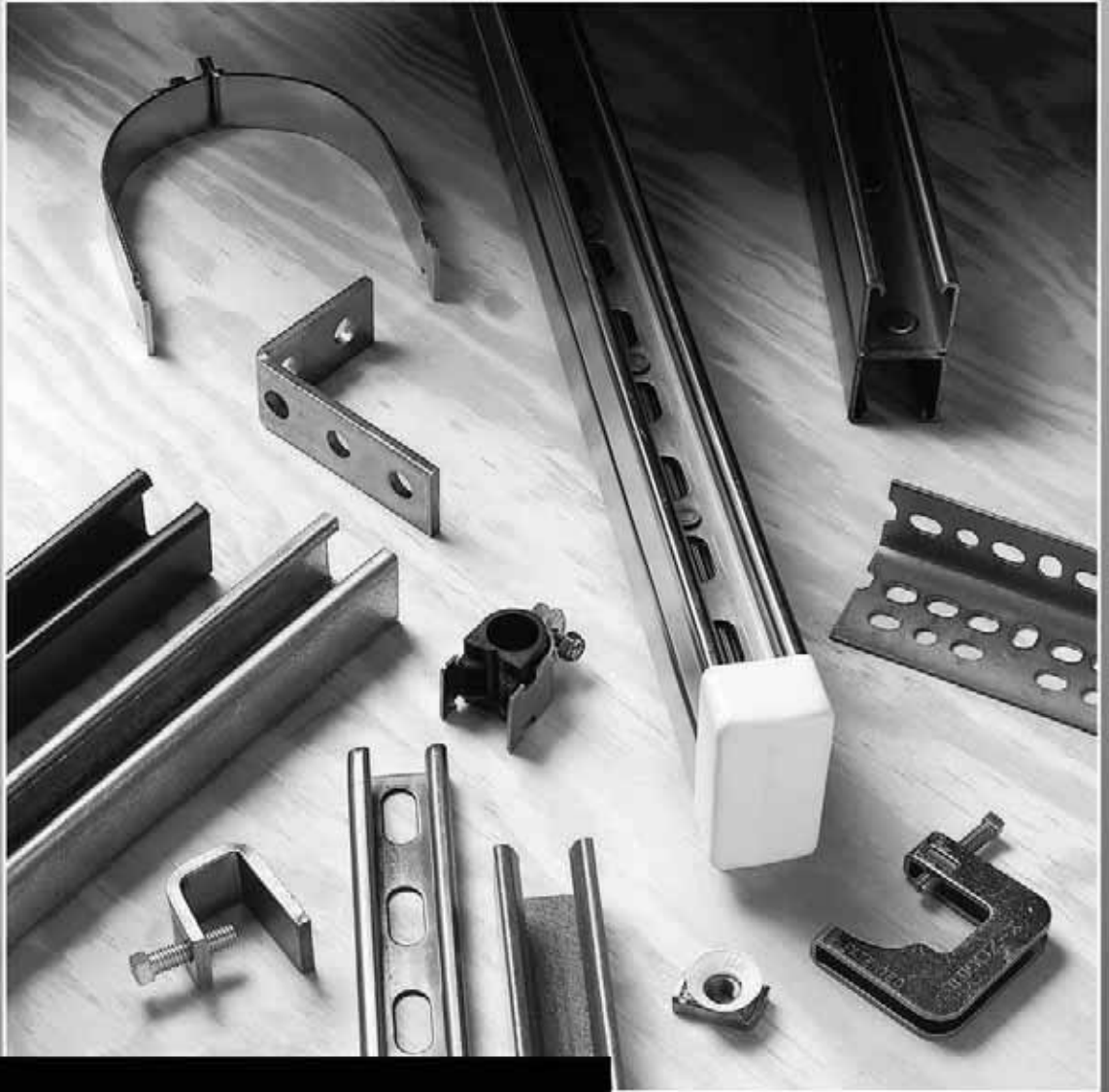

**SECTION 5**  
**PIPE STRAPS, PIPE CLAMPS**  
**AND HANGERS**

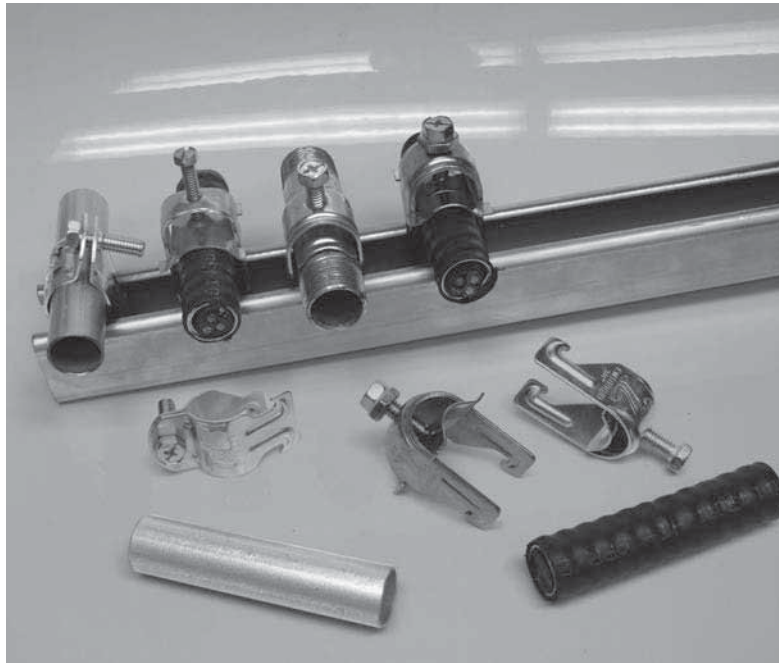
**Material**

Most products are manufactured from hot rolled carbon steel bars or hot rolled strip steel. Pipe rollers are cast iron.

**Design Loads**

Where design loads are indicated, they provide for a safety factor of 3 in conformance with the American Standard Code for Pressure Piping.

**Hanger Design**

Pipe hangers are of advanced design to be user friendly.

**Finishes and Special Materials**

The standard finish is Electrogalvanized (EGC) or GoldGalv®. Some products are offered in Aluminum and Stainless Steel where noted.

**SECTION 5**

**Pipe Straps, Pipe Clamps and Hangers**

**Conduit and Cable Clamps**

**701**  
O.D. Pipe and Conduit Clamp

Machine screw and nut included.

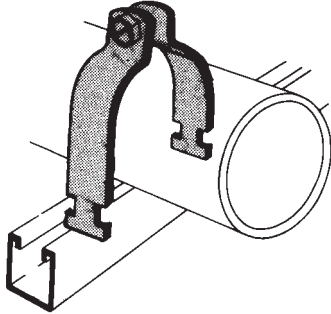

Cat. No.	O.D. of pipe		Rigid Cond.	EMT Cond.	Wt./C. lb	Std Pack
	in.	mm				
701-045PG	.36-.45	9-11.5	—	—	9	10
701-055PG	.46-.55	11.5-14	—	—	10	10
701-065PG	.56-.65	14-17	—	—	11	10
701-075PG	.66-.75	17-19.5	—	1/2	13	10
701-088PG	.76-.88	19.5-22.5	1/2	—	15	10
701-100PG	.89-1.00	22.5-25.4	—	3/4	16	10
701-113PG	1.01-1.13	25.5-29	3/4	—	17	10
701-126PG	1.14-1.26	29-32	—	1	18	10
701-140PG	1.27-1.40	32-36	1	—	18	10
701-153PG	1.41-1.53	36-39	—	1-1/4	19	10
701-167PG	1.54-1.67	39-42.5	1-1/4	—	20	10
701-180PG	1.68-1.80	42.5-46	—	1-1/2	23	10
701-193PG	1.81-1.93	46-49	1-1/2	—	26	10
701-204PG	1.93-2.04	49-52	—	—	30	10
701-225PG	2.10-2.25	53-57.5	—	2	32	10
701-237PG	2.26-2.37	57.5-60	2	—	34	10
701-245PG	2.33-2.45	59.95-62.5	—	—	36	10
701-257PG	2.46-2.57	62.5-65.5	—	—	38	10
701-287PG	2.75-2.87	70-73	2-1/2	2-1/2	40	10
701-294PG	2.88-2.94	73-75	—	—	42	10
701-306PG	2.95-3.06	75-78	—	—	42.5	10
701-319PG	3.07-3.19	78-81	—	—	43	10
701-350PG	3.36-3.50	85.5-89	3	3	45	10
701-356PG	3.51-3.56	89-90	—	—	46	10
701-379PG	3.70-3.79	94-96.5	—	—	48	10
701-400PG	3.80-4.00	96.5-101.5	3-1/2	3-1/2	49	10
701-450PG	4.25-4.50	108-114	4	4	70	10
701-556PG	5.25-5.56	121-141	5	5	75	5
701-665PG	6.25-6.65	146-170	6	6	80	5
701-876PG	8.50-8.75	197-222	8	8	85	5

**Standard Finishes and Materials**

**PG** = Pregalvanized (i.e. 701-045PG)

**AL** = Aluminum (i.e. 701-045AL)  
with zinc plated hardware

**SS6** = Stainless Steel Type 316 (i.e. 701-045SS6)

**FG** = Fiberglass (in conduit sizes 1/2 to 4")

**703**  
Universal Clamp

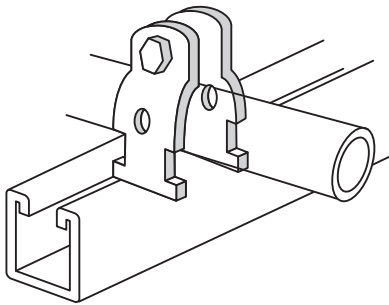

Cat. No.	EMT/ Rigid	Conduit O.D.	Material Thickness	WT./C lb	Std. Ctn.
703-1/2EG	1/2	.706 - .840	16 ga.	400	100
703-3/4EG	3/4	.932 - 1.050	14 ga.	550	100
703-1EG	1	1.163 - 1.315	14 ga.	550	100
703-1-1/4EG	1-1/4	1.508 - 1.660	14 ga.	800	50
703-1-1/2EG	1-1/2	1.738 - 1.900	14 ga.	800	50
703-2EG	2	2.195 - 2.375	14 ga.	800	50

**Standard Finishes -**

**GoldGalv®** (i.e.) 703-1/2

**Electrogalvanized (EG suffix)** (i.e.) 703-1-1/2EG

One size fits both Rigid and Electric Metal Tubing (EMT).  
Individually assembled with screw and nut.



**Pipe Straps, Pipe Clamps and Hangers**

**SECTION 5**

**Conduit and Cable Clamps**

**Quick Clamp II**



Design Load 1 has a safety factor of 4. Design Loads 2 and 3 have a safety factor of 1.

**Ordering information**

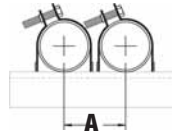

Cat. No.	Dimension A EMT in. (mm)	Dimension A Rigid Conduit in. (mm)	Quantity per Box	Wt./C lb
<b>TBQC050</b>	1-5/16 (33.5)	1-1/4 (31.5)	100	10
<b>TBQC075</b>	1-3/4 (44.5)	1-11/16 (43)	100	12
<b>TBQC100</b>	1-13/16 (46)	1-3/4 (44.5)	100	13
<b>TBQC125</b>	2-1/8 (54)	2 (51)	50	15
<b>TBQC150</b>	2-3/8 (60.5)	2-3/16 (55.5)	50	16
<b>TBQC200</b>	2-5/8 (66.5)	2-1/2 (63.5)	50	19
<b>TBQC250</b>	3-1/16 (78)	3-1/16 (78)	25	29
<b>TBQC300</b>	3-11/16 (93.5)	3-11/16 (93.5)	25	34
<b>TBQC350</b>	4-3/16 (106.5)	4-3/16 (106.5)	25	38
<b>TBQC400</b>	4-11/16 (119)	4-11/16 (119)	25	42

**Loading Data**

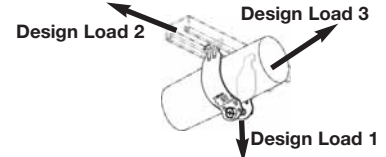

Design Load 1 Static Load Limit lb (kg)	Design Load 2 lb (kg)	Design Load 3 lb (kg)
200 (90)	50 (23)	50 (23)
200 (90)	50 (23)	50 (23)
200 (90)	50 (23)	50 (23)
200 (90)	50 (23)	50 (23)
200 (90)	50 (23)	50 (23)
200 (90)	50 (23)	50 (23)
350 (158)	50 (23)	50 (23)
350 (158)	50 (23)	50 (23)
350 (158)	50 (23)	50 (23)
350 (158)	50 (23)	50 (23)

**Cobra**



Standard material is commercial-grade, bright electrogalvanized steel. Stainless steel 316L is also available; add the suffix "SS6" to catalogue no. (i.e.: CPC050SS6). Stainless steel bolt head is hexagonal and slotted only. Not available in aluminum.

**Ordering information**

Cat. N°	EMT Trade Size	Rigid Con. Trade Size	Cable O.D. Range (in.)	Static Load Limit (lb) Safety Factor = 4	Qty per Box	Wt./C lb
<b>CPC050</b>	1/2	1/2	0.650 - 0.890	200	100	10
<b>CPC075</b>	3/4	3/4	0.860 - 1.110	200	100	12
<b>CPC100</b>	1	1	1.100 - 1.400	200	100	14
<b>CPC125</b>	1 1/4	1 1/4	1.400 - 1.725	200	50	16
<b>CPC150</b>	1 1/2	1 1/2	1.690 - 1.980	200	50	18
<b>CPC200</b>	2	2	1.980 - 2.576	200	50	24
<b>CPC250</b>	2 1/2	2 1/2	2.576 - 3.060	350	25	36
<b>CPC300</b>	3	3	3.060 - 3.626	350	25	42
<b>CPC350</b>	3 1/2	3 1/2	3.626 - 4.126	350	25	46
<b>CPC400</b>	4	4	4.126 - 4.626	350	25	50

**King Cobra**



**Ordering information**

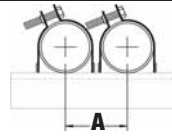

Cat. N°	EMT Trade Size	Rigid Con. Trade Size	Cable O.D. Range (in.)	Qty per Box	Wt./C lb
<b>LKCPC050</b>	1/2	1/2	0.650 - 0.890	100	15
<b>LKCPC075</b>	3/4	3/4	0.860 - 1.110	100	16
<b>LKCPC100</b>	1	1	1.100 - 1.400	50	19
<b>LKCPC125</b>	1 1/4	1 1/4	1.400 - 1.725	50	23
<b>LKCPC150</b>	1 1/2	1 1/2	1.690 - 1.980	50	27
<b>LKCPC200</b>	2	2	1.980 - 2.576	50	38
<b>LKCPC250</b>	2 1/2	2 1/2	2.576 - 3.060	25	44
<b>LKCPC300</b>	3	3	3.060 - 3.626	25	53
<b>LKCPC350</b>	3 1/2	3 1/2	3.626 - 4.126	25	58
<b>LKCPC400</b>	4	4	4.126 - 4.626	25	66

**Loading Data**

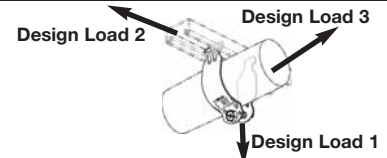

Design Load 1 Static Load Limit lb (kg)	Design Load 2 lb (kg)	Design Load 3 lb (kg)
350 (159)	50 (23)	50 (23)
350 (159)	50 (23)	50 (23)
350 (159)	50 (23)	50 (23)
350 (159)	50 (23)	50 (23)
350 (159)	50 (23)	50 (23)
350 (159)	50 (23)	50 (23)
350 (159)	50 (23)	50 (23)
450 (204)	50 (23)	50 (23)
450 (204)	50 (23)	50 (23)
450 (204)	50 (23)	50 (23)

**SECTION 5**

**Pipe Straps, Pipe Clamps and Hangers**

**Conduit and Cable Clamps**

**CH118**  
Heavy Duty Cable Clamp

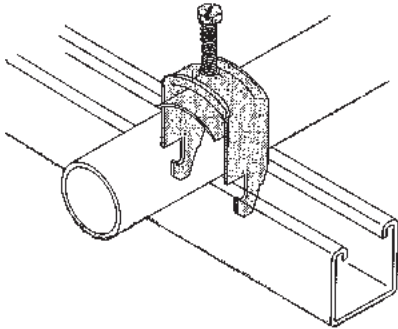

Cat. No.	O.D.		Rigid Cond.	EMT Cond.	Wt./C. lb
	of cable or pipe in.	mm			
CH118-047EG	0.27-0.47	7.5-12	—	—	7
CH118-055EG	0.40-0.55	10-14	—	—	8
CH118-081EG	0.50-0.81	13-21	1/2	1/2	9
CH118-110EG	0.70-1.10	18-28	3/4	3/4	17
CH118-125EG	0.85-1.25	22-27	3/4	1	18
CH118-135EG	1.00-1.35	26-36	1	1	19
CH118-175EG	1.33-1.75	34-44	1-1/4	1-1/2	21
CH118-205EG	1.65-2.05	42-52	1-1/2	—	24
CH118-250EG	2.12-2.50	54-64	2	—	48
CH118-300EG	2.60-3.00	66-76	2-1/2	—	54
CH118-325EG	2.75-3.25	70-82	—	—	65
CH118-375EG	3.25-3.75	82-94	3	—	105
CH118-425EG	3.75-4.25	94-110	3-1/2	—	113
CH118-475EG	4.25-4.75	110-120	4	—	124

**Standard Finishes:**  
 Electrogalvanized (EG)  
 Aluminum (AL) comes complete with Stainless Steel Type 304 saddle and hardware  
 Stainless Steel Type 316 clamp comes with Type 304 stainless steel hardware.

Available in double or triple configurations.

**Example: Double - CH128-047EG**  
**Triple - CH138-047EG**

**CB118 Counterbed**  
**EB118 Extended Bed**  
**DB118 Double Bed**

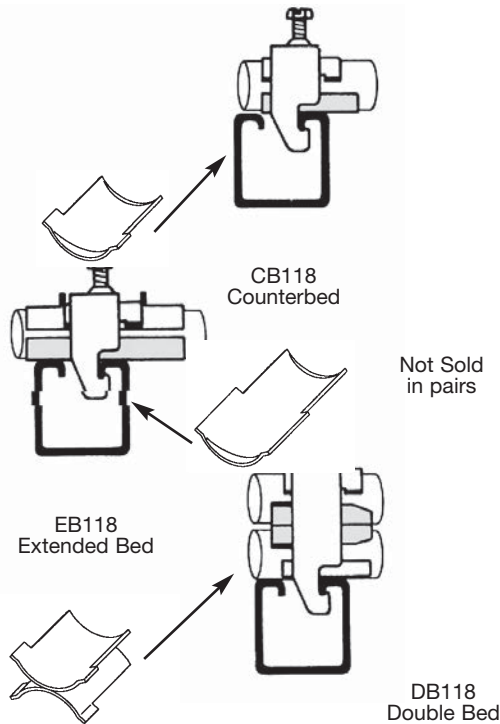

Cat. No.	Wt./C. lb
<b>Counterbed</b>	
CB118-047PG	1
CB118-055PG	1
CB118-070PG	1-1/2
CB118-090PG	2
CB118-110PG	3-1/2
CB118-140PG	4
CB118-175PG	4-1/2
CB118-200PG	5
CB118-250PG	11
CB118-300PG	13
<b>Extended Bed</b>	
EB118-047PG	4
EB118-055PG	4-1/2
EB118-070PG	5-1/2
EB118-090PG	6
EB118-110PG	13-1/2
EB118-140PG	16
EB118-175PG	17
EB118-200PG	20
EB118-250PG	30
EB118-300PG	38
<b>Double Bed</b>	
DB118-047PG	2
DB118-055PG	2
DB118-070PG	3
DB118-090PG	3

**Standard Finishes - Pregalvanized (PG)**

**Pipe Straps, Pipe Clamps and Hangers**

**SECTION 5**

**Conduit and Cable Clamps**

**A716** Snap•Guard® Cushioned Clamp Tube Series

**P716** Snap•Guard® Cushioned Clamp Pipe Series

*Standard Finishes GoldGalv®*

*Available in Stainless Steel - use SS suffix.  
(i.e) A716-1SS*

*ElectroGalvanized (Silver) - use EG suffix.  
(i.e) A716-1EG*

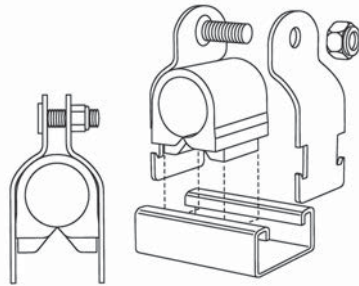

A716 / P716

- Assembly consisting of GoldGalv® finish steel clamp with bolt/locknut and cushion.
- Secure pipes, tubes and hoses for fluid conductors.
- Installation is easy and requires no more time than a simple pipe clamp installation.
- Cushion absorbs the shocks and associated vibrations from fluid surges in tubes, pipes and hoses.
- It can handle temperatures from 149°C to -40°C (300°F to -40°F).
- Cushioned Clamp assemblies are available individually bagged.

Assembly Cat. No.	Tubing		Assembly Cat. No.	Standard Pipe		
	Tube O.D.	Wt./C lb		Nominal Pipe Size	Std. Ctn.	Wt./C lb
A716-1/4	1/4	10	P716-1/4	1/4	25	10
A716-3/8	3/8	14	P716-3/8	3/8	25	14
A716-1/2	1/2	16	P716-1/2	1/2	25	16
A716-5/8	5/8	16	P716-3/4	3/4	25	18
A716-3/4	3/4	18	P716-1	1	25	22
A716-7/8	7/8	18	P716-1-1/4	1-1/4	25	27
A716-1	1	22	P716-1-1/2	1-1/2	10	36
A716-1-1/8	1-1/8	24	P716-2	2	10	43
A716-1-1/4	1-1/4	27	P716-2-1/2	2-1/2	10	49
A716-1-3/8	1-3/8	27	P716-3	3	10	60
A716-1-1/2	1-1/2	36	P716-3-1/2	3-1/2	10	62
A716-1-5/8	1-5/8	37	P716-4	4	10	94
A716-1-3/4	1-3/4	37	-	-	10	-
A716-1-7/8	1-7/8	43	-	-	10	-
A716-2	2	43	-	-	10	-
A716-2-1/8	2-1/8	44	-	-	10	-
A716-2-3/8	2-3/8	49	-	-	10	-
A716-2-5/8	2-5/8	53	-	-	10	-
A716-3-1/8	3-1/8	62	-	-	10	-
A716-4-1/8	4-1/8	94	-	-	10	-

**U716, U717**

**Two Hole Cushioned Clamp**

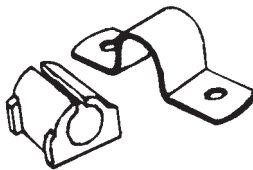

U716 / U717

- Guides, protects, and uniformly spaces line runs. Low cost, time saving method of attaching tubing and hose to equipment.
- Cushion is built to withstand the effects of most oils, chemical and industrial cleaning compounds, in temperatures from -45°C to 121°C (-50°F to 275°F). Interlock edge insures cushion remains in place.
- Attached with two standard fasteners to any flat surface, this clamp eliminates the use of special channels, providing a savings in both space requirements and cost.
- Cushioned clamps reduce vibration, shock, and noise in fluid systems and eliminates electrolysis.

Assembly Cat. No.	Copper and Steel Tubing O.D.	Copper Water Pipe (nom.)	Nominal Pipe Size	Std. Ctn.	Wt./C lb
U716-1/4	1/4	-	-	25	3
U716-3/8	3/8	1/4	-	25	4
U716-1/2	1/2	3/8	1/4	25	6
U716-5/8	5/8	1/2	3/8	25	6
U716-3/4	3/4	5/8	-	25	7
U716-7/8	7/8	3/4	1/2	25	7
U716-1	1	-	-	25	8
U716-1-1/8	1-1/8	1	-	25	8
U716-1-1/4	1-1/4	-	-	10	17
U716-1-3/8	1-3/8	1-1/4	-	10	20
U716-1-1/2	1-1/2	-	-	10	22
U716-1-5/8	1-5/8	1-1/2	-	10	23
U716-2	2	-	-	10	41
U716-2-1/8	2-1/8	-	-	10	41
U716-2-3/8	2-3/8	-	-	10	44

**Standard Finish – GoldGalv®**

**SECTION 5**

**Pipe Straps, Pipe Clamps and Hangers**

**Conduit and Cable Clamps**

**6H Series**

**Conduit and Pipe Hanger**

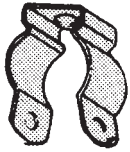

6H Series



6H-B Series  
with Bolt and Hex Nut

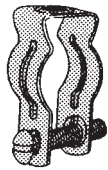

6H-TB  
Threaded Series



6H-T  
Threaded Series

**Features**

- Accommodates 1/2" through 4" EMT or rigid conduit
- Can be used for either vertical or horizontal installation
- 6HTB Series have a built-in nut so there are fewer parts to handle or drop
- Installs easily with a screwdriver

Cat. No.	Conduit Size		Wt./C lb
	Rigid	EMT	
6H0	3/8" - 1/2"	1/2"	5
6H0-B	3/8" - 1/2"	1/2"	7
6H0-T	3/8" - 1/2"	1/2"	5
6H0-TB	3/8" - 1/2"	1/2"	6
6H1	3/4"	3/4"	6
6H1-B	3/4"	3/4"	7
6H1-T	3/4"	3/4"	6
6H1-TB	3/4"	3/4"	7
6H2	1"	1"	7
6H2-B	1"	1"	9
6H2-1/2	-	1-1/4"	8
6H2-1/2-B	-	1-1/4"	10
6H3-SC	1-1/4"	1-1/2"	8
6H3-B	1-1/4"	1-1/2"	10
6H3-TB	1-1/4"	1-1/2"	10
6H4	1-1/2"	-	17
6H4-B	1-1/2"	-	19
6H4-TB	1-1/2"	-	19
6H5	2"	2"	24
6H5-B	2"	2"	26
6H5-TB	2"	2"	26
6H6	2-1/2"	2-1/2"	28
6H6-B	2-1/2"	2-1/2"	30
6H7	3"	3"	36
6H7-B	3"	3"	38
6H8	3-1/2"	3-1/2"	39
6H8-B	3-1/2"	3-1/2"	41
6H9	4"	4"	44
6H9-B	4"	4"	47

Standard Finish - Electrogalvanized (no suffix)  
Available in Stainless Steel 304 (SS)

**Cable Tie Mounting Bases  
For Framing Channel**



Cat. No.	Channel Size	Maximum Tie Width Accom.	Unit Qty.	Std. Pkg.
TC5363X	1-1/2 & 1-5/8	.301	50	250

**INSTALLATION**

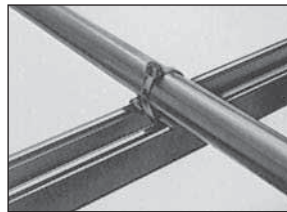
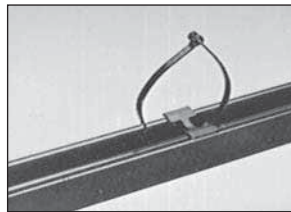
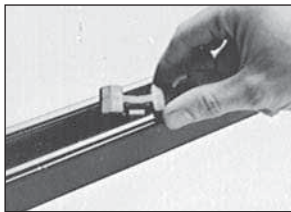

- Installs with a push and twist
- Designed for indoor or outdoor use
- Smooth design protects cable insulation
- Takes range of cable diameters

When fastening wire bundles, cables, or hoses to framing channels, you can cut costs considerably by using this mounting base. It is made of smooth, weather-resistant nylon and designed to protect cable insulation and hoses from the wear or damage that can occur with metal clamps. The mounting base may be used for both indoor or outdoor applications. It installs in the framing channel with a simple push and twist. It requires no screws, nuts or tools. The mounting base fits all 1-1/2" and 1-5/8" channels regardless of channel depth. Ty-Rap® and Ty-Fast® to be ordered separately.

**Pipe Straps, Pipe Clamps and Hangers**

**SECTION 5**

**Conduit and Cable Clamps**

**W716**  
Maple Hardwood Clamps

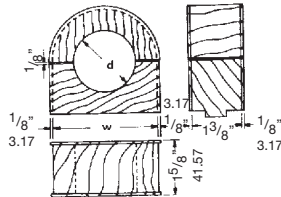
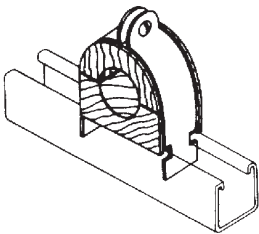

Paraffin impregnated maple.

**Standard Finishes -**  
**Pregalvanized (PG)**  
**Aluminum (AL)**

Cat. No.	Dimensions			
	Depth		Weight	
Hardwood paraffin imp.	in.	mm	in.	mm
W716-3/4PG	3/4	19.0	2-1/8	53.9
W716-1PG	1	25.4	2-1/8	53.9
W716-1-1/4PG	1-1/4	31.7	2-5/8	66.6
W716-1-1/2PG	1-1/2	38.1	2-5/8	66.6
W716-1-3/4PG	1-3/4	44.4	3	76.2
W716-2PG	2	50.8	3-5/8	92.0
W716-2-1/4PG	2-1/4	57.1	3-5/8	92.0
W716-2-1/2PG	2-1/2	63.5	4-5/8	117.7
W716-2-3/4PG	2-3/4	69.8	4-5/8	117.7
W716-3PG	3	76.2	4-5/8	117.7
W716-4PG	4	98.0	5-5/8	143.4

Note: Holding clamp is included with W716 maple hardwood clamps. It is not necessary to order 701 Series separately.

**U861**  
Maple Cable Clamp

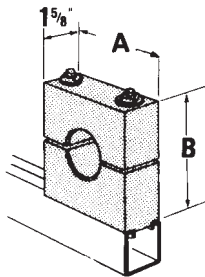

Electrogalvanized hardware included

**Custom made to your needs**

Step 1	Number of holes		
i.e.	U861	1 hole	
	U862	2 holes	
	U863	3 holes	

Step 2	Specify O.D. of cable		
i.e.	3/4" hole	U861	0.75

Contact your Regional Sales Office for quotation.

**WS716**  
Maple Hardwood Saddle

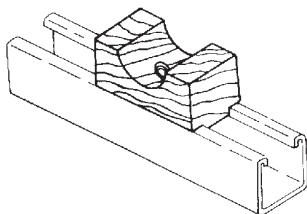

Paraffin impregnated maple.

**STD  
PACK:  
10**

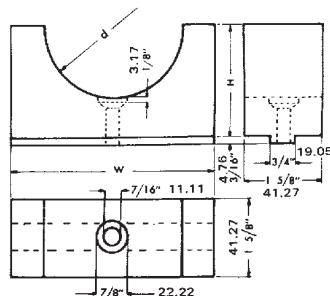

To fasten saddle,  
use 3/8" X 2" screw bolt.

Cat. No.	Dimensions					
	Depth		Width		Height	
Hardwood Paraffin Imp.	in.	mm	in.	mm	in.	mm
WS716-3/4	3/4	19.0	3	76.2	1-3/4	44.4
WS716-1	1	25.4	3	76.2	1-3/4	44.4
WS716-1-1/4	1-1/4	31.7	3-1/2	88.9	2	50.8
WS716-1-1/2	1-1/2	38.1	3-1/2	88.9	2	50.8
WS716-1-3/4	1-3/4	44.4	4	101.6	2-1/4	57.1
WS716-2	2	50.8	4	101.6	2-1/4	57.1
WS716-2-1/4	2-1/4	57.1	4-1/2	114.3	2-1/2	63.5
WS716-2-1/2	2-1/2	63.5	4-1/2	114.3	2-1/2	63.5
WS716-2-3/4	2-3/4	69.8	5	127	2-3/4	69.8
WS716-3	3	76.2	5	127	2-3/4	69.8
WS716-3-1/4	3-1/4	82.5	5-1/2	139.7	2-3/4	76.2
WS716-3-1/2	3-1/2	88.9	5-1/2	139.7	3	76.2
WS716-3-3/4	3-3/4	95.2	6	152.4	3-1/4	82.5
WS716-4	4	101.6	6	152.4	3-1/4	82.5
WS716-4-1/2	4-1/2	114.3	6-1/2	165.1	3-1/2	88.9
WS716-5	5	127	7	177.8	3-3/4	95.2
WS716-5-1/2	5-1/2	139.7	7-1/2	190.5	4	101.6
WS716-6	6	152.4	8	203.2	4-1/4	107.9
WS716-6-1/2	6-1/2	165.1	8-1/2	215.9	4-1/2	114.3
WS716-7	7	177.8	9	228.6	4-3/4	120.6

**SECTION 5**

**Pipe Straps, Pipe Clamps and Hangers**

**Conduit and Cable Clamps**

**AB880**  
3" Porcelain Saddle

**AB881**  
4" Porcelain Saddle

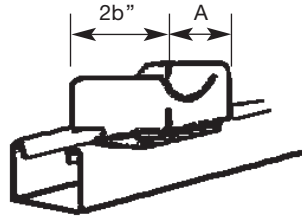

Cat. No.	A	Max. Cable Diam.	Wt./C lb
AB880	3	3	73
AB881	4	4-1/2	104

**C755**  
Porcelain Cable Clamps

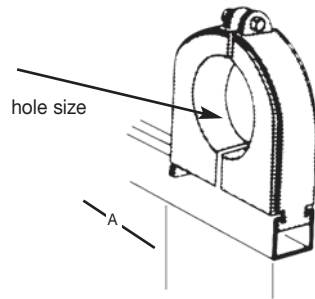

Cat. No.	Hole Size	A	Wt./C lb	Cat. No.	Hole Size	A	Wt./C lb
C755-1A	3/8	1-9/16	50	C755-5C	2-5/8	4-1/4	240
C755-1B	1/2	1-9/16	50	C755-6	2-3/4	4-3/4	250
C755-1C	5/8	1-9/16	50	C755-6A	2-7/8	4-3/4	240
C755-2	3/4	2-5/32	91	C755-6B	3	4-3/4	230
C755-2A	7/8	2-5/32	90	C755-6C	3-1/8	4-3/4	220
C755-2B	1	2-5/32	85	C755-7	3-1/4	5-13/16	340
C755-2C	1-1/8	2-5/32	82	C755-7A	3-3/8	5-13/16	330
C755-3	1-1/4	2-5/8	114	C755-7B	3-1/2	5-13/16	318
C755-3A	1-3/8	2-5/8	110	C755-7C	3-5/8	5-13/16	387
C755-3B	1-1/2	2-5/32	105	C755-8	3-3/4	6-7/8	565
C755-3C	1-5/8	2-5/8	102	C755-8A	3-7/8	6-7/8	550
C755-4	1-3/4	3-3/4	220	C755-8B	4	6-7/8	535
C755-4A	1-7/8	3-3/4	214	C755-8C	4-1/8	6-7/8	520
C755-4B	2	3-3/4	205	C755-8D	4-1/4	6-7/8	490
C755-4C	2-1/8	3-3/4	200	C755-8E	4-3/8	6-7/8	475
C755-5	2-1/4	4-1/4	260	C755-8F	4-1/2	6-7/8	460
C755-5A	2-3/8	4-1/4	250				
C755-5B	2-1/2	4-1/4	243				

**Standard Finish -**  
**GoldGalv® with bronze hardware**  
Also fits 1-1/2" wide channel.  
For minimum order quantities contact customer service.



**Pipe Straps, Pipe Clamps and Hangers**

**SECTION 5**

**Conduit and Cable Clamps**

**S716**  
Cushioned Strip for Isolation & Vibration Applications



For use with 701 O.D. tubing and pipe clamp. To determine 701 clamp size add 1/4" to O.D. tube size to allow for the Cushioned Strip material.

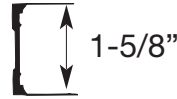
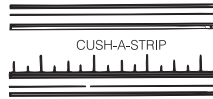

1/4" markings for fast measuring and cutting. Measurement chart is printed on back of carton. **20 feet included in each carton.**

Prevent metal to metal contact with the Cushioned Strip material. It aids in sound insulation, shock absorption and protects against corrosion, distortion and abrasion. Cushioned Strip material is designed for optimal use between -1°C and 149°C (30°F and 300°F).

Cushioned Strip material combined with the Superstrut 701 pipe strap can handle clamping assignments from 1/4" to 6."

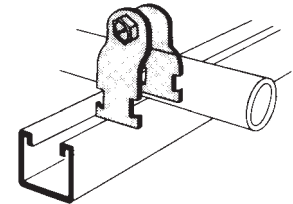

**Order 701 clamp separately.**

**C708U**  
Short Strap for Channel or Wall Mounting

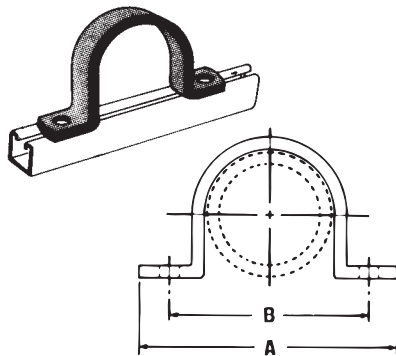

**Standard Finish - GoldGalv®**

**Example: C708U-1/2**

No clearance between pipe and channel.

Pipe Size	A	B	Thickness	Width	Hole Size	Design Load lb	Wt./C lb
1/2	2-7/8	2	1/8	1-5/8	9/32	650	23
3/4	3-1/16	2-3/16	1/8	1-5/8	9/32	650	26
1	3-3/8	2-1/2	1/8	1-5/8	9/32	650	31
1-1/4	3-11/16	2-13/16	1/8	1-5/8	9/32	650	35
1-1/2	3-15/16	3-1/16	1/8	1-5/8	9/32	650	39
2	5-3/4	4-1/8	1/4	1-5/8	7/16	650	94
2-1/2	6-3/16	4-9/16	1/4	1-5/8	7/16	1000	114
3	6-13/16	5-3/16	1/4	1-5/8	7/16	1000	133
3-1/2	7-5/16	5-11/16	1/4	1-5/8	7/16	1000	152
4	7-13/16	6-3/16	1/4	1-5/8	7/16	1200	176
5	8-7/8	7-1/4	1/4	1-5/8	7/16	1200	198
6	9-15/16	8-5/16	1/4	1-5/8	7/16	1200	246

Carbon Steel

**SECTION 5**

**Pipe Straps, Pipe Clamps and Hangers**

**Conduit and Cable Clamps**

**C711**  
"J" Pipe Hanger

**Standard Finishes - GoldGalv®, Electrogalvanized (EG)**

Complies with Specification MSS SP69, Type 5.  
Hole provided for side mounting to wall as bracket.

**Example: C711-1/2**

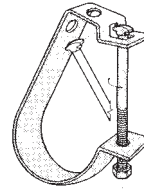

Standard

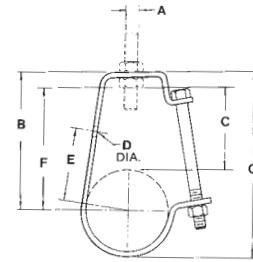

Pipe Size	A Rod Size	Overall Dimension					Bolt Size	G	Thickness	Width	Max. Rec. Approx.	
		B	C	D	E	F					Load lb	Wt./C lb
1/2	3/8	2-5/8	1-3/4	7/16	1-1/2	1-15/16	1/4	3-5/32	12 ga	3/4	400	18
3/4	3/8	2-7/8	1-7/8	7/16	1-11/16	2-1/8	1/4	3-1/2	12 ga	3/4	400	21
1	3/8	2-15/16	1-15/16	7/16	1-13/16	2-5/16	1/4	3-11/16	12 ga	3/4	400	22
1-1/4	3/8	3-1/4	2	7/16	2-1/16	2-5/8	1/4	4-1/8	12 ga	3/4	400	25
1-1/2	3/8	3-9/16	2-3/16	7/16	2-7/16	2-7/8	1/4	4-5/8	12 ga	3/4	400	27
2	3/8	3-11/16	2-1/8	7/16	2-9/16	3-1/16	1/4	5	12 ga	3/4	400	29
2-1/2	1/2	4-7/16	2-7/16	9/16	3-3/16	3-5/8	3/8	6	12 ga	1-1/4	500	64
3	1/2	4-13/16	2-9/16	9/16	3-1/2	4-1/16	3/8	6-21/32	12 ga	1-1/4	500	72
3-1/2	1/2	5-1/8	2-5/8	9/16	3-3/4	4-3/8	3/8	7-5/16	3/16	1-1/4	500	84
4	5/8	6-1/8	3-3/16	9/16	4-5/8	5-3/16	3/8	8-9/16	3/16	1-1/4	550	138
5	5/8	6-3/4	3-1/4	9/16	5-1/16	5-3/5	3/8	9-23/32	3/16	1-1/4	550	162
6*	3/4	7-3/4	3-9/16	9/16	5-13/16	6-5/8	3/8	11-1/4	3/16	1-3/4	600	249
8*	7/8	9-3/16	3-15/16	9/16	6-15/16	8	3/8	13-11/16	3/16	1-3/4	760	291

\*Hangers 6" and over have hole instead of slot.

**C727**  
Adjustable Ring

**Standard Finish - Pregalvanized (no suffix), Stainless Steel (SS)**

Carbon steel. For suspension of non-insulated pipe lines.

Complies with Specification MSS SP69, Type 10.

**Example: C727-1/2**

Tube Size	Rod Size	A	B	C	Thickness	Width	Approx. Max. Rec. Load	Wt./C lb
1/2	3/8	3-1/8	2-5/8	1-3/8	16 ga	1	400	9
3/4	3/8	3-1/8	2-1/2	1-1/8	16 ga	1	400	9
1	3/8	3-3/8	2-5/8	1-1/8	16 ga	1	400	9
1-1/4	3/8	3-3/4	2-7/8	1-1/8	16 ga	1	400	10
1-1/2	3/8	3-7/8	2-7/8	1	16 ga	1	400	11
2	3/8	4-1/4	3	1	16 ga	1	400	12
2-1/2	1/2*	5-3/4	4-1/4	1-5/8	14 ga	1-3/16	600	28
3	1/2*	6	4-1/8	1-1/4	14 ga	1-3/16	600	30
3-1/2	1/2*	7-3/8	5-1/4	2-1/8	14 ga	1-3/16	600	34
4	5/8*	7-3/8	5	2-5/8	14 ga	1-1/4	1000	37
5	5/8**	9	6-1/8	2-1/4	12 ga	1-1/4	1250	83
6	3/4**	9-3/8	6-1/2	1-7/8	12 ga	1-1/4	1250	95

\*3/8" nut is used when NFPA rod sizing is requested.  
\*\*1/2" nut is used when NFPA rod sizing is requested.

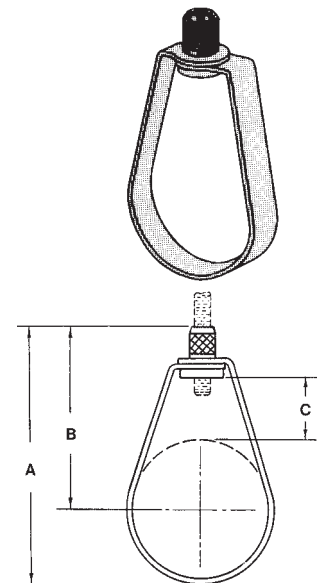

**Pipe Straps, Pipe Clamps and Hangers**

**SECTION 5**

**Pipe Hangers**

**C710**

**Adjustable Clevis Hanger**

**Standard Finishes - GoldGalv®, ElectroGalvanized (EG)**

Complies with Specification MSS SP69, Type 1.

Standard Clevis Hanger also available in Stainless Steel

**Example: C710-1/2EG**

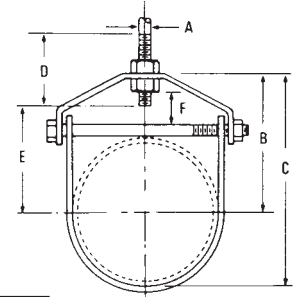

Pipe Size	Size of Steel		A	B	C	D	E	F	Max. Rec. Load, lb	Wt./C lb
	Upper	Lower								
1/2	1/8x1	1/8x1	3/8	1-11/16	2-1/8	2-1/2	7/8	7/16	610	30
3/4	1/8x1	1/8x1	3/8	1-7/8	2-7/16	2-1/2	1	1/2	610	32
1	1/8x1	1/8x1	3/8	2-1/8	2-13/16	2-1/2	1-1/4	5/8	610	36
1-1/4	1/8x1	1/8x1	3/8	2-9/16	3-7/16	2-1/2	1-3/4	7/8	610	42
1-1/2	1/8x1	1/8x1	3/8	3	4	2-1/2	2-1/8	1-1/16	610	55
2	1/8x1	1/8x1	3/8	3-11/16	4-7/8	2-1/2	2-15/16	1-5/8	610	60
2-1/2	3/16x1-1/4	3/16x1-1/4	1/2	4-11/16	6-1/8	3	3-13/16	2	1130	115
3	3/16x1-1/4	3/16x1-1/4	1/2	4-3/4	6-9/16	3	3-7/8	1-3/4	1130	132
3-1/2	3/16x1-1/4	3/16x1-1/4	1/2	4-15/16	6-15/16	3	4-1/16	1-3/4	1130	156
4	1/4x1-1/4	3/16x1-1/4	5/8	5-9/16	7-13/16	3-1/2	4-1/2	1-15/16	1430	190
5	1/4x1-1/4	3/16x1-1/4	5/8	6-3/16	9	3-1/2	5-1/8	1-3/4	1430	240
6	1/4x1-1/2	3/16x1-1/2	3/4	6-13/16	10-1/8	4	5-5/8	1-7/8	1940	320
8	1/4x1-3/4	3/16x1-3/4	7/8	8-5/16	12-5/8	4-1/4	7	2-1/8	1940	500

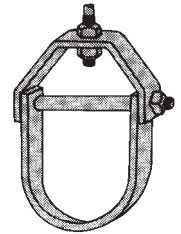

**CL710**

**Light Duty Adjustable Clevis Hanger**

**Standard Finishes - GoldGalv®, Bare (B), ElectroGalvanized (EG), Fiberglass (FG).**

Carbon Steel

Used on non-insulated, stationary pipelines.

A lock nut above the clevis yoke is required for full rated load.

**Example: CL710-3/8B**

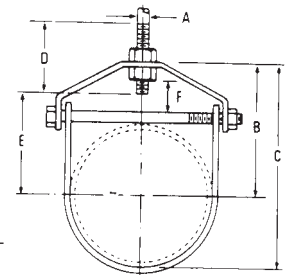

Pipe Size	Thickness of Steel		A	B	C	D	E	F	Max. Rec. Load, lb	Wt./C lb
	Upper	Lower								
3/8	16 ga x 7/8	16 ga x 7/8	3/8	1-7/8	2-3/16	2-1/2	1-1/4	9/16	150	12
1/2	16 ga x 7/8	16 ga x 7/8	3/8	1-3/4	2-3/16	2-1/2	1-1/8	9/16	150	13
3/4	16 ga x 7/8	16 ga x 7/8	3/8	1-7/8	2-1/4	2-1/2	1-1/4	1/2	250	15
1	16 ga x 7/8	16 ga x 7/8	3/8	2-3/16	2-3/4	2-1/2	1-1/2	3/4	250	18
1-1/4	16 ga x 7/8	16 ga x 7/8	3/8	2-5/8	3-3/8	2-1/2	1-3/4	1	250	20
1-1/2	13 ga x 7/8	13 ga x 7/8	3/8	3	3-7/8	2-1/2	2-1/4	1-3/16	250	30
2	13 ga x 7/8	13 ga x 7/8	3/8	3-9/16	4-3/4	2-1/2	2-13/16	1-5/8	250	38
2-1/2	1/8 x 1-1/4	1/8 x 1-1/4	1/2	4	5-1/2	3	3-1/4	1-3/8	350	80
3	1/8 x 1-1/4	1/8 x 1-1/4	1/2	4-9/16	6-1/2	3	3-9/16	1-1/2	350	89
3-1/2	1/8 x 1-1/4	1/8 x 1-1/4	1/2	5	7	3	4-1/8	1-3/4	350	106
4	3/16 x 1-1/4	1/8 x 1-1/4	1/2	5-1/4	7-1/2	3-1/2	4-1/4	1-7/8	400	146



**SECTION 5**

**Pipe Straps, Pipe Clamps and Hangers**

**Pipe Hangers**

**M718**  
Split Pipe Ring

**Standard Finishes - Bare (B) or Electrogalvanized (EG)**

Malleable iron.

For suspension of non-insulated, stationary pipelines.

**Example: M718-3/8B**

Pipe Size	A	B	Max. Rec. Load/lb	Wt./C lb
3/8	3/8	13/16	180	10
1/2	3/8	7/8	180	13
3/4	3/8	1	180	14
1	3/8	1-1/8	180	16
1-1/4	3/8	1-5/16	180	22
1-1/2	3/8	1-7/16	180	24
2	3/8	1-11/16	180	31
2-1/2	1/2	2-1/8	300	60
3	1/2	2-7/16	300	74
4	1/2	2-15/16	300	116

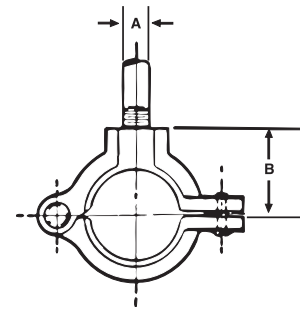
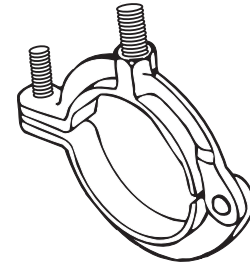

**C725**  
Medium Pipe Clamp

**Standard Finishes - GoldGalv®, Bare (B), Stainless Steel (SS), Electrogalvanized (EG)**

Carbon steel. For suspension of pipelines where little or no insulation is required.

Complies with Specification MSS SP69, Type 23.

**Example: C725-1/2B**

Pipe Size	B	C	D	E	F	H	S	Max. Rec. Load, lb	Wt./C, lb Approx.
1/2	1	7/16	1-5/8	1	5/16	1-1/2	1/8 x 1	500	29
3/4	1-1/8	7/16	1-3/4	1-1/4	5/16	1-3/4	1/8 x 1	500	32
1	1-1/4	7/16	1-13/16	1-1/4	5/16	1-13/16	1/8 x 1	500	33
1-1/4	1-7/16	7/16	2	1-7/16	5/16	2	1/8 x 1	500	38
1-1/2	1-5/8	1/2	2-1/16	1-1/2	5/16	2-1/4	1/8 x 1	715	39
2	2-1/8	9/16	3-1/8	2-1/4	1/2	3	1/4 x 1	1040	117
2-1/2	2-5/16	9/16	3-5/16	2-1/2	1/2	3-1/4	1/4 x 1	1040	128
3	2-3/4	9/16	3-3/4	2-3/4	1/2	3-5/8	1/4 x 1	1040	140
3-1/2	3-7/8	5/8	3-3/4	3	1/2	3-7/8	1/4 x 1	1040	145
4	3-5/16	3/4	4-1/4	3-5/16	5/8	4-1/4	1/4 x 1-1/4	1040	238
6	4-7/8	7/8	5-7/8	5	3/4	5-3/4	3/8 x 1-1/2	1615	542
8	6	1	7	6-1/8	3/4	6-7/8	3/8 x 1-1/2	1615	651
10	7-5/16	1	8-9/16	7-7/16	7/8	8-7/16	1/2 x 2	2490	1360
12	8-1/4	1	9-9/16	8-7/16	7/8	9-3/8	1/2 x 2	2490	1605

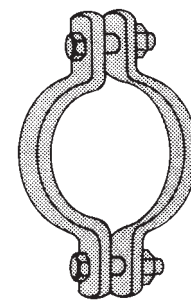
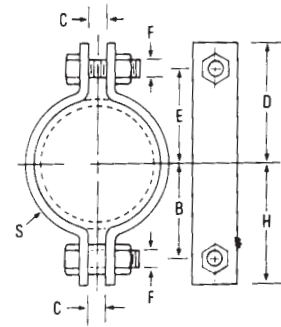

Based on the allowable stresses shown in ANSI Code for pressure piping.  
For sizes 14 to 24, contact Customer Service.

**Pipe Straps, Pipe Clamps and Hangers**

**SECTION 5**

**Pipe Hangers**

**C720**

**Riser Clamp**

**Standard Finishes - GoldGalv®, Bare (B), Stainless Steel (SS)**

Available in sizes 1/2" through 10".

Complies with Specification MSS SP69, Type 8.

**Example: C720-1 1/2B**

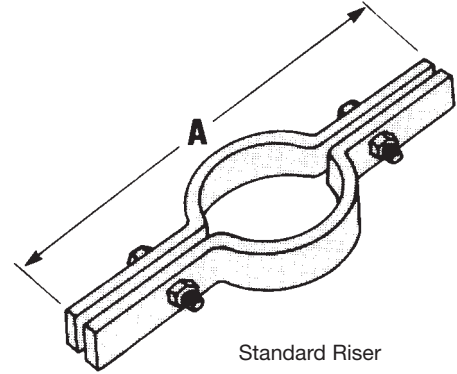

Standard Riser

Pipe Size	A	Thickness	Width	Bolt	Max. Rec. Load, lb	Wt./Ea. Approx.
1/2	9-1/8	3/16	1	3/8 x 1-1/2	220	1.01
3/4	9-1/4	3/16	1	3/8 x 1-1/2	220	1.06
1	9-5/8	3/16	1	3/8 x 1-1/2	220	1.07
1-1/4	9-7/8	1/4	1	3/8 x 1-1/2	250	1.12
1-1/2	10	1/4	1	3/8 x 1-1/2	250	1.20
2	10-1/2	1/4	1	3/8 x 1-1/2	300	1.25
2-1/2	11-1/16	1/4	1	3/8 x 1-1/2	400	1.67
3	11-13/16	1/4	1	3/8 x 1-1/2	500	1.81
3-1/2	13	1/4	1	1/2 x 1-1/2	600	2.12
4	13-1/2	1/4	1	1/2 x 1-1/2	750	2.22
5	14	1/4	1-1/2	1/2 x 1-3/4	1500	3.44
6	15-3/16	1/4	1-1/2	1/2 x 1-3/4	1600	3.65
8	19	3/8	1-1/2	5/8 x 2-1/2	2500	7.24

**C726**

**Double Bolt Pipe Clamp**

**Standard Finish - Bare (B)**

Carbon Steel. For the suspension of insulated pipelines.

Normally used with weldless eye nut.

**Example: C726-1/2B**

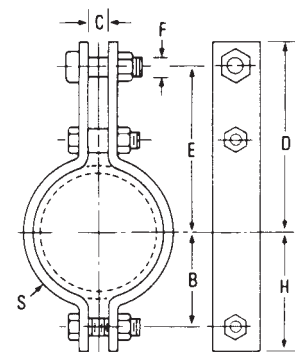

Pipe Size	B	C	D	E	F	H	S	Max. Rec. Load, lb	Approx. Wt. /C
3/4	1-1/16	5/8	3-3/16	2-1/2	3/8	1-11/16	3/16 x 1	950	66
1	1-1/2	5/8	3-3/4	2-1/2	3/8	2-1/16	3/16 x 1	950	69
1-1/4	1-1/2	3/4	3-11/16	2-7/8	3/8	2-1/4	3/16 x 1	950	75
1-1/2	1-13/16	1-1/16	4-7/8	3-3/4	5/8	2-13/16	1/4 x 1-1/4	1545	181
2	2-1/4	1-1/16	5-11/16	4-11/16	5/8	3-3/16	1/4 x 1-1/4	1545	200
2-1/2	2-5/8	1-1/16	6-1/2	5-3/8	5/8	3-1/2	1/4 x 1-1/4	1545	232
3	2-3/4	1-1/16	6-7/8	6	5/8	3-3/4	1/4 x 1-1/4	1545	258
3-1/2	3	1-1/16	7-1/16	6-3/16	5/8	4	1/4 x 1-1/4	1545	264
4	3-3/8	1-1/16	7-5/8	6-1/2	3/4	4-1/2	3/8 x 2	2500	750
5	3-15/16	1-1/16	8-1/8	7	3/4	5	3/8 x 2	2500	813
6	4-3/4	1-7/16	9-15/16	8-9/16	1	6-1/8	3/8 x 2-1/2	2865	1311
8	5-3/4	1-7/16	10-15/16	9-9/16	1	7-1/8	3/8 x 2-1/2	2865	1467

**SECTION 5**

**Pipe Straps, Pipe Clamps and Hangers**

**Seismic Bracing**

Consult Superstrut® seismic Hanger Bulletin (GM141) for additional information

**C749N**

**Seismic Brace**

*Standard Finish - GoldGalv®*

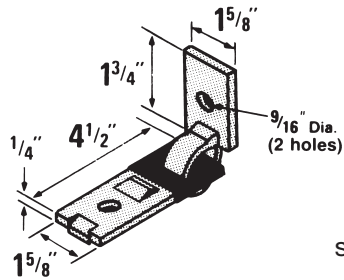

1650 lb. load  
safety factor 3  
Wt./C 61 lb

**C749N-5/8**

**Seismic Brace**

*Standard Finish - GoldGalv®*

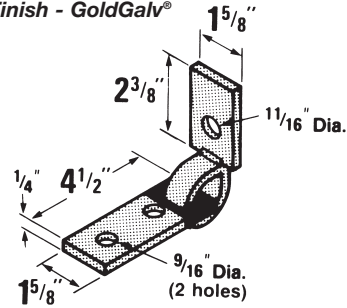

1650 lb. load  
safety factor 3  
Wt./C 56 lb

**C749N-7/8**

**Seismic Brace**

*Standard Finish - GoldGalv®*

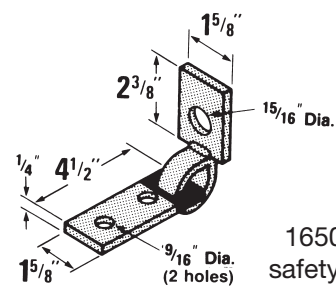

1650 lb. load  
safety factor 3  
Wt./C 74 lb

**C749N-1 1/8**

**Seismic Brace**

*Standard Finish - GoldGalv®*

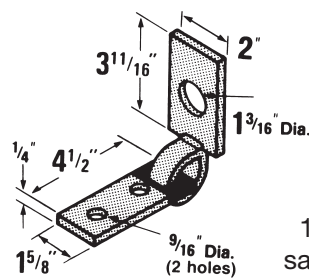

1650 lb. load  
safety factor 3  
Wt./C 72 lb

**ES142**

*Standard Finish - GoldGalv®*

Cat. No.	Bolt Dia.	Wt./C lb
ES-142-1/2 x 1-1/2	1/2	21



Seismic bracing rod  
stiffener connector.  
Wt./C 21 lb

All braces have plastisol coating on the flat member.

Plastisol insulates against vibration noise transmission and eliminates rattle at the connection points.





**Hanger Accessories**

**SECTION 5**

**Hanger Accessories**

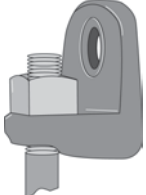
Other products available. Contact your Regional office.

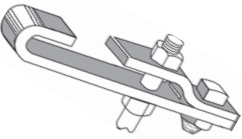
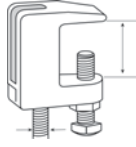
<p><b>C704A</b> Offset J-Hook</p>  <p>Sizes 1/2" thru 3" IPS</p>	<p><b>M732H</b> I-Beam w/Eye Nut</p>  <p>MSS SP69 Type 28</p>	<p><b>M732 / M732 Ext</b> I-Beam Clamp w/Swing Nut</p>  <p>Sizes 3/8" thru 7/8" Rod MSS SP69 Type 30</p>	<p><b>C736</b> Light Welded Steel Bracket</p>  <p>Max. Load 750 Lb MSS SP69 Type 31</p>	<p><b>C739M</b> Medium Welded Steel Bracket</p>  <p>Max. Load 1500 Lb MSS SP69 Type 32</p>
<p><b>C739H</b> Heavy Welded Steel Bracket</p>  <p>Max. Load 3000 Lb MSS SP69 Type 33</p>	<p><b>M750</b> Side Beam Bracket</p>  <p>Sizes 3/8" thru 7/8" Rod MSS SP69 Type 34</p>	<p><b>C785A</b> Pipe Stanchion Saddle</p>  <p>Sizes 4" thru 36" IPS MSS SP69 Type 37</p>	<p><b>C786</b> Adj. Pipe Saddle Support</p>  <p>Sizes 2-1/2" thru 36" IPS MSS SP69 Type 38</p>	<p><b>C789</b> Steel Pipe Covering Protection Saddle</p>  <p>MSS SP69 Type 39</p>
<p><b>C790</b> Insulation Protection Shield for PVC coated pipe lines and insulated copper tubing</p>  <p>Sizes 3/4" thru 12" IPS MSS SP69 Type 40</p>	<p><b>RC729A</b> Single Pipe Roll</p>  <p>Sizes 1" thru 24" IPS MSS SP69 Type 41</p>	<p><b>C729</b> Adj. Roller Hanger</p>  <p>Sizes 1" thru 20" IPS MSS SP69 Type 43</p>	<p><b>S730C</b> Pipe Roll + Base</p>  <p>MSS SP69 Type 44</p>	<p><b>S730D</b> Adj. Pipe Roll &amp; Base</p>  <p>MSS SP69 Type 46</p>
<p><b>C769</b> Top I-Beam Clamp</p>  <p>Sizes 3/4" thru 7/8" Rod MSS SP69 Type 25</p>	<p><b>C755 T / C757 T</b> Center I-Beam Clamp</p>  <p>MSS SP69 Type 21</p>	<p><b>C780</b> Weld attachment as shown or inverted less bolt</p>  <p>MSS SP69 Type 22</p>	<p><b>M778</b> Top Beam C-Clamp</p>  <p>Sizes 3/8" thru 3/4" Rod MSS SP69 Type 19</p>	<p><b>M777</b> Junior Top Beam C-Clamp</p>  <p>Sizes 3/8" thru 1/2" Rod MSS SP69 Type 18</p>

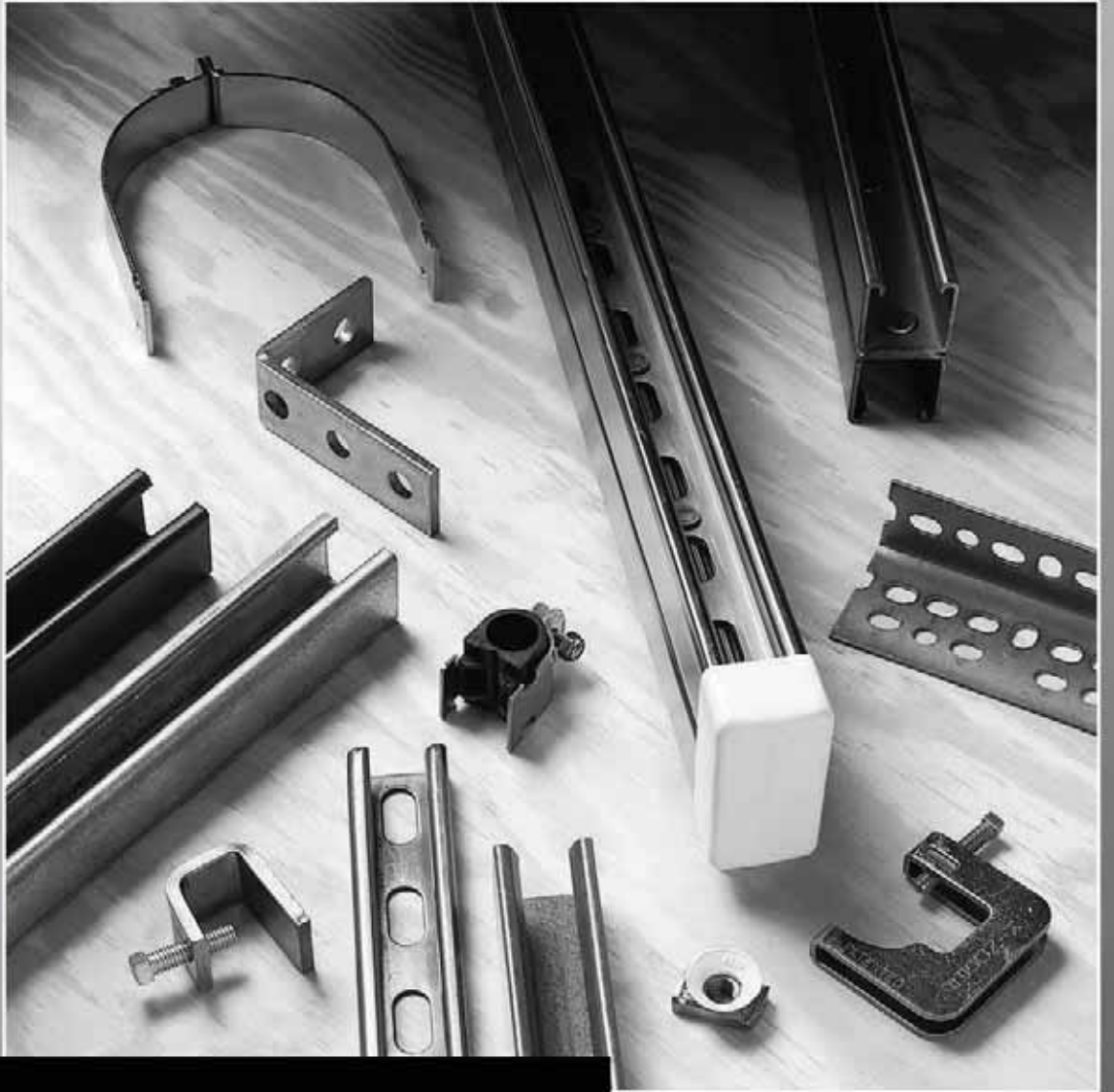

**SECTION 6**  
**SURFACE RACEWAY AND**  
**LIGHTING SYSTEMS**

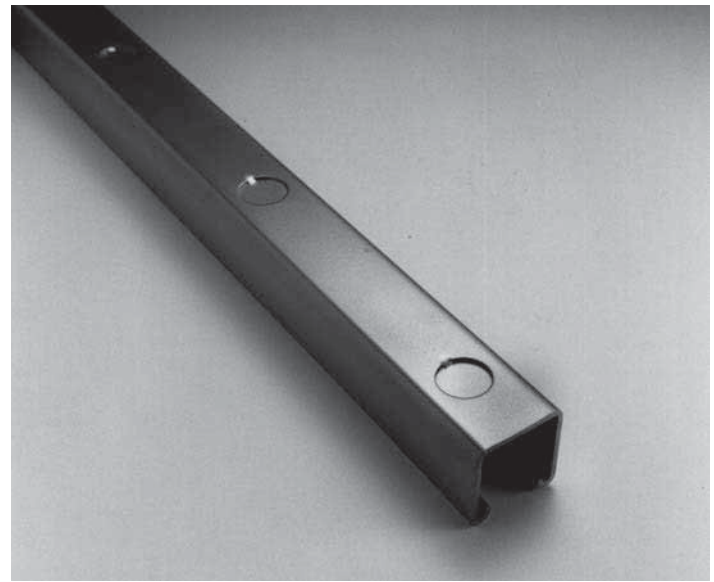
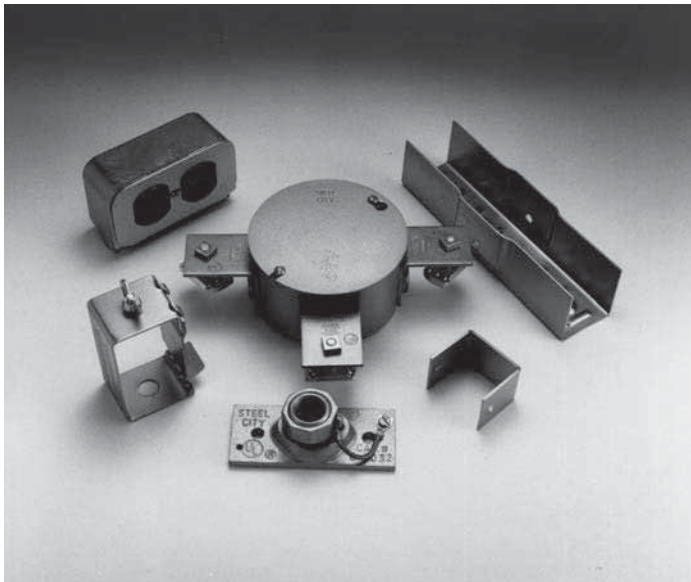

**Material**

Superstrut® electrical raceway, fixture hanging channel, closure strip and accessories are manufactured from hot rolled strip steel. Standard finish for the accessories is GoldGalv®.

**Design Data**

Deflections at various hanger rod spacings for raceway channels based on 40 to 45 lb per fixture.

Channel	Deflection		
	at 10 ft	at 12 ft	at 14 ft
A1200	1/4"	1/2"	3/4"
C1200	3/8"	3/4"	*
A1400	3/8"	3/4"	*

Channel	Deflection		
	at 6 ft	at 7 ft	at 9 ft
B1200	3/8"	9/16"	5/8"
B1400	1"	1/2"	*

\*Not recommended for this spacing.

**Electrical Raceway**

Superstrut channel together with snap-in closure strip is listed by Underwriters Laboratories as a surface metal raceway. Other accessories listed by Underwriters Laboratories are identified on the drawings.

**MAXIMUM NUMBER OF WIRES**

Wire Size AWG	Raceway							
	With or without KO							
	A1200		B1200		C1200		E1200	
	A	B	A	B	A	B	A	B
14	6	10	4	6	5	10	6	10
12	6	10	3	6	4	10	6	10
10	5	8			4	6	5	8
8	4	6			3	4	4	6
6	2	3			2	2	2	3

COLUMN A: Suitable for number of wires indicated when used as a raceway. Also suitable for number of wires indicated when installed to support and supply electrical fixtures when raceway wiring is suitable for not less than 75°C.

By providing clearance between fixture and raceway of not less than 1/2", where suitable for 60°C may be used.

COLUMN B: Suitable for number of wires indicated when used as a raceway. Also suitable for number of wires indicated when installed to support electrical fixtures when clearance of not less than 1/8" is provided between raceway and fixture and when wiring is suitable for 75°C.

**Applicable Channels**

A1200	B1200
A1200-KO	B1400
A1400	C1200
A1400-KO	E1200
	H1200



**SECTION 6**

**Surface Raceway and Lighting Systems**

**Fixture Fittings**

**802**  
Raceway Joiner With  
Reinforcing Plate

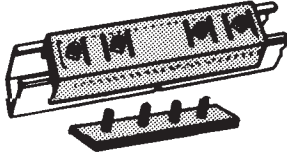

Furnished complete with nuts.

Cat. No.	For Channel	Wt./C lb
A802EG	A Series	158
B802EG	B Series	112
E802EG	E Series	170
H802	H Series	182

**822**  
Raceway Joiner & Seal

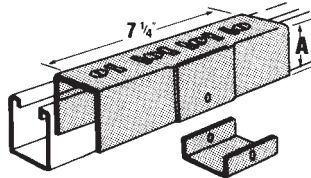

Furnished complete with 1/4" x 5/8" machine screws and AB100-1/4 nuts.

Cat. No.	A	For Channel	Wt./C lb
A822	1-11/16	A Series	75
B822	7/8	B Series	56

**A213**  
Inside Joiner

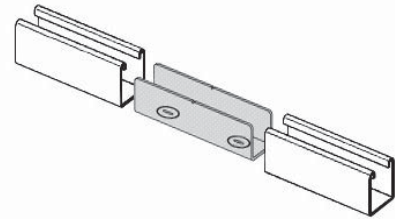

For A1200 series channel  
Only available in GoldGalv® finish

**805**  
End Cap With Knockout

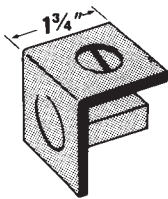

KO for 1/2" conduit.  
Furnished complete with 1/4" x 5/8" flat head machine screw and AB100-1/4 nut.

Cat. No.	For Channel	Wt./C lb
A805EG	A Series	21
H805EG	H Series	31

**809**  
Tapped End Cap

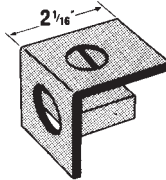

12 ga. steel. For 3/4" or 1" conduit. Furnished complete with 1/4" x 5/8" flat head machine screw and AB100-1/4 nut.

Cat. No.	For Channel	Wt./C lb
A809-3/4EG	A Series	2
E809-3/4EG	E Series	26

**A853**  
Channel Hanger



Use hanger rod 3/8" or 1/2". Use with A, AR, B, BR or C series single channel.

Wt./C 25 lb

**A853L**  
Channel Hanger - Long

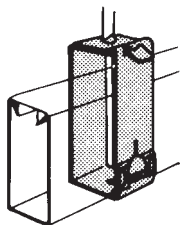

Long type for all series channel.

Wt./C 48 lb

**A854**  
Channel Hanger

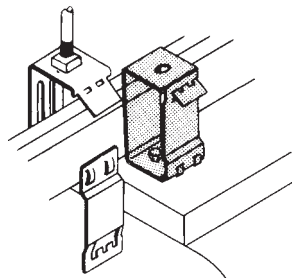

Illustration showing A854 with nut and bolt furnished to attach to fluorescent fixture. Use with A, B, C or D series channel.

Wt./C 34 lb

**A854L**  
Channel Hanger - Long

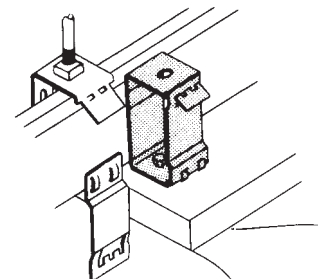
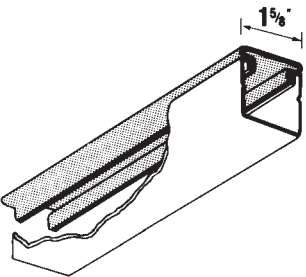

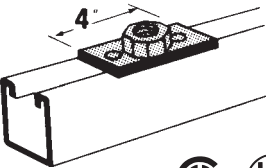

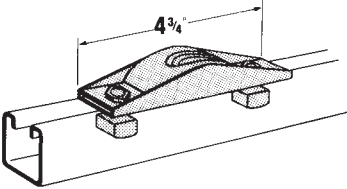
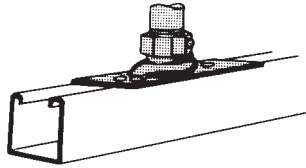
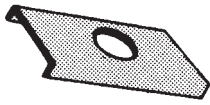
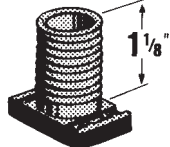
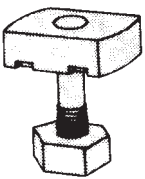
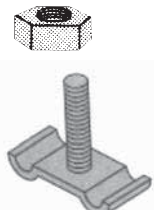
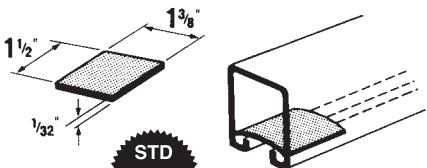



Illustration showing A854L with nut and bolt furnished to attach to fluorescent fixture. Use with E and H series channel as well as A, B, C or D.

Wt./C 51 lb

**Fixture Fittings**













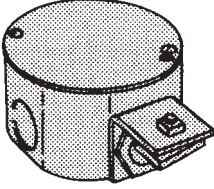

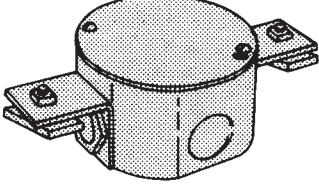

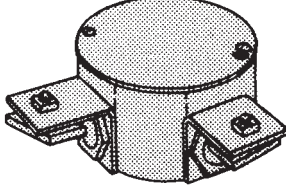

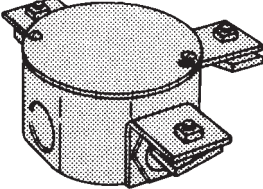

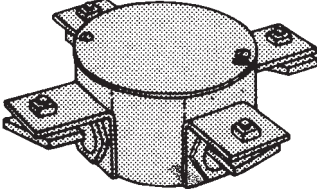

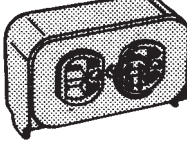
<p><b>AB844PGC</b> Steel Closure Strip</p> <p><b>AB844PC</b> Plastic Closure Strip Colour: Gold</p> <p><b>AB844PCGY</b> Plastic Closure Strip Colour: Grey</p>  <p style="text-align: right;">  </p> <ul style="list-style-type: none"> <li>• When used as a raceway is channel is normally installed with the slot up. After wiring has been completed the closure strip is installed.</li> <li>• For all channels.</li> <li>• Standard length: 10 ft</li> </ul>																	
<p><b>AB803</b> Cast Conduit Connector</p>  <p style="text-align: right;">  </p> <p>To connect 1/2" or 3/4" conduit to raceway channel. Furnished complete with stud nuts and hex nuts. Part has removable bushing to increase size from 1/2" to 3/4".</p> <p style="text-align: right;">Wt./C 60 lb</p>	<p><b>AB815</b> Swing Connector</p>  <p>Nuts and bolts to clamp to channel is included. For 1/2" or 3/4" conduit.</p> <p style="text-align: right;">Wt./C 95 lb</p>	<p><b>AB885</b> 15° Swivel</p>  <p>Nuts and bolts to clamp to channel included. For 1/2" or 3/4" conduit.</p> <p style="text-align: right;">Wt./C 25 lb</p>															
<p><b>AB867</b> Spacer</p>  <p>For use with AB866 wiring stud nuts.</p> <p style="text-align: right;">Wt./C 24 lb</p>	<p><b>AB866</b> Wiring Stud Nut</p>  <p>1/2" Pipe thread</p> <p style="text-align: right;">Wt./C 21 lb</p>																
<p><b>811</b> Stud Nut</p>  <table border="1" style="width: 100%; margin-top: 10px;"> <thead> <tr> <th>Cat. No.</th> <th>For Channel</th> <th>Wt./C lb</th> </tr> </thead> <tbody> <tr> <td>811-1STR</td> <td>1/4 x 1</td> <td>8</td> </tr> <tr> <td>811-2STR</td> <td>1/4 x 1-1/4</td> <td>9</td> </tr> </tbody> </table>	Cat. No.	For Channel	Wt./C lb	811-1STR	1/4 x 1	8	811-2STR	1/4 x 1-1/4	9	<p><b>812</b> Stud Nut</p>  <p>For attaching fixture to slot down channel or to slot up knockouts. Specify length. Hex nut included.</p> <table border="1" style="width: 100%; margin-top: 10px;"> <thead> <tr> <th>Cat. No.</th> <th>For Channel</th> <th>Wt./C lb</th> </tr> </thead> <tbody> <tr> <td>812-1EG</td> <td>1/4 x 1</td> <td>6</td> </tr> </tbody> </table>	Cat. No.	For Channel	Wt./C lb	812-1EG	1/4 x 1	6	<p><b>AB868</b> Fiber Retainer for Cables Until Closure Strip is Installed</p>  <p style="text-align: right;">  </p> <p style="text-align: right;">Wt./C 3 lb</p>
Cat. No.	For Channel	Wt./C lb															
811-1STR	1/4 x 1	8															
811-2STR	1/4 x 1-1/4	9															
Cat. No.	For Channel	Wt./C lb															
812-1EG	1/4 x 1	6															

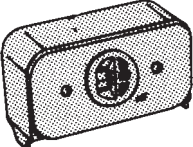

**SECTION 6**

**Surface Raceway and Lighting Systems**

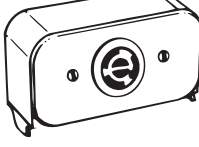
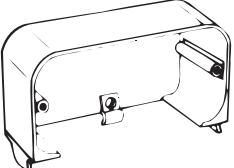
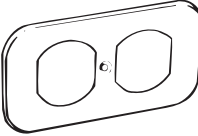
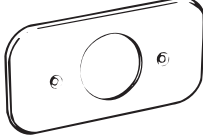
**Kindorf® Channel Boxes and Receptacles**

<p><b>G2000</b>  </p>  <p><i>Finish - GoldGalv®</i> Wt./C 110 lb</p>	<p><b>G2001</b>  </p>  <p><i>Finish - GoldGalv®</i> Wt./C 120 lb</p>	<p><b>G2002</b>  </p>  <p><i>Finish - GoldGalv®</i> Wt./C 120 lb</p>	
<p><b>G2003</b>  </p>  <p><i>Finish - GoldGalv®</i> Wt./C 130 lb</p>	<p><b>G2004</b>  </p>  <p><i>Finish - GoldGalv®</i> Wt./C 140 lb</p>	<p><b>G1038 Duplex Outlet</b>  </p>  <p>Complete unit including housing, standard DUPLEX 3-wire, 15 Amp., 125 volt, ground receptacle and cover plate.</p> <p><i>Finish - GoldGalv®</i> Wt./C 55 lb</p>	
<p><b>G1038A Single Outlet</b>  </p>  <p>Complete unit including housing, standard SINGLE 3-wire, 15 Amp., 125 volt, ground receptacle and cover plate.</p> <p><i>Finish - GoldGalv®</i> Wt./C 50 lb</p>	<p><b>G1038D Raceway Outlet</b>  </p>  <p>Complete unit including housing, duplex, 3-wire, 15 amp. 277 volt-twistlock receptacle and cover plate. U.L.</p> <p><i>Finish - GoldGalv®</i> Wt./C 60 lb</p>	<p><b>G1038E Raceway Outlet</b>  </p>  <p>Complete unit including housing, single, 3-wire, 15 amp. 277 volt-twistlock receptacle and cover plate.</p> <p><i>Finish - GoldGalv®</i> Wt./C 50 lb</p>	
<p><b>G1038B Housing Only</b></p>  <p><i>Finish - GoldGalv®</i> Wt./C 25 lb</p>	<p><b>G1038C Duplex Cover Plate</b></p>  <p><i>Finish - GoldGalv®</i> Wt./C 12 lb</p>	<p><b>G1038CA Single Cover Plate</b></p>  <p>Size of opening: 1.391 diameter</p> <p><i>Finish - GoldGalv®</i> Wt./C 14 lb</p>	<p><b>G1038CX Blank Cover Plate</b></p>  <p><i>Finish - GoldGalv®</i> Wt./C 15 lb</p>



**Surface Raceway and Lighting Systems**

**SECTION 6**

**Kindorf® Fixture Accessories**

**G1017**  
Mercury Vapor Hanger

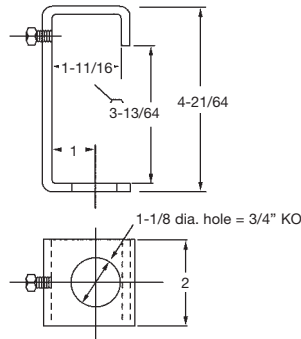
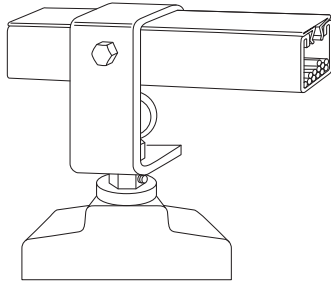

Used with Channel	Depth in.	Wt./C lb
A-1200	4-1/4"	76

**Finish - GoldGalv®**

To support high or low bay mercury vapor or heavy incandescent fixtures from raceway channels. Permits plug-in connections with G-1038 raceway outlets.

**G972HB1/2**  
Steel Fixture Hanger Adapter

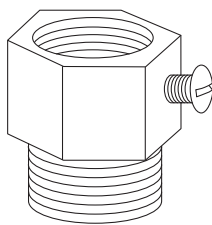

**Finish - GoldGalv®**

The hanger adapter securely mounts the fixture hanger or box to the channel through the 1/2" KO in the base. No special tools are needed for installation of fittings and fixtures. Superstrut® channels, with 1/2" KO's every 6", hangs and feeds the fixtures thereby simplifying installation.

Wt./C 17 lb

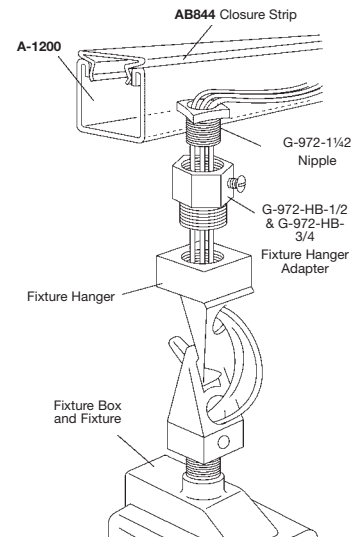

**Electrical Applications**

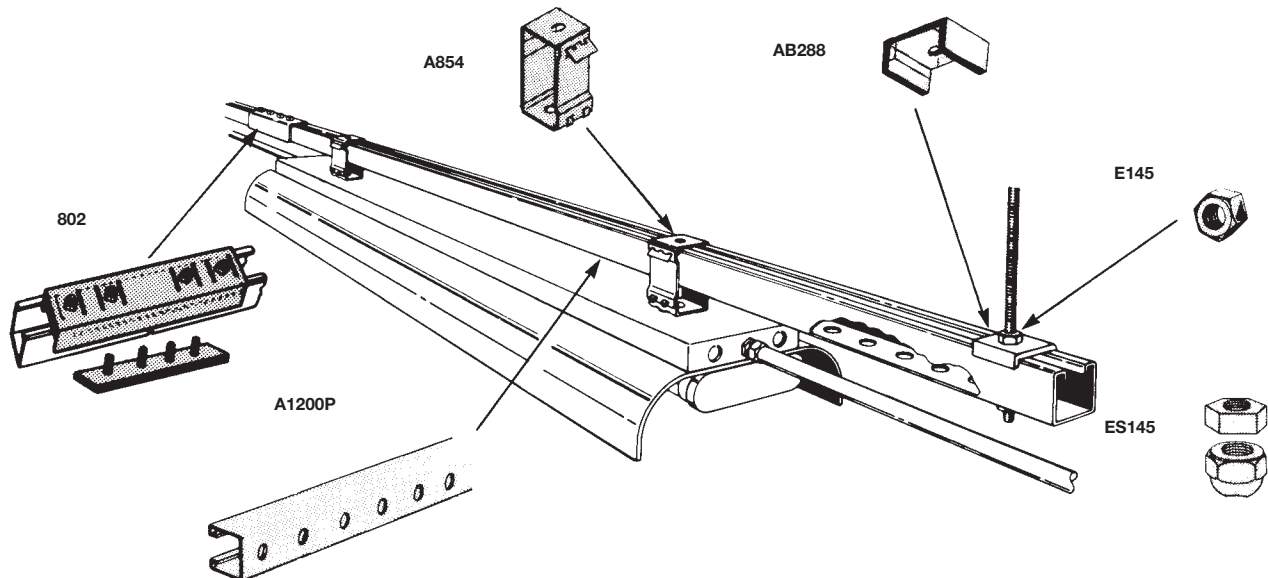

**Electrical Applications**

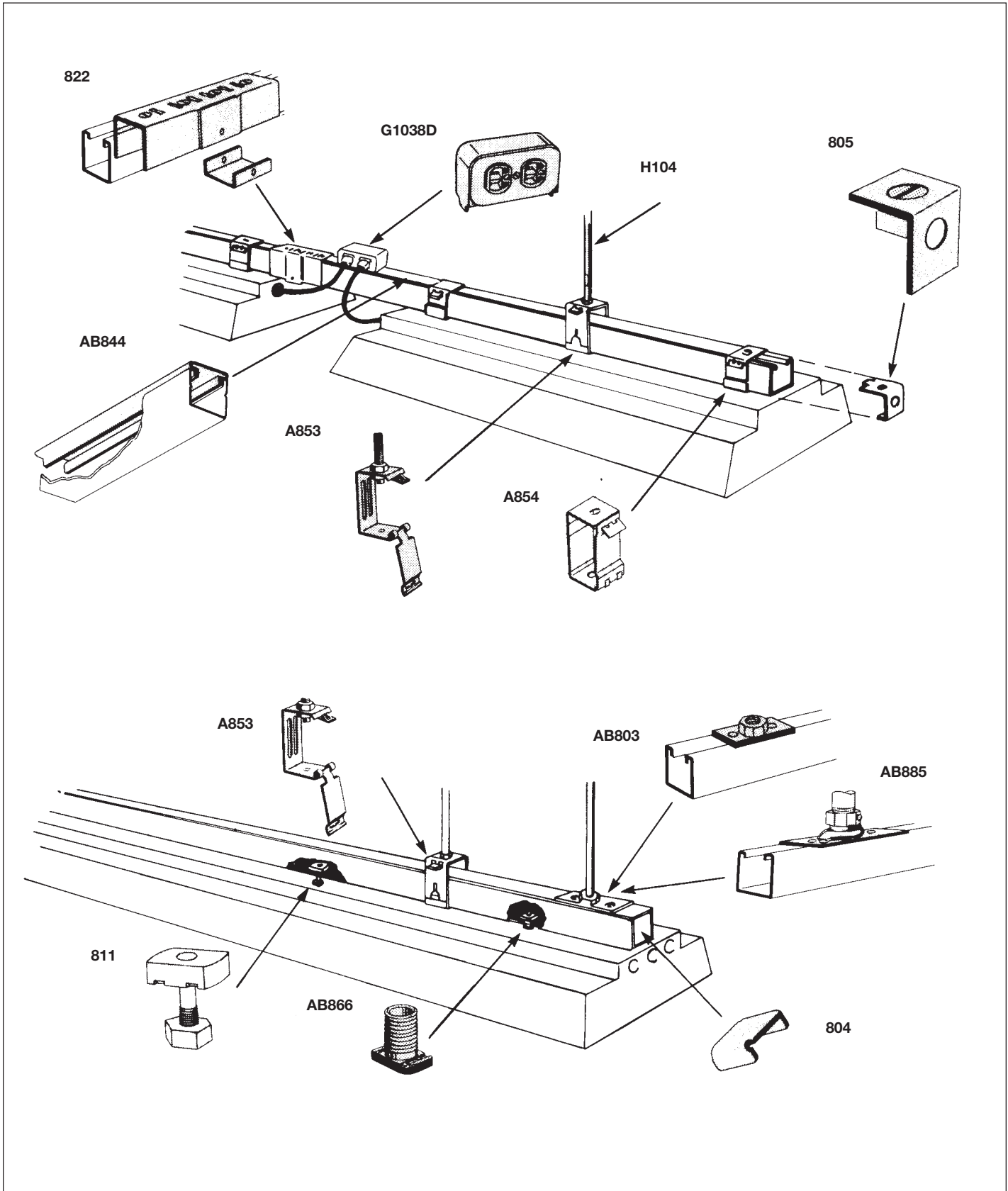

**Electrical Applications**

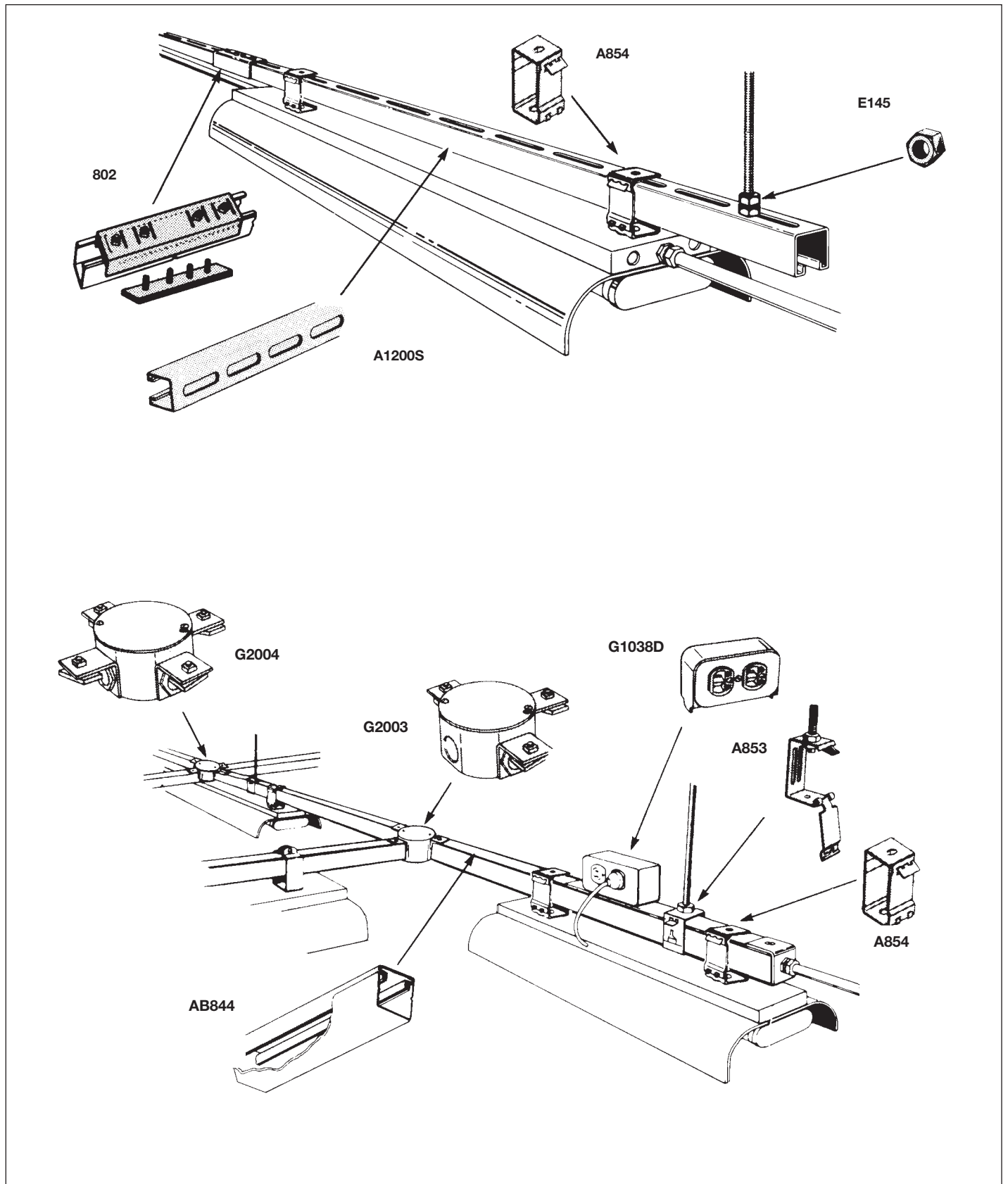

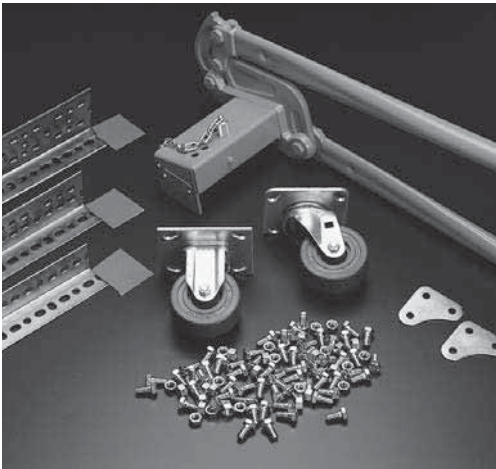

**SECTION 7**  
**RIGHT ANGLE SLOTTED**  
**METAL FRAMING**

**Create the support framing you need**

Right Angle Metal Framing is manufactured from commercial quality steel in three different sizes. The small sizes are 14 ga. steel, the larger is 12 ga. steel. With this offering, an endless variety of metal framing requirements can be met, from lightweight supporting needs to larger shelving for inventory storage.

One of the legs on all sizes is 1-5/8" wide, while the other is either 1-5/8", 2-3/8" or 3-1/8" long. Depending on the frame requirements, a single size can be utilized throughout, or the sizes can be interchanged to get the most efficient usage from the material.

This section will serve as a guide to plan and build your structure.

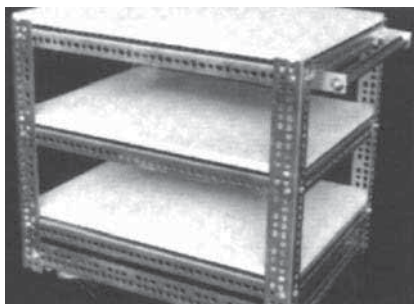
**Installation time is reduced - inventory space is minimal**

Scribe marks are placed every 3/4" which saves planning, layout and cutting time and ensures accuracy. The exclusive slot and hole pattern, repeated every 3", is scientifically designed for ease of assembly and rigidity. No welding is necessary, no holes to drill. A 9/16" wrench is the only tool required for assembly. The proper nuts and bolts are included with the material to ensure fast and easy erection.

Right Angle Metal Framing is packaged in 10' and 12' lengths to minimize cut offs and ensure maximum use of material.

120 feet, 10, 12 foot lengths of Right Angle Metal Framing take up the same amount of space as one 2x4. A standard package includes 5 pieces to a bundle, significantly reducing handling and storage space.

The importance of cutting Right Angle easily, quickly and accurately is the key to time saving assembly. The portable cutter provides these advantages and makes layout and erection of any structure a "light-work" job.

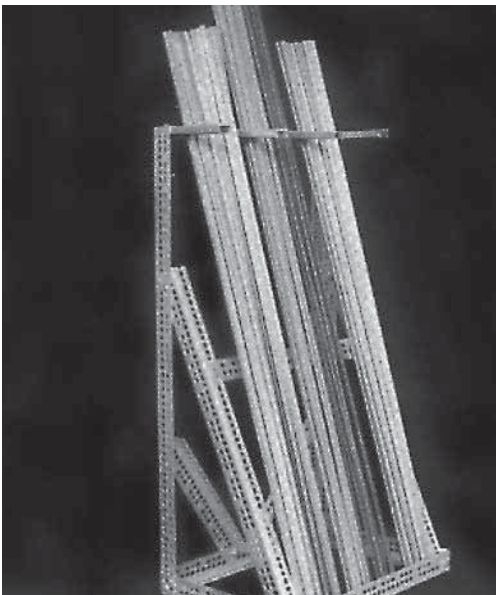
**Finish is designed for long lasting durability**

The standard GoldGalv® hardware finish is applied to all Right Angle Metal Framing after rolling and punching of the holes. This provides you with a number of benefits. First, raw ends resulting from cuts will be protected by the sacrificial quality of zinc. Second, the edges of all holes are protected against formation of rust, to provide a call back free installation. Third, the electrogalvanizing provides an excellent bonding surface for paint if desired for aesthetic reasons.

Note: Product is also available in pregalvanized (PG) sections.

**Flexibility****Simplicity****Economy**

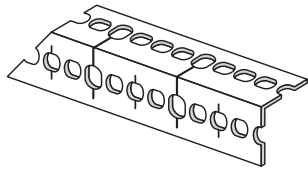

**RA-160**  
14 Gauge

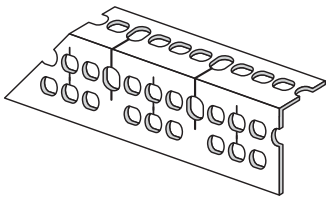

**RA-225**  
14 Gauge

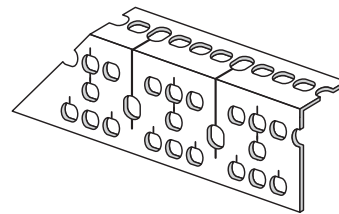

**RA-300**  
12 Gauge

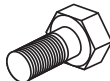
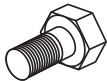

EXTRA NUTS AND BOLTS

Cat. No.	Length ft	No. of ft./per Pkg.
RA-160-10	10	50
RA-160-12	12	60
RA-225-10	10	50
RA-225-12	12	60
RA-300-10	10	50
RA-300-12	12	60

Each package includes 36 nuts and bolts.

Cat. No.	Package 100 Sets	Std. Ctn.
<b>RA-BN-5/8</b> Use with RA-160 & RA-225	2-3/8" - 16 x 1-5/8"	100
<b>RA-BN-3/4</b> Use with RA-300	2-3/8" - 16 x 3/4"	100

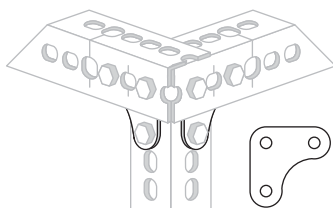

**RA-GP**  
Gusset Plate  
For extra rigid assembly

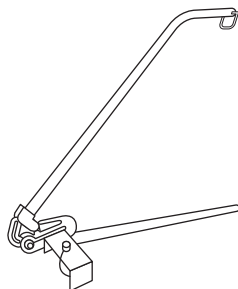

**RA-C**  
Portable Cutter

Cat. No.	Package	Std. Ctn.
<b>RA-GP</b>	25	100
<b>RA-RC</b>	2	2
<b>RA-SC</b>	2	2
<b>RA-C</b>	1	1

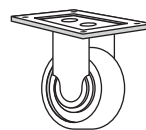

**RA-RC**



**RA-SC**

Rigid & Swivel Casters  
Hard rubber composition 3-1/2" dia. with  
load rating of 225 lb per wheel.







**SECTION 8  
ENGINEERING DATA AND  
SPECIFICATIONS**

**Design Data –  
Metal Framing Channel**

**TABLE 1  
Properties for Design**

**Elements of Sections**

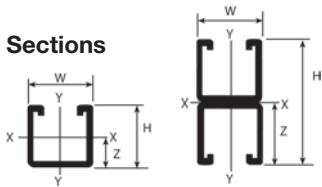

**Single Channels      Double Channels**

**Nominal Thickness  
(inches)**

- 12 ga = .105
- 14 ga = .075
- 16 ga = .060

**Legend**

- I - Moment of inertia
- S - Section Modulus
- r - Radius of Gyration
- Z - Nominal Axis
- A - Area

SECTION MEMBER	WT. lb/ft	H in.	W in.	A in. <sup>2</sup>	X-X AXIS				Y-Y AXIS		
					I in. <sup>4</sup>	S in. <sup>3</sup>	r in.	Z in.	I in. <sup>4</sup>	S in. <sup>3</sup>	r in.
<b>SINGLE CHANNEL</b>											
A1200	1.90	1.625	1.625	.557	.192	.212	.587	.719	.237	.292	.652
B1200	1.28	.813	1.625	.381	.031	.063	.283	.331	.137	.168	.600
C1200	1.70	1.375	1.625	.500	.121	.155	.492	.595	.205	.252	.640
D1200	1.44	1.000	1.625	.424	.053	.092	.356	.403	.159	.196	.616
E1200	2.47	2.438	1.625	.726	.529	.399	.853	1.112	.335	.413	.679
H1200	3.05	3.250	1.625	.897	1.100	.635	1.107	1.507	.436	.536	.697
A1400	1.40	1.625	1.625	.401	.134	.146	.577	.707	.184	.226	.677
B1400	.97	.813	1.625	.280	.024	.051	.295	.338	.103	.127	.607
<b>DOUBLE CHANNEL</b>											
A1202	3.80	3.250	1.625	1.114	.948	.583	.992	1.625	.474	.584	.652
B1202	2.56	1.626	1.625	.762	.147	.181	.439	.813	.274	.337	.600
C1202	3.40	2.750	1.625	1.000	.595	.433	.772	1.375	.409	.504	.640
D1202	2.88	2.000	1.625	.847	.257	.257	.552	1.090	.319	.393	.616
E1202	4.94	4.876	1.625	1.450	2.854	1.171	1.402	2.438	.672	.827	.680
H1202	6.10	6.500	1.625	1.794	6.273	1.930	1.870	3.250	.871	1.072	.697
A1402	2.80	3.250	1.625	.801	.668	.411	.913	1.625	.367	.452	.677
B1402	1.94	1.626	1.625	.560	.112	.138	.447	.813	.206	.254	.607

**TABLE 2  
Maximum Pullout and Slip Loads for Steel Channel and Channel Nuts**

Channel Nut Size / Thread	Channel All Series	Pull-Out Strength		Slip Resistance		Torque	
		lb	kN	lb	kN	ft lb	N-m
1/4 - 20	A1200	600	2.7	300	1.3	6	8
5/16 - 18	B1200	800	3.6	500	2.2	11	15
3/8 - 16	C1200	1000	4.4	800	3.6	19	25
1/2 - 14	D1200	2000	8.9	1500	6.7	50	70
5/8 - 11	E1200	2500	11.1	1500	6.7	100	135
3/4 - 10	H1200	2500	11.1	1700	7.6	125	170
1/4 - 20	A1400	600	2.7	300	1.3	6	8
5/16 - 18	B1400	800	3.6	400	1.8	11	15
3/8 - 16	B1400	1000	4.4	750	3.3	19	25
1/2 - 14	B1400	1400	6.2	1000	4.4	50	70
1/4 - 20	AR1600	600	2.7	300	1.3	6	8
5/16 - 18	BR1600	800	3.6	400	1.8	11	15
3/8 - 16	BR1600	1000	4.4	750	3.3	19	25
1/2 - 14	BR1600	1000	4.4	1000	4.4	50	70

For aluminum channel the pull out load is calculated by multiplying the appropriate data by 50%. For slip resistance multiply by 75%.

**Maximum Pullout and Slip Loads for Fiber Glass Channel and Channel Nuts**

Channel Nut Size / Thread	Channel All Series	Pull-Out Strength		Slip Resistance		Torque	
		lb	kN	lb	kN	ft lb	N-m
1/4 - 20	-	-	-	-	-	-	-
5/16 - 18	-	-	-	-	-	-	-
3/8 - 16	A1200	300	1.3	150	0.6	200	22.6
1/2 - 13	D1200	300	1.3	150	0.6	200	22.6

**Design Data – Metal Framing Channel****TABLE 3**

Design loads for channel used as beam or column

**BEAM LOADS**

Table 3 contains simple beam, uniformly-distributed loads calculated at 25,000 psi material stress. Beam loads are based on channel being loaded across the x-x axis. Loads are also listed at reduced deflections for long spans.

**Maximum loads @ 25,000 psi stress**

Maximum allowable deflections and maximum uniform loads for all spans @ 25,000 psi material stress.

**Reduced load for all 1/180 Span Deflection**

For moderate deflections on the longer spans, reduced loads are listed which will produce a deflection equal to 1/180 of the span. When maximum loads do not induce deflections exceeding 1/180 x the span length reduced loads are not required.

**Reduced load for 1/360 Span Deflection**

For very slight deflections on the longer spans, reduced loads are listed which will produce a deflection equal to 1/360 of the span. When maximum loads do not induce deflections exceeding 1/360 x the span length reduced loads are not required.

**CONCENTRATED LOADS**

To obtain values for concentrated loads from Table 3, multiply uniform load by 0.5 and deflection by 1.25.

**Slotted, Punched, or KO Channel**

Reduce load rating 5%.

**Long span deep beams**

Support in a manner to prevent rotation at supports and tie between supports to prevent twist.

**COLUMN LOADS**

Allowable column loads given are for uniform axial loading with pinned ends. For eccentric loading or other end conditions reduce allowable loads according to standard engineering practice.

**DYNAMIC LOADS**

Allowable dynamic loads may be calculated by dividing the static loads shown in Table 3, by 2.08.

Maximum beam and column loading for special materials is multiplied with the following factors:

Channel Type	Beam Load	Column Load
Stainless Steel	1	1
Aluminum	0.33	0.33

**Warning**

Load tables, charts and design criteria provided in this catalogue are intended as guides only. Selection of proper product, installation intervals, erection, and placement are the responsibility of the user.

Pipe hanger products when improperly used as tools of erection have occasionally failed. The user is cautioned to use the product only as it was intended to avoid an accident.

Thomas & Betts reserves the right to change material and finish specifications without notice, to improve its products.

**Engineering Data & Specifications**

**SECTION 8**

**Design Data – Metal Framing Channel  
TABLE 3 (cont'd.)**

SINGLE CHANNEL									DOUBLE CHANNEL (Single Channels welded back-to-back)										
Cat. No.	Depth	Ga.	Maximum Uniform		1/180		1/360		Col. Load	Cat. No.	Depth	Ga.	Maximum Uniform		1/180		1/360		Col. Load
			Load	Defl.	Load	Defl.	Load	Defl.					Load	Defl.	Load	Defl.	Load	Defl.	
<b>12" BEAM OR COLUMN</b>																			
A1200	1-5/8	12	3,534	.014		.067	.033	10,533	A1202	3-1/4	12		.008		.067	.033	21,177		
B1200	13/16	12	1,050	.026		.067	.033	6,683	B1202	1-5/8	12	3,016	.016		.067	.033	14,110		
C1200	1-3/8	12	2,584	.016		.067	.033	9,345	C1202	2-3/4	12		.010		.067	.033	18,990		
D1200	1	12	1,538	.022		.067	.033	8,670	D1202	2	12		.012		.067	.033	18,312		
E1200	2-7/16	12	6,650	.010		.067	.033	13,830	E1202	4-7/8	12		.005		.067	.033	27,623		
H1200	3-1/4	12	10,583	.008		.067	.033	17,106	H1202	6-1/2	12		.004		.067	.033	34,210		
A1400	1-5/8	14	2,434	.015		.067	.033	7,575	A1402	3-1/4	14		.008		.067	.033	15,250		
B1400	13/16	14	850	.028		.067	.033	4,950	B1402	1-5/8	14	2,300	.016		.067	.033	10,390		
<b>18" BEAM OR COLUMN</b>																			
A1200	1-5/8	12	2,355	.033		.100	.050	10,2100	A1202	3-1/4	12		.018		.100	.050	20,609		
B1200	13/16	12	700	.059		.100	.050	6,058	B1202	1-5/8	12	2,011	.036		.100	.050	13,440		
C1200	1-3/8	12	1,723	.038		.100	.050	8,970	C1202	2-3/4	12	4,811	.021		.100	.050	18,470		
D1200	1	12	1,025	.052		.100	.050	7,930	D1202	2	12		.028		.100	.050	17,942		
E1200	2-7/16	12	4,434	.023		.100	.050	13,482	E1202	4-7/8	12		.013		.100	.050	16,926		
H1200	3-1/4	12	7,055	.016		.100	.050	16,693	H1202	6-1/2	12		.009		.100	.050	33,390		
A1400	1-5/8	14	1,623	.031		.100	.050	7,334	A1402	3-1/4	14		.018		.100	.050	14,867		
B1400	13/16	14	566	.063		.100	.050	4,150	B1402	1-5/8	14	1,534	.036		.100	.050	9,910		
<b>24" BEAM OR COLUMN</b>																			
A1200	1-5/8	12	1,766	.058		.133	.067	9,842	A1202	3-1/4	12	4,858	.031		.133	.067	19,974		
B1200	13/16	12	525	.105		.133	.067	5,315	B1202	1-5/8	12	1,509	.064		.133	.067	12,670		
C1200	1-3/8	12	1,291	.066		.133	.067	8,545	C1202	2-3/4	12	3,609	.038		.133	.067	17,890		
D1200	1	12	769	.087		.133	.067	7,050	D1202	2	12	2,680	.042		.133	.067	17,160		
E1200	2-7/16	12	3,325	.039		.133	.067	13,082	E1202	4-7/8	12		.021		.133	.067	26,143		
H1200	3-1/4	12	5,291	.030		.133	.067	16,277	H1202	6-1/2	12		.016		.133	.067	32,435		
A1400	1-5/8	14	1,216	.056		.133	.067	7,058	A1402	3-1/4	14	3,425	.033		.133	.067	14,426		
B1400	13/16	14	425	.110		.133	.067	4,000	B1402	1-5/8	14	1,150	.064		.133	.067	9,350		
<b>30" BEAM OR COLUMN</b>																			
A1200	1-5/8	12	1,414	.089		.167	.083	9,419	A1202	3-1/4	12	3,886	.049		.167	.083	19,261		
B1200	13/16	12	420	.164		.167	.083	4,465	B1202	1-5/8	12	1,206	.100		.167	.083	11,803		
C1200	1-3/8	12	1,034	.104		.167	.083	8,060	C1202	2-3/4	12	2,886	.059		.167	.083	17,230		
D1200	1	12	615	.129		.167	.083	6,650	D1202	2	12	2,128	.084		.167	.083	16,480		
E1200	2-7/16	12	2,660	.063		.167	.083	12,640	E1202	4-7/8	12	7,806	.034		.167	.083	25,259		
H1200	3-1/4	12	4,234	.046		.167	.083	15,698	H1202	6-1/2	12		.025		.167	.083	31,395		
A1400	1-5/8	14	974	.088		.167	.083	6,753	A1402	3-1/4	14	2,740	.050		.167	.083	13,937		
B1400	13/16	14	340	.172		.167	.083	3,420	B1402	1-5/8	14	920	.100		.167	.083	8,730		

When no numbers are shown, use the maximum uniform load.  
Deflections are given in inches; loads in lb

**SECTION 8**

**Engineering Data & Specifications**

**Design Data – Metal Framing Channel  
TABLE 3 (cont'd.)**

SINGLE CHANNEL									DOUBLE CHANNEL (Single Channels welded back-to-back)										
Cat. No.	Depth	Ga.	Maximum Uniform Load		1/180 Span		1/360 Span		Col. Load	Cat. No.	Depth	Ga.	Maximum Uniform Load		1/180 Span		1/360 Span		Col. Load
			Load	Defl.	Load	Defl.	Load	Defl.					Load	Defl.	Load	Defl.	Load	Defl.	
<b>36" BEAM OR COLUMN</b>																			
A1200	1-5/8	12	1,178	.129	.200	917	.100	8,962	A1202	3-1/4	12	3,239	.071	.200	.100	18,470			
B1200	13/16	12	350	.236	.200	148	.100	3,498	B1202	1-5/8	12	1,005	.144	.200	702	.100	10,840		
C1200	1-3/8	12	861	.149	.200	578	.100	7,525	C1202	2-3/4	12	2,400	.085	.200	.100	16,500			
D1200	1	12	513	.198	.200	217	.100	4,335	D1202	2	12	1,428	.114	.200	1248	.100	15,057		
E1200	2-7/16	12	2,216	.088	.200	.100	12,160	E1202	4-7/8	12	6,505	.048	.200	.100	24,316				
H1200	3-1/4	12	3,528	.068	.200	.100	15,132	H1202	6-1/2	12	.036	.200	.100	30,265					
A1400	1-5/8	14	811	.126	.200	640	.100	6,416	A1402	3-1/4	14	2,284	.071	.200	.100	13,416			
B1400	13/16	14	284	.248	.200	115	.100	2,755	B1402	1-5/8	14	766	.144	.200	535	.100	8,050		
<b>42" BEAM OR COLUMN</b>																			
A1200	1-5/8	12	1,010	.175	.233	674	.117	8,466	A1202	3-1/4	12	2,776	.098	.233	.117	17,635			
B1200	13/16	12	300	.323	.233	109	.117	2,579	B1202	1-5/8	12	863	.195	.233	516	.117	9,790		
C1200	1-3/8	12	738	.203	.233	425	.117	6,945	C1202	2-3/4	12	2,063	.115	.233	.117	15,730			
D1200	1	12	440	.264	.233	160	.117	3,280	D1202	2	12	1,224	.166	.233	1069	.117	13,042		
E1200	2-7/16	12	1,900	.120	.233	.117	11,698	E1202	4-7/8	12	5,576	.065	.233	.117	23,272				
H1200	3-1/4	12	3,024	.091	.233	.117	14,514	H1202	6-1/2	12	.049	.233	.117	29,025					
A1400	1-5/8	14	695	.160	.233	470	.117	6,051	A1402	3-1/4	14	1,958	.225	.233	.117	12,832			
B1400	13/16	14	243	.336	.233	84	.117	2,060	B1402	1-5/8	14	658	.195	.233	393	.117	7,300		
<b>48" BEAM OR COLUMN</b>																			
A1200	1-5/8	12	884	.228	.267	516	.133	7,943	A1202	3-1/4	12	2,429	.128	.267	.133	16,730			
B1200	13/16	12	263	.420	.267	83	.133	1,981	B1202	1-5/8	12	754	.255	.267	395	.133	8,640		
C1200	1-3/8	12	646	.265	.267	325	.133	6,325	C1202	2-3/4	12	1,804	.151	.267	.133	14,890			
D1200	1	12	384	.352	.267	122	.133	2,439	D1202	2	12	1,071	.203	.267	702	.133	11,387		
E1200	2-7/16	12	1,663	.156	.267	.133	11,092	E1202	4-7/8	12	4,879	.085	.267	.133	22,170				
H1200	3-1/4	12	2,646	.120	.267	.133	13,850	H1202	6-1/2	12	.064	.267	.133	27,700					
A1400	1-5/8	14	609	.120	.267	360	.133	5,658	A1402	3-1/4	14	1,713	.128	.267	.133	12,223			
B1400	13/16	14	213	.440	.267	64	.133	1,580	B1402	1-5/8	14	575	.255	.267	301	.133	6,480		
<b>54" BEAM OR COLUMN</b>																			
A1200	1-5/8	12	785	.289	.300	408	.150	7,369	A1202	3-1/4	12	2,159	.161	.300	.150	15,763			
B1200	13/16	12	234	.533	.300	66	.150	1,555	B1202	1-5/8	12	670	.323	.300	312	.150	7,405		
C1200	1-3/8	12	574	.335	.300	257	.150	5,650	C1202	2-3/4	12	1,604	.190	.300	1,263	.150	13,990		
D1200	1	12	341	.466	.300	96	.150	2,012	D1202	2	12	952	.266	.300	624	.150	10,391		
E1200	2-7/16	12	1,478	.198	.300	1,123	.150	10,505	E1202	4-7/8	12	4,338	.108	.300	.150	20,980			
H1200	3-1/4	12	2,351	.151	.300	.150	13,150	H1202	6-1/2	12	7,149	.081	.300	.150	16,280				
A1400	1-5/8	14	541	.286	.300	284	.150	5,241	A1402	3-1/4	14	1,523	.161	.300	.150	11,566			
B1400	13/16	14	189	.556	.300	51	.150	1,250	B1402	1-5/8	14	511	.323	.300	238	.150	5,580		

When no numbers are shown, use the maximum uniform load.  
Deflections are given in inches; loads in lb



**Engineering Data & Specifications**

**SECTION 8**

**Design Data – Metal Framing Channel**  
**TABLE 3 (cont'd.)**

SINGLE CHANNEL										DOUBLE CHANNEL (Single Channels welded back-to-back)									
Cat. No.	Depth	Ga.	Maximum Uniform Load		1/180 Span		1/360 Span		Col. Load	Cat. No.	Depth	Ga.	Maximum Uniform Load		1/180 Span		1/360 Span		Col. Load
			Load	Defl.	Load	Defl.	Load	Defl.					Load	Defl.	Load	Defl.	Load	Defl.	
<b>60" BEAM OR COLUMN</b>																			
A1200	1-5/8	12	706	.358		.333	330	.167	6,762	A1202	3-1/4	12	1,944	.199		.333		.167	14,738
B1200	13/16	12	210	.658	107	.333	53	.167	-	B1202	1-5/8	12	604	.398		.333	253	.167	6,100
C1200	1-3/8	12	516	.414		.333	208	.167	4,920	C1202	2-3/4	12	1,444	.235		.333	1,023	.167	13,050
D1200	1	12	308	.550	157	.333	78	.167	1,561	D1202	2	12	257	.318		.333	449	.167	7,531
E1200	2-7/16	12	1,330	.244		.333	909	.167	9,874	E1202	4-7/8	12	3,904	.133		.333		.167	19,734
H1200	3-1/4	12	2,116	.186		.333		.167	12,406	H1202	6-1/2	12	6,434	.100		.333		.167	24,810
A1400	1-5/8	14	486	.353		.333	231	.167	4,792	A1402	3-1/4	14	1,370	.199		.333		.167	10,878
B1400	13/16	14	170	.687	82	.333	41	.167	-	B1402	1-5/8	14	460	.399		.333	193	.167	4,640
<b>66" BEAM OR COLUMN</b>																			
A1200	1-5/8	12	643	.432		.367	273	.183	6,127	A1202	3-1/4	12	1,766	.240		.367	1,347	.183	13,646
B1200	13/16	12	191	.795	88	.367	44	.183	-	B1202	1-5/8	12	549	.481	418	.367	209	.183	5,055
C1200	1-3/8	12	470	.501	344	.367	172	.183	4,145	C1202	2-3/4	12	1,313	.285		.367	846	.183	12,030
D1200	1	12	280	.675	129	.367	65	.183	1,280	D1202	2	12	779	.377	593	.367	360	.183	6,581
E1200	2-7/16	12	1,210	.295		.367	753	.183	9,211	E1202	4-7/8	12	3,549	.180		.367		.183	18,415
H1200	3-1/4	12	1,924	.226		.367		.183	11,616	H1202	6-1/2	12	5,849	.120		.367		.183	23,230
A1400	1-5/8	14	443	.426		.367	190	.183	4,311	A1402	3-1/4	14	1,245	.241		.367	949	.183	10,133
B1400	13/16	14	155	.831	68	.367	35	.183	-	B1402	1-5/8	14	419	.483	318	.367	159	.183	3,840
<b>72" BEAM OR COLUMN</b>																			
A1200	1-5/8	12	589	.514	459	.400	299	.200	5,436	A1202	3-1/4	12	1,620	.286		.400	1,132	.200	12,500
B1200	13/16	12	175	.946	74	.400	37	.200	-	B1202	1-5/8	12	503	.574	351	.400	176	.200	4,230
C1200	1-3/8	12	430	.595	289	.400	144	.200	3,485	C1202	2-3/4	12	1,203	.339		.400	710	.200	10,980
D1200	1	12	256	.792	108	.400	54	.200	1,084	D1202	2	12	714	.457	468	.400	312	.200	5,230
E1200	2-7/16	12	1,108	.351		.400	632	.200	8,509	E1202	4-7/8	12	3,253	.191		.400		.200	17,023
H1200	3-1/4	12	1,839	.269		.400	1,313	.200	10,782	H1202	6-1/2	12	5,361	.143		.400		.200	21,560
A1400	1-5/8	14	405	.506	320	.400	160	.200	3,809	A1402	3-1/4	14	1,141	.286		.400	798	.200	9,340
B1400	13/16	14	141	.989	57	.400	29	.200	-	B1402	1-5/8	14	384	.574	267	.400	134	.200	3,220
<b>84" BEAM OR COLUMN</b>																			
A1200	1-5/8	12	505	.700	337	.467	168	.233	4,061	A1202	3-1/4	12	1,388	.390		.467	832	.233	9,992
B1200	13/16	12			54	.467	27	.233	-	B1202	1-5/8	12	431	.780	258	.467	129	.233	3,100
C1200	1-3/8	12	369	.811	212	.467	106	.233	2,565	C1202	2-3/4	12	1,031	.461		.467	522	.233	8,670
D1200	1	12	220	1.079	92	.467	58	.233	796	D1202	2	12	612	.623	344	.467	229	.233	3,842
E1200	2-7/16	12	950	.479		.467	464	.233	6,991	E1202	4-7/8	12	2,788	.260		.467		.233	13,993
H1200	3-1/4	12	1,513	.366		.467	965	.233	8,988	H1202	6-1/2	12	4,595	.195		.467		.233	17,975
A1400	1-5/8	14	348	.691	235	.467	118	.233	2,827	A1402	3-1/4	14	979	.390		.467	586	.233	7,682
B1400	13/16	14			42	.467	21	.233	-	B1402	1-5/8	14	329	.781	197	.467	98	.233	2,370

When no numbers are shown, use the maximum uniform load.  
Deflections are given in inches; loads in lb

**SECTION 8**

**Engineering Data & Specifications**

**Design Data – Metal Framing Channel  
TABLE 3 (cont'd.)**

SINGLE CHANNEL										DOUBLE CHANNEL (Single Channels welded back-to-back)									
Cat. No.	Depth	Ga.	Maximum Uniform Load		1/180 Span		1/360 Span		Col. Load	Cat. No.	Depth	Ga.	Maximum Uniform Load		1/180 Span		1/360 Span		Col. Load
			Load	Defl.	Load	Defl.	Load	Defl.					Load	Defl.	Load	Defl.	Load	Defl.	
<b>96" BEAM OR COLUMN</b>																			
A1200	1-5/8	12	441	.914	258	.533	129	.267	3,108	A1202	3-1/4	12	1,215	.509		.533	637	.267	7,675
B1200	13/16	12			42	.533	21	.267	-	B1202	1-5/8	12	378	1.019	197	.533	99	.267	-
C1200	1-3/8	12	323	1.059	163	.533	81	.267	1,960	C1202	2-3/4	12	903	.603		.533	400	.267	6,640
D1200	1	12	192	1.40	998	.533	49	.267	-	D1202	2	12	535	.813	263	.533	176	.267	2,942
E1200	2-7/16	12	831	.730		.533	355	.267	5,423	E1202	4-7/8	12	2,440	.340		.533	1,917	.267	10,875
H1200	3-1/4	12	1,323	.478		.533	739	.267	7,059	H1202	6-1/2	12	4,021	.255		.533		.267	14,120
A1400	1-5/8	14	304	.903	180	.533	90	.267	2,615	A1402	3-1/4	14	856	.509		.533	449	.267	5,951
B1400	13/16	14			32	.533	16	.267	-	B1402	1-5/8	14	288	1.020	150	.533	75	.267	-
<b>108" BEAM OR COLUMN</b>																			
A1200	1-5/8	12	393	1.156	204	.600	102	.300	2,456	A1202	3-1/4	12	1,080	.644		.600	503	.300	6,071
B1200	13/16	12			33	.600	16	.300	-	B1202	1-5/8	12	355	1.290	156	.600	78	.300	-
C1200	1-3/8	12	288	1.350	128	.600	64	.300	-	C1202	2-3/4	12	801	.763	632	.600	316	.300	5,250
D1200	1	12	171	1.783	76	.600	38	.300	-	D1202	2	12	476	1.029	208	.600	139	.300	2,324
E1200	2-7/16	12	739	.790	561	.600	281	.300	4,291	E1202	4-7/8	12	2,169	.430		.600	1,515	.300	8,599
H1200	3-1/4	12	1,176	.605		.600	584	.300	5,579	H1202	6-1/2	12	3,574	.323		.600		.300	11,160
A1400	1-5/8	14	270	1.141	142	.600	71	.300	1,708	A1402	3-1/4	14	761	.644		.600	355	.300	4,702
B1400	13/16	14			25	.600	13	.300	-	B1402	1-5/8	14	255	1.290	119	.600	59	.300	-
<b>120" BEAM OR COLUMN</b>																			
A1200	1-5/8	12	354	1.425	165	.667	83	.333	-	A1202	3-1/4	12	971	.795		.667	408	.333	-
B1200	13/16	12			27	.667	13	.333	-	B1202	1-5/8	12	301	1.588	126	.667	63	.333	-
C1200	1-3/8	12	259	1.663	104	.667	52	.333	-	C1202	2-3/4	12	721	.941	512	.667	256	.333	4,250
D1200	1	12	154	2.202	62	.667	31	.333	-	D1202	2	12	428	1.271	168	.667	112	.333	1,883
E1200	2-7/16	12	665	.976	455	.667	227	.333	3,478	E1202	4-7/8	12	1,951	.531		.667	1,227	.333	6,946
H1200	3-1/4	12	1,059	.746		.667	473	.333	4,521	H1202	6-1/2	12	3,216	.398		.667		.333	9,040
A1400	1-5/8	14	244	1.413	114	.667	57	.333	-	A1402	3-1/4	14	685	.796		.667	287	.333	3,805
B1400	13/16	14			21	.667	10	.33	-	B1402	1-5/8	14	230	1.600	96	.667	48	.333	-
<b>144" BEAM OR COLUMN</b>																			
A1200	1-5/8	12			115	.800	57	.400	-	A1202	3-1/4	12	810	1.145	566	.800	283	.400	-
-										B1202	1-5/8	12			88	.800	44	.400	-
C1200	1-3/8	12			72	.800	36	.400	-	C1202	2-3/4	12	601	1.350	355	.800	178	.400	-
E1200	2-7/16	12	554	1.400	315	.800	158	.400	-	E1202	4-7/8	12	1,626	.764		.800	852	.400	-
H1200	3-1/4	12	883	1.075	657	.800	328	.400	-	H1202	6-1/2	12	2,680	.573		.800	1,873	.400	-
A1400	1-5/8	14			80	.800	40	.400	-	A1402	3-1/4	14	571	1.146	399	.800	199	.400	-
-										B1402	1-5/8	14			67	.800	33	.400	-

When no numbers are shown, use the maximum uniform load.  
Deflections are given in inches; loads in lb

**Engineering Data & Specifications**

**SECTION 8**

**Design Data – Metal Framing Channel  
TABLE 3 (cont'd.)**

SINGLE CHANNEL							DOUBLE CHANNEL (Single Channels welded back-to-back)							
Cat. No.	Depth	Ga.	Maximum Uniform Load	1/180 Span Defl.	1/360 Span Defl.	Col. Load	Cat. No.	Depth	Ga.	Maximum Uniform Load	1/180 Span Defl.	1/360 Span Defl.	Col. Load	
<b>168" BEAM OR COLUMN</b>														
A1200	1-5/8	12		84 .933	42 .467	-	A1202	3-1/4	12	694 1.563	916 .933	208 .467	-	
-							B1202	1-5/8	12		64 .933	32 .467	-	
C1200	1-3/8	12		53 .933	27 .467	-	C1202	2-3/4	12	515 1.850	261 .933	130 .467	-	
E1200	2-7/16	12	475 1.912	233 .933	116 .467	-	E1202	4-7/8	12	1,394 1.040	1,255 .933	626 .467	-	
H1200	3-1/4	12	756 1.463	482 .933	241 .467	-	H1202	6-1/2	12	2,298 .780	.933	1,326 .467	-	
A1400	1-5/8	14		60 .933	30 .467	-	A1402	3-1/4	14	489 1.563	293 .933	147 .467	-	
-							B1402	1-5/8	14		49 .933	25 .467	-	
<b>192" BEAM OR COLUMN</b>														
-							A1202	3-1/4	12		318 1.07	159 .533	-	
-							-							
-							C1202	2-3/4	12		200 1.07	100 .533	-	
E1200	2-7/16	12		178 1.07	89 .533	-	E1202	4-7/8	12	1,220 1.363	958 1.07	479 .533	-	
H1200	3-1/4	12	661 1.91	369 1.07	185 .533	-	H1202	6-1/2	12	2,010 1.019	1.07	1,053 .533	-	
-							A1402	3-1/4	14		224 1.07	112 .533	-	
-							-							
<b>216" BEAM OR COLUMN</b>														
-							A1202	3-1/4	12		252 1.20	126 .600	-	
-							-							
-							C1202	2-3/4	12		158 1.20	79 .600	-	
E1200	2-7/16	12		140 1.20	70 .600	-	E1202	4-7/8	12	1,084 1.725	757 1.20	379 .600	-	
H1200	3-1/4	12		292 1.20	146 .600	-	H1202	6-1/2	12	1,788 1.288	1.20	832 .600	-	
-							A1402	3-1/4	14		177 1.20	89 .600	-	
-							-							
<b>240" BEAM OR COLUMN</b>														
-							A1202	3-1/4	12		204 1.33	102 .667	-	
-							-							
-							C1202	2-3/4	12		128 1.33	64 .667	-	
E1200	2-7/16	12		114 .334	57 .667	-	E1202	4-7/8	12		613 1.33	307 .667	-	
H1200	3-1/4	12		236 .334	118 .667	-	H1202	6-1/2	12	1,609 1.588	1.33	674 .667	-	
-							A1402	3-1/4	14		144 1.33	72 .667	-	
-							-							

When no numbers are shown, use the maximum uniform load. Deflections are given in inches; loads in lb

**Design Data – Metal Framing Channel**

**TABLE 4**

**Safe bearing loads for 1-5/8" channel and combinations.**

Safety factor of 2-1/2

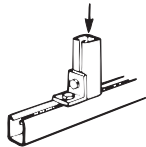

Section	Recommended Load in lb
A1200	5000
A1400	3500
B1200	6000
B1400	3400
C1200	5000
E1200	5000
H1200	4000

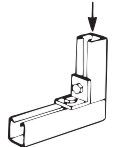

Section	Recommended Load in lb
A1200	3500
A1400	2500
B1200	4000
B1400	2600
C1200	3500
E1200	3500
H1200	2000

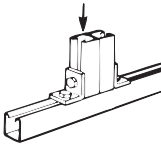

Section	Recommended Load in lb
A1200	8000
A1400	5500
B1200	9000
B1400	4800
C1200	8000
E1200	8000
H1200	5500

**TABLE 5**

**Design load table for typical channel connections.**

Safety factor of 2-1/2 based on ultimate strength of the connection. Load diagrams indicate up to three design loads, for 12 gauge and 14 gauge channel applications.

**90° Fittings (When used in position shown)**

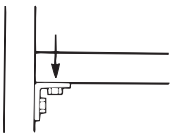
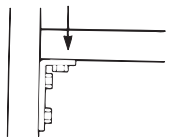
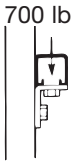
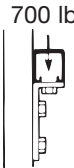
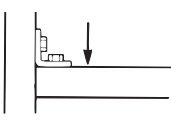
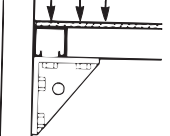
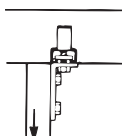
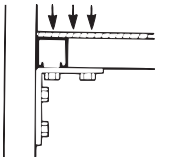
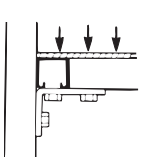
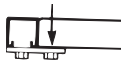
	Both ends supported		Both ends supported		700 lb		700 lb	
AB202	A1200 A1400	1500 lb 1000 lb	AB203	A1200 A1400	2000 lb 1500 lb	AB201	AB203	
	Both ends supported		Both ends supported		1500 lb			
AB202	A1200 A1400	1000 lb 650 lb	AB213 AB214	A1200 A1400	3000 lb 2000 lb	AB20	1500 lb	
	Both ends supported		Both ends supported	<b>Flat Plate Fittings</b>				
AB205 AB216	A1200 A1400	2000 lb 2000 lb	AB204 AB215	A1200 A1400	1500 lb 1000 lb		Both ends supported	
						AB206	A1200 A1400	1000 lb 800 lb

**Design Applications  
CANTILEVER BEAMS**

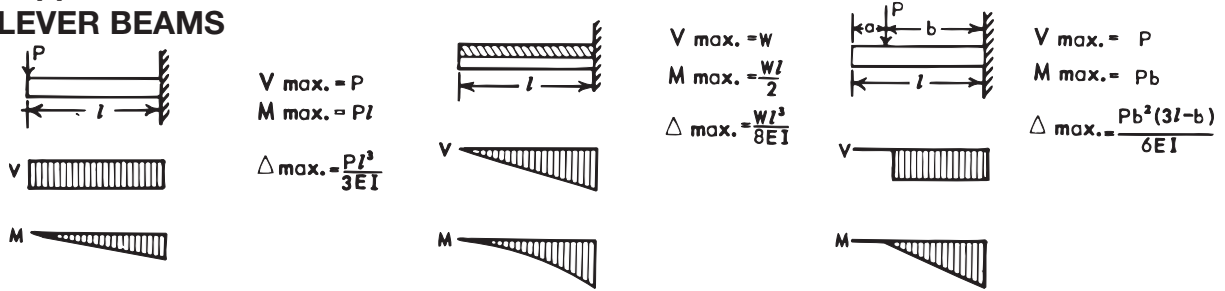

**SIMPLE BEAMS**

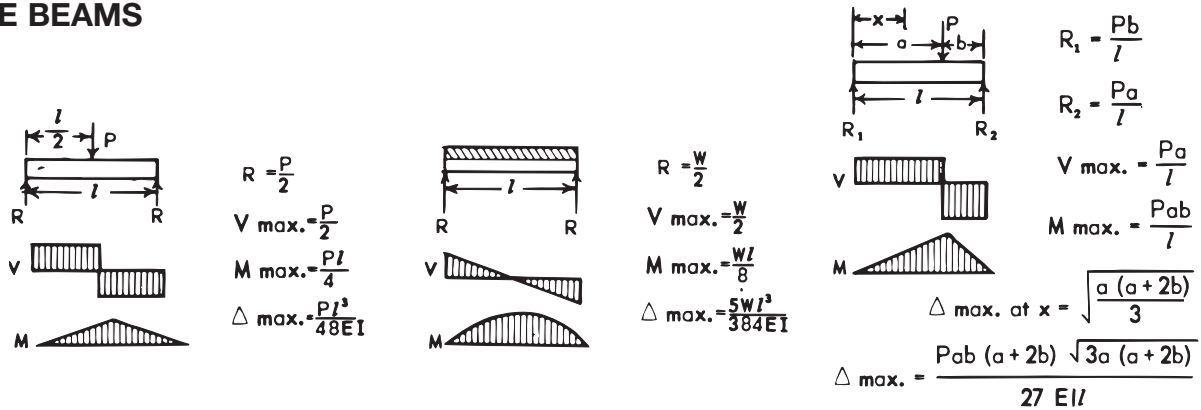

**BEAMS FIXED ON ONE END, SUPPORTED AT OTHER**

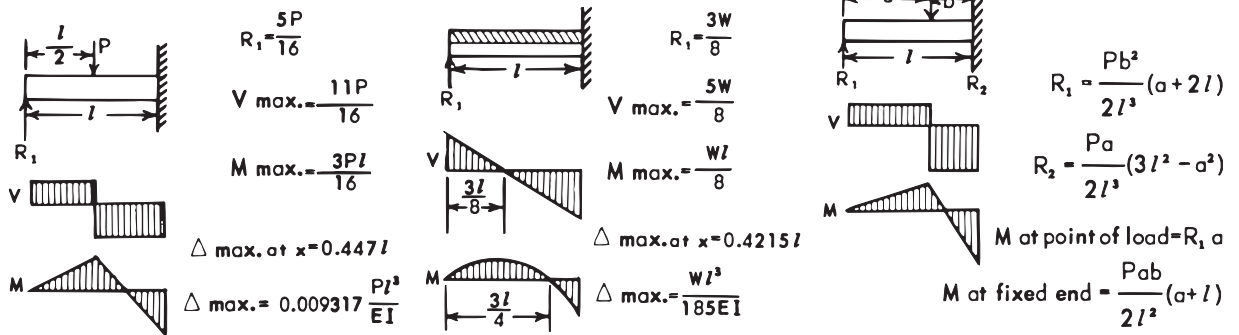

**BEAMS FIXED AT BOTH ENDS**

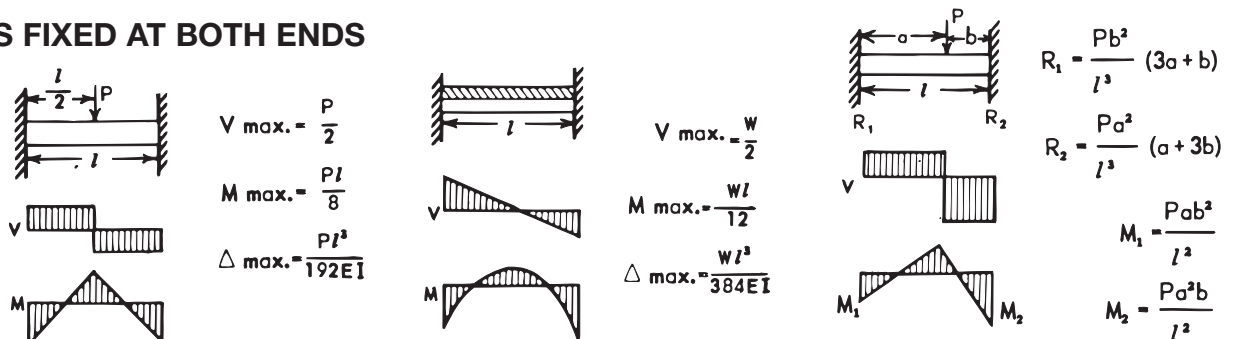

R - Reaction  
M - Moment  
P - Concentrated load

W - Total uniform load  
V - Shear

Δ - Deflection  
E - Modulus of Elasticity  
I - Moment of Inertia







**Design Applications**

**TABLE 6**

**Conversion Factors for Beams with Various Static Loading Conditions**

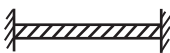
Load tables on pages 104 through 108 for A, B, C, E, and H series channel are for single span beams supported at the ends. These can be used in the majority of cases. There are times when it is necessary to know what happens with other loading

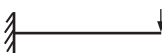
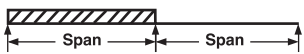
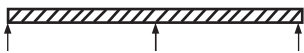
and support conditions. Some common arrangements are shown in Table 6. Simply multiply the loads from the Design Load Tables times the factors given in Table 6. Examples shown on page 112.

LOAD AND SUPPORT CONDITION	LOAD FACTOR	DEFLECTION FACTOR
1. Simple Beam - Uniform Load	1.00	1.00
		
2. Simple Beam - Concentrated Load at Center	.50	1.25
		
3. Simple Beam - Two Equal Concentrated Loads at 1/4 Points	1.00	1.10
		
4. Beam Fixed at Both Ends - Uniform Load	1.50	.30
		
5. Beam Fixed at Both Ends - Concentrated Load at Center	1.00	.40
		
6. Cantilever Beam - Uniform Load	.25	2.40
		
7. Cantilever Beam - Concentrated Load at End	.12	3.20
		
8. Continuous Beam - Two Equal Spans - Uniform Load on One Span	1.30	.92
		
9. Continuous Beam - Two Equal Spans - Uniform Load on Both Ends	1.00	.42
		
10. Continuous Beam - Two Equal Spans - Concentrated Load at Center of One Span	.62	.71
		
11. Continuous Beam - Two Equal Spans - Concentrated Load at Center of Both Spans	.67	.48
		



**Design Applications**

**EXAMPLE I**

**PROBLEM:**

Determine the load and deflection of an A1200 beam continuous over one support and loaded uniformly on one span.



**SOLUTION:**

- A. From load table 3 for A1200 the load for a 5'0" span is 706 lb and deflection is .358".
- B. Multiply by factors from Table 6.  
Load = 706 lb x 1.30 = 917.8 lb  
Deflection = .358 x .92 = .329"

**COLUMN LOADING**

The load bearing capacity of column or compression members is a function of the inherent configurational strength, the unbraced length and design of the end connections.

Values of axial column loading given in Table 3 were calculated using a rotationally free and translation fixed correction at each end (see illustration I). This gives an end condition constant (K) of 1.

**ILLUSTRATION I**

COLUMN HEIGHT

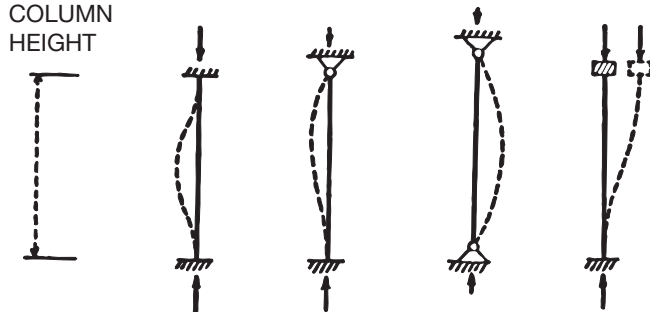

K value            .65            .80            1.0            1.2

**END CONDITION CODE**

- Rotation fixed and translation fixed
- Rotation free and translation fixed
- Rotation fixed and translation free

**EXAMPLE II**

**PROBLEM:**

Determine load and deflection of an E1200 cantilever beam with a concentrated load on the end.

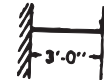

**SOLUTION:**

- A. From load table 3 for E1200 the load for a 3'0" span is 2216 lb and deflection is .088".
- B. Multiply by factors from Table 6.  
Load = 2216 lb x .12 = 265.9 lb  
Deflection = .088 x 3.20 = .282"

If other end conditions are used, axial loading should be calculated using procedures in the AISI specification for the design of cold formed steel structural members (SG671) and the engineering values for Superstrut® channel given in Table 1.

**TABLE 7**  
Load Carrying Capacities of Hot Rolled Steel Rod

Nominal Rod Dia.	Root Area Thread	Design Load lb for Serv. Temperature	
		343°C (650°F)	399°C (750°F)
3/8	.068	610	540
1/2	.126	1130	1010
5/8	.202	1810	1610
3/4	.302	2710	2420
7/8	.419	3770	3360

Dimensions are in inches.  
Safety factor of 5.

**TABLE 8**  
Rod Size Determined by Pipe Size for Fire Protection

Pipe Size	Rod Size
3/4 to 2	3/8
2-1/2 to 3-1/2	1/2
4 to 5	5/8
6	3/4
8 to 12	7/8

Dimensions are in inches.

**SECTION 8**

**Engineering Data & Specifications**

**Design Applications**

**TABLE 9**

**Maximum Spacing between Pipe Supports**

Steel Pipe																				
Nom. Pipe Size (inches)	1/2	3/4	1		1-1/2	2	2-1/2	3	3-1/2	4	5	6	8	10	12	14	16	18	20	24
Max. Spacing (feet)	5	6	7		9	10	11	12	13	14	16	17	19	22	23	25	27	28	30	32

Copper Pipe											
Nom. Pipe Size (inches)	1/2	3/4	1	1-1/4	1-1/2	2	2-1/2	3	3-1/2	4	
Max. Spacing (feet)	5	6	6	7	8	9	10	10	11	12	

**TABLE 10**

**Minimum Spacing (inches) between Centers of Standard Pipe When Using Superstrut #702 Pipe Straps**

Nom. Pipe Size (inches)	1/2	3/4	1	1-1/4	1-1/2	2	2-1/2	3	3-1/2	4	5	6	8
1/2	1-3/16												
3/4	1-5/16	1-7/16											
1	1-1/2	1-5/8	1-3/4										
1-1/4	1-3/4	1-7/8	2	2-1/4									
1-1/2	1-15/16	2-1/16	2-3/16	2-7/16	2-9/16								
2	2-3/16	2-5/16	2-1/2	2-3/4	2-7/8	3-1/8							
2-1/2	2-7/16	2-9/16	2-3/4	3	3-1/8	3-3/8	3-5/8						
3	2-13/16	2-15/16	3-1/16	3-5/16	3-7/16	3-3/4	4	4-5/16					
3-1/2	3-1/8	3-1/4	3-3/8	3-5/8	3-3/4	4-1/16	4-5/16	4-5/8	4-15/16				
4	3-7/16	3-9/16	3-15/16	4-1/16	4-3/8	4-5/8	4-15/16	5-1/4	5-9/16				
6	4-3/4	4-7/8	5	5-1/4	5-3/8	5-5/8	5-7/8	6-3/16	6-1/2	6-13/16	7-7/16	8-1/8	
8	5-7/16	6	6-1/8	6-3/8	6-1/2	6-3/4	7	7-5/16	7-5/8	8	8-9/16	9-1/4	10-3/8

**Design Applications**

**TABLE 11**

**Standard Dimensions and Weights of Piping Materials and Conduit**

<b>Mechanical (ANSI &amp; API Standard, Schedule 40)</b>				
<b>Nominal Std. Pipe Size (inches)</b>	<b>Pipe O.D. (inches)</b>	<b>Coupling O.D. (inches)</b>	<b>Weights of Pipe lb/ft</b>	<b>Weight of Pipe Filled w/Water lb/ft</b>
1/2	.84	1.06	.85	.98
3/4	1.05	1.31	1.13	1.36
1	1.32	1.58	1.68	2.05
1 - 1/4	1.66	1.90	2.27	2.92
1 - 1/2	1.90	2.20	2.72	3.60
2	2.38	2.75	3.65	5.11
2 - 1/2	2.88	3.25	5.79	7.87
3	3.50	4.00	7.58	10.78
3 - 1/2	4.00	4.63	9.11	13.39
4	4.50	5.00	10.79	16.30
5	5.56	6.30	14.62	23.28
6	6.63	7.39	18.97	31.48
8	8.63	9.23	28.56	50.24
10	10.75		41.00	74.00
12	12.75		50.00	99.00
14	14.00		64.00	122.00
16	16.00		63.00	142.00
18	18.00		71.00	172.00
20	20.00		79.00	205.00
22	22.00		87.00	240.00
24	24.00		95.00	277.00
26	26.00		103.00	322.00
28	28.00		111.00	364.00
30	30.00		119.00	410.00

<b>Electrical Conduit</b>					
<b>Nominal Conduit Size</b>	<b>Rigid Steel</b>			<b>Thin Wall (EMT)</b>	
	<b>Conduit O.D. (inches)</b>	<b>Weight of Conduit lb/ft</b>	<b>Weight of Conduit w/Non-lead Covered Conductor lb/ft</b>	<b>Conduit O.D. (inches)</b>	<b>Weight of Conduit lb/ft</b>
1/2	.84	.85	1.04	.71	.29
3/4	1.05	1.13	1.40	.92	.44
1	1.32	1.68	2.35	1.16	.64
1 - 1/4	1.66	2.28	3.58	1.51	.95
2	2.38	3.68	7.21	2.20	1.40
2 - 1/2	2.88	5.82	10.22	2.88	2.30
3	3.50	7.62	14.51	3.50	2.70
4	4.50	10.89	21.48	4.50	4.00

Includes weight of heaviest conductor combination.

**SECTION 8**

**Engineering Data & Specifications**

**Design Applications**

**TABLE 12**

**Extra Strong Pipe (ANSI & API Standard, Schedule 80)**

A.S.A. B36.10 SCHEDULE NOS. AND NOMINAL WALL THICKNESS DESIGNATIONS	Nominal Pipe Size (inches)	O.D. (inches)	Wall Thickness (inches)	I.D. (inches)	Weight of Pipe lb/ft	Water Weight per ft of Pipe lb	Weight of Pipe Filled w/Water lbs/ft
	3/8	.675	.126	.423	.74	.061	.801
	1/2	.840	.147	.546	1.09	.101	1.191
	3/4	1.050	.154	.742	1.47	.188	1.668
	1	1.315	.179	.957	2.17	.311	2.481
	1-1/4	1.660	.191	1.278	3.00	.555	3.555
EXTRA STRONG PIPE and SCHEDULE 80 PIPE (through 8")	1-1/2	1.900	.200	1.500	3.63	.765	4.395
	2	2.375	.218	1.939	5.03	1.279	6.309
	2-1/2	2.875	.276	2.323	7.66	1.834	9.497
	3	3.500	.300	2.900	10.30	2.860	13.160
	3-1/2	4.000	.318	3.364	12.55	3.850	16.350
	4	4.500	.337	3.826	15.00	4.980	19.980
	5	5.563	.375	4.813	20.80	7.890	28.690
	6	6.625	.432	5.761	28.60	11.290	39.890
	8	8.625	.500	7.625	43.40	19.790	63.200
	10	10.750	.500	9.750	54.70	32.300	87.000
	12	12.750	.500	11.750	65.40	47.000	112.400
EXTRA STRONG PIPE (10" through 24" OD)	14 OD	14.000	.500	13.000	72.10	57.500	129.600
	16 OD	16.000	.500	15.000	82.80	76.500	159.300
	18 OD	18.000	.500	17.000	93.50	98.400	191.900
	20 OD	20.000	.500	19.000	104.10	122.800	226.900
	24 OD	24.000	.500	23.000	125.50	180.100	305.600
	10	10.750	.593	9.564	64.300	31.100	95.400
	12	12.750	.687	11.376	88.50	44.000	132.500
SCHEDULE 80 PIPE (10" through 24" OD)	14 OD	14.000	.750	12.500	106.10	53.200	159.300
	16 OD	16.000	.842	14.314	136.50	69.700	206.200
	18 OD	18.000	.937	16.126	170.80	88.500	259.300
	20 OD	20.000	1.031	17.938	208.90	109.400	318.300
	24 OD	24.000	1.218	21.564	296.40	158.300	454.700

**TABLE 13**

**Pipe Covering Weights (Thickness intended as guide, only)**

Thickness and weight of calcium silicate covering.

Nominal Pipe Size	260°		360°		440°		525°		600°		700°		800°	
	Thick. (inches)	lb/ft	Thick. (inches)	lb/ft	Thick. (inches)	lb/ft	Thick. (inches)	lb/ft	Thick. (inches)	lb/ft	Thick. (inches)	lb/ft	Thick. (inches)	lb/ft
1	1	.68	1	.68	1	.68	1	.68	1-1/2	1.19	1-1/2	1.19	1-1/2	1.19
1-1/4	1	.75	1	.75	1	.75	1	.75	1-1/2	1.27	1-1/2	1.27	2	1.82
1-1/2	1	.88	1	.88	1	.88	1	.88	1-1/2	1.45	1-1/2	1.45	2	1.87
2	1	1.01	1	1.01	1	1.01	1-1/2	1.53	1-1/2	1.53	2	2.50	2	2.50
2-1/2	1	1.15	1	1.15	1	1.15	1-1/2	1.69	1-1/2	1.69	2	2.50	2-1/2	3.22
3	1	1.28	1	1.28	1	1.28	1-1/2	2.09	1-1/2	2.09	2	2.98	2-1/2	3.98
3-1/2	1	1.44	1	1.44	1-1/2	2.29	1-1/2	2.29	2	3.00	2	3.12	2-1/2	4.30
4	1	1.60	1	1.60	1-1/2	2.49	1-1/2	2.49	2	3.49	2	3.49	2-1/2	4.62
5	1	1.84	1	1.84	1-1/2	2.84	1-1/2	2.84	2	3.97	2	3.97	2-1/2	5.92
6	1-1/2	3.13	1-1/2	3.13	1-1/2	3.13	1-1/2	3.13	2	4.54	2	4.54	2-1/2	6.75
8	1-1/2	4.06	1-1/2	4.06	1-1/2	4.06	1-1/2	4.06	2	5.56	2	5.56	2-1/2	7.61

**Design Applications**

**TABLE 14**

**Column Loading For Rack Construction**

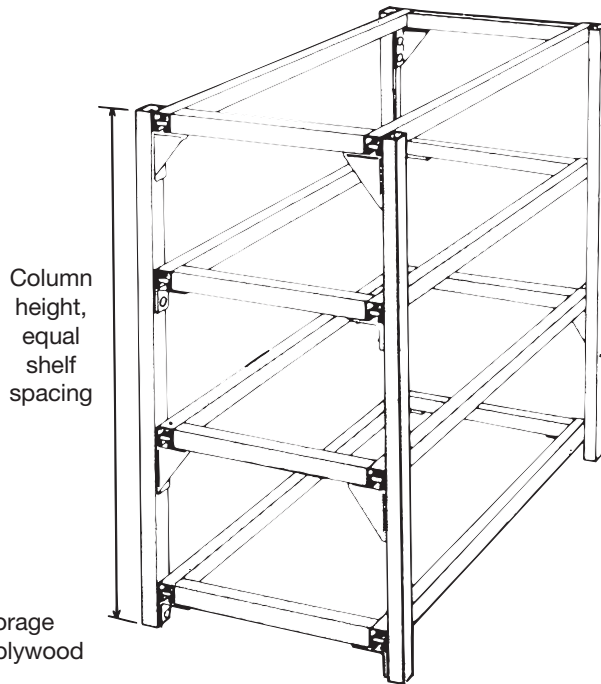

Typical general storage rack for use with plywood or other decking.

**GENERAL STORAGE RACKS**

**PALLET RACKS**

**BARREL RACKS**

**BULK FURNITURE RACKS**

**CABLE RACKS**

**BAR STOCK RACKS**

**DISPLAY RACKS**

**SPECIAL PURPOSE RACKS**

**For Uniform Loads on Horizontal Members  
See Table 3**

**ALLOWABLE LOAD IN LB PER UPRIGHT**

Column Height	Cat. No.	NUMBER OF SHELVES PER UPRIGHT								
		2	3	4	5	6	7	8	9	10
6'	A1200	2237	1925	1650	1437	1290				
	A1202	4170	3580	3100	2730	2450				
	B1400	800	820	790	700	630				
	B1402	1930	1700	1500	1300	1190				
7'	A1200	2150	1850	1630	1425	1280	1150			
	A1202	4000	3525	3000	2700	2430	2200			
	B1400	650	790	760	685	615	550			
	B1402	1800	1650	1450	1300	1180	750			
8'	A1200	2000	1820	1600	1400	1250	1150	1050		
	A1202	3900	3475	3000	2700	2400	2185	2000		
	B1400	580	750	730	660	610	540	510		
	B1402	1650	1610	1450	1300	1160	940	970		
9'	A1200	1950	1780	1575	1400	1250	1130	1030	950	
	A1202	3800	3400	3020	2675	2400	2180	1975	1800	
	B1400	600	600	665	600	580	540	500	475	
	B1402	1500	1500	1430	1275	1160	1000	900	800	
10'	A1200	1870	1700	1500	1300	1200	1100	1000	900	800
	A1202	3600	3300	3000	2650	2350	2000	1975	1800	1650
	B1400	550	650	625	580	535	490	450	425	
	B1402	1450	1480	1400	1250	1140	1040	960	885	825

**Design Applications – Mechanical Support**

**Example 1**

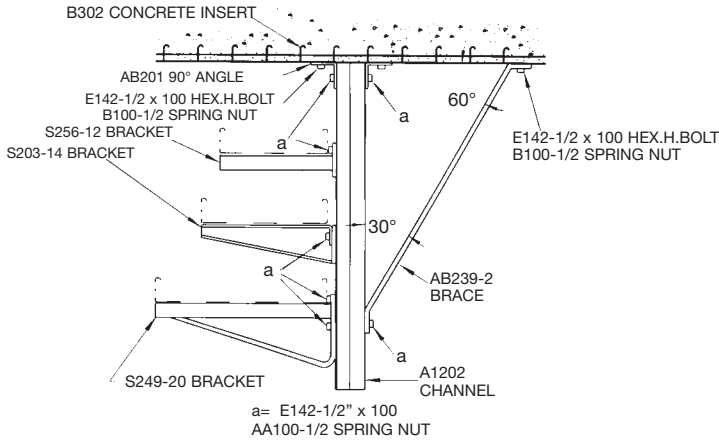

**Suspended column, carrying brackets, braced to the ceiling.**

**Example 2**

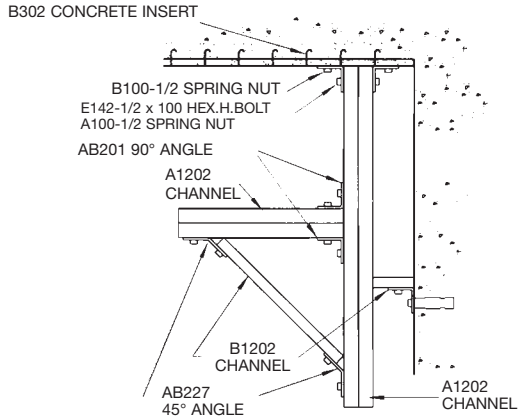

**Suspended column, holding bracket and console braced to wall.**

**Example 3**

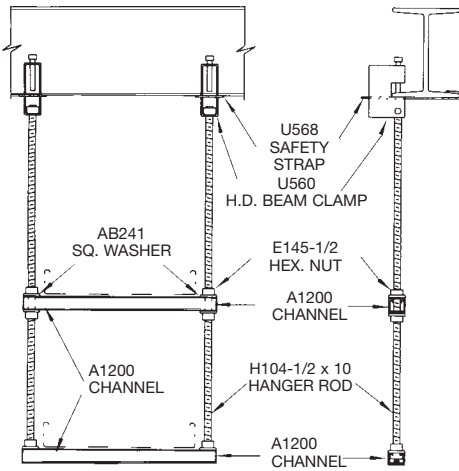

**Trapeze with channels as cross members using beam clamps and hanger rods.**

**Example 4**

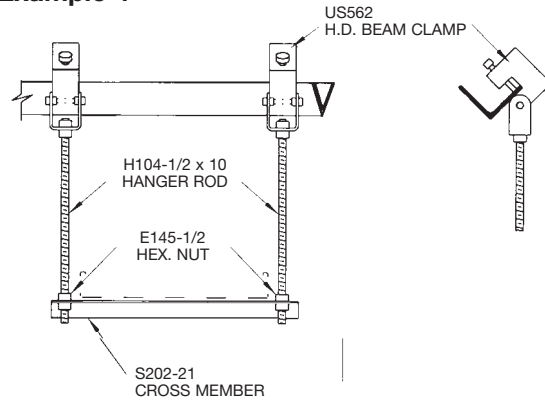

**Sketch depicts the use of beam clamps on slanted beams.**

**Example 5**

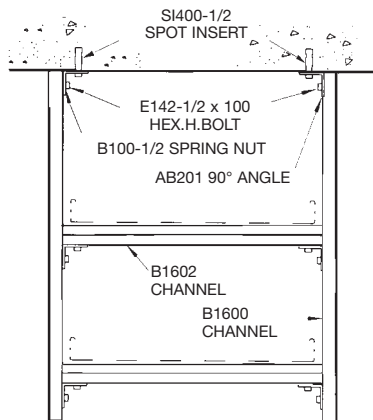

**Trapeze, constructed from channels, fittings. The use of spot inserts is shown (SI400-1/2).**

**Example 6**

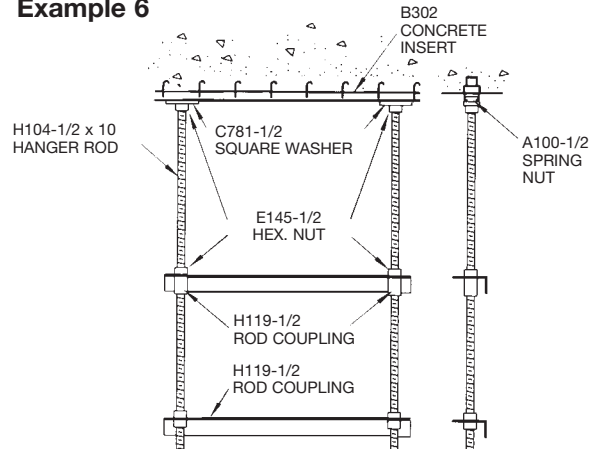

**Trapeze with S202 cross members using hanger rods and concrete inserts.**



**Design Applications – Mechanical Support**

**Example 7**

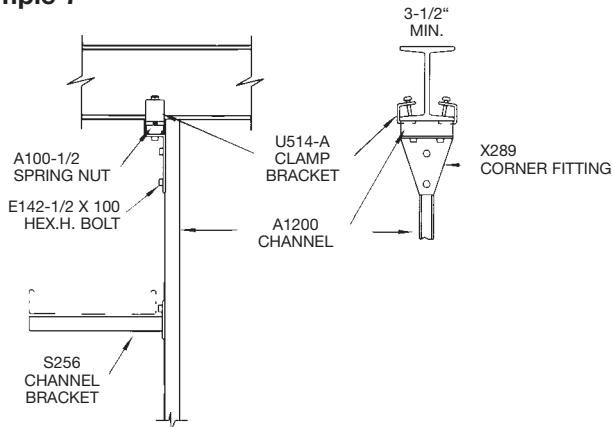

\* NOTE: BRACE SHOULD BE USED FOR LENGTHS GREATER THEN 30"

**Single-sided bracket application**

**Example 8**

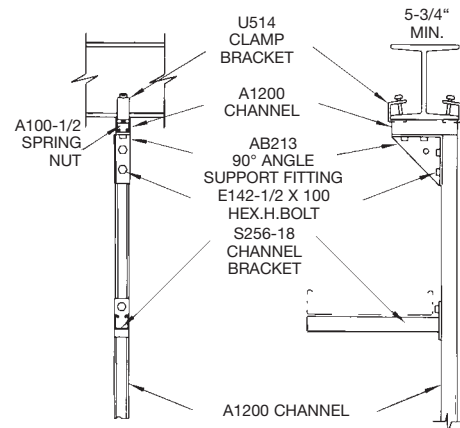

**Single-sided bracket application**

**Example 9**

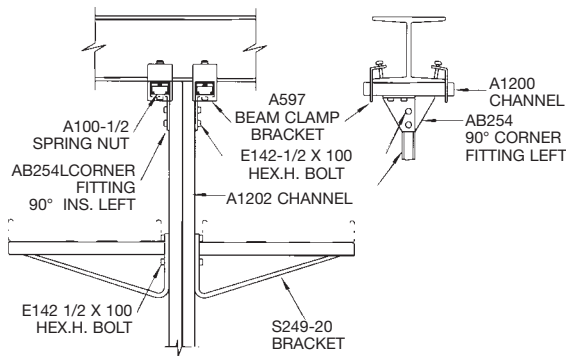

**Two-sided heavy duty application**

**Example 10**

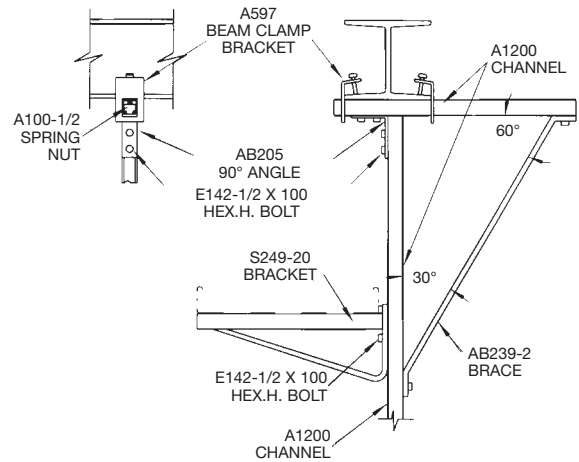

**Heavy duty bracket application**

**Example 11**

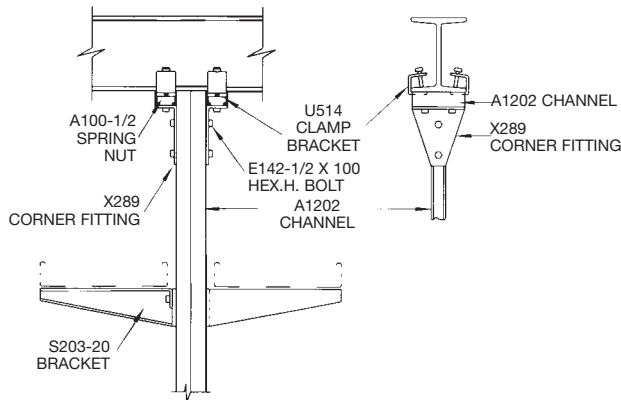

**Brackets parallel to beam**

**Example 12**

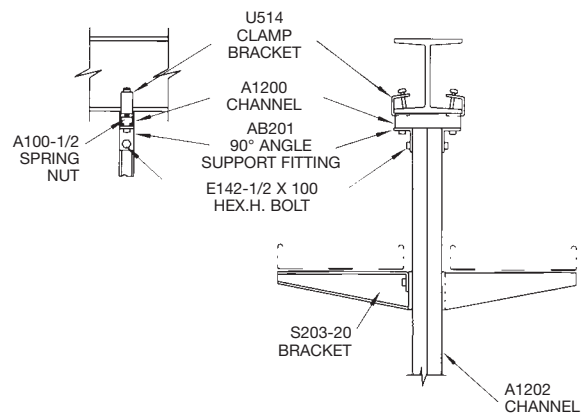

**Brackets perpendicular to beam**

## ALPHANUMERIC INDEX

Catalogue #	Page #	Catalogue #	Page #	Catalogue #	Page #	Catalogue #	Page #
502	36	703-1-1/4EG	42	AB100-1/4	14	AR1600HS	9
507	36	703-1EG	42	AB100-3/4	14	AR1600KO	9
508	36	703-2EG	42	AB100-3/8	14	AR1600P	9
509	36	703-3/4EG	42	AB100-5/16	14	AR1600S	9
510	36	811-1STR	59	AB100-5/8	14	AR1600SW	9
511	36	811-2STR	59	AB102-1/2	14	AW204	25
452TB	11	812-1EG	59	AB102-1/4	14	AW205L	25
460-10TB	11	812-EG	14	AB102-3/4	14	AW205R	25
500SC	36	813EG	14	AB102-3/8	14	AW214	25
503SC	36	A100-1/2EGC	13	AB102-5/8	14	AW215L	25
512U	32	A100-1/2EGC	14	AB102-7/8	14	AW215R	25
540-1/2	38	A100-1/4EGC	13	AB201	21	AW219	25
540-3/4	38	A100-1/4EGC	14	AB202	21	AW220	25
540-3/8	38	A100-3/4	13	AB203	21	AW224	25
540-5/8	38	A100-3/4	14	AB204	21	AW226	25
542-1/2	38	A100-3/8EGC	13	AB205	21	AW228	25
542-3/8	38	A100-3/8EGC	14	AB206	20	B100-1/2EGC	13
6H0	36	A100-5/16EGC	13	AB207	20	B100-1/2EGC	14
6H0	46	A100-5/16EGC	14	AB213	21	B100-1/4EGC	13
6H0-B	46	A100-5/8EGC	14	AB214	21	B100-1/4EGC	14
6H0-T	36	A100-7/8	14	AB216	21	B100-3/8EGC	13
6H0-T	46	A1200	9	AB219	20	B100-3/8EGC	14
6H0-TB	46	A1200HS	9	AB220	20	B100-5/16EGC	13
6H1	36	A1200KO	9	AB225	23	B100-5/16EGC	14
6H1	46	A1200P	9	AB226	23	B1200	9
6H1-B	46	A1200S	9	AB227	23	B1200HS	9
6H1-T	36	A1200SW	9	AB228	23	B1200P	9
6H1-T	46	A1400	9	AB231	23	B1200S	9
6H1-TB	46	A1400HS	9	AB232	23	B1200SW	9
6H2	36	A1400KO	9	AB239-1	23	B1400	9
6H2	46	A1400P	9	AB239-2	23	B209	23
6H2 1/2	36	A1400S	9	AB239-3	23	B210	24
6H2-1/2	46	A1400SW	9	AB240	20	B302-10	11
6H2-1/2-B	46	A177-1/4X100EG	14	AB241-1/2	20	B302-20	11
6H2-B	46	A177-1/4X125EG	14	AB241-1/4	20	B802EG	58
6H3-B	46	A179-3/8X100EG	14	AB241-3/4	20	B804EG	10
6H3-SC	36	A179-3/8X125EG	14	AB241-3/8	20	B804NEOPWH	10
6H3-SC	46	A182-1/4X100EGC	14	AB241-5/16	20	B822	58
6H3-TB	46	A182-1/4X125EGC	14	AB241-5/8	20	BR1600	9
6H4	36	A184-3/8X100EGC	14	AB242	20	BR1600HS	9
6H4	46	A184-3/8X125EGC	14	AB245	24	BR1600P	9
6H4-B	46	A185-1/2X100EGC	14	AB252-1	21	BR1600S	9
6H4-TB	46	A185-1/2X125EG	14	AB252-2	21	BR1600SW	9
6H5	36	A208	10	AB252-3	21	C1200	9
6H5	46	A208	24	AB252-4	21	C1200HS	9
6H5-B	46	A209	23	AB253	20	C209	23
6H5-TB	46	A210	24	AB254L	21	C210	24
6H6	36	A211	24	AB254R	21	C302-10	11
6H6	46	A212	24	AB255	20	C704A	55
6H6-B	46	A213	10	AB257	20	C708U	49
6H7	36	A213	24	AB260L	21	C710	51
6H7	46	A213	58	AB260R	21	C711	50
6H7-B	46	A217	25	AB261	20	C720	53
6H8	36	A218	25	AB263	20	C725	52
6H8	46	A2431	10	AB265	20	C726	53
6H8-B	46	A302-10	11	AB274	21	C727	50
6H9	36	A302-20	11	AB275	21	C728	29
6H9	46	A570HDG	34	AB284L	22	C729	55
6H9-B	46	A597	33	AB284R	22	C736	55
701-045PG	42	A716	45	AB288-1/2	24	C739H	55
701-055PG	42	A716-1	45	AB288-3/8	24	C739M	55
701-065PG	42	A716-1/2	45	AB288-5/8	24	C749N-1 1/8	54
701-075PG	42	A716-1/4	45	AB299	22	C749N-5/8	54
701-088PG	42	A716-1-1/2	45	AB803	59	C749N-7/8	54
701-100PG	42	A716-1-1/4	45	AB815	45	C755	55
701-113PG	42	A716-1-1/8	45	AB844PC	10	C755-1A	48
701-126PG	42	A716-1-3/4	45	AB844PC	59	C755-1B	48
701-140PG	42	A716-1-3/8	45	AB844PCGY	10	C755-1C	48
701-153PG	42	A716-1-5/8	45	AB844PCGY	59	C755-2	48
701-167PG	42	A716-1-7/8	45	AB844PGC	10	C755-2A	48
701-180PG	42	A716-2	45	AB844PGC	59	C755-2B	48
701-193PG	42	A716-2-1/8	45	AB866	59	C755-2C	48
701-204PG	42	A716-2-3/8	45	AB867	59	C755-3	48
701-225PG	42	A716-2-5/8	45	AB868	59	C755-3A	48
701-237PG	42	A716-3/4	45	AB880	48	C755-3B	48
701-245PG	42	A716-3/8	45	AB881	48	C755-3C	48
701-257PG	42	A716-3-1/8	45	AB885	59	C755-4	48
701-287PG	42	A716-4-1/8	45	AC100-1/2EGC	14	C755-4A	48
701-294PG	42	A716-5/8	45	AC100-1/4EG	14	C755-4B	48
701-306PG	42	A716-7/8	45	AC100-3/4EGC	14	C755-4C	48
701-319PG	42	A802EG	58	AC100-3/8EGC	14	C755-5	48
701-350PG	42	A804EG	10	AC100-5/8EG	14	C755-5A	48
701-356PG	42	A804NEOPWH	10	AN211	24	C755-5B	48
701-379PG	42	A805EG	58	AN270-1	29	C755-5C	48
701-400PG	42	A809-3/4EG	58	AN270-1	29	C755-6	48
701-450PG	42	A822	58	AN270-2	29	C755-6A	48
701-556PG	42	A853	58	AP232	28	C755-6B	48
701-665PG	42	A853L	58	AP232SQ	28	C755-6C	48
701-876PG	42	A854	58	AP235	28	C755-7	48
703-1/2EG	42	A854L	58	AP235SQ	28	C755-7A	48
703-1-1/2EG	42	AB100-1/2EG	14	AR1600	9	C755-7B	48

**ALPHANUMERIC INDEX**

Catalogue #	Page #	Catalogue #	Page #	Catalogue #	Page #	Catalogue #	Page #
C755-7C	48	E1200HS	9	G2000	60	RC-1-1/4	37
C755-8	48	E1200KO	9	G2001	60	RC-2-1/2	37
C755-8A	48	E1200P	9	G2002	60	RC-2-SC	37
C755-8B	48	E1200S	9	G2003	60	RC-3	37
C755-8C	48	E142-1/2X100EG	15	G2004	60	RC-3/4	37
C755-8D	48	E142-1/2X150EG	15	G972HB1/2	61	RC-3-1/2	37
C755-8E	48	E142-1/2X200EG	15	H100-1/2EGC	13	RC-4-SC	37
C755-8F	48	E142-1/2X225EG	15	H100-1/2EGC	14	RC729A	55
C769	55	E142-1/2X250EG	15	H100-3/8EGC	13	RCS-1	37
C775L-1/2EG	35	E142-1/2X275EG	15	H100-3/8EGC	14	RCS-1/2	37
C775L-3/4EG	35	E142-1/4X100EG	15	H104-1/2X10EGC	15	RCS-1-1/2	37
C775L-3/8EG	35	E142-1/4X150EG	15	H104-1/4X10EGC	15	RCS-1-1/4	37
C775L-5/8EG	35	E142-3/8X100EG	15	H104-1X10EG	15	RCS-2	37
C775L-7/8EG	35	E142-3/8X150EG	15	H104-3/4X10EGC	15	RCS-3/4	37
C780	55	E145-1/2EGC	14	H104-3/8X10EGC	15	RCS-3/8	37
C781-1	17	E145-1/4EGC	14	H104-5/8X10EGC	15	S202-15	26
C781-1	38	E145-1EGC	14	H104-7/8X10EGC	15	S202-21	26
C781-1/2	17	E145-3/4EGC	14	H115	17	S202-27	26
C781-1/2	38	E145-3/8EGC	14	H119	15	S202-33	26
C781-3/4	17	E145-5/8EG	14	H1200	9	S202-6	26
C781-3/4	38	E145-7/8EG	14	H1200HS	9	S202-9	26
C781-3/8	17	E146-1/4HDGC	14	H1200KO	9	S203-14	26
C781-3/8	38	E146-3/8HDGC	14	H1200P	9	S203-20	26
C781-5/8	17	E146-5/16HDGC	14	H1200S	9	S203-26	26
C781-5/8	38	E146-5/8HDGC	14	H802	58	S203-32	26
C781-7/8	17	E147-1/2EG	15	H804	10	S203-38	26
C781-7/8	38	E147-1/4EG	15	H804NEOPWH	10	S203-8	26
C785A	55	E147-3/4EG	15	H805EG	58	S204	27
C786	55	E147-3/8EG	15	LKCPC050	43	S205	27
C789	55	E147-5/16EG	15	LKCPC075	43	S217	27
C790	55	E147-5/8EG	15	LKCPC100	43	S218	27
C804EG	10	E147-7/8EG	15	LKCPC125	43	S222	27
CB118	44	E148-1/2EG	15	LKCPC150	43	S226	27
CB118-047PG	44	E148-1/4EG	15	LKCPC200	43	S247	26
CB118-055PG	44	E148-3/8EG	15	LKCPC250	43	S248	26
CB118-070PG	44	E148-5/8EG	15	LKCPC300	43	S249-14	26
CB118-090PG	44	E150S-1/2X1-1/2EG	15	LKCPC350	43	S249-20	26
CB118-110PG	44	E150S-1/2X2-1/2EG	15	LKCPC400	43	S249-26	26
CB118-140PG	44	E150S-1/2X2EG	15	M718	52	S249-32	26
CB118-175PG	44	E150S-1/2X3EG	15	M732	55	S249-38	26
CB118-200PG	44	E150S-3/8X1-1/2EG	15	M732H	55	S249-8	26
CB118-250PG	44	E150S-3/8X2-1/2EG	15	M742R-1/2	38	S250-12	26
CB118-300PG	44	E150S-3/8X2EG	15	M742R-3/8	38	S250-14	26
CH118-047EG	44	E150S-3/8X3EG	15	M750	55	S250-18	26
CH118-055EG	44	E151-1/2X10EG	15	M775L-1/2EG	35	S250-20	26
CH118-081EG	44	E151-1/2X4EG	15	M775L-3/4EG	35	S250-24	26
CH118-110EG	44	E151-1/2X6EG	15	M775L-3/8EG	35	S250-26	26
CH118-125EG	44	E151-1/2X8EG	15	M775L-5/8EG	35	S250-6	26
CH118-135EG	44	E151-3/8X10EG	15	M777	55	S250-8	26
CH118-175EG	44	E151-3/8X12EG	15	M778	55	S251-12	26
CH118-205EG	44	E151-3/8X4EG	15	N205	22	S251-14	26
CH118-250EG	44	E151-3/8X6EG	15	N219	22	S251-18	26
CH118-300EG	44	E151-3/8X8EG	15	P716	45	S251-20	26
CH118-325EG	44	E210	24	P716-1	45	S251-24	26
CH118-375EG	44	E802EG	58	P716-1/2	45	S251-26	26
CH118-425EG	44	E804EG	10	P716-1/4	45	S251-30	26
CH118-475EG	44	E809-3/4EG	58	P716-1-1/2	45	S251-32	26
CL710	51	EB118	44	P716-1-1/4	45	S251-36	26
CM100-1/2	13	EB118-047PG	44	P716-2	45	S251-38	26
CM100-1/2	14	EB118-055PG	44	P716-2-1/2	45	S256-12	26
CM100-1/2B	13	EB118-070PG	44	P716-3	45	S256-14	26
CM100-1/4	13	EB118-090PG	44	P716-3/4	45	S256-18	26
CM100-1/4	14	EB118-110PG	44	P716-3/8	45	S256-20	26
CM100-3/8	13	EB118-140PG	44	P716-3-1/2	45	S256-24	26
CM100-3/8	14	EB118-175PG	44	P716-4	45	S256-26	26
CM100B-1/2	14	EB118-200PG	44	PC-1	37	S256-6	26
CN749N	54	EB118-250PG	44	PC-1/2	37	S256-8	26
CPC050	43	EB118-300PG	44	PC-1-1/2	37	S541-3/8	38
CPC075	43	EC-1	37	PC-1-1/4	37	S716	49
CPC100	43	EC-1/2	37	PC-2	37	S730D	55
CPC125	43	EC-1-1/2	37	PC2-1/2	37	S730S	55
CPC150	43	EC-1-1/4	37	PC-3	37	SI400-1/2	11
CPC200	43	EC-2	37	PC-3/4	37	SI400-3/8	11
CPC250	43	EC-2-1/2	37	PC-3/8	37	TBQC050	43
CPC300	43	EC-3	37	PC-3-1/2	37	TBQC075	43
CPC350	43	EC-3/4	37	PC-4	37	TBQC100	43
CPC400	43	EF147-1/4EGC	15	RA-160-10	66	TBQC100	43
CZ209	23	EF147-3/8EGC	15	RA160-12	66	TBQC125	43
D1200	9	ES142-1/2X1-1/2	54	RA225-10	66	TBQC150	43
D1200HS	9	ES145-1/2	14	RA225-12	66	TBQC250	43
D1200P	9	ES145-3/8	14	RA300-10	66	TBQC300	43
D1200S	9	EZ209	23	RA300-12	66	TBQC350	43
D1200SW	9	G1017	61	RA-BN-3/4	66	TBQC400	43
D209	23	G1038	60	RA-BN-5/8	66	TC5363X	46
D210	24	G1038A	60	RA-C	66	TR292	29
DB118	44	G1038B	60	RA-GP	66	TR294	29
DB118-047PG	44	G1038C	60	RA-RC	66	TS272HDG	29
DB118-055PG	44	G1038CA	60	RA-SC	66	TS273HDG	29
DB118-070PG	44	G1038CX	60	RC-1	37	U501	32
DB118-090PG	44	G1038D	60	RC-1/2	37	U502	32
E1200	9	G1038E	60	RC-1-1/2	37	U504	32

**ALPHANUMERIC INDEX**

Catalogue #	Page #	Catalogue #	Page #
U505	.32	WS716-6	.47
U510	.32	WS716-6-1/2	.47
U514	.32	WS716-7	.47
U514-A	.32	X201	.22
U515	.32	X204	.22
U515-B	.32	X207	.20
U520	.33	X208	.20
U521	.33	X289	.22
U522	.33	X299	.22
U543	.33		
U544	.33		
U560-1/2	.35		
U560-1/4	.35		
U560-3/8	.35		
U560-5/8	.35		
U562	.34		
U563	.34		
U564-1/2	.35		
U564-3/8	.35		
U564-5/8	.35		
U568-1EG	.35		
U568-2EG	.35		
U568-3EG	.35		
U568-4EG	.35		
U568-5EG	.35		
U568-6EG	.35		
U568-7EG	.35		
U568-8EG	.35		
U569	.34		
U570-1	.33		
U570-2	.33		
U576-1/2	.39		
U576-3/8	.39		
U577-1/2	.39		
U579-1/2	.39		
U579-3/8	.39		
U716	.45		
U716-1	.45		
U716-1/2	.45		
U716-1/4	.45		
U716-1-1/2	.45		
U716-1-1/4	.45		
U716-1-1/8	.45		
U716-1-3/8	.45		
U716-1-5/8	.45		
U716-2-1/8	.45		
U716-2-3/8	.45		
U716-3/4	.45		
U716-3/8	.45		
U716-5/8	.45		
U716-7/8	.45		
U717	.45		
U861	.47		
UC100-1/2	.13		
UC100-1/2	.14		
UC100-1/4	.13		
UC100-1/4	.14		
UC100-3/8	.13		
UC100-3/8	.14		
US562	.34		
US562	.34		
US563	.34		
W716-1-1/2PG	.47		
W716-1-1/4PG	.47		
W716-1-3/4PG	.47		
W716-1PG	.47		
W716-2-1/2PG	.47		
W716-2-1/4PG	.47		
W716-2-3/4PG	.47		
W716-2PG	.47		
W716-3/4PG	.47		
W716-3PG	.47		
W716-4PG	.47		
WS716-1	.47		
WS716-1-1/2	.47		
WS716-1-1/4	.47		
WS716-1-3/4	.47		
WS716-2	.47		
WS716-2-1/2	.47		
WS716-2-1/4	.47		
WS716-2-3/4	.47		
WS716-3	.47		
WS716-3/4	.47		
WS716-3-1/2	.47		
WS716-3-1/4	.47		
WS716-3-3/4	.47		
WS716-4	.47		
WS716-4-1/2	.47		
WS716-5	.47		
WS716-5-1/2	.47		

