

CEP7 Solid State Overload Relays

Advanced solid state motor protection

The CEP7 solid state overload relay includes advanced technology with several key features like:

- Selectable trip class and field installable modules
- A wide (5:1) set current adjustment range
- A robust mechanical and electrical mounting
- Self-sealed latching mechanism

The basic concept of utilizing Application Specific Integrated Circuits (ASICs) results in an affordable solid state overload relay. This kind of versatility and accuracy is simply not possible with traditional bimetallic or eutectic alloy electromechanical overload relays.



Fewer units means greater application flexibility

The CEP7 Solid State Overload Relay is available in three basic models:

- CEP7-ED1 is a Class 10, manual reset model available up to 45 amperes which covers the most common horsepower motors and your every day application. This model is economically priced to be competitive with adjustable bimetallic overload relays.
- CEP7-EE is a full featured selectable trip class (10, 15, 20 & 30) 3-phase application overload relay with provision for field mountable modules to handle remote reset, jam protection, and other modules previously available only in higher priced electronic overload relays.

Manual reset or automatic reset can be selected with dip switches on the CEP7-EE models.

- CEP7S-EE is a 1-phase application overload relay packing all features of the 3-phase CEP7-EE model.

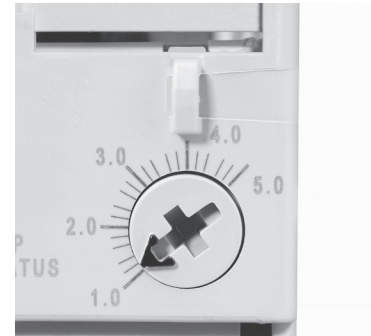

Wide current adjustment range

Thermal or bimetallic overload relays typically have a small current adjustment range of 1.5:1 meaning that the maximum setting is generally 1.5 times the lower setting. The CEP7 caused the industry to take note of the flexibility when it first introduced a 3.2:1 adjustment ratio. A wider adjustment range is the primary reason the industry has been turning to more specifications calling for electronic overload relay protection over thermal overload relays. Sprecher + Schuh's CEP7 overload relay is capable of adjustment to a maximum of five times the minimum set current, which dramatically reduces the number of units required on-hand to cover the full range of current settings up to 200 amperes.

5 : 1 Current Range



45A

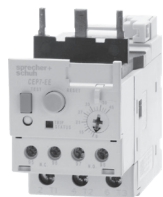

45A



120A



30A 200A

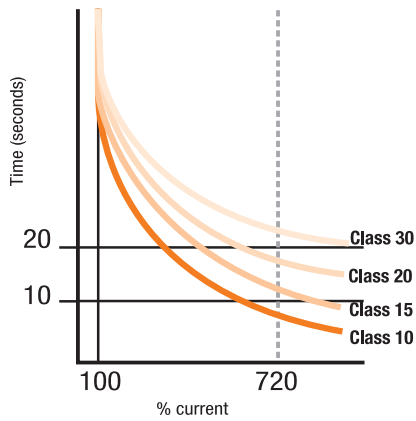

CEP7 overload relays are available with Class 10, 15, 20 or 30 tripping characteristics

Selectable tripping class

Because of today's lighter T-frame motors, Class 10 overload relays (relays that trip within 10 seconds of a locked rotor condition) have become the industry standard. If your application requires a longer motor run-up time, the CEP7-EE Selectable Trip Class has DIP-switches providing Trip Class selection of 10, 15, 20 or 30 seconds. This ability allows you to closely match the Trip Class with the run-up time of the motor.

Choice of reset options

Most industrial applications usually call for an overload relay that must be manually reset in the event of a trip. This allows the cause of the overload to be identified before the motor is restarted. In specialized cases, however, such as rooftop AC units or where restarting the motor will not harm people or equipment, automatic reset may be desired. CEP7-ED1 overload relays are available with Manual Reset exclusively which keeps the cost down. CEP7-EE models have a selectable dip switch for Manual or Automatic Reset modes.

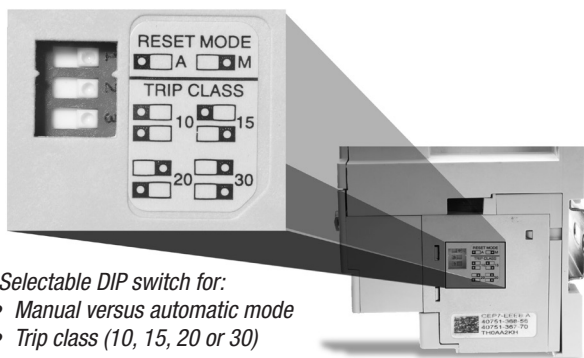

Selectable DIP switch for:
 • Manual versus automatic mode
 • Trip class (10, 15, 20 or 30)

operate in -20°C . or up to 60°C (140°F .) and withstand 3G of vibration or 30G of shock on a mountain up to an altitude of 2000m or in a jungle at 95% humidity. Reliability under every conceivable environmental condition is a quality built into the design of the CEP7 electronic overload relay.

Self-powered design means convenience

By developing the power it requires from the applied voltage, the CEP7 is "self-powered," eliminating the need for a separate control power source. This is not the case with some other electronic overload relays. Since the CEP7 is self-powered and a traditional auxiliary contact is used to interface with the contactor, the user can apply the CEP7 the same way as an electro-mechanical overload. No special connections or control schematic diagram provisions are required in 3-phase applications.

Superior phase failure protection

The CEP7's on-board electronics are constantly monitoring all three phases. If the ASIC board senses that one phase is missing during a steady state running condition on a fully loaded motor, it will trigger in 3 seconds. If a single phase condition is present during starting, the CEP7 will trip within 8 seconds (for a motor $>80\%$ loaded). These times are much faster than any thermal bimetallic overload relay. In addition, CEP7 overload relays detect a 50% phase imbalance in the same way as a phase loss.

Robust design

The CEP7 has been designed to physically extend to the back-pan therefore aligning the mounting of the overload with the corresponding contactor. Further, the mechanical attachment and direct electrical connection to the contactor provides a robust mounting, which means less damage from shipping or during field wire installation. The bipolar latching relay which controls the normally closed trip contacts and normally open alarm circuit contacts have been self-enclosed, therefore insulating the electromagnet and shielding against airborne metal particles and other potential environmental debris. The CEP7 has been tested to

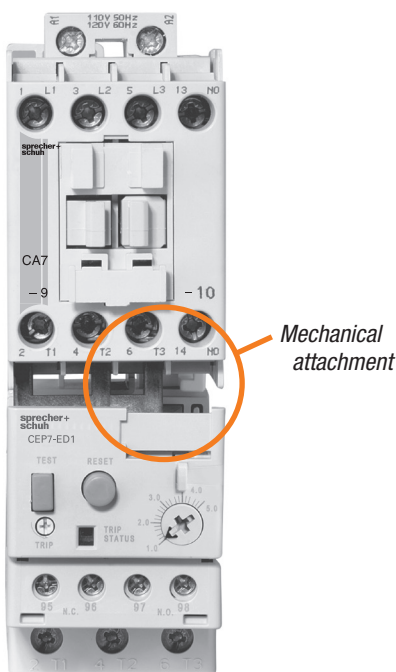

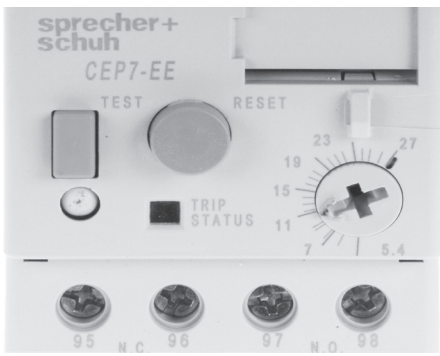

Increased accuracy and improved motor protection

Microelectronics provide flexible and accurate motor overload protection. Unlike traditional overload relays that simulate heat build-up in the motor by passing current through a heater element, CEP7 solid state overload relays measure motor current directly through integrated current transformers. The transformers, in turn, create a magnetic field that induces DC voltage onto the ASIC board. The electronics identify excessive current or loss of phase more accurately, and react to the condition with greater speed and reliability than traditional overload relays. In addition, CEP7 solid state relays offer setting accuracies from 2.5 – 5% and repeat accuracy of 1%.



Additional Protection with Side Mount Modules

The CEP7 offers a variety of field installable accessories for side mount on the left side. Side mount modules provide additional motor protection functionality traditionally found only on more expensive models. Modules include the following additional features.

- **Remote Reset** provision for reset after trip from a remote pilot device
- **Jam Protection/Remote Reset** provides adjustable Jam set points and trip delay plus remote reset
- **Ground Fault Protection/Remote Reset** combined with ground fault current transformers provide adjustable set points for ground fault trip protection of equipment plus remote reset
- **Ground Fault/Jam Protection/Remote Reset** combines all three features as described above
- **PTC Thermistor Relay/Remote Reset** manages thermistor sensor signals from the motor
- **Network Communication Modules** provide motor diagnostic information via **Ethernet** communication
 - Two discreet Inputs and one discreet Output
 - Differentiate between various motor protection algorithms
 - Overload and underload warning
 - Jam protection
 - Proactively alert maintenance personnel just before or when a fault occurs
 - Plus remote reset

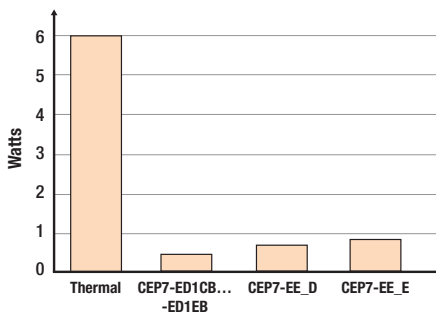

Conventional overload relays dissipate as much as six watts of energy compared with as little as 0.5 watts for a comparable size CEP7

Dramatically lowered energy requirement saves money, reduces panel space

Because traditional overload relays work on the principle of “modeling” the heat generated in the motor (recreating the heat in the bimetal elements or heaters), a significant amount of energy is wasted. In traditional bimetallic overload relays, as many as six watts of heat are dissipated to perform the protective function. Because the CEP7 uses sampling techniques to actually measure the current flowing in the circuit, very little heat is dissipated in the device...as little as 0.5 watts. This not only reduces the total amount of electrical energy consumed in an application, but it can also have a dramatic impact on the design and layout of control panels. The density of motor starters can be much greater because less heat is generated by each of the individual components. Higher density results in smaller control panels. In addition, special ventilation or air conditioning that might have been required to protect sensitive electronic equipment such as PLC’s can now be reduced or eliminated. CEP7 overload relays dramatically reduced energy requirement saves money and reduces panel space.



Directly Mounted CEP7 Solid State Overload Relays, Manual Reset ①②④

| Overload Relay | Directly Mounts to Contactor... ② | Adjustment Range (A) | Trip Class 10 | |
|-----------------------------------------------------------------------------------|-------------------------------------|----------------------|----------------|--------|
| | | | Catalog Number | Price |
| Manual Reset for 30 Applications ① | | | | |
|  | CA7-9...CA7-23 CAN7-12, CAN7-16 | 0.1...0.5 | CEP7-ED1AB | 72.05 |
| | | 0.2...1.0 | CEP7-ED1BB | 72.05 |
| | | 1.0...5.0 | CEP7-ED1CB | 72.05 |
| | | 3.2...16 | CEP7-ED1DB | 72.05 |
| | | 5.4...27 | CEP7-ED1EB | 72.05 |
| | CA7-30...CA7-55 CAN7-37, CAN7-43 | 1.0...5.0 | CEP7-ED1CD | 110.38 |
| | | 3.2...16 | CEP7-ED1DD | 110.38 |
| | | 5.4...27 | CEP7-ED1ED | 110.38 |
| | | 9...45 | CEP7-ED1FD | 110.38 |

Directly Mounted CEP7 Solid State Overload Relays, Automatic/Manual Reset ①②③④

TIP!

Most industrial applications usually call for an overload relay that must be manually reset in the event of a trip. This allows the cause of the overload to be identified before the motor is restarted. An overload relay that resets automatically is generally for specialized, or remote applications, such as rooftop AC units where restarting the motor will not harm people or equipment.

| Overload Relay | Directly Mounts to Contactor... ② | Adjustment Range (A) | Adjustable Trip Class 10, 15, 20 & 30 | |
|-------------------------------------------------------------------------------------|-------------------------------------|----------------------------|---------------------------------------|-----------|
| | | | Catalog Number | Price |
| Automatic or Manual Reset for 30 Applications ① | | | | |
|  | CA7-9...CA7-23 CAN7-12, CAN7-16 | 0.1...0.5 | CEP7-EEAB | 81.45 |
| | | 0.2...1.0 | CEP7-EEBB | 81.45 |
| | | 1.0...5.0 | CEP7-EECB | 81.45 |
| | | 3.2...16 | CEP7-EEDB | 81.45 |
| | | 5.4...27 | CEP7-EEEB | 81.45 |
| | CA7-30...CA7-55 CAN7-37, CAN7-43 | 1.0...5.0 | CEP7-EECD | 129.79 |
| | | 3.2...16 | CEP7-EEDD | 129.79 |
| | | 5.4...27 | CEP7-EEED | 129.79 |
| | | 9...45 | CEP7-EEFD | 129.79 |
| | | 11...55 | CEP7-EEQD | 129.79 |
| | | CA7-60...CA7-97 CAN7-85 | 5.4...27 | CEP7-EEEE |
| | 9...45 | | CEP7-EEFE | 146.15 |
| | CA7-60...CA7-97 CAN7-85 | 18...90 | CEP7-EEGE | 146.15 |
| 60...120 | | CEP7-EEVE | 146.15 | |
| Automatic or Manual Reset for 10 Applications ① | | | | |
|  | CA7-9...CA7-23 CAN7-12, CAN7-16 | 1.0...5.0 | CEP7S-EEPB | 81.45 |
| | | 3.2...16 | CEP7S-EERB | 81.45 |
| | | 5.4...27 | CEP7S-EESB | 81.45 |
| | CA7-30...CA7-43 CAN7-37, CAN7-43 | 9...45 | CEP7S-EETD | 129.79 |
| | CA7-60...CA7-97 CAN7-85 | 18...90 | CEP7S-EEUE | 146.15 |

① 3-phase CEP7 units are only designed for 30 applications. Single phase CEP7S units are only designed for single phase applications.

② This reference is not intended to be a guide for selecting contactors. Size overload relays using the full load current of the motor.

③ The reset time of a CEP7 set in the automatic mode is approximately 120 seconds.

④ CEP7 overload relays do not work with Variable Frequency Drives, DC Applications or Softstarters with braking options.

Pass-Thru CEP7 Solid State Overload Relays ⑤

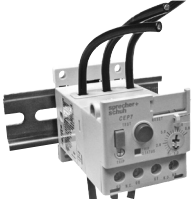
| Overload Relay | Separate Mount for use with... ② | Adjustment Range (A) | Trip Class 10 | |
|---------------------------------------------------------------------------------------------|----------------------------------------------------|----------------------|----------------|-------|
| | | | Catalog Number | Price |
| Manual Reset for 3Ø Applications ①④ | | | | |
|  Fig. 1 | CA8-09...12 CA7-9...CA7-23 CAN7-12...CAN7-37 | 1.0...5.0 | CEP7-ED1CP | 72.05 |
| | | 3.2... 16 | CEP7-ED1DP | 72.05 |
| | | 5.4...27 | CEP7-ED1EP | 72.05 |

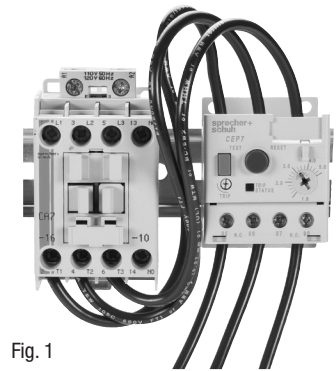
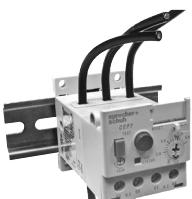
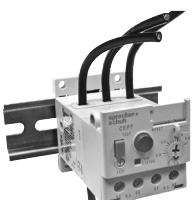

Fig. 1

| Overload Relay | Separate Mount for use with... ② | Adjustment Range (A) | Adjustable Trip Class 10, 15, 20 & 30 | |
|-----------------------------------------------------------------------------------------------|----------------------------------------------------|----------------------|---------------------------------------|-------|
| | | | Catalog Number | Price |
| Automatic or Manual Reset for 3Ø Applications ①③④ | | | | |
|  Fig. 1 | CA8-09...12 CA7-9...CA7-23 CAN7-12...CAN7-37 | 1.0...5.0 | CEP7-EECP | 77.37 |
| | | 3.2... 16 | CEP7-EEDP | 77.37 |
| | | 5.4...27 | CEP7-EEEP | 77.37 |
| Automatic or Manual Reset for 1Ø Applications ①③④ | | | | |
|  Fig. 1 | CA8-09...12 CA7-9...CA7-23 CAN7-12...CAN7-37 | 1.0...5.0 | CEP7S-EERP | 77.37 |
| | | 3.2...16 | CEP7S-EERP | 77.37 |
| | | 5.4...27 | CEP7S-EESP | 77.37 |

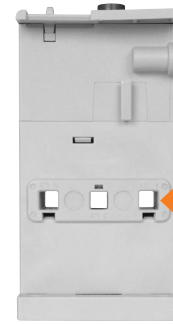

Fig. 2

Pass-thru window

Description

Fig. 1 - The Pass-Thru version of the CEP7 permits separate mounting of the overload relay.

Fig. 2 - Motor load side cables simply pass-thru a window in the overload relay body. The internal current transformers monitor the current flow.

Benefits

- No need for a panel mount adapter as required with direct-connect versions
- Eliminates 3 to 6 wire terminations
- Designed for use with CA8 or CA7 contactors
- Easily replaces outdated overload relays in existing starter assemblies
- Provides state-of-the-art accuracy and motor protection

① 3-phase CEP7 units are only designed for 3Ø applications. Single phase CEP7S units are only designed for single phase applications.
 ② This reference is not intended to be a guide for selecting contactors. Size overload relays using the full load current of the motor.
 ③ The reset time of a CEP7 set in the automatic mode is approximately 120 seconds.
 ④ CEP7 overload relays do not work with Variable Frequency Drives, DC Applications or Softstarters with braking options.
 ⑤ Pass-Thru windows will accept one power wire up to #10 AWG wire (6mm²).



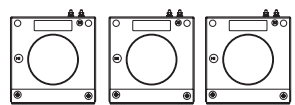

Large Amp CEP7 Solid State Overload Relays, Automatic and Manual Reset ①②③④⑥

| Overload Relay | Directly Mounts to Contactor... ② | CT Ratio | Adjustment Range (A) | Selectable Trip Class (10,15,20 & 30) | |
|---------------------------------------------------------------------------------------------------------------------------------------------------------------|-----------------------------------------|-----------|----------------------|---------------------------------------|----------|
| | | | | Catalog Number | Price |
| Automatic or Manual Reset for 3Ø Applications ①③ | | | | | |
|  <p>CEP7-EEHF</p> | CA6-115...CA6-180 | 150:5 | 30...150 | CEP7-EEHF | 473.19 |
| | CA6-115-EI...CA6-180-EI CAN6-180(EI) | 200:5 | 40...200 | CEP7-EEJF | 473.19 |
| | CA6-210-EI...CA6-420-EI CAN6-300-EI | 200:5 | 40...200 | CEP7-EEJG | 827.82 |
| | | 300:5 | 60...300 | CEP7-EEKG | 827.82 |
| | CA6-630-EI...CA6-860-EI | 500:5 | 100...500 | CEP7-EELG | 827.82 |
| | | 600:5 | 120...600 | CEP7-EEMH | 1,308.16 |
| | 800:5 | 160...800 | CEP7-EENH | 1,308.16 | |
| CA9-116...146(-EI) | 150:5 | 30...150 | CEP7-EEHJ | 473.19 | |
| CA9-190...205(-EI) | 200:5 | 40...200 | CEP7-EEJJ | 473.19 | |
| Current Transformer Kits For use with... CT Ratio | | | | | |
|  <p>Includes three Current Transformers (Overload relay sold separately)</p> | CA9-265...305 | 300:5 | ⑦ | CEP7-CT-UL-300 | 91.98 |
| | CA9-370...580 | 600:5 | ⑦ | CEP7-CT-CE-300 | 408.80 |
| | | | | CEP7-CT-UL-600 | 214.62 |
| | CA9-750...1060 | ~ | ~ | CEP7-CT-CE-400 | 511.00 |
| | | | | Refer to Factory | |

Items in Gray are marked for discontinuation after 2018

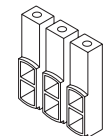
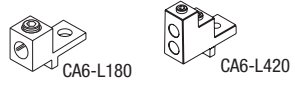
B
CEP7 Overloads

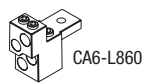



Load Side Lugs & Accessories for use with CA6 Contactors Only

| Lug or Accessory | Description | For Use With... | Catalog Number | |
|--------------------------------------------------------------------------------------------------------------|-----------------------------------------------------------------------------------------------------------------------------------------------------------------------------------------------------------------------------------------------------------------------------------------------------------------------------------------------------------------------|--------------------------------------------------------------------------------------------|----------------------------------------------------------|---------------|
|  <p>CA6-HB</p> | Main Terminal Set, ⑥ Dual Conductor, Touch Safe <ul style="list-style-type: none"> Accommodation for dual connections to each pole Accepts flat or round conductors Touch safe to IP20 according to IEC 60529 Eliminates need for Terminal Shields (price as complete set, containing 2 blocks, 6 lugs) | CEP7-EEHF...CEP7-EEJF, CEP7-EEHJ...CEP7-EEJJ CEP7-EEJG CEP7-EEKG CEP7-EELG | CA6-HB2 CA6-HB3 | See page A129 |
|  <p>CA6-L180 CA6-L420</p> | Screw Type Lugs - <ul style="list-style-type: none"> Accepts round conductors only Copper construction (set of 3 lugs) | CEP7-EEHF...CEP7-EEJF, CEP7-EEHJ...CEP7-EEJJ CEP7-EEJG, CEP7-EEKG, CEP7-EELG | CA6-L180 CA6-L420 | |
|  <p>CA6-L630</p> | Screw Type Lugs - <ul style="list-style-type: none"> Accommodation for dual connections to each pole Copper construction accepts round conductors only (set of 3 lugs) | CEP7-EEMH CEP7-EENH | CA6-L630 | |
|  <p>CA6-L860</p> | Screw Type Lugs - <ul style="list-style-type: none"> Accommodation for dual connections to each pole Copper construction accepts round conductors only (set of 3 lugs) | CEP7-EEMH CEP7-EENH | CA6-L860 | |
|  | Main Terminal Cover - ⑤ <ul style="list-style-type: none"> CA6 touch protection Line or load (price each) IP20; IEC60529 & DIN 40 050 protection | CA6-115(-EI) to 180(-EI) CA6-210-EI to 420-EI CA6-630-EI to 860-EI | CA6-TC180 CA6-TC420 CA6-TC860 | |

- ① 3-phase CEP7 units are only designed for 3Ø applications.
- ② This reference is not intended to be a guide for selecting contactors. Size overload relays using the full load current of the motor.
- ③ The reset time of a CEP7 set in the automatic mode is approximately 120 seconds.
- ④ CEP7 Overload relays do not work with Variable Frequency Drives or any Sprecher + Schuh Softstarter with braking options.
- ⑤ Terminal covers not necessary when using CA6-HB-__ insulated lugs.
- ⑥ CEP7-EEHF...CEP7-EENH include current transformers used to monitor high amperage.
- ⑦ Utilizes UL or CE approved Current Transformers in conjunction with an overload selection. Refer to page B13 for current setting guidance when CEP7-EECB is used.

Accessories - CEP7 Side Mount Modules ①②

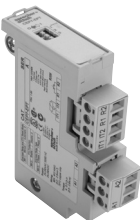
B
CEP7 Overloads



| Accessory | Description | For use with... | Catalog Number | Price | | | | | | | | | | | | | | | | | | | | |
|----------------------------------------------------------------------------------------------------------------|----------------------------------------------------------------------------------------------------------------------------------------------------------------------------------------------------------------------------------------------------------------------------------------------------------------------------------------------------------------------------------------------------------------------------------------------------------------------------------------------------------------------------------------------------------------------------------------------------------------------------------------------------------------------------------------------------------------------------------------------------------------------------------------------------------------------------------------------------------------------------------------------------------------------------------------------------------------------------------------------------------------------------------------------------------------------------------------------------------------------------------------|--------------------------------------|----------------|-------------------|---|-----------------------------------------|--------|-----------------|----------------|------------------|---------------|-------------------------------|-------------|------------------------------|------------|------------------------------------------------------|-----------|-------------------------------------------------------|----------|-------------------|---------------|--------------------------------------|----------|--------|
|  CEP7-ERR | Remote Reset Module (Series B) <ul style="list-style-type: none"> Dip switch adjustable reset mode & type <ul style="list-style-type: none"> - Automatic or Manual reset mode - 1- or 3-Phase relay type operation Provision for reset after trip from remote pilot device | Side-mount to any CEP7-EE_ CEP7S-EE_ | CEP7-ERR | 79.82 | | | | | | | | | | | | | | | | | | | | |
|  CEP7-EJM | Jam Protection and Remote Reset Module ③ <ul style="list-style-type: none"> Dip switch adjustable Jam Protection <ul style="list-style-type: none"> - Jam set points -150%, 200%, 300%, or 400% FLA - Trip delay- 0.5, 1, 2, or 4 sec. Provision for reset after trip from remote pilot device | | CEP7-EJM | 100.87 | | | | | | | | | | | | | | | | | | | | |
|  CEP7-EPT | PTC Thermistor Relay and Remote Reset Module <ul style="list-style-type: none"> PTC Protection and LED Status indication <table border="0" style="margin-left: 20px;"> <tr> <td>Type of Control Unit</td> <td>Mark A</td> </tr> <tr> <td>Number of Sensors</td> <td>6</td> </tr> <tr> <td>Maximum Cold Resistance of Sensor Chain</td> <td>1500 Ω</td> </tr> <tr> <td>Trip Resistance</td> <td>3400 Ω ± 150 Ω</td> </tr> <tr> <td>Reset Resistance</td> <td>1600 Ω ± 50 Ω</td> </tr> <tr> <td>Short Circuit Trip Resistance</td> <td>25 Ω ± 10 Ω</td> </tr> <tr> <td>Open Circuit Trip Resistance</td> <td>> 20,000 Ω</td> </tr> <tr> <td>Maximum Voltage at 1T1 / 1T2 (R_{ptc}=4kΩ)</td> <td>< 7.5 Vdc</td> </tr> <tr> <td>Maximum Voltage at 1T1 / 1T2 (R_{ptc}=open)</td> <td>< 30 Vdc</td> </tr> <tr> <td>PTC Response Time</td> <td>500ms...800ms</td> </tr> </table> Provision for reset after trip from remote pilot device | Type of Control Unit | Mark A | Number of Sensors | 6 | Maximum Cold Resistance of Sensor Chain | 1500 Ω | Trip Resistance | 3400 Ω ± 150 Ω | Reset Resistance | 1600 Ω ± 50 Ω | Short Circuit Trip Resistance | 25 Ω ± 10 Ω | Open Circuit Trip Resistance | > 20,000 Ω | Maximum Voltage at 1T1 / 1T2 (R _{ptc} =4kΩ) | < 7.5 Vdc | Maximum Voltage at 1T1 / 1T2 (R _{ptc} =open) | < 30 Vdc | PTC Response Time | 500ms...800ms | Side-mount to any CEP7-EE_ CEP7S-EE_ | CEP7-EPT | 100.87 |
| Type of Control Unit | Mark A | | | | | | | | | | | | | | | | | | | | | | | |
| Number of Sensors | 6 | | | | | | | | | | | | | | | | | | | | | | | |
| Maximum Cold Resistance of Sensor Chain | 1500 Ω | | | | | | | | | | | | | | | | | | | | | | | |
| Trip Resistance | 3400 Ω ± 150 Ω | | | | | | | | | | | | | | | | | | | | | | | |
| Reset Resistance | 1600 Ω ± 50 Ω | | | | | | | | | | | | | | | | | | | | | | | |
| Short Circuit Trip Resistance | 25 Ω ± 10 Ω | | | | | | | | | | | | | | | | | | | | | | | |
| Open Circuit Trip Resistance | > 20,000 Ω | | | | | | | | | | | | | | | | | | | | | | | |
| Maximum Voltage at 1T1 / 1T2 (R _{ptc} =4kΩ) | < 7.5 Vdc | | | | | | | | | | | | | | | | | | | | | | | |
| Maximum Voltage at 1T1 / 1T2 (R _{ptc} =open) | < 30 Vdc | | | | | | | | | | | | | | | | | | | | | | | |
| PTC Response Time | 500ms...800ms | | | | | | | | | | | | | | | | | | | | | | | |
|  ETHERNET/IP CEP7-ETN | Network Communication Modules <ul style="list-style-type: none"> Delivers direct access to motor performance and diagnostic data on a field bus based network in addition to seamless control Includes integrated I/O <ul style="list-style-type: none"> 2 inputs 1 output Operational and diagnostic data <ul style="list-style-type: none"> Average motor current Percentage of thermal capacity usage Device status Trip and warning identification Trip history (last five trips) Protective functions <ul style="list-style-type: none"> Overload warning <ul style="list-style-type: none"> - 1...100% TCU Jam protection; <ul style="list-style-type: none"> - Trip setting 150...600% FLA - Trip delay 0.5...25 seconds - Warning setting 100...600% FLA Underload warning <ul style="list-style-type: none"> - 20...100% FLA | Side-mount to any CEP7-EE_ CEP7S-EE_ | CEP7-ETN | 376.10 | | | | | | | | | | | | | | | | | | | | |

① Side mount modules must have 24 - 240V, 47 - 63HZ or DC applied to terminals A1 and A2 for control power. CEP7-EPRB and CEP7-ETN require 20.4 - 26.4 VDC only. See B18 for more information.

② See Technical Data, Wiring, and DIP Switch set up starting on page B16 .

③ Dynamic inhibit: Protective function is enabled after the motor current goes above 150% and then falls below 125%.

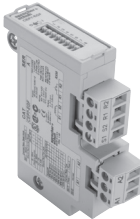
Accessories - CEP7 Side Mount Modules ①③

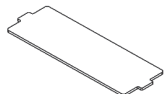
| Accessory | Description | For use with... | Catalog Number | Price |
|-----------------------------------------------------------------------------------------------|-----------------------------------------------------------------------------------------------------------------------------------------------------------------------------------------------------------------------------------------------------------------------------------------------------------------------------------|-----------------------------------------|----------------|--------|
|  CEP7-EGF | Ground Fault Protection and Remote Reset Module ②⑥• Dip switch adjustable Ground Fault Protection > GF Current range set points - 20...100ma - 100...500mA - 0.2...1.0A - 1.0...5.0A > GF Trip level 20%-100% • LED status indication • Provision for reset after trip from remote pilot device | Side-mount to any CEP7-EE_ CEP7S-EE_ | CEP7-EGF | 100.87 |
|  CEP7-EGJ | Ground Fault/Jam Protection and Remote Reset Module ②⑥ • Dip switch adjustable Ground Fault Protection same as CEP7-EGF shown above. • Jam trip when the motor current exceeds 400% FLA setting when enabled. • LED status indication • Provision for reset after trip from remote pilot device | Must use with CEP7-CBCT_ Current Sensor | CEP7-EGJ | 134.90 |
|  | Adjustment Cover for External Modules | All modules with DIP Switches | CEP7-EMC | 17.58 |

CEP7 Ground Fault Sensor Installation

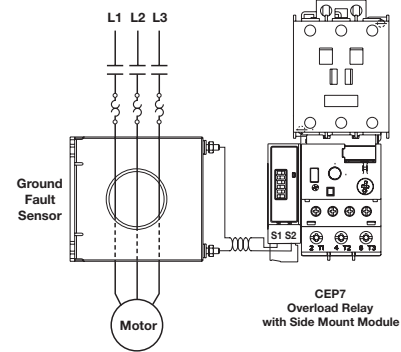

Ground Fault Sensor Control Wiring



CEP7 Ground Fault Sensor Selection ③

Ground fault current is sensed by passing all lines carrying current to and from a motor through the window of a special current transformer called a ground fault sensor. If all the current to the motor returns through the lines in the sensor window, no significant current will be induced in the sensor secondary. If, however, ground fault current returns via a path external to the sensor, such as via the conduit walls, a current will be induced in the sensor secondary. This current will be sensed and amplified by solid state circuits. If the ground fault current is larger than the selected ground fault trip level of the overload relay, the overload relay will trip.



| Sensor Type | Maximum Current | Frequency | Turns Ratio | Sensor Window I.D. | Maximum Recommended Cable Size | For use with CEP7-EGF and CEP7-EGJ and contactor... | Catalog Number | Price |
|-------------------------------------------------------------------------------------|-----------------|-----------|-------------|--------------------|---------------------------------------|-----------------------------------------------------|----------------|--------|
|  | 45A | 50/60 Hz | 1000:1 | 19.1mm (0.75 in.) | 8 AWG @ 600V ④ | CA7-9...CA7-37 | CEP7-CBCT1 | 43.44 |
|  | 90A | 50/60 Hz | 1000:1 | 39.6mm (1.56 in.) | 2 AWG @ 600V ④ | CA7-9...CA7-85 | CEP7-CBCT2 | 164.54 |
| | 180A | 50/60 Hz | 1000:1 | 63.5 mm (2.50 in.) | 250MCM (120mm ²) @ 600V ④ | CA7-9...CA9-190 | CEP7-CBCT3 | 221.77 |
|  | 420A | 50/60 Hz | 1000:1 | 82.3 mm (3.25 in.) | 350MCM (185mm ²) @ 600V ⑤ | CA7-9...CA9-400 | CEP7-CBCT4 | 276.96 |

① Side mount modules must have 24 - 240V, 47 - 63HZ or DC applied to terminals A1 and A2 for control power. See B18 for more information.

② ATTENTION: The CEP7 Overload relay is not a ground fault circuit interrupter for personnel protection as defined in Article 100 of the NEC.

③ See Application Details on page B17.

④ For a three phase system with one cable per phase.

⑤ For a three phase system with two cables per phase.

⑥ Dynamic inhibit: Protective function is enabled after the motor current goes above 150% and then falls below 125%.

Accessories

B
CEP7 Overloads

| Accessory | Description | For use with... | Catalog Number | Price |
|-----------|--------------------------------------------------------------------------------------------------------------------------------------------------------------------------------------|-------------------------------------------------------------------|-------------------------------|-------|
| | Remote Indication Display "Intellibutton" ③ Connects, communicates, and receives power from CEP7 Side Mount Modules to remotely view status of CEP7-EE Overload Relays | CEP7-EJM CEP7-EGF CEP7-EGJ CEP7-EPT CEP7-ERR | CEP7-ERID | 55.39 |
| | Replacement Parts Kit for CEP7-ERID Includes (1) each Mounting Ring (Plastic), Terminal Block Plug, and L.E.D. Fault Code Label | CEP7-ERID | CEP7-NCRID | 26.27 |
| | DIN-rail / Panel Adaptor For separate mounting of overload relay to back pan or top hat DIN-rail | CEP7-ED1...B CEP7(S)-EE...B | CEP7-EPB | 27.08 |
| | | CEP7-ED1..D CEP7(S)-EE...D | CEP7-EPD | 27.08 |
| | | CEP7(S)-EE...E | CEP7-EPE | 33.01 |
| | Current Adjustment Shield Prevents inadvertent adjustment of the current setting | all CEP7-ED1 CEP7-EE | CEP7-BC8 | 11.86 |
| | Solenoid Remote Reset ④ - For remote resetting of the solid state overload relay. Replace * in Catalog Number with Coil Code. | CEP7 all | CEP7-EMR* | 74.71 |
| | External Reset Button Used for manually resetting overloads mounted in enclosures | all CEP7 | Use D7 Reset - See Section H. | |
| | External Reset Button Adaptor Provides a larger "target area" for resetting the overload relay when using an External Reset Button | CEP7-ED1(all), CEP7-EE_B, CEP7-EE_D, CEP7-EE_E, CEP7-EE_P ① | CEP7-ERA | 13.29 |

Solenoid Remote Reset Coil Codes

(Replace * with coil code below)

| A.C. Coil Code | Voltage Range 50 / 60 Hz ⑤ |
|----------------|----------------------------|
| J | 24V |
| D | 120V |
| A | 240V |

| D.C. Coil Code | Voltage ⑥ |
|----------------|-----------|
| Z24 | 24VDC |
| Z48 | 48VDC |
| Z01 | 115VDC |

① CEP7-ERA does not fit CEP7-EE_F/G/H/J units without removing the CEP7 cover.

② Solenoid Reset Modules only mount on CEP7 Series C or later.

③ See page B21 for additional details on installation and LED functions.

④ Coil consumption of AC coils is 8VA.







⑤ Coil consumption of DC coils is 12 watts.







CEP7 Intelli-button Reset Kit with Side Mount Module (For use on CEP7(S)-EE_)

| Accessory | Description | Kit includes... | Catalog Number | Price |
|-------------------------------------------------------------------------------------|----------------------------------------------|--------------------------------------------|----------------|--------|
|  | Remote Reset Only | CEP7-ERID CEP7-ERR | CEP7-IB1 | 178.85 |
| | Jam and Remote Reset | CEP7-ERID CEP7-EJM (B) | CEP7-IB2 | 187.03 |
| | Thermistor Relay and Remote Reset | CEP7-ERID CEP7-EPT | CEP7-IB3 | 200.31 |
|  | Ground Fault and Remote Reset | CEP7-ERID CEP7-EGF CEP7-CBCT1 (45A) | CEP7-IB4 | 231.99 |
| | | CEP7-ERID CEP7-EGF CEP7-CBCT2 (90A) | CEP7-IB5 | 389.38 |
| | | CEP7-ERID CEP7-EGF CEP7-CBCT3 (180A) | CEP7-IB6 | 389.38 |
| | | CEP7-ERID CEP7-EGF CEP7-CBCT4 (420A) | CEP7-IB7 | 443.55 |
|  | Ground Fault and Jam and Remote Reset Module | CEP7-ERID CEP7-EGJ CEP7-CBCT1 (45A) | CEP7-IB8 | 263.68 |
| | | CEP7-ERID CEP7-EGJ CEP7-CBCT2 (90A) | CEP7-IB9 | 375.07 |
| | | CEP7-ERID CEP7-EGJ CEP7-CBCT3 (180A) | CEP7-IB10 | 420.04 |
| | | CEP7-ERID CEP7-EGJ CEP7-CBCT4 (420A) | CEP7-IB11 | 475.23 |

Technical Information

B
CEP7 Overloads

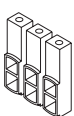
| | | CEP7-ED1...B CEP7(S)-EE...B | CEP7-ED1...D CEP7(S)-EE...D | CEP7(S)-EE...E |
|-----------------------------------------------------------------------------------|----------------|-----------------------------------------------------------------------------------|-----------------------------------------------------------------------------------|-------------------------------------------------------------------------------------|
| Rated Insulation Voltage - U_i | | 690 AC | | |
| Rated Insulation Strength- U_{imp} | | 6 AC | | |
| Rated Operation Voltage - U_e | | 690 AC (IEC) / 600 AC (UL/CSA) | | |
| Rated Operating Frequency | | 50/60 | | |
| Terminal Cross Sections | | | | |
| Terminal Type | |  |  |  |
| Terminal Screw | | M5 | M5 | M8 |
|  | One conductor | 1 x (2.5...16) | 1 x (2.5...16) | 1 x (4...50) |
| | Two conductors | 2 x (2.5...10) ① | 2 x (2.5...10) ① | 2 x (4...25) |
|  | One conductor | 1 x (2.5...25) | 1 x (2.5...25) | 1 x (4...50) |
| | Two conductors | 2 x (6...16) ① | 2 x (6...16) ① | 2 x (4...35) |
|  | One conductor | 1 x (14...6) | 1 x (14...6) | 1 x (12...1/0) |
| | Two conductors | 2 x (14...6) ① | 2 x (14...6) ① | 2 x (8...2) |
| | | | | |
| Poizdrive Screwdriver Size | | 2 | 2 | ---- |
| Slotted screwdriver | | 1 x 6 | 1 x 6 | --- |
| Hexagon Socket Size | | --- | --- | 4 |

| | | CEP7-EE_F | CEP7-EE_G | CEP7-EE_H | CEP7-EE_J |
|-------------------------------------------------------------------------------------|----------------|-------------------------------------------------------------------------------------|-------------------------------------------------------------------------------------|---------------------------------------------------------------------------------------|---------------------------------------------------------------------------------------|
| Rated Insulation Voltage - U_i | | 1000 AC | | | 690 AC |
| Rated Insulation Strength- U_{imp} | | 6 AC | | | 6 AC |
| Rated Operation Voltage - U_e | | 1000 AC (IEC) / 600 AC (UL/CSA) | | | 690 AC (IEC)/600AC (UL) |
| Rated Operating Frequency | | 50/60 | | | 50/60 |
| Terminal Power | | | | | |
| Type | |  |  |  |  |
| Direct Connection | | Hexagonal Bolt | Hexagonal Bolt | Hexagonal Bolt | Hexagonal Bolt |
| Recommended Torque | | M8 x 25 | M10 x 30 | M12 x 40 | M8 x 25 |
| | | 11 | 43 | 68 | 11 |
| | | 100 | 380 | 600 | 100 |
| With Main Terminal Set (CA6...HB...) | | With CA6-HB2 | With CA6-HB3 | | With CA6-HB2 |
|  | sm. opening | 16...50 | 25...240 | ~ | 16...50 |
| | lg. opening | 16...120 | 25...240 | ~ | 16...120 |
|  | sm. opening | 16...50 | 25...240 | ~ | 16...50 |
| | lg. opening | 16...120 | 25...240 | ~ | 16...120 |
|  | b max. | 20 | 25 | ~ | 20 |
| | s. sm. opening | 3...9 | 6...20 | ~ | 3...9 |
| | lg. opening | 3...14 | 6...20 | ~ | 3...14 |
| Recommended Torque | | 10...12 | 20...25 | ~ | 10...12 |
| Wire size per UL/CSA | sm. opening | #6...1 / 0 | #4...600MCM | ~ | #6...1 / 0 |
| | lg. opening | #6...250MCM | #4...600MCM | ~ | #6...250MCM |
| Recommended Torque | | 90...110 | 180...220 | ~ | 90...110 |
| With Screw-type Lugs - Copper Clad (CA6-L...) | | | | W/CEP7-EEMH | W/CEP7-EEHH |
| CA6-L180 | | #6...250 MCM | ~ | ~ | ~ |
| Recommended Torque | | 90...110 | ~ | ~ | ~ |
| CA6-L420 | | ~ | #2...350 MCM | ~ | ~ |
| Recommended Torque | | ~ | 375 | ~ | ~ |
| CA6-L630 | | ~ | ~ | 2/0...500 MCM | ~ |
| Recommended Torque | | ~ | ~ | 400 | ~ |
| CA6-L860 | | ~ | ~ | ~ | 2/0...500 MCM |
| Recommended Torque | | ~ | ~ | ~ | 400 |

① For multiple conductor applications the same style and size of wire must be used.

Technical Information

| | | | |
|--------------------------------------|----------------|----------------|--------------------------------|
| Control Circuit | | | |
| Rated Insulation Voltage - U_i | [V] | | 690 AC |
| Rated Insulation Strength- U_{imp} | [kV] | | 6 AC |
| Rated Operation Voltage - U_e | [V] | | 690 AC (IEC) / 600 AC (UL/CSA) |
| Rated Designation | | | B600 |
| Rated Operating Current | | | NO NC |
| AC-15 | 12...120V | [A] | 3 2 |
| | 220...240V | [A] | 1.5 1.5 |
| | 380...480V | [A] | 0.75 0.75 |
| | 500...600V | [A] | 0.6 0.6 |
| DC-13 at L/R 15ms | 24V | [A] | 1.1 1.1 |
| | 110V | [A] | 0.4 0.4 |
| | 220V | [A] | 0.2 0.2 |
| | 440V | [A] | 0.08 0.08 |
| Thermal Current - I_{the} | | | [A] 5 |
| Contact Reliability | | | [kV] 17V, 5mA |
| Screw Terminal Cross Sections | | | |
| Terminal Screw | | | M3 |
| | One conductor | [mm2] | 1 x (0.5...2.5) |
| | | Torque [Nm] | 0.55 |
| | Two Conductors | [mm2] | 2 x (0.25...1.5) |
| | | Torque [Nm] | 0.55 |
| | One conductor | [mm2] | 1 x (0.5...4) |
| | | Torque [Nm] | 0.55 |
| | Two conductors | [mm2] | 2 x (0.22...2.5) |
| | | Torque [Nm] | 0.55 |
| | One conductor | [AWG] | 1 x (24...10) |
| | | Torque [lb-in] | 5 |
| | Two conductors | [AWG] | 2 x (24...12) |
| | | Torque [lb-in] | 5 |
| Poizdrive Screwdriver Size | | | #1 |
| Slotted Screwdriver Size | | | [mm] 0.6 x 3.5 |

| | |
|---------------------------------------------|-------------------------------|
| Heat Dissipation | Max. Heat Dissipation [Watts] |
| Catalog Number | |
| CEP7-ED1AB or CEP7-EEAB | 0.03 |
| CEP7-ED1BB or CEP7-EEBB | 0.04 |
| CEP7-ED1_B or CEP7-EE_B (other than A or B) | 0.53 |
| CEP7-EE_D | 0.73 |
| CEP7-EE_E | 0.78 |
| CEP7-EEGF | 0.87 |
| CEP7-EE_F (other than G) | 3.52 |
| CEP7-EE_G | 8.94 |
| CEP7-EE_H | 15.53 |
| CEP7-EE_J | ❶ |

B
CEP7 Overloads

Table for using Current Transformers with CEP7-EECB (range 1.0...5.0 amps) overload relay

| Current Setting | CT Ratio 150:5 Equivalent FLA | CT Ratio 200:5 Equivalent FLA | CT Ratio 300:5 Equivalent FLA | CT Ratio 500:5 Equivalent FLA | CT Ratio 600:5 Equivalent FLA | CT Ratio 800:5 Equivalent FLA | CT Ratio 1000:5 Equivalent FLA | CT Ratio 1500:5 Equivalent FLA |
|-----------------|----------------------------------|----------------------------------|----------------------------------|----------------------------------|----------------------------------|----------------------------------|-----------------------------------|-----------------------------------|
| 1.00 | 30 | 40 | 60 | 100 | 120 | 160 | 200 | 300 |
| 1.25 | 38 | 50 | 75 | 125 | 150 | 200 | 250 | 375 |
| 1.50 | 45 | 60 | 90 | 150 | 180 | 240 | 300 | 450 |
| 1.75 | 53 | 70 | 105 | 175 | 210 | 280 | 350 | 525 |
| 2.00 | 60 | 80 | 120 | 200 | 240 | 320 | 400 | 600 |
| 2.25 | 68 | 90 | 135 | 225 | 270 | 360 | 450 | 675 |
| 2.50 | 75 | 100 | 150 | 250 | 300 | 400 | 500 | 750 |
| 2.75 | 83 | 110 | 165 | 275 | 330 | 440 | 550 | 825 |
| 3.00 | 90 | 120 | 180 | 300 | 360 | 480 | 600 | 900 |
| 3.25 | 98 | 130 | 195 | 325 | 390 | 520 | 650 | 975 |
| 3.50 | 105 | 140 | 210 | 350 | 420 | 560 | 700 | 1050 |
| 3.75 | 113 | 150 | 225 | 375 | 450 | 600 | 750 | 1125 |
| 4.00 | 120 | 160 | 240 | 400 | 480 | 640 | 800 | 1200 |

❶ Not available at time of printing.

Technical Information

Environmental Ratings

| | | | |
|----------------------------|-----------|------|-------------------------------------------------------|
| Ambient Temperature | Storage | [°C] | -40...+85 (-40...+185 °F) |
| | Operating | [°C] | -20...+60 (-4...+140 °F) |
| Humidity | Operating | [%] | 5...95, non-condensing |
| | Damp Heat | | per IEC 68-2-3 and IEC 68-2-30 |
| Vibration (per IEC 68-2-6) | | [G] | 3 |
| Shock (per IEC 68-2-27) | | [G] | 30 |
| Maximum Altitude | | [m] | 2000 |
| Pollution Environment | | | Pollution Degree 3 |
| Degree of Protection | | | IP20 |
| Type of Relay | | | Ambient compensated, time delay, phase loss sensitive |
| Nature of Relay | | | Solid-state |
| Trip Rating | | | 120% FLA |
| Trip Class | Type ED | | 10 |
| | Type EE | | 10, 15, 20, 30 |
| Reset Mode | Type ED | | Manual |
| | Type EE | | Manual or Automatic |

Electromagnetic Compatibility

| | | | |
|------------------------------------------|-------------------|-------|--------------------------------------------|
| Electrostatic Discharge Immunity | Test Level | [kV] | 8kV air discharge 6kV contact discharge |
| | Performance Level | | 1 1 2 |
| RF Immunity | Test Level | [V/m] | 10 V/m |
| | Performance Level | | 1 1 2 |
| Electrical Fast Transient Burst Immunity | Test Level | [kV] | 4 kV |
| | Performance Level | | 1 1 2 |
| Surge Immunity | Test Level | [V/m] | 2 kV (L-E) 1 kV (L-L) |
| | Performance Level | | 1 1 2 |

General

| | | | |
|----------------------|-------------------------------------------------------------------------------|----------------------------------------------|-----------------------|
| Standards | UL 508, CSA C22.2 No. 14, NEMA (ICS 2-1993 Part 4, EN 60947-4-1, EN 60947-5-1 | | |
| Approvals | CE, cULus, C-Tick, CCC | | |
| | CEP7-ED1...B CEP7(S)-EE...B | CEP7-ED1...D CEP7(S)-EE...D | CEP7(S)-EE...E |
| Weights (unpackaged) | [Kg] | 0.25 | 0.52 |
| | [Lb] | 0.55 | 1.06 |

Wiring Diagrams

Typical Wiring
for Single Phase Applications

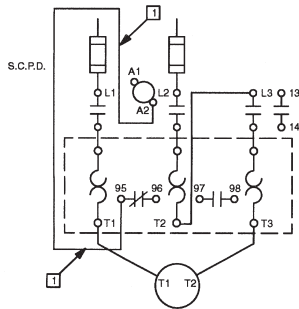

CEP7 Single Phase Overload Relay
Must be connected as shown in Fig. 1 or 2 only.

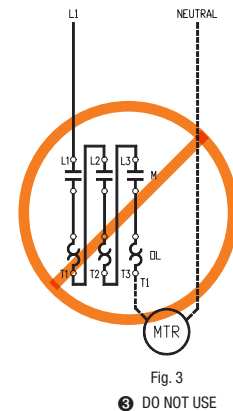
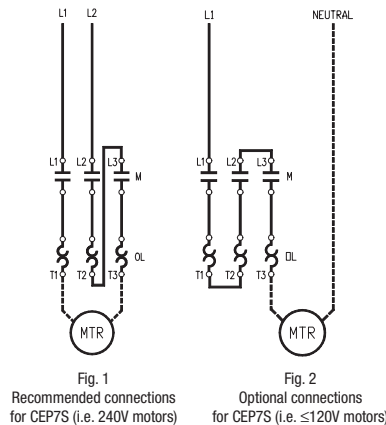

- ❶ Performance Criteria 1 requires the DUT to experience no degradation or loss of performance.
- ❷ Environment 2.
- ❸ If the CEP7S is connected as shown in Fig. 3 the overload will not trip! The CEP7S contains an electronic circuit board that is self powered. If connected as shown in Fig. 3, the CEP7S circuit board will not power up and the CEP7S would not trip.
- ❹ Connecting a CEP7S in this manner powers the electronic circuit board. Connecting a 3-phase CEP7 in this manner to handle 1-phase will NOT work.

Technical Information

Trip Curves ①

B
CEP7 Overloads

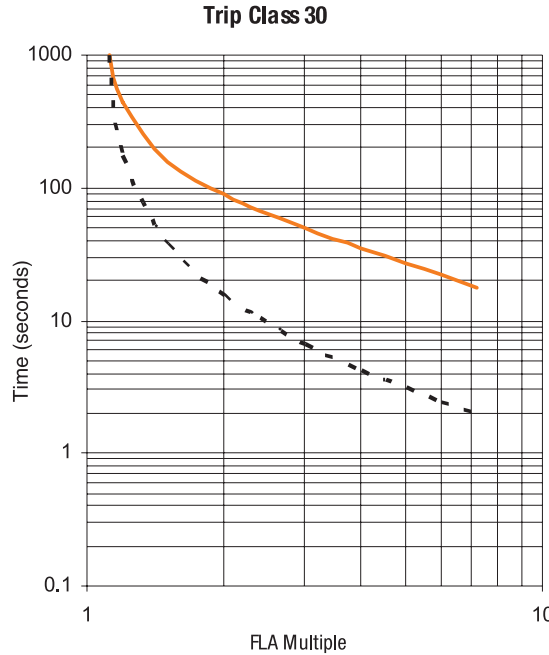
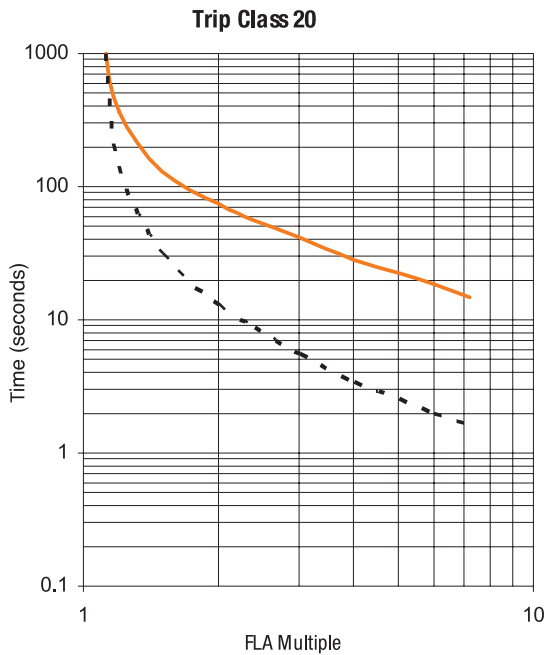
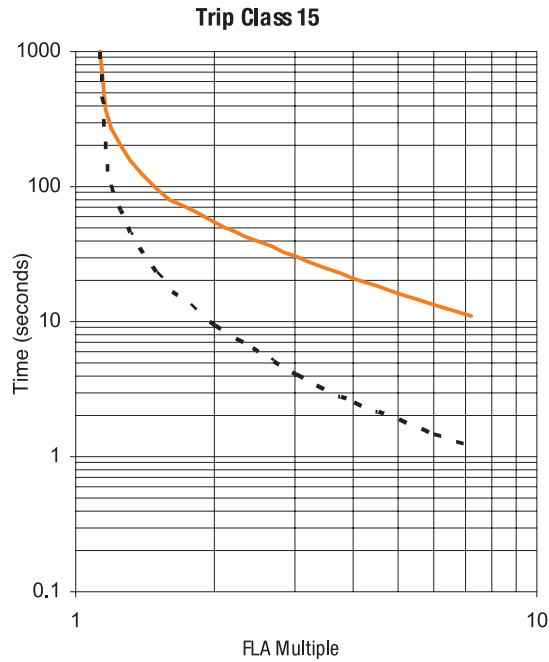
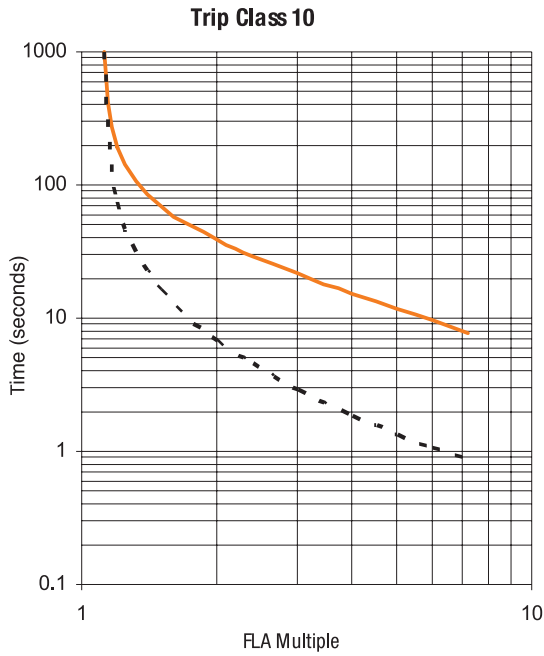

Trip Curve Legend
 Cold Trip ———
 Hot Trip - - - - -

① Typical reset time for CEP7 Second Generation devices set to "automatic reset" mode is 120 seconds.

CEP7-ERR & CEP7-EJM Wiring Diagrams

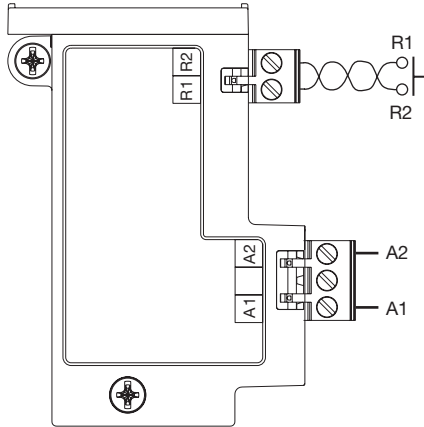

- Apply 24 - 240V, 47 - 63HZ or DC to terminals A1 and A2 for control power.
- Connect remote reset pilot device to Terminals R1 and R2.

CEP7-ERR Operational LED

Status LED:
Steady Green- Module is powered up.

CEP7-ERR Dip Switch

Series B Adjustment Settings

| Overload Relay Remote Reset | | |
|-----------------------------|-----------|--------------|
| SW1 | Manual: 1 | Automatic: 0 |

| Overload Relay Type | | |
|---------------------|------------|------------|
| SW2 | 3 Phase: 1 | 1 Phase: 0 |
| SW3 | Not Used | |

CEP7-EJM Operational LED

Status LED:
Green flash- module powered
Green solid- module powered plus motor current present
Red flash- warning: Fault detected and CEP7 preparing to trip.
Red solid- hardware fault: Internal hardware fault detected and CEP7 trip attempted. Recover fault by cycling supply voltage.

CEP7-EJM Dip Switch

Adjustment Settings

| Overload Relay Reset Mode | | | |
|-------------------------------|-----------|--------------|------|
| SW1 | Manual: 1 | Automatic: 0 | |
| Jam Trip Delay | | | |
| | SW 2 | SW 3 | SW 4 |
| 0.1 sec | 0 | 0 | 0 |
| 0.5 sec | 0 | 0 | 1 |
| 1 sec | 0 | 1 | 0 |
| 2 sec | 0 | 1 | 1 |
| 3 sec | 1 | 0 | 0 |
| 4 sec | 1 | 0 | 1 |
| 5 sec | 1 | 1 | 0 |
| 10 sec | 1 | 1 | 1 |
| Jam Trip Level | | | |
| | SW 5 | SW 6 | SW 7 |
| Disable / OFF | 0 | 0 | 0 |
| 100% FLA | 0 | 0 | 1 |
| 125% FLA | 0 | 1 | 0 |
| 150% FLA | 0 | 1 | 1 |
| 200% FLA | 1 | 0 | 0 |
| 300% FLA | 1 | 0 | 1 |
| 400% FLA | 1 | 1 | 0 |
| 600% FLA | 1 | 1 | 1 |
| SW8 3 Phase: 1 1 Phase: 0 | | | |

CEP7-EPT Wiring Diagrams

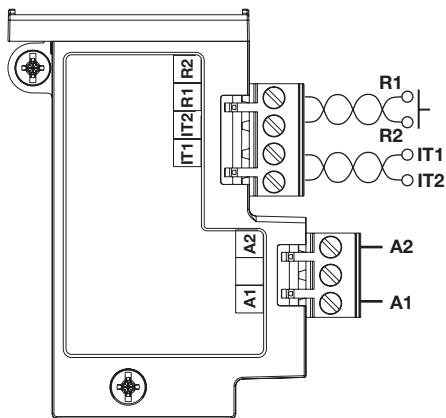

- Apply 24 - 240V, 47 - 63HZ or DC to terminals A1 and A2 for control power.
- Connect remote reset pilot device to Terminals R1 and R2
- Connect Terminal IT1 and IT2 to PTC Chain

CEP7-EPT Operational LED

Status LED:
Steady Green - Module is powered up
Flashing LED - The number of flashes followed by a pause identifies the specific trip code as follows:
(1) Flash - overload trip
(2) Flash - phase loss trip
(3) Flash - PTC trip
(4) Flash - PTC open circuit
(5) Flash - PTC short circuit
Fast Flash - Impending trip. PTC Thermistor fault detected and CEP7 not yet capable of tripping.
Steady Red - Hardware fault. Internal hardware fault detected and CEP7 trip attempted.

CEP7-EPT Dip Switch

Adjustment Settings

| Overload Relay and PTC Reset Mode | | |
|-----------------------------------|-----------|--------------|
| SW1 | Manual: 1 | Automatic: 0 |

| PTC Protection | | |
|----------------|-----------|------------|
| SW2 | Enable: 1 | Disable: 0 |

| Overload Relay Type | | |
|---------------------|------------|------------|
| SW3 | 3 Phase: 1 | 1 Phase: 0 |

① Dynamic inhibit: Protective function is enabled after the motor current goes above 150% and then falls below 125%.

② The delay between the occurrence of a PTC out-of-range fault and a trip of the CEP7 varies, but is generally described by one of the following: a) 500 ms ± 250 ms, typical; or b) < 6 seconds, for a PTC out-of-range fault present at power-up of the side mount module. Under no conditions should a PTC trip take longer than 6 seconds.

CEP7-EGF & CEP7-EGJ Wiring Diagrams ①

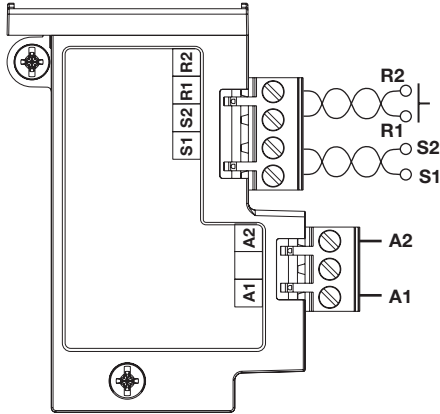

- Apply 24 - 240V, 47 - 63HZ or DC to terminals A1 and A2 for control power.
- Connect remote reset pilot device to Terminals R1 and R2
- Connect current sensor to Terminal S1 and S2

CEP7-EGF Operational LED

Status LED:

- Steady Green** - Module is powered up.
- Flashing LED** - The number of flashes followed by a pause identifies the specific trip code as follows:
 - (1) Flash - overload trip
 - (2) Flash - phase loss trip
 - (3) Flash - ground fault trip
- Fast Flash** - Impending trip Ground fault detected and CEP7 not yet capable of tripping.
- Steady Red** - Hardware fault. Internal hardware fault detected and CEP7 trip attempted.

CEP7-EGF Dip Switch

Adjustment Settings

| Overload Relay Reset Mode | | | |
|----------------------------|------------|--------------|------|
| SW1 | Manual: I | Automatic: 0 | |
| Ground Fault Current Range | | | |
| | SW 2 | SW3 | |
| 20...100mA | 0 | 0 | |
| 100...500mA | 0 | I | |
| 0.2...1.0A | I | 0 | |
| 1.0...5.0A | I | I | |
| Ground Fault Trip Level | | | |
| | SW 4 | SW 5 | SW 6 |
| Disable/Off | 0 | 0 | 0 |
| 20% Max GF Current | 0 | 0 | I |
| 35% Max GF Current | 0 | I | 0 |
| 50% Max GF Current | 0 | I | I |
| 65% Max GF Current | I | 0 | 0 |
| 80% Max GF Current | I | 0 | I |
| 90% Max GF Current | I | I | 0 |
| 100% Max GF Current | I | I | I |
| Overload Relay Type | | | |
| SW7 | 3 Phase: I | 1Phase: 0 | |
| SW8 | Not Used | | |

CEP7-EGF & CEP7-EGJ Installation ①

Ground Fault Sensor Control Wiring

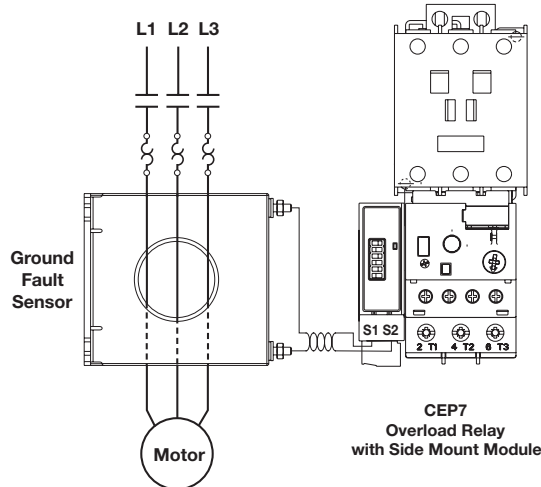

CEP7-EGJ Operational LED

Status LED:

- Steady Green** - Module is powered up.
- Flashing LED** - The number of flashes followed by a pause identifies the specific trip code as follows:
 - (1) Flash - overload trip
 - (2) Flash - phase loss trip
 - (3) Flash - ground fault trip
 - (4) Flash - jam trip
- Fast Flash** - Impending trip Ground fault detected and CEP7 not yet capable of tripping.
- Steady Red** - Hardware fault. Internal hardware fault detected and CEP7 trip attempted.

CEP7-EGJ Dip Switch

Adjustment Settings

| Overload Relay Reset Mode | | | |
|----------------------------|------------|--------------|------|
| SW1 | Manual: I | Automatic: 0 | |
| Ground Fault Current Range | | | |
| | SW 2 | SW3 | |
| 20...100mA | 0 | 0 | |
| 100...500mA | 0 | I | |
| 0.2...1.0A | I | 0 | |
| 1.0...5.0A | I | I | |
| Ground Fault Trip Level | | | |
| | SW 4 | SW 5 | SW 6 |
| Disable/Off | 0 | 0 | 0 |
| 20% Max GF Current | 0 | 0 | I |
| 35% Max GF Current | 0 | I | 0 |
| 50% Max GF Current | 0 | I | I |
| 65% Max GF Current | I | 0 | 0 |
| 80% Max GF Current | I | 0 | I |
| 90% Max GF Current | I | I | 0 |
| 100% Max GF Current | I | I | I |
| Overload Relay Type | | | |
| SW7 | 3 Phase: I | 1Phase: 0 | |
| Jam Protection | | | |
| SW8 | Enable: I | Disable: 0 | |

① Dynamic inhibit: Protective function is enabled after the motor current goes above 150% and then falls below 125%.

Electrical Data

Power Supply Ratings:

| | | |
|-----------------------------------|-------|-------------|
| Rated Supply Voltage | U_s | 24V DC |
| Rated Operating Range | U_e | 20.4 - 26.4 |
| Rated Supply Current | I_e | 0.1 A |
| Maximum Surge Current at Power-Up | | 2.5 A |
| Maximum Power Consumption | | 2.5...2.7 W |

Output Relay Ratings:

| | | |
|----------------------------------------------|-----------|---------------------------------------------------------------------------------|
| Terminals | | |
| OUT A: | | 13/14 |
| Type of Contacts | | Form A SPST - NO |
| Rated Thermal Current | I_{the} | 5 A |
| Rated Insulation Voltage | U_i | 300V AC |
| Rated Operating Voltage | U_e | 240V AC |
| Rated Operating Current | I_e | 3 A (at 120V AC), 1.5 A (at 240V AC) 0.25 A (at 110V DC), 0.1 A (at 220V DC) |
| Minimum Operating Current | | 10 mA at 5V DC |
| Rating Designation | | B300 |
| Utilization Category | | AC-15 |
| Resistive Load Rating (p.f.=1.0) | | 5 A, 250V DC |
| Inductive Load Rating (p.f.=0.4), (L/R=7 ms) | | 2 A, 250V AC |
| Short Circuit Current Rating | | 1,000 A |
| Recommended Control Circuit Fuse | | KTK-R-6 (6 A, 600V) |

Input Ratings:

| | | |
|-------------------------------------|--|-----------------|
| Terminals | | |
| IN1: | | 1 |
| IN2: | | 2 |
| SSV (Sensor Supply Voltage) | | 3 |
| Supply Voltage (Provided by module) | | 20.4 - 26.4V DC |
| Type of Inputs | | Current Sinking |

Jam Protection:

| | | |
|------------|--|-----------------|
| Trip Level | | 150...600% FLA |
| Trip Delay | | 0.1...25.0 sec. |
| Inhibit | | 0...250 sec. |

Standards:

UL 508
CSA 22.2, No. 14
EN 60947-

Mechanical Data

| | | |
|--------------------------|-----------|----------------------------|
| Ambient Temperature | T_{amb} | |
| Storage | | -40...+85°C (-40...+185°F) |
| Operating (Open) | | -20...+60°C (-4...+140°F) |
| Operating (Enclosed) | | -20...+40°C (-4...+104°F) |
| Humidity | | |
| Operating | | 5...95% non-condensing |
| Damp Heat - Steady State | | per IEC 68-2-3 |
| Damp Heat - Cyclic | | per IEC 68-2-30 |
| Maximum Altitude | | 2000 m |
| Degree of Protection | | IP20 |

ETHERNET Communication

| | |
|--------------------------|--------|
| TCP Connection | 150 |
| CIP Connection | 40 |
| CIP Unconnected Messages | 128 |
| I/O Packet Rates | 500/s |
| Explicit Packet Rates | 500/s |
| Speed Duplex (Half/Full) | 10/100 |
| Duplicate IP Detection | Yes |

CEP7-ETN Wiring Diagram

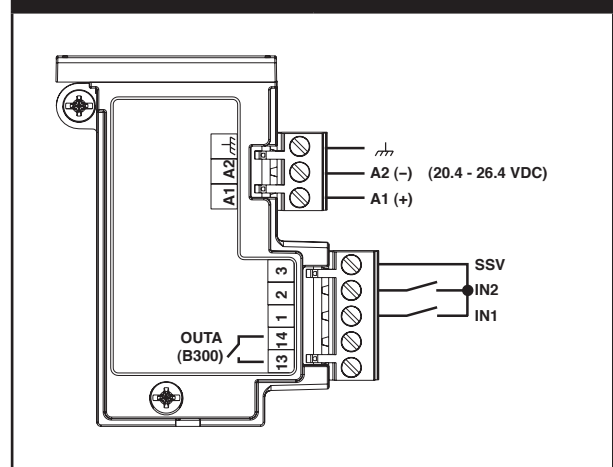

CEP7-CBCT Installation

Dimensions are in millimeters (inches). Dimensions not intended for manufacturing purposes.

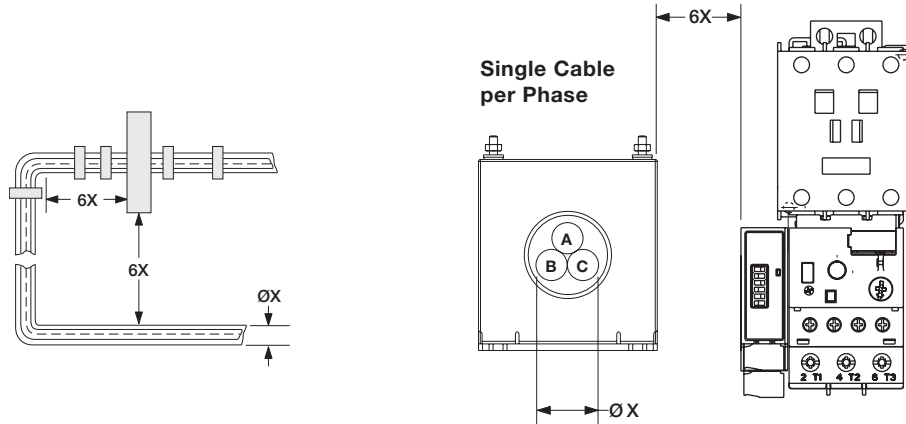

CEP7-CBCT Dimensions

CEP7-CBCT1

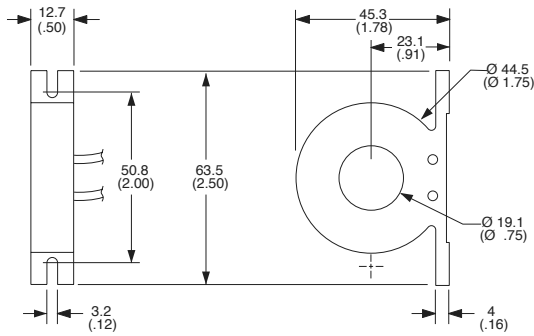

CEP7-CBCT2 & 3

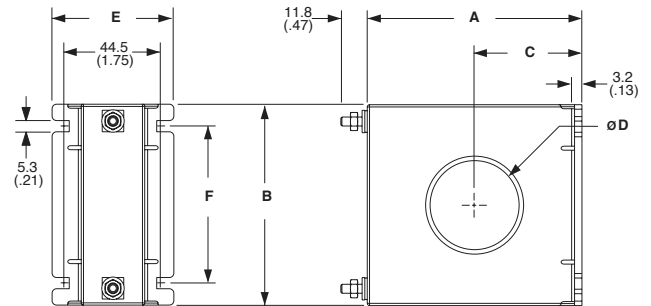

CEP7-CBCT4

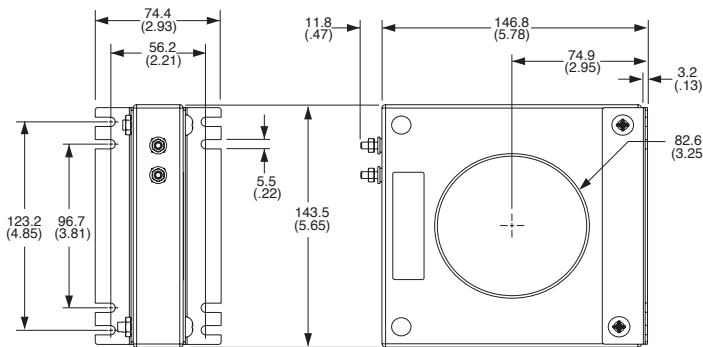

| Catalog Number | A | B | C | ØD | E | F |
|----------------|-----------------|-----------------|----------------|----------------|----------------|----------------|
| CEP7-CBCT2 | 96 (3.78) | 89 (3.53) | 48.3 (1.90) | 39.6 (1.56) | 54.6 (2.15) | 69.9 (2.75) |
| CEP7-CBCT3 | 122.4 (4.82) | 115.9 (4.56) | 59.7 (2.35) | 63.5 (2.50) | 54.1 (2.13) | 96 (3.78) |

CEP7-CBCT Ground Fault Trip Data

ATTENTION: The CEP7 Overload relay is not a ground fault circuit interrupter for personnel protection as defined in Article 100 of the NEC.

Ground fault trip delay: The delay between the occurrence of a ground fault and a trip of the CEP7 varies, but is generally described by one of the following:

- 50 ms ± 20 ms, typical
- < 6 seconds, for a ground fault present at power-up of the side mount module
- < 30 seconds, if the protection inhibit has not been cleared.

Under no conditions should a ground fault trip take longer than 31 seconds.

Dynamic inhibit: Protective function is enabled after the motor current goes above 150% and then falls below 125%.

CEP7 Mounted to CA7 Contactor

Dimensions are in millimeters (inches). Dimensions not intended for manufacturing purposes.

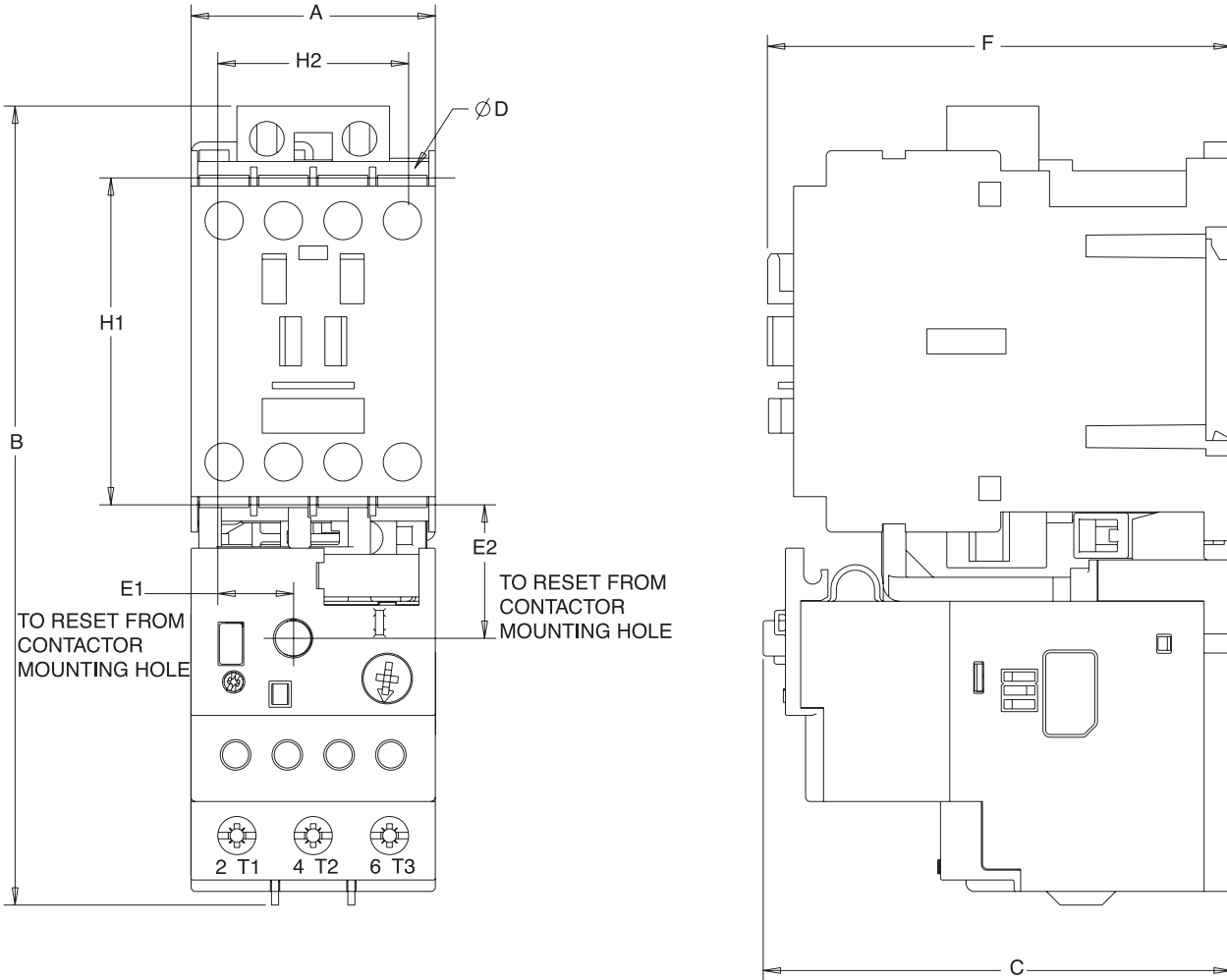

| Overload | Mounted to Contactor | | A Width | B Height | C Depth | D | E1 | E2 | F | H1 | H2 |
|---------------------------------------------|----------------------|---------|--------------|-----------------|-----------------|------------|--------------|--------------|-----------------|---------------|--------------|
| CEP7-ED1...B CEP7-EE...B CEP7S-EE...B | CA7-9...23 | mm (in) | 45 (1-25/32) | 146.6 (5-25/32) | 85.2 (3-23/64) | 4.5 (3/16) | 13.9 (35/64) | 24.5 (31/32) | 86.5 (3-13/32) | 60 (2-23/64) | 35 (1-3/8) |
| CEP7-ED1...D CEP7-EE...D CEP7S-EE...D | CA7-30...37 | mm (in) | 45 (1-25/32) | 146.6 (5-25/32) | 101.2 (3-63/64) | 4.5 (3/16) | 13.9 (35/64) | 24.5 (31/32) | 104 (4-3/32) | 60 (2-23/64) | 35 (1-3/8) |
| CEP7-ED1...D CEP7-EE...D CEP7S-EE...D | CA7-43...55 | mm (in) | 54 (2-1/8) | 146.6 (5-25/32) | 101.2 (3-63/64) | 4.5 (3/16) | 18.9 (3/4) | 24.5 (31/32) | 107 (4-3/32) | 60 (2-23/64) | 45 (1-25/32) |
| CEP7-EE...E CEP7S-EE...E | CA7-60...97 | mm (in) | 72 (2-53/64) | 192.3 (7-37/64) | 120.4 (4-3/4) | 5.4 (7/32) | 23.8 (15/16) | 29 (1-9/64) | 125.5 (4-15/16) | 100 (3-15/16) | 55 (2-11/64) |

CEP7 Pass-thru Overload

Dimensions are in millimeters (inches). Dimensions not intended for manufacturing purposes.

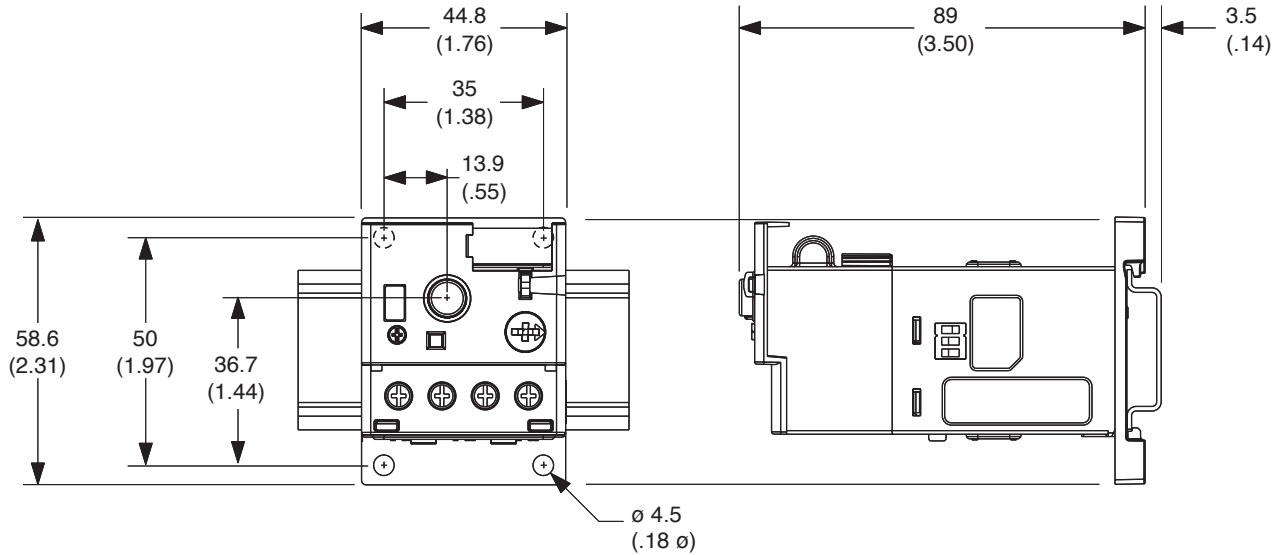

CEP7-ERID Remote Indicator

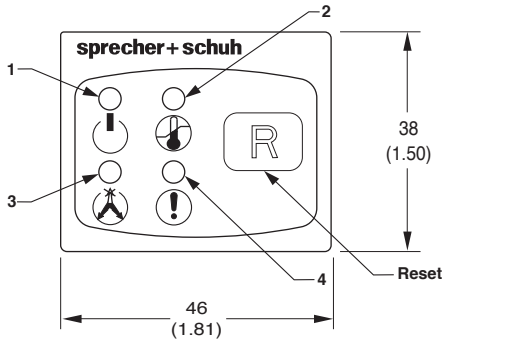

LED Indicators

| L.E.D. | Function | Symbol | Fault or Status | Flash Code |
|--------|-----------------------|--------|------------------------------|----------------|
| 1 | Module Power / Status | | Module Power | Green (Flash) |
| | | | Module Power + Motor Current | Green (Solid) |
| | | | Hardware Fault | Red (Solid) |
| 2 | Overload | | Overload Trip | Red (Solid) |
| | | | Overload Warning (> 110%) | Yellow (Flash) |
| 3 | Phase Loss | | Phase Loss Trip | Red (Solid) |
| 4 | Fault Status | | Ground Fault Trip | 1 Red |
| | | | Jam Trip | 2 Red |
| | | | PTC Trip | 3 Red |
| | | | Fault Detected | Red (Rapid) |
| | | | | |

Operating Temperatures -20°C ... 60°C (-4°F ... +140°F)
Storage Temperatures -40°C ... 85°C (-4°F ... +185°F)

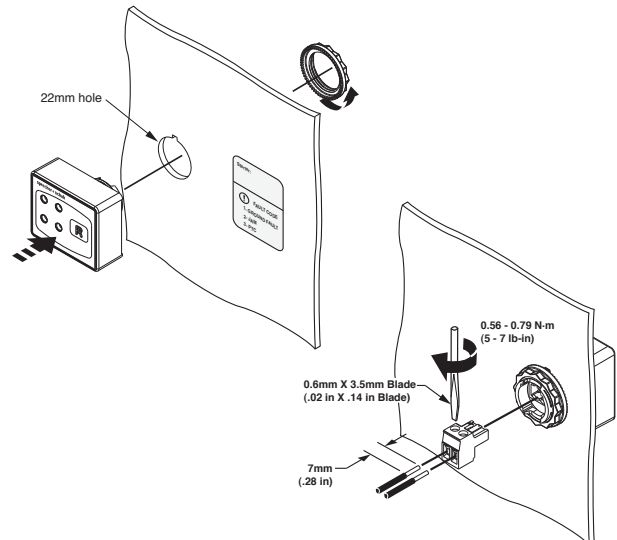
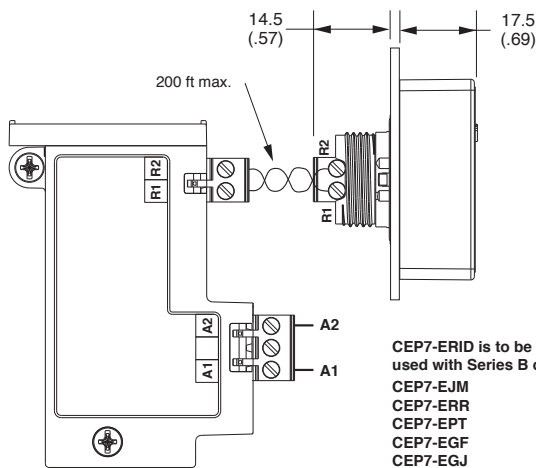

CEP7 Mounted to CA7 Contactor (with side mounted module)

Dimensions are in millimeters (inches). Dimensions not intended for manufacturing purposes.

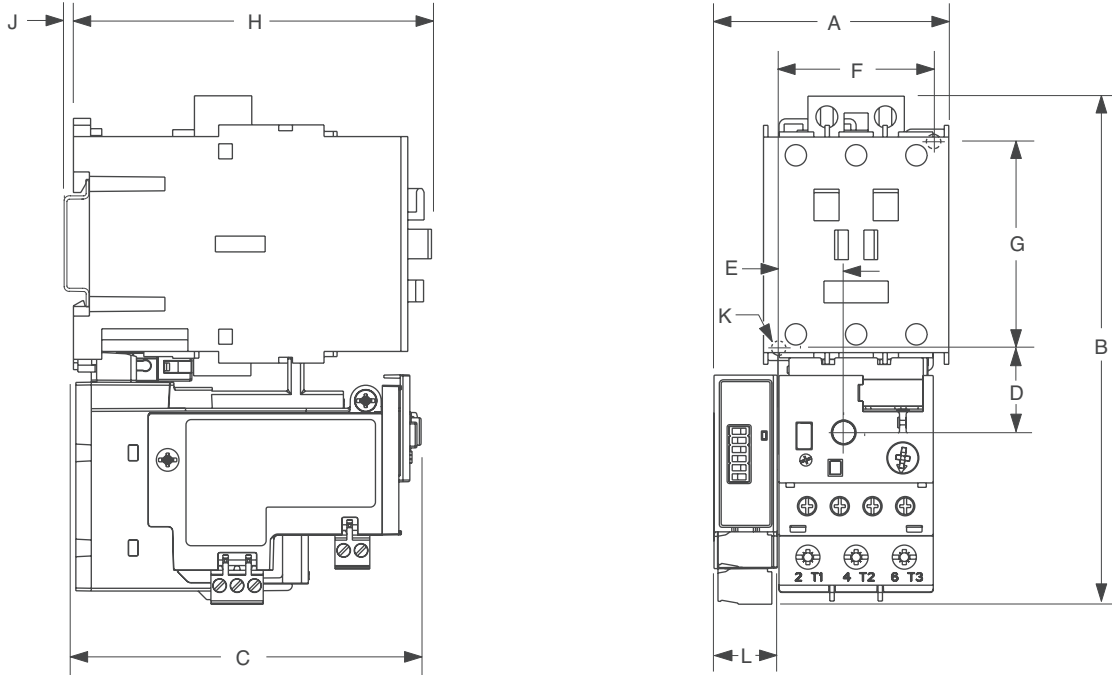

| Contactor Cat. No. | Overload Cat. No. | | A ① | B | C | D | E | F | G | H | J | K | L ① |
|--------------------------------|-------------------|---------|-------------|--------------|--------------|------------|------------|-----------|------------|-------------|---------|-----------|----------|
| CA7-9, CA7-12, CA7-16, CA7-23 | CEP7*-EE_B | mm (in) | 63 (2.48) | 148 (5.83) | 85.2 (3.35) | 24.5 (.96) | 13.9 (.55) | 35 (1.38) | 60 (2.38) | 86.5 (3.40) | 2 (0.8) | 4.5 (.17) | 18 (.71) |
| CA7-30, CA7-37 | CEP7*-EE_D | mm (in) | 63 (2.48) | 148 (5.83) | 101.2 (3.98) | 24.5 (.96) | 13.9 (.55) | 35 (1.38) | 60 (2.38) | 104 (4.09) | 2 (0.8) | 4.5 (.17) | 18 (.71) |
| CA7-43...55 | | mm (in) | 67.5 (2.66) | 148 (5.83) | 101.2 (3.98) | 24.5 (.96) | 18.4 (.74) | 45 (1.77) | 60 (2.38) | 107 (4.09) | 2 (0.8) | 4.5 (.17) | 18 (.71) |
| CA7-60, CA7-72, CA7-85, CA7-97 | CEP7*-EE_E | mm (in) | 90 (3.54) | 191.6 (7.54) | 120.4 (4.74) | 29 (1.14) | 23.8 (.94) | 55 (2.16) | 100 (3.94) | 126 (4.94) | 2 (0.8) | 5.4 (.21) | 18 (.71) |

* No letter indicates 3-phase; "S" indicates 1-phase

① Dimension shown covers all side mount modules EXCEPT CEP7-EPRB and CEP7-ETN, where "L" equals 22mm (0.86 in). Add 4mm (0.16 in) to dimension "A".

CEP7-ERR/EJM/EGE/EGJ/EPT Module Technical Information

Wire Size and Torque Specifications

| | | |
|--|----------|-----------------------------|
| | 1X | 24.....12 AWG |
| | 2X | 24.....16 AWG |
| | 5 lb-in | |
| | | |
| | 1X | 0.2.....2.5 mm ² |
| | 2X | 0.25.....1 mm ² |
| | 0.55 N·m | |
| | | |
| | 1X | 0.2.....2.5 mm ² |
| | 2X | 0.2.....1 mm ² |
| | 0.55 N·m | |
| | | |

- Connect remote reset pilot device to Terminals R1 and R2.
- Do not apply external voltage to R1 and R2. Equipment damage will occur.
- Recommend use of twisted pair for remote reset, #24 AWG minimum.
- Apply 24 - 240V, 47 - 63HZ or DC to terminals A1 and A2 for control power.
- Rated Insulation Voltage (Ui) 300V
- Rated Operating Voltage (Ue) 24 - 240 VAC, 50/60 Hz
24 - 240 VDC
- Power at Rated Operating Voltage (Typical)

| | |
|---------|-------|
| 24 VAC | 0.8 W |
| 120 VAC | 0.8 W |
| 240 VAC | 1.0 W |
- Rated Impulse Withstand Voltage (U imp) 2.5 kV
- Dynamic inhibit on start. A unique circuit within the CEP7 Protection Modules monitors for motor starting inrush current. The circuit inhibits the protection feature during the motor start period and arms the protection function after the inrush current falls to motor rated current. This allows the motor to start and run, avoiding nuisance tripping during the inrush period.

CEP7 with CEP7-EP... Panel Mount Adaptor

Dimensions are in millimeters (inches). Dimensions not intended for manufacturing purposes.

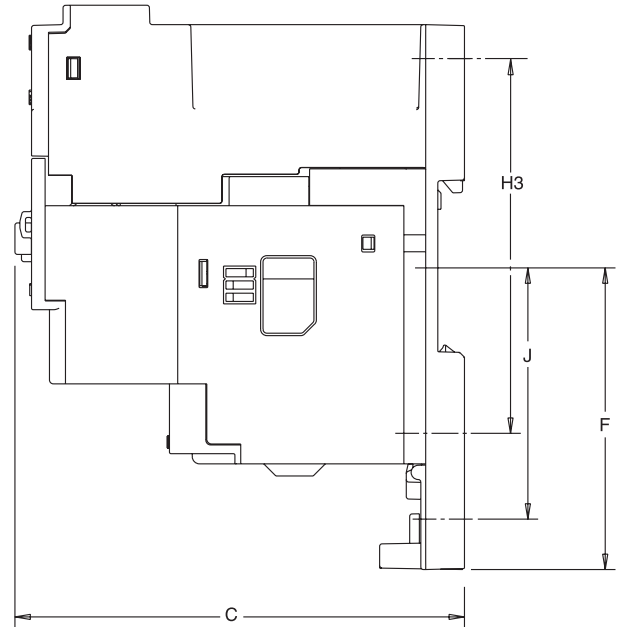
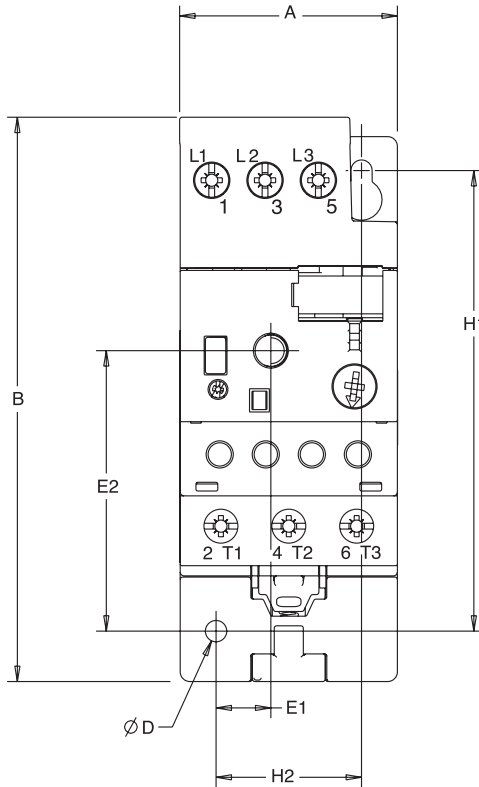

| Panel Mount Adaptor | Overload Relay | A Width | B Height | C Depth | D | E1 | E2 | F | H1 | H2 | H3 | J |
|---------------------|----------------|-----------------|--------------------|-------------------|----------------|-----------------|------------------|-------------------|-----------------|-----------------|-----------------|-------------------|
| CEP7-EPB | CEP7-ED1_B | 45 (1-25/32) | 116.5 (4-9/16) | 92.7 (3-21/32) | 4.4 (11/64) | 11.4 (29/64) | 57.9 (2-9/32) | 62.5 (2-15/32) | 95 (3-3/4) | 30 (1-3/16) | 75 (2-31/32) | 52.1 (2-3/64) |
| | CEP7-ED_B | | | | | | | | | | | |
| | CEP7(S)-EE_B | | | | | | | | | | | |
| CEP7-EPD | CEP7-ED1_D | 45 (1-25/32) | 112.4 (4-7/16) | 108.7 (4-9/32) | 4.4 (11/64) | 11.4 (29/64) | 57.9 (2-9/32) | 62.5 (2-15/32) | 95 (3-3/4) | 30 (1-3/16) | 75 (2-31/32) | 52.1 (2-3/64) |
| | CEP7(S)-EE_D | | | | | | | | | | | |
| | | | | | | | | | | | | |
| CEP7-EPE | CEP7(S)-EE_E | 72 (2-53/64) | 107.4 (4-15/64) | 127 (5-1/64) | 5.5 (5/32) | 26.4 (3/4) | 54.5 (2-9/64) | 48.3 (1-29/32) | 90 (3-23/64) | 60 (2-23/64) | ~ | 43.3 (1-45/64) |

| DIN-rail / Panel Adaptor Terminal Cross Sections | | CEP7-EPB ❶ | CEP7-EPD ❶ | CEP7-EPE |
|--------------------------------------------------|------------------|--------------------------|-------------------------|-------------------------|
| Flexible stranded with ferrule | Single conductor | 1.0...4.0mm ² | 2.5...16mm ² | 4.0...35mm ² |
| | Torque | 1.8 Nm | 2.3 Nm | 4.0 Nm |
| | Two conductor | 1.0...4.0mm ² | 2.5...10mm ² | 4.0...25mm ² |
| | Torque | 1.8 Nm | 2.3 Nm | 4.0 Nm |
| Course stranded / solid | Single conductor | 1.5...6.0mm ² | 2.5...25mm ² | 4.0...50mm ² |
| | Torque | 1.8 Nm | 2.3 Nm | 4.0 Nm |
| | Two conductor | 1.5...6.0mm ² | 2.5...16mm ² | 4.0...35mm ² |
| | Torque | 1.8 Nm | 2.3 Nm | 4.0 Nm |
| Stranded / solid | Single conductor | 14...8 AWG | 16...6 AWG | 12...1 AWG |
| | Torque | 16 lb-in | 20 lb-in | 35 lb-in |
| | Two conductor | 14...10 AWG | 16...6 AWG | 12...2 AWG |
| | Torque | 16 lb-in | 20 lb-in | 35 lb-in |

❶ For multiple conductor applications, the same size and style of wire must be used.

B
CEP7 Overloads

CEP7 Current Transformer Models mounted to CA9 Contactor (116-205A)

Dimensions are in millimeters (inches). Dimensions not intended for manufacturing purposes.

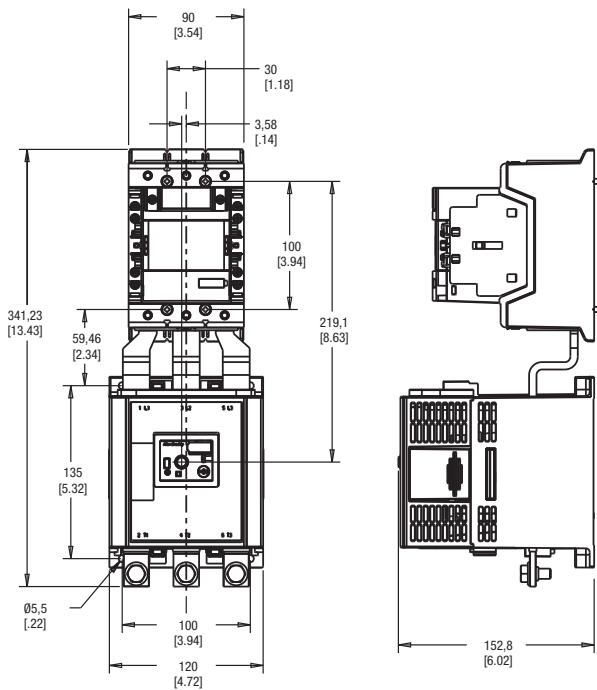

CA9-116 AND CA9-146 CONTACTORS SHOWN

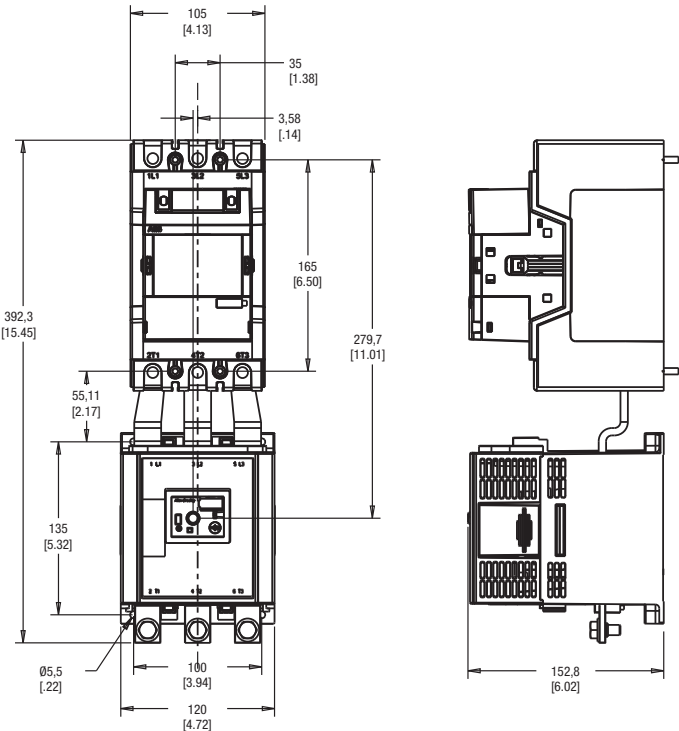

CA9-190 AND CA9-205 CONTACTORS SHOWN

CEP7-CT

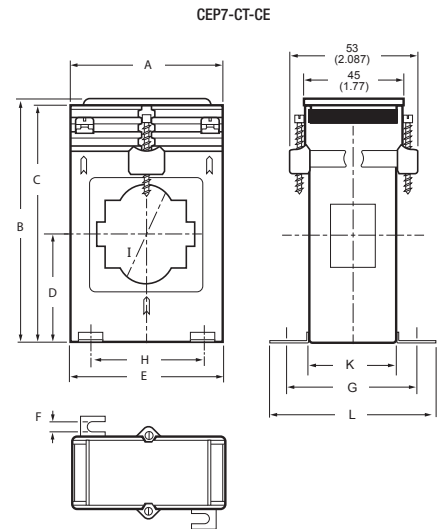
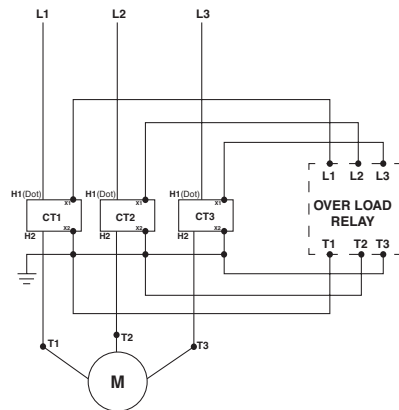
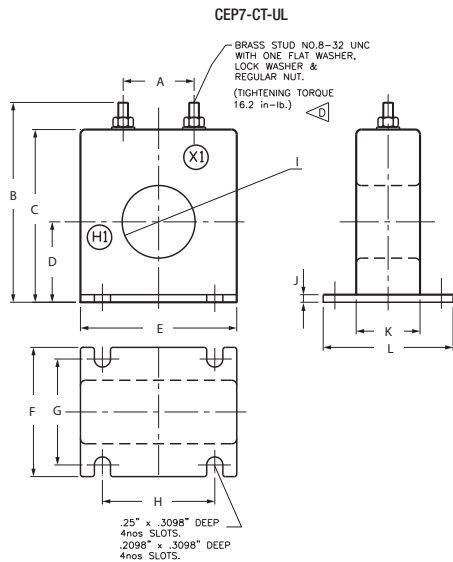

| DIMENSIONS mm (inches) | A | B | C | D | E | F | G | H | I | J | K | L |
|---------------------------|--------------|--------------|--------------|--------------|--------------|-------------|--------------|--------------|-------------|------------|-------------|-------------|
| CEP7-CT-UL-300 | 27.29 (1.09) | 79.5 (3.13) | 68.6 (2.7) | 32.5 (1.27) | 60.96 (2.40) | 50 (1.96) | 40.4 (1.59) | 44.45 (1.75) | 29 (1.14) | 3 (0.118) | 24 (0.94) | 50 (1.96) |
| CEP7-CT-UL-600 | 83.31 (3.28) | 134.4 (5.29) | 123.2 (4.85) | 59.4 (2.34) | 115.8 (4.56) | 54.1 (2.13) | 44.45 (1.75) | 96 (3.78) | 63.5 (2.50) | 4.3 (0.17) | 27.4 (1.08) | 54.1 (2.13) |
| CEP7-CT-CE-300 | 71 (2.80) | 88.5 (3.48) | 85.5 (2.7) | 36.75 (1.27) | 70 (2.75) | 6.5 (0.26) | 57 (2.24) | 50 (1.97) | 32 (1.26) | - | 40 (1.58) | 72 (2.83) |
| CEP7-CT-CE-400 | 96 (3.75) | 108.5 (4.27) | 105.5 (4.85) | 48.3 (1.90) | 95 (3.74) | 4.5 (0.177) | 57 (2.24) | 70 (3.75) | 44 (1.73) | - | 40 (1.58) | 72 (2.83) |

CEP7 Current Transformer Models mounted to CA6 Contactor (Discontinued)

Dimensions are in millimeters (inches). Dimensions not intended for manufacturing purposes.

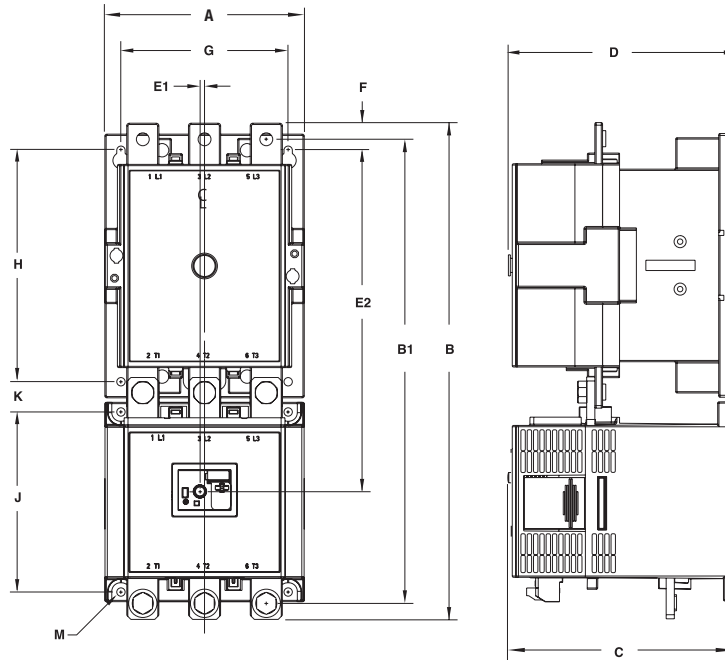

| Overload Relay Cat. | Contactor Cat. | A Width | B Height | | B1 | C Depth | D | E1 | E2 | F | G | H | J | K | M |
|------------------------|----------------|----------------|-------------------------|----------------------|------------------|-----------------|------------------|-------------|------------------|----------------|---------------|---------------|---------------|---------------|-----------------|
| | | | Without Terminal Covers | With Terminal Covers | | | | | | | | | | | |
| CEP7-EEHF CEP7-EEJF | CA6-115 (EI) | 120 (4.72) | 339.8 | 418 | 317.8 (12.51) | 152.7 (6.01) | 156 (6.14) | 36 (.14) | 226.3 (8.91) | 16 (.63) | 100 (3.94) | 145 (5.71) | 135 (5.31) | 22.3 (.88) | ① 5.6 (0.22) |
| | CA6-140 (EI) | | 385.8 | 487.4 | | | | | | | | | | | |
| | CA6-180 (EI) | | 487.4 | 576.5 | | | | | | | | | | | |
| CEP7-EE_G | CA6-210 EI | 155 (6.10) | 385.8 | 487.4 | 360.8 (14.2) | 176.5 (6.95) | 180 (7.09) | 36 (.14) | 265.5 (10.44) | 21 (.83) | 130 (5.12) | 180 (7.09) | 140 (5.51) | 23.5 (.93) | ① 6.5 (0.26) |
| | CA6-300-EI | | 487.4 | 576.5 | | | | | | | | | | | |
| | CA6-420 EI | | 576.5 | 665.6 | | | | | | | | | | | |
| CEP7-EE_H | CA6-630 EI | 255 (10.04) | 552 | 915 | 508 (20) | 269.3 (10.6) | 270.7 (10.66) | 36 (.14) | 384.1 (15.12) | 52.5 (2.07) | 226 (8.90) | 230 (9.06) | 108 (4.25) | 109 (4.29) | ① 13 (0.51) |
| | CA6-860 EI | | 915 | 1004.1 | | | | | | | | | | | |

Assembly Instructions

- CEP7-EE_F: (M5)
3.4 NΣm (30 lb-in)
- CEP7-EE_G: (M6)
5.1 NΣm (45 lb-in)
- CEP7-EE_H: (M12 Provided)
17 NΣm (150 lb-in)

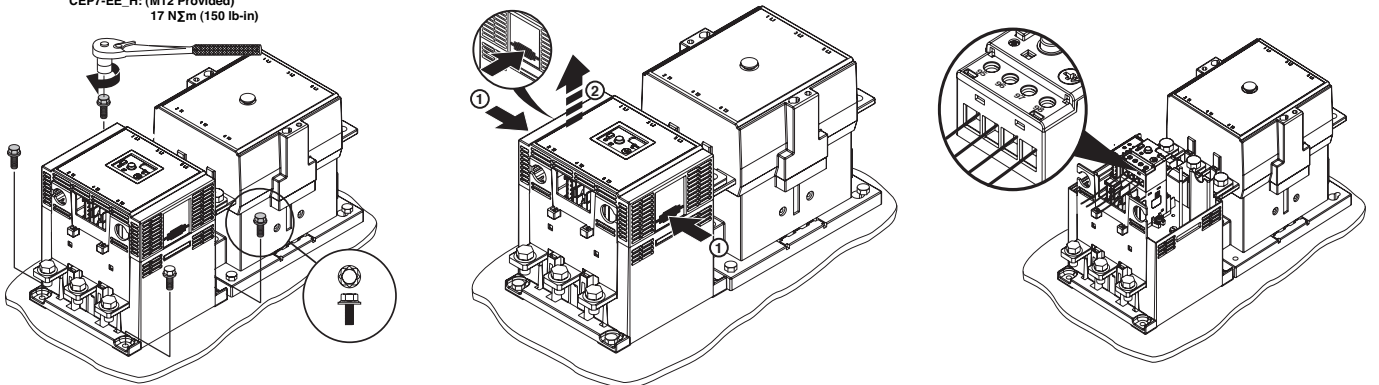

① 8 mounting holes.

