

TABLE OF CONTENTS

HYGROUND™ IRREVERSIBLE COMPRESSION GROUNDING AND INSTALLATION TOOLING

HYGROUND™ Features and Benefits	D-5 - D-6		Type YGIB	D-20 - D-21	
	Type YGL-C	D-7		Type GSTUD-HY	D-22
	Type YGLR-C	D-8		Types YGT & YTTAG	D-23
	Type YGHP-C	D-9		Type YG-B	D-24
	Type YGHP-C	D-10	MECHANICAL GROUNDING		
	Type YGHC-C	D-11		Types KC, K2C	D-25
	Type YGC	D-12		Types KC22J12T13, EQC632C, KS-DB	D-26
	Type YSHG	D-13		Types KS, GKA, KPB, CL50-1	D-27
	Type YGHR-C	D-14		Type GAR	D-28 - D-29
	Type YGHR-C	D-15		Types GAR-BU & GAR 3900 Series & GAR-RB	D-30
	Type YGHA	D-16		Type GAR-TC	D-31
	Type YGHS	D-16	⚡ LIGHTNING PROTECTION INFO.		
	Type YGA	D-17	Basic rules for selection are:		
	Type YGS	D-18	1. Must be like material to the conductor.		
	Type YGF	D-19	2. Two bolts to ground rod — minimum, for mechanical.		
			3. Cable to cable connections can be installed with – one bolt, two bolt, or compression.		
			4. Cable to steel structure must have 8 in. ² contact with steel.		
			5. Heavy duty stacks — mechanical only.		
			6. On all connectors with heavy duty stack rating, we must offer 1/16" thick lead plating as an option. Reason is closest 25 ft. to stack opening must use lead coated product.		
			7. UL 96 Listing.		

TABLE OF CONTENTS

MECHANICAL GROUNDING (Continued)

D-2



















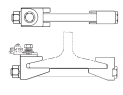

	Type GD	D-32		Types GC, GCM	D-47
	Type GP	D-33		Type GL	D-48
	Type GK	D-33		Type GZ	D-48
	Water Pipe Grounding ..	D-34 - D-39		Type GC-CT	D-49
	Type GC-A	D-40		Type GIE-G	D-50
	Type GG	D-41		Rail Connector	D-51
	Type GQ	D-42		Type QGFL	D-52
	Type GX	D-43		Type GA-H	D-52
	Types GRC, GRL	D-44		Type GRF	D-53 Raised Floor Grounding
	Type B	D-45 - D-46		Types GP-G1, GPRT	D-54 Raised Floor Grounding
	Types GB, GBM	D-47			

TABLE OF CONTENTS

BURNDYWeld™











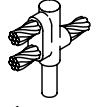
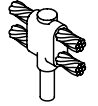

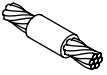
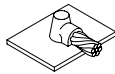

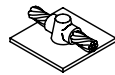
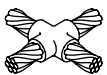

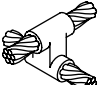

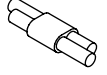

	BURNDY Weld™ IntroductionD-56		Type BCR-17D-68
	Making a BURNDYWeld™ ConnectionD-57		Type BCR-24D-69
	WELD METALD-58		Type BCS-1D-71
	Type BCC-1D-59		Type BCS-8D-71
	Type BCC-2D-60		Type BCS-2D-72
	Type BCC-4D-61		Type BCS-9D-72
	Type BCC-11D-62		Type BCS-3D-73
	Type BCC-6D-63		Type BCS-23D-74
	Type BCC-14D-63		Type BCS-4D-75
	Type BCC-7D-64		Type BCS-6D-75
	Type BCR-1D-65		Type BCS-7D-76
	Type BCR-2D-66		Type BCS-18D-76
	Type BCR-3D-67		Type BCS-5D-77
			Type BCRE-1D-78
			Type BCRE-2D-79

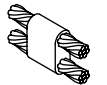
TABLE OF CONTENTS

BURNDYWeld™ (Continued)

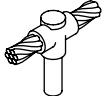
D-4

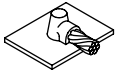
	Type BCRE-3	D-80
---	--------------------------	------

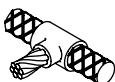
	Type BCRE-4	D-81
---	--------------------------	------

	Type BCRE-6	D-82
---	--------------------------	------

BURNDYWeld™ FILL	D-83
-------------------------------	------

BURNDYWeld™ SET	D-85
------------------------------	------

BURNDYWeld™ Prefabricated Wire Mesh	D-87
--	------

	Types B-106 & B-107 Handle Clamps	D-89
---	---	------

	B40-0106-75 Handle Attachment	D-89
---	---	------

	Mold Support Clamp	D-89
---	--------------------------	------

	Vertical Magnetic Clamps	D-90
---	-----------------------------------	------

	Horizontal & Vertical Chain Clamps	D-90
---	---	------

	
---	--

SINGLE SHOT MOLDS

	Type BCR-1	D-70
---	-------------------------	------

	Type BCR-2	D-70
---	-------------------------	------

	Type BCR-24	D-70
---	--------------------------	------

	Type BCR-25	D-70
---	--------------------------	------

ACCESSORIES

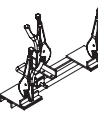
	B38-0330-00 Cable Clamp	D-91
---	--------------------------------------	------

	Cable Cleaning Brush	D-91
---	----------------------------	------

	Card Cloth Brush	D-91
---	------------------------	------

	Mold Cleaning Brush	D-91
---	---------------------------	------

	Mold Cleaners	D-91
---	---------------------	------

	Packing Material	D-91
---	------------------------	------

	BURNDYWeld™ Tool Kit	D-92
---	-----------------------------------	------

BURNDYWeld™ Tools	D-92
--------------------------------	------

	B38-0101-00 Rasp	D-92
---	-------------------------------	------

	B38-0309-00 Flint Ignitor	D-92
---	--	------

	Ground Rod Driving Sleeves	D-93
---	-------------------------------------	------

	Shim Stock and Adapter Sleeves	D-93
---	---	------

Tips	D-94 - D95
-------------------	------------

THE HYGROUND™ IRREVERSIBLE COMPRESSION SYSTEM

BURNDY® has developed an irreversible compression ground system which meets the most stringent safety and performance requirements, including those of OSHA and nuclear power plant design. Performance excellence and long life expectancy are the system's basic design guidelines. It is a complete system which consists of connectors for grid cross connections, taps, splices, cable to ground rod, ground plates and terminations.





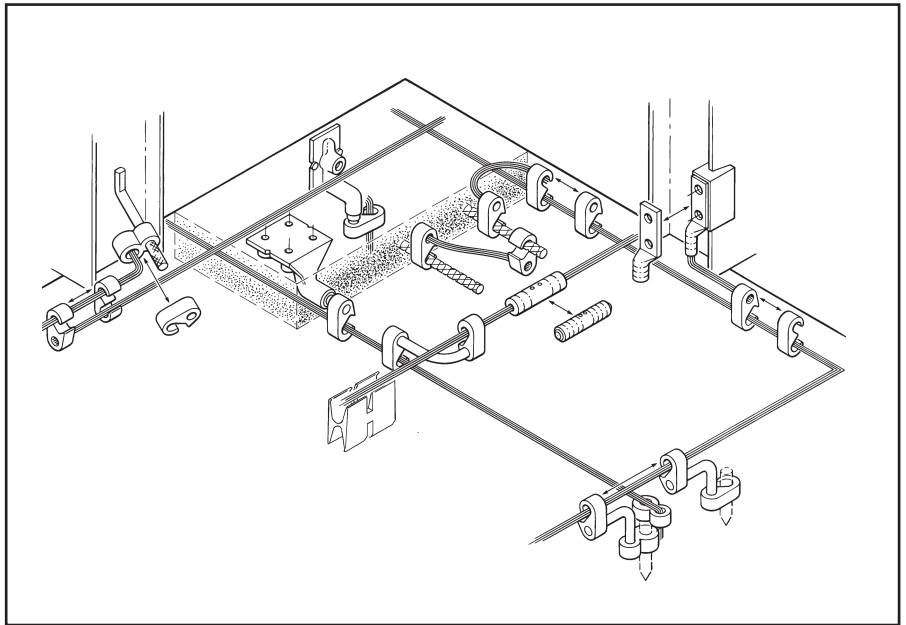

Our irreversible compression ground connectors employ well-proven design principles and technology that have been in existence for over 60 years.

Connectors are just one component of our Irreversible Compression Ground System. Installation tooling is also an integral part of this system. BURNDY® pioneered the compression connector principle and continues today to be the leader in compression technology. Our tooling package is the most extensive in the industry and affords the user many options.

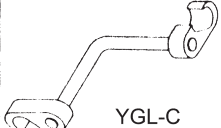
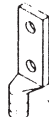
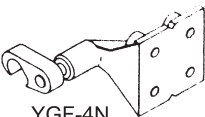
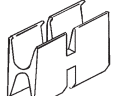

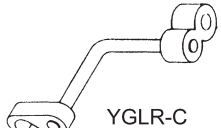
D-5

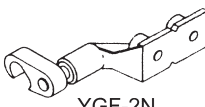
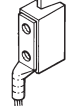
(LEGEND)

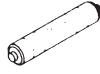
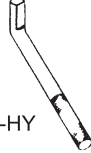
 YGHP-C	 YGL-C	 YGHA	 YGF-4N	 YSHG
 YGHR-C	 YGLR-C	 YGHS	 YGF-2N	 YGIB
 YGHC-C	 YGA	 YGS	 GSTUD-HY	

THE HYGROUND™ IRREVERSIBLE COMPRESSION SYSTEM (Continued)

Features and Benefits

- Irreversible compression.
 - ◇ Meets 1999 NEC code, section 250-50 and 250-64.
- Material-pure wrought copper extrusions, rod and seamless tubing—identical material to the conductor.
 - ◇ Completely eliminates the possibility of corrosion due to dissimilar metals.
- Heavy duty connector design.
 - ◇ All connectors will carry the equivalent or greater current carrying capacity of the conductor while maintaining high mechanical strength and electrical integrity.
- Range taking design—minimum number of connector combinations required to install a conductor range of #6 solid to 500 kcmil plus 1/2", 5/8", 3/4", and 1" ground rods and rebar.
 - ◇ Inventories are kept to a minimum and product selection is simplified.
- System engineered tooling.
 - ◇ Each tooling recommendation has been designed to ensure reliability of the connection.
- Irreversible compression connectors can be installed in all kinds of weather.
 - ◇ Eliminates costly construction delays and enables the installer to better schedule his job.
- May be installed without special training or special tools. Y750 crimps entire range.
 - ◇ Low installed cost.
 - ◇ Simplified installation.
- Each connection can be made in less than 3 minutes.
 - ◇ Low installed cost.
 - ◇ Simplified installation.
- Each connector is clearly marked with catalog number, conductor size and installation die information.
 - ◇ Easy and accurate identification.
- Inspection ports are provided to assure proper insertion of the conductor.
 - ◇ Built-in quality assurance.
- The die index number is embossed on the connector after completion of the crimp.
 - ◇ Facilitates speedy inspection of installed connectors to insure consistently reliable and sound connections.
- Most HYGROUND™ irreversible compression elements are prefilled with PENETROX™ and individually sealed in clear polyethylene sheet.
 - ◇ Ensures that all contact surfaces are in the proper condition for installation.
 - ◇ Ensures the electrical integrity of the finished connection by inhibiting moisture and contaminants from entering the contact area.
- All HYGROUND™ irreversible compression connectors are Listed in conformance with Underwriters Laboratories Standard UL467 and conform to applicable sections of the National Electrical Code.
 - ◇ May be used in direct burial or concrete embedded grounding applications.
- All HYGROUND™ irreversible connectors (with the exception of type YGA and YGS) have been tested successfully according to requirements of Standard IEEE 837 latest revision.
 - ◇ Meets tough industry performance requirements.
 - ◇ UPRECRIMP™ dies give added mechanical strength. UPRECRIMP™ 34 for 3/4" rod, UPRECRIMP™ 12 for 1/2" rod, and UPRECRIMP™ 58 for 5/8" rod (now includes undersized U.S. market place rods).
- Allows connection to most sizes of structural steel with no drilling, tapping, or welding.
 - ◇ Safely installed at low cost. Hot work permits are not required to install in hazardous areas

BURNDY® Products FCI

Grounding

TYPE YGL-C

HYGRID CROSS CONNECTOR

An irreversible compression ground grid cross connector which allows adjustment of the compression elements prior to installation. Only six connectors and four dies are required to install all combinations from #6 solid through 500 kcmil. UL467 Listed. Acceptable for direct burial in earth and concrete. Prefilled with PENETROX™ compound and strip sealed.

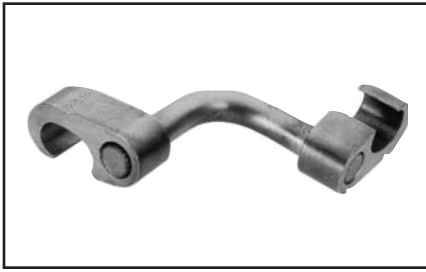

MEETS ALL
IEEE
837 REQUIREMENTS

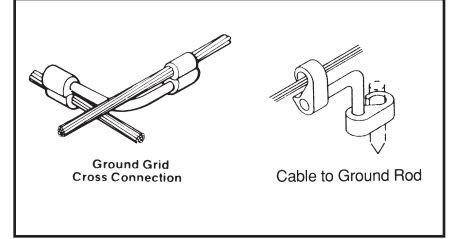
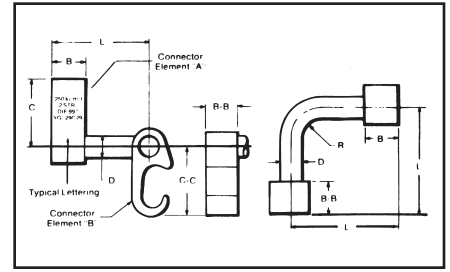

D-7

CATALOG NUMBER	B	B-B	C	C-C	D	L	R
YGL2C2	.75	.75	1.09	1.09	.313	2.50	.31
YGL29C2			1.66	1.66	.500		.50
YGL29C29			2.09	1.09	.313		.31
YGL34C2			1.66	.500	.50		
YGL34C29			2.28	2.28	.750		.75
YGL34C34							

✓ UL96 Listed for Lightning Protection.



ORDERING INFORMATION

CATALOG NUMBER	CABLE TO CABLE		CABLE TO GROUND ROD		TO REBAR
	ELEMENT "A"	ELEMENT "B"	ELEMENT "A"	ELEMENT "B"	ELEMENT "A"
YGL2C2	#6 SOL. (.162) – #2 STR. (.292) {59500} – {59500}	#6 SOL. (.162) – #2 STR. (.292) {59500} – {59500}			
YGL29C2	#1 STR. (.332) – 250 kcmil (.575) {98500} – {131500}	#2 STR. (.292) – 250 kcmil (.575) {65500} – {131500}	1/2" – 5/8" Rod	#6 SOL. (.162) – #2 STR. (.292)	3/8" – 1/2"
YGL29C29	#2 STR. (.292) – 250 kcmil (.575) {65500} – {131500}	#2 STR. (.292) – 250 kcmil (.575) {65500} – {131500}		#2 STR. (.292) – 250 kcmil (.575)	#3 – 4 Rebar
YGL34C2	250 kcmil (.575) – 500 kcmil (.813)	#6 SOL. (.162) – #2 STR. (.292)	5/8" – 3/4" Rod	#6 SOL. (.162) – #2 STR. (.292)	5/8" – 3/4"
YGL34C29		#2 STR. (.292) – 250 kcmil (.575)		#2 STR. (.292) – 250 kcmil (.575)	#5 – 6 Rebar
YGL34C34		250 kcmil (.575) – 500 kcmil (.813)		250 kcmil (.575) – 500 kcmil (.813)	250 kcmil (.575) – 500 kcmil (.813)

Dimensions in brackets { } represent lightning protection conductors.

CATALOG NUMBER	INSTALLATION TOOLS, DIE SET CAT. NO. (NUMBER OF CRIMPS)							
	Y750/Y35/Y39 HYPRESS		PAT750-18V		Y45 HYPRESS		Y46 HYPRESS	
	ELEMENT "A"	ELEMENT "B"	ELEMENT "A"	ELEMENT "B"	ELEMENT "A"	ELEMENT "B"	ELEMENT "A"	ELEMENT "B"
YGL2C2	U-0 (1)	U-0 (1)	U-0 (1)	U-0 (1)	U-0 (1)	U-0 (1)	U-0 (1)	U-0 (1)
YGL29C2	U997 (1)	U-0 (1)	③ U997P (1)	U-0 (1)	U997 (1)	U-0 (1)	U997 (1)	U-0 (1)
YGL29C29	U997 (1)	U997 (1)	③ U997P (1)	③ U997P (1)	U997 (1)	U997 (1)	U997 (1)	U997 (1)
YGL34C2*	PU998 (1)	U-0 (1)	PU998 (1)	U-0 (1)	S998 or PU998 (1)	U-0 (1)	P998 or PU998 (1)	U-0 (1)
YGL34C29*	PU998 (1)	U997 (1)	PU998 (1)	③ U997P (1)	S998 or PU998 (1)	U997 (1)	PU998 or PU998 (1)	U997 (1)
YGL34C34*	U1011 (3)	U1011 (3)	U1011 (3)	U1011 (3)	S1011 (3)	S1011 (3)	P1011 (3)	P1011 (3)

- Where a "U" or "PU" die is recommended with Y45 HYPRESS™, a PT6515 adapter must be used.
- Where a "U" or "PU" die is recommended with the Y46 HYPRESS™, a PUADP-1 adapter must be used.
- ③ Polarized die for the PAT750-18V.

* These connectors can only be installed using the Y750, Y45, or Y46 HYPRESS™ with the recommended dies. These connectors CANNOT be installed with the Y35 and Y39 HYPRESS™.

NOTES:

- Before crimping, both connector elements can be turned on rod diameter "D" to any desired position.
- Clean rust and/or protective coatings from rebar prior to installation.

- When attaching connector to ground rod, ground rod must be embossed with appropriate PRE-CRIMP™ die. For connections that must meet IEEE 837 requirements UPRECRIMP™ - type PRE crimp dies must be used for maximum clamping retention.

GROUND ROD DIA.	PRECRIMP DIES	
1/2"	UPRECRIMP 12	U2CABT
5/8"	UPRECRIMP 58	
3/4"	UPRECRIMP 34	

TYPE YGLR-C

GRIDLOK

High Strength
Irreversible
Compression Ground Rod to
Grid Connector

Ground grid connector for a wide range of copper cable to ground rod. Provides high torque strength on ground rod. UL467 Listed. Acceptable for direct burial in earth and concrete. Prefilled with PENETROX™ compound and strip sealed.

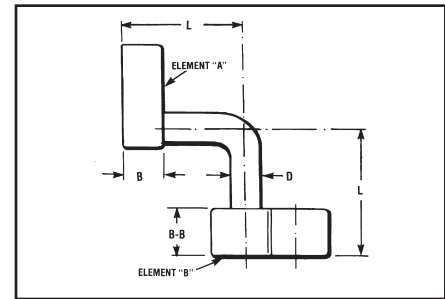
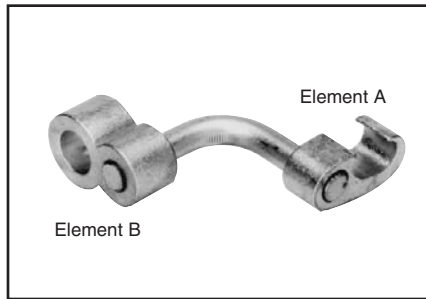

MEETS ALL
IEEE
837 REQUIREMENTS



D-8

CATALOG NUMBER	COMMERCIAL COPPER CABLE RANGE ELEMENT "A"	METRIC COPPER CABLE RANGE ELEMENT "A"	COPPER WELD CABLE RANGE ELEMENT "A"	GROUND ROD DIA. ELEMENT "B"	B	B-B	D	L	INSTALLATION TOOLS, DIE SET CAT. NO., (NUMBER OF CRIMPS)								
									Y35/Y39 HYPRESS™		Y750/PAT750		Y45 HYPRESS™		Y46 HYPRESS™		
									ELEMENT "A"	ELEMENT "B"	ELEMENT "A"	ELEMENT "B"	ELEMENT "A"	ELEMENT "B"	ELEMENT "A"	ELEMENT "B"	
YGLR29C12	#2 Str. (.292 Dia.) thru 250 kcmil (.575 Dia.)	35mm² (7.62mm Dia.) thru 120 mm² (14.40mm Dia.)	91.65 kcmil (.343 Dia.) thru 248.8 kcmil (.572 Dia.)	1/2"						U997 (1)	PU998 (1)	U997 (1)		U997 (1)			
YGLR34C12	250 kcmil (.575 Dia.) thru 500 kcmil (.813 Dia.)	120 mm² (14.40mm Dia.) thru 240 mm² (20.35mm Dia.)	248.8 kcmil (.572 Dia.) thru 498.8 kcmil (.810 Dia.)	[12.7]			.313 [7.9]	2.53 [64.3]		—		U1011 or PU998 (1)		S998 or PU998 (1)		P998 or PU998 (1)	
YGLR29C58	#2 Str. (.292 Dia.) thru 250 kcmil (.575 Dia.)	35 mm² (7.62mm Dia.) thru 120 mm² (14.40mm Dia.)	91.65 kcmil (.343 Dia.) thru 248.8 kcmil (.572 Dia.)	5/8"						U997 (1)	PU998 (1)	U997 (1)		U997 (1)		U997 (1)	
YGLR34C58	250 kcmil (.575 Dia.) thru 500 kcmil (.813 Dia.)	120 mm² (14.40mm Dia.) thru 240 mm² (20.35mm Dia.)	248.8 kcmil (.572 Dia.) thru 498.8 kcmil (.810 Dia.)	[15.9]	.75 [19.1]	.88 [22.4]				—		U1011 or PU998 (1)	U1011 (2) or PU998 (1)	S998 or PU998 (1)	S1012 (2) or PU998 (1)	P998 or PU998 (1)	P1011(2) or PU998 (1)
YGLR29C34	#2 Str. (.292 Dia.) thru 250 kcmil (.575 Dia.)	35 mm² (7.62mm Dia.) thru 120 mm² (14.40mm Dia.)	91.65 kcmil (.343 Dia.) thru 248.8 kcmil (.572 Dia.)	3/4"						U997 (1)	PU998 (1)	U997 (1)		U997 (1)		U997 (1)	
YGLR34C34	250 kcmil (.575 Dia.) thru 500 kcmil (.813 Dia.)	120 mm² (14.40mm Dia.) thru 240 mm² (20.35mm Dia.)	248.8 kcmil (.572 Dia.) thru 496.8 kcmil (.810 Dia.)	[19.1]				.500 [12.7]	2.63 [66.8]			U1011 (2) or PU998		U1011 (2) or PU998		U1011 (2) or PU998	
YGLR29C100	#2 Str. (.292 Dia.) thru 250 kcmil (.575 Dia.)	35 mm² (7.62mm Dia.) thru 120 mm² (14.40mm Dia.)	91.65 kcmil (.343 Dia.) thru 248.8 kcmil (.572 Dia.)	1"						—		U997 (1)		U997 (1)		U997 (1)	
YGLR34C100	250 kcmil (.575 Dia.) thru 500 kcmil (.813 Dia.)	120 mm² (14.40mm Dia.) thru 240 mm² (20.35mm Dia.)	248.8 kcmil (.572 Dia.) thru 498.8 kcmil (.810 Dia.)	[25.4]								U1011 (2) or PU998 (1)		U1011 (2) or PU998		U1011 (2) or PU998	

NOTES:

- Before crimping, both connector elements can be turned on rod diameter 'D' to any desired position.
- Grooves are filled with PENETROX™.
- Suitable for direct burial in earth or concrete.
- The catalog numbers shown are for unplated copper connectors for use on copper clad or stainless steel ground rod. To order electro-tin plated connectors for use on galvanized steel ground rod add suffix "TN" to the catalog number, only if the Figure 8 connector (Element "B") is tin plated, the Figure 6 connector (Element "A") is unplated. Note: The ground rod hole diameter is larger for galvanized steel ground rod in the tin plated connector.
- Ground rod must be pre-crimped with die U2CABT (Index No. 348) when crimping the ground rod element (Element "B") with the PU998 dies in the Y750, Y35, Y39, Y45, or Y46 tools. Pre-crimping is not required when the S1012, P1011 or U1011 dies are used. See precrimp die chart.
- Where a 'U' or 'PU' die is recommended with the Y45 HYPRESS™, a PT6515 adapter must be used.
- Where a 'U' or 'PU' die is recommended with the Y46 HYPRESS™, a PUADP-1 adapter must be used.
- Dimensions in bracket [] are in millimeters.
- Die "1011" appears on Element "B" of the connector only.

GROUND ROD DIA.	PRECRIMP DIES	
1/2"	UPRECRIMP 12	U2CABT
5/8"	UPRECRIMP 58	
3/4"	UPRECRIMP 34	

When attaching connector to ground rod, ground rod must be embossed with appropriate PRECRIMP™ die. For connections that must meet IEEE 837 requirements UPRECRIMP™ - type PRE crimp dies must be used for maximum clamping retention.

TYPE YGHP-C

HYTAP™ CONNECTOR

Irreversible compression ground tap figure 6 can be used as a tap connector or as a tap splice connector. Four die sets and eight connectors can accommodate a conductor range from #8 solid through 500 kcmil plus 1/2", 5/8", and 3/4" copper bonded ground rods. UL467 Listed. Acceptable for direct burial in earth and concrete. Prefilled with PENETROX™ compound and strip sealed.

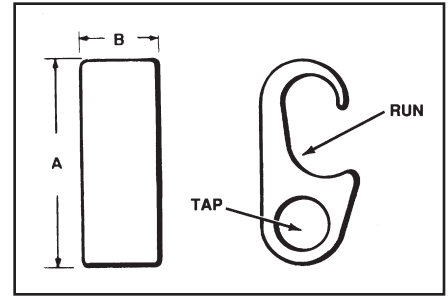

✓ UL96 Listed for Lightning Protection.

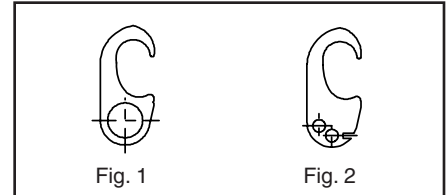

MEETS ALL
IEEE
837 REQUIREMENTS



D-9

CATALOG NUMBER	FIG. NO.	ACCOMMODATES		⑤ CABLE TO REBAR		DIE INDEX NO.	INSTALLATION DATA					
		RUN	TAP	RUN	TAP		B	Y750/Y35		③	④	NO. OF CRIMPS
								Y39	PAT750-18V	Y45	Y46	
YGHP2C2	1	#6 SOL. (0.162) {59500} - #2 STR. (0.292) {59500}	① #6 SOL. (0.162) {#2 STR.} - #2 STR. (0.292) {#2 STR.}	-	-	0	U0	U0	U0	U0	1	
YGHP2C6W6W ^⑧	2	#6 SOL. (0.162) - #2 STR. (0.292)	#8 SOL. (0.128) - 6 STR. (0.184) QTY. 2	-	-	.75 [19]	997	U997	⑦ U997P	U997	U997	1
YGHP29C6W6W ^⑧	2	1/0 STR. (0.372) {98500} - 250 kcmil (0.575) {131500} 1/2" - 5/8" ROD	#8 SOL. (0.128) - 6 STR. (0.184) QTY. 2	#3 REBAR	#8 SOL. - 6 STR.							
YGHP29C2	1		#4 SOL. (0.204) {#4 SOL.} - #2 STR. (0.292) {#2 STR.}	THRU	#2 STR.							
YGHP29C26	1		1/0 STR. (0.372) {98500} - 2/0 STR. (0.419) {98500}	#4 REBAR	1/0 STR. - 2/0 STR.							
YGHP29C29 ^②	1	250 kcmil (0.575) {250 kcmil} - 500 kcmil (0.813) {500 kcmil} 5/8" - 3/4" ROD	3/0 STR. (0.470) {131500} - 250 kcmil (0.575) {211500}	#4 REBAR	3/0 STR. - 250 kcmil							
YGHP34C2 ^⑥	1		#4 SOL. (0.204) - #2 STR. (0.292)	#5 REBAR	-							
YGHP34C26 ^⑥	1		1/0 STR. (0.372) {98500} - 2/0 STR. (0.419) {98500}	5/8	1/0 STR. - 2/0 STR.							
YGHP34C29 ^⑥	1	250 kcmil (0.575) - 500 kcmil (0.813) 5/8" - 3/4" ROD	3/0 STR. (0.470) {131500} - 250 kcmil (0.575) {211500}	THRU	3/0 STR. - 250 kcmil							
YGHP34C34 ^⑥	1		350 kcmil (0.681) - 500 kcmil (0.843)	#6 REBAR	350 kcmil - 500 kcmil	1.10 [28]	1011	⑥U1011	U1011	S1011	P1011	3

Dimensions in brackets { } represent lightning protection conductors.

NOTES:

- ① When using #6 Sol. in tap, fold conductor double to improve fill in YGHP2C2.
- ② For YGHP29C29 when using 3/0 in tap, minimum run conductor is 2/0 STR.
- ③ Where a 'U' or 'PU' die is recommended with the Y45 HYPRESS™, a PT6515 adapter must be used.
- ④ Where a 'U' or 'PU' die is recommended with the Y46 HYPRESS™, a P-UADP-1 adapter must be used.
- ⑤ Clean rust and protective coatings from rebar before connector installation to provide a proper ground connection. Pre-crimping is not required.
- ⑥ These connectors can only be installed using the Y750, Y45 or Y46 HYPRESS™ with the recommended dies. These connectors can not be installed with the Y35 and Y39 HYPRESS™.
- ⑦ Polarized die for the PAT750-18V.
- ⑧ Not UL96/CSA.

GROUND ROD DIA.	PRECRIMP DIES	
1/2"	UPRECRIMP 12	U2CABT
5/8"	UPRECRIMP 58	
3/4"	UPRECRIMP 34	

For increased rotational resistance on ground rods, pre-crimp ground rod with U2CABT die Index 348 or uprecrimp dies may be used for even greater rotation and vibration resistance on ground rods.

**CABLE TO GROUND ROD
CABLE TO REBAR
CABLE TO CABLE
FOR CONCRETE ENCASED
ELECTRODE GROUNDING
APPLICATIONS**

TYPE YGHP-C

HYTAP™ CONNECTOR

High Strength
Copper Irreversible
Compression

Ground Rod Tap
Connector

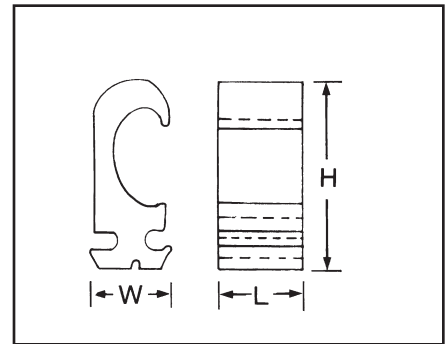
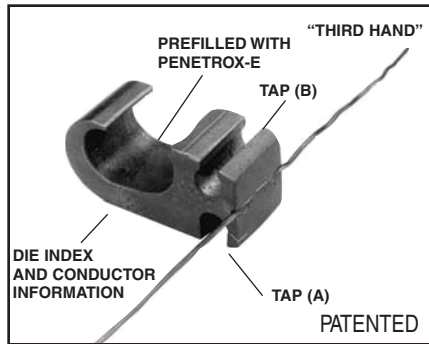

Features and Benefits

- Tap (A) accepts a continuous run on tap conductor
Tap (B) accepts a tap conductor only.
 - ◇ One connector style can be used for many applications, reducing number of connectors in inventory.
- Material is high conductivity wrought copper extrusion, identical material to the conductor.
 - ◇ High-conductivity copper minimizes resistance and voltage drop. Eliminates the possibility of corrosion due to dissimilar metals.
- System engineered tooling.
 - ◇ The tooling recommendation has been designed to ensure a reliable, dependable connection every time.
- The die index number is embossed on conductor after completion of crimp.
 - ◇ Facilitates speedy inspection of installed connectors to insure consistently reliable and dependable connections.
- Prefilled with PENETROX™ and individually sealed in clear polyethylene sheet.
 - ◇ Ensures the electrical integrity of the finished connection by inhibiting moisture and contaminants from entering the contact area. Maintains long-term high-conductivity.
- UL467 Listed.
 - ◇ May be used in direct burial or concrete embedded grounding applications. Provides quality assurance to recognized industry NEC standards from an independent party.
- "Third Hand" constrains conductors while installer completes crimp. Included with each connector.
 - ◇ Simplifies installation, reducing installed cost.

D-10

Type YGHP-C irreversible compression ground tap figure 6 can be used as a ground rod tap connector for both continuous run and tapping applications. An open groove allows ground rod to be connected to a continuous run or tap. The second groove is for a tap only. Prefilled with PENETROX-E™ and strip sealed. UL467 Listed for direct burial in earth or concrete.

MEETS ALL
IEEE
837 REQUIREMENTS



SINGLE TAP

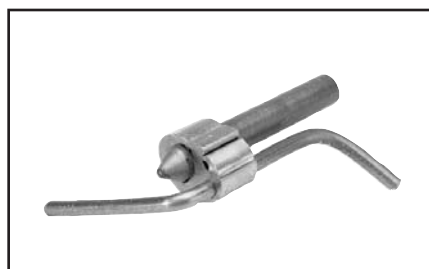

CONTINUOUS RUN



CONTINUOUS RUN AND TAP

CATALOG NUMBER	GROUND ROD DIA. ■	TAP CONDUCTOR +	DIMENSIONS			▲ INSTALLATION TOOLING				DIE INDEX
						Y35/Y750/PAT750		Y46 •		
			H	B	W	DIE NO.	NO. OF CRIMPS	DIE NO.	NO. OF CRIMPS	
YGHP58C2W-2	1/2" - 5/8"	#2 Sol. - #6 Sol. Copper (1) Continuous run and (1) Tap or up to (2) taps may be connected.	1.90"	.75"	.94"	U997	(1)	U997	(1)	997
YGHP58C2W-2TN										

NOTE: A 12" bend radius is recommended for the conductor.
 • Use PUADP-1 with 'U'-dies in Y46.
 ▲ See tooling section in Master Catalog for complete tool and die listing.
 + Either tap position may be left void when fewer than (2) conductors are used.

■ Ground rod must be precrimped with die U2CABT (Index No. 348).
 For even greater rotational resistance use U-PRECRIMP die.
 For Galvanized Steel Rods order YGHP58C2W-2TN.

TYPE YGHC-C

HYTAP™ CONNECTOR

Irreversible compression ground tap figure "C" connectors. Accommodates all cable combinations from #6 solid through 500 kcmil. "C"-shaped opening permits placing two continuous parallel cables into conductor groove. UL 467 Listed. Acceptable for direct burial in earth or concrete. Prefilled with PENETROX™ compound and strip sealed.

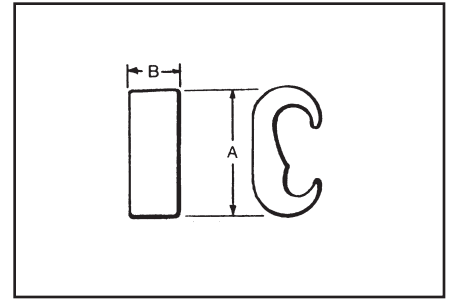

✓ UL96 Listed for Lightning Protection.

MEETS ALL
IEEE
837 REQUIREMENTS



CATALOG NUMBER	COMMERCIAL COPPER CABLE RANGE		STRANDED COPPER CABLE RANGE		A	B	DIE INDEX NO.	INSTALLATION DATA			NO. OF CRIMPS
	RUN	TAP	RUN	TAP				Y750/Y35/PAT750/Y39 HYPRESS™	① Y45 HYPRESS™	② Y46 HYPRESS™	
YGHC2C2	#6 SOL. (0.162) #2 STR. (0.292)	#6 SOL. (0.162) #2 STR. (0.292)	10 mm² (4.12 mm) 35 mm² (7.62 mm)	10 mm² (4.12 mm) 35 mm² (7.62 mm)	1.16 [30]	0.75 [19]	C	U-C	U-C	U-C	1
YGHC26C2	1 STR. (0.328) {98500}	#6 SOL. (0.162) #2 STR. (0.292)	35 mm² (7.62 mm) 70 mm² (10.9 mm)	10 mm² (4.12 mm) 35 mm² (7.62 mm)	1.41 [36]	0.75 [19]	0	U-O	U-O	U-O	1
YGHC26C26	1 STR. (0.328) {98500}	1 STR. (0.328) {98500}	35 mm² (7.62 mm) 70 mm² (10.9 mm)	35 mm² (7.62 mm) 70 mm² (10.9 mm)	1.54 [39]	0.75 [19]	0	U-O	U-O	U-O	1
YGHC29C26	3/0 STR. (0.470) {300 kcmil}	6 SOL. (0.419) {59500}	95 mm² (12.5 mm) 120 mm² (14.4 mm)	10 mm² (4.12 mm) 70 mm² (10.9 mm)	1.97 [50]	0.75 [19]	997	U997	U997	U997	1
YGHC29C29	3/0 STR. (0.470) 250 kcmil (0.575)	3/0 STR. (0.470) 250 kcmil (0.575)	95 mm² (12.5 mm) 120 mm² (14.4 mm)	95 mm² (12.5 mm) 120 mm² (14.4 mm)	2.06 [52]	0.88 [22]	997	U997	U997	U997	1
YGHC34C26 ⑥	300 kcmil (0.630) {300 kcmil}	#6 SOL. (0.162) {59500}	150 mm² (16 mm)	10 mm² (4.12 mm)	2.42 [62]	0.88 [22]	1011	U1011	S1011	P1011	2
YGHC34C29 ⑥	300 kcmil (0.630) 500 kcmil (0.813)	3/0 STR. (0.470) 250 kcmil (0.575)	150 mm² (16 mm) 240 mm² (20.35 mm)	95 mm² (12.5 mm) 120 mm² (14.4 mm)	2.67 [66]	0.88 [22]	1011	U1011	S1011	P1011	2
YGHC34C34 ⑥	300 kcmil (0.630) 500 kcmil (0.813)	300 kcmil (0.630) 500 kcmil (0.813)	150 mm² (16 mm) 240 mm² (20.35 mm)	150 mm² (16 mm) 240 mm² (20.35 mm)	2.91 [74]	1.1 [28]	1011	U1011	S1011	P1011	3

Dimensions in brackets { } represent lightning protection conductors.

NOTES:

- Where a "U" or "PU" die is recommended with the Y45 HYPRESS™, PT6515 adapter must be used.
- Where a "U" or "PU" die is recommended with the Y46 HYPRESS™, a PUADP-1 adapter must be used.
- Listed under UL486A for copper wire connectors
- Dimensions in brackets [] are in millimeters.
- In referencing connectors without PENETROX™ oxide inhibitor add suffix "NP" to the end of the Catalog Number.
- These connectors can only be installed using the Y750, Y45 or Y46 HYPRESS™ with the recommended dies.
These connectors cannot be installed with the Y35 and Y39 HYPRESS™.

TYPE YGC

COPPER CRIMPIT™

UL 467 Listed for direct burial in earth or concrete. Prefilled with PENETROX™ E2 oxide inhibitor.

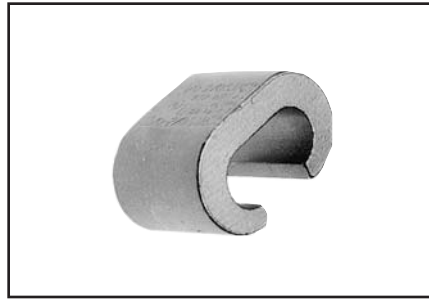

D-12

CATALOG NUMBER	COPPER CONDUCTOR		H	L	INDEX	OUR840	MD6/MD7	CRIMPS
	RUN	TAP						
YGC8C8	#8 SOL.	#8 SOL.	.46	.52	162	W162	W162	2
	#8 STR.	#8 STR.						
YGC6C8	#6 SOL.	#8 SOL.	.73	.62	BG	XBG	WBG	2
	#6 STR.	#8 STR.						
YGC6C6	#6 SOL.	#6 SOL.	.76	.62	BG	XBG	WBG	2
	#6 STR.	#6 STR.						

TYPE YSHG

HIGH STRENGTH COPPER IRREVERSIBLE COMPRESSION

Double H-Tap Connector

Type YSHG Double H-Tap grounding series is comprised of five connectors designed to accommodate wire range sizes #14 through 500 kcmil, including ground rod sizes: 3/4", 1", and rebar sizes: #6, #8 and #9. Prefilled with PENETROX™ E2 and strip sealed.

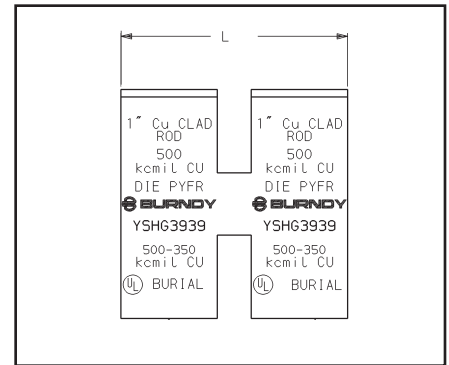

Features and Benefits

- UL467 Listed.
 - ◇ Suitable for direct burial in earth or concrete.
- Material is high conductivity copper extrusion.
 - ◇ Minimizes resistance, eliminates corrosion due to dissimilar metals.
- Grooves are prefilled with PENETROX™ E2 oxide inhibitor and individually sealed.
 - ◇ Inhibits moisture and contaminants ensuring electrical integrity.



D-13

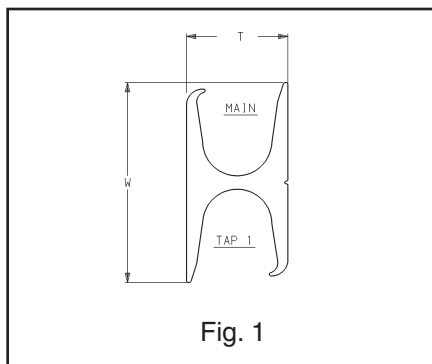

Fig. 1

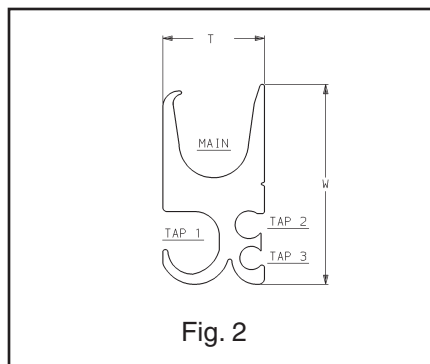

Fig. 2

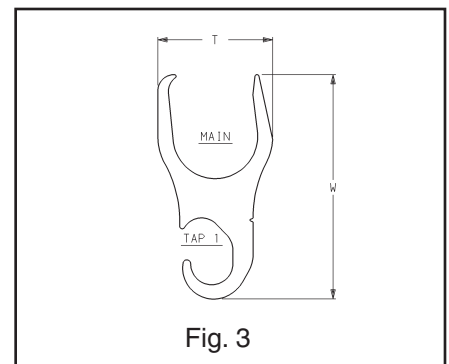

Fig. 3

Catalog Number	Fig. No.	Conductor Sizes				Tooling (number of crimps)		Index Embossment	W ±.06	T ±.04	L ±.06
		Main	Tap 1	Tap 2	Tap 3	PAT750/Y750	Y46				
YSHG4429	3	#9 & #8 Rebar, 1" [25] Ground Rod	250 - 2				PYFR (2)	K-R	3.22 [82]	1.70 [43]	2.44 [62]
* YSHG3939	1	1" [25] Cu Clad Ground Rod 500 kcmil Copper	500 - 350				PYFR (2)	K-R	2.97 [75]	1.50 [38]	2.94 [75]
* YSHG3931	2	#6 Rebar, 1" [25] Cu Clad Ground Rod, 3/4" Ground Rod 500 - 350 kcmil Copper	4/0 - 1/0	1 - 6	2 - 14		PYFR (2)	K-R	2.97 [75]	1.50 [38]	2.34 [59]
YSHG3434	1	#6 Rebar, 3/4" [19] Ground Rod 400 - 250 kcmil COPPER	400 - 4/0			U1104 (4)	P1104 (2) †U1104 (4)	1104	2.43 [62]	1.15 [29]	2.44 [62]
YSHG3429	2	#6 Rebar, 3/4" [19] Ground Rod 400 - 4/0 kcmil Copper	3/0 - 1/0	1 - 4	8 - 14	U1104 (4)	P1104 (2) †U1104 (4)	1104	2.23 [57]	1.31 [33]	2.44 [62]

* NOTE: Not for use on 1" steel ground rod.
† Use PUADP-1 adapter.

BURNDY® Products FCI

Grounding

TYPE YGHR-C

HYTAIL™

High Strength
Irreversible
Compression Ground Rod Tap
Connectors

High torque strength ground rod connectors. Accommodates a wide range of copper conductors to ground rod. UL467 Listed. Acceptable for direct burial in earth or concrete. Prefilled with PENETROX™ compound and strip sealed.

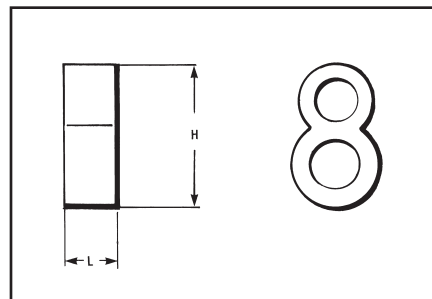

MEETS ALL
IEEE
837 REQUIREMENTS



CATALOG NUMBER	H	B
YGHR26C12	1.94" [49.3]	.88" [22.4]
YGHR26C58	1.97" [50.0]	
YGHR26C34	2.19" [55.6]	
YGHR26C100	2.55" [56.2]	
YGHR29C12	1.94" [49.3]	
YGHR29C58	2.14" [54.4]	
YGHR29C34	2.19" [55.6]	
YGHR29C100	2.45" [62.2]	
YGHR34C58	2.14" [54.4]	
YGHR34C34	2.44" [62.0]	
YGHR34C100	2.70" [68.6]	

CATALOG NUMBER	COMMERCIAL COPPER CABLE RANGE	NOMINAL GROUND ROD DIA.	INSTALLATION TOOLS, DIE SET CAT. NO. (NUMBER OF CRIMPS)				
			PAT750/Y750/Y35/Y39 ①	Y45 HYPRESS ①	Y46 HYPRESS ①		
YGHR26C12	#2 STR. (.292 DIA.) thru	1/2" [12.7]	U1011 (2) ④ PU998 (1)	S1012 (2) ④	P1011 (2) ④ PU998 (1) ③		
YGHR26C58		5/8" [15.9]		PU998 (1) ②			
YGHR26C34		3/4" [19.0]		S1011 (2) S1012 (2) PU998 (1)			
YGHR26C100*	2/0 STR. (.419 DIA.)	1" [25.4]		S1012 (2) ④			
YGHR29C12	#4/0 STR. (.528 DIA.) thru	1/2" [12.7]		S1011 (2) S1012 (2) ④ PU998 (1)		S1012 (2) ④	
YGHR29C58		5/8" [15.9]				PU998 (1) ②	
YGHR29C34		3/4" [19.0]				S1011 (2) S1012 (2) ④ PU998 (1)	
YGHR29C100*	250 kcmil (.575 DIA.)	1" [25.4]				S1012 (2) ④	
YGHR34C58	300 kcmil (.630 DIA.) thru	5/8" [15.9]				S1011 (2)	S1012 (2) ④
YGHR34C34*		3/4" [19.0]					PU998 (1) ②
YGHR34C100*		500 kcmil (.813 DIA.)					1" [25.4]

NOTES:

- The catalog numbers shown are for unplated copper connectors for use on copper clad or stainless steel ground rod. To order electro-tin plated connectors for use on galvanized steel ground rod add suffix "TN" to the catalog number. Note: The ground rod hole diameter is larger for galvanized steel ground rod in the tin plated connector.
- ① Ground rod must be pre-crimped with die U2CABT (Index No. 348) when the PU998 dies are used in the Y750, Y35, Y39, Y45, or Y46 tools. Pre-crimping is not required when the P1011, S1011, S1012 or U1011 dies are used. UPRECRIMP™ dies may be used for additional mechanical resistance on ground rods.

- ② Where a PU998 die is recommended with the Y45 HYPRESS™, a PT6515 adapter must be used.
- ③ Where a PU998 die is recommended with the Y46 HYPRESS™, a PUADP-1 adapter must be used.
- ④ These die numbers do not appear on the connector.
- * These connectors can only be installed using the Y750, Y45 or the Y46 HYPRESS™ with the recommended dies. These connectors CAN NOT be installed with the Y35 and Y39 HYPRESS™. When attaching connector to ground rod, ground rod must be embossed with appropriate PRECRIMP™ die. For connections that must meet IEEE 837 requirements UPRECRIMP™ - type PRE crimp dies must be used for maximum clamping retention.

TYPE YGHR-C

HYTAIL™

High Strength
Irreversible
Compression Ground Rod Tap
Connectors

Type YGHR-C irreversible compression grounding connector is engineered specifically for the Telecommunications Industry for (1, 2 or 3) #2 solid, tinned or bare conductor taps. UL467 Listed. Acceptable for direct burial in earth or concrete. BURNDY® has designed this connector to meet the stringent requirements of OSHA, the National Electric Code (NEC), UL, and the Telecommunications Industry. Performance and long life are this connector's basic design guidelines.

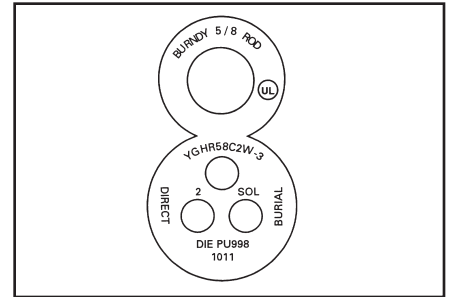

Features and Benefits

- Tap side 1, 2 or 3 conductors.
 - ◊ One connector style can be used for many applications.
- Material is high conductivity wrought copper extrusion, identical material to the conductor.
 - ◊ High-conductivity copper minimizes resistance and voltage drop. Eliminates the possibility of corrosion due to dissimilar metals.
- System engineered tooling.
 - ◊ Each tooling recommendation has been designed to provide a reliable, dependable connection.
- The die index number is embossed on connector after completion of crimp.
 - ◊ Facilitates speedy inspection of installed connectors to ensure consistently reliable and dependable connections.
- Prefilled with PENETROX™ and individually sealed in clear polyethylene sheet.
 - ◊ Ensures the electrical integrity of the finished connection by inhibiting moisture and contaminates from entering the contact area. Maintains long-term high-conductivity.
- UL 467 Listed. Acceptable for direct burial.
 - ◊ May be used in direct burial or concrete embedded grounding applications. Provides quality assurance to recognized industry NEC standards from an independent party.

D-15

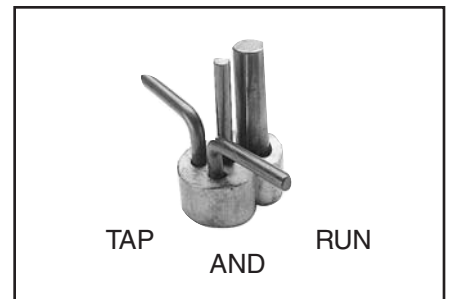

CATALOG NUMBER+	GROUND ROD DIAMETER •	TAP CONDUCTOR ▲	INSTALLATION TOOLING				DIE INDEX
			PAT750/Y35/Y750**		Y46*		
			DIE NO.	NO. OF CRIMPS	DIE NO.	NO. OF CRIMPS	
YGHR58C2W-3	5/8"	#2 Sol. Copper 1, 2, or 3 may be connected	PU998†	(1)	PU998†	(1)	998 or 1011
					U1011	(2)	
			U1011	(2)	P998	(1)	
					P1011	(2)	

• Contact BURNDY® for other ground rod diameters.
 * PU998 and U1011 die sets require PUADP-1 adapter for use in the Y46 HYPRESS™.
 Tap positions may be left void when fewer than (3) conductors are used.
 + To order electro-tin plated connector for use on galvanized steel ground rod add suffix "-TN" to the catalog number.
NOTE: The ground rod hole diameter is larger for galvanized steel ground rod in the tin plated connector.

† Ground rod must be precrimped with die U2CABT (Index No. 348) when PU998 die set is used in the Y35, Y750 or Y46
 ▲ HYPRESS™ tools. For even greater mechanical resistance use UPRECRIMP™ 58 dies.
 ** The Y750 utilizes PU dies and the U1011 die. The Y35 only uses PU998 die set.
NOTE: A 12" bend radius is recommended for the conductor.

BURNDY® Products FCI

Grounding

TYPE YGHA

HYLUG™

Heavy Duty Irreversible Compression Terminals

Heavy duty HYLUG™ irreversible compression terminals designed not only to carry short circuit load, but to also withstand high mechanical stress. Each conductor element has an inspection probe hole to insure proper cable insertion. UL467 Listed. Acceptable for direct burial in earth or concrete. UL486A Listed. Prefilled with PENETROX™ compound and strip sealed.

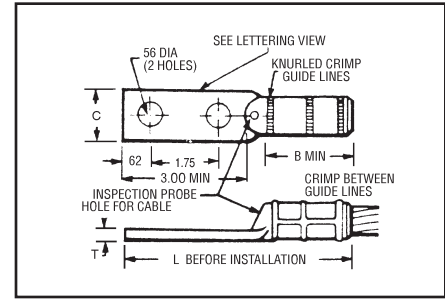
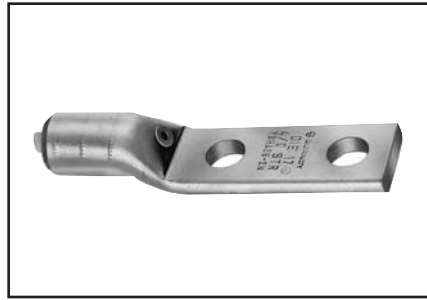

MEETS ALL
IEEE
837 REQUIREMENTS



D-16

CATALOG NUMBER	COPPER CONDUCTOR SIZE	INSTALLATION TOOLS, DIE SET CAT. NO., AND (NUMBER OF CRIMPS)				B	C	L	T
		HYPRESS™ Y35/Y39/Y45 ① /Y46 ② /Y750 /PAT750							
YGHA2C-2N	2 str.	U1CRT (1)				.75	.97	4.21	.26
YGHA25-2N	1/0 str.	U27RT (1)				.83	.91	4.60	.19
YGHA26-2N	2/0 str.	U28RT (1)				.83	.97	4.38	.26
YGHA27-2N	3/0 str.	U29RT (1)				1.18	1.08	4.94	.29
YGHA28-2N	4/0 str.	U30RT (2)				1.18	1.22	4.94	.30
YGHA29-2N	250 kcmil	U31RT (2)				1.18	1.28	4.94	.34
YGHA31-2N	350 kcmil	U34RT (2)				1.18	1.62	5.00	.43
YGHA34-2N	500 kcmil	U36RT (3)				1.48	1.72	5.42	.40

① Where a "U" or "PU" die is recommended with the Y45 HYPRESS™, a PT6515 adapter must be used.

② Where a "U" or "PU" die is recommended with the Y46 HYPRESS™, a PUADP-1 adapter must be used.

TYPE YGHS

HYLINK™

Heavy Duty Irreversible Compression Terminals

Heavy duty HYLINK™ ground splice designed not only to carry short circuit load, but to also withstand high mechanical stress. Each conductor element has an inspection probe hole and a center stop to ensure proper cable insertion. UL467 Listed. Acceptable for direct burial in earth or concrete. UL486A Listed. Prefilled with PENETROX™ compound and strip sealed.

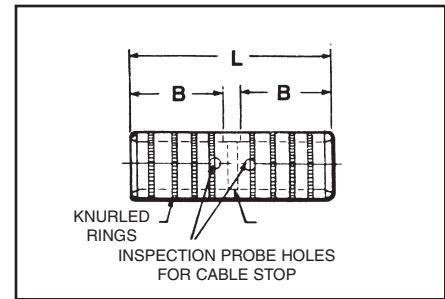

MEETS ALL
IEEE
837 REQUIREMENTS



CATALOG NUMBER	COPPER CONDUCTOR SIZE	INSTALLATION TOOLS, DIE SET CAT. NO., AND (NUMBER OF CRIMPS)		B	L
		HYPRESS™ Y35/Y39/Y45 ① /Y46 ② /Y750 /PAT750			
YGHS2C	2 str.	U1CRT (1)		.75	1.73
YGHS25	1/0 str.	U27RT (1)		.83	1.89
YGHS26	2/0 str.	U28RT (1)		.83	1.89
YGHS27	3/0 str.	U29RT (1)		1.18	2.59
YGHS28	4/0 str.	U30RT (2)		1.18	2.59
YGHS29	250 kcmil	U31RT (2)		1.18	2.59
YGHS31	350 kcmil	U34RT (2)		1.18	2.59
YGHS34	500 kcmil	U36RT (3)		1.48	3.19

① Where a "U" or "PU" die is recommended with the Y45 HYPRESS™, a PT6515 adapter must be used.

② Where a "U" or "PU" die is recommended with the Y46 HYPRESS™, a PUADP-1 adapter must be used.

BURNDY® Products FCI

Grounding

TYPE YGA

HYLUG™

Grounding Irreversible Compression Terminals

Irreversible compression HYLUG™ Ground terminal specifically designed for grounding applications. Each connector has an inspection probe hole to insure proper cable insertion. UL467 Listed. Acceptable for direct burial in earth or concrete. UL486A Listed. Prefilled with PENETROX™ compound and strip sealed.

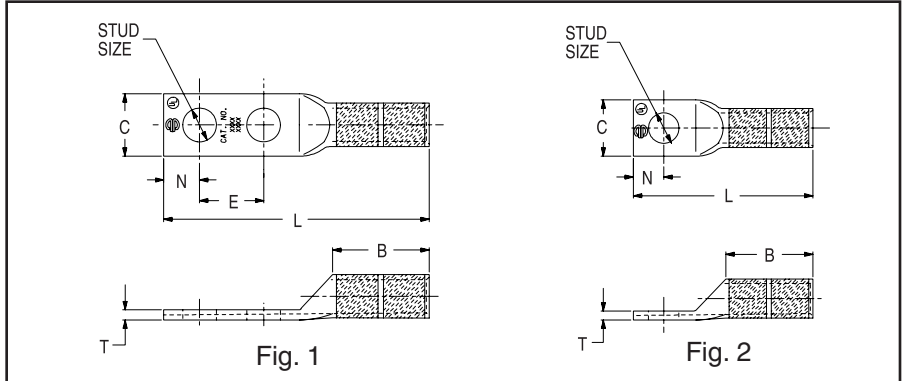

D-17

Catalog Number	Fig. No.	Copper Conductor Size	Installation Tools, Die Set Cat. No., and (number of crimps)				Stud Size	B	C	L	T	E
			Mechanical			Hydraulic						
			Y2MR Die # (# of crimps)	MD7-34R Die # (# of crimps)	OUR840 Die # (# of crimps)	Y35/Y39/Y45/PAT750 ① /Y46 ② /Y750						
YGA8C-TC10	2	8 sol./8 str.	Red (4)	W8CVT (2) X8CRT (2)	U8CRT (2)	#10	.81	.41	1.57	.08	—	
YGA8C-TC14	2	8 sol./8 str.	Red (4)	W8CVT (2) X8CRT (2)	U8CRT (2)	1/4	.81	.44	1.69	.08	—	
YGA8C-TC516	2	8 sol./8 str.	Red (4)	W8CVT (2) X8CRT (2)	U8CRT (2)	5/16	.81	.51	1.75	.06	—	
YGA8C-2N	1	8 sol./8 str.	Red (4)	W8CVT (2) X8CRT (2)	U8CRT (2)	1/2	.81	.71	4.09	.05	—	
YGA6C-TC10	2	6 sol./6 str.	Blue (4)	W5CVT (2) X5CRT (2)	U5CRT (2)	#10	1.12	.42	1.89	.09	—	
YGA6C-TC14	2	6 sol./6 str.	Blue (4)	W5CVT (2) X5CRT (2)	U5CRT (2)	1/4	1.12	.45	2.02	.08	—	
YGA6C-TC516	2	6 sol./6 str.	Blue (4)	W5CVT (2) X5CRT (2)	U5CRT (2)	5/16	1.12	.51	2.08	.07	—	
YGA6C-2TC38E2G1	1	6 sol./6 str.	Blue (4)	W5CVT (2) X5CRT (2)	U5CRT (2)	3/8	1.12	.58	3.42	.06	.75	
YGA6C-2N	1	6 sol./6 str.	Blue (4)	W5CVT (2) X5CRT (2)	U5CRT (2)	1/2	1.12	.83	4.40	.12	1.75	
YGA2C-2TC38	1	2 sol./2 str.	Brown (4)	W2CVT (2) X2CRT (2)	U2CRT (2)	3/8	1.25	.60	3.48	.12	1.00	
YGA2C-2TC38E2G1	1	2 sol./2 str.	Brown (4)	W2CVT (2) X2CRT (2)	U2CRT (2)	3/8	1.25	.60	3.66	.12	.75	
YGA2C-2N	1	2 str.	Brown (4)	W2CVT (2) X2CRT (2)	U2CRT (2)	1/2	1.22	.81	4.71	.12	1.75	
YGA25-2N	1	1/0 str.	—	W25VT (4) X25RT (4)	U25RT (2)	1/2	1.35	.81	4.91	.12	1.75	
YGA26-2N	1	2/0 str.	—	W26VT (4) X26RT (4)	U26RT (2)	1/2	1.45	.81	4.89	.12	1.75	
YGA28-2N	1	4/0 str.	—	W28VT (4) X28RT (4)	U28RT (2)	1/2	1.57	1.00	5.06	.14	1.75	
YGA29-2N	1	250 kcmil	—	W29VT (4)	U29RT (2)	1/2	1.57	1.09	5.16	.16	1.75	
YGA34-2N	1	500 kcmil	—	W34VT (4)	U34RT (4)	1/2	2.20	1.52	5.94	.23	1.75	

① Where a "U" or "PU" die is recommended with the Y45 HYPRESS™, a PT6515 adapter must be used.

② Where a "U" or "PU" die is recommended with the Y46 HYPRESS™, a PUADP-1 adapter must be used.

BURNDY® Products FCI

Grounding

TYPE YGS

HYLINK™

Grounding Irreversible Compression Splices

Irreversible compression HYLINK™ ground splices specifically designed for grounding applications. Each conductor element has an inspection probe hole and a center stop to ensure proper cable insertion. UL467 Listed. Acceptable for direct burial in earth or concrete. UL486A Listed. Prefilled with PENETROX™ compound and strip sealed.

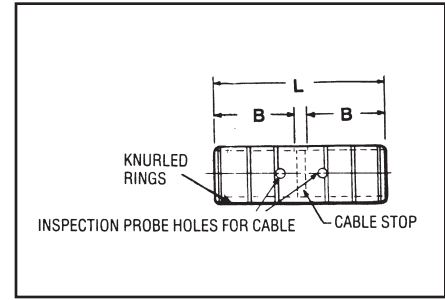
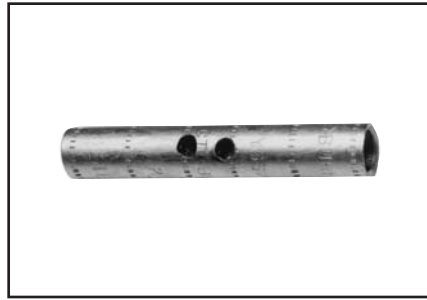

D-18



CATALOG NUMBER	COPPER CONDUCTOR SIZE	INSTALLATION TOOLS, DIE SET CAT. NO., AND (NUMBER OF CRIMPS)				B	L
		MECHANICAL			HYDRAULIC		
		Y2MR	MD7-34R	OUR840	Y35/Y39/Y45 ^①		
		DIE # (# OF CRIMPS)	DIE # (# OF CRIMPS)	DIE # (# OF CRIMPS)	Y46 ^② / Y750/PAT750		
			DIE # (# OF CRIMPS)				
YGS2C	2 str.	Brown (4)	W2CVT (2) X2CRT (2)		U2CRT (2)	1.22	2.67
YGS8C	#8 sol./str.	—	X8CRT, W8CRT, W8CVT ^③		U8CRT (2)	.78	1.75
YGS6C	#6 sol./str.	—	X5CRT, W5CRT, W5CVT ^③		U6CRT (2)	1.09	2.38
YGS25	1/0 str.	—	W25VT (4) X25RT (4)		U25RT (2)	1.35	2.97
YGS26	2/0 str.	—	W26VT (4) X26RT (4)		U26RT (2)	1.45	3.13
YGS28	4/0 str.	—	W28VT (4) X28RT (4)		U28RT (2)	1.57	3.37
YGS29	250 kcmil	—	W29VT (4)		U29RT (2)	1.57	3.37
YGS34	500 kcmil	—	W34VT (4)	—	U34RT (4)	2.20	4.63

① Where a "U" or "PU" die is recommended with the Y45 HYPRESS™, a PT6515 adapter must be used.

② Where a "U" or "PU" die is recommended with the Y46 HYPRESS™, a PUADP-1 adapter must be used.

③ Use "X" with OUR840, "W" with MD6/MD7.

TYPE YGF

GROUNDING PLATE

The irreversible compression ground plate is designed to withstand the rigors of concrete construction. The ground plates are made of high strength, high-conductivity cast copper alloy body with a pure wrought copper compression element. In addition to the tapped NEMA size holes and spacing on the face, the plate comes with a tapped hole on the underside for ease of positioning prior to pouring the concrete. UL467 Listed. Acceptable for direct burial in earth or concrete. Prefilled with PENETROX™ compound and strip sealed.

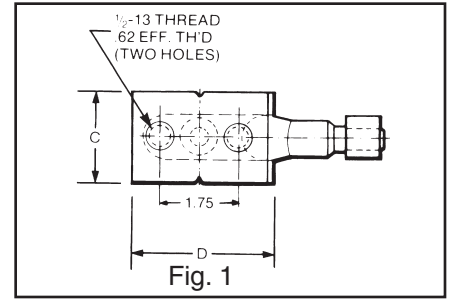
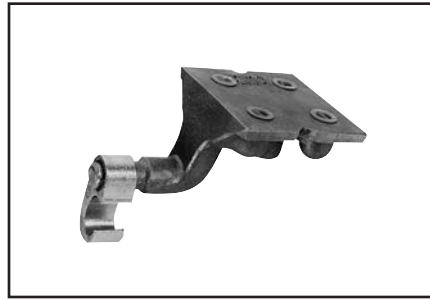

MEETS ALL
IEEE
837 REQUIREMENTS



D-19

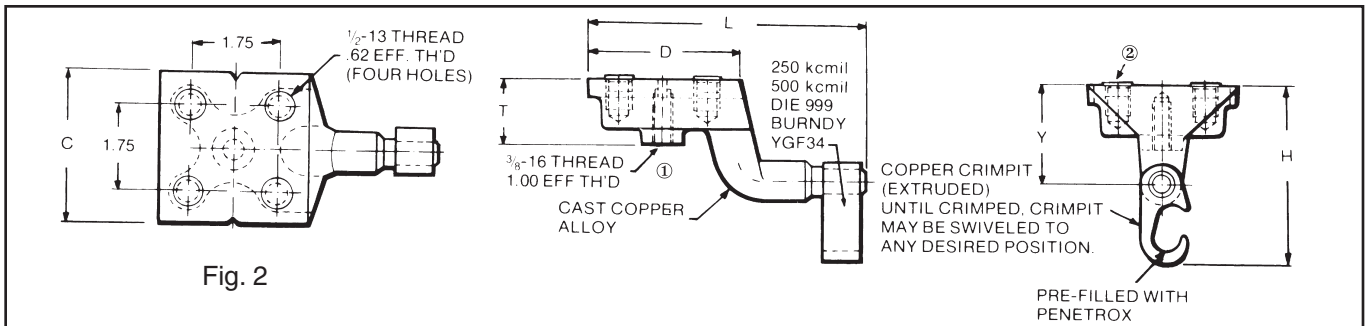

Catalog Number	Fig. No.	C	D	H	L	T	Y
YGF29-2N	1	2.00	3.25	3.62	5.78	1.31	2.00
YGF29-4N	2	3.25	3.25	3.62	5.78	1.31	2.00
YGF34-2N	1	2.00	3.25	4.62	5.40	1.31	2.19
YGF34-4N	2	3.75	3.75	4.62	5.90	1.31	2.19

NOTES:

- ① This tapped hole may be used to position the grounding plate on a threaded rod prior to placement of the concrete.
- ② Plastic plugs are provided to keep dirt out of the threaded holes until the attachment of grounding terminals.
- ③ 3/8-16 thread with 1.00 EFF. Thread is standard. If other thread is required, add appropriate Code No. to Catalog No. for desired thread.
-50 (1/2 -13, .94 EFF. Thread), -62 (5/8 -11, .94 EFF. Thread) and -75 (3/4 -10, .81 EFF. Thread)
Example: YGF34-4N-50 is YGF34-4N with 1/2 -13 Thread

Catalog Number	Copper Conductor Range	Tapped Holes		Installation Tools, Die Set Cat. No., and (number of crimps)		
		Size	Hole Centers	HYPRESS™		
				PAT750/Y750/Y35/Y39	Y45 ①	Y46 ②
YGF29-2N	2 - 250 kcmil	1/2 - 13	1-3/4	U997 (1)	U997 (1)	U997 (1)
YGF29-4N	2 - 250 kcmil	1/2 - 13	1-3/4	U997 (1)	U997 (1)	U997 (1)
YGF34-2N*	250 - 500 kcmil	1/2 - 13	1-3/4	U1011 (3)	S1011 (2)	P1011 (2)
YGF34-4N*	250 - 500 kcmil	1/2 - 13	1-3/4	U1011 (3)	S1011 (2)	P1011 (2)

ORDERING INFORMATION

- ① Where a "U" or "PU" die is recommended with the Y45 HYPRESS™, a PT6515 adapter must be used.
- ② Where a "U" or "PU" die is recommended with the Y46 HYPRESS™, a PUADP-1 adapter must be used.
- * These connectors can only be installed using the Y750, Y45 or Y46 HYPRESS™ with recommended dies. These connectors CAN NOT be installed with the Y35 or Y39 HYPRESS™.

TYPE YGIB

GROUNDLINK™ CONNECTOR

An irreversible compression ground connection which allows attachment to a structural steel standard (angled) or wide flange (parallel) beam. Installed with a required 5-piece die set, Catalog PIBEAMKIT or UIBEAMKIT. Die index 1105. GROUNDLINK™ connectors are made of high-conductivity wrought copper and come pre-filled with PENETROX™ E compound and strip sealed. Order terminal mounting hardware separately.

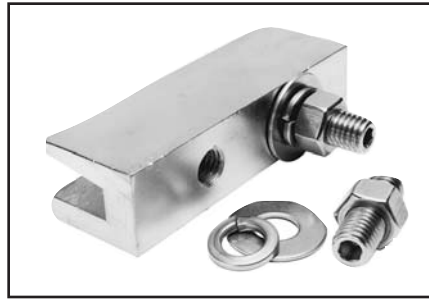

MEETS ALL
IEEE
837 REQUIREMENTS



Connector shipped with thread protection studs only. Order TMHG kits separately.

D-20

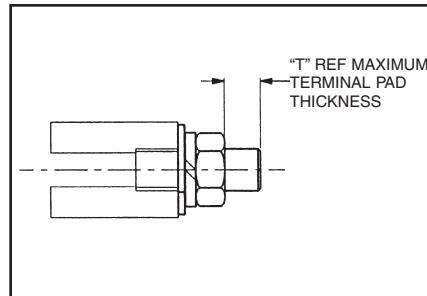
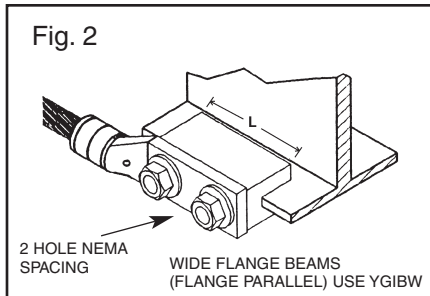
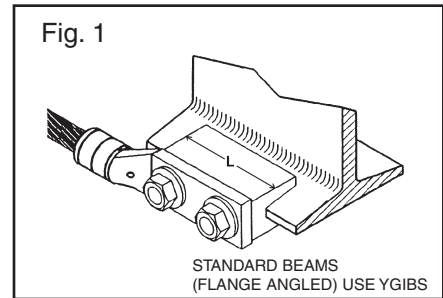
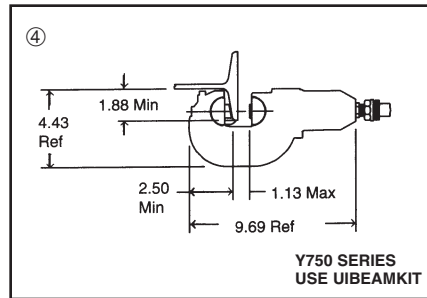
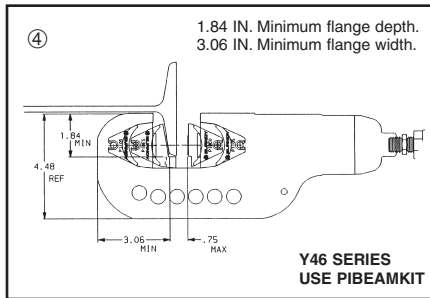

TERMINAL MOUNTING HARDWARE	
CATALOG NUMBER	"T"
TMHG-42	.42
TMHG-92	.92

NOTE: Use TMHG-92 to double stack lugs.

NOTES:

- Terminal connector to be ordered separately. When I-beam connector is used with type "YGHA" terminal, the connection meets IEEE 837-1989 requirements. YGA-2N, YA-2N and other BURNDY® 2-hole NEMA copper terminals are suitable.
- Order "TMHG" Terminal Mounting Hardware Kit separately. Kit consists of 2 studs, 2 flat washers, 2 lockwashers and 2 hex nuts.
- Using the 1/4 hex key wrench, screw the stud into the connector until stud bottoms out in connector. Install a "YGHA" terminal, flat washer, lockwasher and hex nut onto stud. Tighten and torque to 480 pound-inches.
- Dimensions shown reflect the minimum dimensions required on a beam to properly install the I-beam connector.
- To correctly determine the appropriate YGIB connector to use based on flange thickness, order either YGIBGAUGE1 or YGIBKIT1 (KIT1 contains wiremike).

TYPE YGIB

(Continued)

GROUNDLINK™ CONNECTOR

COPPER CONDUCTOR RANGE	CATALOG NUMBER	FIG. NO.	"L"	"J"	I-BEAM FLANGE THICKNESS	SUGGESTED TERMINALS		"T" REF.	
						COPPER CONDUCTOR	TERMINAL		
2 - 4/0 AWG	YGIBS28-338-2N	1	3.00	1/2 - 13	.250" to .338"	#2 STR. AWG	YGHA2C-2N	.26	
	YGIBW28-338-2N	2	3.00			1/0 STR. AWG	YGHA25-2N	.19	
2/0 STR. AWG						YGHA26-2N	.26		
4/0 STR. AWG	YGHA28-2N	.30							
250 - 500 kcmil	YGIBS34-338-2N	1	6.00		.338" to .400"	250 kcmil	YGHA29-2N	.34	
	YGIBW34-338-2N	2				500 kcmil	YGHA34-2N	.40	
2 - 4/0 AWG			YGIBS28-400-2N			1	3.00	.400" to .462"	#2 STR. AWG
	YGIBW28-400-2N	2	3.00			1/0 STR. AWG	YGHA25-2N		.19
2/0 STR. AWG					YGHA26-2N	.26			
4/0 STR. AWG	YGHA28-2N	.30							
250 - 500 kcmil	YGIBS34-400-2N	1	6.00		.462" to .550"	250 kcmil	YGHA29-2N	.34	
	YGIBW34-400-2N	2				500 kcmil	YGHA34-2N	.40	
2 - 4/0 AWG			YGIBS28-462-2N			1	3.00	.550" to .613"	#2 STR. AWG
	YGIBW28-462-2N	2	3.00			1/0 STR. AWG	YGHA25-2N		.19
2/0 STR. AWG					YGHA26-2N	.26			
4/0 STR. AWG	YGHA28-2N	.30							
250 - 500 kcmil	YGIBS34-462-2N	1	6.00		.613" to .675"	250 kcmil	YGHA29-2N	.34	
	YGIBW34-462-2N	2				500 kcmil	YGHA34-2N	.40	
2 - 4/0 AWG			YGIBS28-550-2N			1	3.00	.675" to .750"	#2 STR. AWG
	YGIBW28-550-2N	2	3.00			1/0 STR. AWG	YGHA25-2N		.19
2/0 STR. AWG					YGHA26-2N	.26			
4/0 STR. AWG	YGHA28-2N	.30							
250 - 500 kcmil	YGIBS34-550-2N	1	6.00		.750" to .813"	250 kcmil	YGHA29-2N	.34	
	YGIBW34-550-2N	2				500 kcmil	YGHA34-2N	.40	
2 - 4/0 AWG			YGIBS28-613-2N	1		3.00	.813" to .875"	#2 STR. AWG	YGHA2C-2N
	YGIBW28-613-2N	2	3.00	1/0 STR. AWG		YGHA25-2N		.19	
2/0 STR. AWG				YGHA26-2N	.26				
4/0 STR. AWG	YGHA28-2N	.30							
250 - 500 kcmil	YGIBS34-613-2N	1	6.00	.875" to .938"	250 kcmil	YGHA29-2N	.34		
	YGIBW34-613-2N	2			500 kcmil	YGHA34-2N	.40		
2 - 4/0 AWG			YGIBS28-675-2N		1	3.00	.938" to 1.000"	#2 STR. AWG	YGHA2C-2N
	YGIBW28-675-2N	2	3.00		1/0 STR. AWG	YGHA25-2N		.19	
2/0 STR. AWG				YGHA26-2N	.26				
4/0 STR. AWG	YGHA28-2N	.30							
250 - 500 kcmil	YGIBS34-675-2N	1	6.00	1.000" to 1.063"	250 kcmil	YGHA29-2N	.34		
	YGIBW34-675-2N	2			500 kcmil	YGHA34-2N	.40		

TYPE GSTUD-HY

VERSITAIL™

Structural Steel Grounding Connector

INSTALLATION

1. Weld the VERSITAIL™ to the steel member.
2. Select the proper connector for your specific application.
 - a. FOR COMPRESSION CONNECTORS
Select the proper BURNDY® “YGHP” connector. Clean the conductor, join the VERSITAIL™ and the grounding conductor together with the recommended tool and die set, then crimp the connector over the knurled area of the VERSITAIL™.
 - b. FOR MECHANICAL CONNECTORS
Select the properly sized BURNDY® connector. Clean the conductor, then apply PENETROX™ E oxide inhibiting compound on the contact area for increased effectiveness and service life. Put the connector over the knurled area of the VERSITAIL™ and apply the recommended torque value for correct installation.

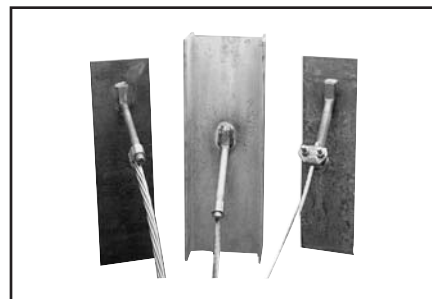

FEATURES

- The VERSITAIL™ may be welded to steel surfaces quickly and easily with normal construction equipment.
- The VERSITAIL™ eliminates costly disk grinding and the need to expose virgin metal. The welding process burns through the oxidation and “scale” to establish excellent electrical grounding continuity.
- The VERSITAIL™ may be installed by the welder in the field or at the steel fabricator based on customer preference.
- The VERSITAIL™ pure copper coating over low carbon, hot rolled steel is compatible with standard welding processes. No toxic gasses are generated.
- The VERSITAIL™ knurled surface is copper plated and specifically designed to ensure excellent mechanical gripping and electrical integrity for BURNDY® compression and mechanical connectors in all grounding applications.
- The VERSITAIL™ may be installed during adverse weather conditions thus eliminating costly construction delays.

SPECIFICATIONS

- Low Carbon, hot rolled steel.
- Pure copper plated finish.

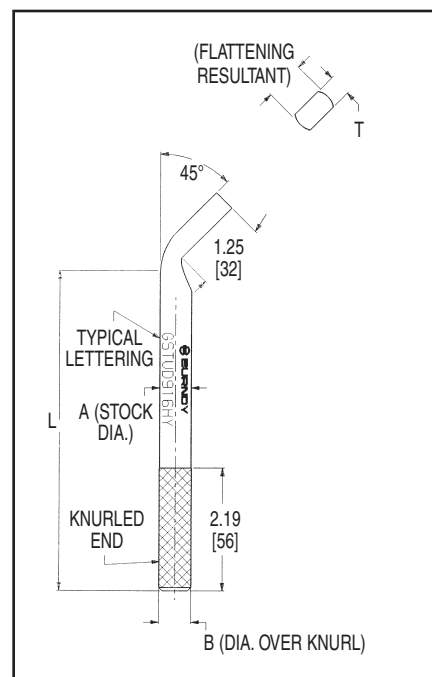

BENEFITS

- Low installation cost.
- No drilling . . . No cleaning . . .
 - No special preparation

CATALOG NUMBER	NOM. ROD SIZE	DIMENSIONS				ELECTRICAL EQUIVALENT COPPER CONDUCTOR SIZE (AWG.)*
		A	B	L	T	
		IN. [MM]	IN. [MM]	IN. [MM]	IN. [MM]	
GSTUD14HY	1/4"	.25 [6.3]	.26 [6.6]	4.81 [122.2]	.19 [4.8]	#6
GSTUD38HY	3/8"	.38 [9.7]	.39 [9.9]	5.81 [147.6]	.25 [6.4]	#3
GSTUD916HY	5/8"	.56 [14.2]	.57 [14.5]	5.68 [144.3]	.38 [9.7]	1/0
GSTUD34HY	3/4"	.75 [19.0]	.76 [19.3]	5.81 [147.6]	.51 [13.0]	4/0

* This is the equivalent rating for continuous service. Larger conductors may be connected using both compression and bolted connectors in potential ground fault applications.

TYPES YGT & YTTAG

STATIC GROUNDING RECEPTACLE

Type YGT static grounding receptacles are designed for static grounding of equipment. The receptacle is connected to the ground grid with HYGROUND™ compression connectors and finished flush with surface to provide a permanent corrosion proof grounding point.

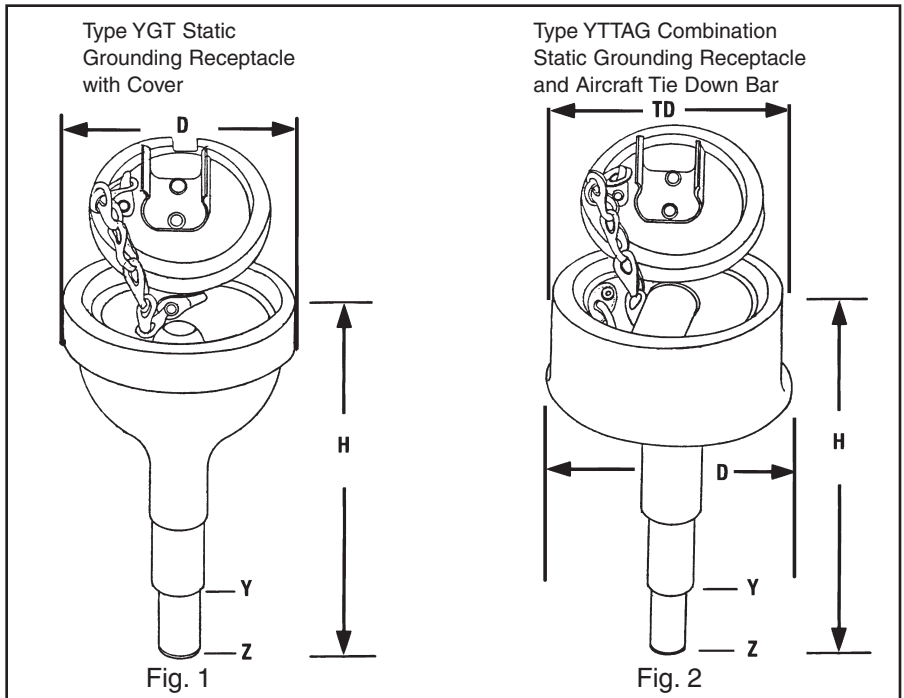

D-23

Catalog Number	Figure Number	* HYGROUND Connector	Dimensions				
			H	D	Y Dia.	Z Dia.	"TD"
YGT275	1	Select suitable YGHR or YGLR for 3/4" ground rod and sized to ground conductor.	5.5	2.75	.75	.56	—
YTTAG388	2		6.5	4.75	.75	.56	4.3

* When using U or PU dies with Y46 HYPRESS™, a PUADP-1 adapter is required.

NOTES:

1. Ground rod must be pre-crimped with U2CABT die set when PU998 die is used or for even higher mechanical resistance use special UPRECRIMP™ dies on ground rods.
2. Pre-crimping of ground is not necessary when P1011 die is used. Install YGHR or YGLR on hub Y. Hub Z is inserted into 1/2" rigid conduit. The conduit is driven into earth to provide support and provide correct level of receptacle prior to cement pour.

TYPE YG-B

BUS BAR CONNECTOR

BURNDY's YG14B2TC2C6C Compression Bus Bar Connector is ideally suited for cellular tower applications and is easier to use than exothermic connections. This high conductivity wrought copper connector allows attachment of the ground conductor to the ground bus with just one crimp using the BURNDY® Y750 HYPRESS™ Hydraulic Compression tool and the U1105 die set. This exclusive patent pending design allows the user to attach #2 AWG sol./str. and/or #6 sol./str. copper conductor to 1/4" thick copper bus bar. This connection is suitable using (1) or (2) conductors for power, grounding and bonding applications. UL Listed to both UL486 and UL467 (suitable for direct burial) ensures that this connector will meet the rigors of either application. Prefilled with PEN-ETROX™ E compound and strip sealed.

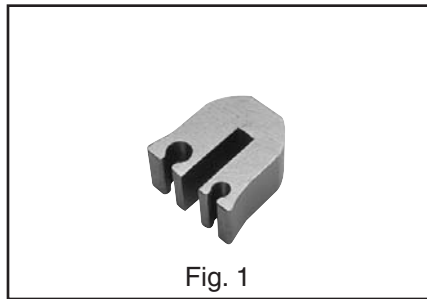

Fig. 1

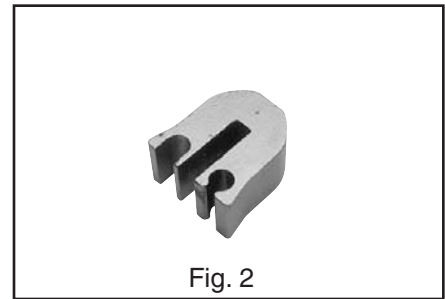

Fig. 2

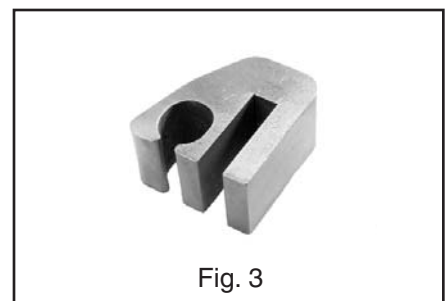
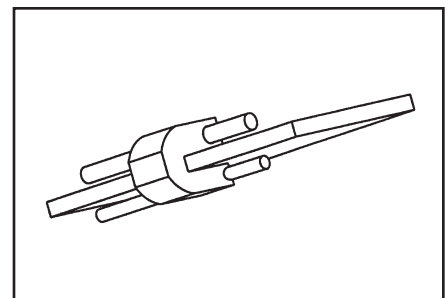
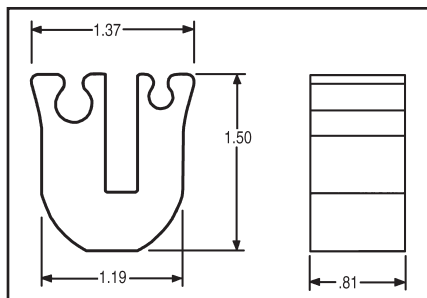

Fig. 3



D-24

CATALOG NUMBER	FIG NO.	GROUND BAR THICKNESS	BUS BAR TAP CONDUCTORS	TOOLING	INSTALLATION DIE NO.	NO. OF CRIMPS
YG14B2TC2C6C	1	1/4"	#2 SOL/and/or STR COPPER #6 SOL/and/or STR COPPER	PAT750, Y750	U1105	1
YG14B2TC2C2C*	2	1/4"	#2 #2	PAT750, Y750	U1105	1
YG14B2TC26	3	1/4"	#1 FLEX CABLE through 2/0 FLEX CABLE	PAT750, Y750	U1105	1
YG14B2TC28	3	1/4"	4/0 AWG STR to 1/0 AWG STR COPPER	PAT750, Y750	U1105	1

NOTE: Suitable for use with either (1) or (2) conductors (excluding YG14B2TC26 and YG14B2TC28).

* For continuous uncut conductor applications.

MECHANICAL GROUNDING CONNECTORS

More than 60 years of technological innovation has made BURNDY® mechanical grounding connectors one of the most widely used, highly respected lines in the industry. There is virtually no grounding application

problem that this diversified line cannot help solve.

All BURNDY® mechanical grounding connectors have been designed for easy installation and for outstanding durability. Only the finest

high copper alloys are used in their manufacture, ensuring top performance under the most extreme environmental conditions.

UL467 Listed for direct burial applications in earth or concrete.

TYPES KC, K2C

SERVIT POST™

For Copper Cable to Flat

SERVIT POST™ used to ground one or two cables to steel structures, fence posts, transformers. Also used to tap one or two cables from bus bar. One-wrench installation.

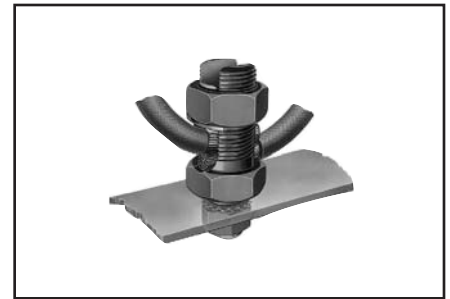

D-25

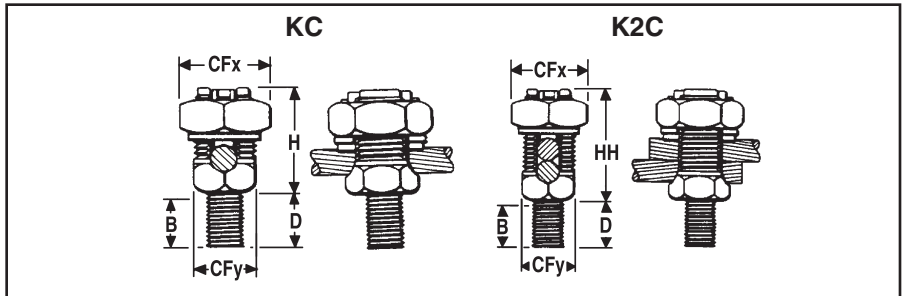

Catalog Number		Conductor		Stud Diameter	B	CFx	CFy	D	H	HH
Type KC †	Type K2C ‡	Stranded	Solid							
KC15	K2C15	12 - 9	12 - 8	1/4 - 20	3/8	1/2	3/8	1/2	5/8	7/8
KC15B1	K2C15B1				7/8			1		
KC17	K2C17	10 - 7	10 - 6	1/4 - 20	3/8	5/8	7/16	1/2	7/8	1
KC17B1	K2C17B1				7/8			1		
KC20	K2C20	10 - 5	10 - 4	5/16 - 18	13/32	11/16	1/2	5/8	7/8	1-1/8
KC20B1	K2C20B1				27/32			1		
KC22	K2C22	10 - 3	10 - 2	3/8 - 16	15/32	3/4	5/8	5/8	1	1-1/4
KC22B1	K2C22B1				31/32			1-1/8		
KC23	K2C23	8 - 2	10 - 1	3/8 - 16	15/32	13/16	5/8	5/8	1	1-3/8
KC23B1	K2C23B1				31/32			1-1/8		
KC25	K2C25	2 - 1/0	2 - 2/0	1/2 - 13	9/16	15/16	3/4	3/4	1-1/8	1-5/8
KC25B1	K2C25B1				1-1/16			1-1/4		
KC26	K2C26	2 - 2/0	2 - 3/0	1/2 - 13	17/32	1	7/8	3/4	1-3/8	1-7/8
KC26B1	K2C26B1				1-1/16			1-1/4		
KC28	K2C28	1 - 4/0	1 - 4/0	5/8 - 11	3/4	1-1/2	1-3/16	1	1-3/4	2-1/4
KC28B1	K2C28B1				1-1/4			1-1/2		
KC31	K2C31	1 - 350	—	5/8 - 11	3/4	1-11/16	1-3/8	1	2-1/4	2-7/8
KC31B1	K2C31B1				1-1/4			1-1/2		
KC34	K2C34	3/0 - 500	—	3/4 - 10	1	2	1-5/8	1-1/4	2-3/8	3-1/4
KC34B1	K2C34B1				1-1/2			1-3/4		

† For 1 conductor.

‡ For 1 or 2 conductors.

Add "NSP" suffix to have connector supplied w/split lockwasher and nut.

TYPES KC22J12T13, EQC632C

TRANSFORMER GROUND CONNECTORS

For Copper

Fits all standard EEI NEMA distribution transformers as a tank grounding terminal.

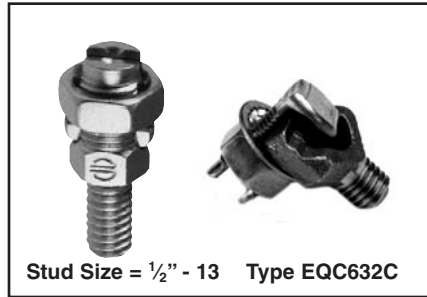

Stud Size = 1/2" - 13 Type EQC632C

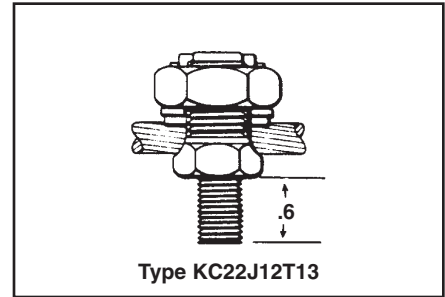

Type KC22J12T13

CATALOG NUMBER	RANGES
KC22J12T13	8 Sol. - 2 Sol.
KC26	2 Sol. - 2/0 Str.
KC34J12T13	3/0 - 500 Str.
EQC632C	8 Sol. - 2 Str.

Both, one-wrench installation.

D-26

TYPE KS

SERVIT™

For Copper

UL467 Listed for direct burial applications in earth or concrete. Compact, high-strength, high copper alloy SERVIT™ split-bolt has free-running threads and easy to grip wrench flats. Highly resistant to cracking and corrosion.



Catalog Number	Cross Flats	L	W	Copper Conductor Range (Sol. - Str.)	Rebar w/ (1) No. 8 Sol. Cu	Recommended Torque In. Lb.
KS15	.50	.85	.38	12 AWG - 8 AWG	N/A	80
KS17	.63	1.14	.45	8 AWG - 6 AWG	N/A	165
KS20	.69	1.20	.51	8 AWG - 4 AWG	N/A	165
KS22	.75	1.50	.60	6 AWG - 3 AWG	N/A	275
KS23	.82	1.54	.62	6 AWG - 2 AWG	N/A	275
KS25	.94	1.77	.73	4 AWG - 1/0	N/A	385
KS26	1.05	1.94	.82	2 AWG - 2/0 6 AWG - 8 AWG Str./Sol.	#3 (3/8")	385
KS27	1.36	1.86	1.17	1 AWG - 3/0	N/A	500
KS29	1.36	2.07	1.17	1 AWG - 250 kcmil 6 AWG - 8 AWG Str./Sol.	#4 (1/2")	650
KS31	1.70	2.51	1.41	1/0 AWG - 350 kcmil 6 AWG - 8 AWG Str./Sol.	#5 (5/8")	650
KS34	1.82	2.79	1.48	2/0 AWG - 500 kcmil 6 AWG - 8 AWG Str./Sol.	#6 (3/4")	825

TYPE GKA

For Copper

UL467 Listed for direct burial applications in earth or concrete. One-piece forged body construction insures mechanical integrity in an underground environment. Supplied with a stainless steel headless screw.

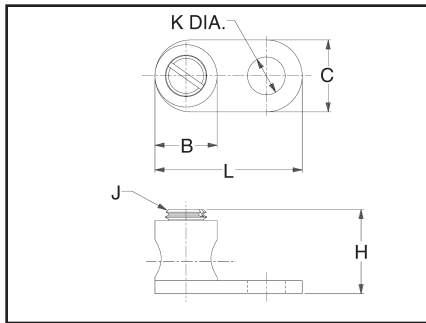

CATALOG NUMBER	CABLE RANGE	B	C	H	J	K	L
GKA8C ¹	#10 SOL. - #8 STR.	.31	.38	.58	#10 - 32	.21	.81
GKA4C ²	#14 SOL. - #4 STR.	.46	.54	.71	5/16 - 24	.28	1.13

1. To be assembled with TMH322 stainless steel hardware kit. Ordered separately.
2. To be assembled with TMH 323 stainless steel hardware kit. Ordered separately.

D-27

TYPE KPB

For Copper

UL467 Listed for direct burial in earth or concrete. UL 486 listed. This exclusive BURNDY® design accommodates #10 - #4 copper where continuous conductor runs are preferable.

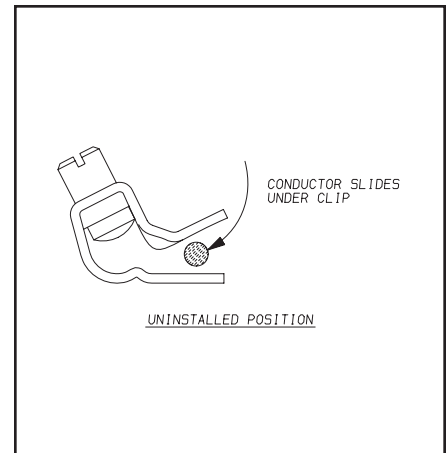
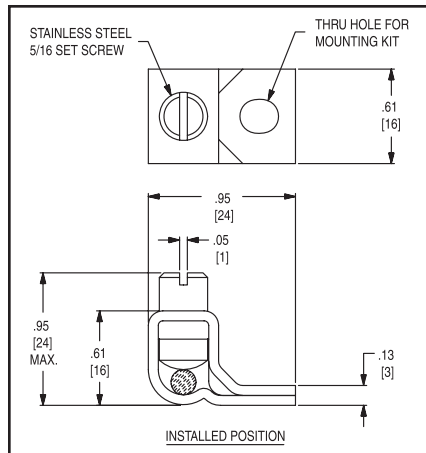

CATALOG NUMBER	RANGE	STUD HOLE
KPB4CG1	#10 - #4 CU	#10 ¹

1. To be assembled with TMH322 stainless steel hardware kit. Ordered separately.

TYPE CL50-1

COPPER LAY-IN QIKLUG™

For Copper

The Lay-In QIKLUG™ is manufactured from high strength pure electrolytic copper to ensure maximum strength and conductivity. UL467 Listed for direct burial in earth or concrete. The open-faced design allows for fast lay-in of the conductor without the need for cutting or breaking.

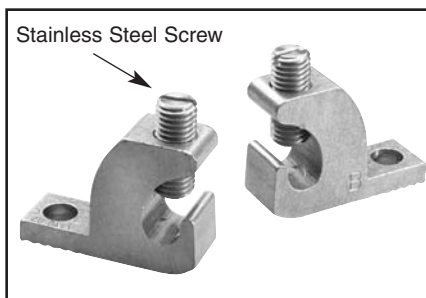

CATALOG NUMBER	WIRE RANGE COPPER	STUD HOLE
CL50-1	#14 - #4 CU	#10

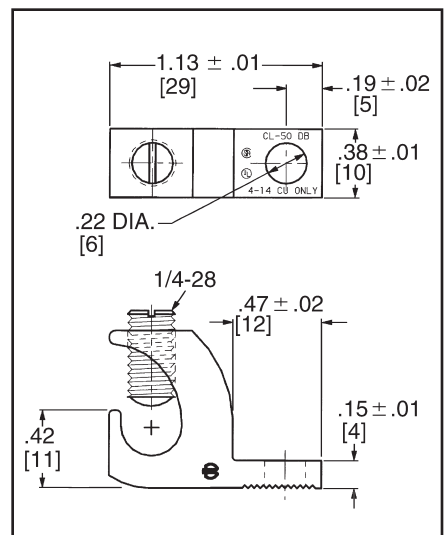

TYPE GAR

FENCE POST GROUNDING CONNECTOR

For Parallel or 90°
Copper Cable
Connection

To Rod or Pipe with
the Same Connector

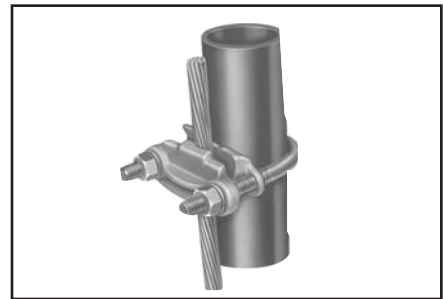
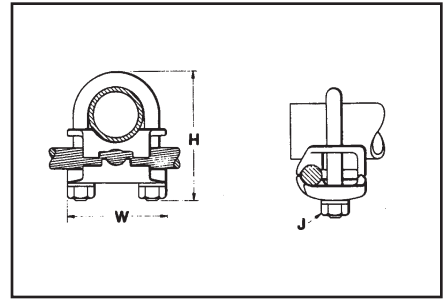
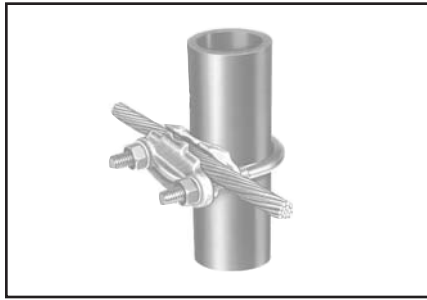

D-28

High copper alloy ground connector for joining a range of cable, parallel or at right angles to rod or tube. Especially good for fence posts. High copper alloy cast body with DURILIUM™ U-bolts, nuts and lockwashers, permit entire connection to be buried in ground or concrete without danger of corrosion.

- One-wrench installation.
- UL467 Listed.
- Acceptable for direct burial.

Catalog Number	Conductor			H	J	W
	Tube I.P.S.	Rod Size or O.D. Range	Cable			
GAR114C	1/4	1/2	8 Sol. - 4 Str.	2-1/2	3/8	1-7/8
GAR1126			4 Sol. - 2/0 Str.			
GAR1129			2/0 Sol. - 250			
GAR644C	3/8	5/8 - 3/4	8 Sol. - 4 Str.	2-7/8		2-1/8
GAR6426			4 Sol. - 2/0 Str.			
GAR6429			2/0 Sol. - 250			
GAR6434	1/2 - 3/4	7/8 - 1	300 - 500	3-1/2	1/2	2-1/2
GAR144C			8 Sol. - 4 Str.	2-3/4	3/8	2-3/8
GAR1426			4 Sol. - 2/0 Str.	3		
GAR1429			2/0 Sol. - 250	3-3/4		
GAR1434	300 - 500					
GAR154C	1	1-1/8 - 1-1/4	8 Sol. - 4 Str.	2-7/8	3/8	2-5/8
GAR1526			4 Sol. - 2/0 Str.			
GAR1529			2/0 Sol. - 250	3-3/8		
GAR1534			300 - 500	4-1/2		
GAR164C	1-1/4	1-3/8 - 1-1/2	8 Sol. - 4 Str.	3-1/2	3/8	3
GAR1626			4 Sol. - 2/0 Str.			
GAR1629			2/0 Sol. - 250			
GAR1634			300 - 500			
GAR174C	1-1/2	1-5/8 - 1-7/8	8 Sol. - 4 Str.	4	3/8	3-1/4
GAR1726			4 Sol. - 2/0 Str.			
GAR1729			2/0 Sol. - 250			
GAR1734			300 - 500			
GAR184C	2	2 - 2-3/8	8 Sol. - 4 Str.	4-1/4	3/8	3-3/4
GAR1826			4 Sol. - 2/0 Str.			
GAR1829			2/0 Sol. - 250	4-1/2		
GAR1834			300 - 500	5-1/4		
GAR194C	2-1/2	2-1/2 - 7/8	8 Sol. - 4 Str.	5	3/8	4-1/4
GAR1926			4 Sol. - 2/0 Str.			
GAR1929			2/0 Sol. - 250			
GAR1934			300 - 500			

TYPE GAR (Continued)

FENCE POST GROUNDING CONNECTOR

Catalog Number	Conductor			H	J	W
	Tube I.P.S.	Rod Size or O.D. Range	Cable			
GAR204C	3	3 - 3-1/2	8 Sol. - 4 Str.	5-5/8	3/8	4-3/4
GAR2026			4 Sol. - 2/0 Str.			
GAR2029			2/0 Sol. - 250			
GAR2034			300 - 500	6-3/8	1/2	5-1/4
GAR214C	3-1/2	3-1/2 - 4	8 Sol. - 4 Str.	6-1/4	3/8	5-3/8
GAR2126			4 Sol. - 2/0 Str.			
GAR2129			2/0 Sol. - 250			
GAR2134			300 - 500	6-3/4	1/2	5-3/4
GAR224C	4	4 - 4-1/2	8 Sol. - 4 Str.	6-3/8	3/8	5-7/8
GAR2226			4 Sol. - 2/0 Str.			
GAR2229			2/0 Sol. - 250			
GAR2234			300 - 500	6-7/8	1/2	6-1/4
GAR244C	5	—	8 Sol. - 4 Str.	7-3/4	3/8	6-7/8
GAR2426			4 Sol. - 2/0 Str.			
GAR2429			2/0 Sol. - 250			
GAR2434			300 - 500	8-5/8	1/2	7-1/4
GAR8629	6	—	2/0 Sol. - 250	8-13/16	1/2	8-3/8

D-29

Contact BURNDY® for additional pipe and wire size combinations not shown.

TYPES GAR-BU AND GAR3902 SERIES

GROUND CONNECTORS

Type GAR-BU is a high-conductivity copper ground connector for connecting a small to medium range copper ground conductor to water pipe as well as structural and reinforcing rod shapes. Universal acceptance of several sizes of cylindrical shapes makes this suitable for industrial construction and maintenance work as well as cathodic protection. Cable clamp swivels to permit parallel grounding of one pipe or 90° degree cable run for grounding several parallel pipes. Single wrench installation. UL467 Listed and CSA certified.

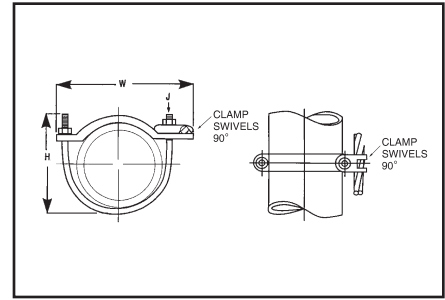

Features and benefits

- Cable clamp swivels at 90°.
 - ◇ Permits parallel grounding of one pipe or a 90° cable run for grounding several parallel pipes.
- One-wrench installation.
 - ◇ Simplified installation.
- DURIUUM™ silicon bronze hardware (-BU Series)*.
 - ◇ Long lasting corrosion resistance and acceptable for direct burial in earth or concrete.
- UL467 Listed.
 - ◇ Provides quality assurance to recognized industry NEC standards from an independent party.

D-30



CATALOG NUMBER *	CABLE RANGE	IPS SIZE	O.D. RANGE	H	J	W	RECOMMENDED TIGHTENING TORQUE
GAR3902-BU	#4 - 4/0 AWG	1/2" - 1"	.840 - 1.32	3.50	3/8" - 16	3.25	240 in. - lbs.
GAR3903-BU		1-1/4" - 2"	1.66 - 2.38	4.00		4.25	
GAR3904-BU		2-1/2" - 3-1/2"	2.88 - 4.00	6.50		6.00	
GAR3905-BU		4" - 5"	4.50 - 5.56	7.50		7.50	
GAR3906-BU		6"	6.62	8.50		8.62	
GAR3907-BU		8"	8.62	10.00		10.62	
GAR3908-BU		10"	10.75	12.00		12.75	
GAR3909-BU		12"	12.75	14.00		14.75	
GAR3902	#4 - 4/0 AWG	1/2" - 1"	.840 - 1.32	3.50	3/8" - 16	3.25	240 in. - lbs.
GAR3903		1-1/4" - 2"	1.66 - 2.38	4.00		4.25	
GAR3904		2-1/2" - 3-1/2"	2.88 - 4.00	6.50		6.00	
GAR3905		4" - 5"	4.50 - 5.56	7.50		7.50	
GAR3906		6"	6.62	8.50		8.62	
GAR3907		8"	8.62	10.00		10.62	
GAR3908		10"	10.75	12.00		12.75	
GAR3909		12"	12.75	14.00		14.75	

* Type GAR-BU is supplied with DURIUUM™ silicon bronze hardware and is listed for direct burial.

TYPE GAR-RB

For Reinforcement Bar



CATALOG NUMBER	REBAR	IPS SIZE	O.D. RANGE	ROD	COPPER CONDUCTOR	
					MIN.	MAX.
GAR644C-RB	#3 - 6 (.375 - .750)	3/8	.625 - .75	5/8 - 3/4	8 Sol.	4 Str.

UL467 listed for direct burial in earth or concrete.

TYPE GAR-TC

WATER PIPE GROUND CONNECTOR

Type GAR-TC is a high-conductivity copper ground connector that features a pre-drilled pad, allowing a 2-hole compression terminal to be directly connected to water pipe as well as structural and reinforcing rod shapes. Universal acceptance of several sizes of cylindrical shapes makes this suitable for industrial construction and maintenance work as well as telecommunications grounding. Terminal may be mounted parallel, 45° or 90° degrees to the pipe. Acceptable for direct burial.

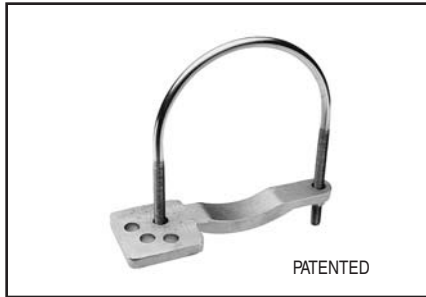

Features and Benefits

- Large, smooth connector contact area between pipe and ground clamp
 - ◇ Provides large surface contact area to maximize contact area between connector and pipe.
- The GAR-TC mounting pad permits parallel, 45° or 90° angle connections to the pipe.
 - ◇ Provides maximum flexibility for field installation.
- Pre-drilled pad for (2) 3/8" bolts on 1" centers.
 - ◇ Allows direct mounting of (2) hole compression terminals up to 750 kmil to pipe.
- DURIMUM™ silicon bronze hardware.
 - ◇ Provide long lasting corrosion resistance acceptable for direct burial in earth or concrete.
- One-wrench installation.
 - ◇ Simplified installation.
- UL467 Listed.
 - ◇ Provides quality assurance to recognized industry NEC standards from an independent party. Type GAR-TC is acceptable for direct burial

D-31

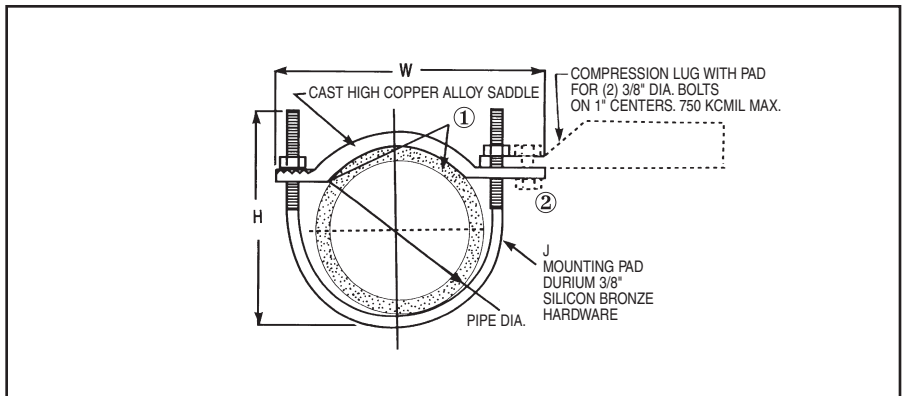
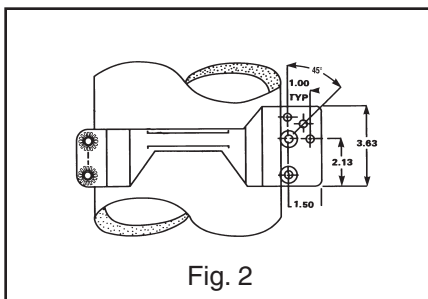
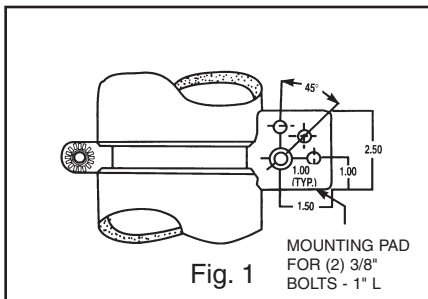

CATALOG NUMBER	FIG. NO.	ACCOMMODATES		H	J	W	RECOMMENDED TIGHTENING TORQUE
		I.P.S.	O.D. SIZE				
GAR3902TC	1	1/2" - 1"	.840 - 1.32	3.50	3/8" - 16	3.75	240 in.-lbs.
GAR3903TC	1	1-1/4" - 2"	1.66 - 2.38	4.00		4.75	
GAR3904TC	1	2-1/2" - 3-1/2"	2.88 - 4.00	6.50		6.50	
GAR3905TC	1	4" - 5"	4.50 - 5.56	7.50		8.00	
GAR3906TC	1	6"	6.62	8.50		9.12	
GAR3907TC	2	8"	8.62	10.00	3/8" - 16	11.25	240 in.-lbs.
GAR3908TC	2	10"	10.75	12.00		13.25	
GAR3909TC	2	12"	12.75	14.00		15.25	

① Add suffix "-TNET" for electro-tin plated connector and electro-tin plated DURIMUM™ silicon bronze hardware. Tin plated catalog number includes mounting hardware for second bolt hole.

② TMH-289 includes (1) 38 x 125 HEB, (1) 38 CHEN, (1) 38 SW and (2) 38 FW. Order separately.

NOTE: Clean pipe surface beneath saddle until virgin metal is exposed, install GAR-TC ground connector and for maximum conductivity, apply PENETROX®-E oxide inhibiting compound around perimeter of the saddle.

TYPE GD

CABLE TO ROD/TUBE GROUND CONNECTOR

For Two Copper Cables to Rod
or Tube

High copper alloy ground connector for joining a range of two parallel cables to rod or pipe. Especially good for grounding fence posts. High copper alloy cast body with DURIUUM™ U-bolts, nuts, and lockwashers make the GD suitable for burial in ground or concrete. One-wrench installation. UL467 Listed. Acceptable for direct burial in earth or concrete.

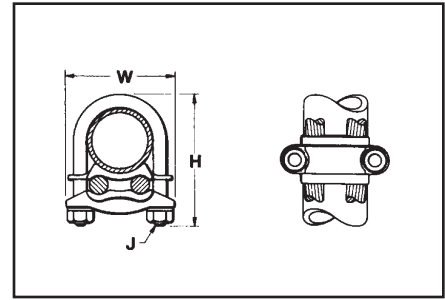

D-32



Catalog Number	Conductor			H	J	W	
	Tube I.P.S.	Rod Size or O.D. Range	Cable				
GD1526	1	1-1/8 - 1-1/4	4 Sol. - 2/0 Str.	3-3/8	3/8	2-5/8	
GD1529			2/0 Sol. - 250				
GD1626	1-1/4	1-3/8 - 1-1/2	4 Sol. - 2/0 Str.	3-1/2		3/8	3
GD1629			2/0 Sol. - 250				
GD174C	1-1/2	1-5/8 - 1-7/8	8 Sol. - 4 Str.	4		1/2	3-1/4
GD1726			4 Sol. - 2/0 Str.				
GD1729			2/0 Sol. - 250				
GD1734	2	2 - 2-3/8	300 - 500	4-5/8	3/8	3-5/8	
GD184C			8 Sol. - 4 Str.				
GD1826			4 Sol. - 2/0 Str.				
GD1829			2/0 Sol. - 250				
GD1834	2-1/2	2-1/2 - 2-7/8	300 - 500	5-3/8	1/2	4-1/8	
GD194C			8 Sol. - 4 Str.				
GD1926			4 Sol. - 2/0 Str.				
GD1929	3	3 - 3-1/2	2/0 Sol. - 250	5	3/8	4-1/4	
GD1934			300 - 500				
GD204C	3-1/2	3-1/2 - 4	8 Sol. - 4 Str.	6-3/8	1/2	5-1/4	
GD2026			4 Sol. - 2/0 Str.				
GD2029			2/0 Sol. - 250				
GD2034	4	4 - 4-1/2	300 - 500	6-7/8	3/8	5-3/8	
GD214C			8 Sol. - 4 Str.				
GD2126			4 Sol. - 2/0 Str.				
GD2129			2/0 Sol. - 250				
GD2134	4	4 - 4-1/2	300 - 500	6-7/8	1/2	5-3/4	
GD224C			8 Sol. - 4 Str.				
GD2226			4 Sol. - 2/0 Str.				
GD2229	4	4 - 4-1/2	2/0 Sol. - 250	6-3/8	3/8	5-7/8	
GD2234			300 - 500				
GD2234	4	4 - 4-1/2	300 - 500	6-7/8	1/2	6-1/4	

Complies with NFPA 78-86 HEAVY DUTY stacks.
(Order: LD for lead plating for HEAVY DUTY stack applications.)

TYPE GP

GROUND CONNECTOR

For Two Copper Cables to Rod or Pipe

High copper alloy ground connector for joining a range of parallel cables perpendicular to rod, pipe or column. Also used with one groove for run, the other for tap to equipment. High copper alloy cast body and DURIMUM™ U-bolts, nuts, and lockwashers make the GP suitable for direct burial in the ground or concrete. One-wrench installation. UL467 Listed. Acceptable for direct burial in earth or concrete.

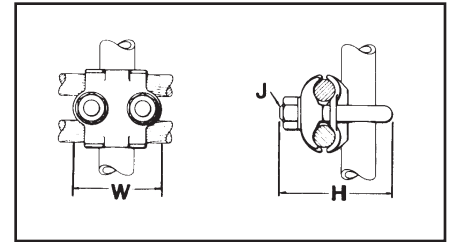

Catalog Number	Conductor			H	J	W
	Tube I.P.S.	Rod Size or O.D. Range	Cable			
GP114C	1/4	1/2	8 Sol. - 4 Str.	2-1/2	3/8	1-7/8
GP1126			4 Sol. - 2/0 Str.			
GP1129			2/0 Sol. - 250			
GP644C	3/8	5/8 - 3/4	8 Sol. - 4 Str.	2-7/8	1/2	2-1/8
GP6426			4 Sol. - 2/0 Str.			
GP6429			2/0 Sol. - 250	3-1/2		2-1/2
GP6434			300 - 500	2-3/4		2-3/8
GP144C	1/2 - 3/4	7/8 - 1	8 Sol. - 4 Str.	3	38	2-3/8
GP1426			4 Sol. - 2/0 Str.			
GP1429			3/0 Sol. - 250			
GP1434			300 - 500	3-3/4	1/2	2-3/4
GP164C	1-1/4	1-5/8	8 Sol. - 4 Str.	3-1/2	3/8	3
GP1629			2/0 Sol. - 250			
GP1726	1-1/2	1-7/8	4 Sol. - 2/0 Str.	4		3-1/4
GP184C	2	2-3/8	8 Sol. - 4 Str.	4-1/8	3/8	3-11/16
GP1826			4 Sol. - 2/0 Str.	4-3/8		
GP2026			4 Sol. - 2/0 Str.	5-1/2		
GP2226	4	4-1/2	4 Sol. - 2/0 Str.	6-3/8		5-13/16

D-33

TYPE GK

GROUND CONNECTOR

For Three Copper Cables to Rod or Pipe

High copper alloy ground connector for joining three equal cables to rod or tube. Cable grooves take a wide range of cable. High copper alloy cast body and DURIMUM™ U-bolts, nuts, and lockwashers make the GK suitable for direct burial in soil or concrete. One-wrench installation. UL467 Listed. Acceptable for direct burial in earth or concrete.

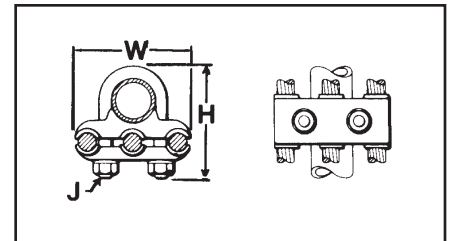
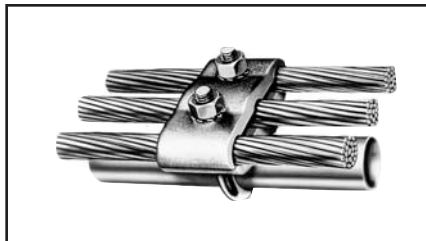

Catalog Number	Conductor			H	J	W
	Tube I.P.S.	Rod Size or O.D. Range	Cable			
GK114C	1/4	1/2	8 Sol. - 4 Str.	2-1/2	3/8	2-1/2
GK1126			4 Sol. - 2/0 Str.			2-3/4
GK1129			2/0 Sol. - 250			3-3/8
GK644C	3/8	5/8 - 3/4	8 Sol. - 4 Str.	2-7/8	3/8	2-5/8
GK6426			4 Sol. - 2/0 Str.			3
GK6429			2/0 Sol. - 250	3-1/2		
GK6434			300 - 500	4		
GK1426	1/2 - 3/4	7/8 - 1	4 Sol. - 2/0 Str.	2-3/4	38	3-1/4
GK1429			2 Sol. - 250	3-7/8		
GK1434			300 - 500	4-3/8		
GK1526	1	1-1/8 - 1-1/4	4 Sol. - 2/0 Str.	3-3/8	3/8	3-1/2
GK1529			2/0 Sol. - 250	3-3/4		4-1/8
GK1626	1-1/4	1-3/8 - 1-1/2	4 Sol. - 2/0 Str.	3-1/2	3/8	3-7/8
GK1629			2/0 Sol. - 250	4-1/4		4-1/2
GK1726	1-1/2	1-5/8 - 1-7/8	4 Sol. - 2/0 Str.	4	3/8	4-1/8
GK1729			2/0 Sol. - 250	4-5/8		4-3/4
GK1826	2	2 - 2-3/8	4 Sol. - 2/0 Str.	4-1/4	3/8	4-5/8
GK1829			2/0 Sol. - 250	4-3/8		5-1/8
GK1926	2-1/2	2-1/2 - 2-7/8	4 Sol. - 2/0 Str.	5	3/8	5-1/8
GK1929			2/0 Sol. - 250	5		5-5/8

CAST BRONZE CLAMPS FOR CONDUIT

Pressure bar type conduit hub adjusts for 1/2", 3/4" EMT or 1/2" rigid conduit. Hub swings 360° for easy alignment. Zinc plated hardware.



CATALOG NUMBER	ACCOMMODATES CONDUCTOR RANGE			REFERENCE DIMENSIONS			RECOMMENDED SCREW TORQUE "INCH POUNDS"	
	WATER PIPE	GROUND	HUB SIZE	H	L	W	PIPE CLAMP	WIRE CLAMP
C-11JPT	1/2 - 1 [13 - 25]	10 - 6 Sol.	1/2 [13]	2.07 [53]	3.19 [81]	2.70 [69]	50 in.-lb.	50 in.-lb.
C-22JPT	1-1/4 - 2 [32 - 51]			2.70 [69]	3.83 [97]			
C-4JPT	2-1/2 - 4 [64 - 102]			4.39 [112]	5.15 [131]			

D-34

CAST BRONZE GROUND CLAMPS

For connecting grounding conductor to water pipe or copper tube. "D" indicates UL467 Listed for direct burial in earth and concrete and are supplied with silicon bronze hardware. "B" indicates brass hardware.



CATALOG NUMBER	ACCOMMODATES CONDUCTOR RANGE			REFERENCE DIMENSIONS				RECOMMENDED SCREW TORQUE "INCH POUNDS"	
	WATER PIPE	REBAR	GROUND	H	L	W	C	PIPE CLAMP	WIRE CLAMP
C-11N	1/2 - 1 [13 - 25]	—	10 - 2 Str.	1.81 [46]	2.25 [56]	.63 [16]	.63 [16]	50 in.-lb.	50 in.-lb.
C-11D		#4 - #6							
C-11B		—							
C-22	1-1/4 - 2 [32 - 51]	—	10 - 2 Str.	2.38 [60]	3.63 [92]	.75 [19]	1.00 [25]		
C-22D									
C-4	2-1/2 - 4 [64 - 114]	—	10 - 2 Str.	4.13 [105]	6.25 [159]	.96 [24]	1.88 [48]		
C-8	4-1/2 - 6 [114 - 165]	—	10 - 2 Str.	4.29 [109]	8.34 [212]	1.25 [32]	1.88 [48]		

BUDGET PRICE CAST BRONZE GROUND CLAMP

Similar to above but lighter duty.



CATALOG NUMBER	ACCOMMODATES CONDUCTOR RANGE			REFERENCE DIMENSIONS				RECOMMENDED SCREW TORQUE "INCH POUNDS"	
	WATER PIPE	REBAR	GROUND	H	L	W	C	PIPE CLAMP	WIRE CLAMP
C-5 (JUNIOR)	1/2 - 1 [13 - 25]	—	10 - 2 Str.	1.56 [40]	2.25 [56]	.56 [14]	.50 [13]	50 in.-lb.	50 in.-lb.

CAST BRONZE GROUND CLAMPS

With Lay-in Feature

For connecting grounding conductor to water pipe, copper tube, ground rod or rebar. The open face design allows for fast lay-in of the tap conductor without the need for cutting. Simply reverse bottom clamp for smaller size rebar or rod. Connectors are provided with Silicon Bronze hardware.

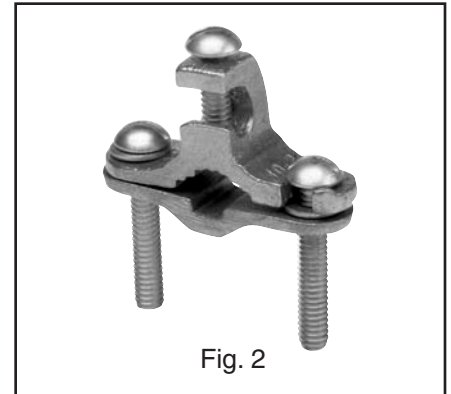
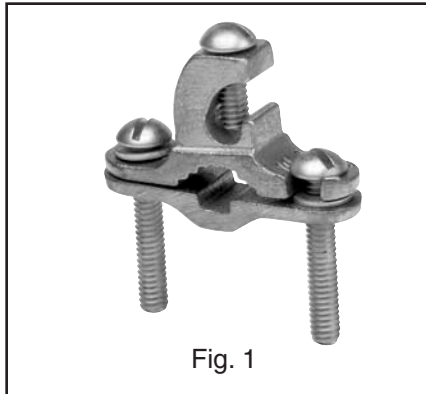

D-35

CATALOG NUMBER	FIG #	ACCOMMODATES CONDUCTOR RANGE				REFERENCE DIMENSIONS			RECOMMENDED SCREW TORQUE "INCH POUNDS"
		MAIN		TAP	H	L	W		
		WATER PIPE	REBAR	GROUND ROD				GROUND	
C11K16D	Fig 1	1/2" - 1"	#4 - #6	3/8" - 1"	#10 - #2 Str.	1.64	2.28	0.66	50 in.-lbs.
C11K17D	Fig 2	[13 - 25]							

DIE CAST CLAMPS

Die cast zinc with zinc plated screws.



CATALOG NUMBER	ACCOMMODATES CONDUCTOR RANGE		REFERENCE DIMENSIONS				RECOMMENDED SCREW TORQUE "INCH POUNDS"	
	WATER PIPE	GROUND	H	L	W	C	PIPE CLAMP	WIRE CLAMP
							50 in.-lb.	50 in.-lb.
CZ-11	1/2 - 1 [13 - 25]	10 - 2 Str.	1.56 [40]	2.25 [56]	.56 [14]	.50 [13]	50 in.-lb.	50 in.-lb.

CAST BRONZE CLAMPS

To connect armored cable to water pipe. Zinc plated screws. Pressure bar grips armor or outer cable insulation. 360° swing hub for easy alignment.



CATALOG NUMBER	ACCOMMODATES CONDUCTOR RANGE		REFERENCE DIMENSIONS			RECOMMENDED SCREW TORQUE "INCH POUNDS"	
	WATER PIPE	ARMORED CONDUCTOR	H	L	W	PIPE CLAMP	WIRE CLAMP
C-11JA	1/2 - 1 [13 - 25]	10 - 6 Sol.	1.38 [35]	3.05 [77]	1.41 [36]	50 in.-lb.	50 in.-lb.
C-22JA	1-1/4 - 2 [32 - 51]		2.60 [66]	3.69 [94]			
C-4JA	2-1/2 - 4 [64 - 102]		4.29 [109]	5.01 [128]			

D-36

CAST BRONZE GROUND CLAMPS

For connecting grounding conductor, EMT or rigid conduit to water pipe, copper tube, ground rod or rebar. Hub swings 360° for easy alignment. Simply reverse bottom clamp for smaller size rebar or rod. Connectors are provided with Silicon Bronze hardware.

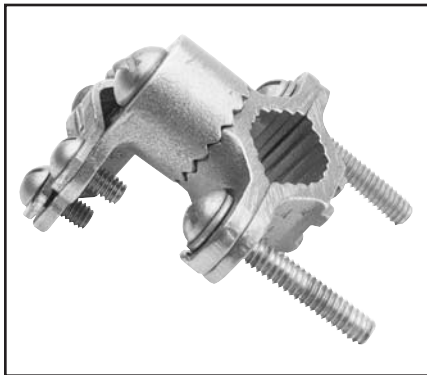

CATALOG NUMBER	ACCOMMODATES CONDUCTOR RANGE				REFERENCE DIMENSIONS			RECOMMENDED SCREW TORQUE "INCH POUNDS"
	MAIN			TAP	H	L	W	
	WATER PIPE	REBAR	GROUND ROD	GROUND				
C11HD4/0DB	1/2" - 1" [13 - 25]	#4 - #6	3/8" - 1"	#8 - 4/0 AWG	2.25	2.65	1.56	50 in.-lbs.
C22HD4/0DB	1-1/4" - 2" [32 - 51]	—	—	#8 - 4/0 AWG	2.70	3.60	1.56	50 in.-lbs.

CAST BRONZE CLAMPS

For connecting armored cable to water pipe. Zinc plated screws. "D" indicates UL467 for direct burial in earth and concrete, supplied with silicon bronze hardware.



CATALOG NUMBER	ACCOMMODATES CONDUCTOR RANGE			REFERENCE DIMENSIONS				RECOMMENDED SCREW TORQUE "INCH POUNDS"	
	WATER PIPE	GROUND	GROUND CLAMP	H	L	W	C	PIPE CLAMP	WIRE CLAMP
C-6	1/2 - 1 [13 - 25]	10 - 2 Str.	Bare Armored Unarmored Wire Cables or Cords	1.60	2.34	1.06	.63	50 in.-lb.	50 in.-lb.
C-6D				[41]	[59]	[27]	[16]		
C-7	1-1/4 - 2 [32 - 51]	10 - 2 Str.		2.38 [60]	3.62 [92]	.94 [24]	1.00 [25]		

BURNDY® Products FCI

Grounding

CAST BRONZE CLAMP FOR RIGID CONDUIT

For grounding rigid conduit systems.
Zinc plated screws.



CATALOG NUMBER	ACCOMMODATES CONDUCTOR RANGE			REFERENCE DIMENSIONS				RECOMMENDED SCREW TORQUE "INCH POUNDS"	
	WATER PIPE	GROUND	HUB SIZE	H	L	W	C	PIPE CLAMP	WIRE CLAMP
C-61	1/2 - 1 [13 - 25]	#6 Sol. Max.	1/2 [13]	2.07 [53]	2.34 [59]	1.34 [34]	1.06 [27]	50 in.-lb.	50 in.-lb.
C-66	1-1/4 - 2 [32 - 51]			2.69 [68]	3.62 [92]	1.34 [34]	1.40 [36]		

D-38

CAST BRONZE CLAMPS FOR CONDUIT

For grounding rigid conduit systems.
Continuity from rigid conduit systems to ground provided by cast bronze threaded conduit hub. Zinc plated screws.



CATALOG NUMBER	ACCOMMODATES CONDUCTOR RANGE			REFERENCE DIMENSIONS				RECOMMENDED SCREW TORQUE "INCH POUNDS"	
	WATER PIPE	GROUND	HUB SIZE	H	L	W	C	PIPE CLAMP	WIRE CLAMP
C-11LH-1	1/2 - 1 [13 - 25]	10 Str. - 6 Sol.	1/2 [13]	2.25 [57]	3.23 [83]	.69 [18]	.97 [25]	50 in.-lb.	50 in.-lb.
C-22LH-1	1-1/4 - 2 [32 - 51]			2.88 [73]	3.50 [89]		1.34 [34]		
C-4LH-1	2-1/2 - 4 [54 - 102]			4.56 [116]	4.82 [122]		2.44 [62]		
C-11LH-2	1/2 - 1 [13 - 25]	2/0 - 10 Str.	3/4 [19]	2.56 [65]	2.86 [73]	1.00 [25]	1.13 [29]		
C-22LH-2	1-1/4 - 2 [32 - 51]			3.19 [65]	3.50 [89]		1.50 [38]		
C-4LH-2	2-1/2 - 4 [64 - 102]			4.88 [124]	4.82 [122]		2.38 [60]		
C-11LH-3	1/2 - 1 [13 - 25]	3/0 - 10 Str.	1 [25]	2.69 [68]	2.86 [73]	1.13 [29]	1.19 [30]		
C-22LH-3	1-1/4 - 2 [32 - 51]			3.32 [59]	3.50 [89]		1.56 [40]		
C-4LH-3	2-1/2 - 4 [63 - 102]			5.01 [127]	4.82 [122]		2.44 [62]		

CAST BRONZE CLAMP WITH COPPER STRAP

For grounding rigid conduit systems. Strap helps protect conduit system from water system vibrations. Zinc plated screws. Strap ETP copper.

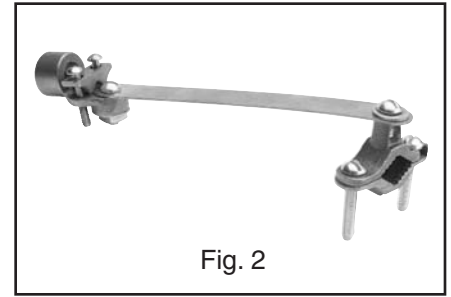
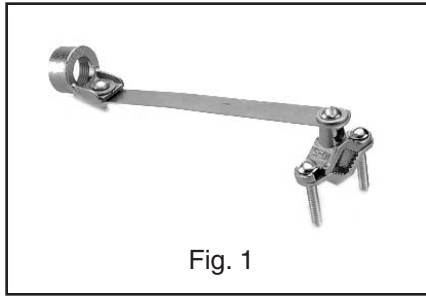

CATALOG NUMBER	FIG. #	ACCOMMODATES CONDUCTOR RANGE			REFERENCE DIMENSIONS					RECOMMENDED SCREW TORQUE "INCH POUNDS"	
		WATER PIPE	GROUND	HUB SIZE	H	L	W	C	D	PIPE CLAMP	WIRE CLAMP
C-11CSH-1	Fig. 1	1/2 - 1 [13 - 25]	6 Sol. Max.	1/2 [13]	1.75 [44]	8.50 [216]	1.06 [27]	1.06 [27]	6.12 [155]	50 in.-lb.	50 in.-lb.
C-11CSH-2	Fig. 1		4/0 Str. Max.	3/4 [19]			1.25 [32]	1.50 [38]			
C-11CSH-3	Fig. 1			1 [25]			1.50 [38]	1.75 [44]			
C11CSLH12	Fig. 2		#10 - 2/0 AWG	1/2 [13]			1.18	1.06 [27]			

D-39

GROUND STRAPS, ADJUSTABLE

BURNDY® adjustable ground straps are made from pure annealed copper. The heavy type is .050" thick and 3/4" wide. The light type is .025" thick and 3/4" wide. The bolts, nuts and washers are plated steel. Four sizes cover a ground pipe range of 3/8" to 4". Ground wire connection can be soldered or solderless.

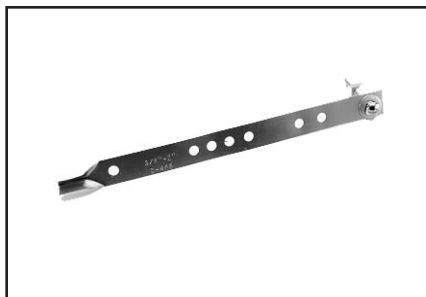

CATALOG NUMBER	ACCOMMODATES	REFERENCE DIMENSIONS			RECOMMENDED SCREW TORQUE "INCH POUNDS"
	WATER PIPE	H	L	W	
GS1T50	3/8 - 1 [10 - 25]	.050 [1]	5.61 [142]	.75 [19]	50 in.-lb.
GS1T25		.025 [1]			
GS2T50	3/8 - 2 [10 - 51]	.050 [1]	9.38 [238]		
GS2T25		.025 [1]			
GS3T50	3/8 - 3 [10 - 76]	.050 [1]	13.20 [335]		
GS3T25		.025 [1]			
GS4T50	3/8 - 4 [10 - 102]	.050 [1]	17.00 [432]		
GS4T25		.025 [1]			

TYPE GC-A

DUAL RATED GROUND CLAMP

For Copper and
Aluminum Cable

GC-A ground clamps are UL Listed for use with either copper or aluminum conductors to copper water pipe, galvanized pipe or steel conduit. All clamps are constructed from tin plated high-strength extruded aluminum alloy. PENETROX™ oxide inhibiting joint compounds are recommended for all aluminum applications.



Features and Benefits

- Clamps are dual rated for both copper and aluminum conductors.
 - ◊ Maximum flexibility of application.
- All connectors are tin plated.
 - ◊ Provide low contact resistance and prevents galvanic corrosion.
- All clamps are range taking.
 - ◊ Only 3 catalog numbers covers complete range of applications from 1/2 - 4 inches.

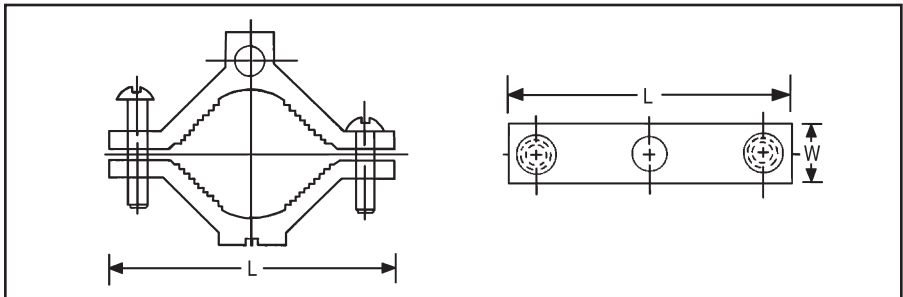

Catalog Number	Conduit, Pipe, or Water Tube Size	Wire Range	Screw Type	W	L	Hex Size
GC15A	1/2 - 3/4 - 1	1/0 - 14	Slotted	11/16	2-1/4	S
GC18A	1-1/4 - 1-1/2 - 2	250 MCM - 6	Hex Socket	13/16	3-3/4	5/16
GC22A	2-1/2 - 3 - 3-1/2 - 4	250 MCM - 6	Hex Socket	1	6-5/16	5/16

TYPE GG

GROUND CONNECTOR

For Copper Bar, Strap, Braid or Cable to Rod or Tube

High copper alloy ground connector for joining bar, strap, braid or cable to rod or tube. High copper alloy cast body, DURIMUM™ U-bolts, nuts and lockwashers make the GG particularly effective for use with braid for ground rods, switch handles, fence posts and gates. One-wrench installation.

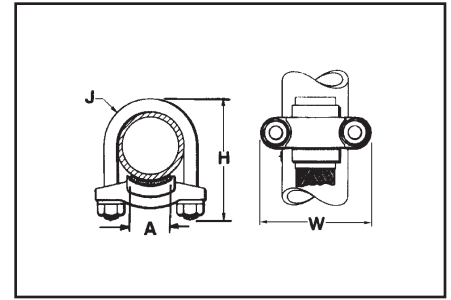

D-41

Catalog Number	Conductor		A	H	J	W
	Tube I.P.S.	Rod				
GG15-1	1	1-1/8 - 1-1/4	1	3-3/8	3/8	2-5/8
GG16-1	1-1/4	1-3/8 - 1-1/2		3		
GG17-1	1-1/2	1-5/8 - 1-7/8		3-1/2		3-1/4
GG17-15			1-1/2			
GG18-1	2	2 - 2-3/8	1	4-1/4	1/2	3-3/4
GG18-15			1-1/2	4-3/8		4-1/8
GG18-2			2	5		4-1/8
GG19-2	2-1/2	2-1/2 - 2-7/8	2	6-3/8	1/2	4-5/8
GG19-25			2-1/2			5-1/4
GG20-2	3	3 - 3-1/2	2	5-7/8	1/2	5-3/4
GG20-25			2-1/2			
GG20-3			3			
GG21-2	3-1/2	3-1/2 - 4	2	6-1/2	1/2	6-1/4
GG21-25			2-1/2			
GG21-3			3			
GG21-35			3-1/2			
GG22-2	4	4 - 4-1/2	2	7-5/8	1/2	7-1/4
GG22-25			2-1/2			
GG22-3			3			
GG22-35			3-1/2			
GG22-4			4			
GG24-2	5	—	2	7-5/8	1/2	7-1/4

See note page D-1

TYPE GQ

GROUND CONNECTOR

For Copper Cable to Tube

High copper alloy ground connector for cross connecting a wide range of cable. High copper alloy, cast body, DURIMUM™ U-bolts, nuts, and lockwashers make the GQ suitable for burial in soil or concrete. One-wrench installation. UL467 Listed. Acceptable for direct burial in earth or concrete.

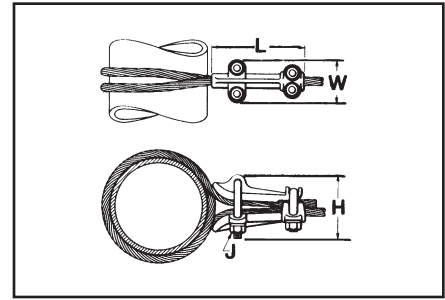
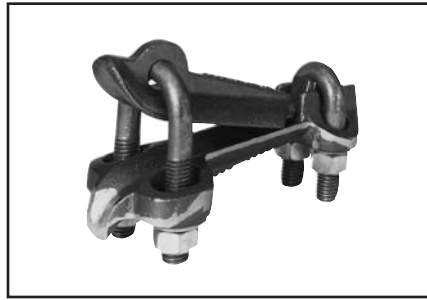

D-42

Catalog Number	Conductor		H	J	L	W
	Tube I.P.S.	Cable				
GQ2626	6" Max.	4 Str. - 2/0 Str.	4-1/2	1/2	5	2-1/2
GQ26-1	Above 6"		7-1/8			
GQ2929	6" Max.	2/0 Str. - 250	4-1/8		6	2-3/4
GQ29-1	Above 6"		7-1/2			

TYPE GX

GROUND CONNECTOR

For Copper Cables

High copper alloy ground connector for cross connecting a wide range of cable. The high copper alloy cast body, DURIMUM™ U-bolts, nuts, and lockwashers make the GX suitable for burial in soil or concrete. One-wrench installation. UL467 Listed. Acceptable for direct burial in earth or concrete.

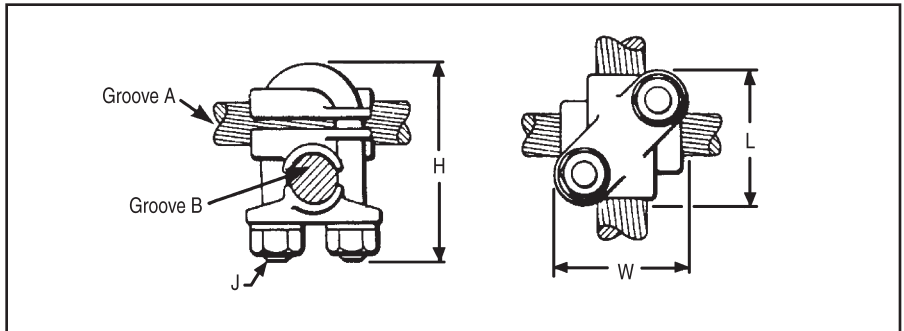
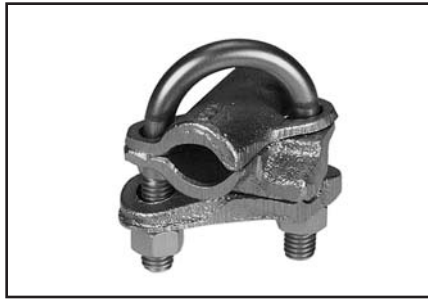

D-43

Catalog Number	Conductor		H	J	L	W
	Groove A	Groove B				
GX4C4C	8 Sol. - 4 Str.	8 Sol. - 4 Str.	1-7/8	3/8	1-5/8	1-5/8
GX264C	4 Sol. - 2/0 Str.	8 Sol. - 4 Str.	2-1/2		1-3/4	1-3/4
GX2626		4 Sol. - 2/0 Str.		2-3/4	1-7/8	1-7/8
GX294C	2/0 Sol. - 250	8 Sol. - 4 Str.	2-3/4			
GX2926		4 Sol. - 2/0 Str.				
GX2929	300 - 500	2/0 Sol. - 250	2-3/4	1-7/8	1-7/8	
GX344C		8 Sol. - 4 Str.				
GX3426	300 - 500	4 Sol. - 2/0 Str.	2-3/4	2-1/8	1-7/8	
GX3429		2/0 Sol. - 250				
GX3434	300 - 500	300 - 500	4-1/4	1/2	2-5/8	2-5/8

TYPE GRC

HIGH STRENGTH GROUND ROD CLAMP

For Copper Cable to Rod

High copper alloy ground connector for joining a range of cable to copper clad, galvanized steel, and stainless steel ground rods. Slips over end of rod, one-wrench installation. UL467 Listed for direct burial in earth and concrete.

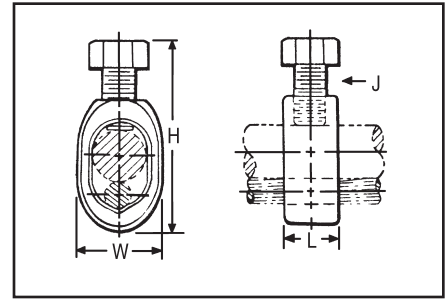

REA LISTED



Catalog Number	Drive Rod	Conductor Range		H	W	L	J
		Min.	Max.				
GRC12	1/2	10 Sol.	2 Str.	2.00	.89	.63	3/8
GRC58	5/8		1 Str.	2.19	.95	.63	
GRC34	3/4	8 Sol.	1/0 Str.	2.47	1.09	.65	

D-44

TYPE GRL

LIGHT DUTY ECONOMICAL GROUND ROD CLAMP

UL 467 Listed. Acceptable for direct burial.



Catalog Number	Rod Size	Conductor Range	
		Minimum	Maximum
GRL3*	3/8	10 AWG	4 AWG
GRL4	1/2	10 AWG	2 AWG
GRL5	5/8	10 AWG	2 AWG
GRL6	3/4	10 AWG	2 AWG

* GRL3 not UL Listed.

TYPE B

FLEXIBLE COPPER BRAID

Flexible copper braid jumpers designed to take up linear expansion and contraction, compensate for misalignment and absorb vibratory movement of electrical equipment and devices.

Made of flat extra flexible, tinned, pure copper braid, with unplated, seamless, pure copper ferrules formed into a rectangular shape on each end.

Last two numbers in catalog number indicate total length of braid in inches (e.g., BD12N or BD12 is 12" long braid jumper).

Other lengths, plating and drilling are available. Refer to factory.

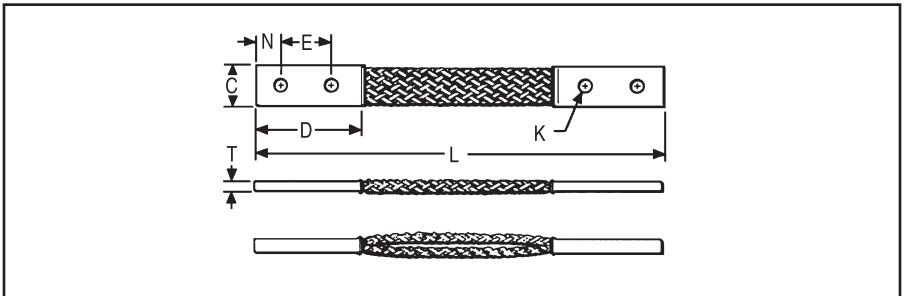
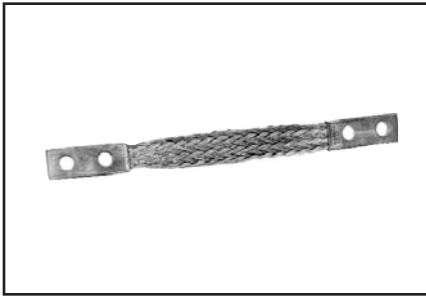

D-45



CATALOG NUMBER	NUMBER OF BRAIDS IN FERRULES	C	D	E	K	L	N	T	APPROXIMATE AMPERE RATING	
									INDOOR	OUTDOOR
BD12 †	1	.94	2.50	1.25	.44	12	.62	.13	190	225
BD12N** †										
BD18 †										
BD18N** †										
BD24 †										
BD24N** †										
BE12 †	1	1.50	3.00	1.50	.44	12	.75	.17	340	405
BE12N** †										
BE18 †										
BE18N** †										
BE24 †										
BE24N** †										
BF12 †	1	1.19	3.00	1.50	.44	12	.75	.25	360	430
BF12N** †										
BF18 †										
BF18N** †										
BF24 †										
BF24N** †										
BG12 †	1	1.50	3.00	1.50	.44	12	.75	.25	415	495
BG12N** †										
BG18 †										
BG18N** †										
BG24 †										
BG24N** †										

* This rating may vary with ambient conditions, orientation of the braid and other service conditions.

** Tongue drilled per (2) hole NEMA standard.

Note: All sizes are listed to UL467 and specific sizes (†) are certified to CSA C22.2, No. 41 Grounding and Bonding Equipment Standards. Equivalent sizes may be designated by suffix letters representing variations in length, mounting configurations, pad size and finish. Contact factory for details.

FLEXIBLE COPPER BRAID

(Continued)

TYPE B



D-46

CATALOG NUMBER	NUMBER OF BRAIDS IN FERRULES	C	D	E	K	L	N	T	APPROXIMATE AMPERE RATING	
									INDOOR	OUTDOOR
B2D12 †	2	.94	2.50	1.25	.44	12	.62	.25	380	455
B2D12N** †			3.00	1.75	.56	12	.62			
B2E12		1.62	3.00	1.50	.44	12	.75	.25	530	635
B2E12N**			3.00	1.75	.56	12	.62			
B2F12		1.38	3.00	1.50	.44	12	.75	.38	600	720
B2F12N**			3.00	1.75	.56	12	.62			
B2G12		1.50	3.00	1.50	.44	12	.75	.50	700	840
B2G12N**			3.00	1.75	.56	12	.62			
B3D12 †	3	1.19	2.50	1.25	.44	12	.62	.25	470	560
B3D12N** †			3.00	1.75	.56	12	.62			
B3E12		1.64	3.00	1.50	.44	12	.75	.31	700	840
B3E12N**			3.00	1.75	.56	12	.62			
B3F12		1.44	3.00	1.50	.44	12	.75	.56	820	980
B3F12N**			3.00	1.75	.56	12	.62			
B3G12		1.69	3.00	1.50	.44	12	.75	.69	960	1150
B3G12N**			3.00	1.75	.56	12	.62			
B4D12	4	1.19	2.50	1.25	.44	12	.62	.32	600	720
B4D12N**			3.00	1.75	.56	12	.62			
B4E12		1.64	3.00	1.50	.44	12	.75	.36	850	1020
B4E12N**			3.00	1.75	.56	12	.62			
B4F12		1.50	3.00	1.50	.44	12	.75	.78	1000	1200
B4F12N**			3.00	1.75	.56	12	.62			
B4G12		1.69	3.00	1.50	.44	12	.75	.94	1200	1440
B4G12N**			3.00	1.75	.56	12	.62			

* This rating may vary with ambient conditions, orientation of the braid and other service conditions.
 ** Tongue drilled per (2) hole NEMA standard.

Note: All sizes are listed to UL467 and specific sizes (†) are certified to CSA C22.2, No. 41 Grounding and Bonding Equipment Standards. Equivalent sizes may be designated by suffix letters representing variations in length, mounting configurations, pad size and finish. Contact factory for details.

TYPES GB, GBM

GROUND CONNECTOR

For Copper Cable to Bar

High copper alloy ground connector for joining a range of cable to 1/4" thick bar.* Type GB separates cable from bar, GBM clamps cable directly on bar surface. One-wrench installation. UL467 Listed. The high copper alloy cast body and DURIMUM™ bolts, nuts, and lockwashers make the GB and GBM suitable for direct burial in concrete or ground.

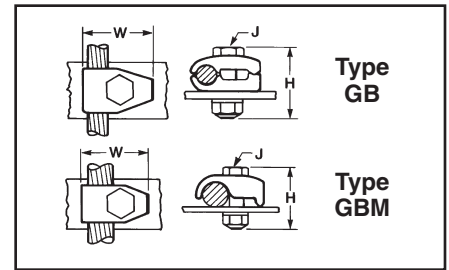
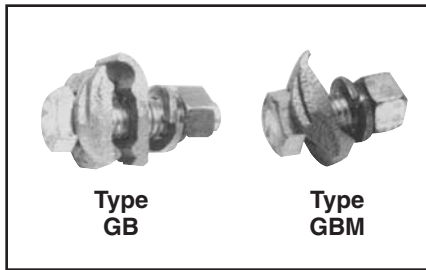

Catalog Number		Conductor	H Type GB/GBL	H Type GBM	J	W Type GB/GBL	W Type GBM
Type GB	Type GBM						
GB4C	GBM4C	8 Sol. - 4 Str.	1-1/2	1-1/2	3/8	1-1/4	1-1/4
GB26	GBM26	4 Sol. - 2/0 Str.				1-1/2	1-1/2
+GBL30		4 Sol. - 300	2	2	1/2	7/8	0
GB29	GBM29	2/0 Sol. - 250				2	2
GB34	GBM34	300 - 500	3	2-1/4		2-3/8	2-3/8

+ GBL30 is not UL listed.

Add "GS" suffix for galvanized steel hardware.

* For other bar thicknesses see note at bottom of page D-46.

D-47

TYPES GC, GCM

GROUND CONNECTOR

For Two Copper
Cables to Bar

High copper alloy ground connector for joining a wide range of two parallel cables to 1/4" thick bar.* Type GC separates cable from bar, GCM clamps cable to bar surface. One-wrench installation. UL467 Listed. The high copper alloy cast body and DURIMUM™ bolts, nuts, and lockwashers make the GC and GCM suitable for direct burial in concrete or ground.

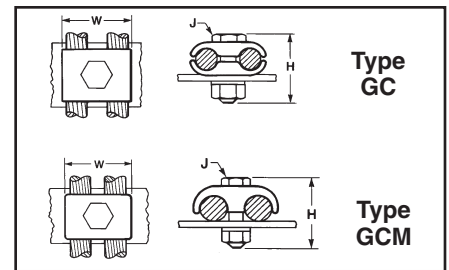
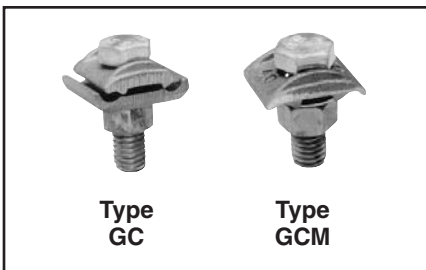

Catalog Number		Conductor	H Type GC/GCL	H Type GCM	J	W Type GC/GCL	W Type GCM
Type GC	Type GCM						
GC4C4C	GCM4C	8 Sol. - 4 Str.	1-1/2	1-1/2	3/8	1-3/8	1
GC2626	GCM26	4 Sol. - 2/0 Str.				2	1-3/4
GCL30	GCM30	4 Str. - 300	2	—	—	1	—
GC2929	GCM29	2/0 Sol. - 250	2-1/4	2	—	2-1/4	2
GC3434	GCM34	300 - 500	2-7/8	2-1/4	1/2	2-7/8	2-5/8

Smooth oval-shank bolts are available upon request for cable-tray applications (example: GC30G3). Also refer to type GC-CT. Add "GS" suffix for galvanized steel hardware.

* For other bar thicknesses see note at bottom of page D-44.

TYPE GL

GROUND CONNECTOR

For Two Copper Cables to Bar

High copper alloy ground connector for joining a wide range of two parallel cables to 1/4" thick bar.* Two-bolt design, separates cable from bar. One-wrench installation. UL467 Listed. The high copper alloy cast body and DURIUM™ bolts, nuts, and lockwashers make them suitable for direct burial in concrete or ground.

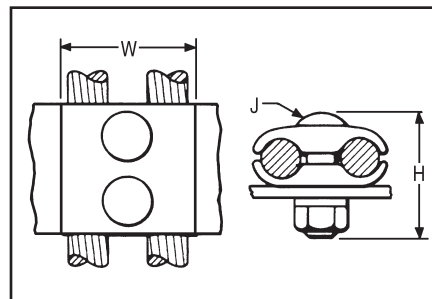

Catalog Number*	Conductor	H	J	W
GL4C4C	8 Sol. - 4 Str.	1-1/2	3/8	1-3/8
GL2626	4 Sol. - 2/0 Str.	2		1-3/4
GL2929	2/0 Sol. - 250	2-1/4	1/2	2-1/4
GL3434	300 - 500	2-7/8		2-7/8

* For other bar thicknesses see note at bottom of page.

D-48



TYPE GZ

GROUND CONNECTOR

For Copper Cable to Bar

High copper alloy ground connector for joining a wide range of cable to 1/4" thick bar*. Cable is gripped by curving it around the clamping bolt in connector groove. UL467 Listed. The high copper alloy cast body and DURIUM™ bolts, nuts, and lockwashers make them suitable for direct burial in concrete or ground.

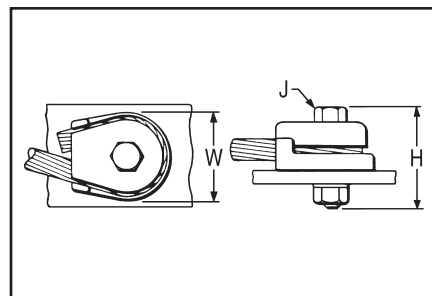

Catalog Number*	Conductor	H	J	W
GZ4C-38	8 Str. - 4 Str.	1-1/2	3/8	1-1/8
GZ4C-12		1-7/8	1/2	1-3/4
GZ4C-58		2	5/8	
GZ26-38	3 Str. - 2/0 Str.	2-1/8	3/8	1-5/8
GZ26-12			1/2	1-3/4
GZ26-58		2-1/4	5/8	
GZ29-38	3/0 Str. - 250	2-3/8	3/8	2-1/4
GZ29-12			1/2	
GZ29-58		2-1/2	5/8	

NOTE:

* The GB, GBM, GC, GCM, GL and GZ are all used for joining a range of cable to bar. The catalog numbers in each table accommodate the indicated cable range and up to 1/4" thick bar. Optional bolt lengths are available to accommodate up to 1" thick bar. For bar thicknesses from 1/4" to 1/2", add the suffix "T4" to the catalog number in the table. For bar thicknesses from 1/2" to 1", add the suffix "T8" to the catalog number in the table.



TYPE GC-CT

CABLETRAY GROUND CLAMP

This unique connector incorporates features which are unmatched. Made of tin-plated cast copper alloy, it accommodates either one or two conductors, copper or aluminum cable. In addition to a low profile head with a deep Phillips recess, the galvanized steel bolt has a ribbed neck which prevents rotation during installation when installed in a .44 diameter hole. When used on aluminum conductor, the cable must be scratch brushed and PENETROX™ A joint compound must be used on cable and connector.

UL467 Listed for copper conductor only.
Suitable for direct burial in concrete or earth.

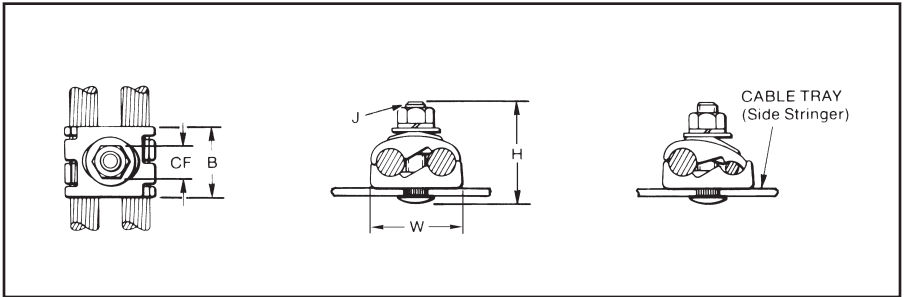

D-49

CATALOG NUMBER	ACCOMMODATES COPPER OR ALUMINUM CONDUCTOR IN EITHER GROOVE	DIMENSIONS				
		B	CF	H	J	W
GC2525CT	#6 Sol. (.162 Dia.) - 1/0 Str. (.372 Dia.)	1.12	.56	1.95	3/8" - 16	1.45
GC2626CT	#2 Sol. (.258 Dia.) - 2/0 Str. (.419 Dia.)	1.12	.56	1.95	3/8" - 16	1.70
GC2929CT	2/0 Str. (.414 Dia.) - 250 kcmil (.575 Dia.)	1.12	.56	2.20	3/8" - 16	1.98

NOTE:

The bolt head is mounted on the inside wall of cabletray to avoid damage to the cable insulation.

May be used with aluminum or galvanized steel cable tray.

TYPE GIE-G

GROUND CONNECTOR

For Vehicle Grounding
Heavy Duty Construction

High-strength copper alloy ground clamps for grounding gasoline trucks, tank cars, aircraft and other vehicles where danger of explosion due to static electricity exists. Corrosion resistant and supplied with nonsparking, adjustable, replaceable contact grip screws. Automatic safety release disconnects should a vehicle unexpectedly move from the grounded area. Accommodates 4 Str. flexible copper cable.

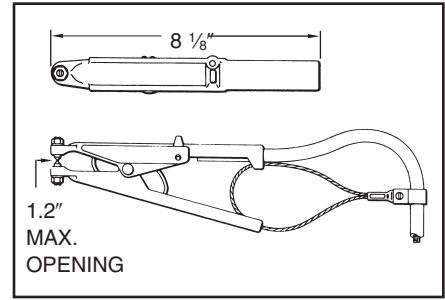
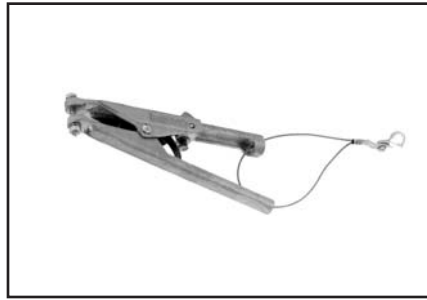

Catalog Number	Replaceable Contact Grip Screws		
	Catalog Number	Material	Point Configuration
GIE4CG3	GIE4CG3P5	Beryllium Copper	Cone Point
	GIE4CG3P7		Cup Point
GIE4CG4	GIE4CG4P5	Stainless Steel	Cone Point
	GIE4CG4P7		Cup Point

D-50

TYPE GIE-G

GROUND CONNECTOR

Accommodates flexible rubber sheath cable ranging from #6 to #2 conductor.

Catalog Number: **GIE2CG3**

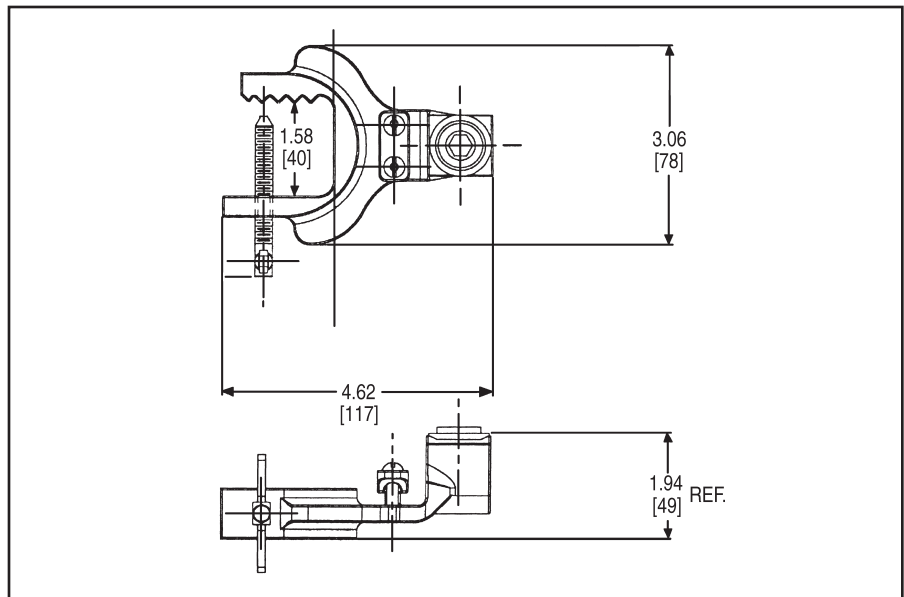
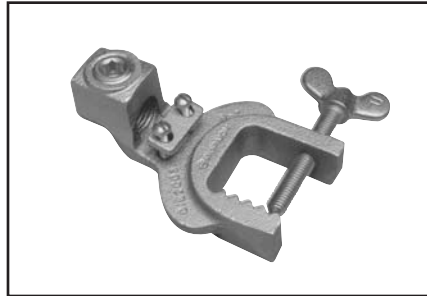

RAIL CONNECTOR

Mechanical clamp connectors designed for use in power, contact or running rail applications. Connectors are cast of a high conductivity copper alloy, tin-plated, and assembled with high-strength DURIIUM™ hardware. Connectors designed for extended service life.

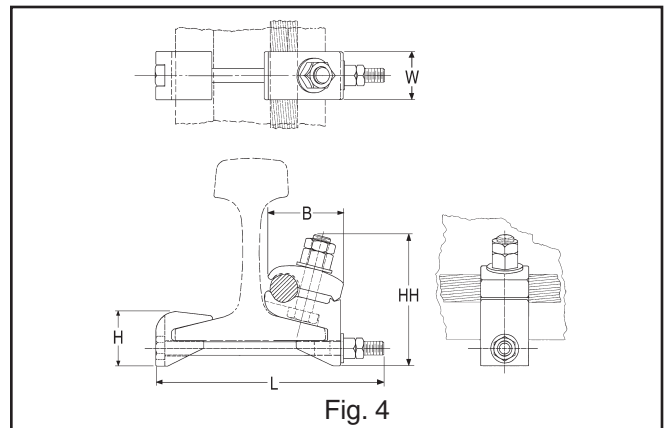
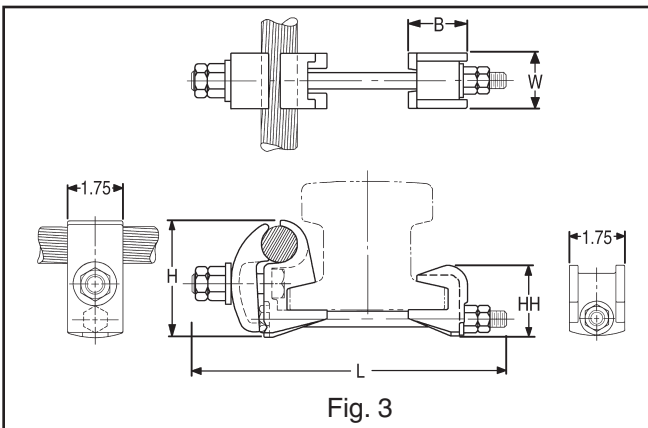
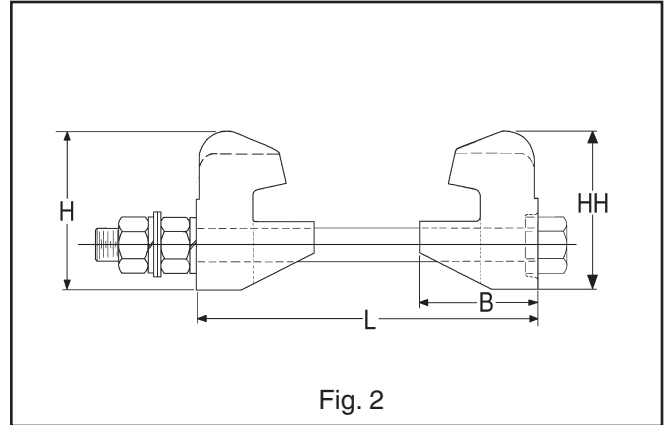
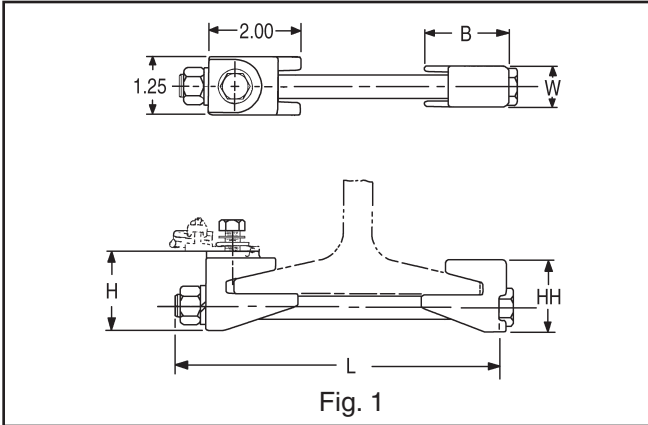

D-51

Catalog Number	Fig. No.	Accommodates	B	H	HH	L	W
J278	1	100 LBS. A.R.E.A. RUNNING RAIL	1.81	1.88	1.72	7.50	.88
J279	1	75 or 90 LBS. RUNNING RAIL	1.81	1.71	1.55	7.50	.88
J280	1	150 LBS. CONTACT RAIL	2.12	2.08	1.92	7.00	1.25
J295	2	150 LBS. THIRD RAIL	2.62	3.50	3.50	7.75	3.00
RGC44G1*	3	150 LBS. NMC CONTACT RAIL and (1) 800-1000 kcmil CU CABLE	1.75	2.82	2.25	10.00	1.75
RGC39G1*	4	115 LBS. CONTACT or RUNNING RAIL and (1) 500-750 kcmil CU CABLE	2.75	2.00	4.78	8.32	1.25

* Tin-plated.

TYPE QGFL

BARTAP™

For Copper Cable to Flat Bar or Pad

High copper alloy BARTAP™ for joining a range of cable to bar or pad. One-wrench installation. DURIUUM™ nut and lockwasher.

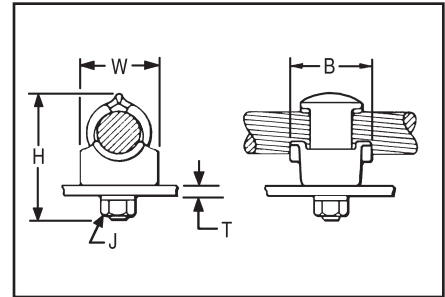
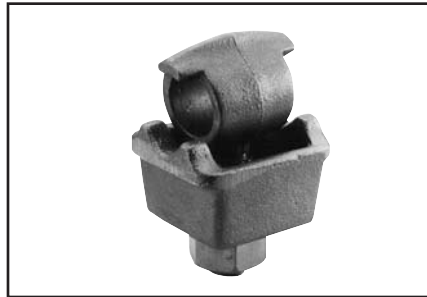

Catalog Number	Conductor	B	H	J	T (Max.)	W
QGFL1CB1	10 Sol. - 1 Str.	1-1/8	1-7/8	3/8	1/4	1
QGFL1CB1T6			2-3/8		3/4	
QGFL26B1	8 Sol. - 2/0 Str.	1-1/4	2-1/8	1/2	1/4	1-1/8
QGFL26B1T6			2-5/8		3/4	
QGFL26B2*		1-1/2	1/4			
QGFL26B2T6*		2-7/8	3/4			
QGFL29B1*	6 Str. - 250	1-5/8	2-5/8	1/2	1/4	1-3/8
QGFL29B1T6*			3-1/8		3/4	
QGFL31B1*	2 Sol. - 350	1-3/4	2-7/8	1/2	1/4	1-5/8
QGFL31B1T6*			3-1/4		3/4	
QGFL34B1	1/0 Sol. - 500	2	3-1/8	1/2	1/4	1-3/4
QGFL34B1T6			3-5/8		3/4	
QGFL39B1	350 - 750	2-1/4	3-1/4	1/2	1/4	1-3/4
QGFL39B1T6			3-5/8		3/4	
QGFL44B1	750 - 1000	2-1/4	3-3/8	1/2	1/4	2-1/8
QGFL44B1T6			4-1/8		3/4	
QGFL46B1	1000 - 1500	2-1/4	4	1/2	1/4	2-1/2
QGFL46B1T6			4-1/2		3/4	
QGFL48B1	1500 - 2000	2-1/4	4-3/4	1/2	1/4	3
QGFL48B1T6			5-1/4		3/4	

* Can be installed side by side or in line on NEMA drilled bar.

TYPE GA-H

GROUND CONNECTOR

For Copper Cable to "H" Beam

High copper alloy ground connector for joining a wide range of cable parallel to "H" beams or square tube. Hardware is made from DURIUUM™ for superior corrosion protection.

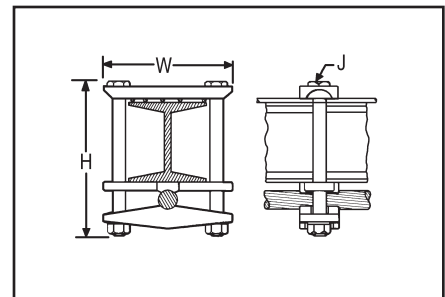
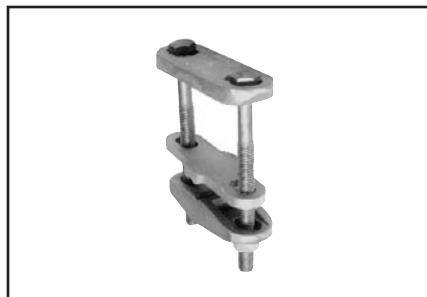

CATALOG NUMBER	CONDUCTOR		H	J	W
	"H" BEAM	CABLE			
GA25H26	1-7/8" × 1-7/8" - 2-1/2" × 2-1/2"	4 Sol. - 2/0 Str.	4-3/4	3/8	4



TYPE GRF

UNIGROUND® RAISED FLOOR GROUNDING CONNECTOR

The BURNDY® UNIGROUND™ is a universal grounding clamp, specifically designed for all raised flooring systems. It can be installed on round or square pedestals and can accommodate one or two grounding wires to make an efficient grid. The underfloor signal reference grid provides the low impedance ground path that attenuates high frequency static and 60 Hz transient noise for cleaner data output. UL467 Listed.



Features and Benefits

- One connector fits all applications.
 - ◇ Ease of specification and installation.
- Single bolt design.
 - ◇ Ease of installation:
 - ◇ — No need to disassemble.
 - ◇ — Single wrench installation.
- Accepts 1 or 2 ground conductors.
 - ◇ Requires less connectors to install signal reference grid.
- Tin plated cast bronze construction.
 - ◇ Resists corrosion and provides extended life ground connection.
- Grounds all pedestals (round or square).
 - ◇ Will handle up to 7/8" square and 1" round.
 - ◇ Ease of installation. One connector does it all
- Serves 3 needs:
 1. Signal Reference Grid.
 2. Static Ground.
 3. Fault Current Ground.
 - ◇ UNIGROUND™ solves all possible grounding problems found in computer applications today.

D-53

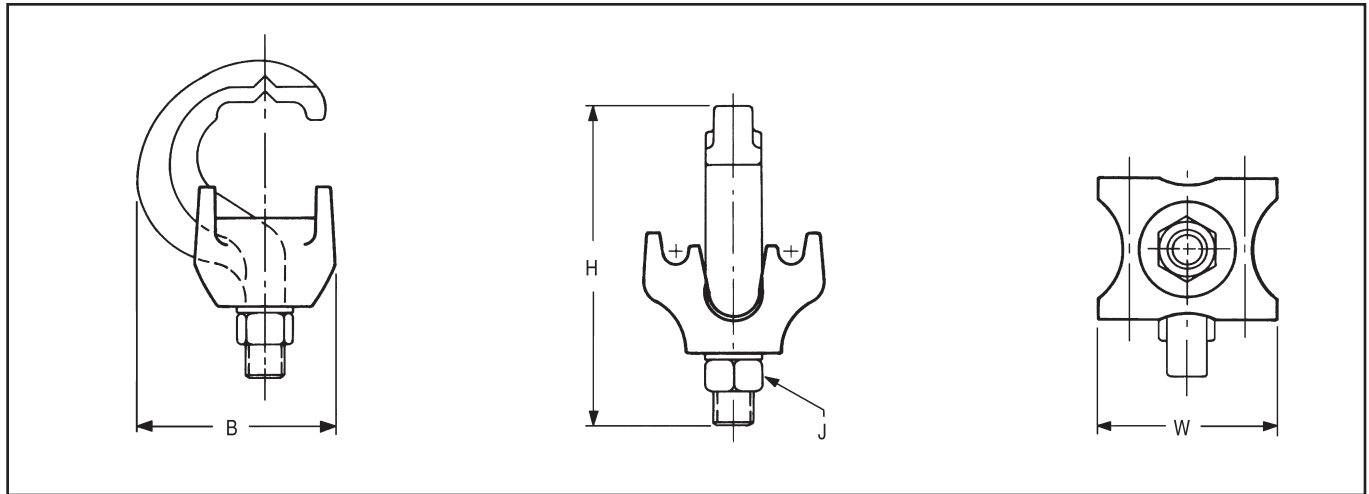

CATALOG NUMBER	NUMBER OF CONDUCTORS	CONDUCTOR SIZE SOL. & STR.	PEDESTAL TYPE		B	H	J	W
			ROUND	SQUARE				
GRF4C-3	1 or 2	#8 - #2	Up to 1"	Up to 7/8"	1.96	3.14	3/8"	1.76
GRF4C-4	1 or 2	#8 - #2	Up to 3/4"	Up to 5/8"	1.79	3.13	3/8"	1.40

TYPES GP-G1, GP-RT

RAISED FLOOR GROUNDING CLAMPS

High copper alloy ground connector for raised floor computer grounding applications. These connectors can be installed on round and square pedestals applications and will accommodate one or two grounding wires to make an efficient grid. The underfloor signal reference grid provides the low impedance ground path that attenuates high frequency static and 60 Hz transient noise for cleaner data output. UL467 Listed.

D-54

In addition we offer the GP1726RT, which is especially designed for penetrating epoxy paint on pedestals. This patented connector offers a low impedance, time saving connection between conductors and the Pedestal.



Features and Benefits



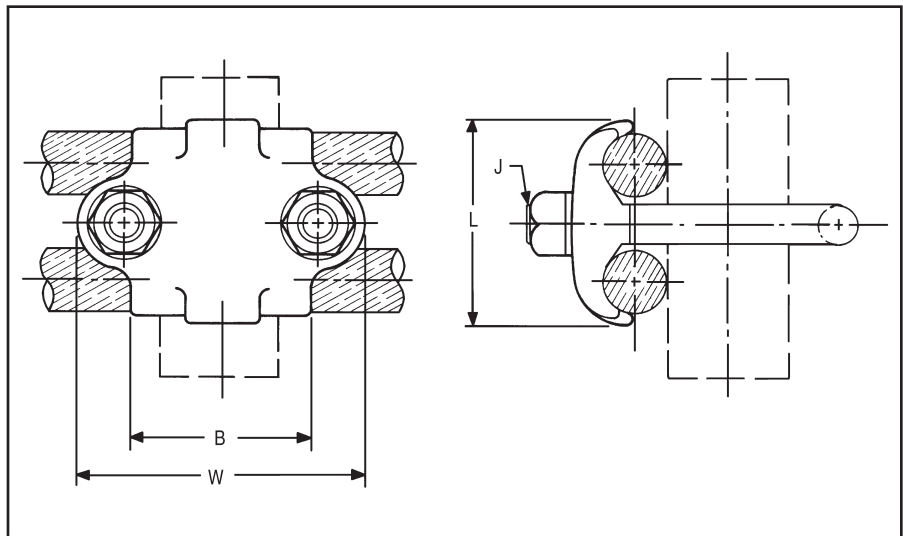







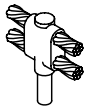
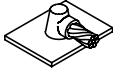
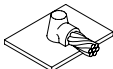

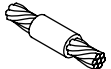
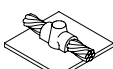

- Accepts 1 or 2 Ground Conductors
 - ◇ Requires less connectors to install signal reference grid.
- Made of copper alloy.
- DURIMUM™ U-Bolts, nuts and lockwashers.
 - ◇ Provides a low impedance ground path for maximum performance.
- Grounds all pedestals (round or square).
- Will handle from 3/4" to 1" round or square.
 - ◇ Ease of installation.
- Serves 3 needs.
 1. Signal Reference Grid.
 2. Static Ground.
 3. Fault Current Ground.
 - ◇ Connectors solves all possible grounding problems found in computer applications today.

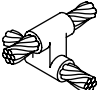

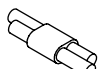
CATALOG NUMBER	NUMBER OF CONDUCTORS	CONDUCTOR SIZE SOL. & STR.	PEDESTAL TYPE	B	J	L	W
			ROUND OR SQUARE				
GP654CG1	1 or 2	#8 Sol. - 4 Str.	3/4" - 1" Round	1.5	3/8"	1.31	2.38
GP64526G1	1 or 2	#4 Sol. - 2/0 Str.	3/4" - 7/8" Square	1.5	3/8"	1.69	2.38
GP1526G1	1 or 2	#4 Sol. - 2/0 Str.	1-1/4" Round	1.75	3/8"	1.69	2.62
GP1726RT	1 or 2	#6 Sol. - 2/0 Str.	2" Round	2.12	3/8"	1.50	3.22

TABLE OF CONTENTS

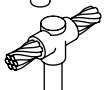
BURNDYWeld™

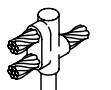
BURNDY Weld™			
Introduction	D-56		Type BCR-24D-69
Making a BURNDYWeld™			Type BCS-1D-71
Connection	D-57		Type BCS-8D-71
 WELD METAL	D-58		Type BCS-2D-72
	Type BCC-1	D-59	
	Type BCC-2	D-60	Type BCS-9
	Type BCC-4	D-61	
	Type BCC-11	D-62	Type BCS-3
	Type BCC-6	D-63	
	Type BCC-14	D-63	Type BCS-23
	Type BCC-7	D-64	
	Type BCR-1	D-65	Type BCS-4
RUS Accepted			
	Type BCR-2	D-66	Type BCS-6
	Type BCR-3	D-67	
	Type BCR-17	D-68	Type BCS-7
			Type BCS-18
			D-76
			BURNDYWeld™ FILL
			D-83
			BURNDYWeld™ SET
			D-85
			BURNDYWeld™ Prefabricated
			Wire Mesh
			D-87

D-55

For mold types or BURNDYWeld™ items not shown, please contact factory or refer to full BURNDYWeld™ catalog.

BURNDYWeld™

D-56

The BURNDYWeld™ connection process is a simple, efficient method of welding copper to copper or copper to steel. One advantage is that NO outside power is required when using the BURNDYWeld™ exothermic process. The BURNDYWeld™ process uses high temperature reaction of powdered copper oxide and aluminum. The reaction takes place in a semi-permanent graphite mold. These molds will last for fifty or more welds if proper care is given. The reaction takes place very rapidly, therefore the total amount of heat applied to the conductors or surfaces is considerably less than that of brazing or soldering. It is important to remember this when welding to insulated cable or thin wall pipe.

This system is very field friendly, since it is light and portable and requires no outside power source. It requires very little time or skill to obtain an efficient, maintenance free connection when using the BURNDYWeld™ process.

For more information visit our website at www.fciconnect.com

The BURNDYWeld™ process has been used to weld materials other than copper for electrical purposes. Materials welded include:

Stainless Steel	Columbium	Brass
Copperweld®	Plain Steel	Bronze
Nichrome V	Everdur®	Niobium
Galvanized Steel	Kama	Chromax
Silicone Bronze	Steel Rail	Cast Iron
Copper Clad Steel	Cor-Ten®	Monel

When welding to galvanized steel it is recommended to resurface exposed bare steel.

The BURNDYWeld™ connection is a molecular weld. The weld metal has the same melting point as copper. These factors along with the increased cross section of the connection, BURNDYWeld™ connections:

1. Will not be affected by a high current surge. Tests have shown that the electrical conductor will melt before the BURNDYWeld™ connection when subjected to high short circuit current. Consult IEEE Standard 837-1989.
2. Will not loosen or corrode at the point of weld. There are no contact surfaces or mechanical pressures involved. A BURNDYWeld™ connection becomes an integral part of the conductor.
3. Have a current-carrying capacity equal to or greater than that of the conductors.

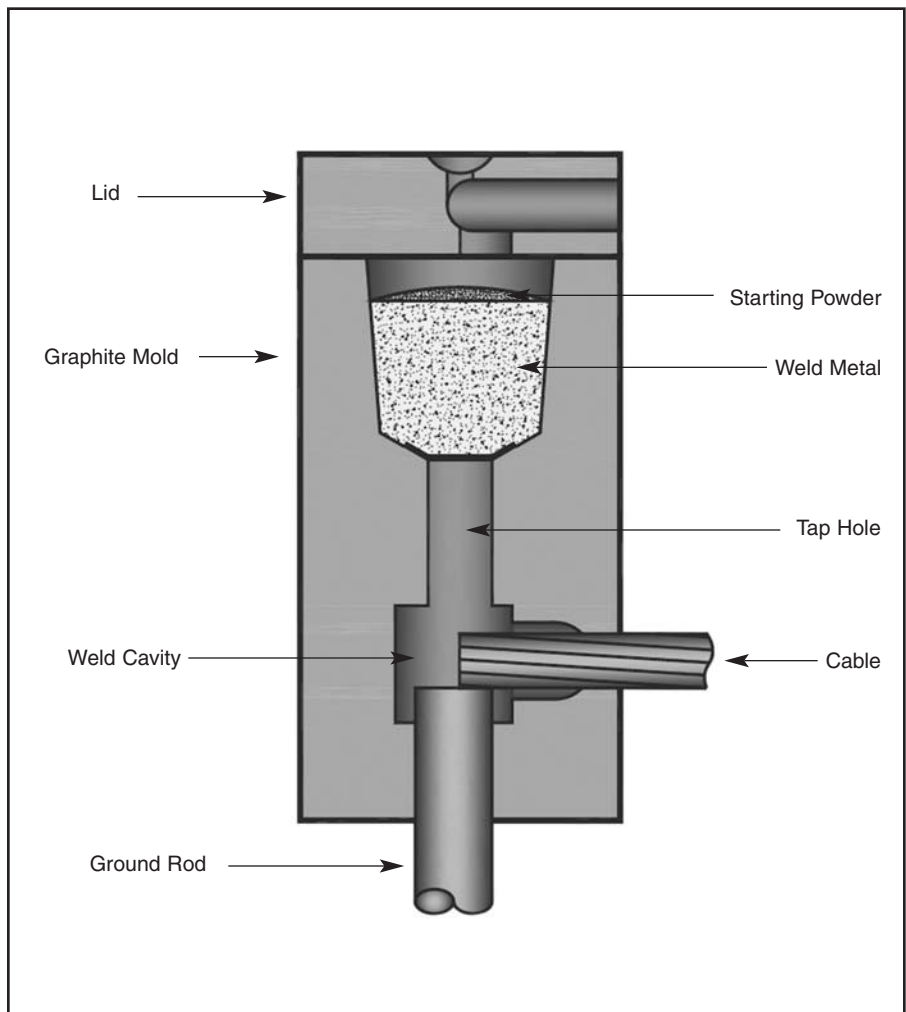

For mold types or BURNDYWeld™ items not shown, please contact factory or refer to full BURNDYWeld™ catalog.

Making a BURNDYWeld™ Connection



Step 1

Position cleaned conductors in mold after making sure mold is dry, by pre-heating or making a test joint.



Step 2

Place metal disc in bottom of mold crucible.



Step 3

Dump powder into crucible, being careful not to loosen all the starting powder.

D-57

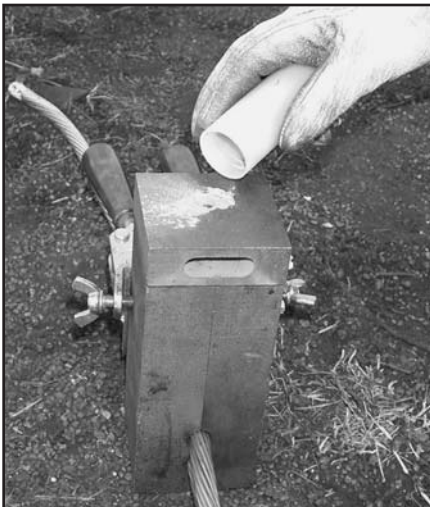

Step 4

Close lid and place a small amount of starting powder in the ignition pocket.



Step 5

Ignite the starting powder with the Flint Ignitor.

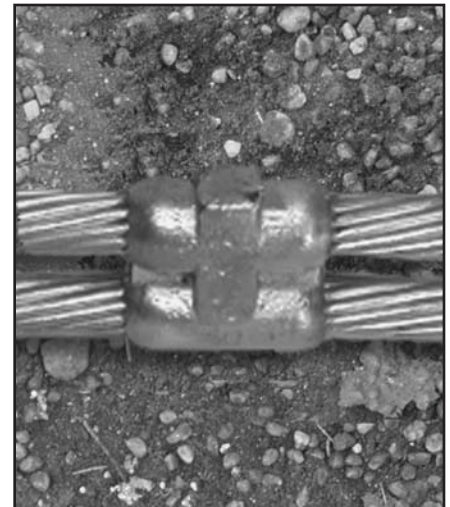

Step 6

Wait 15 seconds, then remove weld and clean mold before making next connection.

For mold types or BURNDYWeld™ items not shown, please contact factory or refer to full BURNDYWeld™ catalog.

WELD METAL

BURNDYWeld™ Weld Metal is packed in moisture-resistant plastic cartridges that have tight fitting caps. These cartridges, along with the necessary steel discs, are then packed in boxes that are hermetically-sealed. This ensures the powder arriving in good condition, always dry and ready for fast positive ignition.



BURNDYWeld™ Weld Metal comes in several types; one for welding copper to copper, copper to steel, copper to rail, copper to cast iron and one for welding copper to steel for cathodic protection. The size and weight (in grams) of the cartridge are marked on each individual cartridge.

D-58

Standard Cartridge Size	Cast Iron Cartridge Size	Cathodic Protection Cartridge Size	Rail Cartridge Size	Cartridges Per Box
15	15CI	15CP	15R	20
25	25CI	25CP	25R	20
32	32CI	32CP	32R	10
45	45CI	45CP	45R	20
65	65CI	65CP	65R	20
90	90CI	—	90R	10
115	115CI	—	115R	10
150	—	—	150R	10
200	—	—	200R	10
250	—	—	250R	10
500	—	—	500R	10

BURNDYWeld™ Weld Metal is sold in box quantities only.

Steel Discs Sold Separately

Weld Metal Size	Catalog Number	Package Quantity
	Steel Discs Only	
15 to 65	B370320-01	20
90 to 115	B370320-02	10
150 to 500	B370320-03	10

For mold types or BURNDYWeld™ items not shown, please contact factory or refer to full BURNDYWeld™ catalog.

BCC-1 TYPE MOLDS

Horizontal End to End

BCC-1 Type Molds are used for horizontal end to end cable connections.

Size range is #6 through 1000 MCM solid or concentric stranded copper conductors.

Contact BURNDY® Products for information on molds for conductors not listed below.

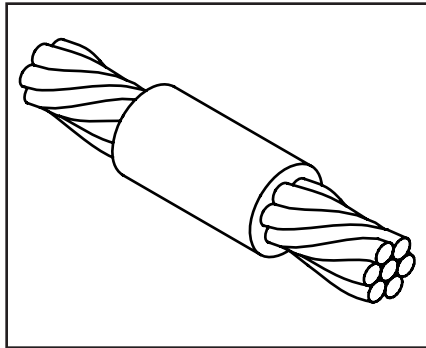

Cable	Mold Number	Price Key	Weld Metal	Handle Clamps
#8	Use Type BCC-14 On Page 16	—	—	—
#6	Use Type BCC-14 On Page 16	—	—	—
#4	B-5623	18 † *	25	N/A
#3	B-5624	18 † *	32	N/A
#2	B-5625	18 † *	32	N/A
#1	B-5626	18 † *	32	N/A
1/0	B-205	4	45	B-106
2/0	B-206	4	65	B-106
3/0	B-207	4	90	B-106
4/0	B-208	4	90	B-106
250 MCM	B-209	4	115	B-106
300 MCM	B-210	4	115	B-106
350 MCM	B-211	4	150	B106
500 MCM	B-213	4	200	B-107
750 MCM	B-214	5	2-150	B-107
1000 MCM	B-215	5	2-200	B-107

D-59

- For sizes not listed, contact BURNDY® Products.
- Molds listed are for concentric stranded cable. Add suffix "-S" to mold number for solid conductors.
- For heavy duty molds, molds with wear plates or molds for Copperweld® cable, contact BURNDY® Products.
- For expedited service, contact BURNDY® Products.

Required Tools:
 Handle Clamps (see chart for correct handles)
 † Sold complete with handles
 * **B38-0309-00** Flint Ignitor (included)
 Other recommended accessories:
B38-3922-00 Mold Cleaning Brush (pg D-85)
B38-0135-00 Cable Cleaning Brush (pg D-85)
B38-0330-00 Cable Clamp (pg D-85)

For mold types or BURNDYWeld™ items not shown, please contact factory or refer to full BURNDYWeld™ catalog.

TYPE BCC-2 MOLDS

Horizontal Cable Tap to Horizontal Cable Run

Type BCC-2 Molds are used to join horizontal cable tap to a horizontal run cable.

Size range is #6 through 750 MCM solid or concentric stranded copper conductors.

Contact BURNDY® Products for information on molds for conductors not listed below.

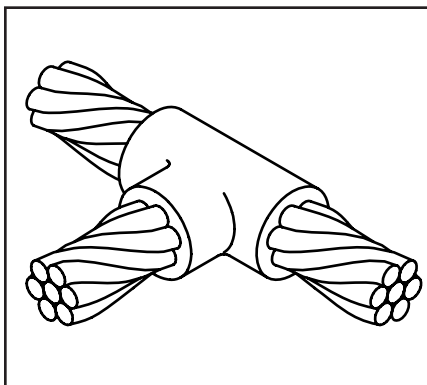

D-60

Cable		Mold Number	Price Key	Weld Metal	Handle Clamps
Run	Tap				
#6	#6	Use Type BCC-14 on Page 16	—	—	—
#4	#4	B-221	4	32	B-106
#2	#2	B-223	4	45	B-106
	#4	B-224	4	45	B-106
#1	#1	B-225	4	45	B-106
	#2	B-226	4	45	B-106
	#4	B-227	4	45	B-106
1/0	1/0	B-228	4	90	B-106
	#1	B-229	4	45	B-106
	#2	B-230	4	45	B-106
	#4	B-231	4	45	B-106
2/0	2/0	B-232	4	90	B-106
	1/0	B-233	4	90	B-106
	#1	B-234	4	45	B-106
	#2	B-235	4	45	B-106
	#4	B-5475	4	45	B-106
3/0	3/0	B-236	4	115	B-106
	2/0	B-237	4	90	B-106
	1/0	B-238	4	90	B-106
	#1	B-239	4	45	B-106
	#2	B-240	4	45	B-106
4/0	#4	B-5574	4	45	B-106
	4/0	B-241	4	150	B-106
	3/0	B-242	4	115	B-106
	2/0	B-243	4	90	B-106
	1/0	B-244	4	90	B-106
	#1	B-245	4	90	B-106
	#2	B-246	4	90	B-106
	#4	B-5021	4	90	B-106
250 MCM	250 MCM	B-247	4	150	B-106
	4/0	B-248	4	150	B-106
	3/0	B-249	4	150	B-106
	2/0	B-250	4	90	B-106
	1/0	B-251	4	90	B-106
	#1	B-252	4	90	B-106
	#2	B-253	4	90	B-106

- For sizes not listed, contact BURNDY® Products.
- Molds listed are for concentric stranded cable. Add suffix "-S" to mold number for solid conductors.
- For heavy duty molds, molds with wear plates or molds for Copperweld® cable, contact BURNDY® Products.
- For expedited service, contact BURNDY® Products.

Cable		Mold Number	Price Key	Weld Metal	Handle Clamps
Run	Tap				
300 MCM	300 MCM	B-254	4	200	B-106
	250 MCM	B-255	4	150	B-106
	4/0	B-256	4	150	B-106
	3/0	B-257	4	150	B-106
	2/0	B-258	4	90	B-106
	1/0	B-259	4	90	B-106
	#1	B-260	4	90	B-106
	#2	B-261	4	90	B-106
350 MCM	350 MCM	B-262	4	200	B-106
	300 MCM	B-263	4	200	B-106
	250 MCM	B-264	4	200	B-106
	4/0	B-265	4	150	B-106
	3/0	B-266	4	150	B-106
	2/0	B-267	4	90	B-106
	1/0	B-268	4	90	B-106
	#1	B-269	4	90	B-106
500 MCM	#2	B-270	4	90	B-106
	500 MCM	B-280	4	2-150	B-106
	350 MCM	B-282	4	200	B-106
	300 MCM	B-283	4	200	B-106
	250 MCM	B-284	4	200	B-106
	4/0	B-285	4	150	B-106
	2/0	B-286	4	90	B-106
	1/0	B-287	4	90	B-106
750 MCM	#1	B-288	4	90	B-106
	#2	B-289	4	90	B-106
	750 MCM	B-290	5	500	B-107
	500 MCM	B-291	5	2-200	B-107
	350 MCM	B-293	4	250	B-106
	300 MCM	B-294	4	200	B-106
	250 MCM	B-295	4	200	B-106
	4/0	B-296	4	150	B-106
750 MCM	2/0	B-297	4	150	B-106
	1/0	B-298	4	150	B-106

- Required Tools:
 Handle Clamps (see chart for correct handles)
B38-0309-00 Flint Ignitor
 Other recommended accessories:
B40-0319-01 Mold Cleaner for cartridge sizes #15-#65 (pg D-85)
B40-0319-03 Mold Cleaner for cartridge sizes #90-#500 (pg D-85)
B38-3922-00 Mold Cleaning Brush (pg D-85)
B38-0135-00 Cable Cleaning Brush (pg D-85)
B38-0330-00 Cable Clamp (pg D-85)

For mold types or BURNDYWeld™ items not shown, please contact factory or refer to full BURNDYWeld™ catalog.

TYPE BCC-4 MOLDS

Horizontal to Horizontal Cable Cross

Type BCC-4 Molds are used to join two horizontal cables at right angles. One cable is cut and the other is a through run.

Size range is #6 through 500 MCM solid or concentric stranded copper conductors.

Contact BURNDY® Products for information on molds for conductors not listed below.

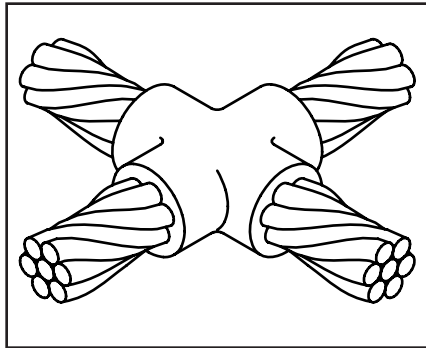

Cable		Mold Number	Price Key	Weld Metal	Handle Clamps
Run	Tap				
#6	#6	Use Type BCC-11 on page 16			
#4	#4	B-423	4	45	B-106
#3	#3	B-424	4	45	B-106
#2	#2	B-425	4	65	B-106
	#4	B-426	4	65	B-106
#1	#1	B-427	4	65	B-106
	#2	B-428	4	65	B-106
	#4	B-429	4	65	B-106
1/0	1/0	B-430	4	90	B-106
	#1	B-431	4	90	B-106
	#2	B-432	4	90	B-106
	#4	B-433	4	90	B-106
2/0	2/0	B-434	4	115	B-106
	1/0	B-435	4	115	B-106
	#1	B-436	4	115	B-106
	#2	B-437	4	115	B-106
3/0	3/0	B-438	4	150	B-106
	2/0	B-439	4	150	B-106
	1/0	B-440	4	115	B-106
	#1	B-441	4	115	B-106
4/0	#2	B-442	4	115	B-106
	4/0	B-443	4	200	B-106
	3/0	B-444	4	200	B-106
	2/0	B-445	4	150	B-106
250 MCM	1/0	B-442	4	150	B-106
	#1	B-447	4	115	B-106
	#2	B-448	4	115	B-106
	250 MCM	B-449	4	200	B-106
	4/0	B-450	4	200	B-106
	3/0	B-451	4	200	B-106
250 MCM	2/0	B-452	4	150	B-106
	1/0	B-453	4	150	B-106
	#1	B-454	4	115	B-106
	#2	B-455	4	115	B-106

- For sizes not listed, contact BURNDY® Products.
- Molds listed are for concentric stranded cable. Add suffix "-S" to mold number for solid conductors.
- For heavy duty molds, molds with wear plates or molds for Copperweld® cable, contact BURNDY® Products.
- For expedited service, contact BURNDY® Products.

Cable		Mold Number	Price Key	Weld Metal	Handle Clamps
Run	Tap				
300 MCM	300 MCM	B-456	4	250	B-106
	250 MCM	B-457	4	250	B-106
	4/0	B-458	4	200	B-106
	3/0	B-459	4	200	B-106
	2/0	B-460	4	150	B-106
	1/0	B-461	4	150	B-106
	#1	B-462	4	115	B-106
	#2	B-463	4	115	B-106
350 MCM	350 MCM	B-464	4	250	B-106
	300 MCM	B-465	4	250	B-106
	250 MCM	B-466	4	250	B-106
	4/0	B-467	4	200	B-106
	3/0	B-468	4	200	B-106
	2/0	B-469	4	200	B-106
	1/0	B-470	4	200	B-106
	#1	B-471	4	150	B-106
500 MCM	#2	B-472	4	150	B-106
	500 MCM	B-483	5	500	B-107
	350 MCM	B-485	5	2-200	B-107
	300 MCM	B-486	5	2-200	B-107
	250 MCM	B-487	5	2-150	B-107
	4/0	B-488	5	2-150	B-107
	3/0	B-489	5	2-150	B-107
	2/0	B-490	4	250	B-106
500 MCM	1/0	B-491	4	250	B-106
	#1	B-492	4	200	B-106
	#2	B-493	4	200	B-106

- Required Tools:
 Handle Clamps (see chart for correct handles)
B38-0309-00 Flint Ignitor
- Other recommended accessories:
B40-0319-01 Mold Cleaner for cartridge sizes #15-#65 (pg D-85)
B40-0319-03 Mold Cleaner for cartridge sizes #90-#500 (pg D-85)
B38-3922-00 Mold Cleaning Brush (pg D-85)
B38-0135-00 Cable Cleaning Brush (pg D-85)
B38-0330-00 Cable Clamp (pg D-85)

For mold types or BURNDYWeld™ items not shown, please contact factory or refer to full BURNDYWeld™ catalog.

TYPE BCC-11 MOLDS

Horizontal to Horizontal Cable Cross

Type BCC-11 Molds are used to join uncut horizontal cables at right angles to each other.

Size range is #6 through 500 MCM solid or concentric stranded copper conductors.

Contact BURNDY® Products for information on molds for conductors not listed below.

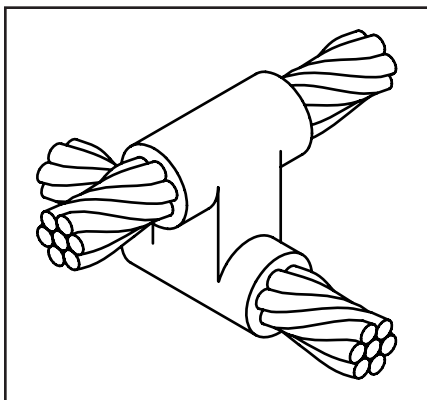

D-62

Cable		Mold Number	Price Key	Weld Metal	Handle Clamps
Run	Tap				
#6	#6	B-5432	191*	45	N/A
#4	#4	B-2687	4	65	B-106
#2	#2	B-2689	4	90	B-106
	#4	B-2690	4	65	B-106
#1	#1	B-2691	4	115	B-106
	#2	B-2692	4	90	B-106
	#4	B-2693	4	90	B-106
1/0	1/0	B-2694	22	150	B-106
	#1	B-2695	22	150	B-106
	#2	B-2696	22	115	B-106
	#4	B-2697	22	115	B-106
2/0	2/0	B-2698	22	200	B-106
	1/0	B-2699	22	200	B-106
	#1	B-2700	22	150	B-106
	#2	B-2701	22	150	B-106
3/0	3/0	B-2702	22	250	B-106
	2/0	B-2703	22	200	B-106
	1/0	B-2704	22	200	B-106
	#1	B-2705	22	150	B-106
	#2	B-2706	22	150	B-106

- For sizes not listed, contact BURNDY® Products.
- Molds listed are for concentric stranded cable. Add suffix "-S" to mold number for solid conductors.
- For heavy duty molds, molds with wear plates or molds for Copperweld® cable, contact BURNDY® Products.
- For expedited service, contact BURNDY® Products.

Cable		Mold Number	Price Key	Weld Metal	Handle Clamps
Run	Tap				
4/0	4/0	B-2707	22	250	B-106
	3/0	B-2708	22	250	B-106
	2/0	B-2709	22	200	B-106
	1/0	B-2710	22	200	B-106
	#1	B-2711	22	150	B-106
	#2	B-2712	22	150	B-106
250 MCM	250 MCM	B-2713	22	2-150	B-106
	4/0	B-2714	22	2-150	B-106
	3/0	B-2715	22	2-150	B-106
	2/0	B-2716	22	250	B-106
	1/0	B-2717	22	150	B-106
	#1	B-2718	22	200	B-106
500 MCM	#2	B-2719	22	150	B-106
	500 MCM	B-2747	23	3-250	B-107
	250 MCM	B-2751	23	500	B-107
	4/0	B-2752	23	500	B-107
	3/0	B-2753	23	500	B-107
	2/0	B-2754	23	2-200	B-107
	1/0	B-2755	22	2-150	B-106
	#1	B-2756	22	250	B-106
	#2	B-2757	22	250	B-106

- Required Tools:
 Handle Clamps (see chart for correct handles)
 † Sold complete with handles
 * **B38-0309-00** Flint Ignitor
- Other recommended accessories:
B40-0319-01 Mold Cleaner for cartridge sizes #15-#65 (pg D-85)
B40-0319-03 Mold Cleaner for cartridge sizes #90-#500 (pg D-85)
B38-3922-00 Mold Cleaning Brush (pg D-85)
B38-0135-00 Cable Cleaning Brush (pg D-85)
B38-0330-00 Cable Clamp (pg D-85)

For mold types or BURNDYWeld™ items not shown, please contact factory or refer to full BURNDYWeld™ catalog.

BCC-6 TYPE MOLDS

Horizontal Parallel Tap

BCC-6 Type Molds are used to join horizontal parallel tap to run connections. The tap cable is over the run cable.

Size range is #6 through 4/0 solid or concentric stranded copper conductors.

Contact BURNDY® Products for information on molds for conductors not listed below.

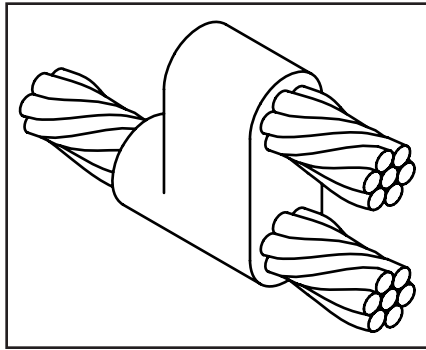

Cable		Mold Number	Price Key	Weld Metal	Handle Clamps
Run	Tap				
#6 Sol	#6 Sol	B-1270	4	25	B-106
#6	#6	B-1271	4	25	B-106
#4	#4	B-1272	4	32	B-106
	#6	B-1273	4	32	B-106
	#6 Sol	B-1274	4	32	B-106
#2	#8 Sol	B-1275	4	32	B-106
	#2	B-1276	4	65	B-106
	#4	B-1277	4	45	B-106
#2	#6	B-1278	4	32	B-106
	#6 Sol	B-1279	4	32	B-106
	#8 Sol	B-1280	4	32	B-106
#1	#1	B-1281	4	65	B-106
	#2	B-1282	4	65	B-106
	#4	B-1283	4	45	B-106
	#6	B-1284	4	45	B-106
	#6 Sol	B-1285	4	45	B-106
	#8 Sol	B-1286	4	45	B-106

- For sizes not listed, contact BURNDY® Products.
- Molds listed are for concentric stranded cable. Add suffix "-S" to mold number for solid conductors.
- For heavy duty molds, molds with wear plates or molds for Copperweld® cable, contact BURNDY® Products.
- For expedited service, contact BURNDY® Products.

Required Tools:

Handle Clamps (see chart for correct handles)
 Sold complete with handles
B38-0309-00 Flint Ignitor

Other recommended accessories:

B38-3922-00 Mold Cleaning Brush (pg D-85)
B38-0135-00 Cable Cleaning Brush (pg D-85)
B38-0330-00 Cable Clamp (pg D-85)

Cable		Mold Number	Price Key	Weld Metal	Handle Clamps
Run	Tap				
1/0	1/0	B-1287	4	90	B-106
	#1	B-1288	4	90	B-106
	#2	B-1289	4	65	B-106
	#4	B-1290	4	65	B-106
	#6	B-1291	4	45	B-106
	#6 Sol	B-1292	4	45	B-106
	#8 Sol	B-1293	4	45	B-106
2/0	2/0	B-1294	4	115	B-106
	1/0	B-1295	4	115	B-106
	#1	B-1296	4	90	B-106
	#2	B-1297	4	90	B-106
	#4	B-1298	4	65	B-106
	#6	B-1299	4	65	B-106
	#6 Sol	B-1300	4	65	B-106
4/0	#8 Sol	B-1301	4	65	B-106
	4/0	B-1302	4	150	B-106
	2/0	B-1303	4	115	B-106
	1/0	B-1304	4	115	B-106
	#1	B-1305	4	115	B-106
	#2	B-1306	4	115	B-106
	#4	B-1307	4	90	B-106
	#6	B-1308	4	90	B-106
	#6 Sol	B-1309	4	90	B-106
	#8 Sol	B-1310	4	90	B-106

BCC-14 TYPE MOLDS

Horizontal Parallel through Cables

BCC-14 Type Molds are used to join horizontal parallel through run cables. Cables run side by side in the mold.

Size range is #8 through #6 solid or concentric stranded copper conductors.

Contact BURNDY® Products for information on molds for conductors not listed.

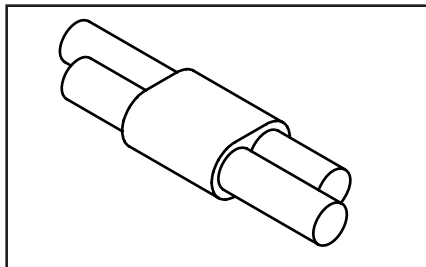

Cable		Mold Number	Price Key	Weld Metal	Handle Clamps
Run	Tap				
#8	#8	B-5709	18+	15	N/A
#6	#6	B-5618	18+	25	N/A

For mold types or BURNDYWeld™ items not shown, please contact factory or refer to full BURNDYWeld™ catalog.

BCC-7 TYPE MOLDS

Horizontal Parallel through Cables

BCC-7 Type Molds are used to join horizontal parallel through run cables. One cable runs above the other cable in the mold.

Size range is #6 through 4/0 solid or concentric stranded copper conductors.

Contact BURNDY® Products for information on molds for conductors not listed below.

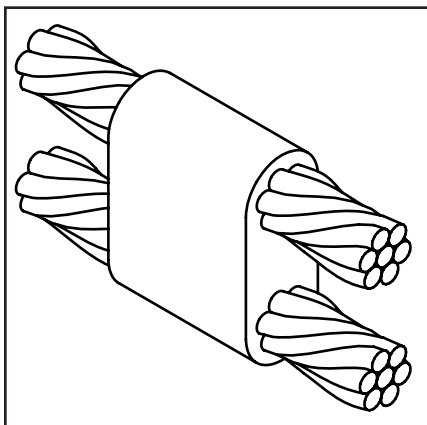

D-64

Cable		Mold Number	Price Key	Weld Metal	Handle Clamps
Run	Tap				
#6	#6	Use Type BCC-14 on Page 16	—	—	—
#4	#4	B-1311	4	32	B-106
	#6	B-5627	4	32	B-106
	#6 Sol	B-8882	4	32	B-106
	#8	B-5629	4	32	B-106
	#8 Sol	B-5630	4	32	B-106
#2	#2	B-1313	4	65	B-106
	#4	B-1314	4	65	B-106
	#6	B-5631	4	45	B-106
	#6 Sol	B-5632	4	45	B-106
	#8	B-5634	4	45	B-106
#1	#8 Sol	B-5635	4	45	B-106
	#1	B-1315	4	65	B-106
	#2	B-1316	4	65	B-106
	#4	B-1317	4	65	B-106
	#6	B-5636	4	65	B-106
1/0	#6 Sol	B-5637	4	65	B-106
	#8	B-5638	4	45	B-106
	#8 Sol	B-5639	4	45	B-106
	1/0	B-1318	4	90	B-106
	#1	B-1319	4	65	B-106
	#2	B-1320	4	65	B-106
	#4	B-1321	4	65	B-106
	#6	B-5642	4	65	B-106
#6 Sol	B-1208	4	65	B-106	
#8	B-5644	4	65	B-106	
#8 Sol	B-5645	4	65	B-106	

- For sizes not listed, contact BURNDY® Products.
- Molds listed are for concentric stranded cable. Add suffix "-S" to mold number for solid conductors.
- For heavy duty molds, molds with wear plates or molds for Copperweld® cable, contact BURNDY® Products.
- For expedited service, contact BURNDY® Products.

Cable		Mold Number	Price Key	Weld Metal	Handle Clamps
Run	Tap				
2/0	2/0	B-1322	4	115	B-106
	1/0	B-1323	4	115	B-106
	#1	B-1324	4	90	B-106
	#2	B-1325	4	90	B-106
	#4	B-5659	4	90	B-106
	#6	B-5342	4	90	B-106
	#6 Sol	B-5652	4	90	B-106
	#8	B-5668	4	65	B-106
3/0	#8 Sol	B-5943	4	65	B-106
	3/0	B-1326	4	150	B-106
	2/0	B-1327	4	150	B-106
	1/0	B-1328	4	115	B-106
	#1	B-1329	4	115	B-106
	#2	B-1330	4	115	B-106
	#4	B-6046	4	115	B-106
	#6	B-5676	4	90	B-106
	#6 Sol	B-5679	4	90	B-106
	#8	B-5680	4	90	B-106
	#8 Sol	B-5682	4	90	B-106
	4/0	4/0	B-1331	4	200
3/0		B-1332	4	200	B-106
2/0		B-1333	4	150	B-106
1/0		B-1334	4	150	B-106
#1		B-1335	4	150	B-106
#2		B-1336	4	150	B-106
#4		B-5340	4	150	B-106
#6		B-5684	4	90	B-106
#6 Sol		B-6552	4	90	B-106
#8		B-5686	4	90	B-106
#8 Sol		B-5688	4	90	B-106

- Required Tools:
- Handle Clamps (see chart for correct handles)
 - B38-0309-00** Flint Ignitor
- Other recommended accessories:
- B38-3922-00** Mold Cleaning Brush (pg D-85)
 - B38-0135-00** Cable Cleaning Brush (pg D-85)
 - B38-0330-00** Cable Clamp (pg D-85)

For mold types or BURNDYWeld™ items not shown, please contact factory or refer to full BURNDYWeld™ catalog.

TYPE BCR-1 MOLDS

Horizontal Cable Terminal to Ground Rod

Type BCR-1 Molds are used to terminate horizontal copper cable at the top of a vertical ground rod.

Size range is #6 through 1000 MCM solid or concentric stranded copper conductors; 1/2" through 1" for the ground rod.

Contact BURNDY® Products for information on molds for conductors not listed below.

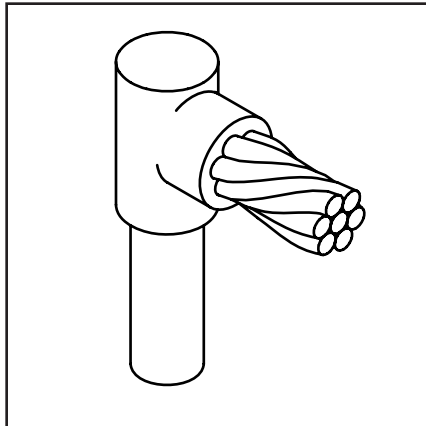

RUS Accepted

D-65

Cable		Mold Number	Price Key	Weld Metal	Handle Clamps
Grd Rod	Tap				
1/2"	#6	B-8402	18†*	25	N/A
	#4	B-8403	18†*	25	N/A
	#2	B-495	4	65	B-106
	#1	B-496	4	65	B-106
	1/0	B-497	4	90	B-106
	2/0	B-498	4	90	B-106
	3/0	B-499	4	90	B-106
	4/0	B-500	4	90	B-106
	250 MCM	B-501	4	90	B-106
	300 MCM	B-502	4	90	B-106
5/8"	#6	B-8414	18†	32	N/A
	#4	B-8415	18†	32	N/A
	#2	B-503	4	65	B-106
	#1	B-504	4	65	B-106
	1/0	B-505	4	90	B-106
	2/0	B-506	4	90	B-106
	3/0	B-507	4	90	B-106
	4/0	B-508	4	90	B-106
	250 MCM	B-509	4	90	B-106
	300 MCM	B-510	4	115	B-106
	350 MCM	B-511	4	115	B-106
	500 MCM	B-513	4	150	B-106

- For sizes not listed, contact BURNDY® Products.
- Molds listed are for concentric stranded cable. Add suffix "-S" to mold number for solid conductors.
- Molds listed are for copperclad ground rods. For welding to steel, stainless steel or galvanized steel ground rods add suffix "-N" to mold number.
- For heavy duty molds, molds with wear plates or molds for Copperweld® cable, contact BURNDY® Products.
- For expedited service, contact BURNDY® Products.

Cable		Mold Number	Price Key	Weld Metal	Handle Clamps
Grd Rod	Tap				
3/4"	#6	B-8422	181*	32	N/A
	#4	B-8426	191*	45	N/A
	#2	B-5781	4	90	B-106
	#1	B-514	4	90	B-106
	1/0	B-515	4	90	B-106
	2/0	B-516	4	90	B-106
	3/0	B-517	4	90	B-106
	4/0	B-518	4	90	B-106
	250 MCM	B-519	4	90	B-106
	300 MCM	B-520	4	115	B-106
	350 MCM	B-521	4	115	B-106
	500 MCM	B-523	4	150	B-106
	750 MCM	B-524	4	250	B-106
	1"	1/0	B-525	4	150
2/0		B-526	4	150	B-106
3/0		B-527	4	150	B-106
4/0		B-528	4	150	B-106
250 MCM		B-529	4	150	B-106
300 MCM		B-530	4	200	B-106
350 MCM		B-531	4	200	B-106
500 MCM		B-533	4	200	B-106
750 MCM		B-534	4	250	B-106
1000 MCM		B-535	5	2-150	B-106

- Required Tools:
- Handle Clamps (see chart for correct handles)
 - † Sold complete with handles
 - * B38-0309-00 Flint Ignitor (included)
- Other recommended accessories:
- B38-3922-00 Mold Cleaning Brush (pg D-85)
 - B38-0135-00 Cable Cleaning Brush (pg D-85)
 - B38-0304-00 File (pg D-85)
 - B38-0330-00 Cable Clamp (pg D-85)

For mold types or BURNDYWeld™ items not shown, please contact factory or refer to full BURNDYWeld™ catalog.

TYPE BCR-2 MOLDS

Horizontal Cable to Ground Rod

Type BCR-2 Molds are used to join horizontal through copper cable to the top of a vertical ground rod.

Size range is #6 through 1000 MCM solid or concentric stranded copper conductors; 1/2" through 1" for the ground rod.

Contact BURNDY® Products for information on molds for conductors not listed below.

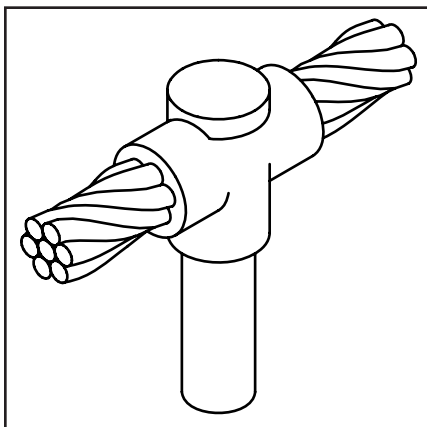

D-66

Cable		Mold Number	Price Key	Weld Metal	Handle Clamps
Grd Rod	Tap				
1/2"	#6	B-8434	181†*	32	N/A
	#4	B-8435	18†*	32	N/A
	#2	B-537	4	90	B-106
	#1	B-538	4	90	B-106
	1/0	B-539	4	90	B-106
	2/0	B-540	4	90	B-106
	3/0	B-541	4	115	B-106
	4/0	B-542	4	115	B-106
	250 MCM	B-543	4	150	B-106
	300 MCM	B-544	4	200	B-106
5/8"	#6	B-8441	18†*	32	N/A
	#4	B-8442	18†*	32	N/A
	#2	B-545	4	90	B-106
	#1	B-546	4	90	B-106
	1/0	B-547	4	90	B-106
	2/0	B-548	4	115	B-106
	3/0	B-549	4	115	B-106
	4/0	B-550	4	115	B-106
	250 MCM	B-551	4	150	B-106
	300 MCM	B-532	4	200	B-106
	350 MCM	B-553	4	200	B-106
	500 MCM	B-555	4	250	B-106

- For sizes not listed, contact BURNDY® Products.
- Molds listed are for concentric stranded cable. Add suffix "-S" to mold number for solid conductors.
- Molds listed are for copperclad ground rods. For welding to steel, stainless steel or galvanized steel ground rods add suffix "-N" to mold number.
- For heavy duty molds, molds with wear plates or molds for Copperweld® cable, contact BURNDY® Products.
- For expedited service, contact BURNDY® Products.

Cable		Mold Number	Price Key	Weld Metal	Handle Clamps
Grd Rod	Tap				
3/4"	#6	B-8452	19†*	45	N/A
	#4	B-8454	19†*	65	N/A
	#2	B-556	4	90	B-106
	#1	B-557	4	90	B-106
	1/0	B-558	4	115	B-106
	2/0	B-559	4	115	B-106
	3/0	B-560	4	115	B-106
	4/0	B-561	4	115	B-106
	250 MCM	B-562	4	150	B-106
	300 MCM	B-563	4	200	B-106
	350 MCM	B-564	4	200	B-106
	500 MCM	B-566	4	250	B-106
	750 MCM	B-567	5	2-200	B-107
	1"	1/0	B-569	4	150
2/0		B-570	4	150	B-106
3/0		B-571	4	150	B-106
4/0		B-572	4	150	B-106
250 MCM		B-573	4	200	B-106
300 MCM		B-574	4	200	B-106
350 MCM		B-575	4	200	B-106
500 MCM		B-577	4	250	B-106
750 MCM		B-578	5	2-200	B-107
1000 MCM		B-579	5	500	B-107

- Required Tools:
 Handle Clamps (see chart for correct handles)
 † Sold complete with handles
 *B38-0309-00 Flint Ignitor (included)
 Other recommended accessories:
 B38-3922-00 Mold Cleaning Brush (pg D-85)
 B38-0135-00 Cable Cleaning Brush (pg D-85)
 B38-0304-00 File (pg D-85)
 B38-0330-00 Cable Clamp (pg D-85)

For mold types or BURNDYWeld™ items not shown, please contact factory or refer to full BURNDYWeld™ catalog.

TYPE BCR-3 MOLDS

Horizontal Through Cable to Ground Rod

Type BCR-3 Molds are used to join horizontal through run cable to the side of a vertical ground rod.

Size range is #6 through 1000 MCM solid or concentric stranded copper conductors; 1/2" through 1" for the ground rod.

Contact BURNDY® Products for information on molds for conductors not listed below.

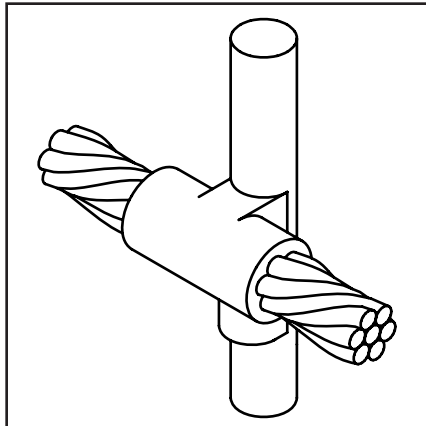

D-67

Cable		Mold Number	Price Key	Weld Metal	Handle Clamps
Grd Rod	Tap				
1/2"	#6	B-5321	24	65	B-106
	#4	B-2154	24	90	B-106
	#2	B-2155	24	90	B-106
	#1	B-2156	24	115	B-106
	1/0	B-1581	24	115	B-106
	2/0	B-1582	24	115	B-106
	4/0	B-1583	24	150	B-106
	250 MCM	B-1584	24	150	B-106
5/8"	#6	B-5660	24	65	B-106
	#4	B-2157	24	90	B-106
	#2	B-2158	24	90	B-106
	#1	B-2159	24	115	B-106
	1/0	B-1586	24	115	B-106
	2/0	B-1587	24	115	B-106
	4/0	B-1588	24	150	B-106
	250 MCM	B-1589	24	150	B-106
	500 MCM	B-1593	13	2-200	B-107

- For sizes not listed, contact BURNDY® Products.
- Molds listed are for concentric stranded cable. Add suffix "-S" to mold number for solid conductors.
- Molds listed are for copperclad ground rods. For welding to steel, stainless steel or galvanized steel ground rods add suffix "-N" to mold number.
- For heavy duty molds, molds with wear plates or molds for Copperweld® cable, contact BURNDY® Products.
- For expedited service, contact BURNDY® Products.

Cable		Mold Number	Price Key	Weld Metal	Handle Clamps
Grd Rod	Tap				
3/4"	#6	B-6630	24	65	B-106
	#4	B-2160	24	90	B-106
	#2	B-2161	24	90	B-106
	#1	B-2162	24	115	B-106
	1/0	B-1594	24	115	B-106
	2/0	B-1595	24	115	B-106
	#4	B-1596	24	150	B-106
	250 MCM	B-1597	24	200	B-106
	500 MCM	B-1601	13	500	B-107
	750 MCM	B-1602	13	3-250	B-107
1"	#6	B-6906	24	90	B-106
	#4	B-2163	24	90	B-106
	#2	B-2164	24	90	B-106
	#1	B-2165	24	115	B-106
	1/0	B-1603	24	15	B-106
	2/0	B-1604	24	115	B-106
	4/0	B-1605	24	150	B-106
	250 MCM	B-1606	24	200	B-106
	500 MCM	B-1610	13	500	B-107
	750 MCM	B-1611	13	3-250	B-107

- Required Tools:
 Handle Clamps (see chart for correct handles)
B38-0309-00 Flint Ignitor
 Other recommended accessories:
B38-3922-00 Mold Cleaning Brush (pg D-85)
B38-0135-00 Cable Cleaning Brush (pg D-85)
B38-0330-00 Cable Clamp (pg D-85)
B38-0304-00 File (pg D-85)

For mold types or BURNDYWeld™ items not shown, please contact factory or refer to full BURNDYWeld™ catalog.

TYPE BCR-17 MOLDS

Horizontal Run and Tap Cables to Ground Rod

Type BCR-17 Molds are used to join horizontal run and tap cables to the top of a vertical ground rod.

Size range is #4 through 750 MCM solid or concentric stranded copper conductors; 1/2" through 1" for the ground rod.

Contact BURNDY® Products for information on molds for conductors not listed below.

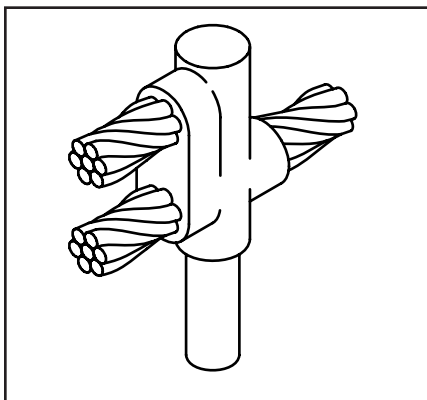

D-68

Cable		Mold Number	Price Key	Weld Metal	Handle Clamps
Grd Rod	Tap				
1/2"	#4	B-5416	4	90	B-106
	#2	B-6165	4	90	B-106
	#1	B-5830	4	90	B-106
	1/0	B-5940	4	115	B-106
	2/0	B-5850	4	150	B-106
	3/0	B-5833	4	200	B-106
	4/0	B-5380	4	200	B-106
5/8"	#4	B-5972	4	90	B-106
	#2	B-5935	4	115	B-106
	#1	B-5699	4	115	B-106
	1/0	B-5746	4	150	B-106
	2/0	B-5963	4	200	B-106
	3/0	B-5734	4	250	B-106
	4/0	B-5732	4	250	B-106
	250 MCM	B-5722	5	2-150	B-107

- For sizes not listed, contact BURNDY® Products.
- Molds listed are for concentric stranded cable. Add suffix "-S" to mold number for solid conductors.
- Molds listed are for copperclad ground rods. For welding to steel, stainless steel or galvanized steel ground rods add suffix "-N" to mold number.
- For heavy duty molds, molds with wear plates or molds for Copperweld® cable, contact BURNDY® Products.
- For expedited service, contact BURNDY® Products.

Cable		Mold Number	Price Key	Weld Metal	Handle Clamps
Grd Rod	Tap				
3/4"	#4	B-5698	4	90	B-106
	#2	B-5294	4	115	B-106
	#1	B-5390	4	115	B-106
	1/0	B-6025	4	150	B-106
	2/0	B-5738	4	200	B-106
	3/0	B-6003	4	250	B-106
	4/0	B-2566	4	250	B-106
	250 MCM	B-5904	5	2-150	B-107
	300 MCM	B-5857	5	2-200	B-107
	350 MCM	B-5777	5	2-200	B-107
	500 MCM	B-5961	5	3-200	B-106
1"	#4	B-5556	4	115	B-106
	#2	B-5555	4	150	B-106
	#1	B-6048	4	150	B-106
	1/0	B-5992	4	200	B-106
	2/0	B-5877	4	250	B-106
	3/0	B-5821	5	2-150	B-107
	4/0	B-5820	5	2-150	B-107
	250 MCM	B-5804	5	2-200	B-107
	300 MCM	B-5803	5	500	B-107
	350 MCM	B-5561	5	500	B-107
	500 MCM	B-5515	6	3-250	B-107
750 MCM	B-5513	6	2-500	B-107	

- Required Tools:
 Handle Clamps (see chart for correct handles)
B38-0309-00 Flint Ignitor
- Other recommended accessories:
B38-3922-00 Mold Cleaning Brush (pg D-85)
B38-0135-00 Cable Cleaning Brush (pg D-85)
B38-0330-00 Cable Clamp (pg D-85)
B38-0304-00 File (pg D-85)

For mold types or BURNDYWeld™ items not shown, please contact factory or refer to full BURNDYWeld™ catalog.

TYPE BCR-24 MOLDS

Horizontal Parallel Run Cables to Ground Rod

Type BCR-24 Molds are used to join horizontal parallel cables to the top of a vertical ground rod.

Size range is #4 through 750 MCM solid or concentric stranded copper conductors; 1/2" through 1" for the ground rod.

Contact BURNDY® Products for information on molds for conductors not listed below.

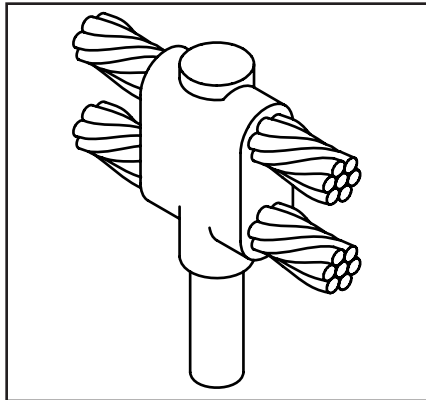

Cable		Mold Number	Price Key	Weld Metal	Handle Clamps
Grd Rod	Tap				
1/2"	#4	B-5640	4	115	B-106
	#2	B-5667	4	115	B-106
	#1	B-6002	4	115	B-106
	1/0	B-5767	4	150	B-106
	2/0	B-5604	4	200	B-106
	3/0	B-5560	4	250	B-106
	4/0	B-6766	4	250	B-106
5/8"	#4	B-6208	4	115	B-106
	#2	B-5702	4	150	B-106
	#1	B-5517	4	150	B-106
	1/0	B-5573	4	200	B-106
	2/0	B-8451	4	250	B-106
	3/0	B-2510	5	2-150	B-107
	4/0	B-5428	5	2-150	B-107
	250 MCM	B-1212	5	2-200	B-107
	300 MCM	B-2084	5	500	B-107
	350 MCM	B-2558	5	500	B-107
500 MCM	B-2450	5	3-250	B-107	

- For sizes not listed, contact BURNDY® Products.
- Molds listed are for concentric stranded cable. Add suffix "-S" to mold number for solid conductors.
- Molds listed are for copperclad ground rods. For welding to steel, stainless steel or galvanized steel ground rods add suffix "-N" to mold number.
- For heavy duty molds, molds with wear plates or molds for Copperweld® cable, contact BURNDY® Products.
- For expedited service, contact BURNDY® Products.

Cable		Mold Number	Price Key	Weld Metal	Handle Clamps
Grd Rod	Tap				
3/4"	#4	B-8011	4	115	B-106
	#2	B-2320	4	150	B-106
	#1	B-2235	4	150	B-106
	1/0	B-6051	4	200	B-106
	2/0	B-8802	4	250	B-106
	3/0	B-8726	5	2-150	B-107
	4/0	B-5677	5	2-150	B-107
	250 MCM	B-8461	5	2-200	B-107
	300 MCM	B-8428	5	500	B-107
	350 MCM	B-6294	5	500	B-107
1"	500 MCM	B-8214	5	3-250	B-107
	750 MCM	B-8027	6	2-500	B-107
	#4	B-5330	4	150	B-106
	#2	B-5332	4	200	B-106
	#1	B-5333	4	200	B-106
	1/0	B-5334	4	250	B-106
	2/0	B-5335	5	2-150	B-107
	3/0	B-5336	5	2-200	B-107
	4/0	B-5337	5	2-200	B-107
	250 MCM	B-5338	5	500	B-107
	300 MCM	B-5341	5	3-200	B-107
	350 MCM	B-5351	5	3-200	B-107
	500 MCM	B-5352	6	2-500	B-107
	750 MCM	B-5353	64	5-250	B-107

- Required Tools:
 Handle Clamps (see chart for correct handles)
B38-0309-00 Flint Ignitor
 ‡ Crucible B-181 required
 Other recommended accessories:
B38-3922-00 Mold Cleaning Brush (pg D-85)
B38-0135-00 Cable Cleaning Brush (pg D-85)
B38-0330-00 Cable Clamp (pg D-85)
B38-0304-00 File (pg D-85)

For mold types or BURNDYWeld™ items not shown, please contact factory or refer to full BURNDYWeld™ catalog.

SINGLE SHOT MOLDS

RUS Accepted

BURNDYWeld™ Single Shot Molds are an economical way to make cable connections onto the top of a ground rod. The Single Shot is a disposable single use ceramic mold that comes complete with everything required except the Flint Ignitor.

D-70

Ground Rod Size	Cable Size		Type	Mold Number	Cadweld® Part #	
	Solid	Stranded				
1/2"	#6, #8	#8	BCR-1	BS-2009	GR1-141G	
	#3, #4	#4, #6	BCR-1	BS-2010	GR1-141L	
	#1, #2	#2, #3	BCR-1	BS-2011	GR1-141V	
	#6, #8	#8	BCR-2	BS-2024	GT1-141G	
	#3, #4	#4, #6	BCR-2	BS-2025	GT1-141L	
	#1, #2	#2, #3	BCR-2	BS-2026	GT1-141V	
5/8"	#6, #8	#8	BCR-1	BS-2012	GT1-161G	
	#3, #4	#4, #6	BCR-1	BS-2013	GT1-161L	
	#1, #2	#2, #3	BCR-1	BS-2014	GR1-161V	
	2/0, 1/0	1/0, #1	BCR-1	BS-2015	GR1-162C	
		2/0	BCR-1	BS-2016	GR1-162G	
	#6, #8	#8	BC R-2	BS-2027	FRT1-161G	
	#3, #4	#4, #6	BCR-2	BS-2028	GT1-161L	
	#1, #2	#2, #3	BCR-2	BS-2029	GT1-161V	
	2/0, 1/0	1/0, #1	BCR-2	BS-2030	GT1-162C	
	#6, #8	#8	BCR-24	BS-2105	NX1-161G	
	#3, #4	#4, #6	BCR-14	BS-2106	NX1-161L	
	#1, #2	#2, #3	BCR-24	BS-2107	NX1-161V	
	#6, #8	#8	BCR-25	BS-2006	NT1-161G	
	#3, #4	#4, #6	BCR-25	BS-2007	NT1-161L	
	#1, #2	#2, #3	BCR-25	BS-2008	NT1-161V	
	3/4"	#6, #8	#8	BCR-1	BS-2017	GR1-181G
		#3, #8	#4, #6	BCR-1	BS-2018	GR1-181L
		#1, #2	#2, #3	BCR-1	BS-2019	GR1-181V
2/1, 1/0		1/0, #1	BCR-1	BS-2020	GR1-182C	
		2/0	BCR-1	BS-2021	GR1-182G	
#6, #8		#8	BCR-2	BS-2031	GT1-181G	
#3, #4		#4, #6	BCR-2	BS-2032	GT1-181L	
#1, #2		#2, #3	BCR-2	BS-2033	GT1-181V	
2/0, 1/0		1/0, #1	BCR-2	BS-2034	T1-182C	
#6, #8		#8	BCR-24	BS-2108	NX1-181G	
#3, #4		#4, #6	BCR-24	BS-2109	NX1-181L	
#1, #2		#2, #3	BCR-24	BS-2110	NX1-181V	
#6, #8		#8	BCR-25	BS-2068	NT1-181G	
#3, #4		#4, #6	BCR-25	BS-2069	NT1-181L	
#1, #2		#2, #3	BCR-25	BS-2070	NT1-181V	

Cadweld® is a registered trademark of the Erico International Corporation

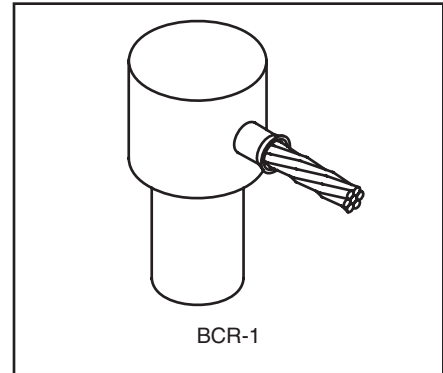

BCR-1

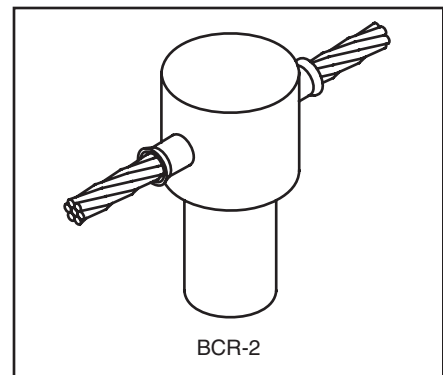

BCR-2

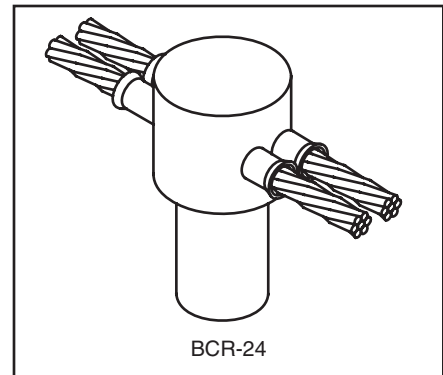

BCR-24

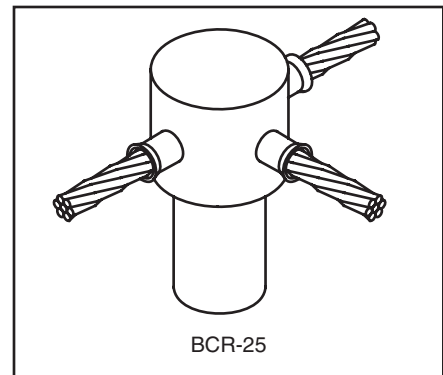

BCR-25

For mold types or BURNDYWeld™ items not shown, please contact factory or refer to full BURNDYWeld™ catalog.

TYPE BCS-1 MOLDS

Horizontal Cable to Horizontal Steel Surface

Type BCS-1 Molds are used to terminate a horizontal copper cable to any horizontal steel surface. Note that the cable is **OFF** the surface.

Size range is 1/0 through 1000 MCM solid or concentric stranded copper conductors.

Contact BURNDY® Products for information on molds for conductors not listed below.

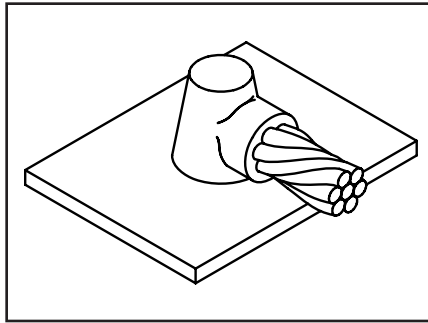

Cable Size	Mold Number	Price Key	Weld Metal	Handle Clamps
1/0	B-644	4	90	B-106
2/0	B-645	4	90	B-106
3/0	B-646	4	115	B-106
4/0	B-647	4	115	B-106
250 MCM	B-648	4	115	B-106
300 MCM	B-649	4	150	B-106
350 MCM	B-650	4	200	B-106
500 MCM	B-652	4	200	B-106
750 MCM	B-653	5	2-150	B-106
1000 MCM	B-654	5	2-200	B-107

- For sizes not listed, contact BURNDY® Products.
- Molds listed are for concentric stranded cable. Add suffix "-S" to mold number for solid conductors.
- For heavy duty molds, molds with wear plates or molds for Copperweld® cable, contact BURNDY® Products.
- For expedited service, contact BURNDY® Products.

Required Tools:
 Handle Clamps (see chart for correct handles)
B38-0309-00 Flint Ignitor
 Other recommended accessories:
B38-3922-00 Mold Cleaning Brush (pg D-85)
B38-0135-00 Cable Cleaning Brush (pg D-85)
B38-0330-00 Cable Clamp (pg D-85)
B38-0101-00 Rasp (pg D-85)

D-71

TYPE BCS-8 MOLDS

Horizontal Cable to Horizontal Steel Surface

Type BCS-8 Molds are used to terminate a horizontal copper cable to any horizontal steel surface. Note that the cable is **ON** the surface.

Size range is #6 through 1000 MCM solid or concentric stranded copper conductors.

Contact BURNDY® Products for information on molds for conductors not listed below.

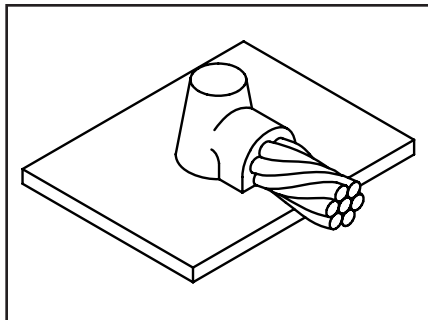

Cable Size	Mold Number	Price Key	Weld Metal	Handle Clamps
#6	B-628	3†**	45	N/A
#4	B-629	3†*	45	N/A
#2	B-630	3†*	45	N/A
#1	B-631	3†*	65	N/A
1/0	B-7146	4	90	B-106
2/0	B-7075	4	90	B-106
3/0	B-2199	4	115	B-106
4/0	B-6114	4	115	B-106
250 MCM	B-2200	4	115	B-106
300 MCM	B-2506	4	150	B-106
350 MCM	B-2507	4	200	B-106
500 MCM	B-2509	4	200	B-106
750 MCM	B-2542	5	2-150	B-107
1000 MCM	B-2511	5	2-200	B-107

- For sizes not listed, contact BURNDY® Products.
- Molds listed are for concentric stranded cable. Add suffix "-S" to mold number for solid conductors.
- For heavy duty molds, molds with wear plates or molds for Copperweld® cable, contact BURNDY® Products.
- For expedited service, contact BURNDY® Products.

Required Tools:
 Handle Clamps (see chart for correct handles)
 † Sold complete with frame
 * **B38-0309-00** Flint Ignitor (included)
 Other recommended accessories:
B38-3922-00 Mold Cleaning Brush (pg D-85)
B38-0135-00 Cable Cleaning Brush (pg D-85)
B38-0330-00 Cable Clamp (pg D-85)
B38-0101-00 Rasp (pg D-85)

For mold types or BURNDYWeld™ items not shown, please contact factory or refer to full BURNDYWeld™ catalog.

TYPE BCS-2 MOLDS

Horizontal Through Cable to Horizontal Steel Surface

Type BCS-2 Molds are used to join horizontal through copper cable to any horizontal steel surface. Note the cable is **OFF** the surface.

Size range is 1/0 through 1000 MCM solid or concentric stranded copper conductors.

Contact BURNDY® Products for information on molds for conductors not listed below.

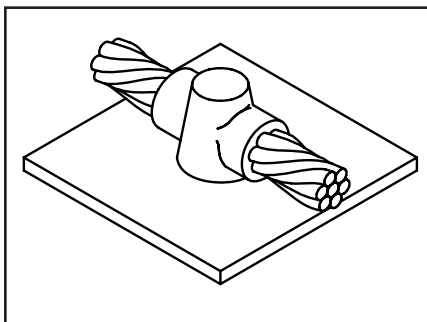

D-72

Cable Size	Mold Number	Price Key	Weld Metal	Handle Clamps
1/0	B-616	4	90	B-106
2/0	B-617	4	115	B-106
3/0	B-618	4	115	B-106
4/0	B-619	4	150	B-106
250 MCM	B-620	4	150	B-106
300 MCM	B-621	4	200	B-106
350 MCM	B-622	4	250	B-106
500 MCM	B-624	5	2-150	B-107
750 MCM	B-625-H	5	3-250	B-107
1000 MCM	B-626-H	5	2-500	B-107

- For sizes not listed, contact BURNDY® Products.
 - Molds listed are for concentric stranded cable. Add suffix "-S" to mold number for solid conductors.
 - For heavy duty molds, molds with wear plates or molds for Copperweld® cable, contact BURNDY® Products.
 - For expedited service, contact BURNDY® Products.
- Required Tools:
 Handle Clamps (see above for correct handles)
B38-0309-00 Flint Ignitor
- Other recommended accessories:
B38-3922-00 Mold Cleaning Brush (pg D-85)
B38-0135-00 Cable Cleaning Brush (pg D-85)
B38-0101-00 Rasp (pg D-85)

TYPE BCS-9 MOLDS

Horizontal Through Cable to Horizontal Steel Surface

Type BCS-9 Molds are used to join horizontal through copper cable to any horizontal steel surface. Note the cable is **ON** the surface.

Size range is #6 through 500 MCM solid or concentric stranded copper conductors.

Contact BURNDY® Products for information on molds for conductors not listed below.

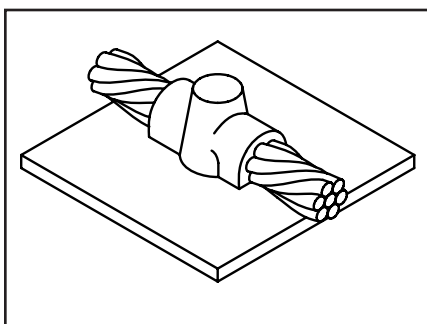

Cable Size	Mold Number	Price Key	Weld Metal	Handle Clamps
#6	B-602	3†	45	N/A
#4	B-603	3†	45	N/A
#2	B-604	3†	45	N/A
#1	B-605	3†	65	N/A
1/0	B-8379	4	90	B-106
2/0	B-5331	4	115	B-106
3/0	B-8381	4	115	B-106
4/0	B-7192	4	150	B-106
250 MCM	B-8413	4	150	B-106
300 MCM	B-8423	4	200	B-106
350 MCM	B-8410	4	250	B-106
500 MCM	B-5065	5	2-150	B-107

- For sizes not listed, contact BURNDY® Products.
 - Molds listed are for concentric stranded cable. Add suffix "-S" to mold number for solid conductors.
 - For heavy duty molds, molds with wear plates or molds for Copperweld® cable, contact BURNDY® Products.
 - For expedited service, contact BURNDY® Products.
- Required Tools:
 Handle Clamps (see chart for correct handles)
 † Sold complete with handle frame
 * **B38-0309-00** Flint Ignitor (included)
- Other recommended accessories:
B40-0319-01 Mold Cleaner for cartridge sizes #15-#65 (pg D-85)
B40-0319-03 Mold Cleaner for cartridge sizes #90-#500 (pg D-85)
B38-3922-00 Mold Cleaning Brush (pg D-85)
B38-0135-00 Cable Cleaning Brush (pg D-85)
B38-0101-00 Rasp (pg D-85)

For mold types or BURNDYWeld™ items not shown, please contact factory or refer to full BURNDYWeld™ catalog.

BURNDY® Products FCI

Grounding

TYPE BCS-3 MOLDS

Angular Cable Drop to Vertical Steel Surface

Type BCS-3 Molds are used to join the end of a copper cable at a 45° angle to a vertical steel surface.

Size range is #6 through 1000 MCM solid or concentric stranded copper conductors.

Contact BURNDY® Products for information on molds for conductors not listed below.

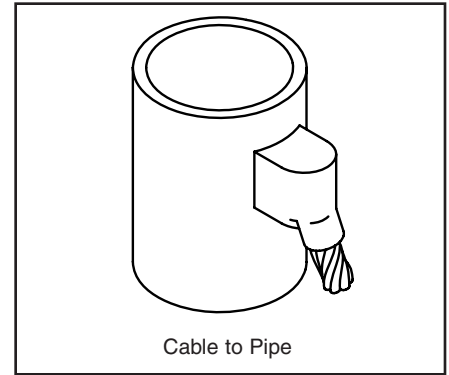
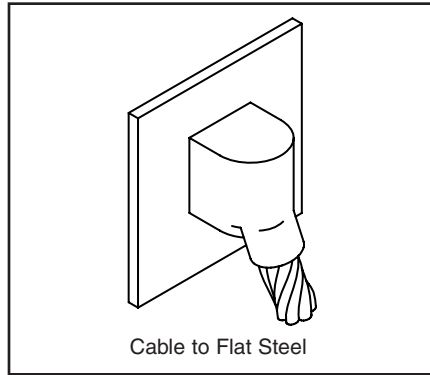

Cable to Flat Steel

Cable Size	Mold Number	Price Key	Weld Metal	Handle Clamps
#6	B-585	4	45	B-106
#4	B-586	4	45	B-106
#3	B-587	4	45	B-106
#2	B-588	4	45	B-106
#1	B-589	4	65	B-106
1/0	B-590	4	90	B-106
2/0	B-591	4	90	B-106
3/0	B-592	4	115	B-106
4/0	B-593	4	115	B-106
250 MCM	B-594	4	115	B-106
300 MCM	B-595	4	150	B-106
350 MCM	B-596	4	200	B-106
500 MCM	B-598	4	200	B-106
750 MCM	B-599	5	2-150	B-107
1000 MCM	B-600	5	2-200	B-107

- For sizes not listed, contact BURNDY® Products.
- Molds listed are for concentric stranded cable. Add suffix "-S" to mold number for solid conductors.
- For heavy duty molds, molds with wear plates or molds for Copperweld® cable, contact BURNDY® Products.
- For expedited service, contact BURNDY® Products.

Required Tools:

Handle Clamps (see chart for correct handles)
B38-0309-00 Flint Ignitor

Other recommended accessories:

Magnetic Clamps to hold molds against vertical steel (pg D-84)
B38-3922-00 Mold Cleaning Brush (pg D-85)
B38-0135-00 Cable Cleaning Brush (pg D-85)
B38-0101-00 Rasp (pg D-85)

Cable to Pipe

Cable Size	Pipe Size	Mold Number	Price Key	Weld Metal	Handle Clamps
#4	1-1/4" to 4"	B-2476	4	45	B-106
	4" to 6"	B-2477	4	45	B-106
	6" to 10"	B-2478	4	45	B-106
	12" & up	B-586‡	4	45	B-106
#2 Sol	1-1/4" to 4"	B-9233-S	4	45	B-106
	4" to 6"	B-2480-S	4	45	B-106
	6" to 10"	B-2583-S	4	45	B-106
	12" & up	B-588-S‡	4	45	B-106
#2	1-1/4" to 4"	B-9233	4	45	B-106
	4" to 6"	B-2480	4	45	B-106
	6" to 10"	B-2688	4	45	B-106
	12" & up	B-588‡	4	45	B-106
#1	1-1/4" to 4"	B-2482	4	65	B-106
	4" to 6"	B-2483	4	65	B-106
	6" to 10"	B-2484	4	65	B-106
	12" & up	B-589‡	4	65	B-106
1/0	1-1/4" to 4"	B-2486	4	90	B-106
	4" to 6"	B2487	4	90	B-106
	6" to 10"	B-2488	4	90	B-106
	12" & up	B-590‡	4	90	B-106
2/0	1-1/4" to 4"	B-8833	4	90	B-106
	4" to 6"	B-2490	4	90	B-106
	6" to 10"	B-2491	4	90	B-106
	12" & up	B-591‡	4	90	B-106
3/0	1-1/4" to 4"	B-2493	4	115	B-106
	4" to 6"	B-2494	4	115	B-106
	6" to 10"	B2495	4	115	B-106
	12" & up	B-592‡	4	115	B-106
4/0	1-1/4" to 4"	B-9021	4	115	B-106
	4" to 6"	B2497	4	115	B-106
	6" to 10"	B2498	4	115	B-106
	12" & up	B593‡	4	115	B-106

- For sizes not listed, contact BURNDY® Products.
- Molds listed are for concentric stranded cable. Add suffix "-S" to mold number for solid conductors.
- For heavy duty molds, molds with wear plates or molds for Copperweld® cable, contact BURNDY® Products.
- For expedited service, contact BURNDY® Products.

Required Tools:

Handle Clamps (see chart for correct handles)
B38-0309-00 Flint Ignitor

Other recommended accessories:

B106-32 Vertical Chain Clamp w/ B-106 Handles for 4" Pipe & smaller
B40-0106-27 20" Chain Extension for 4" to 10" Pipe
 Use (2) 20" Chain Extensions for pipe sizes between 10" and 16"
B38-3922-00 Mold Cleaning Brush (pg D-85)
B38-0135-00 Cable Cleaning Brush (pg D-85)
B38-0101-00 Rasp (pg D-85)

‡ Flat Surface Mold

For mold types or BURNDYWeld™ items not shown, please contact factory or refer to full BURNDYWeld™ catalog.

TYPE BCS-23 MOLDS

Vertical Cable Drop to Vertical Steel Surface

Type BCS-23 Molds are used to join vertical cable down to a vertical steel surface. Note that the cable is **OFF** the surface.

Size range is #6 through 500 MCM solid or concentric stranded copper conductors.

Contact BURNDY® Products for information on molds for conductors not listed below.

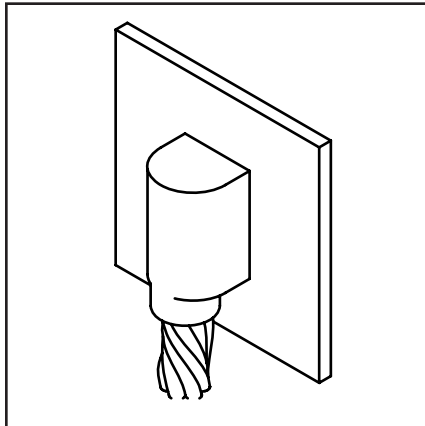

D-74

Cable Size	Mold Number	Price Key	Weld Metal	Handle Clamps
#6	B-5389	4	45	B-106
#4	B-5359	4	65	B-106
#2	B-2781	4	65	B-106
#1	B-5361	4	90	B-106
1/0	B-2189	4	115	B-106
2/0	B-2540	4	115	B-106
3/0	B-5362	4	150	B-106
4/0	B-8718	4	150	B-106
250 MCM	B-8165	4	200	B-106
300 MCM	B-5363	4	200	B-106
350 MCM	B-9029	4	250	B-106
500 MCM	B-8512	17	2-150	B-106

- For sizes not listed, contact BURNDY® Products.
- Molds listed are for concentric stranded cable. Add suffix "-S" to mold number for solid conductors.
- For heavy duty molds, molds with wear plates or molds for Copperweld® cable, contact BURNDY® Products.
- For expedited service, contact BURNDY® Products.

Required Tools:

Handle Clamps (see chart for correct handles)

B38-0309-00 Flint Ignitor

Other recommended accessories:

Magnetic Clamps to hold molds against vertical steel

B38-3922-00 Mold Cleaning Brush (pg D-85)

B38-0135-00 Cable Cleaning Brush (pg D-85)

B38-0101-00 Rasp (pg D-85)

For mold types or BURNDYWeld™ items not shown, please contact factory or refer to full BURNDYWeld™ catalog.

TYPE BCS-4 MOLDS

Vertical Through Cable to Vertical Steel Surface

Type BCS-4 Molds are used to join a vertical through copper cable to a vertical steel surface. Note that the cable is **OFF** the surface. For molds with the cable on the surface, contact BURNDY® Products.

Size range is #6 through 500 MCM solid or concentric stranded copper conductors.

Contact BURNDY® Products for information on molds for conductors not listed below.

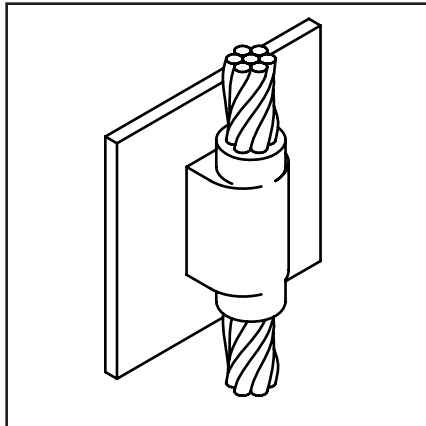

Cable Size	Mold Number	Price Key	Weld Metal	Handle Clamps
#6	B-1215	4	90	B-106
#4	B-1216	4	90	B-106
#2	B-1218	4	115	B-106
#1	B-1219	4	115	B-106
1/0	B-1220	17	200	B-106
2/0	B-1221	17	200	B-106
3/0	B-1222	17	250	B-106
4/0	B-1223	17	250	B-106
250 MCM	B-1224	17	250	B-106
300 MCM	B-1225-H	6	500	B-107
350 MCM	B-1226-H	6	3-200	B-107
500 MCM	B-1228-H	6	3-250	B-107

- For sizes not listed, contact BURNDY® Products.
- Molds listed are for concentric stranded cable. Add suffix "-S" to mold number for solid conductors.
- For heavy duty molds, molds with wear plates or molds for Copperweld® cable, contact BURNDY® Products.
- For expedited service, contact BURNDY® Products.

Required Tools:

Handle Clamps (see chart for correct handles)

B38-0309-00 Flint Ignitor

Other recommended accessories:

Magnetic Clamps to hold molds against vertical steel

B38-3922-00 Mold Cleaning Brush (pg D-85)

B38-0135-00 Cable Cleaning Brush (pg D-85)

B38-0101-00 Rasp (pg D-85)

TYPE BCS-6 MOLDS

Horizontal Through Cable to Vertical Steel Surface

Type BCS-6 Molds are used to join horizontal through copper cable to a vertical steel surface. Note that the cable is **OFF** the surface.

Size range is #6 through 250 MCM solid or concentric stranded copper conductors.

Contact BURNDY® Products for information on molds for conductors not listed below.

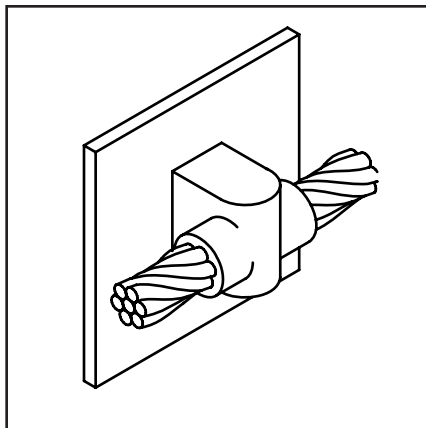

Cable Size	Mold Number	Price Key	Weld Metal	Handle Clamps
#6	B-1626	4	65	B-106
#4	B-1627	4	65	B-106
#2	B-1628	4	65	B-106
#1	B-1629	4	90	B-106
1/0	B-1630	4	115	B-106
2/0	B-1631	4	115	B-106
3/0	B-1632	4	150	B-106
4/0	B-1633	4	150	B-106
250 MCM	B-1634	4	150	B-106

- For sizes not listed, contact BURNDY® Products.
- Molds listed are for concentric stranded cable. Add suffix "-S" to mold number for solid conductors.
- For heavy duty molds, molds with wear plates or molds for Copperweld® cable, contact BURNDY® Products.
- For expedited service, contact BURNDY® Products.

Required Tools:

Handle Clamps (see chart for correct handles)

B38-0309-00 Flint Ignitor

Other recommended accessories:

B40-0319-01 Mold Cleaner for cartridge sizes #15-#65 (pg D-85)

B40-0319-03 Mold Cleaner for cartridge sizes #90-#500 (pg D-85)

B38-3922-00 Mold Cleaning Brush (pg D-85)

B38-0135-00 Cable Cleaning Brush (pg D-85)

B38-0101-00 Rasp (pg D-85)

For mold types or BURNDYWeld™ items not shown, please contact factory or refer to full BURNDYWeld™ catalog.

TYPE BCS-7 MOLDS

Overhead Vertical Tap Cable to Vertical Steel Surface

Type BCS-7 Molds are used to join an overhead vertical copper conductor drop tap to a vertical steel surface.

Size range is #6 through 1000 MCM solid or concentric stranded copper conductors.

Contact BURNDY® Products for information on molds for conductors not listed below.

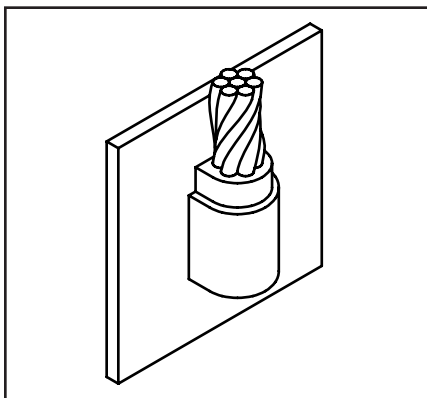

D-76

Cable Size	Mold Number	Price Key	Weld Metal	Handle Clamps
#6	B-1635	4	65	B-106
#4	B-1636	4	65	B-106
#3	B-1637	4	65	B-106
#2	B-1638	4	65	B-106
#1	B-1639	4	90	B-106
1/0	B-1640	4	150	B-106
2/0	B-1641	4	150	B-106
3/0	B-1642	17	200	B-106
4/0	B-1643	17	200	B-106
250 MCM	B-1644	17	200	B-106
300 MCM	B-1645	17	250	B-106
350 MCM	B-1646	6	2-150	B-107
500 MCM	B-1648	6	2-200	B-107
750 MCM	B-1649	6	500	B-107
1000 MCM	B-1650	6	3-200	B-107

- For sizes not listed, contact BURNDY® Products.
 - Molds listed are for concentric stranded cable. Add suffix "-S" to mold number for solid conductors.
 - For heavy duty molds, molds with wear plates or molds for Copperweld® cable, contact BURNDY® Products.
 - For expedited service, contact BURNDY® Products.
- Required Tools:
 Handle Clamps (see chart for correct handles)
B38-0309-00 Flint Ignitor
- Other recommended accessories:
 Magnetic Clamps to hold molds against vertical steel
B38-3922-00 Mold Cleaning Brush (pg D-85)
B38-0135-00 Cable Cleaning Brush (pg D-85)
B38-0101-00 Rasp (pg D-85)

For mold types or BURNDYWeld™ items not shown, please contact factory or refer to full BURNDYWeld™ catalog.

TYPE BCS-18 MOLDS

Horizontal Tap Cable to Vertical Steel Surface

Type BCS-18 Molds are used to connect a horizontal conductor to a vertical steel surface. Note that the cable is

ON the surface.

Size range is #6 through 500 MCM solid or concentric stranded copper conductors.

Contact BURNDY® Products for information on molds for conductors not listed below.

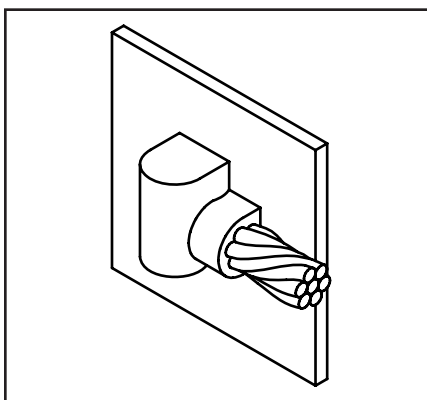

Cable Size	Mold Number	Price Key	Weld Metal	Handle Clamps
#6	B-5910	4	45	B-106
#4	B-2761	4	45	B-106
#2	B-2569	4	45	B-106
#1	B-6060	4	65	B-106
1/0	B-5419	4	90	B-106
2/0	B-2567	4	90	B-106
3/0	B-6072	4	115	B-106
4/0	B-9253	4	115	B-106
250 MCM	B-2568	4	115	B-106
300 MCM	B-6061	4	150	B-106
350 MCM	B-6067	4	200	B-106
500 MCM	B-8359	4	200	B-106

- NOTE:** Add (-R) to mold number for right hand mold or (-L) for left hand mold. Right hand (-R) mold will be furnished if not specified.
- For sizes not listed, contact BURNDY® Products.
 - Molds listed are for concentric stranded cable. Add suffix "-S" to mold number for solid conductors.
 - For heavy duty molds, molds with wear plates or molds for Copperweld® cable, contact BURNDY® Products.
 - For expedited service, contact BURNDY® Products.
- Required Tools:
 Handle Clamps (see chart for correct handles)
B38-0309-00 Flint Ignitor
- Other recommended accessories:
 Vertical Chain Clamps
B38-3922-00 Mold Cleaning Brush (pg D-85)
B38-0135-00 Cable Cleaning Brush (pg D-85)
B38-0101-00 Rasp (pg D-85)

For mold types or BURNDYWeld™ items not shown, please contact factory or refer to full BURNDYWeld™ catalog.

TYPE BCS-5 MOLDS

Horizontal Cable Tap to Horizontal Cast Iron Surface

Type BCS-5 Molds are used to join horizontal cable taps to horizontal cast iron surfaces. Note that the cable is **ON** the surface.

Size range is #6 through #1 solid or concentric stranded copper conductors.

Contact BURNDY® Products for information on molds for conductors not listed below.

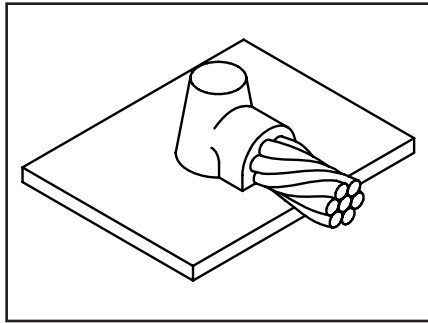

Cable Size	Mold Number	Price Key	Weld Metal	Handle Clamps
#6 Sol	B-1613	3+	2SCl	N/A
#6	B-1614	3+	25Cl	N/A
#4 Sol	B-1615	3+	45Cl	N/A
#4	B-1616	3+	45Cl	N/A
#2 Sol	B-1617	3+	45Cl	N/A
#2	B-1618	3+	45Cl	N/A
#1 Sol	B-1619	3+	65Cl	N/A
#1	B-1620	3+	65Cl	N/A

- For sizes not listed, contact BURNDY® Products.
- Molds listed are for concentric stranded cable. Add suffix “-S” to mold number for solid conductors.
- For heavy duty molds, molds with wear plates or molds for Copperweld® cable, contact BURNDY® Products.
- For expedited service, contact BURNDY® Products.

Required Tools:

- † Sold complete with frame
- B38-0309-00** Flint Ignitor (included)

Other recommended accessories:

- B38-3922-00** Mold Cleaning Brush (pg D-85)
- B38-0135-00** Cable Cleaning Brush (pg D-85)
- B38-0101-00** Rasp (pg D-85)

DO NOT use Type BCS-5 molds on Soil Pipe (ASTM A74-82). A test weld should be made on a section of the pipe being used to determine the possibility of detrimental metallurgical effects.

For mold types or BURNDYWeld™ items not shown, please contact factory or refer to full BURNDYWeld™ catalog.

TYPE BCRE-1 MOLDS

Horizontal Parallel Tap to Rebar

Type BCRE-1 Molds are recommended for parallel, horizontal connections for solid or concentric stranded conductors #6 through 4/0 joined to reinforcing bars #3 through #6 and larger. The high copper content joint has a higher current carrying capacity than the conductors being joined and is impervious to vibration and moisture.

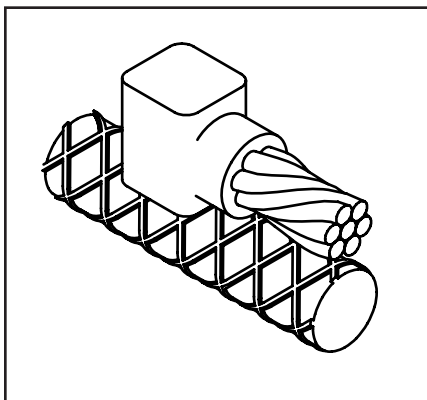

D-78

Contact BURNDY® Products for information on molds for conductors not listed below.

Rebar Size	Cable Size	Mold Number	Packing Material ‡	Price Key	Weld Metal	Handle Clamps
#3	#6	B-7500	B38-4060-00	4	25	B-106
	#4	B-7501	B38-4060-00	4	32	B-106
	#2	B-7502	B38-4060-00	4	45	B-106
	#1	B-7503	B38-4060-00	4	65	B-106
	1/0	B-7504	B38-4060-00	4	90	B-106
	2/0	B-7505	B38-4060-00	4	90	B-106
	3/0	B-7506	B38-4060-00	4	115	B-106
#4 & Larger	4/0	B-7507	B38-4060-00	4	115	B-106
	#6	B-7508	B38-4061-00	3+	25	N/A
	#4	B-7509	B38-4061-00	3+	32	N/A
	#2	B-7510	B38-4061-00	3+	45	N/A
#4	#1	B-7511	B38-4061-00	3+	65	N/A
	1/0	B-7512	B38-4060-00	4	90	B-106
	2/0	B-7513	B38-4060-00	4	90	B-106
	3/0	B-7514	B38-4060-00	4	115	B-106
#5	4/0	B-7515	B38-4060-00	4	115	B-106
	1/0	B-7520	B38-4060-00	4	90	B-106
	2/0	B-7521	B38-4060-00	4	90	B-106
	3/0	B-7522	B38-4060-00	4	115	B-106
#6 & Larger	4/0	B-7523	B38-4060-00	4	115	B-106
	1/0	B-7528	B38-4062-00	14+	90	N/A
	2/0	B-7529	B38-4062-00	14+	90	N/A
	3/0	B-7530	B38-4062-00	14+	115	N/A
	4/0	B-7531	B38-4062-00	14+	115	N/A

‡ PACKING MATERIAL NOTE

A packing pad is necessary when making BURNDYWeld™ connections to Rebar. Packing Material B38-4060-00 is a special, patented copper-wool packing, with enough in each bag to do between 40 and 50 connections. Packing Material No.'s B38-4061-00, B38-4062-00 and B38-4063-00 are a ceramic fiber material and can be used for **one** connection only. Be sure to specify Packing Material No. when ordering Mold and Weld Metal.

- For sizes not listed, contact BURNDY® Products.
- Molds listed are for concentric stranded cable. Add suffix "-S" to mold number for solid conductors.
- For heavy duty molds, molds with wear plates or molds for Copperweld® cable, contact BURNDY® Products.
- For expedited service, contact BURNDY® Products.

Required Tools:

Handle Clamps (see chart for correct handles)

† Sold complete with frame

B38-0309-00 Flint Ignitor

Other recommended accessories:

B38-3922-00 Mold Cleaning Brush (pg D-85)

B38-0135-00 Cable Cleaning Brush (pg D-85)

B38-0304-00 File (pg D-86)

For mold types or BURNDYWeld™ items not shown, please contact factory or refer to full BURNDYWeld™ catalog.

TYPE BCRE-2 MOLDS

Horizontal Cable Tap to Horizontal Rebar Run

Type BCRE-2 Molds are recommended for right angle, horizontal connections for solid or concentric stranded conductors #6 through 4/0 joined to reinforcing bars #3 through #6. The high copper content joint has a higher current carrying capacity than the conductors being joined and is impervious to vibration and moisture.

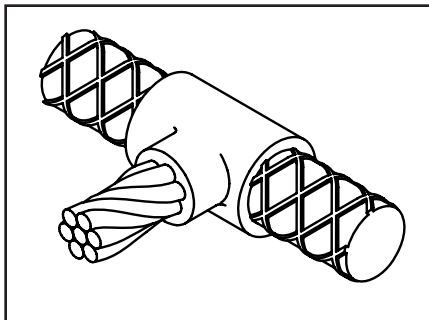

Contact BURNDY® Products for information on molds for conductors not listed below.

D-79

Rebar Size	Cable Size	Mold Number	Packing Material ‡	Price Key	Weld Metal	Handle Clamps
#3	#6	B-7588	B38-4060-00	4	45	B-106
	#4	B-7589	B38-4060-00	4	45	B-106
	#2	B-7590	B38-4060-00	4	65	B-106
	#1	B-7591	B38-4060-00	4	65	B-106
	1/0	B-7592	B38-4060-00	4	90	B-106
	2/0	B-7593	B38-4060-00	4	90	B-106
	3/0	B-7594	B38-406000	4	115	B-106
#4	4/0	B-7595	B38-4060-00	4	115	B-106
	#6	B-7596	B38-4060-00	4	45	B-106
	#4	B-7597	B38-4060-00	4	45	B-106
	#2	B-7598	B38-4060-00	4	65	B-106
	#1	B-7599	B38-4060-00	4	65	B-106
	1/0	B-7600	B38-4060-00	4	90	B-106
	2/0	B-7601	B38-4060-00	4	90	B-106
#5	3/0	B-7602	B38-4060-00	4	115	B-106
	4/0	B-7603	B38-4060-00	4	115	B-106
	#6	B-7604	B38-4606-00	4	90	B-106
	#4	B-7605	B38-4060-00	4	90	B-106
	#2	B-7606	B38-4060-00	4	90	B-106
	#1	B-7607	B38-4060-00	4	90	B-106
	1/0	B-7608	B38-4060-00	4	115	B-106
#6	2/0	B-7609	B38-4060-00	4	115	B-106
	3/0	B-7610	B38-4060-00	4	150	B-106
	4/0	B-7611	B38-4060-00	4	150	B-106
	#6	B-7612	B38-4060-00	4	90	B-106
	#4	B-7613	B38-4060-00	4	90	B-106
	#2	B-7614	B384060-00	4	90	B-106
	#1	B-7615	B38-4060-00	4	90	B-106
#6	1/0	B-7616	B38-4060-00	4	115	B-106
	2/0	B-7617	B38-4060-00	4	115	B-106
	3/0	B-7618	B38-4060-00	4	150	B-106
	4/0	B-7619	B38-4060-00	4	150	B-106

‡ PACKING MATERIAL NOTE

A packing pad is necessary when making BURNDYWeld™ connections to Rebar. Packing Material B38-4060-00 is a special, patented copper-wool packing, with enough in each bag to do between 40 and 50 connections. Packing Material No.'s B38-4061-00, B38-4062-00 and B38-4063-00 are a ceramic fiber material and can be used for **one** connection only. Be sure to specify Packing Material No. when ordering Mold and Weld Metal.

- For sizes not listed, contact BURNDY® Products.
- Molds listed are for concentric stranded cable. Add suffix "-S" to mold number for solid conductors.
- For heavy duty molds, molds with wear plates or molds for Copperweld® cable, contact BURNDY® Products.
- For expedited service, contact BURNDY® Products.

Required Tools:

Handle Clamps (see chart for correct handles)

B38-0309-00 Flint Ignitor

Other recommended accessories

B40-0319-01 Mold Cleaner for cartridge sizes #15-#65 (pg D-85)

B40-0319-03 Mold Cleaner for cartridge sizes #90-#500 (pg D-85)

B38-3922-00 Mold Cleaning Brush (pg D-85)

B38-0135-00 Cable Cleaning Brush (pg D-85)

B38-0304-00 File (pg D-86)

For mold types or BURNDYWeld™ items not shown, please contact factory or refer to full BURNDYWeld™ catalog.

TYPE BCRE-3 MOLDS

Horizontal through Cable to Vertical Rebar

Type BCRE-3 Molds are recommended for horizontal conductors to vertical rebar connections for solid or concentric stranded conductors #6 through 4/0 joined to reinforcing bars #3 through #7 & larger. The high copper content joint has a higher current carrying capacity than the conductors being joined and is impervious to vibration and moisture.

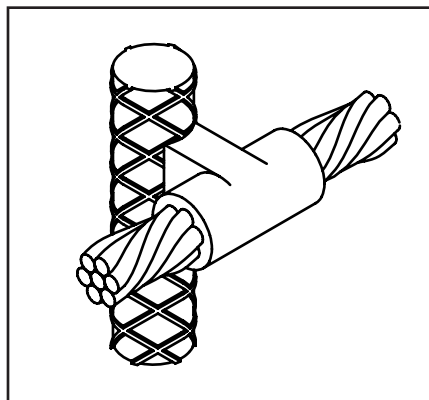

D-80

Contact BURNDY® Products for information on molds for conductors not listed below.

Rebar Size	Cable Size	Mold Number	Packing Material ‡	Price Key	Weld Metal	Handle Clamps
#3	#6	B-7620	B38-4060-00	24	90	B-106
	#4	B-7621	B38-4060-00	24	90	B-106
	#2	B-7622	B38-4060-00	24	90	B-106
	#1	B-7623	B38-4060-00	24	115	B-106
	1/0	B-7624	B38-4060-00	24	115	B-106
	2/0	B-7625	B38-4060-00	24	115	B-106
	3/0	B-7626	B38-4060-00	24	150	B-106
#4	4/0	B-7627	B38-4060-00	24	150	B-106
	#6	B-7628	B38-4060-00	24	90	B-106
	#4	B-7629	B38-4060-00	24	90	B-106
	#2	B-7630	B38-4060-00	24	90	B-106
	#1	B-7631	B38-4060-00	24	115	B-106
	1/0	B-7632	B38-4060-00	24	115	B-106
	2/0	B-7633	B38-4060-00	24	115	B-106
#5	3/0	B-7634	B38-4060-00	24	150	B-106
	4/0	B-7635	B38-4060-00	24	150	B-106
	#6	B-7636	B38-4060-00	24	90	B-106
	#4	B-7637	B38-4060-00	24	90	B-106
	#2	B-7638	B38-4060-00	24	90	B-106
	#1	B-7639	B38-4060-00	24	115	B-106
	1/0	B-7640	B38-4060-00	24	115	B-106
#6	2/0	B-7641	B38-4060-00	24	115	B-106
	3/0	B-7642	B38-4060-00	24	150	B-106
	4/0	B-7643	B38-4060-00	24	150	B-106
	#6	B-7644	B38-4060-00	24	90	B-106
	#4	B-7645	B38-4060-00	24	90	B-106
	#2	B-7646	B38-4060-00	24	90	B-106
	#1	B-7647	B38-4060-00	24	115	B-106
#7 & Larger	1/0	B-7648	B38-4060-00	24	115	B-106
	2/0	B-7649	B38-4060-00	24	115	B-106
	3/0	B-7650	B38-4060-00	24	150	B-106
	4/0	B-7651	B38-4060-00	24	150	B-106
	#6	B-7652	B38-4063-00	4+	90	B-106-41
	#4	B-7653	B38-4063-00	4+	90	B-106-41
	#2	B-7654	B38-4063-00	4+	90	B-106-41
#7 & Larger	#1	B-7655	B38-4063-00	4+	115	B-106-41
	1/0	B-7656	B38-4063-00	4+	115	B-106-41
	2/0	B-7657	B38-4063-00	4+	115	B-106-41
	3/0	B-7658	B38-4063-00	4+	150	B-106-41
	4/0	B-7659	B38-4063-00	4+	150	B-106-41

‡ PACKING MATERIAL NOTE

A packing pad is necessary when making BURNDYWeld™ connections to Rebar. Packing Material B38-4060-00 is a special, patented copper-wool packing, with enough in each bag to do between 40 and 50 connections. Packing Material No.'s B38-4061-00, B38-4062-00 and B38-4063-00 are a ceramic fiber material and can be used for **one** connection only. Be sure to specify Packing Material No. when ordering Mold and Weld Metal.

- For sizes not listed, contact BURNDY® Products.
- Molds listed are for concentric stranded cable. Add suffix "S" to mold number for solid conductors.
- For heavy duty molds, molds with wear plates or molds for Copperweld® cable, contact BURNDY® Products.
- For expedited service, contact BURNDY® Products.

Required Tools:

Handle Clamps (see chart for correct handles)
B38-0309-00 Flint Ignitor

Other recommended accessories:

Vertical Chain Clamps
 † **B40-0319-03** Mold Cleaner for cartridge sizes #90-#500 (pg D-85)
B38-3922-00 Mold Cleaning Brush (pg D-85)
B38-0135-00 Cable Cleaning Brush (pg D-85)
B38-0304-00 File (pg D-85)

For mold types or BURNDYWeld™ items not shown, please contact factory or refer to full BURNDYWeld™ catalog.

TYPE BCRE-4 MOLDS

Horizontal through Cable to Horizontal Rebar

Type BCRE-4 Molds are recommended for horizontal through conductors to horizontal rebar at right angle connections for solid or concentric stranded conductors #6 through 4/0 joined to reinforcing bars #3 through #6 & larger. The high copper content joint has a higher current carrying capacity than the conductors being joined and is impervious to vibration and moisture.

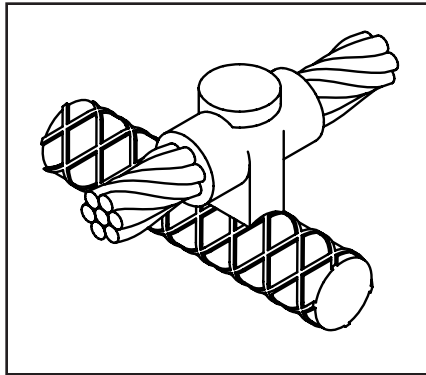

Contact BURNDY® Products for information on molds for conductors not listed below.

Rebar Size	Cable Size	Mold Number	Packing Material ‡	Price Key	Weld Metal	Handle Clamps
#3	#6	B-7708	B38-4060-00	4	90	B-106
	#4	B-7709	B38-4060-00	4	90	B-106
	#2	B-7710	B38-4060-00	4	90	B-106
	#1	B-7711	B38-4060-00	4	115	B-106
	1/0	B-7712	B38-4060-00	22	115	B-106
	2/0	B-7713	B38-4060-00	22	115	B-106
	3/0	B-7714	B38-4060-00	22	150	B-106
#4	4/0	B-7715	B38-4060-00	22	150	B-106
	#6	B-7716	B38-4060-00	4	90	B-106
	#4	B-7717	B38-4060-00	4	90	B-106
	#2	B-7718	B38-4060-00	4	90	B-106
	#1	B-7719	B38-4060-00	22	115	B-106
	1/0	B-7720	B38-4060-00	22	115	B-106
	2/0	B-7721	B38-4060-00	22	115	B-106
#5	3/0	B-7722	B38-4060-00	22	150	B-106
	4/0	B-7723	B38-4060-00	22	150	B-106
	#6	B-7724	B38-4060-00	4	90	B-106
	#4	B-7725	B38-4060-00	4	90	B-106
	#2	B-7726	B38-4060-00	4	90	B-106
	#1	B-7727	B38-4060-00	22	115	B-106
	1/0	B-7728	B38-4060-00	22	115	B-106
#6 & Larger	2/0	B-7729	B38-4060-00	22	115	B-106
	3/0	B-7730	B38-4060-00	22	150	B-106
	4/0	B-7731	B38-4060-00	22	150	B-106
	#6	B-7732	B38-4061-00	14+	90	N/A
	#4	B-7733	B38-4061-00	14+	90	N/A
	#2	B-7734	B38-4061-00	14+	90	N/A
	#1	B-7735	B38-406100	14+	115	N/A
1/0	B-7736	B38-4062-00	14+	115	N/A	
2/0	B-7737	B38-4062-00	14+	115	N/A	
3/0	B-7738	B38-4062-00	14+	150	N/A	
4/0	B-7739	B38-4062-00	14+	150	N/A	

‡ PACKING MATERIAL NOTE

A packing pad is necessary when making BURNDYWeld™ connections to Rebar. Packing Material B38-4060-00 is a special, patented copper-wool packing, with enough in each bag to do between 40 and 50 connections. Packing Material No.'s B38-4061-00, B38-4062-00 and B38-4063-00 are a ceramic fiber material and can be used for **one** connection only. Be sure to specify Packing Material No. when ordering Mold and Weld Metal.

- For sizes not listed, contact BURNDY® Products.
- Molds listed are for concentric stranded cable. Add suffix "-S" to mold number for solid conductors.
- For heavy duty molds, molds with wear plates or molds for Copperweld® cable, contact BURNDY® Products.
- For expedited service, contact BURNDY® Products.

Required Tools:

Handle Clamps (see chart for correct handles)

† Sold complete with frame

B38-0309-00 Flint Ignitor

Other recommended accessories:

B40-0319-03 Mold Cleaner for cartridge sizes #90-#500 (pg D-85)

B38-3922-00 Mold Cleaning Brush (pg D-85)

B38-0135-00 Cable Cleaning Brush (pg D-85)

B38-0304-00 File (pg D-86)

For mold types or BURNDYWeld™ items not shown, please contact factory or refer to full BURNDYWeld™ catalog.

TYPE BCRE-6 MOLDS

Horizontal Cable Tap to Vertical Rebar

Type BCRE-6 Molds are recommended for horizontal conductors terminating at right angles to vertical rebar connections for solid or concentric stranded conductors #6 through 4/0 joined to reinforcing bars #3 through #7 and larger. The high copper content joint has a higher current carrying capacity than the conductors being joined and is impervious to vibration and moisture.

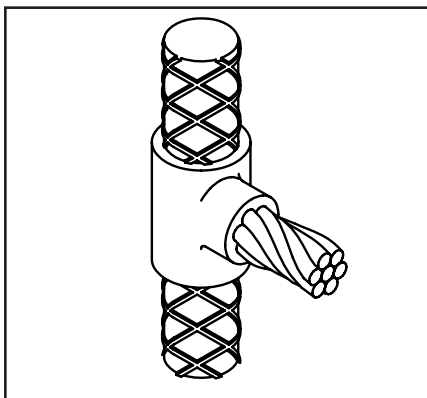

D-82

Contact BURNDY® Products for information on molds for conductors not listed below.

Rebar Size	Cable Size	Mold Number	Packing Material ‡	Price Key	Weld Metal	Handle Clamps
#3	#6	B-7884	B38-4060-00	4	90	B-106
	#4	B-7885	B38-4060-00	4	90	B-106
	#2	B-7886	B38-4060-00	4	90	B-106
	#1	B-7887	B38-4060-00	4	115	B-106
	1/0	B-7888	B38-4060-00	4	115	B-106
	2/0	B-7889	B38-4060-00	4	115	B-106
	3/0	B-7890	B38-4060-00	4	150	B-106
#4	4/0	B-7891	B38-4060-00	4	150	B-106
	#6	B-7892	B38-4060-00	4	90	B-106
	#4	B-7893	B38-4060-00	4	90	B-106
	#2	B-7894	B38-4060-00	4	90	B-106
	#1	B-7895	B38-4060-00	4	115	B-106
	1/0	B-7896	B38-4060-00	4	115	B-106
	2/0	B-7897	B38-4060-00	4	115	B-106
#5	3/0	B-7898	B38-4060-00	4	150	B-106
	4/0	B-7899	B38-4060-00	4	150	B-106
	#6	B-7900	B38-4060-00	4	90	B-106
	#4	B-7901	B38-4060-00	4	90	B-106
	#2	B-7902	B38-4060-00	4	90	B-106
	#1	B-7903	B38-4060-00	4	115	B-106
	1/0	B-7904	B38-4060-00	4	115	B-106
#6	2/0	B-7905	B38-4060-00	4	115	B-106
	3/0	B-7906	B38-4060-00	4	150	B-106
	4/0	B-7907	B38-4060-00	4	150	B-106
	#6	B-7908	B38-4060-00	4	90	B-106
	#4	B-7909	B38-4060-00	4	90	B-106
	#2	B-7910	B38-4060-00	4	90	B-106
	#1	B-7911	B38-4060-00	4	115	B-106
#7 & Larger	1/0	B-7912	B38-4060-00	4	115	B-106
	2/0	B-7913	B38-4060-00	4	115	B-106
	3/0	B-7914	B38-4060-00	4	150	B-106
	4/0	B-7915	B38-4060-00	4	150	B-106
	#6	B-7916	B38-4063-00	4	90	B-106-32
	#4	B-7917	B38-4063-00	4	90	B-106-32
	#2	B-7918	B38-4063-00	4	90	B-106-32
#7 & Larger	#1	B-7919	B38-4063-00	4	115	B-106-32
	1/0	B-7920	B38-4063-00	4	115	B-106-32
	2/0	B-7921	B38-4063-00	4	115	B-106-32
	3/0	B-7922	B38-4063-00	4	150	B-106-32
	4/0	B-7923	B38-4063-00	4	150	B-106-32

‡ PACKING MATERIAL NOTE

A packing pad is necessary when making BURNDYWeld™ connections to Rebar. Packing Material B38-4060-00 is a special, patented copper-wool packing, with enough in each bag to do between 40 and 50 connections. Packing Material No.'s B38-4061-00, B38-4062-00 and B38-4063-00 are a ceramic fiber material and can be used for one connection only. Be sure to specify Packing Material No. when ordering Mold and Weld Metal.

- For sizes not listed, contact BURNDY® Products.
- Molds listed are for concentric stranded cable. Add suffix "S" to mold number for solid conductors.
- For heavy duty molds, molds with wear plates or molds for Copperweld® cable, contact BURNDY® Products.
- For expedited service, contact BURNDY® Products.

Required Tools:

Handle Clamps (see chart for correct handles)

B38-0309-00 Flint Ignitor

Other recommended accessories:

B38-3922-00 Mold Cleaning Brush (pg D-85)

B38-0135-00 Cable Cleaning Brush (pg D-85)

B38-0304-00 File (pg D-86)

*The B106-32 comes complete with a B-106 handle clamp and B40-0106-76 vertical chain clamp. Although good for use on all sizes of rebar, vertical chain clamps are strongly recommended on large size rebar as they hold the mold to the rebar securely. If you already have a B-106 handle clamp, you can purchase the vertical chain clamps separately. See page 76 for a variety of options.

For mold types or BURNDYWeld™ items not shown, please contact factory or refer to full BURNDYWeld™ catalog.

BURNDYWeld FILL*

BURNDYWeld™ FILL is an economical solution for areas with very difficult grounding issues. BURNDYWeld™ FILL is highly conductive in a wet or dry application and does not require moisture to lower the resistance of your grounding system. BURNDYWeld™ FILL contains a corrosion inhibitor which forms a film on copper, creating a barrier against corrosion.

BURNDYWeld™ FILL can be poured in dry or pumped in slurry form. No tamping required. It is very contractor friendly. No special tools required.

*BURNDYWeld™ FILL is the catalog number.

BURNDYWeld™ FILL Advantages:

- Easy to install.
- Electrically conductive.
- Environmentally friendly.
- Will not leach into the ground.
- Positive low resistance, electrical connection to earth.
- Does not contain any hazardous chemicals.
- Compatible with all copper grounding systems.
- Contains a corrosion inhibitor to protect copper.
- Will not expand or shrink.
- Not affected by freezing.
- Excellent shelf life.
- Typical resistivity <10 Ohm-cm

D-83

Material Required Per Linear Foot of Trench												
Width of Trench (Inches)												
Thickness of BURNDYWeld™ FILL (Inches)		4	6	8	10	12	14	16	18	20	22	24
	2	4.1	6.2	8.1	10.1	12.1	14.1	16.2	18.2	20.2	22.2	24.2
	3	6.2	9.3	12.1	15.2	18.2	21.2	24.2	27.3	30.3	33.3	36.4
	4	8.2	12.3	16.2	20.2	24.2	28.3	32.3	36.4	40.4	44.5	48.5
	5	10.3	15.4	20.2	25.3	30.3	35.4	40.4	45.5	50.5	55.6	60.6
	6	12.3	18.5	24.2	30.3	36.4	42.4	48.5	54.6	60.6	66.7	72.7
	7	14.4	21.6	28.3	35.4	42.4	49.5	56.6	63.7	70.7	77.8	84.9
	8	16.4	24.7	32.3	40.4	48.5	56.0	64.7	72.7	80.8	88.9	97.0
	9	18.5	27.8	36.4	45.5	54.6	63.7	72.7	81.8	90.9	100.0	109.1
	10	20.6	30.8	40.4	50.5	60.6	70.7	80.8	90.9	101.0	111.1	121.2

To calculate the lbs. of material required to fill a trench:

- Determine desired thickness.
- Move to the right until you are under the known width of the trench. This number will be the weight of the material in lbs./linear ft.
- Take this number and multiply by the length of the trench in feet. Your answer will be the amount of BURNDYWeld™ FILL material required to fill the trench to the desired level in lbs.

Example:

Thickness: = 6 inches
 Width = 18 inches
 54.6 lbs. per linear ft. (from the table above)
 Answer = 54.6 lbs. per linear ft. x 25 ft. trench = 1,365 lbs. of BURNDYWeld™ FILL
 = 28 (50 lb.) bags of BURNDYWeld™ FILL

For mold types or BURNDYWeld™ items not shown, please contact factory or refer to full BURNDYWeld™ catalog.

BURNDYWeld™ FILL*

Application Information

*BURNDYWeld™ FILL is the catalog number.

Vertical Installation

Drill or bore a hole the desired diameter and depth. Suspend ground electrode in center of hole to be filled. Pour BURNDYWeld™ FILL until desired level is obtained. No tamping is required.

Dry Volume of BURNDYWeld™ FILL vs. Hole Size		Ground Resistance Comparison of Bare Rod vs.	
Hole Size	Lbs. of BURNDYWeld™ FILL Per Ft.	Hole Size with 5/8" x 10' Rod in Center of 15' Hole	Percent Resistance Compared to Rod Only (100%)
4"	6.5	4"	52%
6"	14.5	6"	47%
8"	25.8	8"	44%
10"	40.4	10"	42%
12"	58.1	12"	40%

D-84

Horizontal or Grid Construction†

Pour into horizontal trench until level of ground wire is reached. Place ground wire. Pour in additional BURNDYWeld™ FILL until wire is covered to desired height. Cover with fill. No tamping required.

For grid construction, pour BURNDYWeld™ FILL and spread over ground grid until desired thickness is achieved. Cover with fill.

Length	.475" Diameter Wire Only	Percentage of Resistance with .475" Wire Plus BURNDYWeld™ FILL in Various Diameters Compared to Wire Only (100%)			
		2"	3"	4"	6"
25'	100%	83%	78%	74%	69%
50'	100%	85%	81%	77%	73%
75'	100%	86%	82%	79%	75%
100'	100%	87%	83%	80%	77%
150'	100%	88%	84%	82%	78%
200'	100%	88%	85%	83%	79%
250'	100%	89%	85%	83%	80%
300'	100%	89%	86%	84%	80%

† Entire grounding system should be surrounded by BURNDYWeld™ FILL. Conductors should be insulated as they exit BURNDYWeld™ FILL column.

‡ The use of BURNDYWeld™ FILL around the grounding system will also reduce surge impedance by increasing the effective contact area of the electrode to soil.

Horizontal Construction

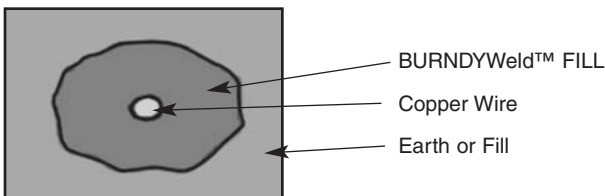

Grid Construction

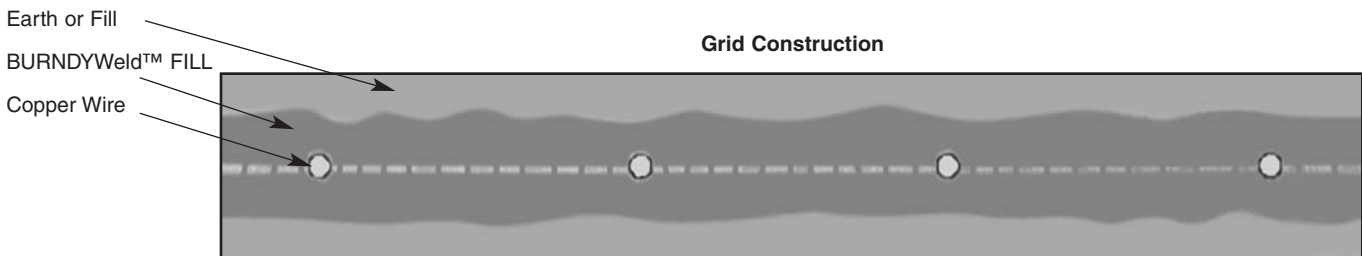

For mold types or BURNDYWeld™ items not shown, please contact factory or refer to full BURNDYWeld™ catalog.

BURNDYWeld SET*

Certain applications require a permanent hardening grounding material. BURNDYWeld™ SET is the product of choice. BURNDYWeld™ SET is compatible with all standard copper grounding systems. It is an economical solution to difficult grounding issues in hard to deal with areas. BURNDYWeld™ SET is manufactured from environmentally safe material and is extremely stable. When mixed with water or exposed to moisture, BURNDYWeld™ SET attains the hardening characteristics of cement while retaining its highly conductive properties. BURNDYWeld™ SET will remain highly conductive during a drought or when exposed to extremely low temperatures. Since BURNDYWeld™ SET does not have any shrinkage or expansion properties it will remain in constant contact with the earth.

BURNDYWeld™ SET can be poured in dry or pumped in slurry form. No tamping required. It is very contractor friendly. No special tools required.

*BURNDYWeld™ SET is the catalog number.

BURNDYWeld™ SET Advantages:

- Easy to install.
- Will attain a hardened state.
- Electrically conductive.
- Environmentally friendly.
- Will not leach into the ground.
- Positively low resistance, electrical connection to the earth.
- Does not contain any hazardous chemicals.
- Compatible with all copper grounding systems.
- Will not expand or shrink.
- Not effected by freezing.
- Excellent shelf life.
- Typical resistivity <10 Ohm-cm

Material Required Per Linear Foot of Trench												
Width of Trench (Inches)												
Thickness of BURNDYWeld™ SET (Inches)		4	6	8	10	12	14	16	18	20	22	24
	2	3.6	5.4	7.2	9.0	10.8	12.6	14.4	16.2	18.0	19.7	21.5
	3	5.4	8.1	10.8	13.5	16.2	18.8	21.5	24.2	26.9	29.6	32.3
	4	7.2	10.8	14.4	18.0	21.5	25.1	28.7	32.3	35.9	39.5	43.1
	5	9.0	13.5	18.0	22.4	26.9	31.4	35.9	40.4	44.9	49.4	53.9
	6	10.8	16.3	21.5	26.9	32.3	37.7	43.1	48.5	53.9	59.2	64.6
	7	12.6	19.0	25.1	31.4	37.7	44.0	50.3	56.5	62.8	69.1	75.4
	8	14.4	21.7	28.7	35.9	43.1	50.3	57.4	64.6	71.8	79.0	86.2
	9	16.3	24.4	32.3	40.4	48.5	56.5	64.6	72.7	80.8	88.9	96.9
	10	18.1	27.1	35.9	44.9	53.9	62.8	71.8	80.8	89.8	98.7	107.7

To calculate the lbs. of material required to fill a trench:

- Determine desired thickness of BURNDYWeld™ SET.
- Move to the right until you are under the known width of the trench. This number will be the weight of the material in lbs./linear ft.
- Take this number and multiply by the length of the trench in feet. Your answer will be the amount of BURNDYWeld™ SET material required to fill the trench to the desired level in lbs.

Example:

Thickness: = 6 inches
 Width = 18 inches
 48.5 lbs. per linear ft. (from the table above)
 Answer = 48.5 lbs. per linear ft. x 25 ft. trench = 1,212.5 lbs. of BURNDYWeld™ SET
 = 24 (50 lb.) bags of BURNDYWeld™ SET

For mold types or BURNDYWeld™ items not shown, please contact factory or refer to full BURNDYWeld™ catalog.

BURNDYWeld™ SET*

Application Information

*BURNDYWeld™ SET is the catalog number.

Vertical Installation

Drill or bore a hole to the desired diameter and depth. Suspend ground electrode in center of hole to be filled. Pour BURNDYWeld™ SET until desired level is obtained. Remove excess water prior to pumping. If necessary, BURNDYWeld™ SET may be premixed and pumped under water.

Dry Volume of BURNDYWeld™ SET vs. Hole Size		Ground Resistance Comparison of Bare Rod vs.	
Hole Size	Lbs. of BURNDYWeld™ SET Per Ft.	Hole Size with 5/8" x 10' Rod in Center of 15' Hole	Percent Resistance Compared to Rod Only (100%)
4"	5.7	4"	52%
6"	12.8	6"	47%
8"	22.7	8"	44%
10"	35.5	10"	42%
12"	51.1	12"	40%

D-86

Horizontal or Grid Construction†

Pour into horizontal trench until level of ground wire is reached. Place ground wire. Pour in additional BURNDYWeld™ SET until wire is covered to desired height. Cover with fill. No tamping required. Remove excess water prior to installation.

For grid construction, pour BURNDYWeld™ SET and spread over ground grid until desired thickness is achieved. Cover with fill. Use ground staples to maintain ground wire in center of BURNDYWeld™ SET.

Steady State Leakage Resistance‡ Using 4/0 Copper Wire vs. BURNDYWeld™ SET					
Length	.475" Diameter Wire Only	Percentage of Resistance with .475" Wire Plus BURNDYWeld™ SET in Various Diameters Compared to Wire Only (100%)			
		2"	3"	4"	6"
25'	100%	83%	78%	74%	69%
50'	100%	85%	81%	77%	73%
75'	100%	86%	82%	79%	75%
100'	100%	87%	83%	80%	77%
150'	100%	88%	84%	82%	78%
200'	100%	88%	85%	83%	79%
250'	100%	89%	85%	83%	80%
300'	100%	89%	86%	84%	80%

† Entire grounding system should be surrounded by BURNDYWeld™ SET. Conductors should be insulated as they exit BURNDYWeld™ SET column. BURNDYWeld™ SET should be used as a ground enhancement material when a setting fill is specified.

‡ The use of BURNDYWeld™ SET around the grounding system will also reduce surge impedance by increasing the effective contact area of the electrode to soil.

Horizontal Construction

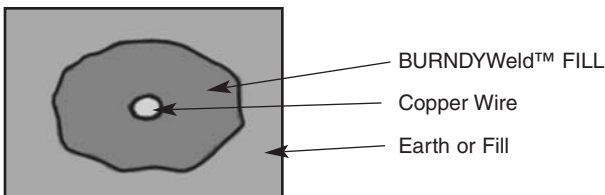

Earth or Fill

BURNDYWeld™ FILL

Copper Wire

Grid Construction



For mold types or BURNDYWeld™ items not shown, please contact factory or refer to full BURNDYWeld™ catalog.

BURNDYWeld™ PREFABRICATED WIRE MESH

**Grounding, Personal Safety
Mats, Equipotential Planes,
Signal Reference Grid**

Prefabricated wire mesh is:

- manufactured from bare solid copper or copperclad conductors.
- spaced on 4", 6" or 12" centers.
- factory silver brazed at each crossover using 35% silver and a non-corrosive flux.
- furnished in sections with widths from 2 ft to 18 ft (length limited by weight).
- shipped on tubes and protected for transporting.
- interconnected in the field using BURNDYWeld™ molds and powder.

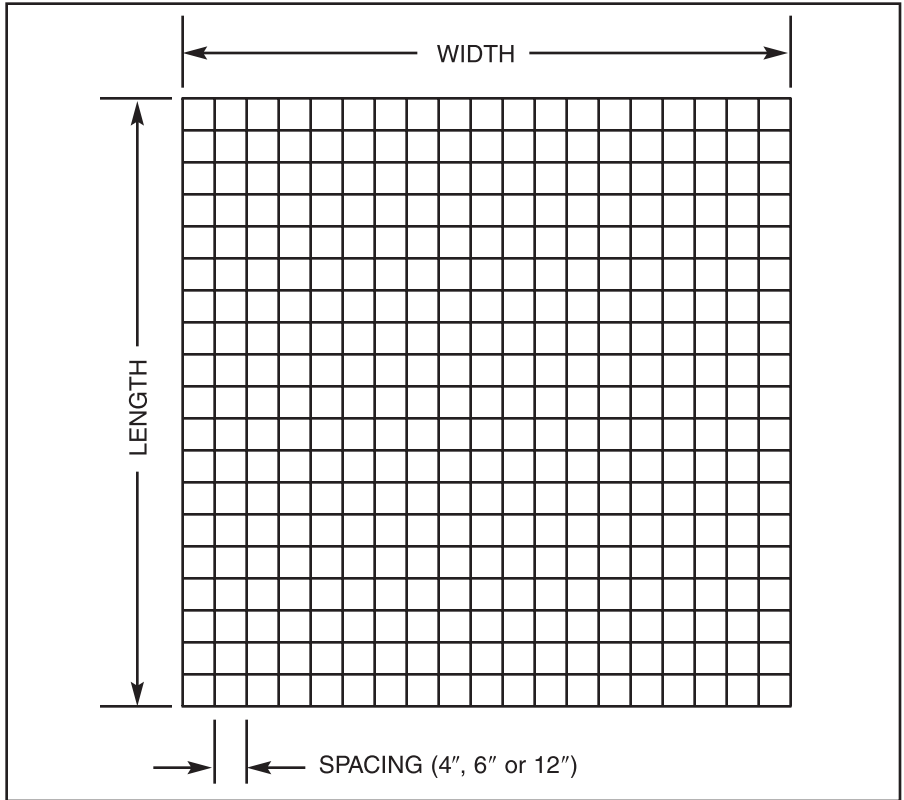

D-87

Prefabricated Wire Mesh		
Part Number	Description	Weight/Sq Ft.
Contact Factory	#10 Solid Copper Wire Mesh on 4" Centers	0.192
	#6 Solid Copper Wire Mesh on 4" Centers	0.487
	#6 Solid Copper Wire Mesh on 6" Centers	0.325
	#6 Solid Copper Wire Mesh on 12" Centers	0.163
Copperclad Wire Mesh may be ordered contact factory for part numbers		

When ordering, specify wire type and size, width, length and spacing.

Molds for Connecting Prefabricated Wire Mesh					
Wire Size	Weld Type	Mold Number	Price Key	Handle Clamp	Weld Metal
#6 Sol Copper	BCC-14	B-6205	18	included	#25
#6 Sol Copperweld	BCC-14	B-6207	18	included	#15
#8 Sol Copper	BCC-14	B-6209	18	included	#15
#8 Sol Copperweld	BCC-14	B-6210	18	included	#15
#10 Sol Copper	BCB-34	B-6211	18	included	#15
#10 Sol Copperweld	BCB-34	B-6212	18	included	#15

**For mold types or
BURNDYWeld™ items not
shown, please contact
factory or refer to full
BURNDYWeld™ catalog.**

Adjoining sections of mesh are to be exothermically welded by installer using BURNDYWeld™ molds and powder.

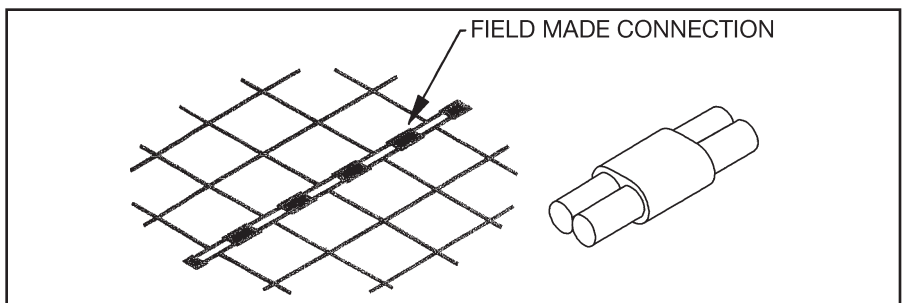

BURNDYWeld™ PREFABRICATED WIRE MESH

The prefabricated wire mesh is a convenient, efficient and economical means of improving grounding systems at facilities where large area grounds are required.

Wire Choices

Wire mesh is made from solid wire, either copper clad steel or pure copper. Copper clad steel wire has the strength of steel combined with the higher conductivity and corrosion resistance of copper. The two metals are permanently bonded and act as a single material.

Silver Brazed Joints

The long wires and cross wires of wire mesh are silver brazed at their crossing points. This method provides joints with a breaking strength strong enough to resist separation during installation and strong enough to bear the traffic of heavy vehicles.

Like the wire itself, the silver brazed joints are highly resistant to corrosion. Moreover, electrical continuity of a silver brazed joint is excellent.

Installation

Wire mesh is easily and economically installed. No expensive, special equipment is necessary, and there are no time consuming special handling procedures. The strong, pliable mesh is simply unrolled over the ground, interconnected using BURNDYWeld™ connections to attach adjacent sections of mesh, and BURNDYWeld™ to the main ground grid or ground rods. The mesh may be covered with a layer of earth or crushed stone.

When used to control step and touch potentials in an electrical substation, the mesh does not replace the main ground grid. However, the main grid can be installed to control the station resistance without regard to the step and touch potentials. A properly designed system employing prefabricated mesh which is periodically interconnected to the main grid, will control the step and touch potentials.

Interconnecting

The BURNDYWeld™ process provides a rapid, economical, permanent, and highly conductive method of interconnecting wire mesh in the field.

The BURNDYWeld™ process is a controlled reaction involving molten, superheated copper. It is ideal for connecting mesh because the reaction occurs quickly which fuses the wires together into a solid mass. The resulting weld is permanent and corrosion resistant. The large weld area provides current carrying capacity equal to the mesh conductors.

A semipermanent graphite mold is used in making the BURNDYWeld™ connections. The mold controls the direction and speed of the molten metal and determines the shape of the weld. The equipment is lightweight, portable and easy to use. No outside source of heat or power is needed, and only a minimum of training is necessary. The mesh can be interconnected by this process even under adverse working conditions.

The adjacent mesh sections are best joined by the exothermic parallel type BCC-14 connection.

B-106 & B-107 HANDLE CLAMPS

BURNDYWeld™ Handle Clamps make possible the use of many different sizes and types of molds with only two different clamps. The two handle clamps are catalog numbers B-106 and B-107. These will fit 95% of all standard BURNDYWeld™ molds.

1. Use B-106 clamps for all molds having a price key 4, 7, 17, 22 or 24. These molds are a nominal 3 1/8" x 3 1/8" square.
2. Use B-107 clamps for all molds having a price key 5, 6, 8 or 23. These molds are a nominal 4" x 4" square.
3. All molds having a price key 2, 3, 9, 10, 11, 12, 14, 15 or 16 have an attached frame; separate handles are not required.

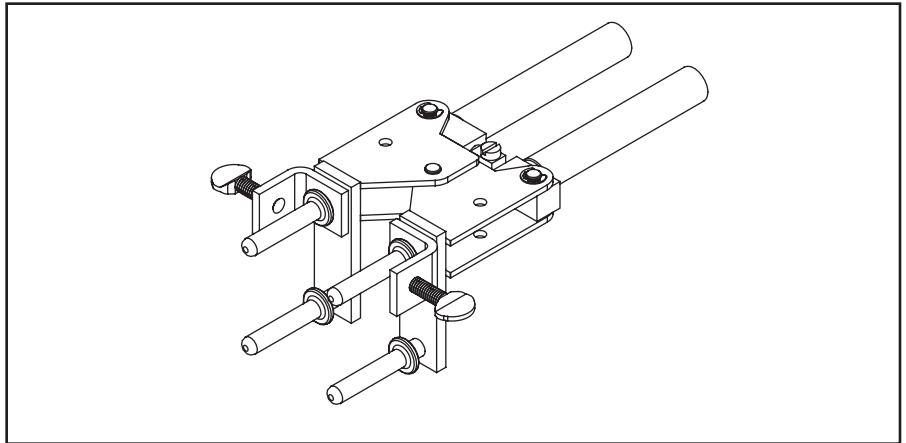

D-89

B40-0106-75 HANDLE ATTACHMENT

This Handle Attachment is used to hold Price Key-14 molds in position. It easily attaches to the B-106 Handle Clamp. This Handle Attachment can be used with weld types BCRE-1 and BCRE-4.

Catalog Number **B40-0106-75**

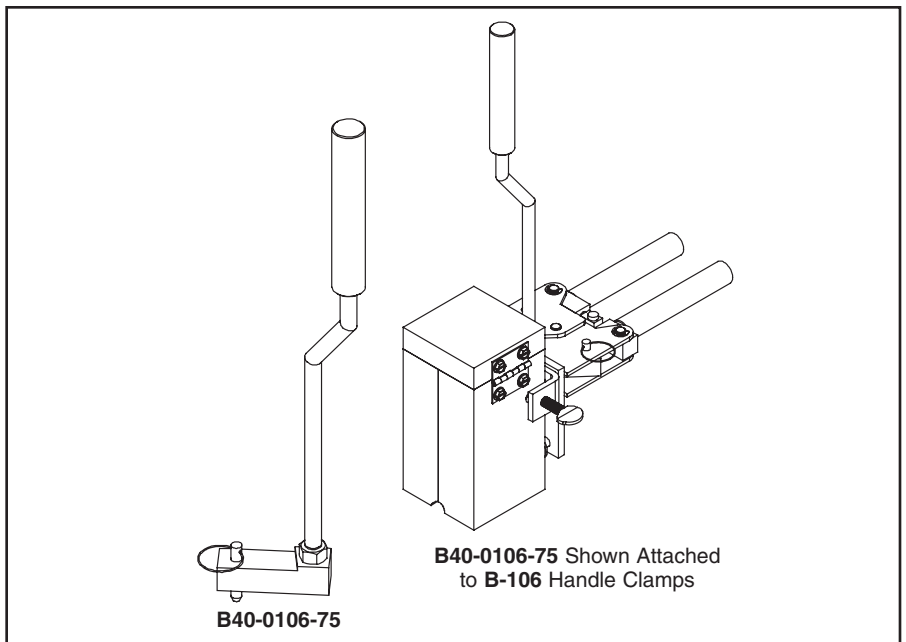

MOLD SUPPORT CLAMP

The Mold Support Clamp is used to hold a mold in position on a vertical steel column or angle. It is easily attached to the Handle Clamps. The Mold Support Clamp can be used with weld types BCS-3, BCS-18, BCS-23 and BCS-27.

Catalog Number **B40-3657-00**

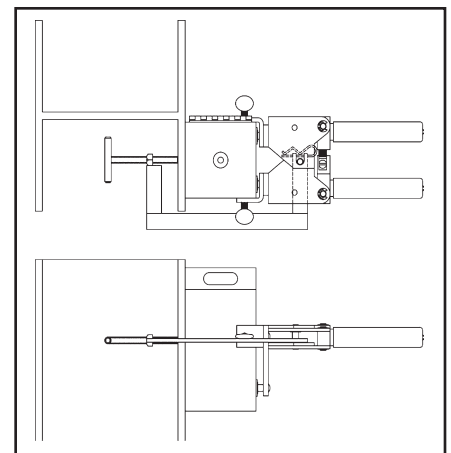
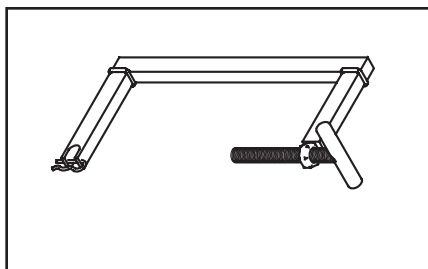

For mold types or BURNDYWeld™ items not shown, please contact factory or refer to full BURNDYWeld™ catalog.

VERTICAL MAGNETIC CLAMPS

Magnetic Clamps are used to hold a mold in position on a vertical steel surface. The magnetic clamp can be purchased complete with B-106 Handle Clamps or if you already have a set of handle clamps, you can order just the magnetic mounting assembly. The mounting assembly can easily be mounted on the prongs of your existing B-106 handle clamps. A minimum of 10" is required.

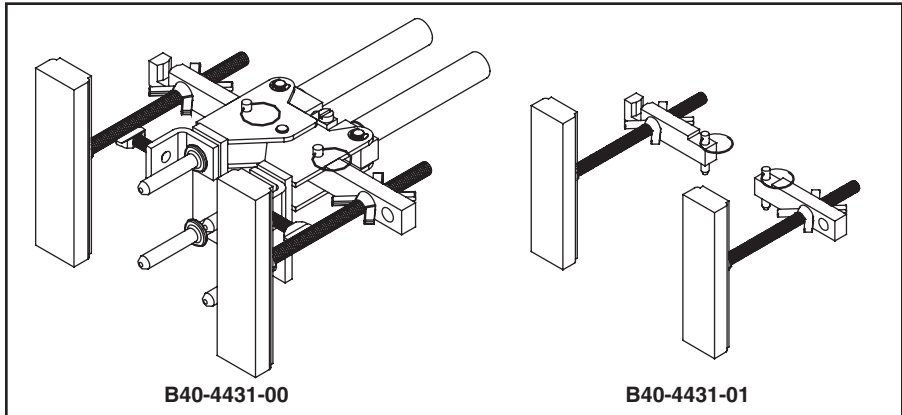

Magnetic Clamps With B106 Handle		
Catalog Number	Fits Molds W/Price Key	For Use With Weld Types
8404431-00	4 & 17	BCS-3, 4, 7 & 23

Magnetic Clamp Only		
Catalog Number	Fits Handle Clamps	For Use With Weld Types
840-4431-01	B-106 & B-107	BCS-3, 4, 7 & 23

D-90

HORIZONTAL & VERTICAL CHAIN CLAMPS

Chain Clamps are used to hold a mold in position on horizontal or vertical pipe up to 4" in diameter. For larger pipe a 20" chain extension is available to allow the chain clamps to be used on pipe up to 10" in diameter. The chain clamp can be purchased complete with B-106 or B-107 Handle Clamps or if you already have a set of handle clamps, you can order just the chain clamp and mounting assembly. The mounting assembly can easily be attached to your existing handle clamps. 20" Chain Extension catalog number B40-0106-27.

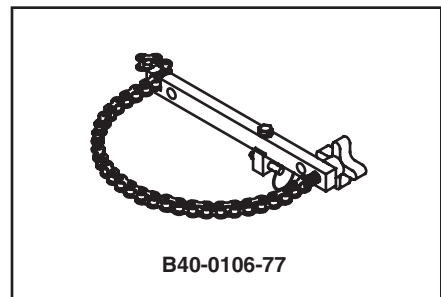
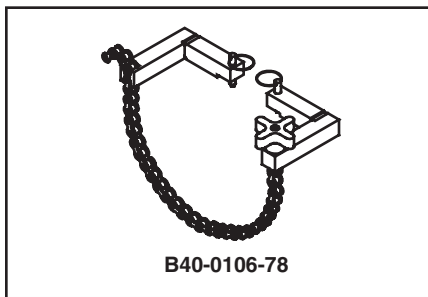
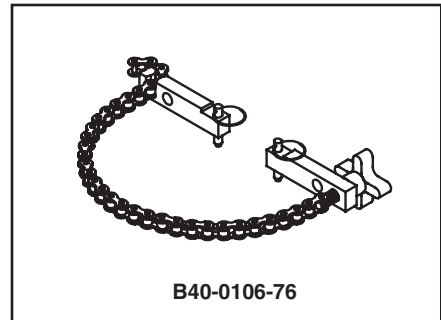
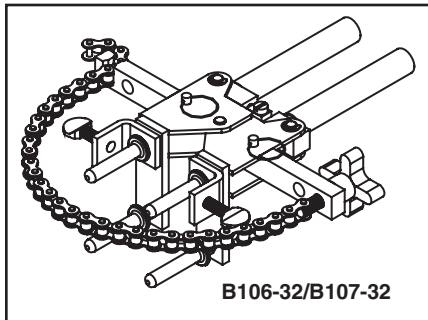

Chain Clamps			
Catalog Number	Fits Molds W/Price Key	For Use With Weld Types	Pipe Position
B106-32	4, 17, 22 & 24	BCS-3, 4, 7, 23 & BCRE-6	Vertical
B107-32	5, 6 & 23	BCS-3, 4, 7 & 23	Vertical
B106-37	4, 17, 22 & 24	BCS-1, 2, 5, 8 & 9	Horizontal
B107-37	5, 6 & 23	BCS-1, 2, 5, 8 & 9	Horizontal
B106-41	4, 17	BCS-6, 18 & BCRE-3	Vertical

Chain Clamp Only (Handle Clamps Not Included)			
Catalog Number	Fits Handle Clamp	For Use With Weld Types	Pipe Position
B40-0106-76	B-106 & B-107	BCS-3, 4, 7, 23 & BCRE-6	Vertical
B40-0106-78	B-106 & B-107	BCS-1, 2, 5, 8 & 9	Horizontal
B40-0106-77	B-106 & B-107	BCS-6, 18 & BCRE-3	Vertical

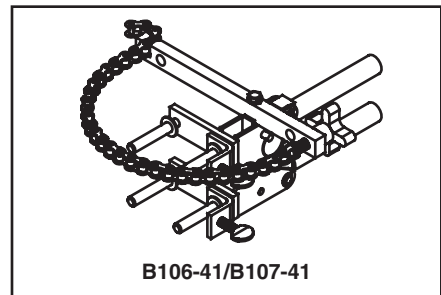

For mold types or BURNDYWeld™ items not shown, please contact factory or refer to full BURNDYWeld™ catalog.

BURNDYWeld™ ACCESSORIES

B38-0330-00 CABLE CLAMP

The BURNDYWeld™ Cable Clamp is recommended for holding a wide range of cables properly in place in molds when welding cables that are under tension. This prevents the cables from pulling out of the mold when the weld is made.

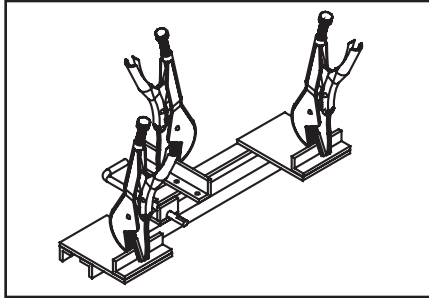

CABLE CLEANING AND CARD CLOTH BRUSH

The Cable Cleaning Brush is recommended for cleaning heavily oxidized cables. The V-shape brushes permit their use over a wide range of cable sizes. Brush assembly consists of a handle with two stiff wire bristle brushes that are rotatable, for longer life and are replaceable.

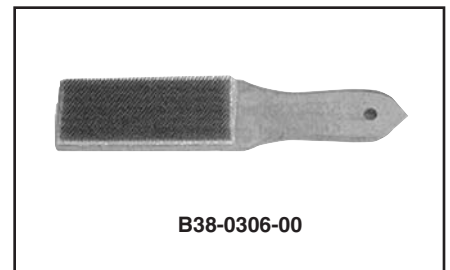
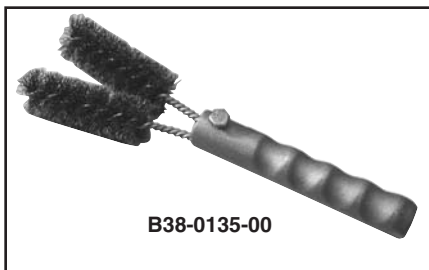

The Card Cloth Brush is used for cleaning large conductors and bus bar. It has short stiff bristles. These brushes are for cleaning cable only, not molds.

Cable Cleaning Brush **B38-0135-00**
 Replacement Brush **B38-0135-01**
 Card Cloth Brush **B38-0306-00**
 Mold Cleaning Brush **B38-3922-00**



The Mold Cleaning Brush B38-3922-00 is used to clean the graphite mold without scratching the mold.

MOLD CLEANERS

Mold Cleaners are used to clean the slag from molds that are not split through the crucible.

- B40-0319-01** for cartridge sizes #15 through #65
- B40-0319-03** for cartridge sizes #90 through #500



PACKING MATERIAL

Packing material is used to prevent the molten weld metal from leaking out of the mold. When the cable opening becomes worn from heavy use, the packing material may be used to prolong mold use. It is also used around 7 strand cable to prevent leaking. Packing material comes in a 1 lb. or 5 lb. package.

Catalog Number	Description
B38-4129-00	1 lb. package
B38-4129-05	5 lb. package

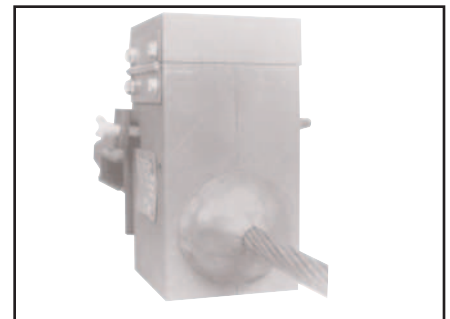

For mold types or BURNDYWeld™ items not shown, please contact factory or refer to full BURNDYWeld™ catalog.

BURNDYWeld™ ACCESSORIES

D-92



BURNDYWeld™ TOOL KIT

- B38-0302-00** Tool Kit with Tools Shown except Rasp
- B38-0302-02** Tool Kit with Tools Shown and Rasp
- B38-0303-00** Tool Box only



BURNDYWeld™ TOOLS

- B38-0309-00** Flint Ignitor
- B38-0304-00** 8" File
- B38-0307-00** Crimping Tool
- B38-3922-00** Mold Cleaning Brush
- B38-0308-00** 6" Screwdriver
- B38-0305-00** Wire Brush
- B38-0101-00** Rasp
- B38-0306-00** Card Cloth Brush

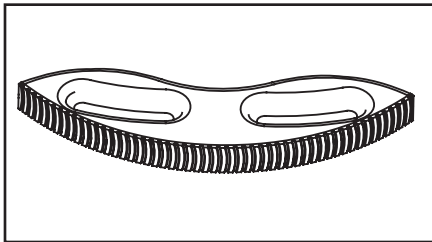

B38-0101-00 RASP

This tempered steel, curved rasp is recommended for removing rust and mill scale from steel and cast iron surfaces. The blade is replaceable. To order replacement rasp blade, specify catalog number **B38-0101-01**.

Not recommended for use on galvanized surfaces.



B38-0309-00 FLINT IGNITOR

The B38-0309-00 Flint Ignitor is used to ignite the starting powder. Each mold that is sold with a frame has a Flint Ignitor included. For added safety a Flint Ignitor extension is available, catalog number **B38-0904-00**, that attaches to the B38-0309-00 Flint Ignitor. This allows installers to stay approximately 36" away from the mold.

To order replacement flints, specify part number **B38-0309-01**.

For mold types or BURNDYWeld™ items not shown, please contact factory or refer to full BURNDYWeld™ catalog.

GROUND ROD DRIVING SLEEVES

Ground Rod Driving Sleeves are placed over the top of a ground rod while driving it into the ground. This prevents the top from mushrooming or flaring out. Ground rod driving sleeves are available in sizes to fit all standard unthreaded ground rods.

Catalog Number	For Use On
B38-3662-01	1/2" Copper Clad or Steel Ground Rod
B38-3662-02	5/8" Copper Clad Ground Rod
B38-3662-05	5/8" Steel Ground Rod
B38-3662-03	3/4" Copper Clad Ground Rod
B38-3662-06	3/4" Steel Ground Rod
B38-3662-04	1" Copper Clad Ground Rod

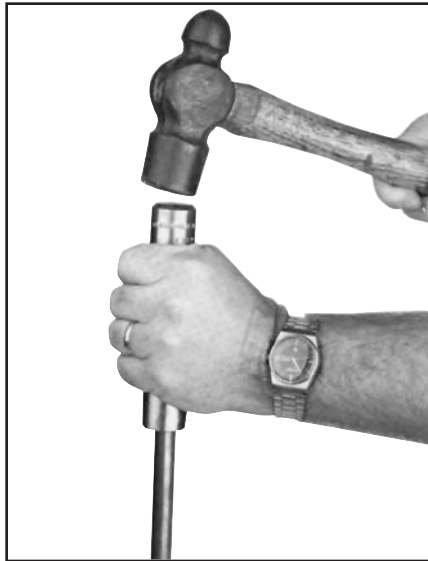

D-93

SHIM STOCK AND ADAPTER SLEEVES

BURNDYWeld™ molds designed for larger cable sizes can be used on smaller diameter cables if copper adapter sleeves or shim stock are utilized. The copper shim stock, .0108" x 1-1/2" x 3", is normally wrapped around cable until the diameter is about equal to the cable opening. A tight fit is not necessary as the shim stock will unwrap slightly and prevent leakage of weld metal. To order shim stock use part number **B38-0329-00**. Shim stock comes 100 pieces per box.

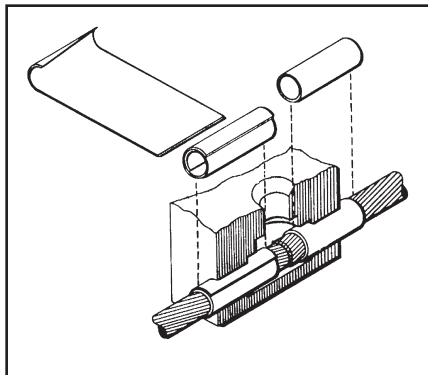

For Use on Cable Size		Part No.	Use in Mold Size	Sleeve Dimensions		
Stranded	Solid			O.D.	I.D.	Length
#12, #14	#10, #12, #14	BA-200	#6 STR & Sol	.156	.111	1.00
#9, #10	#8, #9, #10	BA-208	#4 Sol	.203	.140	1.00
#7, #8, #10	#6, #8	BA-201	#4	.227	.177	1.00
#6	#5	BA-202	#2	.292	.198	1.00
#4, #5	#3, #4	BA-207	#2	.302	.246	1.00
#4	#2	BA-204	#1	.340	.246	1.00
#2	#1	BA-203	1/0	.370	.307	1.00
#1	1/0	BA-209	2/0	.420	.359	1.00
1/0, #1	2/0	BA-205	3/0 & 4/0 Sol	.469	.385	1.00
2/0, 1/0	3/0	BA-240	4/0	.524	.437	1.50
4/0	—	BA-211	300 MCM	.625	.545	1.25
250 MCM	—	BA-212	350 MCM	.677	.595	1.25
350, 400 MCM	—	BA-213	500 MCM	.811	.762	1.50
250, 300, 350 MCM	—	BA-214	500 MCM	.811	.700	1.50
750, 800 MCM	—	BA-215	1000 MCM	1.156	1.05	1.50

For mold types or BURNDYWeld™ items not shown, please contact factory or refer to full BURNDYWeld™ catalog.

TROUBLE SHOOTING TIPS

D-94

PROBLEM	PROBABLE CAUSE	CORRECTION TO MAKE
Insufficient metal to make weld.	Worn mold resulting in leaking weld metal.	Replace mold. If only worn around conductor opening, use duct seal around conductor. Do not get duct seal into mold cavity.
	Wrong size cartridge for mold.	Check ID plate for mold and compare with number on bottom of cartridge.
	Too much spillage when dumping powder.	Carefully open lid while holding over crucible and dump.
	Wrong mold for conductor being used.	Replace with correct mold. In some applications, shim stock or adapter sleeves can be used to enlarge cable to fit mold.
Mold does not close tightly causing weld metal to leak out.	Handle clamps not properly adjusted.	Remove cotter pin between the handles of the mold and adjust handle tension by backing out the eye bolt.
	Dirt or slag stuck in parting line of mold.	Clean mold thoroughly between connections.
	Bent or out-of-round cable.	Straighten or cut out bad section of cable.
Handle clamps will not lock closed.	Handle clamps not properly adjusted.	Remove cotter pin between the handles of the mold and adjust handle tension by backing out the eye bolt.
Excessively high weld, bubbly or gassy appearance, poor weld.	Moisture in mold.	Pre-heat mold to above 220° F with a propane torch, or ignite a sacrificial shot in mold with pieces of scrap conductor in it. If it is a horizontally split mold, shoot 3/4 of the recommended cartridge to make sure you do not lock up mold.
	Oil, grease, moisture or foreign material on conductors.	Pre-heat conductors with propane torch then use a clean wire brush on conductor to remove any residue left on conductors. If welding to cast iron or steel surface, weld area must be cleaned down to bright metal.
	Duct seal in weld cavity.	Take special precautions to keep duct seal out of weld cavity.
	Weld powder has gotten wet.	Replace with fresh, dry weld powder.
Weld metal blows out top of mold.	Mold worn or chipped around disc seal allowing powder to leak into mold cavity.	Replace mold.
	Forgot to use steel disc or did not seat it properly at bottom of crucible.	Make sure disc is seated at bottom of crucible before pouring the powder into crucible.

TROUBLE SHOOTING TIPS (continued)

PROBLEM	PROBABLE CAUSE	CORRECTION TO MAKE
Cannot ignite powder.	Insufficient starting powder in ignition pocket on mold lid.	Place at least half of starting powder in ignition pocket of mold lid. Use all starting powder for each connection.
	Flint ignitor not shooting enough spark.	Clean flint ignitor according to directions on box or replace flint ignitor.
	Starting powder lumped together.	Break up starting powder on lid with edge of powder tube.
	Starting powder has gotten wet.	Remove shot from mold and replace with a dry cartridge.
Mold wearing out too fast.	Improper cleaning of mold.	Use mold cleaner, soft natural bristle brush or clean rag to clean mold between shots. Do not use wire brush or screwdriver on molds.
	Bent or out of round cable causes chipping and premature wear of the mold.	Use caution when closing mold. Do not force mold shut around bent, twisted or out of round conductors.
Poor weld to ground rod.	Weight of mold not supported during reaction causing mold to slip when cable melts.	Use locking pliers on ground rod under mold to support the weight of the mold during the reaction.
	Moisture or contaminant on cable or ground rod.	Pre-heat conductors with propane torch then use a clean wire brush on conductors to remove any residue left on conductors.
Weld will not stick to steel surface.	Improperly cleaned area on steel.	An area larger than the weld area should be cleaned down to bright clean metal.
	Moisture or contaminant on cable or ground rod.	Pre-heat conductors with propane torch then use a clean wire brush on conductors to remove any residue left on conductors.
	Cable is improperly positioned in mold, blocking the flow of weld metal.	Position cable in mold in accordance with directions for mold. If directions are not available, position top of cable in the center of where the liquid weld metal hits the steel.
Weld will not stick to cast iron surface.	All of the causes listed under welding to steel surface also apply to this section.	
	Not using CI (Cast Iron) powder.	Specify "CI" behind cartridge when ordering powder (i.e. 25 CI).
Cable pulls out of mold when it is fired.	Cables are either twisted or under tension.	Use B38-0330-00 cable clamp or other method to remove tension. Cut out severely twisted cable.