

Blackburn® Grounding Systems

Blackburn® Grounding compression and mechanical connectors and accessories represent one of the most comprehensive product lines in the industry for the creation of a safe, code-compliant and reliable grounding.

- **Direct Burial** — Blackburn® Grounding compression products are compliant with IEEE 837, UL® 467, CSA 22.2 and applicable sections of the National Electrical Code® (NEC®). They can be used in direct-burial or concrete-encased applications.
- **Broad Line and No Special Tooling** — Blackburn® Grounding mechanical connectors provide an extensive array of options for grid points, and with no training or special tools required for installation, they are an extraordinarily flexible solution.



At T&B, we're committed to:

- Convenience of single-order, single-shipment to your site for thousands of stocking items
- Expert local point of contact for clear, consistent information regarding training, codes and standards
- Quality brands that have proven themselves over time
- Inventive design and manufacture of problem-solving products
- Offering a best-of-class warranty and returns policy
- Uniform carton labeling with additional bar-coding for convenient inventory management
- Nationwide network of stocking electrical distributors
- Outstanding customer service capability
- Supplying you with the right products, convenient packaging, on-time delivery and competitive pricing



We deliver the solutions that make your job easier and offer the power to bring it all together in one package. Call us today and let us help you profit from sourcing your electrical products from the leader, Thomas & Betts.

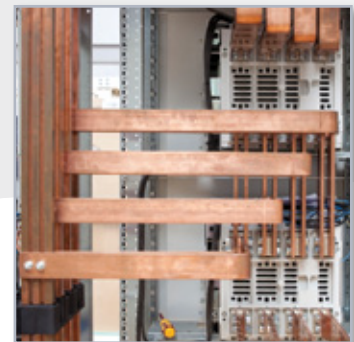

Customer Service

1-800-816-7809

Immediate, Knowledgeable Assistance

Every Thomas & Betts Customer Service Representative is right where the action is — surrounded by all the support and information they need to answer your questions and fill your orders faster than ever. Your calls and faxes are automatically routed to Customer Service Specialists who personally serve your account and can answer questions about products, order status, price and availability, and other service-related inquiries.

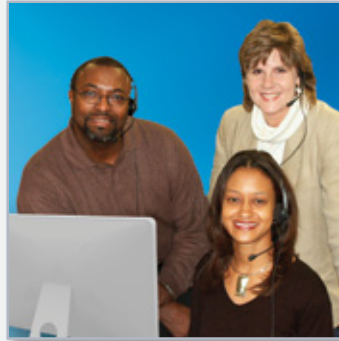

Phone: 1-800-816-7809

Fax: 1-800-816-7810

Email: generalcustomerserviceteam@tnb.com

T&B Access®

tnbaccess.tnb.com



T&B Access® is a global sales tool for our distributor partners, offering:

- Quote Requests
- Stock Checks
- Pricing Inquiries
- Cross Reference
- Order Entry
- Order Resolution
- Shipping Status
- Document Look-Up
- Automatic Order Receiving
- Item History Search
- Multiple-Location User Search
- Context-Sensitive Help
- Shipping Confirmations
- Tracking Data
- Expediting
- Returns Processing
- Quality Issues
- Customer Report Cards
- Web Catalog Look-Up

All of these tools and more are available online 24 hours a day – 7 days a week, without having to make a single phone call. Multi-lingual options are available in English, French and Spanish. T&B Access® now serves over 10,000 satisfied customer users at over 3,500 locations every month.

Contents

T&B Services	2-3
Overview	4-5
EZGround™ Compression Grounding Connectors	6-19
Cast Copper Connectors for Grounding	20
Raised Floor Grounding Systems.....	21-22
Ground Rod Accessories	22-23
Ground Plates	23-24
Ground Rod Clamps	25-27
Cable Tray Grounding Connector.....	27
Structure Grounding.....	28-30
Ground Clamps	31-39
Catalog Number Index	40

Thomas & Betts

A Member of the ABB Group

www.tnb.com

T&B Services

Technical Services

1-888-862-3289

Over 170 Years of Industry Experience

Meeting and exceeding our customers' expectations is a fundamental goal of Thomas & Betts. Call our Technical Services Department and talk LIVE to an expert who'll answer questions and concerns regarding all aspects of our products and services. Our experienced and knowledgeable staff is second to none in the industry!



Tool Services

1-800-284-TOOL

Quality You Can Trust

Trust T&B's dedicated Tool Services Department to answer all questions regarding tool applications, repair, warranties, sales/lease/rental and technical information. Ask about our specialized services, including customer/sales training, demos and calibration/certification of tools.



Web Catalog

www.tnb.com/webcatalog

Thousands of Products at Your Fingertips

U.S. contractors and specifiers have made our web catalog their number one stop. Users can search for technical information by catalog number, UPC code, competitor number, keyword search, product category and/or brand. Having found the item(s) they are searching for, they can then use our **Where To Buy** function to locate a T&B local distributor and/or other support services.



T&B Services

Web CAD Library

www.tnb.com/CADLibrary

Over 4,000 2D and 3D CAD Models Available FREE!

The T&B CAD Library is an on-line source of 2D and 3D CAD models, available FREE to customers who register. Users can download these files to their desktops for import into their working drawings. Drawings are offered in 90 of the most popular native file formats. This is a valuable tool for CAD designers, OEMs and engineering firms, as it will allow them to quickly locate and download T&B drawings into their projects. Over 4,000 drawings of T&B® Fittings, PMA® Cable Protection, Kindorf®, Red•Dot® and Superstrut® products and Steel City® and Carlon® Floor Boxes are currently available, and we're continually adding more products to the library.



BIM Library

Now available to you through Autodesk® Seek (seek.autodesk.com), our BIM (Building Information Modeling) objects can easily be imported to your Revit® models. These BIM objects are fully standards compliant, Revit® Certified and completely configurable.

Autodesk and Revit are registered trademarks of Autodesk, Inc.

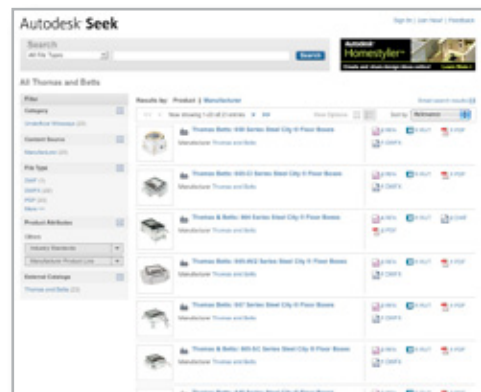

Overview

Blackburn® EZGround™ Compression Connectors represent a low cost, code-approved alternative to welded ground grid connections. EZGround™ Connectors can be safely installed in half the time, with fewer components, and in all weather conditions. The range-taking capability of each EZGround™ series connector translates to fewer parts needed to complete the ground grid. EZGround™ Compression Connectors are installed using the “T&B Method,” which produces an easily inspectable die embossment on the connector indicating that the proper tool has been used and successful crimp has been made. EZGround™ carries the “T&B Method” mark of approval and represents the connection of choice for faster, simpler and safer ground grid system installations.

Meets all applicable specifications

Thomas & Betts grid and ground rod connectors satisfy the requirements of NEC® Article 250 for connecting to the Grounding Electrode System. They also meet the requirements of UL® Std. 467, UL® Std. 486, CSA Std. C22.2 No. 41 and CSA Std. C22.2 No. 65 being acceptable as grounding and bonding equipment suitable for direct burial. Thomas & Betts grid and ground rod connectors also satisfy the recommended practice for the selection of grounding connector joints described in the IEEE 837 standard for qualifying permanent connections used in substation grounding.

The connectors conform to the following IEEE Standard 837 requirements:

- 350° C current cycling
- Freeze-thaw test
- Accelerated aging — nitric acid/salt spray
- Mechanical, tensile and electromagnetic force (EMF) criteria

NEC and National Electrical Code are registered trademarks of the National Fire Protection Association, Inc.

Reliable installations through compression connections

The Thomas & Betts method, utilizing compression tools with matching dies, forms the connector and conductor into a solid, homogeneous mass to provide an optimum electrical bond between connector and conductor. The dies are designed to produce a circumferential, hex-shaped compression rather than a simple indent. The circumferential compression creates a large area of high-pressure contact between cable and connector which, in turn, ensures high conductivity, low resistance and high pull-out values exceeding all industry requirements.



This installation method results in a long-lasting, low-installed cost connection. You can install it and forget it. Before compression, typical cable connector cross section of cable and connector consists of about 75% metal and 25% air. After Thomas & Betts method compression, the cross section shows 100% metal with virtually no air spaces.

Mobile Application Vehicle

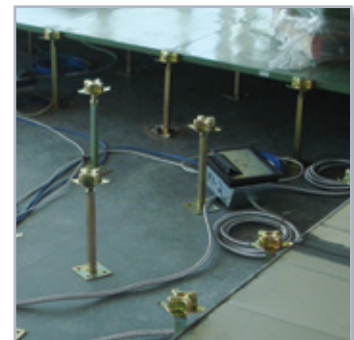

Overview

The EZGround™ System

Thomas & Betts offers its complete line of grid-ground compression connectors. Our EZGround™ connectors are designed for direct burial and offer a safe, efficient alternative to exothermic welding products. Grid-ground installations do not require explosive charges and can be installed in various climate conditions. These range-taking products will reduce the number of connectors and dies needed for your installation.

Thomas & Betts EZGround™ products meet all applicable standards (IEEE 837, UL® 467, CSA 22.2). Connectors are prefilled with oxide inhibitor and sealed.

- | | | | |
|---|---------------------------------|----|--------------------------|
| 1 | C-Taps | 7 | Lug |
| 2 | Figure 8 Connector | 8 | Splice/Two-Way Connector |
| 3 | Steel Grounding Stud TBG Series | 9 | Grounding Plate |
| 4 | Figure 6-8 Connectors | 10 | Pigtail Connectors |
| 5 | Figure 6-6 Connectors | 11 | I-Beam Clamp |
| 6 | GG Connectors | 12 | Figure 6 Connector |

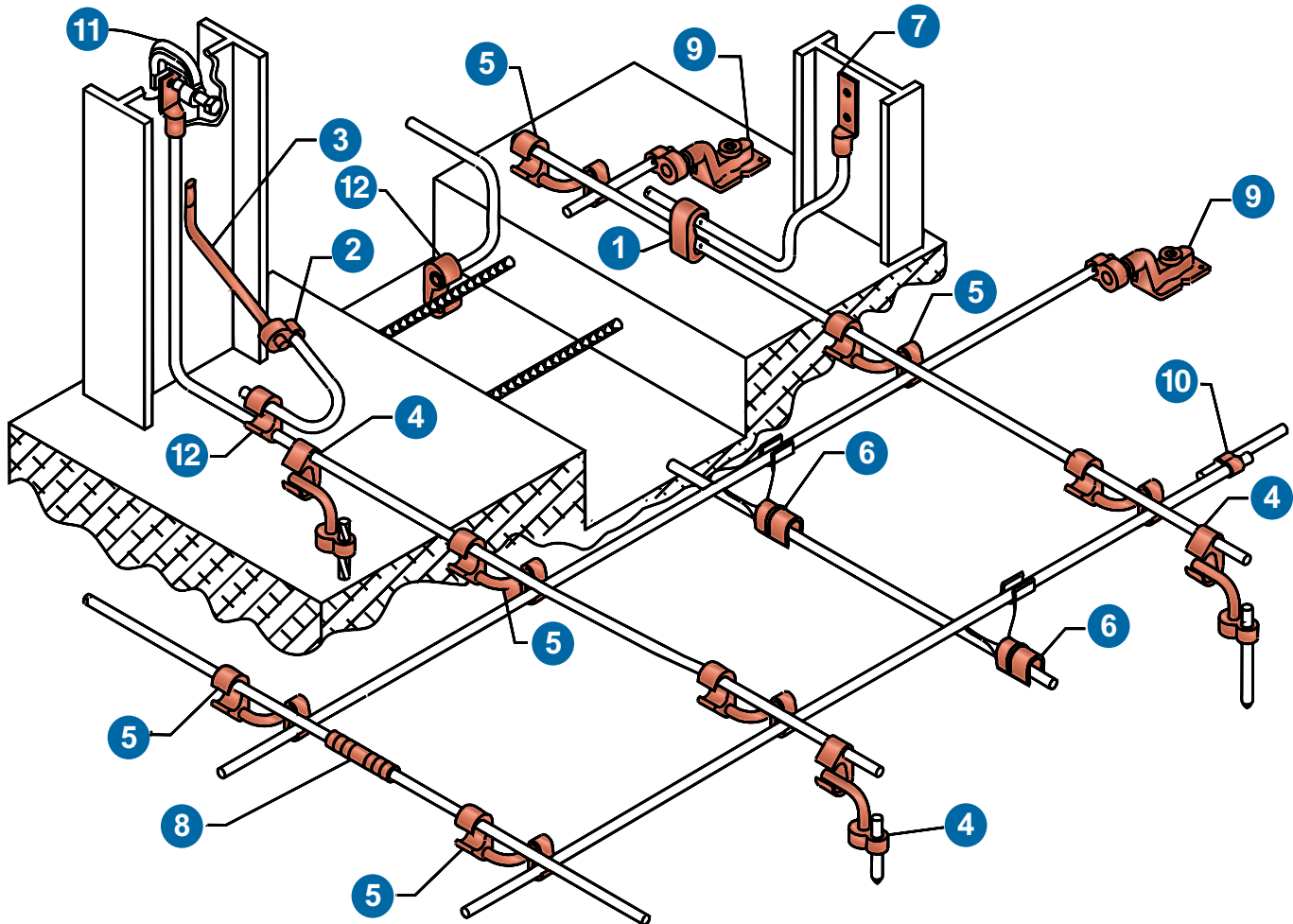

EZGround™ Compression Grounding Connectors

Figure 6 Compression Ground Rod Tap Connector

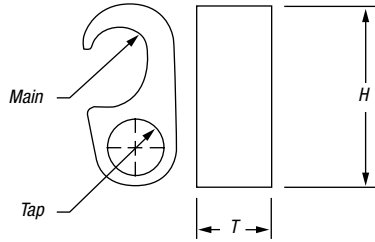

DB MEETS **IEEE** 837 REQUIREMENTS

CAT. NO.	APPLICATION		CABLE TO REBAR APPLICATION		DIMENSIONS (IN.)		DIES FOR TBM 14M, 13100A OR TBM15I
	MAIN	TAP	A GROUND ROD	B CABLE RANGE	T	H	
54855	1/0 Str.–250 kcmil or 1/2"–3/8" Rod	#4 Sol.–#2 Str.	#3 Rebar 3/8" thru 1/2" #4 Rebar	#4 Sol.–#2 Str.	3/4"	1 15/16"	15G86R
54860	1/0 Str.–250 kcmil or 1/2"–3/8" Rod	1/0 Str.–2/0 Str.	#3 Rebar 3/8" thru 1/2" #4 Rebar	1/0 Str.–2/0 Str.	3/4"	2 3/16"	15G86R
54865-CK	1/0 Str.–250 kcmil or 1/2"–3/8" Rod	3/0 Str.–250 kcmil	#3 Rebar 3/8" thru 1/2" #4 Rebar	3/0 Str.–250 kcmil	3/4"	2 3/16"	15G86R
54875	#6 Sol.–#2 Str.	#6 Sol.–#2 Str.	—	—	3/4"	2 3/16"	15501A
54885	250 kcmil–500 kcmil or 5/8"–3/4" Rod	#4 Sol.–#2 Str.	#5 Rebar 3/8" thru 3/4" #6 Rebar	#4 Sol.–#2 Str.	3/4"	1 15/16"	15G126R
54890	250 kcmil–500 kcmil or 5/8"–3/4" Rod	1/0 Str.–2/0 Str.	#5 Rebar 3/8" thru 3/4" #6 Rebar	1/0 Str.–2/0 Str.	3/4"	2 3/16"	15G126R
54895	250 kcmil–500 kcmil or 5/8"–3/4" Rod	3/0 Str.–250 kcmil	#5 Rebar 3/8" thru 3/4" #6 Rebar	3/0 Str.–250 kcmil	3/4"	2 3/16"	15G126R
54900	250 kcmil–500 kcmil or 5/8"–3/4" Rod	350 kcmil–500 kcmil	#5 Rebar 3/8" thru 3/4" #6 Rebar	350 kcmil–500 kcmil	1 3/8"	2 3/16"	15G121R

* Tin-plated version available for galvanized ground rods. Add suffix -TP.

Figure 8 Compression Ground Rod Tap Connector

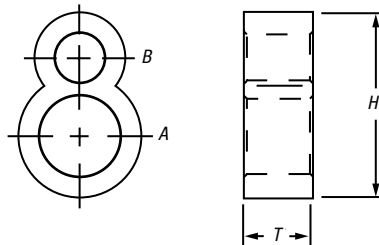

DB MEETS **IEEE** 837 REQUIREMENTS

CAT. NO.	A GROUND ROD	B CABLE RANGE	DIMENSIONS (IN.)		DIES FOR TBM14M, 13100A OR TBM15I
			T	H	
GR12-202	1/2"	#2 AWG–2/0 AWG	7/8"	1 15/16"	15G121R
GR58-202	5/8"	#2 AWG–2/0 AWG	7/8"	1 31/32"	15G121R
GR34-202	3/4"	#2 AWG–2/0 AWG	7/8"	2 3/16"	15G121R
GR1-202	1"	#2 AWG–2/0 AWG	7/8"	2 3/16"	15G121R
GR12-40250	1/2"	3/0 AWG–250 kcmil	7/8"	1 15/16"	15G121R
GR58-40250	5/8"	3/0 AWG–250 kcmil	7/8"	2 1/8"	15G121R
GR34-40250	3/4"	3/0 AWG–250 kcmil	7/8"	2 3/16"	15G121R
GR1-40250	1"	3/0 AWG–250 kcmil	7/8"	2 3/16"	15G121R
GR58-300500	5/8"	300–500 kcmil	7/8"	2 1/8"	15G121R
GR34-300500	3/4"	300–500 kcmil	7/8"	2 3/16"	15G121R
GR1-300500	1"	300–500 kcmil	7/8"	2 11/16"	15G121R

EZGround™ Compression Grounding Connectors

Figure 6 to 8 Compression Ground Rod to Grid Connectors

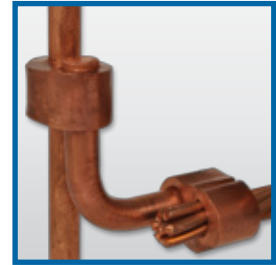
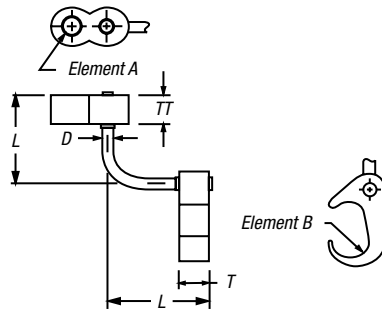
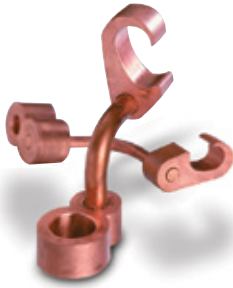

DB MEETS IEEE 837 REQUIREMENTS

CAT. NO.	A GROUND ROD	B CABLE RANGE	DIMENSIONS (IN.)			DIES FOR TBM14M, 13100A OR TBM15I	
			D	L	ELEMENT A	ELEMENT B	
54855LR12*	1/2"	#2 AWG-250 kcmil	5/16"	2 1/2"	15G86R	15G121R	
54885LR12*	1/2"	250 kcmil-500 kcmil	5/16"	2 1/2"	15G126R	15G121R	
54865LR58*	5/8"	#2 AWG-250 kcmil	5/16"	2 1/2"	15G86R	15G121R	
54895LR58*	5/8"	250 kcmil-500 kcmil	5/16"	2 1/2"	15G126R	15G121R	
54875LR34*	3/4"	#2 AWG-250 kcmil	1/2"	2 3/8"	15G86R	15G121R	
54900LR34*	3/4"	250 kcmil-500 kcmil	1/2"	2 3/8"	15G121R	15G121R	
54910LR100	1"	#2 AWG-250 kcmil	1/2"	2 3/8"	15G86R	15G121R	
54920LR100	1"	250 kcmil-500 kcmil	1/2"	2 3/8"	15G126R	15G121R	

* Tin-plated version available for galvanized ground rods. Add suffix -TP.

Figure 6 to 6 Compression Ground Grid Connectors

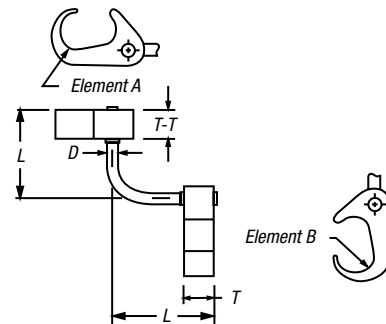
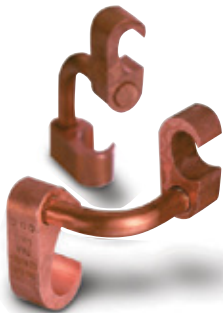

DB MEETS IEEE 837 REQUIREMENTS

CAT. NO.	CABLE TO CABLE		ELEMENT B TO GROUND ROD	ELEMENT B TO REBAR	DIMENSIONS (IN.)			DIE SELECTION FOR TBM14M, 13100A OR TBM15I	
	ELEMENT A	ELEMENT B			D	T	T-T	A	B
54855L	#6 Sol.-#2 Str.	#6 Sol.-#2 Str.	—	—	7/8"	3/4"	3/4"	15501A	15501A
54865L	#1 Str.-250 kcmil	#6 Sol.-#2 Str.	1/2"-5/8"	3/8"-1/2" #3-#4 Rebar	7/8"	3/4"	3/4"	15G86R	15501A
54875L	#2 Str.-250 kcmil	#2 Str.-250 kcmil	1/2"-5/8"	3/8"-1/2" #3-#4 Rebar	7/8"	3/4"	3/4"	15G86R	15G86R
54885L	250 kcmil-500 kcmil	#6 Sol.-#2 Str.	5/8"-1/2"	5/8"-3/4" #5-#6 Rebar	7/8"	3/4"	3/4"	15G126R	15501A
54895L	250 kcmil-500 kcmil	#2 Str.-250 kcmil	5/8"-1/2"	5/8"-3/4" #5-#6 Rebar	7/8"	3/4"	3/4"	15G126R	15G86R
54900L	250 kcmil-500 kcmil	250 kcmil-500 kcmil	5/8"-1/2"	5/8"-3/4" #5-#6 Rebar	7/8"	1 1/8"	1 1/8"	15G121R15	G121R

EZGround™ Compression Grounding Connectors

One-piece construction for cable-to-cable, cable-to-rod, “T” and “X” connections.

Cable-to-Cable or Cable-to-Rod Connectors

- Suitable for direct burial or in concrete
- Replaces exothermic welds
- Made from high-conductivity wrought copper
- Conforms to IEEE 837 standard
- UL® 467

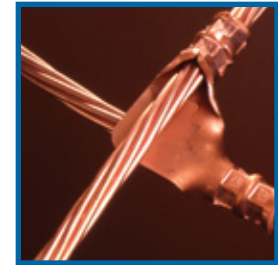

DB

CAT. NO.	CABLE TO CABLE RANGE				GROUND ROD	ROD TO CABLE		
	MAIN	DIE CODE	BRANCH	DIE CODE		DIE CODE	CABLE	DIE CODE
GG21-21	#2 or #1	45	#2 or #1	45	—	—	—	—
GG10-10	1/0	54	1/0	54	—	—	—	—
GG2030-21	2/0 or 3/0	60	#2	45	—	—	—	—
GG2030-10	2/0 or 3/0	60	1/0	54	—	—	—	—
GG2030-2030	2/0 or 3/0	60	2/0 or 3/0	50	—	—	—	—
GG40250-21	4/0 or 250	71	#2	45	1/2"	71	#2 or #1	45
			#1	50	5/8"	80H	#2 or #1	50
GG40250-10	4/0 or 250	71	1/0	54	1/2"	71	1/0	65
					5/8"	80H		
GG40250-2030	4/0 or 250	71	2/0 or 3/0	60	1/2"	71	2/0 or 3/0	60
					5/8"	80H	2/0 or 3/0	60
GG40250-40250	4/0 or 250	71	4/0 or 250	71	1/2"	71	4/0 or 250	71
					5/8"	80H	4/0 or 250	71
GG350-350	350 kcmil	80H	350	80H	—	—	—	—
GG500-40250	500 kcmil	87	4/0 or 250	71	5/8"	80H	500	87
					3/4"	87H	500	87
GG500-500	500 kcmil	87	500	87	3/4"	87	500	87
GG500-350	500 kcmil	87H	350	80	5/8"	87H	350	80H
					3/4"			
GG500-2030	500 kcmil	87H	2/0 or 3/0	60	5/8" 3/4"	87H	2/0 or 3/0	60

EZGround™ Compression Grounding Connectors

For copper cable-to-cableground-grid connections.

Type GRD — Cable-to-Cable Connector

- Cast of high-conductivity bronze alloy
- Suitable for direct burial

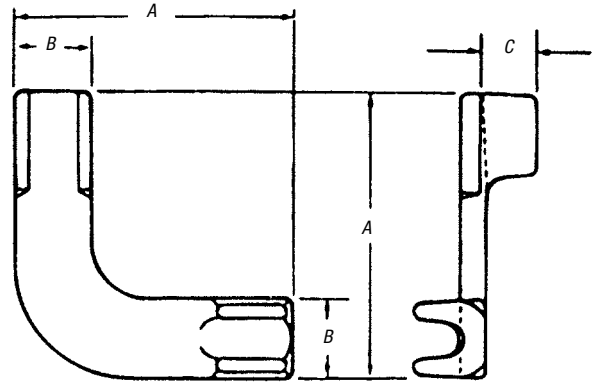

CAT. NO.	CONDUCTOR SIZE								GROUND ROD	HYD. TOOL	DIE	NO. CRIMPS	DIMENSIONS (IN.)		
	MAIN				TAP								A	B	C
	MAX.	MIN.	MAX. (MM ²)	MIN. (MM ²)	MAX.	MIN.	MAX. (MM ²)	MIN. (MM ²)							
GRD2	1	2	42.4	33.6	1	2	42.4	33.6	—	TBM14M	B09CH	1	2½	1¼	1¼
GRD20	2/0	1/0	67.4	53	2/0	1/0	67.4	53	—	TBM14M	B10CH	1	3	1¾	¾
GRD420	250 kcmil	4/0	126.6	107	2/0	1/0	67.4	53	½	TBM14M	B12CH	2	3¾	1¼	1¾
GRD40	250 kcmil	4/0	126.6	107	250 kcmil	4/0	126.6	107	½	TBM14M	B12CH	2	3¾	1¼	1¾

EZGround™ Compression Grounding Connectors

For connecting perpendicular runs of stranded copper cable to ground rod.

Two Cables-to-Ground Rod Connector — Heavy-Duty Cast Copper^{††}

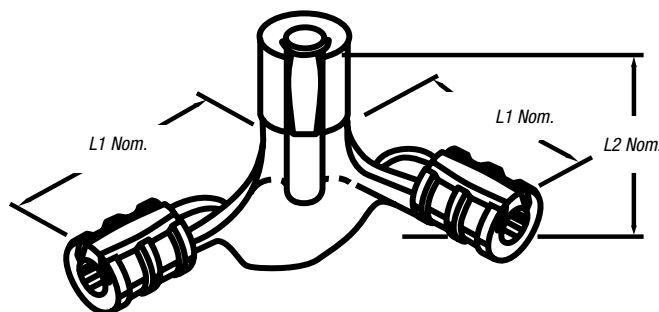

Two Cables-to-Ground Rod Connector — Heavy-Duty Cast Copper^{††}

DB

CAT. NO.	CABLE SIZE		GROUND ROD DIA.	TBM151 DIE FOR CABLE CODE	OVERALL DIM. (IN.)		TBM151 DIE FOR GROUND ROD CODE
	MAIN	TAP			L1	L2	
53065-58GR	250 or 4/0	250 or 4/0	5/8" & 1/2"	87H	4 ¹⁵ / ₁₆	3/4	87H
53065-34GR	250 or 4/0	250 or 4/0	3/4"	87H	4 ¹⁵ / ₁₆	3/4	106H

Installs with Hydraulic Tools with hex crimp dies.
^{††} Does not meet IEEE 837.

Copperweld® Conductors & Rebar — for Use with Cast Copper Connections

CABLE SIZE	REINFORCING ROD SIZE	COPPERWELD® CONDUCTOR SIZE
#2, #1 AWG	—	(3) #8 or (3) #6
1/0, 2/0 AWG	#3	3/8 — (7) #8 or 1/4 — (7) #7
4/0 AWG, 250 kcmil	#4	7/16 — (19) #9 or (7) #5
300–350 kcmil	#5	2 ¹ / ₃₂ — (19) #8 or 5/8 — (7) #4
500 kcmil	#6	1 ³ / ₁₆ — (19) #6

Copperweld is a registered trademark of Copperweld Corporation.
 UL® Listed for use with cast copper connectors.

EZGround™ Compression Grounding Connectors

Grounding Grid Connectors — Heavy-Duty Cast Copper^{††}



53055



53065

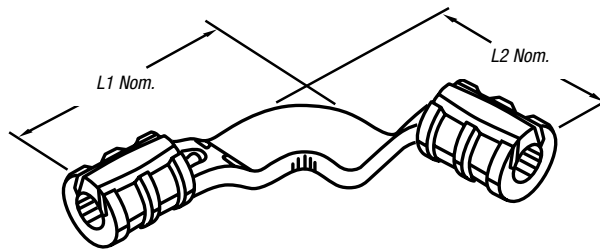

DB

CAT. NO.	ROD TO CABLE RANGE		CABLE TO CABLE RANGE		ROD TO CABLE INSTALLING DIE CODE FOR TBM14M, 13100A OR TBM15I		OVERALL DIMENSION (IN.)	
	ROD SIZE (IN.)	CABLE RANGE	MAIN	BRANCH	ROD BARREL	CABLE BARREL	L1	L2
53055	—	—	1/0–2/0 AWG	1/0–2/0 AWG	—	66	3/8	3/8
53059 [†]	1/2–5/8	#2–#1 AWG	4/0 AWG–250 kcmil	#2–#1 AWG	87H	54H	4 ⁵ / ₃₂	4 ⁹ / ₁₆
53060 [†]	1/2–5/8	1/0–2/0 AWG	4/0 AWG–250 kcmil	1/0–2/0 AWG	87H	87H	4 ¹ / ₁₆	4 ⁵ / ₁₆
53065 [†]	1/2–5/8	4/0 AWG–250 kcmil	4/0 AWG–250 kcmil	4/0 AWG–250 kcmil	87H	87H	4 ¹ / ₁₆	4 ⁵ / ₁₆
53069 [†]	3/4	1/0–2/0 AWG	300–350 kcmil	1/0–2/0 AWG	106H	66	4 ¹⁹ / ₃₂	4 ¹⁹ / ₃₂
53071 [†]	3/4	4/0 AWG–250 kcmil	300–350 kcmil	4/0 AWG–250 kcmil	106H	106H	5 ¹ / ₄	4 ²⁹ / ₃₂
53073 [†]	3/4	1/0–2/0 AWG	500 kcmil	1/0–2/0 AWG	125H*	66	4 ¹³ / ₁₆	4 ⁷ / ₈
53075 [†]	1	4/0 AWG–250 kcmil	500 kcmil	4/0 AWG–250 kcmil	125H*	87H	6 ³ / ₁₆	5
53080 [†]	1	500 kcmil	500 kcmil	500 kcmil	125H*	125H*	5 ³ / ₁₆	5 ³ / ₁₆

Cat. No. 15500 adapter is required for all 15500 Series dies, not for 15600 Series.

[†] Ground rods 4/0–250 wire barrels suitable for 1/2" and 5/8" rod.

500 kcmil wire barrels suitable for 1" rods.

300–500 kcmil wire barrels suitable for 3/4" rods.

Hydraulic tools only.

^{††} Does not meet IEEE 837.

* 125H die for 15-ton tool only.

EZGround™ Compression Grounding Connectors

C-Taps

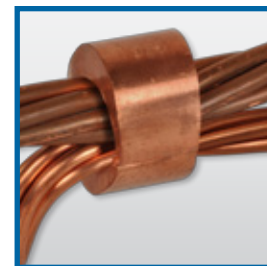
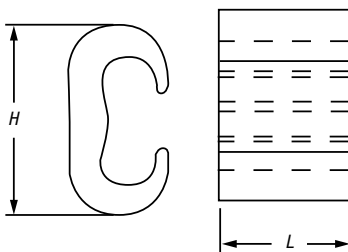

DB MEETS IEEE 837 REQUIREMENTS

CAT. NO.	MAIN	TAP	DIMENSION (IN.)		DIES FOR TBM14M 13100A OR TBM15I *	CRIMPS
			H	L		
CTP22	#6 Sol.-#2 Str.	#6 Sol.-#2 Str.**	1.16	.75	HBKC	1
CTP202	#1 Str.-2/0 Str.	#6 Sol.-#2 Str.**	1.41	.75	15501A	1
CTP2020	#1 Str.-2/0 Str.	#1 Str.-2/0 Str.	1.54	.75	15501A	1
CTP25020	3/0 Str.-250 kcmil	#6 Sol.-2/0**	1.97	.75	15G86R	1
CTP250250	3/0 Str.-250 kcmil	3/0 Str.-250 kcmil	2.06	.88	15G86R	1
CTP50020	300-500 kcmil	#6 Sol.-2/0**	2.42	.88	15G121R	2
CTP500250	300-500 kcmil	3/0 Str.-250 kcmil	2.67	.88	15G121R	2
CTP500500	300-500 kcmil	300-500 kcmil	2.91	1.10	15G121R	3

Material: High-Conductivity Copper.

* Cat. No. 15500 adapter required if using TBM15I and 155XX series dies.

** #6 AWG branch must be doubled.

Copper C-Crimps

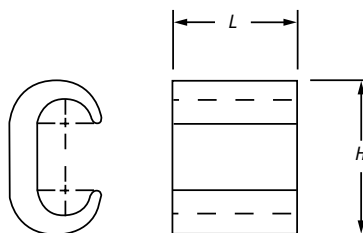

DB

CAT. NO.	RUN	TAP	DIE INDEX	INSTALLING DIE TBM14M 13100A, TBM15I	DIMENSION (IN.)	
					H	L
BC48	#6 Sol.-#4 Str.	#8 Sol.-#8 Str.	BG or 5/8	B58CS	4 ¹ / ₆₄	3 ¹ / ₁₆
BC46-BB	#6 Sol.-#4 Str.	#6 Sol.-#6 Str.	BG or 5/8	B58CS	4 ¹ / ₆₄	3 ¹ / ₄
BC44	#6 Sol.-#4 Str.	#4 Sol.-#4 Str.	BG or 5/8	B58CS	4 ¹ / ₆₄	5 ¹ / ₆₄
BC24	#2 Sol.-#2 Str.	#8 Sol.-#4 Str.	C	HBKC	3 ¹ / ₄	6 ³ / ₆₄
BC22	#2 Sol.-#2 Str.	#2 Sol.-#2 Str.	C	HBKC	3 ¹ / ₄	1 ³ / ₆₄
BC202	1/0 Sol.-2/0 Str.	#8 Sol.-#2 Str.	E or O	HO	1 ⁵ / ₁₆	1 ¹ / ₁₆
BC2020-BB	1/0 Sol.-2/0 Str.	1/0 Str.-2/0 Str.	E or O	HO	1 ⁵ / ₁₆	1 ¹¹ / ₃₂
BC402	3/0 Str.-4/0 Str.	#6 Sol.-#2 Str.	F or D3	HD	1 ¹ / ₁₆	1 ⁵ / ₈
BC4020	3/0 Str.-4/0 Str.	1/0 Sol.-2/0 Str.	F or D3	HD	1 ¹ / ₁₆	1 ⁵ / ₁₆
BC4040	3/0 Str.-4/0 Str.	3/0 Sol.-4/0 Str.	F or D3	HD	1 ¹ / ₁₆	1 ⁵ / ₁₆

¹¹ Does not meet IEEE 837.

Material: High-Conductivity Copper.

UL® 467 Listed.

EZGround™ Compression Grounding Connectors

Perform line tap-offs, dead-ending and grounding on a range of conductors.

Copper C-Type Compression Taps

- Can be held in the dies or jaws of an installation tool, then hooked directly over the line for time-saving installations
- Manufactured from pure electrical-grade copper for a highly conductive, low resistance, reliable connection
- Die references marked on connector for easy identification
- RUS Accepted



CC 4040

Copper C-Type Compression Taps

CAT. NO.	WIRE RANGE		INSTALLING DIES	LENGTH (IN.)
	A GROOVE	B GROOVE		
CC 48	#6 Sol.-#4 Str.	#8 Sol.-#8 Str.		
CC 46	#6 Sol.-#4 Str.	#6 Sol.-#6 Str.	TU, BG, 5/8	5/8
CC 44	#6 Sol.-#4 Str.	#4 Sol.-#4 Str.		
CC 24*	#2 Sol.-#2 Str.	#8 Sol.-#4 Str.	TM or C	3/4
CC 22	#2 Sol.-#2 Str.	#2 Sol.-#2 Str.		
CC 202	1/0 Sol.-2/0 Str.	#8 Sol.-#2 Str.	E or O	7/8
CC 2020	1/0 Sol.-2/0 Str.	1/0 Sol.-2/0 Str.		
CC 402	3/0 Sol.-4/0 Str.	#6 Sol.-#2 Str.		
CC 4020	3/0 Sol.-4/0 Str.	1/0 Sol.-2/0 Str.	F or D3	1 1/16
CC 4040	3/0 Str.-4/0 Str.	3/0 Str.-4/0 Str.		

* When using #1 Str. in the A Groove, the B Groove will accommodate #6 or #8 Str. or #8 Sol.
Note: For tin-plating option, add "-TN" suffix to the catalog number.

Copperweld-Copper Conductor

- 8A — Use C-Tap accommodating #6 str. Copper
- 6A — Use C-Tap accommodating #4 str. Copper
- 4A — Use C-Tap accommodating #2 str. Copper
- 2A — Use C-Tap accommodating 1/0–2/0 Copper

Hex compression intimately bonds cable directly to ground rod.

Pigtail Connectors

- Figure-8 connectors
- Conforms to IEEE 837 standard
- UL® 467 Listed

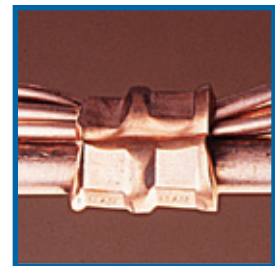
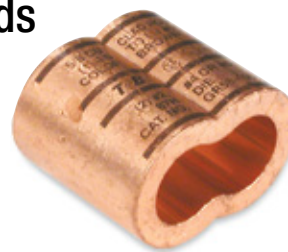

DB   MEETS **IEEE** 837 REQUIREMENTS

CAT. NO.	CABLE RANGE	GROUND ROD	DIE CODE FOR TBM14M, 13100A OR TBM151
GR12-306	One Cable: 3/0 to #6 AWG Two Cables: #2 to #6 AWG	1/2"	87H
GR58-406	One Cable: 4/0 to #6 AWG Two Cables: #2 to #6 AWG	5/8"	87H
GR34-4010	One Cable: 4/0 to 1/0 AWG	3/4"	99H

When connecting cable to ground rod for direct burial or in concrete, the connector shall be wrought copper with minimum conductivity of 99% I.A.C.S., such as Thomas & Betts series GR12-306. Hex compression with die code embossing shall be used.

EZGround™ Compression Grounding Connectors

Ground Plates

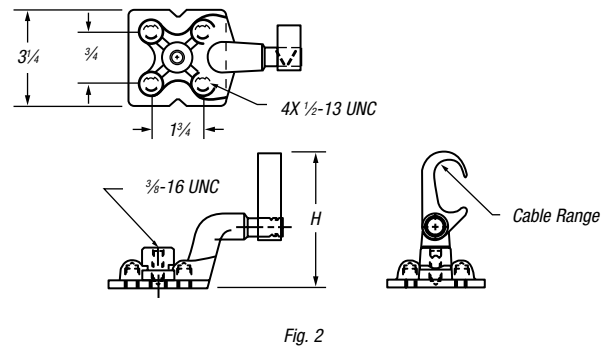
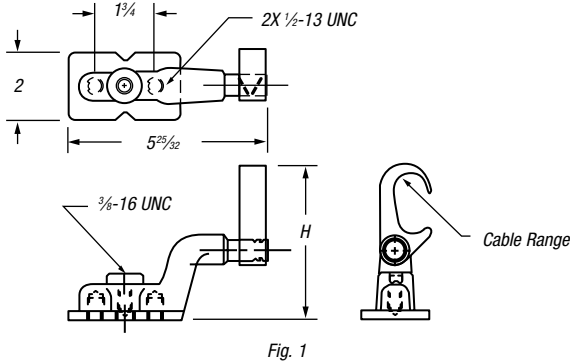

DB   MEETS
IEEE
837 REQUIREMENTS

CAT. NO.	FIG.	CABLE RANGE	H	DIES
GP2250-2	1	#2-250 kcmil	3 5/8"	15G86R
GP2250-4	2	#2-250 kcmil	4 7/32"	15G86R
GP250500-2	1	250-500 kcmil	3 5/8"	15G126R
GP250500-4	2	250-500 kcmil	4 7/32"	15G126R

EZGround™ Compression Grounding Connectors

Knurling ensures excellent mechanical pull-out and electrical continuity.

Type TBGS — Structural Grounding Studs

- Easily welded to steel structures with minimal construction welding equipment
- Connect to grounding conductors with appropriate Thomas & Betts grounding connectors
- Knurled portion of stud resists pull-out and provides electrical continuity to ensure the integrity of the grounding circuit
- Constructed of high-strength steel and coated with corrosion-resistant copper cyanide

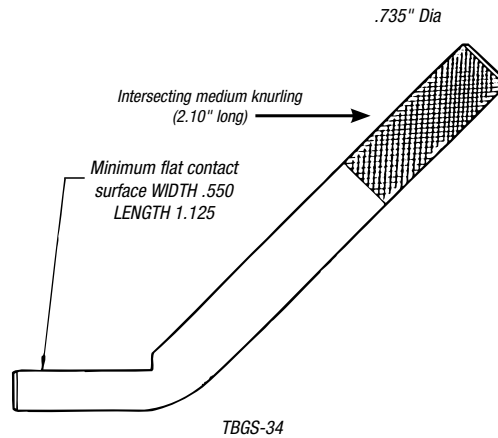
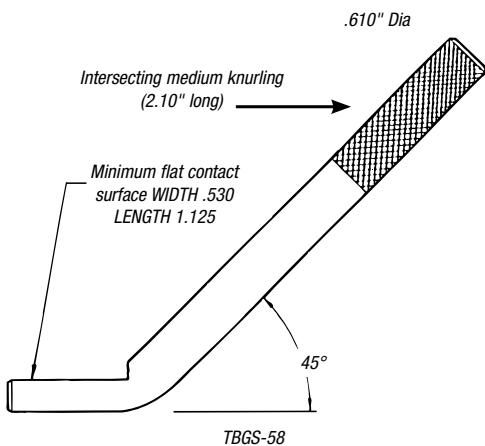
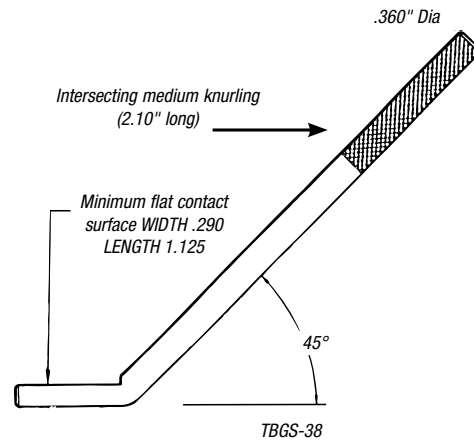
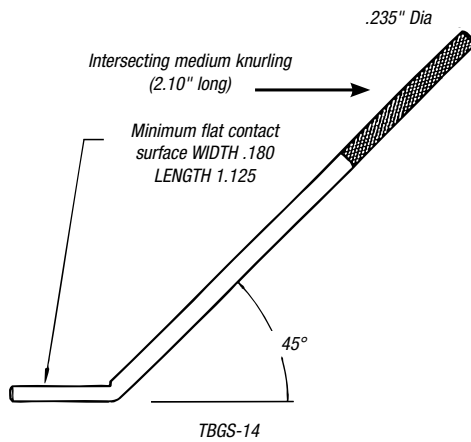

CAT. NO.	ROD SIZE
TBGS-14	1/4"
TBGS-38	3/8"
TBGS-58	5/8"
TBGS-34	3/4"

EZGround™ Compression Grounding Connectors

Connect ground cable to I-beam or any 1" maximum structural steel member — without welding or drilling.

I-Beam Ground Clamp

- Breakaway bolt head shears at predetermined torque to ensure tight connection
- Heavy-duty compression lug provides excellent current-carrying capabilities
- Surface of steel must be cleaned in accordance with installation instruction sheet provided with product
- Connector made of high-conductivity cast copper bright dip
- Clamp made of drop-forged high-grade steel, zinc plated



CAT. NO.	WIRE RANGE	TBM15I INSTALLING TOOL, DIE CODE
IBG2-10	#2 thru 1/0 AWG	71
IBG20-40	2/0 thru 4/0 AWG	87
IBG350-500	350 thru 500 kcmil	115

Use hydraulic tooling with hex crimp dies.

Satisfies requirements of NEC® 250.64(C)(1) for connecting to grounding electrode system.

Cast Copper Two-Way Connector — Heavy-Duty

- Made from high-conductivity cast copper
- Electro-tin-plated finish



CAT. NO.	DIE SIZE	DIE CODE
53504	#8 AWG	29
53505	#6 AWG	29
53506	#4 AWG	29
53507	#2 AWG	45
53508	#1 AWG	45
53509	1/0 AWG	45
53510	2/0 AWG	66
53511	3/0 AWG	66
53512	4/0 AWG	66
53513	250 kcmil	76
53515	350 kcmil	99
53518	500 kcmil	99
53523	750 kcmil	112

Use hydraulic tools with hex dies.

NEC and National Electrical Code are registered trademarks of the National Fire Protection Association, Inc.



EZGround™ Compression Grounding Connectors

Provides a permanent, reliable connection.

Ground Clamp

- Crimps to cable
- Clamps to ground rod and rebar
- Uses standard Blackburn® featuring the Color-Keyed® System hand and hydraulic tools
- Color coded for easy installation die selection
- Made from high-conductivity wrought copper
- Furnished with stainless steel hardware, 1/4" washers, bolts and nuts
- UL® 467 — approved for direct burial

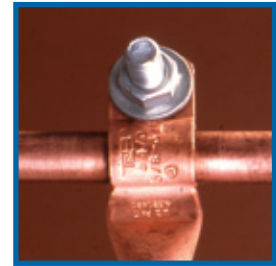

CAT. NO.	WIRE SIZE	GROUND ROD DIAMETER (IN.)	REBAR # (IN.)	BOLT SIZE (IN.)	DIE CODE
CC2C-45R	#2-#3 AWG	1/2 or 3/8	3/8	1/4	33 BROWN
CC1C-45R	#1 AWG	1/2 or 3/8	3/8	1/4	37 GREEN
CC10C-56R	1/0 AWG	5/8 or 3/4	5/8	3/8	42 PINK
CC20C-56R	2/0 AWG	5/8 or 3/4	5/8	3/8	45 BLACK
CC40C-56R	4/0 AWG	5/8 or 3/4	5/8	3/8	54 PURPLE

Terminate or connect continuous runs of copper cable to flat surfaces.

Flat-Surface Ground Clamp

- Captivated "keeper bar" design extends cable range and helps hold cable prior to crimping, facilitating installation
- Saddles marked with conductor size and die code
- Conductor can be assembled to saddle with standard dies and hydraulic tools
- Made from high-conductivity cast copper

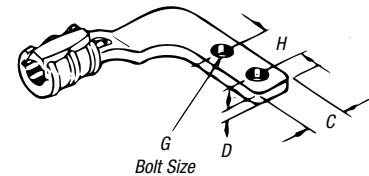

CAT. NO.	WIRE RANGE	BOLT HOLE	DIE CODE NO.*	UNIT QUAN.	STD. PKG.	WT. PER 100	HEX DIE		INCHES				
							CAT. NO.	DIE CODE NO.	L1	L2	D	C	H
53055FL	1/0-2/0 AWG	3/8"	66	2	10	75	15534*	66	4 3/32	3 21/32	9/32	1 3/8	1
53065FL	4/0 AWG- 250 kcmil	3/8"	87H	2	10	112	15506**	87H	4 1/2	4 3/32	5/16	1 3/8	1

* TM14M, 13100A, TBM15I with hex crimp dies.

** TBM15I with hex crimp dies only.

EZGround™ Compression Grounding Connectors

Bond copper conductors to steel or aluminum fence post or top rail of round fence posts.

Grid-to-Fence Ground Clamp

- Provides quick, dependable installation at low installed cost
- Uses no incendiary materials
- Body made from cast copper alloy with steel U-bolt

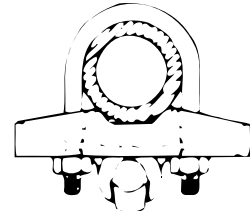

CAT. NO.	GROUND CABLE RANGE	DIE CODE	STEEL & ALUMINUM LINE POST RANGE (IN.)
FG2040R2	2/0–3/0–4/0 Str.	76	2
FG2040R25	2/0–3/0–4/0 Str.	76	2½
FG2040R3	2/0–3/0–4/0 Str.	76	3
FG210R2	#2–#1–1/0 Sol. or Str.	66	2
FG210R25	#2–#1–1/0 Sol. or Str.	66	2½
FG210R3	#2–#1–1/0 Sol. or Str.	66	3

Install with hydraulic tooling with hex crimp dies.

Cuts installation time in half — with results superior to conventional connectors.

Bus Bar Connector

- Unique design
- Fast and easy installation
- Superior low-resistance, high-conductivity connections
- Produces a permanent connection with any combination of copper from #6 to #2 solid or stranded conductor, to ¼" copper bus bar
- Installs with conventional compression tools
- Made from pure wrought copper and prefilled with oxide inhibitor
- UL® Listed and CSA certified
- Insulated with die HDF



Use this side of the connector when using only one wire.

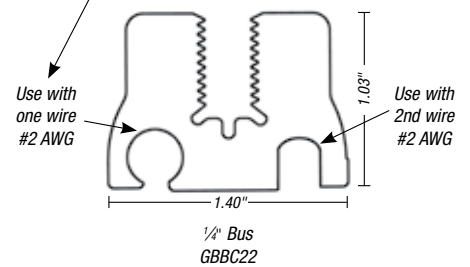

Use this side of the connector only when using two wires.

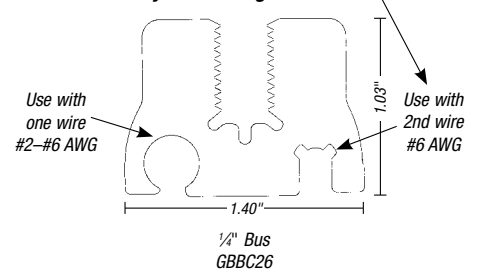

CAT. NO.	BUS BAR THICKNESS (IN.)	CONDUCTOR RANGE	STD. PKG. QTY.
GBBC22	¼	#2 AWG–#2 AWG	1
GBBC26	¼	#6 AWG–#2 AWG	1

EZGround™ Bus Bar Connectors install in less than two minutes with one easy crimp! The connector attaches directly to the bus, saving the labor-intensive process of drilling and tapping. The unique jaw interface of the EZGround™ Bus Bar Connector grips the copper bus, resulting in a low-resistance, high-conductivity connection. The EZGround™ Bus Bar Connector can be used in OEM applications or telecom applications — cellular, PCS and others. It provides a continuous ground to the copper bus bar, making it ideal for hut and tower applications. The design enables installation in virtually any position, horizontal or vertical, and is suitable for inside and outside plant use. Installation can be completed using any T&B compression tool that accepts U-shaped die sets and is rated 12-ton or higher.

EZGround™ Compression Grounding Connectors

A “snap” to assemble — no special tools required.

SnapTap™ Connector

- Designed for bonding and grounding applications using copper, steel strand and ground rod
- Easily installed with channel locks or pliers
- Made from high-strength aluminum alloy with tin plating
- Offers excellent electrical and mechanical characteristics
- UL® 467 tested — exceeds performance requirements

With the SnapTap™ Connector, you can achieve an electrically superior, pressure-fit connection in seconds without expensive tooling. The connector is also easy to disassemble, requiring only a flat-head screwdriver to release the connected body. A one-piece design keeps parts together, minimizing loss of components prior to assembly. Simply separate the pieces and snap them in place for installation. An audible “snap” indicates that the connection is complete and properly installed.

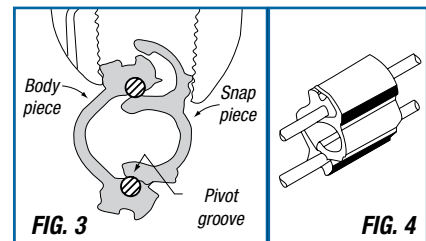
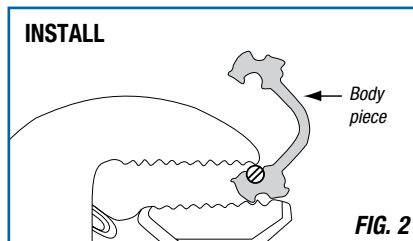
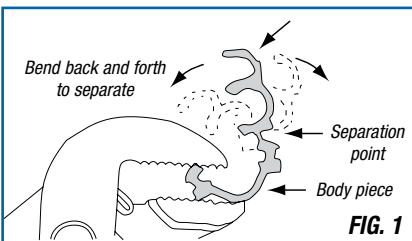

General Usage Instructions

Separate

No special tools required. Use ordinary parallel jaw pliers to separate the connector into two parts. Hold one side of connector with pliers and bend opposite side back and forth until parts separate (see **Fig. 1**).

Caution: Be careful not to pinch fingers or thumb when separating parts. Keep fingers out of bend path when bending part against plier jaws.

Installation

1. Strip the insulation from each de-energized conductor. Be careful not to nick the conductor. Clean the conductor ends with a wire brush or emery cloth if necessary.
2. Place each conductor into the grooves in BODY piece. Press conductors with pliers to align and seat into grooves (see **Fig. 2**).
3. Hold the conductors and BODY piece until it stops. Use parallel jaw pliers and grip the SNAP and BODY pieces as shown (see **Fig. 3**). Apply pressure until connector “snaps” into place. Visually inspect snap to verify full insertion. The connection is now complete (see **Fig. 4**).

Removal

The connector can be disassembled using a flat-head screwdriver to pry the SNAP piece from BODY piece.

CAT. NO.	CONNECTOR DESCRIPTION		PACKAGING		STANDARD ORDER QUANTITY
	MAIN	BRANCH	INNER PACK	OUTER PACK	
JP62	#2 AWG Sol. Copper	#6 AWG Sol. Copper	20	200	200
JP66	#6 AWG Sol. Copper	#6 AWG Sol. Copper	20	200	200
JP146	¼" Steel Strand	#6 AWG Sol. Copper	20	200	200
JP5166	⅝" Steel Strand	#6 AWG Sol. Copper	20	200	200
JP386	⅜" Steel Strand	#6 AWG Sol. Copper	20	200	200
JP126	½" Steel Strand	#6 AWG Sol. Copper	20	200	200
JP126G	½" Ground Rod	#6 AWG Sol. Copper	20	200	200
JP2614	¼" Steel Strand	(2) #6 AWG Sol. Copper	20	200	200
JP26516	⅝" Steel Strand	(2) #6 AWG Sol. Copper	20	200	200
JP2638	⅜" Steel Strand	(2) #6 AWG Sol. Copper	20	200	200
JP2612G*	½" Ground Rod	(2) #6 AWG Sol. Copper	20	200	200

Note: All Toolless Connectors are UL Listed. Only items with () are CSA listed.*

Cast Copper Connectors for Grounding

A low-cost method of connecting directly to bus bar, eliminating an interface connection.

Riser Cable Flag Connectors for 600V Applications

- Made from high-conductivity wrought copper, plain finish
- All bolt holes are 3/8" on 1" centers



Installing tools: T&B Cat. No. TBM15I, TBM15BSCR, 13100A, TBM14M and TBM14BSCR hydraulic tools only.

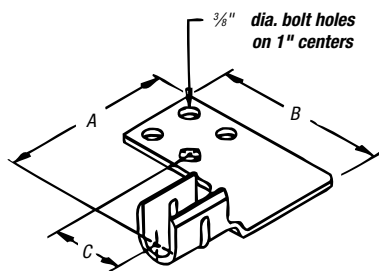

Fig. 1

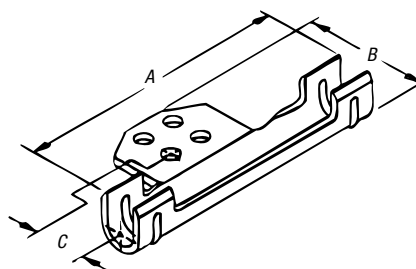

Fig. 2



CAT. NO.	FIG. NO.	CABLE SIZE	COLOR KEY	DIE CODE	NO. OF CRIMPS	MATERIAL THK. (IN.)	DIMENSIONS (IN.)		
							A	B	C
GFL2-1	1	#2-#1 AWG	PINK	42	1	3/32	3 5/8	4	2 5/16
		150/24 175/24							
GFL10-20	1	1/0 AWG	BLACK	45	1	3/32	3 5/8	4	2 5/16
		2/0 AWG	ORANGE	50					
		225/24	BLACK	45					
		275/24	BLACK	45					
GFL40-250	1	4/0-250 kcmil	RED	71	2	5/32	4 1/4	4 1/4	2 5/16
		325/24							
		450/24							
		550/24							
GFL350	1	350 kcmil	N/A	80	2	5/32	4 1/4	4 1/2	2 3/8
		650/24 775/24							
GFL5001	1	500 kcmil 925/24	BROWN	94	2	5/32	5 1/4	4 7/8	2 3/8
GFL7501, 2	2	750 kcmil	BLACK	106	4	5/32	8 5/8	4 3/4	2 5/8
		1100/24							
		1325/24							
		1600/24							

¹TBM15I only.

²Both "U" barrels must be crimped to a single, continuous length of conductor. It is not to be used as a splice.

Raised Floor Grounding Systems

Compresses #8 AWG through 4/0 AWG cable.

Signal Reference Grid Connector

- Clamps onto pedestal posts up to 1" diameter square and 1 1/4" round
- Can be used as an "X" or "T" configuration cable to post
- High-conductivity wrought-copper construction

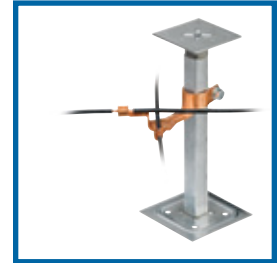

INSTALLING TOOLS AND DIE CODES TBM14M AND TBM15I

CAT. NO.	CONDUCTOR	DIE CAT. NO.	DIE CODE	COLOR CODE
SRG8-4	#8	15527	29	GRAY
	#6 to #4	15528	33	BROWN
SRG2-1	#2 & #1	15508	42	PINK
SRG10-20	1/0 & 2/0	15530	50	ORANGE
SRG30-40	3/0 & 4/0	15511	54	PURPLE

Secures signal reference grid wire to raised-floor support posts.

Signal Reference Grid Clamp

- Range-taking design accepts #8 to #4 AWG grid wire and fits 1" round and 3/4" square trade size support posts
- Lay-in feature means no kinks or bends
- Quick, easy installation
- Only one screw to tighten
- Enables grid wire to make direct, low-resistance contact Stamped-steel construction, zinc plated



CAT. NO.	DESCRIPTION	WIRE RANGE
3900	3/4" Square to 1" Round	#8-#4
3900BP (BULK PACK)	3/4" Square to 1" Round	#8-#4

UL® File No. E-3060.

Approved for grounding and bonding per UL® 467.

Raised Floor Grounding Systems and Ground Rod Accessories

Ground Electrode Boxes



CAT. NO.	DESCRIPTION	WT./100		STANDARD PACKAGE
		LB.	KG	
51628	Pregalvanized Steel	1180	536.3	5
51629	Hot-Dip Galvanized	1200	545.4	5

14-gauge steel. 10" diameter, 12" depth.

Streamlined design reduces driving friction.

Type C — Sectional Ground Rod Couplings

- Threaded couplings of high-strength, corrosion-resistant alloy
- Tapped for use on all standard threaded sectional rods



CAT. NO.	SIZE (NOMINAL DIAMETER)	THREAD SIZE
50C	½"	½"-13 UNS
50LC*†	½" L	¾"-12 UNS
60C*‡	⅝"	⅝"-11 UNS
70C*	¾"	¾"-10 UNS
80C*	1"	1"-8 UNS

* UL® Listed 467 (425H).

† CSA lists rods ½" and larger, 10' and longer.

‡ RUS Accepted.

Use with all standard threaded couplings.

Type DS — Driving Studs

- Made of high-strength steel
- Compatible with all standard threaded couplings



CAT. NO.	SIZE (NOMINAL DIAMETER)	THREAD SIZE
50DS	½"	½"-13 UNS
50LDS*†	½" L	¾"-12 UNS
60DS*‡	⅝"	⅝"-11 UNS
70DS*	¾"	¾"-10 UNS
80DS*	1"	1"-8 UNS

* UL® Listed 467 (425H).

† CSA lists rods ½" and larger, 10' and longer.

‡ REA Accepted.

Ground Rod Accessories and Ground Plates

For joining non-threaded, copper-bonded steel ground rods.

Threadless Couplings and Driving Cap

- Couplings manufactured of high-strength, corrosion-resistant copper alloy
- High-strength hardened steel driving cap prevents “mushrooming” of ground rod while driving to ensure proper fit of coupling



CAT. NO.	DESCRIPTION	DIMENSIONS (IN.)	
		LENGTH	DIAMETER
50LCNT*	1/2" L Threadless Coupling	3.0	.78
60CNT2*	5/8" Threadless Coupling	2.5	.69
70CNT*	3/4" Threadless Coupling	3.0	.97
60DSNT	5/8" Threadless Driving Cap	4.0	.88

* UL® Listed.

As efficient as two 10-ft. x 5/8" ground rods.

Galvanized Ground Plates

- 1/4" thick, hot-dipped galvanized
- Must be buried at least 600mm (24") below finish grade level, according to CEC Rule 10-702

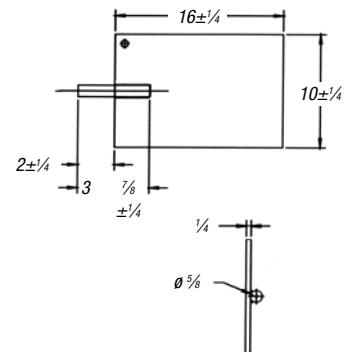

CAT. NO.	DESCRIPTION	CONDUCTOR RANGE
1016TB	Galvanized Ground Plates	#8 Sol. to 1/0 Str.
1016BTB	Galvanized Ground Plates with JAB58H Connector	#8 Sol. to 1/0 Str.

Ground Plates

More efficient than butt-wrapping poles.

Type GP — Copper Pole Bottom Ground Plates for Multigrounded Neutral Construction

- Made of electrolytic sheet copper
- Built-in high-pressure connector for ground lead, or supplied with #6 AWG copper pigtail pre-attached
- Plates are grooved for trapping moisture



CAT. NO.	PIGTAIL WIRE RANGE				DIAMETER OF PLATE	
	MIN.	MAX.	MIN. (MM ²)	MAX. (MM ²)	(IN.)	(MM)
GP100	#14 Str.	#4 Sol.	6.3	25.6	7½	191
GP110	#14 Str.	#4 Sol.	6.3	25.6	10	254
GP114	#14 Str.	#4 Sol.	6.3	25.6	14	356
GP1003	#6 AWG Solid Cu Pigtail with 18" Conductor		—	—	7½	191
GP1008	#6 AWG Solid Cu Pigtail with 8-ft. Conductor		—	—	7½	191
GP1108	#6 AWG Solid Cu Pigtail with 8-ft. Conductor		—	—	10	254

Installed cost considerably less than butt-wrapped poles.

Type PB — Copper Pole Ground Plates

- Installed on butt end of utility poles to provide an economical, low-resistance neutral ground
- Plate portion fabricated of .025" pure copper
- PBGW connector is eye-bolt type, cast of corrosion-resistant aluminum bronze alloy, with silicon bronze nut and lockwasher
- PBH connector features riveted all-copper terminal lug for connecting to grounding conductor

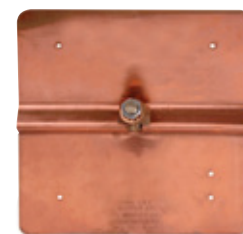

CAT. NO.	WIRE RANGE SURFACE AREA		FINISHED SIZE	SQ. IN.
	MAX.	MIN.		
PBGW	2/0 Str.	#10 Sol.	7 x 7½	56
PBH†	#4 Str.	#14 Sol.	7 x 7½	56

† RUS Accepted.

Ground Rod Clamps

UL® Listed for both copper-clad and galvanized ground rods.

Type JWR — Wide-Range Ground Rod Clamp

- UL® Listed for direct burial in earth/concrete
- Constructed from bronze alloy and high-performance stainless steel bolt
- Provides wide range of connection sizes
- More than 300 lbs. torque capacity

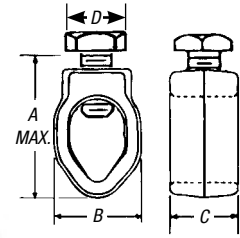

CAT. NO.	NOMINAL ROD DIA.		WIRE RANGE			DIMENSIONS (IN.)				
	(IN.)	(MM)	MAX.	MIN.	MAX. (MM²)	MIN. (MM²)	A (MAX.) BOLT	B	C	D
JWR	3/8*	9.5	1/0 Str.	10 Sol.	53.4	5.2	1.535	1.050	.812	.652
	1/2	12.7	1/0 Str.	10 Sol.	53.4	5.2	1.535	1.050	.812	.652
	5/8	15.8	1/0 Str.	10 Sol.	53.4	5.2	1.535	1.050	.812	.652
	3/4	19.0	1/0 Str.	8 Sol.	53.4	8.3	1.535	1.050	.812	.652

*3/8" rod not recognized/listed by UL.

Long bearing surface of clamp on ground wire secures ground connection.

Type JAB — Ground Rod Clamps

- Cast of high-strength corrosion-resistant copper alloy
- Both hex head bolts and socket set screws available
- UL® Listed for direct burial

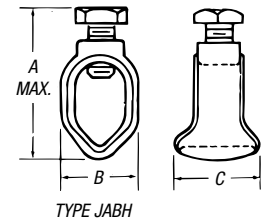

CAT. NO.		NOMINAL ROD DIA.		WIRE RANGE				DIMENSIONS (IN.)					
SOCKET SET SCREW	HEX HEAD BOLT	(IN.)	(MM)	MAX.	MIN.	MAX. (MM²)	MIN. (MM²)	A (MAX.) SOCKET SCREW	A (MAX.) HEX BOLT	SCREW THREAD SIZE UNC-2A	B	C	D
								JAB12*	JAB12H				
JAB58	JAB58H	5/8	15.8	1/0 Str.	8 Sol.	53.4	8.3	1 27/32	2 13/64	7/16-14	29/32	1	1 1/16
JAB34	JAB34H	3/4	19.0	1/0 Str.	8 Sol.	53.4	8.3	2	2 11/32	7/16-14	1 1/16	1	5/16
—	JAB34C	3/4 + 5/8	15.8 to 19.0	4/0 Str.	8 Sol.	95.0	8.3	—	2 11/32	7/16-14	1 1/8	1 1/2	1 9/16
JAB1	JAB1H	1	25.0	4/0 Str.	8 Sol.	107.1	8.3	2 1/4	3	7/16-14	1 11/32	1 1/16	1

* Not CSA listed
Add suffix P to Cat. No. for tin-plated clamp.

Ground Rod Clamps

A dependable ground connection offered at a substantial savings.

Type G — Budget-Line Ground Clamps

- Cast of high-strength corrosion-resistant copper alloy
- Furnished with hex head bolts
- Simplified, compact design makes lasting, trouble-free connection
- UL® Listed for direct burial

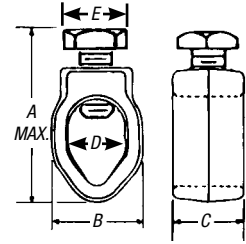

CAT. NO.	NOMINAL ROD DIA.		WIRE RANGE				A (MAX.) BOLT	SCREW THREAD SIZE UNC-2A	DIMENSIONS (IN.)			
	(IN.)	(MM)	MAX.	MIN.	MAX. (MM²)	MIN. (MM²)			B	C	D	E
G3*	3/8	9.5	4 Str.	10 Sol.	21.1	5.2	1 1/8	7/16-18	1 1/16	1/2	27/64	3/8
G4	1/2	12.7	2 Str.	10 Sol.	33.6	5.2	—	3/8-16	27/32	3/8	37/64	1/2
G5‡	5/8	15.8	2 Str.	10 Sol.	33.6	5.2	—	3/8-16	29/32	3/8	43/64	1/2
G6	3/4	19.0	2 Str.	10 Sol.	33.6	5.2	—	3/8-16	1 1/16	3/8	13/16	1/2

* Not UL Listed.
 ‡ RUS Accepted.
 Add suffix P to Cat. No. for tin-plated clamp.

Axial groove keeps wire and rod in perfect alignment.

Types GG and GGH — Heavy-Duty Ground Rod Clamps

- Cast of high-strength corrosion-resistant copper alloy
- Both hex head bolts and socket set screws available
- Floating pressure bar distributes pressure evenly over large area of ground wire

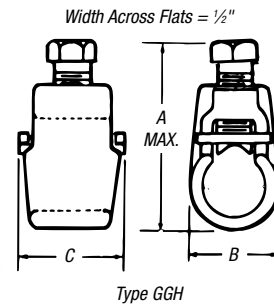
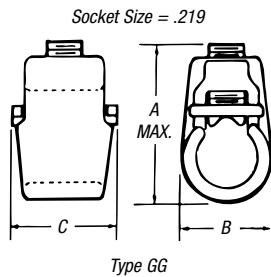

CAT. NO.*		NOMINAL ROD DIA.		WIRE RANGE				DIMENSIONS (IN.)				
SOCKET SET SCREW	HEX HEAD BOLT	(IN.)	(MM)	MAX.	MIN.	MAX. (MM²)	MIN. (MM²)	A (MAX.) SOCKET SCREW	A (MAX.) HEX BOLT	SCREW THREAD SIZE UNC-2A	B	C
GG12	GG12H	1/2	12.7	2 Str.	8 Sol.	33.6	8.3	1 13/64	1 13/16	7/16-14	27/32	15/16
GG58	GG58H	5/8	15.8	2 Str.	8 Sol.	53.6	8.3	1 51/64	2 1/32	7/16-14	61/64	15/16
—	GG34H	3/4	19.0	4/0 Str.	8 Sol.	120.6	8.3	—	3	1/2-14	1 3/8	1 1/4

* Add suffix P to Cat. No. for tin-plated clamp.
 GG34H has no pressure bar or axial groove.

Ground Rod Clamps

Drive-on design provides easy, tool-free installation, high-reliability compression-fit connection and room for one or two ground leads.

Type DGC — Drive-On Ground Clamps

- High-strength copper alloy provides increased tensile strength and long-term corrosion resistance for direct-burial applications
- UL® 486A and UL® 467 Listed
- RUS Listed



CAT. NO.	GROUND ROD SIZE	GROUND WIRE SIZE
DGC58-44 [†]	5/8 (.555-.565)	(1) or (2) #4 Sol.
DGC58-66 [†]	5/8 (.555-.565)	(1) or (2) #6 Sol.
DGC58-46 [*]	5/8 (.555-.565)	(1) #4 Sol., (1) #6 Sol.

[†] RUS Listed

^{*} Not UL® Listed



Cable Tray Grounding Connector

- Malleable iron construction
- For use on cable tray up to 5/32" thick



CAT. NO.	GROUND WIRE RANGE (AWG)	CARRIAGE BOLT SIZE
10102-TB	#8 Solid to #2 Stranded	5/16"-18
10103-TB	#4 Stranded to 4/0 Stranded	3/8"-16

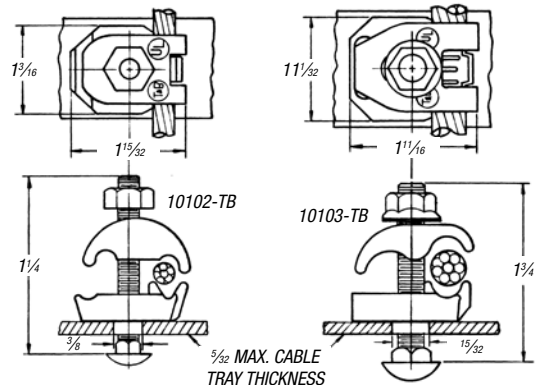

Structure Grounding

Bolt features square shank to prevent turning and enable clamp to be tightened with a single wrench.

Type GTC — Tower Ground Clamps

- Castings of high-strength, corrosion-resistant copper alloy
- GTC23 and GTC24 are two-piece clamps for connecting ground lead cable to flat metal surface — ideal for grounding substations on tower footings
- GTC13 and GTC14 are economical one-piece clamps, which perform the same function as two-piece clamps, except under-pad support is omitted and conductor connects directly to tower
- Add suffix L to catalog number for 1/2" channel thickness

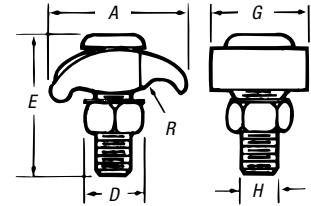

Type GTC 13 and 14

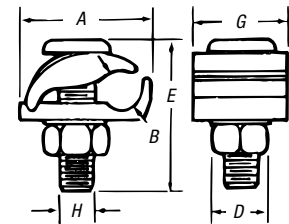

Type GTC 23 and 24



CAT. NO.	CONDUCTOR RANGE				CHANNEL THICKNESS	DIMENSION (IN.)						
	MAX.	MIN.	MAX. (MM ²)	MIN. (MM ²)		A	B	D	E	G	H	R
GTC13	2/0 Str.	#4 Sol.	67.4	21.1	1/4	1 15/32	—	9/16	1 21/32	1 3/32	3/8	7/32
GTC14	250 kcmil	2/0 Str.	126.6	67.4	1/4	1 15/16	—	3/4	1 15/16	1 13/32	1/2	5/16
GTC23	2/0 Str.	#4 Sol.	67.4	21.1	1/4	1 41/64	7/16	9/16	1 21/32	1 3/32	3/8	—
GTC24	250 kcmil	2/0 Str.	126.6	21.1	1/4	1 61/64	5/8	3/4	1 15/16	1 1/8	1/2	—

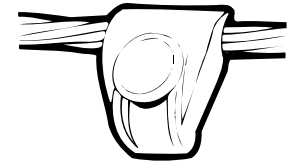

For use with aluminum or copper conductors.

CTG250 Wide-Range Tower Ground Clamp

- May be used in aluminum or galvanized-steel cable tray
- Ribbed neck on the bolt prevents rotation during tightening if .440" dia. hole is used

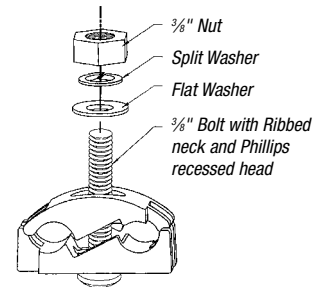

CAT. NO.	WIDE RANGE (2 SIDES)	HEIGHT	WIDTH	DEPTH	NUT (FLATS)
CTG250	#2 Sol. (.258 Dia.) 250 kcmil (.575 Dia.)	1.95	2.00	1.13	.560

Tin-plate body
Galvanized hardware

Structure Grounding

Dual-rated for both copper and aluminum conductor.

Aluminum Lay-in Lug Connector

- Manufactured from 6061-T6 aluminum alloy for maximum strength and conductivity
- Open-faced design enables installer to quickly lay-in grounding conductor as jumper to multiple conduits with no break in ground conductor

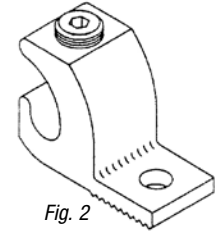
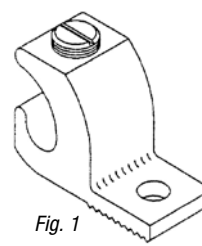
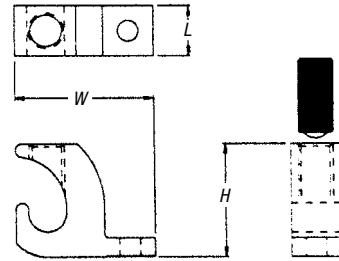

Fig. 1

Fig. 2



CAT. NO.	FIG. NO.	COND. RANGE AWG		STUD SIZE		DIMENSIONS					
		IN.	(MM ²)	IN.	(MM)	H		W		L	
						IN.	(MM)	IN.	(MM)	IN.	(MM)
LL414	1	4-14	16-1.5	.22	5.59	.78	19.81	.38	9.65	1.07	27.18
LL1014	1	1/0-14	50-1.5	.27	6.86	1.17	29.72	.60	15.24	1.50	38.10
LL306	2	3/0-6	70-16	.33	8.38	1.56	39.62	.80	20.32	2.00	50.80
LL2506	2	250-6	120-16	.33	8.38	1.79	45.47	.80	20.32	2.20	55.88

90° C Rating (486B Listed)

UL® Listed for direct burial. Copper Lay-in Lug Connector

- Ideal for swimming pool grounding applications
- Carries "DB" marking for direct burial
- Open-faced design enables installer to quickly lay-in grounding conductor as jumper to multiple conduits with no break in ground conductor



CAT. NO.	COND. RANGE AWG		STUD SIZE		DIMENSIONS					
	IN.	(MM ²)	IN.	(MM)	H		W		L	
					IN.	(MM)	IN.	(MM)	IN.	(MM)
CULL414	4-14	16-1.5	.22	5.59	.78	19.81	.38	9.65	1.07	27.18
CULL414-TP*	4-14	16-1.5	.22	5.59	.78	19.81	.38	9.65	1.07	27.18

90° C Rating (486B Listed)

* Tin plated

Structure Grounding

Designed for grounding one or two cables to steel structure or transformer.

Service Post Connectors

- For copper-to-copper connections
- Can also be used to tap one or two cables from bus bar
- Bolts machined from high-conductivity bronze alloy
- Nuts cold-formed from high-strength, corrosion-resistant copper alloy
- Pressure bars copper through 4/0 and copper alloy for 350 kcmil and above
- Bolts and nuts of traditional Blackburn hex design for easy installation
- Available in sizes to accommodate AWG copper conductor ranges of #12–500 kcmil stranded and #12–#2 solid
- Both single- and double-conductor and short- and long-stud versions available
- UL® 486A and UL® 467 Listed

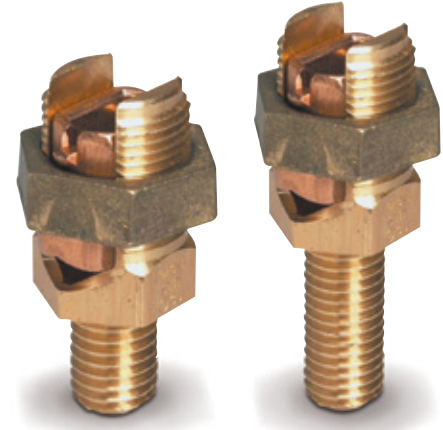

Type SP-S — Service Post Connectors, Short Stud



CAT. NO. CONDUCTOR		CONDUCTORS STRANDED		AWG MM ² SOLID		DIAMETER RANGE (IN.)	STUD SIZE
DOUBLE	SINGLE	MAX.	MIN.	MAX.	MIN.		
SP0DS	SP0SS	8	12	8	12	.146-.081	¼-20 x ½
		6mm ²	4mm ²	10mm ²	4mm ²	—	
SP1DS	SP1SS	7	10	6	10	.164-.102	¼-20 x ½
		10mm ²	6mm ²	10mm ²	6mm ²	—	
SP2DS	SP2SS	5	10	4	10	.206-.102	⅝-18 x ⅝
		16mm ²	6mm ²	—	—	—	
SP3DS	SP3SS	3	10	2	10	.26-.102	⅜-16 x ⅝
		25mm ²	6mm ²	—	—	—	
SP4DS	SP4SS	1	8	2	8	.332-.129	⅜-16 x ⅝
		35mm ²	10mm ²	—	—	—	
SP5DS	SP5SS	1/0	2	1/0	2	.373-.258	½-13 x ¾
		50mm ²	35mm ²	—	—	—	
SP6DS	SP6SS	2/0	2	2/0	2	.419-.258	½-13 x ¾
		50mm ²	35mm ²	—	—	—	
SP8DS	SP8SS	4/0	2	4/0	1	.528-.289	⅝-11 x 1
		95mm ²	35mm ²	—	—	—	
SP9DS	SP9SS	350	1/0	—	—	.681-.373	⅝-11 x 1
		150mm ²	50mm ²	—	—	—	
SP10DS	SP10SS	500	3/0	—	—	.814-.47	¾-10 x 1¼
		240mm ²	95mm ²	—	—	—	

Type SP-L — Service Post Connectors, Long Stud



CAT. NO. CONDUCTOR		CONDUCTORS STRANDED		AWG MM ² SOLID		DIAMETER RANGE (IN.)	STUD SIZE
DOUBLE	SINGLE	MAX.	MIN.	MAX.	MIN.		
SP0DL	SP0SL	8	12	8	12	.146-.081	¼-20 x 1
		6mm ²	4mm ²	10mm ²	4mm ²	—	
SP1DL	SP1SL	7	10	6	10	.164-.102	¼-20 x 1
		10mm ²	6mm ²	10mm ²	6mm ²	—	
SP2DL	SP2SL	5	10	4	10	.206-.102	⅝-18 x 1
		16mm ²	6mm ²	—	—	—	
SP3DL	SP3SL	3	10	2	10	.26-.102	⅜-16 x 1½
		25mm ²	6mm ²	—	—	—	
SP4DL	SP4SL	1	8	2	8	.332-.129	⅜-16 x 1½
		35mm ²	10mm ²	—	—	—	
SP5DL	SP5SL	1/0	2	1/0	2	.373-.258	½-13 x 1¼
		50mm ²	35mm ²	—	—	—	
SP6DL	SP6SL	2/0	2	2/0	2	.419-.258	½-13 x 1¼
		50mm ²	35mm ²	—	—	—	
SP8DL	SP8SL	4/0	2	4/0	1	.528-.289	⅝-11 x 1½
		95mm ²	35mm ²	—	—	—	
SP9DL	SP9SL	350	1/0	—	—	.681-.373	⅝-11 x 1½
		150mm ²	50mm ²	—	—	—	
SP10DL	SP10SL	500	3/0	—	—	.814-.47	¾-10 x 1¾
		240mm ²	95mm ²	—	—	—	

Ground Clamps

Excellent for connecting multiple electrodes with a single cable, such as in substation grounding.

Type GUV — U-Bolt Ground Clamps

- For connecting copper or copper-clad steel grounding conductor to ground rod or pipe
- Specially designed spacer provides proper alignment between cable and electrode and affords more positive contact area
- All components cast or forged from copper alloy
- UL® 467 Listed for direct burial

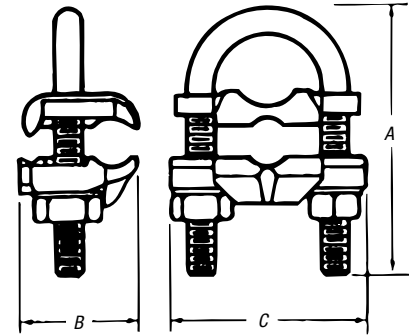

CAT. NO.*	CONDUCTOR RANGE (CU)		NOMINAL ROD SIZE (IN)		IPS PIPE SIZE		DIMENSIONS (IN.)		
	MAX.	MIN.	MAX.	MIN.	MAX.	MIN.	A	B	C
GUV584	4	8	3/4	5/8	3/8	—	2 1/16	1 1/16	2 1/4
GUV5821	2/0	4	3/4	5/8	3/8	—	2 1/16	1 1/16	2 1/4
GUV5825	250	2/0	3/4	5/8	3/8	—	2 1/16	1 1/16	2 1/4
GUV784	4	8	1	7/8	3/4	1/2	2 3/4	1 1/16	2 5/8
GUV7821	2/0	4	1	7/8	3/4	1/2	2 3/4	1 1/16	2 5/8
GUV7825	250	2/0	1	7/8	3/4	1/2	2 3/4	1 1/16	2 5/8
GUV1184	4	8	1 1/4	1 1/8	1	—	3 5/16	1 1/16	2 3/4
GUV11821	2/0	4	1 1/4	1 1/8	1	—	3 5/16	1 1/16	2 3/4
GUV1384	4	8	1 1/2	1 3/8	1 1/4	—	3 7/16	1 1/16	2 5/8
GUV13821	2/0	4	1 1/2	1 3/8	1 1/4	—	3 7/16	1 1/16	2 5/8
GUV13825	250	2/0	1 1/2	1 3/8	1 1/4	—	3 7/16	1 1/16	2 5/8
GUV1584	4	8	1 7/8	1 5/8	1 1/2	—	3 9/16	1 1/16	3 3/16
GUV15821	2/0	4	1 7/8	1 5/8	1 1/2	—	3 9/16	1 1/16	3 3/16
GUV15825	250	2/0	1 7/8	1 5/8	1 1/2	—	3 9/16	1 1/16	3 3/16
GUV204	4	8	2 3/8	2	2	—	4 1/16	1 1/16	3 1 1/16
GUV2021	2/0	4	2 3/8	2	2	—	4 1/16	1 1/16	3 1 1/16
GUV2025	250	2/0	2 3/8	2	2	—	4 1/16	1 1/16	3 1 1/16
GUV21221	2/0	4	2 7/8	2 1/2	2 1/2	—	4 5/16	1 1/16	4 3/16
GUV21225	250	2/0	2 7/8	2 1/2	2 1/2	—	4 5/16	1 1/16	4 3/16
GUV3021	2/0	4	3 1/2	3	3	—	5 5/16	1 1/16	4 3/8
GUV3025	250	2/0	3 1/2	3	3	—	5 5/16	1 1/16	4 3/8
GUV31221	2/0	4	4	3 1/2	3 1/2	—	6 1/16	1 1/16	5 1/2
GUV4021	2/0	4	4 1/2	4	4	—	6 5/16	1 1/16	5 1 1/16
GUV4025	250	2/0	4 1/2	4	4	—	6 5/16	1 1/16	5 1 1/16

* For tin plating, add suffix P to Cat. No. Contact factory for price and availability.
UL® does not list tin-plated bronze grounding devices.

Ground Clamps

Water Pipe Ground Clamps



CAT. NO.	GROUND WIRE SIZE	WATER PIPE SIZE
2-TB	#6, #4, #2	½", ¾", 1" or rebar 4-10
3-TB	#6, #4, #2	1¼", 1½" or 2"
4	#6, #4, #2	2½", 3" or 3½"
5-TB	#6, #4, #2	4", 4½" or 5"
6	#6, #4, #2	6"

Malleable iron. #6 – #2 AWG ground wire.



Water Pipe Ground Clamps



CAT. NO.	GROUND WIRE SIZE	WATER PIPE SIZE	CAT. NO.	GROUND WIRE SIZE	WATER PIPE SIZE
3902	#4-4/0 AWG	½"-1"	3902BU*	#4-4/0 AWG	½"-1"
3903	#4-4/0 AWG	1¼"-2"	3903BU*	#4-4/0 AWG	1¼"-2"
3904	#4-4/0 AWG	2½"-3½"	3904BU*	#4-4/0 AWG	2½"-3½"
3905-TB	#4-4/0 AWG	4"-5"	3905BU*	#4-4/0 AWG	4"-5"
3906-TB	#4-4/0 AWG	6"	3906BU*	#4-4/0 AWG	6"
3907	#4-4/0 AWG	8"	3907BU*	#4-4/0 AWG	8"
3908	#4-4/0 AWG	10"	3908BU*	#4-4/0 AWG	10"
3909-TB	#4-4/0 AWG	12"	3909BU*	#4-4/0 AWG	12"

* UL Listed for direct burial



For connecting grounding conductor to either steel or copper pipe, rod or tubing.

Aluminum Water Pipe Clamp

- For use with copper or aluminum conductor
- Tin plated for corrosion resistance

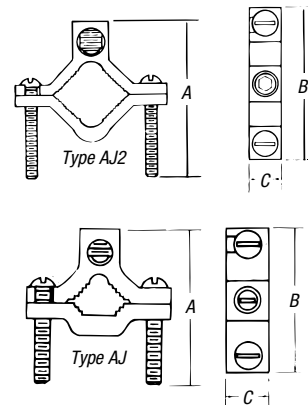

CAT. NO.	WATER PIPE SIZE	CONDUCTOR RANGE		DIMENSIONS (IN.)			STEEL CLAMP SCREW	ALUMINUM WIRE SCREW
		MAX.	MIN.	A	B	C		
AJ	½-1	1/0 Str.	#14 Sol.	2½	2¼	¾	¼-20	¼-20 slot
AJ-2	1½-2	250 kcmil	#6	3¾	3¾	¾	¾-18	¼-20 socket
AJ-2124	2½-4	250 kcmil	#6	5⅞	6⅞	¾	¾-16	¼-20 socket

UL Listed for both copper and aluminum conductors to steel pipe and copper water tubing

Ground Clamps

Economically priced clamps.

Die-Cast Clamps

- Made of die-cast zinc alloy with zinc-plated screws
- Model BJA for use with armored cable



CAT. NO.	WATER PIPE SIZE	CONDUCTOR RANGE	
		MAX.	MIN.
BJ-1	1/2"–1"	#2 str.	#10 sol.
BJA*	1/2"–1"	#6 AWG	#8 AWG

* Not UL Listed



Flexible copper strap makes alignment easy.

Cast Bronze Clamps with Copper Strap

- For grounding rigid conduit systems
- Same features as “JP” clamp plus flexible copper strap
- Strap helps protect conduit system from water system vibrations
- Furnished with zinc-plated screws

CAT. NO.	CONDUIT SIZE	WATER PIPE SIZE	CONDUCTOR RANGE	
			MAX.	MIN.
JPS-12	1/2"	1/2"–1"	#6 sol.	#10 sol.
JPS-34	3/4"	1/2"–1"	2/0 str.	#10 sol.
JPS-1	1"	1/2"–1"	3/0 str.	#10 sol.

Add suffix C to Cat. No. to specify plating.



Ground Clamps

Connects copper ground wire to water pipe or copper tubing.

Cast Bronze Ground Clamps

- High-strength, high-conductivity copper alloy (over 80% copper)
- UL® 467 Listed for direct burial



CAT. NO.	WATER PIPE SIZE	CONDUCTOR RANGE
JD	½"–1"	#2 str.–#10 str.
J2D	1¼"–2"	#2 str.–#10 str.



For connecting grounding conductor to water pipe or copper tube.

Type J — Cast Bronze Ground Clamps

- Cast of high-strength, highly conductive copper alloy
- Screws plated for corrosion resistance
- UL® Listed

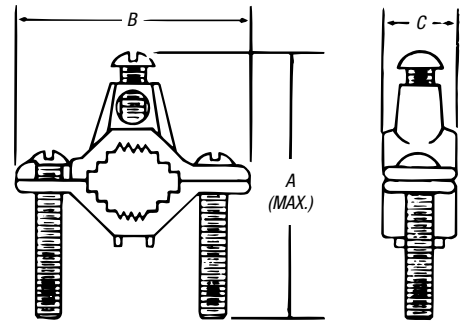

CAT. NO.	WATER PIPE SIZE	CONDUCTOR RANGE		DIMENSIONS (IN.)		
		MAX.	MIN.	A (MAX.)	B	C
J	½"–1"	#2 str.	#10 sol.	2¾	2⅛	2⅜
J2BB	1¼"–2"	#2 str.	#10 sol.	3¾	3½	1⅜
J2124	2½"–4"	#4 str.	#10 sol.	6	6⅞	1
J6	4¼"–6"	#4 str.	#10 sol.	7¼	8⅞	1

Ground Clamps

Similar to aluminum water pipe clamp but lighter in construction.

Budget Price Cast Bronze Clamp

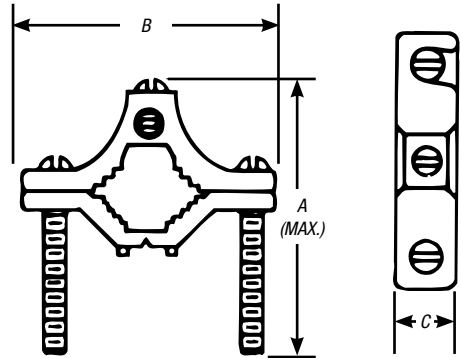

CAT. NO.	WATER PIPE SIZE	CONDUCTOR RANGE		DIMENSIONS (IN.)		
		MAX.	MIN.	A	B	C
JJR	1/2"-1"	#4 Str.	#10 Sol.	2 15/32	2 5/32	1 7/32

Add suffix C to Cat. No. to specify plating.

Lay-in feature reduces installation time for difficult bends or continuous loops of ground wire.

Type JDLI — Direct-Burial Ground Clamp

- UL® Listed for direct burial in earth/concrete
- UL® Listed for connection to ground rod, pipe or rebar up to 1"
- Constructed from bronze alloy and high performance stainless steel bolts
- Designed for easy installation of difficult bends or continuous loops

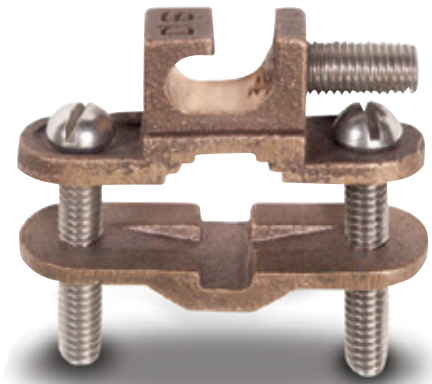

CAT. NO.	PIPE SIZE	REBAR SIZE	GROUND ROD SIZE	CONDUCTOR RANGE	MECH. CONN./SPICE (UL LISTED)
JDLI	1/2"-1"	3/8"-1"	1/4"-1"	#10 Sol.-#2 Str.	(2) #8 Sol.

Ground Clamps

For connecting armored cable to water pipe.

Cast Bronze Clamp

- Clamping portion similar to standard “J” clamp
- Special pressure bar grips armor or outer cable insulation to reduce chance of grounding conductor being pulled out
- Furnished with zinc-plated screws

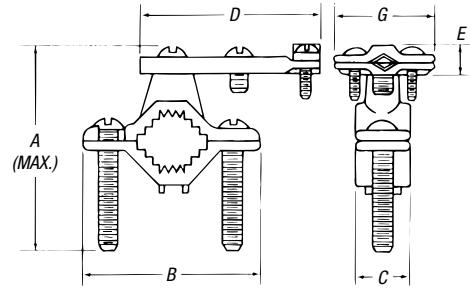

CAT. NO.	WATER PIPE SIZE	CONDUCTOR RANGE		DIMENSIONS (IN.)					
		MAX.	MIN.	A	B	C	D	E	G
JA	½"–1"	#6 sol.	#10 sol.	2¾	2 ¹¹ / ₃₂	2 ³ / ₃₂	2 ³ / ₃₂	1 ⁵ / ₃₂	1 ³ / ₈
JA-2	1¼"–2"	#6 sol.	#10 sol.	3¾	3½	1 ¹⁵ / ₁₆	2 ³ / ₃₂	1 ⁵ / ₃₂	1 ³ / ₈
JA-2124	2½"–4"	#6 sol.	#10 sol.	6	6 ⁵ / ₁₆	1	2 ³ / ₃₂	1 ⁵ / ₃₂	1 ³ / ₈

Add suffix C to Cat. No. to specify plating.

For grounding rigid conduit systems.

Cast Bronze Clamps for Conduit

- Continuity from rigid conduit system to ground provided by cast bronze threaded conduit hub
- Hub swings 360° for easy alignment
- Heavy brass washer protects clamped grounding conductor
- Furnished with zinc-plated screws
- Cast bronze pipe clamping portion identical to that used in “JA” clamp

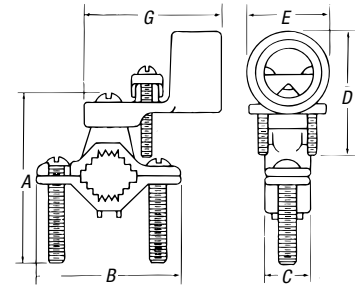

CAT. NO.	CONDUIT SIZE	WATER PIPE SIZE	CONDUCTOR RANGE		DIMENSIONS (IN.)					
			MAX.	MIN.	A	B	C	D	E	G
JP-12	½	½"–1"	#6 sol.	#10 sol.	2¾	2 ¹¹ / ₃₂	2 ³ / ₃₂	1 ⁹ / ₆₄	1	2½
JP-212	½	1¼"–2"	#6 sol.	#10 sol.	3¾	3½	1 ¹⁵ / ₁₆	1 ⁹ / ₆₄	1	2½
JP-212412	½	2½"–4"	#6 sol.	#10 sol.	6	6 ⁵ / ₁₆	1	1 ⁹ / ₆₄	1	2½
JP-34	¾	½"–1"	#2/0 str.	#10 sol.	2¾	2 ¹¹ / ₃₂	2 ³ / ₃₂	2 ⁵ / ₁₆	1¼	2 ³ / ₁₆
JP-234	¾	1¼"–2"	#2/0 str.	#10 sol.	3¾	3½	1 ¹³ / ₁₆	2 ⁵ / ₁₆	1¼	2 ³ / ₁₆
JP-212434	¾	2½"–4"	#2/0 str.	#10 sol.	6	6 ⁵ / ₁₆	1	2 ⁵ / ₁₆	1¼	2 ³ / ₁₆
JP-1	1	½"–1"	#3/0 str.	#10 sol.	2¾	2 ¹¹ / ₃₂	2 ³ / ₃₂	2 ⁵ / ₁₆	1½	2 ³ / ₈
JP-21	1	1¼"–2"	#3/0 str.	#10 sol.	3¾	3½	1 ¹⁵ / ₁₆	2 ⁵ / ₁₆	1½	2 ³ / ₈
JP-21241	1	2½"–4"	#3/0 str.	#10 sol.	6	6 ⁵ / ₁₆	1	2 ⁵ / ₁₆	1½	2 ³ / ₈

Add suffix C to Cat. No. to specify plating.

Ground Clamps

Hub swings 360° for ease of alignment.

Type JPT — Cast Bronze Clamps for Conduit

- Pipe clamping portion identical to “JA” clamp
- Pressure-bar type conduit hub adjusts to fit ½" or ¾" EMT or ½" rigid conduit
- Brass washer provides positive contact with grounding conductor
- Furnished with zinc-plated screws



CAT. NO.	CONDUIT SIZE	PIPE SIZE	CONDUCTOR RANGE	
			MAX.	MIN.
JPT		½" to 1"		
JPT2	½" or ¾" EMT	1¼" to 2"	#6 Sol.	#10 Sol.
JPT4	½" Rigid	2½" to 4"		

Conduit Hubs

CAT. NO.	GROUND WIRE SIZE AWG	CONDUIT SIZE
3930	#8 to #2	½" Conduit
3940	#8 to #2	¾" Conduit
3950	#8 to 3/0	1" Conduit
3951	#8 to 4/0	1¼" Conduit

Material: Malleable iron



Provides positive connection between rigid conduit and water system.

Type CH — Bronze Conduit Hubs

- Used in conjunction with “J” clamp
- Rugged cast-bronze threaded hub

CAT. NO.	CONDUIT SIZE (IN.)	CONDUCTOR RANGE	
		MAX.	MIN.
CH12	½	#6 Sol.	#10 Sol.
CH34	¾	2/0 Str.	#10 Sol.
CH1BB	1	3/0 Str.	#10 Sol.



Ground Clamps

Ground Clamp



CAT. NO.	MATERIAL	WATER PIPE, COPPER TUBING SIZE	GRD. ROD SIZE
3826†	M.I.	½", ¾"	½"-1"
3846†	Bronze	½", ¾"	½"-1"
3849•	Brass	½"-1" O.D.	
3840-TB*	M.I.	½", ¾" or 1"	

† For unarmored copper wire #6, #4.

• For copper and aluminum conductors; for 14 thru 2 cu. unarmored copper wire — corrosive and outdoor use. UL® approved for direct burial.

* #8 thru #4 AWG. Not CSA Certified.



3826



3849



3840-TB

Ground Clamps for K&L Grade Copper Tubing Only



CAT. NO.	GROUND WIRE RANGE	WATER PIPE & GROUND ROD SIZE/ DESC.
3844*	#8-#4	½"-1"
3888†	#8-#4	½"-1" also rebar 4-10
961	#8	¾"-1"
962**	#8	¾"-2"
963**	#8	¾"-3"

CAT. NO.	DESCRIPTION/CABLE SIZE
31215	Strain-Relief Grounding Lug, #6-#2
31216	Grounding Clamp, 1" Hook-Type, #6-#2
31253	Grounding Clamp, 1-½" Hook-Type, #6-#2
31217	Ground Clamp, 1" Straight-Type, #6-#2
31224	Grounding Clamp, 1-½" Straight-Type, #6-#2
31230	Wing Screw only

* With steel screws.

** With bronze screws, not CSA Certified — or UL® Listed.

† UL® approved for direct burial. Silicon bronze screws.



3844

For armored and unarmored wire

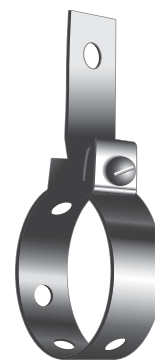

961

For radio, motor frame and equipment grounding

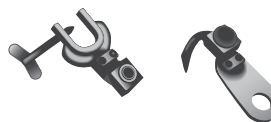

31215

Disconnect static ground clamp and lug, straight-type (cable not supplied), UL not applicable

Cable Tray Ground Clamp

Material: Malleable iron

Standard Finish: Zinc plated



CAT. NO.	DESCRIPTION
10105*	For Single Conductors #4 sol. to 2/0 str.
10109**	For Single Conductors 2/0 sol. to 4/0 str.

* UL® Listed #4 to 2/0 AWG copper.

** UL® Listed 2/0 to 4/0 AWG copper/aluminum.

CSA File No. 2884.



Ground Clamps

For aluminum and steel cable trays with regular or reinforced flanges.

Tray Clamps

- Serrations and biting teeth on clamping saddle provide a high-quality bond between conduit and clamp
- Can be clamped to any position in a 90° arc
- Hardened steel screws bite into tray and provide positive bond
- Malleable iron hub and steel U-bolt accept conduit from any angle



CAT. NO.	CLAMP TYPE	CONDUIT SIZE
6209	Swivel	½"–¾"
6210	Straight	½"–¾"
6211	Swivel	1"–1¼"
6212	Straight	1"–1¼"
6214	Swivel	1½"–2"
6216	Swivel	2½"–3"
6218	Swivel	3½"–4"



Efficiently grounds trailer frames, cable trays, CATV and telephone pedestals.

Beam Grounding Clamp

- Connects #6 to #14 solid copper conductor to metal frames where continuity of grounding can be assured
- 7/16" silicon bronze hex-head bolt installs with cam-wrench, socket or crescent wrench
- Tin-plated square-head bolt enables installation with pliers when tighter ground connection is needed
- Ground wire hole access from four directions minimizes need to bend ground wire
- Designed so ground wire may be installed on clamp prior to mounting clamp on metal frame, reducing installation time
- Beam and ground wire connection can be tightened separately with disconnecting integrity of ground circuit
- High-strength copper alloy (91% nom.) provides greater conductivity, durability and corrosion resistance without the need for plating
- High-strength anchoring bolt penetrates paint or metal oxide



CAT. NO.	DESCRIPTION	CONDUCTOR SIZE (AWG)
TGC	Square-Head Tin-Plated Steel Bolt	#6 to #14 sol.

Listed to UL® 467



Catalog Number Index

Index

CAT. NO.	PAGE NO.	CAT. NO.	PAGE NO.	CAT. NO.	PAGE NO.	CAT. NO.	PAGE NO.	CAT. NO.	PAGE NO.
10102-TB	27	53512	16	CC20C-56R	17	GR34-300500	6	JP2612G	19
10103-TB	27	53513	16	CC2C-45R	17	GR34-4010	13	JP2614	19
10105	38	53515	16	CC40C-56R	17	GR34-40250	6	JP2638	19
10109	38	53518	16	CH12	37	GR58-202	6	JP26516	19
1016BTB	23	53523	16	CH1BB	37	GR58-300500	6	JP386	19
1016TB	23	54855	6	CH34	37	GR58-40250	6	JP5166	19
15506	17	54855L	7	CTG250	28	GR58-406	13	JP62	19
15534	17	54855LR12	7	CTP202	12	GRD2	9	JP66	19
2-TB	32	54860	6	CTP2020	12	GRD20	9	JPS-1	33
3-TB	32	54865-CK	6	CTP22	12	GRD40	9	JPS-12	33
31215	38	54865L	7	CTP25020	12	GRD420	9	JPS-34	33
31216	38	54865LR58	7	CTP250250	12	GTC13	28	JPT	37
31217	38	54875	6	CTP50020	12	GTC14	28	JPT2	37
31224	38	54875L	7	CTP500250	12	GTC23	28	JPT4	37
31230	38	54875LR34	7	CTP500500	12	GTC24	28	JWR	25
31253	38	54885	6	CULL414	29	GUV11821	31	LL1014	29
3826	38	54885L	7	CULL414-TP	29	GUV1184	31	LL2506	29
3840-TB	38	54885LR12	7	DGC58-44	27	GUV13821	31	LL306	29
3844	38	54890	6	DGC58-46	27	GUV13825	31	LL414	29
3846	38	54895	6	DGC58-66	27	GUV1384	31	PBGW	24
3849	38	54895L	7	FG2040R2	18	GUV15821	31	PBH	24
3888	38	54895LR58	7	FG2040R25	18	GUV15825	31	SPDI	30
3900	21	54900	6	FG2040R3	18	GUV1584	31	SPODS	30
3900BP	21	54900L	7	FG210R2	18	GUV2021	31	SPOSI	30
3902	32	54900LR34	7	FG210R25	18	GUV2025	31	SPOSS	30
3902BU	32	54910LR100	7	FG210R3	18	GUV204	31	SP10DI	30
3903	32	54920LR100	7	G3	26	GUV21221	31	SP10DS	30
3903BU	32	6	32	G4	26	GUV21225	31	SP10SI	30
3904	32	60C	22	G5	26	GUV3021	31	SP10SS	30
3904BU	32	60CNT2	23	G6	26	GUV3025	31	SP1DI	30
3905-TB	32	60DS	22	GBBC22	18	GUV31221	31	SP1DS	30
3905BU	32	60DSNT	23	GBBC26	18	GUV4021	31	SP1SI	30
3906-TB	32	6209	39	GFL10-20	20	GUV4025	31	SP1SS	30
3906BU	32	6210	39	GFL2-1	20	GUV5821	31	SP2DI	30
3907	32	6211	39	GFL350	20	GUV5825	31	SP2DS	30
3907BU	32	6212	39	GFL40-250	20	GUV584	31	SP2SI	30
3908	32	6214	39	GFL5001	20	GUV7821	31	SP2SS	30
3908BU	32	6216	39	GFL7501, 2	20	GUV7825	31	SP3DI	30
3909-TB	32	6218	39	GG10-10	8	GUV784	31	SP3DS	30
3909BU	32	70C	22	GG12	26	IBG2-10	16	SP3SI	30
3930	37	70CNT	23	GG12H	26	IBG20-40	16	SP3SS	30
3940	37	70DS	22	GG2030-10	8	IBG350-500	16	SP4DI	30
3950	37	80C	22	GG2030-2030	8	J	34	SP4DS	30
3951	37	80DS	22	GG2030-21	8	J2124	34	SP4SI	30
4	32	961	38	GG21-21	8	J2BB	34	SP4SS	30
5-TB	32	962	38	GG34H	26	J2D	34	SP5DI	30
50C	22	963	38	GG350-350	8	J6	34	SP5DS	30
50DS	22	AJ	32	GG40250-10	8	JA	36	SP5SI	30
50LC	22	AJ-2	32	GG40250-2030	8	JA-2	36	SP5SS	30
50LCNT	23	AJ-2124	32	GG40250-21	8	JA-2124	36	SP6DI	30
50LDS	22	BC202	12	GG40250-40250	8	JAB1	25	SP6DS	30
51628	22	BC2020-BB	12	GG500-2030	8	JAB12	25	SP6SI	30
51629	22	BC22	12	GG500-350	8	JAB12H	25	SP6SS	30
53055	11	BC24	12	GG500-40250	8	JAB1H	25	SP8DI	30
53055FL	17	BC402	12	GG500-500	8	JAB34	25	SP8DS	30
53059	11	BC4020	12	GG58	26	JAB34C	25	SP8SI	30
53060	11	BC4040	12	GG58H	26	JAB34H	25	SP8SS	30
53065-34GR	10	BC44	12	GP100	24	JAB58	25	SP9DI	30
53065-58GR	10	BC46-BB	12	GP1003	24	JAB58H	25	SP9DS	30
53065	11	BC48	12	GP1008	24	JD	34	SP9SI	30
53065FL	17	BJ-1	33	GP110	24	JDLI	35	SP9SS	30
53069	11	BJA	33	GP1108	24	JJR	35	SRG10-20	21
53071	11	CC 202	13	GP114	24	JP-1	36	SRG2-1	21
53073	11	CC 2020	13	GP2250-2	14	JP-12	36	SRG30-40	21
53075	11	CC 22	13	GP2250-4	14	JP-21	36	SRG8-4	21
53080	11	CC 24	13	GP250500-2	14	JP-212	36	TBGS-14	15
53504	16	CC 402	13	GP250500-4	14	JP-21241	36	TBGS-34	15
53505	16	CC 4020	13	GR1-202	6	JP-212412	36	TBGS-38	15
53506	16	CC 4040	13	GR1-300500	6	JP-212434	36	TBGS-58	15
53507	16	CC 44	13	GR1-40250	6	JP-234	36	TGC	39
53508	16	CC 46	13	GR12-202	6	JP-34	36		
53509	16	CC 48	13	GR12-306	13	JP126	19		
53510	16	CC10C-56R	17	GR12-40250	6	JP126G	19		
53511	16	CC1C-45R	17	GR34-202	6	JP146	19		

A Global Leader in Innovative...

Wire & Cable Management

Carlton *Catamount* **EZCODE** *Kindorf* **redodot**
Steel City **Superstrut** *T&B Cable Tray* *Ty-Duct* *Ty-Rap*



Cable Protection Systems

Adaptaflex **Carlton** *Harnessflex* **KOPEX-EX** *Ocal*
PMA **redodot** *Steel City* *T&B Fittings*

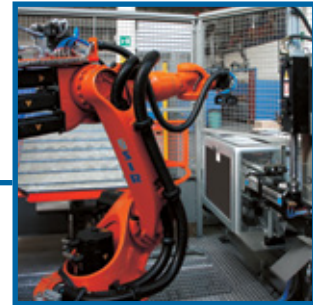

Power Connection & Control

Blackburn Compression *Blackburn Grounding* *Blackburn Mechanical*
CYBEREX *elastimold* **FISHER PIERCE** **Hi-Tech**
HOMAC **JENNINGS TECHNOLOGY** **JOSLYN** *Pos-E-Kon* *Russellstoll* *Sta-Kon*



Safety Technology

AMERACE **Current Technology** **EMERGI-LITE**
Hazlux **JOSLYN** *Lightalarms*



Thomas & Betts

A Member of the ABB Group

www.tnb.com

Visit our world of electrical product solutions

Visit the "Electrical World" section of our web site at www.tnb.com for more information on Thomas & Betts solutions including our newest products, plus user-friendly catalog and competitive part number search, application and technical support and other useful information. Click on the Electrical World icon or go to: tnbelectricalworld.tnb.com.

Industry codes and specifications

Thomas & Betts products meet or exceed applicable industry specifications or codes which are detailed in the appropriate T&B product literature.



Online CAD library

Thomas & Betts offers free download of two- and three-dimensional CAD models of many of its products in more than 90 native CAD formats at: www.tnb.com/cadlibrary

Thomas & Betts Corporation

8155 T&B Boulevard
Memphis, TN 38125
901.252.8000

www.tnb.com

United States

Thomas & Betts Corporation
Electrical Division Headquarters
8155 T&B Boulevard
Memphis, TN 38125
Phone: 901.252.8000
Fax: 901.252.1354
Technical Services:
888.862.3289

Canada

Thomas & Betts Ltd
700 Avenue Thomas
St.-Jean-sur-Richelieu
Quebec J2X 2M9
Phone: 450.347.5318
Fax: 450.347.1976

Latin America

Mexico: 01-800-TNB-HELP
Central America & Caribbean:
+52.81.8329.7707
South America:
+52.81.8329.7643
Email: servicioclientes@tnb.com

Europe/Africa

T&B European Centre
200 Chaussée de Waterloo
B-1640 Rhode-St-Genèse
Belgium
Phone: +32.235.98200
Email: europe_inquiry@tnb.com

Middle East

Thomas & Betts Ltd
PO Box 54567
Office 107 5EA East Wing
Dubai Airport Free Zone
Dubai
United Arab Emirates
Phone: +9714.609.1635
Fax: +9714.609.1636

Asia Pacific

Thomas & Betts Asia Pte Ltd
10 Ang Mo Kio Street 65
#06-07 Techpoint
Singapore 569059
Phone: +65.6720.8828
Fax: +65.6720.8780
Email: asia_inquiry@tnb.com

American Recovery and Reinvestment Act (ARRA)



Get certification letters for
compliant products online at:

www.tnb.com/ARRA