

North American Power Fuses

The most popular North American power fuses to meet the most popular protection priorities



Your problem:

Today, you need a time-delay power fuse that can handle normal surges. Tomorrow, it's a power fuse with a high interrupting rating and the added security of rejection dimensions. The day after that, one of those economical one-time power fuses will do the trick. But where can you turn for all three?

Our solution: Mersen's comprehensive power fuse offering covers a complete range of applications and a complete range of circuit-protection needs. Whether it's the characteristics of our Tri-Onic® Time-delay fuses. The high current-limiting capacity of our original Amp-Trap® power fuses. The cost-efficient protection of our One-Time fuses. Or some other application-specific power fuse solution.

Want more information fast? For more technical or application-specific information, please call our power fuse experts, at 978-462-6662; 416-252-9371 in Canada; or visit our website at ep-us.mersen.com.

B North American Power Fuses

- Class RK5 / Tri-Onic® TR & TRS B2
- Class RK5 / Tri-Onic® TRS-RDC B4
- Class J / Amp-Trap® HSJ B6
- Class J / Amp-Trap® A4J B8
- Class L / Amp-Trap® A4BY B10
- Class L / Amp-Trap® A4BT B12
- Class T / Amp-Trap® A3T & A6T B14
- Class RK1 / Amp-Trap® A2K & A6K.. B16
- Class G / Amp-Trap® AG B18
- Class CC / Amp-Trap® ATMR B19
- Class K-5 / One-time OT & OTS B20
- Class H / Renewable RF & RFS B22
- Plug Fuses B24

FERRAZ SHAWMUT IS NOW MERSEN

MERSEN

TR-R & TRS-R Time-delay/Class RK5

The industry's most popular fuse for motor circuit protection

With advanced material technology added to the existing product, the Tri-Onic® TR and TRS current-limiting time-delay fuses are engineered for overcurrent protection of motors and transformers, service entrance equipment, feeder and branch circuits. Tri-Onic fuse's proven time-delay characteristic safely handles harmless starting currents and inrush currents associated with today's motors and transformers. Now available with optional SmartSpot® blown fuse indication technology.

Features/Benefits:

- Optional solid state SmartSpot blown fuse indicator
- Time-delay for motor start-ups and transformer inrush currents without nuisance opening
- Current-limiting for low peak let-thru current
- Rejection-style design prevents replacement errors (when used with recommended fuse blocks)
- Easy-to-read label for quick brand recognition and replacement
- Metal-embossed date and catalog number for traceability and lasting identification
- Fiberglass body provides dimensional stability in harsh industrial settings
- High-grade silica filler ensures fast arc quenching and high current limitation

Highlights:

- Time-delay
- Current-limiting
- AC & DC rated

Applications:

- Motor circuits
- Mains
- Feeders
- Branch circuits
- Transformers
- Service entrance equipment
- General-purpose equipment



Ratings:

TR-R

Volts : 250VAC
: 250VDC (.1-2.8A; 35-400A)
: 160VDC (3-30A; 450-600A)

Amps : 1/10 to 600A

IR : 200kA I.R. AC / 20kA I.R. DC

TRS-R

Volts : 600VAC
: 600VDC (.1-12A; 70-600A)
: 300VDC (15-60A)

Amps : 1/10 to 600A

IR : 200kA I.R. AC
: 1/10A to 60A -> 20kA I.R. DC
: 70A to 600A -> 100kA I.R. DC

Approvals:

- UL listed to standard 248-12 File E2137
- CSA certified to standard C22.2 no. 248.12
- DC listed to UL standard 248 TRS only



TR-R & TRS-R Time-delay/Class RK5

Catalog Numbers (amps)

250V			600V		
TR1/10R*	TR3-1/2R*	TR50R	TRS1/10R*	TRS3-1/2R*	TRS50R
TR15/100R*	TR4R*	TR60R	TRS15/100R*	TRS4R*	TRS60R
TR2/10R*	TR4-1/2R*	TR70R	TRS2/10R*	TRS4-1/2R*	TRS70R
TR3/10R*	TR5R*	TR75R*	TRS3/10R*	TRS5R*	TRS75R*
TR4/10R*	TR5-6/10R*	TR80R	TRS4/10R*	TRS5-6/10R*	TRS80R
TR1/2R*	TR6R*	TR90R	TRS1/2R*	TRS6R*	TRS90R
TR6/10R*	TR6-1/4R*	TR100R	TRS6/10R*	TRS6-1/4R*	TRS100R
TR8/10R*	TR7R*	TR110R	TRS8/10R*	TRS7R*	TRS110R
TR1R*	TR8R	TR125R	TRS1R*	TRS8R	TRS125R
TR1-1/8R*	TR9R	TR150R	TRS1-1/8R*	TRS9R	TRS150R
TR1-1/4R*	TR10R	TR175R	TRS1-1/4R*	TRS10R	TRS175R
TR1-4/10R*	TR12R	TR200R	TRS1-4/10R*	TRS12R	TRS200R
TR1-6/10R*	TR15R	TR225R	TRS1-6/10R*	TRS15R	TRS225R
TR1-8/10R*	TR17-1/2R	TR250R	TRS1-8/10R*	TRS17-1/2R	TRS250R
TR2R*	TR20R	TR300R	TRS2R*	TRS20R	TRS300R
TR2-1/4R*	TR25R	TR350R	TRS2-1/4R*	TRS25R	TRS350R
TR2-1/2R*	TR30R	TR400R	TRS2-1/2R*	TRS30R	TRS400R
TR2-8/10R*	TR35R	TR450R	TRS2-8/10R*	TRS35R	TRS450R
TR3R*	TR40R	TR500R	TRS3R*	TRS40R	TRS500R
TR3-2/10R*	TR45R	TR600R	TRS3-2/10R*	TRS45R	TRS600R

Recommended Fuse Blocks With Box Connectors For Tri-Onic® Class RK5 Fuses

Fuse Ampere Rating	Catalog Number			
	250V		600V	
	1-Pole	3-Pole	1-Pole	3-Pole
0-30	20306R	20308R	60306R	60308R
31-60	20606R	20608R	60606R	60608R
61-100	21036R	21038R	61036R	61038R
101-200	22001R	22003R	62001R	62003R
201-400	24001R	24003R	64001R	64003R
401-600	2631R	2633R	6631R	6633R

A variety of pole configurations and termination provisions are available. Refer to Section H for details.

Note: Optional blown fuse visual indication available. To order, place "ID" at the end of the catalog number. Example: #TRS30RID

* Not available with optional blow fuse indicator.

Tin plated end caps are available on Non-ID fuses less than 60A. Example Part # TRP30R, TRSP30R

Dimensions

Ampere Rating	A		B		C		D		E	
	In.	mm	In.	mm	In.	mm	In.	mm	In.	mm
250V-TR Fuses										
0-30	2	51	9/16	14	-	-	-	-	-	-
31-60	3	76	13/16	21	-	-	-	-	-	-
61-100	5-7/8	149	1-1/16	27	1/8	3	3/4	19	1	25
101-200	7-1/8	181	1-9/16	40	3/16	5	1-1/8	28	1-3/8	35
201-400	8-5/8	219	2-1/16	53	1/4	6	1-5/8	41	1-7/8	48
401-600	10-3/8	264	2-9/16	66	1/4	6	2	51	2-1/4	57
600V-TRS Fuses										
0-30	5	127	13/16	21	-	-	-	-	-	-
31-60	5-1/2	139	1-1/16	27	-	-	-	-	-	-
61-100	7-7/8	200	1-5/16	34	1/8	3	3/4	19	1	25
101-200	9-5/8	244	1-13/16	46	3/16	5	1-1/8	28	1-3/8	35
201-400	11-5/8	295	2-9/16	66	1/4	6	1-5/8	41	1-7/8	48
401-600	13-3/8	340	3-1/8	80	1/4	6	2	51	2-1/4	57

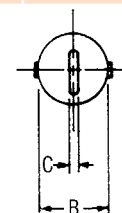
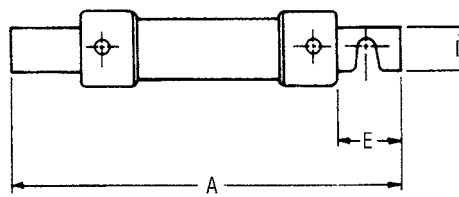
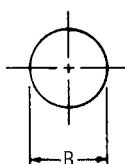
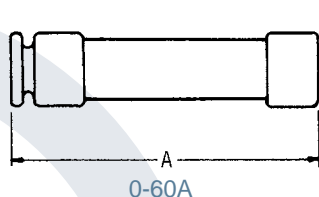

TRS-RDC Time-delay/Class RK5

DC Rated for tough DC applications

The Tri-Onic® DC fuse series is designed for DC circuit protection in surface and underground mines. The TRS-RDC is MSHA approved and meets the industry's most severe third party requirements for 600VDC rated fuses. The TRS-RDC is a time-delay fuse with essentially the same time-current characteristic as the standard Tri-Onic fuse.

Features/Benefits:

- DC rated for mine duty and other long time-constant applications
- Time-delay for motor start-ups and high inrush loads without nuisance opening
- Rugged glass melamine body for superior reliability in harsh environments

Highlights:

- Time-delay
- DC rated

Applications:

- Mine circuits
- Trailing cables
- Pump motors
- Rail heaters



Ratings:

Volts : 300VDC (0.1 to 30A)
: 600VDC (35 to 400A)

Amps : 1/10 to 400A

IR : 20kA I.R. DC

**consult factory for availability*

Approvals:

- MSHA approval no. 28-26-0

TRS-RDC Time-delay/Class RK5

Catalog Numbers (amps)

TRS1/10RDC	TRS1-1/4RDC	TRS3-1/2RDC	TRS12RDC	TRS70RDC
TRS15/100RDC	TRS1-4/10RDC	TRS4RDC	TRS15RDC	TRS80RDC
TRS2/10RDC	TRS1-6/10RDC	TRS4-1/2RDC	TRS17-1/2RDC	TRS90RDC
TRS3/10RDC	TRS1-8/10RDC	TRS5RDC	TRS20RDC	TRS100RDC
TRS4/10RDC	TRS2RDC	TRS5-6/10RDC	TRS30RDC	TRS125RDC
TRS1/2RDC	TRS2-1/4RDC	TRS6RDC	TRS35RDC	TRS150RDC
TRS6/10RDC	TRS2-1/2RDC	TRS6-1/4RDC	TRS40RDC	TRS175RDC
TRS8/10RDC	TRS2-8/10RDC	TRS8RDC	TRS45RDC	TRS200RDC
TRS1RDC	TRS3RDC	TRS9RDC	TRS50RDC	TRS250RDC
TRS1-1/8RDC	TRS3-2/10RDC	TRS10RDC	TRS60RDC	TRS300RDC
				TRS400RDC

Recommended Fuse Blocks With Box Connectors For Tri-Onic® Class RK5 Fuses

Fuse Ampere Rating	Catalog Number			
	250V		600V	
	1-Pole	3-Pole	1-Pole	3-Pole
0-30	20306R	20308R	60306R	60308R
31-60	20606R	20608R	60606R	60608R
61-100	21036R	21038R	61036R	61038R
101-200	22001R	22003R	62001R	62003R
201-400	24001R	24003R	64001R	64003R

A variety of pole configurations and termination provisions are available. Refer to Section H for details.

Dimensions

Ampere Rating	A		B		C		D		E	
	In.	mm	In.	mm	In.	mm	In.	mm	In.	mm
0-30	5	127	13/16	21	-	-	-	-	-	-
31-60	5-1/2	139	1-1/16	27	-	-	-	-	-	-
61-100	7-7/8	200	1-5/16	34	1/8	3	3/4	19	1	25
101-200	9-5/8	244	1-13/16	46	3/16	5	1-1/8	28	1-3/8	35
201-400	11-5/8	295	2-9/16	66	1/4	6	1-5/8	41	1-7/8	48

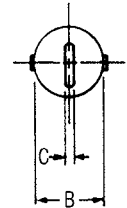
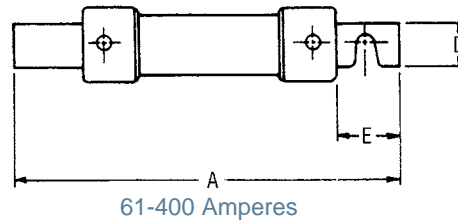
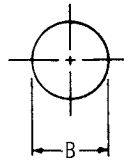
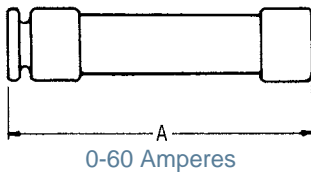

HSJ High Speed/Class J

Protect your wiring and power semiconductors with a single fuse

The High Speed J (HSJ) fuse combines the low I^2t of a semiconductor fuse and the branch circuit performance of a Class J UL listed fuse. This fuse was designed for the starting characteristics of solid state motor controllers. The HSJ can provide branch circuit protection per NEC requirements, as well as very low I^2t for protection of power semiconductors such as Diodes, SCR's, GTO's and SSR's.

Features/Benefits:

- Optimized over-load capability for withstanding elevated levels of current during electronic motor controller starts
- Low I^2t (low thermal energy)
- Excellent cycling ability for frequent starts/stops without nuisance opening

Highlights:

- Current-limiting
- AC & DC ratings
- Low I^2t
- Compact size

Applications:

- Branch circuits
- Control panels
- Electronic motor controllers
- Phase controllers
- Drives
- Soft-starters
- Solid state relays



Ratings:

Volts : 600VAC
: 500VDC

Amps : 1 to 600A (AC)
: 15 to 600A (DC)

IR : 200kA I.R. AC
: 100kA I.R. DC
: L/R =10mS or less

(Self Certified for 600VAC, 300kA I.R., UL witnessed.)

Approvals:

- UL listed to standard 248-8 File E2137
- CSA certified to standard C22.2 no. 248.8
- DC listed to UL 248



HSJ High Speed/Class J

Catalog Numbers (amps)

HSJ1	HSJ90
HSJ3	HSJ100
HSJ6	HSJ110
HSJ10	HSJ125
HSJ15	HSJ150
HSJ17-1/2	HSJ175
HSJ20	HSJ200
HSJ25	HSJ225
HSJ30	HSJ250
HSJ35	HSJ300
HSJ40	HSJ350
HSJ45	HSJ400
HSJ50	HSJ450
HSJ60	HSJ500
HSJ70	HSJ600
HSJ80	

Recommended Fuse Blocks With Box Connectors for Amp-Trap® Class J Fuses

Fuse Ampere Rating	Catalog Number 600V or Less	
	1-Pole	3-Pole
0-30	US3J1I	US3J3I
31-60	US6J1I	US6J3I
61-100	61036J	61038J
101-200	62001J	62003J
201-400	64031J	64033J
401-600	6631J	6633J

A variety of pole configurations and termination provisions are available. Refer to Section H for details.

Dimensions

Ampere Rating	A		B		C		D		E		F		G		H	
	in	mm	in	mm	in	mm	in	mm	in	mm	in	mm	in	mm	in	mm
1-30	2-1/4	57	13/16	21	-	-	-	-	-	-	-	-	-	-	-	-
31-60	2-3/8	60	1-1/16	27	-	-	-	-	-	-	-	-	-	-	-	-
61-100	4-4/8	117	1-1/8	29	1/8	3.2	3/4	19	1	25	3-5/8	92	3/8	10	9/32	7
101-200	5-3/4	146	1-5/8	41	3/16	4.8	1-1/8	29	1-3/8	35	4-3/8	111	3/8	10	9/32	7
201-400	7-1/8	181	2-1/8	54	1/4	6.3	1-5/8	41	1-7/8	48	5-1/4	133	17/32	13	13/32	10
401-600	8	203	2-1/2	64	3/8	9.5	2	51	2-1/8	54	6	152	11/16	18	17/32	13

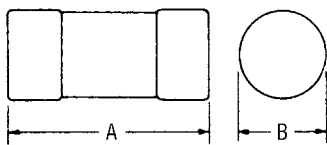

1-60A

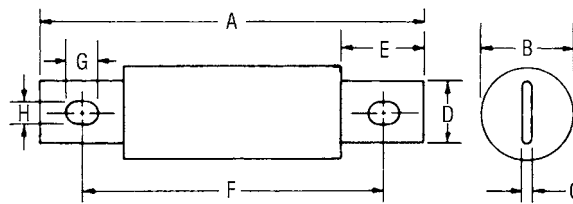

61-600A

A4J Fast Acting/Class J

For excellent current-limiting protection

A4J Class J fuses deliver excellent current-limiting protection to a wide variety of applications. Their unique dimensions prevent the substitution of other fuses with lower voltage ratings, interrupting ratings, or current-limiting capability.

Features/Benefits:

- High current limitation for low peak let-thru current
- Unique dimensions prevent replacement by other fuse classes
- Fiberglass body provides dimensional stability in harsh industrial environments
- Easy-to-read imprint label for quick recognition and replacement

Highlights:

- Fast-acting
- Very current-limiting
- DC ratings

Applications:

- Capacitors
- Load centers
- Panelboards
- Switchboards
- Bus duct
- Feeder circuits
- Circuit breakers
- Lighting, heating, and general loads



Ratings:

Volts	: 600VAC
	: 300VDC
Amps	: 1 to 600A
IR	: 200kA I.R. AC
	: 100kA I.R. DC

Approvals:

- UL listed to standard 248-8 File E2137
- CSA certified to standard C22.2 no. 248.8
- DC listed to UL 248
- IEC 269-2-1



A4J Fast Acting/Class J

Catalog Numbers (amps)

A4J1	A4J50	A4J200
A4J3	A4J60	A4J225
A4J6	A4J70	A4J250
A4J10	A4J75	A4J300
A4J15	A4J80	A4J350
A4J20	A4J90	A4J400
A4J25	A4J100	A4J450
A4J30	A4J110	A4J500
A4J35	A4J125	A4J600
A4J40	A4J150	
A4J45	A4J175	

Recommended Fuse Blocks With Box Connectors for Amp-Trap® Class J Fuses

Fuse Ampere Rating	Catalog Number 600V or Less	
	1-Pole	3-Pole
0-30	US3J1I	US3J3I
31-60	US6J1I	US6J3I
61-100	61036J	61038J
101-200	62001J	62003J
201-400	64031J	64033J
401-600	6631J	

A variety of pole configurations and termination provisions are available. Refer to Section H for details.

Dimensions

Ampere Rating	A		B		C		D		E		F		G		H	
	in	mm	in	mm	in	mm	in	mm	in	mm	in	mm	in	mm	in	mm
1-30	2-1/4	57	13/16	21	-	-	-	-	-	-	-	-	-	-	-	-
31-60	2-3/8	60	1-1/16	27	-	-	-	-	-	-	-	-	-	-	-	-
61-100	4-4/8	117	1-1/8	29	1/8	3.2	3/4	19	1	25	3-5/8	92	3/8	10	9/32	7
101-200	5-3/4	146	1-5/8	41	3/16	4.8	1-1/8	29	1-3/8	35	4-3/8	111	3/8	10	9/32	7
201-400	7-1/8	181	2-1/8	54	1/4	6.3	1-5/8	41	1-7/8	48	5-1/4	133	17/32	13	13/32	10
401-600	8	203	2-1/2	64	3/8	9.5	2	51	2-1/8	54	6	152	11/16	18	17/32	13

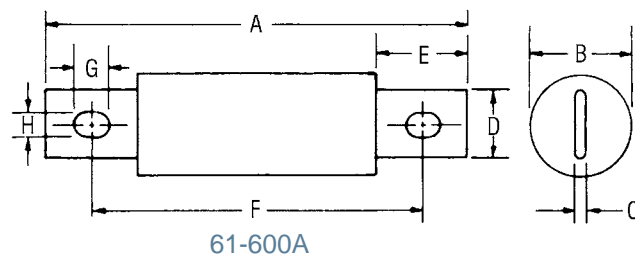
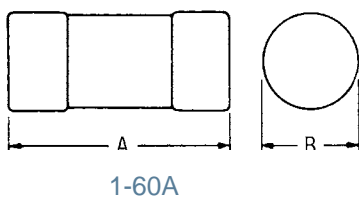

A4BY Class L

Count on the high interrupting rating of our most widely used class L fuse

When it comes to protecting service entrance equipment, feeder circuits, and circuit breakers, A4BY fuses are the industry's favorite. The A4BY is a 100% rated device and may be applied at continuous currents up to its ampere rating. A 4-second minimum time-delay at 500% rating allows the A4BY to pass normal current surges and to coordinate with ground fault relays.

Features/Benefits:

- Unique dimensions prevent replacement by other fuse classes
- Blade stamped catalog numbers for permanent identification
- Glass melamine body and plated terminals provide superior reliability in harsh environments

Highlights:

- Current-limiting
- 4-second time-delay
- DC ratings
- Uniform characteristics in all ampere ratings

Applications:

- Mains, feeders
- Circuit breakers
- Load centers
- Panelboards
- Switchboards
- Metering centers



Ratings:

- Volts** : 600VAC
: 300VDC
- Amps** : 200 to 6,000A (AC)
: 200 to 2,500A (DC)
- IR** : 200kA I.R. AC
: 100kA I.R. DC

Approvals:

- UL listed to standard 248-10 (601-6000A) File E2137
- CSA certified to standard C22.2 No. 248.10 (601-6000A)
- Self-certified for DC per UL248 (601-6000A)



A4BY Class L

Catalog Numbers (amps)

A4BY200	A4BY801	A4BY2000
A4BY250	A4BY900	A4BY2001
A4BY300	A4BY1000	A4BY2200
A4BY350	A4BY1100	A4BY2500
A4BY400	A4BY1200	A4BY3000
A4BY450	A4BY1201	A4BY3001
A4BY500	A4BY1350	A4BY3500
A4BY600	A4BY1400	A4BY4000
A4BY601	A4BY1500	A4BY4001
A4BY650	A4BY1600	A4BY4500
A4BY700	A4BY1601	A4BY5000
A4BY750	A4BY1800	A4BY6000
A4BY800		

Recommended Fuse Blocks for Amp-Trap® Class L Fuses

Fuse Ampere Rating	Catalog Number 600V or Less 3-Pole
100-800	P48F
801-1200	P412F

Catalog number P48F is UL recognized
Catalog number P412F is self-certified

A variety of pole configurations and termination provisions are available. Refer to Section H for details.

Note: For optional blown fuse trigger indicator add "-TI" to the end of part number.
Example: A4BY1600-TI. Consult factory for availability.

Dimensions

Ampere Rating	A		B		C		D		E	
	in	mm	in	mm	in	mm	in	mm	in	mm
200-600	8-5/8	219	2	51	5/16	8	1-5/8	41	2-13/32	61
601-800	8-5/8	219	2-1/2	63	3/8	9	2	51	2-13/32	61
801-1200	10-3/4	273	2-1/2	63	3/8	9	2	51	3-15/32	88
1201-1600	10-3/4	273	3	76	7/16	11	2-3/8	60	3-15/32	88
1601-2000	10-3/4	273	3-1/2	89	1/2	13	2-3/4	70	3-15/32	88
2001-2500	10-3/4	273	4-1/2	114	3/4	19	3-1/2	89	3-15/32	88
2501-3000	10-3/4	273	5	127	3/4	19	4	102	3-15/32	88
3001-4000	10-3/4	273	5-3/4	146	3/4	19	4-3/4	121	3-15/32	88
4001-5000	10-3/4	273	6-1/4	159	1	25	5-1/4	133	3-15/32	88
5001-6000	10-3/4	273	7-1/8	181	1	25	5-3/4	146	3-15/32	88

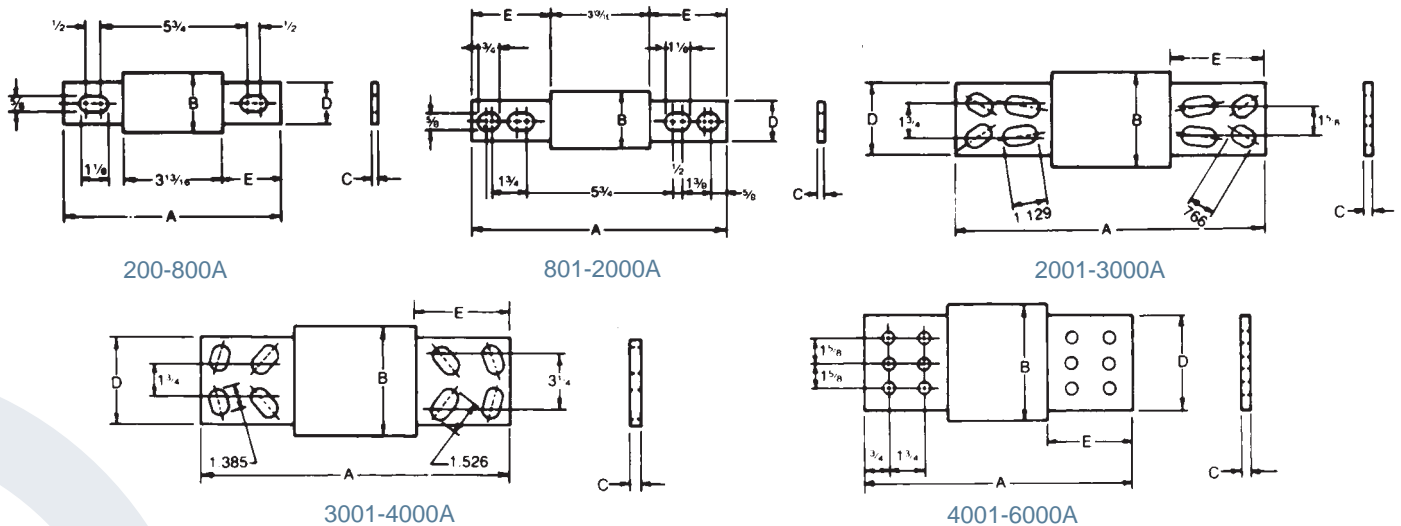

A4BT Time-delay/Class L

When your heavier loads need protection A4BT fuses won't let you down

The high interrupting rating of A4BT current-limiting fuses is ideally suited for protecting mains, feeders, and general circuits. The 10-second time-delay at 500% of fuse rating is ideal for large motors and other loads with a high inrush. A4BT fuses are suitable for DC applications up to 500VDC. An A4BT fuse can be applied to normal loads up to its full ampere rating to allow 100% rating of equipment, while also providing superior current-limiting ability.

Features/Benefits:

- Unique dimensions prevent replacement by other fuse classes.
- Blade-stamped catalog numbers for permanent identification
- Glass melamine body and plated terminals provide superior reliability in harsh environments

Highlights:

- Current-limiting
- Full 10-second delay
- DC ratings
- Uniform characteristics in all ampere ratings

Applications:

- Motors
- Motor controllers
- Transformers
- Mains
- Feeders



Ratings:

Volts	: 600VAC
	: 500VDC
Amps	: 200 to 2,000A
IR	: 200kA I.R. AC
	: 100kA I.R. DC

Approvals:

- UL Listed to standard 248-10 (601-2000A) File E2137
- CSA Certified to standard C22.2 No. 248.10 (601-2000A)
- Self-certified for DC per UL248 (601-2000)



A4BT Time-delay/Class L

Catalog Numbers (amps)

A4BT200	A4BT601	A4BT1100
A4BT250	A4BT650	A4BT1200
A4BT300	A4BT700	A4BT1400
A4BT350	A4BT750	A4BT1500
A4BT400	A4BT800	A4BT1600
A4BT450	A4BT900	A4BT1800
A4BT500	A4BT1000	A4BT2000
A4BT600		

Recommended Fuse Blocks for Amp-Trap® Class L Fuses

Fuse Ampere Rating	Catalog Number 600V or Less 3-Pole
100-800	P48F
801-1200	P412F

Catalog number P48F is UL recognized
Catalog number P412F is self-certified

A variety of pole configurations and termination provisions are available. Refer to Section H for details.

Dimensions

Ampere Rating	A		B		C		D		E	
	in	mm	in	mm	in	mm	in	mm	in	mm
200-600	8-5/8	219	2	51	5/16	8	1-5/8	41	2-13/32	61
601-800	8-5/8	219	2-1/2	63	3/8	9	2	51	2-13/32	61
801-1200	10-3/4	273	2-1/2	63	3/8	9	2	51	3-15/32	88
1201-1600	10-3/4	273	3	76	7/16	11	2-3/8	60	3-15/32	88
1601-2000	10-3/4	273	3-1/2	89	1/2	13	2-3/4	70	3-15/32	88

Safety Note: Class L fuses are dimensioned for one-way interchangeability.

A Class L fuse of any lower ampere rating can be substituted for a given Class L fuse.

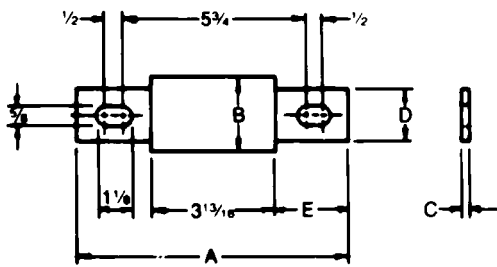

200-800A

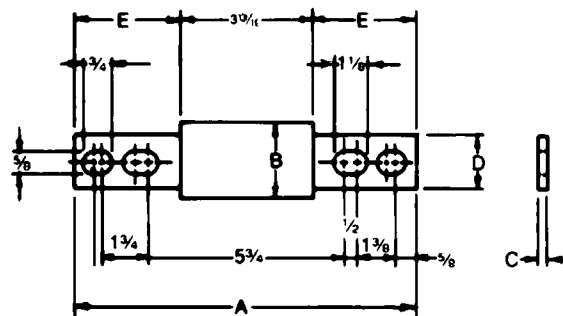

801-2000A

A3T & A6T Fast Acting/Class T

These small dimension fuses are the right fit... for a tight fit

Fast-acting A3T and A6T Class T fuses combine two highly desirable features - high current limitation and a small physical size. Their unique dimensions prevent the substitution of other fuses with lower voltage ratings or current-limiting capability. These fuses have glass melamine bodies for superior dimensional stability and catalog numbers stamped into the blades for permanent identification.

Features/Benefits:

- Extremely current-limiting for low peak let-thru current
- Unique dimensions prevent replacement by other fuse classes
- Blade-stamped catalog numbers for permanent identification
- Small physical size for greater design flexibility

Highlights:

- Fast-acting
- Extremely current-limiting
- Small physical size
- DC ratings

Applications:

- Loadcenters
- Panelboards
- Switchboards
- Circuit breakers
- Metering centers



Ratings:

A3T

Volts : 300VAC / 160VDC
Amps : 1 to 1200A
IR : 200kA I.R. AC
: 50kA I.R. DC

A6T

Volts : 600VAC / 300VDC
Amps : 1 to 800A
IR : 200kA I.R. AC
: 100kA I.R. DC

Approvals:

- UL listed to standard 248-15 File E2137
- CSA certified to standard C22.2 no. 248.15
- DC listed to UL standard 248



A3T & A6T Fast Acting/Class T

Catalog Numbers (amps)

300V			600V		
A3T1	A3T60	A3T300	A6T1	A6T60	A6T300
A3T3	A3T70	A3T350	A6T3	A6T70	A6T350
A3T6	A3T80	A3T400	A6T6	A6T80	A6T400
A3T10	A3T90	A3T450	A6T10	A6T90	A6T450
A3T15	A3T100	A3T500	A6T15	A6T100	A6T500
A3T20	A3T110	A3T600	A6T20	A6T110	A6T600
A3T25	A3T125	A3T700	A6T25	A6T125	A6T700
A3T30	A3T150	A3T800	A6T30	A6T150	A6T800
A3T35	A3T175	A3T1000	A6T35	A6T175	
A3T40	A3T200	A3T1200	A6T40	A6T200	
A3T45	A3T225		A6T45	A6T225	
A3T50	A3T250		A6T50	A6T250	

Recommended Fuse Blocks With Box Connectors for Amp-Trap® Class T Fuses

Ampere Rating	Catalog Number			
	300V		600V	
	1-Pole	3-Pole	1-Pole	3-Pole
1-30	30306T	30308T	60306T	60308T
31-60	30606T	30608T	60606T	60608T
61-100	31001T	31003T	61031T	61033T
101-200	32031T	32033T	62031T	62033T
201-400	34031T	34033T	64031T	-
401-600	36031T	-	66031T	-

A variety of pole configurations and termination provisions are available. Refer to Section H for details.

Dimensions

Ampere Rating	A		B		C		D		E		F		G	
	in	mm	in	mm	in	mm	in	mm	in	mm	in	mm	in	mm
300V-A3T Fuses														
1-30	.88	22.4	.41	10.3	-	-	-	-	-	-	-	-	-	-
31-60	.88	22.4	.56	14.1	-	-	-	-	-	-	-	-	-	-
61-100	2.16	54.9	.81	20.6	.12	3.2	.75	19.0	1.56	39.6	.28	7.1	.82	20.8
101-200	2.44	62.0	1.06	26.9	.19	4.8	.88	22.4	1.70	43.2	.34	8.6	.83	21.1
201-400	2.75	69.8	1.33	33.8	.25	6.4	1.00	25.4	1.84	46.7	.41	10.4	.84	21.3
401-600	3.06	77.7	1.62	41.1	.31	7.8	1.25	31.8	2.03	51.6	.48	12.2	.84	21.3
601-800	3.38	85.8	2.08	52.8	.38	9.7	1.75	44.4	2.22	56.4	.55	14.0	.88	22.4
801-1200	4.00	102	2.52	64.0	.44	11.2	2.00	50.8	2.53	64.3	.61	15.5	1.03	26.2
600V-A6T Fuses														
1-30	1.50	38.1	.57	14.5	-	-	-	-	-	-	-	-	-	-
31-60	1.57	39.9	.81	20.6	1.51	38.4	1.00	25.4	-	-	-	-	-	-
61-100	2.95	75.0	.82	20.8	.12	3.2	.75	19.0	2.35	59.7	.28	7.1	1.58	40.1
101-200	3.26	82.8	1.07	27.2	.19	4.8	.88	22.4	2.51	63.7	.34	8.6	1.61	41.0
201-400	3.62	92.1	1.62	41.3	.25	6.4	1.00	25.4	2.72	69.1	.41	10.4	1.70	43.2
401-600	3.98	101.2	2.06	52.4	.31	7.9	1.25	31.8	2.95	75.0	.48	12.2	1.70	43.2
601-800	4.33	110.0	2.50	63.5	.37	9.5	1.75	44.4	3.17	80.5	.56	14.1	1.70	43.2

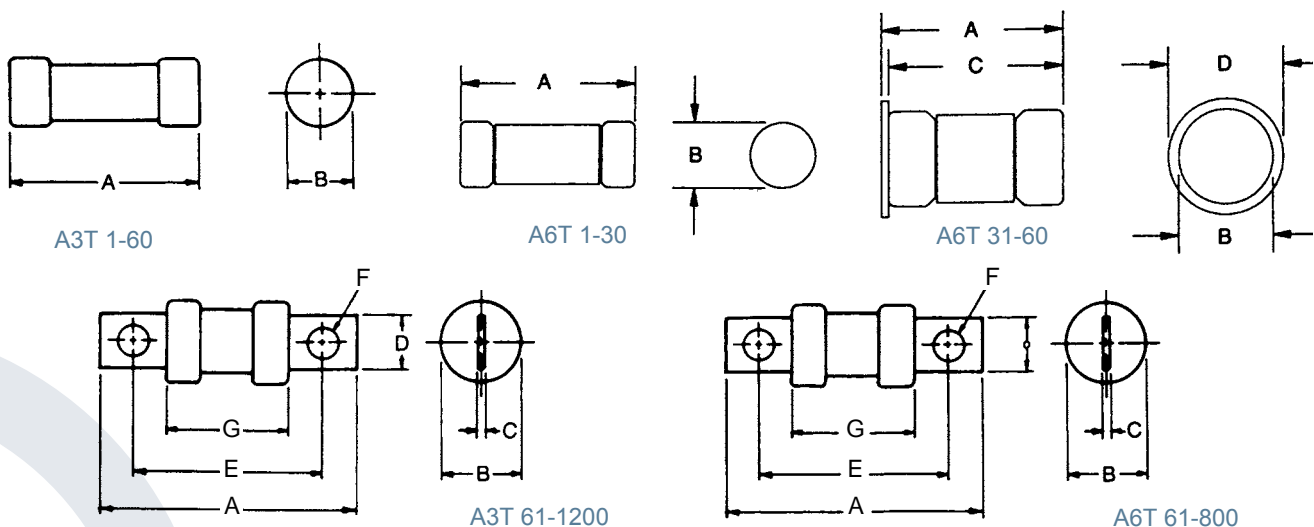

A2K-R & A6K-R Fast Acting/Class RK1

These fast-acting fuses deliver a high degree of current limitation where you need it most

Current-limiting A2K and A6K fuses provide excellent protection where high available short circuit currents exist. These fast-acting fuses are particularly good for branch/feeder circuits and back-up protection.

Features/Benefits:

- Rejection style design prevents replacement by other fuse classes
- Fiberglass body provides dimensional stability in harsh industrial environments
- Easy-to-read imprint label for quick recognition and replacement
- High degree of current limitation for low peak let-thru current

Highlights

- Highly current-limiting
- Fast-acting
- Rejection style

Applications:

- Loadcenters
- Panelboards
- Switchboards
- Bus duct
- Feeder circuits
- Non-inductive loads
- Lighting circuits



Ratings:

A2K

Volts : 250VAC / DC
Amps : 1 to 600A
IR : 200kA I.R. AC
: 20kA I.R. DC

A6K

Volts : 600VAC / 300VDC
Amps : 1 to 600A
IR : 200kA I.R. AC
: 20kA I.R. DC

Approvals:

- UL listed to standard 248-12 File E2137
- CSA certified to standard C22.2 No. 248.12
- Self-certified for DC per UL248



A2K-R & A6K-R Fast Acting/Class RK1

Catalog Numbers (amps)

250V			600V		
A2K1R	A2K35R	A2K175R	A6K1R	A6K35R	A6K175R
A2K3R	A2K40R	A2K200R	A6K3R	A6K40R	A6K200R
-	A2K45R	A2K225R	A6K4R	A6K45R	A6K225R
A2K5R	A2K50R	A2K250R	A6K5R	A6K50R	A6K250R
A2K6R	A2K60R	A2K300R	A6K6R	A6K60R	A6K300R
-	A2K70R	A2K350R	A6K8R	A6K70R	A6K350R
A2K10R	A2K80R	A2K400R	A6K10R	A6K80R	A6K400R
A2K15R	A2K100R	A2K500R	A6K15R	A6K100R	A6K500R
A2K20R	A2K110R	A2K600R	A6K20R	A6K110R	A6K600R
A2K25R	A2K125R		A6K25R	A6K125R	
A2K30R	A2K150R		A6K30R	A6K150R	

Recommended Fuse Blocks With Box Connectors For Amp-Trap® Class RK1 Fuses

Fuse Ampere Rating	Catalog Number			
	250V		600V	
	1-Pole	3-Pole	1-Pole	3-Pole
0-30	20306R	20308R	60306R	60308R
31-60	20606R	20608R	60606R	60608R
61-100	21036R	21038R	61036R	61038R
101-200	22001R	22003R	62001R	62003R
201-400	24001R	24003R	64001R	64003R
401-600	2631R	2633R	6631R	6633R

A variety of pole configurations and termination provisions are available. Refer to Section H for details.

Dimensions

Ampere Rating	A		B		C		D		E	
	in	mm	in	mm	in	mm	in	mm	in	mm
250V-A2K Fuses										
0-30	2	51	9/16	14	-	-	-	-	-	-
31-60	3	76	13/16	21	-	-	-	-	-	-
61-100	5-7/8	149	1-1/16	27	1/8	3	3/4	19	1	25
101-200	7-1/8	181	1-9/16	40	3/16	5	1-1/8	28	1-3/8	35
201-400	8-5/8	219	2-1/16	53	1/4	6	1-5/8	41	1-7/8	48
401-600	10-3/8	264	2-9/16	66	1/4	6	2	51	2-1/4	57
600V-A6K Fuses										
0-30	5	127	13/16	21	-	-	-	-	-	-
31-60	5-1/2	139	1-1/16	27	-	-	-	-	-	-
61-100	7-7/8	200	1-5/16	34	1/8	3	3/4	19	1	25
101-200	9-5/8	244	1-13/16	46	3/16	5	1-1/8	28	1-3/8	35
201-400	11-5/8	295	2-9/16	66	1/4	6	1-5/8	41	1-7/8	48
401-600	13-3/8	340	3-1/8	80	1/4	6	2	51	2-1/4	57

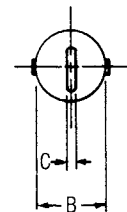
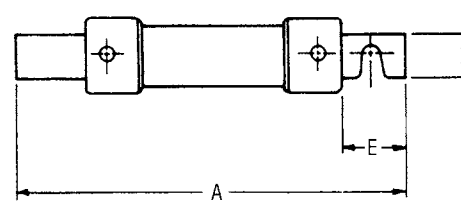
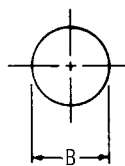
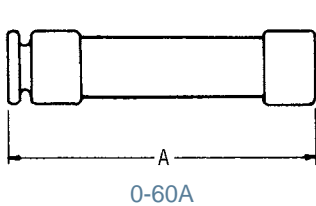

AG Class G

Amp-Trap® AG fuses fit right in to a wide variety of industrial applications

The Mersen Amp-Trap AG fuse series is a complete line of Class G fuses. AG fuses safely fit a wide variety of applications. Class G fuses are made in four physical sizes and provide superior branch-circuit protection for lighting, heating, and appliance circuits.

Features/Benefits:

- Four unique sizes from 1/2-60 amperes do not allow inter-changeability with other fuse classes
- Fiberglass bodies provide dimensional stability in harsh industrial settings

Highlights:

- Current-limiting
- Time-delay (above 5A)

Applications:

- Lighting
- Heating*
- Appliances

**except in Canada where fuses must be "P" or "D" type.*

Catalog Numbers (amps)

AG1/2	AG15
AG1	AG20
AG1-1/2	AG25
AG2	AG30
AG3	AG35
AG4	AG40
AG5	AG45
AG6	AG50
AG8	AG60
AG10	

Dimensions

Ampere Rating	A		B		C	
	in	mm	in	mm	in	mm
1/2-15A	1.31	33.3	.406	10.3	.28	7.1
20A	1.41	35.8	.406	10.3	.28	7.1
25, 30A	1.62	41.2	.406	10.3	.28	7.1
35-60A	2.25	57.2	.406	10.3	.50	

Cross Reference: AG will replace the following fuses: Bussmann SC, Littelfuse SLC

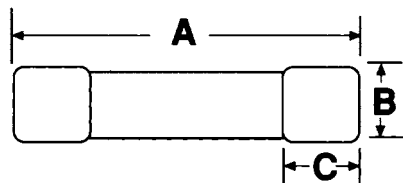

Ratings:

Volts	: 600VAC (1/2 to 20A)
	: 480VAC (25 to 60A)
Amps	: 1/2 to 60A
IR	: 100kA I.R. AC

Approvals:

- UL listed to standard 248-5 File E2137
- CSA certified to standard C22.2 No. 248.5



ATMR Fast Acting/Class CC

Small fuse - big protection for general circuits

Amp-Trap® ATMR fuses, in the Class CC family, are the smallest dimension 600VAC/DC fuses suitable for branch circuit protection. The ATMR is a popular choice for economical protection of control circuits and control circuit transformers where available short circuit currents exceed 10,000 amperes. ATMR's rejection dimensions prevent substitution by lesser rated fuses. These fast acting fuses give current-limiting protection to general circuits.

Features/Benefits:

- Rejection-style design prevents replacement errors when used with recommended fuse blocks
- Versatile design for individual component and branch circuit protection

Highlights:

- Fast-acting
- Very current-limiting

Applications:

- Control circuits
- Lighting
- General loads
- Branch circuit protection

Catalog Numbers (amps)

ATMR1/10	ATMR3-1/2
ATMR1/8	ATMR4
ATMR2/10	ATMR5
ATMR1/4	ATMR6
ATMR3/10	ATMR7
ATMR1/2	ATMR8
ATMR3/4	ATMR9
ATMR1	ATMR10
ATMR1-1/4	ATMR12
ATMR1-1/2	ATMR15
ATMR2	ATMR20
ATMR2-1/2	ATMR25
ATMR3	ATMR30

Dimensions

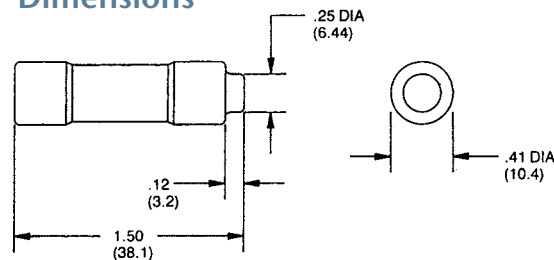

Ratings:

Volts : 600VAC / DC
Amps : 1/10 to 30A
IR : 200kA 1.R. AC
: 100kA 1.R. DC

Approvals:

- UL Listed to Standard 248-4 File E2137
- CSA Certified to Standard C22.2 No. 248.4
- DC listed to UL Standard 248



Recommended Fuse Blocks For Amp-Trap® Class CC Fuses

Number of Poles	UltraSafe™ Indicating Fuse Holders	Screw Connector with Double Quick Connects	Pressure Plate Connector with Double Quick Connects	Cooper Box Connector
Adder		30310R	30320R	30350R
1	USCC1I	30311R	30321R	30351R
2	USCC2I	30312R	30322R	30352R
3	USCC3I	30313R	30323R	30353R
3	USFMCCI			

A variety of pole configurations and termination provisions are available. Refer to Section H for details.

OT/OTN/OTS Class K-5

For versatility and economy, these general purpose fuses are hard to beat

OT, OTN and OTS general purpose fuses provide low cost protection for feeder and branch circuits serving lighting, heating, and other non-motor loads. OT, OTN and OTS fuses will safely interrupt available short circuit currents up to 50,000 amperes in all ratings. OT, OTN and OTS fuses are not rejection fuses – care should be taken to ensure that replacement fuses do not have lower interrupting ratings than original fuses. OTN 15 through 60 satisfy the Canadian electrical code requirement for Type “P,” low melting-point, non-time-delay fuses.

Features/Benefits:

- Easy to read imprint label for quick recognition and replacement
- Low cost for high protection value

Highlights:

- Versatile
- Lowest cost protection for circuits serving non-inductive loads

Applications:

- Feeders
- Branch circuits
- Resistive heating
- Residential and small commercial installations



Ratings:

OT

Volts : 250VAC / DC
Amps : 1 to 600A
IR : 50kA I.R. AC
: 20kA I.R. DC

OTN (Canada)*

Volts : 250VAC
Amps: : 15 to 60A
IR : 50kA I.R. AC

OTS

Volts : 600VAC / 300VDC
Amps : 1 to 600A
IR : 50kA I.R. AC
: 20kA I.R. DC

Approvals:

- UL Listed to Standard 248-9 File E2137
- CSA Certified to Standard C22.2 No. 248.9*
- Self-certified for DC per UL248

*The Canadian Electrical Code requires these fuses in ratings 15 through 60A to be of the low melting point design use OTN 15-60.



OT/OTN/OTS Class K-5

Catalog Numbers (amps)

250V			600V		
OT1	OT30, OTN30*	OT125	OTS1	OTS30	OTS125
OT2	OT35, OTN35*	OT150	OTS2	OTS35	OTS150
OT3	OT40, OTN40*	OT175	OTS3	OTS40	OTS175
OT4	OT45, OTN45*	OT200	OTS4	OTS45	OTS200
OT5	OT50, OTN50*	OT225	OTS5	OTS50	OTS225
OT6	OT60, OTN60*	OT250	OTS6	OTS60	OTS250
OT7	OT65	OT300	-	-	OTS300
OT8	OT70	OT350	OTS8	OTS70	OTS350
OT10	OT75	OT400	OTS10	OTS75	OTS400
OT12	OT80	OT450	OTS12	OTS80	OTS450
OT15, OTN15*	OT90	OT500	OTS15	OTS90	OTS500
OT20, OTN20*	OT100	OT600	OTS20	OTS100	OTS600
OT25, OTN25*	OT110		OTS25	OTS110	

* In Canada

Recommended Fuse Blocks With Box Connectors For One-Time Class K-5 Fuses

Ampere Fuse Rating	Catalog Number			
	250V		600V	
	1-Pole	3-Pole	1-Pole	3-Pole
0-30	20306	20308	60306	60308
31-60	20606	20608	60606	60608
61-100	21036	21038	61036	61038
101-200	22001	22003	62001	62003
201-400	24001	24003	64001	64003
401-600	2631	2633	6631	6633

A variety of pole configurations and termination provisions are available. Refer to Section H for details.

Dimensions

Ampere Rating	A		B		C		D		E	
	in	mm	in	mm	in	mm	in	mm	in	mm
250V-OT, OTN Fuses										
0-30	2	51	9/16	14	-	-	-	-	-	-
31-60	3	76	13/16	21	-	-	-	-	-	-
61-100	5-7/8	149	1-1/16	27	1/8	3	3/4	19	1	25
101-200	7-1/8	181	1-9/16	40	3/16	5	1-1/8	28	1-3/8	35
201-400	8-5/8	219	2-1/16	53	1/4	6	1-5/8	41	1-7/8	48
401-600	10-3/8	264	2-9/16	66	1/4	6	2	51	2-1/4	57
600V-OTS Fuses										
0-30	5	127	13/16	21	-	-	-	-	-	-
31-60	5-1/2	139	1-1/16	27	-	-	-	-	-	-
61-100	7-7/8	200	1-5/16	34	1/8	3	3/4	19	1	25
101-200	9-5/8	244	1-13/16	46	3/16	5	1-1/8	28	1-3/8	35
201-400	11-5/8	295	2-9/16	66	1/4	6	1-5/8	41	1-7/8	48
401-600	13-3/8	340	3-1/8	80	1/4	6	2	51	2-1/4	57

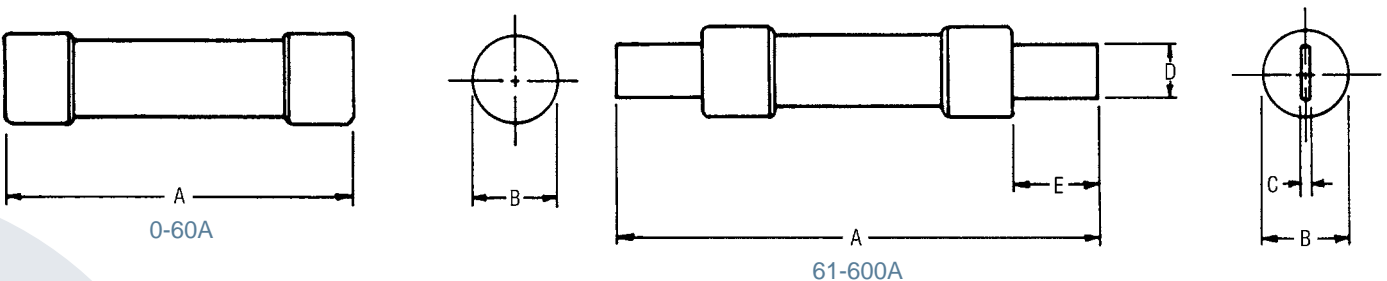

RF/RFS Class H

Traditional protection for circuits with less than 10,000A

RF and RFS general purpose fuses are suitable for applications where available short circuit currents do not exceed 10,000 amperes. RF and RFS renewable fuses use matched RL and RLS die-cut zinc links from 1 to 600 amperes in 32 ratings.

Features/Benefits:

- Knurled bushings for ease of disassembly
- Rugged construction for maximum service life
- Precision die-cut renewal links renew quickly and give repeatable performance

Highlights:

- Renewable
- 32 Renewable link ratings

Applications:

- General purpose loads where short circuits are 10,000 amperes or less

Safety note:

Class H fuses of the renewable type shall be permitted to be used only for replacement in existing installations where there is no evidence of overfusing or tampering (NFPA 70, Article 240.60 (D)).



Ratings:

RF

Volts : 250VAC
Amps : 1 to 600A
IR : 10kA I.R. AC

RFS

Volts : 600VAC
Amps : 1 to 600A
IR : 10kA I.R. AC

Approvals:

- UL listed to standard 248-7 File E2137
- CSA certified to standard C22.2 no. 248.7



RF/RFS Class H

Catalog Numbers (amps)

250V			600V		
RF1/RL1	RF45/RL45	RF225/RL225	RFS1/RLS1	RFS45/RLS45	RFS225/RLS225
RF2/RL2	RF50/RL50	RF250/RL250	RFS2/RLS2	RFS50/RLS50	RFS250/RLS250
RF3/RL3	RF60/RL60	RF300/RL300	RFS3/RLS3	RFS60/RLS60	RFS300/RLS300
RF5/RL5	RF70/RL70	RF350/RL350	RFS5/RLS5	RFS70/RLS70	RFS350/RLS350
RF6/RL6	RF80/RL80	RF400/RL400	RFS6/RLS6	RFS80/RLS80	RFS400/RLS400
RF10/RL10	RF90/RL90	RF450/RL450	RFS10/RLS10	RFS90/RLS90	RFS450/RLS450
RF15/RL15	RF100/RL100	RF500/RL500	RFS15/RLS15	RFS100/RLS100	RFS500/RLS500
RF20/RL20	RF110/RL110	RF600/RL600	RFS20/RLS20	RFS110/RLS110	RFS600/RLS600
RF25/RL25	RF125/RL125		RFS25/RLS25	RFS125/RLS125	
RF30/RL30	RF150/RL150		RFS30/RLS30	RFS150/RLS150	
RF35/RL35	RF175/RL175		RFS35/RLS35	RFS175/RLS175	
RF40/RL40	RF200/RL200		RFS40/RLS40	RFS200/RLS200	

Note: Order RF/RFS for Class H Renewable Fuse Order RL/RLS for Renewable Fuse Links

Recommended Fuse Blocks With Box Connectors For Renewable Class H

Ampere Fuse Rating	Catalog Number			
	250V		600V	
	1-Pole	3-Pole	1-Pole	3-Pole
0-30	20306	20308	60306	60308
31-60	20606	20608	60606	60608
61-100	21036	21038	61036	61038
101-200	22001	22003	62001	62003
201-400	24001	24003	64001	64003
401-600	2631	2633	6631	6633

A variety of pole configurations and termination provisions are available. Refer to Section H for details.

Dimensions

Ampere Rating	A		B		C		D		E	
	in	mm	in	mm	in	mm	in	mm	in	mm
250V-RF Fuses										
0-30	2	51	9/16	14	-	-	-	-	-	-
31-60	3	76	13/16	21	-	-	-	-	-	-
61-100	5-7/8	149	1-1/16	27	1/8	3	3/4	19	1	25
101-200	7-1/8	181	1-9/16	40	3/16	5	1-1/8	28	1-3/8	35
201-400	8-5/8	219	2-1/16	53	1/4	6	1-5/8	41	1-7/8	48
401-600	10-3/8	264	2-9/16	66	1/4	6	2	51	2-1/4	57
600V-RFS Fuses										
0-30	5	127	13/16	21	-	-	-	-	-	-
31-60	5-1/2	139	1-1/16	27	-	-	-	-	-	-
61-100	7-7/8	200	1-5/16	34	1/8	3	3/4	19	1	25
101-200	9-5/8	244	1-13/16	46	3/16	5	1-1/8	28	1-3/8	35
201-400	11-5/8	295	2-9/16	66	1/4	6	1-5/8	41	1-7/8	48
401-600	13-3/8	340	3-1/8	80	1/4	6	2	51	2-1/4	57

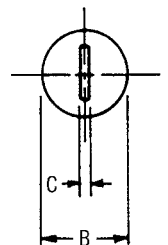
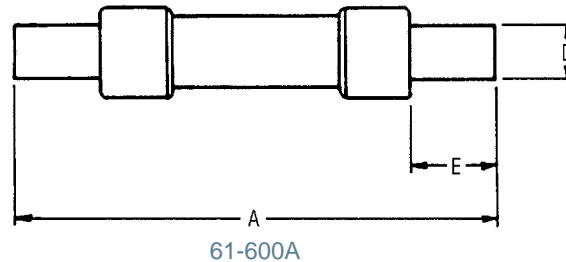
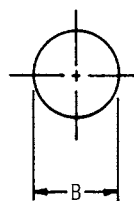
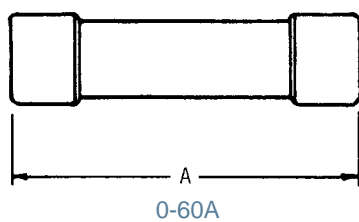

Plug Fuses

Plug Fuses: G/GP/TD/GW/GTL/GT/GSL

Mersen Plug Fuses are for industrial and residential applications. Standard non-time delay fuses are for receptacle and lighting circuits. Standard time delay fuses are for motor loads. For Canadian requirements, a type “P” fuse is used for non-motor loads and type “D” fuses are used for electric heating and cycling loads circuits. Both fuses have low melting-point temperature elements. Low-Temp time delay plug fuses have thermal sensitivity are also for cycling loads and motor circuits. Type “S” plug fuses are time delay and tamper-resistant.

Catalog Numbers (amps)

Catalog Number						
Edison Base						Type S
Non-Time Delay UL	Non-Time Delay CSA	Time-delay UL	“P” Type Non-time Delay CSA	Low-Temp Time-delay UL	“D” Type Time-delay CSA	Rejection* Time-delay UL
GW3	G3	-	-	-	-	-
GW6	G6	-	-	-	-	-
GW10	G10	-	-	-	-	-
GW15	-	GTL15	GP15	GT15	TD15	GSL15
GW20	-	GTL20	GP20	GT20	TD20	GSL20
GW25	-	GTL25	GP25	GT25	TD25	GSL25
GW30	-	GTL30	GP30	GT30	TD30	GSL30

FR15 Rejector Rings available

FRW Rejection removal tool available to remove FR15

*Must be used with an SAG adaptor to fit an Edison base fuse holder.

Type S Plug Fuse Adaptors

Cat.No./Rating	Fuse Range - Amps
SAG3-2/10	1-8/10 - 3-2/10
SAG6-1/4	3-1/2 - 6-1/4
SAG15	7 - 15
SAG20	20
SAG30	25 - 30

Type S adaptors screw into the Edison base and allow Type S fuses to be installed. Type S adaptors prevent the wrong ampere size fuse from being used.



Ratings:

Volts : 125VAC
 Amps : 3 to 30A
 IR : 10kA I.R. AC

Choice of Edison Base, Types “P”, “D”, or “S”

Approvals:

- UL Listed Guide JEFV, File E76208
- CSA Certified Class 142301, File 15525

