

CATALOG



PW[®]
CABLE TRAY

2013

designed to be better.™

 **legrand[®]**

PW CABLE TRAY

Built to Handle the Load

QUALITY AND INNOVATION FOR OVER 60 YEARS.

Cable tray, introduced in the mid 1940's, has proved to be a very efficient cable management solution. It provides system flexibility and expandability with substantial savings in installation labor and material costs. For more than six decades the PW brand has played a leadership role in the cable tray industry, providing advanced cable management solutions.



Our latest innovation is Itray. It's aluminum cable tray that been redesigned with stronger side rails and faster splicing options to streamline the engineering, purchasing and installation of cable tray. And continue to look to PW cable management to support extremely heavy cabling and bridge roadways, our exclusive long span/heavy duty cable tray is designed with up to 10" I-beam side rails that can span up to 50' and meet exacting industry and load standards.

Legrand continues to provide contractors and end users with the specific products they need — from standard designs to custom-built products. With our national distribution partnerships and our manufacturing facilities in North America, we are perfectly positioned to supply any sized project — offering excellent service with the best lead times in the industry.

TABLE OF CONTENTS

INTRODUCTION
PAGES 1-7

PW CABLE TRAY
PAGES 8-79

CENTER SPINE CABLE TRAY
PAGES 80-87

CHANNEL SYSTEMS
PAGES 88-97

CABLE RUNWAY
PAGES 98-103

SEISMIC BRACING
PAGES 104-110

INDEX
PAGES 111-IBC

PW CABLE TRAY SYSTEMS



NEW ITRAY ALUMINUM LADDER, TROUGH AND SOLID BOTTOM SYSTEMS

Itray is the newest addition to the PW Line of cable tray products. It was designed to streamline the engineering, purchasing and installation of cable tray. Itray replaces our current "C" aluminum 4" to 7' side rail height cable tray line.

Itray's patent-pending, all-aluminum construction features a space saving I-beam design, a side rail engineered with structural offsets and a matching splice. The I-beam design minimizes total tray width and creates a smooth transition between straight sections and fittings. And Itray splices reduce hardware needs by 50%. These features allow Itray to be installed up to 30% faster than standard tray.

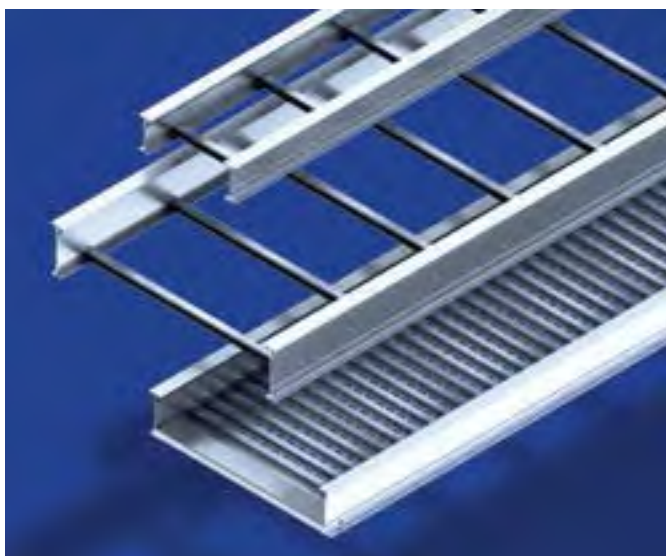

SPLICING MADE EASY

The structural offset side rail and splice design makes a splice that is strong and easy to install. The stronger splice allows mid-span splicing while maintaining full NEMA load class. This simplifies the design process and reduces the overall number of spliced sections that require jobsite fabrication. During installation the splice simply snaps in place and keeps tray sections aligned while the installer inserts and tightens 4 bolts. Itray's all aluminum construction features a space saving I-beam design, a side rail engineered with structural offsets and a matching splice. The I-beam design minimizes total tray width and creates a smooth transition between straight sections and fittings. And Itray splices reduce hardware needs by 50%. These features allow Itray to be installed up to 30% faster than standard tray.



VIEW THIS VIDEO FOR A COMPLETE PRESENTATION ON ITRAY



STRONGER I-BEAM RUNG DESIGN



Itray also features the strongest rungs in the industry. Its I-beam design reduces twist and deflection under load and heavier I-beam rungs are standard on wider tray without special order.

SMOOTHER FINISHED INSTALLATIONS

Itray straight sections and fittings match perfectly creating a smooth side rail edge for a natural cable pathway that makes pulling cable easier and with less chance of damage to the cable sheath. Itray features a 3" tangent that follows industry standards and the symmetric side rail design allows smooth ceiling to wall transitions without the need for field fabrication. Transition splices are available for older, existing installations.

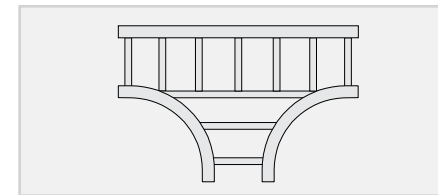

METALLIC AND FIBERGLASS LADDER, TROUGH AND SOLID BOTTOM SYSTEMS

PW cable tray is a fabricated structure consisting of two side rails connected by individual rungs or bottom. Side rails are 4" to 10" high. Widths are 6" to 36". Bottom options include Ladder, Vented Corrugated Bottom, Solid Corrugated Bottom, and Flat-Sheet Solid Bottom designs.

A wide range of load and span designations are available for every possible application, from trays for commercial use where spans over 8' are required, to trays for longer spans required in industrial applications. Also available are trays built for extremely long spans – up to 50' – for special applications like roadway crossings and pipe bridges.

Our product line includes trays, fittings, covers, firewall penetration sleeves, and other accessories. These products are available in hot-dipped galvanized steel. For extremely corrosive applications we have product lines in 304 and 316 stainless steel or polyester and vinylester fiberglass.

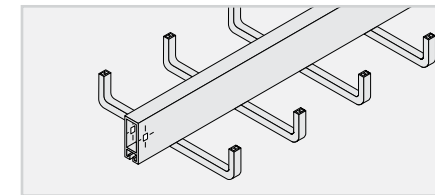

CENTER SPINE

Center Spine Cable Tray is designed for safety, reliability and flexibility for future expansion. Field modifiable fittings combine to allow installers to easily maneuver around unforeseen obstructions and changes in elevation. Preassembled couplings are provided with each tray to reduce install time. Center Spine can be used to construct a complete FiberReady® cable tray system with controlled 2" [51mm] nominal bend radius to meet specifications for fiber optic and UTP/STP cabling and exceeds TIA 569 requirements for communication pathways. Designed for use in retrofit, new or existing applications.

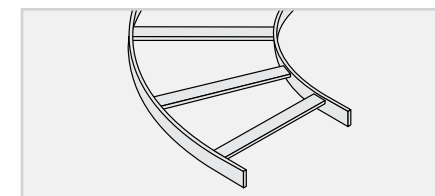

CABLE RUNWAY

Cable Runway is available in a lightweight version with tubular side rails and a solid bar side rail option for maximum support strength. Both styles have tubular steel rungs. Commonly used in telecommunication, voice, and data applications, runway is typically mounted directly above or to computer racking systems, enclosures, and relay rack cabinets. Cable Runway is available in yellow-zinc dichromate as required for UL Classified installations as an equipment ground conductor, and a range of powder-coated finishes.

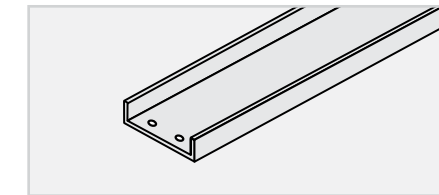

CHANNEL TRAY

Channel tray is a one-piece ventilated or solid-bottom cable tray with sizes up to 6" wide. It is commonly used for small runs of cable or for drops from main cable tray runs to equipment or junction boxes. These products are available in aluminum, mill galvanized steel and hot-dipped galvanized steel. For extremely corrosive applications we have products in 304 and 316 stainless steel or polyester and vinylester fiberglass. A complete line of accessories is available, including covers and fittings in 12" to 36" radius.

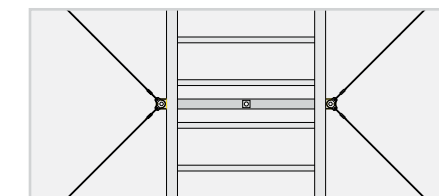

SEISMIC BRACING

Threaded rods used to support cable trays offer little resistance to the horizontal forces of a seismic event. Seismic Bracing or sway bracing, is used to prevent horizontal movement during seismic events. The PW solution is wire rope/cable bracing design that complies with building codes, and installs in one-third the time needed for conventional pipe, angle, and strut bracing systems. This cost effective alternative, reduces both material costs and installation labor. Wire rope/cable can be supplied on spools in bulk lengths and is UL Listed.

PW CABLE TRAY

Understanding Our Products

TRAY OPTIONS

It is essential to consider the type and quantity of cables to be installed in the cable tray when planning your project. Refer to Article 392 of the National Electrical Code (NEC) for guidelines on calculating the cable tray depth and width.

LOAD DEPTH: Interior depth of the cable tray that is available for cable fill. Specifications for cable trays should include a specific requirement for the tray load depth. Due to design variations between different manufacturers, it is important to specify an exact load depth to ensure equal performance. The load depth may differ slightly based on choice of tray bottom.

WIDTH: Interior width of the tray or channel that is available for cable fill.

SIDE RAIL HEIGHT: The overall height of the cable tray side rail. In general, side rail heights for PW cable trays are 1" greater than the load depth.

BOTTOM TYPE: Legrand offers numerous tray bottom types and options to accommodate a wide variety of wire management solutions.

LENGTH: The overall length of each cable tray straight section. The spacing of the cable tray supports will determine the length requirements for straight trays. The support span should not be greater than the straight section length to ensure that no more than one splice plate connection is located between supports.

LOAD/SPAN CLASS DESIGNATION

THE LOAD/SPAN CLASSIFICATION describes the cable tray's load-carrying capability for a specific support span. A classification should be selected that reflects the actual working load and support span for each application. This designation directly affects the cost of the tray, so the proper selection is essential to determine the most economical cable tray system necessary for each project. Please consult with Legrand for working loads and support spans that fall outside the boundaries of the Load/Span Classes shown.

CONCENTRATED STATIC LOAD: In addition to an evenly distributed cable load, it is occasionally required that the cable tray system be capable of supporting a concentrated static load. A concentrated static load represents a static weight applied on the centerline of the cable tray at midspan. The concentrated static load in lbs. may be converted to an equivalent uniform load (W_e) in lbs./ft., using the following formula, and added to the static weight of cables in the tray. A NEMA Load Class can then be selected that reflects the combination of the cable load and converted static load.

$$W_e = \frac{2 \times (\text{concentrated static load, lbs.})}{\text{support span length, ft.}}$$

Example: A 200 lb. concentrated load is to be applied to a cable tray that is supported on a 12 ft. support span. Using the formula above, the equivalent uniform load $W_e = 2 \times 200 / 12 = 33$ lbs. per linear foot. This should be added to the anticipated cable load to determine the appropriate Load/Span Class for the cable tray.

Note: To accommodate concentrated loads, some circumstances may require cable trays to have reinforced side rails or bottom members. Therefore, it is recommended that you consult with Legrand when considering concentrated loads or any other special cable tray loading requirements.

WORKING LOAD lbs/ft (kg/m)	LOAD/SPAN CLASS DESIGNATIONS			
	SUPPORT SPAN, ft. (m)			
	8 ft. (2.4 m)	10 ft. (3.0 m)	12 ft. (3.7 m)	20 ft. (6.0 m)
25 (37)	—	A	—	—
45 (67)	—	—	—	D
50 (74)	8A	—	12A	20A
65 (97)	—	C	—	—
75 (112)	8B	—	12B	E or 20B
100 (149)	8C	—	12C	20C
120 (179)	—	D	—	—
200 (299)	—	E	—	—

WORKING LOAD: Total load of cables installed and uniformly distributed in the cable tray.

SUPPORT SPAN: Maximum distance between cable tray supports.

CLASSES 8, 12, 20 / A, B, C: NEMA designations, published by the National Electrical Manufacturers Assoc. in Standard VE1.

CLASSES A, C, D, AND E: CSA designations, published by the Canadian Standards Association in Standard C22.2, No. 126.

PW CABLE TRAY

FITTINGS, ACCESSORIES AND HARDWARE

A complete cable tray system includes fittings, accessories, supports, and hardware. Consider the following components when designing a cable tray system:

FITTING RADIUS: The nominal bend radius for fittings should not be less than the minimum allowable bending radius for the cables to be installed in the tray. Cable manufacturers typically publish the minimum bending radius as a multiple of the cable diameter.

EXPANSION CONNECTORS AND SUPPORTS: It is important to consider thermal expansion and contraction in the cable tray system, especially for outdoor applications. NEMA Standards Pub. VE2 addresses the proper installation and spacing of expansion connectors, expansion guides, hold down clamps, tray supports, and bonding jumpers.

COVERS: Cable tray covers are often needed to contain and protect tray contents. Carefully select a specific cover design and specify the proper attachment hardware needed for indoor, outdoor, or vertical installations.

DIVIDERS: In some applications, the NEC requires the use of tray dividers to separate cables. Multiple dividers can also easily help manage complex wiring systems.

GROUNDING: All aluminum and galvanized steel cable trays manufactured by Legrand are classified by UL as equipment grounding conductors with specific ampere ratings per NEC 392. To maintain electrical continuity, bonding jumpers should be installed at mechanically discontinuous locations and sized in accordance with the rating of the cable tray system.

HARDWARE: Screws, nuts, bolts, etc. for assembling cable tray connectors and accessories are normally provided in zinc plated or geomet steel, adequate for most applications. Some moist, outdoor, or corrosive environments may require the use of stainless steel hardware for better performance. All PW cable tray connectors and most accessories are available with optional Type 316 stainless steel hardware.

MATERIALS

The selection of cable tray material depends on many factors including environmental conditions, corrosion resistance, aesthetics, and material handling.

		DRY INTERIORS	EXTERIORS	CORROSIVE	HIGHLY CORROSIVE	FASTENER FINISHES
A	ALUMINUM 6063-T6, 5052-H32 & 3003	●	●			ZN GE S6
M	MILL GALVANIZED STEEL (Before Fabrication) ASTM A653 G90	●				ZN
Z	ELECTRO-GALVANIZED STEEL ASTM B633 SC2	●				CD
G	HOT-DIP GALVANIZED STEEL (After Fabrication) ASTM A123		●	●		CD
L	STAINLESS STEEL AISI Type 304L			●		S4 S6
T	STAINLESS STEEL AISI Type 316L			●	●	S6
F	FIBERGLASS ASTM E-84 Class 1				●	S6 FG FE
P	SPECIAL FINISHES ASTM D3451 (for powder paint only)	●	●	●		
C	COPPER					
N	NYLON					
V	VINYL					

● Recommended ● Possible

Understanding Our Products

SPECIFYING YOUR ORDER

Itray Aluminum Tray

The numbering system for Itray Aluminum 4" to 7" tray is new and easier to use. Please review these examples before specifying your order.

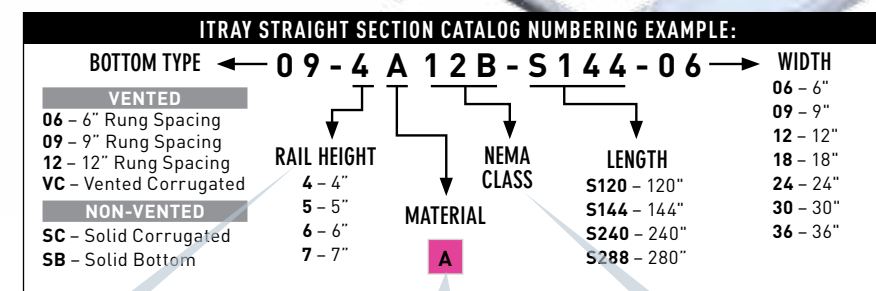

Overall rail height is clearly marked with 4" to 7" heights available.

The tray material is listed as well. Currently Itray will only be offered in Aluminum. Stronger I-beam construction means no series choice is needed.

The tray system number is the same as the NEMA Class - no cross-reference needed.

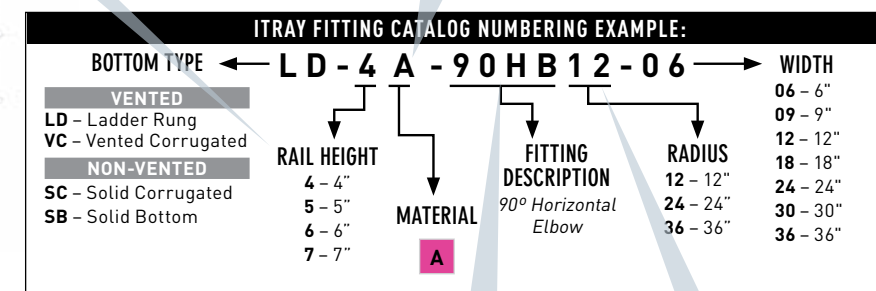

No complicated Fitting System Number or Product Number. The Fitting Description is now an abbreviated form of the product name.

Radius measurement is now clearly shown.

Itray COMPATIBLE

Look for the Itray Compatible designation throughout the Ladder, Trough and Solid Bottom section of this catalog for products that also fit Itray specifications.

The numbering system for all other tray lines has not changed.

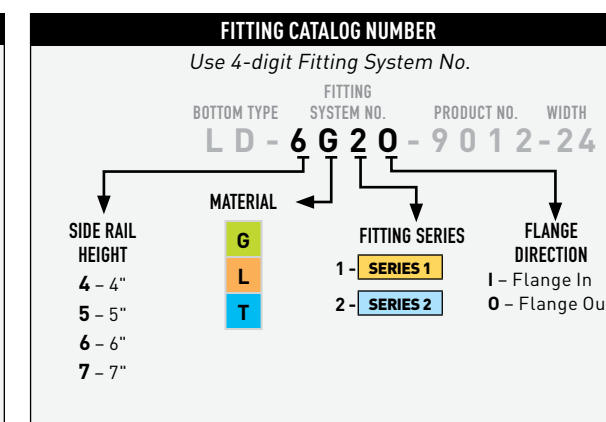
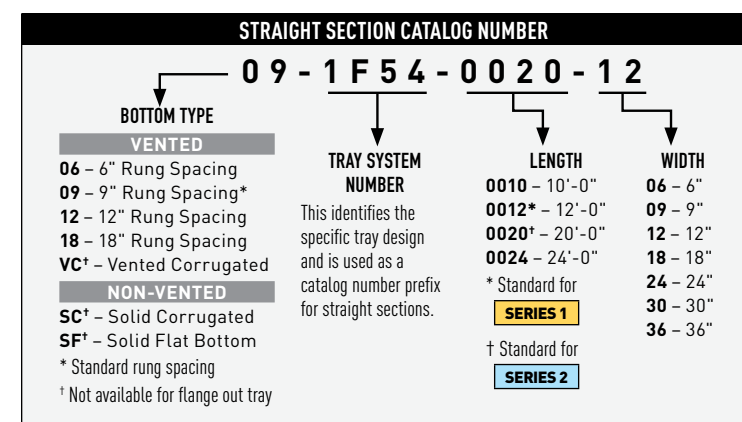

LADDER, TROUGH & SOLID BOTTOM

ITRAY ALUMINUM TRAY

- 10 STRAIGHT SECTIONS
- 12 FITTINGS
- 20 COVERS
- 22 SPLICES & CONNECTORS
- 24 ACCESSORIES

METALLIC

- 26 LONG-SPAN TRAY
- 28 STEEL TRAY
- 30 STAINLESS STEEL TRAY
- 32 FITTINGS
- 42 COVERS
- 45 SPLICES & CONNECTORS
- 49 ACCESSORIES
- 57 FASTENERS
- 58 FIRESTOP SYSTEMS
- 60 REFERENCE INFORMATION
- 63 RUNG OPTIONS

FIBERGLASS

- 70 STRAIGHT SECTIONS
- 72 FITTINGS
- 76 COVERS
- 77 SPLICES & CONNECTORS
- 78 ACCESSORIES



The PW Line of cable tray products is offered in a wide variety of sizes, designs and finishes to meet exacting industry standards. Choose from our extensive selection of rail, rung and bottom styles that are available in a variety of finishes. Also choose from fittings, accessories, fire stop systems and fasteners that will complete your installation.

Legrand representatives have the experience to insure that your cable management needs will be fulfilled on time and to your specifications.

MC POWER CABLE FILL TABLE

LADDER TRAY	MAX NUMBER OF CABLES PER CODE*			
	THHN TypeMC AlumArmor			
	2C (12 AWG)	3C (12 AWG)	3C (AWG 4/0)	3C (500 kcmil)
6	35 cbls	31 cbls	3 cbls	2 cbls
9	52 cbls	45 cbls	5 cbls	3 cbls
12	71 cbls	63 cbls	7 cbls	5 cbls
18	107 cbls	94 cbls	11 cbls	7 cbls
24	143 cbls	126 cbls	15 cbls	10 cbls
30	178 cbls	157 cbls	18 cbls	12 cbls
36	214 cbls	204 cbls	22 cbls	15 cbls

* Vented cable tray only.

TRAY MATERIAL	SIDE RAIL HEIGHTS INCHES	VENTED		NON-VENTED	
		LADDER STANDARD RUNG	VENTILATED TROUGH CORRUGATED	SOLID BOTTOM CORRUGATED	SOLID BOTTOM FLAT SHEET
A ITRAY ALUMINUM	4 5 6 7	6", 9" and 12" rung spacing	7/8" wide ribs are 1/2" deep on 2" centers with air vents	7/8" wide ribs are 1/2" deep on 2" centers	Flat sheet over 12" rung spacing
A LONG-SPAN ALUMINUM G HOT-DIP GALVANIZED STEEL	8 10	9", 12" and 18" rung spacing	N/A	N/A	N/A
G STEEL HOT-DIP GALVANIZED STEEL	4 5 6 7	6", 9" and 12" rung spacing	7/8" wide ribs are 1/2" deep on 2" centers with air vents	7/8" wide ribs are 1/2" deep on 2" centers	N/A
L STAINLESS STEEL 304L T STAINLESS STEEL 316L	4 5 6 7	6", 9" and 12" rung spacing	N/A	N/A	Flat sheet only
F FIBERGLASS	4 6	6", 9" and 12" rung spacing	N/A	N/A	Flat sheet under 12" rung spacing

DATA CABLE FILL TABLE

LADDER TRAY		MAX NUMBER OF CABLES PER CODE			
WIDTH (IN.)	LOAD DEPTH (IN.)	Cat 5e 4-pr Plenum (.17 IN.)	Cat 5e w4-pr Non-Plenum (.19 IN.)	Cat 6e 4-pr Plenum (.22 IN.)	Cat 6a 4-pr Plenum (.30 IN.)
6	3	396 cbls	317 cbls	236 cbls	127 cbls
9	3	594 cbls	476 cbls	355 cbls	190 cbls
12	3	793 cbls	634 cbls	473 cbls	254 cbls
18	3	1189 cbls	952 cbls	710 cbls	381 cbls
24	3	1586 cbls	1269 cbls	947 cbls	509 cbls
30	3	1982 cbls	1587 cbls	1183 cbls	636 cbls
36	3	2379 cbls	1904 cbls	1420 cbls	763 cbls
6	4	527 cbls	422 cbls	314 cbls	169 cbls
9	4	803 cbls	643 cbls	480 cbls	258 cbls
12	4	1055 cbls	844 cbls	629 cbls	338 cbls
18	4	1582 cbls	1266 cbls	944 cbls	508 cbls
24	4	2110 cbls	1689 cbls	1259 cbls	677 cbls
30	4	2679 cbls	2145 cbls	1600 cbls	860 cbls
36	4	3215 cbls	2574 cbls	1920 cbls	1032 cbls

LADDER TRAY		MAX NUMBER OF CABLES PER CODE			
WIDTH (IN.)	LOAD DEPTH (IN.)	Cat 5e 4-pr Plenum (.17 IN.)	Cat 5e w4-pr Non-Plenum (.19 IN.)	Cat 6e 4-pr Plenum (.22 IN.)	Cat 6a 4-pr Plenum (.30 IN.)
6	5	660 cbls	529 cbls	394 cbls	212 cbls
9	5	991 cbls	793 cbls	591 cbls	318 cbls
12	5	1321 cbls	1058 cbls	789 cbls	424 cbls
18	5	1982 cbls	1587 cbls	1183 cbls	636 cbls
24	5	2643 cbls	2116 cbls	1578 cbls	848 cbls
30	5	3304 cbls	2645 cbls	1972 cbls	1061 cbls
36	5	3965 cbls	3174 cbls	2367 cbls	1273 cbls
6	6	788 cbls	631 cbls	469 cbls	277 cbls
9	6	1189 cbls	952 cbls	710 cbls	381 cbls
12	6	1515 cbls	1213 cbls	905 cbls	486 cbls
18	6	2273 cbls	1820 cbls	1357 cbls	730 cbls
24	6	3031 cbls	2427 cbls	1810 cbls	973 cbls
30	6	3965 cbls	3174 cbls	2367 cbls	1273 cbls
36	6	4758 cbls	3809 cbls	2841 cbls	1527 cbls

ITRAY

A ALUMINUM

CONNECTORS & FITTINGS:

Necessary connectors and fasteners are supplied with all trays and fittings. Extra connectors for field cuts or spares must be ordered separately.

SAFE LOAD:

Allowable cable load in pounds per linear foot uniformly distributed. Based on tray with standard rung on 9" centers and supported on simple beam with safety factor of 1.5 per NEMA VE1.

CONCENTRATED LOAD:

All ladders with solid rungs and trays with corrugated bottoms will support a 200 lb. concentrated load applied at the center of the tray in addition to the NEMA-rated cable load without collapse.

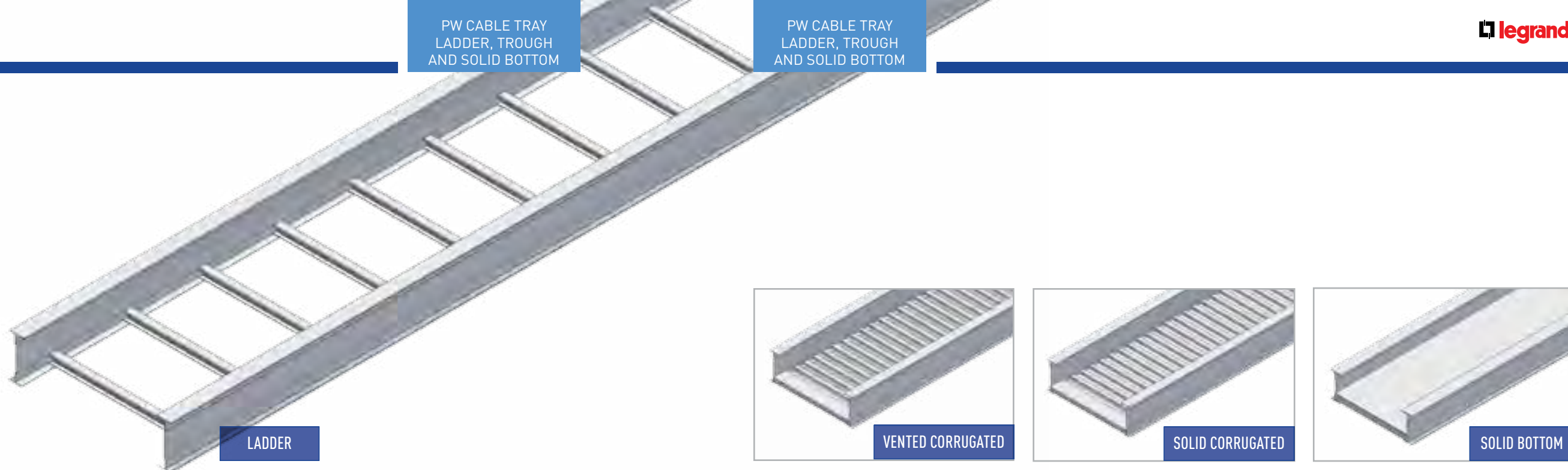

LADDER

VENTED CORRUGATED

SOLID CORRUGATED

SOLID BOTTOM

RAIL HEIGHT (IN.)	LOAD DEPTH (IN.)	NEMA CLASS	AVAILABLE LENGTHS (FT.)					WIDTHS (IN)	TRAY SYSTEM NUMBER	AMP RATING	SUPPORT SPAN (FT.)																																					
			10	12	15	18	24				30	6	8	10	12	14	16	18	20	22	24	26	28	30																								
4	3	12B	10	12	-	-	-	6-36	4A12B	1000	300	0.46	169	0.81	108	1.27	75	1.83																														
	3	12C	10	12	20	-	-	6-36	4A12C	1000	400	0.49	225	0.86	144	1.35	100	1.94																														
	3	20B	-	12	20	24	-	6-36	4A20B	1600			469	0.92	300	1.43	208	2.06	153	2.80	117	3.66	93	4.63	75	5.72	61	6.92	50	8.24																		
5	4	12C	10	12	20	-	-	6-36	5A12C	1000	400	0.28	225	0.50	144	0.78	100	1.12																														
	4	20B	-	12	20	24	-	6-36	5A20B	1600			469	0.60	300	0.95	208	1.36	153	1.85	117	2.42	93	3.06	75	3.78	61	4.57	50	5.44																		
6	5	12C	10	12	20	-	-	6-36	6A12C	1000	400	0.24	225	0.42	144	0.66	100	0.95																														
	5	20B	-	12	20	24	-	6-36	6A20B	1600			469	0.43	300	0.67	208	0.96	153	1.31	117	1.71	93	2.16	75	2.67	61	3.23	50	3.84																		
	5	20C	-	12	20	24	-	6-36	6A20C	1600					400	0.78	278	1.12	204	1.53	156	2.00	123	2.53	100	3.12	81	3.78	66	4.49																		
7	5	24C	-	-	20	24	30	6-36	6A24C	1600						400	1.04	294	1.41	225	1.84	178	2.33	144	2.88	119	3.48	100	4.14	84	4.86	71	5.64	61	6.47													
	6	12C	10	12	20	-	-	6-36	7A12C	1000	400	0.15	225	0.27	144	0.42	100	0.61																														
	6	20B	-	12	20	24	-	6-36	7A20B	1600			469	0.32	300	0.50	208	0.72	153	0.98	117	1.29	93	1.63	75	2.01	61	2.43	50	2.89																		
	6	20C	-	12	20	24	-	6-36	7A20C	1600					400	0.55	278	0.78	204	1.07	156	1.40	123	1.77	100	2.18	81	2.64	66	3.14																		
6	24C	-	-	20	24	30	6-36	7A24C	1600						400	0.90	294	1.23	225	1.60	178	2.03	144	2.50	119	3.03	100	3.60	84	4.23	71	4.90	61	5.63														

ITRAY - STRAIGHT SECTIONS

- WIDTHS (W) INCHES
 6 | 9 | 12 | 18 | 24 | 30 | 36
- RAIL HEIGHTS (H) INCHES
 4 | 5 | 6 | 7

All Legrand aluminum and steel cable trays are Classified by UL as equipment grounding conductors per NEC 392.60. (UL File No. E60796)

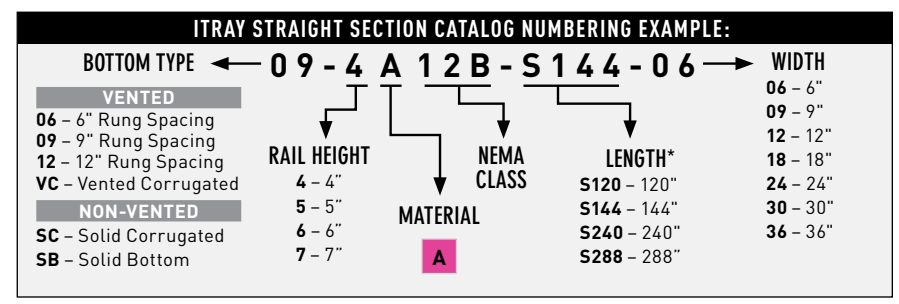

ITRAY - STRAIGHT SECTIONS

90HB
HORIZONTAL 90° ELBOW A

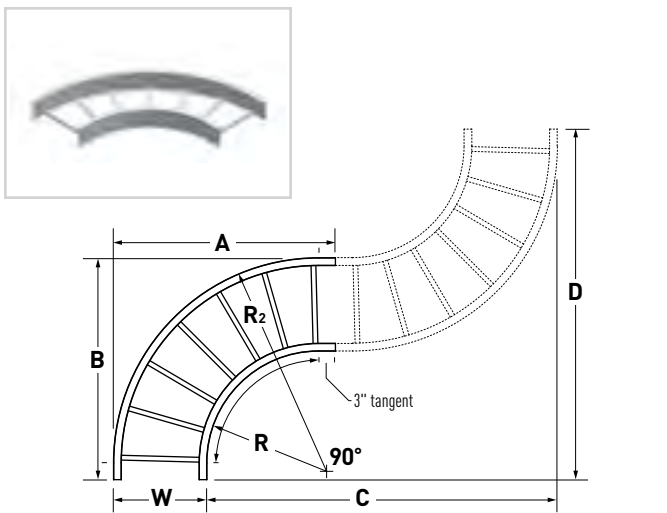

RADIUS R	WIDTH W	RADIUS 2 R2	A	B	C	D
12	6	18	21	21	36	36
	9	21	24	24	39	39
	12	24	27	27	42	42
	18	30	33	33	48	48
	24	36	39	39	54	54
	30	42	45	45	60	60
24	6	30	33	33	60	60
	9	33	36	36	63	63
	12	36	39	39	66	66
	18	42	45	45	72	72
	24	48	51	51	78	78
	30	54	57	57	84	84
36	6	42	45	45	84	84
	9	45	48	48	87	87
	12	48	51	51	90	90
	18	54	57	57	96	96
	24	60	63	63	102	102
	30	66	69	69	108	108
36	72	75	75	114	114	

60HB
HORIZONTAL 60° ELBOW A

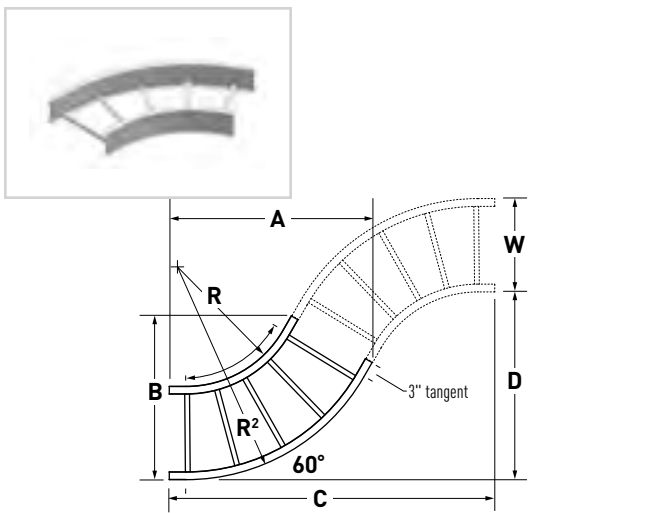

RADIUS R	WIDTH W	RADIUS 2 R2	A	B	C	D
12	6	18	20 1/8	14 5/8	35	20 1/4
	9	21	22 5/8	17 5/8	37 5/8	21 3/4
	12	24	25 1/4	20 5/8	40 1/8	23 1/4
	18	30	30 1/2	26 5/8	45 3/8	26 1/4
	24	36	35 5/8	32 5/8	50 5/8	29 1/4
	30	42	40 7/8	38 5/8	55 3/4	32 1/4
24	6	30	30 1/2	20 5/8	55 3/4	32 1/4
	9	33	33 1/8	23 5/8	58 3/8	33 3/4
	12	36	35 5/8	26 5/8	61	35 1/4
	18	42	40 7/8	32 5/8	66 1/8	38 1/4
	24	48	46 1/8	38 5/8	71 3/8	41 1/4
	30	54	51 1/4	44 5/8	76 1/2	44 1/4
36	6	42	40 7/8	26 5/8	76 1/2	44 1/4
	9	45	43 1/2	29 5/8	79 1/8	45 3/4
	12	48	46 1/8	32 5/8	81 3/4	47 1/4
	18	54	51 1/4	38 5/8	87	50 1/4
	24	60	56 1/2	44 5/8	92 1/8	53 1/4
	30	66	61 5/8	50 5/8	97 3/8	56 1/4
36	72	66 7/8	56 5/8	102 1/2	59 1/4	

45HB
HORIZONTAL 45° ELBOW A

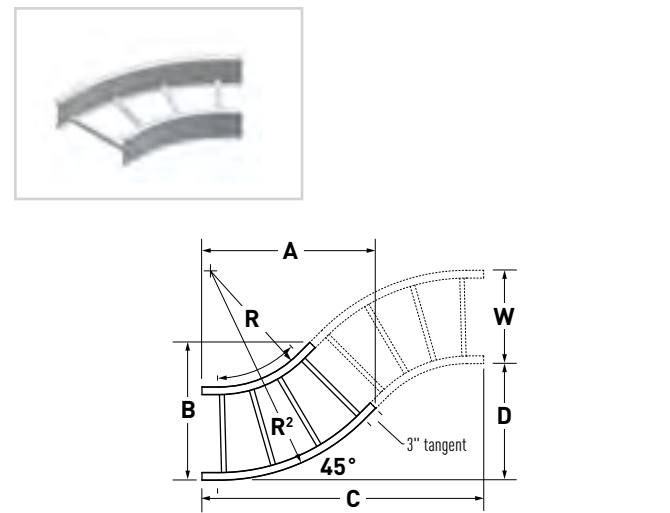

RADIUS R	WIDTH W	RADIUS 2 R2	A	B	C	D
12	6	18	17 7/8	11 5/8	31 1/2	13
	9	21	20	14 5/8	33 5/8	13 7/8
	12	24	22 1/8	17 5/8	35 3/4	14 3/4
	18	30	26 3/8	23 5/8	40	16 1/2
	24	36	30 5/8	29 5/8	44 1/8	18 1/4
	30	42	34 7/8	35 5/8	48 3/8	20
24	6	30	26 3/8	15 1/8	48 3/8	20
	9	33	28 1/2	18 1/8	50 1/2	21
	12	36	30 5/8	21 1/8	52 5/8	21 7/8
	18	42	34 7/8	27 1/8	56 7/8	23 5/8
	24	48	39	33 1/8	61 1/8	25 3/8
	30	54	43 1/4	39 1/8	65 3/8	27 1/8
36	6	42	34 7/8	18 5/8	65 3/8	27 1/8
	9	45	37	21 5/8	67 1/2	28
	12	48	39	24 5/8	69 5/8	28 7/8
	18	54	43 1/4	30 5/8	73 7/8	30 5/8
	24	60	47 1/2	36 5/8	78 1/8	32 3/8
	30	66	51 3/4	42 5/8	82 3/8	34 1/8
36	72	56	48 5/8	86 5/8	35 7/8	

30HB
HORIZONTAL 30° ELBOW A

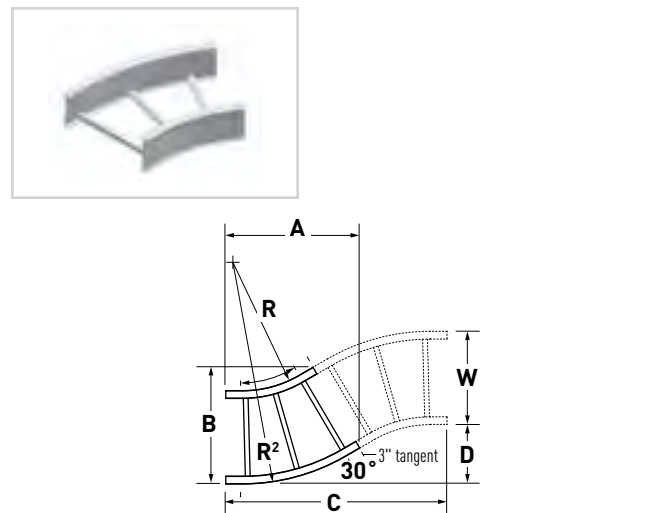

RADIUS R	WIDTH W	RADIUS 2 R2	A	B	C	D
12	6	18	14 1/2	9 1/8	26 1/4	7
	9	21	16 1/8	12 1/8	27 3/4	7 3/8
	12	24	17 5/8	15 1/8	29 1/4	7 7/8
	18	30	20 5/8	21 1/8	32 1/4	8 5/8
	24	36	23 5/8	27 1/8	35 1/4	9 3/8
	30	42	26 5/8	33 1/8	38 1/4	10 1/4
24	6	30	20 5/8	10 3/4	38 1/4	10 1/4
	9	33	22 1/8	13 3/4	39 3/4	10 5/8
	12	36	23 5/8	16 3/4	41 1/4	11
	18	42	26 5/8	22 3/4	44 1/4	11 7/8
	24	48	29 5/8	28 3/4	47 1/4	12 5/8
	30	54	32 5/8	34 3/4	50 1/4	13 1/2
36	6	42	26 5/8	12 3/8	50 1/4	13 1/2
	9	45	28 1/8	15 3/8	51 3/4	13 7/8
	12	48	29 5/8	18 3/8	53 1/4	14 1/4
	18	54	32 5/8	24 3/8	56 1/4	15
	24	60	35 5/8	30 3/8	59 1/4	15 7/8
	30	66	38 5/8	36 3/8	62 1/4	16 5/8
36	72	41 5/8	42 3/8	65 1/4	17 1/2	

- WIDTHS (W) INCHES**
6 | 9 | 12 | 18 | 24 | 30 | 36
- RAIL HEIGHTS (H) INCHES**
4 | 5 | 6 | 7
- RADIUS (R) INCHES**
12 | 24 | 36

ITRAY HORIZONTAL ELBOW CATALOG NUMBERING EXAMPLE:

BOTTOM TYPE ← LD - 4 A - 90HB 12 - 06 → **WIDTH**

LD - Ladder Rung
VC - Vented Corrugated
SC - Solid Corrugated
SB - Solid Bottom

RAIL HEIGHT
4 - 4"
5 - 5"
6 - 6"
7 - 7"

MATERIAL
A

FITTING CODE
90HB
60HB
45HB
30HB

RADIUS
12 - 12"
24 - 24"
30 - 30"
36 - 36"

06 - 6"
09 - 9"
12 - 12"
18 - 18"
24 - 24"
30 - 30"
36 - 36"

SR / LR / RR
HORIZONTAL REDUCERS

A

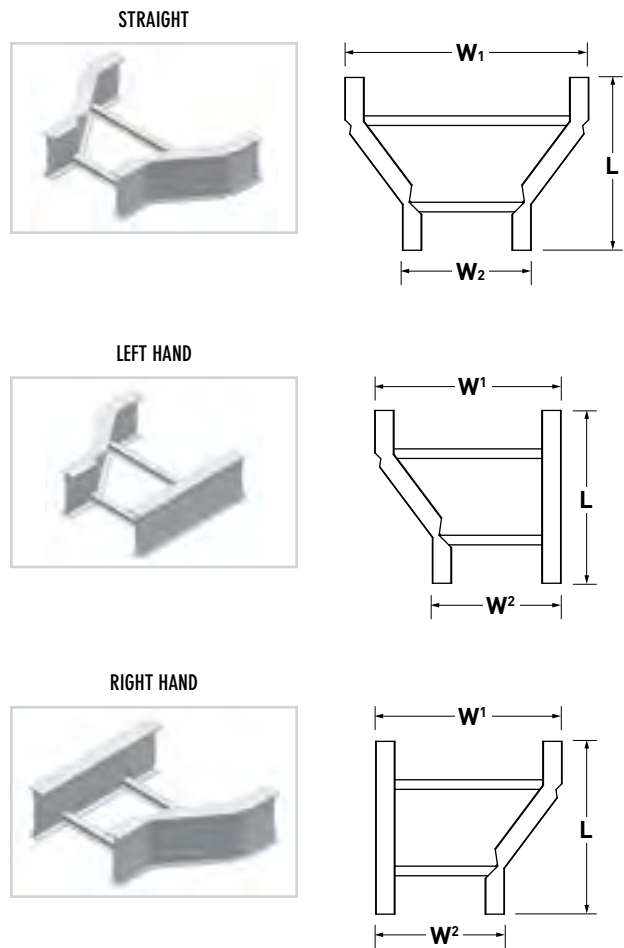

LENGTH	MAIN WIDTH W1	AVAILABLE BRANCH WIDTHS W2					
		6	9	12	18	24	30
18	9	6	-	-	-	-	-
	12	6	9	-	-	-	-
	18	6	9	12	-	-	-
	24	6	9	12	18	-	-
	30	6	9	12	18	24	-
	36	6	9	12	18	24	30

HT
HORIZONTAL STANDARD TEE

A

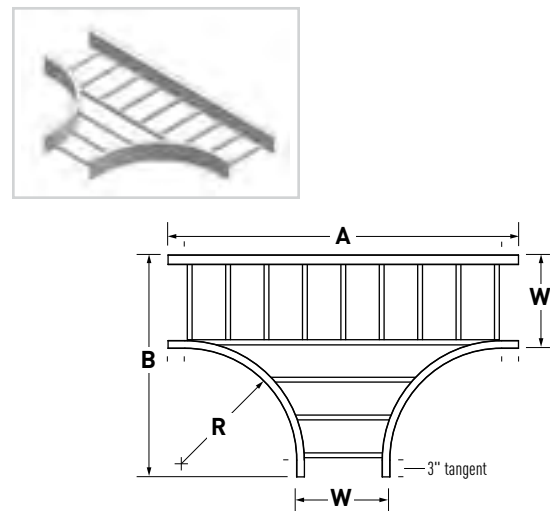

RADIUS R	WIDTH W	A	B
12	6	36	21
	9	39	24
	12	42	27
	18	48	33
	24	54	39
24	30	60	45
	36	66	51
	6	60	33
	9	63	36
	12	66	39
36	18	72	45
	24	78	51
	30	84	57
	36	90	63
	6	84	45
36	9	87	48
	12	90	51
	18	96	57
	24	102	63
	30	108	69
	36	114	75

RT / ET
HORIZONTAL REDUCING/EXPANDING TEES

A

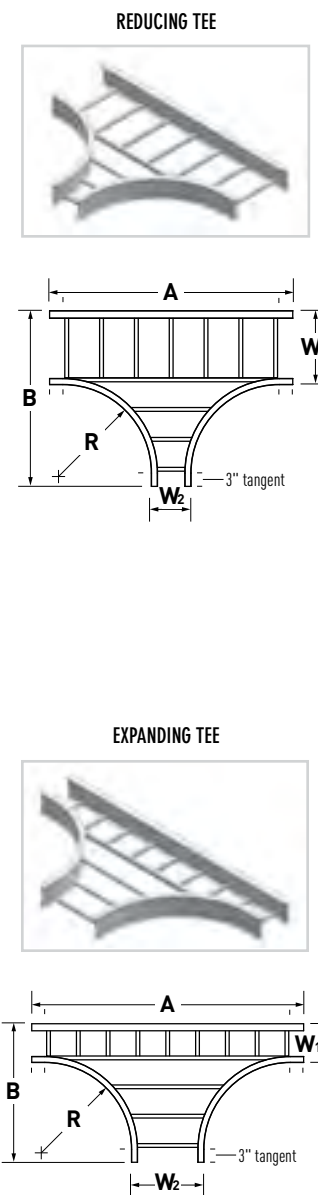

MAIN WIDTH W1	BRANCH WIDTH W2	RADIUS R	A	B	RADIUS R	A	B	RADIUS R	A	B
9	6	12	36	24	24	60	36	36	84	48
	12		6	36		27	60		39	84
18			9	39		27	63		39	87
	24		6	36		33	60		45	84
30			9	39		33	63		45	87
	36		12	42		33	66		45	90
6			6	36		39	60		51	84
	9		9	39		39	63		51	87
12			12	42		39	66		51	90
	18		18	48		39	72		51	96
24			24	54		39	78		51	102
	30		30	60		39	84		51	108
36		36	66	39	90	51	114	63		
	6	6	36	45	60	57	84	69		
9		9	39	45	63	57	87	69		
	12	12	42	45	66	57	90	69		
18		18	48	45	72	57	96	69		
	24	24	54	45	78	57	102	69		
30		30	60	45	84	57	108	69		
	36	36	66	45	90	57	114	69		
6		6	36	51	60	63	84	75		
	9	9	39	51	63	63	87	75		
12		12	42	51	66	63	90	75		
	18	18	48	51	72	63	96	75		
24		24	54	51	78	63	102	75		
	30	30	60	51	84	63	108	75		
36		36	66	51	90	63	114	75		

MAIN WIDTH W1	BRANCH WIDTH W2	RADIUS R	A	B	RADIUS R	A	B	RADIUS R	A	B
6	9	12	39	21	24	63	33	36	87	45
	12		42	21		66	33		90	45
	18		48	21		72	33		96	45
	24		54	21		78	33		102	45
	30		60	21		84	33		108	45
9	36		66	21		90	33		114	45
	12		42	24		66	36		90	48
	18		48	24		72	36		96	48
	24		54	24		78	36		102	48
	30		60	24		84	36		108	48
12	36		66	24		90	36		114	48
	18		48	27		72	39		96	51
	24	54	27	78	39	102	51			
	30	60	27	84	39	108	51			
	36	66	27	90	39	114	51			
18	24	54	33	78	45	102	57			
	30	60	33	84	45	108	57			
	36	66	33	90	45	114	57			
	24	54	39	84	51	108	63			
	30	60	39	90	51	114	63			
36	36	66	39	96	51	120	63			
	36	66	45	90	57	114	69			

ITRAY HORIZONTAL REDUCER CATALOG NUMBERING EXAMPLE:

BOTTOM TYPE ← **LD-4A-SR09-06** → WIDTH 2*

VENTED
LD - Ladder Rung
VC - Vented Corrugated
NON-VENTED
SC - Solid Corrugated
SB - Solid Bottom

RAIL HEIGHT
4 - 4"
5 - 5"
6 - 6"
7 - 7"

FITTING CODE
SR
LR
RR

WIDTH 1
09 - 9"
12 - 12"
18 - 18"
24 - 24"
30 - 30"
36 - 36"

MATERIAL
A

ITRAY HORIZONTAL TEE CATALOG NUMBERING EXAMPLE:

BOTTOM TYPE ← **LD-4A-RT12-1206** → WIDTH 2*

VENTED
LD - Ladder Rung
VC - Vented Corrugated
NON-VENTED
SC - Solid Corrugated
SB - Solid Bottom

RAIL HEIGHT
4 - 4"
5 - 5"
6 - 6"
7 - 7"

FITTING CODE
ST*
RT
ET

RADIUS
12 - 12"
24 - 24"
36 - 36"

WIDTH 1
06 - 6"
09 - 9"
12 - 12"
18 - 18"
24 - 24"
30 - 30"
36 - 36"

MATERIAL
A

* Width 2 does not apply to Standard Tee (ST).

YL / YR
HORIZONTAL WYE BRANCHES

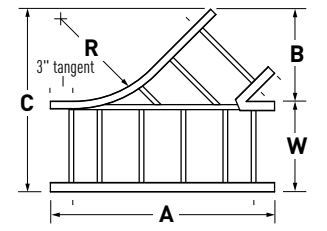

WIDTH W	RADIUS R	A	B	C
6	24	27 ³ / ₈	4 ¹ / ₂	27 ⁷ / ₈
9		31 ⁵ / ₈	7 ¹ / ₂	39 ¹ / ₈
12		35 ⁷ / ₈	10 ¹ / ₂	46 ³ / ₈
18		44 ³ / ₈	16 ¹ / ₂	60 ⁷ / ₈
24		52 ⁷ / ₈	22 ¹ / ₂	75 ³ / ₈
30		61 ³ / ₈	28 ¹ / ₂	89 ⁷ / ₈
36	69 ⁷ / ₈	34 ¹ / ₂	104 ³ / ₈	

HX
HORIZONTAL STANDARD CROSS

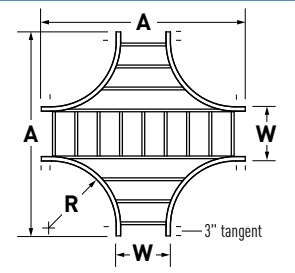

WIDTH W	RADIUS R	A	RADIUS R	A	RADIUS R	A
6	12	36	24	60	36	84
9		39		63		87
12		42		66		90
18		48		72		96
24		54		78		102
30		60		84		108
36	66	90	90	114		

RX
HORIZONTAL REDUCING CROSS

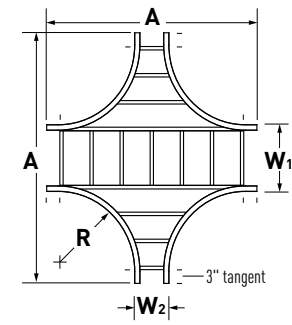

MAIN WIDTH W1	BRANCH WIDTH W2	RADIUS R	A	B	RADIUS R	A	B	RADIUS R	A	B
9	6	12	36	39	24	60	63	36	84	87
	12		6	36		42	60		66	84
9	9		39	42		63	66		87	90
18	6		36	48		60	72		84	96
	9		39	48		63	72		87	96
	12		42	48		66	72		90	96
24	6		36	54		60	78		84	102
	9		39	54		63	78		87	102
	12		42	54		66	78		90	102
	18		48	54		72	78		96	102
30	6		36	60		60	84		84	108
	9		39	60		63	84		87	108
	12	42	60	66	84	90	108			
	18	48	60	72	84	96	108			
36	24	54	60	78	84	102	108			
	6	36	66	60	90	84	114			
	9	39	66	63	90	87	114			
	12	42	66	66	90	90	114			
	18	48	66	72	90	96	114			
	24	54	66	78	90	102	114			
30	60	66	84	90	108	114				

90VO
VERTICAL OUTSIDE 90° ELBOW

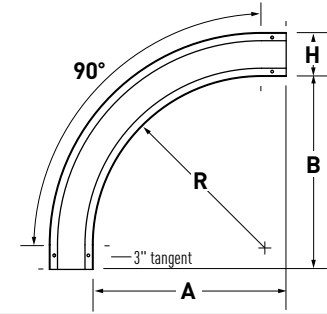

RADIUS R	WIDTH W	RAIL HEIGHT H	A	B
12	6-36	4-7	15	15
24			27	27
36			39	39

60VO
VERTICAL OUTSIDE 60° ELBOW

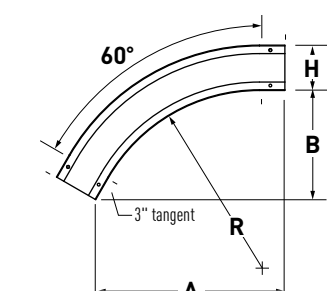

RADIUS R	WIDTH W	RAIL HEIGHT H	A	B
12	6-36	4-7	15	8 ⁵ / ₈
24			25 ¹ / ₄	14 ⁵ / ₈
36			35 ⁵ / ₈	20 ⁵ / ₈

45VO
VERTICAL OUTSIDE 45° ELBOW

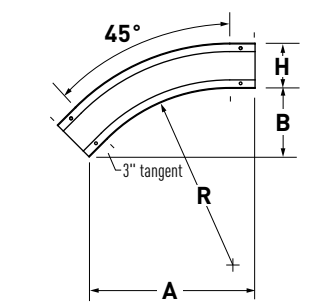

RADIUS R	WIDTH W	RAIL HEIGHT H	A	B
12	6-36	4-7	13 ⁵ / ₈	5 ⁵ / ₈
24			22 ¹ / ₈	9 ¹ / ₈
36			30 ⁵ / ₈	12 ⁵ / ₈

30VO
VERTICAL OUTSIDE 30° ELBOW

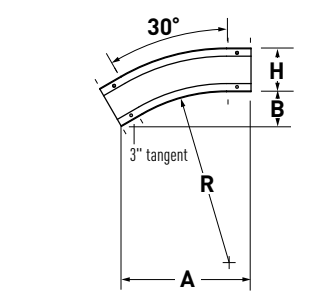

RADIUS R	WIDTH W	RAIL HEIGHT H	A	B
12	6-36	4-7	11 ⁵ / ₈	3 ¹ / ₈
24			17 ⁵ / ₈	4 ³ / ₄
36			23 ⁵ / ₈	6 ³ / ₈

ITRAY HORIZONTAL REDUCING CROSS CATALOG NUMBERING EXAMPLE:

BOTTOM TYPE ← **LD-4A-RX12-0906** → WIDTH 2

VENTED
LD - Ladder Rung
VC - Vented Corrugated
NON-VENTED
SC - Solid Corrugated
SB - Solid Bottom

RAIL HEIGHT
4-4"
5-5"
6-6"
7-7"

FITTING CODE
RX

RADIUS
12-12"
18-18"
24-24"
30-30"
36-36"

WIDTH 1
06-6"
09-9"
12-12"
18-18"
24-24"
30-30"
36-36"

MATERIAL **A**

- WIDTHS (W) INCHES
6 | 9 | 12 | 18 | 24 | 30 | 36
- RAIL HEIGHTS (H) INCHES
4 | 5 | 6 | 7
- RADIUS (R) INCHES
12 | 24 | 36

ITRAY VERTICAL INSIDE ELBOW CATALOG NUMBERING EXAMPLE:

BOTTOM TYPE ← **LD-6A-90VO12-06** → WIDTH

VENTED
LD - Ladder Rung
VC - Vented Corrugated
NON-VENTED
SC - Solid Corrugated
SB - Solid Bottom

RAIL HEIGHT
4-4"
5-5"
6-6"
7-7"

FITTING CODE
90VO
60VO
45VO
30VO

RADIUS
12-12"
24-24"
36-36"

MATERIAL **A**

WIDTH
06-6"
09-9"
12-12"
18-18"
24-24"
30-30"
36-36"

90VI
VERTICAL INSIDE 90° ELBOW

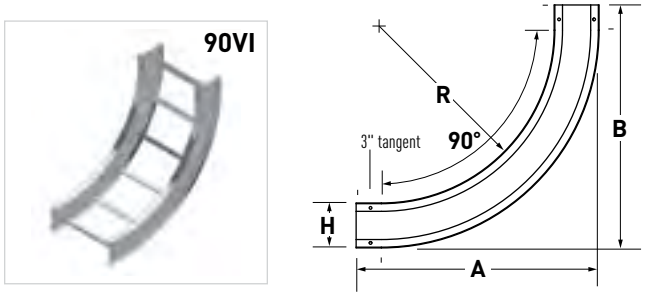

WIDTH W	RADIUS R	H = 4		H = 5		H = 6		H = 7	
		A	B	A	B	A	B	A	B
ALL	12	19	19	20	20	21	21	22	22
	24	31	31	32	32	33	33	34	34
	36	43	43	44	44	45	45	46	46

60VI
VERTICAL INSIDE 60° ELBOW

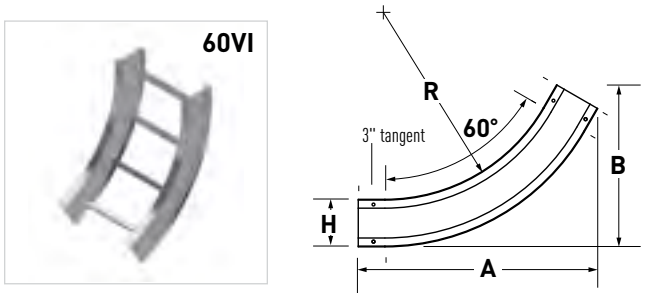

WIDTH W	RADIUS R	H = 4		H = 5		H = 6		H = 7	
		A	B	A	B	A	B	A	B
ALL	12	18 3/8	10 5/8	19 1/4	11 1/8	20 1/8	11 5/8	21	12 1/8
	24	28 3/4	16 5/8	29 5/8	17 1/8	30 1/2	17 5/8	31 3/8	18 1/8
	36	39 1/8	22 5/8	40	23 1/8	40 7/8	23 5/8	41 3/4	24 1/8

45VI
VERTICAL INSIDE 45° ELBOW

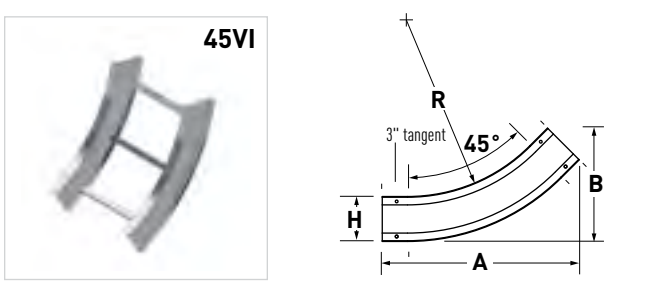

WIDTH W	RADIUS R	H = 4		H = 5		H = 6		H = 7	
		A	B	A	B	A	B	A	B
ALL	12	16 3/8	6 3/4	17 1/8	7 1/8	17 7/8	7 3/8	18 1/2	7 5/8
	24	24 7/8	10 3/8	25 5/8	10 5/8	26 3/8	10 7/8	27	11 1/4
	36	33 3/8	13 7/8	34 1/8	14 1/8	34 7/8	14 3/8	35 1/2	14 3/4

30VI
VERTICAL INSIDE 30° ELBOW

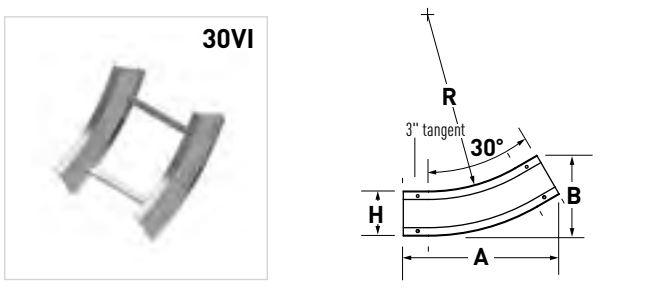

WIDTH W	RADIUS R	H = 4		H = 5		H = 6		H = 7	
		A	B	A	B	A	B	A	B
ALL	12	13 5/8	3 5/8	14 1/8	3 3/4	14 5/8	3 7/8	15 1/8	4
	24	19 5/8	5 1/4	20 1/8	5 3/8	20 5/8	5 1/2	21 1/8	5 5/8
	36	25 5/8	6 7/8	26 1/8	7	26 5/8	7 1/8	27 1/8	7 1/4

TD / TU
VERTICAL TEES

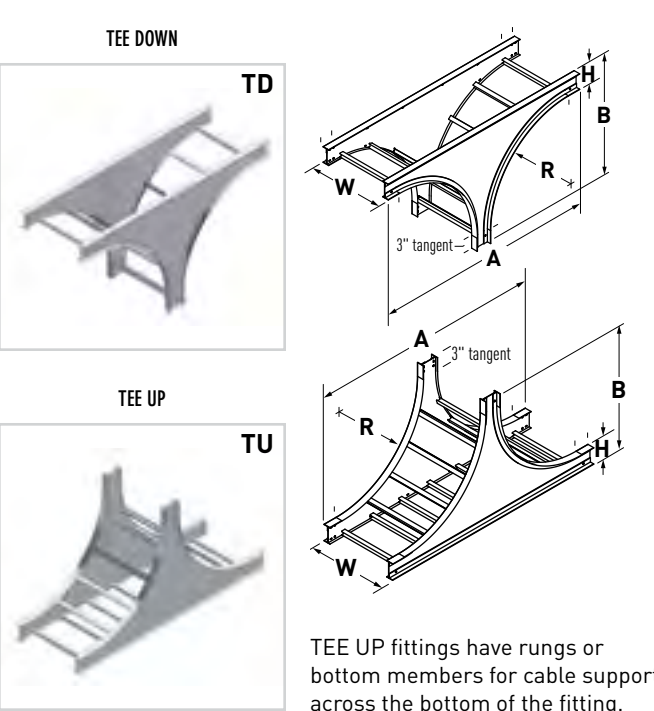

WIDTH W	RADIUS R	RAIL HEIGHT H	A	B
ALL	24	4	58	31
		5	59	32
		6	60	33
		7	61	34

VX
VERTICAL CROSS

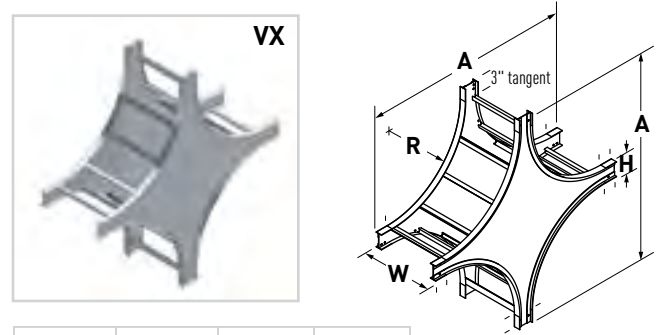

WIDTH W	RADIUS R	RAIL HEIGHT H	A
ALL	24	4	58
		5	59
		6	60
		7	61

CS
VERTICAL CABLE SUPPORT ELBOW

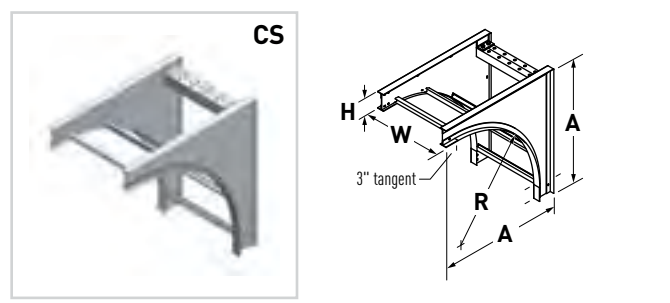

Supports cables at the top of long vertical drops where the weight of the vertical cable may be excessive. Hooks (sold separately) attach to the brace in the elbow; when used with cable grips (supplied by others), tension in the vertical cable is relieved and transferred to the elbow.

WIDTH W	RAIL HEIGHT H	RADIUS R	A	RADIUS R	A	RADIUS R	A
ALL	4	12	19	24	31	36	43
	5		20		32		44
	6		21		33		45
	7		22		34		46

- WIDTHS (W) INCHES
6 | 9 | 12 | 18 | 24 | 30 | 36
- RAIL HEIGHTS (H) INCHES
4 | 5 | 6 | 7
- RADIUS (R) INCHES
12 | 24 | 36

ITRAY VERTICAL INSIDE ELBOW CATALOG NUMBERING EXAMPLE:

LD - 4 A - 90VI 12 - 09

- BOTTOM TYPE:** LD (Ladder Rung)
- RAIL HEIGHT:** 4 (4 inches)
- MATERIAL:** A (Solid Bottom)
- FITTING CODE:** 90VI (90 degree)
- RADIUS:** 12 (12 inches)
- WIDTH:** 09 (9 inches)

ITRAY VERTICAL TEE CATALOG NUMBERING EXAMPLE:

LD - 4 A - TU 24 - 09

- BOTTOM TYPE:** LD (Ladder Rung)
- RAIL HEIGHT:** 4 (4 inches)
- MATERIAL:** A (Solid Bottom)
- FITTING CODE:** TU (tee up)
- RADIUS:** 24 (24 inches)
- WIDTH:** 09 (9 inches)

SFF / LFF / SPF COVERS

A

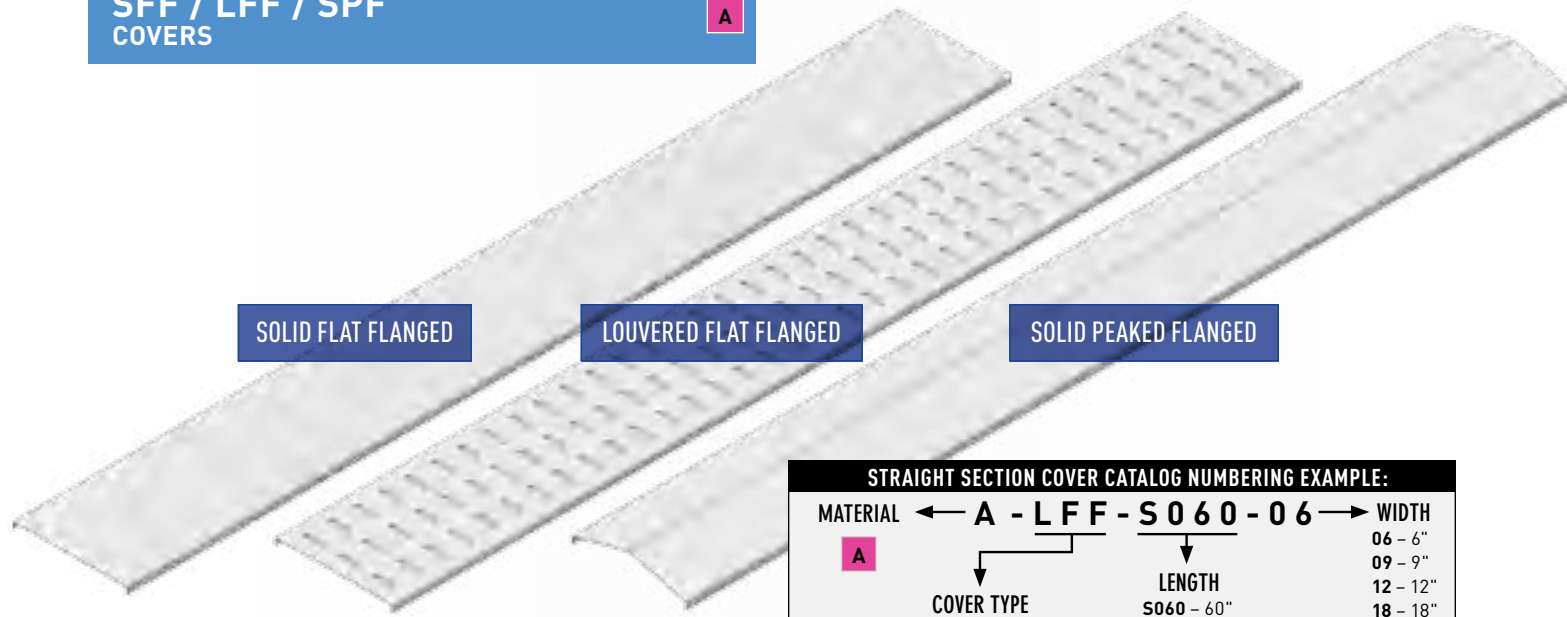

SOLID FLAT FLANGED

LOUVERED FLAT FLANGED

SOLID PEAKED FLANGED

STRAIGHT SECTION COVER CATALOG NUMBERING EXAMPLE:

MATERIAL ← **A - LFF - S060 - 06** → WIDTH

A COVER TYPE LENGTH

SFF - Solid Flat Flanged S060 - 60"

LFF - Louvered Flat Flanged S072 - 72"

SPF - Solid Peaked Flanged S120 - 120"

S144 - 144"

06 - 6"

09 - 9"

12 - 12"

18 - 18"

24 - 24"

30 - 30"

36 - 36"

FOR HORIZONTAL ELBOWS (90HB/60HB/45HB/30HB)

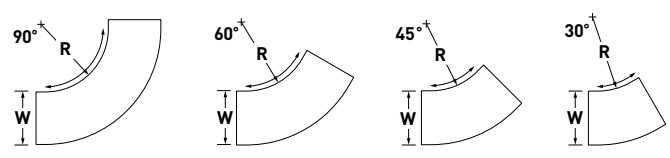

HORIZONTAL ELBOW COVER CATALOG NUMBERING EXAMPLE:

MATERIAL ← **A - SFF - 90HB12 - 06** → WIDTH

A COVER TYPE FITTING CODE RADIUS

SFF - Solid Flat Flanged 90HB 12 - 12"

LFF - Louvered Flat Flanged 60HB 24 - 24"

SPF - Solid Peaked Flanged 45HB 36 - 36"

30HB

06 - 6"

09 - 9"

12 - 12"

18 - 18"

24 - 24"

30 - 30"

36 - 36"

FOR VERTICAL OUTSIDE ELBOWS (90VO/60VO/45VO/30VO)

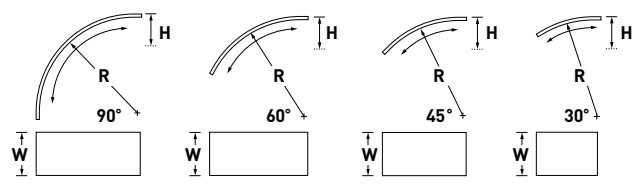

VERTICAL OUTSIDE ELBOW COVER CATALOG NUMBERING EXAMPLE:

MATERIAL ← **A - SFF - 90VO24 - 12 - 4** → WIDTH RAIL HEIGHT

A COVER TYPE FITTING CODE RADIUS

SFF - Solid Flat Flanged 90VO 12 - 12"

LFF - Louvered Flat Flanged 60VO 24 - 24"

SPF - Solid Peaked Flanged 45VO 36 - 36"

30VO

06 - 6"

09 - 9"

12 - 12"

18 - 18"

24 - 24"

30 - 30"

36 - 36"

4 - 4"

5 - 5"

6 - 6"

7 - 7"

FOR VERTICAL INSIDE ELBOWS (90VI/60VI/45VI/30VI)

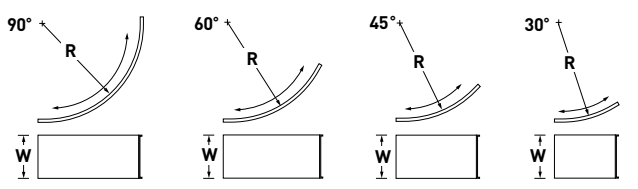

VERTICAL INSIDE ELBOW COVER CATALOG NUMBERING EXAMPLE:

MATERIAL ← **A - SFF - 90VI 24 - 12** → WIDTH

A COVER TYPE FITTING CODE RADIUS

SFF - Solid Flat Flanged 90VI 12 - 12"

LFF - Louvered Flat Flanged 60VI 24 - 24"

SPF - Solid Peaked Flanged 45VI 36 - 36"

30VI

06 - 6"

09 - 9"

12 - 12"

18 - 18"

24 - 24"

30 - 30"

36 - 36"

FOR HORIZONTAL TEE (HT) AND CROSS (HX)

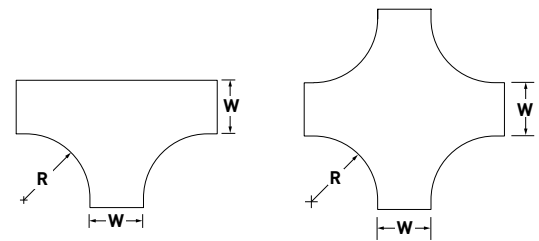

FOR HORIZONTAL REDUCING TEE (RT), EXPANDING TEE (ET) AND REDUCING CROSS (RX)

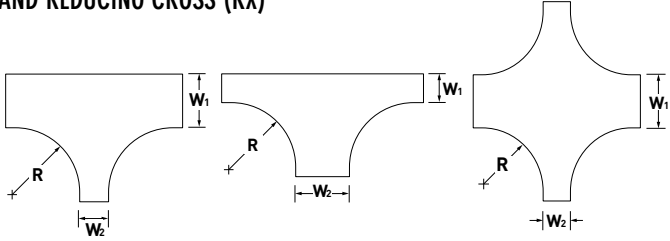

FOR HORIZONTAL STRAIGHT REDUCER (SR), LEFT HAND REDUCER (LR) AND RIGHT HAND REDUCER (RR)

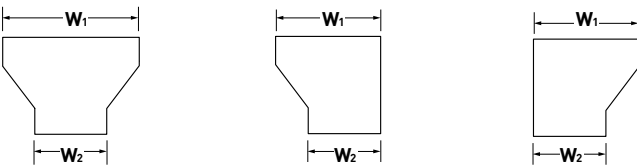

FOR HORIZONTAL LEFT HAND WYE (YL) AND RIGHT HAND WYE (YR)

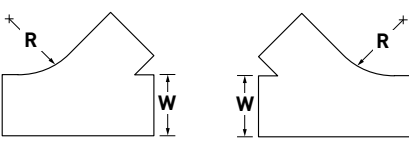

HORIZONTAL TEE COVER CATALOG NUMBERING EXAMPLE:

MATERIAL ← **A - SFF - HT12 - 06** → WIDTH

A COVER TYPE FITTING CODE RADIUS

SFF - Solid Flat Flanged HT 12 - 12"

LFF - Louvered Flat Flanged HX 24 - 24"

SPF - Solid Peaked Flanged 36 - 36"

06 - 6"

09 - 9"

12 - 12"

18 - 18"

24 - 24"

30 - 30"

36 - 36"

HORIZONTAL REDUCING TEE COVER CATALOG NUMBERING EXAMPLE:

MATERIAL ← **A - SFF - RT12 - 1206** → W1 W2*

A COVER TYPE FITTING CODE RADIUS

SFF - Solid Flat Flanged RT 12 - 12"

LFF - Louvered Flat Flanged ET 24 - 24"

SPF - Solid Peaked Flanged RX 36 - 36"

06 - 6"

09 - 9"

12 - 12"

18 - 18"

24 - 24"

30 - 30"

36 - 36"

* Available branch widths dependant on main width selection. See tables below.

HORIZONTAL STRAIGHT REDUCER COVER CATALOG NUMBERING EXAMPLE:

MATERIAL ← **A - SFF - SR - 1206** → W1 W2*

A COVER TYPE FITTING CODE

SFF - Solid Flat Flanged SR 12 - 12"

LFF - Louvered Flat Flanged LR 24 - 24"

SPF - Solid Peaked Flanged RR 30 - 30"

06 - 6"

09 - 9"

12 - 12"

18 - 18"

24 - 24"

30 - 30"

36 - 36"

* Available reducing widths dependant on main width selection. See reducing table below.

HORIZONTAL LEFT HAND WYE COVER CATALOG NUMBERING EXAMPLE:

MATERIAL ← **A - SFF - YL24 - 12** → WIDTH

A COVER TYPE FITTING CODE RADIUS

SFF - Solid Flat Flanged YL 24 - 24"

LFF - Louvered Flat Flanged YR

SPF - Solid Peaked Flanged

06 - 6"

09 - 9"

12 - 12"

18 - 18"

24 - 24"

30 - 30"

36 - 36"

MAIN WIDTHS (W1)	AVAILABLE REDUCING BRANCH WIDTHS (W2)					
9	6	-	-	-	-	-
12	6	9	-	-	-	-
18	6	9	12	-	-	-
24	6	9	12	18	-	-
30	6	9	12	18	24	-
36	6	9	12	18	24	30

MAIN WIDTHS (W1)	AVAILABLE EXPANDING BRANCH WIDTHS (W2)					
6	9	12	18	24	30	36
9	12	18	24	30	36	-
12	18	24	30	36	-	-
18	24	30	36	-	-	-
24	30	36	-	-	-	-
30	36	-	-	-	-	-

FCC FLAT COVER CONNECTOR

A

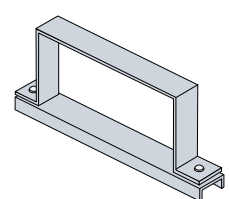

PRODUCT CODE	FASTENER OPTIONS
FCC	GE S6

CATALOG NUMBERING EXAMPLE:
H / Material Width Fasteners
4A - FCC - 06 - GE

PCC PEAKED COVER CONNECTOR

A

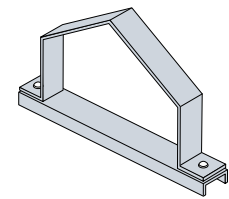

PRODUCT CODE	FASTENER OPTIONS
PCC	GE S6

CATALOG NUMBERING EXAMPLE:
H / Material Width Fasteners
4A - PCC - 06 - S6

SSP
STRAIGHT SPLICE KIT A



PRODUCT CODE	FASTENER OPTIONS
SSP	GE S6
CATALOG NUMBERING EXAMPLE:	
H / Material	Fasteners
4 A - SSP	-S6

- 12" length
- Designed for splicing Itray straight sections
- Includes splices and tray connection hardware

FSP
FITTING SPLICE KIT A



PRODUCT CODE	FASTENER OPTIONS
FSP	GE S6
CATALOG NUMBERING EXAMPLE:	
H / Material	Fasteners
4 A - FSP	-GE

- 6" length
- Designed for splicing Itray fittings
- Includes splices and tray connection hardware

90SP
90° CONNECTOR SPLICE KIT A



PRODUCT CODE	FASTENER OPTIONS
90SP	GE S6
CATALOG NUMBERING EXAMPLE:	
Rail Height / Material	Fasteners
4 A - 90SP	-GE

- Includes 8 splice bolts for connecting trays

FFSP
FLOOR FLANGE SPLICE KIT A



PRODUCT CODE	FASTENER OPTIONS
FFSP	GE S6
CATALOG NUMBERING EXAMPLE:	
Rail Height / Material	Fasteners
4 A - FFSP	-S6

- Includes splices and tray connection hardware

USP
UNIVERSAL SPLICE KIT A



PRODUCT CODE	FASTENER OPTIONS
USP	GE S6
CATALOG NUMBERING EXAMPLE:	
H / Material	Fasteners
4 A - USP	-GE

- Designed to transition to PW C-channel and other I-beam systems
- Includes splices and tray connection hardware

USPB
UNIVERSAL BLANK SPLICE KIT A



PRODUCT CODE	FASTENER OPTIONS
USPB	GE S6
CATALOG NUMBERING EXAMPLE:	
H / Material	Fasteners
4 A - USPB	-S6

- Field drill for connection to trays from other manufacturers
- Includes splices and tray connection hardware

HASP
HORIZONTAL ADJUSTABLE SPLICE KIT A

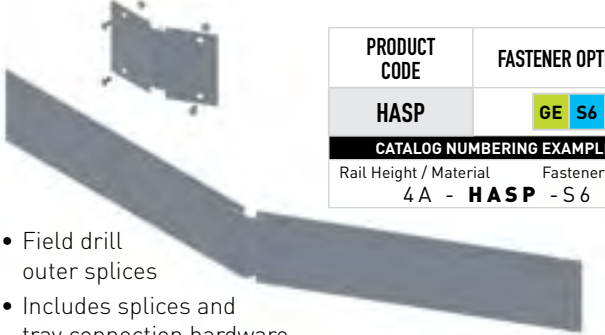

PRODUCT CODE	FASTENER OPTIONS
HASP	GE S6
CATALOG NUMBERING EXAMPLE:	
Rail Height / Material	Fasteners
4 A - HASP	-S6

- Field drill outer splices
- Includes splices and tray connection hardware

VASP
VERTICAL ADJUSTABLE SPLICE KIT A



PRODUCT CODE	FASTENER OPTIONS
VASP	GE S6
CATALOG NUMBERING EXAMPLE:	
H / Material	Fasteners
4 A - VASP	-GE

- Includes splices and tray connection hardware

EXSP
EXPANSION SPLICE KIT A



PRODUCT CODE	FASTENER OPTIONS
EXSP	GE S6
CATALOG NUMBERING EXAMPLE:	
H / Material	Fasteners
4 A - EXSP	-S6

- Install as required P.xx or NEMA VE-2 (see p. 61)
- Includes splices and tray connection hardware

VHSP
VERTICAL HANGER SPLICE KIT A



PRODUCT CODE	FASTENER OPTIONS
VHSP	GE S6
CATALOG NUMBERING EXAMPLE:	
H / Material	Fasteners
4 A - VHSP	-GE

- For vertical tray support with threaded rods
- Includes splices and tray connection hardware

SRSP
STRAIGHT REDUCER SPLICE KIT A



Each side is RN/2.

PRODUCT CODE	FASTENER OPTIONS
SRSP	GE S6
CATALOG NUMBERING EXAMPLE:	
H / Material	RN Fasteners
4 A - SRSP	-06-GE

- Includes splices and tray connection hardware

ORSP
OFFSET REDUCER SPLICE KIT A



PRODUCT CODE	FASTENER OPTIONS
ORSP	GE S6
CATALOG NUMBERING EXAMPLE:	
H / Material	RN Fasteners
4 A - ORSP	-06-S6

- Includes splices and tray connection hardware

WIDTHS (W) INCHES

6 | 9 | 12 | 18 | 24 | 30 | 36

RAIL HEIGHTS (H) INCHES

4 | 5 | 6 | 7

TRAY WIDTH REDUCTION (RN) INCHES

3 | 6 | 9 | 12 | 15 | 18 | 21 | 24 | 27

For detailed material and finish descriptions, see page 6. For other products that fit Itray specifications, look for the Itray Compatible logo on pages 40 thru 57.

RHSP
REDUCING HEIGHT SPLICE KIT A



PRODUCT CODE	FASTENER OPTIONS
RHSP	GE S6
CATALOG NUMBERING EXAMPLE:	
H1 / H2 / Material	Fasteners
5 4 A - RHSP - GE	

H1	H2 OPTIONS
5	4 - -
6	4 5 -
7	4 5 6

- Includes splices and tray connection hardware

TBC
TRAY-TO-BOX CONNECTOR (FRAME TYPE) A



PRODUCT CODE	FASTENER OPTIONS
TBC	GE S6
CATALOG NUMBERING EXAMPLE:	
H / Material	RN Fasteners
4 A - TBC - 06 - S6	

- Includes one frame and connection hardware
- Designed to support Itray at connection to electrical enclosures

OCK
OUTDOOR CONVERSION KIT A

Makes ladder tray wall penetrations weather resistant to minimize water intrusions. Removable cover/shield fastens to tray and wall penetration sleeve for the utmost in weather protection.

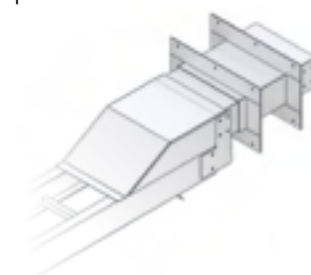

PRODUCT CODE	FASTENER OPTIONS
OCK	GE S6
CATALOG NUMBERING EXAMPLE:	
H / Material	W Fasteners
4 A - OCK - 06 - S6	

WPS
WALL PENETRATION SLEEVE M G

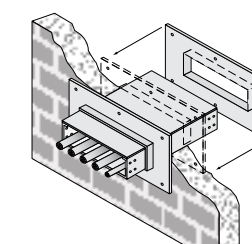

Provides a rigid support for cable tray at wall penetrations. Overall length of the sleeve is 20". Will fit walls up to 8" thick. Bonding jumpers are not required for use with wall sleeves. Two pairs of splice plates and fasteners are included for tray attachment.

PRODUCT CODE	FASTENER OPTIONS
WPS	GE S6
CATALOG NUMBERING EXAMPLE:	
H / Material	W Fasteners
4 M - WPS - 06 - S6	

BE
BLIND END KIT A



PRODUCT CODE	FASTENER OPTIONS
BE	GE S6
CATALOG NUMBERING EXAMPLE:	
H / Material	W Fasteners
4 A - BE - 06 - S6	

- Includes one frame and connection hardware

DO
DROP OUT KIT A



PRODUCT CODE	FASTENER OPTIONS
DO	GE S6
CATALOG NUMBERING EXAMPLE:	
Material	W Fasteners
A - DO - 06 - S6	

- Snaps in place over I-rung

FWPS
FIRE WALL PENETRATION SLEEVE M G

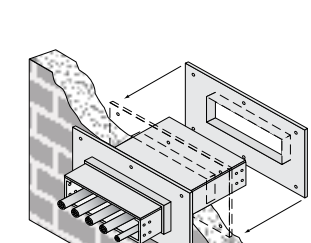

PRODUCT CODE	FASTENER OPTIONS
FWPS	GE S6
CATALOG NUMBERING EXAMPLE:	
H / Material	W Fasteners
4 G - FWPS - 06 - S6	

Fabricated cable tray fire stop sleeves from Legrand, combined with Hilti Firestop products, are an economical alternative to the high cost of fabricating protective fire wall and floor penetration sleeves in the field.

This firestop system provides a rigid support for cable tray in a UL classified system approved for fire wall and floor penetrations. After the sleeve is placed in the wall or floor, the loose collar slides over it. Hardware for the tray connection only is included. Hardware required to mount sleeves to the wall or floor is not included.

The Hilti Fire Block is a compressible fire stop brick, well-suited for installations where frequent cable changes may be required. Blocks are easily cut to fit any space, and can be removed and reinstalled when cable configurations change. When exposed to fire, the blocks expand to lock the seal in place.

Each cable tray firestop sleeve includes:

- One penetration sleeve with flanges
- Hilti Fire Blocks
- One Hilti Firestop Putty Stick
- Hardware for cable tray connection to the wall sleeve

DIV
VERTICAL ELBOW DIVIDERS A



PRODUCT CODE	FASTENER OPTIONS
DIV	S6
CATALOG NUMBERING EXAMPLE:	
H / Material	Elbow R Fasteners
6 A - DIV - 90V0 - 24 - S6	

RADIUS (R) INCHES • Each divider includes four self-drilling screws
12 | 24 | 36

WIDTHS (W) INCHES
6 | 9 | 12 | 18 | 24 | 30 | 36

RAIL HEIGHTS (H) INCHES
4 | 5 | 6 | 7

REDUCTION (RN) INCHES
3 | 6 | 9 | 12 | 15 | 18 | 21 | 24 | 27

CCLMP
CABLE CLAMP Z



PRODUCT CODE	CABLE SIZES
CCLMP	
CATALOG NUMBERING EX:	
Cable Size	
CCLMP 21	
INCHES	MM
0.25-0.84	6-21
0.85-1.35	22-35
1.25-1.75	32-45
1.55-2.05	40-52
2.00-2.50	51-64
2.50-3.00	64-76
3.25-3.75	83-95
3.75-4.25	95-108

- Secures MC cable to Itray in vertical installations. One hand installation. Combination bolt/Phillips head.
- Use maximum mm cable size when specifying clamp.

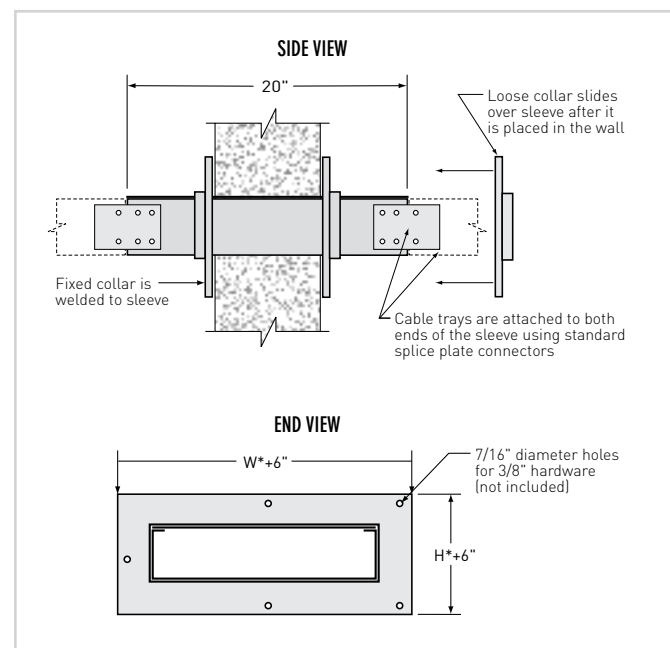

UL classified for use with:
2-hr concrete or block walls
2-hr concrete floors
1-hr gypsum walls
2-hr gypsum walls

SLEEVE WIDTH	NUMBER OF HILTI FIRE BLOCKS INCLUDED WITH EACH SLEEVE			
	SIDE RAIL HEIGHT (IN.)			
	4	5	6	7
6	2	2	3	3
9	3	3	4	4
12	3	4	5	6
18	5	6	7	8
24	6	8	9	11
30	8	10	12	14
36	9	12	14	16

LONG-SPAN

Trays for extremely heavy loads and long spans have I-beam side rails and are available in lengths up to 50'.

A	ALUMINUM
G	HOT-DIP GALVANIZED STEEL

WIDTHS (W) INCHES

12 | 18 | 24 | 30 | 36

RAIL HEIGHTS (H) INCHES

8 | 10

LENGTHS (L) FEET

20 | 24 | 30 | 40 | 50

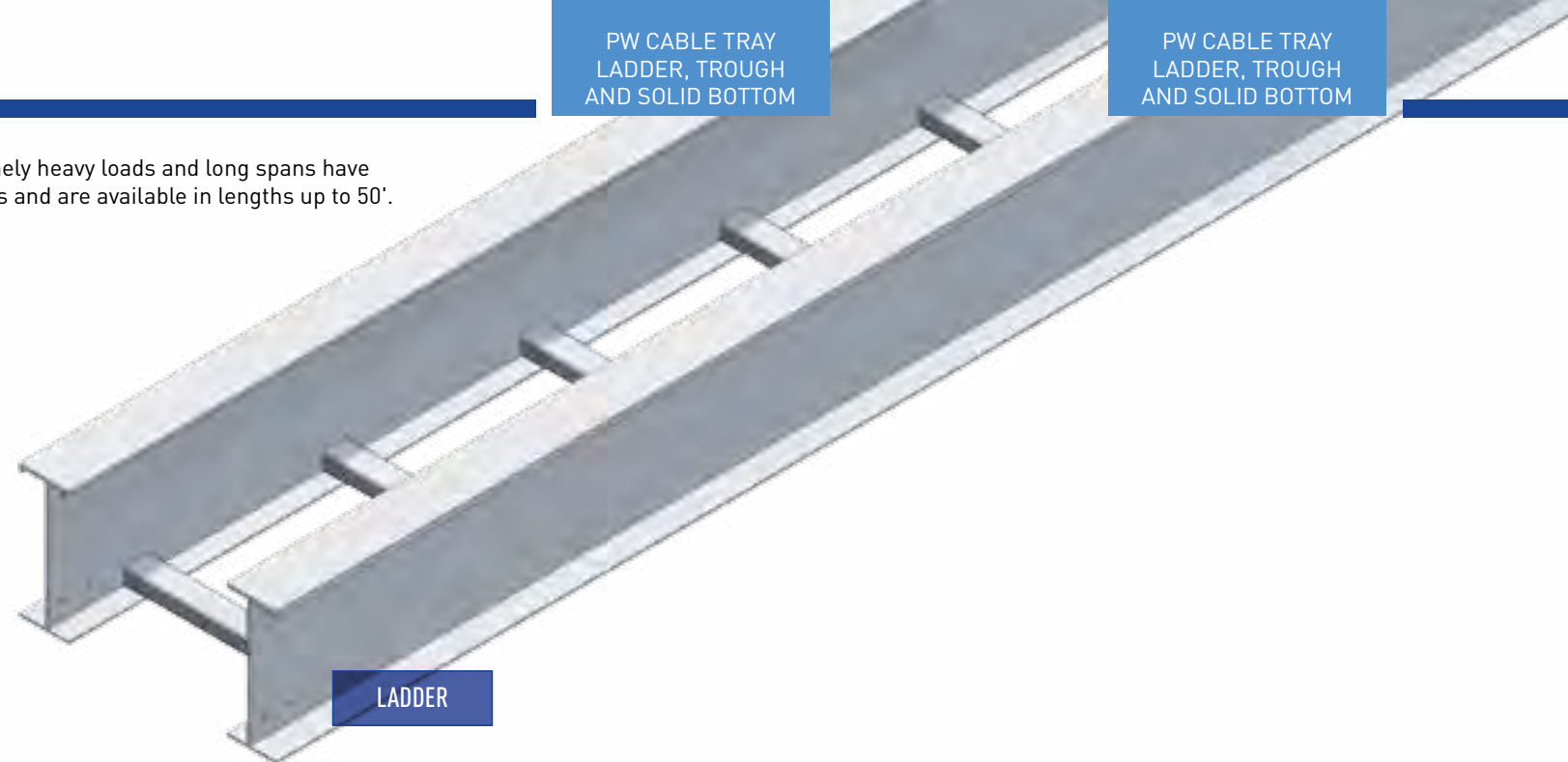

CONNECTORS & FITTINGS:

Necessary connectors and fasteners are supplied with all trays and fittings. Extra connectors for field cuts or spares must be ordered separately.

SAFE LOAD:

Allowable cable load in pounds per linear foot uniformly distributed. Based on tray with standard rung on 9" centers and supported on simple beam with safety factor of 1.5 per NEMA VE1.

CONCENTRATED LOAD:

All ladders with solid rungs and trays with corrugated bottoms will support a 200 lb. concentrated load applied at the center of the tray in addition to the NEMA-rated cable load without collapse.

RAIL HEIGHT (IN.)	LOAD DEPTH (IN.)	RAIL FLANGE (IN.)	NEMA CLASS	CSA CLASS	SERIES	TRAY SYSTEM NUMBER	AMP RATING	SUPPORT SPAN (FT.)												
								20	22	24	26	28	30	34	36	40				
8	7	3	20C+	E. 6M	S2	4823	2000	SAFE LOAD DATA (LBS./FT.) / DEFLECTION (IN.) / SAFETY FACTOR 1.5												
	6	2 1/2						270	1.88	218	2.22	179	2.58	150	2.98	127	3.39	108	3.81	76
10	8	4	20C+	E. 6M	S2	4812	2000	SAFE LOAD DATA (LBS./FT.) / DEFLECTION (IN.) / SAFETY FACTOR 1.5												
								292	2.00	236	2.37	194	2.75	162	3.17	137	3.60	117	4.05	82
			20C+	E. 6M	S2	4904	2000	SAFE LOAD DATA (LBS./FT.) / DEFLECTION (IN.) / SAFETY FACTOR 1.5												
								400	1.15	331	1.39	278	1.66	237	1.94	204	2.25	178	2.59	138

RAIL HEIGHT (IN.)	LOAD DEPTH (IN.)	RAIL FLANGE (IN.)	NEMA CLASS	CSA CLASS	SERIES	TRAY SYSTEM NUMBER	AMP RATING	SUPPORT SPAN (FT.)																				
								20	22	24	26	28	30	32	34	36	38	40	45	50								
8	6	2 1/4	20C+	-	S2	1952	600	SAFE LOAD DATA (LBS./FT.) / DEFLECTION (IN.) / SAFETY FACTOR 1.5																				
		4						203	0.88	167	1.06	141	1.27	120	1.49	103	1.72	90	1.98	81	2.22	68	2.47	60	2.72	54	3.06	48
10	5	4	20C+	-	S2	1953	600	SAFE LOAD DATA (LBS./FT.) / DEFLECTION (IN.) / SAFETY FACTOR 1.5																				
									360	0.98	298	1.18	250	1.41	213	1.65	184	1.92	160	2.20	139	2.47	121	2.74	107	3.05	95	3.35
			20C+	-	S2	1954†	600	SAFE LOAD DATA (LBS./FT.) / DEFLECTION (IN.) / SAFETY FACTOR 1.5																				
								900	1.04	744	1.26	625	1.50	533	1.77	459	2.05	400	2.35	347	2.64	304	2.95	268	3.26	238	3.60	212

† Fittings not available

SPLICES

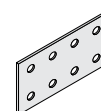

SERIES2

Fitting side rails have 5" tangents at the end of each fitting, to accommodate splice plates with eight holes.



Legrand trays marked with CSA load class have been tested (loading, finish and electrical) by UL to CSA standard 126 22.2 .



All Legrand aluminum and steel cable trays are Classified by UL as equipment grounding conductors per NEC 392.60. [UL File No. E60796]

LONG-SPAN STRAIGHT SECTION CATALOG NUMBERING EXAMPLE:

BOTTOM TYPE ← 09 - 4823 - 0020 - 36 → **WIDTH**

09 - 9" Rung Spacing*
12 - 12" Rung Spacing
18 - 18" Rung Spacing
* Standard rung spacing

VENTED

TRAY SYSTEM NUMBER
This identifies the specific tray design and is used as a product number prefix for straight sections.

LENGTH
0020 - 20'-0"
0024 - 24'-0"
0030 - 30'-0"
0040 - 40'-0"
0050 - 50'-0"

12 - 12"
18 - 18"
24 - 24"
30 - 30"
36 - 36"

STEEL

G HOT-DIP GALVANIZED STEEL

WIDTHS (W) INCHES
6 | 9 | 12 | 18 | 24 | 30 | 36

RAIL HEIGHTS (H) INCHES
4 | 5 | 6 | 7

LENGTHS (L) FEET
10 | 12 | 20 | 24

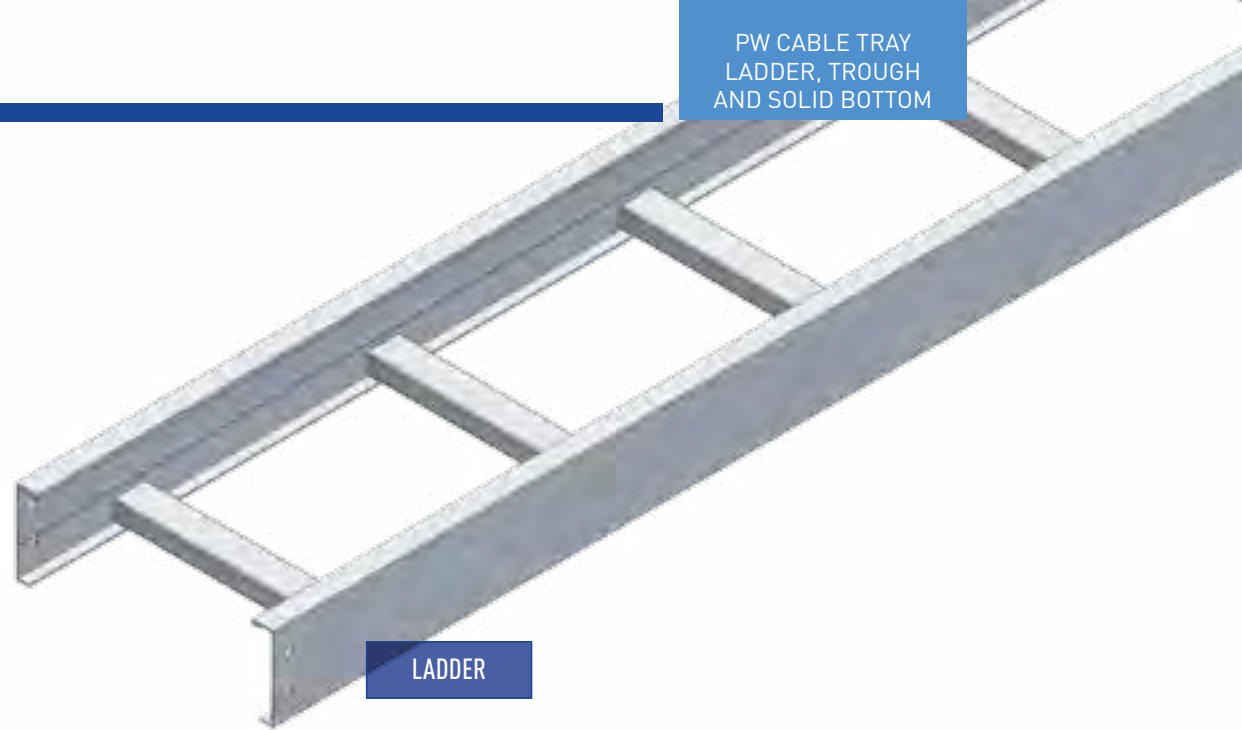

CONNECTORS & FITTINGS:

Necessary connectors and fasteners are supplied with all trays and fittings. Extra connectors for field cuts or spares must be ordered separately.

SAFE LOAD:

Allowable cable load in pounds per linear foot uniformly distributed. Based on tray with standard rung on 9" centers and supported on simple beam with safety factor of 1.5 per NEMA VE1.

CONCENTRATED LOAD:

All ladders with solid rungs and trays with corrugated bottoms will support a 200 lb. concentrated load applied at the center of the tray in addition to the NEMA-rated cable load without collapse.

RAIL HEIGHT (IN.)	LOAD DEPTH (IN.)	RAIL FLANGE (IN.)	NEMA CLASS	CSA CLASS	SERIES	TRAY SYSTEM NUMBER		AMP RATING	SUPPORT SPAN (FT.)																			
						□	□		6	8	10	12	14	16	18	20	22	24										
4	3	1 3/4	12C, 16A	D, 3M	S1	A457	-	100	439	0.31	250	0.55	160	0.86	111	1.24	78	1.61	58	2.06								
			20A, 16B	-	S2	1D80	1D81	200	439	0.20	338	0.51	216	0.79	150	1.14	110	1.55	84	2.02	67	2.56	54	3.16	44	3.74	34	4.07
			20B, 16C	D, 6M	S2	1D82	1D83	400	439	0.16	439	0.50	312	0.88	217	1.26	159	1.72	122	2.25	96	2.84	78	3.51	63	4.18	52	4.87
			20C	E, 6M	S2	1D69*	1D70	400			439	0.39	400	0.87	278	1.25	204	1.70	156	2.21	123	2.80	100	3.46	81	4.09	66	4.77
5	4	1 3/4	12C, 16A	D, 3M	S1	1E72	-	100	400	0.21	225	0.38	144	0.59	100	0.85	71	1.13	52	1.40								
			20B, 16C	-	S2	1E45	1E46	400	439	0.11	439	0.37	304	0.62	211	0.90	155	1.22	119	1.59	94	2.02	76	2.49	61	2.92	50	3.38
			20C	D, 6M	S2	1E53*	1E54	400			439	0.34	400	0.75	278	1.08	204	1.47	156	1.92	123	2.43	100	3.00	81	3.54	60	4.13
6	5	1 3/4	12C, 16A	D, 3M	S1	A639	-	100	420	0.13	236	0.22	151	0.35	105	0.50	74	0.65	55	0.83								
			20B, 16C	E, 6M	S2	1F45*	1F46	400	439	0.08	439	0.25	336	0.47	233	0.68	171	0.92	131	1.20	104	1.52	84	1.88	68	2.24	53	2.47
			20C	E, 6M	S2	1F53*	1F54	400			439	0.20	439	0.50	319	0.75	235	1.02	180	1.34	142	1.69	115	2.09	93	2.48	73	2.75
7	6	1 3/4	12C, 16A	D, 3M	S1	1772	-	100	400	0.10	225	0.18	144	0.28	100	0.40	71	0.53	52	0.66								
			20B, 16C	E, 6M	S2	1755*	1756	400	439	0.07	439	0.22	300	0.38	208	0.54	153	0.73	117	0.96	93	1.22	75	1.50	61	1.79	50	2.08
			20C	E, 6M	S2	1753	1754	400			439	.017	439	0.42	319	0.63	235	0.86	180	1.12	142	1.42	115	1.75	93	2.11	76	2.52

*1D69, 1F45, and 1F53 corrugated bottom tray systems have a CSA load class D,6M rating. 1E53 and 1755 corrugated bottom tray systems do not have CSA load class ratings.



Legrand trays marked with CSA load class have been tested (loading, finish and electrical) by UL to CSA standard 126 22.2.



All Legrand steel cable trays are Classified by UL as equipment grounding conductors per NEC 392.60. (UL File No. E60796)

SPLICES Match above to determine the connectors you need.

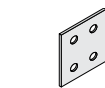

SERIES 1

Fitting side rails have 2" tangents (flat portion beyond curvature) at the end of each fitting, to accommodate splice plates with four holes.

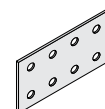

SERIES 2

Fitting side rails have 5" tangents at the end of each fitting, to accommodate splice plates with eight holes.

STEEL STRAIGHT SECTION CATALOG NUMBERING EXAMPLE:

09 - A 4 5 7 - 0 0 1 2 - 3 6 -

SYSTEM NO. 09 - **PRODUCT NO.** A 4 5 7 - 0 0 1 2 - 3 6 -

TRAY SYSTEM NUMBER
This identifies the specific tray design and is used as a product number prefix for straight sections.

LENGTH
0010 - 10'-0"
0012* - 12'-0"
0020* - 20'-0"
0024 - 24'-0"
* Standard for **SERIES 1**
† Standard for **SERIES 2**

WIDTH
06 - 6"
09 - 9"
12 - 12"
18 - 18"
24 - 24"
30 - 30"
36 - 36"

RUNG OPTION
Add suffix for non-standard rung. See page 63 for details and other rung options.

VENTED
06 - 6" Rung Spacing
09 - 9" Rung Spacing*
12 - 12" Rung Spacing
18 - 18" Rung Spacing**
VC† - Vented Corrugated

NON-VENTED
SC† - Solid Corrugated
* Standard rung spacing
† Not available for flange out tray

STAINLESS STEEL

L	STAINLESS STEEL AISI Type 304L
T	STAINLESS STEEL AISI Type 316L

WIDTHS (W) INCHES

6 | 9 | 12 | 18 | 24 | 30 | 36

RAIL HEIGHTS (H) INCHES

4 | 5 | 6 | 7

LENGTHS (L) FEET

10 | 12 | 20 | 24

CONNECTORS & FITTINGS:

Necessary connectors and fasteners are supplied with all trays and fittings. Extra connectors for field cuts or spares must be ordered separately.

SAFE LOAD:

Allowable cable load in pounds per linear foot uniformly distributed. Based on tray with standard rung on 9" centers and supported on simple beam with safety factor of 1.5 per NEMA VE1.

CONCENTRATED LOAD:

All ladders with solid rungs and trays with corrugated bottoms will support a 200 lb. concentrated load applied at the center of the tray in addition to the NEMA-rated cable load without collapse.

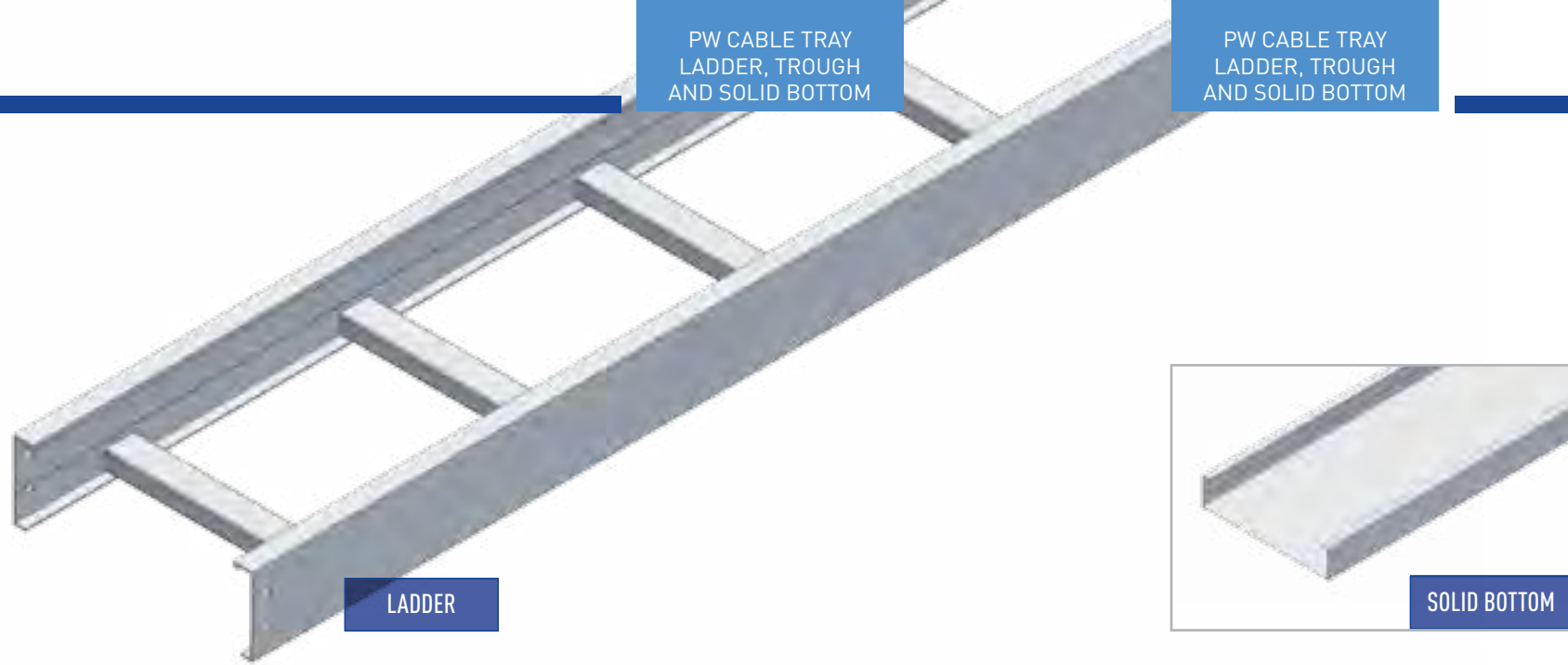

RAIL HEIGHT (IN.)	LOAD DEPTH (IN.)	RAIL FLANGE (IN.)	NEMA CLASS	SERIES	TRAY SYSTEM NUMBER				SUPPORT SPAN (FT.)																			
					[]	[]	[]	[]	6	8	10	12	14	16	18	20	22	24										
					SAFE LOAD DATA (LBS./FT.) / DEFLECTION (IN.) / SAFETY FACTOR 1.5																							
4	3	1	12B	S1	3408	3416	-	-	300	0.30	169	0.54	108	0.85	75	1.22												
			12C, 16A	S1	3409	3417	-	-	400	0.32	225	0.57	144	0.90	100	1.29	71	1.71	52	2.13								
			20A, 16B	S2	3476	3D85	3D63	3D82	556	0.31	313	0.55	200	0.86	139	1.24	102	1.69	78	2.20	62	2.79	50	3.44				
			20B, 16C	S2	3456	3D92	3D93	3D58	564	0.24	469	0.62	300	0.97	208	1.39	153	1.89	117	2.47	93	3.13	75	3.70	86	4.60	48	5.13
			20C	S2	3406	3445	3407	3446			564	0.54	400	0.94	278	1.36	204	1.85	156	2.41	123	3.05	100	3.77	81	4.45	63	4.96
5	4	1	12B	S1	3504	3514	-	-	300	0.20	169	0.35	108	0.55	75	0.79												
			12C, 16A	S1	3505	3515	-	-	400	0.23	225	0.41	144	0.64	100	0.93	71	1.23	52	1.53								
			20B, 16C	S2	3551	3594	3550	3582	564	0.16	469	0.42	300	0.66	208	0.95	153	1.29	117	1.69	93	2.14	75	2.64	61	3.14	48	3.51
			20C	S2	3587	3593	3592	3583			564	0.46	400	0.80	278	1.16	204	1.57	156	2.05	123	2.60	100	3.21	81	3.79	63	4.22
											564	0.31	400	0.54	278	0.77	204	1.05	156	1.38	123	1.74	100	2.15	81	2.54	63	2.83
6	5	1	12B	S1	3603	3620	-	-	300	0.11	169	0.20	108	0.31	75	0.45												
			12C, 16A	S1	3604	3621	-	-	400	0.14	225	0.24	144	0.38	100	0.54	71	0.71	52	0.89								
			20B, 16C	S2	3F67	3F85	3F68	3F66	564	0.12	469	0.32	300	0.51	208	0.73	153	0.99	117	1.30	93	1.64	75	2.03	61	2.42	48	2.70
			20C	S2	3645	3F35	3F58	3F61			564	0.31	400	0.54	278	0.77	204	1.05	156	1.38	123	1.74	100	2.15	81	2.54	63	2.83
											564	0.28	400	0.48	278	0.69	204	0.93	156	1.22	123	1.55	100	1.91	81	2.05	63	2.28
7	6	1	12B	S1	3734	3738	-	-	300	0.10	169	0.17	108	0.27	75	0.39												
			12C, 16A	S1	3735	3739	-	-	400	0.11	225	0.19	144	0.30	100	0.43	71	0.57	52	0.71								
			20B, 16C	S2	3701	3723	3754	3756	564	0.10	469	0.26	300	0.41	208	0.58	153	0.79	117	1.04	93	1.31	75	1.62	61	1.93	48	2.15
			20C	S2	3714	3724	3722	3760			564	0.28	400	0.48	278	0.69	204	0.93	156	1.22	123	1.55	100	1.91	81	2.05	63	2.28
											564	0.28	400	0.48	278	0.69	204	0.93	156	1.22	123	1.55	100	1.91	81	2.05	63	2.28

SPLICES

Match above to determine the connectors you need.

SERIES 1

Fitting side rails have 2" tangents (flat portion beyond curvature) at the end of each fitting, to accommodate splice plates with four holes.

SERIES 2

Fitting side rails have 5" tangents at the end of each fitting, to accommodate splice plates with eight holes.

STAINLESS STEEL STRAIGHT SECTION CATALOG NUMBERING EXAMPLE:

BOTTOM TYPE ← 09 - 3620 - 0012 - 18 -

- 06 - 6" Rung Spacing
- 09 - 9" Rung Spacing*
- 12 - 12" Rung Spacing
- 18 - 18" Rung Spacing

TRAY SYSTEM NUMBER

This identifies the specific tray design and is used as a product number prefix for straight sections.

LENGTH

- 0010 - 10'-0"
- 0012* - 12'-0"
- 0020† - 20'-0"
- 0024 - 24'-0"

* Standard for **SERIES 1**

† Standard for **SERIES 2**

WIDTH

- 06 - 6"
- 09 - 9"
- 12 - 12"
- 18 - 18"
- 24 - 24"
- 30 - 30"
- 36 - 36"

RUNG OPTION

Add suffix for non-standard rung. See page 63 for details and other rung options.

HORIZONTAL REDUCERS

G L T

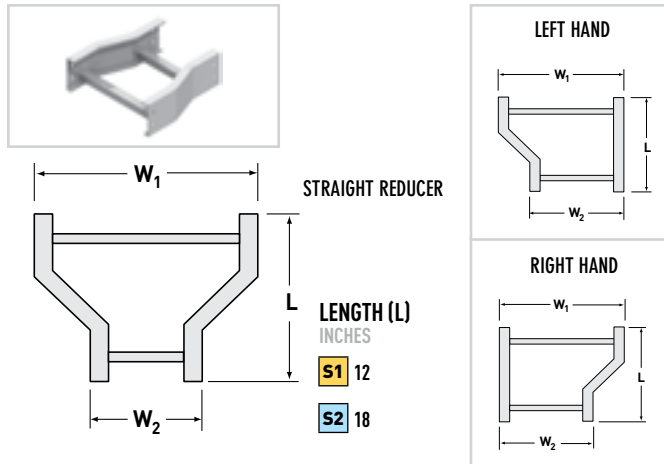

MAIN WIDTH (IN.) W1	BRANCH WIDTH (IN.) W2	PRODUCT NUMBER		
		STRAIGHT	LEFT HAND	RIGHT HAND
9	6	0109	0709	0809
12	6	0112	0712	0812
	9	0112	0712	0812
18	6	0118	0718	0818
	9	0118	0718	0818
24	6	0124	0724	0824
	9	0124	0724	0824
30	6	0130	0730	0830
	9	0130	0730	0830
36	6	0136	0736	0836
	9	0136	0736	0836
36	12	0136	0736	0836
	18	0136	0736	0836
36	24	0136	0736	0836
	30	0136	0736	0836

HORIZONTAL STANDARD TEE

G L T

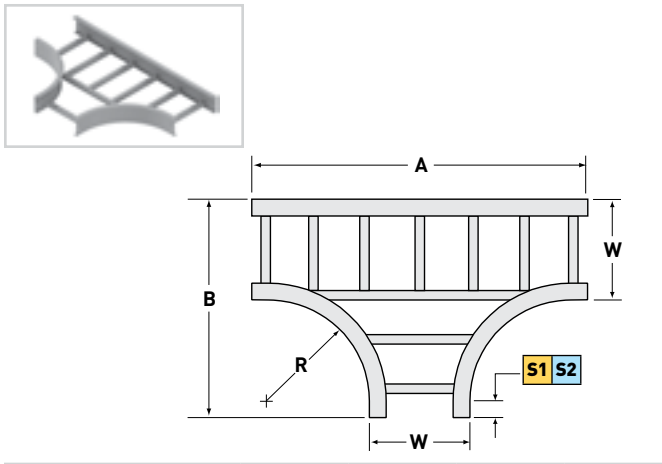

PRODUCT NUMBER RADIUS (IN.)	W	SERIES1		SERIES2	
		A	B	A	B
2012 12	6	34	20	40	23
	9	37	23	43	26
	12	40	26	46	29
	18	46	32	52	35
	24	52	38	58	41
	30	58	44	64	47
2024 24	6	58	32	64	35
	9	61	35	67	38
	12	64	38	70	41
	18	70	44	76	47
	24	76	50	82	53
	30	82	56	88	59
2036 36	6	82	44	88	47
	9	85	47	91	50
	12	88	50	94	53
	18	94	56	100	59
	24	100	62	106	65
	30	106	68	112	71
36	112	74	118	77	

HORIZONTAL REDUCING/EXPANDING TEES

G L T

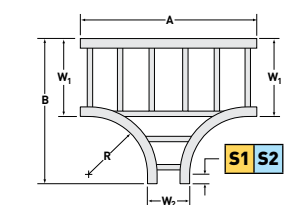

MAIN WIDTH W1	BRANCH WIDTH W2	PRODUCT NUMBER RADIUS (IN.)	SERIES1		SERIES2		PRODUCT NUMBER RADIUS (IN.)	SERIES1		SERIES2		PRODUCT NUMBER RADIUS (IN.)	SERIES1		SERIES2	
			A	B	A	B		A	B	A	B		A	B		
9	6	2012 12	34	23	40	26	2024 24	58	35	64	38	2036 36	82	47	88	50
	12		34	26	40	29		58	38	64	41		82	50	88	53
18	6		34	32	40	35		58	44	64	47		82	56	88	59
	9		37	32	43	35		61	44	67	47		85	56	91	59
24	6		34	38	40	41		64	44	70	47		88	56	94	59
	9		37	38	43	41		61	50	67	53		85	62	91	65
30	6		40	38	46	41		64	50	70	53		88	62	94	65
	9		46	38	52	41		70	50	76	53		94	62	100	65
36	6		34	44	40	47		58	56	64	59		82	68	88	71
	9		37	44	43	47		61	56	67	59		85	68	91	71
36	12		40	44	46	47		64	56	70	59		88	68	94	71
	18		46	44	52	47		70	56	76	59		94	68	100	71
36	24	52	44	58	47	76	56	82	59	100	68	106	71			
	30	58	50	64	53	82	62	88	65	106	74	112	77			
6	9	2012 12	37	20	43	23	2024 24	61	32	67	35	2036 36	85	44	91	47
	12		40	20	46	23		64	32	70	35		88	44	94	47
18	46		20	52	23	70		32	76	35	94		44	100	47	
24	52		20	58	23	76		32	82	35	100		44	106	47	
30	58		20	64	23	82		32	88	35	106		44	112	47	
36	64		20	70	23	88		32	94	35	112		44	118	47	
9	12		40	23	46	26		64	35	70	38		88	47	94	50
	18		46	23	52	26		70	35	76	38		94	47	100	50
12	24		52	23	58	26		76	35	82	38		100	47	106	50
	30		58	23	64	26		82	35	88	38		106	47	112	50
18	36		64	23	70	26		88	35	94	38		112	47	118	50
	24		46	26	52	29		70	38	76	41		94	50	100	53
24	30	52	26	58	29	76	38	82	41	100	50	106	53			
	36	58	26	64	29	82	38	88	41	106	50	112	53			
30	24	64	26	70	29	88	38	94	41	112	50	118	53			
	30	52	32	58	35	76	44	82	47	100	56	106	59			
36	30	58	32	64	35	82	44	88	47	106	56	112	59			
	36	64	32	70	35	88	44	94	47	112	56	118	59			
24	30	58	38	64	41	82	50	88	53	106	62	112	65			
	36	64	38	70	41	88	50	94	53	112	62	118	65			
30	36	64	44	70	47	88	56	94	59	112	68	118	71			

METALLIC FITTINGS

- WIDTHS (W) INCHES: 6 | 9 | 12 | 18 | 24 | 30 | 36
- RAIL HEIGHTS (H) INCHES: 4 | 5 | 6 | 7
- RADIUS (R) INCHES: 12 | 24 | 36

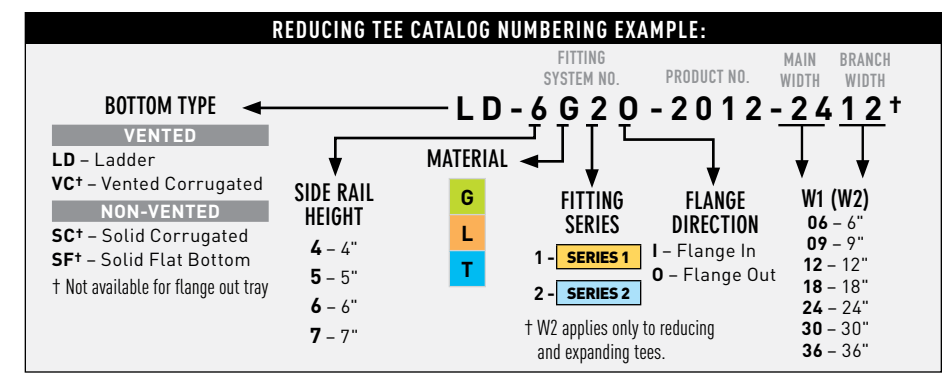
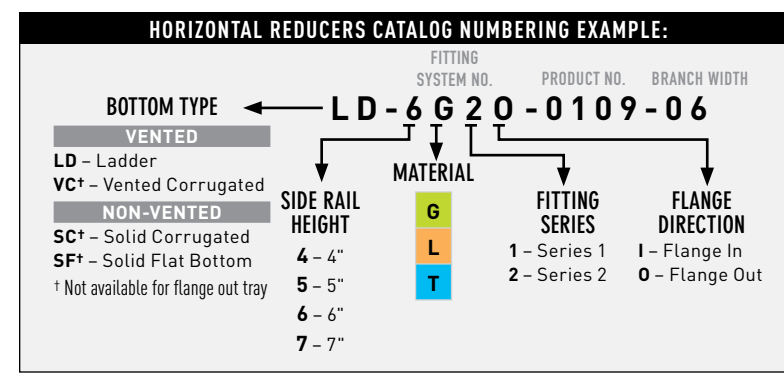

METALLIC FITTINGS

HORIZONTAL CROSSES

G L T

STANDARD CROSS

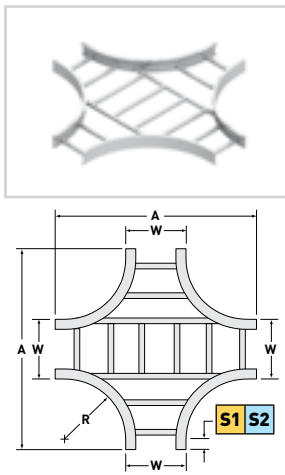

W	PRODUCT NUMBER RADIUS (IN.)	SERIES 1		SERIES 2		PRODUCT NUMBER RADIUS (IN.)	SERIES 1		SERIES 2	
		A	A	A	A		A	A		
6	1012 12	34	40	1024 24	58	64	1036 36	82	88	
9		37	43		61	67		85	91	
12		40	46		64	70		88	94	
18		46	52		70	76		94	100	
24		52	58		76	82		100	106	
30		58	64		82	88		106	112	
36	64	70	88	94	112	118				

REDUCING CROSS

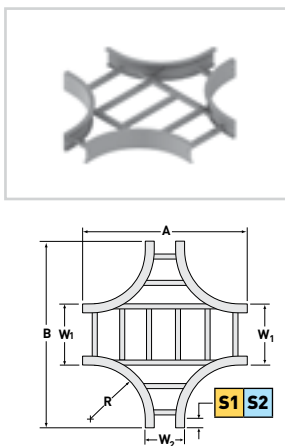

MAIN WIDTH W1	BRANCH WIDTH W2	PROD. NUM. RADIUS	SERIES 1		SERIES 2		PROD. NUM. RADIUS	SERIES 1		SERIES 2		PROD. NUM. RADIUS	SERIES 1		SERIES 2	
			A	B	A	B		A	B	A	B		A	B		
9	6	1012 12	34	37	40	43	1024 24	58	61	64	67	1036 36	82	85	88	91
	12		34	40	40	46		58	64	64	70		82	88	88	94
12	9		37	40	43	46		61	64	67	70		85	88	91	94
	6		34	46	40	52		58	70	64	76		82	94	88	100
18	9		37	46	43	52		61	70	67	76		85	94	91	100
	12		40	46	46	52		64	70	70	76		88	94	94	100
24	6		34	52	40	58		58	76	64	82		82	100	88	106
	9		37	52	43	58		61	76	67	82		85	100	91	106
24	12		40	52	46	58		64	76	70	82		88	100	94	106
	18		46	52	52	58		70	76	76	82		94	100	100	106
30	6		34	58	40	64		58	82	64	88		82	106	88	112
	9		37	58	43	64		61	82	67	88		85	106	91	112
30	12	40	58	46	64	64	82	70	88	88	106	94	112			
	18	46	58	52	64	70	82	76	88	94	106	100	112			
30	24	52	58	58	64	76	82	82	88	100	106	106	112			
	6	34	64	40	70	58	88	64	94	82	112	88	118			
36	9	37	64	43	70	61	88	67	94	85	112	91	118			
	12	40	64	46	70	64	88	70	94	88	112	94	118			
36	18	46	64	52	70	70	88	76	94	94	112	100	118			
	24	52	64	58	70	76	88	82	94	100	112	106	118			
30	30	58	64	64	70	82	88	88	94	106	112	112	118			

REDUCING CROSS CATALOG NUMBERING EXAMPLE:

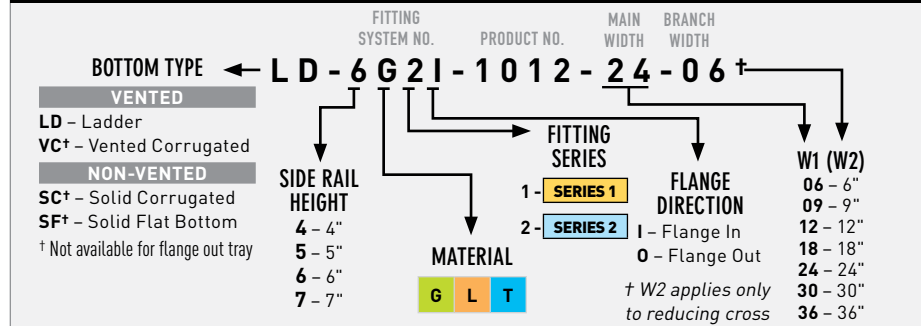

- WIDTHS (W) INCHES
6 | 9 | 12 | 18 | 24 | 30 | 36
- RAIL HEIGHTS (H) INCHES
4 | 5 | 6 | 7
- RADIUS (R) INCHES
12 | 24 | 36

HORIZONTAL WYE BRANCHES

G L T

LEFT HAND

RIGHT HAND

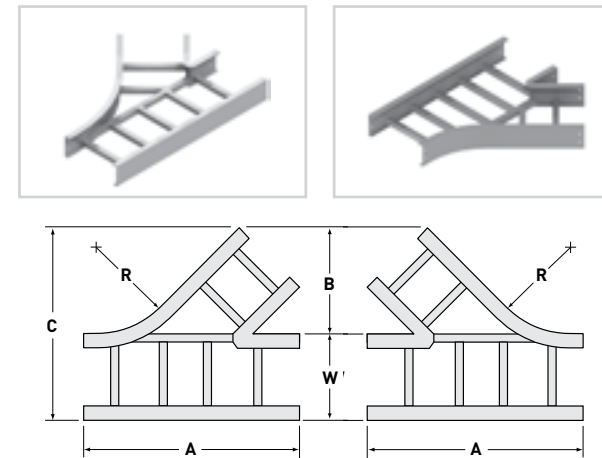

W	PRODUCT NUMBER		SERIES 1			SERIES 2		
	LH RADIUS (IN.)	RH RADIUS (IN.)	A	B	C	A	B	C
6	4024 24	4124 24	26 ³ / ₈	10 ¹ / ₄	16 ¹ / ₄	29 ³ / ₈	10 ¹ / ₄	16 ¹ / ₄
9			30 ³ / ₈	12 ³ / ₈	21 ³ / ₈	33 ³ / ₈	12 ³ / ₈	21 ³ / ₈
12			34 ³ / ₈	14 ¹ / ₂	26 ¹ / ₂	37 ³ / ₈	14 ¹ / ₂	26 ¹ / ₂
18			43 ³ / ₈	18 ³ / ₈	36 ³ / ₈	46 ³ / ₈	18 ³ / ₈	36 ³ / ₈
24			51 ⁷ / ₈	23	47	54 ⁷ / ₈	23	47
30			60 ³ / ₈	27 ¹ / ₄	57 ¹ / ₄	63 ³ / ₈	27 ¹ / ₄	57 ¹ / ₄
36	68 ⁷ / ₈	31 ¹ / ₂	67 ¹ / ₂	71 ⁷ / ₈	31 ¹ / ₂	67 ¹ / ₂		

HORIZONTAL ADJUSTABLE ELBOW

G L T

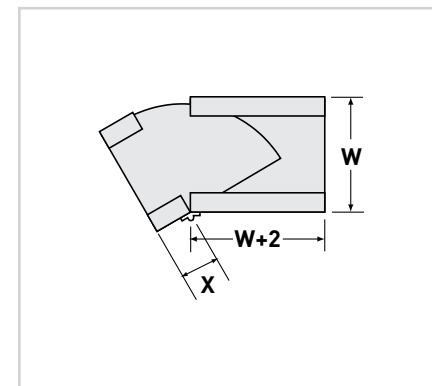

PRODUCT NUMBER	W	SERIES 1	SERIES 2
		X	X
0401	6	4	7
	9	4	7
	12	4	7
	18	4	7
	24	4	7
	30	4	7
36	4	7	

HORIZONTAL WYE BRANCH CATALOG NUMBERING EXAMPLE:

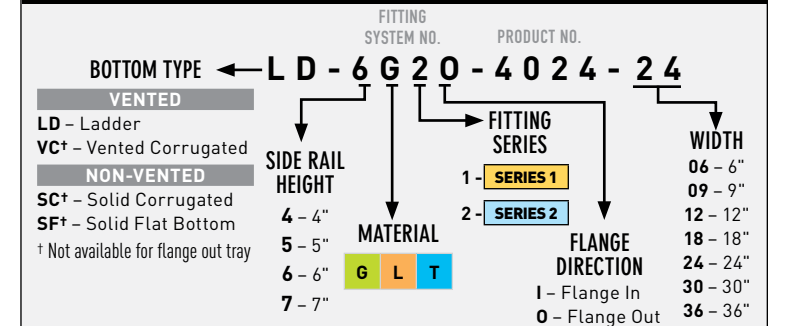

- WIDTHS (W) INCHES
6 | 9 | 12 | 18 | 24 | 30 | 36
- RAIL HEIGHTS (H) INCHES
4 | 5 | 6 | 7
- RADIUS (R) INCHES
12 | 24 | 36

VERTICAL OUTSIDE 90° ELBOW **G L T**

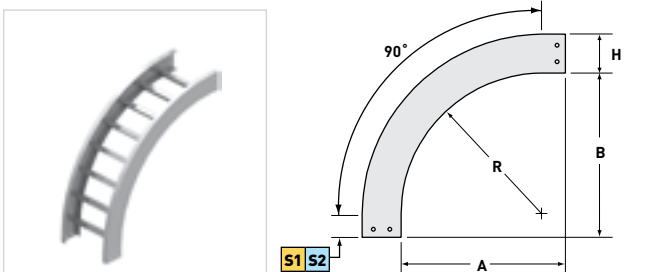

RAIL HEIGHT (IN.) >		4, 5, 6, 7			
PRODUCT NUMBER RADIUS (IN.)	W*	SERIES 1		SERIES 2	
		A	B	A	B
9212 12	ALL	14	14	17	17
9224 24	ALL	26	26	29	29
9236 36	ALL	38	38	41	41

VERTICAL OUTSIDE 60° ELBOW **G L T**

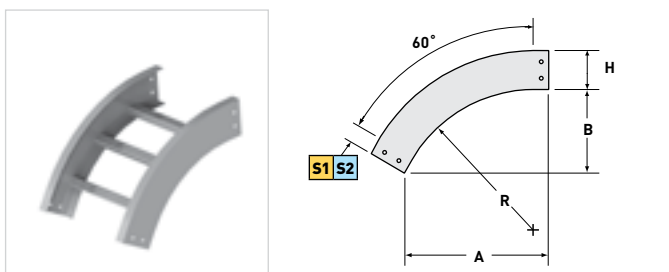

RAIL HEIGHT (IN.) >		4, 5, 6, 7			
PRODUCT NUMBER RADIUS (IN.)	W*	SERIES 1		SERIES 2	
		A	B	A	B
6212 12	ALL	13 1/2	7 3/4	18	1 3/8
6224 24	ALL	23 7/8	13 3/4	28 3/8	16 3/8
6236 36	ALL	34 1/4	19 3/4	38 3/4	22 3/8

VERTICAL OUTSIDE 45° ELBOW **G L T**

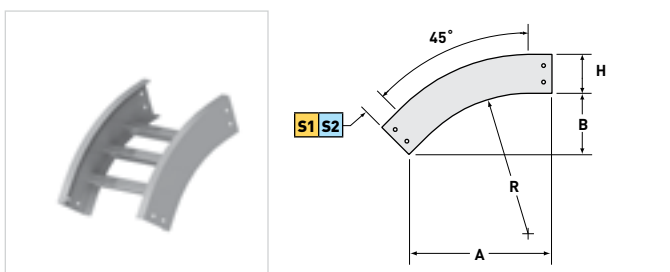

RAIL HEIGHT (IN.) >		4, 5, 6, 7			
PRODUCT NUMBER RADIUS (IN.)	W*	SERIES 1		SERIES 2	
		A	B	A	B
4712 12	ALL	12	5	17 1/8	7 1/8
4724 24	ALL	20 1/2	8 1/2	25 5/8	10 5/8
4736 36	ALL	28 7/8	12	34	14 1/8

VERTICAL OUTSIDE 30° ELBOW **G L T**

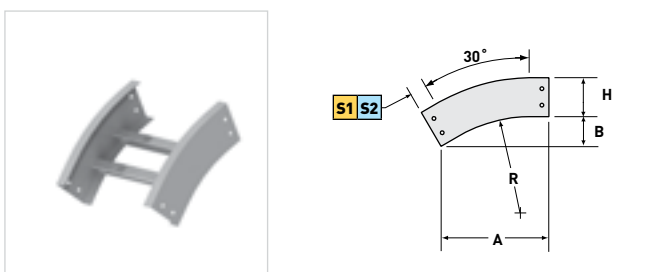

RAIL HEIGHT (IN.) >		4, 5, 6, 7			
PRODUCT NUMBER RADIUS (IN.)	W*	SERIES 1		SERIES 2	
		A	B	A	B
3212 12	ALL	9 3/4	2 5/8	15 3/8	4 1/8
3224 24	ALL	15 3/4	4 1/4	21 3/8	5 3/4
3236 36	ALL	21 3/4	5 7/8	27 3/8	7 3/8

SPLICES Match above to determine the connectors you need.

SERIES 1
Fitting side rails have 2" tangents (flat portion beyond curvature) at the end of each fitting, to accommodate splice plates with four holes.

SERIES 2
Fitting side rails have 5" tangents at the end of each fitting, to accommodate splice plates with eight holes.

- WIDTHS (W) INCHES
6 | 9 | 12 | 18 | 24 | 30 | 36
- RAIL HEIGHTS (H) INCHES
4 | 5 | 6 | 7
- RADIUS (R) INCHES
12 | 24 | 36

VERTICAL INSIDE 90° ELBOW **G L T**

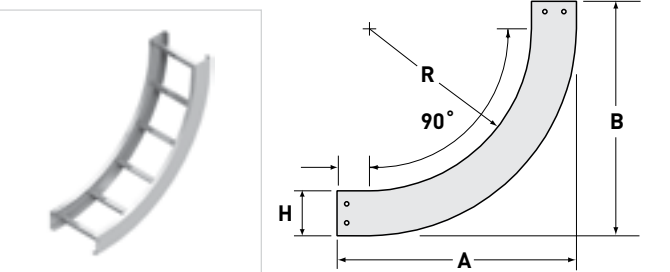

VERTICAL INSIDE 45° ELBOW **G L T**

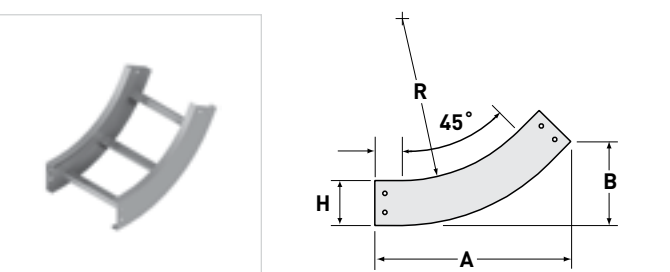

VERTICAL INSIDE 60° ELBOW **G L T**

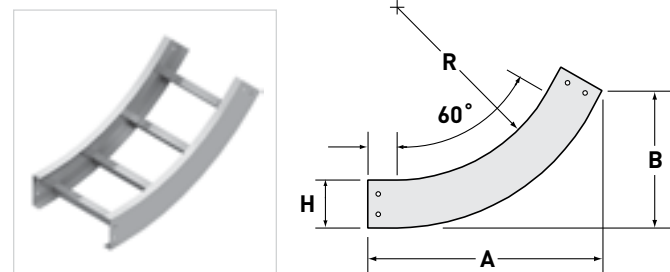

VERTICAL INSIDE 30° ELBOW **G L T**

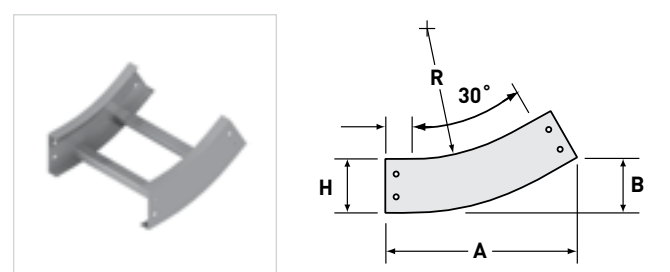

RAIL HEIGHT >		4				5				6				7					
PRODUCT NUMBER RADIUS (IN.)	R	W	SERIES 1		SERIES 2		SERIES 1		SERIES 2		SERIES 1		SERIES 2		SERIES 1		SERIES 2		
			A	B	A	B	A	B	A	B	A	B	A	B	A	B			
90°	9112	12	ALL	18	18	21	21	19	19	22	22	20	20	23	23	21	21	24	24
	9124	24	ALL	30	30	33	33	31	31	34	34	32	32	35	35	33	33	36	36
	9136	36	ALL	42	42	45	45	43	43	46	46	44	44	47	47	45	45	48	48
60°	6112	12	ALL	16 7/8	9 3/4	21 3/8	12 3/8	17 3/4	10 1/4	22 1/4	12 7/8	18 5/8	10 3/4	23 1/8	13 3/8	19 1/2	11 1/4	24	13 7/8
	6124	24	ALL	27 1/4	15 3/4	31 3/4	18 3/8	28 1/8	16 1/4	32 3/8	18 7/8	29	16 3/4	33 1/2	19 3/8	29 7/8	17 1/4	34 3/8	19 7/8
	6136	36	ALL	37 3/4	21 3/4	42 1/4	24 3/8	38 5/8	22 1/4	43 1/8	24 7/8	39 3/8	22 3/4	43 7/8	25 3/8	40 1/4	23 1/4	44 3/4	25 7/8
45°	4612	12	ALL	14 3/4	6 1/8	19 7/8	8 1/4	15 1/2	6 1/2	20 5/8	8 5/8	16 1/4	6 3/4	21 3/8	8 7/8	16 7/8	7	22	9 1/8
	4624	24	ALL	23 1/4	9 5/8	28 3/8	11 3/4	24	10	29 1/8	12 1/8	24 5/8	10 1/4	29 3/4	12 3/8	25 3/8	10 1/2	30 1/2	12 5/8
	4636	36	ALL	31 3/4	13 1/4	36 7/8	15 1/4	32 1/2	13 1/2	37 5/8	15 5/8	33 1/8	13 3/4	38 1/4	15 7/8	33 7/8	14	39	16 1/4
30°	3112	12	ALL	11 3/4	3 1/4	17 3/8	4 3/4	12 1/4	3 1/4	17 7/8	4 3/4	12 3/4	3 3/8	18 3/8	4 7/8	13 1/4	3 5/8	18 7/8	5 1/8
	3124	24	ALL	17 3/4	4 3/4	23 3/8	6 1/4	18 1/4	4 7/8	23 7/8	6 3/8	18 3/4	5	24 3/8	6 1/2	19 1/4	5 1/4	24 7/8	6 3/4
	3136	36	ALL	23 3/4	6 3/8	29 3/8	7 7/8	24 1/4	6 1/2	29 7/8	8	24 3/4	6 5/8	30 3/8	8 1/8	25 1/4	6 7/8	30 7/8	8 3/8

VERTICAL ELBOW CATALOG NUMBERING EXAMPLE:

FITTING SYSTEM NO. PRODUCT NO.

LD - 6 G 2 I - 6 1 2 4 - 2 4

WIDTH: 06 - 6" | 09 - 9" | 12 - 12" | 18 - 18" | 24 - 24" | 30 - 30" | 36 - 36"

BOTTOM TYPE: LD - Ladder, VC† - Vented Corrugated, NON-VENTED, SC† - Solid Corrugated, SF† - Solid Flat Bottom

SIDE RAIL HEIGHT: 4 - 4", 5 - 5", 6 - 6", 7 - 7"

MATERIAL: G, L, T

FITTING SERIES: 1 - SERIES 1, 2 - SERIES 2

FLANGE DIRECTION: I - Flange In, O - Flange Out

† Not available for flange out tray

For detailed material and finish descriptions, see page 6. For other products that fit ltray specifications, look for the ltray Compatible logo on pages 40 thru 57.

VERTICAL TEES

G L T

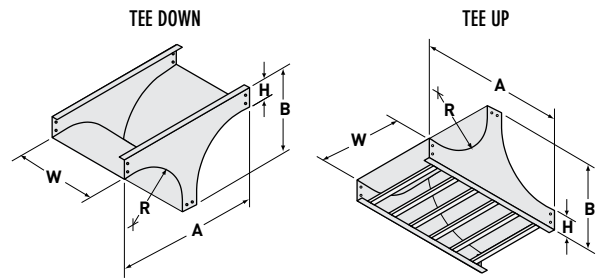

TEE UP fittings have rungs or bottom members for cable support across the bottom of the fitting.

PRODUCT NUMBER RADIUS (IN.)		W	H	SERIES 1		SERIES 2	
TEE DOWN	TEE UP			A	B	A	B
2124 24	2224 24	ALL	4	56	30	62	33
			5	57	31	63	34
			6	58	32	64	35
			7	59	33	65	36

VERTICAL CROSS

G L T

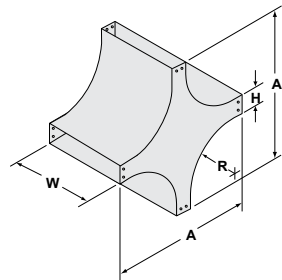

PRODUCT NUMBER RADIUS (IN.)	W	H	SERIES 1	SERIES 2
			A	A
1124 24	ALL	4	56	62
		5	57	63
		6	58	64
		7	59	65

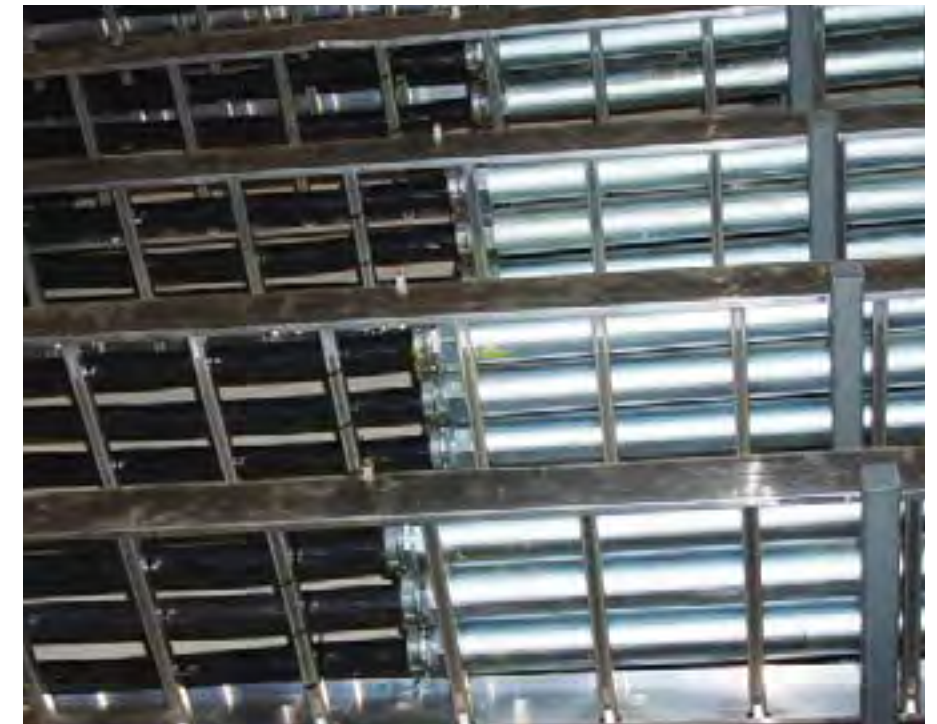

VERTICAL 90° SUPPORT ELBOW

G L T

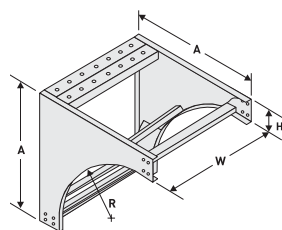

Supports cables at the top of long vertical drops where the weight of the vertical cable may be excessive. Hooks (sold separately) attach to the brace in the elbow; when used with cable grips (supplied by others), tension in the vertical cable is relieved and transferred to the elbow.

PRODUCT NUMBER RADIUS	W	H	SERIES 2
			A
9312 12	ALL	4	21
		5	22
		6	23
		7	24
9324 24	ALL	4	33
		5	34
		6	35
		7	36
9336 36	ALL	4	45
		5	46
		6	47
		7	48

CABLE SUPPORT HOOK

G L T

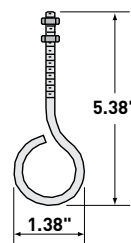

COMPLETE CATALOG NO.
DS-1841-ZN

Itray
COMPATIBLE

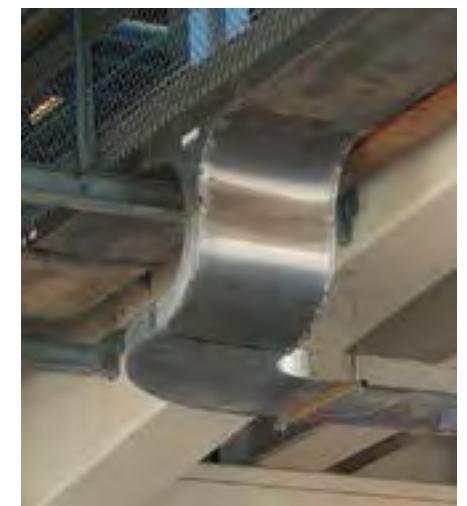

VERTICAL TEE DOWN CATALOG NUMBERING EXAMPLE:

FITTING SYSTEM NO. PRODUCT NO.

LD-6G2I-2124-24

BOTTOM TYPE	LD - Ladder	VC† - Vented Corrugated	NON-VENTED	SC† - Solid Corrugated	SF† - Solid Flat Bottom	† Not available for flange out tray
SIDE RAIL HEIGHT	4 - 4"	5 - 5"	6 - 6"	7 - 7"		
MATERIAL	G	L	T			
FITTING SERIES	1 - SERIES 1	2 - SERIES 2				
WIDTH	06 - 6"	09 - 9"	12 - 12"	18 - 18"	24 - 24"	30 - 30"
FLANGE DIRECTION	I - Flange In	0 - Flange Out				

- WIDTHS (W) INCHES**
6 | 9 | 12 | 18 | 24 | 30 | 36
- RAIL HEIGHTS (H) INCHES**
4 | 5 | 6 | 7
- RADIUS (R) INCHES**
12 | 24 | 36

TRAY COVERS

Covers protect and contain cables. They are highly recommended to avoid damage to the tray contents and to protect against the elements. Some covers can also be attached to the tray with hinges; please contact Legrand for more information.

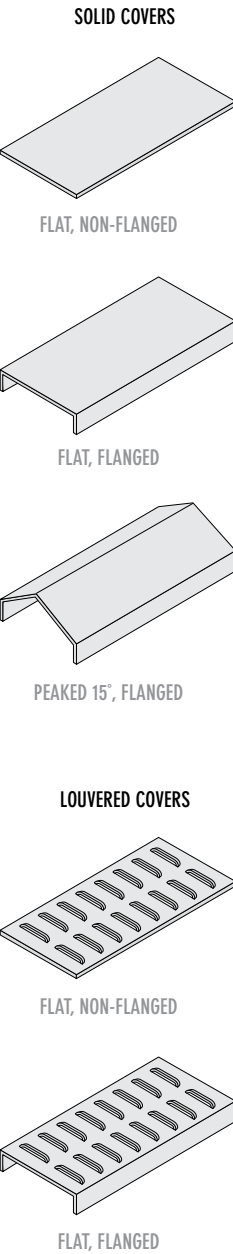

	FLANGE IN	1 3/4" FLANGE OUT
	SERIES 2	
	SOLID, FLAT — NON-FLANGED PRODUCT NUMBER	
M	2002	2067
L	3002	3038
T	3042	3039
	SOLID, FLAT — FLANGED* PRODUCT NUMBER	
M	2000	2066
G	1000	1066
L	3000	3036
T	3005	3029
	SOLID, PEAKED 15° — FLANGED† PRODUCT NUMBER	
M	2140	2114
G	1140	1114
L	3128	3131
T	3017	3040
	LOUVERED, FLAT — NON-FLANGED PRODUCT NUMBER	
M	2006	2112
L	3050	3117
T	3041	3112
	LOUVERED, FLAT — FLANGED* PRODUCT NUMBER	
M	2007	2104
G	1007	1104
L	3070	3003
T	3076	3113

WIDTHS (W) INCHES
6 | 9 | 12 | 18 | 24 | 30 | 36

RAIL HEIGHTS (H) INCHES
4 | 5 | 6 | 7

* Flange is 3/8" wide.
† 15° is standard angle for peaked covers. Flange is 3/8" wide.

COVER CATALOG NUMBERING EXAMPLE:

COVER SYSTEM NO. **60-2000** - LENGTH OR FITTING PRODUCT NO. **0012-36** - FITTING TANGENT **05** - COVER THICKNESS **B**

Side rail height: 40-4", 50-5", 60-6", 70-7"

Length: 0006** - 6', 0010 - 10', 0012 - 12' or **9224** FITTING PRODUCT NO.

Width: 05 - **SERIES 2** (5" Tangents)

Standards: **G** 18 Ga., **M L T** 20 Ga.

A - 18 Gage (0.048")
B - 16 Gage (0.060")
C - 14 Gage (0.075")

* Side rail height necessary for outside vertical fitting covers.
** Standard length for steel covers hot-dip galvanized after fabrication per ASTM-A-123 is 6'-0".

FLAT COVER CONNECTORS

For use with indoor, outdoor, or vertical flat covers. Top and bottom pieces are 1 1/2" wide. Install one connector over each cover joint and space additional connectors on 36"- 48" centers.

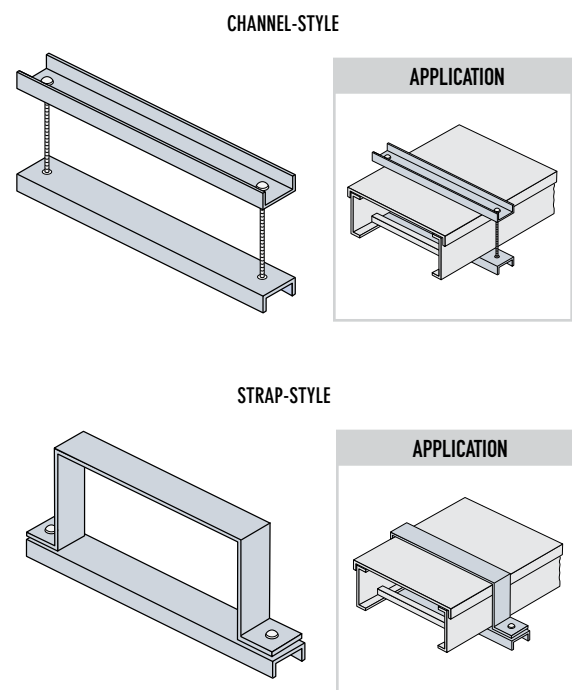

DESCRIPTION	PRODUCT NUMBER	FASTENERS
CHANNEL	1400	ZN S6
STRAP	1423	CD S6

PEAKED COVER CONNECTORS

For use with indoor, outdoor, or vertical peaked covers. Top and bottom pieces are 1 1/2" wide. Install one connector over each cover joint and space additional connectors on 36"- 48" centers. Standard angle of peaked cover is 15°, but custom angles are possible. Please contact Legrand for more information.

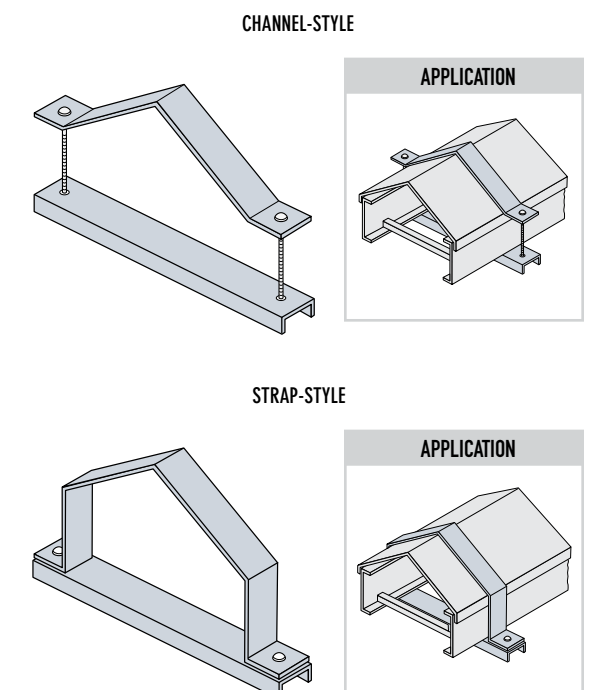

DESCRIPTION	PRODUCT NUMBER	FASTENERS
CHANNEL	1411	ZN S6
STRAP	1440	CD S6

SPLICES Match above to determine the connectors you need.

SERIES 1 Fitting side rails have 2" tangents (flat portion beyond curvature) at the end of each fitting, to accommodate splice plates with four holes.

SERIES 2 Fitting side rails have 5" tangents at the end of each fitting, to accommodate splice plates with eight holes.

COVER CONNECTOR CATALOG NUMBERING EXAMPLE:

FITTING SYSTEM NO. **6A20** - PRODUCT NO. **1411-24-S6**

Side Rail Height: 6
Fitting Series: A
Material: 20
Flange Direction: 14
Width: 11
Fasteners: 24-S6

MATERIAL: **L T G***
FASTENERS: **ZN CD S6**

*optional

COVER CONNECTOR CLIPS T

For use with indoor, horizontal covers. Flange-in clip requires tray with 1" side rail flanges. Flange-out clip works with any side rail flange width. Sold individually.

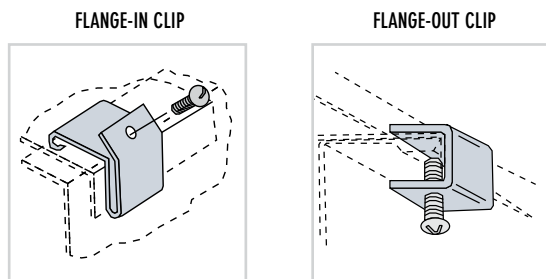

DESCRIPTION	PRODUCT NUMBER	FASTENER INCLUDED
FLANGE-IN	1410	S6
FLANGE-OUT	1853	
CATALOG NUMBERING EXAMPLE (EA.):		
Material	Fasteners	
T	- 1410	- S6



H-BINDER COVER JOINT CLIP A

Closes gaps at cover joints. Notched for the tray side rail. No fasteners required.

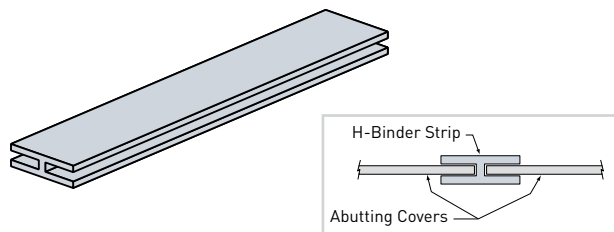

DESCRIPTION	PRODUCT NUMBER
FLAT COVER CLIP	0925
PEAKED COVER CLIP	0926
CATALOG NUMBERING EXAMPLE (EA.):	
Connector System No.†	Width
A20	- 0925 - 06
†A1, A10 and A20 are the only three Connector System No. possibilities for this part.	

RAISED COVER CONNECTOR M T G*

For use with all covers, indoors and outdoors. Covers are attached to uprightmounted "C" channel on the top of the cable tray. Install 36"-48" on center.

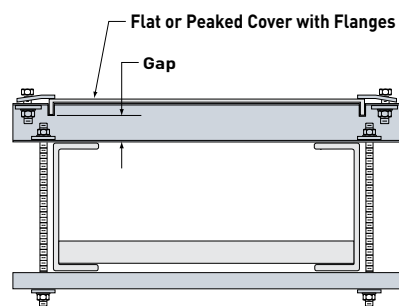

GAP DIMENSION (IN.)	PRODUCT NUMBER	FASTENER OPTIONS
1	1441	ZN S6
2	1442	
3	1443	
4	1444	
CATALOG NUMBERING EXAMPLE:		
Fitting System No.	Width	Fasteners
6 T20	- 1441	- 06 - S6

RAIL HEIGHTS (H) INCHES

4 | 5 | 6 | 7

RAISED COVER CONNECTOR A M T

Raised cover connectors allow for ventilation of ladder tray installations while protecting cables from possible falling objects. Raised cover connectors allow a gap of 1", 2", 3" or 4".



PRODUCT NUMBER	FASTENER INCLUDED
1432	S6
CATALOG NUMBERING EXAMPLE (EA.):	
Material	Fasteners
M	- 1432 - S6

Cadmium-plated steel fasteners are standard for all splice plate connectors on aluminum and steel cable tray systems. **All splices are supplied in pairs.** Type 316 stainless steel fasteners are standard on stainless steel systems, but are available as an option on all aluminum and steel systems. Sufficient connector pairs with fasteners are automatically included with each shipment of straight sections and fittings. Extras for field cuts or spares must be ordered separately. Bonding jumpers are required for all expansion splice plates, adjustable connectors, and tray discontinuities. The symbol indicates that bonding jumpers are required.

STANDARD SPLICE G T

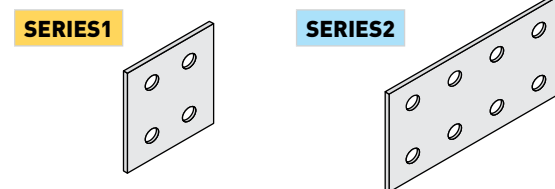

PRODUCT NUMBER	FASTENER OPTIONS
1302	CD S6
CATALOG NUMBERING EXAMPLE:	
Connector System No.	Fasteners
4 G1	- 1302 - CD

MID-SPAN SPLICE G T

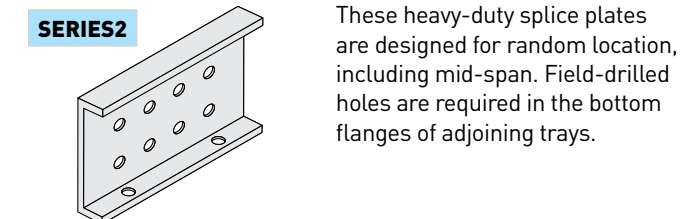

PRODUCT NUMBER	FASTENER OPTIONS
1385	CD S6
CATALOG NUMBERING EXAMPLE:	
Connector System No.†	Fasteners
4 G2	- 1385 - S6
†This item must be specified as Series 2 in the System No.	

These heavy-duty splice plates are designed for random location, including mid-span. Field-drilled holes are required in the bottom flanges of adjoining trays.

UNIVERSAL SPLICE G T

These splice plates are designed to connect to existing cable tray.

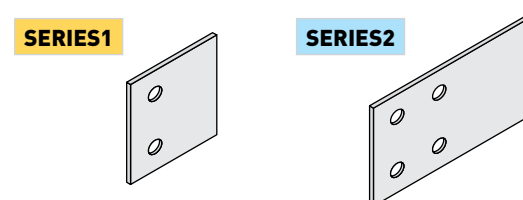

PRODUCT NUMBER	FASTENER OPTIONS
1335	CD S6
CATALOG NUMBERING EXAMPLE:	
Connector System No.†	Fasteners
4 G1	- 1335 - CD

REDUCING HEIGHT SPLICE G T

These splice plates are designed to connect cable tray side rails with different heights. The connector system number includes the larger side rail height. Choose the product number depending on the reduced side rail height.

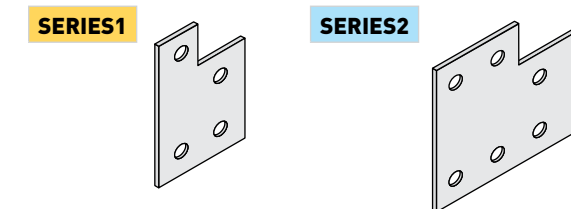

PRODUCT NUMBER	SIZE	FASTENER OPTIONS
1386	REDUCES TO 4" HIGH TRAY	CD S6
1379	REDUCES TO 5" HIGH TRAY	
1355	REDUCES TO 6" HIGH TRAY	
CATALOG NUMBERING EXAMPLE:		
Connector System No.	Fasteners	
6 G2	- 1386 - CD	

SPLICES Match above to determine the connectors you need.

- SERIES1**
Fitting side rails have 2" tangents (flat portion beyond curvature) at the end of each fitting, to accommodate splice plates with four holes.
- SERIES2**
Fitting side rails have 5" tangents at the end of each fitting, to accommodate splice plates with eight holes.

Cadmium-plated steel fasteners are standard for all splice plate connectors on aluminum and steel cable tray systems. **All splices are supplied in pairs.** Type 316 stainless steel fasteners are standard on stainless steel systems, but are available as an option on all aluminum and steel systems. Sufficient connector pairs with fasteners are automatically included with each shipment of straight sections and fittings. Extras for field cuts or spares must be ordered separately. Bonding jumpers are required for all expansion splice plates, adjustable connectors, and tray discontinuities. The  symbol indicates that bonding jumpers are required.

EXPANSION SPLICE G T

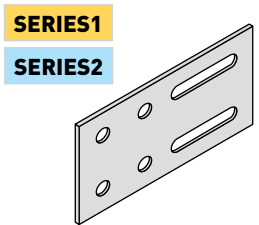

Permits thermal contraction and expansion in a cable tray installation. The length of the straight cable tray run and the temperature differential govern the number and spacing of expansion connectors. Expansion splice plates permit 2" of movement.

PRODUCT NUMBER	FASTENER OPTIONS
1314	CD S6
CATALOG NUMBERING EXAMPLE:	
Connector System No.	Fasteners
4 G 2 - 1314 - CD	



STRAIGHT REDUCER SPLICE G T

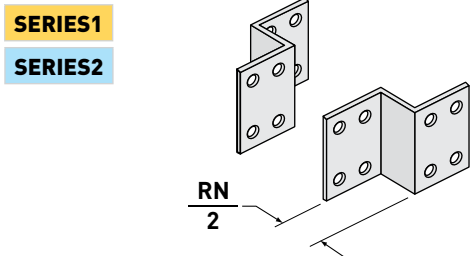

PRODUCT NUMBER	FASTENER OPTIONS
1303	CD S6
CATALOG NUMBERING EXAMPLE:	
Connector System No.	RN Fasteners
4 G 2 - 1303 - 06 - CD	

OFFSET REDUCER SPLICE G T

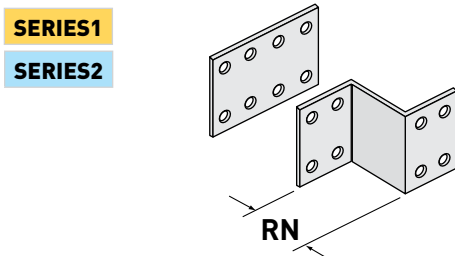

PRODUCT NUMBER	FASTENER OPTIONS
1304	CD S6
CATALOG NUMBERING EXAMPLE:	
Connector System No.	RN Fasteners
4 G 2 - 1304 - 12 - S6	

90° CONNECTOR G T

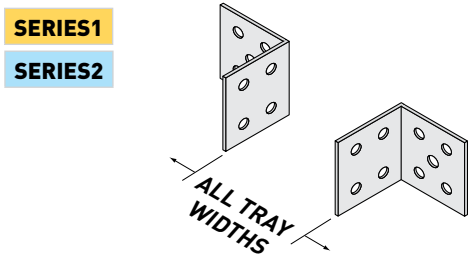

PRODUCT NUMBER	FASTENER OPTIONS
1320	CD S6
CATALOG NUMBERING EXAMPLE:	
Connector System No.	Fasteners
4 G 2 - 1320 - CD	

- WIDTHS (W) INCHES**
6 | 9 | 12 | 18 | 24 | 30 | 36
- RAIL HEIGHTS (H) INCHES**
4 | 5 | 6 | 7
- REDUCTION (RN) INCHES**
3 | 6 | 9 | 12 | 15 | 18 | 21 | 24 | 27 | 30

SPLICES Match above to determine the connectors you need.

- SERIES1**
Fitting side rails have 2" tangents (flat portion beyond curvature) at the end of each fitting, to accommodate splice plates with four holes.
- SERIES2**
Fitting side rails have 5" tangents at the end of each fitting, to accommodate splice plates with eight holes.

All splices are supplied in pairs. Bonding jumpers are required for use with all adjustable splices. 

FLOOR FLANGE / TRAY-TO-BOX CONNECTOR G T

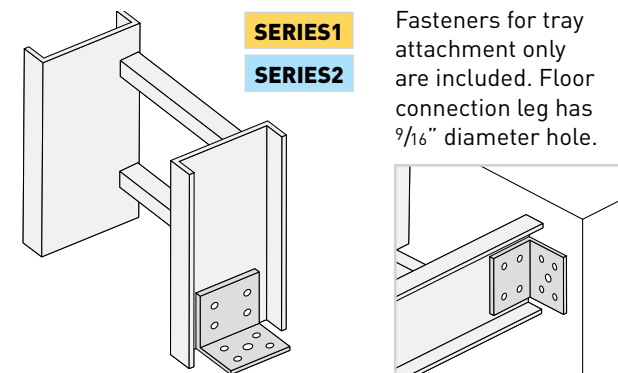

PRODUCT NUMBER	FASTENER OPTIONS
1864	CD S6
CATALOG NUMBERING EXAMPLE:	
Connector System No.	Fasteners
4 G 2 - 1864 - CD	

HORIZONTAL ADJUSTABLE SPLICE G T

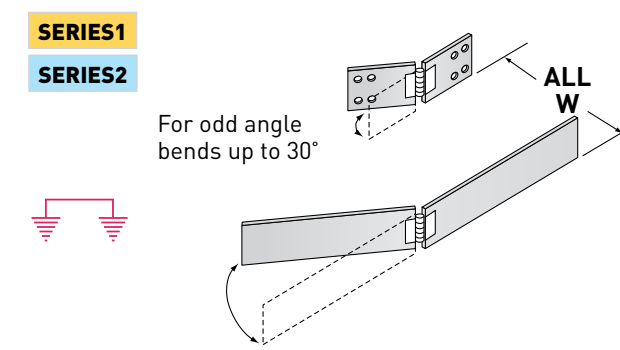

PRODUCT NUMBER	FASTENER OPTIONS
1305	CD S6
CATALOG NUMBERING EXAMPLE:	
Connector System No.	Fasteners
4 G 2 - 1305 - CD	

VERTICAL ADJUSTABLE SPLICE G T

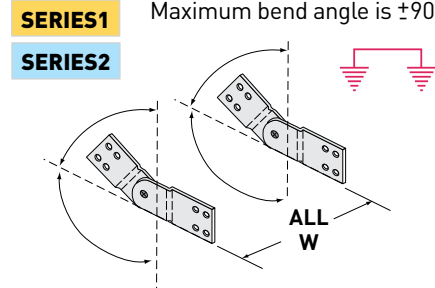

PRODUCT NUMBER	FASTENER OPTIONS
1307	CD S6
CATALOG NUMBERING EXAMPLE:	
Connector System No.	Fasteners
4 G 2 - 1307 - CD	

VERTICAL HANGER SPLICE G T

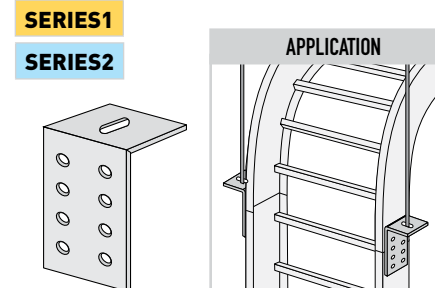

PRODUCT NUMBER	FASTENER OPTIONS
0356	CD S6
CATALOG NUMBERING EXAMPLE:	
Connector System No.	Fasteners
6 G 2 - 0356 - S6	

TRAY-TO-BOX FRAME CONNECTOR G T

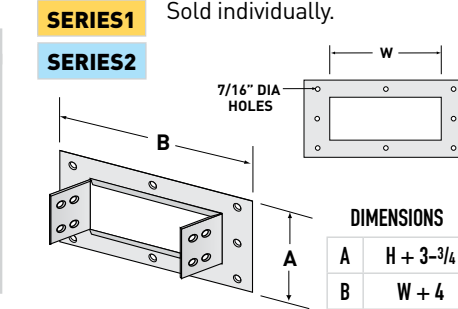

PRODUCT NUMBER	FASTENER OPTIONS
0403	CD S6
CATALOG NUMBERING EXAMPLE:	
Connector System No.	Width Fasteners
4 G 2 - 0403 - 12 - CD	

All connectors on these pages are designed to fit Series 1 and 2 systems. When ordering, however, they should be specified as Series 2.

BONDING JUMPERS

Use across all discontinuities, expansion joints, and adjustable connectors to maintain electrical continuity in the cable tray system. Also use to bond the cable tray system to the building ground. Bonding jumpers are not required at standard or rigid splice locations. Fasteners for bonding jumpers must be ordered separately.

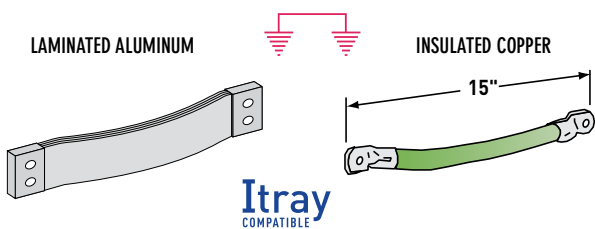

Laminated Aluminum: Use (4) 3/8" x 1" bolts per Bonding Jumper.

Insulated Copper: Made with flame-retardant, moisture- and heat-resistant, insulated copper cable. Tin plated copper lugs have one hole, sized for 3/8" x 3/4" bolt. Length is 15" to the center of the lug holes. Special lengths, lugs, and cables are also available.

LAMINATED ALUMINUM A		
PRODUCT NUMBER	L	RATED AMPS (N.E.C. 250-122)
1877	15" OR 22"	2000
CATALOG NUMBERING EXAMPLE (EA.):		
Material		Length
A - 1877		- 15
INSULATED COPPER C		
PRODUCT NUMBER	COPPER CABLE SIZE	RATED AMPS (N.E.C. 250-122)
A806	#6	200
A807	#4	300
A804	#2	500
A803	#1	600
A808	1/0	800
A809	2/0	1000
A805	3/0	1200
A810	4/0	1600
A814*	4/0 WELDING CABLE 2107 STRANDS	1800
CATALOG NUMBERING EXAMPLE (EA.):		
Material		
C - A806		

*Length is 30" to the center of the lug holes. One-hole tin-plated copper lugs are sized for 1/2" bolt.

SPLICE FASTENERS



Knurled Bolt: Specially designed for cable tray connectors, the ribbed neck firmly grips the tray side rail to prevent screw rotation while tightening. Bolt can also be tightened with a Phillips screwdriver.



Flanged Hex Nut: "Free spinning" lock-type nut with a serrated face, eliminating the need for a washer. Nuts require a 9/16" wrench. Tighten to approximately 19-25 ft-lbs of torque.



Locking Hex Nut: For use with expansion connectors. Deformed threads cause this nut to lock on to the bolt after just a few turns, allowing movement of the bolt in the expansion slot without possibility of the nut backing off. Typically identified by a rectangular indentation on the side of the nut.



Flat Washer: For use with expansion connectors. Install under the locking hex nut in the expansion slots. Prevents binding in the expansion slot during movement of the tray due to thermal expansion.

DESCRIPTION	SIZE	COMPLETE CATALOG NUMBER	
KNURLED BOLT	3/8"-16 x 3/4"	DS-8530-01-CD	CD
		DS-8926-01-S6	S6
FLANGED HEX NUT	3/8" DIA.	DS-8524-01-CD	CD
		DS-8927-01-S6	S6
LOCKING HEX NUT	3/8" DIA.	DS-8575-02-CD	CD
		DS-8576-01-S6	S6
FLAT WASHER	3/8" DIA.	DS-8596-01-CD	CD
		DS-8600-01-S6	S6



RAIL HEIGHTS (H) INCHES

4 | 5 | 6 | 7

STRAIGHT HORIZONTAL DIVIDER A M T G*

For use with all straight tray. Furnished with four #10 self-drilling screws.

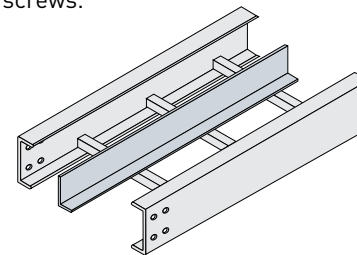

PRODUCT NUMBER	L	FASTENER OPTIONS
0012-99	12	ZN S6
CATALOG NUMBERING EXAMPLE:		
Accessory System No.		Fasteners
4 A - 0012-99		- Z N

FLEXIBLE HORIZONTAL DIVIDER A M T G*

For use with all horizontal fittings of any radius. Furnished with three #10 self-drilling screws.

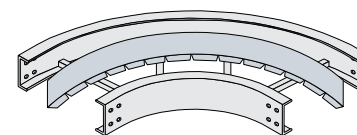

PRODUCT NUMBER	L	FASTENER OPTIONS
0606-99	6'	ZN S6
CATALOG NUMBERING EXAMPLE:		
Accessory System No.		Fasteners
4 T - 0606-99		- S 6

VERTICAL FITTING DIVIDER A M T G*

Furnished with two #10 self-drilling screws.

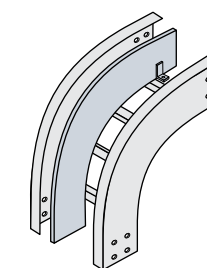

PRODUCT NUMBER	R	DIVIDER TYPE
9112-99	12	90° INSIDE ELBOW
9124-99	24	
9136-99	36	
9212-99	12	90° OUTSIDE ELBOW
9224-99	24	
9236-99	36	
6112-99	12	60° INSIDE ELBOW
6124-99	24	
6136-99	36	
6212-99	12	60° OUTSIDE ELBOW
6224-99	24	
6236-99	36	
4612-99	12	45° INSIDE ELBOW
4624-99	24	
4636-99	36	
4712-99	12	45° OUTSIDE ELBOW
4724-99	24	
4736-99	36	
3112-99	12	30° INSIDE ELBOW
3124-99	24	
3136-99	36	
3212-99	12	30° OUTSIDE ELBOW
3224-99	24	
3236-99	36	
FASTENER OPTIONS		ZN S6
CATALOG NUMBERING EXAMPLE:		
Accessory System No.		Fasteners
4 A - 9212-99		- Z N

G* = optional

For detailed material and finish descriptions, see page 6.

DIVIDER HOLD DOWN CLIP M T G*

Purchased separately. Supplied with carriage bolt and flanged hex nut. Designed for use with ladders with box-shaped rungs (Types BX & BH—see pages 66-67).

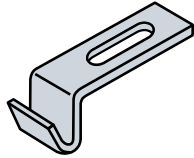

PRODUCT NUMBER	FASTENER OPTIONS
1852	ZN S6
CATALOG NUMBERING EXAMPLE: Material Fasteners M - 1852 - ZN	

5" VINYL DIVIDER SPLICE V

Splices joints of abutting divider strips. Vinyl edge strip is also available in bulk lengths.

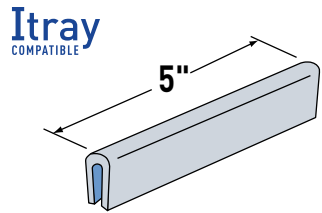

PRODUCT NUMBER	
0930	
CATALOG NUMBERING EXAMPLE: Material V - 0930	

BLIND END PLATE M T G*

Seals off the open end of a cable tray. Attaches to the tray using standard 3/8" dia. connector fasteners.

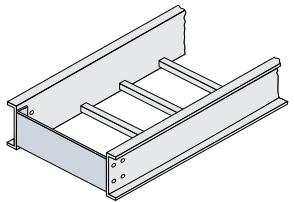

PRODUCT NUMBER	FASTENER OPTIONS
0402	CD S6
CATALOG NUMBERING EXAMPLE: Material Fasteners M - 0402 - ZN	

CABLE DROPOUT A M T G*

Provides a smooth, rounded surface for cables dropping out of the bottom of the cable tray.

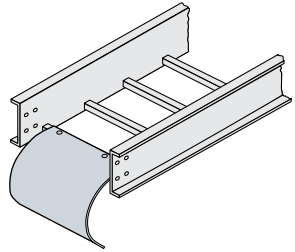

PRODUCT NUMBER	R
0253	3/4
0254	5
FASTENER OPTIONS	ZN S6
CATALOG NUMBERING EXAMPLE: Material - Flange Width Fasteners A I - 0253 - 06 - S 6	

TRAY WIDTH (NOMINAL)	6	9	12	18	24	30	36	
DROPOUT WIDTH (FLG IN)	2 1/4	5 1/4	8 1/4	14 1/4	20 1/4	26 1/4	32 1/4	IN
DROPOUT WIDTH (FLG OUT)	5 1/4	8 1/4	11 3/4	17 3/4	23 3/4	29 3/4	35 3/4	

DIVIDER SPLICE

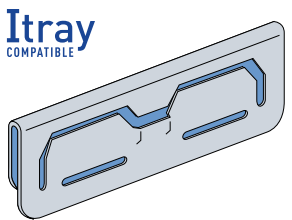

Sold in bags of 25.

	COMPLETE CAT. NO.
A	COTJ-AL
M	COTJ-PG
T	COTJ-316

SELF-DRILLING SCREW



Provided with all dividers, but extras can be ordered separately.

COMPLETE CATALOG NO.		SIZE
DS-8930-01-ZN	ZN	#10 X 3/4"
DS-8930-01-S6	S6	#10 X 3/4"

WALL PENETRATION SLEEVE M G T

Provides a rigid support for cable tray at wall penetrations. Overall length of the sleeve is 20". Will fit walls up to 8" thick. Bonding jumpers are not required for use with wall sleeves. Two pairs of splice plates and fasteners are included for tray attachment.

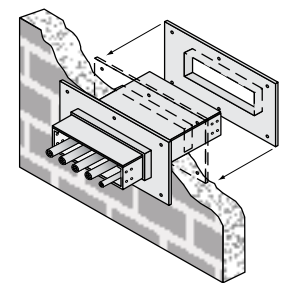

PRODUCT NUMBER	FASTENER OPTIONS
0424	CD S6
CATALOG NUMBERING EXAMPLE: Connector System No Width Fasteners 4 T 2 - 0424 - 12 - S 6	

OUTDOOR CONVERSION FOR WALL PENETRATION G T

Makes ladder tray wall penetrations weather resistant to minimize water intrusions. Removable cover/shield fastens to tray and wall penetration sleeve for the utmost in weather protection.

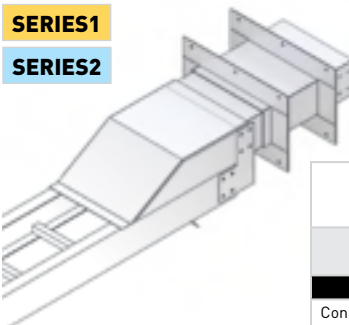

- Fits Standard Hot-Dip Galvanized or Stainless "0424" or "0440" wall penetrations (see page 58.)
- Sized to fit flange-in or flange-out trays

PRODUCT NUMBER	FASTENER OPTIONS
0434	CD S6
CATALOG NUMBERING EXAMPLE: Connector System No Width Fasteners 4 G 2 - 0434 - 06 - CD	

The wall penetration sleeve and outdoor conversion kit are designed to fit Series 1 and 2 systems. When ordering, however, they should be specified as Series 2.

G* = optional

For detailed material and finish descriptions, see page 6.

HOLD DOWN/EXPANSION CLAMP A Z T

Works as an expansion guide and flips over for use as a hold down clamp for use with all ladder trays. Sold individually.

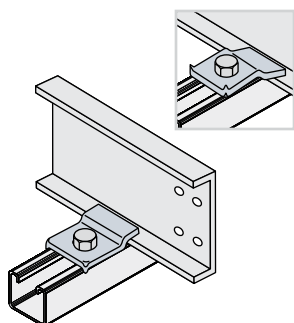

PRODUCT NUMBER	FASTENER OPTIONS
1893-01*	ZN S6
1893-02	NONE
1893-03†	ZN S6
CATALOG NUMBERING EXAMPLE:	
Material A - 1893-01	Fasteners - ZN

* Includes 3/8" x 1 1/2" hex bolt, 3/8" flanged nut.
† Includes 3/8" x 1 1/2" hex bolt, 3/8" spring nut.

Itray
COMPATIBLE

Z-HOLD DOWN/EXPANSION GUIDE M T G*

Wraps around the tray side rail for use with all solid bottom trays. Can also be used with any flange-in tray system. Expansion guide is slightly taller to permit longitudinal tray movement caused by thermal expansion. Sold individually.

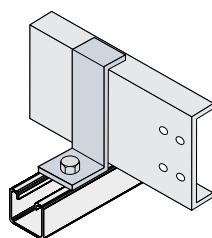

PRODUCT NUMBER		FASTENER OPTIONS
Z-HOLD DOWN	EXPANSION	
1866-01*	1867-01	ZN S6
1866-02	1867-02	None
1866-03†	1867-03	ZN S6
CATALOG NUMBERING EXAMPLE:		
Accessory System No. 4 M - 1866-01	Fasteners - ZN	

* Includes 1/4" x 3/4" carriage bolt, 1/4" flanged nut.
† Includes 1/4" x 1 1/2" screw, 1/4" spring nut.

I-BEAM HOLD DOWN CLAMP/EXPANSION GUIDE Z T

Hold Down Clamp firmly attaches the cable tray to the flange of an I-beam type support. Expansion Guide attaches the clamp to the flange of an I-beam type support, allowing movement of the tray side rail due to thermal contraction and expansion.

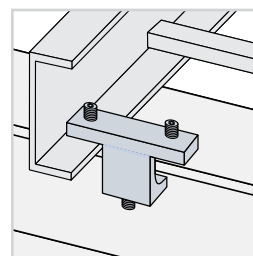

PRODUCT NUMBER		FASTENER OPTIONS
HOLD DOWN	EXPANSION	
A802-01*	A802-02†	CD S6
CATALOG NUMBERING EXAMPLE:		
Accessory System No. Z - A802-01	Fasteners - S6	

* Includes (2) 1/2" x 5/8" screws and (1) 1/2" x 1 1/2" screw.
† Includes (1) 1/2" x 1 1/2" screw.
No drilling is required for either installation.

Itray
COMPATIBLE

SINGLE OVERHEAD HANGER CLAMP M

Attaches to the tray bottom flange and supports the cable tray directly from a threaded rod without the need for an additional support member. Threaded rod purchased separately.

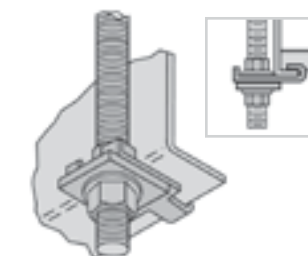

SERIES1

PRODUCT NUMBER	ROD DIA.	FASTENERS INCLUDED
1899-01	1/2"	ZN S6
1899-02	3/8"	ZN S6
CATALOG NUMBERING EXAMPLE:		
Material M - 1899-01	Fasteners - S6	

HEAVY-DUTY HOLD DOWN BRACKETS A G T

Designed for use with all trays. 3/8" diameter hardware for tray attachment only is included. Holes for structure attachment are sized for 1/2" diameter fasteners. Ideal for vertical tray support. Sold in pairs.

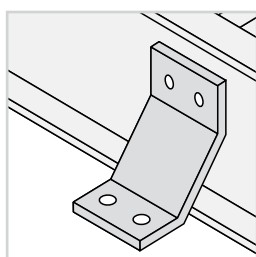

PRODUCT NUMBER	FASTENER OPTIONS
A845	CD S6
CATALOG NUMBERING EXAMPLE:	
Material T - A845	Fasteners - S6

Itray
COMPATIBLE

WIRE MESH-TO-LADDER CLAMP Z T

This unique clamp allows wire mesh cable tray to be attached to the side rails of any ladder tray and a pre-installed setscrew secures the junction for a permanent installation.

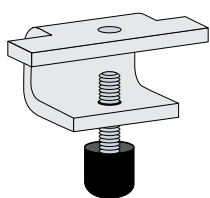

Itray
COMPATIBLE

PRODUCT NUMBER	FASTENER OPTIONS
WMC 2LA	CD S6
CATALOG NUMBERING EXAMPLE:	
Material T - WMC 2LA	Fasteners - S6

HANGER BRACKETS M T G*

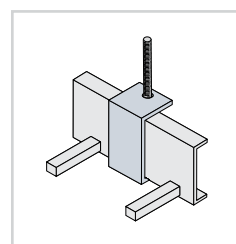

SINGLE: Supports a single tray side rail from a 1/2" threaded rod. For use with all flange-out ladder tray systems. Safe load = 300 lbs. per bracket.

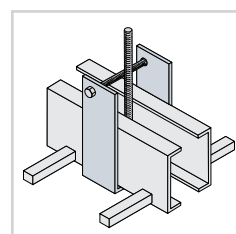

DOUBLE: Supports two tray side rails that are installed side-by-side from a single 1/2" threaded rod. For use with all flange-out ladder tray systems. Safe load = 300 lbs. per bracket.

PRODUCT NUMBER		FASTENER OPTIONS
SINGLE	DOUBLE	
A836	A837*	ZN S6
CATALOG NUMBERING EXAMPLE:		
Accessory System No. 4 M 1 - A837	Fasteners - ZN	

* Includes 1/4" x 5" hex head bolt and 1/4" flanged nut.

NYLON ISOLATION PAD N

Made of extruded black nylon. Can be installed between the cable tray and support member to provide electrical isolation of the tray system. Can also be used to facilitate cable tray movement caused by thermal contraction and expansion. No fasteners required.

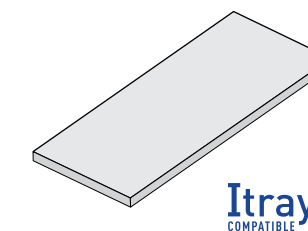

Itray
COMPATIBLE

PRODUCT NUMBER	DIMENSIONS
8945	1/8" X 3" X 6"
CATALOG NUMBERING EXAMPLE:	
Material N - 8945	

WIDTHS (W) INCHES
6 | 9 | 12 | 18 | 24 | 30 | 36

RAIL HEIGHTS (H) INCHES
4 | 5 | 6 | 7

SPLICES Match above to determine the connectors you need.



SERIES1

Fitting side rails have 2" tangents (flat portion beyond curvature) at the end of each fitting, to accommodate splice plates with four holes.

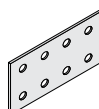

SERIES2

Fitting side rails have 5" tangents at the end of each fitting, to accommodate splice plates with eight holes.

G* = optional

For detailed material and finish descriptions, see page 6.

SINGLE HANGER CHANNEL A M G T

Made from 12-gage strut. Hangers have 9/16" diameter holes 13/16" from each end to accept 1/2" threaded rod. Kit includes fasteners. When used with Z-type hold-down clamps, select hanger with flange out dimensions.

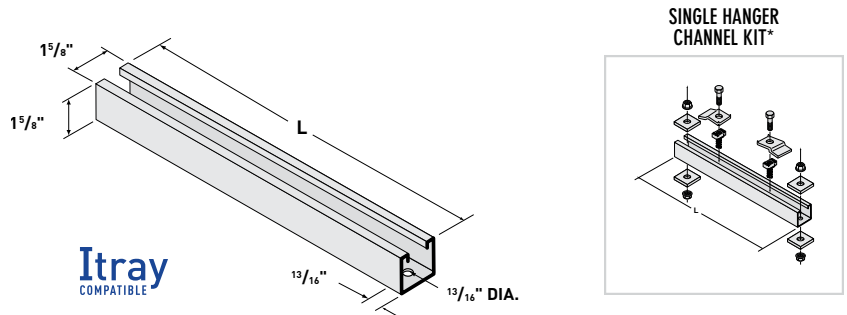

TRAY WIDTH	PRODUCT NUMBER		FLANGE IN		FLANGE OUT	
	HANGER	KIT	L (W+4)	L (W+10)		
6	0373	0393	10	16		
9			13	19		
12			16	22		
18			22	28		
24			28	34		
30			34	40		
36	40	46				
FASTENERS INCLUDED WITH KIT ONLY* ZN S6						
CATALOG NUMBERING EXAMPLE:						
Material		Length		Fasteners		
M - 0393-10		- S6		*		

DOUBLE HANGER CHANNEL A M G T

Made from 12-gage struts welded back-to-back. Hangers have 9/16" dia. holes 13/16" from each end to accept 1/2" threaded rod. When used with Z-type hold-down clamps, select hanger with flange out dimensions.

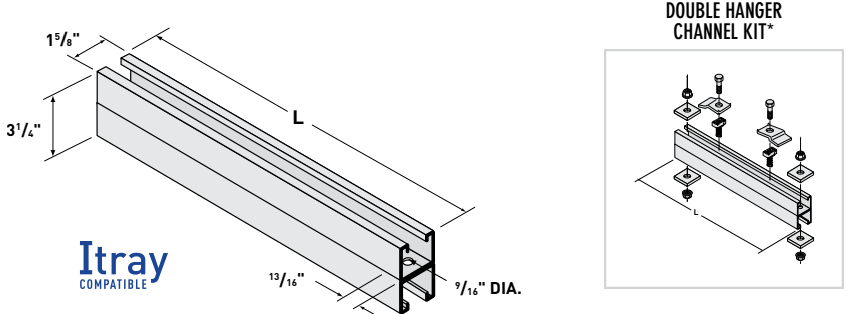

TRAY WIDTH	PRODUCT NUMBER		FLANGE IN		FLANGE OUT	
	HANGER	KIT	L (W+4)	L (W+10)		
6	0371	0394	10	16		
9			13	19		
12			16	22		
18			22	28		
24			28	34		
30			34	40		
36	40	46				
FASTENERS INCLUDED WITH KIT ONLY* ZN S6						
CATALOG NUMBERING EXAMPLE:						
Material		Length		Fasteners		
M - 0394-16		- S6		*		

CENTER HANGER CHANNEL M G T

Mounts with one 1/2" threaded rod to allow cable installation from both sides. Cable should be loaded evenly on both sides of the center support to remain level. 12-gage strut accepts channel nuts for hold down clamps with no drilling required. Not recommended for trays over 24" wide. When used with Z-type hold-down clamps, select hanger with flange out dimensions.

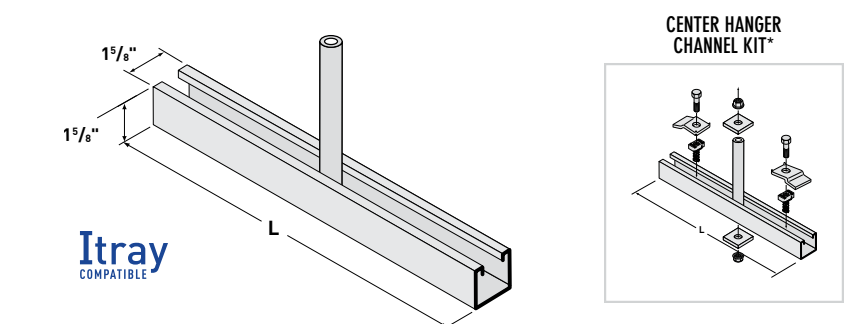

TRAY WIDTH	PRODUCT NUMBER		FLANGE IN		FLANGE OUT	
	HANGER	KIT	L (W+4)	L (W+10)		
6	0369	0395	8	12		
9			11	15		
12			14	18		
18			20	24		
24			26	30		
FASTENERS INCLUDED WITH KIT ONLY* ZN S6						
CATALOG NUMBERING EXAMPLE:						
Material		Length		Fasteners		
M - 0395-10		- S6		*		

WALL BRACKET G T

Recommended for use with flange-in cable trays.

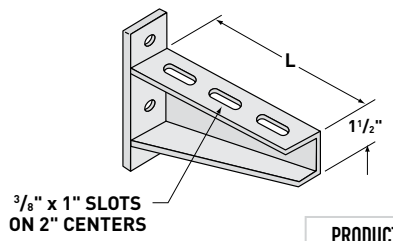

PRODUCT NUMBER	L	H	DESIGN LOAD - UNIFORM (LBS.)
0353	7	6	900
	10	6	
	13	6	
	19	7 1/2	
	25	7 1/2	
CATALOG NUMBERING EXAMPLE:			
Material		Length	
G - 0353-13			

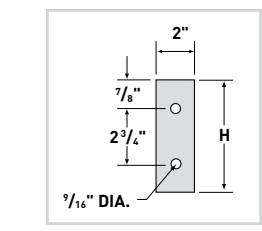

SINGLE STRUT BRACKET G T

Made with 1 5/8" x 1 5/8" x 12 gage steel struts.

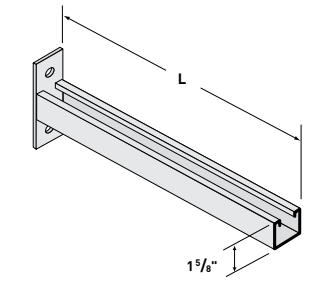

PRODUCT NUMBER	L	DESIGN LOAD - UNIFORM (LBS.)
0215	7	1000
	10	720
	13	550
	16	450
	19	380
	22	320
25	290	
CATALOG NUMBERING EXAMPLE:		
Material		Length
G - 0215-13		

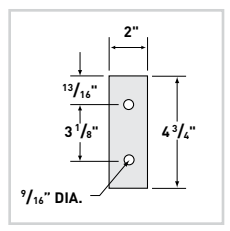

DOUBLE STRUT BRACKET G T

Made with 1 5/8" x 1 5/8" x 12 gage steel struts.

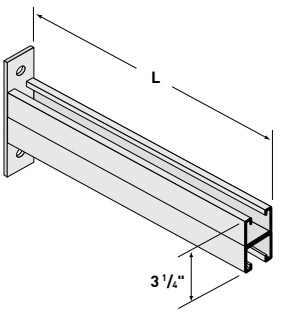

PRODUCT NUMBER	L	DESIGN LOAD - UNIFORM (LBS.)
0216	7	3000
	10	2400
	13	1850
	16	1500
	19	1250
	22	1100
	25	960
	31	770
	37	650
	43	560
	CATALOG NUMBERING EXAMPLE:	
Material		Length
T - 0216-13		

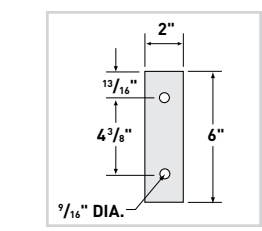

HEAVY-DUTY STRUT BRACKET G T

Made with 1 5/8" x 1 5/8" x 12 gage steel struts.

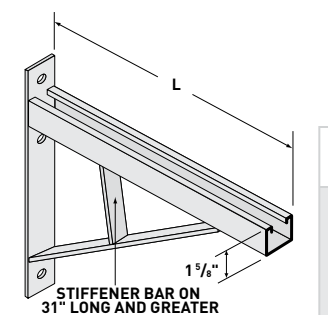

PRODUCT NUMBER	L	H	DESIGN LOAD - UNIFORM (LBS.)
0392	13	10	1600
	19	15	1200
	25	18	900
	31	22	750
	37	25	675
	43	29	580
	49	32	500
CATALOG NUMBERING EXAMPLE:			
Material		Length	
G - 0392-13			

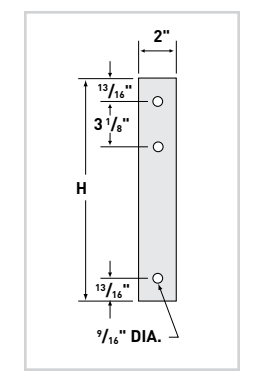

METALLIC ACCESSORIES

*Kits include hardware for ladder trays. Contact Legrand for other design options.

METALLIC ACCESSORIES

CABLE CLAMP T

For use with all ladder cable trays with box-shaped rungs.

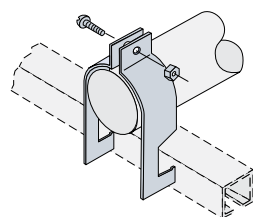

PRODUCT NUMBER	CABLE SIZE
1916-06	3/4"
1916-07	7/8"
1916-08	1"
1916-09	1 1/8"
1916-10	1 1/4"
1916-11	1 3/8"
1916-12	1 1/2"
1916-13	1 5/8"
1916-14	1 3/4"
1916-15	1 7/8"
1916-16	2"
1916-17	2 1/8"
1916-18	2 1/4"
1916-19	2 3/8"
1916-20	2 1/2"
1916-21	2 5/8"
1916-22	2 3/4"
1916-23	2 7/8"
1916-24	3"
1916-25	3 1/8"
1916-26	3 1/4"
1916-27	3 3/8"
1916-28	3 1/2"
1916-29	3 5/8"
1916-30	3 3/4"
1916-31	3 7/8"
1916-32	4"

FASTENERS INCLUDED	
Material	Fasteners
T - 1916-06	- S6

CATALOG NUMBERING EXAMPLE:
Material Fasteners
T - 1916-06 - S6

GROUND WIRE ATTACHMENT CLAMP Z T

Holds one or two bare copper or aluminum ground wires against the cable tray side rail using included 3/8" diameter fasteners. This clamp does not bond the ground wire to the tray.

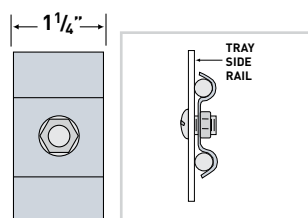

PROD. NO.	CONDUCTOR SIZE
1873-02	#2, #1 AND 1/0
1873-03	#6 TO #4
1873-04	2/0, 3/0 AND 4/0

FASTENER OPTIONS	
Material	Fasteners
Z - 1873-02	- S6

CATALOG NUMBERING EXAMPLE:
Material Fasteners
Z - 1873-02 - S6

CONDUIT BRACKET CLAMP Z T

Attaches conduit to the cable tray side rail.

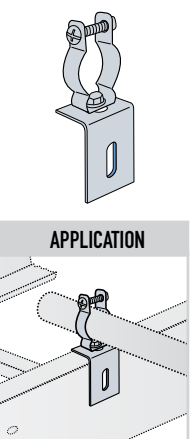

PROD. NO.	CONDUIT DIA.	EMT DIA.
0228-05	3/8"-1/2"	1/2"
0228-06	3/4"	3/4"
0228-10	1"	1"
0228-11	1 1/4"	1 1/4"
0228-12	1 1/2"	1 1/2"
0228-20	2"	2"
0228-25	2 1/2"	2 1/2"
0228-30	3"	3"
0228-40	4"	4"

FASTENER OPTIONS	
Material	Fasteners
T - 0228-05	- S4

CATALOG NUMBERING EXAMPLE:
Material Fasteners
T - 0228-05 - S4

CONDUIT PLATE CLAMP A M

Attaches conduit to the ladder tray rungs.

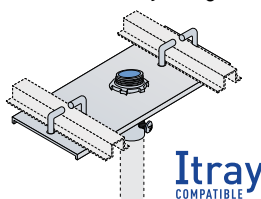

PRODUCT NUMBER	EMT DIA.
0226-05	1/2"
0226-06	3/4"
0226-10	1"
0226-11	1 1/4"
0226-12	1 1/2"
0226-20	2"
0226-25*	2 1/2"
0226-30*	3"
0226-40*	4"

FASTENERS INCLUDED	
Material	Fasteners
M - 0226-11	- CD

CATALOG NUMBERING EXAMPLE:
Rung Spacing Material Fasteners
09 - M - 0226-11 - CD

RUNG SPACING INCHES

9" PLATE	6	9
18" PLATE	12	18

*Can also be used with medium-wall (IMC) and thick-wall (rigid) conduit.

CABLE TRAY GROUNDING CLAMP A

Provides an excellent ground for copper or aluminum ground wires to the cable tray. A 1/4" hex wrench is used to tighten both tray and conductor set screws. Clamps are tin-plated, extruded aluminum. Conductor Range: #6AWG to 250 MCM.

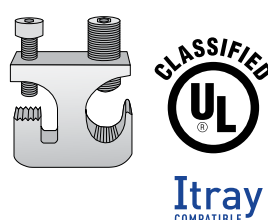

PRODUCT NUMBER	FASTENERS INCLUDED
A840-01	ZN

CATALOG NUMBERING EXAMPLE:
Material Fasteners
A - A840-01 - ZN

CLAMP BRACKET M T

Permits attachment of clamps or other components to the cable tray side rail. Conduit clamps are purchased separately.

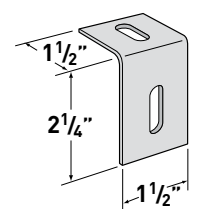

PRODUCT NUMBER	FASTENER OPTIONS
1818	ZN S6

CATALOG NUMBERING EXAMPLE:
Material Fasteners
T - 1818 - S6

MAPLE CABLE BLOCKS

Paraffin impregnated and furnished with 1/4" dia. fasteners. Contact Legrand with quantities, cable dimensions, cable spacing, and cable tray system information. Can be custom designed for a wide variety of applications.

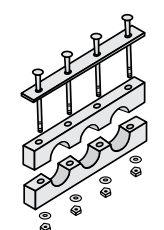

PRODUCT NUMBER	FASTENERS INCLUDED
0950	AS SPECIFIED

SLIP-ON LOCK NUT® ZN S4

Allows the user to slip the nut onto a rod, without actually threading it. Ideal for when nuts must be added to a rod, but cannot be threaded due to previously-installed equipment.

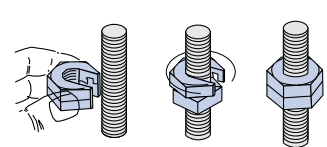

PRODUCT NUMBER	SIZE
SON 1/4	1/4"-20
SON 3/8	3/8"-16
SON 1/2	1/2"-13

CATALOG NUMBERING EXAMPLE:
Fasteners
SON 3/8 - ZN

PLASTIC SAFETY SIGN



Sign measures 8"x12".

COMPLETE CATALOG NUMBER
P-0949-01

INSTALLATION FASTENERS

DESCRIPTION	SIZE	COMPLETE CATALOG NUMBER	
		ZN	S6
THREADED ROD	1/4"-20 x 6'	DS-0254-06-ZN	DS-0254-06-S6
	3/8"-16 x 12'	DS-0255-12-ZN	DS-0255-12-S6
	1/2"-13 x 12'	DS-0256-12-ZN	DS-0256-12-S6
ROD COUPLING NUT	1/4"-20	DS-0237-02-ZN	DS-0237-02-S6
	3/8"-16	DS-0237-04-ZN	DS-0237-04-S6
	1/2"-13	DS-0237-05-ZN	DS-0237-05-S6
CHANNEL NUT W/ SPRING	1/4"-20	DS-0102-03-ZN	DS-0102-03-S6
	3/8"-16	DS-0102-05-ZN	DS-0102-05-S6
CHANNEL NUT W/O SPRING	1/4"-20	DS-0103-03-ZN	DS-0103-03-S6
	3/8"-16	DS-0103-05-ZN	DS-0103-05-S6
HEX NUT	1/4"-20	DS-8585-01-ZN	DS-8585-01-S6
	3/8"-16	DS-8575-01-ZN	DS-8575-01-S6
FLANGED HEX NUT	1/4"-20	DS-8845-01-ZN	DS-8929-01-S6
	3/8"-16	DS-8524-01-ZN	DS-8927-01-S6
SQUARE CHANNEL WASHER	1 1/2" w/ 1/4" HOLE	DS-0113-01-ZN	DS-0113-01-S6
	1 1/2" w/ 3/8" HOLE	DS-0113-02-ZN	DS-0113-02-S6
	1 1/2" w/ 1/2" HOLE	DS-0113-03-ZN	DS-0113-03-S6
FLAT ROUND WASHER	1/4"	DS-8598-01-ZN	DS-8674-01-S6
	3/8"	DS-8596-01-ZN	DS-8600-01-S6
	1/2"	DS-8595-01-ZN	DS-8657-01-S6
HEX HEAD BOLT	1/4"-20 x 3/4"	DS-8502-01-ZN	DS-8720-01-S6
	3/8"-16 x 1 1/2"	DS-8520-05-ZN	DS-8694-05-S6
	1/2"-13 x 1 1/2"	DS-8515-15-ZN	DS-8533-02-S6
SLOTTED, ROUND-HEAD SCREW	1/4"-20 x 3/4"	DS-8540-02-ZN	DS-8543-01-S6
	3/8"-16 x 3/4"	DS-8535-01-ZN	DS-8542-02-S6
	1/2"-13 x 1 1/2"	DS-8678-04-ZN	DS-8548-01-S6
BEAM CLAMP	FOR 1/4" ROD	DS-0221-01-ZN*	DS-0221-01-S6*
	FOR 3/8" ROD	DS-0221-04-ZN†	DS-0221-04-S6†
	FOR 1/2" ROD	DS-0221-06-ZN‡	DS-0221-06-S6‡

Safe Load: *750 lbs.; †1100 lbs.; ‡1600 lbs.



METALLIC ACCESSORIES

METALLIC FASTENERS

FIRE WALL PENETRATION SLEEVE

M G T

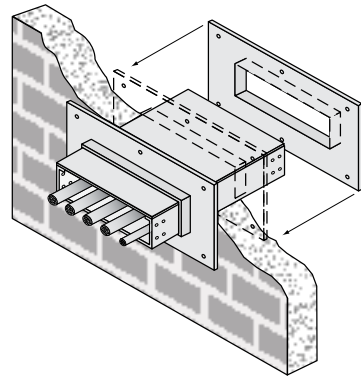

PRODUCT NUMBER	FASTENER OPTIONS
0440	CD S6

Fabricated cable tray fire stop sleeves from Legrand, combined with Hilti Firestop products, are an economical alternative to the high cost of fabricating protective fire wall and floor penetration sleeves in the field.

This firestop system provides a rigid support for cable tray in a UL classified system approved for fire wall and floor penetrations. After the sleeve is placed in the wall or floor, the loose collar slides over it. Hardware for the tray connection only is included. Hardware required to mount sleeves to the wall or floor is not included.

The Hilti Fire Block is a compressible fire stop brick, well-suited for installations where frequent cable changes may be required. Blocks are easily cut to fit any space, and can be removed and reinstalled when cable configurations change. When exposed to fire, the blocks expand to lock the seal in place.

Each cable tray firestop sleeve includes:

- One penetration sleeve with flanges
- Hilti Fire Blocks
- One Hilti Firestop Putty Stick
- Hardware for cable tray connection to the wall sleeve:
 - Metallic and fiberglass cable trays with two side rails. The Firestop kit includes two pairs of splice plates with nuts & bolts; 316 stainless steel is recommended for use with fiberglass systems.

SLEEVE WIDTH	NUMBER OF HILTI FIRE BLOCKS INCLUDED WITH EACH SLEEVE			
	SIDE RAIL HEIGHT (IN.)			
	4	5	6	7
6	2	2	3	3
9	3	3	4	4
12	3	4	5	6
18	5	6	7	8
24	6	8	9	11
30	8	10	12	14
36	9	12	14	16



UL classified for use with:
 2-hr concrete or block walls
 2-hr concrete floors
 1-hr gypsum walls
 2-hr gypsum walls

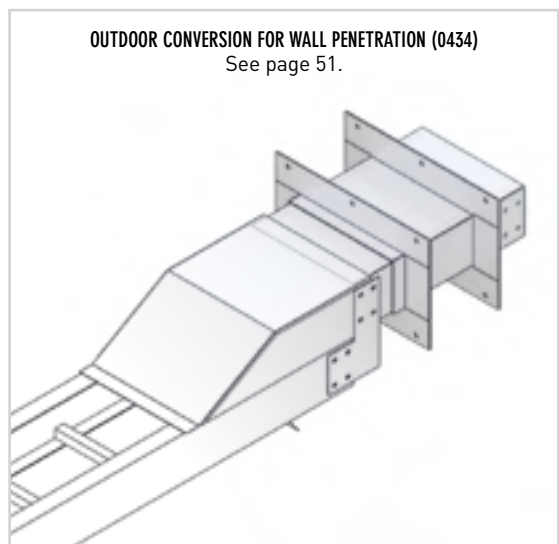
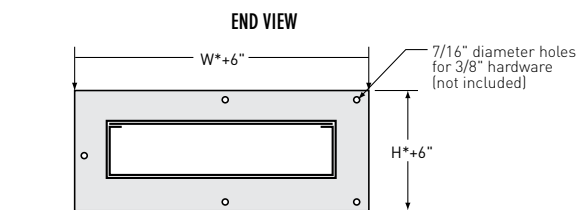
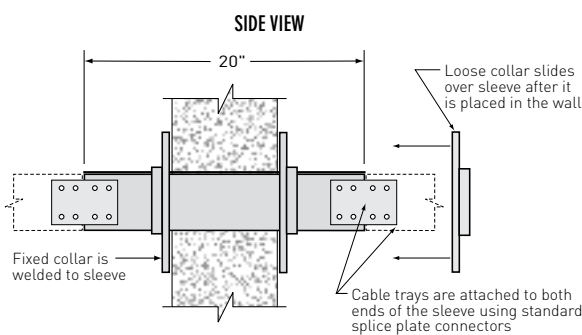

Floor Firestop Sleeve Example
 0440 product used as a floor sleeve per UL assembly W-L-3226 and C-AJ-3232

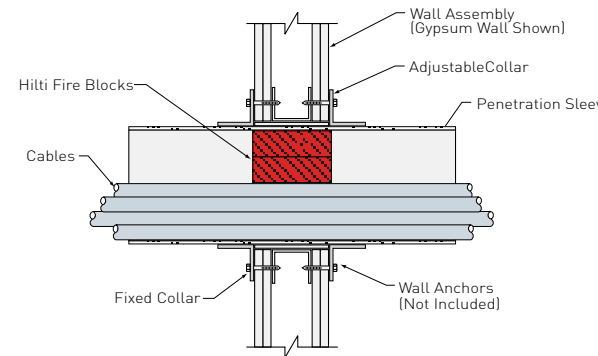

WALL/FLOOR SLEEVE DESCRIPTION

Designed for single runs of cable tray, having a height and width to match the tray system specified. One end of the 20 inch sleeve has a flange attached 6 inches from the end, while the flange for the other end is "floating" and is free to slide directly against the face of the wall as needed. The 20 inch length of the sleeve will accommodate a wall thickness of up to 8 inches. A wall thickness of 8 inches will result in the sleeve protruding 6 inches from each side of the wall. Both ends of the sleeve are punched with holes for attaching cable tray splice plates or hardware needed for the tray system specified.

INSTALLATION

The opening in the wall should be within 1 inch of the nominal height and width of the cable tray. The flanges of the sleeve have 7/16" diameter mounting holes for attachment to the wall using 3/8" diameter hardware. Hardware for wall attachment is not included. After the sleeve is mounted in the wall or floor, the cable trays on either side of the sleeve can be connected using the hardware supplied with the sleeve. When the trays are in place, the cables should be pulled through the wall and sleeve as needed. After all of the cables are installed in the tray, install the Fire Blocks as described. Any voids between cables should be filled with the Firestop Putty Stick.

Floor Firestop Sleeve Example
 0440 product used as a floor sleeve per UL assembly F-A-3022

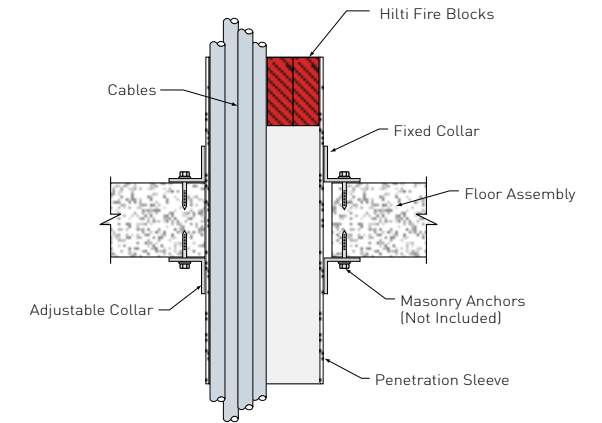

TECHNICAL DATA

ConstructionArc Welded
 Sleeve
 Dimensions20" x Tray Width x Tray Height
 Flange
 Dimensions(Tray Width + 6") x (Tray Height + 6")
 UL ClassificationQualifies for use as an equipment grounding conductor per N.E.C. 392.7. Cross-sectional area and ampere ratings are based on the cable tray system attached to the sleeve.

HILTI FIRE BLOCKS INSTALLATION:

Walls: Hilti Fire Blocks shall be installed with 5" dimension projecting through and centered within wall assembly.
Floors: Hilti Fire Blocks shall be installed with 5" dimension projecting through opening, flush with the top surface of sleeve or recessed within sleeve at any level above the top surface of floor. Fire blocks fill the annular space between the cables and the sleeve. Fire Blocks may be cut to match the profile of cables or to fit opening. Any voids should be filled with 0618 Firestop Putty Stick.

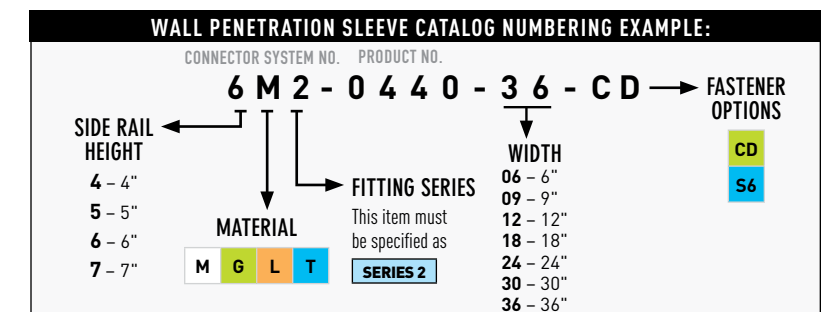

METALS

PW from Legrand, a pioneer in the development of cable trays, first made a complete study of the metals available in order to create those systems that would be unmatched in economy and strength. Inherent are the problems connected with the environment and its effect on the life of metals, including weathering and corrosion by electro-chemical and chemical attack.

Steel – Hot-Dip Galvanized After All Fabrication and Welding

Commercial quality steel is used for this type of coating, which is described below. This steel is either hot rolled, pickled and oiled, or cold rolled, mild carbon steel.

Steel – Mill Galvanized (Pre-Galvanized)

Where heavy zinc coating is not necessary, steel with a continuous hot rolled zinc coating conforming to ASTM specification A653 designation G90 is used. Products made with mill galvanized steel are generally lower in cost than the same products that are hot dip galvanized after fabrication. However, see the limitations under "Finishes" later on this page.

Stainless Steel

18-8 stainless steel type 304 and marine-grade type 316 is available for most PW products. Certain products such as raceway push clips, Stack-A-Tube yoke clamps, and some hardware items are made only from 18-8 stainless steel. Stainless steel components are compatible for use with hot dip galvanized, mill galvanized, and aluminum products. Complete cable tray systems can be furnished in stainless steel.

Aluminum Alloys

The principal aluminum used for tray side rails, rungs, and channels is extruded, copper-free alloy 6063-T6. This alloy is used for structural members where extreme stiffness and high tensile strength are mechanically required to resist high unit stresses. This is called a "magnesium alloy".

Alloy 5052-H32 is used for components fabricated from sheet (except covers) such as connectors, blind ends, dropouts, etc. This is a "magnesium alloy", copper free, and very compatible with alloy 6063-T6. This alloy possesses excellent characteristics for stamped and formed components.

Alloys 3003 and 3105 are used for aluminum covers. These alloys are very compatible with alloys 6063-T6 and 5052-H32.

FINISHES

Steel – Hot-Dip Galvanized After All Fabrication and Welding:

This high-quality coating is created in a multi-step process and applied to the completed product after all fabrication and welding. First the steel is cleaned by immersing it in a caustic dip tank, then pickled, and finally washed. The article is then dipped into a molten zinc bath. All surfaces are thoroughly coated. Hot dip galvanizing after all fabrication and welding is done on PW products in accordance with ASTM Specification A123. This coating, applied to steel trays, provides greatest protection at lower cost.

Due to the high temperatures associated with the hot dip process, some warping of the metal is common. This occurs most frequently with products having large, flat surfaces such as covers. To minimize warping, PW uses thicker sheet metal for covers. This does reduce warping, but does not eliminate it.

Mill Galvanized (Pre-Galvanized)

This coating is applied onto steel sheets at the mill in accordance with ASTM Specification A653 and results in a coating thickness of 0.90 ounces per square foot total for both sides. This coating adheres tightly to the base metal at bends and compound curves. Being a hot dip coating prior to tray fabrication, and of a controlled thickness about one-third that of hot dip galvanized after fabrication, it is not generally used outdoors. It is not recommended for areas where there is a concentration of moisture and/or chemical deposits. This material gives excellent service in dry, normal, or controlled atmospheres.

Some Helpful Hints On Which Zinc Coating To Select

1. Protection of the base metal is directly proportional to the zinc coating thickness. Hence, thicker coating means longer life. At sheared or punched locations, zinc on mill galvanized steel is wiped down over approximately 1/3 of the metal thickness giving some sacrificial protection in the presence of an electrolyte. On hot dip galvanized after fabrication, all edges are coated but the original cost is higher.
2. The edges of holes in mill galvanized steel will have no coating; however, a small sacrificial protection is afforded by the top and bottom surfaces of the sheet. The hot dip galvanized comment above applies here.
3. If moisture and drippings accumulate, consider hot dip galvanized after fabrication to avoid premature deterioration at those locations.
4. Covers are typically made from mill galvanized steel in order to avoid the poor appearance caused by severe warping of such large flat surfaces when hot dip galvanized after fabrication.

Other Coatings

Occasionally, other highly special coatings are required such as powder coating, epoxy painting, standard painting, primer paint, and others. Legrand engineers are available for consultation on these coatings and their application to PW trays.

THERMAL CONTRACTION AND EXPANSION

Expansion Splice Plate Installation

It is important that thermal contraction and expansion be considered when installing cable tray systems. The length of the straight cable trays runs and the temperature differential govern the number of expansion splice plates required (see Table 1).

Proper operation of the expansion splice plates depends upon correct placement of the tray supports, hold down clamps and expansion guides as shown.

Hold Down Clamps should be used at the support point nearest to the midpoint between expansion gaps.

Expansion Guide Clamps should be used at all support points other than the midpoint. These clamps should be installed in such a way to allow the tray to slide freely under the clamp when thermal contraction and expansion takes place.

Supports with expansion guide clamps should be located within 24" of each side of expansion splice plates.

Accurate gap settings between trays at the expansion joint at the time of installation are necessary for the proper operation of the expansion splice plates. Use the following procedure to determine the correct gap setting:

- A Determine what the maximum temperature will be at the installation location and plot this point on the graph on the max. temp line. (Example value = 100)
- B Determine what the minimum temperature will be at the installation location and plot this point on the graph on the min. temp line. (Example value = -30).
- C Draw a line between the maximum and minimum points.
- D At the time of installation, determine the air temperature. (Example = 50). Plot this point on the line drawn between the maximum and minimum temperatures to determine the correct gap setting at the expansion plate. (Example = 3/8").

Table 1

TEMPERATURE DIFFERENTIAL		MAXIMUM SPACING BETWEEN EXPANSION JOINTS FOR 1" MOVEMENT (FT.)						
°F	°C	A	M	G	L	T	F	
25	14	260					512	667
50	28	130					256	333
75	42	87					171	222
100	56	65					128	167
125	70	52					102	133
150	83	43					85	111
175	97	37					73	95

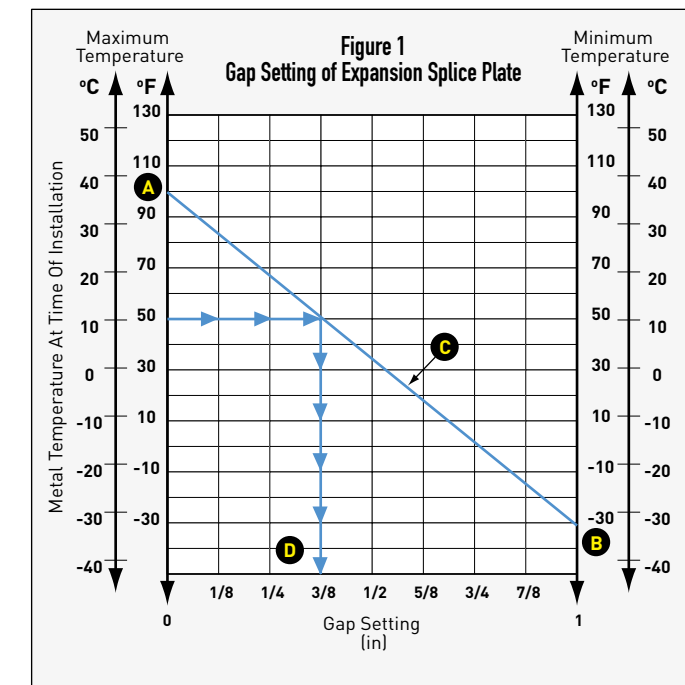

Expansion splice plates should be placed on the outside of the cable tray on both side rails. The screw heads should be on the inside and nuts on the outside of the cable tray. Tighten the lock nuts on the screws in the slotted holes just a few turns, allowing the bolt to move freely in the slot.

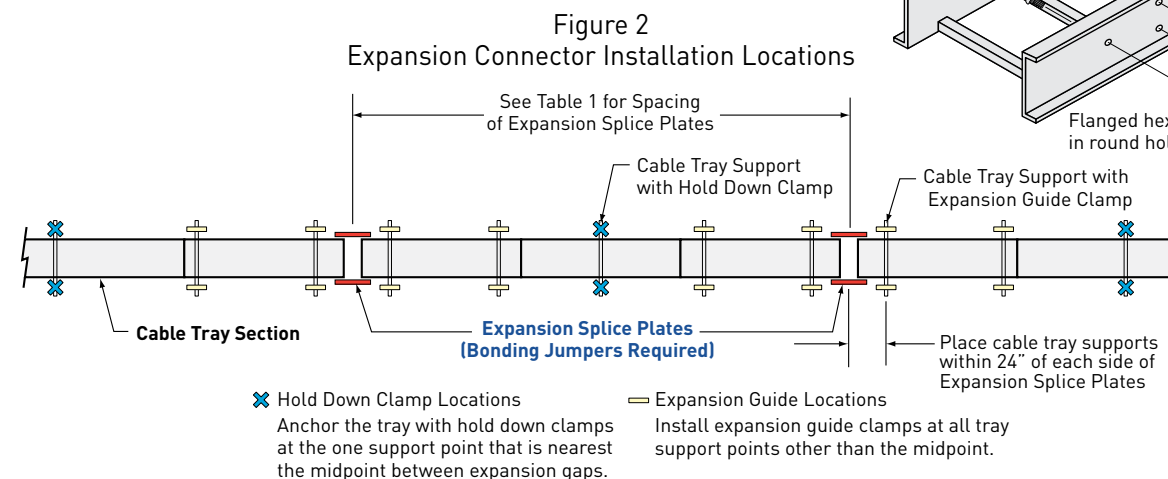
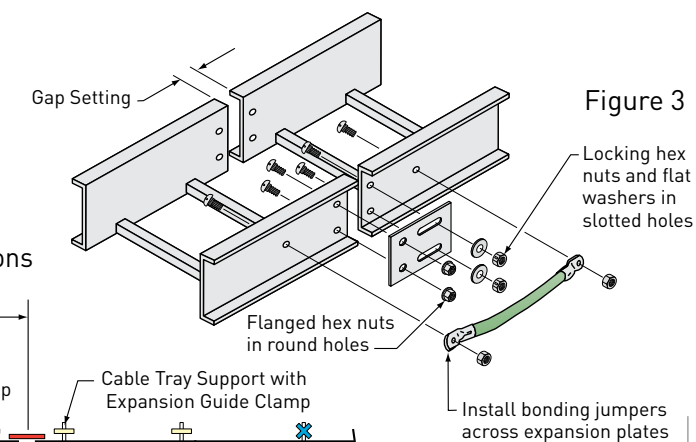

CABLE TRAY SIDE RAILS



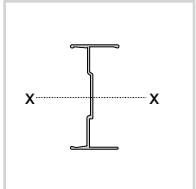
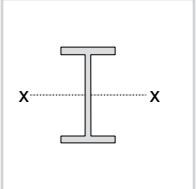

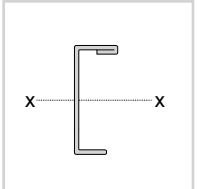
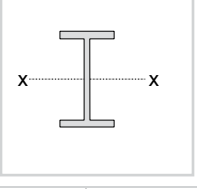



The mechanical properties of cable tray side rails for straight tray sections are shown for all standard systems. Side rails used for fittings may have slightly different dimensions since they must be suitable for bending into curved sections. Fitting side rails are designed to meet or exceed the loading requirements of the straight tray sections with which they are used when supported per NEMA VE2 installation guidelines. Although the cross-sectional dimensions of the fitting side rails may be slightly different than the straight section side rails, all aspects of fitting design are in accordance with NEMA VE1 requirements. Please contact Legrand for detailed information on fitting side rails.

 ITRAY I-BEAM A				
RAIL HEIGHT (IN.)	NEMA CLASS	PRODUCT NUMBER	I_x MOMENT OF INERTIA (IN. ⁴)	S_x SECTION MODULUS (IN. ³)
4	12B	4A12B	1.343	0.626
	12C	4A12C	1.418	0.646
	20B	4A20B	2.717	1.103
5	12C	5A12C	2.288	0.859
	20B	5A20B	3.344	1.146
6	12C	6A12C	3.993	1.182
	20B	6A20B	5.441	1.549
	20C	6A20C	6.380	1.836
	24C	6A24C	8.128	2.349
7	12C	7A12C	5.403	1.106
	20B	7A20B	7.675	1.896
	20C	7A20C	9.803	2.471
	24C	7A24C	12.092	3.005
 I-BEAM A				
8	20C+	S2	25.8053	7.1067
			26.3140	7.3722
10			70.3837	15.2789

 C-CHANNEL G					
RAIL HEIGHT	NEMA CLASS	SERIES	I_x MOMENT OF INERTIA (IN. ⁴)	S_x SECTION MODULUS (IN. ³)	
4	12B	S1	0.6214	0.3517	
	12C, 16A		0.7417	0.4110	
	20A, 16B	S2	1.0593	0.5860	
20B, 16C	1.3781		0.7984		
5	20C	S2	1.7934	1.0044	
	12B		S1	1.0785	0.4796
	12C, 16A		S2	1.2925	0.5645
	20B, 16C			2.3334	1.0632
20C	3.1670	1.4398			
6	12B	S1	1.7047	0.6234	
	12C, 16A		1.7873	0.6733	
	20B, 16C	S2	2.7718	1.0001	
	20C		3.4185	1.2324	
7	12B	S1	2.5243	0.7830	
	12C, 16A		2.6403	0.8411	
	20B, 16C	S2	4.0298	1.2366	
	20C		4.9763	1.5260	
 I-BEAM G					
8"	20C+	S2	18.5	4.62	
			30.8	7.81	
10"			68.9	13.8	

RUNG DESIGNS

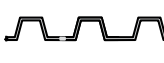
PW offers a wide range of rung design options for special load applications. Extremely heavy cable loads, concentrated static loads, and heavy snow or ice loads may require rungs with greater load capacities than standard designs. Rung substitutions are designated by suffixes added to the tray catalog numbers.

STANDARD RUNGS AND BOTTOMS - ALUMINUM A			STANDARD RUNGS AND BOTTOMS - STEEL M G L T		
TYPE	USE		TYPE	USE	
AL		I-BEAM RUNG, 1" DEEP STANDARD FOR MOST LADDERS UP TO 24" WIDE	HL HH		HAT RUNGS, SOLID STANDARD FOR LADDER TRAYS
AH		HEAVY I-BEAM RUNG, 1" DEEP STANDARD FOR MOST LADDERS 30" AND WIDER	BX BH		BOX RUNG, 1" DEEP STANDARD FOR LADDER TRAYS
SR		SLOTTED STRUT RUNG, 1 5/8" DEEP STANDARD FOR LONG-SPAN LADDER TRAY WITH SIDERAIL OF 8" OR LARGER	RS		SLOTTED STRUT RUNG, 1 5/8" DEEP STANDARD FOR LONG-SPAN LADDER TRAY WITH SIDERAIL OF 8" OR LARGER
CA		CORRUGATED SHEET BOTTOM SOLID TROUGH	CS		CORRUGATED SHEET BOTTOM SOLID TROUGH NOT AVAILABLE IN STAINLESS STEEL
UPGRADE RUNG - ALUMINUM A			UPGRADE RUNG - STEEL M G L T		
ST		SLOTTED STRUT RUNG, 1" DEEP UPGRADE OPTION FOR LADDERS SEE BELOW FOR SLOT DETAIL	SU		SLOTTED STRUT RUNG, 1" DEEP UPGRADE OPTION FOR LADDERS SEE BELOW FOR SLOT DETAIL

RUNG OPTIONS

SLOTTED RUNGS

All PW cable tray metallic ladder systems are available with slotted strut rungs for cable ties. Slots are 0.75" long to accommodate stainless steel banding used in marine applications or any location where extra cable support requires the use of cable ties. Slotted strut rungs are provided with alternating slots up and down to allow for strut accessories to be used both inside the tray and below the cable area. Slotted rungs are designated by the suffix ST (aluminum) or SU (steel) added to the straight sections and fittings catalog numbers.

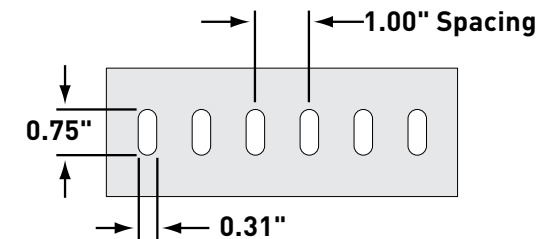

STANDARD RUNGS

This is the standard rung for all 6"-24" wide aluminum ladder trays.

RUNG TYPE		MECHANICAL PROPERTIES
AL	I-BEAM	MINIMUM THICKNESS = 0.050" MOMENT OF INERTIA: $I_x = 0.044 \text{ IN}^4$ SECTION MODULUS: $S_x = 0.0869 \text{ IN}^3$

RUNG SPACING	LOAD TYPE	SAFE LOAD LIMITS (LBS/FT)									
		TRAY WIDTH (IN.)									
		6	9	12	18	24	30	36	42	48	
6	1	5330	3553	2665	1777	1332	AH	AH	AH	AH	AH
	2	6814	4276	3007	1738	1104	AH	AH	AH	AH	AH
9	1	3553	2369	1777	1184	888	AH	AH	AH	AH	AH
	2	4543	2851	2005	1159	736	AH	AH	AH	AH	AH
12*	1	2665	1777	1332	888	667	AH	AH	AH	AH	AH
	2	3407	2138	1504	869	552	AH	AH	AH	AH	AH
18	1	1777	1184	888	592	444	AH	AH	AH	AH	AH
	2	2271	1425	1002	579	368	AH	AH	AH	AH	AH

This is the standard rung for all aluminum ladder trays 30" and wider.

RUNG TYPE		MECHANICAL PROPERTIES
AH	I-BEAM	MINIMUM THICKNESS = 0.070" MOMENT OF INERTIA: $I_x = 0.0510 \text{ IN}^4$ SECTION MODULUS: $S_x = 0.0981 \text{ IN}^3$

RUNG SPACING	LOAD TYPE	SAFE LOAD LIMITS (LBS/FT)									
		TRAY WIDTH (IN.)									
		6	9	12	18	24	30	36	42	48	
6	1	AL	AL	AL	AL	AL	1360	1134	972	850	
	2	AL	AL	AL	AL	AL	1143	819	588	415	
9	1	AL	AL	AL	AL	AL	907	756	648	567	
	2	AL	AL	AL	AL	AL	762	546	392	276	
12*	1	AL	AL	AL	AL	AL	680	567	486	425	
	2	AL	AL	AL	AL	AL	572	410	294	207	
18	1	AL	AL	AL	AL	AL	453	378	324	283	
	2	AL	AL	AL	AL	AL	381	273	196	138	

Standard rung for 8" and larger siderail cable trays. Designed for extremely heavy load applications. This profile will accept strut hardware and accessories. Trays which use this rung will have a load depth equal to the side rail height minus 15/8". SR rungs are installed alternating slot up and slot down.

RUNG TYPE		MECHANICAL PROPERTIES
SR	SLOTTED†	MINIMUM THICKNESS = 0.102" MOMENT OF INERTIA: $I_x = 0.1848 \text{ IN}^4$ SECTION MODULUS: $S_x = 0.2039 \text{ IN}^3$

RUNG SPACING	LOAD TYPE	SAFE LOAD LIMITS (LBS/FT)									
		TRAY WIDTH (IN.)									
		6	9	12	18	24	30	36	42	48	
6	1	9999	8700	6525	4350	3262	2610	2175	1864	1631	
	2	9999	8700	6525	4350	3262	2610	2175	1864	1576	
9	1	8700	5800	4350	2900	2175	1740	1450	1243	1087	
	2	8700	5800	4350	2900	2175	1740	1450	1243	1050	
12*	1	6525	4350	3262	2175	1631	1305	1087	932	816	
	2	6525	4350	3262	2175	1631	1305	1087	932	788	
18	1	4350	2900	2175	1450	1087	870	725	621	544	
	2	4350	2900	2175	1450	1087	870	725	621	525	

STANDARD CORRUGATED BOTTOM

This is the standard corrugated bottom used for all aluminum, solid-bottom tray systems up to and including NEMA Class 20C. Corrugated bottoms are not available in widths greater than 36". For extremely heavy load applications, Ladder type tray is recommended.

RUNG TYPE		MECHANICAL PROPERTIES
CA	SOLID OR VENTILATED	MINIMUM THICKNESS = 0.032"

LOAD TYPE	SAFE LOAD LIMITS (LBS/FT)							
	TRAY WIDTH (IN.)							
	6	9	12	18	24	30	36	
1	2000	1333	1000	667	500	400	333	
2	2000	1333	1000	600	350	200	100	

UPGRADE BOTTOM

This is the upgrade slotted rung for all aluminum ladder cable trays with 6", 9", or 12" rung spacing, but is the standard rung for all aluminum ladder cable trays with 18" rung spacing. This rung is also available for all aluminum ladders for extremely heavy load applications. ST rungs are installed alternating slot up and slot down.

RUNG TYPE		MECHANICAL PROPERTIES
ST	SLOTTED†	MINIMUM THICKNESS = 0.105" MOMENT OF INERTIA: $I_x = 0.0531 \text{ IN}^4$ SECTION MODULUS: $S_x = 0.0917 \text{ IN}^3$

RUNG SPACING	LOAD TYPE	SAFE LOAD LIMITS (LBS/FT)									
		TRAY WIDTH (IN.)									
		6	9	12	18	24	30	36	42	48	
6	1	6602	4402	3301	2201	1651	1320	1100	943	825	
	2	6602	4402	3301	2201	1604	1123	803	574	402	
9	1	4402	2934	2201	1467	1100	880	734	629	550	
	2	4402	2934	2201	1467	1069	749	535	382	268	
12*	1	3301	2201	1651	1100	825	660	550	472	413	
	2	3301	2201	1651	1100	802	562	401	287	201	
18	1	2201	1467	1100	734	550	440	367	314	275	
	2	2201	1467	1100	734	535	374	268	191	134	

- 1 Safe Load/Cable Load Only: Allowable uniformly-distributed cable load expressed in lbs/linear foot of tray length, based on the load carrying capability of the rung with a safety factor of 1.5. To convert Safe Load/Cable Load Only to reflect a safety factor of 2.0, multiply the safe loads shown by 0.75.
 - 2 Safe Load / Cable Load +200 lbs: Allowable uniformly-distributed cable load expressed in lbs/linear foot of tray length, based on the load carrying capability of the rung with a 200 lb. concentrated static load applied at the center of the rung, without collapse.
 - 3 Will not support a 200 lb. concentrated static load applied at the center of the rung.
- [XX] Two digit code in the safe load limit tables indicates recommended rung option for specified width.

* Single rung load capacity: The data shown for 12" rung spacing is equivalent to the load capacity of the single rung.

† Slotted rungs are installed alternating slot up and slot down.

STANDARD RUNGS

M G

This is the standard solid rung for the following steel cable trays, up to 24" wide: NEMA Class 12B and 12C ladder with flange-in side rails. NEMA Class 20A, 20B and 20C, mill galvanized, and ladder.

RUNG TYPE	MECHANICAL PROPERTIES	RUNG SPACING	LOAD TYPE	SAFE LOAD LIMITS (LBS/FT)																				
				TRAY WIDTH (IN.)																				
HL	SOLID	THICKNESS = 0.038" MOMENT OF INERTIA: $I_x = 0.0143 \text{ IN}^4$ SECTION MODULUS: $S_x = 0.0374 \text{ IN}^3$		5	1	3351	2234	1676	1117	838	HH	HH	SU	SU	2	3351	2234	1480	667	260	HH	HH	SU	SU
					6	1	2793	1862	1396	931	698	HH	HH	SU		SU	2	2793	1862	1233	556	217	HH	HH
				9		1	1862	1241	931	621	465	HH	HH	SU	SU	2	1862	1241	822	370	144	HH	HH	SU
					12*	1	1396	931	698	465	349	HH	HH	SU	SU	2	1396	931	617	278	108	HH	HH	SU

This is the standard solid rung for the following steel cable trays, 30" and 36" wide: NEMA Class 12B and 12C ladder trays with flange-in side rails. NEMA Class 20A, 20B and 20C, mill galvanized, ladder trays.

RUNG TYPE	MECHANICAL PROPERTIES	RUNG SPACING	LOAD TYPE	SAFE LOAD LIMITS (LBS/FT)																				
				TRAY WIDTH (IN.)																				
HH	SOLID	THICKNESS = 0.048" MOMENT OF INERTIA: $I_x = 0.0175 \text{ IN}^4$ SECTION MODULUS: $S_x = 0.0456 \text{ IN}^3$		5	1	HL	HL	HL	HL	HL	948	790	SU	SU	2	HL	HL	HL	HL	HL	481	241	SU	SU
					6	1	HL	HL	HL	HL	HL	790	659	SU		SU	2	HL	HL	HL	HL	HL	401	201
				9		1	HL	HL	HL	HL	HL	527	439	SU	SU	2	HL	HL	HL	HL	HL	267	134	SU
					12*	1	HL	HL	HL	HL	HL	395	329	SU	SU	2	HL	HL	HL	HL	HL	201	101	SU

This is the standard rung for all flange-out steel ladders and all flange-in, NEMA Class 20A, 20B, and 20C, hot-dip galvanized steel ladders 6"-24" wide. Please contact Legrand for catalog numbers if this rung is desired for other tray systems.

RUNG TYPE	MECHANICAL PROPERTIES	RUNG SPACING	LOAD TYPE	SAFE LOAD LIMITS (LBS/FT)																				
				TRAY WIDTH (IN.)																				
BX	SOLID	MINIMUM THICKNESS = 0.048" MOMENT OF INERTIA: $I_x = 0.0188 \text{ IN}^4$ SECTION MODULUS: $S_x = 0.0343 \text{ IN}^3$		6	1	3243	2162	1621	1081	811	BH	BH	BH	BH	2	3243	2162	1561	774	381	BH	BH	BH	BH
					9	1	2162	1441	1081	721	540	BH	BH	BH		BH	2	2162	1441	1041	516	254	BH	BH
				12*		1	1621	1081	811	540	405	BH	BH	BH	BH	2	1621	1081	781	387	190	BH	BH	BH
					18	1	1081	721	540	360	270	BH	BH	BH	BH	2	1081	721	520	258	127	BH	BH	BH

STANDARD RUNGS

M G

This is the standard rung for all flange-out steel ladders and all flange-in, NEMA Class 20A, 20B, and 20C, hot-dipped galvanized steel ladders 30" and 36" wide. Please contact Legrand for catalog numbers if this rung is desired for other tray systems.

RUNG TYPE	MECHANICAL PROPERTIES	RUNG SPACING	LOAD TYPE	SAFE LOAD LIMITS (LBS/FT)																				
				TRAY WIDTH (IN.)																				
BH	SOLID	THICKNESS = 0.060" MOMENT OF INERTIA: $I_x = 0.0227 \text{ IN}^4$ SECTION MODULUS: $S_x = 0.0414 \text{ IN}^3$		6	1	BX	BX	BX	BX	BX	816	680	583	510	2	BX	BX	BX	BX	BX	388	190	49	3
					9	1	BX	BX	BX	BX	BX	544	453	389		340	2	BX	BX	BX	BX	BX	259	127
				12		1	BX	BX	BX	BX	BX	408	340	291	255	2	BX	BX	BX	BX	BX	194	95	24
					18	1	BX	BX	BX	BX	BX	272	227	194	170	2	BX	BX	BX	BX	BX	129	63	16

UPGRADE RUNG

This is the upgrade slotted rung for all steel ladder cable trays. SU rungs are installed alternating slot up and slot down.

RUNG TYPE	MECHANICAL PROPERTIES	RUNG SPACING	LOAD TYPE	SAFE LOAD LIMITS (LBS/FT)																				
				TRAY WIDTH (IN.)																				
SU	SLOTTED†	THICKNESS = 0.120" MOMENT OF INERTIA: $I_x = 0.0531 \text{ IN}^4$ SECTION MODULUS: $S_x = 0.0921 \text{ IN}^3$		6	1	3999	3999	3066	2044	1533	1226	1022	876	766	2	3999	3999	3066	2044	1499	1040	733	514	350
					9	1	3999	2725	2044	1363	1022	818	681	584		511	2	3999	2725	2044	1363	1000	693	489
				12*		1	3066	2044	1533	1022	766	613	511	438	383	2	3066	2044	1533	1022	750	520	366	257
					18	1	2044	1363	1022	681	511	409	341	292	255	2	2044	1363	1022	681	500	347	244	171

- 1** Safe Load/Cable Load Only: Allowable uniformly-distributed cable load expressed in lbs/linear foot of tray length, based on the load carrying capability of the rung with a safety factor of 1.5. To convert Safe Load/Cable Load Only to reflect a safety factor of 2.0, multiply the safe loads shown by 0.75.
 - 2** Safe Load / Cable Load +200 lbs: Allowable uniformly-distributed cable load expressed in lbs/linear foot of tray length, based on the load carrying capability of the rung with a 200 lb. concentrated static load applied at the center of the rung, without collapse.
 - 3** Will not support a 200 lb. concentrated static load applied at the center of the rung.
- [XX] Two digit code in the safe load limit tables indicates recommended rung option for specified width.

* Single rung load capacity: The data shown for 12" rung spacing is equivalent to the load capacity of the single rung.

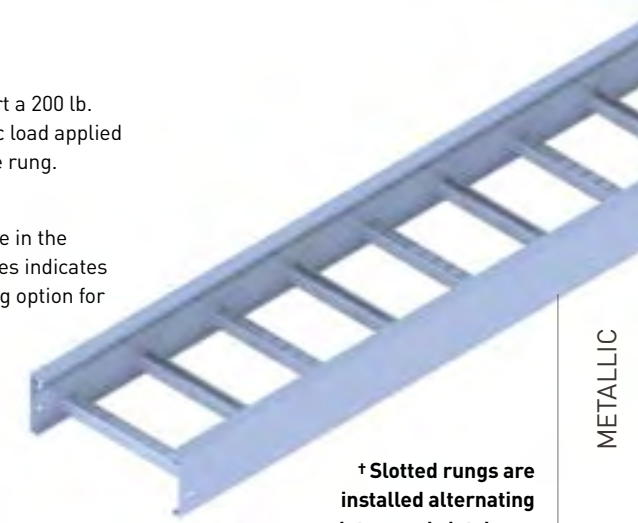

† Slotted rungs are installed alternating slot up and slot down.

STANDARD RUNGS

M G

This rung is available for steel ladder tray systems for extremely heavy load applications. This profile will accept strut fasteners and accessories. RS rungs are installed alternating slot up and slot down.

RUNG TYPE	MECHANICAL PROPERTIES	RUNG SPACING	LOAD TYPE	SAFE LOAD LIMITS (LBS/FT)									
				TRAY WIDTH (IN.)									
RS	SLOTTED† THICKNESS = 0.120" MOMENT OF INERTIA: I _x = 0.1848 IN ⁴ SECTION MODULUS: S _x = 0.2040 IN ³	6	1	9999	9991	7494	4996	3747	2997	2498	2141	1873	
			2	9999	9991	7494	4996	3747	2997	2498	2141	1873	
		9	1	9991	6661	4996	3330	2498	1998	1665	1427	1249	
			2	9991	6661	4996	3330	2498	1998	1665	1427	1249	
		12*	1	7494	4996	3747	2498	1873	1499	1249	1071	937	
			2	7494	4996	3747	2498	1873	1499	1249	1071	937	
		18	1	4996	3330	2498	1665	1249	999	833	714	624	
			2	4996	3330	2498	1665	1249	999	833	714	624	

This is the standard corrugated bottom used for all steel, solid-bottom tray systems up to and including NEMA Class 20C. Corrugated bottoms are not available in widths greater than 36". Please contact Legrand when considering solid bottom trays for extreme load applications.

RUNG TYPE	MECHANICAL PROPERTIES	LOAD TYPE	SAFE LOAD LIMITS (LBS/FT)						
			TRAY WIDTH (IN.)						
CS	SOLID OR VENTILATED MINIMUM THICKNESS = 0.032"	1	6	9	12	18	24	30	36
			2	2007	1338	1003	669	502	401
		2	6	1338	1003	599	350	200	100

- 1 Safe Load/Cable Load Only:** Allowable uniformly-distributed cable load expressed in lbs/linear foot of tray length, based on the load carrying capability of the rung with a safety factor of 1.5. To convert Safe Load/Cable Load Only to reflect a safety factor of 2.0, multiply the safe loads shown by 0.75.
 - 2 Safe Load / Cable Load +200 lbs:** Allowable uniformly-distributed cable load expressed in lbs/linear foot of tray length, based on the load carrying capability of the rung with a 200 lb. concentrated static load applied at the center of the rung, without collapse.
 - 3** Will not support a 200 lb. concentrated static load applied at the center of the rung.
- [XX] Two digit code in the safe load limit tables indicates recommended rung option for specified width.

* Single rung load capacity: The data shown for 12" rung spacing is equivalent to the load capacity of the single rung.

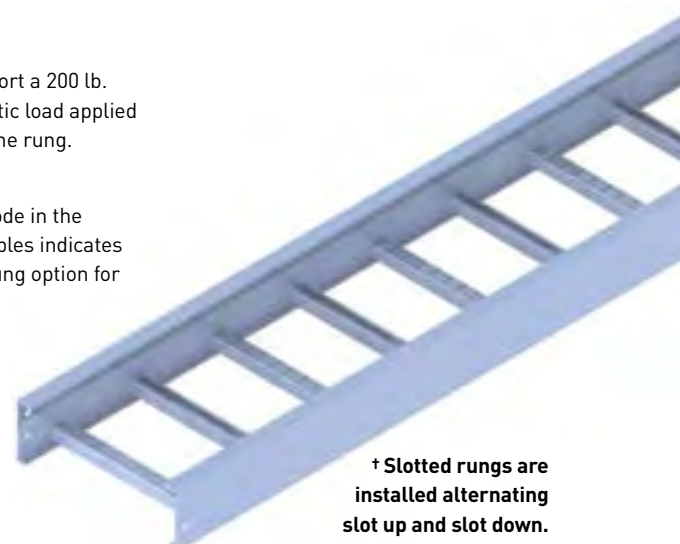

† Slotted rungs are installed alternating slot up and slot down.

TRAY LABELS

This is a typical label attached to all PW cable tray straight sections and fittings. It presents important information about the cable tray component and is in accordance with NEMA VE1 guidelines. Labels for fiberglass and stainless steel tray systems are similar. Because these trays are not classified by UL as equipment grounding conductors, they do not have the UL logo or the UL classification text.

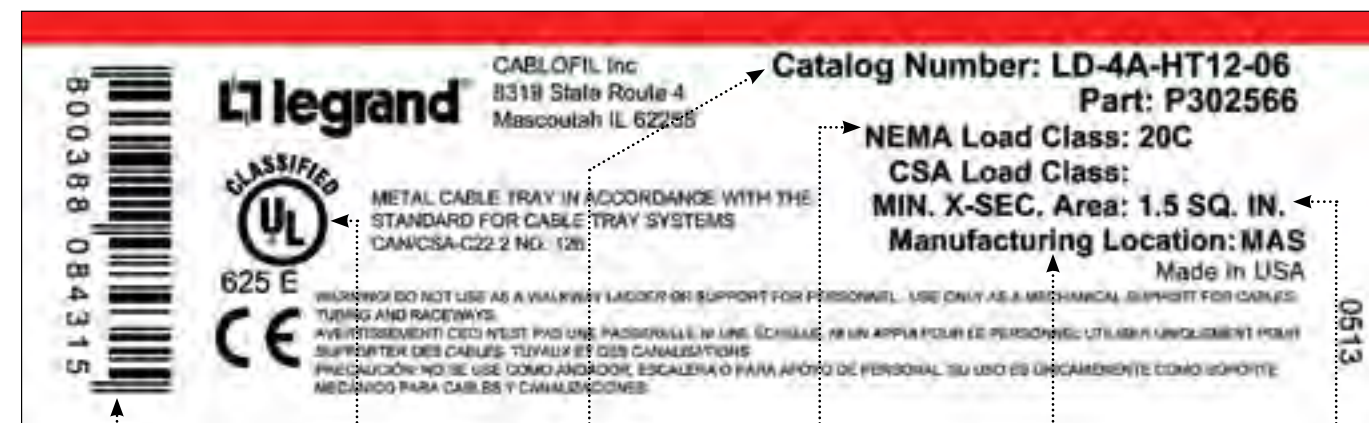

The **UPC code** is used for inventory control.

UL Classification details and the UL logo express the product's grounding qualifications, including the area of metal in the tray side rails.

Catalog Number indicates bottom type, depth, material type and part description per NEMA VE1.

NEMA Load Class is clearly marked.

Manufacturing Location indicates the Legrand manufacturing location from which this product was shipped.

Min. X-Sec. Area Cross sectional area of both tray side rails per NEC Table SB 392.60 (A).

FABRICATION OPTIONS AND ENGINEERING SERVICES

No matter which product you choose, Legrand offers its customers a wide variety of fabrication options and engineering services. We pride ourselves in providing you with the products you need, built to your exact specifications. To help do so, take advantage of our wide range of ancillary services including:

- Take-off and estimating assistance
- Marking special identification numbers on tray labels
- Special identification labels and warning signs
- Custom drawing and design services
- Special packaging and shipment options
- Staging per customer-defined areas

We are pleased to provide customized cable tray to fit your specific needs. Examples of the types of modifications that can be made include but are not limited to:

- Factory-installed divider strips
- Pre-attached connector plates on trays and fittings
- Holes added to tray components for accessory attachments

Contact Legrand at 1-800-658-4641 so that we may discuss your exact job requirements.

FIBERGLASS

F	FIBERGLASS
----------	------------

WIDTHS (W) INCHES

6 | 9 | 12 | 18 | 24 | 30 | 36

RAIL HEIGHTS (H) INCHES

4 | 6

LENGTHS (L) FEET

10 | 20

RAIL HEIGHT (IN.)	LOAD DEPTH (IN.)	RAIL FLANGE (IN.)	NEMA CLASS	CSA CLASS	SERIES	TRAY SYSTEM NUMBER		SUPPORT SPAN (FT.)															
						LADDER	SOLID BOTTOM	6	8	10	12	14	16	18	20								
4	2 ⁷ / ₈	1 ¹ / ₄	12B	C	S1	7400	7D20	196	0.38	164	0.85	138	1.61	80	2.08	56	2.57	41	3.04				
	4 ⁷ / ₈	2	12C, 16A	D, 3M	S1	7615	7F20			174	0.53	159	0.88	128	1.24	105	1.59	82	1.95	50	2.45		
6	4 ³ / ₄	1 ⁵ / ₈	20C	E, 6M	S2	7625	7F24					278	1.25	246	2.03	215	2.79	183	3.56	152	4.31	120	5.09

MATERIAL:

Manufactured from polyester isophthalic resin conforming with ASTM E-84 Class 1. This material displays good corrosion resistance, including self extinguishing fire retardant properties that comply: UL94 VO, ASTM D-635, ASTM E-662, and FTMS 406-2023.

MECHANICAL PROPERTIES:

- Tensile Strength:** 20-30.6 kgf/mm²
28.4-43.5 ksi
- Compression Strength:** 20-30.6 kgf/mm²
28.4-43.5 ksi
- Flexural Strength:** 20-33.6 kfg/mm²
28.4-43.5 ksi
- Shear Strength:** 6.1 kgf/mm²
8.7 ksi
- Density:** 1.7-1.9 g/cm³
0.061-0.069lb/in³

THERMAL PROPERTIES:

- Thermal Conductivity:** 0.2-0.3 kcal/(mh °C)
- Oxygen Index:** 42%
- Operating Temperature:** -140 to +120 °C
-220 to 248 ° F

TEMPERATURE		Polyester resin % of strength
F°	C°	
75	25	100%
100	38	90%
125	50	78%
150	68	68%
175	79	60%
200	90	52%

WEATHER RESISTANCE:

- Water Absorption:** 24 h = 0.15%
4 days = 0.25%
- Weight Increase:** After 500 h = 0.7%

ELECTRICAL PROPERTIES:

- Dielectric Strength:** 7-15 kV/mm
- Insulation Resistance:** 10¹³ -10¹⁶ ohm

MITA pultruded profiles display excellent resistance to the effects of UV and weathering.

RESISTANCE TO VARIOUS CHEMICAL AGENTS			
CHEMICAL AGENT	CONC.	TEMP C°	TEMP F°
Acetic Acid	5%	65	149
Aluminum Sulphate		95	203
Ammonium Nitrate	100%	95	203
Beer		20	68
Benzene		20	68
Calcium Chloride		95	203
Chlorine Gas/Water		20	68
Chromic Acid	5%	95	203
Copper Sulphate		95	203
Ethylene Chlorohydrin		65	149
Ethylene Glycol		95	203
Ferrous Sulphate		95	203
Fatty Acids	100%	95	203
Hydrochloric Acid	1%	95	203
Hydrochloric Acid	10%	65	149
Hydrochloric Acid	37%	25	77
Kerosene		95	203
Magnesium Chloride		95	203
Napthaline		95	203

RESISTANCE TO VARIOUS CHEMICAL AGENTS			
CHEMICAL AGENT	CONC.	TEMP C°	TEMP F°
Nitric Acid	30%	20	68
Phosphoric Acid	10%	95	203
Phosphoric Acid	85%	65	149
Salt Water		65	149
Sodium Bicarbonate		65	149
Sodium Bisulphate		25	77
Sodium Carbonate		25	77
Sodium Chloride		95	203
Sodium Hypochlorite	5%	65	149
Sodium Nitrate	100%	95	203
Sodium Silicate		25	77
Sodium Sulphate		95	203
Sulphuric Acid	1%	95	203
Sulphuric Acid	5%	65	149
Sulphuric Acid	10%	76	169
Sulphuric Acid	30%	25	77
Trisodium Phosphate		25	77
Water Sea/rap	100%	50	122
Zinc Sulphate		65	149

CONNECTORS & FITTINGS:

Necessary connectors are supplied with all trays. Extra connectors for field cuts or spares must be ordered separately. Supplied in pairs with 316 stainless steel hardware. Fiberglass and fiberglass encapsulated hardware is also available.



SPLICING

All fiberglass fittings have 5" tangents and splices with 8 predrilled holes. The vertical height of the splice is based upon the tray series.

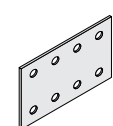

FIBERGLASS STRAIGHT SECTION CATALOG NUMBERING EXAMPLE:

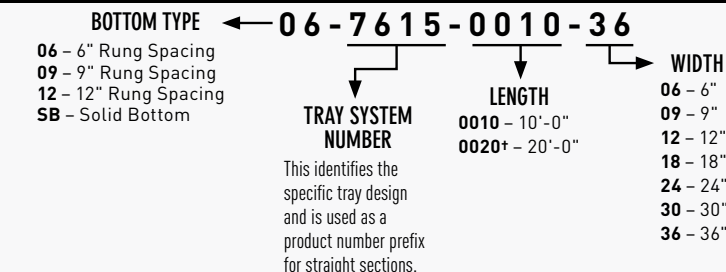

HORIZONTAL 90° ELBOW

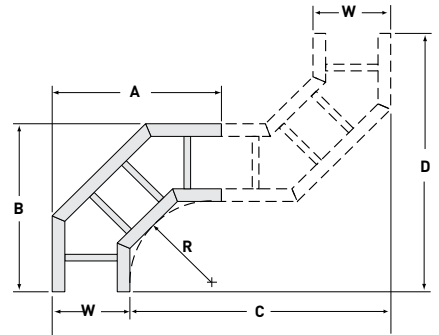

PRODUCT NUMBER RADIUS (IN.)	W	A	B	C	D
9012 12	6	20	20	34	34
	9	23	23	37	37
	12	26	26	40	40
	18	32	32	46	46
	24	38	38	52	52
	30	44	44	58	58
	36	50	50	64	64
9024 24	6	32	32	58	58
	9	35	35	61	61
	12	38	38	64	64
	18	44	44	70	70
	24	50	50	76	76
	30	56	56	82	82
	36	62	62	88	88
9036 36	6	44	44	82	82
	9	47	47	85	85
	12	50	50	88	88
	18	56	56	94	94
	24	62	62	100	100
	30	68	68	106	106
	36	74	74	112	112

HORIZONTAL 60° ELBOW

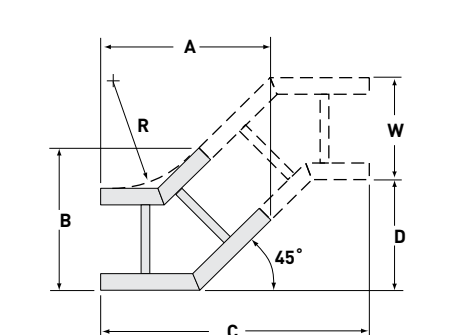

PRODUCT NUMBER RADIUS (IN.)	W	A	B	C	D
4512 12	6	16 1/8	11	27 1/8	11 1/2
	9	18 1/4	14	30	12 1/2
	12	20 3/8	17	32 3/8	13 3/8
	18	24 5/8	23	36 3/8	15 1/8
	24	28 3/4	29	40 3/4	16 7/8
	30	33 1/8	35	44 7/8	18 5/8
	36	37 3/8	41	49 1/8	20 3/8
4524 24	6	24 5/8	14 1/2	44 7/8	18 5/8
	9	26 3/4	17 1/2	47	19 1/2
	12	28 7/8	20 1/2	49 1/8	20 3/8
	18	33 1/8	26 1/2	53 3/8	22 1/8
	24	37 3/8	32 1/2	57 3/8	23 7/8
	30	41 5/8	38 1/2	61 7/8	25 5/8
	36	45 7/8	44 1/2	66 1/8	27 3/8
4536 36	6	33 1/8	18	61 7/8	25 5/8
	9	35 1/4	21	64	26 1/2
	12	37 3/8	24	66 1/8	27 3/8
	18	41 5/8	30	70 3/8	29 1/8
	24	45 7/8	36	74 5/8	30 7/8
	30	50 1/8	42	78 7/8	32 5/8
	36	54 1/4	48	83 1/8	34 3/8

HORIZONTAL 30° ELBOW

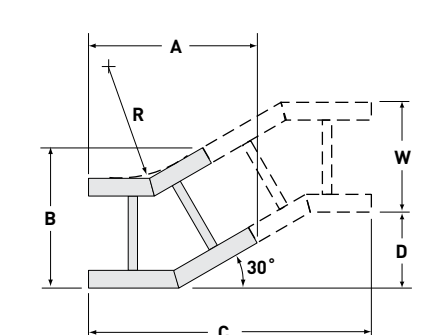

PRODUCT NUMBER RADIUS (IN.)	W	A	B	C	D
3012 12	6	12 3/4	8 3/4	22 3/8	6
	9	14 1/4	11 3/4	23 7/8	6 3/8
	12	15 3/4	14 3/4	25 3/8	6 3/4
	18	18 3/4	20 3/4	28 3/8	7 5/8
	24	21 3/4	26 3/4	31 3/8	8 3/8
	30	24 3/4	32 3/4	34 3/8	9 1/4
	36	27 3/4	38 3/4	37 3/8	10
3024 24	6	18 3/4	10 3/4	34 3/8	9 1/4
	9	20 1/4	13 3/4	35 7/8	9 5/8
	12	21 3/4	16 3/4	37 3/8	10
	18	24 3/4	22 3/4	40 3/8	10 3/4
	24	27 3/4	28 3/4	43 3/8	11 5/8
	30	30 3/4	34 3/4	46 3/8	12 3/8
	36	33 3/4	40 3/4	49 3/8	13 1/4
3036 36	6	24 3/4	12	46 3/8	12 3/8
	9	26 1/4	15	47 7/8	12 7/8
	12	27 3/4	18	49 3/8	13 1/4
	18	30 3/4	24	52 3/8	14
	24	33 3/4	30	55 3/8	14 7/8
	30	36 3/4	36	58 3/8	15 5/8
	36	39 3/4	42	61 3/8	16 1/2

HORIZONTAL STRAIGHT REDUCER

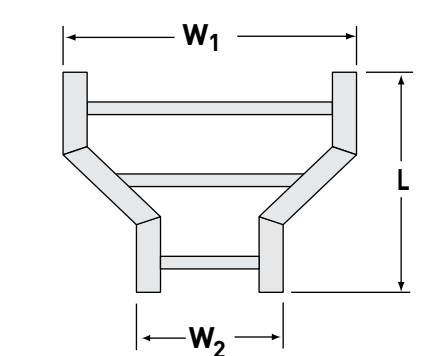

MAIN WIDTH W1	BRANCH WIDTH W2	PRODUCT NUMBER	L
9	6	0109	18 1/4
12	6	0112	17 5/8
12	9	0112	18 1/4
18	6	0118	20 5/8
18	9	0118	19 1/8
18	12	0118	17 5/8
24	6	0124	23 5/8
24	9	0124	22 1/8
24	12	0124	20 5/8
24	18	0124	17 5/8
30	6	0130	26 5/8
30	9	0130	25 1/8
30	12	0130	23 5/8
30	18	0130	20 5/8
30	24	0130	17 5/8
36	6	0136	29 5/8
36	9	0136	28 1/8
36	12	0136	26 5/8
36	18	0136	23 5/8
36	24	0136	20 5/8
36	30	0136	17 5/8

HORIZONTAL LEFT HAND REDUCER

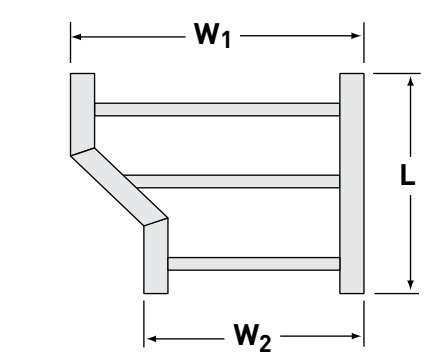

MAIN WIDTH W1	BRANCH WIDTH W2	PRODUCT NUMBER	L
9	6	0709	17 5/8
12	6	0712	20 5/8
12	9	0712	17 5/8
18	6	0718	26 5/8
18	9	0718	23 5/8
18	12	0718	20 5/8
24	6	0724	32 5/8
24	9	0724	29 5/8
24	12	0724	26 5/8
24	18	0724	20 5/8
30	6	0730	38 5/8
30	9	0730	35 5/8
30	12	0730	32 5/8
30	18	0730	26 5/8
30	24	0730	20 5/8
36	6	0736	44 5/8
36	9	0736	41 5/8
36	12	0736	38 5/8
36	18	0736	32 5/8
36	24	0736	26 5/8
36	30	0736	20 5/8

HORIZONTAL RIGHT HAND REDUCER

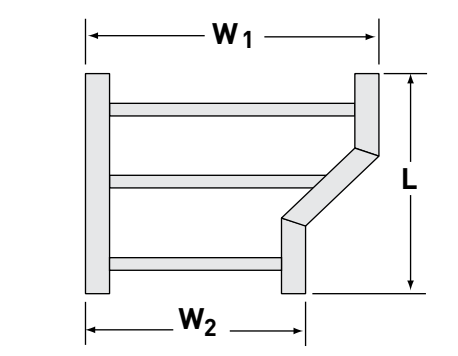

MAIN WIDTH W1	BRANCH WIDTH W2	PRODUCT NUMBER	L
9	6	0809	17 5/8
12	6	0812	20 5/8
12	9	0812	17 5/8
18	6	0818	26 5/8
18	9	0818	23 5/8
18	12	0818	20 5/8
24	6	0824	32 5/8
24	9	0824	29 5/8
24	12	0824	26 5/8
24	18	0824	20 5/8
30	6	0830	38 5/8
30	9	0830	35 5/8
30	12	0830	32 5/8
30	18	0830	26 5/8
30	24	0830	20 5/8
36	6	0836	44 5/8
36	9	0836	41 5/8
36	12	0836	38 5/8
36	18	0836	32 5/8
36	24	0836	26 5/8
36	30	0836	20 5/8

FIBERGLASS FITTINGS
 WIDTHS (W) INCHES
 6 | 9 | 12 | 18 | 24 | 30 | 36
 RAIL HEIGHTS (H) INCHES
 4 | 6

FIBERGLASS HORIZONTAL ELBOW CATALOG NUMBERING EXAMPLE:

PRODUCT NO. ← **LD - 7 6 15 - 4 5 1 2 - 3 6** → WIDTH

LD - Ladder
 SB - Solid Bottom

TRAY SYSTEM NUMBER
 This identifies the specific tray design and is used as a product number prefix for straight sections.

06 - 6"
 09 - 9"
 12 - 12"
 18 - 18"
 24 - 24"
 30 - 30"
 36 - 36"

FIBERGLASS HORIZONTAL REDUCER CATALOG NUMBERING EXAMPLE:

PRODUCT NO. ← **SB - 7 F 20 - 0 1 1 8 - 1 2**

LD - Ladder
 SB - Solid Bottom

TRAY SYSTEM NUMBER
 This identifies the specific tray design and is used as a product number prefix for straight sections.

W1 W2
 06 - 6"
 09 - 9"
 12 - 12"
 18 - 18"
 24 - 24"
 30 - 30"
 36 - 36"

HORIZONTAL TEE

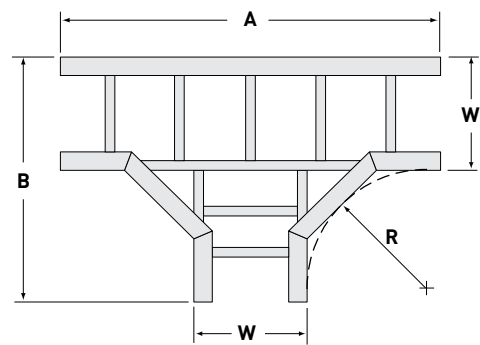

PRODUCT NUMBER RADIUS (IN.)	W	A	B
12	6	34	20
	9	37	23
	12	40	26
	18	46	32
	24	52	38
	30	58	44
	36	64	50
2024			
24	6	58	32
	9	61	35
	12	64	38
	18	70	44
	24	76	50
	30	82	56
	36	88	62
2036			
36	6	82	44
	9	85	47
	12	88	50
	18	94	56
	24	100	62
	30	106	68
	36	112	74

HORIZONTAL CROSS

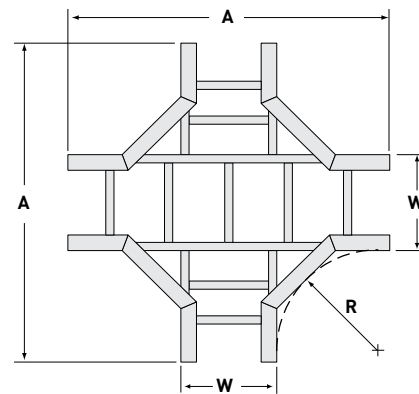

PRODUCT NUMBER RADIUS (IN.)	W	A
12	6	34
	9	37
	12	40
	18	46
	24	52
	30	58
	36	64
1024		
24	6	58
	9	61
	12	64
	18	70
	24	76
	30	82
	36	88
1036		
36	6	82
	9	85
	12	88
	18	94
	24	100
	30	106
	36	112

VERTICAL INSIDE ELBOWS

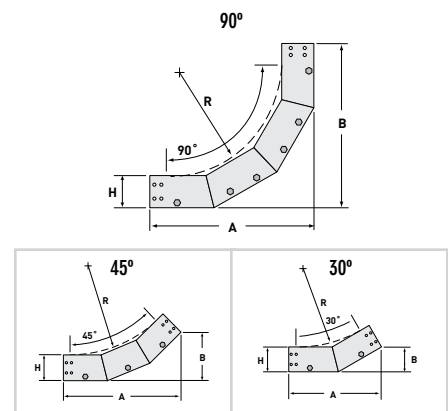

	PRODUCT NUMBER RADIUS (IN.)	W	RAIL HEIGHT (IN.)			
			4		6	
			A	B	A	B
90°	9112 12	ALL	18	18	20	20
	9124 24	ALL	30	30	32	32
	9136 36	ALL	42	42	44	44
45°	4612 12	ALL	14 ³ / ₄	6 ¹ / ₈	16 ¹ / ₈	6 ⁵ / ₈
	4624 24	ALL	23 ¹ / ₄	9 ⁵ / ₈	24 ⁵ / ₈	10 ¹ / ₄
	4636 36	ALL	31 ³ / ₄	13 ¹ / ₈	33 ¹ / ₈	13 ³ / ₄
30°	3112 12	ALL	11 ³ / ₄	3 ¹ / ₈	12 ³ / ₄	3 ³ / ₈
	3124 24	ALL	17 ³ / ₄	4 ³ / ₈	18 ³ / ₄	5
	3136 36	ALL	23 ³ / ₄	6 ³ / ₈	24 ³ / ₄	6 ⁵ / ₈

VERTICAL OUTSIDE ELBOWS

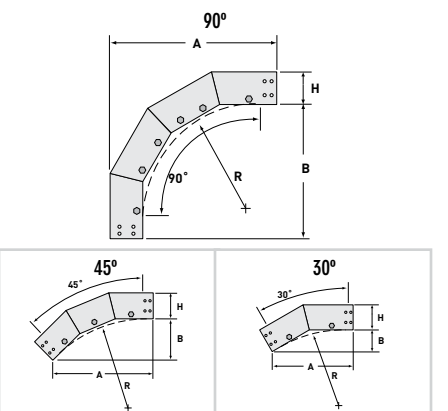

	PRODUCT NUMBER RADIUS (IN.)	W	RAIL HEIGHT (IN.)			
			4		6	
			A	B	A	B
90°	9212 12	ALL	18	14	20	14
	9224 24	ALL	30	26	32	26
	9236 36	ALL	42	38	44	38
45°	4712 12	ALL	11 ⁷ / ₈	4 ⁷ / ₈	11 ⁷ / ₈	4 ⁷ / ₈
	4724 24	ALL	20 ³ / ₈	8 ¹ / ₂	20 ³ / ₈	8 ¹ / ₂
	4736 36	ALL	28 ⁷ / ₈	12	28 ⁷ / ₈	12
30°	3212 12	ALL	9 ³ / ₄	2 ⁵ / ₈	9 ³ / ₄	2 ⁵ / ₈
	3224 24	ALL	15 ³ / ₄	4 ¹ / ₈	15 ³ / ₄	4 ¹ / ₈
	3236 36	ALL	21 ³ / ₄	5 ⁷ / ₈	21 ³ / ₄	5 ⁷ / ₈

VERTICAL TEES

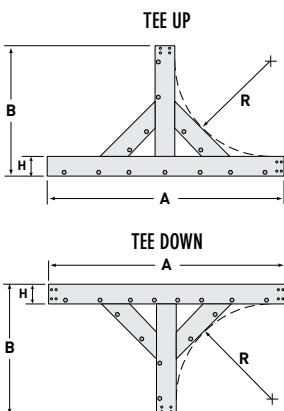

	PRODUCT NUMBER RADIUS (IN.)	W	RAIL HEIGHT (IN.)			
			4		6	
			A	B	A	B
TEE UP	2124 24	ALL	56	30	58	32
TEE DOWN	2224 24	ALL	56	30	58	32

VERTICAL CROSS

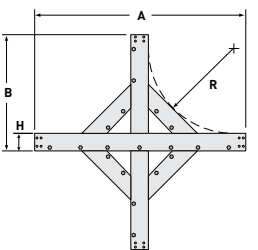

PRODUCT NUMBER RADIUS (IN.)	W	RAIL HEIGHT (IN.)			
		4		6	
		A	B	A	B
1124 24	ALL	56	30	58	32

- WIDTHS (W) INCHES: 6 | 9 | 12 | 18 | 24 | 30 | 36
- RAIL HEIGHTS (H) INCHES: 4 | 6
- RADIUS (R) INCHES: 12 | 24 | 36

FIBERGLASS HORIZONTAL TEE CATALOG NUMBERING EXAMPLE:

PRODUCT NO. ← LD - 7 6 15 - 4 5 12 - 12 → WIDTH

LD - Ladder
SB - Solid Bottom

TRAY SYSTEM NUMBER

This identifies the specific tray design and is used as a product number prefix for straight sections.

06 - 6"
09 - 9"
12 - 12"
18 - 18"
24 - 24"
30 - 30"
36 - 36"

FIBERGLASS INSIDE ELBOW CATALOG NUMBERING EXAMPLE:

PRODUCT NO. ← LD - 7 6 15 - 9 1 12 - 24 → WIDTH

LD - Ladder
SB - Solid Bottom

TRAY SYSTEM NUMBER

This identifies the specific tray design and is used as a product number prefix for straight sections.

06 - 6"
09 - 9"
12 - 12"
18 - 18"
24 - 24"
30 - 30"
36 - 36"

COVERS

Covers are highly recommended to avoid damage to the tray contents and to protect against the elements. Flat covers are available for both straight sections and fittings, while peaked covers are available for straight trays only. Peaked covers are constructed with two flat sheets that are glued to an angle at the top of the peak, which is 22½°. Covers are made from fire-retardant polyester resin per ASTM E84 Class 1, light gray color. Standard cover thickness is 1/8" and length is 10'-0". Side rail height is necessary for outside vertical fitting covers. Please contact Legrand for more information.

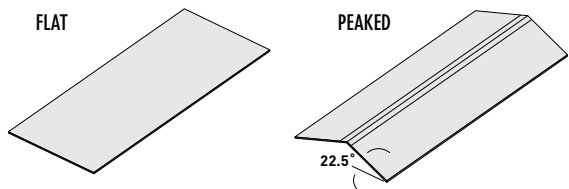

	LENGTH (FT.)	SYSTEM NUMBER
FLAT	10	7130
PEAKED	10	7230

DRIVE RIVET

Only for use with indoor, horizontal covers. Drive rivets are the most economical method of cover attachment. Requires field drilling. Install on 24" centers.

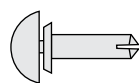

COMPLETE CATALOG NUMBER

DS-8935-PL

FLAT COVER CONNECTORS

For use with indoor, outdoor, or vertical flat covers. The 1400 cover connector is 1" wide fiberglass. The 1423 cover connector is 1½" wide stainless steel. Install one connector over each cover joint and 36"-48" spacing between joints.

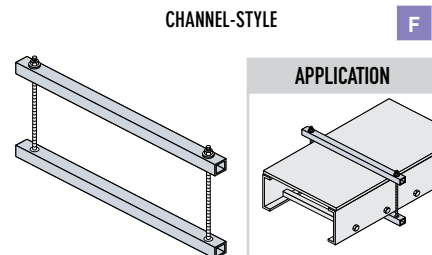

CHANNEL-STYLE **F**

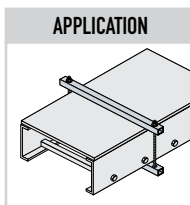

APPLICATION

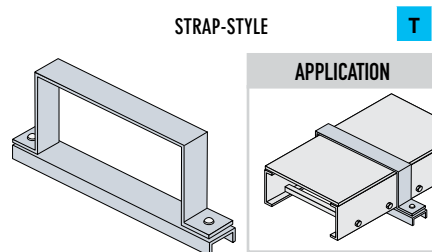

STRAP-STYLE **T**

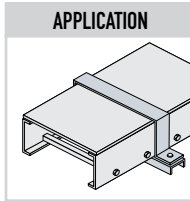

APPLICATION

	PRODUCT NUMBER	FASTENERS INCLUDED
CHANNEL	1400	FG S6
STRAP	1423	S6

CATALOG NUMBERING EXAMPLE:
System No. Width Fasteners
6 FI - **1400** - 24 - S6

WIDTHS (W) INCHES

6 | 9 | 12 | 18 | 24 | 30 | 36

RAIL HEIGHTS (H) INCHES

4 | 6

LENGTH (L) FEET

10

FIBERGLASS PREFIX OPTIONS

F1	SERIES1
F2	SERIES2
F1	Flange In

PEAKED COVER CONNECTOR **T**

For use with indoor, outdoor, or vertical peaked covers. Top and bottom pieces are 316 stainless steel, 1½" wide. Install one connector over each cover joint and 36"-48" spacing between joints.

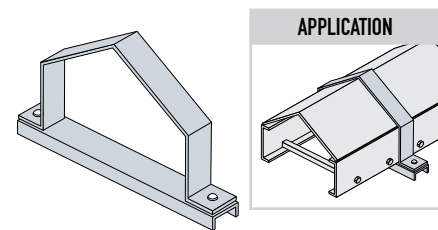

APPLICATION

	PRODUCT NUMBER	FASTENERS INCLUDED
PEAKED STRAP	1440	S6

CATALOG NUMBERING EXAMPLE:
System No. Width Fasteners
6 FI - **1440** - 12 - S6

RAISED COVER CONNECTOR **F**

For use with all covers, indoors and outdoors. Covers are attached to upright-mounted "C" channel on the top of the cable tray. Install 36"-48" on center.

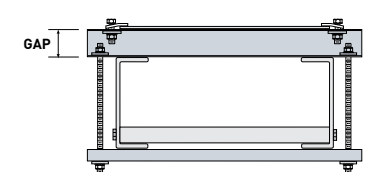

GAP DIMENSION (IN.)	PRODUCT NUMBER	FASTENERS INCLUDED
1	1441	FG S6
2	1442	FG S6

CATALOG NUMBERING EXAMPLE:
System No. Width Fasteners
6 FI - **1441** - 24 - S6

FIBERGLASS FLAT COVER CATALOG NUMBERING EXAMPLE:

LENGTH OR PRODUCT FITTING NO. → WIDTH

7130 - **0010** - **36**

TRAY SYSTEM NUMBER: 7130
This identifies the specific tray design and is used as a product number prefix for straight sections.

LENGTH: 0010 - 10'
or
9112
FITTING PRODUCT NO.
This identifies fitting type and radius.

WIDTH: 06 - 6" | 09 - 9" | 12 - 12" | 18 - 18" | 24 - 24" | 30 - 30" | 36 - 36"

STANDARD SPLICE **F**

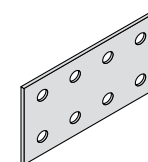

PRODUCT NUMBER	FASTENERS
1302	S6 FG FE

CATALOG NUMBERING EXAMPLE:
System No. Fasteners
F1 - **1302** - S6

HORIZONTAL ADJUSTABLE SPLICE **F**

Joins trays at adjustable bend angles up to 30°.

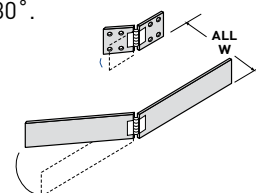

PRODUCT NUMBER	FASTENERS
1305	S6 FG FE

CATALOG NUMBERING EXAMPLE:
System No. Fasteners
F1 - **1305** - S6

TRAY-TO-BOX CONNECTOR **F**

Connects tray to the wall or a vertical upright. Hardware for tray attachment only is included.

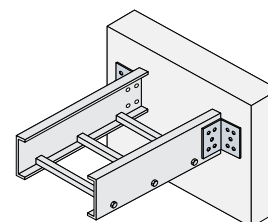

PRODUCT NUMBER	FASTENERS
1864	S6 FG FE

CATALOG NUMBERING EXAMPLE:
System No. Fasteners
F1 - **1864** - S6

EXPANSION SPLICE **F**

Allows thermal contraction and expansion of tray of up to 1". Tray length and temperature differential govern the spacing and quantity needed.

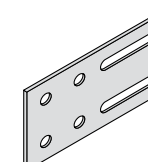

PRODUCT NUMBER	FASTENERS
1314	S6 FG FE

CATALOG NUMBERING EXAMPLE:
System No. Fasteners
F1 - **1314** - S6

VERTICAL ADJUSTABLE SPLICE **F**

Joins trays at adjustable bend angles up to 90°.

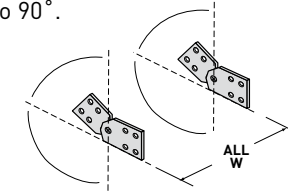

PRODUCT NUMBER	FASTENERS
1307	S6 FG FE

CATALOG NUMBERING EXAMPLE:
System No. Fasteners
F1 - **1307** - S6

HORIZONTAL ANGLED COUPLER **T**

Joins tray side rails at fixed angles. Makes either left or right bends. Ideally suited for field modifications.

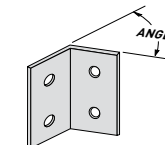

ANGLE	PRODUCT NUMBER	FASTENERS
30°	2730	
45°	2745	S6
90°	2790	

CATALOG NUMBERING EXAMPLE:
System No. Fasteners
T1 - **2730** - S6

90° CONNECTOR **F**

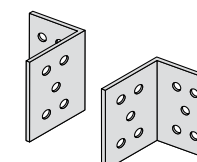

PRODUCT NUMBER	FASTENERS
1320	S6 FG FE

CATALOG NUMBERING EXAMPLE:
System No. Fasteners
F1 - **1320** - S6

VERTICAL HANGER SPLICE **F**

Provides vertical support point for trays.

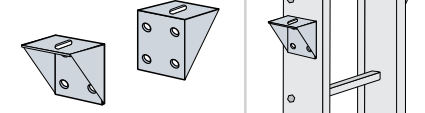

APPLICATION

PRODUCT NUMBER	FASTENERS
0356	S6 FG FE

CATALOG NUMBERING EXAMPLE:
System No. Fasteners
F1 - **0356** - S6

VERTICAL ANGLED COUPLER **T**

Joins tray side rails at fixed angles. Makes either inside or outside bends. Ideally suited for field modifications.

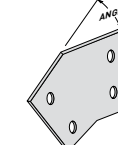

ANGLE	PRODUCT NUMBER	FASTENERS
30°	2830	
45°	2845	S6
90°	2890	

CATALOG NUMBERING EXAMPLE:
System No. Fasteners
T1 - **2845** - S6

ADDITIONAL RUNG

F

Add or replace a tray rung using the hardware provided. Field drilling may be required. Rungs include factory-installed threaded collets.

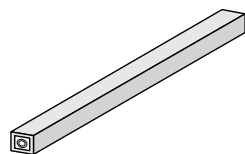

PRODUCT NUMBER	FASTENERS
8200	S6
CATALOG NUMBERING EXAMPLE:	
Material	Width Fasteners
F - 8200	-12-S6

BLIND END PLATE

F

Seals off the open end of a cable tray. Attaches to the tray using standard 3/8" dia. connector hardware.

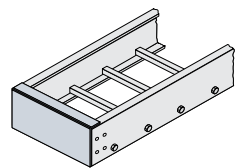

RAIL HEIGHTS (H)
INCHES
4 | 6

PRODUCT NUMBER	FASTENERS
0402	S6 FG FE
CATALOG NUMBERING EXAMPLE:	
System No.	Width Fasteners
6FI - 0402	-12-S6

CABLE DROPOUT

T

Provides a smooth, rounded surface for cables dropping out of the bottom of the cable tray.

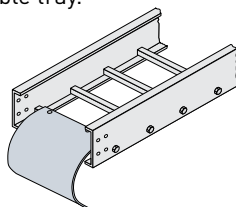

RADIUS	PRODUCT NUMBER	FASTENERS
5	0254	S6
CATALOG NUMBERING EXAMPLE:		
System No.	Width Fasteners	
FI - 0254	-24-S6	

DIVIDER STRIPS

F

Straight strips are for use with all straight ladder tray; flexible strips are for use with all horizontal fittings of any radius. Field-drilled holes are required for installation of all divider strips. Clips should be attached to rungs on alternating sides of the divider strip.

RAIL HEIGHTS (H)

INCHES

4 | 6

STRAIGHT HORIZONTAL DIVIDER

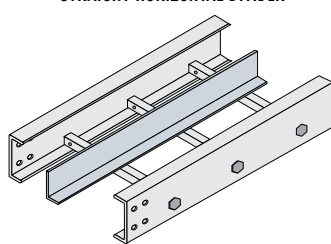

FLEXIBLE HORIZONTAL DIVIDER

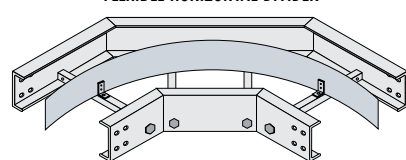

VERTICAL FITTING DIVIDER

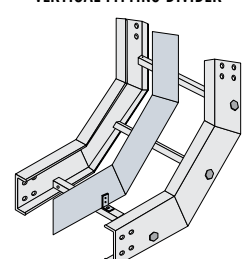

TYPE	PRODUCT NUMBER	LENGTH (FT)
STRAIGHT HORIZONTAL	0010-99	10
(5) THERMOPLASTIC DRIVE RIVETS INCLUDED		

TYPE	PRODUCT NUMBER	LENGTH (FT)
FLEXIBLE HORIZONTAL	0606-99	6
(4) HOLD DOWN CLIPS INCLUDED		

TYPE	PRODUCT NUMBER	RADIUS
VERTICAL 90° INSIDE ELBOW	9112-99	12
	9124-99	24
	9136-99	36
VERTICAL 90° OUTSIDE ELBOW	9212-99	12
	9224-99	24
	9236-99	36
	VERTICAL 45° INSIDE ELBOW	4612-99
4624-99		24
	4636-99	36
	VERTICAL 45° OUTSIDE ELBOW	4712-99
4724-99		24
	4736-99	36
	VERTICAL 30° INSIDE ELBOW	3112-99
3124-99		24
3136-99		36
VERTICAL 30° OUTSIDE ELBOW	3212-99	12
	3224-99	24
	3236-99	36

(2) HOLD DOWN CLIPS INCLUDED

CATALOG NUMBERING EXAMPLE:
System No. 6F - 0010-99

THERMOPLASTIC DRIVE RIVET

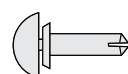

COMPLETE CATALOG NO.

DS-8935-PL

HOLD DOWN CLIP

F

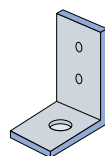

COMPLETE CATALOG NO.

F-1852-PL

(3) THERMOPLASTIC DRIVE RIVETS INCLUDED

FIELD CUTTING SEALANT



Used to reseal fiberglass after field modifications. Can is one pint. Includes two brushes.

COMPLETE CATALOG NO.

0941

FIBERGLASS PREFIX OPTIONS

F1	SERIES1
F2	SERIES2
FI	Flange In

EXPANSION GUIDE CLAMP

T

Works as an expansion guide and flips over as a hold down clamp. For use with all ladder tray systems.

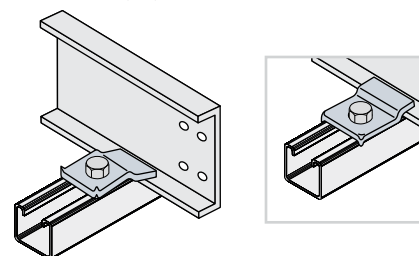

PRODUCT NUMBER	FASTENERS INCLUDED
1893-01	S6 3/8" x 1 1/2" hex bolt, 3/8" flanged nut
1893-02	NONE
1893-03	S6 3/8" x 1 1/2" hex bolt, 3/8" spring nut
CATALOG NUMBERING EXAMPLE:	
Material	Fasteners
T - 1893-01	-S6

HOLD DOWN CLAMP

F

Securely fastens the tray to the support member. For use with all ladder tray systems.

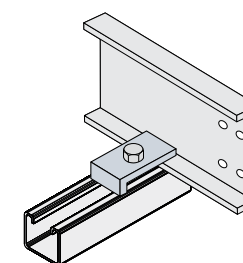

PRODUCT NUMBER	FASTENERS INCLUDED
1811-01	S6 FG 3/8" x 1 1/2" hex bolt, 3/8" flanged nut
1811-02	NONE
1811-03	S6 FG 3/8" x 1 1/2" hex bolt, 3/8" channel nut
CATALOG NUMBERING EXAMPLE:	
Material	Fasteners
F - 1811-01	-S6

Z-HOLD DOWN CLAMP

F T

Securely fastens the tray to the support member and prevents lateral movement. For use with all flange-in tray systems.

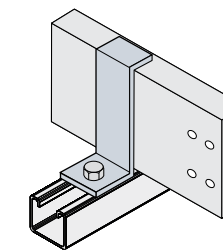

RAIL HEIGHTS (H)
INCHES
4 | 6

PRODUCT NUMBER	FASTENERS INCLUDED
1866-01	S6 1/4"x1 1/2" hex bolt, 1/4" flanged nut FG 3/8"x1 1/2" hex bolt, 3/8" flanged nut
1866-02	NONE
1866-03	S6 1/4" x 1 1/2" hex bolt, 1/4" spring nut FG 3/8" x 1 1/2" hex bolt, 3/8" spring nut
CATALOG NUMBERING EXAMPLE:	
System No.	Fasteners
6T - 1866-01	-S6

SUPPORT BRACKETS

F

Support brackets use 1 5/8" x 1 5/8" struts. Uniform Design Load is based on a safety factor of 2.0. When selecting "L", allow extra for flanges when supporting a solid bottom tray system.

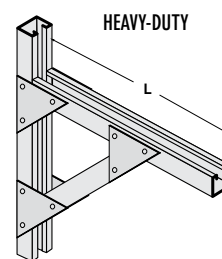
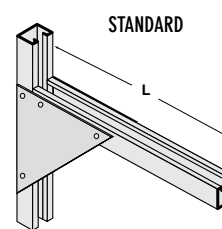

L	STANDARD		HEAVY-DUTY	
	PRODUCT NUMBER	DESIGN LOAD (LBS.)	PRODUCT NUMBER	DESIGN LOAD (LBS.)
7	0386	245	-	-
10	0386	237	-	-
13	0386	230	-	-
16	0386	217	-	-
19	0386	205	0387	610
22	0386	192	-	-
25	0386	180	0387	590
31	-	-	0387	700
37	-	-	0387	700
43	-	-	0387	700
ASSEMBLY HARDWARE				
S6				
CATALOG NUMBERING EXAMPLE:				
Material	Length			
F - 0326	- 10			

TRAPEZE HANGER SUPPORT KIT (STANDARD DUTY)

F T

Made with 1 5/8" x 1 5/8" fiberglass strut, designed to accept 1/2" threaded rod (sold separately). Includes hardware for ladder trays. For other designs contact Legrand.

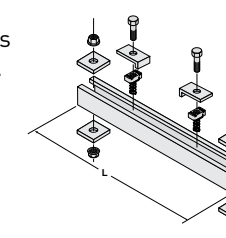

TRAY WIDTH	PRODUCT NUMBER
6	0385-10
9	0385-13
12	0385-16
18	0385-22
24	0385-28
30	0385-34
36	0385-40
FASTENERS INCLUDED	
FG S6	
CATALOG NUMBERING EXAMPLE:	
Material	Length Fasteners
F - 0385-10	- S6

CENTER SPINE CABLE TRAY

82 STRAIGHT SECTIONS

84 FITTINGS, SPLICES & CONNECTORS

86 TECHNICAL DATA

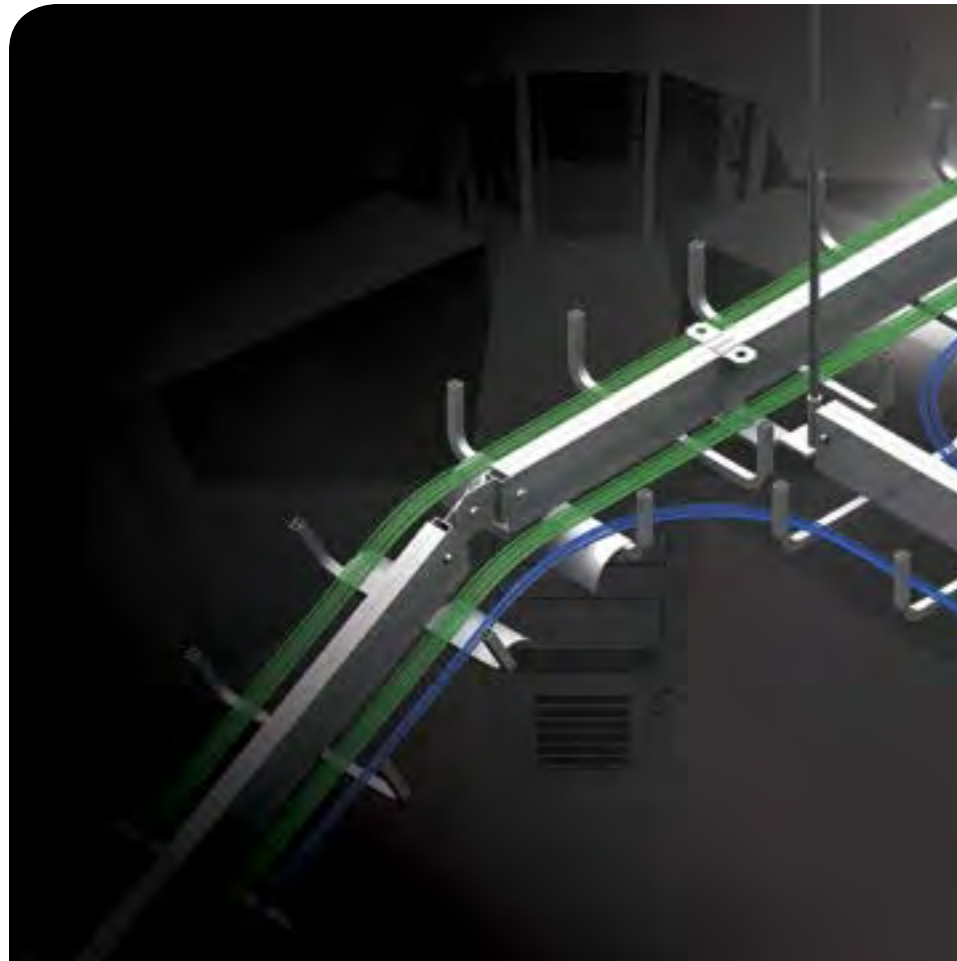

Today's workspaces have rapidly evolving data, communications and security demands. Center Spine Cable Tray is an easily installed cable support system designed to provide safety, reliability and flexibility for future expansion. Field modifiable fittings combine to allow installers to easily maneuver cable pathways around obstructions and changes in elevation.

- Center spine style tray installs in half the time of conventional ladder tray.
- Cable can be loaded from one or two sides of the tray.
- Only half the hanging and joining material of conventional ladder tray are required.
- Allows for full cable visibility and requires less space for access.
- Can be hung as close to ceiling as code allows.

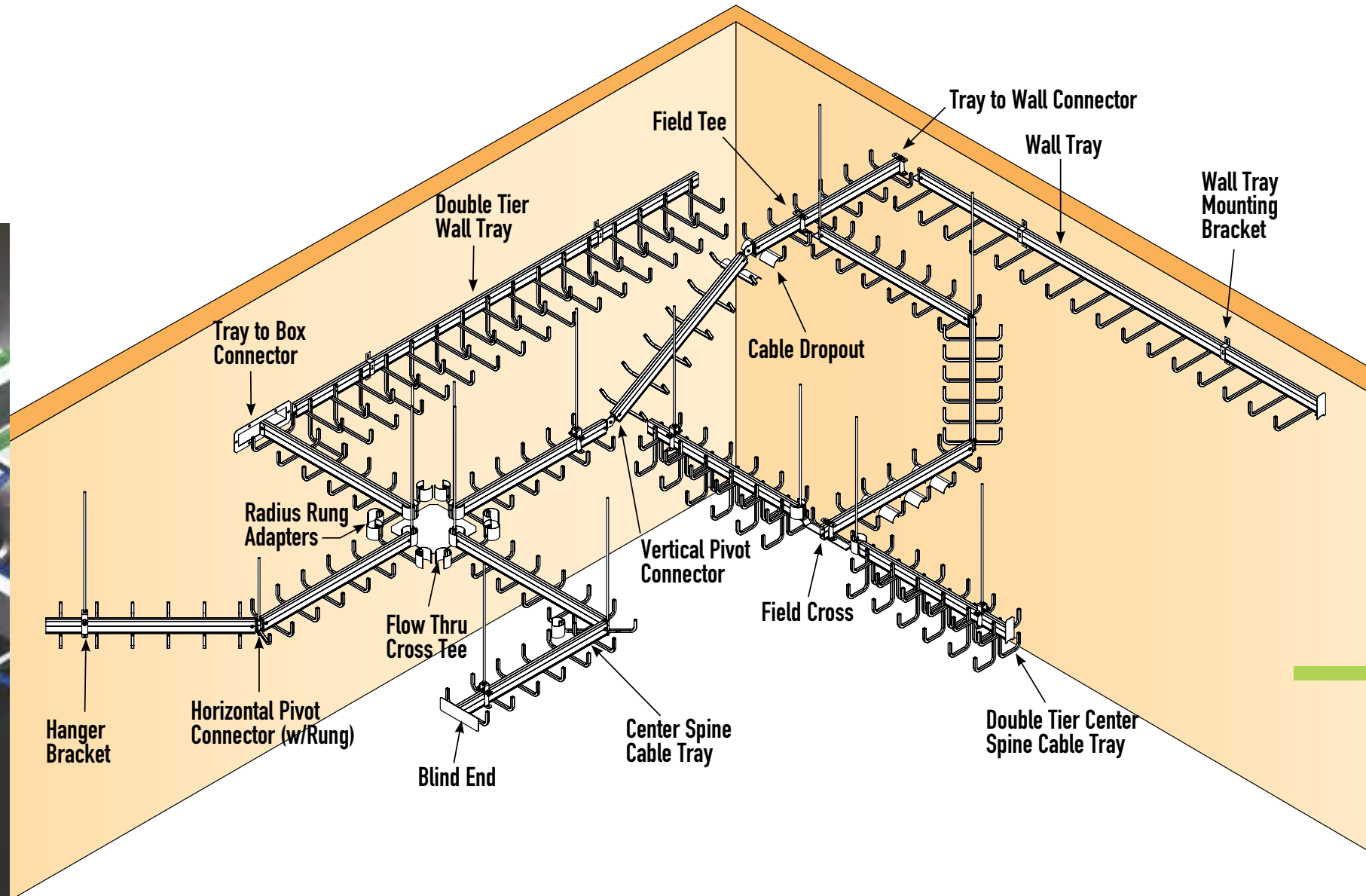

CABLOFIL CENTER SPINE CABLE TRAY IS DESIGNED WITH ADVANCED FEATURES THAT MAKE IT A CLEAR CHOICE FOR DESIGN ENGINEERS AND INSTALLERS ALIKE.

- **Cable bend radius control fittings.** Bend radius adapter and cable drop out fittings can be added to any installation to meet bend radius compliance standards. These parts meet the specifications for Fiber Optic and UTP/STP cabling and exceed TIA569 requirements.
- **3" center spine serves as a barrier between services.** The inherent design of center spine tray serves as a natural barrier separating one channel of the tray from the other.

CS
CENTER SPINE SINGLE TIER

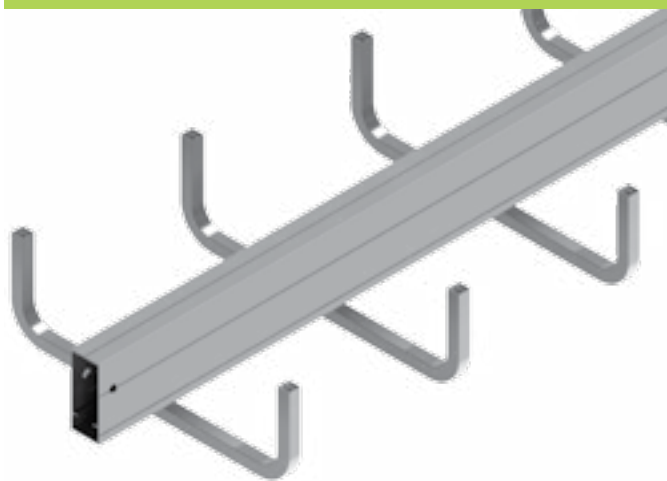

WS
WALL SPINE SINGLE TIER

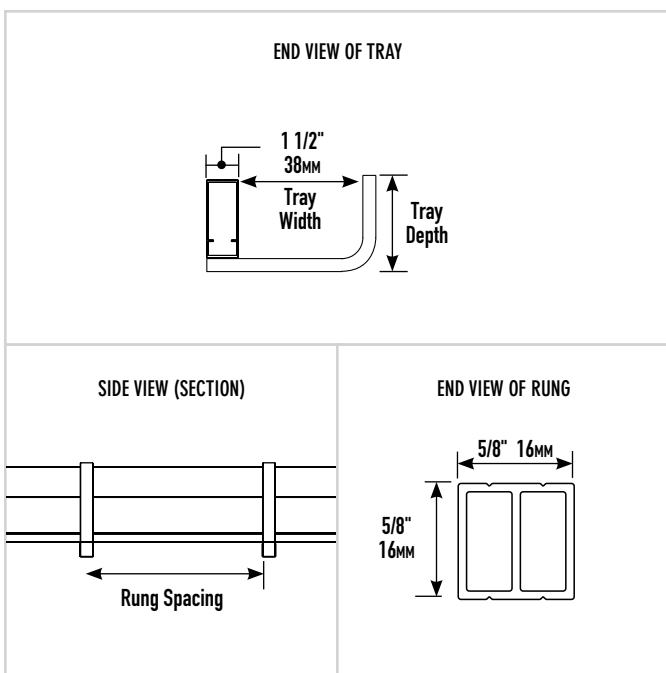
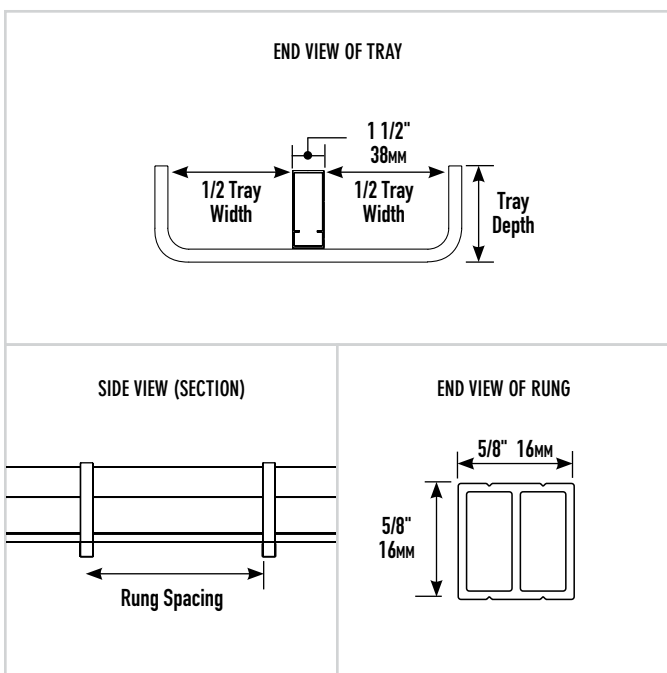

SINGLE TIER STRAIGHT SECTION CATALOG NUMBERING EXAMPLE:

SERIES CS WS	CS	12	03	09	18	TRAY WIDTH*
LENGTH	03 - 3"	04 - 4"	06 - 6"	09 - 9"	12 - 12"	06 - 6" 152mm 09 - 9" 229mm 12 - 12" 305mm 18 - 18" 457mm** 24 - 24" 610mm**
TRAY DEPTH	03 - 3" 76mm 04 - 4" 102mm 06 - 6" 152mm	06 - 6" 152mm	09 - 9" 229mm	12 - 12" 305mm		
RUNG SPACING						

* Measured at inside of rungs as shown above. When ordering a tray 18" in width or larger, the use of a stiffener bar (CSSB) should be considered to stabilize eccentric loading.
**For CS only

CSDT
CENTER SPINE DOUBLE TIER



WSDT
WALL SPINE DOUBLE TIER

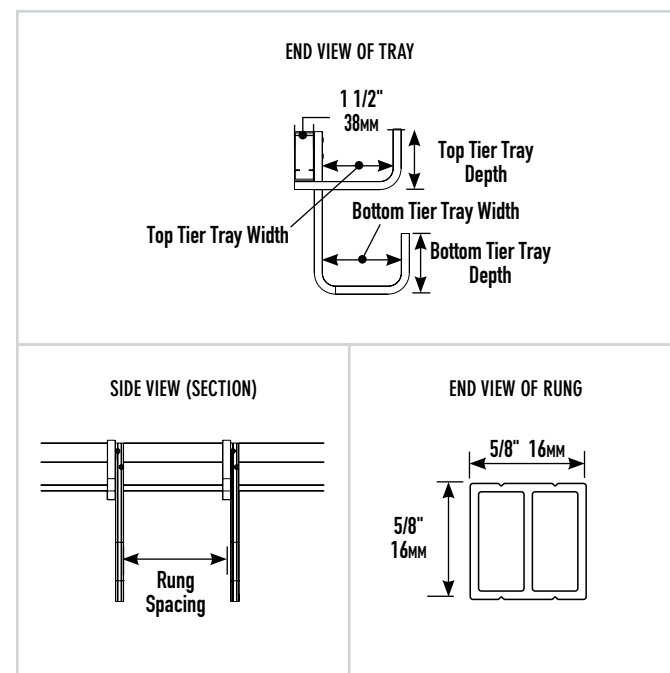
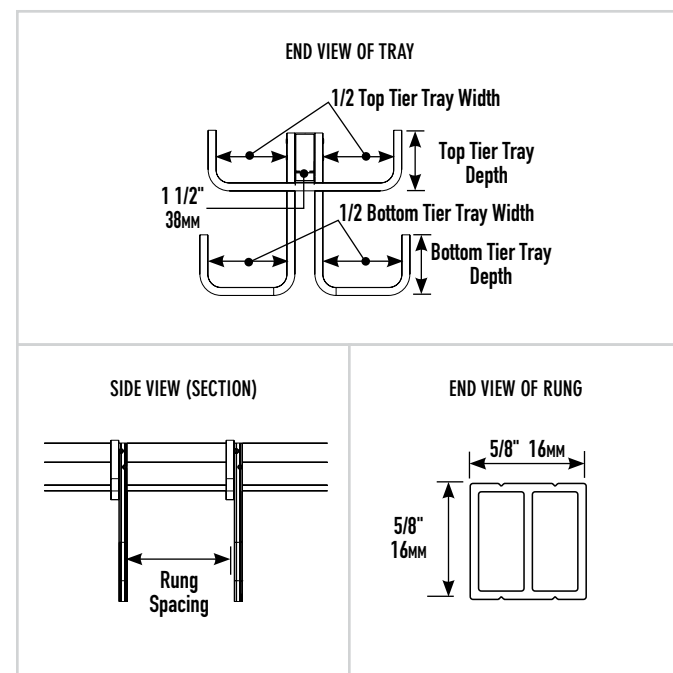

DOUBLE TIER STRAIGHT SECTION CATALOG NUMBERING EXAMPLE:

SERIES CSDT WSDT	WSDT	10	3	4[†]	09	12	12[†]	TRAY WIDTH*
LENGTH	10 - 10' 3.0m 12 - 12' 3.6m	03 - 3" 76mm 04 - 4" 102mm 06 - 6" 152mm	06 - 6" 152mm	09 - 9" 229mm	12 - 12" 305mm	06 - 6" 152mm 09 - 9" 229mm 12 - 12" 305mm 18 - 18" 457mm** 24 - 24" 610mm**		
TRAY DEPTH								
RUNG SPACING								

† Second measurement refers to bottom tier. The second tier width must be equal or greater to the top tier width.
* Measured at inside of rungs as shown above. When ordering a tray 18" in width or larger, the use of a stiffener bar (CSSB) should be considered to stabilize eccentric loading.
**For CSDT only

**CSSC
SPLICE CONNECTOR**

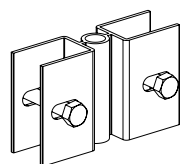

Allows the connection of any two pieces of CS/WS Series Tray. Hole in center accepts 1/2" threaded rod for hanging.

**CSFT
FIELD TEE**

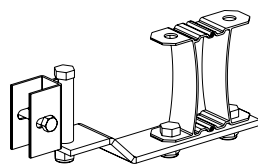

Used to make a tee in the field for trays with any rung spacing. Specify CS tray width (double for WS tray).

TRAY WIDTH INCHES
6 | 9 | 12 | 18 | 24

CATALOG NUMBERING EXAMPLE:
Product No. W
CFST - 6

**CSHPR
HORIZONTAL PIVOT CONNECTOR WITH RUNG**

Provides additional cable support on horizontal connections for all CS/WS Series Tray. Can be used for any angle horizontal connection.

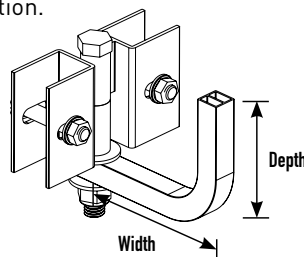

RUNG DEPTH INCHES
3 | 4 | 6
RUNG WIDTH INCHES
3 | 4.5 | 6 | 9 | 12

CATALOG NUMBERING EXAMPLE:
Product No. D W
CSHPR - 3 - 12

**CSVV
VERTICAL PIVOT CONNECTOR**

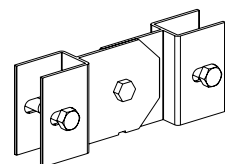

Allows for vertical bends for all CS/WS Series trays.

**CSCP
CONDUIT CONNECTOR**

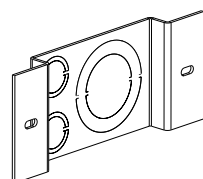

Connects conduit to tray. 1/2", 3/4", 1 1/4", and 2" trade size knockouts provided.

RUNG SPACING INCHES
6 | 9 | 12

CATALOG NUMBERING EXAMPLE:
Product No. D
CSCP - 3

**CSHP
HORIZONTAL PIVOT CONNECTOR**

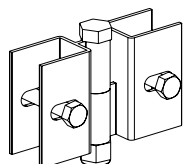

Allows any angle horizontal connection for all CS/WS Series Tray. For 90° or wider angles, the use of a Horizontal Pivot Connector with Rung is recommended.

**CSFC
FIELD CROSS**

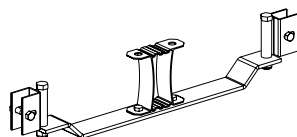

Used to make a cross in the field. For any rung spacing. Specify tray width.

TRAY WIDTH INCHES
6 | 9 | 12 | 18 | 24

CATALOG NUMBERING EXAMPLE:
Product No. W
CSFC - 12

**CSRA
FIBERREADY 2" RADIUS RUNG ADAPTER**

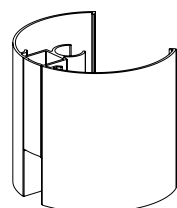

Slips onto any CS/WS Series rung and provides a 2" radius on either side for cable dropout protection or tee or cross transition.

RUNG DEPTH INCHES
3 | 4 | 6

CATALOG NUMBERING EXAMPLE:
Product No. D
CSRA - 3

**CSFLT
FLO-THRU CROSS TEE**

Tee, cross or "Y" turn with no barrier between channels.

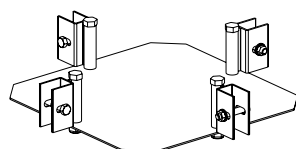

TRAY WIDTH INCHES
6 | 9 | 12 | 18 | 24

CATALOG NUMBERING EXAMPLE:
Product No. W
CSFLT - 12

**CSTW
TRAY-TO-WALL CONNECTOR END CAP**

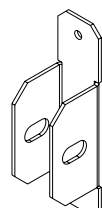

Connects tray to wall.

**CSJH
J RUNG**

A single rung in the shape of a "J". Supports cables on walls.

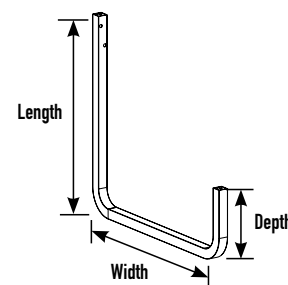

RUNG DEPTH INCHES
3 | 4 | 6
RUNG WIDTH INCHES
4 | 6 | 9 | 12
RUNG LENGTH INCHES
6 | 8

CATALOG NUMBERING EXAMPLE:
Product No. D W L
CSJH - 3 - 6 - 8

**CSDO
FIBER READY CABLE DROPOUT**

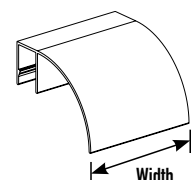

Extruded aluminum fitting provides a 2" cable bend radius for cables dropping out of all CS/WS Series trays.

RUNG WIDTH INCHES
3 | 4.5 | 6 | 9 | 12

CATALOG NUMBERING EXAMPLE:
Product No. W
CSDO - 6

**CSHB
HANGER BRACKET**

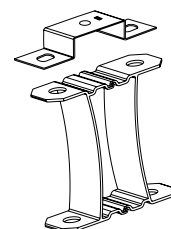

Provides support for the tray at any point other than at the splice connector without drilling. May also be used to develop seismic restraint - consult factory. Hole is pre-punched to accept 1/2" threaded rod.

**CSSB
STIFFENER BAR**

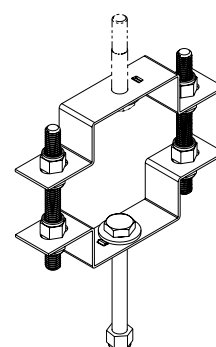

Provides additional support to offset eccentric loading.

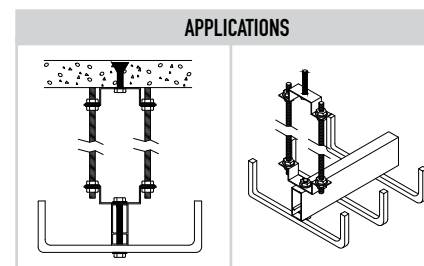

**CSGH
G RUNG**

A single rung, bent in the shape of a "G". Supports cables on walls and ceilings.

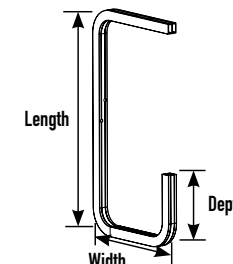

RUNG DEPTH INCHES
3 | 4 | 6
RUNG WIDTH INCHES
4 | 6 | 9 | 12
RUNG LENGTH INCHES
6 | 8

CATALOG NUMBERING EXAMPLE:
Product No. D W L
CSGH - 4 - 6 - 8

**CSFS
FLOOR SUPPORT BRACKET**

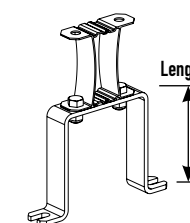

Provides support for trays used in raised floor applications.

BRACKET LENGTH INCHES
4 | 6 | 8 | 10 | 12

CATALOG NUMBERING EXAMPLE:
Product No. L
CSFS - 6

**CSDS
DIVIDER STRIP**

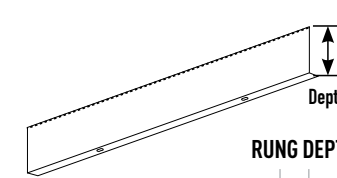

Creates cable barrier for additional organization. Specify rung depth. All strips come in 12' sections.

RUNG DEPTH INCHES
3 | 4 | 6

CATALOG NUMBERING EXAMPLE:
Product No. D
CSDS - 6

**CSEB
BLIND END**

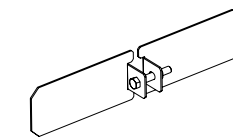

Closes off the end of the tray.

TRAY WIDTH INCHES
6 | 9 | 12 | 18 | 24

CATALOG NUMBERING EXAMPLE:
Product No. W
CSEB - 18

**CSTB
TRAY-TO-BOX CONNECTOR**

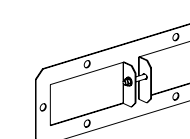

Provides a frame for cables entering the tray from or through a wall.

RUNG DEPTH INCHES
3 | 4 | 6
TRAY WIDTH INCHES
6 | 9 | 12 | 18 | 24

CATALOG NUMBERING EXAMPLE:
Product No. D W
CSTB - 3 - 12

CENTER SPINE CABLE TRAY WIRE FILL CAPACITY – 3" [76mm] TALL RUNG								
CABLE/ WIRE TYPE	CABLE/ WIRE SIZE	O.D.		NUMBER OF WIRES (HEIGHT X WIDTH)				
		INCHES	MM	3X6	3X9	3X12	3X18	3X24
UNSHIELDED TWISTED PAIR	2-PAIR, 24 AWG	0.150	3.8	508	763	1017	1525	2034
	4-PAIR, 24 AWG, CAT 3	0.190	4.8	317	475	634	951	1268
	4-PAIR, 24 AWG, CAT 5E	0.210	5.3	260	390	520	780	1039
	4-PAIR, 24 AWG, CAT 6	0.250	6.4	183	275	367	550	733
	4-PAIR, 24 AWG, CAT 6A	0.354	9.0	91	137	183	274	366
	25-PAIR, 24 AWG	0.360	9.0	88	133	177	265	354
COAXIAL	RG6/U	0.270	7.0	157	236	314	471	628
FIBER OPTIC	2-STRAND (ZIP CORD)	0.118X0.236	3X6	323	485	646	970	1293
	ROUND 4 STRAND FIBER	0.187	4.7	328	492	655	983	1311
	ROUND 6 STRAND FIBER	0.256	6.5	175	262	350	525	699

CENTER SPINE CABLE TRAY WIRE FILL CAPACITY – 4" [102mm] TALL RUNG									
CABLE/ WIRE TYPE	CABLE/ WIRE SIZE	O.D.		NUMBER OF WIRES (HEIGHT X WIDTH)					
		INCHES	MM	4X6	4X9	4X12	4X18	4X19	4X24
UNSHIELDED TWISTED PAIR	2-PAIR, 24 AWG	0.150	3.8	678	1017	1356	2034	2034	2712
	4-PAIR, 24 AWG, CAT 3	0.190	4.8	423	634	845	1268	1268	1690
	4-PAIR, 24 AWG, CAT 5E	0.210	5.3	346	520	693	1039	1039	1386
	4-PAIR, 24 AWG, CAT 6	0.250	6.4	244	367	489	733	733	978
	4-PAIR, 24 AWG, CAT 6A	0.354	9.0	122	183	244	366	366	488
	25-PAIR, 24 AWG	0.360	9.0	118	177	236	354	354	472
COAXIAL	RG6/U	0.270	7.0	209	314	419	628	628	838
FIBER OPTIC	2-STRAND (ZIP CORD)	0.118X0.236	3X6	431	646	862	1293	1293	1724
	ROUND 4 STRAND FIBER	0.187	4.7	437	655	874	1311	1311	1748
	ROUND 6 STRAND FIBER	0.256	6.5	233	350	466	699	699	933

CENTER SPINE CABLE TRAY WIRE FILL CAPACITY – 6" [152mm] TALL RUNG								
CABLE/ WIRE TYPE	CABLE/ WIRE SIZE	O.D.		NUMBER OF WIRES (HEIGHT X WIDTH)				
		INCHES	MM	6X6	6X9	6X12	6X18	6X24
UNSHIELDED TWISTED PAIR	2-PAIR, 24 AWG	0.150	3.8	1017	1525	2034	3051	4068
	4-PAIR, 24 AWG, CAT 3	0.190	4.8	2353	951	1268	1901	2535
	4-PAIR, 24 AWG, CAT 5E	0.210	5.3	2079	780	1039	1559	2079
	4-PAIR, 24 AWG, CAT 6	0.250	6.4	1467	550	733	1100	1467
	4-PAIR, 24 AWG, CAT 6A	0.354	9.0	732	274	366	549	732
	25-PAIR, 24 AWG	0.360	9.0	707	265	354	530	707
COAXIAL	RG6/U	0.270	7.0	1257	471	628	942	1257
FIBER OPTIC	2-STRAND (ZIP CORD)	0.118X0.236	3X6	2585	970	1293	1939	2585
	ROUND 4 STRAND FIBER	0.187	4.7	2622	983	1311	1966	2622
	ROUND 6 STRAND FIBER	0.256	6.5	1399	525	699	1049	1399

NOTE: Values are based on fill capacity only – cable weights must also be checked to ensure that load capacity of the tray is not exceeded. Fill values are based on NEC fill requirement stating a maximum allowable fill of 50% of tray cross sectional area. In reality, this is a fully loaded tray due to spaces between cables.

NEMA LOAD/SPAN DESIGNATIONS		
NEMA CLASS	SUPPORT SPAN	WORKING LOAD*
12A	12 FT.	50 LB./FT.
12B	12 FT.	75 LB./FT.
12C	12 FT.	100 LB./FT.

* The working load is the total weight of all cables and tubing to be placed in the tray.

CSA LOAD CLASS CAPACITIES AT VARYING SUPPORT SPACINGS				
CSA CLASS	SUPPORT SPACING			
	1.5M	2.0M	2.5M	3.0M
WORKING LOAD*				
A	99KG/M	62KG/M	45KG/M	37KG/M
C1	259KG/M	164KG/M	119KG/M	97KG/M
D1	N/A	N/A	N/A	179KG/M
E	N/A	N/A	N/A	299KG/M

Standard Material
Cable Tray Spine, Rungs and Fittings: 6063T6 Aluminum
Alloy Liners and Covers: 5052 Aluminum Alloy

Third Party Certifications
UL File No. E60796

Member of:



All CS12 series Cable Trays are NEMA 12C Rated, CSA C1 Rated.
All CS10 Series Cable Trays are NEMA 10C Rated, CSA C1 Rated.

When designing, specifying or installing a cable tray system, please consider the following (from the Canadian Electrical Code, Appendix B 12-2202):

- a. Some fittings (particularly horizontal elbows) may require additional support depending on the loading.

Per NEMA Standard Publication VE-1, Cable Tray is designed as a support for power or control cables, or both, and is not intended or designed to be a walkway for personnel. The user is urged to display appropriate warnings against the use of this support as a walkway. Each section of tray has a warning label.

CHANNEL SYSTEMS

METALLIC

89 STRAIGHT SECTIONS & COVER

90 FITTINGS

93 SPLICES & CONNECTORS

95 FASTENERS

FIBERGLASS

96 STRAIGHT SECTIONS & COVERS

97 FITTINGS

Channel tray is a fabricated metal tray constructed with a one-piece ventilated bottom or solid-bottom channel section. It is commonly used for small runs of cable and for drops from the main cable tray run to equipment or junction boxes.

We offer channel tray in a complete range of materials including aluminum, mill galvanized steel, and steel that is hot-dip galvanized after fabrication. For extremely corrosive applications we offer a wide range of designs in types 304 and 316 stainless steels, polyester and vinylester fiberglass.

Additionally, our product line includes a complete line of accessories including covers and fittings designed to support large-diameter cables.

- Horizontal and vertical fittings are available in 12", 24", and 36" radius
- 4" and 6" widths
- Available in solid and ventilated designs



CHANNEL TRAY DESIGN OPTIONS – SOLID BOTTOM

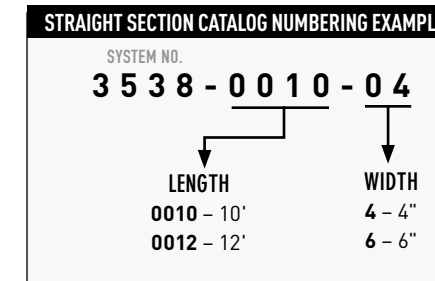
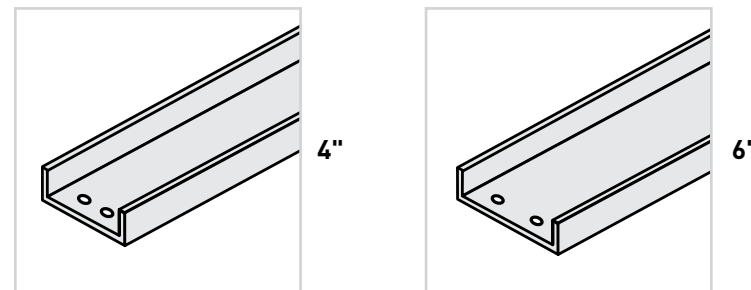

CHANNEL TRAY DESIGN OPTIONS – VENTILATED BOTTOM

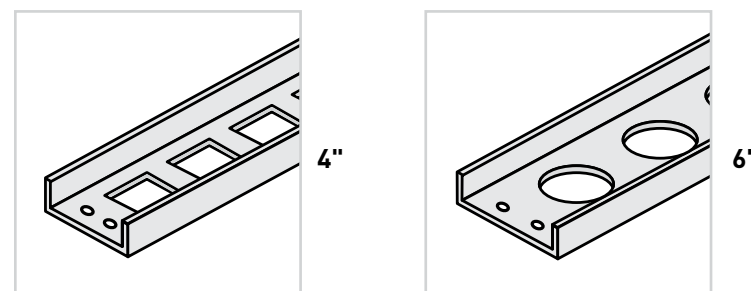

TRAY DEPTH	CHANNEL STYLE	A	M	G	L	T
1 3/4"	SOLID	5509	2509	1509	3538	3529
	VENTILATED*	5508	2508	1508	3532	3528
CLASSIFIED UL	U.L. AREA	0.20 IN ²	0.20 IN ²	0.20 IN ²	N/A	N/A
	AMPS	200	200	200	N/A	N/A

WIDTHS (W) INCHES
4 | 6

LENGTHS (L) FEET
10 | 12

*Available in straight sections only. All fittings have solid bottom.

CHANNEL COVER

A M G L T

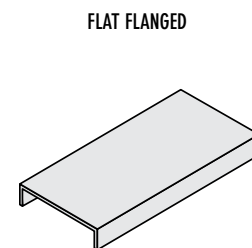

LENGTH (L) FEET

0010 | 10
0012 | 12

WIDTH (W) INCHES

04 | 4
06 | 6

A	M	G	L	T
5088	2085	1085*	3014	3095
CATALOG NUMBERING EXAMPLE (EA.):				
System Number		Length	Width	
5088		0010	04	

*Available in 6' length only.

COVER CONNECTOR

A M T G

CHANNEL-STYLE

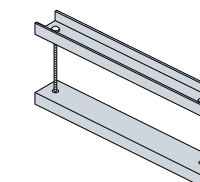

DESCRIPTION	PRODUCT NUMBER	FASTENERS
CHANNEL	1400	ZN S6
CATALOG NUMBERING EXAMPLE (EA.):		
Material	Width	Fasteners
A - 1400	04	S6

HORIZONTAL 90° ELBOW

A M G L T

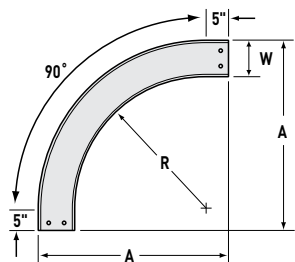

PRODUCT NUMBER RADIUS (IN.)	W	A	B	C	D
9012 12	4	21	-	-	-
	6	23	-	-	-
9024 24	4	33	-	-	-
	6	35	-	-	-
9036 36	4	45	-	-	-
	6	47	-	-	-

HORIZONTAL 60° ELBOW

A M G L T

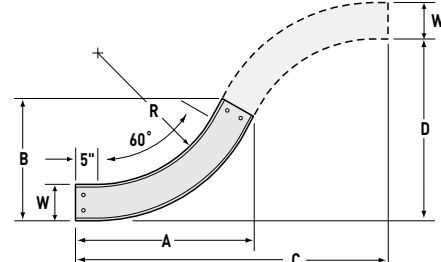

PRODUCT NUMBER RADIUS (IN.)	W	A	B	C	D
6012 12	4	21 ^{3/8}	14 ^{3/8}	39 ^{1/4}	22 ^{3/4}
	6	23 ^{1/8}	16 ^{3/8}	41	23 ^{3/4}
6024 24	4	31 ^{3/4}	20 ^{3/8}	60	34 ^{5/8}
	6	33 ^{1/2}	22 ^{3/8}	61 ^{3/4}	35 ^{5/8}
6036 36	4	42 ^{1/8}	26 ^{3/8}	80 ^{3/4}	46 ^{3/4}
	6	43 ^{7/8}	28 ^{3/8}	82 ^{5/8}	47 ^{3/4}

HORIZONTAL 45° ELBOW

A M G L T

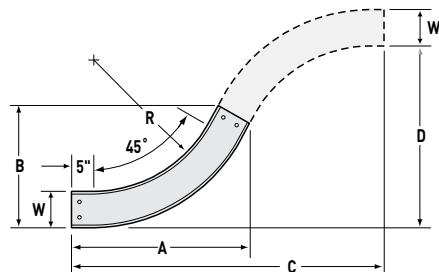

PRODUCT NUMBER RADIUS (IN.)	W	A	B	C	D
4512 12	4	19 ^{7/8}	11 ^{1/8}	36 ^{7/8}	15 ^{1/4}
	6	21 ^{1/4}	13 ^{1/8}	38 ^{1/4}	15 ^{7/8}
4524 24	4	28 ^{3/8}	14 ^{5/8}	53 ^{7/8}	22 ^{3/8}
	6	29 ^{3/4}	16 ^{5/8}	55 ^{1/4}	22 ^{7/8}
4536 36	4	36 ^{7/8}	18 ^{1/8}	70 ^{3/4}	29 ^{3/8}
	6	38 ^{1/4}	20 ^{1/8}	72 ^{1/4}	30

HORIZONTAL 30° ELBOW

A M G L T

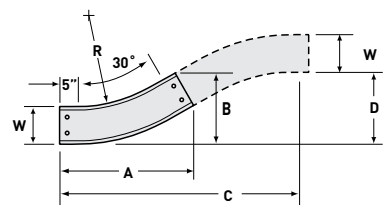

PRODUCT NUMBER RADIUS (IN.)	W	A	B	C	D
3012 12	4	17 ^{3/8}	8 ^{1/8}	32 ^{3/4}	8 ^{1/4}
	6	18 ^{3/8}	10 ^{1/8}	33 ^{3/4}	9
3024 24	4	23 ^{3/8}	9 ^{3/4}	44 ^{3/4}	12
	6	24 ^{3/8}	11 ^{3/4}	45 ^{3/4}	12 ^{1/4}
3036 36	4	29 ^{3/8}	11 ^{3/8}	56 ^{3/4}	14 ^{1/2}
	6	30 ^{3/8}	13 ^{3/8}	57 ^{3/4}	15 ^{1/2}

HORIZONTAL ELBOW CATALOG NUMBERING EXAMPLE:

SYSTEM NO. PRODUCT NO. WIDTH

5509 - 9012 - 06

This identifies the solid bottom straight section tray to be used as a catalog number prefix for all fittings. All fittings are solid bottom only and can be used with ventilated bottom tray.

5509 - **A**
2509 - **M**
1509 - **G**
3538 - **L**
3529 - **T**

04 - 4"
06 - 6"

VERTICAL 90° ELBOW

A M G L T

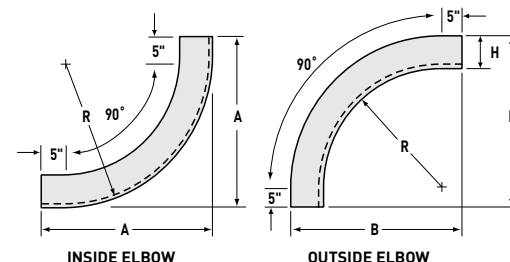

PRODUCT NUMBER RADIUS (IN.)		W	A	B
INSIDE	OUTSIDE			
9112 12	9212 12	4	17	18 ^{3/4}
		6		
9124 24	9224 24	4	29	30 ^{3/4}
		6		
9136 36	9236 36	4	41	42 ^{3/4}
		6		

VERTICAL 60° ELBOW

A M G L T

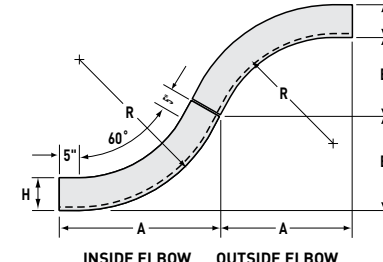

PRODUCT NUMBER RADIUS (IN.)		W	A	B
INSIDE	OUTSIDE			
6112 12	6212 12	4	17 ^{7/8}	10 ^{3/8}
		6		
6124 24	6224 24	4	28 ^{1/4}	16 ^{3/8}
		6		
6136 36	6236 36	4	38 ^{5/8}	22 ^{3/8}
		6		

VERTICAL 45° ELBOW

A M G L T

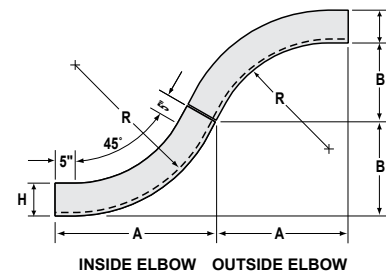

PRODUCT NUMBER RADIUS (IN.)		W	A	B
INSIDE	OUTSIDE			
4612 12	4712 12	4	17	7
		6		
4624 24	4724 24	4	25 ^{1/2}	10 ^{5/8}
		6		
4636 36	4736 36	4	34	14 ^{1/8}
		6		

VERTICAL 30° ELBOW

A M G L T

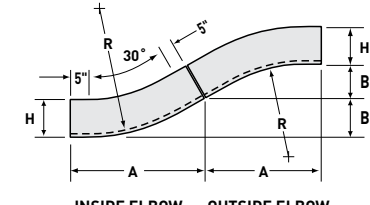

PRODUCT NUMBER RADIUS (IN.)		W	A	B
INSIDE	OUTSIDE			
3112 12	3212 12	4	15 ^{3/8}	4 ^{1/8}
		6		
3124 24	3224 24	4	21 ^{3/8}	5 ^{3/4}
		6		
3136 36	3236 36	4	27 ^{3/8}	7 ^{3/8}
		6		

VERTICAL ELBOW CATALOG NUMBERING EXAMPLE:

SYSTEM NO. PRODUCT NO. WIDTH

3529 - 9212 - 04

This identifies the solid bottom straight section tray to be used as a catalog number prefix for all fittings. All fittings are solid bottom only and can be used with ventilated bottom tray.

5509 - **A**
2509 - **M**
1509 - **G**
3538 - **L**
3529 - **T**

04 - 4"
06 - 6"

HORIZONTAL TEE

A M G L T

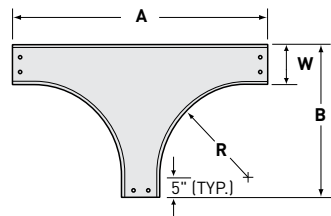

PRODUCT NUMBER	RADIUS (IN.)	W	A	B
2012	12	4	38	21
	24	6	40	23
2024	24	4	62	33
	36	6	64	35
2036	36	4	86	45
	48	6	88	47

HORIZONTAL CROSS

A M G L T

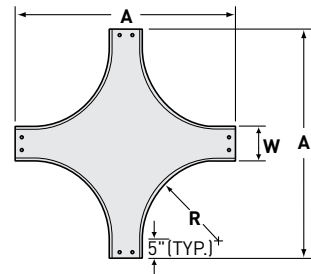

PRODUCT NUMBER	RADIUS (IN.)	W	A
1012	12	4	38
	24	6	40
1024	24	4	62
	36	6	64
1036	36	4	86
	48	6	88

CABLE DROPOUT

A M T G*

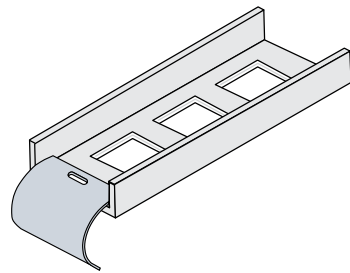

PRODUCT NUMBER	RADIUS	FASTENERS INCLUDED
0253	3/4"	ZN S6

CATALOG NUMBERING EXAMPLE:
Material Width Fasteners
A - 0253 - 04 - ZN

BLIND END PLATE

A M T G*

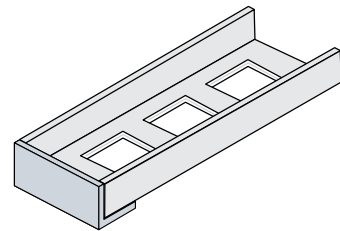

PRODUCT NUMBER	FASTENERS INCLUDED
0402	CD S6

CATALOG NUMBERING EXAMPLE:
Material Width Fasteners
A - 0402 - 06 - S6

WIDTHS (W) INCHES

4 | 6

RADIUS (R) INCHES

12 | 24 | 36

HORIZONTAL TEE CATALOG NUMBERING EXAMPLE:

SYSTEM NO.	PRODUCT NO.	WIDTH
5509	2012	06

This identifies the specific solid bottom straight section tray design and is used as a catalog number prefix for all fittings.

5509 -	A	03 - 3"
2509 -	M	04 - 4"
1509 -	G	06 - 6"
3538 -	L	
3529 -	T	

STANDARD SPLICE

A G T

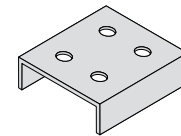

PRODUCT NO.	FASTENERS INCLUDED
1301	CD S6

CATALOG NUMBERING EXAMPLE:
Material Width Fasteners
T - 1301 - 04 - S6

HORIZONTAL ADJUSTABLE SPLICE

A G T

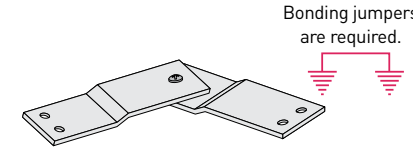

PRODUCT NO.	FASTENERS INCLUDED
1305	CD S6

CATALOG NUMBERING EXAMPLE:
Material Width Fasteners
A - 1305 - 06 - CD

VERTICAL ADJUSTABLE SPLICE

A G T

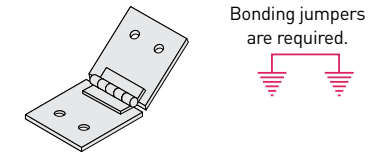

PRODUCT NO.	FASTENERS INCLUDED
1307	CD S6

CATALOG NUMBERING EXAMPLE:
Material Width Fasteners
T - 1307 - 06 - S6

CHANNEL-TO-TRAY CONNECTOR

A G T

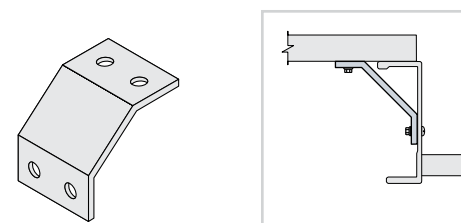

PRODUCT NO.	FASTENERS INCLUDED
1338	CD S6

CATALOG NUMBERING EXAMPLE:
Material Width Fasteners
A - 1338 - 04 - CD

MOUNTING BRACKET

A G T

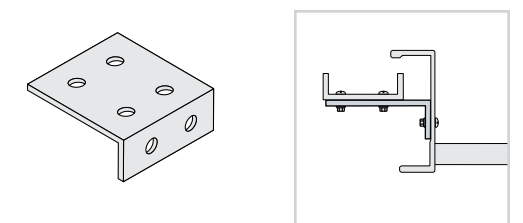

PRODUCT NO.	FASTENERS INCLUDED
1357	CD S6

CATALOG NUMBERING EXAMPLE:
Material Width Fasteners
A - 1357 - 04 - S6

OVERHEAD HANGER BRACKET

G T

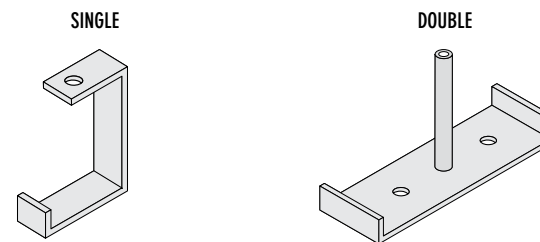

DESCRIPTION	PRODUCT NUMBER	ROD SIZE
SINGLE	0333	1/2"
	0341	3/8"
DOUBLE	0334	1/2"

CATALOG NUMBERING EXAMPLE (EA.):
Material Width
G - 0333 - 04

G* = optional

For detailed material and finish descriptions, see page 6.

WWW.LEGRAND.US/CABLOFIL

CHANNEL-TO-BOX CONNECTOR

A G T

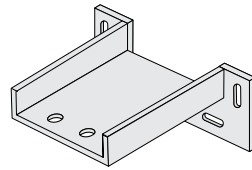

PRODUCT NUMBER	FASTENERS
0403	CD S4
CATALOG NUMBERING EXAMPLE:	
Material	Width Fasteners
A - 0403	- 04 - CD

CHANNEL-TO-FLOOR BASE PLATE

G T

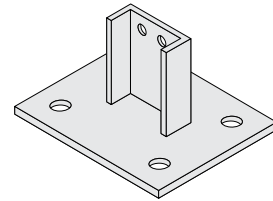

PRODUCT NUMBER	
1812	
CATALOG NUMBERING EXAMPLE:	
Material	Width
G - 1812	- 04

VERTICAL HANGER SPLICE

A G T

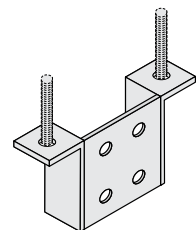

Functions as a splice plate while offering a means of supporting the channel vertically from two 1/2" threaded rods (purchased separately). Fasteners for channel connection only is included.

PRODUCT NUMBER	FASTENERS
0357	CD S6
CATALOG NUMBERING EXAMPLE:	
Material	Width Fasteners
A - 0357	- 04 - CD

WALL BRACKET

G T

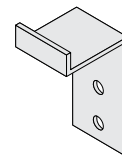

PRODUCT NUMBER	
1803	
CATALOG NUMBERING EXAMPLE:	
Material	Width
G - 1803	- 04

HOLD DOWN CLAMP

A M T G*

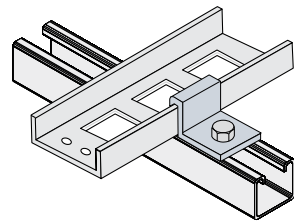

PRODUCT NUMBER	
1870	
CATALOG NUMBERING EXAMPLE:	
Material	
T - 1870	

EXPANSION GUIDE CLAMP

A M T G*

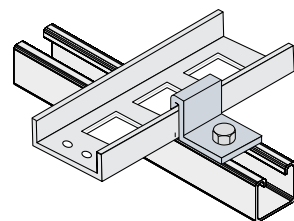

PRODUCT NUMBER	
1871	
CATALOG NUMBERING EXAMPLE:	
Material	
A - 1871	

HOLD DOWN/COVER CLAMP

A M T G*

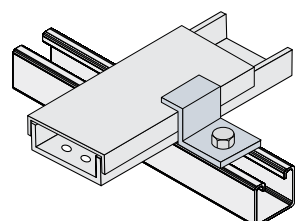

PRODUCT NUMBER	
1872	
CATALOG NUMBERING EXAMPLE:	
Material	
T - 1872	

SLIP-ON LOCK NUT®

ZN S4

Allows the user to slip the nut onto a rod, without actually threading it. Ideal for when nuts must be added to a rod, but cannot be threaded due to previously-installed equipment.

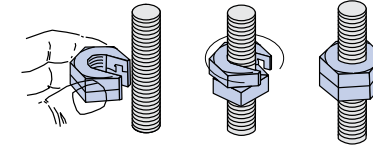

PRODUCT NO.	SIZE
SON 1/4	1/4"-20
SON 3/8	3/8"-16
SON 1/2	1/2"-13
CATALOG NUMBERING EXAMPLE:	
Fasteners	
SON 3/8 - ZN	

FIBERGLASS ENCAPSULATED STAINLESS STEEL HEX BOLT/NUT

FE

To obtain the strength of stainless steel as well as the corrosion resistance of fiberglass, use PW's 316 stainless steel hex nut and hex bolt encapsulated in fire retardant fiberglass.

Designed for use with all PW fiberglass cable trays shown in this catalog. Other bolt lengths between 3/4" and 2 1/2" are also available on a special order basis; contact Legrand for more information.

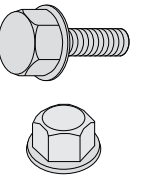

DESCRIPTION	COMPLETE CATALOG NO.	SIZE	GRIP RANGE
BOLT	DS-8953-05-FE	3/8"-16 x 1"	0.35" TO 0.50"
NUT	DS-8954-01-FE	3/8"	N/A

DESCRIPTION	SIZE	COMPLETE CATALOG NUMBER					
		NY	NYLON	FG	FIBERGLASS	S6	316 STAINLESS
THREADED ROD	3/8"-16 x 4'		DS-0255-04-NY		DS-0255-04-FG		DS-0255-04-S6
	3/8"-16 x 8'		DS-0255-08-NY		DS-0255-08-FG		DS-0255-08-S6
	1/2"-13 x 4'		DS-0256-04-NY		DS-0256-04-FG		DS-0256-04-S6
	1/2"-13 x 8'		DS-0256-08-NY		DS-0256-08-FG		DS-0256-08-S6
ROD COUPLING NUT	3/8"-16		N/A		DS-0237-04-FG		DS-0237-04-S6
	1/2"-13		N/A		DS-0237-05-FG		DS-0237-05-S6
CHANNEL NUT WITHOUT SPRING	1/4"-20		N/A		DS-0103-03-FG		DS-0103-03-S6
	3/8"-16		N/A		DS-0103-05-FG		DS-0103-05-S6
	1/2"-13		N/A		DS-0103-07-FG		DS-0103-07-S6
HEX NUT	1/4"-20		DS-8586-01-NY		N/A		DS-8586-01-S6
	3/8"-16		DS-8554-01-NY		DS-8554-01-FG		DS-8554-01-S6
	1/2"-13		DS-8574-01-NY		DS-8574-01-FG		DS-8574-01-S6
FLANGED HEX NUT	3/8"-16		N/A		DS-8524-01-FG		DS-8927-01-S6
	1/2"-13		N/A		DS-8644-01-FG		DS-8932-01-S6
SQUARE CHANNEL WASHER	1/4"		N/A		N/A		DS-0113-01-S6
	3/8"		N/A		DS-0113-02-FG		DS-0113-02-S6
	1/2"		N/A		DS-0113-03-FG		DS-0113-03-S6
FLAT, ROUND WASHER	1/4"		DS-8674-01-NY		N/A		DS-8674-01-S6
	3/8"		DS-8600-01-NY		DS-8600-01-FG		DS-8600-01-S6
	1/2"		DS-8657-01-NY		DS-8657-01-FG		DS-8657-01-S6
HEX HEAD BOLT	1/4"-20 x 3/4"		DS-8720-01-NY		N/A		DS-8720-01-S6
	1/4"-20 x 1 1/2"		DS-8720-10-NY		N/A		DS-8720-01-S6
	3/8"-16 x 3/4"		DS-8694-04-NY		DS-8694-04-FG		DS-8694-04-S6
	3/8"-16 x 1 1/2"		DS-8694-05-NY		DS-8694-05-FG		DS-8694-05-S6
	1/2"-13 x 1 1/2"		DS-8533-02-NY		DS-8533-02-FG		DS-8533-02-S6
BEAM CLAMP	FOR 3/8" ROD		N/A		DS-0221-04-FG		DS-0221-04-S6
	FOR 1/2" ROD		N/A		DS-0221-06-FG		DS-0221-06-S6

G* = optional

For detailed material and finish descriptions, see page 6.

WWW.LEGRAND.US/CABLOFIL

FIBERGLASS CHANNEL TRAY

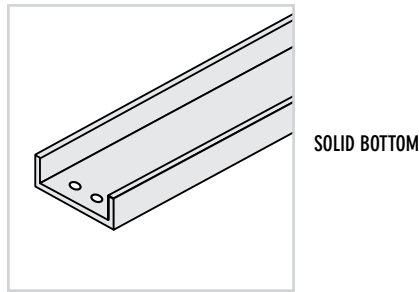

SOLID BOTTOM

CHANNEL STYLE	F
SOLID	7509
VENTILATED*	7508

COVER (NOT SHOWN)	F
FLAT, SOLID	7134

*Available in straight sections only. All fittings have solid bottom.

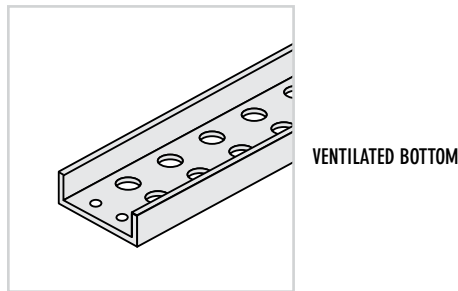

VENTILATED BOTTOM

WIDTHS (W) INCHES
4 6
LENGTHS (H) FEET
10 20

HORIZONTAL ELBOWS

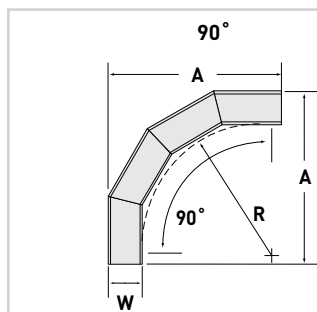

PRODUCT NUMBER	W	A
9012	4	18
12	6	20
9024	4	30
24	6	32
9036	4	42
36	6	44

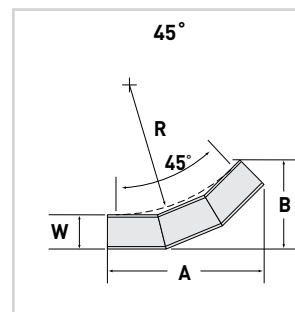

PRODUCT NUMBER	W	A	B
4512	4	14 ³ / ₈	8 ⁷ / ₈
12	6	16 ¹ / ₈	10 ⁷ / ₈
4524	4	23 ¹ / ₄	12 ¹ / ₂
24	6	24 ⁵ / ₈	14 ¹ / ₂
4536	4	31 ³ / ₄	16
36	6	33 ¹ / ₈	18

WIDTHS (W) INCHES

4 | 6

LENGTHS (H) FEET

10 | 20

RADIUS (W) INCHES

12 | 24 | 36

HORIZONTAL ELBOW CATALOG NUMBERING EXAMPLE:

SYSTEM NO.	PRODUCT NO.	WIDTH
7509	9012	06

Solid bottom straight section tray design is used as a catalog number prefix for all fittings. **7509 - F**
 WIDTH 4 - 4" / 6 - 6"

HORIZONTAL TEE

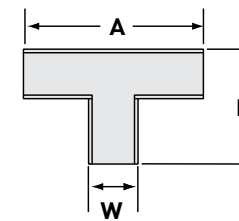

PRODUCT NUMBER	W	A	B
2000	4	14	9
	6	16	11

HORIZONTAL CROSS

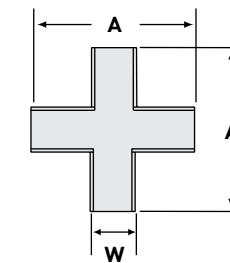

PRODUCT NUMBER	W	A
1000	4	14
	6	16

90° VERTICAL ELBOWS

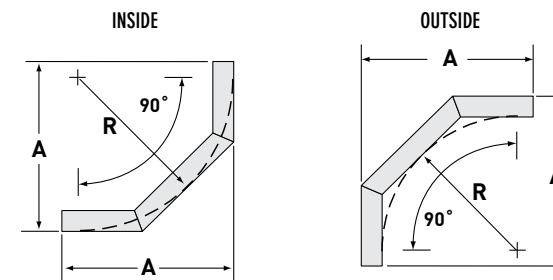

W	PRODUCT NUMBER RADIUS (IN.)	INSIDE		OUTSIDE	
		A	PRODUCT NUMBER RADIUS (IN.)	A	
4	9112	14	9212	15	
6	12	14	12	15 ⁷ / ₈	
4	9124	26	9224	27	
6	24	26	24	27 ⁷ / ₈	
4	9136	38	9236	39	
6	36	38	36	39 ⁷ / ₈	

45° VERTICAL ELBOWS

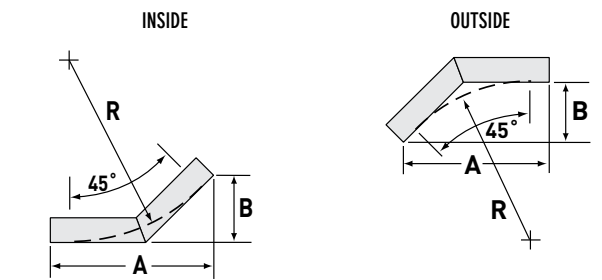

W	PRODUCT NUMBER RADIUS (IN.)	INSIDE			OUTSIDE		
		A	B	PRODUCT NUMBER RADIUS (IN.)	A	B	
4	4612	12	5	4712	11 ³ / ₄	4 ⁷ / ₈	
6	12	12	5	12	11 ³ / ₄	4 ⁷ / ₈	
4	4624	20 ³ / ₈	8 ¹ / ₂	4724	20 ¹ / ₄	8 ³ / ₈	
6	24	20 ³ / ₈	8 ¹ / ₂	24	20 ¹ / ₄	8 ³ / ₈	
4	4636	28 ⁷ / ₈	12	4736	28 ³ / ₄	11 ⁷ / ₈	
6	36	28 ⁷ / ₈	12	36	28 ³ / ₄	11 ⁷ / ₈	

HORIZONTAL TEE CATALOG NUMBERING EXAMPLE:

SYSTEM NO.	PRODUCT NO.	WIDTH
7509	2000	06

Solid bottom straight section tray design is used as a catalog number prefix for all fittings. **7509 - F**
 WIDTH 4 - 4" / 6 - 6"

CABLE RUNWAY

- 99 STRAIGHT SECTIONS
- 100 FITTINGS, SPLICES & CONNECTORS
- 102 ACCESSORIES
- 103 FASTENERS



Cable Runway is available in two styles, tubular side rails that are lightweight yet strong and solid-bar side rails that offer maximum support strength. Both styles utilize rungs made of tubular steel.

Cable runway is commonly used in telecommunications and voice and data applications. Specific application examples include, computer data centers, server farms, 911 call centers, network control centers, telephone/wireless communication centers, and phone/data closets in commercial office buildings.

Available finishes include Yellow-zinc dichromate that is ideally used where the runway needs to be UL Classified for use as an equipment ground conductor. Powder-coated finishes are available in a range of standard colors with an infinite variety of special colors.

- Available in 6" to 24" widths
- Available in Solid and Tubular side rail designs
- All rails are 10' in length

CABLE RUNWAY DESIGN OPTIONS – TUBULAR SIDE RAILS

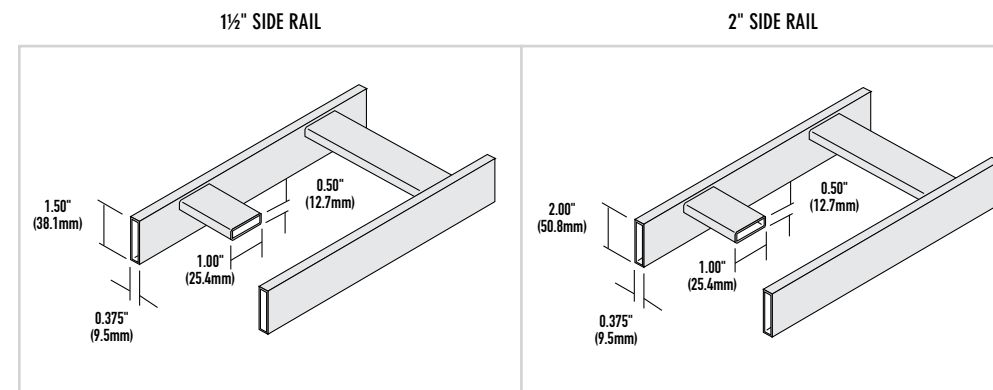

CLASSIFIED
UL

COLOR COATING CHART

Standard: Black (BK)

Options:

- Yellow Zinc Dichromate (YZ)
- Light Gray (GY)

CABLE RUNWAY DESIGN OPTIONS – SOLID SIDE RAILS

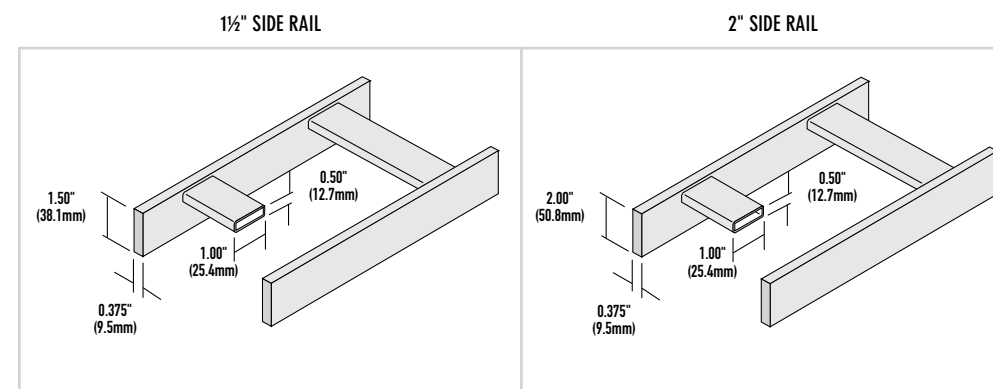

TYPE	PRODUCT NUMBER	RAIL HEIGHT*	SUPPORT SPAN (FT.) SAFE LOAD (LBS./FT.) / DEFLECTION (IN.)									
			4	5	6	7	8					
TUBULAR	8104	1 1/2	248	0.41	159	0.63	110	1.19	81	1.24	62	1.62
	8204	2	300*	0.29	274	0.65	190	0.93	140	1.27	107	1.66
SOLID	8106	1 1/2	300*	0.26	300*	0.62	251	1.08	184	1.47	141	1.92
	8206	2	300*	0.11	300*	0.26	300*	0.54	246	0.82	188	1.07

* 1 1/2 rail height is standard; 2" is available by special order only.

SAFE LOAD: Allowable uniformly distributed load based on simple beam type supports with a safety factor of 1.5. Safe load data is based on the performance of the cable runway side rails. An asterisk (*) denotes rung limitation.

DEFLECTION: Side rail deflection measured at the midspan of the runway, based on simple beam type supports and uniformly distributed loads. When trays are erected in a continuous system, the midspan deflection decreases by as much as 40%.

MATERIAL: Rectangular Steel Tube per ASTM-A-513 and Rectangular Steel Solid Bar per ASTM-A-36.

CONSTRUCTION: Rungs are attached to side rails by arc welding.

RAIL HEIGHTS (H) INCHES

1.5 | 2

WIDTH (W) INCHES

6 | 9 | 12 | 18 | 24

LENGTH (L) FEET

10

STRAIGHT SECTION CATALOG NUMBERING EXAMPLE:

PRODUCT NO.
09 - 8104 - 0010 - 12 BK

- ↓ RUNG SPACING: 09 - 9"
- ↓ TRAY LENGTH: 10' (Actual runway length is 116 1/2" without connectors)
- ↓ WIDTH: 06 - 6", 09 - 9", 12 - 12", 18 - 18", 24 - 24". Other widths available.
- ↓ COATING COLOR: See chart above.

90° HORIZONTAL ELBOW

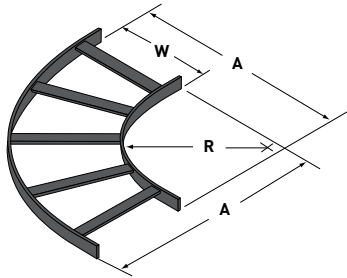

CATALOG NUMBER RADIUS	W	A
9012 12	4	19
	6	21
	9	24
	12	27
	18	33
	24	39

90° VERTICAL INSIDE ELBOW

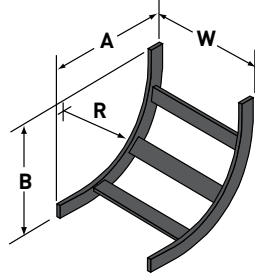

CATALOG NUMBER RADIUS	W	SIDE RAIL HEIGHT			
		1 1/2		2	
		A	B	A	B
9112 12	4	16 1/2	16 1/2	17	17
	6	16 1/2	16 1/2	17	17
	9	16 1/2	16 1/2	17	17
	12	16 1/2	16 1/2	17	17
	18	16 1/2	16 1/2	17	17
	24	16 1/2	16 1/2	17	17

90° VERTICAL OUTSIDE ELBOW

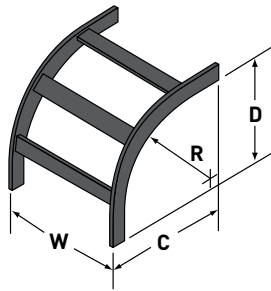

CATALOG NUMBER RADIUS	W	SIDE RAIL HEIGHT			
		1 1/2		2	
		C	D	C	D
9212 12	4	16 1/2	15	17	15
	6	16 1/2	15	17	15
	9	16 1/2	15	17	15
	12	16 1/2	15	17	15
	18	16 1/2	15	17	15
	24	16 1/2	15	17	15

SPLICE

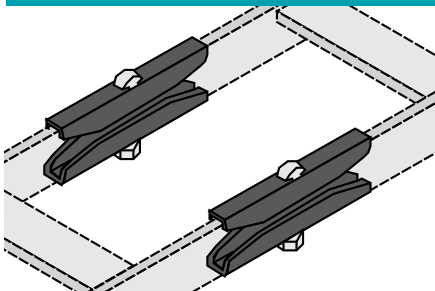

Connects runway sections. Sold in pairs as a separate line item.

CLASSIFIED	PRODUCT NUMBER	FASTENERS INCLUDED
UL	1302	ZN
CATALOG NUMBERING EXAMPLE:		
System No.	Fasteners	Coating
1 R -	1302	- ZN - BK

90° HORIZONTAL CONNECTOR

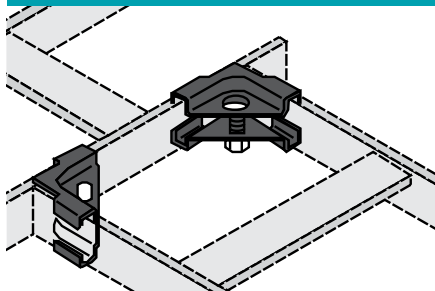

Joins runway sections at a 90-degree horizontal angle. Sold in pairs.

CLASSIFIED	PRODUCT NUMBER	FASTENERS INCLUDED
UL	1320	ZN
CATALOG NUMBERING EXAMPLE:		
System No.	Fasteners	Coating
1 R -	1320	- ZN - BK

90° VERTICAL CONNECTOR

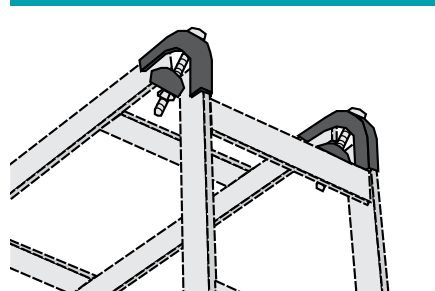

Joins runway sections at a 90-degree vertical angle. Sold in pairs.

CLASSIFIED	PRODUCT NUMBER	FASTENERS INCLUDED
UL	1331-90	ZN
CATALOG NUMBERING EXAMPLE:		
System No.	Fasteners	Coating
1 R -	1331-90	- ZN - BK

WIDTHS (W) INCHES

6 | 9 | 12 | 18 | 24

RUNWAY PREFIX OPTIONS

R	ALL SIZES
1R	1 1/2" SIDERAIL (8104, 8106)
2R	2" SIDERAIL (8204, 8206)

HORIZONTAL ELBOW CATALOG NUMBERING EXAMPLE:

SYSTEM NO. PRODUCT NO.
09-8104-9012-24 BK

RUNG SPACING
09 - 9"

WIDTH
06 - 6"
09 - 9"
12 - 12"
18 - 18"
24 - 24"

COATING COLOR

COLOR COATING CHART

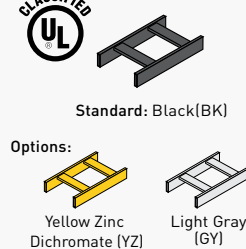

45° VERTICAL CONNECTOR

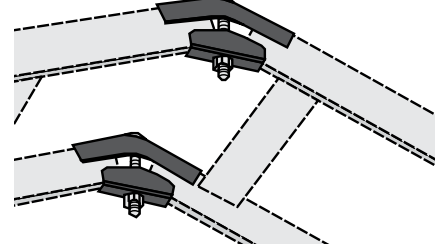

Joins runway sections at a 45° vertical angle. Sold in pairs.

CLASSIFIED	PRODUCT NUMBER	FASTENERS INCLUDED
UL	1331-45	ZN
CATALOG NUMBERING EXAMPLE:		
System No.	Fasteners	Coating
1 R -	1331-45	- ZN - BK

FLOOR/WALL SUPPORT BRACKET KIT

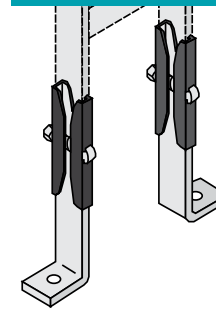

Connects runway to the floor or wall and acts as a support point. Includes the splice connector and foot support. Attachment hardware is not included. Sold in pairs.

PRODUCT NUMBER	FASTENERS INCLUDED
0339	ZN
CATALOG NUMBERING EXAMPLE:	
System No.	Fasteners
1 R -	0339 - ZN - BK

BONDING JUMPER - #1 COPPER

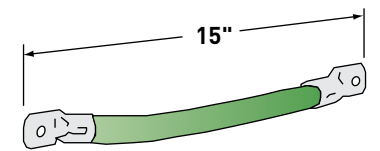

600 amperes rating per N.E.C.

COMPLETE CATALOG NO.
C-A803

CABLE DROPOUT

Provides a smooth surface for cables to drop out of runway with a 5" radius bend.

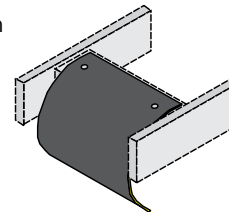

PRODUCT NUMBER	
0254	
CATALOG NUMBERING EXAMPLE:	
System No.	W Fasteners Coating
1 R -	0254 - 06 - ZN - BK

VERTICAL WALL BRACKET

Secures runway to the wall or floor. Hardware is not included. Sold in pairs.

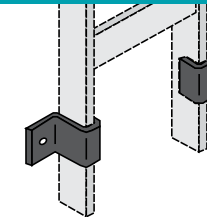

PRODUCT NUMBER	
0426	
CATALOG NUMBERING EXAMPLE:	
System No.	Fasteners
1 R -	0426 - BK

PROTECTIVE END CAP

Protects the exposed ends of runway side rails. Plastic material. Sold in pairs.

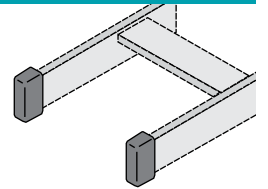

PRODUCT NUMBER	
0410	
CATALOG NUMBERING EXAMPLE:	
System No.	
1 R -	0410

CABLE RETAINING POSTS

Posts add load depth to cable runway. Includes one post, one bracket, and one end cap. Posts are typically installed on 12" centers.

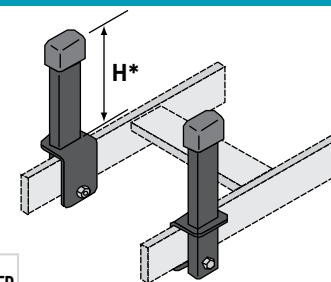

PRODUCT NUMBER	FASTENERS INCLUDED
A330	ZN
CATALOG NUMBERING EXAMPLE:	
System No.	H Fasteners Coating
1 R -	A330-08 - ZN - BK

HEIGHTS (H) INCHES

4 | 6 | 8

L-BRACKET

Bracket provides a separate facility for running power conductors or other cables that should be physically separated from main cables.

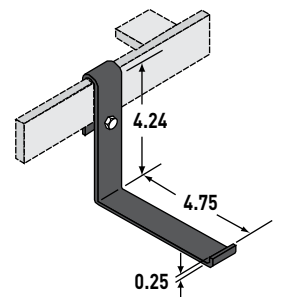

PRODUCT NUMBER	FASTENERS INCLUDED
A834	ZN
CATALOG NUMBERING EXAMPLE:	
System No.	Fasteners Coating
1 R -	A834 - ZN - BK

WALL ANGLE SUPPORT KIT

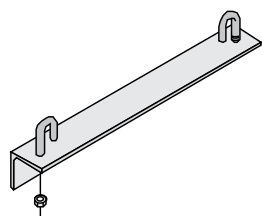

Supports cable runway against wall or upright vertical surface. Angle length and hole spacing is based on the specified width. Kit includes hardware for tray attachment, but wall attachment hardware is not included. Standard finish is epoxy powder coat, light gray color.

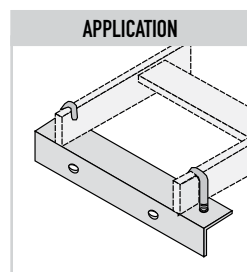

PRODUCT NUMBER	FASTENERS INCLUDED
0403	ZN
CATALOG NUMBERING EXAMPLE:	
System No. R - 0403	W Fasteners Coating 06 - ZN - BK

CENTER HUNG SUPPORT KIT

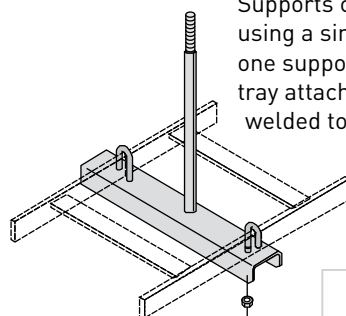

Supports cable runway from the ceiling using a single threaded rod. Kit includes one support bracket and hardware for tray attachment. Threaded rod cover is welded to the support bracket. Standard finish is epoxy powder coat, light gray color. Threaded rod is purchased separately.

PRODUCT NUMBER	FASTENERS INCLUDED
0345	ZN
CATALOG NUMBERING EXAMPLE:	
System No. R - 0345	W Fasteners Coating 12 - ZN - BK

WALL BRACKET

Supports cable runway against the wall or an upright vertical surface. Hardware for runway attachment is included. Standard finish is epoxy powder coat, light gray color.

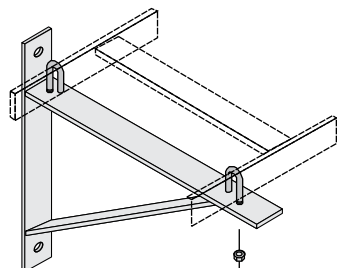

PRODUCT NUMBER	FASTENERS INCLUDED
0349	ZN
CATALOG NUMBERING EXAMPLE:	
System No. R - 0349	W Fasteners Coating 09 - ZN - BK

TRAPEZE SUPPORT KIT

Supports cable runway from the ceiling with threaded rods. Kit includes one ceiling support bracket, one runway side rail support bracket and hex nuts. Threaded rod is purchased separately.

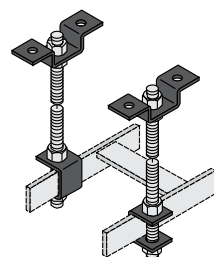

PRODUCT NUMBER	ROD SIZE	FASTENERS INCLUDED
0327	3/8	ZN
0328	1/2	ZN
0331	5/8	ZN
CATALOG NUMBERING EXAMPLE:		
System No. 1 R - 0327	Fasteners Coating	ZN - BK

CEILING SUPPORT BRACKET

Attaches threaded rod to the ceiling. Sold individually. Hardware purchased separately.

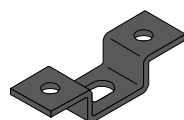

PRODUCT NUMBER	USE WITH FASTENERS
A823-01	3/8
A824-01	1/2 or 5/8
CATALOG NUMBERING EXAMPLE:	
System No. R - A823	Coating 01 - BK

SIDE RAIL SUPPORT BRACKET

Used in conjunction with threaded rod to support cable runway from ceiling. Sold individually. Hardware is purchased separately.

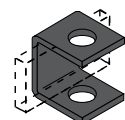

PRODUCT NUMBER	USE WITH FASTENERS
A838-01	3/8
A839-01	1/2 or 5/8
CATALOG NUMBERING EXAMPLE:	
System No. 1 R - A839	Coating 01 - BK

SLOTTED SUPPORT BRACKET

Used in conjunction with threaded rod to support cable runway from the ceiling. Hardware is purchased separately.

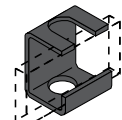

PRODUCT NUMBER	USE WITH FASTENERS
A842-01	3/8
A843-01	1/2
A844-01	5/8
CATALOG NUMBERING EXAMPLE:	
System No. 1 R - A842	Coating 01 - BK

WIDTHS (W) INCHES

6	9	12	18	24
---	---	----	----	----

RUNWAY PREFIX OPTIONS

R	ALL SIZES
1R	1 1/2" SIDERAIL (8104, 8106)
2R	2" SIDERAIL (8204, 8206)

COLOR COATING CHART

Options:
 Standard: Black (BK) Yellow Zinc Dichromate (YZ) Light Gray (GY)

Wall Angle Support, Center Hung Support and Wall Bracket are also available in black and grey colors.

INSTALLATION FASTENERS

THREADED ROD	ROD COUPLING NUT	CHANNEL NUT W/ SPRING	CHANNEL NUT W/O SPRING
HEX NUT	FLANGED HEX NUT	SQUARE CHANNEL WASHER	FLAT, ROUND WASHER
HEX HEAD BOLT	CARRIAGE BOLT	J-BOLT	BEAM CLAMP

DESCRIPTION	SIZE	COMPLETE CATALOG NUMBER	
		ZN	S6
THREADED ROD	3/8"-16 x 12'	DS-0255-12-ZN	DS-0255-12-S6
	1/2"-13 x 12'	DS-0256-12-ZN	DS-0256-12-S6
	5/8"-11 x 12'	DS-0257-12-ZN	DS-0257-12-S6
ROD COUPLING NUT	3/8"-16	DS-0237-04-ZN	DS-0237-04-S6
	1/2"-13	DS-0237-05-ZN	DS-0237-05-S6
	5/8"-11	DS-0237-06-ZN	DS-0237-06-S6
CHANNEL NUT W/ SPRING	3/8"-16	DS-0102-05-ZN	DS-0102-05-S6
	1/2"-13	DS-0102-07-ZN	DS-0102-07-S6
	5/8"-11	DS-0102-08-ZN	DS-0102-08-S6
CHANNEL NUT W/O SPRING	3/8"-16	DS-0103-05-ZN	DS-0103-05-S6
	1/2"-13	DS-0103-07-ZN	DS-0103-07-S6
	5/8"-11	DS-0103-08-ZN	DS-0103-08-S6
HEX NUT	3/8"-16	DS-8575-01-ZN	DS-8554-01-S6
	1/2"-13	DS-8570-01-ZN	DS-8574-01-S6
	5/8"-11	DS-8532-01-ZN	DS-8723-01-S6
FLANGED HEX NUT	1/4"-20	DS-8845-01-ZN	DS-8929-01-S6
	3/8"-16	DS-8524-01-ZN	DS-8927-01-S6
	1/2"-13	DS-8644-01-ZN	DS-8932-01-S6
SQUARE CHANNEL WASHER	1 1/2" w/ 3/8" HOLE	DS-0113-02-ZN	DS-0113-02-S6
	1 1/2" w/ 1/2" HOLE	DS-0113-03-ZN	DS-0113-03-S6
	1 1/2" w/ 5/8" HOLE	DS-0113-04-ZN	DS-0113-04-S6

DESCRIPTION	SIZE	COMPLETE CATALOG NUMBER	
		ZN	S6
FLAT, ROUND WASHER	1/4"	DS-8598-01-ZN	DS-8674-01-S6
	3/8"	DS-8596-01-ZN	DS-8600-01-S6
	1/2"	DS-8595-01-ZN	DS-8657-01-S6
	5/8"	DS-8594-01-ZN	DS-8798-01-S6
HEX HEAD BOLT	1/4"-20 x 3/4"	DS-8502-01-ZN	DS-8720-01-S6
	1/4"-20 x 1"	DS-8502-06-ZN	DS-8720-09-S6
	1/4"-20 x 1 1/4"	DS-8502-08-ZN	DS-8720-02-S6
	1/4"-20 x 1 1/2"	DS-8502-10-ZN	DS-8720-10-S6
	3/8"-16 x 1 1/2"	DS-8520-05-ZN	DS-8694-05-S6
CARRIAGE BOLT	1/2"-13 x 1 1/2"	DS-8515-15-ZN	DS-8533-02-S6
	3/8"-16 x 1 1/2"	DS-8510-04-ZN	DS-8716-04-S6
	3/8"-16 x 2 1/2"	DS-8510-08-ZN	DS-8716-05-S6
	3/8"-16 x 3"	DS-8510-10-ZN	DS-8716-06-S6
	3/8"-16 x 3 1/2"	DS-8510-11-ZN	DS-8716-07-S6
	3/8"-16 x 4"	DS-8510-12-ZN	DS-8716-08-S6
J-BOLT	3/8"-16	DS-8937-01-ZN	N/A
BEAM CLAMP	FOR 1/4" ROD	DS-0221-01-ZN*	DS-0221-01-S6*
	FOR 3/8" ROD	DS-0221-04-ZN†	DS-0221-04-S6†
	FOR 1/2" ROD	DS-0221-06-ZN‡	DS-0221-06-S6‡

Safe Load: *750 lbs.; †1100 lbs.; ‡1600 lbs.

GO TO WWW.LEGRAND.US/CABLOFIL FOR COMPLETE SEISMIC CATALOG



Approved Fixed Equipment Anchorage
California Office of Statewide Health Planning and Development (OSHPD)
Based on CBC 2001 OPA-0619

City of Los Angeles Tested and Approved
For all mechanical, plumbing and electrical piping, conduit, equipment and systems—including fire sprinklers

SEISMIC Wire Rope/Cable™ BRACING
Break Strength Certified - Color Coded - Prestretched

SWAY BRACE LOCATIONS AND SPACING

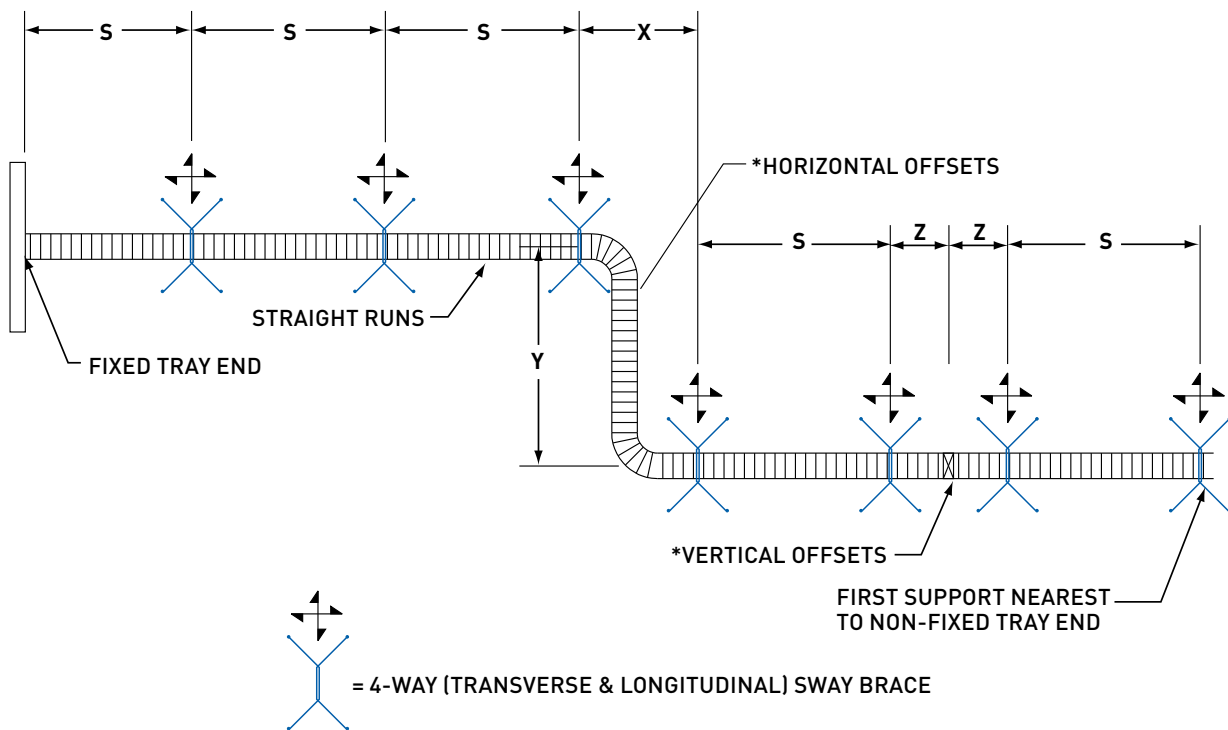

NOTES:

- (1) For horizontal offsets, a sway brace should be located at the cable tray support nearest to one end of the offset.
- (2) It is recommended that the max. Vertical offset without a sway brace be 30 feet and that the max. Spacing for sway braces on vertical trays should be 40 feet.

BRACED COMPONENT DESCRIPTION	MAXIMUM "S"	MAXIMUM "X" + "Y"	MAXIMUM "Z"
CABLE TRAY	40 FT.	40 FT.	5 FT.

Refer to specifications, LOOS & CO., INC. manual and tables for brace spacing, required brace locations, load calculations procedures, sizing, and allowable loads on brace assemblies and fasteners.



Approved Fixed Equipment Anchorage
California Office of Statewide Health Planning and Development (OSHPD)
Based on CBC 2001 OPA-0619

City of Los Angeles Tested and Approved
For all mechanical, plumbing and electrical piping, conduit, equipment and systems—including fire sprinklers

SEISMIC Wire Rope/Cable™ BRACING
Break Strength Certified - Color Coded - Prestretched

COMBINATION TRANSVERSE / LONGITUDINAL EARTHQUAKE SWAY BRACE FOR PW INDUSTRIES (DOUBLE RAIL) CABLE TRAY

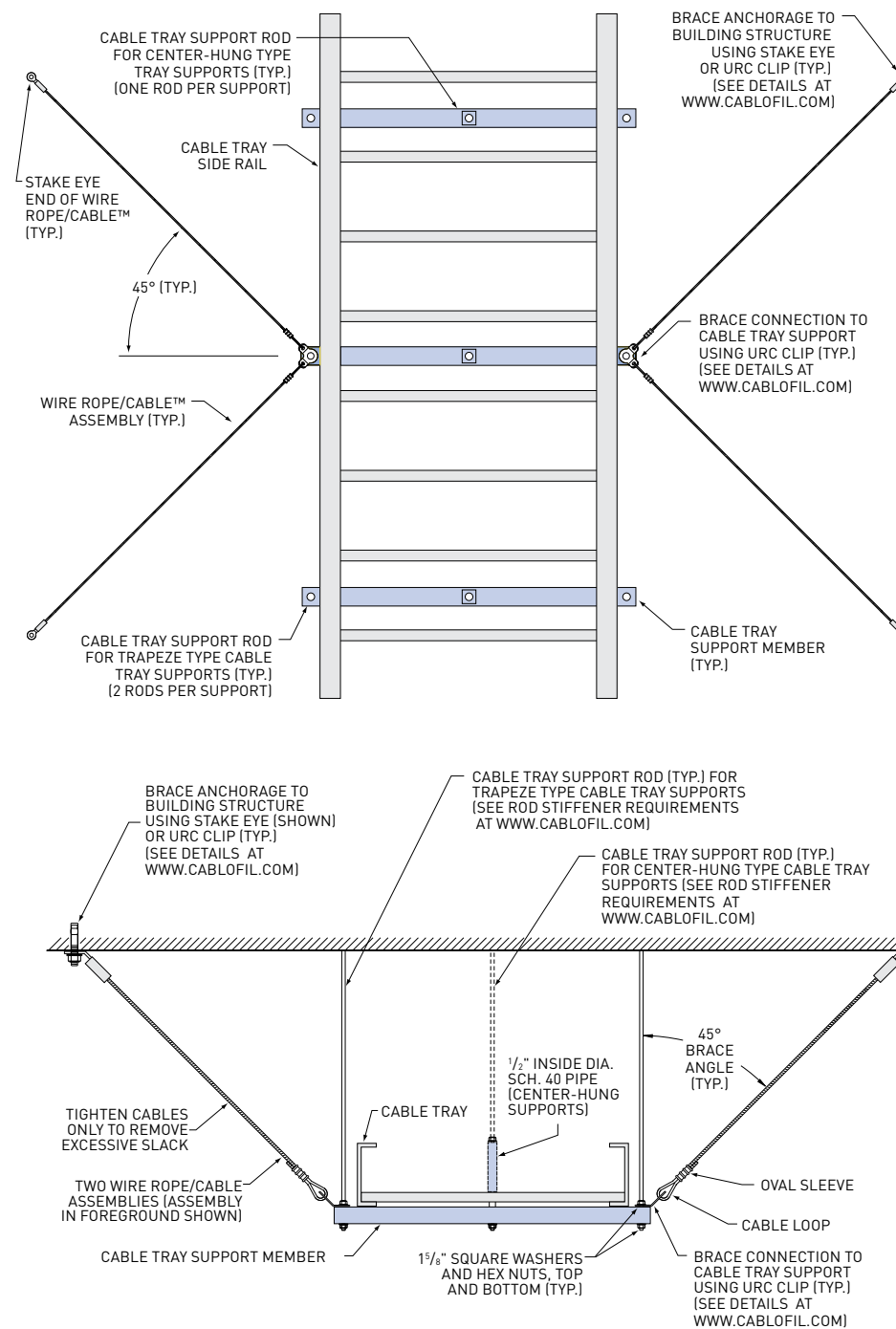

Refer to specifications, LOOS & CO., INC. manual and tables for brace spacing, required brace locations, load calculations procedures, sizing, and allowable loads on brace assemblies and fasteners.

GO TO WWW.LEGRAND.US/CABLOFIL FOR COMPLETE SEISMIC CATALOG

SEISMIC Wire Rope/Cable™ BRACING

Standard Part Numbers and Descriptions

4-WAY SEISMIC BRACING KITS



PW12-C25-7

Each kit includes:

- Four cables
- Two URC, URCR or NPC clips (optional)
- Four oval sleeves

COMPLETE CATALOG NO.	CABLE SIZE	BRACE LENGTH (FT.)	STAKE EYE HOLE DIA.* (IN.)
PW12-C25-7	12	7	3/8
PW12-C25-10	12	10	3/8
PW12-C25-20	12	20	3/8
PW18-C25-7	18	7	3/8
PW18-C25-10	18	10	3/8
PW18-C25-20	18	20	3/8
PW18-C26-7	18	7	1/2
PW18-C26-10	18	10	1/2
PW18-C26-20	18	20	1/2
PW36-C25-7	36	7	3/8
PW36-C25-10	36	10	3/8
PW36-C25-20	36	20	3/8
PW36-C26-7	36	7	1/2
PW36-C26-10	36	10	1/2
PW36-C26-20	36	20	1/2

*Hole dia. shown for stake eyes indicates the diameter of hardware to be used with the part Order PW-URC size separately

BULK WIRE ROPE/CABLE™



PW-12-CBL



PW-18-CBL



PW-36-CBL



PW-48-CBL

COMPLETE CATALOG NO.	CABLE SIZE	BOX QTY.	DESCRIPTION
PW-12-CBL	12	250	(1) 250' SPOOL OF RED #12 CABLE
PW-18-CBL	18	250	(1) 250' SPOOL OF WHITE #18 CABLE
PW-36-CBL	36	250	(1) 250' SPOOL OF BLUE #36 CABLE
PW-48-CBL	48	250	(1) 250' SPOOL OF YELLOW #48 CABLE

OVAL SLEEVES



COMPLETE CATALOG NO.	CABLE SIZE	BOX QTY.	DESCRIPTION
PW-12-SLV	12	100	(1) BOX OF 100 #12 OVAL SLEEVES
PW-18-SLV	18	100	(1) BOX OF 100 #18 OVAL SLEEVES
PW-36-SLV	36	100	(1) BOX OF 100 #36 OVAL SLEEVES
PW-48-SLV	48	50	(1) BOX OF 50 #48 OVAL SLEEVES

UNIVERSAL RESTRAINT CLIPS



COMPLETE CATALOG NO.	CABLE SIZE	HOLE DIA.	DESCRIPTION
PW-URC-1/4P	ALL	1/4"	URC FOR 1/4" FASTENERS
PW-URC-3/8P	ALL	3/8"	URC FOR 3/8" FASTENERS
PW-URC-1/2P	ALL	1/2"	URC FOR 1/2" FASTENERS
PW-URC-5/8P	ALL	5/8"	URC FOR 5/8" FASTENERS
PW-URC-3/4P	ALL	3/4"	URC FOR 3/4" FASTENERS
PW-URC-7/8P	ALL	7/8"	URC FOR 7/8" FASTENERS

SUPPORT ROD STIFFENER CLIPS

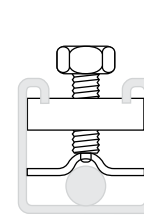

0602

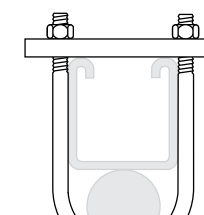

0603

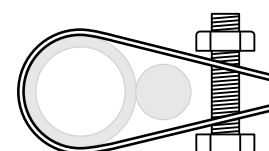

RS-1

PRODUCT NUMBER	TYPE	ROD SIZE
0602	STRUT	3/8"-5/8"
0603	STRUT	3/4"-1"
RS-1	PIPE	1/2"-1"

See page 110 for product details and requirements.

NO PRY CLIP



COMPLETE CATALOG NO.	CABLE SIZE	HOLE DIA.	DESCRIPTION
PW-NPC-1/4P	ALL	1/4"	URC FOR 1/4" FASTENERS
PW-NPC-3/8P	ALL	3/8"	URC FOR 3/8" FASTENERS
PW-NPC-1/2P	ALL	1/2"	URC FOR 1/2" FASTENERS
PW-NPC-5/8P	ALL	5/8"	URC FOR 5/8" FASTENERS
PW-NPC-3/4P	ALL	3/4"	URC FOR 3/4" FASTENERS
PW-NPC-7/8P	ALL	7/8"	URC FOR 7/8" FASTENERS

ASSEMBLY TOOLS

COMPLETE CATALOG NO.	DESCRIPTION
PW-1-3-SBHS	(1) LOCOLOC HAND SWAGER FOR CRIMPING OVAL SLEEVES
PW-1-SBHS	(1) LOCOLOC LARGE SWAGER FOR CRIMPING OVAL SLEEVES

The Locoloc® Hand Swager IS THE CORRECT TOOL FOR THE JOB. It is capable of crimping all three sizes of oval sleeves for the braces in this manual. These tools are factory calibrated and are furnished with gauges and instructions to insure the proper crimping of oval sleeves. The Locoloc® Hand Swager is 26 inches long and weighs 6.5 pounds.

PW-C7	(1) FELCO CABLE CUTTER FOR #12 AND #18 CABLES
PW-C9	(1) FELCO CABLE CUTTER FOR #12, #18 AND #36 CABLES
PW-C11	(1) FELCO CABLE CUTTER FOR #12, #18, #36 AND #48 CABLES



PW-1-3-SBHS



PW-1-SBHS



PW-C7



PW-C9/C11

The Felco type C-7 and type C-9 Precision Cable Cutters are ideal for cutting and trimming excess cable. The C-7 cutter is 8 inches long, weighs 10 ounces and is used to cut size 12 and 18 cables with one hand. The type C-9 cutter is a two-handed tool that cuts all three cable sizes with ease.

GO TO WWW.LEGRAND.US/CABLOFIL FOR COMPLETE SEISMIC CATALOG



Approved Fixed Equipment Anchorage
California Office of Statewide Health Planning and Development (OSHPD)
Based on CBC 2001 OPA-0619

City of Los Angeles Tested and Approved
For all mechanical, plumbing and electrical piping, conduit, equipment and systems—including fire sprinklers

SEISMIC Wire Rope/Cable™ BRACING

Break Strength Certified - Color Coded - Prestretched

SUPPORT ROD STIFFENER DETAILS AND REQUIREMENTS (AT SWAY BRACE LOCATIONS ONLY)

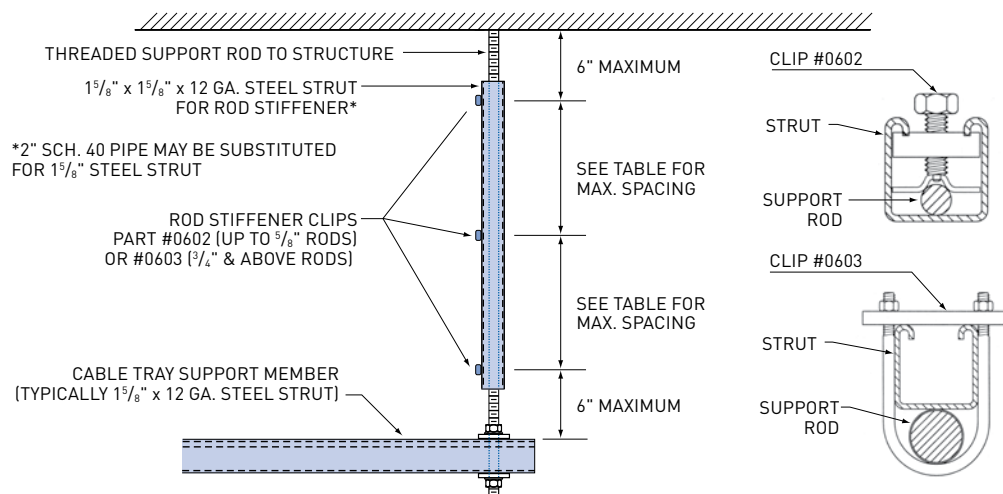

MAXIMUM ROD LENGTH WITHOUT STIFFENER	
ROD DIA.	MAXIMUM LENGTH
3/8"	16
1/2"	22
5/8"	28
3/4"	34
7/8"	40
1"	46

MAXIMUM SPACING OF ROD STIFFENER CLIPS	
ROD DIA.	MAXIMUM SPACING
3/8"	13
1/2"	18
5/8"	23
3/4"	28
7/8"	33
1"	38

1. Maximum allowable length of 1 5/8" x 1 5/8" x 12 ga. steel strut for rod stiffener is 9'-0".
2. For support rods 9'-1" to 13'-1", sleeve the support rod with 2" schedule 40 pipe.
3. For multi-tier support systems, the steel strut rod stiffener shall be installed such that it be secured to the side of the bottom support member, in contact with the structure, and held in position by securing to the side of one other horizontal support member, using the rod stiffener clips shown above.

SAMPLE DETAILS OF CABLE BRACE ANCHORAGE TO STRUCTURE FOR CABLOFIL CABLE TRAY

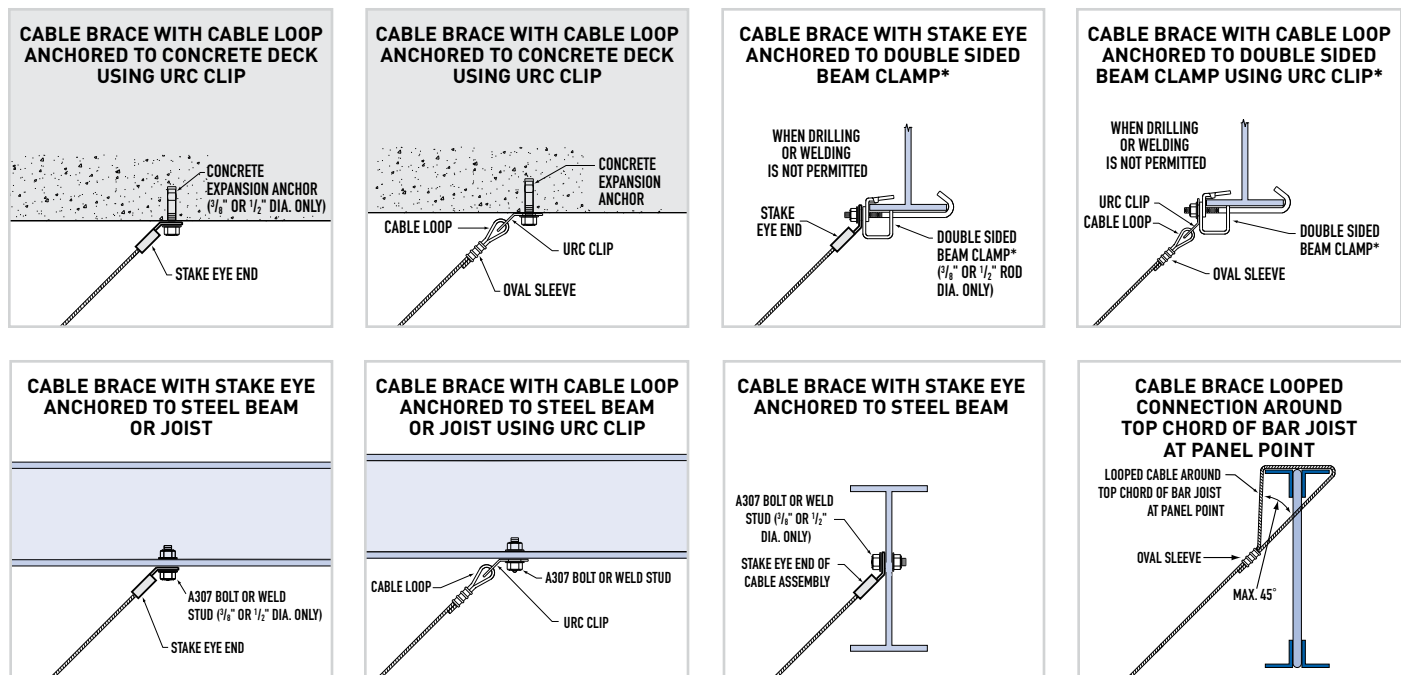

[*MIN. CLAMP ROD DIA. PER COL. 'B' OF BRACING TABLES]

NOTE: Refer to specifications, LOOS & CO., INC. manual and tables for brace spacing, required brace locations, load calculations procedures, sizing, and allowable loads on brace assemblies and fasteners.

PW — by Product Description

ITRAY ALUMINUM TRAY

Straight Sections 10

Fittings

90HB Horizontal 90° Elbow 12

60HB Horizontal 60° Elbow 12

45HB Horizontal 45° Elbow 13

30HB Horizontal 30° Elbow 13

SR / LR / RR Horizontal Reducers 14

HT Horizontal Standard Tee 14

RT / ET Horizontal Reducing/ Expanding Tees 15

YL / YR Horizontal Wye Branches 16

RX Horizontal Reducing Cross 16

HX Horizontal Standard Cross 16

90VO Vertical Outside 90° Elbow 17

45VO Vertical Outside 45° Elbow 17

60VO Vertical Outside 60° Elbow 17

30VO Vertical Outside 30° Elbow 17

90VI Vertical Inside 90° Elbow 18

45VI Vertical Inside 45° Elbow 18

60VI Vertical Inside 60° Elbow 18

30VI Vertical Inside 30° Elbow 18

TD / TU Vertical Tees 19

VX Vertical Cross 19

CS Vertical Cable Support Elbow 19

Covers & Cover Connectors

SFF / LFF / SPF Covers 20

FCC Flat Cover Connector 21

PCC Peaked Cover Connector 21

Accessories

SSP Straight Splice Kit 22

USP Universal Splice Kit 22

EXSP Expansion Splice Kit 22

FSP Fitting Splice Kit 22

USPB Universal Blank Splice Kit 22

VHSP Vertical Hanger Splice Kit 22

90SP 90° Connector Splice Kit 23

HASP Horizontal Adjustable Splice Kit 23

SRSP Straight Reducer Splice Kit 23

FFSP Floor Flange Splice Kit 23

VASP Vertical Adjustable Splice Kit 23

ORSP Offset Reducer Splice Kit 23

RHSP Reducing Height Splice Kit 24

DO Drop Out Kit 24

CCLMP Cable Clamp 24

TBC Tray-To-Box Connector (Frame Type) 24

BE Blind End Kit 24

DIV Vertical Elbow Dividers 24

OCC Outdoor Conversion Kit 25

WPS Wall Penetration Sleeve 25

FWPS Fire Wall Penetration Sleeve 25

LADDER, TROUGH & SOLID BOTTOM SYSTEMS—METALLIC

Straight Sections

Long-Span 26

Steel 28

Stainless Steel 30

Fittings

Horizontal 90° Elbow 32

Horizontal 60° Elbow 32

Horizontal 45° Elbow 33

Horizontal 30° Elbow 33

Horizontal Reducers 34

Horizontal Standard Tee 34

Horizontal Reducing/ Expanding Tees 35

Horizontal Crosses 36

Horizontal Wye Branches 37

Horizontal Adjustable Elbow 37

Vertical Outside 90° Elbow 38

Vertical Outside 45° Elbow 38

Vertical Outside 60° Elbow 38

Vertical Outside 30° Elbow 38

Vertical Inside 90° Elbow 39

Vertical Inside 45° Elbow 39

Vertical Inside 60° Elbow 39

Vertical Inside 30° Elbow 39

Vertical Tees 40

Vertical 90° Support Elbow 40

Vertical Cross 40

Cable Support Hook 40

Covers & Cover Connectors

Covers 42

Flat Cover Connectors 43

Peaked Cover Connectors 43

Cover Connector Clips 44

Raised Cover Connector 44

H-Binder Cover Joint Clip 44

Raised Cover Connector 44

Accessories

Standard Splice 45

Universal Splice 45

Mid-Span Splice 45

Reducing Height Splice 45

Expansion Splice 46

Offset Reducer Splice 46

Straight Reducer Splice 46

90° Connector 46

Floor Flange/Tray-to-Box Connector 47

Vertical Adjustable Splice 47

Vertical Hanger Splice 47

Horizontal Adjustable Splice 47

Tray-to-Box Frame Connector 47

Bonding Jumpers 48

Splice Fasteners 48

Straight Horizontal Divider 49

Flexible Horizontal Divider 49

Vertical Fitting Divider 49

Divider Hold Down Clip 50

Divider Splice 50

5" Vinyl Divider Splice 50

Self-Drilling Screw 50

Blind End Plate 51

Wall Penetration Sleeve 51

Cable Dropout 51

Outdoor Conversion for Wall Penetration 51

Expansion Guide 53

Hanger Brackets 53

Single Overhead Hanger Clamp 53

Nylon Isolation Pad 53

Single Hanger Channel 54

Double Hanger Channel 54

Center Hanger Channel 54

Wall Bracket 55

Double Strut Bracket 55

Single Strut Bracket 55

Heavy-Duty Strut Bracket 55

Cable Clamp 56

Cable Tray Grounding Clamp 56

Ground Wire Attachment Clamp 56

Conduit Bracket Clamp 56

Conduit Plate Clamp 56

Clamp Bracket 57

Maple Cable Blocks 57

Slip-On Lock Nut 57

Plastic Safety Sign 57

Installation Fasteners 57

Fire Wall Penetration Sleeve 58

Reference Information

Metals 60

Finishes 60

Thermal Contraction/Expansion 61

Cable Tray Side Rails 62

Rung Options 63

Tray Labels 69

Fabrication Options/ Engineering Services 69

LADDER & SOLID BOTTOM SYSTEMS—FIBERGLASS

Straight Sections 71

Fittings

Horizontal 90° Elbow 72

Horizontal 60° Elbow 72

Horizontal 30° Elbow 72

Horizontal Straight Reducer 73

Horizontal Left Hand Reducer 73

Horizontal Right Hand Reducer 73

Horizontal Tee 74

Horizontal Cross 74

Vertical Inside Elbows 75

Vertical Outside Elbows 75

Vertical Tees 75

Vertical Cross 75

Covers & Cover Connectors

Covers 76

Flat Cover Connectors 76

Peaked Cover Connector 76

Drive Rivet 76

Raised Cover Connector 76

Accessories

Standard Splice 77

Horizontal Adjustable Splice 77

Tray-to-Box Connector 77

Expansion Splice 77

Vertical Adjustable Splice 77

Horizontal Angled Coupler 77

90° Connector 77

Vertical Hanger Splice 77

Vertical Angled Coupler 77

Additional Rung 78

Divider Strips 78

Blind End Plate 78

Cable Dropout 78

Thermoplastic Drive Rivet 78

Hold Down Clip 78

Field Cutting Sealant 78

Expansion Guide Clamp 79

Support Brackets 79

Hold Down Clamp 79

Z-Hold Down Clamp 79

Trapeze Hanger Support Kit (Standard Duty) 79

CENTER SPINE SYSTEMS

Straight Sections

CS Center Spine Single Tier 82

WS Wall Spine Single Tier 82

CSDT Center Spine Double Tier 83

WSDT Wall Spine Double Tier 83

Fittings & Connectors

CSVC Splice Connector 84

CSFT Field Tee 84

CSHPR Horizontal Pivot Connector with Rung 84

CSVP Vertical Pivot Connector 84

CSCP Conduit Connector 84

CSHP Horizontal Pivot Connector 84

CSFC Field Cross 84

CSRA Fiberready 2" Radius Rung Adapter 84

CSFLT Flo-thru Cross Tee 84

CSTW Tray-to-Wall Connector End Cap 84

CSJH J Rung 85

CSDO Fiber Ready Cable Dropout 85

CSHB Hanger Bracket 85

CSSB Stiffener Bar 85

CSGH G Rung 85

CSFS Floor Support Bracket 85

CSDS Divider Strip 85

CSEB Blind End 85

CSTB Tray-to-Box Connector 85

Reference Information

Load Tables 86

Technical Data 87

CHANNEL SYSTEMS—METALLIC

Straight Sections 89

Cover & Cover Connector 89

Fittings

Horizontal 90° Elbow 90

Horizontal 45° Elbow 90

Horizontal 60° Elbow 90

Horizontal 30° Elbow 90

Vertical 90° Elbow 91

Vertical 45° Elbow 91

Vertical 60° Elbow 91

Vertical 30° Elbow 91

Horizontal Tee 92

Horizontal Cross 92

Accessories

Cable Dropout 92

Blind End Plate 92

Standard Splice 93

Channel-to-Tray Connector 93

Channel-to-Box Connector 94

Channel-to-Floor Base Plate 94

Overhead Hanger Bracket 93

Horizontal Adjustable Splice 93

Mounting Bracket 93

Vertical Adjustable Splice 93

Vertical Hanger Splice 94

Hold Down Clamp 94

Expansion Guide Clamp 94

Wall Bracket 94

Hold Down/Cover Clamp 94

Slip-On Lock Nut® 95

Fiberglass Encapsulated Stainless Steel Hex Bolt/Nut 95

CHANNEL SYSTEMS—FIBERGLASS

Straight Sections 96

Fittings

Horizontal Elbows 96

Horizontal Tee 97

Horizontal Cross 97

90° Vertical Elbows 97

45° Vertical Elbows 97

CABLE RUNWAY

Straight Sections 99

Fittings

90° Horizontal Elbow 100

90° Vertical Inside Elbow 100

90° Vertical Outside Elbow 100

Connectors & Accessories

Splice 100

90° Horizontal Connector 100

90° Vertical Connector 100

45° Vertical Connector 101

Cable Dropout 101

Cable Retaining Posts 101

Floor/Wall Support Bracket Kit 101

Vertical Wall Bracket 101

L-Bracket 101

Bonding Jumper—#1 Copper 101

Protective End Cap 101

Wall Angle Support Kit 102

Wall Bracket 102

Ceiling Support Bracket 102

Side Rail Support Bracket 102

Center Hung Support Kit 102

Trapeze Support Kit 102

Slotted Support Bracket 102

Installation Fasteners 103

SEISMIC BRACING SYSTEMS

Technical Data 104

4-Way Seismic Bracing Kits 108

Bulk Wire Rope/Cable™ 108

CSEB Blind End 109

Oval Sleeves 109

Universal Restraint Clips 109

Support Rod Stiffener Clips 109

No Pry Clip 109

Assembly Tools 109

SEISMIC BRACING

INDEX



©2013 Legrand - All Rights Reserved CAB_CAT_PW_0613

designed to be better.™



Electrical Wiring Systems

8319 State Route 4
Mascoutah, IL 62258
800.658.4641
www.legrand.us/cablofil

570 Applewood Crescent
Vaughan, Ontario L4K 4B4
905.738.9195
www.legrand.ca

