

Cable Tray

CT-16

B-LINE
SERIES

Cable tray systems



EATON

Powering Business Worldwide



Energizing a world that demands more.

Discover today's Eaton.

Powering business worldwide

As a global power management company, we help customers worldwide manage the power needed for buildings, aircraft, trucks, cars, machinery and businesses.

Eaton's innovative technologies help customers manage electrical, hydraulic and mechanical power more reliably, efficiently, safely and sustainably.



EATON

Powering Business Worldwide



We deliver:

- **Electrical solutions** that use less energy, improve power reliability and make the places we live and work safer and more comfortable
- **Hydraulic and electrical solutions** that enable machines to deliver more productivity without wasting power
- **Aerospace solutions** that make aircraft lighter, safer and less costly to operate, and help airports operate more efficiently
- **Vehicle drivetrain and powertrain solutions** that deliver more power to cars, trucks and buses, while reducing fuel consumption and emissions

We provide integrated solutions that help make energy, in all its forms, more practical and accessible.

With 2015 sales of \$20.9 billion, Eaton has approximately 100,000 employees around the world and sells products in more than 175 countries.



Eaton's electrical business

Eaton is a global leader with expertise in:

- Power distribution and circuit protection
- Backup power protection
- Solutions for harsh and hazardous environments
- Lighting and security
- Structural solutions and wiring devices
- Control and automation
- Engineering services

Eaton is positioned through its global solutions to answer today's most critical electrical power management challenges. With 100 years of electrical experience behind us, we're energized by the challenge of powering up a world that demands twice as much energy as today. We're anticipating needs, engineering products and creating solutions to energize our markets today and in the future.

We are dedicated to ensuring that reliable, efficient and safe power is available when it's needed most.

Eaton.com

CoSPEC, the Specifier Center, is designed to help you easily SELECT, VIEW and DOWNLOAD B-Line series product design content in any one of nearly one hundred non-proprietary and proprietary CAD, BIM, PDMS, and graphics formats, which helps speed the integration of the content into your design project.

Features

- Easy integration and configuration
- Comprehensive library of 2D drawings and 3D models for CAD, BIM, PDMS, SP3D, and graphics output
- The most up to date software versions and product data information are always available
- Submittals and specification sheets in PDF format
- Proprietary file format outputs are native to the chosen software

Nearly a Hundred Download Options

- Aveva PDMS and Intergraph SmartPlant SP3D (on select products) content
- Autodesk Revit output available
- Proprietary formats from AutoCAD to SolidWorks to Catia
- Non-proprietary formats like DXF and STEP, and more
- Graphics files in a number of formats including EPS

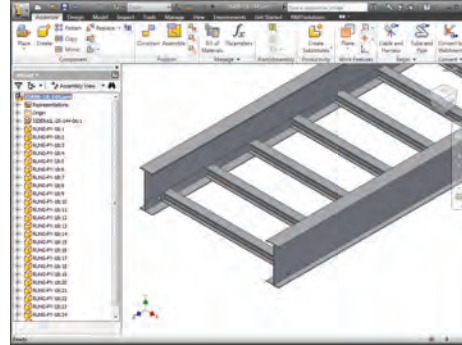

To get started planning your next project, visit www.cooperblineline.com/CoSPEC

Select



View



Download

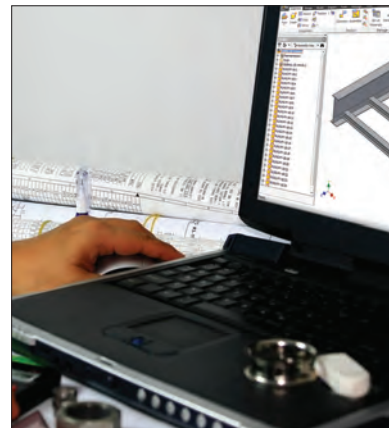

Co-SPEC B-Line series Specifier Center - Available Outputs

2D Native	2D Neutral & Graphics	3D Native	3D Neutral
<ul style="list-style-type: none"> • Allplan 2008 • AutoCAD >=V14 • Cadkey CDL >=V19 • Catia IUA - V4 • HP ME 10 >=V9 • Medusa >=2000i • Microstation (DGN) >=V8 • SolidEdge >=V17 • VX (Varimetrix) >=V5.0 	<ul style="list-style-type: none"> • BMP (2D & 3D View) • DWF-ASCII 5.5, Binary 5.5 and Compressed 5.5 • DWG >=V14 • DXF-V12/HPGL-V2 • IGES >=V5.0 • JPEG (2D & 3D Views) • Metafile 2D-V1, & PS2-V2 • MI >=V8 • PDF Datasheet • Postscript EPS • SVG • TIFF (2D & 3D View) 	<ul style="list-style-type: none"> • Autodesk 3D Studio MAX • Allplan = 2008 • AutoCAD >=V14 • AVEVA PDMS/Marine (Equipment Spec) • Caddy++ via SAT-V4.2 • Catis >=V5 R8 and IUA-V4 • EMS • Google SketchUp • Autodesk Inventor >=R5.3, R10, R11 • Mechanical Desktop >=V5 • Nupas/Cadmatic • One Space Modeling >=2007 • Pro/E Wildfire >=1 • PRO-Desktop • Autodesk Revit >= 2009* (coming soon) • SolidEdge >=V17 • SolidWorks >=2001+ • Think3 >=2006.2 • Tribon M3 • Unigraphics >=NX3 • VX (Varimetrix) >=V5 	<ul style="list-style-type: none"> • CIP • DWG >=V14 • DXF V14 • IGES • JT • Metafile 3D (PS3)-V2 • Parasolid-Binary V15 and Text V15 • PDF 3D-7.01 • SAT - V2.0 through V6.0 • STEP-AP203, AP215a & AP214b • STL • U3D (Universal 3D) • VRML >=V1.0 • XGL

To get started, visit www.cooperblineline.com/CoSPEC

Don't Leave Your Seismic Compliance To Chance

Rely on Eaton's B-Line series support from pre-bid to inspection

Pre-Bid To System Design Support

Codes and requirements differ from location per project. Eaton's B-Line series seismic experts understand the codes and can help support customers in the pre-bid process. In fact, the earlier our customers engage us in the process, the earlier we can start reviewing the project to provide a solution that complies with the building code and project specifications.

Our knowledgeable team will also work to find the lowest installed cost solution through the utilization of our labor-saving seismic bracing products.

Advantages

- 45+ years of seismic bracing experience
- Lowest total installed cost solution
- Knowledgeable seismic engineers and staff
- Professional engineer certification
- Project management assistance
- Patented Tolco™ seismic bracing products
- Products that meet or exceed codes & certifications
 - OSHPD Approval
 - NFPA
 - UL Listed
 - FM Approved
- One-source solution for seismic bracing, cable tray, pipe hangers, vibration isolation, strut systems and fasteners

Services

- Detailed review of project requirements
- Complete quote of products and services
- Structural engineering recommendations
- Seismic force calculations
- Seismic restraint layout for utilities
- BIM modeling
- Seismic layout designs
- Point of load analysis ("halo drawing")
- Full submittal package for final approval
- Plan revisions as needed

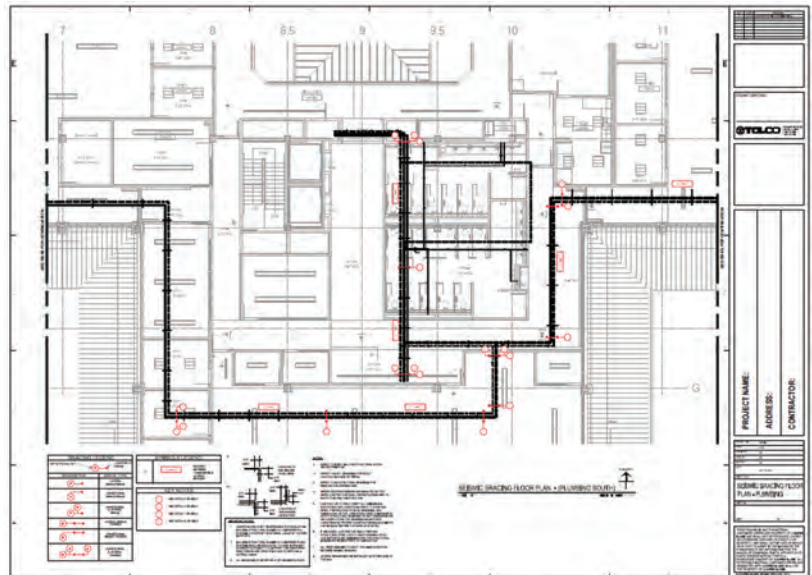

Seismic Solutions for Cable Tray

Product & Installation Support

Eaton's B-Line series seismic experts will work to establish the lowest total installed cost, so that customers can know that they have the right products at the right time for their installation and inspection.

B-Line series Tolco seismic bracing products inherent labor and time-saving features are designed to help speed the process of installation. Many of the Tolco seismic bracing products allow for universal applications, reducing the number of SKUs required on the job-site. And with built-in visual verification features of the Tolco seismic bracing products, the installer can be assured that they have properly installed the product, and inspectors can easily be assured of correct installation torque without the use of a torque wrench.

Features

- Universal application reduce the number of SKUs on the job-site
- Visual verification feature helps ensure proper installation and inspection
- Patented labor and time-saving Tolco seismic bracing products
- One-source solution for seismic bracing, cable tray, pipe hangers, vibration isolation, strut systems and fasteners

Services

- Installation manuals
- Detailed drawings and layouts
- Packaged and labeled products for room to room / floor to floor installation
- Project management assistance
- Sales engineer job-site visits

Trapeze Cable Brace Details

ALLOWABLE ASSEMBLY LOAD (WORLD SEISMIC) CABLE TRANS LONG 1/8" 689 - 3/16" 1469 - 1/4" 2227 -	TRANSVERSE CABLE BRACING FOR TRAPEZE SUPPORTED ELECTRICAL CABLE TRAY	DETAIL 15
--	--	--------------

SEE SECTION 11 FOR STRUCTURAL ATTACHMENTS FOR HANGER AND BRACE ANCHORAGE

NOTES:
 1.) SEE PAGE 8 - 24 FOR OPTIONAL AND/OR ADDITIONAL BRACE CONFIGURATIONS.

ZUBAIR SHEIKH
Structural Engineer S 4039

COOPER B-Line | **TOLCO**

1375 Sampson Avenue • Corona, CA 92879
 Phone: 951-737-5599 • Fax: 951-737-0330

December 1, 2012

Page No.
8-7

Inspection And After Sale Support

Eaton's B-Line series seismic experts are available before, during and after the sale. At the most critical point of the project, Eaton is available to support the project with on-site visits and inspection support.

Advantages & Service

- Certified installations
- Visual verification features help ensure proper installation
- Sales engineer job-site visits
- Project management support
- Peace of mind

Additional Resources

- CoSPECSM Specifier Center
- TOLBraceTM software for fire protection seismic bracing
- OSHPD approval catalogs
- Website: www.tolco.com



Simply contact us at tolcosupport@eaton.com

No matter what stage you are in your project, Eaton is available to assist from pre-bid to inspection. All we need is for you to contact us and we can help you step by step.

- Phone: 800-851-7415
- Fax: 618-654-1917
- Support: TolcoSupport@Eaton.com
- Quotes: SeismicQuotes@Eaton.com

For more information on cable tray seismic bracing solutions, please refer to our seismic bracing catalog, and the State of California OSHPD Pre-Approved Seismic Restraint Guidelines OPM-0052. These resources and other valuable information can be found online at www.cooperbline.com/tolco.



Manufacturers Standardization Society
of the Valve and Fitting Industry, Inc.



ISO 9001:2008



Minimizing design time and associated costs



The latest version of TrayCAD is intended to minimize design time and associated costs. The software easily incorporates B-Line series cable tray systems into a construction drawing.

The free software is compatible with the latest versions of AutoCAD®† and allows any user to create a 3-Dimensional representation of a cable tray system. Once a user is finished with any design, the software has the ability to generate a full bill of materials for the cable tray system and will completely eliminate the need for costly estimation services.

Features

- Utilizes accurate 3D models of B-Line series cable tray components
- Easily configure any style of B-Line series cable tray
- Quickly construct a cable tray in seconds
- Develop a full cable tray bill of materials (BOM):
 - Straight Sections
 - Fittings
 - Accessories (covers, cover clamps, hold down clamps, expansion splices)
- Easily export BOM to spreadsheet format
- Compatible with the latest versions of AutoCAD
- Free download from Eaton's website



View the completed design in 3D orbit.

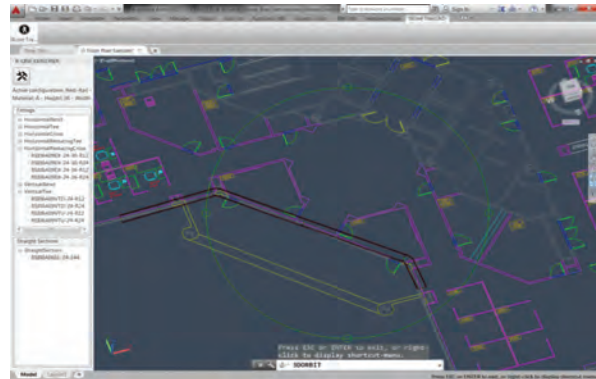

To get started planning your next project, visit www.cooperbline.com

† Mark shown is property of respective owner

For over 50 years, Eaton has been the leader in B-Line series cable management systems. Today, we have state of the art manufacturing facilities to support our customers around the globe. This coupled with our knowledgeable customer service, sales and sales engineering team, we are positioned to support cable management requirements from small to large scale commercial, industrial, and datacomm applications.

Eaton's Cable Management Systems Manufacturing Locations

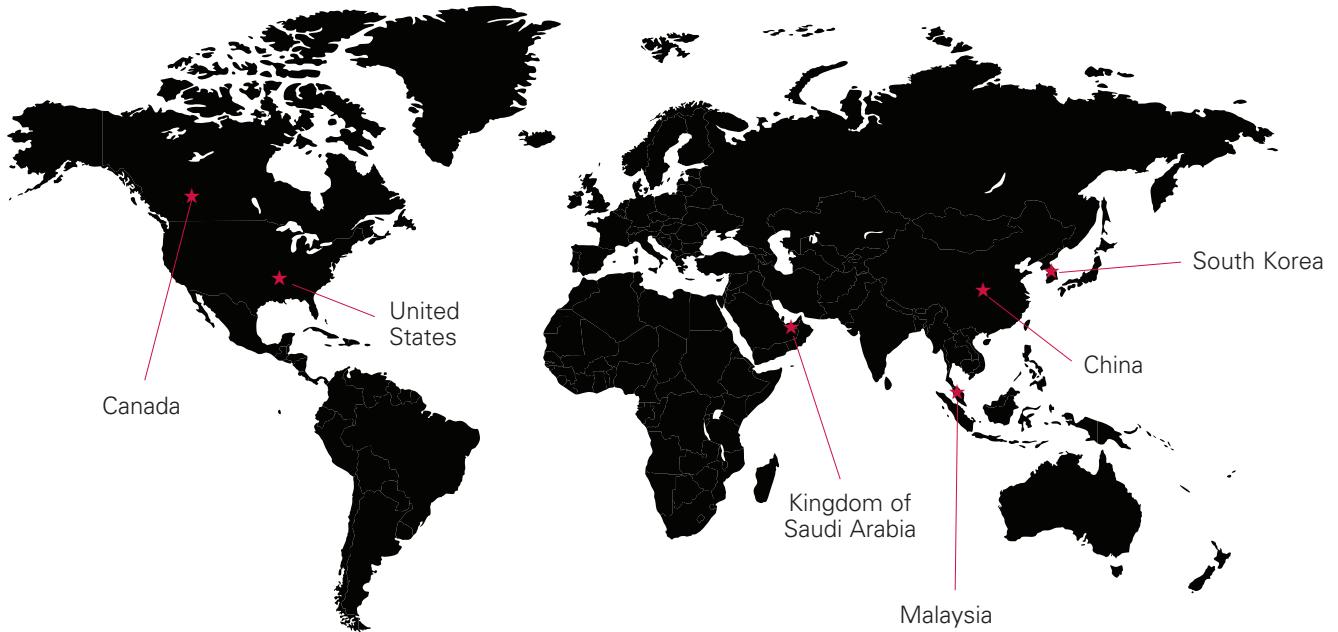

For more information, visit www.eaton.com/b-lineseries.



B-Line series cable trays conform to the requirements of IEC Standard 61537, 2006 Ed.



Important notice: No warranty, either expressed or implied, is made as to either its applicability to or its compatibility with specific requirements of this information, nor for damages consequential to its use. All design characteristics, specifications, tolerances and similar information are subject to change without notice.

NOTICE

Eaton reserves the right to change the specifications, materials, equipment, prices or the availability of products at any time without prior notice. While every effort has been made to assure the accuracy of information contained in this catalog at the time of publication, Eaton is not responsible for inaccuracies resulting from undetected errors or omissions.

Section Guide

Section TC
Table of Contents

Section A
Cable Tray Information

Section B
B-Line Series About Us

Section C
Cable Tray Selection

Sections TC, A, B, C

FLEXTRAY™ System

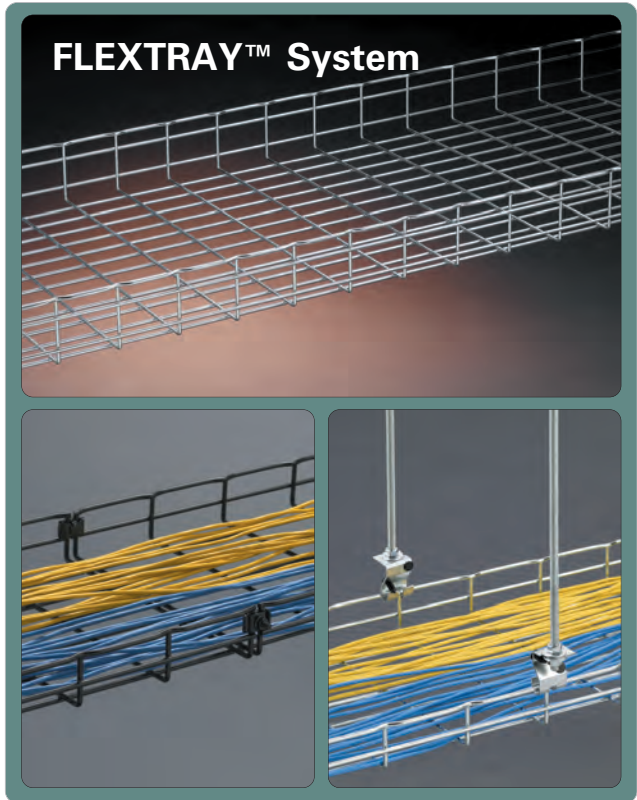

Section D

Channel
Cable
Tray



Section E

REDI-RAIL™ System



Section F



Section G



Section H



Section I



Section J



Section K



Section L

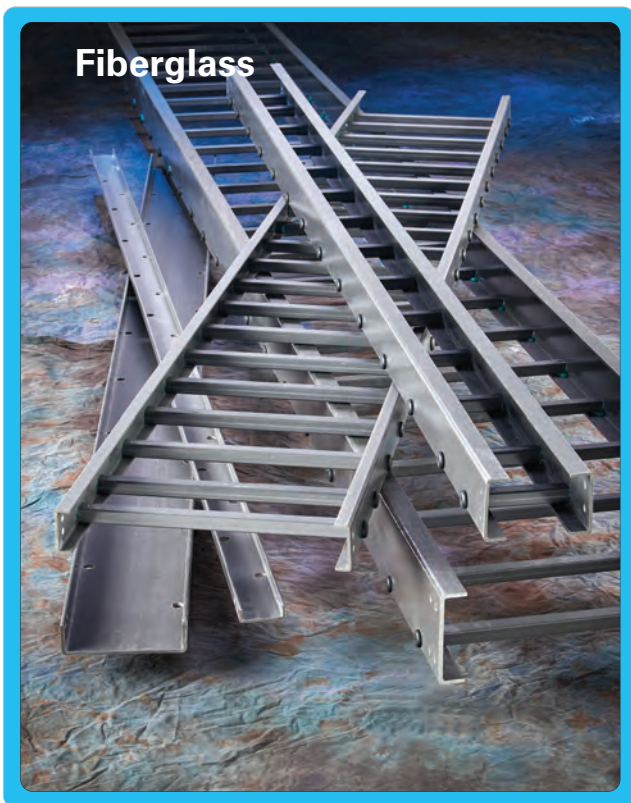

Section M



Section N



Section O

Appendix

Appendix - Bottom Design Options

These options are in addition to the Standard Ladder Rungs, Ventilated Trough and Solid Trough type Cable Trays.

Marine Rung (Available in Aluminum, HDGAF Steel and Stainless Steel)

- Designed for Series 1 and Series 2-5 systems.
- Special rung design to accommodate stainless steel banding of cables (U.S. Coast Guard requirement with 43P x 70P slots).
- Has applications on land, vertical installation, any location where extra cable positioning/attachment is required.
- Strut orientation may be channel opening up, channel opening down, or alternating - standard is alternating unless specified otherwise.
- New design provides combination of strut fastening and marine rung fastening.

Examples: 46A12MR-36-288 or 46G12MR-36-288

*"MR" Strut rung on 12" centers with channel opening down (Note: replace "DN" with "UP" for channel opening up.)

Special Rung Spacings: 4" & 18" rung spacing available upon request.

Non-Ventilated

- Solid flat sheet welded into the Cable Tray above the rungs.
- Standard rung spacing is 12 inches.
- The flat sheet may be installed under the rungs, if preferred.
- The flat sheet may be installed over B54 rungs "slot down".

Examples: 24ASB-36-144
Flat sheet bottom over standard rung on 12" spacing.
24ASB54-36-144
Flat sheet bottom over B54 strut rung slot down on 12" spacing.

Eaton **APP-1** B-Line series Cable Tray Systems

Section APP

Cable Tray Manual

2014

CABLE TRAY MANUAL

Based on the
2014 National Electrical Code®

© Mark shown is the property of its respective owner.

B-Line series Cable Tray Systems **MAN-1** Eaton

Section MAN

Index

Index - Straight Sections

Cable Tray Straight Sections			
Catalog No.	Page	Catalog No.	Page
REDI-RAIL™ only Example: RSI 06A 09 SL - 12 - 120 Series: 06, 09, SL, 12, 120 Height/Material: 09, SL Rung Spacing/Bottom: 12, 120		Aluminum Examples: 24 A 12 - 24 - 144 Series: 24, 12, 24, 144 Material: A Rung Spacing: 12, 24	
REDI-RAIL™ Aluminum Cable Tray RSI04A SL - 3 - 3 F-3 RSI05A SL - 3 - 3 F-3 RSI06A SL - 3 - 3 F-4 RSI07A SL - 3 - 3 F-4 A = Aluminum		Series 2, 3, 4, & 5 Aluminum Cable Tray 24A SL - 3 - 3 I-3 & I-4 25A SL - 3 - 3 I-5 & I-6 26A SL - 3 - 3 I-7 & I-8 34A SL - 3 - 3 I-3 & I-4 35A SL - 3 - 3 I-5 & I-6 36A SL - 3 - 3 I-7 & I-8 37A SL - 3 - 3 I-9 & I-10 46A SL - 3 - 3 I-7 & I-8 47A SL - 3 - 3 I-9 & I-10 57A SL - 3 - 3 I-9 & I-10 H46A SL - 3 - 3 I-7 & I-8 H47A SL - 3 - 3 I-9 & I-10 S8A SL - 3 - 3 I-11 A = Aluminum	
KwikSplice™ only Example: KS A 4 A 09 - 12 - 144 Series: 4, A, 09, 12, 144 NEMA Class: A Height: 09 Material: A		Steel, Stainless Steel Examples: 148 + 12 - 24 - 144 Series: 148, 12, 24, 144 Material: + Rung Spacing: 12, 24	
KwikSplice™ Aluminum Cable Tray KSA SL - 3 - 3 G-3 & G-4 KSB SL - 3 - 3 G-5 & G-6		Series 1 Steel Cable Tray 148 G SL - 3 - 3 H-3 148 P SL - 3 - 3 H-3 156 G SL - 3 - 3 H-4 156 P SL - 3 - 3 H-4 166 G SL - 3 - 3 H-5 166 P SL - 3 - 3 H-5 176 G SL - 3 - 3 H-6 176 P SL - 3 - 3 H-6 G = Hot Dipped Galvanized Steel P = Pre-Galvanized Steel	
		Series 2, 3, 4, & 5 Stainless Steel Cable Tray 348SS4 SL - 3 - 3 K-3 348SS5 SL - 3 - 3 K-3 388SS4 SL - 3 - 3 K-4 388SS5 SL - 3 - 3 K-4 388SS4 SL - 3 - 3 K-5 388SS5 SL - 3 - 3 K-5 464SS4 SL - 3 - 3 K-5 464SS5 SL - 3 - 3 K-5 E54 = Stainless Steel 304 S56 = Stainless Steel 316	

Eaton **IDX-1** B-Line series Cable Tray Systems

Section IDX

Table of Contents

Cable Tray Information	
General Information	A-1 & A-2
Tray Selection Charts	A-3 – A-6
Cable Tray System	A-7

Cable Tray Information

About Us	
The Company	B-1
The Product	B-2 & B-3
The Extras	B-4

About Us

Cable Tray Selection	
Selection Process	C-1
Materials and Finishes	
Material Standards	C-2
Finish Standards	C-3
Coatings	C-4
Corrosion	C-5 – C-7
Thermal Contraction & Expansion	C-8
Installation Considerations (Electrical Grounding)	C-9
Strength	
Environmental Loads	C-10 & C-11
Support Span	C-12
Deflection	C-13
Load Capacity	
(NEMA & CSA Load Classes)	C-14 & C-15
Cable Data	C-16
Width and Depth Cable Fill Per 1999 NEC 318	C-17 & C-22
Straight Section Length	C-23
Loading Possibilities	C-24
Bottom Type	C-25
Fitting Bend Radius	C-25

Cable Tray Selection

FLEXTRAY™ Wire Basket	
Finishes	D-3
Load & Fill Charts	D-4
Straight Sections	D-5 & D-6
Splicing Accessories	D-8 – D-16
Ceiling Support Methods	D-18 – D-24
Wall Support Methods	D-26 – D-30
FAST System	D-32 – D-38
Accessories	D-40 – D-48
Installation	D-50 – D-58

FLEXTRAY

Channel Type Cable Tray	
Straight Sections	E-3
Accessories	E-4 – E-7
Fittings	E-8 – E-15
Specifications	E-16

Cable Channel

REDI-RAIL™ Cable Tray (Aluminum)	
Straight Sections	F-3 & F-4
Accessories	F-5 – F-16
Specifications	F-17 & F-18
Fittings	F-19 – F-29

REDI-RAIL







KwikSplice™ Cable Tray (Aluminum)		
Straight Sections	G-3 – G-6	
Accessories	G-7 – G-18	
Specifications	G-19 - G-20	
Fittings	G-21 – G-31	
Series 1 Cable Tray (Steel)		
Straight Sections	H-3 – H-6	
Accessories	H-7 – H-13	
Specifications	H-14	
Fittings	H-15 – H-23	
Series 2,3,4 & 5 Cable Tray - Aluminum		
Straight Sections	I-3 – I-11	
Accessories	I-13 – I-23	
Specifications	I-24	
Series 2,3,4 & 5 Cable Tray - Steel		
Straight Sections	J-3 – J-10	
Accessories	J-11 – J-21	
Specifications	J-22	
Series 3, 4, & 5 Cable Tray - Stainless Steel		
Straight Sections	K-3 – K-5	
Accessories	K-6 – K-13	
Specifications	K-14	
Series 2, 3, 4, & 5 Fittings - Aluminum, Steel, Stainless Steel		
Fitting Numbering System	L-3	
Horizontal Bends	L-4 & L-5	
Tees & Crosses	L-6	
Reducers	L-7	
Horizontal Reducing & Expanding Tees	L-8 & L-9	
Horizontal Reducing & Expanding Crosses	L-10	
Horizontal Wyes	L-11	
Vertical Bends	L-12 – L-15	
Vertical Tees - Up & Down	L-16	
Cable Support Fittings	L-17	
Fiberglass Cable Tray System		
Technical Information	M-3 – M-12	
Specifications	M-13 – M-19	
Straight Sections	M-20 – M-26	
Fittings	M-27 – M-44	
Covers & Cover Accessories	M-45	
Accessories	M-46 – M-48	
Cable Channel		
Straight Sections	M-49	
Fittings	M-49 & M-50	
Accessories	M-50 & M-51	
Appendix	M-52	

Table of Contents

Cable Cleats	
Products	N-2 & N-3
Selection	N-4 & N-5

Cable Cleats

Firestop	
Products	O-2 – O-6

Firestop

Appendix	
Special Applications	APP-1 – APP-5
Side Rails (Aluminum & Steel)	APP-6
Cable Tray Weights	APP-7 & APP-8
Metric Conversion Charts	APP-9 & APP-10
Master Cable Tray Systems Specifications	APP-11 – APP-14
Cable Tray Sizing Requirements	APP-15
Installation Data	APP-16
Support Channels & Channel Nuts	APP-17
Concrete Inserts & Channel Fittings	APP-18

Appendix

Cable Tray Manual	
2014 Cable Tray Manual	
Based on 2014 National Electrical Code	MAN-1 – MAN-53

Cable Tray Manual

Cable Tray Part Number Index

Straight Sections

Cable Tray

REDI-RAIL™ Aluminum	IDX-1
KwikSplice™ Aluminum	IDX-1
Series 2, 3, 4 & 5 Aluminum	IDX-1
Series 1 Steel	IDX-1
Series 2, 3, 4 & 5 Steel	IDX-1
Series 2, 3, 4 & 5 Stainless Steel	IDX-1
Fiberglass	IDX-2

Cable Channel

Aluminum	IDX-2
Steel	IDX-2
Stainless Steel	IDX-2
Fiberglass	IDX-2

FLEXTRAY™ Wire Basket	IDX-3
-----------------------------	-------

Fittings

Cable Tray

REDI-RAIL™ Aluminum	IDX-4
KwikSplice™ Aluminum	IDX-4
Series 2, 3, 4 & 5 Aluminum	IDX-4
Series 1 Steel	IDX-4
Series 2, 3, 4 & 5 Steel	IDX-5
Series 2, 3, 4 & 5 Stainless Steel	IDX-5
Fiberglass	IDX-5

Cable Channel

Aluminum	IDX-6
Steel	IDX-6
Stainless Steel	IDX-6
Fiberglass	IDX-6

Index

Covers

Cable Tray	
REDI-RAIL™ Aluminum	IDX-7
KwikSplice™ Aluminum	IDX-7
Series 2, 3, 4 & 5 Aluminum	IDX-7
Series 1 Steel	IDX-7
Series 2, 3, 4 & 5 Steel	IDX-7
Series 2, 3, 4 & 5 Stainless Steel	IDX-8
Fiberglass	IDX-8
Cable Channel	
Aluminum	IDX-8
Steel	IDX-8
Stainless Steel	IDX-8
FLEXTRAY™ Wire Basket	IDX-8

Accessories

Cable Tray	
REDI-RAIL™ Aluminum	IDX-9
KwikSplice™ Aluminum	IDX-10
Series 2, 3, 4 & 5 Aluminum	IDX-11 & IDX-12
Series 1 Steel	IDX-13 & IDX-14
Series 2, 3, 4 & 5 Steel	IDX-15 & IDX-16
Series 2, 3, 4 & 5 Stainless Steel	IDX-17 & IDX-18
Fiberglass	IDX-19
Cable Channel	
Aluminum	IDX-20
Steel	IDX-20
Stainless Steel	IDX-21
Fiberglass	IDX-21
FLEXTRAY™ Wire Basket	IDX-22 & IDX-23
Cable Cleats	IDX-23
Firestop	IDX-23

Index

Cable Tray Systems

Cable tray is a mechanical support system that can support cables and raceways. Cable tray is not a raceway. Cable tray systems are required to be electrically continuous but not mechanically continuous.

Advantages of Eaton's B-Line series Cable Tray Systems

- **Safety**
- **Dependability**
- **Space Savings**
- **Cost Savings**
- **Design Cost Savings**
- **Material Savings**
- **Installation Cost & Time Savings**
- **Maintenance Savings**

For more information refer to the Cable Tray Manual (Pages MAN-1 thru MAN-53) or call us at 1-800-851-7415

Quick List Selection Process

See pages C-20 & C-21 for expanded selection process.

1. Support Span Issues are: Strength and Length

It is very important to first consider the support span as it affects the strength of the system and the length of the straight sections required.

- Short Span, 6 to 8 foot support spacing - use 12 foot sections.
- Intermediate Span, 8 to 12 foot support spacing - use 12 foot sections.
- Long Span, 16 to 20 foot support spacing - use 20 foot sections.
- Extra Long Span, over 20 foot to 30 foot support spacing - use 24 or 30 foot sections.

2. Working Load Issues are: Size (Width, Loading Depth, and Strength)

Cable Load

- Types and numbers of cables to support - Total cable load in lbs. per linear foot (lbs/ft)
- Power - is single layer - issue width (refer to local electrical code)
- Low Voltage - is stacked - issue loading depth and width (refer to affecting code)
- See chart of listed cable load guidelines (refer to page C-24)

Additional Loads

- 200 lb. concentrated load - Industrial installations
- Ice, Wind, Snow loads - Outdoor installations

Select a Cable Tray system that meets the working load for the support span required and a straight section length that fits the installation. NEMA VE 2 - Straight sections equal to or larger than span.

www.cabletrays.com

3. Installation Environment Issues are: Material and Finish

- Indoor Dry - Institutional, Office, Commercial, Light Industrial
Aluminum, Pre-Galvanized Steel
- Indoor Industrial - Automotive, Pulp and Paper, Power Plants
Aluminum, Pre-Galvanized Steel, Possibly Hot-Dipped Galvanized After Fabrication (HDGAF)
- Outdoor Industrial - Petrochemical, Automotive, Power Plants
Aluminum, Hot-Dipped Galvanized After Fabrication (HDGAF)
- Outdoor Marine - Off Shore Platforms
Aluminum, Stainless Steel, Fiberglass
- Special - Petrochemical, Pulp and Paper, Environmental Air
Contact B-Line (1-800-851-7415)

Cable Tray Product Offering

1. Support Span Issues are: Strength and Length

It is very important to first consider the support span as it affects the strength of the system and the length

Two Side Rail Systems

- Aluminum, Pre-Galvanized Steel, Hot Dip Galvanized After Fabrication Steel, 304 and 316L Stainless Steel, Fiberglass in Polyester Resin, Vinyl Ester, Zero Halogen, and Dis-Stat
- KwikSplice™ System incorporates unique two-bolt splice connection minimizing the labor required to install
- Redi-Rail™ System loaded with special installation and cable friendly features.
- Systems tested to 100+ lbs/ft on a 40 foot span
- Special bottom options and splices
- Highest quality fittings
- Unmatched accessories supplied with attachment hardware

Cable Channel (See Cable Channel Section - pages E-1 – E-6)

- 3, 4, and 6 inch widths in Aluminum, Pre-Galvanized Steel, Hot Dip Galvanized after Fabrication Steel and 304 or 316L Stainless Steel
- 3, 4, 6, and 8 inch widths in Fiberglass in Polyester Resin, Vinyl Ester, Zero Halogen, and Dis-Stat
- Unmatched fitting and accessory offering
- Special bottom options and splices
- Highest quality fittings
- Unmatched accessories supplied with attachment hardware

FLEXTRAY™ Wire Basket (See FLEXTRAY Section - pages D-1 – D-58)

- One of the best finishes in the industry, ASTM B633, SC2 (ZN)
- Strong straight top wire design maximizes strength and minimizes weight
- Unmatched accessory package

Advantage of Using Eaton's B-Line series Cable Tray? Selection!

What kind of B-Line series cable tray will work for your project?

First, answer three questions.

- 1. Location:** Where will the project be located?
 - A.** Is the installation inside or outside?
(decision dealing with thermal and weather conditions)
 - B.** Any contact of corrosive materials?
(decision on cable tray material or finish)
 - C.** Is the location for the cable tray confined or open?
(decision on the size and type of cable tray)
- 2. Span:** What would be the longest and shortest spans between supporting locations for the installation of cables? (decision on type or combination of types of cable tray design needed to be the most efficient and economical)
- 3. Cables:** How many and what type of cables are involved in the support installation?
(decision on the strength of the cable tray)

All these variables are important to the cost savings and safety of Eaton's B-Line series Cable Tray installation project.

Important notice: The information herein has been carefully checked for accuracy and is believed to be correct and current. No warranty, either expressed or implied, is made as to either its applicability to or its compatibility with specific requirements of this information, nor for damages consequential to its use. All design characteristics, specifications, tolerances and similar information are subject to change without notice.

Cable Tray Selection Charts

Short Span 6 - 8 Foot (distance between the supports)

Recommended Short Span Cable Tray Selection Use 10 ft or 12 ft Sections

Catalog Number	Rail Height	Load Depth	Span Load lbs/ft		Available Widths	Material*	Straight Sections & Accessories Pages	Fittings Pages
			6'	8'				
FT2X2X10	2.380"	2.000"	28	20	2"	S	D-4 - D-6 & D-8 - D-56	--
FT2X4X10	2.380"	2.000"	43	27	4"	S	D-4 - D-6 & D-8 - D-56	--
FT2X6X10	2.380"	2.000"	47	27	6"	S	D-4 - D-6 & D-8 - D-56	--
FT2X8X10	2.380"	2.000"	47	27	8"	S	D-4 - D-6 & D-8 - D-56	--
FT2X12X10	2.380"	2.000"	47	27	12"	S	D-4 - D-6 & D-8 - D-56	--
FT2X18X10	2.380"	2.000"	47	27	18"	S	D-4 - D-6 & D-8 - D-56	--
FT2X20X10	2.380"	2.000"	47	27	20"	S	D-4 - D-6 & D-8 - D-56	--
FT2X24X10	2.380"	2.000"	47	27	24"	S	D-4 - D-6 & D-8 - D-56	--
FT4X4X10	4.380"	4.000"	49	36	4"	S	D-4 - D-6 & D-8 - D-56	--
FT4X8X10	4.380"	4.000"	77	46	8"	S	D-4 - D-6 & D-8 - D-56	--
FT4X12X10	4.380"	4.000"	83	47	12"	S	D-4 - D-6 & D-8 - D-56	--
FT4X18X10	4.380"	4.000"	83	47	18"	S	D-4 - D-6 & D-8 - D-56	--
FT4X20X10	4.380"	4.000"	83	47	20"	S	D-4 - D-6 & D-8 - D-56	--
FT4X24X10	4.380"	4.000"	89	50	24"	S	D-4 - D-6 & D-8 - D-56	--
FT6X12X10	6.380"	6.000"	86	48	12"	S	D-4 - D-6 & D-8 - D-56	--
FT6X18X10	6.380"	6.000"	89	50	18"	S	D-4 - D-6 & D-8 - D-56	--
FT6X20X10	6.380"	6.000"	98	55	20"	S	D-4 - D-6 & D-8 - D-56	--
FT6X24X10	6.380"	6.000"	107	60	24"	S	D-4 - D-6 & D-8 - D-56	--
ACC-03	1.250"	1.250"	15	10	3"	A	E-3 - E-4 & E-5 - E-9	E-10 - E-17
ACC-04	1.750"	1.750"	33	20.5	4"	A	E-3 - E-4 & E-5 - E-9	E-10 - E-17
ACC-06	1.750"	1.750"	36	22.5	6"	A	E-3 - E-4 & E-5 - E-9	E-10 - E-17
†CC-03	1.250"	1.250"	17	11.5	3"	S, SS_	E-3 - E-4 & E-5 - E-9	E-10 - E-17
†CC-04	1.750"	1.750"	36	24.5	4"	S, SS_	E-3 - E-4 & E-5 - E-9	E-10 - E-17
†CC-06	1.750"	1.750"	41	28	6"	S, SS_	E-3 - E-4 & E-5 - E-9	E-10 - E-17
FCC-03	1.000"	1.000"	8	--	3"	F	M-49	M-50 & M-51
FCC-04	1.125"	1.125"	12	--	4"	F	M-49	M-50 & M-51
FCC-06	1.625"	1.625"	58	--	6"	F	M-49	M-50 & M-51
FCC-08	2.188"	2.188"	87	--	8"	F	M-49	M-50 & M-51
RSI04A	3.540"	2.680"	108	75	6" - 36"	A	F-3 & F-5 - F-18	F-21 - F-31
RSI05A	4.530"	3.660"	119	83	6" - 36"	A	F-3 & F-5 - F-18	F-21 - F-31
RSI06A	5.510"	4.640"	118	82	6" - 36"	A	F-4 & F-5 - F-18	F-21 - F-31
RSI07A	6.500"	5.630"	176	122	6" - 36"	A	F-4 & F-5 - F-18	F-21 - F-31
KSA4A	3.858"	3.033"	221	124	6" - 36"	A	G-3 - G-4 & G-7 - G-17	G-21 - G-33
KSA5A	4.858"	4.033"	219	123	6" - 36"	A	G-3 - G-4 & G-7 - G-17	G-21 - G-33
KSB4A	3.883"	3.048"	--	198	6" - 36"	A	G-5 - G-6 & G-7 - G-17	G-21 - G-33
KSB5A	4.883"	4.048"	--	188	6" - 36"	A	G-5 - G-6 & G-7 - G-17	G-21 - G-33
KSB6A	5.883"	5.048"	--	179	6" - 36"	A	G-5 - G-6 & G-7 - G-17	G-21 - G-33
148	3.625"	3.077"	204	115	6" - 36"	S	H-3 - H-6 & H-7 - H-16	H-18 - H-26
156	4.188"	3.628"	304	171	6" - 36"	S	H-3 - H-6 & H-7 - H-16	H-18 - H-26
166	5.188"	4.628"	308	173	6" - 36"	S	H-3 - H-6 & H-7 - H-16	H-18 - H-26
176	6.188"	5.628"	-	194	6" - 36"	S	H-3 - H-6 & H-7 - H-16	H-18 - H-26
13F	3.000"	2.000"	257	145	6" - 24"	F	M-21 & M-45 - M-48	M-27 - M-44

*Material: A = Aluminum • S = Steel • SS_ = Stainless Steel Type 304 or 316 • F = Fiberglass

† = G for HDGAF • P for Pre-Galvanized • SS4 for 304 or SS6 for 316 Stainless Steel

① Insert 2, 3, 4, 5 or 6 for number of tiers • ② Insert 2, 3 or 4 for number of tiers

FLEXTRAY™

Cable Channel

REDI-RAIL™

KwikSplice™

Cable Tray
Steel
Fiber

Recommended Intermediate Span Cable Tray Selection Use 12 ft Sections

Intermediate Span 10 - 12 Foot (distance between the supports)

	Catalog Number	Rail Height	Load Depth	Span Load lbs/ft		Available Widths	Material*	Straight Sections & Accessories Pages	Fittings Pages	
				10'	12'					
REDI-RAIL™	RSI04A	3.540"	2.680"	108	75	6" - 36"	A	F-3 & F-5 -F-18	F-21 - F-31	
	RSI05A	4.530"	3.660"	119	83	6" - 36"	A	F-3 & F-5 -F-18	F-21 - F-31	
	RSI06A	5.510"	4.640"	118	82	6" - 36"	A	F-4 & F-5 -F-18	F-21 - F-31	
	RSI07A	6.500"	5.630"	176	122	6" - 36"	A	F-4 & F-5 -F-18	F-21 - F-31	
KwikSplice™	KSA4A	3.858"	3.033"	79	55	6" - 36"	A	G-3 - G-4 & G-7 - G-17	G-21 - G-33	
	KSA5A	4.858"	4.033"	79	55	6" - 36"	A	G-3 - G-4 & G-7 - G-17	G-21 - G-33	
	KSB4A	3.883"	3.048"	127	88	6" - 36"	A	G-5 - G-6 & G-7 - G-17	G-21 - G-33	
	KSB5A	4.883"	4.048"	120	88	6" - 36"	A	G-5 - G-6 & G-7 - G-17	G-21 - G-33	
	KSB6A	5.883"	5.048"	114	79	6" - 36"	A	G-5 - G-6 & G-7 - G-17	G-21 - G-33	
	Aluminum	24A	4.120"	3.050"	181	126	6" - 36"	A	I-3 - I-4 & I-13 - I-25	L-3 - L-17
25A		5.000"	3.930"	200	139	6" - 36"	A	I-5 - I-6 & I-13 - I-25	L-3 - L-17	
26A		6.120"	5.040"	204	142	6" - 36"	A	I-7 - I-8 & I-13 - I-25	L-3 - L-17	
27A		7.140"	6.050"	177	123	6" - 36"	A	I-9 - I-10 & I-13 - I-25	L-3 - L-17	
37A		7.140"	6.050"	--	222	6" - 36"	A	I-9 - I-10 & I-13 - I-25	L-3 - L-17	
148		3.625"	3.077"	73	51	6" - 36"	S	H-3 & H-7 - H-16	H-18 - H-26	
156		4.188"	3.628"	109	76	6" - 36"	S	H-4 & H-7 - H-16	H-18 - H-26	
166		5.188"	4.628"	111	77	6" - 36"	S	H-5 & H-7 - H-16	H-18 - H-26	
176		6.188"	5.628"	124	86	6" - 36"	S	H-6 & H-7 - H-16	H-18 - H-26	
248		4.188"	3.140"	148	103	6" - 36"	S	J-3 - J-4 & J-11 - J-23	L-3 - L-17	
Steel	258	5.188"	4.140"	157	109	6" - 36"	S	J-5 - J-6 & J-11 - J-23	L-3 - L-17	
	268	6.188"	5.140"	158	110	6" - 36"	S	J-7 - J-8 & J-11 - J-23	L-3 - L-17	
	378	7.188"	6.140"	204	142	6" - 36"	S	J-9 - J-10 & J-11 - J-23	L-3 - L-17	
	Stainless Steel	348	4.188"	3.130"	180	125	6" - 36"	SS_	K-3 & K-6 - K-17	L-3 - L-17
		358	5.188"	4.130"	248	172	6" - 36"	SS_	K-4 & K-6 - K-17	L-3 - L-17
		368	6.188"	5.130"	236	164	6" - 36"	SS_	K-5 & K-6 - K-17	L-3 - L-17
	Fiberglass	13F	3.000"	2.000"	93	64	6" - 24"	F	M-21 & M-45 - M-48	M-27 - M-44
		24F	4.000"	3.000"	226	157	6" - 36"	F	M-22 & M-45 - M-48	M-27 - M-44

*Material
 A = Aluminum
 S = Steel
 SS_ = Stainless Steel Type 304 or 316
 F = Fiberglass

Cable Tray Selection Charts

Long 16 - 20 Foot (distance between the supports)

Recommended Intermediate Span Cable Tray Selection Use 20 ft Sections

Cable Tray Information

	Catalog Number	Rail Height	Load Depth	Span Load lbs/ft			Available Widths	Material*	Straight Sections & Accessories Pages	Fittings Pages
				16'	18'	20'				
Aluminum	H24A	4.180"	3.090"	88	70	56	6" - 36"	A	I-3 - I-4 & I-13 - I-25	L-3 - L-17
	25A	5.000"	3.930"	78	62	50	6" - 36"	A	I-5 - I-6 & I-13 - I-25	L-3 - L-17
	34A	4.200"	3.080"	125	99	80	6" - 36"	A	I-3 - I-4 & I-13 - I-25	L-3 - L-17
	35A	5.060"	3.960"	121	96	77	6" - 36"	A	I-5 - I-6 & I-13 - I-25	L-3 - L-17
	26A	6.120"	5.040"	80	63	51	6" - 36"	A	I-7 - I-8 & I-13 - I-25	L-3 - L-17
	36A	6.170"	5.060"	131	104	84	6" - 36"	A	I-7 - I-8 & I-13 - I-25	L-3 - L-17
	37A	7.140"	6.050"	125	99	80	6" - 36"	A	I-9 - I-10 & I-13 - I-25	L-3 - L-17
	46A	6.190"	5.080"	161	127	103	6" - 36"	A	I-7 - I-8 & I-13 - I-25	L-3 - L-17
	47A	7.240"	6.130"	156	123	100	6" - 36"	A	I-9 - I-10 & I-13 - I-25	L-3 - L-17
	H46A	6.240"	5.090"	261	206	167	6" - 36"	A	I-7 - I-8 & I-13 - I-25	L-3 - L-17
	H47A	7.240"	6.090"	233	184	149	6" - 36"	A	I-9 - I-10 & I-13 - I-25	L-3 - L-17
	Steel	346	4.188"	3.130"	98	78	63	6" - 36"	S	J-3 - J-4 & HDS-11 - HDS-21
356		5.188"	4.130"	108	85	69	6" - 36"	S	J-5 - J-6 & HDS-11 - HDS-21	L-3 - L-17
366		6.188"	5.140"	117	93	75	6" - 36"	S	J-7 - J-8 & HDS-11 - HDS-21	L-3 - L-17
378		7.188"	6.140"	80	63	51	6" - 36"	S	J-9 - J-10 & HDS-11 - HDS-21	L-3 - L-17
444		4.188"	3.110"	142	112	91	6" - 36"	S	J-3 - J-4 & HDS-11 - HDS-21	L-3 - L-17
454		5.188"	4.110"	166	131	106	6" - 36"	S	J-5 - J-6 & HDS-11 - HDS-21	L-3 - L-17
464		6.188"	5.110"	192	152	51	6" - 36"	S	J-7 - J-8 & HDS-11 - HDS-21	L-3 - L-17
476		7.188"	6.130"	120	95	77	6" - 36"	S	J-9 - J-10 & HDS-11 - HDS-21	L-3 - L-17
574		7.188"	6.110"	203	160	130	6" - 36"	S	J-9 - J-10 & HDS-11 - HDS-21	L-3 - L-17
Stainless Steel		348	4.188"	3.130"	70	56	45	6" - 36"	SS_	K-3 & K-6 - K-17
	358	5.188"	4.130"	97	77	62	6" - 36"	SS_	K-4 & K-6 - K-17	L-3 - L-17
	368	6.188"	5.130"	92	73	59	6" - 36"	SS_	K-5 & K-6 - K-17	L-3 - L-17
	464	6.188"	5.110"	192	152	123	6" - 36"	SS_	K-5 & K-6 - K-17	L-3 - L-17
Fiberglass	36F	6.000"	5.000"	139	109	89	6" - 36"	F	M-23 & M-45 - M-48	M-27 - M-44
	46F	6.000"	5.000"	221	174	141	6" - 36"	F	M-24 & M-45 - M-48	M-27 - M-44
	H46F	6.000"	5.000"	239	188	153	6" - 36"	F	M-25 & M-45 - M-48	M-27 - M-44

*Material
 A = Aluminum
 S = Steel
 SS_ = Stainless Steel Type 304 or 316
 F = Fiberglass

Recommended Extra Long Span Cable Tray Selection

Use 24 ft or 30 ft Sections
(40 ft with S8A)

Extra Long Span 24 - 30 Foot (distance between the supports)

Cable Tray	Catalog Number	Rail Height	Load Depth	Span Load lbs/ft		Available Widths	Material*	Straight Sections & Accessories Pages	Fittings Pages
				24'	30'				
Aluminum	46A	6.190"	5.080"	72	-	6" - 36"	A	I-7 - I-8 & I-13 - I-25	L-3 - L-17
	47A	7.240"	6.130"	69	-	6" - 36"	A	I-9 - I-10 & I-13 - I-25	L-3 - L-17
	57A	7.400"	6.230"	161	102	12" - 36"	A	I-9 - I-10 & I-13 - I-25	L-3 - L-17
	H46A	6.240"	5.090"	116	-	6" - 36"	A	I-7 - I-8 & I-13 - I-25	L-3 - L-17
	H47A	7.240"	6.090"	103	-	6" - 36"	A	I-9 - I-10 & I-13 - I-25	L-3 - L-17
	S8A	8.000"	6.200"	252	161	12" - 36"	A	I-11 & I-12	I-12
Steel	444	4.188"	2.110"	63	-	6" - 36"	S	J-3 - J-4 & HDS-11 - HDS-21	L-3 - L-17
	454	5.188"	4.110"	74	-	6" - 36"	S	J-5 - J-6 & HDS-11 - HDS-21	L-3 - L-17
	464	6.188"	5.110"	85	-	6" - 36"	S	J-7 - J-8 & HDS-11 - HDS-21	L-3 - L-17
	476	7.188"	6.130"	53	-	6" - 36"	S	J-9 - J-10 & HDS-11 - HDS-21	L-3 - L-17
	574	7.188"	6.110"	90	-	6" - 36"	S	J-9 - J-10 & HDS-11 - HDS-21	L-3 - L-17
SS	464	6.188"	5.110"	85	-	6" - 36"	SS_	K-5 & K-6 - K-17	L-3 - L-17

*Material
 A = Aluminum
 S = Steel
 SS_ = Stainless Steel Type 304 or 316

Cable Tray Systems

Eaton's B-Line series cable trays -

Designed for Your Cable Support Requirements

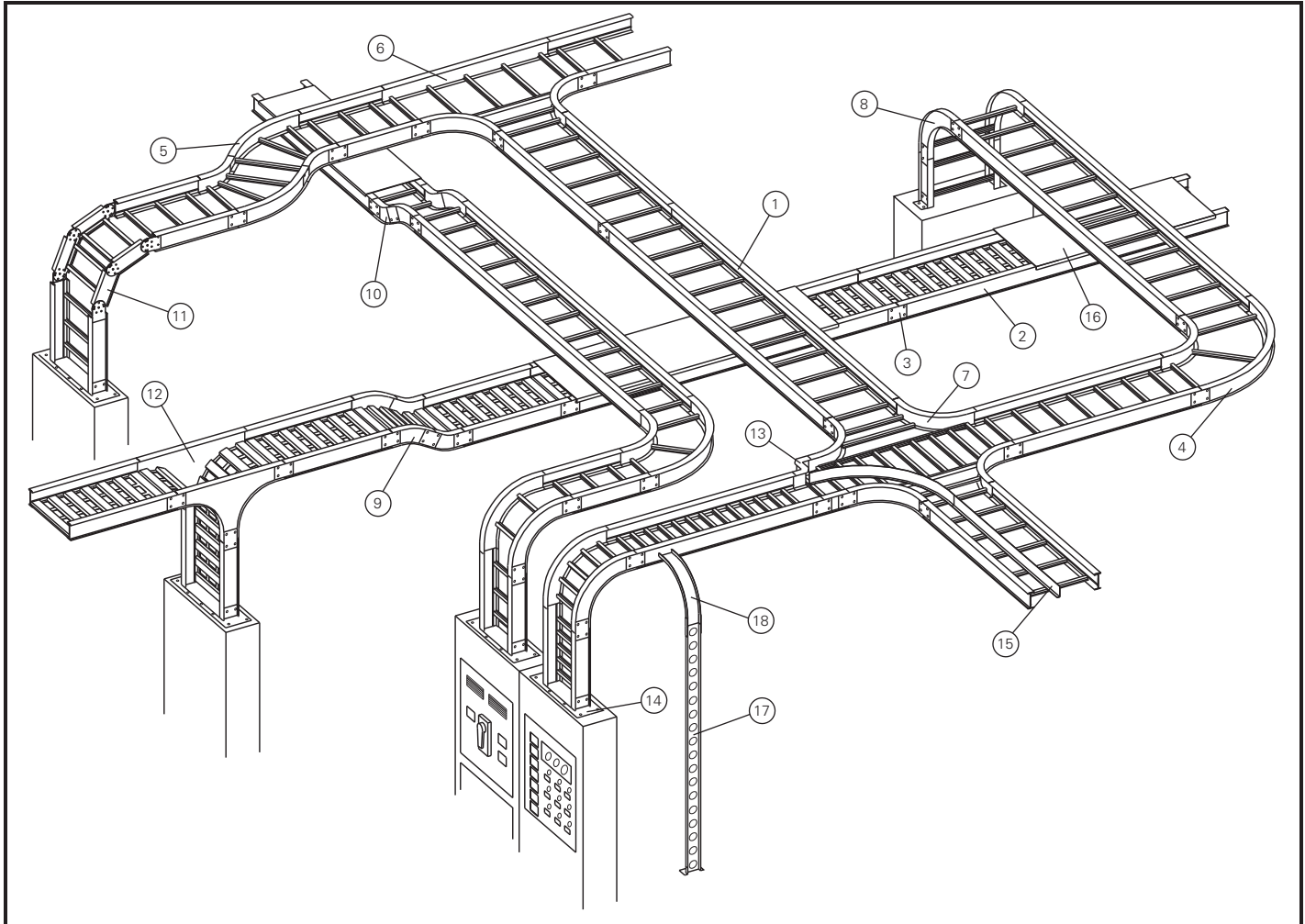

Nomenclature

- | | |
|---|--|
| ① Ladder Type Cable Tray | ⑩ 30° Vertical Inside Bend, Ladder Type Cable Tray |
| ② Ventilated Trough Type Cable Tray | ⑪ Vertical Bend Segment (VBS) |
| ③ Straight Splice Plate | ⑫ Vertical Tee Down, Ventilated Trough Type Cable Tray |
| ④ 90° Horizontal Bend, Ladder Type Cable Tray | ⑬ Left Hand Reducer, Ladder Type Cable Tray |
| ⑤ 45° Horizontal Bend, Ladder Type Cable Tray | ⑭ Frame Type Box Connector |
| ⑥ Horizontal Tee, Ladder Type Cable Tray | ⑮ Barrier Strip Straight Section |
| ⑦ Horizontal Cross, Ladder Type Cable Tray | ⑯ Solid Flanged Tray Cover |
| ⑧ 90° Vertical Outside Bend, Ladder Type Cable Tray | ⑰ Ventilated Channel Straight Section |
| ⑨ 45° Vertical Outside Bend, Ventilated Type Cable Tray | ⑱ Channel Cable Tray, 90° Vertical Outside Bend |

- Committed to the Success of its Customers through Manufacturing, Engineering and Service.
- Positioned to Serve.

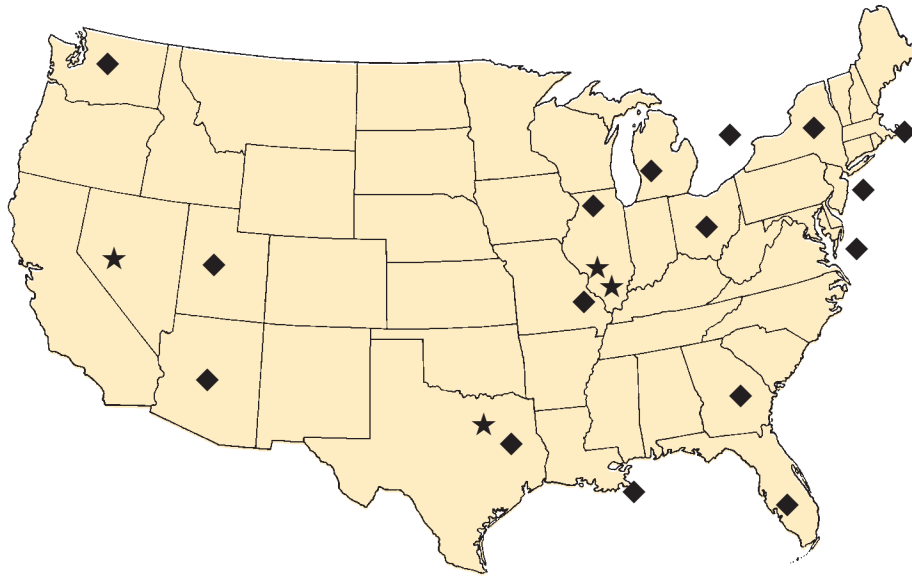

- Four United States cable tray fabrication sites: (★)
Troy, IL Sherman, TX Pinckneyville, IL Reno, NV
- Sixteen factory inventories (◆)
- A Proven Industry Leader.
- Over forty years experience
- Industry Involvement.
 - NEMA - 5VE Member - Metallic Cable Tray Section
 - NEMA - 5FG Member - Nonmetallic Cable Tray Section
 - Cable Tray Institute (CTI) - A Founding Member
 - B-Line series cable trays conform to the requirements of IEC Standard 61537, 2006 Ed.
- Unmatched Cable Support Systems.
 - Cable Tray - Two Side Rail (Metallic)
 - Cable Tray - Two Side Rail (Metallic) REDI-RAIL™ Design
 - Cable Tray - Two Side Rail (Nonmetallic)
 - Cable Tray - FLEXTRAY™ Cable Support Systems
 - Cable Runways - Telecom
 - NEMA Wireways

Aluminum Cable Tray, Series 2, 3, 4 & 5

- **Side Rails**

Our I-Beam - the most efficient structural shape

Using "Copper-free"
6063-T6 Aluminum Alloy

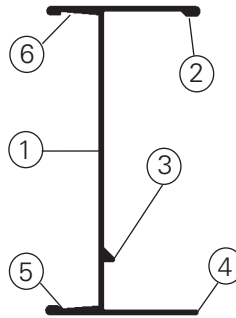

1. **I-beam side rail design**
 - maximize strength-to-weight ratio
2. **Added material to top flange to increase cable tray stiffness**
3. **Welding bead**
 - positive rung lock
 - added material disperses heat
4. **Bottom flange inside**
 - positive rung support
5. **Bottom flange outside**
 - strong lower flange for hold down clamps and expansion guides
6. **Top flange outside**
 - strong upper flange for securing the tray cover or the conduit-to-tray adapter

- **Rungs** - provide system integrity

The rungs can represent 40% of your cable tray system.



Rung A - Standard for widths through 24"



Rung B - Standard for widths greater than 24"

- For industrial applications – 200 lb. concentrated loads
- New P-Rung design allows P-Clamp cable fastening at any location.

- **Splices** - provide system integrity

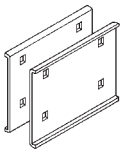

With the unique Wedge Lock splice system:

- Channel-shaped for extra strength
- Snaps into the side rail
- Positions and holds for bolting, a labor-saving feature
- Four bolt patterns, a labor-saving feature
- 316 Stainless Steel hardware is available as an option

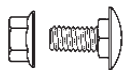

- **Fittings** - provide system integrity

Surpasses NEMA VE 1 requirements
3" straight tangents for splice integrity

- **A 200 lb. Concentrated Load** - providing system integrity

Side rails engineered to support a 200 lb. concentrated load + cable load
Rungs engineered to support a 200 lb. concentrated load + cable load

- Reliable time-tested products.

Steel Cable Tray, Series 2, 3, 4 & 5

- **Side Rails**

Our I-Beam - the most efficient structural shape

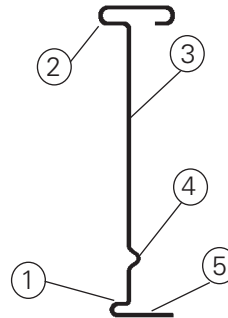

1. Roll formed for extra strength
2. Enlarged top flange for stiffness
3. Structural grade traceable steel
4. Rung top lock
5. Rung bottom rest

Side rails and rungs are stamped every 18" with:

- Company Name
- Part Number
- Material
- Heat Trace Number

- **Rungs** - provide system integrity

The rungs can represent 40% of your cable tray system.



Rung - Standard for all widths

- For industrial applications - 200 lb. concentrated loads.
- Rungs are roll formed from traceable structural grade steel

- **Splices** - provide system integrity

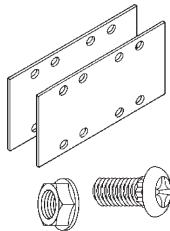

The Splices - the engineered connection:

- Special high strength eleven gauge steel
- Eight bolt connection for required strength
- Finish and hardware options

- **Hot Dip Galvanized After Fabrication (HDGAF)** providing system integrity

- ASTM A123/CSA Type I
- In plant post-dip inspection and deburr
- ASTM F-1136-88 Grade 3 Splice hardware exceeds NEMA requirements.
- ASTM A123 Covers available - system compatibility

- **Pre-Galvanized- Hot Dip Mill Galvanized** providing system integrity

- ASTM A653SS Gr.33 G90/ CSA Type II
- Anti-corrosive silicon bronze welds eliminate cosmetic painting

- **Reliable time-tested products**

- 200 lb. Concentrated Load- side rail and rungs
- Splice integrity - 3" fitting tangents

- **Special Packaging**



- For less than truckload (LTL) shipments
- Helps reduce freight claims over 50%
- A positive package for all

- **New Mid Span Aluminum Splice**

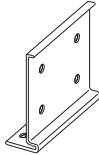

- The standard splice for H46A, H47A and 57A systems
- Optional availability for other systems
- See appendix page APP-2 for details

- **Special Aluminum Long Span Systems**



- 57A12-36-360 Tested to 102 lbs./ft. on 30' span - safety factor 1.5 (Page I-9 & I-10)
- S8A12-36-480 Tested to 101 lbs./ft. on 40' span - safety factor 1.5 (Page I-11 & I-12)

- **REDI-RAIL™ Aluminum Cable Tray Systems** (See REDI-RAIL Section F)



- 3, 4, 5 and 6 inch cable fill depths
- NEMA classes up to 12C
- Unique fabrication method provides unmatched installation options
- Industry leading accessory package

- **Wire Basket Cable Support Systems** (See FLEXTRAY™ Section D)

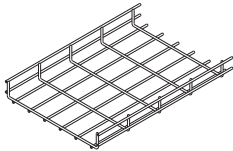

- Field adaptable - no fittings to order
- Low profile in 2", 4" and 6" loading depths
- Rugged welded steel, wire mesh construction

- **Non-Metallic Cable Tray** (See Fiberglass Section M)

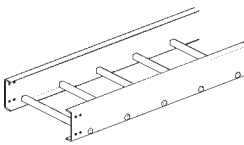

- For corrosive environments
- For voltage isolation
- A complete line offering
- Request latest catalog

- **KwikSplice™ Aluminum Cable Tray** (See KwikSplice Section G)

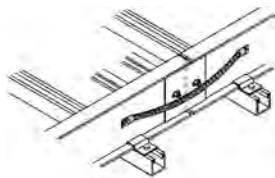

- 3, 4, 5 inch cable fill depths
- NEMA Classes 12A & 12B
- Patent Pending splice retention groove
- 2-bolt splice connection for straights and fittings



B-Line series cable trays conform to the requirements of IEC Standard 61537, 2001 Ed.

The following factors should be considered when determining the appropriate cable tray system.

1. Material & Finish

- Standards Available (Pages C-2 – C-4)
- Corrosion (Pages C-5 – C-7)
- Thermal Contraction and Expansion (Page C-8)
- Installation Considerations and Electrical Grounding Capacity (Page C-9)

2. Strength

- Environmental Loads (Pages C-10 & C-11)
- Concentrated Loads (Page C-11)
- Support Span (Page C-11)
- Deflection (Page C-12)
- Rung/Trough Data (Page C-13)
- Load Capacity (NEMA & CSA Classes) (Pages C-14 & C-15)
- Cable Data (Page C-16)

3. Width & Available Loading Depth

- Cable Diameter (Page C-16)
- Allowable Cable Fill (Pages C-17 - C-21)
- Barrier Requirements (Page C-22)
- Future Expansion Requirements (Page C-22)
- Space Limitations (Page C-22)

4. Length

- Lengths Available (Page C-23)
- Support Spans (Not to exceed the length of straight sections) (Page C-23)
- Space Limitations (Page C-23)
- Installation (Page C-23)

5. Loading Possibilities

- Power Application (Page C-24)
- Data/Communication Cabling (Page C-24)
- Other Factors to Consider (Page C-24)

6. Bottom Type

- Type of Cable (Page C-25)
- Cost vs. Strength (Page C-25)
- Cable Exposure (Page C-25)
- Cable Attachment (Page C-25)

7. Fitting Radius

- Cable Flexibility (Page C-25)
- Space Limitations (Page C-25)

Cable Tray Selection - Material & Finish

Standards Available

Material	Material Specification	Advantages
Aluminum	6063-T6 (Side rails, Rungs and Splice Plates) 5052-H32 (Trough Bottoms, Covers and Accessories)	<ul style="list-style-type: none"> • Corrosion Resistance • Easy Field Fabrication & Installation • Excellent Strength to Weight Ratio • Excellent Grounding Conductor
Steel	ASTM A1011 SS Gr. 33 (14 Gauge Plain Steel) ASTM A1008 Gr. 33 Type 2 (16 & 18 Gauge Plain) ASTM A653SS Gr. 33 G90 (Pre-Galvanized) ASTM A510 Gr. 1008 (FLEXTRAY) (plain wire)	<ul style="list-style-type: none"> • Electric Shielding • Finish Options • Low Thermal Expansion • Limited Deflection
Stainless Steel	AISI Type 304 or AISI Type 316/316L ASTM A240	<ul style="list-style-type: none"> • Superior Corrosion Resistance • Withstands High Temperatures

Note: Fiberglass available - see page M-5

Aluminum

Aluminum cable trays are fabricated from structural grade "copper free" (marine grade) aluminum extrusions. Aluminum's excellent corrosion resistance is due to its ability to form an aluminum oxide film that when scratched or cut reforms the original protective film. Aluminum has excellent resistance to "weathering" in most outdoor applications. Aluminum cable tray has excellent corrosion resistance in many chemical environments and has been used for over thirty years in petro-chemical plants and paper mills along the gulf coast from Texas to Florida. Typically, aluminum cable trays can perform indefinitely, with little or no degradation over time, making it ideal for many chemical and marine environments. The resistance to chemicals, indoor and outdoor, can best be determined by tests conducted by the user with exposure to the specific conditions for which it is intended. For further information, contact us or the Aluminum Association.

Some common chemicals which aluminum resists are shown on pages C-6 & C-7.

Aluminum Cable Tray

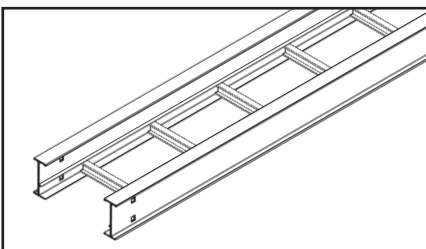

Steel

Steel cable trays are fabricated from continuous roll-formed structural quality steel. By roll-forming steel, the mechanical properties are increased allowing the use of a lighter gauge steel to carry the required load. This reduces the dead weight that must be carried by the supports and the installers. Using structural quality steel, we assure that the material will meet the minimum yield and tensile strengths of applicable ASTM standards. All cable tray side rails, rungs and splice plates are numbered for material traceability. The corrosion resistance of steel varies widely with coating and alloy.

Steel and Stainless Steel Cable Tray

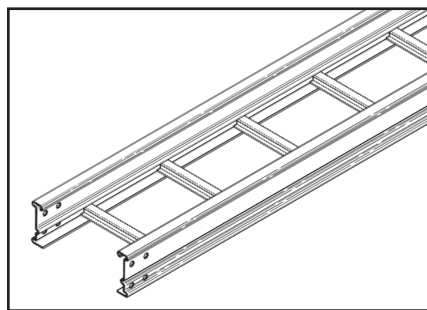

Note:

For help choosing proper cable tray material, see our Technical Paper Series.

(bline.com/engineer/Technical.asp)

Stainless Steel

Stainless Steel cable trays are fabricated from continuous roll-formed AISI Type 304 or AISI Type 316/316L stainless steel. Both are non-magnetic and belong to the group called austenitic stainless steels. Like carbon steel, they exhibit increased strength when cold worked by roll-forming or bending.

Several important conditions could make the use of stainless steel imperative. These include long term maintenance costs, corrosion resistance, appearance and locations where product contamination is undesirable. Stainless steel exhibits stable structural properties such as yield strength and high creep strength at elevated temperatures.

Our stainless steel cable trays are welded using stainless steel welding wire to ensure each weldment exhibits the same corrosion resistant characteristic as the base metal. Localized staining in the weld area or heat affected zone may occur in severe environments. Specialized shielding gases and low carbon materials are used to minimize carbon contamination during welding and reduce staining and stress corrosion. Specify passivation after fabrication per ASTM A380 to minimize staining, improve aesthetics and further improve corrosion resistance.

A detailed study of the corrosive environment is recommended when considering a stainless steel design (see pages C-6 & C-7).

Standards Available

Finish	Specification	Recommended Use
Electrogalvanized Zinc	ASTM B633 (For Cable Tray Hardware and Accessories, Alum. and Pre-Galv.) (For Flextray Standard is B633 SC2)	Indoor
Chromium Zinc	ASTM F-1136-88 (Hardware for Hot Dip Galvanized Cable Tray)	Indoor/Outdoor
Pre-Galvanized Zinc	ASTM A653SS Gr.33 G90 (CSA Type 2) (Steel Cable Tray and Fittings)	Indoor
Hot Dip Galvanized Zinc After Fabrication	ASTM A123 (CSA Type 1) (Steel Cable Tray and Fittings)	Indoor/Outdoor
Special Paint	Per Customer Specification (Aluminum or Steel Cable Tray & Fittings)	Indoor

Zinc Coatings

Zinc protects steel in two ways. First it protects the steel as a coating and second as a sacrificial anode to repair bare areas such as cut edges, scratches, and gouges. The corrosion protection of zinc is directly related to its thickness and the environment. This means a .2 mil coating will last twice as long as a .1 mil coating in the same environment.

Galvanizing also protects cut and drilled edges.

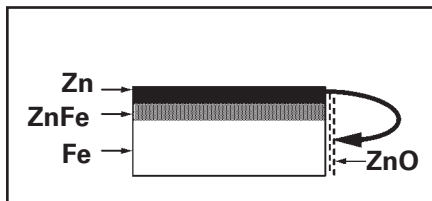

Electrogalvanized Zinc

Electrogalvanized Zinc (also known as zinc plated or electroplated) is the process by which a coating of zinc is deposited on the steel by electrolysis from a bath of zinc salts. This finish is standard for cable tray hardware and some accessories for aluminum and pre-galvanized systems.

A rating of SC3, our standard, provides a minimum zinc coating thickness of .5 mils (excluding threaded rod, which is SC1 = .2 mils)

When exposed to air and moisture, zinc forms a tough, adherent, protective film consisting of a mixture of zinc oxides, hydroxides, and carbonates. This film is in itself a barrier coating which slows subsequent corrosive attack on the zinc. This coating is usually recommended for indoor use in relatively dry areas, as it provides ninety-six hours protection in salt spray testing per ASTM B117.

Chromium/Zinc

Chromium/Zinc is a corrosion resistant composition, which was developed to protect fasteners and small bulk items for automotive use. The coating applications have since been extended to larger parts and other markets.

Chromium/Zinc composition is an aqueous coating dispersion containing chromium, proprietary organics, and zinc flake.

This finish provides 720 hours protection in salt spray testing per ASTM B117, exceeding NEMA VE-1 requirements by 300%.

Pre-Galvanized Zinc (Mill galvanized, hot dip mill galvanized or continuous hot dip galvanized)

Pre-Galvanized steel is produced by coating coils of sheet steel with zinc by continuously rolling the material through molten zinc at the mills. This is also known as mill galvanized or hot dip mill galvanized. These coils are then slit to size and fabricated by roll forming, shearing, punching, or forming to produce our pre-galvanized cable tray products.

The G90 specification calls for a coating of .90 ounces of zinc per square foot of steel. This results in a coating of .45 ounces per square foot on each side of the sheet. This is important when comparing this finish to hot dip galvanized after fabrication.

During fabrication, cut edges and welded areas are not normally zinc coated; however, the zinc near the uncoated metal becomes a sacrificial anode to protect the bare areas after a short period of time.

To further insure a quality product, our welds all pre-galvanized cable trays with a silicon bronze welding wire

allowing only a small heat affected zone to be exposed. This small area quickly repairs itself by the same process as cut edges.

Hot Dip Galvanized After Fabrication

(Hot dip galvanized or batch hot dip galvanized)

Hot Dip Galvanized After Fabrication cable tray products are fabricated from steel and then completely immersed in a bath of molten zinc. A metallic bond occurs resulting in a zinc coating that completely coats all surfaces, including edges and welds.

Another advantage of this method is coating thickness. Cable, trays hot dip galvanized after fabrication, have a minimum thickness of 1.50 ounces per square foot on each side, or a total 3.0 ounces per square foot of steel, according to ASTM A123.

The zinc thickness is controlled by the amount of time each part is immersed in the molten zinc bath as well as the speed at which it is removed. The term "double dipping" refers to parts too large to fit into the galvanizing kettle and, therefore, must be dipped one end at a time. It does not refer to extra coating thickness.

The layer of zinc which bonds to steel provides a dual protection against corrosion. It protects first as an overall barrier coating. If this coating happens to be scratched or gouged, zinc's secondary defense is called upon to protect the steel by galvanic action.

Hot dip galvanized after fabrication is recommended for prolonged outdoor exposure and will protect steel for many years in most outdoor environments and in many aggressive industrial environments (see charts on page C-4).

Cable Tray Selection - Material & Finish

Standards Available

**Service Life is defined as the time to 5% rusting of the steel surface.
Anticipated Life of Zinc Coatings In Various Atmospheric Environments**

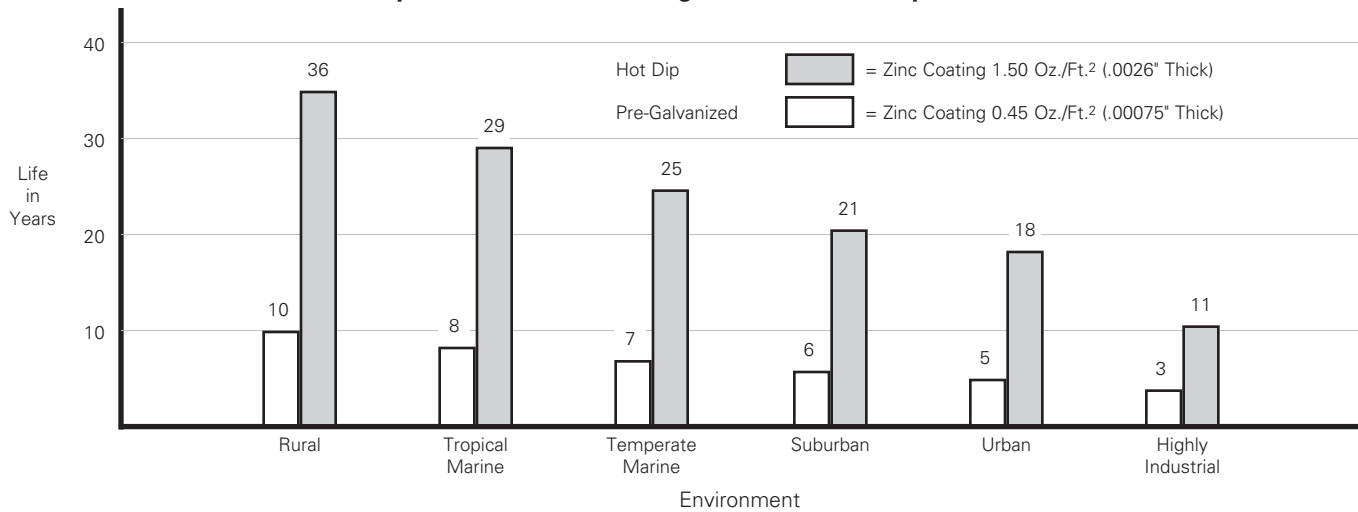

PVC Coating

PVC coating aluminum or steel cable tray is not recommended and has been removed from our cable tray line.

The application of a 15 mil PVC coating to aluminum or steel cable tray was a somewhat popular finish option 15 or more years ago. The soft PVC coating must be completely intact for the finish to be effective. In a caustic atmosphere, a pinhole in the coating can render it useless and corrode the cable tray. The shipment of the cable tray consistently damages the coating, as does installation. The splice hardware, splice plates and ground straps require field removal of the coating to ensure connections. PVC coated cable tray drastically increases the product's cost and delivery time.

We recommend using fiberglass - See Fiberglass section, or stainless steel cable tray systems in highly corrosive areas.

Painting Cable Tray

We offer painted cable tray to any color specified by the customer. It is important to note that there are key advantages and disadvantages to ordering factory painted cable tray. We typically do not recommend factory painted cable tray for most applications.

Painted cable tray is often used in "open ceiling" applications, where all the overhead equipment and structure is painted the same color. In this type of application, additional painting is often necessary in the field, after installation, to ensure all of the supporting components, such as hanger rods, clamps and attaching hardware have been painted uniformly. Pre-painted cable tray interferes with common grounding practices, requiring the paint to be removed at splice locations, and/or the addition of bonding jumpers that were otherwise unnecessary. This additional field modification not only increases the installation cost, but causes potential damage to the special painted finish.

It is typically more cost effective to use an Aluminum or Pre-Galvanized Steel cable tray and paint it after installation, along with the other un-painted building components. Consult painting contractor for proper surface preparation.

Special Paint

Our cable tray and supports can be painted or primed to meet the customers requirements. We have several colors available, consult the factory.

If a non-standard color is required the following information needs to be specified:

1. Type of material preparation (primer, etc.)
2. Type of paint, manufacturer and paint number or type of paint with chip.
3. Dry film thickness.

Material/Finish Prefix Designation Chart

Catalog Number Prefix	Material to be Furnished
A	Aluminum
P	Pre-Galvanized
G	Hot Dip Galvanized
ZN	Zinc Plated
S	Plain Steel
SS4	Type 304 Stainless Steel
SS6	Type 316 Stainless Steel

Corrosion

All metal surfaces are affected by corrosion. Depending on the physical properties of the metal and the environment to which it is exposed, chemical or electromechanical corrosion may occur.

Atmospheric Corrosion

Atmospheric corrosion occurs when metal is exposed to airborne liquids, solids or gases. Some sources of atmospheric corrosion are moisture, salt, dirt and sulphuric acid. This form of corrosion is typically worse outdoors, especially near marine environments.

Chemical Corrosion

Chemical corrosion takes place when metal comes in direct contact with a corrosive solution. Some factors which affect the severity of chemical corrosion include: chemical concentration level, duration of contact, frequency of washing, and operating temperature.

Storage Corrosion

Wet storage stain (White rust) is caused by the entrapment of moisture between surfaces of closely packed and poorly ventilated material for an extended period. Wet storage stain is usually superficial, having no effect on the properties of the metal.

Light staining normally disappears with weathering. Medium to heavy buildup should be removed, in order to allow the formation of normal protective film.

Proper handling and storage will help to assure stain-free material. If product arrives wet, it should be unpacked and dried before storage. Dry material should be stored in a well ventilated "low moisture" environment to avoid condensation formation. Outdoor storage is undesirable, and should be avoided whenever possible.

Galvanic Corrosion

Galvanic corrosion occurs when two or more dissimilar metals are in contacts in the presence of an electrolyte (ie. moisture). An electrolytic cell is created and the metals form an anode or a cathode depending on their relative position on the Galvanic Series Table. The anodic material will be the one to corrode. Whether a material is anodic depends on the relative position of the other material. For example: If zinc and steel are in contact, the zinc acts as the anode and will corrode; the steel acts as the cathode, and will be protected. If steel and copper are in contact, the steel is now the anode and will corrode.

The rate at which galvanic corrosion occurs depends on several factors:

1. The amount and concentration of electrolyte present- An indoor, dry environment will have little or no galvanic corrosion compared to a wet atmosphere.
2. The relative size of the materials- A small amount of anodic material in contact with a large cathodic material will result in greater corrosion. Likewise, a large anode in contact with a small cathode will decrease the rate of attack.
3. The relative position on the Galvanic Series Table - The further apart in the Galvanic Series Table, the greater the potential for corrosion of the anodic material.

Galvanic Series In Sea Water

Anodic End

More Anodic	Magnesium
	Magnesium Alloys
	Zinc
	Beryllium
	Aluminum - Zinc Alloys (7000 series)
	Aluminum - Magnesium Alloys (5000 series)
	Aluminum (1000 series)
	Aluminum - Magnesium Alloys (3000 series)
	Aluminum - Magnesium - Silicon Alloys (6000 series)
	Cadmium
	Aluminum - Copper Alloys (2000 series)
	Cast Iron, Wrought Iron, Mild Steel
	Austenitic Nickel Cast Iron
	Type 410 Stainless Steel (active)
	Type 316 Stainless Steel (active)
	Type 304 Stainless Steel (active)
	Naval Brass, Yellow Brass, Red Brass
	Tin
	Copper
	Lead-Tin Solders
	Admiralty Brass, Aluminum Brass
	Manganese Bronze
	Silicon Bronze
	Tin Bronze
	Type 410 Stainless Steel (passive)
	Nickel - Silver
	Copper Nickel Alloys
	Lead
	Nickel - Aluminum Bronze
	Silver Solder
Nickel 200	
Silver	
Type 316 Stainless Steel (passive)	
Type 304 Stainless Steel (passive)	
Incoloy 825	
Hastelloy B	
Titanium	
Hastelloy C	
Platinum	
Graphite	

Cathodic End

Cable Tray Selection - Material & Finish

Corrosion Guide

Chemical	Cable Tray Material								
	Aluminum			Stainless Type 304			Stainless Type 316		
	Cold	Warm	Hot	Cold	Warm	Hot	Cold	Warm	Hot
Acetone	R	R	R	R	R	R	R	R	R
Aluminum Chloride Solution	NR	NR	NR	NR	--	--	F	--	--
Anhydrous Aluminum Chloride	R	R	R	NR	--	--	F	--	--
Aluminum Sulfate	R	R	R	R	R	R	R	R	R
Ammonium Chloride 10%	F	F	NR	R	R	R	R	R	R
Ammonium Hydroxide	F	F	F	R	R	R	R	R	R
Ammonium Phosphate	F	F	NR	R	--	--	R	--	--
Ammonium Sulfate	F	--	--	R	R	R	R	R	R
Ammonium Thiocyanate	R	R	R	R	--	--	R	R	R
Amyl Acetate	R	R	R	R	R	R	R	R	R
Amyl Alcohol	R	R	R	R	--	--	R	R	R
Arsenic Acid	F	F	F	R	R	--	R	R	R
Barium Chloride	F	F	NR	R	R	R	R	R	R
Barium Sulfate	R	R	R	R	R	--	R	R	--
Barium Sulfide	NR	NR	NR	R	R	--	R	R	--
Benzene	R	R	R	R	R	R	R	R	R
Benzoic Acid	F	F	NR	R	R	R	R	R	R
Boric Acid	R	R	F	R	R	R	R	R	R
Bromine Liquid or Vapor	NR	NR	NR	NR	NR	NR	NR	NR	NR
Butyl Acetate	R	R	R	R	--	--	R	R	R
Butyl Alcohol	R	R	R	R	R	R	R	R	R
Butyric Acid	F	F	F	R	R	R	R	R	R
Calcium Chloride 20%	F	F	NR	R	--	--	R	--	--
Calcium Hydroxide	N	--	--	R	R	F	R	R	R
Calcium Hypochlorite 2 - 3%	F	--	--	R	--	--	R	--	--
Calcium Sulfate	R	R	--	R	R	--	R	R	--
Carbon Monoxide Gas	R	R	R	R	R	R	R	R	R
Carbon Tetrachloride	F	F	NR	F	F	F	R	R	R
Chloroform Dry	R	NR	NR	R	R	--	R	R	--
Chloroform Solution	R	NR	NR	--	--	--	--	--	--
Chromic Acid 10% CP	R	R	--	R	R	F	R	R	R
Citric Acid	F	F	F	R	R	NR	R	R	R
Copper Cyanide	NR	NR	NR	R	R	R	R	R	R
Copper Sulfate 5%	NR	NR	NR	R	R	R	R	R	R
Ethyl Alcohol	R	R	R	R	R	R	R	R	R
Ethylene Glycol	R	R	F	R	R	--	R	R	R
Ferric Chloride	NR	NR	NR	NR	NR	NR	NR	NR	NR
Ferrous Sulfate 10%	R	NR	NR	R	R	--	R	R	--
Formaldehyde 37%	R	R	R	R	R	R	R	R	R
Formic Acid 10%	R	R	--	R	R	NR	R	R	R
Gallic Acid 5%	R	R	NR	R	R	R	R	R	R
Hydrochloric Acid 25%	NR	NR	NR	NR	NR	NR	NR	NR	NR
Hydrofluoric Acid 10%	NR	NR	NR	NR	NR	NR	NR	NR	NR
Hydrogen Peroxide 30%	R	R	R	R	R	R	R	R	R
Hydrogen Sulfide Wet	R	--	--	NR	NR	NR	R	R	R

R = Recommended

F = May be used under some conditions

NR = Not Recommended

-- = Information not available

The corrosion data given in this table is for general comparison only. (Reference Corrosion Resistance Tables, Second Edition)

The presence of contaminants in chemical environments can greatly affect the corrosion rate of any material.

We strongly suggest that field service tests or simulated laboratory tests using actual environmental conditions be conducted in order to determine the proper materials and finishes to be selected.

For questionable environments see Fiberglass Cable Tray Corrosion Guide (Pages M-3 & M-4).

Cold = 50 - 80°F Warm = 130 - 170°F Hot = 200 - 212°F

Corrosion Guide

Chemical	Cable Tray Material								
	Aluminum			Stainless Type 304			Stainless Type 316		
	Cold	Warm	Hot	Cold	Warm	Hot	Cold	Warm	Hot
Lactic Acid 10%	R	F	NR	R	R	F	R	R	R
Lead Acetate 5%	NR	NR	NR	R	R	R	R	R	R
Magnesium Chloride 1%	NR	NR	NR	R	--	F	R	--	R
Magnesium Hydroxide	R	R	R	R	R	--	R	R	--
Magnesium Nitrate 5%	R	--	--	R	R	R	R	R	R
Nickel Chloride	NR	NR	NR	R	--	--	R	--	--
Nitric Acid 15%	NR	NR	NR	R	R	R	R	R	R
Oleic Acid	R	R	F	R	R	F	R	R	R
Oxalic Acid 10%	R	F	NR	NR	NR	NR	R	R	R
Phenol CP	R	R	R	R	R	R	R	R	R
Phosphoric Acid 50%	NR	NR	NR	R	R	R	R	F	NR
Potassium Bromide 100%	R	F	NR	R	R	--	R	R	R
Potassium Carbonate 100%	F	F	--	R	R	R	R	R	R
Potassium Chloride 5%	R	R	R	R	R	R	R	R	R
Potassium Dichromate	R	R	R	R	R	R	R	R	R
Potassium Hydroxide 50%	NR	NR	NR	R	R	R	R	R	R
Potassium Nitrate 50%	R	R	R	R	R	R	R	R	R
Potassium Sulfate 5%	R	R	R	R	R	R	R	R	R
Propyl Alcohol	R	R	R	R	R	R	R	R	R
Sodium Acetate 20%	R	F	F	R	R	R	R	R	R
Sodium Bisulfate 10%	R	F	F	R	R	R	R	R	R
Sodium Borate	R	F	F	R	R	R	R	R	R
Sodium Carbonate 18%	R	F	F	R	R	R	R	R	R
Sodium Chloride 5%	R	NR	NR	R	R	R	R	R	R
Sodium Hydroxide 50%	NR	NR	NR	R	R	R	R	R	R
Sodium Hypochlorite 5%	R	F	F	F	--	--	R	--	--
Sodium Nitrate 100%	R	R	R	R	R	R	R	R	R
Sodium Nitrite 100%	R	R	R	R	R	R	R	R	R
Sodium Sulfate 100%	R	R	F	R	R	R	R	R	R
Sodium Thiosulfate	R	R	R	R	R	R	R	R	R
Sulfur Dioxide (Dry)	R	R	R	R	R	R	R	R	R
Sulfuric Acid 5%	NR	NR	--	F	NR	NR	R	--	--
Sulfuric Acid 10%	NR	NR	NR	NR	NR	NR	NR	NR	NR
Sulfuric Acid 50%	NR	NR	NR	NR	NR	NR	NR	NR	NR
Sulfuric Acid 75 - 98%	NR	NR	NR	NR	NR	NR	NR	NR	NR
Sulfuric Acid 98 - 100%	NR	NR	--	R	--	--	R	R	F
Tannic Acid 10 & 50%	NR	NR	NR	R	R	R	R	R	R
Tartaric Acid 10 & 50%	F	NR	NR	R	R	R	R	R	R
Vinegar	F	F	F	R	R	R	R	R	R
Zinc Chloride 5 & 20%	F	NR	NR	R	F	NR	R	R	R
Zinc Nitrate	F	NR	NR	R	R	R	R	R	R
Zinc Sulfate	F	NR	NR	R	R	R	R	R	R

R = Recommended
 F = May be used under some conditions
 NR = Not Recommended
 -- = Information not available

The corrosion data given in this table is for general comparison only. (Reference Corrosion Resistance Tables, Second Edition)

The presence of contaminants in chemical environments can greatly affect the corrosion rate of any material.

We strongly suggest that field service tests or simulated laboratory tests using actual environmental conditions be conducted in order to determine the proper materials and finishes to be selected.

For questionable environments see Fiberglass Cable Tray Corrosion Guide (Pages M-3 & M-4).

Cold = 50 - 80°F Warm = 130 - 170°F Hot = 200 - 212°F

Cable Tray Selection - Material & Finish

Thermal Contraction and Expansion

It is important that thermal contraction and expansion be considered when installing cable tray systems. The length of the straight cable tray runs and the temperature differential govern the number of expansion splice plates required (see Table 1 below).

The cable tray should be anchored at the support nearest to its midpoint between the expansion splice plates and secured by expansion guides at all other support locations (see Figure 1). The cable tray should be permitted longitudinal movement in both directions from that fixed point. When used, covers should be overlapped at expansion splices.

Accurate gap settings at the time of installation are necessary for the proper operation of the expansion splice plates. The following procedure should assist the installer in determining the correct gap: (see Figure 2)

- 1 Plot the highest expected metal temperature on the maximum temperature line.
- 2 Plot the lowest expected metal temperature on the minimum temperature line.
- 3 Draw a line between the maximum and minimum points.
- 4 Plot the metal temperature at the time of installation to determine the gap setting.

Figure 1

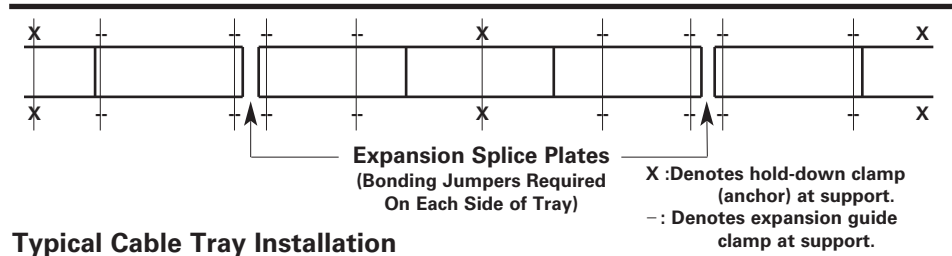

Typical Cable Tray Installation

Figure 2

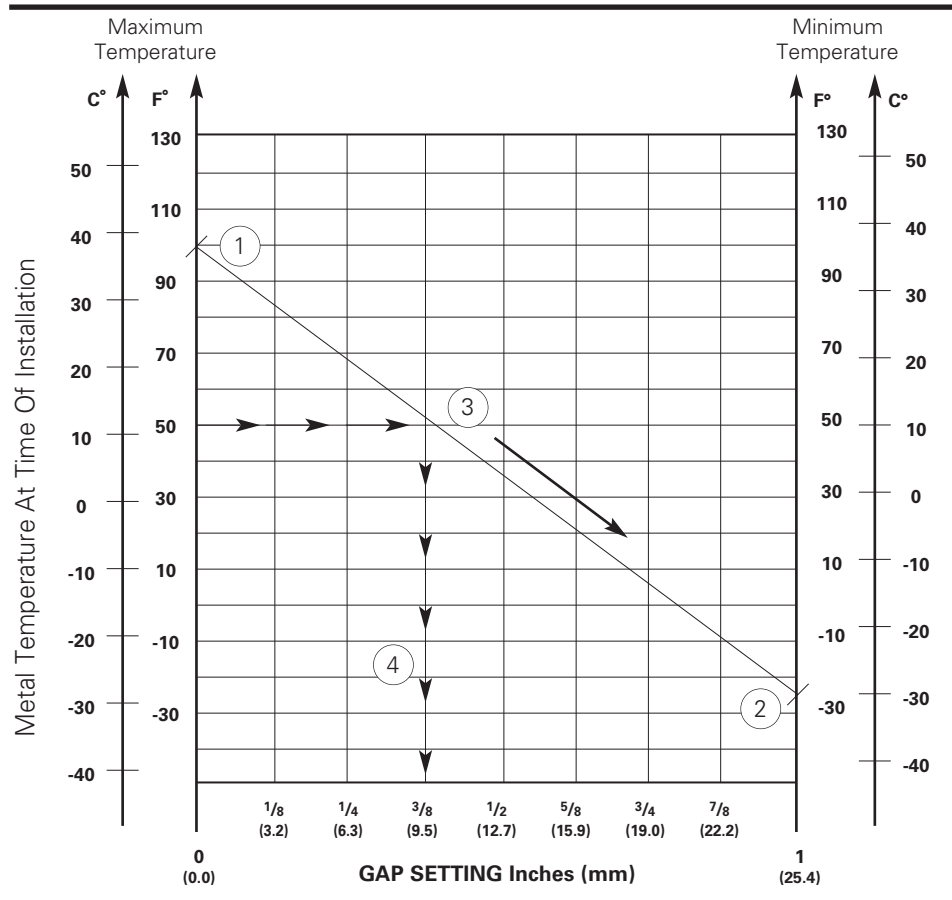

Table 1

Temperature Differential °F (°C)	Maximum Spacing Between Expansion Joints For 1" Movement							
	Steel		Aluminum		Stainless Steel		Fiberglass	
	Feet (m)	Feet (m)	Feet (m)	304 Feet (m)	316 Feet (m)	Feet (m)	Feet (m)	
25 (13.9)	512 (156.0)	260 (79.2)	347 (105.7)	379 (115.5)	417 (127.1)			
50 (27.8)	256 (78.0)	130 (39.6)	174 (53.0)	189 (57.6)	208 (63.4)			
75 (41.7)	171 (52.1)	87 (26.5)	116 (35.4)	126 (38.4)	139 (42.3)			
100 (55.6)	128 (39.0)	65 (19.8)	87 (26.5)	95 (29.0)	104 (31.7)			
125 (69.4)	102 (31.1)	52 (15.8)	69 (21.0)	76 (23.2)	76 (25.3)			
150 (83.3)	85 (25.9)	43 (13.1)	58 (17.7)	63 (19.2)	63 (21.0)			
175 (97.2)	73 (22.2)	37 (11.3)	50 (15.2)	54 (16.4)	59 (18.0)			

Notes: Every pair of expansion splice plates requires two bonding jumpers for grounding continuity.

For gap set and hold down/guide location, see installation instruction above. 1" (25.4mm) slotted holes in each expansion connector allow 5/8" (15.9mm) total expansion or contraction.

Installation Considerations

Weight

The weight of an aluminum cable tray is approximately half that of a comparable steel tray. Some factors to consider include: shipping costs, material, handling, project weight restrictions and the strength of support members.

Field Modifications

Aluminum cable tray is easier to cut and drill than steel cable tray since it is a “softer” material. Similarly, galvanized steel cable tray is easier to cut and drill than stainless steel cable tray. Our aluminum cable tray uses a four bolt splice, resulting in half as much drilling and hardware installation as most steel cable tray, which uses an eight bolt splice. Hot dip galvanized and painted steel cable tray finishes must be repaired when field cutting or drilling. Failure to repair coatings will impair the cable tray’s corrosion resistance.

Availability

Aluminum, pre-galvanized, stainless steel and fiberglass cable tray can normally be shipped from the factory in a short period of time. Hot dip galvanized and painted cable tray requires an additional coating process, adding several days of preparation before final shipment. Typically, a coated cable tray will be sent to an outside source for coating, requiring additional packing and shipping.

Electrical Grounding Capacity

The National Electrical Code, Article 392.6 allows cable tray to be used as an equipment grounding conductor. All standard steel and aluminum cable trays are classified by Underwriter’s Laboratories per NEC Table 392.6 based on their cross-sectional area.

The corresponding cross-sectional area for each side rail design (2 side rails) is listed on a fade resistant UV stabilized label (see Figure 3). This cable tray label is attached to each straight section and fitting that is U.L. classified. U.L. assigned cross-sectional area is also stated in the loading charts in this catalog for each system.

NEMA Installation Guide

The new NEMA VE 2 is a cable tray installation guideline and is available from NEMA, CTI or us. For free download see www.cabletrays.com.

Table 392.6(B)(2)
Metal Area Requirements for Cable Trays
Used as Equipment Grounding Conductors

Maximum Fuse Ampere Rating, Circuit Breaker Ampere Trip Setting, or Circuit Breaker Protective Relay Ampere Trip Setting for Ground Fault Protection of any Cable Circuit in the Cable Tray System	Minimum Cross-Sectional Area of Metal* In Square Inches	
	Steel Cable Trays	Aluminum Cable Trays
60	0.20	0.20
100	0.40	0.20
200	0.70	0.20
400	1.00	0.40
600	1.50**	0.40
1000	–	0.60
1200	–	1.00
1600	–	1.50
2000	–	2.00**

For SI units: one square inch = 645 square millimeters.

* Total cross-sectional area of both side rails for ladder or trough-type cable trays; or the minimum cross-sectional area of metal in channel-type cable trays or cable trays of one-piece construction.

** Steel cable trays shall not be used as equipment grounding conductors for circuits with ground-fault protection above 600 amperes. Aluminum cable trays shall not be used as equipment grounding conductors for circuits with ground-fault protection above 2000 amperes.

For larger ampere ratings an additional grounding conductor must be used.

Figure 3

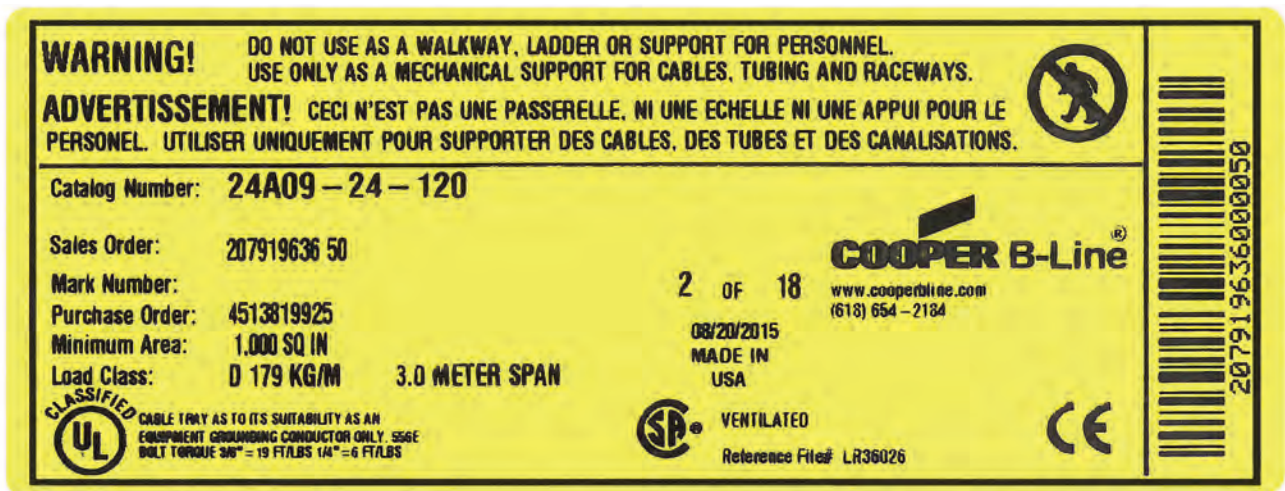

Cable Tray Selection - Strength

Environmental Loads

Wind Loads

Wind loads need to be determined for all outdoor cable tray installations. Most outdoor cable trays are ladder type trays, therefore the most severe loading to be considered is impact pressure normal to the cable tray side rails (see detail 1).

Detail 1



The impact pressure corresponding to several wind velocities are given below in Table 2.

Table 2

Impact Pressures

V(mph)	P(lbs/ft ²)	V(mph)	P(lbs/ft ²)
15	0.58	85	18.5
20	1.02	90	20.7
25	1.60	95	23.1
30	2.30	100	25.6
35	3.13	105	28.2
40	4.09	110	30.9
45	5.18	115	33.8
50	6.39	120	36.8
55	7.73	125	40.0
60	9.21	130	43.3
65	10.80	135	46.6
70	12.50	140	50.1
75	14.40	145	53.8
80	16.40	150	57.6

V = Wind Velocity

P = Impact Pressure

Note: These values are for an air density of 0.07651 lbs/ft³ corresponding to a temperature of 60° F and barometric pressure of 14.7 lbs/in².

Example Calculation:

Side load for 6" side rail with 100 mph wind

$$\frac{25.6 \times 6}{12} = 12.8 \text{ lbs/ft}$$

When covers are installed on outdoor cable trays, another factor to be considered is the aerodynamic effect which can produce a lift strong enough to separate a cover from a tray. Wind moving across a covered tray (see Detail 2) creates a positive pressure inside the tray and a negative pressure above the cover. This pressure difference can lift the cover off the tray. We recommend the use of heavy duty wrap-around cover clamps when covered trays are installed in an area where strong winds occur.

Detail 2

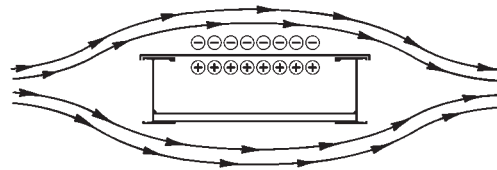

Special Notice:

Covers on wide cable tray and/or cable tray installed at elevations high off the ground may require additional heavy duty clamps or thicker cover material.

Ice Loads

Glaze ice is the most commonly seen form of ice build-up. It is the result of rain or drizzle freezing on impact with an exposed object. Generally, only the top surface (or the cover) and the windward side of a cable tray system is significantly coated with ice. The maximum design load to be added due to ice should be calculated as follows:

$$LI = \left(\frac{W \times TI}{144} \right) \times DI \text{ where;}$$

LI= Ice Load (lbs/linear foot)

W= Cable Tray Width (inches)

TI= Maximum Ice Thickness (inches)

DI= Ice Density = 57 lbs/ft³

the maximum ice thickness will vary depending on location. A thickness of 1/2" can be used as a conservative standard.

Example Calculation:

Ice Loads for 24" wide tray with 1/2" thick ice;

$$\frac{24 \times .5}{144} \times 57 = 4.75 \text{ lbs/ft}$$

Environmental Loads

Snow Loads

Snow is measured by density and thickness. The density of snow varies almost as much as its thickness. The additional design load from snowfall should be determined using the building codes which apply for each installation.

Seismic Loads

A great deal of seismic testing and evaluation of cable tray systems, and their supports, has been performed. The conclusions reached from these evaluations is that cable tray is stronger laterally than vertically, since it acts as a truss in the lateral direction. Other factors that contribute to the stability of cable tray are the energy dissipating motion of the cables within the tray, and the high degree of ductility of the cable tray and the support material. These factors, working in conjunction with a properly designed cable tray system, should afford reasonable assurance to withstand even strong motion earthquakes.

When seismic bracing is required for a cable tray system, it should be applied to the supports and not the cable tray itself. Our "Seismic Restraints" brochure provides OSHPD approved methods of bracing cable tray supports using standard Eaton's B-Line series products. Contact us to receive a copy of this brochure.

Concentrated Loads

A concentrated static load represents a static weight applied at a single point between the side rails. Tap boxes, conduit attachments and long cable drops are just some of the many types of concentrated loads. When so specified, these concentrated static loads may be converted to an equivalent, uniform load (W_e) by using the following formula:

$$W_e = \frac{2 \times (\text{concentrated Static Load})}{\text{span length}}$$

Our cable tray side rails, rungs and bottoms will withstand a 200 lb. static load without collapse (series 14 excluded)*. However, it should be noted that per NEMA Standard Publication VE1 cable tray is designed as a support for power or control cables, or both, and is not intended or designed to be a walkway for personnel. Each section of the Cable Tray has a label stating the following message:

**Warning! Not to be used as a walkway, ladder or support for personnel.
To be used only as a mechanical support for cables and raceway.
Failure to adhere to these warnings may result in serious injury or property damage.**

Support Span

The strength of a cable tray is largely determined by the strength of its side rails. The strength of a cable tray side rail is proportionate to the distance between the supports on which it is installed, commonly referred to as the “support span”. Therefore, the strength of a cable tray system can be altered by changing the support span. However, there is a limit to how much the strength of a cable tray system can be increased by reducing the support span, because the strength of the cable tray bottom members could become the determining factor of strength.

Once the load requirement of a cable tray system has been established, the following factors should be considered:

1. Sometimes the location of existing structural beams will dictate the cable tray support span. This is typical with outdoor installations where adding intermediate supports could be financially prohibitive. For this situation the appropriate cable tray must be selected to accommodate the existing span.
2. When cable tray supports are randomly located, the added cost of a higher strength cable tray system should be compared to the cost of additional supports. Typically, adding supports is more costly than installing a stronger series of cable tray. The stronger cable tray series (e.g. from 75 lbs./ft. on 20' span to 100 lbs./ft. on 20' span) will increase the price of the cable tray system minimally, possibly less than \$1/ft., with little or no additional labor cost for installation. Alternately, one extra support may cost \$100.00 (material and labor) for a simple trapeze. Future cable additions or the capability of supporting equipment, raceways for example, also favor stronger cable tray systems. *In summary, upgrading to a stronger cable tray series is typically more cost-effective than using the recommended additional supports for a lighter duty cable tray series.*
3. The support span lengths should be equal to or less than unspliced straight section lengths, to ensure that no more than one splice is placed between supports as stated in the NEMA VE 2 Cable Tray Installation Guideline.

Deflection

Deflection in a cable tray system is primarily an aesthetic consideration. When a cable tray system is installed in a prominent location, a maximum simple beam deflection of 1/200 of support span can be used as a guideline to minimize visual deflection.

It is important at this point to mention that there are two typical beam configurations, simple beam and continuous beam, and to clarify the difference.

A good example of a simple beam is a single straight section of cable tray supported, but not fastened at either end. When the tray is loaded the cable tray is allowed to flex. Simple beam analysis is used almost universally for beam comparisons even though it is seldom practical in the field installations. The three most prominent reasons for using a simple beam analysis are: ① calculations are simplified; ② it represents the worst case loading; and ③ testing is simple and reliable. The published load data in our cable tray catalog is based on the simple beam analysis per NEMA & CSA Standards.

Simple Beam

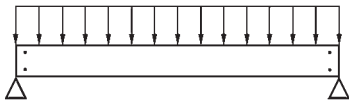

Continuous beam is the beam configuration most commonly used in cable tray installations. An example of this configuration is where cable trays are installed across several supports to form a number of spans. The continuous beam possesses traits of both the simple and fixed beams. When equal loads are applied to all spans simultaneously, the counterbalancing effect of the loads on both sides of a support restricts the movement of the cable tray at the support. The effect is similar to that of a fixed beam. The end spans behave substantially like simple beams. When cable trays of identical design are compared, the continuous beam installation will typically have approximately half the deflection of a simple beam of the same span. Therefore, simple beam data should be used only as a general comparison. The following factors should be considered when addressing cable tray deflection:

Continuous Beam

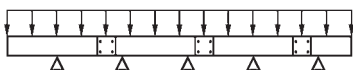

1. Economic consideration must be considered when addressing cable deflection criteria.
2. Deflection in a cable tray system can be reduced by decreasing the support span, or by using a taller or stronger cable tray.
3. When comparing cable trays of equivalent strength, a steel cable tray will typically exhibit less deflection than an aluminum cable tray since the modulus of elasticity of steel is nearly three times that of aluminum.
4. The location of splices in a continuous span will affect the deflection of the cable tray system. The splices should be located at points of minimum stress whenever practical. NEMA Standards VE 1 limits the use of splice plates as follows:

Unspliced straight sections should be used on all simple spans and on end spans of continuous span runs. Straight section lengths should be equal to or greater than the span length to ensure not more than one splice between supports.

See the figures below for splicing configuration samples.

Typical Continuous Span Configuration

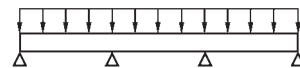

+ Maximum Positive Moment
- Maximum Negative Moment

Preferred Splice Plate Locations

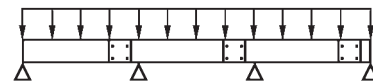

Undesirable Splice Plate Locations

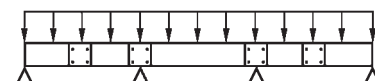

Cable Tray Selection - Strength

Load Capacity

Calculate each anticipated load factor, then add them to obtain a total load.

(Example: Working Load = Cable + Concentrated + Wind + Snow + Ice Loads).

The Working Load should be used, along with the maximum support spacing, to select a span/load class designation from Table 3. Table 4 (page C-15) contains the most common load/span class designations per the US and Canadian metallic cable tray standard, CSA, C22.2 No. 126.1-98 First Addition, NEMA VE 1-1998.

Table 3
These Loading Classes Are Historical and Supplied For Reference Only

Load Class	Class Designations for lengths of										
	lb/ft	(kg/m)	ft	m	ft	m	ft	m	ft	m	
		8	(2.4)	10	(3.0)	12	(3.7)	16	(4.9)	20	(6.0)
25	(37)	--		A		--		--		--	
45	(67)	--		--		--		--		D	
50	(74)	8A		--		12A		16A		20A	
65	(97)	--		C		--		--		--	
75	(112)	8B		--		12B		16B		E or 20B	
100	(149)	8C		--		12C		16C		20C	
120	(179)	--		D		--		--		--	
200	(299)	--		E		--		--		--	

Note: 8A/B/C, 12A/B/C, 16A/B/C, and 20A/B/C were the traditional NEMA designations. A, C, D, and E were the conventional CSA designations. Actual tested loadings per span will be stated on the product labels.

Cable Tray Selection - Strength

Table 4
B-Line series Cable Tray Load Classes

Aluminum Copper free							Steel HDGAF/Pre-Galvanized					
Series	Load Depth	Load lb/ft (kg/m)	Span ft (m)	Former Classes		Series	Load Depth	Load lb/ft (kg/m)	Span ft (m)	Former Classes		
				NEMA	CSA					NEMA	CSA	
KSA4A	3.03	55 (82)	12 (3.7)	12A	C (3m)	148*	3	51 (76)	12 (3.7)	12A	C ₁ (3m)	
RSI04A	2.68	75 (112)	12 (3.7)	12B	C (3m)	248*	3	103 (153)	12 (3.7)	12C	D ₁ (3m)	
KSB4A	4.03	55 (81)	12 (3.7)	12A	C (3m)	346*	3	63 (943)	20 (6.1)	20A	D ₁ (6m)	
24A	3	126 (187)	12 (3.7)	12C	D ₁ (3m)	444*	3	91 (135)	20 (6.1)	20B	E (3m)	
H24A	3.09	56 (83)	20 (6.1)	20A	D (6m)	156*	4	76 (113)	12 (3.7)	12B	C ₁ (3m)	
34A	3	80 (119)	20 (6.1)	20B	E (6m)	258*	4	109 (162)	12 (3.7)	12C	D ₁ (3m)	
KSA5A	3.05	88 (131)	12 (3.7)	12B	D (3m)	356*	4	69 (103)	20 (6.1)	16C	D ₁ (6m)	
RSI05A	3.66	83 (123)	12 (3.7)	12B	C (3m)	358*	4	62 (92)	20 (6.1)	20A	D ₁ (6m)	
KSB5A	4.05	83 (124)	12 (3.7)	12B	D (3m)	454*	4	106 (158)	20 (6.1)	20C	E (6m)	
25A	4	50 (74)	20 (6.1)	16B	D ₁ (6m)	166*	5	77 (115)	12 (3.7)	12B	C ₁ (3m)	
35A	4	121 (180)	16 (4.9)	20B	E (3m)	268*	5	110 (164)	12 (3.7)	12C	D ₁ (3m)	
RSI06A	4.64	82 (121)	12 (3.7)	12C	D ₁ (3m)	368†	5	59 (88)	20 (6.1)	20A	D ₁ (3m)	
KSB6A	5.05	79 (118)	12 (3.7)	12B	D (3m)	366*	5	75 (112)	20 (6.1)	20B	E (6m)	
26A	5	51 (76)	20 (6.1)	20A	D ₁ (6m)	464* †	5	123 (183)	20 (6.1)	119# @ 20'	E (6m)	
36A	5	84 (125)	20 (6.1)	20B	E (6m)	176*	6	86 (128)	12 (3.7)	12B	137 kg/m (3.7m)	
46A	5	103 (153)	20 (6.1)	20C	E (6m)	378*	6	51 (76)	20 (6.1)	20A	D ₁ (3m)	
H46A	5	167 (248)	20 (6.1)	167# @ 20'	131 kg/m (7.6m)	476*	6	77 (115)	20 (6.1)	20B	D ₁ (6m)	
RSI07A	5.63	122 (182)	12 (3.7)	12C	D ₁ (3m)	574*	6	130 (193)	20 (6.1)	117# @ 20'	E (6m)	
27A	6.05	123 (183)	12 (3.7)	12C	D (6m)	348†	3	125 (186)	12 (3.7)	12C	C ₁ (3m)	
37A	6	80 (119)	20 (6.1)	20B		358†	4	62 (92)	20 (6.1)	20A	89 kg/m (6.1m)	
47A	6	100 (149)	20 (6.1)	20C		FT1.5X12	1 1/2	11 (16)	8 (2.4)			
H47A	6	149 (222)	20 (6.1)	149# @ 20'		FT2X2	2	20 (30)	8 (2.4)			
57A	6	102 (152)	30 (9.1)	102# @ 30'	152 kg/m (9.1m)	FT2X4	2	27 (40)	8 (2.4)			
S8A	6	161 (240)	30 (9.1)	161# @ 30'	240 kg/m (9.1m)	FT2X6	2	27 (40)	8 (2.4)			
						FT2X8	2	27 (40)	8 (2.4)			
						FT2X12	2	27 (40)	8 (2.4)			
						FT2X16	2	27 (40)	8 (2.4)			
						FT2X18	2	27 (40)	8 (2.4)			
						FT2X20	2	27 (40)	8 (2.4)			
						FT2X24	2	27 (40)	8 (2.4)			
						FT2X30	2	27 (40)	8 (2.4)			
						FT2X36	2	27 (40)	8 (2.4)			
						FT4X4	4	36 (53)	8 (2.4)			
						FT4X6	4	46 (53)	8 (2.4)			
						FT4X8	4	47 (70)	8 (2.4)			
						FT4X12	4	47 (70)	8 (2.4)			
						FT4X16	4	47 (70)	8 (2.4)			
						FT4X18	4	47 (70)	8 (2.4)			
						FT4X20	4	47 (70)	8 (2.4)			
						FT4X24	4	50 (74)	8 (2.4)	8A		
						FT4X30	4	50 (74)	8 (2.4)	8A		
						FT6X8	6	43 (64)	8 (2.4)	8A		
						FT6X12	6	48 (71)	8 (2.4)	8A		
						FT6X16	6	50 (74)	8 (2.4)	8A		
						FT6X18	6	50 (74)	8 (2.4)	8A		
						FT6X20	6	55 (82)	8 (2.4)	8A		
						FT6X24	6	60 (89)	8 (2.4)	8A		

* G denotes CSA Type 1 (HDGAF) or P denotes CSA Type 2 (Mill-Galvanized)

† SS4 (Type 304 Stainless) or SS6 (Type 316 Stainless)

Cable Tray Selection - Strength

Cable Data

The cable load is simply the total weight of all the cables to be placed in the tray. This load should be expressed in lbs/ft.

The data on this page provides average weights for common cable sizes.

Multiconductor Cable Type TC, 600V with XHHW Conductors, Copper

Size	3 conductors with ground			4 conductors with ground		
	Diameter in.	Area in. ²	Weight lbs/ft	Diameter in.	Area in. ²	Weight lbs/ft
8	0.66	0.34	0.33	0.72	0.41	0.42
6	0.74	0.43	0.45	0.81	0.52	0.58
4	0.88	0.61	0.66	0.96	0.72	0.84
2	1.00	0.79	0.96	1.10	0.95	1.20
1	1.13	1.00	1.17	1.25	1.23	1.55
1/0	1.22	1.17	1.43	1.35	1.43	1.84
2/0	1.31	1.35	1.72	1.45	1.65	2.20
3/0	1.42	1.58	2.14	1.58	1.96	2.80
4/0	1.55		2.64	1.77		3.46
250	1.76		3.18	1.93		4.04
350	1.98		4.29	2.18		5.48
500	2.26		5.94	2.50		7.64
750	2.71		9.01	3.12		11.40
1000	3.10		11.70			

Multiconductor Cable Type MC, 600V with XHHW Conductors, Copper

Size	3 conductors with ground						4 conductors with ground					
	Diameter in.		Area in. ²		Weight lbs/ft		Diameter in.		Area in. ²		Weight lbs/ft	
	Without Jacket	With Jacket	Without Jacket	With Jacket	Alum. Armor	Steel Armor	Without Jacket	With Jacket	Without Jacket	With Jacket	Alum. Armor	Steel Armor
8	0.70	0.80	0.38	0.50	0.41	0.57	0.76	0.86	0.45	0.58	0.51	0.68
6	0.78	0.88	0.48	0.61	0.55	0.74	0.85	0.95	0.57	0.71	0.69	0.87
4	0.89	0.99	0.62	0.77	0.74	0.95	0.97	1.07	0.74	0.90	0.93	1.15
2	1.01	1.12	0.80	0.99	1.08	1.32	1.10	1.22	0.95	1.17	1.29	1.56
1	1.16	1.27	1.06	1.27	1.38	1.63	1.25	1.36	1.23	1.45	1.61	1.91
1/0	1.23	1.34	1.19	1.41	1.56	1.86	1.35	1.46	1.43	1.67	1.94	2.27
2/0	1.32	1.43	1.37	1.61	1.85	2.20	1.46	1.56	1.67	1.91	2.36	2.72
3/0	1.46	1.57	1.67	1.94	2.35	2.67	1.58	1.71	1.96	2.30	2.94	3.33
4/0	1.56	1.68			2.82	3.21	1.75	1.88			3.64	3.97
250	1.74	1.86			3.31	3.94	1.92	2.04			4.21	4.64
350	1.96	2.10			4.48	4.97	2.16	2.30			5.71	6.12
500	2.24	2.37			6.08	6.58	2.47	2.63			7.91	8.39
750	2.68	2.84			8.96	9.70	3.03	3.22			11.48	12.17

Single Conductor Cable 600V

Size	XHHW			THHN, THWN			TW, THW			USE, RHH, RHW		
	Diameter in.	Area in. ²	Weight lbs/ft	Diameter in.	Area in. ²	Weight lbs/ft	Diameter in.	Area in. ²	Weight lbs/ft	Diameter in.	Area in. ²	Weight lbs/ft
1/0	0.48		0.37	0.50		0.37	0.53		0.39	0.53		0.39
2/0	0.52		0.46	0.54		0.46	0.57		0.48	0.57		0.49
3/0	0.58		0.57	0.60		0.57	0.62		0.60	0.63		0.60
4/0	0.63		0.71	0.66		0.71	0.68		0.74	0.68		0.75
250	0.70	0.38	0.85	0.72	0.41	0.85	0.75	0.44	0.88	0.76	0.45	0.89
300	0.75	0.44	1.02	0.77	0.47	1.02	0.81	0.52	1.04	0.81	0.52	1.05
350	0.80	0.50	1.17	0.83	0.54	1.17	0.86	0.58	1.21	0.86	0.58	1.22
400	0.85	0.57	1.33	0.87	0.59	1.33	0.90	0.64	1.37	0.91	0.65	1.38
500	0.93	0.68	1.64	0.96	0.72	1.64	0.98	0.75	1.69	0.99	0.77	1.70
600	1.04	0.85	2.03	1.06	0.88	2.01	1.09	0.93	2.03	1.10	0.95	2.07
750	1.14	1.02	2.24	1.17	1.08	2.48	1.19	1.11	2.51	1.20	1.13	2.55
1000	1.29		2.52	1.32		3.30	1.34		3.31	1.35		3.33

For allowable cable types see the Appendix page APP-5.

The following guidelines are based on the 2011 National Electrical Code, Article 392.

I) Number of Multiconductor Cables rated 2000 volts or less in the Cable Tray

(1) 4/0 or Larger Cables

The ladder cable tray must have an inside available width equal to or greater than the sum of the diameters (Sd) of the cables, which must be installed in a single layer. When using solid bottom cable tray, the sum of the cable diameters is not to exceed 90% of the available cable tray width.

Example: Cable Tray width is obtained as follows:

List Cable Sizes	(D) List Cable Outside Diameter	(N) List Number of Cables	Multiply (D) x (N) = Subtotal of the Sum of the Cable Diameters	
	3/C - #500 kcmil	2.26 inches	1	2.26 inches
	3/C - #250 kcmil	1.76 inches	2	3.52 inches
	3/C - #4/0 AWG	1.55 inches	4	6.20 inches

The sum of the diameters (Sd) of all cables = 2.26 + 3.52 + 6.20 = 11.98 inches; therefore a cable tray with an available width of at least 12 inches is required.

(2) Cables Smaller Than 4/0

The total sum of the cross-sectional areas of all the cables to be installed in the cable tray must be equal to or less than the allowable cable area for the tray width, as indicated in Table 5.

When using solid bottom cable tray, the allowable cable area is reduced by 22%.

Table 5

Inside Width of Cable Tray inches	Allowable Cable Area square inches
6	7.0
9	10.5
12	14.0
18	21.0
24	28.0

Example: The cable tray width is obtained as follows:

List Cable Sizes	(A) List Cable Cross Sectional Areas	(N) List Number of Cables	Multiply (A) x (N) + Total of the Cross-Sectional Area for each Size
3/C - #12 AWG	0.167 sq. in.	10	1.67 sq. in.
4/C - #12 AWG	0.190 sq. in.	8	1.52 sq. in.
3/C - # 6 AWG	0.430 sq. in.	6	2.58 sq. in.
3/C - # 2 AWG	0.800 sq. in.	9	7.20 sq. in.

The sum of the total areas is 1.67 + 1.52 + 2.58 + 7.20 = 12.97 inches.

Using Table 5, a 12-inch wide tray with an allowable cable area of 14 sq. inches should be used.

Note: Increasing the cable tray loading depth does not permit an increase in allowable cable area for power and lighting cables. The maximum allowable cable area for all cable tray with a 3 inch or greater loading depth is limited to the allowable cable area for a 3 inch loading depth.

(3) 4/0 or Larger Cables Installed with Cables Smaller than 4/0

The ladder cable tray needs to be divided into two zones (a barrier or divider is not required but one can be used if desired) so that the No. 4/0 and larger cables have a dedicated zone, as they are to be placed in a single layer.

continued on C-18

Cable Tray Selection - Width & Available Loading Depth

Allowable Cable Fill

A direct method to determine the correct cable tray width is to figure the cable tray widths required for each of the cable combinations per steps (2) & (3).

Then add the widths in order to select the proper cable tray width.

Example: The cable tray width is obtained as follows:

Part A- Width required for #4/0 AWG and larger multiconductor cables

List Cable Size	(D) List Cable Outside Diameter	(N) List Number of Cables	Multiply (D) x (N) = Subtotal of the Sum of the Cable Diameters (Sd)
3/C - #500 kcmil	2.26 inches	1	2.26 inches
3/C - #4/0 AWG	1.55 inches	2	3.10 inches

Cable tray width (inches) required for large cables = 2.26 + 3.10 = 5.36 inches.

Part B- Width required for multiconductor cables smaller than #4/0 AWG

List Cable Sizes	(A) List Cable Cross Sectional Areas	(N) List Number of Cables	Multiply (A) x (N) = Total of the Cross-Sectional Area for each Size
3/C - #12 AWG	0.167 sq. in.	10	1.67 sq. in.
3/C - #6 AWG	0.430 sq. in.	8	3.44 sq. in.
3/C - #2 AWG	0.800 sq. in.	2	1.60 sq. in.

The sum of the total areas (inches) = 1.67 + 3.44 + 1.60 = 6.71 sq. inches.

From Table 5 (page 33), the cable tray width required for small cables is 6 inches.

The total cable tray width (inches) = 5.36 + 6.00 = 11.36 inches. A 12-inch wide cable tray is required.

(4) Multiconductor Control and/or Signal Cables Only

A ladder cable tray containing only control and/or signal cables, may have 50% of its total available cable area filled with cable. When using solid bottom cable tray pans, the allowable cable area is reduced from 50% to 40%.

Example: Cable tray width is obtained as follows:

2/C- #16 AWG instrumentation cable cross sectional area = 0.04 sq. in.

Total cross sectional area for 300 Cables = 12.00 sq. in.

Minimum available cable area needed = 12.00 x 2 = 24.00 sq. in.; therefore the cable tray width required for 4 inch available loading depth tray = 24.00/4 = 6 inches.

II) Number of Single Conductor Cables Rated 2000 Volts or Less in the Cable Tray

All single conductor cables to be installed in the cable tray must be 1/0 or larger, and are not to be installed with continuous bottom pans.

(1) 1000 KCMIL or Larger Cables

The sum of the diameters (Sd) for all single conductor cables to be installed shall not exceed the cable tray width. See Table 6.

Table 6

Inside Width of Cable Tray inches	Allowable Cable Area square inches
6	6.50
9	9.50
12	13.00
18	19.50
24	26.00
30	32.50
36	39.00

continued on C-19

Allowable Cable Fill

(2) 250 KCMIL to 1000 KCMIL Cables

The total sum of the cross-sectional areas of all the single conductor cables to be installed in the cable tray must be equal to or less than the allowable cable area for the tray width, as indicated in Table 6 (page C-18). (Reference Table 8)

(3) 1000 KCMIL or Larger Cables Installed with Cables Smaller Than 1000 KCMIL

The total sum of the cross-sectional areas of all the single conductor cables to be installed in the cable tray must be equal to or less than the allowable cable area for the tray width, as indicated in Table 7.

Table 7

Inside Width of Cable Tray inches	Allowable Cable Area square inches
6	6.50 - (1.1 Sd)
9	9.50 - (1.1 Sd)
12	13.00 - (1.1 Sd)
18	19.50 - (1.1 Sd)
24	26.00 - (1.1 Sd)
30	32.50 - (1.1 Sd)
36	39.00 - (1.1 Sd)

(4) Single Conductor Cables 1/0 through 4/0

These single conductors must be installed in a single layer. See Table 8.

Note: It is the opinion of some that this practice may cause problems with unbalanced voltages. To avoid these potential problems, the individual conductors for this type of cable tray wiring system should be bundled with ties. The bundle should contain all of the three-phase conductors for the circuit, plus the neutral if used. The single conductor cables bundle should be firmly tied to the cable tray assembly at least every 6 feet.

Table 8

Number of 600 Volt Single Conductor Cables That May Be Installed in Ladder Cable Tray

Single Conductor Size	Outside Diameter in.	Area sq. in.	Cable Tray Width				
			6 in.	9 in.	12 in.	18 in.	24 in.
1/0	0.58	-	10	15	20	31	41
2/0	0.62	-	9	14	19	29	38
3/0	0.68	-	8	13	17	26	35
4/0	0.73	-	8	12	16	24	32
250 Kcmil	0.84	.55	11	18	24	35	47
350 Kcmil	0.94	.69	9	14	19	28	38
500 Kcmil	1.07	.90	7	11	14	22	29
750 Kcmil	1.28	1.29	5	8	10	15	20
1000 Kcmil	1.45	-	4	6	8	12	16

Cable diameters used are those for Oknite-Okolon 600 volt single conductor power cables.

III) Number of Type MV and MC Cables Rated 2001 Volts or Over in the Cable Tray

The sum of the diameters (Sd) of all cables, rated 2001 volts or over, is not to exceed the cable tray width.

Cable Tray Selection - Width & Available Loading Depth

Sizing Cable Tray Per 2014 NEC 392

Start Here

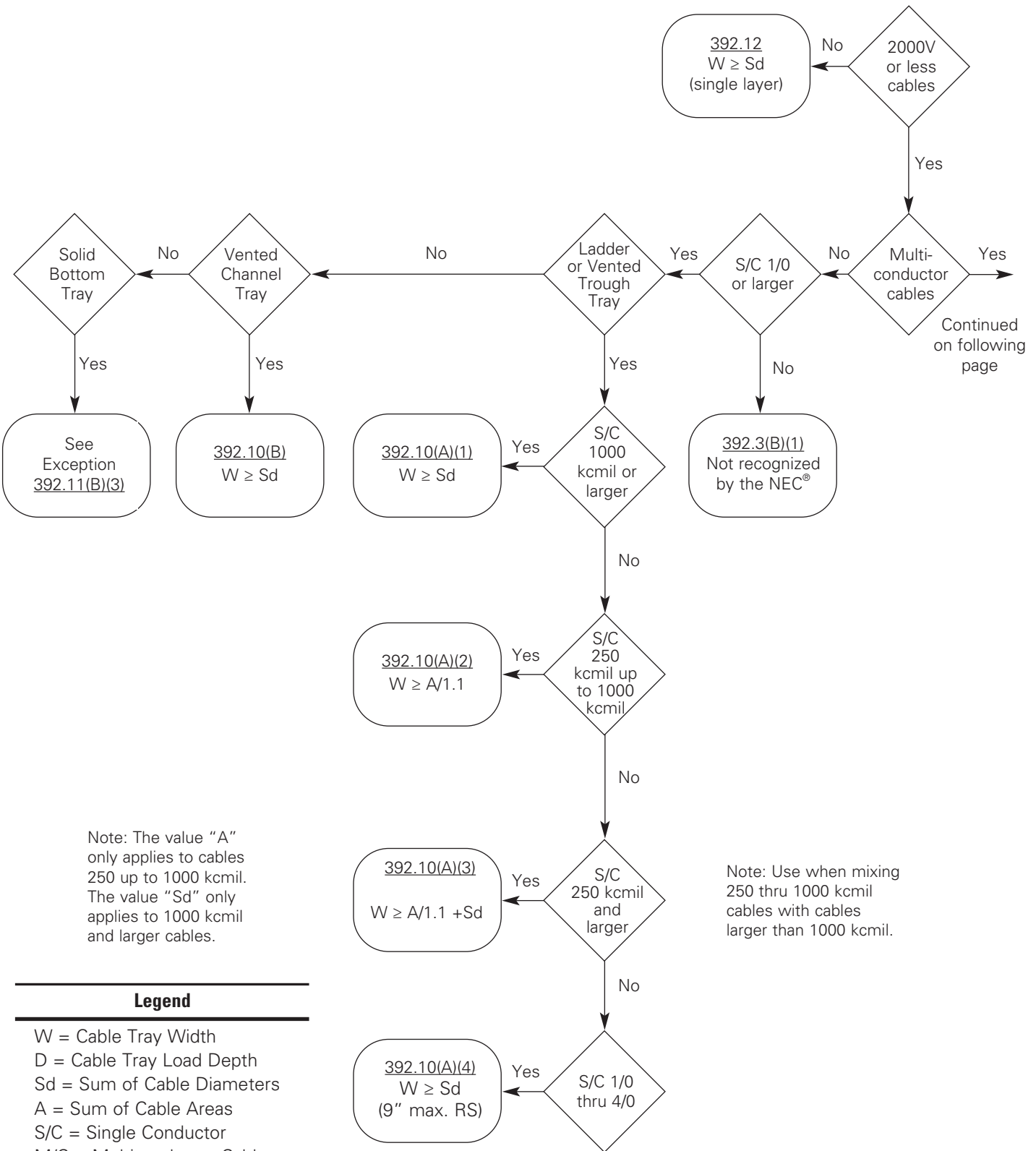

Note: The value "A" only applies to cables 250 up to 1000 kcmil. The value "Sd" only applies to 1000 kcmil and larger cables.

Note: Use when mixing 250 thru 1000 kcmil cables with cables larger than 1000 kcmil.

Legend

W = Cable Tray Width
 D = Cable Tray Load Depth
 Sd = Sum of Cable Diameters
 A = Sum of Cable Areas
 S/C = Single Conductor
 M/C = Multiconductor Cables
 RS = Ladder Rung Spacing

Cable Tray Selection - Width & Available Loading Depth

Note: See appendix on page APP-15 for additional information regarding cable ampacity and hazardous (classified) location requirements which might affect the cable tray sizing flow chart.

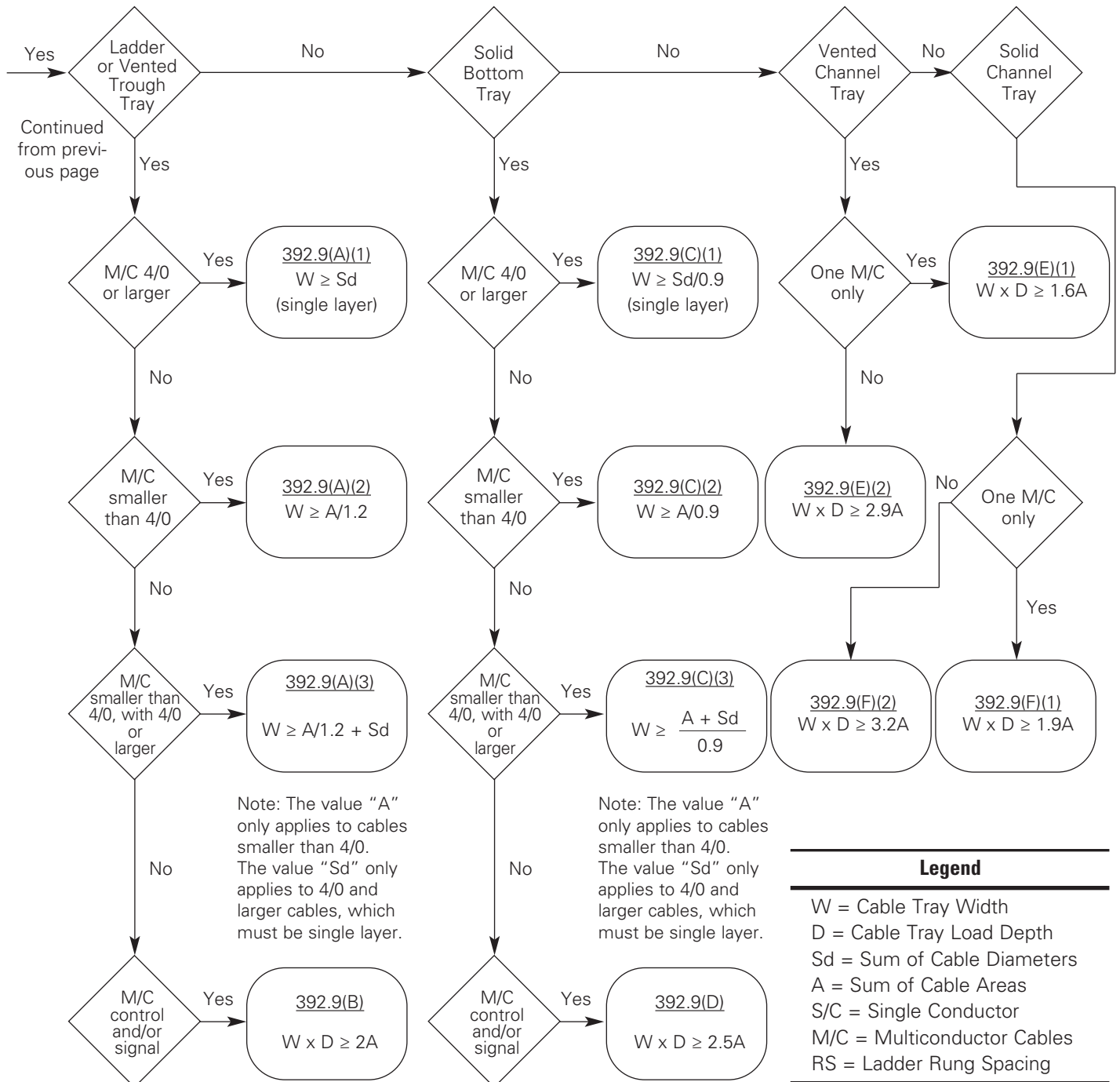

Cable Tray Selection

Cable Tray Selection - Width & Available Loading Depth

Barrier Requirements

Barrier strips are used to separate cable systems, such as when cables above and below 600 volts per NEC 392.6(F) are installed in the same cable tray. However, when MC type cables rated over 600 volts are installed in the same cable tray with cables rated 600 volts or less, no barriers are required. The barriers should be made of the same material type as the cable tray. When ordering the barrier, the height must match the *loading depth* of the cable tray into which it is being installed.

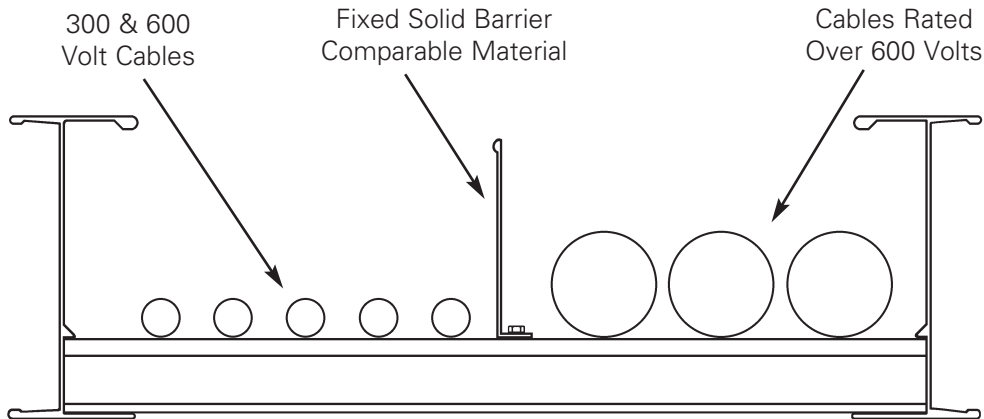

Future Expansion Requirements

One of the many features of cable tray is the ease of adding cables to an existing system. Future expansion should always be considered when selecting a cable tray, and allowance should be made for additional *fill area* and *load capacity*. A minimum of 50% expansion allowance is recommended.

Space Limitations

Any obstacles which could interfere with a cable tray installation should be considered when selecting a cable tray width and height. Adequate clearances should be allowed for installation of supports and for cable accessibility.

Note: The overall cable tray dimensions typically exceed the nominal tray width and loading depth.

Lengths Available

The current Cable Tray Standard, NEMA VE 1 and C22.2 No. 126.1, lists typical lengths as 3000 mm (10 ft), 3660 mm (12 ft), 6000 mm (20 ft), and 7320 mm (24 ft). It is impractical to manufacture either lighter systems in the longer lengths or heavier systems in the shorter lengths. For that reason, we have introduced a primary and secondary length for each system.

These straight section lengths were selected to direct the user to lengths that best suit support span demands and practical loading requirements. The primary length is the one that is the most appropriate for the strength of the system and that will provide the fastest service levels. The secondary lengths will be made available to service additional requirements. Special lengths are available with extended lead times.

Support Span

Per the NEMA VE 2, the support span on which a cable tray is installed should not exceed the length of the unspliced straight section. Thus installations with support spans greater than 12 feet should use 240" (20 feet) or 288" (24 feet) cable tray lengths.

Space Limitations

Consideration should be given to the space available for moving the cable tray from delivery to its final installation location. Obviously, shorter cable tray allows for more maneuverability in tight spaces.

Installation

Shorter cable tray lengths are typically easier to maneuver on the job site during installation. Two people may be needed to manipulate longer cable tray sections, while shorter sections might be handled by one person. Although longer cable tray lengths are more difficult to maneuver, they can reduce installation time due to the fact that there are fewer splice connections. This trade-off should be evaluated for each set of job site restrictions.

Cable Tray Selection - Loading Possibilities

Power Application:

Power application can create the heaviest loading. The heaviest cable combination found was for large diameter cables (i.e. steel armor, 600V, 4 conductor 750 kcmil). The cables weigh less than 3.8 lbs. per inch width of cable tray. As power cables are installed in a single layer, the width of the cable affects the possible loading.

36" Wide 140 lbs/ft	30" Wide 115 lbs/ft	24" Wide 90 lbs/ft	18" Wide 70 lbs/ft	12" Wide 45 lbs/ft	9" Wide 35 lbs/ft	6" Wide 23 lbs/ft
------------------------	------------------------	-----------------------	-----------------------	-----------------------	----------------------	----------------------

Data/Communication Cabling:

Low voltage cables can be stacked as there is no heat generation problems. The NEC employs a calculation of the total cross sectional area of the cables not exceeding 50% of the fill area of the cable tray. As the cable fill area of the cable tray system affects the possible loading, both the loading depth and width of the systems must be considered. For this example, 4UTP category 5 cable (O.D. = .21, .026 lbs./ft.) were used.

Calculated Cable Weight in Lbs/Ft

	36" Wide	30" Wide	24" Wide	18" Wide	12" Wide	9" Wide	6" Wide
6" Fill	81	64	52	41	27	20	14
5" Fill	68	53	43	34	23	17	12
4" Fill	54	43	35	27	18	13	9
3" Fill	41	32	26	21	14	10	7



The picture shows a 12" cable tray with a 3" load depth. The tray contains 520 4 UTP Category 5 cables with a .21" diameter.

The National Electrical Code allows for 50% fill of ventilated and ladder cable tray for control or signal wiring (Article 392.9(B)). ANSI/EIA/TIA 569-A Section 4.5* also requires that the fill ratio of cable tray is not to exceed 50%.

Calculation Example:
 Tray Area = 12 in. x 3 in. = 36 sq. in.
 50% Fill = 36 sq. in. x .5 = 18 sq. in.
 Cable Area = (.21 in.)² x 3.14/4 = .0346 sq. in.
 Number of Cables = 18 sq. in. / .0346 sq. in. = 520 cables

*Section 4.5 is currently under review.

Other Factors To Consider

- **Support Span** - The distance between the supports affects the loading capabilities exponentially. To calculate loading values not cataloged use:

$$W_1 L_1^2 = W_2 L_2^2$$

W_1 - tested loading
 L_1 - span in feet, a tested span
 W_2 - loading in question
 L_2 - known span for new loading

- **Other Loads** - Ice, wind, snow for outdoor systems see pages C-10 and C-11 for information. A 200 lb. concentrated load for industrial systems. The affect of a concentrated load can be calculated as follows

$$\frac{2 \times (\text{concentrated static load})}{\text{span in feet}}$$

When considering concentrated loads the rung strength should be considered.

- **Length Of The Straight Sections:**

The VE 2, Cable Tray Installation Guide, states that the support span shall not be greater than the straight section length. If a 20C system is manufactured in 12 foot sections the greatest span for supports would be 12 feet. This dramatically affects the loading of the system.

$$W_1 L_1^2 = W_2 L_2^2$$

$$100 (20^2) = W_2 (12^2)$$

$$40,000 = 144 W_2$$

$$W_2 = 277 \text{ lbs. per foot}$$

Type of Cable

According to NEC Article 392, multiconductor tray cable may be installed in any standard cable tray bottom type. According to the 2014 NEC Article 392.11(8)(3), single conductor tray cable may be installed in any standard cable tray bottom type. Solid bottom cable trays are not allowed to be installed in Class II, Division 2 locations (2014 NEC Section 502.4(B)). In general, small, highly flexible cables should be installed in solid bottom, vented bottom or 6" rung spacing ladder type cable trays. Sensitive cables (e.g. fiber optic) are typically installed in flat, solid bottom cable trays, instead of corrugated trough bottoms. Larger, less flexible cables are typically installed in ladder type cable trays having 9" or 12" rung spacing. Ladder type cable trays having 18" rung spacing should be used for large, stiff cables to reduce cost and facilitate cable drop-outs.

Cost vs Strength

Often, more than one bottom type is acceptable. In this case, the economic difference should be considered. Ladder cable trays have a lower cost than either non-ventilated or ventilated bottom configurations. Typically, the cost of ladder type cable tray decreases as rung spacing increases. However, the effect of rung spacing on load capacity for ladder type cable trays with 18" rung spacing should be evaluated, since NEMA published load capacities are based on 12" rung spacing. Rung spacing can affect individual rung and side rail loading as well as system load capacity. Rung loads applied during cable installation should also be considered.

Cable Exposure

Tray cables are manufactured to withstand the environment without additional protection, favoring the use of the ladder type cable tray. Some areas may benefit from the limited exposure of solid or vented bottom cable tray. Solid bottom metal cable tray with solid metal covers can be utilized in other spaces used for environmental air to support non plenum rated tray cables (2014 NEC® 300.22(C)(1)).

Cable Attachment

The major advantage of ladder type cable tray is the freedom of entry and exit of the cables. Another advantage of ladder type cable tray is the ability to secure cables in the cable tray. With standard rungs, the cables may be attached with either cable ties or cable clamps. The ladder type cable tray is also available with special purpose, slotted marine or strut rungs to facilitate banding or clamping cables. Cable attachment is particularly important on vertical runs or when the tray is installed on its side. Ladder rung spacing should be chosen to provide adequate cable attachment points while allowing the cables to exit the system.

Cable Tray Selection - Fitting Radius

Cable Flexibility

The proper bend radius for cable tray fittings is usually determined by the bend radius and stiffness of the tray cables to be installed. Typically, the tray cable manufacturer will recommend a minimum bend allowance for each cable. The fitting radius should be equal to or larger than the minimum bend radius of the largest cable which may ever be installed in the system. When several cables are to be installed in the same cable tray, a larger bend radius may be desirable to ease cable installation.

Space Limitations

The overall dimensions for a cable tray fitting will increase as the bend radius increases. Size and cost make the smallest acceptable fitting radius most desirable. When large radius fittings are required, the system layout must be designed to allow adequate space.

FLEXTRAY™ Wire Basket

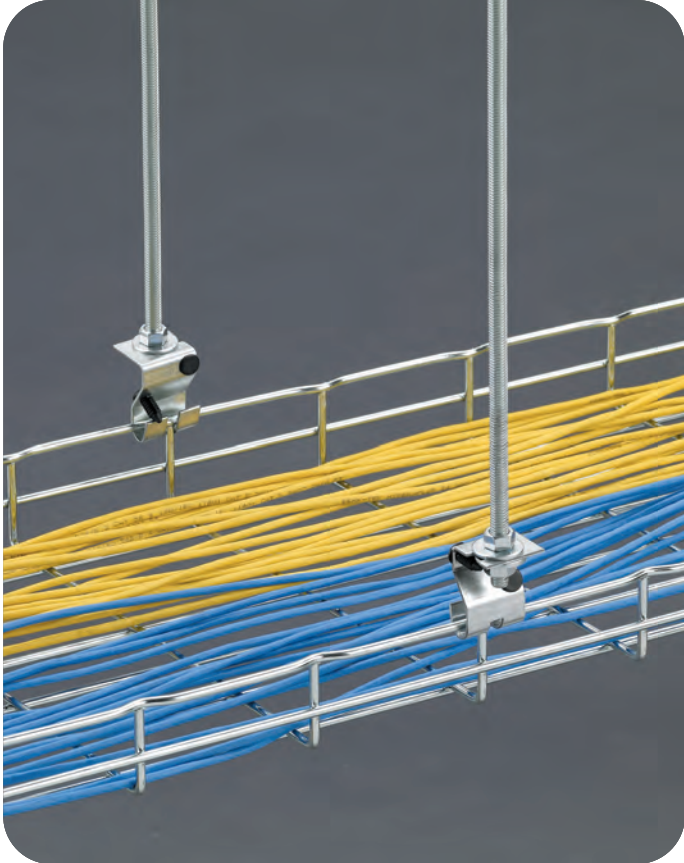
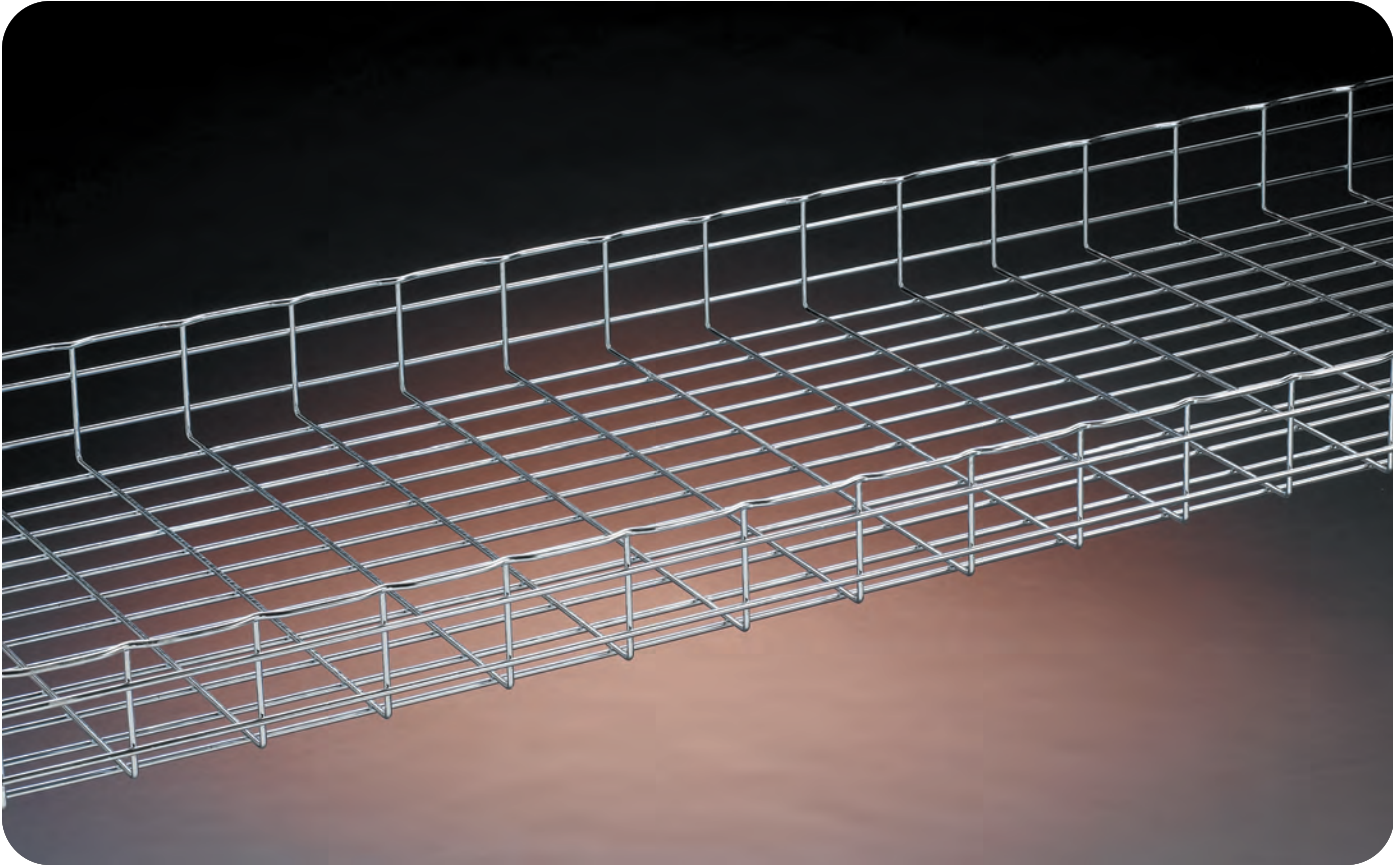

FLEXTRAY

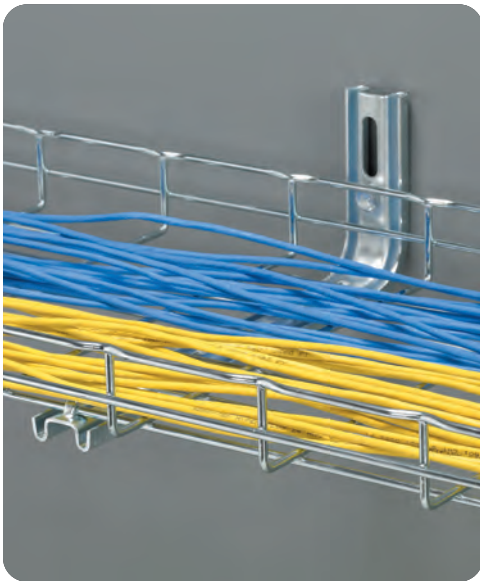

The Flextray system is a flexible, field-adaptable way to manage cables throughout your project. The tray can be cut and bent to the needs of the installer on the jobsite, allowing cable runs to be adjusted as needed. The wide range of sizes offered makes Flextray a great choice for everything from a small cable drop to a large trunk of cables. Our tray has the market-preferred "T" weld safety edge, protecting both the cable and the installer during cable installation. Flextray is also UL Classified as an equipment grounding conductor.

The F.A.S.T.™ System is Foldable, Adjustable, Stackable, and Tool-less, providing many options to manage cables inside your raised floor space. With only a few parts, you can create everything from a basic single layer installation to a cantilevered, multiple-tier cable run. Make the most of your raised floor space and your time with the F.A.S.T. System!

Finish Information

FLEXTRAY cable tray and accessories are available in a wide variety of finishes to meet the environmental or aesthetic requirements of customer installations. Use the list below to find the finish and suffix that will meet your needs.

Available product finishes will be listed on individual pages throughout the catalog.

Finish codes shown in bold type are the standard for that product.

Plain wire: ASTM A510, Grade 1008

- EG** Electroplated zinc galvanized finish applied after fabrication
(ELG) Recommended applications: Controlled interior
UL/CSA Classified as an equipment ground conductor when spliced as recommended
ASTM B633 - Average thickness of 0.3 mils (8 microns)
- GS** Pre-galvanized zinc finish applied before fabrication
(GLV) Recommended applications: Limited industrial & interior
UL/CSA Classified as an equipment ground conductor when spliced as recommended
ASTM A641
- BLE** Black powder coat finish applied after fabrication
Recommended applications: Controlled interior
UL/CSA Classified as an equipment ground conductor when coating has been removed at splice contact points
Average paint thickness of 1.2 mils (30 microns) to 3.0 mils (75 microns)
- HD** Hot dip galvanized finish applied after fabrication
(HDG) Recommended applications: Exterior, corrosive. Not intended for clean room applications.
UL/CSA Classified as an equipment ground conductor when spliced as recommended
ASTM A123 - Average thickness of 2.4 mils (60 microns) to 3.2 mils (80 microns)
- 304S** 304L Stainless steel
(SS4) Recommended applications: Food preparation, wash-down areas
ASTM A580
- 316S** 316L Stainless steel
(SS6) Recommended applications: Highly corrosive applications & marine environments
ASTM A580
- Custom powder coat finish applied after fabrication
Recommended applications: Controlled interior
UL/CSA Classified as an equipment ground conductor when coating has been removed at splice contact points
No Specification

Grounding Information

Statement for all UL Classified products:



This product is classified by Underwriters Laboratories, Inc. as to its suitability as an equipment grounding conductor only. 556E



Most sizes of the FLEXTRAY system are UL Classified to serve as an Equipment Ground Conductor. The ground path can be achieved in one of two ways listed on page D-4:

Grounding Information (cont.)

1. Use the recommended quantity of UL Classified splices™ to connect sections and at places where the tray is cut.
2. Run an appropriately sized ground wire alongside the tray and attach it to each tray section and on both sides of a cut in the tray. (This method is recommended by NEMA VE-2 Installation Manual.)

Load & Fill Chart

FLEXTRAY Series		Support Span / Loading Capacity* Lbs/Ft (max)				Actual Area Inside Tray (in ²)	Cable Fill (50% fill)**		
Part Number	Size height x width	5'-0"	6'-0"	7'-0"	8'-0"		Number of CAT 5e Cables***	Number of CAT 6 Cables***	Number of CAT 6A Cables***
FT1.5X12	1 1/2" x 12"	29	17	14	11	12.2	176	124	95
FT2X2	2" x 2"	34	28	24	20	4.3	61	43	33
FT2X4	2" x 4"	52	43	35	27	8.2	118	83	64
FT2X6	2" x 6"	66	47	35	27	12.1	175	123	95
FT2X8	2" x 8"	66	47	35	27	16.1	231	163	125
FT2X12	2" x 12"	68	47	35	27	23.9	345	243	187
FT2X16	2" x 16"	68	47	35	27	31.8	459	324	249
FT2X18	2" x 18"	68	47	35	27	35.8	516	364	280
FT2X20	2" x 20"	68	47	35	27	39.7	573	404	311
FT2X24	2" x 24"	68	47	35	27	47.5	686	484	372
FT2X30	2" x 30"	68	47	35	27	59.8	862	608	468
FT2X32	2" x 32"	77	53	39	30	63.3	914	645	496
FT4X4	4" x 4"	58	49	42	36	15.8	227	160	123
FT4X6	4" x 6"	93	77	60	46	23.6	341	240	185
FT4X8	4" x 8"	94	78	61	47	31.5	454	321	247
FT4X12	4" x 12"	119	83	61	47	47.5	686	484	372
FT4X16	4" x 16"	119	83	61	47	63.5	917	647	498
FT4X18	4" x 18"	119	83	61	47	71.5	1032	728	560
FT4X20	4" x 20"	119	83	61	47	79.5	1148	810	623
FT4X24	4" x 24"	128	89	65	50	95.5	1379	973	749
FT4X30	4" x 30"	128	89	65	50	119.5	1725	1217	936
FT6X8	6" x 8"	111	77	57	43	47.3	682	481	370
FT6X12	6" x 12"	124	86	63	48	71.6	1034	729	561
FT6X16	6" x 16"	128	89	65	50	95.3	1375	970	746
FT6X18	6" x 18"	128	89	65	50	107.3	1549	1092	840
FT6X20	6" x 20"	141	98	72	55	118.9	1716	1211	932
FT6X24	6" x 24"	154	107	78	60	143.3	2068	1459	1123

* Published load chart has not been tested with Flexmate™ splice. Please consult the factory for load information when using the Flexmate option.

** FLEXTRAY fill capacity is based on NEC allowable fill of 50%. The NEC rule requires that the cable cross-sectional areas together may not exceed 50% of the tray area (width x depth = fill). Cables will nearly completely fill the cable tray when reaching the 50% cable fill, due to empty space between the surface of the cables. TIA recommends 40% fill ratio. Flextray loads shown in the loading chart will not be exceeded at 50% fill.

*** CAT 5e 4-pr non-plenum approximated at .21 in. diameter, CAT 6 4-pr non-plenum approximated at .25 in. diameter, CAT 6A approximated at .285 diameter. Actual diameters vary by cable manufacturer.

FLEXTRAY™ Wire Basket - Straight Sections

1.5" Deep FLEXTRAY

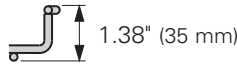
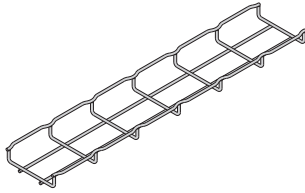

Height: 1.38" (35 mm)
Length: 118.312" (3 meter)
Wire Dia. Minimum: .196" (5.0 mm)
Finishes:
 EG, GS, BLE, HD, 304S, 316S



Part Number	Width		Wt. Per Pc.	
	in.	(mm)	lbs.	(kg)
FT1.5X4X10	4	(100)	5.8	(2.63)
FT1.5X6X10	6	(150)	7.4	(3.35)
FT1.5X8X10	8	(200)	9.0	(4.08)
FT1.5X12X10	12	(300)	12.1	(5.49)

Only FT1.5X12 (12" wide) is UL Classified

2" Deep FLEXTRAY

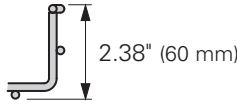
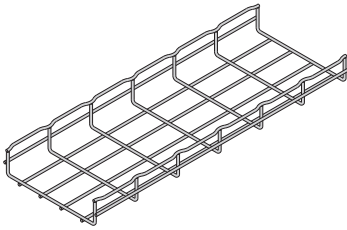

Height: 2.38" (60 mm)
Length: 118.312" (3 meter)
Wire Dia. Minimum: .196" (5.0 mm)
Finishes:
 EG, GS, BLE, HD, 304S, 316S

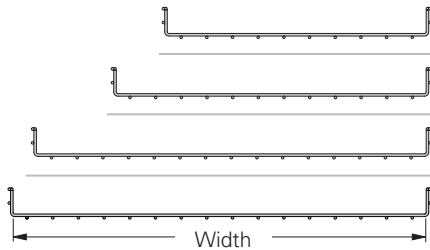

Part Number	Width		Wt. Per Pc.	
	in.	(mm)	lbs.	(kg)
FT2X2X10	2	(50)	6.6	(2.99)
FT2X4X10	4	(100)	8.2	(3.72)
FT2X6X10	6	(150)	9.7	(4.40)
FT2X8X10	8	(200)	11.2	(5.08)
FT2X12X10	12	(300)	14.3	(6.48)
FT2X16X10	16	(400)	17.4	(7.89)
FT2X18X10	18	(450)	18.9	(8.57)
FT2X20X10	20	(500)	20.4	(9.25)
FT2X24X10	24	(600)	23.5	(10.66)
FT2X30X10	30	(750)	28.1	(12.74)
FT2X32X10	32	(800)	29.7	(13.47)

FT2X6 (6" wide) through FT2X32 (32" wide) are UL Classified

FLEXTRAY™ Wire Basket - Straight Sections

4" Deep FLEXTRAY

Part Number	Width		Wt. Per Pc.	
	in.	(mm)	lbs.	(kg)
FT4X4X10	4	(100)	11.25	(5.10)
FT4X6X10	6	(150)	12.79	(5.80)
FT4X8X10	8	(200)	14.32	(6.49)
FT4X12X10	12	(300)	17.39	(7.89)
FT4X16X10	16	(400)	20.45	(9.27)
FT4X18X10	18	(450)	21.99	(9.97)
FT4X20X10	20	(500)	23.52	(10.67)
FT4X24X10	24	(600)	26.59	(12.06)
FT4X30X10	30	(750)	31.19	(14.15)

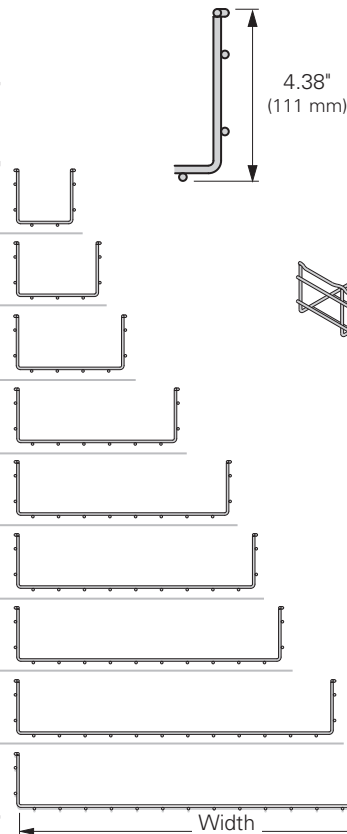

Height: 4.38" (111 mm)
Length: 118.312" (3 meter)
Wire Diameter Minimum: .196" (5.0 mm)
Finishes: EG, GS, BLE, HD, 304S, 316S

All 4" deep Flextrays are UL Classified

6" Deep FLEXTRAY

Part Number	Width		Wt. Per Pc.	
	in.	(mm)	lbs.	(kg)
FT6X8X10	8	(200)	17.39	(7.89)
FT6X12X10	12	(300)	20.45	(9.27)
FT6X16X10	16	(400)	23.52	(10.67)
FT6X18X10	18	(450)	25.06	(11.37)
FT6X20X10	20	(500)	26.59	(12.06)
FT6X24X10	24	(600)	29.66	(13.45)

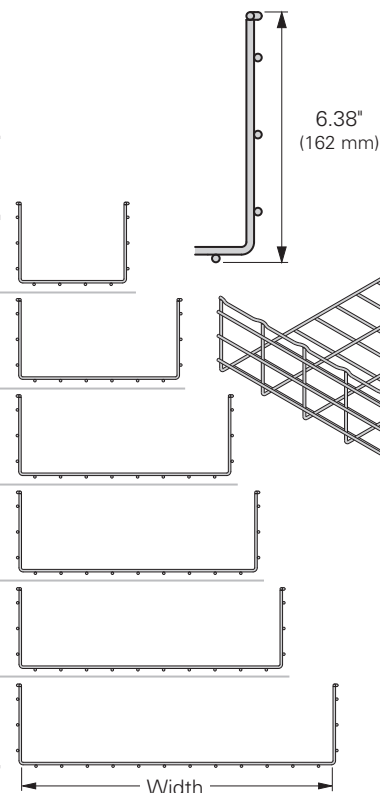

Height: 6.38" (162 mm)
Length: 118.312" (3 meter)
Wire Diameter Minimum: .196" (5.0 mm)
Finishes: EG, GS, BLE, HD, 304S, 316S

All 6" deep Flextrays are UL Classified

See page D-3 for finish information

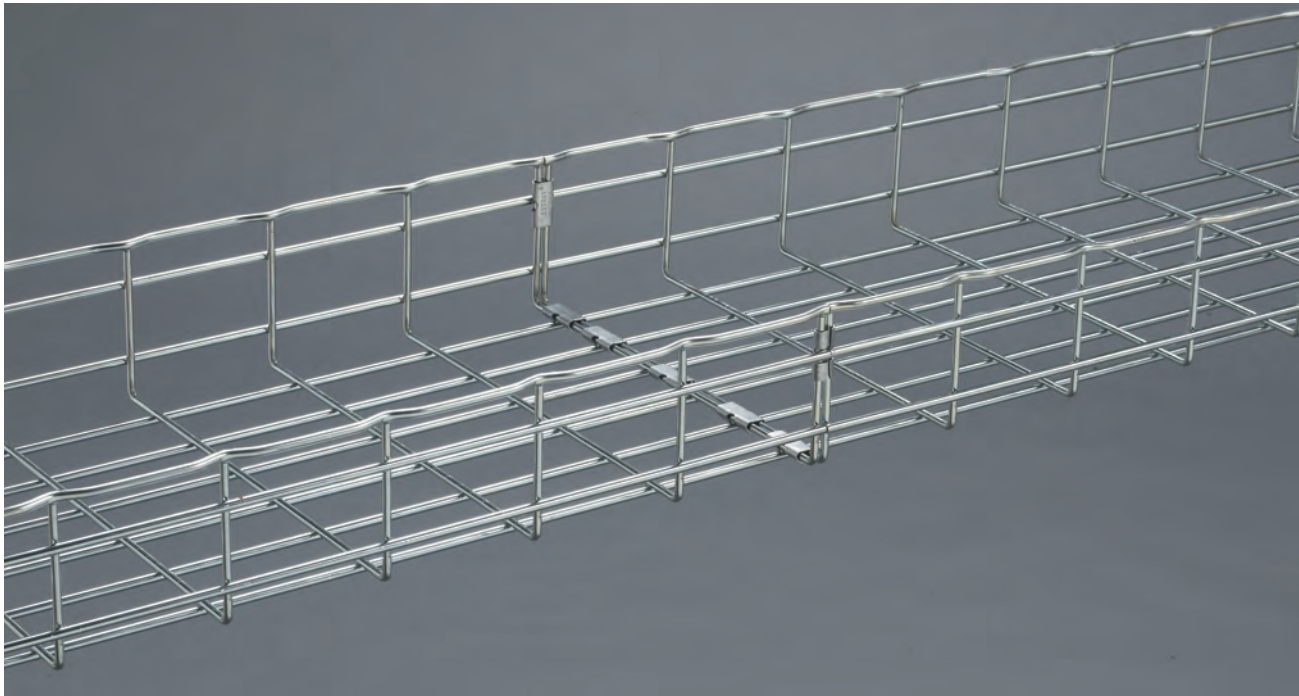
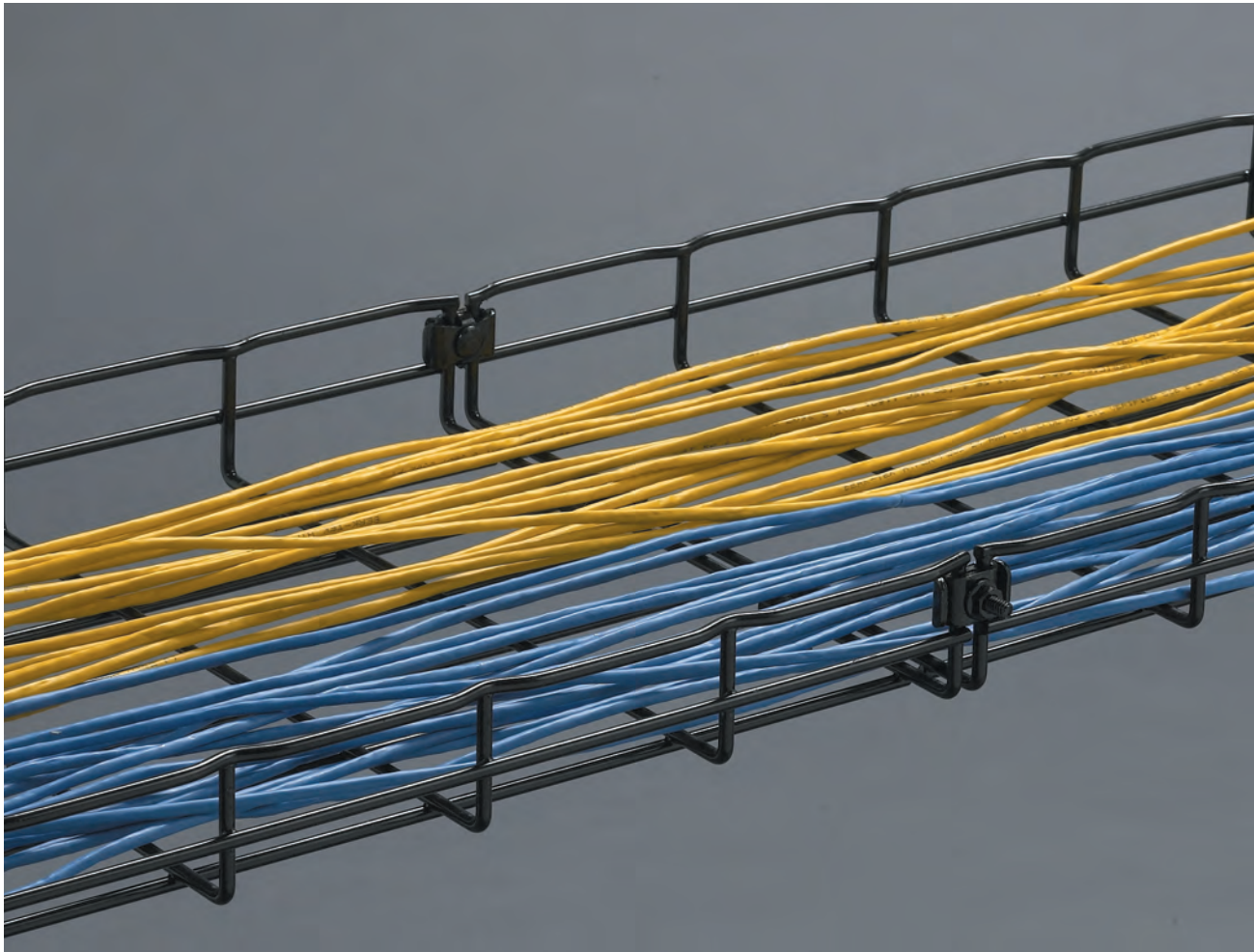

FLEXTRAY

Washer Splice Kit

- Washer is staked to bolt, holding part stationary during installation
- Fewer parts to handle
- For use with all tray widths and sizes
- Finishes __: **EG, BLE**

BLE suffix indicates black zinc finish for this part only



Part Number	Description	Qty./Box	Wt./Box lbs. (kg)
WASHER SPL KIT__	Assembly of Staked Washer Stud/Washer & Finned Nut	100	4.5 (2.04)

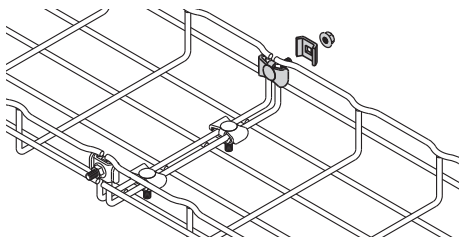

Splicing Chart (number of splices required for UL Classification)

Tray Height	Tray Width - number of splices									
	2" (50mm)	4" (100mm)	6" (150mm)	8" (200mm)	12" (300mm)	16" (400mm)	18" (450mm)	20" (500mm)	24" (600mm)	>24" (>600mm)
2"	NC	NC	3	3	3	4	4	4	4	5
4"	NM	3	3	3	3	4	4	4	4	5
6"	NM	NM	3	3	3	4	4	4	4	5

NC = Not UL Classified in this size NM = FLEXTRAY is not manufactured in this size

Splice Hardware Components

- Works with all splicing needs
- For use with all tray widths and sizes
- Components are sold separately
- Finishes __: **EG, BLE, 304S, 316S**

FTHDWE 1/4 not available in **BLE**.



Part Number	Description	Qty./Box	Wt./Box lbs. (kg)
FTHDWE 1/4__	1/4" x 1" Carriage Bolt & Finned nut	50	2.4 (1.08)
TOP WASHER__	1" Square Splice Washer	100	2.8 (1.26)
BTM WASHER__	1 3/16" Square Splice Washer	100	4.0 (1.82)

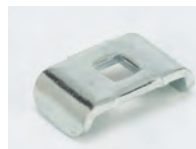
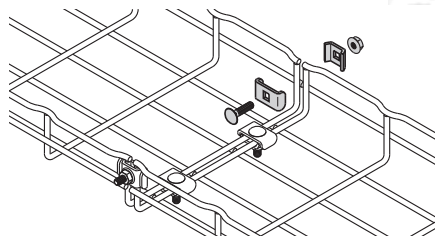

BTM WASHER



FTHDWE1/4



TOP WASHER

Splicing Chart (number of splices required for UL Classification)

Tray Height	Tray Width - number of splices									
	2" (50mm)	4" (100mm)	6" (150mm)	8" (200mm)	12" (300mm)	16" (400mm)	18" (450mm)	20" (500mm)	24" (600mm)	>24" (>600mm)
2"	NC	NC	3	3	3	4	4	4	4	5
4"	NM	3	3	3	3	4	4	4	4	5
6"	NM	NM	3	3	3	4	4	4	4	5

NC = Not UL Classified in this size NM = FLEXTRAY is not manufactured in this size

See page D-3 for finish and grounding information

FLEXTRAY™ Wire Basket - Splicing Accessories

Connecting Hardware

Part Number	Description	Qty./Box	Wt./Box lbs. (kg)
FTSCH__	Connecting Hardware	50	2.0 (0.91)

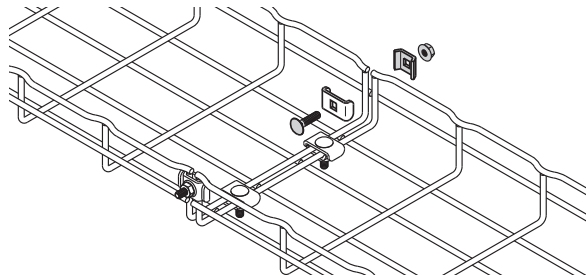

- Adaptable and designed for use with splice plate (FTS3SP), SPLICE BAR, and long splice bar (FTS36SB).
- Finishes __: EG, BLE-BLO, 304S, 316S

Splicing Chart (number of splices required for UL Classification)

Tray Height	Tray Width - number of splices									
	2" (50mm)	4" (100mm)	6" (150mm)	8" (200mm)	12" (300mm)	16" (400mm)	18" (450mm)	20" (500mm)	24" (600mm)	>24" (>600mm)
2"	NC	NC	3	3	3	4	4	4	4	5
4"	NM	3	3	3	3	4	4	4	4	5
6"	NM	NM	3	3	3	4	4	4	4	5

NC = Not UL Classified in this size NM = FLEXTRAY is not manufactured in this size

Wing Splice™

Part Number	Description	Qty./Box	Wt./Box lbs. (kg)
FTSWN__	Wing Splice	50	3.0 (1.38)

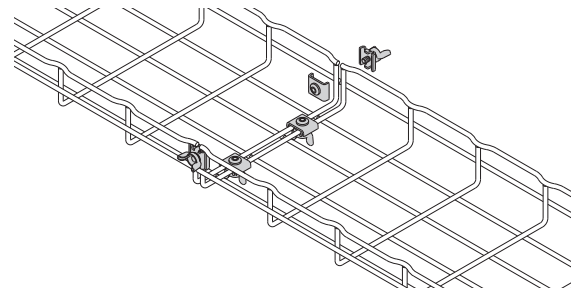

- Two piece design for easy handling
- Tool-less installation
- Reduces installation time, especially when used on fittings and bends
- Finish__: ZN

Splicing Chart (number of splices required for UL Classification)

Tray Height	Tray Width - number of splices									
	2" (50mm)	4" (100mm)	6" (150mm)	8" (200mm)	12" (300mm)	16" (400mm)	18" (450mm)	20" (500mm)	24" (600mm)	>24" (>600mm)
2"	NC	NC	3	3	3	4	4	4	4	5
4"	NM	3	3	3	3	4	4	4	4	5
6"	NM	NM	3	3	3	4	4	4	4	5

NC = Not UL Classified in this size NM = FLEXTRAY is not manufactured in this size

See page D-3 for finish and grounding information

Splice Plate (only)

Part Number	Description	Length in. (mm)	Height in. (mm)	Hole Diameter in. (mm)	Qty./ Box	Wt./Box lbs. (kg)
FTS3SP__	Splice Plate	2.7" (68.5)	1.6" (40.6)	0.27" (6.8)	50	6.1 (2.76)

- Splice plate is designed for use with connecting hardware (FTSCH) to provide added stability of splice connections
- Hardware sold separately
- Finish__: **ZN**, SS6
- Note: FT2x2x10 and FT2x4x10 are not UL Classified

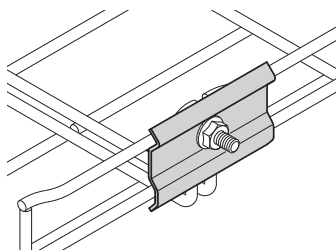

FLEXMATE™ Splice System

- Fastest splice connection method available in the industry
- For use with 4" (100mm) to 12" (300mm) wide tray
- FLEXMATE clips and tool sold separately
- Finishes __: **GS**, BLE

Note: Tray widths larger than 12" (300mm) are not UL Classified. We recommend that splice/supports comply with NEMA VE-2 installation requirements

Part Number	Description	Qty./Box	Wt./Box lbs. (kg)
FLEXMATE2__	Flexmate Splice Clips	100	1.0 (0.45)
FLEXMATE TOOL	Flexmate Splice Tool	1	0.7 (0.32)



FLEXMATE TOOL

Flexmate Tool is used to install splices quickly.

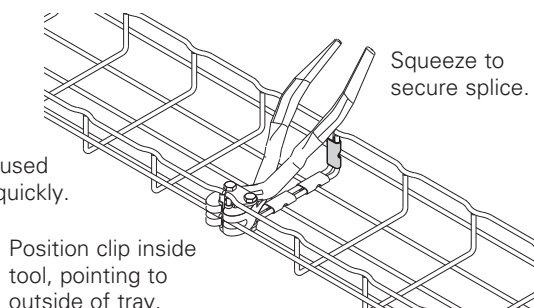

Squeeze to secure splice.

Position clip inside tool, pointing to outside of tray.

Splicing Chart (number of splices required for UL Classification)

Tray Height	Tray Width - number of splices				
	2" (50mm)	4" (100mm)	6" (150mm)	8" (200mm)	12" (300mm)
2"	2	2	4	4	4
4"	NM	4	5	6	6
6"	NM	NM	NM	6	6

NC = Not UL Classified in this size

NM = FLEXTRAY is not manufactured in this size

See page D-3 for finish and grounding information

Tab-Loc Connector

Part Number	Description	Length in. (mm)	Qty./Box	Wt./Box lbs. (kg)
FTSTLC__	Tab-Loc Connectors	9.29" (235.9)	50	7.2 (3.26)



- Fast splice for straight runs of tray
- For use with 2" (50mm) to 32" (800mm) wide tray to connect straight sections only
- Finishes __: **ZN**, SS6

Application Requirements

The recommendations listed are equal for all depths (except as noted).

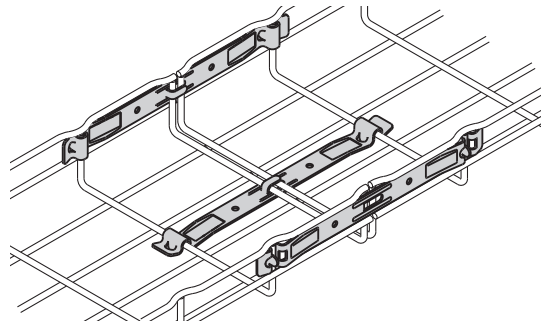

Splicing Chart (number of splices required for UL Classification)

Tray Height	Tray Width - number of splices								
	2" (50mm)	4" (100mm)	6" (150mm)	8" (200mm)	12" (300mm)	16" (400mm)	18" (450mm)	20" (500mm)	24" (600mm)
2"	2	2	4	4	4	4	4	5	5
4"	NM	4	5	6	6	7	7	7	8
6"	NM	NM	NM	6	6	7	7	7	8

NM = FLEXTRAY is not manufactured in this size

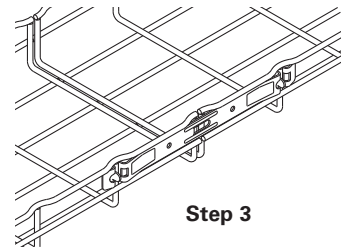
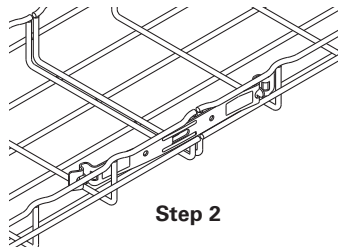
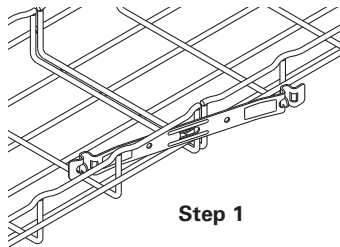

Tab-Loc security without special tools.

Screwdriver can also be used to bend tab-locs (hold connector ends while bending).

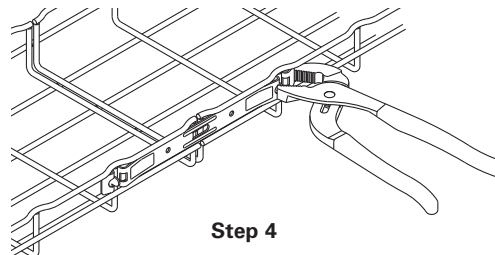

- Adds rigidity to washer splice methods
- Used on side rails only (not for use in tray bottom)
- For use on trays when using splice hardware FTSCHE
- Hardware sold separately
- Finishes __: **EG**, BLE, HD, 304S, 316S

Splice Bar

Part Number	Bar Length in. (mm)	Qty./Box	Wt./Box lbs. (kg)
SPLICE BAR__	10 ^{13/16} " (274.6)	50	14.0 (6.35)

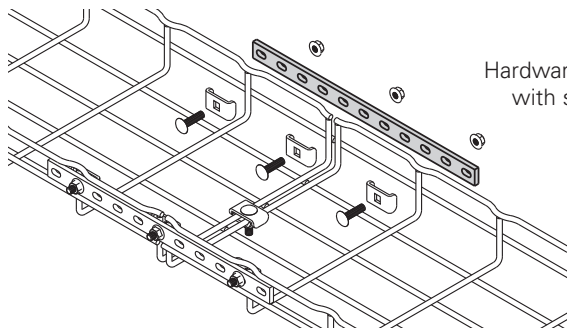

Hardware is not sold with splice bar.



Each splice bar requires three (3) each of Hardware Splice Components - TOP WASHER, and FTHDWE 1/4 to complete connection. These items must be ordered separately.

Washer Splice Kits (WASHER SPL KIT) are required for connections on bottom of tray.

Splicing Chart (number of splices required for UL Classification)

Tray Height	Tray Width - number of splices								
	2" (50mm)	4" (100mm)	6" (150mm)	8" (200mm)	12" (300mm)	16" (400mm)	18" (450mm)	20" (500mm)	24" (600mm)
2"	NC	NC	2	2	2	2	2	2	2
4"	NM	2	2	2	2	2	2	2	2
6"	NM	NM	2	2	2	2	2	2	2

NC = Not UL Classified in this size NM = FLEXTRAY is not manufactured in this size

Splice Bar Kit

- Adds rigidity
- Includes two (2) SPLICE BAR and hardware
- Finishes __: **ZN**, FB, SS6

Part Number	Bar Length in. (mm)	Qty./Box	Wt./Box lbs. (kg)
FTSBK__	12" (304.8)	5 Sets	6.4 (2.90)

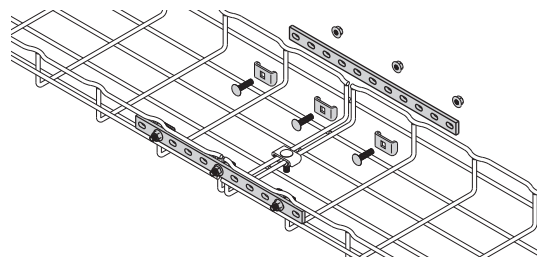

Splicing Chart (number of splices required for UL Classification)

Tray Height	Tray Width - number of splices								
	2" (50mm)	4" (100mm)	6" (150mm)	8" (200mm)	12" (300mm)	16" (400mm)	18" (450mm)	20" (500mm)	24" (600mm)
2"	NC	NC	2	2	2	2	2	2	2
4"	NM	2	2	2	2	2	2	2	2
6"	NM	NM	2	2	2	2	2	2	2

NC = Not UL Classified in this size NM = FLEXTRAY is not manufactured in this size

See page D-3 for finish and grounding information

FLEXTRAY™ Wire Basket - Splicing Accessories

Expansion Splice Kit

Part Number	Bar Length in. (mm)	Qty./Box	Wt./Box lbs. (kg)
FTS12ESK__	12" (304.8)	1 Kit	0.45 (0.20)

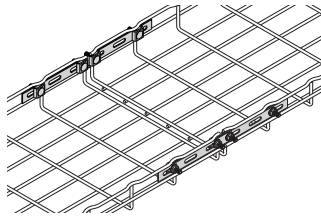

- Allows 1³/₄" (44mm) of expansion between two pieces of Flextray at expansion joints.
- To install, tighten nylon loc-nut until nut comes into contact with splice bar, then loosen approximately 1/4 turn.
- Includes two (2) splice bars and eight (8) sets of hardware
- Finishes __: **ZN**

Long Splice Bar (only)

Part Number	Bar Length in. (mm)	Qty./Box	Wt./Box lbs. (kg)
FTS12SB__	12" (304.8)	1	0.13 (0.06)
FTS36SB__	36" (914.4)	1	0.40 (0.18)



- FTS36SB long splice bar is used for assembly of large radius horizontal bends or field cut into short splice bars
- Splice Bars are designed for use with connecting hardware (FTSCH)
- Hardware sold separately
- Finishes __: **ZN, FB, SS6**

Hold Down Plate

Part Number	Description	Qty./Box	Wt./Box lbs. kg
SUPT WASHER__	.28" x .70" (7.1mm x 17.8mm)	100	9.4 (4.26)
FTA6HD__	.40" x .70" (10.1mm x 17.8mm)	100	7.0 (3.17)

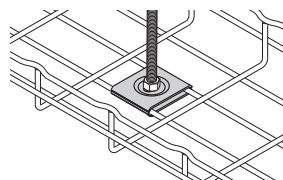
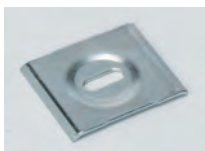

- Easy way to mount 4" (100mm) wide tray for raceway run.
- Use 1/4" screws to attach SUPT WASHER to your specific wall/stud application (hardware sold separately).
- FTA6HD can be used in pairs to create a center-hung support using 3/8" rod.
- To protect cables use threaded rod protector (page D-21).
- To complete 3/8" center hanger assembly use:
 - 2 - FTA6HD
 - 2 - HN 3/8"-16 hex nuts
- Finish: **ZN, SS6**

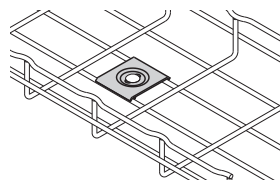

See page D-3 for finish and grounding information

FLEXTRAY™ Wire Basket - Splicing Accessories

- Horizontal adjustable kit can be used to create horizontal angles from prepared FLEXTRAY straight sections
- Conveniently poly-bagged
- Finishes __: **EG**, BLE, 316S

Horizontal Adjustable Kit

Part Number	Description	Qty./Box	Wt./Box lbs. (kg)
FTSHAK__	Horizontal Adjustable Kit	10	2.4 (1.09)

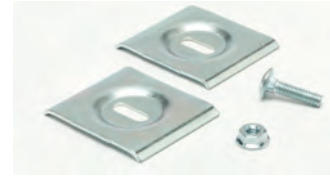
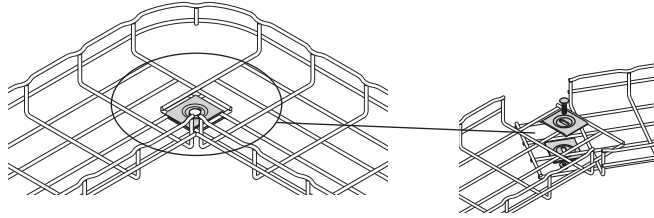

- For fast assembly of 90° turns and tee fittings
- For use with all tray widths and sizes
- One kit will make two 90° turns or one tee fitting
- 90 DEGREE KIT includes: two (2) 90° splice bars and eight (8) FTSCH
- Finishes __: **EG**, BLE, 316S

90 Degree Kit

Part Number	Description	Qty./Box	Wt./Box lbs. (kg)
90 DEGREE KIT__	90 degree splice bar & hardware	1	1.3 (0.59)

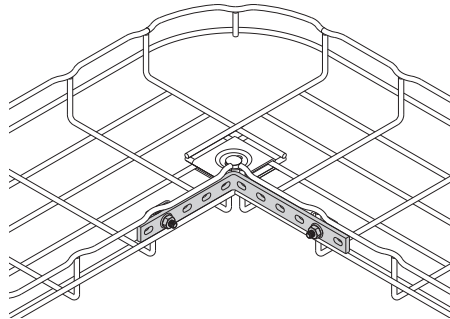

- Helps eliminate need for field fabrication and is quick to install
- Built in tab features for positioning onto side rails at transition locations
- For fast assembly of a 90° bend, tee, and cross fittings
- One kit will make one 90° bend, two kits will make one tee, and four kits will make one cross fitting
- Kit includes: one (1) corner radius and two (2) WASHER SPL KIT
- Finishes __: **EG**, BLE, 316S

Corner Radius Kit

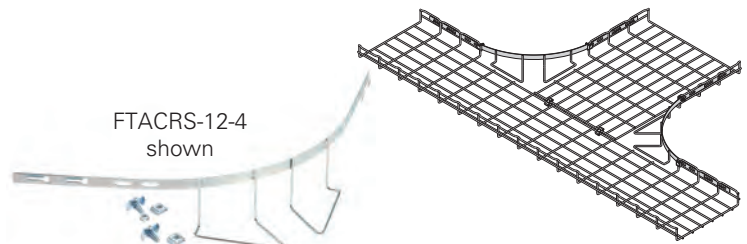
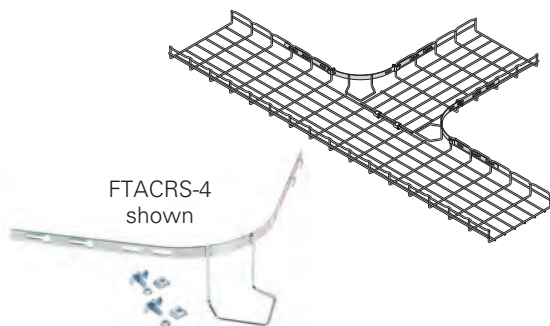

Part Number	Height in. (mm)	Radius in. (mm)	Qty. per Box	Wt./Box lbs. (kg)
FTACRS-2	2" (50.8)	6" (152.4)	1	1.3 (0.59)
FTACRS-4	4" (101.6)	6" (152.4)	1	1.3 (0.59)
FTACRS-6	6" (152.4)	6" (152.4)	1	1.3 (0.59)
FTACRS-12-2	2" (50.8)	12" (304.8)	1	1.3 (0.59)
FTACRS-12-4	4" (101.6)	12" (304.8)	1	1.3 (0.59)
FTACRS-12-6	6" (152.4)	12" (304.8)	1	1.3 (0.59)



See page D-3 for finish and grounding information

FLEXTRAY™ Wire Basket - Splicing Accessories

Components Required to Connect Two Sections of FLEXTRAY

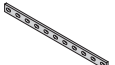
System Part Number	System Width in. (mm)	Connector Assembly WASHER SPL KIT	Connecting Hardware FTSCH	Splice Plate FTS3SP	Splice Bar SPLICE BAR
					
FT2X2 †	2" (50)	2	-	-	-
FT2X4 †	4" (100)	2	-	-	-
FT2X6	6" (150)	3 ¹	-	-	-
FT2X8	8" (200)	3 ¹	-	-	-
FT2X12	12" (300)	3 ¹	-	-	-
FT2X16	16" (400)	4 ¹	-	-	-
FT2X18	18" (450)	4 ¹	-	-	-
FT2X20	20" (500)	4 ¹	-	-	-
FT2X24	24" (600)	4 ¹	-	-	-
FT2X30	30" (750)	5 ¹	-	-	-
FT2X32	32" (800)	5 ¹	-	-	-
FT4X4	4" 100	3 ¹	-	-	-
FT4X6	6" 150	3 ¹	-	-	-
FT4X8	8" 200	3 ²	-	-	-
FT(*)X12	12" 300	3 ²	-	-	-
FT(*)X16	16" 400	4 ²	-	-	-
FT(*)X18	18" (450)	4 ²	-	-	-
FT(*)X20	20" 500	4 ²	-	-	-
FT(*)X24	24" 600	4 ²	-	-	-
FT(*)X30	30" (750)	5 ²	-	-	-
FT2X2 †	2" (50)	-	2	2	-
FT2X4 †	4" (100)	-	2	2	-
FT2X6	6" (150)	1	2	2	-
FT2X8	8" (200)	1	2	2	-
FT2X12	12" (300)	1	2	2	-
FT2X16	16" (400)	2	2	2	-
FT2X18	18" (450)	2	2	2	-
FT2X20	20" (500)	2	2	2	-
FT2X24	24" (600)	2	2	2	-
FT2X30	30" (750)	3	2	2	-
FT2X32	32" (800)	3	2	2	-
FT4X4	4" (100)	1	2	2	-
FT4X6	6" (150)	1	2	2	-
FT4X8	8" (200)	1	2	2	-
FT(*)X12	12" (300)	1	2	2	-
FT(*)X16	16" (400)	2	2	2	-
FT(*)X18	18" (450)	2	2	2	-
FT(*)X20	20" (500)	2	2	2	-
FT(*)X24	24" (600)	2	2	2	-
FT(*)X30	30" (750)	3	2	2	-
FT2X2 †	2" (50)	-	6	-	2
FT2X4 †	4" (100)	-	6	-	2
FT2X6	6" (150)	1	6	-	2
FT2X8	8" (200)	1	6	-	2
FT2X12	12" (300)	1	6	-	2
FT2X16	16" (400)	2	6	-	2
FT2X18	18" (450)	2	6	-	2
FT2X20	20" (500)	2	6	-	2
FT2X24	24" (600)	2	6	-	2
FT2X30	30" (750)	3	6	-	2
FT2X32	32" 800	3	6	-	2
FT4X4	4" (100)	1	6	-	2
FT4X6	6" (150)	1	6	-	2
FT4X8	8" (200)	1	6	-	2
FT(*)X12	12" (300)	1	6	-	2
FT(*)X16	16" (400)	2	6	-	2
FT(*)X18	18" (450)	2	6	-	2
FT(*)X20	20" (500)	2	6	-	2
FT(*)X24	24" (600)	2	6	-	2
FT(*)X30	30" (750)	3	6	-	2

(*) 4 for 4" Deep FLEXTRAY
6 for 6" Deep FLEXTRAY

Washer Splice Kits

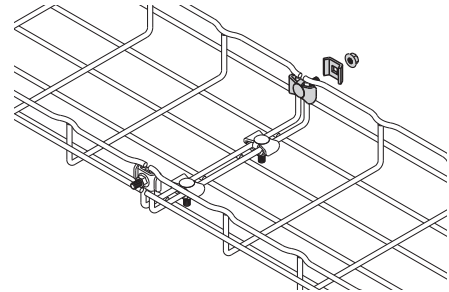

- 1 Install one kit on each side and remaining kit(s) on bottom.
- 2 Install two kits on each side and remaining kits on bottom.

Splice Plates

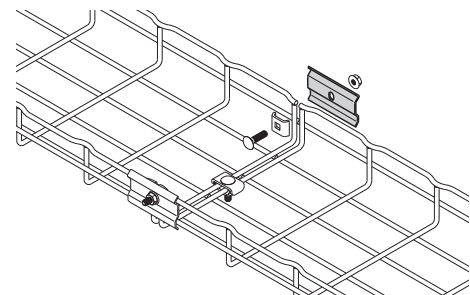

Install splice plates on sides and WASHER SPL KIT on bottom.

Splice Bars

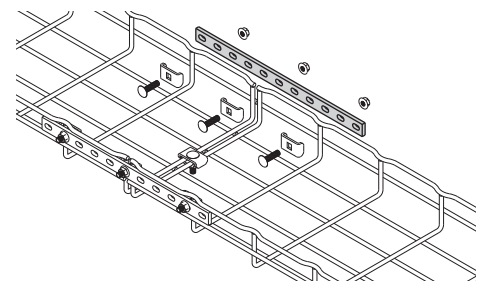

Install splice bars on sides and WASHER SPL KIT on bottom.

† Sizes not UL Classified

Splice Plate Kits for 2" Deep FLEXTRAY

Part Number	System Width		Weight Per 100		Box Quantity	Conveniently poly-bagged for use with 2" Deep FLEXTRAY
	in.	(mm)	lbs.	(kg)		
FTS20SK	2"	(50)	2.91	(1.32)	10	
	4"	(100)				
FTS21SK	6"	(150)	3.63	(1.64)	10	
	8"	(200)				
FTS22SK	12"	(300)	4.35	(1.97)	10	
	18"	(450)				
	20"	(500)				
	24"	(600)				

Splice Plate Kits for 4" & 6" Deep FLEXTRAY

Part Number	System Width		Weight Per 100		Box Quantity	Conveniently poly-bagged for use with 4" & 6" Deep FLEXTRAY
	in.	(mm)	lbs.	(kg)		
FTS23SK	4"	(100)	5.07	(2.30)	10	
	6"	(150)				
	8"	(200)				
	12"	(300)				
FTS24SK	18"	(450)	5.79	(2.62)	10	
	20"	(500)				
	24"	(600)				

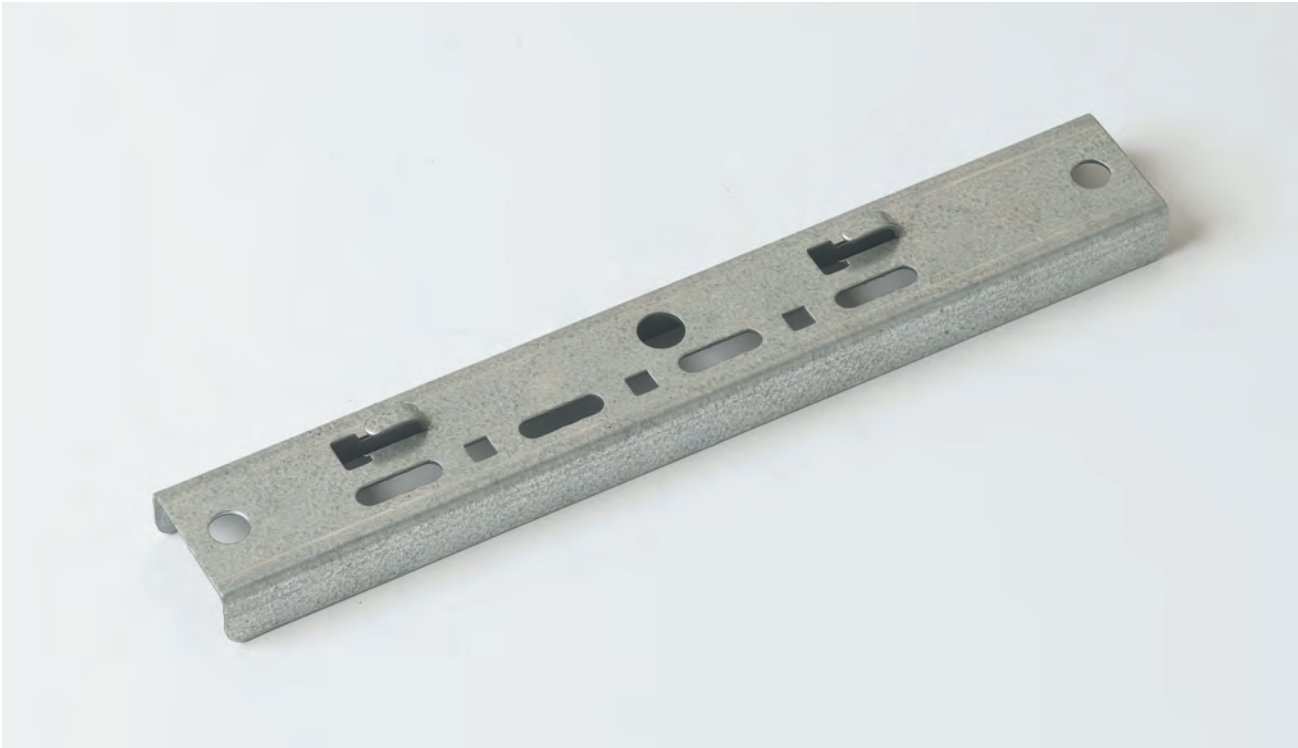
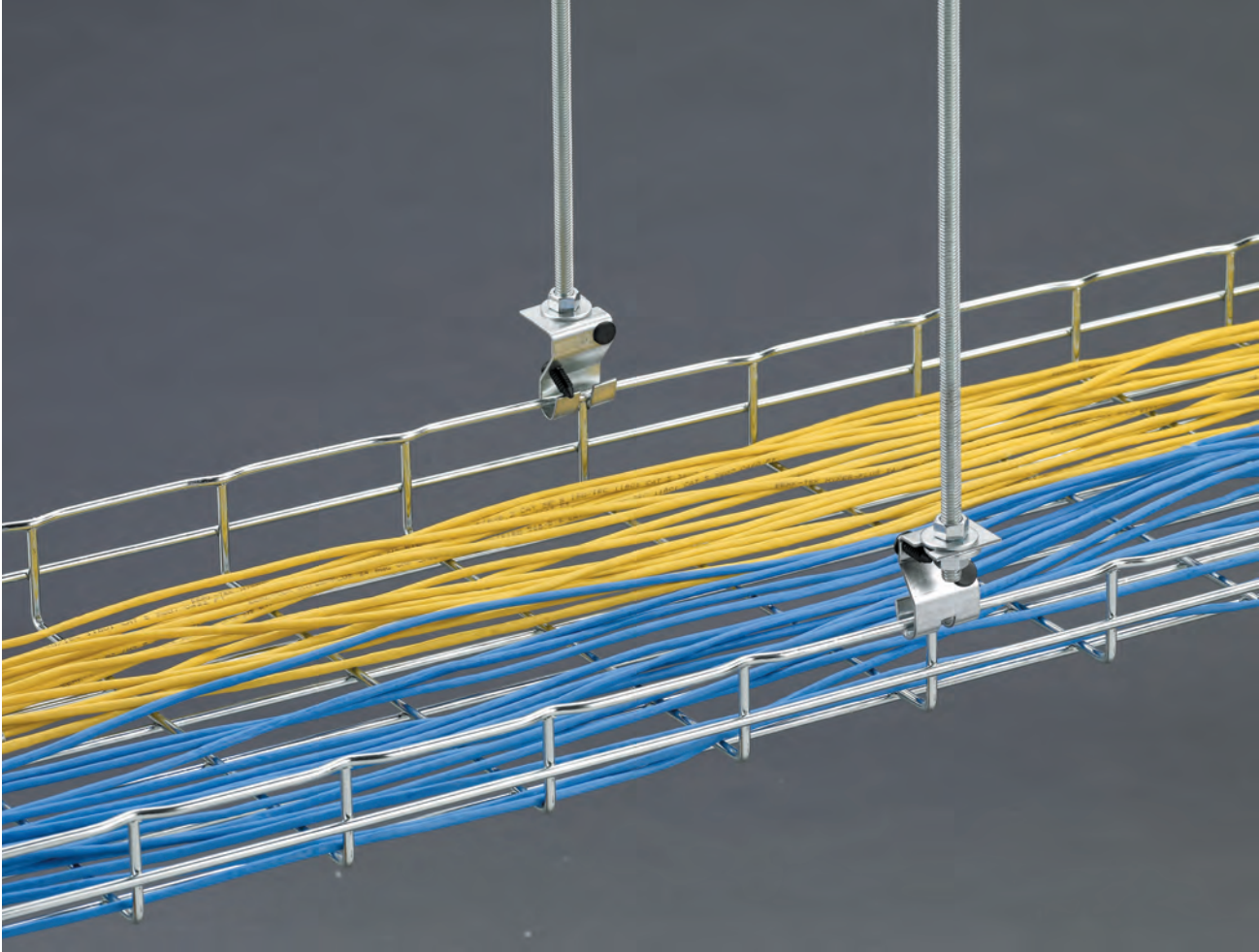

FLEXTRAY

FLEXTRAY™ Wire Basket - Ceiling Support Methods

Flip Clip™

- Accommodates 1/4" and 3/8" rod sizes
- Installs quickly with a screwdriver or pliers thus reducing installation time
- Requires only one hex nut (not included) to hang and level the FLEXTRAY
- Retainer tabs can be bent over to lock-in the threaded rod and wire basket
- Finishes __: **ZN**, FB, SS6

Part Number	Description	Qty./Box	Wt./Box lbs. (kg)
WB46H__	Flip Clip	50	5.2 (2.36)

Snap retainer stops in place after cable is loaded.

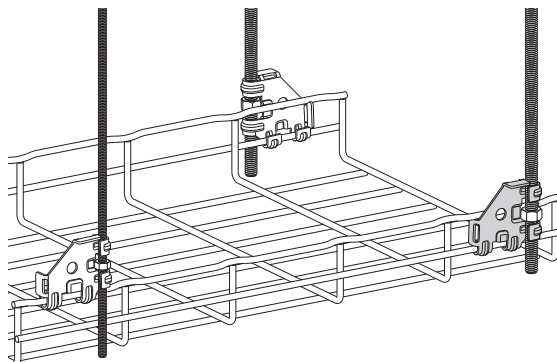

Trapeze Support

- Trapeze Clip installs fast
- For use with trays up to 4" (100mm) deep, 12" (300mm) wide, and spans up to 8'-0" (2.44m)
- Tray can be released from support to allow side cable loading
- Accepts 1/4" and 3/8" threaded rod sizes
- Finishes __: **GS**, BLE

Part Number	Description	Qty./Box	Wt./Box lbs. (kg)
TRAPEZE SUPT2__	Trapeze Support Clip	50 trapeze clips 100 retainer stops	7.0 (3.17)

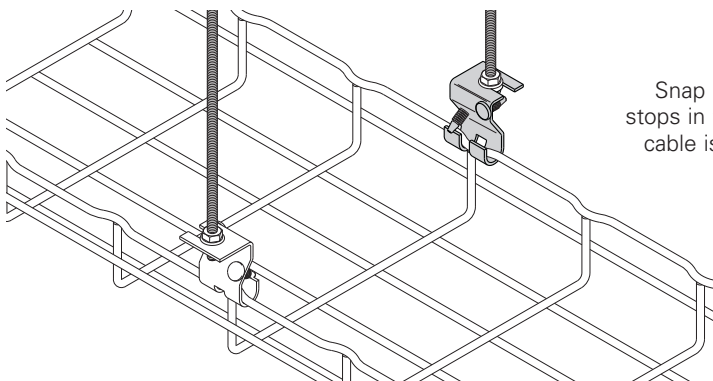

Snap retainer stops in place after cable is loaded.



See page D-3 for finish information

FLEXTRAY™ Wire Basket - Ceiling Support Methods

2" Center Hanger

Part Number	Description	Qty./Box	Wt./Box lbs. (kg)
2 IN CTR SUPT__	Center Support Hanger for FT2x2	50	5.0 (2.27)

- For use with 2" (50mm) tray widths only
- Accepts 1/4" threaded rod
- Hardware sold separately
- Finishes __: **GS**, BLE
- Assemble with ATTACHMENT CLP & FTHDWE 1/4 hardware

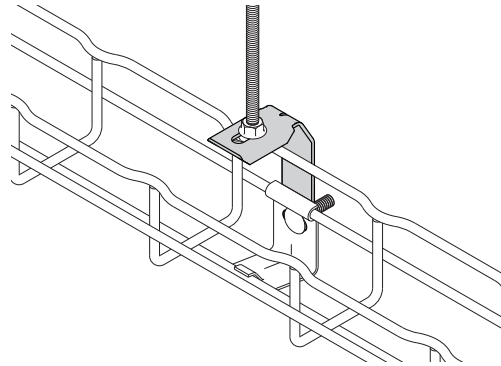

Hold Down Plate

Part Number	Description	Qty./Box	Wt./Box lbs. (kg)
SUPT WASHER__	.28" x .70" (7.1mm x 17.8mm)	100	9.4 (4.26)
FTA6HD__	.40" x .70" (10.1mm x 17.8mm)	100	7.0 (3.18)

- Easy way to mount 4" (100mm) wide tray for raceway run.
- Use 1/4" screws to attach SUPT WASHER to your specific wall/stud application (hardware sold separately).
- FTA6HD can be used in pairs to create a center-hung support using 3/8" rod.
- To protect cables use threaded rod protector (page D-20).
- To complete 3/8" center hanger assembly use:
2 - FTA6HD
2 - HN 3/8"-16 hex nuts
- Finish: **ZN**, SS6

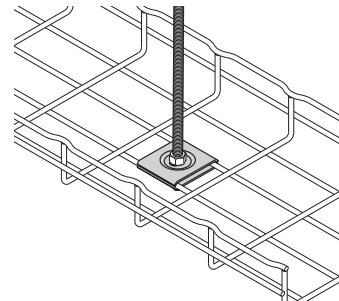
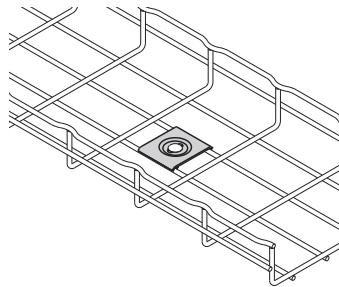
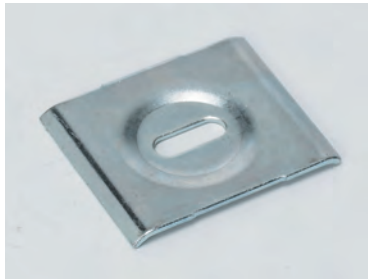

See page D-3 for finish information

FLEXTRAY™ Wire Basket - Ceiling Support Methods

Mounting Bracket

- Designed to support FT2X2X10 Flextray
- Click tabs for FLEXTRAY attachment
- Use 1/4" hardware and washer (not included) to mount bracket
- Finishes __: **SS6**

Part Number	Description	Qty./Box	Wt./Box lbs. (kg)
FTB2UB__	Light Duty Wall/Rack Bracket	10	2.1 (0.95)

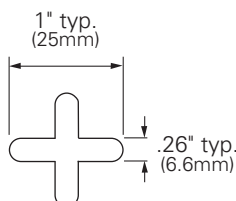
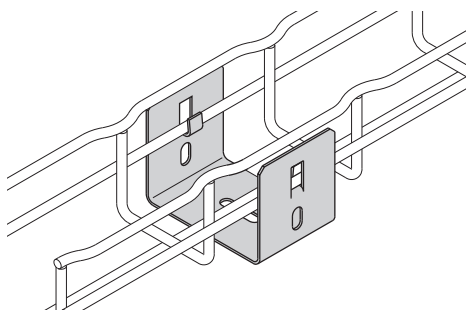

- Use for light duty cabling applications
- For use with 1 1/2" (38mm) & 2" (51mm) deep tray with 4" (100mm) and 6" (150mm) widths
- When hanging 4" (100mm) wide tray, center hung clip must be run parallel with the tray
- Built-in hold down tab
- Accepts 1/4" threaded rod
- Threaded rod and nuts sold separately
- Finishes __: **GS**, BLE

Center Hung Clip

Part Number	Description	Qty./Box	Wt./Box lbs. (kg)
CTR HUNG CLP__	Light Duty Center Hanger	50	4.0 (1.81)

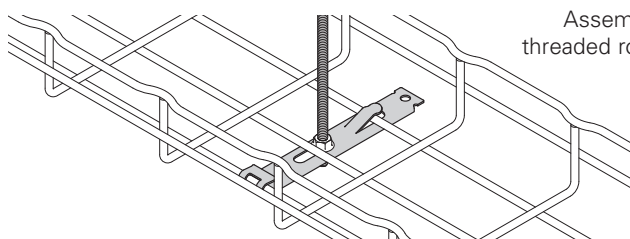

Assemble with 1/4" threaded rod and finned nut



- Use to protect cables from 1/4" to 1/2" threaded rod
- PVC UL94V-O material
- Color: Gray
- Not plenum rated

Threaded Rod Protector

Part Number	Description	Qty./Box	Wt./Box lbs. (kg)
SB301-1/2x8	Rod Protector	1	0.03 (0.013)

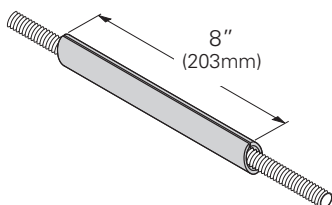

See page D-3 for finish information

FLEXTRAY™ Wire Basket - Ceiling Support Methods

Center Trapeze Hanger

Part Number	Maximum Tray Width		Actual Length		Wt./Pc.	
	in.	(mm)	in.	(mm)	lbs.	(kg)
FTB06CT	6"	(150)	9.78"	(248)	0.61	(0.27)
FTB08CT	8"	(200)	11.75"	(298)	0.74	(0.33)
FTB12CT	12"	(300)	15.69"	(398)	0.98	(0.44)
FTB16CT	16"	(400)	19.63"	(498)	1.61	(0.73)
FTB18CT	18"	(450)	21.59"	(548)	1.77	(0.80)
FTB20CT	20"	(500)	23.56"	(598)	1.93	(0.87)
FTB24CT	24"	(600)	27.50"	(698)	2.25	(1.02)

- Can be installed as center-hung or traditional trapeze hanger
- Multiple options to secure FLEXTRAY to hanger
 - Built in hold down tabs (use screwdriver to bend down tab)
 - Compatible with TOOLLESS CLIP with snap-in locking pin
 - Compatible with WBUHD hold down clip when tray crosswire is aligned over top of hanger
 - Slots and holes for optional hardware attachment
- Corrosion resistant pre-galvanized zinc finish (other finishes available upon request)
- Center hole for up to 1/2" rod
- Hole on each end for up to 3/8" rod
- Threaded rod protector available (SB301-1/2 x 8) see page D-20
- When 1/2" trapeze rods are required, add -1/2 to end of part number when ordering

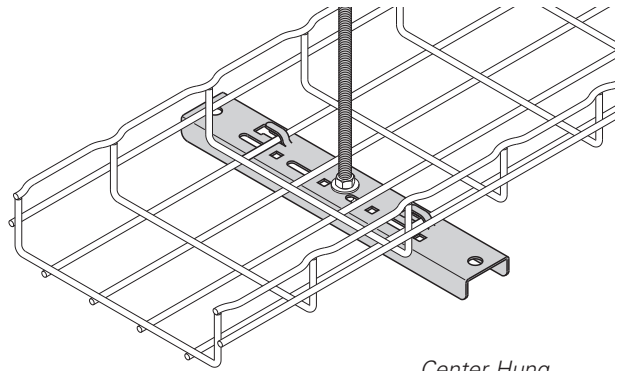

Center Hung

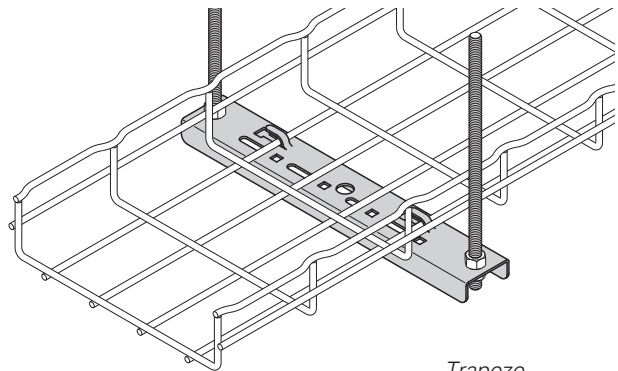

Trapeze

See page D-3 for finish information

KwikWire™ Clamps & Wire Rope

- KwikWire system replaces jack chain or ATR to support lighting, ductwork, and FLEXTRAY.
- Can be quickly installed around beams - No drilling required.
- Ideal for sloped ceilings - can hang objects at up to 60° angles.
- Simple height adjustments are made by releasing locking tab, no tools required.
- Spools of wire can be cut to length in field, reducing waste and up front planning.

Part No.	Clamps - For Use With Wire Rope Diameters	Box Qty.
BKC100	1/16" (1.6mm) & 3/32" (2.3mm)	100
BKC200	1/8" (3.2mm) & 3/16" (4.7mm)	50



Part No.	Rope Dia. in. (mm)	Working Load Lbs. (kg)	Spool
BKW063 ⁽¹⁾	1/16" (1.6)	96 (43.5)	500 ft.
BKW094 ⁽¹⁾	3/32" (2.3)	184 (83.4)	500 ft.
BKW125 ⁽¹⁾	1/8" (3.2)	340 (154.2)	500 ft.
BKW188 ⁽²⁾	3/16" (4.8)	840 (381.0)	250 ft.



Wire Rope Construction



(1) 7 x 7



(2) 7 x 19

KwikWire Clamp Working Loads*

Clamp Part No.	Wire Rope Dia.	Lbs. Safety Factor 5
BKC100	1/16"	0-75
BKC100	3/32"	25-150
BKC200	1/8"	25-250
BKC200	3/16"	50-640

* Working loads shown are for hanging vertically. For suspending at 15°, 30°, 45° or 60° angles from vertical, use the following percentage of the working loads from the chart:

15° = 96%
30° = 86%
45° = 70%
60° = 50%

Cutter Part No.	Box Qty.
BKCC	1



- KwikPak includes a supply of kwik-clamps and a spool of wire rope.
- KwikPak are shipped in a specially designed dispenser box to ease field cutting of wire.

KwikPak™ Wire Rope & Clamps

Part No.	For Use With Wire Rope Diameters	Box Qty.
BKP10063	BKC100 (100 pcs.) 1/16" Ø Wire Rope (500 ft.)	1
BKP10094	BKC100 (100 pcs.) 3/32" Ø Wire Rope (500 ft.)	1
BKP20125	BKC200 (50 pcs.) 1/8" Ø Wire Rope (500 ft.)	1
BKP20188	BKC200 (50 pcs.) 3/16" Ø Wire Rope (250 ft.)	1



See page D-3 for finish information

FLEXTRAY™ Wire Basket - Ceiling Support Methods

KwikWire™ Accessory Features

- Helps reduce on the job installation time
- Can be installed quickly without drilling into existing structure
- Increases versatility in the field
- KwikWire accessory system helps reduce inventory and shipping costs
- No more sawing, filing, or fixing nuts
- Designed for use with cable tray, lighting, and HVAC
- Eliminates the need for all threaded rod
- Cost effective solution for jack chain
- "Y" style accessories require 50% less drilling



KwikWire Accessory Numbering System

Product Line	Assembly Configuration	Leg Termination	Leg Length	Wire Rope Diameter	Straight Length	Assembly or Kit
BK = KwikWire	Blank = Single Leg Y = 2 Legs 3 - 3 Legs	A = Angle Bracket w/Pin H = Hook L = Loop T = Toggle W = Fuse Cut B25 = Bolt w/ 1/4"-20 Thread B38 = Bolt w/ 3/8"-16 Thread BM6 = Bolt w/ M6 Thread BM8 = Bolt w/ M8 Thread BM10 = Bolt w/ M10 Thread	Blank = See Straight Length 18 = 18" Leg 30 = 30" Leg	063 = 1/16" 094 = 3/32"	Blank = Loop w/ Plastic Tube 18 = 18" 30 = 30" 40 = 40" 80 = 80" 120 = 120" 180 = 180" 240 = 240" 360 = 360"	Blank = Assembly Only K = Kit (Assembly & BKC100 Clamp)

Examples

BKYT18-094-120K



KwikWire Accessory

2 legs - toggle leg termination - 18" legs - 1/16" diameter wire - 120" straight length - kit with clamp

BKL-063-120K



KwikWire Accessory

single leg - looped leg termination - 1/16" diameter wire - 120" straight length - kit with clamp

See page D-3 for finish information

KwikWire™ 'Y' Style Hook Termination

Part No.	Leg Length		Wire Rope Dia.		Length	
	in.	(mm)	in.	(mm)	in.	(mm)
BKYH18-094-40	18"	(457)	3/32"	(2.3)	40"	(1016)
BKYH18-094-80	18"	(457)	3/32"	(2.3)	80"	(2032)
BKYH18-094-120	18"	(457)	3/32"	(2.3)	120"	(3048)
BKYH18-094-180	18"	(457)	3/32"	(2.3)	180"	(4572)
BKYH18-094-240	18"	(457)	3/32"	(2.3)	240"	(6096)
BKYH18-094-360	18"	(457)	3/32"	(2.3)	360"	(9144)
BKYH30-094-40	30"	(762)	3/32"	(2.3)	40"	(1016)
BKYH30-094-80	30"	(762)	3/32"	(2.3)	80"	(2032)
BKYH30-094-120	30"	(762)	3/32"	(2.3)	120"	(3048)
BKYH30-094-180	30"	(762)	3/32"	(2.3)	180"	(4572)
BKYH30-094-240	30"	(762)	3/32"	(2.3)	240"	(6096)
BKYH30-094-360	30"	(762)	3/32"	(2.3)	360"	(9144)



Box Quantity - 10
5 bags containing 2 pieces per bag

KwikWire™ 'Y' Style Hook Termination With Loop

Part No.	Wire Rope Dia.		Length	
	in.	(mm)	in.	(mm)
BKYH18-094	3/32"	(2.3)	18"	(457)
BKYH30-094	3/32"	(2.3)	30"	(762)

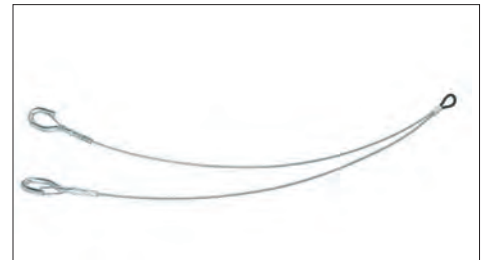

Box Quantity - 10
5 bags containing 2 pieces per bag

- Hook designed for up to 3/8" diameter wire.
- Available as a wire rope with hook termination only or as a ready-to-use kit with a BKC100 clamp.
- Available in lengths of 40", 80", 120", 180", 240", and 360".
- Available in single, double (Y), and triple (3) leg styles

For more information on KwikWire accessories see the KwikWire catalog.

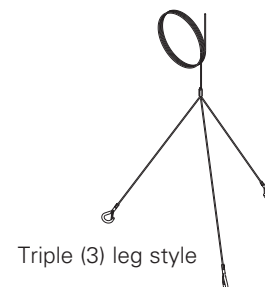

See page D-3 for finish information

FLEXTRAY™ Wire Basket - Wall Support Methods

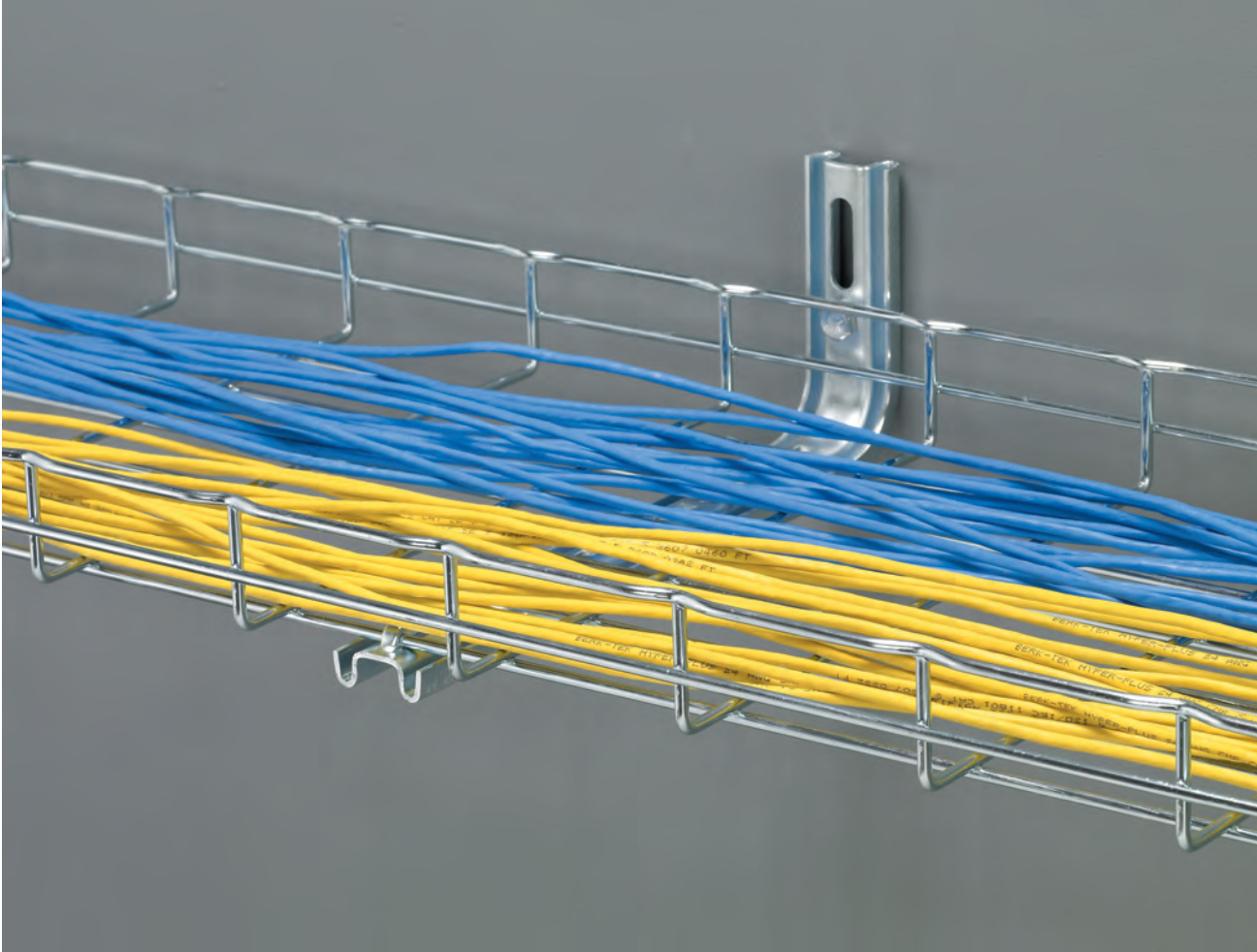

FLEXTRAY

Shelf Brackets

- Heavy-duty support bracket
- For use with 6" (150mm) to 24" (600mm) wide trays
- Built-in tab for hold down
- Optional hardware (FTSCH) sold separately
- Finishes __: **GLV**, HDG, SS6

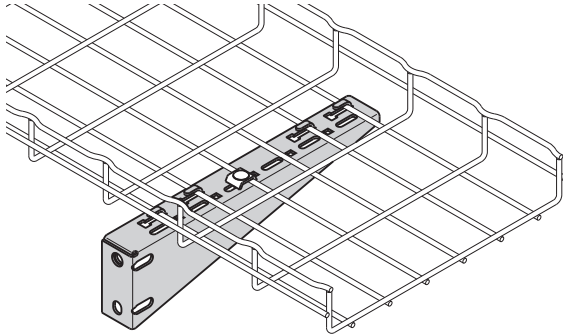

Part Number	Use With Tray Width		Qty./Box	Wt./Pc. lbs. (kg)
	in.	(mm)		
FTB06CS __	6"	(150)	1	0.5 (0.22)
FTB08CS __	8"	(200)	1	0.6 (0.27)
FTB12CS __	12"	(300)	1	1.2 (0.54)
FTB16CS __	16"	(400)	1	1.7 (0.77)
FTB18CS __	18"	(450)	1	1.9 (0.86)
FTB20CS __	20"	(500)	1	2.6 (1.18)
FTB24CS __	24"	(600)	1	3.2 (1.45)



FTB24CS shown

L Brackets

- Installs tray to wall cleanly
- Built-in tab for hold down (not available in stainless steel)
- For use with 4" (100mm) to 24" (600mm) wide trays
- Use with pedestal clamp in raised floor applications
- Optional hardware (FTSCH) sold separately
- Finishes __: **EG**, HD, BLE, 316S

Part Number	Use With Tray Width		Qty./Box	Wt./Pc. lbs. (kg)
	in.	(mm)		
4 L BRKT __	4"	(150)	1	0.6 (0.27)
8 L BRKT __	6" 8"	(150) (200)	1	0.8 (0.36)
12 L BRKT __	12"	(300)	1	1.3 (0.59)
16 L BRKT __	16"	(400)	1	1.4 (0.63)
20 L BRKT __	18" 20"	(450) (500)	1	2.0 (0.91)
24 L BRKT __	24"	(600)	1	2.3 (1.04)

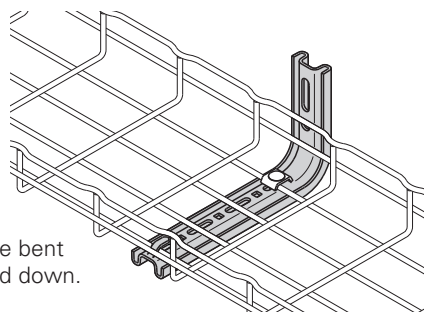

Tab can be bent over for hold down.



12 L BRKT

See page D-3 for finish information

FLEXTRAY™ Wire Basket - Wall Support Methods

Z Brackets

Part Number	Description	Qty./Box	Wt./Box lbs. (kg)
Z BRKT__	Z Bracket	25	14.0 (6.35)

- Used for horizontal and/or vertical mounting
- 8" (200mm) wide bracket for use with 4" (100mm) to 32" (800mm) wide trays
- Can be used to offset trays from floor
- Can be used to terminate tray run at wall
- Multiple brackets can be used for wider tray widths
- Finishes __: **GS**, BLE

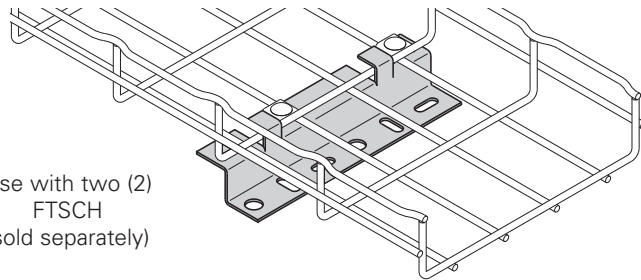
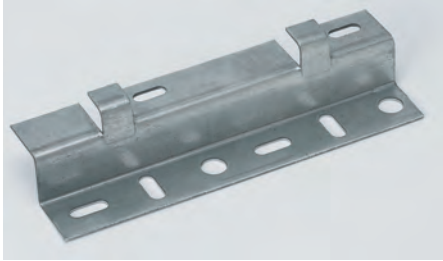

Use with two (2) FTSCH (sold separately)

Hold Down Plate

Part Number	Description	Qty./Box	Wt./Box lbs. (kg)
SUPT WASHER__	.28" x .70" (7.1mm x 17.8mm)	50	4.7 (2.13)
FTA6HD__	.40" x .70" (10.1mm x 17.8mm)	50	3.5 (1.59)

- Easy way to mount 4" (100mm) wide tray for raceway run.
- Use 1/4" screws to attach SUPT WASHER to your specific wall/stud application (hardware sold separately).
- FTA6HD can be used in pairs to create a center-hung support using 3/8" rod.
- To protect cables use threaded rod protector (page D-20).
- To complete 3/8" center hanger assembly use:
 - 2 - FTA6HD
 - 2 - HN 3/8"-16 hex nuts
- Finish: **ZN**, SS6

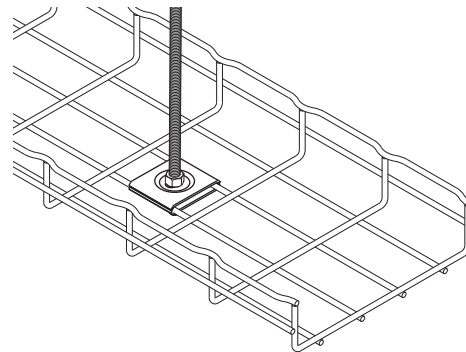
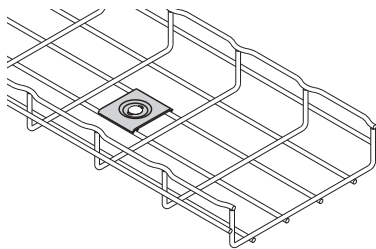
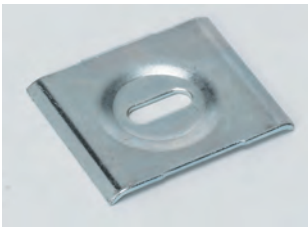

See page D-3 for finish information

Attachment Clips

- Wall attachment for 2" (50mm) wide tray only (FT2X2X10)
- Low-profile appearance
- Built-in tab to hold down tray
- Can also be used with 2" (50mm) Center Hanger (see page D-19)
- Hardware sold separately
- Finishes __: **GS**, BLE

Part Number	Description	Qty./Box	Wt./Box lbs. (kg)
ATTACHMENT CLP__	Support for FT2x2x10	50	3.4 (1.54)

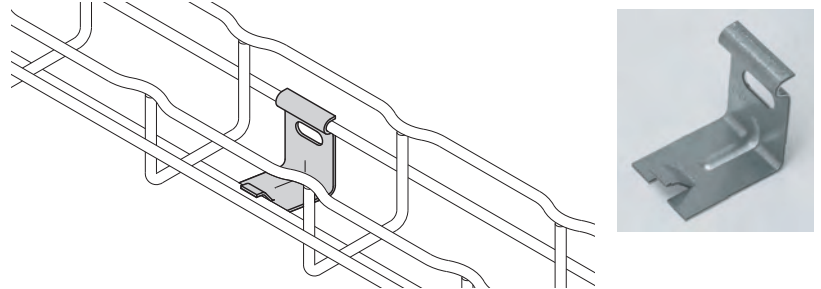

Mounting Bracket

- Designed to support FT2X2X10 FLEXTRAY
- Click tabs for FLEXTRAY attachment
- Use 1/4" hardware and washer (not included) to mount bracket
- Finishes __: **SS6**

Part Number	Description	Qty./Box	Wt./Box lbs. (kg)
FTB2UB__	Light Duty Wall/Rack Bracket	10	2.1 (0.95)

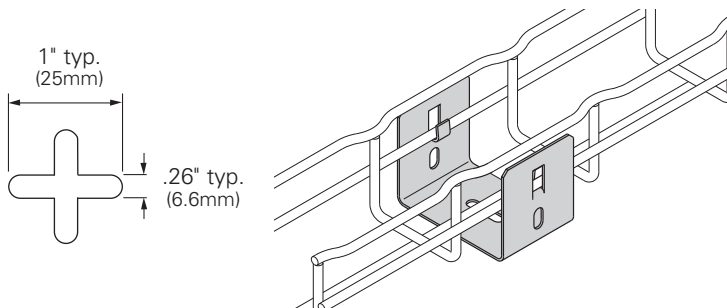

Wall Supports

- Used to attach 2" (50mm) or 4" (100mm) wide trays to walls, struts or cabinets
- Use for raceway mounting
- Mount to metal framing for vertical support
- Tabs are built in for tray hold down
- Mount to side rail for electrical box connection
- Finishes __: **GLV**

Part Number	Description	Qty./Box	Wt./Box lbs. (kg)
FTA050CC__	Wall Support Bracket	1	0.8 (0.36)

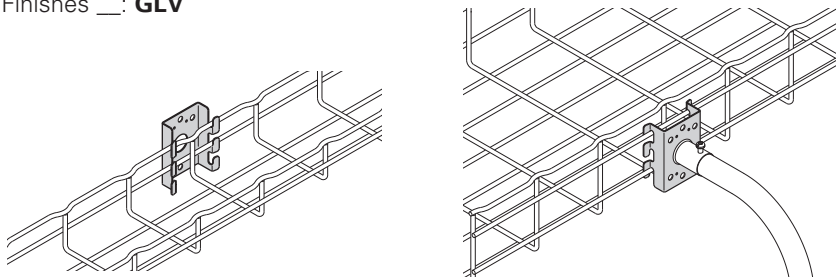

See page D-3 for finish information

FLEXTRAY™ Wire Basket - Wall Support Methods

Wall Termination Kit

Part Number	Length in. (mm)	Qty./Box	Wt./Box lbs. (kg)
FTA9WTK__	9" (228.6)	1	1.3 (0.59)

- Kit includes all hardware necessary to support FLEXTRAY when terminated at a wall
- Mount slotted angle to wall with up to 3/8" hardware (not included)
- Finishes __: **ZN**, FB, SS6

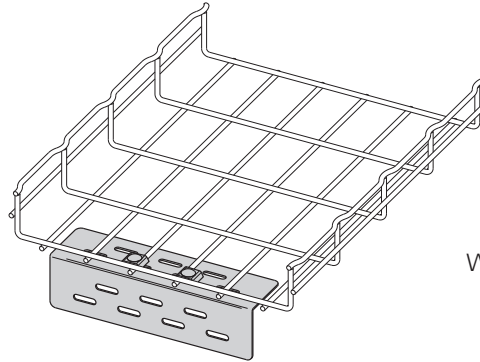

Wall Termination Kit includes:

- 1 - Angle with Slots
- 2 - FTSCH

Wall Mount Kit

Part Number	Length in. (mm)	Qty./Box	Wt./Box lbs. (kg)
WB48WMK__	8" (203.2)	1	0.76 (0.35)
WB1224WMK__	12" (304.8)	1	1.22 (0.55)

- Kit includes all components necessary to mount FLEXTRAY to a wall horizontally or vertically
- Mount strut to wall with up to 1/2" hardware (not included)
- Finish: Channel - **GLV**
Hardware - **ZN**
Available in SS6



WB1224WMK shown

Wall Mount Kit includes:

WB48WMK	WB1224WMK	
1	1	B54SH Strut
1	2	SUPT WASHER Hold Downs
1	2	1/4"-20 x 1" Slotted Head Screw
1	2	N224WO Channel Nut

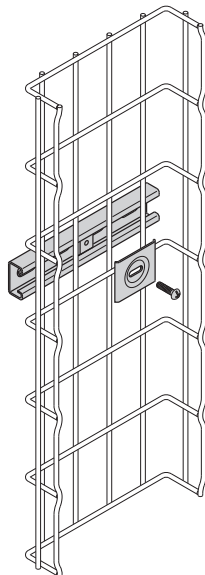

Vertically Mounted

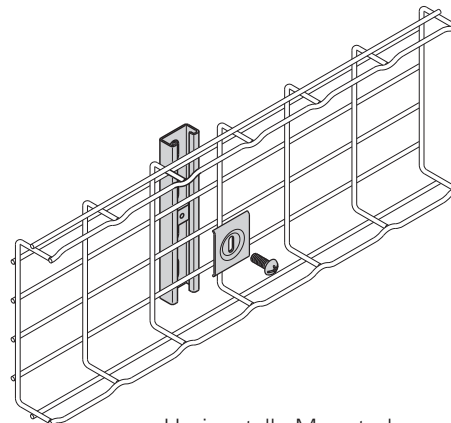

Horizontally Mounted

See page D-3 for finish information

C Brackets

- Tab can be used for hold down (stainless steel will not have these tabs)
- For use with 4" (100mm) to 12" (300mm) wide trays
- C bracket attaches to hard ceiling types
- All brackets are 7⁷/₈" (200mm) tall
- Cables can be side loaded
- L brackets (page D-26) and C brackets can be combined for layered tray runs
- Finishes __: **EG**, BLE, HD

Part Number	Tray Width - Up To in. (mm)	Qty./Box	Wt./Box lbs. (kg)
4 C BRKT__	4" (100)	1	1.2 (0.54)
8 C BRKT__	8" (200)	1	1.4 (0.63)
12 C BRKT__	12" (300)	1	1.9 (0.86)

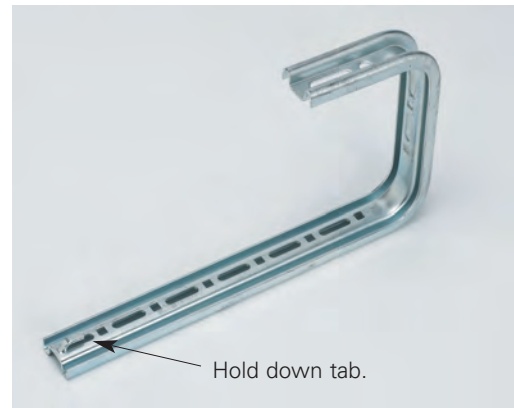
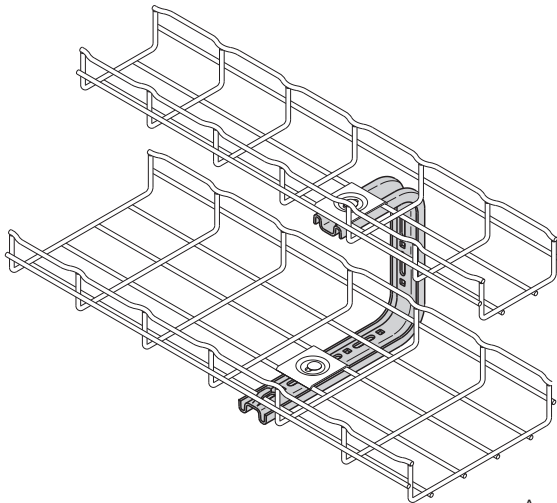

Assemble with
SUPT WASHER &
FTHDWE 1/4.

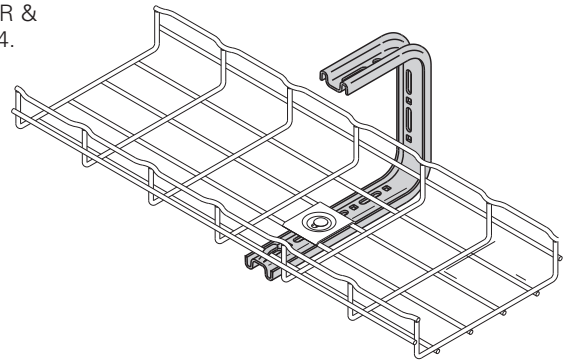
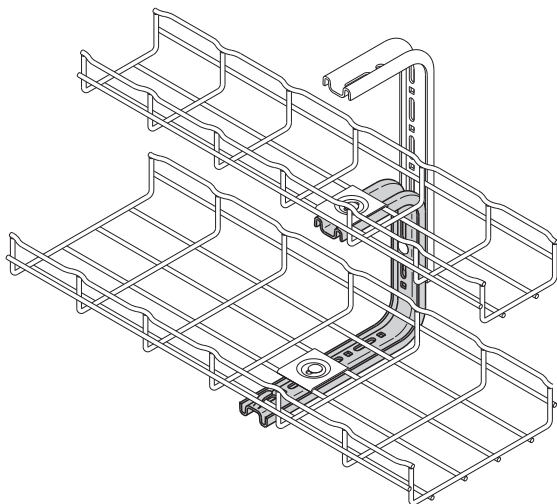

See page D-3 for finish information

FLEXTRAY™ - F.A.S.T.™ Underfloor System

The F.A.S.T. System is an innovative and flexible way to support and manage cables in raised floor applications. This Foldable, Adjustable, Stackable, Tool-less System uses FLEXTRAY, stands, and accessories to provide a variety of options for your project and the fastest installation time on the market. Best of all, it does not attach to the raised floor structure and can be installed either before or after floor is in place.



FLEXTRAY

F.A.S.T. System Flextray

- Rounded ends on all wires
- UL Classified (see technical data for details)
- Depths: 2" (50mm), 4" (100mm), & 6" (150mm) nominal
- Lengths: 24" (609mm), 48" (1219mm), & 118" (2997mm)
- Use flat fitting (WBUFLT) for turns
- Wire Diameter: 0.191" (4.9mm)
- Standard finishes: **GLV**

Consult customer service for other available finishes

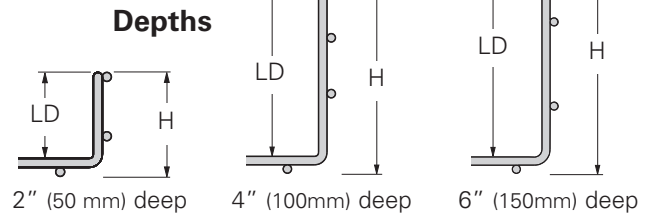
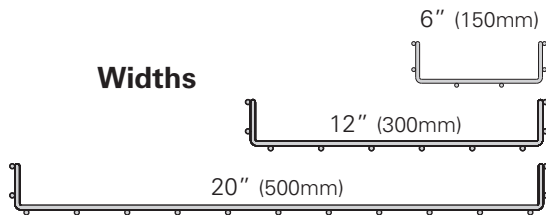
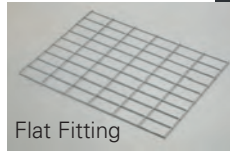
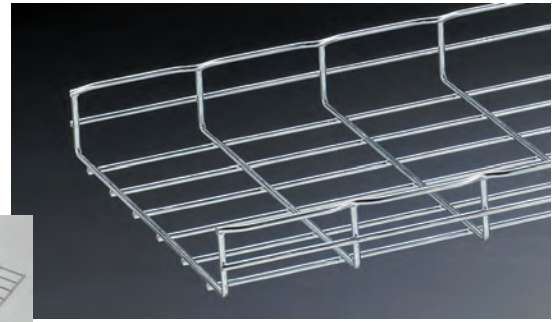

	Part Number	Width		Length		LD		H		Wt. Per Pc.	
		in.	(mm)	in.	(mm)	in.	(mm)	in.	(mm)	lbs.	(kg)
2" (50mm) deep	FTU2X6X2	6"	(150)	23.9"	(603)	2.38"	(60)	2.77"	(70)	2.03	(0.92)
	FTU2X6X4	6"	(150)	47.5"	(1206)	2.38"	(60)	2.77"	(70)	3.95	(1.79)
	FTU2X6X10	6"	(150)	118.4"	(3008)	2.38"	(60)	2.77"	(70)	9.72	(4.41)
	FTU2X12X2	12"	(300)	23.9"	(603)	2.38"	(60)	2.77"	(70)	2.99	(1.36)
	FTU2X12X4	12"	(300)	47.5"	(1206)	2.38"	(60)	2.77"	(70)	5.82	(2.64)
	FTU2X12X10	12"	(300)	118.4"	(3008)	2.38"	(60)	2.77"	(70)	14.32	(6.50)
	FTU2X20X2	20"	(500)	23.9"	603	2.38"	(60)	2.77"	(70)	4.28	(1.94)
	FTU2X20X4	20"	(500)	47.5"	(1206)	2.38"	(60)	2.77"	(70)	8.33	(3.78)
	FTU2X20X10	20"	(500)	118.4"	(3008)	2.38"	(60)	2.77"	(70)	20.45	(9.28)
4" (100mm) deep	FTU4X6X2	6"	(150)	23.9"	(603)	4.38"	(111)	4.77"	(121)	2.67	(1.21)
	FTU4X6X4	6"	(150)	47.5"	(1206)	4.38"	(111)	4.77"	(121)	5.20	(2.36)
	FTU4X6X10	6"	(150)	118.4"	(3008)	4.38"	(111)	4.77"	(121)	12.79	(5.80)
	FTU4X12X2	12"	(300)	23.9"	(603)	4.38"	(111)	4.77"	(121)	3.64	(1.65)
	FTU4X12X4	12"	(300)	47.5"	(1206)	4.38"	(111)	4.77"	(121)	7.08	(3.21)
	FTU4X12X10	12"	(300)	118.4"	(3008)	4.38"	(111)	4.77"	(121)	17.39	(7.89)
	FTU4X20X2	20"	(500)	23.9"	603	4.38"	(111)	4.77"	(121)	4.93	(2.24)
	FTU4X20X4	20"	(500)	47.5"	(1206)	4.38"	(111)	4.77"	(121)	9.58	(4.35)
	FTU4X20X10	20"	(500)	118.4"	(3008)	4.38"	(111)	4.77"	(121)	23.52	(10.67)
6" (150mm) deep	FTU6X6X2	6"	(150)	23.9"	(603)	6.38"	(162)	6.77"	(172)	3.32	(1.51)
	FTU6X6X4	6"	(150)	47.5"	(1206)	6.38"	(162)	6.77"	(172)	6.45	(2.93)
	FTU6X6X10	6"	(150)	118.4"	(3008)	6.38"	(162)	6.77"	(172)	15.85	(7.19)
	FTU6X12X2	12"	(300)	23.9"	(603)	6.38"	(162)	6.77"	(172)	4.28	(1.94)
	FTU6X12X4	12"	(300)	47.5"	(1206)	6.38"	(162)	6.77"	(172)	8.33	(3.78)
	FTU6X12X10	12"	(300)	118.4"	(3008)	6.38"	(162)	6.77"	(172)	20.45	(9.28)
	FTU6X20X2	20"	(500)	23.9"	(603)	6.38"	(162)	6.77"	(172)	5.57	(2.53)
	FTU6X20X4	20"	(500)	47.5"	(1206)	6.38"	(162)	6.77"	(172)	10.83	(4.91)
	FTU6X20X10	20"	(500)	118.4"	(3008)	6.38"	(162)	6.77"	(172)	26.59	(12.06)
Flats	WBUFLT	20"	(500)	24"	(604)	-	-	-	-	2.96	(1.34)
	WBUFLT-12	12"	(300)	24"	(604)	-	-	-	-	1.50	(0.68)
	WBUFLT-06	6"	(150)	24"	(604)	-	-	-	-	1.00	(0.45)

FLEXTRAY

Stands

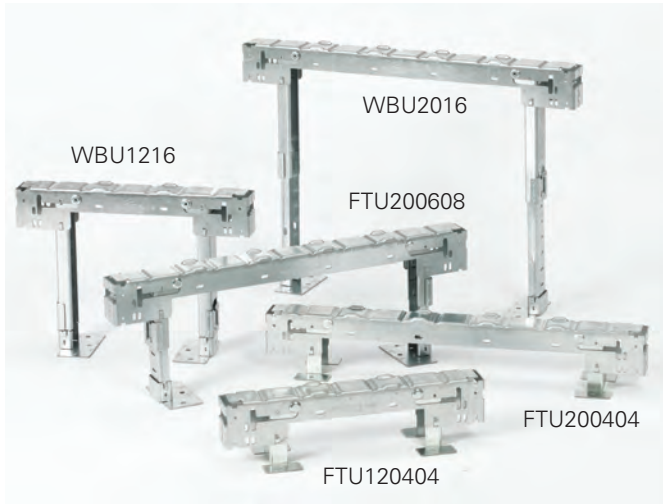

- No tools required for installation
- Formed top surface free of protrusions or sharp edges
- Up to 6" height adjustment
- Inside and outside leg positioning
- Folded and boxed for ease in shipping
- Patent Pending
- Stand part number includes:
 - one (1) stand
 - two (2) feet
 - two (2) adhesive pads
 - two (2) hold down clips
- Standard finish: Pre-Galvanized

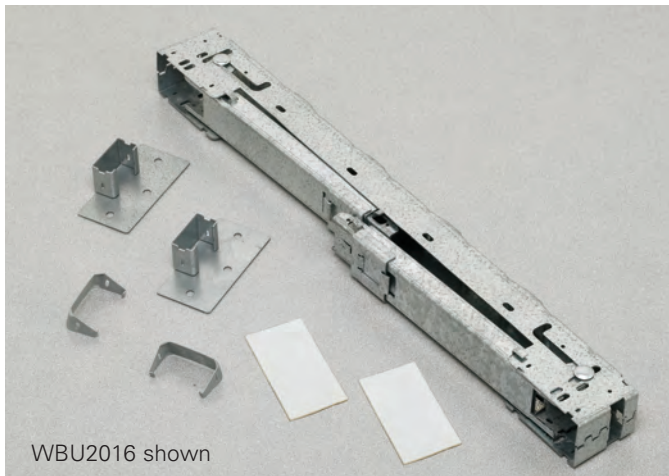

WBU2016 shown

WBU2016 stands shown in double tier application.
Feet and adhesive pads not required for second tier assembly.

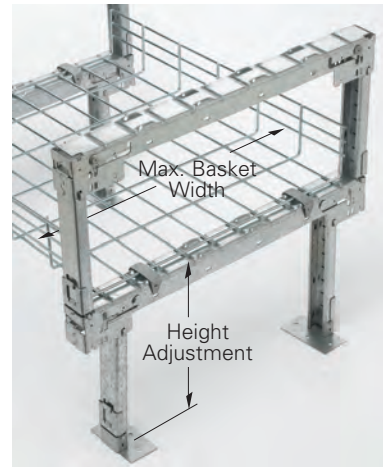

Part Number	Max. Basket Width		Height Adjustment		Stands Per Box	Wt. Per Box	
	in.	(mm)	in.	(mm)		lbs.	(kg)
FTU120404	12"	(300)	4"	(101)	2	1.82	(0.82)
FTU120608	12"	(300)	6"-8"	(152-203)	2	2.79	(1.26)
WBU1216	12"	(300)	10"-16"	(254-406)	2	7.44	(3.37)
WBU1224 *	12"	(300)	18"-24"	(457-609)	2	9.06	(4.11)
WBU1231 *	12"	(300)	25"-31"	(635-787)	2	10.52	(4.77)
FTU200404	20"	(500)	4"	(101)	2	2.34	(1.06)
FTU200608	20"	(500)	6"-8"	(152-203)	2	3.36	(1.52)
WBU2016	20"	(500)	10"-16"	(254-406)	2	8.56	(3.88)
WBU2024	20"	(500)	18"-24"	(457-609)	2	10.20	(4.62)
WBU2031 *	20"	(500)	25"-31"	(635-787)	2	11.64	(5.28)

* Legs are packed separately in box and not inserted in stand.

See page D-3 for finish information

Cantilever Kits & Accessories



- No tools required for installation
- Simple design for tiered applications
- Available in kits or individual parts
- Adjustable shelf height
- Formed top surface has no sharp edges
- Can be installed independent of raised floor
- Standard finish: Pre-Galvanized

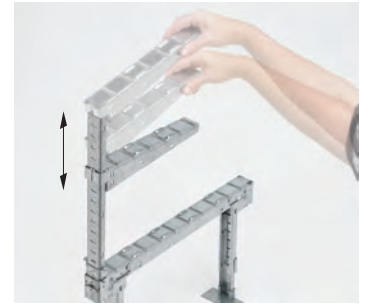

Adjustability of shelf brackets

WBUCK812 Double Tier Cantilever Kit Shown with WBU2016 Stand

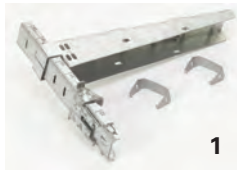

1

WBUCK12 - Single Tier Cantilever Kit Includes

- (1) WBUCK12
- (1) WBUL16
- (1) WBUCKF
- (2) WBUHD



2

WBUCK812 - Double Tier Cantilever Kit Includes

- (1) WBUCK8
- (1) WBUCK12
- (1) WBUL24
- (1) WBUCKF
- (3) WBUHD



3

WBUCK8



4

WBUCK12

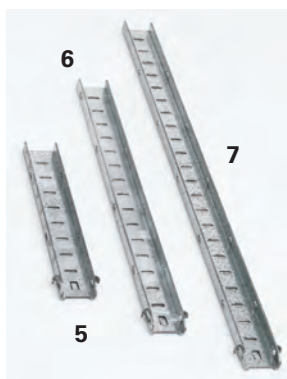
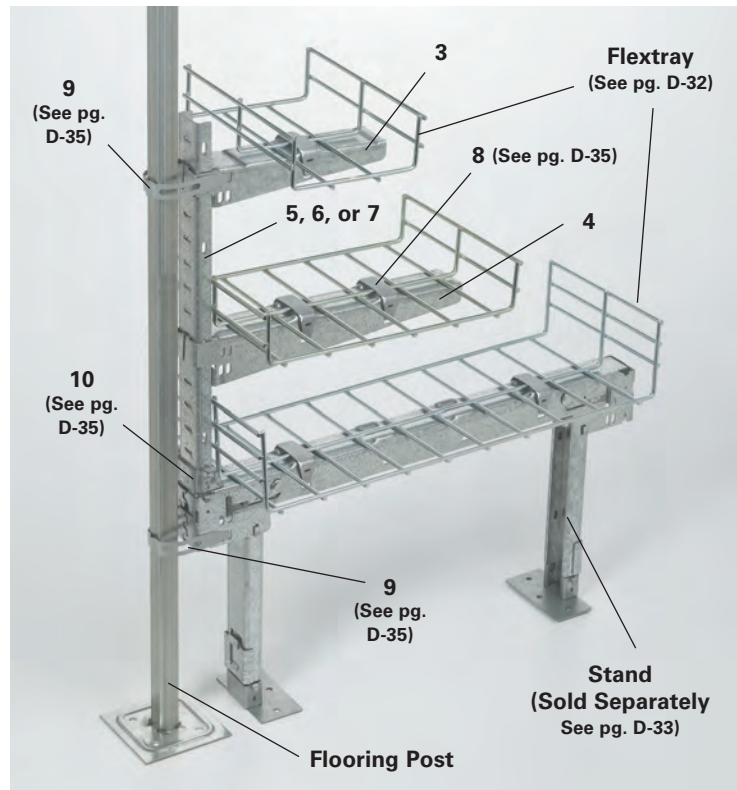

5

6

7

Part Number	Item #	Description	Max Height †		Box Qty.	Wt. Per Box	
			in.	(mm)		lbs.	(kg)
WBUCK12 *	1 ^Δ	Cantilever Kit - Single Tier with 12" Bracket	7.30"	(185)	10	15.62	(7.08)
WBUCK812	2 ^Δ	Cantilever Kit - Double Tier with 8" & 12" Brackets	15.25"	(387)	10	25.40	(11.52)
WBUCK8	3	8" Cantilever Bracket for 6" Flextray	-	-	10	5.51	(2.50)
WBUCK12	4	12" Cantilever Bracket for up to 12" Flextray	-	-	10	9.16	(4.15)
WBUL16	5	Short Vertical Support	7.30"	(185)	10	4.37	(1.98)
WBUL24	6	Medium Vertical Support	15.25"	(387)	10	8.45	(3.83)
WBUL31	7	Tall Vertical Support	22.25"	(565)	10	12.07	(5.47)

* For use with 2" and 4" deep Flextray on the lower level.

† Height - from top of stand

Δ Stand not included

FLEXTRAY™ - F.A.S.T.™ Underfloor System

Hold Down Clip



- Spring steel clip to attach Flextray to stands
- No tools required for installation
- Holds both continuous and spliced wire sections securely
- Works with stands and cantilever brackets

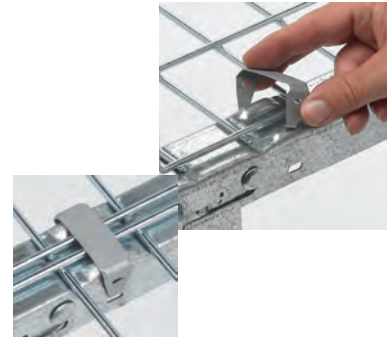

Part Number	Item #	Description	Box Qty.	Wt. Per Box	
				lbs.	(kg)
WBUHD	8	Basket Clip	50	1.10	(0.50)

Pedestal Clip



- Optional spring steel clip to give added rigidity to system
- Works with stands and cantilever brackets



Part Number	Item #	Description	Box Qty.	Wt. Per Box	
				lbs.	(kg)
WBUPC	9	Pedestal Clip	50	1.65	(0.75)

Cantilever Foot



Part Number	Item #	Description	Box Qty.	Wt. Per Box	
				lbs.	(kg)
WBUFC	10	Cantilever Foot	50	8.65	(3.92)

Under Floor Stand



- Heights of 3", 4", 5" or 6"
- Leg cutout allows for airflow
- No tools required to mount FLEXTRAY to stand
- Use WBUHD hold down clips to secure basket
- Stand width is 12"
- Fasten to floor for maximum stability
- Floor mounting slot size: .313" (7.9mm) x .813" (20.6mm) for 1/4" hardware

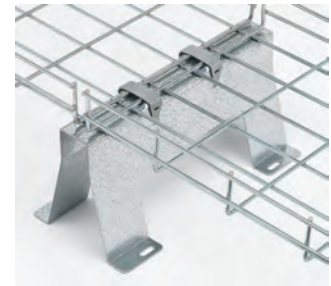

Part Number	Overall Height	Wt. Per Each
	in. (mm)	lbs. (kg)
WBU1203	3" (76)	1.32 (0.60)
WBU1204	4" (101)	1.60 (0.72)
WBU1205	5" (127)	1.88 (0.85)
WBU1206	6" (152)	2.17 (0.98)

See page D-3 for finish information

L Bracket & Toolless Clip

- For use when access to ground floor is limited
- Use with round post sizes 0.9" (25mm) through 1.2" (30mm)
- Use with square posts
- Order clamps and brackets separately
- Built-in tab for hold down
- Tool-less clip (plenum-rated material) - Snap-in locking pin securely holds basket to bracket



Illustration photos only.
All parts are sold separately.



TOOLLESS CLIP

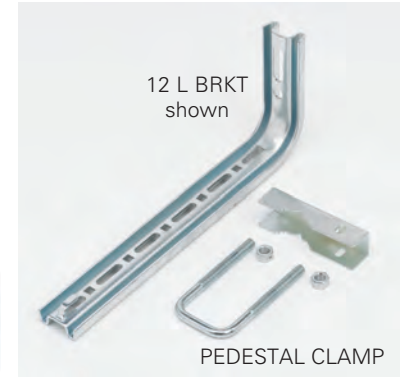

12 L BRKT
shown

PEDESTAL CLAMP

Part Number	Description	Qty.	Wt. Per Box lbs. (kg)
TOOLLESS CLIP	Tool-less Hold-Down Clip	50/Box	1.00 (0.45)

Brackets (Zinc Plated)

Part Number	System Width in. (mm)	Length in. (mm)	Box Qty.	Wt. Per Box lbs. (kg)
8 L BRKT	6"-8" (150-200)	8" (200)	1	0.80 (0.36)
12 L BRKT	12" (300)	12" (300)	1	1.30 (0.59)

Pedestal Clamp & Kit

- Clamps to existing raised-access floor stanchion
- Use L BRKT (shown above) or full pedestal kit to support trays under the raised access floor (sold separately)
- For tray widths 2" (50mm) to 20" (500mm)
- *Pedestal Clamp Kit includes two (2) pedestal clamps, 28" (711mm) profile section, bolts & nuts
- Kits include hardware
- SUPTWASHER & FTWDWE 1/4 sold separately
- Finishes __: **EG**



Part Number	Description	Qty./Box	Wt./Box lbs. (kg)
PEDESTAL CLAMP__	Pedestal Clamp	1	0.6 (0.27)
PEDESTAL KIT__	Pedestal Clamp Kit	1*	3.3 (1.49)

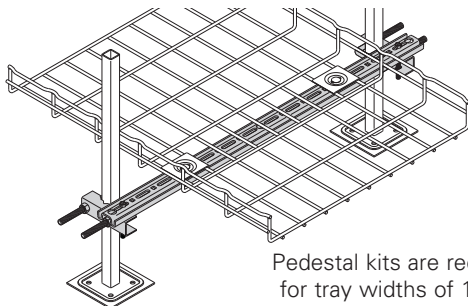

Pedestal kits are recommended for tray widths of 16" (400mm) or greater

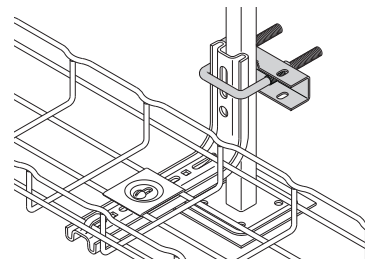

See page D-3 for finish information

Under Floor Support Bracket



- Under floor support bracket provides rugged support for FLEXTRAY System from access floor post.
- To complete the installation, the following hardware must be ordered separately.
 - (2) - B501 U-Bolts
 - (1) - SUPT WASHER Hold Down
 - (1) - 1/4"-20 x 1" Slotted Head Screw
 - (1) - N224WO Channel Nut
- Finish: **ZN**

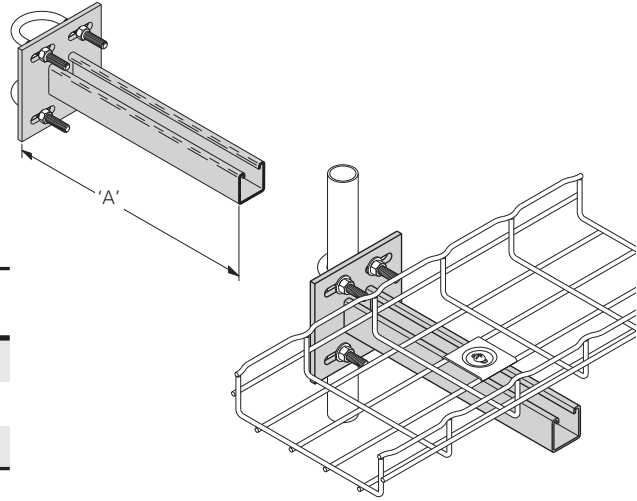

Part Number	'A' in. (mm)	Box Quantity	Wt. Per Each lbs. (kg)
B409UF-12	12" (300)	1	3.6 (1.63)
B409UF-18	18" (450)	1	4.5 (2.04)
B409UF-21	21" (533)	1	5.4 (2.45)

U-Bolts



- Designed for attachment of under floor support brackets to access floor post. Each U-Bolt includes two (2) hex nuts.
- Finish: **ZN**

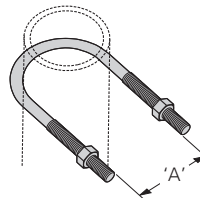

Part Number	'A' in. (mm)	Thread Size	Box Quantity	Wt. Per Box lbs. (kg)
B501-1	1 ³ / ₈ " (30)	5/16"-18	50	7.0 (3.17)
B501-1 ¹ / ₂	2" (50)	5/16"-18	50	8.0 (3.63)
B501-2	2 ⁷ / ₁₆ " (62)	3/8"-16	20	5.4 (2.45)
B501-2 ¹ / ₂	2 ¹⁵ / ₁₆ " (75)	3/8"-16	25	8.0 (3.63)

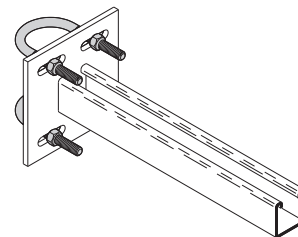

See page D-3 for finish information

Ground Bolt

- Attaches up to #1 ground wire to each tray section when separate ground wire is required
- Used for UL grounding compliance.
- When using color powder coated finish or paint, coating must be removed at the points of contact.
- Finish: Copper Plated

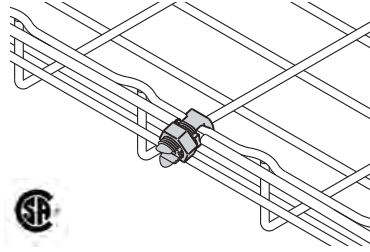

Part Number	Description	Qty./Box	Wt./Box lbs. (kg)
GROUND BOLT	Ground Bolt	1	0.11 (0.05)



Adhesive & Feet

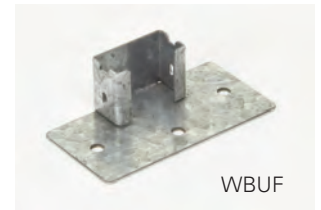
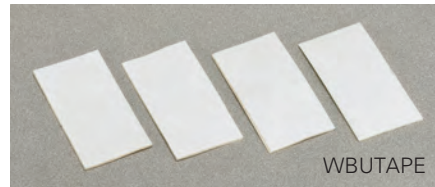

- WBUTAPE - Double-sided adhesive pads for temporary positioning of floor stands
Pad Size: 2" (50mm) x 4" (100mm)
- WBUBA - Adhesive to secure stand to floor

Part Number	Description	Box Quantity	Wt. Per Box lbs. (kg)
WBUF	Stand Foot	10	2.36 (1.07)
WBUTAPE	Double-Sided Tape	50	2.50 (1.13)
WBUBA	Floor Adhesive	1 Gallon	10.78 (4.89)

Floor Stand

- Non-metallic snap lock floor stand is designed for use under access floors.
- Floor stand elevates FLEXTRAY System 1⁵/₈" (41.3mm) above the floor.
- To attach floor stand, use construction adhesive or anchors.
- Elevation increments of 1³/₈" (35mm) can be obtained by stacking floor stands.
- Sized for 1/4" hardware (order separately).
- Material: Black Plenum-rated Plastic

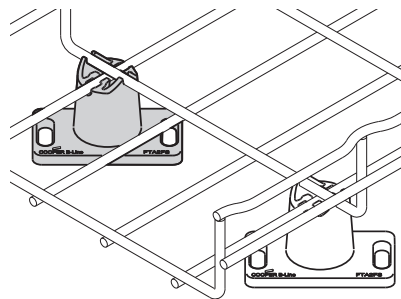

Part Number	Wt. Per Pc. lbs. (kg)	Box Quantity
FTA2FS	0.44" (0.20)	10

See page D-3 for finish information

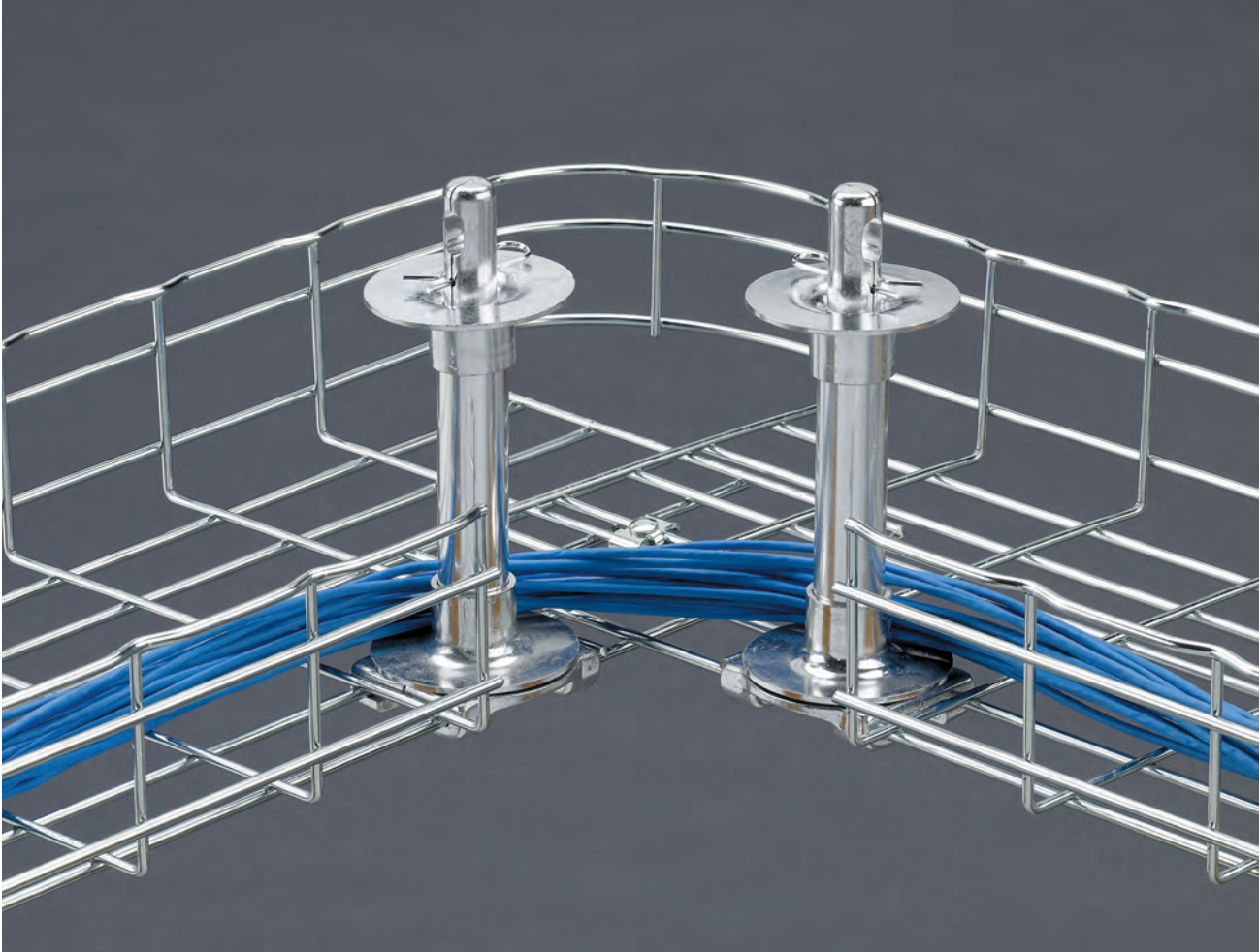

FLEXTRAY

Covers

- Protects cable from debris and dust
- Adds security to cable installation
- Easy bend-over tabs secure cover to trays
- Available for 2" (50mm) to 24" (600mm) wide trays
- Comes in 118" (2997mm) length
- Finishes __: **GS**, BLE, 304S, 316S

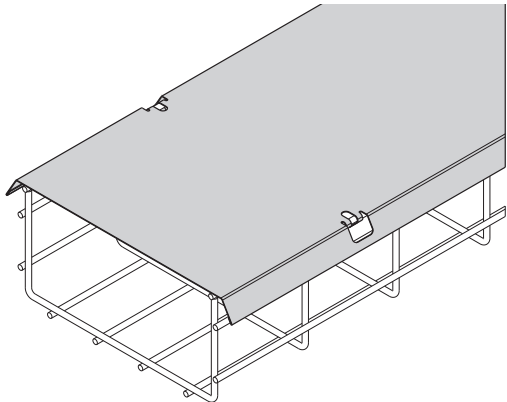

Part Number	For Tray Width Of in. (mm)	Qty./Box	Wt./Box lbs. (kg)
2 IN COVER __	2" (50)	1	3.8 (1.72)
4 IN COVER __	4" (100)	1	5.7 (2.58)
6 IN COVER __	6" (150)	1	6.7 (3.04)
8 IN COVER __	8" (200)	1	8.7 (3.94)
12 IN COVER __	12" (300)	1	11.6 (5.26)
16 IN COVER __	16" (400)	1	15.6 (7.07)
18 IN COVER __	18" (450)	1	17.0 (7.71)
20 IN COVER __	20" (500)	1	18.5 (8.39)
24 IN COVER __	24" (600)	1	22.0 (9.98)

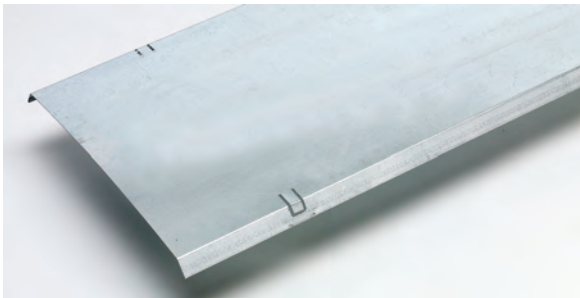

Dividers

- Allows cable separation within a single tray
- Hemmed/rounded edge provides cable jacket safety
- Hardware included
- Field miter for bends and turns
- Dual slots every 24" (609mm) for field cutting
- Available in 2" (50mm), 4" (100mm) and 6" (150mm) heights
- Comes in 118.125" (3000mm) length
- Finishes __: **GS**, BLE, 304S, 316S

Part Number	For Tray Depth Of in. (mm)	Qty./Box	Wt./Box lbs. (kg)
2 IN DIVIDER __	2" (50)	1	3.5 (1.59)
4 IN DIVIDER __	4" (100)	1	9.6 (4.35)
6 IN DIVIDER __	6" (150)	1	14.5 (6.58)

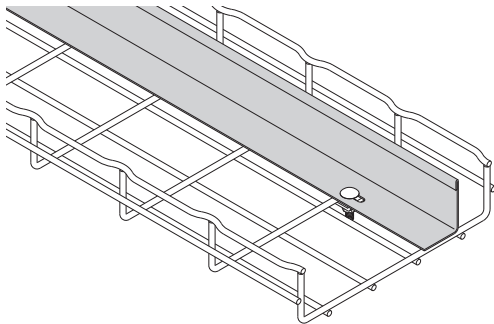

Dividers include hardware shown below

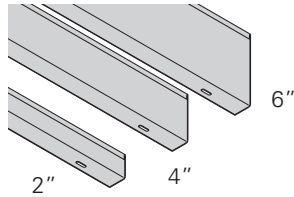
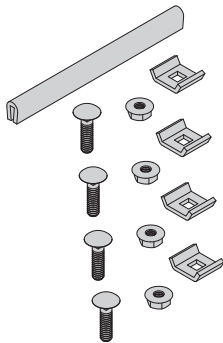

See page D-3 for finish information

Solid Bottom Inserts

Part Number	For Tray Width Of		Qty./Box	Wt./Box	
	in.	mm		lbs.	kg
INSERT 4X118__	4"	(100)	1	6.8	(3.08)
INSERT 6X118__	6"	(150)	1	9.8	(4.44)
INSERT 8X118__	8"	(200)	1	13.3	(6.03)
INSERT 12X118__	12"	(300)	1	21.6	(9.80)
INSERT 16X118__	16"	(400)	1	26.4	(11.97)
INSERT 18X118__	18"	(450)	1	32.4	(14.69)
INSERT 20X118__	20"	(500)	1	32.9	(14.92)
INSERT 24X118__	24"	(600)	1	39.3	(17.82)

Attach with
FTHDWE 1/4
& Top Washer



- Continuous support for sensitive cables
- Security of cable in high-traffic areas
- Hardware included
- Available for 4" (100mm) to 24" (600mm) wide trays
- Comes in 118" (2997mm) length
- Finishes __: **GS**, BLE, 304S, 316S

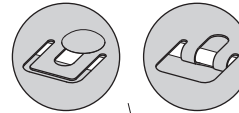

Attachment
methods

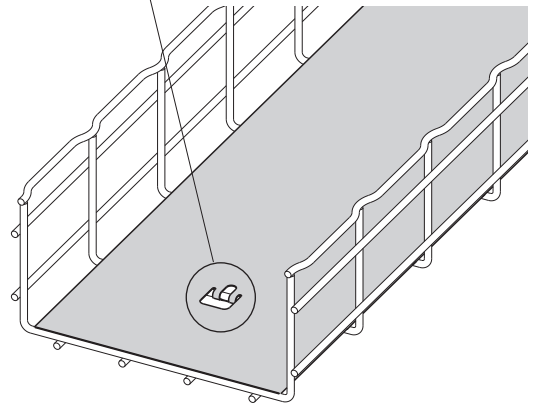

Blind Ends

Part Number	'A' in. (mm)	Height in. (mm)	Box Quantity
FT BE 2X2	2" (50)	2" (50)	1
FT BE (*)X4	4" (100)	(*) (*)	1
FT BE (*)X6	6" (150)	(*) (*)	1
FT BE (**)X8	8" (200)	(*) (*)	1
FT BE (**)X12	12" (300)	(**) (**)	1
FT BE (**)X16	16" (400)	(**) (**)	1
FT BE (**)X18	18" (450)	(**) (**)	1
FT BE (**)X20	20" (500)	(**) (**)	1
FT BE (**)X24	24" (600)	(**) (**)	1

- Tab features eliminate need for hardware
- Forms a closure for a dead-end FLEXTRAY
- Hardware included
- Finish: **GLV**, SS6

(*) Insert: 2 = 2" (50 mm), 4 = 4" (100 mm) for height

(**) Insert: 2 = 2" (50 mm), 4 = 4" (100 mm),
6 = 6" (150 mm) for height

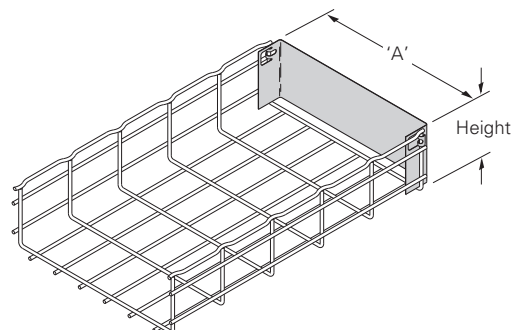

See page D-3 for finish information

Cable Roller

- Protects and maintains recommended cable radii for Cat 5, Cat 5E, Cat 6, Cat 6A, Fiber, etc.
- Height of roller can be adjusted to tray depth
- Installs in seconds with no tools
- Reduces cable installation time
- Prevents migration of cables
- For use with 4" (100mm) to 32" (800mm) tray widths
- Finish: Cast Aluminum

Part Number	Description	Qty./Box	Wt./Box lbs. (kg)
CABLE ROLLER	Cable Roller	1	1.0 (0.45)

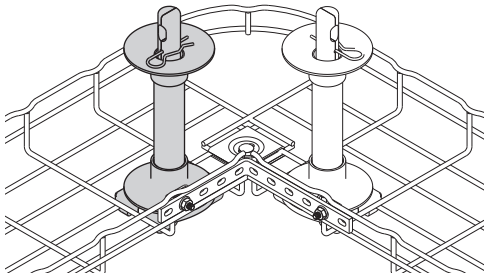

Quick, snap-together design

Toolless Clip

- Securely holds tray to support
- Snap-in locking pin
- No tools or fastening required
- Fastest hold-down method available
- For use with the following:
 - FTB_CS (see pg. D-26)
 - L BRKT (see pg. D-26)
 - C BRKT (see pg. D-30)
- Finish: Plenum rated resin (black)

Part Number	Description	Qty./Box	Wt./Box lbs. (kg)
TOOLLESS CLIP	Toolless Hold-Down Clip	50	1.0 (0.45)



Strut Mounting Clip

- Use to secure FLEXTRAY to horizontal strut support
- Designed for use as shown in drawing (no load rating)
- Finish: Black Zinc Phosphate

Part Number	Description	Qty./Box	Wt./Box lbs. (kg)
BW4	Strut Mounting Clip	100	0.9 (0.41)

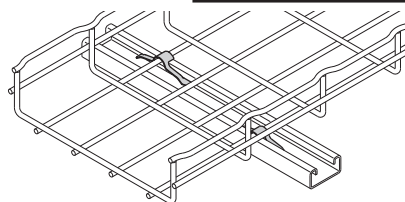

See page D-3 for finish information

Drop Out Fitting

Part Number	Description	Qty./Box	Wt./Box lbs. (kg)
DROP OUT__	Drop Out Fitting	50	15.0 (6.8)

- Keeps cable radius secure at drop point
- Retention tabs to secure positioning
- For use with 4" (100mm) to 32" (800mm) wide trays
- Attaches to tray without hardware
- Drop outs can be attached at bottom, side or ends of tray
- Retention tabs on bottom of drop out to secure positioning
- Finishes __: **EG**, BLE, SS6

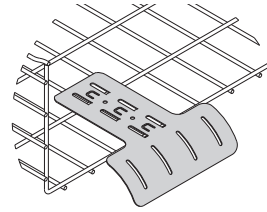
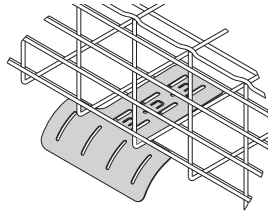

Side Drop Out Fitting

Part Number	Width in. (mm)	Qty./Box	Wt./Box lbs. (kg)
FTA6SDO	6.0 (152.4)	10	7.17 (3.2)
FTA8SDO	8.0 (203.2)	10	9.57 (4.3)
FTA12SDO	12.0 (304.8)	10	14.35 (6.5)

- Keeps cable radius secure at drop point
- For use with 4" (100mm) to 32" (800mm) wide trays (Fig. 1)
- For use with 6" (152mm) to 12" (300mm) wide trays (Fig. 2)
- Drop outs can be attached at side or ends of tray as shown
- Finishes __: **EG**, BLE, SS6

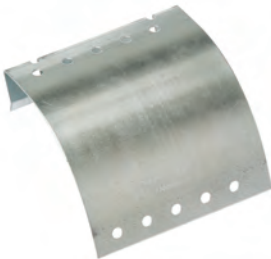

(Fig. 1)

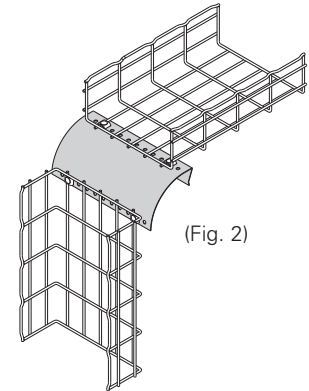
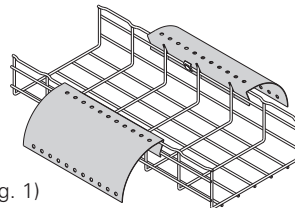

(Fig. 2)

Cable Drop Out

Part Number	Description	Qty./Box	Wt./Box lbs. (kg)
FTA2DO	Cable Drop Out	10	0.17 (0.08)

- Non-metallic 2" (50mm) radius Cable Drop-Out snap locks into mesh bottom and protects cables from sharp bend
- Material: Black Plenum-rated Plastic

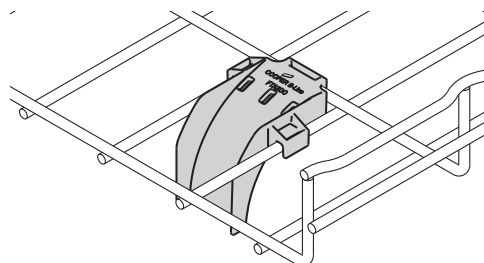

See page D-3 for finish information

Conduit Connector

- Conduit connector is designed to connect conduit to the side or bottom of FLEXTRAY
- Conduit bushing will remain outside of tray to keep cable pathway clear
- Bend tabs to secure connector to tray
- No hardware included
- Finishes __: **GLV**

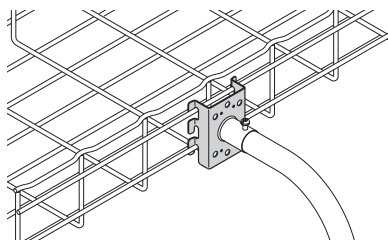

Part Number	Conduit Size in. (mm)	Qty./Box	Wt./Box lbs. (kg)
FTA050CC__	1/2" (15)	10	2.0 (0.91)
FTA075CC __	3/4" (20)	10	2.0 (0.91)
FTA100CC __	1" (25)	10	2.0 (0.91)
FTA125CC __	1 1/4" (32)	10	2.0 (0.91)



Rack Clamp

- Securely holds tray down to rack
- Installs without drilling
- Black-painted finish to match rack
- Finish __: **BLE**

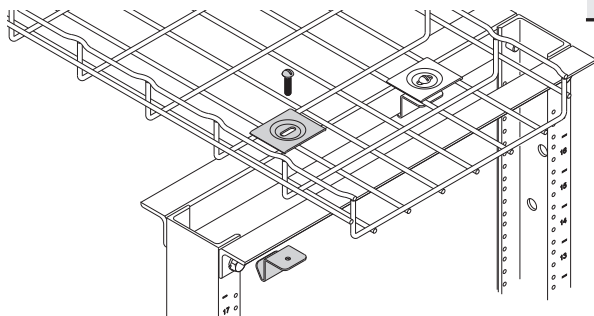

Part Number	Description	Qty./Box	Wt./Box lbs. (kg)
RACK CLAMP__	Rack Clamp	4	4.7 (2.13)



Adaptor Kit

- Adaptor kit includes all hardware necessary to connect Flextray system to top of relay rack at right angle or parallel position
- Finish __: **YZN (Yellow Zinc Chromate)**

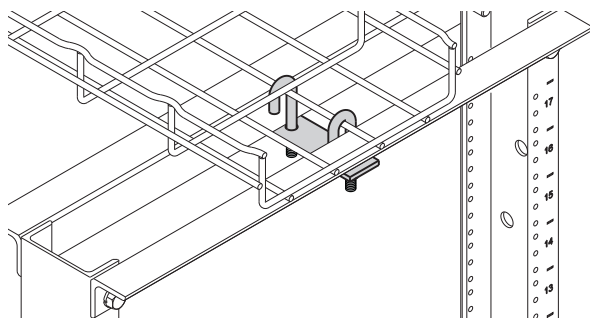

Part Number	Description	Qty./Box	Wt./Box lbs. (kg)
SB2204__	Adaptor Kit	1	0.37 (0.17)

- Adaptor Kit includes:
- (1) - Mounting Plate
 - (2) - 5/16"-18 x 2" "J"-Bolts
 - (2) - HN 5/16"-18 Hex Nuts
 - (2) - LW 5/16" Lock Washers



See page D-3 for finish information

Radius Shield

Part Number	Height A in. (mm)	Qty./Box	Wt./Box lbs. (kg)
FTA2RS	2.5 (63)	50	4.0 (1.8)
FTA4RS	4.3 (110)	50	7.0 (3.2)
FTA6RS	5.9 (150)	25	5.0 (2.3)

- Provides a smooth inside radius surface.
- No tools or fasteners needed to install.
- Sizes for 2", 4" & 6" deep FLEXTRAY; 90° horizontal bends, tees, and crosses.
- Installs in seconds. Simply hold in place and bend back tabs.
- Slick surface to reduce cable friction.
- Material: Black Polycarbonate

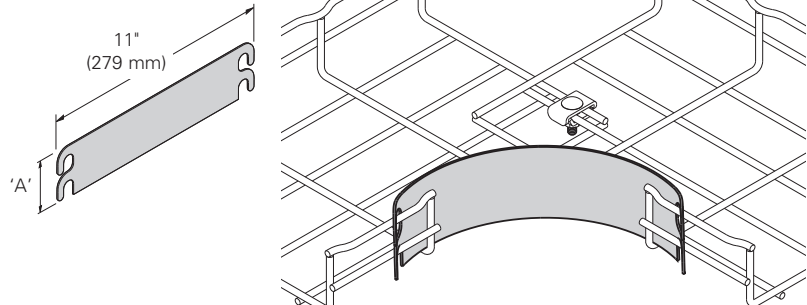

Rubber Cap

Part Number	Box Quantity	Wt. Per 100 lbs. (kg)
B719EB	100	0.20 (0.10)

- Install on wire ends if required. Fits all wire diameters
- Sold as each

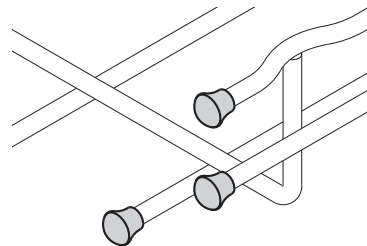

Part Number	Color	Qty./Box	Wt./Box lbs. (kg)
SB420ATG	Gray Lacquer	1	0.9 (0.41)
SB420AFB	Flat Black Lacquer	1	0.9 (0.41)
SB420ACW	Computer White Lacquer	1	0.9 (0.41)
B999	Silver Zinc-Rich Paint	1	0.9 (0.41)

- Size: 12 ounce aerosol can
- Cannot ship air freight

See page D-3 for finish information

Label Clip

- Clips easily into trays
- Use for identifying your cable pathways
- Can be used on all tray sizes
- Will not fit on side of 1 1/2" deep FLEXTRAY
- Finish: Non-plenum-rated resins

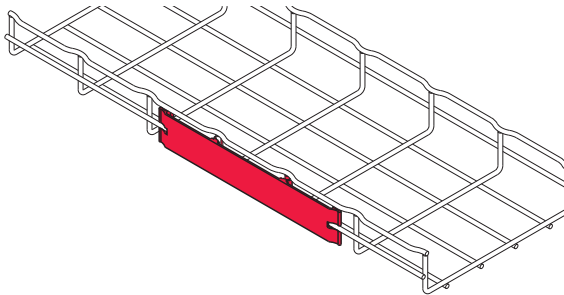

Part Number	Length in. (mm)	Qty./Box	Wt./Box lbs. (kg)
LABEL CLIP	10 1/2" (267)	10	0.6 (0.27)



Ground Bolt

- Attaches up to #1 ground wire to each tray section when separate ground wire is required
- Used for UL grounding compliance.
- When using color powder coated finish or paint, coating must be removed at the points of contact.
- Finish: Copper Plated

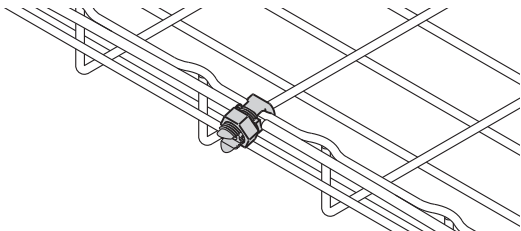

Part Number	Description	Qty./Box	Wt./Box lbs. (kg)
GROUND BOLT	Ground Bolt	100	1.0 (0.45)



Ground Wire Supports

- Supports ground wire along side of tray
- Can be used on all trays
- Finish __: Zinc Plated

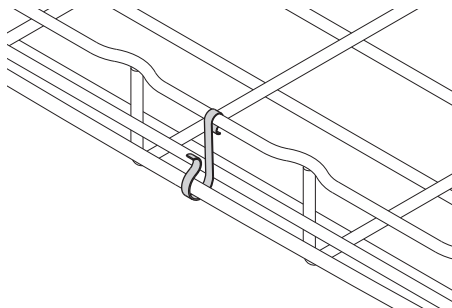

Part Number	Description	Qty./Box	Wt./Box lbs. (kg)
GROUND SUPT GL	Ground Wire Support	100	0.6 (0.27)



See page D-3 for finish information

FLEXTRAY™ - Accessories

- Complete source of hardware for ceiling connections
- Available in stock
- Strut can be purchased in pre-cut lengths and various colors
- All hardware is zinc plated

Threaded Rod



Part Number	Size	Qty.	Wt./Qty. lbs. (kg)
ATR1/4x72	1/4" x 72" (1828mm)	1	0.7 (0.31)
ATR1/4x120	1/4" x 120" (3048mm)	1	1.2 (0.54)
ATR1/4x144	1/4" x 144" (3657mm)	1	1.4 (0.63)
ATR3/8x72	3/8" x 72" (1828mm)	1	1.7 (0.77)
ATR3/8x120	3/8" x 120" (3048mm)	1	2.9 (1.31)
ATR3/8x144	3/8" x 144" (3657mm)	1	3.5 (1.58)
ATR1/2x72	1/2" x 72" (1828mm)	1	3.2 (1.45)
ATR1/2x120	1/2" x 120" (3048mm)	1	5.4 (2.45)
ATR1/2x144	1/2" x 144" (3657mm)	1	6.5 (2.95)

Rod Couplings



Part Number	Size	Qty.	Wt./Qty. lbs. (kg)
B655-1/4	1/4"-20	50	2.0 (0.91)
B655-3/8	3/8"-16	50	5.5 (2.49)
B655-1/2	1/2"-13	50	6.0 (2.72)

Hex Nuts



Part Number	Size	Qty.	Wt./Qty. lbs. (kg)
1/4HN	1/4"-20	100	0.6 (0.27)
3/8HN	3/8"-16	100	1.6 (0.72)
1/2HN	1/2"-13	100	4.3 (1.95)

Lock Washers



Part Number	Size	Qty.	Wt./Qty. lbs. (kg)
1/4LW	1/4"	200	0.6 (0.27)
3/8LW	3/8"	200	1.6 (0.72)
1/2LW	1/2"	200	2.0 (0.91)

Flat Washers

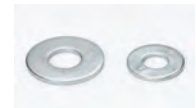

Part Number	Size	Qty.	Wt./Qty. lbs. (kg)
1/4FW	1/4"	200	1.2 (0.54)
3/8FW	3/8"	200	3.0 (1.36)
1/2FW	1/2"	200	6.6 (2.99)

Square Washers



Part Number	Size	Qty.	Wt./Qty. lbs. (kg)
B201	7/16	50	6.0 (2.72)
B202	9/16	50	7.0 (3.17)

Beam Clamps



Part Number	Size	Qty.	Wt./Qty. lbs. (kg)
B3036L-3/8	3/8"-16	100	60.0 (27.2)
B3036L-1/2	1/2"-13	100	140.0 (63.5)

See page D-3 for finish information

Beam Clamps



Part Number	Size	Qty.	Wt./Qty. lbs. (kg)
B444-1/4	1/4"-20	100	160 (72.5)
B444-3/8	3/8"-16	100	430 (195.0)
B444-1/2	1/2"-13	100	430 (195.0)

U-Bolt Clamps



Part Number	Size	Qty.	Wt./Qty. lbs. (kg)
B441-22	3/8"-16 x 3 3/8" long	100	160 (72.5)

Spring Nuts



Part Number	Thread Size	Qty.	Wt./Qty. lbs. (kg)
N224	1/4"-20	100	6.5 (2.95)
N228	3/8"-16	100	9.3 (4.22)
N225	1/2"-13	100	11.3 (5.12)

Strut Channels



Part Number	Channel Size	Qty.	Wt./Qty. lbs. (kg)
B22SGALV120	1 5/8" x 120" - 12 ga.	1	6.0 (2.72)
B22SHGALV120	1 5/8" x 120" - 12 ga.	1	6.0 (2.72)
B56SGALV120	1 3/16" x 120" - 15 ga.	1	7.0 (3.17)
B56SHGALV120	1 3/16" x 120" - 15 ga.	1	6.0 (2.72)

Concrete Rapid Rod™ Hanger



Part Number	Rod Size	Shank Size	Qty.	Wt./Qty. lbs. (kg)
ARC-37-150	3/8"	1/4" x 1 1/2"	100	3.4 (1.54)

Wood Rapid Rod™ Hanger



Part Number	Rod Size	Shank Size	Qty.	Wt./Qty. lbs. (kg)
ARW-37-200	3/8"	1/4" x 2"	100	3.4 (1.54)
ARW-37-200SW	3/8"	1/4" x 2"	100	3.4 (1.54)

SW = Side Mount

Steel Rapid Rod™ Hanger



Part Number	Rod Size	Shank Size	Qty.	Wt./Qty. lbs. (kg)
ARS-37-150	3/8"	1/4" x 1 1/2"	100	3.4 (1.54)
ARS-37-150SW	3/8"	1/4" x 1"	100	3.4 (1.54)

SW = Side Mount

Sockets for Rapid Rod Hangers

Part Number	Size	Qty.	Wt./Qty. lbs. (kg)
7187	Universal Steel & Wood Socket	1	4.5 (2.04)
7197	3/8" Concrete Socket	1	4.5 (2.04)

See page D-3 for finish information

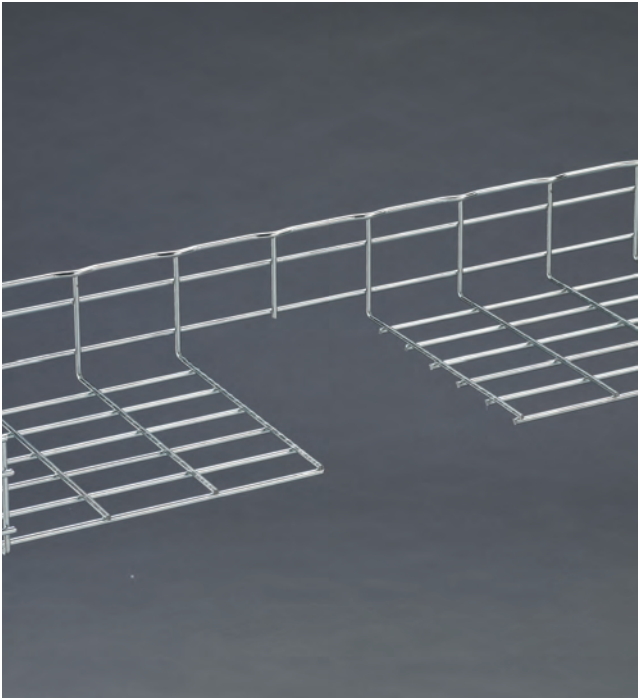

FLEXTRAY

Flextray Cutters

- Exclusive, patented CLEANSHEAR™ cuts tray fast
- No sharp edges
- Designed specifically for cutting Flextray
- Safely cut and bend Flextray into any configuration

Part Number	Description	Qty./Box	Wt./Box lbs. (kg)
CLEANSHEAR	CLEANSHEAR Cutting Tool	1	4.3 (1.95)



Patented



1 Face tray up. Slide cutter next to vertical wire and cut.



2 Turn tray to the side with open side facing you. Repeat step 1 to cut wire.



3 Finish cutting all side wires.



4 Turn tray open-side down and cut wires from bottom of tray.



5 Finish cutting by moving to other side of tray to cut remaining wires,

- CLEANSHEAR bender has our exclusive bending attachment
- Makes bending larger trays easy
- Recommended for bending tray widths of 16" (400mm) or greater

Flextray Bender

Part Number	Description	Qty./Box	Wt./Box lbs. (kg)
CLEANSHEAR BEND	CLEANSHEAR Cutting Tool With Bender Attachment	1	5.4 (2.45)



Patented

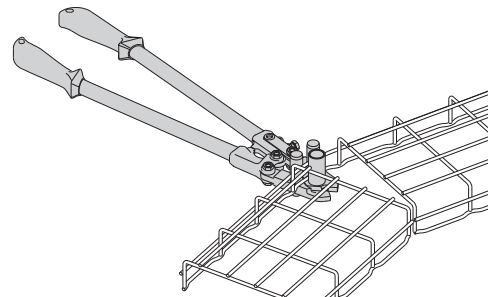

Angular Bolt Cutter

Part Number	Description	Qty./Box	Wt./Box lbs. (kg)
WB30BC	Bolt Cutter	1	6.8 (3.1)
WB30RB	Replacement Blade	1	1.3 (0.6)

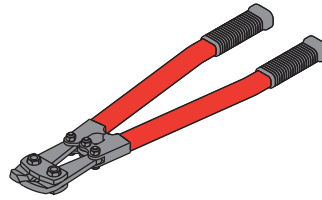

WB30BC
Angular Bolt Cutter

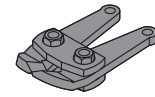

WB30RB
Replacement Blade

Completely adaptable, the Flextray system is designed to accommodate jobsite changes. Cut wires with our Angular Bolt Cutter, bend to create a bend, tee, or reducer.

Cut and remove each wire as illustrated below. Follow cutting pattern and blade positioning. Placing Flextray open side down provides the optimum cutting angle.

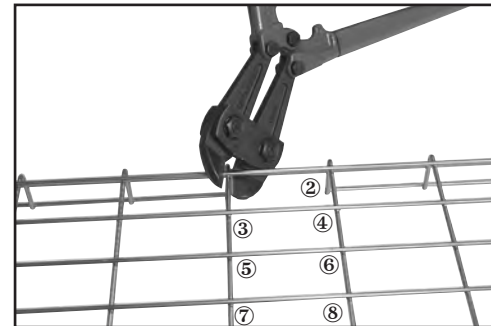
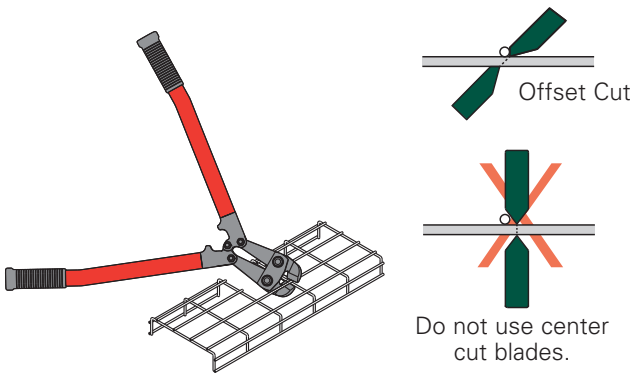

Cutting Order

For the best results, use a WB30BC angular blade offset bolt cutter with 24" (600 mm) long handles.

The offset blade cutter produces a clean cut. Position bolt cutter blades near the cross wire and perpendicular to wire to be cut (see illustration above). Proper cut will make the assembly faster, easier and safer while minimizing grinding.

Part Number	Length in. (mm)	Wt. Per Cutter lbs. (kg)	Box Quantity
WB50WC	12 ³ / ₄ " (324)	3.0 (1.3)	1

Part Number	Description	Box Quantity
WB50RB	Replacement Blade	1
WB50BA	Replacement Battery	1

The Greenlee®† cable wire cutter makes flush cuts without burrs. Will cut .191" (4.8mm) diameter wire in 2 seconds. Cutting head rotates 330° for ease of positioning and the tool automatically retracts when cut is complete.

Comes with 2 batteries, charger, and carrying case. Approximately 250 cuts per charge.



† Mark shown is the property of its respective owner.

90° Horizontal Bends (Short Radius)

- Make your own field cut horizontal bends using CLEANSHEAR™ to make safe, smooth cuts
- Can be made from any tray width and depth with any available finish
- SUPT WASHER & FTHDWE 1/4 hardware may be used on bottom of tray instead of WASHER SPL KIT where desired

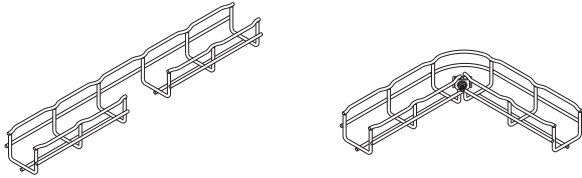

2" (50mm) Tray Width

Flextray Depth in. (mm)	Required Hardware Description	Quantity
2" (50)	WASHER SPL KIT	1

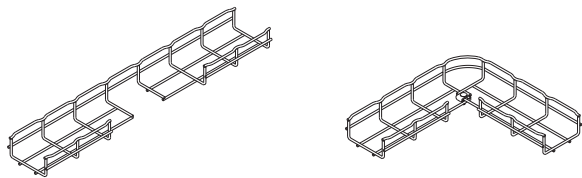

4" (100mm) Tray Width

Flextray Depth in. (mm)	Required Hardware Description	Quantity
1 1/2" (38)	WASHER SPL KIT	1
2" (50)	WASHER SPL KIT	1
4" (100)	WASHER SPL KIT	1

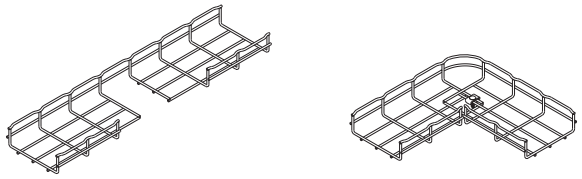

6" (150mm) Tray Width

Flextray Depth in. (mm)	Required Hardware Description	Quantity
1 1/2" (38)	WASHER SPL KIT	1
2" (50)	WASHER SPL KIT	1
4" (100)	WASHER SPL KIT	1

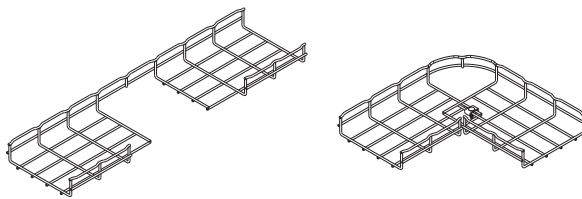

8" (200mm) Tray Width

Flextray Depth in. (mm)	Required Hardware Description	Quantity
1 1/2" (38)	WASHER SPL KIT	1
2" (50)	WASHER SPL KIT	1
4" (100)	WASHER SPL KIT	1
6" (150)	WASHER SPL KIT	1

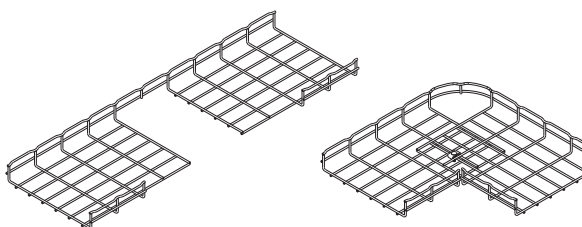

12" (300mm) Tray Width

Flextray Depth in. (mm)	Required Hardware Description	Quantity
1 1/2" (38)	WASHER SPL KIT	1
2" (50)	WASHER SPL KIT	1
4" (100)	WASHER SPL KIT	1
6" (150)	WASHER SPL KIT	1

90° Horizontal Bends (Short Radius)

- Make your own field cut horizontal bends using CLEANSHEAR™ to make safe, smooth cuts
- Can be made from any tray width and depth with any available finish
- SUPT WASHER & FTHDWE 1/4 hardware may be used on bottom of tray instead of WASHER SPL KIT where desired

16" (400mm) Tray Width

Flextray Depth in. (mm)	Required Hardware Description	Quantity
2" (50)	WASHER SPL KIT	3
4" (100)	WASHER SPL KIT	3
6" (150)	WASHER SPL KIT	3

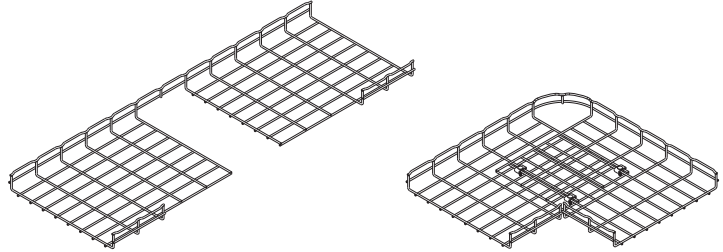

18" (450mm) Tray Width

Flextray Depth in. (mm)	Required Hardware Description	Quantity
2" (50)	WASHER SPL KIT	3
4" (100)	WASHER SPL KIT	3
6" (150)	WASHER SPL KIT	3

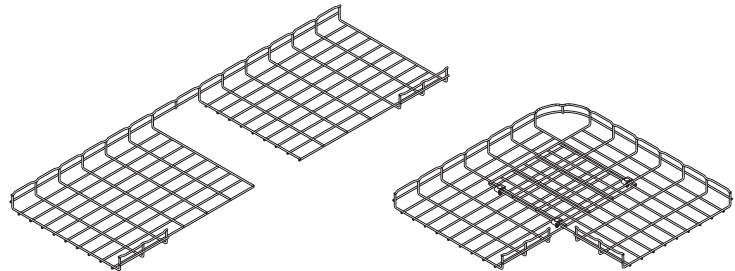

20" (500mm) Tray Width

Flextray Depth in. (mm)	Required Hardware Description	Quantity
2" (50)	WASHER SPL KIT	3
4" (100)	WASHER SPL KIT	3
6" (150)	WASHER SPL KIT	3

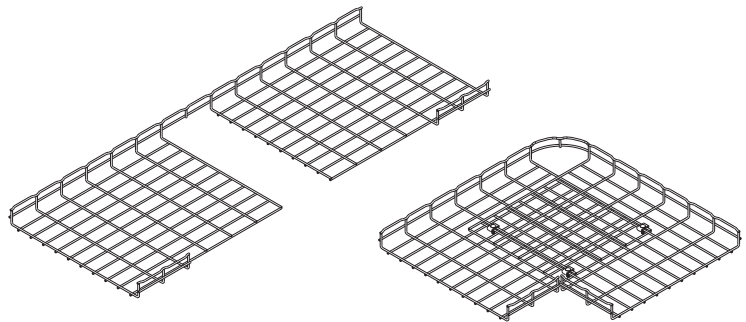

24" (600mm) Tray Width

Flextray Depth in. (mm)	Required Hardware Description	Quantity
2" (50)	WASHER SPL KIT	3
4" (100)	WASHER SPL KIT	3
6" (150)	WASHER SPL KIT	3

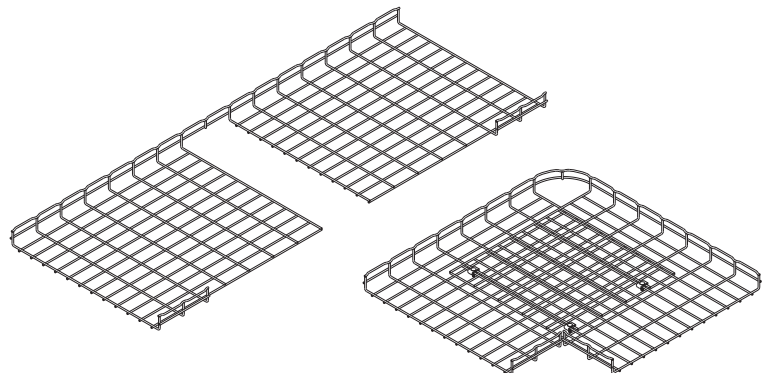

90° Horizontal Bends (Long Radius)

- Make your own field cut horizontal sweeps using CLEANSHEAR™ to make safe, smooth cuts
 - Can be made from any tray width and depth with any available finish
 - Cut as many segments as required to control sweep radius (use chart for recommendations)
 - One (1) WASHER SPL KIT is required to connect each cut segment minus one, this segment uses one (1) SPLICE BAR, two (2) FTHDWE 1/4 and two (2) BTM WASHER
- Illustration shown below is for a 8" (200mm) width
 - 1.5" deep FLEXTRAY has only one (1) side wire
 - 2" deep FLEXTRAY has two (2) side wires - shown
 - 4" deep FLEXTRAY has three (3) side wires
 - 6" deep FLEXTRAY has four (4) side wires

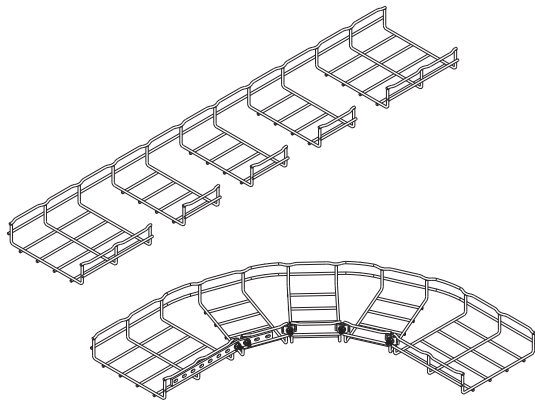

Flextray Width in. (mm)	Segments To Be Removed	Component Qty.		
		WASHER SPL KIT	FTHDWE 1/4 & BTM WASHER	SPLICE BAR
4" (100)	2	1	2	1
6" (150)	3	2	2	1
8" (200)	4	3	2	1
12" (300)	6	5	2	1
16" (400)	7	6	2	1
18" (450)	8	7	2	1
20" (500)	10	9	2	1
24" (600)	11	10	2	1
30" (750)	13	12	2	1
32" (800)	13	12	2	1

90° Horizontal Bend From (2) Straight Sections

- Cut required number of wire side sections listed in chart per the illustration below (Illustration is for a 8" (200mm) width)
- 1.5" deep FLEXTRAY has only one (1) side wire
- 2" deep FLEXTRAY has two (2) side wires - shown
- 4" deep FLEXTRAY has three (3) side wires
- 6" deep FLEXTRAY has four (4) side wires

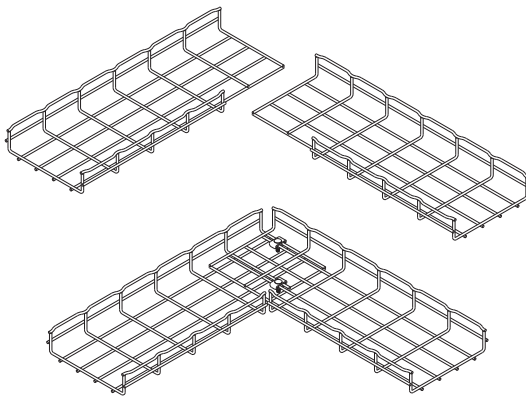

Flextray Width in. (mm)	Side Sections To Be Removed	WASHER SPL KIT Qty.
4" (100)	1	2
6" (150)	2	2
8" (200)	2	2
12" (300)	3	2
16" (400)	4	2
18" (450)	5	2
20" (500)	5	2
24" (600)	6	2
30" (750)	8	2
32" (800)	8	2

Reducers

Large Flextray Width		WASHER SPL KIT		Component Qty. FTHDWE 1/4 & BTM WASHER		SPLICE BAR	
in.	(mm)	(SR)	(LRR)	(SR)	(LRR)	(SR)	(LRR)
4"	(100)	-	1	-	2	-	1
6"	(150)	-	2	-	2	-	1
8"	(200)	1	2	4	2	2	1
12"	(300)	2	3	4	2	2	1
16"	(400)	2	3	4	2	2	1
18"	(450)	2	3	4	2	2	1
20"	(500)	3	3	4	2	2	1
24"	(600)	3	3	4	2	2	1
30"	(750)	3	3	4	2	2	1
32"	(800)	3	3	4	2	2 </td <td>1</td>	1

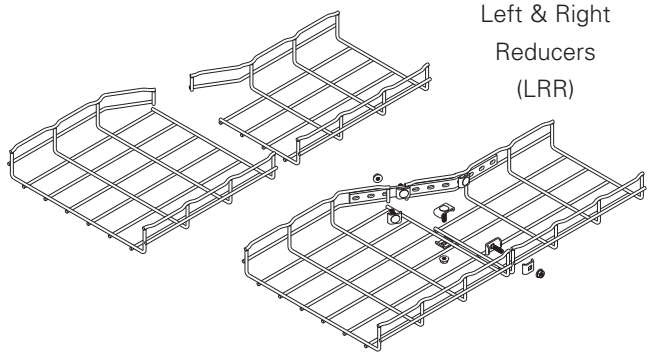
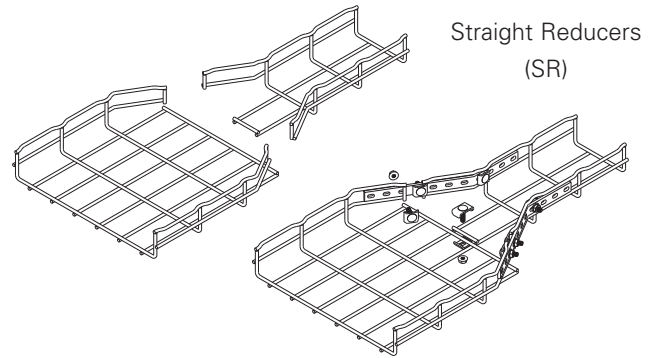

- 1.5" deep FLEXTRAY has only one (1) side wire
- 2" deep FLEXTRAY has two (2) side wires - shown
- 4" deep FLEXTRAY has three (3) side wires
- 6" deep FLEXTRAY has four (4) side wires

Vertical Inside & Outside Bends

- Cut wire section as shown and bend to desired angle
- 1.5" deep FLEXTRAY has only one (1) side wire
- 2" deep FLEXTRAY has two (2) side wires - shown
- 4" deep FLEXTRAY has three (3) side wires
- 6" deep FLEXTRAY has four (4) side wires

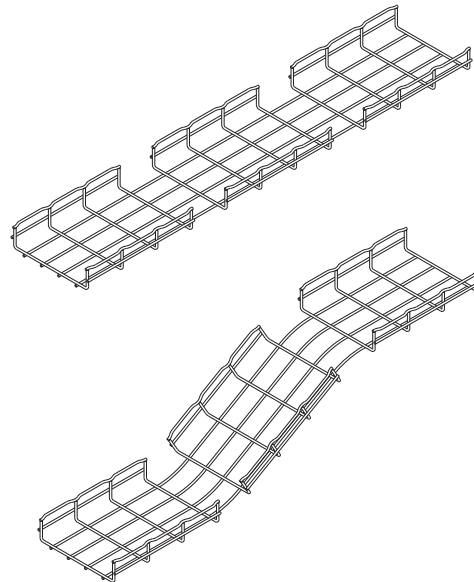

Horizontal Tees (and crosses)

- Cut wire side sections as shown in the illustration below (Illustration is for a 8" (200mm) width)
- 1.5" deep FLEXTRAY has only one (1) side wire
- 2" deep FLEXTRAY has two (2) side wires - shown
- 4" deep FLEXTRAY has three (3) side wires
- 6" deep FLEXTRAY has four (4) side wires
- For crosses, duplicate process on opposite side

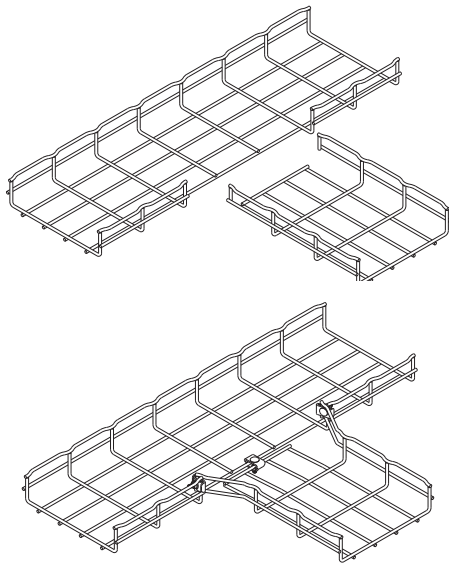

Tray Width in. (mm)	WASHER SPL KIT Qty.
2" (50)	2
4" (100)	2
6" (150)	3
8" (200)	3
12" (300)	4
16" (400)	4
18" (450)	4
20" (500)	4
24" (600)	4
30" (750)	5
32" (800)	5

Channel Cable Tray - Straight Sections



Cable Channel

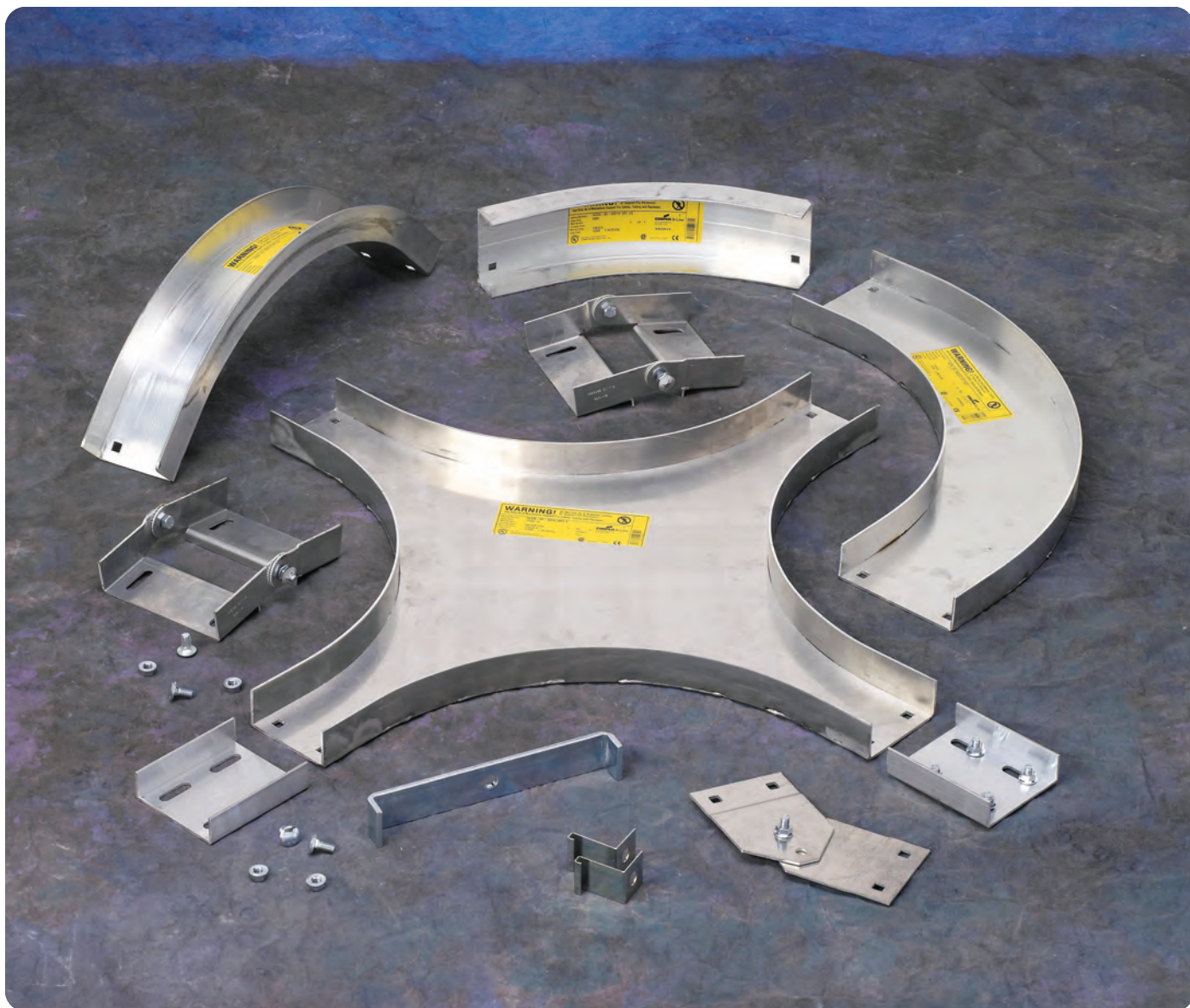

How The Service Advisor Works

We know that your time is important! That's why the color-coding system in this catalog is designed to help you select products that fit your service needs. Products are marked to indicate the typical lead time for orders of 50 pieces or less.

Customer: How do I select my cable channel product so that I get the quickest turnaround?

Service Advisor: Each part of our selection chart is shown in colors. If any section of a part number is a different color, the part will typically ship with the longer lead time represented by the colors.

- Green = Fastest shipped items
- Black = Normal lead-time items
- Red = Normally long lead-time items

Example:

A **CC** **03** **-** **144**
● ● ● ●

Part will have a normal lead time because of the 03 width.

Changing the part number to 04 width instead of 03 will reduce the lead time.

Channel Cable Tray - Straight Sections

Straight Section Part Numbering

Prefix
Example: **A CC - 04 - 120**

Material

- **A** = Aluminum 6063-T4
- **G** = Type 1 - HDGAF
- **P** = Type 2 - Pre-Galvanized
- **SS4** = 304 Stainless Steel
- **SS6** = 316 Stainless Steel

Type

- **CC** = Ventilated Cable Channel
- **CCN** = Non-Ventilated Cable Channel

Width

- **03** = 3"
- **04** = 4"
- **06** = 6"

Length

- ^① **144** = 12 ft.
- ^② **120** = 10 ft.

① Primary Length.
② Secondary Length.

See page C-23 for explanation of lengths.

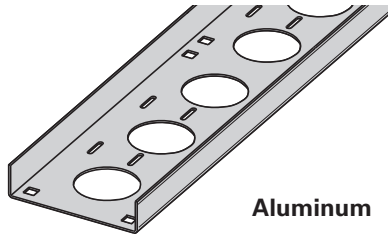

Aluminum

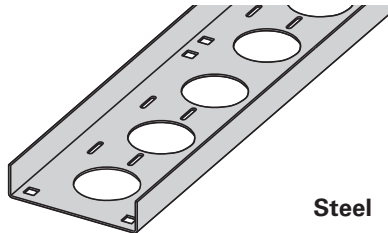

Steel

Ventilated

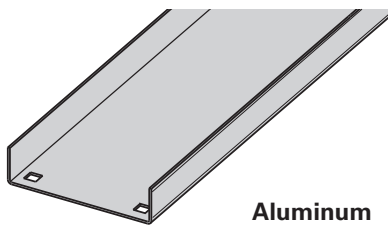

Aluminum

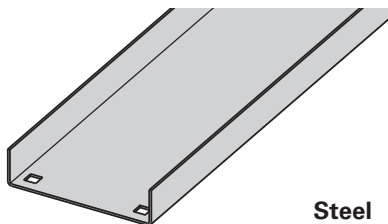

Steel

Non-Ventilated

ACC & ACCN03

3" (75mm) wide
1 1/4" (32mm) deep



ACC & ACCN04

4" (100mm) wide
1 3/4" (44mm) deep



ACC & ACCN06

6" (150mm) wide
1 3/4" (44mm) deep



PCC & PCCN03 SS4CC & SS4CCN03 SS6CC & SS6CCN03

3" (75mm) wide
1 1/4" (32mm) deep



PCC & PCCN04 SS4CC & SS4CCN04 SS6CC & SS6CCN04

4" (100mm) wide
1 3/4" (44mm) deep



PCC & PCCN06 SS4CC & SS4CCN06 SS6CC & SS6CCN06

6" (150mm) wide
1 3/4" (44mm) deep

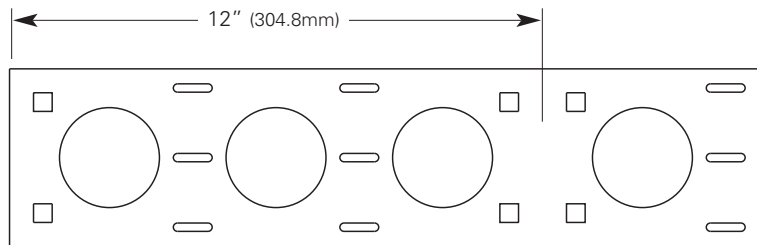

4" wide pattern shown

Ventilated straight sections contain 2 1/4" (57.1mm) diameter holes and 3/16" (4.7mm) x 7/8" (22.2mm) slots for cable attachment. Ventilated straight sections also have splice holes repeating every 12" (304.8mm) to simplify field modifications.

● Green = Fastest shipped items ● Black = Normal lead-time items ● Red = Normally long lead-time items

Channel Cable Tray - Straight Sections

Tray Data & Loading

Material Type	Tray Series	Width		Depth		UL Cross-Sectional Area	Span		Loading			
		in.	(mm)	in.	(mm)		ft.	(m)	lbs/ft	Deflection Multiplier	(kg/m)	Deflection Multiplier
Aluminum Ventilated	ACC-03	3	(76)	1 1/4	(32)	0.40 in ²	5	(1.5)	17	0.020	(26)	0.350
							6	(1.8)	12	0.042	(18)	0.720
							10	(3.0)	4	0.326	(6)	5.600
							12	(3.7)	3	0.676	(4)	12.000
Aluminum Ventilated	ACC-04	4	(101)	1 3/4	(44)	0.60 in ²	5	(1.5)	46	0.007	(69)	0.130
							6	(1.8)	32	0.015	(48)	0.260
							10	(3.0)	12	0.118	(17)	2.000
							12	(3.7)	8	0.244	(12)	4.200
Aluminum Ventilated	ACC-06	6	(152)	1 3/4	(44)	0.60 in ²	5	(1.5)	60	0.006	(90)	0.110
							6	(1.8)	42	0.013	(62)	0.230
							10	(3.0)	15	0.102	(22)	1.700
							12	(3.7)	10	0.211	(16)	3.600
Aluminum Non-Ventilated	ACCN-03	3	(76)	1 1/4	(32)	0.40 in ²	5	(1.5)	23	0.020	(34)	0.350
							6	(1.8)	16	0.042	(24)	0.720
							10	(3.0)	6	0.326	(9)	5.600
							12	(3.7)	4	0.676	(6)	12.000
Aluminum Non-Ventilated	ACCN-04	4	(101)	1 3/4	(44)	0.60 in ²	5	(1.5)	46	0.007	(69)	0.130
							6	(1.8)	32	0.015	(48)	0.260
							10	(3.0)	12	0.118	(17)	2.000
							12	(3.7)	8	0.244	(12)	4.200
Aluminum Non-Ventilated	ACCN-06	6	(152)	1 3/4	(44)	0.60 in ²	5	(1.5)	60	0.006	(90)	0.110
							6	(1.8)	42	0.013	(62)	0.230
							10	(3.0)	15	0.102	(22)	1.700
							12	(3.7)	10	0.211	(16)	3.600
Steel & Stainless Steel Ventilated	PCC-03 SS4CC-03 SS6CC-03	3	(76)	1 1/4	(32)	0.20 in ²	5	(1.5)	24	0.013	(36)	0.220
							6	(1.8)	17	0.028	(25)	0.480
							10	(3.0)	6	0.216	(9)	3.700
							12	(3.7)	4	0.447	(6)	7.600
Steel & Stainless Steel Ventilated	PCC-03 SS4CC-03 SS6CC-03	4	(101)	1 3/4	(44)	0.40 in ²	5	(1.5)	52	0.0039	(77)	0.070
							6	(1.8)	36	0.0082	(54)	0.140
							10	(3.0)	13	0.063	(19)	1.100
							12	(3.7)	9	0.130	(13)	2.200
Steel & Stainless Steel Ventilated	PCC-03 SS4CC-03 SS6CC-03	6	(152)	1 3/4	(44)	0.40 in ²	5	(1.5)	59	0.003	(88)	0.050
							6	(1.8)	41	0.0063	(61)	0.110
							10	(3.0)	15	0.049	(22)	0.840
							12	(3.7)	10	0.101	(15)	1.700
Steel & Stainless Steel Non-Ventilated	PCCN-03 SS4CCN-03 SS6CCN-03	3	(76)	1 1/4	(32)	0.20 in ²	5	(1.5)	24	0.013	(36)	0.220
							6	(1.8)	17	0.028	(25)	0.480
							10	(3.0)	6	0.216	(9)	3.700
							12	(3.7)	4	0.447	(6)	7.600
Steel & Stainless Steel Non-Ventilated	PCCN-03 SS4CCN-03 SS6CCN-03	4	(101)	1 3/4	(44)	0.40 in ²	5	(1.5)	52	0.0039	(77)	0.070
							6	(1.8)	36	0.0082	(54)	0.140
							10	(3.0)	13	0.063	(19)	1.100
							12	(3.7)	9	0.130	(13)	2.200
Steel & Stainless Steel Non-Ventilated	PCCN-03 SS4CCN-03 SS6CCN-03	6	(152)	1 3/4	(44)	0.40 in ²	5	(1.5)	59	0.003	(88)	0.050
							6	(1.8)	41	0.0063	(61)	0.110
							10	(3.0)	15	0.049	(22)	0.840
							12	(3.7)	10	0.101	(15)	1.700

Channel Cable Tray - Accessories

Splice Plate

The Splice Plate has the standard 4-hole pattern for all cable channel.

- Provided with straight sections and fittings.
- Furnished as one plate with hardware.
- (*) Insert **A** **G** **P** **SS4** **SS6**

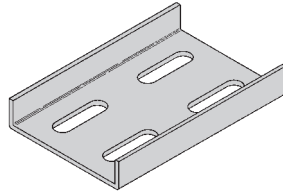

Catalog No.	Channel Width	
	in.	(mm)
9(*)-1043	3	(76)
9(*)-1044	4	(101)
9(*)-1044-6	6	(152)

Horizontal Adjustable Splice Plate

The Horizontal Adjustable Splice Plate adapts to changes in direction in a horizontal plane, beyond the capability of the standard horizontal fittings.

- Furnished as one plate with hardware.
- (*) Insert **A** **G** **P** **SS4** **SS6**

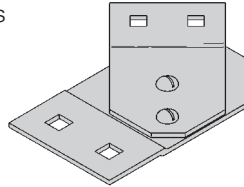

Requires supports within 24" on both sides, per NEMA VE 2.

Catalog No.	Channel Width	
	in.	(mm)
9(*)-1743	3	(76)
9(*)-1744	4	(101)
9(*)-1746	6	(152)

Box Connector

The Box Connector is used to attach the end of a cable channel run to a distribution box or a control center.

- Furnished as one connector with hardware.
- (*) Insert **A** **G** **P** **SS4** **SS6**

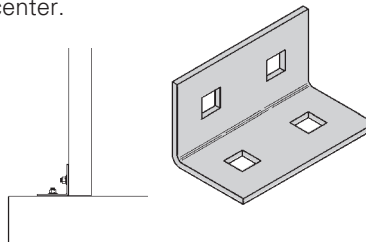

Catalog No.	Channel Width	
	in.	(mm)
9(*)-1543	3	(76)
9(*)-1544	4	(101)
9(*)-1546	6	(152)

Channel Reducer Plate

The Channel Reducer Plate is used to join cable channel sections of different widths.

- Furnished as one plate with hardware.
- (*) Insert **A** **G** **P** **SS4** **SS6**

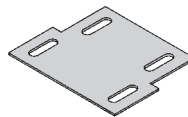

Catalog No.	Channel Width	
	in.	(mm)
9(*)-1843	4 to 3	(101 to 76)
9(*)-1863	6 to 3	(152 to 76)
9(*)-1864	6 to 4	(152 to 101)

Blind End Plate

The Blind End Plate forms a closure for any cable channel dead end.

- Furnished as one plate with hardware.
- (*) Insert **A** **G** **P** **SS4** **SS6**

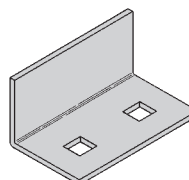

Catalog No.	Channel Width	
	in.	(mm)
9(*)-1583	3	(76)
9(*)-1584	4	(101)
9(*)-1586	6	(152)

● Green = Fastest shipped items ● Black = Normal lead-time items ● Red = Normally long lead-time items

All dimensions in shaded areas are millimeters unless otherwise specified.

Vertical Adjustable Splice Plate

The Adjustable Splice Plate allows changes in elevation where standard vertical fittings are not applicable.

- Furnished as one plate with hardware.
- (*) Insert **A G P SS4 SS6**

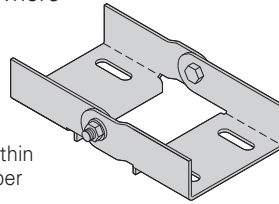

Requires supports within 24" on both sides, per NEMA VE 2.

Catalog No.	Channel Width	
	in.	(mm)
9(*)-1643	3	(76)
9(*)-1644	4	(101)
9(*)-1646	6	(152)

Channel To Tray or Channel To Channel Connector

The Channel Connector is used to link a cable channel to a cable tray, or a cable channel to cable channel.

- Furnished as one plate with hardware.
- (*) Insert **A G P SS4 SS6**

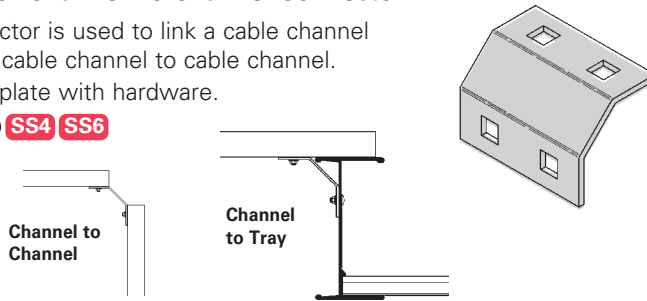

Catalog No.	Channel Width	
	in.	(mm)
9(*)-1261-3	3	(76)
9(*)-1261-4	4	(101)
9(*)-1261-6	6	(152)

Mounting Bracket - Channel To Tray

The Mounting Bracket allows a parallel run of cable channel to be attached to the side of a cable tray. It can also serve as a support splice connection.

- Furnished as one bracket.
- Order hardware separately.
- (*) Insert **A G ZN SS4 SS6**

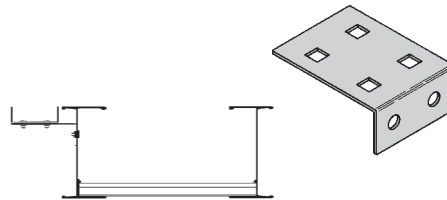

Catalog No.	Channel Width	
	in.	(mm)
9(*)-1237-3	3	(76)
9(*)-1237-4	4	(101)
9(*)-1237-6	6	(152)

Expansion Guide Clamp

The Expansion Guide Clamp allows cable channel to expand and contract in the horizontal plane, but not in the transverse plane.

- Furnished as one clamp.
- Order 1/2" hardware separately.
- (*) Insert **A G ZN SS4 SS6**

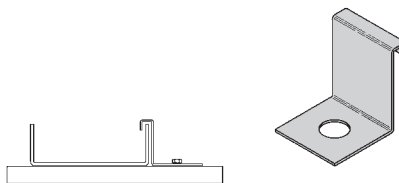

Catalog No.	Channel Width	
	in.	(mm)
9(*)-1243	3	(76)
9(*)-1244	4	(101)
9(*)-1244	6	(152)

Hold-Down Clamp

The Hold-Down Clamp secures cable channel to a support member.

- Furnished as one clamp.
- Order 1/2" hardware separately.
- (*) Insert **A G ZN SS4 SS6**

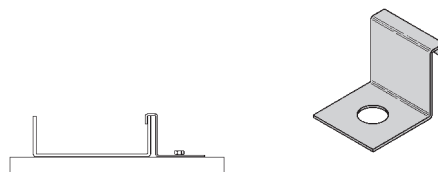

Catalog No.	Channel Width	
	in.	(mm)
9(*)-1245	3	(76)
9(*)-1246	4	(101)
9(*)-1246	6	(152)

● Green = Fastest shipped items ● Black = Normal lead-time items ● Red = Normally long lead-time items

All dimensions in shaded areas are millimeters unless otherwise specified.

Channel Cable Tray - Accessories

Channel To Floor Base Plate

The Channel to Floor Base Plate is used to attach the end of a cable channel run to the floor or to an equipment mounting pad.

- Anchors and hardware are ordered separately.
- (*) Insert **A** **G** **ZN** **SS4** **SS6**

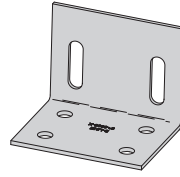

Catalog No.	Channel Width	
	in.	(mm)
9(*)-3305-3	3	(76)
9(*)-3305-4	4	(101)
9(*)-3305-6	6	(152)

Cable Channel Bushing

The Cable Channel Bushing is a snap-in plastic bushing used to protect cable insulation from mechanical wear.

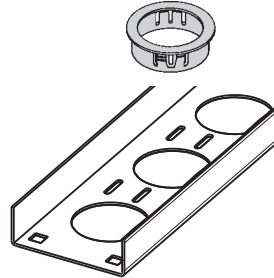

Catalog No.
99-1125

Cable Channel Bracket

- Uniform Load: 225 lbs (1.00 kN) Safety Factor of 2.5
- Finishes available: **ZN** **G**

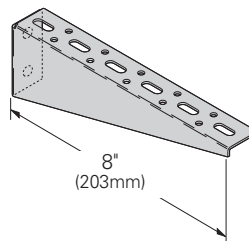

Catalog No.	Channel Width	
	in.	(mm)
B185CCL	3 to 6	(76 to 152)

Cable Channel Bracket

- Safety Factor of 2.5
- Finishes available: **ZN** **G** **GRN**

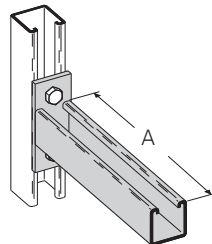

Catalog No.	Channel Width		Uniform Load		A	
	in.	(mm)	lbs	(kN)	in.	(mm)
B409-6	3	(76)	1920	(8.54)	6	(152)
B409-9	4, 6	(101, 152)	1280	(5.69)	9	(228)

Cable Channel Hanger

Designed for 1/2" threaded rod, double nut installation

Single Cable Channel Hanger and Wall Mount

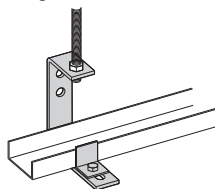

150 lb.
Safety Factor 3.0

Material	Channel Width		
	in. (mm)	in. (mm)	in. (mm)
	3 (76)	4 (101)	6 (152)
Zinc Plated Steel			
Double Channel	● 9ZN-1232-3	● 9ZN-1232-4	● 9ZN-1232-6
Single Channel	● 9ZN-1231-3 & 4	● 9ZN-1231-3 & 4	● 9ZN-1231-6
HDGAF Steel (18 Ga.)			
Double Channel	● 9G-1232-3	● 9G-1232-4	● 9G-1232-6
Single Channel	● 9G-1231-3 & 4	● 9G-1231-3 & 4	● 9G-1231-6

Double Cable Channel Hanger

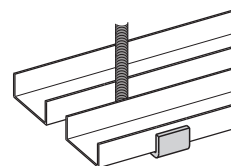

265 lb.
Safety Factor 3.0

● Green = Fastest shipped items ● Black = Normal lead-time items ● Red = Normally long lead-time items

All dimensions in shaded areas are millimeters unless otherwise specified.

Cable Channel Covers

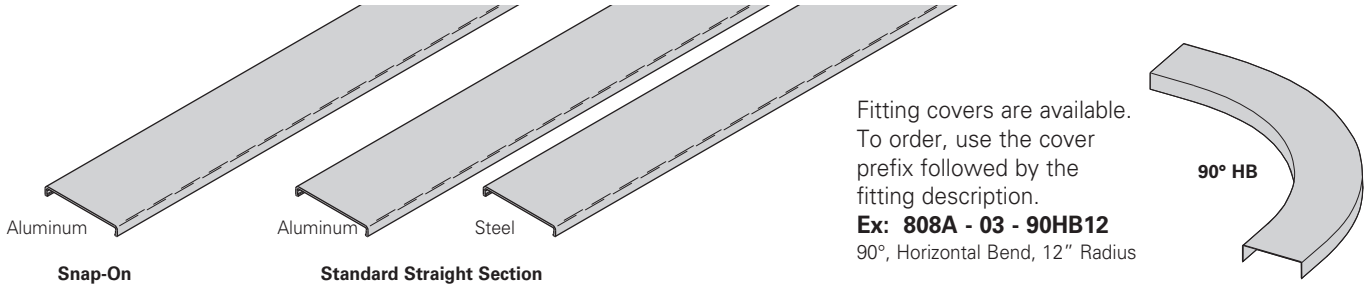

Covers Part Numbering

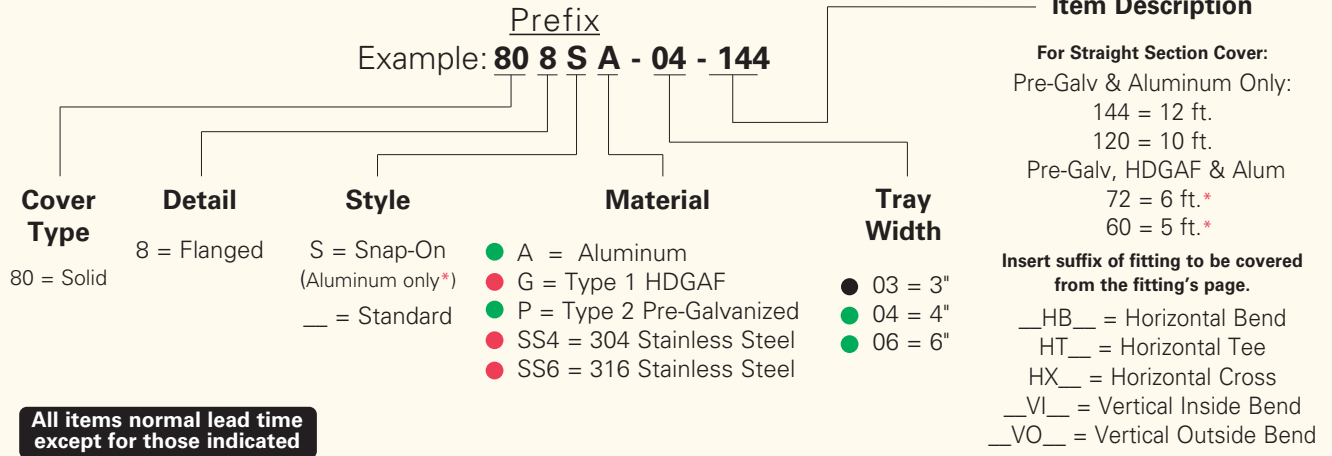

Material	Length		Channel Width - Straight Section Part Number		
	ft	(m)	in. (mm)	in. (mm)	in. (mm)
● Aluminum (.032) ● Solid	12	3.56m	3 (76)	4 (101)	6 (152)
	10	3.05m	808A-03-144	808A-04-144	808A-06-144
● Type II Pre-Galvanized Steel (20 Ga.) ● Solid	12	3.56m	808A-03-120	808A-04-120	808A-06-120
	10	3.05m	808P-03-144	808P-04-144	808P-06-144
● Type I Hot Dip Galvanized Steel (18 Ga.) ● Solid	12	3.56m	808P-03-120	808P-04-120	808P-06-120
	10	3.05m	808G-03-72	808G-04-72	808G-06-72
			808G-03-60	808G-04-60	808G-06-60

Wrap-Around Cover Clamp

Wrap-Around Cover Clamps are used to securely hold a cover on cable channel in locations where strong winds can prevail.

- Furnished as one clamp with hardware.
- (*) Insert **A G P SS4 SS6**

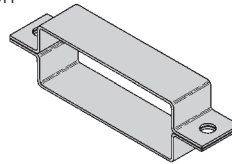

Catalog No.	Channel Width
	in. (mm)
9(*)-9033	3 (76)
9(*)-9034	4 (101)
9(*)-9036	6 (152)

Combination Hold-Down & Cover Clamp

This clamp is used to hold both the cable channel and cover in place at the same time.

- Furnished as one clamp.
- Order 1/4" hardware separately.
- (*) Insert **A G P SS6**

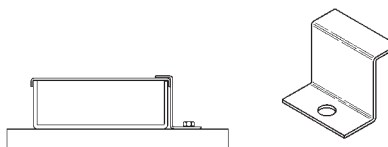

Catalog No.	Channel Width
	in. (mm)
9(*)-9023	3 (76)
9(*)-9024	4 (101)
9(*)-9024	6 (152)

● Green = Fastest shipped items ● Black = Normal lead-time items ● Red = Normally long lead-time items

All dimensions in shaded areas are millimeters unless otherwise specified.

Channel Cable Tray - Accessories

Channel Cable Tray Connectors

Fast, economical, space saving Channel Cable Tray Connectors
 Patent No. 5,628,481; 5,782,439. Other patents pending.

Horizontal:

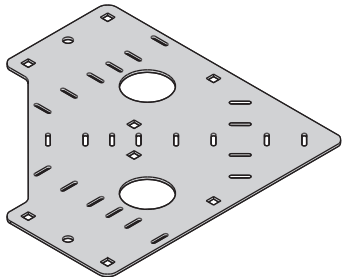

90° Bend

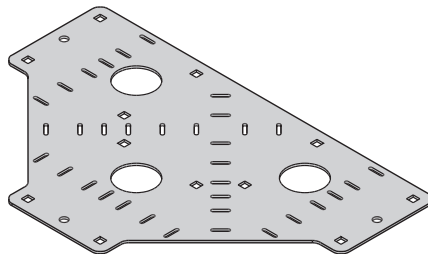

Tee

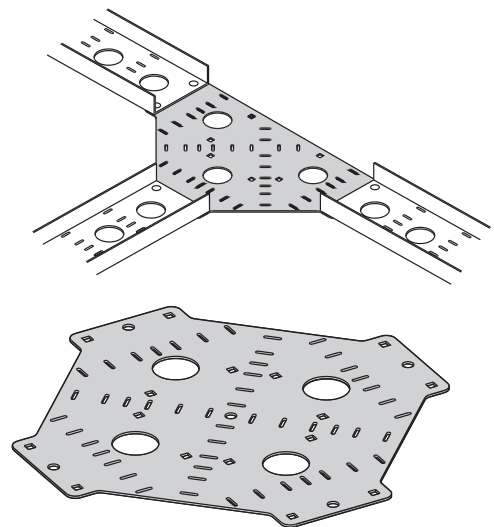

Cross

- Provides 0 or 6-inch radius connection for Cable Channel
- The Pivot Connector is available for custom angle adjustment
 - up to +/- 45° angle adjustment
 - order the desired quantity separately
- Slotted for easy cable fastening
- Shipped with the required hardware

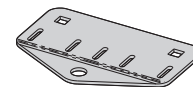

Pivot Connector

Vertical:

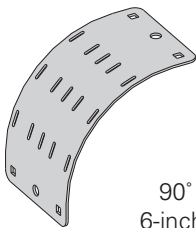

90° Bend
6-inch radius

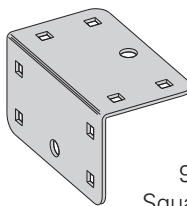

90° Vertical
Square Connector
0-inch radius

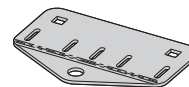

Pivot Connector

- Use the same part for VO and VI applications
- Slotted for easy cable fastening
- The Pivot Connector is available for custom angle adjustment (order separately)
- Shipped with the required hardware

Connector Part Numbering

Prefix
 Example: **A CC - 04 - 90HC 060**

Material

- A = Aluminum
- G = Type 1 HDGAF

Tray Type

CC = Ventilated
Cable Channel

Width

- 03 = 3"
- 04 = 4"
- 06 = 6"

Connector Type

- 90HC = 90° Horizontal
- HTC = Horizontal Tee
- HXC = Horizontal Cross
- 90VC = 90° Vertical
- PC = Pivot Connector

Radius

Horizontal Connectors
 060 = 0" & 6" Radii
Vertical Connectors
 00 = 0" Radius
 06 = 6" Radius

**All items normal lead time
 except for those indicated**

● Green = Fastest shipped items ● Black = Normal lead-time items ● Red = Normally long lead-time items

All dimensions in shaded areas are millimeters unless otherwise specified.

Channel Cable Tray - Fittings

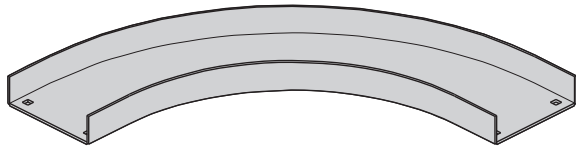

ACCN-04-90HB12
Non-Ventilated Horizontal Bend

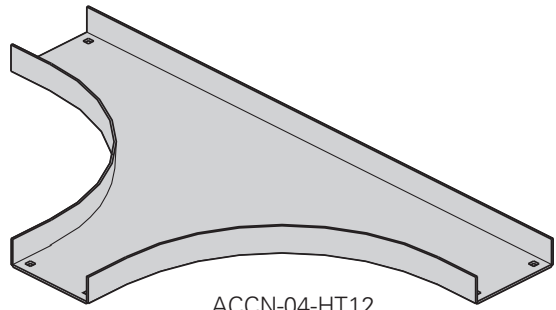

ACCN-04-HT12
Non-Ventilated Tee

Fittings engineered with 3" tangents for splicing integrity.

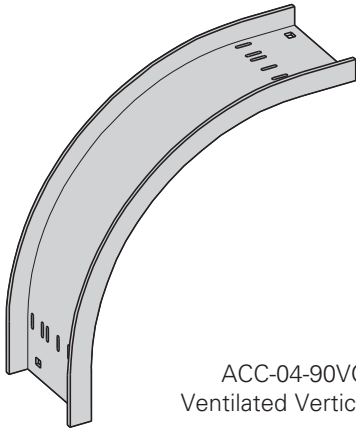

ACC-04-90VO12
Ventilated Vertical Bend

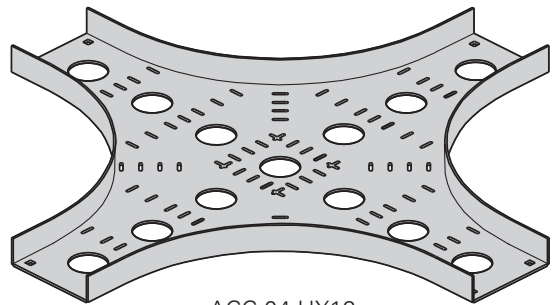

ACC-04-HX12
Ventilated Horizontal Cross

Fittings Part Numbering

Example: ^{Prefix} **A C C N - 04 - 90 H B 24**

Material

Tray Type

Width

Angle

Fitting Type

Radius

- A = Aluminum
- G = Type 1 HDGAF
- SS4 = 304 Stainless Steel
- SS6 = 316 Stainless Steel
- P = †

- *CC = Ventilated Cable Channel
- CCN = Non-ventilated Cable Channel

- 03 = 3"
- 04 = 4"
- 06 = 6"

- 30 = 30°
- 45 = 45°
- 60 = 60°
- 90 = 90°

- HB = Horizontal Bend
- HT = Horizontal Tee
- HX = Horizontal Cross
- VI = Vertical Inside Bend
- VO = Vertical Outside Bend

- 12 = 12"
- 24 = 24"
- 36 = 36"
- 48 = 48"

* Ventilated Cable Channel Fittings are available only in 12" and 24" radii.

† - Due to multiple piece welded construction, P fittings are not available - substitute G.

All items normal lead time except for those indicated

● Green = Fastest shipped items ● Black = Normal lead-time items ● Red = Normally long lead-time items

All dimensions in shaded areas are millimeters unless otherwise specified.

Channel Cable Tray - Fittings

Horizontal Bends 90°, 60° (HB)

1 splice plate with hardware included.

Bend Radius R	Tray Width	90° Horizontal Bend Dimensions			
		Catalog No.	A	B	C
in. (mm)	in. (mm)		in. (mm)	in. (mm)	in. (mm)
12 (305)	3 (76)	(Pre)-03-90HB12	16 ¹ / ₂ (419)	16 ¹ / ₂ (419)	16 ¹ / ₂ (419)
	4 (101)	(Pre)-04-90HB12	17 (432)	17 (432)	17 (432)
	6 (152)	(Pre)-06-90HB12	18 (457)	18 (457)	18 (457)
24 (609)	3 (76)	(Pre)-03-90HB24	28 ¹ / ₂ (723)	28 ¹ / ₂ (723)	28 ¹ / ₂ (723)
	4 (101)	(Pre)-04-90HB24	29 (737)	29 (737)	29 (737)
	6 (152)	(Pre)-06-90HB24	30 (762)	30 (762)	30 (762)
36 (915)	3 (76)	(Pre)-03-90HB36	40 ¹ / ₂ (1029)	40 ¹ / ₂ (1029)	40 ¹ / ₂ (1029)
	4 (101)	(Pre)-04-90HB36	41 (1041)	41 (1041)	41 (1041)
	6 (152)	(Pre)-06-90HB36	42 (1067)	42 (1067)	42 (1067)
48 (1218)	3 (76)	(Pre)-03-90HB48	52 ¹ / ₂ (1334)	52 ¹ / ₂ (1334)	52 ¹ / ₂ (1334)
	4 (101)	(Pre)-04-90HB48	53 (1346)	53 (1346)	53 (1346)
	6 (152)	(Pre)-06-90HB48	54 (1372)	54 (1372)	54 (1372)

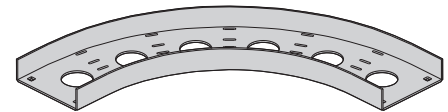

90° Horizontal Bend
Ventilated Horizontal Bend

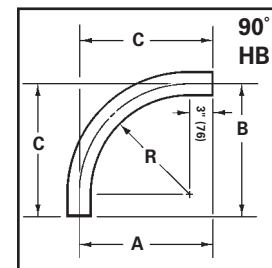

60° Horizontal Bend					
Bend Radius R	Tray Width	Catalog No.	A	B	C
in. (mm)	in. (mm)		in. (mm)	in. (mm)	in. (mm)
12 (305)	3 (76)	(Pre)-03-60HB12	16 ¹ / ₄ (412)	9 ³ / ₈ (239)	10 ³ / ₄ (273)
	4 (101)	(Pre)-04-60HB12	16 ⁵ / ₈ (422)	9 ⁵ / ₈ (245)	11 ¹ / ₈ (283)
	6 (152)	(Pre)-06-60HB12	17 ¹ / ₂ (445)	10 (254)	11 ⁵ / ₈ (296)
24 (609)	3 (76)	(Pre)-03-60HB24	26 ⁵ / ₈ (676)	15 ³ / ₈ (391)	17 ³ / ₄ (451)
	4 (101)	(Pre)-04-60HB24	27 (686)	15 ⁵ / ₈ (397)	18 (450)
	6 (152)	(Pre)-06-60HB24	27 ⁷ / ₈ (708)	16 (406)	18 ⁵ / ₈ (466)
36 (915)	3 (76)	(Pre)-03-60HB36	37 (940)	21 ³ / ₈ (543)	24 ⁵ / ₈ (625)
	4 (101)	(Pre)-04-60HB36	37 ³ / ₈ (949)	21 ⁵ / ₈ (549)	25 (635)
	6 (152)	(Pre)-06-60HB36	38 ¹ / ₄ (972)	22 (559)	25 ¹ / ₂ (648)
48 (1218)	3 (76)	(Pre)-03-60HB48	47 ³ / ₈ (1203)	27 ³ / ₈ (695)	31 ⁵ / ₈ (803)
	4 (101)	(Pre)-04-60HB48	47 ⁷ / ₈ (1216)	27 ⁵ / ₈ (702)	31 ⁷ / ₈ (810)
	6 (152)	(Pre)-06-60HB48	48 ⁵ / ₈ (1235)	28 (711)	32 ¹ / ₂ (826)

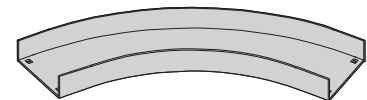

60° Horizontal Bend
Non-Ventilated Horizontal Bend

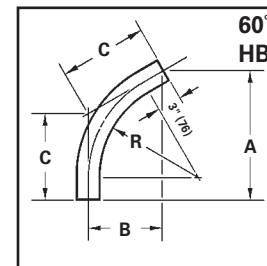

(Pre) See page E-10 for catalog number prefix.

All dimensions in shaded areas are millimeters unless otherwise specified.

Horizontal Bends 45°, 30° (HB)

1 splice plate with hardware included.



45° Horizontal Bend
Ventilated Horizontal Bend

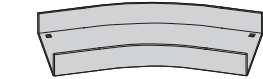
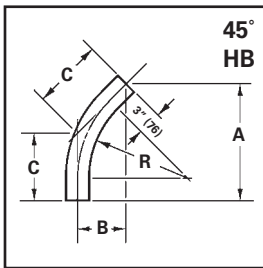

30° Horizontal Bend
Non-Ventilated Horizontal Bend

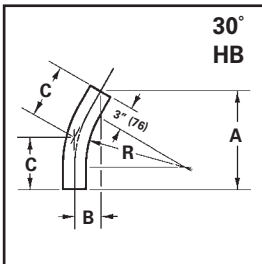

Bend Radius R	Tray Width	45° Horizontal Bend Dimensions			
		Catalog No.	A	B	C
in. (mm)	in. (mm)		in. (mm)	in. (mm)	in. (mm)
12 (305)	3 (76)	(Pre)-03-45HB12	14 ⁵ / ₈ (371)	6 ¹ / ₈ (156)	8 ⁵ / ₈ (219)
	4 (101)	(Pre)-04-45HB12	15 (381)	6 ¹ / ₄ (159)	8 ⁷ / ₈ (225)
	6 (152)	(Pre)-06-45HB12	15 ³ / ₄ (400)	6 ¹ / ₂ (165)	9 ¹ / ₄ (235)
24 (609)	3 (76)	(Pre)-03-45HB24	23 ¹ / ₈ (587)	9 ⁵ / ₈ (244)	13 ⁵ / ₈ (346)
	4 (101)	(Pre)-04-45HB24	23 ¹ / ₂ (597)	9 ³ / ₄ (248)	13 ³ / ₄ (349)
	6 (152)	(Pre)-06-45HB24	24 ¹ / ₈ (613)	10 (254)	14 ¹ / ₈ (359)
36 (915)	3 (76)	(Pre)-03-45HB36	31 ⁵ / ₈ (803)	13 ¹ / ₈ (334)	18 ⁵ / ₈ (473)
	4 (101)	(Pre)-04-45HB36	32 (813)	13 ¹ / ₄ (337)	18 ³ / ₄ (476)
	6 (152)	(Pre)-06-45HB36	32 ³ / ₄ (832)	13 ¹ / ₂ (343)	19 ¹ / ₈ (486)
48 (1218)	3 (76)	(Pre)-03-45HB48	40 ¹ / ₈ (1019)	16 ⁵ / ₈ (422)	23 ¹ / ₂ (597)
	4 (101)	(Pre)-04-45HB48	40 ¹ / ₂ (1029)	16 ³ / ₄ (425)	23 ³ / ₄ (603)
	6 (152)	(Pre)-06-45HB48	41 ¹ / ₈ (1045)	17 (432)	24 ¹ / ₈ (613)

30° Horizontal Bend					
Bend Radius R	Tray Width	Catalog No.	A	B	C
			in. (mm)	in. (mm)	in. (mm)
12 (305)	3 (76)	(Pre)-03-30HB12	12 ³ / ₈ (314)	3 ¹ / ₄ (83)	6 ⁵ / ₈ (168)
	4 (101)	(Pre)-04-30HB12	12 ⁵ / ₈ (321)	3 ³ / ₈ (86)	6 ³ / ₄ (171)
	6 (152)	(Pre)-06-30HB12	13 ¹ / ₈ (334)	3 ¹ / ₂ (89)	7 (178)
24 (609)	3 (76)	(Pre)-03-30HB24	18 ³ / ₈ (467)	4 ⁷ / ₈ (124)	9 ⁷ / ₈ (251)
	4 (101)	(Pre)-04-30HB24	18 ⁵ / ₈ (473)	5 (127)	10 (254)
	6 (152)	(Pre)-06-30HB24	19 ¹ / ₈ (486)	5 ¹ / ₈ (130)	10 ¹ / ₄ (260)
36 (915)	3 (76)	(Pre)-03-30HB36	24 ³ / ₈ (619)	6 ¹ / ₂ (165)	13 (330)
	4 (101)	(Pre)-04-30HB36	24 ⁵ / ₈ (626)	6 ⁵ / ₈ (168)	13 ¹ / ₈ (334)
	6 (152)	(Pre)-06-30HB36	25 ¹ / ₈ (638)	6 ³ / ₄ (171)	13 ¹ / ₂ (343)
48 (1218)	3 (76)	(Pre)-03-30HB48	30 ³ / ₈ (772)	8 ¹ / ₈ (207)	16 ¹ / ₄ (413)
	4 (101)	(Pre)-04-30HB48	30 ⁵ / ₈ (778)	8 ¹ / ₄ (210)	16 ³ / ₈ (416)
	6 (152)	(Pre)-06-30HB48	31 ¹ / ₈ (791)	8 ³ / ₈ (213)	16 ⁵ / ₈ (422)

(Pre) See page E-10 for catalog number prefix.

All dimensions in shaded areas are millimeters unless otherwise specified.

Channel Cable Tray - Fittings

Horizontal Tee (HT)

2 splice plates with hardware included.

Bend Radius R in. (mm)	Tray Width in. (mm)	Horizontal Tee Dimensions		
		Catalog No.	A in. (mm)	B in. (mm)
12 (305)	3 (76)	(Pre)-03-HT12	16 ¹ / ₂ (419)	33 (838)
	4 (101)	(Pre)-04-HT12	17 (432)	34 (864)
	6 (152)	(Pre)-06-HT12	18 (457)	36 (914)
24 (609)	3 (76)	(Pre)-03-HT24	28 ¹ / ₂ (723)	57 (1448)
	4 (101)	(Pre)-04-HT24	29 (737)	58 (1473)
	6 (152)	(Pre)-06-HT24	30 (762)	60 (1524)
36 (915)	3 (76)	(Pre)-03-HT36	40 ¹ / ₂ (1029)	81 (2057)
	4 (101)	(Pre)-04-HT36	41 (1041)	82 (2083)
	6 (152)	(Pre)-06-HT36	42 (1067)	84 (2134)
48 (1218)	3 (76)	(Pre)-03-HT48	52 ¹ / ₂ (1334)	105 (2667)
	4 (101)	(Pre)-04-HT48	53 (1346)	106 (2692)
	6 (152)	(Pre)-06-HT48	54 (1372)	108 (2743)

(Pre) See page E-10 for catalog number prefix.

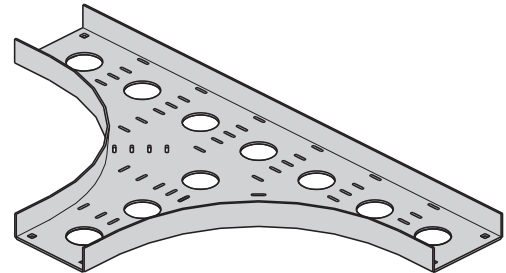

Horizontal Tee
Ventilated Horizontal Tee

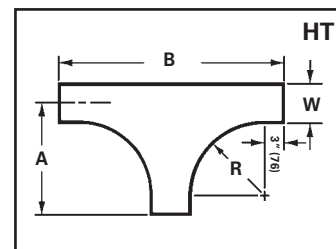

Horizontal Cross (HX)

3 splice plates with hardware included.

Bend Radius R in. (mm)	Tray Width in. (mm)	Horizontal Cross Dimensions		
		Catalog No.	A in. (mm)	B in. (mm)
12 (305)	3 (76)	(Pre)-03-HX12	16 ¹ / ₂ (419)	33 (838)
	4 (101)	(Pre)-04-HX12	17 (432)	34 (864)
	6 (152)	(Pre)-06-HX12	18 (457)	36 (914)
24 (609)	3 (76)	(Pre)-03-HX24	28 ¹ / ₂ (723)	57 (1448)
	4 (101)	(Pre)-04-HX24	29 (737)	58 (1473)
	6 (152)	(Pre)-06-HX24	30 (762)	60 (1524)
36 (915)	3 (76)	(Pre)-03-HX36	40 ¹ / ₂ (1029)	81 (2057)
	4 (101)	(Pre)-04-HX36	41 (1041)	82 (2083)
	6 (152)	(Pre)-06-HX36	42 (1067)	84 (2134)
48 (1218)	3 (76)	(Pre)-03-HX48	52 ¹ / ₂ (1334)	105 (2667)
	4 (101)	(Pre)-04-HX48	53 (1346)	106 (2692)
	6 (152)	(Pre)-06-HX48	54 (1372)	108 (2743)

(Pre) See page E-10 for catalog number prefix.

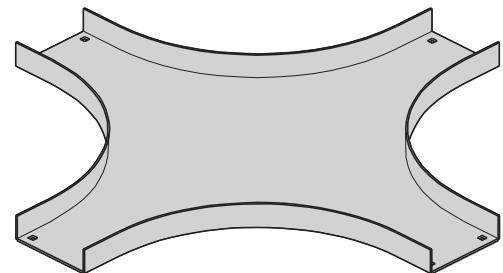

Horizontal Cross
Non-Ventilated Horizontal Cross

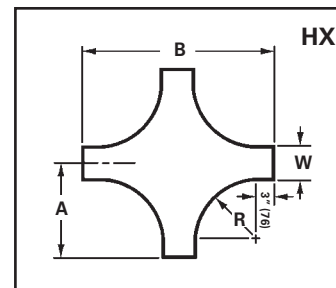

All dimensions in shaded areas are millimeters unless otherwise specified.

Vertical Outside Bends 90°, 60° (VO)

1 splice plate with hardware included.

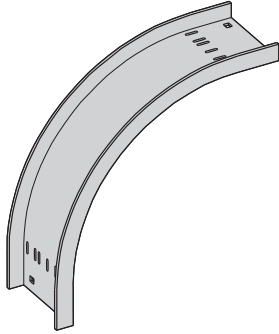

90° Vertical Outside Bend
Ventilated Vertical Outside Bend

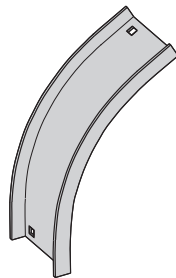
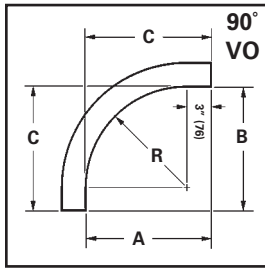

60° Vertical Outside Bend
Non-Ventilated Vertical Outside Bend

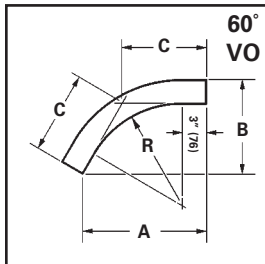

Bend Radius R	Tray Width	90° Vertical Outside Bend Dimensions			
		Catalog No.	A	B	C
in. (mm)	in. (mm)		in. (mm)	in. (mm)	in. (mm)
12 (305)	3 (76)	(Pre)-03-90VO12	15 (381)	15 (381)	15 (381)
	4 (101)	(Pre)-04-90VO12	15 (381)	15 (381)	15 (381)
	6 (152)	(Pre)-06-90VO12	15 (381)	15 (381)	15 (381)
24 (609)	3 (76)	(Pre)-03-90VO24	27 (686)	27 (686)	27 (686)
	4 (101)	(Pre)-04-90VO24	27 (686)	27 (686)	27 (686)
	6 (152)	(Pre)-06-90VO24	27 (686)	27 (686)	27 (686)
36 (915)	3 (76)	(Pre)-03-90VO36	39 (991)	39 (991)	39 (991)
	4 (101)	(Pre)-04-90VO36	39 (991)	39 (991)	39 (991)
	6 (152)	(Pre)-06-90VO36	39 (991)	39 (991)	39 (991)
48 (1218)	3 (76)	(Pre)-03-90VO48	51 (1295)	51 (1295)	51 (1295)
	4 (101)	(Pre)-04-90VO48	51 (1295)	51 (1295)	51 (1295)
	6 (152)	(Pre)-06-90VO48	51 (1295)	51 (1295)	51 (1295)

60° Vertical Outside Bend					
Bend Radius R	Tray Width	Catalog No.	A	B	C
			in. (mm)	in. (mm)	in. (mm)
12 (305)	3 (76)	(Pre)-03-60VO12	14 ⁷ / ₈ (378)	8 ¹ / ₂ (216)	9 ⁷ / ₈ (251)
	4 (101)	(Pre)-04-60VO12	14 ⁷ / ₈ (378)	8 ¹ / ₂ (216)	9 ⁷ / ₈ (251)
	6 (152)	(Pre)-06-60VO12	14 ⁷ / ₈ (378)	8 ¹ / ₂ (216)	9 ⁷ / ₈ (251)
24 (609)	3 (76)	(Pre)-03-60VO24	25 ³ / ₈ (645)	14 ⁵ / ₈ (372)	16 ⁷ / ₈ (428)
	4 (101)	(Pre)-04-60VO24	25 ³ / ₈ (645)	14 ⁵ / ₈ (372)	16 ⁷ / ₈ (428)
	6 (152)	(Pre)-06-60VO24	25 ³ / ₈ (645)	14 ⁵ / ₈ (372)	16 ⁷ / ₈ (428)
36 (915)	3 (76)	(Pre)-03-60VO36	35 ³ / ₈ (905)	20 ⁵ / ₈ (524)	23 ³ / ₄ (603)
	4 (101)	(Pre)-04-60VO36	35 ³ / ₈ (905)	20 ⁵ / ₈ (524)	23 ³ / ₄ (603)
	6 (152)	(Pre)-06-60VO36	35 ³ / ₈ (905)	20 ⁵ / ₈ (524)	23 ³ / ₄ (603)
48 (1218)	3 (76)	(Pre)-03-60VO48	46 ¹ / ₈ (1172)	26 ⁵ / ₈ (676)	30 ³ / ₄ (781)
	4 (101)	(Pre)-04-60VO48	46 ¹ / ₈ (1172)	26 ⁵ / ₈ (676)	30 ³ / ₄ (781)
	6 (152)	(Pre)-06-60VO48	46 ¹ / ₈ (1172)	26 ⁵ / ₈ (676)	30 ³ / ₄ (781)

(Pre) See page E-10 for catalog number prefix.

All dimensions in shaded areas are millimeters unless otherwise specified.

Channel Cable Tray - Fittings

Vertical Outside Bends 45°, 30° (VO)

1 splice plate with hardware included.

Bend Radius R	Tray Width	45° Vertical Outside Bend Dimensions			
		Catalog No.	A	B	C
in. (mm)	in. (mm)		in. (mm)	in. (mm)	in. (mm)
12 (305)	3 (76)	(Pre)-03-45VO12	13 ⁵ / ₈ (346)	5 ⁵ / ₈ (143)	8 (203)
	4 (101)	(Pre)-04-45VO12	13 ⁵ / ₈ (346)	5 ⁵ / ₈ (143)	8 (203)
	6 (152)	(Pre)-06-45VO12	13 ⁵ / ₈ (346)	5 ⁵ / ₈ (143)	8 (203)
24 (609)	3 (76)	(Pre)-03-45VO24	22 ¹ / ₄ (565)	9 ¹ / ₄ (235)	13 (330)
	4 (101)	(Pre)-04-45VO24	22 ¹ / ₄ (565)	9 ¹ / ₄ (235)	13 (330)
	6 (152)	(Pre)-06-45VO24	22 ¹ / ₄ (565)	9 ¹ / ₄ (235)	13 (330)
36 (915)	3 (76)	(Pre)-03-45VO36	30 ¹ / ₂ (775)	12 ⁵ / ₈ (321)	17 ⁷ / ₈ (454)
	4 (101)	(Pre)-04-45VO36	30 ¹ / ₂ (775)	12 ⁵ / ₈ (321)	17 ⁷ / ₈ (454)
	6 (152)	(Pre)-06-45VO36	30 ¹ / ₂ (775)	12 ⁵ / ₈ (321)	17 ⁷ / ₈ (454)
48 (1218)	3 (76)	(Pre)-03-45VO48	39 (991)	16 ¹ / ₈ (410)	22 ⁷ / ₈ (581)
	4 (101)	(Pre)-04-45VO48	39 (991)	16 ¹ / ₈ (410)	22 ⁷ / ₈ (581)
	6 (152)	(Pre)-06-45VO48	39 (991)	16 ¹ / ₈ (410)	22 ⁷ / ₈ (581)

30° Vertical Outside Bend					
12 (305)	3 (76)	(Pre)-03-30VO12	11 ⁵ / ₈ (296)	3 ¹ / ₈ (79)	6 ¹ / ₄ (158)
	4 (101)	(Pre)-04-30VO12	11 ⁵ / ₈ (296)	3 ¹ / ₈ (79)	6 ¹ / ₄ (158)
	6 (152)	(Pre)-06-30VO12	11 ⁵ / ₈ (296)	3 ¹ / ₈ (79)	6 ¹ / ₄ (158)
24 (609)	3 (76)	(Pre)-03-30VO24	17 ¹ / ₂ (445)	4 ⁷ / ₈ (124)	9 ³ / ₈ (238)
	4 (101)	(Pre)-04-30VO24	17 ¹ / ₂ (445)	4 ⁷ / ₈ (124)	9 ³ / ₈ (238)
	6 (152)	(Pre)-06-30VO24	17 ¹ / ₂ (445)	4 ⁷ / ₈ (124)	9 ³ / ₈ (238)
36 (915)	3 (76)	(Pre)-03-30VO36	23 ¹ / ₂ (597)	6 ³ / ₈ (162)	12 ⁵ / ₈ (321)
	4 (101)	(Pre)-04-30VO36	23 ¹ / ₂ (597)	6 ³ / ₈ (162)	12 ⁵ / ₈ (321)
	6 (152)	(Pre)-06-30VO36	23 ¹ / ₂ (597)	6 ³ / ₈ (162)	12 ⁵ / ₈ (321)
48 (1218)	3 (76)	(Pre)-03-30VO48	29 ⁵ / ₈ (753)	8 (203)	15 ⁷ / ₈ (403)
	4 (101)	(Pre)-04-30VO48	29 ⁵ / ₈ (753)	8 (203)	15 ⁷ / ₈ (403)
	6 (152)	(Pre)-06-30VO48	29 ⁵ / ₈ (753)	8 (203)	15 ⁷ / ₈ (403)

(Pre) See page E-10 for catalog number prefix.

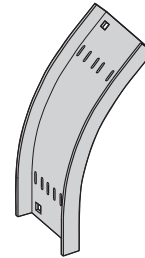

45° Vertical Outside Bend
Ventilated Vertical Outside Bend

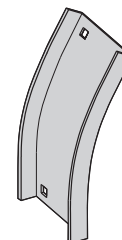
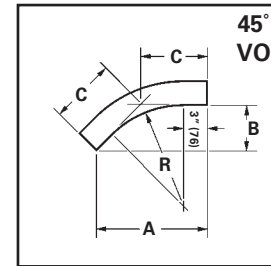

30° Vertical Outside Bend
Non-Ventilated Vertical Outside Bend

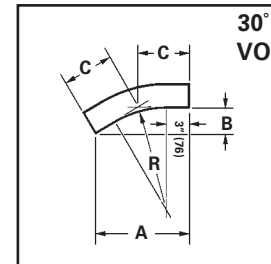

All dimensions in shaded areas are millimeters unless otherwise specified.

Vertical Inside Bends 90°, 60° (VI)

1 splice plate with hardware included.

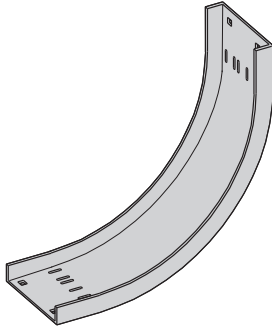

90° Vertical Inside Bend
Ventilated Vertical Inside Bend

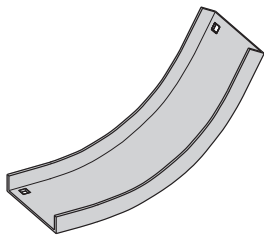
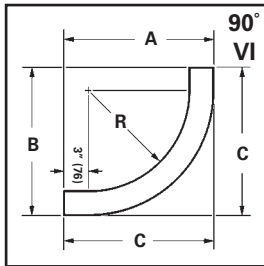

60° Vertical Inside Bend
Non-Ventilated Vertical Inside Bend

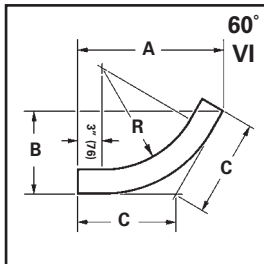

Bend Radius R	Tray Width	90° Vertical Inside Bend Dimensions			
		Catalog No.	A	B	C
in. (mm)	in. (mm)		in. (mm)	in. (mm)	in. (mm)
12 (305)	3 (76)	(Pre)-03-90VI12	16 ¹ / ₄ (413)	16 ¹ / ₄ (413)	16 ¹ / ₄ (413)
	4 (101)	(Pre)-04-90VI12	16 ³ / ₄ (425)	16 ³ / ₄ (425)	16 ³ / ₄ (425)
	6 (152)	(Pre)-06-90VI12	16 ³ / ₄ (425)	16 ³ / ₄ (425)	16 ³ / ₄ (425)
24 (609)	3 (76)	(Pre)-03-90VI24	28 ¹ / ₄ (718)	28 ¹ / ₄ (718)	28 ¹ / ₄ (718)
	4 (101)	(Pre)-04-90VI24	28 ³ / ₄ (730)	28 ³ / ₄ (730)	28 ³ / ₄ (730)
	6 (152)	(Pre)-06-90VI24	28 ³ / ₄ (730)	28 ³ / ₄ (730)	28 ³ / ₄ (730)
36 (915)	3 (76)	(Pre)-03-90VI36	40 ¹ / ₄ (1024)	40 ¹ / ₄ (1024)	40 ¹ / ₄ (1024)
	4 (101)	(Pre)-04-90VI36	40 ³ / ₄ (1035)	40 ³ / ₄ (1035)	40 ³ / ₄ (1035)
	6 (152)	(Pre)-06-90VI36	40 ³ / ₄ (1035)	40 ³ / ₄ (1035)	40 ³ / ₄ (1035)
48 (1218)	3 (76)	(Pre)-03-90VI48	52 ¹ / ₄ (1327)	52 ¹ / ₄ (1327)	52 ¹ / ₄ (1327)
	4 (101)	(Pre)-04-90VI48	52 ³ / ₄ (1340)	52 ³ / ₄ (1340)	52 ³ / ₄ (1340)
	6 (152)	(Pre)-06-90VI48	52 ³ / ₄ (1340)	52 ³ / ₄ (1340)	52 ³ / ₄ (1340)

60° Vertical Inside Bend					
Bend Radius	Tray Width	Catalog No.	A	B	C
in. (mm)	in. (mm)		in. (mm)	in. (mm)	in. (mm)
12 (305)	3 (76)	(Pre)-03-60VI12	16 (406)	9 ¹ / ₄ (235)	10 ⁵ / ₈ (270)
	4 (101)	(Pre)-04-60VI12	16 ¹ / ₂ (419)	9 ¹ / ₂ (241)	11 (280)
	6 (152)	(Pre)-06-60VI12	16 ¹ / ₂ (419)	9 ¹ / ₂ (241)	11 (280)
24 (609)	3 (76)	(Pre)-03-60VI24	26 ¹ / ₂ (673)	15 ¹ / ₄ (387)	17 ⁵ / ₈ (448)
	4 (101)	(Pre)-04-60VI24	26 ⁷ / ₈ (683)	15 ¹ / ₂ (394)	17 ⁷ / ₈ (454)
	6 (152)	(Pre)-06-60VI24	26 ⁷ / ₈ (683)	15 ¹ / ₂ (394)	17 ⁷ / ₈ (454)
36 (915)	3 (76)	(Pre)-03-60VI36	36 ³ / ₄ (933)	21 ¹ / ₄ (540)	24 ¹ / ₂ (622)
	4 (101)	(Pre)-04-60VI36	37 ¹ / ₈ (943)	21 ³ / ₈ (543)	24 ³ / ₄ (629)
	6 (152)	(Pre)-06-60VI36	37 ¹ / ₈ (943)	21 ³ / ₈ (543)	24 ³ / ₄ (629)
48 (1218)	3 (76)	(Pre)-03-60VI48	47 ¹ / ₈ (1197)	27 ¹ / ₈ (689)	31 ³ / ₈ (797)
	4 (101)	(Pre)-04-60VI48	47 ⁵ / ₈ (1210)	27 ¹ / ₂ (699)	31 ³ / ₄ (806)
	6 (152)	(Pre)-06-60VI48	47 ⁵ / ₈ (1210)	27 ¹ / ₂ (699)	31 ³ / ₄ (806)

(Pre) See page E-10 for catalog number prefix.

All dimensions in shaded areas are millimeters unless otherwise specified.

Channel Cable Tray - Fittings

Vertical Inside Bends 45°, 30° (VI)

1 splice plate with hardware included.

Bend Radius R	Tray Width	45° Vertical Inside Bend Dimensions			
		Catalog No.	A	B	C
in. (mm)	in. (mm)		in. (mm)	in. (mm)	in. (mm)
12 (305)	3 (76)	(Pre)-03-45VI12	14 ¹ / ₂ (368)	6 (152)	8 ¹ / ₂ (216)
	4 (101)	(Pre)-04-45VI12	14 ⁷ / ₈ (373)	6 ¹ / ₈ (156)	8 ³ / ₄ (222)
	6 (152)	(Pre)-06-45VI12	14 ⁷ / ₈ (373)	6 ¹ / ₈ (156)	8 ³ / ₄ (222)
24 (609)	3 (76)	(Pre)-03-45VI24	23 (584)	9 ¹ / ₂ (241)	13 ¹ / ₂ (343)
	4 (101)	(Pre)-04-45VI24	23 ¹ / ₄ (591)	9 ⁵ / ₈ (245)	13 ⁵ / ₈ (346)
	6 (152)	(Pre)-06-45VI24	23 ¹ / ₄ (591)	9 ⁵ / ₈ (245)	13 ⁵ / ₈ (346)
36 (915)	3 (76)	(Pre)-03-45VI36	31 ³ / ₈ (797)	13 (330)	18 ³ / ₈ (467)
	4 (101)	(Pre)-04-45VI36	31 ³ / ₄ (806)	13 ¹ / ₈ (334)	18 ⁵ / ₈ (473)
	6 (152)	(Pre)-06-45VI36	31 ³ / ₄ (806)	13 ¹ / ₈ (334)	18 ⁵ / ₈ (473)
48 (1218)	3 (76)	(Pre)-03-45VI48	39 ⁷ / ₈ (1013)	16 ¹ / ₂ (419)	23 ³ / ₈ (594)
	4 (101)	(Pre)-04-45VI48	40 ³ / ₈ (1026)	16 ³ / ₄ (425)	23 ⁵ / ₈ (600)
	6 (152)	(Pre)-06-45VI48	40 ³ / ₈ (1026)	16 ³ / ₄ (425)	23 ⁵ / ₈ (600)

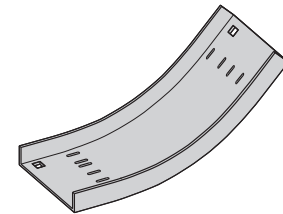

45° Vertical Inside Bend
Ventilated Vertical Inside Bend

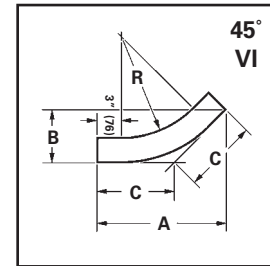

30° Vertical Inside Bend					
Bend Radius R	Tray Width	30° Vertical Inside Bend Dimensions			
		Catalog No.	A	B	C
in. (mm)	in. (mm)		in. (mm)	in. (mm)	in. (mm)
12 (305)	3 (76)	(Pre)-03-30VI12	12 ¹ / ₈ (308)	3 ¹ / ₈ (83)	6 ¹ / ₂ (165)
	4 (101)	(Pre)-04-30VI12	12 ³ / ₈ (314)	3 ³ / ₈ (86)	6 ⁵ / ₈ (163)
	6 (152)	(Pre)-06-30VI12	12 ³ / ₈ (314)	3 ³ / ₈ (86)	6 ⁵ / ₈ (163)
24 (609)	3 (76)	(Pre)-03-30VI24	18 ¹ / ₈ (461)	4 ³ / ₄ (121)	9 ³ / ₄ (248)
	4 (101)	(Pre)-04-30VI24	18 ³ / ₈ (467)	4 ⁷ / ₈ (124)	9 ⁷ / ₈ (251)
	6 (152)	(Pre)-06-30VI24	18 ³ / ₈ (467)	4 ⁷ / ₈ (124)	9 ⁷ / ₈ (251)
36 (915)	3 (76)	(Pre)-03-30VI36	24 ¹ / ₄ (616)	6 ¹ / ₂ (165)	13 (330)
	4 (101)	(Pre)-04-30VI36	24 ¹ / ₂ (622)	6 ⁵ / ₈ (168)	13 ¹ / ₈ (334)
	6 (152)	(Pre)-06-30VI36	24 ¹ / ₂ (622)	6 ⁵ / ₈ (168)	13 ¹ / ₈ (334)
48 (1218)	3 (76)	(Pre)-03-30VI48	30 ³ / ₈ (772)	8 ¹ / ₈ (207)	16 ¹ / ₄ (413)
	4 (101)	(Pre)-04-30VI48	30 ⁵ / ₈ (778)	8 ¹ / ₄ (210)	16 ³ / ₈ (416)
	6 (152)	(Pre)-06-30VI48	30 ⁵ / ₈ (778)	8 ¹ / ₄ (210)	16 ³ / ₈ (416)

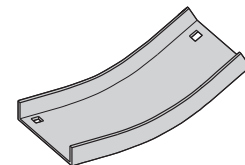

30° Vertical Inside Bend
Non-Ventilated Vertical Inside Bend

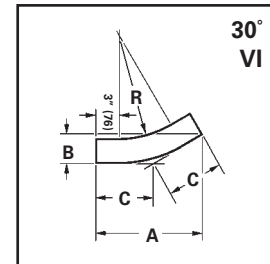

(Pre) See page E-10 for catalog number prefix.

All dimensions in shaded areas are millimeters unless otherwise specified.

Section 1- Acceptable Manufacturers

- 1.01 Manufacturer: Subject to compliance with these specifications, B-Line series channel cable tray systems shall be as manufactured by Eaton.

Section 2- Selection and Components

- 2.01 General: Except as otherwise indicated, provide ventilated metal channel cable trays, of types, classes and sizes indicated with splice connectors, fittings and all other necessary accessories for a complete system. Provide channel cable tray with rounded edges and smooth surfaces in compliance with applicable standards, and with the following additional requirements.
- 2.02 Materials and finishes: Material and finishes specifications for each channel cable tray are as follows:
1. Aluminum: Extruded components shall be made from Aluminum Association Alloy 6063. All fabricated parts shall be made from Aluminum Association Alloy 5052.
 2. Pre-Galvanized Steel: Straight sections and fittings shall be made from structural quality mill galvanized 14 gauge steel meeting the properties of ASTM A653SS, coating designation G90.
 3. Hot Dip Galvanized Steel: Straight sections and fittings shall be made from 14 gauge structural quality steel meeting the minimum mechanical properties of ASTM A1011 SS, Grade 33 and shall be hot-dip galvanized after fabrication in accordance with ASTM A123.
All hot dip galvanized after fabrication cable trays must be returned to point of manufacture after coating for inspection, conditioning and labeling.
 4. Stainless Steel: Straight sections and fittings shall be AISI Type [304] [316].
- 2.03 Channel cable tray straight sections shall be constructed with ventilated flat bottom. Ventilating bottom shall be perforated with 2.25" diameter holes and have slots to facilitate the use of cable ties to secure the cables.
- 2.04 Straight sections shall be supplied in standard [12 foot] [10 foot (3 m)] lengths, except where shorter lengths are permitted to facilitate tray assembly as shown on drawings.
- 2.05 Ventilating straight sections shall have splice holes every 12 inches to simplify field modifications.
- 2.06 Channel cable tray width shall be [3] [4] [6] inches with a minimum loading depth of 1¹/₄".
- 2.07 Fittings will have a minimum radius of [12] [24] [36] [48] inches.
- 2.08 Splice plates and hardware shall be included with each straight section and fitting.

REDI-RAIL™ - Straight Sections

REDI-RAIL

REDI-RAIL Rung

An "I"-Beam shaped rung provides a great strength-to-weight ratio. Patented fastener hole is designed to provide maximum grip for the fastener threads.



REDI-RAIL Rung Fastener

Specially designed and finished rung fastener. Rung pullout tested to over 3000 lbs. Vibration tested for your confidence.

Multi-Functional Pre-Punched Holes

Act as holes for splice plate hardware: allow for field cutting to any length, no field-drilling necessary. Holes also allow rungs to be repositioned. Holes allow for easy attachment of accessory items requiring 1/4" hardware (or smaller).



Patent Information
U.S. Patent D361982; 5,580,014
Canada 2,137,879
UK Patent 2,285,343
Other United States and foreign patents are pending.



How The Service Advisor Works

We know that your time is important! That's why the color-coding system in this catalog is designed to help you select products that fit your service needs. Products are marked to indicate the typical lead time for orders of 50 pieces or less.

Customer: How do I select my straight sections, covers, or fittings so that I get the quickest turnaround?

Service Advisor: Each part of our selection chart is shown in colors. If any section of a part number is a different color, the part will typically ship with the longer lead time represented by the colors.

- Green = Fastest shipped items
- Black = Normal lead-time items
- Red = Normally long lead-time items

Example: **RSI 04A 075KO 09SL - 12 - 120**
 ● ● ● ● ● ●

Part will have a normal lead time because of the 075KO knockout type.

RSI04A and RSI05A Straight Sections

Straight Section Part Numbering

Prefix
Example: **RSI 06 A 075KO 09 SL - 12 - 120**

Series	Height	Material	Knockout Type	Bottom Type	Construction	Width	Length
● RSI	● 04 = 4" ● 05 = 5"	A = Aluminum	● Blank = None ● 050KO = 1/2" KO ● 075KO = 3/4" KO ● 100KO = 1" KO	Ladder- ● 06 = 6" rung spacing ● 09 = 9" rung spacing ● 12 = 12" rung spacing Trough- ● VB = Vented Bottom ● SB = Solid Bottom	SL = Straight Ladder	● 06 = 6" ● 09 = 9" ● 12 = 12" ● 18 = 18" ● 24 = 24" ● 30 = 30" ● 36 = 36"	● ① 144 = 12 ft. ● ② 120 = 10 ft.

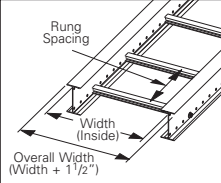

Values are based on simple beam tests per VE-1 on 36" wide cable tray with rungs spaced on 12" centers. The published load safety factor is 1.5. To convert 1.5 safety factor to 2.0, multiply the published load by 0.75. To obtain mid-span deflection, multiply a load by the deflection multiplier. Cable tray must be supported on spans shorter than or equal to the length of the tray. These systems will support without collapse a 200 lb. concentrated load.

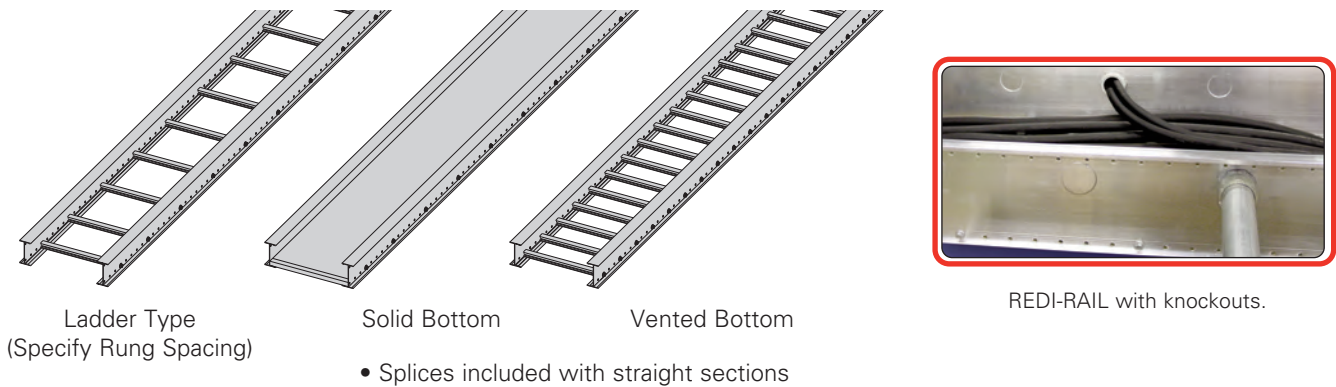

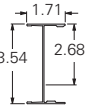
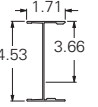
B-Line Series	Side Rail Dimensions	NEMA, CSA & UL Classifications	Span ft	Load lbs/ft	Deflection Multiplier	Design Factors for Two Rails	Span meters	Load kg/m	Deflection Multiplier	Design Factors for Two Rails
RSI04A		NEMA: 12B CSA: 112kg/m 3.7m UL Cross Sectional Area: 0.40 in ²	6	224	0.0015	Area=0.93 in ² Sx=1.11 in ³ Ix=1.96 in ⁴	1.8	333	0.025	Area=5.99 cm ³ Sx=18.10 cm ³ Ix=81.70 cm ⁴
			8	169	0.0047		2.4	252	0.080	
			10	108	0.0115		3.0	161	0.196	
			12	75	0.0238		3.7	112	0.406	
RSI05A		NEMA: 12B CSA: 123kg/m 3.7m UL Cross Sectional Area: 0.60 in ²	6	224	0.0008	Area=1.08 in ² Sx=1.55 in ³ Ix=3.53 in ⁴	1.8	333	0.014	Area=6.95 cm ³ Sx=25.40 cm ³ Ix=147.00 cm ⁴
			8	187	0.0026		2.4	278	0.045	
			10	119	0.0064		3.0	178	0.109	
			12	83	0.0132		3.7	123	0.225	

When cable trays are used in continuous spans, the deflection of the cable tray is reduced by as much as 50%. Design factors: Ix = Moment of Inertia, Sx = Section Modulus.

● Green = Fastest shipped items ● Black = Normal lead-time items ● Red = Normally long lead-time items

RSI06A and RSI07A Straight Sections

Straight Section Part Numbering

Prefix
 Example: **RSI 06 A 075KO 09 SL - 12 - 120**

Series	Height	Material	Knockout Type	Bottom Type	Construction	Width	Length
● RSI	● 06 = 6" ● 07 = 7"	A = Aluminum	● Blank = None ● 050KO = 1/2" KO ● 075KO = 3/4" KO ● 100KO = 1" KO ● 125KO = 1 1/4" KO ● 150KO = 1 1/2" KO	Ladder- ● 06 = 6" rung spacing ● 09 = 9" rung spacing ● 12 = 12" rung spacing Trough- ● VB = Vented Bottom ● SB = Solid Bottom	SL = Straight Ladder	● 06 = 6" ● 09 = 9" ● 12 = 12" ● 18 = 18" ● 24 = 24" ● 30 = 30" ● 36 = 36"	● ① 144 = 12 ft. ● ② 120 = 10 ft.

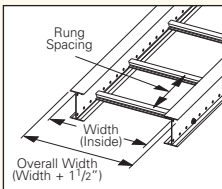

Values are based on simple beam tests per VE-1 on 36" wide cable tray with rungs spaced on 12" centers. The published load safety factor is 1.5. To convert 1.5 safety factor to 2.0, multiply the published load by 0.75. To obtain mid-span deflection, multiply a load by the deflection multiplier. Cable tray must be supported on spans shorter than or equal to the length of the tray. These systems will support without collapse a 200 lb. concentrated load.

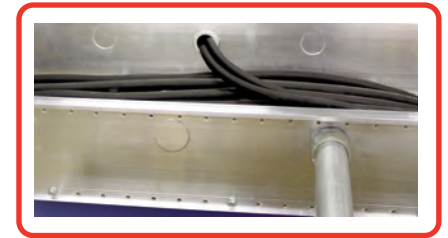
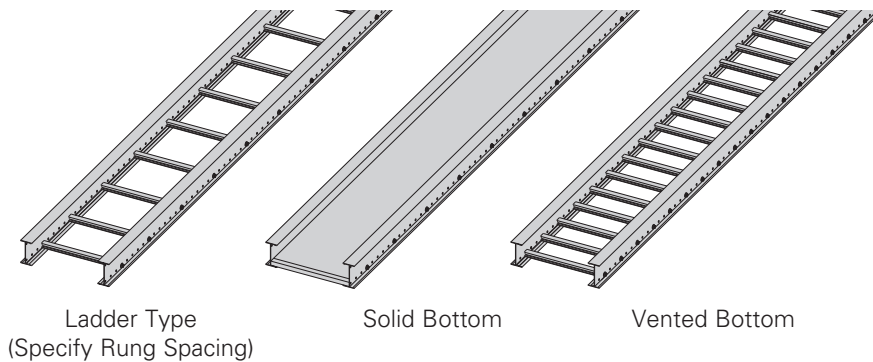

REDI-RAIL with knockouts.

• Splices included with straight sections

B-Line Series	Side Rail Dimensions	NEMA, CSA & UL Classifications	Span ft	Load lbs/ft	Deflection Multiplier	Design Factors for Two Rails	Span meters	Load kg/m	Deflection Multiplier	Design Factors for Two Rails
RSI06A		NEMA: 12B CSA: 121kg/m 3.7m UL Cross Sectional Area: 0.60 in ²	6	224	0.0005	Area=1.18 in ² Sx=1.98 in ³ Ix=5.51 in ⁴	1.8	333	0.009	Area=7.59 cm ³ Sx=32.50 cm ³ Ix=230.00 cm ⁴
			8	184	0.0017		2.4	273	0.029	
			10	118	0.0041		3.0	175	0.070	
			12	82	0.0085		3.7	121	0.144	
RSI07A		NEMA: 12C CSA: 182kg/m 3.7m UL Cross Sectional Area: 0.60 in ²	6	224	0.0003	Area=1.50 in ² Sx=2.69 in ³ Ix=8.79 in ⁴	1.8	333	0.006	Area=9.68 cm ³ Sx=44.10 cm ³ Ix=366.00 cm ⁴
			8	224	0.0010		2.4	333	0.018	
			10	176	0.0026		3.0	262	0.044	
			12	122	0.0053		3.7	182	0.091	

When cable trays are used in continuous spans, the deflection of the cable tray is reduced by as much as 50%. Design factors: Ix = Moment of Inertia, Sx = Section Modulus.

● Green = Fastest shipped items ● Black = Normal lead-time items ● Red = Normally long lead-time items

Standard Splice Plate

- Furnished in pairs with 1/4" hardware.
- UL Classified.
- One pair including hardware provided with each straight section. (Expansion splice quantity subtracted)

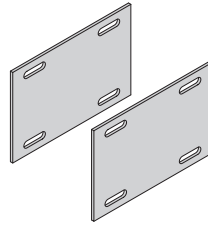

Tray Series	Catalog No.
RSI04A	● R4A-SSP
RSI05A	● R5A-SSP
RSI06A	● R6A-SSP
RSI07A	● R7A-SSP

Expansion Splice Plate

- Furnished in pairs with 1/4" hardware.
- Bonding jumpers required on each side rail.

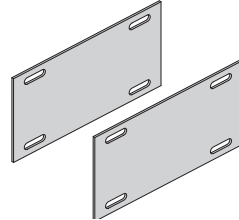

Tray Series	Catalog No.
RSI04A	● R4A-ESP
RSI05A	● R5A-ESP
RSI06A	● R6A-ESP
RSI07A	● R7A-ESP

Step Down Splice Plate

- Furnished in pairs with 1/4" hardware.
- UL Classified.

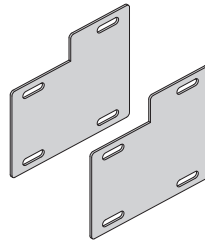

Tray Series	Catalog No.
RSI05A to RSI04A	● RAA-DSP-45
RSI06A to RSI04A	● RAA-DSP-46
RSI07A to RSI04A	● RAA-DSP-47
RSI06A to RSI05A	● RAA-DSP-56
RSI07A to RSI05A	● RAA-DSP-57
RSI07A to RSI06A	● RAA-DSP-67

Vertical Adjustable Splice Plate

- Furnished in pairs with 1/4" hardware.
- UL Classified.
- Bonding jumpers not required.

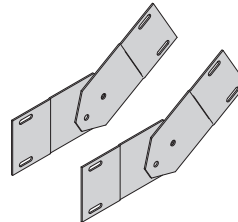

Tray Series	Catalog No.
RSI04A	● R4A-VSP
RSI05A	● R5A-VSP
RSI06A	● R6A-VSP
RSI07A	● R7A-VSP

Requires supports within 24" on both sides, per NEMA VE 2.

FLEX-MOUNT™ Adjustable Splice Plates

- Furnished in pairs with 1/4" hardware.
- Horizontally adjustable to 90°.
- Vertically adjustable to 15°.
- UL Classified.
- For optional rung, see page F-17.

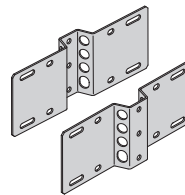

Tray Series	Catalog No.
RSI04A	● R4A-FSP
RSI05A	● R5A-FSP
RSI06A	● R6A-FSP
RSI07A	● R7A-FSP

Requires supports within 24" on both sides, per NEMA VE 2.

Adaptor Splice Plate

- Furnished in pairs with 1/4" hardware.
- Horizontally adjustable to 90°.
- For connecting to old Redi-Rail system.

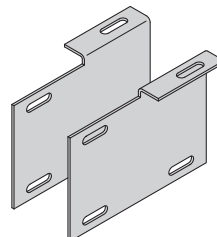

Tray Series	Catalog No.
RSI04A	● R4A-ASP
RSI05A	● R5A-ASP
RSI06A	● R6A-ASP
RSI07A	● R7A-ASP

● Green = Fastest shipped items ● Black = Normal lead-time items ● Red = Normally long lead-time items

All dimensions in parentheses are millimeters unless otherwise specified.

Offset Reducing Splice Plate

- Furnished in pairs with 1/4" hardware.
- UL Classified.

Specify the following:

- † C = center reducer
- S = side reducer

r (tray reduction) 3", 6", 9", 12", 15", 18", 21", 24", 27", or 30"

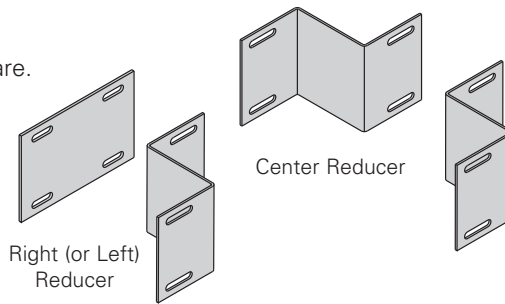

Tray Series	Catalog No.
RSI04A	● R4A-RSP-†
RSI05A	● R5A-RSP-†
RSI06A	● R6A-RSP-†
RSI07A	● R7A-RSP-†

Tray To Box Splice Plates

- Furnished in pairs with 1/4" hardware.
- UL Classified.

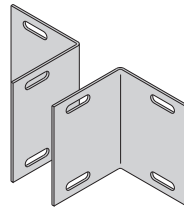

Tray Series	Catalog No.
RSI04A	● R4A-TTB
RSI05A	● R5A-TTB
RSI06A	● R6A-TTB
RSI07A	● R7A-TTB

Frame Type Box Connector

- Furnished with 1/4" hardware for tray connection.

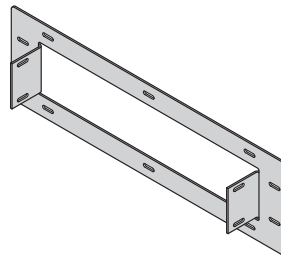

Tray Series	Catalog No.
RSI04A	● R4A-FTB-†
RSI05A	● R5A-FTB-†
RSI06A	● R6A-FTB-†
RSI07A	● R7A-FTB-†

† = tray width

Blind End

- Furnished as one plate with 1/4" hardware.

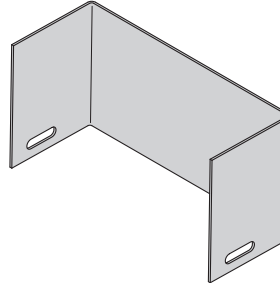

Tray Series	Catalog No.
RSI04A	● R4A-END-†
RSI05A	● R5A-END-†
RSI06A	● R6A-END-†
RSI07A	● R7A-END-†

† = tray width

Drop-Out

- Provides 4" (101mm) radius.
- Holes provided to secure cables.

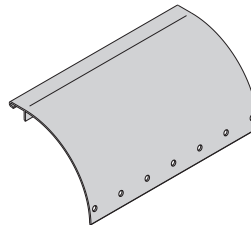

Tray Series	Catalog No.
All	● RAA-OUT-†

† = tray width

Bonding Jumper

- Furnished in pairs with 1/4" hardware.
- UL Classified.
- 14 1/2" (368mm) length.

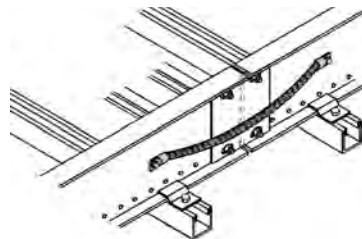

Ampacity	Catalog No.
1200	● 99-30

† = tray width

● Green = Fastest shipped items ● Black = Normal lead-time items ● Red = Normally long lead-time items

All dimensions in parentheses are millimeters unless otherwise specified.

Conduit To Tray Adaptors

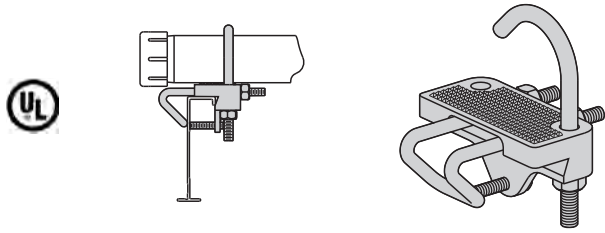

Conduit Size		Catalog No.
in	mm	
1/2, 3/4	(15, 20)	● 9G-1158-1/2, 3/4
1, 1 1/4	(25, 32)	● 9G-1158-1, 1 1/4
1 1/2, 2	(40, 50)	● 9G-1158-1 1/2, 2
2 1/2, 3	(65, 80)	● 9G-1158-2 1/2, 3
3 1/2, 4	(90, 100)	● 9G-1158-3 1/2, 4

Conduit To Tray Adaptors

- Mounting hardware not included.

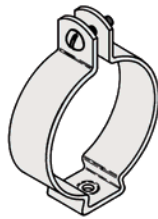

Conduit Size		Catalog No.
in	mm	
1/2	(15)	● BL1400
3/4	(20)	● BL1410
1	(25)	● BL1420
1 1/2	(40)	● BL1430

REDI-RAIL™ Clamp/Guide

- Features a no-twist design.
- Has four times the strength of the traditional design.
- Each side is labeled to ensure proper installation.
- Designed for 1/4" hardware.
- Furnished in pairs with or without hardware.

Patent No.
RE35479

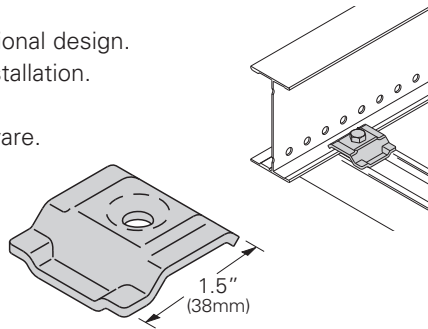

Catalog No.	
● 9ZN-1204	(without hardware)
● 9ZN-1204NB	(with hardware)

Hanger Rod Bracket

- Furnished as pair of studded clamps with 1/4" serrated flanged lock nuts.
- Loading is 1,000 lbs. (4.45kN) per pair with safety factor of 3.
- Position ATR 3" (76mm) wider than cable tray.

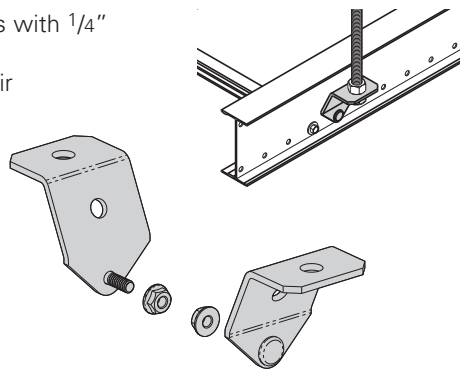

Support ATR Size	Catalog No.
3/8"	● 9(*)-R238
1/2"	● 9(*)-R250

(*) Insert ZN or SS

● Green = Fastest shipped items ● Black = Normal lead-time items ● Red = Normally long lead-time items

All dimensions in parentheses are millimeters unless otherwise specified.

Trapeze Support Kit

Trapeze kits provide the components required for a single trapeze support in one package. These kits are available in pre-galvanized steel with zinc-plated hardware or hot dip galvanized steel with 316 stainless steel hardware.

The SH channel provides the convenience of pre-punched slots, which eliminate the need for field drilling.

The illustrated hardware is sealed in a plastic bag and boxed with the channel, which is pre-cut to the appropriate length as shown in the chart.

Designed for use with 1/2" threaded rod. (order separately)

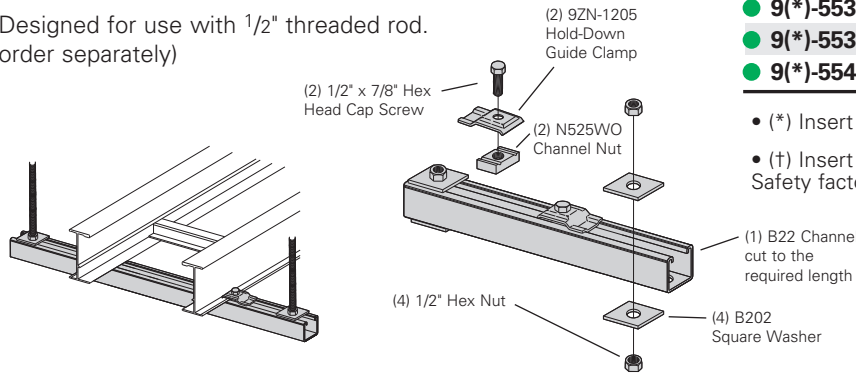

Catalog No.	Tray Width in. (mm)	Channel Length in. (mm)	Uniform Load lbs (kN)
● 9(*)-5506-22SH(+)	6 (152)	16 (406)	1600 (7.11)
● 9(*)-5509-22SH(+)	9 (229)	18 (457)	1250 (5.56)
● 9(*)-5512-22SH(+)	12 (305)	22 (559)	1125 (5.00)
● 9(*)-5518-22SH(+)	18 (457)	28 (711)	865 (3.85)
● 9(*)-5524-22SH(+)	24 (610)	34 (864)	700 (3.11)
● 9(*)-5530-22SH(+)	30 (762)	40 (1016)	590 (2.62)
● 9(*)-5536-22SH(+)	36 (914)	46 (1168)	510 (2.27)
● 9(*)-5542-22SH(+)	42 (1067)	52 (1321)	450 (2.00)

- (*) Insert **P** or **G**
- (+) Insert 3/8 for 3/8" threaded rod hardware. Safety factor of 3.0 on all loads.

Heavy Duty Trapeze Support Kit

Trapeze kits provide the components required for a single trapeze support in one package. These kits are available in Dura Green™ epoxy coated steel with zinc-plated hardware or hot dip galvanized steel with 316 stainless steel hardware.

The SH channel provides the convenience of pre-punched slots, which eliminates the need for field drilling.

The illustrated hardware is sealed in a plastic bag and boxed with the channel, which is pre-cut to the appropriate length as shown in the chart.

Designed for use with 1/2" threaded rod. (order rod separately)

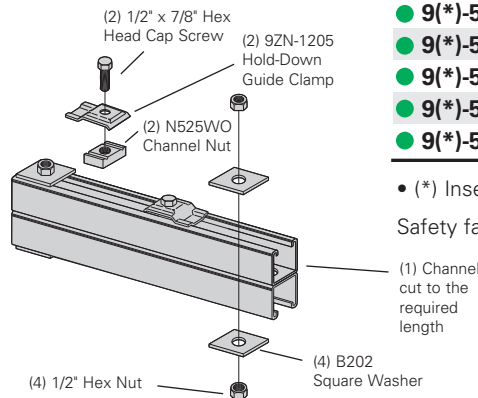

Catalog No.	Tray Width in. (mm)	Channel Length in. (mm)	Uniform Load lbs (kN)
● 9(*)-5506-22SHA	6 (152)	16 (406)	1350 (6.01)
● 9(*)-5509-22SHA	9 (229)	18 (457)	1350 (6.01)
● 9(*)-5512-22SHA	12 (305)	22 (559)	1350 (6.01)
● 9(*)-5518-22SHA	18 (457)	28 (711)	1350 (6.01)
● 9(*)-5524-22SHA	24 (610)	34 (864)	1350 (6.01)
● 9(*)-5530-22SHA	30 (762)	40 (1016)	1350 (6.01)
● 9(*)-5536-22SHA	36 (914)	46 (1168)	1350 (6.01)
● 9(*)-5542-22SHA	42 (1067)	52 (1321)	1350 (6.01)

- (*) Insert **G** or **GRN**
- Safety factor of 3.0 on all loads.

Trapeze Hardware Kit

- Kit sold in plastic bag.

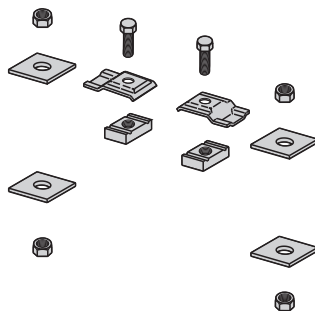

Catalog No.	
● 9ZN-5500-1/2	● 9G-5500-1/2
1 pr. 9ZN-1205	1 pr. 9G-1205
2 HHC Screw 1/2 x 7/8" ZN	2 HHC Screw 1/2 x 7/8" SS6
2 N525 WO ZN	2 N525 WO SS6
4 B202 ZN 1/2" sq washer	4 B202 HDG 1/2" sq washer
4 HN 1/2" ZN	4 HN 1/2" SS6

● Green = Fastest shipped items ● Black = Normal lead-time items ● Red = Normally long lead-time items

All dimensions in parentheses are millimeters unless otherwise specified.

Center Hung Tray Support

- Center Hung Cable Tray Support allows cable to be laid-in from both sides.
- Helps eliminate costly cable pulling and field cutting of cable tray supports. Labor costs can be dramatically reduced.
- Required hardware and threaded rod material for trapeze assemblies are reduced by 50%.
- Designed for use with 1/2" threaded rod. (order separately)
- Use with all aluminum and steel cable trays through 24" (610mm) width.
- Load capacity is 700 lbs. (3.11Kn) per support. Safety factor of 3.0. Eccentric loading is not to exceed a 60% vs. 40% load differential.
- The maximum recommended unsupported span length is 144"/12 ft. (3.66 m).
- Hardware shown is furnished.

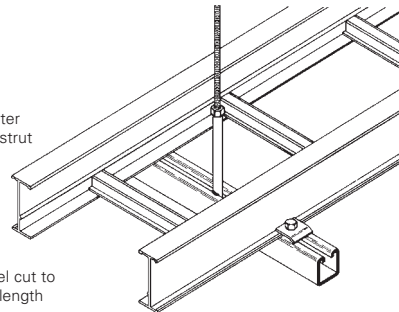
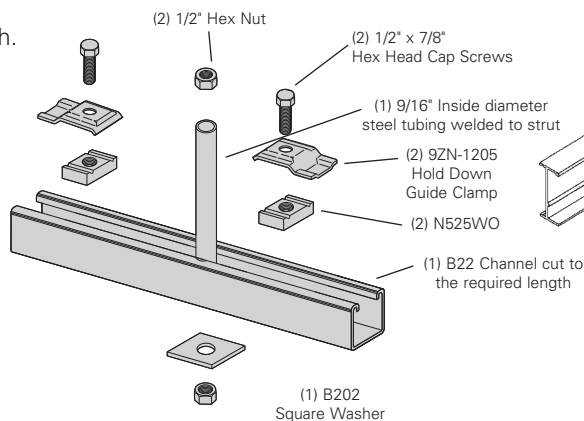

Catalog No.	Tray Width in. (mm)	Channel Length in. (mm)
● 9ZN-5212	6 (152), 9 (229), 12 (305)	18 (457)
● 9ZN-5224	18 (457), 24 (610)	30 (762)

ZN = Zinc Plated

Center Hung Support Hardware Kit

- Kit sold in plastic bag.

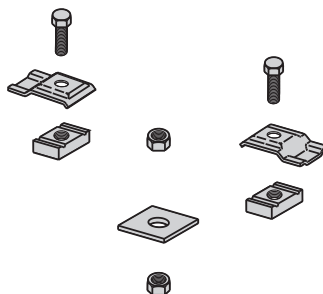

Catalog No.
● 9ZN-5200
1 pr. 9ZN-1205
2 HHC Screw 1/2" x 7/8" ZN
2 N525 WO ZN
1 B202 ZN 1/2" sq washer
2 HN 1/2" ZN

Bracket (12" - 42")

- Finishes available: **ZN** **GRN** or **HDG**
- Safety Load Factor 2.5

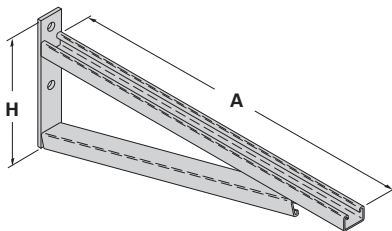

Bottom brace is B42 channel on B494-24 and smaller and B22 channel on B494-30 and larger

Catalog No.	Uniform Load lbs (kN)	Tray Width in. (mm)	'A' in. (mm)	'H' in. (mm)
B494-12	2500 (11.12)	6 & 9 (152 & 229)	12 (305)	8 ³ / ₄ (222)
B494-18	1700 (7.56)	12 (305)	18 (457)	8 ³ / ₄ (222)
B494-24	1300 (5.78)	18 (457)	24 (610)	8 ³ / ₄ (222)
B494-30	1600 (7.11)	24 (610)	30 (762)	11 ¹ / ₄ (286)
B494-36	1100 (4.89)	30 (762)	36 (914)	11 ¹ / ₄ (286)
B494-42	980 (4.36)	36 (914)	42 (1067)	16 (406)

For more dimensional data see Strut Systems catalog

● Green = Fastest shipped items ● Black = Normal lead-time items ● Red = Normally long lead-time items

All dimensions in parentheses are millimeters unless otherwise specified.

Cantilever Bracket

- Finishes available: **ZN** **GRN** **HDG** **SS4** or **SS6**
- Safety Load Factor 2.5

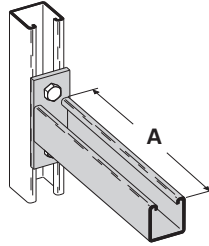

Catalog No.	Uniform Load		Tray Width		'A'	
	lbs	kN	in.	mm	in.	mm
B409-12	960	(4.27)	6 & 9	(152 & 229)	12	(305)
B409-18	640	(2.84)	12	(305)	18	(457)
B409-24	480	(2.13)	18	(457)	24	(610)

Cantilever Bracket

- Finishes available: **ZN** **GRN** **HDG** or **SS4**
- Safety Load Factor 2.5

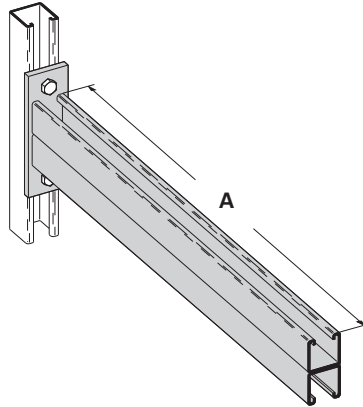

Catalog No.	Uniform Load		Tray Width		'A'	
	lbs	kN	in.	mm	in.	mm
B297-12	1660	(7.38)	6 & 9	(152 & 229)	12	(305)
B297-18	1100	(4.89)	12	(305)	18	(457)
B297-24	835	(3.71)	18	(457)	24	(610)
B297-30	665	(2.95)	24	(610)	30	(762)
B297-36	550	(2.44)	30	(762)	36	(914)
B297-42	465	(2.06)	36	(914)	42	(1067)

Underfloor Support (U-Bolts not included)

- Finish available: **ZN**
- Safety Load Factor 2.5

U-Bolt Size	Fits Pipe O.D.
B501-3/4	.841 - 1.050
B501-1	1.051 - 1.315
B501-1 1/4	1.316 - 1.660
B501-1 1/2	1.661 - 1.900
B501-2	1.901 - 2.375
B501-2 1/2	2.376 - 2.875

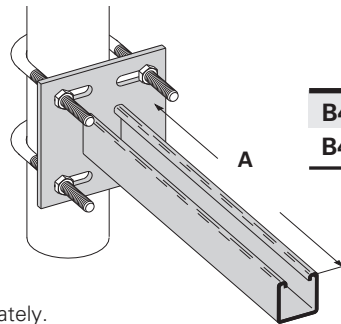

Catalog No.	Uniform Load		Tray Width		'A'	
	lbs	kN	in.	mm	in.	mm
B409UF-12	800	(3.55)	6 & 9	(152 & 229)	12	(305)
B409UF-21	450	(2.00)	12 & 18	(305 & 457)	21	(533)

- Order properly sized U-Bolts separately.

Heavy Duty Hold Down Bracket - Two Bolt

- Design load is 2000 lbs (8.9kN) per pair.
- Two bolt design.
- Sold in pairs.
- 3/8" cable tray attachment hardware provided.
- 1/2" support attachment hardware **not** provided.
- (*) Insert **ZN** **SS4** or **SS6**

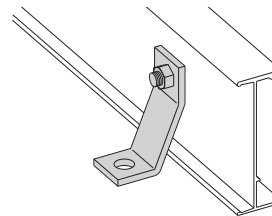

Catalog No.

9(*)-1241

Heavy Duty Hold Down Bracket - Four Bolt

- Design load is 4000 lbs (17.8kN) per pair.
- Four bolt design.
- Sold in pairs.
- 3/8" cable tray attachment hardware provided.
- 1/2" support attachment hardware **not** provided.
- (*) Insert **ZN** **SS4** or **SS6**

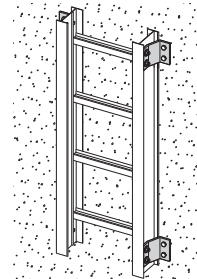
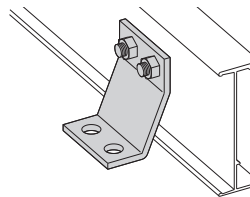

Catalog No.

9(*)-1242

● Green = Fastest shipped items ● Black = Normal lead-time items ● Red = Normally long lead-time items

All dimensions in parentheses are millimeters unless otherwise specified.

Mounting Bracket

- Furnished with 1/4" hardware.
- #12-24 U-Nuts sold separately.
- Attaches to REDI-RAIL in over 20 positions.
- EIA/TIA panel mounting holes - both sides.
- Mounting holes for NEMA outlet/junction boxes.
- Zinc plated steel.
- Includes mounting screws.
- Inside flange application bracket must match side rail height.
- See page RER-16 for Voice/Data/Video and Power Options.

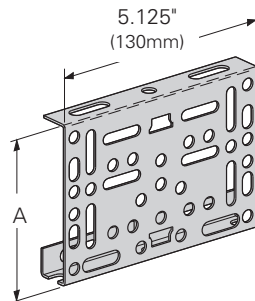

Outside Side Rail Flange Application

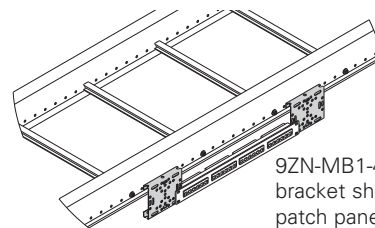

9ZN-MB1-4 mounting bracket shown with patch panels.

Inside Side Rail Flange Application

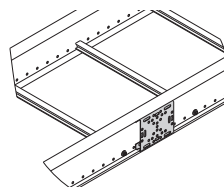

9ZN-MB1-4 mounting bracket shown.

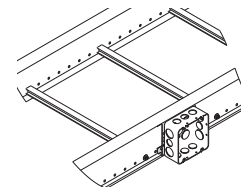

9ZN-MB1-4 mounting bracket shown with 4" electrical box.

Catalog No.	Inside Flange Application	Outside Flange Application	A in (mm)
● 9ZN-MB1-4	4" for RSI04	4" or 5" as desired	3 ⁵ / ₈ (92)
● 9ZN-MB1-5	5" for RSI05	4" or 5" as desired	4 ⁵ / ₈ (117)

Low Voltage Adapter

- Mounting for low voltage wall plates.
- Snaps into mounting bracket 9ZN-MB1-4 or 9ZN-MB1-5.
- Zinc plated steel.
- #6 - 32 U-nuts included.
- See page RER-16 for Voice/Data/Video and Power Options.

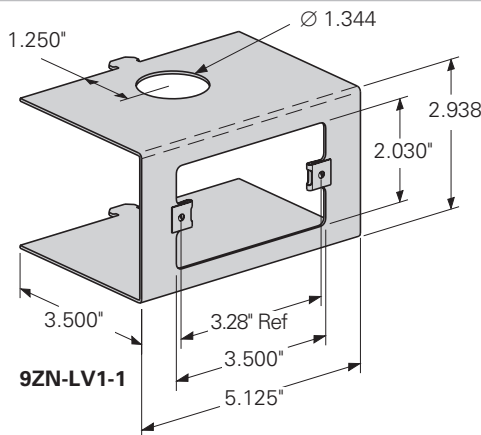

9ZN-LV1-1 shown

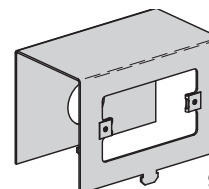
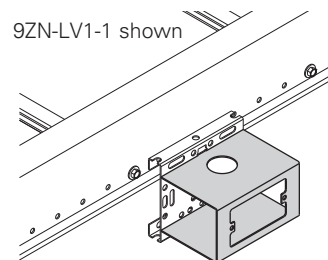

9ZN-LV1A-1

Catalog No.

- 9ZN-LV1-1 (cutout on front)
- 9ZN-LV1A-1 (cutout on bottom)

Under Rung Fastener Attachment

- Supports electrical fixtures from bottom of rung or siderails.
- Wing nut included.
- Various 1/4"-20 stud lengths available.
- Static Load Capacity: 75 Lbs. (34kg).

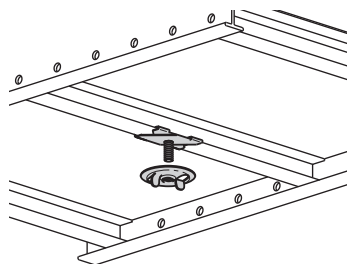
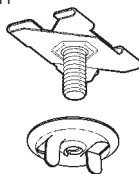

Catalog No.	Stud Length
● BAX-4-16	5/8" (16mm)
● BAX-4-16-24	1 1/2" (38mm)
● BAX-4-16-32	2" (51mm)
● BAX-4-16-48	3" (76mm)

Rooftop Support Bases with B22 Channel

- Designed as a superior rooftop support for cable tray.
- UV resistant and approved for most roofing material or other flat surfaces.
- Can be used with any of Eaton's B-Line series cable tray clamps and guides.
- Ultimate Load Capacity:
1,000 lbs. (4.45kN) - uniform load



Catalog No.	Height x Width x Length
● DB10-28	5 5/8" x 6" x 28.0"
● DB10-36	5 5/8" x 6" x 36.0"
● DB10-42	5 5/8" x 6" x 42.0"
● DB10-50	5 5/8" x 6" x 50.0"
● DB10-60	5 5/8" x 6" x 60.0"

LEEDS credit available, base made from 100% recycled material.

General Note: Consult roofing manufacturer or engineer for roof load capacity. The weakest point may be the insulation board beneath the rubber membrane.

● Green = Fastest shipped items ● Black = Normal lead-time items ● Red = Normally long lead-time items

All dimensions in parentheses are millimeters unless otherwise specified.

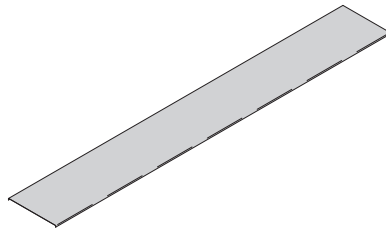

Covers for RSI04A, RSI05A, RSI06A, and RSI07A

Aluminum Cover Part Numbering

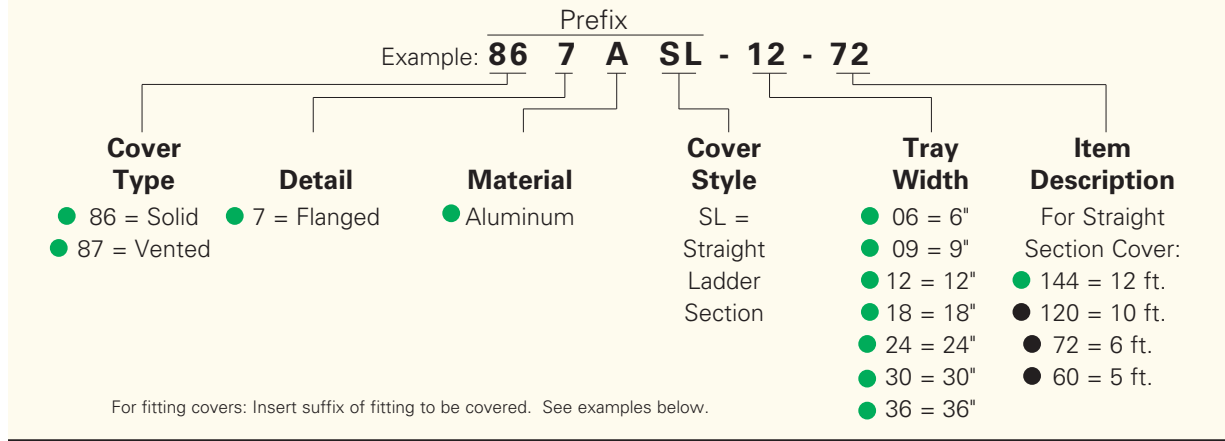

Examples of Catalog Numbers for Fitting Covers:

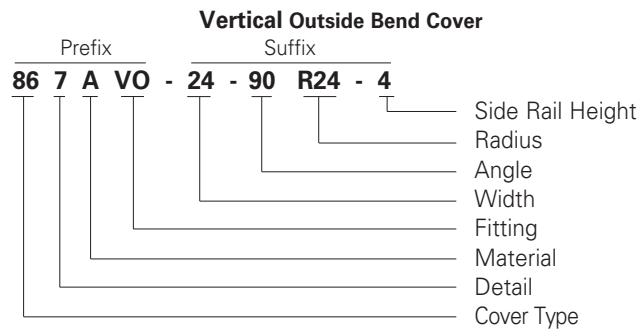
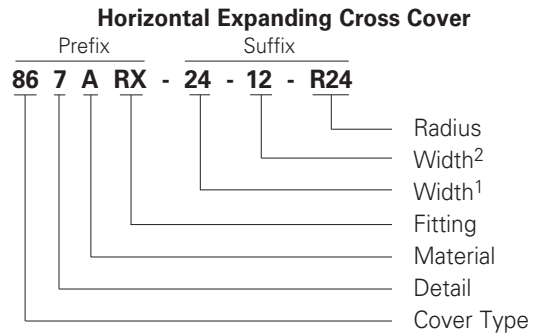
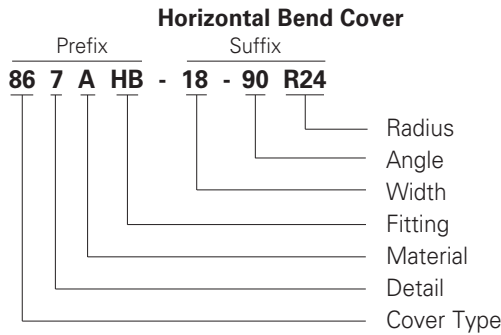

● Green = Fastest shipped items ● Black = Normal lead-time items ● Red = Normally long lead-time items

All dimensions in parentheses are millimeters unless otherwise specified.

Standard Cover Clamp

- Setscrew included.
- For indoor service only.
- Sold per clamp.
- EIA/TIA panel

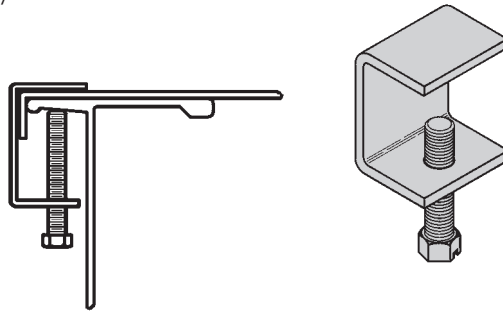

Tray Type	Side Rail Height	Catalog No.
Aluminum	All Sizes	● 9ZN-9012
		● 9A-9012

Heavy Duty Cover Clamp

- For heavy duty application.
- Sold per clamp.

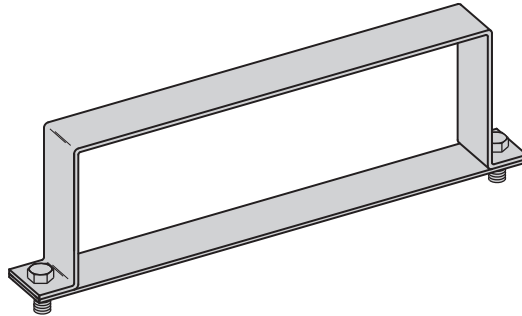

Tray Series	Catalog No.
RSI04A	● R4A-HDCC-†
RSI05A	● R5A-HDCC-†
RSI06A	● R6A-HDCC-†
RSI07A	● R7A-HDCC-†

† = tray width

Quantity of Standard Cover Clamps Required

Straight Section 60" or 72"	4 pcs.
Straight Section 120" or 144"	6 pcs.
Horizontal/Vertical Bends	4 pcs.
Tees	6 pcs.
Crosses	8 pcs.

Notes:

When using the Heavy Duty Cover Clamp, only one-half the number of clamps stated above are required.

Additional clamps may be necessary in extreme wind applications.

● Green = Fastest shipped items ● Black = Normal lead-time items ● Red = Normally long lead-time items

All dimensions in parentheses are millimeters unless otherwise specified.

Out Board Rungs

- Formed aluminum rung with attachment screw.
- Field installs as required.
- Torque rung fasteners to 6 ft•lbs.
- See page RER-16 for Voice/Data/Video and Power Options.
- Uniform load capacity on rung: 10 lbs. (0.04kN)

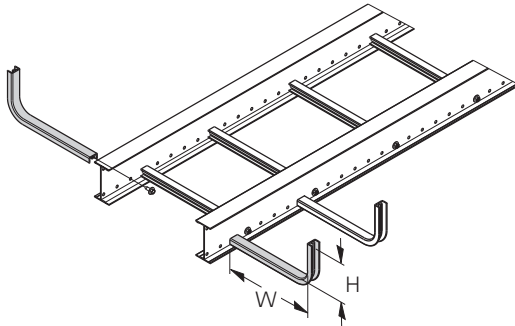

Catalog No.	Fill Depth 'H' in (mm)	For Tray Width 'W' in (mm)
● 9A-SR0406	4 101	6 152
● 9A-SR0409	4 101	9 226
● 9A-SR0506	5 127	6 152
● 9A-SR0509	5 127	9 226

Add-A-Rung™ Kit

- Kit allows an additional rung to be added to a desired location throughout the tray system.
- Pre-cut rung sections supplied.
- Attachment hardware is included.
- Torque rung fasteners to 18 ft•lbs.

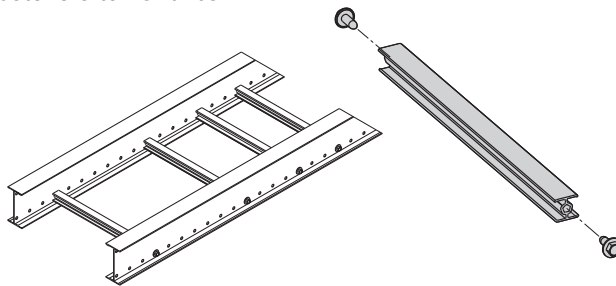

Tray Width in (mm)	Catalog No.
6 (152)	● 9A-R06RK
9 (226)	● 9A-R09RK
12 (305)	● 9A-R12RK
18 (452)	● 9A-R18RK
24 (609)	● 9A-R24RK
30 (762)	● 9A-R30RK
36 (914)	● 9A-R36RK

Barrier Strip Clip

- Provides attachment to Redi-Rail rung.
- Allows for installed barrier adjustment.
- Asymmetrical clip provides a wide range for screw location.
- Barriers strip clips and hardware are included with all barriers.

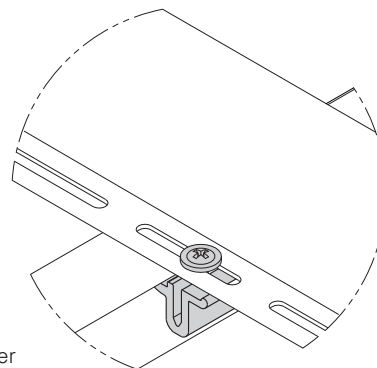
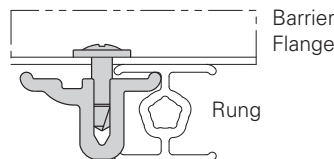
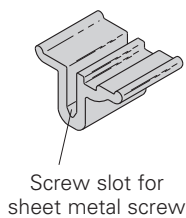

Catalog No.
● 9A-RBC

● Green = Fastest shipped items ● Black = Normal lead-time items ● Red = Normally long lead-time items

All dimensions in parentheses are millimeters unless otherwise specified.

Universal Fitting

- Aluminum construction.
- 2" smooth radius.
- UL Classified.
- Shipped as a 90° horizontal bend.
- Field modify to create a tee or cross.
- Includes four pairs of toolless hinge splice plates.
- Patent Pending.

Tray Series	Catalog No.	
	Punched	Solid
RSI04A	● R4A-UF-(†)	● R4ASB-UF-(†)
RSI05A	● R5A-UF-(†)	● R5ASB-UF-(†)
RSI06A	● R6A-UF-(†)	● R6ASB-UF-(†)
RSI07A	● R7A-UF-(†)	● R7ASB-UF-(†)

(†) Insert Tray Width 6" (152mm) to 24" (609mm)

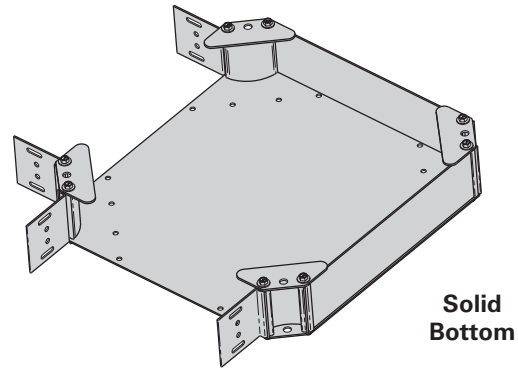
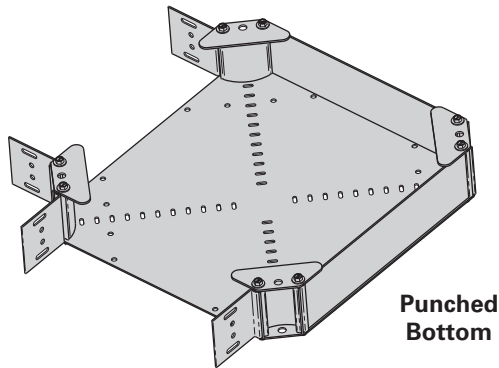

Corner Post For Universal Fitting

- Use to create reducing fittings.
- Furnished with hardware.
- 2" inside radius.
- Used on punched bottom only.
- UL Classified.
- Patent Pending.

Loading Depth	Catalog No.
In. (mm)	
3" (76)	● R4A-CP
4" (101)	● R5A-CP
5" (127)	● R6A-CP
6" (152)	● R7A-CP

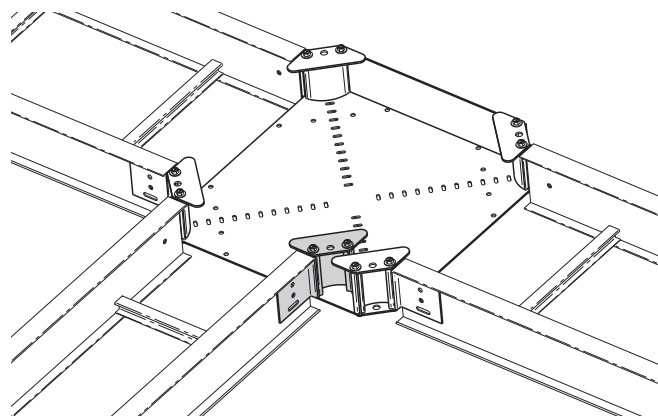
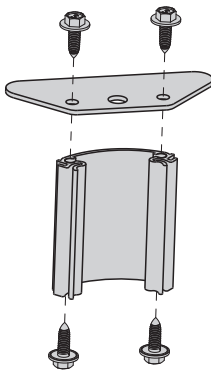

Universal Fitting Shown as a Reducing Tee

● Green = Fastest shipped items ● Black = Normal lead-time items ● Red = Normally long lead-time items

All dimensions in parentheses are millimeters unless otherwise specified.

Straight Section Barrier Strips

- Furnished with four (4) barrier strip clips, mounting hardware and splice.
- Standard lengths are 144" or 12 ft (3.7m) & 120" or 10 ft (3.0m).
- Order catalog number based on loading depth 'H'.

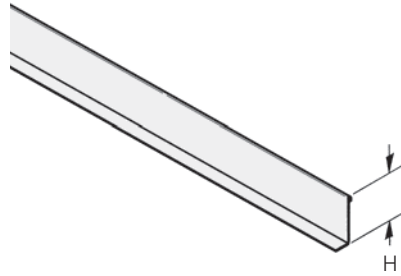

Tray Series	Catalog No.	H in (mm)
RSI04A	● R4A-DSL-Length	3 (76)
RSI05A	● R5A-DSL-Length	4 (101)
RSI06A	● R6A-DSL-Length	5 (127)
RSI07A	● R7A-DSL-Length	6 (152)

Horizontal Bend Barrier Strips

- Furnished with four (4) barrier strip clips, mounting hardware and splice.
- Standard lengths are 72" or 6 ft (1.8m).
- Flexible to fit desired angles.
- Order catalog number based on loading depth 'H'.

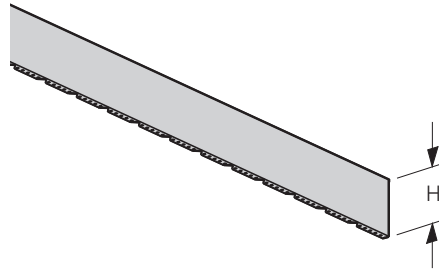

Tray Series	Catalog No.	H in (mm)
RSI04A	● R4A-DHB	3 (76)
RSI05A	● R5A-DHB	4 (101)
RSI06A	● R6A-DHB	5 (127)
RSI07A	● R7A-DHB	6 (152)

Vertical Bend Barrier Strips

- Furnished with three (3) barrier strip clips, mounting hardware and splice.

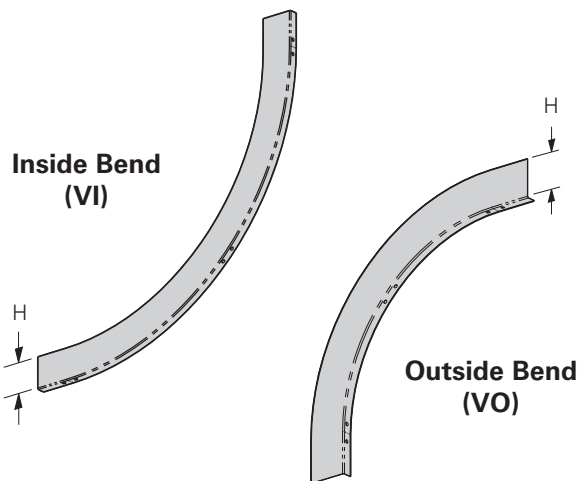

Tray Series	Catalog No.		H in (mm)
	Inside Bend	Outside Bend	
RSI04A	● R4A-DVI-(**R(t))	● R4A-DVO-(**R(t))	3 (76)
RSI05A	● R5A-DVI-(**R(t))	● R5A-DVO-(**R(t))	4 (101)
RSI06A	● R6A-DVI-(**R(t))	● R6A-DVO-(**R(t))	5 (127)
RSI07A	● R7A-DVI-(**R(t))	● R7A-DVO-(**R(t))	6 (152)

(**) Insert for angles: 30°, 45°, 60°, or 90°

(t) Insert for radius: 12 = 12" (305mm) or 24 = 24" (609mm)

● Green = Fastest shipped items ● Black = Normal lead-time items ● Red = Normally long lead-time items

All dimensions in parentheses are millimeters unless otherwise specified.

How to miter cut REDI-RAIL cable tray for use with FLEX-MOUNT™ splice plates.

- Mark desired hole/cut locations per chart.
- Remove any rungs (if necessary) affected by cuts.
- Cut side rails through center of required holes per chart.
- Mount outside FLEX-MOUNT splice plate with provided hardware and bend REDI-RAIL sections to desired angle.
- Form inside FLEX-MOUNT splice plate to fit contour of inner rails and bolt into place.
- Reinstall (if necessary) appropriate rungs. Torque to 18 ft•lbs.
- If Splice Rung Kit (see below) is required, order separately.
- Recommend adding one to the value in the chart if the first hole is less than 3/8" (9.5mm) from the end of tray.

Tray Width	Number Of Holes For Desired Angle				Angle Adjustment Allowed
	30°	45°	60°	90°	
6	1	2	2	4	± 14.5
9	2	2	3	6	± 9.7
12	2	3	4	8	± 7.3
18	3	5	7	11	± 4.9
24	4	6	9	15	± 3.6
30	5	8	11	19	± 2.9
36	6	10	13	23	± 2.4

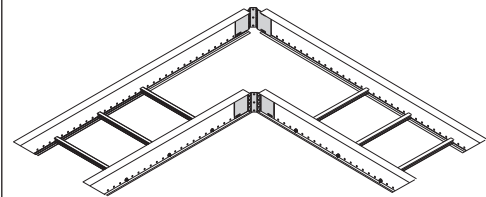
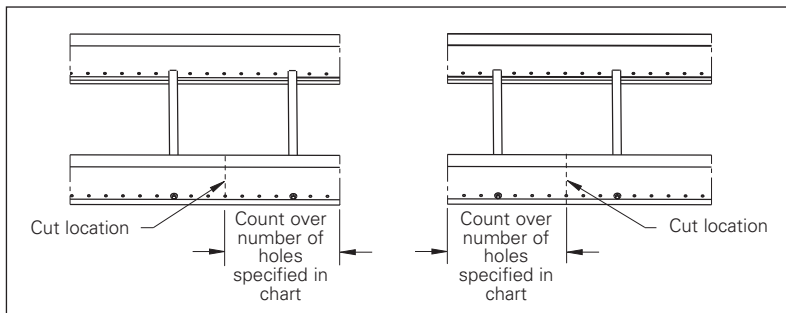

RSI05A09SL-12-144 Straight Section shown with required side rail removed to form 90° fitting.

Example: For a 12" (305mm) wide 90° bend, the cuts must be made through the eighth hole from the end.

FLEX-MOUNT™ Splice Rung Kit

- Kit allows a support rung to be added to flex-mount splice plates so that cables may be supported through a bend.
- The support rung is available in three lengths and should be ordered based upon tray width.
- The rung length is sized so that it will fit a maximum tray width when FLEX-MOUNT splices are used to make a bend up to 90°.
- Once the FLEX-MOUNT splices are installed in the cable tray system, the distance between the splice mounting surfaces should be measured.

Cut support rung to the measured distance and install using the hardware included. Torque to 18 ft•lbs.

For Tray Width		Catalog No.	Actual Rung Length	
in.	(mm)		in.	(mm)
Up to 12	(Up to 305)	● 9A-RFM-12RK	20"	(508)
18 & 24	(453 to 609)	● 9A-RFM-24RK	37"	(940)
30 & 36	(762 to 914)	● 9A-RFM-36RK	54"	(1448)

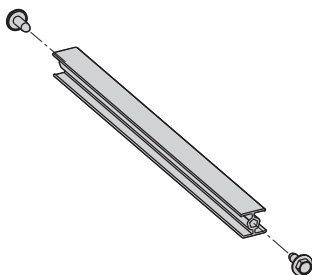

Example: Flex connectors are installed on an 18" (452mm) wide tray with approximately a 45° bend. The correct support rung kit is 9A-RFM-24RK. The tray width is 24" (609mm) or less and the angle is less than 90°.

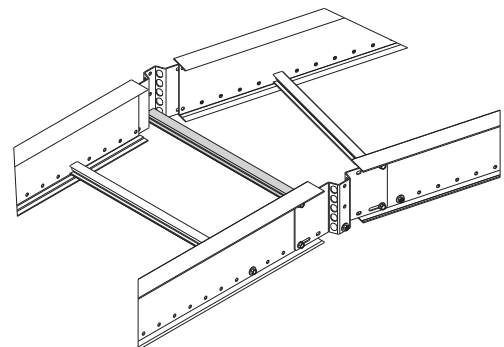

● Green = Fastest shipped items ● Black = Normal lead-time items ● Red = Normally long lead-time items

All dimensions in parentheses are millimeters unless otherwise specified.

Voice / Data / Video Options

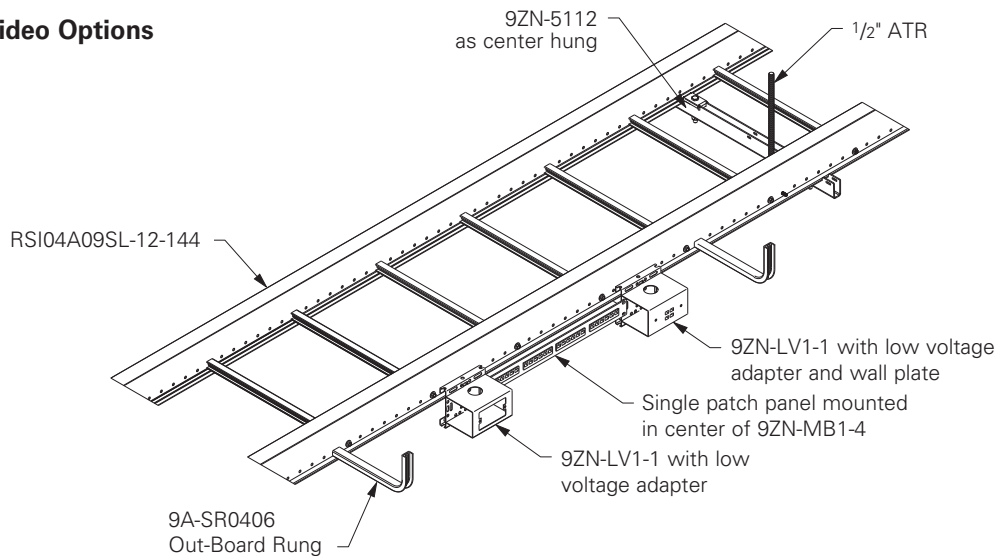

Power Options

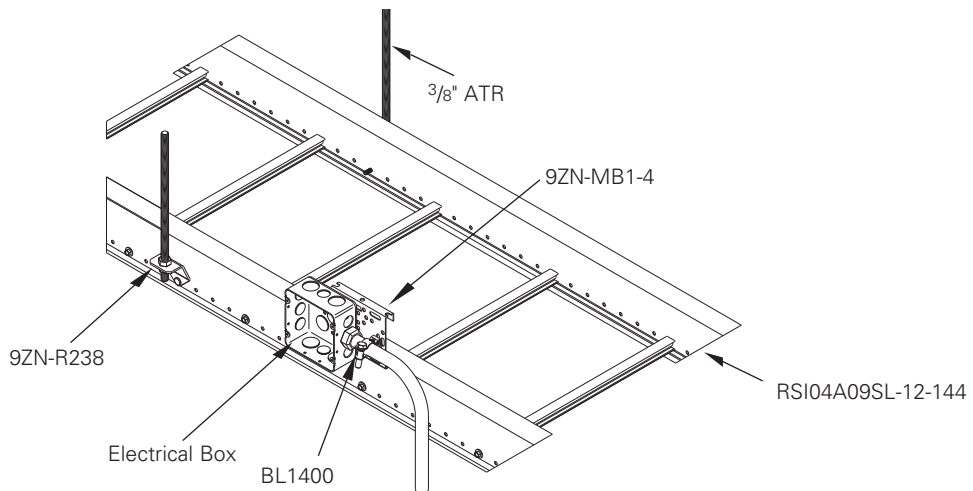

Data Cables

The National Electrical Code allows for 50% fill of ventilated cable tray for control or signal wiring (Article 392-9(b)). This rule requires that all the individual cable cross-sectional areas added up may not exceed one half the cable tray area. The cable tray area is equal to the width times the load depth.

In actual practice with data cables, however, the cable tray becomes completely full in reaching the "50% cable fill". See the picture below. The tray is completely full, but the sum of the cable areas is only 50% of the tray area, due to the empty spaces between the cables.



"50%" Fill Per NEC Cross Sectional Area Calculation

Data Cable Fill and Weight Chart

Number of Category 5/5e/6 Cables and Calculated Cable Weight in Lbs/Ft

Tray Depth in (mm)	Tray Width													
	6" (152mm)		9" (228mm)		12" (305mm)		18" (457mm)		24" (609mm)		30" (762mm)		36" (914mm)	
	Cables	lbs/ft	Cables	lbs/ft	Cables	lbs/ft	Cables	lbs/ft	Cables	lbs/ft	Cables	lbs/ft	Cables	lbs/ft
3" (76)	260	7	390	10	520	14	780	21	1040	26	1299	32	1559	41
4" (101)	347	9	520	13	693	18	1040	27	1386	35	1733	43	2079	54
5" (127)	433	12	650	17	866	23	1299	34	1733	43	2166	53	2599	68
6" (152)	520	14	780	20	1040	27	1559	41	2079	52	2599	64	3119	81

This chart was based on 50% fill of 4 UTP Category 5, 5e, or 6 cables (O.D. = .21" .026 lbs/ft).

In the above loading grid, the weight of the cables is not the issue. The volume capacity of the tray governs.

For example, the worst case (6" load depth, 36" wide) has a total cable weight of 81 lbs/ft.

● Green = Fastest shipped items ● Black = Normal lead-time items ● Red = Normally long lead-time items

All dimensions in parentheses are millimeters unless otherwise specified.

Section 161xx - REDI-RAIL™ Cable Tray

Part 1 - General

1.01 Section Includes

- A. The work covered under this section consists of the furnishing of all necessary labor, supervision, materials, equipment, tests and services to install complete cable tray systems as shown on the drawings.
- B. Cable tray systems are defined to include, but are not limited to straight sections of [ladder type] [vented bottom type] [solid bottom type] cable trays, bends, tees, elbows, drop-outs, supports and accessories.

1.02 References

- A. ANSI/NFPA 70 - National Electrical Code
- B. NEMA VE 1-2009 - Metallic Cable Tray Systems
- C. NEMA VE 2-2006 - Cable Tray installation Guidelines

1.03 Drawings

- A. The drawings, which constitute a part of these specifications, indicate the general route of the cable tray systems. Data presented on these drawings are as accurate as preliminary surveys and planning can determine until final equipment selection is made. Accuracy is not guaranteed and field verification, of all dimensions, routing, etc., is directed.
- B. Specifications and drawings are for assistance and guidance, but exact routing, locations, distances and levels will be governed by actual field conditions. Contractor is directed to make field surveys as part of his work prior to submitting system layout drawings.

1.04 Submittals

- A. Submittal Drawings: Submit drawings of cable tray and accessories including clamps, brackets, hanger rods, splice plate connectors, expansion joint assemblies, and fittings, showing accurately scaled components.
- B. Product Data: Submit manufacturer's data on cable tray including, but not limited to, types, materials, finishes, rung spacings, inside depths and fitting radii. For side rails and rungs, submit cross sectional properties including Section Modulus (Sx) and Moment of Inertia (Ix).

1.05 Quality Assurance

- A. Manufacturers: Firms regularly engaged in manufacture of cable trays and fittings of types and capacities required, whose products have been in satisfactory use in similar service for not less than 5 years.
- B. NEMA Compliance: Comply with NEMA Standards Publication Number VE 1, "Cable Tray Systems".
- C. NEC Compliance: Comply with NEC, as applicable to construction and installation of cable tray and cable channel systems (Article 392, NEC).
- D. UL Compliance: Provide products that are UL-classified and labeled.
- E. NFPA Compliance: Comply with NFPA 70B, "Recommended Practice for Electrical Equipment Maintenance" pertaining to installation of cable tray systems.

1.06 Delivery, Storage and Handling

- A. Deliver cable tray systems and components carefully to avoid breakage, denting and scoring finishes. Do not install damaged equipment.
- B. Store cable trays and accessories in original cartons and in clean dry space; protect from weather and construction traffic. Wet materials should be unpacked and dried before storage.

Part 2 - Products

2.01 Acceptable Manufacturers

- A. Subject to compliance with these specifications, B-Line series cable tray systems shall be as manufactured by Eaton.

2.02 Cable Tray Sections and Components

- A. General: Except as otherwise indicated, provide metal cable trays, of types, classes, and sizes indicated; with splice plates, bolts, nuts and washers or connecting units. Construct units with rounded edges and smooth surfaces; in compliance with applicable standards; and with the following additional construction features. Cable tray shall be installed according to the latest revision of NEMA VE-2.
- B. Material and Finish: Straight sections, fitting side rails, rungs and splice plates shall be extruded from Aluminum Association Alloy 6063. All fabricated parts shall be made from Aluminum Association Alloy 5052.

(continued on page F-20)

(continued from page RER-19)

2.03 Type of Tray System

- A. Ladder Cable Trays shall consist of two longitudinal members (side rails) with transverse members (rungs) mechanically fastened to the side rails. Rungs shall be spaced [6] [9] [12] inches on center. Rung spacing in radiused fittings shall be industry standard 9" and measured at the center of the tray's width. Each rung must be capable of supporting a 200 lb. concentrated load at the center of a 18" wide cable tray with a safety factor of 1.5. Rungs shall be capable of easy removal, reinstallation, or replacement if necessary.
- B. Ventilated Bottom Cable Trays shall consist of two longitudinal members (side rails) with rungs spaced 4" on center.
- C. Solid Bottom Cable Trays shall consist of two longitudinal members (side rails) with a solid sheet over rungs spaced on 12" centers.
- D. Cable tray loading depth shall be [3] [4] [5] [6] inches per NEMA VE-1.
- E. Straight sections shall be supplied in standard [10 foot (3.05m)] [12 foot (3.65m)] lengths.
- F. Cable tray widths shall be [6] [9] [12] [18] [24] [30] [36] inches or as shown on drawings.
- G. Splice plates shall have (4) four nuts and bolts per plate. The resistance of fixed splice connections between adjacent sections of tray shall not exceed 0.00033 ohms. Splice plates shall be furnished with straight sections and fittings.
- H. All fittings must have a minimum radius of [12] [24] inches.

2.04 Loading Capacities

- A. Cable trays shall meet NEMA class designation: [75 lbs./ft. on 12 ft. span].
Or
- A. Cable tray shall be capable of carrying a uniformly distributed load of _____ lbs./ft on a _____ foot support span with a safety factor of 1.5 when supported as a simple span and tested per NEMA VE 1 Section 5.2.

Part 3 - Execution

3.01 Installation

- A. Install cable trays as indicated: Installation shall be in accordance with equipment manufacturer's instructions, and with recognized industry practices to ensure that cable tray equipment comply with requirements of NEC and applicable portions of NFPA 70B. Reference NEMA VE-2 for general cable tray installation guidelines.
- B. Coordinate cable tray with other electrical work as necessary to properly integrate installation of cable tray work with other work.
- C. Provide sufficient space encompassing cable trays to permit access for installing and maintaining cables.
- D. Cable tray fitting supports shall be located such that they meet the strength requirements of straight sections. Install fitting supports per NEMA VE-2 guidelines, or in accordance with manufacturer's instructions.

3.02 Testing

- A. Test cable trays to ensure electrical continuity of bonding and grounding connections, and to demonstrate compliance with specified maximum grounding resistance. See NFPA 70B, Chapter 18, for testing and test methods.
- B. Manufacturer shall provide test reports witnessed by an independent testing laboratory of the "worst case" loading conditions outlined in this specification and performed in accordance with the latest revision of NEMA VE-1-2002/CSA C22.2 No. 126.1-02.

End Of Section.

Fittings For RSI04A, RSI05A, RSI06A and RSI07A

Horizontal Bend

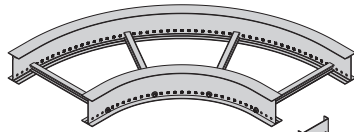

Horizontal Tee

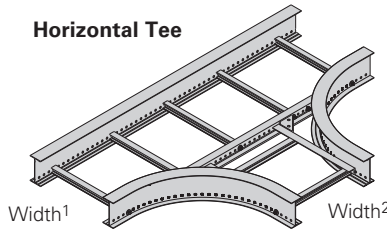

• Furnished with splice plates.

Vertical Inside

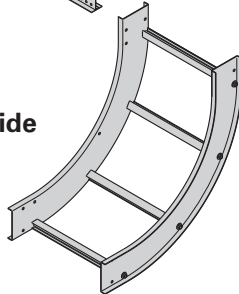

Vertical Outside

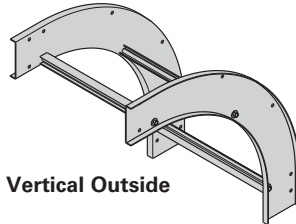

Vertical Tee
Down shown

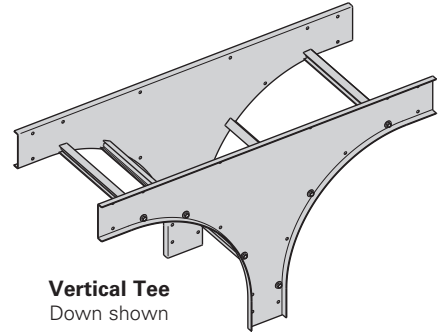

Fittings Part Numbering

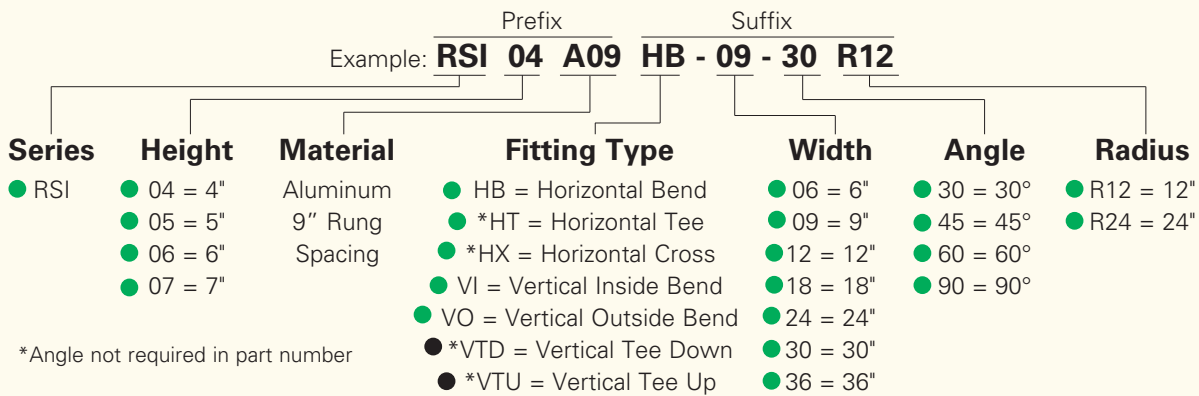

Horizontal Reducing / Expanding Tee or Cross Fittings Part Numbering

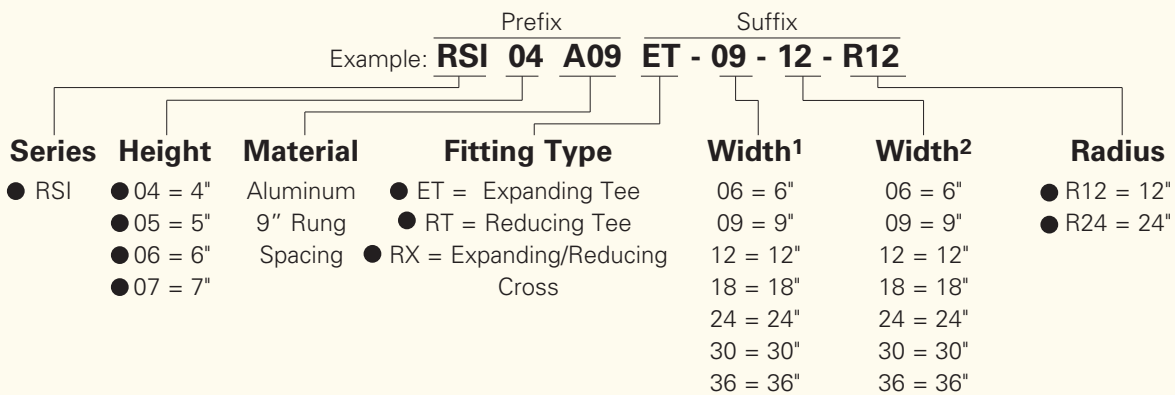

For aluminum 4", 5", 6", 7" vented or non-vented bottom add VB or SB as shown below.

Prefix
RSI05AVBHB - 24 - 90R24
Vented Bottom

Prefix
RSI05ASBHB - 24 - 90R24
Non-Vented Bottom

● Green = Fastest shipped items ● Black = Normal lead-time items ● Red = Normally long lead-time items

All dimensions in parentheses are millimeters unless otherwise specified.

Horizontal Bends 90° 60° 45° 30° (HB)

1 pair splice plates with hardware included.

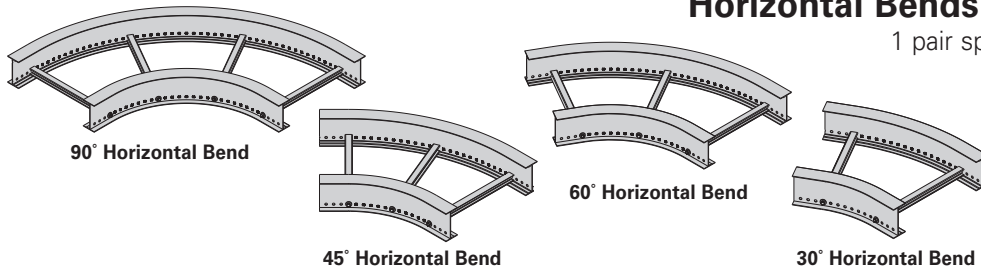

Bottoms manufactured:
09 = 9" Rung Spacing
VB = 4" Rung Spacing
SB = Flat sheet over 12" Rung Spacing

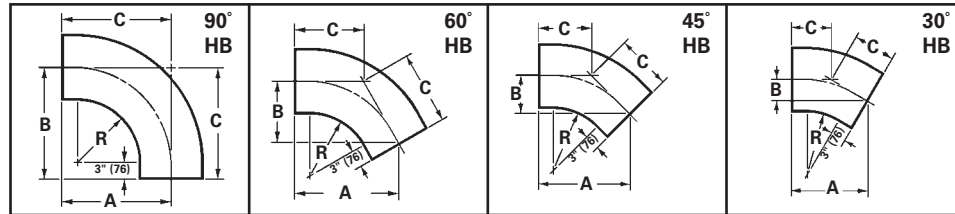

Bend Radius R in. (mm)	Tray Width in. (mm)	90° Horizontal Bend Dimensions				60° Horizontal Bend Dimensions			
		Catalog No.	A in. (mm)	B in. (mm)	C in. (mm)	Catalog No.	A in. (mm)	B in. (mm)	C in. (mm)
12 (305)	6 (152)	(Pre)HB-06-90R12	18 ¹ / ₁₆ (459)	18 ¹ / ₁₆ (459)	18 ¹ / ₁₆ (459)	(Pre)HB-06-60R12	17 ⁹ / ₁₆ (445)	10 ¹ / ₈ (258)	11 ¹¹ / ₁₆ (297)
	9 (228)	(Pre)HB-09-90R12	19 ⁹ / ₁₆ (497)	19 ⁹ / ₁₆ (497)	19 ⁹ / ₁₆ (497)	(Pre)HB-09-60R12	18 ¹³ / ₁₆ (478)	10 ⁷ / ₈ (277)	12 ⁹ / ₁₆ (319)
	12 (305)	(Pre)HB-12-90R12	21 ¹ / ₁₆ (535)	21 ¹ / ₁₆ (535)	21 ¹ / ₁₆ (535)	(Pre)HB-12-60R12	20 ¹ / ₈ (511)	11 ⁵ / ₈ (296)	13 ⁷ / ₁₆ (341)
	18 (457)	(Pre)HB-18-90R12	24 ¹ / ₁₆ (611)	24 ¹ / ₁₆ (611)	24 ¹ / ₁₆ (611)	(Pre)HB-18-60R12	22 ³ / ₄ (577)	13 ¹ / ₈ (334)	15 ³ / ₁₆ (385)
	24 (609)	(Pre)HB-24-90R12	27 ¹ / ₁₆ (687)	27 ¹ / ₁₆ (687)	27 ¹ / ₁₆ (687)	(Pre)HB-24-60R12	25 ⁵ / ₁₆ (643)	14 ⁵ / ₈ (372)	16 ⁷ / ₈ (429)
	30 (762)	(Pre)HB-30-90R12	30 ¹ / ₁₆ (763)	30 ¹ / ₁₆ (763)	30 ¹ / ₁₆ (763)	(Pre)HB-30-60R12	27 ¹⁵ / ₁₆ (709)	16 ¹ / ₈ (410)	18 ⁵ / ₈ (473)
	36 (914)	(Pre)HB-36-90R12	33 ¹ / ₁₆ (840)	33 ¹ / ₁₆ (840)	33 ¹ / ₁₆ (840)	(Pre)HB-36-60R12	30 ¹ / ₂ (775)	17 ⁵ / ₈ (448)	20 ³ / ₈ (517)
24 (609)	6 (152)	(Pre)HB-06-90R24	30 ¹ / ₁₆ (763)	30 ¹ / ₁₆ (763)	30 ¹ / ₁₆ (763)	(Pre)HB-06-60R24	27 ¹⁵ / ₁₆ (709)	16 ¹ / ₈ (410)	18 ⁵ / ₈ (473)
	9 (228)	(Pre)HB-09-90R24	31 ⁹ / ₁₆ (802)	31 ⁹ / ₁₆ (802)	31 ⁹ / ₁₆ (802)	(Pre)HB-09-60R24	29 ¹ / ₄ (742)	16 ⁷ / ₈ (429)	19 ¹ / ₂ (495)
	12 (305)	(Pre)HB-12-90R24	33 ¹ / ₁₆ (840)	33 ¹ / ₁₆ (840)	33 ¹ / ₁₆ (840)	(Pre)HB-12-60R24	30 ¹ / ₂ (775)	17 ⁵ / ₈ (448)	20 ³ / ₈ (517)
	18 (457)	(Pre)HB-18-90R24	36 ¹ / ₁₆ (916)	36 ¹ / ₁₆ (916)	36 ¹ / ₁₆ (916)	(Pre)HB-18-60R24	33 ¹ / ₈ (841)	19 ¹ / ₈ (486)	22 ¹ / ₈ (561)
	24 (609)	(Pre)HB-24-90R24	39 ¹ / ₁₆ (992)	39 ¹ / ₁₆ (992)	39 ¹ / ₁₆ (992)	(Pre)HB-24-60R24	35 ³ / ₄ (907)	20 ⁵ / ₈ (524)	23 ¹³ / ₁₆ (605)
	30 (762)	(Pre)HB-30-90R24	42 ¹ / ₁₆ (1068)	42 ¹ / ₁₆ (1068)	42 ¹ / ₁₆ (1068)	(Pre)HB-30-60R24	38 ⁵ / ₁₆ (973)	22 ¹ / ₈ (562)	25 ⁹ / ₁₆ (649)
	36 (914)	(Pre)HB-36-90R24	45 ¹ / ₁₆ (1144)	45 ¹ / ₁₆ (1144)	45 ¹ / ₁₆ (1144)	(Pre)HB-36-60R24	40 ¹⁵ / ₁₆ (1039)	23 ⁵ / ₈ (600)	27 ⁵ / ₁₆ (693)
45° Horizontal Bend					30° Horizontal Bend				
12 (305)	6 (152)	(Pre)HB-06-45R12	15 ³ / ₄ (400)	6 ¹ / ₂ (165)	9 ³ / ₁₆ (233)	(Pre)HB-06-30R12	13 ³ / ₁₆ (338)	3 ⁹ / ₁₆ (90)	7 ¹ / ₁₆ (180)
	9 (228)	(Pre)HB-09-45R12	16 ¹³ / ₁₆ (427)	6 ¹⁵ / ₁₆ (176)	9 ¹³ / ₁₆ (249)	(Pre)HB-09-30R12	13 ¹⁵ / ₁₆ (354)	3 ³ / ₄ (95)	7 ¹ / ₂ (190)
	12 (305)	(Pre)HB-12-45R12	17 ⁷ / ₈ (454)	7 ⁷ / ₁₆ (189)	10 ¹ / ₂ (267)	(Pre)HB-12-30R12	14 ¹¹ / ₁₆ (373)	3 ¹⁵ / ₁₆ (100)	7 ⁷ / ₈ (200)
	18 (457)	(Pre)HB-18-45R12	20 ¹ / ₂ (521)	8 ⁵ / ₁₆ (211)	11 ⁴ / ₄ (298)	(Pre)HB-18-30R12	16 ³ / ₁₆ (411)	4 ⁵ / ₁₆ (110)	8 ¹¹ / ₁₆ (220)
	24 (609)	(Pre)HB-24-45R12	22 ¹ / ₁₆ (560)	9 ³ / ₁₆ (233)	12 ¹⁵ / ₁₆ (328)	(Pre)HB-24-30R12	17 ¹¹ / ₁₆ (449)	4 ³ / ₄ (120)	9 ¹ / ₂ (241)
	30 (762)	(Pre)HB-30-45R12	24 ⁵ / ₁₆ (617)	10 ¹ / ₁₆ (255)	14 ¹ / ₄ (362)	(Pre)HB-30-30R12	19 ³ / ₁₆ (487)	5 ¹ / ₈ (131)	10 ⁵ / ₁₆ (261)
	36 (914)	(Pre)HB-36-45R12	26 ⁷ / ₁₆ (671)	10 ¹⁵ / ₁₆ (278)	15 ⁷ / ₁₆ (392)	(Pre)HB-36-30R12	20 ¹¹ / ₁₆ (525)	5 ⁹ / ₁₆ (141)	11 ¹ / ₁₆ (282)
24 (609)	6 (152)	(Pre)HB-06-45R24	24 ⁵ / ₁₆ (617)	10 ¹ / ₁₆ (255)	14 ³ / ₁₆ (360)	(Pre)HB-06-30R24	19 ³ / ₁₆ (487)	5 ¹ / ₈ (131)	10 ⁵ / ₁₆ (261)
	9 (228)	(Pre)HB-09-45R24	25 ¹ / ₄ (641)	10 ¹ / ₂ (267)	14 ¹³ / ₁₆ (376)	(Pre)HB-09-30R24	19 ¹⁵ / ₁₆ (506)	5 ⁵ / ₁₆ (136)	10 ¹¹ / ₁₆ (271)
	12 (305)	(Pre)HB-12-45R24	26 ⁷ / ₁₆ (671)	10 ¹⁵ / ₁₆ (278)	15 ⁷ / ₁₆ (392)	(Pre)HB-12-30R24	20 ¹¹ / ₁₆ (525)	5 ⁹ / ₁₆ (141)	11 ¹ / ₁₆ (282)
	18 (457)	(Pre)HB-18-45R24	28 ⁹ / ₁₆ (725)	11 ¹³ / ₁₆ (300)	16 ¹¹ / ₁₆ (424)	(Pre)HB-18-30R24	22 ³ / ₁₆ (563)	5 ¹⁵ / ₁₆ (161)	11 ⁷ / ₈ (302)
	24 (609)	(Pre)HB-24-45R24	30 ¹¹ / ₁₆ (779)	12 ¹¹ / ₁₆ (322)	17 ¹⁵ / ₁₆ (456)	(Pre)HB-24-30R24	23 ¹¹ / ₁₆ (601)	6 ³ / ₈ (161)	12 ¹¹ / ₁₆ (322)
	30 (762)	(Pre)HB-30-45R24	32 ¹³ / ₁₆ (833)	13 ⁹ / ₁₆ (345)	19 ³ / ₁₆ (487)	(Pre)HB-30-30R24	25 ³ / ₁₆ (640)	6 ³ / ₄ (171)	13 ¹ / ₂ (343)
	36 (914)	(Pre)HB-36-45R24	34 ¹⁵ / ₁₆ (887)	14 ⁷ / ₁₆ (367)	20 ⁷ / ₁₆ (519)	(Pre)HB-36-30R24	26 ¹¹ / ₁₆ (678)	7 ¹ / ₈ (182)	14 ⁵ / ₁₆ (363)

(Pre) See page F-21 for catalog number prefix.

Width dimensions are to inside wall. Manufacturing tolerances apply to all dimensions.

All dimensions in parentheses are millimeters unless otherwise specified.

Horizontal Tee (HT)

2 pair splice plates with hardware included.

REDI-RAIL

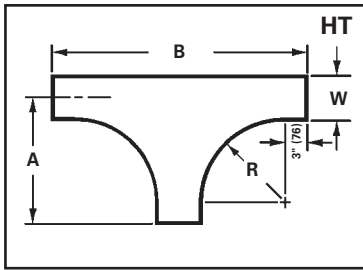
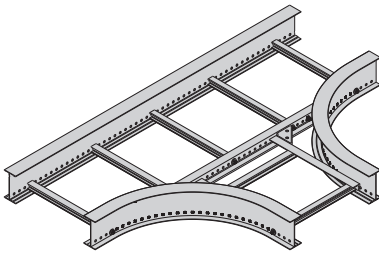

Bend Radius R in. (mm)	Tray Width W in. (mm)	Horizontal Tee Dimensions		
		Catalog No.	A in. (mm)	B in. (mm)
12 (305)	6 (152)	(Prefix)HT-06-R12	18 ¹ / ₁₆ (458)	36 ³ / ₄ (933)
	9 (228)	(Prefix)HT-09-R12	19 ⁹ / ₁₆ (497)	39 ⁷ / ₈ (1013)
	12 (305)	(Prefix)HT-12-R12	21 ¹ / ₁₆ (535)	42 ¹ / ₄ (1073)
	18 (457)	(Prefix)HT-18-R12	24 ¹ / ₁₆ (611)	48 ¹ / ₂ (1232)
	24 (609)	(Prefix)HT-24-R12	27 ¹ / ₁₆ (687)	54 ¹³ / ₁₆ (1392)
	30 (762)	(Prefix)HT-30-R12	30 ¹ / ₁₆ (763)	60 ¹ / ₄ (1530)
24 (609)	36 (914)	(Prefix)HT-36-R12	33 ¹ / ₁₆ (839)	66 ⁹ / ₁₆ (1691)
	6 (152)	(Prefix)HT-06-R24	30 ¹ / ₁₆ (763)	60 ¹ / ₁₆ (1525)
	9 (228)	(Prefix)HT-09-R24	31 ⁹ / ₁₆ (801)	63 ¹ / ₄ (1606)
	12 (305)	(Prefix)HT-12-R24	33 ¹ / ₁₆ (839)	66 ⁹ / ₁₆ (1691)
	18 (457)	(Prefix)HT-18-R24	36 ¹ / ₁₆ (916)	72 ¹ / ₁₆ (1830)
	24 (609)	(Prefix)HT-24-R24	39 ¹ / ₁₆ (992)	78 ³ / ₈ (1991)
	30 (762)	(Prefix)HT-30-R24	42 ¹ / ₁₆ (1068)	84 ⁵ / ₈ (2150)
	36 (914)	(Prefix)HT-36-R24	45 ¹ / ₁₆ (1144)	90 ¹⁵ / ₁₆ (2310)

(Prefix) See page F-21 for catalog number prefix.

Horizontal Cross (HX)

3 pair splice plates with hardware included.

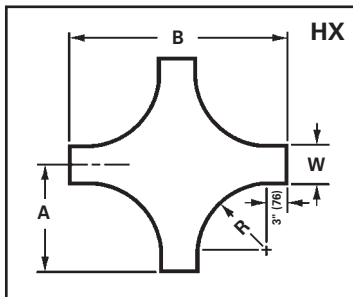
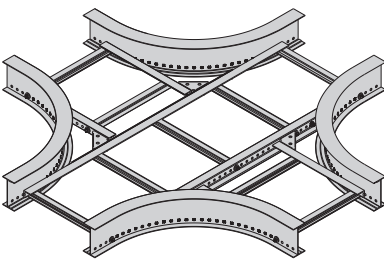

Bend Radius R in. (mm)	Tray Width W in. (mm)	Horizontal Tee Dimensions		
		Catalog No.	A in. (mm)	B in. (mm)
12 (305)	6 (152)	(Prefix)HX-06-R12	18 ¹ / ₁₆ (458)	36 ³ / ₄ (933)
	9 (228)	(Prefix)HX-09-R12	19 ⁹ / ₁₆ (497)	39 ⁷ / ₈ (1013)
	12 (305)	(Prefix)HX-12-R12	21 ¹ / ₁₆ (535)	42 ¹ / ₄ (1073)
	18 (457)	(Prefix)HX-18-R12	24 ¹ / ₁₆ (611)	48 ¹ / ₂ (1232)
	24 (609)	(Prefix)HX-24-R12	27 ¹ / ₁₆ (687)	54 ¹³ / ₁₆ (1392)
	30 (762)	(Prefix)HX-30-R12	30 ¹ / ₁₆ (763)	60 ¹ / ₄ (1530)
24 (609)	36 (914)	(Prefix)HX-36-R12	33 ¹ / ₁₆ (839)	66 ⁹ / ₁₆ (1691)
	6 (152)	(Prefix)HX-06-R24	30 ¹ / ₁₆ (763)	60 ¹ / ₁₆ (1525)
	9 (228)	(Prefix)HX-09-R24	31 ⁹ / ₁₆ (801)	63 ¹ / ₄ (1606)
	12 (305)	(Prefix)HX-12-R24	33 ¹ / ₁₆ (839)	66 ⁹ / ₁₆ (1691)
	18 (457)	(Prefix)HX-18-R24	36 ¹ / ₁₆ (916)	72 ¹ / ₁₆ (1830)
	24 (609)	(Prefix)HX-24-R24	39 ¹ / ₁₆ (992)	78 ³ / ₈ (1991)
	30 (762)	(Prefix)HX-30-R24	42 ¹ / ₁₆ (1068)	84 ⁵ / ₈ (2150)
	36 (914)	(Prefix)HX-36-R24	45 ¹ / ₁₆ (1144)	90 ¹⁵ / ₁₆ (2310)

(Prefix) See page F-21 for catalog number prefix.

Width dimensions are to inside wall. Manufacturing tolerances apply to all dimensions.

All dimensions in parentheses are millimeters unless otherwise specified.

Horizontal Reducing Tee (RT)

2 pair splice plates with hardware included.

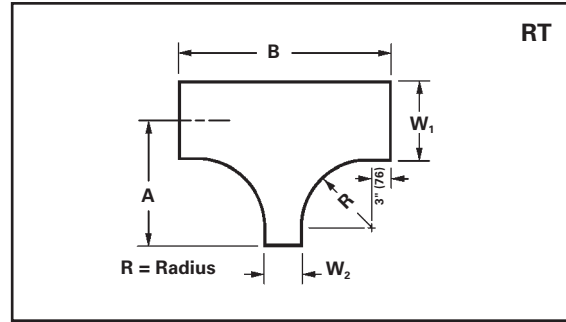
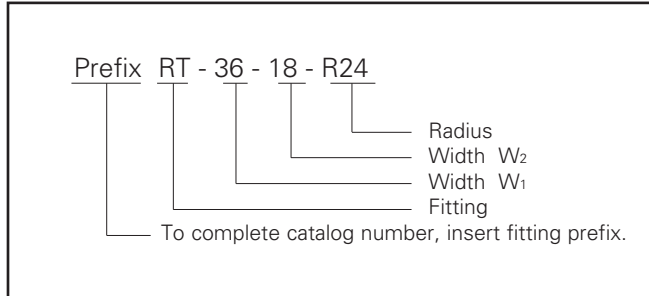
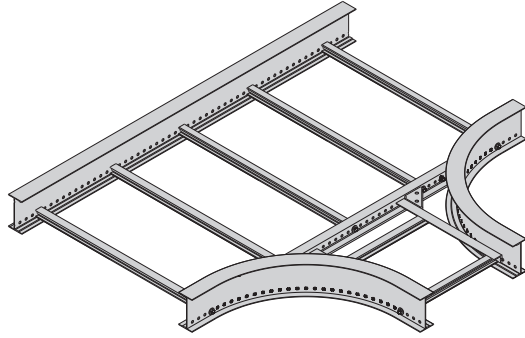

REDI-RAIL

Tray Width		* Insert Radius (12 for 12", 24 for 24") Catalog No.	12" Radius		24" Radius	
W1 in. (mm)	W2 in. (mm)		A in. (mm)	B in. (mm)	A in. (mm)	B in. (mm)
9 (228)	6 (152)	(Prefix)RT-09-06-R*	19 ⁹ / ₁₆ (497)	36 ³ / ₄ (933)	31 ⁹ / ₁₆ (801)	61 ¹ / ₁₆ (1551)
12 (305)	6 (152)	(Prefix)RT-12-06-R*	21 ¹ / ₁₆ (535)	36 ³ / ₄ (933)	33 ¹ / ₁₆ (839)	61 ¹ / ₁₆ (1551)
	9 (228)	(Prefix)RT-12-09-R*	21 ¹ / ₁₆ (535)	39 ⁷ / ₈ (1013)	33 ¹ / ₁₆ (839)	64 ¹ / ₄ (1830)
18 (457)	6 (152)	(Prefix)RT-18-06-R*	24 ¹ / ₁₆ (611)	36 ³ / ₄ (933)	36 ¹ / ₁₆ (916)	61 ¹ / ₁₆ (1551)
	9 (228)	(Prefix)RT-18-09-R*	24 ¹ / ₁₆ (611)	39 ⁷ / ₈ (1013)	36 ¹ / ₁₆ (916)	64 ¹ / ₄ (1830)
	12 (305)	(Prefix)RT-18-12-R*	24 ¹ / ₁₆ (611)	42 ¹ / ₄ (1073)	36 ¹ / ₁₆ (916)	66 ⁹ / ₁₆ (1691)
24 (609)	6 (152)	(Prefix)RT-24-06-R*	27 ¹ / ₁₆ (687)	36 ³ / ₄ (933)	39 ¹ / ₁₆ (992)	61 ¹ / ₁₆ (1551)
	9 (228)	(Prefix)RT-24-09-R*	27 ¹ / ₁₆ (687)	39 ⁷ / ₈ (1013)	39 ¹ / ₁₆ (992)	64 ¹ / ₄ (1830)
	12 (305)	(Prefix)RT-24-12-R*	27 ¹ / ₁₆ (687)	42 ¹ / ₄ (1073)	39 ¹ / ₁₆ (992)	66 ⁹ / ₁₆ (1691)
	18 (457)	(Prefix)RT-24-18-R*	27 ¹ / ₁₆ (687)	48 ¹ / ₂ (1232)	39 ¹ / ₁₆ (992)	72 ¹ / ₁₆ (1830)
30 (762))	6 (152)	(Prefix)RT-30-06-R*	30 ¹ / ₁₆ (763)	36 ³ / ₄ (933)	42 ¹ / ₁₆ (1068)	61 ¹ / ₁₆ (1551)
	9 (228)	(Prefix)RT-30-09-R*	30 ¹ / ₁₆ (763)	39 ⁷ / ₈ (1013)	42 ¹ / ₁₆ (1068)	64 ¹ / ₄ (1830)
	12 (305)	(Prefix)RT-30-12-R*	30 ¹ / ₁₆ (763)	42 ¹ / ₄ (1073)	42 ¹ / ₁₆ (1068)	66 ⁹ / ₁₆ (1691)
	18 (457)	(Prefix)RT-30-18-R*	30 ¹ / ₁₆ (763)	48 ¹ / ₂ (1232)	42 ¹ / ₁₆ (1068)	72 ¹ / ₁₆ (1830)
	24 (609)	(Prefix)RT-30-24-R*	30 ¹ / ₁₆ (763)	54 ¹³ / ₁₆ (1392)	42 ¹ / ₁₆ (1068)	78 ³ / ₈ (1991)
36 (914)	6 (152)	(Prefix)RT-36-06-R*	33 ¹ / ₁₆ (839)	36 ³ / ₄ (933)	45 ¹ / ₁₆ (1144)	61 ¹ / ₁₆ (1551)
	9 (228)	(Prefix)RT-36-09-R*	33 ¹ / ₁₆ (839)	39 ⁷ / ₈ (1013)	45 ¹ / ₁₆ (1144)	64 ¹ / ₄ (1830)
	12 (305)	(Prefix)RT-36-12-R*	33 ¹ / ₁₆ (839)	42 ¹ / ₄ (1073)	45 ¹ / ₁₆ (1144)	66 ⁹ / ₁₆ (1691)
	18 (457)	(Prefix)RT-36-18-R*	33 ¹ / ₁₆ (839)	48 ¹ / ₂ (1232)	45 ¹ / ₁₆ (1144)	72 ¹ / ₁₆ (1830)
	24 (609)	(Prefix)RT-36-24-R*	33 ¹ / ₁₆ (839)	54 ¹³ / ₁₆ (1392)	45 ¹ / ₁₆ (1144)	78 ³ / ₈ (1991)
	36 (914)	(Prefix)RT-36-30-R*	33 ¹ / ₁₆ (839)	60 ¹ / ₄ (1530)	45 ¹ / ₁₆ (1144)	84 ⁵ / ₈ (2149)

(Prefix) See page F-21 for catalog number prefix.
 Width dimensions are to inside wall.
 Manufacturing tolerances apply to all dimensions.

All dimensions in parentheses are millimeters unless otherwise specified.

Horizontal Expanding Tee (ET)

2 pair splice plates with hardware included.

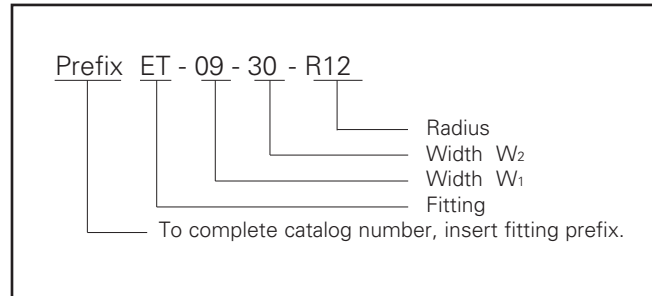
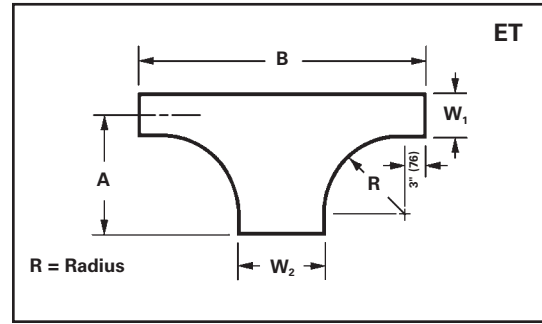
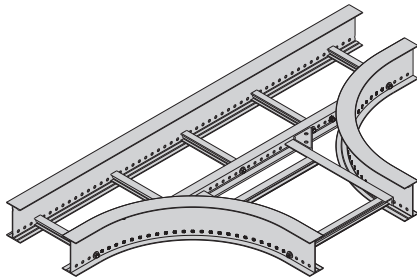

Tray Width		* Insert Radius (12 for 12", 24 for 24") Catalog No.	12" Radius		24" Radius	
W1 in. (mm)	W2 in. (mm)		A in. (mm)	B in. (mm)	A in. (mm)	B in. (mm)
6 (152)	9 (228)	(Prefix)ET-06-09-R*	18 ¹ / ₁₆ (458)	39 ⁷ / ₈ (1013)	30 ¹ / ₁₆ (763)	64 ¹ / ₄ (1632)
	12 (305)	(Prefix)ET-06-12-R*	18 ¹ / ₁₆ (458)	42 ¹ / ₄ (1073)	30 ¹ / ₁₆ (763)	66 ⁹ / ₁₆ (1691)
	18 (457)	(Prefix)ET-06-18-R*	18 ¹ / ₁₆ (458)	48 ¹ / ₂ (1232)	30 ¹ / ₁₆ (763)	72 ¹ / ₁₆ (1830)
	24 (609)	(Prefix)ET-06-24-R*	18 ¹ / ₁₆ (458)	54 ¹³ / ₁₆ (1392)	30 ¹ / ₁₆ (763)	78 ³ / ₈ (1991)
	30 (762)	(Prefix)ET-06-30-R*	18 ¹ / ₁₆ (458)	60 ¹ / ₄ (1530)	30 ¹ / ₁₆ (763)	84 ⁵ / ₈ (2149)
	36 (914)	(Prefix)ET-06-36-R*	18 ¹ / ₁₆ (458)	66 ⁹ / ₁₆ (1691)	30 ¹ / ₁₆ (763)	90 ¹⁵ / ₁₆ (2310)
9 (228)	12 (305)	(Prefix)ET-09-12-R*	19 ⁹ / ₁₆ (497)	42 ¹ / ₄ (1073)	31 ⁹ / ₁₆ (801)	66 ⁹ / ₁₆ (1691)
	18 (457)	(Prefix)ET-09-18-R*	19 ⁹ / ₁₆ (497)	48 ¹ / ₂ (1232)	31 ⁹ / ₁₆ (801)	72 ¹ / ₁₆ (1830)
	24 (609)	(Prefix)ET-09-24-R*	19 ⁹ / ₁₆ (497)	54 ¹³ / ₁₆ (1392)	31 ⁹ / ₁₆ (801)	78 ³ / ₈ (1991)
	30 (762)	(Prefix)ET-09-30-R*	19 ⁹ / ₁₆ (497)	60 ¹ / ₄ (1530)	31 ⁹ / ₁₆ (801)	84 ⁵ / ₈ (2149)
	36 (914)	(Prefix)ET-09-36-R*	19 ⁹ / ₁₆ (497)	66 ⁹ / ₁₆ (1691)	31 ⁹ / ₁₆ (801)	90 ¹⁵ / ₁₆ (2310)
12 (305)	18 (457)	(Prefix)ET-12-18-R*	21 ¹ / ₁₆ (535)	48 ¹ / ₂ (1232)	33 ¹ / ₁₆ (839)	72 ¹ / ₁₆ (1830)
	24 (609)	(Prefix)ET-12-24-R*	21 ¹ / ₁₆ (535)	54 ¹³ / ₁₆ (1392)	33 ¹ / ₁₆ (839)	78 ³ / ₈ (1991)
	30 (762)	(Prefix)ET-12-30-R*	21 ¹ / ₁₆ (535)	60 ¹ / ₄ (1530)	33 ¹ / ₁₆ (839)	84 ⁵ / ₈ (2149)
	36 (914)	(Prefix)ET-12-36-R*	21 ¹ / ₁₆ (535)	66 ⁹ / ₁₆ (1691)	33 ¹ / ₁₆ (839)	90 ¹⁵ / ₁₆ (2310)
18 (457)	24 (609)	(Prefix)ET-18-24-R*	24 ¹ / ₁₆ (611)	54 ¹³ / ₁₆ (1392)	36 ¹ / ₁₆ (916)	78 ³ / ₈ (1991)
	30 (762)	(Prefix)ET-18-30-R*	24 ¹ / ₁₆ (611)	60 ¹ / ₄ (1530)	36 ¹ / ₁₆ (916)	84 ⁵ / ₈ (2149)
	36 (914)	(Prefix)ET-18-36-R*	24 ¹ / ₁₆ (611)	66 ⁹ / ₁₆ (1691)	36 ¹ / ₁₆ (916)	90 ¹⁵ / ₁₆ (2310)
24 (609)	30 (762)	(Prefix)ET-24-30-R*	27 ¹ / ₁₆ (687)	60 ¹ / ₄ (1530)	39 ¹ / ₁₆ (992)	84 ⁵ / ₈ (2149)
	36 (914)	(Prefix)ET-24-36-R*	27 ¹ / ₁₆ (687)	66 ⁹ / ₁₆ (1691)	39 ¹ / ₁₆ (992)	90 ¹⁵ / ₁₆ (2310)
30 (762)	36 (914)	(Prefix)ET-30-36-R*	30 ¹ / ₁₆ (763)	66 ⁹ / ₁₆ (1691)	42 ¹ / ₁₆ (1068)	90 ¹⁵ / ₁₆ (2310)

(Prefix) See page F-21 for catalog number prefix.

Width dimensions are to inside wall.

Manufacturing tolerances apply to all dimensions.

All dimensions in parentheses are millimeters unless otherwise specified.

Horizontal Expanding/Reducing Cross (RX)

3 pair splice plates with hardware included.

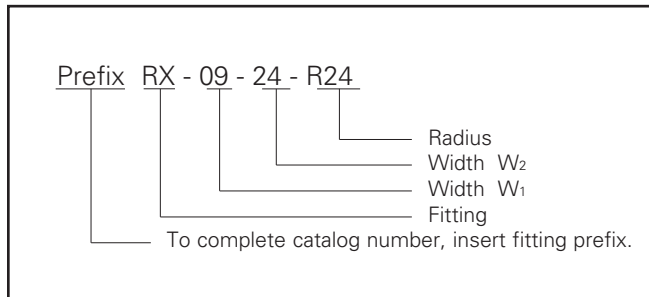
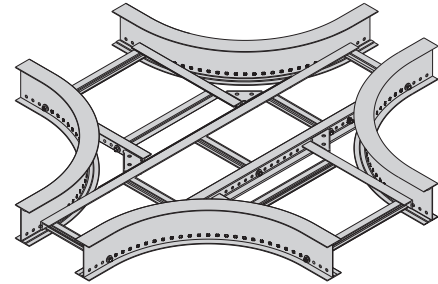
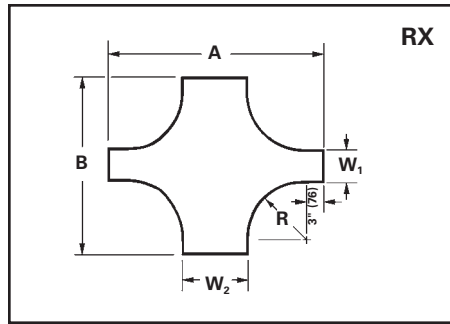

Tray Width		* Insert Radius (12 for 12", 24 for 24") Catalog No.	12" Radius		24" Radius	
W1 in. (mm)	W2 in. (mm)		A in. (mm)	B in. (mm)	A in. (mm)	B in. (mm)
6 (152)	9 (228)	(Prefix)RX-06-09-R*	36 ³ / ₄ (933)	39 ⁷ / ₈ (1013)	60 ¹ / ₁₆ (1525)	64 ¹ / ₄ (1632)
	12 (305)	(Prefix)RX-06-12-R*	36 ³ / ₄ (933)	42 ¹ / ₄ (1073)	60 ¹ / ₁₆ (1525)	66 ⁹ / ₁₆ (1691)
	18 (457)	(Prefix)RX-06-18-R*	36 ³ / ₄ (933)	48 ¹ / ₂ (1232)	60 ¹ / ₁₆ (1525)	72 ¹ / ₁₆ (1830)
	24 (609)	(Prefix)RX-06-24-R*	36 ³ / ₄ (933)	54 ¹³ / ₁₆ (1392)	60 ¹ / ₁₆ (1525)	78 ³ / ₈ (1991)
	30 (762)	(Prefix)RX-06-30-R*	36 ³ / ₄ (933)	60 ¹ / ₄ (1530)	60 ¹ / ₁₆ (1525)	84 ⁵ / ₈ (2149)
	36 (914)	(Prefix)RX-06-36-R*	36 ³ / ₄ (933)	66 ⁹ / ₁₆ (1691)	60 ¹ / ₁₆ (1525)	90 ¹⁵ / ₁₆ (2310)
9 (228)	12 (305)	(Prefix)RX-09-12-R*	39 ⁷ / ₈ (1013)	42 ¹ / ₄ (1073)	64 ¹ / ₄ (1632)	66 ⁹ / ₁₆ (1691)
	18 (457)	(Prefix)RX-09-18-R*	39 ⁷ / ₈ (1013)	48 ¹ / ₂ (1232)	64 ¹ / ₄ (1632)	72 ¹ / ₁₆ (1830)
	24 (609)	(Prefix)RX-09-24-R*	39 ⁷ / ₈ (1013)	54 ¹³ / ₁₆ (1392)	64 ¹ / ₄ (1632)	78 ³ / ₈ (1991)
	30 (762)	(Prefix)RX-09-30-R*	39 ⁷ / ₈ (1013)	60 ¹ / ₄ (1530)	64 ¹ / ₄ (1632)	84 ⁵ / ₈ (2149)
	36 (914)	(Prefix)RX-09-36-R*	39 ⁷ / ₈ (1013)	66 ⁹ / ₁₆ (1691)	64 ¹ / ₄ (1632)	90 ¹⁵ / ₁₆ (2310)
12 (305)	18 (457)	(Prefix)RX-12-18-R*	42 ¹ / ₄ (1073)	48 ¹ / ₂ (1232)	66 ⁹ / ₁₆ (1691)	72 ¹ / ₁₆ (1830)
	24 (609)	(Prefix)RX-12-24-R*	42 ¹ / ₄ (1073)	54 ¹³ / ₁₆ (1392)	66 ⁹ / ₁₆ (1691)	78 ³ / ₈ (1991)
	30 (762)	(Prefix)RX-12-30-R*	42 ¹ / ₄ (1073)	60 ¹ / ₄ (1530)	66 ⁹ / ₁₆ (1691)	84 ⁵ / ₈ (2149)
	36 (914)	(Prefix)RX-12-36-R*	42 ¹ / ₄ (1073)	66 ⁹ / ₁₆ (1691)	66 ⁹ / ₁₆ (1691)	90 ¹⁵ / ₁₆ (2310)
18 (457)	24 (609)	(Prefix)RX-18-24-R*	48 ¹ / ₂ (1232)	54 ¹³ / ₁₆ (1392)	72 ¹ / ₁₆ (1830)	78 ³ / ₈ (1991)
	30 (762)	(Prefix)RX-18-30-R*	48 ¹ / ₂ (1232)	60 ¹ / ₄ (1530)	72 ¹ / ₁₆ (1830)	84 ⁵ / ₈ (2149)
	36 (914)	(Prefix)RX-18-36-R*	48 ¹ / ₂ (1232)	66 ⁹ / ₁₆ (1691)	72 ¹ / ₁₆ (1830)	90 ¹⁵ / ₁₆ (2310)
24 (609)	30 (762)	(Prefix)RX-24-30-R*	54 ¹³ / ₁₆ (1392)	60 ¹ / ₄ (1530)	78 ³ / ₈ (1991)	84 ⁵ / ₈ (2149)
	36 (914)	(Prefix)RX-24-36-R*	54 ¹³ / ₁₆ (1392)	66 ⁹ / ₁₆ (1691)	78 ³ / ₈ (1991)	90 ¹⁵ / ₁₆ (2310)
30 (762)	36 (914)	(Prefix)RX-30-36-R*	60 ¹ / ₄ (1530)	66 ⁹ / ₁₆ (1691)	84 ⁵ / ₈ (2149)	90 ¹⁵ / ₁₆ (2310)

(Prefix) See page F-21 for catalog number prefix.

Width dimensions are to inside wall.

Manufacturing tolerances apply to all dimensions.

All dimensions in parentheses are millimeters unless otherwise specified.

Vertical Bend 90° (VO, VI)

1 pair splice plates with hardware included.

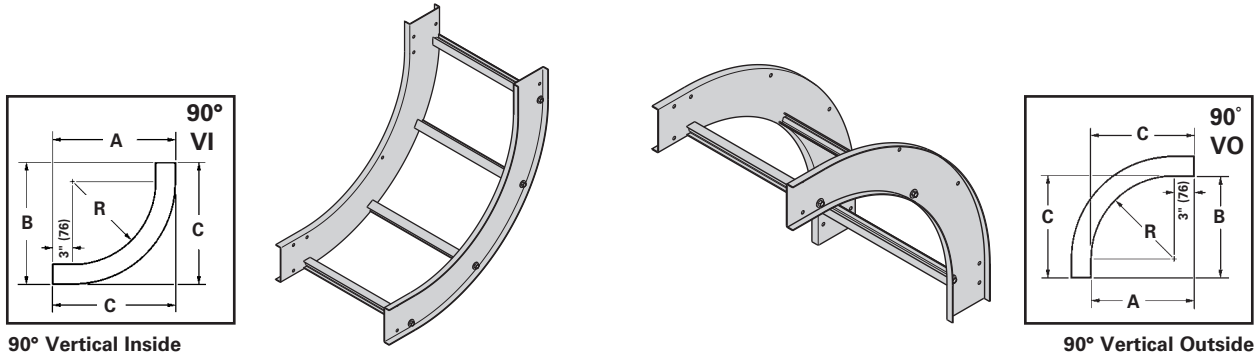

90° Vertical Inside

90° Vertical Outside

90° Vertical Inside (VI) Bend

Bend Radius R in. (mm)	Width in. (mm)	Catalog No.	Siderail Height											
			4"			5"			6"			7"		
			A	B	C	A	B	C	A	B	C	A	B	C
12 (305)	6 (152)	(Pre)VI-06-90R12												
	9 (228)	(Pre)VI-09-90R12												
	12 (305)	(Pre)VI-12-90R12	18 1/2"	18 1/2"	18 1/2"	19 1/2"	19 1/2"	19 1/2"	20 1/2"	20 1/2"	20 1/2"	21 1/2"	21 1/2"	21 1/2"
	18 (457)	(Pre)VI-18-90R12	(470)	(470)	(470)	(495)	(495)	(495)	(521)	(521)	(521)	(546)	(546)	(546)
	24 (609)	(Pre)VI-24-90R12												
	36 (914)	(Pre)VI-36-90R12												
24 (609)	6 (152)	(Pre)VI-06-90R24												
	9 (228)	(Pre)VI-09-90R24												
	12 (305)	(Pre)VI-12-90R24	30 1/2"	30 1/2"	30 1/2"	31 1/2"	31 1/2"	31 1/2"	32 1/2"	32 1/2"	32 1/2"	33 1/2"	33 1/2"	33 1/2"
	18 (457)	(Pre)VI-18-90R24	(851)	(851)	(851)	(800)	(800)	(800)	(825)	(825)	(825)	(851)	(851)	(851)
	24 (609)	(Pre)VI-24-90R24												
	30 (762)	(Pre)VI-30-90R24												
36 (914)	(Pre)VI-36-90R24													

90° Vertical Inside (VO) Bend

Bend Radius R in. (mm)	Width in. (mm)	Catalog No.	Siderail Height 4"-7"		
			A	B	C
12 (305)	6 (152)	(Pre)VO-06-90R12			
	9 (228)	(Pre)VO-09-90R12			
	12 (305)	(Pre)VO-12-90R12	15"	15"	15"
	18 (457)	(Pre)VO-18-90R12	(381)	(381)	(381)
	24 (609)	(Pre)VO-24-90R12			
	36 (914)	(Pre)VO-36-90R12			
24 (609)	6 (152)	(Pre)VO-06-90R24			
	9 (228)	(Pre)VO-09-90R24			
	12 (305)	(Pre)VO-12-90R24	27"	27"	27"
	18 (457)	(Pre)VO-18-90R24	(686)	(686)	(686)
	24 (609)	(Pre)VO-24-90R24			
	36 (914)	(Pre)VO-36-90R24			

(Pre) See page F-21 for catalog number prefix.
Manufacturing tolerances apply to all dimensions.

All dimensions in parentheses are millimeters unless otherwise specified.

Vertical Bend 60° (VO, VI)

1 pair splice plates with hardware included.

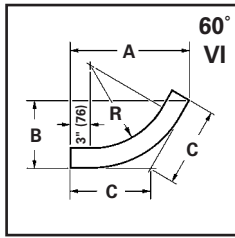

60° Vertical Inside

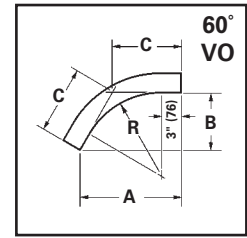
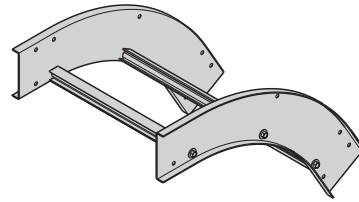
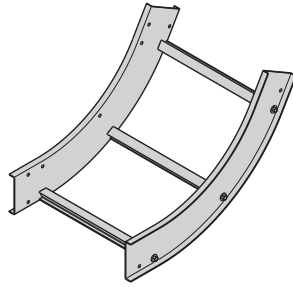

60° Vertical Outside

60° Vertical Inside (VI) Bend

Bend Radius R in. (mm)	Width in. (mm)	Catalog No.	Siderail Height											
			4"			5"			6"			7"		
			A	B	C	A	B	C	A	B	C	A	B	C
12 (305)	6 (152)	(Pre)VI-06-60R12												
	9 (228)	(Pre)VI-09-60R12												
	12 (305)	(Pre)VI-12-60R12	18"	10 ³ / ₈ "	12"	18 ¹³ / ₁₆ "	10 ⁷ / ₈ "	12 ⁹ / ₁₆ "	19 ¹¹ / ₁₆ "	11 ³ / ₈ "	13 ¹ / ₈ "	20 ⁹ / ₁₆ "	11 ⁷ / ₈ "	13 ¹¹ / ₁₆ "
	18 (457)	(Pre)VI-18-60R12	(457)	(263)	(305)	(478)	(276)	(319)	(500)	(289)	(333)	(522)	(301)	(347)
	24 (609)	(Pre)VI-24-60R12												
	30 (762)	(Pre)VI-30-60R12												
24 (609)	6 (152)	(Pre)VI-06-60R24												
	9 (228)	(Pre)VI-09-60R24												
	12 (305)	(Pre)VI-12-60R24	28 ³ / ₈ "	16 ³ / ₈ "	18 ¹⁵ / ₁₆ "	29 ¹ / ₄ "	16 ⁷ / ₈ "	19 ¹ / ₂ "	30 ¹ / ₁₆ "	17 ³ / ₈ "	20 ¹ / ₁₆ "	30 ¹⁵ / ₁₆ "	17 ⁷ / ₈ "	20 ⁵ / ₈ "
	18 (457)	(Pre)VI-18-60R24	(721)	(416)	(481)	(743)	(428)	(495)	(763)	(441)	(509)	(786)	(454)	(524)
	24 (609)	(Pre)VI-24-60R24												
	30 (762)	(Pre)VI-30-60R24												
	36 (914)	(Pre)VI-36-60R24												

60° Vertical Inside (VO) Bend

Bend Radius R in. (mm)	Width in. (mm)	Catalog No.	Siderail Height 4"-7"		
			A	B	C
12 (305)	6 (152)	(Pre)VO-06-60R12			
	9 (228)	(Pre)VO-09-60R12			
	12 (305)	(Pre)VO-12-60R12	14 ⁷ / ₈ "	8 ⁵ / ₈ "	9 ¹⁵ / ₁₆ "
	18 (457)	(Pre)VO-18-60R12	(378)	(219)	(252)
	24 (609)	(Pre)VO-24-60R12			
	30 (762)	(Pre)VO-30-60R12			
24 (609)	6 (152)	(Pre)VO-06-60R24			
	9 (228)	(Pre)VO-09-60R24			
	12 (305)	(Pre)VO-12-60R24	25 ⁵ / ₁₆ "	14 ⁵ / ₈ "	16 ⁷ / ₈ "
	18 (457)	(Pre)VO-18-60R24	(643)	(371)	(428)
	24 (609)	(Pre)VO-24-60R24			
	30 (762)	(Pre)VO-30-60R24			
	36 (914)	(Pre)VO-36-60R24			

(Pre) See page F-21 for catalog number prefix.
Manufacturing tolerances apply to all dimensions.

All dimensions in parentheses are millimeters unless otherwise specified.

Vertical Bend 45° (VO, VI)

1 pair splice plates with hardware included.

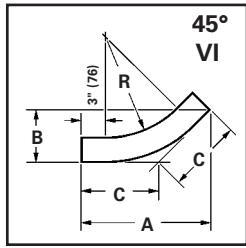

45° Vertical Inside

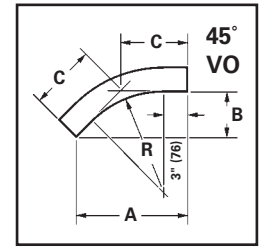
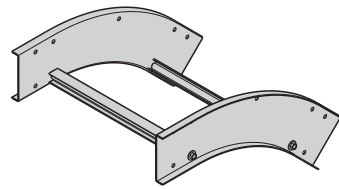
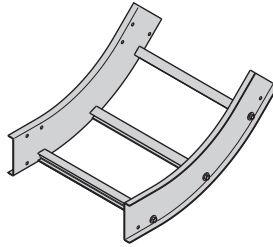

45° Vertical Outside

45° Vertical Inside (VI) Bend

Bend Radius R in. (mm)	Width in. (mm)	Catalog No.	Siderail Height											
			4"			5"			6"			7"		
			A	B	C	A	B	C	A	B	C	A	B	C
12 (305)	6 (152)	(Pre)VI-06-45R12												
	9 (228)	(Pre)VI-09-45R12												
	12 (305)	(Pre)VI-12-45R12	16 ¹ / ₈ "	6 ¹ / ₁₆ "	9 ⁷ / ₁₆ "	16 ⁷ / ₈ "	7"	9 ⁷ / ₈ "	17 ⁹ / ₁₆ "	7 ¹ / ₄ "	10 ¹ / ₄ "	18 ¹ / ₄ "	7 ⁹ / ₁₆ "	10 ¹¹ / ₁₆ "
	18 (457)	(Pre)VI-18-45R12	(409)	(170)	(239)	(428)	(178)	(251)	(446)	(184)	(260)	(463)	(192)	(271)
	24 (609)	(Pre)VI-24-45R12												
	36 (914)	(Pre)VI-36-45R12												
24 (609)	6 (152)	(Pre)VI-06-45R24												
	9 (228)	(Pre)VI-09-45R24												
	12 (305)	(Pre)VI-12-45R24	24 ⁵ / ₈ "	10 ³ / ₁₆ "	14 ⁷ / ₁₆ "	25 ⁵ / ₁₆ "	10 ¹ / ₂ "	14 ¹³ / ₁₆ "	26"	10 ³ / ₄ "	15 ¹ / ₄ "	26 ³ / ₄ "	11 ¹ / ₁₆ "	15 ⁵ / ₈ "
	18 (457)	(Pre)VI-18-45R24	(625)	(259)	(366)	(643)	(267)	(376)	(660)	(273)	(387)	(679)	(281)	(397)
	24 (609)	(Pre)VI-24-45R24												
	36 (914)	(Pre)VI-36-45R24												

45° Vertical Inside (VO) Bend

Bend Radius R in. (mm)	Width in. (mm)	Catalog No.	Siderail Height 4"-7"		
			A	B	C
12 (305)	6 (152)	(Pre)VO-06-45R12			
	9 (228)	(Pre)VO-09-45R12			
	12 (305)	(Pre)VO-12-45R12	13 ⁵ / ₈ "	5 ⁵ / ₈ "	8"
	18 (457)	(Pre)VO-18-45R12	(346)	(136)	(203)
	24 (609)	(Pre)VO-24-45R12			
	36 (914)	(Pre)VO-36-45R12			
24 (609)	6 (152)	(Pre)VO-06-45R24			
	9 (228)	(Pre)VO-09-45R24			
	12 (305)	(Pre)VO-12-45R24	22 ¹ / ₈ "	14 ³ / ₁₆ "	12 ¹⁵ / ₁₆ "
	18 (457)	(Pre)VO-18-45R24	(562)	(233)	(328)
	24 (609)	(Pre)VO-24-45R24			
	36 (914)	(Pre)VO-36-45R24			

(Pre) See page F-21 for catalog number prefix.
Manufacturing tolerances apply to all dimensions.

All dimensions in parentheses are millimeters unless otherwise specified.

Vertical Bend 30° (VO, VI)

1 pair splice plates with hardware included.

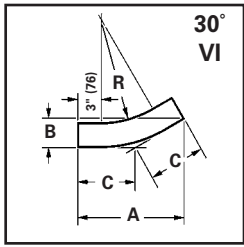

30° Vertical Inside

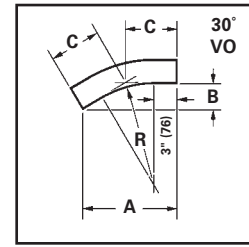
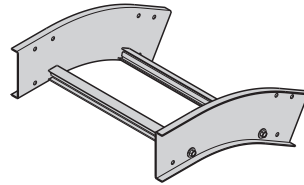
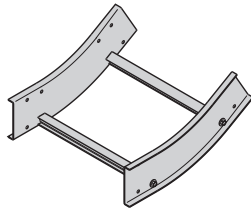

30° Vertical Outside

30° Vertical Inside (VI) Bend

Bend Radius R in. (mm)	Width in. (mm)	Catalog No.	Siderail Height											
			4"			5"			6"			7"		
			A	B	C	A	B	C	A	B	C	A	B	C
12 (305)	6 (152)	(Pre)VI-06-30R12												
	9 (228)	(Pre)VI-09-30R12												
	12 (305)	(Pre)VI-12-30R12	13 ⁷ / ₁₆ "	3 ⁵ / ₈ "	7 ³ / ₁₆ "	13 ¹⁵ / ₁₆ "	3 ³ / ₄ "	7 ⁷ / ₁₆ "	14 ⁷ / ₁₆ "	3 ⁷ / ₈ "	7 ³ / ₄ "	14 ⁷ / ₈ "	4"	8"
	18 (457)	(Pre)VI-18-30R12	(341)	(92)	(182)	(354)	(95)	(189)	(366)	(98)	(197)	(378)	(101)	(203)
	24 (609)	(Pre)VI-24-30R12												
	30 (762)	(Pre)VI-30-30R12												
24 (609)	6 (152)	(Pre)VI-06-30R24												
	9 (228)	(Pre)VI-09-30R24												
	12 (305)	(Pre)VI-12-30R24	19 ⁷ / ₁₆ "	5 ³ / ₁₆ "	10 ⁷ / ₁₆ "	19 ¹⁵ / ₁₆ "	5 ⁵ / ₁₆ "	10 ¹¹ / ₁₆ "	20 ⁷ / ₁₆ "	5 ⁷ / ₁₆ "	10 ¹⁵ / ₁₆ "	20 ⁷ / ₈ "	5 ⁵ / ₈ "	11 ³ / ₁₆ "
	18 (457)	(Pre)VI-18-30R24	(493)	(132)	(265)	(506)	(135)	(271)	(519)	(138)	(278)	(530)	(143)	(284)
	24 (609)	(Pre)VI-24-30R24												
	30 (762)	(Pre)VI-30-30R24												
36 (914)	(Pre)VI-36-30R24													

30° Vertical Inside (VO) Bend

Bend Radius R in. (mm)	Width in. (mm)	Catalog No.	Siderail Height 4"-7"		
			A	B	C
12 (305)	6 (152)	(Pre)VO-06-30R12			
	9 (228)	(Pre)VO-09-30R12			
	12 (305)	(Pre)VO-12-30R12	11 ⁵ / ₈ "	3 ¹ / ₈ "	6 ¹ / ₄ "
	18 (457)	(Pre)VO-18-30R12	(295)	(79)	(159)
	24 (609)	(Pre)VO-24-30R12			
	30 (762)	(Pre)VO-30-30R12			
24 (609)	6 (152)	(Pre)VO-06-30R24			
	9 (228)	(Pre)VO-09-30R24			
	12 (305)	(Pre)VO-12-30R24	17 ⁵ / ₈ "	4 ³ / ₄ "	9 ⁷ / ₁₆ "
	18 (457)	(Pre)VO-18-30R24	(447)	(120)	(239)
	24 (609)	(Pre)VO-24-30R24			
	30 (762)	(Pre)VO-30-30R24			
36 (914)	(Pre)VO-36-30R24				

(Pre) See page F-21 for catalog number prefix.
Manufacturing tolerances apply to all dimensions.

All dimensions in parentheses are millimeters unless otherwise specified.

Vertical Tee Up/Down (VTU/VTD)

2 pair splice plates with hardware included.

REDI-RAIL

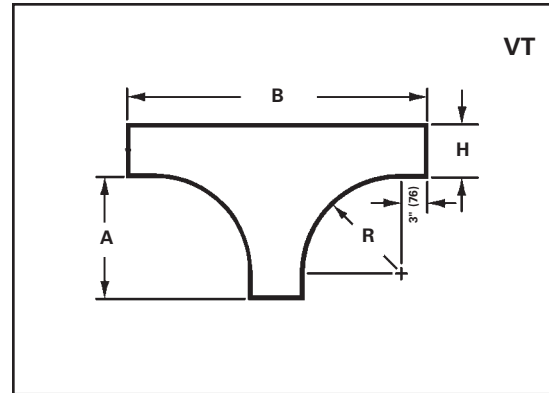
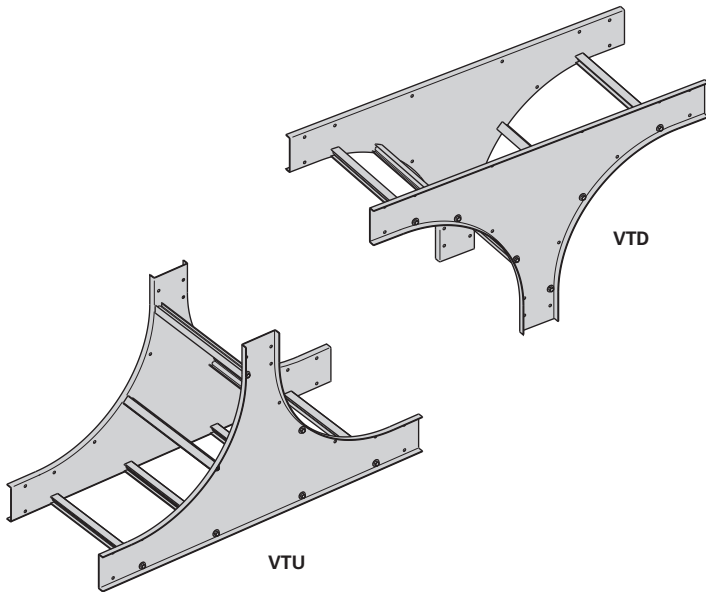

Bend Radius R in. (mm)	Tray Width in. (mm)	(*) Insert U for Tee Up Insert D for Tee Down Catalog No.	Side Rail Height "H"				
			4" - 7"	4"	5"	6"	7"
			A in. (mm)	B in. (mm)	B in. (mm)	B in. (mm)	B in. (mm)
12" (305)	6 (152)	(Prefix)VT(*)-06-R12	15 (381)	33 ⁷ / ₁₆ (849)	34 ³ / ₈ (874)	35 ³ / ₈ (899)	36 ³ / ₈ (924)
	9 (228)	(Prefix)VT(*)-09-R12					
	12 (305)	(Prefix)VT(*)-12-R12					
	18 (457)	(Prefix)VT(*)-18-R12					
	24 (609)	(Prefix)VT(*)-24-R12					
	30 (762)	(Prefix)VT(*)-30-R12					
	36 (914)	(Prefix)VT(*)-36-R12					
24" (609)	6 (152)	(Prefix)VT(*)-06-R24	27 (686)	57 ⁷ / ₁₆ (1458)	58 ³ / ₈ (1483)	59 ³ / ₈ (1508)	60 ³ / ₈ (1533)
	9 (228)	(Prefix)VT(*)-09-R24					
	12 (305)	(Prefix)VT(*)-12-R24					
	18 (457)	(Prefix)VT(*)-18-R24					
	24 (609)	(Prefix)VT(*)-24-R24					
	30 (762)	(Prefix)VT(*)-30-R24					
	36 (914)	(Prefix)VT(*)-36-R24					

(Prefix) See page F-21 for catalog number prefix.
Manufacturing tolerances apply to all dimensions.

All dimensions in parentheses are millimeters unless otherwise specified.

Lined area for notes with horizontal ruling lines.



KwikSplice™ Aluminum Cable Tray - Straight Sections & Accessories



Straight Sections - see pages G-3 – G-6
Covers - see page G-13

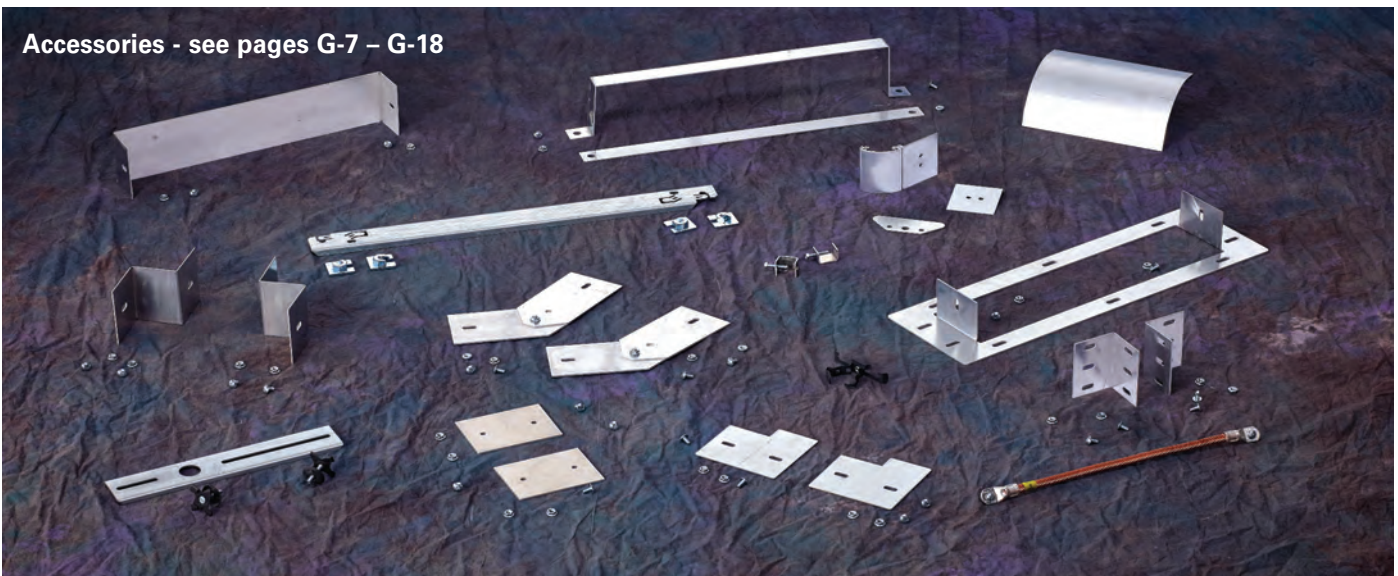

Accessories - see pages G-7 – G-18

Fittings - see pages 21-33



KwikSplice Cable Tray

How The Service Advisor Works

We know that your time is important! That's why the color-coding system in this catalog is designed to help you select products that fit your service needs. Products are marked to indicate the typical lead time for orders of 50 pieces or less.

Customer: How do I select my straight sections, covers, or fittings so that I get the quickest turnaround?

Service Advisor: Each part of our selection chart is shown in colors. If any section of a part number is a different color, the part will typically ship with the longer lead time represented by the colors.

- Green = Fastest shipped items
- Black = Normal lead-time items
- Red = Normally long lead-time items

Example: **KSA** **4** **A** **SB** - **12** - **144**
 ● ● ● ● ● ●

Part will have a normal lead time because of the solid bottom.

KSA4A and KSA5A Straight Sections

Straight Section Part Numbering

Prefix

Example: **KS A 4 A 09 - 12 - 144**

Series	NEMA Class	Height	Material	Type	Width	Length
KS	A = 50 Lbs/Ft NEMA 12A (12 ft. span)	4 = 4" 5 = 5"	A = Aluminum	Ladder- 06 = 6" rung spacing 09 = 9" rung spacing 12 = 12" rung spacing Trough- 04 = 4" rung spacing SB = Solid Bottom	06 = 6" 09 = 9" 12 = 12" 18 = 18" 24 = 24" 30 = 30" 36 = 36"	①144 = 12 ft. ②120 = 10 ft. ①Primary ②Secondary

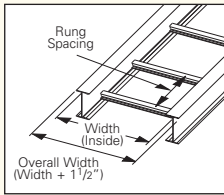

Values are based on simple beam tests per VE-1 on 36" wide cable tray with rungs spaced on 12" centers. The published load safety factor is 1.5. To convert 1.5 safety factor to 2.0, multiply the published load by 0.75. To obtain mid-span deflection, multiply a load by the deflection multiplier. Cable tray must be supported on spans shorter than or equal to the length of the tray.

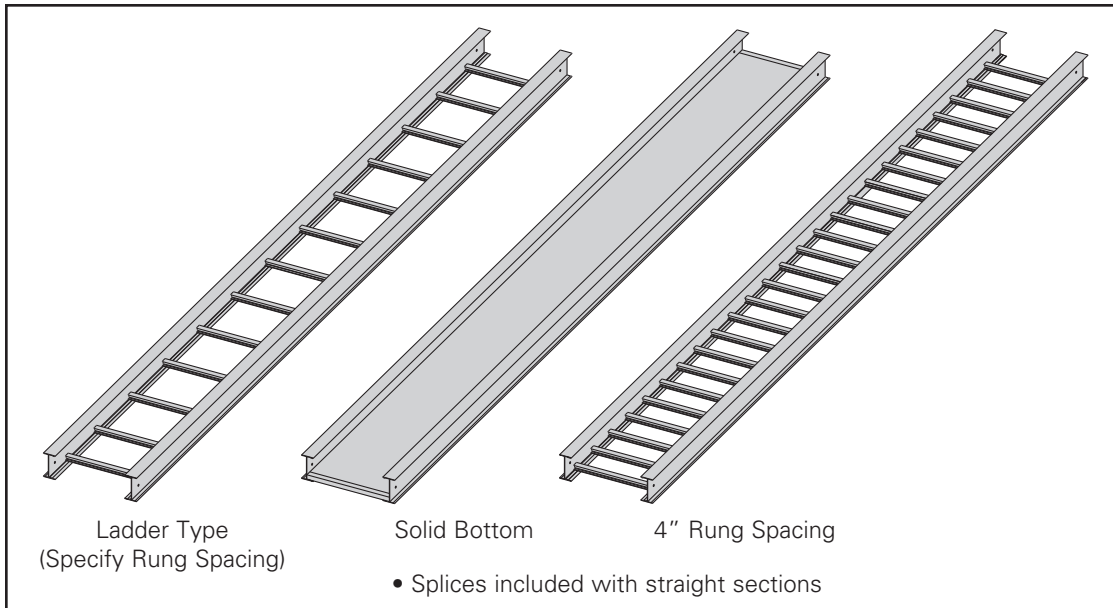

All dimensions in parentheses are millimeters unless otherwise specified.

KSA4A and KSA5A Straight Section Technical Data

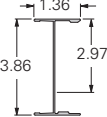
B-Line Series Side Rail Dimensions	NEMA, CSA & UL Classifications	Span ft	Load lbs/ft	Deflection Multiplier	Design Factors for Two Rails	Span meters	Load kg/m	Deflection Multiplier	Design Factors for Two Rails
KSA4A 	NEMA: 12A	6	221	0.0016	Area = 0.80 in ² Sx = 0.90 in ³ Ix = 1.79 in ⁴	1.8	328	0.028	Area = 5.16 cm ² Sx = 14.75 cm ³ Ix = 74.51 cm ⁴
	CSA: C-3m	8	124	0.0051		2.4	185	0.088	
	UL Cross-Sectional	10	79	0.0126		3.0	125	0.215	
	Area: 0.60 in ²	12	55	0.0261		3.7	82	0.445	

B-Line Series Side Rail Dimensions	NEMA, CSA & UL Classifications	Span ft	Load lbs/ft	Deflection Multiplier	Design Factors for Two Rails	Span meters	Load kg/m	Deflection Multiplier	Design Factors for Two Rails
KSA5A 	NEMA: 12A	6	219	0.0009	Area = 0.92 in ² Sx = 1.24 in ³ Ix = 3.08 in ⁴	1.8	326	0.016	Area = 5.94 cm ² Sx = 20.32 cm ³ Ix = 128.20 cm ⁴
	CSA: C-3m	8	123	0.0030		2.4	183	0.051	
	UL Cross-Sectional	10	79	0.0073		3.0	120	0.125	
	Area: 0.60 in ²	12	55	0.0151		3.7	81	0.259	

When cable trays are used in continuous spans, the deflection of the cable tray is reduced by as much as 50%.
 Design factors: Ix = Moment of Inertia, Sx = Section Modulus.

KSB4A, KSB5A, and KSB6A Straight Sections

Straight Section Part Numbering

Example: **KS B 4 A 09 - 12 - 144**

Prefix

Series	NEMA Class	Height	Material	Type	Width	Length
KS	B = 75 Lbs/Ft NEMA 12B (12 ft. span)	4 = 4" 5 = 5" 6 = 6"	A = Aluminum	Ladder- 06 = 6" rung spacing 09 = 9" rung spacing 12 = 12" rung spacing Trough- 04 = 4" rung spacing SB = Solid Bottom	06 = 6" 09 = 9" 12 = 12" 18 = 18" 24 = 24" 30 = 30" 36 = 36"	①144 = 12 ft. ②120 = 10 ft. ①Primary ②Secondary

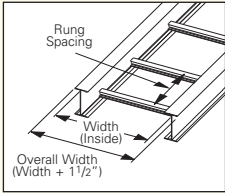

Values are based on simple beam tests per VE-1 on 36" wide cable tray with rungs spaced on 12" centers. The published load safety factor is 1.5. To convert 1.5 safety factor to 2.0, multiply the published load by 0.75. To obtain mid-span deflection, multiply a load by the deflection multiplier. Cable tray must be supported on spans shorter than or equal to the length of the tray.

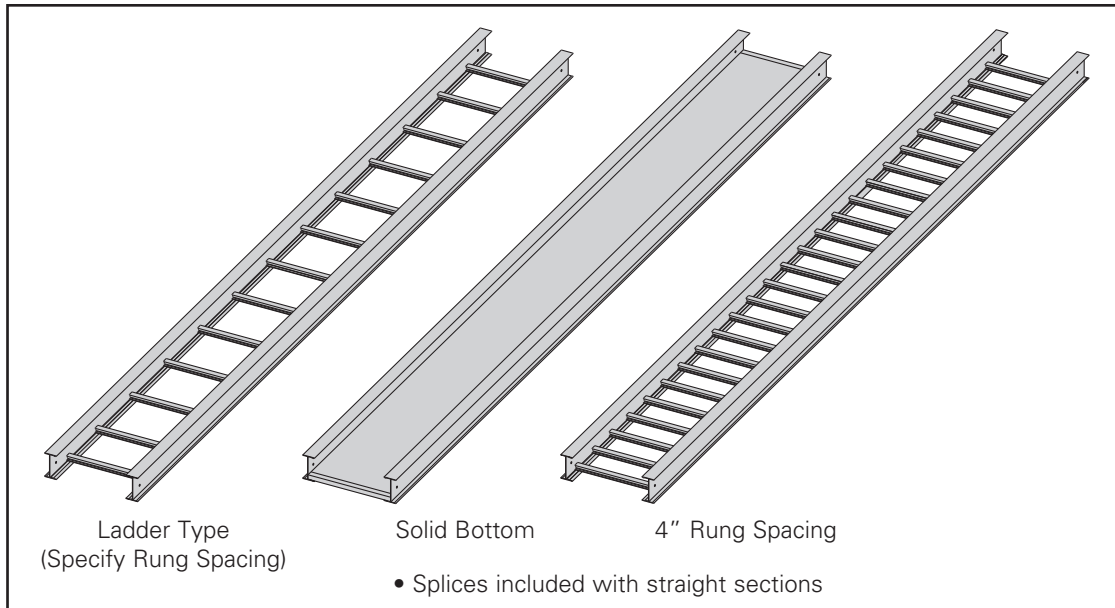

All dimensions in parentheses are millimeters unless otherwise specified.

KSB4A, KSB5A and KSB6A Straight Section Technical Data

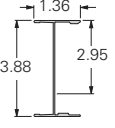
B-Line Series Side Rail Dimensions	NEMA, CSA & UL Classifications	Span ft	Load lbs/ft	Deflection Multiplier	Design Factors for Two Rails	Span meters	Load kg/m	Deflection Multiplier	Design Factors for Two Rails
KSB4A 	NEMA: 12B CSA: D-3m UL Cross-Sectional Area: 0.60 in ²	8	198	0.0040	Area = 0.99 in ² Sx = 1.07 in ³ Ix = 2.32 in ⁴	2.4	295	0.068	Area = 6.39 cm ² Sx = 17.53 cm ³ Ix = 96.57 cm ⁴
		10	127	0.0097		3.0	195	0.166	
		12	88	0.0201		3.7	131	0.343	

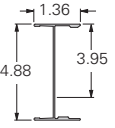
B-Line Series Side Rail Dimensions	NEMA, CSA & UL Classifications	Span ft	Load lbs/ft	Deflection Multiplier	Design Factors for Two Rails	Span meters	Load kg/m	Deflection Multiplier	Design Factors for Two Rails
KSB5A 	NEMA: 12B CSA: D-3m UL Cross-Sectional Area: 0.60 in ²	8	188	0.0023	Area = 1.12 in ² Sx = 1.47 in ³ Ix = 3.96 in ⁴	2.4	279	0.040	Area = 7.23 cm ² Sx = 24.09 cm ³ Ix = 164.83 cm ⁴
		10	120	0.0057		3.0	180	0.097	
		12	83	0.0228		3.7	124	0.201	

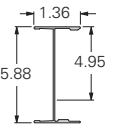
B-Line Series Side Rail Dimensions	NEMA, CSA & UL Classifications	Span ft	Load lbs/ft	Deflection Multiplier	Design Factors for Two Rails	Span meters	Load kg/m	Deflection Multiplier	Design Factors for Two Rails
KSB6A 	NEMA: 12B CSA: D-3m UL Cross-Sectional Area: 1.00 in ²	8	170	0.0015	Area = 1.25 in ² Sx = 1.91 in ³ Ix = 6.16 in ⁴	2.4	266	0.026	Area = 8.06 cm ² Sx = 31.30 cm ³ Ix = 256.40 cm ⁴
		10	114	0.0037		3.0	179	0.062	
		12	79	0.0076		3.7	118	0.129	

When cable trays are used in continuous spans, the deflection of the cable tray is reduced by as much as 50%.
 Design factors: Ix = Moment of Inertia, Sx = Section Modulus.

All dimensions in parentheses are millimeters unless otherwise specified.

KwikSplice™ Aluminum Cable Tray - Accessories

Standard Splice Plates

- Furnished in pairs with 1/4" hardware.
- UL Classified.
- One pair including hardware provided with each straight section. (Expansion splice quantity subtracted)

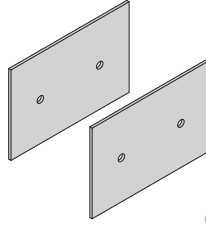

Tray Series	Catalog No.
KS_4A	KS4A-SSP
KS_5A	KS5A-SSP
KS_6A	KS6A-SSP

— Can be used with both NEMA Class A and B KwikSplice trays.

Expansion Splice Plates

- Furnished in pairs with 1/4" hardware.
- Bonding jumpers required on each side rail.

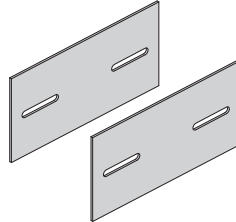

Tray Series	Catalog No.
KS_4A	KS4A-ESP
KS_5A	KS5A-ESP
KS_6A	KS6A-ESP

Step Down Splice Plates

- Furnished in pairs with 1/4" hardware.
- UL Classified.

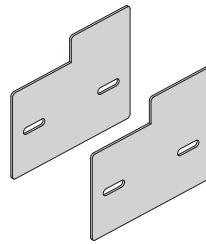

Tray Series	Catalog No.
KS_4A	KS4A-DSP
KS_5A	KS5A-DSP
KS_6A	KS6A-DSP

Vertical Adjustable Splice Plates

- Furnished in pairs with 1/4" hardware.
- UL Classified.
- Bonding jumpers not required.

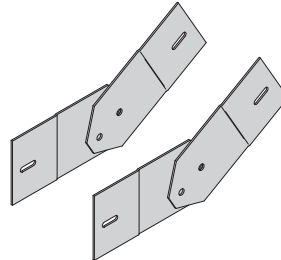

Requires supports within 24" on both sides, per NEMA VE 2.

Tray Series	Catalog No.
KS_4A	KS4A-VSP
KS_5A	KS5A-VSP
KS_6A	KS6A-VSP

Horizontal Adjustable Splice Plates

- Furnished in pairs with 1/4" hardware.
- Horizontally adjustable to 90°.
- Vertically adjustable to 15°.
- UL Classified.
- For optional rung, see page KSA-17.

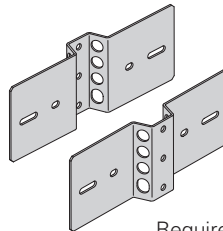

Requires supports within 24" on both sides, per NEMA VE 2.

Tray Series	Catalog No.
KS_4A	KS4A-FSP
KS_5A	KS5A-FSP
KS_6A	KS6A-FSP

Tray To Box Splice Plates

- Furnished in pairs with 1/4" hardware.
- UL Classified.

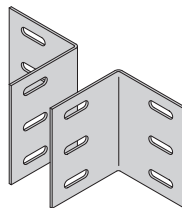

Tray Series	Catalog No.
KS_4A	KS4A-TTB
KS_5A	KS5A-TTB
KS_6A	KS6A-TTB

All dimensions in parentheses are millimeters unless otherwise specified.

KwikSplice™ Aluminum Cable Tray - Accessories

Offset Reducing Splice Plates

- Furnished in pairs with 1/4" hardware.
- UL Classified.

Specify the following:

† C = center reducer
S = side reducer

r (tray reduction) 3", 6", 9", 12",
15", 18", 21", 24", 27", or 30"

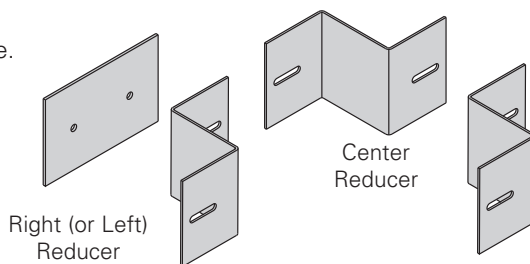

Tray Series	Catalog No.
KS_4A	KS4A-RSP-tr
KS_5A	KS5A-RSP-tr
KS_6A	KS6A-RSP-tr

— Can be used with both NEMA Class A and B KwikSplice trays.

Bonding Jumper

- Furnished in pairs with 1/4" hardware.
- UL Classified.
- Length: 14 1/2" (368mm)

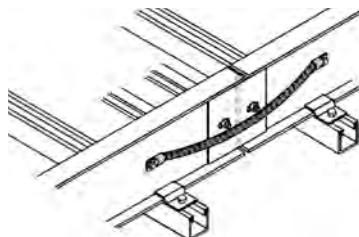

Ampacity	Catalog No.
1200	99-30

Grounding Clamp

- Accepts #6 AWG to 250 MCM.
- UL Classified as to its suitability as an equipment grounding conductor.

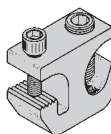

Material	Catalog No.
Tin Plated Aluminum	9A-2130

Conduit to Tray Adaptors

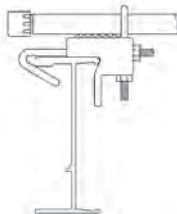
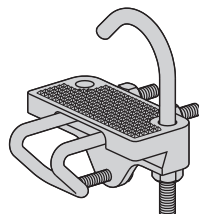

Conduit Size in. (mm)	Catalog No.
1/2, 3/4 (15, 20)	9G-1158-1/2, 3/4
1, 1 1/4 (25, 32)	9G-1158-1, 1 1/4
1 1/2, 2 (40, 50)	9G-1158-1 1/2, 2
2 1/2, 3 (65, 80)	9G-1158-2 1/2, 3
3 1/2, 4 (90, 100)	9G-1158-3 1/2, 4

Guide-Rite™ Conduit to Tray Adaptor

- Assemblies support 1/2", 3/4", & 1" conduit.
- Attaches to top or bottom of I-Beam side rail flange.

Patent #4958792

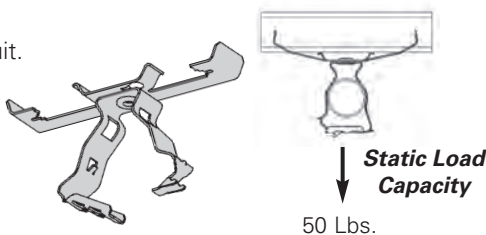

Conduit Size in. (mm)	Catalog No.
1/2, 3/4 (15, 20)	BG-8-12-W2
1, 1 1/4 (25, 32)	BG-16-W2

Vertical Conduit Hanger Adapter

- Furnished as one plate with fastener attachments.
- Utilizes (2) BAX-4-16 Under Rung Fastener Attachments.
- Accepts 1/2" to 4" conduit.

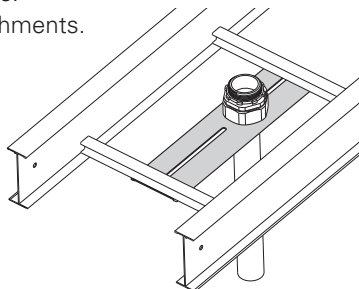
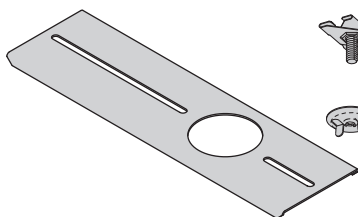

Conduit Size in. (mm)	Catalog No.
1/2 (15)	KSA-VCH-1/2
3/4 (20)	KSA-VCH-3/4
1 (25)	KSA-VCH-1
1 1/4 (32)	KSA-VCH-1 1/4
1 1/2 (40)	KSA-VCH-1 1/2
2 (50)	KSA-VCH-2
3 (75)	KSA-VCH-3
4 (100)	KSA-VCH-4

All dimensions in parentheses are millimeters unless otherwise specified.

KwikSplice™ Aluminum Cable Tray - Accessories

Drop-Out

- Snaps on to cable tray side rail.
- Provides 4" (101mm) radius.
- Holes provided to secure cables.

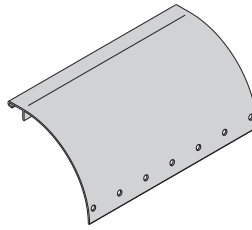

Catalog No.
KSA-OUT-†

† = Insert tray width

Side Rail Drop-Out

- Snaps on to cable tray side rail.
- Provides 4" (101mm) radius.
- Holes provided to secure cables.

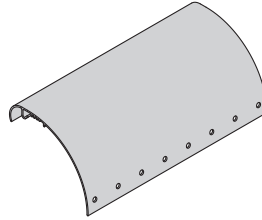
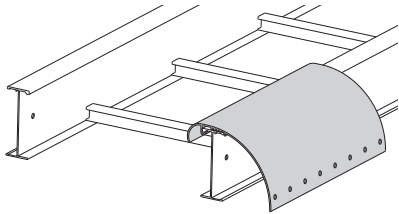

Catalog No.	Length	
	in.	(mm)
KSA-SDO-06	6	(152)
KSA-SDO-12	12	(305)
KSA-SDO-18	18	(457)

Clamp/Guide

- Features a no-twist design.
- Each side is labeled to ensure proper installation.
- Designed for 1/4" hardware.
- Furnished in pairs with or without hardware.

Patent No.
RE35479

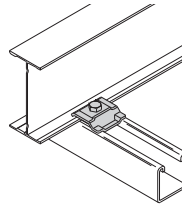
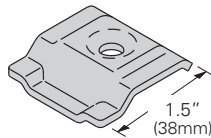

Catalog No.

9ZN-1204 (without hardware)
9ZN-1204NB (with hardware)

Frame Type Box Connector

- Furnished with 1/4" hardware for tray connection.

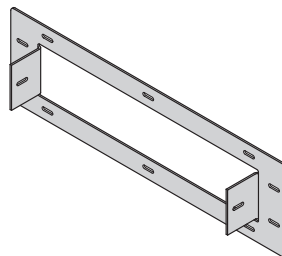

Tray Series	Catalog No.
KS_4A	KS4A-FTB-†
KS_5A	KS5A-FTB-†
KS_6A	KS6A-FTB-†

† = Insert tray width

Blind End

- Furnished as one plate with 1/4" hardware.

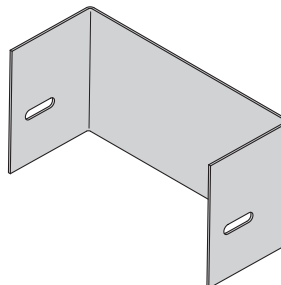

Tray Series	Catalog No.
KS_4A	KS4A-END-†
KS_5A	KS5A-END-†
KS_6A	KS6A-END-†

† = Insert tray width

— Can be used with both NEMA Class A and B Kwik Splice trays.

All dimensions in parentheses are millimeters unless otherwise specified.

KwikSplice™ Aluminum Cable Tray - Accessories

Tab & Lock Trapeze Support

- Hardware purchased separately.
- Accepts up to 3/8" rod.
- Accepts traditional hold down clamps (9ZN-1204) if necessary.
- Ability to adjust tabs with flat head screw driver (not included).
- Tabs clamp cable tray to trapeze support.
- Load capacity: Rated for maximum load of KwikSplice cable tray system.
- Corrosion resistant pre-galvanized zinc finish.
- Other finishes available upon request.

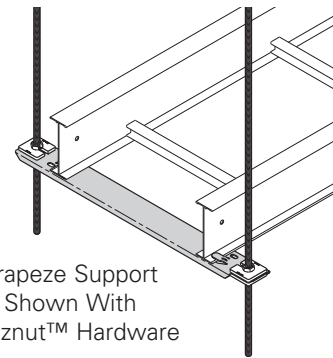

Trapeze Support Only

Hardware	Qty.	Catalog No
Standard	(4)	B201
	(4)	3/8" HN
or		
Buzznut	(4)	SLWN3/8

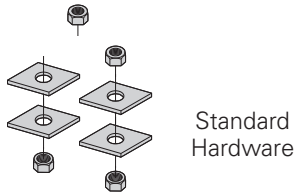

Catalog No.	Tray Width in. (mm)
KSA-6CT	6 (152)
KSA-9CT	9 (229)
KSA-12CT	12 (305)
KSA-18CT	18 (457)
KSA-24CT	24 (610)
KSA-30CT	30 (762)
KSA-36CT	36 (914)

Trapeze Support Kit

Our trapeze kits provide the components required for a single trapeze support in one package. These kits are available in pre-galvanized steel with zinc-plated hardware or hot dip galvanized steel with 316 stainless steel hardware.

The SH channel provides the convenience of pre-punched slots, which eliminate the need for field drilling.

The illustrated hardware is sealed in a plastic bag and boxed with the channel, which is pre-cut to the appropriate length as shown in the chart.

Designed for use with 1/2" threaded rod. Order rod separately.

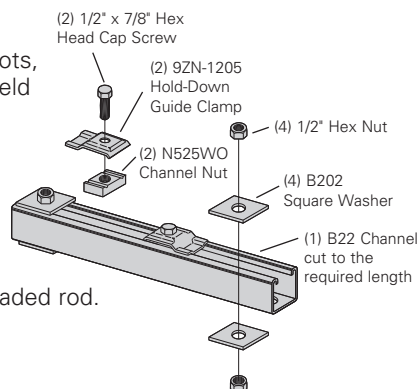
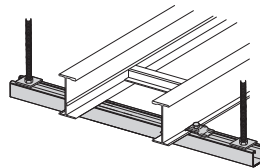

Catalog No.	Tray Width in. (mm)	Channel Length in. (mm)	Uniform Load lbs (kN)
9(*)-5506-22SH(†)	6 (152)	16 (406)	1600 (7.11)
9(*)-5509-22SH(†)	9 (229)	18 (457)	1250 (5.56)
9(*)-5512-22SH(†)	12 (305)	22 (559)	1125 (5.00)
9(*)-5518-22SH(†)	18 (457)	28 (711)	865 (3.85)
9(*)-5524-22SH(†)	24 (610)	34 (864)	700 (3.11)
9(*)-5530-22SH(†)	30 (762)	40 (1016)	590 (2.62)
9(*)-5536-22SH(†)	36 (914)	46 (1168)	510 (2.27)

- (*) Insert **P** or **G**
- (†) Insert 3/8 for 3/8" threaded rod hardware. Safety factor of 3.0 on all loads.

Trapeze Hardware Kit

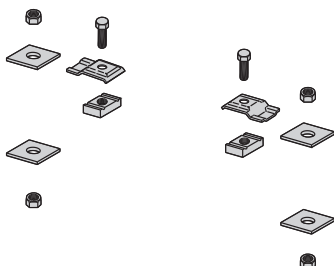

Catalog No.	9ZN-5500-1/2	9G-5500-1/2
In plastic bag	(1) pr. 9ZN-1205 (2) HHC Screw 1/2 x 7/8 ZN (2) N525 WO ZN (4) B202 ZN 1/2" sq washer (4) HN 1/2 ZN	(1) pr. 9G-1205 (2) HHC Screw 1/2 x 7/8 SS6 (2) N525 WO SS6 (4) B202 HDG 1/2" sq washer (4) HN 1/2 SS6

All dimensions in parentheses are millimeters unless otherwise specified.

KwikSplice™ Aluminum Cable Tray - Accessories

Bracket (12" - 42")

- Finishes available: ZN, GRN, or HDG
- Safety Load Factor 2.5

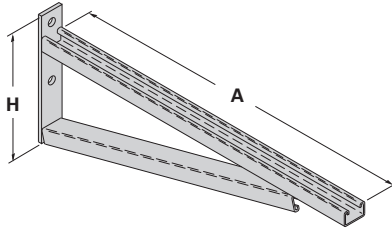

Bottom brace is B42 channel on B494-24 and smaller and B22 channel on B494-30 and larger

Catalog No.	Uniform Load		Tray Width		'A'		'H'	
	lbs	(kN)	in.	(mm)	in.	(mm)	in.	(mm)
B494-12	2500	(11.12)	6 & 9	(152 & 229)	12	(305)	8 ³ / ₄	(222)
B494-18	1700	(7.56)	12	(305)	18	(457)	8 ³ / ₄	(222)
B494-24	1300	(5.78)	18	(457)	24	(610)	8 ³ / ₄	(222)
B494-30	1600	(7.11)	24	(610)	30	(762)	11 ¹ / ₄	(286)
B494-36	1100	(4.89)	30	(762)	36	(914)	11 ¹ / ₄	(286)
B494-42	980	(4.36)	36	(914)	42	(1067)	16	(406)

For more dimensional data see Strut Systems catalog

Cantilever Bracket (12"-24")

- Finishes available: ZN, GRN, HDG, SS4 or SS6
- Safety Load Factor 2.5

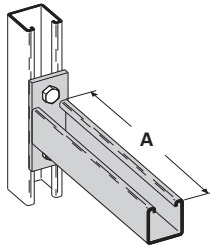

Catalog No.	Uniform Load		Tray Width		'A'	
	lbs	(kN)	in.	(mm)	in.	(mm)
B409-12	960	(4.27)	6 & 9	(152 & 229)	12	(305)
B409-18	640	(2.84)	12	(305)	18	(457)
B409-24	480	(2.13)	18	(457)	24	(610)

For more dimensional data see Strut Systems catalog

Cantilever Bracket (12"-42")

- Finishes available: ZN, GRN, HDG, or SS4
- Safety Load Factor 2.5

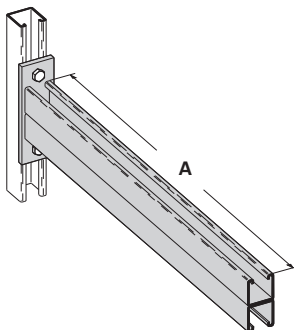

Catalog No.	Uniform Load		Tray Width		'A'	
	lbs	(kN)	in.	(mm)	in.	(mm)
B297-12	1660	(7.38)	6 & 9	(152 & 229)	12	(305)
B297-18	1100	(4.89)	12	(305)	18	(457)
B297-24	835	(3.71)	18	(457)	24	(610)
B297-30	665	(2.95)	24	(610)	30	(762)
B297-36	550	(2.44)	30	(762)	36	(914)
B297-42	465	(2.06)	36	(914)	42	(1067)

For more dimensional data see Strut Systems catalog

All dimensions in parentheses are millimeters unless otherwise specified.

KwikSplice™ Aluminum Cable Tray - Accessories

Underfloor Support (U-Bolts not included)

- Finishes available: ZN
- Safety Load Factor 2.5

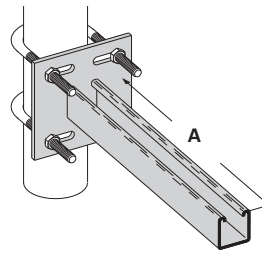

U-Bolt Size	Fits Pipe O.D.	
	in.	(mm)
B501-3/4	.841 - 1.050	(21 - 26)
B501-1	1.051 - 1.315	(27 - 33)
B501-1 1/4	1.316 - 1.660	(33 - 42)
B501-1 1/2	1.661 - 1.900	(42 - 48)
B501-2	1.901 - 2.375	(48 - 60)
B501-2 1/2	2.376 - 2.875	(60 - 73)

- Order 2 properly sized U-Bolts (sold separately) for each underfloor support.

Catalog No.	Uniform Load		Tray Width		'A'	
	lbs	(kN)	in.	(mm)	in.	(mm)
B409UF-12	800	(3.55)	6 & 9	(152 & 229)	12	(305)
B409UF-21	450	(2.00)	12 & 18	(305 & 457)	21	(533)

Heavy Duty Hold Down Bracket

- Design load is 2000 lbs/pair.
- Two bolt design.
- Sold in pairs.
- 3/8" cable tray attachment hardware provided.
- 1/2" support attachment hardware **not** provided.
- (*) Insert ZN, SS4, or SS6

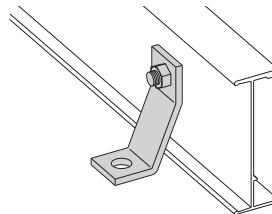

Catalog No.

9(*)-1241

Under Rung Fastener Attachment

- Supports electrical fixtures from bottom of rung or siderails.
- Wing nut included.
- Various 1/4"-20 stud lengths available.
- Static Load Capacity: 75 Lbs. (34kg).

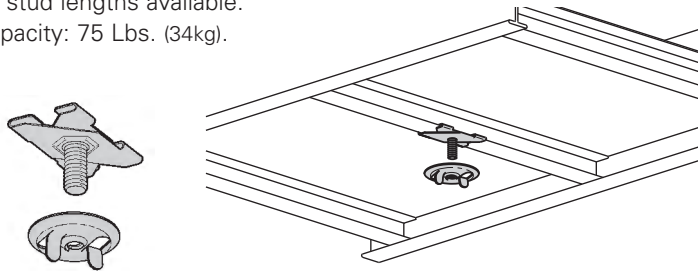

Catalog No.	Stud Length
	in. (mm)
BAX-4-16	5/8 (16)
BAX-4-16-24	1 1/2 (38)
BAX-4-16-32	2 (51)
BAX-4-16-48	3 (76)

DURA-BLOK™ Support Bases with B22 Channel

- Designed as a superior rooftop support for cable tray, UV resistant and approved for most roofing material or other flat surfaces.
- Can be used with any of our cable tray clamps and guides.
- Ultimate Uniform Load Capacity: 1,000 lbs. (4.45kN)



Catalog No.	Height x Width x Length	
	in.	(mm)
DB10-28	5 5/8 x 6 x 28	(143 x 152 x 711)
DB10-36	5 5/8 x 6 x 36	(143 x 152 x 914)
DB10-42	5 5/8 x 6 x 42	(143 x 152 x 1067)
DB10-50	5 5/8 x 6 x 50	(143 x 152 x 1270)
DB10-60	5 5/8 x 6 x 60	(143 x 152 x 1524)

General Note: Consult roofing manufacturer or engineer for roof load capacity. The weakest point may be the insulation board beneath the rubber membrane.



LEEDS credit available, base made from 100% recycled material.

All dimensions in parentheses are millimeters unless otherwise specified.

KwikSplice™ Aluminum Cable Tray - Accessories

Covers for KSA4A, KSA5A, KSB4A, KSB5A, and KSB6A

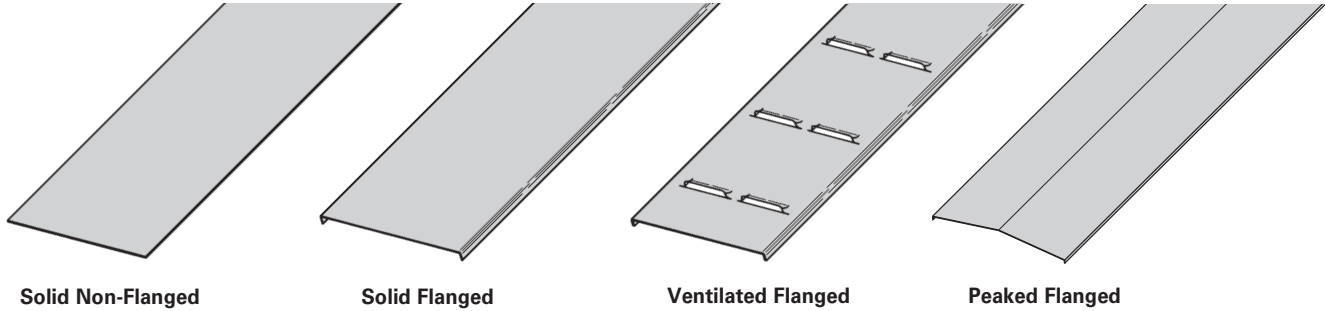

A full range of covers are available for straight sections and fittings.

Solid covers should be used when maximum enclosure of the cable is desired and no accumulation of heat is expected.

Ventilated covers provide cable protection, while allowing heat to escape.

Flanged covers have a 1/2 in. (13 mm) flange. Cover clamps are not included with the cover and must be ordered separately.

We recommend that covers be placed on vertical cable tray runs to a height of 6 ft. (1.83 m) to 8 ft. (2.44 m) above the floor to isolate both cables and protect personnel.

Aluminum Cover Part Numbering

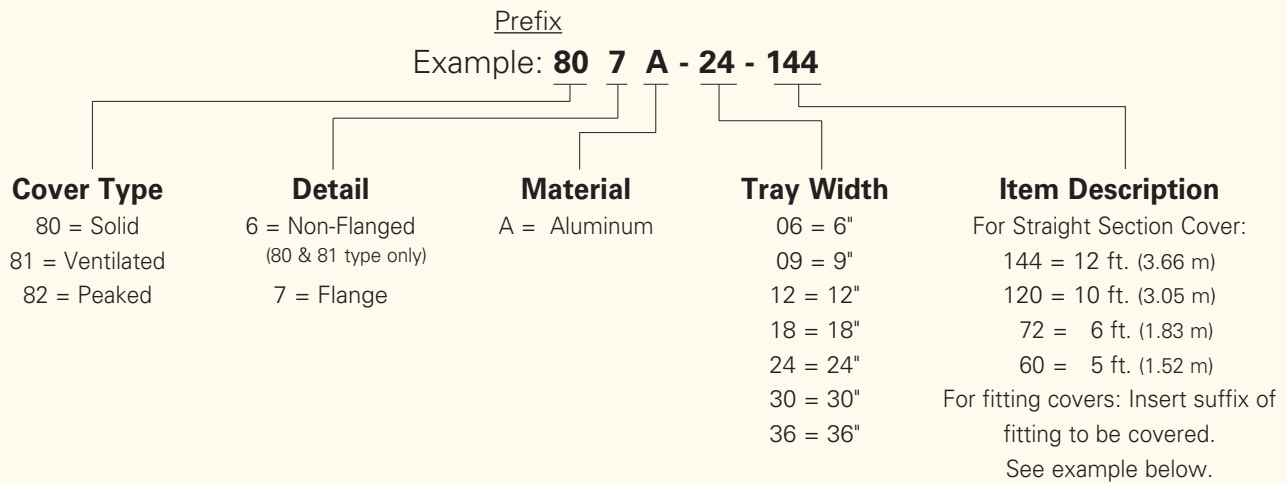

Examples of Catalog Numbers for Fitting Covers:

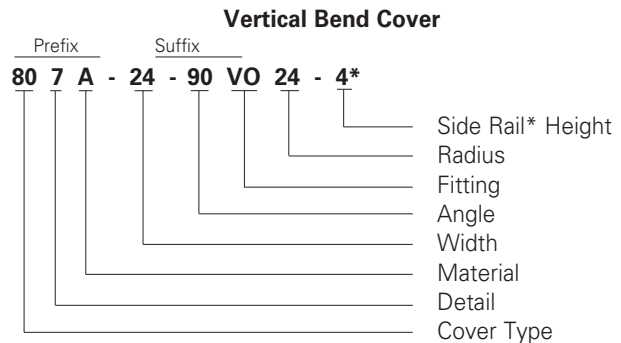
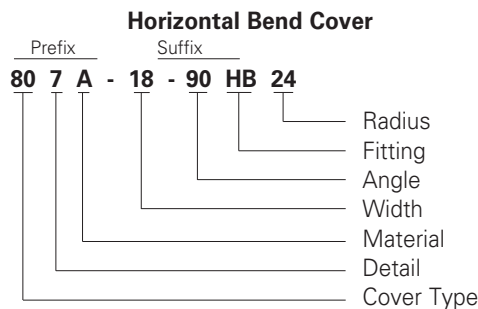

* Required for VO fittings only

All dimensions in parentheses are millimeters unless otherwise specified.

KwikSplice™ Aluminum Cable Tray - Accessories

Standard Cover Clamp

- For indoor service only.
- Setscrew included.
- Sold per piece.



Tray Type	Side Rail Height	Catalog No.
KS Series	All Sizes	9ZN-9012
		9A-9012

Heavy Duty Cover Clamp

- Recommended for outdoor service.

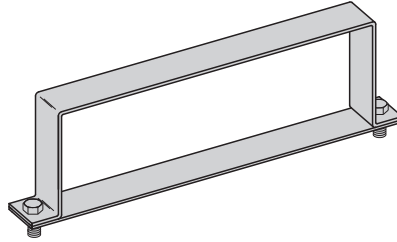

Side Rail Height in. (mm)	Catalog No.
4 (101)	KS4A-HDCC-(‡)
5 (127)	KS5A-HDCC-(‡)
6 (152)	KS6A-HDCC-(‡)

(‡) Insert tray width

Quantity of Standard Cover Clamps Required

Straight Section 60" or 72"	4 pcs.
Straight Section 120" or 144"	6 pcs.
Horizontal/Vertical Bends	4 pcs.
Tees	6 pcs.
Crosses	8 pcs.

Notes:

When using the Heavy Duty Cover Clamp, only one-half the number of clamps stated above is required.

Additional clamps may be necessary in extreme wind applications.

Cover Joint Strip

- Used to join covers
- Plastic
- (‡) Insert tray width

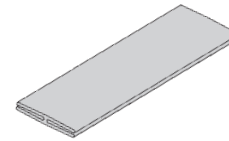

Catalog No.
99-9980-(‡)

Cable Cleats

(see Cable Tray Systems catalog)

Trefoil Cable Cleats

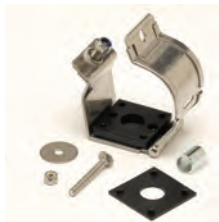

Single Cable Cleats

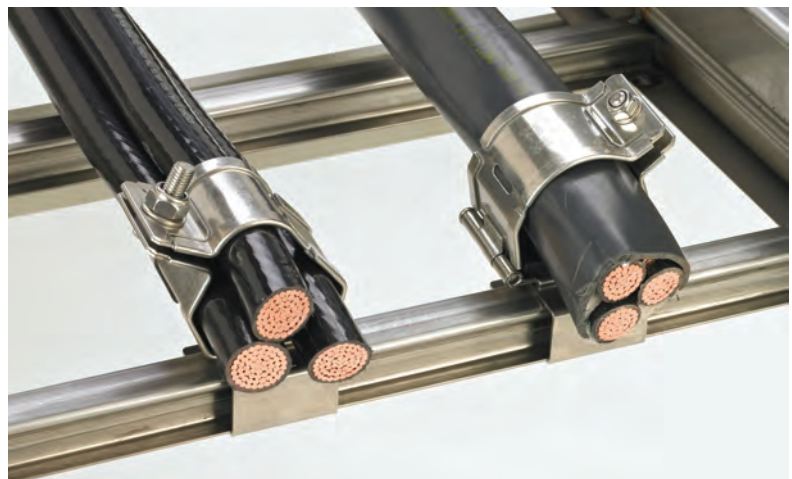

All dimensions in parentheses are millimeters unless otherwise specified.

KwikSplice™ Aluminum Cable Tray - Accessories

Universal Fitting

- Aluminum construction.
- 2" smooth radius.
- UL Classified.
- Shipped as a 90° horizontal bend.
- Field modify to create a tee or cross.
- Includes four pairs of toolless hinge splice plates.
- Patent Pending.

Tray Series	Catalog No.	
	Punched	Solid
KS_4A	KS4A-UF-(†)	KS4ASB-UF-(†)
KS_5A	KS5A-UF-(†)	KS5ASB-UF-(†)
KS_6A	KS6A-UF-(†)	KS6ASB-UF-(†)

(†) Insert Tray Width 6" (152mm) to 24" (609mm)

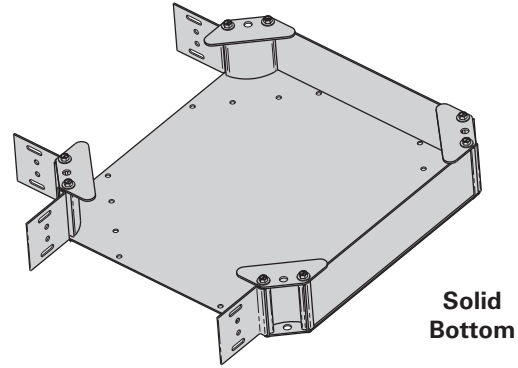
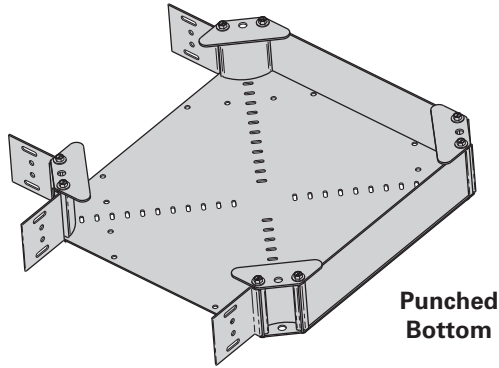

Corner Post For Universal Fitting

- Use to create reducing fittings.
- Furnished with hardware.
- 2" inside radius.
- Used on punched bottom only.
- UL Classified.
- Patent Pending.

Tray Series	Catalog No.
KS_4A	KS4A-CP
KS_5A	KS5A-CP
KS_6A	KS6A-CP

† = tray width

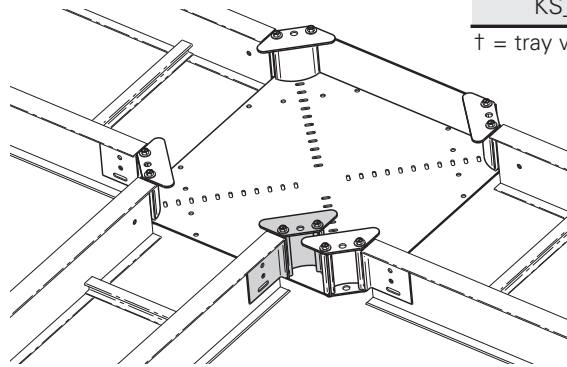
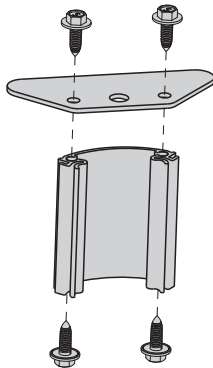

Universal Fitting Shown as a Reducing Tee

Barrier Strip Clip

- Provides attachment to KwikSplice rung.
- Allows for installed barrier adjustment.
- Asymmetrical clip provides a wide range for screw location.
- Barrier strip clips and hardware are included with all barriers.

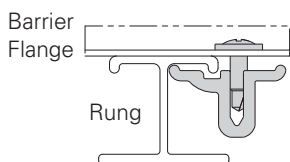

Screw slot for sheet metal screw

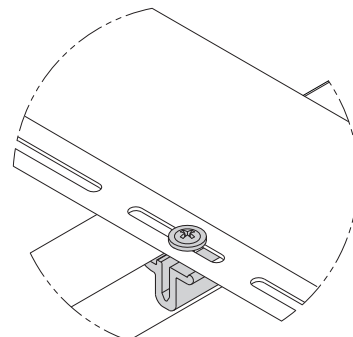
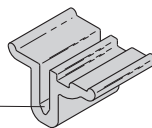

Catalog No.
9A-RBC

All dimensions in parentheses are millimeters unless otherwise specified.

Straight Section Barrier Strip

- Furnished with four (4) barrier strip clips, mounting hardware and splice.
- Standard lengths are 144" or 12 ft (3.7m) & 120" or 10 ft (3.0m).
- Order catalog number based on loading depth 'H'.

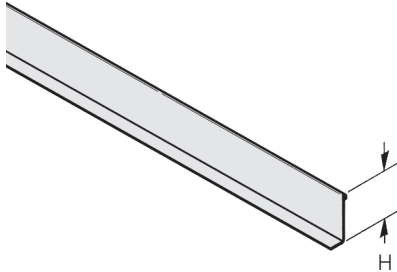

Tray Series	Catalog No.	H	
		in.	(mm)
KS_4A	R4A-DSL-Length	3	(76)
KS_5A	R5A-DSL-Length	4	(101)
KS_6A	R6A-DSL-Length	5	(127)

Horizontal Bend Barrier Strip

- Furnished with three (3) barrier strip clips, mounting hardware and splice.
- Standard length is 72" or 6 ft (1.8m).
- Flexible to fit desired angles.
- Order catalog number based on loading depth 'H'.

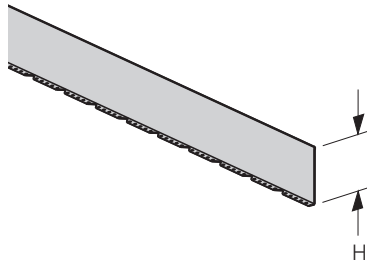

Tray Series	Catalog No.	H	
		in.	(mm)
KS_4A	R4A-DHB	3	(76)
KS_5A	R5A-DHB	4	(101)
KS_6A	R6A-DHB	5	(127)

Vertical Bend Barrier Strip

- Furnished with three (3) barrier strip clips, mounting hardware and splice.

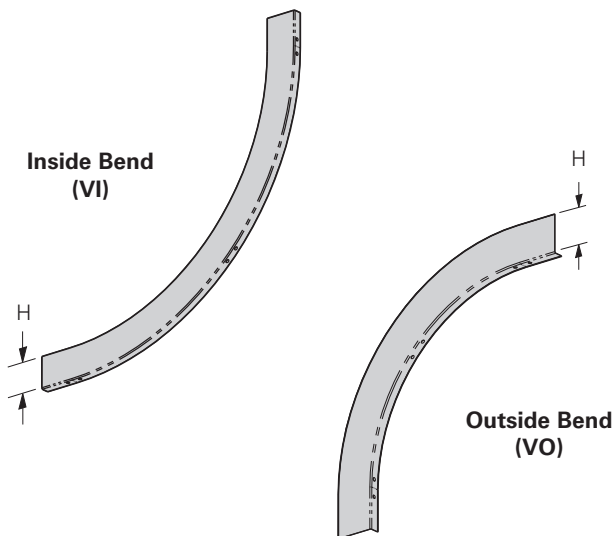

Tray Series	Catalog No.		H	
	Inside Bend	Outside Bend	in.	(mm)
KS_4A	R4A-DVI-(**)R(†)	R4A-DVO-(**)R(†)	3	(76)
KS_5A	R5A-DVI-(**)R(†)	R5A-DVO-(**)R(†)	4	(101)
KS_6A	R6A-DVI-(**)R(†)	R6A-DVO-(**)R(†)	5	(127)

(**) Insert 30°, 45°, 60°, 90° for angles
 (†) Insert 12, 24 for radius

All dimensions in parentheses are millimeters unless otherwise specified.

KwikSplice™ Aluminum Cable Tray - Accessories

How to miter cut KwikSplice cable tray for use with Horizontal Adjustable splice plates.

- Mark desired hole/cut locations per chart.
- Remove any rungs (if necessary) affected by cuts.
- Cut side rails through center of required holes per chart.
- Mount outside Horizontal Adjustable splice plate with provided hardware and bend KwikSplice sections to desired angle.
- Form inside Horizontal Adjustable splice plate to fit contour of inner rails and bolt into place.
- Reinstall (if necessary) appropriate rungs. Torque to 18 ft•lbs.
- If Splice Rung Kit (see below) is required, order separately.
- Recommend adding one to the value in the chart if the first hole is less than 3/8" (9.5mm) from the end of tray.

Tray Width in. (mm)	Cut Length from Rail End For Desired Angle			
	30° in. (mm)	45° in. (mm)	60° in. (mm)	90° in. (mm)
6 (152)	1 ⁵ / ₈ (41.3)	3 ¹ / ₈ (79.4)	3 ¹ / ₈ (79.4)	6 ¹ / ₄ (158.7)
9 (228)	3 ¹ / ₈ (79.4)	3 ¹ / ₈ (79.4)	4 ³ / ₄ (120.6)	9 ³ / ₈ (238.2)
12 (305)	3 ¹ / ₈ (79.4)	4 ¹ / ₈ (120.6)	6 ¹ / ₄ (158.7)	12 ⁵ / ₈ (320.7)
18 (457)	4 ³ / ₄ (120.6)	7 ⁷ / ₈ (200.0)	11 (279.4)	17 ¹ / ₄ (438.1)
24 (609)	6 ¹ / ₄ (158.7)	9 ³ / ₈ (238.2)	14 ¹ / ₈ (358.8)	23 ⁵ / ₈ (600.1)
30 (762)	7 ⁷ / ₈ (200.0)	12 ⁵ / ₈ (320.7)	17 ¹ / ₄ (438.1)	29 ⁷ / ₈ (758.8)
36 (914)	9 ³ / ₈ (238.2)	15 ³ / ₄ (400.0)	20 ³ / ₈ (517.5)	36 ¹ / ₈ (917.6)

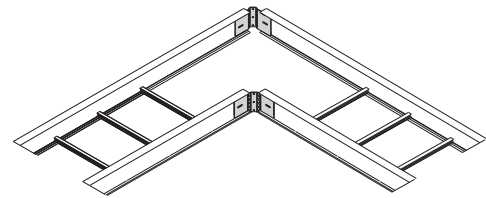
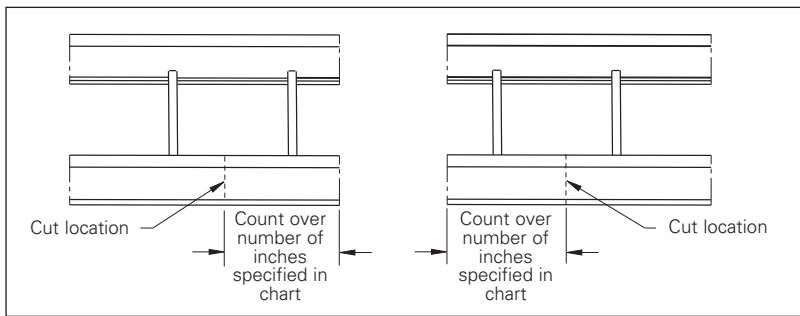

KSA5A09-12-144 Straight Section shown with required side rail removed to form 90° fitting.

Example: For a 12" (305mm) wide 90° bend, the cuts must be made 12⁵/₈" (320.7mm) from the end.

Horizontal Adjustable Splice Rung Kit

- Kit allows a support rung to be added to Horizontal Adjustable splice plates so that cables may be supported through a bend.
- The support rung is available in three lengths and should be ordered based upon tray width.
- The rung length is sized so that it will fit a maximum tray width when Horizontal Adjustable splices are used to make a bend up to 90°.
- Once the Horizontal Adjustable splices are installed in the cable tray system, the distance between the splice mounting surfaces should be measured. Cut support rung to the measured distance and install using the hardware included. Torque to 18 ft•lbs.

For Tray Width in. (mm)	Catalog No.	Actual Rung Length in. (mm)
Up to 12 (Up to 305)	9A-RFM-12RK	20" (508)
18 & 24 (453 to 609)	9A-RFM-24RK	37" (940)
30 & 36 (762 to 914)	9A-RFM-36RK	54" (1448)

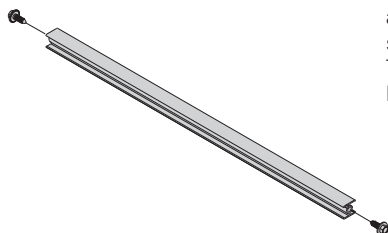

Example: Flex connectors are installed on an 18" (452mm) wide tray with approximately a 45° bend. The correct support rung kit is 9A-RFM-24RK. The tray width is 24" (609mm) or less and the angle is less than 90°.

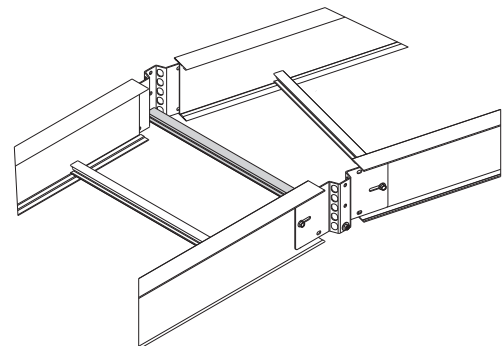

All dimensions in parentheses are millimeters unless otherwise specified.

Data Cables

The National Electrical Code allows for 50% fill of ventilated cable tray for control or signal wiring (Article 392-9(b)).

This rule requires that all the individual cable cross-sectional areas added up may not exceed one half the cable tray area.

The cable tray area is equal to the width times the load depth.

In actual practice with data cables, however, the cable tray becomes completely full in reaching the "50% cable fill".

The tray is completely full, but the sum of the cable areas is only 50% of the tray area, due to the empty spaces between the cables.

Data Cable Fill and Weight Chart

Number of Category 5/5e/6 Cables and Calculated Cable Weight in Lbs/Ft

Tray Depth in (mm)	Tray Width													
	6" (152mm)		9" (228mm)		12" (305mm)		18" (457mm)		24" (609mm)		30" (762mm)		36" (914mm)	
	Cables	lbs/ft	Cables	lbs/ft	Cables	lbs/ft	Cables	lbs/ft	Cables	lbs/ft	Cables	lbs/ft	Cables	lbs/ft
4" (101)	347	9	520	13	693	18	1040	27	1386	35	1733	43	2079	54
5" (127)	433	12	650	17	866	23	1299	34	1733	43	2166	53	2599	68
6" (152)	520	14	780	20	1040	27	1559	41	2079	52	2599	64	3119	81

This chart was based on 50% fill of 4 UTP Category 5, 5e, or 6 cables (O.D. = .21" .026 lbs/ft).

In the above loading grid, the weight of the cables is not the issue. The volume capacity of the tray governs. For example, the worst case (6" load depth, 36" wide) has a total cable weight of 81 lbs/ft.

All dimensions in parentheses are millimeters unless otherwise specified.

Section 161xx - KwikSplice™ Cable Tray

PART 1 GENERAL

- 1.1 Summary
 - A. The work covered under this section consists of the furnishing of all necessary labor, supervision, materials, equipment, tests and services to install complete cable tray systems as shown on the drawings.
 - B. Cable tray systems are defined to include, but are not limited to straight sections of cable trays, fittings, drop-outs, supports and accessories.
- 1.2 References
 - A. NEMA VE 1-2009 - Metal Cable Tray Systems.
 - B. NEMA VE 2-2013 - Cable Tray Installation Guidelines.
 - C. ANSI/NFPA 70 – National Electrical Code
- 1.3 Drawings
 - A. The drawings, which constitute a part of these specifications, indicate the general route of the cable runway systems. Data presented on these drawings is as accurate as preliminary surveys and planning can determine until final equipment selection is made. Accuracy is not guaranteed and field verification of all dimensions, routing, etc., is required.
 - B. Specifications and drawings are for assistance and guidance, but exact routing, locations, distances and levels will be governed by actual field conditions. Contractor is directed to make field surveys as part of his work prior to submitting system layout drawings.
- 1.4 Quality Assurance
 - A. Manufacturers: Firms regularly engaged in manufacture of cable trays and fittings of types and capacities required, whose products have been in satisfactory use in similar service for not less than 10 years.
 - B. NEMA Compliance: Comply with NEMA Standards Publication Number VE1, "Cable Tray Systems".
 - C. NEC Compliance: Comply with NEC, as applicable to construction and installation of cable tray and cable channel systems (Article 392, NEC).
 - D. UL Compliance: Provide products that are UL-classified and labeled.
 - E. NFPA Compliance: Comply with NFPA 70B, "Recommended Practice for Electrical Equipment Maintenance" pertaining to installation of cable tray systems.
- 1.5 Delivery, Storage and Handling
 - A. Deliver cable tray systems and components carefully to avoid breakage, denting and scoring finishes. Do not install damaged equipment.
 - B. Store cable trays and accessories in original cartons and in clean dry space; protect from weather and construction traffic. Wet materials should be unpacked and dried before storage.
- 1.6 Submittals
 - A. Shop Drawings: Indicate tray type, dimensions, support points, and finishes.
 - B. Product Data: Submit fittings and accessories.
 - C. Manufacturer's Installation Instructions: Submit application conditions and limitations of use stipulated by Product testing agency specified under Regulatory Requirements. Include instructions for storage, handling, protection, examination, preparation, and installation of Product.

PART 2 PRODUCTS

- 2.1 Acceptable Manufacturers
 - A. Manufacturer: Subject to compliance with these specifications, B-Line series cable tray systems shall be as manufactured by Eaton.
- 2.2 Cable Tray Sections and Components
 - A. General: Except as otherwise indicated, provide metal cable trays, of types, classes, and sizes indicated; with splice plates, bolts, nuts and washers for connecting units. Construct units with rounded edges and smooth surfaces; in compliance with applicable standards; and with the following additional construction features. Cable tray shall be installed according to the latest revision of NEMA VE-2.
 - B. Material and Finish: Straight section, fitting side rails, rungs and splice plates shall be extruded from Aluminum Association Alloy 6063. All fabricated parts shall be made from Aluminum Association Alloy 5052.
- 2.3 Type of Tray System
 - A. Ladder Cable Trays shall consist of two longitudinal members (side rails) with transverse members (rungs) welded to both side rails. Both side rails and rungs shall be I-beam configuration. Side rails shall have a splice retention groove to accept a splice plate. Rungs shall be spaced [4] [6] [9] [12] inches on center. Rung spacing in radiused fittings shall be industry standard 9" and measured at the center of the tray's width.

(continued on page G-20)

(continued from page KSA-19)

- B. Ventilated Bottom Cable Trays shall consist of two longitudinal members (side rails) with rungs spaced 4" on center.
- C. Solid Bottom Cable Trays shall consist of two longitudinal members (side rails) with a solid sheet over rungs spaced on 12" centers.
- D. Cable tray loading depth shall be [3] [4] [5] inches per NEMA VE-1.
- E. Straight sections shall be supplied in standard [10 foot (3.05m)] [12 foot (3.65m)] lengths.
- F. Cable tray widths shall be [6] [9] [12] [18] [24] [30] [36] inches or as shown on drawings.
- G. Splice plates shall have a maximum of (2) two nuts and bolts per plate. The resistance of fixed splice connections between adjacent sections of tray shall not exceed 0.00033 ohms. Splice plates shall be furnished with straight sections and fittings. All horizontal fittings (horizontal bend, horizontal tee, horizontal cross) to be installed utilizing Eaton's B-Line series Kwik Splice™ Universal Fitting. All vertical fittings must have a minimum radius of [12] [24] inches.

***** [OR] *****

All fittings must have a minimum radius of [12] [24] inches.

2.4 Loading Capacities

- A. Cable trays shall meet NEMA class designation:

{NEMA 12A: [50 lbs./ft. on a 12 ft. span]} OR {NEMA 12B: [75 lbs./ft. on a 12 ft. span]}.

***** [OR] *****

- B. Cable tray shall be capable of carrying a uniformly distributed load of _____ lbs./ft on a _____ foot support span with a safety factor of 1.5 when supported as a simple span and tested per NEMA VE 1 Section 5.2.

2.5 Accessories

- A. Covers:

1. Furnish only where indicated on the Drawings.
2. Solid or ventilated as indicated.
3. Same manufacturer and material as the tray.
4. Secure covers with manufacturer's approved clamps.
5. Clamp spacing per manufacturer's recommendations.

- B. Dividers:

1. Manufactured by the cable tray manufacturer of the same material as the tray.

- C. Mounting hardware:

1. Zinc coated tray bolts, nuts, and fasteners: quantity not to exceed two each per splice plate.

- D. Trapeze Supports

1. Manufactured by the cable tray manufacturer.

- E. Cable Exit Options

1. Radiused drop outs must be utilized for cables exiting the cable tray through the rungs or over either side rail

***** [OR] *****

2. Conduit connectors must be utilized to securely connect the conduit runs to the cable tray when a cable exits through the rungs or over either side rail.

PART 3 EXECUTION

3.1 Installation

- A. Install cable trays as indicated: Installation shall be in accordance with equipment manufacturer's instructions, and with recognized industry practices to ensure that cable tray equipment comply with requirements of NEC and applicable portions of NFPA 70B. Reference NEMA-VE2 for general cable tray installation guidelines.
- B. Coordinate cable tray with other electrical work as necessary to properly integrate installation of cable tray work with other work.
- C. Provide sufficient space encompassing cable trays to permit access for installing and maintaining cables.
- D. Cable tray fitting supports shall be located such that they meet the strength requirements of straight sections. Install fitting supports per NEMA VE-2 guidelines, or in accordance with manufacturer's instructions.

3.2 Testing

- A. Test cable trays to ensure electrical continuity of bonding and grounding connections, and to demonstrate compliance with specified maximum grounding resistance. See NFPA 70B, Chapter 18, for testing and test methods.
- B. Manufacturer shall provide test reports witnessed by an independent testing laboratory of the "worst case" loading conditions outlined in this specification and performed in accordance with the latest revision of NEMA VE-1/CSA C22.2 No. 126. 1-09.

END OF SECTION

KwikSplice™ Aluminum Cable Tray - Fittings

Fittings For KSA4A, KSA5A, KSB4A, KSB5A and KSB6A

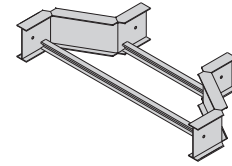
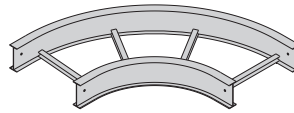
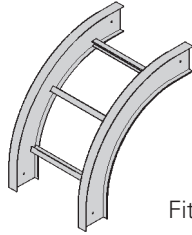
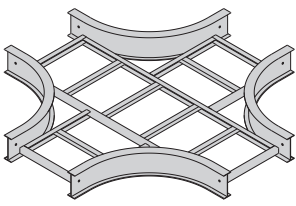

Fittings engineered with 3" tangents for splicing integrity.

Fitting Part Numbering

Example: **KS 4 A 09 - 12 - 90 HB 24**

Series	Height	Material	Type	Width	Angle*	Fitting Type	Radius
KS = KwikSplice	4 = 4" 5 = 5" 6 = 6"	A = Aluminum	Ladder 09 = 9" rung spacing Other 04 = 4" rung spacing SB = Solid Bottom	06 = 6" 09 = 9" 12 = 12" 18 = 18" 24 = 24" 30 = 30" 36 = 36"	30 = 30° 45 = 45° 60 = 60° 90 = 90°	*HB = Horizontal Bend HT = Horizontal Tee HX = Horizontal Cross *VI = Vertical Inside Bend *VO = Vertical Outside Bend VT = Vertical Tee, Down VTU = Vertical Tee, Up LR = Left Reducer RR = Right Reducer SR = Straight Reducer	12 = 12" 24 = 24"

Expanding & Reducing Horizontal Tee & Cross Fitting Part Numbering

Example: **KS 4 A 04 - 24 - 12 - HT 24**

Series	Height	Material	Type	Width 1	Width 2	Fitting Type	Radius
KS = KwikSplice	4 = 4" 5 = 5" 6 = 6"	A = Aluminum	Ladder 09 = 9" rung spacing Other 04 = 4" rung spacing SB = Solid Bottom	06 = 6" 09 = 9" 12 = 12" 18 = 18" 24 = 24" 30 = 30" 36 = 36"	06 = 6" 09 = 9" 12 = 12" 18 = 18" 24 = 24" 30 = 30" 36 = 36"	HT = Horizontal Tee (Reducing - where Width 1 is larger than Width 2) (Expanding - where Width 1 is smaller than Width 2) HX = Horizontal Cross (Reducing/Expanding - where Width 1 is larger than Width 2)	12 = 12" 24 = 24"

For ventilated or solid bottom, add 04 or SB as shown below: Available 6" thru 36"

Prefix
KS5A04 - 24 - 90HB24

4" Rung Spacing Bottom

Prefix
KS5ASB - 24 - 90HB24

Solid Bottom

All dimensions in parentheses are millimeters unless otherwise specified.

Horizontal Bend 90° 60° (HB)

1 pair splice plates with hardware included.

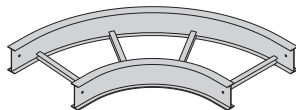

90° Horizontal Bend

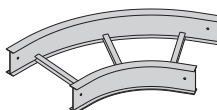

60° Horizontal Bend

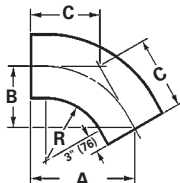
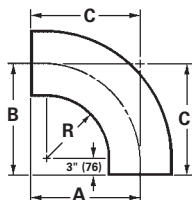

Bottoms manufactured:

Ladder = 9" Rung Spacing

04 = 4" Rung Spacing

SB = Flat sheet over 9" Rung Spacing

Bend Radius R	Tray Width	90° Horizontal Bend Dimensions				60° Horizontal Bend Dimensions			
		Catalog No.	A	B	C	Catalog No.	A	B	C
in. (mm)	in. (mm)		in. (mm)	in. (mm)	in. (mm)		in. (mm)	in. (mm)	in. (mm)
12 (305)	6 (152)	(Pre)-06-90HB12	18 (457)	18 (457)	18 (457)	(Pre)-06-60HB12	17 ¹ / ₂ (445)	10 ¹ / ₈ (257)	11 ¹¹ / ₁₆ (297)
	9 (228)	(Pre)-09-90HB12	19 ¹ / ₂ (495)	19 ¹ / ₂ (495)	19 ¹ / ₂ (495)	(Pre)-09-60HB12	18 ¹³ / ₁₆ (478)	10 ⁷ / ₈ (276)	12 ¹ / ₂ (318)
	12 (305)	(Pre)-12-90HB12	21 (533)	21 (533)	21 (533)	(Pre)-12-60HB12	20 ¹ / ₁₆ (510)	11 ⁵ / ₈ (295)	13 ³ / ₈ (340)
	18 (457)	(Pre)-18-90HB12	24 (610)	24 (610)	24 (610)	(Pre)-18-60HB12	22 ¹¹ / ₁₆ (576)	13 ¹ / ₈ (333)	15 ¹ / ₈ (384)
	24 (610)	(Pre)-24-90HB12	27 (686)	27 (686)	27 (686)	(Pre)-24-60HB12	25 ⁵ / ₁₆ (643)	14 ⁵ / ₈ (372)	16 ⁷ / ₈ (429)
	30 (762)	(Pre)-30-90HB12	30 (762)	30 (762)	30 (762)	(Pre)-30-60HB12	27 ⁷ / ₈ (708)	16 ¹ / ₈ (410)	18 ⁹ / ₁₆ (472)
	36 (914)	(Pre)-36-90HB12	33 (838)	33 (838)	33 (838)	(Pre)-36-60HB12	30 ¹ / ₂ (775)	17 ⁵ / ₈ (448)	20 ⁵ / ₁₆ (516)
24 (610)	6 (152)	(Pre)-06-90HB24	30 (762)	30 (762)	30 (762)	(Pre)-30-60HB12	27 ⁷ / ₈ (708)	16 ¹ / ₈ (410)	18 ⁹ / ₁₆ (472)
	9 (228)	(Pre)-09-90HB24	31 ¹ / ₂ (800)	31 ¹ / ₂ (800)	31 ¹ / ₂ (800)	(Pre)-09-60HB24	29 ³ / ₁₆ (741)	16 ⁷ / ₈ (429)	19 ⁷ / ₁₆ (494)
	12 (305)	(Pre)-12-90HB24	33 (838)	33 (838)	33 (838)	(Pre)-36-60HB12	30 ¹ / ₂ (775)	17 ⁵ / ₈ (448)	20 ⁵ / ₁₆ (516)
	18 (457)	(Pre)-18-90HB24	36 (914)	36 (914)	36 (914)	(Pre)-18-60HB24	33 ¹ / ₁₆ (708)	19 ¹ / ₈ (486)	22 ¹ / ₁₆ (560)
	24 (610)	(Pre)-24-90HB24	39 (991)	39 (991)	39 (991)	(Pre)-24-60HB24	35 ¹¹ / ₁₆ (907)	20 ⁵ / ₈ (524)	23 ¹³ / ₁₆ (605)
	30 (762)	(Pre)-30-90HB24	42 (1067)	42 (1067)	42 (1067)	(Pre)-30-60HB24	38 ¹ / ₄ (972)	22 ¹ / ₈ (564)	25 ¹ / ₂ (648)
	36 (914)	(Pre)-36-90HB24	45 (1143)	45 (1143)	45 (1143)	(Pre)-36-60HB24	40 ⁷ / ₈ (1038)	23 ⁵ / ₈ (600)	27 ¹ / ₄ (692)

(Pre) See page G-21 for catalog number prefix.

Width dimensions are to inside wall. For aluminum fittings add 1.5 inches for total outside width.

Manufacturing tolerances apply to all dimensions.

All dimensions in parentheses are millimeters unless otherwise specified.

KwikSplice™ Aluminum Cable Tray - Fittings

Horizontal Bend 45° 30° (HB)

1 pair splice plates with hardware included.

Bottoms manufactured:

Ladder = 9" Rung Spacing

04 = 4" Rung Spacing

SB = Flat sheet over 9" Rung Spacing

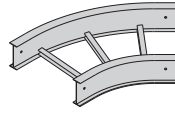

45° Horizontal Bend

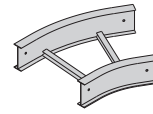

30° Horizontal Bend

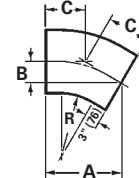
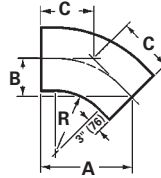

KwikSplice Cable Tray

Bend Radius R	Tray Width	45° Horizontal Bend Dimensions				30° Horizontal Bend Dimensions			
		Catalog No.	A	B	C	Catalog No.	A	B	C
in. (mm)	in. (mm)		in. (mm)	in. (mm)	in. (mm)		in. (mm)	in. (mm)	in. (mm)
12 (305)	6 (152)	(Pre)-06-45HB12	15 ³ / ₄ (400)	6 ¹ / ₂ (165)	9 ³ / ₁₆ (233)	(Pre)-06-30HB12	13 ¹ / ₈ (333)	3 ¹ / ₂ (89)	7 (179)
	9 (228)	(Pre)-09-45HB12	16 ¹³ / ₁₆ (427)	6 ¹⁵ / ₁₆ (176)	9 ¹³ / ₁₆ (249)	(Pre)-09-30HB12	13 ⁷ / ₈ (352)	3 ¹¹ / ₁₆ (94)	7 ⁷ / ₁₆ (189)
	12 (305)	(Pre)-12-45HB12	17 ⁷ / ₈ (454)	7 ³ / ₈ (187)	10 ⁷ / ₁₆ (265)	(Pre)-12-30HB12	14 ⁵ / ₈ (372)	3 ¹⁵ / ₁₆ (100)	7 ¹³ / ₁₆ (198)
	18 (457)	(Pre)-18-45HB12	20 (508)	8 ¹ / ₄ (210)	11 ¹¹ / ₁₆ (297)	(Pre)-18-30HB12	16 ¹ / ₈ (410)	4 ⁵ / ₁₆ (109)	8 ⁵ / ₈ (219)
	24 (610)	(Pre)-24-45HB12	22 ¹ / ₁₆ (560)	9 ¹ / ₈ (232)	12 ¹⁵ / ₁₆ (329)	(Pre)-24-30HB12	17 ⁵ / ₈ (448)	4 ¹¹ / ₁₆ (119)	9 ⁷ / ₁₆ (240)
	30 (762)	(Pre)-30-45HB12	24 ³ / ₁₆ (614)	10 (254)	14 ³ / ₁₆ (360)	(Pre)-30-30HB12	19 ¹ / ₈ (486)	5 ¹ / ₈ (130)	10 ¹ / ₄ (260)
	36 (914)	(Pre)-36-45HB12	26 ⁵ / ₁₆ (668)	10 ¹⁵ / ₁₆ (278)	15 ⁷ / ₁₆ (392)	(Pre)-36-30HB12	20 ⁵ / ₈ (524)	5 ¹ / ₂ (140)	11 ¹ / ₁₆ (281)
24 (610)	6 (152)	(Pre)-06-45HB24	24 ³ / ₁₆ (614)	10 (254)	14 ³ / ₁₆ (360)	(Pre)-06-30HB24	19 ¹ / ₈ (486)	5 ¹ / ₈ (130)	10 ¹ / ₄ (260)
	9 (228)	(Pre)-09-45HB24	25 ¹ / ₄ (641)	10 ¹ / ₂ (267)	14 ¹³ / ₁₆ (376)	(Pre)-09-30HB24	19 ⁷ / ₈ (505)	5 ⁵ / ₁₆ (135)	10 ⁵ / ₈ (270)
	12 (305)	(Pre)-12-45HB24	26 ⁵ / ₁₆ (668)	10 ¹⁵ / ₁₆ (278)	15 ⁷ / ₁₆ (392)	(Pre)-12-30HB24	20 ⁵ / ₈ (524)	5 ¹ / ₂ (140)	11 ¹ / ₁₆ (281)
	18 (457)	(Pre)-18-45HB24	28 ⁷ / ₁₆ (722)	11 ¹³ / ₁₆ (300)	16 ¹¹ / ₁₆ (424)	(Pre)-18-30HB24	22 ¹ / ₈ (562)	5 ¹⁵ / ₁₆ (151)	11 ¹³ / ₁₆ (300)
	24 (610)	(Pre)-24-45HB24	30 ⁹ / ₁₆ (766)	12 ¹¹ / ₁₆ (322)	17 ¹⁵ / ₁₆ (456)	(Pre)-24-30HB24	23 ⁵ / ₈ (600)	6 ⁵ / ₁₆ (160)	12 ⁵ / ₈ (321)
	30 (762)	(Pre)-30-45HB24	32 ¹¹ / ₁₆ (830)	13 ⁹ / ₁₆ (344)	19 ¹ / ₈ (486)	(Pre)-30-30HB24	25 ¹ / ₈ (638)	6 ³ / ₄ (172)	13 ⁷ / ₁₆ (341)
	36 (914)	(Pre)-36-45HB24	34 ¹³ / ₁₆ (884)	14 ⁷ / ₁₆ (367)	20 ³ / ₈ (518)	(Pre)-36-30HB24	26 ⁵ / ₈ (676)	7 ¹ / ₈ (181)	14 ¹ / ₄ (362)

(Pre) See page G-21 for catalog number prefix.

Width dimensions are to inside wall. For aluminum fittings add 1.5 inches for total outside width.

Manufacturing tolerances apply to all dimensions.

All dimensions in parentheses are millimeters unless otherwise specified.

KwikSplice™ Aluminum Cable Tray - Fittings

Horizontal Tee (HT)

2 pair splice plates with hardware included.

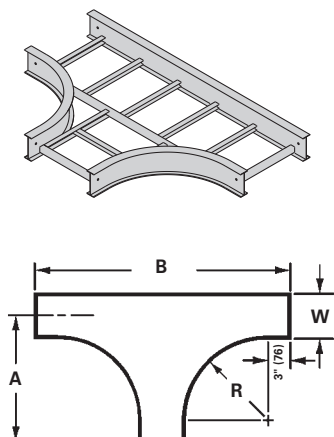

Horizontal Cross (HX)

3 pair splice plates with hardware included.

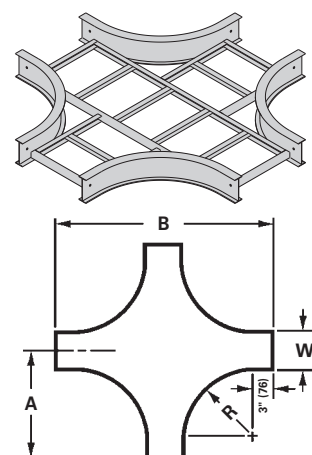

Bend Radius R in. (mm)	Tray Width in. (mm)	Horizontal Tee Dimensions			Horizontal Cross Dimensions		
		Catalog Number	A in. (mm)	B in. (mm)	Catalog Number	A in. (mm)	B in. (mm)
12 (305)	6 (152)	(Prefix)-06-HT12	18 (457)	36 (914)	(Prefix)-06-HX12	18 (457)	36 (914)
	9 (229)	(Prefix)-09-HT12	19 1/2 (496)	39 (991)	(Prefix)-09-HX12	19 1/2 (496)	39 (991)
	12 (305)	(Prefix)-12-HT12	21 (533)	42 (1067)	(Prefix)-12-HX12	21 (533)	42 (1067)
	18 (457)	(Prefix)-18-HT12	24 (609)	48 (1219)	(Prefix)-18-HX12	24 (609)	48 (1219)
	24 (609)	(Prefix)-24-HT12	27 (686)	54 (1372)	(Prefix)-24-HX12	27 (686)	54 (1372)
	30 (762)	(Prefix)-30-HT12	30 (762)	60 (1524)	(Prefix)-30-HX12	30 (762)	60 (1524)
	36 (914)	(Prefix)-36-HT12	33 (838)	66 (1676)	(Prefix)-36-HX12	33 (838)	66 (1676)
24 (610)	6 (152)	(Prefix)-06-HT24	30 (762)	60 (1524)	(Prefix)-06-HX24	30 (762)	60 (1524)
	9 (229)	(Prefix)-09-HT24	31 1/2 (800)	63 (1600)	(Prefix)-09-HX24	31 1/2 (800)	63 (1600)
	12 (305)	(Prefix)-12-HT24	33 (838)	66 (1676)	(Prefix)-12-HX24	33 (838)	66 (1676)
	18 (457)	(Prefix)-18-HT24	36 (914)	72 (1828)	(Prefix)-18-HX24	36 (914)	72 (1828)
	24 (609)	(Prefix)-24-HT24	39 (991)	78 (1982)	(Prefix)-24-HX24	39 (991)	78 (1982)
	30 (762)	(Prefix)-30-HT24	42 (1067)	84 (2134)	(Prefix)-30-HX24	42 (1067)	84 (2134)
	36 (914)	(Prefix)-36-HT24	45 (1143)	90 (2286)	(Prefix)-36-HX24	45 (1143)	90 (2286)

(Prefix) See page G-21 for catalog number prefix.

Width dimensions are to inside wall. For aluminum fittings add 1.5 inches for total outside width.

Manufacturing tolerances apply to all dimensions.

All dimensions in parentheses are millimeters unless otherwise specified.

KwikSplice™ Aluminum Cable Tray - Fittings

Reducers (LR, SR, RR)

1 pair splice plates with hardware included.

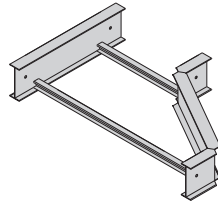

Left Reducer - LR

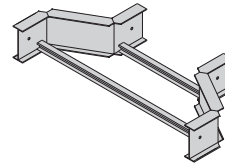

Straight Reducer -SR

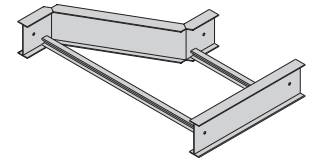

Right Reducer - RR

Reducer Part Numbering

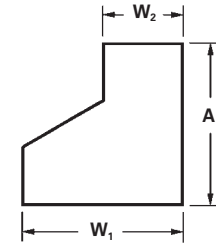
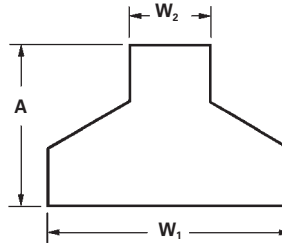
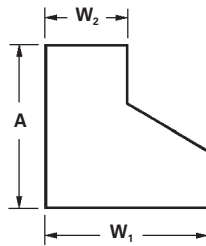
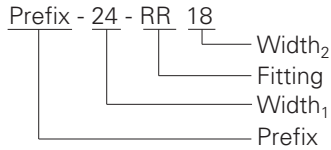

Tray Width		Left Reducer - LR		Straight Reducer - SR		Right Reducer - RR	
W ₁	W ₂	Catalog No.	A	Catalog No.	A	Catalog No.	A
in. (mm)	in. (mm)		in. (mm)		in. (mm)		in. (mm)
9 (228)	6 (152)	(Prefix)-09-LR06	9 ³ / ₄ (248)	(Prefix)-09-SR06	8 ⁷ / ₈ (225)	(Prefix)-09-RR06	9 ³ / ₄ (248)
12 (305)	6 (152)	(Prefix)-12-LR06	11 ¹ / ₂ (292)	(Prefix)-12-SR06	9 ³ / ₄ (248)	(Prefix)-12-RR06	11 ¹ / ₂ (292)
	9 (228)	(Prefix)-12-LR09	9 ³ / ₄ (248)	(Prefix)-12-SR09	8 ⁷ / ₈ (225)	(Prefix)-12-RR09	9 ³ / ₄ (248)
18 (457)	6 (152)	(Prefix)-18-LR06	14 ¹⁵ / ₁₆ (379)	(Prefix)-18-SR06	11 ¹ / ₂ (292)	(Prefix)-18-RR06	14 ¹⁵ / ₁₆ (379)
	9 (228)	(Prefix)-18-LR09	13 ³ / ₁₆ (335)	(Prefix)-18-SR09	10 ⁵ / ₈ (270)	(Prefix)-18-RR09	13 ³ / ₁₆ (335)
	12 (305)	(Prefix)-18-LR12	11 ¹ / ₂ (292)	(Prefix)-18-SR12	9 ³ / ₄ (248)	(Prefix)-18-RR12	11 ¹ / ₂ (292)
24 (609)	6 (152)	(Prefix)-24-LR06	18 ³ / ₈ (467)	(Prefix)-24-SR06	13 ³ / ₁₆ (335)	(Prefix)-24-RR06	18 ³ / ₈ (467)
	9 (228)	(Prefix)-24-LR09	16 ¹¹ / ₁₆ (424)	(Prefix)-24-SR09	12 ³ / ₈ (314)	(Prefix)-24-RR09	16 ¹¹ / ₁₆ (424)
	12 (305)	(Prefix)-24-LR12	14 ¹⁵ / ₁₆ (379)	(Prefix)-24-SR12	11 ¹ / ₂ (292)	(Prefix)-24-RR12	14 ¹⁵ / ₁₆ (379)
	18 (457)	(Prefix)-24-LR18	11 ¹ / ₂ (292)	(Prefix)-24-SR18	9 ³ / ₄ (248)	(Prefix)-24-RR18	11 ¹ / ₂ (292)
30 (762)	6 (152)	(Prefix)-30-LR06	21 ⁷ / ₈ (555)	(Prefix)-30-SR06	14 ¹⁵ / ₁₆ (379)	(Prefix)-30-RR06	21 ⁷ / ₈ (555)
	9 (228)	(Prefix)-30-LR09	20 ¹ / ₈ (511)	(Prefix)-30-SR09	14 ¹ / ₁₆ (358)	(Prefix)-30-RR09	20 ¹ / ₈ (511)
	12 (305)	(Prefix)-30-LR12	18 ³ / ₈ (467)	(Prefix)-30-SR12	13 ³ / ₁₆ (335)	(Prefix)-30-RR12	18 ³ / ₈ (467)
	18 (457)	(Prefix)-30-LR18	14 ¹⁵ / ₁₆ (379)	(Prefix)-30-SR18	11 ¹ / ₂ (292)	(Prefix)-30-RR18	14 ¹⁵ / ₁₆ (379)
	24 (609)	(Prefix)-30-LR24	11 ¹ / ₂ (292)	(Prefix)-30-SR24	9 ³ / ₄ (248)	(Prefix)-30-RR24	11 ¹ / ₂ (292)
36 (914)	6 (152)	(Prefix)-36-LR06	25 ⁵ / ₁₆ (643)	(Prefix)-36-SR06	16 ¹¹ / ₁₆ (424)	(Prefix)-36-RR06	23 ⁵ / ₁₆ (643)
	9 (228)	(Prefix)-36-LR09	23 ⁹ / ₁₆ (598)	(Prefix)-36-SR09	15 ¹³ / ₁₆ (402)	(Prefix)-36-RR09	23 ⁹ / ₁₆ (598)
	12 (305)	(Prefix)-36-LR12	21 ⁷ / ₈ (555)	(Prefix)-36-SR12	14 ¹⁵ / ₁₆ (379)	(Prefix)-36-RR12	21 ⁷ / ₈ (555)
	18 (457)	(Prefix)-36-LR18	18 ³ / ₈ (467)	(Prefix)-36-SR18	13 ³ / ₁₆ (335)	(Prefix)-36-RR18	18 ³ / ₈ (467)
	24 (609)	(Prefix)-36-LR24	14 ¹⁵ / ₁₆ (379)	(Prefix)-36-SR24	11 ¹ / ₂ (292)	(Prefix)-36-RR24	14 ¹⁵ / ₁₆ (379)
	30 (762)	(Prefix)-36-LR30	11 ¹ / ₂ (292)	(Prefix)-36-SR30	9 ³ / ₄ (248)	(Prefix)-36-RR30	11 ¹ / ₂ (292)

(Prefix) See page G-21 for catalog number prefix.

Width dimensions are to inside wall. For aluminum fittings add 1.5 inches for total outside width. Manufacturing tolerances apply to all dimensions.

All dimensions in parentheses are millimeters unless otherwise specified.

Horizontal Reducing Tee (HT)

2 pair splice plates with hardware included.

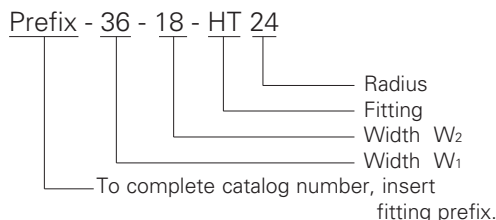
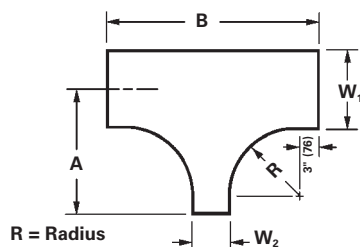
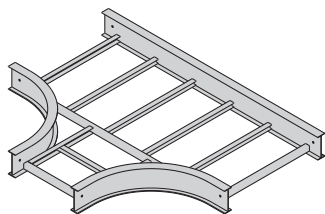

Tray Width		* Insert Radius (12" or 24") Catalog No.	R = 12" Radius (305)		R = 24" Radius (609)	
W1 in. (mm)	W2 in. (mm)		A in. (mm)	B in. (mm)	A in. (mm)	B in. (mm)
9 (228)	6 (152)	(Prefix)-09-06-HT*	19 ¹ / ₂ (496)	36 (914)	31 ¹ / ₂ (800)	60 (1524)
12 (305)	6 (152)	(Prefix)-12-06-HT*	21 (533)	36 (914)	33 (838)	60 (1524)
	9 (228)	(Prefix)-12-09-HT*	21 (533)	39 (991)	33 (838)	63 (1600)
18 (457)	6 (152)	(Prefix)-18-06-HT*	24 (609)	36 (914)	36 (914)	60 (1524)
	9 (228)	(Prefix)-18-09-HT*	24 (609)	39 (991)	36 (914)	63 (1600)
	12 (305)	(Prefix)-18-12-HT*	24 (609)	42 (1067)	36 (914)	66 (1676)
24 (609)	6 (152)	(Prefix)-24-06-HT*	27 (686)	36 (914)	39 (991)	60 (1524)
	9 (228)	(Prefix)-24-09-HT*	27 (686)	39 (991)	39 (991)	63 (1600)
	12 (305)	(Prefix)-24-12-HT*	27 (686)	42 (1067)	39 (991)	66 (1676)
	18 (457)	(Prefix)-24-18-HT*	27 (686)	48 (1219)	39 (991)	72 (1829)
30 (762)	6 (152)	(Prefix)-30-06-HT*	30 (762)	36 (914)	42 (1067)	60 (1524)
	9 (228)	(Prefix)-30-09-HT*	30 (762)	39 (991)	42 (1067)	63 (1600)
	12 (305)	(Prefix)-30-12-HT*	30 (762)	42 (1067)	42 (1067)	66 (1676)
	18 (457)	(Prefix)-30-18-HT*	30 (762)	48 (1219)	42 (1067)	72 (1829)
	24 (609)	(Prefix)-30-24-HT*	30 (762)	54 (1372)	42 (1067)	78 (1981)
36 (914)	6 (152)	(Prefix)-36-06-HT*	33 (838)	36 (914)	45 (1143)	60 (1524)
	9 (228)	(Prefix)-36-09-HT*	33 (838)	39 (991)	45 (1143)	63 (1600)
	12 (305)	(Prefix)-36-12-HT*	33 (838)	42 (1067)	45 (1143)	66 (1676)
	18 (457)	(Prefix)-36-18-HT*	33 (838)	48 (1219)	45 (1143)	72 (1829)
	24 (609)	(Prefix)-36-24-HT*	33 (838)	54 (1372)	45 (1143)	78 (1981)
	30 (762)	(Prefix)-36-30-HT*	33 (838)	60 (1524)	45 (1143)	84 (2134)

(Prefix) See page G-21 for catalog number prefix.

Width dimensions are to inside wall. For aluminum fittings add 1.5 inches for total outside width.

Manufacturing tolerances apply to all dimensions.

All dimensions in parentheses are millimeters unless otherwise specified.

KwikSplice™ Aluminum Cable Tray - Fittings

Horizontal Expanding Tee (HT)

2 pair splice plates with hardware included.

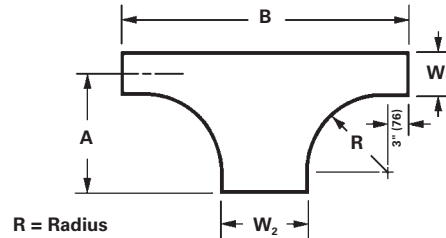
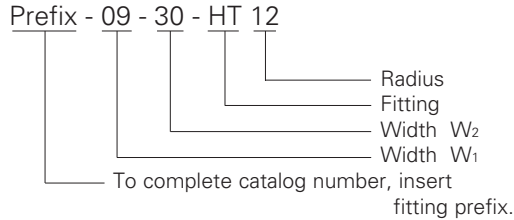
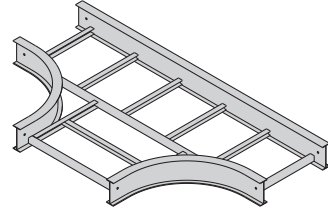

KwikSplice Cable Tray

Tray Width		* Insert Radius (12" or 24") Catalog No.	R = 12" Radius (305)		R = 24" Radius (609)	
W ₁ in. (mm)	W ₂ in. (mm)		A in. (mm)	B in. (mm)	A in. (mm)	B in. (mm)
6 (152)	9 (228)	(Prefix)-06-09-HT*	18 (457)	39 (991)	30 (762)	63 (1600)
	12 (305)	(Prefix)-06-12-HT*	18 (457)	42 (1067)	30 (762)	66 (1676)
	18 (457)	(Prefix)-06-18-HT*	18 (457)	48 (1219)	30 (762)	72 (1829)
	24 (609)	(Prefix)-06-24-HT*	18 (457)	54 (1372)	30 (762)	78 (1981)
	30 (762)	(Prefix)-06-30-HT*	18 (457)	60 (1524)	30 (762)	84 (2134)
	36 (914)	(Prefix)-06-36-HT*	18 (457)	66 (1676)	30 (762)	90 (2286)
9 (228)	12 (305)	(Prefix)-09-12-HT*	19 ¹ / ₂ (496)	42 (1067)	31 ¹ / ₂ (800)	66 (1676)
	18 (457)	(Prefix)-09-18-HT*	19 ¹ / ₂ (496)	48 (1219)	31 ¹ / ₂ (800)	72 (1829)
	24 (609)	(Prefix)-09-24-HT*	19 ¹ / ₂ (496)	54 (1372)	31 ¹ / ₂ (800)	78 (1981)
	30 (762)	(Prefix)-09-30-HT*	19 ¹ / ₂ (496)	60 (1524)	31 ¹ / ₂ (800)	84 (2134)
	36 (914)	(Prefix)-09-36-HT*	19 ¹ / ₂ (496)	66 (1676)	31 ¹ / ₂ (800)	90 (2286)
12 (305)	18 (457)	(Prefix)-12-18-HT*	21 (533)	48 (1219)	33 (838)	72 (1829)
	24 (609)	(Prefix)-12-24-HT*	21 (533)	54 (1372)	33 (838)	78 (1981)
	30 (762)	(Prefix)-12-30-HT*	21 (533)	60 (1524)	33 (838)	84 (2134)
	36 (914)	(Prefix)-12-36-HT*	21 (533)	66 (1676)	33 (838)	90 (2286)
18 (457)	24 (609)	(Prefix)-18-24-HT*	24 (609)	54 (1372)	36 (914)	78 (1981)
	30 (762)	(Prefix)-18-30-HT*	24 (609)	60 (1524)	36 (914)	84 (2134)
	36 (914)	(Prefix)-18-36-HT*	24 (609)	66 (1676)	36 (914)	90 (2286)
24 (609)	30 (762)	(Prefix)-24-30-HT*	27 (686)	60 (1524)	39 (991)	84 (2134)
	36 (914)	(Prefix)-24-36-HT*	27 (686)	66 (1676)	39 (991)	90 (2286)
36 (762)	36 (914)	(Prefix)-30-36-HT*	30 (762)	66 (1676)	42 (1067)	90 (2286)

(Prefix) See page G-21 for catalog number prefix.

Width dimensions are to inside wall. For aluminum fittings add 1.5 inches for total outside width.

Manufacturing tolerances apply to all dimensions.

All dimensions in parentheses are millimeters unless otherwise specified.

Horizontal Expanding/Reducing Cross (HX)

3 pair splice plates with hardware included.

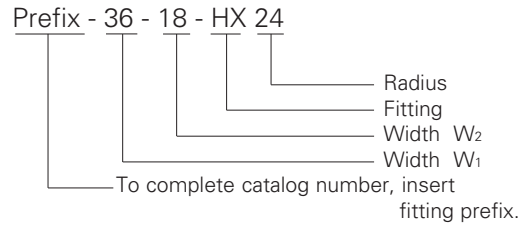
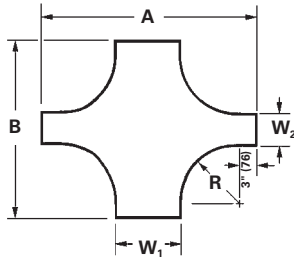
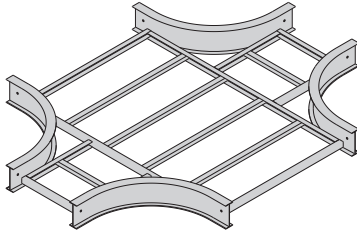

Tray Width		* Insert Radius (12" or 24") Catalog No.	R = 12" Radius (305)		R = 24" Radius (609)	
W ₁ in. (mm)	W ₂ in. (mm)		A in. (mm)	B in. (mm)	A in. (mm)	B in. (mm)
9 (228)	6 (152)	(Prefix)-09-06-HX*	39 (991)	36 (914)	63 (1600)	60 (1524)
12 (305)	6 (152)	(Prefix)-12-06-HX*	42 (1067)	36 (914)	66 (1676)	60 (1524)
	9 (228)	(Prefix)-12-09-HX*	42 (1067)	39 (991)	66 (1676)	63 (1600)
18 (457)	6 (152)	(Prefix)-18-06-HX*	48 (1219)	36 (914)	72 (1829)	60 (1524)
	9 (228)	(Prefix)-18-09-HX*	48 (1219)	39 (991)	72 (1829)	63 (1600)
	12 (305)	(Prefix)-18-12-HX*	48 (1219)	42 (1067)	72 (1829)	66 (1676)
24 (609)	6 (152)	(Prefix)-24-06-HX*	54 (1372)	36 (914)	78 (1981)	60 (1524)
	9 (228)	(Prefix)-24-09-HX*	54 (1372)	39 (991)	78 (1981)	63 (1600)
	12 (305)	(Prefix)-24-12-HX*	54 (1372)	42 (1067)	78 (1981)	66 (1676)
	18 (457)	(Prefix)-24-18-HX*	54 (1372)	48 (1219)	78 (1981)	72 (1829)
30 (762)	6 (152)	(Prefix)-30-06-HX*	60 (1524)	36 (914)	84 (2134)	60 (1524)
	9 (228)	(Prefix)-30-09-HX*	60 (1524)	39 (991)	84 (2134)	63 (1600)
	12 (305)	(Prefix)-30-12-HX*	60 (1524)	42 (1067)	84 (2134)	66 (1676)
	18 (457)	(Prefix)-30-18-HX*	60 (1524)	48 (1219)	84 (2134)	72 (1829)
	24 (609)	(Prefix)-30-24-HX*	60 (1524)	54 (1372)	84 (2134)	78 (1981)
36 (914)	6 (152)	(Prefix)-36-06-HX*	66 (1676)	36 (914)	90 (2286)	60 (1524)
	9 (228)	(Prefix)-36-09-HX*	66 (1676)	39 (991)	90 (2286)	63 (1600)
	12 (305)	(Prefix)-36-12-HX*	66 (1676)	42 (1067)	90 (2286)	66 (1676)
	18 (457)	(Prefix)-36-18-HX*	66 (1676)	48 (1219)	90 (2286)	72 (1829)
	24 (609)	(Prefix)-36-24-HX*	66 (1676)	54 (1372)	90 (2286)	78 (1981)
	30 (762)	(Prefix)-36-30-HX*	66 (1676)	60 (1524)	90 (2286)	84 (2134)

(Prefix) See page G-21 for catalog number prefix.

Width dimensions are to inside wall. For aluminum fittings add 1.5 inches for total outside width.

Manufacturing tolerances apply to all dimensions.

All dimensions in parentheses are millimeters unless otherwise specified.

KwikSplice™ Aluminum Cable Tray - Fittings

Vertical Bend 90° (VO, VI)

1 pair splice plates with hardware included.

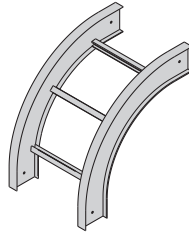

90° Vertical Outside

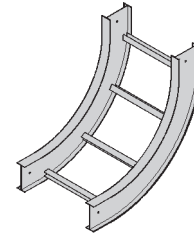

90° Vertical Inside

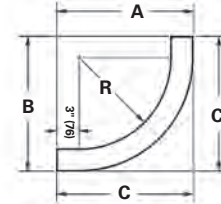
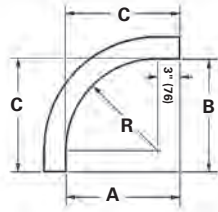

KwikSplice Cable Tray

Bend Radius R	Tray Width Insert	(*) Insert "VO" for Vert. Outside Bend "VI" for Vert. Inside Bend Catalog No.	VO Side Rail Height			VI Side Rail Height								
			4" - 6" (101-152)			4" (101)			5" (127)			6" (152)		
in. (mm)	in. (mm)		A in. (mm)	B in. (mm)	C in. (mm)	A in. (mm)	B in. (mm)	C in. (mm)	A in. (mm)	B in. (mm)	C in. (mm)	A in. (mm)	B in. (mm)	C in. (mm)
12 (305)	6 (152)	(Prefix)-06-90(*)12												
	9 (228)	(Prefix)-09-90(*)12												
	12 (305)	(Prefix)-12-90(*)12												
	18 (457)	(Prefix)-18-90(*)12	15 (381)	15 (381)	15 (381)	19 (483)	19 (483)	19 (483)	20 (508)	20 (508)	20 (508)	21 (533)	21 (533)	21 (533)
	24 (609)	(Prefix)-24-90(*)12												
	30 (762)	(Prefix)-30-90(*)12												
36 (914)	(Prefix)-36-90(*)12													
24 (609)	6 (152)	(Prefix)-06-90(*)24												
	9 (228)	(Prefix)-09-90(*)24												
	12 (305)	(Prefix)-12-90(*)24												
	18 (457)	(Prefix)-18-90(*)24	27 (686)	27 (686)	27 (686)	31 (787)	31 (787)	31 (787)	32 (813)	32 (813)	32 (813)	33 (838)	33 (838)	33 (838)
	24 (609)	(Prefix)-24-90(*)24												
	30 (762)	(Prefix)-30-90(*)24												
36 (914)	(Prefix)-36-90(*)24													

(Prefix) See page G-21 for catalog number prefix.

Manufacturing tolerances apply to all dimensions.

All dimensions in parentheses are millimeters unless otherwise specified.

Vertical Bend 60° (VO, VI)

1 pair splice plates with hardware included.

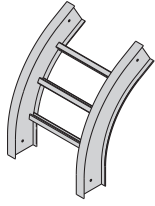

60° Vertical Outside

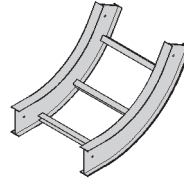

60° Vertical Inside

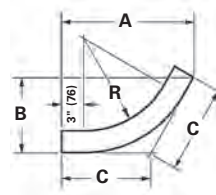
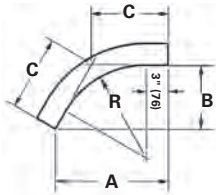

Bend Radius R	Tray Width Insert	(*) Insert "VO" for Vert. Outside Bend "VI" for Vert. Inside Bend Catalog No.	VO Side Rail Height			VI Side Rail Height									
			4" - 6" (101-152)			4" (101)			5" (127)			6" (152)			
in. (mm)	in. (mm)		A	B	C	A	B	C	A	B	C	A	B	C	
			in. (mm)	in. (mm)	in. (mm)	in. (mm)	in. (mm)	in. (mm)	in. (mm)	in. (mm)	in. (mm)	in. (mm)	in. (mm)	in. (mm)	in. (mm)
12 (305)	6 (152)	(Prefix)-06-60(*)12													
	9 (228)	(Prefix)-09-60(*)12													
	12 (305)	(Prefix)-12-60(*)12													
	18 (457)	(Prefix)-18-60(*)12	147/8 (378)	85/8 (219)	915/16 (253)	183/8 (467)	105/8 (270)	121/4 (311)	191/4 (489)	111/8 (283)	1213/16 (326)	201/16 (510)	115/8 (296)	133/8 (340)	
	24 (609)	(Prefix)-24-60(*)12													
	30 (762)	(Prefix)-30-60(*)12													
24 (609)	6 (152)	(Prefix)-06-60(*)24													
	9 (228)	(Prefix)-09-60(*)24													
	12 (305)	(Prefix)-12-60(*)24													
	18 (457)	(Prefix)-18-60(*)24	255/16 (643)	145/8 (372)	167/8 (428)	283/4 (730)	165/8 (422)	193/16 (488)	295/8 (753)	171/8 (435)	193/4 (502)	301/2 (775)	175/8 (448)	205/16 (516)	
	24 (609)	(Prefix)-24-60(*)24													
	30 (762)	(Prefix)-30-60(*)24													
	36 (914)	(Prefix)-36-60(*)24													

(Prefix) See page G-21 for catalog number prefix.
Manufacturing tolerances apply to all dimensions.

All dimensions in parentheses are millimeters unless otherwise specified.

KwikSplice™ Aluminum Cable Tray - Fittings

Vertical Bend 45° (VO, VI)

1 pair splice plates with hardware included.

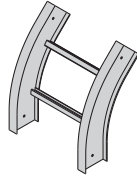

45° Vertical Outside

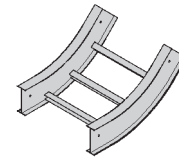

45° Vertical Inside

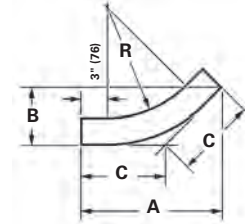
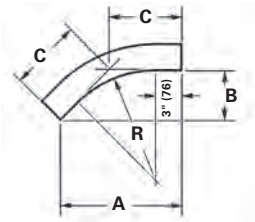

KwikSplice Cable Tray

Bend Radius R	Tray Width Insert	(*) Insert "VO" for Vert. Outside Bend "VI" for Vert. Inside Bend Catalog No.	VO Side Rail Height			VI Side Rail Height								
			4" - 6" (101-152)			4" (101)			5" (127)			6" (152)		
in. (mm)	in. (mm)		A	B	C	A	B	C	A	B	C	A	B	C
in. (mm)	in. (mm)		in. (mm)	in. (mm)	in. (mm)	in. (mm)	in. (mm)	in. (mm)	in. (mm)	in. (mm)	in. (mm)	in. (mm)	in. (mm)	in. (mm)
12 (305)	6 (152)	(Prefix)-06-45(*)12												
	9 (228)	(Prefix)-09-45(*)12												
	12 (305)	(Prefix)-12-45(*)12												
	18 (457)	(Prefix)-18-45(*)12	13 ⁵ / ₈ (346)	5 ⁵ / ₈ (143)	8 (203)	16 ⁷ / ₁₆ (417)	6 ¹³ / ₁₆ (173)	9 ⁵ / ₈ (245)	17 ¹ / ₈ (435)	7 ¹ / ₈ (181)	10 ¹ / ₁₆ (256)	17 ⁷ / ₈ (454)	7 ³ / ₈ (188)	10 ⁷ / ₁₆ (265)
	24 (609)	(Prefix)-24-45(*)12												
	30 (762)	(Prefix)-30-45(*)12												
36 (914)	(Prefix)-36-45(*)12													
24 (609)	6 (152)	(Prefix)-06-45(*)24												
	9 (228)	(Prefix)-09-45(*)24												
	12 (305)	(Prefix)-12-45(*)24												
	18 (457)	(Prefix)-18-45(*)24	22 ¹ / ₁₆ (561)	9 ¹ / ₈ (232)	12 ¹⁵ / ₁₆ (329)	24 ¹⁵ / ₁₆ (634)	10 ⁵ / ₁₆ (262)	14 ⁵ / ₈ (372)	25 ⁵ / ₈ (651)	10 ⁵ / ₈ (270)	15 (381)	26 ⁵ / ₁₆ (668)	10 ¹⁵ / ₁₆ (278)	15 ⁷ / ₁₆ (392)
	24 (609)	(Prefix)-24-45(*)24												
	30 (762)	(Prefix)-30-45(*)24												
36 (914)	(Prefix)-36-45(*)24													

(Prefix) See page G-21 for catalog number prefix.

Manufacturing tolerances apply to all dimensions.

All dimensions in parentheses are millimeters unless otherwise specified.

Vertical Bend 30° (VO, VI)

1 pair splice plates with hardware included.

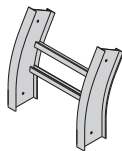

30° Vertical Outside

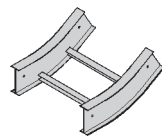

30° Vertical Inside

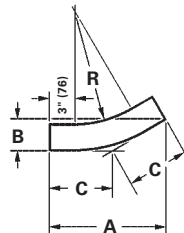
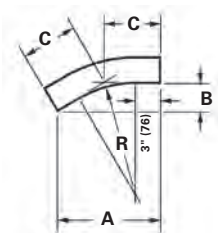

Bend Radius R	Tray Width Insert	(*) Insert "VO" for Vert. Outside Bend "VI" for Vert. Inside Bend Catalog No.	VO Side Rail Height			VI Side Rail Height								
			4" - 6" (101-152)			4" (101)			5" (127)			6" (152)		
in. (mm)	in. (mm)		A	B	C	A	B	C	A	B	C	A	B	C
			in. (mm)	in. (mm)	in. (mm)	in. (mm)	in. (mm)	in. (mm)	in. (mm)	in. (mm)	in. (mm)	in. (mm)	in. (mm)	in. (mm)
12 (305)	6 (152)	(Prefix)-06-30(*)12												
	9 (228)	(Prefix)-09-30(*)12												
	12 (305)	(Prefix)-12-30(*)12												
	18 (457)	(Prefix)-18-30(*)12	11 ⁵ / ₈ (296)	3 ¹ / ₈ (79)	6 ³ / ₁₆ (157)	13 ⁵ / ₈ (346)	3 ⁵ / ₈ (92)	7 ⁵ / ₁₆ (186)	14 ¹ / ₈ (359)	3 ³ / ₄ (95)	7 ⁹ / ₁₆ (192)	14 ⁵ / ₈ (372)	3 ¹⁵ / ₁₆ (100)	7 ¹³ / ₁₆ (199)
	24 (609)	(Prefix)-24-30(*)12												
	30 (762)	(Prefix)-30-30(*)12												
	36 (914)	(Prefix)-36-30(*)12												
24 (609)	6 (152)	(Prefix)-06-30(*)24												
	9 (228)	(Prefix)-09-30(*)24												
	12 (305)	(Prefix)-12-30(*)24												
	18 (457)	(Prefix)-18-30(*)24	17 ⁵ / ₈ (448)	4 ¹¹ / ₁₆ (120)	9 ⁷ / ₁₆ (240)	19 ⁵ / ₈ (499)	5 ¹ / ₄ (133)	10 ¹ / ₂ (267)	20 ¹ / ₈ (511)	5 ³ / ₈ (137)	10 ³ / ₄ (273)	20 ⁵ / ₈ (524)	5 ¹ / ₂ (140)	11 ¹ / ₁₆ (282)
	24 (609)	(Prefix)-24-30(*)24												
	30 (762)	(Prefix)-30-30(*)24												
	36 (914)	(Prefix)-36-30(*)24												

(Prefix) See page G-21 for catalog number prefix.

Manufacturing tolerances apply to all dimensions.

All dimensions in parentheses are millimeters unless otherwise specified.

KwikSplice™ Aluminum Cable Tray - Fittings

Vertical Tee Up/Down (VTU/VT)

2 pair splice plates with hardware included.

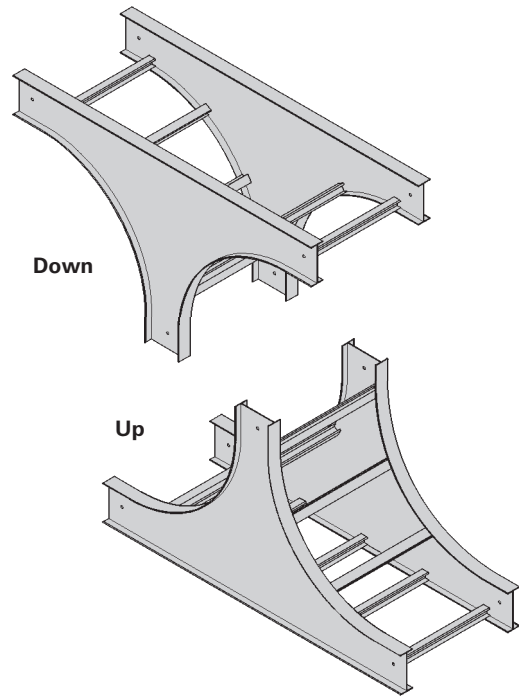
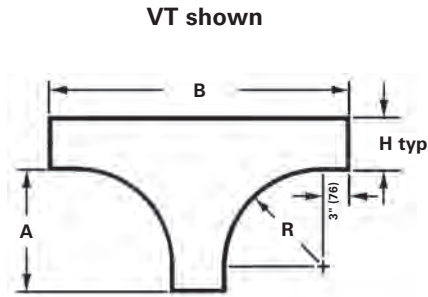

KwikSplice Cable Tray

Bend Radius R in. (mm)	Tray Width in. (mm)	Vertical Tee Down Catalog No.	Vertical Tee Up Catalog No.	Side Rail Height "H"					
				4" (101)		5" (127)		6" (152)	
				A in. (mm)	B in. (mm)	A in. (mm)	B in. (mm)	A in. (mm)	B in. (mm)
12 (305)	6 (152)	(Prefix)-06-VT12	(Prefix)-06-VTU12						
	9 (228)	(Prefix)-09-VT12	(Prefix)-09-VTU12						
	12 (305)	(Prefix)-12-VT12	(Prefix)-12-VTU12						
	18 (457)	(Prefix)-18-VT12	(Prefix)-18-VTU12	15 (381)	34 (846)	15 (381)	35 (889)	15 (381)	36 (914)
	24 (609)	(Prefix)-24-VT12	(Prefix)-24-VTU12						
	30 (762)	(Prefix)-30-VT12	(Prefix)-30-VTU12						
	36 (914)	(Prefix)-36-VT12	(Prefix)-36-VTU12						
24 (609)	6 (152)	(Prefix)-06-VT24	(Prefix)-06-VTU24						
	9 (228)	(Prefix)-09-VT24	(Prefix)-09-VTU24						
	12 (305)	(Prefix)-12-VT24	(Prefix)-12-VTU24						
	18 (457)	(Prefix)-18-VT24	(Prefix)-18-VTU24	27 (686)	58 (1473)	27 (686)	59 (1498)	27 (686)	60 (1524)
	24 (609)	(Prefix)-24-VT24	(Prefix)-24-VTU24						
	30 (762)	(Prefix)-30-VT24	(Prefix)-30-VTU24						
	36 (914)	(Prefix)-36-VT24	(Prefix)-36-VTU24						

(Prefix) See page G-21 for catalog number prefix.

Manufacturing tolerances apply to all dimensions.

All dimensions in parentheses are millimeters unless otherwise specified.

Series 1 Steel - Straight Sections



Series 1 Steel

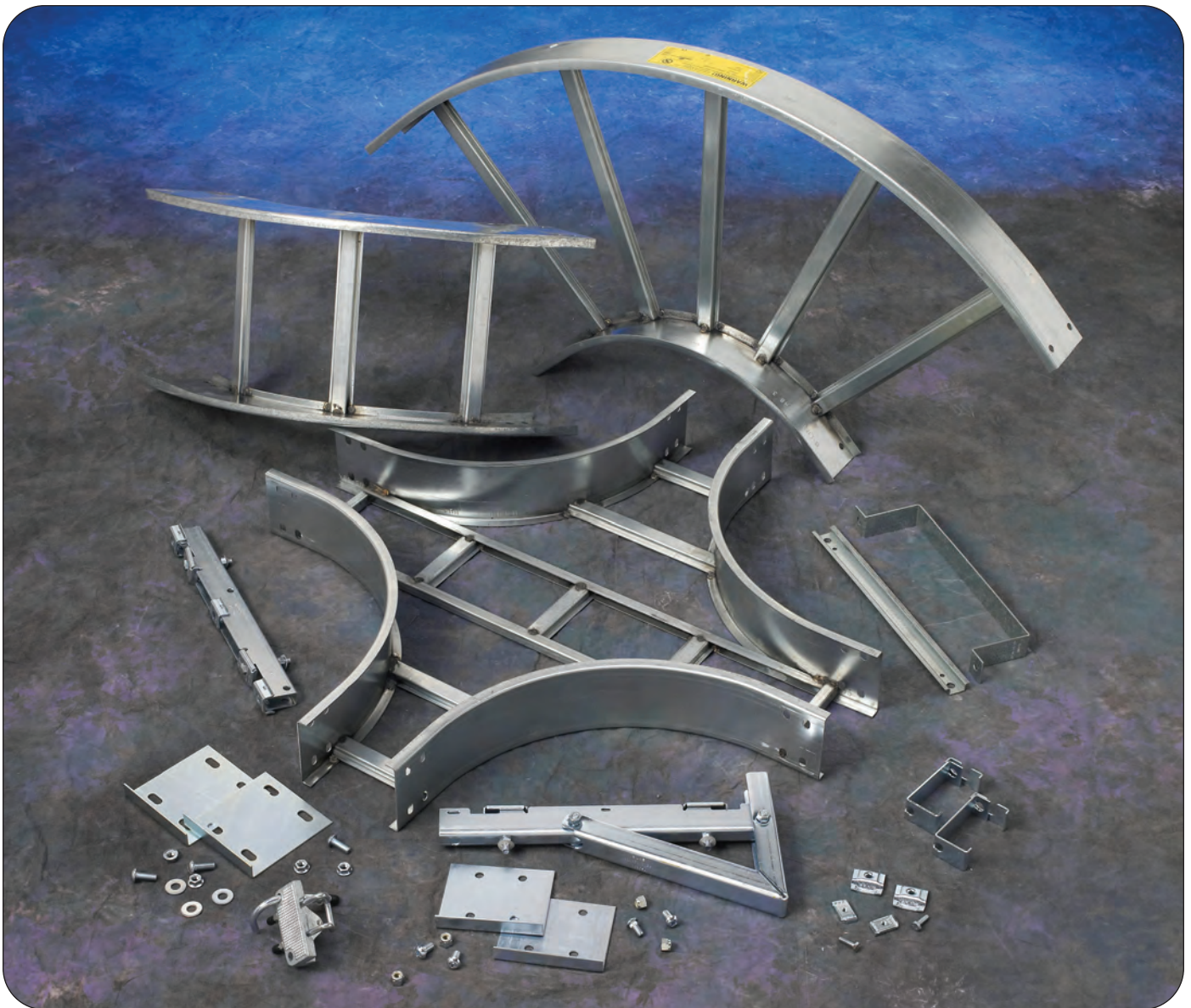

How The Service Advisor Works

We know that your time is important! That's why the color-coding system in this catalog is designed to help you select products that fit your service needs. Products are marked to indicate the typical lead time for orders of 50 pieces or less.

Customer: How do I select my straight sections, covers, or fittings so that I get the quickest turnaround?

Service Advisor: Each part of our selection chart is shown in colors. If any section of a part number is a different color, the part will typically ship with the longer lead time represented by the colors.

- Green = Fastest shipped items
- Black = Normal lead-time items
- Red = Normally long lead-time items

Example: 156G 09 - 24 - 144

● ● ● ●

● ● ● ●

Part will have a long lead time because of the 156G material.

Changing the part number from 156G to 156P will change the coding to black for all sections and reduce lead time.

3" NEMA VE 1 Loading Depth Actual Loading Depth = 3.077"

Straight Section Part Numbering

Example: **148 P 09 - 24 - 144**

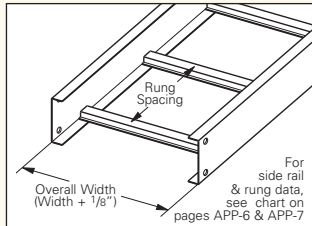
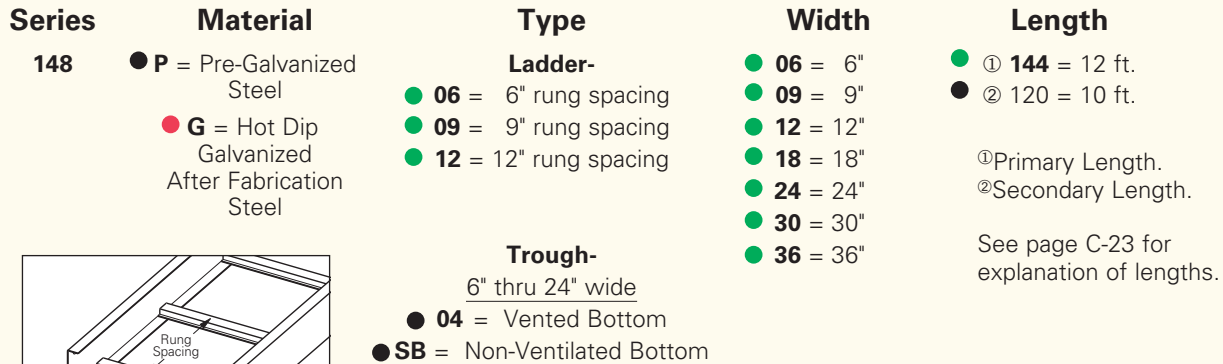

See page APP-1 for additional rung options. *SB available for all widths.

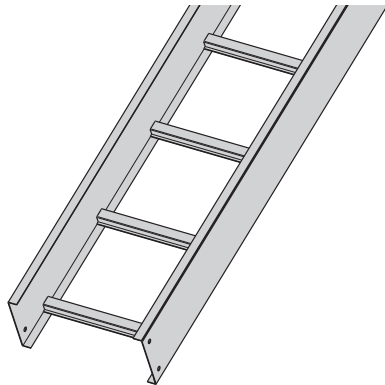

Ladder Type
(Specify Rung Spacing)

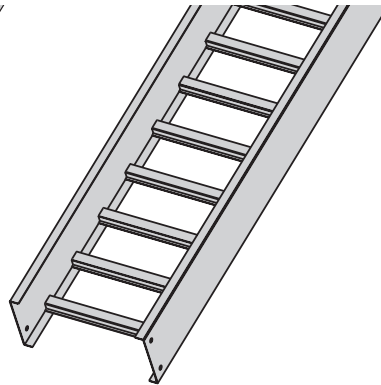

Ventilated Bottom

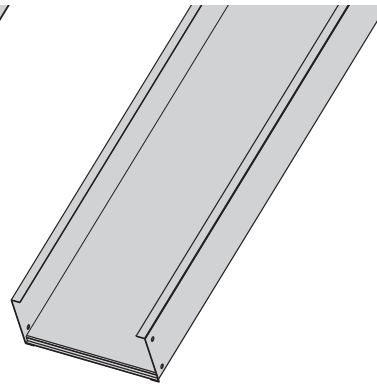

Non-Ventilated

Values are based on simple beam tests per NEMA VE 1 on 36" wide cable tray with rungs spaced on 12" centers. The published load safety factor is 1.5. To convert 1.5 safety factor to 2.0, multiply the published load by 0.75. To obtain mid-span deflection, multiply a load by the deflection multiplier. Cable tray must be supported on spans shorter than or equal to the length of the cable tray being installed.

B-Line Series Slide Rail Dimensions	NEMA, CSA & UL Classifications	Span ft	Load lbs/ft	Deflection Multiplier	Design Factors for Two Rails	Span meters	Load kg/m	Deflection Multiplier	Design Factors for Two Rails
	NEMA: 12A, 8C	6	204*	0.0011	Area = 0.510 in ²	1.8	304*	0.019	Area = 3.290 cm ²
	CSA: C1-3m	8	115	0.0036	Sx = 0.480 in ³	2.4	171	0.061	Sx = 7.870 cm ³
	UL Cross-Sectional	10	73	0.0087	Ix = 0.890 in ⁴	3.0	109	0.149	Ix = 37.04 cm ⁴
	Area: 0.40 in ²	12	51	0.0181		3.7	76	0.309	

*When using 12" rung spacing load capacity is limited to 195 lbs/ft (290.16 kg/m) for 36" tray width. When cable trays are used in continuous spans, the deflection of the cable tray is reduced by as much as 50%.

Design factors: Ix = Moment of Inertia, Sx = Section Modulus.

● Green = Fastest shipped items ● Black = Normal lead-time items ● Red = Normally long lead-time items

4" NEMA VE 1 Loading Depth Actual Loading Depth = 3.628"

Straight Section Part Numbering

Prefix
Example: **156 P 09 - 24 - 144**

Series	Material	Type	Width	Length
156	<ul style="list-style-type: none"> ● P = Pre-Galvanized Steel ● G = Hot Dip Galvanized After Fabrication Steel 	Ladder- <ul style="list-style-type: none"> ● 06 = 6" rung spacing ● 09 = 9" rung spacing ● 12 = 12" rung spacing Trough- 6" thru 24" wide <ul style="list-style-type: none"> ● 04 = Vented Bottom ● SB = Non-Ventilated Bottom 	<ul style="list-style-type: none"> ● 06 = 6" ● 09 = 9" ● 12 = 12" ● 18 = 18" ● 24 = 24" ● 30 = 30" ● 36 = 36" 	<ul style="list-style-type: none"> ● ① 144 = 12 ft. ● ② 120 = 10 ft. <p>① Primary Length. ② Secondary Length.</p> <p>See page C-23 for explanation of lengths.</p>

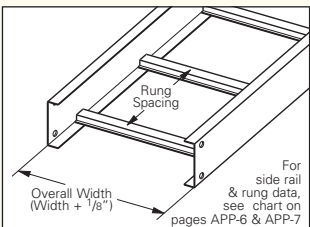

See page APP-1 for additional rung options. *SB available for all widths.

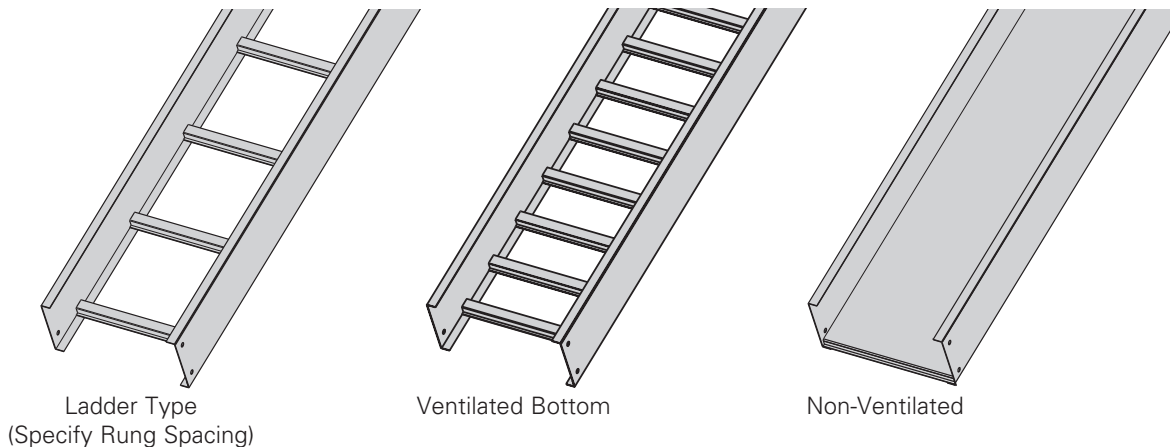

Values are based on simple beam tests per NEMA VE 1 on 36" wide cable tray with rungs spaced on 12" centers. Cable trays will support without collapse a 200 lb. (90.7 kg) concentrated load over and above the published loads. The published load safety factor is 1.5. To convert 1.5 safety factor to 2.0, multiply the published load by 0.75. To obtain mid-span deflection, multiply a load by the deflection multiplier. Cable tray must be supported on spans shorter than or equal to the length of the cable tray being installed.

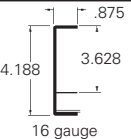
B-Line Series Slide Rail Dimensions	NEMA, CSA & UL Classifications	Span ft	Load lbs/ft	Deflection Multiplier	Design Factors for Two Rails	Span meters	Load kg/m	Deflection Multiplier	Design Factors for Two Rails
156 	NEMA: 12B, 8C	6	304*	0.0007	Area = 0.690 in ² Sx = 0.724 in ³ Ix = 1.517 in ⁴	1.8	452*	0.011	Area = 4.390 cm ² Sx = 11.860 cm ³ Ix = 63.140 cm ⁴
	CSA: C1-3m	8	171	0.0021		2.4	254	0.036	
	UL Cross-Sectional	10	109	0.0051		3.0	163	0.087	
	Area: 0.40 in ²	12	76	0.0011		3.7	113	0.181	

*When using 12" rung spacing, load capacity is limited to 234 lbs/ft (348.192 kg/m) for 30" tray width and 195 lbs/ft (290.16 kg/m) for 36" tray width. When trays are used in continuous spans, the deflection of the tray is reduced by as much as 50%. Design factors: Ix = Moment of Inertia, Sx = Section Modulus.

● Green = Fastest shipped items ● Black = Normal lead-time items ● Red = Normally long lead-time items

All dimensions in parentheses are millimeters unless otherwise specified.

Series 1 Steel - Straight Sections

5" NEMA VE 1 Loading Depth Actual Loading Depth = 4.628"

Straight Section Part Numbering

Example: **166 P 09 - 24 - 144**

Series

166

Material

- **P** = Pre-Galvanized Steel
- **G** = Hot Dip Galvanized After Fabrication Steel

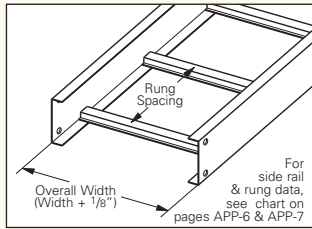

Type

Ladder-

- **06** = 6" rung spacing
- **09** = 9" rung spacing
- **12** = 12" rung spacing

Trough-

6" thru 24" wide

- **04** = Vented Bottom
- **SB** = Non-Ventilated Bottom

Width

- **06** = 6"
- **09** = 9"
- **12** = 12"
- **18** = 18"
- **24** = 24"
- **30** = 30"
- **36** = 36"

Length

- ① **144** = 12 ft.
- ② **120** = 10 ft.

① Primary Length.
② Secondary Length.

See page C-23 for explanation of lengths.

See page APP-1 for additional rung options. *SB available for all widths.

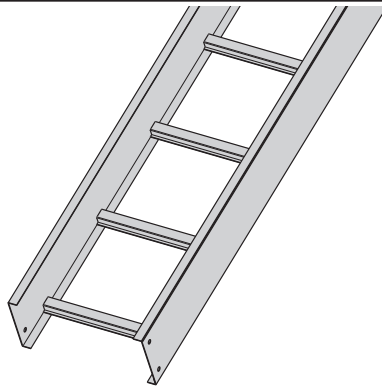

Ladder Type
(Specify Rung Spacing)

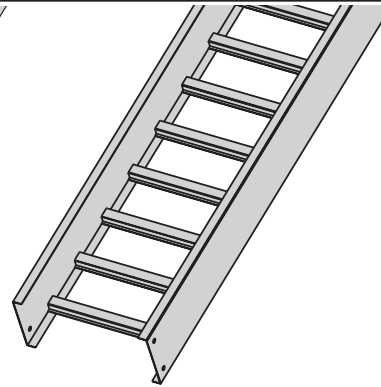

Vented Bottom

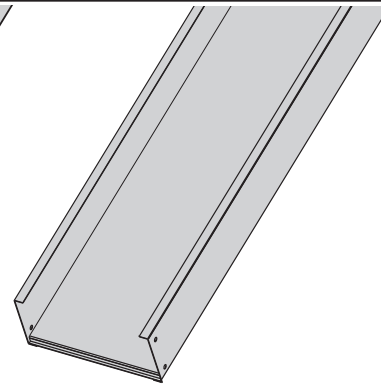

Non-Ventilated

Values are based on simple beam tests per NEMA VE 1 on 36" wide cable tray with rungs spaced on 12" centers. Cable trays will support without collapse a 200 lb. (90.7 kg) concentrated load over and above published loads. The published load safety factor is 1.5. To convert 1.5 safety factor to 2.0, multiply the published load by 0.75. To obtain mid-span deflection, multiply a load by the deflection multiplier. Cable tray must be supported on spans shorter than or equal to the length of the cable tray being installed.

B-Line Series Side Rail Dimensions	NEMA, CSA & UL Classifications	Span ft	Load lbs/ft	Deflection Multiplier	Design Factors for Two Rails	Span meters	Load kg/m	Deflection Multiplier	Design Factors for Two Rails
	NEMA: 12B, 8C CSA: C1-3m UL Cross-Sectional Area: 0.70 in ²	6	308*	0.0004	Area = 0.770 in ² Sx = 0.930 in ³ Ix = 2.400 in ⁴	1.8	458*	0.007	Area = 4.970 cm ²
		8	173	0.0013		2.4	258	0.023	Sx = 15.240 cm ³
		10	111	0.0032		3.0	165	0.055	Ix = 99.900 cm ⁴
		12	77	0.0067		3.7	115	0.114	

*When using 12" rung spacing, the load capacity is limited to 234 lbs/ft (348.192 kg/m) for 30" tray width and 195 lbs/ft (290.16 kg/m) for 36" tray width. When trays are used in continuous spans, the deflection of the tray is reduced by as much as 50%. Design factors: Ix = Moment of Inertia, Sx = Section Modulus.

● Green = Fastest shipped items ● Black = Normal lead-time items ● Red = Normally long lead-time items

All dimensions in parentheses are millimeters unless otherwise specified.

6" NEMA VE 1 Loading Depth Actual Loading Depth = 5.628"

Straight Section Part Numbering

Prefix
Example: **176 P 09 - 24 - 144**

Series	Material	Type	Width	Length
176	<ul style="list-style-type: none"> ● P = Pre-Galvanized Steel ● G = Hot Dip Galvanized After Fabrication Steel 	Ladder- <ul style="list-style-type: none"> ● 06 = 6" rung spacing ● 09 = 9" rung spacing ● 12 = 12" rung spacing Trough- 6" thru 24" wide <ul style="list-style-type: none"> ● 04 = Vented Bottom ● SB = Non-Ventilated Bottom 	<ul style="list-style-type: none"> ● 06 = 6" ● 09 = 9" ● 12 = 12" ● 18 = 18" ● 24 = 24" ● 30 = 30" ● 36 = 36" 	<ul style="list-style-type: none"> ● ① 144 = 12 ft. ● ② 120 = 10 ft. <p>① Primary Length. ② Secondary Length.</p> <p>See page C-23 for explanation of lengths.</p>

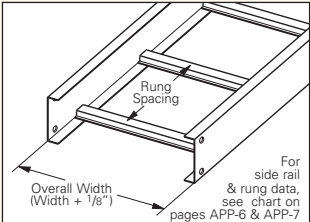

See page APP-1 for additional rung options. *SB available for all widths.

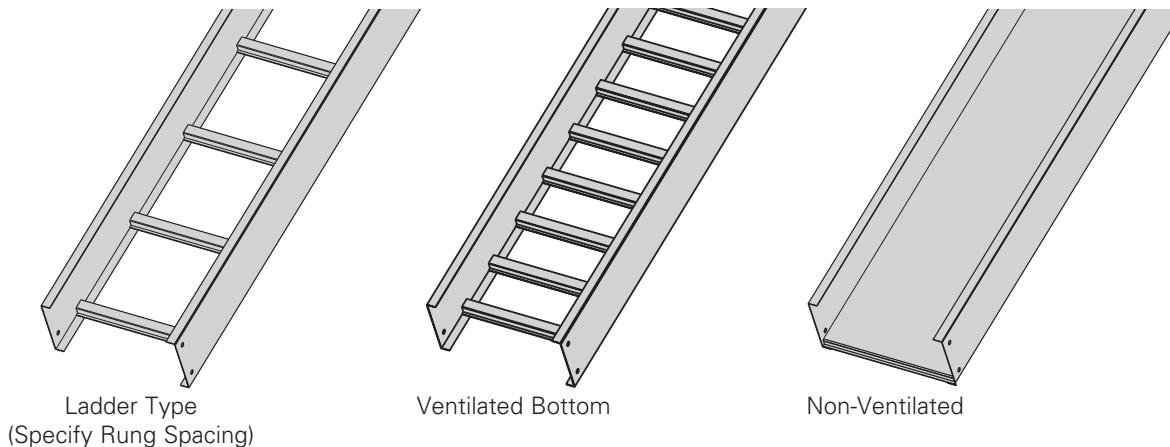

Values are based on simple beam tests per NEMA VE 1 on 36" wide cable tray with rungs spaced on 12" centers. Cable trays will support without collapse a 200 lb. (90.7 kg) concentrated load over and above published loads. The published load safety factor is 1.5. To convert 1.5 safety factor to 2.0, multiply published load by 0.75. To obtain mid-span deflection, multiply a load by the deflection multiplier. Cable tray must be supported on spans shorter than or equal to the length of the cable tray being installed.

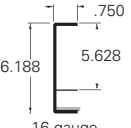
B-Line Series Slide Rail Dimensions	NEMA, CSA & UL Classifications	Span ft	Load lbs/ft	Deflection Multiplier	Design Factors for Two Rails	Span meters	Load kg/m	Deflection Multiplier	Design Factors for Two Rails
 <p>176</p>	NEMA: 12B, 8C CSA: 137 kg/m 3.7m UL Cross-Sectional Area: 0.70 in ²	8	194	0.0008	Area = 0.890 in ²	2.4	458*	0.014	Area = 5.740 cm ²
		10	124	0.0020	Sx = 1.230 in ³	3.0	258	0.035	Sx = 20.160 cm ³
		12	86	0.0042	Ix = 3.800 in ⁴	3.7	165	0.072	Ix = 158.200 cm ⁴

When cable trays are used in continuous spans, the deflection of the tray is reduced by as much as 50%.
Design factors: Ix = Moment of Inertia, Sx = Section Modulus.

● Green = Fastest shipped items ● Black = Normal lead-time items ● Red = Normally long lead-time items

All dimensions in parentheses are millimeters unless otherwise specified.

Series 1 Steel - Accessories

Standard (L-Shaped) Splice Plates

- One pair including hardware provided with each section. (Expansion splice quantity subtracted)
- Furnished in pairs with hardware.
- Prepackaged in pairs in a plastic bag, with hardware.
- 4-hole pattern L-shaped splice plates.
- L-shaped lay-in design.
- (*) Insert **ZN** or **G**

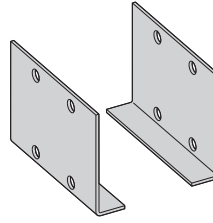

Tray Series	Catalog No.
148	9(*)-4004
156	9(*)-4005
166	9(*)-4006
176	9(*)-4007

Expansion (L-Shaped) Splice Plates

- Expansion plates allow for one inch expansion or contraction of the cable tray, or where expansion joints occur in the supporting structure.
- Bonding Jumpers are required on each side rail. Order Separately.
- L-shaped lay-in design.
- Furnished in pairs with hardware.
- (*) Insert **ZN** or **G**

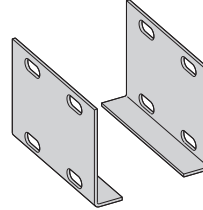

Tray Series	Catalog No.
148	9(*)-4014
156	9(*)-4015
166	9(*)-4016
176	9(*)-4017

Universal Splice Plates

- Used to splice to existing cable tray systems.
- Furnished in pairs with hardware.
- (*) Insert **P** or **G**

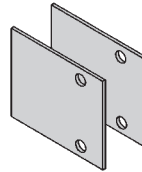

Tray Series	Catalog No.
148	9(*)-2004-1/2
156	9(*)-2005-1/2
166	9(*)-2006-1/2
176	9(*)-2007-1/2

Step Down Splice Plates

- These splice plates are offered for connecting cable tray sections having side rails of different heights.
- Furnished in pairs with hardware.
- (*) Insert **ZN** or **G**

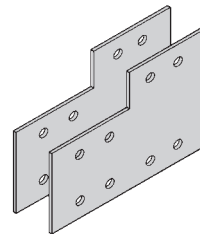

Tray Series	Catalog No.
156 to 148	9(*)-8044
166 to 156 or 148	9(*)-8045
176 to 156 or 148	9(*)-8046
176 to 166	9(*)-8060

Vertical Adjustable Splice Plates

- These plates provide for changes in elevation that do not conform to standard vertical fittings.
- Bonding jumpers not required.
- Furnished in pairs with hardware.
- (*) Insert **ZN** or **G**
- (***) Insert **P** or **G**

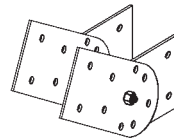

Requires supports within 24" on both sides, per NEMA VE 2.

Tray Series	Catalog No.
148	9(**)-7024
156	9(*)-8024
166	9(*)-8025
176	9(*)-8026

Horizontal Adjustable Splice Plates

- Offered to adjust a cable tray run for changes in direction in a horizontal plane that do not conform to standard horizontal fittings.
- Furnished in pairs with hardware.
- Bonding jumpers not required.
- (*) Insert **ZN** or **G**
- (X) Insert 4 for series 148 or 156, 5 for series 166, or 6 for series 176

9(*)-803(X)-12 or 9(*)-803(X)-36
One pair splice plates with extensions.

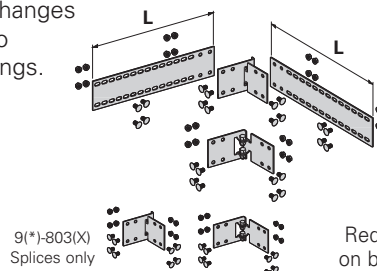

Catalog No.	Cable Tray End Cut	Tray Width	'L'
9(*)-803(X)	Mitered	Thru 36"	N/A
9(*)-803(X)-12	Not mitered	Thru 12"	16"
9(*)-803(X)-36	Not mitered	Thru 36"	41"

Requires supports within 24" on both sides, per NEMA VE 2.

● Green = Fastest shipped items ● Black = Normal lead-time items ● Red = Normally long lead-time items

All dimensions in parentheses are millimeters unless otherwise specified.

Branch Pivot Connectors

- Branch from existing cable tray runs at any point.
- Pivot to any required angle.
- UL Classified for grounding (bonding jumpers are not required).
- Furnished in pairs with hardware.
- (*) Insert **ZN** or **G**

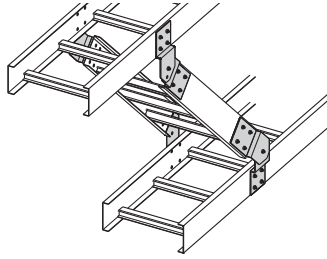

Tray Series	Catalog No.
156 to 148	9(*)-8244
166	9(*)-8245
176	9(*)-8246

Offset Reducing Splice Plate

- This plate is used for joining cable trays having different widths. When used in pairs they form a straight reduction; when used singly with a standard splice plate they form an offset reduction.
- Furnished as one plate with hardware.
- (‡) Insert reduction
- (*) Insert **P** or **G**

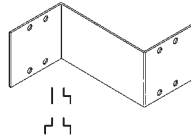

Tray Series	Catalog No.
148	9(*)-8064-(‡)
156	9(*)-8064-(‡)
166	9(*)-8065-(‡)
176	9(*)-8066-(‡)

Tray to Box Splice Plates

- Used to attach the end of a cable tray run to a distribution box or control panel.
- Furnished in pairs with hardware.
- (*) Insert **P** or **G**

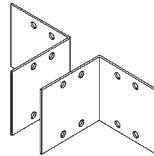

Tray Series	Catalog No.
148	9(*)-8054
156	9(*)-8054
166	9(*)-8055
176	9(*)-8056

Frame Type Box Connector

- Designed to attach the end of a cable tray run to a distribution cabinet or control center to help reinforce the box at the point of entry.
- Furnished with tray connection hardware.
- (‡) Insert tray width
- (*) Insert **ZN** or **G**

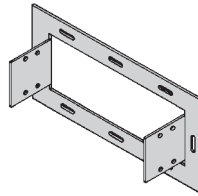

Tray Series	Catalog No.
148	9(*)-8074-(‡)
156	9(*)-8074-(‡)
166	9(*)-8075-(‡)
176	9(*)-8076-(‡)

Blind End

- This plate forms a closure for a dead end cable tray.
- Furnished as one plate with hardware.
- (‡) Insert tray width
- (*) Insert **P** or **G**

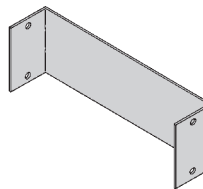

Tray Series	Catalog No.
148	9(*)-8084-(‡)
156	9(*)-8084-(‡)
166	9(*)-8085-(‡)
176	9(*)-8086-(‡)

Tray Hardware

Pre-Galvanized Tray Hardware

Catalog No. ● **RNCB 3/8"-16 x 3/4" Znplt**
Ribbed Neck Carriage Bolt ASTM A307 Grade A

Catalog No. ● **SFHN 3/8"-16 Znplt**
Serrated Flange Hex Nut ASTM A563 Grade A

Finish: Zinc Plated ASTM B633, SC1

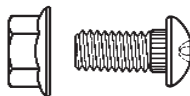

Hot Dip Galvanized Tray Hardware

Catalog No. ● **RNCB 3/8"-16 x 3/4" CZ** Ribbed Neck Carriage Bolt Chromium Zinc ASTM F-1136-88

Catalog No. ● **SFHN 3/8"-16 CZ** Serrated Flange Hex Nut Chromium Zinc ASTM F-1136-88

● Green = Fastest shipped items ● Black = Normal lead-time items ● Red = Normally long lead-time items

All dimensions in parentheses are millimeters unless otherwise specified.

Series 1 Steel - Accessories

Conduit to Tray Adaptor

- For easy attachment of conduit terminating at a cable tray.
- Use on aluminum or steel cable trays.

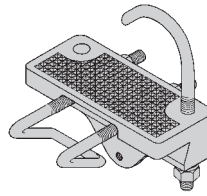
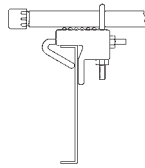

Conduit Size		Catalog No.
in.	(mm)	
1/2, 3/4	(15, 20)	9G-1159-1/2, 3/4
1, 1 1/4	(25, 32)	9G-1159-1, 1 1/4
1 1/2, 2	(40, 50)	9G-1159-1 1/2, 2
2 1/2, 3	(65, 80)	9G-1159-2 1/2, 3
3 1/2, 4	(90, 100)	9G-1159-3 1/2, 4

Conduit to Tray Adaptor

- Assembly required.
- Mounting hardware included.
- Conduit clamp included
- (‡) = Conduit size (1/2" thru 4").

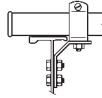

Catalog No.
9ZN-1150-(‡)

Cable Tie (Ladder Tray)

- Nylon ties provide easy attachment of cable to ladder rungs; maximum cable O.D. of 3" (76 mm).

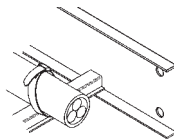

Catalog No.
99-2125-15

Cable Tray Clamp/Guide

- Features a no-twist design.
- Has four times the strength of the traditional design.
- Each side is labeled to ensure proper installation.
- Furnished in pairs, with or without hardware.

Patent # RE35479

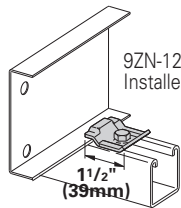

9ZN-1204 shown. Installed as a guide.

1 1/2" (39mm)

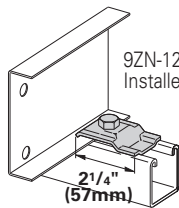

9ZN-1208 shown. Installed as a clamp.

2 1/4" (57mm)

Catalog No.		Overall Length in. (mm)	Hardware Size	Finish
Without Hardware	With Hardware			
9ZN-1204	9ZN-1204NB	1 1/2 38	1/4"	G90
9ZN-1208	9ZN-1208NB	2 1/4 57	3/8"	G90

Bonding Jumper

Use at each expansion splice and where the cable tray is not mechanically/electrically continuous to ground.

Sold individually.

- Hardware included.
- See table 392.7(B)(2) on page C-9 for amperage ratings required to match the UL cross-sectional area of the tray.
- 600 amp rating.
- Bonding jumper is 14 1/2" (368mm) long.

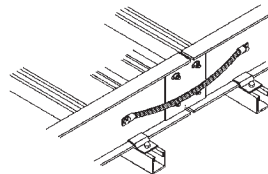

Catalog No.	Copper Wire Size
99-N1	#1

Grounding Clamp

Eaton's B-Line series cable tray is UL® classified as to its suitability as an equipment grounding conductor. If a separate conductor for additional grounding capability is desired, we offer this clamp for bolting the conductor at least once to each tray section.

- Tin plated Aluminum clamp accepts #6 AWG to 250 MCM.

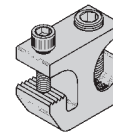

Catalog No.
9A-2130

Ground Wire Clamp

- Mechanically attaches grounding cables to cable tray.
- Hardware included.
- (*) Insert **ZN** or **SS4**

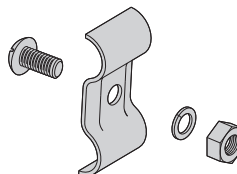

Catalog No.	Cable Size
9(*)-2351	#1 thru 2/0
9(*)-2352	3/0 thru 250 MCM

● Green = Fastest shipped items ● Black = Normal lead-time items ● Red = Normally long lead-time items

All dimensions in parentheses are millimeters unless otherwise specified.

Threaded Rod (ATR) & Rod Coupling

- Loading based on safety factor 5.
- Standard Finish: Zinc plated

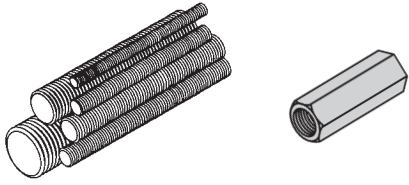

Size	Loading lbs. (kN)	Threaded Rod Catalog No.	Available Lengths in. (mm)	Coupling Cat. No.
3/8-16	730 (3.25)	● ATR 3/8 x Length	36, 72, 120, 144 (914, 1829, 3048, 3657)	● B655-3/8
1/2-13	1350 (6.00)	● ATR 3/8 x Length	36, 72, 120, 144 (914, 1829, 3048, 3657)	● B655-1/2

See B-Line series Strut Systems Catalog for other sizes and finishes.

Hanger Rod Clamp

- For 1/2" ATR.
- Furnished in pairs.
- Order ATR and hex nuts separately.
- Two piece "J"-hanger design.
- 9ZN-1113 has 275 lbs./pair safety factor 3.
- 9ZN-532(X) has 1500 lbs./pair safety factor 3.

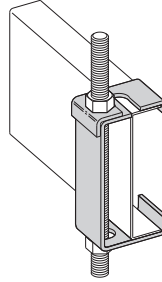

Tray Series	Catalog No.
148	● 9ZN-1113
156	● 9ZN-5324
166	● 9ZN-5325
176	● 9ZN-5326

Support Bracket

- Designed for center hung or trapeze supports.
- Used with ladder or vented bottom tray only.
- Can be purchased as a wall mounted bracket.
- Load capacity is 600 lbs. (272.1 kg), safety factor 3.
- All components are zinc plated.
- 1/2" threaded rod and 1/2" hex nuts not included.

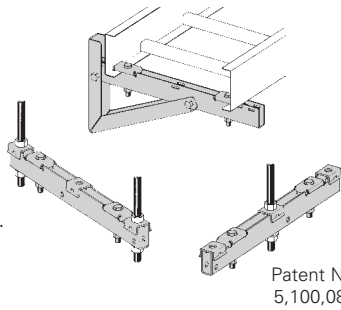

Patent No.
5,100,086

Catalog No.		For Cable Tray Width in. (mm)
Center Hung or Trapeze	Wall Mount	
● 9ZN-5106	● 9ZN-5106-WB	6 (152)
● 9ZN-5109	● 9ZN-5109-WB	9 (226)
● 9ZN-5112	● 9ZN-5112-WB	12 (305)
● 9ZN-5118	● 9ZN-5118-WB	18 (452)
● 9ZN-5124	● 9ZN-5124-WB	24 (609)

Cantilever Bracket (12" - 42")

- Finishes available:
● ZN ● GRN or ● HDG
- Safety Load Factor 2.5

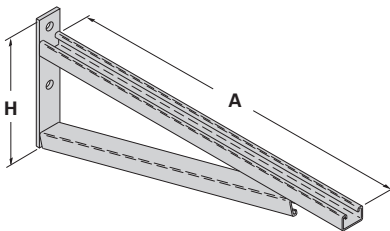

Bottom brace is B42 channel on B494-24 and smaller and B22 channel on B494-30 and larger

Catalog No.	Uniform Load lbs (kN)	Tray Width in. (mm)	'A' in. (mm)	'H' in. (mm)
● B494-12	2500 (11.12)	6 & 9 (152 & 229)	12 (305)	8 ³ / ₄ (222)
● B494-18	1700 (7.56)	12 (305)	18 (457)	8 ³ / ₄ (222)
● B494-24	1300 (5.78)	18 (457)	24 (610)	8 ³ / ₄ (222)
B494-30	1600 (7.11)	24 (610)	30 (762)	11 ¹ / ₄ (286)
B494-36	1100 (4.89)	30 (762)	36 (914)	11 ¹ / ₄ (286)
B494-42	980 (4.36)	36 (914)	42 (1067)	16 (406)

For more dimensional data see Strut Systems catalog

● Green = Fastest shipped items ● Black = Normal lead-time items ● Red = Normally long lead-time items

All dimensions in parentheses are millimeters unless otherwise specified.

Series 1 Steel - Accessories

Cantilever Bracket

- Finishes available: **ZN** **GRN** **HDG** **SS4** or **SS6**
- Safety Load Factor 2.5

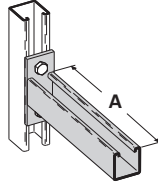

Catalog No.	Uniform Load		Tray Width		'A'	
	lbs	(kN)	in.	(mm)	in.	(mm)
B409-12	960	(4.27)	6 & 9	(152 & 229)	12	(304.8)
B409-18	640	(2.84)	12	(305)	18	(457.2)
B409-24	480	(2.13)	18	(457)	24	(609.6)

Cantilever Bracket

- Finishes available: **ZN** **GRN** **HDG** or **SS4**
- Safety Load Factor 2.5

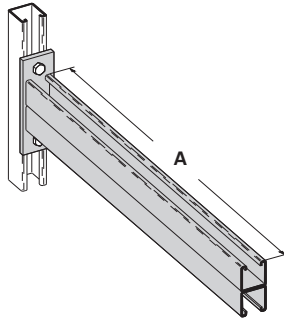

Catalog No.	Uniform Load		Tray Width		'A'	
	lbs	(kN)	in.	(mm)	in.	(mm)
B297-30	665	(2.95)	24	(609.6)	30	(762.0)
B297-36	550	(2.44)	30	(762.0)	36	(914.4)
B297-42	465	(2.06)	36	(914.4)	42	(1066.8)

Underfloor Support (U-Bolts not included)

- Finishes available: **ZN**
- Safety Load Factor 2.5
- Order properly sized U-Bolts separately.

U-Bolt Size	Fits Pipe O.D.
B501-3/4	.841 - 1.050
B501-1	1.051 - 1.315
B501-1 1/4	1.316 - 1.660
B501-1 1/2	1.661 - 1.900
B501-2	1.901 - 2.375
B501-2 1/2	2.376 - 2.875

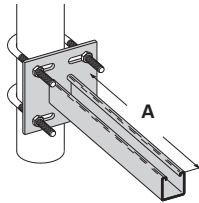

Catalog No.	Uniform Load		Tray Width		'A'	
	lbs	(kN)	in.	(mm)	in.	(mm)
B409UF-12	800	(3.55)	6 & 9	(152 & 229)	12	(304.8)
B409UF-21	450	(2.00)	12 & 18	(305 & 457)	21	(533.4)

Beam Clamp

- Finishes available: **ZN** or **HDG**
- Sold in pieces with hardware.
- Design load when used in pairs. Safety Load Factor 5.0

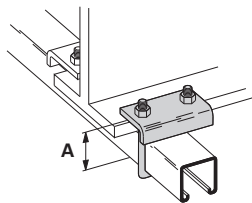

Catalog No.	Design Load*		'A'	
	lbs	(kN)	in.	(mm)
B441-22	1200	(5.34)	3 3/8	(86)
B441-22A	1200	(5.34)	5	(127)

Steel C-Clamp With Locknut

- Finishes available:
 - ZN** for 3/8 & 1/2
 - ZN** for 5/8 & 3/4
 - SS4** all sizes
- Safety Load Factor 5.0

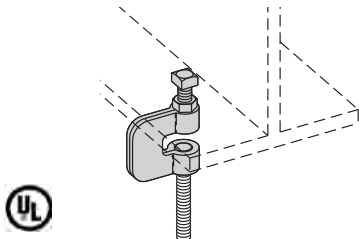

Catalog Number	Rod Size	Design Load	
		lbs	(kN)
B351L-3/8	3/8"-16	300	(0.89)
B351L-1/2	1/2"-13	380	(1.69)
B351L-5/8	5/8"-11	550	(2.44)
B351L-3/4	3/4"-10	630	(2.80)

● Green = Fastest shipped items ● Black = Normal lead-time items ● Red = Normally long lead-time items

All dimensions in parentheses are millimeters unless otherwise specified.

Beam Clamp

- Finishes available: **ZN** **GRN** or **HDG**
- Setscrew included.
- Sold in pieces.
- Design load when used in pairs.
Safety Load Factor 5.0

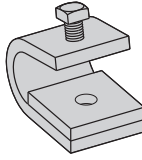

Cat. No.	B210	B210A
Design Load	800 lbs. (3.56kN)	300 lbs. (1.33kN)
Tap Size	1/2"-13	3/8"-16
Mat'l. Thickness	3/8" (9.5mm)	1/4" (6.4mm)

Beam Clamp

- Finishes available: **ZN** **GRN** or **HDG**
- Setscrew included.
- Sold in pieces.
- Design load when used in pairs.
Safety Load Factor 5.0

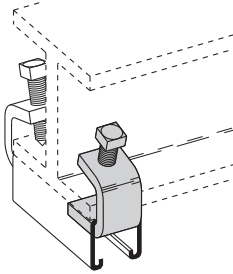

Cat. No.	B212-1/4	B212-3/8
Design Load	800 lbs. (3.56kN)	1000 lbs. (4.45kN)
Max. Flange Thick.	3/4" (19.0mm)	1 1/8" (28.6mm)
Mat'l. Thickness	1/4" (6.4mm)	3/8" (9.5mm)

B305 Thru B308 & B321 Series Beam Clamps

- Finishes available: **ZN** or **HDG**
- Setscrew included.
- Safety Load Factor 5.0

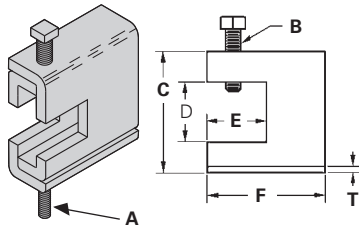

Cat. No.	A	B	C	D	E	F	T	Design Load
			in. (mm)	in. (mm)	in. (mm)	in. (mm)	in. (mm)	lbs (kN)
B305	3/8"-16	3/8"-16	2 5/16 (58.7)	7/8 (22.2)	1 1/8 (28.6)	2 1/2 (63.5)	11 Ga. (3.0)	600 (2.67)
B306	3/8"-16	1/2"-13	2 7/16 (61.9)	7/8 (22.2)	1 1/8 (28.6)	2 1/2 (63.5)	7 Ga. (4.5)	1100 (4.90)
B307	1/2"-13	1/2"-13	2 7/16 (61.9)	7/8 (22.2)	1 1/8 (28.6)	2 1/2 (63.5)	7 Ga. (4.5)	1100 (4.90)
B308	1/2"-13	1/2"-13	2 9/16 (65.1)	7/8 (22.2)	1 1/8 (28.6)	2 1/2 (63.5)	1/4 (6.3)	1500 (6.68)
B321-1	3/8"-16	1/2"-13	3 9/16 (90.5)	1 11/16 (42.8)	1 5/8 (41.3)	3 1/4 (82.5)	1/4 (6.3)	1300 (5.79)
B321-2	1/2"-13	1/2"-13	3 9/16 (90.5)	1 11/16 (42.8)	1 5/8 (41.3)	3 1/4 (82.5)	1/4 (6.3)	1400 (6.23)

B312 Anchor Strap

- Finishes available: **ZN** or **HDG**
- For a maximum beam thickness of 3/4".
- For thicker beams, step up one flange width size.

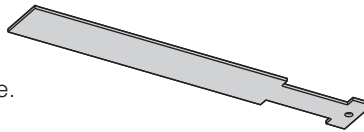

Cat. No.	Flange Width
	in. (mm)
B312-6	Up to 6 (up to 152.4)
B312-9	6 - 9 (152.4 to 228.6)
B312-12	9 - 12 (228.6 to 304.8)

B751 Bottom Beam Clamp and Accessories

- Setscrew included.
- Finish available: ZN

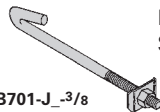

Loading position A - 500 lbs.
Loading position B - 300 lbs.
Safety Load Factor 5.0

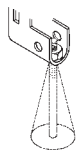
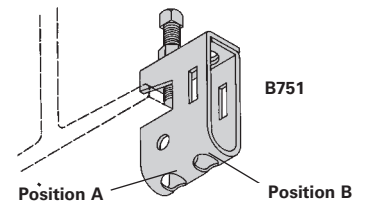
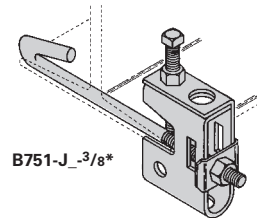

B753

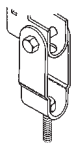

B752

Provides a full 15° swivel in any direction. (State the desired rod size.)

Assembly No.	B751	B701J_	B752	B753
Fits Flange Sizes	Clamp, Setscrew & J-Hook	J-Hook, Clip & Square Nut	Swivel & Bolt Only	Swivel Nut Only
in. (mm)				
4 - 5 7/8 (101 - 149)	● B751-J4-3/8*	● B701-J4-3/8	● B752	● B753-**
6 - 8 7/8 (152 - 225)	● B751-J6-3/8*	● B701-J6-3/8	● B752	● B753-**
9 - 11 7/8 (228 - 301)	● B751-J9-3/8*	● B701-J9-3/8	● B752	● B753-**

* Clamp Assembly complete with J-Hook Assembly. Setscrew included.

** Insert 1/4, 3/8 or 1/2 for the desired rod size.

● Green = Fastest shipped items ● Black = Normal lead-time items ● Red = Normally long lead-time items

All dimensions in parentheses are millimeters unless otherwise specified.

Series 1 Steel - Accessories

Trapeze Support Kit

Trapeze kits provide the components required for a single trapeze support in one package. These kits are available in pre-galvanized steel with zinc-plated hardware or hot dip galvanized steel with 316 stainless steel hardware.

The SH channel provides the convenience of pre-punched slots, which eliminate the need for field drilling.

The illustrated hardware is sealed in a plastic bag and boxed with the channel, which is pre-cut to the appropriate length as shown in the chart.

Designed for use with 1/2" threaded rod. (order separately)

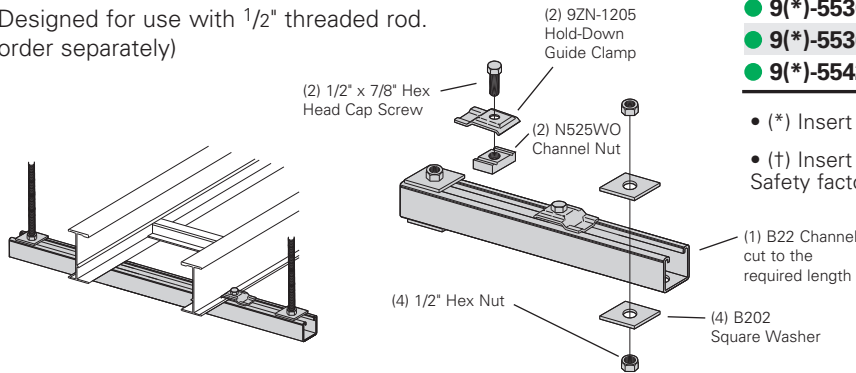

Catalog No.	Tray Width in. (mm)	Channel Length in. (mm)	Uniform Load lbs (kN)
● 9(*)-5506-22SH(+)	6 (152)	16 (406)	1600 (7.11)
● 9(*)-5509-22SH(+)	9 (229)	18 (457)	1250 (5.56)
● 9(*)-5512-22SH(+)	12 (305)	22 (559)	1125 (5.00)
● 9(*)-5518-22SH(+)	18 (457)	28 (711)	865 (3.85)
● 9(*)-5524-22SH(+)	24 (610)	34 (864)	700 (3.11)
● 9(*)-5530-22SH(+)	30 (762)	40 (1016)	590 (2.62)
● 9(*)-5536-22SH(+)	36 (914)	46 (1168)	510 (2.27)
● 9(*)-5542-22SH(+)	42 (1067)	52 (1321)	450 (2.00)

- (*) Insert **P** or **G**
- (+) Insert 3/8 for 3/8" threaded rod hardware. Safety factor of 3.0 on all loads.

Heavy Duty Trapeze Support Kit

Trapeze kits provide the components required for a single trapeze support in one package. These kits are available in Dura Green™ epoxy coated steel with zinc-plated hardware or hot dip galvanized steel with 316 stainless steel hardware.

The SH channel provides the convenience of pre-punched slots, which eliminates the need for field drilling.

The illustrated hardware is sealed in a plastic bag and boxed with the channel, which is pre-cut to the appropriate length as shown in the chart.

Designed for use with 1/2" threaded rod. (order rod separately)

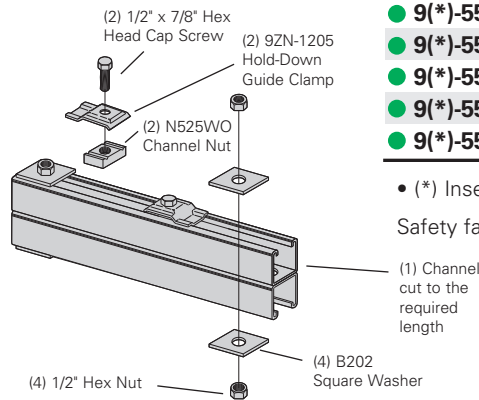

Catalog No.	Tray Width in. (mm)	Channel Length in. (mm)	Uniform Load lbs (kN)
● 9(*)-5506-22SHA	6 (152)	16 (406)	1350 (6.01)
● 9(*)-5509-22SHA	9 (229)	18 (457)	1350 (6.01)
● 9(*)-5512-22SHA	12 (305)	22 (559)	1350 (6.01)
● 9(*)-5518-22SHA	18 (457)	28 (711)	1350 (6.01)
● 9(*)-5524-22SHA	24 (610)	34 (864)	1350 (6.01)
● 9(*)-5530-22SHA	30 (762)	40 (1016)	1350 (6.01)
● 9(*)-5536-22SHA	36 (914)	46 (1168)	1350 (6.01)
● 9(*)-5542-22SHA	42 (1067)	52 (1321)	1350 (6.01)

- (*) Insert **G** or **GRN**
- Safety factor of 3.0 on all loads.

Trapeze Hardware Kit

- Kit sold in plastic bag.

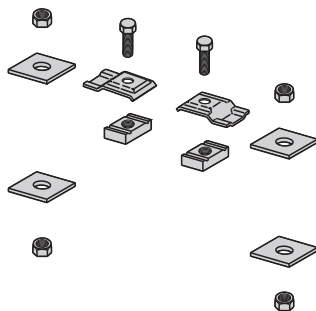

Catalog No.	
● 9ZN-5500-1/2	● 9G-5500-1/2
(1) pr. 9ZN-1205	(1) pr. 9G-1205
(2) HHC Screw 1/2 x 7/8" ZN	(2) HHC Screw 1/2" x 7/8" SS6
(2) N525 WO ZN	(2) N525 WO SS6
(4) B202 ZN 1/2" sq washer	(4) B202 HDG 1/2" sq washer
(4) HN 1/2" ZN	(4) HN 1/2" SS6

● Green = Fastest shipped items ● Black = Normal lead-time items ● Red = Normally long lead-time items

All dimensions in parentheses are millimeters unless otherwise specified.

Ladder Drop-Out

- This special designed, easy to install drop-out provides a 4" (101.6 mm) radius to protect cables exiting the cable tray from damage.
- Attaches to a ladder rung.
- Hardware included.
- (*) Insert **P** or **G**
- (‡) Insert tray width

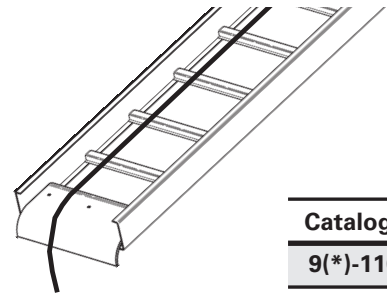
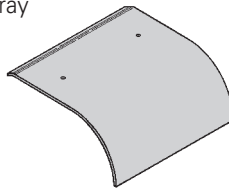

Catalog No.
9(*)-1104T-(‡)

Straight Section

- Standard length: 120" (3 m) 144" (12 ft.).
- Order catalog number based on loading depth.
- Furnished with four #10 x 1/2" plated self-drilling screws and a 99-9982 splice.
- (*) Insert **P** or **G**

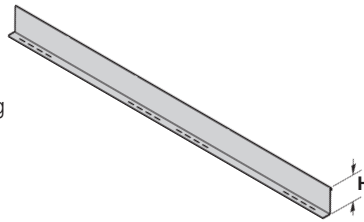

Length =
144 for 12' or 120 for 10'



Tray Series	Catalog No.	H	
		in.	(mm)
148	72(*)-Length	2.8	(58)
156	737(*)-Length	3.4	(70)
166	747(*)-Length	4.4	(91)
176	757(*)-Length	5.4	(112)

Horizontal Bend

- Horizontal Bend Barriers are flexible in order to conform to any horizontal fitting radius. Cut to length.
- Order catalog number based on loading depth.
- Furnished with three #10 x 1/2" zinc plated self-drilling screws and a 99-9982 Barrier Strip Splice.
- Standard length is 72" [6 ft.] (1829mm), sold individually.
- (*) Insert **P** or **G**

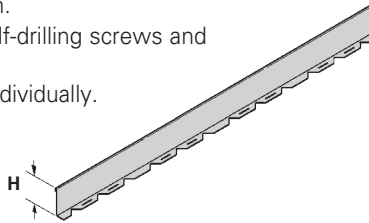

Tray Series	Catalog No.	H	
		in.	(mm)
148	72(*)-90HBFL	2.8	(58)
156	737(*)-90HBFL	3.4	(70)
166	747(*)-90HBFL	4.4	(91)
176	757(*)-90HBFL	5.4	(112)

Vertical Bend Barriers

- Vertical Bend Barriers are preformed to conform to a specific vertical fitting.
- Furnished with three #10 x 1/2" plated self-drilling screws and a 99-9982 Barrier Strip Splice.
- (*) Insert **P** or **G**
- (***) Insert 30, 45, 60 or 90 for degrees
- (t) Insert 12, 24, or 36 for radius

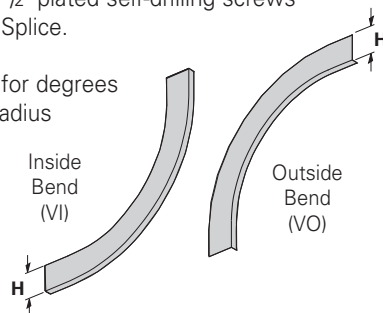

Tray Series	Catalog No.		H	
	Inside Bend	Outside Bend	in.	(mm)
148	72(*)-(***)VI(t)	72(*)-(***)VO(t)	2.8	(58)
156	737(*)-(***)VI(t)	737(*)-(***)VO(t)	3.4	(70)
166	747(*)-(***)VI(t)	747(*)-(***)VO(t)	4.4	(91)
176	757(*)-(***)VI(t)	757(*)-(***)VO(t)	5.4	(112)

Barrier Strip Splice

- Plastic splice holds adjoining barrier strips in straight alignment.
- 3" (76.2mm) long

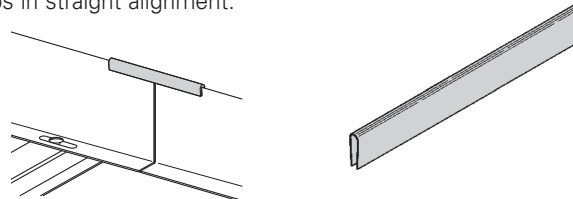

Catalog No.
● 99-9982

● Green = Fastest shipped items ● Black = Normal lead-time items ● Red = Normally long lead-time items

All dimensions in parentheses are millimeters unless otherwise specified.

Covers

Solid covers should be used when maximum enclosure of the cables is desired and no accumulation of heat is expected. **Ventilated covers** provide an overhead cable shield yet allow heat to escape.

We recommend that covers on vertical cable tray runs to a height of 6 ft. (1.83 m) to 8 ft. (2.44 m) above the floor to isolate both cables and personnel. **Flanged covers** have a .30 in. (7.6 mm) flange. Cover clamps are not included with the cover and must be ordered separately.

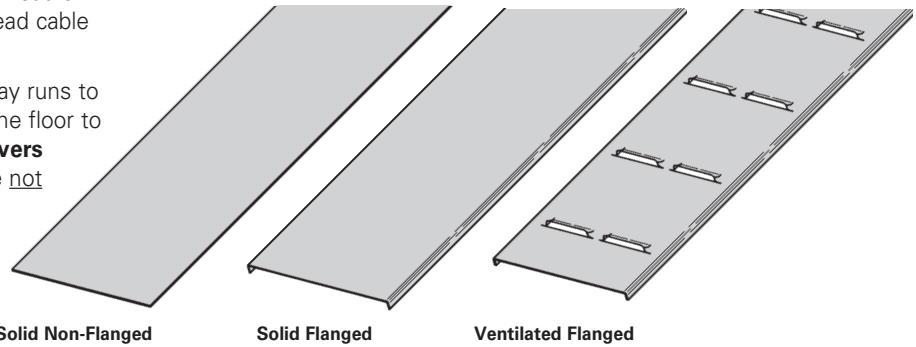

Solid Non-Flanged

Solid Flanged

Ventilated Flanged

Covers Part Numbering

Prefix
Example: 80 1 P - 24 - 144

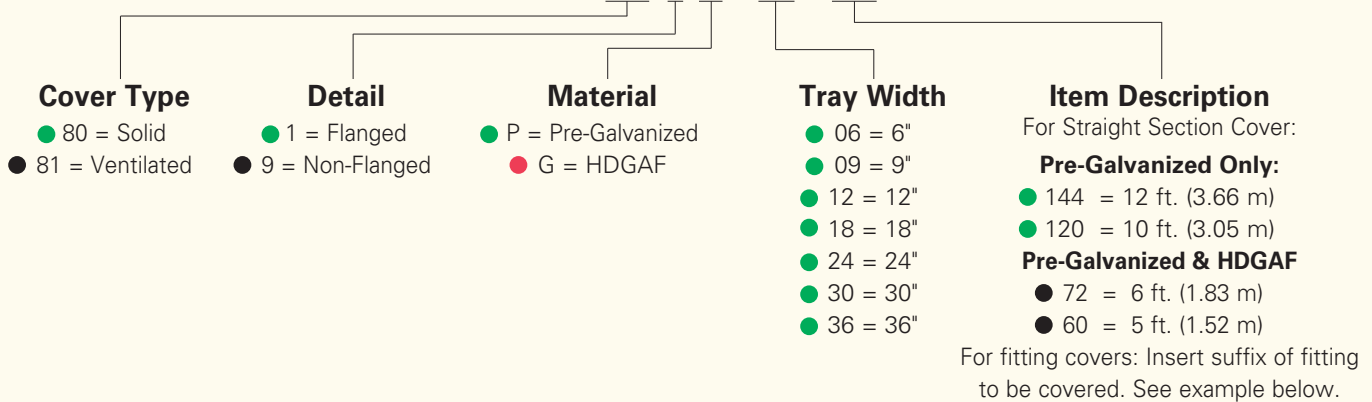

Example of Catalog Number for Fitting Cover:

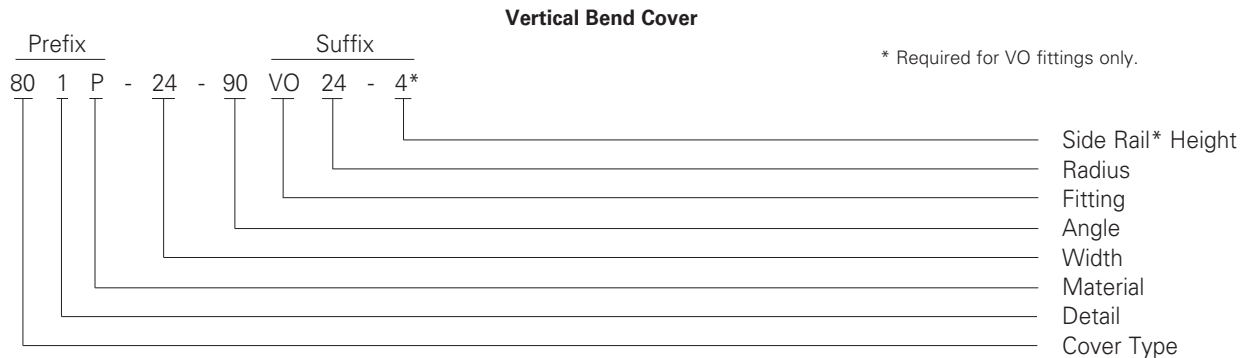

Quantity of Standard Cover Clamps Required

Straight Section 60" or 72"	4 pcs.
Straight Section 120" or 144"	6 pcs.
Horizontal/Vertical Bends	4 pcs.
Tees	6 pcs.
Crosses	8 pcs.

Note: When using the Heavy Duty Cover Clamp, only one-half the number of clamps stated above is required.

● Green = Fastest shipped items ● Black = Normal lead-time items ● Red = Normally long lead-time items

All dimensions in parentheses are millimeters unless otherwise specified.

Cover Joint Strip

- Used to join covers
- Plastic
- (‡) Insert tray width

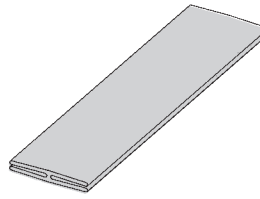

Catalog No.

● 99-9980-(‡)

Standard Cover Clamp

- Sold per piece
- For indoor service only

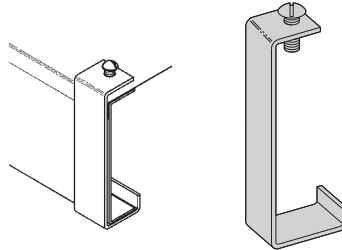

Tray Series	Catalog No.	
	Znplt	HDGAF
148	● 9ZN-9019	● 9G-9019
156	● 9ZN-9014	● 9G-9014
166	● 9ZN-9015	● 9G-9015
176	● 9ZN-9016	● 9G-9016

Combination Hold Down & Cover Clamp

- Sold per piece
- For indoor service only

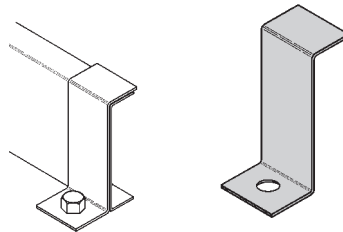

Tray Series	Catalog No.	
	Znplt/Pre-Galv	HDGAF
148	● 9ZN-9243	● 9G-9243
156	● 9P-9043	● 9G-9043
166	● 9P-9053	● 9G-9053
176	● 9P-9063	● 9G-9063

Heavy Duty Cover Clamp

- (‡) Insert tray width

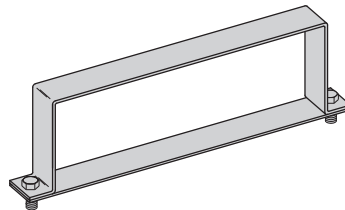

Tray Series	Catalog No.	
	Pre-Galv	HDGAF
148	● 9P-(‡)-9040	● 9G-(‡)-9040
156	● 9P-(‡)-9044	● 9G-(‡)-9044
166	● 9P-(‡)-9054	● 9G-(‡)-9054
176	● 9P-(‡)-9064	● 9G-(‡)-9064

Raised Cover Clamp

- For indoor service only.
- Sold per piece
- For use with flanged covers only.

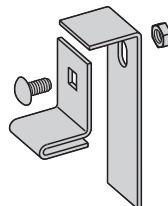

† Specify gap of 1", 2", 3" or 4".

Tray Series	Catalog No.		Gap in. (mm)
	Catalog No.		
Series 1	9ZN-9101		1 (25.4)
	9ZN-9102		2 (50.8)
	9ZN-9103		3 (76.2)
	9ZN-9104		4 (101.6)

● Green = Fastest shipped items ● Black = Normal lead-time items ● Red = Normally long lead-time items

All dimensions in parentheses are millimeters unless otherwise specified.

Section 1- Acceptable Manufacturers

- 1.01 Manufacturer: Subject to compliance with these specifications, Eaton's B-Line series cable tray systems shall be as manufactured by Eaton.

Section 2- Cable Tray Sections and Components

- 2.01 General: Except as otherwise indicated, provide metal cable trays, of types, classes and sizes indicated; with splice plates, bolts, nuts and washers for connecting units. Construct units with rounded edges and smooth surfaces; in compliance with applicable standards; and with the following additional construction features. Cable tray shall be installed according to the latest revision of NEMA VE 2.
- 2.02 Pre-Galvanized Steel: Straight sections, fitting side rails, rungs, and covers shall be made from structural quality steel meeting the minimum mechanical properties and mill galvanized in accordance with ASTM A653 SS, Grade 33, coating designation G90. Hardware finish shall be electro-galvanized zinc per ASTM B633.
- 2.03 Hot dip Galvanized Steel: All side rails, covers, splice plates, and rungs shall be made from structural quality steel meeting the minimum mechanical properties of ASTM A1011 SS, Grade 33 for 14 gauge and heavier, ASTM A1008, Grade 33 Type 2 for 16 gauge and lighter, and shall be hot dip galvanized after fabrication in accordance with ASTM A123. Mill galvanized covers are not acceptable for hot dipped galvanized cable tray. Hardware finish shall be chromium zinc per ASTM F-1136-88.
- 2.04 Ladder Cable Trays shall consist of two longitudinal members (side rails) with transverse members (rungs) welded to the side rails. Rungs shall be spaced [6] [9] [12] inches on center. Rung spacing in radiused fittings shall be industry standard 9" and measured at the center of the tray's width. No portion of the rungs shall protrude below the bottom plane of the side rails.
- 2.05 Ventilated Trough Cable Trays shall consist of two longitudinal members (side rails) with a corrugated bottom welded to the side rails or rungs spaced 4" on center. The peaks of the corrugated bottom shall have a minimum flat cable bearing surface of 2³/₄" and shall be spaced on 6" centers. To provide ventilation in the tray, the valleys of the corrugated bottom shall have 2¹/₄" x 4" rectangular holes punched along the width of the bottom.
- 2.06 Non-Ventilated Bottom Trough Cable Trays shall consist of two longitudinal members (side rails) with a corrugated bottom welded to the side rails or a solid sheet over rungs. The peaks of the corrugated bottom shall have a minimum flat cable bearing surface of 2³/₄" and shall be spaced on 6" centers.
- 2.07 Cable tray loading depth shall be [3] [4] [5] [6] inches per NEMA VE 1.
- 2.08 Straight sections shall be supplied in standard [12 foot] [10 foot (3 m)] lengths.
- 2.09 Cable tray widths shall be [6] [9] [12] [18] [24] [30] [36] inches or as shown on drawings.
- 2.10 Splice plates shall be L-shaped with 4 nuts and bolts per plate. The resistance of fixed splice connections between an adjacent section of tray shall not exceed 0.00033 ohm.
- 2.11 All fittings must have a minimum radius of [12] [24] inches.

Section 3- Loading Capacities and Testing

- 3.01 Cable tray shall be capable of carrying a uniformly distributed load of _____ lbs./ft. on a _____ ft. support span with a safety factor of 1.5 when supported as a simple span and tested per NEMA VE 1 5.2. Cable tray shall be made to manufacturing tolerances as specified by NEMA.
- 3.02 Upon request, manufacturer shall provide test reports in accordance with the latest revision of NEMA VE 1 or CSA C22.2 No. 126.

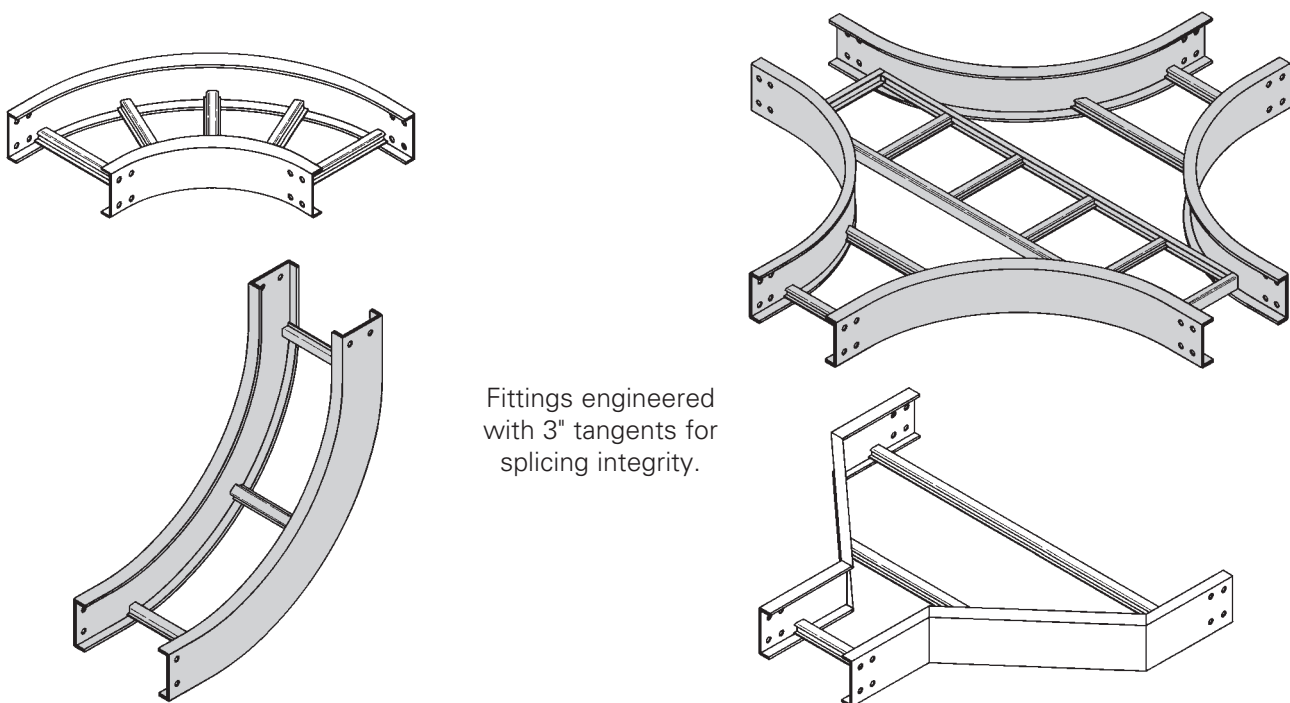

Fittings Part Numbering

Example: ^{Prefix} **1 4 P - 24 - 90 HB 24** (9" rung spacing is standard)

Series	Height	Material	Width	Angle	Type	Radius
1	<ul style="list-style-type: none"> ● 4 = 148 ● 5 = 156 ● 6 = 166 ● 7 = 176 	<ul style="list-style-type: none"> ● P = Pre-Galvanized ● G = HDGAF 	<ul style="list-style-type: none"> ● 06 = 6" (152) ● 09 = 9" (228) ● 12 = 12" (305) ● 18 = 18" (457) ● 24 = 24" (609) ● 30 = 30" (762) ● 36 = 36" (914) 	<ul style="list-style-type: none"> ● 30 = 30° ● 45 = 45° ● 60 = 60° ● 90 = 90° 	<ul style="list-style-type: none"> ● HB = Horizontal Bend ● HT = Horizontal Tee ● HX = Horizontal Cross ● VI = Vertical Inside Bend ● VO = Vertical Outside Bend ● LR = Left Reducer ● RR = Right Reducer ● SR = Straight Reducer 	<ul style="list-style-type: none"> ● 12 = 12" (305) ● 24 = 24" (609) ● 36 = 36" (914)

For steel 4", 5", 6", 7" vented or non-vented add 04 or SB as shown below.

^{Prefix}
15P04 - 24 - 90HB24
Vented Bottom

^{Prefix}
15PSB - 24 - 90HB24
Non-Ventilated

● Green = Fastest shipped items ● Black = Normal lead-time items ● Red = Normally long lead-time items

All dimensions in parentheses are millimeters unless otherwise specified.

Series 1 Steel - Fittings

Horizontal Bends 90° 60° 45° 30° (HB)

1 pair splice plates with hardware included.

Bottoms manufactured:
Ladder = 9" Rung Spacing
04 = 4" Rung Spacing
SB = Flat sheet over 12" Rung Spacing

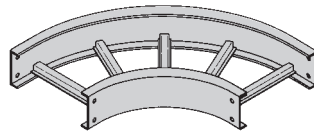

90° Horizontal Bend

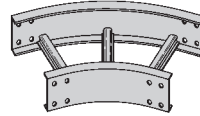

45° Horizontal Bend

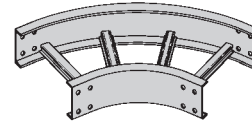

60° Horizontal Bend

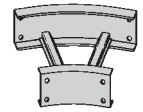

30° Horizontal Bend

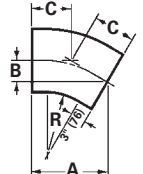
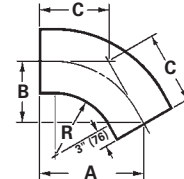
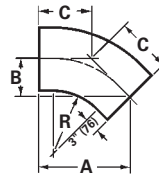
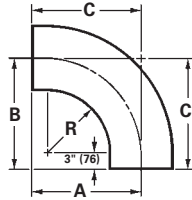

Bend Radius R	Tray Width	90° Horizontal Bend Dimensions				60° Horizontal Bend Dimensions			
		Catalog No.	A	B	C	Catalog No.	A	B	C
in. (mm)	in. (mm)		in. (mm)	in. (mm)	in. (mm)		in. (mm)	in. (mm)	in. (mm)
12 (305)	6 (152)	(Pre)-06-90HB12	18 (457)	18 (457)	18 (457)	(Pre)-06-60HB12	17 ¹ / ₂ (445)	10 ¹ / ₈ (257)	11 ¹¹ / ₁₆ (297)
	9 (228)	(Pre)-09-90HB12	19 ¹ / ₂ (495)	19 ¹ / ₂ (495)	19 ¹ / ₂ (495)	(Pre)-09-60HB12	18 ¹³ / ₁₆ (478)	10 ⁷ / ₈ (276)	12 ¹ / ₂ (318)
	12 (305)	(Pre)-12-90HB12	21 (533)	21 (533)	21 (533)	(Pre)-12-60HB12	20 ¹ / ₁₆ (510)	11 ⁵ / ₈ (295)	13 ³ / ₈ (340)
	18 (457)	(Pre)-18-90HB12	24 (610)	24 (610)	24 (610)	(Pre)-18-60HB12	22 ¹¹ / ₁₆ (576)	13 ¹ / ₈ (333)	15 ¹ / ₈ (384)
	24 (609)	(Pre)-24-90HB12	27 (686)	27 (686)	27 (686)	(Pre)-24-60HB12	25 ⁵ / ₁₆ (643)	14 ⁵ / ₈ (372)	16 ⁷ / ₈ (429)
	30 (762)	(Pre)-30-90HB12	30 (762)	30 (762)	30 (762)	(Pre)-30-60HB12	27 ⁷ / ₈ (708)	16 ¹ / ₈ (410)	18 ⁹ / ₁₆ (472)
	36 (914)	(Pre)-36-90HB12	33 (838)	33 (838)	33 (838)	(Pre)-36-60HB12	30 ¹ / ₂ (775)	17 ⁵ / ₈ (448)	20 ⁵ / ₁₆ (516)
24 (609)	6 (152)	(Pre)-06-90HB24	30 (762)	30 (762)	30 (762)	(Pre)-06-60HB24	27 ⁷ / ₈ (708)	16 ¹ / ₈ (410)	18 ⁹ / ₁₆ (472)
	9 (228)	(Pre)-09-90HB24	31 ¹ / ₂ (800)	31 ¹ / ₂ (800)	31 ¹ / ₂ (800)	(Pre)-09-60HB24	29 ³ / ₁₆ (741)	16 ⁷ / ₈ (429)	19 ⁷ / ₁₆ (494)
	12 (305)	(Pre)-12-90HB24	33 (838)	33 (838)	33 (838)	(Pre)-12-60HB24	30 ¹ / ₂ (775)	17 ⁵ / ₈ (448)	20 ⁵ / ₁₆ (516)
	18 (457)	(Pre)-18-90HB24	36 (914)	36 (914)	36 (914)	(Pre)-18-60HB24	33 ¹ / ₁₆ (840)	19 ¹ / ₈ (486)	22 ¹ / ₁₆ (560)
	24 (609)	(Pre)-24-90HB24	39 (991)	39 (991)	39 (991)	(Pre)-24-60HB24	35 ¹¹ / ₁₆ (907)	20 ⁵ / ₈ (524)	23 ¹³ / ₁₆ (605)
	30 (762)	(Pre)-30-90HB24	42 (1067)	42 (1067)	42 (1067)	(Pre)-30-60HB24	38 ¹ / ₄ (972)	22 ¹ / ₈ (562)	25 ¹ / ₂ (648)
	36 (914)	(Pre)-36-90HB24	45 (1143)	45 (1143)	45 (1143)	(Pre)-36-60HB24	40 ⁷ / ₈ (1038)	23 ⁵ / ₈ (600)	27 ¹ / ₄ (692)
		45° Horizontal Bend				30° Horizontal Bend			
12 (305)	6 (152)	(Pre)-06-45HB12	15 ³ / ₄ (400)	6 ¹ / ₂ (165)	9 ³ / ₁₆ (233)	(Pre)-06-30HB12	13 ¹ / ₈ (333)	3 ¹ / ₂ (89)	7 (175)
	9 (228)	(Pre)-09-45HB12	16 ¹³ / ₁₆ (427)	6 ¹⁵ / ₁₆ (176)	9 ¹³ / ₁₆ (249)	(Pre)-09-30HB12	13 ⁷ / ₈ (352)	3 ¹¹ / ₁₆ (94)	7 ⁷ / ₁₆ (189)
	12 (305)	(Pre)-12-45HB12	17 ⁷ / ₈ (454)	7 ³ / ₈ (187)	10 ⁷ / ₁₆ (265)	(Pre)-12-30HB12	14 ⁵ / ₈ (372)	3 ¹⁵ / ₁₆ (100)	7 ¹³ / ₁₆ (198)
	18 (457)	(Pre)-18-45HB12	20 (500)	8 ¹ / ₄ (210)	11 ¹¹ / ₁₆ (297)	(Pre)-18-30HB12	16 ¹ / ₈ (410)	4 ⁵ / ₁₆ (135)	8 ⁵ / ₈ (219)
	24 (609)	(Pre)-24-45HB12	22 ¹ / ₁₆ (560)	9 ¹ / ₈ (232)	12 ¹⁵ / ₁₆ (329)	(Pre)-24-30HB12	17 ⁵ / ₈ (448)	4 ¹¹ / ₁₆ (119)	9 ⁷ / ₁₆ (240)
	30 (762)	(Pre)-30-45HB12	24 ³ / ₁₆ (614)	10 (250)	14 ³ / ₁₆ (360)	(Pre)-30-30HB12	19 ¹ / ₈ (486)	5 ¹ / ₈ (130)	10 ¹ / ₄ (260)
	36 (914)	(Pre)-36-45HB12	26 ⁵ / ₁₆ (668)	10 ¹⁵ / ₁₆ (278)	15 ⁷ / ₁₆ (392)	(Pre)-36-30HB12	20 ⁵ / ₈ (524)	5 ¹ / ₂ (140)	11 ¹ / ₁₆ (281)
24 (609)	6 (152)	(Pre)-06-45HB24	24 ³ / ₁₆ (614)	10 (250)	14 ³ / ₁₆ (360)	(Pre)-06-30HB24	19 ¹ / ₈ (486)	5 ¹ / ₈ (130)	10 ¹ / ₄ (260)
	9 (228)	(Pre)-09-45HB24	25 ¹ / ₄ (641)	10 ¹ / ₂ (267)	14 ¹³ / ₁₆ (376)	(Pre)-09-30HB24	19 ⁷ / ₈ (505)	5 ⁵ / ₁₆ (135)	10 ⁵ / ₈ (270)
	12 (305)	(Pre)-12-45HB24	26 ⁵ / ₁₆ (668)	10 ¹⁵ / ₁₆ (278)	15 ⁷ / ₁₆ (392)	(Pre)-12-30HB24	20 ⁵ / ₈ (524)	5 ¹ / ₂ (140)	11 ¹ / ₁₆ (281)
	18 (457)	(Pre)-18-45HB24	28 ⁷ / ₁₆ (722)	11 ¹³ / ₁₆ (300)	16 ¹¹ / ₁₆ (424)	(Pre)-18-30HB24	22 ¹ / ₈ (562)	5 ¹⁵ / ₁₆ (151)	11 ¹³ / ₁₆ (300)
	24 (609)	(Pre)-24-45HB24	30 ⁹ / ₁₆ (776)	12 ¹¹ / ₁₆ (322)	17 ¹⁵ / ₁₆ (456)	(Pre)-24-30HB24	23 ⁵ / ₈ (600)	6 ⁵ / ₁₆ (160)	12 ⁵ / ₈ (321)
	30 (762)	(Pre)-30-45HB24	32 ¹¹ / ₁₆ (830)	13 ⁹ / ₁₆ (345)	19 ¹ / ₈ (486)	(Pre)-30-30HB24	25 ¹ / ₈ (638)	6 ³ / ₄ (172)	13 ⁷ / ₁₆ (341)
	36 (914)	(Pre)-36-45HB24	34 ¹³ / ₁₆ (884)	14 ⁷ / ₁₆ (367)	20 ³ / ₈ (518)	(Pre)-36-30HB24	26 ⁵ / ₈ (676)	7 ¹ / ₈ (181)	14 ¹ / ₄ (362)

(Pre) See page H-18 for catalog number prefix.

Width dimensions are to inside wall. Manufacturing tolerances apply to all dimensions.

All dimensions in parentheses are millimeters unless otherwise specified.

Horizontal Tee (HT)

2 pair splice plates with hardware included.

Bend Radius R	Tray Width	Horizontal Tee Dimensions		
		Catalog No.	A	B
in. (mm)	in. (mm)		in. (mm)	in. (mm)
12 (305)	6 (152)	(Prefix)-06-HT12	18 (457)	36 (914)
	9 (228)	(Prefix)-09-HT12	19 ¹ / ₂ (495)	39 (991)
	12 (305)	(Prefix)-12-HT12	21 (533)	42 (1067)
	18 (457)	(Prefix)-18-HT12	24 (610)	48 (1219)
	24 (609)	(Prefix)-24-HT12	27 (686)	54 (1372)
	30 (762)	(Prefix)-30-HT12	30 (762)	60 (1524)
24 (609)	36 (914)	(Prefix)-36-HT12	33 (838)	66 (1676)
	6 (152)	(Prefix)-06-HT24	30 (762)	60 (1524)
	9 (228)	(Prefix)-09-HT24	31 ¹ / ₂ (800)	63 (1600)
	12 (305)	(Prefix)-12-HT24	33 (838)	66 (1676)
	18 (457)	(Prefix)-18-HT24	36 (914)	72 (1829)
	24 (609)	(Prefix)-24-HT24	39 (991)	78 (1981)
	30 (762)	(Prefix)-30-HT24	42 (1067)	84 (2134)
	36 (914)	(Prefix)-36-HT24	45 (1143)	90 (2286)

(Prefix) See page H-18 for catalog number prefix.

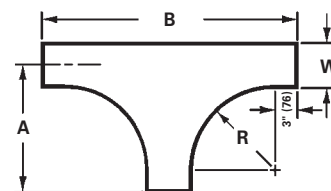
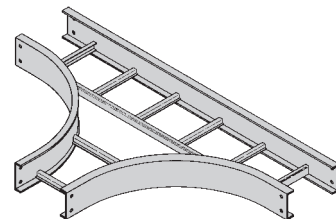

Horizontal Cross (HX)

3 pair splice plates with hardware included.

Bend Radius R	Tray Width	Horizontal Cross Dimensions		
		Catalog No.	A	B
in. (mm)	in. (mm)		in. (mm)	in. (mm)
12 (305)	6 (152)	(Prefix)-06-HX12	18 (457)	36 (914)
	9 (228)	(Prefix)-09-HX12	19 ¹ / ₂ (495)	39 (991)
	12 (305)	(Prefix)-12-HX12	21 (533)	42 (1067)
	18 (457)	(Prefix)-18-HX12	24 (610)	48 (1219)
	24 (609)	(Prefix)-24-HX12	27 (686)	54 (1372)
	30 (762)	(Prefix)-30-HX12	30 (762)	60 (1524)
24 (609)	36 (914)	(Prefix)-36-HX12	33 (838)	66 (1676)
	6 (152)	(Prefix)-06-HX24	30 (762)	60 (1524)
	9 (228)	(Prefix)-09-HX24	31 ¹ / ₂ (800)	63 (1600)
	12 (305)	(Prefix)-12-HX24	33 (838)	66 (1676)
	18 (457)	(Prefix)-18-HX24	36 (914)	72 (1829)
	24 (609)	(Prefix)-24-HX24	39 (991)	78 (1981)
	30 (762)	(Prefix)-30-HX24	42 (1067)	84 (2134)
	36 (914)	(Prefix)-36-HX24	45 (1143)	90 (2286)

(Prefix) See page H-18 for catalog number prefix.

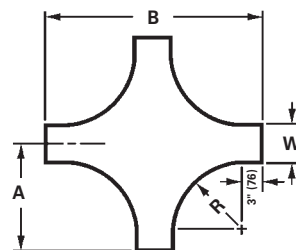
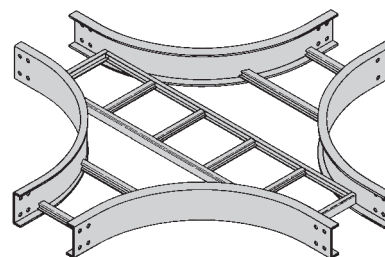

Width dimensions are to inside wall. Manufacturing tolerances apply to all dimensions.

All dimensions in parentheses are millimeters unless otherwise specified.

Series 1 Steel - Fittings

Reducers (LR, SR, RR)

1 pair splice plates with hardware included.

Reducer Part Numbering

14P - 24 - RR 18

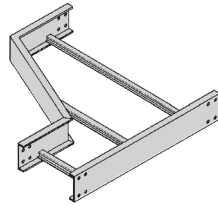
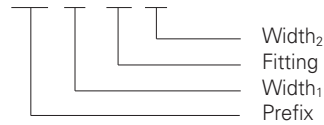

Left Reducer - LR

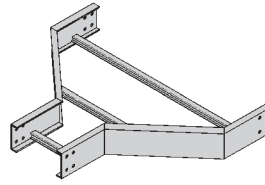

Straight Reducer - SR

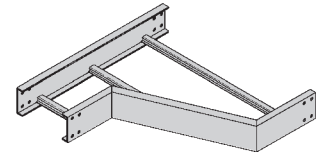

Right Reducer - RR

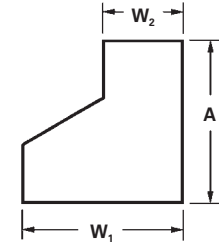
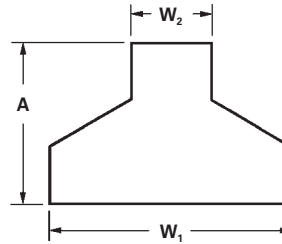
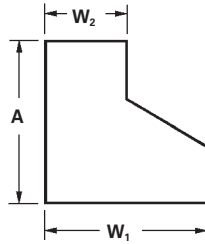

Tray Width		Left Reducer - LR		Straight Reducer - SR		Right Reducer - RR	
W ₁	W ₂	Catalog No.	A	Catalog No.	A	Catalog No.	A
in. (mm)	in. (mm)		in. (mm)		in. (mm)		in. (mm)
9 (228)	6 (152)	(Prefix)-09-LR06	9 ³ / ₄ (248)	(Prefix)-09-SR06	8 ⁷ / ₈ (225)	(Prefix)-09-RR06	9 ³ / ₄ (248)
12 (305)	6 (152)	(Prefix)-12-LR06	11 ¹ / ₂ (292)	(Prefix)-12-SR06	9 ³ / ₄ (248)	(Prefix)-12-RR06	11 ¹ / ₂ (292)
	9 (228)	(Prefix)-12-LR09	9 ³ / ₄ (248)	(Prefix)-12-SR09	8 ⁷ / ₈ (225)	(Prefix)-12-RR09	9 ³ / ₄ (248)
18 (457)	6 (152)	(Prefix)-18-LR06	14 ¹⁵ / ₁₆ (379)	(Prefix)-18-SR06	11 ¹ / ₂ (292)	(Prefix)-18-RR06	14 ¹⁵ / ₁₆ (379)
	9 (228)	(Prefix)-18-LR09	13 ³ / ₁₆ (335)	(Prefix)-18-SR09	10 ⁵ / ₈ (270)	(Prefix)-18-RR09	13 ³ / ₁₆ (335)
	12 (305)	(Prefix)-18-LR12	11 ¹ / ₂ (292)	(Prefix)-18-SR12	9 ³ / ₄ (248)	(Prefix)-18-RR12	11 ¹ / ₂ (292)
24 (609)	6 (152)	(Prefix)-24-LR06	18 ³ / ₈ (467)	(Prefix)-24-SR06	13 ³ / ₁₆ (335)	(Prefix)-24-RR06	18 ³ / ₈ (467)
	9 (228)	(Prefix)-24-LR09	16 ¹¹ / ₁₆ (424)	(Prefix)-24-SR09	12 ³ / ₈ (314)	(Prefix)-24-RR09	16 ¹¹ / ₁₆ (424)
	12 (305)	(Prefix)-24-LR12	14 ¹⁵ / ₁₆ (379)	(Prefix)-24-SR12	11 ¹ / ₂ (292)	(Prefix)-24-RR12	14 ¹⁵ / ₁₆ (379)
	18 (457)	(Prefix)-24-LR18	11 ¹ / ₂ (292)	(Prefix)-24-SR18	9 ³ / ₄ (248)	(Prefix)-24-RR18	11 ¹ / ₂ (292)
30 (762)	6 (152)	(Prefix)-30-LR06	21 ⁷ / ₈ (555)	(Prefix)-30-SR06	14 ¹⁵ / ₁₆ (379)	(Prefix)-30-RR06	21 ⁷ / ₈ (555)
	9 (228)	(Prefix)-30-LR09	20 ¹ / ₈ (511)	(Prefix)-30-SR09	14 ¹ / ₁₆ (358)	(Prefix)-30-RR09	20 ¹ / ₈ (511)
	12 (305)	(Prefix)-30-LR12	18 ³ / ₈ (467)	(Prefix)-30-SR12	13 ³ / ₁₆ (335)	(Prefix)-30-RR12	18 ³ / ₈ (467)
	18 (457)	(Prefix)-30-LR18	14 ¹⁵ / ₁₆ (379)	(Prefix)-30-SR18	11 ¹ / ₂ (292)	(Prefix)-30-RR18	14 ¹⁵ / ₁₆ (379)
	24 (609)	(Prefix)-30-LR24	11 ¹ / ₂ (292)	(Prefix)-30-SR24	9 ³ / ₄ (248)	(Prefix)-30-RR24	11 ¹ / ₂ (292)
36 (914)	6 (152)	(Prefix)-36-LR06	25 ⁵ / ₁₆ (643)	(Prefix)-36-SR06	16 ¹¹ / ₁₆ (424)	(Prefix)-36-RR06	23 ⁵ / ₁₆ (643)
	9 (228)	(Prefix)-36-LR09	23 ⁹ / ₁₆ (598)	(Prefix)-36-SR09	15 ¹³ / ₁₆ (402)	(Prefix)-36-RR09	23 ⁹ / ₁₆ (598)
	12 (305)	(Prefix)-36-LR12	21 ⁷ / ₈ (555)	(Prefix)-36-SR12	14 ¹⁵ / ₁₆ (379)	(Prefix)-36-RR12	21 ⁷ / ₈ (555)
	18 (457)	(Prefix)-36-LR18	18 ³ / ₈ (467)	(Prefix)-36-SR18	13 ³ / ₁₆ (335)	(Prefix)-36-RR18	18 ³ / ₈ (467)
	24 (609)	(Prefix)-36-LR24	14 ¹⁵ / ₁₆ (379)	(Prefix)-36-SR24	11 ¹ / ₂ (292)	(Prefix)-36-RR24	14 ¹⁵ / ₁₆ (379)
	30 (762)	(Prefix)-36-LR30	11 ¹ / ₂ (292)	(Prefix)-36-SR30	9 ³ / ₄ (248)	(Prefix)-36-RR30	11 ¹ / ₂ (292)

(Prefix) See page H-18 for catalog number prefix.

Width dimensions are to inside wall. Manufacturing tolerances apply to all dimensions.

All dimensions in parentheses are millimeters unless otherwise specified.

Vertical Bend 90° (VO, VI)

1 pair splice plates with hardware included.

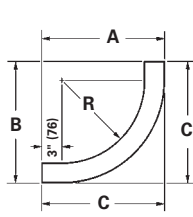

90° Vertical Inside

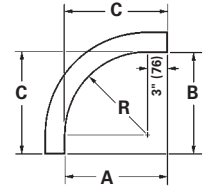
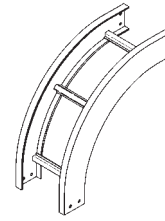
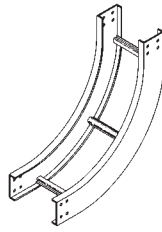

90° Vertical Outside

90° Vertical Inside Bend (VI)

Bend Radius R in. (mm)	Width in. (mm)	Catalog No.	VI Dimensions [in. (mm)]											
			Series 14 Steel			Series 15 Steel			Series 16 Steel			Series 17 Steel		
			A	B	C	A	B	C	A	B	C	A	B	C
12 (305)	6 (152)	(Pre)-06-90VI12												
	9 (228)	(Pre)-09-90VI12												
	12 (305)	(Pre)-12-90VI12												
	18 (457)	(Pre)-18-90VI12	18 ⁷ / ₁₆ (468)	18 ⁷ / ₁₆ (468)	18 ⁷ / ₁₆ (468)	19 ³ / ₁₆ (487)	19 ³ / ₁₆ (487)	19 ³ / ₁₆ (487)	20 ³ / ₁₆ (513)	20 ³ / ₁₆ (513)	20 ³ / ₁₆ (513)	21 ³ / ₁₆ (538)	21 ³ / ₁₆ (538)	21 ³ / ₁₆ (538)
	24 (609)	(Pre)-24-90VI12												
	30 (762)	(Pre)-30-90VI12												
24 (609)	6 (152)	(Pre)-06-90VI24												
	9 (228)	(Pre)-09-90VI24												
	12 (305)	(Pre)-12-90VI24												
	18 (457)	(Pre)-18-90VI24	30 ⁷ / ₁₆ (773)	30 ⁷ / ₁₆ (773)	30 ⁷ / ₁₆ (773)	31 ³ / ₁₆ (792)	31 ³ / ₁₆ (792)	31 ³ / ₁₆ (792)	32 ³ / ₁₆ (817)	32 ³ / ₁₆ (817)	32 ³ / ₁₆ (817)	33 ³ / ₁₆ (843)	33 ³ / ₁₆ (843)	33 ³ / ₁₆ (843)
	24 (609)	(Pre)-24-90VI24												
	30 (762)	(Pre)-30-90VI24												
	36 (914)	(Pre)-36-90VI24												

90° Vertical Outside Bend (VO)

Bend Radius R in. (mm)	Width in. (mm)	Catalog No.	VO Dimensions [in. (mm)]		
			All Series 1		
			A	B	C
12 (305)	6 (152)	(Pre)-06-90VO12			
	9 (228)	(Pre)-09-90VO12			
	12 (305)	(Pre)-12-90VO12			
	18 (457)	(Pre)-18-90VO12	15 (381)	15 (381)	15 (381)
	24 (609)	(Pre)-24-90VO12			
	30 (762)	(Pre)-30-90VO12			
24 (609)	6 (152)	(Pre)-06-90VO24			
	9 (228)	(Pre)-09-90VO24			
	12 (305)	(Pre)-12-90VO24			
	18 (457)	(Pre)-18-90VO24	27 (686)	27 (686)	27 (686)
	24 (609)	(Pre)-24-90VO24			
	30 (762)	(Pre)-30-90VO24			
	36 (914)	(Pre)-36-90VO24			

(Pre) See page H-18 for catalog number prefix.

Manufacturing tolerances apply to all dimensions.

All dimensions in parentheses are millimeters unless otherwise specified.

Series 1 Steel - Fittings

Vertical Bend 60° (VO, VI)

1 pair splice plates with hardware included.

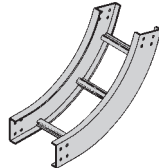
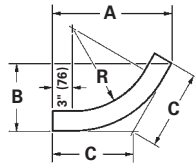

60° Vertical Inside

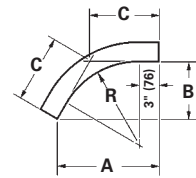
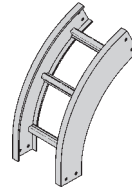

60° Vertical Outside

60° Vertical Inside Bend (VI)

Bend Radius R in. (mm)	Width in. (mm)	Catalog No.	VI Dimensions [in. (mm)]											
			Series 14 Steel			Series 15 Steel			Series 16 Steel			Series 17 Steel		
			A	B	C	A	B	C	A	B	C	A	B	C
12 (305)	6 (152)	(Pre)-06-60VI12												
	9 (228)	(Pre)-09-60VI12												
	12 (305)	(Pre)-12-60VI12												
	18 (457)	(Pre)-18-60VI12	18 ¹ / ₁₆ (459)	10 ⁷ / ₁₆ (265)	12 (305)	18 ¹ / ₂ (470)	10 ¹¹ / ₁₆ (271)	12 ³ / ₈ (314)	19 ³ / ₈ (492)	11 ³ / ₁₆ (284)	12 ¹⁵ / ₁₆ (328)	20 ¹ / ₄ (514)	11 ¹¹ / ₁₆ (297)	13 ¹ / ₂ (343)
	24 (609)	(Pre)-24-60VI12												
	30 (762)	(Pre)-30-60VI12												
24 (609)	6 (152)	(Pre)-06-60VI24												
	9 (228)	(Pre)-09-60VI24												
	12 (305)	(Pre)-12-60VI24												
	18 (457)	(Pre)-18-60VI24	28 ⁷ / ₁₆ (722)	16 ⁷ / ₁₆ (417)	18 ¹⁵ / ₁₆ (481)	28 ¹⁵ / ₁₆ (735)	18 ¹¹ / ₁₆ (424)	19 ¹ / ₄ (489)	29 ³ / ₄ (755)	17 ³ / ₁₆ (436)	19 ⁷ / ₈ (505)	30 ⁵ / ₈ (778)	17 ¹¹ / ₁₆ (449)	20 ⁷ / ₁₆ (519)
	24 (609)	(Pre)-24-60VI24												
	30 (762)	(Pre)-30-60VI24												
36 (914)	(Pre)-36-60VI24													

60° Vertical Outside Bend (VO)

Bend Radius R in. (mm)	Width in. (mm)	Catalog No.	VO Dimensions [in. (mm)]		
			All Series 1		
			A	B	C
12 (305)	6 (152)	(Pre)-06-60VO12			
	9 (228)	(Pre)-09-60VO12			
	12 (305)	(Pre)-12-60VO12			
	18 (457)	(Pre)-18-60VO12	14 ⁷ / ₈ (378)	8 ⁵ / ₈ (219)	9 ¹⁵ / ₁₆ (252)
	24 (609)	(Pre)-24-60VO12			
	30 (762)	(Pre)-30-60VO12			
24 (609)	6 (152)	(Pre)-06-60VO24			
	9 (228)	(Pre)-09-60VO24			
	12 (305)	(Pre)-12-60VO24			
	18 (457)	(Pre)-18-60VO24	25 ⁵ / ₁₆ (643)	14 ⁵ / ₈ (371)	16 ⁷ / ₈ (428)
	24 (609)	(Pre)-24-60VO24			
	30 (762)	(Pre)-30-60VO24			
36 (914)	(Pre)-36-60VO24				

(Pre) See page H-18 for catalog number prefix.
Manufacturing tolerances apply to all dimensions.

All dimensions in parentheses are millimeters unless otherwise specified.

Vertical Bend 45° (VO, VI)

1 pair splice plates with hardware included.

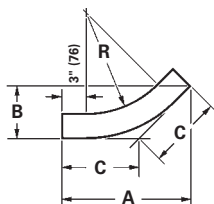

45° Vertical Inside

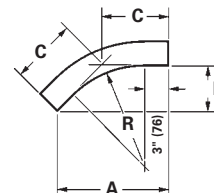
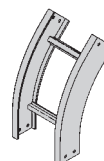
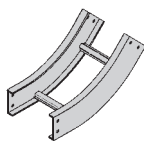

45° Vertical Outside

45° Vertical Inside Bend (VI)

Bend Radius R in. (mm)	Width in. (mm)	Catalog No.	VI Dimensions [in. (mm)]											
			Series 14 Steel			Series 15 Steel			Series 16 Steel			Series 17 Steel		
			A	B	C	A	B	C	A	B	C	A	B	C
12 (305)	6 (152)	(Pre)-06-45VI12	16 ³ / ₁₆ (411)	6 ¹ / ₁₆ (170)	9 ¹ / ₂ (241)	16 ⁹ / ₁₆ (420)	6 ⁷ / ₈ (174)	9 ¹ / ₁₆ (246)	17 ¹ / ₄ (438)	7 ³ / ₁₆ (182)	10 ¹ / ₈ (257)	18 (457)	7 ⁷ / ₁₆ (189)	10 ⁹ / ₁₆ (268)
	9 (228)	(Pre)-09-45VI12												
	12 (305)	(Pre)-12-45VI12												
	18 (457)	(Pre)-18-45VI12												
	24 (609)	(Pre)-24-45VI12												
	30 (762)	(Pre)-30-45VI12												
36 (914)	(Pre)-36-45VI12													
24 (609)	6 (152)	(Pre)-06-45VI24	24 ¹ / ₁₆ (627)	10 ³ / ₁₆ (259)	14 ⁷ / ₁₆ (367)	25 ¹ / ₁₆ (792)	10 ³ / ₈ (792)	14 ¹ / ₁₆ (373)	25 ³ / ₄ (654)	10 ¹ / ₁₆ (271)	15 ¹ / ₁₆ (382)	26 ¹ / ₂ (673)	11 (279)	15 ¹ / ₂ (394)
	9 (228)	(Pre)-09-45VI24												
	12 (305)	(Pre)-12-45VI24												
	18 (457)	(Pre)-18-45VI24												
	24 (609)	(Pre)-24-45VI24												
	30 (762)	(Pre)-30-45VI24												
36 (914)	(Pre)-36-45VI24													

45° Vertical Outside Bend (VO)

Bend Radius R in. (mm)	Width in. (mm)	Catalog No.	VO Dimensions [in. (mm)]		
			All Series 1		
			A	B	C
12 (305)	6 (152)	(Pre)-06-45VO12	13 ⁵ / ₈ (346)	5 ⁵ / ₈ (143)	8 (203)
	9 (228)	(Pre)-09-45VO12			
	12 (305)	(Pre)-12-45VO12			
	18 (457)	(Pre)-18-45VO12			
	24 (609)	(Pre)-24-45VO12			
	30 (762)	(Pre)-30-45VO12			
36 (914)	(Pre)-36-45VO12				
24 (609)	6 (152)	(Pre)-06-45VO24	22 ¹ / ₁₆ (560)	9 ¹ / ₈ (232)	12 ¹⁵ / ₁₆ (328)
	9 (228)	(Pre)-09-45VO24			
	12 (305)	(Pre)-12-45VO24			
	18 (457)	(Pre)-18-45VO24			
	24 (609)	(Pre)-24-45VO24			
	30 (762)	(Pre)-30-45VO24			
36 (914)	(Pre)-36-45VO24				

(Pre) See page H-18 for catalog number prefix.

Manufacturing tolerances apply to all dimensions.

All dimensions in parentheses are millimeters unless otherwise specified.

Series 1 Steel - Fittings

Vertical Bend 30° (VO, VI)

1 pair splice plates with hardware included.

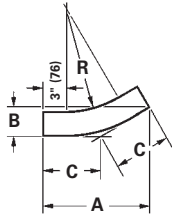

30° Vertical Inside

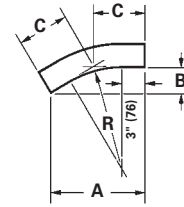
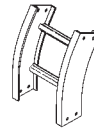
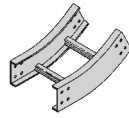

30° Vertical Outside

30° Vertical Inside Bend (VI)

Bend Radius R in. (mm)	Width in. (mm)	Catalog No.	VI Dimensions [in. (mm)]											
			Series 14 Steel			Series 15 Steel			Series 16 Steel			Series 17 Steel		
			A	B	C	A	B	C	A	B	C	A	B	C
12 (305)	6 (152)	(Pre)-06-30VI12												
	9 (228)	(Pre)-09-30VI12												
	12 (305)	(Pre)-12-30VI12												
	18 (457)	(Pre)-18-30VI12	13 ⁷ / ₁₆ (341)	3 ⁵ / ₈ (92)	7 ³ / ₁₆ (182)	13 ¹¹ / ₁₆ (347)	3 ¹ / ₁₆ (93)	7 ⁵ / ₁₆ (186)	14 ³ / ₁₆ (360)	3 ¹³ / ₁₆ (97)	7 ⁵ / ₈ (193)	14 ¹¹ / ₁₆ (373)	3 ¹⁵ / ₁₆ (100)	7 ⁷ / ₈ (200)
	24 (609)	(Pre)-24-30VI12												
	30 (762)	(Pre)-30-30VI12												
24 (609)	6 (152)	(Pre)-06-30VI24												
	9 (228)	(Pre)-09-30VI24												
	12 (305)	(Pre)-12-30VI24												
	18 (457)	(Pre)-18-30VI24	19 ⁷ / ₁₆ (494)	5 ³ / ₁₆ (132)	10 ⁷ / ₁₆ (265)	19 ¹¹ / ₁₆ (500)	5 ⁵ / ₁₆ (135)	10 ⁹ / ₁₆ (268)	20 ³ / ₁₆ (513)	5 ⁷ / ₁₆ (138)	10 ¹³ / ₁₆ (274)	20 ¹¹ / ₁₆ (525)	5 ⁹ / ₁₆ (141)	11 ¹ / ₁₆ (281)
	24 (609)	(Pre)-24-30VI24												
	30 (762)	(Pre)-30-30VI24												
	36 (914)	(Pre)-36-30VI24												

30° Vertical Outside Bend (VO)

Bend Radius R in. (mm)	Width in. (mm)	Catalog No.	VO Dimensions [in. (mm)]		
			All Series 1		
			A	B	C
12 (305)	6 (152)	(Pre)-06-30VO12			
	9 (228)	(Pre)-09-30VO12			
	12 (305)	(Pre)-12-30VO12			
	18 (457)	(Pre)-18-30VO12	11 ⁵ / ₈ (295)	3 ¹ / ₈ (79)	6 ³ / ₁₆ (157)
	24 (609)	(Pre)-24-30VO12			
	30 (762)	(Pre)-30-30VO12			
24 (609)	6 (152)	(Pre)-06-30VO24			
	9 (228)	(Pre)-09-30VO24			
	12 (305)	(Pre)-12-30VO24			
	18 (457)	(Pre)-18-30VO24	17 ⁵ / ₈ (448)	4 ¹¹ / ₁₆ (119)	9 ⁷ / ₁₆ (240)
	24 (609)	(Pre)-24-30VO24			
	30 (762)	(Pre)-30-30VO24			
	36 (914)	(Pre)-36-30VO24			

(Pre) See page H-18 for catalog number prefix.

Manufacturing tolerances apply to all dimensions.

All dimensions in parentheses are millimeters unless otherwise specified.

Vertical Bend Segments (VBS)

Adjustable Vertical Bends are made up of one or more vertical bend segments and can be used as a vertical inside (VI) or vertical outside (VO) bend. This design provides for vertical changes in direction with angles 45°, 60° and 90° for 12" (305 mm) or 24" (609 mm) radius. The chart below shows the number of segments required for the various combinations of angles and radii. The VBS-1, VBS-2 and VBS-3 include one, two or three segments respectively with splice plates and hardware. Holes for setting standard angles are pre-punched in each segment. Other angles can be set by field drilling another hole for the locking bolt.

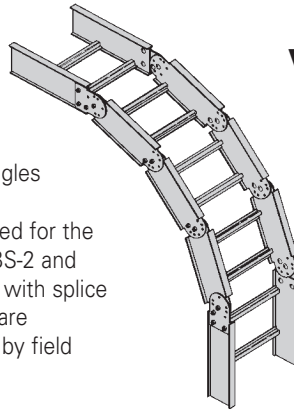

Available for **148P** and **148G** only.

Nominal Bend Radius in. (mm)	Catalog No.	Dimensions					
		VO			VI		
		A in. (mm)	B in. (mm)	R in. (mm)	A in. (mm)	B in. (mm)	R in. (mm)
90° Vertical Inside or Outside							
12 (305)	14(*)†-(‡)-VBS-1	8 ¹ / ₄ (210)	8 ¹ / ₄ (210)	6 ¹ / ₂ (165)	12 ¹ / ₈ (303)	12 ¹ / ₈ (303)	10 ¹ / ₂ (267)
24 (609)	14(*)†-(‡)-VBS-3	24 (610)	24 (610)	22 ¹ / ₄ (565)	27 ⁷ / ₈ (708)	27 ⁷ / ₈ (708)	26 ¹ / ₄ (667)
60° Vertical Inside or Outside							
12 (305)	14(*)†-(‡)-VBS-1	11 ³ / ₄ (298)	6 ¹ / ₂ (165)	12 (305)	14 ³ / ₄ (375)	8 ¹ / ₂ (216)	16 (406)
24 (609)	14(*)†-(‡)-VBS-2	11 ³ / ₄ (298)	6 ¹ / ₂ (165)	12 (305)	14 ³ / ₄ (375)	8 ¹ / ₂ (216)	16 (406)
45° Vertical Inside or Outside							
12 (305)	14(*)†-(‡)-VBS-1	12 ³ / ₄ (324)	5 ¹ / ₄ (133)	17 ¹ / ₈ (435)	15 ¹ / ₂ (394)	6 ⁷ / ₈ (175)	21 (540)
24 (609)	14(*)†-(‡)-VBS-1	12 ³ / ₄ (324)	5 ¹ / ₄ (133)	17 ¹ / ₈ (435)	15 ¹ / ₂ (394)	6 ⁷ / ₈ (175)	21 (540)

Notes:

- (*) Insert material type: P=Pre Galvanized, G=HDGAF
- (†) Contact home office for information on Ventilated Trough and Solid Trough availability
- (‡) Insert width 6, 9, 12, 18, 24, 30, 36

Fitting Hole Pattern

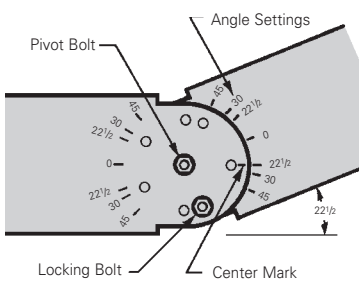

Setting the Angle

To find correct angle setting, divide angle of offset by the number of segments plus one. The result is equal to the angle setting stamped on the vertical bend segment and the splice plate. After inserting center pivot bolt, align the mark at the end of the segment or splice plate with the angle and insert locking bolt in the pre-punched hole.

Example: 90° bend, 24" radius requires 3 segments
 3 segments + 1 = 4
 90° divided by 4 = 22¹/₂°
 Set all vertical segments at 22¹/₂°

Offset Dimensions

One vertical bend segment can be used to complete a vertical offset. Offset dimensions are shown.

Angle ∅	A in. (mm)	B in. (mm)
45°	12 (305)	8 ¹ / ₂ (216)
30°	14 (355)	5 ³ / ₄ (146)
22 ¹ / ₂ °	14 ¹ / ₄ (362)	5 (127)

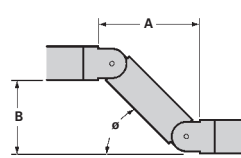

VBS-1 (1 Segment)

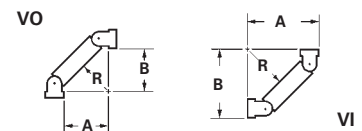

VBS-2 (2 Segments)

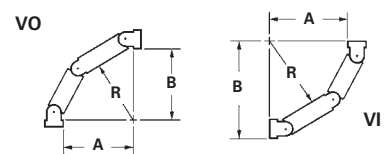

VBS-3 (3 Segments)

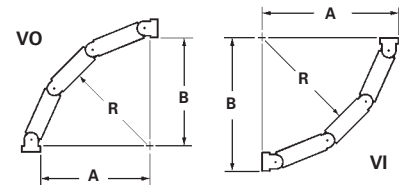

● Green = Fastest shipped items ● Black = Normal lead-time items ● Red = Normally long lead-time items

All dimensions in parentheses are millimeters unless otherwise specified.

Series 2, 3, 4, & 5 Aluminum - Straight Sections



Series 2, 3, 4, & 5 Aluminum

For Aluminum Fittings
see fittings section pages
L-1 thru L-17

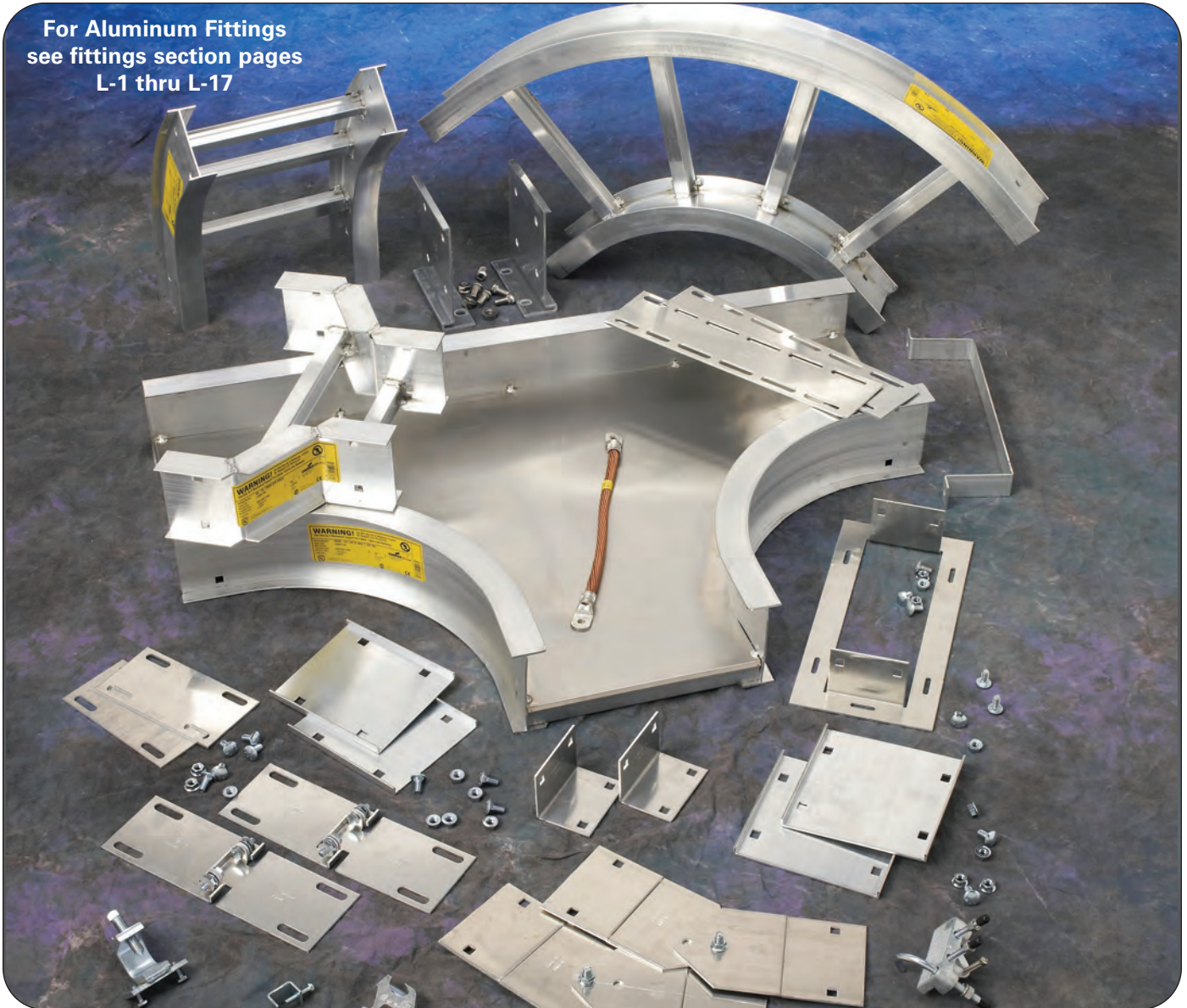

How The Service Advisor Works

We know that your time is important! That's why the color-coding system in this catalog is designed to help you select products that fit your service needs. Products are marked to indicate the typical lead time for orders of 50 pieces or less.

Customer: How do I select my straight sections, covers, or fittings so that I get the quickest turnaround?

Service Advisor: Each part of our selection chart is shown in colors. If any section of a part number is a different color, the part will typically ship with the longer lead time represented by the colors.

- Green = Fastest shipped items
- Black = Normal lead-time items
- Red = Normally long lead-time items

Example: 34A VT - 24 - 144
 ● ● ● ●

Part will have a normal lead time because of the VT bottom type.

3" NEMA VE 1 Loading Depth 4" Side Rail Height

Straight Section Part Numbering

Example: ^{Prefix} **24 A 09 - 24 - 144**

Series

● **24**

● **H24**

● **34**

Material

● **A** = Aluminum

*Type

Ladder-

- **06** = 6" rung spacing
- **09** = 9" rung spacing
- **12** = 12" rung spacing

Trough-

6" thru 36" wide

- **VT** = Ventilated Trough
- **ST** = Non-Ventilated Trough

*Width

- **06** = 6"
- **09** = 9"
- **12** = 12"
- **18** = 18"
- **24** = 24"
- **30** = 30"
- **36** = 36"

Length

- ① **144** = 12 ft. 24
- ② **120** = 10 ft. H24
- ① **240** = 20 ft. H24
- ② **144** = 12 ft. H24
- ① **240** = 20 ft. 34
- ② **144** = 12 ft. 34

① Primary Length.

② Secondary Length.

See page C-23 for explanation of lengths.

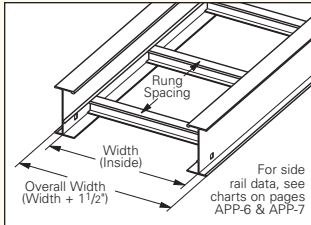

See page APP-1 for additional rung options. *Special sizes available.

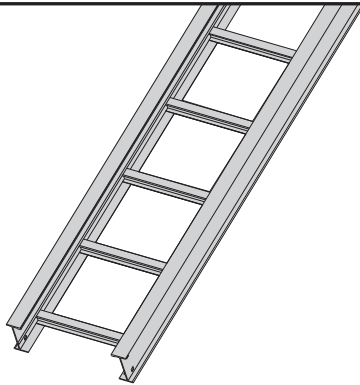

Ladder Type
(Specify Rung Spacing)

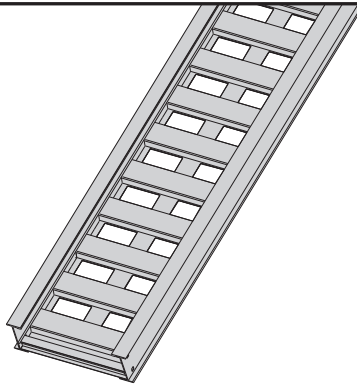

Ventilated Trough

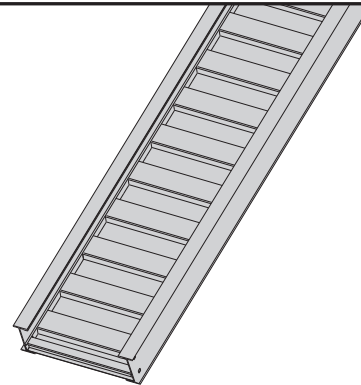

Non-Ventilated Trough

● Green = Fastest shipped items ● Black = Normal lead-time items ● Red = Normally long lead-time items

All dimensions in parentheses are millimeters unless otherwise specified.

Series 2, 3, 4, & 5 Aluminum - Straight Sections

3" NEMA VE 1 Loading Depth 4" Side Rail Height

Values are based on simple beam tests per NEMA VE 1 on 36" wide cable tray with rungs spaced on 12" centers. Cable trays will support without collapse a 200 lb. (90.7 kg) concentrated load over and above published loads. Published load safety factor is 1.5. To convert 1.5 safety factor to 2.0, multiply the published load by 0.75. To obtain mid-span deflection, multiply a load by the deflection multiplier. Cable tray must be supported on spans shorter than or equal to the length of the cable tray being installed.

Individual rungs will support without collapse a 200 lb. (90.7 kg) concentrated load applied at the mid-span of the rung, over and above the NEMA rated cable load with a 1.5 safety factor for highlighted NEMA spans and loads.

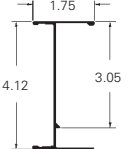
B-Line Series	Side Rail Dimensions	NEMA, CSA & UL Classifications	Span ft	Load lbs/ft	Deflection Multiplier	Design Factors for Two Rails	Span meters	Load kg/m	Deflection Multiplier	Design Factors for Two Rails
24		NEMA: 16A, 12C CSA: 277 kg/m 3.0m D-3m UL Cross-Sectional Area: 1.00 in ²	6	487*	0.001	Area = 1.05 in ² Sx = 1.34 in ³ Ix = 2.85 in ⁴	1.8	725*	0.017	Area = 6.77 cm ² Sx = 21.96 cm ³ Ix = 118.63 cm ⁴
			8	284	0.003		2.4	422	0.055	
			10	181	0.008		3.0	270	0.136	
			12	126	0.016		3.7	187	0.279	
			14	93	0.030		4.3	138	0.618	
			16	71	0.052		4.9	105	0.883	

When trays are used in continuous spans, the deflection of the tray is reduced by as much as 50%. Design factors: Ix = Moment of Inertia, Sx = Section Modulus.

* When using 18" rung spacing, load capacity is limited to 394 lbs/ft (586.27 kg/m) for 30" tray width and 325 lbs/ft (483.6 kg/m) for 36" tray width.

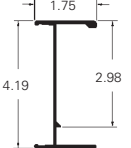
B-Line Series	Side Rail Dimensions	NEMA, CSA & UL Classifications	Span ft	Load lbs/ft	Deflection Multiplier	Design Factors for Two Rails	Span meters	Load kg/m	Deflection Multiplier	Design Factors for Two Rails
H24		NEMA: 20A CSA: 84 kg/m 6.1m D-6m UL Cross-Sectional Area: 1.00 in ²	10	225	0.006	Area = 1.32 in ² Sx = 1.57 in ³ Ix = 3.69 in ⁴	3.0	330	0.106	Area = 8.52 cm ² Sx = 25.73 cm ³ Ix = 153.59 cm ⁴
			12	156	0.013		3.7	226	0.222	
			14	115	0.023		4.3	171	0.400	
			16	88	0.040		4.9	129	0.693	
			18	70	0.064		5.5	103	1.093	
			20	56	0.098		6.1	83	1.682	

When trays are used in continuous spans, the deflection of the tray is reduced by as much as 50%. Design factors: Ix = Moment of Inertia, Sx = Section Modulus.

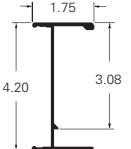
B-Line Series	Side Rail Dimensions	NEMA, CSA & UL Classifications	Span ft	Load lbs/ft	Deflection Multiplier	Design Factors for Two Rails	Span meters	Load kg/m	Deflection Multiplier	Design Factors for Two Rails
34		NEMA: 20B, 16C CSA: 112 kg/m 6.0m E-6m UL Cross-Sectional Area: 1.50 in ²	10	320	0.005	Area = 1.82 in ² Sx = 2.10 in ³ Ix = 4.98 in ⁴	3.0	476	0.077	Area = 11.74 cm ² Sx = 34.41 cm ³ Ix = 207.28 cm ⁴
			12	222	0.009		3.7	331	0.160	
			14	163	0.017		4.3	243	0.296	
			16	125	0.030		4.9	186	0.505	
			18	99	0.047		5.5	147	0.810	
			20	80	0.072		6.1	119	1.234	

When trays are used in continuous spans, the deflection of the tray is reduced by as much as 50%. Design factors: Ix = Moment of Inertia, Sx = Section Modulus.

All dimensions in parentheses are millimeters unless otherwise specified.

4" NEMA VE 1 Loading Depth 5" Side Rail Height

Straight Section Part Numbering

Example: ^{Prefix} 25 A 09 - 24 - 144

Series

- 25
- 35

Material

- A = Aluminum

*Type

Ladder-

- 06 = 6" rung spacing
- 09 = 9" rung spacing
- 12 = 12" rung spacing

Trough-

6" thru 36" wide

- VT = Ventilated Trough
- ST = Non-Ventilated Trough

*Width

- 06 = 6"
- 09 = 9"
- 12 = 12"
- 18 = 18"
- 24 = 24"
- 30 = 30"
- 36 = 36"

Length

- ① 144 = 12 ft. 25
- ② 120 = 10 ft.
- ① 240 = 20 ft. 35
- ② 144 = 12 ft.

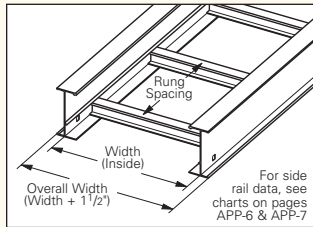

For side rail data, see charts on pages APP-6 & APP-7

① Primary Length.
② Secondary Length.

See page C-23 for explanation of lengths.

See page APP-1 for additional rung options. *Special sizes available.

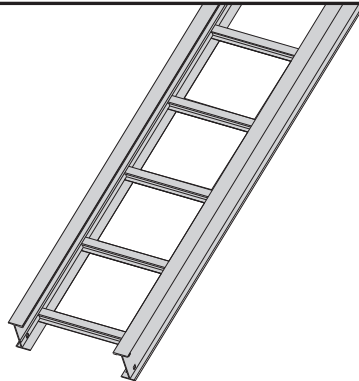

Ladder Type
(Specify Rung Spacing)

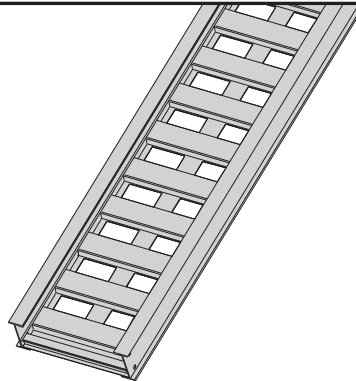

Ventilated Trough

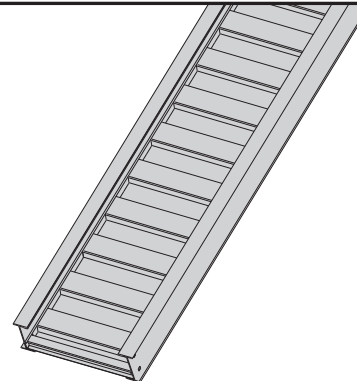

Non-Ventilated Trough

● Green = Fastest shipped items ● Black = Normal lead-time items ● Red = Normally long lead-time items

All dimensions in parentheses are millimeters unless otherwise specified.

Series 2, 3, 4, & 5 Aluminum - Straight Sections

4" NEMA VE 1 Loading Depth 5" Side Rail Height

Values are based on simple beam tests per NEMA VE 1 on 36" wide cable tray with rungs spaced on 12" centers. Cable trays will support without collapse a 200 lb. (90.7 kg) concentrated load over and above published loads. Published load safety factor is 1.5. To convert 1.5 safety factor to 2.0, multiply published load by 0.75. To obtain mid-span deflection, multiply a load by the deflection multiplier. Cable tray must be supported on spans shorter than or equal to the length of the cable tray being installed.

Individual rungs will support without collapse a 200 lb. (90.7 kg) concentrated load applied at the mid-span of the rung, over and above the NEMA rated cable load with a 1.5 safety factor for highlighted NEMA spans and loads.

B-Line Series	Side Rail Dimensions	NEMA, CSA & UL Classifications	Span ft	Load lbs/ft	Deflection Multiplier	Design Factors for Two Rails	Span meters	Load kg/m	Deflection Multiplier	Design Factors for Two Rails
25		NEMA: 20A, 12C CSA: 67 kg/m 6.0m D-6m UL Cross-Sectional Area: 1.00 in ²	10	200	0.0049	Area = 1.24 in ² S _x = 1.80 in ³ I _x = 4.62 in ⁴	3.0	298	0.083	Area = 8.00 cm ² S _x = 29.50 cm ³ I _x = 192.30 cm ⁴
			12	139	0.010		3.7	207	0.172	
			14	102	0.019		4.3	152	0.319	
			16	78	0.032		4.9	116	0.545	
			18	62	0.051		5.5	92	0.873	
			20	50	0.078		6.1	74	1.330	

When trays are used in continuous spans, the deflection of the tray is reduced by as much as 50%. Design factors: I_x = Moment of Inertia, S_x = Section Modulus.

B-Line Series	Side Rail Dimensions	NEMA, CSA & UL Classifications	Span ft	Load lbs/ft	Deflection Multiplier	Design Factors for Two Rails	Span meters	Load kg/m	Deflection Multiplier	Design Factors for Two Rails
35		NEMA: 20B, 16C CSA: 112 kg/m 6.0m E-6m UL Cross-Sectional Area: 1.50 in ²	10	310	0.0036	Area = 1.67 in ² S _x = 2.35 in ³ I _x = 6.37 in ⁴	3.0	461	0.060	Area = 10.77 cm ² S _x = 38.51 cm ³ I _x = 265.14 cm ⁴
			12	215	0.0073		3.7	320	0.125	
			14	158	0.014		4.3	235	0.232	
			16	121	0.023		4.9	180	0.395	
			18	96	0.037		5.5	142	0.633	
			20	77	0.057		6.1	115	0.965	

When trays are used in continuous spans, the deflection of the tray is reduced by as much as 50%. Design factors: I_x = Moment of Inertia, S_x = Section Modulus.

5" NEMA VE 1 Loading Depth 6" Side Rail Height

Straight Section Part Numbering

Example: ^{Prefix} **26 A 09 - 24 - 144**

Series

- 26
- 36
- 46
- H46
- 56

Material

- A = Aluminum

*Type

Ladder-

- 06 = 6" rung spacing
- 09 = 9" rung spacing
- 12 = 12" rung spacing

*Width

- 06 = 6"
- 09 = 9"
- 12 = 12"
- 18 = 18"
- 24 = 24"
- 30 = 30"
- 36 = 36"
- 42 = 42"†
- 48 = 48"†

Length

- ① 144 = 12 ft. 26
- ② 120 = 10 ft.
- ① 240 = 20 ft. 36
- ② 144 = 12 ft.
- ① 240 = 20 ft. 46
- ② 288 = 24 ft.
- ① 240 = 20 ft. H46
- ② 300 = 25 ft.
- ① 240 = 20 ft. 57
- ② 288 = 24 ft.
- ② 300 = 25 ft.
- ② 360 = 30 ft.

† For 56A only

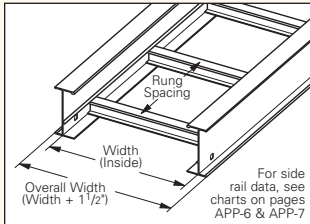

Trough-

6" thru 36" wide

- VT = Ventilated Trough
- ST = Non-Ventilated Trough

① Primary Length.
② Secondary Length.

See page C-23 for explanation of lengths.

See page APP-1 for additional rung options. *Special sizes available.



Ladder Type
(Specify Rung Spacing)

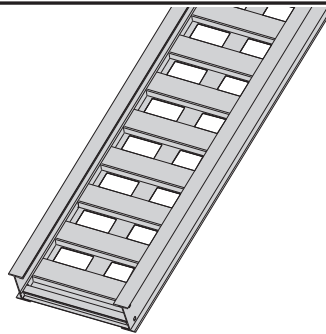

Ventilated Trough

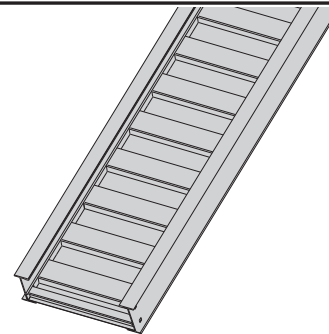

Non-Ventilated Trough

● Green = Fastest shipped items ● Black = Normal lead-time items ● Red = Normally long lead-time items

All dimensions in parentheses are millimeters unless otherwise specified.

Series 2, 3, 4, & 5 Aluminum - Straight Sections

5" NEMA VE 1 Loading Depth 6" Side Rail Height

Values are based on simple beam tests per NEMA VE 1 on 36" wide cable tray with rungs spaced on 12" centers. Cable trays will support, without collapse, a 200 lb. (90.7 kg) concentrated load over and above published loads. Published load safety factor is 1.5. To convert 1.5 safety factor to 2.0, multiply the published load by 0.75. To obtain mid-span deflection, multiply a load by the deflection multiplier. Cable tray must be supported on spans shorter than or equal to the length of the cable tray being installed.

Individual rungs will support without collapse a 200 lb. (90.7 kg) concentrated load applied at the mid-span of the rung, over and above the NEMA rated cable load with a 1.5 safety factor for highlighted NEMA spans and loads.

B-Line Series	Side Rail Dimensions	NEMA, CSA & UL Classifications	Span ft	Load lbs/ft	Deflection Multiplier	Design Factors for Two Rails	Span meters	Load kg/m	Deflection Multiplier	Design Factors for Two Rails
26		NEMA: 20A, 16B CSA: 67 kg/m 6.0m D-6m UL Cross-Sectional Area: 1.00 in ²	10	204	0.0028	Area = 1.41 in ² Sx = 2.53 in ³ Ix = 7.915 in ⁴	3.0	304	0.049	Area = 9.10 cm ² Sx = 41.46 cm ³ Ix = 329.45 cm ⁴
			12	142	0.006		3.7	211	0.101	
			14	104	0.011		4.3	155	0.186	
			16	80	0.019		4.9	119	0.318	
			18	63	0.030		5.5	94	0.509	
			20	51	0.045		6.1	76	0.776	

When trays are used in continuous spans, the deflection of the tray is reduced by as much as 50%. Design factors: Ix = Moment of Inertia, Sx = Section Modulus.

B-Line Series	Side Rail Dimensions	NEMA, CSA & UL Classifications	Span ft	Load lbs/ft	Deflection Multiplier	Design Factors for Two Rails	Span meters	Load kg/m	Deflection Multiplier	Design Factors for Two Rails
36		NEMA: 20B, 16C CSA: 112 kg/m 6.0m E-6m UL Cross-Sectional Area: 1.50 in ²	12	233	0.0043	Area = 1.81 in ² Sx = 3.36 in ³ Ix = 10.85 in ⁴	3.7	347	0.073	Area = 11.68 cm ² Sx = 55.06 cm ³ Ix = 451.61 cm ⁴
			14	171	0.008		4.3	255	0.136	
			16	131	0.014		4.9	195	0.232	
			18	104	0.022		5.5	154	0.372	
			20	84	0.033		6.1	125	0.566	
			22	69	0.049		6.7	103	0.829	

When trays are used in continuous spans, the deflection of the tray is reduced by as much as 50%. Design factors: Ix = Moment of Inertia, Sx = Section Modulus.

B-Line Series	Side Rail Dimensions	NEMA, CSA & UL Classifications	Span ft	Load lbs/ft	Deflection Multiplier	Design Factors for Two Rails	Span meters	Load kg/m	Deflection Multiplier	Design Factors for Two Rails
46		NEMA: 20C CSA: 168 kg/m 6.1m E-6m UL Cross-Sectional Area: 1.50 in ²	14	210	0.0071	Area = 2.06 in ² Sx = 3.59 in ³ Ix = 12.18 in ⁴	4.3	313	0.121	Area = 13.29 cm ² Sx = 58.83 cm ³ Ix = 506.97 cm ⁴
			16	161	0.012		4.9	239	0.207	
			18	127	0.019		5.5	189	0.331	
			20	103	0.030		6.1	153	0.505	
			22	85	0.043		6.7	127	0.739	
			24	72	0.061		7.3	106	1.046	

When trays are used in continuous spans, the deflection of the tray is reduced by as much as 50%. Design factors: Ix = Moment of Inertia, Sx = Section Modulus.

B-Line Series	Side Rail Dimensions	NEMA, CSA & UL Classifications	Span ft	Load lbs/ft	Deflection Multiplier	Design Factors for Two Rails	Span meters	Load kg/m	Deflection Multiplier	Design Factors for Two Rails
H46		NEMA: 20C+ CSA: 131 kg/m 7.6m E-6m UL Cross-Sectional Area: 2.00 in ²	16	261	0.0085	Area = 2.95 in ² Sx = 5.33 in ³ Ix = 17.30 in ⁴	4.9	388	0.145	Area = 19.03 cm ² Sx = 87.34 cm ³ Ix = 720.08 cm ⁴
			18	206	0.014		5.5	307	0.233	
			20	167	0.021		6.1	248	0.355	
			22	138	0.030		6.7	205	0.520	
			24	116	0.043		7.3	173	0.737	
			25	88	0.051		7.6	131	0.867	

When trays are used in continuous spans, the deflection of the tray is reduced by as much as 50%. Design factors: Ix = Moment of Inertia, Sx = Section Modulus.

B-Line Series	Side Rail Dimensions	NEMA, CSA & UL Classifications	Span ft	Load lbs/ft	Deflection Multiplier	Design Factors for Two Rails	Span meters	Load kg/m	Deflection Multiplier	Design Factors for Two Rails
56		NEMA: 20C+ CSA: 112 kg/m 9.1m E-6m UL Cross-Sectional Area: 2.00 in ²	20	169	0.016	Area = 3.63 in ² Sx = 6.12 in ³ Ix = 22.63 in ⁴	6.1	251	0.272	Area = 23.42 cm ² Sx = 100.29 cm ³ Ix = 941.86 cm ⁴
			22	139	0.023		6.7	208	0.398	
			24	117	0.033		7.3	174	0.563	
			26	100	0.045		7.9	149	0.776	
			28	86	0.061		8.5	128	1.043	
			30	75	0.081		9.1	112	1.375	

When trays are used in continuous spans, the deflection of the tray is reduced by as much as 50%. Design factors: Ix = Moment of Inertia, Sx = Section Modulus.

All dimensions in parentheses are millimeters unless otherwise specified.

Series 2, 3, 4, & 5 Aluminum - Straight Sections

6" NEMA VE 1 Loading Depth 7" Side Rail Height

Straight Section Part Numbering

Example: ^{Prefix} **37 A 09 - 24 - 144**

Series

● 27

● 37

● 47

● H47†

● 57

Material

● A = Aluminum

*Type

Ladder-

- 06 = 6" rung spacing
- 09 = 9" rung spacing
- 12 = 12" rung spacing

*Width

- 06 = 6"
- 09 = 9"
- 12 = 12"
- 18 = 18"
- 24 = 24"
- 30 = 30"
- 36 = 36"

Length

- ① 144 = 12 ft. 27
- ② 120 = 10 ft.
- ① 240 = 20 ft. 37
- ② 144 = 12 ft.
- ① 240 = 20 ft. 47
- ② 288 = 24 ft.
- ① 240 = 20 ft. H47
- ② 300 = 25 ft.
- ① 360 = 30 ft. 57
- ② 300 = 25 ft.

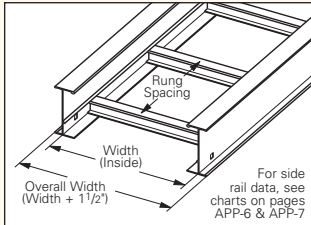

- Trough-
- 6" thru 36" wide
- VT = Ventilated Trough
- ST = Non-Ventilated Trough

† H47A & 57A only available in ladder type 9" and 12" rung spacing.
See page APP-2.

① Primary Length.
② Secondary Length.

See page C-23 for explanation of lengths.

See page APP-1 for additional rung options. *Special sizes available.



Ladder Type
(Specify Rung Spacing)

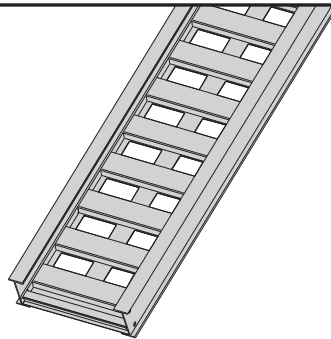

Ventilated Trough

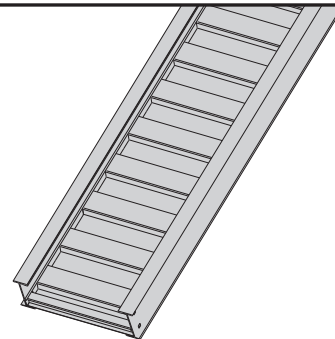

Non-Ventilated Trough

57A available in
(9" & 12" rung spacing in
12" to 36" widths)

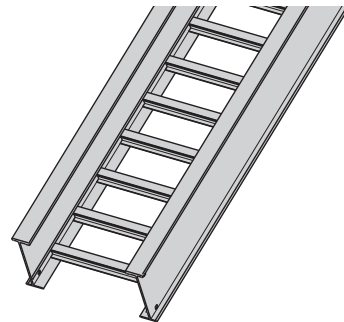

● Green = Fastest shipped items ● Black = Normal lead-time items ● Red = Normally long lead-time items

All dimensions in parentheses are millimeters unless otherwise specified.

Series 2, 3, 4, & 5 Aluminum - Straight Sections

6" NEMA VE 1 Loading Depth 7" Side Rail Height

Values are based on simple beam tests per NEMA VE 1 on 36" wide cable tray with rungs spaced on 12" centers. Cable trays will support without collapse a 200 lb. (90.7 kg) concentrated load over and above published loads. Published load safety factor is 1.5. To convert 1.5 safety factor to 2.0, multiply the published load by 0.75. To obtain mid-span deflection, multiply a load by the deflection multiplier. Cable tray must be supported on spans shorter than or equal to the length of the cable tray being installed.

Individual rungs will support without collapse a 200 lb. (90.7 kg) concentrated load applied at the mid-span of the rung, over and above the NEMA rated cable load with a 1.5 safety factor for highlighted NEMA spans and loads.

B-Line Series	Side Rail Dimensions	NEMA, CSA & UL Classifications	Span ft	Load lbs/ft	Deflection Multiplier	Design Factors for Two Rails	Span meters	Load kg/m	Deflection Multiplier	Design Factors for Two Rails
27		NEMA: 12C CSA: 68 kg/m 6.0m D-6m UL Cross-Sectional Area: 1.50 in ²	10	177	0.006	Area = 1.63 in ² Sx = 2.93 in ³ Ix = 11.28 in ⁴	3.0	269	0.033	Area = 10.52 cm ² Sx = 48.01 cm ³ Ix = 469.51 cm ⁴
			12	123	0.013		3.7	177	0.073	
			14	90	0.023		4.3	134	0.131	
			16	69	0.040		4.9	101	0.227	
			18	54	0.064		5.5	81	0.357	
			20	44	0.098		6.1	67	0.534	
37		NEMA: 20B, 16C CSA: 101 kg/m 6.1m D-6m UL Cross-Sectional Area: 1.50 in ²	12	222	0.0035	Area = 1.81 in ² Sx = 3.77 in ³ Ix = 13.50 in ⁴	3.7	331	0.059	Area = 11.68 cm ² Sx = 61.78 cm ³ Ix = 561.91 cm ⁴
			14	163	0.0064		4.3	243	0.109	
			16	125	0.011		4.9	186	0.186	
			18	99	0.017		5.5	147	0.299	
			20	80	0.027		6.1	119	0.455	
			22	66	0.039		6.7	98	0.666	
47		NEMA: 20C CSA: 142 kg/m 6.1m E-6m UL Cross-Sectional Area: 2.00 in ²	14	204	0.0048	Area = 2.38 in ² Sx = 4.94 in ³ Ix = 17.88 in ⁴	4.3	305	0.083	Area = 15.35 cm ² Sx = 80.95 cm ³ Ix = 744.22 cm ⁴
			16	156	0.0082		4.9	233	0.141	
			18	123	0.0132		5.5	184	0.225	
			20	100	0.0201		6.1	149	0.344	
			22	83	0.0295		6.7	123	0.503	
			24	69	0.0418		7.3	103	0.713	
H47		NEMA: 20C+ CSA: 241 kg/m 6.1m E-6m UL Cross-Sectional Area: 2.00 in ²	16	233	0.0064	Area = 3.04 in ² Sx = 6.10 in ³ Ix = 22.91 in ⁴	4.9	346	0.110	Area = 19.61 cm ² Sx = 99.96 cm ³ Ix = 953.59 cm ⁴
			18	184	0.010		5.4	274	0.176	
			20	149	0.016		6.1	222	0.268	
			22	123	0.023		6.7	183	0.393	
			24	103	0.033		7.3	154	0.556	
			25	95	0.038		7.6	142	0.655	
57		NEMA: 20C+ CSA: 151 kg/m 9.1m E-6m UL Cross-Sectional Area: 2.00 in ²	20	232	0.011	Area = 4.22 in ² Sx = 7.73 in ³ Ix = 32.86 in ⁴	6.1	345	0.187	Area = 27.73 cm ² Sx = 126.67 cm ³ Ix = 1367.74 cm ⁴
			22	192	0.016		6.7	285	0.274	
			24	161	0.023		7.3	240	0.388	
			26	136	0.031		7.9	202	0.534	
			28	117	0.042		8.5	174	0.718	
			30	102	0.055		9.1	152	0.947	

When trays are used in continuous spans, the deflection of the tray is reduced by as much as 50%. Design factors: Ix = Moment of Inertia, Sx = Section Modulus.

All dimensions in parentheses are millimeters unless otherwise specified.

Series 2, 3, 4, & 5 Aluminum - Straight Sections

6" NEMA VE 1 Loading Depth 8" Side Rail Height

Straight Section Part Numbering

Example: ^{Prefix} **S8 A 09 - 24 - 144**

Series	Material	*Type	*Width	Length
● S8	● A = Aluminum	Ladder-	● 12 = 12"	● 480 = 40 ft.
		● 09 = 9" rung spacing	● 18 = 18"	● ① 360 = 30 ft.
		● 12 = 12" rung spacing	● 24 = 24"	● ② 300 = 25 ft.
			● 30 = 30"	
			● 36 = 36"	

① Primary Length.
② Secondary Length.

See page C-23 for explanation of lengths.

See page APP-1 for additional rung options. *Special sizes available.

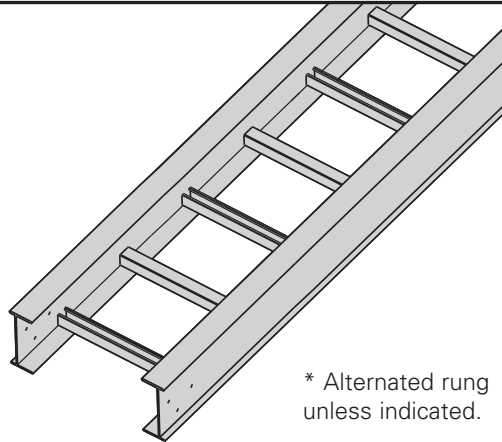
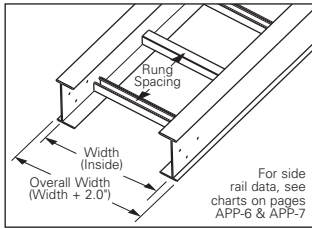

Values are based on simple beam tests per NEMA VE 1 on 36" wide cable tray with rungs spaced on 12" centers. Cable trays will support without collapse a 200 lb. (90.7 kg) concentrated load over and above published loads. Published load safety factor is 1.5. To convert 1.5 safety factor to 2.0, multiply the published load by 0.75. To obtain mid-span deflection, multiply a load by the deflection multiplier. Cable tray must be supported on spans shorter than or equal to the length of the cable tray being installed.

Individual rungs will support without collapse a 200 lb. (90.7 kg) concentrated load applied at the mid-span of the rung, over and above the NEMA rated cable load with a 1.5 safety factor for highlighted NEMA spans and loads.

B-Line Series	Side Rail Dimensions	NEMA, CSA & UL Classifications	Span ft	Load lbs/ft	Deflection Multiplier	Design Factors for Two Rails	Span meters	Load kg/m	Deflection Multiplier	Design Factors for Two Rails
S8A		NEMA: 20C+	20	363	0.007	Area=5.50 in ² Sx=15.39 in ³ Ix=55.35 in ⁴	6.1	540	0.111	Area=35.48 cm ² Sx=252.20 cm ³ Ix=2303.84 cm ⁴
		CSA: 240 kg/m 9.1m	22	300	0.010		6.7	446	0.163	
		UL Cross-Sectional Area: 2.00 in ²	24	252	0.013		7.3	375	0.230	
			26	215	0.019		7.9	320	0.317	
			28	185	0.025		8.5	276	0.427	
			30	161	0.033		9.1	240	0.562	
			40	101	0.146		12.2	151	2.488	

● Green = Fastest shipped items ● Black = Normal lead-time items ● Red = Normally long lead-time items

All dimensions in parentheses are millimeters unless otherwise specified.

The following is a list of accessories and fittings that can be provided with S8A tray. For more information on these items, contact our Engineering Department.

● Fittings

Horizontal Bends

- 30° Bends with 24", 36", or 48" radius
- 45° Bends with 24", 36", or 48" radius
- 60° Bends with 24", 36", or 48" radius
- 90° Bends with 24", 36", or 48" radius

Horizontal Tees & Crosses

With 24", 36", or 48" radius

Vertical Outside Bends

- 30° Bends with 24", 36", or 48" radius
- 45° Bends with 24", 36", or 48" radius
- 60° Bends with 24", 36", or 48" radius
- 90° Bends with 24", 36", or 48" radius

Vertical Inside Bends

- 30° Bends with 24", 36", or 48" radius
- 45° Bends with 24", 36", or 48" radius
- 60° Bends with 24", 36", or 48" radius
- 90° Bends with 24", 36", or 48" radius

Reducing Fittings

● Accessories - (standard hardware is stainless steel Type 316)

Splice Plate - 9A-1008

Expansion Splice Plate - 9A-1018

Horizontal Adjustable Splice Plate - 9A-1038

Vertical Adjustable Splice Plate - 9A-1028

Hold Down Clamps - 9ZN-1281, 9G-1281, 9A-1281

Guides - S9ZN-1202, S9G-1202

Step Down Splice Plate -

9A-1048 = 8" to 4"

9A-1051 = 8" to 5"

9A-1050 = 8" to 6"

9A-1078 = 8" to 7"

Other Accessories Include:

Offset Splice Plates

Blind Ends

Covers - Standard aluminum cover number with S in front (Example: S807A40)

● Green = Fastest shipped items ● Black = Normal lead-time items ● Red = Normally long lead-time items

All dimensions in parentheses are millimeters unless otherwise specified.

Series 2, 3, 4, & 5 Aluminum - Accessories

Wedge Lock Splice Plates

- Furnished in pairs with 1/4" hardware.
- Standard 4-hole pattern.
- Furnished in pairs, with hardware.
- One pair including hardware provided with each section.
(Expansion splice quantity subtracted)
- Boxed in pairs with hardware.
- For field installation drill 13/32" hole.

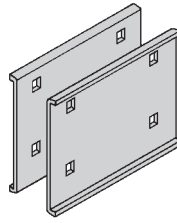

Catalog No.	Height in. mm
● 9A-1004	4 (101)
● 9A-1005	5 (127)
● 9A-1006	6 (152)
● 9A-1007	7 (178)

H46A, H47A and 57A Mid-Span Splice

- Furnished in pairs with 1/4" hardware.
- Standard for H46A, H47A and 57A straight sections.
- Six bolt design 1/2" Stainless Steel Type 316 hardware standard.
- Available on ladder bottoms only. 09 and 12" rung spacing.
- Furnished in pairs with hardware.

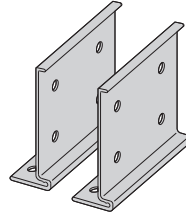

Catalog No.	Tray Series
● 9A-6006	H46A
● 9A-6007	H47A, 57A

Expansion Splice Plates

- Expansion plates allow for one inch expansion or contraction of the cable tray, or where expansion joints occur in the supporting structure.
- Furnished in pairs with hardware.
- **Bonding Jumpers are required on each siderail. Order Separately.**

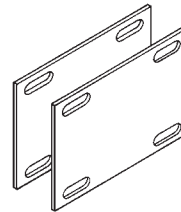

Catalog No.	Height in. mm
● 9A-1014	4 (101)
● 9A-1015	5 (127)
● 9A-1016	6 (152)
● 9A-1017	7 (178)

For heavy duty expansion splice plates see page APP-3.

Universal Splice Plates

- Furnished in pairs with 1/4" hardware.
- UL Classified.

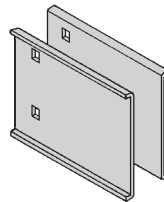

Catalog No.	Height in. mm
● 9A-1004-1/2	4 (101)
● 9A-1005-1/2	5 (127)
● 9A-1006-1/2	6 (152)
● 9A-1007-1/2	7 (178)

Step Down Splice Plates

- These splice plates are offered for connecting cable tray sections having side rails of different heights.
- Furnished in pairs with hardware.

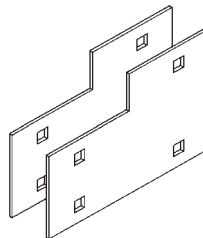

Requires supports within 24" on both sides, per NEMA VE 2.

Catalog No.	Height in. mm
● 9A-1045	5 to 4 (127 to 101)
● 9A-1046	6 to 4 (152 to 101)
● 9A-1060	6 to 5 (152 to 127)
● 9A-1047	7 to 4 (178 to 101)
● 9A-1061	7 to 5 (178 to 127)
● 9A-1062	7 to 6 (178 to 152)

Vertical Adjustable Splice Plates

- These plates provide for changes in elevation that do not conform to standard vertical fittings.
- Furnished in pairs with hardware.
- Bonding Jumpers not required.

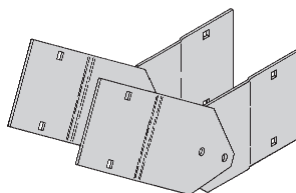

Catalog No.	Height in. mm
● 9A-1024	4 (101)
● 9A-1025	5 (127)
● 9A-1026	6 (152)
● 9A-1027	7 (178)

● Green = Fastest shipped items ● Black = Normal lead-time items ● Red = Normally long lead-time items

All dimensions in parentheses are millimeters unless otherwise specified.

Horizontal Adjustable Splice Plates

- Offered to adjust a cable tray run for changes in direction in a horizontal plane that do not conform to standard horizontal fittings.
- Furnished in pairs with hardware.
- Bonding jumpers **not** required.
- (X) Insert 4, 5, 6 or 7 for side rail height.

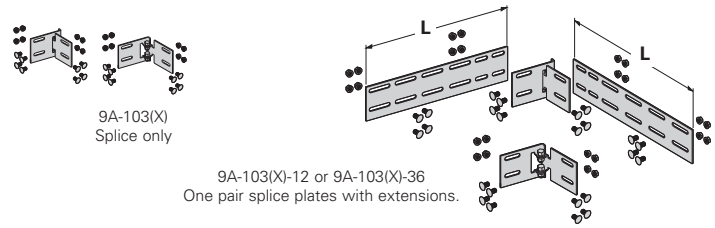

Requires supports within 24" on both sides, per NEMA VE 2.

Catalog No.	Cable Tray End Cut	Thru Tray Width		'L'
		in.	(mm)	in. (mm)
● 9A-103(X)	Mitered	36	(914)	N/A (NA)
● 9A-103(X)-12	Not mitered	12	(305)	16 (406)
● 9A-103(X)-36	Not mitered	36	(914)	41 (1041)

Branch Pivot Connectors

- Branch from existing cable tray runs at any point.
- Pivot to any required angle.
- UL Classified for grounding (bonding jumpers not required).
- Furnished in pairs with hardware.

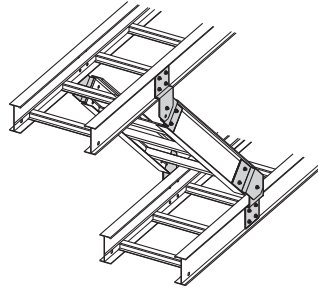

Catalog No.	Height	
	in.	mm
● 9A-2044	4	(101)
● 9A-2045	5	(127)
● 9A-2046	6	(152)
● 9A-2047	7	(178)

Offset Reducing Splice Plate

- This plate is used for joining cable trays having different widths. When used in pairs they form a straight reduction; when used singly with a standard splice plate, they form an offset reduction.
- Furnished as one plate with hardware.
- (‡) Insert reduction

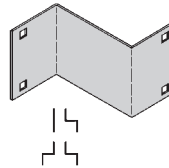

Catalog No.	Height	
	in.	mm
● 9A-1064-(‡)	4	(101)
● 9A-1065-(‡)	5	(127)
● 9A-1066-(‡)	6	(152)
● 9A-1067-(‡)	7	(178)

Tray to Box Splice Plates

- Used to attach the end of a cable tray run to a distribution box or control panel.
- Furnished in pairs with hardware

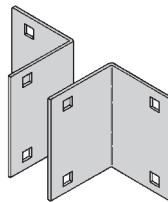

Catalog No.	Height	
	in.	mm
● 9A-1054	4	(101)
● 9A-1055	5	(127)
● 9A-1056	6	(152)
● 9A-1057	7	(178)

Frame Type Box Connector

- Designed to attach the end of a cable tray run to a distribution cabinet or control center to help reinforce the box at the point of entry.
- Furnished with tray connection hardware.

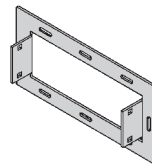

Catalog No.	Height	
	in.	mm
● 9A-1074-(‡)	4	(101)
● 9A-1075-(‡)	5	(127)
● 9A-1076-(‡)	6	(152)
● 9A-1077-(‡)	7	(178)

Blind End

- This plate forms a closure for a dead end cable tray.
- Furnished as one plate with hardware.
- (‡) Insert tray width

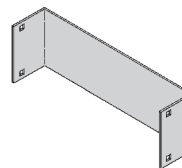

Catalog No.	Height	
	in.	mm
● 9A-1084-(‡)	4	(101)
● 9A-1085-(‡)	5	(127)
● 9A-1086-(‡)	6	(152)
● 9A-1087-(‡)	7	(178)

● Green = Fastest shipped items ● Black = Normal lead-time items ● Red = Normally long lead-time items

All dimensions in parentheses are millimeters unless otherwise specified.

Series 2, 3, 4, & 5 Aluminum - Accessories

Standard Tray Hardware (for field installation drill $1\frac{3}{32}$ " hole)

- Finish: Zinc Plated ASTM B633 SC1

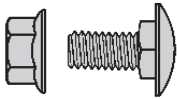

Catalog No.	Description
● SNCB $\frac{3}{8}$" x $\frac{3}{4}$" ZN	Square Neck Carriage Bolt ASTM A307 Grade A
● SFHN $\frac{3}{8}$"-16 ZN	Serrated Flange Hex Nut ASTM A563 Grade A

Optional Tray Hardware (for field installation drill $1\frac{3}{32}$ " hole)

- To order 316 stainless steel hardware add SS6 suffix to catalog number - Example: 9A1004SS6

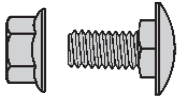

Catalog No.	Description
● SNCB $\frac{3}{8}$" x $\frac{3}{4}$" SS6	Square Neck Carriage Bolt AISI 316 Stainless Steel
● SFHN $\frac{3}{8}$"-16 SS6	Serrated Flange Hex Nut AISI 316 Stainless Steel

Cross Connector Bracket

- For field connecting crossing section.
- Furnished in pairs with $\frac{3}{8}$ " hardware.

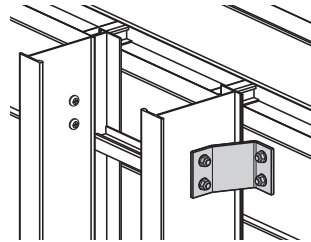
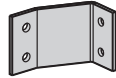

Catalog No.
● 9A-1240

Conduit to Cable Tray Adaptor

- For easy attachment of conduit terminating at a cable tray.
- Use on aluminum or steel cable trays.

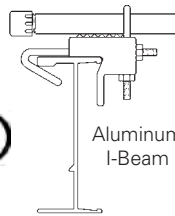
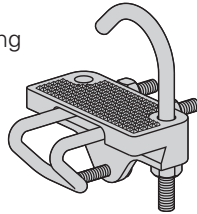

Aluminum I-Beam

Catalog No.	Conduit Size	
	in.	mm
● 9G-1158-$1\frac{1}{2}$, $\frac{3}{2}$	$\frac{1}{2}$, $\frac{3}{4}$	(15, 20)
● 9G-1158-1, $1\frac{1}{4}$	1, $1\frac{1}{4}$	(25, 32)
● 9G-1158-$1\frac{1}{2}$, 2	$1\frac{1}{2}$, 2	(40, 50)
● 9G-1158-$2\frac{1}{2}$, 3	$2\frac{1}{2}$, 3	(65, 80)
● 9G-1158-$3\frac{1}{2}$, 4	$3\frac{1}{2}$, 4	(90, 100)

Conduit to Cable Tray Adaptor

- Assembly required.
- Mounting hardware included.
- Conduit clamps provided.
- (‡) = Insert conduit size ($\frac{1}{2}$ " thru 4").

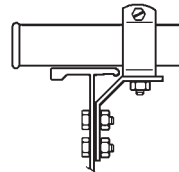

Catalog No.
● 9ZN-1150-(‡)

Conduit to Cable Tray Adaptor

- Assembly required.
- Conduit clamps included.
- (‡) = Insert conduit size ($\frac{1}{2}$ " thru 4").

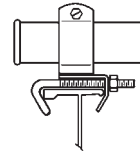
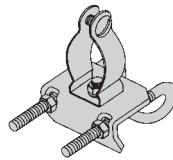

Catalog No.
● 9ZN-1155-(‡)

Cable Tie (Ladder Tray)

- Nylon ties provide easy attachment of cable to ladder rungs; maximum cable O.D. is 3" (76mm).

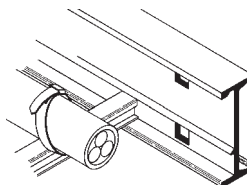

Overall Length 15" (381mm)

Catalog No.
● 99-2125-15

● Green = Fastest shipped items ● Black = Normal lead-time items ● Red = Normally long lead-time items

All dimensions in parentheses are millimeters unless otherwise specified.

Ladder Drop-Out

- Specially-designed Ladder Drop-Outs provide a rounded surface with 4" (101 mm) radius to protect cable as it exits from the cable tray, preventing damage to insulation. The drop-out will attach to any desired rung.
- (‡) Insert tray width

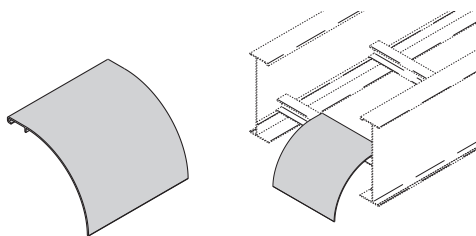

Catalog No.
● 9A-1104-(‡)

Trough Drop-Out & Drop-Out Bushing

- These devices provide a rounded surface to protect cable as it exits from the trough-type cable tray.
- Hardware is included for attachment of the trough bottom drop-out.
- (‡) Insert tray width

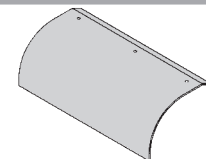
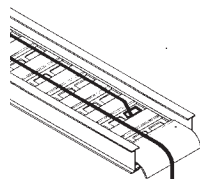

Trough-Type Drop-Out

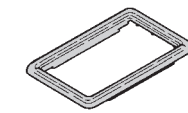

Snap-In Plastic Bushing

Catalog No.
● 9A-1104T-(‡)

Catalog No.
● 99-1124

Barrier - Straight Section

- Length: Insert 120 for [120" - 10 ft.] (3.0 m) or 144 for [144" - 12 ft.] (3.6 m)
- Order catalog number based on loading depth.
- Furnished with four #10 x 1/2" plated self-drilling screws and a 99-9982 Barrier Strip Splice.

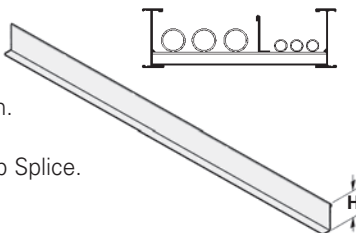

Catalog No.	Side Rail Height in. mm	Loading Depth 'H' in. mm
● 73A-Length	4 (101)	3 (76)
● 74A-Length	5 (127)	4 (101)
● 75A-Length	6 (152)	5 (127)
● 76A-Length	7 (178)	6 (152)

Barrier - Horizontal Bend

- Horizontal Bend Barriers are flexible in order to conform to any horizontal fitting radius. Can be cut to desired length.
- Standard length is 72" [6 ft.] (1.8 m) - sold individually
- Order catalog number based on loading depth.
- Furnished with three #10 x 1/2" plated self-drilling screws and a 99-9982 Barrier Strip Splice.

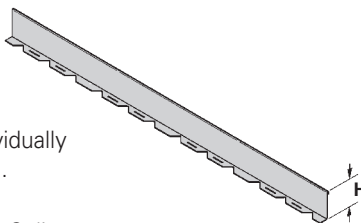

Catalog No.	Side Rail Height in. mm	Loading Depth 'H' in. mm
● 73A-90HBFL	4 (101)	3 (76)
● 74A-90HBFL	5 (127)	4 (101)
● 75A-90HBFL	6 (152)	5 (127)
● 76A-90HBFL	7 (178)	6 (152)

Barrier - Vertical Outside Bend

- Vertical Outside Bend Barriers are preformed to conform to a specific vertical outside bend fitting.
- Furnished with three #10 x 1/2" plated self-drilling screws and a 99-9982 Barrier Strip Splice.
- (*) Insert 30, 45, 60 or 90 for degrees
- (t) Insert 12, 24, 36 or 48 for radius

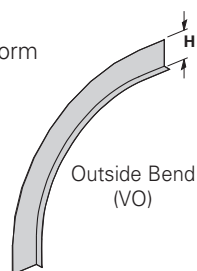

Catalog No.	Side Rail Height in. mm	Loading Depth 'H' in. mm
● 73A-(*)VO(†)	4 (101)	3 (76)
● 74A-(*)VO(†)	5 (127)	4 (101)
● 75A-(*)VO(†)	6 (152)	5 (127)
● 76A-(*)VO(†)	7 (178)	6 (152)

Barrier - Vertical Inside Bend

- Vertical Inside Bend Barriers are preformed to conform to a specific vertical inside bend fitting.
- Furnished with three #10 x 1/2" plated self-drilling screws and a 99-9982 Barrier Strip Splice.
- (*) Insert 30, 45, 60 or 90 for degrees
- (t) Insert 12, 24, 36 or 48 for radius

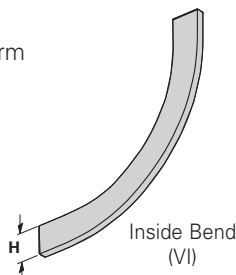

Catalog No.	Side Rail Height in. mm	Loading Depth 'H' in. mm
● 73A-(*)VI(†)	4 (101)	3 (76)
● 74A-(*)VI(†)	5 (127)	4 (101)
● 75A-(*)VI(†)	6 (152)	5 (127)
● 76A-(*)VI(†)	7 (178)	6 (152)

● Green = Fastest shipped items ● Black = Normal lead-time items ● Red = Normally long lead-time items

All dimensions in parentheses are millimeters unless otherwise specified.

Series 2, 3, 4, & 5 Aluminum - Accessories

Barrier Strip Clip

- Provides attachment to rung.
- Allows for installed barrier adjustment.
- Asymmetrical clip provides a wide range for screw location.
- Barrier strip clips not included with barriers.
(Must be ordered separately)

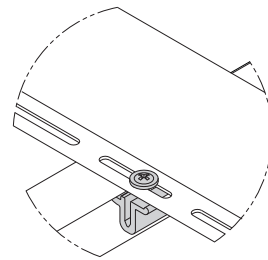
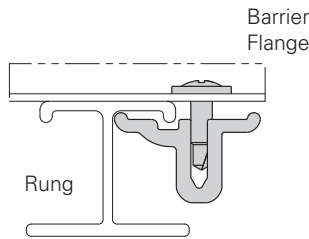
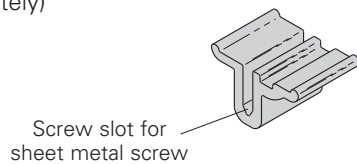

Catalog No.

● 9A-RBC

Barrier Strip Splice

- Plastic splice holds adjoining barrier strips in straight alignment.
- 3" (76mm) long.

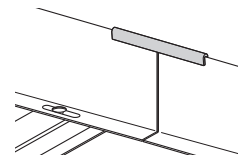
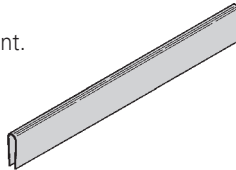

Catalog No.

● 99-9982

Bonding Jumper

Use at each expansion splice and where the cable tray is not mechanically/electrically continuous to ground. Sold individually.

- Hardware included.
- See table 392.6(B)(2) on page CTS-9 for amperage ratings required to match the UL cross-sectional area of the tray.
- See tray loading chart for UL cross-sectional area.
- Bonding jumper is 14¹/₂" (368mm) long.

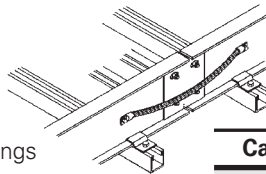

Catalog No.	Copper Wire Size	Ampacity
● 99-N1	#1	600
● 99-40	4/0	1600
● 99-1620	250 MCM	2000

Grounding Clamp

Eaton's B-Line series cable tray is UL® classified as to its suitability as an equipment grounding conductor. If a separate conductor for additional grounding capability is desired, B-Line offers this clamp for bolting the conductor at least once to each cable tray section.

- Accepts #6 AWG to 250 MCM.

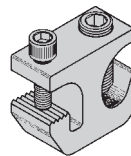

Catalog No.	Material
● 9A-2130	Tin Plated Aluminum

Ground Wire Clamp

- Mechanically attaches grounding cables to cable tray.
- Hardware included.
- (*) Insert **ZN** or **SS4**

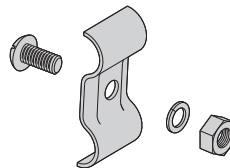

Catalog No.	Material
9(*)-2351	#1 thru 2/0
9(*)-2352	3/0 thru 250 MCM

Thread Rod (ATR) & Rod Couplings

Loading based on safety factor 5.

Standard Finish: Zinc plated

See B-Line series Strut Systems Catalog for other sizes and finishes.

B655
Rod Coupling

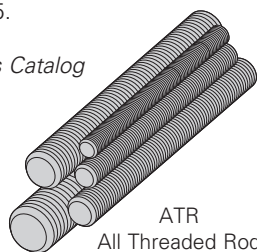
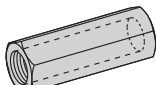

ATR
All Threaded Rod

Size	Catalog No.	Available Length	Loading
All Threaded Rod			
3/8"-16	● ATR 3/8" x Length	36", 72", 120", 144"	730 lbs.
1/2"-13	● ATR 1/2" x Length	36", 72", 120", 144"	1350 lbs.
Rod Coupling			
3/8"-16	● B655-3/8"	NA	730 lbs.
1/2"-13	● B655-1/2"	NA	1350 lbs.

● Green = Fastest shipped items ● Black = Normal lead-time items ● Red = Normally long lead-time items

All dimensions in parentheses are millimeters unless otherwise specified.

Stainless Steel Cable Clamp 'P'

- Fits with series 2, 3, & 4 rungs.
- Attaches to rung at any point.
- 14 gauge Type 316 stainless steel material to minimize corrosion and induction heating.
- Plated steel and aluminum also available.

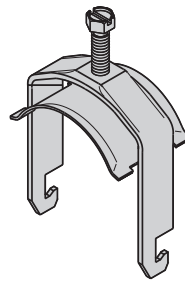
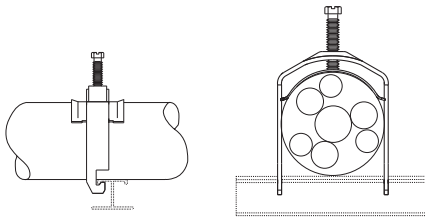

Refer to Section CF
Cable Fixing

Catalog No.	Cable Size	
	in.	mm
● BP081SS	.250 - .840	(6.4 - 21.3)
● BP110SS	.810 - 1.100	(20.6 - 28.0)
● BP135SS	.850 - 1.350	(21.6 - 34.8)
● BP175SS	1.250 - 1.750	(31.8 - 44.5)
● BP205SS	1.550 - 2.050	(39.4 - 52.1)
● BP250SS	2.000 - 2.500	(50.8 - 63.5)
● BP300SS	2.500 - 3.000	(63.5 - 76.2)
● BP325SS	2.750 - 3.250	(69.9 - 82.6)
● BP375SS	3.250 - 3.750	(82.6 - 95.3)
● BP425SS	3.750 - 4.250	(95.3 - 108.0)
● BP475SS	4.250 - 4.750	(108.0 - 120.7)

Hanger Rod Clamp

- For 1/2" ATR.
- Furnished in pairs.
- Order ATR and hex nuts separately.
- Two-piece "J"-hanger design.
- 1500 lbs./pair capacity safety factor 3.
- (*) Insert **ZN** or **G**

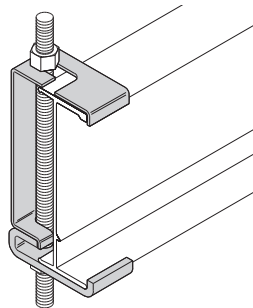

Catalog No.	Height	
	in.	mm
9(*)-5324	4	(101)
9(*)-5325	5	(127)
9(*)-5326	6	(152)
9(*)-5327	7	(178)

Cable Tray Clamp/Guide

- Features a no-twist design.
- Has four times the strength of the traditional design.
- Each side is labeled to ensure proper installation.
- Furnished in pairs, with or without hardware.
- Not recommended for vertical support.

Note: For heavy duty or vertical applications see 9(*)-1241 or 9(*)-1242 page HAT-20

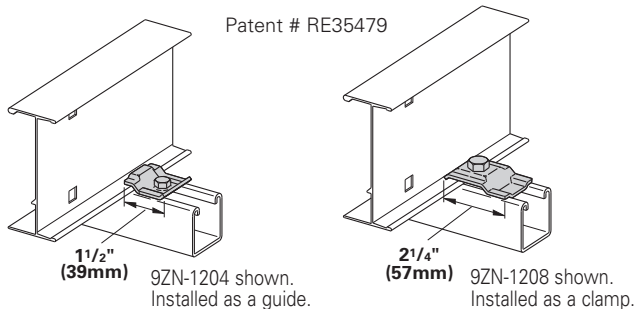

Catalog No.		Overall Length in. (mm)	Hardware Size in.	Finish
Without Hardware	With Hardware			
● 9ZN-1204	● 9ZN-1204NB	1 1/2 (38)	1/4"	G90
● 9ZN-1208	● 9ZN-1208NB	2 1/4 (57)	3/8"	G90
● 9A-1205	--	2 1/4 (57)	1/2"	Alum.
● 9G-1205	--	2 1/4 (57)	1/2"	HDGAF
● 9SS6-1205	--	2 1/4 (57)	1/2"	316SS
● 9ZN-1205	--	2 1/4 (57)	1/2"	G90

Isolator Pad

- Use as a friction reducer and/or as a dissimilar metal isolator barrier.
- UV resistant HDPE.
- Temperature range: -100 to 160° F.
- Designed to use with 9(*)-1205 or 9(*)-1208 clamp/guide.
- Color - White.

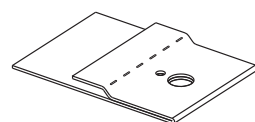

Isolation pad shown as when used with a guide.

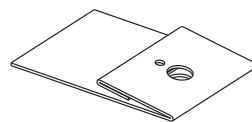

Isolation pad shown with top flange doubled under for clamp application.

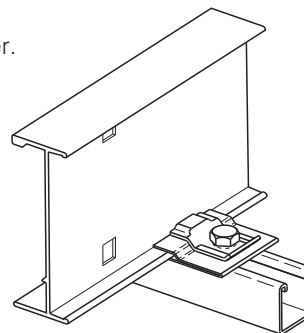

Catalog No.

● 99-PE34

● Green = Fastest shipped items ● Black = Normal lead-time items ● Red = Normally long lead-time items

All dimensions in parentheses are millimeters unless otherwise specified.

Series 2, 3, 4, & 5 Aluminum - Accessories

Cable Tray Clamp

- Hold-down clamps for single or double cable tray runs.
- No drilling of support I-beam or channel is required.
- Sold in pieces - two clamps are required per tray.
- Maximum beam flange thickness 1 1/8" (28.58 mm).

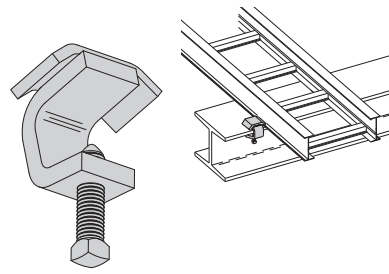

Catalog No.	Finish
● 9ZN-1249HD	Znplt
● 9G-1249HD	HDGAF

Cable Tray Guide

- Expansion guide for single or double cable tray runs.
- Guide allows for longitudinal movement of the cable tray.
- No field drilling of support I-beam or channel is required.
- Guides are required on both sides of cable tray to prevent lateral movement - can be placed on either the inside or outside flange of cable tray.
- Guides are sold in pieces - two guides are required per tray.
- Maximum flange thickness 1 1/8" (28.58 mm).

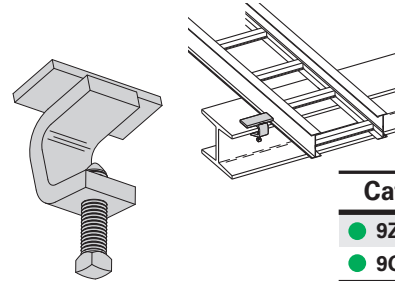

Catalog No.	Finish
● 9ZN-1249	Znplt
● 9G-1249	HDGAF

Nylon Pad

- Use for friction reduction.
- Hardness: Shore D80.
- Low friction coefficient.
- UV resistant.
- Excellent weatherability.
- UL - 94HB.

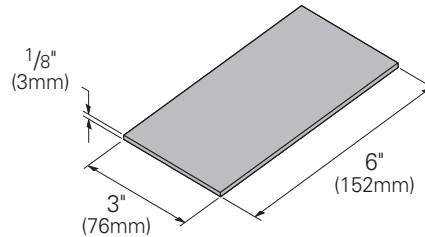

Catalog No.
● 99-PE36

Neoprene Roll

- Use for material isolation.
- 1/8" x 2" x 25' roll.
- Hardness: Shore A60.
- Good weatherability.

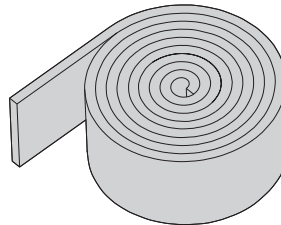

Catalog No.
● 99-NP300

DURA-BLOK™ Rooftop Support Bases with B22 Channel

- Designed as a superior rooftop support for cable tray,
- UV resistant and approved for most roofing material or other flat surfaces.
- Can be used with any of B-Line series cable tray clamps and guides.
- Ultimate Load Capacity: 1,000 lbs. (uniform load)



Catalog No.	Height x Width x Length in. (mm)
● DB10-28	5 5/8 x 6 x 28.0 (143 x 152 x 711)
● DB10-36	5 5/8 x 6 x 36.0 (143 x 152 x 914)
● DB10-42	5 5/8 x 6 x 42.0 (143 x 152 x 1067)
● DB10-50	5 5/8 x 6 x 50.0 (143 x 152 x 1270)
● DB10-60	5 5/8 x 6 x 60.0 (143 x 152 x 1524)



LEEDS credit available, base made from 100% recycled material.

General Note: Consult roofing manufacturer or engineer for roof load capacity. The weakest point may be the insulation board beneath the rubber membrane.

● Green = Fastest shipped items ● Black = Normal lead-time items ● Red = Normally long lead-time items

All dimensions in parentheses are millimeters unless otherwise specified.

Trapeze Support Kit

- Eaton's B-Line series trapeze kits provide the components required for a single trapeze support in one package. These kits are available in pre-galvanized steel with zinc-plated hardware, hot dip galvanized steel with 316 stainless steel hardware, or DURA GREEN™ painted steel with zinc-plated hardware.
- The SH channel provides the convenience of pre-punched slots, which eliminate the need for field drilling.
- The illustrated hardware is sealed in a plastic bag and boxed with the channel, which is pre-cut to the appropriate length as shown in the chart.
- Designed for use with 1/2" threaded rod. Order rod separately.

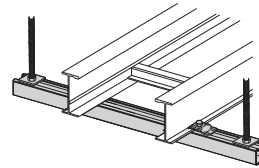
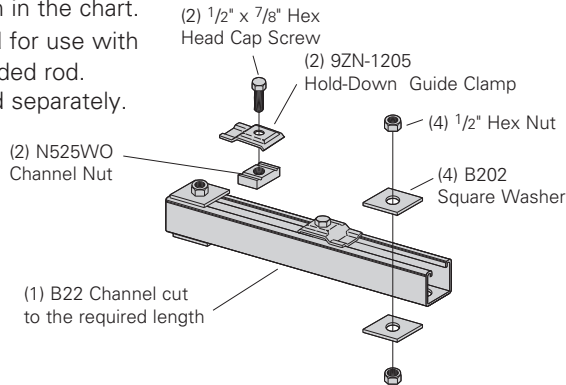

Catalog No.	Tray Width		Channel Length		Uniform Load	
	in.	mm	in.	mm	lbs	kN
● 9(*)-5506-22SH(†)	6	(152)	16	(406)	1350	(6.00)
● 9(*)-5509-22SH(†)	9	(229)	18	(457)	1250	(5.56)
● 9(*)-5512-22SH(†)	12	(305)	22	(559)	1125	(5.00)
● 9(*)-5518-22SH(†)	18	(457)	28	(711)	865	(3.85)
● 9(*)-5524-22SH(†)	24	(610)	34	(864)	700	(3.11)
● 9(*)-5530-22SH(†)	30	(762)	40	(1016)	590	(2.62)
● 9(*)-5536-22SH(†)	36	(914)	46	(1168)	510	(2.27)
● 9(*)-5542-22SH(†)	42	(1067)	52	(1321)	450	(2.00)

- (*) Insert **P** **G** or **GRN**
- (†) Insert 3/8 for 3/8" threaded rod hardware. Safety factor of 3.0 on all loads.

Heavy Duty Trapeze Support Kit

- Eaton's B-Line series trapeze kits provide the components required for a single trapeze support in one package. These kits are available in pre-galvanized steel with zinc-plated hardware, hot dip galvanized steel with 316 stainless steel hardware, or DURA GREEN™ painted steel with zinc-plated hardware.
- The SH channel provides the convenience of pre-punched slots, which eliminates the need for field drilling.
- The illustrated hardware is sealed in a plastic bag and boxed with the channel, which is pre-cut to the appropriate length as shown in the chart.
- Designed for use with 1/2" threaded rod. Order rod separately.

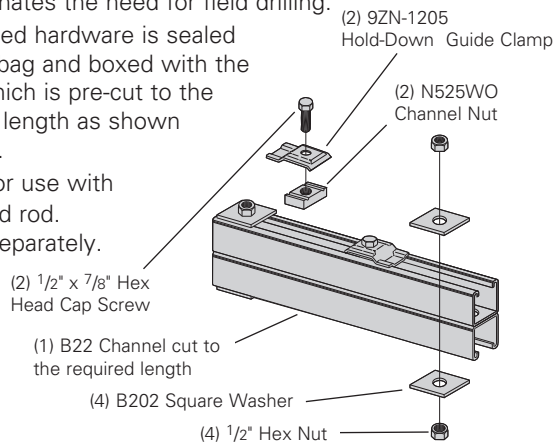

Catalog No.	Tray Width		Channel Length		Uniform Load	
	in.	mm	in.	mm	lbs	kN
● 9(*)-5506-22SHA	6	(152)	16	(406)	1350	(6.00)
● 9(*)-5509-22SHA	9	(229)	18	(457)	1350	(6.00)
● 9(*)-5512-22SHA	12	(305)	22	(559)	1350	(6.00)
● 9(*)-5518-22SHA	18	(457)	28	(711)	1350	(6.00)
● 9(*)-5524-22SHA	24	(610)	34	(864)	1350	(6.00)
● 9(*)-5530-22SHA	30	(762)	40	(1016)	1350	(6.00)
● 9(*)-5536-22SHA	36	(914)	46	(1168)	1350	(6.00)
● 9(*)-5542-22SHA	42	(1067)	52	(1321)	1350	(6.00)

- (*) Insert **P** **G** or **GRN**
- Safety factor of 3.0 on all loads.

Trapeze Hardware Kit

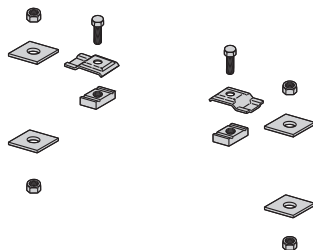

Catalog No.	● 9ZN-5500-1/2	● 9G-5500-1/2
In plastic bag	1 pr. 9ZN-1205 2 HHC Screw 1/2 x 7/8 ZN 2 N525 WO ZN 4 B202 ZN 1/2" sq washer 4 HN 1/2" ZN	1 pr. 9G-1205 2 HHC Screw 1/2 x 7/8 SS6 2 N525 WO SS6 4 B202 HDG 1/2" sq washer 4 HN 1/2" SS6

- Green = Fastest shipped items
- Black = Normal lead-time items
- Red = Normally long lead-time items

All dimensions in parentheses are millimeters unless otherwise specified.

Series 2, 3, 4, & 5 Aluminum - Accessories

Center Hung Tray Support

- Center Hung Cable Tray Support allows cable to be laid-in from both sides.
- Eliminates costly cable pulling and field cutting of cable tray supports. Labor costs are dramatically reduced.
- Required hardware and threaded rod material for trapeze assemblies are reduced by up to 50%.
- Designed for use with 1/2" threaded rod. (Order rod separately)
- Use with all aluminum and steel cable trays through 24" width.
- Load capacity is 700 lbs. (311kN) per support. Safety factor of 3.0. Eccentric loading is not to exceed a 60% vs. 40% load differential.
- The maximum recommended unsupported span length is 144"/12 ft. (3.66 m).
- Hardware shown is furnished.
- Finish available: Zinc Plated

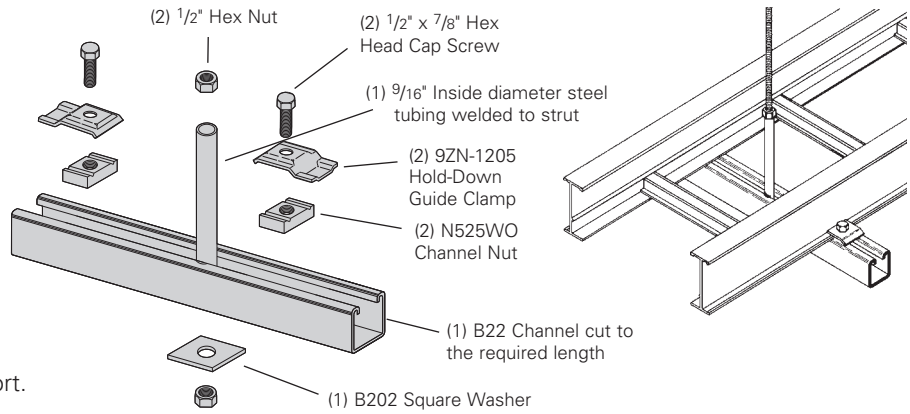

Catalog No.	Tray Width		Channel Length	
	in.	(mm)	in.	(mm)
● 9ZN-5212	6", 9", 12"	(152, 228, 305)	18"	(457)
● 9ZN-5224	18", 24"	(457, 609)	30"	(762)

Center Hung Support Hardware Kit

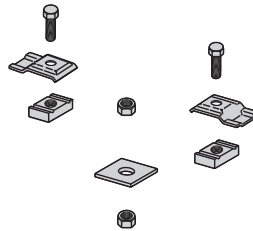

Catalog No.	● 9ZN-5200
In plastic bag	1 pr. 9ZN-1205 2 HHC Screw 1/2 x 7/8 ZN 2 N525 WO ZN 1 B202 ZN 1/2" sq washer 4 HN 1/2 ZN

Bracket (12" - 48")

- (*) Insert available finish: **ZN** **GRN** or **HDG**
- Safety Load Factor 2.5

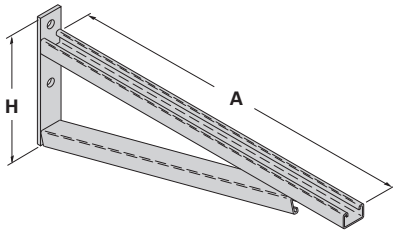

Bottom brace is B42 channel on B494-24 and smaller and B22 channel on B494-30 and larger

Catalog No.	Uniform Load lbs (kN)	Tray Width		'A'		'H'	
		in.	(mm)	in.	(mm)	in.	(mm)
● B494-12	2500 (11.12)	6 & 9	(152 & 229)	12	(305)	8 ³ / ₄	(222)
● B494-18	1700 (7.56)	12	(305)	18	(457)	8 ³ / ₄	(222)
● B494-24	1300 (5.78)	18	(457)	24	(610)	8 ³ / ₄	(222)
● B494-30	1600 (7.11)	24	(610)	30	(762)	11 ¹ / ₄	(286)
● B494-36	1100 (4.89)	30	(762)	36	(914)	11 ¹ / ₄	(286)
● B494-42	980 (4.36)	36	(914)	42	(1067)	16	(406)
● B494-48	980 (4.36)	42	(1067)	48	(1219)	16	(406)

For more dimensional data see Strut Systems catalog

Cantilever Bracket

- (*) Insert available finish: **ZN** **GRN** **HDG** **SS4** or **SS6**
- Safety Load Factor 2.5

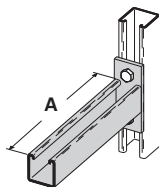

Catalog No.	Uniform Load		Tray Width		'A'	
	lbs	kN	in.	mm	in.	mm
B409-12	960	(4.27)	6 & 9	(152 & 229)	12	(305)
B409-18	640	(2.84)	12	(305)	18	(457)
B409-24	480	(2.13)	18	(457)	24	(610)

● Green = Fastest shipped items ● Black = Normal lead-time items ● Red = Normally long lead-time items

All dimensions in parentheses are millimeters unless otherwise specified.

Series 2, 3, 4, & 5 Aluminum - Accessories

Cantilever Bracket

- (*) Insert available finish: **ZN** **GRN** **HDG** or **SS4**
- Safety Load Factor 2.5

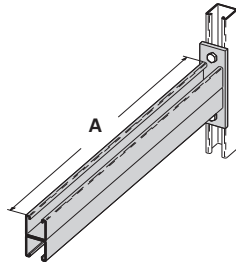

Catalog No.	Uniform Load		Tray Width		'A'	
	lbs	kN	in.	mm	in.	mm
B297-12	1660	(7.38)	6 & 9	(152 & 229)	12	(305)
B297-18	1100	(4.89)	12	(305)	18	(457)
B297-24	835	(3.71)	18	(457)	24	(610)
B297-30	665	(2.93)	24	(610)	30	(762)
B297-36	550	(2.44)	30	(762)	36	(914)
B297-42	465	(2.06)	36	(914)	42	(1067)

Underfloor Support (U-Bolts not included)

- Finishes available: **ZN**
- Safety Load Factor 2.5

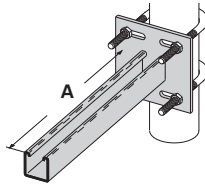

U-Bolt Size	Fits Pipe O.D.
B501-3/4	.841 - 1.050
B501-1	1.051 - 1.315
B501-1 1/4	1.316 - 1.660
B501-1 1/2	1.661 - 1.900
B501-2	1.901 - 2.375
B501-2 1/2	2.376 - 2.875

Catalog No.	Uniform Load		Tray Width		'A'	
	lbs	(kN)	in.	(mm)	in.	(mm)
B409UF-12	800	(3.56)	6 & 9	(152 & 229)	12	(305)
B409UF-21	450	(2.00)	12 & 18	(305 & 457)	21	(533)

Vertical Hanger Splice Plates

- Design load is 1500 lbs (6.67kN) per pair.
- Safety Factor of 2.5
- Furnished in pairs.
- Hole size: 9/16" (14mm) for 1/2" threaded rod.

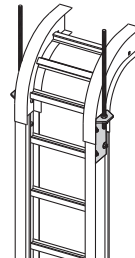
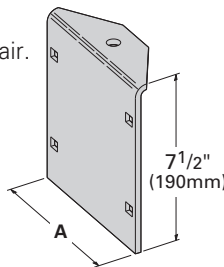

Catalog No.	Outside Cable Tray Ht.		'A'	
	in.	(mm)	in.	(mm)
● 9A-1224	4"		3.84	(97.54)
● 9A-1225	5"		4.73	(120.14)
● 9A-1226	6"		5.84	(148.34)
● 9A-1227	7"		6.84	(173.74)

Heavy Duty Hold Down Bracket

- Design load is 2000 lbs (8.89kN) per pair.
- Two bolt design.
- Sold in pairs.
- 3/8" cable tray attachment hardware provided.
- 1/2" support attachment hardware **not** provided.
- (*) Insert **ZN** **SS4** or **SS6**
- Recommended for support of vertical trays.

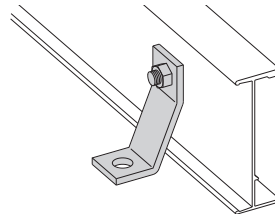

Catalog No.
9(*)-1241

Heavy Duty Hold Down Bracket

- Design load is 4000 lbs (17.79kN) per pair.
- Four bolt design.
- Sold in pairs.
- 3/8" cable tray attachment hardware provided
- 1/2" support attachment hardware **not** provided.
- (*) Insert **ZN** **SS4** or **SS6**
- Recommended for support of vertical trays.

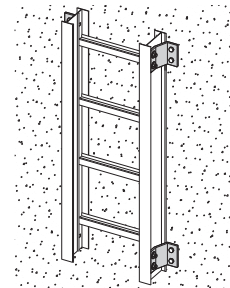
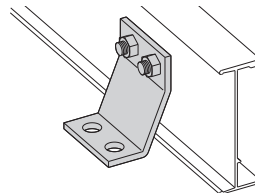

Catalog No.
9(*)-1242

Beam Clamp

- Finishes available: **ZN** **GRN** **HDG** or **SS4**
- Sold in pieces.
- Design load is 1200 lbs (5.34kN) per pair.
- Safety Load Factor 5.0.
- Order HHCS and Channel Nuts separately.

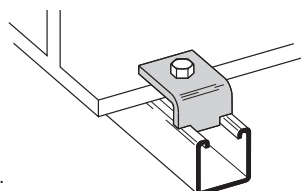

Catalog No.
B355

● Green = Fastest shipped items ● Black = Normal lead-time items ● Red = Normally long lead-time items

All dimensions in parentheses are millimeters unless otherwise specified.

Series 2, 3, 4, & 5 Aluminum - Accessories

Beam Clamp

- Finishes available: **ZN** or **HDG**
- Sold in pieces.
- *Design load when used in pairs.
Safety Load Factor 5.0

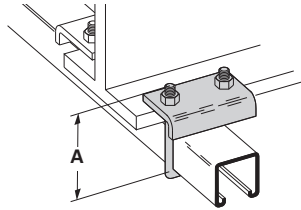

Catalog No.	Design Load lbs (kN)	'A' in. (mm)
B441-22	1200 (5.34)	3 ³ / ₈ (86)
B441-22A	1200 (5.34)	5 (127)

Beam Clamp

- Finishes available: **ZN** **GRN** or **HDG**
- Sold in pieces.
- *Design load when used in pairs.
Safety Load Factor 5.0

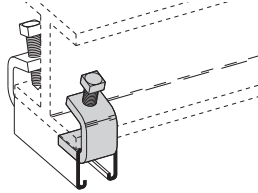

Catalog No.	B212-1/4	B212-3/8
Design Load *	600 lbs. (2.67kN)	1000 lbs. (4.45 kN)
Max. Flange Thick	3/4" (19 mm)	1 1/8" (28.6 mm)
Mat'l. Thickness	1/4" (6.3 mm)	3/8" (9.5 mm)

B305 Thru B308 & B321 Series Beam Clamps

- Finishes available: **ZN** or **HDG**
- Setscrew included.
- Safety Load Factor 5.0

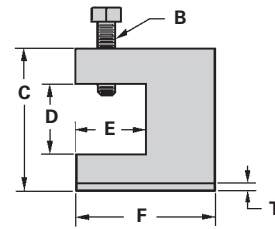
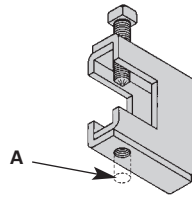

Catalog No.	Rod Size A	B	C in. (mm)	D in. (mm)	E in. (mm)	F in. (mm)	T in. (mm)	Design Load lbs (kN)
B305	3/8"-16	3/8"-16	2 ⁵ / ₁₆ (58.7)	7/8 (22.2)	1 1/8 (28.6)	2 1/2 (63.5)	11 Ga. (3.0)	600 (2.67)
B306	3/8"-16	1/2"-13	2 ⁷ / ₁₆ (61.9)	7/8 (22.2)	1 1/8 (28.6)	2 1/2 (63.5)	7 Ga. (4.5)	1100 (4.90)
B307	1/2"-13	1/2"-13	2 ⁷ / ₁₆ (61.9)	7/8 (22.2)	1 1/8 (28.6)	2 1/2 (63.5)	7 Ga. (4.5)	1100 (4.90)
B308	1/2"-13	1/2"-13	2 ⁹ / ₁₆ (65.1)	7/8 (22.2)	1 1/8 (28.6)	2 1/2 (63.5)	1/4 (6.3)	1500 (6.68)
B321-1	3/8"-16	1/2"-13	3 ⁹ / ₁₆ (90.5)	1 11/16 (42.9)	1 ⁵ / ₈ (41.3)	3 1/4 (82.5)	1/4 (6.3)	1300 (5.79)
B321-2	1/2"-13	1/2"-13	3 ⁹ / ₁₆ (90.5)	1 11/16 (42.9)	1 ⁵ / ₈ (41.3)	3 1/4 (82.5)	1/4 (6.3)	1400 (6.23)

Anchor Strap - for B305 thru B308 & B321 Series

- Finish available: **ZN**
- For a maximum beam thickness of 3/4" (19mm).
- For thicker beams, step up one flange width size.

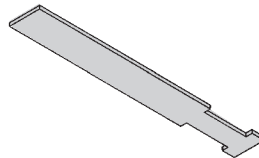

Catalog No.	Flange Width in. (mm)
B312-6	Up to 6 (Up to 152)
B312-9	6 - 9 (152 to 228)
B312-12	9 - 12 (228 to 305)

Beam Clamp

- Finish available: **ZN**
- Design Load 500 lbs. (2.22 kN)
- Safety Load Factor 5.0
- Recommended torque:
'J'-Hook Nut 125 In.-Lbs. (14.1 kN/m)
- Maximum flange thickness
of 3/4" (19mm).

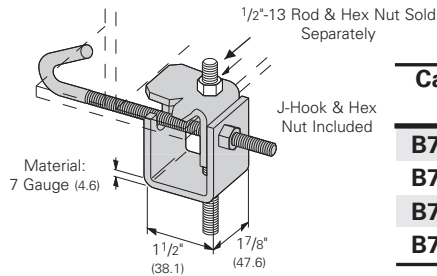

Catalog No.	For Flange Width in. (mm)	Wt./C lbs (kg)
B750-J4	3 - 6 (76.2 - 152.4)	109 (49.4)
B750-J6	5 - 9 (127.0 - 228.6)	124 (56.2)
B750-J9	8 - 12 (203.2 - 304.8)	135 (61.2)
B750-J12	11 - 15 (279.4 - 381.0)	147 (66.7)

'J'-Hook

- Finishes available: **ZN**
- Hex Nut included.

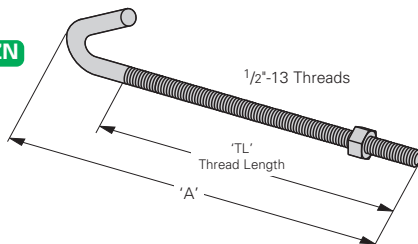

Catalog No.	'A' in. (mm)	'TL' in. (mm)	Wt./C lbs (kg)
B700-J4	8 1/2 (215.9)	5 (127.0)	44 (19.9)
B700-J6	11 1/2 (292.1)	6 (152.4)	53 (24.0)
B700-J9	12 1/4 (368.3)	6 (152.4)	63 (28.6)
B700-J12	17 1/2 (444.5)	6 (152.4)	78 (35.4)

● Green = Fastest shipped items ● Black = Normal lead-time items ● Red = Normally long lead-time items

All dimensions in parentheses are millimeters unless otherwise specified.

Covers

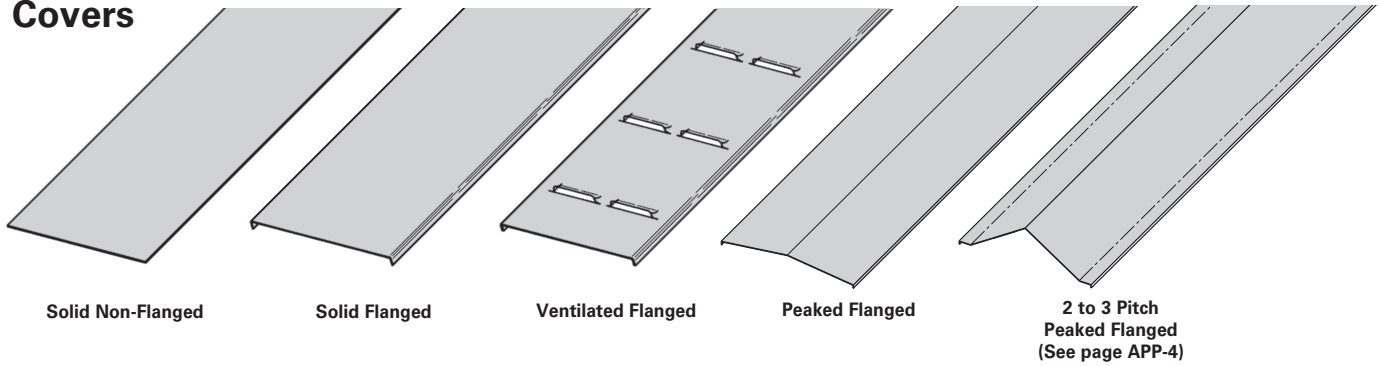

A full range of covers is available for straight sections and fittings.

Solid covers should be used when maximum enclosure of the cable is desired and no accumulation of heat is expected.

Ventilated covers provide an overhead cable shield, yet allow heat to escape.

We recommend that covers be placed on vertical cable tray runs to a height of 6 ft. (1.83 m) to 8 ft. (2.44 m) above the floor to isolate both cables and personnel. **Flanged covers** have a 1/2 in. (13 mm) flange. Cover clamps are not included with the cover and must be ordered separately. All **peaked covers** are flanged. Standard peaked covers have 1/2" peak. Special purpose peaked covers, having a 2 to 3 pitch, provide additional slope and material thickness. The 2 to 3 pitch fitting covers are of multiple piece, welded construction.

Aluminum Cover Part Numbering

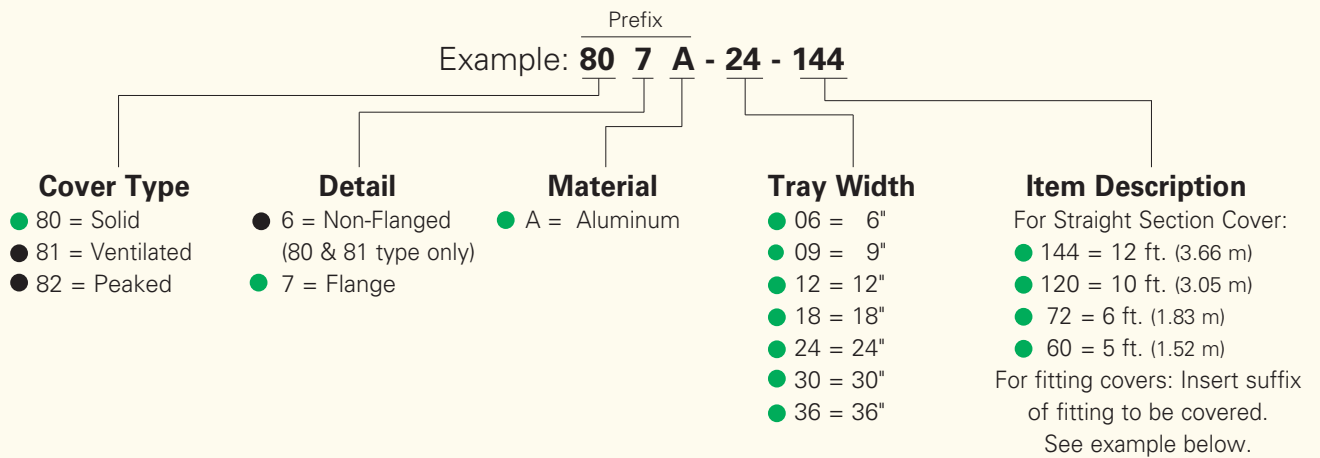

Examples of Catalog Numbers for Fitting Covers:

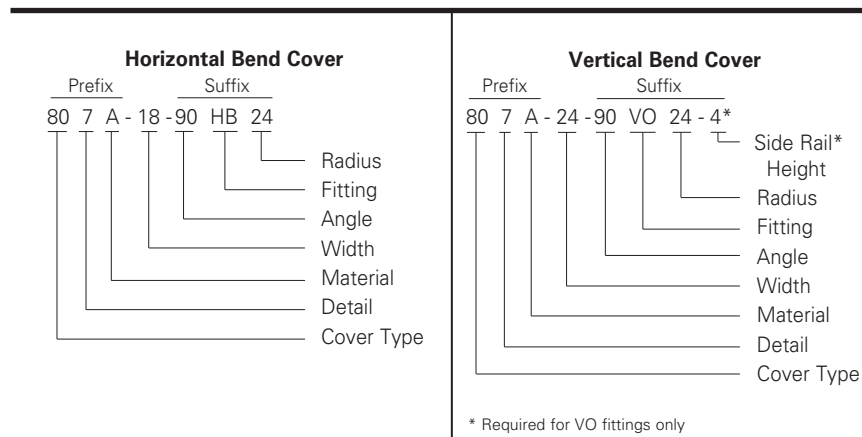

● Green = Fastest shipped items ● Black = Normal lead-time items ● Red = Normally long lead-time items

All dimensions in parentheses are millimeters unless otherwise specified.

Series 2, 3, 4, & 5 Aluminum - Accessories

Standard Cover Clamp

- For indoor service only.
- Setscrew included.
- Sold per piece.

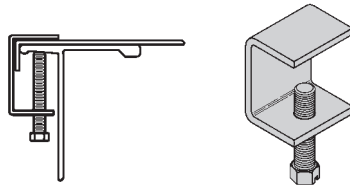

Tray Type	Catalog No.	Side Rail Height
Aluminum	● 9ZN-9012	All Sizes
	● 9A-9012	

Combination Cover and Hold Down Clamp

- Sold per piece.
- For indoor service only.

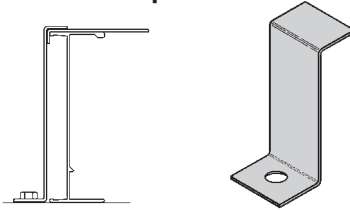

Tray Type	Catalog No.	Side Rail Height	
		in.	(mm)
Aluminum	● 9A-9043	4	(101)
	● 9A-9053	5	(127)
	● 9A-9063	6	(152)
	● 9A-9073	7	(78)

Raised Cover Clamp

- For indoor service only.
- For use with flanged covers only.
† Specify gap of 1", 2", 3" or 4".

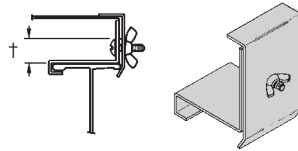

Tray Type	Catalog No.	Side Rail Height
Aluminum	● 9ZN-9112-†	4 & 5 Deep
	● 9ZN-9113-†	6 & 7 Deep

Heavy Duty Cover Clamp

- Recommended for outdoor service.
- (‡) Insert tray width
† Add P to Catalog No.
for peaked cover clamp.

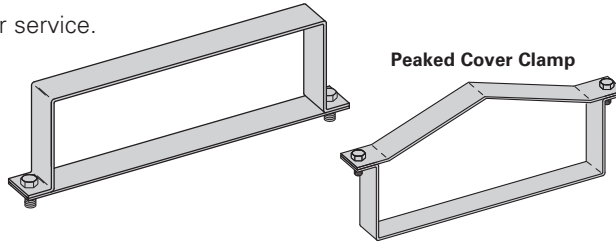

Catalog No.	Side Rail Height	
	in.	mm
● 9A-(‡)-9044†	4	(101)
● 9A-(‡)-9054†	5	(127)
● 9A-(‡)-9064†	6	(152)
● 9A-(‡)-9074†	7	(178)

Quantity of Standard Cover Clamps Required

Notes:

When using the Heavy Duty Cover Clamp, only on-half the number of clamps stated above is required.

Additional clamps may be necessary in extreme wind applications.

Straight Section 60" or 72"	4 pcs.
Straight Section 120" or 144"	6 pcs.
Horizontal/Vertical Bends	4 pcs.
Tees	6 pcs.
Crosses	8 pcs.

Cover Joint Strip

- Used to join covers
- Plastic
- (‡) Insert tray width

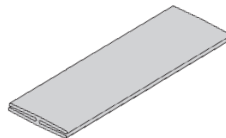

Catalog No.
● 99-9980-(‡)

Cable Cleats

(see pages O-1 thru O-5) Standard

Trefoil
Cable
Cleats



Single
Cable
Cleats

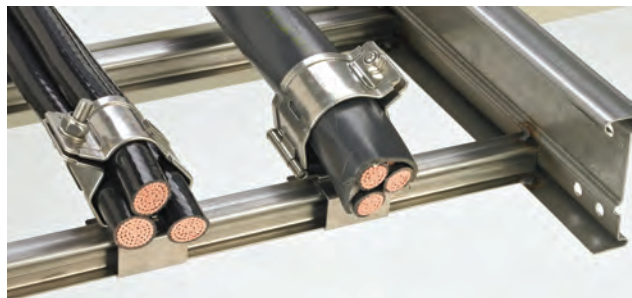
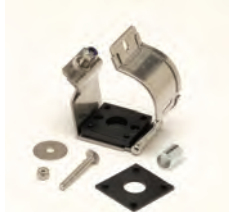

● Green = Fastest shipped items ● Black = Normal lead-time items ● Red = Normally long lead-time items

All dimensions in parentheses are millimeters unless otherwise specified.

Section 1- Acceptable Manufacturers

- 1.01 Manufacturer: Subject to compliance with these specifications, Eaton's B-Line series cable tray systems shall be as manufactured by Eaton.

Section 2- Cable Tray Sections and Components

- 2.01 General: Except as otherwise indicated, provide metal cable trays, of types, classes and sizes indicated; with splice plates, bolts, nuts and washers for connecting units. Construct units with rounded edges and smooth surfaces; in compliance with applicable standards; and with the following additional construction features. Cable tray shall be installed according to the latest revision of NEMA VE 2.
- 2.02 Materials and Finish: Straight section and fitting side rails and rungs shall be extruded from Aluminum Association Alloy 6063. All fabricated parts shall be made from Aluminum Association Alloy 5052.
- 2.03 Ladder Cable Trays shall consist of two longitudinal members (side rails) with transverse members (rungs) welded to the side rails. Rungs shall be spaced [6] [9] [12] inches on center. Rung spacing in radiused fittings shall be industry standard 9" and measured at the center of the tray's width. Each rung must be capable of supporting a 200 lb. concentrated load at the center of the cable tray over and above the cable load with a safety factor of 1.5.
- 2.04 Ventilated Trough Cable Trays shall consist of two longitudinal members (side rails) with a corrugated bottom welded to the side rails or rungs spaced 4" on center. The peaks of the corrugated bottom shall have a minimum flat cable bearing surface of 2³/₄" and shall be spaced on 6" centers. To provide ventilation in the tray, the valleys of the corrugated bottom shall have 2¹/₄" x 4" rectangular holes punched along the width of the bottom.
- 2.05 Non-Ventilated Bottom Trough Cable Trays shall consist of two longitudinal members (side rails) with a corrugated bottom welded to the side rails or a solid sheet over rungs. The peaks of the corrugated bottom shall have a minimum flat cable bearing surface of 2³/₄" and shall be spaced on 6" centers.
- 2.06 Cable tray loading depth shall be [3] [4] [5] [6] inches per NEMA VE 1.
- 2.07 Straight sections shall have side rails fabricated as I-beams. Straight sections shall be supplied in standard [12 foot] [24 foot] [10 foot (3 m)] [20 foot (6 m)] lengths.
- 2.08 Cable tray widths shall be [6] [9] [12] [18] [24] [30] [36] inches or as shown on drawings.
- 2.09 Splice plates shall be the Wedge-Lock design with 4 nuts and bolts per plate. The resistance of fixed splice connections between an adjacent section of tray shall not exceed 0.00033 ohm.
- 2.10 All fittings must have a minimum radius of [12] [24] [36] [48] inches.

Section 3- Loading Capacities and Testing

- 3.01 Cable tray shall be capable of carrying a uniformly distributed load of _____ lbs./ft. on a _____ ft. support span with a safety factor of 1.5 when supported as a simple span and tested per NEMA VE 1 5.2. In addition to the uniformly distributed load the cable tray shall support 200 lbs. concentrated load at mid-point of span. Load and safety factors specified are applicable to both the side rails and rung capacities. Cable tray shall be made to manufacturing tolerances as specified by NEMA.
- 3.02 Upon request, manufacturer shall provide test reports in accordance with the latest revision of NEMA VE 1 or CSA C22.2 No. 126.

Series 2, 3, 4, & 5 Steel - Straight Sections

Series 2, 3, 4, & 5 Steel



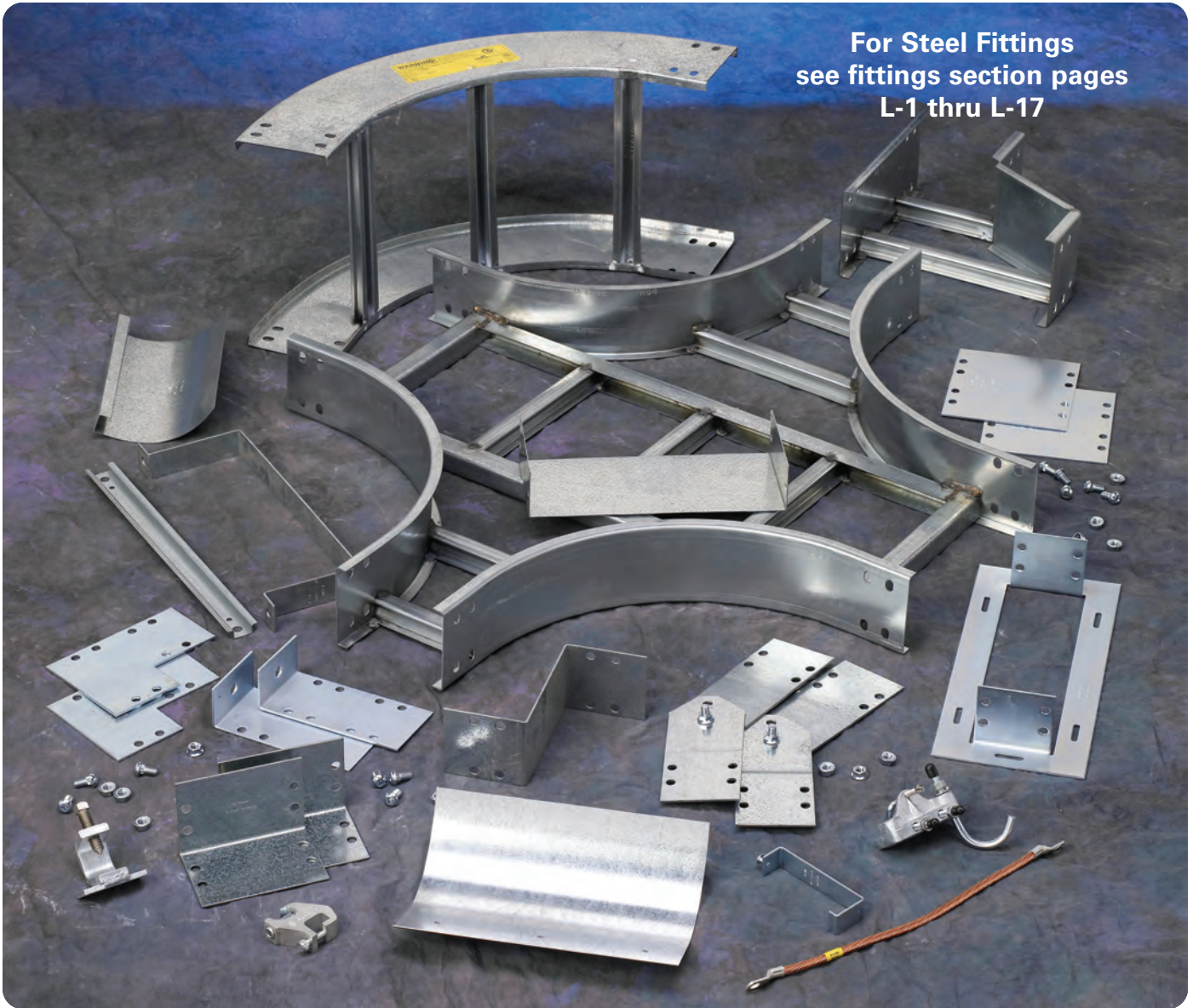

How The Service Advisor Works

We know that your time is important! That's why the color-coding system in this catalog is designed to help you select products that fit your service needs. Products are marked to indicate the typical lead time for orders of 50 pieces or less.

Customer: How do I select my straight sections, covers, or fittings so that I get the quickest turnaround?

Service Advisor: Each part of our selection chart is shown in colors. If any section of a part number is a different color, the part will typically ship with the longer lead time represented by the colors.

- Green = Fastest shipped items
- Black = Normal lead-time items
- Red = Normally long lead-time items

Example: 258G 12 - 24 - 144
 ● ● ● ●

Part will have a long lead time because of the 258G material.

Changing the part number from 258G to 258P will change the coding to black and reduce lead time.

3" NEMA VE 1 Loading Depth 4" Side Rail Height

Straight Section Part Numbering

Example: ^{Prefix} **248 P 09 - 24 - 144**

Series	Material	*Type	*Width	Length
● 248	● P = Pre-Galvanized ● G = HDGAF	Ladder- ● 06 = 6" rung spacing ● 09 = 9" rung spacing ● 12 = 12" rung spacing	● 06 = 6" ● 09 = 9" ● 12 = 12" ● 18 = 18" ● 24 = 24" ● 30 = 30" ● 36 = 36"	● ① 144 = 12 ft. ● ② 120 = 10 ft.
● 346				● ① 240 = 20 ft. ● ② 144 = 12 ft.
● 444				● ① 240 = 20 ft. ● ② 288 = 24 ft.

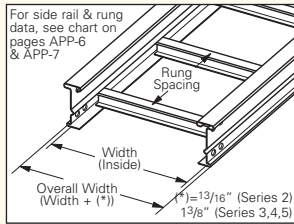

Trough- 6" thru 36" wide

- VT = Ventilated Trough
- ST = Non-Ventilated Trough

① Primary Length.
② Secondary Length.

See page C-23 for explanation of lengths.

See page APP-1 for additional rung options. *Special sizes available.

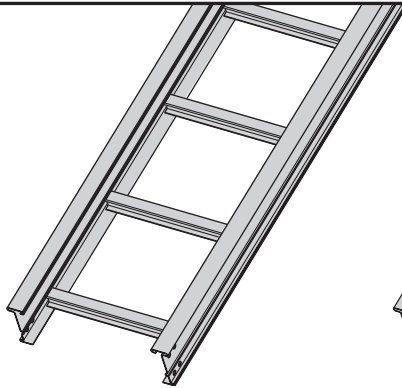

Ladder Type
(Specify Rung Spacing)

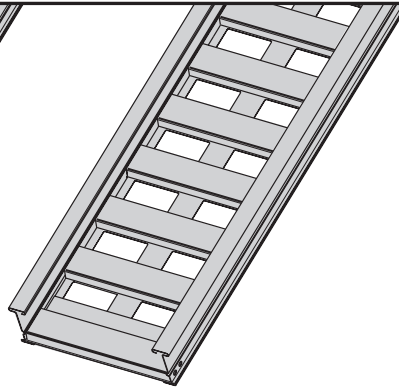

Ventilated Trough

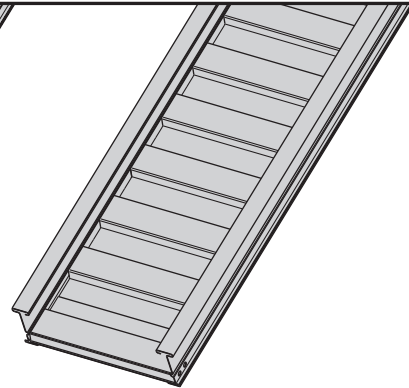

Non-Ventilated Trough

● Green = Fastest shipped items ● Black = Normal lead-time items ● Red = Normally long lead-time items

All dimensions in parentheses are millimeters unless otherwise specified.

3" NEMA VE 1 Loading Depth 4" Side Rail Height

Values are based on simple beam tests per NEMA VE 1 on 36" wide cable tray with rungs spaced on 12" centers. Cable trays will support without collapse a 200 lb. (90.7 kg) concentrated load over and above published loads. Published load safety factor is 1.5. To convert 1.5 safety factor to 2.0, multiply published load by 0.75. To obtain mid-span deflection, multiply a load by the deflection multiplier. Cable tray must be supported on spans shorter than or equal to the length of the cable tray being installed.

Individual rungs will support without collapse a 200 lb. (90.7 kg) concentrated load applied at the mid-span of the rung, over and above the NEMA rated cable load with a 1.5 safety factor for highlighted NEMA spans and loads.

B-Line Series	Side Rail Dimensions	NEMA, CSA & UL Classifications	Span ft	Load lbs/ft	Deflection Multiplier	Design Factors for Two Rails	Span meters	Load kg/m	Deflection Multiplier	Design Factors for Two Rails
248		NEMA: 16A, 12C CSA: D1-3m UL Cross-Sectional Area: 0.40 in ²	6	412*	0.0007	Area = 0.62 in ² Sx = 0.64 in ³ Ix = 1.43 in ⁴	1.8	613*	0.012	Area = 4.00 cm ² Sx = 10.49 cm ³ Ix = 59.52 cm ⁴
			8	232	0.0022		2.4	345	0.038	
			10	148	0.0054		3.0	221	0.093	
			12	103	0.011		3.7	153	0.192	
			14	76	0.021		4.3	113	0.356	
			16	58	0.036		4.9	86	0.607	

B-Line Series	Side Rail Dimensions	NEMA, CSA & UL Classifications	Span ft	Load lbs/ft	Deflection Multiplier	Design Factors for Two Rails	Span meters	Load kg/m	Deflection Multiplier	Design Factors for Two Rails
346		NEMA: 20A, 16B CSA: D1-6m UL Cross-Sectional Area: 0.70 in ²	10	252	0.0036	Area = 0.89 in ² Sx = 0.96 in ³ Ix = 2.22 in ⁴	3.0	375	0.060	Area = 5.74 cm ² Sx = 15.73 cm ³ Ix = 92.40 cm ⁴
			12	175	0.0072		3.7	260	0.124	
			14	129	0.013		4.3	191	0.229	
			16	98	0.023		4.9	146	0.391	
			18	78	0.037		5.5	116	0.626	
			20	63	0.056		6.1	94	0.955	

B-Line Series	Side Rail Dimensions	NEMA, CSA & UL Classifications	Span ft	Load lbs/ft	Deflection Multiplier	Design Factors for Two Rails	Span meters	Load kg/m	Deflection Multiplier	Design Factors for Two Rails
444		NEMA: 20B, 16C CSA: E-3m UL Cross-Sectional Area: 1.00 in ²	12	253	0.0055	Area = 1.19 in ² Sx = 1.27 in ³ Ix = 2.94 in ⁴	3.7	376	0.093	Area = 7.68 cm ² Sx = 20.81 cm ³ Ix = 122.37 cm ⁴
			16	142	0.027		4.9	212	0.295	
			18	112	0.028		5.5	167	0.473	
			20	91	0.042		6.1	135	0.721	
			22	75	0.062		6.7	112	1.055	
			24	63	0.088		7.3	94	1.495	

*When using 18" rung spacing, load capacity is limited to 394 lbs/ft (586.272 kg/m) for 30" cable tray width and 325 lbs/ft (483.6 kg/m) for 36" cable tray width. When cable trays are used in continuous spans, the deflection of the cable tray is reduced by as much as 50%. Design factors: Ix = Moment of Inertia, Sx = Section Modulus.

All dimensions in parentheses are millimeters unless otherwise specified.

4" NEMA VE 1 Loading Depth 5" Side Rail Height

Straight Section Part Numbering

Example: ^{Prefix} **258 P 09 - 24 - 144**

Series	Material	*Type	*Width	Length	
● 258	● P = Pre-Galvanized ● G = HDGAF	Ladder- ● 06 = 6" rung spacing ● 09 = 9" rung spacing ● 12 = 12" rung spacing	● 06 = 6" ● 09 = 9" ● 12 = 12" ● 18 = 18" ● 24 = 24" ● 30 = 30" ● 36 = 36"	● ① 144 = 12 ft. ● ② 120 = 10 ft.	258
● 356				● ① 240 = 20 ft. ● ② 144 = 12 ft.	356
● 454				● ① 240 = 20 ft. ● ② 288 = 24 ft.	454

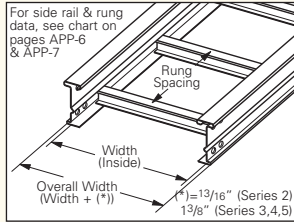

Trough- 6" thru 36" wide

- VT = Ventilated Trough
- ST = Non-Ventilated Trough

① Primary Length.
② Secondary Length.

See page C-23 for explanation of lengths.

See page APP-1 for additional rung options. *Special sizes available.

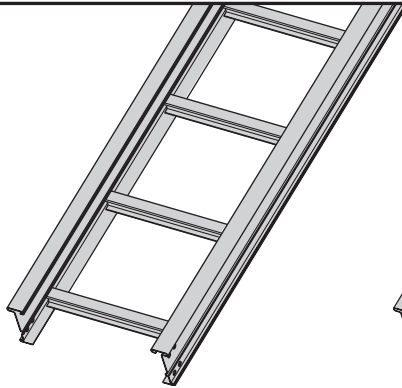

Ladder Type
(Specify Rung Spacing)

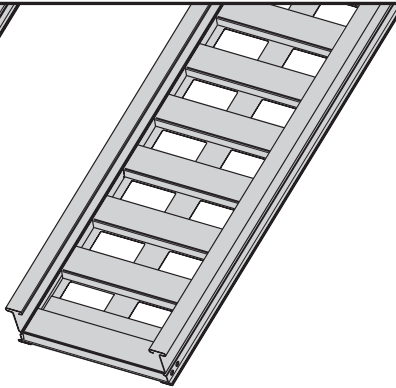

Ventilated Trough

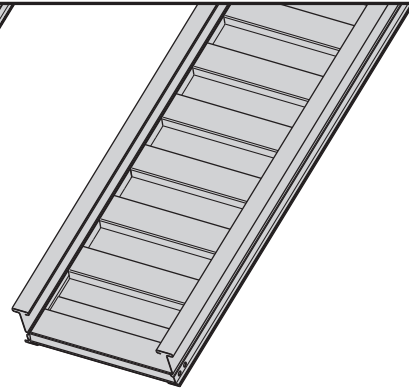

Non-Ventilated Trough

● Green = Fastest shipped items ● Black = Normal lead-time items ● Red = Normally long lead-time items

All dimensions in parentheses are millimeters unless otherwise specified.

4" NEMA VE 1 Loading Depth 5" Side Rail Height

Values are based on simple beam tests per NEMA VE 1 on 36" wide cable tray with rungs spaced on 12" centers. Cable trays will support without collapse a 200 lb. (90.7 kg) concentrated load over and above published loads. Published load safety factor is 1.5. To convert 1.5 safety factor to 2.0, multiply published load by 0.75. To obtain mid-span deflection, multiply a load by the deflection multiplier. Cable tray must be supported on spans shorter than or equal to the length of the cable tray being installed.

Individual rungs will support without collapse a 200 lb. (90.7 kg) concentrated load applied at the mid-span of the rung, over and above the NEMA rated cable load with a 1.5 safety factor for highlighted NEMA spans and loads.

B-Line Series	Side Rail Dimensions	NEMA, CSA & UL Classifications	Span ft	Load lbs/ft	Deflection Multiplier	Design Factors for Two Rails	Span meters	Load kg/m	Deflection Multiplier	Design Factors for Two Rails
258		NEMA: 16A, 12C CSA: D1-3m UL Cross-Sectional Area: 0.40 in ²	6	436*	0.0004	Area = 0.71 in ² Sx = 0.89 in ³ Ix = 2.44 in ⁴	1.8	649*	0.007	Area = 4.58 cm ² Sx = 14.58 cm ³ Ix = 101.56 cm ⁴
			8	245	0.0013		2.4	365	0.022	
			10	157	0.0032		3.0	234	0.054	
			12	109	0.0066		3.7	162	0.113	
			14	80	0.012		4.3	119	0.209	
			16	61	0.021		4.9	91	0.356	

B-Line Series	Side Rail Dimensions	NEMA, CSA & UL Classifications	Span ft	Load lbs/ft	Deflection Multiplier	Design Factors for Two Rails	Span meters	Load kg/m	Deflection Multiplier	Design Factors for Two Rails
356		NEMA: 20A, 16C CSA: D1-6m UL Cross-Sectional Area: 0.70 in ²	10	276	0.0021	Area = 1.00 in ² Sx = 1.31 in ³ Ix = 3.73 in ⁴	3.0	411	0.036	Area = 6.45 cm ² Sx = 21.47 cm ³ Ix = 155.25 cm ⁴
			12	192	0.0043		3.7	285	0.074	
			14	141	0.0080		4.3	210	0.136	
			16	108	0.014		4.9	160	0.233	
			18	85	0.022		5.5	127	0.373	
			20	69	0.033		6.1	103	0.568	

B-Line Series	Side Rail Dimensions	NEMA, CSA & UL Classifications	Span ft	Load lbs/ft	Deflection Multiplier	Design Factors for Two Rails	Span meters	Load kg/m	Deflection Multiplier	Design Factors for Two Rails
454		NEMA: 20C CSA: E-6m UL Cross-Sectional Area: 1.00 in ²	12	294	0.0032	Area = 1.34 in ² Sx = 1.75 in ³ Ix = 4.96 in ⁴	3.7	438	0.055	Area = 8.65 cm ² Sx = 28.68 cm ³ Ix = 206.45 cm ⁴
			16	166	0.010		4.9	246	0.175	
			18	131	0.016		5.5	195	0.280	
			20	106	0.026		6.1	158	0.427	
			22	88	0.037		6.7	130	0.625	
			24	74	0.052		7.3	110	0.886	

*When using 18" rung spacing, load capacity is limited to 394 lbs/ft (586.272 kg/m) for 30" cable tray width and 325 lbs/ft (483.6 kg/m) for 36" cable tray width. When cable trays are used in continuous spans, the deflection of the cable tray is reduced by as much as 50%. Design factors: Ix = Moment of Inertia, Sx = Section Modulus.

All dimensions in parentheses are millimeters unless otherwise specified.

5" NEMA VE 1 Loading Depth 6" Side Rail Height

Straight Section Part Numbering

Example: $\frac{\text{Prefix}}{268 \text{ P } 09 - 24 - 144}$

Series	Material	*Type	*Width	Length
● 268	● P = Pre-Galvanized ● G = HDGAF	Ladder- ● 06 = 6" rung spacing ● 09 = 9" rung spacing ● 12 = 12" rung spacing	● 06 = 6" ● 09 = 9" ● 12 = 12" ● 18 = 18" ● 24 = 24" ● 30 = 30" ● 36 = 36"	● ① 144 = 12 ft. ● ② 120 = 10 ft.
● 366				● ① 240 = 20 ft. ● ② 144 = 12 ft.
● 464				● ① 240 = 20 ft. ● ② 288 = 24 ft.

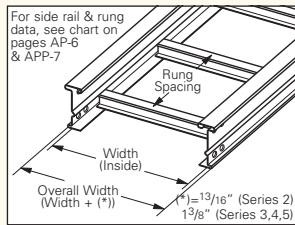

- Trough-**
6" thru 36" wide
- VT = Ventilated Trough
 - ST = Non-Ventilated Trough

① Primary Length.
② Secondary Length.
See page C-23 for explanation of lengths.

See page APP-1 for additional rung options. *Special sizes available.

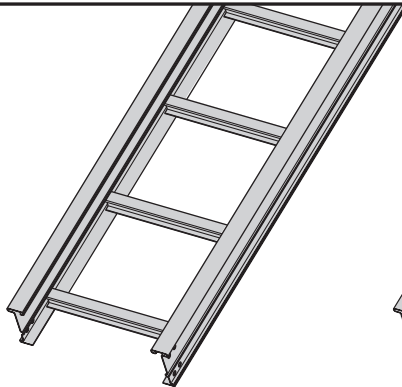

Ladder Type
(Specify Rung Spacing)

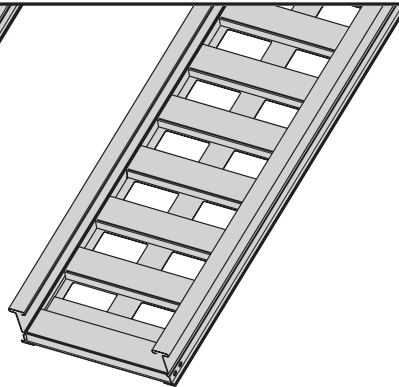

Ventilated Trough

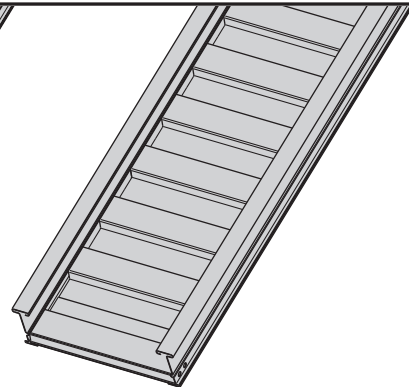

Non-Ventilated Trough

● Green = Fastest shipped items ● Black = Normal lead-time items ● Red = Normally long lead-time items

All dimensions in parentheses are millimeters unless otherwise specified.

5" NEMA VE 1 Loading Depth 6" Side Rail Height

Values are based on simple beam tests per NEMA VE 1 on 36" wide cable tray with rungs spaced on 12" centers. Cable trays will support without collapse a 200 lb. (90.7 kg) concentrated load over and above published loads. Published load safety factor is 1.5. To convert 1.5 safety factor to 2.0, multiply published load by 0.75. To obtain mid-span deflection, multiply a load by the deflection multiplier. Cable tray must be supported on spans shorter than or equal to the length of the cable tray being installed.

Individual rungs will support without collapse a 200 lb. (90.7 kg) concentrated load applied at the mid-span of the rung, over and above the NEMA rated cable load with a 1.5 safety factor for highlighted NEMA spans and loads.

B-Line Series	Side Rail Dimensions	NEMA, CSA & UL Classifications	Span ft	Load lbs/ft	Deflection Multiplier	Design Factors for Two Rails	Span meters	Load kg/m	Deflection Multiplier	Design Factors for Two Rails
268		NEMA: 16A, 12C CSA: D1-3m UL Cross-Sectional Area: 0.70 in ²	6	440*	0.0003	Area = 0.80 in ² Sx = 1.18 in ³ Ix = 3.81 in ⁴	1.8	655*	0.005	Area = 5.16 cm ² Sx = 19.34 cm ³ Ix = 158.58 cm ⁴
			8	248	0.0008		2.4	368	0.014	
			10	158	0.0020		3.0	236	0.035	
			12	110	0.0042		3.7	164	0.072	
			14	81	0.0078		4.3	120	0.134	
			16	62	0.013		4.9	92	0.228	

B-Line Series	Side Rail Dimensions	NEMA, CSA & UL Classifications	Span ft	Load lbs/ft	Deflection Multiplier	Design Factors for Two Rails	Span meters	Load kg/m	Deflection Multiplier	Design Factors for Two Rails
366		NEMA: 20B, 16C CSA: E-6m UL Cross-Sectional Area: 1.00 in ²	10	300	0.0014	Area = 1.11 in ² Sx = 1.71 in ³ Ix = 5.74 in ⁴	3.0	446	0.023	Area = 7.16 cm ² Sx = 28.02 cm ³ Ix = 238.92 cm ⁴
			12	208	0.0028		3.7	310	0.048	
			14	153	0.0052		4.3	228	0.089	
			16	117	0.0089		4.9	174	0.151	
			18	93	0.014		5.5	138	0.242	
			20	75	0.022		6.1	112	0.369	

B-Line Series	Side Rail Dimensions	NEMA, CSA & UL Classifications	Span ft	Load lbs/ft	Deflection Multiplier	Design Factors for Two Rails	Span meters	Load kg/m	Deflection Multiplier	Design Factors for Two Rails
464		NEMA: 20C CSA: E-6m UL Cross-Sectional Area: 1.00 in ²	12	342*	0.002	Area = 1.49 in ² Sx = 2.27 in ³ Ix = 7.65 in ⁴	3.7	508*	0.035	Area = 9.61 cm ² Sx = 37.36 cm ³ Ix = 318.42 cm ⁴
			16	192	0.007		4.9	286	0.113	
			18	152	0.011		5.5	226	0.182	
			20	123	0.016		6.1	183	0.277	
			22	102	0.024		6.7	151	0.406	
			24	85	0.034		7.3	127	0.574	

*When using 18" rung spacing, load capacity is limited to 394 lbs/ft (586.272 kg/m) for 30" cable tray width and 325 lbs/ft (483.6 kg/m) for 36" cable tray width. When cable trays are used in continuous spans, the deflection of the cable tray is reduced by as much as 50%. Design factors: Ix = Moment of Inertia, Sx = Section Modulus.

All dimensions in parentheses are millimeters unless otherwise specified.

6" NEMA VE 1 Loading Depth 7" Side Rail Height

Straight Section Part Numbering

Example: ^{Prefix} **378 P 09 - 24 - 144**

Series	Material	*Type	*Width	Length	
● 378	● P = Pre-Galvanized ● G = HDGAF	Ladder- ● 06 = 6" rung spacing ● 09 = 9" rung spacing ● 12 = 12" rung spacing	● 06 = 6" ● 09 = 9" ● 12 = 12" ● 18 = 18" ● 24 = 24" ● 30 = 30" ● 36 = 36"	● ① 144 = 12 ft. ● ② 120 = 10 ft. ● ① 240 = 20 ft. ● ② 288 = 24 ft. ● ① 240 = 20 ft. ● ② 288 = 24 ft.	378 476 574

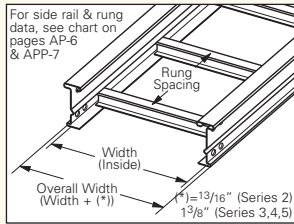

Trough-

6" thru 36" wide

- **VT** = Ventilated Trough
- **ST** = Non-Ventilated Trough

① Primary Length.
② Secondary Length.

See page C-23 for explanation of lengths.

See page APP-1 for additional rung options. *Special sizes available.

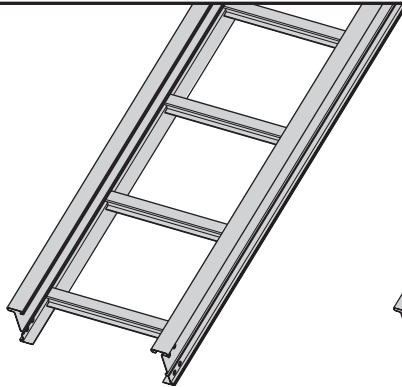

Ladder Type
(Specify Rung Spacing)

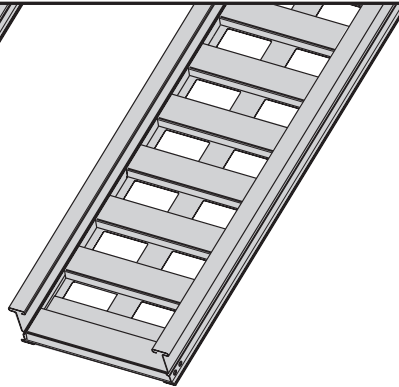

Ventilated Trough

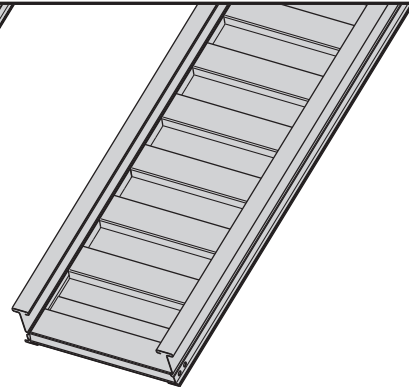

Non-Ventilated Trough

● Green = Fastest shipped items ● Black = Normal lead-time items ● Red = Normally long lead-time items

All dimensions in parentheses are millimeters unless otherwise specified.

6" NEMA VE 1 Loading Depth 7" Side Rail Height

Values are based on simple beam tests per NEMA VE 1 on 36" wide cable tray with rungs spaced on 12" centers. Cable trays will support without collapse a 200 lb. (90.7 kg) concentrated load over and above published loads. Published load safety factor is 1.5. To convert 1.5 safety factor to 2.0, multiply published load by 0.75. To obtain mid-span deflection, multiply a load by the deflection multiplier. Cable tray must be supported on spans shorter than or equal to the length of the cable tray being installed.

Individual rungs will support without collapse a 200 lb. (90.7 kg) concentrated load applied at the mid-span of the rung, over and above the NEMA rated cable load with a 1.5 safety factor for highlighted NEMA spans and loads.

B-Line Series	Side Rail Dimensions	NEMA, CSA & UL Classifications	Span ft	Load lbs/ft	Deflection Multiplier	Design Factors for Two Rails	Span meters	Load kg/m	Deflection Multiplier	Design Factors for Two Rails
378		NEMA: 20A, 16B CSA: D1-3m UL Cross-Sectional Area: 0.70 in ²	8	319	0.0006	Area = 1.01 in ² S _x = 1.77 in ³ I _x = 6.90 in ⁴	2.4	474	0.009	Area = 6.52 cm ² S _x = 29.01 cm ³ I _x = 287.20 cm ⁴
			10	204	0.0014		3.0	304	0.023	
			12	142	0.0028		3.7	211	0.048	
			14	104	0.0052		4.3	155	0.089	
			16	80	0.0089		4.9	119	0.151	
			18	63	0.014		5.5	94	0.242	
			20	51	0.022		6.1	76	0.369	

B-Line Series	Side Rail Dimensions	NEMA, CSA & UL Classifications	Span ft	Load lbs/ft	Deflection Multiplier	Design Factors for Two Rails	Span meters	Load kg/m	Deflection Multiplier	Design Factors for Two Rails
476		NEMA: 20B, 16C CSA: D1-6m UL Cross-Sectional Area: 1.00 in ²	12	214	0.0019	Area = 1.22 in ² S _x = 2.14 in ³ I _x = 8.30 in ⁴	3.7	318	0.033	Area = 7.87 cm ² S _x = 35.07 cm ³ I _x = 345.47 cm ⁴
			16	129	0.0061		4.9	179	0.105	
			18	95	0.010		5.5	141	0.168	
			20	77	0.015		6.1	115	0.255	
			22	64	0.022		6.7	95	0.374	
			24	53	0.031		7.3	80	0.529	

B-Line Series	Side Rail Dimensions	NEMA, CSA & UL Classifications	Span ft	Load lbs/ft	Deflection Multiplier	Design Factors for Two Rails	Span meters	Load kg/m	Deflection Multiplier	Design Factors for Two Rails
574		NEMA: 20C CSA: E-6m UL Cross-Sectional Area: 1.50 in ²	12	361	0.0014	Area = 1.64 in ² S _x = 2.87 in ³ I _x = 11.10 in ⁴	3.7	537	0.025	Area = 10.58 cm ² S _x = 47.03 cm ³ I _x = 462.02 cm ⁴
			16	203	0.0046		4.9	302	0.078	
			18	160	0.0073		5.5	239	0.125	
			20	130	0.011		6.1	193	0.191	
			22	107	0.016		6.7	160	0.280	
			24	90	0.023		7.3	134	0.396	

When cable trays are used in continuous spans, the deflection of the cable tray is reduced by as much as 50%. Design factors:
 I_x = Moment of Inertia, S_x = Section Modulus.

All dimensions in parentheses are millimeters unless otherwise specified.

Series 2, 3, 4, & 5 Steel - Accessories

Splice Plates

- Standard 8-hole pattern for all steel splice plates.
- Furnished in pairs with hardware.
- One pair including hardware provided with straight section. (Expansion splice quantity subtracted)
- Boxed in pairs with hardware.
- (*) Insert Z**N** or G

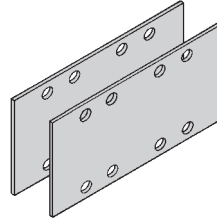

Catalog No.	Height in. mm
9(*)-8004	4 (101)
9(*)-8005	5 (127)
9(*)-8006	6 (152)
9(*)-8007	7 (178)

Expansion Splice Plates

- Expansion plates allow for one inch expansion or contraction of the cable tray, or where expansion joints occur in the support structure.
- Furnished in pairs with hardware.
- Bonding Jumpers are required on each siderail. Order Separately.
- (*) Insert Z**N** or G

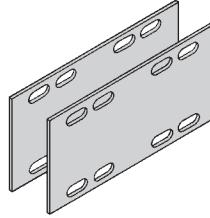

For heavy duty expansion splice plates see page APP-3.

Catalog No.	Height in. mm
9(*)-8014	4 (101)
9(*)-8015	5 (127)
9(*)-8016	6 (152)
9(*)-8017	7 (178)

Universal Splice Plates

- Used to splice to existing cable tray systems.
- Furnished in pairs with hardware.
- (*) Insert Z**N** or G

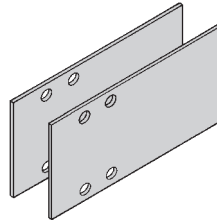

Catalog No.	Height in. mm
9(*)-8004-1/2	4 (101)
9(*)-8005-1/2	5 (127)
9(*)-8006 -1/2	6 (152)
9(*)-8007 -1/2	7 (178)

Step Down Splice Plates

- These splice plates are offered for connecting cable tray sections having side rails of different heights.
- Furnished in pairs with hardware.
- (*) Insert Z**N** or G

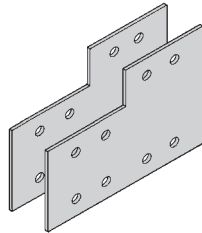

Catalog No.	Height in. mm
9(*)-8045	5 to 4 (127 to 101)
9(*)-8046	6 to 4 (152 to 101)
9(*)-8060	6 to 5 (152 to 127)
9(*)-8047	7 to 4 (178 to 101)
9(*)-8061	7 to 5 (178 to 127)
9(*)-8062	7 to 6 (178 to 152)

Vertical Adjustable Splice Plates

- These plates provide for changes in elevation that do not conform to standard vertical fittings.
- Furnished in pairs with hardware.
- **Bonding Jumpers not required.**
- (*) Insert G or P

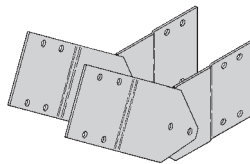

Requires supports within 24" on both sides, per NEMA VE 2.

Catalog No.	Height in. mm
9(*)-8024	4 (101)
9(*)-8025	5 (127)
9(*)-8026	6 (152)
9(*)-8027	7 (178)

Branch Pivot Connectors

- Branch from existing cable tray runs at any point.
- Pivot to any required angle.
- UL Classified for grounding (bonding jumpers not required).
- Furnished in pairs with hardware.
- (*) Insert Z**N** or G

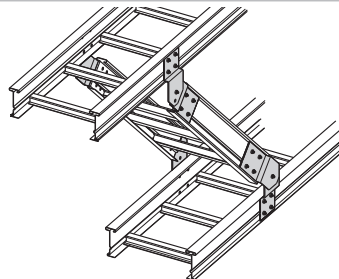

Catalog No.	Height in. mm
9(*)-8244	4 (101)
9(*)-8245	5 (127)
9(*)-8246	6 (152)
9(*)-8247	7 (178)

● Green = Fastest shipped items ● Black = Normal lead-time items ● Red = Normally long lead-time items

All dimensions in parentheses are millimeters unless otherwise specified.

Horizontal Adjustable Splice Plates

- Offered to adjust a cable tray run for changes in direction in a horizontal plane that do not conform to standard horizontal fittings.
- Furnished in pairs with hardware.
- Bonding jumpers **not** required.
- (*) Insert **ZN** or **G**
- (X) Insert 4, 5, 6 or 7 for side rail height.

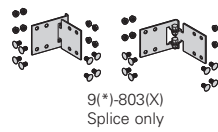

9(*)-803(X)-12 or 9(*)-803(X)-36
One pair splice plates with extensions.

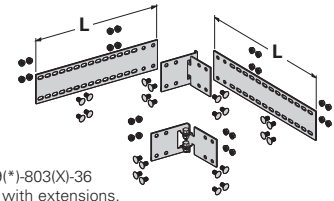

Catalog No.	Cable Tray End Cut	Thru Tray Width		'L'
		in.	(mm)	in. (mm)
9(*)-803(X)	Mitered	36	(914)	N/A (NA)
9(*)-803(X)-12	Not mitered	12	(305)	16 (406)
9(*)-803(X)-36	Not mitered	36	(914)	41 (1041)

Requires supports within 24" on both sides, per NEMA VE 2.

Offset Reducing Splice Plate

- This plate is used for joining cable trays having different widths. When used in pairs they form a straight reduction; when used singly with a standard splice plate, they form an offset reduction.
- Furnished as one plate with hardware.
- (‡) Insert reduction
- (*) Insert **G** or **P**

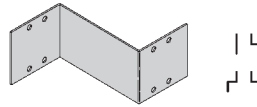

Catalog No.	Height	
	in.	mm
9(*)-8064-(‡)	4	(101)
9(*)-8065-(‡)	5	(127)
9(*)-8066-(‡)	6	(152)
9(*)-8067-(‡)	7	(178)

Tray to Box Splice Plates

- Used to attach the end of a cable tray run to a distribution box or control panel.
- Furnished in pairs with hardware.
- (*) Insert **G** or **P**

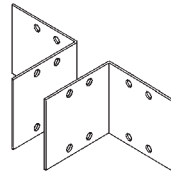

Catalog No.	Height	
	in.	mm
9(*)-8054	4	(101)
9(*)-8055	5	(127)
9(*)-8056	6	(152)
9(*)-8057	7	(178)

Frame Type Box Connector

- Designed to attach the end of a cable tray run to a distribution cabinet or control center to help reinforce the box at the point of entry.
- Furnished with tray connection hardware.
- (*) Insert **ZN** or **G**
- (‡) Insert tray width

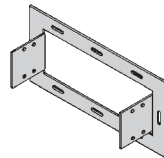

Catalog No.	Height	
	in.	mm
9(*)-8074-(‡)	4	(101)
9(*)-8075-(‡)	5	(127)
9(*)-8076-(‡)	6	(152)
9(*)-8077-(‡)	7	(178)

Blind End

- This plate forms a closure for a dead end cable tray.
- Furnished as one plate with hardware.
- (*) Insert **G** or **P**
- (‡) Insert tray width

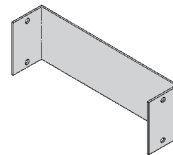

Catalog No.	Height	
	in.	mm
9(*)-8084-(‡)	4	(101)
9(*)-8085-(‡)	5	(127)
9(*)-8086-(‡)	6	(152)
9(*)-8087-(‡)	7	(178)

Cross Connector Bracket

- For field connecting crossing section.
- Furnished in pairs with ³/₈" hardware.
- (*) Insert **ZN** or **G**

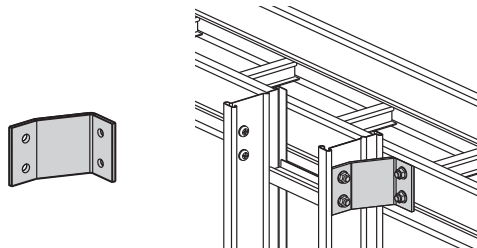

Catalog No.
9(*)-1240

● Green = Fastest shipped items ● Black = Normal lead-time items ● Red = Normally long lead-time items

All dimensions in parentheses are millimeters unless otherwise specified.

Series 2, 3, 4, & 5 Steel - Accessories

Standard Tray Hardware (for field installation drill $1\frac{3}{32}$ " hole)

- Finishes: [ZN] Zinc Plated ASTM B633 SC1 for pre-galvanized tray
- [CZ] Chromium Zinc Plated F1136-88 Grade A for hot dip galvanized tray

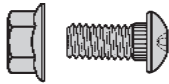

Catalog No.	Description
● RNCB $\frac{3}{8}$" x $\frac{3}{4}$" ZN	Ribbed Neck Carriage Bolt ASTM A307 Grade A
● SFHN $\frac{3}{8}$"-16 ZN	Serrated Flange Hex Nut ASTM A563 Grade A
● RNCB $\frac{3}{8}$" x $\frac{3}{4}$" CZ	Ribbed Neck Carriage Bolt ASTM F1136-88 Grade 3
● SFHN $\frac{3}{8}$"-16 CZ	Serrated Flange Hex Nut ASTM F1136-88 Grade A

Optional Tray Hardware (for field installation drill $1\frac{3}{32}$ " hole)

- To order 316 stainless steel hardware add SS6 suffix to catalog number - Example: 9G-8004SS6

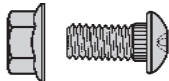

Catalog No.	Description
● RNCB $\frac{3}{8}$" x $\frac{3}{4}$" SS6	Ribbed Neck Carriage Bolt AISI 316 Stainless Steel
● SFHN $\frac{3}{8}$"-16 SS6	Serrated Flange Hex Nut AISI 316 Stainless Steel

Conduit to Cable Tray Adaptor

- For easy attachment of conduit terminating at a cable tray.
- Use on aluminum or steel cable trays.

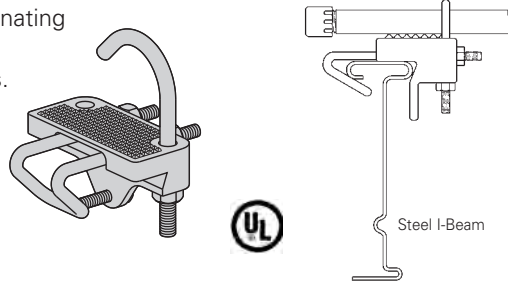

Catalog No.	Conduit Size	
	in.	mm
● 9G-1158-1/2, 3/2	$1\frac{1}{2}, \frac{3}{4}$	(15, 20)
● 9G-1158-1, 1 1/4	1, $1\frac{1}{4}$	(25, 32)
● 9G-1158-1 1/2, 2	$1\frac{1}{2}, 2$	(40, 50)
● 9G-1158-2 1/2, 3	$2\frac{1}{2}, 3$	(65, 80)
● 9G-1158-3 1/2, 4	$3\frac{1}{2}, 4$	(90, 100)

Conduit to Cable Tray Adaptor

- Assembly required.
- Mounting hardware included.
- Conduit clamps provided.
- (‡) = Insert conduit size ($\frac{1}{2}$ " thru 4").

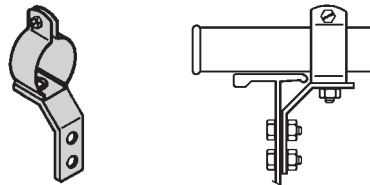

Catalog No.
● 9ZN-1150-(‡)

Conduit to Cable Tray Adaptor

- Assembly required.
- Conduit clamps included.
- (‡) = Insert conduit size ($\frac{1}{2}$ " thru 4").

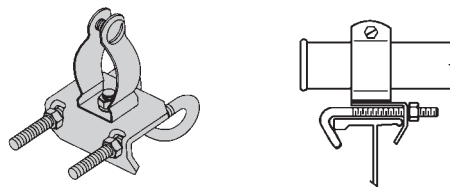

Catalog No.
● 9ZN-1155-(‡)

Cable Tie (Ladder Tray)

- Nylon ties provide easy attachment of cable to ladder rungs; maximum cable O.D. is 3" (76mm).

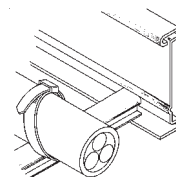
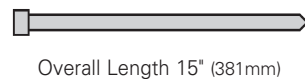

Catalog No.
● 99-2125-15

● Green = Fastest shipped items ● Black = Normal lead-time items ● Red = Normally long lead-time items

All dimensions in parentheses are millimeters unless otherwise specified.

Ladder Drop-Out

- Specially-designed Ladder Drop-Outs provide a rounded surface with 4" (101 mm) radius to protect cable as it exits the cable tray, preventing damage to insulation. The drop-out will attach to any desired rung.
- (*) Insert **P** or **G**
- (‡) Insert tray width

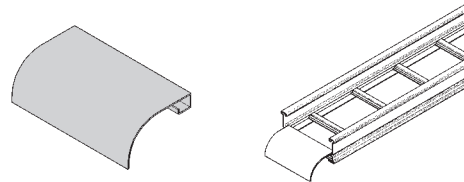

Catalog No.
● 9(*)-1104-(‡)

Trough Drop-Out & Drop-Out Bushing

- These devices provide a rounded surface to protect cable as it exits from the trough-type cable tray.
- Hardware is included for attachment of the trough bottom drop-out.
- (*) Insert **P** or **G**
- (‡) Insert tray width

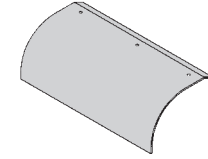
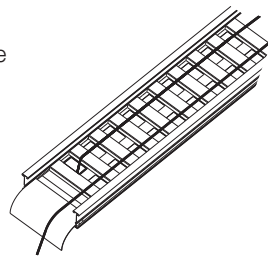

Trough-Type Drop-Out

Catalog No.
● 9(*)-1104T-(‡)

Snap-In Plastic Bushing

Catalog No.
● 99-1124

Barrier - Straight Section

- Length: Insert 120 for [120" - 10 ft.] (3.0 m) or 144 for [144" - 12 ft.] (3.6 m)
- Order catalog number based on loading depth.
- Furnished with four #10 x 1/2" plated self-drilling screws and a 99-9982 Barrier Strip Splice.
- (*) Insert **P** or **G**

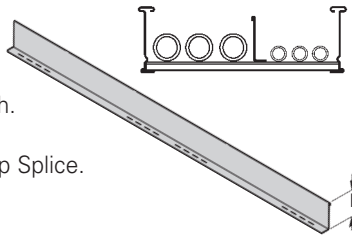

Catalog No.	Side Rail Height in. mm	Loading Depth 'H' in. mm
73(*)-Length	4 (101)	3 (76)
74(*)-Length	5 (127)	4 (101)
75(*)-Length	6 (152)	5 (127)
76(*)-Length	7 (178)	6 (152)

Barrier - Horizontal Bend

- Horizontal Bend Barriers are flexible in order to conform to any horizontal fitting radius. Can be cut to desired length.
- Standard length is 72" [6 ft.] (1.8 m) - sold individually
- Order catalog number based on loading depth.
- Furnished with three #10 x 1/2" plated self-drilling screws and a 99-9982 Barrier Strip Splice.
- (*) Insert **P** or **G**

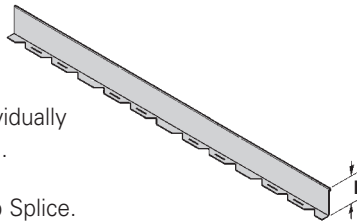

Catalog No.	Side Rail Height in. mm	Loading Depth 'H' in. mm
73(*)-90HBFL	4 (101)	3 (76)
74(*)-90HBFL	5 (127)	4 (101)
75(*)-90HBFL	6 (152)	5 (127)
76(*)-90HBFL	7 (178)	6 (152)

Barrier - Vertical Outside Bend

- Vertical Outside Bend Barriers are preformed to conform to a specific vertical outside bend fitting.
- Furnished with three #10 x 1/2" plated self-drilling screws and a 99-9982 Barrier Strip Splice.
- (*) Insert **P** or **G**
- (**) Insert 30, 45, 60 or 90 for degrees
- (t) Insert 12, 24, 36 or 48 for radius

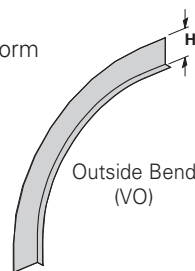

Catalog No.	Side Rail Height in. mm	Loading Depth 'H' in. mm
73(*)-(**)VO(t)	4 (101)	3 (76)
74(*)-(**)VO(t)	5 (127)	4 (101)
75(*)-(**)VO(t)	6 (152)	5 (127)
76(*)-(**)VO(t)	7 (178)	6 (152)

Barrier - Vertical Inside Bend

- Vertical Inside Bend Barriers are preformed to conform to a specific vertical inside bend fitting.
- Furnished with three #10 x 1/2" plated self-drilling screws and a 99-9982 Barrier Strip Splice.
- (*) Insert **P** or **G**
- (**) Insert 30, 45, 60 or 90 for degrees
- (t) Insert 12, 24, 36 or 48 for radius

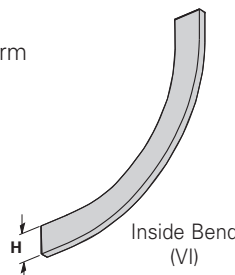

Catalog No.	Side Rail Height in. mm	Loading Depth 'H' in. mm
73(*)-(**)VI(t)	4 (101)	3 (76)
74(*)-(**)VI(t)	5 (127)	4 (101)
75(*)-(**)VI(t)	6 (152)	5 (127)
76(*)-(**)VI(t)	7 (178)	6 (152)

● Green = Fastest shipped items ● Black = Normal lead-time items ● Red = Normally long lead-time items

All dimensions in parentheses are millimeters unless otherwise specified.

Series 2, 3, 4, & 5 Steel - Accessories

Series 2, 3, 4, & 5 Steel

Barrier Strip Clip

- Zinc plated steel barrier clip fastens to either aluminum or steel ladder rung.
- Furnished with one #10 x 1/2" zinc plated self-drilling screw.

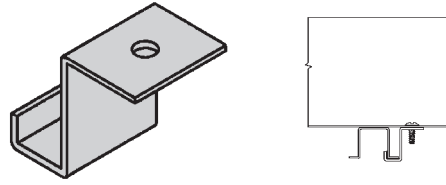

Catalog No.

● 92N-9002

Barrier Strip Splice

- Plastic splice holds adjoining barrier strips in straight alignment.
- 3" (76mm) long.

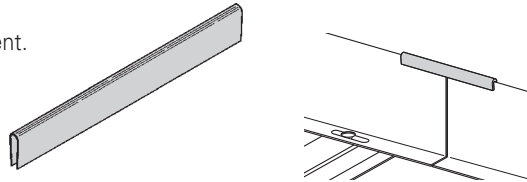

Catalog No.

● 99-9982

Bonding Jumper

Use at each expansion splice and where the cable tray is not mechanically/electrically continuous to ground. Sold individually.

- Hardware included.
- See table 392.7(B)(2) on page CTS-9 for amperage ratings required to match the UL cross-sectional area of the tray.
- See tray loading chart for UL cross-sectional area.
- Bonding jumper is 14 1/2" (368mm) long.

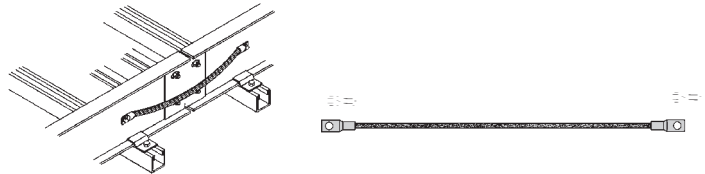

Catalog No.	Copper Wire Size	Ampacity
● 99-N1	#1	600

Grounding Clamp

B-Line series cable tray is UL® classified as to its suitability as an equipment grounding conductor. If a separate conductor for additional grounding capability is desired, we offer this clamp for bolting the conductor at least once to each cable tray section.

- Accepts #6 AWG to 250 MCM.

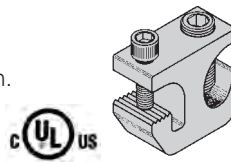

Catalog No.	Material
● 9A-2130	Tin Plated Aluminum

Ground Wire Clamp

- Mechanically attaches grounding cables to cable tray.
- Hardware included.
- (*) Insert **ZN** or **SS4**

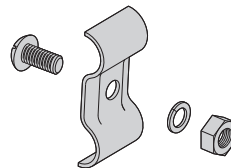

Catalog No.	Material
9(*)-2351	#1 thru 2/0
9(*)-2352	3/0 thru 250 MCM

Thread Rod (ATR) & Rod Couplings

Loading based on safety factor 5.

Standard Finish: Zinc plated
See B-Line series Strut Systems Catalog for other sizes and finishes.

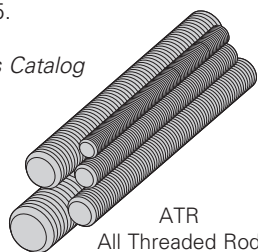
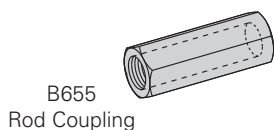

Size	Catalog No.	Available Length	Loading
All Threaded Rod			
3/8"-16	● ATR 3/8" x Length	36", 72", 120", 144"	730 lbs.
1/2"-13	● ATR 1/2" x Length	36", 72", 120", 144"	1350 lbs.
Rod Coupling			
3/8"-16	● B655-3/8"	NA	730 lbs.
1/2"-13	● B655-1/2"	NA	1350 lbs.

● Green = Fastest shipped items ● Black = Normal lead-time items ● Red = Normally long lead-time items

All dimensions in parentheses are millimeters unless otherwise specified.

Stainless Steel Cable Clamp

- Fits with series 2, 3, 4 & 5 standard steel rungs.
- Shipped flat. Field form around the cable at the time of installation.

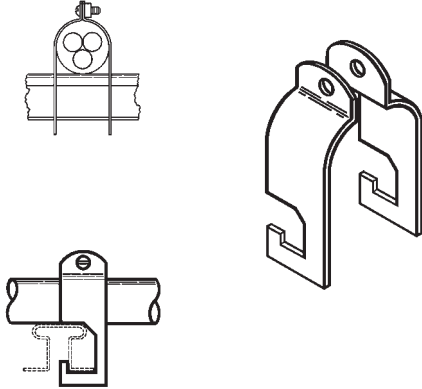

Refer to Section CF
Cable Fixing

Catalog No.	Cable Size	
	in.	mm
● 9SS4-4050	0.50 - 0.75	(13 - 19)
● 9SS4-4075	0.75 - 1.00	(19 - 25)
● 9SS4-4100	1.00 - 1.25	(25 - 32)
● 9SS4-4125	1.25 - 1.50	(32 - 38)
● 9SS4-4150	1.50 - 1.75	(38 - 45)
● 9SS4-4175	1.75 - 2.00	(45 - 51)
● 9SS4-4200	2.00 - 2.25	(51 - 57)
● 9SS4-4225	2.25 - 2.50	(57 - 64)
● 9SS4-4250	2.50 - 2.75	(64 - 70)
● 9SS4-4275	2.75 - 3.00	(70 - 76)
● 9SS4-4300	3.00 - 3.25	(76 - 82)
● 9SS4-4325	3.25 - 3.50	(82 - 89)
● 9SS4-4350	3.50 - 3.75	(89 - 95)
● 9SS4-4375	3.75 - 4.00	(95 - 100)
● 9SS4-4400	4.00 - 4.25	(100 - 106)
● 9SS4-4425	4.25 - 4.50	(106 - 113)
● 9SS4-4450	4.50 - 4.75	(113 - 121)
● 9SS4-4475	4.75 - 5.00	(121 - 125)

Hanger Rod Clamp

- For 1/2" ATR.
- Furnished in pairs.
- Order ATR and hex nuts separately.
- Two-piece "J"-hanger design.
- 1500 lbs./pair capacity safety factor 3.
- (*) Insert **ZN** or **G**

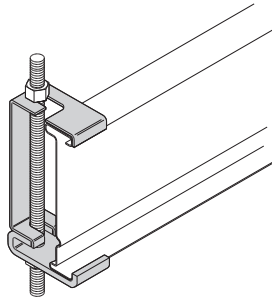

Catalog No.	Height	
	in.	mm
9(*)-5324	4	(101)
9(*)-5325	5	(127)
9(*)-5326	6	(152)
9(*)-5327	7	(178)

Cable Tray Clamp/Guide

- Features a no-twist design.
- Has four times the strength of the traditional design.
- Each side is labeled to ensure proper installation.
- Furnished in pairs, with or without hardware.
- Not recommended for vertical support.

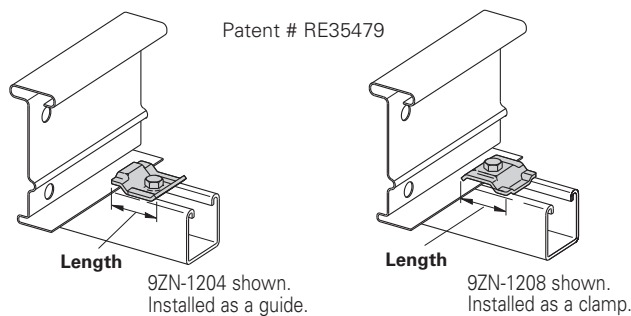

When installing this device as an expansion guide on the outside flange of *Steel Side Rail*, use the Catalog No. **B202** Square Washer in order to properly elevate the guide.

Note: For heavy duty or vertical applications see 9(*)-1241 or 9(*)-1242 page HAT-20

Catalog No.		Overall Length in. (mm)	Hardware Size in.	Finish
Without Hardware	With Hardware			
● 9ZN-1204	● 9ZN-1204NB	1 1/2 (38)	1/4"	G90
● 9ZN-1208	● 9ZN-1208NB	2 1/4 (57)	3/8"	G90
● 9A-1205	--	2 1/4 (57)	1/2"	Alum.
● 9G-1205	--	2 1/4 (57)	1/2"	HDGAF
● 9SS6-1205	--	2 1/4 (57)	1/2"	316SS
● 9ZN-1205	--	2 1/4 (57)	1/2"	G90

● Green = Fastest shipped items ● Black = Normal lead-time items ● Red = Normally long lead-time items

All dimensions in parentheses are millimeters unless otherwise specified.

Series 2, 3, 4, & 5 Steel - Accessories

Cable Tray Clamp

- Hold-down clamps for single or double cable tray runs.
- No drilling of support I-beam or channel is required.
- Sold in pieces - two clamps are required per tray.
- Maximum beam flange thickness 1 1/8" (28.58 mm).

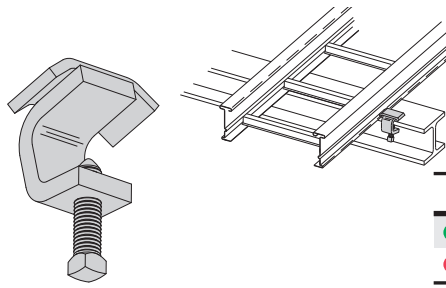

Catalog No.	Finish
● 9ZN-1249HD	Znplt
● 9G-1249HD	HDGAF

Cable Tray Guide

- Expansion guide for single or double cable tray runs.
- Guide allows for longitudinal movement of the cable tray.
- No field drilling of support I-beam or channel is required.
- Guides are required on both sides of cable tray to prevent lateral movement - can be placed on either the inside or outside flange of cable tray.
- Guides are sold in pieces - two guides are required per tray.
- Maximum flange thickness 1 1/8" (28.58 mm).

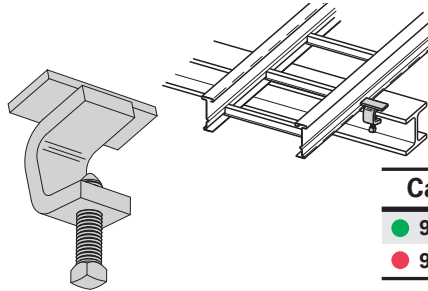

Catalog No.	Finish
● 9ZN-1249	Znplt
● 9G-1249	HDGAF

Nylon Pad

- Use for friction reduction.
- Hardness: Shore D80.
- Low friction coefficient.
- UV resistant.
- Excellent weatherability.
- UL - 94HB.

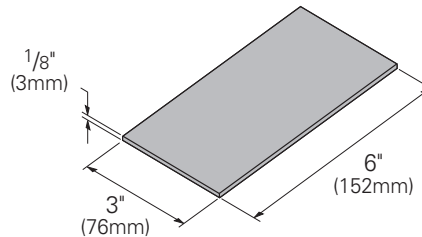

Catalog No.
● 99-PE36

Neoprene Roll

- Use for material isolation.
- 1/8" x 2" x 25' roll.
- Hardness: Shore A60.
- Good weatherability.

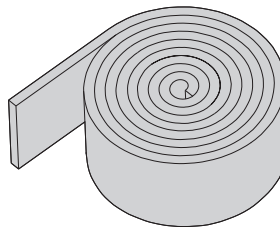

Catalog No.
● 99-NP300

DURA-BLOK™ Rooftop Support Bases with B22 Channel

- Designed as a superior rooftop support for cable tray.
- UV resistant and approved for most roofing material or other flat surfaces.
- Can be used with any of B-Line series cable tray clamps and guides.
- Ultimate Load Capacity: 1,000 lbs. (uniform load)



Catalog No.	Height x Width x Length in. (mm)
● DB10-28	5 5/8 x 6 x 28.0 (143 x 152 x 711)
● DB10-36	5 5/8 x 6 x 36.0 (143 x 152 x 914)
● DB10-42	5 5/8 x 6 x 42.0 (143 x 152 x 1067)
● DB10-50	5 5/8 x 6 x 50.0 (143 x 152 x 1270)
● DB10-60	5 5/8 x 6 x 60.0 (143 x 152 x 1524)



LEEDS credit available, base made from 100% recycled material.

General Note: Consult roofing manufacturer or engineer for roof load capacity. The weakest point may be the insulation board beneath the rubber membrane.

● Green = Fastest shipped items ● Black = Normal lead-time items ● Red = Normally long lead-time items

All dimensions in parentheses are millimeters unless otherwise specified.

Trapeze Support Kit

- Eaton's B-Line series trapeze kits provide the components required for a single trapeze support in one package. These kits are available in pre-galvanized steel with zinc-plated hardware, hot dip galvanized steel with 316 stainless steel hardware, or DURA GREEN™ painted steel with zinc-plated hardware.
- The SH channel provides the convenience of pre-punched slots, which eliminate the need for field drilling.
- The illustrated hardware is sealed in a plastic bag and boxed with the channel, which is pre-cut to the appropriate length as shown in the chart.
- Designed for use with 1/2" threaded rod. Order rod separately.

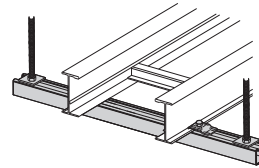
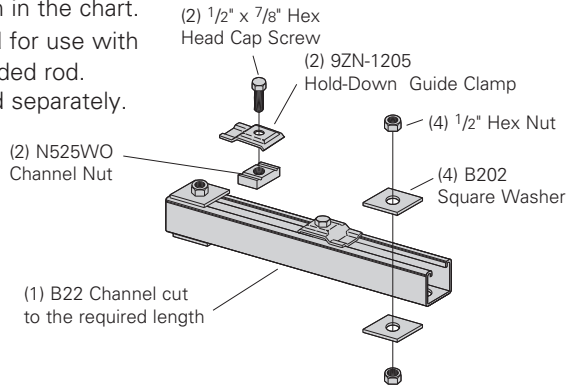

Catalog No.	Tray Width		Channel Length		Uniform Load	
	in.	mm	in.	mm	lbs	kN
● 9(*)-5506-22SH(†)	6	(152)	16	(406)	1350	(6.00)
● 9(*)-5509-22SH(†)	9	(229)	18	(457)	1250	(5.56)
● 9(*)-5512-22SH(†)	12	(305)	22	(559)	1125	(5.00)
● 9(*)-5518-22SH(†)	18	(457)	28	(711)	865	(3.85)
● 9(*)-5524-22SH(†)	24	(610)	34	(864)	700	(3.11)
● 9(*)-5530-22SH(†)	30	(762)	40	(1016)	590	(2.62)
● 9(*)-5536-22SH(†)	36	(914)	46	(1168)	510	(2.27)
● 9(*)-5542-22SH(†)	42	(1067)	52	(1321)	450	(2.00)

- (*) Insert **P** **G** or **GRN**
- (†) Insert 3/8 for 3/8" threaded rod hardware. Safety factor of 3.0 on all loads.

Heavy Duty Trapeze Support Kit

- Eaton's B-Line series trapeze kits provide the components required for a single trapeze support in one package. These kits are available in pre-galvanized steel with zinc-plated hardware, hot dip galvanized steel with 316 stainless steel hardware, or DURA GREEN™ painted steel with zinc-plated hardware.
- The SH channel provides the convenience of pre-punched slots, which eliminates the need for field drilling.
- The illustrated hardware is sealed in a plastic bag and boxed with the channel, which is pre-cut to the appropriate length as shown in the chart.
- Designed for use with 1/2" threaded rod. Order rod separately.

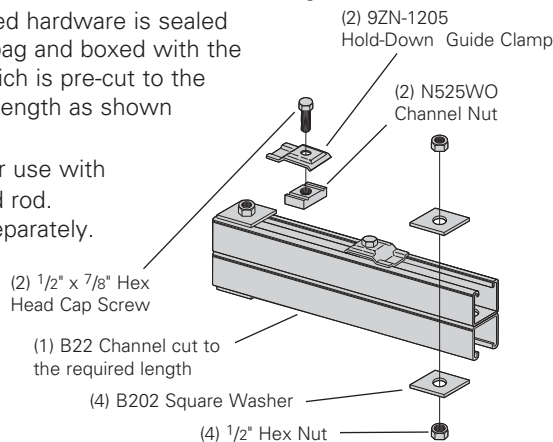

Catalog No.	Tray Width		Channel Length		Uniform Load	
	in.	mm	in.	mm	lbs	kN
● 9(*)-5506-22SHA	6	(152)	16	(406)	1350	(6.00)
● 9(*)-5509-22SHA	9	(229)	18	(457)	1350	(6.00)
● 9(*)-5512-22SHA	12	(305)	22	(559)	1350	(6.00)
● 9(*)-5518-22SHA	18	(457)	28	(711)	1350	(6.00)
● 9(*)-5524-22SHA	24	(610)	34	(864)	1350	(6.00)
● 9(*)-5530-22SHA	30	(762)	40	(1016)	1350	(6.00)
● 9(*)-5536-22SHA	36	(914)	46	(1168)	1350	(6.00)
● 9(*)-5542-22SHA	42	(1067)	52	(1321)	1350	(6.00)

- (*) Insert **P** **G** or **GRN**
- Safety factor of 3.0 on all loads.

Trapeze Hardware Kit

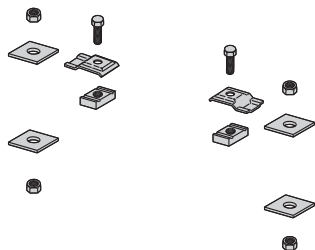

Catalog No.	● 9ZN-5500-1/2	● 9G-5500-1/2
In plastic bag	1 pr. 9ZN-1205 2 HHC Screw 1/2 x 7/8 ZN 2 N525 WO ZN 4 B202 ZN 1/2" sq washer 4 HN 1/2 ZN	1 pr. 9G-1205 2 HHC Screw 1/2 x 7/8 SS6 2 N525 WO SS6 4 B202 HDG 1/2" sq washer 4 HN 1/2 SS6

● Green = Fastest shipped items ● Black = Normal lead-time items ● Red = Normally long lead-time items

All dimensions in parentheses are millimeters unless otherwise specified.

Series 2, 3, 4, & 5 Steel - Accessories

Series 2, 3, 4, & 5 Steel

Center Hung Tray Support

- Center Hung Cable Tray Support allows cable to be laid-in from both sides.
- Eliminates costly cable pulling and field cutting of cable tray supports. Labor costs are dramatically reduced.
- Required hardware and threaded rod material for trapeze assemblies are reduced by up to 50%.
- Designed for use with 1/2" threaded rod. (Order rod separately)
- Use with all aluminum and steel cable trays through 24" width.
- Load capacity is 700 lbs. (311kN) per support. Safety factor of 3.0. Eccentric loading is not to exceed a 60% vs. 40% load differential.
- The maximum recommended unsupported span length is 144"/12 ft. (3.66 m).
- Hardware shown is furnished.
- Finish available: Zinc Plated

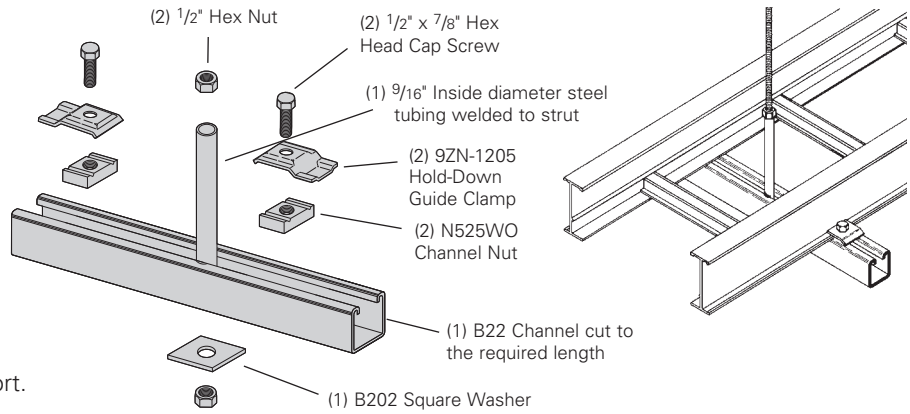

Catalog No.	Tray Width		Channel Length	
	in.	(mm)	in.	(mm)
● 9ZN-5212	6", 9", 12"	(152, 228, 305)	18"	(457)
● 9ZN-5224	18", 24"	(457, 609)	30"	(762)

Center Hung Support Hardware Kit

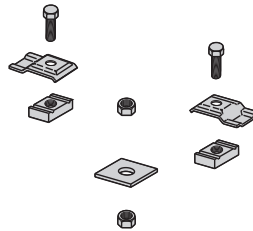

Catalog No.	● 9ZN-5200
In plastic bag	1 pr. 9ZN-1205 2 HHC Screw 1/2 x 7/8 ZN 2 N525 WO ZN 1 B202 ZN 1/2" sq washer 4 HN 1/2 ZN

Bracket (12" - 48")

- (*) Insert available finish: **ZN** **GRN** or **HDG**
- Safety Load Factor 2.5

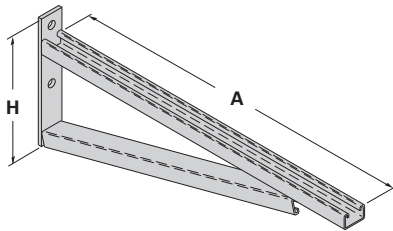

Bottom brace is B42 channel on B494-24 and smaller and B22 channel on B494-30 and larger

Catalog No.	Uniform Load lbs (kN)	Tray Width		'A'		'H'	
		in.	(mm)	in.	(mm)	in.	(mm)
● B494-12	2500 (11.12)	6 & 9	(152 & 229)	12	(305)	8 ³ / ₄	(222)
● B494-18	1700 (7.56)	12	(305)	18	(457)	8 ³ / ₄	(222)
● B494-24	1300 (5.78)	18	(457)	24	(610)	8 ³ / ₄	(222)
B494-30	1600 (7.11)	24	(610)	30	(762)	11 ¹ / ₄	(286)
B494-36	1100 (4.89)	30	(762)	36	(914)	11 ¹ / ₄	(286)
B494-42	980 (4.36)	36	(914)	42	(1067)	16	(406)
B494-48	980 (4.36)	42	(1067)	48	(1219)	16	(406)

For more dimensional data see Strut Systems catalog

Cantilever Bracket

- (*) Insert available finish: **ZN** **GRN** or **HDG**
- Safety Load Factor 2.5

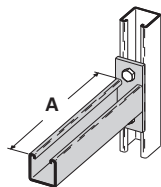

Catalog No.	Uniform Load lbs kN	Tray Width		'A'	
		in.	mm	in.	mm
B409-12	960 (4.27)	6 & 9	(152 & 229)	12	(305)
B409-18	640 (2.84)	12	(305)	18	(457)
B409-24	480 (2.13)	18	(457)	24	(610)

● Green = Fastest shipped items ● Black = Normal lead-time items ● Red = Normally long lead-time items

All dimensions in parentheses are millimeters unless otherwise specified.

Cantilever Bracket

- (*) Insert available finish: **ZN** **GRN** or **HDG**
- Safety Load Factor 2.5

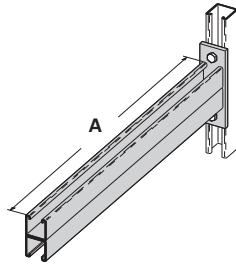

Catalog No.	Uniform Load		Tray Width		'A'	
	lbs	kN	in.	mm	in.	mm
B297-12	1660	(7.38)	6 & 9	(152 & 229)	12	(305)
B297-18	1100	(4.89)	12	(305)	18	(457)
B297-24	835	(3.71)	18	(457)	24	(610)
B297-30	665	(2.93)	24	(610)	30	(762)
B297-36	550	(2.44)	30	(762)	36	(914)
B297-42	465	(2.06)	36	(914)	42	(1067)

Underfloor Support (U-Bolts not included)

- Finishes available: **ZN**
- Safety Load Factor 2.5

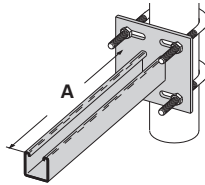

U-Bolt Size	Fits Pipe O.D.
B501-3/4	.841 - 1.050
B501-1	1.051 - 1.315
B501-1 1/4	1.316 - 1.660
B501-1 1/2	1.661 - 1.900
B501-2	1.901 - 2.375
B501-2 1/2	2.376 - 2.875

Catalog No.	Uniform Load		Tray Width		'A'	
	lbs	(kN)	in.	(mm)	in.	(mm)
B409UF-12	800	(3.56)	6 & 9	(152 & 229)	12	(305)
B409UF-21	450	(2.00)	12 & 18	(305 & 457)	21	(533)

Vertical Hanger Splice Plates

- Design load is 1500 lbs (6.67kN) per pair.
- Safety Factor of 2.5
- Furnished in pairs.
- Hole size: 9/16" (14mm) for 1/2" threaded rod.
- (*) Insert **ZN** or **G**

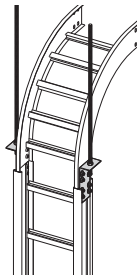
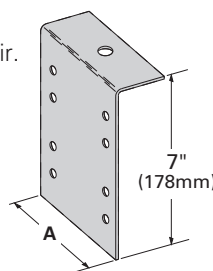

Catalog No.	Outside	'A'	
	Cable Tray Ht.	in.	(mm)
● 9(*)-8224	4"	3.84	(97.54)
● 9(*)-8225	5"	4.73	(120.14)
● 9(*)-8226	6"	5.84	(148.34)
● 9(*)-8227	7"	6.84	(173.74)

Heavy Duty Hold Down Bracket

- Design load is 2000 lbs (8.89kN) per pair.
- Two bolt design.
- Sold in pairs.
- 3/8" cable tray attachment hardware provided.
- 1/2" support attachment hardware **not** provided.
- (*) Insert **ZN** or **G**
- Recommended for support of vertical trays.

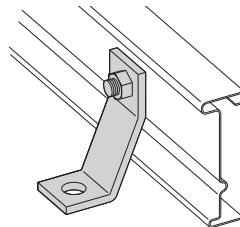

Catalog No.
9(*)-1241

Heavy Duty Hold Down Bracket

- Design load is 4000 lbs (17.79kN) per pair.
- Four bolt design.
- Sold in pairs.
- 3/8" cable tray attachment hardware provided
- 1/2" support attachment hardware **not** provided.
- (*) Insert **ZN** or **G**
- Recommended for support of vertical trays.

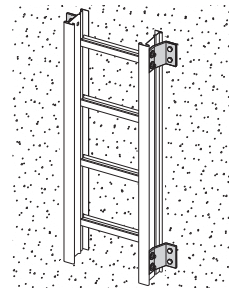
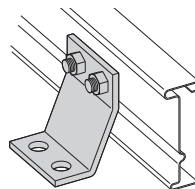

Catalog No.
9(*)-1242

Beam Clamp

- Finishes available: **ZN** **GRN** **HDG** or **SS4**
- Sold in pieces.
- Design load is 1200 lbs (5.34kN) per pair.
- Safety Load Factor 5.0.
- Order HHCS and Channel Nuts separately.

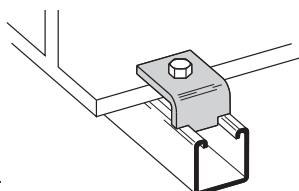

Catalog No.
B355

● Green = Fastest shipped items ● Black = Normal lead-time items ● Red = Normally long lead-time items

All dimensions in parentheses are millimeters unless otherwise specified.

Series 2, 3, 4, & 5 Steel - Accessories

Series 2, 3, 4, & 5 Steel

Beam Clamp

- Finishes available: **ZN** or **HDG**
- Sold in pieces.
- *Design load when used in pairs. Safety Load Factor 5.0

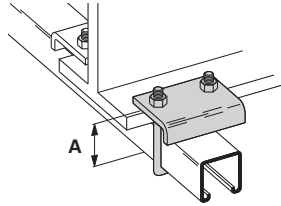

Catalog No.	Design Load lbs (kN)	'A' in. (mm)
B441-22	1200 (5.34)	3 ³ / ₈ (86)
B441-22A	1200 (5.34)	5 (127)

Beam Clamp

- Finishes available: **ZN** **GRN** or **HDG**
- Sold in pieces.
- *Design load when used in pairs. Safety Load Factor 5.0

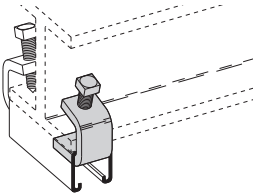

Catalog No.	B212-1/4	B212-3/8
Design Load *	600 lbs. (2.67kN)	1000 lbs. (4.45 kN)
Max. Flange Thick	3/4" (19 mm)	1 1/8" (28.6 mm)
Mat'l. Thickness	1/4" (6.3 mm)	3/8" (9.5 mm)

B305 Thru B308 & B321 Series Beam Clamps

- Finishes available: **ZN** or **HDG**
- Setscrew included.
- Safety Load Factor 5.0

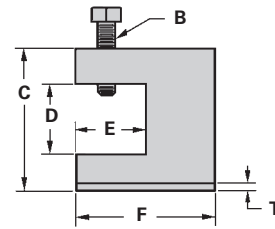
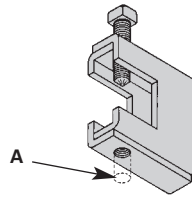

Catalog No.	Rod Size A	B	C		D		E		F		T		Design Load	
			in.	(mm)	in.	(mm)	in.	(mm)	in.	(mm)	in.	(mm)	lbs	(kN)
B305	3/8"-16	3/8"-16	2 ⁵ / ₁₆	(58.7)	7/8	(22.2)	1 1/8	(28.6)	2 1/2	(63.5)	11 Ga.	(3.0)	600	(2.67)
B306	3/8"-16	1/2"-13	2 ⁷ / ₁₆	(61.9)	7/8	(22.2)	1 1/8	(28.6)	2 1/2	(63.5)	7 Ga.	(4.5)	1100	(4.90)
B307	1/2"-13	1/2"-13	2 ⁷ / ₁₆	(61.9)	7/8	(22.2)	1 1/8	(28.6)	2 1/2	(63.5)	7 Ga.	(4.5)	1100	(4.90)
B308	1/2"-13	1/2"-13	2 ⁹ / ₁₆	(65.1)	7/8	(22.2)	1 1/8	(28.6)	2 1/2	(63.5)	1/4	(6.3)	1500	(6.68)
B321-1	3/8"-16	1/2"-13	3 ⁹ / ₁₆	(90.5)	1 11/16	(42.9)	1 ⁵ / ₈	(41.3)	3 1/4	(82.5)	1/4	(6.3)	1300	(5.79)
B321-2	1/2"-13	1/2"-13	3 ⁹ / ₁₆	(90.5)	1 11/16	(42.9)	1 ⁵ / ₈	(41.3)	3 1/4	(82.5)	1/4	(6.3)	1400	(6.23)

Anchor Strap - for B305 thru B308 & B321 Series

- Finish available: **ZN**
- For a maximum beam thickness of 3/4" (19mm).
- For thicker beams, step up one flange width size.

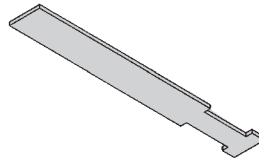

Catalog No.	Flange Width	
	in.	(mm)
B312-6	Up to 6	(Up to 152)
B312-9	6 - 9	(152 to 228)
B312-12	9 - 12	(228 to 305)

Beam Clamp

- Finish available: **ZN**
- Design Load 500 lbs. (2.22 kN)
- Safety Load Factor 5.0
- Recommended torque:
'J'-Hook Nut 125 In.-Lbs. (14.1 kN/m)
- Maximum flange thickness of 3/4" (19mm).

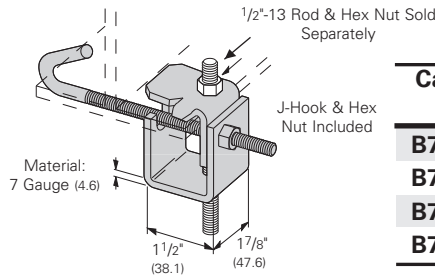

Catalog No.	For Flange Width		Wt./C	
	in.	(mm)	lbs	(kg)
B750-J4	3 - 6	(76.2 - 152.4)	109	(49.4)
B750-J6	5 - 9	(127.0 - 228.6)	124	(56.2)
B750-J9	8 - 12	(203.2 - 304.8)	135	(61.2)
B750-J12	11 - 15	(279.4 - 381.0)	147	(66.7)

'J'-Hook

- Finishes available: **ZN**
- Hex Nut included.

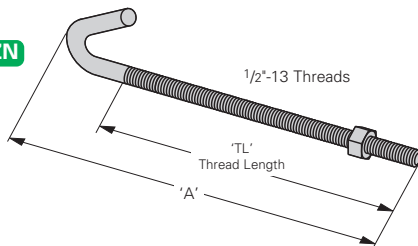

Catalog No.	'A'		'TL'		Wt./C	
	in.	(mm)	in.	(mm)	lbs	(kg)
B700-J4	8 1/2	(215.9)	5	(127.0)	44	(19.9)
B700-J6	11 1/2	(292.1)	6	(152.4)	53	(24.0)
B700-J9	12 1/4	(368.3)	6	(152.4)	63	(28.6)
B700-J12	17 1/2	(444.5)	6	(152.4)	78	(35.4)

● Green = Fastest shipped items ● Black = Normal lead-time items ● Red = Normally long lead-time items

All dimensions in parentheses are millimeters unless otherwise specified.

Covers

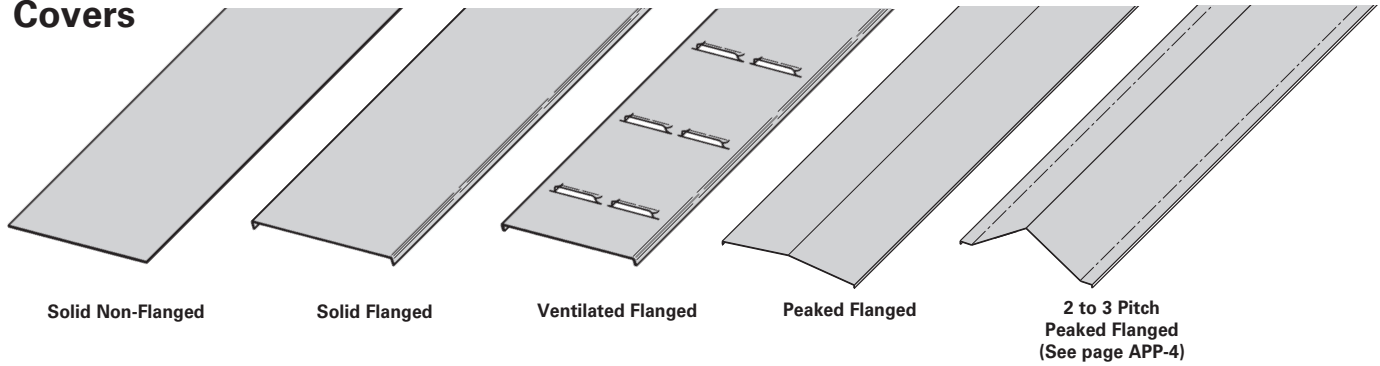

A full range of covers is available for straight sections and fittings.

Solid covers should be used when maximum enclosure of the cable is desired and no accumulation of heat is expected.

Ventilated covers provide an overhead cable shield, yet allow heat to escape.

We recommend that covers be placed on vertical cable tray runs to a height of 6 ft. (1.83 m) to 8 ft. (2.44 m) above the floor to isolate both cables and personnel. **Flanged covers** have a 1/2 in. (13 mm) flange. Cover clamps are not included with the cover and must be ordered separately. All **peaked covers** are flanged. Standard peaked covers have 1/2" peak. Special purpose peaked covers, having a 2 to 3 pitch, provide additional slope and material thickness. The 2 to 3 pitch fitting covers are of multiple piece, welded construction.

Steel Cover Part Numbering

Example: ^{Prefix} **80 2 P - 24 - 144**

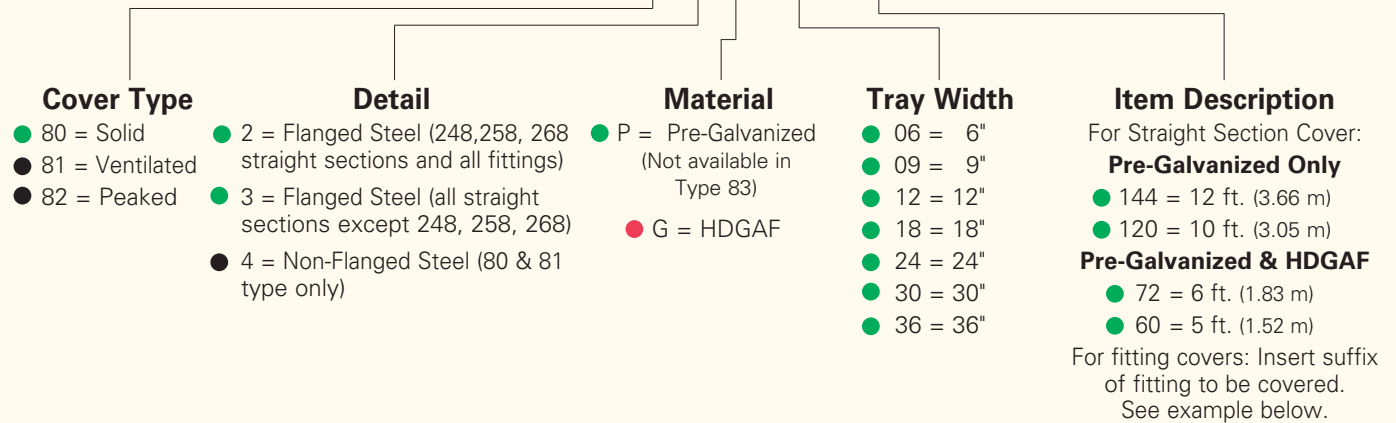

Examples of Catalog Numbers for Fitting Covers:

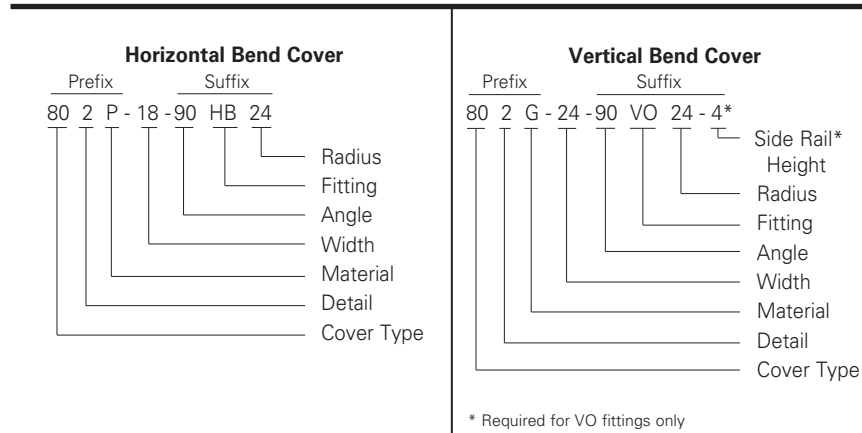

● Green = Fastest shipped items ● Black = Normal lead-time items ● Red = Normally long lead-time items

All dimensions in parentheses are millimeters unless otherwise specified.

Series 2, 3, 4, & 5 Steel - Accessories

Series 2, 3, 4, & 5 Steel

Standard Cover Clamp

- For indoor service only.
- Screw included.
- Sold per piece.
- (*) Insert **ZN** or **G**

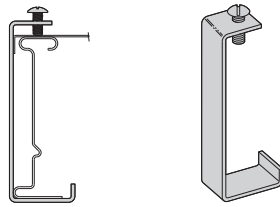

Tray Type	Catalog No.	Side Rail Height in. (mm)
Steel	9(*)-9014	4 (101)
	9(*)-9015	5 (127)
	9(*)-9016	6 (152)
	9(*)-9017	7 (78)

Combination Cover and Hold Down Clamp

- Sold per piece.
- For indoor service only.
- (*) Insert **P** or **G**

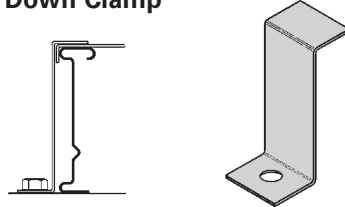

Tray Type	Catalog No.	Side Rail Height in. (mm)
Steel	9(*)-9043	4 (101)
	9(*)-9053	5 (127)
	9(*)-9063	6 (152)
	9(*)-9073	7 (78)

Raised Cover Clamp

- For indoor service only.
- For use with flanged covers only.
- † Specify gap of 1", 2", 3" or 4".

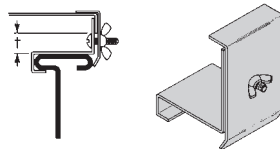

Tray Type	Catalog No.	Tray Type
● 9ZN-9114-†	Series 2 Steel Straight Section	
● 9ZN-9115-†	Series 3 & 4 Steel Straight Section	
● 9ZN-910†	All Steel Fittings (Also Series 1 Steel Straight Sections)	

Heavy Duty Cover Clamp

- Recommended for outdoor service.
- (‡) Insert tray width
- † Add P to Catalog No. for peaked cover clamp.
- (*) Insert **P** or **G**

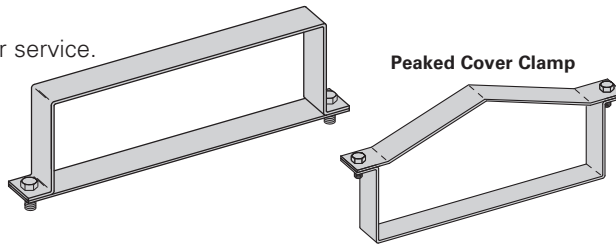

Catalog No.	Side Rail Height in. mm
9(*)-(‡)-9044†	4 (101)
9(*)-(‡)-9054†	5 (127)
9(*)-(‡)-9064†	6 (152)
9(*)-(‡)-9074†	7 (178)

Quantity of Standard Cover Clamps Required

Notes:

When using the Heavy Duty Cover Clamp, only on-half the number of clamps stated above is required.

Additional clamps may be necessary in extreme wind applications.

Straight Section 60" or 72"	4 pcs.
Straight Section 120" or 144"	6 pcs.
Horizontal/Vertical Bends	4 pcs.
Tees	6 pcs.
Crosses	8 pcs.

Cover Joint Strip

- Used to join covers
- Plastic
- (‡) Insert tray width

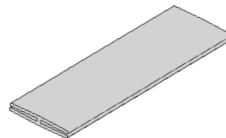

Catalog No.
● 99-9980-(‡)

Cable Cleats

(see pages O-1 thru O-5) Standard

Trefoil Cable Cleats



Single Cable Cleats

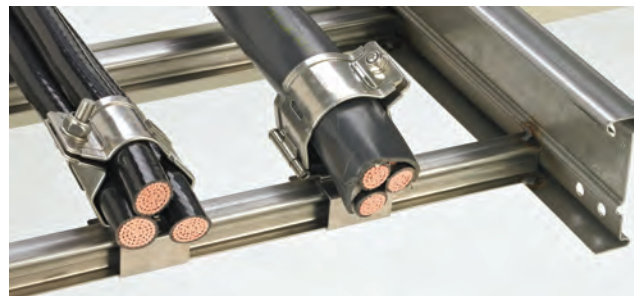

● Green = Fastest shipped items ● Black = Normal lead-time items ● Red = Normally long lead-time items

All dimensions in parentheses are millimeters unless otherwise specified.

Section 1- Acceptable Manufacturers

- 1.01 Manufacturer: Subject to compliance with these specifications, Eaton's B-Line series cable tray systems shall be as manufactured by Eaton.

Section 2- Cable Tray Sections and Components

- 2.01 General: Except as otherwise indicated, provide metal cable trays, of types, classes and sizes indicated; with splice plates, bolts, nuts and washers for connecting units. Construct units with rounded edges and smooth surfaces; in compliance with applicable standards; and with the following additional construction features. Cable tray shall be installed according to the latest revision of NEMA VE 2.
- 2.02 Pre-Galvanized Steel: Straight sections, fitting side rails, rungs, and covers shall be made from structural quality steel meeting the minimum mechanical properties and mill galvanized in accordance with ASTM A653 SS, Grade 33, coating designation G90. Hardware finish shall be electrogalvanized zinc per ASTM B633.
- 2.03 Hot Dip Galvanized Steel: All side rails, covers, splice plates, and rungs shall be made from structural quality steel meeting the minimum mechanical properties of ASTM A1011 SS, Grade 33 for 14 gauge and heavier, ASTM A1008, Grade 33 Type 2 for 16 gauge and lighter, and shall be hot dip galvanized after fabrication in accordance with ASTM A123. Mill galvanized covers are not acceptable for hot dip galvanized cable tray. Hardware finish shall be chromium zinc per ASTM F-1136-88.
- 2.04 Ladder Cable Trays shall consist of two longitudinal members (side rails) with transverse members (rungs) welded to the side rails. Rungs shall be spaced [6] [9] [12] inches on center. Rung spacing in radiused fittings shall be industry standard 9" and measured at the center of the tray's width. No portion of the rungs shall protrude below the bottom plane of the side rails. Each rung must be capable of supporting a 200 lb. concentrated load at the center of the cable tray over and above the cable load with a safety factor of 1.5.
- 2.05 Ventilated Trough Cable Trays shall consist of two longitudinal members (side rails) with a corrugated bottom welded to the side rails or rungs spaced 4" on center. The peaks of the corrugated bottom shall have a minimum flat cable bearing surface of 2³/₄" and shall be spaced on 6" centers. To provide ventilation in the tray, the valleys of the corrugated bottom shall have 2¹/₄" x 4" rectangular holes punched along the width of the bottom.
- 2.06 Non-Ventilated Bottom Trough Cable Trays shall consist of two longitudinal members (side rails) with a corrugated bottom welded to the side rails or a solid sheet over rungs. The peaks of the corrugated bottom shall have a minimum flat cable bearing surface of 2³/₄" and shall be spaced on 6" centers.
- 2.07 Cable tray loading depth shall be [3] [4] [5] [6] inches per NEMA VE 1.
- 2.08 Straight sections shall have side rails fabricated as I-beams. Straight sections shall be supplied in standard [12 foot] [24 foot] [10 foot (3 m)] [20 foot (6 m)] lengths.
- 2.09 Cable tray widths shall be [6] [9] [12] [18] [24] [30] [36] inches or as shown on drawings.
- 2.10 Splice plates shall be manufactured of high strength steel, meeting the minimum mechanical properties of ASTM A1011 HSLAS, Grade 50, Class 1 and be secured with 8 nuts and bolts per plate. The resistance of fixed splice connections between an adjacent section of tray shall not exceed 0.00033 ohm.
- 2.11 All fittings must have a minimum radius of [12] [24] [36] [48] inches.

Section 3- Loading Capacities and Testing

- 3.01 Cable tray shall be capable of carrying a uniformly distributed load of _____ lbs./ft. on a _____ ft. support span with a safety factor of 1.5 when supported as a simple span and tested per NEMA VE 1 5.2. In addition to the uniformly distributed load the cable tray shall support 200 lbs. concentrated load at mid-point of span. Load and safety factors specified are applicable to both the side rails and rung capacities. Cable tray shall be made to manufacturing tolerances as specified by NEMA.
- 3.02 Upon request, manufacturer shall provide test reports in accordance with the latest revision of NEMA VE 1 or CSA C22.2 No. 126.

Series 3 & 4 Stainless Steel - Straight Sections

Series 3 & 4 Stainless Steel



For Stainless Steel Fittings
see fittings section pages L-1 thru L-17

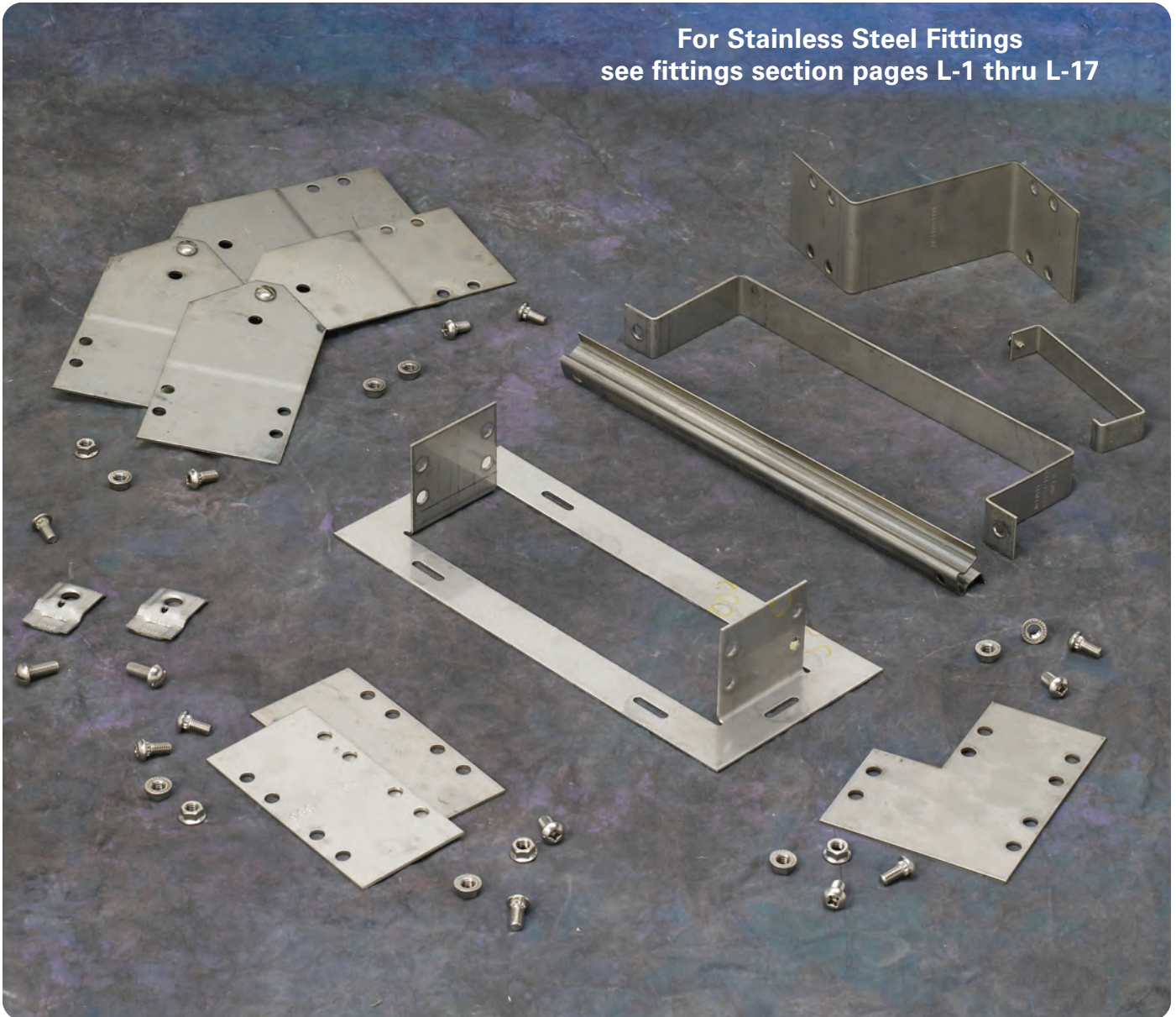

How The Service Advisor Works

We know that your time is important! That's why the color-coding system in this catalog is designed to help you select products that fit your service needs. Products are marked to indicate the typical lead time for orders of 50 pieces or less.

Customer: How do I select my straight sections, covers, or fittings so that I get the quickest turnaround?

Service Advisor: Each part of our selection chart is shown in colors. If any section of a part number is a different color, the part will typically ship with the longer lead time represented by the colors.

- Green = Fastest shipped items
- Black = Normal lead-time items
- Red = Normally long lead-time items

Example: 348SS4 09 - 12 - 144
 ● ● ● ●

Part will have a long lead time.

Series 3 & 4 Stainless Steel - Straight Sections

3" NEMA VE 1 Loading Depth 4" Side Rail Height

Straight Section Part Numbering

Example: ^{Prefix} **348 SS6 09 - 24 - 144**

Series	Material	*Type	*Width	Length
● 348	● SS4 = 304 Stainless Steel	Ladder-	● 06 = 6"	● ① 144 = 12 ft.
	● SS6 = 316 Stainless Steel	● 06 = 6" rung spacing	● 09 = 9"	● ② 120 = 10 ft.
		● 09 = 9" rung spacing	● 12 = 12"	①Primary Length.
		● 12 = 12" rung spacing	● 18 = 18"	②Secondary Length.
		Trough-	● 24 = 24"	See page C-23 for
		6" and Wider	● 30 = 30"	explanation of lengths.
		● 04 = Vented Bottom	● 36 = 36"	Passivation available
		● SB = Non-Ventilated		see page C-2.

See page APP-1 for additional rung options. *Special sizes available.

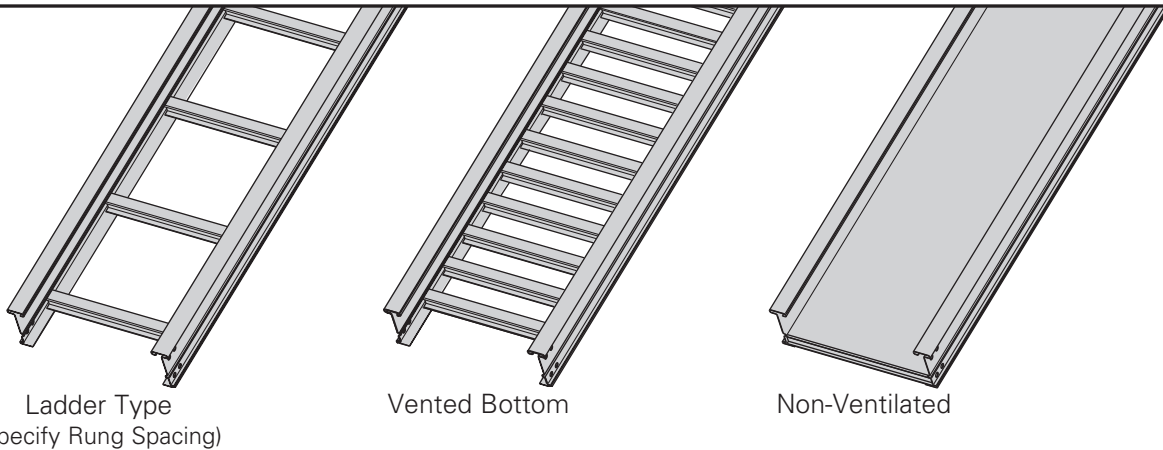
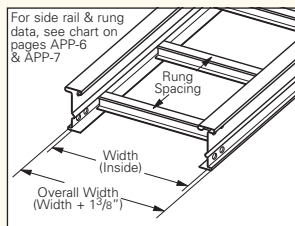

Values are based on simple beam tests per NEMA VE 1 on 36" wide cable tray rungs spaced on 12" centers. Cable trays will support without collapse a 200 lb. (90.7 kg) concentrated load over and above published loads. Published load safety factor is 1.5. To convert 1.5 safety factor to 2.0, multiply published load by 0.75. To obtain mid-span deflection, multiply a load by the deflection multiplier. Cable tray must be supported on spans shorter than or equal to the length of the cable being installed.

B-Line Series	Side Rail Dimensions	NEMA, CSA & UL Classifications	Span ft	Load lbs/ft	Deflection Multiplier	Design Factors for Two Rails	Span meters	Load kg/m	Deflection Multiplier	Design Factors for Two Rails
348 SS†		NEMA: 16A, 12C CSA: C1-3m UL Cross-Sectional Area: 0.40 in ²	10	180	0.0042	Area = 0.74 in ² Sx = 0.79 in ³ Ix = 1.85 in ⁴	3.0	268	0.072	Area = 4.77 cm ² Sx = 12.95 cm ³ Ix = 77.00 cm ⁴
			12	125	0.009		3.7	186	0.148	
			14	92	0.016		4.3	137	0.275	
			16	70	0.027		4.9	105	0.469	
			18	56	0.044		5.5	83	0.752	
			20	45	0.067		6.1	67	1.145	

When cable trays are used in continuous spans, the deflection of the cable tray is reduced by as much as 50%. Design factors: Ix = Moment of Inertia, Sx = Section Modulus. † Insert 4 for 304 stainless steel or 6 for 316 stainless steel.

● Green = Fastest shipped items ● Black = Normal lead-time items ● Red = Normally long lead-time items

All dimensions in parentheses are millimeters unless otherwise specified.

4" NEMA VE 1 Loading Depth 5" Side Rail Height

Straight Section Part Numbering

Example: **358 SS6 09 - 24 - 144**

Series	Material	*Type	*Width	Length
● 358	● SS4 = 304 Stainless Steel ● SS6 = 316 Stainless Steel	Ladder- ● 06 = 6" rung spacing ● 09 = 9" rung spacing ● 12 = 12" rung spacing Trough- 6" and Wider ● 04 = Vented Bottom ● SB = Non-Ventilated	● 06 = 6" ● 09 = 9" ● 12 = 12" ● 18 = 18" ● 24 = 24" ● 30 = 30" ● 36 = 36"	● ① 144 = 12 ft. 358 ● ② 120 = 10 ft. ①Primary Length. ②Secondary Length. See page C-23 for explanation of lengths. Passivation available see page C-2.

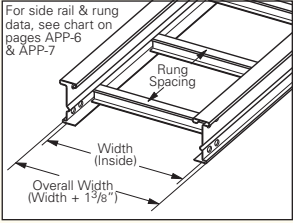

For side rail & rung data, see chart on pages APP-6 & APP-7

See page APP-1 for additional rung options. *Special sizes available.

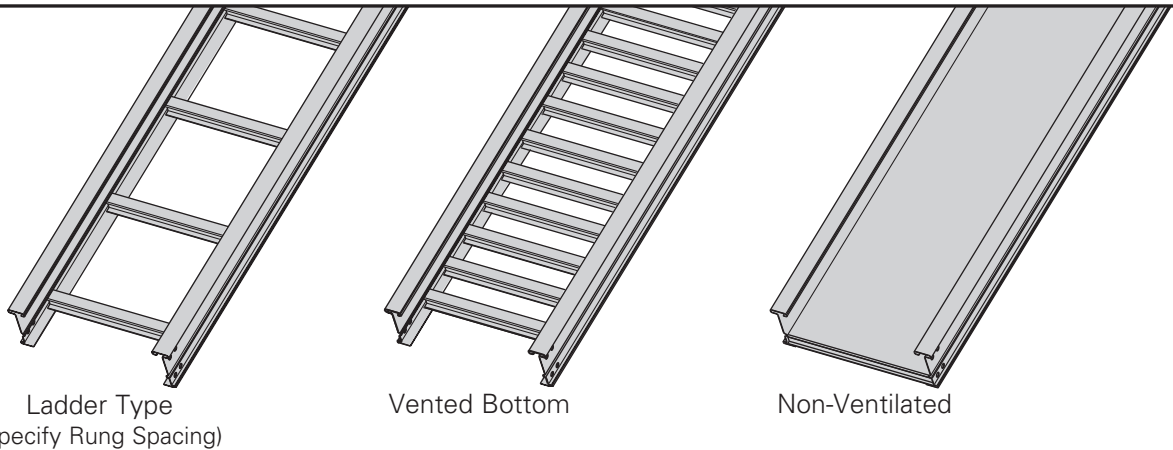

Values are based on simple beam tests per NEMA VE 1 on 36" wide cable tray rungs spaced on 12" centers. Cable trays will support without collapse a 200 lb. (90.7 kg) concentrated load over and above published loads. Published load safety factor is 1.5. To convert 1.5 safety factor to 2.0, multiply published load by 0.75. To obtain mid-span deflection, multiply a load by the deflection multiplier. Cable tray must be supported on spans shorter than or equal to the length of the cable being installed.

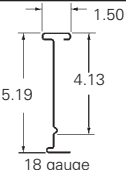
B-Line Series	Side Rail Dimensions	NEMA, CSA & UL Classifications	Span ft	Load lbs/ft	Deflection Multiplier	Design Factors for Two Rails	Span meters	Load kg/m	Deflection Multiplier	Design Factors for Two Rails
358 SS†		NEMA: 20A , 16B CSA: 89kg/m 6.1m UL Cross-Sectional Area: 0.70 in ²	10	248	0.0025	Area = 0.83 in ² Sx = 1.09 in ³ Ix = 3.10 in ⁴	3.0	369	0.043	Area = 5.35 cm ² Sx = 17.86 cm ³ Ix = 129.03 cm ⁴
			12	172	0.0052		3.7	256	0.089	
			14	127	0.010		4.3	188	0.164	
			16	97	0.016		4.9	144	0.280	
			18	77	0.026		5.5	114	0.448	
			20	62	0.040		6.1	92	0.684	

When cable trays are used in continuous spans, the deflection of the cable tray is reduced by as much as 50%. Design factors: Ix = Moment of Inertia, Sx = Section Modulus. † Insert 4 for 304 stainless steel or 6 for 316 stainless steel.

● Green = Fastest shipped items ● Black = Normal lead-time items ● Red = Normally long lead-time items

All dimensions in parentheses are millimeters unless otherwise specified.

Series 3 & 4 Stainless Steel - Straight Sections

5" NEMA VE 1 Loading Depth 6" Side Rail Height

Straight Section Part Numbering

Example: ^{Prefix} **358 SS6 09 - 24 - 144**

Series	Material	*Type	*Width	Length
● 368	● SS4 = 304 Stainless Steel	Ladder-	● 06 = 6"	● ① 144 = 12 ft. 368
● 464	● SS6 = 316 Stainless Steel	● 06 = 6" rung spacing	● 09 = 9"	● ② 120 = 10 ft. 464
		● 09 = 9" rung spacing	● 12 = 12"	① 144 = 12 ft.
		● 12 = 12" rung spacing	● 18 = 18"	② 120 = 10 ft.
		Trough-	● 24 = 24"	① Primary Length.
		6" and Wider	● 30 = 30"	② Secondary Length.
		● 04 = Vented Bottom	● 36 = 36"	See page C-23 for explanation of lengths.
		● SB = Non-Ventilated		Passivation available see page C-2.

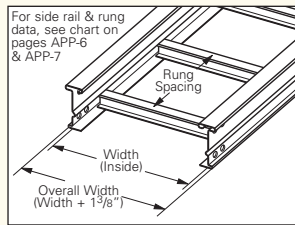

See page APP-1 for additional rung options. *Special sizes available.

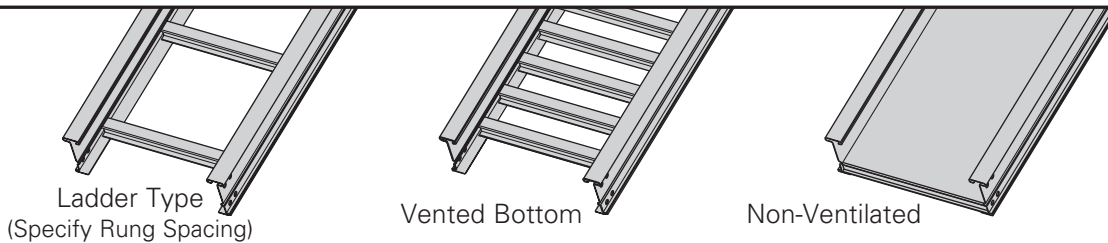

Values are based on simple beam tests per NEMA VE 1 on 36" wide cable tray rungs spaced on 12" centers. Cable trays will support without collapse a 200 lb. (90.7 kg) concentrated load over and above published loads. Published load safety factor is 1.5. To convert 1.5 safety factor to 2.0, multiply published load by 0.75. To obtain mid-span deflection, multiply a load by the deflection multiplier. Cable tray must be supported on spans shorter than or equal to the length of the cable being installed.

B-Line Series	Side Rail Dimensions	NEMA, CSA & UL Classifications	Span ft	Load lbs/ft	Deflection Multiplier	Design Factors for Two Rails	Span meters	Load kg/m	Deflection Multiplier	Design Factors for Two Rails
368 SS†		NEMA: 20A, 16B CSA: D1-3m UL Cross-Sectional Area: 0.70 in ²	10	236	0.0016	Area = 0.92 in ² Sx = 1.41 in ³ Ix = 4.77 in ⁴	3.0	351	0.028	Area = 5.94 cm ² Sx = 23.11 cm ³ Ix = 198.54 cm ⁴
			12	164	0.0034		3.7	244	0.058	
			14	120	0.0062		4.3	179	0.107	
			16	92	0.011		4.9	137	0.182	
			18	73	0.017		5.5	108	0.291	
			20	59	0.026		6.1	88	0.444	

B-Line Series	Side Rail Dimensions	NEMA, CSA & UL Classifications	Span ft	Load lbs/ft	Deflection Multiplier	Design Factors for Two Rails	Span meters	Load kg/m	Deflection Multiplier	Design Factors for Two Rails
464 SS†		NEMA: 20C+ CSA: E-6m UL Cross-Sectional Area: 1.00 in ²	12	342	0.002	Area = 1.49 in ² Sx = 2.28 in ³ Ix = 7.65 in ⁴	3.7	508	0.036	Area = 9.61 cm ² Sx = 37.36 cm ³ Ix = 318.42 cm ⁴
			16	192	0.007		4.9	286	0.113	
			18	152	0.011		5.5	226	0.182	
			20	123	0.016		6.1	183	0.277	
			22	102	0.024		6.7	151	0.406	
			24	85	0.034		7.3	127	0.574	

When cable trays are used in continuous spans, the deflection of the cable tray is reduced by as much as 50%. Design factors: Ix = Moment of Inertia, Sx = Section Modulus. † Insert 4 for 304 stainless steel or 6 for 316 stainless steel.

● Green = Fastest shipped items ● Black = Normal lead-time items ● Red = Normally long lead-time items

All dimensions in parentheses are millimeters unless otherwise specified.

Splice Plates

- Standard 8-hole pattern for all steel splice plates.
- Furnished in pairs with hardware.
- One pair including hardware provided with straight section. (Expansion splice quantity subtracted)
- Boxed in pairs with hardware.
- (*) Insert **SS4** or **SS6**

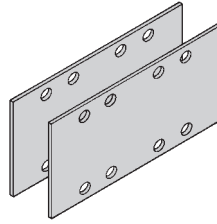

Catalog No.	Height	
	in.	mm
9(*)-8004	4	(101)
9(*)-8005	5	(127)
9(*)-8006	6	(152)

Expansion Splice Plates

- Expansion plates allow for one inch expansion or contraction of the cable tray, or where expansion joints occur in the support structure.
- Furnished in pairs with hardware.
- Bonding Jumpers are required on each side rail. Order Separately.
- (*) Insert **SS4** or **SS6**

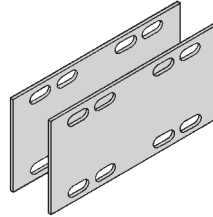

For heavy duty expansion splice plates see page APP-3.

Catalog No.	Height	
	in.	mm
9(*)-8014	4	(101)
9(*)-8015	5	(127)
9(*)-8016	6	(152)

Universal Splice Plates

- Used to splice to existing cable tray systems.
- Furnished in pairs with hardware.
- (*) Insert **SS4** or **SS6**

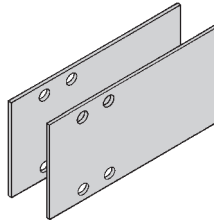

Catalog No.	Height	
	in.	mm
9(*)-8004-1/2	4	(101)
9(*)-8005-1/2	5	(127)
9(*)-8006 -1/2	6	(152)

Step Down Splice Plates

- These splice plates are offered for connecting cable tray sections having side rails of different heights.
- Furnished in pairs with hardware.
- (*) Insert **SS4** or **SS6**

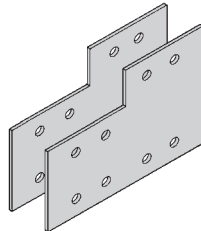

Catalog No.	Height	
	in.	mm
9(*)-8045	5 to 4	(127 to 101)
9(*)-8046	6 to 4	(152 to 101)
9(*)-8060	6 to 5	(152 to 127)

Vertical Adjustable Splice Plates

- These plates provide for changes in elevation that do not conform to standard vertical fittings.
- Furnished in pairs with hardware.
- Bonding Jumpers not required.
- (*) Insert **SS4** or **SS6**

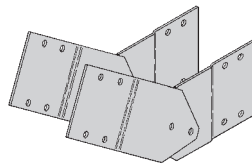

Requires supports within 24" on both sides, per NEMA VE 2.

Catalog No.	Height	
	in.	mm
9(*)-8024	4	(101)
9(*)-8025	5	(127)
9(*)-8026	6	(152)

Branch Pivot Connectors

- Branch from existing cable tray runs at any point.
- Pivot to any required angle.
- UL Classified for grounding (bonding jumpers not required).
- Furnished in pairs with hardware.
- (*) Insert **SS4** or **SS6**

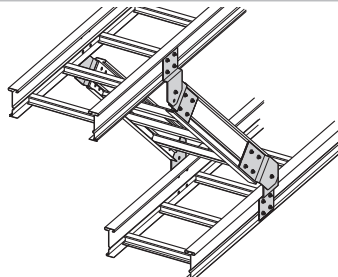

Catalog No.	Height	
	in.	mm
9(*)-8244	4	(101)
9(*)-8245	5	(127)
9(*)-8246	6	(152)

● Green = Fastest shipped items ● Black = Normal lead-time items ● Red = Normally long lead-time items

All dimensions in parentheses are millimeters unless otherwise specified.

Series 3 & 4 Stainless Steel - Accessories

Horizontal Adjustable Splice Plates

- Offered to adjust a cable tray run for changes in direction in a horizontal plane that do not conform to standard horizontal fittings.
- Furnished in pairs with hardware.
- Bonding jumpers **not** required.
- (*) Insert **SS4** or **SS6**
- (X) Insert 4, 5, 6 or 7 for side rail height.

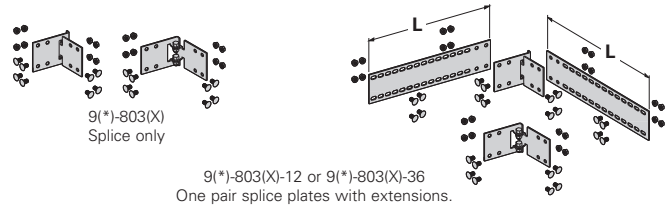

Catalog No.	Cable Tray End Cut	Thru Tray Width		'L'
		in.	(mm)	
9(*)-803(X)	Mitered	36	(914)	N/A (NA)
9(*)-803(X)-12	Not mitered	12	(305)	16 (406)
9(*)-803(X)-36	Not mitered	36	(914)	41 (1041)

Requires supports within 24" on both sides, per NEMA VE 2.

Offset Reducing Splice Plate

- This plate is used for joining cable trays having different widths. When used in pairs they form a straight reduction; when used singly with a standard splice plate, they form an offset reduction.
- Furnished as one plate with hardware.
- (‡) Insert reduction
- (*) Insert **SS4** or **SS6**

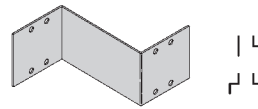

Catalog No.	Height	
	in.	mm
9(*)-8064-(‡)	4	(101)
9(*)-8065-(‡)	5	(127)
9(*)-8066-(‡)	6	(152)

Tray to Box Splice Plates

- Used to attach the end of a cable tray run to a distribution box or control panel.
- Furnished in pairs with hardware.
- (*) Insert **SS4** or **SS6**

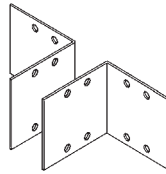

Catalog No.	Height	
	in.	mm
9(*)-8054	4	(101)
9(*)-8055	5	(127)
9(*)-8056	6	(152)

Frame Type Box Connector

- Designed to attach the end of a cable tray run to a distribution cabinet or control center to help reinforce the box at the point of entry.
- Furnished with tray connection hardware.
- (*) Insert **SS4** or **SS6**
- (‡) Insert tray width

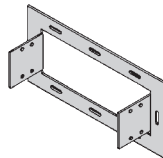

Catalog No.	Height	
	in.	mm
9(*)-8074-(‡)	4	(101)
9(*)-8075-(‡)	5	(127)
9(*)-8076-(‡)	6	(152)

Blind End

- This plate forms a closure for a dead end cable tray.
- Furnished as one plate with hardware.
- (*) Insert **SS4** or **SS6**
- (‡) Insert tray width

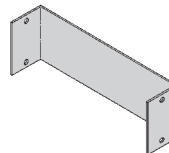

Catalog No.	Height	
	in.	mm
9(*)-8084-(‡)	4	(101)
9(*)-8085-(‡)	5	(127)
9(*)-8086-(‡)	6	(152)

Cross Connector Bracket

- For field connecting crossing section.
- Furnished in pairs with ³/₈" hardware.
- (*) Insert **SS4** or **SS6**

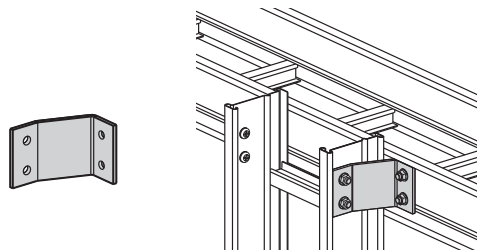

Catalog No.
9(*)-1240

● Green = Fastest shipped items ● Black = Normal lead-time items ● Red = Normally long lead-time items

All dimensions in parentheses are millimeters unless otherwise specified.

Standard Tray Hardware (for field installation drill $13/32$ " hole)

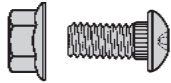

Catalog No.	Description
● RNCB $3/8$" x $3/4$" SS6	Ribbed Neck Carriage Bolt AISI 316 Stainless Steel
● SFHN $3/8$"-16 SS6	Serrated Flange Hex Nut AISI 316 Stainless Steel

Conduit to Cable Tray Adaptor

- For easy attachment of conduit terminating at a cable tray.
- Use on aluminum or steel cable trays.

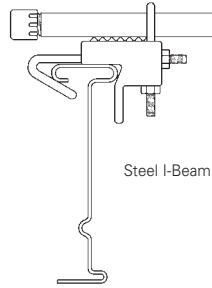
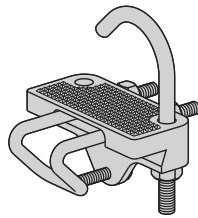

Steel I-Beam

Catalog No.	Conduit Size	
	in.	mm
● 9G-1158-$1/2, 3/2$	$1/2, 3/4$	(15, 20)
● 9G-1158-1, $1 1/4$	1, $1 1/4$	(25, 32)
● 9G-1158-$1 1/2, 2$	$1 1/2, 2$	(40, 50)
● 9G-1158-$2 1/2, 3$	$2 1/2, 3$	(65, 80)
● 9G-1158-$3 1/2, 4$	$3 1/2, 4$	(90, 100)

Conduit to Cable Tray Adaptor

- Assembly required.
- Mounting hardware included.
- Conduit clamps provided.
- (‡) = Insert conduit size ($1/2$ " thru 4").

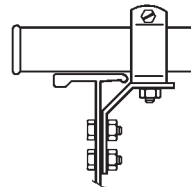

Catalog No.
● 9SS4-1150-(‡)

Conduit to Cable Tray Adaptor

- Assembly required.
- Conduit clamps included.
- (‡) = Insert conduit size ($1/2$ " thru 4").

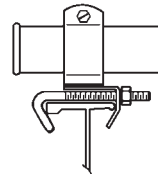
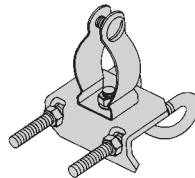

Catalog No.
● 9SS4-1155-(‡)

Cable Tie (Ladder Tray)

- Nylon ties provide easy attachment of cable to ladder rungs; maximum cable O.D. is 3" (76mm).



Overall Length 15" (381mm)

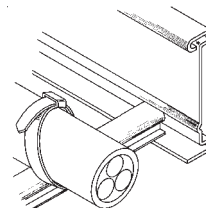

Catalog No.
● 99-2125-15

● Green = Fastest shipped items ● Black = Normal lead-time items ● Red = Normally long lead-time items

All dimensions in parentheses are millimeters unless otherwise specified.

Series 3 & 4 Stainless Steel - Accessories

Ladder Drop-Out

- Specially-designed Ladder Drop-Outs provide a rounded surface with 4" (101 mm) radius to protect cable as it exits from the cable tray, preventing damage to insulation. The drop-out will attach to any desired rung.
- (*) Insert **SS4** or **SS6**
- (‡) Insert tray width

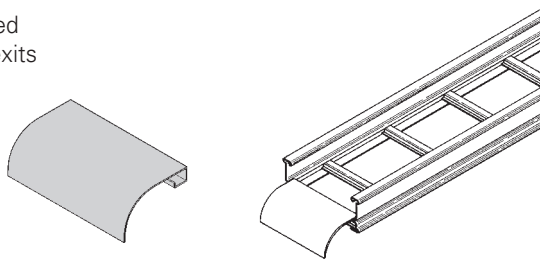

Catalog No.
● 9(*)-1104-(‡)

Barrier - Straight Section

- Length: Insert 120 for [120" - 10 ft.] (3.0 m) or 144 for [144" - 12 ft.] (3.6 m)
- Order catalog number based on loading depth.
- Furnished with four #10 x 1/2" plated self-drilling screws and a 99-9982 Barrier Strip Splice.
- (*) Insert **SS4** or **SS6**

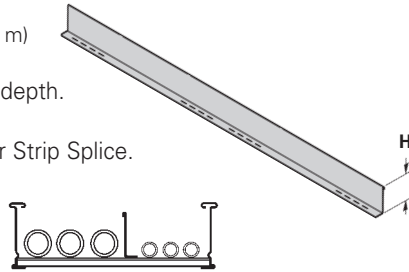

Catalog No.	Side Rail Height in. mm	Loading Depth 'H' in. mm
73(*)-Length	4 (101)	3 (76)
74(*)-Length	5 (127)	4 (101)
75(*)-Length	6 (152)	5 (127)

Barrier - Horizontal Bend

- Horizontal Bend Barriers are flexible in order to conform to any horizontal fitting radius. Can be cut to desired length.
- Standard length is 72" [6 ft.] (1.8 m) - sold individually
- Order catalog number based on loading depth.
- Furnished with three #10 x 1/2" plated self-drilling screws and a 99-9982 Barrier Strip Splice.
- (*) Insert **SS4** or **SS6**

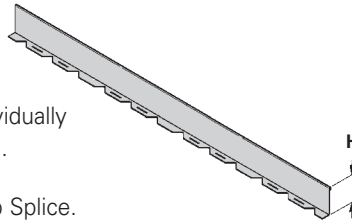

Catalog No.	Side Rail Height in. mm	Loading Depth 'H' in. mm
73(*)-90HBFL	4 (101)	3 (76)
74(*)-90HBFL	5 (127)	4 (101)
75(*)-90HBFL	6 (152)	5 (127)

Barrier - Vertical Outside Bend

- Vertical Outside Bend Barriers are preformed to conform to a specific vertical outside bend fitting.
- Furnished with three #10 x 1/2" plated self-drilling screws and a 99-9982 Barrier Strip Splice.
- (*) Insert or
- (***) Insert 30, 45, 60 or 90 for degrees
- (†) Insert 12, 24, 36 or 48 for radius

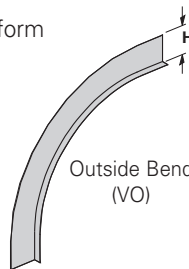

Catalog No.	Side Rail Height in. mm	Loading Depth 'H' in. mm
73(*)-(***)VO(†)	4 (101)	3 (76)
74(*)-(***)VO(†)	5 (127)	4 (101)
75(*)-(***)VO(†)	6 (152)	5 (127)

Barrier - Vertical Inside Bend

- Vertical Inside Bend Barriers are preformed to conform to a specific vertical inside bend fitting.
- Furnished with three #10 x 1/2" plated self-drilling screws and a 99-9982 Barrier Strip Splice.
- (*) Insert or
- (***) Insert 30, 45, 60 or 90 for degrees
- (†) Insert 12, 24, 36 or 48 for radius

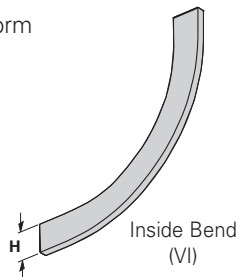

Catalog No.	Side Rail Height in. mm	Loading Depth 'H' in. mm
73(*)-(***)VI(†)	4 (101)	3 (76)
74(*)-(***)VI(†)	5 (127)	4 (101)
75(*)-(***)VI(†)	6 (152)	5 (127)

● Green = Fastest shipped items ● Black = Normal lead-time items ● Red = Normally long lead-time items

All dimensions in parentheses are millimeters unless otherwise specified.

Barrier Strip Clip

- Barrier clip fastens to either aluminum or steel ladder rung.
- Furnished with one #10 x 1/2" zinc plated self-drilling screw.
- (*) Insert **SS4** or **SS6**

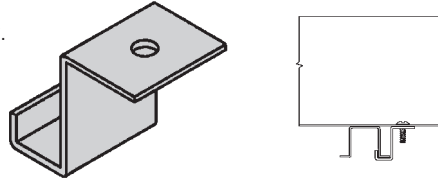

Catalog No.
9(*)-9002

Barrier Strip Splice

- Plastic splice holds adjoining barrier strips in straight alignment.
- 3" (76mm) long.

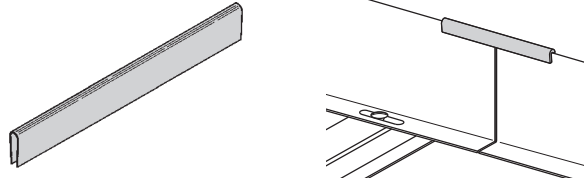

Catalog No.
99-9982

Thread Rod (ATR) & Rod Couplings

Loading based on safety factor 5.

Standard Finish: SS4 or SS6

See *B-Line series Strut Systems Catalog* for other sizes and finishes.

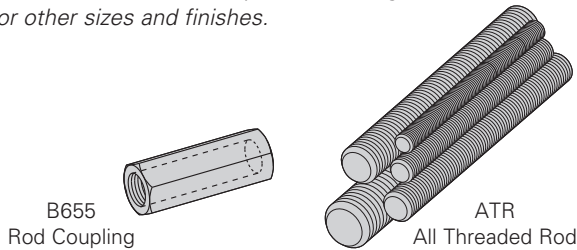

Size	Catalog No.	Available Length	Loading
All Threaded Rod			
3/8"-16	● ATR 3/8" x Length	36", 72", 120", 144"	730 lbs.
1/2"-13	● ATR 1/2" x Length	36", 72", 120", 144"	1350 lbs.
Rod Coupling			
3/8"-16	● B655-3/8"	NA	730 lbs.
1/2"-13	● B655-1/2"	NA	1350 lbs.

Stainless Steel Cable Clamp

- Fits with series 2, 3, 4 & 5 standard steel rungs.
- Shipped flat. Field form around the cable at the time of installation.

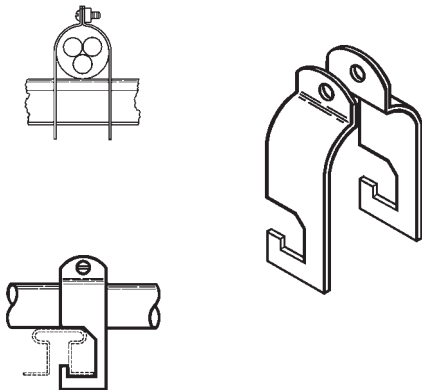

Refer to Section CF
Cable Fixing

Catalog No.	Cable Size	
	in.	mm
● 9SS4-4050	0.50 - 0.75	(13 - 19)
● 9SS4-4075	0.75 - 1.00	(19 - 25)
● 9SS4-4100	1.00 - 1.25	(25 - 32)
● 9SS4-4125	1.25 - 1.50	(32 - 38)
● 9SS4-4150	1.50 - 1.75	(38 - 45)
● 9SS4-4175	1.75 - 2.00	(45 - 51)
● 9SS4-4200	2.00 - 2.25	(51 - 57)
● 9SS4-4225	2.25 - 2.50	(57 - 64)
● 9SS4-4250	2.50 - 2.75	(64 - 70)
● 9SS4-4275	2.75 - 3.00	(70 - 76)
● 9SS4-4300	3.00 - 3.25	(76 - 82)
● 9SS4-4325	3.25 - 3.50	(82 - 89)
● 9SS4-4350	3.50 - 3.75	(89 - 95)
● 9SS4-4375	3.75 - 4.00	(95 - 100)
● 9SS4-4400	4.00 - 4.25	(100 - 106)
● 9SS4-4425	4.25 - 4.50	(106 - 113)
● 9SS4-4450	4.50 - 4.75	(113 - 121)
● 9SS4-4475	4.75 - 5.00	(121 - 125)

● Green = Fastest shipped items ● Black = Normal lead-time items ● Red = Normally long lead-time items

All dimensions in parentheses are millimeters unless otherwise specified.

Series 3 & 4 Stainless Steel - Accessories

Cable Tray Clamp/Guide

- Features a no-twist design.
- Has four times the strength of the traditional design.
- Each side is labeled to ensure proper installation.
- Furnished in pairs without hardware.
- Not recommended for vertical support.

When installing this device as an expansion guide on the outside flange of *Steel Side Rail*, use the Catalog No. **B202** Square Washer in order to properly elevate the guide.

Note: For heavy duty or vertical applications see 9(*)-1241 or 9(*)-1242 page HAT-20

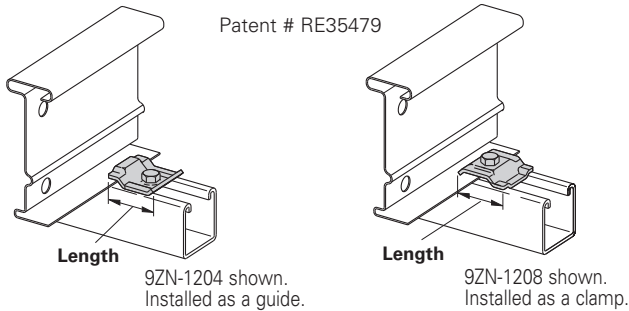

Catalog No.		Overall Length in. (mm)	Hardware Size in.	Finish
Without Hardware	With Hardware			
● 9SS6-1205	--	2 1/4 (57)	1/2"	316SS

Vertical Hanger Splice Plates

- Design load is 1500 lbs (6.67kN) per pair.
- Safety Factor of 2.5
- Furnished in pairs.
- Hole size: 9/16" (14mm) for 1/2" threaded rod.
- (*) Insert **SS4** or **SS6**

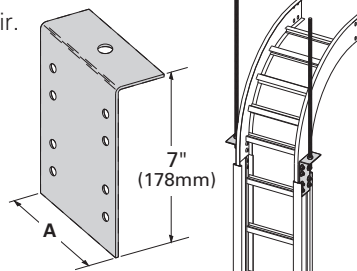

Catalog No.	Outside Cable Tray Ht.	'A'	
		in.	(mm)
9(*)-8224	4"	3.84	(97.54)
9(*)-8225	5"	4.73	(120.14)
9(*)-8226	6"	5.84	(148.34)
9(*)-8227	7"	6.84	(173.74)

Cable Tray Clamp

- Hold-down clamps for single or double cable tray runs.
- No drilling of support I-beam or channel is required.
- Sold in pieces - two clamps are required per tray.
- Maximum beam flange thickness 1 1/8" (28.58 mm).
- (*) Insert **SS4** or **SS6**

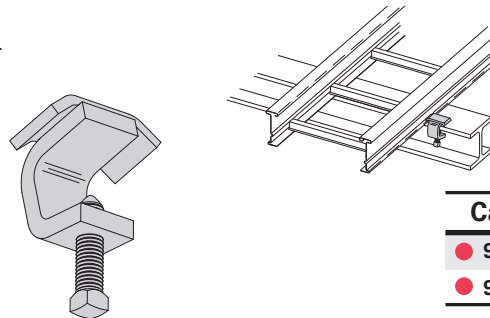

Catalog No.	Finish
● 9SS4-1249HD	304SS
● 9SS6-1249HD	316SS

Cable Tray Guide

- Expansion guide for single or double cable tray runs.
- Guide allows for longitudinal movement of the cable tray.
- No field drilling of support I-beam or channel is required.
- Guides are required on both sides of cable tray to prevent lateral movement - can be placed on either the inside or outside flange of cable tray.
- Guides are sold in pieces - two guides are required per tray.
- Maximum flange thickness 1 1/8" (28.58 mm).
- (*) Insert **SS4** or **SS6**

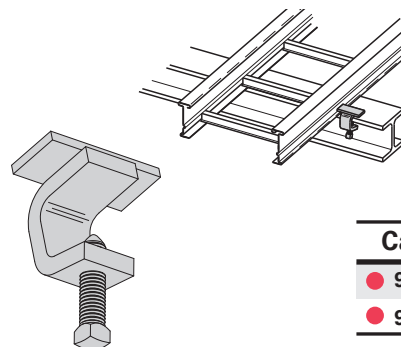

Catalog No.	Finish
● 9SS4-1249	304SS
● 9SS6-1249	316SS

● Green = Fastest shipped items ● Black = Normal lead-time items ● Red = Normally long lead-time items

All dimensions in parentheses are millimeters unless otherwise specified.

Nylon Pad

- Use for friction reduction.
- Hardness: Shore D80.
- Low friction coefficient.
- UV resistant.
- Excellent weatherability.
- UL - 94HB.

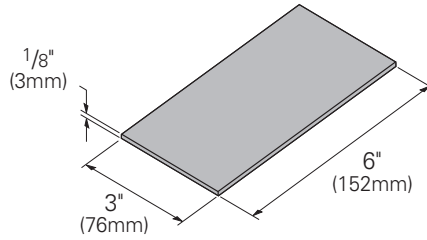

Catalog No.

● 99-PE36

Neoprene Roll

- Use for material isolation.
- 1/8" x 2" x 25' roll.
- Hardness: Shore A60.
- Good weatherability.

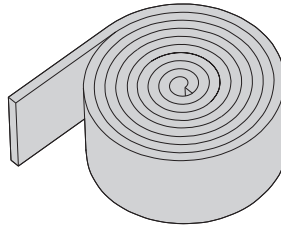

Catalog No.

● 99-NP300

DURA-BLOK™ Rooftop Support Bases with B22 Channel

- Designed as a superior rooftop support for cable tray,
- UV resistant and approved for most roofing material or other flat surfaces.
- Can be used with any of B-Line series cable tray clamps and guides.
- Ultimate Load Capacity: 1,000 lbs. (uniform load)

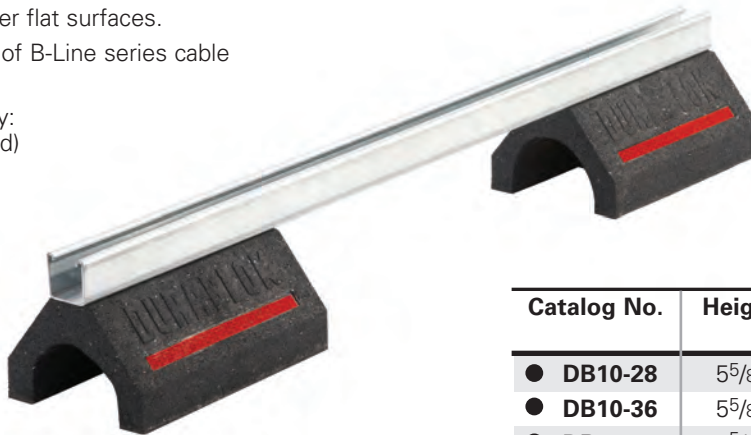

Catalog No.	Height x Width x Length	
	in.	(mm)
● DB10-28	5 ⁵ / ₈ x 6 x 28.0	(143 x 152 x 711)
● DB10-36	5 ⁵ / ₈ x 6 x 36.0	(143 x 152 x 914)
● DB10-42	5 ⁵ / ₈ x 6 x 42.0	(143 x 152 x 1067)
● DB10-50	5 ⁵ / ₈ x 6 x 50.0	(143 x 152 x 1270)
● DB10-60	5 ⁵ / ₈ x 6 x 60.0	(143 x 152 x 1524)



LEEDS credit available, base made from 100% recycled material.

General Note: Consult roofing manufacturer or engineer for roof load capacity. The weakest point may be the insulation board beneath the rubber membrane.

● Green = Fastest shipped items ● Black = Normal lead-time items ● Red = Normally long lead-time items

All dimensions in parentheses are millimeters unless otherwise specified.

Series 3 & 4 Stainless Steel - Accessories

Trapeze Support Kit

- Eaton's B-Line series trapeze kits provide the components required for a single trapeze support in one package. These kits are available in Type 304 or Type 316 stainless steel.
- The SH channel provides the convenience of pre-punched slots, which eliminate the need for field drilling.
- The illustrated hardware is sealed in a plastic bag and boxed with the channel, which is pre-cut to the appropriate length as shown in the chart.
- Designed for use with 1/2" threaded rod. Order rod separately.

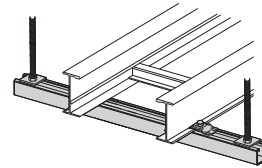
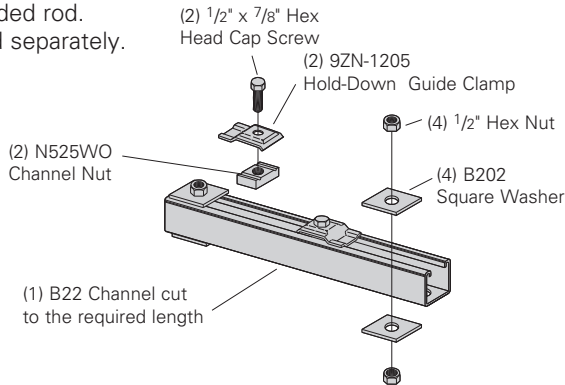

Catalog No.	Tray Width		Channel Length		Uniform Load	
	in.	mm	in.	mm	lbs	kN
● 9(*)-5506-22SH(†)	6	(152)	16	(406)	1350	(6.00)
● 9(*)-5509-22SH(†)	9	(229)	18	(457)	1250	(5.56)
● 9(*)-5512-22SH(†)	12	(305)	22	(559)	1125	(5.00)
● 9(*)-5518-22SH(†)	18	(457)	28	(711)	865	(3.85)
● 9(*)-5524-22SH(†)	24	(610)	34	(864)	700	(3.11)
● 9(*)-5530-22SH(†)	30	(762)	40	(1016)	590	(2.62)
● 9(*)-5536-22SH(†)	36	(914)	46	(1168)	510	(2.27)
● 9(*)-5542-22SH(†)	42	(1067)	52	(1321)	450	(2.00)

- (*) Insert **SS4** or **SS6**
- (†) Insert 3/8 for 3/8" threaded rod hardware. Safety factor of 3.0 on all loads.

Series 3 & 4 Stainless Steel

Heavy Duty Trapeze Support Kit

- Eaton's B-Line series trapeze kits provide the components required for a single trapeze support in one package. These kits are available in Type 304 or Type 316 stainless steel.
- The SH channel provides the convenience of pre-punched slots, which eliminates the need for field drilling.
- The illustrated hardware is sealed in a plastic bag and boxed with the channel, which is pre-cut to the appropriate length as shown in the chart.
- Designed for use with 1/2" threaded rod. Order rod separately.

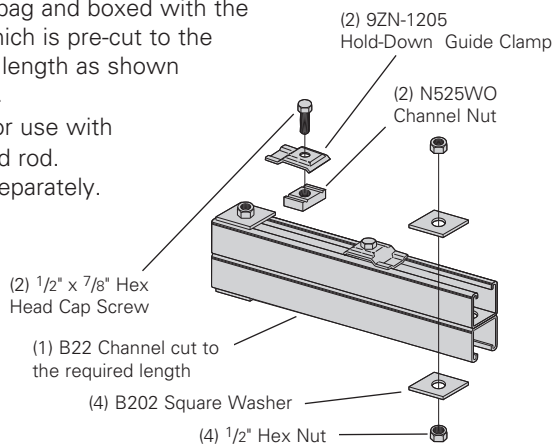

Catalog No.	Tray Width		Channel Length		Uniform Load	
	in.	mm	in.	mm	lbs	kN
● 9(*)-5506-22SHA	6	(152)	16	(406)	1350	(6.00)
● 9(*)-5509-22SHA	9	(229)	18	(457)	1350	(6.00)
● 9(*)-5512-22SHA	12	(305)	22	(559)	1350	(6.00)
● 9(*)-5518-22SHA	18	(457)	28	(711)	1350	(6.00)
● 9(*)-5524-22SHA	24	(610)	34	(864)	1350	(6.00)
● 9(*)-5530-22SHA	30	(762)	40	(1016)	1350	(6.00)
● 9(*)-5536-22SHA	36	(914)	46	(1168)	1350	(6.00)
● 9(*)-5542-22SHA	42	(1067)	52	(1321)	1350	(6.00)

- (*) Insert **SS4** or **SS6**
- Safety factor of 3.0 on all loads.

Trapeze Hardware Kit

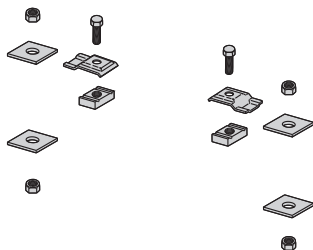

Catalog No.	● 9SS4-5500-1/2	● 9SS6-5500-1/2
In plastic bag	1 pr. 9SS6-1205 2 HHC Screw 1/2 x 7/8 SS4 2 N525 WO SS6 4 B202 SS4 1/2" sq washer 4 HN 1/2 SS4	1 pr. SS6-1205 2 HHC Screw 1/2 x 7/8 SS6 2 N525 WO SS6 4 B202 SS6 1/2" sq washer 4 HN 1/2" SS6

● Green = Fastest shipped items ● Black = Normal lead-time items ● Red = Normally long lead-time items

All dimensions in parentheses are millimeters unless otherwise specified.

Bracket (12"-42")

- (*) Insert available finish: **SS4** or **SS6**
- Safety Load Factor 2.5

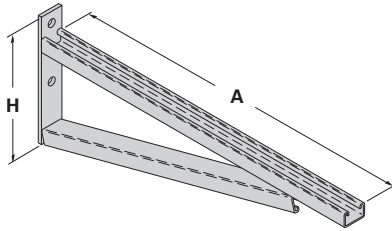

Bottom brace is B42 channel on B494-24 and smaller and B22 channel on B494-30 and larger

Catalog No.	Uniform Load		Tray Width		'A'		'H'	
	lbs	(kN)	in.	(mm)	in.	(mm)	in.	(mm)
B494-12	2500	(11.12)	6 & 9	(152 & 229)	12	(305)	8 ³ / ₄	(222)
B494-18	1700	(7.56)	12	(305)	18	(457)	8 ³ / ₄	(222)
B494-24	1300	(5.78)	18	(457)	24	(610)	8 ³ / ₄	(222)
B494-30	1600	(7.11)	24	(610)	30	(762)	11 ¹ / ₄	(286)
B494-36	1100	(4.89)	30	(762)	36	(914)	11 ¹ / ₄	(286)
B494-42	980	(4.36)	36	(914)	42	(1067)	16	(406)
B494-48	980	(4.36)	42	(1067)	48	(1219)	16	(406)

For more dimensional data see Strut Systems catalog

Cantilever Bracket

- (*) Insert available finish: **SS4** or **SS6**
- Safety Load Factor 2.5

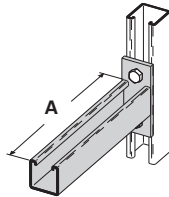

Catalog No.	Uniform Load		Tray Width		'A'	
	lbs	kN	in.	mm	in.	mm
B409-12(*)	960	(4.27)	6 & 9	(152 & 229)	12	(305)
B409-18(*)	640	(2.84)	12	(305)	18	(457)
B409-24(*)	480	(2.13)	18	(457)	24	(610)

Cantilever Bracket

- (*) Insert available finish: **SS4** or **SS6**
- Safety Load Factor 2.5

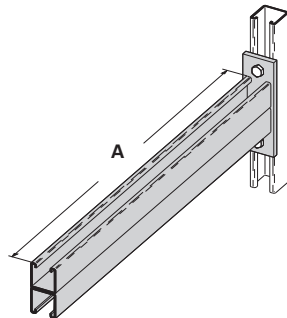

Catalog No.	Uniform Load		Tray Width		'A'	
	lbs	kN	in.	mm	in.	mm
B297-12(*)	1660	(7.38)	6 & 9	(152 & 229)	12	(305)
B297-18(*)	1100	(4.89)	12	(305)	18	(457)
B297-24(*)	835	(3.71)	18	(457)	24	(610)
B297-30(*)	665	(2.93)	24	(610)	30	(762)
B297-36(*)	550	(2.44)	30	(762)	36	(914)
B297-42(*)	465	(2.06)	36	(914)	42	(1067)

● Green = Fastest shipped items ● Black = Normal lead-time items ● Red = Normally long lead-time items

All dimensions in parentheses are millimeters unless otherwise specified.

Series 3 & 4 Stainless Steel - Accessories

Heavy Duty Hold Down Bracket

- Design load is 2000 lbs (8.89kN) per pair.
- Two bolt design.
- Sold in pairs.
- 3/8" cable tray attachment hardware provided.
- 1/2" support attachment hardware **not** provided.
- (*) Insert **SS4** or **SS6**
- Recommended for support of vertical trays.

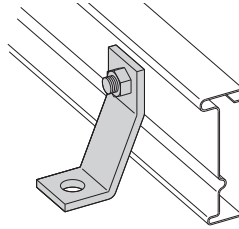

Catalog No.

9(*)-1241

Heavy Duty Hold Down Bracket

- Design load is 4000 lbs (17.79kN) per pair.
- Four bolt design.
- Sold in pairs.
- 3/8" cable tray attachment hardware provided.
- 1/2" support attachment hardware **not** provided.
- (*) Insert **SS4** or **SS6**
- Recommended for support of vertical trays.

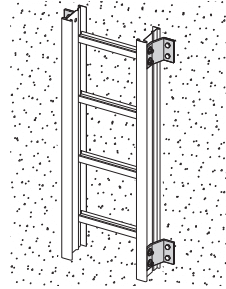
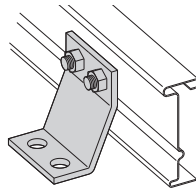

Catalog No.

9(*)-1242

Beam Clamp

- Finishes available: **SS4**
- Sold in pieces.
- Design load is 1200 lbs (5.34kN) per pair.
- Safety Load Factor 5.0.
- Order HHCS and Channel Nuts separately.

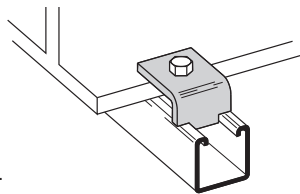

Catalog No.

B35SS4

Beam Clamp

- (*) Insert **SS4** or **SS6**
- Sold in pieces.
- *Design load when used in pairs. Safety Load Factor 5.0

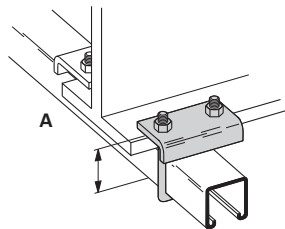

Catalog No.	Design Load		'A'	
	lbs	(kN)	in.	(mm)
B441-22(*)	1200	(5.34)	3 ³ / ₈	(86)
B441-22A(*)	1200	(5.34)	5	(127)

Beam Clamp

- Finishes available: **SS4**
- Sold in pieces.
- *Design load when used in pairs. Safety Load Factor 5.0

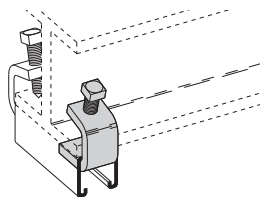

Catalog No.	B212-1/4SS4	B212-3/8SS6
Design Load *	600 lbs. (2.67kN)	1000 lbs. (4.45 kN)
Max. Flange Thick	3/4" (19 mm)	1 1/8" (28.6 mm)
Mat'l. Thickness	1/4" (6.3 mm)	3/8" (9.5 mm)

● Green = Fastest shipped items ● Black = Normal lead-time items ● Red = Normally long lead-time items

All dimensions in parentheses are millimeters unless otherwise specified.

Covers

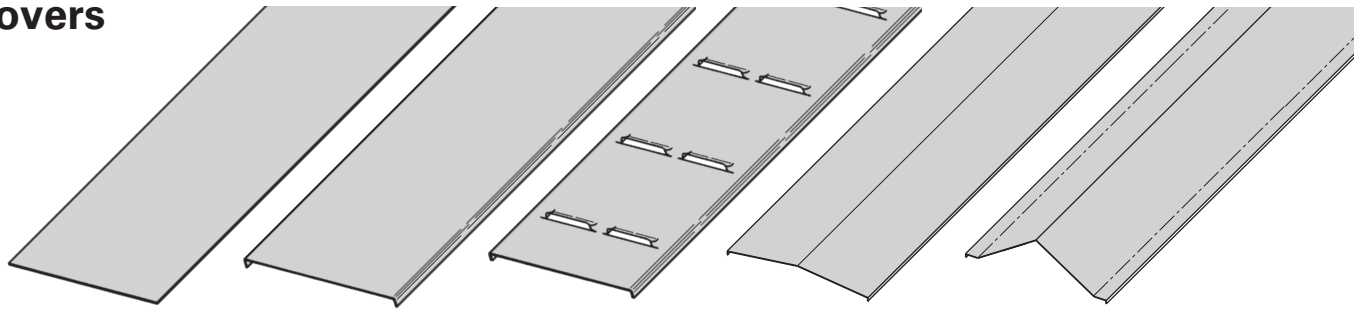

Solid Non-Flanged

Solid Flanged

Ventilated Flanged

Peaked Flanged

2 to 3 Pitch Peaked Flanged
(See page APP-4)

A full range of covers is available for straight sections and fittings.

Solid covers should be used when maximum enclosure of the cable is desired and no accumulation of heat is expected.

Ventilated covers provide an overhead cable shield yet allow heat to escape.

We recommends that covers be placed on vertical cable tray runs to a height of 6 ft. (1.83 m) to 8 ft. (2.44 m) above the floor to isolate both cables and personnel. **Flanged covers** have a 1/2 in. (13 mm) flange. Cover clamps are not included with the cover and must be ordered separately. All **peaked covers** are flanged. Standard peaked covers have 1/2" peak. Special purpose peaked covers, having a 2 to 3 pitch, provide additional slope and material thickness. The 2 to 3 pitch fitting covers are of multiple piece, welded construction.

Steel Cover Part Numbering

Example: **80 2 SS4 - 24 - 144**

Cover Type	Detail	Material	Tray Width	Item Description
<ul style="list-style-type: none"> ● 80 = Solid ● 81 = Ventilated ● 82 = Peaked 	<ul style="list-style-type: none"> ● 2 = Flanged Stainless Steel (all fittings) ● 3 = Flanged Steel (all straight sections) ● 4 = Non-Flanged Stainless Steel (80 & 81 type only) 	<ul style="list-style-type: none"> ● SS4 = 304 Stainless Steel ● SS6 = 316 Stainless Steel 	<ul style="list-style-type: none"> ● 06 = 6" ● 09 = 9" ● 12 = 12" ● 18 = 18" ● 24 = 24" ● 30 = 30" ● 36 = 36" 	<p>For Straight Section Cover:</p> <ul style="list-style-type: none"> ● 144 = 12 ft. (3.66 m) ● 120 = 10 ft. (3.05 m) ● 72 = 6 ft. (1.83 m) ● 60 = 5 ft. (1.52 m) <p>For fitting covers: Insert suffix of fitting to be covered. See example below.</p>

Examples of Catalog Numbers for Fitting Covers:

Horizontal Bend Cover						Vertical Bend Cover					
Prefix			Suffix			Prefix			Suffix		
80	2	SS4	- 18	- 90	HB 24	80	2	SS4	- 24	- 90	VO 24 - 4*
					Radius						Side Rail*
					Fitting						Height
					Angle						Radius
					Width						Fitting
					Material						Angle
					Detail						Width
					Cover Type						Material
											Detail
											Cover Type

* Required for VO fittings only

● Green = Fastest shipped items ● Black = Normal lead-time items ● Red = Normally long lead-time items

All dimensions in parentheses are millimeters unless otherwise specified.

Series 3 & 4 Stainless Steel - Accessories

Standard Cover Clamp

- For indoor service only.
- Screw included.
- Sold per piece.

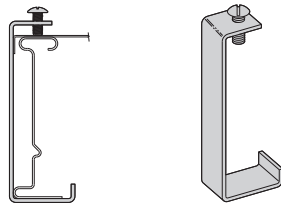

Tray Type	Catalog No.	Side Rail Height	
		in.	(mm)
Stainless Steel	9SS6-9014	4	(101)
	9SS6-9015	5	(127)
	9SS6-9016	6	(152)

Combination Cover and Hold Down Clamp

- Sold per piece.
- For indoor service only.
- (*) Insert **SS4** or **SS6**

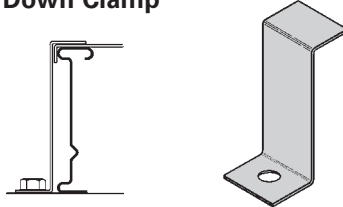

Tray Type	Catalog No.	Side Rail Height	
		in.	(mm)
Stainless Steel	9(*)-9043	4	(101)
	9(*)-9053	5	(127)
	9(*)-9063	6	(152)

Raised Cover Clamp

- For indoor service only.
- For use with flanged covers only.
- † Specify gap of 1", 2", 3" or 4".
- (*) Insert **SS4** or **SS6**

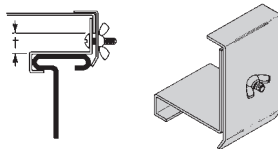

Tray Type	Catalog No.	Tray Type
● 9(*)-9115-†	Series 3 & 4 Steel Straight Section	
● 9(*)-910†	All Steel Fittings (Also Series 1 Steel Straight Sections)	

Heavy Duty Cover Clamp

- Recommended for outdoor service.
- (‡) Insert tray width
- † Add P to Catalog No. for peaked cover clamp.
- (*) Insert **SS4** or **SS6**

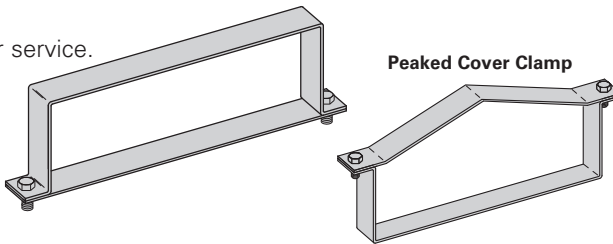

Catalog No.	Side Rail Height	
	in.	mm
9(*)-(‡)-9044†	4	(101)
9(*)-(‡)-9054†	5	(127)
9(*)-(‡)-9064†	6	(152)

Quantity of Standard Cover Clamps Required

Notes:

When using the Heavy Duty Cover Clamp, only on-half the number of clamps stated above is required.

Additional clamps may be necessary in extreme wind applications.

Straight Section 60" or 72"	4 pcs.
Straight Section 120" or 144"	6 pcs.
Horizontal/Vertical Bends	4 pcs.
Tees	6 pcs.
Crosses	8 pcs.

Cover Joint Strip

- Used to join covers
- Plastic
- (‡) Insert tray width

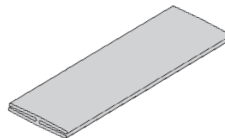

Catalog No.
● 99-9980-(‡)

Cable Cleats

(see pages O-1 thru O-5) Standard

Trefoil Cable Cleats



Single Cable Cleats

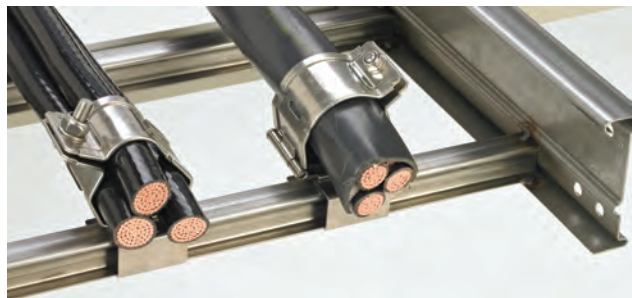
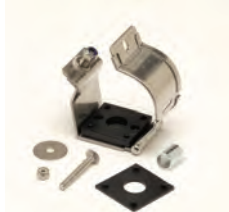

● Green = Fastest shipped items ● Black = Normal lead-time items ● Red = Normally long lead-time items

All dimensions in parentheses are millimeters unless otherwise specified.

Section 1- Acceptable Manufacturers

- 1.01 Manufacturer: Subject to compliance with these specifications, Eaton's B-Line series cable tray systems shall be as manufactured by Eaton.

Section 2- Cable Tray Sections and Components

- 2.01 General: Except as otherwise indicated, provide metal cable trays, of types, classes and sizes indicated; with splice plates, bolts, nuts and washers for connecting units. Construct units with rounded edges and smooth surfaces; in compliance with applicable standards; and with the following additional construction features. Cable tray shall be installed according to the latest revision of NEMA VE 2.
- 2.02 Stainless Steel: Straight section and fitting side rails and rungs shall be made of AISI Type [304] [316] stainless steel. Transverse members (rungs) or corrugated bottoms shall be welded to the side rails with Type 316 stainless steel welding wire. Hardware shall be AISI Type 316 stainless steel.
- 2.03 Ladder Cable Trays shall consist of two longitudinal members (side rails) with transverse members (rungs) welded to the side rails. Rungs shall be spaced [6] [9] [12] inches on center. Rung spacing in radiused fittings shall be industry standard 9" and measured at the center of the tray's width. Each rung must be capable of supporting a 200 lb. concentrated load at the center of the cable tray with a safety factor of 1.5.
- 2.04 Ventilated Trough Cable Trays shall consist of two longitudinal members (side rails) with a corrugated bottom welded to the side rails or rungs spaced 4" on center. The peaks of the corrugated bottom shall have a minimum flat cable bearing surface of $2\frac{3}{4}$ " and shall be spaced on 6" centers. To provide ventilation in the tray, the valleys of the corrugated bottom shall have $2\frac{1}{4}$ " x 4" rectangular holes punched along the width of the bottom.
- 2.05 Non-Ventilated Bottom Trough Cable Trays shall consist of two longitudinal members (side rails) with a corrugated bottom welded to the side rails or a solid sheet over rungs. The peaks of the corrugated bottom shall have a minimum flat cable bearing surface of $2\frac{3}{4}$ " and shall be spaced on 6" centers.
- 2.06 Cable tray loading depth shall be [3] [4] [5] inches per NEMA VE 1.
- 2.07 Straight sections shall be fabricated as I-beams. Straight sections shall be supplied in standard [12 foot] [24 foot] [10 foot (3 m)] [20 foot (6 m)] lengths.
- 2.08 Cable tray widths shall be [6] [9] [12] [18] [24] [30] [36] inches or as shown on drawings.
- 2.09 Splice plates shall be manufactured of high strength steel and be secured with 8 nuts and bolts per plate. The resistance of fixed splice connections between an adjacent section of tray shall not exceed 0.00033 ohm.
- 2.11 All fittings must have a minimum radius of [12] [24] [36] [48] inches.

Section 3- Loading Capacities and Testing

- 3.01 Cable tray shall be capable of carrying a uniformly distributed load of _____ lbs./ft. on a _____ ft. support span with a safety factor of 1.5 when supported as a simple span and tested per NEMA VE 1 5.2. In addition to the uniformly distributed load the cable tray shall support 200 lbs. concentrated load at mid-point of span. Load and safety factors specified are applicable to both the side rails and rung capacities. Cable tray shall be made to manufacturing tolerances as specified by NEMA.
- 3.02 Upon request, manufacturer shall provide test reports in accordance with the latest revision of NEMA VE 1 or CSA C22.2 No. 126.

Series 2, 3, 4, & 5 - Fittings



Series 2, 3, 4, & 5 Fittings



How The Service Advisor Works

We know that your time is important! That's why the color-coding system in this catalog is designed to help you select products that fit your service needs. Products are marked to indicate the typical lead time for orders of 50 pieces or less.

Customer: How do I select my fittings so that I get the quickest turnaround?

Service Advisor: Each part of our selection chart is shown in colors. If any section of a part number is a different color, the part will typically ship with the longer lead time represented by the colors.

- Green = Fastest shipped items
- Black = Normal lead-time items
- Red = Normally long lead-time items

Example: 5 G - 09 - 90 HB 24

● ● ● ● ● ●

Part will have a long lead time because of the G material.

Changing the part number from G to A or P will change the coding to black and reduce lead time.

Series 2, 3, 4, & 5 - Fittings

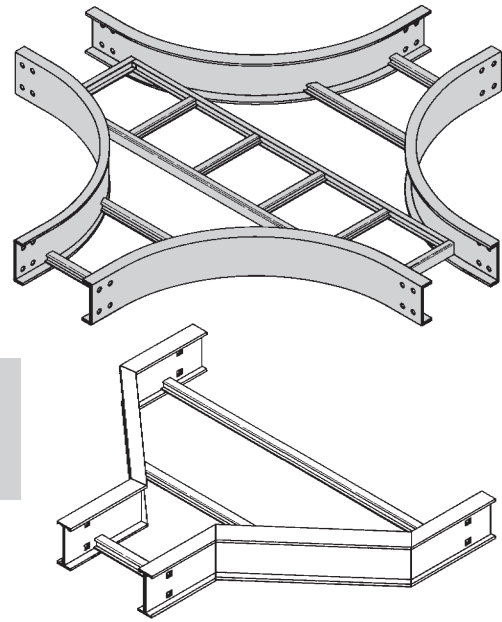
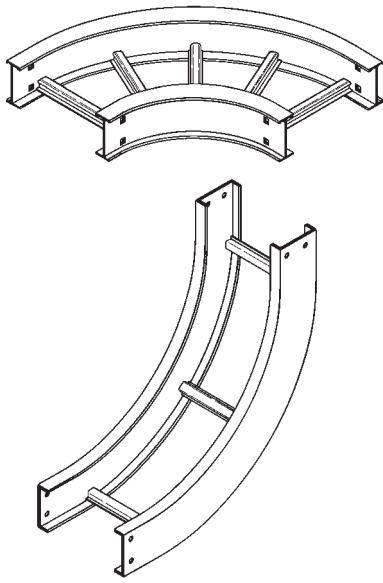

Fittings engineered with 3" tangents for splicing integrity.

Series 2, 3, 4, & 5 Fittings

Fittings Part Numbering

Example: **4 A - 24 - 90 HB 24** (9" rung spacing is standard)

Side Rail Height	Material	Width	Angle	Type	Radius
● 4 = 4" (101)	● A = Aluminum	● 06 = 6" (152)	● 30 = 30°	● HB = Horizontal Bend	● 12 = 12" (305)
● 5 = 5" (127)	● G = HDGAF	● 09 = 9" (228)	● 45 = 45°	● HT = Horizontal Tee	● 24 = 24" (609)
● 6 = 6" (152)	● P = Pre-Galvanized	● 12 = 12" (305)	● 60 = 60°	● HX = Horizontal Cross	● 36 = 36" (914)
● 7 = 7" (178)	● SS4 = 304 Stainless Steel	● 18 = 18" (457)	● 90 = 90°	● VI = Vertical Inside Bend	● 48 = 48" (1219)
	● SS6 = 316 Stainless Steel	● 24 = 24" (609)		● VO = Vertical Outside Bend	
		● 30 = 30" (762)		● VT = Vertical Tee	
		● 36 = 36" (914)		● VTU = Vertical Tee, Up	
				● HYR = Horizontal Wye, Right	
				● HYL = Horizontal Wye, Left	
				● CSF = Cable Support Fitting	
				● LR = Left Reducer Fitting	
				● RR = Right Reducer Fitting	
				● SR = Straight Reducer Fitting	

See page APP-2 for 6" fittings with 9A-6006 and 9A-6007 splice plates.

For ventilated trough, solid trough, ventilated bottom or solid bottom, add VT, ST, 04 or SB as shown below: Available 6" thru 36"

Prefix
4AVT - 24 - 90HB24
Vented Trough

Prefix
4PST - 24 - 90HB24
Non-Ventilated Trough

For flat non-ventilated: Available 6" and Wider

Prefix
5PSB - 24 - 90HB24
Non-Ventilated

Note: Horizontal crosses and tees 30" or wider, with a radius of 36" or larger, will be of two-piece construction.

● Green = Fastest shipped items ● Black = Normal lead-time items ● Red = Normally long lead-time items

All dimensions in parentheses are millimeters unless otherwise specified.

Series 2, 3, 4, & 5 - Fittings

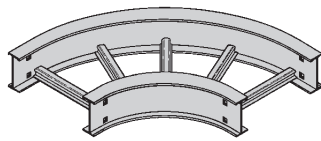

90° Horizontal Bend

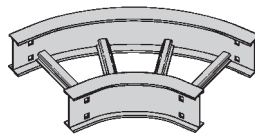

60° Horizontal Bend

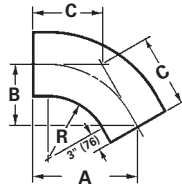
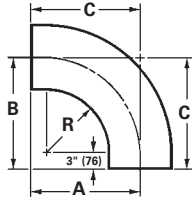

Horizontal Bend 90° 60° (HB)

1 pair splice plates with hardware included.

Bottoms manufactured:

Ladder = 9" Rung Spacing

VT & 04 = 4" Rung Spacing

ST & SB = Flat sheet over 12" Rung Spacing

Bend Radius R	Tray Width	90° Horizontal Bend Dimensions				60° Horizontal Bend Dimensions			
		Catalog No.	A	B	C	Catalog No.	A	B	C
in. (mm)	in. (mm)		in. (mm)	in. (mm)	in. (mm)		in. (mm)	in. (mm)	in. (mm)
12 (305)	6 (152)	(Pre)-06-90HB12	18 (457)	18 (457)	18 (457)	(Pre)-06-60HB12	17 ¹ / ₂ (445)	10 ¹ / ₈ (257)	11 ¹¹ / ₁₆ (297)
	9 (228)	(Pre)-09-90HB12	19 ¹ / ₂ (495)	19 ¹ / ₂ (495)	19 ¹ / ₂ (495)	(Pre)-09-60HB12	18 ¹³ / ₁₆ (478)	10 ⁷ / ₈ (276)	12 ¹ / ₂ (318)
	12 (305)	(Pre)-12-90HB12	21 (533)	21 (533)	21 (533)	(Pre)-12-60HB12	20 ¹ / ₁₆ (510)	11 ⁵ / ₈ (295)	13 ³ / ₈ (340)
	18 (457)	(Pre)-18-90HB12	24 (610)	24 (610)	24 (610)	(Pre)-18-60HB12	22 ¹¹ / ₁₆ (576)	13 ¹ / ₈ (333)	15 ¹ / ₈ (384)
	24 (609)	(Pre)-24-90HB12	27 (686)	27 (686)	27 (686)	(Pre)-24-60HB12	25 ⁵ / ₁₆ (643)	14 ⁵ / ₈ (372)	16 ⁷ / ₈ (429)
	30 (762)	(Pre)-30-90HB12	30 (762)	30 (762)	30 (762)	(Pre)-30-60HB12	27 ⁷ / ₈ (708)	16 ¹ / ₈ (410)	18 ⁹ / ₁₆ (472)
	36 (914)	(Pre)-36-90HB12	33 (838)	33 (838)	33 (838)	(Pre)-36-60HB12	30 ¹ / ₂ (775)	17 ⁵ / ₈ (448)	20 ⁵ / ₁₆ (516)
42 (1067)	(Pre)-42-90HB12	36 (914)	36 (914)	36 (914)	(Pre)-42-60HB12	33 ¹ / ₁₆ (840)	19 ¹ / ₈ (486)	22 ¹ / ₁₆ (560)	
24 (610)	6 (152)	(Pre)-06-90HB24	30 (762)	30 (762)	30 (762)	(Pre)-06-60HB24	27 ⁷ / ₈ (708)	16 ¹ / ₈ (410)	18 ⁹ / ₁₆ (472)
	9 (228)	(Pre)-09-90HB24	31 ¹ / ₂ (800)	31 ¹ / ₂ (800)	31 ¹ / ₂ (800)	(Pre)-09-60HB24	29 ³ / ₁₆ (741)	16 ⁷ / ₈ (429)	19 ⁷ / ₁₆ (494)
	12 (305)	(Pre)-12-90HB24	33 (838)	33 (838)	33 (838)	(Pre)-12-60HB24	30 ¹ / ₂ (775)	17 ⁵ / ₈ (448)	20 ⁵ / ₁₆ (516)
	18 (457)	(Pre)-18-90HB24	36 (914)	36 (914)	36 (914)	(Pre)-18-60HB24	33 ¹ / ₁₆ (708)	19 ¹ / ₈ (486)	22 ¹ / ₁₆ (560)
	24 (609)	(Pre)-24-90HB24	39 (991)	39 (991)	39 (991)	(Pre)-24-60HB24	35 ¹¹ / ₁₆ (907)	20 ⁵ / ₈ (524)	23 ¹³ / ₁₆ (605)
	30 (762)	(Pre)-30-90HB24	42 (1067)	42 (1067)	42 (1067)	(Pre)-30-60HB24	38 ¹ / ₄ (972)	22 ¹ / ₈ (564)	25 ¹ / ₂ (648)
	36 (914)	(Pre)-36-90HB24	45 (1143)	45 (1143)	45 (1143)	(Pre)-36-60HB24	40 ⁷ / ₈ (1038)	23 ⁵ / ₈ (600)	27 ¹ / ₄ (692)
42 (1067)	(Pre)-42-90HB24	48 (1219)	48 (1219)	48 (1219)	(Pre)-42-60HB24	43 ¹ / ₂ (1105)	25 ¹ / ₈ (638)	29 (737)	
36 (914)	6 (152)	(Pre)-06-90HB36	42 (1067)	42 (1067)	42 (1067)	(Pre)-06-60HB36	38 ¹ / ₄ (971)	22 ¹ / ₈ (562)	25 ¹ / ₂ (648)
	9 (228)	(Pre)-09-90HB36	43 ¹ / ₂ (1105)	43 ¹ / ₂ (1105)	43 ¹ / ₂ (1105)	(Pre)-09-60HB36	39 ⁹ / ₁₆ (1005)	22 ⁷ / ₈ (581)	26 ³ / ₈ (670)
	12 (305)	(Pre)-12-90HB36	45 (1143)	45 (1143)	45 (1143)	(Pre)-12-60HB36	40 ⁷ / ₈ (1038)	23 ⁵ / ₈ (600)	27 ¹ / ₄ (692)
	18 (457)	(Pre)-18-90HB36	48 (1219)	48 (1219)	48 (1219)	(Pre)-18-60HB36	43 ¹ / ₂ (1105)	25 ¹ / ₈ (638)	29 (737)
	24 (609)	(Pre)-24-90HB36	51 (1295)	51 (1295)	51 (1295)	(Pre)-24-60HB36	46 ¹ / ₁₆ (1170)	26 ⁵ / ₈ (676)	30 ¹¹ / ₁₆ (780)
	30 (762)	(Pre)-30-90HB36	54 (1372)	54 (1372)	54 (1372)	(Pre)-30-60HB36	48 ¹ / ₁₆ (1237)	28 ¹ / ₈ (714)	32 ⁷ / ₁₆ (824)
	36 (914)	(Pre)-36-90HB36	57 (1448)	57 (1448)	57 (1448)	(Pre)-36-60HB36	51 ¹ / ₄ (1302)	29 ⁵ / ₈ (753)	34 ³ / ₁₆ (869)
42 (1067)	(Pre)-42-90HB36	60 (1524)	60 (1524)	60 (1524)	(Pre)-42-60HB36	53 ⁷ / ₈ (1368)	31 ¹ / ₈ (791)	35 ¹⁵ / ₁₆ (913)	
48 (1220)	6 (152)	(Pre)-06-90HB48	54 (1372)	54 (1372)	54 (1372)	(Pre)-06-60HB48	48 ¹ / ₁₆ (1221)	28 ¹ / ₈ (715)	32 ¹¹ / ₁₆ (830)
	9 (228)	(Pre)-09-90HB48	55 ¹ / ₂ (1410)	55 ¹ / ₂ (1410)	55 ¹ / ₂ (1410)	(Pre)-09-60HB48	49 ¹⁵ / ₁₆ (1268)	28 ⁷ / ₈ (734)	33 ⁵ / ₁₆ (846)
	12 (305)	(Pre)-12-90HB48	57 (1448)	57 (1448)	57 (1448)	(Pre)-12-60HB48	51 ¹ / ₄ (1302)	29 ⁵ / ₈ (753)	34 ³ / ₁₆ (869)
	18 (457)	(Pre)-18-90HB48	60 (1524)	60 (1524)	60 (1524)	(Pre)-18-60HB48	53 ⁷ / ₈ (1368)	31 ¹ / ₈ (737)	35 ¹⁵ / ₁₆ (913)
	24 (609)	(Pre)-24-90HB48	63 (1600)	63 (1600)	63 (1600)	(Pre)-24-60HB48	56 ⁷ / ₁₆ (1434)	32 ⁵ / ₈ (829)	37 ⁵ / ₈ (956)
	30 (762)	(Pre)-30-90HB48	66 (1676)	66 (1676)	66 (1676)	(Pre)-30-60HB48	59 ¹ / ₁₆ (1500)	34 ¹ / ₈ (867)	39 ³ / ₈ (1000)
	36 (914)	(Pre)-36-90HB48	69 (1753)	69 (1753)	69 (1753)	(Pre)-36-60HB48	61 ¹¹ / ₁₆ (1567)	35 ⁵ / ₈ (905)	41 ¹ / ₈ (1045)
42 (1067)	(Pre)-42-90HB48	72 (1829)	72 (1829)	72 (1829)	(Pre)-42-60HB48	64 ¹ / ₄ (1632)	37 ¹ / ₈ (943)	42 ¹³ / ₁₆ (1087)	

(Pre) See page L-3 for catalog number prefix.

Width dimensions are to inside wall. For aluminum fittings add 1.5 inches (38mm) for total outside width.

Manufacturing tolerances apply to all dimensions.

All dimensions in parentheses are millimeters unless otherwise specified.

Series 2, 3, 4, & 5 - Fittings

Horizontal Bend 45° 30° (HB)

1 pair splice plates with hardware included.

Bottoms manufactured:

Ladder = 9" Rung Spacing

VT & 04 = 4" Rung Spacing

ST & SB = Flat sheet over 12" Rung Spacing

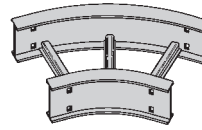

45° Horizontal Bend

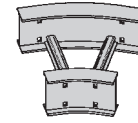

30° Horizontal Bend

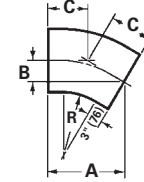
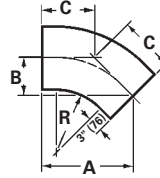

Bend Radius R	Tray Width	45° Horizontal Bend Dimensions				30° Horizontal Bend Dimensions			
		Catalog No.	A	B	C	Catalog No.	A	B	C
in. (mm)	in. (mm)		in. (mm)	in. (mm)	in. (mm)		in. (mm)	in. (mm)	in. (mm)
12 (305)	6 (152)	(Pre)-06-45HB12	15 ³ / ₄ (400)	6 ¹ / ₂ (165)	9 ³ / ₁₆ (233)	(Pre)-06-30HB12	13 ¹ / ₈ (333)	3 ¹ / ₂ (89)	7 (179)
	9 (228)	(Pre)-09-45HB12	16 ¹³ / ₁₆ (427)	6 ¹⁵ / ₁₆ (176)	9 ¹³ / ₁₆ (249)	(Pre)-09-30HB12	13 ⁷ / ₈ (352)	3 ¹¹ / ₁₆ (94)	7 ⁷ / ₁₆ (189)
	12 (305)	(Pre)-12-45HB12	17 ⁷ / ₈ (454)	7 ³ / ₈ (187)	10 ⁷ / ₁₆ (265)	(Pre)-12-30HB12	14 ⁵ / ₈ (372)	3 ¹⁵ / ₁₆ (100)	7 ¹³ / ₁₆ (198)
	18 (457)	(Pre)-18-45HB12	20 (508)	8 ¹ / ₄ (210)	11 ¹¹ / ₁₆ (297)	(Pre)-18-30HB12	16 ¹ / ₈ (410)	4 ⁵ / ₁₆ (135)	8 ⁵ / ₈ (219)
	24 (609)	(Pre)-24-45HB12	22 ¹ / ₁₆ (560)	9 ¹ / ₈ (232)	12 ¹⁵ / ₁₆ (329)	(Pre)-24-30HB12	17 ⁵ / ₈ (448)	4 ¹¹ / ₁₆ (119)	9 ⁷ / ₁₆ (240)
	30 (762)	(Pre)-30-45HB12	24 ³ / ₁₆ (614)	10 (254)	14 ³ / ₁₆ (360)	(Pre)-30-30HB12	19 ¹ / ₈ (486)	5 ¹ / ₈ (130)	10 ¹ / ₄ (260)
	36 (914)	(Pre)-36-45HB12	26 ⁵ / ₁₆ (668)	10 ¹⁵ / ₁₆ (278)	15 ⁷ / ₁₆ (392)	(Pre)-36-30HB12	20 ⁵ / ₈ (524)	5 ¹ / ₂ (140)	11 ¹ / ₁₆ (281)
	42 (1067)	(Pre)-42-45HB12	28 ⁷ / ₁₆ (722)	11 ¹³ / ₁₆ (300)	16 ¹¹ / ₁₆ (424)	(Pre)-42-30HB12	22 ¹ / ₈ (562)	5 ¹⁵ / ₁₆ (151)	11 ¹³ / ₁₆ (300)
24 (610)	6 (152)	(Pre)-06-45HB24	24 ³ / ₁₆ (614)	10 (254)	14 ³ / ₁₆ (360)	(Pre)-06-30HB24	19 ¹ / ₈ (486)	5 ¹ / ₈ (130)	10 ¹ / ₄ (260)
	9 (228)	(Pre)-09-45HB24	25 ¹ / ₄ (641)	10 ¹ / ₂ (267)	14 ¹³ / ₁₆ (376)	(Pre)-09-30HB24	19 ⁷ / ₈ (505)	5 ⁵ / ₁₆ (135)	10 ⁵ / ₈ (270)
	12 (305)	(Pre)-12-45HB24	26 ⁵ / ₁₆ (668)	10 ¹⁵ / ₁₆ (278)	15 ⁷ / ₁₆ (392)	(Pre)-12-30HB24	20 ⁵ / ₈ (524)	5 ¹ / ₂ (140)	11 ¹ / ₁₆ (281)
	18 (457)	(Pre)-18-45HB24	28 ⁷ / ₁₆ (722)	11 ¹³ / ₁₆ (300)	16 ¹¹ / ₁₆ (424)	(Pre)-18-30HB24	22 ¹ / ₈ (562)	5 ¹⁵ / ₁₆ (151)	11 ¹³ / ₁₆ (300)
	24 (609)	(Pre)-24-45HB24	30 ⁹ / ₁₆ (766)	12 ¹¹ / ₁₆ (322)	17 ¹⁵ / ₁₆ (456)	(Pre)-24-30HB24	23 ⁵ / ₈ (600)	6 ⁵ / ₁₆ (160)	12 ⁵ / ₈ (321)
	30 (762)	(Pre)-30-45HB24	32 ¹¹ / ₁₆ (830)	13 ⁹ / ₁₆ (344)	19 ¹ / ₈ (486)	(Pre)-30-30HB24	25 ¹ / ₈ (638)	6 ³ / ₄ (172)	13 ⁷ / ₁₆ (341)
	36 (914)	(Pre)-36-45HB24	34 ¹³ / ₁₆ (884)	14 ⁷ / ₁₆ (367)	20 ³ / ₈ (518)	(Pre)-36-30HB24	26 ⁵ / ₈ (676)	7 ¹ / ₈ (181)	14 ¹ / ₄ (362)
	42 (1067)	(Pre)-42-45HB24	36 ¹⁵ / ₁₆ (938)	15 ⁵ / ₁₆ (389)	21 ⁵ / ₈ (549)	(Pre)-42-30HB24	28 ¹ / ₈ (715)	7 ¹ / ₂ (191)	15 ¹ / ₁₆ (383)
36 (914)	6 (152)	(Pre)-06-45HB36	32 ¹¹ / ₁₆ (830)	13 ⁹ / ₁₆ (344)	19 ¹ / ₈ (486)	(Pre)-06-30HB36	25 ¹ / ₈ (638)	6 ³ / ₄ (171)	13 ⁷ / ₁₆ (341)
	9 (228)	(Pre)-09-45HB36	33 ³ / ₄ (857)	14 (356)	19 ³ / ₄ (502)	(Pre)-09-30HB36	25 ⁷ / ₈ (657)	6 ¹⁵ / ₁₆ (176)	13 ⁷ / ₈ (352)
	12 (305)	(Pre)-12-45HB36	34 ¹³ / ₁₆ (884)	14 ⁷ / ₁₆ (367)	20 ³ / ₈ (518)	(Pre)-12-30HB36	26 ⁵ / ₈ (676)	7 ¹ / ₈ (181)	14 ¹ / ₄ (362)
	18 (457)	(Pre)-18-45HB36	36 ¹⁵ / ₁₆ (938)	15 ⁵ / ₁₆ (389)	21 ⁵ / ₈ (549)	(Pre)-18-30HB36	28 ¹ / ₈ (715)	7 ¹ / ₂ (191)	15 ¹ / ₁₆ (383)
	24 (609)	(Pre)-24-45HB36	39 ¹ / ₁₆ (992)	16 ³ / ₁₆ (411)	22 ⁷ / ₈ (581)	(Pre)-24-30HB36	29 ⁵ / ₈ (753)	7 ¹⁵ / ₁₆ (202)	15 ⁷ / ₈ (403)
	30 (762)	(Pre)-30-45HB36	41 ³ / ₁₆ (1046)	17 ¹ / ₁₆ (433)	24 ¹ / ₈ (613)	(Pre)-30-30HB36	31 ¹ / ₈ (790)	8 ⁵ / ₁₆ (211)	16 ¹¹ / ₁₆ (424)
	36 (914)	(Pre)-36-45HB36	43 ⁵ / ₁₆ (1100)	17 ¹⁵ / ₁₆ (456)	25 ³ / ₈ (645)	(Pre)-36-30HB36	32 ⁵ / ₈ (829)	8 ³ / ₄ (222)	17 ¹ / ₂ (445)
	42 (1067)	(Pre)-42-45HB36	45 ⁷ / ₁₆ (1154)	18 ¹³ / ₁₆ (478)	26 ⁵ / ₈ (676)	(Pre)-42-30HB36	34 ¹ / ₈ (867)	9 ¹ / ₈ (232)	18 ¹ / ₄ (464)
48 (1220)	6 (152)	(Pre)-06-45HB48	41 ³ / ₁₆ (1046)	17 ¹ / ₁₆ (433)	24 ¹ / ₈ (613)	(Pre)-06-30HB48	31 ¹ / ₈ (791)	8 ⁵ / ₁₆ (211)	16 ¹¹ / ₁₆ (424)
	9 (228)	(Pre)-09-45HB48	42 ¹ / ₄ (1073)	17 ¹ / ₂ (445)	24 ³ / ₄ (629)	(Pre)-09-30HB48	31 ⁷ / ₈ (810)	8 ⁹ / ₁₆ (218)	17 ¹ / ₁₆ (433)
	12 (305)	(Pre)-12-45HB48	43 ⁵ / ₁₆ (1100)	17 ¹⁵ / ₁₆ (456)	25 ³ / ₈ (645)	(Pre)-12-30HB48	32 ⁵ / ₈ (829)	8 ³ / ₄ (222)	17 ¹ / ₂ (445)
	18 (457)	(Pre)-18-45HB48	45 ⁷ / ₁₆ (1154)	18 ¹³ / ₁₆ (478)	26 ⁵ / ₈ (676)	(Pre)-18-30HB48	34 ¹ / ₈ (867)	9 ¹ / ₈ (232)	18 ¹ / ₄ (464)
	24 (609)	(Pre)-24-45HB48	47 ⁹ / ₁₆ (1208)	19 ¹¹ / ₁₆ (500)	27 ⁷ / ₈ (708)	(Pre)-24-30HB48	35 ⁵ / ₈ (905)	9 ⁹ / ₁₆ (243)	19 ¹ / ₁₆ (484)
	30 (762)	(Pre)-30-45HB48	49 ¹¹ / ₁₆ (1262)	20 ⁹ / ₁₆ (522)	29 ¹ / ₈ (740)	(Pre)-30-30HB48	37 ¹ / ₈ (943)	9 ¹⁵ / ₁₆ (252)	19 ⁷ / ₈ (505)
	36 (914)	(Pre)-36-45HB48	51 ¹³ / ₁₆ (1316)	21 ⁷ / ₁₆ (545)	30 ⁵ / ₁₆ (770)	(Pre)-36-30HB48	38 ⁵ / ₈ (981)	10 ⁵ / ₁₆ (262)	20 ¹¹ / ₁₆ (525)
	42 (1067)	(Pre)-42-45HB48	54 ¹⁵ / ₁₆ (1395)	22 ⁵ / ₁₆ (567)	31 ⁹ / ₁₆ (802)	(Pre)-42-30HB48	40 ¹ / ₈ (1019)	10 ³ / ₄ (273)	21 ¹ / ₂ (546)

(Pre) See page L-3 for catalog number prefix.

Width dimensions are to inside wall. For aluminum fittings add 1.5 inches (38mm) for total outside width. Manufacturing tolerances apply to all dimensions.

All dimensions in parentheses are millimeters unless otherwise specified.

Horizontal Tee (HT)

2 pair splice plates with hardware included.

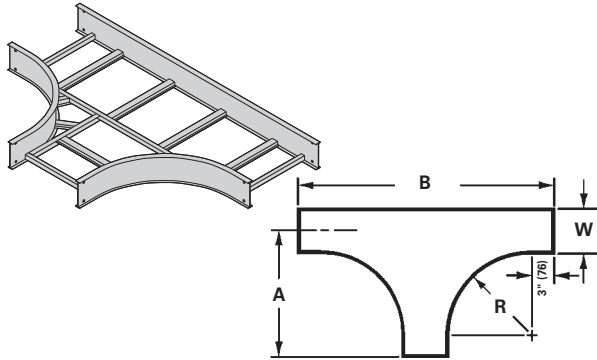

Horizontal Cross (HX)

3 pair splice plates with hardware included.

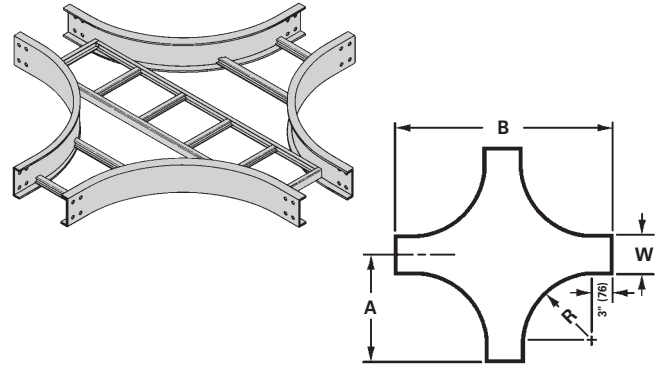

Bend Radius R	Tray Width	Horizontal Tee			Horizontal Cross		
		Catalog Number	Dimensions		Catalog Number	Dimensions	
			A	B		A	B
in. (mm)	in. (mm)	in. (mm)	in. (mm)	in. (mm)	in. (mm)	in. (mm)	
12 (305)	6 (152)	(Prefix)-06-HT12	18 (457)	36 (914)	(Prefix)-06-HX12	18 (457)	36 (914)
	9 (229)	(Prefix)-09-HT12	19 1/2 (496)	39 (991)	(Prefix)-09-HX12	19 1/2 (496)	39 (991)
	12 (305)	(Prefix)-12-HT12	21 (533)	42 (1067)	(Prefix)-12-HX12	21 (533)	42 (1067)
	18 (457)	(Prefix)-18-HT12	24 (609)	48 (1219)	(Prefix)-18-HX12	24 (609)	48 (1219)
	24 (609)	(Prefix)-24-HT12	27 (686)	54 (1372)	(Prefix)-24-HX12	27 (686)	54 (1372)
	30 (762)	(Prefix)-30-HT12	30 (762)	60 (1524)	(Prefix)-30-HX12	30 (762)	60 (1524)
	36 (914)	(Prefix)-36-HT12	33 (838)	66 (1676)	(Prefix)-36-HX12	33 (838)	66 (1676)
42 (1067)	(Prefix)-42-HT12	36 (914)	72 (1829)	(Prefix)-42-HX12	36 (914)	72 (1829)	
24 (610)	6 (152)	(Prefix)-06-HT24	30 (762)	60 (1524)	(Prefix)-06-HX24	30 (762)	60 (1524)
	9 (229)	(Prefix)-09-HT24	31 1/2 (800)	63 (1600)	(Prefix)-09-HX24	31 1/2 (800)	63 (1600)
	12 (305)	(Prefix)-12-HT24	33 (838)	66 (1676)	(Prefix)-12-HX24	33 (838)	66 (1676)
	18 (457)	(Prefix)-18-HT24	36 (914)	72 (1829)	(Prefix)-18-HX24	36 (914)	72 (1829)
	24 (609)	(Prefix)-24-HT24	39 (991)	78 (1982)	(Prefix)-24-HX24	39 (991)	78 (1982)
	30 (762)	(Prefix)-30-HT24	42 (1067)	84 (2134)	(Prefix)-30-HX24	42 (1067)	84 (2134)
	36 (914)	(Prefix)-36-HT24	45 (1143)	90 (2286)	(Prefix)-36-HX24	45 (1143)	90 (2286)
42 (1067)	(Prefix)-42-HT24	48 (1219)	96 (2438)	(Prefix)-42-HX24	48 (1219)	96 (2438)	
36 (914)	6 (152)	(Prefix)-06-HT36	42 (1067)	84 (2134)	(Prefix)-06-HX36	42 (1067)	84 (2134)
	9 (229)	(Prefix)-09-HT36	43 1/2 (1105)	87 (2210)	(Prefix)-09-HX36	43 1/2 (1105)	87 (2210)
	12 (305)	(Prefix)-12-HT36	45 (1143)	90 (2286)	(Prefix)-12-HX36	45 (1143)	90 (2286)
	18 (457)	(Prefix)-18-HT36	48 (1219)	96 (2438)	(Prefix)-18-HX36	48 (1219)	96 (2438)
	24 (609)	(Prefix)-24-HT36	51 (1295)	102 (2590)	(Prefix)-24-HX36	51 (1295)	102 (2590)
	30 (762)	(Prefix)-30-HT36	54 (1372)	108 (2744)	(Prefix)-30-HX36	54 (1372)	108 (2744)
	36 (914)	(Prefix)-36-HT36	57 (1448)	114 (2896)	(Prefix)-36-HX36	57 (1448)	114 (2896)
42 (1067)	(Prefix)-42-HT36	60 (1524)	120 (3048)	(Prefix)-42-HX36	60 (1524)	120 (3048)	
48 (1220)	6 (152)	(Prefix)-06-HT48	54 (1372)	108 (2744)	(Prefix)-06-HX48	54 (1372)	108 (2744)
	9 (229)	(Prefix)-09-HT48	55 1/2 (1410)	111 (2820)	(Prefix)-09-HX48	55 1/2 (1410)	111 (2820)
	12 (305)	(Prefix)-12-HT48	57 (1448)	114 (2896)	(Prefix)-12-HX48	57 (1448)	114 (2896)
	18 (457)	(Prefix)-18-HT48	60 (1524)	120 (3048)	(Prefix)-18-HX48	60 (1524)	120 (3048)
	24 (609)	(Prefix)-24-HT48	63 (1600)	126 (3200)	(Prefix)-24-HX48	63 (1600)	126 (3200)
	30 (762)	(Prefix)-30-HT48	66 (1676)	132 (3353)	(Prefix)-30-HX48	66 (1676)	132 (3353)
	36 (914)	(Prefix)-36-HT48	69 (1753)	138 (3535)	(Prefix)-36-HX48	69 (1753)	138 (3535)
42 (1067)	(Prefix)-42-HT48	72 (1829)	144 (3658)	(Prefix)-42-HX48	72 (1829)	144 (3658)	

(Prefix) See page L-3 for catalog number prefix.

Width dimensions are to inside wall. For aluminum fittings add 1.5 inches (38mm) for total outside width.

Manufacturing tolerances apply to all dimensions.

All dimensions in parentheses are millimeters unless otherwise specified.

Series 2, 3, 4, & 5 - Fittings

Reducers (LR, SR, RR)

1 pair splice plates with hardware included.

Reducer Part Numbering

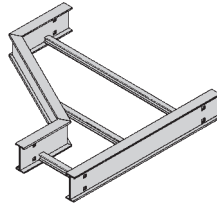
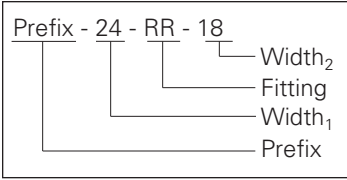

Left Reducer - LR

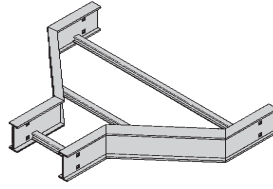

Straight Reducer SR

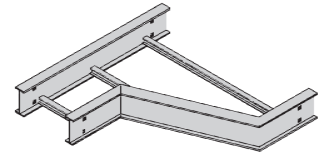

Right Reducer -RR

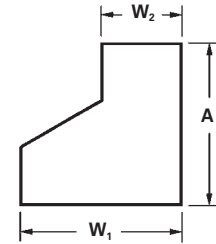
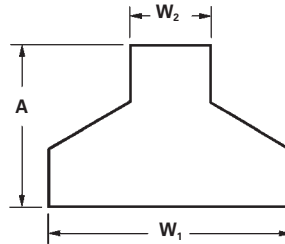
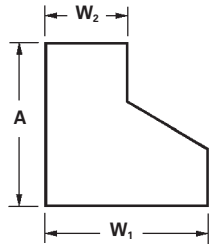

Tray Width		Left Hand Reducer		Straight Reducer		Right Hand Reducer	
W1	W2	Catalog No.	A	Catalog No.	A	Catalog No.	A
in. (mm)	in. (mm)		in. (mm)		in. (mm)		in. (mm)
9 (228)	6 (152)	(Prefix)-09-LR06	9 ³ / ₄ (248)	(Prefix)-09-SR06	8 ¹⁵ / ₁₆ (227)	(Prefix)-09-RR06	9 ³ / ₄ (248)
12 (305)	6 (152)	(Prefix)-12-LR06	11 ¹ / ₂ (292)	(Prefix)-12-SR06	9 ³ / ₄ (248)	(Prefix)-12-RR06	11 ¹ / ₂ (292)
	9 (228)	(Prefix)-12-LR09	9 ³ / ₄ (248)	(Prefix)-12-SR09	8 ¹⁵ / ₁₆ (227)	(Prefix)-12-RR09	9 ³ / ₄ (248)
18 (457)	6 (152)	(Prefix)-18-LR06	14 ¹⁵ / ₁₆ (379)	(Prefix)-18-SR06	11 ¹ / ₂ (292)	(Prefix)-18-RR06	14 ¹⁵ / ₁₆ (379)
	9 (228)	(Prefix)-18-LR09	13 ³ / ₁₆ (340)	(Prefix)-18-SR09	10 ⁵ / ₈ (270)	(Prefix)-18-RR09	13 ³ / ₁₆ (340)
	12 (305)	(Prefix)-18-LR12	11 ¹ / ₂ (292)	(Prefix)-18-SR12	9 ³ / ₄ (248)	(Prefix)-18-RR12	11 ¹ / ₂ (292)
24 (609)	6 (152)	(Prefix)-24-LR06	18 ³ / ₈ (467)	(Prefix)-24-SR06	13 ¹ / ₄ (336)	(Prefix)-24-RR06	18 ³ / ₈ (467)
	9 (228)	(Prefix)-24-LR09	16 ¹¹ / ₁₆ (424)	(Prefix)-24-SR09	12 ³ / ₈ (314)	(Prefix)-24-RR09	16 ¹¹ / ₁₆ (424)
	12 (305)	(Prefix)-24-LR12	14 ¹⁵ / ₁₆ (379)	(Prefix)-24-SR12	11 ¹ / ₂ (292)	(Prefix)-24-RR12	14 ¹⁵ / ₁₆ (379)
	18 (457)	(Prefix)-24-LR18	11 ¹ / ₂ (292)	(Prefix)-24-SR18	9 ³ / ₄ (248)	(Prefix)-24-RR18	11 ¹ / ₂ (292)
30 (762)	6 (152)	(Prefix)-30-LR06	21 ⁷ / ₈ (555)	(Prefix)-30-SR06	14 ¹⁵ / ₁₆ (379)	(Prefix)-30-RR06	21 ⁷ / ₈ (555)
	9 (228)	(Prefix)-30-LR09	20 ¹ / ₈ (511)	(Prefix)-30-SR09	14 ¹ / ₈ (359)	(Prefix)-30-RR09	20 ¹ / ₈ (511)
	12 (305)	(Prefix)-30-LR12	18 ³ / ₈ (467)	(Prefix)-30-SR12	13 ¹ / ₄ (336)	(Prefix)-30-RR12	18 ³ / ₈ (467)
	18 (457)	(Prefix)-30-LR18	14 ¹⁵ / ₁₆ (379)	(Prefix)-30-SR18	11 ¹ / ₂ (292)	(Prefix)-30-RR18	14 ¹⁵ / ₁₆ (379)
	24 (609)	(Prefix)-30-LR24	11 ¹ / ₂ (292)	(Prefix)-30-SR24	9 ³ / ₄ (248)	(Prefix)-30-RR24	11 ¹ / ₂ (292)
36 (914)	6 (152)	(Prefix)-36-LR06	25 ⁵ / ₁₆ (643)	(Prefix)-36-SR06	16 ¹¹ / ₁₆ (424)	(Prefix)-36-RR06	25 ⁵ / ₁₆ (643)
	9 (228)	(Prefix)-36-LR09	23 ⁹ / ₁₆ (598)	(Prefix)-36-SR09	15 ¹³ / ₁₆ (402)	(Prefix)-36-RR09	23 ⁹ / ₁₆ (598)
	12 (305)	(Prefix)-36-LR12	21 ⁷ / ₈ (555)	(Prefix)-36-SR12	14 ¹⁵ / ₁₆ (379)	(Prefix)-36-RR12	21 ⁷ / ₈ (555)
	18 (457)	(Prefix)-36-LR18	18 ³ / ₈ (467)	(Prefix)-36-SR18	13 ¹ / ₄ (336)	(Prefix)-36-RR18	18 ³ / ₈ (467)
	24 (609)	(Prefix)-36-LR24	14 ¹⁵ / ₁₆ (379)	(Prefix)-36-SR24	11 ¹ / ₂ (292)	(Prefix)-36-RR24	14 ¹⁵ / ₁₆ (379)
	30 (762)	(Prefix)-36-LR30	11 ¹ / ₂ (292)	(Prefix)-36-SR30	9 ³ / ₄ (248)	(Prefix)-36-RR30	11 ¹ / ₂ (292)
42 (1067)	6 (152)	(Prefix)-42-LR06	28 ³ / ₄ (730)	(Prefix)-42-SR06	18 ³ / ₈ (467)	(Prefix)-42-RR06	28 ³ / ₄ (730)
	9 (228)	(Prefix)-42-LR09	27 ¹ / ₁₆ (687)	(Prefix)-42-SR09	17 ⁹ / ₁₆ (446)	(Prefix)-42-RR09	27 ¹ / ₁₆ (687)
	12 (305)	(Prefix)-42-LR12	25 ⁵ / ₁₆ (643)	(Prefix)-42-SR12	16 ¹¹ / ₁₆ (424)	(Prefix)-42-RR12	25 ⁵ / ₁₆ (643)
	18 (457)	(Prefix)-42-LR18	21 ⁷ / ₈ (555)	(Prefix)-42-SR18	14 ¹⁵ / ₁₆ (379)	(Prefix)-42-RR18	21 ⁷ / ₈ (555)
	24 (609)	(Prefix)-42-LR24	18 ³ / ₈ (467)	(Prefix)-42-SR24	13 ¹ / ₄ (336)	(Prefix)-42-RR24	18 ³ / ₈ (467)
	30 (762)	(Prefix)-42-LR30	14 ¹⁵ / ₁₆ (379)	(Prefix)-42-SR30	11 ¹ / ₂ (292)	(Prefix)-42-RR30	14 ¹⁵ / ₁₆ (379)
	36 (914)	(Prefix)-42-LR36	11 ¹ / ₂ (292)	(Prefix)-42-SR36	9 ³ / ₄ (248)	(Prefix)-42-RR36	11 ¹ / ₂ (292)

(Prefix) See page L-3 for catalog number prefix.

Width dimensions are to inside wall. For aluminum fittings add 1.5 inches (38mm) for total outside width.

Manufacturing tolerances apply to all dimensions.

All dimensions in parentheses are millimeters unless otherwise specified.

Horizontal Reducing Tee (HT)

2 pair splice plates with hardware included.

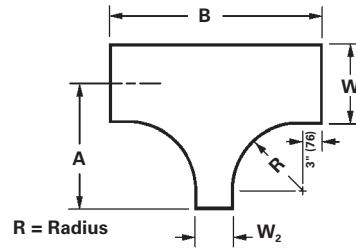
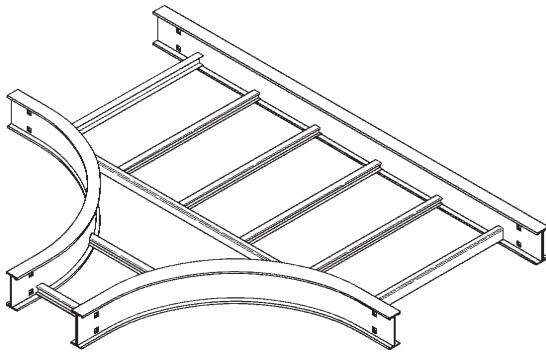

Prefix - 36 - 18 HT 24

Radius
Fitting
Width W₂
Width W₁

To complete catalog number, insert fitting prefix.

Tray Width		* Insert Radius (12", 24", 36", or 48") Catalog No.	12" Radius		24" Radius		36" Radius		48" Radius	
W1	W2		A	B	A	B	A	B	A	B
in.	mm		in.	mm	in.	mm	in.	mm	in.	mm
9 (228)	6 (152)	(Prefix)-09-06-HT*	19 1/2 (496)	36 (914)	31 1/2 (800)	60 (1524)	43 (1092)	84 (2134)	55 1/2 (1410)	108 (2743)
12 (305)	6 (152)	(Prefix)-12-06-HT*	21 (533)	36 (914)	33 (838)	60 (1524)	45 (1143)	84 (2134)	57 (1448)	108 (2743)
	9 (228)	(Prefix)-12-09-HT*	21 (533)	39 (991)	33 (838)	63 (1600)	45 (1143)	87 (2210)	57 (1448)	111 (2819)
18 (457)	6 (152)	(Prefix)-18-06-HT*	24 (609)	36 (914)	36 (914)	60 (1524)	48 (1143)	84 (2134)	60 (1524)	108 (2743)
	9 (228)	(Prefix)-18-09-HT*	24 (609)	39 (991)	36 (914)	63 (1600)	48 (1219)	87 (2210)	60 (1524)	111 (2819)
	12 (305)	(Prefix)-18-12-HT*	24 (609)	42 (1067)	36 (914)	66 (1676)	48 (1219)	90 (2286)	60 (1524)	114 (2895)
24 (609)	6 (152)	(Prefix)-24-06-HT*	27 (686)	36 (914)	39 (991)	60 (1524)	51 (1295)	84 (2134)	63 (1600)	108 (2743)
	9 (228)	(Prefix)-24-09-HT*	27 (686)	39 (991)	39 (991)	63 (1600)	51 (1295)	87 (2210)	63 (1600)	111 (2819)
	12 (305)	(Prefix)-24-12-HT*	27 (686)	42 (1067)	39 (991)	66 (1676)	51 (1295)	90 (2286)	63 (1600)	114 (2895)
	18 (457)	(Prefix)-24-18-HT*	27 (686)	48 (1219)	39 (991)	72 (1829)	51 (1295)	96 (2438)	63 (1600)	120 (3048)
30 (762)	6 (152)	(Prefix)-30-06-HT*	30 (762)	36 (914)	42 (1067)	60 (1524)	54 (1372)	84 (2134)	66 (1676)	108 (2743)
	9 (228)	(Prefix)-30-09-HT*	30 (762)	39 (991)	42 (1067)	63 (1600)	54 (1372)	87 (2210)	66 (1676)	111 (2819)
	12 (305)	(Prefix)-30-12-HT*	30 (762)	42 (1067)	42 (1067)	66 (1676)	54 (1372)	90 (2286)	66 (1676)	114 (2895)
	18 (457)	(Prefix)-30-18-HT*	30 (762)	48 (1219)	42 (1067)	72 (1829)	54 (1372)	96 (2438)	66 (1676)	120 (3048)
	24 (609)	(Prefix)-30-24-HT*	30 (762)	54 (1372)	42 (1067)	78 (1981)	54 (1372)	102 (2591)	66 (1676)	126 (3200)
36 (914)	6 (152)	(Prefix)-30-06-HT*	33 (838)	36 (914)	45 (1143)	60 (1524)	57 (1448)	84 (2134)	69 (1753)	108 (2743)
	9 (228)	(Prefix)-36-09-HT*	33 (838)	39 (991)	45 (1143)	63 (1600)	57 (1448)	87 (2210)	69 (1753)	111 (2819)
	12 (305)	(Prefix)-36-12-HT*	33 (838)	42 (1067)	45 (1143)	66 (1676)	57 (1448)	90 (2286)	69 (1753)	114 (2895)
	18 (457)	(Prefix)-36-18-HT*	33 (838)	48 (1219)	45 (1143)	72 (1829)	57 (1448)	96 (2438)	69 (1753)	120 (3048)
	24 (609)	(Prefix)-36-24-HT*	33 (838)	54 (1372)	45 (1143)	78 (1981)	57 (1448)	102 (2591)	69 (1753)	126 (3200)
42 (1067)	30 (762)	(Prefix)-36-30-HT*	33 (838)	60 (1524)	45 (1143)	84 (2134)	57 (1448)	108 (2743)	69 (1753)	132 (3353)
	6 (152)	(Prefix)-42-06-HT*	36 (914)	36 (914)	48 (1219)	60 (1524)	60 (1524)	84 (2134)	72 (1829)	108 (2743)
	9 (228)	(Prefix)-42-09-HT*	36 (914)	39 (991)	48 (1219)	63 (1600)	60 (1524)	87 (2210)	72 (1829)	111 (2819)
	12 (305)	(Prefix)-42-12-HT*	36 (914)	42 (1067)	48 (1219)	66 (1676)	60 (1524)	90 (2286)	72 (1829)	114 (2895)
	18 (457)	(Prefix)-42-18-HT*	36 (914)	48 (1219)	48 (1219)	72 (1829)	60 (1524)	96 (2438)	72 (1829)	120 (3048)
	24 (609)	(Prefix)-42-24-HT*	36 (914)	54 (1372)	48 (1219)	78 (1981)	60 (1524)	102 (2591)	72 (1829)	126 (3200)
30 (762)	30 (762)	(Prefix)-42-30-HT*	36 (914)	60 (1524)	48 (1219)	84 (2134)	60 (1524)	108 (2743)	72 (1829)	132 (3353)
	36 (914)	(Prefix)-42-36-HT*	36 (914)	66 (1676)	48 (1219)	90 (2286)	60 (1524)	114 (2895)	72 (1829)	138 (3505)

(Prefix) See page L-3 for catalog number prefix.

Width dimensions are to inside wall. For aluminum fittings add 1.5 inches (38mm) for total outside width.

Manufacturing tolerances apply to all dimensions.

All dimensions in parentheses are millimeters unless otherwise specified.

Series 2, 3, 4, & 5 - Fittings

Horizontal Expanding Tee (HT)

2 pair splice plates with hardware included.

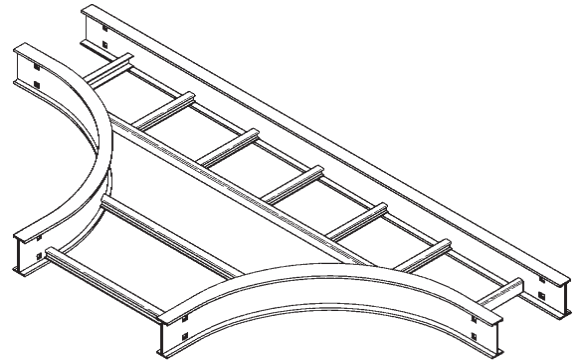
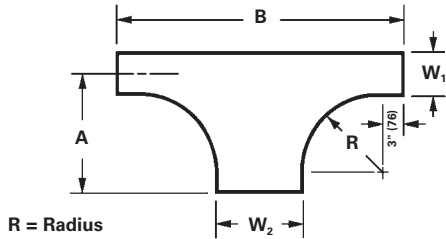

Prefix - 09 - 30 HT 12

- Radius
- Fitting
- Width W₂
- Width W₁

To complete catalog number, insert fitting prefix.

Series 2, 3, 4, & 5 Fittings

Tray Width		* Insert Radius (12", 24", 36", or 48") Catalog No.	12" Radius		24" Radius		36" Radius		48" Radius	
W1 in. mm	W2 in. mm		A in. mm	B in. mm	A in. mm	B in. mm	A in. mm	B in. mm	A in. mm	B in. mm
6 (152)	9 (228)	(Prefix)-06-09-HT*	18 (457)	39 (991)	30 (762)	63 (1600)	42 (1067)	87 (2210)	54 (1372)	111 (2819)
	12 (305)	(Prefix)-06-12-HT*	18 (457)	42 (1067)	30 (762)	66 (1676)	42 (1067)	90 (2286)	54 (1372)	114 (2895)
	18 (457)	(Prefix)-06-18-HT*	18 (457)	48 (1219)	30 (762)	72 (1829)	42 (1067)	96 (2438)	54 (1372)	120 (3048)
	24 (609)	(Prefix)-06-24-HT*	18 (457)	54 (1372)	30 (762)	78 (1981)	42 (1067)	102 (2591)	54 (1372)	126 (3200)
	30 (762)	(Prefix)-06-30-HT*	18 (457)	60 (1524)	30 (762)	84 (2134)	42 (1067)	108 (2743)	54 (1372)	132 (3353)
	36 (914)	(Prefix)-06-36-HT*	18 (457)	66 (1676)	30 (762)	90 (2286)	42 (1067)	114 (2895)	54 (1372)	138 (3503)
42 (1067)	(Prefix)-06-42-HT*	18 (457)	72 (1829)	30 (762)	96 (2438)	42 (1067)	120 (3048)	54 (1372)	144 (3658)	
9 (228)	12 (305)	(Prefix)-09-12-HT*	19 1/2 (496)	42 (1067)	31 1/2 (800)	66 (1676)	43 1/2 (1105)	90 (2286)	55 1/2 (1410)	114 (2895)
	18 (457)	(Prefix)-09-18-HT*	19 1/2 (496)	48 (1219)	31 1/2 (800)	72 (1829)	43 1/2 (1105)	96 (2438)	55 1/2 (1410)	120 (3048)
	24 (609)	(Prefix)-09-24-HT*	19 1/2 (496)	54 (1372)	31 1/2 (800)	78 (1981)	43 1/2 (1105)	102 (2591)	55 1/2 (1410)	126 (3200)
	30 (762)	(Prefix)-09-30-HT*	19 1/2 (496)	60 (1524)	31 1/2 (800)	84 (2134)	43 1/2 (1105)	108 (2743)	55 1/2 (1410)	132 (3353)
	36 (914)	(Prefix)-09-36-HT*	19 1/2 (496)	66 (1676)	31 1/2 (800)	90 (2286)	43 1/2 (1105)	114 (2895)	55 1/2 (1410)	138 (3503)
	42 (1067)	(Prefix)-09-42-HT*	19 1/2 (496)	72 (1829)	31 1/2 (800)	96 (2438)	43 1/2 (1105)	120 (3048)	55 1/2 (1410)	144 (3658)
12 (305)	18 (457)	(Prefix)-12-18-HT*	21 (533)	48 (1219)	33 (838)	72 (1829)	45 (1143)	96 (2438)	57 (1448)	120 (3048)
	24 (609)	(Prefix)-12-24-HT*	21 (533)	54 (1372)	33 (838)	78 (1981)	45 (1143)	102 (2591)	57 (1448)	126 (3200)
	30 (762)	(Prefix)-12-30-HT*	21 (533)	60 (1524)	33 (838)	84 (2134)	45 (1143)	108 (2743)	57 (1448)	132 (3353)
	36 (914)	(Prefix)-12-36-HT*	21 (533)	66 (1676)	33 (838)	90 (2286)	45 (1143)	114 (2895)	57 (1448)	138 (3503)
	42 (1067)	(Prefix)-12-42-HT*	21 (533)	72 (1829)	33 (838)	96 (2438)	45 (1143)	120 (3048)	57 (1448)	144 (3658)
18 (457)	24 (609)	(Prefix)-18-24-HT*	24 (609)	54 (1372)	36 (914)	78 (1981)	48 (1219)	102 (2591)	60 (1524)	126 (3200)
	30 (762)	(Prefix)-18-30-HT*	24 (609)	60 (1524)	36 (914)	84 (2134)	48 (1219)	108 (2743)	60 (1524)	132 (3353)
	36 (914)	(Prefix)-18-36-HT*	24 (609)	66 (1676)	36 (914)	90 (2286)	48 (1219)	114 (2895)	60 (1524)	138 (3503)
	42 (1067)	(Prefix)-18-42-HT*	24 (609)	72 (1829)	36 (914)	96 (2438)	48 (1219)	120 (3048)	60 (1524)	144 (3658)
24 (609)	30 (762)	(Prefix)-24-30-HT*	27 (686)	60 (1524)	39 (991)	84 (2134)	51 (1295)	108 (2743)	63 (1600)	132 (3353)
	36 (914)	(Prefix)-24-36-HT*	27 (686)	66 (1676)	39 (991)	90 (2286)	51 (1295)	114 (2895)	63 (1600)	138 (3503)
	42 (1067)	(Prefix)-24-42-HT*	27 (686)	72 (1829)	39 (991)	96 (2438)	51 (1295)	120 (3048)	63 (1600)	144 (3658)
30 (762)	36 (914)	(Prefix)-30-36-HT*	30 (762)	66 (1676)	42 (1067)	90 (2286)	54 (1372)	114 (2895)	66 (1676)	138 (3503)
	42 (1067)	(Prefix)-30-42-HT*	30 (762)	72 (1829)	42 (1067)	96 (2438)	54 (1372)	120 (3048)	66 (1676)	144 (3658)
36 (914)	42 (1067)	(Prefix)-36-42-HT*	33 (838)	72 (1829)	45 (1143)	96 (2438)	57 (1448)	120 (3048)	69 (1753)	144 (3658)

(Prefix) See page L-3 for catalog number prefix.

Width dimensions are to inside wall. For aluminum fittings add 1.5 inches (38mm) for total outside width.

Manufacturing tolerances apply to all dimensions.

All dimensions in parentheses are millimeters unless otherwise specified.

Horizontal Expanding/Reducing Cross (HX)

3 pair splice plates with hardware included.

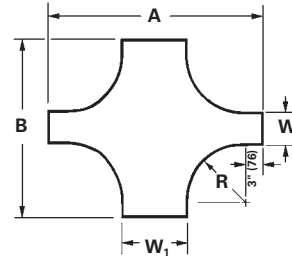
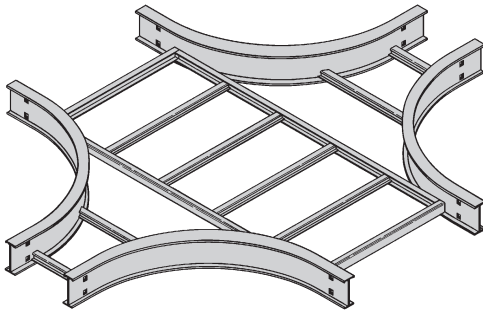

Prefix - 36 - 18 HX 24

Radius
Fitting
Width W₂
Width W₁
To complete catalog number, insert fitting prefix.

Tray Width		* Insert Radius (12", 24", 36", or 48") Catalog No.	12" Radius		24" Radius		36" Radius		48" Radius											
W1	W2		A	B	A	B	A	B	A	B										
in.	mm		in.	mm	in.	mm	in.	mm	in.	mm	in.	mm								
9	(228)	6	(152)	(Prefix)-09-06-HX*	39	(991)	36	(914)	63	1600	60	(1524)	87	(2210)	84	(2134)	111	2819	108	(2743)
12	(305)	6	(152)	(Prefix)-12-06-HX*	42	(1067)	36	(914)	66	(1676)	60	(1524)	90	(2286)	84	(2134)	114	(2895)	108	(2743)
		9	(228)	(Prefix)-12-09-HX*	42	(1067)	39	(991)	66	(1676)	63	(1600)	90	(2286)	87	(2210)	114	(2895)	111	(2819)
18	(457)	6	(152)	(Prefix)-18-06-HX*	48	(1219)	36	(914)	72	(1829)	60	(1524)	96	(2438)	84	(2134)	120	(3048)	108	(2743)
		9	(228)	(Prefix)-18-09-HX*	48	(1219)	39	(991)	72	(1829)	63	(1600)	96	(2438)	87	(2210)	120	(3048)	111	(2819)
		12	(305)	(Prefix)-18-12-HX*	48	(1219)	42	(1067)	72	(1829)	66	(1676)	96	(2438)	90	(2286)	120	(3048)	114	(2895)
24	(609)	6	(152)	(Prefix)-24-06-HX*	54	(1372)	36	(914)	78	(1981)	60	(1524)	102	(2591)	84	(2134)	126	(3200)	108	(2743)
		9	(228)	(Prefix)-24-09-HX*	54	(1372)	39	(991)	78	(1981)	63	(1600)	102	(2591)	87	(2210)	126	(3200)	111	(2819)
		12	(305)	(Prefix)-24-12-HX*	54	(1372)	42	(1067)	78	(1981)	66	(1676)	102	(2591)	90	(2286)	126	(3200)	114	(2895)
		18	(457)	(Prefix)-24-18-HX*	54	(1372)	48	(1219)	78	(1981)	72	(1829)	102	(2591)	96	(2438)	126	(3200)	120	(3048)
30	(762)	6	(152)	(Prefix)-30-06-HX*	60	(1524)	36	(914)	84	(2134)	60	(1524)	108	(2743)	84	(2134)	132	(3353)	108	(2743)
		9	(228)	(Prefix)-30-09-HX*	60	(1524)	39	(991)	84	(2134)	63	(1600)	108	(2743)	87	(2210)	132	(3353)	111	(2819)
		12	(305)	(Prefix)-30-12-HX*	60	(1524)	42	(1067)	84	(2134)	66	(1676)	108	(2743)	90	(2286)	132	(3353)	114	(2895)
		18	(457)	(Prefix)-30-18-HX*	60	(1524)	48	(1219)	84	(2134)	72	(1829)	108	(2743)	96	(2438)	132	(3353)	120	(3048)
		24	(609)	(Prefix)-30-24-HX*	60	(1524)	54	(1372)	84	(2134)	78	(1981)	108	(2743)	102	(2591)	132	(3353)	126	(3200)
36	(914)	6	(152)	(Prefix)-30-06-HX*	66	(1676)	36	(914)	90	(2286)	60	(1524)	114	(2895)	84	(2134)	138	(3505)	108	(2743)
		9	(228)	(Prefix)-36-09-HX*	66	(1676)	39	(991)	90	(2286)	63	(1600)	114	(2895)	87	(2210)	138	(3505)	111	(2819)
		12	(305)	(Prefix)-36-12-HX*	66	(1676)	42	(1067)	90	(2286)	66	(1676)	114	(2895)	90	(2286)	138	(3505)	114	(2895)
		18	(457)	(Prefix)-36-18-HX*	66	(1676)	48	(1219)	90	(2286)	72	(1829)	114	(2895)	96	(2438)	138	(3505)	120	(3048)
		24	(609)	(Prefix)-36-24-HX*	66	(1676)	54	(1372)	90	(2286)	78	(1981)	114	(2895)	102	(2591)	138	(3505)	126	(3200)
42	(1067)	30	(762)	(Prefix)-36-30-HX*	66	(1676)	60	(1524)	90	(2286)	84	(2134)	114	(2895)	108	(2743)	138	(3505)	132	(3353)
		6	(152)	(Prefix)-42-06-HX*	72	(1829)	36	(914)	96	(2438)	60	(1524)	120	(3048)	84	(2134)	144	(3658)	108	(2743)
		9	(228)	(Prefix)-42-09-HX*	72	(1829)	39	(991)	96	(2438)	63	(1600)	120	(3048)	87	(2210)	144	(3658)	111	(2819)
		12	(305)	(Prefix)-42-12-HX*	72	(1829)	42	(1067)	96	(2438)	66	(1676)	120	(3048)	90	(2286)	144	(3658)	114	(2895)
		18	(457)	(Prefix)-42-18-HX*	72	(1829)	48	(1219)	96	(2438)	72	(1829)	120	(3048)	96	(2438)	144	(3658)	120	(3048)
		24	(609)	(Prefix)-42-24-HX*	72	(1829)	54	(1372)	96	(2438)	78	(1981)	120	(3048)	102	(2591)	144	(3658)	126	(3200)
30	(762)	60	(1524)	(Prefix)-42-30-HX*	72	(1829)	60	(1524)	96	(2438)	84	(2134)	120	(3048)	108	(2743)	144	(3658)	132	(3353)
		36	(914)	(Prefix)-42-36-HX*	72	(1829)	66	(1676)	96	(2438)	90	(2286)	120	(3048)	114	(2895)	144	(3658)	138	(3505)

(Prefix) See page L-3 for catalog number prefix.

Width dimensions are to inside wall. For aluminum fittings add 1.5 inches (38mm) for total outside width.

Manufacturing tolerances apply to all dimensions.

All dimensions in parentheses are millimeters unless otherwise specified.

Series 2, 3, 4, & 5 - Fittings

Horizontal Wye (HYL, HYR)

2 pair splice plates with hardware included.

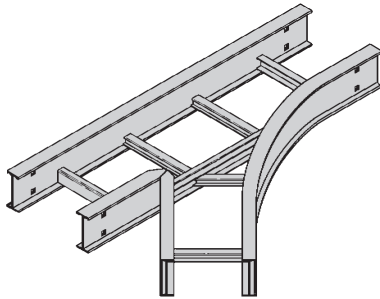

Left Hand Wye - HYL

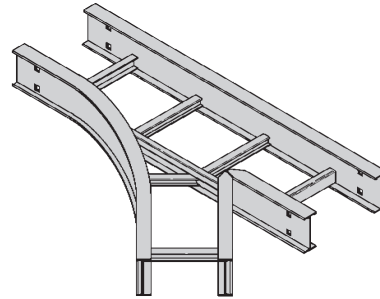

Right Hand Wye - HYR

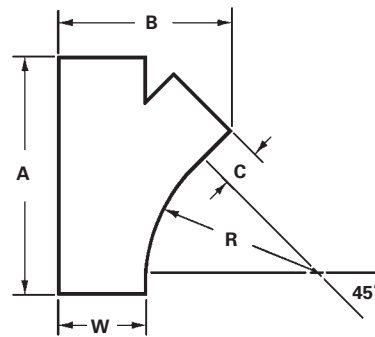
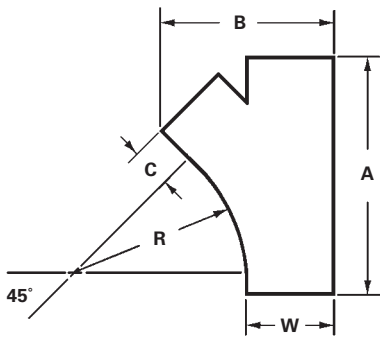

R = Radius

Bend Radius in. mm	Tray Width in. mm	Left Hand Wye Catalog No.	Right Hand Wye Catalog No.	A		B		C	
				in.	mm	in.	mm	in.	mm
24 (609)	6 (152)	(Prefix)-06-HYL	(Prefix)-06-HYR	28 ⁷ / ₁₆	(722)	15 ³ / ₁₆	(386)	3 ¹ / ₁₆	(77)
	9 (228)	(Prefix)-09-HYL	(Prefix)-09-HYR	32 ¹¹ / ₁₆	(831)	20 ⁵ / ₁₆	(516)	6 ¹ / ₁₆	(154)
	12 (305)	(Prefix)-12-HYL	(Prefix)-12-HYR	36 ¹⁵ / ₁₆	(938)	25 ⁷ / ₁₆	(646)	9 ¹ / ₁₆	(231)
	18 (457)	(Prefix)-18-HYL	(Prefix)-18-HYR	45 ³ / ₈	(1153)	35 ¹³ / ₁₆	(910)	15 ¹ / ₁₆	(383)
	24 (609)	(Prefix)-24-HYL	(Prefix)-24-HYR	53 ⁷ / ₈	(1368)	45 ¹⁵ / ₁₆	(1167)	21 ¹ / ₁₆	(535)
	30 (762)	(Prefix)-30-HYL	(Prefix)-30-HYR	62 ³ / ₈	(1585)	56 ³ / ₁₆	(1427)	27 ¹ / ₁₆	(688)
	36 (914)	(Prefix)-36-HYL	(Prefix)-36-HYR	70 ⁷ / ₈	(1800)	66 ⁷ / ₁₆	(1687)	33 ¹ / ₁₆	(840)
42 (1067)	(Prefix)-42-HYL	(Prefix)-42-HYR	79 ³ / ₈	(2016)	76 ⁵ / ₈	(1946)	39 ¹ / ₁₆	(992)	

(Prefix) See page L-3 for catalog number prefix.

Width dimensions are to inside wall. For aluminum fittings add 1.5 inches (38mm) for total outside width.

Manufacturing tolerances apply to all dimensions.

All dimensions in parentheses are millimeters unless otherwise specified.

Vertical Bend 90° (VO, VI)

1 pair splice plates with hardware included.

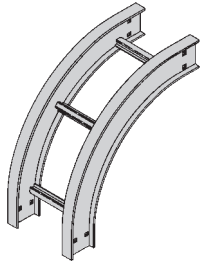

90° Vertical Outside - VO

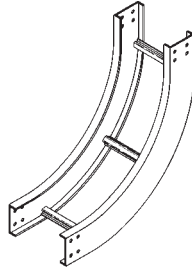

90° Vertical Inside - VI

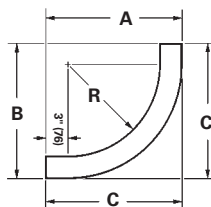
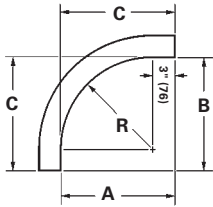

Bend Radius R	Tray Width Insert	(*) Insert "VO" for Vert. Outside Bend "VI" for Vert. Inside Bend Catalog No.	VO Side Rail Height 4" - 7"			VI Side Rail Height													
			4" - 7"			4"			5"			6"			7"				
			in./(mm)			in./(mm)			in./(mm)			in./(mm)			in./(mm)				
in./(mm)	in. (mm)		A	B	C	A	B	C	A	B	C	A	B	C	A	B	C		
12 (305)	6 (152)	(Prefix)-06-90(*)12																	
	9 (228)	(Prefix)-09-90(*)12																	
	12 (305)	(Prefix)-12-90(*)12																	
	18 (457)	(Prefix)-18-90(*)12	15	15	15	19	19	19	20	20	20	21	21	21	22	22	22	22	
	24 (609)	(Prefix)-24-90(*)12	(381)	(381)	(381)	(483)	(483)	(483)	(508)	(508)	(508)	(533)	(533)	(533)	(559)	(559)	(559)	(559)	
	30 (762)	(Prefix)-30-90(*)12																	
	36 (914)	(Prefix)-36-90(*)12																	
42 (1067)	(Prefix)-42-90(*)12																		
24 (609)	6 (152)	(Prefix)-06-90(*)24																	
	9 (228)	(Prefix)-09-90(*)24																	
	12 (305)	(Prefix)-12-90(*)24																	
	18 (457)	(Prefix)-18-90(*)24	27	27	27	31	31	31	32	32	32	33	33	33	34	34	34	34	
	24 (609)	(Prefix)-24-90(*)24	(686)	(686)	(686)	(787)	(787)	(787)	(813)	(813)	(813)	(838)	(838)	(838)	(864)	(864)	(864)	(864)	
	30 (762)	(Prefix)-30-90(*)24																	
	36 (914)	(Prefix)-36-90(*)24																	
42 (1067)	(Prefix)-42-90(*)24																		
36 (914)	6 (152)	(Prefix)-06-90(*)36																	
	9 (228)	(Prefix)-09-90(*)36																	
	12 (305)	(Prefix)-12-90(*)36																	
	18 (457)	(Prefix)-18-90(*)36	39	39	39	43	43	43	44	44	44	45	45	45	46	46	46	46	
	24 (609)	(Prefix)-24-90(*)36	(991)	(991)	(991)	(1092)	(1092)	(1092)	(1118)	(1118)	(1118)	(1143)	(1143)	(1143)	(1168)	(1168)	(1168)	(1168)	
	30 (762)	(Prefix)-30-90(*)36																	
	36 (914)	(Prefix)-36-90(*)36																	
42 (1067)	(Prefix)-42-90(*)36																		
48 (1219)	6 (152)	(Prefix)-06-90(*)48																	
	9 (228)	(Prefix)-09-90(*)48																	
	12 (305)	(Prefix)-12-90(*)48																	
	18 (457)	(Prefix)-18-90(*)48	51	51	51	55	55	55	56	56	56	57	57	57	58	58	58	58	
	24 (609)	(Prefix)-24-90(*)48	(1295)	(1295)	(1295)	(1397)	(1397)	(1397)	(1422)	(1422)	(1422)	(1448)	(1448)	(1448)	(1473)	(1473)	(1473)	(1473)	
	30 (762)	(Prefix)-30-90(*)48																	
	36 (914)	(Prefix)-36-90(*)48																	
42 (1067)	(Prefix)-42-90(*)48																		

(Prefix) See page L-3 for catalog number prefix.

Width dimensions are to inside wall. For aluminum fittings add 1.5 inches (38mm) for total outside width.

Manufacturing tolerances apply to all dimensions.

All dimensions in parentheses are millimeters unless otherwise specified.

Series 2, 3, 4, & 5 - Fittings

Vertical Bend 60° (VO, VI)

1 pair splice plates with hardware included.

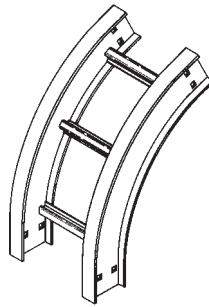

60° Vertical Outside - VO

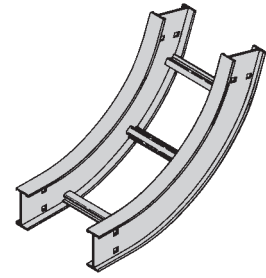

60° Vertical Inside - VI

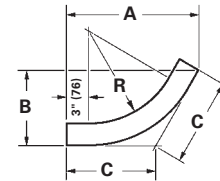
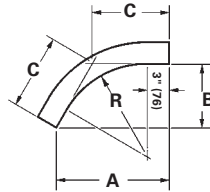

Bend Radius R	Tray Width Insert	(*) Insert "VO" for Vert. Outside Bend "VI" for Vert. Inside Bend Catalog No.	VO Side Rail Height 4" - 7"		VI Side Rail Height													
			4"			5"			6"			7"						
			in./(mm)			in./(mm)			in./(mm)			in./(mm)						
in./(mm)	in. (mm)		A	B	C	A	B	C	A	B	C	A	B	C	A	B	C	
12 (305)	6 (152)	(Prefix)-06-60(*)12																
	9 (228)	(Prefix)-09-60(*)12																
	12 (305)	(Prefix)-12-60(*)12																
	18 (457)	(Prefix)-18-60(*)12	147/8	85/8	915/16	183/8	107/8	121/4	191/4	111/8	1213/16	201/16	115/8	133/8	2115/16	121/8	14	
	24 (609)	(Prefix)-24-60(*)12	(378)	(219)	(253)	(467)	(270)	(311)	(489)	(283)	(326)	(510)	(296)	(340)	(557)	(308)	(356)	
	30 (762)	(Prefix)-30-60(*)12																
36 (914)	(Prefix)-36-60(*)12																	
42 (1067)	(Prefix)-42-60(*)12																	
24 (609)	6 (152)	(Prefix)-06-60(*)24																
	9 (228)	(Prefix)-09-60(*)24																
	12 (305)	(Prefix)-12-60(*)24																
	18 (457)	(Prefix)-18-60(*)24	255/16	145/8	167/8	283/4	165/8	193/16	295/8	171/8	193/4	301/2	175/8	205/16	313/8	181/8	207/8	
	24 (609)	(Prefix)-24-60(*)24	(643)	(372)	(428)	(730)	(422)	(488)	(753)	(435)	(502)	(775)	(448)	(516)	(797)	(461)	(530)	
	30 (762)	(Prefix)-30-60(*)24																
36 (914)	(Prefix)-36-60(*)24																	
42 (1067)	(Prefix)-42-60(*)24																	
36 (914)	6 (152)	(Prefix)-06-60(*)36																
	9 (228)	(Prefix)-09-60(*)36																
	12 (305)	(Prefix)-12-60(*)36																
	18 (457)	(Prefix)-18-60(*)36	351/16	205/8	2313/16	391/8	225/8	261/8	40	231/8	2611/16	407/8	235/8	271/4	413/4	241/8	2713/16	
	24 (609)	(Prefix)-24-60(*)36	(907)	(524)	(605)	(994)	(575)	(663)	(1016)	(587)	(687)	(1038)	(600)	(692)	(1060)	(613)	(706)	
	30 (762)	(Prefix)-30-60(*)36																
36 (914)	(Prefix)-36-60(*)36																	
42 (1067)	(Prefix)-42-60(*)36																	
48 (1219)	6 (152)	(Prefix)-06-60(*)48																
	9 (228)	(Prefix)-09-60(*)48																
	12 (305)	(Prefix)-12-60(*)48																
	18 (457)	(Prefix)-18-60(*)48	461/16	265/8	3011/16	499/16	285/8	33	503/8	291/8	335/8	511/4	295/8	343/16	521/8	301/8	343/4	
	24 (609)	(Prefix)-24-60(*)48	(1170)	(676)	(780)	(1259)	(727)	(838)	(1280)	(740)	(854)	(1302)	(753)	(868)	(1324)	(765)	(883)	
	30 (762)	(Prefix)-30-60(*)48																
36 (914)	(Prefix)-36-60(*)48																	
42 (1067)	(Prefix)-42-60(*)48																	

(Prefix) See page L-3 for catalog number prefix.

Width dimensions are to inside wall. For aluminum fittings add 1.5 inches (38mm) for total outside width.

Manufacturing tolerances apply to all dimensions.

All dimensions in parentheses are millimeters unless otherwise specified.

Vertical Bend 45° (VO, VI)

1 pair splice plates with hardware included.

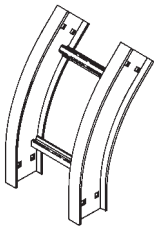

45° Vertical Outside -VO

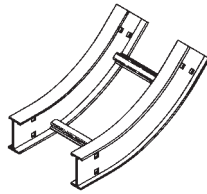

45° Vertical Inside -VI

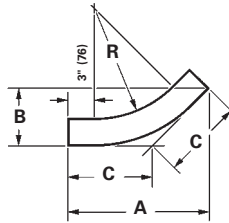
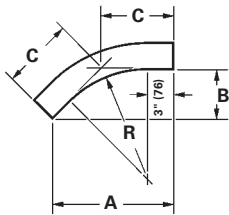

Bend Radius R	Tray Width Insert	(*) Insert "VO" for Vert. Outside Bend "VI" for Vert. Inside Bend Catalog No.	VO Side Rail Height 4" - 7"			VI Side Rail Height											
			in./(mm)			4"			5"			6"			7"		
			A	B	C	A	B	C	A	B	C	A	B	C	A	B	C
12 (305)	6 (152)	(Prefix)-06-45(*)12	13 ⁵ / ₈ (346)	5 ⁵ / ₈ (143)	8 (203)	16 ⁷ / ₁₆ (417)	6 ¹³ / ₁₆ (173)	9 ⁵ / ₈ (245)	17 ¹ / ₈ (435)	7 ¹ / ₈ (181)	10 ¹ / ₁₆ (256)	17 ⁷ / ₈ (454)	7 ³ / ₈ (188)	10 ⁷ / ₁₆ (265)	18 ⁹ / ₁₆ (471)	7 ¹¹ / ₁₆ (195)	10 ⁷ / ₈ (2176)
	9 (228)	(Prefix)-09-45(*)12															
	12 (305)	(Prefix)-12-45(*)12															
	18 (457)	(Prefix)-18-45(*)12															
	24 (609)	(Prefix)-24-45(*)12															
	30 (762)	(Prefix)-30-45(*)12															
	36 (914)	(Prefix)-36-45(*)12															
42 (1067)	(Prefix)-42-45(*)12																
24 (609)	6 (152)	(Prefix)-06-45(*)24	22 ¹ / ₁₆ (561)	9 ¹ / ₈ (232)	12 ¹⁵ / ₁₆ (329)	24 ¹⁵ / ₁₆ (634)	10 ⁵ / ₁₆ (262)	14 ⁵ / ₈ (372)	25 ⁵ / ₈ (651)	10 ⁵ / ₈ (270)	15 (381)	26 ⁵ / ₁₆ (668)	10 ¹⁵ / ₁₆ (278)	15 ⁷ / ₁₆ (392)	27 ¹ / ₁₆ (687)	11 ³ / ₁₆ (284)	15 ¹³ / ₁₆ (402)
	9 (228)	(Prefix)-09-45(*)24															
	12 (305)	(Prefix)-12-45(*)24															
	18 (457)	(Prefix)-18-45(*)24															
	24 (609)	(Prefix)-24-45(*)24															
	30 (762)	(Prefix)-30-45(*)24															
	36 (914)	(Prefix)-36-45(*)24															
42 (1067)	(Prefix)-42-45(*)24																
36 (914)	6 (152)	(Prefix)-06-45(*)36	30 ⁹ / ₁₆ (776)	12 ¹¹ / ₁₆ (323)	17 ¹⁵ / ₁₆ (456)	33 ³ / ₈ (848)	13 ¹³ / ₁₆ (351)	19 ⁹ / ₁₆ (497)	34 ¹ / ₈ (867)	14 ¹ / ₈ (359)	20 (508)	34 ¹³ / ₁₆ (885)	14 ⁷ / ₁₆ (367)	20 ³ / ₈ (518)	35 ¹ / ₂ (902)	14 ¹¹ / ₁₆ (284)	20 ¹³ / ₁₆ (402)
	9 (228)	(Prefix)-09-45(*)36															
	12 (305)	(Prefix)-12-45(*)36															
	18 (457)	(Prefix)-18-45(*)36															
	24 (609)	(Prefix)-24-45(*)36															
	30 (762)	(Prefix)-30-45(*)36															
	36 (914)	(Prefix)-36-45(*)36															
42 (1067)	(Prefix)-42-45(*)36																
48 (1219)	6 (152)	(Prefix)-06-45(*)48	39 ¹ / ₁₆ (992)	16 ³ / ₁₆ (411)	22 ⁷ / ₈ (581)	41 ⁷ / ₈ (1064)	17 ³ / ₈ (441)	24 ⁹ / ₁₆ (624)	42 ⁵ / ₈ (1083)	17 ⁵ / ₈ (448)	24 ¹⁵ / ₁₆ (633)	43 ⁵ / ₁₆ (1100)	17 ¹⁵ / ₁₆ (456)	25 ³ / ₈ (645)	44 (1118)	18 ¹ / ₄ (464)	25 ¹³ / ₁₆ (656)
	9 (228)	(Prefix)-09-45(*)48															
	12 (305)	(Prefix)-12-45(*)48															
	18 (457)	(Prefix)-18-45(*)48															
	24 (609)	(Prefix)-24-45(*)48															
	30 (762)	(Prefix)-30-45(*)48															
	36 (914)	(Prefix)-36-45(*)48															
42 (1067)	(Prefix)-42-45(*)48																

(Prefix) See page L-3 for catalog number prefix.

Width dimensions are to inside wall. For aluminum fittings add 1.5 inches (38mm) for total outside width.

Manufacturing tolerances apply to all dimensions.

All dimensions in parentheses are millimeters unless otherwise specified.

Series 2, 3, 4, & 5 - Fittings

Vertical Bend 30° (VO, VI)

1 pair splice plates with hardware included.

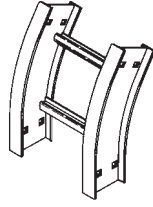

30° Vertical Outside -VO

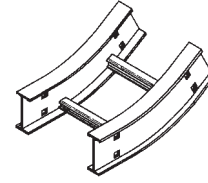

30° Vertical Inside -VI

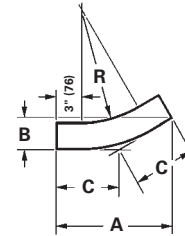
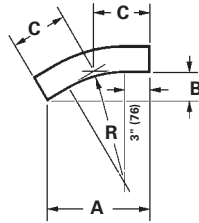

Bend Radius R	Tray Width Insert	(*) Insert "VO" for Vert. Outside Bend "VI" for Vert. Inside Bend Catalog No.	VO Side Rail Height 4" - 7"			VI Side Rail Height											
			in./(mm)			4"			5"			6"			7"		
			A	B	C	A	B	C	A	B	C	A	B	C	A	B	C
12 (305)	6 (152)	(Prefix)-06-30(*)12	11 ⁵ / ₈ (296)	3 ¹ / ₈ (79)	6 ³ / ₁₆ (157)	13 ⁵ / ₈ (346)	3 ⁵ / ₈ (92)	7 ⁵ / ₁₆ (186)	14 ¹ / ₈ (359)	3 ³ / ₄ (95)	7 ⁹ / ₁₆ (192)	14 ⁵ / ₈ (372)	3 ¹⁵ / ₁₆ (100)	7 ¹³ / ₁₆ (199)	15 ¹ / ₈ (384)	4 ¹ / ₁₆ (103)	8 ¹ / ₁₆ (205)
	9 (228)	(Prefix)-09-30(*)12															
	12 (305)	(Prefix)-12-30(*)12															
	18 (457)	(Prefix)-18-30(*)12															
	24 (609)	(Prefix)-24-30(*)12															
	30 (762)	(Prefix)-30-30(*)12															
	36 (914)	(Prefix)-36-30(*)12															
42 (1067)	(Prefix)-42-30(*)12																
24 (609)	6 (152)	(Prefix)-06-30(*)24	17 ⁵ / ₈ (448)	4 ¹¹ / ₁₆ (120)	9 ⁷ / ₁₆ (240)	19 ⁵ / ₈ (499)	5 ¹ / ₄ (133)	10 ¹ / ₂ (267)	20 ¹ / ₈ (511)	5 ³ / ₈ (137)	10 ³ / ₄ (273)	20 ⁵ / ₈ (524)	5 ¹ / ₂ (140)	11 ¹ / ₁₆ (282)	21 ¹ / ₈ (537)	5 ⁵ / ₈ (143)	11 ⁵ / ₁₆ (287)
	9 (228)	(Prefix)-09-30(*)24															
	12 (305)	(Prefix)-12-30(*)24															
	18 (457)	(Prefix)-18-30(*)24															
	24 (609)	(Prefix)-24-30(*)24															
	30 (762)	(Prefix)-30-30(*)24															
	36 (914)	(Prefix)-36-30(*)24															
42 (1067)	(Prefix)-42-30(*)24																
36 (914)	6 (152)	(Prefix)-06-30(*)36	23 ⁵ / ₈ (600)	6 ⁵ / ₁₆ (160)	12 ⁵ / ₈ (321)	25 ⁵ / ₈ (651)	6 ⁷ / ₈ (174)	13 ¹¹ / ₁₆ (348)	26 ¹ / ₈ (663)	7 (175)	14 (356)	26 ⁵ / ₈ (676)	7 ¹ / ₈ (181)	14 ¹ / ₄ (362)	27 ¹ / ₈ (689)	7 ¹ / ₄ (184)	14 ¹ / ₂ (287)
	9 (228)	(Prefix)-09-30(*)36															
	12 (305)	(Prefix)-12-30(*)36															
	18 (457)	(Prefix)-18-30(*)36															
	24 (609)	(Prefix)-24-30(*)36															
	30 (762)	(Prefix)-30-30(*)36															
	36 (914)	(Prefix)-36-30(*)36															
42 (1067)	(Prefix)-42-30(*)36																
48 (1219)	6 (152)	(Prefix)-06-30(*)48	29 ⁵ / ₈ (753)	7 ¹⁵ / ₁₆ (202)	15 ⁷ / ₈ (403)	31 ⁵ / ₈ (803)	8 ⁷ / ₁₆ (214)	16 ¹⁵ / ₁₆ (430)	32 ¹ / ₈ (816)	8 ⁵ / ₈ (219)	17 ³ / ₁₆ (437)	32 ⁵ / ₈ (829)	8 ³ / ₄ (222)	17 ¹ / ₂ (445)	33 ¹ / ₈ (842)	8 ⁷ / ₈ (226)	17 ³ / ₄ (451)
	9 (228)	(Prefix)-09-30(*)48															
	12 (305)	(Prefix)-12-30(*)48															
	18 (457)	(Prefix)-18-30(*)48															
	24 (609)	(Prefix)-24-30(*)48															
	30 (762)	(Prefix)-30-30(*)48															
	36 (914)	(Prefix)-36-30(*)48															
42 (1067)	(Prefix)-42-30(*)48																

(Prefix) See page L-3 for catalog number prefix.

Width dimensions are to inside wall. For aluminum fittings add 1.5 inches (38mm) for total outside width.

Manufacturing tolerances apply to all dimensions.

All dimensions in parentheses are millimeters unless otherwise specified.

Vertical Tee Up/Down (VTU/VT)

2 pair splice plates with hardware included.

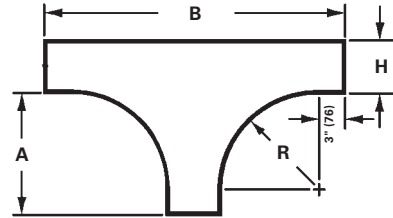
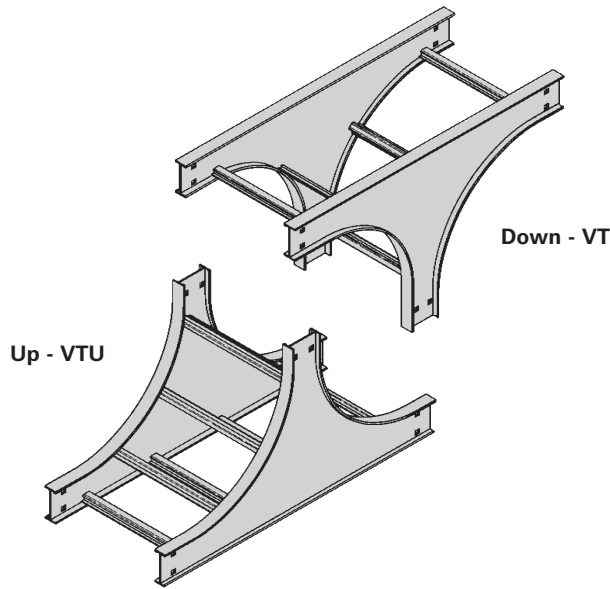

Bend Radius R in./mm	Tray Width in. mm	Vertical Tee Down Catalog No.	Vertical Tee Up Catalog No.	Side Rail Height "H"							
				4"		5"		6"		7"	
				A in./mm	B in./mm	A in./mm	B in./mm	A in./mm	B in./mm	A in./mm	B in./mm
12 (305)	6 (152)	(Prefix)-06-VT12	(Prefix)-06-VTU12	15 (381)	34 (846)	15 (381)	35 (889)	15 (381)	36 (914)	15 (381)	37 (940)
	9 (228)	(Prefix)-09-VT12	(Prefix)-09-VTU12								
	12 (305)	(Prefix)-12-VT12	(Prefix)-12-VTU12								
	18 (457)	(Prefix)-18-VT12	(Prefix)-18-VTU12								
	24 (609)	(Prefix)-24-VT12	(Prefix)-24-VTU12								
	30 (762)	(Prefix)-30-VT12	(Prefix)-30-VTU12								
	36 (914)	(Prefix)-36-VT12	(Prefix)-36-VTU12								
42 (1067)	(Prefix)-42-VT12	(Prefix)-42-VTU12									
24 (609)	6 (152)	(Prefix)-06-VT24	(Prefix)-06-VTU24	27 (6867)	58 (1473)	27 (686)	59 (1498)	27 (686)	60 (1524)	27 (686)	61 (1549)
	9 (228)	(Prefix)-09-VT24	(Prefix)-09-VTU24								
	12 (305)	(Prefix)-12-VT24	(Prefix)-12-VTU24								
	18 (457)	(Prefix)-18-VT24	(Prefix)-18-VTU24								
	24 (609)	(Prefix)-24-VT24	(Prefix)-24-VTU24								
	30 (762)	(Prefix)-30-VT24	(Prefix)-30-VTU24								
	36 (914)	(Prefix)-36-VT24	(Prefix)-36-VTU24								
42 (1067)	(Prefix)-42-VT24	(Prefix)-42-VTU24									
36 (914)	6 (152)	(Prefix)-06-VT36	(Prefix)-06-VTU36	39 (991)	82 (2083)	39 (991)	83 (2108)	39 (991)	84 (2134)	39 (991)	85 (2159)
	9 (228)	(Prefix)-09-VT36	(Prefix)-09-VTU36								
	12 (305)	(Prefix)-12-VT36	(Prefix)-12-VTU36								
	18 (457)	(Prefix)-18-VT36	(Prefix)-18-VTU36								
	24 (609)	(Prefix)-24-VT36	(Prefix)-24-VTU36								
	30 (762)	(Prefix)-30-VT36	(Prefix)-30-VTU36								
	36 (914)	(Prefix)-36-VT36	(Prefix)-36-VTU36								
42 (1067)	(Prefix)-42-VT36	(Prefix)-42-VTU36									
48 (1219)	6 (152)	(Prefix)-06-VT48	(Prefix)-06-VTU48	51 (1295)	106 (2692)	51 (1295)	107 (2718)	51 (1295)	108 (2743)	51 (1295)	109 (2769)
	9 (228)	(Prefix)-09-VT48	(Prefix)-09-VTU48								
	12 (305)	(Prefix)-12-VT48	(Prefix)-12-VTU48								
	18 (457)	(Prefix)-18-VT48	(Prefix)-18-VTU48								
	24 (609)	(Prefix)-24-VT48	(Prefix)-24-VTU48								
	30 (762)	(Prefix)-30-VT48	(Prefix)-30-VTU48								
	36 (914)	(Prefix)-36-VT48	(Prefix)-36-VTU48								
42 (1067)	(Prefix)-42-VT48	(Prefix)-42-VTU48									

Series 2, 3, 4, & 5 Fittings

(Prefix) See page L-3 for catalog number prefix.

Width dimensions are to inside wall. For aluminum fittings add 1.5 inches (38mm) for total outside width.

Manufacturing tolerances apply to all dimensions.

All dimensions in parentheses are millimeters unless otherwise specified.

Series 2, 3, 4, & 5 - Fittings

Cable Support Fittings (CSF)

1 pair splice plates with hardware included.

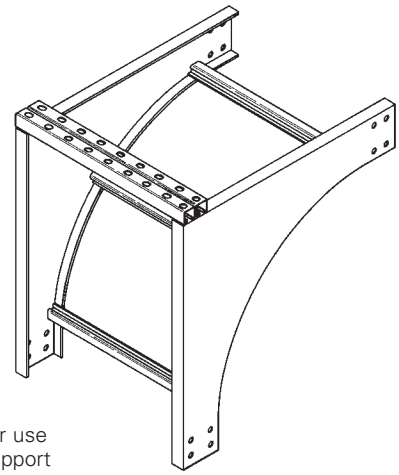
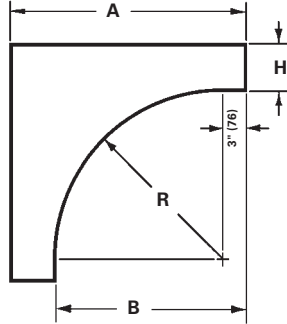

This fitting is recommended for use at the top of vertical runs to support the weight of the cables. The top cross brace is drilled for installing eyebolts, ordered separately.

Series 2, 3, 4, & 5 Fittings

Bend Radius R in./(mm)	Tray Width in. mm	Catalog No.	Side Rail Height "H"								
			4"		5"		6"		7"		
			A in./(mm)	B in./(mm)	A in./(mm)	B in./(mm)	A in./(mm)	B in./(mm)	A in./(mm)	B in./(mm)	
12 (305)	6 152	(Prefix)-06-CSF12									
	9 228	(Prefix)-09-CSF12									
	12 305	(Prefix)-12-CSF12									
	18 457	(Prefix)-18-CSF12	19	15	20	15	21	15	22	15	
	24 609	(Prefix)-24-CSF12	(483)	(381)	(508)	(381)	(533)	(381)	(559)	(381)	
	30 762	(Prefix)-30-CSF12									
	36 914	(Prefix)-36-CSF12									
42 1067	(Prefix)-42-CSF12										
24 (609)	6 152	(Prefix)-06-CSF24									
	9 228	(Prefix)-09-CSF24									
	12 305	(Prefix)-12-CSF24									
	18 457	(Prefix)-18-CSF24	31	27	32	27	33	27	34	27	
	24 609	(Prefix)-24-CSF24	(787)	(686)	(813)	(686)	(838)	(686)	(864)	(686)	
	30 762	(Prefix)-30-CSF24									
	36 914	(Prefix)-36-CSF24									
42 1067	(Prefix)-42-CSF24										
36 (914)	6 152	(Prefix)-06-CSF36									
	9 228	(Prefix)-09-CSF36									
	12 305	(Prefix)-12-CSF36									
	18 457	(Prefix)-18-CSF36	43	39	44	39	45	39	46	39	
	24 609	(Prefix)-24-CSF36	(1092)	(991)	(1118)	(991)	(1143)	(991)	(1168)	(991)	
	30 762	(Prefix)-30-CSF36									
	36 914	(Prefix)-36-CSF36									
42 1067	(Prefix)-42-CSF36										
48 (1219)	6 152	(Prefix)-06-CSF48									
	9 228	(Prefix)-09-CSF48									
	12 305	(Prefix)-12-CSF48									
	18 457	(Prefix)-18-CSF48	55	51	56	51	57	51	58	51	
	24 609	(Prefix)-24-CSF48	(1397)	(1295)	(1422)	(1295)	(1448)	(1295)	(1473)	(1295)	
	30 762	(Prefix)-30-CSF48									
	36 914	(Prefix)-36-CSF48									
42 1067	(Prefix)-42-CSF48										

(Prefix) See page L-3 for catalog number prefix.

Width dimensions are to inside wall. For aluminum fittings add 1.5 inches (38mm) for total outside width.

Manufacturing tolerances apply to all dimensions.

All dimensions in parentheses are millimeters unless otherwise specified.

Fiberglass - Straight Sections



Fiberglass

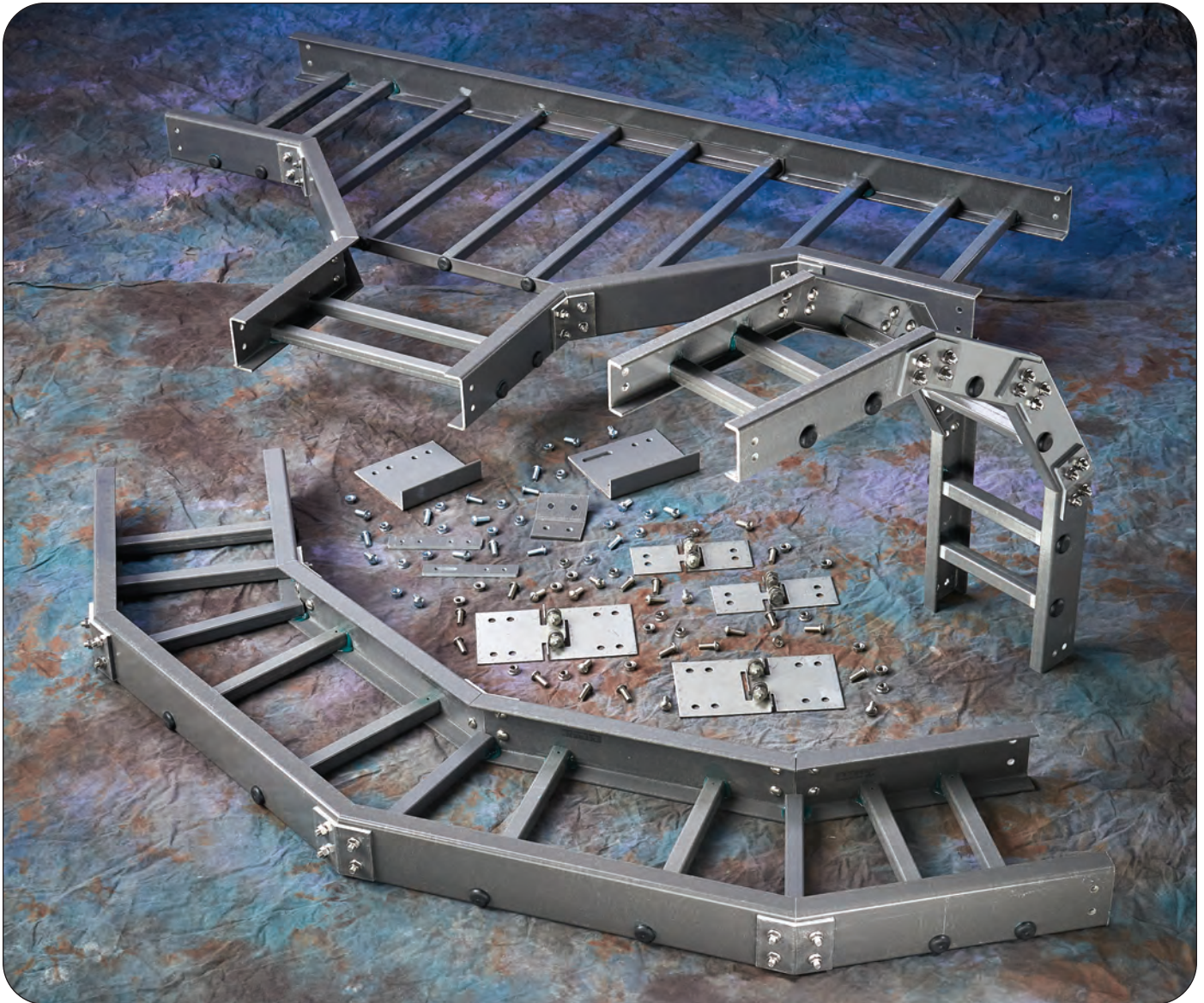

How The Service Advisor Works

We know that your time is important! That's why the color-coding system in this catalog is designed to help you select products that fit your service needs. Products are marked to indicate the typical lead time for orders of 50 pieces or less.

Customer: How do I select my straight sections, covers, or fittings so that I get the quickest turnaround?

Service Advisor: Each part of our selection chart is shown in colors. If any section of a part number is a different color, the part will typically ship with the longer lead time represented by the colors.

- Green = Fastest shipped items
- Black = Normal lead-time items
- Red = Normally long lead-time items

Example:

13	FA	-	09	-	24	-	144
●	●		●		●		●
3-5	15		3-5		3-5		3-5

Part will have a long lead time because of the FA material.

Changing the part number from 13FA to 13F will change the coding to black for all sections and reduce the lead time.

Fiberglass - Technical Data

Corrosion Guide

The information shown in this corrosion guide is based on full immersion laboratory tests and data generated from resin manufacturer's data. It should be noted that in some of the environments listed, splashes and spill situations may result in a more corrosive situation than indicated due to the evaporation of water. Regular wash down is recommended in these situations.

All data represents the best available information and is believed to be correct. The data should not be construed as a warranty of performance for that product as presented in these tables. User tests should be performed to determine suitability of service if there is any doubt or concern. Such variables as concentration, temperature, time and combined chemical effects of mixtures of chemicals make it impossible to specify the exact suitability of fiber reinforced plastics in all environments. We will be happy to supply material samples for testing. These recommendations should only be used as a guide and we do not take responsibility for design or suitability of materials for service intended. In no event will we be liable for any consequential or special damages for any defective material or workmanship including without limitation, labor charge, other expense or damage to properties resulting from loss of materials or profits or increased expenses of operations.

CHEMICAL ENVIRONMENT	POLYESTER		VINYL ESTER	
	Max Wt. %	Max Oper. Temp °F	Max Wt. %	Max Oper. Temp °F
Acetic Acid	10	190	10	210
Acetic Acid	50	125	50	180
Acetone	N/R	N/R	100	75
Aluminum Chloride	SAT	170	SAT	200
Aluminum Hydroxide	SAT	160	SAT	170
Aluminum Nitrate	SAT	150	SAT	170
Aluminum Sulfate	SAT	180	SAT	200
Ammonium Chloride	SAT	170	SAT	190
Ammonium Hydroxide	1	100	10	150
Ammonium Hydroxide	28	N/R	28	100
Ammonium Carbonate	N/R	N/R	SAT	150
Ammonium Bicarbonate	15	125	SAT	130
Ammonium Nitrate	SAT	160	SAT	190
Ammonium Persulfate	SAT	N/R	SAT	150
Ammonium Sulfate	SAT	170	SAT	200
Amyl Alcohol	ALL	N/R	ALL	90
Amyl Alcohol Vapor	-	140	-	120
Benzene	N/R	N/R	100	140
Benzene Sulfonic Acid	25	110	SAT	200
Benzoic Acid	SAT	150	SAT	200
Benzoyl Alcohol	100	N/R	100	N/R
Borax	SAT	170	SAT	200
Calcium Carbonate	SAT	170	SAT	200
Calcium Chloride	SAT	170	SAT	200
Calcium Hydroxide	25	70	25	165
Calcium Nitrate	SAT	180	SAT	200
Calcium Sulfate	SAT	180	SAT	200
Carbon Disulfide	N/R	N/R	N/R	N/R
Carbonic Acid	SAT	130	SAT	180
Carbon Dioxide Gas	-	200	-	200
Carbon Monoxide Gas	-	200	-	200
Carbon Tetrachloride	N/R	N/R	100	75
Chlorine, Dry Gas	-	140	-	170
Chlorine, Wet Gas	-	N/R	-	180
Chlorine Water	SAT	80	SAT	180

CHEMICAL ENVIRONMENT	POLYESTER		VINYL ESTER	
	Max Wt. %	Max Oper. Temp °F	Max Wt. %	Max Oper. Temp °F
Chromic Acid	5	70	10	120
Citric Acid	SAT	170	SAT	200
Copper Chloride	SAT	170	SAT	200
Copper Cyanide	SAT	170	SAT	200
Copper Nitrate	SAT	170	SAT	200
Crude Oil, Sour	100	170	100	200
Cyclohexane	N/R	N/R	N/R	N/R
Cyclohexane, Vapor	ALL	100	ALL	130
Diesel Fuel	100	160	100	180
Diethyl Ether	N/R	N/R	N/R	N/R
Dimethyl Phthalate	N/R	N/R	N/R	N/R
Ethanol	50	75	50	90
Ethyl Acetate	N/R	N/R	N/R	N/R
Ethylene Chloride	N/R	N/R	N/R	N/R
Ethylene Glycol	100	90	100	200
Fatty Acids	SAT	180	SAT	200
Ferric Chloride	SAT	170	SAT	200
Ferric Nitrate	SAT	170	SAT	200
Ferric Sulfate	SAT	170	SAT	200
Ferrous Chloride	SAT	170	SAT	200
Fluoboric Acid	N/R	N/R	SAT	165
Fluosilicic Acid	N/R	N/R	SAT	70
Formaldehyde	50	75	50	100
Formic Acid	N/R	N/R	50	100
Gasoline	100	80	100	150
Glucose	100	170	100	200
Glycerine	100	150	100	200
Heptane	100	110	100	120
Hexane	100	90	100	130
Hydrobromic Acid	50	120	50	120
Hydrochloric Acid	10	150	10	200
Hydrochloric Acid	20	140	20	190
Hydrochloric Acid	37	75	37	95
Hydrofluoric Acid	N/R	N/R	15	80
Hydrogen Bromide, Dry	100	190	100	200

-: No Information Available

N/R: Not Recommended

SAT: Saturated Solution

FUM: Fumes

Corrosion Guide

CHEMICAL ENVIRONMENT	POLYESTER		VINYL ESTER		CHEMICAL ENVIRONMENT	POLYESTER		VINYL ESTER	
	Max Wt. %	Max Oper. Temp °F	Max Wt. %	Max Oper. Temp °F		Max Wt. %	Max Oper. Temp °F	Max Wt. %	Max Oper. Temp °F
Hydrogen Bromide, Wet	100	75	100	130	Potassium Hydroxide	N/R	N/R	25	150
Hydrogen Chloride	-	120	-	200	Potassium Nitrate	SAT	170	SAT	200
Hydrogen Peroxide	5	100	30	100	Potassium Permanganate	100	80	100	210
Hydrogen Sulfide, Dry	100	170	100	210	Potassium Sulfate	SAT	170	SAT	200
Hydrogen Sulfide, Wet	100	170	100	210	Propylene Glycol	ALL	170	ALL	200
Hypochlorous Acid	20	80	20	150	Phthalic Acid	-	-	SAT	200
Isopropyl Alcohol	N/R	N/R	15	80	Sodium Acetate	SAT	160	SAT	200
Kerosene	100	140	100	180	Sodium Benzoate	SAT	170	SAT	200
Lactic Acid	SAT	170	SAT	200	Sodium Bicarbonate	SAT	160	SAT	175
Lead Acetate	SAT	170	SAT	200	Sodium Bisulfate	ALL	170	ALL	200
Lead Chloride	SAT	140	SAT	200	Sodium Bromide	ALL	170	ALL	200
Lead Nitrate	SAT	-	SAT	200	Sodium Carbonate	10	80	35	160
Linseed Oil	100	150	100	190	Sodium Chloride	SAT	170	SAT	200
Lithium Chloride	SAT	150	SAT	190	Sodium Cyanide	SAT	170	SAT	200
Magnesium Carbonate	SAT	140	SAT	170	Sodium Hydroxide	N/R	N/R	50	150
Magnesium Chloride	SAT	170	SAT	200	Sodium Hydroxide	N/R	N/R	25	80
Magnesium Hydroxide	SAT	150	SAT	190	Sodium Hypochloride	N/R	N/R	10	150
Magnesium Nitrate	SAT	140	SAT	180	Sodium Monophosphate	SAT	170	SAT	200
Magnesium Sulfate	SAT	170	SAT	190	Sodium Nitrate	SAT	170	SAT	200
Mercuric Chloride	SAT	150	SAT	190	Sodium Sulfate	SAT	170	SAT	200
Mercurous Chloride	SAT	140	SAT	180	Sodium Thiosulfate	ALL	100	ALL	120
Methyl Ethyl Ketone	N/R	N/R	N/R	N/R	Stannic Chloride	SAT	160	SAT	190
Mineral Oils	100	170	100	200	Styrene	N/R	N/R	N/R	N/R
Monochlorobenzene	N/R	N/R	N/R	N/R	Sulfated Detergent	0/50	170	0/50	200
Naphtha	100	140	100	170	Sulfur Dioxide	100	80	100	200
Nickel Chloride	SAT	170	SAT	200	Sulfur Trioxide	100	80	100	200
Nickel Nitrate	SAT	170	SAT	200	Sulfuric Acid	93	N/R	93	N/R
Nickel Sulfate	SAT	170	SAT	200	Sulfuric Acid	50	N/R	50	180
Nitric Acid	5	140	5	150	Sulfuric Acid	25	75	25	190
Nitric Acid	20	70	20	100	Sulfurous Acid	SAT	80	N/R	N/R
Oleic Acid	100	170	100	190	Tartaric Acid	SAT	170	SAT	200
Oxalic Acid	ALL	75	ALL	120	Tetrachloroethylene	N/R	N/R	FUM	75
Paper Mill Liquors	-	100	-	120	Toluene	N/R	N/R	N/R	N/R
Perchloroethylene	100	N/R	100	N/R	Trisodium Phosphate	N/R	N/R	SAT	175
Perchloric Acid	N/R	N/R	10	150	Urea	SAT	130	SAT	140
Perchloric Acid	N/R	N/R	30	80	Vinegar	100	170	100	200
Phosphoric Acid	10	160	10	200	Water, Distilled	100	170	100	190
Phosphoric Acid	100	120	100	200	Water, Tap	100	170	100	190
Potassium Aluminum Sulfate	SAT	170	SAT	200	Water, Sea	SAT	170	SAT	190
Potassium Bicarbonate	50	80	50	140	Xylene	N/R	N/R	N/R	N/R
Potassium Carbonate	10	N/R	10	120	Zinc Chloride	SAT	170	SAT	200
Potassium Chloride	SAT	170	SAT	200	Zinc Nitrate	SAT	170	SAT	200
Potassium Dichromate	SAT	170	SAT	200	Zinc Sulfate	SAT	170	SAT	200

-: No Information Available

N/R: Not Recommended

SAT: Saturated Solution

FUM: Fumes

Fiberglass - Technical Data

Load Data

Fiberglass Cable Tray and Cable Channel are offered in three (3) versions for applications as follows:

Standard Series	Resin Type	Color	Meets
13F, 24F, 36F, 46F, 48F FCC-03, FCC-04, FCC-06, FCC-08	Fire Retardant Polyester	Gray	ASTM E-84 Class 1 - UL94 VO Good Corrosion Resistance in most environments
High Performance 13FV, 24FV, 36FV, 46FV, 48FV FCCV-03, FCCV-04, FCCV-06, FCCV-08	Fire Retardant Vinyl Ester	Beige	ASTM E-84 Class 1 - UL94 VO Improved Corrosion Resistance For more severe environments Higher Heat Distortion Temperature
Dis-Stat/Low Smoke 13FA, 24FA, 36FA, 46FA, 48FA FCCA-03, FCCA-04, FCCA-06, FCCA-08	Fire Retardant Zero Halogen/Dis-Stat	Black	ASTM E-84 Class 1 - UL94 VO ASTM D257-99 Dissipates Static Charge Smoke Generation and Toxicity for Mass Transit Requirements and Off Shore application



Effect of Temperature

Strength properties of reinforced plastics are reduced when continuously exposed to elevated temperatures. Working loads shall be reduced based on the chart to the right:

NEMA Standard 8-10-1986

If unusual temperature conditions exist, the manufacturer should be consulted. Authorized Engineering information 8-20-1986

Temperature in Degrees F	Approximate Percent of Strength
75	100
100	90
125	78
150	68
175	60
200	52

Typical Properties of Pultruded Components

Eaton B-Line Division Fiberglass Cable Tray systems are manufactured from glass fiber-reinforced plastic shapes that meet ASTM E-84, Smoke Density rating for polyester of 680, for vinyl ester 1025, Class 1 Flame Rating and self-extinguishing requirements of ASTM D-635. A surface veil is applied during pultrusion to insure a resin-rich surface and ultraviolet resistance.

Flame Resistance (FTMS 406-2023) ign/burn, seconds	75/75
Intermittent Flame Test (HLT-15), rating	100
Flammability Test (ASTM D635) Ignition Burning Time	none 0 sec.

Properties	Test Method	Unit/ Value	3" & 4" Cable Tray, Cable Channel		6" Cable Tray	
			Longitudinal	Transverse	Longitudinal	Transverse
Density	ASTM D1505	lbs/in ³	.058-.062	-	.072 - .076	-
Coefficient of Thermal Expansion	ASTM D696	in/in/F	5.0 x 10 ⁻⁶	-	5.0 x 10 ⁻⁶	-
Water Absorption	ASTM D570	Max %	0.5	-	0.5	-
Dielectric Strength	ASTM D149	V/mil (vpm)	200	-	200	-
Flammability Classification	UL94	VO	-	-	-	-
Flame Spread	ASTM E-84	20 Max	-	-	-	-

Expansion or Contraction for Various Temperature Differences

Temperature Differential	Cable Tray Length for 1" Expansion	Tray Length for Each Expansion Connector*
25°F (13.9°C)	667 Feet (203.3m)	417 Feet (127.1m)
50°F (27.8°C)	333 Feet (101.5m)	208 Feet (63.4m)
75°F (41.7°C)	222 Feet (67.6m)	139 Feet (42.3m)
100°F (55.6°C)	167 Feet (50.9m)	104 Feet (31.7m)
125°F (69.4°C)	133 Feet (40.5m)	83 Feet (25.3m)
150°F (83.3°C)	111 Feet (33.8m)	69 Feet (21.0m)
175°F (97.2°C)	95 Feet (28.9m)	59 Feet (18.0m)

Note for gap set and hold down/guide location, see installation instruction above.

*1" (25.4mm) slotted holes in each expansion connector allow 5/8" (15.9mm) total expansion or contraction.

Authorized Engineering Information 8-20-1986

Cable Tray Installation Guide

Installation of B-Line fiberglass cable tray should be made in accordance with the standards set by NEMA Publication VE-2, Cable Tray Installation Guide, and National Electrical Code, Article 318.

- Always observe common safety practices when assembling tray and fittings. Installations generally require some field cutting. Dust created during fabrication presents no serious health hazard, but skin irritation may be experienced by some workers.
- Operators of saws and drills should wear masks, long sleeve shirts or coveralls.
- Fabrication with fiberglass is relatively easy and comparable to working with wood. Ordinary hand tools may be used in most cases.
- Avoid excessive pressure when sawing or drilling. Too much force can rapidly dull tools and also produce excessive heat which softens the bonding resin in the fiberglass resulting in a ragged edge rather than a clean-cut edge.
- Field cutting is simple and can be accomplished with a circular power saw with an abrasive cut-off wheel (masonry type) or hack saw (24 to 32 teeth per inch).
- Drill fiberglass as you would drill hard wood. Standard twist drills are more than adequate.
- Any surface that has been drilled, cut, sanded or otherwise broken, **must be sealed** with a compatible resin. (see page M-48)
- Carbide tipped saw blades and drill bits are recommended when cutting large quantities.
- Support the fiberglass material firmly during cutting operations to keep material from shifting which may cause chipping at the cut edge.
- Each tray section length should be equal to or greater than the support span.
- When possible, the splice should be located at quarter span.
- Fittings should be supported as per NEMA FG-1.

Recommended Fiberglass Trapeze Hanging Systems

Notes:

- 1) A snug three to four ft.-lbs. torque is sufficient for all thread rod nuts.
- 2) When supporting cable tray, the spacing between each trapeze should not exceed the distance between splice plates.
- 3) When hanging from beam, B-Line series BFV751 series clamps provide extra thread engagement necessary for load ratings. All thread rod must be fully engaged in the clamp.
- 4) Design load safety factor is 3:1

BF22A Strut: 2" max between material being supported and rod

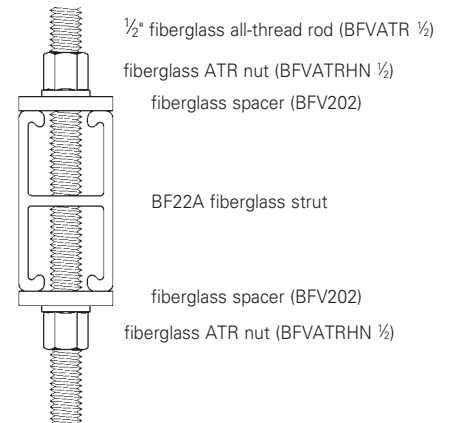
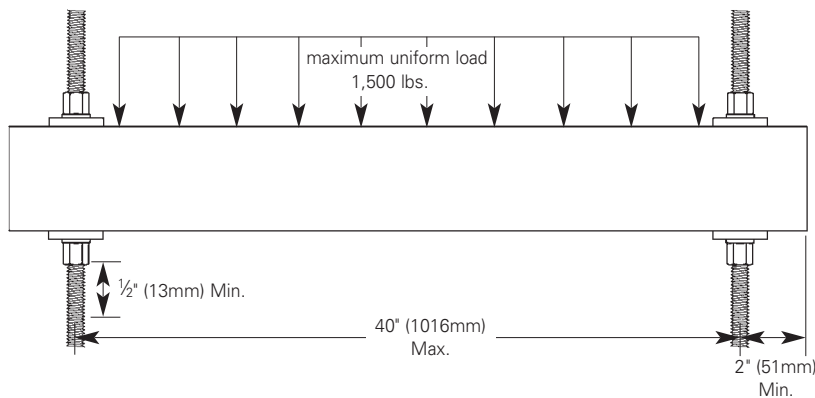

BF22 Strut: 2" max between material being supported and rod

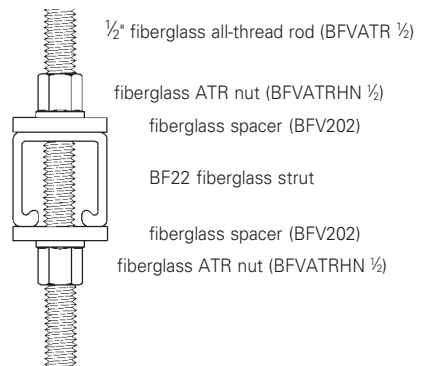
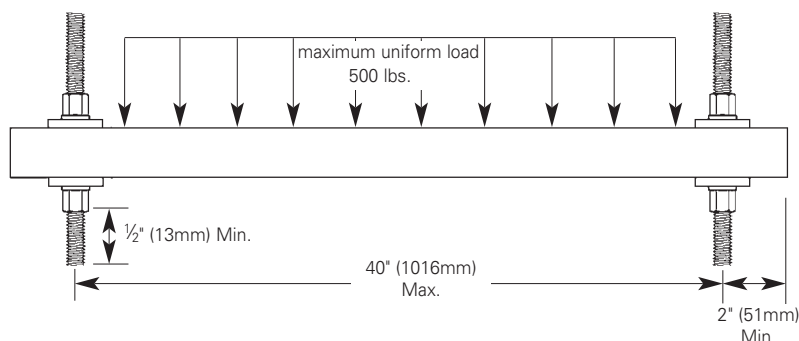

For vinyl ester resin, 'V' must be added appropriately to part number. Example: BFV22A.

SECTION 161xx NON-METALLIC CABLE TRAY POLYESTER, VINYL ESTER

PART 1 - GENERAL

1.01 SECTION INCLUDES

- A. The work covered under this section consists of the furnishing of all necessary labor, supervision, materials, equipment, tests and services to install complete cable tray systems as shown on the drawings.
- B. Cable tray systems are defined to include, but are not limited to straight sections of [ladder type] [vented bottom type] [solid bottom type] cable trays, bends, tees, elbows, drop-outs, supports and accessories.

1.02 REFERENCES

- A. ANSI/NFPA 70 – National Electrical Code
- B. NEMA FG 1-2002 – Non-Metallic Cable Tray Systems
- C. NEMA VE 2-2002 – Cable Tray Installation Guidelines

1.03 DRAWINGS

- A. The drawings, which constitute a part of these specifications, indicate the general route of the cable tray systems. Data presented on these drawings are as accurate as preliminary surveys and planning can determine until final equipment selection is made. Accuracy is not guaranteed and field verification, of all dimensions, routing, etc., is directed.
- B. Specifications and drawings are for assistance and guidance, but exact routing, locations, distances and levels will be governed by actual field conditions. Contractor is directed to make field surveys as part of his work prior to submitting system layout drawings.

1.04 SUBMITTALS

- A. Submittal Drawings: Submit drawings of cable tray and accessories including clamps, brackets, hanger rods, splice plate connectors, expansion joint assemblies, and fittings, showing accurately scaled components.
- B. Product Data: Submit manufacturer's data on cable tray including, but not limited to, types, materials, finishes, rung spacings, inside depths and fitting radii. For side rails and rungs, submit cross sectional properties including Section Modulus (Sx) and Moment of Inertia (Ix).

1.05 QUALITY ASSURANCE

- A. Manufacturers: Firms regularly engaged in manufacture of cable trays and fittings of types and capacities required, whose products have been in satisfactory use in similar service for not less than 5 years.
- B. NEMA Compliance: Comply with NEMA Standards Publication Number FG-1, "Non-Metallic Cable Tray Systems".
- C. NEC Compliance: Comply with NEC, as applicable to construction and installation of cable tray and cable channel systems (Article 318, NEC).

1.06 DELIVERY, STORAGE AND HANDLING

- A. Deliver cable tray systems and components carefully to avoid breakage, denting and scoring finishes. Do not install damaged equipment.
- B. Store cable trays and accessories in original cartons and in clean dry space; protect from weather and construction traffic. Wet materials should be unpacked and dried before storage.

continued on page M-8

PART 2 - PRODUCTS

2.01 ACCEPTABLE MANUFACTURERS

- A. Subject to compliance with these specifications, Eaton's B-Line series cable tray systems shall be as manufactured by Eaton.

2.02 CABLE TRAY SECTIONS AND COMPONENTS

- A. General: Except as otherwise indicated, provide non-metallic cable trays, of types, classes, and sizes indicated; with splice plates, bolts, nuts and washers for connecting units. Construct units with rounded edges and smooth surfaces; in compliance with applicable standards; and with the following additional construction features. Cable tray shall be installed according to the latest revision of NEMA VE 2.
- B. Material and Finish: Straight section structural elements; side rails, rungs and splice plates shall be pultruded from glass fiber reinforced polyester resin, vinyl ester resin or dis-stat.
- C. Pultruded shapes shall be constructed with a surface veil to insure a resin-rich surface and ultraviolet resistance.
- D. Pultruded shapes shall meet ASTM E-84, Class 1 flame rating and self-extinguishing requirements of ASTM D-635.

2.03 TYPE OF TRAY SYSTEM

- A. Ladder Cable Trays shall consist of two longitudinal members (side rails) with transverse members (rungs) mechanically fastened and adhesively bonded to the side rails. Rungs shall be spaced [6] [9] [12] inches on center. Rung spacing in radiused fittings shall be industry standard 9" and measured at the center of the tray's width. Each rung must be capable of supporting a 200 lb. concentrated load at the center of the cable tray with a safety factor of 1.5 (See following rung loading table).
- B. Ventilated Bottom Cable Trays shall consist of two longitudinal members (side rails) with rungs spaced 4" on center.
- C. Solid Bottom Cable Trays shall consist of two longitudinal members (side rails) with a solid sheet over rungs spaced on 12" centers.
- D. Cable tray loading depth shall be [2] [3] [5] inches per NEMA FG 1.
- E. Straight sections shall be supplied in standard [10 foot (3m)] [20 foot (6m)] lengths.
- F. Cable tray inside widths shall be [6] [9] [12] [18] [24] [30] [36] inches or as shown on drawings. Outside width shall not exceed inside by more than a total of 2".
- G. Straight and expansion splice plates will be of "L" shaped lay-in design with an eight-bolt pattern in 5" fill systems and four-bolt pattern in 3" and 2" fill systems. Splice plates shall be furnished with straight sections and fittings.
- H. All fittings must have a minimum radius of [12] [24] [36].
- I. Fittings shall be of mitered construction.
- J. Dimension tolerances will be per NEMA FG 1.

2.04 LOADING CAPACITIES

- A. Cable trays shall meet NEMA class designation: [8C] [12C] [20B] [20C].

Or

- A. Cable tray shall be capable of carrying a uniformly distributed load of _____ lbs./ft on a _____ foot support span with a safety factor of 1.5 when supported as a simple span and tested per NEMA VE 1 Section 5.2.

continued on page M-9

PART 3 - EXECUTION

3.01 INSTALLATION

- A.** Install cable trays as indicated: Installation shall be in accordance with equipment manufacturer's instructions, and with recognized industry practices to ensure that cable tray equipment comply with requirements of NEC and applicable portions of NFPA 70B. Reference NEMA VE 2 for general cable tray installation guidelines.
- B.** Coordinate cable tray with other electrical work as necessary to properly integrate installation of cable tray work with other work.
- C.** Provide sufficient space encompassing cable trays to permit access for installing and maintaining cables.
- D.** Cable tray fitting supports shall be located such that they meet the strength requirements of straight sections. Install fitting supports per NEMA VE 2 guidelines, or in accordance with manufacturer's instructions.

3.02 TESTING

- A.** Upon request manufacturer shall provide test reports witnessed by an independent testing laboratory of the "worst case" loading conditions outlined in this specification and performed in accordance with the latest revision of NEMA FG 1.

SECTION 161xx

LOW SMOKE, ZERO HALOGEN, NON-METALLIC CABLE TRAY

PART 1 - GENERAL

1.01 SECTION INCLUDES

- A. The work covered under this section consists of the furnishing of all necessary labor, supervision, materials, equipment, tests and services to install complete cable tray systems as shown on the drawings.
- B. Cable tray systems are defined to include, but are not limited to straight sections of ladder type cable trays, bends, tees, elbows, drop-outs, supports and accessories.

1.02 REFERENCES

- A. ANSI/NFPA 70 – National Electrical Code
- B. NEMA FG 1-2002 – Non-Metallic Cable Tray Systems
- C. NEMA VE 2-2002 – Cable Tray Installation Guidelines

1.03 DRAWINGS

- A. The drawings, which constitute a part of these specifications, indicate the general route of the cable tray systems. Data presented on these drawings are as accurate as preliminary surveys and planning can determine until final equipment selection is made. Accuracy is not guaranteed and field verification, of all dimensions, routing, etc., is directed.
- B. Specifications and drawings are for assistance and guidance, but exact routing, locations, distances and levels will be governed by actual field conditions. Contractor is directed to make field surveys as part of his work prior to submitting system layout drawings.

1.04 SUBMITTALS

- A. Submittal Drawings: Submit drawings of cable tray and accessories including clamps, brackets, hanger rods, splice plate connectors, expansion joint assemblies, and fittings, showing accurately scaled components.
- B. Product Data: Submit manufacturer's data on cable tray including, but not limited to, types, materials, finishes, rung spacings, inside depths and fitting radii. For side rails and rungs, submit cross sectional properties including Section Modulus (Sx) and Moment of Inertia (Ix).

1.05 QUALITY ASSURANCE

- A. Manufacturers: Firms regularly engaged in manufacture of cable trays and fittings of types and capacities required, whose products have been in satisfactory use in similar service for not less than 5 years.
- B. NEMA Compliance: Comply with NEMA Standards Publication Number FG-1, "Non-Metallic Cable Tray Systems".
- C. NEC Compliance: Comply with NEC, as applicable to construction and installation of cable tray and cable channel systems (Article 392, NEC).

continued on page M-11

Fiberglass - Recommended Tray Specification

1.06 DELIVERY, STORAGE AND HANDLING

- A. Deliver cable tray systems and components carefully to avoid breakage, denting and scoring finishes. Do not install damaged equipment.
- B. Store cable trays and accessories in original cartons and in clean dry space; protect from weather and construction traffic. Wet materials should be unpacked and dried before storage.

PART 2 - PRODUCTS

2.01 ACCEPTABLE MANUFACTURERS

- A. Subject to compliance with these specifications, cable tray systems shall be part number **24FA09-12-240** as manufactured by B-Line, Inc. [or engineer approved equal].

2.02 CABLE TRAY SECTIONS AND COMPONENTS

- A. General: Except as otherwise indicated, provide non-metallic cable trays, of types, classes, and sizes indicated; with splice plates, bolts, nuts and washers for connecting units. Construct units with rounded edges and smooth surfaces; in compliance with applicable standards; and with the following additional construction features. Cable tray shall be installed according to the latest revision of NEMA VE 2.
- B. Material and Finish: Straight section structural elements; side rails, rungs and splice plates shall be pultruded from glass fiber reinforced zero halogen resin.
- C. Pultruded shapes shall be constructed with a surface veil to insure a resin-rich surface and ultraviolet resistance.
- D. Pultruded shapes shall meet the following criteria shown in Table 1:

Table 1

Test Performed	Specified Requirement
Flexural Strength	25,000 psi, Min.
Flexural Modulus	1,000,000 psi, Min.
Tensile Strength	17,000 psi, Min.
Tensile Modulus	900,000 psi, Min.
Impact Strength	25 ft-lb./in., Min.
Dielectric Strength	170 volts/mil, Min.
Arc Resistance	180 seconds, Min.
Water Absorption	0.2%, Max.
Thermal Expansion	0.000007 in./in./°F., Max.
Flame Spread Index	60, Max.
Flame Resistance	UL 94 V-0, Min.
Tracking Resistance	600 minutes, Min. at 2500V
Specific Optical	200 Max. within 4 minutes
Smoke Density	after start of test.

continued on page M-12

SMOKE TOXICITY

<u>Gases</u>	<u>Maximum Quantities</u>
Hydrogen Chloride	10 ppm
Hydrogen Bromide	10 ppm
Hydrogen Cyanide	10 ppm
Hydrogen Sulfide	10 ppm
Vinyl Chloride	10 ppm
Ammonia	500 ppm
Aldehydes	30 ppm
Oxides of Nitrogen	100 ppm
Carbon Dioxide	15,000 ppm
Carbon Monoxide	1,000 ppm

Fiberglass pultruded shapes are manufactured per Creative Pultrusions Inc. Fiberglass Transportation Products-130 specifications.

2.03 TYPE OF TRAY SYSTEM

- A.** Ladder Cable Trays shall consist of two longitudinal members (side rails) with transverse members (rungs) mechanically fastened and adhesively bonded to the side rails. Ladder Cable Tray shall be B-Line part number 24FT09-12-240 [or engineered approved equal]. Rung spacing in radiused fittings shall be industry standard 9" and measured at the center of the tray's width.
- B.** Straight and expansion splice plates will be of "L" shaped lay-in design with a four-bolt pattern. Splice plates shall be furnished with straight sections and fittings.
- C.** All fittings must have a minimum radius of [12] [24] [36].
- D.** All fittings shall be of mitered construction.
- E.** Dimension tolerances will be per NEMA FG 1.

2.04 LOADING CAPACITIES

- A.** Cable tray shall be capable of carrying a uniformly distributed load of _____ lbs./ft on a _____-foot support span with a safety factor of 1.5 when supported as a simple span and tested per NEMA VE 1 Section 5.2.

continued on page M13

PART 3 - EXECUTION

3.01 INSTALLATION

- A.** Install cable trays as indicated: Installation shall be in accordance with equipment manufacturer's instructions, and with recognized industry practices to ensure that cable tray equipment comply with requirements of NEC and applicable portions of NFPA 70B. Reference NEMA VE 2 for general cable tray installation guidelines.
- B.** Coordinate cable tray with other electrical work as necessary to properly integrate installation of cable tray work with other work.
- C.** Provide sufficient space encompassing cable trays to permit access for installing and maintaining cables.
- D.** Cable tray fitting supports shall be located such that they meet the strength requirements of straight sections. Install fitting supports per NEMA VE 2 guidelines, or in accordance with manufacturer's instructions.

3.02 TESTING

- A.** Upon request manufacturer shall provide test reports witnessed by an independent testing laboratory of the "worst case" loading conditions outlined in this specification and performed in accordance with the latest revision of NEMA FG 1.

Fiberglass - Cable Tray Numbering System

To order a Fiberglass straight section of cable tray, select the appropriate size and material from the charts below and place those symbols in the sequence shown to form the complete catalog number.

Procedure:

1. Select the correct **B-Line series Fiberglass** tray using the Load Data for straight sections shown on page M-15 for 3", page M-16 for 4", page M-17 & M-18 for 6", and page M-19 for 8" fittings.
2. Select the resin required. Polyester, Vinyl Ester, or Zero Halogen/Dis-Stat. Refer to Corrosion Guide on pages M-3 and M-4, for the effect of environmental conditions on the desired material and the effective temperature range on page M-5.
3. The tray prefix is completed by inserting the rung spacing.
4. Select the desired width in inches.
5. Finally select the straight section length in inches. Fiberglass 120 [10'] (3m) or 240 [20'] (6m)

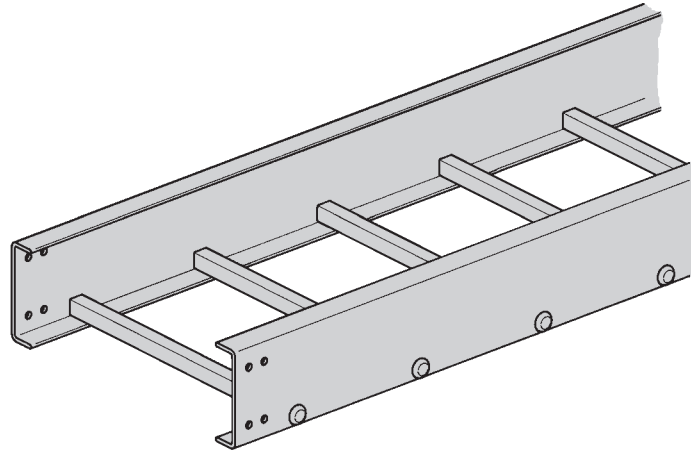

Straight Section Part Numbering

Example: **24 F 09 - 24 - 120**

Prefix

Series	Material	Rung Spacing	Width	Length
13	F - Fiberglass (Gray)	06 = 6" (152)	06 = 6" (152)	120 = 120" (3m)
24	Polyester Resin	09 = 9" (228)	09 = 9" (228)	240 = 240" (6m)
36	FV - Fiberglass (Beige)	12 = 12" (305)	12 = 12" (305)	
46	Vinyl Ester Resin	† SB = Solid Bottom	18 = 18" (457)	
48	FA - Zero Halogen/ Dis-Stat (Black)	*See page APP-1 for Marine Rung option.	24 = 24" (609) 30 = 30" (762) 36 = 36" (914)	

Note: One pair of splice plates with SS6 hardware included. † Solid bottom sheets ship separately with connecting hardware and assembled on site.

Fitting Section Part Selector

Example: **4 F SB - 24 - 90 HB 24**

Prefix

Height	Material	Bottom	Width	Angle	Type	Radius
3" (76)	F - Fiberglass (Gray)	Blank =	6" (152)	45°	HB - Horizontal Bend	12" (305)
4" (101)	Polyester Resin	Ladder Type	9" (228)	90°	HT - Horizontal Tee	24" (609)
6" (152)	FV - Fiberglass (Beige)	SB =	12" (305)		HX - Horizontal Cross	36" (914)
8" (203)	Vinyl Ester Resin	Solid Bottom	18" (457)		VI - Vertical Inside Bend	
	FA - Zero Halogen/ Dis-Stat (Black)		24" (609)		VO - Vertical Outside Bend	
			30" (762)		VT - Vertical Tee	
			36" (914)		VTU - Vertical Tee, Up	
					RR - Right Reducer	
					LR - Left Reducer	
					SR - Straight Reducer	

Notes: Standard rung spacing on fittings is 9" (225). Splice plates with SS6 hardware included.

Fiberglass - 3" Straight Section

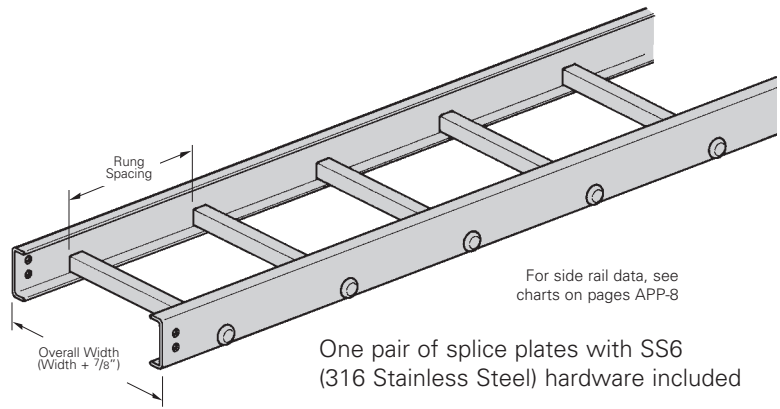
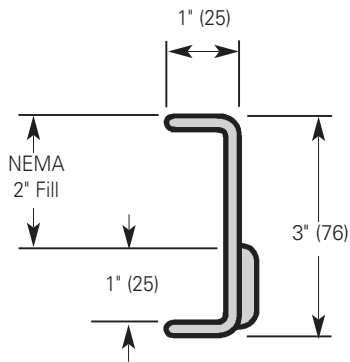

One pair of splice plates with SS6 (316 Stainless Steel) hardware included

For side rail data, see charts on pages APP-8

Series 13 Fiberglass Straight Section Part Numbering

Example: ^{Prefix} **13 F 09 - 24 - 120**

Series
13

Material

- **F** = Polyester
- **FV** = Vinyl Ester
- **FA** = Zero Halogen/Dis-Stat

Type

- Ladder -**
- **06** = 6" rung spacing
 - **09** = 9" rung spacing
 - **12** = 12" rung spacing
 - **SB** = Solid bottom †

Width

- **06** = 6"
- **09** = 9"
- **12** = 12"
- **18** = 18"
- **24** = 24"

Length

- ① **120** = 10 ft.
- ② **240** = 20 ft.

① Primary Length.
② Secondary Length.

FA = Zero Halogen/Dis-Stat is



See page C-23 for explanation of lengths.

See page M-38 for additional rung options.

† Solid bottom sheets ship separately with connecting hardware and assembled on site.

B-Line Series	Side Rail Dimensions	NEMA Classifications	Span ft	Load lbs/ft	Deflection Multiplier	Span meters	Load kg/m	Deflection Multiplier
13F 13FV		NEMA: 8C	6	257	0.005	1.8	382	0.086
			8	145	0.016	2.4	216	0.267
			10	93	0.040	3.0	138	0.681
			12	64	0.083	3.7	95	1.411
			14	47	0.153	4.3	70	2.614

B-Line Series	Side Rail Dimensions	NEMA Classifications	Span ft	Load lbs/ft	Deflection Multiplier	Span meters	Load kg/m	Deflection Multiplier
13FA		NEMA: 8C	6	178	—	1.8	264	—
			8	100	—	2.4	149	—
			10	64	—	3.0	95	—
			12	44	—	3.7	65	—

Values are based on simple beam tests per NEMA FG-1 on 24" wide cable tray rungs spaced on 12" centers. Published load safety factor is 1.5. To convert 1.5 safety factor to 2.0, multiply published load by 0.75. To obtain mid-span deflection, multiply a load by the deflection multiplier. Cable tray must be supported on spans shorter than or equal to the length of the cable being installed.

When trays are used in continuous spans, the deflection of the tray is reduced by as much as 50%.

● Green = Fastest shipped items ● Black = Normal lead-time items ● Red = Normally long lead-time items

Dimensions shown in parentheses are in millimeters, unless otherwise specified.

Fiberglass - 4" Straight Section

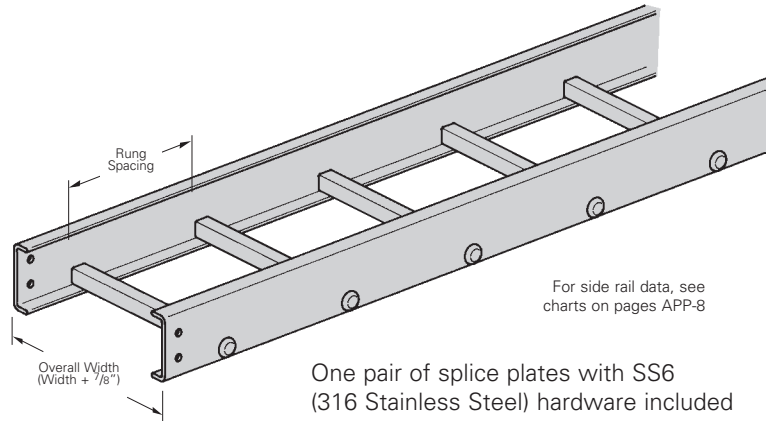
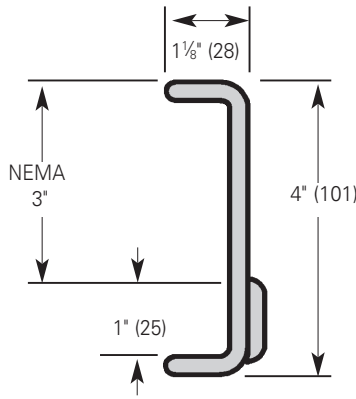

Series 24 Fiberglass Straight Section Part Numbering

Example: ^{Prefix} **24 F 09 - 24 - 120**

Series	Material	Type	Width	Length
24	<ul style="list-style-type: none"> ● F = Polyester ● FV = Vinyl Ester ● FA = Zero Halogen/Dis-Stat 	Ladder - <ul style="list-style-type: none"> ● 06 = 6" rung spacing ● 09 = 9" rung spacing ● 12 = 12" rung spacing ● SB = Solid bottom † 	<ul style="list-style-type: none"> ● 06 = 6" ● 09 = 9" ● 12 = 12" ● 18 = 18" ● 24 = 24" ● 30 = 30" ● 36 = 36" 	<ul style="list-style-type: none"> ● ① 120 = 10 ft. ● ② 240 = 20 ft. <p>①Primary Length. ②Secondary Length.</p> <p>See page C-23 for explanation of lengths.</p>

FA = Zero Halogen/Dis-Stat is



† Solid bottom sheets ship separately with connecting hardware and assembled on site.

See page M-38 for additional rung options.

B-Line Series	Side Rail Dimensions	NEMA & CSA Classifications	Span ft	Load lbs/ft	Deflection Multiplier	Span meters	Load kg/m	Deflection Multiplier
24F 24FV		NEMA: 12C CSA: E-3m	6	627	0.001	1.8	933	0.023
			8	353	0.004	2.4	525	0.074
			10	226	0.011	3.0	336	0.182
			12	157	0.022	3.7	233	0.378
24FA		NEMA: 12C	6	400	--	1.8	595	--
			8	226	--	2.4	336	--
			10	144	--	3.0	214	--
			12	100	--	3.7	149	--

Values are based on simple beam tests per NEMA FG-1 on 36" wide cable tray rungs spaced on 12" centers. Published load safety factor is 1.5. To convert 1.5 safety factor to 2.0, multiply published load by 0.75. To obtain mid-span deflection, multiply a load by the deflection multiplier. Cable tray must be supported on spans shorter than or equal to the length of the cable being installed.

When trays are used in continuous spans, the deflection of the tray is reduced by as much as 50%.

● Green = Fastest shipped items ● Black = Normal lead-time items ● Red = Normally long lead-time items

Dimensions shown in parentheses are in millimeters, unless otherwise specified.

Fiberglass - 6" Straight Section

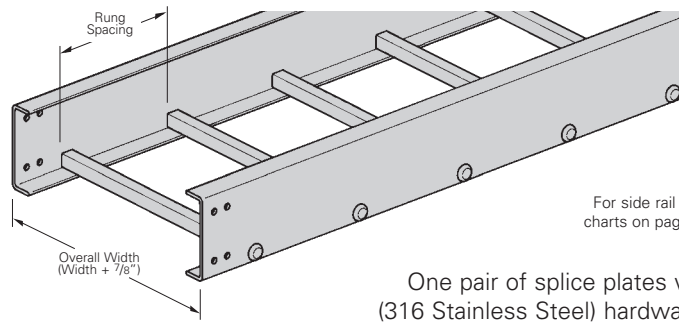
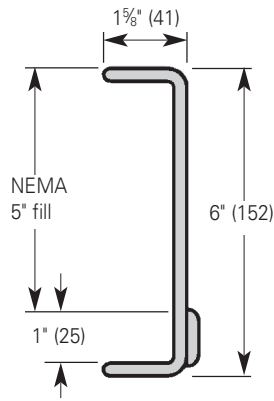

For side rail data, see charts on pages APP-8

One pair of splice plates with SS6 (316 Stainless Steel) hardware included

Series 36 Fiberglass Straight Section Part Numbering

Example: ^{Prefix} **36 F 09 - 24 - 120**

Series	Material	Type	Width	Length
36	<ul style="list-style-type: none"> ● F = Polyester ● FV = Vinyl Ester ● FA = Zero Halogen/Dis-Stat 	Ladder - <ul style="list-style-type: none"> ● 06 = 6" rung spacing ● 09 = 9" rung spacing ● 12 = 12" rung spacing ● SB = Solid bottom † 	<ul style="list-style-type: none"> ● 06 = 6" ● 09 = 9" ● 12 = 12" ● 18 = 18" ● 24 = 24" ● 30 = 30" ● 36 = 36" 	<ul style="list-style-type: none"> ● ① 120 = 10 ft. ● ② 240 = 20 ft. <p>①Primary Length. ②Secondary Length.</p> <p>See page C-23 for explanation of lengths.</p>

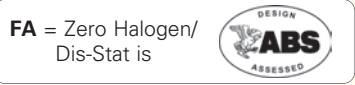

See page M-38 for additional rung options.

† Solid bottom sheets ship separately with connecting hardware and assembled on site.

B-Line Series	Side Rail Dimensions	NEMA & CSA Classifications	Span ft	Load lbs/ft	Deflection Multiplier	Span meters	Load kg/m	Deflection Multiplier
36F 36FV		NEMA: 20B CSA: E-6m	12	241	0.005	3.7	359	0.081
			14	177	0.009	4.3	264	0.151
			16	136	0.015	4.9	202	0.257
			18	107	0.024	5.5	159	0.411
			20	87	0.037	6.1	129	0.627
36FA		NEMA: 20A	12	147	0.008	3.7	219	0.142
			14	108	0.015	4.3	161	0.263
			16	83	0.026	4.9	123	0.449
			18	66	0.042	5.5	97	0.720
			20	53	0.064	6.1	79	1.097

Values are based on simple beam tests per NEMA FG-1 on 36" wide cable tray rungs spaced on 12" centers. Published load safety factor is 1.5. To convert 1.5 safety factor to 2.0, multiply published load by 0.75. To obtain mid-span deflection, multiply a load by the deflection multiplier. Cable tray must be supported on spans shorter than or equal to the length of the cable being installed.

When trays are used in continuous spans, the deflection of the tray is reduced by as much as 50%.

● Green = Fastest shipped items ● Black = Normal lead-time items ● Red = Normally long lead-time items

Dimensions shown in parentheses are in millimeters, unless otherwise specified.

Fiberglass - 6" Straight Section

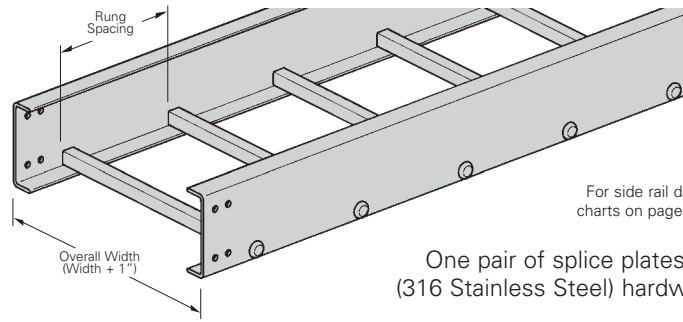
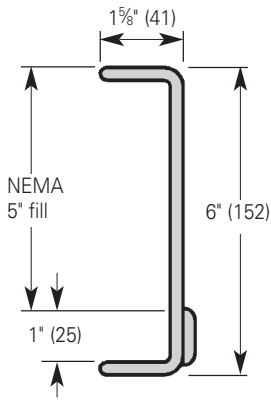

For side rail data, see charts on pages APP-8

One pair of splice plates with SS6 (316 Stainless Steel) hardware included

Series 46 Fiberglass Straight Section Part Numbering

Example: **46 F 09 - 24 - 120**

Series	Material	Type	Width	Length
46	<ul style="list-style-type: none"> ● F = Polyester ● FV = Vinyl Ester ● FA = Zero Halogen/Dis-Stat 	Ladder - <ul style="list-style-type: none"> ● 06 = 6" rung spacing ● 09 = 9" rung spacing ● 12 = 12" rung spacing ● SB = Solid bottom † 	<ul style="list-style-type: none"> ● 06 = 6" ● 09 = 9" ● 12 = 12" ● 18 = 18" ● 24 = 24" ● 30 = 30" ● 36 = 36" 	<ul style="list-style-type: none"> ● ① 120 = 10 ft. ● ② 240 = 20 ft. <p>①Primary Length. ②Secondary Length.</p> <p>See page C-23 for explanation of lengths.</p>

FA = Zero Halogen/Dis-Stat is



† Solid bottom sheets ship separately with connecting hardware and assembled on site.

See page M-38 for additional rung options.

B-Line Series	Side Rail Dimensions	NEMA & CSA Classifications	Span ft	Load lbs/ft	Deflection Multiplier	Span meters	Load kg/m	Deflection Multiplier
46F 46FV		NEMA: 20C+ CSA: E-6m	12	393	0.005	3.7	584	0.079
			14	288	0.009	4.3	429	0.145
			16	221	0.015	4.9	329	0.246
			18	174	0.023	5.5	260	0.396
			20	141	0.035	6.1	210	0.605
B-Line Series	Side Rail Dimensions	NEMA Classifications	Span ft	Load lbs/ft	Deflection Multiplier	Span meters	Load kg/m	Deflection Multiplier
46FA		NEMA: 20C+	12	278	--	3.7	413	--
			14	204	--	4.3	303	--
			16	156	--	4.9	232	--
			18	123	--	5.5	183	--
			20	100	--	6.1	149	--

Values are based on simple beam tests per NEMA FG-1 on 36" wide cable tray rungs spaced on 12" centers. Published load safety factor is 1.5. To convert 1.5 safety factor to 2.0, multiply published load by 0.75. To obtain mid-span deflection, multiply a load by the deflection multiplier. Cable tray must be supported on spans shorter than or equal to the length of the cable being installed.

When trays are used in continuous spans, the deflection of the tray is reduced by as much as 50%.

● Green = Fastest shipped items ● Black = Normal lead-time items ● Red = Normally long lead-time items

Dimensions shown in parentheses are in millimeters, unless otherwise specified.

Fiberglass - 8" Straight Section

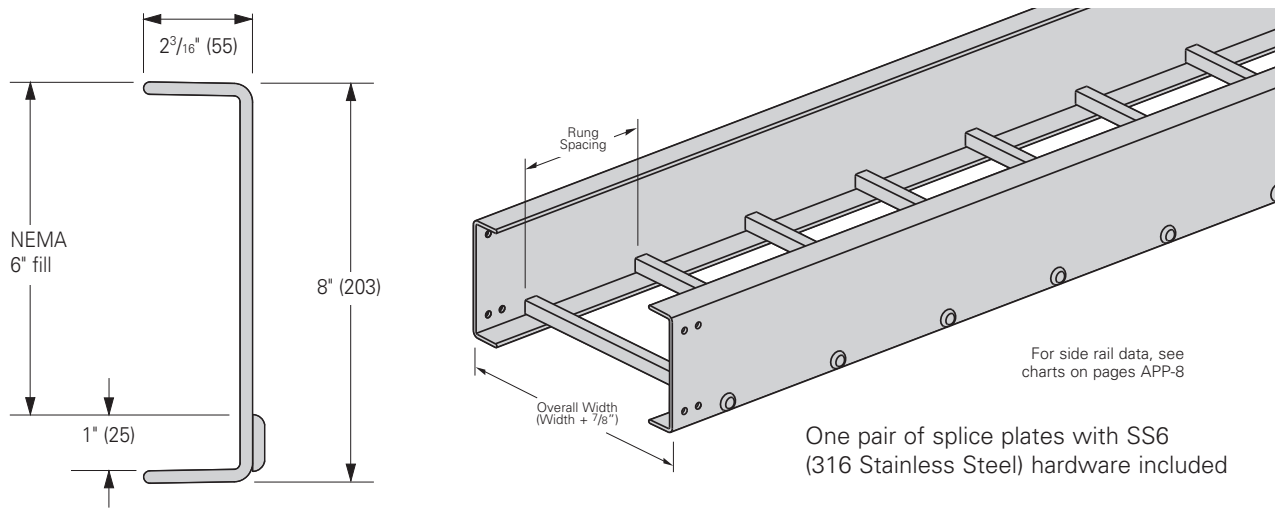

One pair of splice plates with SS6 (316 Stainless Steel) hardware included

Series 48 Fiberglass Straight Section Part Numbering

Example: ^{Prefix} **48 F 09 - 24 - 120**

Series	Material	Type	Width	Length
48	<ul style="list-style-type: none"> ● F = Polyester ● FV = Vinyl Ester ● FA = Zero Halogen/Dis-Stat 	Ladder - <ul style="list-style-type: none"> ● 06 = 6" rung spacing ● 09 = 9" rung spacing ● 12 = 12" rung spacing ● SB = Solid bottom † 	<ul style="list-style-type: none"> ● 06 = 6" ● 09 = 9" ● 12 = 12" ● 18 = 18" ● 24 = 24" ● 30 = 30" ● 36 = 36" 	<ul style="list-style-type: none"> ● ① 120 = 10 ft. ● ② 240 = 20 ft. <p>① Primary Length. ② Secondary Length.</p> <p>See page C-23 for explanation of lengths.</p>

FA = Zero Halogen/Dis-Stat is

† Solid bottom sheets ship separately with connecting hardware and assembled on site.

See page M-38 for additional rung options.

B-Line Series	Side Rail Dimensions	NEMA Classifications	Span ft	Load lbs/ft	Deflection Multiplier	Span meters	Load kg/m	Deflection Multiplier
48F 48FV		NEMA: 20C+	12	348	0.003	3.7	518	0.052
			14	256	0.006	4.3	381	0.097
			16	196	0.010	4.9	291	0.165
			18	155	0.015	5.5	231	0.210
			20	125	0.024	6.1	187	0.401
48FA		NEMA: 20C+	12	278	--	3.7	413	--
			14	204	--	4.3	303	--
			16	156	--	4.9	232	--
			18	123	--	5.5	183	--
			20	100	--	6.1	149	--

Values are based on simple beam tests per NEMA FG-1 on 36" wide cable tray rungs spaced on 12" centers. Published load safety factor is 1.5. To convert 1.5 safety factor to 2.0, multiply published load by 0.75. To obtain mid-span deflection, multiply a load by the deflection multiplier. Cable tray must be supported on spans shorter than or equal to the length of the cable being installed.

When trays are used in continuous spans, the deflection of the tray is reduced by as much as 50%.

● Green = Fastest shipped items ● Black = Normal lead-time items ● Red = Normally long lead-time items

Dimensions shown in parentheses are in millimeters, unless otherwise specified.

Fiberglass

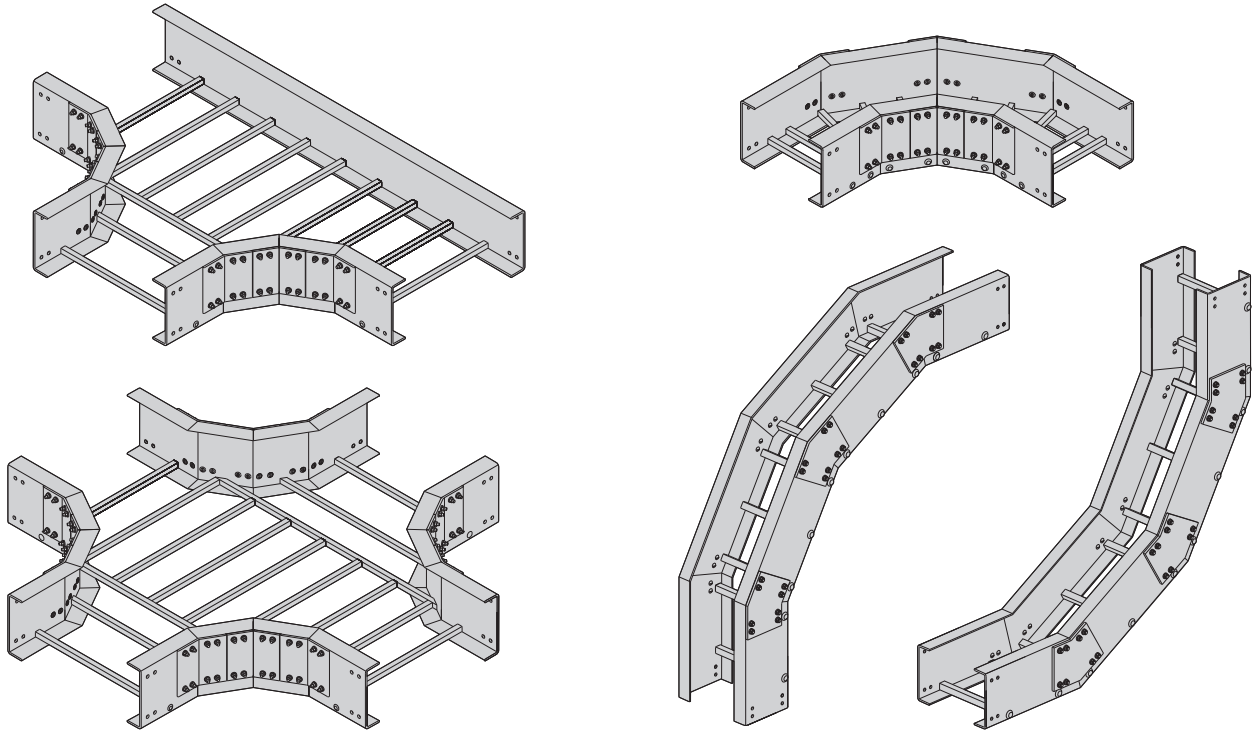

Fiberglass Fittings Part Numbering

Example: ^{Prefix} **4 F SB - 12 - 90 HB 12** (9" rung spacing is standard)

Height	Material	Bottom	Width	Angle	Type	Radius
<ul style="list-style-type: none"> ● 3 = 3" ** ● 4 = 4" ● 6 = 6" ● 8 = 8" 	<ul style="list-style-type: none"> ● F = Polyester ● FV = Vinyl Ester ● FA = Zero Halogen Dis-Stat 	<ul style="list-style-type: none"> ● Blank = Ladder Type ● SB = Solid Bottom† 	<ul style="list-style-type: none"> ● 06 = 6" (152) ● 09 = 9" (228) ● 12 = 12" (305) ● 18 = 18" (457) ● 24 = 24" (609) ● 30 = 30" (762) ● 36 = 36" (914) 	<ul style="list-style-type: none"> ● 45 = 45° ● 90 = 90° 	<ul style="list-style-type: none"> ● HB = Horizontal Bend ● HT = Horizontal Tee ● HX = Horizontal Cross ● VI = Vertical Inside Bend ● VO = Vertical Outside Bend ● LR = Left Reducer ● RR = Right Reducer ● SR = Straight Reducer 	<ul style="list-style-type: none"> ● 12 = 12" (305) ● 24 = 24" (609) ● 36 = 36" (914)

** 3" deep fittings are available in 6" thru 24" widths and 12" radius only.

† Solid bottom sheets ship separately with connecting hardware and assembled on site.

● Green = Fastest shipped items ● Black = Normal lead-time items ● Red = Normally long lead-time items

Dimensions shown in parentheses are in millimeters, unless otherwise specified.

Horizontal Bend 90° (HB)

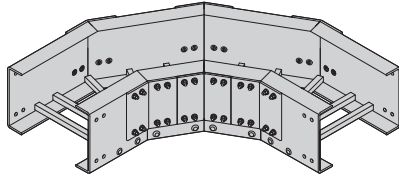

One pair of splice plates with SS6 hardware included.

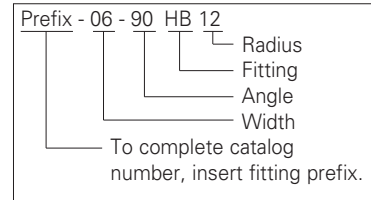
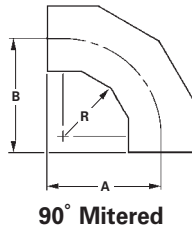

(Prefix) See page M-20 for catalog number prefix.
Dimensions for reference only, when critical contact factory.

- R - Bend Radius in. (mm)	Tray Width in. (mm)	90° Horizontal Bend - Mitered Dimensions				
		Catalog No.	A		B	
			in.	(mm)	in.	(mm)
12 (305)	6 (152)	(Prefix)-06-90HB12	28 ^{11/16}	(728)	28 ^{11/16}	(728)
	9 (228)	(Prefix)-09-90HB12	30 ^{3/16}	(767)	30 ^{3/16}	(767)
	12 (305)	(Prefix)-12-90HB12	31 ^{11/16}	(805)	31 ^{11/16}	(805)
	18 (457)	(Prefix)-18-90HB12	34 ^{11/16}	(881)	34 ^{11/16}	(881)
	24 (609)	(Prefix)-24-90HB12	37 ^{11/16}	(957)	37 ^{11/16}	(957)
	30 (762)	(Prefix)-30-90HB12	40 ^{11/16}	(1033)	40 ^{11/16}	(1033)
	36 (914)	(Prefix)-36-90HB12	43 ^{11/16}	(1109)	43 ^{11/16}	(1109)
24 (609)	6 (152)	(Prefix)-06-90HB24	41	(1041)	41	(1041)
	9 (228)	(Prefix)-09-90HB24	42 ^{1/2}	(1079)	42 ^{1/2}	(1079)
	12 (305)	(Prefix)-12-90HB24	44	(1117)	44	(1117)
	18 (457)	(Prefix)-18-90HB24	47	(1193)	47	(1193)
	24 (609)	(Prefix)-24-90HB24	50	(1269)	50	(1269)
	30 (762)	(Prefix)-30-90HB24	53	(1346)	53	(1346)
	36 (914)	(Prefix)-36-90HB24	56	(1422)	56	(1422)
36 (914)	6 (152)	(Prefix)-06-90HB36	53 ^{1/4}	(1353)	53 ^{1/4}	(1353)
	9 (228)	(Prefix)-09-90HB36	54 ^{3/4}	(1391)	54 ^{3/4}	(1391)
	12 (305)	(Prefix)-12-90HB36	56 ^{1/4}	(1429)	56 ^{1/4}	(1429)
	18 (457)	(Prefix)-18-90HB36	59 ^{1/4}	(1505)	59 ^{1/4}	(1505)
	24 (609)	(Prefix)-24-90HB36	62 ^{1/4}	(1582)	62 ^{1/4}	(1582)
	30 (762)	(Prefix)-30-90HB36	65 ^{1/4}	(1658)	65 ^{1/4}	(1658)
	36 (914)	(Prefix)-36-90HB36	68 ^{1/4}	(1734)	68 ^{1/4}	(1734)

For 3" Fittings

(Tray Widths - 6" thru 24" • Radius 12" only)
Polyester, Vinyl Ester, Zero Halogen/Dis-Stat
All are mitered

For 6" Fittings

(Tray Widths - 6" thru 36" • Radius 12", 24" & 36")
Polyester, Vinyl Ester, Zero Halogen/Dis-Stat
All radius are mitered

For 4" Fittings

(Tray Widths - 6" thru 36" • Radius 12", 24" & 36")
Polyester, Vinyl Ester, Zero Halogen/Dis-Stat
All radius are mitered

For 8" Fittings

(Tray Widths - 6" thru 36" • Radius 12", 24" & 36")
Polyester, Vinyl Ester, Zero Halogen/Dis-Stat
All radius are mitered

● Green = Fastest shipped items ● Black = Normal lead-time items ● Red = Normally long lead-time items

Dimensions shown in parentheses are in millimeters, unless otherwise specified.

Horizontal Bend 45° (HB)

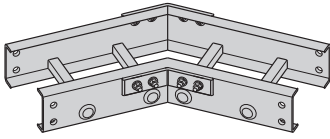

One pair of splice plates with SS6 hardware included.

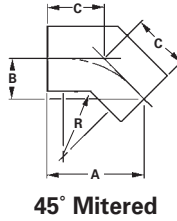

45° Mitered

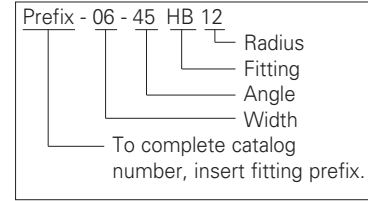

(Prefix) See page M-20 for catalog number prefix.
Dimensions for reference only, when critical contact factory.

- R - Bend Radius in. (mm)	Tray Width in. (mm)	45° Horizontal Bend - Mitered Dimensions			
		Catalog No.	A in. (mm)	B in. (mm)	C in. (mm)
12 (305)	6 (152)	(Prefix)-06-45HB12	24 ²¹ / ₃₂ (626)	10 ⁷ / ₃₂ (259)	14 ⁷ / ₁₆ (367)
	9 (228)	(Prefix)-09-45HB12	25 ²³ / ₃₂ (653)	10 ²¹ / ₃₂ (271)	15 ¹ / ₁₆ (383)
	12 (305)	(Prefix)-12-45HB12	26 ²⁵ / ₃₂ (680)	11 ³ / ₃₂ (282)	15 ¹¹ / ₁₈ (398)
	18 (457)	(Prefix)-18-45HB12	28 ²⁹ / ₃₂ (734)	11 ³¹ / ₃₂ (304)	16 ¹⁵ / ₁₆ (430)
	24 (609)	(Prefix)-24-45HB12	31 ¹ / ₃₂ (788)	12 ²⁷ / ₃₂ (326)	18 ⁵ / ₃₂ (462)
	30 (762)	(Prefix)-30-45HB12	33 ⁵ / ₃₂ (842)	13 ³ / ₄ (349)	19 ¹³ / ₃₂ (493)
	36 (914)	(Prefix)-36-45HB12	35 ¹ / ₄ (896)	14 ⁵ / ₈ (371)	20 ²¹ / ₃₂ (525)
24 (609)	6 (152)	(Prefix)-06-45HB12	24 ²¹ / ₃₂ (626)	10 ⁷ / ₃₂ (259)	14 ⁷ / ₁₆ (367)
	9 (228)	(Prefix)-09-45HB12	25 ²³ / ₃₂ (653)	10 ²¹ / ₃₂ (271)	15 ¹ / ₁₆ (383)
	12 (305)	(Prefix)-12-45HB12	26 ²⁵ / ₃₂ (680)	11 ³ / ₃₂ (282)	15 ¹¹ / ₁₈ (398)
	18 (457)	(Prefix)-18-45HB12	28 ²⁹ / ₃₂ (734)	11 ³¹ / ₃₂ (304)	16 ¹⁵ / ₁₆ (430)
	24 (609)	(Prefix)-24-45HB12	31 ¹ / ₃₂ (788)	12 ²⁷ / ₃₂ (326)	18 ⁵ / ₃₂ (462)
	30 (762)	(Prefix)-30-45HB12	33 ⁵ / ₃₂ (842)	13 ³ / ₄ (349)	19 ¹³ / ₃₂ (493)
	36 (914)	(Prefix)-36-45HB12	35 ¹ / ₄ (896)	14 ⁵ / ₈ (371)	20 ²¹ / ₃₂ (525)
36 (914)	6 (152)	(Prefix)-06-45HB12	24 ²¹ / ₃₂ (626)	10 ⁷ / ₃₂ (259)	14 ⁷ / ₁₆ (367)
	9 (228)	(Prefix)-09-45HB12	25 ²³ / ₃₂ (653)	10 ²¹ / ₃₂ (271)	15 ¹ / ₁₆ (383)
	12 (305)	(Prefix)-12-45HB12	26 ²⁵ / ₃₂ (680)	11 ³ / ₃₂ (282)	15 ¹¹ / ₁₈ (398)
	18 (457)	(Prefix)-18-45HB12	28 ²⁹ / ₃₂ (734)	11 ³¹ / ₃₂ (304)	16 ¹⁵ / ₁₆ (430)
	24 (609)	(Prefix)-24-45HB12	31 ¹ / ₃₂ (788)	12 ²⁷ / ₃₂ (326)	18 ⁵ / ₃₂ (462)
	30 (762)	(Prefix)-30-45HB12	33 ⁵ / ₃₂ (842)	13 ³ / ₄ (349)	19 ¹³ / ₃₂ (493)
	36 (914)	(Prefix)-36-45HB12	35 ¹ / ₄ (896)	14 ⁵ / ₈ (371)	20 ²¹ / ₃₂ (525)

For 3" Fittings

(Tray Widths - 6" thru 24" • Radius 12" only)
Polyester, Vinyl Ester, Zero Halogen/Dis-Stat
All are mitered

For 6" Fittings

(Tray Widths - 6" thru 36"
Radius 12", 24" & 36")
Polyester, Vinyl Ester, Zero Halogen/Dis-Stat
All radius are mitered

For 4" Fittings

(Tray Widths - 6" thru 36"
Radius 12", 24" & 36")
Polyester, Vinyl Ester, Zero Halogen/Dis-Stat
All radius are mitered

For 8" Fittings

(Tray Widths - 6" thru 36"
Radius 12", 24" & 36")
Polyester, Vinyl Ester, Zero Halogen/Dis-Stat
All radius are mitered

Dimensions shown in parentheses are in millimeters, unless otherwise specified.

Horizontal Tee (HT)

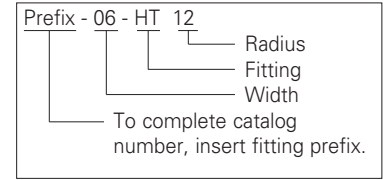
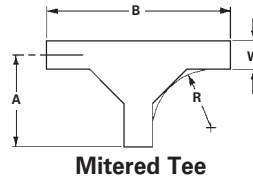
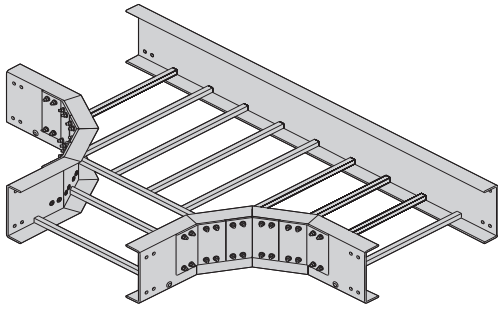

(Prefix) See page M-20 for catalog number prefix.
Dimensions for reference only, when critical contact factory.

Two pair of splice plates with SS6 hardware included.

- R - Bend Radius in. (mm)	Tray Width in. (mm)	Horizontal Tee - Mitered Dimensions		
		Catalog No.	A in. (mm)	B in. (mm)
12 (305)	6 (152)	(Prefix)-06-HT12	28 ⁷ / ₃₂ (716)	56 ¹³ / ₃₂ (1433)
	9 (228)	(Prefix)-09-HT12	29 ¹¹ / ₁₆ (754)	59 ¹³ / ₃₂ (1509)
	12 (305)	(Prefix)-12-HT12	31 ⁷ / ₃₂ (792)	62 ¹³ / ₃₂ (1585)
	18 (457)	(Prefix)-18-HT12	34 ⁷ / ₃₂ (869)	68 ¹³ / ₃₂ (1737)
	24 (609)	(Prefix)-24-HT12	37 ⁷ / ₃₂ (945)	74 ¹³ / ₃₂ (1890)
	30 (762)	(Prefix)-30-HT12	40 ⁷ / ₃₂ (1021)	80 ¹³ / ₃₂ (2042)
	36 (914)	(Prefix)-36-HT12	43 ⁷ / ₃₂ (1097)	86 ¹³ / ₃₂ (2195)
24 (609)	6 (152)	(Prefix)-06-HT24	40 ⁷ / ₃₂ (1021)	80 ¹³ / ₃₂ (2042)
	9 (228)	(Prefix)-09-HT24	41 ¹¹ / ₁₆ (1059)	83 ¹³ / ₃₂ (2118)
	12 (305)	(Prefix)-12-HT24	43 ⁷ / ₃₂ (1097)	86 ¹³ / ₃₂ (2195)
	18 (457)	(Prefix)-18-HT24	46 ⁷ / ₃₂ (1173)	92 ¹³ / ₃₂ (2347)
	24 (609)	(Prefix)-24-HT24	49 ⁷ / ₃₂ (1250)	98 ¹³ / ₃₂ (2499)
	30 (762)	(Prefix)-30-HT24	52 ⁷ / ₃₂ (1326)	104 ¹³ / ₃₂ (2652)
	36 (914)	(Prefix)-36-HT24	55 ⁷ / ₃₂ (1402)	110 ¹³ / ₃₂ (2804)
36 (914)	6 (152)	(Prefix)-06-HT36	52 ⁷ / ₃₂ (1326)	104 ¹³ / ₃₂ (2652)
	9 (228)	(Prefix)-09-HT36	53 ¹¹ / ₁₆ (1364)	107 ¹³ / ₃₂ (2728)
	12 (305)	(Prefix)-12-HT36	55 ⁷ / ₃₂ (1402)	110 ¹³ / ₃₂ (2804)
	18 (457)	(Prefix)-18-HT36	58 ⁷ / ₃₂ (1478)	116 ¹³ / ₃₂ (2957)
	24 (609)	(Prefix)-24-HT36	61 ⁷ / ₃₂ (1554)	122 ¹³ / ₃₂ (3109)
	30 (762)	(Prefix)-30-HT36	64 ⁷ / ₃₂ (1631)	128 ¹³ / ₃₂ (3261)
	36 (914)	(Prefix)-36-HT36	67 ⁷ / ₃₂ (1707)	134 ¹³ / ₃₂ (3414)

For 3" Fittings

(Tray Widths - 6" thru 24" • Radius 12" only)
Polyester, Vinyl Ester, Zero Halogen/Dis-Stat
All are mitered

For 6" Fittings

(Tray Widths - 6" thru 36" • Radius 12", 24" & 36")
Polyester, Vinyl Ester, Zero Halogen/Dis-Stat
All radius are mitered

For 4" Fittings

(Tray Widths - 6" thru 36" • Radius 12", 24" & 36")
Polyester, Vinyl Ester, Zero Halogen/Dis-Stat
All radius are mitered

For 8" Fittings

(Tray Widths - 6" thru 36" • Radius 12", 24" & 36")
Polyester, Vinyl Ester, Zero Halogen/Dis-Stat
All radius are mitered

Dimensions shown in parentheses are in millimeters, unless otherwise specified.

Horizontal Cross (HX)

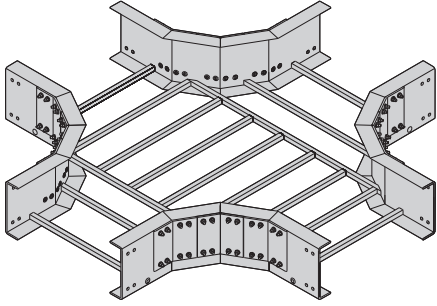

Three pair of splice plates with SS6 hardware included.

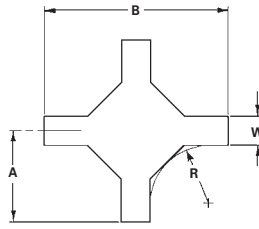

Mitered Cross

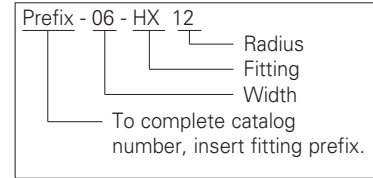

(Prefix) See page M-20 for catalog number prefix.
Dimensions for reference only, when critical contact factory.

- R - Bend Radius in. (mm)	Tray Width in. (mm)	Horizontal Cross - Mitered Dimensions		
		Catalog No.	A in. (mm)	B in. (mm)
12 (305)	6 (152)	(Prefix)-06-HX12	28 ³ / ₁₆ (716)	56 ¹³ / ₃₂ (1433)
	9 (228)	(Prefix)-09-HX12	29 ¹¹ / ₁₆ (754)	59 ¹³ / ₃₂ (1509)
	12 (305)	(Prefix)-12-HX12	31 ³ / ₁₆ (792)	62 ¹³ / ₃₂ (1585)
	18 (457)	(Prefix)-18-HX12	34 ³ / ₁₆ (869)	68 ¹³ / ₃₂ (1737)
	24 (609)	(Prefix)-24-HX12	37 ³ / ₁₆ (945)	74 ¹³ / ₃₂ (1890)
	30 (762)	(Prefix)-30-HX12	40 ³ / ₁₆ (1021)	80 ¹³ / ₃₂ (2042)
24 (609)	6 (152)	(Prefix)-06-HX24	40 ³ / ₁₆ (1021)	80 ¹³ / ₃₂ (2042)
	9 (228)	(Prefix)-09-HX24	41 ¹¹ / ₁₆ (1059)	83 ¹³ / ₃₂ (2118)
	12 (305)	(Prefix)-12-HX24	43 ³ / ₁₆ (1097)	86 ¹³ / ₃₂ (2195)
	18 (457)	(Prefix)-18-HX24	46 ³ / ₁₆ (1173)	92 ¹³ / ₃₂ (2347)
	24 (609)	(Prefix)-24-HX24	49 ³ / ₁₆ (1250)	98 ¹³ / ₃₂ (2499)
	30 (762)	(Prefix)-30-HX24	52 ³ / ₁₆ (1326)	104 ¹³ / ₃₂ (2652)
36 (914)	6 (152)	(Prefix)-06-HX36	52 ³ / ₁₆ (1326)	104 ¹³ / ₃₂ (2652)
	9 (228)	(Prefix)-09-HX36	53 ¹¹ / ₁₆ (1364)	107 ¹³ / ₃₂ (2728)
	12 (305)	(Prefix)-12-HX36	55 ³ / ₁₆ (1402)	110 ¹³ / ₃₂ (2804)
	18 (457)	(Prefix)-18-HX36	58 ³ / ₁₆ (1478)	116 ¹³ / ₃₂ (2957)
	24 (609)	(Prefix)-24-HX36	61 ³ / ₁₆ (1554)	122 ¹³ / ₃₂ (3109)
	30 (762)	(Prefix)-30-HX36	64 ³ / ₁₆ (1631)	128 ¹³ / ₃₂ (3261)
	36 (914)	(Prefix)-36-HX36	67 ³ / ₁₆ (1707)	134 ¹³ / ₃₂ (3414)

For 3" Fittings

(Tray Widths - 6" thru 24" • Radius 12" only)
Polyester, Vinyl Ester, Zero Halogen/Dis-Stat
All are mitered

For 6" Fittings

(Tray Widths - 6" thru 36"
Radius 12", 24" & 36")
Polyester, Vinyl Ester, Zero Halogen/Dis-Stat
All radius are mitered

For 4" Fittings

(Tray Widths - 6" thru 36"
Radius 12", 24" & 36")
Polyester, Vinyl Ester, Zero Halogen/Dis-Stat
All radius are mitered

For 8" Fittings

(Tray Widths - 6" thru 36"
Radius 12", 24" & 36")
Polyester, Vinyl Ester, Zero Halogen/Dis-Stat
All radius are mitered

Dimensions shown in parentheses are in millimeters, unless otherwise specified.

Reducers (LR) (SR) (RR)

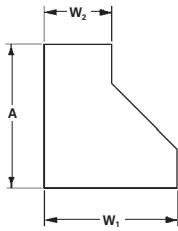
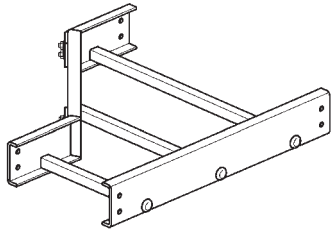

Left Reducer

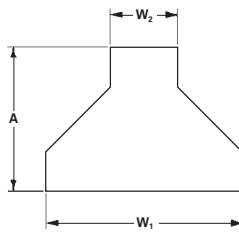
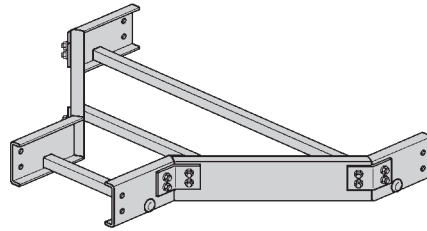

Straight Reducer

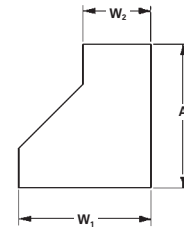
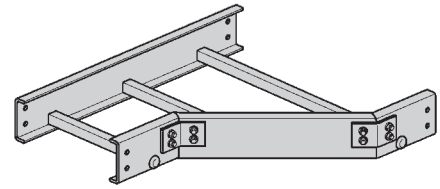

Right Reducer

One pair of splice plates with SS6 hardware included.

3" Fittings

(Only available in W_1 widths of 9", 12", 18" & 24")

4", 6" & 8" Fittings

(Available in all W_1 widths shown in chart)

Reducers are all of mitered construction.

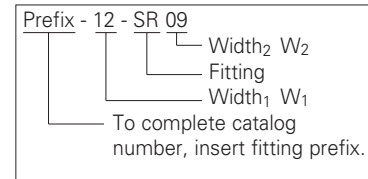

(Prefix) See page M-20 for catalog number prefix.
Dimensions for reference only, when critical contact factory.

Tray Width		Left Hand Reducer		Straight Reducer		Right Hand Reducer	
W_1 in. (mm)	W_2 in. (mm)	Catalog No.	A in. (mm)	Catalog No.	A in. (mm)	Catalog No.	A in. (mm)
9 (228)	6 (152)	(Prefix)-09-LR06	21 (533)	(Prefix)-09-SR06	19 1/2 (495)	(Prefix)-09-RR06	21 (533)
12 (305)	6 (152)	(Prefix)-12-LR06	24 (609)	(Prefix)-12-SR06	21 (533)	(Prefix)-12-RR06	24 (609)
	9 (228)	(Prefix)-12-LR09	21 (533)	(Prefix)-12-SR09	19 1/2 (495)	(Prefix)-12-RR09	21 (533)
18 (457)	6 (152)	(Prefix)-18-LR06	30 (762)	(Prefix)-18-SR06	24 (609)	(Prefix)-18-RR06	30 (762)
	9 (228)	(Prefix)-18-LR09	27 (686)	(Prefix)-18-SR09	22 1/2 (571)	(Prefix)-18-RR09	27 (686)
	12 (305)	(Prefix)-18-LR12	24 (609)	(Prefix)-18-SR12	21 (533)	(Prefix)-18-RR12	24 (609)
24 (609)	6 (152)	(Prefix)-24-LR06	36 (914)	(Prefix)-24-SR06	27 (686)	(Prefix)-24-RR06	36 (914)
	9 (228)	(Prefix)-24-LR09	33 (838)	(Prefix)-24-SR09	25 1/2 (648)	(Prefix)-24-RR09	33 (838)
	12 (305)	(Prefix)-24-LR12	30 (762)	(Prefix)-24-SR12	24 (609)	(Prefix)-24-RR12	30 (762)
	18 (457)	(Prefix)-24-LR18	24 (609)	(Prefix)-24-SR18	21 (533)	(Prefix)-24-RR18	24 (609)
30 (762)	6 (152)	(Prefix)-30-LR06	42 (1067)	(Prefix)-30-SR06	30 (762)	(Prefix)-30-RR06	42 (1067)
	9 (228)	(Prefix)-30-LR09	39 (990)	(Prefix)-30-SR09	28 1/2 (724)	(Prefix)-30-RR09	39 (990)
	12 (305)	(Prefix)-30-LR12	36 (914)	(Prefix)-30-SR12	27 (686)	(Prefix)-30-RR12	36 (914)
	18 (457)	(Prefix)-30-LR18	30 (762)	(Prefix)-30-SR18	24 (609)	(Prefix)-30-RR18	30 (762)
	24 (609)	(Prefix)-30-LR24	24 (609)	(Prefix)-30-SR24	21 (533)	(Prefix)-30-RR24	24 (609)
36 (914)	6 (152)	(Prefix)-36-LR06	48 (1219)	(Prefix)-36-SR06	33 (838)	(Prefix)-36-RR06	48 (1219)
	9 (228)	(Prefix)-36-LR09	45 (1143)	(Prefix)-36-SR09	31 1/2 (800)	(Prefix)-36-RR09	45 (1143)
	12 (305)	(Prefix)-36-LR12	42 (1067)	(Prefix)-36-SR12	30 (762)	(Prefix)-36-RR12	42 (1067)
	18 (457)	(Prefix)-36-LR18	36 (914)	(Prefix)-36-SR18	27 (686)	(Prefix)-36-RR18	36 (914)
	24 (609)	(Prefix)-36-LR24	30 (762)	(Prefix)-36-SR24	24 (609)	(Prefix)-36-RR24	30 (762)
	30 (762)	(Prefix)-36-LR30	24 (609)	(Prefix)-36-SR30	21 (533)	(Prefix)-36-RR30	24 (609)

Dimensions shown in parentheses are in millimeters, unless otherwise specified.

Horizontal Reducing Tee (HT)

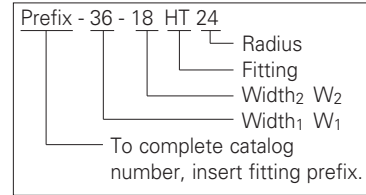
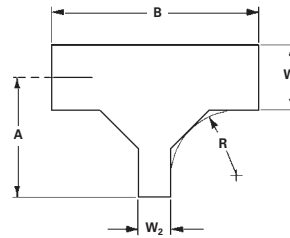
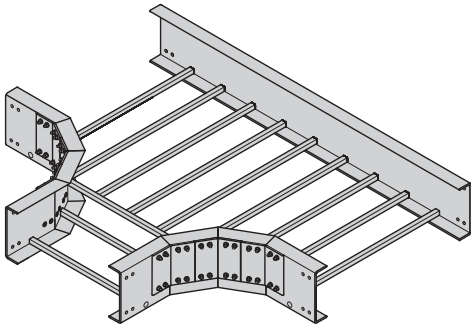

(Prefix) See page M-20 for catalog number prefix.
Dimensions for reference only, when critical contact factory.

Mitered Reducing Tee

Two pair of splice plates with SS6 hardware included.

Mitered Fittings

Tray Width		Catalog No. * Insert radius (12", 24" or 36")	12" Radius (305)		24" Radius (609)		36" Radius (914)	
W ₁ in. (mm)	W ₂ in. (mm)		A in. (mm)	B in. (mm)	A in. (mm)	B in. (mm)	A in. (mm)	B in. (mm)
9 (228)	6 (152)	(Prefix)-09-06-HT*	29 ¹¹ / ₁₆ (754)	56 ¹³ / ₃₂ (1433)	41 ¹¹ / ₁₆ (1059)	80 ¹³ / ₃₂ (2042)	53 ¹¹ / ₁₆ (1364)	104 ¹³ / ₃₂ (2652)
12 (305)	6 (152)	(Prefix)-12-06-HT*	31 ³ / ₁₆ (792)	56 ¹³ / ₃₂ (1433)	43 ³ / ₁₆ (1097)	80 ¹³ / ₃₂ (2042)	55 ³ / ₁₆ (1402)	104 ¹³ / ₃₂ (2652)
	9 (228)	(Prefix)-12-09-HT*	31 ³ / ₁₆ (792)	59 ¹³ / ₃₂ (1509)	43 ³ / ₁₆ (1097)	83 ¹³ / ₃₂ (2118)	55 ³ / ₁₆ (1402)	107 ¹³ / ₃₂ (2728)
18 (457)	6 (152)	(Prefix)-18-06-HT*	34 ³ / ₁₆ (869)	56 ¹³ / ₃₂ (1433)	46 ³ / ₁₆ (1173)	80 ¹³ / ₃₂ (2042)	58 ³ / ₁₆ (1478)	104 ¹³ / ₃₂ (2652)
	9 (228)	(Prefix)-18-09-HT*	34 ³ / ₁₆ (869)	59 ¹³ / ₃₂ (1509)	46 ³ / ₁₆ (1173)	83 ¹³ / ₃₂ (2118)	58 ³ / ₁₆ (1478)	107 ¹³ / ₃₂ (2728)
	12 (305)	(Prefix)-18-12-HT*	34 ³ / ₁₆ (869)	62 ¹³ / ₃₂ (1585)	46 ³ / ₁₆ (1173)	86 ¹³ / ₃₂ (2195)	58 ³ / ₁₆ (1478)	110 ¹³ / ₃₂ (2804)
24 (609)	6 (152)	(Prefix)-24-06-HT*	37 ³ / ₁₆ (945)	56 ¹³ / ₃₂ (1433)	49 ³ / ₁₆ (1250)	80 ¹³ / ₃₂ (2042)	61 ³ / ₁₆ (1554)	104 ¹³ / ₃₂ (2652)
	9 (228)	(Prefix)-24-09-HT*	37 ³ / ₁₆ (945)	59 ¹³ / ₃₂ (1509)	49 ³ / ₁₆ (1250)	83 ¹³ / ₃₂ (2118)	61 ³ / ₁₆ (1554)	107 ¹³ / ₃₂ (2728)
	12 (305)	(Prefix)-24-12-HT*	37 ³ / ₁₆ (945)	62 ¹³ / ₃₂ (1585)	49 ³ / ₁₆ (1250)	86 ¹³ / ₃₂ (2195)	61 ³ / ₁₆ (1554)	110 ¹³ / ₃₂ (2804)
	18 (457)	(Prefix)-24-18-HT*	37 ³ / ₁₆ (945)	68 ¹³ / ₃₂ (1737)	49 ³ / ₁₆ (1250)	92 ¹³ / ₃₂ (2347)	61 ³ / ₁₆ (1554)	116 ¹³ / ₃₂ (2957)
30 (762)	6 (152)	(Prefix)-30-06-HT*	40 ³ / ₁₆ (1021)	56 ¹³ / ₃₂ (1433)	52 ³ / ₁₆ (1326)	80 ¹³ / ₃₂ (2042)	64 ³ / ₁₆ (1631)	104 ¹³ / ₃₂ (2652)
	9 (228)	(Prefix)-30-09-HT*	40 ³ / ₁₆ (1021)	59 ¹³ / ₃₂ (1509)	52 ³ / ₁₆ (1326)	83 ¹³ / ₃₂ (2118)	64 ³ / ₁₆ (1631)	107 ¹³ / ₃₂ (2728)
	12 (305)	(Prefix)-30-12-HT*	40 ³ / ₁₆ (1021)	62 ¹³ / ₃₂ (1585)	52 ³ / ₁₆ (1326)	86 ¹³ / ₃₂ (2195)	64 ³ / ₁₆ (1631)	110 ¹³ / ₃₂ (2804)
	18 (457)	(Prefix)-30-18-HT*	40 ³ / ₁₆ (1021)	68 ¹³ / ₃₂ (1737)	52 ³ / ₁₆ (1326)	92 ¹³ / ₃₂ (2347)	64 ³ / ₁₆ (1631)	116 ¹³ / ₃₂ (2957)
	24 (609)	(Prefix)-30-24-HT*	40 ³ / ₁₆ (1021)	74 ¹³ / ₃₂ (1890)	52 ³ / ₁₆ (1326)	98 ¹³ / ₃₂ (2499)	64 ³ / ₁₆ (1631)	122 ¹³ / ₃₂ (3109)
36 (914)	6 (152)	(Prefix)-36-06-HT*	43 ³ / ₁₆ (1097)	56 ¹³ / ₃₂ (1433)	55 ³ / ₁₆ (1402)	80 ¹³ / ₃₂ (2042)	67 ³ / ₁₆ (1707)	104 ¹³ / ₃₂ (2652)
	9 (228)	(Prefix)-36-09-HT*	43 ³ / ₁₆ (1097)	59 ¹³ / ₃₂ (1509)	55 ³ / ₁₆ (1402)	83 ¹³ / ₃₂ (2118)	67 ³ / ₁₆ (1707)	107 ¹³ / ₃₂ (2728)
	12 (305)	(Prefix)-36-12-HT*	43 ³ / ₁₆ (1097)	62 ¹³ / ₃₂ (1585)	55 ³ / ₁₆ (1402)	86 ¹³ / ₃₂ (2195)	67 ³ / ₁₆ (1707)	110 ¹³ / ₃₂ (2804)
	18 (457)	(Prefix)-36-18-HT*	43 ³ / ₁₆ (1097)	68 ¹³ / ₃₂ (1737)	55 ³ / ₁₆ (1402)	92 ¹³ / ₃₂ (2347)	67 ³ / ₁₆ (1707)	116 ¹³ / ₃₂ (2957)
	24 (609)	(Prefix)-36-24-HT*	43 ³ / ₁₆ (1097)	74 ¹³ / ₃₂ (1890)	55 ³ / ₁₆ (1402)	98 ¹³ / ₃₂ (2499)	67 ³ / ₁₆ (1707)	122 ¹³ / ₃₂ (3109)
	30 (762)	(Prefix)-36-30-HT*	43 ³ / ₁₆ (1097)	80 ¹³ / ₃₂ (2042)	55 ³ / ₁₆ (1402)	104 ¹³ / ₃₂ (2652)	67 ³ / ₁₆ (1707)	128 ¹³ / ₃₂ (3261)

For 3" Fittings

(Radius 12" only)
W₁ tray widths - 9", 12", 18" & 24"
Polyester, Vinyl Ester, Zero Halogen/Dis-Stat
All are mitered

For 6" Fittings

(Radius 12", 24" & 36")
W₁ tray widths - 9" thru 36"
Polyester, Vinyl Ester, Zero Halogen/Dis-Stat
All radius are mitered

For 4" Fittings

(Radius 12", 24" & 36")
W₁ tray widths - 9" thru 36"
Polyester, Vinyl Ester, Zero Halogen/Dis-Stat
All radius are mitered

For 8" Fittings

(Radius 12", 24" & 36")
W₁ tray widths - 9" thru 36"
Polyester, Vinyl Ester, Zero Halogen/Dis-Stat
All radius are mitered

Dimensions shown in parentheses are in millimeters, unless otherwise specified.

Horizontal Expanding Tee (HT)

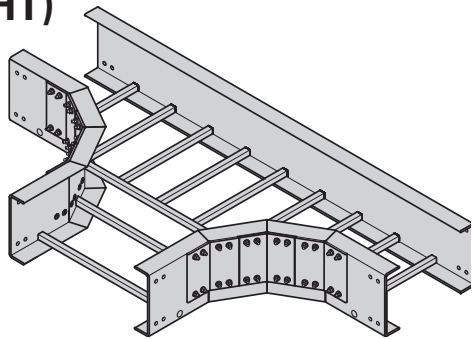

Two pair of splice plates with SS6 hardware included.

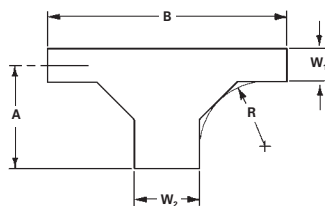

Mitered

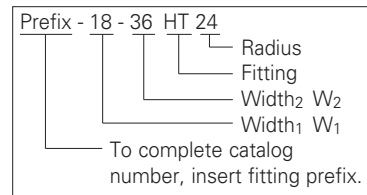

(Prefix) See page M-20 for catalog number prefix.
Dimensions for reference only, when critical contact factory.

Mitered Fittings

Tray Width		Catalog No. * Insert radius (12", 24" or 36")	12" Radius (305)		24" Radius (609)		36" Radius (914)	
W ₁ in. (mm)	W ₂ in. (mm)		in. A (mm)	in. B (mm)	in. A (mm)	in. B (mm)	in. A (mm)	in. B (mm)
6 (152)	9 (228)	(Prefix)-06-09-HT*	28 ³ / ₁₆ (716)	59 ¹³ / ₃₂ (1509)	40 ³ / ₁₆ (1021)	83 ¹³ / ₃₂ (2118)	52 ³ / ₁₆ (1326)	107 ¹³ / ₃₂ (2728)
	12 (305)	(Prefix)-06-12-HT*	28 ³ / ₁₆ (716)	62 ¹³ / ₃₂ (1585)	40 ³ / ₁₆ (1021)	86 ¹³ / ₃₂ (2195)	52 ³ / ₁₆ (1326)	110 ¹³ / ₃₂ (2804)
	18 (457)	(Prefix)-06-18-HT*	28 ³ / ₁₆ (716)	68 ¹³ / ₃₂ (1737)	40 ³ / ₁₆ (1021)	92 ¹³ / ₃₂ (2347)	52 ³ / ₁₆ (1326)	116 ¹³ / ₃₂ (2957)
	24 (609)	(Prefix)-06-24-HT*	28 ³ / ₁₆ (716)	74 ¹³ / ₃₂ (1890)	40 ³ / ₁₆ (1021)	98 ¹³ / ₃₂ (2499)	52 ³ / ₁₆ (1326)	122 ¹³ / ₃₂ (3109)
	30 (762)	(Prefix)-06-30-HT*	28 ³ / ₁₆ (716)	80 ¹³ / ₃₂ (2042)	40 ³ / ₁₆ (1021)	104 ¹³ / ₃₂ (2652)	52 ³ / ₁₆ (1326)	128 ¹³ / ₃₂ (3261)
	36 (914)	(Prefix)-06-36-HT*	28 ³ / ₁₆ (716)	86 ¹³ / ₃₂ (2195)	40 ³ / ₁₆ (1021)	110 ¹³ / ₃₂ (2804)	52 ³ / ₁₆ (1326)	134 ¹³ / ₃₂ (3414)
9 (228)	12 (305)	(Prefix)-09-12-HT*	29 ¹¹ / ₁₆ (754)	62 ¹³ / ₃₂ (1585)	41 ¹¹ / ₁₆ (1059)	86 ¹³ / ₃₂ (2195)	53 ¹¹ / ₁₆ (1364)	110 ¹³ / ₃₂ (2804)
	18 (457)	(Prefix)-09-18-HT*	29 ¹¹ / ₁₆ (754)	68 ¹³ / ₃₂ (1737)	41 ¹¹ / ₁₆ (1059)	92 ¹³ / ₃₂ (2347)	53 ¹¹ / ₁₆ (1364)	116 ¹³ / ₃₂ (2957)
	24 (609)	(Prefix)-09-24-HT*	29 ¹¹ / ₁₆ (754)	74 ¹³ / ₃₂ (1890)	41 ¹¹ / ₁₆ (1059)	98 ¹³ / ₃₂ (2499)	53 ¹¹ / ₁₆ (1364)	122 ¹³ / ₃₂ (3109)
	30 (762)	(Prefix)-09-30-HT*	29 ¹¹ / ₁₆ (754)	80 ¹³ / ₃₂ (2042)	41 ¹¹ / ₁₆ (1059)	104 ¹³ / ₃₂ (2652)	53 ¹¹ / ₁₆ (1364)	128 ¹³ / ₃₂ (3261)
	36 (914)	(Prefix)-09-36-HT*	29 ¹¹ / ₁₆ (754)	86 ¹³ / ₃₂ (2195)	41 ¹¹ / ₁₆ (1059)	110 ¹³ / ₃₂ (2804)	53 ¹¹ / ₁₆ (1364)	134 ¹³ / ₃₂ (3414)
12 (305)	18 (457)	(Prefix)-12-18-HT*	31 ³ / ₁₆ (792)	68 ¹³ / ₃₂ (1737)	43 ³ / ₁₆ (1097)	92 ¹³ / ₃₂ (2347)	55 ³ / ₁₆ (1402)	116 ¹³ / ₃₂ (2957)
	24 (609)	(Prefix)-12-24-HT*	31 ³ / ₁₆ (792)	74 ¹³ / ₃₂ (1890)	43 ³ / ₁₆ (1097)	98 ¹³ / ₃₂ (2499)	55 ³ / ₁₆ (1402)	122 ¹³ / ₃₂ (3109)
	30 (762)	(Prefix)-12-30-HT*	31 ³ / ₁₆ (792)	80 ¹³ / ₃₂ (2042)	43 ³ / ₁₆ (1097)	104 ¹³ / ₃₂ (2652)	55 ³ / ₁₆ (1402)	128 ¹³ / ₃₂ (3261)
	36 (914)	(Prefix)-12-36-HT*	31 ³ / ₁₆ (792)	86 ¹³ / ₃₂ (2195)	43 ³ / ₁₆ (1097)	110 ¹³ / ₃₂ (2804)	55 ³ / ₁₆ (1402)	134 ¹³ / ₃₂ (3414)
18 (457)	24 (609)	(Prefix)-18-24-HT*	34 ³ / ₁₆ (869)	74 ¹³ / ₃₂ (1890)	46 ³ / ₁₆ (1173)	98 ¹³ / ₃₂ (2499)	58 ³ / ₁₆ (1478)	122 ¹³ / ₃₂ (3109)
	30 (762)	(Prefix)-18-30-HT*	34 ³ / ₁₆ (869)	80 ¹³ / ₃₂ (2042)	46 ³ / ₁₆ (1173)	104 ¹³ / ₃₂ (2652)	58 ³ / ₁₆ (1478)	128 ¹³ / ₃₂ (3261)
	36 (914)	(Prefix)-18-36-HT*	34 ³ / ₁₆ (869)	86 ¹³ / ₃₂ (2195)	46 ³ / ₁₆ (1173)	110 ¹³ / ₃₂ (2804)	58 ³ / ₁₆ (1478)	134 ¹³ / ₃₂ (3414)
24 (609)	30 (762)	(Prefix)-24-30-HT*	37 ³ / ₁₆ (945)	80 ¹³ / ₃₂ (2042)	49 ³ / ₁₆ (1250)	104 ¹³ / ₃₂ (2652)	61 ³ / ₁₆ (1554)	128 ¹³ / ₃₂ (3261)
	36 (914)	(Prefix)-24-36-HT*	37 ³ / ₁₆ (945)	86 ¹³ / ₃₂ (2195)	49 ³ / ₁₆ (1250)	110 ¹³ / ₃₂ (2804)	61 ³ / ₁₆ (1554)	134 ¹³ / ₃₂ (3414)
30 (762)	36 (914)	(Prefix)-30-36-HT*	40 ³ / ₁₆ (1021)	86 ¹³ / ₃₂ (2195)	52 ³ / ₁₆ (1326)	110 ¹³ / ₃₂ (2804)	64 ³ / ₁₆ (1631)	134 ¹³ / ₃₂ (3414)

For 3" Fittings

(Radius 12" only)
W₁ tray widths - 6" thru 18"
W₂ tray widths - 9" thru 24"
Polyester, Vinyl Ester, Zero Halogen/Dis-Stat
All are mitered

For 6" Fittings

(Radius 12", 24" & 36")
W₁ tray widths - 6" thru 30"
W₂ tray widths - 9" thru 36"
Polyester, Vinyl Ester, Zero Halogen/Dis-Stat
All radius are mitered

For 4" Fittings

(Radius 12", 24" & 36")
W₁ tray widths - 6" thru 30"
W₂ tray widths - 9" thru 36"
Polyester, Vinyl Ester, Zero Halogen/Dis-Stat
All radius are mitered

For 8" Fittings

(Radius 12", 24" & 36")
W₁ tray widths - 6" thru 30"
W₂ tray widths - 9" thru 36"
Polyester, Vinyl Ester, Zero Halogen/Dis-Stat
All radius are mitered

Dimensions shown in parentheses are in millimeters, unless otherwise specified.

Horizontal Expanding/Reducing Cross (HX)

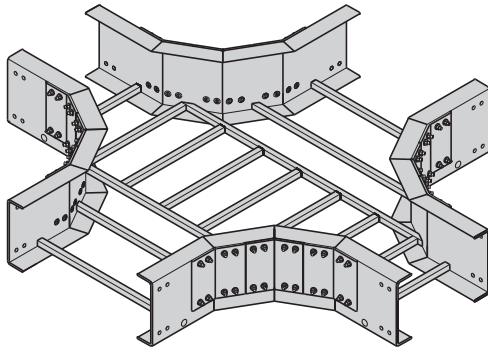

Three pair of splice plates with SS6 hardware included.

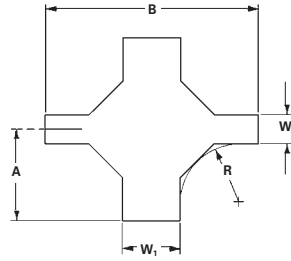

Mitered

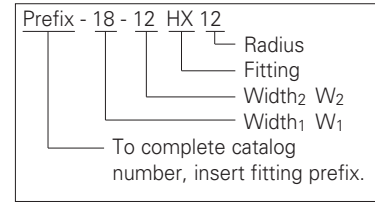

(Prefix) See page M-20 for catalog number prefix.
Dimensions for reference only, when critical contact factory.

Mitered Fittings

Tray Width		Catalog No. * Insert radius (12", 24" or 36")	12" Radius (305)		24" Radius (609)		36" Radius (914)	
W ₁ in. (mm)	W ₂ in. (mm)		A in. (mm)	B in. (mm)	A in. (mm)	B in. (mm)	A in. (mm)	B in. (mm)
9 (228)	6 (152)	(Prefix)-09-06-HX*	28 ³ / ₁₆ (716)	59 ¹³ / ₃₂ (1509)	40 ³ / ₁₆ (1021)	83 ¹³ / ₃₂ (2118)	52 ³ / ₁₆ (1326)	107 ¹³ / ₃₂ (2728)
12 (305)	6 (152)	(Prefix)-12-06-HX*	28 ³ / ₁₆ (716)	62 ¹³ / ₃₂ (1585)	40 ³ / ₁₆ (1021)	86 ¹³ / ₃₂ (2195)	52 ³ / ₁₆ (1326)	110 ¹³ / ₃₂ (2804)
	9 (228)	(Prefix)-12-09-HX*	29 ¹¹ / ₁₆ (754)	62 ¹³ / ₃₂ (1585)	41 ¹¹ / ₁₆ (1059)	86 ¹³ / ₃₂ (2195)	53 ¹¹ / ₁₆ (1364)	110 ¹³ / ₃₂ (2804)
18 (457)	6 (152)	(Prefix)-18-06-HX*	28 ³ / ₁₆ (716)	68 ¹³ / ₃₂ (1737)	40 ³ / ₁₆ (1021)	92 ¹³ / ₃₂ (2347)	52 ³ / ₁₆ (1326)	116 ¹³ / ₃₂ (2957)
	9 (228)	(Prefix)-18-09-HX*	29 ¹¹ / ₁₆ (754)	68 ¹³ / ₃₂ (1737)	41 ¹¹ / ₁₆ (1059)	92 ¹³ / ₃₂ (2347)	53 ¹¹ / ₁₆ (1364)	116 ¹³ / ₃₂ (2957)
	12 (305)	(Prefix)-18-12-HX*	31 ³ / ₁₆ (792)	68 ¹³ / ₃₂ (1737)	43 ³ / ₁₆ (1097)	92 ¹³ / ₃₂ (2347)	55 ³ / ₁₆ (1402)	116 ¹³ / ₃₂ (2957)
24 (609)	6 (152)	(Prefix)-24-06-HX*	28 ³ / ₁₆ (716)	74 ¹³ / ₃₂ (1890)	40 ³ / ₁₆ (1021)	98 ¹³ / ₃₂ (2499)	52 ³ / ₁₆ (1326)	122 ¹³ / ₃₂ (3109)
	9 (228)	(Prefix)-24-09-HX*	29 ¹¹ / ₁₆ (754)	74 ¹³ / ₃₂ (1890)	41 ¹¹ / ₁₆ (1059)	98 ¹³ / ₃₂ (2499)	53 ¹¹ / ₁₆ (1364)	122 ¹³ / ₃₂ (3109)
	12 (305)	(Prefix)-24-12-HX*	31 ³ / ₁₆ (792)	74 ¹³ / ₃₂ (1890)	43 ³ / ₁₆ (1097)	98 ¹³ / ₃₂ (2499)	55 ³ / ₁₆ (1402)	122 ¹³ / ₃₂ (3109)
	18 (457)	(Prefix)-24-18-HX*	34 ³ / ₁₆ (869)	74 ¹³ / ₃₂ (1890)	46 ³ / ₁₆ (1173)	98 ¹³ / ₃₂ (2499)	58 ³ / ₁₆ (1478)	122 ¹³ / ₃₂ (3109)
30 (762)	6 (152)	(Prefix)-30-06-HX*	28 ³ / ₁₆ (716)	80 ¹³ / ₃₂ (2042)	40 ³ / ₁₆ (1021)	104 ¹³ / ₃₂ (2652)	52 ³ / ₁₆ (1326)	128 ¹³ / ₃₂ (3261)
	9 (228)	(Prefix)-30-09-HX*	29 ¹¹ / ₁₆ (754)	80 ¹³ / ₃₂ (2042)	41 ¹¹ / ₁₆ (1059)	104 ¹³ / ₃₂ (2652)	53 ¹¹ / ₁₆ (1364)	128 ¹³ / ₃₂ (3261)
	12 (305)	(Prefix)-30-12-HX*	31 ³ / ₁₆ (792)	80 ¹³ / ₃₂ (2042)	43 ³ / ₁₆ (1097)	104 ¹³ / ₃₂ (2652)	55 ³ / ₁₆ (1402)	128 ¹³ / ₃₂ (3261)
	18 (457)	(Prefix)-30-18-HX*	34 ³ / ₁₆ (869)	80 ¹³ / ₃₂ (2042)	46 ³ / ₁₆ (1173)	104 ¹³ / ₃₂ (2652)	58 ³ / ₁₆ (1478)	128 ¹³ / ₃₂ (3261)
	24 (609)	(Prefix)-30-24-HX*	37 ³ / ₁₆ (945)	80 ¹³ / ₃₂ (2042)	49 ³ / ₁₆ (1250)	104 ¹³ / ₃₂ (2652)	61 ³ / ₁₆ (1554)	128 ¹³ / ₃₂ (3261)
36 (914)	6 (152)	(Prefix)-36-06-HX*	28 ³ / ₁₆ (716)	86 ¹³ / ₃₂ (2195)	40 ³ / ₁₆ (1021)	110 ¹³ / ₃₂ (2804)	52 ³ / ₁₆ (1326)	134 ¹³ / ₃₂ (3414)
	9 (228)	(Prefix)-36-09-HX*	29 ¹¹ / ₁₆ (754)	86 ¹³ / ₃₂ (2195)	41 ¹¹ / ₁₆ (1059)	110 ¹³ / ₃₂ (2804)	53 ¹¹ / ₁₆ (1364)	134 ¹³ / ₃₂ (3414)
	12 (305)	(Prefix)-36-12-HX*	31 ³ / ₁₆ (792)	86 ¹³ / ₃₂ (2195)	43 ³ / ₁₆ (1097)	110 ¹³ / ₃₂ (2804)	55 ³ / ₁₆ (1402)	134 ¹³ / ₃₂ (3414)
	18 (457)	(Prefix)-36-18-HX*	34 ³ / ₁₆ (869)	86 ¹³ / ₃₂ (2195)	46 ³ / ₁₆ (1173)	110 ¹³ / ₃₂ (2804)	58 ³ / ₁₆ (1478)	134 ¹³ / ₃₂ (3414)
	24 (609)	(Prefix)-36-24-HX*	37 ³ / ₁₆ (945)	86 ¹³ / ₃₂ (2195)	49 ³ / ₁₆ (1250)	110 ¹³ / ₃₂ (2804)	61 ³ / ₁₆ (1554)	134 ¹³ / ₃₂ (3414)
	30 (762)	(Prefix)-36-30-HX*	40 ³ / ₁₆ (1021)	86 ¹³ / ₃₂ (2195)	52 ³ / ₁₆ (1326)	110 ¹³ / ₃₂ (2804)	64 ³ / ₁₆ (1631)	134 ¹³ / ₃₂ (3414)

For 3" Fittings

(Radius 12" only)
W₁ tray widths - 9" thru 24"
W₂ tray widths - 6" thru 18"
Polyester, Vinyl Ester, Zero Halogen/Dis-Stat
All are mitered

For 4" Fittings

(Radius 12", 24" & 36")
W₁ tray widths - 9" thru 36"
W₂ tray widths - 6" thru 30"
Polyester, Vinyl Ester, Zero Halogen/Dis-Stat
All radius are mitered

For 6" Fittings

(Radius 12", 24" & 36")
W₁ tray widths - 9" thru 36"
W₂ tray widths - 6" thru 30"
Polyester, Vinyl Ester, Zero Halogen/Dis-Stat
All radius are mitered

For 8" Fittings

(Radius 12", 24" & 36")
W₁ tray widths - 9" thru 36"
W₂ tray widths - 6" thru 30"
Polyester, Vinyl Ester, Zero Halogen/Dis-Stat
All radius are mitered

Dimensions shown in parentheses are in millimeters, unless otherwise specified.

Fiberglass - Fittings

Vertical Bends 90° (VO) (VI)

One pair of splice plates with SS6 hardware included.

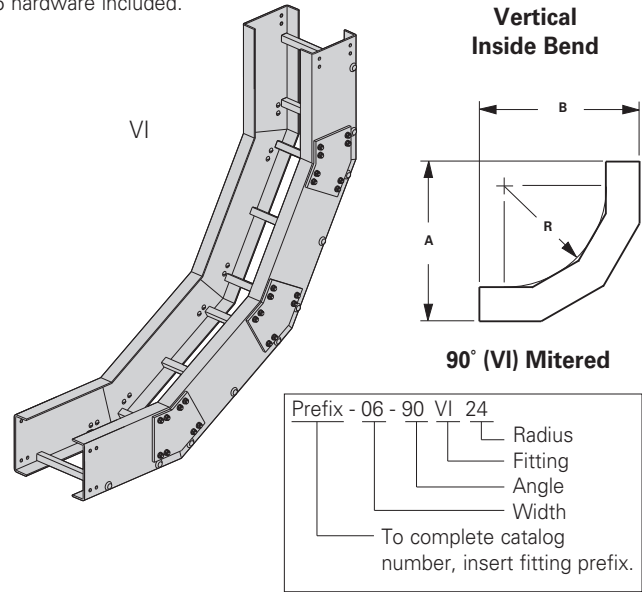
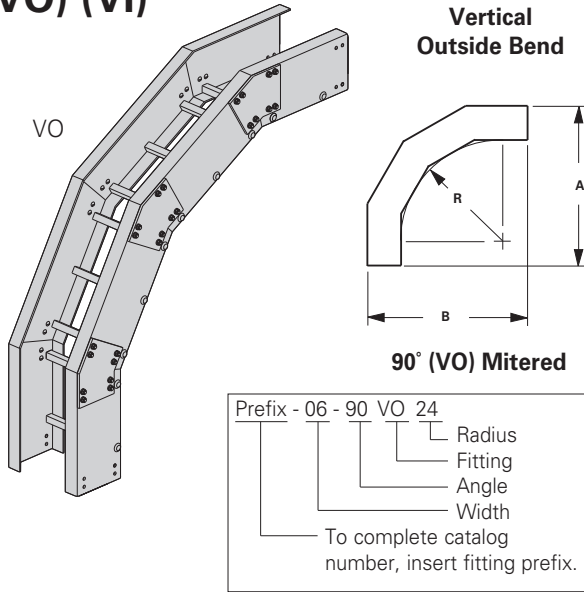

(Prefix) See page M-20 for catalog number prefix. Dimensions for reference only, when critical contact factory.

- R - Bend Radius in. (mm)	Tray Width in. (mm)	90° Mitered		
		Catalog No.	VO & VI Bend	
			A in. / (mm)	B in. / (mm)
12 (305)	6 (152)	(Prefix)-06-90(*)12	27 ⁵ / ₃₂ (690)	27 ⁵ / ₃₂ (690)
	9 (228)	(Prefix)-09-90(*)12		
	12 (305)	(Prefix)-12-90(*)12		
	18 (457)	(Prefix)-18-90(*)12		
	24 (609)	(Prefix)-24-90(*)12		
	36 (914)	(Prefix)-36-90(*)12		
24 (609)	6 (152)	(Prefix)-06-90(*)24	36 ²³ / ₃₂ (933)	36 ²³ / ₃₂ (933)
	9 (228)	(Prefix)-09-90(*)24		
	12 (305)	(Prefix)-12-90(*)24		
	18 (457)	(Prefix)-18-90(*)24		
	24 (609)	(Prefix)-24-90(*)24		
	36 (914)	(Prefix)-36-90(*)24		
36 (914)	6 (152)	(Prefix)-06-90(*)36	44 ²⁹ / ₃₂ (1141)	44 ²⁹ / ₃₂ (1141)
	9 (228)	(Prefix)-09-90(*)36		
	12 (305)	(Prefix)-12-90(*)36		
	18 (457)	(Prefix)-18-90(*)36		
	24 (609)	(Prefix)-24-90(*)36		
	36 (914)	(Prefix)-36-90(*)36		

For 3" Fittings

(Radius 12" only • Tray widths - 6" thru 24")
Polyester, Vinyl Ester, Zero Halogen/Dis-Stat
All are mitered

For 4" Fittings

(Radius 12", 24" & 36"
Tray widths - 6" thru 36")
Polyester, Vinyl Ester, Zero Halogen/Dis-Stat
All radius are mitered

For 6" Fittings

(Radius 12", 24" & 36"
Tray widths - 6" thru 36")
Polyester, Vinyl Ester, Zero Halogen/Dis-Stat
All radius are mitered

For 8" Fittings

(Radius 12", 24" & 36"
Tray widths - 6" thru 36")
Polyester, Vinyl Ester, Zero Halogen/Dis-Stat
All radius are mitered

(*) Insert 'VO' for Vertical Outside Bend or 'VI' for Vertical Inside Bend.

Dimensions shown in parentheses are in millimeters, unless otherwise specified.

Vertical Outside Bend

VO

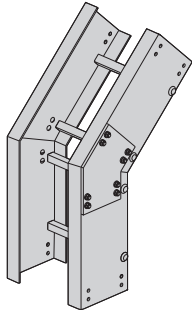

One pair of splice plates with SS6 hardware included.

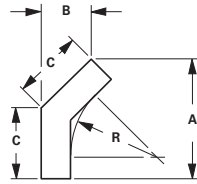

45° (VO) Mitered

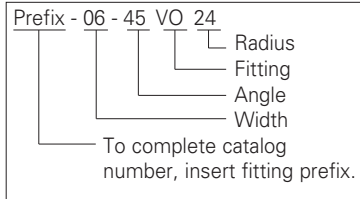

Vertical Inside Bend

VI

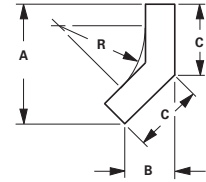
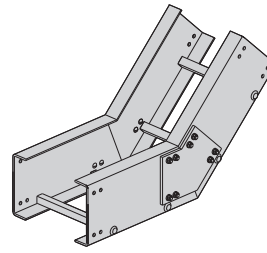

45° (VI) Mitered

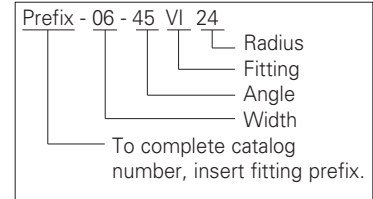

(Prefix) See page M-20 for catalog number prefix. Dimensions for reference only, when critical contact factory.

- R - Bend Radius in. mm	Tray Width in. mm	45° Mitered			
		Catalog No.	VO & VI Bend		
			A in. / (mm)	B in. / (mm)	C in. / (mm)
12 (305)	6 (152)	(Prefix)-06-45(*)12	23 ¹ / ₁₆ (585)	9 ⁹ / ₁₆ (242)	13 ¹ / ₂ (343)
	9 (228)	(Prefix)-09-45(*)12			
	12 (305)	(Prefix)-12-45(*)12			
	18 (457)	(Prefix)-18-45(*)12			
	24 (609)	(Prefix)-24-45(*)12			
	30 (762)	(Prefix)-30-45(*)12			
36 (914)	(Prefix)-36-45(*)12				
24 (609)	6 (152)	(Prefix)-06-45(*)24	23 ¹ / ₁₆ (585)	9 ⁹ / ₁₆ (242)	13 ¹ / ₂ (343)
	9 (228)	(Prefix)-09-45(*)24			
	12 (305)	(Prefix)-12-45(*)24			
	18 (457)	(Prefix)-18-45(*)24			
	24 (609)	(Prefix)-24-45(*)24			
	30 (762)	(Prefix)-30-45(*)24			
36 (914)	(Prefix)-36-45(*)24				
36 (914)	6 (152)	(Prefix)-06-45(*)36	23 ¹ / ₁₆ (585)	9 ⁹ / ₁₆ (242)	13 ¹ / ₂ (343)
	9 (228)	(Prefix)-09-45(*)36			
	12 (305)	(Prefix)-12-45(*)36			
	18 (457)	(Prefix)-18-45(*)36			
	24 (609)	(Prefix)-24-45(*)36			
	30 (762)	(Prefix)-30-45(*)36			
36 (914)	(Prefix)-36-45(*)36				

(*) Insert 'VO' for Vertical Outside Bend or 'VI' for Vertical Inside Bend. 60° and 30° vertical bends available in mitered construction.

Dimensions shown in parentheses are in millimeters, unless otherwise specified.

For 3" Fittings

(Radius 12" only • Tray widths - 6" thru 24")
Polyester, Vinyl Ester, Zero Halogen/Dis-Stat
All are mitered

For 4" Fittings

(Radius 12", 24" & 36"
Tray widths - 6" thru 36")
Polyester, Vinyl Ester, Zero Halogen/Dis-Stat
All radius are mitered

For 6" Fittings

(Radius 12", 24" & 36"
Tray widths - 6" thru 36")
Polyester, Vinyl Ester, Zero Halogen/Dis-Stat
All radius are mitered

For 8" Fittings

(Radius 12", 24" & 36"
Tray widths - 6" thru 36")
Polyester, Vinyl Ester, Zero Halogen/Dis-Stat
All radius are mitered

Fiberglass - Covers & Cover Accessories

Covers

Material Thickness: .090" (2.3)

Cover Length: 10' (3m)

Standard Mounting Hardware: (10 each) #10 x 3/4" stainless, self drilling screws provided with each section

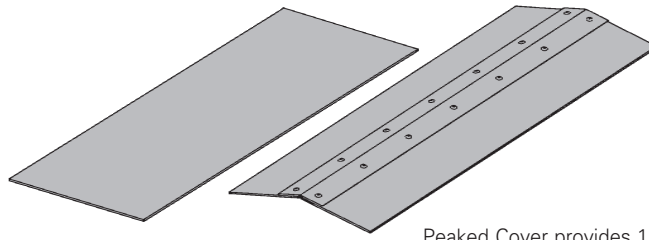

Peaked Cover provides 1 to 3.7 pitch
Peaked covers available for straight sections only.
No Hardware provided.

Covers

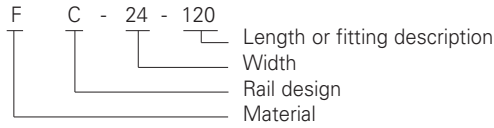

- F C - 24 - 120 = Flat polyester
- FV C - 24 - 120 = Flat vinyl ester
- FA C - 24 - 120 = Flat zero halogen/Dis-Stat
- FP C - 24 - 120 = Peaked polyester
- FVP C - 24 - 120 = Peaked vinyl ester
- FAP C - 24 - 120 = Peaked zero halogen/Dis-Stat

Quantity of Standard Cover Clamps Required

Straight Section 60" or 72"	4 pcs.
Straight Section 120" or 144"	6 pcs.
Horizontal/Vertical Bends	4 pcs.
Tees	6 pcs.
Crosses	8 pcs.

Note: When using the Heavy Duty Cover Clamp, only one-half the number of clamps stated above is required.

Standard Cover Clamp

- Furnished in pairs with hardware.

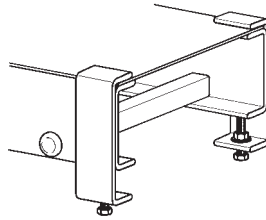

Catalog No.	Side Rail Height	
	in.	(mm)
9(Δ)-9013	3	(76)
9(Δ)-9014	4	(101)
9(Δ)-9016	6	(152)

Heavy Duty Cover Clamp

Recommended for outdoor service.

- W = tray width
- Heavy duty cover clamp available for flat covers only

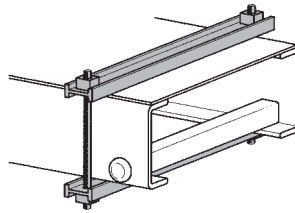

Catalog No.	Side Rail Height	
	in.	(mm)
9F-W-9034	3	(76)
9F-W-9044	4	(101)
9F-W-9064	6	(152)
9F-W-9084	8	(203)

Peaked Cover Clamp

- W = tray width

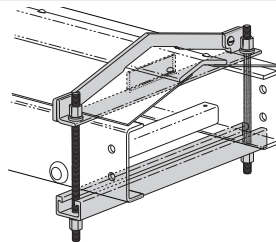

Catalog No.	Side Rail Height	
	in.	(mm)
9F-W-9034P	3	(76)
9F-W-9044P	4	(101)
9F-W-9064P	6	(152)
9F-W-9084P	8	(203)

Thermo Plastic Drive Rivet

- Sold individually.
- Shipped in packages of 25 pcs.

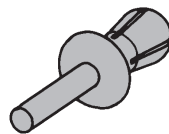

Catalog No.

- TPDR

Material Designations

(Δ) Insert one of the following material designations when required.

- F = Polyester Resin (Example: 9F-9013)
- FV = Vinyl Ester Resin (Example: 9FV-9013)
- FA = Zero Halogen/Dis-Stat Resin (Example: 9FA-9013)

● Green = Fastest shipped items ● Black = Normal lead-time items ● Red = Normally long lead-time items

Dimensions shown in parentheses are in millimeters, unless otherwise specified.

Part Number with Hardware Explanation

Note: All hardware is 3/8"

- Example:** 9F-4004 SS6: pair of 4-hole splice plates for 4" (101) system with stainless steel hardware
 9FV-8006 SS6: pair of 8-hole vinyl ester splice plates for 6" (152) system with stainless steel hardware

Hardware Option	316 Stainless Steel
	SS6

Standard Lay-In Splice Plates

- Furnished in pairs with 316 stainless steel hardware
- One pair including hardware provided with straight section. (Expansion splice quantity subtracted)

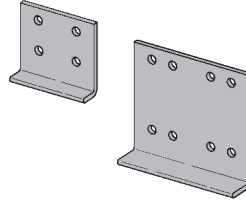

Material	Height in. (mm)	Catalog No.
Fiberglass	3" (76)	9(Δ)-4003SS6
	4" (101)	9(Δ)-4004SS6
	6" (152)	9(Δ)-8006SS6
	8" (203)	9(Δ)-8008SS6

Expansion Lay-In Splice Plates

- Furnished in pairs with 316 stainless steel hardware

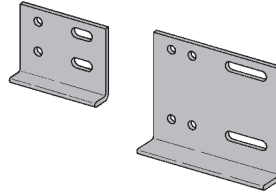

Material	Height in. (mm)	Catalog No.
Fiberglass	3" (76)	9(Δ)-4013SS6
	4" (101)	9(Δ)-4014SS6
	6" (152)	9(Δ)-8016SS6
	8" (203)	9(Δ)-8018SS6

Tray to Box Splice Plates

These plates are used to attach the end of a tray run to a distribution box or control center.

- Furnished in pairs with 316 stainless steel hardware

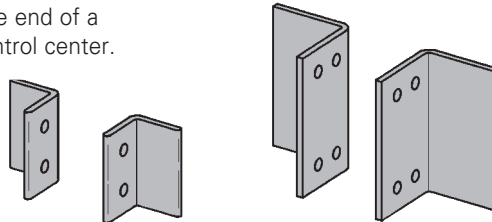

Material	Height in. (mm)	Catalog No.
Fiberglass	3" (76)	9(Δ)-4053SS6
	4" (101)	9(Δ)-4054SS6
	6" (152)	9(Δ)-8056SS6
	8" (203)	9(Δ)-8058SS6

Step Down Splice Plates

These plates are offered for connecting cable tray sections having side rails of different heights.

- Furnished in pairs with 316 stainless steel hardware

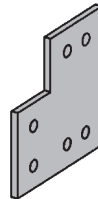

Material	Height in. (mm)	Catalog No.
Fiberglass	8" to 6" (203 to 152)	9(Δ)-8086SS6
	8" to 4" (203 to 101)	9(Δ)-8084SS6
	6" to 3" (152 to 76)	9(Δ)-8063SS6
	6" to 4" (152 to 101)	9(Δ)-8064SS6
	4" to 3" (101 to 76)	9(Δ)-4043SS6

Blind End Plate

This plate forms a closure for any tray that dead ends.

- Furnished as one plate
- W = tray width

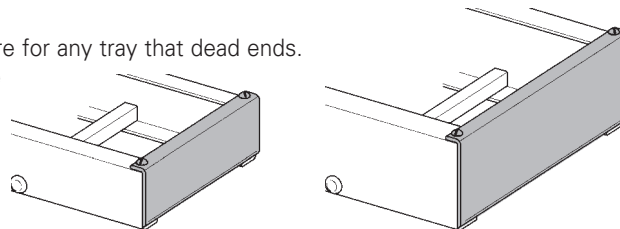

Material	Height in. (mm)	Catalog No.
Fiberglass	3" (76)	9(Δ)-1083-WSS6
	4" (101)	9(Δ)-1084-WSS6
	6" (152)	9(Δ)-1086-WSS6
	8" (203)	9(Δ)-1088-WSS6

Resin Seal Kit

To reseal fiberglass after field modifications.

- 1 pint (473ml)
- Contents: Sealant and Applicator.



Catalog No.
RSK-010

Fiberglass - Accessories

Horizontal Adjustable Splice Plates

These plates provide for changes in the horizontal direction that do not conform to standard fittings.

- Furnished in pairs with 316 stainless steel hardware
- Body made from 316 stainless steel
- Used for all material finishes

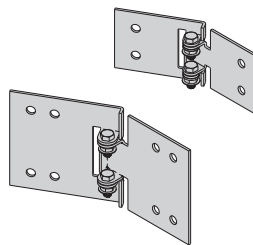

Material	Height in. (mm)	Catalog No.
Fiberglass	3" (76)	9F-403SS6
	4" (101)	9F-4034SS6
	6" (152)	9F-8036SS6
	8" (203)	9F-8038SS6

Horizontal Splice Plates

- Furnished in pairs with 316 stainless steel hardware

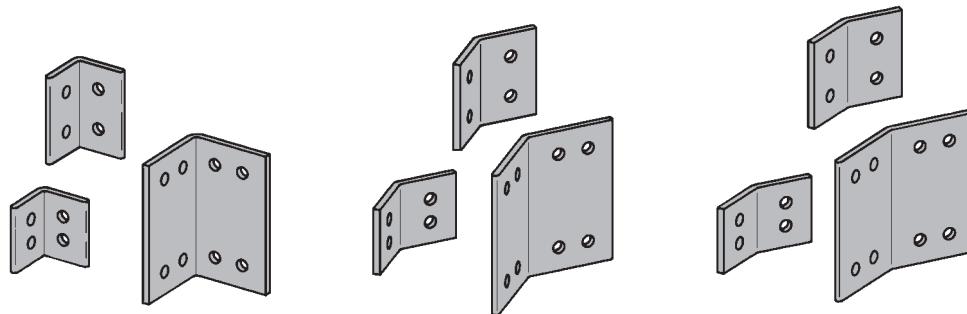

Material	Height in. (mm)	Catalog No.		
		90°	45°	30°
Fiberglass	3" (76)	9(Δ)-4903HSS6	9(Δ)-4453HSS6	9(Δ)-4303HSS6
	4" (101)	9(Δ)-4904HSS6	9(Δ)-4454HSS6	9(Δ)-4304HSS6
	6" (152)	9(Δ)-8906HSS6	9(Δ)-8456HSS6	9(Δ)-8306HSS6
	8" (203)	9(Δ)-8908HSS6	9(Δ)-8458HSS6	9(Δ)-8308HSS6

Vertical Adjustable Splice Plates

These plates provide for changes in elevation that do not conform to standard vertical fittings.

- Furnished in pairs with 316 stainless steel hardware

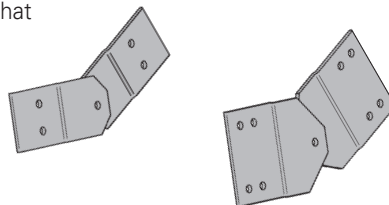

Material	Height in. (mm)	Catalog No.
Fiberglass	3" (76)	9(Δ)-4023SS6
	4" (101)	9(Δ)-4024SS6
	6" (152)	9(Δ)-8026SS6
	8" (203)	9(Δ)-8028SS6

Vertical Splice Plates

- Furnished in pairs with 316 stainless steel hardware

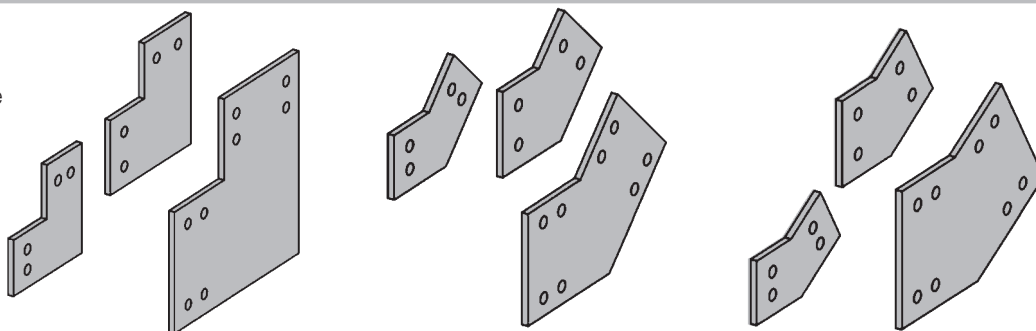

Material	Height in. (mm)	Catalog No.		
		90°	45°	30°
Fiberglass	3" (76)	9(Δ)-4903VSS6	9(Δ)-4453VSS6	9(Δ)-4303VSS6
	4" (101)	9(Δ)-4904VSS6	9(Δ)-4454VSS6	9(Δ)-4304VSS6
	6" (152)	9(Δ)-8906VSS6	9(Δ)-8456VSS6	9(Δ)-8306VSS6
	8" (203)	9(Δ)-8908VSS6	9(Δ)-8458VSS6	9(Δ)-8308VSS6

(Δ) See page M-31 for material selection

Dimensions shown in parentheses are in millimeters, unless otherwise specified.

Ladder Drop-Out

Specially-designed Ladder Drop-Outs provide a rounded surface with adequate radius to protect cable as it exits from the tray, preventing damage to insulation.

- 4" (101) radius
- W = tray width
- Furnished with #10 x 3/4" self-drilling stainless steel screws

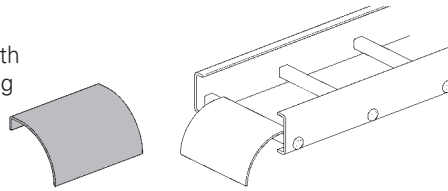

Catalog No.

9(Δ)-1104-W

Barriers

- Furnished with #10 x 3/4" self-drilling stainless steel screws

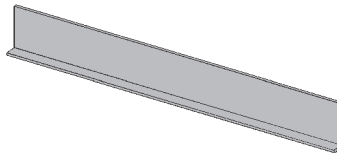

Catalog No.	Side Rail Height in. (mm)
72(Δ)-120	3" (76)
73(Δ)-120	4" (101)
75(Δ)-120	6" (152)
77(Δ)-120	8" (203)

Flexible Horizontal Barrier Kit

One kit allows up to a 36" (914) radius position of the barrier.

Kit Contents:

- 1 pc — 72" (1829) Straight Barrier
 - 4 pc — 9F-9002 Barrier Strip Clip
 - 8 pc — Thermo Plastic Drive Rivet
 - 4 pc — #10 x 3/4" Stainless Steel Self-Drilling Screw
- Assembly required — directions included.

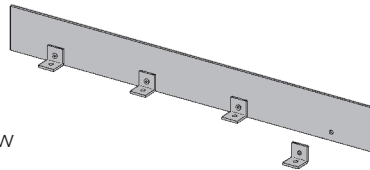

Catalog No.	Side Rail Height in. (mm)
72(Δ)-90HBFL	3" (76)
73(Δ)-90HBFL	4" (101)
75(Δ)-90HBFL	6" (152)
77(Δ)-90HBFL	8" (203)

Vertical Bend Barriers

- Furnished with #10 x 3/4" self-drilling stainless steel screws
- * Insert 2 for 3" (76) siderail height
- 3 for 4" (101) siderail height
- 5 for 6" (152) siderail height

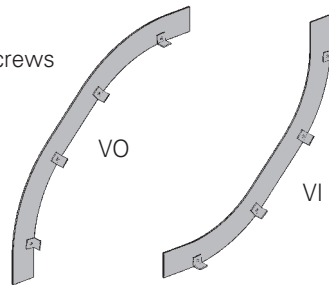

7* (Δ) - 90 VO 24



Clamp/Guide - Fiberglass

- Nonmetallic
- Designed for 3/8" hardware - not included
- Combination hold down clamp and guide
- Material: Glass reinforced polyurethane
- Sold in pairs

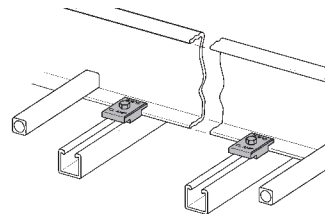

Catalog No.

9F-1208

Fiberglass Conduit to Cable Tray Adapter

- For rigid or PVC conduit
- Furnished in pairs with 316 stainless steel hardware

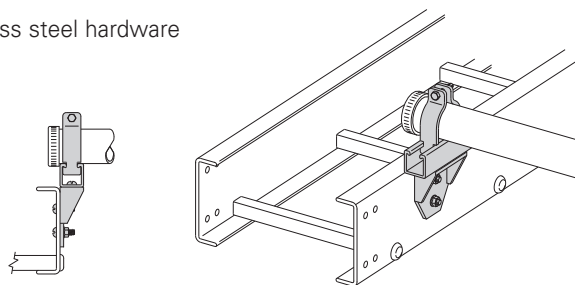

Catalog No.	Conduit Size in. (mm)
9FV-2008	0.50 (15)
9FV-2009	0.75 (20)
9FV-2010	1.00 (25)
9FV-2011	1.25 (32)
9FV-2012	1.50 (40)
9FV-2013	2.00 (50)
9FV-2014	2.50 (65)
9FV-2015	3.00 (80)
9FV-2016	3.50 (90)
9FV-2017	4.00 (100)

(Δ) See page M-31 for material selection

Dimensions shown in parentheses are in millimeters, unless otherwise specified.

Fiberglass - Cable Channel & Fittings

Straight Section

- Load data was interpolated from CSA testing.
- Loads shown are for FCCN series.
- Loads shown are for 6 ft. (1.83m) span with deflection of .7 (18.26) inches.
- One pair of splice plates included with each straight section.

FCC Fiberglass
Cable Channel Ventilated

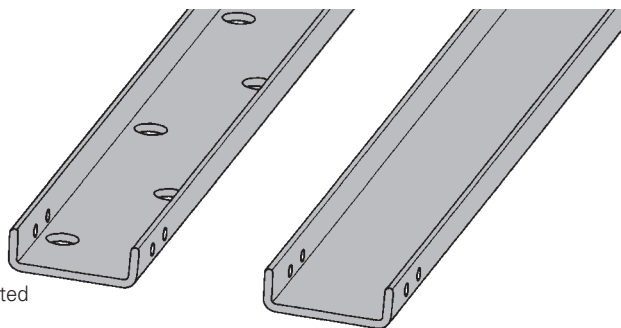

FCCN Fiberglass Cable
Channel Non-Ventilated

Catalog No.		Width in. (mm)	Length ft. (m)	Height in. (mm)	Load Lbs/Ft (kg/m)
Ventilated	Non-Ventilated				
(*)-03-120	(*)N-03-120	3 (76)	10 (3)	1 (25)	8 (12)
(*)-03-240	(*)N-03-240	3 (76)	20 (6)	1 (25)	8 (12)
(*)-04-120	(*)N-04-120	4 (101)	10 (3)	1 1/8 (28)	12 (18)
(*)-04-240	(*)N-04-240	4 (101)	20 (6)	1 1/8 (28)	12 (18)
(*)-06-120	(*)N-06-120	6 (152)	10 (3)	1 5/8 (35)	58 (86)
(*)-06-240	(*)N-06-240	6 (152)	20 (6)	1 5/8 (35)	58 (86)
(*)-08-120	(*)N-08-120	8 (203)	10 (3)	2 3/16 (55)	87 (129)
(*)-08-240	(*)N-08-240	8 (203)	20 (6)	2 3/16 (55)	87 (129)

Cable Channel Fittings

All fittings are of mitered construction with 12" (305) radius.

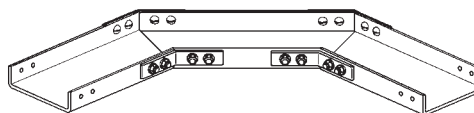

Horizontal	3" series	4" series	6" series	8" series
90°	(*)N-03-90HB12	(*)N-04-90HB12	(*)N-06-90HB12	(*)N-08-90HB12
45°	(*)N-03-45HB12	(*)N-04-45HB12	(*)N-06-45HB12	(*)N-08-45HB12

One pair of splice plates included.

Vertical	3" series	4" series	6" series	8" series
90°	(*)N-03-90V*12	(*)N-04-90V*12	(*)N-06-90V*12	(*)N-08-90V*12
45°	(*)N-03-45V*12	(*)N-04-45V*12	(*)N-06-45V*12	(*)N-08-45V*12

One pair of splice plates included.

- (*) Insert material type
- FCC for Polyester Resin
 - FCCV for Vinyl Ester Resin
 - FCCA for Zero Halogen/Dis-Stat Resin

● Green = Fastest shipped items ● Black = Normal lead-time items ● Red = Normally long lead-time items

Dimensions shown in parentheses are in millimeters, unless otherwise specified.

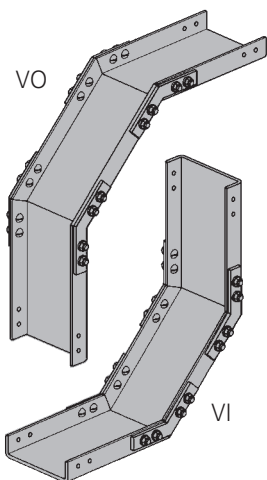

Fiberglass - Cable Channel Fittings & Accessories

Horizontal Tees

- Two pair of splice plates included.

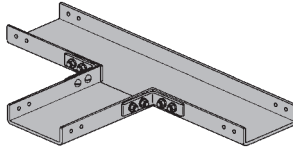

Catalog No.	Width in. (mm)
FCC(*)N-03-HT12	3 (76)
FCC(*)N-04-HT12	4 (101)
FCC(*)N-06-HT12	6 (152)
FCC(*)N-08-HT12	8 (203)

(*) See page fitting material selection bottom of page M-35

All fittings are of mitered construction with 12" (305) radius.

Horizontal Crosses

- Three pair of splice plates included.

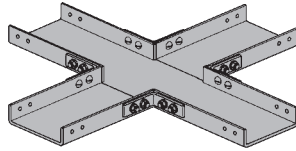

Catalog No.	Width in. (mm)
FCC(*)N-03-HX12	3 (76)
FCC(*)N-04-HX12	4 (101)
FCC(*)N-06-HX12	6 (152)
FCC(*)N-08-HX12	8 (203)

(*) See page fitting material selection bottom of page M-35

All fittings are of mitered construction with 12" (305) radius.

Splice Plates

- Sold in pairs - included with tray sections.
- Uses 1/4"-20 316SS hardware

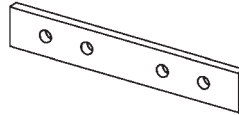

Catalog No.
9(Δ)-1001SS6

Expansion Splice Plates

- Sold in pairs
- Uses 1/4"-20 316SS hardware

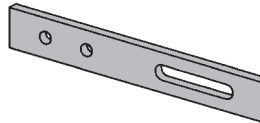

Catalog No.
9(Δ)-1013SS6

Horizontal 90° Splice Plates

- Sold in pairs
- Uses 1/4"-20 316SS hardware

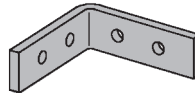

Catalog No.
9(Δ)-1901HSS6

Horizontal 45° Splice Plates

- Sold in pairs
- Uses 1/4"-20 316SS hardware

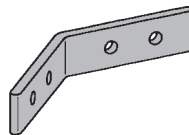

Catalog No.
9(Δ)-1451HSS6

Horizontal 30° Splice Plates

- Sold in pairs
- Uses 1/4"-20 316SS hardware

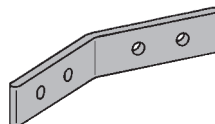

Catalog No.
9(Δ)-1301HSS6

Splice plates included with cable channel sections.
Hardware for splice plates is 1/4"-20 (316SS).

(Δ) See page M-31 for material selection

Dimensions shown in parentheses are in millimeters, unless otherwise specified.

Fiberglass - Cable Channel Accessories

Horizontal 90° Splice Plates

- Sold in pairs
- Uses 1/4"-20 316SS hardware

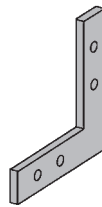

Catalog No.

9(Δ)-1901VSS6

Horizontal 45° Splice Plates

- Sold in pairs
- Uses 1/4"-20 316SS hardware

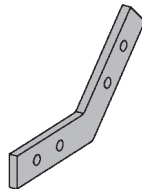

Catalog No.

9(Δ)-1451VSS6

Horizontal 30° Splice Plates

- Sold in pairs
- Uses 1/4"-20 316SS hardware

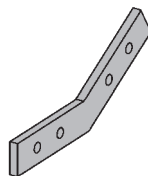

Catalog No.

9(Δ)-1301VSS6

Horizontal Adjustable Splice Plates

- Sold per piece
- Uses 3/8"-16 316SS hardware

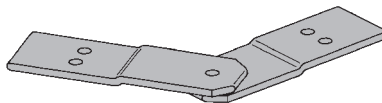

Catalog No.

9(Δ)-1023SS6

Vertical Adjustable Splice Plates

- Sold per piece
- Uses 3/8"-16 316SS hardware
- Boby made from 316 stainless steel
- Used for all material finishes

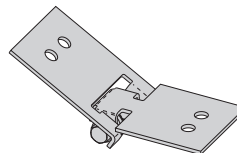

Catalog No.

9F-1033SS6

Expansion Guide Clamp

- Sold per clamp
- Order 1/2" hardware separately

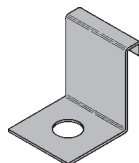

Catalog No.	Width in. (mm)
● 9SS6-1248-3	3 (76)
● 9SS6-1248-4	4 (101)
● 9SS6-1248-6	6 (152)
● 9SS6-1248-8	8 (203)

Hold-Down Clamp

- Sold per clamp
- Order 1/2" hardware separately

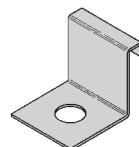

Catalog No.	Width in. (mm)
● 9SS6-1247-3	3 (76)
● 9SS6-1247-4	4 (101)
● 9SS6-1247-6	6 (152)
● 9SS6-1247-8	8 (203)

● Green = Fastest shipped items ● Black = Normal lead-time items ● Red = Normally long lead-time items

(Δ) See page M-31 for material selection

Dimensions shown in parentheses are in millimeters, unless otherwise specified.

Marine Rung Cable Tray/Fiberglass

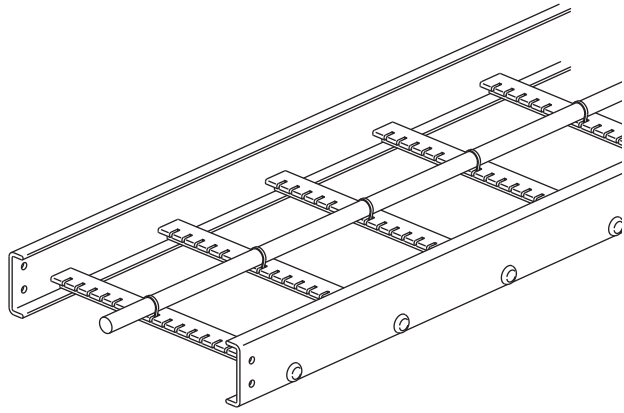

Features:

- For Coast Guard Requirements
 - Allows stainless steel banding of cables
 - $\frac{5}{32}$ " (15.9) slots 1" (25.4) on centers
 - Accommodates up to $\frac{5}{8}$ " (15.9) banding
- Has applications on land
 - Vertical installation
 - Any location where extra cable positioning is required
- Designed for Eaton's B-Line series Fiberglass Cable Trays
- Part Number Indication
 - Add MR after rung spacing
 - Example: 46F09MR-36-240

Rung design provides:

- 2" (50.8) cable support surface
- Both mechanical and adhesive rung to side rail connection

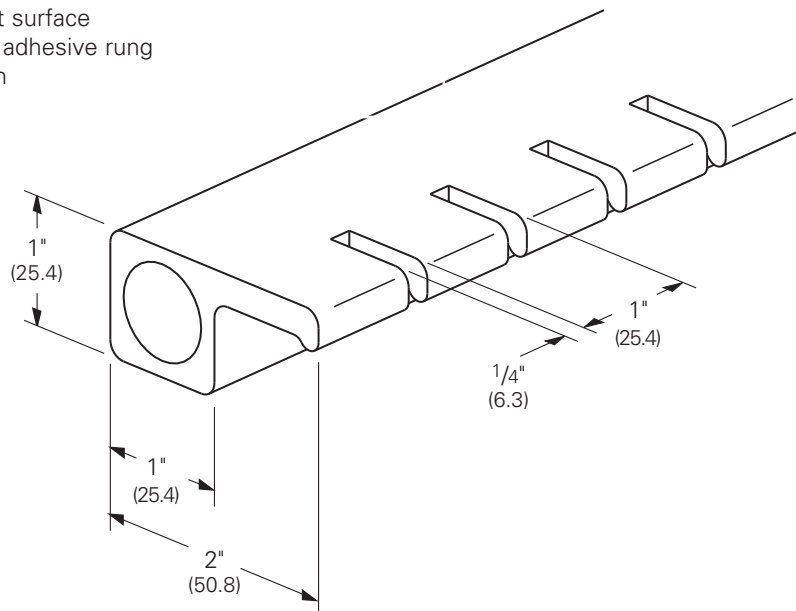

Dimensions shown in parentheses are in millimeters, unless otherwise specified.

Cable Cleats

Cable Cleats



Trefoil Cable Cleat with LSF Pad

1. Recommended for installations where the highest levels of short circuit withstand are required.
2. Short circuit current tested in accordance with BS EN 50368:2003 standard.
3. Available for single and trefoil cable applications.
4. LSF-pad incorporates an integral low smoke, low fume, zero halogen pad.
5. Hardware to attach cleat to rung attachment bracket is included with cleat. Bracket must be ordered separately.

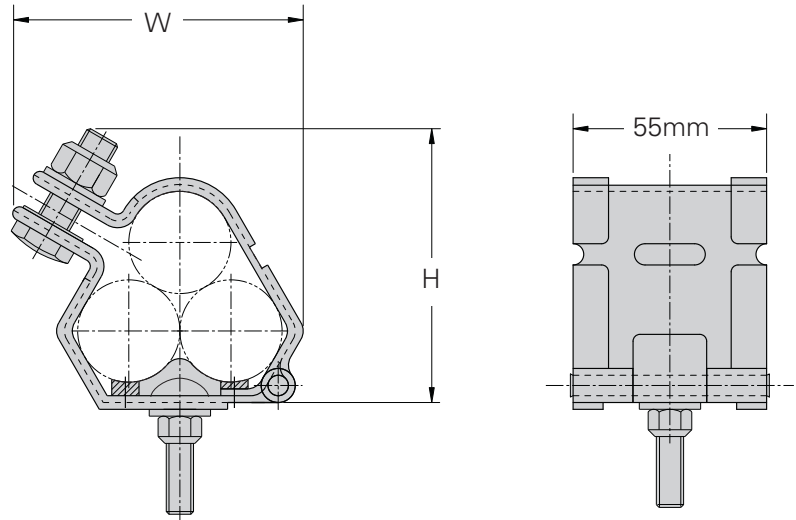

BS EN 50368:2003 (Cable Cleats for Electric Installations) Classification

Cleat Type	Composite
Resistance to Electromechanical Force	130 kA peak / 50 kA RMS 600 mm spacing
Lateral Load Test	3,439 kg average
Axial Load Test	Pass
Operating Temperature Range	-40°C to +60°C
Impact Resistance	Very Heavy
Needle Flame Test	30 seconds

Technical Specifications

Frame	50mm x 2mm Marine grade, Non-magnetic 316L
Closure Hardware	Captive 316 Stainless Steel M8 or M10 (M12 available) bolt and nylon-lock nut (Optional Hex Flange Lock Nut available)
Integral Pad	Low Smoke, Low Fume, Zero Halogen
Tools Required	Impact Wrench
Mounting Bolt	Provided with Cable Cleat

Part No.	Cable Range (mm)		Dimensions (mm)	
	Min. Dia.	Max. Dia.	H	W
9SS6-CCT1323	13	22	74	66
9SS6-CCT2125	21	25	77	70
9SS6-CCT2329	23	29	81	78
9SS6-CCT2531	25	31	84	81
9SS6-CCT2733	27	33	86	83
9SS6-CCT2935	29	35	90	89
9SS6-CCT3238	32	38	94	95
9SS6-CCT3541	35	41.5	98	100
9SS6-CCT3844	38	44.5	101	104
9SS6-CCT4248	42	48	105	111
9SS6-CCT4551	45	51	109	117
9SS6-CCT4753	47	53	111	120
9SS6-CCT4955	49	55	114	124
9SS6-CCT5157	51	57	116	127
9SS6-CCT5359	53	59	119	133
9SS6-CCT5561	55	61	127	137
9SS6-CCT5763	57	63	126	140
9SS6-CCT5965	59	65	128	144
9SS6-CCT6167	61	67	132	147
9SS6-CCT6369	63	69	136	150

Part No.	Cable Range (mm)		Dimensions (mm)	
	Min. Dia.	Max. Dia.	H	W
9SS6-CCT6571	65	71	140	153
9SS6-CCT6773	67	73	143	156
9SS6-CCT6975	69	75	147	160
9SS6-CCT7177	71	77	151	163
9SS6-CCT7379	73	79	154	166
9SS6-CCT7581	75	81	158	169
9SS6-CCT7783	77	83	161	173
9SS6-CCT7985	79	85	164	176
9SS6-CCT8187	81	87	169	179
9SS6-CCT8389	83	89	173	182
9SS6-CCT8692	86	92	177	187
9SS6-CCT8896	88	96	181	192
9SS6-CCT9199	91	99	185	196
9SS6-CCT96103	96	103	190	201
9SS6-CCT99107	99	107	194	202
9SS6-CCT103111	103	111	199	204
9SS6-CCT107115	107	115	203	208
9SS6-CCT111119	111	119	208	213
9SS6-CCT115123	115	123	213	217
9SS6-CCT119128	119	128	217	221

Single Cable Cleat with LSF Pad

1. Recommended for installations where the highest levels of short circuit withstand are required.
2. Short circuit current tested in accordance with BS EN 50368:2003 standard.
3. Available for single and trefoil cable applications.
4. LSF-pad incorporates an integral low smoke, low fume, zero halogen pad.
5. Hardware to attach cleat to rung attachment bracket is included with cleat. Bracket must be ordered separately.

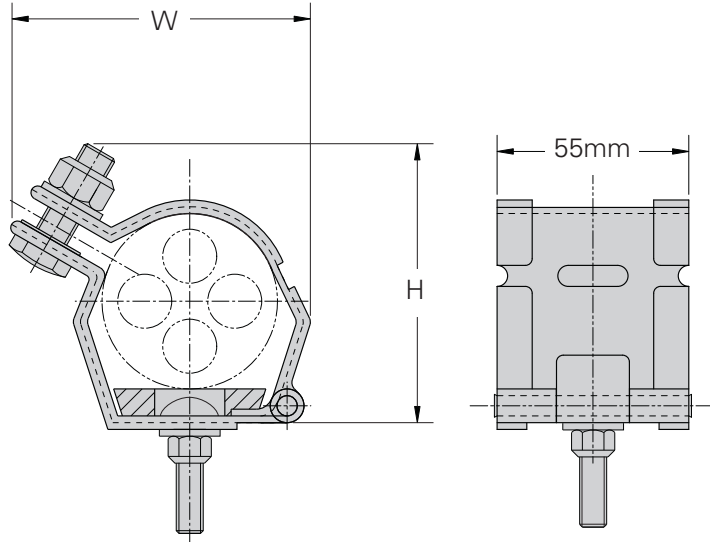
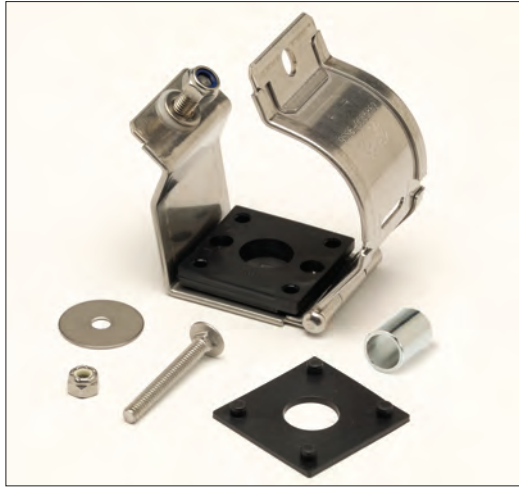

BS EN 50368:2003 (Cable Cleats for Electric Installations) Classification

Cleat Type	Composite
Resistance to Electromechanical Force	130 kA peak / 50 kA RMS 600 mm spacing
Lateral Load Test	3.439 kg average
Axial Load Test	Pass
Operating Temperature Range	-40°C to +60°C
Impact Resistance	Very Heavy
Needle Flame Test	30 seconds

Technical Specifications

Frame	50mm x 2mm Marine grade, Non-magnetic 316L
Closure Hardware	Captive 316 Stainless Steel M8 or M10 (M12 available) bolt and nylon-lock nut (Optional Hex Flange Lock Nut available)
Integral Pad	Low Smoke, Low Fume, Zero Halogen
Tools Required	Impact Wrench
Mounting Bolt	Provided with Cable Cleat

Part No.	Cable Range (mm)		Dimensions (mm)	
	Min. Dia.	Max. Dia.	H	W
9SS6-CCS2832	28	32	61	55
9SS6-CCS3034	30	34	63	57
9SS6-CCS3236	32	36	65	59
9SS6-CCS3438	34	38	67	61
9SS6-CCS3640	36	40	71	63
9SS6-CCS3842	38	42	69	65
9SS6-CCS4044	40	44	71	67
9SS6-CCS4246	42	46	72	69
9SS6-CCS4448	44	48	74	71
9SS6-CCS4650	46	50	75	73
9SS6-CCS4852	48	52	77	75
9SS6-CCS5054	50	54	79	77
9SS6-CCS5256	52	56	80	79
9SS6-CCS5458	54	58	81	81
9SS6-CCS5660	56	60	83	83
9SS6-CCS5862	58	62	85	85
9SS6-CCS6064	60	64	86	87
9SS6-CCS6266	62	66	88	89
9SS6-CCS6468	64	68	90	91
9SS6-CCS6670	66	70	91	93

Part No.	Cable Range (mm)		Dimensions (mm)	
	Min. Dia.	Max. Dia.	H	W
9SS6-CCS6872	68	72	93	95
9SS6-CCS7074	70	74	95	97
9SS6-CCS7276	72	76	97	99
9SS6-CCS7478	74	78	99	101
9SS6-CCS7680	76	80	101	103
9SS6-CCS7682	76	82	103	105
9SS6-CCS8084	80	84	105	107
9SS6-CCS8286	82	86	107	109
9SS6-CCS8488	84	88	109	111
9SS6-CCS8690	86	90	110	113
9SS6-CCS88192	88	192	113	117
9SS6-CCS9094	90	94	116	120
9SS6-CCS9296	92	96	126	127
9SS6-CCS94106	94	106	135	133
9SS6-CCS100112	100	112	140	139
9SS6-CCS106118	106	118	145	145
9SS6-CCS112124	112	124	153	155
9SS6-CCS118130	118	130	162	165
9SS6-CCS127139	127	139	161	167
9SS6-CCS132144	132	144	165	173
9SS6-CCS138150	138	150	170	179

Step 1: Know Your Cables

- What type of cable is being used?
 - Single or Multi-conductor
- What is the outside diameter of the cable(s)?
- What is the cable arrangement (single conductor cables only)?
 - Flat or Trefoil
- If a ground wire will be installed within the cleat, you will need the ground wire outside diameter.

Step 2: Know Your System

- What is the available short circuit current (RMS or i_p (peak))?
- What type of B-Line cable tray is installed?

Step 3: Select Your Cable Cleats

- See Pages CFX-2 & CFX-3

Step 4: Select Your Mounting Bracket

Mounting brackets are used to attach cable cleats to the rungs of the ladder type cable trays. Your tray type will determine the mounting bracket used.

B-Line Tray Types	Mounting Bracket
Aluminum welded rung trays with standard rungs. Steel Series 2, 3, 4 or 5, trays with standard rungs Fiberglass trays with standard rungs	9SS6-CCB-C
REDI-Rail™ Cable Tray, KwikSplice™ Cable Tray	9SS6-CCB-D
Steel trays with strut rungs Aluminum trays with "Marine Rungs"	9SS6-CCB-B
Steel Series 1 trays with standard rungs	9SS6-CCB-A

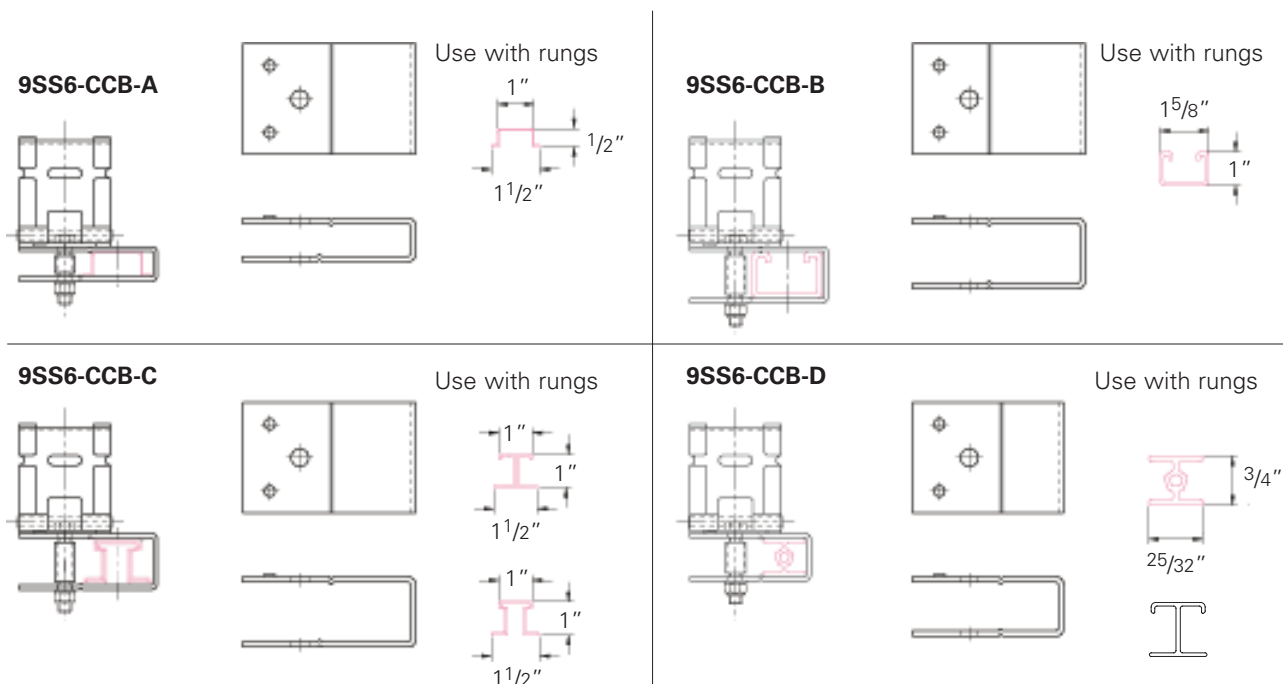

Cable Cleats

Step 5: Determine Cleat Spacing for Installation

Your cable diameter is equal to the spacing between conductor centers shown below. Find your cable diameter at the top of the table and look down at the column below it. Find the value equal to or greater than the available short circuit for your system.

Single Conductor Short Circuit Withstand Table

Max. Cable Cleat Spacing (A)		Spacing Between Conductor Centers (mm)											
		23	25	27	29	31	33	35	37	39	41	43	45
mm	In.	i_p peak (kA)											
225	9	179	187	194	203	209	216	220	229	234	240	246	250
300	12	155	163	168	174	181	187	192	198	203	209	214	215
450	18	128	133	137	144	148	152	157	161	165	170	174	178
600	24	110	115	119	124	128	132	135	139	143	148	150	153
675	27	104	108	113	117	121	124	128	132	135	139	143	147
900	36	89	93	97	102	104	108	110	115	117	121	124	127

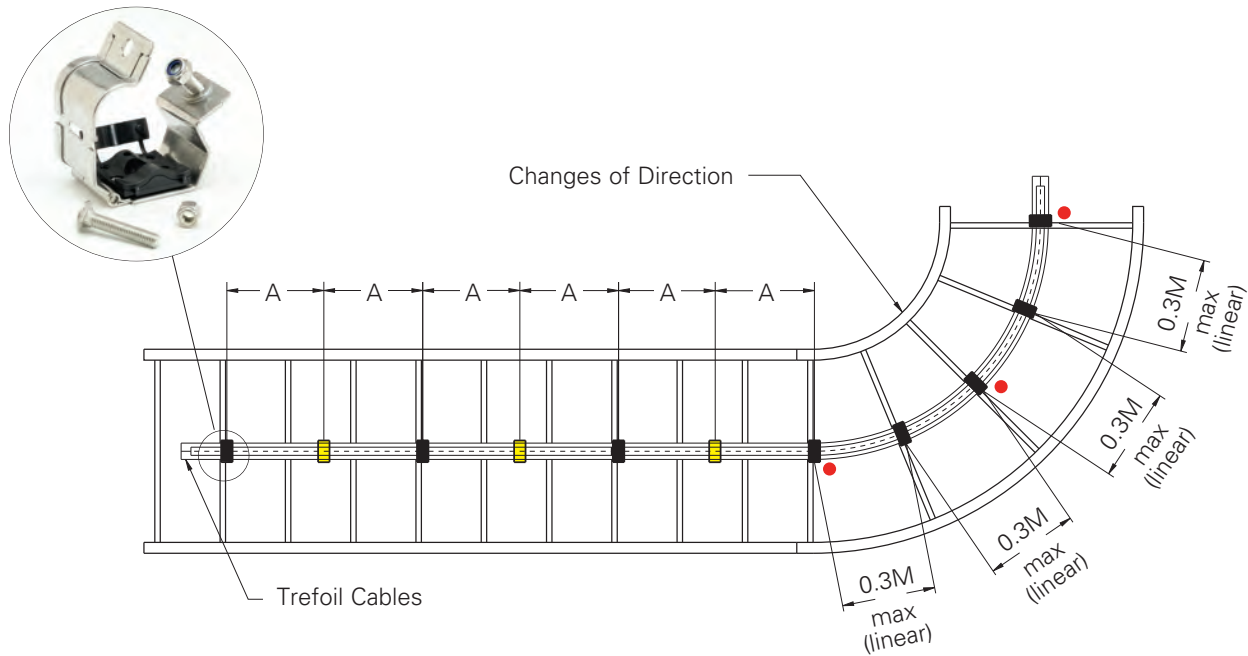

IMPORTANT: Recommended Installation Procedures

It is important that the cleats are installed properly to secure your cables:

- It is not necessary for every cleat to be attached to the tray. Every other cleat (■) must be attached to the tray system to mount cable in tray. Unattached cleats (□) provide additional restraint to keep cables bundled.
- The bend radius should be 8 to 12 times the cable diameter.
- Cleats should always be installed at the beginning, middle and end of a bend (●), and at no time should the distance between cleats on a bend be more than 0.3M center to center.

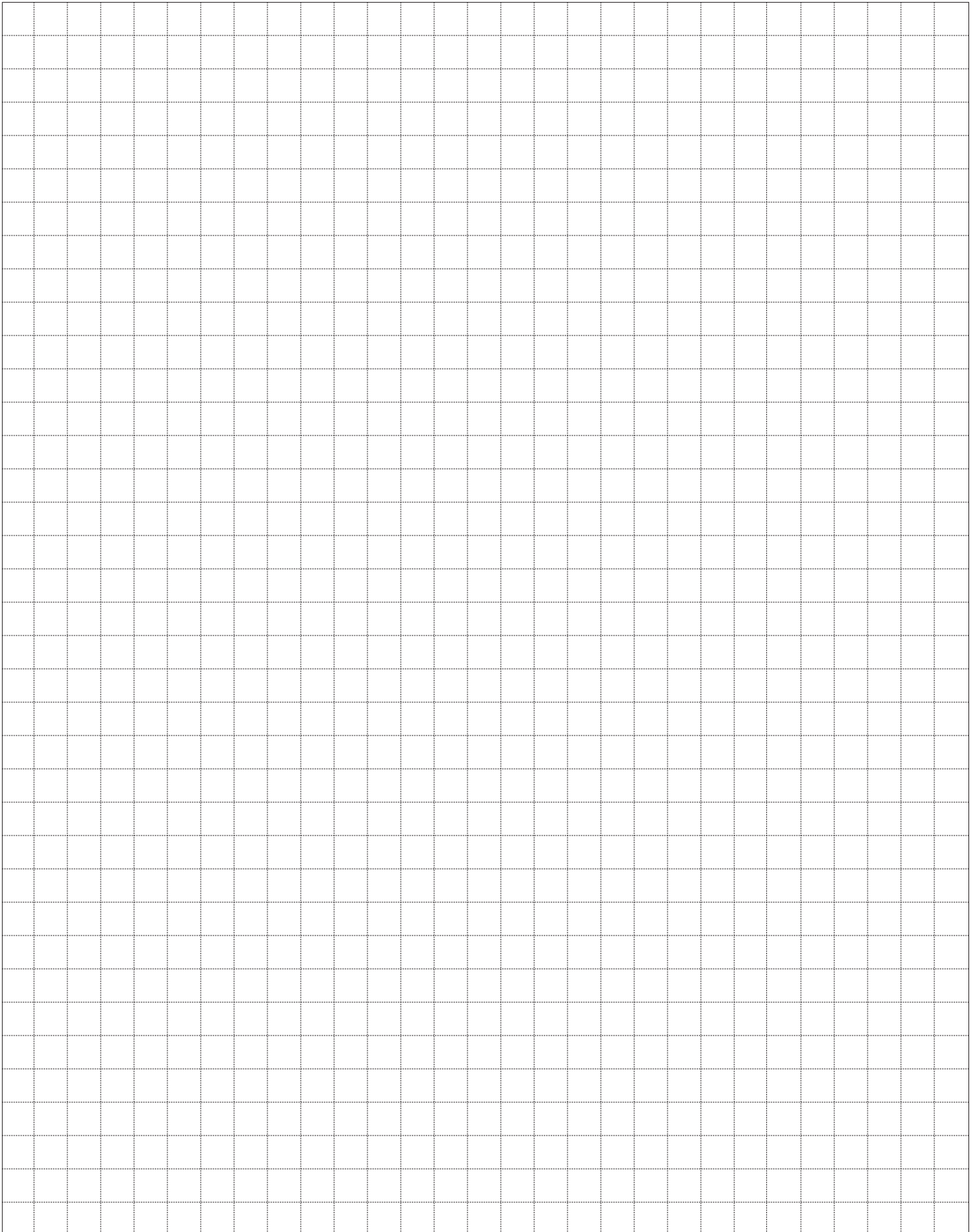



Firestop



3M™† Fire Barrier Self-Locking Pillows

Features & Benefits

- Extremely easy to install - saves time and labor
- Easy removal and fully reusable - with no blocking or fusing of materials
- No cutting required, no left over debris
- Up to three-hour UL Listed F-Rating
- UL Listed systems up to 540 sq. in. opening
- Passes hose stream test without cumbersome wire mesh
- Smoke seal tested and listed
- Listed for blank or filled openings in gypsum wallboard or concrete
- Available in three (3) sizes
- One (1) or two (2) cable trays per opening

This product will intumesce and lock tightly into place eliminating the prep work of cutting or leaving any messy debris. The resulting barrier retards the transmission of smoke, fire, and toxic gases from spreading between adjacent rooms and floors for the rated time period.



Catalog Number	Type	Pillow Size	
		in.	(mm)
FSP-SLP-S	Small	2" x 4" x 9"	(51 x 101 x 228)
FSP-SLP-M	Medium	2" x 6" x 9"	(51 x 152 x 228)
FSP-SLP-L	Large	3" x 6" x 9"	(76 x 152 x 228)

The following charts give the number of 3M pillows needed to completely firestop an opening that cable tray passes through.* Two (2) sticks of moldable putty (part number FSP-MPS) are also needed for each opening.

Width	Height			
	1.5	2	4	6
2	--	4	--	--
4	4	5	7	--
6	5	6	8	--
8	7	7	10	13
12	8	10	13	17
16	--	12	17	21
18	--	13	18	24
20	--	15	20	26
24	--	17	24	30
30	--	21	29	--
36	--	22	--	--

Width	Height			
	4	5	6	7
6	8	9	10	11
9	11	12	14	15
12	13	15	17	19
18	18	21	24	26
24	24	27	30	34
30	29	33	37	41
36	34	39	44	49
42	39	45	51	56
48	45	51	57	64

Width	Height		
	3	4	6
3	5	5	7
6	7	8	10
9	9	11	14
12	11	13	17
18	16	18	24
24	20	24	30

Width	Height		
	4	5	6
6	8	9	10
9	11	12	14
12	13	15	17
18	18	21	24
24	24	27	30
30	29	33	37
36	34	39	44

UL Listed Systems

Concrete Wall - C-AJ-4056 3 HR F-Rating, 3/4 HR T-Rating

Gypsum Wall - W-L-4037 1 HR and 2 HR F-Ratings, 0 HR and 1/2 HR T-Ratings

For tray larger than 4" x 24", or a tray style other than ladder tray call 1-800-328-1687 then option 8 to obtain a free engineering judgement letter.

* Number of pillows refers to 3M's medium self-locking pillows (part number FSP-SLP-M) and are based on an opening that is 1.5" larger than the tray on all sides.

Example: For a 4" x 12" tray the recommended opening would be 7" x 15".

† 3M™ is a registered trademark of the 3M Company

3M™† Fire Barrier Moldable Putty+



Features & Benefits

- Pliable. Easy to mold into any shape
- Adheres. Sticks well to most surfaces but not to the applicator's hands
- Conformable. Pads easily conform and adhere to a wide variety of metallic and non-metallic electrical outlet boxes
- UL Listed. Wide range of UL Listed systems
- Ages Well. Excellent aging properties



3M Fire Barrier Moldable Putty+ is a one-part, halogen-free product designed to firestop electrical outlet boxes and a wide variety of through-penetrations including cable, conduit, insulated pipe and metal pipe, which penetrate fire-rated construction.

Catalog Number	Type	Size	
		in.	(mm)
FSP-MPP-4x8	Small Pad	4" x 8"	(101 x 203)
FSP-MPP-7x7	Medium Pad	7" x 7"	(178 x 178)
FSP-MPP-9x9	Large Pad	9 1/2" x 9 1/2"	(241 x 241)

3M™† Fire Barrier CS-195+ Composite Sheets



Features & Benefits

- Ideal for fire-stopping blank openings and through-penetrations of multiple cable, pipe ducts, buss ducts and cable trays
- Intumescent
- Lightweight and easy to handle - just cut and form to fit
- Easy to install using common trade tools
- Easy to fasten - bolt punch or drill through and use self-tapping screws or anchor bolts
- Bottom-of-floor applications available
- No mixing or damming required
- Re-enterable
- Documented aging properties

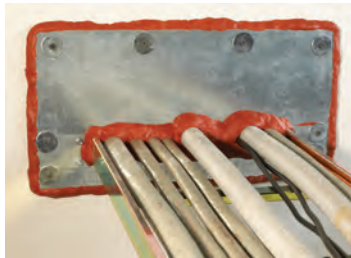

This organic/inorganic elastomeric sheet is bonded on one side to a layer of 28-gauge galvanized steel. The other side is reinforced with a steel-wire mesh and covered with aluminum foil.

Catalog Number	Type	Size	
		in.	(mm)
FSP-CS-16x28	Sheet	16" x 28"	(406 x 711)
FSP-CS-28x52	Sheet	28" x 52"	(711 x 1320)
FSP-CS-36x24	Sheet	36" x 24"	(914 x 609)
FSP-CS-36x36	Sheet	36" x 36"	(914 x 914)
FSP-CS-36x41	Sheet	36" x 41"	(914 x 1041)

† 3M™ is a registered trademark of the 3M Company

3M™† Fire Barrier Quick Pass Devices



Features & Benefits

- Hinged for existing cables
- Stackable for multiple penetrations
- Optional mounting brackets - single or triplex
- Install before or after gypsum wall assembly
- Easily identified red color
- Quick to pass cables
- JCAHO and NFPA Life Safety Code 101 compliant
- UL Classified 1, 2 and 3 hour fire (F) and temperature (T) rating
- UL Classified L rating, Hot and Cold Smoke Seal
- ULC

The Quick Pass Device makes installation and retrofitting a snap. Simply follow the instructions located on the product. Use this product in new construction or update your fire protection in a renovation - the optional mounting bracket opens easily allowing retrofit installations. As your needs change, reuse the device for additional cables and wiring.

Catalog Number	Type	Size
FSP-QPS-2	Square Device	2 1/2" (63mm) Square
FSP-QPS-2BRK	Optional Mounting Bracket for FSP-QPS-2	--
FSP-QPS-4	Square Device	4" (101mm) Square
FSP-QPS-4BRK	Optional Mounting Bracket for FSP-QPS-4	--
FSP-QPR-4	Square Device	4" (101mm) Round
FSP-QPR-4BRK	Optional Mounting Bracket for FSP-QPR-4	--

† 3M™ is a registered trademark of the 3M Company

Firestop

3M™† Fire Barrier CP-25WB+ Caulk



Features & Benefits

- Water based - easy cleanup and routine disposal with no special handling
- One-part system - no mixing or measuring required
- Intumescent and endothermic
- No-sag, non-halogen formula
- Fast drying - tack-free in approximately 10 to 15 minutes
- Water-resistant seal
- Paintable
- Documented aging properties

Our premium, intumescent latex/water-based caulk. CP 25WB Caulk can be installed with a standard caulking gun



Catalog Number	Type
FSP-BC-25	10.1 ounce Tube

3M™† Fire Barrier IC-15WB+ Caulk



Features & Benefits

- Cost effective
- UL tested
- Distinctive yellow color makes inspections easier
- For use as a one-part fire, smoke, noxious gas and water sealant

This is an affordable firestop caulk that helps you stay on budget. Its unique intumescent property allows IC 15WB Caulk to effectively contain fire and smoke at its origin. IC 15WB Caulk can be installed with a standard caulking gun



Catalog Number	Type
FSP-BC-15	10.1 ounce Tube

3M™ Aluminum Foil Tape 425



Features & Benefits

- 3-mil aluminum foil
- Acrylic adhesive performs in high temperatures

Designed to seal the cut edges of 3M™ Interam Mats to complete the total encapsulation.

Catalog Number	Type
FSP-AT-425	4" (101mm) x 180' (27.5m) Roll

† 3M™ is a registered trademark of the 3M Company

3M™† Interam™† E-5 Series Mat

Features & Benefits

- Provides up to three (3) hours of electrical circuit protection
- Made of a combination of organic/inorganic materials
- Outdoor durable
- Endothermic
- Available with a stainless-steel or aluminum backing
- Outstanding performance in high-intensity fires
- Easy to install in new applications or directly over existing fire protection

Blocks heat penetration by chemically absorbing heat energy to protect structural steel and cable trays.

Catalog Number	Type
FSP-EMAT	24 1/2" (622mm) x 20' (3.05m) Roll

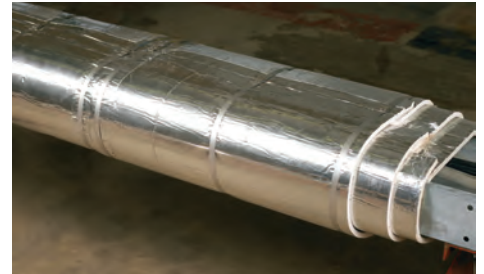
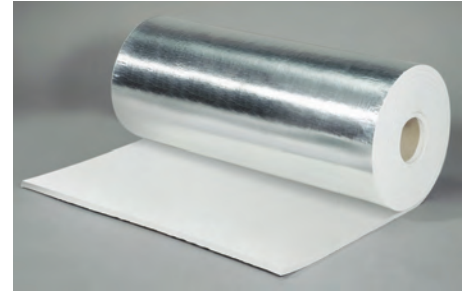

† 3M™ and Interam™ are registered trademarks of the 3M Company

Wall & Fire Wall Sleeve Kits & Accessories



'CT' Type Fire Wall Sleeve
FWS (Fire Wall Sleeve) Shown
Sleeve is 20" long



'D' Type Fire Wall Sleeve
FWS (Fire Wall Sleeve) Shown
Sleeve is 20" long



'U' Type Wall Sleeve
WS (Wall Sleeve) Shown
Sleeve is 20" long

- "CT" Type tray includes two (2) pair 9ZN-800* splice plates with 3/8" zinc plated hardware.
- "D" Type tray includes two (2) pieces of CAC-UFB pivot connectors with zinc plated hardware.
- "U" Type tray does not include splices. Example uses include Wire Basket or Half-Rack.

* Insert tray height.



FSP-1043
Fire Stop Pillow
3" thick, 4" wide, 9.6" long
(orange bag)



FSP-1312
Fire Stop Putty
1" thick, 3" wide, 12" long
(wrapped in paper)

FSP-1043 and FSP-1312
can be ordered separately if
required.



Through-Penetration products for use in Through-Penetration firestop systems. See UL Fire Resistance Director. 23XP
Classified by Underwriters Laboratories, Inc. as to its suitability as an equipment grounding conductor only. 556E

Wall & Fire Wall Sleeve Part Numbering

Example: **9P - xxx - CT - 4 - 12**

Finish	Type	Tray Type	Tray Height	Tray Width
P = Pregalvanized	WS = Wall Sleeve FWS = Fire Wall Sleeve**	CT = Cable Tray † U = Universal	4 5 6 7	06 = 6" 09 = 9" 12 = 12" 18 = 18" 24 = 24" 30 = 30" 36 = 36"

** Includes Nelson Fire Stop Pillows & Putty
† 'CT' Type furnished with steel splice plates (9ZN-800*). For aluminum cable trays use the furnished splice plates and field drill 13/32" diameter holes in the aluminum side rails.

These options are in addition to the Standard Ladder Rungs, Ventilated Trough and Solid Trough type Cable Trays.

Marine Rung (Available in Aluminum, HDGAF Steel and Stainless Steel)

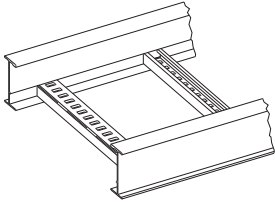

(Aluminum Shown)

- Designed for Series 1 and Series 2-5 systems.
- Special rung design to accommodate stainless steel banding of cables (U.S. Coast Guard requirement) with .438" x .720" slots.
- Has applications on land, vertical installation, any location where extra cable positioning/attachment is required.
- Strut orientation may be channel opening up, channel opening down, or alternating - standard is alternating unless specified otherwise.
- New design provides combination of strut fastening and marine rung fastening.

Examples: 46A12MR-36-288 or 464G12MR-36-288

- "MR" Strut rung on 12" centers with channel opening down
(Note: replace "DN" with "UP" for channel opening up.)

Special Rung Spacings: 4" & 18" rung spacing available upon request.

Non-Ventilated

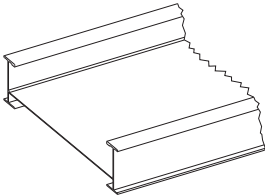

- Solid flat sheet welded into the Cable Tray above the rungs.
- Standard rung spacing is 12 inches.
- The flat sheet may be installed under the rungs, if preferred.
- The flat sheet may be installed over B54 rungs "slot down".

Examples: 24ASB-36-144

Flat sheet bottom over standard rung on 12" spacing.

24ASBB54-36-144

Flat sheet bottom over B54 strut rung slot down on 12" spacing.

9A-6006 and 9A-6007 Aluminum Mid-Span Splice

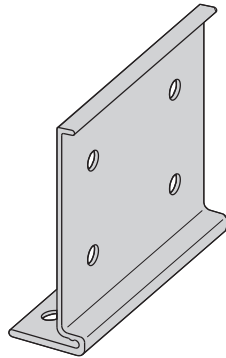

Features

- Standard for H46A, H47A and 57A straight sections.
- Allows random splice location.
- Six bolt design furnished with standard 1/2" Stainless Steel Type 316 hardware.
- Furnished in pairs.
- Available on ladder bottoms only. 09" and 12" rung spacing.

Tray Series	Catalog No.
H46A	9A-6006
H47A	9A-6007
57A	9A-6007

Cable Tray:

H46A

Tested to:

- 167 lbs/ft (safety factor 1.5)
- 125 lbs/ft (safety factor 2.0)
- 20 ft. simple beam test
12" rung spacing - 36" wide

H47A

Tested to:

- 149 lbs/ft (safety factor 1.5)
- 112 lbs/ft (safety factor 2.0)
- 20 ft. simple beam test
12" rung spacing - 36" wide

Splice:

9A-6006

Tested to:

- 135 lbs/ft (safety factor 1.5)
- 101 lbs/ft (safety factor 2.0)
- 20 ft. simple beam test
mid-span splice

9A-6007

Tested to:

- 143 lbs/ft (safety factor 1.5)
- 107 lbs/ft (safety factor 2.0)
- 20 ft. simple beam test
mid-span splice

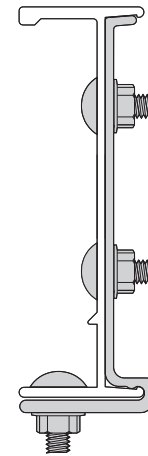

Options: The 9A-6006 and 9A-6007 splice is also available with B-Line 46A and 47A series cable tray systems

- Available on ladder bottoms only (09" and 12" rung spacing).
- Available on 240" (20') or longer span straight sections.
- To order add MS* to part number: Ex. 46AMS09-24-288.
- For standard 6A or 7A fittings with H46A or H47A systems an additional pair of standard splice plates is required (9A-1006 or 9A-1007).

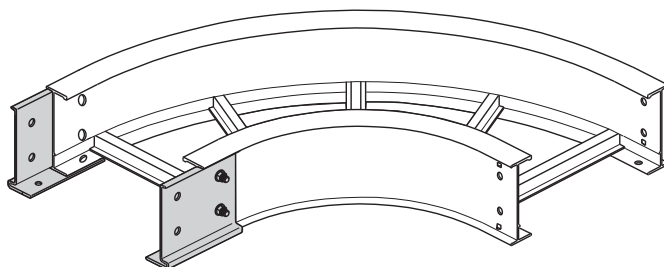

One pair 9A-6006 or 9A-6007 included.

* MS designates additional hole punches in side rail to accept mid-span splices.

Also available: H6A and H7A Fittings

- Ladder bottom only (09" RS).
- Incorporates the 9A-6006 or 9A-6007 splice.
- Example: H6A-12-90HB24 or H7A-12-90HB24

Heavy Duty Expansion Splice Plates 9A-6016 and 9A-6017 (aluminum) 9G-6016 and 9G-6017 (HDG steel) 9SS6-6016 (stainless steel)

The Heavy Duty Expansion Splice Plate is engineered to eliminate the NEMA recommended additional supports at each expansion joint where expansion splice plates are utilized. Expansion splices are common in long-run outdoor applications, where temperature variations result in thermal expansion and contraction of the cable tray system. The installer using the traditional expansion splice would be required to install two supports, one on either side of the expansion splice. By utilizing the Heavy Duty Expansion Splice Plate, no additional supports are required when the splice is placed at quarter span.

- NEMA VE 2 Compliant
- Lowest total cost of installation solution
- “Wrap around” design that supports the side rail on the bottom of each tray section
- Available in lightweight, marine-grade 6063-T6 aluminum material, hot dip galvanized steel, and stainless steel 316 for easy installation in a variety of applications
- Visit www.cooperblinc.com/expansion for detailed installation instructions
- Splice plate hardware included
- Furnished in pairs
- Cannot be used with solid bottom or trough bottom styles of cable tray.

Heavy Duty Expansion Splice Plates are currently available with aluminum (H46A, H47A & 57A), steel (464, 476 & 574), and stainless steel (464) tray systems. These tray systems are heavy duty ladders that are ideal for long-span, outdoor applications.

Patented: Patent No. US8459604 B2

Options: The 9A-6006 and 9A-6007 splice is also available with B-Line 46A and 47A series cable tray systems

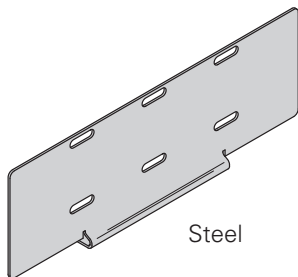

Steel	
Tray Series	Catalog No.
464	9G-6016 or 9SS6-6016
476	9G-6017
574	9G-6017

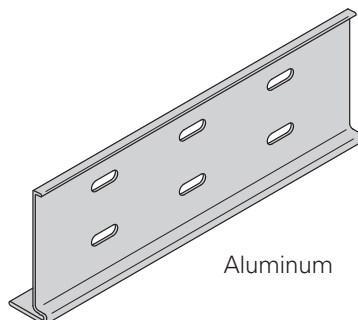

Aluminum	
Tray Series	Catalog No.
46A *	9A-6016
H46A	9A-6016
H47A	9A-6017
57A	9A-6017

* Additional field drilling is required

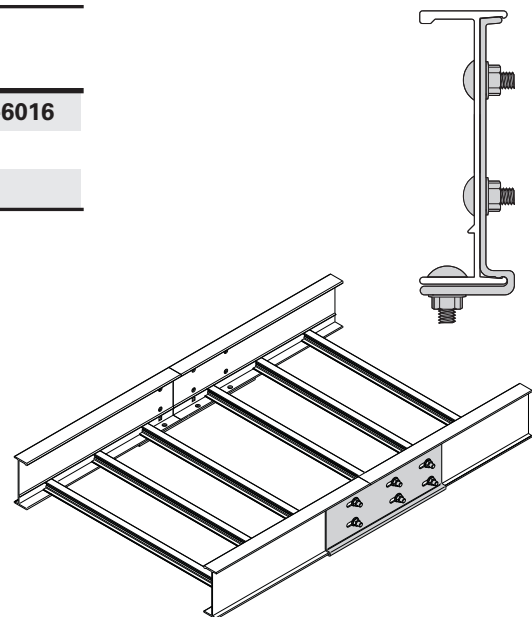

Aluminum heavy-duty expansion splice plates shown.

Note: 24" (609mm) bonding jumper (**99-1620-24**) available.

Special Purpose 2 to 3 Pitch Peaked Covers

These covers are not available for Series 1 system or in steel with a pre-galvanized finish.

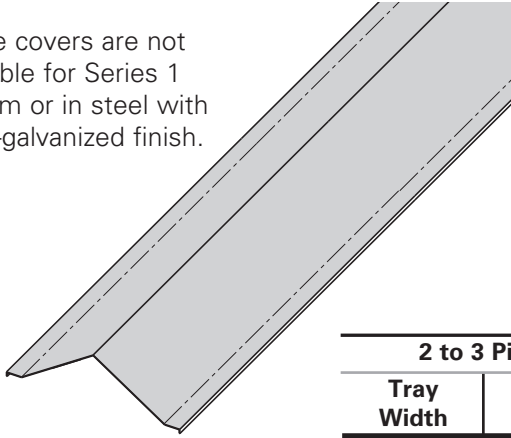

Features

- 33° slope to shed precipitants.
- Heavy construction - made for the industrial environment.
- Available in aluminum and steel; hot dip galvanized after fabrication (HDGAF ASTM A-123), 304 stainless and 316 stainless.
- Available in flanged design only.
- Fittings are in multiple piece welded construction.
- Expanding/Reducing HT and HX covers are not available.

2 to 3 Pitch	
Tray Width	Peak Height
6"	2"
9"	3"
12"	4"
18"	6"
24"	8"
30"	10"
36"	12"

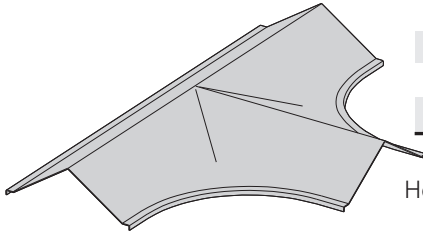

Horizontal Tee



Horizontal Bend

Vertical Outside Bend

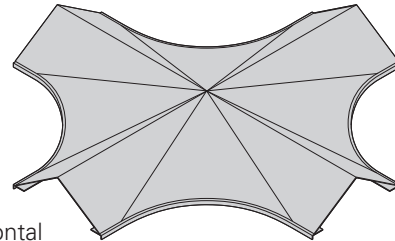

Horizontal Cross

Catalog Number Selector

Example: **83** **7** **A** **80** - **24** - **144**

Cover Type	Detail	Material	Material Thickness	Tray Width	Item Description
● 83 = 2 to 3 Pitch Peaked	7 = Flanged Aluminum 2 = Flanged Steel (248, 258, 268 straight sections & fittings) 3 = Flanged Steel (All straight sections except 248, 258, 268)	A = Aluminum G = HDGAF ASTM A-123 SS4 = 304 Stainless Steel SS6 = 316 Stainless Steel	80 = .080 Aluminum straight section 125 = .125 Aluminum fittings 16 = 16 Ga. Steel straight sections. 18 = 16 Ga. Steel fittings.	06 = 6" 09 = 9" 12 = 12" 18 = 18" 24 = 24" 30 = 30" 36 = 36"	144 = 12 ft. (3.66 m) 120 = 10 ft. (3.05 m) 72 = 6 ft. (1.83 m) 60 = 5 ft. (1.52 m)

2 to 3 Pitch Cover Clamp

- Recommended for outdoor service.

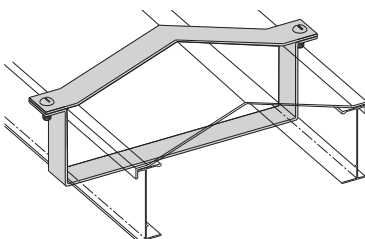

Side Rail Height in. (mm)	Catalog No. Aluminum	Catalog No. Steel	Catalog No. Stainless Steel
4 (101)	● 9A-(#)-9P44	● 9G-(#)-9P44	● 9**-(#)-9P44
5 (127)	● 9A-(#)-9P54	● 9G-(#)-9P54	● 9**-(#)-9P54
6 (152)	● 9A-(#)-9P64	● 9G-(#)-9P64	● 9**-(#)-9P64
7 (178)	● 9A-(#)-9P74	● 9G-(#)-9P74	● 9**-(#)-9P74

(#) Insert tray width

(**) Insert SS4 or SS6

● Green = Fastest shipped items ● Black = Normal lead-time items ● Red = Normally long lead-time items

Appendix - Reference Material - Methods Permitted

Wiring methods permitted in cable tray per the 2011 NEC®

1. Armored cable (Article 320)
2. Electrical metallic tubing (Article 358)
3. Electrical nonmetallic tubing (Article 362)
4. Fire alarm cables (Article 760)
5. Flexible metal conduit (Article 348)
6. Flexible metallic tubing (Article 360)
7. Instrumentation tray cable (Article 727)
8. Intermediate metal conduit (Article 342)
9. Liquidtight flexible metal conduit (Article 350)
10. Liquidtight flexible nonmetallic conduit (Article 356)
11. Metal-clad cable (Article 330)
12. Mineral-insulated, metal-sheathed cable (Article 332)
13. Multiconductor service-entrance cable (Article 338)
14. Multiconductor underground feeder and branch-circuit cable (Article 340)
15. Multipurpose and communications cables (Article 800)
16. Nonmetallic-sheathed cable (Article 334)
17. Power and control tray cable (Article 336)
18. Power-limited tray cable (Section 725.61(C) and 725.71(E))
19. Optical fiber cables (Article 770)
20. Other factory-assembled, multiconductor control, signal, or power cables that are specifically approved for installation in cable trays
21. Rigid metal conduit (Article 344)
22. Rigid nonmetallic conduit (Article 352)

Appendix - Reference Material - Formulas

Formulas

• Allowable load: $w = \frac{F96Sx}{L^2}$

• Deflection: $\Delta = \frac{5wL^3}{384EIx}$
 $= \frac{5wL^4}{4608EIx}$

• Stress: $F = \frac{wL^2}{96Sx}$

• Deflection Multiplier (K) = $\frac{\text{deflection}}{w}$
 $= \frac{5L^4}{4608EIx}$

• Max. Working Load = $\frac{\text{Max. deflection}}{\text{Deflection Multiplier}}$

Legend

w	= load (lbs/ft)
W	= total load across span (lbs)
F	= design stress (lbs/in ²)
L	= span (inches)
Sx	= section modulus for 2 rails (in ³) (see page APP-6 for Sx values)
E	= 10 million for Alum. (lb/in. ²) 29 million for Steel (lb/in. ²)
Ix	= moment of inertia for 2 rails (in ⁴) (see page APP-6 for Ix values)

Cable Tray Side Rails

Design Data For One Rail

Aluminum	B-Line Series	Side Rail Height	A (in.)	B (in.)	C (in.)	D (in.)	E (in.)	Sx (in. ³)	Ix (in. ⁴)	Area (in. ²)	Weight (lbs./ft.)
	KSA4A	4	3.86	2.970	.059	1.36	.750	0.450	0.895	0.400	0.467
	KSA5A	5	4.860	3.970	.059	1.36	.750	0.620	1.540	0.458	0.536
	KSB4A	4	3.880	2.950	.067	1.36	.750	0.535	1.160	0.494	0.578
	KSB5A	5	4.880	3.950	.067	1.36	.750	0.735	1.980	0.559	0.654
	KSB6A	6	5.880	4.950	.067	1.36	.750	0.955	3.080	0.624	0.730
	RSI04	4	3.540	2.680	.059	1.71	.768	0.550	0.980	0.465	0.540
	RSI05	5	4.530	3.660	.061	1.71	.770	0.750	1.760	0.540	0.630
	RSI06	6	5.510	4.640	.059	1.71	.768	0.990	2.750	0.559	0.690
	RSI07	7	6.50	5.630	.075	1.71	.784	1.340	4.390	0.750	0.880
	24	4	4.120	3.050	.060	1.75	.740	0.670	1.430	0.525	0.620
	H24	4	4.185	3.105	.070	1.75	.750	0.785	1.845	0.640	0.745
	34	4	4.200	3.080	.100	1.75	.750	1.050	2.490	0.902	1.060
	25	5	5.000	3.930	.068	1.75	.748	0.900	2.310	0.620	0.720
	35	5	5.060	3.960	.090	1.75	.745	1.180	3.190	0.857	0.980
	26	6	6.120	5.040	.065	2.00	.745	1.260	3.950	0.698	0.820
	36	6	6.170	5.060	.075	2.00	.725	1.680	5.420	0.903	1.050
	46	6	6.190	5.080	.085	2.00	.650	1.790	6.090	0.989	1.170
	56	6	6.433	5.263	.140	2.12	.760	3.059	11.316	1.185	2.113
	H46	6	6.240	5.090	.130	2.00	.750	2.670	8.650	1.473	1.740
	27	7	7.140	6.058	.075	2.00	.725	1.465	5.640	0.810	0.943
	37	7	7.140	6.050	.075	2.00	.750	1.880	6.750	0.904	1.060
	47	7	7.240	6.130	.100	2.00	.675	2.470	8.940	1.189	1.400
	H47	7	7.240	6.090	.125	2.00	.675	3.050	11.460	1.520	1.770
	57	7	7.400	6.230	.160	2.00	.875	3.860	16.430	2.114	2.460
	S8A	8	8.000	6.170	.170	3.00	1.000	7.690	27.670	2.754	3.200

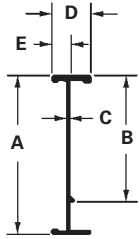

Steel	B-Line Series	Side Rail Height	A (in.)	B (in.)	C (in.)	D (in.)	E (in.)	Sx (in. ³)	Ix (in. ⁴)	Area (in. ²)	Weight (lbs./ft.)
	148	4	3.625	3.125	.048	.875	--	.250	.450	.251	.840
	156	5	4.188	3.688	.060	.875	--	.360	.760	.340	1.160
	166	6	5.188	4.688	.060	.750	--	.460	1.200	.385	1.310
	176	7	6.188	5.688	.060	.750	--	.640	1.900	.444	1.520
	248	4	4.188	3.140	.048	1.000	.392	.320	.720	.313	1.170
	346	4	4.188	3.130	.060	1.500	.655	.480	1.110	.449	1.640
	444	4	4.188	3.110	.075	1.500	.670	.640	1.470	.561	2.020
	258	5	5.188	4.140	.048	1.000	.392	.450	1.220	.361	1.340
	356	5	5.188	4.130	.060	1.500	.655	.660	1.860	.509	1.860
	454	5	5.188	4.110	.075	1.500	.670	.870	2.480	.636	2.290
	268	6	6.188	5.140	.048	1.000	.392	.590	1.900	.409	1.520
	368	6	6.188	5.130	.048	1.500	.643	.710	2.390	.457	1.700
	366	6	6.188	5.140	.060	1.500	.655	.850	2.870	.569	2.080
	464	6	6.188	5.110	.075	1.500	.670	1.140	3.830	.711	2.560
	378	7	7.188	6.140	.048	1.500	.643	.890	3.450	.505	1.880
	476	7	7.188	6.130	.060	1.500	.655	1.070	4.150	.629	2.300
	574	7	7.188	6.110	.075	1.500	.670	1.430	5.550	.792	2.830

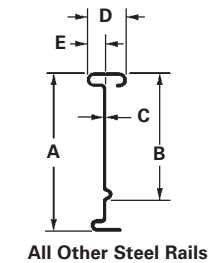
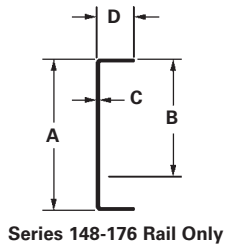

A - Side Rail Height B - Loading Depth C - Web Thickness D - Flange Width
Design Factors: Ix = Moment of Inertia, Sx = Section Modulus

Appendix - Reference Material - Cable Tray Weights

Series 1

Steel Side Rail Weights

Tray Series		148	156	166	176
Weight for 2 Side Rails	lbs/ft	1.68	2.32	2.62	3.03
	kg/m	2.50	3.45	3.90	4.51

Example:
 Weight for 148P09-12-144
 = 1.68 lbs/ft + .51 lbs/ft = 2.19 lbs/ft
 = (2.19 lbs/ft) (12 ft) = 26.28 lbs.

Tray Bottom Weights

Tray Width (inches)			6	9	12	18	24	30	36
All Series 1 Steel	6" Spacing Rung Weight	lbs/ft	0.38	0.57	0.76	1.14	1.52	2.25	2.70
		kg/m	0.57	0.85	1.13	1.70	2.26	3.35	4.02
	9" Spacing Rung Weight	lbs/ft	0.25	0.38	0.51	0.76	1.01	1.50	1.80
		kg/m	0.38	0.57	0.75	1.13	1.51	2.23	2.68
	12" Spacing Rung Weight	lbs/ft	0.19	0.29	0.38	0.57	0.76	1.13	1.35
		kg/m	0.29	0.43	0.57	0.85	1.13	1.68	2.01
Series 148 Steel	Vented Trough Weight	lbs/ft	0.48	0.72	0.95	1.43	1.91	2.39	2.86
		kg/m	0.71	1.06	1.42	2.13	2.84	3.55	4.26
	Solid Trough Weight	lbs/ft	0.60	0.90	1.20	1.80	2.39	2.99	3.59
		kg/m	0.89	1.34	1.78	2.67	3.56	4.45	5.34
Series 156, 166 & 176 Steel	4" Vented Rung Weight	lbs/ft	0.57	0.86	1.14	1.71	2.28	3.37	3.42
		kg/m	0.85	1.27	1.70	2.54	3.39	5.02	5.09
	Solid Bottom Weight	lbs/ft	1.01	1.51	2.01	3.02	4.02	5.20	6.25
		kg/m	1.50	2.24	2.99	4.49	5.98	7.74	9.29

When using steel tray that is hot dip galvanized after fabrication add 9.6% to weights.

Series 2, 3, 4 or 5

Aluminum Side Rail Weights

Tray Series		24	H24	34	25	35	26	36	46	H46	56	27	37	47	H47	57
Weight for 2 Side Rails	lbs/ft	1.23	1.49	2.12	1.44	1.96	1.64	2.09	2.33	3.47	4.22	1.88	2.12	2.80	3.54	4.92
	kg/m	1.83	2.22	3.15	2.14	2.92	2.44	3.11	3.47	5.16	6.29	2.80	3.15	4.16	5.27	7.32

Steel Side Rail Weights

Tray Series		248	346	444	258	356	454	268	368	366	464	378	476	574
Weight for 2 Side Rails	lbs/ft	2.34	3.28	4.04	2.68	3.72	4.58	3.04	3.40	4.16	5.12	3.76	4.60	5.66
	kg/m	3.48	4.88	6.01	3.99	5.54	6.82	4.52	5.06	6.19	7.62	5.59	6.84	8.42

Series 2, 3, 4 or 5 weights continued on page 387.

Appendix - Reference Material - Cable Tray Weights

Series 2, 3, 4 or 5

Tray Bottom Weights

Tray Width (inches)			6	9	12	18	24	30	36	42
All Series 2,3,4 Aluminum	6" Spacing Rung Weight	lbs/ft	0.30	0.44	0.59	0.89	1.18	1.70	2.04	2.38
		kg/m	0.44	0.66	0.88	1.32	1.76	2.53	3.04	3.54
	9" Spacing Rung Weight	lbs/ft	0.20	0.29	0.39	0.59	0.78	1.13	1.36	1.58
		kg/m	0.29	0.44	0.58	0.87	1.16	1.68	2.02	2.35
	12" Spacing Rung Weight	lbs/ft	0.15	0.22	0.29	0.44	0.58	0.85	1.02	1.19
		kg/m	0.22	0.32	0.43	0.65	0.86	1.26	1.52	1.77
	18" Spacing Rung Weight	lbs/ft	0.10	0.15	0.20	0.30	0.40	0.57	0.68	0.80
		kg/m	0.15	0.22	0.30	0.45	0.60	0.85	1.02	1.19
	Vented Trough Weight	lbs/ft	0.25	0.38	0.50	0.75	1.00	1.25	1.50	1.75
		kg/m	0.37	0.56	0.74	1.12	1.49	1.86	2.23	2.60
	Solid Trough Weight	lbs/ft	0.31	0.46	0.61	0.92	1.22	1.53	1.83	2.14
		kg/m	0.45	0.68	0.91	1.36	1.82	2.27	2.72	3.18
All Series 2,3,4,5 Steel	6" Spacing Rung Weight	lbs/ft	0.62	0.92	1.23	1.85	2.46	3.67	4.40	5.14
		kg/m	0.92	1.37	1.83	2.75	3.66	5.46	6.55	7.65
	9" Spacing Rung Weight	lbs/ft	0.41	0.62	0.82	1.23	1.64	2.45	2.94	3.43
		kg/m	0.61	0.92	1.22	1.83	2.44	3.65	4.37	5.10
	12" Spacing Rung Weight	lbs/ft	0.31	0.47	0.62	0.93	1.24	1.84	2.21	2.58
		kg/m	0.46	0.69	0.92	1.38	1.85	2.74	3.29	3.83
	18" Spacing Rung Weight	lbs/ft	0.21	0.31	0.41	0.62	0.82	1.22	1.46	1.71
		kg/m	0.31	0.46	0.61	0.92	1.22	1.82	2.18	2.54
	Vented Trough Weight	lbs/ft	0.53	0.80	1.06	1.59	2.12	2.65	3.18	3.71
		kg/m	0.79	1.18	1.58	2.37	3.15	3.94	4.73	5.52
	Solid Trough Weight	lbs/ft	0.67	1.00	1.33	2.00	2.66	3.33	3.99	4.66
		kg/m	0.99	1.48	1.98	2.97	3.96	4.95	5.94	6.93

When using steel tray that is hot dip galvanized after fabrication add 9.6% to weights.

Fiberglass

Fiberglass Side Rail Weights

Tray Series		13	24	36	46	H46	48
Weight for 2 Side Rails	lbs/ft	1.40	1.78	2.82	3.72	3.72	4.66
	kg/m	2.08	2.65	4.20	5.54	5.54	6.93

Fiberglass Bottom Weights

Tray Width (inches)			6	9	12	18	24	30	36
All Series Fiberglass	6" Spacing Rung Weight	lbs/ft	0.54	0.81	1.08	1.62	2.16	2.70	3.23
		kg/m	0.80	1.20	1.60	2.41	3.21	4.01	4.81
	9" Spacing Rung Weight	lbs/ft	0.35	0.53	0.70	1.05	1.40	1.75	2.10
		kg/m	0.52	0.78	1.04	1.56	2.09	2.61	3.13
	12" Spacing Rung Weight	lbs/ft	0.27	0.40	0.54	0.81	1.08	1.35	1.62
		kg/m	0.40	0.60	0.80	1.20	1.60	2.01	2.41
	18" Spacing Rung Weight	lbs/ft	0.19	0.28	0.38	0.57	0.75	0.94	1.13
		kg/m	0.28	0.42	0.56	0.84	1.12	1.40	1.68
	6" Spacing Marine Rung Wt.	lbs/ft	0.75	1.12	1.49	2.24	2.98	3.73	4.48
		kg/m	1.11	1.67	2.22	3.33	4.44	5.55	6.66
	9" Spacing Marine Rung Wt.	lbs/ft	0.48	0.73	0.97	1.45	1.94	2.42	2.91
		kg/m	0.72	1.08	1.44	2.16	2.89	3.61	4.33
	12" Spacing Marine Rung Wt.	lbs/ft	0.37	0.56	0.75	1.12	1.49	1.87	2.24
		kg/m	0.56	0.83	1.11	1.67	2.22	2.78	3.33
	18" Spacing Marine Rung Wt.	lbs/ft	0.26	0.39	0.52	0.78	1.04	1.31	1.57
		kg/m	0.39	0.58	0.78	1.17	1.55	1.94	2.33

Appendix - Reference Material - Metric Conversion

Metric Conversion Chart

To Convert From	To	Multiply By
Angle		
degree	radian (rad)	0.01745329
radian (rad)	degree	57.295780
Area		
foot ²	square meter (m ²)	0.09290304
inch ²	square meter (m ²)	0.0064516 x 10 ⁻²
circular mil	square meter (m ²)	0.00005067075 x 10 ⁻⁵
sq. centimeter (cm ²)	square inch (in ²)	0.15500030
square meter (m ²)	foot ²	10.763910
square meter (m ²)	inch ²	1550.0030
square meter (m ²)	circular mil	1973523000.0
Temperature		
degree Fahrenheit	degree Celsius	$t^{\circ}\text{C} = (t^{\circ}\text{F} - 32) / 1.8$
degree Celsius	degree Fahrenheit	$t^{\circ}\text{F} = 1.8t^{\circ}\text{C} + 32$
Force		
pounds - force (lbf)	newtons (N)	4.4482220
Length		
foot (ft)	meter (m)	0.30480
inch (in)	meter (m)	0.02540
mil	meter (m)	0.002540 x 10 ⁻³
inch	micrometer (μm)	25400.0
millimeters	inch (in)	0.039370
meter (m)	foot (ft)	3.280840
meter (m)	inch (in)	39.370080
meter (m)	mil	39370.0080
micrometer (μm)	inch (in)	0.039370080 x 10 ⁻³
Volume		
foot ³	cubic meter (m ³)	0.028316850
inch ³	cubic meter (m ³)	0.016387060 x 10 ⁻³
cubic centimeter (cm ³)	cubic inch (in ³)	0.061023740
cubic meter (m ³)	foot ³	35.314660
cubic meter (m ³)	inch ³	61023.760
gallon (U.S. liquid)	cubic meter (m ³)	0.0037854120
Section Properties		
section modulus S (in ³)	S (m ³)	0.016387060 x 10 ⁻³
moment of inertia I (in ⁴)	I (m ⁴)	0.00041623140 x 10 ⁻³
modulus of elasticity E (psi)	E (Pa)	6894.7570
section modulus S (m ³)	S (in ³)	61023.740
moment of inertia I (m ⁴)	I (in ⁴)	2402510.0
modulus of elasticity E (Pa)	E (psi)	0.014503770 x 10 ⁻²

Appendix - Reference Material - Metric Conversion

Metric Conversion Chart (Cont.)

To Convert From	To	Multiply By
Bending Moment or Torque		
lbf • ft	newton meter (N•m)	1.3558180
lbf • in	newton meter (N•m)	0.11298480
N•m	lbf • ft	0.73756210
N•m	lbf • in	8.8507480
Mass		
ounce (avoirdupois)	kilogram (kg)	0.028349520
pound (avoirdupois)	kilogram (kg)	0.45359240
ton (short, 2000 lb)	kilogram (kg)	907.18470
ton (long, 2240 lb)	kilogram (kg)	1016.0470
kilogram (kg)	ounce (avoirdupois)	35.273960
kilogram (kg)	pound (avoirdupois)	2.2046220
kilogram (kg)	ton (short, 2000 lb)	0.0011023110
kilogram (kg)	ton (long, 2240 lb)	0.98420640 × 10 ⁻³
Mass Per Unit Length		
lb/ft	kilogram per meter (kg/m)	1.4881640
lb/in	kilogram per meter (kg/m)	17.857970
kilogram per meter (kg/m)	lb/ft	0.67196890
kilogram per meter (kg/m)	lb/in	0.55997410
Mass Per Unit Volume		
lb/ft ³	kilogram per cubic meter (kg/m ³)	16.018460
lb/in ³	kilogram per cubic meter (kg/m ³)	27679.90
kilogram per cubic meter (kg/m ³)	lb/ft ³	0.062427970
kilogram per cubic meter (kg/m ³)	lb/in ³	0.03612730 × 10 ⁻³
lb/ft ³	lb/in ³	1728.0
Mass Per Unit Area		
lb/ft ²	kilogram per square meter (kg/m ²)	4.8824280
kg/m ²	pound per square foot (lb/ft ²)	0.20481610
Pressure or Stress		
lbf/in ² (psi)	pascal (Pa)	6894.7570
kip/in ² (ksi)	pascal (Pa)	6894757.0
lbf/in ² (psi)	megapascals (MPa)	0.0068947570
pascal (Pa)	pound-force per square inch (psi)	0.0014503770 × 10 ⁻¹
pascal (Pa)	kip per square inch (ksi)	0.0014503770 × 10 ⁻⁴
megapascals (MPa)	lbf/in ² (psi)	145.03770
Metric Symbols		
m = meter	N = newton	
cm = centimeter	kN = kilonewton	
mm = millimeter	Pa = pascal	
µm = micrometer	MPa = megapascal	
kg = kilogram		

SECTION 16114 CABLE TRAYS

PART I - GENERAL

1.01 SECTION INCLUDES

- A. The work covered under this section consists of the furnishing of all necessary labor, supervision, materials, equipment, tests and services to install complete cable tray systems as shown on the drawings.
- B. Cable tray systems are defined to include, but are not limited to straight sections of [ladder type] [trough type] [solid bottom type] [channel type] cable trays, bends, tees, elbows, drop-outs, supports and accessories.

1.02 REFERENCES

- A. ANSI/NFPA 70 - National Electrical Code.
- B. ASTM A123 - Specification for Zinc (Hot Galvanized) Coatings on Products Fabricated from Rolled, Pressed, and Forged Steel Shapes, Plates, Bars, and Strip.
- C. ASTM A653 - Specification for Steel Sheet, Zinc-Coated (Galvanized) by the Hot Dip Process, Structural (Physical) Quality.
- D. ASTM A1011 - Specification for Steel, Sheet and Strip, Hot-Rolled, Carbon, Structural, High-Strength Low-Alloy and High Strength Low Alloy with Improved Formability.
- E. ASTM A1008 - Specification for Steel, Sheet, Cold-Rolled, Carbon, Structural, High-Strength Low-Alloy and High-Strength Low-Alloy with Improved Formability.
- F. ASTM B633 - Specification for Electrodeposited Coatings of Zinc on Iron and Steel.
- G. NEMA VE 1 - Metallic Cable Tray Systems.
- H. NEMA VE 2 - Cable Tray Installation Guidelines.

1.03 DRAWINGS

- A. The drawings which constitute a part of these specifications indicate the general route of the cable tray systems. Data presented on these drawings is as accurate as preliminary surveys and planning can determine until final equipment selection is made. Accuracy is not guaranteed and field verification of all dimensions, routing, etc., is required.
- B. Specifications and drawings are for assistance and guidance, but exact routing, locations, distances and levels will be governed by actual field conditions. Contractor is directed to make field surveys as part of his work prior to submitting system layout drawings.

1.04 SUBMITTALS

- A. Submittal Drawings: Submit drawings of cable tray and accessories including clamps, brackets, hanger rods, splice plate connectors, expansion joint assemblies, and fittings, showing accurately scaled components.
- B. Product Data: Submit manufacturer's data on cable tray including, but not limited to, types, materials, finishes, rung spacings, inside depths and fitting radii. For side rails and rungs, submit cross sectional properties including Section Modulus (Sx) and Moment of Inertia (Ix).

1.05 QUALITY ASSURANCE

- A. Manufacturers: Firms regularly engaged in manufacture of cable trays and fittings of types and capacities required, whose products have been in satisfactory use in similar service for not less than 5 years.
- B. NEMA Compliance: Comply with NEMA Standards Publication Number VE 1, "Cable Tray Systems".
- C. NEC Compliance: Comply with NEC, as applicable to construction and installation of cable tray and cable channel systems (Article 392, NEC).
- D. UL Compliance: Provide products which are UL classified and labeled.
- E. NFPA Compliance: Comply with NFPA 70B, "Recommended Practice for Electrical Equipment Maintenance" pertaining to installation of cable tray systems.

1.06 DELIVERY, STORAGE AND HANDLING

- A. Deliver cable tray systems and components carefully to avoid breakage, denting and scoring finishes. Do not install damaged equipment.
- B. Store cable trays and accessories in original cartons and in clean dry space; protect from weather and construction traffic.

PART 2 - PRODUCTS

2.01 ACCEPTABLE MANUFACTURERS

- A. Manufacturer: Subject to compliance with these specifications, Eaton's B-Line series cable tray and cable channel, systems to be installed shall be as manufactured by Eaton.

2.02 CABLE TRAY SECTIONS AND COMPONENTS

- A. General: Except as otherwise indicated, provide metal cable trays, of types, classes and sizes indicated; with splice plates, bolts, nuts and washers for connecting units. Construct units with rounded edges and smooth surfaces; in compliance with applicable standards; and with the following additional construction features.
- B. Materials and Finish: Material and finish specifications for each tray type are as follows:
 - 1. Aluminum: Straight section and fitting side rails and rungs shall be extruded from Aluminum Association Alloy 6063. All fabricated parts shall be made from Aluminum Association Alloy 5052.
 - 2. Pre-Galvanized Steel: Straight sections, fitting side rails, rungs, and covers shall be made from structural quality steel meeting the minimum mechanical properties and mill galvanized in accordance with ASTM A653 SS, Grade 33, coating designation G90. Covers for all steel trays will also be furnished from mill galvanized steel in accordance with ASTM A653 G90.
 - 3. Hot Dip Galvanized Steel: Straight section and fitting side rails and rungs shall be made from structural quality steel meeting the minimum mechanical properties of ASTM A1011 SS, Grade 33 for 14 gauge and heavier, ASTM A1008, Grade 33, Type 2 for 16 gauge and lighter, and shall be hot dip galvanized after fabrication in accordance with ASTM A123. All covers and splice plates must also be hot dip galvanized after fabrication; mill galvanized covers are not acceptable for hot dipped galvanized cable tray. All hot dip galvanized after fabrication steel cable trays must be returned to point of manufacture after coating for inspection and removal of all icicles and excess zinc. Failure to do so can cause damage to cables and/or injury to installers.
 - 4. Stainless Steel: Straight section and fitting side rails and rungs shall be made of AISI Type 304 or Type 316 stainless steel. Transverse members (rungs) shall be welded to the side rails with Type 316 stainless steel welding wire.

2.03 TYPE OF TRAY SYSTEM

- A. Ladder type trays shall consist of two longitudinal members (side rails) with transverse members (rungs) welded to the side rails. Rungs shall be spaced [6] [9] [12] inches on center. Spacing in radiused fittings shall be 9 inches and measured at the center of the tray's width. Rungs shall have a minimum cable bearing surface of $\frac{7}{8}$ " with radiused edges. No portion of the rungs shall protrude below the bottom plane of the side rails.** Each rung must be capable of supporting the cable load, with a safety factor of 1.5, and a 200 lb. concentrated load when tested in accordance with NEMA VE 1, section 5.4.
***Omit text for Series 1 cable tray systems.*
- B. Ventilated trough type trays shall consist of two longitudinal members (side rails) with a corrugated bottom welded to the side rails. The peaks of the corrugated bottom shall have a minimum flat cable bearing surface of $2\frac{3}{4}$ " and shall be spaced on 6" centers. To provide ventilation in the tray, the valleys of the corrugated bottom shall have $2\frac{1}{4}$ " x 4" rectangular holes punched along the width of the bottom.

Appendix - Full Cable Tray Systems Specification

- C. Non-Ventilated bottom trough type trays shall consist of two longitudinal members (side rails) with a corrugated bottom welded to the side rails. The peaks of the corrugated bottom shall have a minimum flat cable bearing surface of 2³/₄" and shall be spaced on 6" centers.
- D. Tray Sizes shall have [3] [4] [5] [6] inch minimum usable load depth, or as noted on the drawing.
- E. Straight tray sections shall have side rails fabricated as I-Beams. All straight sections shall be supplied in standard [10] [12] [20] [24] foot lengths, except where shorter lengths are permitted to facilitate tray assembly lengths as shown on drawings.
- F. Tray widths shall be [6] [9] [12] [18] [24] [30] [36] inches or as shown on drawings.
- G. All fittings must have a three inch tangent and a minimum radius of [12] [24] [36] [48] inches.
- H. Splice plates shall be the bolted type made as indicated below for each tray type. The resistance of fixed splice connections between an adjacent section of tray shall not exceed .00033 ohm. Splice plate construction shall be such that a splice may be located anywhere within a continuously supported span without diminishing rated loading capacity of the cable tray.
 - 1. Aluminum Tray - Splice plates shall be made of 6063-T6 aluminum, using four square neck carriage bolts and serrated flange locknuts. Hardware shall be zinc plated in accordance with ASTM B633, SC1. If aluminum cable tray is to be used outdoors, then hardware shall be Type 316 stainless steel.
 - 2. Steel (including Pre-Galvanized and Hot Dip Galvanized) - Splice plates shall be manufactured of high strength steel, meeting the minimum mechanical properties of ASTM A1011 HSLAS, Grade 50, Class 1. Each splice plate shall be attached with ribbed neck carriage bolts and serrated flange locknuts. Hardware shall be zinc plated in accordance with ASTM B633 SC1 for pre-galvanized cable trays, or Chromium Zinc in accordance with ASTM F-1136-88 for hot dip galvanized cable trays.

Splice plates shall be furnished with straight sections and fittings.

- I. Cable Tray Supports: Shall be placed so that the support spans do not exceed the maximum span indicated on drawings. Supports shall be constructed from 12 gauge steel formed shape channel members 1⁵/₈" x 1⁵/₈" with necessary hardware such as Trapeze Support Kits (9G-55XX-22SH) as manufactured by Eaton [or engineer approved equal]. Cable trays installed adjacent to walls shall be supported on wall mounted brackets such as B409 as manufactured by B-Line [or engineer-approved equal].
- J. Trapeze hangers and center hung supports shall be supported by 1/2" (minimum) diameter rods.
- K. Barrier Strips: Shall be placed as specified on drawings and be fastened into the tray with self drilling screws.
- L. Accessories: Special accessories shall be furnished as required to protect, support, and install a cable tray system. Accessories shall consist of, but are not limited to; section splice plates, expansion plates, blind-end plates, specially-designed ladder drop-outs, barriers, etc.

2.04 LOADING CAPACITIES

- A. Cable tray shall be capable of carrying a uniformly distributed load of _____ lbs./ft. on a _____ ft. support span with a safety factor of 1.5 when supported as a simple span and tested per NEMA VE 1, section 5.2. **In addition to the uniformly distributed load the cable tray shall support 200 lbs. concentrated load at mid-point of span.** Load and safety factors specified are applicable to both the side rails and rung capacities. Cable tray shall be made to manufacturing tolerances as specified by NEMA.

***Omit text for Series 1 cable tray systems.*

PART 3 - EXECUTION

3.01 INSTALLATION

- A. Install cable trays as indicated; in accordance with equipment manufacturer's instructions, and with recognized industry practices (NEMA VE 2), to ensure that the cable tray equipment complies with requirements of NEC, and applicable portions of NFPA 70B and NECA's "Standards of Installation" pertaining to general electrical installation practices.
- B. Coordinate cable tray with other electrical work as necessary to properly interface installation of cable tray work with other work.
- C. Provide sufficient space encompassing cable trays to permit access for installing and maintaining cables.

3.02 TESTING

- A. Test cable trays to ensure electrical continuity of bonding and grounding connections, and to demonstrate compliance with specified maximum grounding resistance. See NFPA 70B, Chapter 18, for testing and test methods.
- B. Manufacturer shall provide test reports witnessed by an independent testing laboratory of the "worst case" loading conditions outlined in this specification and performed in accordance with the latest revision of NEMA VE 1.

END OF SECTION

Appendix - Additional Cable Tray Sizing Requirements

AMPACITY:

Multiconductor Cables (2000 Volts or Less)

Cable ampacities shall comply with Tables 310.16 and 310.18 of the NEC® subject to the provisions below:

1. If there are more than 3 current carrying conductors in a cable, derate cable ampacity per section 310.15(B)(2)(A).
2. If tray has solid covers, use 95% of the ampacity values shown in Tables 310.16 and 310.18.
3. If cables are placed in a single layer, with a maintained spacing of not less than 1 cable diameter between cables, the ampacity of the cables shall not exceed the allowable ambient temperature-corrected ampacities of multiconductor cables with not more than 3 insulated conductors in free air in accordance with Section 310.15(C) and Table B.310.3. You must use the ambient ampacity correction factors, found below Table B.310.3, for ambient temperatures other than 40°C (104°F).

Multiconductor Cables (2001 Volts and over) Type MV and Type MC Cables

1. Where cable trays are covered for more than 6 ft. with solid, unventilated covers, use not more than 95% of the ampacity values of Tables 310.75 and 310.76.
2. Where cables are installed in a single layer in uncovered trays with a maintained spacing of not less than one cable diameter between cables, you can use the ampacity values listed in Tables 310.71 and 310.72.

Single Conductor Cables

Ampacity of Cables Rated 2000 Volts or Less in Cable Tray (single conductor cables)

Cable Sizes	Solid Unventilated Cable Tray Cover ?	Applicable Ampacity Tables (*)	Mult. Amp. Table Values By	Special Conditions
600 kcmil and Larger	No (**)	310.17 and 310.19	0.75	
600 kcmil and Larger	Yes	310.17 and 310.19	0.70	
1/0 AWG through 500 kcmil	No (**)	310.17 and 310.19	0.65	
1/0 AWG through 500 kcmil	Yes	310.17 and 310.19	0.60	
1/0 AWG & Larger In Single Layer	No (**)	310.17 and 310.19	1.00	Maintained Spacing Of One Cable Diameter
Single Conductors In Triangle Config. 1/0 AWG and Larger	No (**)	310.20 [See NEC Section 310.15(B)]	1.00	Spacing Of 2.15 x One Conductor O.D. Between Cables

Ampacity of Type MV and Type MC Cables (2001 Volts or over) in Cable Trays (single conductor cables)

Cable Sizes	Solid Unventilated Cable Tray Cover ?	Applicable Ampacity Tables (*)	Mult. Amp. Table Values By	Special Conditions
1/0 AWG and Larger	No (**)	310.69 and 310.70	0.75	
1/0 AWG and Larger	Yes	310.69 and 310.70	0.70	
1/0 AWG & Larger In Single Layer	No (**)	310.69 and 310.70	1.00	Maintained Spacing Of One Cable Diameter
Single Conductors In Triangle Config. 1/0 AWG and Larger	No (**)	310.67 and 310.68	1.05	Spacing Of 2.15 x One Conductor O.D. Between Cables

(*) The ambient ampacity correction factors must be used.

(**) At a specific position, where it is determined that the tray cables require mechanical protection, a single cable tray cover of six feet or less in length can be installed.

Cable Fill in Hazardous (Classified) Locations:

Section 392.3 of the NEC regulates the use of cable tray wiring systems in hazardous (classified) locations. This section states that if cable tray wiring systems are installed in hazardous (classified) locations, the cables that they support must be suitable for installation in those hazardous (classified) locations. The cable carries the installation restriction, not the cable tray except that the cable tray installation must comply with Section 392.4.

Some hazardous (classified) locations require special spacing of the cables. When installing Type MC, MI & TC cables in cable tray in Class II, Division 2 Hazardous (classified) areas, (combustible dusts), the cables are limited to a single layer with spacing between cables equal to the diameter of the largest adjacent cable. This is the only hazardous (classified) location where the spacing of the cables is required although it is recommended that this wiring method also be employed in Class III, Division I, and Class III, Division 2 (Ignitable Fibers & Flyings). Please note that this will alter the cable tray sizing information obtained from the sizing flow chart on page C-20 & C-21 of this catalog.

Please reference **NEMA VE 2**, metal cable tray installation guideline, for more complete information.
www.cabletrays.com

Supports - Eaton's B-Line cable tray shall be sized and installed as a complete cable support system appropriate for the cable types installed. Recommended cable tray support locations are as shown below. Do not exceed the maximum support spacing and design load as printed on the side rail label. Refer to Canadian Electrical Code (CEC) section 12-2202 for minimum cable tray clearances.

Splice Plates - Use factory supplied splice plates only. Splice plates located at the quarter span between supports are preferred. Avoid placing splices at midspan and directly above supports. Torque all splice plate fasteners to 19 ft. - lbs. for $\frac{3}{8}$ " and 50 ft. - lbs. for $\frac{1}{2}$ ". Expansion splice plate fasteners should be loosened $\frac{1}{2}$ turn after reaching full torque to allow for travel. Set the side rail gap for expansion plates according to the chart on page C-8 and ensure that a support is located within 2 feet on each side of the expansion splice.

Conductors - The Cable Tray system installation shall be completed prior to pulling conductors. Cable support distances for conductor size should be referenced in CEC Part 1, Table 21. Single conductor cables placed one diameter or more apart in ventilated or ladder type tray are allowed to use the free air rating per the CEC. Any conductor in vertical runs of cable tray and all single conductor cables must be fastened to the rungs with nylon cable ties or stainless steel clamps. Carbon steel cable clamps should not be used due to induction heating, per CEC section 12-2204 (5).

Covers - Vertical cable trays which penetrate dry floors must be covered for 2m (two meter) above the floor level. All cable tray dead ends must be closed with blind ends per CEC section 12-2202.

Handling - Cable tray is shipped without exterior crating, therefore careful material handling practices should be used. Cable tray straight sections should be lifted with wide slings and an overhead crane. If a crane is not available and a fork lift is to be used, only single bundles should be lifted. Ensure that each bundle is properly centered. Cable tray fittings that are not crated should be unbanded and off-loaded by hand.

Storage - All cable tray materials are subject to storage stain (white rust) if improperly stored. If cable tray is stored as shipped, it must be stored indoors. If the cable tray material must be stored outside, it must be unbanded and loosely stacked on an angle to minimize the components' contact area as well as provide for adequate drainage.

NEMA RECOMMENDED SUPPORT LOCATIONS FOR FITTINGS

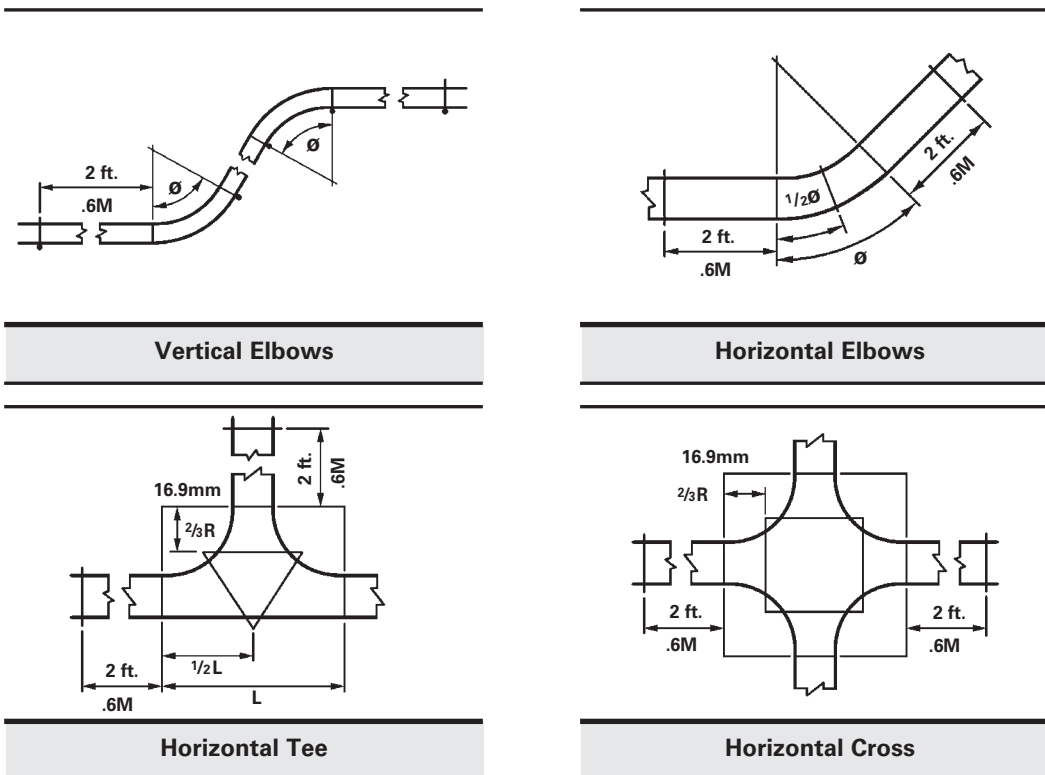

Appendix - Support Channels & Channel Nuts

Channel Sizes & Hole Patterns Selection Chart

Channel Type	Channel Dimensions		Material & Thickness				Channel Hole Patterns **			
	Height	Width	Stainless Steel				SH	S	H17/8	TH
			1	2	3	4				
Steel	Aluminum	Type 304	Type 316							
B11	3 1/4"	1 5/8"	12 Ga.	--	--	--	1	1	1	--
B12	2 7/16"	1 5/8"	12 Ga.	.105	--	--	1,2	1	1,2	--
B22	1 5/8"	1 5/8"	12 Ga.	.105	12 Ga.	12 Ga.	1,2,3,4	1	1,2,3,4	1
B24	1 5/8"	1 5/8"	14 Ga.	.080	14 Ga.	14 Ga.	1,2,3,4	1	1,2,3,4	--
B26	1 5/8"	1 5/8"	16 Ga.	--	--	--	1	1	1	--
B32	1 3/8"	1 5/8"	12 Ga.	--	12 Ga.	--	1,3	1	1,3	--
B42	1"	1 5/8"	12 Ga.	--	12 Ga.	--	1,3	1	1,3	--
B52	1 3/16"	1 5/8"	12 Ga.	--	12 Ga.	--	1,3	1	1,3	--
B54	1 3/16"	1 5/8"	14 Ga.	.080	14 Ga.	14 Ga.	1,2,3,4	1	1,2,3,4	--
B56	1 3/16"	1 5/8"	16 Ga.	--	--	--	1	1	1	--

Available Finishes on Steel: Plain (Oil Coated), Dura-Green Epoxy, Pre-Galvanized, and Hot Dip Galvanized are standard.

** 1 - Steel
 2 - Aluminum
 3 - Type 304 Stainless Steel
 4 - Type 316 Stainless Steel

Appendix

Channel Nuts

With Spring			Without Spring		Twirl Nut		Thread Size	Thickness
B11 B12	B22 B24 B32	B42 B52 B54	B11 B12 B24 B32	B42 B52 B54	B11 B12 B24 B32	B42 B52 B54		
N728	N228	N528	N228WO	N228WO	TN228	TN228	3/8"-16	3/8" for all nuts
N725	N225	N525	N225WO	N525WO	TN225	TN525	1/2"-13	1/2" for N725,N225,N225WO,TN225 3/8" for N525,N525WO,TN525
N755	N255	N555	N255WO	N555WO	--	--	5/8"-11	1/2" for N755,N255,N255WO 3/8" for N555,N555WO

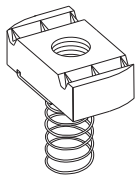

Channel Nut With Spring

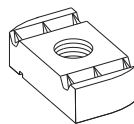

Channel Nut Without Spring

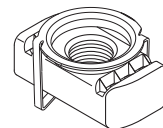

Twirl Nut

For other channels, channel nuts, and fittings see B-Line Strut Systems Catalog.

Continuous Concrete Insert

Catalog Number for Channel		Channel Size	Maximum Depth	Load
120" (10 ft.)	240" (20 ft.)			
B22I-120	B22I-240	B22	1 ⁵ / ₈ "	2000 lbs./ft.
B32I-120	B32I-240	B32	1 ³ / ₈ "	2000 lbs./ft.
B52I-120	B52I-240	B52	1 ³ / ₁₆ "	1500 lbs./ft.

Safety factor of 3 on loading.

Other lengths available upon request.

Furnished with end caps and styrofoam filler installed.

Standard finishes:
 Plain (Oil Coated)
 Dura Green Epoxy
 Pre-Galvanized
 Hot Dip Galvanized

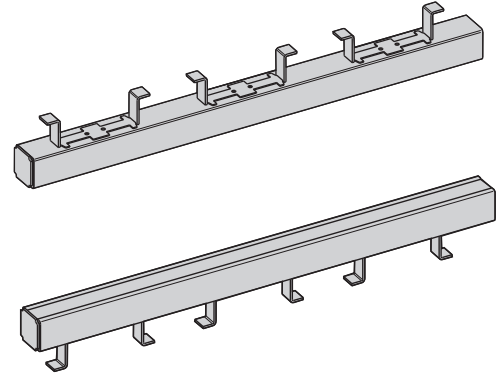

B2500 Spot Insert & N2500 Insert Nut

Standard Finish: Zinc Plated

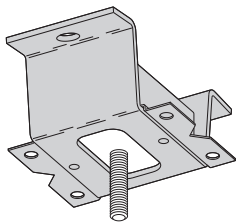

B2500 Insert

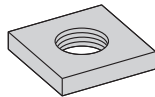

N2500 Insert Nut
 Insert rod size behind part number.

Square Nuts for Spot Inserts

Concrete Insert Applications

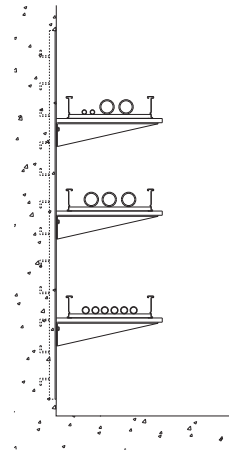

Continuous inserts used vertically are ideal mounting bases for cable tray brackets.

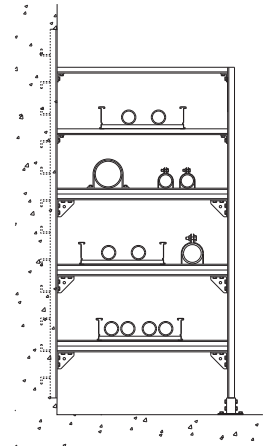

For multi-tiered tray assemblies, inserts function as the anchors for each stanchion.

Angle Fittings

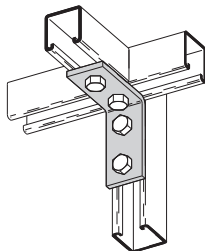

B104

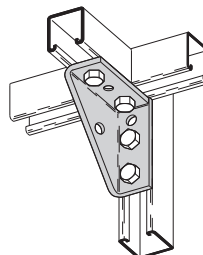

B844

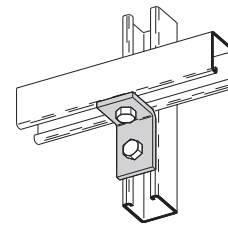

B101

2014

CABLE TRAY MANUAL

Based on the
2014 National Electrical Code^{®†}

®† Mark shown is the property of its respective owner.

Table of Contents

	Page No.
Introduction	MAN-3
Why Cable Tray?	
Safety	MAN-4
Dependability	MAN-4 – MAN-5
Space Savings	MAN-5
Cost Savings	MAN-5 – MAN-8
An In-depth Look at the 2011 NEC®, Section 392	
Types of Cable Trays (NEC® 392.1 Scope)	MAN-9 – MAN-10
EMI/RFI Cable Tray	MAN-10
Cable Tray Materials	MAN-11
392.2 Definition of Cable Tray System	MAN-11
392.10 Uses for Cable Tray	MAN-11 – MAN-16
(A) Wiring Methods and Cable Types	MAN-12 – MAN-13
(B) Industrial Usage	MAN-13 – MAN-14
(1) Single Conductor Cable	MAN-13 – MAN-14
(2) Medium Voltage Cable	MAN-14
(C) Hazardous (Classified) Locations	MAN-14 – MAN-16
(D) Usage of Nonmetallic Tray	MAN-16
392.12 Uses Not Permitted	MAN-16
392.18 Cable Tray Installation	MAN-16 – MAN-20
(A) Complete System	MAN-16 – MAN-18
(B) Completed Before Installation	MAN-18
(C) Covers	MAN-19
(D) Through Partitions & Walls	MAN-19
(E) Exposed & Accessible	MAN-19
(F) Adequate Access	MAN-19
(G) Raceways, Cables, Boxes, and Conduit Bodies Supported from Cable Tray Systems	MAN-19 – MAN-20
392.20 Cables and Conduit Installation	MAN-21 – MAN-22
(A) Multiconductor Cables, 600V or less	MAN-21
(B) Cables Rated over 600V	MAN-21
(C) Connected in Parallel	MAN-21 – MAN-22
(D) Single Conductor	MAN-22
392.22 Number of Conductor of Cable	MAN-23 – MAN-26
392.30 Securing and Supporting Cables and Conductors	MAN-26
392.46 Bushed Conduit and Tubing	MAN-27
392.56 Cable Splices	MAN-27
392.60 Grounding and Bonding	MAN-28 – MAN-31
392.80 Ampacity of Conductors	MAN-31 – MAN-33
392.100 Construction Specifications	MAN-33 – MAN-35
(A) Strength and Rigidity	MAN-33 – MAN-35
(B) Smooth Edges	MAN-35
(C) Corrosion Protection	MAN-35
(D) Siderails	MAN-35
(E) Fittings	MAN-35
(F) Nonmetallic Cable Tray	MAN-35
Cable Tray Wiring System Design and Installation Hints	MAN-36
Cable Tray Accessories	MAN-37
Fireproofing Tray	MAN-37
Cable Tray Maintenance & Repair	MAN-37
Expansion and Contraction	MAN-38 – MAN-39
Appendix Index & Appendix Sheets	MAN-40 – MAN-47
Cable Tray Sizing Flowchart	MAN-48 – MAN-49
Cable Tray Installation & Specification Checklists	MAN-50 – MAN-51
Footnotes	MAN-52

INTRODUCTION

The B-Line series Cable Tray Manual was produced by our technical staff. We recognize the need for a complete cable tray reference source for electrical engineers and designers. The following pages address the 2014 **National Electrical Code**® requirements for cable tray systems as well as design solutions from practical experience. The information has been organized for use as a reference guide for both those unfamiliar and those experienced with cable tray.

Nearly every aspect of cable tray design and installation has been explored for the use of the reader. If a topic has not been covered sufficiently to answer a specific question or if additional information is desired, contact the engineering department at B-Line. We sincerely hope you will find the Cable Tray Manual a helpful and informative addition to your technical library.

The information contained herein has been carefully checked for accuracy and is believed to be correct and current. No warranty, either expressed or implied, is made as to either its applicability to, or its compatibility with, specific requirements, of this information, nor for damages consequent to its use. All design characteristics, specifications, tolerances and similar information are subject to change without notice.

Eaton

B-Line Division

509 West Monroe Street

Highland, IL 62249-0326

Tel: (800) 851-7415

www.eaton.com/b-lineseries

NFPA 70® - 2014, **National Electrical Code**® and **NEC**® are registered trademarks of the National Fire Protection Association, Quincy, MA.

Reproduced with permission from NFPA 70-2014, National Electrical Code®, Copyright © 2013, National Fire Protection Association, Quincy, MA. This reprinted material is not the complete and official position of the NFPA on the referenced subject, which is represented only by the standard in its entirety.

WHY CABLE TRAY?

BECAUSE A CABLE TRAY WIRING SYSTEM PROVIDES SAFE AND DEPENDABLE WAYS TO SAVE NOW AND LATER

Large numbers of electrical engineers have limited detail knowledge concerning wiring systems. There is the tendency by engineers to avoid becoming involved in the details of wiring systems, leaving the wiring system selection and design to designers or contractors. Certain decisions must be made for any wiring system installation, and these decisions should be made in the design and construction activities' chain where maximum impact is achieved at the lowest possible cost. Deferring design decisions to construction can result in increased costs and wiring systems incompatible with the owner's future requirements. Early in the project's design life, the costs and features of various applicable wiring systems should be objectively evaluated in detail. Unfortunately, such evaluations are often not made because of the time and money involved. It is important to realize that these initial evaluations are important and will save time and money in the long run. The evaluation should include the safety, dependability, space and cost requirements of the project. Many industrial and commercial electrical wiring systems have excessive initial capital costs, unnecessary power outages and require excessive maintenance. Moreover, the wiring system may not have the features to easily accommodate system changes and expansions, or provide the maximum degree of safety for the personnel and the facilities.

Cable tray wiring systems are the preferred wiring system when they are evaluated against equivalent conduit wiring systems in terms of safety, dependability, space and cost. To properly evaluate a cable tray wiring system vs. a conduit wiring system, an engineer must be knowledgeable of both their installation and the system features. The advantages of cable tray installations are listed below and explained in the following paragraphs.

- Safety Features
- Dependability
- Space Savings
- Cost Savings
- Design Cost Savings
- Material Cost Savings
- Installation Cost & Time Savings
- Maintenance Savings

CABLE TRAY SAFETY FEATURES

A properly engineered and installed cable tray wiring system provides some highly desirable safety features that are not obtainable with a conduit wiring system.

- Tray cables do not provide a significant path for the transmission of corrosive, explosive, or toxic gases while conduits do. There have been explosions in industrial facilities in which the conduit systems were a

link in the chain of events that set up the conditions for the explosions. These explosions would not have occurred with a cable tray wiring system since the explosive gas would not have been piped into a critical area. This can occur even though there are seals in the conduits. There does have to be some type of an equipment failure or abnormal condition for the gas to get into the conduit, however this does occur. Conduit seals prevent explosions from traveling down the conduit (pressure piling) but they do not seat tight enough to prevent moisture or gas migration until an explosion or a sudden pressure increase seats them. The October 6, 1979 Electrical Substation Explosion at the Cove Point, Maryland Columbia Liquefied Natural Gas Facility is a very good example of where explosive gas traveled through a two hundred foot long conduit with a seal in it. The substation was demolished, the foreman was killed and an operator was badly burned. This explosion wouldn't have occurred if a cable tray wiring system had been installed instead of a conduit wiring system. A New Jersey chemical plant had the instrumentation and electrical equipment in one of its control rooms destroyed in a similar type incident.

- In addition to explosive gases, corrosive gases and toxic gases from chemical plant equipment failures can travel through the conduits to equipment or control rooms where the plant personnel and the sensitive equipment will be exposed to the gases.
- In facilities where cable tray may be used as the equipment grounding conductor in accordance with **NEC**® Sections 392.60(A) & 392.60(B), the grounding equipment system components lend themselves to visual inspection as well as electrical continuity checks.

CABLE TRAY DEPENDABILITY

A properly designed and installed cable tray system with the appropriate cable types will provide a wiring system of outstanding dependability for the control, communication, data handling, instrumentation, and power systems. The dependability of cable tray wiring systems has been proven by a 50 year track record of excellent performance.

- Cable tray wiring systems have an outstanding record for dependable service in industry. It is the most common industrial wiring system in Europe. In continuous process systems, an electrical system failure can cost millions of dollars and present serious process safety problems for the facility, its personnel and the people in the surrounding communities. A properly designed and installed cable tray system with the appropriate cable types will provide a wiring system of outstanding dependability for process plants.

- Television broadcast origination facilities and studios make use of cable tray to support and route the large volumes of cable needed for their operations with a high degree of dependability. It would be impossible to have the wiring system flexibility they need with a conduit wiring system.
- Large retail and warehouse installations use cable tray to support their data communication cable systems. Such systems must be dependable so that there are no outages of their continuous inventory control systems.
- Cable tray wiring systems have been widely used to support cabling in both commercial and industrial computer rooms overhead and beneath the floor to provide orderly paths to house and support the cabling. These types of installations need a high degree of dependability which can be obtained using cable tray wiring systems.

CABLE TRAY SPACE SAVINGS

When compared to a conduit wiring system, an equivalent cable tray wiring system installation requires substantially less space.

Increasing the size of a structure or a support system to handle a high space volume conduit wiring system is unnecessary when this problem can be avoided by the selection of a cable tray wiring system.

- Facilities with high density wiring systems devoted to control, instrumentation, data handling and branch circuit wiring have the choice of selecting cable tray or conduit wiring systems. A conduit wiring system is often a poor choice because large conduit banks require significant space, competing with other systems and equipment. Choosing a cable tray wiring system greatly reduces this problem.
- Financial institutions with large computer installations have high density wiring systems under floors or in overhead plenum areas that are best handled by cable tray wiring systems.
- Airport facilities have extensive cable tray wiring systems to handle the ever expanding needs of the airline industry.
- Cable tray is used in many facilities because of the ever present need of routing more and more cables in less space at lower costs.
- Large health care facilities have high density wiring systems that are ideal candidates for cable tray.

CABLE TRAY WIRING SYSTEM COST SAVINGS

Usually, the initial capital cost is the major factor in selecting a project's wiring system when an evaluation is made comparing cable tray wiring systems and conduit wiring systems. Such an evaluation often covers just the conductors, material, and installation labor costs. The results of these initial cost evaluations

usually show that the installed cable tray wiring system will cost 10 to 60 percent less than an equivalent conduit wiring system. The amount of cost savings depends on the complexity and size of the installation.

There are other savings in addition to the initial installation cost savings for cable tray wiring systems over conduit wiring systems. They include reduced engineering costs, reduced maintenance costs, reduced expansion costs, reduced production losses due to power outages, reduced environmental problems due to continuity of power and reduced data handling system costs due to the continuity of power. The magnitudes of many of these costs savings are difficult to determine until the condition exists which makes them real instead of potential cost savings.

DESIGN COST SAVINGS

- Most projects are roughly defined at the start of design. For projects that are not 100 percent defined before design start, the cost of and time used in coping with continuous changes during the engineering and drafting design phases will be substantially less for cable tray wiring systems than for conduit wiring systems. A small amount of engineering is required to change the width of a cable tray to gain additional wiring space capacity. Change is a complex problem when conduit banks are involved.
- The final drawings for a cable tray wiring system may be completed and sent out for bid or construction more quickly than for a conduit wiring system. Cable tray simplifies the wiring system design process and reduces the number of details.
- Cable tray wiring systems are well suited for computer aided design drawings. A spread sheet based wiring management program may be used to control the cable fills in the cable tray. While such a system may also be used for controlling conduit fill, large numbers of individual conduits must be monitored. For an equal capacity wiring system, only a few cable tray runs would have to be monitored.
- Dedicated cable tray installation zones alert other engineering disciplines to avoid designs that will produce equipment and material installation conflicts in these areas. As more circuits are added, the cable tray installation zone will increase only a few inches; the space required for the additional conduits needed would be much greater.
- **The fact that a cable can easily enter and exit cable tray anywhere along its route**, allows for some unique opportunities that provide highly flexible designs.
- Fewer supports have to be designed and less coordination is required between the design disciplines for the cable tray supports compared to conduit supports.

Cable Tray Manual

- Excluding conductors, the cost of the cable trays, supports, and miscellaneous materials will provide a savings of up to 80% as compared to the cost of the conduits, supports, pull boxes, and miscellaneous materials. An 18 inch wide cable tray has an allowable fill area of 21 square inches. It would take 7 - 3 inch conduits to obtain this allowable fill area (7 x 2.95 square inches = 20.65 square inches).
- The cost of 600 volt insulated multiconductor cables listed for use in cable tray is greater than the cost of 600 volt insulated individual conductors used in conduit. The cost differential depends on the insulation systems, jacket materials and cable construction.
- For some electrical loads, parallel conductors are installed in conduit and the conductors must be derated, requiring larger conductors to make up for the deration. If these circuits were installed in cable tray, the conductor sizes would not need to be increased since the parallel conductor derating factors do not apply to three conductor or single conductor cables in cable tray.

- Typical 300 volt insulated multiconductor instrumentation tray cables (ITC) and power limited tray cables (PLTC) cost the same for both cable tray and conduit wiring systems. This applies for instrumentation circuits, low level analog and digital signal circuits, logic input/output (I/O) circuits, etc. There are other cable tray installations which require a higher cost cable than the equivalent conduit installation. Such installations are limited to areas where low smoke emission and/or low flame spread ITC or PLTC cables must be used.
- Conduit banks often require more frequent and higher strength supports than cable trays. 3 inch and larger rigid metal conduits are the only sizes allowed to be supported on 20 foot spans.
- When a cable tray width is increased 6 inches, the cable tray cost increase is less than 10 percent. This substantially increases the cable tray's wiring capacity for a minimal additional cost. To obtain such an increase in capacity for a conduit wiring system would be very costly.

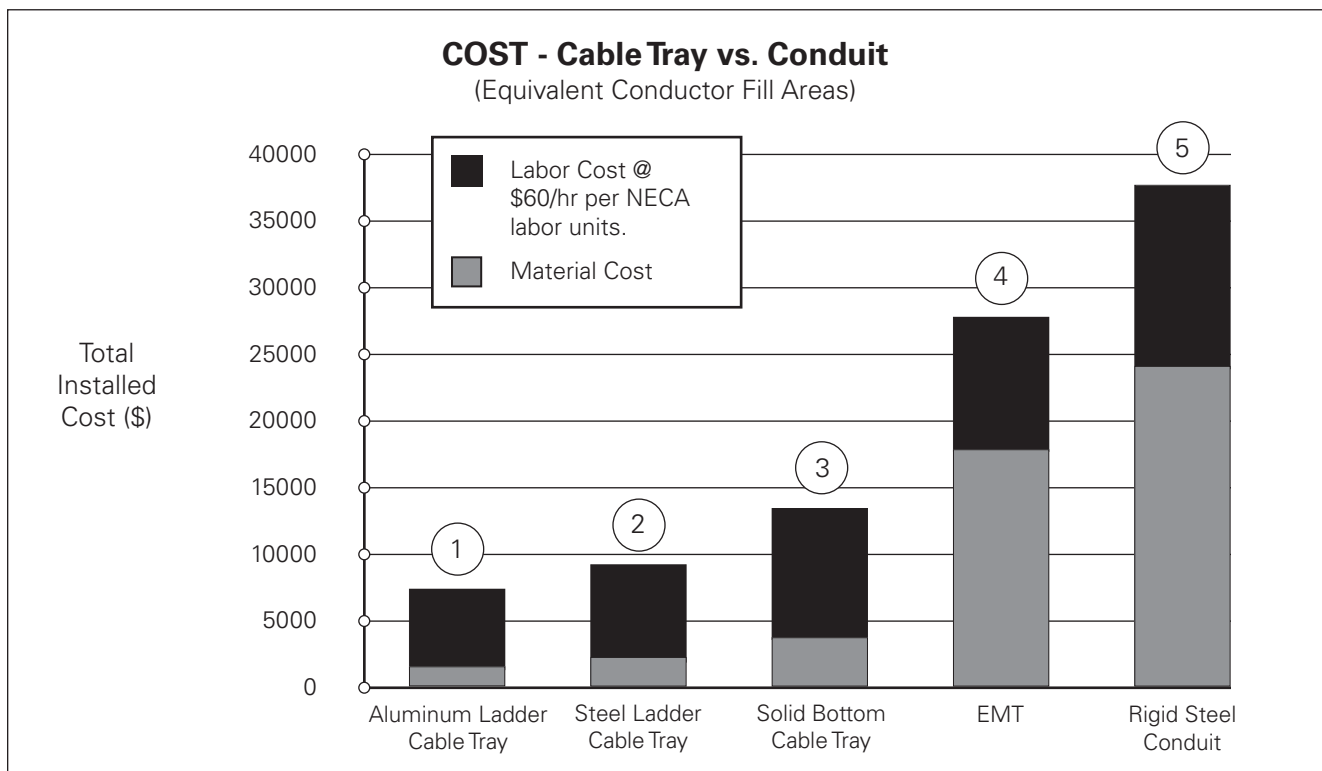

Installation: 200 linear feet of cable supported with four 90° direction changes and all trapeze supports on 8 ft. spans.

1. Aluminum, 18" wide, ladder cable tray (9" rung spacing) with all hardware.
2. Hot dip galvanized steel, 18" wide, ladder cable tray (9" rung spacing) with all hardware.
3. Hot dip galvanized steel, 18" wide, solid bottom cable tray and all hardware.
4. 7 parallel runs of 3" diameter EMT with concentric bends.
5. 7 parallel runs of 3" diameter galvanized conduit with concentric bends.

Note: Above costs do not include cable and cable pulling costs. Cable costs differ per installation and cable/conductor pulling costs have been shown to be considerably less for cable tray than for conduit.

INSTALLATION COST AND TIME SAVINGS

- Depending on the complexity and magnitude of the wiring system, the total cost savings for the initial installation (labor, equipment and material) may be up to 75 percent for a cable tray wiring system over a conduit wiring system. When there are banks of conduit to be installed that are more than 100 feet long and consist of four or more 2 inch conduits or 12 or more smaller conduits, the labor cost savings obtained using cable tray wiring systems are very significant.
- Many more individual components are involved in the installation of a conduit system and its conductors compared to the installation of a cable tray system and its cables. This results in the handling and installing of large amounts of conduit items vs. small amounts of cable tray items for the same wiring capacity.
- The higher the elevation of the wiring system, the more important the number of components required to complete the installation. Many additional man-hours will be required just moving the components needed for the conduit system up to the work location.
- Conduit wiring systems require pull boxes or splice boxes when there is the equivalent of more than 360 degrees of bends in a run. For large conductors, pull or junction boxes may be required more often to facilitate the conductor's installation. Cable tray wiring systems do not require pull boxes or splice boxes.
- Penetrating a masonry wall with cable tray requires a smaller hole and limited repair work.
- More supports are normally required for rigid steel conduit due to the requirements of **NEC®** Table 344.30(B)(2).
- Concentric conduit bends for direction changes in conduit banks are very labor intensive and difficult to make. However if they are not used, the installation will be unattractive. The time required to make a concentric bend is increased by a factor of 3-6 over that of a single shot bend. This time consuming practice is eliminated when cable tray wiring systems are used.
- Conductor pulling is more complicated and time consuming for conduit wiring systems than for cable tray wiring systems. Normally, single conductor wire pulls for conduit wiring systems require multiple reel setups. For conduit wiring systems, it is necessary to pull from termination equipment enclosure to termination equipment enclosure. Tray cables being installed in cable trays do not have to be pulled into the termination equipment enclosures. Tray cable may be pulled from near the first termination enclosure along the cable tray route to near the second termination enclosure. Then, the tray cable is inserted into the equipment enclosures for termination. For projects with significant numbers of large conductors terminating in switchgear, this may be a very desirable feature that can save hours of an electrician's time. Unnecessary power outages can be eliminated since tray cable pulls

may be made without de-energizing the equipment. For conduit installations, the equipment will have to be de-energized for rubber safety blanketing to be installed, otherwise the conductor pulls might have to be made on a weekend or on a holiday at premium labor costs to avoid shutting down production or data processing operations during normal working hours.

- Conductor insulation damage is common in conduits since jamming can occur when pulling the conductors. Jamming is the wedging of conductors in a conduit when three conductors lay side by side in a flat plane. This may occur when pulling around bends or when the conductors twist. Ninety-two percent of all conductor failures are the result of the conductor's insulation being damaged during the conductor's installation. Many common combinations of conductors and conduits fall into critical jam ratio values. Critical jam ratio (J.R.= Conduit ID/Conductor OD) values range from 2.8 to 3.2. The J. R. for 3 single conductor THHN/THWN insulated 350 kcmil conductors in a 2¹/₂ inch conduit would be 3.0 (2.469 inches/ 0.816 inches). If conductor insulation damage occurs, additional costs and time are required for replacing the conductors. This cannot occur in a cable tray wiring system.
- Smaller electrician crews may be used to install the equivalent wiring capacity in cable tray. This allows for manpower leveling, the peak and average crew would be almost the same number, and the electrician experience level required is lower for cable tray installations.
- Since the work is completed faster there is less work space conflict with the other construction disciplines. This is especially true if installations are elevated and if significant amounts of piping are being installed on the project.

MAINTENANCE SAVINGS

- One of the most important features of cable tray is that tray cable can easily be installed in existing trays if there is space available. Cable tray wiring systems allow wiring additions or modifications to be made quickly with minimum disruption to operations. Any conceivable change that is required in a wiring system can be done at lower cost and in less time for a cable tray wiring system than for a conduit wiring system.
- Moisture is a major cause of electrical equipment and material failures. Breathing due to temperature cycling results in the conduits accumulating relatively large amounts of moisture. The conduits then pipe this moisture into the electrical equipment enclosures which over a period of time results in the deterioration of the equipment insulation systems and their eventual failure. Also, moisture may become a factor in the corrosion failure of some of the critical electrical equipment's metallic components. Conduit seals are not effective in blocking the movement of moisture. The conduit systems may be designed to reduce the

Cable Tray Manual

moisture problems but not to completely eliminate it. Few designers go into the design detail necessary to reduce the effects of moisture in the conduit systems. Tray cables do not provide internal moisture paths as do conduits.

- In the event of external fires in industrial installations, the damage to the tray cable and cable tray is most often limited to the area of the flame contact plus a few feet on either side of the flame contact area. For such a fire enveloping a steel conduit bank, the steel conduit is a heat sink and the conductor insulation will be damaged for a considerable distance inside the conduit. Thermoplastic insulation may be fused to the steel conduit and the conduit will need to be replaced for many feet. This occurred in an Ohio chemical plant and the rigid steel conduits had to be replaced for 90 feet. Under such conditions, the repair cost for fire damage would normally be greater for a conduit wiring system than for cable tray and tray cable. In the Ohio chemical plant fire, there were banks of conduits and runs of cable tray involved. The cable tray wiring systems were repaired in two days. The conduit wiring systems were repaired in six days and required a great deal more manpower.

- In the event of an external fire, the conduit becomes a heat sink and an oven which decreases the time required for the conductor insulation systems to fail. The heat decomposes the cable jackets and the conductor insulation material. If these materials contain PVC as do most cables, hydrogen chloride vapors will come out the ends of the conduits in the control rooms. These fumes are very corrosive to the electronic equipment. They are also hazardous to personnel. A flame impingement on a cable tray system will not result in the fumes going into the control room as there is no containment path for them. They will be dispersed into the atmosphere.

IN MOST CASES AN OBJECTIVE EVALUATION OF THE REQUIREMENTS FOR MOST HIGH DENSITY WIRING SYSTEMS WILL SHOW THAT A CABLE TRAY WIRING SYSTEM PROVIDES A WIRING SYSTEM SUPERIOR TO A CONDUIT WIRING SYSTEM.

Abandoned Cables

Easily identified, marked, or removed - all possible from an open Cable Tray System

For the 2002 *National Electrical Code*, several proposals were submitted to the NFPA to revise the 1999 **NEC**® for Articles 300, 640, 645, 725, 760, 770, 800, 820, and 830 to require all abandoned cables to be removed from plenum spaces.

The purpose of the proposals is to remove the cables as a source of excess combustibles from plenums and other confined spaces such as raised floors and drop ceilings. All of the Code Making Panels agreed that this

should be acceptable practice except Code Making Panel 3, which oversees Article 300. Because Article 300 is exempt from this requirement only low-voltage and communication cables are affected.

Each Article adopted a definition of abandoned cables and the rule for removal. The general consensus is that abandoned cable is cable that is not terminated at equipment or connectors and is not identified for future use with a tag. Please refer to each individual **NEC**® Article for specifics.

Having to tag, remove, or rearrange cables within an enclosed raceway can be a time consuming and difficult job. Without being able to clearly see the cables and follow their exact routing throughout a facility, identifying abandoned cables would be very difficult and expensive.

With the open accessibility of cable tray, these changes can be implemented with ease. Abandoned cables can be identified, marked, rearranged, or removed with little or no difficulty.

AN IN-DEPTH LOOK AT 2011 NEC® ARTICLE 392 - CABLE TRAY

(The following code explanations are to be used with a copy of the 2014 NEC®.)

To obtain a copy of the NEC® contact:
National Fire Protection Association®
1 Batterymarch Park • P.O. Box 9101
Quincy, Massachusetts 02269-9101
1-800-344-3555

392.1. Scope.

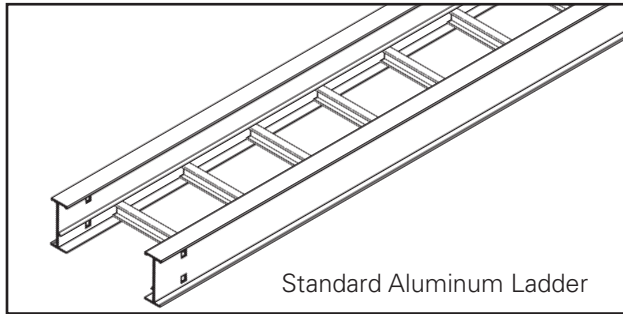

Of the types of cable trays listed in this section, ladder cable tray is the most widely used type of cable tray due to several very desirable features.

- The rungs provide a convenient anchor for tying down cables in vertical runs or where the positions of the cables must be maintained in horizontal runs.
- Cables may exit or enter through the top or the bottom of the tray.
- A ladder cable tray without covers provides for the maximum free flow of air, dissipating heat produced in current carrying conductors.
- Moisture cannot accumulate in ladder cable trays and be piped into electrical equipment as happens in conduit systems.
- Ladder cable tray cannot pipe hazardous or explosive gases from one area to another as happens with conduit systems.
- In areas where there is the potential for dust to accumulate, ladder cable trays should be installed. The dust buildup in ladder cable trays will be less than the dust buildup in ventilated trough or solid bottom cable trays.

Ladder cable trays are available in widths of 6, 9, 12, 18, 24, 30, 36, 42, and 48 inches with rung spacings of 6, 9, 12, or 18 inches. Wider rung spacings and wider cable tray widths decrease the overall strength of the cable tray. Specifiers should be aware that some cable tray manufacturers do not account for this load reduction in their published cable tray load charts. B-Line uses stronger rungs in wider cable trays to safely bear the loads published (42 and 48 inch widths require load reductions).

With one exception, the specifier selects the rung spacing that he or she feels is the most desirable for the installation. The exception is that 9 inches is the maximum allowable rung spacing for a ladder cable tray supporting any 1/0 through 4/0 single conductor cables [See Section 392.10(B)(1)(a)].

Where the ladder cable tray supports small diameter multiconductor control and instrumentation cables; 6, 9, or 12 inch rung spacings should be specified. Quality Type TC, Type PLTC, or Type ITC small diameter multiconductor control and instrumentation cables will not be damaged due to the cable tray rung spacing selected, but the installation may not appear neat if there is significant drooping of the cables between the rungs.

For ladder cable trays supporting large power cables, 9 inch or wider rung spacings should be selected. For many installations, the cable trays are routed over the top of a motor control center (MCC) or switchgear enclosure. Cables exit out the bottom of the cable trays and into the top of the MCC or switchgear enclosure. For these installations, the cable manufacturer's recommended minimum bending radii for the specific cables must not be violated. If the rung spacing is too close, it may be necessary to remove some rungs in order to maintain the proper cable bending radii. This construction site modification can usually be avoided by selecting a cable tray with 12 or 18 inch rung spacing.

If you are still uncertain as to which rung spacing to specify, 9 inch rung spacing is the most common and is used on 80% of the ladder cable tray sold.

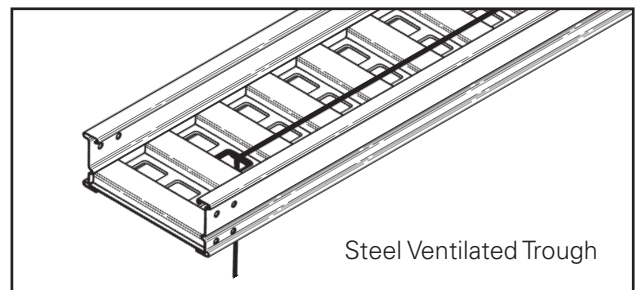

The 1999 NEC® added the word 'ventilated' in front of trough to clear up some confusion that solid trough is treated the same as ventilated trough. It is not. Solid trough is recognized as solid bottom cable tray.

Cable Tray Manual

Ventilated trough cable tray is often used when the specifier does not want to use ladder cable tray to support small diameter multiconductor control and instrumentation cables. As no drooping of the small diameter cables is visible, ventilated trough cable trays provide neat appearing installations. Small diameter cables may exit the ventilated trough cable tray through the bottom ventilation holes as well as out the top of the cable tray. For installations where the cables exit the bottom of the cable tray and the system is subject to some degree of vibration, it is advisable to use B-Line Trough Drop-Out Bushings (Cat. No. 99-1124). These snap-in bushings provide additional abrasion protection for the cable jackets. Just as for ladder cable tray, ventilated trough cable tray will not pipe moisture into electrical equipment.

Standard widths for ventilated trough cable tray systems are 6, 9, 12, 18, 24, 30, and 36 inches. The standard bottom configuration for ventilated trough cable tray is a corrugated bottom with $2\frac{7}{8}$ inch bearing surfaces - 6 inches on centers and $2\frac{1}{4}$ inch x 4 inch ventilation openings. Since a corrugated bottom cannot be bent horizontally, the standard bottom configuration for horizontal bend fittings consists of rungs spaced on 4 inch centers. This difference in bottom construction may be objectionable to some owners, so be sure you are aware of the owner's sensitivity to aesthetics for the cable tray installation.

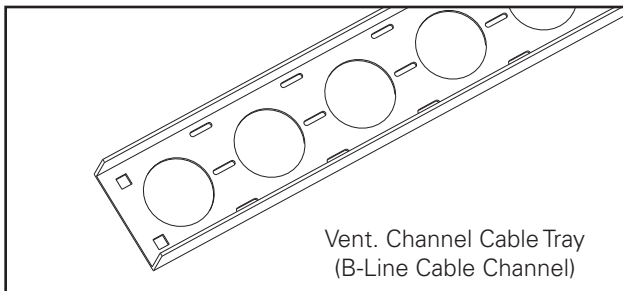

Channel cable tray systems (B-Line cable channel) are available in 3, 4, and 6 inch widths with ventilated or solid bottoms. **The NEC® now recognizes solid bottom cable channel.** Prior to the 2002 Code, the NEC® did not have any specific provisions for the use of solid cable channel.

Instead of large conduits, cable channel may be used very effectively to support cable drops from the cable tray run to the equipment or device being serviced and is ideal for cable tray runs involving a small number of cables. Cable channel may also be used to support push buttons, field mounted instrumentation devices, etc. Small diameter cables may exit ventilated cable channel through the bottom ventilation holes, out the top or through the end. For installations where the cables exit through the ventilation openings and the cable channel or the cables are subject to some degree of vibration, it is advisable to use B-Line Cable Channel Bushings (Cat. No. 99-1125). These snap-in plastic bushings provide additional abrasion protection for the cable jackets.

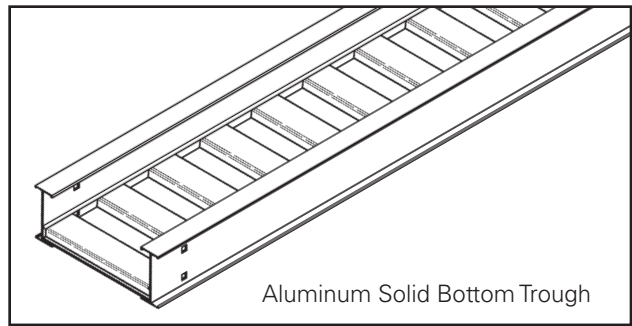

Some specifiers prefer solid bottom cable tray to support large numbers of small diameter control and multiconductor instrumentation cables. Solid bottom steel cable trays with solid covers and wrap around cover clamps can be used to provide EMI/RFI shielding protection for sensitive circuits.

Unlike ladder and ventilated trough cable trays, solid bottom cable trays can collect and retain moisture. Where they are installed outdoors or indoors in humid locations and EMI/RFI shielding protection is not required, it is recommended that $\frac{1}{4}$ inch weep holes be drilled in their bottoms at the sides and in the middle every 3 feet to limit water accumulation.

The words "and other similar structures." were incorporated in Section 392.1 for future types of cable tray that might be developed, such as center supported type cable tray. All the technical information developed by the 1973 NEC® Technical Subcommittee on Cable Tray for Article 318 - Cable Trays was based on cable trays with side rails and this technical information is still the basis for the 2014 NEC® Article 392 - Cable Trays.

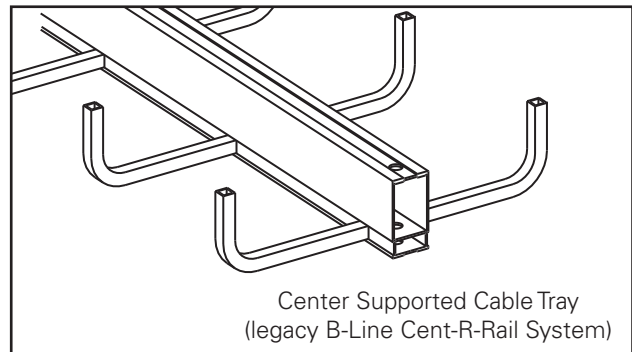

The standard lengths for cable trays are 10, 12, 20 and 24 feet - up to 40 foot lengths are available (consult B-Line for the availability of nonstandard cable tray lengths). Selecting a cable tray length is based on several criteria. Some of these criteria include the required load that the cable tray must support, the distance between the cable tray supports, and ease of handling and installation. **One industry standard that is strongly recommended is that only one cable tray splice be placed between support spans** and, for long span trays, that they ideally be placed at $\frac{1}{4}$ -span. This automatically limits the length of tray you choose, as the tray must be longer than or equal to the support span you have selected. Matching the tray length to

your support span can help ensure that your splice locations are controlled.

Cable trays can be organized into 4 categories: Short Span, Intermediate Span, Long Span, and Extra-Long Span.

Short Span trays, typically used for non-industrial indoor installations, are usually supported every 6 to 8 feet, while Intermediate Span trays are typically supported every 10 to 12 feet. A 10 or 12 foot cable tray is usually used for both of these types of installations. To keep from allowing two splices to occur between supports, a 12 foot tray should be used for any support span greater than 10 feet, up to 12 feet. Placing the cable tray splices at $\frac{1}{4}$ -span is not critical in a short or intermediate span application given that most trays have sufficiently strong splice plates.

In an indoor industrial installation 10 or 12 foot tray sections may be easier to handle and install as you may have piping or ducting to maneuver around. However, using 20 foot instead of 12 foot straight sections may provide labor savings during installation by reducing the number of splice joints. If this is done, the selected tray system should meet the loading requirements for the support span you are using. If you are interested in supporting 100 lbs/ft and you are buying 20 foot tray sections while supporting it every 12 feet, it isn't necessary to specify a NEMA 20C tray (100 lbs/ft on a 20 foot span). A NEMA 20A tray (50 lbs/ft on a 20 foot span) will support over 130 lbs/ft when supported on a 12 ft span with a safety factor of 1.5. Specifying a 20C tray is not an economical use of product. If you desire to use 20 foot sections of cable tray, it makes more sense to increase your support span up to 20 feet. This not only saves labor by decreasing the number of splices, but also by decreasing the number of supports that must be installed.

Long Span trays are typically supported anywhere from 14 to 20 foot intervals with 20 feet being the most popular. In long span situations, the placement of the splice locations at $\frac{1}{4}$ -span becomes much more important. Matching the tray length to your support span can help control your splice locations.

Extra-Long Span trays are supported on spans exceeding 20 feet. Some outdoor cable tray installations may have to span anywhere from 20 to 40 feet to cross roads or to reduce the number of expensive outdoor supports. The distance between supports affects the tray strength exponentially; therefore the strength of the cable tray system selected should be designed around the specific support span chosen for that run.

[See Section 392.100(A) on page 431 for additional information on cable tray strength and rigidity.]

B-Line has many cataloged fittings and accessory items for ladder, ventilated trough, ventilated channel, and solid bottom cable trays which eliminate the need for the costly field fabrication of such items. When properly selected and installed, these factory fabricated

fittings and accessories improve the appearance of the cable tray system in addition to reducing labor costs.

Cable Tray Materials

Metallic cable trays are readily available in aluminum, pregalvanized steel, hot-dip galvanized after fabrication, and stainless steel. Aluminum cable tray should be used for most installations unless specific corrosion problems prohibit its use. Aluminum's light weight significantly reduces the cost of installation when compared to steel.

A fine print note is included in the 2014 **NEC**[®] that references the National Electrical Manufacturers Association (NEMA) documents for further information on cable tray. These documents: ANSI/NEMA VE-1, Metal Cable Tray Systems; NEMA VE-2, Cable Tray Installation Guidelines; and NEMA FG-1, Non Metallic Cable Tray Systems, are an excellent industry resource in the application, selection, and installation of cable trays both metallic and non metallic. Contact B-Line for more information concerning these helpful documents.

392.2. Definition. Cable Tray System.

This section states that cable tray is a rigid structural support system used to securely fasten or support cables and raceways. Cable trays are not raceways. Cable trays are mechanical supports just as strut systems are mechanical supports. **NEC**[®] Article 392 - Cable Trays is an article dedicated to a type of mechanical support. It is very important that the personnel involved with engineering and installing cable tray utilize it as a mechanical support system and not attempt to utilize it as a raceway system. There are items in the **NEC**[®] that apply to raceways and not to cable tray. There are also items in the **NEC**[®] that apply to cable tray and not to raceways. These differences will be covered at the appropriate locations in this manual.

392.10. Uses Permitted. Cable tray installations shall not be limited to industrial establishments.

The text in Section 392.10 clearly states that cable tray may be used in non-industrial establishments. The use of cable tray should be based on sound engineering and economic decisions.

For clarity, the **NEC**[®] now lists all types of circuits to explicitly permit their use in cable trays. These circuit types include: services, feeders, branch circuits, communication circuits, control circuits, and signaling circuits.

The 2002 **NEC**[®] also added a new requirement that where cables in tray are exposed to the direct rays of the sun, they shall be identified as sunlight resistant for all occupancies, not just industrial.

392.10. Uses Permitted. (A) Wiring Methods.

This section identifies the 300 & 600 volt multi-conductor cables that may be supported by cable tray. The "Uses Permitted" or "Uses Not Permitted" sections in the appropriate **NEC**[®] cable articles provide the details as to where that cable type may be used. Where the cable type may be used, cable tray may be installed to support it except as per Section 392.12 which states that cable trays shall not be installed in hoistways or where subject to severe physical damage. Where not subject to severe physical damage, cable tray may be used in any hazardous (classified) area to support the appropriate cable types in accordance with the installation requirements of the various Articles that make up **NEC**[®] Chapter 5 or in any non-hazardous (unclassified) area.

It should be noted that Section 300.8 of the NEC[®] states that cable trays containing electric conductors cannot contain any other service that is not electrical. This includes any pipe or tube containing steam, water, air, gas or drainage.

For commercial and industrial cable tray wiring systems: Type ITC, Type MC, Type TC, and Type PLTC multiconductor cables are the most commonly used cables. Type MI and Optical-Fiber cables are special application cables that are desirable cables for use in some cable tray wiring systems. The following paragraphs provide information and comments about these cable types.

Type MI Cable: *Mineral-Insulated, Metal Sheathed Cable (Article 332)*. This cable has a liquid and gas tight continuous copper sheath over its copper conductors and magnesium oxide insulation. Developed in the late 1920's by the French Navy for submarine electrical wiring systems, properly installed MI cable is the safest electrical wiring system available. In Europe, Type MI cable has had a long, successful history of being installed (with PVC jackets for corrosion protection) in cable trays as industrial wiring systems. This cable may be installed in hazardous (classified) areas or in non-hazardous (unclassified) areas. The single limitation on the use of Type MI cable is that it may not be used where it is exposed to destructive corrosive conditions unless protected by materials suitable for the conditions. Type MI cable without overall nonmetallic coverings may be installed in ducts or plenums used for environmental air and in other space used for environmental air in accordance with Sections 300.22(B) and (C). Cable tray may be installed as a support for Type MI cable in any location except where the cable is installed in a hoistway. Section 332-30 states that MI cable shall be securely supported at intervals not exceeding 6 feet (1.83 m). Type MI cable has a UL two hour fire resistive rating when properly installed. An installation requirement for this rating is that the cable be securely supported every 3 feet. Steel or stainless steel cable trays should be used to support Type MI cable being used for critical circuit service. During severe fire conditions, steel or stainless steel cable tray will remain intact and provide support longer than aluminum or fiberglass reinforced plastic cable trays.

Type MC Cable: *Metal-clad cable (Article 330)*. There are large amounts of Type MC cable installed in industrial plant cable tray systems. This cable is often used for feeder and branch circuit service and provides excellent service when it is properly installed. The metallic sheath may be interlocking metal tape or it may be a smooth or corrugated metal tube. A nonmetallic jacket is often extruded over the aluminum or steel sheath as a corrosion protection measure. Regular MC cable, without nonmetallic sheath, may be supported by cable tray in any hazardous (classified) area except Class I and Class II, Division 1 areas. For Type MC cables to qualify for installation in Class I and Class II Division I areas (Section 501-4(A) (1) (c & d), they must have a gas/vapor tight continuous corrugated aluminum sheath with a suitable plastic jacket over the sheath. They must also contain equipment grounding conductors and listed termination fittings must be used where the cables enter equipment. Type MC Cable employing an impervious metal sheath without overall nonmetallic coverings may be installed in ducts or plenums used for environmental air in accordance with Section 300.22(B) and may be installed in other space used for environmental air in accordance with Section 300.22(C). The maximum support spacing is 6 feet (1.83 m).

Type TC Cable: *Power and control tray cable (Article 336)*. This cable type was added to the 1975 **NEC**[®] (as an item associated with the revision of Article 318-Cable Trays). Type TC cable is a multiconductor cable with a flame retardant nonmetallic sheath that is used for power, lighting, control, and signal circuits. It is the most common cable type installed in cable tray for 480 volt feeders, 480 volt branch circuits, and control circuits. Where Type TC cables comply with the crush and impact requirements of Type MC cable and is identified for such use, they are permitted as open wiring between a cable tray and the utilization equipment or device. In these instances where the cable exits the tray, the cable must be supported and secured at intervals not exceeding 6 feet (See Section 336.10(6)). The service record of UL listed Type TC cable where properly applied and installed has been excellent.

For those installations where the **NEC**[®] allows its use, a cost savings is realized by using Type TC cables instead of Type MC cables. Type TC cable may be installed in cable tray in hazardous (classified) industrial plant areas as permitted in Articles 392, 501, 502, 504 and 505 provided the conditions of maintenance and supervision assure that only qualified persons will service the installation [See Section 336.10(3)].

Where a cable tray wiring system containing Type TC cables will be exposed to any significant amount of hot metal splatter from welding or the torch cutting of metal during construction or maintenance activities, temporary metal or plywood covers should be installed on the cable tray in the exposure areas to prevent cable jacket and conductor insulation damage. It is desirable to use only quality Type TC cables that will pass the IEEE 383 and UL Vertical Flame Tests (70,000 BTU/hr). Type TC cable assemblies may contain optical fiber members as per the UL 1277 standard.

Type ITC Cable: Instrumentation Tray Cable (Article 727). Although this was a new cable article in the 1996 **NEC**[®], it is not a new type of cable. Thousands of miles of ITC cable have been installed in industrial situations since the early 1960's. This is a multiconductor cable that most often has a nonmetallic jacket. The No. 22 through No. 12 insulated conductors in the cables are 300 volt rated. A metallic shield or a metallized foil shield with a drain wire usually encloses the cable's conductors. These cables are used to transmit the low energy level signals associated with the industrial instrumentation and data handling systems. These are very critical circuits that impact on facility safety and on product quality. Type ITC cable must be supported and secured at intervals not exceeding 6 feet [See Section 727.4].

Type ITC Cable may be installed in cable trays in hazardous (classified) areas as permitted in Articles 392, 501, 502, 504 and 505. It states in Article 727 that Type ITC cables that comply with the crush and impact requirements of Type MC cable and are identified for such use, are permitted as open wiring in lengths not to exceed 50 ft. between a cable tray and the utilization equipment or device. Where a cable tray wiring system containing Type ITC cables will be exposed to any significant amount of hot metal splatter from welding or the torch cutting of metal during construction or maintenance activities, temporary metal or plywood covers should be installed on the cable tray to prevent cable jacket or conductor insulation damage. It is desirable to use only quality Type ITC cables that will pass the IEEE 383 and UL Vertical Flame Tests (70,000BTU/hr).

Type PLTC Cable: Power-Limited Tray Cable (Sections 725-154(C), and 725-154(E)). This is a multiconductor cable with a flame retardant nonmetallic sheath. The No. 22 through No. 12 insulated conductors in the cables are 300 volt rated. A metallic shield or a metallized foil shield with drain wire usually encloses the cable's conductors. This cable type has high usage in communication, data processing, fire protection, signaling, and industrial instrumentation wiring systems.

There are versions of this cable with insulation and jacket systems made of materials with low smoke emission and low flame spread properties which make them desirable for use in plenums. In Industrial Establishments where the conditions of maintenance and supervision ensure that only qualified persons service the installation and where the cable is not subject to physical damage Type PLTC cable may be installed in cable trays hazardous (classified) areas as permitted in Section 501.10(B)(1), 501.10(B)(4) and 504.20. Type PLTC cables that comply with the crush and impact requirements of Type MC cable and are identified for such use, are permitted as open wiring in lengths not to exceed a total of 50 ft. between a cable tray and the utilization equipment or device. In this situation, the cable needs to be supported and secured at intervals not exceeding 6 ft. Where a cable tray wiring system containing Type PLTC cables will be exposed to any significant amount of hot metal splatter from welding or the torch cutting of metal during construction or maintenance activities, temporary metal

or plywood covers should be installed on the cable tray to prevent cable jacket and conductor insulation damage. It is desirable to use only quality Type PLTC cables that will pass the IEEE 383 and UL Vertical Flame Tests (70,000 BTU/hr). Type PLTC cable assemblies may contain optical fiber members as per the UL 1277 standard.

Optical Fiber Cables (Article 770). The addition of optical fiber cables in the Section 392.10(A) cable list for the 1996 NEC was not a technical change. Optical fiber cables have been allowed to be supported in cable trays as per Section 770.6. Optical fibers may also be present in Type TC cables as per UL Standard 1277.

For the 1999 **NEC**[®] code, Article 760 - Fire Alarm Cables and Articles 800 - Multipurpose and Communications Cables were added to the list of cables permitted to be installed in cable tray systems.

For the 1993 **NEC**[®], the general statement in the 1990 **NEC**[®] which allowed all types of raceways to be supported by cable trays was replaced by individual statements for each of the ten specific raceway types that may now be supported by cable tray. The chances of any such installations being made are very low, since strut is a more convenient and economic choice than cable tray to support raceway systems.

392.10. Uses Permitted. (B) In Industrial Establishments.

This section limits the installation of single conductor cables and Type MV multiconductor cables in cable trays to qualifying industrial establishments as defined in this section.

Per the 2002 **NEC**[®] solid bottom cable trays are now permitted to support single conductor cables only in industrial establishments where conditions of maintenance and supervision ensure that only qualified persons will service the installed cable tray system. However, at this time, no fill rules for single conductor cables in solid bottom cable tray have been established. [see Section 392.10(B)]

392.10. Uses Permitted. (B) In Industrial Establishments. (1) Single Conductor.

Section 392.10(B)(1) covers 600 volt and Type MV single conductor cables.

There are several sections which cover the requirements for the use of single conductor cables in cable tray even though they only comprise a small percentage of cable tray wiring systems. Such installations are limited to qualifying industrial facilities [See Section 392.10(B)]. Many of the facility engineers prefer to use three conductor power cables. Normally, three conductor power cables provide more desirable electrical wiring systems than single conductor power cables in cable tray (See Section 392.20. Cable and conductor installation - three conductor vs. single conductor cables).

Cable Tray Manual

392.10(B)(1)(a)

Single conductor cable shall be No. 1/0 or larger and shall be of a type listed and marked on the surface for use in cable trays. Where Nos. 1/0 through 4/0 single conductor cables are used, the maximum allowable rung spacing for ladder cable tray is 9 inches.

392.10(B)(1)(b)

Welding cables shall comply with Article 630, Part IV which states that the cable tray must provide support at intervals not to exceed 6 inches. A permanent sign must be attached to the cable tray at intervals not to exceed 20 feet. The sign must read "CABLE TRAY FOR WELDING CABLES ONLY".

392.10(B)(1)(c)

This section states that single conductors used as equipment grounding conductors (EGCs) in cable trays shall be No. 4 or larger insulated, covered or bare.

The use of a single conductor in a cable tray as the EGC is an engineering design option. Section 300.3(B) states that all conductors of the same circuit and the EGC, if used, must be contained within the same cable tray.

The other options are to use multiconductor cables that each contain their own EGC or to use the cable tray itself as the EGC in qualifying installations [see Section 392.60(A)]

If an aluminum cable tray is installed in a moist environment where the moisture may contain materials that can serve as an electrolyte, a bare copper EGC should not be used. Under such conditions, electrolytic corrosion of the aluminum may occur. For such installations, it is desirable to use a low cost 600 volt insulated conductor and remove the insulation where connections to equipment or to equipment grounding conductors are made. (See Section 392.60. Grounding and Bonding, for additional information on single conductors used as the EGC for cable tray systems).

392.10. Uses Permitted. (B) In Industrial Establishment (2) Medium Voltage.

Single and multiconductor type MV cables must be sunlight resistant if exposed to direct sunlight. Single conductors shall be installed in accordance with 392.10(B)(1)

392.10. Uses Permitted. (C) Hazardous (Classified) Locations.

This section states that if cable tray wiring systems are installed in hazardous (classified) areas, the cables that they support must be suitable for installation in those hazardous (classified) areas. The cable carries the installation restriction. The installation restriction is not on the cable tray except that the cable tray installations must comply with Section 392.12. The following is an

explanation of the parts of the code which affect the use of cable tray in hazardous locations.

501.10. Wiring Methods - Listed Termination Fittings. (A) Class I, Division 1 (Gases or Vapors). 501.10(A)(1)(b) Type MI cable may be installed in cable tray in this type of hazardous (classified) area.

501.10(A)(1)(c) allows Type MC-HL cables to be installed in Class I, Division I areas if they have a gas/vapor tight continuous corrugated aluminum sheath with a suitable plastic jacket over the sheath. They must also contain equipment grounding conductors sized as per Section 250.122 and listed termination fittings must be used where the cables enter equipment.

501.10(A)(1)(d) allows Type ITC-HL cable to be installed in Class I, Division I areas if they have a gas/vapor tight continuous corrugated aluminum sheath with a suitable plastic jacket over the sheath and provided with termination fittings listed for the application.

501.10. Wiring Methods. (B) Class I, Division 2 (Gases or Vapors). Types ITC, PLTC, MI, MC, MV, or TC cables may be installed in cable tray in this type of hazardous (classified) area. Under the conditions specified in Section 501.15(E), Cable seals are required in Class 1, Division 2 areas. Cable seals should be used only when absolutely necessary.

501.15. Sealing and Drainage. (E) Cable Seals, Class 1, Division 2. (1) Cables will be required to be sealed only where they enter certain types of enclosures used in Class 1, Division 2 areas. Factory sealed push buttons are an example of enclosures that do not require a cable seal at the entrance of the cable into the enclosure.

501.15. Sealing and Drainage. (E) Cable Seals, Class 1, Division 2. (2) Gas blocked cables are available from some cable manufacturers but they have not been widely used. For gas to pass through the jacketed multi-conductor cable's core, a pressure differential must be maintained from one end of the cable to the other end or to the point where there is a break in the cable's jacket. The existence of such a condition is extremely rare and would require that one end of the cable be in a pressure vessel or a pressurized enclosure and the other end be exposed to the atmosphere. The migration of any significant volume of gas or vapor through the core of a multiconductor cable is very remote. This is one of the safety advantages that cable tray wiring systems have over conduit wiring systems. There are documented cases of industrial explosions caused by the migration of gases and vapors through conduits when they came in contact with an ignition source. There are no known cases of cables in cable tray wiring systems providing a path for gases or vapors to an ignition source which produced an industrial explosion.

501.15. Sealing and Drainage. (E) Cable Seals, Class 1, Division 2. (3)

Exception: Cables with an unbroken gas/vapor-tight continuous sheath shall be permitted to pass through a Class 1, Division 2 location without seals.

This is an extremely important exception stating that cable seals are not required when a cable goes from an unclassified area through a classified area then back to an unclassified area.

501.15. Sealing and Drainage. (E) Cable Seals, Class 1, Division 2. (4)

If you do not have a gas/vapor-tight continuous sheath, cable seals are required at the boundary of the Division 2 and unclassified location.

The sheaths mentioned above may be fabricated of metal or a nonmetallic material.

502.10. Wiring Methods. (A) Class II, Division 1 (Combustible Dusts).

Type MI cable may be installed in cable tray in this type of hazardous (classified) area.

The Exception allows Type MC cables to be installed in Class II, Division 1 areas if they have a gas/vapor tight continuous corrugated aluminum sheath with a suitable plastic jacket over the sheath. They must also contain equipment grounding conductors sized as per Section 250.122 and listed termination fittings must be used where the cables enter equipment.

502.10. Wiring Methods. (B) Class II, Division 2 (Combustible Dusts).

This section states:

Type ITC and PLTC cables may be installed in ladder or ventilated cable trays following the same practices as used in non-hazardous (unclassified) areas. No spacing is required between the ITC or PLTC cables. This is logical as the ITC and PLTC cable circuits are all low energy circuits which do not produce any significant heat or heat dissipation problems.

Type MC, MI and TC [See Section 336.4(3)] cables may be installed in ladder, ventilated trough, or ventilated cable channel, but they are not allowed to be installed in solid bottom cable trays.

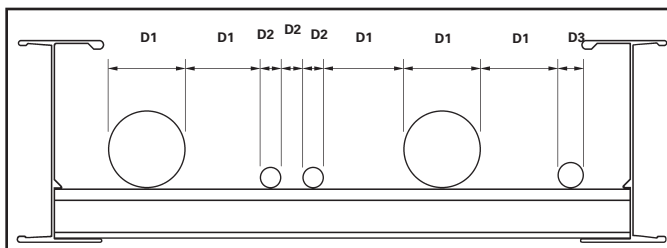

Required Spacing in Cable Trays for Type MC, MI & TC Cables in Class II, Division 2 Hazardous (Classified) Areas

Note 1. The cables are limited to a single layer with spacing between cables equal to the diameter of the largest adjacent cable. This means that the cables must be tied down at frequent intervals in horizontal as well as vertical cable trays to maintain the cable spacing. A reasonable distance between ties in the horizontal cable tray would be approximately 6 feet (See Section 392.30(B)).

Note 2. Spacing the cables a minimum of 1 inch from the side rails to prevent dust buildup is recommended. This is not an NEC requirement but a recommended practice.

Where cable tray wiring systems with current carrying conductors are installed in a dust environment, ladder type cable trays should be used since there is less surface area for dust buildup than in ventilated trough cable trays. The spacing of the cables in dust areas will prevent the cables from being totally covered with a solid dust layer. In dusty areas, the top surfaces of all equipment, raceways, supports, or cable jacket surfaces where dust layers can accumulate will require cleanup housekeeping at certain time intervals. Good house-keeping is required for personnel health, personnel safety and facility safety. Excessive amounts of dust on raceways or cables will act as a thermal barrier which may not allow the power and lighting insulated conductors in a raceway or cable to safely dissipate internal heat. This condition may result in the accelerated aging of the conductor insulation. A cable tray system that is properly installed and maintained will provide a safe dependable wiring system in dust environments.

Exception: Type MC cable listed for use in Class II, Division I locations shall be permitted to be installed without the above spacing limitations. This was a new exception for the 1999 **NEC®** code.

For this type of wiring there is no danger of the cables being overheated when covered with dust. The current flow in these circuits is so low that the internally generated heat is insufficient to heat the cables and cable spacing is not a necessity. Even under such conditions, layers of dust should not be allowed to accumulate to critical depths as they may be ignited or explode as the result of problems caused by other than the electrical system.

502.10(B)(3). Nonincendive Field Wiring

Wiring in nonincendive circuits shall be permitted using any of the wiring methods suitable for wiring in ordinary locations.

503.10. Wiring Methods. (A) Class III, Division 1 and (B) Class III, Division 2 (Ignitable Fibers or Flyings).

Type MI or MC cables may be installed in cable tray in these types of hazardous (classified) areas. The installations should be made using practices that minimize the build-up of materials in the trays. This can be done by using ladder cable tray with a minimum spacing between the cables equal to the diameter of the

Cable Tray Manual

largest adjacent cable. In some cases, a greater spacing between cables than that based on the cable diameters might be desirable depending on the characteristics of the material that requires the area to be classified. Here again, it must be emphasized that good housekeeping practices are required for all types of wiring systems to insure the safety of the personnel and the facility.

504.20. Wiring Methods. This section allows intrinsically safe wiring systems to be installed in cable trays in hazardous (classified) areas. Section 504.30 specifies the installation requirements for intrinsically safe wiring systems that are installed in cable trays. Section 504.70 specifies the sealing requirements for cables that may be part of a cable tray wiring system. Section 504.80(B) states that cable trays containing intrinsically safe wiring must be identified with permanently affixed labels. Cable trays are ideal for supporting both intrinsically safe and nonintrinsically safe cable systems as the cables may be easily spaced and tied in position or a standard metallic barrier strip may be installed between the intrinsically and nonintrinsically safe circuits.

505.15. Wiring Methods. This section was added to the 2002 **NEC**® to explicitly permit cable trays in hazardous areas classified by the international zone system, if the cables comply with the cable requirements for zone locations.

392.10. Uses Permitted. (D) Nonmetallic Cable Tray.

There are limited numbers of applications where nonmetallic cable trays might be preferred over metallic cable trays for electrical safety reasons and/or for some corrosive conditions. An example of an electrical safety application would be in an electrolytic cell room. Here, the amperages are very high and significant stray current paths are present. Under such conditions, there is the possibility for a high amperage short circuit if a low resistance metallic path (metallic cable tray or metallic raceway) is present [See information under Section 392.5(F) Nonmetallic Cable Trays].

392.12. Uses Not Permitted.

This is the only place in the **NEC**® where all the various types of cable tray have limitations on their place of use. No cable trays can be used in hoistways or where subject to severe physical damage. The designer must identify the zones of installation where a cable tray might be subjected to severe physical damage. Usually such areas are limited and provisions can be made to protect the cable tray by relocating it to a more desirable location or as a last resort to provide protection using the appropriate structural members.

Metallic cable trays may support cable types approved for installation in ducts, plenums, and other air-handling spaces as per Section 300.22(B) and the cable types approved for installation in Other Space Used for Environmental Air as per Section 300.22(C).

The second sentence of Section 300.22(C)(1) is as follows:

Other types of cables and conductors shall be permitted to be installed in electrical metallic tubing, flexible metallic tubing, intermediate metal conduit, rigid metal conduit without an overall non-metallic covering, flexible metal conduit, or, where accessible, surface metal raceway or metal wireway with metal covers or solid bottom metal cable tray with solid metal covers.

Reprinted with permission from NFPA 70-2014, the National Electrical Code®, Copyright© 2013, National Fire Protection Association, Quincy, MA 02169. This reprinted material is not the complete and official position of the National Fire Protection Association, on the referenced subject which is represented only by the standard in its entirety.

This part of Section 300.22(C) is confusing. The statement as underlined in the above paragraph leads some to assume, for installations in Other Spaces Used for Environmental Air, that the types of insulated single conductors which are installed in raceway installations may also be installed in solid bottom metal cable trays with metal covers. This is not so. Only the appropriate multiconductor cable types as per Section 392.10(A) may be installed in solid bottom cable trays. Cable tray may be used to support data process wiring systems in air handling areas below raised floors as per Sections 300.22(D) and 800.52(D).

392.18. Cable Tray Installation. (A) Complete System.

This section states that cable tray systems can have mechanically discontinuous segments, and that the mechanically discontinuous segment cannot be greater than 6 feet. A bonding jumper sized per Section 250.102 is necessary to connect across any discontinuous segment. The bonding of the system should be in compliance with Section 250.96.

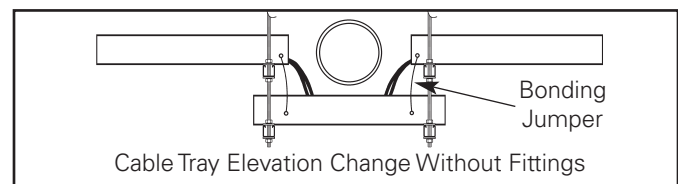

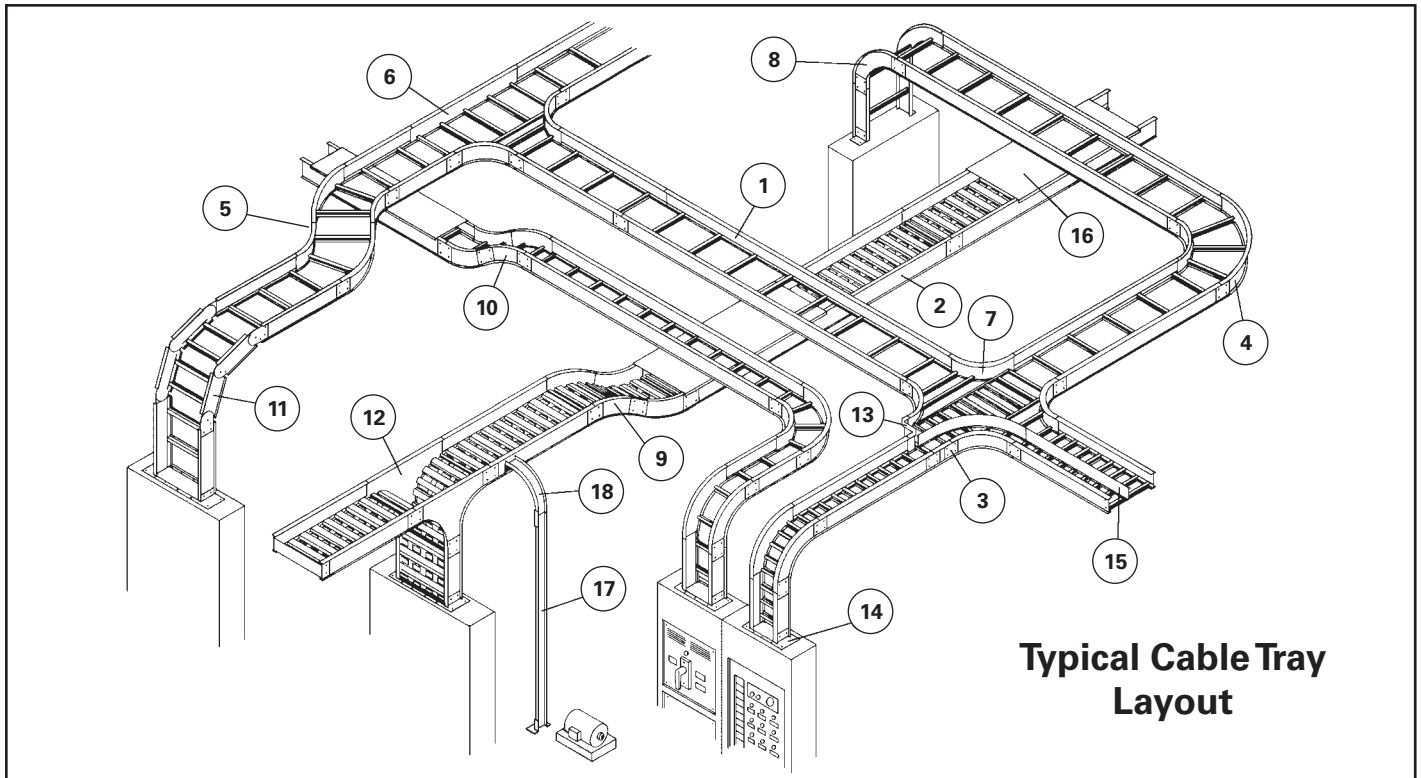

Typical Cable Tray Layout

Nomenclature

- | | |
|--|--|
| 1. Ladder Type Cable Tray | 10. 30° Vertical Inside Bend, Ladder Type Tray |
| 2. Ventilated Trough Type Cable Tray | 11. Vertical Bend Segment (VBS) |
| 3. Splice Plate | 12. Vertical Tee Down, Ventilated Trough Type Tray |
| 4. 90° Horizontal Bend, Ladder Type Tray | 13. Left Hand Reducer, Ladder Type Tray |
| 5. 45° Horizontal Bend, Ladder Type Tray | 14. Frame Type Box Connector |
| 6. Horizontal Tee, Ladder Type Tray | 15. Barrier Strip Straight Section |
| 7. Horizontal Cross, Ladder Type Tray | 16. Solid Flanged Tray Cover |
| 8. 90° Vertical Outside Bend, Ladder Type Tray | 17. Cable Channel Straight Section, Ventilated |
| 9. 45° Vertical Outside Bend, Ventilated Type Tray | 18. Cable Channel, 90° Vertical Outside Bend |

There are some designers, engineers, and inspectors that do not think that cable tray is a mechanical support system just as strut is a mechanical support system. Cable tray is not a raceway in the **NEC**® but some designers, engineers, and inspectors attempt to apply the requirements for raceway wiring systems to cable tray wiring systems even when they are not applicable. Cable tray wiring systems have been used by American industry for over 50 years with outstanding safety and continuity of service records. The safety service record of cable tray wiring systems in industrial facilities has been significantly better than those of conduit wiring systems. There have been industrial fires and explosions that have occurred as a direct result of the wiring system being a conduit wiring system. In these cases, cable tray wiring systems would not have provided the fires and explosions that the conduit systems did by providing an explosion gas flow path to the ignition source even though the conduit systems contained seals.

The most significant part of this section is that the metallic cable tray system must have electrical continuity over its entire length and that the support for the cables must be maintained. These requirements can be adequately met even though there will be installation conditions where the cable tray is mechanically discontinuous, such as at a firewall penetration, at an expansion gap in a long straight cable tray run, where there is a change in elevation of a few feet between two horizontal cable tray sections of the same run, or where the cables drop from an overhead cable tray to enter equipment. In all these cases, adequate bonding jumpers must be used to bridge the mechanical discontinuity.

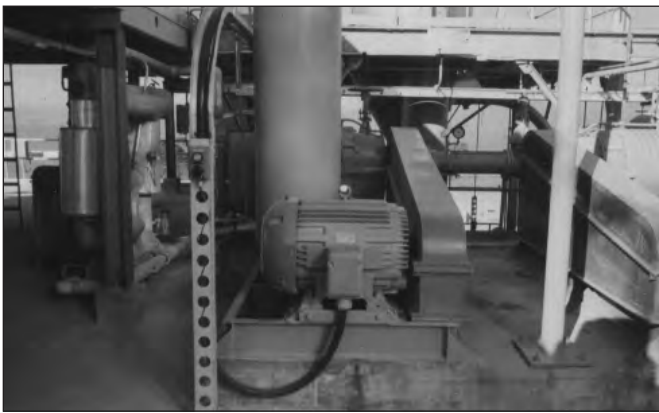

Cable Entering Motor Terminal Box from 6 Inch Channel Cable Tray System (Bottom entries provide drip loops to prevent moisture flow into enclosures.)



Cables Exiting 480 Volt Outdoor Switchgear and Entering Cable Tray System (Cable fittings with clamping glands are required to prevent moisture flow into equipment due to the cable's overhead entry into the switchgear enclosure).



Cables Entering and Exiting Motor Control Centers from Cable Tray Systems.

392.18. Cable Tray Installation. (B) Completed Before Installation.

This means that the final cable tray system must be in place before the cables are installed. It does not mean that the cable tray must be 100% mechanically continuous. The electrical bonding of the metallic cable tray system must be complete before any of the circuits in the cable tray system are energized whether the cable tray system is being utilized as the equipment grounding conductor in qualifying installations or if the bonding is being done to satisfy the requirements of Section 250.96.

392.18. Cable Tray Installation. (C) Covers.

Cable tray covers provide protection for cables where cable trays are subject to mechanical damage. The most serious hazard to cable in cable trays is when the cables are exposed to significant amounts of hot metal spatter during construction or maintenance from torch cutting of metal and welding activities. For these exposure areas, the cable tray should be temporarily covered with plywood sheets. If such exposure is to be a frequent occurrence, cable tray covers should be installed in the potential exposure areas. Where cable trays contain power and lighting conductors, raised or ventilated covers are preferable to solid covers since the raised or ventilated covers allow the cable heat to be vented from the cable tray.

When covers are required to be installed outdoors, they should be attached to the cable trays with heavy duty wrap around clamps instead of standard duty clips. During high winds, the light duty clips are not capable of restraining the covers. Outdoor cover installations should be overlapped at expansion joint locations to eliminate cover buckling. Covers which fly off the cable tray create a serious hazard to personnel, as was the case at a Texas gulf coast chemical plant where operators would not leave their control room because hurricane force winds had stripped many light gauge stainless steel covers off a large cable tray system. These sharp edged metal covers were flying through the air all during the high wind period, posing a serious threat to the worker's safety.

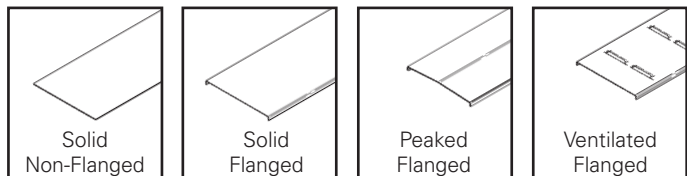

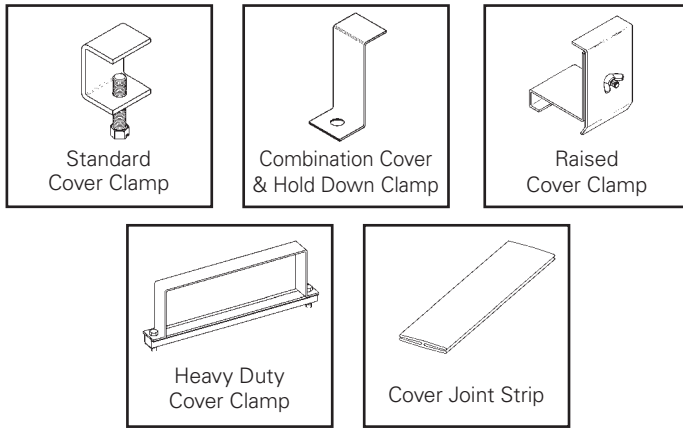

Aluminum Cable Tray Cover Accessories

Equivalent items are available for Steel Cable Trays.

392.18. Cable Tray Installation. (D) Through Partitions and Walls.

Whether penetrating fire rated walls with tray cable only or cable tray and tray cable, the designer should review with the local building inspector the method he proposes to use to maintain the fire rating integrity of the wall at the penetration. Many methods for sealing fire wall penetrations are available, including bag or pillow, caulk, cementitious, foam, putty and mechanical barrier systems.

Many designers prefer to run only the tray cable through fire rated walls. Sealing around the cables is easier than sealing around the cables and the cable tray. Also, should the cable tray or its supports become damaged, the tray will not exert forces which could damage the wall or the penetration.

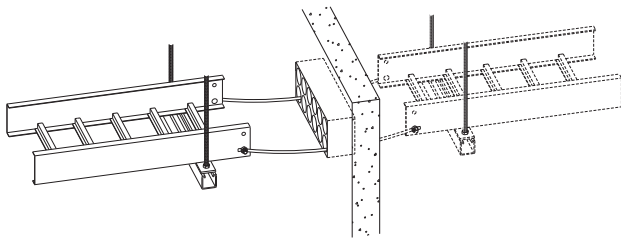

392.18. Cable Tray Installation. (E) Exposed and Accessible.

Article 100 - Definitions.

Exposed: (as applied to wiring methods) on or attached to the surface or behind panels designed to allow access.

Accessible: (As applied to wiring methods) Capable of being removed or exposed without damaging the building structure or finish, or not permanently closed in by the structure or finish of the building.

Reproduced with permission from NFPA 70®-2014, National Electrical Code®, Copyright © 2013, National Fire Protection Association, Quincy, MA. This reprinted material is not the complete and official position of the NFPA on the referenced subject, which is represented only by the standard in its entirety.

392.18. Cable Tray Installation. (F) Adequate Access.

Cable tray wiring systems should be designed and installed with adequate room around the cable tray to allow for the set up of cable pulling equipment. Also, space around the cable tray provides easy access for installation of additional cables or the removal of surplus cables. Where cable trays are mounted one above the other, a good rule to follow is to allow 12 to 18 inches between the underside and the top of adjacent cable trays or between the structure's ceiling and the top of the cable tray.

392.18. Cable Tray Installation. (G) Raceways, Cables, Boxes, and Conduit Bodies Supported from Cable Tray Systems.

For the 1996 **NEC**®, a significant change was made in this section. The installations covered in this section may now only be made in qualifying industrial facilities. In Section 392.6(J) of the 1993 **NEC**®, cable tray installations that supplied support for conduits were not restricted to qualifying industrial facilities. The 1996 **NEC**®, Section 392.6(J) text restricts the use of such installations even though there is no documented history of problems in non-industrial installations.

As a result of the change in this section, identical functional installations in non-qualifying installations (commercial and industrial) and qualifying industrial installations have different physical requirements. In a qualifying industrial installation, a conduit terminated on a cable tray may be supported from the cable tray. In a commercial or non-qualifying industrial installation, the conduit that is terminated on the cable tray must be securely fastened to a support that is within 3 feet of the cable tray or securely fastened to a support that is within 5 feet of the cable tray where structural members don't readily permit a secure fastening within 3 feet. The conduit of the non-qualifying installation still needs to be bonded to the cable tray.

A fitting may be used for this bonding even though it will not count as a mechanical support. Over 99 percent of the conduits supported on cable trays are the result of conduits being terminated on the cable tray side rails [See Section 392.46]. For over 40 years, it has been common practice to house the cables exiting the cable tray in conduits or cable channel where the distance from the cable tray system to the cable terminations requires the cable be supported. Several manufacturers supply UL approved cable tray to conduit clamps such as the B-Line 9ZN-1158.

Cable Tray Manual

In addition to conduit and cables being supported from cable tray; industrial companies have been mounting instrumentation devices, push buttons, etc. on cable tray and cable channel for over 40 years. This section once lead some to believe that only conduit or cables may be supported from cable trays which is not correct as cable tray is a mechanical support just as strut is a mechanical support. Because of this, the wording in

Section 392.6(J) of the 2002 **NEC**[®] was changed. Instead of allowing only cable and conduit to be supported from cable tray, the code now states that **raceways, cables, boxes and conduit bodies** are now permitted to be supported from the cable tray. Where boxes or conduit bodies are attached to the bottom or side of the cable tray, they must be fastened and supported in accordance with Section 314.23.

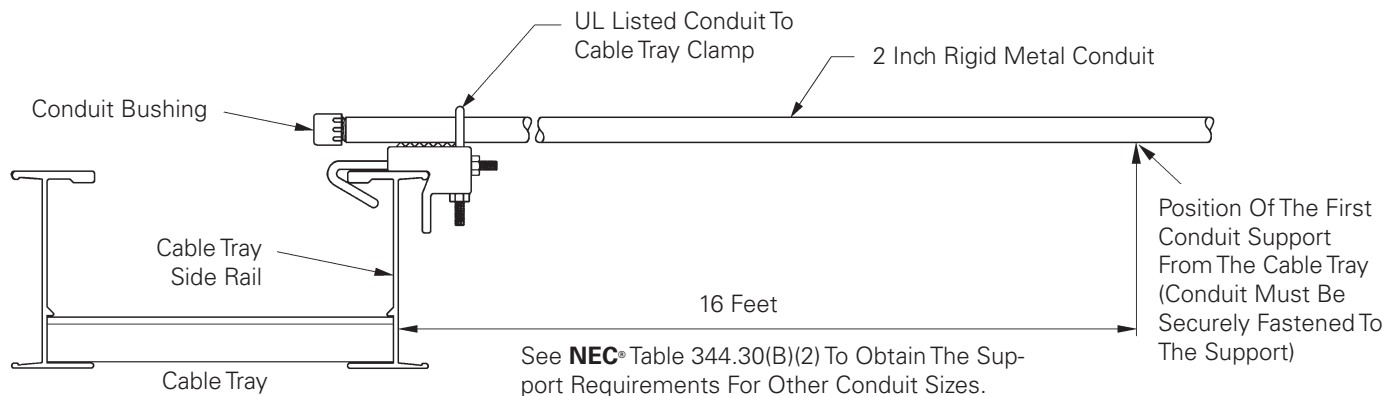

**Conduit Terminated On And Supported By The Cable Tray Side Rail.
Installation For Qualifying Industrial Facilities As Per 392.18(G).**

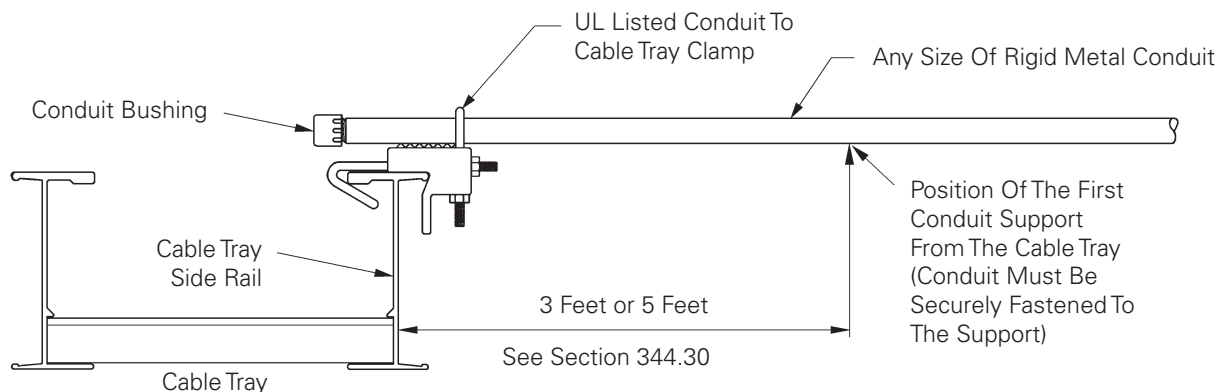

**Conduit Terminated On The Cable Tray Side Rail.
Installation For Commercial And Non-Qualifying Industrial Facilities As Per 392.18(G).**

392.18. Cable Tray Installation. (H) Marking.

This section was added to the 2011 **NEC**[®]. This requires cable trays containing conductors rated 600V or more to be affixed with a permanent label carrying the wording "DANGER HIGH VOLTAGE - KEEP AWAY". The label should be positioned on the cable tray in a clearly visible location not to exceed spacing intervals of 10 feet. All labels should be in compliance with Section 110.21(B). Acquiring and applying the labels in accordance with **NEC**[®] requirements is the responsibility of cable tray installer.

392.20. Cables and Conductor Installation. (A) Multiconductor Cables Rated 600 Volts or Less.

Cables containing 300 or 600 volt insulated conductors may be installed intermingled in the same cable tray which is different from the requirements for raceways. This is a reasonable arrangement because a person may safely touch a 300 or 600 volt cable which is in good condition, so having the cables come into contact with each other is not a problem either. Many cable tray users separate the instrumentation cables from the power and control cables by installing them in separate cable trays or by installing barriers in the cable trays. Often, because of the volume of the instrumentation cable, using separate cable trays is the most desirable installation practice.

Numerous cable tray systems have been installed where the instrumentation cables and branch circuit cables are installed in the same cable trays with and without barriers with excellent performance and reliability. Most problems that occur involving instrumentation circuits are due to improper grounding practices. For analog and digital instrumentation circuits, good quality twisted pair Type ITC and Type PLTC cables with a cable shield and a shield drain wire should be used. Do not purchase this type of cable on price alone, it should be purchased because of its high quality. Engineers specifying cables should be knowledgeable of the cable's technical details in order to design systems which will provide trouble free operation.

392.20. Cable and Conductor Installation. (B) Cables Rated Over 600 Volts.

Cables with insulation rated 600 volts or less may be installed with cables rated over 600 volts if either of the following provisions are met.

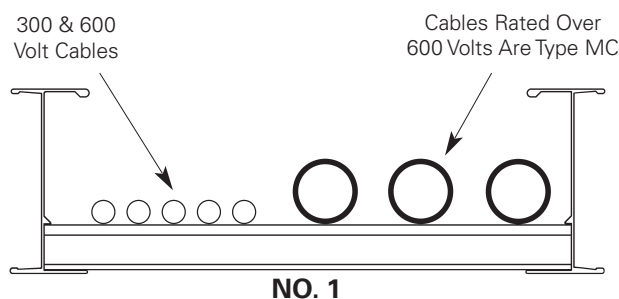

No. 1: Where the cables over 600 volts are Type MC.

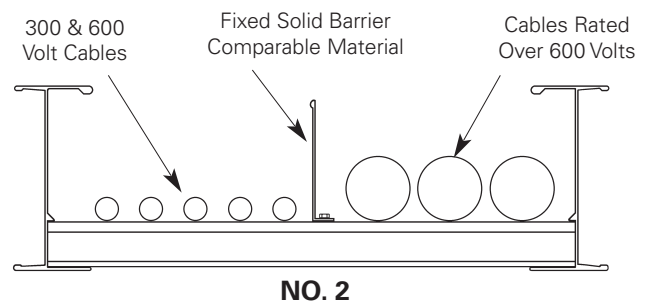

No. 2: Where separated with a fixed solid barrier of a material compatible with the cable tray.

392.20. Cable and Conductor Installation. (C) Connected in Parallel.

Section 310.10(H)(2). Conductors in Parallel. States the following:

The paralleled conductors in each phase, neutral or grounded conductor shall:

- (1) Be the same length.
- (2) Have the same conductor material.
- (3) Be the same size in circular mil area.
- (4) Have the same insulation type.
- (5) Be terminated in the same manner.

Where run in separate raceways or cables, the raceways or cables shall have the same physical characteristics. Conductors of one phase, neutral, or grounded circuit shall not be required to have the same physical characteristics as those of another phase, neutral, or grounded circuit conductor to achieve balance.

A difference between parallel conductors in raceways and those in cable trays is that the conductors in the cable tray are not derated unless there are more than three current carrying conductors in a cable assembly [as per Exception No.2 of Section 310.15(B)(3)(a) and Section 392.80(A)(1)(a)]. Where the single conductor cables are bundled together as per Section 392.20(C) and if there are neutrals that are carrying currents due to the type of load involved (harmonic currents) it may be prudent to derate the bundled single conductor cables.

The high amperages flowing under fault conditions in 1/0 and larger cables produce strong magnetic fields which result in the conductors repelling each other until the circuit protective device either de-energizes the circuit or the circuit explodes. Under such fault conditions, the cables thrash violently and might even be forced out of the cable tray. This happened at a northern Florida textile plant where several hundred feet of Type MV single conductor cable was forced out of a cable tray run by an electrical fault because the cables were not restrained properly. This potential safety threat is precisely why Article 392.20(C) requires single conductor cables be securely bound in circuit groups to prevent excessive movement due to fault-current magnetic forces. For a three-phase trefoil or triangular

Cable Tray Manual

arrangement (the most common single conductor application), these forces can be calculated according to the formula:

$$F_t = (0.17 \times i_p^2) / S.$$

F_t =Maximum Force on Conductor (Newtons/meter)

i_p =Peak Short Circuit Current (kilo-Amperes)

S =Spacing between Conductors (meters) = Cable Outside Diameter for Triplex (trefoil) Installations.

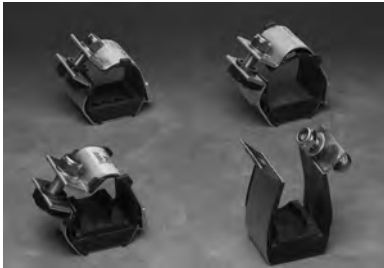

One technique to prevent excessive movement of cables is to employ fault-rated cable cleats.

To maintain the minimum distance between conductors, the single conductor cables should be securely bound in circuit groups using fault rated cable cleats. If the cleat spacing is properly chosen according to the available fault-current, the resulting cable grouping will inherently maintain a minimum distance between conductors. These circuit groups provide the lowest possible circuit reactance which is a factor in determining the current balance among various circuit groups.

For installations that involve phase conductors of three conductor or single conductor cables installed in parallel, cable tray installations have conductor cost savings advantages over conduit wiring systems. This is because the conductors required for a cable tray wiring system are often a smaller size than those required for a conduit wiring system for the same circuit. No paralleled conductor ampacity adjustment is required for single conductor or three conductor cables in cable trays [See **NEC**® Section 392.80(A)(1)].

There were changes in the 1993 **NEC**® and 1996 **NEC**® for installations where an equipment grounding conductor is included in a multiconductor cable: the equipment grounding conductor must be fully rated per Section 250.122. If multiconductor cables with internal equipment grounding conductors are paralleled, each multiconductor cable must have a fully rated equipment grounding conductor.

Section 250.122 now prohibits the use of standard three conductor cables with standard size EGCs when they are installed in parallel and the EGCs are paralleled. There have been no safety or technical problems due to operating standard three conductor cables with standard sized EGCs in parallel. This has been a standard industrial practice for over 40 years with large numbers

of such installations in service. This change was made without any safety or technical facts to justify this change.

To comply with Section 250.122, Three options are available: 1. Order special cables with increased sized EGCs which increases the cost and the delivery time. 2. Use three conductor cables without EGCs and install a single conductor EGC in the cable tray or use the cable tray as the EGC in qualifying installations. 3. Use standard cables but don't utilize their EGCs, use a single conductor EGC or the cable tray as the EGC in qualifying installations.

Should industry be required to have special cables fabricated for such installations when there have been absolutely no safety problems for over 40 years? Each designer and engineer must make his own decision on this subject. If the installations are properly designed, quality materials are used, and quality workmanship is obtained, there is no safety reason for not following the past proven practice of paralleling the EGCs of standard three conductor cable.

392.20. Cable and Conductor Installation. (D) Single Conductors.

This section states that single conductors in ladder or ventilated trough cable tray that are Nos. 1/0 through 4/0, must be installed in a single layer.

In addition to the fill information that is in Section 392.20(D), an exception was added which allows the cables in a circuit group to be bound together rather than have the cables installed in a flat layer. The installation practice in the exception is desirable to help balance the reactance's in the circuit group. This reduces the magnitudes of voltage unbalance in three phase circuits.

Where ladder or ventilated trough cable trays contain multiconductor power or lighting cables, or any mixture of multiconductor power, lighting, control, or signal cables, the maximum number of cables that can be installed in a cable tray are limited to the Table 392.22(A) allowable fill areas. The cable tray fill areas are related to the cable ampacities. Overfill of the cable tray with the conductors operating at their maximum ampacities will result in cable heat dissipation problems with the possibility of conductor insulation and jacket damage.

Compatibility Of Cable Tray Types And Cable Trays Based On The NEC®

3", 4", & 6" Wide Solid or Ventilated Channel Cable Tray

Solid Bottom Cable Tray

Ventilated Trough Cable Tray

Ladder Cable Tray

Multiconductor Cables 300 & 600 Volt *	X	X	X	X
Single Conductor Cables - 600 Volt *	***	X	X	X
Type MV Multiconductor Cables **	X	X		X
Type MV Single Conductor Cables **	X	X		X

X - Indicates the Installations Allowed by Article 392

* - For cables rated up to 2000 volts.

** - For cables rated above 2000 volts.

*** - For 1/0 - 4/0 AWG single conductor cables installed in ladder cable tray, maximum rung spacing is 9 inches.

392.22. Number of Conductor of Cables. (A) Number of Multiconductor Cables, Rated 2000 Volts or Less, in Cable Trays. (1) Ladder or Ventilated Trough Cable Trays Containing Any Mixture of Cables. (a) 4/0 or Larger Cables

The ladder or ventilated trough cable tray must have an inside usable width equal to or greater than the sum of the diameters (Sd) of the cables to be installed in it. For an example of the procedure to use in selecting a cable tray width for the type of cable covered in this section see page MAN-43 (Appendix Sheet 3), [Example 392.22(A)(1)(a)].

Increasing the cable tray side rail depth increases the strength of the cable tray but the greater side rail depth does not permit an increase in cable fill area for power or lighting cables or combinations of power, lighting, control and signal cables. The maximum allowable fill area for all cable tray with a 3 inch or greater loading depth side rail is limited to the 38.9 percent fill area for a 3 inch loading depth side rail (Example: 3 inches x 6 inches inside cable tray width x 0.389 = 7.0 square inch fill area. This is the first value in Column 1 of Table 392.22(A). All succeeding values for larger cable tray widths are identically calculated).

392.22. Number of Conductor of Cables. (A) Number of Multiconductor Cables, Rated 2000 Volts or Less, in Cable Trays. (1) Ladder or Ventilated Trough Cable Trays Containing Any Mixture of Cables. (b) Cables Smaller Than 4/0

The allowable fill areas for the different ladder or ventilated trough cable tray widths are indicated in square inches in Column 1 of Table 392.22(A). The total sum of the cross-sectional areas of all the cables to be installed in the cable tray must be equal to or less than the cable tray allowable fill area. For an example of the procedure to use in selecting a cable tray width for the type of cable covered in this section see page MAN-44 (Appendix Sheet 4), [Example 392.22(A)(1)(b)].

392.22. Number of Conductor of Cables. (A) Number of Multiconductor Cables, Rated 2000 Volts or Less, in Cable Trays. (1) Ladder or Ventilated Trough Cable Trays Containing Any Mixture of Cables. (c) 4/0 of Larger Cables Installed With Cables Smaller Than 4/0

The ladder or ventilated trough cable tray needs to be divided into two zones (a barrier or divider is not required but one can be used if desired) so that the No. 4/0 and larger cables have a dedicated zone as they are to be placed in a single layer.

The formula for this type of installation is shown in Column 2 of Table 392.22(A). This formula is a trial and error method of selecting a cable tray of the proper width. A direct method for determining the cable tray width is available by figuring the cable tray widths that are required for each of the cable combinations and then adding these widths together to select the proper cable tray width. [Sd (sum of the diameters of the No. 4/0 and larger cables)] + [Sum of Total Cross Sectional Area of all Cables No. 3/0 and Smaller] x (6 inches/7 square inches) = The Minimum Width of Cable Tray Required. For an example of the procedure to use in selecting a cable tray width for the type of cable covered in this section, see page MAN-45, (Appendix Sheet 5), [EXAMPLE 392.22(A)(1)(c)].

392.22. Number of Conductor of Cables. (A) Number of Multiconductor Cables, Rated 2000 Volts or Less, in Cable Trays. (2) Ladder or Ventilated Trough Cable Trays Containing Multiconductor or Control and/or Signal Cables Only.

A ladder or ventilated trough cable tray, having a loading depth of 6 inches or less containing only control and/or signal cables, may have 50 percent of its cross-sectional area filled with cable. If the cable tray has a loading depth in excess of 6 inches, that figure cannot be used in calculating the allowable fill area as a 6 inch depth is the maximum value that can be used for the cross-sectional area calculation. For an example of the procedure to use in selecting a cable tray width for the type of cable covered in this section, see page MAN-46 (Appendix Sheet 6), [Example 392.22(A)(2)].

Cable Tray Manual

**392.22. Number of Conductor of Cables.
(A) Number of Multiconductor Cables, Rated 2000 Volts or Less, in Cable Trays. (3) Solid Bottom Cable Trays Containing Any Mixture of Cables.**

For solid bottom cable tray, the allowable cable fill area is reduced to approximately 30 percent as indicated by the values in Columns 3 and 4 of Table 392.22(A). The first value in Column 3 was obtained as follows: 3 in. loading depth x 6 in. inside width x 0.305 = 5.5 square inches. The other values in Column 3 were obtained in a like manner. The Sd term in Column 4 has a multiplier of 1 vs. the multiplier of 1.2 for Column 2.

**392.22. Number of Conductor of Cables.
(A) Number of Multiconductor Cables, Rated 2000 Volts or Less, in Cable Trays. (3) Solid Bottom Cable Trays Containing Any Mixture of Cables. (a) 4/0 or Larger Cables.**

The procedure used in selecting a cable tray width for the type of cable covered in this section is similar to that shown on Appendix Sheet 3 page MAN-43, but only 90 percent of the cable tray width can be used.

**392.22. Number of Conductor of Cables.
(A) Number of Multiconductor Cables, Rated 2000 Volts or Less, in Cable Trays. (3) Solid Bottom Cable Trays Containing Any Mixture of Cables. (b) Cables Smaller Than 4/0.**

The procedure used in selecting a cable tray width for the type of cable covered in this section is similar to that shown on Appendix Sheet 4 page MAN-44. The maximum allowable cable fill area is in Column 3 of Table 392.22(A).

**392.22. Number of Conductor of Cables.
(A) Number of Multiconductor Cables, Rated 2000 Volts or Less, in Cable Trays. (3) Solid Bottom Cable Trays Containing Any Mixture of Cables. (c) 4/0 or Larger Cables With Cables Smaller Than 4/0.**

No. 4/0 and larger cables must have a dedicated zone in the tray in order to be installed in one layer. Therefore the cable tray needs to be divided into two zones (a barrier or divider is not required but one can be used if desired).

The formula for this type of installation is shown in Column 4 of Table 392.22(A). This formula is a trial and error method of selecting a cable tray of the proper width. A direct method for determining the cable tray width is available by figuring the cable tray widths that are required for each of the cable combinations and then adding these widths together to select the proper cable tray width. [Sd (sum of the diameters of the No. 4/0 and larger cables) x (1.11)] + [(Sum of Total Cross-Sectional Area of all Cables No. 3/0 and Smaller) x (6 inches/5.5 square inches) = The Minimum Width of

Cable Tray Required. The procedure used in selecting a cable tray width for the type of cables covered in this section is similar to that shown on Appendix Sheet 5 page MAN-45.

**392.22. Number of Conductor of Cables.
(A) Number of Multiconductor Cables, Rated 2000 Volts or Less, in Cable Trays. (4) Solid Bottom Cable Trays Containing Multiconductor Control and/or Signal Cables Only.**

This is the same procedure as for ladder and ventilated trough cable trays except that the allowable fill has been reduced from 50 percent to 40 percent. The procedure used in selecting a cable tray width for the type of cable covered in this section is similar to that shown on Appendix Sheet 6 page MAN-46. [Example 392.22(A)(2)]

**392.22. Number of Conductor of Cables.
(A) Number of Multiconductor Cables, Rated 2000 Volts or Less, in Cable Trays. (5) Ventilated Channel Cable Trays Containing Multiconductor Cables of Any Type.**

392.22(A)(5)(a)

Where only one multiconductor cable is installed in a ventilated channel cable tray.

Ventilated Channel Cable Tray Size	Maximum Cross-Sectional Area of the Cable
3 Inch Wide	2.3 Square Inches
4 Inch Wide	4.5 Square Inches
6 Inch Wide	7.0 Square Inches

392.22(A)(5)(b)

The fill areas for combinations of multiconductor cables of any type installed in ventilated channel cable tray.

Ventilated Channel Cable Tray Size	Maximum Allowable Fill Area
3 Inch Wide	1.3 Square Inches
4 Inch Wide	2.5 Square Inches
6 Inch Wide	3.8 Square Inches

**392.22. Number of Conductor of Cables.
(A) Number of Multiconductor Cables, Rated 2000 Volts or Less, in Cable Trays. (6) Solid Channel Cable Trays Containing Multiconductor Cables of Any Type.**

392.22(A)(6)(a)

Where only one multiconductor cable is installed in a solid channel cable tray.

Solid Channel Cable Tray Size	Maximum Cross-Sectional Area of the Cable
2 Inch Wide	1.3 Square Inches
3 Inch Wide	2.0 Square Inches
4 Inch Wide	3.7 Square Inches
6 Inch Wide	5.5 Square Inches

392.22(A)(6)(b)

The fill areas for combinations of multiconductor cables of any type installed in solid channel cable tray.

Solid Channel Cable Tray Size	Maximum Allowable Fill Area
2 Inch Wide	0.8 Square Inches
3 Inch Wide	1.1 Square Inches
4 Inch Wide	2.1 Square Inches
6 Inch Wide	3.2 Square Inches

392.22. Number of Conductor or Cables, (B) Number of Single Conductor Cables, Rated 2000 Volts or Less, in Cable Trays.

Installation of single conductors in cable tray is restricted to industrial establishments where conditions of maintenance and supervision assure that only qualified persons will service the installed cable tray systems. Single conductor cables for these installations must be 1/0 or larger, and they may not be installed in solid bottom cable trays.

392.22. Number of Conductor of Cables. (B) Number of Single Conductor Cables, Rated 2000 Volts or Less, in Cable Trays. (1) Ladder or Ventilated Trough Cable Trays. (a) 1000 KCMIL Through 900 KCMIL Cables.

The sum of the diameters (Sd) of all single conductor cables shall not exceed the cable tray width, and the cables shall be installed in a single layer.

392.22. Number of Conductor of Cables. (B) Number of Single Conductor Cables, Rated 2000 Volts or Less, in Cable Trays. (1) Ladder or Ventilated Trough Cable Trays. (b) 250 KCMIL Through 900 KCMIL Cables.

Number Of 600 Volt Single Conductor Cables That May Be Installed In Ladder Or Ventilated Trough Cable Tray - Section 392.10(A) (2)

Single Conductor Size	Dia. In. (Note #1)	Area Sq. In.	Cable Tray Width								(Note #2) 42 In.
			6 In.	9 In.	12 In.	18 In.	24 In.	30 In.	36 In.		
1/0	0.58	--	10	15	20	31	41	51	62	72	
2/0	0.62	--	9	14	19	29	38	48	58	67	
3/0	0.68	--	8	13	17	26	35	44	52	61	
4/0	0.73	--	8	12	16	24	32	41	49	57	
250 Kcmil	0.84	0.55	11	18	24	35	47	59	71	82	
350 Kcmil	0.94	0.69	9	14	19	28	38	47	57	65	
500 Kcmil	1.07	0.90	7	11	14	22	29	36	43	50	
750 Kcmil	1.28	1.29	5	8	10	15	20	25	30	35	

Notes:

- #1. Cable diameter's used are those for Okonite-Okolon 600 volt single conductor power cables.
- #2. 42 inch wide is ladder cable tray only.
- #3. Such installations are to be made only in qualifying industrial facilities as per Sections 392.10(B) & (B)(1).
- #4. To avoid problems with unbalanced voltages, the cables should be bundled with ties every three feet or four feet. The bundle must contain the circuit's three phase conductors plus the neutral if one is used.
- #5. The single conductor cables should be firmly tied to the cable trays at six foot or less intervals.

392.22. Number of Conductor of Cables. (B) Number of Single Conductor Cables, Rated 2000 Volts or Less, in Cable Trays. (1) Ladder or Ventilated Trough Cable Trays. (c) 1000 KCMIL or Larger Cables Installed With Cables Smaller Than 1000 KCMIL.

Such installations are very rare.

392.22. Number of Conductor of Cables. (B) Number of Single Conductor Cables, Rated 2000 Volts or Less, in Cable Trays. (1) Ladder or Ventilated Trough Cable Trays. (d) Cables 1/0 Through 4/0.

The sum of the diameters (Sd) of all 1/0 through 4/0 cables shall not exceed the inside width of the cable tray.

Cable Tray Manual

392.22. Number of Conductor of Cables. (B) Number of Single Conductor Cables, Rated 2000 Volts or Less, in Cable Trays. (2) Ventilated Channel Cable Trays.

The sum of the diameters (Sd) of all single conductors shall not exceed the inside width of the ventilated cable channel.

Number Of 600 Volt Single Conductor Cables That May Be Installed In A Ventilated Channel Cable Tray - Section 392.22(B)(2)

Single Conductor Size	Diameter Inches (Note #1)	3 Inch V. Channel C.T.	4 Inch V. Channel C.T.	6 Inch V. Channel C.T.
1/0 AWG	0.58	5	6	10
2/0 AWG	0.62	4	6	9
3/0 AWG	0.68	4	5	8
4/0 AWG	0.73	4	5	8
250 Kcmil	0.84	3	4	7
350 Kcmil	0.94	3	4	6
500 Kcmil	1.07	2	3	5
750 Kcmil	1.28	2	3	4
1000 Kcmil	1.45	2	2	4

Notes:

- #1. Cable diameter's used are those for Okonite-Okolon 600 volt single conductor power cables.
- #2. Such installations are to be made only in qualifying industrial facilities as per Sections 392.10(B) & (B)(1).
- #3. The phase, neutral, and EGCs cables are all counted in the allowable cable fill for the ventilated channel cable tray.
- #4. To avoid problems with unbalanced voltages, the cables should be bundled with ties every three feet or four feet. The bundle must contain the circuit's three phase conductors plus the neutral if one is used. If a cable is used as the EGC, it should also be in the cable bundle. If the designer desires, the ventilated channel cable tray may be used as the EGC as per Table 392.60(A).
- #5. The single conductor cables should be firmly tied to the ventilated channel cable tray at six foot or less intervals.

392.22. Number of Conductors of Cables. (C) Number of Type MV and Type MC Cables (2001 Volts or Over) in Cable Trays.

Sum the diameters of all the cables (Sd) to determine the minimum required cable tray width. Triplexing or quadruplexing the cables does not change the required cable tray width. Whether the cables are grouped or ungrouped, all installations must be in a single layer.

392.30. Securing and Supporting. (B) Cables and Conductors.

The intent of this section is to ensure that the conductor insulation and cable jackets will not be damaged due to stress caused by improper support. Multiconductor 600 volt Type TC cables and 300 volt Type PLTC cables exhibit a high degree of damage resistance when exposed to mechanical abuse at normal temperatures.

During an inspection of industrial installations by the 1973 **NEC**® Technical Subcommittee on Cable Tray, a test setup was constructed of an 18 inch wide Class 20C aluminum cable tray supported three feet above ground level containing several sizes of multiconductor cables. This installation was continuously struck in the same area with eight pound sledge hammers until the cable tray was severely distorted, the cables however, exhibited only cosmetic damage. When these cables were tested electrically, they checked out as new tray cable. Since that time, significant improvements have been made in cable jacket and conductor insulation materials so that the cables available today are of better quality than the 1973 test cables. Although tray cables are capable of taking a great deal of abuse without any problems, cable tray installations must be designed by taking appropriate measures to ensure that the tray cables will not be subjected to mechanical damage.

392.30. Securing and Supporting. (B) Cables and Conductors. (1) Other Than Horizontal Runs.

In seismic, high-shock and vibration prone areas, cables (especially unarmored cables) should be secured to the cable tray at 1 to 2 foot intervals to prevent the occurrence of sheath chafing. Otherwise, there is no safety or technical reason to tie down multiconductor cables in horizontal cable tray runs unless the cable spacing needs to be maintained or the cables need to be confined to a specific location in the cable tray. In non-horizontal cable tray runs, small multiconductor cables should be tied down at 3 or 4 foot intervals and larger (1 inch diameter and above) Type MC and Type TC multiconductor cable should be tied down at 6 foot intervals. If used outdoors, plastic ties should be sunlight, ultraviolet (UV), resistant and be made of a material that is compatible with the industrial environment. Installed outdoors, white nylon plastic ties without a UV resistant additive will last 8 to 14 months before breaking. Also available for these applications are cable cleats, stainless steel ties and P-clamps.

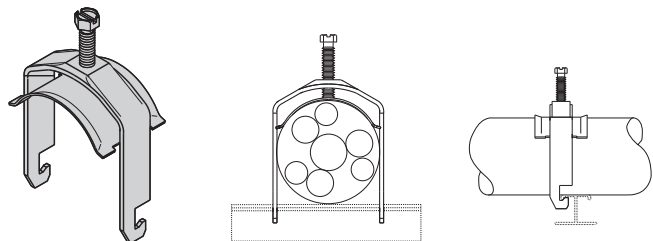

(P-Clamp shown installed on industrial aluminum rung)

392.46. Bushed Conduit and Tubing.

For most installations, using a conduit to cable tray clamp for terminating conduit on cable tray is the best method. Where a cable enters a conduit from the cable tray, the conduit must have a bushing to protect the cable jacket from mechanical damage; a box is not required

[See Section 300.15(C). Boxes, Conduit Bodies, or Fittings - Where Required. Where cables enter or exit from conduit or tubing that is used to provide cable support or protection against physical damage.

A fitting shall be provided on the end(s) of the conduit or tubing to protect the wires or cables from abrasion.] There are some special installations where the use of conduit knockouts in the cable tray side rail for terminating conduit is appropriate. This would not be a good standard practice because it is costly and labor intensive, and if randomly used may result in damaging and lowering the strength of the cable tray.

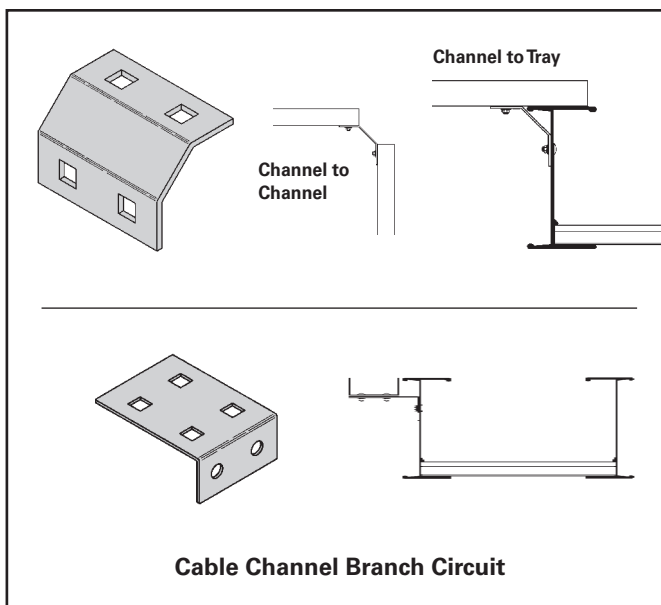

392.56. Cable Splices.

There is no safety problem due to cable splices being made in cable trays if quality splicing kits are used, provided that the splice kits do not project above the siderails and that they are accessible. A box or fitting is not required for a cable splice in a cable tray.

Cable Tray Manual

392.60. Grounding and Bonding, (A) Metallic Cable Trays.

Cable tray may be used as the EGC in any installation where qualified persons will service the installed cable tray system. There is no restriction as to where the cable tray system is installed. The metal in cable trays may be used as the EGC as per the limitations of table 392.60(A).

All metallic cable trays shall be grounded as required in Article 250.96 regardless of whether or not the cable

tray is being used as an equipment grounding conductor (EGC).

The EGC is the most important conductor in an electrical system as its function is electrical safety.

There are three wiring options for providing an EGC in a cable tray wiring system: (1) An EGC conductor in or on the cable tray. (2) Each multiconductor cable with its individual EGC conductor. (3) The cable tray itself is used as the EGC in qualifying facilities.

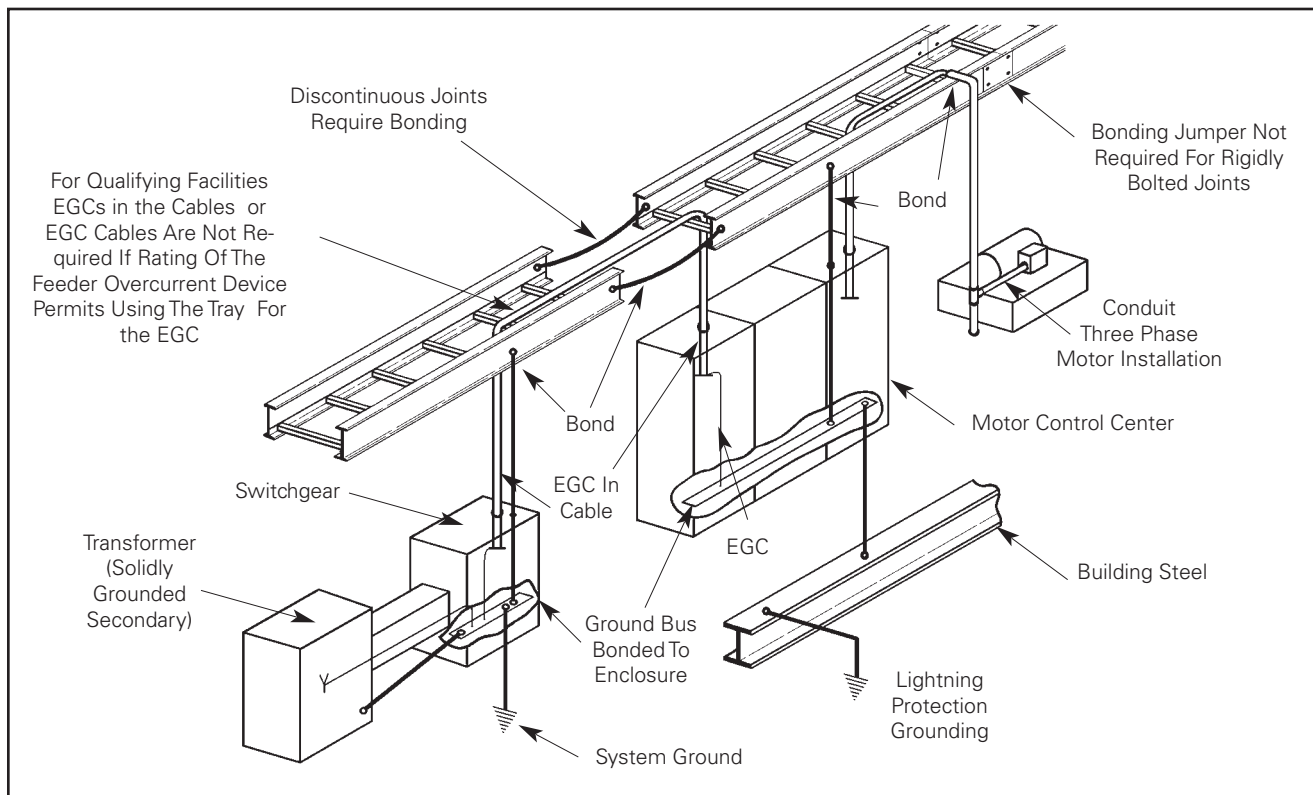

Correct Bonding Practices To Assure That The Cable Tray System Is Properly Grounded

If an EGC cable is installed in or on a cable tray, it should be bonded to each or alternate cable tray sections via grounding clamps (this is not required by the **NEC**[®] but it is a desirable practice). In addition to providing an electrical connection between the cable tray sections and the EGC, the grounding clamp mechanically anchors the EGC to the cable tray so that under fault current conditions the magnetic forces do not throw the EGC out of the cable tray.

A bare copper equipment grounding conductor should not be placed in an aluminum cable tray due to the potential for electrolytic corrosion of the aluminum cable tray in a moist environment. For such installations, it is best to use an insulated conductor and to remove the insulation where bonding connections are made to the cable tray, raceways, equipment enclosures, etc. with tin or zinc plated connectors.

See Table 250.122 on page MAN-47 for the minimum size EGC for grounding raceway and equipment.

Aluminum Cable Tray Systems. (1) & (2)

**Table 392.60(A).
Metal Area Requirements for Cable Trays
Used as Equipment Grounding Conductors**

Maximum Fuse Ampere Rating, Circuit Breaker Ampere Trip Setting, or Circuit Breaker Protective Relay Ampere Trip Setting for Ground-Fault Protection of Any Cable Circuit In the Cable Tray System	Minimum Cross-Sectional Area of Metal* In Square Inches	
	Steel Cable Trays	Aluminum Cable Trays
60	0.20	0.20
100	0.40	0.20
200	0.70	0.20
400	1.00	0.40
600	1.50**	0.40
1000	---	0.60
1200	---	1.00
1600	---	1.50
2000	---	2.00**

For SI units: one square inch = 645 square millimeters.

* Total cross-sectional area of both side rails for ladder or trough cable trays; or the minimum cross-sectional area of metal in channel cable trays or cable trays of one-piece construction.

** Steel cable trays shall not be used as equipment grounding conductors for circuits with ground-fault protection above 600 amperes. Aluminum cable trays shall not be used as equipment grounding conductors for circuits with ground-fault protection above 2000 amperes.

Reproduced with permission from NFPA 70-2014, National Electrical Code®, Copyright © 2013, National Fire Protection Association, Quincy, MA. This reprinted material is not the complete and official position of the NFPA on the referenced subject, which is represented only by the standard in its entirety.

Table 392.60(A) "Metal Area Requirements for Cable Trays used as Equipment Grounding Conductors" shows the minimum cross-sectional area of cable tray side rails (total of both side rails) required for the cable tray to be used as the Equipment Grounding Conductor (EGC) for a specific Fuse Rating, Circuit Breaker Ampere Trip Rating or Circuit Breaker Ground Fault Protective Relay Trip Setting. These are the actual trip settings for the circuit breakers and not the maximum permissible trip settings which in many cases are the same as the circuit breaker frame size. If the maximum ampere rating of the cable tray is not sufficient for the protective device to be used, the cable tray cannot be used as the EGC and a separate EGC must be included within each cable assembly or a separate EGC has to be installed in or attached to the cable tray. [See also Section 250-120 for additional information]

The subject of using cable tray for equipment grounding conductors was thoroughly investigated by the 1973 **NEC**® Technical Subcommittee on Cable Tray. Many calculations were made and a number of tests were performed by Monsanto Company Engineers at the Bussman High Current Laboratory. The test setup

to verify the capability of cable tray to be used as the EGC is shown in Figure 1 on page MAN-30. The test amperes available were forced through one cable tray side rail which had three splice connections in series. No conductive joint compound was used at the connections and the bolts were wrench tight. Copper jumper cables were used from the current source to the cable tray. The cable tray was NEMA Class 12B. The test results are shown on page MAN-41 (Appendix Sheet 1), Table I for aluminum and Table II for steel cable tray.

One of the most interesting results of the tests was for an aluminum cable tray with a corroded joint and only two nylon bolts. 34,600 amperes for 14 cycles produced only a 34° C temperature rise at the splice plate area. If the protective devices work properly, the temperature rises recorded at the cable tray splices during these tests would not be sufficient to damage the cables in the cable tray. Also note that in these tests only one side rail was used, but in a regular installation, both side rails would conduct fault current and the temperature rise at the splice plate areas would be even lower.

When the cable tray is used as the EGC, consideration has to be given to the conduit or ventilated channel cable tray connections to the cable tray so that the electrical grounding continuity is maintained from the cable tray to the equipment utilizing the electricity. Conduit connections to the cable tray were also tested. At that time, no commercial fittings for connecting conduit to cable tray were available, so right angle beam clamps were used with very good results. There are now UL Listed fittings for connecting and bonding conduit to cable tray. This test setup and results are shown on page MAN-42 (Appendix Sheet 2).

Temperature Rise Test

Material Thickness: 0.125" Aluminum or 14 Gauge Steel

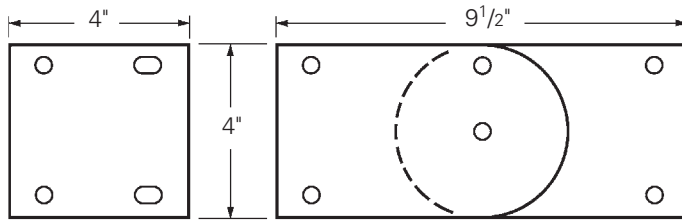

Rigid

Adjustable Vertical

Cable Tray Connectors

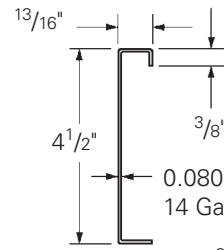

Cross Section Area,
2 Rails:
Aluminum - 1.00 sq. in.
Steel - 0.76 sq. in.

3/8" Bolting Hardware

Cross Section Cable Tray Side Rail

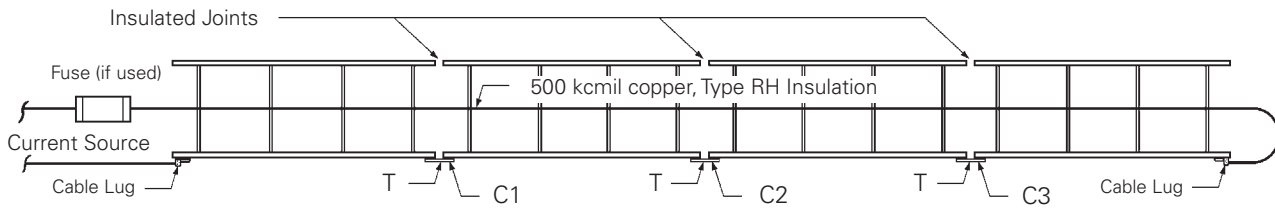

T - Temperature Measurement at each Tray Connection C1,
C2, & C3 - Cable Tray Connectors or Bonding Jumpers

Figure 1
(See Page MAN-41 Appendix Sheet 1)

Cable Tray Label

WARNING! DO NOT USE AS A WALKWAY, LADDER OR SUPPORT FOR PERSONNEL.
USE ONLY AS A MECHANICAL SUPPORT FOR CABLES, TUBING AND RACEWAYS.

ADVERTISSEMENT! CECI N'EST PAS UNE PASSERELLE, NI UNE ECHELLE NI UNE APPUI POUR LE PERSONNEL. UTILISER UNIQUEMENT POUR SUPPORTER DES CABLES, DES TUBES ET DES CANALISATIONS.

Catalog Number: **24A09-24-120**

Sales Order: 207919636 50

Mark Number: 4513819925

Purchase Order: 4513819925

Minimum Area: 1,000 SQ IN

Load Class: D 179 KG/M 3.0 METER SPAN

2 OF 18

COOPER B-Line[®]
www.cooperbline.com
(618) 654-2184

08/20/2015
MADE IN
USA

UL CLASSIFIED CABLE TRAY AS TO ITS SUITABILITY AS AN EQUIPMENT GROUNDING CONDUCTOR ONLY. 556E
BOLT TORQUE 3/8" = 19 FT/LBS 1/4" = 6 FT/LBS

SP VENTILATED
Reference File# LR36026

CE



392.60. Grounding and Bonding. (B) Steel or Aluminum Cable Tray Systems. (3) & (4)

For a cable tray to be used as an EGC the manufacturer must provide a label showing the cross-sectional area available. This also holds true for some mechanically constructed cable tray systems such as Redi-Rail®. Redi-Rail has been tested and UL Classified as an EGC. B-Line label is shown at the bottom of page MAN-30.

The cable tray system must be electrically continuous whether or not it is going to serve as the EGC. At certain locations (expansion joints, discontinuities, most adjustable splice plates, etc.), bonding jumpers will be required. Section 250.96. Bonding Other Enclosures states that cable tray shall be effectively bonded where necessary to assure electrical continuity and to provide the capacity to conduct safely any fault current likely to be imposed on them (also see Sections 250.92(A)(1) & 250.118(12)).

It is NOT necessary to install bonding jumpers at standard splice plate connections. The splice connection is UL classified as an EGC component of the cable tray system.

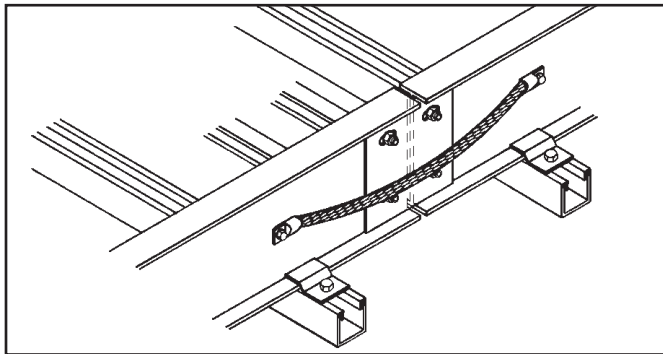

99-N1
600 amps max.

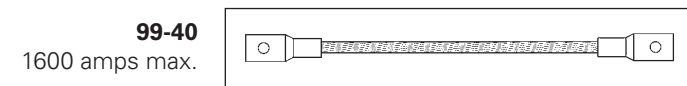

99-40
1600 amps max.

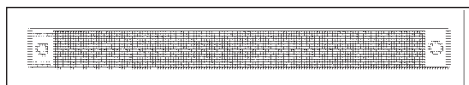

99-1620
2000 amps max.

NOTE: The **NEC**® only recognizes aluminum and steel cable trays as EGC's. As with all metallic cable trays, stainless steel cable trays must be bonded according to **NEC**® guidelines. Fiberglass cable trays do not require bonding jumpers since fiberglass is non-conductive.

392.80. Ampacity of Conductors. (A) Ampacity of

Cables. Rated 2000 Volts or Less in Cable Trays.

Ampacity Tables 310.15(B)(16) and 310.15(B)(18) are to be used for multiconductor cables which are installed in cable tray using the allowable fill areas as per Section 392.22(A). The ampacities in Table 310.15(B)(16) are based on an ambient temperature of 30° Celsius. Conduit and cable tray wiring systems are often installed in areas where they will be exposed to high ambient temperatures. For such installations, some designers and engineers neglect using the Ampacity Correction Factors listed below the Wire Ampacity Tables which results in the conductor insulation being operated in excess of its maximum safe temperature. These correction factors must be used to derate a cable for the maximum temperature it will be subjected to anywhere along its length.

392.80(A)(1)(a)

Section 310.15(B)(3)(a) refers to Section 392.80 which states that the derating information of Table 310.15(B)(3)(a) applies to multiconductor cables with more than three current carrying conductors but not to the number of conductors in the cable tray.

392.80(A)(1)(b)

Where cable trays are continuously covered for more than 6 feet (1.83m) with solid unventilated covers, not over 95 percent of the allowable ampacities of Tables 310.15(B)(16) and 310.15(B)(18) shall be permitted for multiconductor cables.

This is for multiconductor cables installed using Table 310.15(B)(16) or 310.15(B)(18). If these cables are installed in cable trays with solid unventilated covers for more than 6 feet the cables must be derated. Where cable tray covers are to be used, it is best to use raised or ventilated covers so that the cables can operate in a lower ambient temperature.

392.80(A)(1)(c)

Where multiconductor cables are installed in a single layer in uncovered trays, with a maintained spacing of not less than one cable diameter between cables, the ampacity shall not exceed the allowable ambient temperature corrected ampacities of multiconductor cables, with not more than three insulated conductors rated 0-2000 volts in free air, in accordance with Section 310.15(C).

By spacing the cables one diameter apart, the engineer may increase the allowable ampacities of the cables to the free air rating as per Section 310.15(C) and Table B-310.3 in Appendix B. Notice that the allowable fill of the cable tray has been decreased in this design due to the cable spacing.

Cable Tray Manual

392.80. Ampacity of Conductors. (A) Ampacity of Cables. Rated 2000 Volts or Less in Cable Trays. (2) Single Conductor Cables.

Single conductor cables can be installed in a cable tray cabled together (triplexed, quadruplexed, etc.) if desired. Where the cables are installed according to the requirements of Section 392.22(B), the ampacity requirements are shown in the following chart as per Section 392.80(A)(2), (a), (b), (c), and (d):

An exception is listed under 392.80(A)(2)(c). Stating that the capacity for single conductor cables be placed in solid bottom shall be determined by 310.15(C).

Sec. No.	Cable Sizes	Solid Unventilated Cable Tray Cover	Applicable Ampacity Tables (*)	Mult. Amp. Table Values By	Special Conditions
(1)	600 kcmil and Larger	No Cover Allowed (**)	310.15(B)(17) and 310.15(B)(19)	0.75	
(1)	600 kcmil and Larger	Yes	310.15(B)(17) and 310.15(B)(19)	0.70	
(2)	1/0 AWG through 500 kcmil	No Cover Allowed (**)	310.15(B)(17) and 310.15(B)(19)	0.65	
(2)	1/0 AWG through 500 kcmil	Yes	310.15(B)(17) and 310.15(B)(19)	0.60	
(3)	1/0 AWG & Larger In Single Layer	No Cover Allowed (**)	310.15(B)(17) and 310.15(B)(19)	1.00	Maintained Spacing Of One Cable Diameter
(4)	Single Conductors In Triangle Config. 1/0 AWG and Larger	No Cover Allowed (**)	310.15(B)(20) [See NEC Section 310.15(B)]	1.00	Spacing Of 2.15 x One Conductor O.D. Between Cables(***)

(*) The ambient ampacity correction factors must be used.

(**) At a specific position, where it is determined that the tray cables require mechanical protection, a single cable tray cover of six feet or less in length can be installed.

The wording of Section 392.80(A)(2)(d) states that a spacing of 2.15 times one conductor diameter is to be maintained between circuits. Two interpretations of this statement are possible.

Interpretation #1. - The 2.15 times one conductor diameter is the distance between the centerlines of the circuits (the center lines of the conductor bundles).

Interpretation #2. - The 2.15 times one conductor diameter is the free air distance between the adjacent cable bundles. The use of the word "circuit" is unfortunate as its presence promotes Interpretation #1. An installation based on Interpretation #1 is not desirable as a free air space equal to 2.15 times one conductor diameter between the cable bundles should be maintained to promote cable heat dissipation.

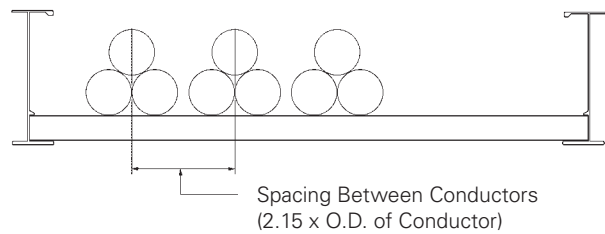

Technically Undesirable Installation

Interpretation #1

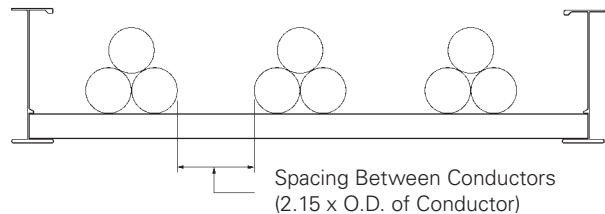

Technically Desirable Installation

Interpretation #2

392.80. Ampacity of Conductors. (B) Ampacity of Type MV and Type MC Cables (2001 Volts or Over) in Cable Trays. (1) Multiconductor Cables (2001 Volts or Over)

Provision No. 1: Where cable trays are continuously covered for more than six feet (1.83 m) with solid unventilated covers, not more than 95% of the allowable ampacities of Tables 310.60(C)(75) and 310.60(C)(76) shall be permitted for multiconductor cables.

Cables installed in cable trays with solid unventilated covers must be derated. Where cable tray covers are to be used, it is best to use raised or ventilated covers so that the cables can operate in a lower ambient temperature.

Provision No. 2: Where multiconductor cables are installed in a single layer in uncovered cable trays with a maintained spacing of not less than one cable diameter between cables, the ampacity shall not exceed the allowable ampacities of Table 310.60(C)(71) and 310.60(C)(72).

If the cable tray does not have covers and the conductors are installed in a single layer spaced not less than one cable diameter apart, the cable conductor ampacities can be 100 percent of the ambient temperature corrected capacities in Tables 310.60(C)(71) or 310.60(C)(72).

392.80. Ampacity of Conductors. (B) Ampacity of Type MV and Type MC Cables (2001 Volts or Over) in Cable Trays. (2) Single-Conductor Cables (2001 Volts or Over)

Sec. No.	Cable Sizes	Solid Unventilated Cable Tray Cover	Applicable Ampacity Tables (*)	Mult. Amp. Table Values By	Special Conditions
(1)	1/0 AWG and Larger	No Cover Allowed (**)	310.60(C)(69) and 310.60(C)(70)	0.75	
(1)	1/0 AWG and Larger	Yes	310.60(C)(69) and 310.60(C)(70)	0.70	
(2)	1/0 AWG & Larger In Single Layer	No Cover Allowed (**)	310.60(C)(69) and 310.60(C)(70)	1.00	Maintained Spacing Of One Cable Diameter
(3)	Single Conductors In Triangle Config. 1/0 AWG and Larger	No Cover Allowed (**)	310.60(C)(67) and 310.60(C)(68)	1.00	Spacing Of 2.15 x One Conductor O.D. Between Cables(***)

(*) The ambient ampacity correction factors must be used.

(**) At a specific position, where it is determined that the tray cables require mechanical protection, a single cable tray cover of six feet or less in length can be installed.

The wording of Section 392.80(B)(2)(c) states that a spacing of 2.15 times one conductor diameter is to be maintained between circuits. Two interpretations of this statement are possible.

Interpretation #1. - The 2.15 times one conductor diameter is the distance between the centerlines of the circuits (the center lines of the conductor bundles).

Interpretation #2. - The 2.15 times one conductor diameter is the free air distance between the adjacent cable bundles. The use of the word "circuit" is unfortunate as its presence promotes Interpretation #1. An installation based on Interpretation #1 is not desirable as a free air space equal to 2.15 times one conductor diameter between the cable bundles should be maintained to promote cable heat dissipation.

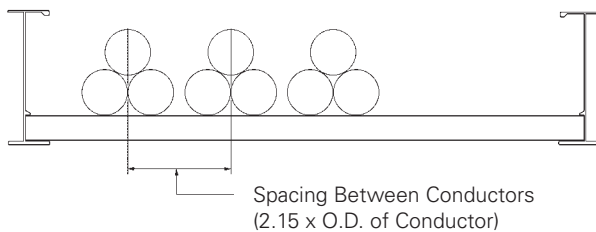

Technically Undesirable Installation

Interpretation #1

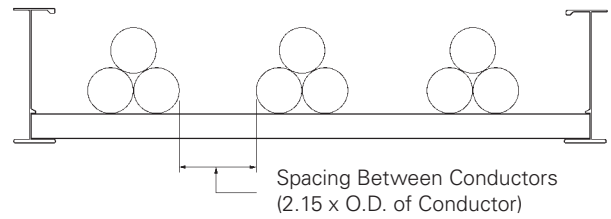

Technically Desirable Installation

Interpretation #2

392.100. Construction Specifications. (A) Strength and Rigidity.

The designer must properly select a structurally satisfactory cable tray for their installation. This selection is based on the cable tray's strength, the cable tray loading and the spacing of the supports. The ANSI/NEMA Metallic Cable Tray Systems Standard Publication VE-1 contains the cable tray selection information and it is duplicated in B-Line Cable Tray Systems Catalog.

The NEMA Standard provides for a static load safety factor of 1.5. A number (Span in Feet - the distance between supports) and letter (Load in lbs/ft) designation is used to properly identify the cable tray class on drawings, in specifications, in quotation requisitions, and in purchase requisitions to guarantee that the cable tray with the proper characteristics will be received and installed. The designer must specify the cable tray type, the material of construction, section lengths, minimum bend radius, width, rung spacing (for a ladder type cable tray), and the total loading per foot for the cables on a maximum support spacing (See pages MAN-50 & MAN-51 for cable tray specifications checklist). For many installations, the cable trays must be selected so that they are capable of supporting specific concentrated loads, the weight of any equipment or materials attached to the cable tray, ice and snow loading, and for some installations the impact of wind loading and/or earthquakes must be considered.



Most cable trays are utilized as continuous beams with distributed and concentrated loads. Cable trays can be subjected to static loads like cable loads and dynamic loads such as wind, snow, ice, and even earthquakes. The total normal and abnormal loading for the cable tray is determined by adding all the applicable component

loads. The cable load + the concentrated static loads + ice load (if applicable) + snow load (if applicable) + wind load (if applicable) + any other logical special condition loads that might exist. This total load is used in the selection of the cable tray.

The following is an explanation of the 'historical' NEMA cable tray load classifications found in ANSI/NEMA VE-1.

There used to be four cable tray support span categories, 8, 12, 16, and 20 feet, which are coupled with one of three load designations, "A" for 50 lbs/ft, "B" for 75 lbs/ft, and "C" for 100 lbs/ft. For example, a NEMA class designation of 20B identifies a cable tray that is to be supported at a maximum of every 20 feet and can support a static load of up to 75 lbs/linear foot.

The cable load per foot is easy to calculate using the cable manufacturer's literature. If the cable tray has space available for future cable additions, a cable tray has to be specified that is capable of supporting the final future load. Although these historical load designations are still useful in narrowing down the choices of cable trays, NEMA has recently changed the VE-1 document. ANSI/NEMA VE-1 now requires the marking on the cable trays to indicate the exact rated load on a particular span. Trays are no longer limited to the four spans and three loads listed above. Now, for example, a tray may be rated for 150 lbs/ft on a 30 ft. span. It is recommended when specifying cable tray, to specify the required load, support span and straight section length to best match the installation.

Example of Cable Loading per foot:

- 10 - 3/C No. 4/0 (2.62 lbs/ft)
Total = 26.20 lbs/ft
- 3 - 3/C No. 250 kcmil (3.18 lbs/ft)
Total = 9.54 lbs/ft
- 4 - 3/C No. 500 kcmil (5.87 lbs/ft)
Total = 23.48 lbs/ft

Total Weight of the Cables = **59.22 lbs/ft**

These cables would fill a 30 inch wide cable tray and if a 36 inch wide cable tray were used there would be space available for future cables (See pages M-43 thru M-45 for information on calculating tray width.). To calculate the proper cable tray design load for the 36" wide cable tray multiply 59.22 lbs/ft x 36 inches/30 inches = 71.06 lbs/ft. If this cable tray is installed indoors, a load symbol "B" cable tray would be adequate. If there were additional loads on the cable tray or the cable tray were installed outdoors, it would be necessary to calculate all the additional potential loads. The potential load most often ignored is installation loads. The stresses of pulling large cables through cable trays can produce 3 times the stress of the cables' static load. If the installation load is not evaluated the cable tray may be damaged during installation. A 16C or 20C NEMA Class should be specified if large cables are to be pulled.

Even though walking on cable tray is not recommended by cable tray manufacturers and OSHA regulations, many designers will want to specify a cable tray which can support a 200 lb. concentrated load "just in case". A concentrated static load applied at the midspan of a cable tray is one of the most stressful conditions a cable tray will experience. To convert a static concentrated load at midspan to an equivalent distributed load take twice the concentrated load and divide it by the support span [(2 x 200 lbs.)/Span]. The strength of the rung is also a very important consideration when specifying a concentrated load. The rung must be able to withstand the load for any tray width, as well as additional stresses from cable installation. Excessive rung deflection can weaken the entire cable tray system. B-Line uses heavier rungs on their wider industrial trays as a standard. Most cable tray manufacturer's rungs are not heavy enough to withstand concentrated loads at 36" and beyond tray widths.

For outdoor installations a cable tray might be subject to ice, snow, and wind loading. Section 25 of the National Electrical Safety Code (published by the Institute of Electrical and Electronic Engineers) contains a weather loading map of the United States to determine whether the installation is in a light, medium, or heavy weather load district. NESC Table 250-1 indicates potential ice thicknesses in each loading district as follows: 0.50 inches for a heavy loading district, 0.25 inches for a medium loading district, and no ice for a light loading district. To calculate the ice load use 57 pounds per cubic foot for the density of glaze ice. Since tray cables are circular and the cable tray has an irregular surface the resulting ice load on a cable tray can be 1.5 to 2.0 times greater than the glaze ice load on a flat surface.

Snow load is significant for a cable tray that is completely full of cables or a cable tray that has covers. The density of snow varies greatly due to its moisture content, however the minimum density that should be used for snow is 5 pounds per cubic foot. The engineer will have to contact the weather service to determine the potential snow falls for the installation area or consult the local building code for a recommended design load.

Usually cable trays are installed within structures such that the structure and equipment shelter the cable trays from the direct impact of high winds. If wind loading is a potential problem, a structural engineer and/or the potential cable tray manufacturer should review the installation for adequacy. To determine the wind speed for proper design consult the Basic Wind Speed Map of the United States in the NESC (Figure 250-2).

For those installations located in earthquake areas, design engineers can obtain behavioral data for B-Line cable trays under horizontal, vertical and longitudinal loading conditions. Testing done for nuclear power plants in the 1970's indicates that cable trays act like large trusses when loaded laterally and are actually stronger than when loaded vertically. Cable tray

supports may still need to be seismically braced and designers should consult the B-Line Seismic Restraints Catalog for detailed design information.

The midspan deflection multipliers for all B-Line series cable trays are listed in the Cable Tray Systems catalog. Simply pick your support span and multiply your actual load by the deflection multiplier shown for that span. The calculated deflections are for simple beam installations at your specified load capacity. If a deflection requirement will be specified, extra care needs to be taken to ensure that it does not conflict with the load requirement and provides the aesthetics necessary. Keep in mind that continuous beam applications are more common and will decrease the deflection values shown by up to 50%. Also, aluminum cable trays will deflect 3 times more than steel cable trays of the same NEMA class.

To complete the design, the standard straight section length and minimum bend radius must be chosen. When selecting the recommended length of straight sections, be sure that the standard length is greater than or equal to the maximum support span. Choose a fitting radius which will not only meet or exceed the minimum bend radius of the cables but will facilitate cable installation.

[See pages MAN-9 - MAN-11 for more information on selecting the appropriate cable tray length]

392.100. Construction Specifications. (B) Smooth Edges.

This is a quality statement for cable tray systems and their construction. B-Line series cable tray is designed and manufactured to the highest standards to provide easy, safe installation of both the cable tray and cables.

392.100. Construction Specifications. (C) Corrosion Protection.

Cable tray shall be protected from corrosion per Section 300.6, which lists some minimum criteria for different corrosive environments. The B-Line series Cable Tray Catalog contains a corrosion chart for cable tray materials. Cable trays may be obtained in a wide range of materials including aluminum, pregalvanized steel, hot dipped galvanized steel (after fabrication), Type 304 or 316 stainless steel, or steel and also nonmetallic (fiber reinforced plastic). Check with a metallurgist to determine which metals and coatings are compatible with a particular corrosive environment. B-Line has corrosion information available and may be able to recommend a suitable material. Remember that no material is totally impervious to corrosion. Stainless steel can deteriorate when attacked by certain chemicals and nonmetallic cable trays can deteriorate when attacked by certain solvents.

392.100. Construction Specifications. (D) Side Rails.

The technical information in Article 392 was originally developed for cable trays with rigid side rails by the 1973 **NEC**® Technical Subcommittee on Cable Tray. "Equivalent Structural Members" was added later to incorporate new styles of cable tray such as center rail type tray and 'mesh' or wire basket tray.

392.100. Construction Specifications. (E) Fittings.

This section has been misinterpreted to mean that cable tray fittings must be used for all changes in direction and elevation [See Section 392.18(A) Complete system for further explanation]. When two cable tray runs cross at different elevations, lacing a cable between the rungs of one tray and dropping into the other is a common practice which changes the direction of the cable while providing adequate cable support. Although the use of cable tray fittings is not mandatory, it is often desirable to use them when possible to improve the appearance of the installation.

392.100. Construction Specifications. (F) Nonmetallic Cable Tray.

This type of cable tray is usually made of Fiberglass Reinforced Plastic (FRP). Applications for FRP cable tray systems include some corrosive atmospheres and where non-conductive material is required. B-Line fiberglass cable tray systems are manufactured from glass fiber reinforced plastic shapes that meet ASTM flammability and self-extinguishing requirements. A surface veil is applied during pultrusion to ensure a resin rich surface and increase ultraviolet resistance, however, for extended exposure to direct sunlight, additional measures, such as painting the tray, are sometimes employed to insure the longevity of the product. Ambient temperature is also a design consideration when FRP cable tray is used. An ambient temperature of 100°F will decrease the loading capacity of polyester resin fiberglass cable tray by 10%.

Cable Tray Manual

CABLE TRAY WIRING SYSTEM DESIGN AND INSTALLATION HINTS.

Cable tray wiring systems should have a standardized cabling strategy. Standard cable types should be used for each circuit type. Most of the following circuits should be included; feeder circuits, branch circuits, control circuits, instrumentation circuits, programmable logic controller input and output (I/O) circuits, low level analog or digital signals, communication circuits and alarm circuits. Some cables may satisfy the requirements for several circuit types. Minimizing the number of different cables used on a project reduces installed costs. Some companies have cable standards based on volume usage to minimize the numbers of different cables used on a project. For example: if a 6 conductor No. 14 control cable is needed but 7 conductor No. 14 control cable is stocked, a 7 conductor control cable would be specified and the extra conductor would not be used. Following such a practice can reduce the number of different cables handled on a large project without increasing the cost since high volume cable purchases result in cost savings. Orderly record keeping also helps provide quality systems with lower installation costs. The following items should be included in the project's cable records:

- Cable Tray Tag Numbers - The tagging system should be developed by the design personnel with identification numbers assigned to cable tray runs on the layout drawings. Cable tray tag numbers are used for controlling the installation of the proper cable tray in the correct location, routing cables through the tray system and controlling the cable fill area requirements.
- Cable Schedules - A wire management system is required for any size project. Cable schedules must be developed to keep track of the cables. This is especially true for projects involving more than just a few feeder cables. A typical cable schedule would contain most or all of the following:
 - The Cable Number, the Cable Manufacturer & Catalog Number, Number of conductors, the conductor sizes, and the approximate cable length.
 - Cable Origin Location - The origin equipment ID with the compartment or circuit number and terminals on which the cable conductors are to be terminated. It should also include the origin equipment layout drawing number, and the origin equipment connection diagram number.
 - Cable Routing - Identifies the cable tray sections or runs that a cable will occupy. Cable tray ID tag numbers are used to track the routing.
 - Cable Termination Location - The device or terminal equipment on which the cable conductors are to be terminated. It should also include the termination equipment layout drawing number, and the termination equipment connection diagram number.

Some design consultants and corporate engineering departments use spread sheets to monitor the cable tray runs for cable fill. With such a program, the cable tray fill area values for each cable tray run or section can be continuously upgraded. If a specified cable tray run or section becomes overfilled, it will be flagged for corrective action by the designer.

- Cable Installation Provisions - The cable tray system must be designed and installed, to allow access for cable installation. For many installations, the cables may be hand laid into the cable trays and no cable pulling equipment is required. There are other installations where sufficient room must be allotted for all the cable pulling activities and equipment.

The cable manufacturers will provide installation information for their cables such as maximum pulling tension, allowable sidewall pressures, minimum bending radii, maximum permissible pulling length etc.. Lubricants are not normally used on cables being installed in cable trays.

The engineer and designers should discuss in detail the installation of the cables with the appropriate construction personnel. This will help to avoid installation problems and additional installation costs. It is important that the cable pull is in the direction that will result in the lowest tension on the cables. Keep in mind there also needs to be room at the ends of the pulls for the reel setups and for the power pulling equipment. Cable pulleys should be installed at each direction change. Triple pulleys should be used for 90 degree horizontal bends and all vertical bends. Single pulleys are adequate for horizontal bends less than 90 degrees. Use rollers in-between pulleys and every 10 to 20 feet depending on the cable weight. Plastic jacketed cables are easier to pull than are the metallic jacketed cables and there is less chance of cable damage. The pulling eye should always be attached to the conductor material to avoid tensioning the insulation. For interlocked armor cables, the conductors and the armor both have to be attached to the pulling eye.

Normally, the cables installed in cable trays are not subjected to the damage suffered by insulated conductors pulled into conduit. Depending on the size of the insulated conductors and the conduit, jamming can take place which places destructive stresses on the cable insulation. In the October, 1991 issue of EC&M magazine, the article on cable pulling stated that 92 percent of the insulated conductors that fail do so because they were damaged in installation.

CABLE TRAY ACCESSORIES.

B-Line manufactures a full line of prefabricated accessories for all types of B-Line series cable trays. The use of the appropriate accessories will provide installation cost and time savings. In addition to providing desirable electrical and mechanical features for the cable tray system, the use of the appropriate accessories improves the physical appearance of the cable tray system. Some of the most common accessories are shown below and on the following page.

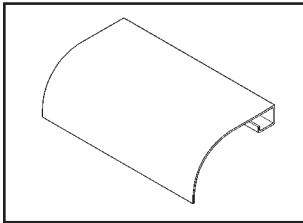

Ladder Dropout

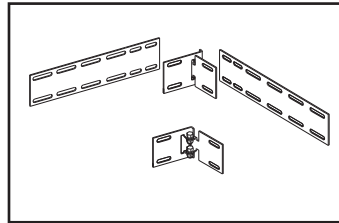

Horizontal Adjustable Splice
Requires supports within 24" on both sides, per NEMA VE 2.

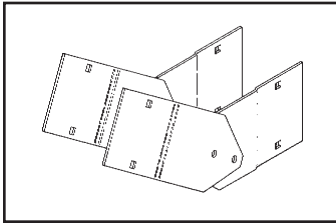

Vertical Adjustable Splice
Requires supports within 24" on both sides, per NEMA VE 2.

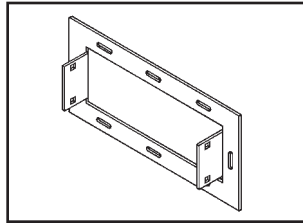

Frame Box Connector

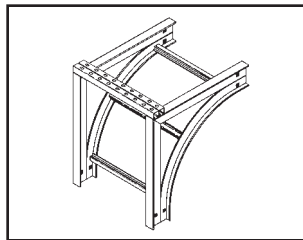

Cable Support Fitting

FIREPROOFING CABLE TRAY

Cable trays should not be encapsulated for fire protection purposes other than for the short lengths at fire rated walls unless the cables are adequately derated. Encapsulation to keep fire heat out will also keep conductor heat in. If conductors cannot dissipate their heat, their insulation systems will deteriorate. If the cable tray will be encapsulated, the cable manufacturer should be consulted for derating information.

CABLE TRAY MAINTENANCE AND REPAIR

If the cable tray finish and load capacity is properly specified and the tray is properly installed, virtually no maintenance is required.

Pre-Galvanized - This finish is for dry indoor locations. No maintenance is required.

Hot Dip Galvanized - This finish is maintenance free for many years in all but the most severe environments. If components have been cut or drilled in the field, the exposed steel area should be repaired with a cold galvanizing compound. B-Line has a spray on zinc coating available which meets the requirements of ASTM A780, *Repair of Hot Dip Finishes*.

Aluminum - Our cable tray products are manufactured from type 6063-T6 aluminum alloy with a natural finish. The natural oxide finish is self healing and requires no repair if it is field modified.

Non-metallic - Fabrication with fiberglass is relatively easy and comparable to working with wood. Any surface that has been drilled, cut, sanded, or otherwise broken, **must be sealed** with a comparable resin. Polyester or vinyl ester sealing kits are available.

Cable tray should be visually inspected each year for structural damage i.e., broken welds, bent rungs or severely deformed side rails. If damage is evident, from abuse or installation, it is recommended that the damaged section of cable tray be replaced rather than repaired. It is much easier to drop a damaged section of tray out from under the cables than it is to shield the cables from weld spatter.

Cable Tray Manual

CABLE TRAY. THERMAL CONTRACTION AND EXPANSION

All materials expand and contract due to temperature changes. Cable tray installations should incorporate features which provide adequate compensation for thermal contraction and expansion. Installing expansion joints in the cable tray runs only at the structure expansion joints does not normally compensate adequately for the cable tray's thermal contraction and expansion. The supporting structure material and the cable tray material will have different thermal expansion values. They each require unique solutions to control thermal expansion.

NEC® Section 300.7(B) states that 'Raceways shall be provided with expansion joints where necessary to compensate for thermal expansion or contraction.' NEC® Section 392 does not address thermal contraction and expansion of cable tray. One document which addresses expansion is the NEMA Standards Publication No. VE 2, Section 3.4.2. NEMA VE-2-2013 Table 3-2 shows the allowable lengths of steel and aluminum cable tray between expansion joints for the temperature differential values.

Reprinted with permission from NFPA 70-2014, the National Electrical Code®, Copyright© 2013, National Fire Protection Association, Quincy, MA 02269. This reprinted material is not the complete and official position of the National Fire Protection Association, on the referenced subject which is represented only by the standard in its entirety.

**Table 4-2
Maximum Spacing Between Expansion Joints
That Provide For One Inch (25.4 mm) Movement**

Temp. Differential		Steel		Aluminum		Stainless Steel				FRP	
°F	(°C)	Feet	(m)	Feet	(m)	304		316		Feet	(m)
25	(13.9)	512	(156.0)	260	(79.2)	347	(105.7)	379	(115.5)	667	(203.3)
50	(27.8)	256	(78.0)	130	(39.6)	174	(53.0)	189	(57.6)	333	(101.5)
75	(41.7)	171	(52.1)	87	(26.5)	116	(35.4)	126	(38.4)	222	(67.6)
100	(55.6)	128	(39.0)	65	(19.8)	87	(26.5)	95	(29.0)	167	(50.9)
125	(69.4)	102	(31.1)	52	(15.8)	69	(21.0)	76	(23.2)	133	(40.5)
150	(83.3)	85	(25.9)	43	(13.1)	58	(17.7)	63	(19.2)	111	(33.8)
175	(97.2)	73	(22.2)	37	(11.3)	50	(15.2)	54	(16.4)	95	(28.9)

For a 100°F differential (winter to summer), a steel cable tray will require an expansion joint every 128 feet and an aluminum cable tray every 65 feet. The temperature at the time of installation will dictate the gap setting.

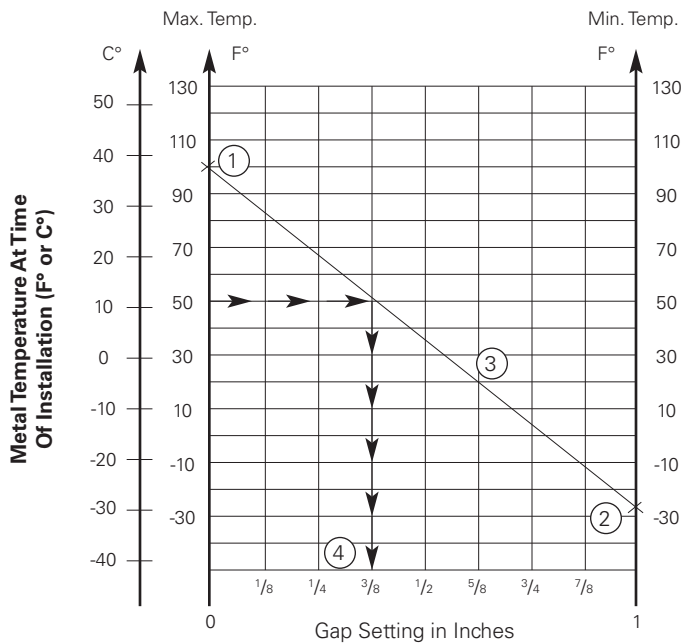

Figure 4.13B
Gap Setting Of Expansion Splice Plate
1" (25.4 mm) Gap Maximum

The Gap

Setting of the Expansion Joint Splice Plate is used as follows per the example indicated in VE-2 Figure 4.13B.

Step 1. Plot the highest expected cable tray metal temperature during the year on the maximum temperature vertical axis. Example's Value: 100 Degrees F.

Step 2. Plot the lowest expected cable tray metal temperature during the year on the minimum temperature vertical axes. Example's Value: - 28 Degrees F.

Step 3. Draw a line between these maximum and minimum temperature points on the two vertical axis.

Step 4. To determine the required expansion joint gap setting at the time of the cable tray's installation: Plot the cable tray metal temperature at the time of the cable tray installation on the maximum temperature vertical axis (Example's Value: 50 Degrees F). Project over from the 50 Degrees F point on the maximum temperature vertical axis to an intersection with the line between the maximum and minimum cable tray metal temperatures. From this intersection point, project down to the gap setting horizontal axis to find the correct gap setting value (Example's Value: 3/8 inch gap setting). This is the length of the gap to be set between the cable tray sections at the expansion joint.

The plotted High - Low Temperature Range in Figure 4-13B is 128° F. The 125° F line in Table 4-1 shows that installations in these temperature ranges would require 3/8" expansion joints approximately every 102 feet for Steel and every 52 feet for Aluminum cable tray.

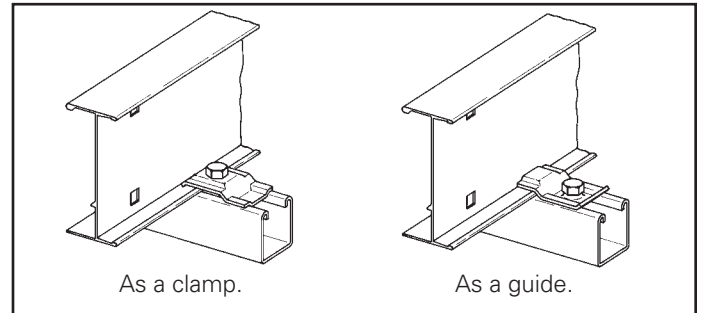

Another item essential to the operation of the cable tray expansion splices is the type of hold down clamps used. The cable tray must not be clamped to each support so firmly that the cable tray cannot contract and expand without distortion. The cable tray needs to be anchored at the support closest to the midpoint between the expansion joints with **hold down clamps** and secured by **expansion guides** at all other support locations. The expansion guides allow the cable tray to slide back and forth as it contracts and expands. Supports must also be located on both sides of an expansion splice. The supports should be located within two feet of the expansion splice to ensure that the splice will operate properly. If these guidelines for cable tray thermal contraction and expansion are not followed, there is the potential for the cable trays to tear loose from their supports, and for the cable trays to bend and collapse.

Appendix Sheet 1	MAN-41
Temperature Rise Tests, Cable Tray Connectors, Class II Aluminum & Steel Ladder Tray	
Appendix Sheet 2	MAN-42
Temperature Rise Tests, Conduit Clamps For Bonding Rigid Conduit To Cable Tray	
Appendix Sheet 3	MAN-43
Example - NEC ® Section 392.22(A)(1)(a)	
Appendix Sheet 4	MAN-44
Example - NEC ® Section 392.22(A)(1)(b)	
Appendix Sheet 5	MAN-45
Example - NEC ® Section 392.22(A)(1)(c)	
Appendix Sheet 6	MAN-46
Example - NEC ® Section 392.22(A)(2)	
Appendix Sheet 7	MAN-47
Table 250.122 Minimum Size EGC for Raceway and Equipment	
Appendix Sheet 8	MAN-48 – MAN-49
Cable Tray Sizing Flowchart	
Appendix Sheet 9	MAN-50 – MAN-51
Cable Tray Installation & Specification Checklist	
Footnotes	MAN-52
Additional Cable Tray Resources and Engineering Software	

TABLE I
TEMPERATURE RISE TESTS, CABLE TRAY CONNECTORS,
CLASS II ALUMINUM LADDER CABLE TRAY

Test Current Amps And Fuse Size*	Test Time Cycles	I ² T mult. by 10 ⁶	Connector Data								
			C1			C2			C3		
			Type Of Connector	No. & Type Bolts	Temp. Rise °C	Type Of Connector	No. & Type Bolts	Temp. Rise °C	Type Of Connector	No. & Type Bolts	Temp. Rise °C
7,900 1,200A Fuse	66	69	Adj. Vert. 1 Bolt**	4 Steel	6	3/0 CU Bond	AL-CU Lugs	18	Rigid Clean	2 Steel	8
7,900 1,200A Fuse	82	85	Rigid Corroded	4 Steel	10	3/0 CU Bond	AL-CU Lugs	22	Rigid Clean	2 Steel	9
12,000	120	288	Rigid Corroded	2 Nylon	50	3/0 CU Bond	AL-CU Lugs	104	Rigid Clean	2 Steel	32
12,000	124	297	Rigid Corroded	4 Steel	40	Rigid Corroded	4 Lugs	46	Rigid Clean	4 Steel	21
34,600	14	280	Rigid Corroded	2 Nylon	34	3/0 CU Bond	AL-CU Lugs	75	Rigid Clean	2 Steel	29
34,400	14	276	Rigid Corroded	4 Nylon	28	Rigid Corroded	4 Steel	35	Rigid Clean	4 Steel	20

TABLE II
TEMPERATURE RISE TESTS, CABLE TRAY CONNECTORS,
CLASS II STEEL LADDER CABLE TRAY

Test Current Amps And Fuse Size*	Test Time Cycles	I ² T mult. by 10 ⁶	Connector Data								
			C1			C2			C3		
			Type Of Connector	No. & Type Bolts	Temp. Rise °C	Type Of Connector	No. & Type Bolts	Temp. Rise °C	Type Of Connector	No. & Type Bolts	Temp. Rise °C
1,980 200A, FU	52	3.4	Adj. Vert. 1 Bolt**	4	2	No. 6 CU Bond	AL-CU Lugs	10	Rigid	2	3
1,970 400A, FU	394	25.5	Adj. Vert. 1 Bolt**	4	9	No. 6 CU Bond	AL-CU Lugs	***	Rigid	2	15
1,960 400A, FU	8100	51.8	Adj. Vert. 1 Bolt**	4	18	Rigid	4	23	Rigid	2	32
12,000	120	288	Adj. Vert. 2 Bolts**	4	94	Adj. Vert. 2 Bolts**	4	89	Rigid	4	81
12,000	123	295	Rigid	4	70	Rigid	4	87	Rigid	4	85
34,000	13	250	Rigid	4	71	Rigid	4	57	Rigid	4	69

* Test current was interrupted in a predetermined time when a fuse was not used.

** 1 or 2 Bolts - Number of bolts installed on the adjustable vertical connector hinge.

*** The No. 6 bonding jumper melted and opened the circuit when protected by 400A fuse.

(See Page MAN-30 - Figure 1 for Temperature Rise Test illustration)

Appendix Sheet 1

Cable Tray Manual

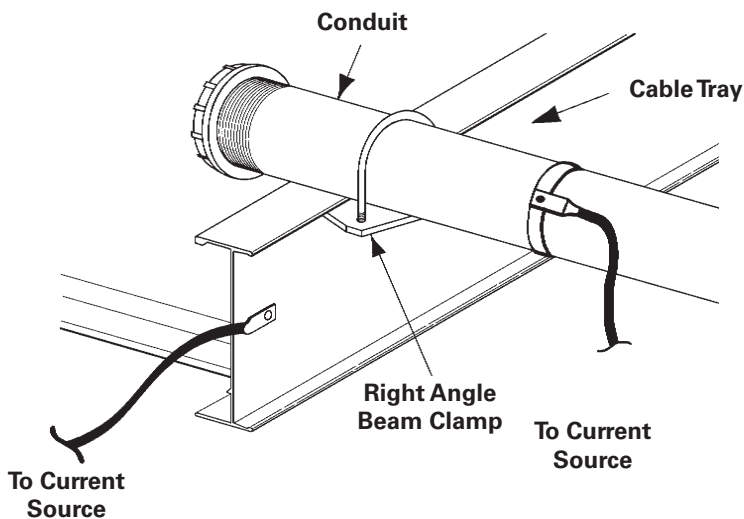

Test Set-Up

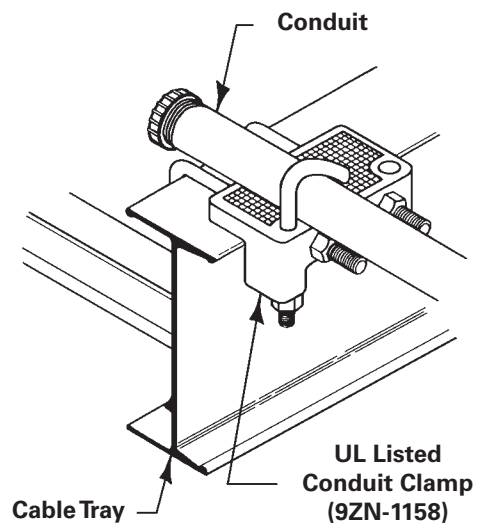

Conduit Clamp Detail

CIRCUIT ARRANGEMENT FOR RIGID CONDUIT TEMPERATURE RISE TESTS

TABLE III
TEMPERATURE RISE TESTS, CONDUIT CLAMPS FOR BONDING RIGID CONDUIT TO CABLE TRAY

Test Current Amperes	Test Time Cycles	I ² T mult. 10 ⁶	Rigid Conduit		Cable Tray		Temp. Rise °C	Condition After Test
			Size	Material	Class	Material		
36,000	16	344.7	4"	Aluminum	II	Aluminum	19	No arcing or damage
20,900	60.5	441.2	4"	Aluminum	II	Aluminum	70	No arcing or damage
12,100	178	433.3	4"	Aluminum	II	Aluminum	74	No arcing or damage
21,000	20	146.8	4"	Steel	II	Steel	(?)	Zinc melted at point where conduit contacted with tray
3,260	900	159.5	4"	Steel	II	Steel	63	No arcing or damage
21,000	30	220	2"	Aluminum	II	Aluminum	21	No arcing or damage
12,100	120.5	294.2	2"	Aluminum	II	Aluminum	59	No arcing or damage
8,000	245	261.1	2"	Aluminum	II	Aluminum	44	No arcing or damage
21,000	14	103.8	2"	Steel	II	Steel	62	Zinc melted at point where conduit contacted with tray
12,000	60.5	145.4	2"	Steel	II	Steel	22	Slight arc between clamp and tray
3,240	600	104.9	2"	Steel	II	Steel	49	No arcing or damage
21,000	20	146.8	1"	Aluminum	II	Aluminum	20	No arcing or damage
12,200	60.5	150.3	1"	Aluminum	II	Aluminum	24	No arcing or damage
12,100	14.5	35.3	1"	Steel	II	Steel	6	No arcing or damage
8,000	63.5	67.84	1"	Steel	II	Steel	59	No arcing or damage
1,980 200A FU	44.5	2.9	1"	Steel	II	Steel	1	No arcing or damage

Appendix Sheet 2

Example - NEC® Section 392.22(A)(1)(a)

Width selection for cable tray containing 600 volt multiconductor cables, sizes #4/0 AWG and larger only. Cable installation is limited to a single layer. The sum of the cable diameters (Sd) must be equal to or less than the usable cable tray width.

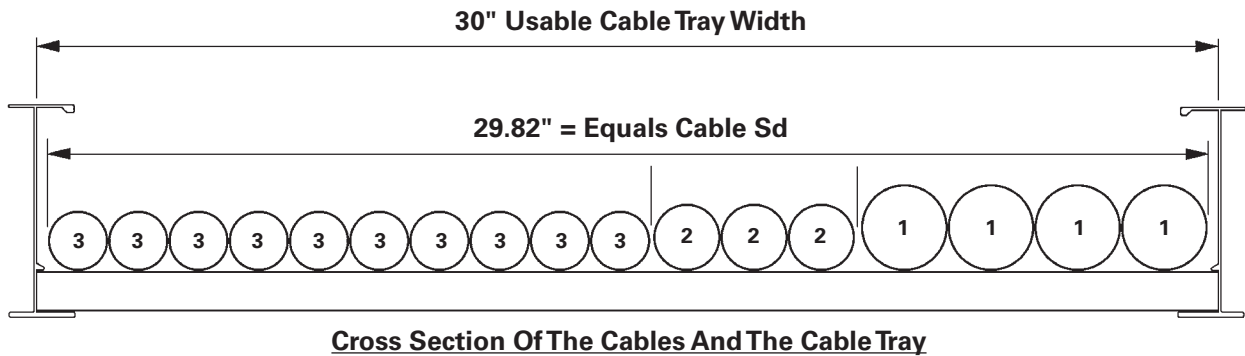

Cable tray width is obtained as follows:

Item Number	List Cable Sizes	(D) List Cable Outside Diameter	(N) List Number of Cables	Multiply (D) x (N) Subtotal of the Sum of the Cables Diameters (Sd)
1.	3/C - #500 kcmil	2.26 inches	4	9.04 inches
2.	3/C - #250 kcmil	1.76 inches	3	5.28 inches
3.	3/C - #4/0 AWG	1.55 inches	10	15.50 inches

The sum of the diameters (Sd) of all cables (Add Sds for items 1, 2, & 3.)

$$9.04 \text{ inches} + 5.28 \text{ inches} + 15.50 \text{ inches} = 29.82 \text{ inches (Sd)}$$

A cable tray with a usable width of 30 inches is required. For a 10% increase in cost a 36 inch wide cable tray could be purchased which would provide for some future cable additions.

Notes:

- The cable sizes used in this example are a random selection.
- Cables - copper conductors with cross linked polyethylene insulation and a PVC jacket. (These cables could be ordered with or without an equipment grounding conductor.)
- Total cable weight per foot for this installation.
61.4 lbs./ft. (without equipment grounding conductors)
69.9 lbs./ft. (with equipment grounding conductors)
This load can be supported by a load symbol "B" cable tray - 75 lbs./ft.

Appendix Sheet 3

Cable Tray Manual

Example - NEC® Section 392.22(A)(1)(b)

Width selection for cable tray containing 600 volt multiconductor cables, sizes #3/0 AWG and smaller. Cable tray allowable fill areas are listed in Column 1 of Table 392.22(A).

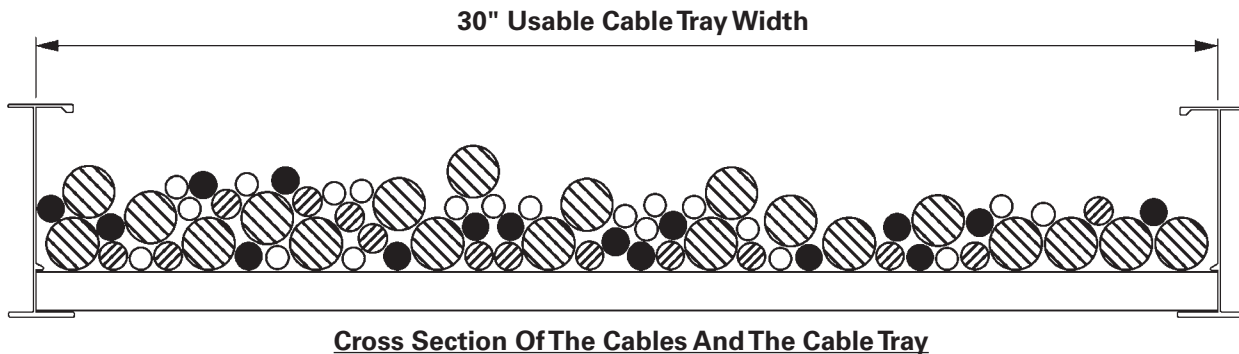

Cable tray width is obtained as follows:

Item Number	List Cable Sizes	(A) List Cable Cross Sectional Areas	(N) List Number of Cables	Multiply (A) x (N) Total of the Cross Sectional Area for Each Item
1.	3/C #12 AWG	0.17 sq. in.	20	3.40 sq. in.
2.	4/C #12 AWG	0.19 sq. in.	16	3.04 sq. in.
3.	3/C #6 AWG	0.43 sq. in.	14	6.02 sq. in.
4.	3/C #2 AWG	0.80 sq. in.	20	16.00 sq. in.

Method 1.

The sum of the total areas for items 1, 2, 3, & 4:

$$3.40 \text{ sq. in.} + 3.04 \text{ sq. in.} + 6.02 \text{ sq. in.} + 16.00 \text{ sq. in.} = 28.46 \text{ sq. inches}$$

From Table 392.9 Column 1 a 30 inch wide tray with an allowable fill area of 35 sq. in. must be used. The 30 inch cable tray has the capacity for additional future cables (6.54 sq. in. additional allowable fill area can be used.)

Method 2.

The sum of the total areas for items 1, 2, 3, & 4 multiplied by

$$\left(\frac{6 \text{ in.}}{7 \text{ sq. in.}} \right) = \text{cable tray width required}$$

$$3.40 \text{ sq. in.} + 3.04 \text{ sq. in.} + 6.02 \text{ sq. in.} + 16.00 \text{ sq. in.} = 28.46 \text{ sq. in.}$$

$$\left(\frac{28.46 \text{ sq. in.} \times 6 \text{ in.}}{7 \text{ sq. in.}} \right) = 24.39 \text{ inch cable tray width required}$$

Use a 30 inch wide cable tray.

Notes:

- The cable sizes used in this example are a random selection.
- Cables - copper conductors with cross linked polyethylene insulation and a PVC jacket. (These cables could be ordered with or without an equipment grounding conductor.)
- Total cable weight per foot for this installation.
31.9 lbs./ft. (Cables in this example do not contain equipment grounding conductors.)
This load can be supported by a load symbol "A" cable tray - 50 lbs./ft.

Appendix Sheet 4

Example - NEC® Section 392.22(A)(1)(c)

Width selection for cable tray containing 600 volt multiconductor cables, sizes #4/0 AWG and larger (single layer required) and #3/0 AWG and smaller. These two groups of cables must have dedicated areas in the cable tray.

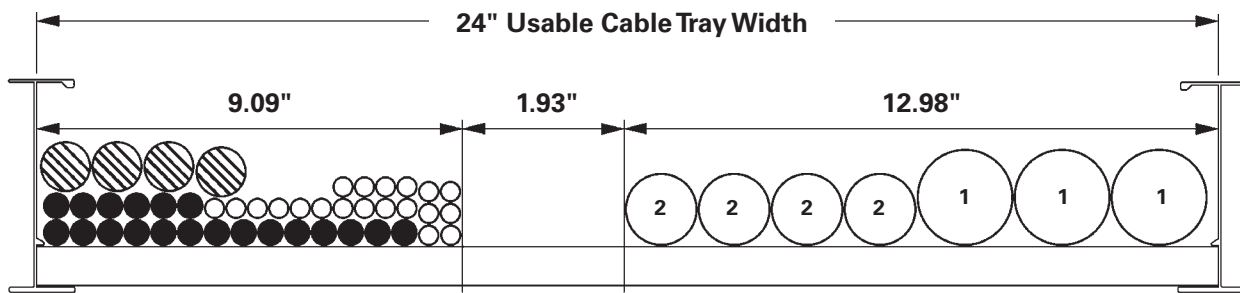

Cross Section Of The Cables And The Cable Tray

Cable tray width is obtained as follows:

A - Width required for #4/0 AWG and larger multiconductor cables -

Item Number	List Cable Sizes	(D) List Cable Outside Diameter	(N) List Number of Cables	Multiply (D) x (N) Subtotal of the Sum of the Cables Diameters (Sd)
1.	3/C - #500 kcmil	2.26 inches	3	6.78 inches
2.	3/C - #4/0 AWG	1.55 inches	4	6.20 inches

Total cable tray width required for items 1 & 2 = 6.78 inches + 6.20 inches = 12.98 inches

B - Width required for #3/0 AWG and smaller multiconductor cables -

Item Number	List Cable Sizes	(A) List Cable Cross Sectional Area	(N) List Number of Cables	Multiply (A) x (N) Total of the Cross Sectional Area For Each Item
3.	3/C #12 AWG	0.17 sq. in.	20	3.40 sq. in.
4.	3/C #10 AWG	0.20 sq. in.	20	4.00 sq. in.
5.	3/C #2 AWG	0.80 sq. in.	4	3.20 sq. in.

Total cable tray width required for items 3, 4, & 5

$$(3.40 \text{ sq. in.} + 4.00 \text{ sq. in.} + 3.20 \text{ sq. in.}) \left(\frac{6 \text{ in.}}{7 \text{ sq. in.}} \right)^1 = (10.6 \text{ sq. in.}) \left(\frac{6 \text{ in.}}{7 \text{ sq. in.}} \right)^1 = 9.09 \text{ inches}$$

Actual cable tray width is A - Width (12.98 in.) + B - Width (9.09 in.) = 22.07 inches

A 24 inch wide cable tray is required. The 24 inch cable tray has the capacity for additional future cables (1.93 inches or 2.25 sq. inches allowable fill can be used).

Notes:

1. This ratio is the inside width of the cable tray in inches divided by its maximum fill area in sq. inches from Column 2 Table 392.22(A).
2. The cable sizes used in this example are a random selection.
3. Cables - copper conductors with cross linked polyethylene insulation and a PVC jacket.
4. Total cable weight per foot for this installation.
40.2 lbs./ft. (Cables in this example do not contain equipment grounding conductors.)
This load can be supported by a load symbol "A" cable tray - 50 lbs./ft.

Appendix Sheet 5

Example - NEC® Section 392.22(A)(2)

Cable Tray containing Type ITC or Type PLTC Cables

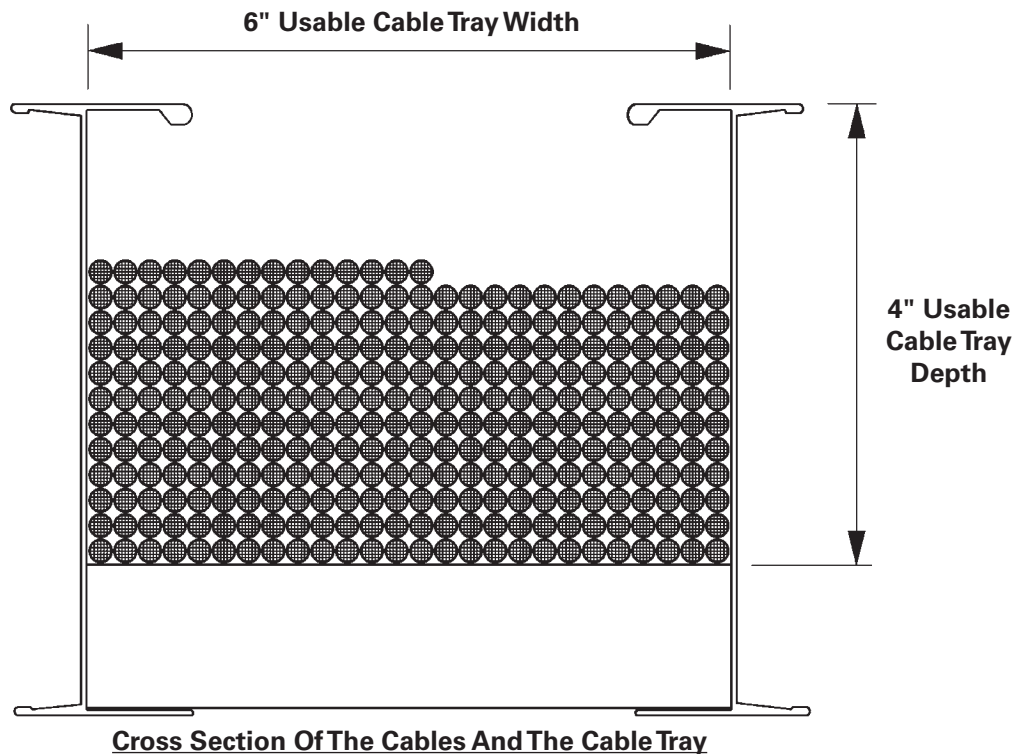

50% of the cable tray useable cross sectional area can contain type PLTC cables

4 inches x 6 inches x .050 = 12 square inches allowable fill area.

2/C - #16 AWG 300 volt shielded instrumentation cable O.D. = 0.224 inches.

Cross Sectional Area = 0.04 square inches.

$$\frac{12 \text{ sq. in.}}{0.04 \text{ sq. in./cable}} = 300 \text{ cables can be installed in this cable tray.}$$

$$\frac{300 \text{ cables}}{26 \text{ cables/rows}} = 11.54 \text{ rows can be installed in this cable tray.}$$

Notes:

1. The cable sizes used in this example are a random selection.
2. Cables - copper conductors with PVC insulation, aluminum/mylar shielding, and PVC jacket.

Table 250.122. Minimum Size Equipment Grounding Conductors for Grounding Raceways and Equipment

Rating or Setting of Automatic Overcurrent Device in Circuit Ahead of Equipment, Conduit, etc., Not Exceeding (Amperes)	Size (AWG or kcmil)	
	Copper	Aluminum or Copper-Clad Aluminum*
15	14	12
20	12	10
60	10	8
100	8	6
200	6	4
300	4	2
400	3	1
500	2	1/0
600	1	2/0
800	1/0	3/0
1000	2/0	4/0
1200	3/0	250
1600	4/0	350
2000	250	400
2500	350	600
3000	400	600
4000	500	750
5000	700	1200
6000	800	1200

Reproduced with permission from NFPA 70-2011, National Electrical Code®, Copyright © 2010, National Fire Protection Association, Quincy, MA. This reprinted material is not the complete and official position of the NFPA on the referenced subject, which is represented only by the standard in its entirety.

Appendix Sheet 7

CABLE TRAY SIZING FLOWCHART

Sizing Cable Tray Per NEC 392

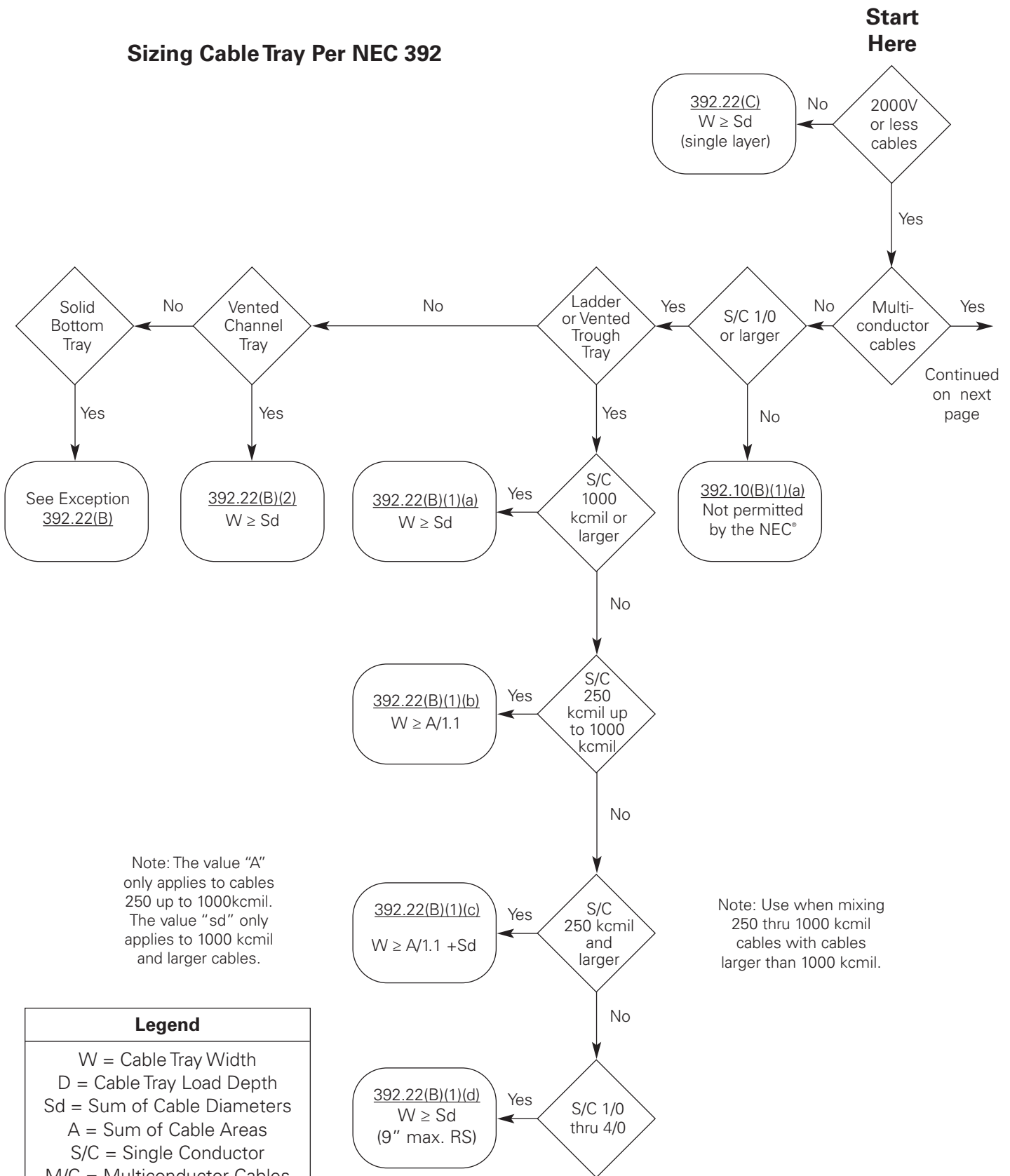

Legend

W = Cable Tray Width
 D = Cable Tray Load Depth
 Sd = Sum of Cable Diameters
 A = Sum of Cable Areas
 S/C = Single Conductor
 M/C = Multiconductor Cables
 RS = Ladder Rung Spacing

Appendix Sheet 8

CABLE TRAY SIZING FLOWCHART

Ampacity: See pages MAN-28 – MAN-30 for information on cable ampacity that might affect the cable tray sizing flowchart.

See pages MAN-9 – MAN-12 for information on hazardous (classified) areas that might affect the cable tray sizing flowchart.

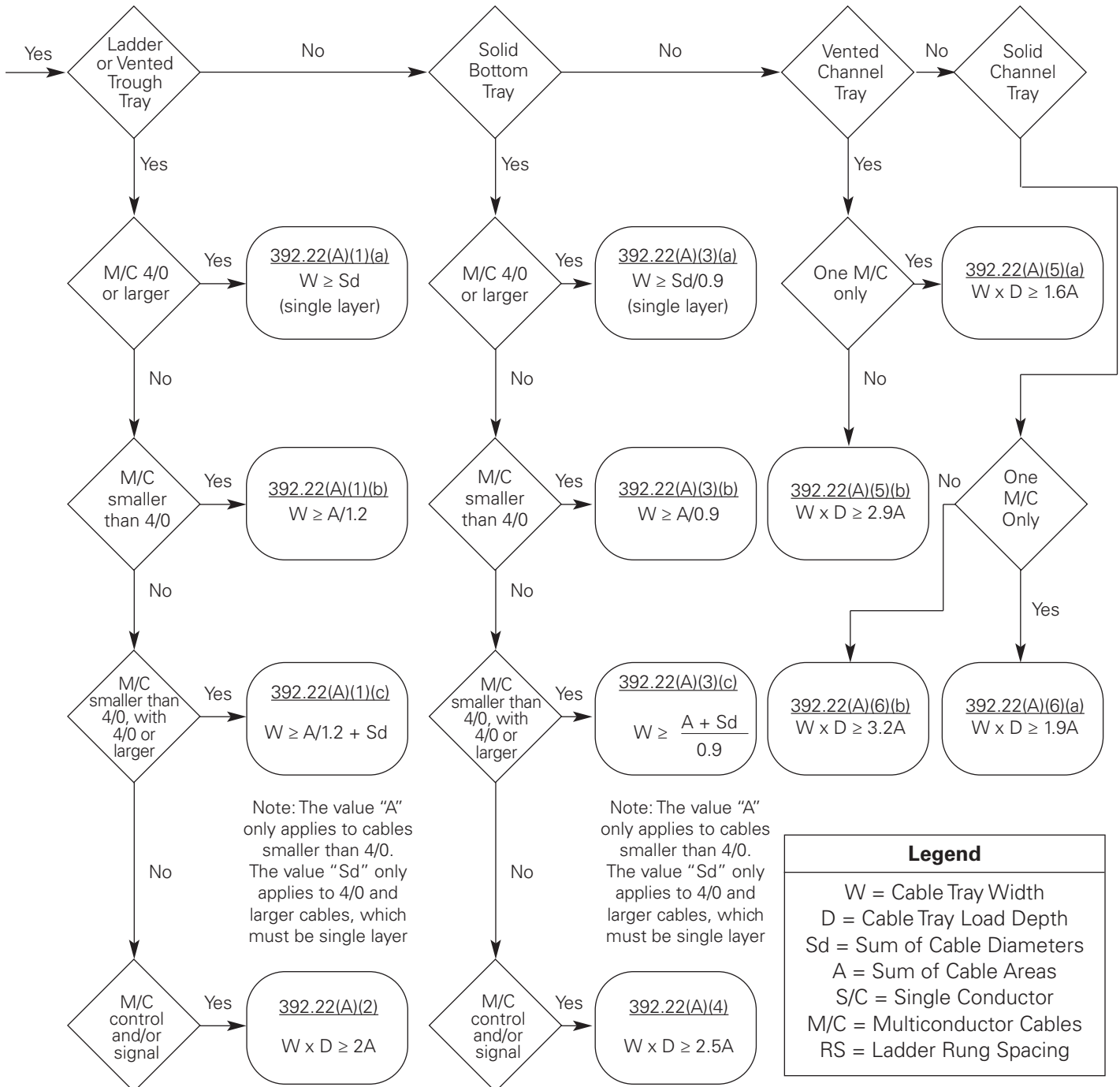

Appendix Sheet 8

Cable Tray Manual

CABLE TRAY INSTALLATION & SPECIFICATION CHECKLIST

Project Information

Project Name: _____ # _____
 Location: _____
 Contractor/Engineer: _____
 Phone: _____

Project Information

Distributor Name: _____
 Location: _____
 Contact: _____
 Phone: _____ Fax: _____

Cable Tray

<u>Material</u>		<u>NEMA Load Depth*</u>	
Aluminum	<input type="checkbox"/>	2" **	<input type="checkbox"/>
Pre-Galvanized Steel	<input type="checkbox"/>	3"	<input type="checkbox"/>
Hot-Dip Galvanized Steel	<input type="checkbox"/>	4"	<input type="checkbox"/>
304 Stainless Steel	<input type="checkbox"/>	5"	<input type="checkbox"/>
316 Stainless Steel	<input type="checkbox"/>	6"	<input type="checkbox"/>
Fiberglass-Polyester Resin	<input type="checkbox"/>	* Load depth is 1" less than siderail height.	
Fiberglass-Vinyl Ester Resin	<input type="checkbox"/>	** Fiberglass and wire mesh.	
Fiberglass-Zero Halogen	<input type="checkbox"/>		
Fiberglass-Dis Stat	<input type="checkbox"/>		

<u>Width</u>	<u>Bottom Styles</u>	<u>Length</u>	<u>Fitting Radius</u>
6" <input type="checkbox"/>	6" <input type="checkbox"/>	<u>Metallic</u>	12" <input type="checkbox"/>
9" <input type="checkbox"/>	9" <input type="checkbox"/>	120" <input type="checkbox"/>	24" <input type="checkbox"/>
12" <input type="checkbox"/>	12" <input type="checkbox"/>	144" <input type="checkbox"/>	36" <input type="checkbox"/>
18" <input type="checkbox"/>	18" <input type="checkbox"/>	240" <input type="checkbox"/>	48" <input type="checkbox"/>
24" <input type="checkbox"/>	Ventilated Trough <input type="checkbox"/>	288" <input type="checkbox"/>	
30" <input type="checkbox"/>	Non-Ventilated Trough <input type="checkbox"/>		
36" <input type="checkbox"/>	Non-Ventilated Bottom <input type="checkbox"/>	<u>Non-Metallic</u>	
42" <input type="checkbox"/>		120" <input type="checkbox"/>	
		240" <input type="checkbox"/>	

Tray Series

B-Line series _____ OR _____

System Loading

(50 lbs./ft.)
 (75 lbs./ft.)
 (100 lbs./ft.)

Support Span _____ ft.
 Load Rating _____ lbs./ft.
 Safety Factor _____

CABLE TRAY INSTALLATION & SPECIFICATION CHECKLIST

Cable Channel

<u>Material</u>		<u>Width</u>	
Aluminum	<input type="checkbox"/>	3"	<input type="checkbox"/>
Pre-Galvanized Steel	<input type="checkbox"/>	4"	<input type="checkbox"/>
Hot-Dip Galvanized Steel	<input type="checkbox"/>	6"	<input type="checkbox"/>
304 Stainless Steel	<input type="checkbox"/>	8" *	<input type="checkbox"/>
316 Stainless Steel	<input type="checkbox"/>	* Fiberglass only.	
Fiberglass-Polyester Resin	<input type="checkbox"/>	<u>Fitting Radius</u>	
Fiberglass-Vinyl Ester Resin	<input type="checkbox"/>	0"	<input type="checkbox"/>
Fiberglass-Zero Halogen	<input type="checkbox"/>	12"	<input type="checkbox"/>
Fiberglass-Dis Stat	<input type="checkbox"/>	24"	<input type="checkbox"/>
<u>Type</u>		36"	<input type="checkbox"/>
Ventilated	<input type="checkbox"/>		
Non-Ventilated	<input type="checkbox"/>		

KwikSplice™

<u>Material</u>		<u>Depth*</u>	
Aluminum	<input type="checkbox"/>	3"	<input type="checkbox"/>
		4"	<input type="checkbox"/>
		5"	<input type="checkbox"/>
<u>Width*</u>	<u>Rung Spacing*</u>	<u>Length</u>	<u>Fitting Radius</u>
6" <input type="checkbox"/>	<u>Ladder</u>	120" <input type="checkbox"/>	12" <input type="checkbox"/>
9" <input type="checkbox"/>	6" <input type="checkbox"/>	144" <input type="checkbox"/>	24" <input type="checkbox"/>
12" <input type="checkbox"/>	9" <input type="checkbox"/>		
18" <input type="checkbox"/>	12" <input type="checkbox"/>		
24" <input type="checkbox"/>	<u>Trough</u>	<u>System Loading</u>	
30" <input type="checkbox"/>	4" Rung Spacing <input type="checkbox"/>	(50 lbs./ft.)	<input type="checkbox"/>
36" <input type="checkbox"/>	Solid Bottom <input type="checkbox"/>	(75 lbs./ft.)	<input type="checkbox"/>

* Options shown are not available for all systems. Please check B-Line Kwik-Splice Catalog section for availability.

FLEXTRAY™

<u>Width*</u>	<u>Depth*</u>	<u>Wire Mesh Size</u>	<u>Length</u>
2" <input type="checkbox"/>	1.5" <input type="checkbox"/>	2 x 4	118" (3 meters)
4" <input type="checkbox"/>	2" <input type="checkbox"/>		
6" <input type="checkbox"/>	4" <input type="checkbox"/>		
8" <input type="checkbox"/>	6" <input type="checkbox"/>		
12" <input type="checkbox"/>	* Widths shown are not available for all depths.		
16" <input type="checkbox"/>			
18" <input type="checkbox"/>			
20" <input type="checkbox"/>			
24" <input type="checkbox"/>			
30" <input type="checkbox"/>			
32" <input type="checkbox"/>			

Appendix Sheet 9

Footnotes:

¹NEMA Standard VE-2, Section 4, Installation 4.3 Straight Section Installation - 4.3.1. Horizontal Cable Tray Straight Sections states that straight section lengths should be equal to or greater than the span length to ensure not more than one splice between supports.

Additional Cable Tray Resources

Cable Tray Institute
1300 N. 17th Street
Rosslyn, VA 22209
www.cabletrays.com

National Electrical Manufacturers Association
1300 N. 17th Street
Rosslyn, VA 22209
www.nema.org

Engineering Software

Eaton's B-Line series TrayCAD™ Software

TrayCAD is a Cable Tray layout design program that works within the AutoCAD® environment. TrayCAD is a windows based program and installs as an add-on to your AutoCAD system. Use the TrayCAD toolbar to add cable tray to your existing plans by drawing a single 3D representation of the tray run. Then, with the click of a button, the program will build a full-scale 3-D wire-frame model of the cable tray and all the appropriate fittings. The program also automatically creates a Bill of Material and contains a library of modifiable details.

CoSPEC Specifier Center

CoSPEC (CoSPEC Specifier Center) is designed to help you easily select, view, and download Eaton's B-Line series design content in any one of nearly one hundred non-proprietary and proprietary CAD, BIM, PDMS, and graphic formats, which helps speed the integration of the content into your design project..

B-Line Wire Management Resources

Eaton B-Line series Product Lines

- Cable Tray Systems
Metallic, Two Siderail System
Commercial and Industrial Applications
- Fiberglass Cable Tray
Non-Metallic, Two Siderail Trays
Non-Metallic Strut Systems
- REDI-RAIL™
Pre-Punched Aluminum Side Rail Design
Unmatched Job Site Adaptability for a Two
Side Rail System - Load Depths 3" to 6"
- KwikSplice™
Patent Pending Aluminum Side Rail Design
Splice retention groove allows for two-bolt
splice connection
Load Depths 3" to 5"
- FLEXTRAY™
Unmatched Adaptability to Site Conditions
Pre-Packaged Installation Kits and Accessories
Fast - Adaptable - Economical

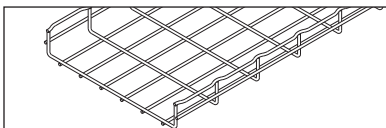
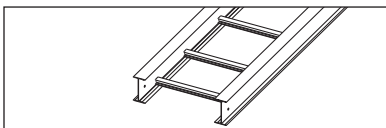
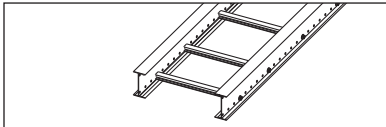
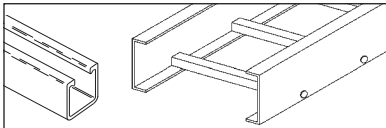
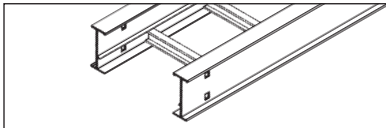

Other Wire Management Systems

- Telecom
Cable Runway, Relay Racks, and
Unequal Flange Racks
- Cable Hooks
Supports all Cat 5, Fiber Optic, Innerduct
and Low Voltage Cabling Requirements
- Wireway
Houses Runs of Control and Power Cable
Available in NEMA 12, Type 1 & Type 3R

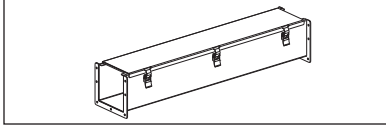
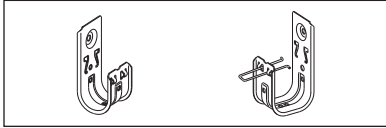
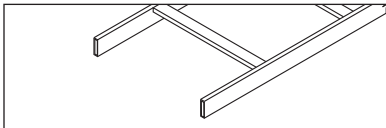

Mechanical Support Systems

- Strut Systems
Metal Framing Support System. Fully Adjustable
and Reusable, with a Complete Line of Channel,
Fittings and Accessories for Multi-Purpose Applications
- Tolco™ Seismic Restraints
Multi-Directional Bracing for Electrical Conduit,
Cable Tray and Mechanical Piping Systems.
OSHPD Pre-Approved Details

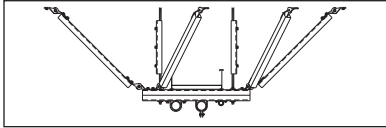
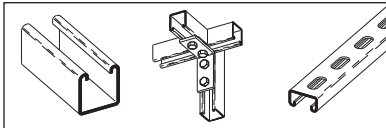

Index - Straight Sections

Index

Cable Tray Straight Sections

Catalog No.	Page	Catalog No.	Page	Catalog No.	Page
<p>REDI-RAIL™ only Example: RSI 06A 09 SL - 12 - 120</p> <p>① Series ④ Straight Ladder ② Height/Material ⑤ Width ③ Rung Spacing/Bottom ⑥ Length</p>		<p>Aluminum Example: 24 A 12 - 24 - 144</p> <p>① Series ④ Width ② Material ⑤ Length ③ Rung Spacing</p>		<p>Series 2, 3, 4, & 5 Steel Cable Tray</p> <p>248 G ③-④-⑤ J-3 & J-4 248 P ③-④-⑤ J-3 & J-4 258 G ③-④-⑤ J-5 & J-6 258 P ③-④-⑤ J-5 & J-6 268 G ③-④-⑤ J-7 & J-8 268 P ③-④-⑤ J-7 & J-8 346 G ③-④-⑤ J-3 & J-4 346 P ③-④-⑤ J-3 & J-4 356 G ③-④-⑤ J-5 & J-6 356 P ③-④-⑤ J-5 & J-6 366 G ③-④-⑤ J-7 & J-8 366 P ③-④-⑤ J-7 & J-8 378 G ③-④-⑤ J-9 & J-10 378 P ③-④-⑤ J-9 & J-10 444 G ③-④-⑤ J-3 & J-4 444 P ③-④-⑤ J-3 & J-4 454 G ③-④-⑤ J-5 & J-6 454 P ③-④-⑤ J-5 & J-6 464 G ③-④-⑤ J-7 & J-8 464 P ③-④-⑤ J-7 & J-8 476 G ③-④-⑤ J-9 & J-10 476 P ③-④-⑤ J-9 & J-10 574 G ③-④-⑤ J-9 & J-10 574 P ③-④-⑤ J-9 & J-10 G = Hot Dipped Galvanized Steel P = Pre-Galvanized Steel</p>	
<p>REDI-RAIL™ Aluminum Cable Tray</p> <p>RSI04A ③ SL-⑤-⑥ F-3 RSI05A ③ SL-⑤-⑥ F-3 RSI06A ③ SL-⑤-⑥ F-4 RSI07A ③ SL-⑤-⑥ F-4 A = Aluminum</p>		<p>Series 2, 3, 4, & 5 Aluminum Cable Tray</p> <p>24A ③-④-⑤ I-3 & I-4 25A ③-④-⑤ I-5 & I-6 26A ③-④-⑤ I-7 & I-8 34A ③-④-⑤ I-3 & I-4 35A ③-④-⑤ I-5 & I-6 36A ③-④-⑤ I-7 & I-8 37A ③-④-⑤ I-9 & I-10 46A ③-④-⑤ I-7 & I-8 47A ③-④-⑤ I-9 & I-10 57A ③-④-⑤ I-9 & I-10 H46A ③-④-⑤ I-7 & I-8 H47A ③-④-⑤ I-9 & I-10 S8A ③-④-⑤ I-11 A = Aluminum</p>			
<p>KwikSplice™ only Example: KS A 4 A 09 - 12 - 144</p> <p>① Series ⑤ Rung Type ② NEMA Class ⑥ Width ③ Height ⑦ Length ④ Material</p>		<p>Steel, Stainless Steel Example: 148 * 12 - 24 - 144</p> <p>① Series ④ Width ② Material ⑤ Length ③ Rung Spacing</p>			
<p>KwikSplice™ Aluminum Cable Tray</p> <p>KSA ③A ⑤-⑥-⑦ G-3 & G-4 KSB ③A ⑤-⑥-⑦ G-5 & G-6</p>		<p>Series 1 Steel Cable Tray</p> <p>148 G ③-④-⑤ H-3 148 P ③-④-⑤ H-3 156 G ③-④-⑤ H-4 156 P ③-④-⑤ H-4 166 G ③-④-⑤ H-5 166 P ③-④-⑤ H-5 176 G ③-④-⑤ H-6 176 P ③-④-⑤ H-6 G = Hot Dipped Galvanized Steel P = Pre-Galvanized Steel</p>		<p>Series 2, 3, 4, & 5 Stainless Steel Cable Tray</p> <p>348SS4 ③-④-⑤ K-3 348SS6 ③-④-⑤ K-3 358SS4 ③-④-⑤ K-4 358SS6 ③-④-⑤ K-4 368SS4 ③-④-⑤ K-5 368SS6 ③-④-⑤ K-5 464SS4 ③-④-⑤ K-5 464SS6 ③-④-⑤ K-5 SS4 = Stainless Steel 304 SS6 = Stainless Steel 316</p>	

Index - Straight Sections

Index

FLEXTRAY™ Straight Sections					
Catalog No.	Page	Catalog No.	Page	Catalog No.	Page
<p>Example: FT 2 X 12 X 10</p> <p>① ② ③ ④</p> <p>① Flextray ③ Width ② Loading Height ④ Length 118"</p>					
<p>FLEXTRAY™ Straight Sections</p> <p>FT1.5X4X10 D-5 FT1.5X6X10 D-5 FT1.5X8X10 D-5 FT1.5X10X10 D-5 FT2X2X10 D-5 FT2X4X10 D-5 FT2X6X10 D-5 FT2X8X10 D-5 FT2X12X10 D-5 FT2X16X10 D-5 FT2X18X10 D-5 FT2X20X10 D-5 FT2X24X10 D-5 FT2X30X10 D-5 FT2X22X10 D-5 FT4X4X10 D-6 FT4X6X10 D-6 FT4X8X10 D-6 FT4X12X10 D-6 FT4X16X10 D-6 FT4X18X10 D-6 FT4X20X10 D-6 FT4X24X10 D-6 FT4X30X10 D-6 FT6X8X10 D-6 FT6X12X10 D-6 FT6X16X10 D-6 FT6X18X10 D-6 FT6X20X10 D-6 FT6X24X10 D-6</p>					

Cable Tray Fittings

Catalog No.	Page	Catalog No.	Page	Catalog No.	Page
<p>REDI-RAIL™ only Example: RSI 04 A09 HB - 09 - 30 R12</p> <p>① ② ③ ④ ⑤ ⑥ ⑦</p> <p>① Series ④ Fitting Type ② Height ⑤ Width ③ Material/Rung Spacing ⑥ Angle (HB, VI, VO) ⑦ Radius</p>		<p>Aluminum Example: 4 A x - 24 - 90 HB 24</p> <p>① ② ③ ④ ⑤ ⑥ ⑦</p> <p>① Series/Height ④ Width ② Material ⑤ Angle (HB, VI, VO) ③ Bottom ⑥ Type ⑦ Radius</p>		<p>Steel Example: 4 * x - 24 - 90 HB 24</p> <p>① ② ③ ④ ⑤ ⑥ ⑦</p> <p>① Series/Height ④ Width ② Material ⑤ Angle (HB, VI, VO) ③ Bottom ⑥ Type ⑦ Radius</p>	
<p>REDI-RAIL™ Aluminum Cable Tray Fittings</p> <p>RSI ② A09HB-⑥-⑥-⑦ F-20 RSI ② A09HT-⑥-⑦ F-21 – F-23 RSI ② A09HX-⑥-⑦ F-21 & F-24 RSI ② A09VI-⑥-⑥-⑦ F-25 – F-28 RSI ② A09VO-⑥-⑥-⑦ F-25 – F-28 RSI ② A09VTD-⑥-⑦ F-29 RSI ② A09VTU-⑥-⑦ F-29</p> <p>② = Insert 04 for 4", 05 for 5", 06 for 6" or 07 for 7" side rail heights</p>		<p>Series 2, 3, 4, & 5 Aluminum Cable Tray Fittings</p> <p>① A ③-④ CFS ⑦ L-17 ① A ③-④-⑤ HB ⑦ L-4 & L-5 ① A ③-④ HT ⑦ L-6, 8 & L-9 ① A ③-④ HX ⑦ L-6 & L-10 ① A ③-④ HYL L-11 ① A ③-④ HYR L-11 ① A ③-④ LR ⑦ L-7 ① A ③-④ RR ⑦ L-7 ① A ③-④ SR ⑦ L-7 ① A ③-④-⑤ VI ⑦ L-12 – L-15 ① A ③-④-⑤ VO ⑦ L-12 – L-15 ① A ③-④ VT ⑦ L-16 ① A ③-④ VTU ⑦ L-16</p> <p>A = Aluminum ① = Insert 4 for 4", 5 for 5", 6 for 6" or 7 for 7" side rail heights</p>		<p>Series 1 Steel Cable Tray Fittings</p> <p>14G ③-④ VBS ⑦ L-23 1 ① G ③-④-⑤ HB ⑦ L-16 1 ① G ③-④ HT ⑦ L-17 1 ① G ③-④ HX ⑦ L-17 1 ① G ③-④ LR ⑦ L-18 1 ① G ③-④ RR ⑦ L-18 1 ① G ③-④ SR ⑦ L-18 1 ① G ③-④-⑤ VI ⑦ L-19 – L-22 1 ① G ③-④-⑤ VO ⑦ L-19 – L-22</p> <p>14P ③-④ VBS ⑦ L-23 1 ① P ③-④-⑤ HB ⑦ L-16 1 ① P ③-④ HT ⑦ L-17 1 ① P ③-④ HX ⑦ L-17 1 ① P ③-④ LR ⑦ L-18 1 ① P ③-④ RR ⑦ L-18 1 ① P ③-④ SR ⑦ L-18 1 ① P ③-④-⑤ VI ⑦ L-19 – L-22 1 ① P ③-④-⑤ VO ⑦ L-19 – L-22</p> <p>G = Hot-Dipped Galvanized Steel P = Pre-Galvanized Steel ① = Insert 4 for 4", 5 for 5", 6 for 6" or 7 for 7" side rail heights</p>	
<p>KwikSplice™ only Example: KS 4 A 09 - 12 - 90 HB 24</p> <p>① ② ③ ④ ⑤ ⑥ ⑦ ⑧</p> <p>① Series ⑤ Width ② Height ⑥ Angle (HB, VI, VO) ③ Material ⑦ Fitting Type ④ Type ⑧ Radius ⑨ Width (reduced)</p>					
<p>KwikSplice™ Aluminum Cable Tray Fittings</p> <p>KS ② A ④-⑤-⑥ HB ⑧ G-22 & G-23 KS ② A ④-⑤-HT ⑧ G-24, G-26 & G-27 KS ② A ④-⑤-HX ⑧ G-24 & G-28 KS ② A ④-⑤-LR ⑧ G-25 KS ② A ④-⑤-RR ⑧ G-25 KS ② A ④-⑤-SR ⑧ G-25 KS ② A ④-⑤-⑥-VI ⑧ G-29 – G-32 KS ② A ④-⑤-⑥-VO ⑧ G-29 – G-32 KS ② A ④-⑤-VT ⑧ G-33 KS ② A ④-⑤-VTU ⑧ G-33</p> <p>② = Insert 04 for 4", 05 for 5" or 06 for 6" side rail heights</p>					

Index - Fittings

Index

Cable Tray Fittings

Catalog No.	Page	Catalog No.	Page	Catalog No.	Page
<p>Steel Example: 4 * x - 24 - 90 HB 24 ① ② ③ ④ ⑤ ⑥ ⑦</p> <p>① Series/Height ④ Width ② Material ⑤ Angle (HB, VI, VO) ③ Bottom ⑥ Type ⑦ Radius</p>		<p>Stainless Steel Example: 4 * x - 24 - 90 HB 24 ① ② ③ ④ ⑤ ⑥ ⑦</p> <p>① Series/Height ④ Width ② Material ⑤ Angle (HB, VI, VO) ③ Bottom ⑥ Type ⑦ Radius</p>		<p>Fiberglass Example: 4 * x - 24 - 90 HB 24 ① ② ③ ④ ⑤ ⑥ ⑦</p> <p>① Series/Height ④ Width ② Material ⑤ Angle (HB, VI, VO) ③ Bottom ⑥ Type ⑦ Radius</p>	
<p>Series 2, 3, 4, & 5 Steel Cable Tray Fittings</p> <p>① G ③-④ CFS ⑦ L-17 ① G ③-④-⑤ HB ⑦ L-4 & L-5 ① G ③-④ HT ⑦ L-6, L-8 & L-9 ① G ③-④ HX ⑦ L-6 & L-10 ① G ③-④ HYL L-11 ① G ③-④ HYR L-11 ① G ③-④ LR ⑦ L-7 ① G ③-④ RR ⑦ L-7 ① G ③-④ SR ⑦ L-7 ① G ③-④-⑤ VI ⑦ L-12 – L-15 ① G ③-④-⑤ VO ⑦ L-12 – L-15 ① G ③-④ VT ⑦ L-16 ① G ③-④ VTU ⑦ L-16</p> <p>① P ③-④ CFS ⑦ L-17 ① P ③-④-⑤ HB ⑦ L-4 & L-5 ① P ③-④ HT ⑦ L-6, L-8 & L-9 ① P ③-④ HX ⑦ L-6 & L-10 ① P ③-④ HYL L-11 ① P ③-④ HYR L-11 ① P ③-④ LR ⑦ L-7 ① P ③-④ RR ⑦ L-7 ① P ③-④ SR ⑦ L-7 ① P ③-④-⑤ VI ⑦ L-12 – L-15 ① P ③-④-⑤ VO ⑦ L-12 – L-15 ① P ③-④ VT ⑦ L-16 ① P ③-④ VTU ⑦ L-16</p> <p>G = Hot-Dipped Galvanized Steel P = Pre-Galvanized Steel ① = Insert 4 for 4", 5 for 5", 6 for 6" or 7 for 7" side rail heights</p>		<p>Series 2, 3, 4, & 5 Stainless Steel Cable Tray Fittings</p> <p>① SS4 ③-④ CFS ⑦ L-17 ① SS4 ③-④-⑤ HB ⑦ L-4 & L-5 ① SS4 ③-④ HT ⑦ L-6, L-8 & L-9 ① SS4 ③-④ HX ⑦ L-6 & L-10 ① SS4 ③-④ HYL L-11 ① SS4 ③-④ HYR L-11 ① SS4 ③-④ LR ⑦ L-7 ① SS4 ③-④ RR ⑦ L-7 ① SS4 ③-④ SR ⑦ L-7 ① SS4 ③-④-⑤ VI ⑦ L-12 – L-15 ① SS4 ③-④-⑤ VO ⑦ L-12 – L-15 ① SS4 ③-④ VT ⑦ L-16 ① SS4 ③-④ VTU ⑦ L-16</p> <p>① SS6 ③-④ CFS ⑦ L-17 ① SS6 ③-④-⑤ HB ⑦ L-4 & L-5 ① SS6 ③-④ HT ⑦ L-6, L-8 & L-9 ① SS6 ③-④ HX ⑦ L-6 & L-10 ① SS6 ③-④ HYL L-11 ① SS6 ③-④ HYR L-11 ① SS6 ③-④ LR ⑦ L-7 ① SS6 ③-④ RR ⑦ L-7 ① SS6 ③-④ SR ⑦ L-7 ① SS6 ③-④-⑤ VI ⑦ L-12 – L-15 ① SS6 ③-④-⑤ VO ⑦ L-12 – L-15 ① SS6 ③-④ VT ⑦ L-16 ① SS6 ③-④ VTU ⑦ L-16</p> <p>SS4 = Stainless Steel 304 SS6 = Stainless Steel 316 ① = Insert 4 for 4", 5 for 5", 6 for 6" or 7 for 7" side rail heights</p>		<p>Fiberglass Cable Tray Fittings</p> <p>① F-④-⑤ HB ⑦ M-28 & M-29 ① F-④-HT ⑦ M-30, M-33 – M-36 ① F-④-HX ⑦ M-31, M-37 & M-38 ① F-④-LR ⑦ M-32 ① F-④-RR ⑦ M-32 ① F-④-SR ⑦ M-32 ① F-④-⑤ VI ⑦ M-39 – M-42 ① F-④-⑤ VO ⑦ M-39 – M-42 ① F-④-VT ⑦ M-43 & M-44 ① F-④-VTU ⑦ M-43 & M-44</p> <p>① FA-④-⑤ HB ⑦ M-28 & M-29 ① FA-④-HT ⑦ M-30, M-33 – M-36 ① FA-④-HX ⑦ M-31, M-37 & M-38 ① FA-④-LR ⑦ M-32 ① FA-④-RR ⑦ M-32 ① FA-④-SR ⑦ M-32 ① FA-④-⑤ VI ⑦ M-39 – M-42 ① FA-④-⑤ VO ⑦ M-39 – M-42 ① FA-④-VT ⑦ M-43 & M-44 ① FA-④-VTU ⑦ M-43 & M-44</p> <p>① FV-④-⑤ HB ⑦ M-28 & M-29 ① FV-④-HT ⑦ M-30, M-33 – M-36 ① FV-④-HX ⑦ M-31, M-37 & M-38 ① FV-④-LR ⑦ M-32 ① FV-④-RR ⑦ M-32 ① FV-④-SR ⑦ M-32 ① FV-④-⑤ VI ⑦ M-39 – M-42 ① FV-④-⑤ VO ⑦ M-39 – M-42 ① FV-④-VT ⑦ M-43 & M-44 ① FV-④-VTU ⑦ M-43 & M-44</p> <p>F = Polyester Resin, FA = Zero Halogen/Dis-Stat FV = Vinyl Ester Resin ① = Insert 3 for 3", 4 for 4", 6 for 6" or 8 for 8" side rail heights</p>	

Cable Channel Fittings					
Catalog No.	Page	Catalog No.	Page	Catalog No.	Page
<p>Aluminum, Steel, Example: G CC - 04 - 45 VI 12</p> <p>① ② ③ ④ ⑤ ⑥</p> <p>① Material ④ Angle ② Series ⑤ Type (HB, VI, VO) ③ Width ⑥ Radius</p>		<p>Stainless Steel Example: SS4 CC - 04 - 45 VI 12</p> <p>① ② ③ ④ ⑤ ⑥</p> <p>① Material ④ Angle ② Series ⑤ Type (HB, VI, VO) ③ Width ⑥ Radius</p>		<p>Fiberglass Example: SS4 CC - 04 - 45 VI 12</p> <p>① ② ③ ④ ⑤ ⑥</p> <p>① Material ④ Angle ② Series ⑤ Type (HB, VI, VO) ③ Width ⑥ Radius</p>	
<p>Aluminum Cable Channel Fittings</p> <p>ACC-③-④ HB⑥ E-11 & E-12 ACC-③-④ HC⑥ E-9 ACC-③ HT⑥ E-13 ACC-③ HTC⑥ E-9 ACC-③ HX⑥ E-13 ACC-③ HXC⑥ E-9 ACC-③ PC⑥ E-9 ACC-③-④ VC⑥ E-9 ACC-③-④ VI⑥ E-16 & E-17 ACC-③-④ VO⑥ E-14 & E-15 ACCN-③-④ HB⑥ ... E-11 & E-12 ACCN-③ HT⑥ E-13 ACCN-③ HX⑥ E-13 ACCN-③-④ VI⑥ E-16 & E-17 ACCN-③-④ VO⑥ ... E-14 & E-15 A = Aluminum</p>		<p>Stainless Steel Cable Channel Fittings</p> <p>SS4CC-③-④ HB⑥ .. CCT-9 & 10 SS4CC-③ HT⑥ CCT-11 SS4CC-③ HX⑥ CCT-11 SS4CC-③-④ VI⑥ ... CCT-14 & 15 SS4CC-③-④ VO⑥ ... CCT-12 & 13 SS4CCN-③-④ HB⑥ .. CCT-9 & 10 SS4CCN-③ HT⑥ CCT-11 SS4CCN-③ HX⑥ CCT-11 SS4CCN-③-④ VI⑥ ... CCT-14 & 15 SS4CCN-③-④ VO⑥ ... CCT-12 & 13 SS6CC-③-④ HB⑥ .. CCT-9 & 10 SS6CC-③ HT⑥ CCT-11 SS6CC-③ HX⑥ CCT-11 SS6CC-③-④ VI⑥ ... CCT-14 & 15 SS6CC-③-④ VO⑥ ... CCT-12 & 13 SS6CCN-③-④ HB⑥ .. CCT-9 & 10 SS6CCN-③ HT⑥ CCT-11 SS6CCN-③ HX⑥ CCT-11 SS6CCN-③-④ VI⑥ ... CCT-14 & 15 SS6CCN-③-④ VO⑥ ... CCT-12 & 13 SS4 = Stainless Steel 304 SS6 = Stainless Steel 316</p>		<p>Fiberglass Cable Channel Fittings</p> <p>FCC(†)N-(xx)-45HB12 M-49 FCC(†)N-(xx)-90HB12 M-49 FCC(†)N-(xx)-HT12 M-49 FCC(†)N-(xx)-HX12 M-49 FCC(†)N-(xx)-45VI12 M-49 FCC(†)N-(xx)-45VO12 M-49 FCC(†)N-(xx)-90VI12 M-49 FCC(†)N-(xx)-90VO12 M-49 (†) For Polyester Resin leave blank FA = Zero Halogen/Dis-Stat For Vinyl Ester Resin insert V (xx) = Insert 03 for 3", 04 for 4", 06 for 6" or 08 for 8" side rail heights</p>	
<p>Steel Cable Channel Fittings</p> <p>GCC-③-④ HB⑥ E-11 & E-12 GCC-③-④ HC⑥ E-9 GCC-③ HT⑥ E-13 GCC-③ HTC⑥ E-9 GCC-③ HX⑥ E-13 GCC-③ HXC⑥ E-9 GCC-③ PC⑥ E-9 GCC-③-④ VC⑥ E-9 GCC-③-④ VI⑥ E-16 & E-17 GCC-③-④ VO⑥ E-14 & E-15 GCCN-③-④ HB⑥ ... E-11 & E-12 GCCN-③ HT⑥ E-13 GCCN-③ HX⑥ E-13 GCCN-③-④ VI⑥ E-16 & E-17 GCCN-③-④ VO⑥ ... E-14 & E-15 G = Hot-Dipped Galvanized Steel Note: Not available in Pre-Galvanized</p>					

Cable Tray Covers

Catalog No.	Page	Catalog No.	Page	Catalog No.	Page
<p>REDI-RAIL™ only Example: 867 A SL - 12 - 72</p> <p>① Series ③ Straight Ladder ② Material ④ Width ⑤ Length</p>		<p>Aluminum Example: Example: 801 * 40 - 24 - 144</p> <p>① Series ④ Width ② Material ⑤ Length or Fitting Type ③ Thickness</p>		<p>Steel Series 2, 3, 4, 5 Example: Example: 801 * 20 - 24 - 144</p> <p>① Series ④ Width ② Material ⑤ Length or Fitting Type ③ Thickness</p>	
<p>REDI-RAIL™ Aluminum Cable Tray Covers</p> <p>867A 40SL-④-⑤ F-12 877A 40SL-④-⑤ F-12</p> <p>A = Aluminum</p> <p>Contact B-Line Engineering for fitting cover information. See page F-12 for fitting cover examples.</p>		<p>Series 2, 3, 4, & 5 Aluminum Cable Tray Covers</p> <p>806 A 40-④-⑤ I-24 807 A 40-④-⑤ I-24 816 A 40-④-⑤ I-24 817 A 40-④-⑤ I-24 826 A 40-④-⑤ I-24 827 A 40-④-⑤ I-24</p> <p>A = Aluminum</p> <p>Contact B-Line Engineering for fitting cover information. See page I-24 for fitting cover examples.</p>		<p>Series 2, 3, 4, & 5 Steel Cable Tray Covers</p> <p>802 G 18-④-⑤ J-20 802 P 20-④-⑤ J-20 803 G 18-④-⑤ J-20 803 P 20-④-⑤ J-20 804 G 18-④-⑤ J-20 804 P 20-④-⑤ J-20 812 G 18-④-⑤ J-20 812 P 20-④-⑤ J-20 813 G 18-④-⑤ J-20 813 P 20-④-⑤ J-20 814 G 18-④-⑤ J-20 814 P 20-④-⑤ J-20 822 G 18-④-⑤ J-20 822 P 20-④-⑤ J-20 823 G 18-④-⑤ J-20 823 P 20-④-⑤ J-20 824 G 18-④-⑤ J-20 824 P 20-④-⑤ J-20</p> <p>G = Hot Dipped Galvanized Steel P = Pre-Galvanized Steel</p> <p>Contact B-Line Engineering for fitting cover information. See page J-20 for fitting cover examples.</p>	
<p>KwikSplice™ Aluminum Example: 807 A - 24 - 144</p> <p>① Series & Detail ③ Width ② Material ④ Length or Fitting Type</p>		<p>Steel Series 1 Example: Example: 801 * 20 - 24 - 144</p> <p>① Series ④ Width ② Material ⑤ Length or Fitting Type ③ Thickness</p>			
<p>KwikSplice™ Aluminum Cable Tray Covers</p> <p>806 A-④-⑤ G-13 807 A-④-⑤ G-13 816 A-④-⑤ G-13 817 A-④-⑤ G-13 826 A-④-⑤ G-13 827 A-④-⑤ G-13</p> <p>A = Aluminum</p> <p>Contact B-Line Engineering for fitting cover information. See page G-13 for fitting cover examples.</p>		<p>Series 1 Steel Cable Tray Covers</p> <p>801 G 18-④-⑤ H-15 801 P 20-④-⑤ H-15 809 G 18-④-⑤ H-15 809 P 20-④-⑤ H-15 811 G 18-④-⑤ H-15 811 P 20-④-⑤ H-15 819 G 18-④-⑤ H-15 819 P 20-④-⑤ H-15</p> <p>G = Hot Dipped Galvanized Steel P = Pre-Galvanized Steel</p> <p>Contact B-Line Engineering for fitting cover information. See page H-15 for fitting cover examples.</p>			

Cable Tray Covers		Cable Channel Covers																																																																																	
Catalog No.	Page	Catalog No.	Page																																																																																
<p style="margin: 0;">Stainless Steel Example: Example: 802 * 20 - 24 - 144</p> <p style="margin: 0; font-size: small;"> ① Series ④ Width ② Material ⑤ Length or Fitting Type ③ Thickness </p>		<p style="margin: 0;">Fiberglass Example: Example: F C - 24 - 144</p> <p style="margin: 0; font-size: small;"> ① Material ③ Width ② Rail Design ④ Length or Fitting Type </p>		<p style="margin: 0;">Aluminum, Steel, Stainless Steel Example: Example: 808 * - 04 - 120</p> <p style="margin: 0; font-size: small;"> ① Series ③ Width ② Material ④ Length or Fitting Type </p>																																																																															
<p style="text-align: center;">Series 2, 3, 4, & 5 Stainless Steel Cable Tray Covers</p> <table style="width: 100%; border-collapse: collapse;"> <tr><td>802 SS4 20-④-⑤</td><td>.....</td><td>K-16</td></tr> <tr><td>802 SS6 20-④-⑤</td><td>.....</td><td>K-16</td></tr> <tr><td>803 SS4 20-④-⑤</td><td>.....</td><td>K-16</td></tr> <tr><td>803 SS6 20-④-⑤</td><td>.....</td><td>K-16</td></tr> <tr><td>804 SS4 20-④-⑤</td><td>.....</td><td>K-16</td></tr> <tr><td>804 SS6 20-④-⑤</td><td>.....</td><td>K-16</td></tr> <tr><td>812 SS4 20-④-⑤</td><td>.....</td><td>K-16</td></tr> <tr><td>812 SS6 20-④-⑤</td><td>.....</td><td>K-16</td></tr> <tr><td>813 SS4 20-④-⑤</td><td>.....</td><td>K-16</td></tr> <tr><td>813 SS6 20-④-⑤</td><td>.....</td><td>K-16</td></tr> <tr><td>814 SS4 20-④-⑤</td><td>.....</td><td>K-16</td></tr> <tr><td>814 SS6 20-④-⑤</td><td>.....</td><td>K-16</td></tr> <tr><td>822 SS4 20-④-⑤</td><td>.....</td><td>K-16</td></tr> <tr><td>822 SS6 20-④-⑤</td><td>.....</td><td>K-16</td></tr> <tr><td>823 SS4 20-④-⑤</td><td>.....</td><td>K-16</td></tr> <tr><td>823 SS6 20-④-⑤</td><td>.....</td><td>K-16</td></tr> <tr><td>824 SS4 20-④-⑤</td><td>.....</td><td>K-16</td></tr> <tr><td>824 SS6 20-④-⑤</td><td>.....</td><td>K-16</td></tr> </table> <p style="font-size: small;">SS4 = Stainless Steel 304 SS6 = Stainless Steel 316 Contact B-Line Engineering for fitting cover information. See page K-16 for fitting cover examples.</p>		802 SS4 20-④-⑤	K-16	802 SS6 20-④-⑤	K-16	803 SS4 20-④-⑤	K-16	803 SS6 20-④-⑤	K-16	804 SS4 20-④-⑤	K-16	804 SS6 20-④-⑤	K-16	812 SS4 20-④-⑤	K-16	812 SS6 20-④-⑤	K-16	813 SS4 20-④-⑤	K-16	813 SS6 20-④-⑤	K-16	814 SS4 20-④-⑤	K-16	814 SS6 20-④-⑤	K-16	822 SS4 20-④-⑤	K-16	822 SS6 20-④-⑤	K-16	823 SS4 20-④-⑤	K-16	823 SS6 20-④-⑤	K-16	824 SS4 20-④-⑤	K-16	824 SS6 20-④-⑤	K-16	<p style="text-align: center;">Fiberglass Cable Tray Covers</p> <table style="width: 100%; border-collapse: collapse;"> <tr><td>F-C-④-⑤</td><td>.....</td><td>M-45</td></tr> <tr><td>FA-C-④-⑤</td><td>.....</td><td>M-45</td></tr> <tr><td>FAP-C-④-⑤</td><td>.....</td><td>M-45</td></tr> <tr><td>FP-C-④-⑤</td><td>.....</td><td>M-45</td></tr> <tr><td>FV-C-④-⑤</td><td>.....</td><td>M-45</td></tr> <tr><td>FVP-C-④-⑤</td><td>.....</td><td>M-45</td></tr> </table> <p style="font-size: small;">F = Polyester Resin FA = Zero Halogen/Dis-Stat FV = Vinyl Ester Resin C = Cover Covers are flat unless a P is added to part number P = Peaked Contact B-Line Engineering for fitting cover information.</p>		F-C-④-⑤	M-45	FA-C-④-⑤	M-45	FAP-C-④-⑤	M-45	FP-C-④-⑤	M-45	FV-C-④-⑤	M-45	FVP-C-④-⑤	M-45	<p style="text-align: center;">Aluminum Cable Channel Covers</p> <table style="width: 100%; border-collapse: collapse;"> <tr><td>808 A-③-④</td><td>.....</td><td>E-8</td></tr> <tr><td>808 SA-③-④</td><td>.....</td><td>E-8</td></tr> </table> <p style="font-size: small;">A = Aluminum Contact B-Line Engineering for fitting cover information. See page E-8 for fitting cover examples.</p>		808 A-③-④	E-8	808 SA-③-④	E-8
802 SS4 20-④-⑤	K-16																																																																																	
802 SS6 20-④-⑤	K-16																																																																																	
803 SS4 20-④-⑤	K-16																																																																																	
803 SS6 20-④-⑤	K-16																																																																																	
804 SS4 20-④-⑤	K-16																																																																																	
804 SS6 20-④-⑤	K-16																																																																																	
812 SS4 20-④-⑤	K-16																																																																																	
812 SS6 20-④-⑤	K-16																																																																																	
813 SS4 20-④-⑤	K-16																																																																																	
813 SS6 20-④-⑤	K-16																																																																																	
814 SS4 20-④-⑤	K-16																																																																																	
814 SS6 20-④-⑤	K-16																																																																																	
822 SS4 20-④-⑤	K-16																																																																																	
822 SS6 20-④-⑤	K-16																																																																																	
823 SS4 20-④-⑤	K-16																																																																																	
823 SS6 20-④-⑤	K-16																																																																																	
824 SS4 20-④-⑤	K-16																																																																																	
824 SS6 20-④-⑤	K-16																																																																																	
F-C-④-⑤	M-45																																																																																	
FA-C-④-⑤	M-45																																																																																	
FAP-C-④-⑤	M-45																																																																																	
FP-C-④-⑤	M-45																																																																																	
FV-C-④-⑤	M-45																																																																																	
FVP-C-④-⑤	M-45																																																																																	
808 A-③-④	E-8																																																																																	
808 SA-③-④	E-8																																																																																	
		<p style="text-align: center;">Steel Cable Channel Covers</p> <table style="width: 100%; border-collapse: collapse;"> <tr><td>808 G-③-④</td><td>.....</td><td>E-8</td></tr> <tr><td>808 P-③-④</td><td>.....</td><td>E-8</td></tr> </table> <p style="font-size: small;">G = Hot Dipped Galvanized Steel P = Pre-Galvanized Steel Contact B-Line Engineering for fitting cover information. See page E-8 for fitting cover examples.</p>		808 G-③-④	E-8	808 P-③-④	E-8																																																																										
808 G-③-④	E-8																																																																																	
808 P-③-④	E-8																																																																																	
		<p style="text-align: center;">Stainless Steel Cable Channel Covers</p> <table style="width: 100%; border-collapse: collapse;"> <tr><td>808 SS4-③-④</td><td>.....</td><td>E-8</td></tr> <tr><td>808 SS6-③-④</td><td>.....</td><td>E-8</td></tr> </table> <p style="font-size: small;">SS4 = Stainless Steel 304 SS6 = Stainless Steel 316 Contact B-Line Engineering for fitting cover information. See page E-8 for fitting cover examples.</p>		808 SS4-③-④	E-8	808 SS6-③-④	E-8																																																																										
808 SS4-③-④	E-8																																																																																	
808 SS6-③-④	E-8																																																																																	
		<p style="text-align: center;">FLEXTRAY™ Covers</p> <table style="width: 100%; border-collapse: collapse;"> <tr><td>2 IN COVER</td><td>.....</td><td>D-40</td></tr> <tr><td>4 IN COVER</td><td>.....</td><td>D-40</td></tr> <tr><td>6 IN COVER</td><td>.....</td><td>D-40</td></tr> <tr><td>8 IN COVER</td><td>.....</td><td>D-40</td></tr> <tr><td>12 IN COVER</td><td>.....</td><td>D-40</td></tr> <tr><td>16 IN COVER</td><td>.....</td><td>D-40</td></tr> <tr><td>18 IN COVER</td><td>.....</td><td>D-40</td></tr> <tr><td>20 IN COVER</td><td>.....</td><td>D-40</td></tr> <tr><td>24 IN COVER</td><td>.....</td><td>D-40</td></tr> </table>		2 IN COVER	D-40	4 IN COVER	D-40	6 IN COVER	D-40	8 IN COVER	D-40	12 IN COVER	D-40	16 IN COVER	D-40	18 IN COVER	D-40	20 IN COVER	D-40	24 IN COVER	D-40																																																					
2 IN COVER	D-40																																																																																	
4 IN COVER	D-40																																																																																	
6 IN COVER	D-40																																																																																	
8 IN COVER	D-40																																																																																	
12 IN COVER	D-40																																																																																	
16 IN COVER	D-40																																																																																	
18 IN COVER	D-40																																																																																	
20 IN COVER	D-40																																																																																	
24 IN COVER	D-40																																																																																	

Index - Accessories

Aluminum REDI-RAIL™ Cable Tray Accessories

Not all accessories for Redi-Rail cable tray are aluminum only. Those finishes and part numbers will be listed in this section.

Catalog No.	Page	Catalog No.	Page	Catalog No.	Page
REDI-RAIL™ Tray Accessories					
99-30	F-6	BAX-4-16-48	F-11	R6A-DVO-R (radius)	F-16
9A-9012	F-13	BL1400	F-7	R6A-END Series	F-6
9A-R06RK	F-14	BL1410	F-7	R6A-ESP	F-5
9A-R09RK	F-14	BL1420	F-7	R6A-FSP	F-5
9A-R12RK	F-14	BL1430	F-7	R6A-FTB Series	F-6
9A-R18RK	F-14	DB10-28	F-11	R6A-HDDC Series	F-13
9A-R24RK	F-14	DB10-36	F-11	R6A-RSP-CR	F-6
9A-R30RK	F-14	DB10-42	F-11	R6A-RSP-SR	F-6
9A-R36RK	F-14	DB10-50	F-11	R6A-SBUF	F-15
9A-RBC	F-14	DB10-60	F-11	R6A-SSP	F-5
9A-RFM-12RK	F-17	R4A-ASP	F-5	R6A-TTB	F-6
9A-RFM-24RK	F-17	R4A-CP	F-15	R6A-UF	F-15
9A-RFM-36RK	F-17	R4A-DHB-Length	F-16	R6A-VSP	F-5
9A-SR0406	F-14	R4A-DSL-Length	F-16	R7A-ASP	F-5
9A-SR0409	F-14	R4A-DVI-R (radius)	F-16	R7A-CP	F-15
9A-SR0506	F-14	R4A-DVO-R (radius)	F-16	R7A-DHB-Length	F-16
9A-SR0509	F-14	R4A-END Series	F-6	R7A-DSL-Length	F-16
9G-1158 Series	F-7	R4A-ESP	F-5	R7A-DVI-R (radius)	F-16
9G-5500-1/2	F-8	R4A-FSP	F-5	R7A-DVO-R (radius)	F-16
9G-55XX-22SHA Series	F-8	R4A-FTB Series	F-6	R7A-END Series	F-6
9GRN-55XX-22SHA Series	F-8	R4A-HDDC Series	F-13	R7A-ESP	F-5
9P-55XX-22SH Series	F-8	R4A-RSP-CR	F-6	R7A-FSP	F-5
9SS-R238	F-7	R4A-RSP-SR	F-6	R7A-FTB Series	F-6
9SS-R250	F-7	R4A-SBUF	F-15	R7A-HDDC Series	F-13
9SS4-1241	F-10	R4A-SSP	F-5	R7A-RSP-CR	F-6
9SS4-1242	F-10	R4A-TTB	F-6	R7A-RSP-SR	F-6
9SS6-1241	F-10	R4A-UF	F-15	R7A-SBUF	F-15
9SS6-1242	F-10	R4A-VSP	F-5	R7A-SSP	F-5
9ZN-1204	F-7	R5A-ASP	F-5	R7A-TTB	F-6
9ZN-1204NB	F-7	R5A-CP	F-15	R7A-UF	F-15
9ZN-1241	F-10	R5A-DHB-Length	F-16	R7A-VSP	F-5
9ZN-1242	F-10	R5A-DSL-Length	F-16	RAA-OUT Series	F-6
9ZN-5200	F-9	R5A-DVI-R (radius)	F-16	RRA-DSP-45	F-5
9ZN-5212	F-9	R5A-DVO-R (radius)	F-16	RRA-DSP-46	F-5
9ZN-5224	F-9	R5A-END Series	F-6	RRA-DSP-47	F-5
9ZN-5500-1/2	F-8	R5A-ESP	F-5	RRA-DSP-56	F-5
9ZN-9012	F-13	R5A-FSP	F-5	RRA-DSP-57	F-5
9ZN-LV1-1	F-11	R5A-FTB Series	F-6	RRA-DSP-67	F-5
9ZN-LV1A-1	F-11	R5A-HDDC Series	F-13		
9ZN-MB1-4	F-11	R5A-RSP-CR	F-6	A = Aluminum	
9ZN-MB1-5	F-11	R5A-RSP-SR	F-6	G = Hot-Dipped Galvanized	
9ZN-R238	F-7	R5A-SBUF	F-15	SS = Stainless Steel 304	
9ZN-R250	F-7	R5A-SSP	F-5	ZN = Zinc Plated	
B297 Series	F-10	R5A-TTB	F-6		
B409 Series	F-10	R5A-UF	F-15		
B409UF-12 & 21	F-10	R5A-VSP	F-5		
B494 Series	F-19	R6A-ASP	F-5		
BAX-4-16	F-11	R6A-CP	F-15		
BAX-4-16-24	F-11	R6A-DHB-Length	F-16		
BAX-4-16-32	F-11	R6A-DSL-Length	F-16		
		R6A-DVI-R (radius)	F-16		

KwikSplice™ Aluminum Cable Tray Accessories

Not all accessories for aluminum cable tray are aluminum only. Those finishes and part numbers will be listed in this section.

Catalog No.	Page	Catalog No.	Page	Catalog No.	Page
KwikSplice Aluminum Tray Accessories		KS4A-TTB	G-7	R4A-DSL-Length	G-16
99-30	G-8	KS4A-UF	G-15	R4A-DVI-(Angle)R(Radius)	G-16
99-2130	G-8	KS4A-VSP	G-7	R4A-DVO-(Angle)R(Radius)	G-16
99-9980-Width	G-14	KS5A-CP	G-15	R5A-DHB	G-16
9A-9012	G-14	KS5A-DSP	G-7	R5A-DSL-Length	G-16
9A-RBC	G-15	KS5A-END-Width	G-9	R5A-DVI-(Angle)R(Radius)	G-16
9A-RFM-12RK	G-17	KS5A-ESP	G-7	R5A-DVO-(Angle)R(Radius)	G-16
9A-RFM-24RK	G-17	KS5A-FSP	G-7	R6A-DHB	G-16
9A-RFM-36RK	G-17	KS5A-FTB-Width	G-9	R6A-DSL-Length	G-16
9G-1158 Series	G-8	KS5A-HDCC-Width	G-14	R6A-DVI-(Angle)R(Radius)	G-16
9G-5500-1/2	G-10	KS5A-RSPC	G-7	R6A-DVO-(Angle)R(Radius)	G-16
9G-55xx-22SH Series	G-10	KS5A-RSPS	G-7		
9P-5500-1/2	G-10	KS5A-SB-UF	G-15	A = Aluminum	
9P-55xx-22SH Series	G-10	KS5A-SSP	G-7	G = Hot-Dipped Galvanized	
9SS4-1241	G-12	KS5A-TTB	G-7	P = Pre-Galvanized Steel	
9SS6-1241	G-12	KS5A-UF	G-15	SS4 = Stainless Steel 304	
9ZN-1204	G-9	KS5A-VSP	G-7	SS6 = Stainless Steel 316	
9ZN-1204NB	G-9	KS6A-CP	G-15	ZN = Zinc Plated	
9ZN-1241	G-12	KS6A-DSP	G-7		
9ZN-9012	G-14	KS6A-END-Width	G-9		
B297 Series	G-11	KS6A-ESP	G-7		
B409 Series	G-11	KS6A-FSP	G-7		
B409UF Series	G-12	KS6A-FTB-Width	G-9		
B494 Series	G-11	KS6A-HDCC-Width	G-14		
BAX-4-16	G-12	KS6A-RSPC	G-7		
BG-8-12-W2	G-8	KS6A-RSPS	G-7		
BG-16-W2	G-8	KS6A-SB-UF	G-15		
DB10-28	G-12	KS6A-SSP	G-7		
DB10-36	G-12	KS6A-TTB	G-7		
DB10-42	G-12	KS6A-UF	G-15		
DB10-50	G-12	KS6A-VSP	G-7		
DB10-60	G-12	KSA-6CT	G-10		
KS4A-CP	G-15	KSA-9CT	G-10		
KS4A-DSP	G-7	KSA-12CT	G-10		
KS4A-END-Width	G-9	KSA-18CT	G-10		
KS4A-ESP	G-7	KSA-24CT	G-10		
KS4A-FSP	G-7	KSA-30CT	G-10		
KS4A-FTB-Width	G-9	KSA-36CT	G-10		
KS4A-HDCC-Width	G-14	KSA-OUT-Width	G-9		
KS4A-RSPC	G-7	KSA-SDO-06	G-9		
KS4A-RSPS	G-7	KSA-SDO-12	G-9		
KS4A-SB-UF	G-15	KSA-SDO-18	G-9		
KS4A-SSP	G-7	KSA-VCH-Series	G-8		
		R4A-DHB	G-16		

Index

Index - Accessories

Series 2, 3, 4, & 5 Aluminum Cable Tray Accessories

Not all accessories for aluminum cable tray are aluminum only. Those finishes and part numbers will be listed in this section.

Catalog No.	Page	Catalog No.	Page	Catalog No.	Page
Aluminum Tray Accessories					
73A-Length	I-16	9A-1006	I-13	9A-1067-reduction	I-14
73A-90HBFL	I-16	9A-1006-1/2	I-13	9A-1074-tray width	I-14
73A-(angle)VI(radius)	I-16	9A-1007	I-13	9A-1075-tray width	I-14
73A-(angle)VO(radius)	I-16	9A-1007-1/2	I-13	9A-1076-tray width	I-14
74A-Length	I-16	9A-1008	I-12	9A-1077-tray width	I-14
74A-90HBFL	I-16	9A-1014	I-13	9A-1078	I-12
74A-(angle)VI(radius)	I-16	9A-1015	I-13	9A-1084-tray width	I-14
74A-(angle)VO(radius)	I-16	9A-1016	I-13	9A-1085-tray width	I-14
75A-Length	I-16	9A-1017	I-13	9A-1086-tray width	I-14
75A-90HBFL	I-16	9A-1018	I-12	9A-1087-tray width	I-14
75A-(angle)VI(radius)	I-16	9A-1024	I-13	9A-1104-tray width	I-16
75A-(angle)VO(radius)	I-16	9A-1025	I-13	9A-1104T-tray width	I-16
76A-Length	I-16	9A-1026	I-13	9A-1205	I-18
76A-90HBFL	I-16	9A-1027	I-13	9A-1224	I-22
76A-(angle)VI(radius)	I-16	9A-1028	I-12	9A-1225	I-22
76A-(angle)VO(radius)	I-16	9A-1034	I-14	9A-1226	I-22
99-40	I-17	9A-1034-12	I-14	9A-1227	I-22
99-1124	I-16	9A-1034-36	I-14	9A-1240	I-15
99-1620	I-17	9A-1035	I-14	9A-1281	I-12
99-2125-15	I-15	9A-1035-12	I-14	9A-2044	I-14
99-9980-tray width	I-25	9A-1035-36	I-14	9A-2045	I-14
99-9982	I-17	9A-1036	I-14	9A-2046	I-14
99-N1	I-17	9A-1036-12	I-14	9A-2047	I-14
99-NP300	I-19	9A-1036-36	I-14	9A-2130	I-17
99-PE34	I-18	9A-1037	I-14	9A-6006	I-13
99-PE36	I-19	9A-1037-12	I-14	9A-6007	I-13
9A-RBC	I-17	9A-1037-36	I-14	9A-6016	APP-3
9A-tray width-9P44	APP-4	9A-1038	I-12	9A-6017	APP-3
9A-tray width-9P54	APP-4	9A-1045	I-13	9A-9012	I-25
9A-tray width-9P64	APP-4	9A-1046	I-13	9A-9043	I-25
9A-tray width-9P74	APP-4	9A-1047	I-13	9A-9053	I-25
9A-tray width-9044	I-25	9A-1048	I-12	9A-9063	I-25
9A-tray width-9044P	I-25	9A-1050	I-12	9A-9073	I-25
9A-tray width-9054	I-25	9A-1051	I-12	9G-1158 Series	I-15
9A-tray width-9054P	I-25	9A-1054	I-14	9G-1205	I-18
9A-tray width-9064	I-25	9A-1055	I-14	9G-1249	I-19
9A-tray width-9064P	I-25	9A-1056	I-14	9G-1249HD	I-19
9A-tray width-9074	I-25	9A-1057	I-14	9G-1281	I-12
9A-tray width-9074P	I-25	9A-1060	I-13	9G-5324	I-18
9A-1004	I-13	9A-1061	I-13	9G-5325	I-18
9A-1004-1/2	I-13	9A-1062	I-13	9G-5326	I-18
9A-1005	I-13	9A-1064-reduction	I-14	9G-5327	I-18
9A-1005-1/2	I-13	9A-1065-reduction	I-14	9G-5500-1/2	I-20
		9A-1066-reduction	I-14		

continued on next page

Series 2, 3, 4, & 5 Aluminum Cable Tray Accessories

Not all accessories for aluminum cable tray are aluminum only. Those finishes and part numbers will be listed in this section.

Catalog No.	Page	Catalog No.	Page	Catalog No.	Page
9G-55xx-22SH Series	I-20	B355	I-22		
9G-55xx-22SHA Series	I-20	B409 Series	I-21		
9GRN-55xx-22SH Series	I-20	B409UF-12 or 21	I-22		
9GRN-55xx-22SHA Series	I-20	B441-22	I-23		
9P-55xx-22SH Series	I-20	B441-22A	I-23		
9P-55xx-22SHA Series	I-20	B494 Series	I-21		
9SS4-1241	I-22	B501 Series	I-22		
9SS4-1242	I-22	B655- ³ / ₈	I-17		
9SS4-2351	I-17	B655- ¹ / ₂	I-17		
9SS4-2352	I-17	B700-Jx Series	I-23		
9SS6-1205	I-18	B750-Jx Series	I-23		
9SS6-1241	I-22	BP081SS	I-18		
9SS6-1242	I-22	BP110SS	I-18		
9ZN-1150 Series	I-15	BP135SS	I-18		
9ZN-1155 Series	I-15	BP175SS	I-18		
9ZN-1204	I-18	BP205SS	I-18		
9ZN-1204NB	I-18	BP250SS	I-18		
9ZN-1205	I-18	BP300SS	I-18		
9ZN-1208	I-18	BP325SS	I-18		
9ZN-1208NB	I-18	BP375SS	I-18		
9ZN-1241	I-22	BP425SS	I-18		
9ZN-1242	I-22	BP475SS	I-18		
9ZN-1249	I-19	DB10-28	I-19		
9ZN-1249HD	I-19	DB10-36	I-19		
9ZN-1281	I-12	DB10-42	I-19		
9ZN-2351	I-17	DB10-50	I-19		
9ZN-2352	I-17	DB10-60	I-19		
9ZN-5200	I-21	S9G-1202	I-12		
9ZN-5212	I-21	S9ZN-1202	I-12		
9ZN-5224	I-21	SFHN ³ / ₈ "-16	I-15		
9ZN-5324	I-18	SNCB ³ / ₈ " x ³ / ₄ "	I-15		
9ZN-5325	I-18				
9ZN-5326	I-18	A = Aluminum			
9ZN-5327	I-18	G = Hot-Dipped Galvanized			
9ZN-5500- ¹ / ₂	I-20	GRN = Dura-Green Painted			
9ZN-9012	I-25	P = Pre-Galvanized Steel			
9ZN-9112 Series	I-25	SS = Stainless Steel 304			
9ZN-9113 Series	I-25	SS4 = Stainless Steel 304			
ATR Series	I-17	SS6 = Stainless Steel 316			
B212- ¹ / ₄ or ³ / ₈	I-23	ZN = Zinc Plated			
B297 Series	I-22				
B305-B308	I-23				
B312 Series	I-23				
B321 Series	I-23				

Index

Index - Accessories

Index

Series 1 Steel Cable Tray Accessories

Not all accessories for steel cable tray are steel only. Those finishes and part numbers will be listed in this section.

Catalog No.	Page	Catalog No.	Page	Catalog No.	Page
Series 1 Steel Cable Tray Accessories					
72G-Length	H-14	9G-2007-1/2	H-7	9G-8246	H-7
72G-90HBFL	H-14	9G-4004	H-7	9G-9014	H-16
72G-(angle)VI(radius)	H-14	9G-4005	H-7	9G-9015	H-16
72G-(angle)VO(radius)	H-14	9G-4006	H-7	9G-9016	H-16
72P-Length	H-14	9G-4007	H-7	9G-9019	H-16
72P-90HBFL	H-14	9G-4014	H-7	9G-tray width-9040	H-16
72P-(angle)VI(radius)	H-14	9G-4015	H-7	9G-9043	H-16
72P-(angle)VO(radius)	H-14	9G-4016	H-7	9G-tray width-9044	H-16
737G-Length	H-14	9G-4017	H-7	9G-9053	H-16
737G-90HBFL	H-14	9G-5500-1/2	H-13	9G-tray width-9054	H-16
737G-(angle)VI(radius)	H-14	9G-55xx-22SH Series	H-13	9G-9063	H-16
737G-(angle)VO(radius)	H-14	9G-55xx-22SHA Series	H-13	9G-tray width-9064	H-16
737P-Length	H-14	9G-7024	H-7	9G-9243	H-16
737P-90HBFL	H-14	9G-8024	H-7	9GRN-55xx-22SHA Series	H-13
737P-(angle)VI(radius)	H-14	9G-8025	H-7	9P-1104T-tray width	H-17
737P-(angle)VO(radius)	H-14	9G-8026	H-7	9P-2004-1/2	H-7
747G-Length	H-14	9G-8034	H-7	9P-2005-1/2	H-7
747G-90HBFL	H-14	9G-8034-12	H-7	9P-2006-1/2	H-7
747G-(angle)VI(radius)	H-14	9G-8034-36	H-7	9P-2007-1/2	H-7
747G-(angle)VO(radius)	H-14	9G-8035	H-7	9P-55xx-22SH Series	H-13
747P-Length	H-14	9G-8035-12	H-7	9P-8024	H-7
747P-90HBFL	H-14	9G-8035-36	H-7	9P-8025	H-7
747P-(angle)VI(radius)	H-14	9G-8036	H-7	9P-8026	H-7
747P-(angle)VO(radius)	H-14	9G-8036-12	H-7	9P-8054	H-8
757G-Length	H-14	9G-8036-36	H-7	9P-8055	H-8
757G-90HBFL	H-14	9G-8045	H-7	9P-8056	H-8
757G-(angle)VI(radius)	H-14	9G-8044	H-7	9P-8064-reduction	H-8
757G-(angle)VO(radius)	H-14	9G-8045	H-7	9P-8065-reduction	H-8
757P-Length	H-14	9G-8046	H-7	9P-8066-reduction	H-8
757P-90HBFL	H-14	9G-8054	H-8	9P-8084-tray width	H-8
757P-(angle)VI(radius)	H-14	9G-8055	H-8	9P-8085-tray width	H-8
757P-(angle)VO(radius)	H-14	9G-8056	H-8	9P-8086-tray width	H-8
99-2125-15	H-9	9G-8060	H-7	9P-tray width-9040	H-16
99-9980	H-16	9G-8064-reduction	H-8	9P-9043	H-16
99-9982	H-14	9G-8065-reduction	H-8	9P-tray width-9044	H-16
99-N1	H-9	9G-8066-reduction	H-8	9P-9053	H-16
9A-2130	H-9	9G-8074-tray width	H-8	9P-tray width-9054	H-16
9G-1104T-tray width	H-10	9G-8075-tray width	H-8	9P-9063	H-16
9G-1158 Series	H-4	9G-8076-tray width	H-8	9P-tray width-9064	H-16
9G-2004-1/2	H-7	9G-8084-tray width	H-8	9SS4-2351	H-9
9G-2005-1/2	H-7	9G-8085-tray width	H-8	9SS4-2352	H-9
9G-2006-1/2	H-7	9G-8086-tray width	H-8	9ZN-1113	H-10
		9G-8244	H-7	9ZN-1150 Series	H-9
		9G-8245	H-7		

continued on next page

Series 1 Steel Cable Tray Accessories

Not all accessories for steel cable tray are steel only. Those finishes and part numbers will be listed in this section.

Catalog No.	Page	Catalog No.	Page	Catalog No.	Page
9ZN-1204	H-9	9ZN-8060	H-7		
9ZN-1204NB	H-9	9ZN-8074-tray width	H-8		
9ZN-1208	H-9	9ZN-8075-tray width	H-8		
9ZN-1208NB	H-9	9ZN-8076-tray width	H-8		
9ZN-2351	H-9	9ZN-8244	H-8		
9ZN-2352	H-9	9ZN-8245	H-8		
9ZN-4004	H-7	9ZN-8246	H-8		
9ZN-4005	H-7	9ZN-9014	H-16		
9ZN-4006	H-7	9ZN-9015	H-16		
9ZN-4007	H-7	9ZN-9016	H-16		
9ZN-4014	H-7	9ZN-9019	H-16		
9ZN-4015	H-7	9ZN-9101	H-16		
9ZN-4016	H-7	9ZN-9102	H-16		
9ZN-4017	H-7	9ZN-9103	H-16		
9ZN-5106	H-10	9ZN-9104	H-16		
9ZN-5106-WB	H-10	9ZN-9243	H-16		
9ZN-5109	H-10	ATR Series	H-10		
9ZN-5109-WB	H-10	B210	H-12		
9ZN-5112	H-10	B210A	H-12		
9ZN-5112-WB	H-10	B212 Series	H-12		
9ZN-5118	H-10	B297 Series	H-11		
9ZN-5118-WB	H-10	B305-B308	H-12		
9ZN-5124	H-10	B312 Series	H-12		
9ZN-5124-WB	H-10	B321 Series	H-12		
9ZN-5324	H-10	B351L Series	H-11		
9ZN-5325	H-10	B409 Series	H-11		
9ZN-5326	H-10	B409UF-Series	H-11		
9ZN-5500-1/2	H-13	B441-22 Series	H-11		
9ZN-7024	H-7	B441-22A Series	H-11		
9ZN-8024	H-7	B494 Series	H-10		
9ZN-8025	H-7	B655 Series	H-10		
9ZN-8026	H-7	B701-Jx Series	H-12		
9ZN-8034	H-7	B751-Jx Series	H-12		
9ZN-8034-12	H-7	B752	H-12		
9ZN-8034-36	H-7	B753 Series	H-12		
9ZN-8035	H-7	RNCB 3/8"-16 x 3/4"	H-8		
9ZN-8035-12	H-7	SFHN 3/8"-16	H-8		
9ZN-8035-36	H-7				
9ZN-8036	H-7				
9ZN-8036-12	H-7				
9ZN-8036-36	H-7				
9ZN-8044	H-7				
9ZN-8045	H-7				
9ZN-8046	H-7				

A = Aluminum
 G = Hot-Dipped Galvanized
 P = Pre-Galvanized Steel
 SS4 = Stainless Steel 304
 ZN = Zinc Plated

Index

Index - Accessories

Index

Series 2, 3, 4, & 5 Steel Cable Tray Accessories

Not all accessories for steel cable tray are steel only. Those finishes and part numbers will be listed in this section.

Catalog No.	Page	Catalog No.	Page	Catalog No.	Page
Series 2, 3, 4, & 5 Steel Cable Tray Accessories					
73G-Length	J-14	9G-1249	J-17	9G-8067-reduction	J-12
73G-90HBFL	J-14	9G-1249HD	J-17	9G-8074-tray width	J-12
73G-(angle)VI(radius)	J-14	9G-5324	J-16	9G-8075-tray width	J-12
73G-(angle)VO(radius)	J-14	9G-5325	J-16	9G-8076-tray width	J-12
73P-Length	J-14	9G-5326	J-16	9G-8077-tray width	J-12
73P-90HBFL	J-14	9G-5327	J-16	9G-8084-tray width	J-12
73P-(angle)VI(radius)	J-14	9G-5500-1/2	J-18	9G-8085-tray width	J-12
73P-(angle)VO(radius)	J-14	9G-55xx-22SHA Series	J-18	9G-8086-tray width	J-12
74G-Length	J-14	9G-6016	APP-3	9G-8087-tray width	J-12
74G-90HBFL	J-14	9G-6017	APP-3	9G-8224	J-20
74G-(angle)VI(radius)	J-14	9G-8004	J-11	9G-8225	J-20
74G-(angle)VO(radius)	J-14	9G-8004-1/2	J-11	9G-8226	J-20
74P-Length	J-14	9G-8005	J-11	9G-8227	J-20
74P-90HBFL	J-14	9G-8005-1/2	J-11	9G-8244	J-11
74P-(angle)VI(radius)	J-14	9G-8006	J-11	9G-8245	J-11
74P-(angle)VO(radius)	J-14	9G-8006-1/2	J-11	9G-8246	J-11
75G-Length	J-14	9G-8007	J-11	9G-8247	J-11
75G-90HBFL	J-14	9G-8007-1/2	J-11	9G-9014	J-23
75G-(angle)VI(radius)	J-14	9G-8014	J-11	9G-9015	J-23
75G-(angle)VO(radius)	J-14	9G-8015	J-11	9G-9016	J-23
75P-Length	J-14	9G-8016	J-11	9G-9017	J-23
75P-90HBFL	J-14	9G-8017	J-11	9G-9043	J-23
75P-(angle)VI(radius)	J-14	9G-8024	J-11	9G-tray width-9P44	APP-4
75P-(angle)VO(radius)	J-14	9G-8025	J-11	9G-tray width-9P54	APP-4
76G-Length	J-14	9G-8026	J-11	9G-tray width-9P64	APP-4
76G-90HBFL	J-14	9G-8027	J-11	9G-tray width-9P74	APP-4
76G-(angle)VI(radius)	J-14	9G-8034	J-12	9G-tray width-9044	J-23
76G-(angle)VO(radius)	J-14	9G-8034-12	J-12	9G-tray width-9044P	J-23
76P-Length	J-14	9G-8034-36	J-12	9G-9053	J-23
76P-90HBFL	J-14	9G-8035	J-12	9G-tray width-9054	J-23
76P-(angle)VI(radius)	J-14	9G-8035-12	J-12	9G-tray width-9054P	J-23
76P-(angle)VO(radius)	J-14	9G-8035-36	J-12	9G-9063	J-23
99-1124	J-14	9G-8036	J-12	9G-tray width-9064	J-23
99-2125-15	J-13	9G-8036-12	J-12	9G-tray width-9064P	J-23
99-9980-tray width	J-23	9G-8036-36	J-12	9G-9073	J-23
99-9982	J-15	9G-8037	J-12	9G-tray width-9074	J-23
99-N1	J-15	9G-8037-12	J-12	9G-tray width-9074P	J-23
99-NP300	J-17	9G-8037-36	J-12	9GRN-55xx-22SHA Series	J-18
99-PE36	J-17	9G-8045	J-11	9P-1104-tray width	J-14
9A-1205	J-16	9G-8046	J-11	9P-1104T-tray width	J-14
9A-2130	J-15	9G-8047	J-11	9G-55xx-22SH Series	J-18
9G-1104-tray width	J-14	9G-8054	J-12	9GRN-55xx-22SH Series	J-18
9G-1104T-tray width	J-14	9G-8055	J-12	9P-55xx-22SH Series	J-18
9G-1158 Series	J-13	9G-8056	J-12	9P-55xx-22SHA Series	J-18
9G-1205	J-16	9G-8057	J-12	9P-8024	J-11
9G-1240	J-12	9G-8060	J-11	9P-8025	J-11
9G-1241	J-20	9G-8061	J-11	9P-8026	J-11
9G-1242	J-20	9G-8062	J-11	9P-8027	J-11
		9G-8064-reduction	J-12	9P-8054	J-12
		9G-8065-reduction	J-12	9P-8055	J-12
		9G-8066-reduction	J-12		

continued on next page

Series 2, 3, 4, & 5 Steel Cable Tray Accessories

Not all accessories for steel cable tray are steel only. Those finishes and part numbers will be listed in this section.

Catalog No.	Page	Catalog No.	Page	Catalog No.	Page
9P-8056	J-12	9ZN-1240	J-12	9ZN-8226	J-20
9P-8057	J-12	9ZN-1241	J-20	9ZN-8227	J-20
9P-8064-reduction	J-12	9ZN-1242	J-20	9ZN-8244	J-11
9P-8065-reduction	J-12	9ZN-1249	J-17	9ZN-8245	J-11
9P-8066-reduction	J-12	9ZN-1249HD	J-17	9ZN-8246	J-11
9P-8067-reduction	J-12	9ZN-2351	J-15	9ZN-8247	J-11
9P-8084-tray width	J-12	9ZN-2352	J-15	9ZN-9002	J-15
9P-8085-tray width	J-12	9ZN-5200	J-19	9ZN-9014	J-23
9P-8086-tray width	J-12	9ZN-5212	J-19	9ZN-9015	J-23
9P-8087-tray width	J-12	9ZN-5224	J-19	9ZN-9016	J-23
9P-9043	J-23	9ZN-5324	J-16	9ZN-9017	J-23
9P-tray width-9044	J-23	9ZN-5325	J-16	9ZN-9101	J-23
9P-tray width-9044P	J-23	9ZN-5326	J-16	9ZN-9102	J-23
9P-9053	J-23	9ZN-5327	J-16	9ZN-9103	J-23
9P-tray width-9054	J-23	9ZN-5500-1/2	J-18	9ZN-9104	J-23
9P-tray width-9054P	J-23	9ZN-8004	J-11	9ZN-9114 Series	J-23
9P-9063	J-23	9ZN-8004-1/2	J-11	9ZN-9115 Series	J-23
9P-tray width-9064	J-23	9ZN-8005	J-11	ATR Series	J-15
9P-tray width-9064P	J-23	9ZN-8005-1/2	J-11	B212 Series	J-21
9P-9073	J-23	9ZN-8006	J-11	B297 Series	J-20
9P-tray width-9074	J-23	9ZN-8006-1/2	J-11	B305-B308	J-21
9P-tray width-9074P	J-23	9ZN-8007	J-11	B312 Series	J-21
9SS4-2351	J-15	9ZN-8007-1/2	J-11	B321 Series	J-21
9SS4-2352	J-15	9ZN-8014	J-11	B355 Series	J-20
9SS4-4050	J-16	9ZN-8015	J-11	B409 Series	J-19
9SS4-4075	J-16	9ZN-8016	J-11	B409UF-Series	J-20
9SS4-4100	J-16	9ZN-8017	J-11	B441-22 Series	J-21
9SS4-4125	J-16	9ZN-8034	J-12	B441-22A Series	J-21
9SS4-4150	J-16	9ZN-8034-12	J-12	B494 Series	J-19
9SS4-4175	J-16	9ZN-8034-36	J-12	B501 Series	J-20
9SS4-4200	J-16	9ZN-8035	J-12	B655 Series	J-15
9SS4-4225	J-16	9ZN-8035-12	J-12	B700-Jx Series	J-21
9SS4-4250	J-16	9ZN-8035-36	J-12	B750-Jx Series	J-21
9SS4-4275	J-16	9ZN-8036	J-12	DB10-28	J-17
9SS4-4300	J-16	9ZN-8036-12	J-12	DB10-36	J-17
9SS4-4325	J-16	9ZN-8036-36	J-12	DB10-42	J-17
9SS4-4350	J-16	9ZN-8037	J-12	DB10-50	J-17
9SS4-4375	J-16	9ZN-8037-12	J-12	DB10-60	J-17
9SS4-4400	J-16	9ZN-8037-36	J-12	RNCB 3/8"-16 x 3/4"	J-13
9SS4-4425	J-16	9ZN-8045	J-11	SFHN 3/8"-16	J-13
9SS4-4450	J-16	9ZN-8046	J-11	A = Aluminum	
9SS4-4475	J-16	9ZN-8047	J-11	G = Hot-Dipped Galvanized	
9SS6-1205	J-16	9ZN-8060	J-11	GRN = Dura-Green Painted	
9SS6-6016	APP-3	9ZN-8061	J-11	P = Pre-Galvanized Steel	
9ZN-1150 Series	J-13	9ZN-8062	J-11	SS4 = Stainless Steel 304	
9ZN-1155 Series	J-13	9ZN-8074-tray width	J-12	SS6 = Stainless Steel 316	
9ZN-1204	J-16	9ZN-8075-tray width	J-12	ZN = Zinc Plated	
9ZN-1204NB	J-16	9ZN-8076-tray width	J-12		
9ZN-1205	J-16	9ZN-8077-tray width	J-12		
9ZN-1208	J-16	9ZN-8224	J-20		
9ZN-1208NB	J-16	9ZN-8225	J-20		

Index

Index - Accessories

Series 2, 3, 4, & 5 Stainless Steel Cable Tray Accessories

Not all accessories for steel cable tray are steel only. Those finishes and part numbers will be listed in this section.

Catalog No.	Page	Catalog No.	Page	Catalog No.	Page
Series 2, 3, 4, & 5 Stainless Steel Cable Tray Accessories					
73SS4-Length	K-9	9SS4-4175	K-10	9SS4-8064	K-7
73SS4-90HBFL	K-9	9SS4-4200	K-10	9SS4-8065	K-7
73SS4-(angle)VI(radius)	K-9	9SS4-4225	K-10	9SS4-8066	K-7
73SS4-(angle)VO(radius)	K-9	9SS4-4250	K-10	9SS4-8074-tray width	K-7
73SS6-Length	K-9	9SS4-4275	K-10	9SS4-8075-tray width	K-7
73SS6-90HBFL	K-9	9SS4-4300	K-10	9SS4-8076-tray width	K-7
73SS6-(angle)VI(radius)	K-9	9SS4-4325	K-10	9SS4-8084-tray width	K-7
73SS6-(angle)VO(radius)	K-9	9SS4-4350	K-10	9SS4-8085-tray width	K-7
74SS4-Length	K-9	9SS4-4375	K-10	9SS4-8086-tray width	K-7
74SS4-90HBFL	K-9	9SS4-4400	K-10	9SS4-8224	K-11
74SS4-(angle)VI(radius)	K-9	9SS4-4425	K-10	9SS4-8225	K-11
74SS4-(angle)VO(radius)	K-9	9SS4-4450	K-10	9SS4-8226	K-11
74SS6-Length	K-9	9SS4-4475	K-10	9SS4-8227	K-11
74SS6-90HBFL	K-9	9SS4-5500-1/2	K-13	9SS4-8244	K-6
74SS6-(angle)VI(radius)	K-9	9SS4-55xx-22SH	K-13	9SS4-8245	K-6
74SS6-(angle)VO(radius)	K-9	9SS4-55xx-22SHA	K-13	9SS4-8246	K-6
75SS4-Length	K-9	9SS4-8004	K-6	9SS4-9002	K-10
75SS4-90HBFL	K-9	9SS4-8004-1/2	K-6	9SS4-9043	K-17
75SS4-(angle)VI(radius)	K-9	9SS4-8005	K-6	9SS4-tray width-9P44	APP-4
75SS4-(angle)VO(radius)	K-9	9SS4-8005-1/2	K-6	9SS4-tray width-9P54	APP-4
75SS6-Length	K-9	9SS4-8006	K-6	9SS4-tray width-9P64	APP-4
75SS6-90HBFL	K-9	9SS4-8006-1/2	K-6	9SS4-tray width-9P74	APP-4
75SS6-(angle)VI(radius)	K-9	9SS4-8014	K-6	9SS4-tray width-9044	K-17
75SS6-(angle)VO(radius)	K-9	9SS4-8015	K-6	9SS4-tray width-9044P	K-17
99-2125-15	K-8	9SS4-8016	K-6	9SS4-9053	K-17
99-9980-tray width	K-17	9SS4-8024	K-6	9SS4-tray width-9054	K-17
99-9982	K-10	9SS4-8025	K-6	9SS4-tray width-9054P	K-17
99-NP300	K-12	9SS4-8026	K-6	9SS4-9063	K-17
99-PE36	K-12	9SS4-8034	K-7	9SS4-tray width-9064	K-17
9G-1158 Series	K-8	9SS4-8034-12	K-7	9SS4-tray width-9064P	K-17
9SS4-1104-tray width	K-9	9SS4-8034-36	K-7	9SS4-9101	K-17
9SS4-1150 Series	K-8	9SS4-8035	K-7	9SS4-9102	K-17
9SS4-1155 Series	K-8	9SS4-8035-12	K-7	9SS4-9103	K-17
9SS4-1240	K-7	9SS4-8035-36	K-7	9SS4-9104	K-17
9SS4-1241	K-15	9SS4-8036	K-7	9SS4-9115 Series	K-17
9SS4-1242	K-15	9SS4-8036-12	K-7	9SS6-1104-tray width	K-9
9SS4-1249	K-11	9SS4-8036-36	K-7	9SS6-1205	K-11
9SS4-1249HD	K-11	9SS4-8037	K-7	9SS6-1240	K-7
9SS4-4050	K-10	9SS4-8037-12	K-7	9SS6-1241	K-15
9SS4-4075	K-10	9SS4-8037-36	K-7	9SS6-1242	K-15
9SS4-4100	K-10	9SS4-8046	K-6	9SS6-1249	K-11
9SS4-4125	K-10	9SS4-8054	K-7	9SS6-1249HD	K-11
9SS4-4150	K-10	9SS4-8055	K-7	9SS6-5500-1/2	K-13
		9SS4-8056	K-7	9SS6-55xx-22SH	K-13
		9SS4-8060	K-6	9SS6-55xx-22SHA	K-13

continued on next page

Series 2, 3, 4, & 5 Stainless Steel Cable Tray Accessories

Catalog No.	Page	Catalog No.	Page	Catalog No.	Page
9SS6-6016	APP-3	9SS6-8245	K-6		
9SS6-8004	K-6	9SS6-8246	K-6		
9SS6-8004-1/2	K-6	9SS6-9002	K-10		
9SS6-8005	K-6	9SS6-9014	K-17		
9SS6-8005-1/2	K-6	9SS6-9015	K-17		
9SS6-8006	K-6	9SS6-9016	K-17		
9SS6-8006-1/2	K-6	9SS6-9043	K-17		
9SS6-8014	K-6	9SS6-tray width-9P44	APP-4		
9SS6-8015	K-6	9SS6-tray width-9P54	APP-4		
9SS6-8016	K-6	9SS6-tray width-9P64	APP-4		
9SS6-8024	K-6	9SS6-tray width-9P74	APP-4		
9SS6-8025	K-6	9SS6-tray width-9044	K-17		
9SS6-8026	K-6	9SS6-tray width-9044P	K-17		
9SS6-8034	K-7	9SS6-9053	K-17		
9SS6-8034-12	K-7	9SS6-tray width-9054	K-17		
9SS6-8034-36	K-7	9SS6-tray width-9054P	K-17		
9SS6-8035	K-7	9SS6-9063	K-17		
9SS6-8035-12	K-7	9SS6-tray width-9064	K-17		
9SS6-8035-36	K-7	9SS6-tray width-9064P	K-17		
9SS6-8036	K-7	9SS6-9101	K-17		
9SS6-8036-12	K-7	9SS6-9102	K-17		
9SS6-8036-36	K-7	9SS6-9103	K-17		
9SS6-8037	K-7	9SS6-9104	K-17		
9SS6-8037-12	K-7	9SS6-9115 Series	K-17		
9SS6-8037-36	K-7	ATR Series	K-10		
9SS6-8045	K-6	B212 Series	K-15		
9SS6-8046	K-6	B297 Series	K-14		
9SS6-8054	K-7	B355 Series	K-15		
9SS6-8055	K-7	B409 Series	K-14		
9SS6-8056	K-7	B441-22 Series	K-15		
9SS6-8060	K-6	B441-22A Series	K-15		
9SS6-8064	K-7	B494 Series	K-14		
9SS6-8065	K-7	B655 Series	K-10		
9SS6-8066	K-7	DB10-28	K-12		
9SS6-8074-tray width	K-7	DB10-36	K-12		
9SS6-8075-tray width	K-7	DB10-42	K-12		
9SS6-8076-tray width	K-7	DB10-50	K-12		
9SS6-8084-tray width	K-7	DB10-60	K-12		
9SS6-8085-tray width	K-7	RNCB 3/8"-16 x 3/4"	K-8		
9SS6-8086-tray width	K-7	SFHN 3/8"-16	K-8		
9SS6-8224	K-11				
9SS6-8225	K-11	G = Hot-Dipped Galvanized			
9SS6-8226	K-11	SS4 = Stainless Steel 304			
9SS6-8227	K-11	SS6 = Stainless Steel 316			
9SS6-8244	K-6				

Index

Index - Accessories

Index

Fiberglass Cable Tray Accessories

Catalog No.	Page	Catalog No.	Page	Catalog No.	Page
Fiberglass Cable Tray Accessories		9(x)-8018	M-46	75(x)-90VI-24	M-48
9(x)-1083-W	M-46	9(x)-8026	M-47	75(x)-90VO-24	M-48
9(x)-1084-W	M-46	9(x)-8028	M-47	77(x)-120	M-48
9(x)-1086-W	M-46	9(x)-8036	M-46	77(x)-90HBLF	M-48
9(x)-1088-W	M-46	9(x)-8038	M-46	77(x)-90VI-24	M-48
9(x)-1104-W	M-48	9(x)-8056	M-46	77(x)-90VO-24	M-48
9F-1208	M-48	9(x)-8058	M-46	RSK-010	M-46
9FV-2008	M-48	9(x)-8063	M-46	TPDR	M-45
9FV-2009	M-48	9(x)-8064	M-46		
9FV-2010	M-48	9(x)-8084	M-46	(x) = Insert F for Polyester Resin	
9FV-2011	M-48	9(x)-8086	M-46	Insert FA for Zero Halogen/Dis-Stat	
9FV-2012	M-48	9(x)-8306H	M-47	Insert FV for Vinyl Ester Resin	
9FV-2013	M-48	9(x)-8306V	M-47		
9FV-2014	M-48	9(x)-8308H	M-47		
9FV-2015	M-48	9(x)-8308V	M-47		
9FV-2016	M-48	9(x)-8456H	M-47		
9FV-2017	M-48	9(x)-8456V	M-47		
9(x)-4003	M-46	9(x)-8458H	M-47		
9(x)-4004	M-46	9(x)-8458V	M-47		
9(x)-4013	M-46	9(x)-8906H	M-47		
9(x)-4014	M-46	9(x)-8906V	M-47		
9(x)-4023	M-47	9(x)-8908H	M-47		
9(x)-4024	M-47	9(x)-8908V	M-47		
9(x)-4033	M-46	9(x)-9013	M-45		
9(x)-4034	M-46	9(x)-9014	M-45		
9(x)-4043	M-46	9(x)-9015	M-45		
9(x)-4053	M-46	9F-W-9034	M-45		
9(x)-4054	M-46	9F-W-9034P	M-45		
9(x)-4303H	M-47	9F-W-9044	M-45		
9(x)-4303V	M-47	9F-W-9044P	M-45		
9(x)-4304H	M-47	9F-W-9064	M-45		
9(x)-4304V	M-47	9F-W-9064P	M-45		
9(x)-4453H	M-47	9F-W-9084	M-45		
9(x)-4453V	M-47	9F-W-9084P	M-45		
9(x)-4454H	M-47	72(x)-120	M-48		
9(x)-4454V	M-47	72(x)-90HBLF	M-48		
9(x)-4903H	M-47	72(x)-90VI-24	M-48		
9(x)-4903V	M-47	72(x)-90VO-24	M-48		
9(x)-4904H	M-47	73(x)-120	M-48		
9(x)-4904V	M-47	73(x)-90HBLF	M-48		
9(x)-8006	M-46	73(x)-90VI-24	M-48		
9(x)-8008	M-46	73(x)-90VO-24	M-48		
9(x)-8016	M-46	75(x)-120	M-48		
		75(x)-90HBLF	M-48		

Cable Channel Accessories					
Catalog No.	Page	Catalog No.	Page	Catalog No.	Page
Aluminum Cable Channel Accessories		Steel Cable Channel Accessories			
99-1125	E-7	99-1125	E-7	9P-1261-3	E-6
9A-1043	E-5	9G-1043	E-5	9P-1261-4	E-6
9A-1044	E-5	9G-1044	E-5	9P-1261-6	E-6
9A-1044-6	E-5	9G-1044-6	E-5	9P-1543	E-5
9A-1237-3	E-6	9G-1231-3 & 4	E-7	9P-1544	E-5
9A-1237-4	E-6	9G-1231-6	E-7	9P-1546	E-5
9A-1237-6	E-6	9G-1232-3	E-7	9P-1583	E-5
9A-1243	E-6	9G-1232-4	E-7	9P-1584	E-5
9A-1244	E-6	9G-1232-6	E-7	9P-1586	E-5
9A-1245	E-6	9G-1237-3	E-7	9P-1643	E-6
9A-1246	E-6	9G-1237-4	E-7	9P-1644	E-6
9A-1261-3	E-6	9G-1237-6	E-7	9P-1646	E-6
9A-1261-4	E-6	9G-1243	E-6	9P-1743	E-5
9A-1261-6	E-6	9G-1244	E-6	9P-1744	E-5
9A-1543	E-5	9G-1245	E-6	9P-1746	E-5
9A-1544	E-5	9G-1246	E-6	9P-1843	E-5
9A-1546	E-5	9G-1261-3	E-6	9P-1844	E-5
9A-1583	E-5	9G-1261-4	E-6	9P-1846	E-5
9A-1584	E-5	9G-1261-6	E-6	9P-9023	E-8
9A-1586	E-5	9G-1543	E-5	9P-9024	E-8
9A-1643	E-6	9G-1544	E-5	9P-9033	E-8
9A-1644	E-6	9G-1546	E-5	9P-9034	E-8
9A-1646	E-6	9G-1583	E-5	9P-9036	E-8
9A-1743	E-5	9G-1584	E-5	9ZN-1231-3 & 4	E-7
9A-1744	E-5	9G-1586	E-5	9ZN-1231-6	E-7
9A-1746	E-5	9G-1643	E-6	9ZN-1232-3	E-7
9A-1843	E-5	9G-1644	E-6	9ZN-1232-4	E-7
9A-1844	E-5	9G-1646	E-6	9ZN-1232-6	E-7
9A-1846	E-5	9G-1743	E-5	9ZN-1237-3	E-7
9A-3305-3	E-7	9G-1744	E-5	9ZN-1237-4	E-7
9A-3305-4	E-7	9G-1746	E-5	9ZN-1237-6	E-7
9A-3305-6	E-7	9G-1843	E-5	9ZN-1243	E-6
9A-9023	E-8	9G-1844	E-5	9ZN-1244	E-6
9A-9024	E-8	9G-1846	E-5	9ZN-1245	E-6
9A-9033	E-8	9G-3305-3	E-7	9ZN-1246	E-6
9A-9034	E-8	9G-3305-4	E-7	9ZN-3305-3	E-7
9A-9036	E-8	9G-3305-6	E-7	9ZN-3305-4	E-7
B185CCL	E-7	9G-9023	E-8	9ZN-3305-6	E-7
		9G-9024	E-8	B185CCL	E-7
		9G-9033	E-8	B409-6	E-7
		9G-9034	E-8	B409-9	E-7
		9G-9036	E-8		
		9P-1043	E-5		
		9P-1044	E-5		
		9P-1044-6	E-5		

A = Aluminum
 G = Hot-Dipped Galvanized
 ZN = Zinc Plated

G = Hot-Dipped Galvanized
 P = Pre-Galvanized Steel
 ZN = Zinc Plated

Index

Index - Accessories

Index

Cable Channel Accessories

Catalog No.	Page	Catalog No.	Page	Catalog No.	Page
Stainless Steel Cable Channel Accessories				Fiberglass Cable Channel Accessories	
99-1125	E-7	9SS6-1245	E-6	9(x)-1001	M-50
9SS4-1043	E-5	9SS6-1246	E-6	9(x)-1013	M-50
9SS4-1044	E-5	9SS6-1261-3	E-6	9(x)-1023	M-51
9SS4-1044-6	E-5	9SS6-1261-4	E-6	9(x)-1033	M-51
9SS4-1237-3	E-6	9SS6-1261-6	E-6	9SS6-1247-3	M-51
9SS4-1237-4	E-6	9SS6-1543	E-5	9SS6-1247-4	M-51
9SS4-1237-6	E-6	9SS6-1544	E-5	9SS6-1247-6	M-51
9SS4-1243	E-6	9SS6-1546	E-5	9SS6-1247-8	M-51
9SS4-1244	E-6	9SS6-1583	E-5	9SS6-1248-3	M-51
9SS4-1245	E-6	9SS6-1584	E-5	9SS6-1248-4	M-51
9SS4-1246	E-6	9SS6-1586	E-5	9SS6-1248-6	M-51
9SS4-1261-3	E-6	9SS6-1643	E-6	9SS6-1248-8	M-51
9SS4-1261-4	E-6	9SS6-1644	E-6	9(x)-1301H	M-50
9SS4-1261-6	E-6	9SS6-1646	E-6	9(x)-1301V	M-51
9SS4-1543	E-5	9SS6-1743	E-5	9(x)-1451H	M-50
9SS4-1544	E-5	9SS6-1744	E-5	9(x)-1451V	M-51
9SS4-1546	E-5	9SS6-1746	E-5	9(x)-1901H	M-50
9SS4-1583	E-5	9SS6-1843	E-5	9(x)-1901V	M-51
9SS4-1584	E-5	9SS6-1844	E-5		
9SS4-1586	E-5	9SS6-1846	E-5		
9SS4-1643	E-6	9SS6-3305-3	E-7		
9SS4-1644	E-6	9SS6-3305-4	E-7		
9SS4-1646	E-6	9SS6-3305-6	E-7		
9SS4-1743	E-5	9SS6-9023	E-8		
9SS4-1744	E-5	9SS6-9024	E-8		
9SS4-1746	E-5	9SS6-9033	E-8		
9SS4-1843	E-5	9SS6-9034	E-8		
9SS4-1844	E-5	9SS6-9036	E-8		
9SS4-1846	E-5				
9SS4-3305-3	E-7				
9SS4-3305-4	E-7				
9SS4-3305-6	E-7				
9SS4-9023	E-8				
9SS4-9024	E-8				
9SS4-9033	E-8				
9SS4-9034	E-8				
9SS4-9036	E-8				
9SS6-1043	E-5				
9SS6-1044	E-5				
9SS6-1044-6	E-5				
9SS6-1237-3	E-6				
9SS6-1237-4	E-6				
9SS6-1237-6	E-6				
9SS6-1243	E-6				
9SS6-1244	E-6				

SS6 = Stainless Steel 316
(x) = Insert F for Polyester Resin
Insert A for Zero Halogen/Dis-Stat
Insert V for Vinyl Ester Resin

G = Hot-Dipped Galvanized
SS4 = Stainless Steel 304
SS6 = Stainless Steel 316
ZN = Zinc Plated

FLEXTRAY™ Accessories

Catalog No.	Page	Catalog No.	Page	Catalog No.	Page
Flextray™ Accessories					
1/4 FW	D-47	B444-1/4	D-48	FTA075CC	D-44
1/4 HN	D-47	B444-3/8	D-48	FTA100CC	D-44
1/4 LW	D-47	B444-1/2	D-48	FTA125CC	D-44
3/8 FW	D-47	B501-1	D-37	FTACRS-2	D-14
3/8 HN	D-47	B501-11/2	D-37	FTACRS-4	D-14
3/8 LW	D-47	B501-2	D-37	FTACRS-6	D-14
1/2 FW	D-47	B501-21/2	D-37	FTACRS-12-2	D-14
1/2 HN	D-47	B655-1/4	D-47	FTACRS-12-4	D-14
1/2 LW	D-47	B655-3/8	D-47	FTACRS-12-6	D-14
2 IN DIVIDER	D-40	B655-1/2	D-47	FTB2UB	D-20, D-28
2 IN CTR SUPT	D-19	B719EB	D-45	FTB06CS	D-26
4 C BRKT	D-30	B999	D-45	FTB06CT	D-21
4 IN DIVIDER	D-40	B3036L-3/8	D-47	FTB08CS	D-26
4 L BRKT	D-26	B3036L-1/2	D-47	FTB08CT	D-21
6 IN DIVIDER	D-40	BKC100	D-22	FTB12CS	D-26
8 C BRKT	D-30	BKC200	D-22	FTB12CT	D-21
8 L BRKT	D-26, D-36	BKCC	D-22	FTB16CS	D-26
12 C BRKT	D-30	BKP10063	D-22	FTB16CT	D-21
12 L BRKT	D-26, D-36	BKP10094	D-22	FTB18CS	D-26
16 L BRKT	D-26	BKP15094	D-22	FTB18CT	D-21
20 L BRKT	D-26	BKP15125	D-22	FTB20CS	D-26
24 L BRKT	D-26	BKP20125	D-22	FTB20CT	D-21
90 DEGREE KIT	D-14	BKP20188	D-22	FTB24CS	D-26
7187	D-48	BKW063	D-22	FTB24CT	D-21
7197	D-48	BKW094	D-22	FT BE 2X2	D-41
ARC-37-150	D-48	BKW125	D-22	FT BE 2X4	D-41
ARS-37-150	D-48	BKW188	D-22	FT BE 2X6	D-41
ARS-37-150SW	D-48	BKYH-18-094	D-24	FT BE 2X8	D-41
ARW-37-200	D-48	BKYH-18-094-Length	D-24	FT BE 2X12	D-41
ARW-37-200SW	D-48	BKYH-30-094	D-24	FT BE 2X16	D-41
ATR1/4X72	D-47	BKYH-30-094-Length	D-24	FT BE 2X18	D-41
ATR1/4X120	D-47	BTM WASHER	D-8	FT BE 2X20	D-41
ATR1/4X144	D-47	BW4	D-42	FT BE 2X24	D-41
ATR3/8X72	D-47	CABLE ROLLER	D-42	FT BE 4X4	D-41
ATR3/8X120	D-47	CLEANSHEAR	D-50	FT BE 4X6	D-41
ATR3/8X144	D-47	CLEANSHEAR BEND	D-50	FT BE 4X8	D-41
ATR1/2X72	D-47	CTR HUNG CLP	D-20	FT BE 4X12	D-41
ATR1/2X120	D-47	DROP OUT	D-43	FT BE 4X16	D-41
ATR1/2X144	D-47	FLEXMATE2	D-10	FT BE 4X18	D-41
ATTACHMENT CLP	D-28	FLEXMATE TOOL	D-10	FT BE 4X20	D-41
B22SGALV120	D-48	FTA2DO	D-43	FT BE 4X24	D-41
B22SHGALV120	D-48	FTA2FS	D-38	FT BE 6X8	D-41
B56SGALV120	D-48	FTA2RS	D-45	FT BE 6X12	D-41
B56SHGALV120	D-48	FTA4RS	D-45	FT BE 6X16	D-41
B201	D-47	FTA6HD	D-13, D-19, D-27	FT BE 6X18	D-41
B202	D-47	FTA6RS	D-45	FT BE 6X20	D-41
B409UF-12	D-37	FTA6SDO	D-43	FT BE 6X24	D-41
B409UF-18	D-37	FTA8SDO	D-43	FTHDWE 1/4	D-8
B409UF-21	D-37	FTA9WTK	D-29	FTS3SP	D-10
B441-22	D-48	FTA12SDO	D-43	FTS12ESK	D-13
		FTA050CC	D-28, D-44	FTS12SB	D-13

Index

Index - Accessories

Index

FLEXTRAY™ Accessories				Cable Cleats, & Firestop	
Catalog No.	Page	Catalog No.	Page	Catalog No.	Page
				Cable Cleats	
FTS20SK	D-16	SB301-1/2X8	D-20	9SS6-CCS Series	N-3
FTS21SK	D-16	SB420ACW	D-45	9SS6-CCT Series	N-2
FTS22SK	D-16	SB420AFB	D-45	9SS6-CCB-A	N-4
FTS23SK	D-16	SB420ATG	D-45	9SS6-CCB-B	N-4
FTS24SK	D-16	SB2204	D-44	9SS6-CCB-C	N-4
FTS36SB	D-13	SPLICE BAR	D-12	9SS6-CCB-D	N-4
FTSBK	D-12	SUPT WASHER	D-13, D-19, D-27		
FTSCH	D-9	TOOLLESS CLIP	D-36, D-42		
FTSHAK	D-14	TOP WASHER	D-8		
FTSTLC	D-11	TRAPEZE SUPT2	D-18		
FTSWN	D-9	WASHER SPL KIT	D-8		
FTU2X6X2	D-32	WB30BC	D-51		
FTU2X6X4	D-32	WB30RB	D-51		
FTU2X6X10	D-32	WB46H	D-18		
FTU2X12X2	D-32	WB48WMK	D-29		
FTU2X12X4	D-32	WB50BA	D-51		
FTU2X12X10	D-32	WB50RB	D-51		
FTU2X20X2	D-32	WB50WC	D-51		
FTU2X20X4	D-32	WB1224WMK	D-29		
FTU2X20X10	D-32	WBU1203	D-35		
FTU4X6X2	D-32	WBU1204	D-35		
FTU4X6X4	D-32	WBU1205	D-35		
FTU4X6X10	D-32	WBU1206	D-35		
FTU4X12X2	D-32	WBU1216	D-33		
FTU4X12X4	D-32	WBU1224	D-33		
FTU4X12X10	D-32	WBU1231	D-33		
FTU4X20X2	D-32	WBU2016	D-33		
FTU4X20X4	D-32	WBU2024	D-33		
FTU4X20X10	D-32	WBU2031	D-33		
FTU6X6X2	D-32	WBUCB8	D-34		
FTU6X6X4	D-32	WBUCB12	D-34		
FTU6X6X10	D-32	WBUCF	D-35		
FTU6X12X2	D-32	WBUCK12	D-34		
FTU6X12X4	D-32	WBUCK812	D-34		
FTU6X12X10	D-32	WBUF	D-38		
FTU6X20X2	D-32	WBUFA	D-38		
FTU6X20X4	D-32	WBUFLT	D-32		
FTU6X20X10	D-32	WBUFLT-06	D-32		
FTU120404	D-33	WBUFLT-12	D-32		
FTU120608	D-33	WBUHD	D-35		
FTU200404	D-33	WBUL16	D-34		
FTU200608	D-33	WBUL24	D-34		
GROUND BOLT	D-38, D-46	WBUL31	D-34		
GROUND SUPT GL	D-46	WBUPC	D-35		
LABEL CLIP	D-46	WBUTAPE	D-38		
N224	D-48	Z BRKT	D-27		
N225	D-48				
N228	D-48				
PEDESTAL CLAMP	D-36				
PEDESTAL KIT	D-36				
RACK CLAMP	D-44				
				Firestop	
				9P-FWS	O-6
				9P-WS	O-6
				FSP-AT-4	O-5
				FSP-BC-15	O-5
				FSP-BC-25	O-5
				FSP-CS-16x28	O-3
				FSP-CS-28x52	O-3
				FSP-CS-36x24	O-3
				FSP-CS-36x36	O-3
				FSP-CS-36x41	O-3
				FSP-EMAT	O-6
				FSP-MPP-4x8	O-3
				FSP-MPP-7x7	O-3
				FSP-MPP-9x9	O-3
				FSP-MPS	O-3
				FSP-QPR-4	O-4
				FSP-QPR-4BRK	O-4
				FSP-QPS-2	O-4
				FSP-QPS-2BRK	O-4
				FSP-QPS-4	O-4
				FSP-QPS-4BRK	O-4
				FSP-SLP-L	O-2
				FSP-SLP-M	O-2
				FSP-SLP-S	O-2

U.S. Customer Service Center is staffed Monday through Friday
from 7 a.m. to 5:00 p.m. Central Standard Time.
For more information, visit www.eaton.com/b-lineseries

Eaton
509 West Monroe Street
Highland, IL 62249
United States
Phone: (800) 851-7415
www.cooperbline.com/contactus

Eaton
Walrow Industrial Estate
Somerset, TA9 4AQ
United Kingdom
Phone: (44) 1278 772600
www.cooperbline.com/contactuk

Eaton
5925 McLaughlin Road
Mississauga, ON L5R 1B8
Canada
Phone: (800) 569-3660
www.cooperbline.com/contactca

Eaton
PO Box 70160 - Al Khobar - 31952
Kingdom of Saudi Arabia
Phone: 00966 3 812 2236
www.cooperbline.com/contactme

Eaton
1000 Eaton Boulevard
Cleveland, OH 44122
United States
Eaton.com

Eaton's B-Line Division
509 West Monroe Street
Highland, IL 62249
Phone: 800-851-7415
Fax: 618-654-1917
www.bline.com

© 2016 Eaton
All Rights Reserved
Printed in USA
Publication No. CT-16
July 2016 30M

Eaton is a registered trademark
All other trademarks are property
of their respective owners.