



2015
LG Lighting
Catalog



LG Electronics : A History of Innovation



Since 1947, LG Electronics has enjoyed a legacy of innovation, developing exceptional products that meet customers' needs while exceeding their expectations. Now, LG has brought that expertise to LED lighting, offering designers, property owners and contractors versatile retrofit options while assuring significant energy savings and fast payback with long-term return on investment.

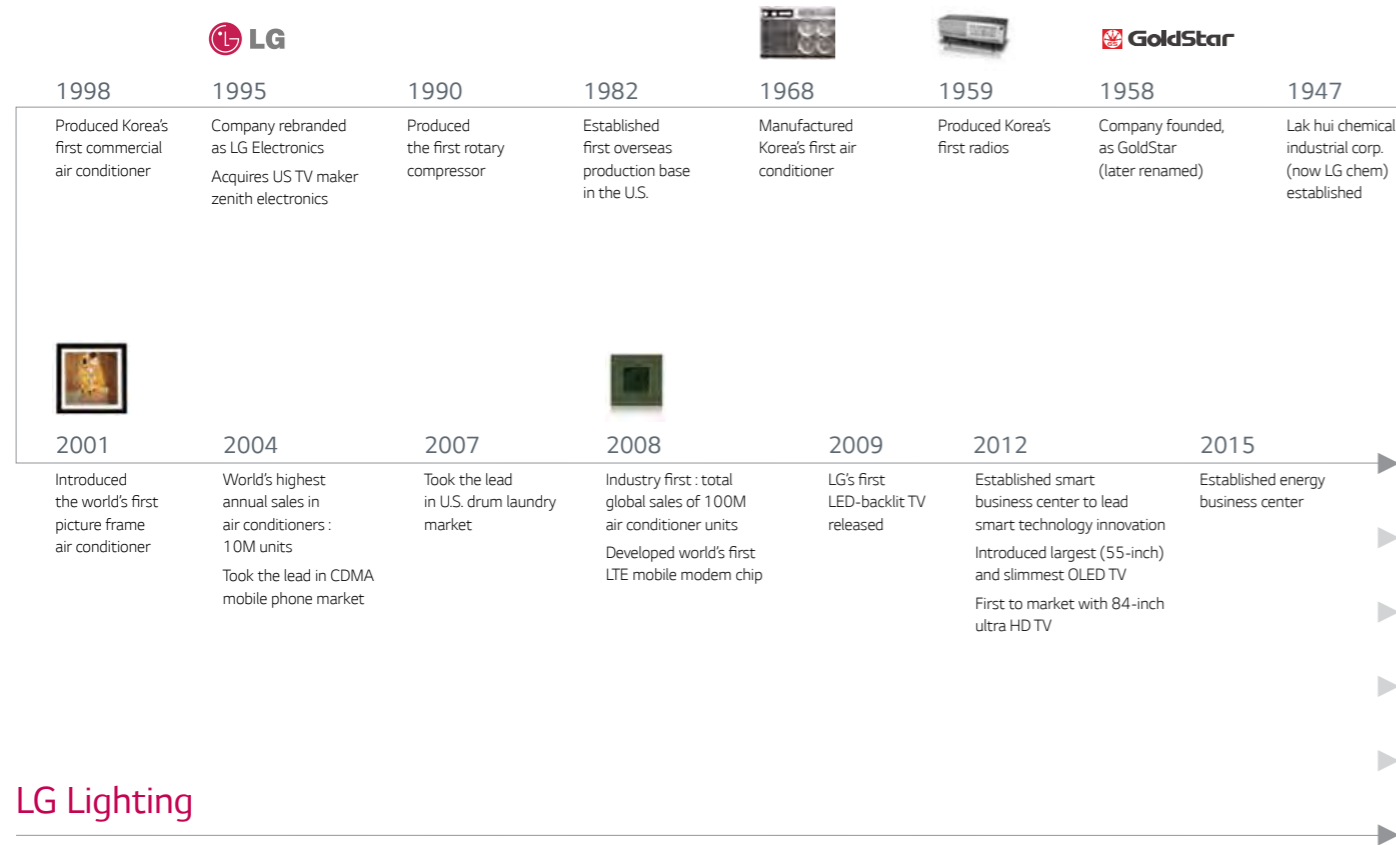

LG Lighting

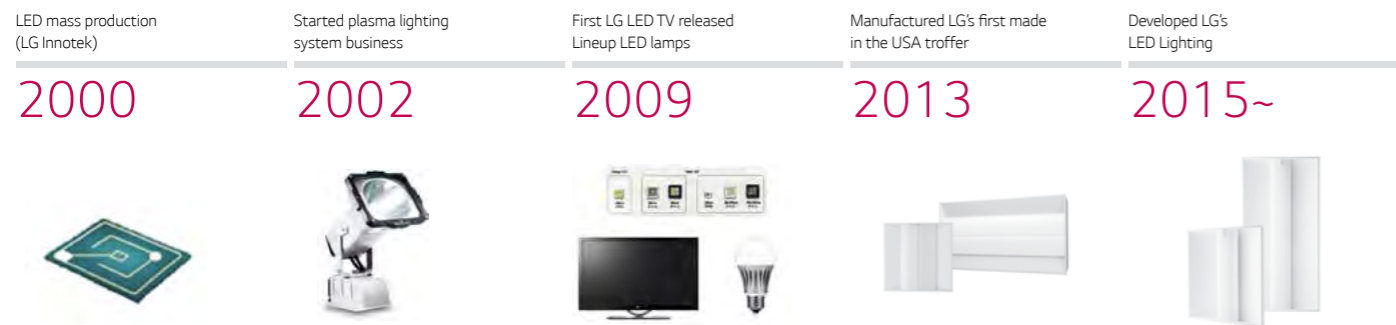

The LG Lighting Difference

LG is focused on driving profitability and payback in your retrofit project. That means increasing the return on investment with the highest efficacy troffers listed on the DLC. That efficiency pays back both in terms of reduced energy consumption and improved incentive eligibility. Improving payback is also about reducing first install costs by making installation easier. LG is also focused on protect your project budget and timeline by delivering products that meet rigorous quality controls using a vertically integrated supply chain.

LG Value
Rapid payback with high efficiency

LG Design
Superior light performance and aesthetics

LG Technology
ZigBee® wireless embedded

LG Quality
Rigorous quality control standards

LG Vertical Integration
Unmatched supply chain reliability



Performance Troffer

Premium aesthetics and light performance

Features

- Available in T-Bar lay-in, retrofit and emergency backup types
- Retrofit versions can be installed in 5–7 minutes, retaining the backframe of the existing luminaire
- High system efficacy up to 133 lm/W
- Diffuser with large luminous area provides soft light and visual comfort
- Standard 0-10 V dimming
- Wireless lighting control ready (ZigBee®)
- Integral emergency backup fixtures available
- Lumen maintenance of L85 at 50,000 hours
- 5-year warranty
- Made in USA

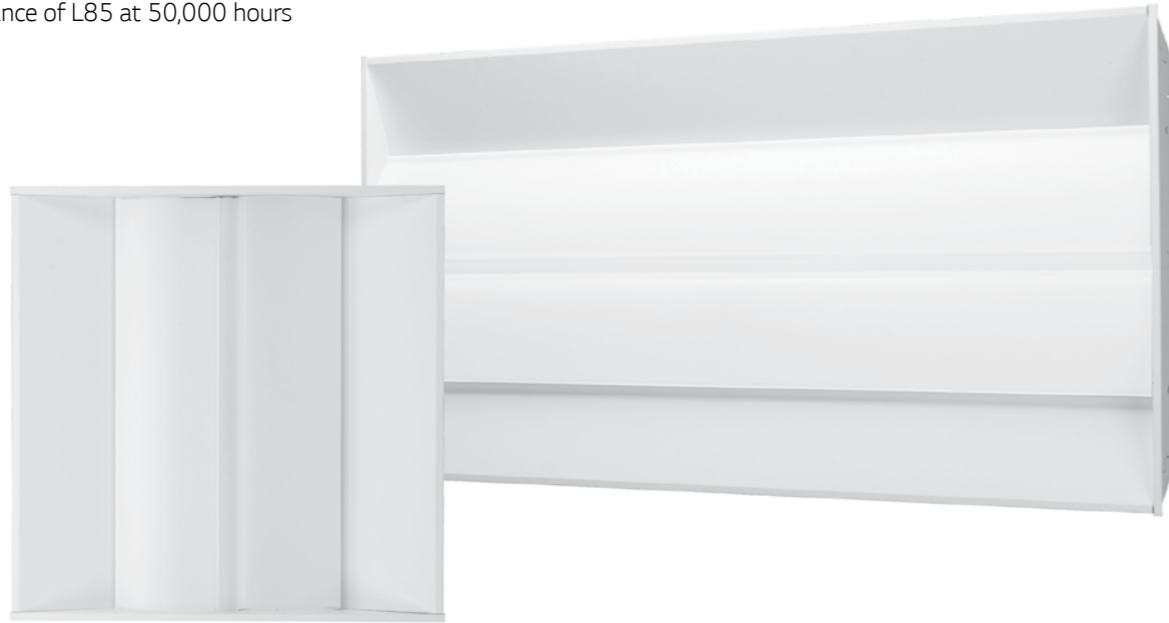

Product details

Quick upgrade solution (retrofit fixture)

Retrofit fixtures install simply in 5-7 minutes, using mounting brackets that attach to the existing housing. This retrofit solution saves on labor costs while delivering the aesthetics and light performance of a brand new LED fixture.



Dimension

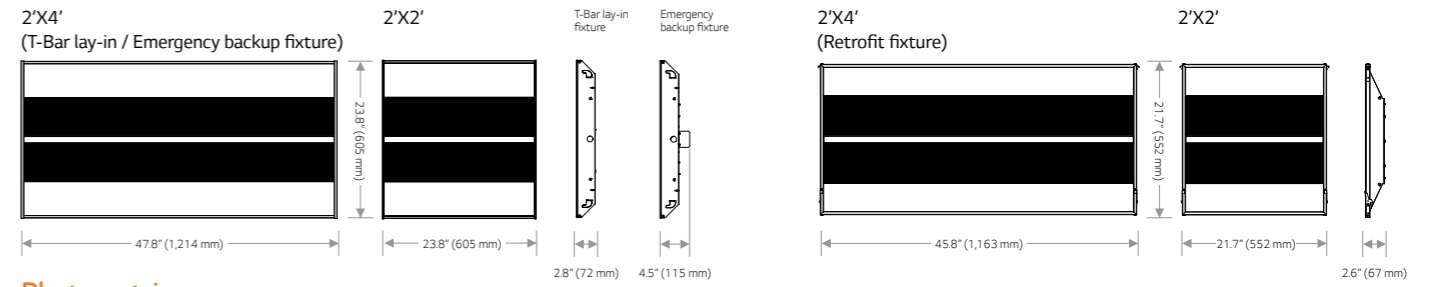

Photometrics

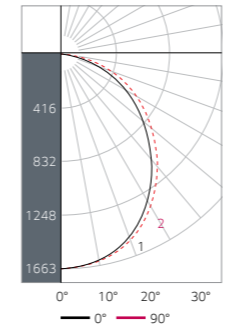

Coefficients of utilization - zonal cavity method

RC	Effective floor cavity reflectance 0.20			
	80	50	30	10
RW	70	50	30	10
RCR	0	119	119	119
1	109	104	100	96
2	99	91	84	79
3	91	80	72	66
4	83	71	62	56
5	76	64	55	48
6	71	57	49	42
7	66	52	43	37
8	61	48	39	33
9	57	44	36	30
10	54	40	33	27

Zonal lumen summary

Zone	Lumen	%Fixture
0-20	603	13.7
0-30	1269	28.8
0-40	2052	46.6
0-60	3522	80.0
0-80	4326	98.3
0-90	4400	100.0

Test : 2'X4', 34 W, 3500 K
Lumen : 4400 lm
Spacing creation (0-180) : 1.20
Spacing creation (90-270) : 1.24

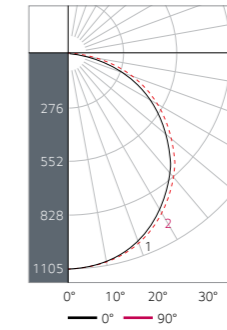

Coefficients of utilization - zonal cavity method

RC	Effective floor cavity reflectance 0.20			
	80	50	30	10
RW	70	50	30	10
RCR	0	119	119	119
1	109	104	99	95
2	99	90	83	77
3	90	79	71	64
4	82	70	61	54
5	75	62	53	46
6	70	56	47	40
7	64	51	42	36
8	60	46	38	32
9	56	42	34	29
10	53	39	31	26

Zonal lumen summary

Zone	Lumen	%Fixture
0-20	403	12.6
0-30	856	26.8
0-40	1403	43.8
0-60	2493	77.9
0-80	3140	98.1
0-90	3200	100.0

Test : 2'X2', 32 W, 3500 K
Lumen : 3200 lm
Spacing creation (0-180) : 1.24
Spacing creation (90-270) : 1.26

Specifications & ordering information

Product type	Model code (US order code)	Input power	Delivered light output	Efficacy	CCT	IP	UGR	Beam angle	CRI	Input voltage	Power factor	Operating temperature	Dimensions	Optical unit	Weight	Controls												
		W	lm	lm/W	K	-	-	°	-	Vac	-	F (°C)	inch (mm)	-	lb (kg)	-												
T-Bar lay-in fixture	FRR626D2HOABUAAWAA (LGE-2X4RT-26-35-3400-TB)	26	3380	130	3500	20	≤18	105	82	120 - 277	≥0.9	-4 - 122 (-20 - 50)	23.8X47.8X2.8 (605X1,214X72)	Frost (PMMA)	16.5 (7.5)	0-10 V (ZigBee ready)												
	FRR626D3HOABUAAWAA (LGE-2X4RT-26-40-3400-TB)	26	3400	131	4000																							
	FRR634D2HOBBUAAWAA (LGE-2X4RT-34-35-4400-TB)	34	4400	129	3500																							
	FRR634D3HOBBUAAWAA (LGE-2X4RT-34-40-4500-TB)	34	4500	132	4000																							
	FRR648D2HOABUAAWAA (LGE-2X4RT-48-35-5800-TB)	48	5550	116	3500																							
	FRR648D3HOABUAAWAA (LGE-2X4RT-48-40-6000-TB)	48	5750	120	4000																							
	FRS618D2HOABUAAWAA (LGE-2X2RT-18-35-2350-TB)	18	2350	131	3500																							
	FRS618D3HOABUAAWAA (LGE-2X2RT-18-40-2400-TB)	18	2400	133	4000																							
	FRS632D2HOABUAAWAA (LGE-2X2RT-32-35-3400-TB)	32	3200	100	3500																							
	FRS632D3HOABUAAWAA (LGE-2X2RT-32-40-3400-TB)	32	3250	102	4000																							
Retrofit fixture	FRR626D2HRABUAAWBB (LGE-2X4RT-26-35-3400-R(W))	26	3380	130	3500	20	≤18	105	82	120 - 277	≥0.9	-4 - 122 (-20 - 50)	21.7X45.8X2.6 (552X1,163X67)	Frost (PMMA)	14.6 (6.6)	0-10 V (ZigBee ready)												
	FRR626D3HRABUAAWBB (LGE-2X4RT-26-40-3400-R(W))	26	3400	131	4000																							
	FRR634D2HRBUAAWBB (LGE-2X4RT-34-35-4400-R(W))	34	4400	129	3500																							
	FRR634D3HRBUAAWBB (LGE-2X4RT-34-40-4500-R(W))	34	4500	132	4000																							
	FRS618D2HRABUAAWBB (LGE-2X2RT-18-35-2350-R(W))	18	2350	131	3500																							
	FRS618D3HRABUAAWBB (LGE-2X2RT-18-40-2400-R(W))	18	2400	133	4000																							
	FRS632D2HRABUAAWBB (LGE-2X2RT-32-35-3400-R(W))	32	3200	100	3500																							
	FRS632D3HRABUAAWBB (LGE-2X2RT-32-40-3400-R(W))	32	3250	102	4000																							
	Emergency backup fixture	FRR641D2H5BUBUAAWAA (LGE-2X4RT-41-35-4400-EM)	41	4400	107												3500	20	≤18	105	82	120 - 277	≥0.9	-4 - 122 (-20 - 50)	23.8X47.8X4.5 (605X1,214X115)	Frost (PMMA)	19.2 (8.7)	0-10 V (ZigBee ready)
		FRR641D3H5BUBUAAWAA (LGE-2X4RT-41-40-4500-EM)	41	4500	110												4000											
FRS639D2H5AUBUAAWAA (LGE-2X2RT-39-35-3300-EM)		39	3300	85	3500																							
FRS639D3H5AUBUAAWAA (LGE-2X2RT-39-40-3350-EM)		39	3350	86	4000																							

• Emergency initial lumens : 1400 lm • Emergency operating time : 90 minutes +

Compliance

T-Bar lay-in fixture

- cULus Listed to UL 1598, suitable for damp location use
- DesignLights Consortium qualified products
- Based on photometric testing consistent with IES LM-79

Retrofit fixture

- cULus Listed to UL 1598C, suitable for damp location use
- DesignLights Consortium qualified products
- Based on photometric testing consistent with IES LM-79

Emergency backup fixture

- cULus listed to UL 924, suitable for damp location use
- Suitable for operation in ambient not exceeding 104 °F
- DesignLights Consortium qualified products
- Based on photometric testing consistent with IES LM-79



Simple Choice Troffer with sensor connect option

Delivering faster payback through reduced upfront cost

Features

- System efficacy up to 100 lm/W
- Standard 0-10 V dimming
- Wireless lighting control ready (ZigBee®)
- Sensor-embedded (occupancy sensing & daylight harvesting) models are available for additional energy savings
- Lumen maintenance of L78 at 50,000 hours
- 5-year warranty



Product details



Occupancy sensing & daylight harvesting

- No re-circuiting or mounting for sensors
- Wireless control
- Pre-programmed optimal values



Rugged housing

The rugged housing doesn't easily get distorted when handled and the matt finish prevents fingerprints.

Soft light

When looking directly at the luminaire, the light is soft with low glare.



Dimension

- Simple choice / Sensor connect

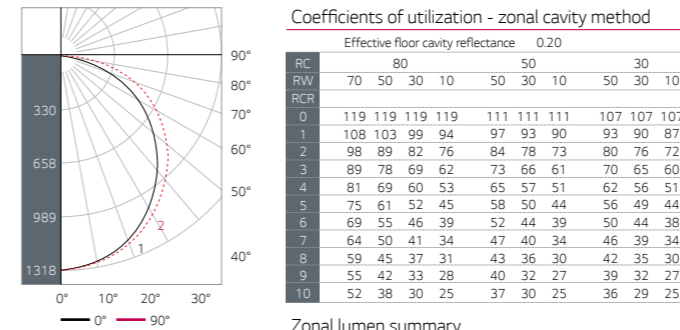
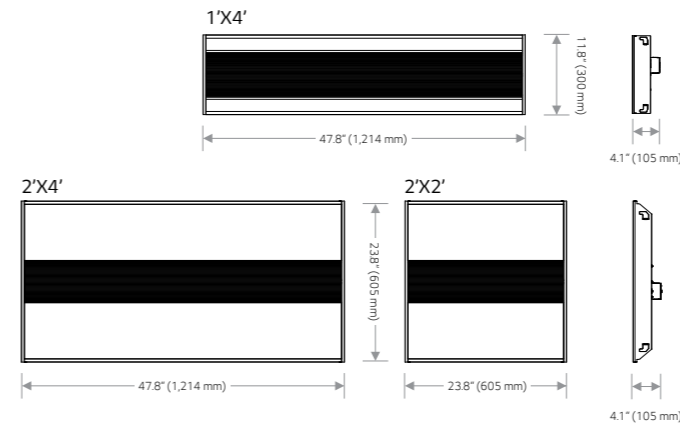

Test: 2'X4', 40 W, 3500 K
Lumen: 4000 lm
Spacing criterion (0-180): 1.24
Spacing criterion (90-270): 1.28

Zone	Lumen	%Fixture
0-20	480	12.0
0-30	1021	25.5
0-40	1673	41.8
0-60	3017	75.4
0-80	3900	97.5
0-90	4000	100.0

Photometrics

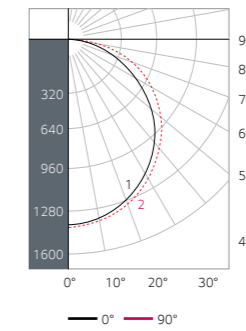

Test: 1'X4', 40 W, 3500 K
Lumen: 4000 lm
Spacing criterion (0-180): 1.26
Spacing criterion (90-270): 1.26

		Effective floor cavity reflectance 0.20									
		80		50		30		10		10	
RC	RW	70	50	30	10	50	30	10	50	30	10
RCR	0	119	119	119	119	111	111	111	106	106	106
	1	109	104	100	96	98	95	92	94	91	89
	2	99	91	84	78	85	80	75	82	78	74
	3	90	80	71	65	75	69	63	72	67	62
	4	83	70	62	55	67	59	54	64	58	53
	5	76	63	54	47	60	52	46	58	51	46
	6	70	57	48	41	54	46	41	52	45	40
	7	65	51	42	36	49	41	36	47	41	36
	8	60	47	38	32	45	37	32	43	37	32
	9	56	43	35	29	41	34	29	40	33	29
	10	53	40	32	26	38	31	26	37	31	26

Zone	Lumen	%Fixture
0-20	513	12.8
0-30	1089	27.2
0-40	1786	44.6
0-60	3173	79.2
0-80	3946	98.6
0-90	4004	100.0

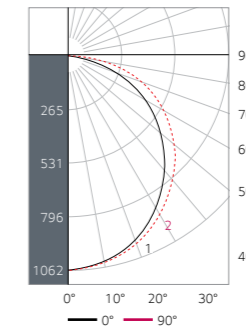

Test: 2'X2', 32 W, 3500 K
Lumen: 3200 lm
Spacing criterion (0-180): 1.24
Spacing criterion (90-270): 1.30

		Effective floor cavity reflectance 0.20									
		80		50		30		10		10	
RC	RW	70	50	30	10	50	30	10	50	30	10
RCR	0	119	119	119	119	111	111	111	106	106	106
	1	108	103	98	94	96	93	90	92	90	87
	2	98	89	82	76	84	78	73	80	76	72
	3	89	78	69	62	73	67	61	70	65	60
	4	81	69	60	53	65	57	52	63	56	51
	5	75	61	52	45	58	50	44	56	49	44
	6	69	55	46	39	52	45	39	51	44	38
	7	64	50	41	35	47	40	34	46	39	34
	8	59	45	37	31	43	36	31	42	35	30
	9	55	42	33	28	40	32	27	39	32	27
	10	52	38	30	25	37	30	25	36	29	25

Zone	Lumen	%Fixture
0-20	387	12.1
0-30	823	25.7
0-40	1354	42.3
0-60	2430	75.9
0-80	3125	97.7
0-90	3200	100.0

Specifications & ordering information

Product type	Model code (US order code)	Input power	Delivered light output	Efficacy	CCT	IP	UGR	Beam angle	CRI	Input voltage	Power factor	Operating temperature	Dimensions	Optical unit	Weight	Controls
		W	lm	lm/W	K	-	-	°	-	Vac	-	°F (°C)	inch (mm)	-	lb (kg)	-
Simple choice	F4035TB1131.BUAAWAA (LGE-1X4SI-40-35-4000-TB)	40	4000	100	3500	20	≤19	120	82	120 - 277	≥0.9	-4 - 104 (-20 - 40)	11.8X47.8X4.14 (300X1,214X105)	White (PC)	7.9 (3.6)	0-10 V (ZigBee ready)
	F4040TB1131.BUAAWAA (LGE-1X4SI-40-40-4000-TB)	40	4000		4000											
	FRR640D2H0A.BUAAWAA (LGE-2X4SI-40-35-4000-TB)	40	4000		3500											
	FRR640D3H0A.BUAAWAA (LGE-2X4SI-40-40-4000-TB)	40	4000		4000											
	FRS632D2H0B.BUAAWAA (LGE-2X2SI-32-35-3200-TB)	32	3200		3500											
	FRS632D3H0B.BUAAWAA (LGE-2X2SI-32-40-3200-TB)	32	3200		4000											
Sensor connect	F4035TB1S31.BUAAWAA (LGE-1X4SC-40-35-4000-TB)	40	4000	100	3500	20	≤19	120	82	120 - 277	≥0.9	-4 - 104 (-20 - 40)	11.8X47.8X4.14 (300X1,214X105)	White (PC)	12.6 (5.7)	ZigBee
	F4040TB1S31.BUAAWAA (LGE-1X4SC-40-40-4000-TB)	40	4000		4000											
	FRR640D2H0C.BUAAWAA (LGE-2X4SC-40-35-4000-TB)	40	4000		3500											
	FRR640D3H0C.BUAAWAA (LGE-2X4SC-40-40-4000-TB)	40	4000		4000											
	FRS632D2H0C.BUAAWAA (LGE-2X2SC-32-35-3200-TB)	32	3200		3500											
	FRS632D3H0C.BUAAWAA (LGE-2X2SC-32-40-3200-TB)	32	3200		4000											

- Motion sensor specification
 - Mounting height: Max. 11.5 ft
 - Dimming level adjustment: 0/30,100%
 - Delay time adjustment: 0.5-20 min.
 - Sensor coverage: (1.6 X h) X (2.0 X h) m² @ height(h)

Compliance

- cULus Listed to UL 1598, suitable for damp location use (2'X4' / 2'X2')
- cETLus Listed to UL 1598, suitable for damp location use (1'X4')
- DesignLights Consortium qualified products
- Based on photometric testing consistent with IES LM-79



Retrofit Board & Driver Kit

The simplest way to upgrade to LED lighting

Features

- Simple retrofit solution for typical 2' or 4' troffers
- Efficacy up to 130 lm/W (light source level)
- Standard 0-10 V dimming
- Wireless lighting control ready (ZigBee®)
- Lumen maintenance of L85 at 50,000 hours
- 5-year warranty



Product details

Easy installation

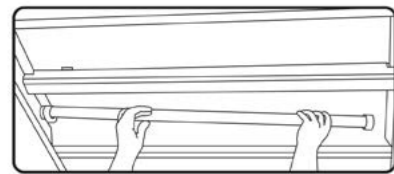

Remove lens frame and existing fluorescent tubes and ballast

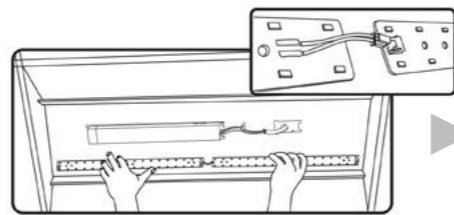

Install LED boards and driver

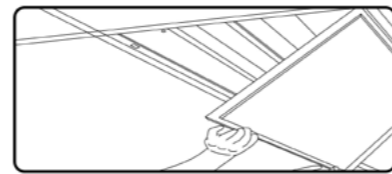

Re-install lens frame, turn power back on

Kit includes

- 2 LED boards for 2'X2'; 4 LED boards for 2'X4'
- Driver
- Driver screw
- Mounting tape on the back that allows the installer to ensure alignment during screw-in installation
- UL1598C certification label
- Installation manual

Dimension

Retrofit board
2'X4'

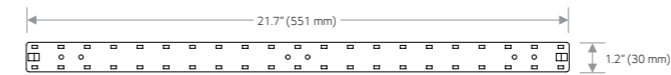

2'X2'

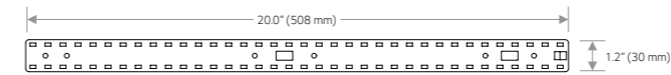

Driver

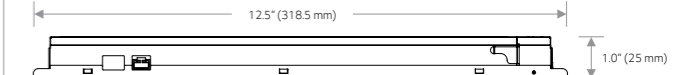
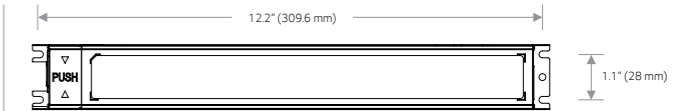

Photometrics

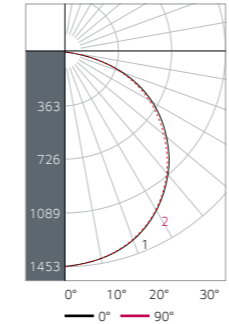

Coefficients of utilization - zonal cavity method

RC	Effective floor cavity reflectance									
	0.20					0.30				
RW	70	50	30	10	50	30	10	50	30	10
RCR										
0	119	119	119	119	111	111	111	106	106	106
1	109	104	100	96	97	94	91	93	91	88
2	99	90	84	78	85	80	75	82	77	73
3	90	79	71	64	75	68	63	72	66	62
4	82	70	61	54	66	59	53	64	58	53
5	75	62	53	47	59	52	46	57	51	45
6	70	56	47	41	53	46	40	52	45	40
7	65	51	42	36	48	41	35	47	40	35
8	60	46	38	32	44	37	32	43	36	31
9	56	43	34	29	41	33	28	40	33	28
10	53	39	31	26	38	31	26	37	30	26

Zonal lumen summary

Zone	Lumen	%Fixture
0-20	534	12.5
0-30	1140	26.6
0-40	1880	43.9
0-60	3370	78.7
0-80	4208	98.3
0-90	4280	100.0

Test: 2'X4'; 34 W, 3500 K
Lumen: 4280 lm
Spacing creation (0-180): 1.28
Spacing creation (90-270): 1.28

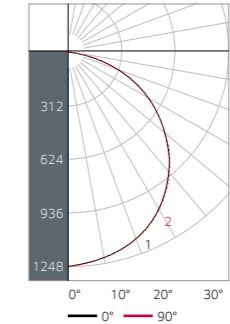

Coefficients of utilization - zonal cavity method

RC	Effective floor cavity reflectance									
	0.20					0.30				
RW	70	50	30	10	50	30	10	50	30	10
RCR										
0	119	119	119	119	111	111	111	106	106	106
1	109	104	100	96	97	94	91	94	91	88
2	99	90	84	78	85	80	75	82	77	73
3	90	79	71	64	75	68	63	72	66	62
4	82	70	61	54	66	59	53	64	58	53
5	76	63	53	47	59	52	46	57	51	45
6	70	56	47	41	53	46	40	52	45	40
7	65	51	42	36	49	41	35	47	40	35
8	60	46	38	32	44	37	32	43	36	31
9	56	43	34	29	41	34	28	40	33	28
10	53	39	31	26	38	31	26	37	30	26

Zonal lumen summary

Zone	Lumen	%Fixture
0-20	458	12.5
0-30	977	26.7
0-40	1612	44.0
0-60	2887	78.9
0-80	3601	98.4
0-90	3660	100.0

Test: 2'X2'; 29 W, 3500 K
Lumen: 3660 lm
Spacing creation (0-180): 1.28
Spacing creation (90-270): 1.28

Specifications & ordering information

Product type	Model code (US order code)	Input power	Delivered light output	Efficacy	CCT	UGR	Beam angle	CRI	Input voltage	Power factor	Operating temperature	Dimensions		Weight	Controls
												inch (mm)	lb (kg)		
Retrofit board & driver kit	FRR634D1HZZ.BJAAWAA (LGE-4BDK-34-30-4200)	34	4240	125	3000				Vac			12.5X1.1X1.0 (319X28X25)	1.4 (0.6)	0-10 V (ZigBee ready)	
	FRR634D2HZZ.BJAAWAA (LGE-4BDK-34-35-4300)	34	4280	126	3500										
	FRR634D3HZZ.BJAAWAA (LGE-4BDK-34-40-4400)	34	4420	130	4000										
	FRR629D2HZZ.BJAAWAA (LGE-4BDK-29-35-3700)	29	3660	126	3500	≤19	117	82	120 - 277	≥0.9	-4 - 122 (-20 - 50)	12.5X1.1X1.0 (319X28X25)	1.1 (0.5)		
	FRR629D3HZZ.BJAAWAA (LGE-4BDK-29-40-3800)	29	3770	130	4000										
	FRS629D2HZZ.BJAAWAA (LGE-2BDK-29-35-3700)	29	3660	126	3500										
	FRS629D3HZZ.BJAAWAA (LGE-2BDK-29-40-3800)	29	3770	130	4000										

Compliance

- Retrofit board: cULus classified to UL 1598C, suitable for damp location use
- Driver: cULus recognized to UL 8750, suitable for damp location use
- DesignLights Consortium qualified products
- Based on photometric testing consistent with IES LM-79



LED Tube (T8) 2-Lamps & 1-Driver System

Wireless-enabled LED Tube

Features

- LED tube with a dedicated remote driver
- Better reliability and longer lifespan than LED tubes with internal drivers
- System efficacy up to 111 lm/W
- Wide beam angle 180° (the angle light reaches is 270°)
- Standard 0-10 V dimming
- Wireless lighting control ready (ZigBee®)
- Lumen maintenance of L85 at 50,000 hours
- 5-year warranty



Dimension

LED Tube

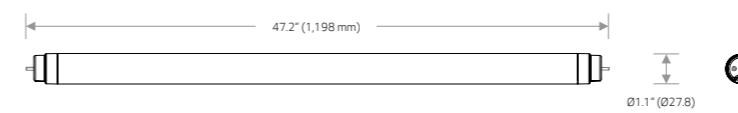

Driver

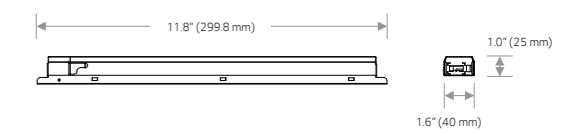

Photometrics

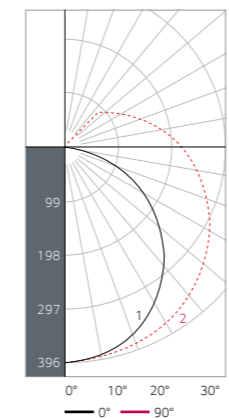

Coefficients of utilization - zonal cavity method

RC	Effective floor cavity reflectance 0.20									
	80			50			30			
RW	70	50	30	10	50	30	10	50	30	10
0	111	111	111	111	97	97	97	88	88	88
1	98	92	87	83	80	77	73	73	70	68
2	88	79	72	65	69	63	58	63	58	54
3	80	69	60	53	60	53	48	54	49	44
4	73	60	51	44	53	46	40	48	42	37
5	67	53	44	37	47	40	34	43	37	32
6	61	48	39	32	42	35	30	38	32	28
7	57	43	34	28	38	31	26	35	29	24
8	53	39	31	25	35	28	23	32	26	22
9	49	36	28	22	32	25	20	29	24	19
10	46	33	25	20	29	23	18	27	21	17

Test : 18 W, 4000 K (1 lamp)
Lumen : 1900 lm
Spacing creation (0-180) : 1.26
Spacing creation (90-270) : 1.42

Zonal lumen summary

Zone	Lumen	%Lamp
0-20	146.3	7.7
0-30	315.4	16.6
0-40	526.3	27.7
0-60	993.7	52.3
0-80	1379.4	72.6
0-90	1512.4	79.6
10-90	1474.4	77.6
20-40	380.0	20.0
20-50	613.7	32.3
40-70	678.3	35.7
60-80	385.7	20.3
70-80	174.8	9.2
80-90	133.0	7.0
90-110	199.5	10.5
90-120	271.7	14.3
90-130	323.0	17.0
90-150	343.9	18.1
90-180	387.6	20.4
110-180	186.2	9.8
0-180	1900.0	100.0

Specifications & ordering information

LED Tube

Model code (US order code)	Input power	Delivered light output	Efficacy	CCT	Beam angle	CRI	Input voltage	Power factor	Operating temperature	Dimensions	Weight
	W	lm	lm/W	K	°	-	Vac	-	°F (°C)	inch (mm)	lb (kg)
T1840GE502DBUAAWAA (LGE-TUBE-18-40-1900-ED2)	18	1900	106	4000	180	83	120 - 277	≥0.9	-4 - 122 (-20 - 50)	Ø1.1X47.2 (Ø27.8X1,198)	0.7 (0.3)
T1850GE502DBUAAWAA (LGE-TUBE-18-50-2000-ED2)		2000	111	5000							

Driver

Model code (US order code)	Control	Dimensions
		inch (mm)
TC362ZHC.BUAAWAA (LGE-TUBE-DRIVER-2TUBE)	0-10 V (ZigBee ready)	11.8X1.6X1.0 (299.8X40X25)

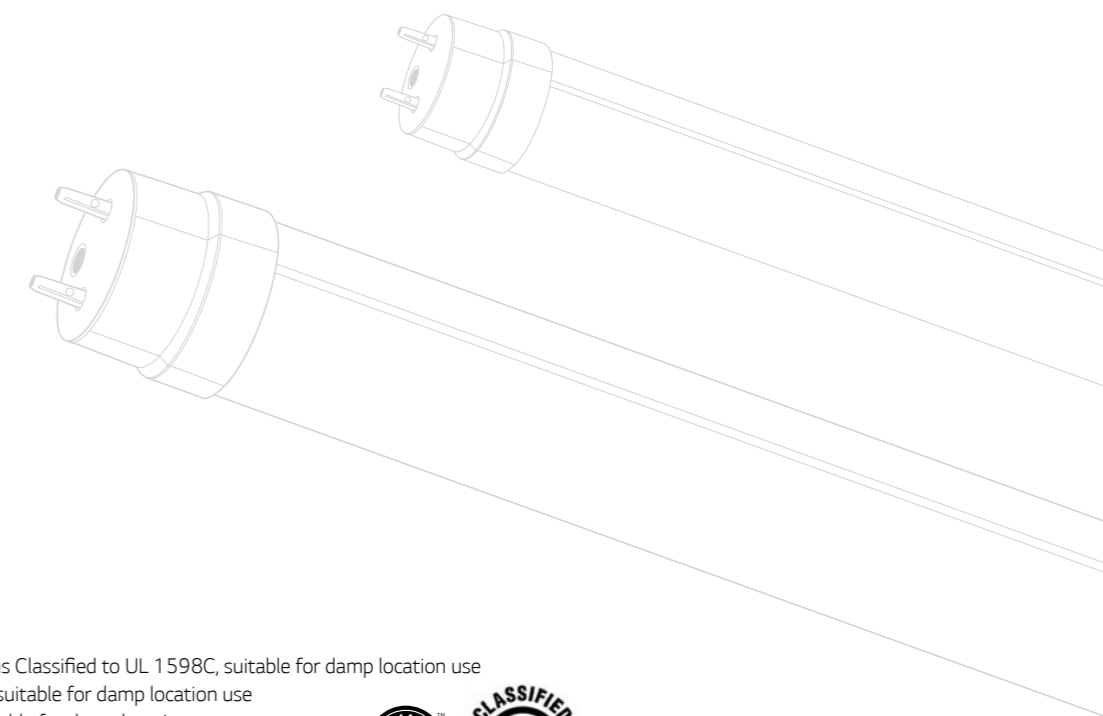

Compliance

- LED retrofit luminaire conversion kit: cULus Classified to UL 1598C, suitable for damp location use
- LED Tube: cULus recognized to UL 1993, suitable for damp location use
- Driver: cULus recognized to UL 8750, suitable for damp location use
- DesignLights Consortium qualified products
- Based on photometric testing consistent with IES LM-79



Simple Choice High Bay

Reliable performance with a low installation cost

Features

- System efficacy up to 104 lm/W
- Precision optics – medium and wide distribution
- Steel housing, powder-coating
- Provides two carabiners for easy connection
- Wireless lighting control ready (ZigBee®)
- Step dimming with plug-and-play motion sensor
- Ambient operating temperature -22 °F ~104 °F
- 230 W : L85 at 50,000 hours, 120 W : L76 at 50,000 hours
- 5-year warranty



Product details

Easy installation

Factory included carabiners mount the fixture easily to a chain



Light weight

Light weight ensure easy handling and installation



Motion sensor

- Easy plug-and-play motion sensor
- Adjustable time delay and dimming level

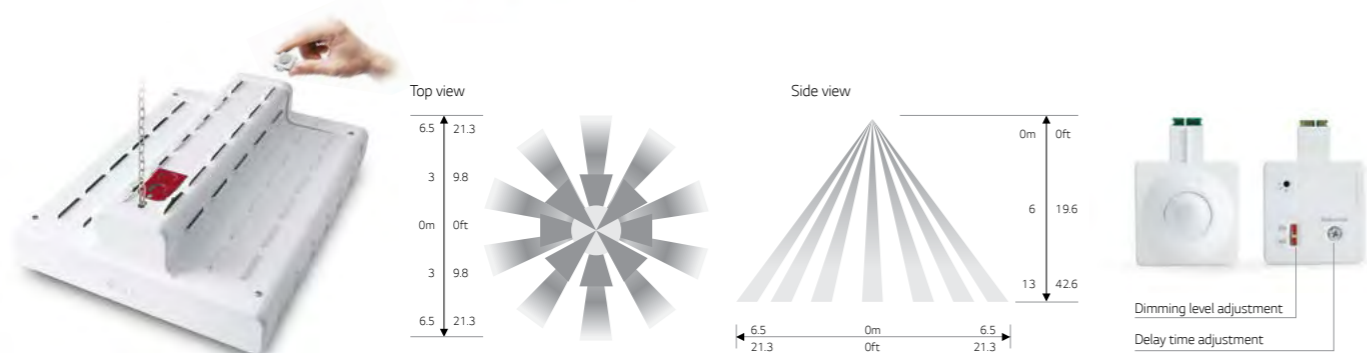

Dimension

120 W

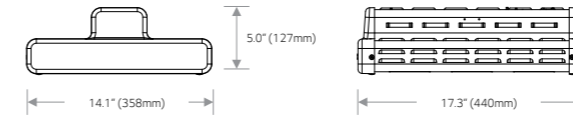

230 W

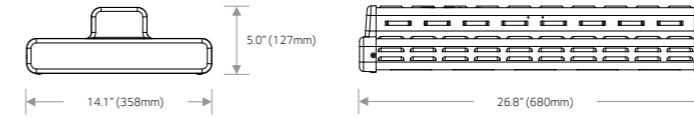

Photometrics

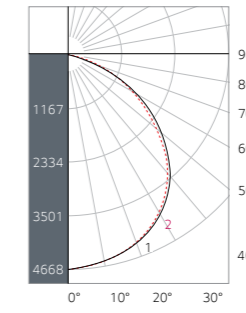

Test : 120 W, 120°
Lumen : 12000 lm
Spacing creation (0-180) : 1.28
Spacing creation (90-270) : 1.26

Coefficients of utilization - zonal cavity method

RC	Effective floor cavity reflectance						0.20						
	70	50	30	10	50	30	10	50	30	10	50	30	10
RW	80	50	30	10	111	111	111	106	106	106			
RCR	0	119	119	119	119	111	111	111	106	106	106		
	1	110	106	102	98	99	96	94	95	93	91		
	2	101	93	87	82	88	83	79	85	81	77		
	3	92	82	75	69	78	72	67	75	70	66		
	4	85	73	65	59	70	63	58	67	62	57		
	5	78	66	57	51	63	56	50	61	55	50		
	6	72	59	51	45	57	50	44	55	49	44		
	7	67	54	46	40	52	44	39	50	44	39		
	8	62	49	41	35	47	40	35	46	40	35		
	9	58	45	37	32	44	37	32	43	36	32		
	10	55	42	34	29	40	33	29	39	33	29		

Zonal lumen summary

Zone	Lumen	%Fixture
0-20	1713	14.3
0-30	3656	30.5
0-40	6003	50.0
0-60	10286	85.7
0-80	11906	99.2
0-90	12000	100.0

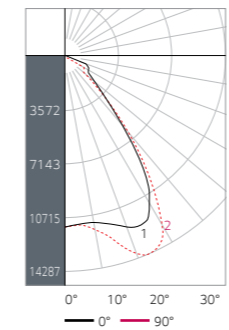

Test : 230 W, 85°
Lumen : 24000 lm
Spacing creation (0-180) : 1.34
Spacing creation (90-270) : 1.40

Coefficients of utilization - zonal cavity method

RC	Effective floor cavity reflectance						0.20						
	70	50	30	10	50	30	10	50	30	10	50	30	10
RW	80	50	30	10	111	111	111	106	106	106			
RCR	0	119	119	119	119	111	111	111	106	106	106		
	1	111	108	104	101	101	99	96	97	95	94		
	2	103	97	91	87	92	87	84	88	85	82		
	3	96	87	81	75	83	78	74	80	76	72		
	4	89	79	72	66	76	70	65	74	68	64		
	5	83	72	65	59	69	63	58	67	62	58		
	6	78	66	59	53	64	57	53	62	56	52		
	7	73	61	53	48	59	52	48	57	52	47		
	8	68	56	49	44	54	48	43	53	47	43		
	9	64	52	45	40	51	44	40	50	44	40		
	10	60	49	41	37	47	41	36	46	40	36		

Zonal lumen summary

Zone	Lumen	%Fixture
0-20	4516	18.8
0-30	10606	44.2
0-40	1678	69.5
0-60	21616	90.1
0-80	23929	99.7
0-90	24000	100.0

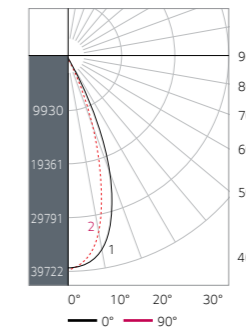

Test : 230 W, 50°
Lumen : 24000 lm
Spacing creation (0-180) : 0.72
Spacing creation (90-270) : 0.60

Coefficients of utilization - zonal cavity method

RC	Effective floor cavity reflectance						0.20						
	70	50	30	10	50	30	10	50	30	10	50	30	10
RW	80	50	30	10	111	111	111	106	106	106			
RCR	0	119	119	119	119	111	111	111	106	106	106		
	1	113	110	107	104	103	101	99	100	98	96		
	2	107	101	97	93	96	93	90	93	90	88		
	3	101	94	89	84	90	86	82	87	84	81		
	4	96	88	82	77	84	80	76	82	78	75		
	5	91	83	77	72	80	75	71	78	74	70		
	6	87	78	72	67	76	71	67	74	70	66		
	7	83	74	68	64	72	67	63	71	66	63		
	8	80	70	64	60	69	63	60	68	63	60		
	9	76	67	61	57	66	60	57	65	60	57		
	10	73	64	58	55	63	58	54	62	57	54		

Zonal lumen summary

Zone	Lumen	%Fixture
0-20	12037	50.2
0-30	17864	74.4
0-40	19762	82.3
0-60	21942	91.4
0-80	23943	99.8
0-90	24008	100.0

Specifications & ordering information

High Bay

Model code (US order code)	Input power	Delivered light output	Efficacy	CCT	IP	UGR	Beam angle	CRI	Input voltage	Power factor	Operating temperature	Dimensions	Optical unit	Weight	Controls
H1240PA2N0A-ACWB000 (LGE-HB-120-40-12000)	120	12000	100	4000	20	28	120	83	120 - 277	≥0.9	-22 - 104 (-30 - 40)	17.3X14.1X5.0 (440X358X127)	Tempered glass	9.9 (4.5)	Motion sensor (Step dimming)
H1257PA2N0A-ACWB000 (LGE-HB-120-57-12000)	120	12000	100	5700	20	28	120	83	120 - 277	≥0.9	-22 - 104 (-30 - 40)	17.3X14.1X5.0 (440X358X127)	Tempered glass	9.9 (4.5)	Motion sensor (Step dimming)
H2440P50N0A-ACWB000 (LGE-HB-230-40-24000-50D)	230	24000	104	4000	20	25	50	83	200 - 277	≥0.9	-22 - 104 (-30 - 40)	26.8X14.1X5.0 (680X358X127)	Tempered glass	20.9 (9.5)	Motion sensor (Step dimming)
H2440P85N0A-ACWB000 (LGE-HB-230-40-24000-85D)	230	24000	104	4000	20	25	85	83	200 - 277	≥0.9	-22 - 104 (-30 - 40)	26.8X14.1X5.0 (680X358X127)	Tempered glass	20.9 (9.5)	Motion sensor (Step dimming)

Motion sensor

Model code (US order code)	Input Power	Input Voltage	Frequency	Communication type	Dimensions	Mounting Height	Dimming level adjustment	Delay time adjustment	Operating Temperature
9SD751TVDA-ALWB000 (LGE-HB-OSZ)	0.17	3.3	2405-2480	ZigBee	3.0X2.1X1.0 (75X54X25)	ft. Max. 42.6	% 0/30,100	min. 0.5 - 20	°F (-20 - 50)

Compliance

- cULus listed to UL 1598, suitable for damp location use
- DesignLights Consortium qualified products
- Based on photometric testing consistent with IES LM-79
- Suitable for operation in ambient not exceeding 104 °F



Wireless Lighting Control

Benefits of wireless lighting control

Although lighting control solutions have been proven to significantly reduce lighting energy consumption, many parts of commercial building market have been hesitant due to cost, complexity and applicability. However, new wireless technologies are eliminating these concerns, while expanding the lighting control capabilities.

Removing the wires

A new generation of lighting control systems is reducing cost and eliminating complexity concerns by removing the dedicated control wiring.

Flexibility

Instead of placing controls where wiring permits, building owners are free to place controls where they are needed to improve building performance. As the needs of a space change, changes can be made at any point, or new devices and control strategies added, simply by reprogramming.

Scalability

Once a wireless network is established, that network can grow to cover an ever-expanding area at a low additional cost. Additional sensors, switches and lights require minimal labor and disruption, and utilize the same wireless control system without the need to add a new control infrastructure.

Lighting control strategy

Lighting control manages and automates the delivery of the correct amount of light, where you want it, when you want it. Lights can automatically turn on/off or dim at set times or under set conditions, and users can have control over their own lighting levels to provide optimal working conditions. A lighting control solution automates and simplifies cost- and energy-saving strategies such as belows.

Scheduling

Turn on/off and dim lights at specified times during the day—for example, automatically turn lights on at the start of business hours, and off after workers leave at night.

Occupancy sensors

Detect when a room is occupied, to automatically turn lights on when someone enters and off (or dim) shortly after they leave.

Daylight harvesting

Use photosensors to detect levels of natural lighting, and automatically dim lights when sunlight is streaming into windows. This reduces energy use and provides consistent lighting levels.

Demand response

Utility companies frequently offer their customers incentives to encourage them to reduce energy consumption, especially at times of peak usage or when retail energy prices are high. Lighting control solutions can automatically respond to these events and reduce energy consumed by lighting to pre-set levels.

LG Lighting with ZigBee® wireless capability

LG Lighting is designed as a wireless-embedded system, which users can control wirelessly by simply inserting a compact communication dongle into the driver. By adopting ZigBee®, an open wireless protocol, the system not only works seamlessly with devices that use the same protocol, but also integrates with the control systems of solution providers like DaintreeNetworks.

Easy installation & scalability



Total control system with DaintreeNetworks

LG Electronics adopts ZigBee®, an open wireless protocol, so that the system not only works seamlessly with devices that use the same protocol, but also integrates with the control systems of solution providers like DaintreeNetworks.

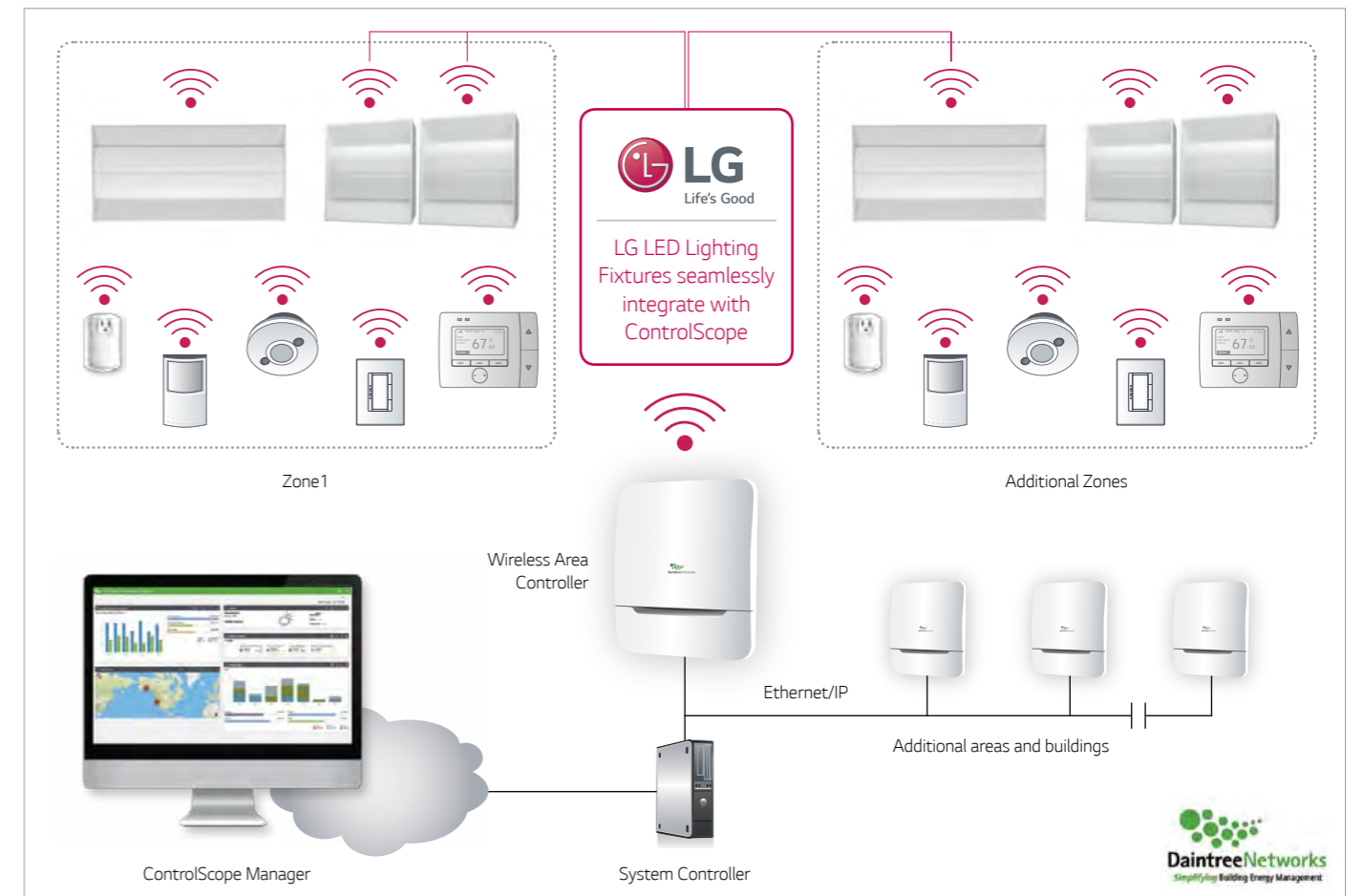

LG Sensor Connect

Benefits of LG Sensor Connect

The LG Sensor Connect system from LG Electronics meets the needs of small and medium-sized buildings that require a wireless lighting control solution but are constrained by cost. ZigBee® wireless mesh control platform & sensors (occupancy sensing, daylight harvesting) embedded into luminaires, touting the exact same integration benefits with wireless lighting control solutions.

LG solves your problems



Specifiers

- Simple stand-alone system



Installers (facility managers)

- No re-circuiting or new control wiring
- Easy installation & maintenance



Building owners

- Saving installation & energy costs
- Provide optimum lighting control

A new generation of much simpler lighting control system

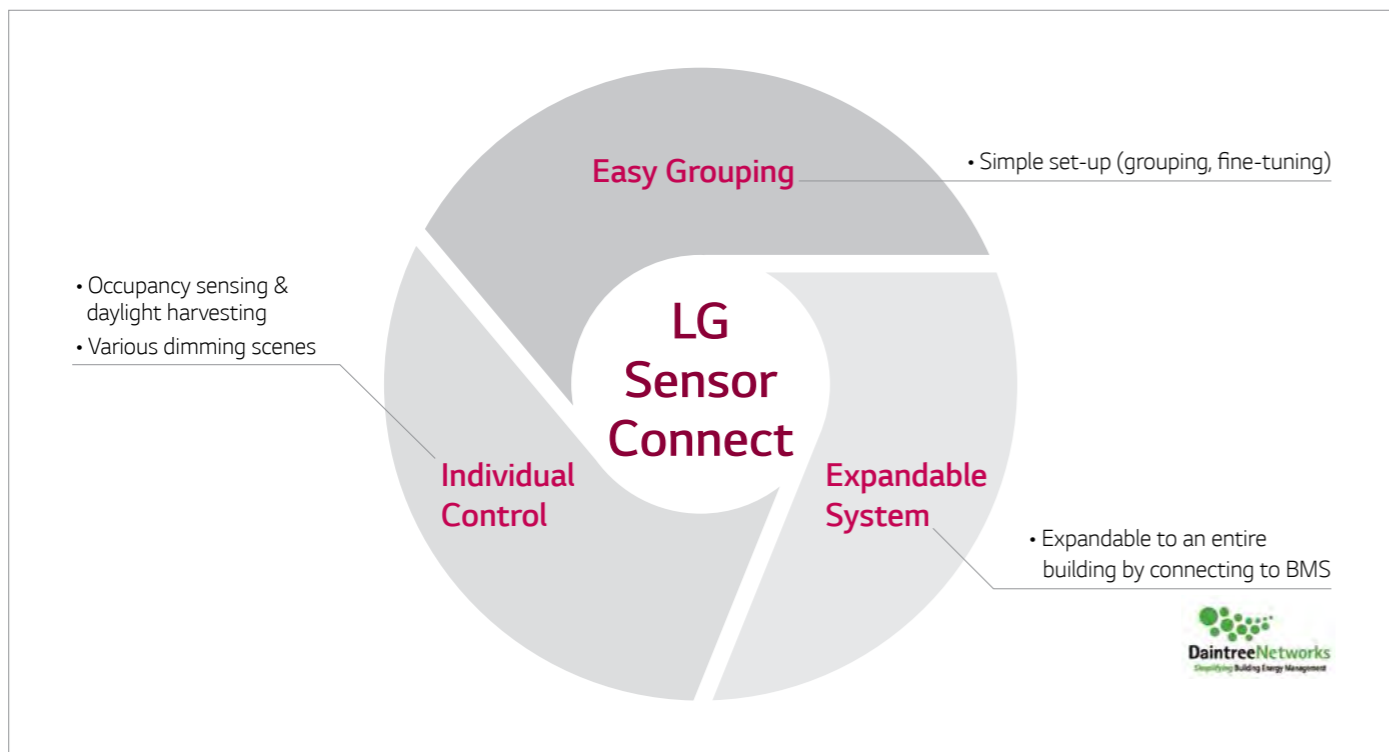

Simple yet powerful commissioning App

For office

For industry



How LG Sensor Connect system works for open-plan office

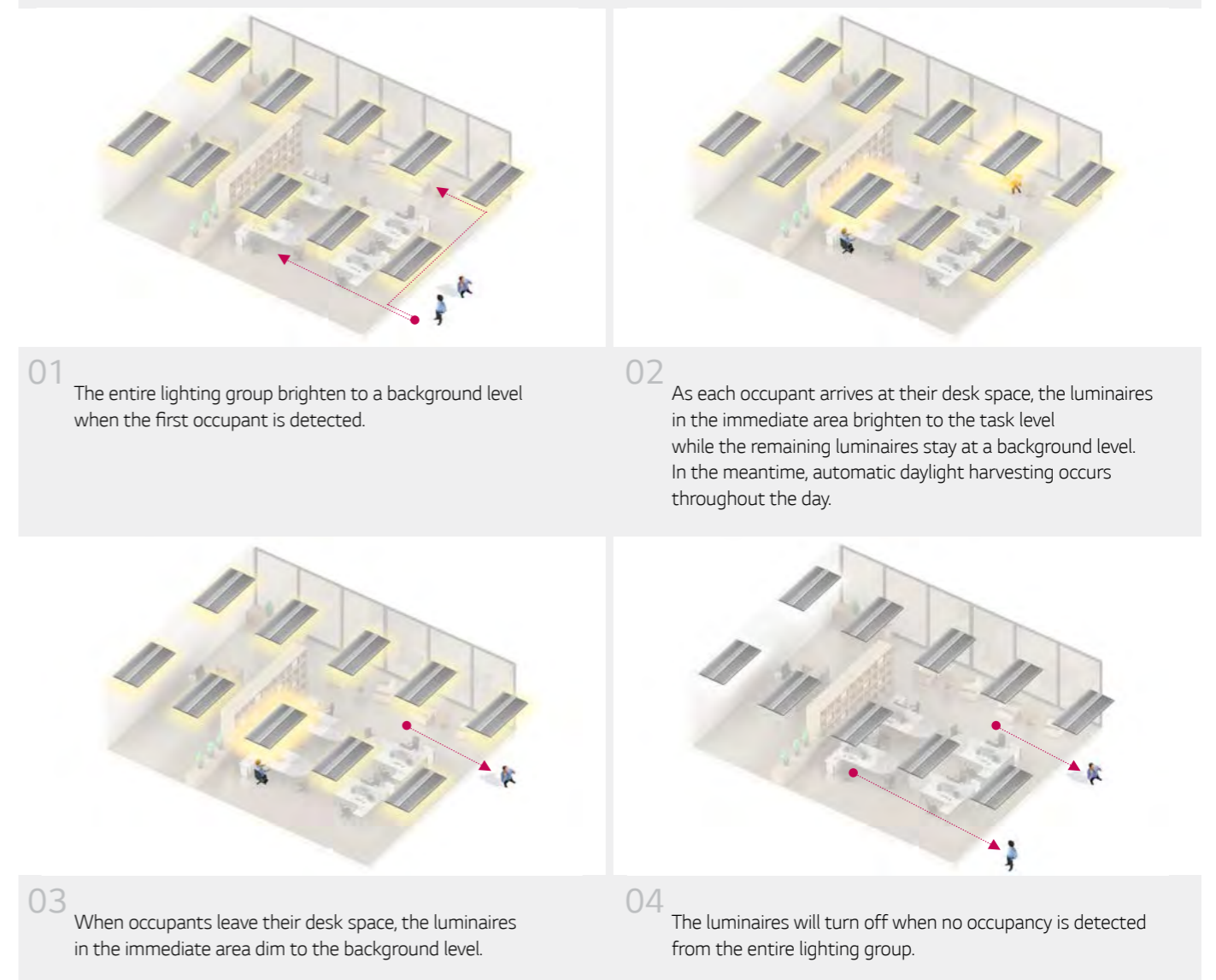

Commercial Term and Conditions

Terms

- Credit accounts : Invoice payments are required to be paid in Net Thirty (30) Days.
- Cash account : 100% balance of payment due before shipping.
- 1.5% monthly service charge can be imposed on all accounts past due in excess of thirty (30) days on the unpaid balance, except where prohibited by law.
- Customer may be held responsible for any fees arising from third party collection efforts.

Orders

- The minimum order charge for LGE LED Lighting lamps, fixtures, or control is \$100.00
- Orders will be accepted by facsimile or electronic means only (E.D.I. preferably).
- Hold for Release (HFR) orders will only be accepted with an approximate release date, and are subject to applicable price increases.

Cancellations

- Orders cannot be cancelled without prior written LGE consent.
- All cancellation requests must be submitted in writing to LGE and may be subject to restocking fees.

Return policy

- All product or order return requests must be submitted in writing to LGE.
 - Return requests without prior written LGE authorization will not be accepted.
 - All returns must be marked with the LGE RMA number or LGE reserves the right to refuse return.
- All returns are subject to a possible restocking fee, with that fee being a maximum of 30% of the order.
- Freight on returns will not be credited. Collect return shipments will not be accepted.
- LGE has the right to repair or replace any warranty item. LGE has the right to substitute any warranty item not on the current price / product list.
- Returns of new, uninstalled merchandise must be requested within 90 days of invoice date.
- LGE will not accept returns of installed products, or items older than 90 days past invoice date.
- Returned merchandise must be in original LGE packaging and deemed suitable for resale by LGE.
 - All returns to be inspected by LGE.
 - Damaged products will be credited less repair costs or at salvage value.

Freight

- The following prepaid freight terms apply to orders shipped from LG Electronics U.S.A., Inc. warehouses.
- For LG LED Lighting order of \$5,000 or greater, customer will receive LG pre-paid freight services.
- Special freight handling , including international deliveries, must be submitted in writing to LGE.
 - All special freight charges (including overnight airfare) will be billed to the customer requesting the special freight handling.
- All shipments are subject to availability.
- Requests to ship partials must be submitted in writing and freight will be charged per each shipment.
- All next day air shipments must be submitted in writing and received before 12 PM Eastern Time.
- All freight claims for damaged or lost-in-transit material must be made directly to the carrier.

Point of contact

- For more information, please contact LG Electronics order management at (201)816-2000
Please visit www.lglightingus.com



LG Electronics U.S.A., Inc.
Confidential



Product selection guide

Troffers

Product type	Model code (US order code)	Input power	Delivered light output	Efficacy	CCT	IP	UGR	Beam angle	CRI	Input voltage	Power factor	Operating temperature	Dimensions	Optical unit	Weight	Controls										
		W	lm	lm/W	K	-	-	°	-	Vac	-	F (°C)	inch (mm)	-	lb (kg)	-										
T-Bar lay-in fixture	FRR626D2H0ABUAAWAA (LGE-2X4RT-26-35-3400-TB)	26	3380	130	3500	20	≤18	105	82	120 - 277	≥0.9	-4 - 122 (-20 - 50)	23.8X47.8X2.8 (605X1,214X72)	Frost (PMMA)	16.5 (7.5)	0-10 V (ZigBee ready)										
	FRR626D3H0ABUAAWAA (LGE-2X4RT-26-40-3400-TB)	26	3400	131	4000																					
	FRR634D2H0BBUAAWAA (LGE-2X4RT-34-35-4400-TB)	34	4400	129	3500																					
	FRR634D3H0BBUAAWAA (LGE-2X4RT-34-40-4500-TB)	34	4500	132	4000																					
	FRR648D2H0ABUAAWAA (LGE-2X4RT-48-35-5800-TB)	48	5550	116	3500																					
	FRR648D3H0ABUAAWAA (LGE-2X4RT-48-40-6000-TB)	48	5750	120	4000																					
	FRS618D2H0ABUAAWAA (LGE-2X2RT-18-35-2350-TB)	18	2350	131	3500																					
	FRS618D3H0ABUAAWAA (LGE-2X2RT-18-40-2400-TB)	18	2400	133	4000																					
	FRS632D2H0ABUAAWAA (LGE-2X2RT-32-35-3400-TB)	32	3200	100	3500																					
	FRS632D3H0ABUAAWAA (LGE-2X2RT-32-40-3400-TB)	32	3250	102	4000																					
Retrofit fixture	FRR626D2HRABUAAWBB (LGE-2X4RT-26-35-3400-R(W))	26	3380	130	3500	20	≤18	105	82	120 - 277	≥0.9	-4 - 122 (-20 - 50)	21.7X45.8X2.6 (552X1,163X67)	Frost (PMMA)	14.6 (6.6)	0-10 V (ZigBee ready)										
	FRR626D3HRABUAAWBB (LGE-2X4RT-26-40-3400-R(W))	26	3400	131	4000																					
	FRR634D2HRBUAAWBB (LGE-2X4RT-34-35-4400-R(W))	34	4400	129	3500																					
	FRR634D3HRBUAAWBB (LGE-2X4RT-34-40-4500-R(W))	34	4500	132	4000																					
	FRS618D2HRABUAAWBB (LGE-2X2RT-18-35-2350-R(W))	18	2350	131	3500																					
	FRS618D3HRABUAAWBB (LGE-2X2RT-18-40-2400-R(W))	18	2400	133	4000																					
	FRS632D2HRABUAAWBB (LGE-2X2RT-32-35-3400-R(W))	32	3200	100	3500																					
	FRS632D3HRABUAAWBB (LGE-2X2RT-32-40-3400-R(W))	32	3250	102	4000																					
	FRR641D2H5BUAAWAA (LGE-2X4RT-41-35-4400-EM)	41	4400	107	3500									20			≤18	105	82	120 - 277	≥0.9	-4 - 122 (-20 - 50)	23.8X47.8X4.5 (605X1,214X115)	Frost (PMMA)	19.2 (8.7)	0-10 V (ZigBee ready)
	FRR641D3H5BUAAWAA (LGE-2X4RT-41-40-4500-EM)	41	4500	110	4000																					
FRS639D2H5ABUAAWAA (LGE-2X2RT-39-35-3300-EM)	39	3300	85	3500																						
FRS639D3H5ABUAAWAA (LGE-2X2RT-39-40-3350-EM)	39	3350	86	4000																						
Simple choice	F4035TB1131BUAAWAA (LGE-1X45I-40-35-4000-TB)	40	4000		3500	20	≤19	120	82	120 - 277	≥0.9	-4 - 104 (-20 - 40)	11.8X47.8X4.14 (300X1,214X105)	White (PC)	12.3 (5.6)	0-10 V (ZigBee ready)										
	F4040TB1131BUAAWAA (LGE-1X45I-40-40-4000-TB)	40	4000		4000																					
	FRR640D2H0ABUAAWAA (LGE-2X45I-40-35-4000-TB)	40	4000	100	3500																					
	FRR640D3H0ABUAAWAA (LGE-2X45I-40-40-4000-TB)	40	4000		4000																					
	FRS632D2H0BBUAAWAA (LGE-2X25I-32-35-3200-TB)	32	3200		3500																					
	FRS632D3H0BBUAAWAA (LGE-2X25I-32-40-3200-TB)	32	3200		4000																					
	F4035TB1531BUAAWAA (LGE-1X45C-40-35-4000-TB)	40	4000		3500																					
	F4040TB1531BUAAWAA (LGE-1X45C-40-40-4000-TB)	40	4000		4000																					
	FRR640D2H0C BUAAWAA (LGE-2X45C-40-35-4000-TB)	40	4000	100	3500																					
	FRR640D3H0C BUAAWAA (LGE-2X45C-40-40-4000-TB)	40	4000		4000																					
Sensor connect	FRS632D2H0C BUAAWAA (LGE-2X25C-32-35-3200-TB)	32	3200		3500	20	≤19	120	82	120 - 277	≥0.9	-4 - 104 (-20 - 40)	23.8X47.8X4.1 (605X1,214X105)	White (PC)	12.6 (5.7)	ZigBee										
	FRS632D3H0C BUAAWAA (LGE-2X25C-32-40-3200-TB)	32	3200		4000																					
	F4035TB1531BUAAWAA (LGE-1X45C-40-35-4000-TB)	40	4000		3500																					
	F4040TB1531BUAAWAA (LGE-1X45C-40-40-4000-TB)	40	4000		4000																					

Retrofit Board & Driver Kit

Product type	Model code (US order code)	Input power	Delivered light output	Efficacy	CCT	UGR	Beam angle	CRI	Input voltage	Power factor	Operating temperature	Dimensions	Weight	Controls
		W	lm	lm/W	K	-	°	-	Vac	-	F (°C)	inch (mm)	lb (kg)	-
Retrofit board & driver kit	FRR634D1HZZBUAAWAA (LGE-4BDK-34-30-4200)	34	4240	125	3000	≤19	117	82	120-277	≥0.9	-4 - 122 (-20 - 50)	21.7X1.2 (551X30)	1.4 (0.6)	0-10 V (ZigBee ready)
	FRR634D2HZZBUAAWAA (LGE-4BDK-34-35-4300)	34	4280	126	3500									
	FRR634D3HZZBUAAWAA (LGE-4BDK-34-40-4400)	34	4420	130	4000									
	FRR629D2HZZBUAAWAA (LGE-4BDK-29-35-3700)	29	3660	126	3500									
	FRR629D3HZZBUAAWAA (LGE-4BDK-29-40-3800)	29	3770	130	4000									
	FRS629D2HZZBUAAWAA (LGE-2BDK-29-35-3700)	29	3660	126	3500									
FRS629D3HZZBUAAWAA (LGE-2BDK-29-40-3800)	29	3770	130	4000										

LED Tube

Product type	Model code (US order code)	Input power	Delivered light output	Efficacy	CCT	Beam angle	CRI	Input voltage	Power factor	Operating temperature	Dimensions	Weight
		W	lm	lm/W	K	°	-	Vac	-	F (°C)	inch (mm)	lb (kg)
LED Tube	T1840GE502DBUAAWAA (LGE-TUBE-18-40-1900-ED2)	18	1900	106	4000	180	83	120 - 277	≥0.9	-4 - 122 (-20 - 50)	Ø1.1X47.2 (Ø27.8X1,198)	0.7 (0.3)
	T1850GE502DBUAAWAA (LGE-TUBE-18-50-2000-ED2)	18	2000	111	5000							
Product type	Model code (US order code)	Control										Dimensions
Driver	TC362ZHC BUAAWAA (LGE-TUBE-DRIVER-2TUBE)	0-10 V (ZigBee ready)										11.8X1.6X1.0 (299.8X40X25)

High Bay

Model code (US order code)	Input power	Delivered light output	Efficacy	CCT	IP	UGR	Beam angle	CRI	Input voltage	Power factor	Operating temperature	Dimensions	Optical unit	Weight	Controls
	W	lm	lm/W	K	-	-	°	-	Vac	-	F (°C)	inch (mm)	-	lb (kg)	-
H1240PA2N0AACWB000 (LGE-HB-120-40-12000)	120	12000	100	4000	20	28	120	83	120 - 277	≥0.9	-22 - 104 (-30 - 40)	17.3X14.1X5.0 (440X358X127)	Tempered glass	9.9 (4.5)	Motion sensor (Step dimming)
H1257PA2N0AACWB000 (LGE-HB-120-57-12000)	120	12000	100	5700	20	28	120	83	120 - 277					20.9 (9.5)	
H2440P50N0AACWB000 (LGE-HB-230-40-24000-50D)	230	24000	104	4000	20	25	50	83	200 - 277						
H2440P85N0AACWB000 (LGE-HB-230-40-24000-85D)	230	24000	104	4000	20	25	85	83	200 - 277						

Control Device

Product type	Model code (US order code)	Input Power	Input Voltage	Frequency	Communication type	Dimensions	Mounting Height	Dimming level adjustment	Delay time adjustment	Operating temperature
		W	VdC	MHz	-	Inch (mm)	ft	%	min	F (°C)
High Bay Motion Sensor	9SD751TVDAALWB000 (LGE-HB-OSZ)	0.17	3.3	2405-2480	ZigBee	3.0X2.1X1.0 (75X54X25)	Max 42.6	0/30,100	0.5 - 20	-4 - 122 (-20 - 50)
Product type	Model code (US order code)	Input Power	Input Voltage	Frequency	Communication type	Dimensions	Operating temperature			
		W	VdC	MHz	-	Inch (mm)	°F (°C)			
ZHA Module (Dongle)	9CM2315VD1AWBZOU (LGE-DONGLE)	0.17	3.3	2405-2480	ZigBee	0.9X1.0X0.3 (22X25X8)	-22 - 185 (-30 - 85)			

PRODUCT SHEET DISCLAIMER(S) : All prices are approved by LG Electronics. Prices shown do not include shipping, handling, taxes, or installation. Prices are subject to change without notice. LG Electronics reserves the right to correct errors. Only LGE LED Lighting is authorized to change prices. Please contact LGE LED Lighting Sales for details.





LG Electronics, U.S.A.

1000 Sylvan Avenue
Englewood Cliffs, NJ 07632

www.LGLightingUS.com

© 2015 LG Electronics U.S.A., Inc., Englewood Cliffs, NJ. All rights reserved.
LG Life's Good is a registered trademark of LG Corporation.
Specifications are subject to change without prior notice.