

Steel City®

Steel City® Commercial Fittings

In this section...



Steel City® Commercial Fittings

Overview	E-520–E-521
Electrical Metallic Tubing (EMT) Fittings	E-522–E-529
Rigid Conduit/IMC Fittings	E-530–E-537
Non-Metallic Sheathed Cable Fittings	E-538–E-539
Armored Cable/Flexible Metallic Conduit Fittings	E-540–E-545
Accessories	E-546–E-549
Liquidtight Flexible Metallic Conduit Fittings: Zinc Die Cast	E-550–E-552

Thomas & Betts

www.tnb.com

Overview

Steel City® Fittings

Steel City® Conduit Fittings provide long-lasting service in commercial, industrial and residential construction. Our fittings are manufactured within strict tolerances to maintain consistent performance. Installers can be assured that every fitting with the Steel City® name will work every time. So when you select Steel City® Conduit Fittings, that means fewer headaches and call-backs.

Steel City® products symbolize the highest quality standards in manufacturing and innovative design, with one of the most complete offerings available. Contact a T&B distributor nearest you to select the right Steel City® product for your requirements.



Advantages of Steel City® Commercial Conduit Fittings

Compression Fittings

Dependable Pipe Stop

- Strong, thick protrusion that does not exceed thickness of EMT. Keeps forcefully inserted conduit from breaking through the opposite side of the coupling, while not interfering with the pulling of conductors



Heavy-Duty Thick Steel Body/Glands with Continuous Threading

- True hexagonal shape. The non-circular design has actual flats for gripping power using hand or tool force



Extra-Thick Electro-Plated Zinc Finish

- Ensures corrosion resistance while the clear chromate coating gives the fittings their quality shine and luster

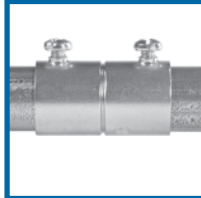

Couplings and Connectors

Superior Quality and Design

- Strict tolerances throughout fitting ensures a straight conduit run with no sagging over extreme lengths
- Chamfered entry provides lead-in for conduit insertion



Dependable Pipe Stop

- 360° groove traveling the circumference ensures that conduit forcefully inserted won't break through to the opposite side of the fitting. Also, it does not exceed thickness of EMT and prevents interference with pulling conductors



Extra-Large Head Tri-Drive Set Screw

- Accommodates Phillips, slotted and square drives



Enhanced Locknut Construction

- Heavy-duty turned sharp teeth, double-threaded

Overview

Here's How the Steel City® Catalog Number System Works

Easy-to-identify alphabetical prefixes:

BG – Bushings, Grounding
BI – Bushings, Insulated
BL – Blanks
BR – Rigid Spacer
BS – Box Spacer
BT – Thinwall Spacer
BU – Bushings
CB – Clamp Back
CP – Cable Protector
EK – 3-Piece Coupling
FA – Fire Alarm
GA – Ground Clamp (Armored Ground Wire)
GC – Ground Clamp
H – Hub
HA – Heavywall Adapter
HC – Heavywall Connector
HK – Heavywall Coupling
HL – Heavywall Elbow
HO – Heavywall Offset
HS – Heavywall Strap
LG – Locknut, Grounding
LN – Locknut
LT – Liquidtight
NC – Non-Metallic Sheathed Cable Connector
NS – Non-Metallic Sheathed Cable Strap
RB – Reducing Bushings
RT – Raintight

SH – Service Entrance Fitting
SL – Service Ells
SR – Sealing Rings
SS – Stainless Steel
LS – Locknut, Sealing
TC – Thinwall Connectors
TK – Thinwall Couplings
TL – Thinwall Elbow
TO – Thinwall Offset
TS – Thinwall Strap
TX – Thinwall to Flexible Metallic Conduit Fitting
UC – Utility Connector
USA – Made in USA
WA – Washer
XC – Armored Cable or Flexible Metallic Conduit Connector
XK – Armored Cable or Flexible Metallic Conduit Coupling

1st Digit — Material

1 = Steel
2 = Die Cast
3 = Combination Steel and Die Cast
4 = Malleable
5 = Plastic
6 = Aluminum
7 = Steel Insulated
8 = Die Cast Insulated
9 = Malleable Insulated

2nd Digit — Method

1 = Compression
2 = Set Screw
3 = Other

3rd/4th Digit — Size

0 = 3/8"
1 = 1/2"
2 = 3/4"
3 = 1"
4 = 1 1/4"
5 = 1 1/2"
6 = 2"
7 = 2 1/2"
8 = 3"
9 = 3 1/2"
10 = 4"
11 = 5"
12 = 6"

A few examples of the three-digit identification system for thinwall fittings are:

TK-111A: 1/2" steel, compression-type coupling

TC-714A: 1 1/4" steel insulated compression-type connector

TC-822SC: 3/4" die-cast, insulated, set-screw type connector



Electrical Metallic Tubing (EMT) Fittings

Ideal for use in Recovery Act projects requiring
MADE IN USA components!

Made In USA Steel EMT Fittings

High-Quality Steel Construction — Made in the USA!

- Available in sizes for ½" to 4" electrical metallic tubing (EMT)
- Steel construction for strength and durability
- Electroplated zinc finish for corrosion protection
- Use couplings to join two lengths of EMT
- Use connectors (insulated or non-insulated) to join EMT to a box or enclosure
- Set-screw couplings and connectors are for use in dry locations and are concrete-tight when taped
- Compression couplings and connectors are concrete-tight
- MADE IN USA for use on American Recovery and Reinvestment Act (ARRA) projects

NEW!



Thomas & Betts

E-522

United States
Tel: 901.252.8000
800.816.7809
Fax: 901.252.1354

Technical Services
Tel: 888.862.3289

www.tnb.com

Electrical Metallic Tubing (EMT) Fittings

Insulated EMT
Set-Screw Connectors



TC724US



TC722US



Insulated EMT Compression
Connector (TC7110US)

EMT Compression
Couplings



TK111US



TK114US



EMT Set-Screw
Coupling
(TK128US)

Insulated EMT Set-Screw
Connector (TC729US)



Made In USA Steel EMT Fittings

CAT. NO.	HUB SIZE
EMT Compression Connectors, Non-Insulated	
TC111US	1/2"
TC112US	3/4"
TC113US	1"
TC114US	1 1/4"
TC115US	1 1/2"
TC116US	2"
TC117US	2 1/2"
TC118US	3"
TC119US	3 1/2"
TC1110US	4"
EMT Compression Connectors, Insulated	
TC711US	1/2"
TC712US	3/4"
TC713US	1"
TC714US	1 1/4"
TC715US	1 1/2"
TC716US	2"
TC717US	2 1/2"
TC718US	3"
TC719US	3 1/2"
TC7110US	4"

CAT. NO.	HUB SIZE
EMT Set-Screw Connectors, Non-Insulated	
TC121US	1/2"
TC122US	3/4"
TC123US	1"
TC124US	1 1/4"
TC125US	1 1/2"
TC126US	2"
TC127US	2 1/2"
TC128US	3"
TC129US	3 1/2"
TC1210US	4"
EMT Set-Screw Connectors, Insulated	
TC721US	1/2"
TC722US	3/4"
TC723US	1"
TC724US	1 1/4"
TC725US	1 1/2"
TC726US	2"
TC727US	2 1/2"
TC728US	3"
TC729US	3 1/2"
TC7210US	4"

CAT. NO.	HUB SIZE
EMT Compression Couplings	
TK111US	1/2"
TK112US	3/4"
TK113US	1"
TK114US	1 1/4"
TK115US	1 1/2"
TK116US	2"
TK117US	2 1/2"
TK118US	3"
TK119US	3 1/2"
TK1110US	4"
EMT Set-Screw Couplings	
TK121US	1/2"
TK122US	3/4"
TK123US	1"
TK124US	1 1/4"
TK125US	1 1/2"
TK126US	2"
TK127US	2 1/2"
TK128US	3"
TK129US	3 1/2"
TK1210US	4"

Electrical Metallic Tubing (EMT) Fittings

Set-Screw Connectors — Steel

- Concrete tight when taped
- Zinc plated



Non-Insulated



"A" CAT. NO.	CONDUIT SIZE (IN.)	INNER PACK	OUTER PACK
TC121A	½	50	500
TC122A	¾	50	250
TC123A	1	25	100
TC124A	1¼	—	25
TC125A	1½	—	25
TC126A	2	—	25
TC127A	2½	—	10
TC128A	3	—	5
TC129A	3½	—	5
TC1210A	4	—	5
TC121A-FA	½	50	500
TC122A-FA	¾	50	250
TC123A-FA	1	25	100

UL File No. E-16592.

FA — Fire Alarm.

Insulated



"A" CAT. NO.	CONDUIT SIZE (IN.)	INNER PACK	OUTER PACK
TC-721A	½	50	500
TC722A	¾	50	250
TC-723A	1	25	100
TC724A	1¼	—	25
TC725A	1½	—	25
TC726A	2	—	25
TC727A	2½	—	10
TC728A	3	—	5
TC729A	3½	—	5
TC7210A	4	—	5
TC721A-FA	½	50	500
TC722A-FA	¾	50	250
TC723A-FA	1	25	100

UL File No. E-16592.

FA — Fire Alarm.

Set-Screw Couplings — Steel

- Concrete tight when taped
- Zinc plated
- Fire Alarm (FA) painted red for fire alarm identification



"A" CAT. NO.	CONDUIT SIZE (IN.)	INNER PACK	OUTER PACK
TK121A	½	50	500
TK122A	¾	50	250
TK123A	1	25	100
TK124A	1¼	—	25
TK125A	1½	—	25
TK126A	2	—	25
TK127A	2½	—	10

UL File No. E-16592.



"A" CAT. NO.	CONDUIT SIZE (IN.)	INNER PACK	OUTER PACK
TK128A	3	—	5
TK129A	3½	—	5
TK1210A	4	—	5
TK121A-FA	½	50	500
TK122A-FA	¾	50	250
TK123A-FA	1	25	100

UL File No. E-16592.

Compression Connectors — Steel

- ½"-4" concrete tight
- Zinc plated
- RT — Raintight



Non-Insulated



"A" CAT. NO.	CONDUIT SIZE (IN.)	INNER PACK	OUTER PACK
TC111A	½	50	500
TC112A	¾	50	250
TC113A	1	25	100
TC114A*	1¼	—	25
TC115A*	1½	—	25
TC116A*	2	—	25
TC117A	2½	—	10
TC118A	3	—	5
TC119A	3½	—	5
TC1110A	4	—	5
TC111A-RT	½	50	500
TC112A-RT	¾	50	250
TC113A-RT	1	25	100
TC114A-RT*	1¼	—	25
TC115A-RT*	1½	—	25
TC116A-RT*	2	—	25
TC117ART	2½	—	10
TC118ART	3	—	5
TC119ART	3½	—	5
TC1110ART	4	—	5

UL File No. E-16592.

*0-rings are supplied.

Insulated



"A" CAT. NO.	CONDUIT SIZE (IN.)	INNER PACK	OUTER PACK
TC711A	½	50	500
TC712A	¾	50	250
TC713A	1	25	100
TC714A	1¼	—	25
TC715A	1½	—	25
TC716A	2	—	25
TC717A	2½	—	10
TC718A	3	—	5
TC719A	3½	—	5
TC7110A	4	—	5
TC711A-RT	½	50	500
TC712A-RT	¾	50	250
TC713A-RT	1	25	100
TC714A-RT*	1¼	—	25
TC715A-RT*	1½	—	25
TC716A-RT*	2	—	25
TC717ART	2½	—	10
TC718ART	3	—	5
TC719ART	3½	—	5
TC7110ART	4	—	5

UL File No. E-16592.

Steel City® Raintight EMT Compression Fittings feature a distinctive design and a vibrant gold gland nut, enabling inspectors to visually inspect conformance from a distance. There's no close-up inspection required!

Note: A sealing ring is required when fitting is used outside, on the top and on the sides of an enclosure.

Electrical Metallic Tubing (EMT) Fittings

Compression Couplings — Steel



- ½"–4" concrete tight
- Zinc plated
- RT — Raintight

Steel City® Raintight EMT Compression Fittings feature a distinctive design and a vibrant gold gland nut, enabling inspectors to visually inspect conformance from a distance. There's no close-up inspection required!

"A" CAT. NO.	CONDUIT SIZE (IN.)	INNER PACK	OUTER PACK
TK111A	½	50	250
TK112A	¾	50	250
TK113A	1	25	100
TK114A	1¼	—	25
TK115A	1½	—	25
TK116A	2	—	25
TK117A	2½	—	10
TK118A	3	—	5
TK119A	3½	—	5
TK1110A	4	—	5

UL File No. E-16592.

"A" CAT. NO.	CONDUIT SIZE (IN.)	INNER PACK	OUTER PACK
TK111A-RT	½	50	250
TK112A-RT	¾	50	250
TK113A-RT	1	25	100
TK114A-RT	1¼	—	25
TK115A-RT	1½	—	25
TK116A-RT	2	—	25
TK117A-RT	2½	—	10
TK118A-RT	3	—	5
TK119A-RT	3½	—	5
TK1110A-RT	4	—	5

UL File No. E-16592.

Combination Compression Couplings — Heavywall to Liquidtight Flexible Metal Conduit — Steel

- Steel
- Raintight
- Zinc plated

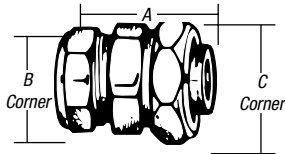

CAT. NO.	CONDUIT SIZE (IN.)	DIMENSIONS (IN.)			STD. CTN.
		A	B	C	
LTH 111	½ Rigid to ½ Liquidtight	1⅞	1⅞	1⅞	100

Combination Compression Couplings — Thinwall to Liquidtight Flexible Metal Conduit — Steel

- Steel
- Raintight
- Zinc plated

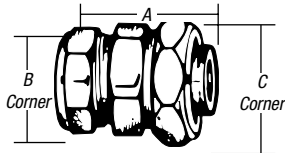

CAT. NO.	CONDUIT SIZE (IN.)	DIMENSIONS (IN.)			STD. CTN.
		A	B	C	
LTT 111	½ EMT to ½ Liquidtight	1¼	1⅝	1⅞	100
LTT-112	¾ EMT to ¾ Liquidtight	1¼	1⅞	1⅞	50
LTT-113	1 EMT to 1 Liquidtight	1⅝	1½	1¾	25

EMT LOK Conduit Connector — Steel

- Simple, one-piece installation with no locknuts
- Available in insulated or non-insulated throat
- Screw designed for exceptional pullout resistance
- Captive screw ensures that the screw is intact for installation and resists backing out after installation
- Corrosion-resistant, zinc-chromatic plating
- Positive grounding
- Vibration-resistant screw design
- UL Listed and CSA certified

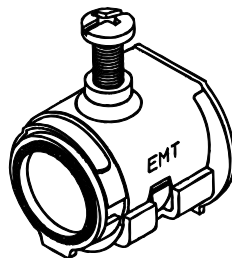

CAT. NO.	DESCRIPTION	STD. CTN.
TC101-SC	½" Uninsulated	500
TC-102-SC	¾" Uninsulated	250
TC-701-SC	½" Insulated	500
TC-702-SC	¾" Insulated	250

UL Listing No. E16592, CSA Listing No. LR-12798.

Installation using either slotted or Phillips screwdriver head, 35-in.-lb. of torque onto the EMT.

Note: Excessive torque could damage EMT or housing.

Electrical Metallic Tubing (EMT) Fittings

Compression Connectors — Die-Cast Zinc



- ½"–4" concrete tight

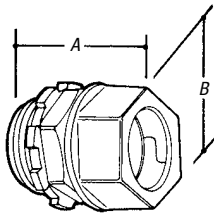

CAT. NO.	CONDUIT SIZE (IN.)	DIMENSIONS (IN.)		STD. CTN.
		A	B	
Non-Insulated				
TC-211-SC	½	1¼	1	500
TC-212-SC	¾	1 ¹¹ / ₃₂	1 ¹ / ₃₂	250
TC-213-SC	1	1 ²⁹ / ₆₄	1 ¹ / ₃₂	200
TC-214-SC	1¼	1 ¹³ / ₁₆	1 ² / ₃₂	100
TC-215-SC	1½	1 ⁷ / ₈	2 ¹ / ₁₆	40
TC-216-SC	2	2 ⁵ / ₃₂	2 ¹ / ₃₂	20
TC-217-SC	2½	2 ⁴⁵ / ₆₄	3¼	12
TC-218-SC	3	2 ⁷ / ₈	3 ¹ / ₁₆	12
TC-219-SC	3½	2 ⁴⁷ / ₆₄	4 ⁷ / ₁₆	10
TC-2110-SC	4	2 ¹³ / ₁₆	4 ⁵ / ₁₆	6

UL File No. E-16592 — ½"–4". CSA File No. LR-12798 — ½"–2".

CAT. NO.	CONDUIT SIZE (IN.)	DIMENSIONS (IN.)		STD. CTN.
		A	B	
Insulated				
TC-811-SC	½	1 ²³ / ₆₄	6 ³ / ₆₄	500
TC-812-SC	¾	1 ¹ / ₃₂	1 ⁵ / ₁₆	250
TC-813-SC	1	1 ³ / ₆₄	1 ¹ / ₃₂	200
TC-814-SC	1¼	1 ²⁹ / ₃₂	1 ² / ₃₂	100
TC-815-SC	1½	1 ³ / ₃₂	2 ¹ / ₁₆	40
TC-816-SC	2	2¼	2 ¹ / ₃₂	20
TC-817-SC	2½	2 ²⁹ / ₃₂	3¼	12
TC-818-SC	3	2 ³ / ₃₂	3 ¹ / ₁₆	12
TC-819-SC	3½	2 ²⁷ / ₃₂	4 ⁷ / ₁₆	10
TC-8110-SC	4	2 ²⁹ / ₃₂	4 ⁵ / ₁₆	6

Offset Compression Connectors — Die-Cast Zinc

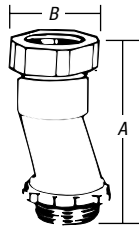

CAT. NO.	OFFSET (IN.)	CONDUIT SIZE (IN.)	DIMENSIONS (IN.)		STD. CTN.
			A	B	
TO-211SC	¾	½	2 ¹³ / ₆₄	1	200

UL File No. E-16592.

Capped Corner Couplings — Die-Cast Zinc

- Concrete tight when taped

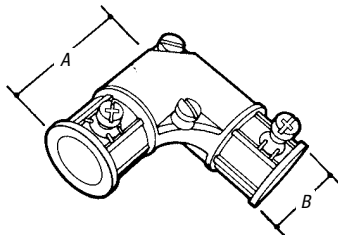

CAT. NO.	CONDUIT SIZE (IN.)	DIMENSIONS (IN.)		STD. CTN.
		A	B	
TL-291	½	1.81	1.00	100
TL-292	¾	2.00	1.25	50

UL File No. E-16592.

CSA File No. LR-12798.

Compression Couplings — Die-Cast Zinc

- ½"–4" concrete tight

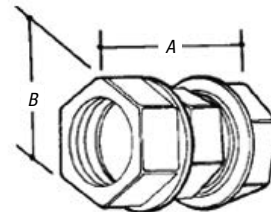

CAT. NO.	CONDUIT SIZE (IN.)	DIMENSIONS (IN.)		STD. CTN.
		A	B	
TK-211-SC	½	1½	1 ³ / ₃₂	500
TK-212-SC	¾	1 ⁵ / ₈	1 ³ / ₁₆	250
TK-213-SC	1	1 ⁵ / ₈	1 ⁴ / ₆₄	200
TK-214-SC	1¼	1 ¹³ / ₁₆	2 ³ / ₃₂	100
TK-215-SC	1½	2 ³ / ₃₂	2 ¹ / ₆₄	40
TK-216-SC	2	2 ¹ / ₃₂	2 ²⁹ / ₃₂	20
TK-217-SC	2½	3 ¹ / ₆₄	3 ¹ / ₆₄	12
TK-218-SC	3	3 ³ / ₃₂	4½	12
TK-219-SC	3½	3 ³ / ₆₄	5 ¹ / ₁₆	10
TK-2110-SC	4	3 ¹ / ₁₆	5 ¹ / ₆₄	6

UL File No. E-16592 — ½"–4".

CSA File No. LR-12798 — ½"–1¼", 2½"–4".

Electrical Metallic Tubing (EMT) Fittings

Set-Screw Connectors — Die-Cast Zinc



- Concrete tight when taped

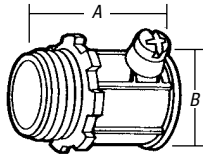

CAT. NO.	CONDUIT SIZE (IN.)	A (IN.)			STD. CTN.
		TC-221 SERIES	TC-821 SERIES	B (IN.)	
Non-Insulated					
TC-221-SC	½	1½/2	1¹¹/₆₄	¹⁵/₁₆	500
TC-222-SC	¾	1¹⁹/₃₂	1³³/₆₄	1½/₃₂	250
TC-223-SC	1	1¹⁹/₁₆	1²¹/₃₂	1²/₆₄	200
TC-224-SC	1¼	1¹⁵/₁₆	2¹/₃₂	1¹³/₁₆	100
TC-225-SC	1½	2³/₃₂	2³/₆	2³/₆₄	40
TC-226-SC	2	2³³/₆₄	2³³/₆₄	2¹¹/₃₂	20
TC-227-SC	2½	3¹¹/₁₆	3³/₃₂	3¹³/₆₄	12
TC-228-SC	3	3²⁵/₆₄	3³¹/₆₄	4¹/₁₆	12
TC-229-SC	3½	3¹³/₆₄	3¹⁹/₃₂	4¹¹/₃₂	10
TC-2210-SC	4	3⁷/₆₄	3³³/₆₄	5¹/₁₆	6

UL File No. E-16592 — ½"-2".

UL File No. E-23018 — 2½"-4".

CSA File No. LR-12798 — ½"-1", 2½"-4".

CAT. NO.	CONDUIT SIZE (IN.)	A (IN.)			STD. CTN.
		TC-221 SERIES	TC-821 SERIES	B (IN.)	
Insulated					
TC-821-SC	½	1½/2	1¹¹/₆₄	¹⁵/₁₆	500
TC-822-SC	¾	1¹⁹/₃₂	1³³/₆₄	1½/₃₂	250
TC-823-SC	1	1¹⁹/₁₆	1²¹/₃₂	1²⁷/₆₄	200
TC-824-SC	1¼	1¹⁵/₁₆	2¹/₃₂	1¹³/₁₆	100
TC-825-SC	1½	2³/₃₂	2³/₆	2³/₆₄	40
TC-826-SC	2	2³³/₆₄	2³³/₆₄	2¹¹/₃₂	20
TC-827-SC	2½	3¹¹/₁₆	3³/₃₂	3¹³/₆₄	12
TC-828-SC	3	3²⁵/₆₄	3³¹/₆₄	4¹/₁₆	12
TC-829-SC	3½	3¹³/₆₄	3¹⁹/₃₂	4¹¹/₃₂	10
TC-8210-SC	4	3⁷/₆₄	3³³/₆₄	5¹/₁₆	6

UL File No. E-16592 — ½"-2".

UL File No. E-23018 — 2½"-4".

CSA File No. LR 12798 — ½"-2".

Offset Set-Screw Connectors — Die-Cast Zinc



- Concrete tight when taped

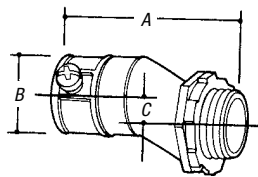

CAT. NO.	OFFSET (IN.)	CONDUIT SIZE (IN.)	DIMENSIONS (IN.)			STD. CTN.
			A	B	C	
TO 221	³/₈	½	2.00	.90	.37	100
TO 222	¾	¾	2.98	1.16	.25	100
TO-223	¾	1	3.15	1.42	.75	100

UL File No. E-16592.

CSA File No. LR-18130M57.

Set-Screw Couplings — Die-Cast Zinc



- Concrete tight when taped

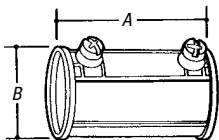

CAT. NO.	CONDUIT SIZE (IN.)	DIMENSIONS (IN.)		STD. CTN.
		A	B	
TK-221	½	1³³/₆₄	⁵⁹/₆₄	500
TK-222	¾	1²⁹/₃₂	1½/₃₂	250
TK-223	1	2	1¹/₁₆	200
TK-224	1¼	2³³/₆₄	1²⁷/₃₂	100
TK-225	1½	2²⁷/₃₂	2¹/₁₆	40

UL File No. E-16592 — ½"-2".

UL File No. E-23018 — 2½"-4".

CSA File No. LR-12798 — ½"-1¼", 2½"-4".

CAT. NO.	CONDUIT SIZE (IN.)	DIMENSIONS (IN.)		STD. CTN.
		A	B	
TK-226A	2	3¹³/₃₂	2½	20
TK-227	2½	4⁷/₃₂	3¹⁹/₆₄	12
TK-228	3	4¹¹/₁₆	4³/₆₄	12
TK-229	3½	4²⁷/₃₂	4¹¹/₃₂	10
TK-2210	4	5¹⁵/₃₂	4⁷/₁₆	6

Combination Set-Screw Couplings — Thinwall to Heavywall — Die-Cast Zinc



- Concrete tight when taped

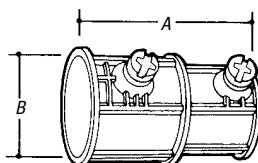

CAT. NO.	CONDUIT SIZE (IN.)	DIMENSIONS (IN.)		STD. CTN.
		A	B	
HT 221	½ EMT to ½ Rigid	1.67	1.07	500
HT-222	¾ EMT to ¾ Rigid	1.98	1.29	250
HT-223	1 EMT to 1 Rigid	2.15	1.58	100

UL File No. E-23018.

www.tnb.com

United States
Tel: 901.252.8000
800.816.7809
Fax: 901.252.1354

Technical Services
Tel: 888.862.3289

Thomas & Betts

Electrical Metallic Tubing (EMT) Fittings

Combination Set-Screw Couplings

- Concrete tight when taped



CAT. NO.	CONDUIT SIZE (IN.)	DIMENSIONS (IN.)		STD. CTN.
		A	B	
<i>Die-Cast Zinc Flexible Metal Conduit to EMT</i>				
TX-220	3/8 Flex to 1/2 EMT	1 5/8	1/2	500
TX-221	1/2 Flex to 1/2 EMT	1 13/16	1 3/32	250
TX-222	3/4 Flex to 3/4 EMT	1 31/32	1 1/32	150
TX-223	1 Flex to NMT	2 7/64	1 3/8	150

UL File No. E-23018

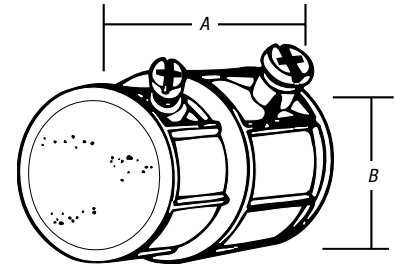

Combination Couplings

CAT. NO.	TRADE FIG.	SIZE (IN.)	DIMENSIONS (IN.)			STD. CTN.
			A (MIN.)	A (MAX.)	B	
<i>EMT to Flex Set-Screw Type — Die-Cast Zinc</i>						
TX210	1	1/2-3/8	.15	.61	1.16	250
TX211	2	1/2-1/2	.60	1.00	1.71	250
TX-212	2	3/4-3/4	.78	1.20	1.93	200

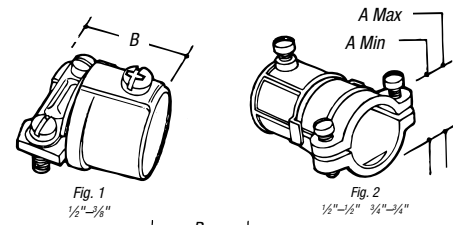

CAT. NO.	TRADE SIZE (IN.)	DIMENSIONS (IN.)		STD. CTN.
		A	B	
<i>EMT to Flex Compression to Screw-In Type — Die-Cast Zinc</i>				
TX201	1/2	.84	1.10	500
TX-202	3/4	.95	1.30	250

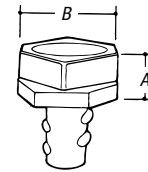

EMT to Box Set-Screw Type — Die-Cast Zinc



CAT. NO.	CONDUIT SIZE (IN.)	DIMENSIONS (IN.)		STD. CTN.
		A	B	
<i>EMT to Flex Compression to Screw-In Type — Die-Cast Zinc</i>				
TL-211	1/2	1.31	.93	100
TL-212	3/4	1.47	1.22	50

UL File No. E-23018.

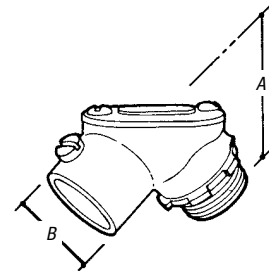

EMT to Box Set-Screw Type — Die-Cast Zinc



CAT. NO.	CONDUIT SIZE (IN.)	DIMENSIONS (IN.)		STD. CTN.
		A	B	
<i>EMT to Flex Compression to Screw-In Type — Die-Cast Zinc</i>				
TL 201	1/2	1.31	1.10	100
TL-202-SC	3/4	1.60	1.24	50
TL-203	1	1.94	1.59	25
TL-204	1 1/4	2.26	1.97	25

UL File No. E-23018.

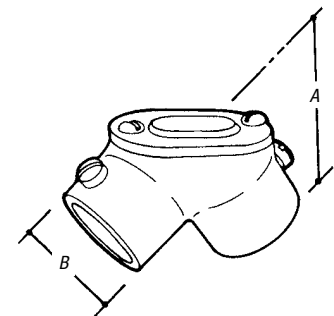

Electrical Metallic Tubing (EMT) Fittings

EMT Connectors — Die-Cast Zinc

CAT. NO.	TRADE SIZE (IN.)	DIMENSIONS (IN.)		STD. CTN.
		A	B	
Two-Piece Type				
TC-201-SC	½	.68	1.05	1,000

UL File No. E16592.

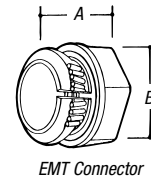

CAT. NO.	TRADE TYPE (IN.)	SIZE (IN.)	DIMENSIONS (IN.)			STD. CTN.
			A	B	C	
90° Angle						
TC921	Set-Screw Type	½	1.27	1.15	.45	200
TC-911-SC	Compression Type	½	1.37	1.15	.45	200
TC-912-SC	Compression Type	¾	1.86	.95	.52	200

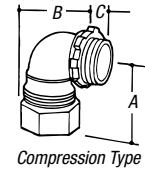
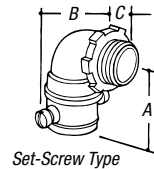

One-Hole Snap Straps — Steel

- Steel
- Zinc plated

CAT. NO.	CONDUIT SIZE (IN.)	DIMENSIONS (IN.)		STAINLESS STEEL STD. CTN.	REGULAR STD. CTN.
		A	B		
EMT to Flex Compression to Screw-In Type — Die-Cast Zinc					
TS 101	½	.57	1.79	25	100
TS-102	¾	.62	1.96	25	50
TS-103	1	.75	2.25	25	50
TS-104	1¼	.88	2.85	10	25
TS-105	1½	.99	3.16	5	20
TS-106	2	1.10	3.93	5	10
HS-107	2½	1.28	5.00	5	25
HS-108	3	1.28	5.55	5	25
HS-109	3½	1.28	6.37	5	10
HS-110	4	1.28	6.87	5	10

Add SS suffix to part number for Stainless Steel.

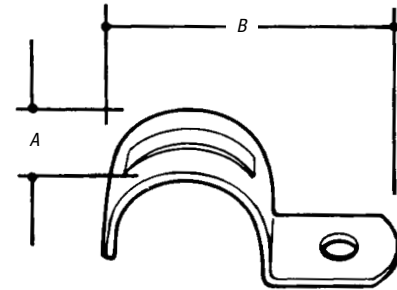

Two-Hole EMT Straps — Steel — Malleable Insulated

- Steel
- Zinc plated

CAT. NO.	CONDUIT SIZE (IN.)	DIMENSIONS (IN.)		STAINLESS STEEL STD. CTN.	REGULAR STD. CTN.
		A	B		
TS-901	½	.56	2.20	25	250
TS-902	¾	.62	2.67	25	200
TS-903	1	.68	2.97	25	100
TS-904	1¼	.75	3.67	10	50
TS-905	1½	.88	4.22	5	5
TS-906	2	1.00	4.91	5	25

Add SS suffix to part number for Stainless Steel.

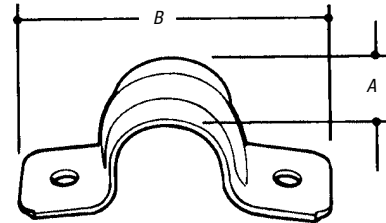

Space Caps — Plastic

CAT. NO.	CONDUIT SIZE (IN.)	DIMENSIONS (IN.)		STD. CTN.
		A	B	
BT-501	½	2 ¹⁵ / ₃₂	1 ³⁹ / ₆₄	100
BT-502	¾	2 ¹⁹ / ₃₂	1 ⁴⁷ / ₆₄	100
BT-503	1	2 ¹⁵ / ₃₂	1 ³¹ / ₃₂	100
BT-504	1¼	2 ¹⁹ / ₃₂	2 ²⁹ / ₆₄	100
BT-505	1½	2 ¹⁵ / ₃₂	3 ¹ / ₃₂	100

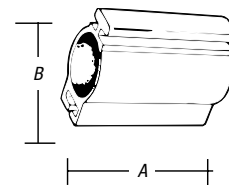

Nail Straps — Steel

- Steel
- Zinc plated

CAT. NO.	RIGID/MC SIZE (IN.)	EMT SIZE (IN.)	FLEX SIZE (IN.)	DIMENSIONS (IN.)		STD. CTN.
				A	B	
N-101-SC	—	½	¾	1 ¹⁵ / ₁₆	1 ¹ / ₆₄	1,000
N-102-SC	½	¾	½	2 ³ / ₁₆	1 ¹⁷ / ₃₂	1,000
N-103-SC	¾	1	—	2 ³ / ₈	1 ¹⁵ / ₃₂	1,000

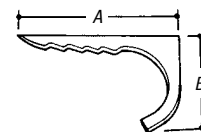

Rigid Conduit/IMC Fittings

Threadless Compression Connectors

- Malleable iron/zinc plated



CAT. NO.	CONDUIT SIZE (IN.)	STD. CTN.
Die-Cast Zinc Flexible Metal Conduit to EMT		
HC 401	½	300
HC-402	¾	150
HC-403	1	90
HC-404	1¼	60
HC-405	1½	30
HC-406	2	12
HC-407	2½	12
HC-408	3	6
HC-409	3½	6
HC-410	4	6

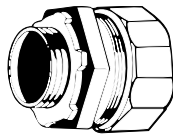

Suggested use — rigid conduit only.

UL File No. E-23018 ½"–1¼".

Threadless Compression Couplings

- Malleable iron/zinc plated



CAT. NO.	CONDUIT SIZE (IN.)	STD. CTN.
HK 401	½	300
HK 402	¾	150
HK 403	1	90
HK 404	1¼	60
HK 405	1½	30
HK 406	2	6
HK 407	2½	6
HK 408	3	4
HK 409	3½	4
HK 410	4	4

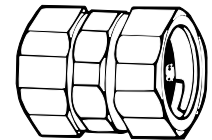

Suggested use — rigid conduit only.

UL File No. E-23018 ½"–1¼".

Set-Screw Connectors

- Steel
- Zinc plated



CAT. NO.	CONDUIT SIZE (IN.)	DIMENSIONS (IN.)		STD. CTN.
		A	B	
Die-Cast Zinc Flexible Metal Conduit to EMT				
HC 101	½	1⅞	1⅞	100
HC-102	¾	1⅞	1½	50
HC-103	1	⅝	1⅞	50
HC-104	1¼	2	2	25
HC-105	1½	2½	2⅞	25
HC-106	2	2¾	2⅞	20
HC-107	2½	3⅜	3⅞	10
HC-108	3	4½	3⅞	5
HC-109	3½	4⅞	3⅞	5
HC-110	4	5¾	4¾	5

One set screw or two. Two set screws starting at 2" trade size.

Suggested use — rigid conduit only.

UL File No. E-23018 ½"–1¼".

Insulated



CAT. NO.	CONDUIT SIZE (IN.)	DIMENSIONS (IN.)		STD. CTN.
		A	B	
Die-Cast Zinc Flexible Metal Conduit to EMT				
HC 701	½	1⅞	1⅞	100
HC-702	¾	1⅞	1½	50
HC-703	1	⅝	1⅞	25
HC-704	1¼	2	2	25
HC-705	1½	2½	2⅞	25
HC-706	2	2¾	2⅞	20
HC-707	2½	3⅜	3⅞	10
HC-708	3	4½	3⅞	5
HC-709	3½	4¾	4⅞	5
HC-710	4	4¾	4⅞	5

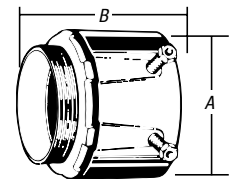

One set screw or two. Two set screws starting at 2" trade size.

Suggested use — rigid conduit only.

UL File No. E-23018 ½"–1¼".

Set-Screw Couplings

- Steel (concrete tight) when taped
- Zinc plated



CAT. NO.	CONDUIT SIZE (IN.)	DIMENSIONS (IN.)		STD. CTN.
		A	B	
HK-101	½	1⅞	2⅜	100
HK-102	¾	1⅞	2⅜	50
HK-103	1	1⅞	2⅜	25
HK-104	1¼	2	2⅞	25
HK-105	1½	2¼	3⅜	25

Two set screws starting at 2".

UL File No. E-23018.

CAT. NO.	CONDUIT SIZE (IN.)	DIMENSIONS (IN.)		STD. CTN.
		A	B	
HK-106	2	2¾	3⅜	20
HK-107	2½	3⅞	3⅞	10
HK-108	3	4⅞	4⅞	5
HK-109	3½	4⅞	4⅞	5
HK-110	4	5⅞	5⅞	5

Two set screws starting at 2".

UL File No. E-23018.

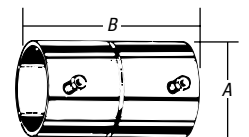

Rigid Connectors — Set-Screw Type — Die-Cast Zinc

CAT. NO.	TRADE SIZE (IN.)	DIMENSIONS (IN.)		STD. CTN.
		A	B	
HC-203	1	1.54	.49	100
HC-802	¾	1.44	.45	250
HC-803	1	1.54	.49	100

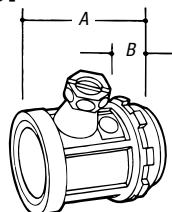

Rigid Connectors — Set-Screw Type — Die-Cast Zinc

CAT. NO.	TRADE SIZE (IN.)	DIMENSIONS (IN.)		STD. CTN.
		A	B	
HK 201	½	1.77	1.09	250
HK-203	1	2.29	1.61	100

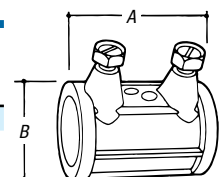

Rigid Conduit/IMC Fittings

90° Short-Radius Elbows — Die-Cast Zinc

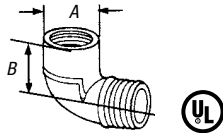

CAT. NO.	SIZE (IN.)	DIMENSIONS (IN.)		SHF. CTF./SHIP QTY.
		A	B	
HL-202-SC	¾	1.17	1.04	25/250

Use: To join rigid or IMC conduit at right angles where lack of room prevents using a standard sweep elbow or to terminate a run of rigid or IMC conduit at a box.

UL® Listing E37148.

Three-Piece Couplings

- ½"-2½" — Steel
- 2½"-6" — Malleable iron
- Zinc plated

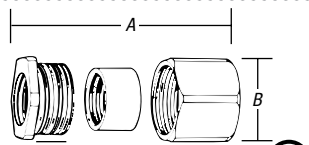

CAT. NO.	CONDUIT SIZE (IN.)	DIMENSIONS (IN.)		STD. CTN.
		A (ASSEMBLED)	B	
EK 401	½	1¼	1⅝	100
EK 402	¾	1⅞	1⅞	50
EK 403	1	1⅞	1⅞	25
EK 404	1¼	1⅞	2⅞	25
EK 405	1½	1⅞	2⅞	25
EK 406	2	2	3⅜	20
EK 407	2½	2½	3⅜	10
EK 408	3	3⅞	4⅞	6
EK 409	3½	3⅞	5⅞	5
EK 410	4	3⅞	5⅞	5
EK 411	5	4⅞	7	1

One set screw or two. Two set screws starting at 2" trade size.

Suggested use — rigid conduit only.

UL File No. E-23018 ½"-1¼".

Rigid Couplings — Three-Piece Type — Die-Cast Zinc

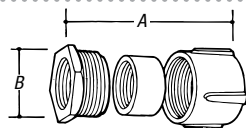

CAT. NO.	TRADE SIZE (IN.)	DIMENSIONS (IN.)		STD. CTN.
		A (ASSEMBLED)	B	
EK 201	½	1.39	1.31	100
EK-202	¾	1.53	1.58	50

Rigid to Box with Gasket — Die-Cast Zinc

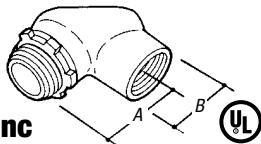

CAT. NO.	CONDUIT SIZE (IN.)	DIMENSIONS (IN.)		STD. CTN.
		A (ASSEMBLED)	B	
HL-611	½	1.31	1.09	100
HL-612	¾	1.47	1.29	50

UL File No. E-23018.



H050-SC Series Hub

The T&B® Hub — Die-Cast Zinc with Insulated Throat*

- The T&B Hub with sealing ring that will not fall out
- Color blue is a registered trademark of Thomas & Betts Corporation
- Provides superior sealing for exceptional watertight performance

CAT. NO.	HUB SIZE (IN.)	STD. CTN.
H050-SC	½	100
H075-SC	¾	100
H100-SC	1	25
H125-SC	1¼	25
H150-SC	1½	10
H200-SC	2	5
H250-SC	2½	5
H300-SC	3	2
H350-SC	3½	2
H400-SC	4	1
H500-SC	5	1
H600-SC	6	1

*Available in nickel-chrome plating or with PVC coating.

Consult customer service for price and delivery.

UL File No. E-23018.

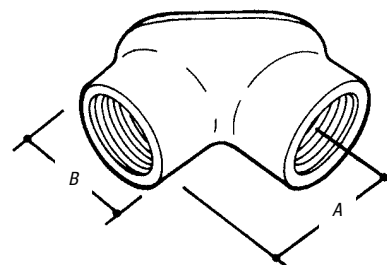

Pull Corner Elbows — Die-Cast Zinc

CAT. NO.	CONDUIT SIZE (IN.)	DIMENSIONS (IN.)		STD. CTN.
		A	B	
HL-601	½	1.31	1.10	100
HL-602	¾	1.60	1.24	50
HL-603	1	1.95	1.59	25
HL-604	1¼	2.26	1.97	30

UL File No. E-23018.

Rigid Conduit/IMC Fittings

Conduit Nipples — Iron/Zinc Plated

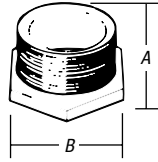

CAT. NO.	CONDUIT SIZE (IN.)	DIMENSIONS (IN.)		STD. CTN.
		A	B	
841-TB	3/8	9/16	11/16	500
HA-401	1/2	33/64	15/16	500
HA-402	3/4	43/64	13/16	200
HA-403	1	7/8	17/16	100
HA-404	1 1/4	1 1/8	1 3/4	100
HA-405	1 1/2	1 1/8	2 1/16	50
HA-406	2	1 7/16	2 9/16	50
HA-407	2 1/2	1 1/4	3	20
HA-408	3	1 1/2	3 3/4	10
HA-409	3 1/2	1 3/4	4 3/8	5
HA-410	4	—	—	5

UL File No. E16592.

Conduit Nipples Die-Cast Zinc — 1" Long

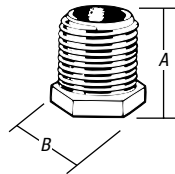

CAT. NO.	CONDUIT SIZE (IN.)	DIMENSIONS (IN.)		STD. CTN.
		A	B	
HA-211	1/2	1	15/16	1,000
HA-212	3/4	1	13/16	500
HA-213	1	1	17/16	250

UL File No. E-23018 1/2" & 3/4" only.

Conduit Nipples Die-Cast Zinc — Insulated

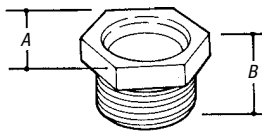

CAT. NO.	CONDUIT SIZE (IN.)	DIMENSIONS (IN.)		STD. CTN.
		A	B	
HA-801	1/2	.98	.59	1,000
HA-802	3/4	1.18	.70	500
HA-803	1	1.50	.80	250
HA-804	1 1/4	1.75	1.06	250
HA-805	1 1/2	2.11	1.01	100
HA-806	2	2.61	1.20	40
HA-807	2 1/2	3.13	1.49	25
HA-808	3	3.90	1.65	10
HA-809	3 1/2	4.20	1.68	10
HA-810	4	4.79	1.73	10

UL File No. E-23018 1/2" & 3/4" only.

Conduit Nipples Iron/Zinc Plated — Insulated

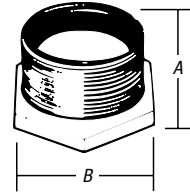

CAT. NO.	CONDUIT SIZE (IN.)	DIMENSIONS (IN.)		STD. CTN.
		A	B	
HA-901	1/2	49/64	1 13/16	500
HA-902	3/4	1 9/16	1 7/32	200
HA-903	1	7/8	1 7/16	100
HA-904	1 1/4	1 1/8	1 3/4	100
HA-905	1 1/2	1 1/8	2 1/16	50
HA-906	2	1 7/16	2 9/16	50

Offset Nipples — Die-Cast Zinc

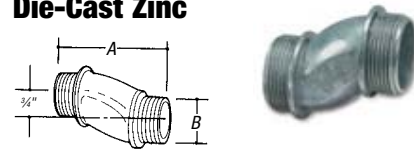

CAT. NO.	CONDUIT SIZE (IN.)	DIMENSIONS (IN.)		STD. CTN.
		A	B	
HO-221	1/2	2.60	1.00	100
HO-222	3/4	2.62	1.32	100
HO-223	1	2.68	1.51	100
HO-224	1 1/4	2.85	1.85	50
HO-225	1 1/2	2.88	2.08	50
HO-226	2	3.19	2.71	20

3/4" offset.

UL File No. E-23018.

Conduit Nipples Die-Cast Zinc — Non-Insulated

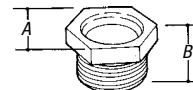

CAT. NO.	CONDUIT SIZE (IN.)	DIMENSIONS (IN.)		STD. CTN.
		A	B	
HA-201	1/2	.98	.59	1,000
HA-202	3/4	1.18	.70	500
HA-203	1	1.50	.80	250
HA-204	1 1/4	1.75	1.06	250
HA-205	1 1/2	2.11	1.01	100
HA-206	2	2.61	1.20	40
HA-207	2 1/2	3.13	1.49	40
HA-208	3	3.90	1.65	40
HA-209	3 1/2	4.20	1.68	40
HA-210	4	4.79	1.73	20

UL File No. E-23018 1/2"—2".

Rigid Conduit/IMC Fittings

Locknuts — Steel/Zinc Plated

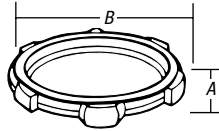

CAT. NO.	CONDUIT SIZE (IN.)	DIMENSIONS (IN.)		STD. CTN.
		A	B	
LN-100-SC	3/8	—	—	1,000
LN-101-SC	1/2	.125	1.140	1,000
LN-102	3/4	.140	1.420	1,000
LN-103	1	.170	1.770	500
LN-104	1 1/4	.170	2.281	200
LN-105	1 1/2	.170	2.598	100
LN-106	2	.187	3.175	50
LN-107	2 1/2	.375	3.562	30
LN-108	3	.375	4.250	25
LN-109	3 1/2	.438	4.803	25
LN-110	4	.438	5.402	25
LN-111	5	.500	6.674	10
LN-112	6	.561	7.934	10

Sealing Locknuts — Steel/Zinc Plated

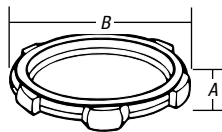

CAT. NO.	CONDUIT SIZE (IN.)	DIMENSIONS (IN.)		STD. CTN.
		A (MIN.)	B (MAX.)	
LS 101	1/2	.26	1.12	1,000
LS-102	3/4	.27	1.37	1,000
LS-103	1	.28	1.75	500
LS-104	1 1/4	.32	2.06	200
LS-105	1 1/2	.32	2.37	100
LS-106	2	.32	2.87	50
LS-107	2 1/2	.32	3.43	50
LS-108	3	.32	4.12	50
LS-109	3 1/2	.32	4.62	50
LS-110	4	.32	5.18	25

Locknuts — Non-Metallic

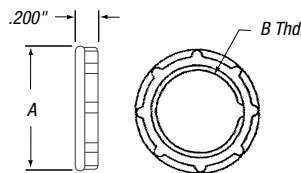

CAT. NO.	TRADE SIZE (IN.)	A DIA. (IN.)	B THD. (IN.)	STD. CTN.
LN-501	1/2	1.3	1/2-14	100
LN-502	3/4	1.4	3/4-14	100
LN-503	1	1.7	1-11 1/2	50

Material: Nylon 6/6.

Color: Gray.

Locknuts Die-Cast Zinc

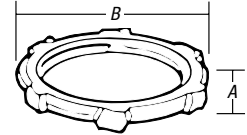

CAT. NO.	CONDUIT SIZE (IN.)	DIMENSIONS (IN.)		STD. CTN.
		A	B	
LN-201	1/2	.125	1.140	2,000
LN-202	3/4	.140	1.420	1,000
LN-203	1	.170	1.770	1,000
LN-204	1 1/4	.170	2.281	500
LN-205	1 1/2	.170	2.598	500
LN-206	2	.187	3.175	200
LN-207	2 1/2	.375	3.562	100
LN-208	3	.375	4.250	100
LN-209	3 1/2	.438	4.803	40
LN-210	4	.438	5.402	40

CSA File No. LR- 12798.

Grounding Locknuts — Malleable Iron/Zinc Plated

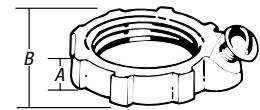

CAT. NO.	CONDUIT SIZE (IN.)	DIMENSIONS (IN.)		STD. CTN.
		A (MIN.)	B (MAX.)	
LG-401	1/2	.125	1.140	100
LG-402	3/4	.140	1.420	100
LG-403	1	.170	1.770	50
LG-404	1 1/4	.170	2.281	50
LG-405	1 1/2	.170	2.598	50
LG-406	2	.187	3.175	25
LG-407	2 1/2	.375	3.562	10
LG-408	3	.375	4.250	10
LG-409	3 1/2	.438	4.803	50
LG 410	4	.438	5.402	5

Thin Construction Locknuts — Steel/Zinc Plated

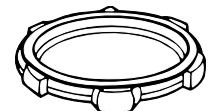

CAT. NO.	CONDUIT SIZE (IN.)	UNIT QTY	STD. CTN.
SPLN-107	2 1/2	30	30
SPLN-108	3	25	25
SPLN-109	3 1/2	25	25
SPLN-110	4	25	25

Rigid Conduit/IMC Fittings

Conduit Bushings — Die-Cast Zinc — Insulated

- 105° C thermoplastic liners
- Heavy reinforced ribs



CAT. NO.	CONDUIT SIZE (IN.)	DIMENSIONS (IN.)		STD. CTN.
		A	B	
BU-801	½	1.06	.43	1,000
BU-802	¾	1.31	.43	1,000
BU-803	1	1.59	.48	500
BU-804	1¼	1.96	.56	250
BU-805	1½	2.18	.60	250

CAT. NO.	CONDUIT SIZE (IN.)	DIMENSIONS (IN.)		STD. CTN.
		A	B	
BU-806	2	2.68	.56	250
BU-807	2½	3.25	.90	50
BU-808	3	3.87	.85	25
BU-809	3½	4.37	.93	25
BU-810	4	5.00	.93	10

UL File No. E-23018.

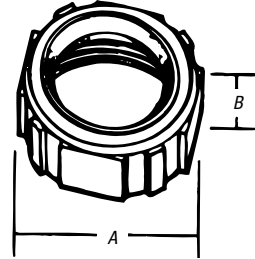

Conduit Bushings — Die-Cast Zinc — Heavy Reinforced Ribs



CAT. NO.	CONDUIT SIZE (IN.)	DIMENSIONS (IN.)		STD. CTN.
		A (MIN.)	B (MAX.)	
BU201	½	1.05	.37	1,000
BU-202	¾	1.32	.37	1,000
BU-203	1	1.58	.47	500
BU-204	1¼	1.94	.50	250
BU-205	1½	2.20	.52	250

CAT. NO.	CONDUIT SIZE (IN.)	DIMENSIONS (IN.)		STD. CTN.
		A (MIN.)	B (MAX.)	
BU-206	2	2.69	.52	250
BU-207	2½	3.23	.85	50
BU-208	3	3.84	.85	25
BU-209	3½	4.35	.85	25
BU-210	4	5.02	.85	10

UL File No. E-23018.

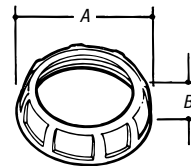

Insulated Bushings — Thermoplastic



CAT. NO.	CONDUIT SIZE (IN.)	DIMENSIONS (IN.)		STD. CTN.
		A	B	
BU-501	½	1 ¹³ / ₃₂	1 ¹ / ₁₆	400
BU-502	¾	1 ¹³ / ₃₂	1 ¹ / ₁₆	400
BU-503	1	1 ⁹ / ₁₆	1 ¹ / ₁₆	200
BU-504	1¼	1 ⁹ / ₁₆	1 ²⁹ / ₃₂	100
BU-505	1½	1 ⁹ / ₁₆	2 ³ / ₁₆	100
BU-506	2	1 ⁵ / ₈	2 ¹ / ₁₆	60

CAT. NO.	CONDUIT SIZE (IN.)	DIMENSIONS (IN.)		STD. CTN.
		A	B	
BU-507	2½	2 ²³ / ₃₂	3 ³ / ₁₆	20
BU-508	3	2 ⁹ / ₁₆	3 ²⁷ / ₃₂	20
BU-509	3½	3 ¹ / ₄	4 ²³ / ₆₄	5
BU-510	4	3 ²³ / ₃₂	4 ²⁷ / ₃₂	5
BU-511	5	4 ¹ / ₈	6 ³ / ₁₆	5
BU-512	6	5 ¹ / ₈	7 ¹ / ₁₆	5

UL File No. E-23018 ½"-4" only.

Rated 105° C.

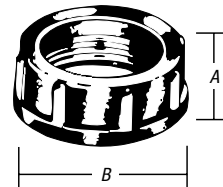

Bushings — Iron/Zinc Plated



CAT. NO.	CONDUIT SIZE (IN.)	DIMENSIONS (IN.)		STD. CTN.
		A	B	
BU-401	½	1 ¹ / ₃₂	7 ¹ / ₁₆	1,000
BU-402	¾	1¼	7 ¹ / ₁₆	1,000
BU-403	1	1 ¹ / ₁₆	½	500
BU-404	1¼	1 ¹ / ₁₆	1 ¹ / ₃₂	200
BU-405	1½	2 ³ / ₆₄	9 ¹ / ₁₆	100
BU-406	2	2 ⁵ / ₆₄	9 ¹ / ₁₆	50

CAT. NO.	CONDUIT SIZE (IN.)	DIMENSIONS (IN.)		STD. CTN.
		A	B	
BU-401	½	1 ¹ / ₃₂	7 ¹ / ₁₆	1,000
BU-402	¾	1¼	7 ¹ / ₁₆	1,000
BU-403	1	1 ¹ / ₁₆	½	500
BU-404	1¼	1 ¹ / ₁₆	1 ¹ / ₃₂	200
BU-405	1½	2 ³ / ₆₄	9 ¹ / ₁₆	100
BU-406	2	2 ⁵ / ₆₄	9 ¹ / ₁₆	50

UL File No. E-23018.

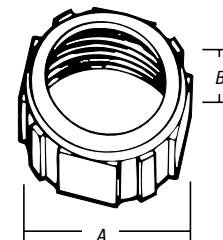

Grounding Bushings — Die-Cast Zinc — Insulated with Aluminum Lay-in Type Lug

- 105° C thermoplastic liners
- Heavy reinforced ribs



CAT. NO.	TRADE SIZE (IN.)	GROUNDING LUG WIRE SIZE		STD. CTN.
		MIN.	MAX.	
BG201	½	14 AWG	4 AWG	500
BG-202	¾	14 AWG	4 AWG	500
BG-203	1	14 AWG	4 AWG	250
BG-204A	1¼	14 AWG	4 AWG	200
BG-204	1¼	8 AWG	1/0 AWG	200
BG-205A	1½	11 AWG	4 AWG	100
BG-205	1½	8 AWG	1/0 AWG	50
BG-206A	1	14 AWG	4 AWG	100
BG-206	2	8 AWG	1/0 AWG	50

CAT. NO.	TRADE SIZE (IN.)	GROUNDING LUG WIRE SIZE		STD. CTN.
		MIN.	MAX.	
BG-207	2½	8 AWG	1/0 AWG	50
BG-207A	2½	6 AWG	250 kcmil	50
BG-208	3	8 AWG	1/0 AWG	50
BG-208A	3	6 AWG	250 kcmil	50
BG-209	3½	8 AWG	1/0 AWG	10
BG-209A	3½	6 AWG	250 kcmil	10
BG-210	4	8 AWG	1/0 AWG	10
BG-210A	4	6 AWG	250 kcmil	10

UL File No. E-3060.

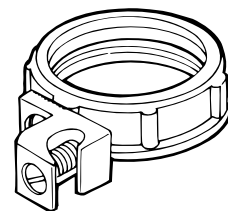

Rigid Conduit/IMC Fittings

Insulated Bushings — Iron/Zinc Plated



CAT. NO.	CONDUIT SIZE (IN.)	DIMENSIONS (IN.)		STD. CTN.
		A	B	
BI-901	1/2	1 1/32	1/2	1,000
BI-902	3/4	1 1/4	1/2	1,000
BI-903	1	1 5/16	5/8	500
BI-904	1 1/4	1 15/16	19/32	200
BI-905	1 1/2	2 13/64	5/8	100

UL File No. E-23018.



CAT. NO.	CONDUIT SIZE (IN.)	DIMENSIONS (IN.)		STD. CTN.
		A	B	
BI-906	2	2 5/64	5/8	50
BI-907	2 1/2	3 3/32	9/16	30
BI-908	3	3 27/32	9/16	25
BI-909	3 1/2	4 1/16	7/8	25
BI910	4	4 31/32	2 3/32	25

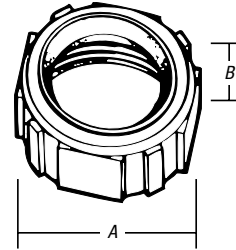

Insulated Grounding Bushings — Malleable Iron/Zinc Plated



CAT. NO.	TRADE SIZE (IN.)	GROUNDING LUG WIRE CAPACITY	DIMENSIONS (IN.)		STD. CTN.
			A	B	
BG-801	1/2	—	1 1/32	1/2	500
BG-802	3/4	#14-#4 CU	1 1/4	1/2	500
BG-803	1	or	1 1/16	5/16	250
BG-804	1 1/4	#12-#4 AL	1 15/16	19/32	150
BG-805	1 1/2	—	2 13/64	5/8	150

UL File No. E-3060.

1/2"-2" Iron, 2 1/2"-4" Die-Cast Zinc.



CAT. NO.	TRADE SIZE (IN.)	GROUNDING LUG WIRE CAPACITY	DIMENSIONS (IN.)		STD. CTN.
			A	B	
BG-806	2	—	2 5/64	5/8	100
BG-807	2 1/2	#14-1/0 CU	3 3/16	9/16	60
BG-808	3	or #12-1/0 AL	3 3/8	9/16	30
BG-809	3 1/2	#6-250 kcmil	4 1/16	7/8	30
BG-810	4	CU or AL	4 21/32	2 3/32	30

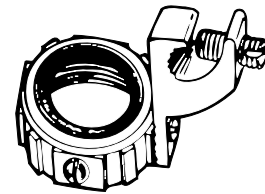

Grounding Bushings Malleable Iron/Zinc Plated — Insulated with Aluminum Lug

- For copper or aluminum bare ground wire
- 105° C thermoplastic liners
- Heavy reinforced ribs



CAT. NO.	TRADE SIZE (IN.)	GROUNDING LUG WIRE SIZE		STD. CTN.
		MIN.	MAX.	
BG801A	1/2	14 AWG	6 AWG	500
BG-802A	3/4	14 AWG	6 AWG	500
BG-803A	1	14 AWG	6 AWG	250
BG-804A	1 1/4	14 AWG	2 AWG	200
BG-805A	1 1/2	14 AWG	2 AWG	100
BG-806A	2	14 AWG	2 AWG	100

UL File No. E-3060.



CAT. NO.	TRADE SIZE (IN.)	GROUNDING LUG WIRE SIZE		STD. CTN.
		MIN.	MAX.	
BG-807A	2 1/2	14 AWG	2/0 AWG	50
BG-808A	3	14 AWG	2/0 AWG	50
BG-809A	3 1/2	14 AWG	2/0 AWG	10
BG-810A	4	14 AWG	2/0 AWG	10
BG-810B	4	6 AWG	250 kcmil	10

Reducing Bushings

- RB-121 thru RB-165 — Steel
- RB-175 thru RB-187 — Malleable iron (concrete tight), zinc plated



CAT. NO.	CONDUIT SIZE (IN.)	DIMENSIONS (IN.)		STD. CTN.
		A	B	
RB-121	3/4-1/2	5/16	7/8	100
RB-131	1-1/2	5/8	1 1/8	50
RB-132	1-3/4	5/8	1 1/8	50
RB-141	1 1/4-1/2	1 1/16	1 1/16	50
RB-142	1 1/4-3/4	1 1/16	1 1/16	50
RB-143	1 1/4-1	1 1/16	1 1/16	50
RB-151	1 1/2-1/2	2 3/32	1 11/16	50
RB-152	1 1/2-3/4	2 3/32	1 11/16	50
RB-153	1 1/2-1	2 3/32	1 11/16	50
RB-154	1 1/2-1 1/4	2 3/32	1 11/16	50

UL File No. E-23018.



CAT. NO.	CONDUIT SIZE (IN.)	DIMENSIONS (IN.)		STD. CTN.
		A	B	
RB-161	2-1/2	2 7/32	2 3/32	25
RB-162	2-3/4	2 7/32	2 3/32	25
RB-163	2-1	2 7/32	2 3/32	25
RB-164	2-1 1/4	2 7/32	2 3/32	25
RB-165	2-1 1/2	2 7/32	2 3/32	25
RB-175	2 1/2-1 1/2	7/8	2 13/16	25
RB-176	2 1/2-2	7/8	2 13/16	25
RB-186	3-2	2 9/32	2 1/16	25
RB-187	3-2 1/2	2 9/32	2 1/16	25

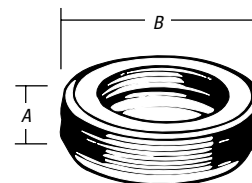

Rigid Conduit/IMC Fittings

Reducers — Malleable Iron/Zinc Plated

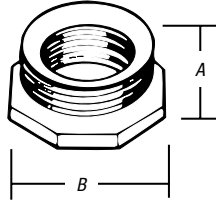

CAT. NO.	CONDUIT SIZE (IN.)	DIMENSIONS (IN.)		STD. CTN.
		A	B	
RB-421	3/4-1/2	5/8	1 1/16	100
RB-432	1/2-3/4	1	1 1/16	100
RB-443	1-3/4	1 1/16	1 3/16	50

UL File No. E-23018.

Reducing Washers — Steel/Zinc Plated

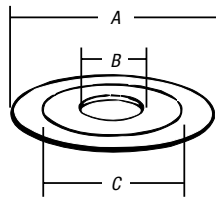

CAT. NO.	CONDUIT SIZE (IN.)	DIMENSIONS (IN.)			STD. CTN.
		A	B	C	
WA-110	1/2-3/8	1 1/16	1 1/16	27/32	500
WA-121	3/4-1/2	1 1/2	7/8	1 1/16	500
WA-131	1-1/2	1 3/4	7/8	1 1/16	500
WA-132	1-3/4	1 3/4	1 3/32	1 1/16	500
WA-141	1 1/4-1/2	2 1/16	7/8	1 11/16	200
WA-142	1 1/4-3/4	2 1/16	1 3/32	1 11/16	200
WA-143	1 1/4-1	2 1/16	1 23/64	1 11/16	200
WA-151	1 1/2-1/2	2 3/8	7/8	1 7/8	200
WA-152	1 1/2-3/4	2 3/8	1 3/32	1 7/8	200
WA-153	1 1/2-1	2 3/8	1 23/64	1 7/8	200
WA-154	1 1/2-1 1/4	2 3/8	1 23/32	1 7/8	200
WA-161	2-1/2	3 1/4	7/8	2 3/8	100
WA-162	2-3/4	3 1/4	1 3/32	2 3/8	100
WA-163	2-1	3 1/4	1 23/64	2 3/8	100
WA-164	2-1 1/4	3 1/4	1 23/32	2 3/8	100
WA-165	2-1 1/2	3 1/4	1 31/32	2 3/8	100
WA-171	2 1/2-1/2	3 1/4	7/8	2 7/8	100
WA-172	2 1/2-3/4	3 1/4	1 3/32	2 7/8	100
WA-173	2 1/2-1	3 1/4	1 23/64	2 7/8	100
WA-174	2 1/2-1 1/4	3 1/4	1 23/32	2 7/8	100
WA-175	2 1/2-1 1/2	3 1/4	1 31/32	2 7/8	100
WA-176	2 1/2-2	3 1/4	2 1/16	2 7/8	100
WA-181	3-1/4	4 1/2	7/8	3 1/2	100
WA-182	3-3/4	4 1/2	1 23/32	3 1/2	100
WA-183	3-1	4 1/2	1 23/64	3 1/2	100
WA-184	3-1 1/4	4 1/2	1 23/32	3 1/2	100
WA-185	3-1 1/2	4 1/2	1 31/32	3 1/2	100
WA-186	3-2	4 1/2	2 1/16	3 1/2	100
WA-187	3-2 1/2	4 1/2	2 1/16	3 1/2	100

WA-121 thru WA-165 CSA Listed.

One-Hole Straps — Steel/Zinc Plated

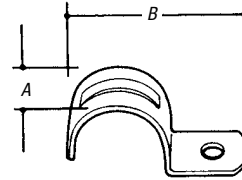

CAT. NO.	SCREW SIZE	CONDUIT SIZE (IN.)	DIMENSIONS (IN.)		STD. CTN.
			A	B	
HS-100-SC	10	3/8	3/4	1 1/4	1,000
HS-101	1/4	1/2	1	1 1/16	500
HS-102	1/4	3/4	1	2 5/16	500
HS-103	1/4	1	1	2 13/32	250
HS-104	3/16	1 1/4	1	3 3/32	100
HS-105	3/8	1 1/2	1 1/16	3 13/32	100
HS-106	3/8	2	1 1/16	3 7/32	100
HS-107	7/16	2 1/2	1 1/4	5 1/16	25
HS-108	1/2	3	1 3/8	5 7/8	25
HS-109	1/2	3 1/2	1 3/8	6 1/4	10
HS-110	1/2	4	1 3/8	6 7/8	10

Available in one-hole and two-hole in stainless steel.

Add SS suffix to catalog number for Stainless Steel.

Two-Hole Straps — Steel/Zinc Plated

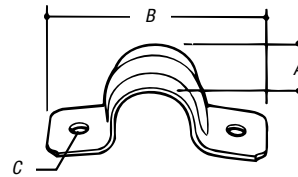

CAT. NO.	SCREW SIZE	CONDUIT SIZE (IN.)	DIMENSIONS (IN.)			STD. CTN.
			A	B	C	
HS-901	8	1/2	3/4	2 1/16	3/16	1,200
HS-902	10	3/4	3/4	2 11/16	3/16	900
HS-903	1/4	1	3/4	3 7/16	3/16	600
HS-904	1/4	1 1/4	3/4	3 7/32	3/16	450
HS-905	1/4	1 1/2	3/4	4 1/16	3/16	50
HS-906	1/4	2	3/4	4 7/16	3/16	150
HS-907	1/4	2 1/2	1	5 5/8	1/4	150
HS-908	1/2	3	1	6 1/16	1/4	60
HS-909	1/4	3 1/2	1	7 3/16	1/4	60
HS-910	1/4	4	1	8 11/16	1/4	60

CSA Certified.

Add SS suffix to catalog number for Stainless Steel.

Rigid Conduit/IMC Fittings

Pipe Straps — Malleable Iron/Zinc Plated

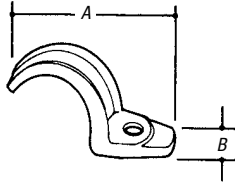

CAT. NO.	SCREW SIZE	CONDUIT SIZE (IN.)	DIMENSIONS (IN.)		STD. CTN.
			A	B	
HS-400	10	3/8	1 11/16	1 1/32	500
HS-401	1/4	1/2	2 1/64	5/8	500
HS-402	1/4	3/4	2 1/16	1 3/16	500
HS-403	1/4	1	2 7/8	1 5/16	100
HS-404-SC	5/16	1 1/4	3 5/16	1 1/32	100
HS-405	3/8	1 1/2	3 3/4	1 1/8	50
HS-406	1/2	2	4 19/32	1 1/16	25
HS-407	5/8	2 1/2	5 11/16	1 3/8	25
HS-408	5/8	3	6 7/8	1 7/8	25
HS-409	3/4	3 1/2	7 23/32	2 1/8	10
HS-410	3/4	4	8 7/16	2 3/8	10
HS-411	3/4	5	10 3/32	2 5/8	5

Available in one-hole and two-hole in Stainless Steel.

Add SS suffix to part number for Stainless Steel.

Nail Strap — Stamped Steel/ Zinc Plated

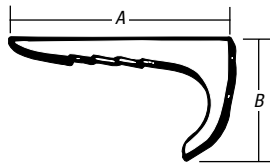

CAT. NO.	RIGID/MC SIZE (IN.)	EMT SIZE (IN.)	FLEX SIZE (IN.)	DIMENSIONS (IN.)		STD. CTN.
				A	B	
N-101-SC	—	1/2	3/8	2 5/32	1 5/64	1,000
N-102-SC	1/2	3/4	1/2	2 5/16	1 1/32	1,000
N-103-SC	3/4	1	—	2 7/8	1 15/32	1,000

Flange Plates — Malleable Iron/ Zinc Plated

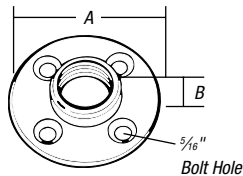

CAT. NO.	CONDUIT SIZE (IN.)	DIA. A (IN.)	DEPTH B (IN.)	STD. CTN.
FP-402	3/4	3 3/8	.656	50
FP-403	1	3 5/8	.765	50
FP-404	1 1/4	4	.875	25
FP-405	1 1/2	4 3/8	.937	25
FP-406	2	4 7/8	.843	25

Pipe Spacers for Rigid/Intermediate or Thinwall — Die-Cast Zinc

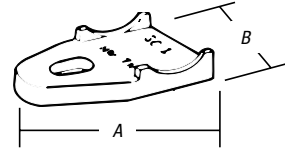

CAT. NO.	CONDUIT SIZE (IN.)	DIA. A (IN.)	DEPTH B (IN.)	STD. CTN.
CB-202	3/4	2 3/8	1 1/16	500
CB-203	1	2 3/4	1 1/16	500
CB-204	1 1/4	3 3/8	1 1/2	250
CB-205	1 1/2	3 13/16	1 5/8	100
CB-206	2	4 1/2	2	50

Rigid/Intermediate Space Caps — Plastic

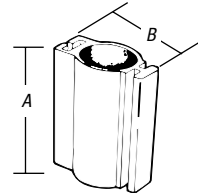

CAT. NO.	CONDUIT SIZE (IN.)	DIMENSIONS (IN.)		STD. CTN.
		A (IN.)	B (IN.)	
BR-501	1/2	2 15/32	1 21/32	100
BR-502	3/4	2 15/32	1 59/64	100
BR-503	1	2 15/32	2 1/8	100
BR-504	1 1/4	2 15/32	2 61/64	100
BR-505	1 1/2	2 15/32	3 13/64	100

Snap-In Blanks

- Steel
- Zinc plated



CAT. NO.	CONDUIT SIZE (IN.)	DIAMETER (IN.)	STD. CTN.
BL-112	3/4	1 1/4	1,000
BL-113	1	1 1/2	1,000
BL-114	1 1/4	1 13/16	500
BL-115	1 1/2	2 7/32	500
BL-116	2	2 11/16	250

Box Spacer — Die Cast Zinc (1/4" Space)

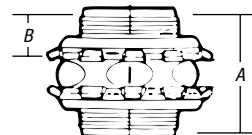

CAT. NO.	CONDUIT SIZE (IN.)	DIMENSIONS (IN.)		STD. CTN.
		A	B	
BS 201	1/2	1 1/8	1 13/32	500

UL File No. E-23018.

Non-Metallic Sheathed Cable Fittings

All-Plastic Connector for NM Cable and Flexible Cord



Snap captive locking wedge into connector's cavity.



Press locking wedge into cavity that locks onto cable.



Cat. No. 3201-TB is ideal for multiple flexible cords and cable.

- High-impact thermoplastic: UL94V-1
- Features push-in design
- Captive locking wedge secures cable with single squeeze of standard electrician's pliers
- Provides excellent insulation, strain-relief and high pull-out value



CAT. NO.	DESCRIPTION
3300	For use with 10-2, 12-2 and 14-2 NM cables; 18-2 and 18-3 SJ and SJO cords and 18-2 SV, SVO, SJT and SJTO cords, single or multiple; cord capacity .125-.300" diameter
3201-TB	For use with 10-3, 12-3, 14-3, 10-2, 12-2, 4-2 NM cables; multiple (2) 12-2 and 14-2 NM cables; single and multiple flexible cords in wire range .300-.600"
3202	For use with 8-3 and 6-3 NM cables; (2) 14-3, 14-2, 12-2 and 10-2 NM cables; single and multiple flexible cords in wire range .500-.850"

Temperature Rating: 105° C. CSA File Nos. 584 and 2884. UL File No. E-17583.

Dimensions

CAT. NO.	KO SIZE (IN.)	FIG.	DIMENSIONS (IN.)					MAX. THK. ENCLOSURE	H (IN.)	STD. CTN.
			A	B	C	D	E			
3300	1/2	2	1 1/32	1 1/16	3/8	.880	.795	.080	5/16 x 3/16	500
3201-TB	1/2	1	1 1/32	1	7/16	.880	.795	.080	2 1/2 dia.	500
3202	3/4	1	1 1/2	1 1/16	7/16	1.100	1.005	.090	7/8 dia.	250

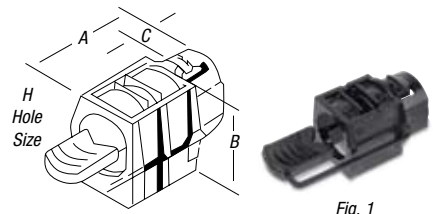

Fig. 1

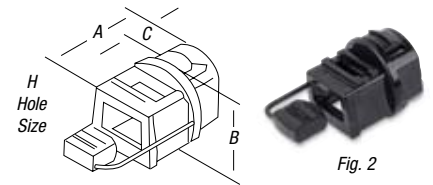

Fig. 2

Hit Lock® Connectors



NC-501-SC



CAT. NO.	DESCRIPTION	STD. CTN.
NC-501SC	1/2" Hit Lock® Connector	500
NC-501DBL-SC	1/2" Double Hit Lock® Connector	500
NC-502SC	3/4" Hit Lock® Connector	100
SB1216-SC	Twist It Bushing For Metal Studs	50

UL File No. E-17583.

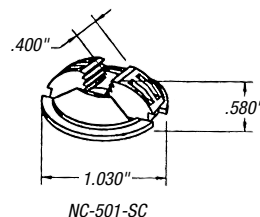

NC-501-SC

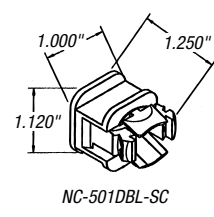

NC-501DBL-SC

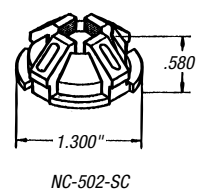

NC-502-SC

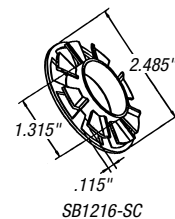

SB1216-SC

Non-Metallic Sheathed Cable Fittings

NM Clamp-Type Connector — Die-Cast Zinc

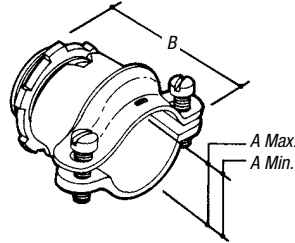

CAT. NO.	CONDUIT SIZE (IN.)	DIMENSIONS (IN.)			STD. CTN.
		A (MIN.)	A (MAX.)	B	
NC-201	½	.40	.95	1.87	250
NC-202	¾	.50	1.10	1.84	200
NC-203	1	.62	1.14	2.00	100
NC-204	1¼	.50	1.38	2.28	100
NC-205	1½	.75	1.61	2.49	50
NC-206	2	.90	2.04	3.35	50

CSA File No. LR-12798.

UL File No. E-17583.

Clamp-Type Connector — Die-Cast Zinc

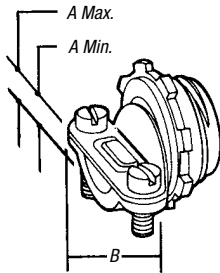

CAT. NO.	CONDUIT SIZE (IN.)	DIMENSIONS (IN.)			STD. CTN.
		A (MIN.)	A (MAX.)	B	
NC301	¾ (½ KO)	.18	.64	1.16	1,000
NC-302	¾	.41	.82	1.87	500
NC-303	1	.34	.94	2.01	250

CSA File No. LR-12798.

UL File No. E-17583.

Clamp-Type Connectors Non-Watertight — Die-Cast Zinc

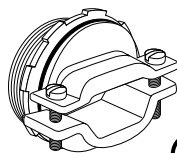

CAT. NO.	CONDUIT SIZE (IN.)	DIMENSIONS (IN.)			STD. CTN.
		A (MIN.)	A (MAX.)	B	
NC041	1¼	.27	.75	2.02	100
NC-051	1½	.54	.95	2.50	50
NC-061	2	.75	1.12	3.41	40

UL File No. E-15170 — 1¼"–1½".

UL File No. E-17583 — 2".

Duplex Clamp-Type Connector — Die-Cast Zinc

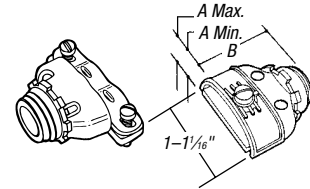

- For use with aluminum, smooth, extruded metal-clad cable. (min. dia. .410" — max. dia. .500").



CAT. NO.	CONDUIT SIZE (IN.)	DIMENSIONS (IN.)			STD. CTN.
		A (MIN.)	A (MAX.)	B	
XC-210	¾ (½ KO)	.13	.65	1.56	250
XC-211-SC	¾	.24	.63	1.59	200
XC-222-SC	¾	.24	.63	1.59	200

CONDUIT/CABLE	FMC (IN.)	AC	MCC	MCI
Max. Size	¾	10/2	.565	.565
Min. Size	¾	14/2	.425	.425

NM Flex Connectors Saddle-Type — Die-Cast Zinc

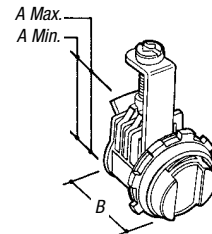

CAT. NO.	SIZE (IN.)	DIMENSIONS (IN.)			STD. CTN.
		A (MIN.)	A (MAX.)	B	
XC-2200-C	¾	.12	.63	.98	500

Tilt-In Connector — Electro-Galvanized Metallic Steel

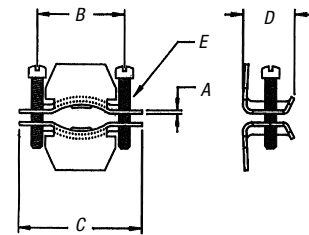

CAT. NO.	SIZE (IN.)	DIMENSIONS (IN.)					STD. CTN.
		A	B	C	D	E	
NC-850	½	.050	.950	1.312	.650	8–32 x ¾	1,000
NC-851	¾–1	.050	1.250	1.750	.760	8–32 x 1	500
NC-852	1–¼	.062	1.625	2.125	.760	10–32 x 1	250
NC-853	1–½	.062	1.970	2.500	.785	10–32 x 12	100

Armored Cable/Flexible Metallic Conduit Fittings

Straight Squeeze-Type Connectors — Malleable Iron

CAT. NO.	CONDUIT SIZE (IN.)	UNIT QTY.	STD. CTN.
XC-400	3/8 (1/2 KO)	50	100
XC-401	1/2	25	100
XC-402	3/4	25	100
XC-403	1	25	100
XC-404	1 1/4	5	10
XC-405	1 1/2	10	10
XC-406	2	10	10
XC-407	2 1/2	5	5
XC-408	3	5	5

UL File No. E-1383 1/2"-3/4".

UL File No. E-23018 1"-3".

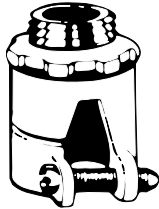

Straight Squeeze-Type Connectors — Insulated Malleable Iron

CAT. NO.	CONDUIT SIZE (IN.)	UNIT QTY.	STD. CTN.
XC-901	1/2	25	100
XC-902	3/4	25	100
XC-903	1	25	100
XC-904	1 1/4	5	10
XC-905	1 1/2	10	10
XC-906	2	10	10
XC-907	2 1/2	5	5
XC-908	3	5	5

UL File No. E-1383 1/2"-3/4".

UL File No. E-23018 1"-3".

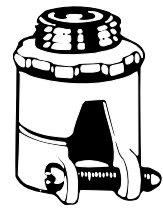

Clamp Straight Set, 90° and Duplex Connectors

90° Angle Squeeze-Type Connectors — Steel or Malleable Iron/Zinc Plated

CAT. NO.	CONDUIT SIZE (IN.)	UNIT QTY.	STD. CTN.
XC-490	3/8 (1/2 KO)	50	100
XC-491	1/2	25	100
XC-492	3/4	25	50
XC-493	1	25	25
XC-494	1 1/4	10	10
XC-495	1 1/2	10	10
XC-496	2	5	5
XC-497	2 1/2	1	1
XC-498	3	1	1

UL File No. E-1383 3/8" & 3/4".

UL File No. E-23018 1"-3".

3/8"-3/4" — Steel.

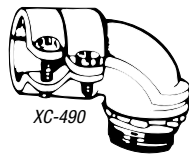

XC-490

Note: For die-cast armored cable/flexible metallic conduit fittings and combination fittings, see Steel City® Die-Cast Conduit Fittings, pages E-550-E-552.

Straight Squeeze-Type Connectors — Die-Cast Zinc

CAT. NO.	FIG.	SIZE (IN.)	DIMENSIONS (IN.)			STD. CTN.
			A (MIN.)	A (MAX.)	B	
XC-269	1	3/8 (1/2 KO)	.45	.60	.96	500
XC-270	1	1/2	.74	.92	1.43	250
XC-272	1	3/4	.88	1.10	1.59	250
XC-273	2	1	1.10	1.35	1.60	100
XC-274	2	1 1/4	1.48	1.65	1.91	100
XC-275	2	1 1/2	1.68	2.00	2.12	50
XC-276	3	2	2.12	2.47	2.54	40
XC-277	3	2 1/2	2.71	3.08	2.88	10
XC-278	3	3	3.15	3.60	3.88	5
XC-278A	3	3 1/2	3.20	4.03	5.04	1
XC-2710	3	4	3.15	4.25	5.04	—

UL File No. E-1383 3/8" & 3/4".

UL File No. E-23018 1"-3".

3/8"-3/4" — Steel.

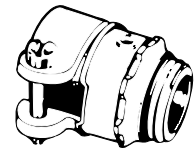

Armored Cable/Flexible Metallic Conduit Fittings

Straight Squeeze-Type Connectors — Insulated Die-Cast Zinc

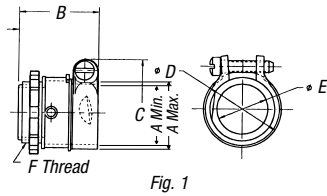

Fig. 1

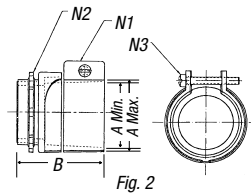

Fig. 2

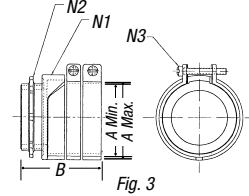

Fig. 3



CAT. NO.	FIG.	SIZE (IN.)	DIMENSIONS (IN.)			STD. CTN.
			A (MIN.)	A (MAX.)	B	
XC-870	1	½	.74	.92	1.43	250
XC-872	1	¾	.88	1.10	1.59	250
XC-873	2	1	1.10	1.35	1.60	100
XC-874	2	1¼	1.48	1.65	1.91	50
XC-875	2	1½	1.68	2.00	2.12	50
XC-876	3	2	2.12	2.47	2.54	10
XC-877	3	2½	2.71	3.08	2.88	10
XC-878	3	3	3.15	3.60	3.88	5
XC-879	3	3½	3.20	4.03	5.04	1
XC-8710	3	4	3.15	4.25	5.04	1

UL File No. E-17909 — ½"–¾"
 UL File No. E-23018 — 1¼"
 CSA File No. LR-12798.

Squeeze-Type BX Flex Connectors

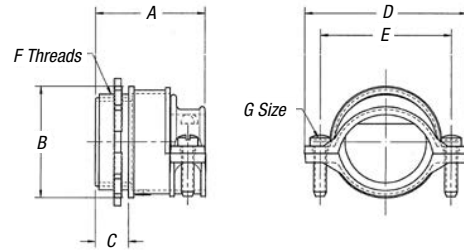

CAT. NO.	TRADE SIZE (IN.)	DIMENSIONS (IN.)					F THREADS	G SIZE	RANGE
		A	B	C	D	E			
XC-201	½	1 ²⁵ / ₆₄	1 ⁷ / ₆₄	1 ³ / ₃₂	1 ⁵⁵ / ₆₄	1 ³ / ₈	½–14NPS	10–24 x 7/8	.40–.95
XC-202	¾	1 ¹ / ₂	1 ¹ / ₄	½	1 ⁵⁹ / ₆₄	1 ³ / ₈	¾–14NPS	10–24 x 7/8	.50–1.10
XC-203	1	1 ³ / ₄	1 ²³ / ₃₂	9 ¹ / ₁₆	2 ⁹ / ₃₂	1 ⁷ / ₈	1–11 ½NPS	10–24 x 7/8	.62–1.14
XC-204	1¼	1 ⁷ / ₈	1 ⁵⁷ / ₆₄	9 ¹ / ₁₆	2 ⁷ / ₆₄	2 ¹ / ₃₂	1¼–11 ½NPS	10–24 x 7/8	.50–1.38

All dimensions are approximated to the nearest 1/64".

Armored Cable/Flexible Metallic Conduit Fittings

Steel City® Cable Lok®

- Simple, one-piece installation with no locknuts
- Screw designed for exceptional pullout resistance
- Captive screw ensures that the screw is intact for installation and resists backing out after installation
- Corrosion-resistant, zinc-chromatic plating
- Positive grounding
- Vibration-resistant screw design
- UL Listed and CSA Certified



Simple, fast steps to install the Steel City® Cable Lok®.



1. Simply snap into place. No locknuts required!

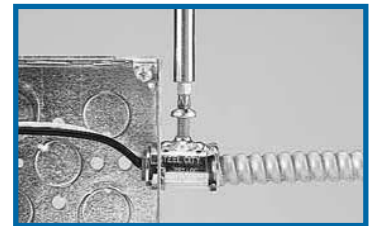

2. Insert cord and twist set screw. Connector tightens as screw is set.

Specifications

- Material: Body: Steel (spring steel);
Finish: Zinc;
Insulator: Nylon;
Temp.: 105° C
- Listing: UL, CSA Listed
- O.D. for over armor .400"—.510"
- No set screws, locknuts or tools are required to attach MC cable to a box or enclosure
- One-piece spring-steel construction
- Accommodates the widest range of MC cable sizes in the industry — 14-2 to 10-3

- Compact, low-profile design saves space in the box or enclosure
- Fittings can be used in adjacent knockouts in the corner of the box
- Removable and reusable
- Ideal for commercial construction or prefabricated electrical wiring assemblies



CAT. NO.	SIZE RANGE (IN.)	AC STEEL	AC ALUMINUM INTERLOCKED	MC (I) STEEL	MC (I) ALUMINUM	FLEX RW	STD. CTN.
XC-730		14/2 14/3 14/4	14/2 14/3 14/4	14/2 14/3 14/4	14/2 14/3 14/4	3/8" Steel	50
	.450/.610	12/2 12/3 12/4	12/2 12/3 12/4	12/2 12/3 12/4	12/2 12/3 12/4	& AL	
	1/2 KO	10/2		10/2 10/3	1/2" KO	10/2 10/3	
XC-731		14/2 14/3 14/4	14/2 14/3 14/4	14/2 14/3 14/4	14/2 14/3 14/4	—	50
	.450/.610	12/2 12/3 12/4	12/2 12/3 12/4	12/2 12/3 12/4	12/2 12/3 12/4	—	
	1/2 KO	10/2		10/2 10/3	1/2" KO	10/2 10/3	
XC-732		10/3 10/4 10/5	—	10/4 10/5	—	3/8" Steel	25
	.610/.875	8/3 8/4	—	8/3 8/4	—	& AL	
	3/4 KO	6/2		6/2	3/4" KO		
XC-7300		14/2 14/3 14/4	14/2 14/3 14/4	14/2 14/3 14/4	14/2 14/3 14/4	—	25
	.450/.610	12/2 12/3 12/4	12/2 12/3 12/4	12/2 12/3 12/4	12/2 12/3 12/4	—	
	1/2 KO	10/2		10/2 10/3	1/2" KO	10/2 10/3	

UL File No. E-1383.
CSA File No. LR-12798.

Snap-In Fitting for MC Cable — Steel



CAT. NO.	DESCRIPTION	STD. CTN.
XC-130	Steel Snap-In Fitting for MC Cable (14-2+G to 10-3+G)	500



Armored Cable/Flexible Metallic Conduit Fittings

90° Clamp-Type Connectors — Die-Cast Zinc

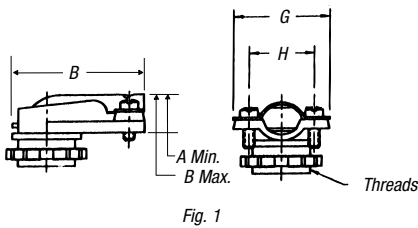

Fig. 1

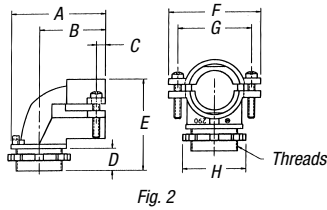

Fig. 2

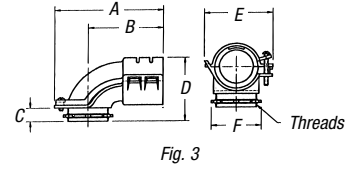

Fig. 3



XC-290

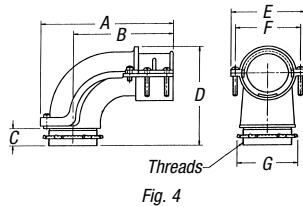

Fig. 4

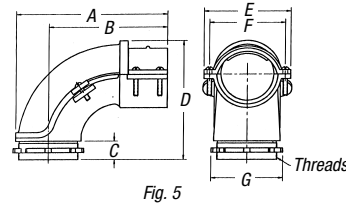

Fig. 5

Non-Insulated



CAT. NO.	FIG	SIZE (IN)	DIMENSIONS (IN.)			STD. CTN.
			A (MIN.)	A (MAX.)	B	
XC-290	1	3/8 (1/2 KO)	.40	.63	1.80	500
XC-291	1	1/2	.65	1.00	2.08	250
XC-292	1	3/4	.83	1.25	2.27	100
XC-293	2	1	1.27	1.50	2.60	50
XC-294	2	1 1/4	1.49	1.85	3.10	30
XC-295	3	1 1/2	1.51	2.47	6.05	5
XC-296	3	2	1.51	2.47	6.05	5
XC-297	4	2 1/2	2.45	3.50	7.75	2
XC-298	5	3	3.07	4.02	8.88	1
XC-299	4	3 1/2	3.63	4.34	12.75	1
XC-2910	4	4	3.68	5.17	12.75	1

UL File No. E-1383.
CSA File No. LR-18130M57.

Insulated



CAT. NO.	FIG	SIZE (IN)	DIMENSIONS (IN.)			STD. CTN.
			A (MIN.)	A (MAX.)	B	
XC-890	1	3/8	.40	.63	1.81	500
XC-891	1	1/2	.65	.97	2.18	250
XC-892	1	3/4	.77	1.12	2.38	100
XC-893	2	1	1.06	1.40	2.87	50
XC-894	2	1 1/4	1.34	1.65	3.93	30
XC-895	3	1 1/2	1.51	2.47	6.05	5
XC-896	3	2	1.51	2.47	6.05	5
XC-897	4	2 1/2	2.45	3.50	7.75	2
XC-898	5	3	3.07	4.02	8.88	1
XC-899	4	3 1/2	3.63	4.34	12.75	1
XC-8910	4	4	3.68	5.17	12.75	1

UL File No. E-1383.
CSA File No. LR-12798.

Clamp-Type Connector — Die-Cast Zinc



CAT. NO.	CONDUIT SIZE (IN.)	DIMENSIONS (IN.)			STD. CTN.
		A (MIN.)	A (MAX.)	B	
XC-280	3/8 (1/2 KO)	.18	.64	1.16	1,000

UL File No. E-1383.
CSA File No. LR-18130M57.



Duplex Clamp-Type Connector — Die-Cast Zinc



CAT. NO.	CONDUIT SIZE (IN.)	DIMENSIONS (IN.)			STD. CTN.
		A (MIN.)	A (MAX.)	B	
XC-210	3/8 (1/2 KO)	.13	.65	1.56	250

CSA File No. LR-18130M57.

Armored Cable/Flexible Metallic Conduit Fittings

Snap-In Connector for Flexible Metal Conduit — 105° C Rated

- No locknut required
- No special tools required
- High-impact thermoplastic with steel insert

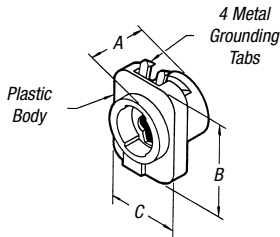

CAT. NO.	CONDUIT SIZE (IN.)	KO SIZE (IN.)	UNIT QTY.	STD. CTN.
100-TB	¾"	½"	50	500
100BP	¾"	½"	250	1,000

BX Flex Bushings — Anti-Short

- Packed in polybags
- Available bulk packed — 10,000 per carton
- Plastic



CAT. NO.	FITS STANDARD CABLE RANGE	UNIT SIZE	QTY.	STD. CTN.
IT 100 SC	14/2-14/3-12/2	0	100	100
IT-101	14/4-12/3-6/1-4/1	1	100	35
IT-102	12/4-10/2-10/3-2/1	2	50	50
IT-103	10/4-8/2-8/3-1/1	3	50	50
IT-104	8/4-6/2-6/3-4/2-4/3-6/4	4	50	50

Ordered by Bags.

Note: For die-cast armored cable/flexible metallic conduit fittings and combination fittings, see Steel City® Die-Cast Conduit Fittings, pages E-550-E-552.

Straight Set-Screw Connectors — Non-Insulated Die-Cast Zinc

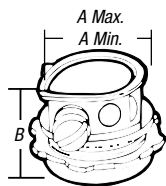

XC-220SC

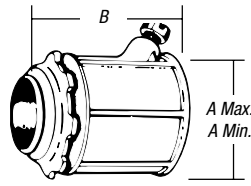

XC-221
XC-821



CAT. NO.	SIZE (IN.)	DIMENSIONS (IN.)			STD. CTN.
		A (MIN.)	A (MAX.)	B	
XC-220SC	¾" (½" KO)	.38	.63	.84	1,000
XC-221	½"	.74	.94	1.46	250
XC-821	½"	.74	.94	1.46	250

XC-220 and XC-221: UL File No. E-1383 ¾".
UL File No. E-23018 ½".
XC-821: UL File No. E-1275 ½".

BX Flex Saddle-Type Connectors — Die-Cast Zinc

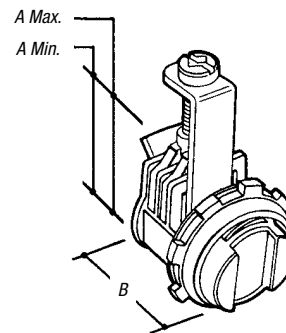

CAT. NO.	SIZE (IN.)	DIMENSIONS (IN.)			STD. CTN.
		A (MIN.)	A (MAX.)	B	
XC-2200-C	¾"	.12	.63	.98	500

Armored Cable/Flexible Metallic Conduit Fittings

Screw-In Connectors — Non-Insulated Die-Cast Zinc

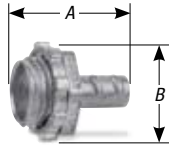

CAT. NO.	SIZE (IN.)	DIMENSIONS (IN.)		STD. CTN.
		A	B	
XC-240	3/8 (1/2 KO)	1.31	.92	500
XC-241	1/2	1.38	.92	500
XC-242	3/4	1.62	1.12	125
XC-243	1	1.94	1.37	125
XC-244	1 1/4	2.12	1.75	50
XC-245	1 1/2	2.31	2.13	50
XC-246	2	2.58	2.67	50

UL File No. E-23018.

CSA File No. LR-18130M57 3/8"-1/2".

Screw-In Connectors — Insulated Die-Cast Zinc

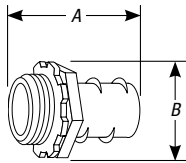

CAT. NO.	SIZE (IN.)	DIMENSIONS (IN.)		STD. CTN.
		A	B	
XC-840	3/8 (1/2 KO)	1.31	.92	500
XC-841	1/2	1.38	.92	500
XC-842	3/4	1.62	1.12	125
XC-843	1	1.94	1.37	125
XC-844	1 1/4	2.12	1.75	50
XC-845	1 1/2	2.31	2.13	50
XC-846	2	2.58	2.67	50

UL File No. E-23018.

CSA File No. LR-18130M57 3/8"-1/2".

Screw-In Couplings — Die-Cast Zinc

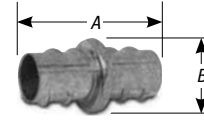

CAT. NO.	SIZE (IN.)	DIMENSIONS (IN.)		STD. CTN.
		A	B	
XK 241	1/2	1.81	.92	250
XK-242	3/4	2.09	1.12	250
XK-243	1	2.41	1.37	125
XK-244	1 1/4	2.75	1.81	50
XK-245	1 1/2	3.05	2.12	50
XK-246	2	3.28	2.67	50

UL File No. E-23018.

Watertight Connectors

- For type SE, style U, flat; two insulating conductors, one bare

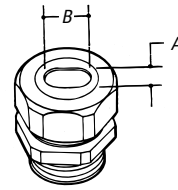

CAT. NO.	TRADE SIZE (IN.)	FITS CABLE	RUBBER GROMMET OPENING (IN.)		STD. CTN.
			A	B	
WT203A	1	3#8	.500	.750	100
WT-203B	1	3#6	.563	.844	100
WT-203C	1	3#4	.625	.938	100
WT-204A	1 1/4	3#3	.625	1.000	50
WT-204B	1 1/4	3#2	.580	.960	50
WT-204C	1 1/4	3#1	.660	1.090	50
WT-204D	1 1/4	3#1/0	.750	1.125	50
WT-205A	1 1/2	3#1/0 & 3#2/0	.735	1.240	20
WT-205B	1 1/2	3#2/0 & 3#3/0	.875	1.375	20
WT-205C	1 1/2	3#2/0 & 3#3/0	.938	1.438	20
WT-206A	2	3#1/0 & 3#2/0	.735	1.240	20
WT-206B	2	3#2/0 & 3#3/0	.875	1.375	20
WT-206C	2	3#2/0 & 3#3/0	.938	1.438	20
WT-206D	2	3#4/0	.890	1.550	20
WT-206E	2	3#4/0	1.063	1.688	20

For Underground Feeder Cable

UF201	1/2	2#14	.210	.440	250
UF-202	3/4	3#14	.220	.660	250

Accessories

Aluminum Service Caps — Clamp-Type for Rigid/Intermediate or Thinwall

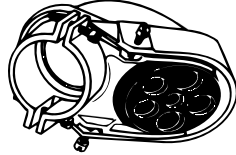

CAT. NO.	CONDUIT SIZE (IN.)	NO. HOLES	SIZE	STD. CTN.
SH-101	½	4	4 (⅜")	50
SH-102	¾	5	2 (⅝") 3 (⅜")	50
SH-103	1	5	2 (⅞") 3 (½")	10
SH-104	1¼	5	2 (1½") 3 (⅝")	10
SH-105	1½	6	2 (1½") 1 (⅞") 3 (¾")	5
SH-106	2	6	2 (¾") 3 (1") 1 (1½")	5
SH-107	2½	7	3 (⅞") 1 (1") 3 (1½")	1
SH-108	3	7	4 (1½") 3 (1¾")	1
SH-109	3½	4	4 (1¾") 2 (1½")	1
SH-110	4	4	4 (1¾") 2 (1½")	1

CSA File No. LR-12798.
UL File No. E-13938.

Cable Protector



CAT. NO.	DESCRIPTION	STD. CTN.
CP-1	Steel	100

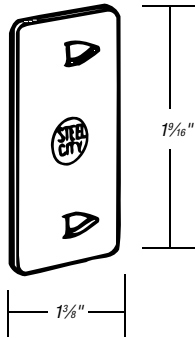

Service Cable Caps — Oval

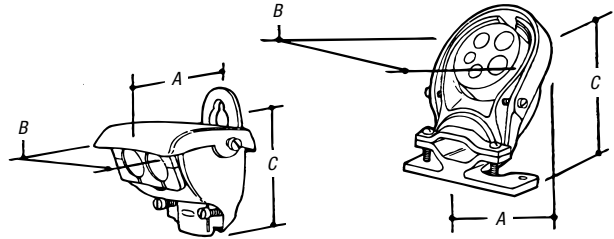

CAT. NO.	FITS CABLE	DIMENSIONS (IN.)			STD. CTN.
		A	B	C	
50130	To 2/0-3	5.00	3.31	4.75	10
50130A	To 4/0-3	6.75	4.62	6.00	5
<i>With Split Insulator</i>					
SC1000	3#3-2	2.37	2.12	2.25	25
SC2001	3#3/0-4/0	4.93	3.12	3.75	10

Extra-large body for additional wiring space.

Cable Clip

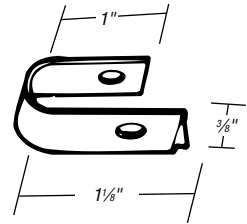

CAT. NO.	DESCRIPTION	STD. CTN.
NS 100	Steel	1,000

Accessories

One-Hole Strap for 3/8" Armored Cable and Flexible Metal Conduit

CAT. NO.	STD. CTN.	WT./100 (LBS.)
FS100-SC	250	1.70

R-Series Continuous-Thread Rod — Galvanized

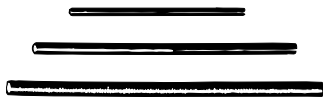

CAT. NO.	ROD SIZE (IN.)	ULTIMATE [†] LOAD IN LBS.	ROOT AREA THREAD	DATA FOR PRESSURE PIPING		STD. CTN.
				NOMINAL PIPE SIZE (IN.)	MAX. SAFE LOAD AT 450°	
R628-6 FT.	1/4-20	900	.027	—	—	300
R638-6 FT.	3/8-16	1,900	.068	3/4-2	610	150
R648-6 FT.	1/2-13	3,500	.126	2 1/2-3 1/2	1,130	60
R1028-10 FT.	1/4-20	900	.027	—	—	500
R1038-10 FT.	3/8-16	1,900	.068	3/4-2	610	250
R1048-10 FT.	1/2-13	3,500	.126	2 1/2-3 1/2	1,130	100

[†] Load Ratings based on safety factor of three.

One-Hole Service Cable Straps



CAT. NO.	FITS CABLE	SHELF CTN.	SHIP CASE	STD. CTN.
SE-100	3#8, 3#6, 3#4	100	1,000	1,000
SE101	3#3, 3#2	100	1,000	1,000
SE102	3#1, 3#0, 3#1/0, 3#2/0	25	250	250
SE103	3#3/0, 3#4/0	25	250	250

Two-Hole Service Cable Straps



CAT. NO.	FITS CABLE	SHELF CTN.	SHIP CASE	STD. CTN.
SE-900	3#8, 3#6, 3#4	100	1,000	1,000
SE901	3#3, 3#2	100	1,000	1,000
SE902	3#1, 3#0, 3#1/0, 3#2/0	25	250	250
SE903	3#3/0, 3#4/0	25	250	250

H-195 Steel Rod Coupling

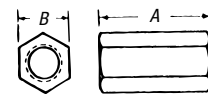

CAT. NO.	ROD SIZE (IN.)	DIMENSIONS (IN.)		STD. CTN.
		A	B	
H-195-1/4	1/4	3/4	3/8	1,000
H-195-3/8	3/8	1	1/2	500
H-195-1/2	1/2	1	5/8	500
H-195-5/8	5/8	1 1/2	3/4	50

Accessories

Beam Clamps

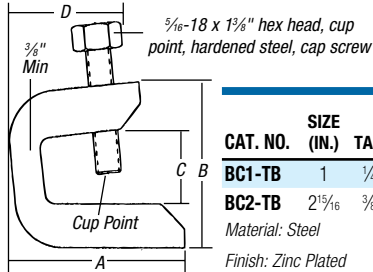

CAT. NO.	SIZE (IN.)	TAPPED	DIMENSIONS (IN.)				STD. CTN.
			A	B	C	D	
BC1-TB	1	1/4-20	1 1/16	1 3/8	3/4	1 3/16	250
BC2-TB	2 1/16	3/8-16	2 1/8	2 1/16	3/4	1 1/16	25

Material: Steel
Finish: Zinc Plated

Beam Clamps — Malleable Iron, Electroplated Finish

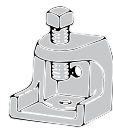

CAT. NO.	BASE SIZE (IN.)		JAW OPENING INCHES	TAPPING OF BASE AND BACK HOLES	LOAD RATING [†]	STD. CTN.
	A	B				
510	2 7/32	1 1/8	3/8	1/4-20	400	100
511-SC	2 7/32	1 1/8	3/8	10-24	400	100
500-SC	1	1 1/4	1 5/16	1/4-20	450	50
509	1	1 1/4	1 5/16	10-24	375	100
501	1 1/2	1 3/8	7/8	3/8-18	800	50
502	2	2	1	3/8-16	1,300	50
503-SC	2 5/8	2 1/2	1	1/2-13	1,300	20
507	2 1/2	2 3/8	1 3/8	1/2-13	1,700	20
508	2 1/2	2 3/8	2 1/8	1/2-13	1,700	10

[†]Safety factor of 3.

Load ratings based on bottom hole of beam clamp.

CSA File No. LR-52208.

Conduit/Pipe to Beam Clamps

EC Series

- For mounting pipe or conduit vertically across the beam
- Add HDG suffix for hot-dip galvanized

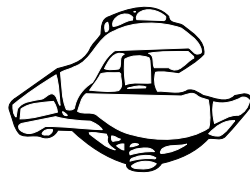

EC Series

CAT. NO. & SIZE	O.D. OF CONDUIT OR PIPE	DIMENSIONS (IN.) NOM. CONDUIT OR PIPE SIZE	STD. CTN.
EC Clamp — Malleable Iron			
EC 1/2	.840	1/2	50
EC-3/4	1.050	3/4	50
EC-1	1.315	1	25
EC-1-1/4	1.660	1 1/4	25
EC-1-1/2	1.900	1 1/2	25
EC-2	2.375	2	25
EC-2-1/2	2.875	2 1/2	10

Conduit/Pipe to Beam Clamps

- For mounting pipe or conduit at right angles to the beam
- Add SS316 suffix for stainless steel
- Add HDG suffix for hot-dip galvanized



RCS Series

CAT. NO. & SIZE	O.D. OF CONDUIT OR PIPE	DIMENSIONS (IN.) NOM. CONDUIT OR PIPE SIZE	STD. CTN.
RCS Clamp — Steel			
RCS-1/2	.840	1/2	50
RCS-3/4	1.050	3/4	50
RCS-1	1.315	1	50
RCS-1-1/4	1.660	1 1/4	50
RCS-1-1/2	1.900	1 1/2	50
RCS-2	2.375	2	50
RC Clamp — Malleable Iron			
RC-3/8	.675	3/8	50
RC-1/2	.840	1/2	50
RC-3/4	1.050	3/4	50
RC-1	1.315	1	50
RC-1-1/4	1.660	1 1/4	50
RC-1-1/2	1.900	1 1/2	50
RC-2-SC	2.375	2	50
RC-2-1/2	2.875	2 1/2	25
RC-3	3.500	3	25
RC-3-1/2	4.000	3 1/2	25
RC-4-SC	4.500	4	20

PC Series

- For mounting pipe or conduit parallel to the beam
- Add HDG suffix for hot-dip galvanized

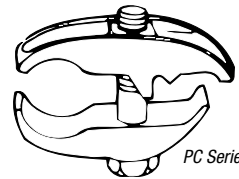

PC Series

CAT. NO. & SIZE	O.D. OF CONDUIT OR PIPE	DIMENSIONS (IN.) NOM. CONDUIT OR PIPE SIZE	STD. CTN.
PC Clamp — Malleable Iron			
PC-3/8	.675	3/8	50
PC 1/2	.840	1/2	50
PC-3/4	1.050	3/4	50
PC-1	1.315	1	50
PC-1-1/4	1.660	1 1/4	25
PC-1-1/2	1.900	1 1/2	25
PC-2	2.375	2	25
PC-2-1/2	2.875	2 1/2	25
PC-3	3.500	3	10
PC-3-1/2	4.000	3 1/2	10
PC-4	4.500	4	10

Accessories

Ground Clamps — Die-Cast Zinc, Brass Colored

- Two-screw ground connection for armored ground wire



CAT. NO.	CONDUIT SIZE (IN.)	STD. CTN.
GC-203-B	½; 1	200

6H Series Conduit and Pipe Hangers — Without Bolt

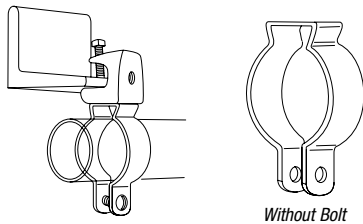

All Steel City 6H Hanger Bolts include a combination Slot-Phillips Head.

For hanging conduit (rigid or EMT) and pipe.

The 6H series hangers are fast, easy and economical to use. May be fastened directly to a #500 beam clamp through a hole in the base of the hanger by means of a ¼-20 stove bolt or suspended on ¼" hanger rod.

CAT. NO.	RIGID CONDUIT OR PIPE SIZE (IN.)	EMT SIZE (IN.)	DIMENSIONS (IN.)				LOAD RATING	STD. CTN.
			A	B	C	D (DIA.)		
6H0	¾-½	½	¾	.045	1 ² / ₃₂	¾ ₃₂	500	100
6H0 T	¾-½	½	¾	.045	1 ² / ₃₂	¾ ₃₂	500	100
6H1	¾	¾	¾	.045	1 ³ / ₃₂	¾ ₃₂	500	100
6H1-T	¾	¾	¾	.045	2 ³ / ₃₂	¾ ₃₂	500	100
6H2	1	1	¾	.045	2 ³ / ₃₂	¾ ₃₂	500	100
6H2 1/2	—	1¼	¾	.045	2 ³ / ₃₂	¾ ₃₂	500	100
6H3-SC	1¼	1½	¾	.045	2 ³ / ₃₂	¾ ₃₂	500	100
6H4	1½	—	1	.071	3 ³ / ₃₂	1 ¹ / ₃₂	500	100
6H5	2	2	1¼	.071	3 ³ / ₃₂	1 ¹ / ₃₂	500	50
6H6	2½	—	1¼	.071	4 ³ / ₃₂	1 ¹ / ₃₂	500	50
6H7	3	—	1¼	.071	5 ³ / ₁₆	1 ¹ / ₃₂	500	25
6H8	3½	—	1¼	.071	5 ⁷ / ₁₆	1 ¹ / ₃₂	500	25
6H9	4	4	1¼	.071	5 ⁷ / ₁₆	1 ¹ / ₃₂	500	10

UL File No. E-160899.

Add SS suffix to catalog number for Type 302 Stainless Steel.

Load rating is 500 lbs. with a safety factor of 3. Available with or without closure bolt.

Standard finishes: Electro-Galvanized.

6H Series Conduit and Pipe Hangers — With Bolt

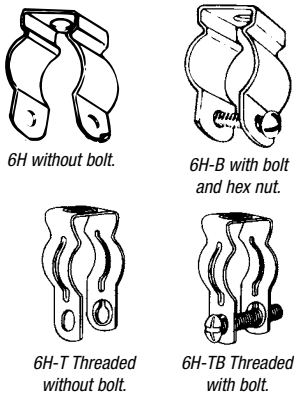

6H without bolt.

6H-B with bolt and hex nut.

6H-T Threaded without bolt.

6H-TB Threaded with bolt.

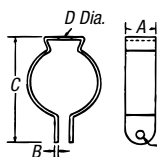

CAT. NO.	RIGID CONDUIT OR PIPE SIZE (IN.)	EMT SIZE (IN.)	DIMENSIONS (IN.)				LOAD RATING	STD. CTN.
			A	B	C	D (DIA.)		
6H0 B	¾-½	½	¾	.045	1 ² / ₃₂	¾ ₃₂	500	100
6H0 TB	¾-½	½	¾	.045	1 ² / ₃₂	¾ ₃₂	500	100
6H1-B	¾	¾	¾	.045	1 ³ / ₃₂	¾ ₃₂	500	100
6H1-TB	¾	¾	¾	.045	2 ³ / ₃₂	¾ ₃₂	500	100
6H2-B	1	1	¾	.045	2 ³ / ₃₂	¾ ₃₂	500	100
6H2-B	1	1¼	¾	.045	2 ³ / ₃₂	¾ ₃₂	500	100
6H3-B	1¼	1½	¾	.045	2 ³ / ₃₂	¾ ₃₂	500	100
6H4-B	1½	—	1	.071	3 ³ / ₃₂	1 ¹ / ₃₂	500	100
6H5-B	2	2	1¼	.071	3 ³ / ₃₂	1 ¹ / ₃₂	500	50
6H6-B	2½	—	1¼	.071	4 ³ / ₃₂	1 ¹ / ₃₂	500	50
6H7-B	3	—	1¼	.071	5 ³ / ₁₆	1 ¹ / ₃₂	500	25
6H8-B	3½	—	1¼	.071	5 ⁷ / ₁₆	1 ¹ / ₃₂	500	25
6H9-B	4	4	1¼	.071	5 ⁷ / ₁₆	1 ¹ / ₃₂	500	10

UL File No. E-160899.

Add SS suffix to part number for Type 302 Stainless Steel.

Load rating is 500 lbs. with a safety factor of 3.

Available with or without closure bolt.

Standard finishes: Electro-Galvanized.

Liquidtight Flexible Metallic Conduit Fittings: Zinc Die Cast

Outdoor XTRA FLEX® Raceway System (Type B)

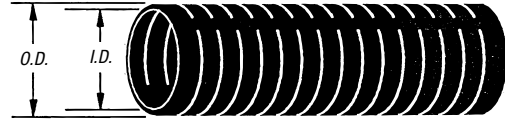

Specifications

- Color: Gray
- Length: 100 ft. for LTC038GY thru LTC125GY
50 ft. for LTC150GY and LTC200GY
- UL Temperature Rating:
80° C dry, 60° C wet
70° C oil resistant, sunlight resistant,
outdoor, direct burial
- CSA Certified: File LR 80349-2
- CSA Temperature Rating: -18° C to 75° C
- Material: PVC Helix reinforcement surrounded
with flexible PVC
- Voltage Rating: 600V

CAT. NO. SERIES	TRADE SIZE (IN.)	I.D. (IN.)		O.D. (IN.)		STD. CTN.
		MIN.	MAX.	MIN.	MAX.	
LTC038GY	3/8	.484	.504	.690	.710	100
LTC050GY	1/2	.622	.642	.820	.840	100
LTC075GY	3/4	.820	.840	1.030	1.050	100
LTC100GY	1	1.041	1.066	1.290	1.315	100
LTC125GY	1 1/4	1.380	1.410	1.630	1.660	100
LTC150GY	1 1/2	1.575	1.600	1.865	1.900	50
LTC200GY	2	2.020	2.045	2.340	2.375	50

UL Listed: File E95745.

For use with Thomas & Betts LT38P, LT38M, LT500 series
and Liquidtight Flexible Metal Conduit Fittings.

Liquidtight Whip Assembly



CAT. NO.	CONDUIT SIZE (IN.)	LENGTH (FT.)	WIRE GAUGE	STD. CTN.
LTWHIP 12-6-10	1/2	6	#10 AWG	6
LTWHIP 12-4-10	1/2	4	#10 AWG	6
LTWHIP 34-6-8	3/4	6	#8 AWG	6
LTWHIP 34-4-8	3/4	4	#8 AWG	6
Whip with Metallic Fittings — One Straight, One 90°				
LTWM 12-6-10	1/2	6	#10 AWG	6
LTWM 12-4-10	1/2	4	#10 AWG	6
LTWM 34-6-8	3/4	6	#8 AWG	6
LTWM 34-4-8	3/4	4	#8 AWG	6

Conduit Cutter for Non-Metallic Flexible Conduit



CAT. NO.	DESCRIPTION
XF-CUT	For Cutting Non-Metallic Flexible Conduit up to 1"
XF-BLADE	Replacement Blade for XF-CUT

Liquidtight Flexible Metallic Conduit Fittings: Zinc Die Cast

Liquidtight Fittings — Straight

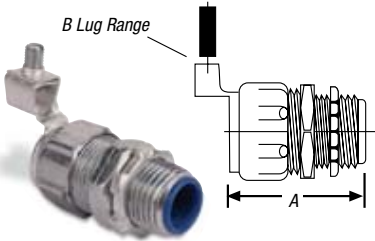

CAT. NO.	GROUNDING DEVICE (LUG ONLY)		TRADE SIZE (IN.)	A (IN.)	B	STD. CTN.	CAT. NO.	GROUNDING DEVICE (LUG ONLY)		TRADE SIZE (IN.)	A (IN.)	B	STD. CTN.
	CAT. NO.							CAT. NO.					
5331GR	38GR-TB		3/8	1 1/2	14-4	100	5233GR	34GR-TB		3/4	1 1/8	14-4	25
5332GR	12GR-TB		1/2	1 1/8	14-4	100	5234GR	1GR-TB		1	2 1/8	14-4	50
5333GR	34GR-TB		3/4	1 3/8	14-4	25	5231ALGR	38GR-TB		3/8	1 1/2	14-4	100
5334GR	1GR-TB		1	2 1/8	14-4	50	5232ALGR	12GR-TB		1/2	1 1/8	14-4	100
5231GR	38GR-TB		3/8	1 1/2	14-4	100	5233ALGR	13GR-TB		3/4	1 1/8	14-4	50
5232GR	12GR-TB		1/2	1 1/8	14-4	100	5234ALGR	1GR-TB		1	2 1/8	14-4	50

Liquidtight Fittings — 45° Angle

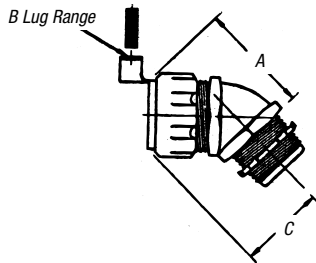

CAT. NO.	TRADE SIZE (IN.)	A (IN.)	B	C (IN.)	STD. CTN.
5341GR	3/8	1 1/8	14-4	1 1/8	50
5342GR	1/2	1 1/4	14-4	1 3/8	50
5343GR	3/4	2 1/8	14-4	1 3/8	50
5344GR	1	2 3/4	14-4	1 3/4	25
5241GR	3/8	1 1/8	14-4	1 1/8	50
5242GR	1/2	1 1/4	14-4	1 3/8	50
5243GR	3/4	2 1/8	14-4	1 3/8	50
5244GR	1	2 3/4	14-4	1 3/4	25

Liquidtight Fittings — 90° Angle

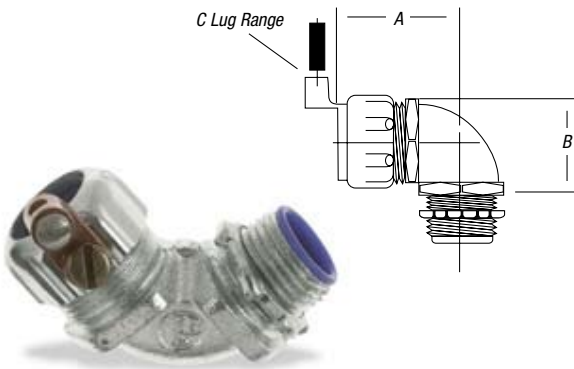

CAT. NO.	GROUNDING DEVICE (LUG ONLY)		TRADE SIZE (IN.)	A (IN.)	B (IN.)	C	STD. CTN.
	CAT. NO.						
5351GR	38GR-TB		3/8	1 3/8	1 1/4	14-4	50
5352GR	12GR-TB		1/2	1 1/8	1 1/8	14-4	50
5353GR	34GR-TB		3/4	1 3/4	1 3/8	14-4	50
5354GR	1GR-TB		1	2 3/8	2 1/8	14-4	25
5251GR	38GR-TB		3/8	1 3/8	1 1/4	14-4	50
5252GR	12GR-TB		1/2	1 1/8	1 1/8	14-4	50
5253GR	34GR-TB		3/4	1 3/4	1 3/8	14-4	50
5254GR	1GR-TB		1	2 3/8	2 1/8	14-4	25
5251ALGR	38GR-TB		3/8	1 3/8	1 1/4	14-4	50
5252ALGR	12GR-TB		1/2	1 1/8	1 1/8	14-4	50
5253ALGR	13GR-TB		3/4	1 3/4	1 3/8	14-4	50
5254ALGR	1GR-TB		1	2 3/8	2 1/8	14-4	25

Liquidtight to Rigid External Ground Adapter

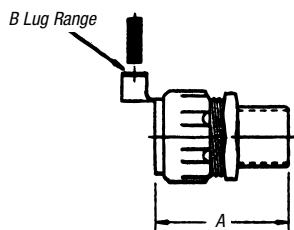

CAT. NO.	TRADE SIZE (IN.)	A (IN.)	B	STD. CTN.
5271GR	3/8	1 1/32	14-4	50
5272GR	1/2	1 1/8	14-4	50
5273GR	3/4	1 1/32	14-4	50
5274GR	1	1 1/8	14-4	25

Liquidtight Flexible Metallic Conduit Fittings: Zinc Die Cast

Straight Connectors — Die-Cast Zinc

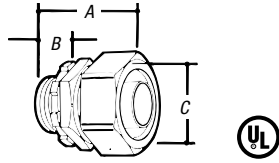

CAT. NO.	CONDUIT SIZE (IN.)	DIMENSIONS (IN.)			STD. CTN.
		A	B	C	
LT-200	3/8	1.81	.50	1.06	100
LT-201	1/2	1.88	.61	1.19	100
LT-202	3/4	2.03	.56	1.44	100
LT-203	1	2.28	.63	1.75	50
LT-204	1 1/4	2.59	.69	2.44	40
LT-205	1 1/2	2.78	.78	2.75	20
LT-206	2	3.22	.78	3.53	20
LT-207	2 1/2	3.53	.84	4.28	1
LT-208	3	3.91	.88	4.72	1
LT-209	3 1/2	4.04	.91	5.42	1
LT-210	4	4.16	.94	5.91	1

UL File No. E-23018.

Straight Connectors — Die-Cast Zinc with Insulated Throat

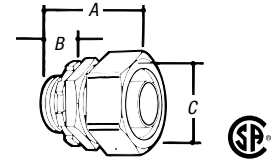

CAT. NO.	CONDUIT SIZE (IN.)	DIMENSIONS (IN.)			STD. CTN.
		A	B	C	
LT-800	3/8	1.81	.50	1.06	100
LT-801	1/2	1.88	.61	1.19	100
LT-802	3/4	2.03	.56	1.44	100
LT-803	1	2.28	.63	1.75	50
LT-804	1 1/4	2.59	.69	2.44	40
LT-805	1 1/2	2.78	.78	2.75	20
LT-806	2	3.22	.78	3.53	20
LT-807	2 1/2	3.53	.84	4.28	1
LT-808	3	3.91	.88	4.72	1
LT-809	3 1/2	4.04	.91	5.42	1
LT-810	4	4.16	.94	5.91	1

CSA File No. LR-12798.

90° Connectors — Die-Cast Zinc

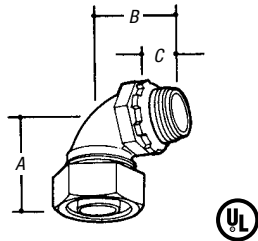

CAT. NO.	CONDUIT SIZE (IN.)	DIMENSIONS (IN.)			STD. CTN.
		A	B	C	
LT-290	3/8	1.88	1.38	.50	100
LT-291	1/2	2.00	1.41	.50	100
LT-292	3/4	2.19	1.66	.56	100
LT-293	1	2.56	1.88	.63	50
LT-294	1 1/4	3.00	2.00	.69	40
LT-295	1 1/2	3.38	2.56	.78	20
LT-296	2	4.06	3.00	.78	10
LT-297	2 1/2	5.03	3.72	.84	1
LT-298	3	5.63	4.66	.88	1
LT-299	3 1/2	6.10	4.82	.91	1
LT-2910	4	6.56	4.97	.94	1

UL File No. E-23018.

90° Connectors — Die-Cast Zinc with Insulated Throat

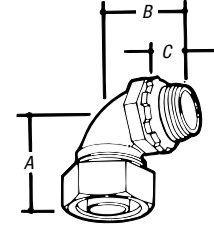

CAT. NO.	CONDUIT SIZE (IN.)	DIMENSIONS (IN.)			STD. CTN.
		A	B	C	
LT-890	3/8	1.88	1.38	.50	100
LT-891	1/2	2.00	1.41	.50	100
LT-892	3/4	2.19	1.66	.56	100
LT-893	1	2.56	1.88	.63	50
LT-894	1 1/4	3.00	2.00	.69	20
LT-896	2	4.06	3.00	.78	10
LT-897	2 1/2	5.03	3.72	.84	1

UL File No. E-23018.

Sealing O-Rings



CAT. NO.	CONDUIT SIZE (IN.)	STD. CTN.
SR 101	1/2	500
SR-102	3/4	500
SR-103	1	500
SR-104	1 1/4	250
SR-105	1 1/2	250
SR-106	2	250

Material: Neoprene