

# *Thomas & Betts* MORE POWER TO YOU



For over 70 years, Canadian electrical contractors, plant engineers and engineering consultants have placed their trust in Thomas & Betts electrical components. Today, Thomas & Betts offers a complete package of market-driven products and services designed to give you the power to succeed in today's economy.

## **THE POWER OF T&B ENGINEERED PRODUCTS AND SERVICES**

Our products and services continue to set new standards for quality, reliability and innovation.

- Highly-focused sales, product support and customer service teams dedicated to serving the industrial MRO and OEM markets
- Guaranteed, competitive pricing
- The broadest offering of field-proven, brand name products available from one manufacturer
- "One order, one shipment" for thousands of standard products through Thomas & Betts and your Signature Service distributor
- Reduced lead time on critical products through your Signature Service distributor
- Technical support via phone, fax on demand and the internet
- ISO-certified manufacturing — quality engineering and manufacturing
- Local and national inventory support
- T&B Tool Lease program — the tools you need today without tomorrow's investment

# *Thomas & Betts*



## THE POWER OF CHOICE

As North America's largest single source for electrical components, Thomas & Betts is powered by the longest and most complete list of reputable brand name products available from one manufacturer in the industry today. With services like "one order, one shipment" available through your Thomas & Betts distributor, the more T&B purchases you make, the more you can save. To request information about any of these products, contact your Regional Sales Office.

- All-Struct*® aluminum and steel structures
- Amerace*® airfield lighting
- Battpac*™ battery-powered compression tools
- Blackburn*® compression connectors
- Blackburn*® grounding products
- Color-Keyed*® compression connectors
- Deltec*™ aerial cable support systems
- Diamond*™ pole line hardware
- Elastimold*® premolded connectors  
for underground distribution applications
- Emergi-Lite*® emergency lighting systems
- ExpressTray*® wire-mesh cable management system
- E-Z-Code*® wire marker systems
- E Z Ground*® compression connectors
- Furseweld*™ exothermic connectors
- Hazlux*™ hazardous location lighting
- Iberville*® "roughing-in" products
- Iberville*® steel boxes and covers
- Kold-n-Klose*™ forced encapsulated closures  
and sheath repair systems
- LRC*™ connectors, splices, adaptors and accessories
- Lumacell*® emergency lighting systems
- Marrette*® wire connectors and nonmetallic boxes
- Meyer*® transmission and light duty  
engineered steel poles
- Microelectric*® meter sockets and pole line hardware
- Mipco*® plugs, receptacles, modules,  
power outlets and connectors
- Ocal*™ coated products
- Partex*™ wire marker systems
- Pos-E-Kon*® industrial connectors
- Ready-Lite*® emergency lighting systems
- Red•Dot*® weatherproof boxes and covers
- Reznor*® heating, ventilation and cooling systems
- Russellstoll*® plugs, receptacles and connectors
- Sachs*™ drop line and construction hardware, grounding  
and bonding products, signal security hardware
- Safe-Ty*™ low profile in-line fasteners
- Shield-Kon*® grounding connectors and tools
- Shrink-Kon*™ insulation products
- South River*™ wireless antenna mounts and hardware
- Sta-Kon*® terminals and application tools
- StarTeck*® fittings for teck cable
- Steel City*® floor boxes, access modules and poke throughs
- Superstrut*™ metal framing, channel and accessories
- T&B*™ cable tray systems
- T&B*™ conduit fittings
- Ty-Duct*™ wiring duct
- Ty-Fast*® one-piece ties and accessories
- Ty-Rap*® cable ties



# **Blackburn®**

## **Section 1**

Mechanical Connectors and Accessories — Quick Reference . . . . . 4–5  
Mechanical Connectors . . . . . 6–36  
Compression Connectors — Quick Reference . . . . . 37  
Compression Connectors . . . . . 38–57

## **Section 2**

Quick Reference . . . . . 58–62  
Grounding Connectors and Accessories . . . . . 63–102

## **Section 3**

Quick Reference . . . . . 103–105  
Installation Dies and Tools . . . . . 106–140

## **Reference Tables**

Competitive Cross Reference . . . . . 141–157  
Tool Cross Reference . . . . . 158–159  
Conductor Reference . . . . . 160–168

**Index Alphanumerical** . . . . . 171–176



**Mechanical Connectors and Accessories — Quick Reference**

**Mechanical  
and Accessories  
Quick Reference**

**Type H, HPS, HPW**



Copper Split Bolt Connectors

pp. 6–7

**Type APS, AAW**



Aluminum Split Bolt Connectors

pp. 8–9

**Type SP**

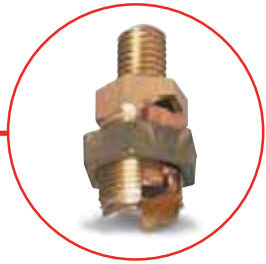

Service Post Connectors

pp. 10–11

**Type IPC**



Insulator Piercing Connectors

p. 12

**Type 2B, 2BX, 2BW**



Two-Bolt Connectors

pp. 13–14

**AMT**



AMT Connectors

pp. 15–19

**Type PDS**



Power Distribution Blocks

pp. 20–21

**Type L, TL**



Copper Mechanical Connectors

pp. 22–23

**Type S**



Copper Splice Connectors

p. 23

## Mechanical Connectors and Accessories — Quick Reference

### Type STC, BTC

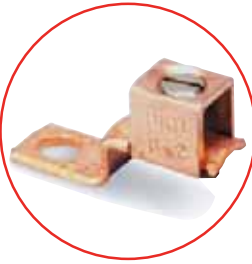

Copper Mechanical Connectors

p. 24

### Type ADR, ASL



One, Two, Three and four Conductor-Dual-Rated mechanical connectors  
pp. 25–32

### Type ASR



Splice Reducer

p. 33

### Type BX



Rectangular Connectors

pp. 33–34

### Type BB, HN, SW



Silicon Bronze Hardware

p. 35

### Type BW, FW

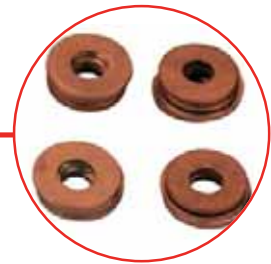

Washers

p. 36

## Split Bolt Connectors

Mechanical and Accessories

### For copper to copper connections Type H — High Strength Split Bolt Connectors

- Bolt and nut of high strength corrosion-resistant bronze alloy
- Pressure bar is copper through 40H; copper alloy is used for 350 kcmil and above
- Bolt and nut of hex design up to 350 kcmil
- CSA Certified and UL Listed

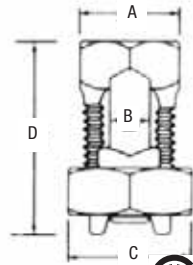

Cat. No.	Conductor Range (AWG or kcmil)		Dimensions (in.)			
	Range for equal Main and Tap	Min. Tap with one Max. Main	A	B	C	D
<b>9H</b>	10 str.–12 sol.	14 sol.	3/8	0.146	1/2	25/32
<b>8H</b>	8 str.–10 sol.	14 sol.	3/8	0.146	1/2	25/32
<b>8H3*</b>	8 str.–12 sol.	16 str.	3/8	0.146	1/2	29/32
<b>6H</b>	6 sol.–8 sol.	14 sol.	15/32	0.170	21/32	31/32
<b>6H3*</b>	6 sol.–10 sol.	16 str.	15/32	0.170	21/32	1-1/8
<b>4H</b>	4 sol.–8 sol.	14 sol.	17/32	0.235	23/32	1-1/16
<b>4H3*</b>	4 sol.–8 sol.	16 str.	17/32	0.235	23/32	1-9/32
<b>3H</b>	3 sol.–8 sol.	16 str.	17/32	0.235	23/32	1-1/16
<b>3H3*</b>	4 str.–8 sol.	16 str.	17/32	0.235	23/32	1-9/32
<b>2H</b>	2 sol.–6 sol.	14 sol.	19/32	0.271	25/32	1-1/4
<b>2H3*</b>	2 sol.–6 sol.	14 sol.	19/32	0.271	25/32	1-15/32
<b>1H</b>	2 str.–6 sol.	14 sol.	11/16	0.330	7/8	1-11/32
<b>1H3**</b>	2 str.–6 sol.	14 sol.	11/16	0.330	7/8	1-5/8
<b>10H</b>	1/0 str.–4 sol.	14 sol.	3/4	0.385	15/16	1-19/32
<b>20H</b>	2/0 str.–2 sol.	14 sol.	7/8	0.443	1-1/16	1-13/16
<b>30H</b>	4/0 str.–2 sol.	6 sol.	1	0.580	1-5/16	2-5/32
<b>40H</b>	250 kcmil–1 str.	8 sol.	1	0.580	1-5/16	2-5/32
<b>350M</b>	350 kcmil–250 kcmil	1/0 str.	1-5/16	0.717	1-21/32	2-11/16
<b>500M</b>	500 kcmil–400 kcmil	2/0 str.	1-1/2	0.842	1-7/8	3-1/32
<b>750M</b>	750 kcmil–600 kcmil	4/0 str.	1-15/16	1.029	2-1/4	3-21/32
<b>1000M</b>	1000 kcmil–800 kcmil	4/0 str.	2-1/4	1.185	2-17/32	4-1/32

\* Will accommodate 3 wires of maximum size.

\*\* Will accommodate 3 #2 str. wires.

U.L. recognizes solid and stranded conductor configurations for sizes #8 and smaller and stranded configurations only for sizes #6 and larger.

## Split Bolt Connectors

For use on copper, aluminum and ACSR conductors

### Type HPS — Plated Split-Bolt Connectors with Spacer

- Most connectors are CSA Certified and U.L. Listed for copper conductors only
- Bolt and pressure bar of copper alloy completely tin plated
- Contoured spacer of electrolytic copper up through 4/0; bronze alloy 350 kcmil and above, all tin plated
- Blackburn Contax recommended when used on aluminum conductors

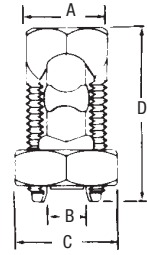

Cat. No.	Conductor Range (AWG or kcmil)			Dimensions (in.)			
	Range for equal Main and Tap	Range for equal Main and Tap	Min. Tap with One Max. Main	A	B	C	D
	ACSR	Copper or Aluminum					
<b>9HPS</b>	—	10 str.–12 sol.	12 sol.	3/8	0.146	1/2	29/32
<b>8HPS</b>	—	8 str.–12 sol.	12 sol.	3/8	0.146	1/2	29/32
<b>6HPS</b>	8	6 str.–12 sol.	12 sol.	15/32	0.170	21/32	1-1/8
<b>4HPS</b>	6–8	4 sol.–12 sol.	12 sol.	17/32	0.235	23/32	1-9/32
<b>2HPS</b>	4–8	2 sol.–8 sol.	8 sol.	19/32	0.274	25/32	1-15/32
<b>1HPS</b>	2–8	1 str.–8 sol.	8 sol.	11/16	0.330	7/8	1-5/8
<b>10HPS</b>	1–6	1/0 str.–6 sol.	6 sol.	3/4	0.385	15/16	1-13/16
<b>20HPS</b>	1/0–6	2/0 str.–6 sol.	6 sol.	7/8	0.443	1-1/16	2-1/16
<b>40HPS</b>	4/0–4	4/0 str.–4 sol.	4 sol.	1	0.580	1-5/16	2-15/32
<b>350HPS</b>	266.8–1/0	350 kcmil–1/0 str.	2 sol.	1-5/16	0.717	1-21/32	2-11/16
<b>500HPS*</b>	397.5–1/0	500 kcmil–1/0 str.	1/0 str.	1-1/2	0.842	1-7/8	3-1/32
<b>750HPS*</b>	666.6–4/0	750 kcmil–4/0 str.	2/0 str.	1-15/16	1.029	2-1/4	3-21/32
<b>1000HPS*</b>	900–477	1000 kcmil–500 kcmil	4/0 str.	2-1/4	1.185	2-17/32	4-1/32

\* CSA non applicable U.L. 486A.

For use on combinations of copper, aluminum and ACSR conductors

### Type HPW — Plated Split-Bolt Connectors with spacer and washer

- Bolt and pressure bar of high strength copper alloy completely tin plated; spacer and washer of electrolytic copper up through 4/0; bronze alloy 350 kcmil and above, all tin plated
- Contoured spacer and bell mouth washer distribute pressure over large area of conductor
- Large contoured spacer provides wide separation between copper and aluminum conductors
- Blackburn Contax recommended when used with aluminum conductors
- CSA Certified and UL Listed

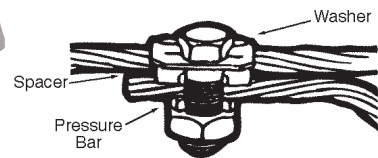

Cat. No.	Conductor Range (AWG or kcmil)			Dimensions (in.)			
	Range for equal Main and Tap	Range for equal Main and Tap	Min. Tap with One Max. Main	A	B	C	D
	ACSR	Copper or Aluminum					
<b>6HPW</b>	8	6 sol.–12 sol.	12 sol.	15/32	0.170	21/32	1-1/8
<b>4HPW</b>	6–8	4 sol.–12 sol.	12 sol.	17/32	0.235	23/32	1-9/32
<b>2HPW</b>	4–8	2 sol.–8 sol.	8 sol.	19/32	0.271	25/32	1-15/32
<b>1HPW</b>	2–8	1 str.–8 sol.	8 sol.	11/16	0.330	7/8	1-5/8
<b>10HPW</b>	1–6	1/0 str.–6 sol.	6 sol.	3/4	0.385	15/16	1-13/16
<b>20HPW</b>	1/0–6	2/0 str.–6 sol.	6 sol.	7/8	0.443	1-1/16	2-1/16
<b>40HPW*</b>	4/0–4	4/0 str.–4 sol.	4 sol.	1	0.580	1-5/16	2-15/32

\* CSA non applicable.

## Split Bolt Connectors

Accommodate all aluminum and copper conductor combinations

### Type APS — Aluminum Dual-Rated Split Bolts

- 6 bolts cover the range from #10 to 4/0 AWG
- Can be installed with standard wrenches
- Corrosion resistant tin plated aluminum
- CSA Certified and UL Listed to 90°C 600V



Cat. No.	Conductor Range (AWG or kcmil)	Dimensions (in.)				
	Range for equal Main and Tap	A	B	C	D	E
<b>APS06</b>	6–10 str.	17/32	0.21	23/32	1.27	1-1/4
<b>APS04</b>	4–10 str.	19/32	0.27	25/32	1.48	1-1/4
<b>APS02</b>	2–8 str.	11/16	0.33	7/8	1.63	1-1/4
<b>APS11</b>	1/0–4 str.	7/8	0.44	1-1/8	2.07	1-1/2
<b>APS21</b>	2/0–4 str.	7/8	0.44	1-1/8	2.07	1-1/2
<b>APS41</b>	4/0–2 str.	1	0.57	1-1/4	2.47	1-23/32
<b>APS350*</b>	350 kcmil–4 str.	1-7/16	0.70	1-11/16	3.36	2-1/4
<b>APS500*</b>	500 kcmil–2 str.	1-11/16	0.84	2	3.62	2-5/8

\* Square head design CSA non applicable.

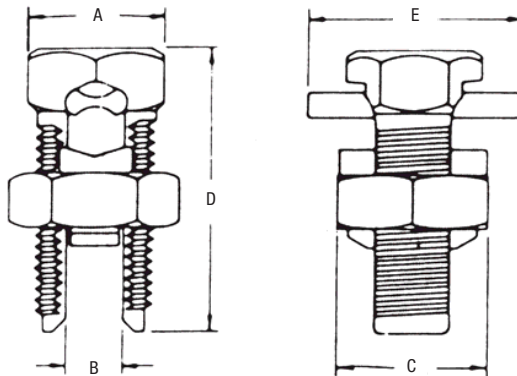



## Split Bolt Connectors

For all aluminum applications

### Type AAW — Aluminum Split Bolt Connectors with Spacer and Washers



- Bolt, nut, pressure bar and contoured spacer of aluminum alloy
- Large contoured spacer gives wide separation
- Nut anodized to prevent thread galling
- Blackburn Contax recommended when used on aluminum conductors

Cat. No.	Conductor Range (AWG or kcmil)			Dimensions (in.)			
	Range for equal Main and Tap	Range for equal Main and Tap	Min. Tap with One Max. Main	A	B	C	D
	ACSR	Aluminum					
<b>6AAW</b>	6-8	4 sol.-8 sol.	10 sol.	17/32	0.236	23/32	1-9/32
<b>4AAW</b>	4-8	2 sol.-8 sol.	8 sol.	19/32	0.272	25/32	1-15/32
<b>2AAW</b>	2-8	1 str.-8 sol.	8 sol.	11/16	0.330	7/8	1-5/8
<b>1AAW</b>	1-4	1/0 str.-8 sol.	4 sol.	7/8	0.443	1-1/8	2-1/16
<b>10AAW</b>	1/0-4	2/0 str.-8 sol.	4 sol.	7/8	0.443	1-1/8	2-1/16
<b>40AAW</b>	4/0-4	4/0 str.-4 sol.	4 sol.	1	0.580	1-1/4	2-15/32

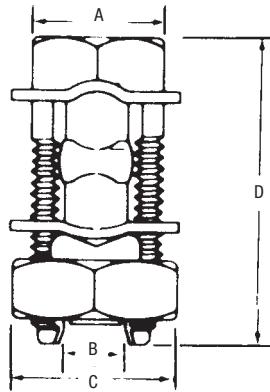

## Service Post Connectors

### Single or Double Conductors Short Stud

#### Application

The Blackburn line of Service Post Connectors is designed for applications including steel structure, fence post or transformer grounding involving one or two cables. Service Posts can also be used to tap one or two cables from a bus bar.

#### Construction and Ratings

Bolts used in the Service Post are machined from high conductivity bronze alloy while the nuts are cold-formed from high strength, corrosion resistant copper alloy. Pressure bars are copper through 4/0 size, while copper alloy is used for 350 kcmil size and above. Bolts and nuts are of the traditional Blackburn hex design for easy installation.

Service Post Connectors are available in sizes accommodating AWG copper conductor ranges of #12-500 kcmil stranded (4mm<sup>2</sup>-240mm<sup>2</sup>) and #12-#2 solid (4mm<sup>2</sup>-35mm<sup>2</sup>).

The line includes single conductor and double conductor connectors.

- For copper to copper connections
- For grounding of steel structures, fence posts, transformers using one or two cables
- For tapping one or two cables from a bus bar
- Hex design bolts machined from high conductivity bronze alloy
- Nuts and pressure bars cold-formed from high-strength copper or copper alloy
- CSA Certified and UL Listed



Cat. No.	Cat. No.	Conductor Range (AWG mm <sup>2</sup> )				Maximum Diameter Range (in.)	Stud Size	Dimensions (in.)					
		Stranded		Solid				A	AA	B	C	D	E
		max.	min.	max.	min.								
SP0DS	SP0SS	8	8	8	12	0.146-0.080	1/4 - 20 x 1/2	11/16	13/16	1/2	23/64	15/32	1/2
		-	4 mm <sup>2</sup>	10 mm <sup>2</sup>	4 mm <sup>2</sup>								
SP1DS	SP1SS	7	10	6	10	0.170-0.102	1/4 - 20 x 1/2	13/16	31/32	1/2	23/64	15/32	21/32
		10 mm <sup>2</sup>	6 mm <sup>2</sup>	10 mm <sup>2</sup>	6 mm <sup>2</sup>								
SP2DS	SP2SS	5	10	4	10	0.217-0.102	5/16 - 18 x 5/8	15/16	1-1/8	5/8	25/64	17/32	23/32
		16 mm <sup>2</sup>	6 mm <sup>2</sup>	16 mm <sup>2</sup>	6 mm <sup>2</sup>								
SP3DS	SP3SS	3	10	2	10	0.271-0.102	3/8 - 16 x 5/8	1/2	1-1/4	5/8	29/64	5/8	25/32
		25 mm <sup>2</sup>	6 mm <sup>2</sup>	35 mm <sup>2</sup>	6 mm <sup>2</sup>								
SP4DS	SP4SS	1	8	2	8	0.332-0.128	3/8 - 16 x 5/8	1-1/16	1-3/8	5/8	29/64	11/16	7/8
		35 mm <sup>2</sup>	6 mm <sup>2</sup>	35 mm <sup>2</sup>	10 mm <sup>2</sup>								
SP5DS	SP5SS	1/0	2	2	-	0.385-0.258	1/2 - 13 x 3/4	1-1/4	1-19/32	3/4	37/64	3/4	15/16
		50 mm <sup>2</sup>	35 mm <sup>2</sup>	35 mm <sup>2</sup>	-								
SP6DS	SP6SS	2/0	2	2	-	0.443-0.258	1/2 - 13 x 3/4	1-13/32	1-13/16	3/4	37/64	7/8	1-1/16
		70 mm <sup>2</sup>	35 mm <sup>2</sup>	35 mm <sup>2</sup>	-								
SP8DS	SP8SS	4/0	1	-	-	0.570-0.289	5/8 - 11 x 1	1-9/16	2-1/16	1	51/64	1	1-5/16
		95 mm <sup>2</sup>	35 mm <sup>2</sup>	-	-								
SP9DS	SP9SS	350	1/0	-	-	0.715-0.373	5/8 - 11 x 1	2	2-3/4	1	51/64	1-5/16	1-11/16
		150 mm <sup>2</sup>	70 mm <sup>2</sup>	-	-								
SP10DS	SP10SS	500	3/0	-	-	0.840-0.464	3/4 - 10 x 1-1/4	2-1/4	3-1/8	1-1/4	63/64	1-1/2	1-7/8
		240 mm <sup>2</sup>	95 mm <sup>2</sup>	-	-								

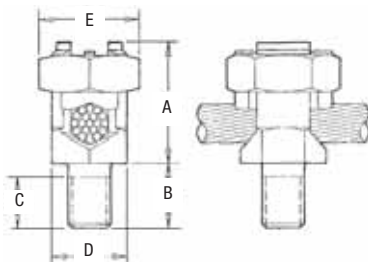

Single Conductor Short Stud

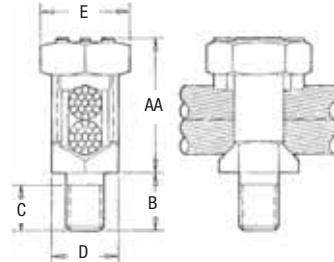

Double Conductors Short Stud

## Service Post Connectors

### Single or Double Conductors Long Stud



Mechanical and Accessories



Cat. No.	Cat. No.	Conductor Range (AWG mm <sup>2</sup> )				Maximum Diameter Range (in.)	Stud Size	Dimensions (in.)					
		Stranded		Solid				A	AA	B	C	D	E
		max.	min.	max.	min.								
SP0SL	SP0DL	8 -	8 4 mm <sup>2</sup>	8 10 mm <sup>2</sup>	12 4 mm <sup>2</sup>	0.146-0.080	1/4 - 20 x 1	11/16	13/16	1	55/64	15/32	1/2
SP1SL	SP1DL	7 10 mm <sup>2</sup>	10 6 mm <sup>2</sup>	6 10 mm <sup>2</sup>	10 6 mm <sup>2</sup>	0.170-0.102	1/4 - 20 x 1	13/16	31/32	1	55/64	15/32	21/32
SP2SL	SP2DL	5 16 mm <sup>2</sup>	10 6 mm <sup>2</sup>	4 16 mm <sup>2</sup>	10 6 mm <sup>2</sup>	0.217-0.102	5/16 - 18 x 1	15/16	1-1/8	1	53/64	17/32	23/32
SP3SL	SP3DL	3 25 mm <sup>2</sup>	10 6 mm <sup>2</sup>	2 35 mm <sup>2</sup>	10 6 mm <sup>2</sup>	0.271-0.102	3/8 - 16 x 1-1/8	1/2	1-1/4	1-1/8	61/64	5/8	25/32
SP4SL	SP4DL	1 35 mm <sup>2</sup>	8 6 mm <sup>2</sup>	2 35 mm <sup>2</sup>	8 10 mm <sup>2</sup>	0.332-0.128	3/8 - 16 x 1-1/8	1-1/16	1-3/8	1-1/8	61/64	11/16	7/8
SP5SL	SP5DL	1/0 50 mm <sup>2</sup>	2 35 mm <sup>2</sup>	2 35 mm <sup>2</sup>	-	0.385-0.258	1/2 - 13 x 1-1/4	1-1/4	1-19/32	1-1/4	1-5/64	3/4	15/16
SP6SL	SP6DL	2/0 70 mm <sup>2</sup>	2 35 mm <sup>2</sup>	2 35 mm <sup>2</sup>	-	0.443-0.258	1/2 - 13 x 1-1/4	1-13/32	1-13/16	1-1/2	1-19/64	7/8	1-1/16
SP8SL	SP8DL	4/0 95 mm <sup>2</sup>	1 35 mm <sup>2</sup>	-	-	0.570-0.289	5/8 - 11 x 1-1/2	1-9/16	2-1/16	1-1/2	1-19/64	1	1-5/16
SP9SL	SP9DL	350 150 mm <sup>2</sup>	1/0 70 mm <sup>2</sup>	-	-	0.715-0.373	5/8 - 11 x 1-1/2	2	2-3/4	1-1/2	1-19/64	1-5/16	1-11/16
SP10SL	SP10DL	500 240 mm <sup>2</sup>	3/0 95 mm <sup>2</sup>	-	-	0.840-0.464	3/4 - 10 x 1-3/4	2-1/4	3-1/8	1-3/4	1-31/64	1-1/2	1-7/8

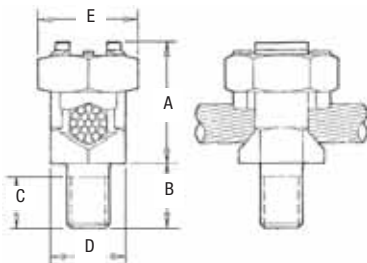

Single Conductor Long Stud

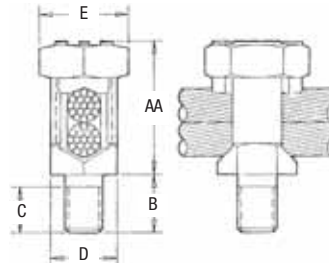

Double Conductors Long Stud

## Insulated Conductor Connectors

### Type IPC — Talon™ Insulation Piercing Connectors

- Perform as a splice or tap for non-tension applications up to 600 Volts depending on the size of the connector
- Eliminate need for conductor insulation stripping
- Self-insulated for hot line applications
- No taping required after installation
- For copper to copper, copper to aluminum and aluminum to aluminum applications
- For use on insulated conductors only
- Six connector line covers the range from #10-500 kcmil
- CSA Certified and UL Listed (AL9CU – 90°C rated)



Cat. No.	AL or CU Conductor Range (AWG/kcmil)		No. of Bolts	Fig.	Dimensions (in.)		
	Main	Tap			W	H	L
<b>IPC1102*</b>	1/0-8 50-6	2-8 35-6	1	1	2-9/16	2	1-17/32
<b>IPC4111</b>	4/0-1/0 95-50	1/0-6 50-16	2	2	2-1/2	3	1-19/32
<b>IPC4141</b>	4/0-1/0 95-50	4/0-1/0 95-50	2	2	2-5/8	3-1/4	1-29/32
<b>IPC5041*</b>	500-350 240-185	4/0-4 90-25	1	1	2	2-1/2	2-1/8
<b>IPC3535</b>	350-4/0 185-95	350-4/0 185-95	2	2	2-1/16	2-1/2	2-1/8
<b>IPC3541</b>	350-4/0 185-95	4/0-10 95-6	1	1	2-3/4	3	2-5/8

\* 600 Volt Rating (All others 300 Volts).

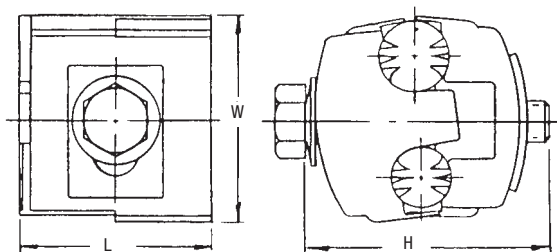

Fig. 1

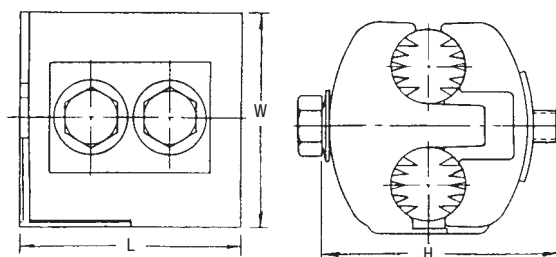

Fig. 2



## Two-Bolt Connectors without Spacer

### Type 2B — Two-Bolt Connectors without Spacer

- Castings and bolts of high-strength copper alloy
- Removable neoprene washers capture each bolt in bottom casting, aiding installation
- CSA Certified and UL Listed

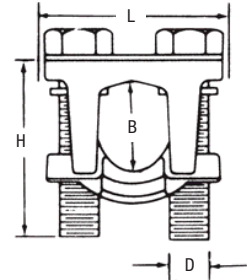

Cat. No.	Conductor Range (AWG or kcmil)				Conductor Diameter (B)		Bolt Head (in.)	Dimensions (in.)		
	Main		Tap		max.	min.		L	H	D
	max.	min.	max.	min.						
<b>2B10</b>	1/0 str.	2 str.	1/0 str.	10 sol.	0.746	0.394	1/2	1-5/16	1-3/4	5/16
<b>2B20BB</b>	2/0 str.	2 str.	2/0 str.	8 sol.	0.838	0.420	1/2	1-5/16	1-1/4	5/16
<b>2B40</b>	4/0 str.	1/0 str.	4/0 str.	6 sol.	1.056	0.530	9/16	1-23/32	1-3/4	3/8
<b>2B350</b>	350 kcmil	4/0 str.	350 kcmil	4 sol.	1.362	0.726	3/4	2-1/8	2	1/2
<b>2B500</b>	500 kcmil	350 kcmil	500 kcmil	4 sol.	1.626	0.883	3/4	2-1/4	2-1/2	1/2
<b>2B800</b>	800 kcmil	600 kcmil	800 kcmil	2 sol.	2.062	1.149	3/4	2-1/2	2-1/2	1/2
<b>2B1000</b>	1000 kcmil	750 kcmil	1000 kcmil	2 sol.	2.304	1.255	15/16	2-31/32	2-3/4	5/8

U.L. 486A

### Type 2B — One-Piece Two-Bolt Connectors without Spacer

- Castings and bolts of high-strength copper alloy
- One-piece construction
- Free bolt is held in place with neoprene washer during installation
- One extra length bolt allows top casting to swing free over two conductors of maximum range
- CSA Certified and UL Listed

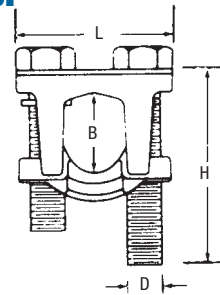

Cat. No.	Conductor Range (AWG or kcmil)				Conductor Diameter (B)		Bolt Head (in.)	Dimensions (in.)		
	Main		Tap		max.	min.		L	H	D
	max.	min.	max.	min.						
<b>2B10X</b>	1/0 str.	2 str.	1/0 str.	10 sol.	0.746	0.394	1/2	1-5/16	1-1/2	5/16
<b>2B20X</b>	2/0 str.	2 str.	2/0 str.	8 sol.	0.838	0.420	1/2	1-5/16	1-1/2	5/16
<b>2B40X</b>	4/0 str.	1/0 str.	4/0 str.	6 sol.	1.056	0.530	9/16	1-23/32	1-7/8	3/8
<b>2B350X</b>	350 kcmil	4/0 str.	350 kcmil	4 sol.	1.362	0.726	3/4	2-1/8	2-1/4	1/2
<b>2B500X</b>	500 kcmil	350 kcmil	500 kcmil	4 sol.	1.626	0.883	3/4	2-1/4	2-1/2	1/2
<b>2B800X</b>	800 kcmil	600 kcmil	800 kcmil	2 sol.	2.062	1.149	3/4	2-1/2	2-3/4	1/2
<b>2B1000X</b>	1000 kcmil	750 kcmil	1000 kcmil	2 sol.	2.304	1.255	15/16	2-31/32	3-1/4	5/8

U.L. 486A

## Two-Bolt Connectors with Spacer

### Type 2BW — One-Piece Two-Bolt Connectors with Spacer

- CSA Certified and UL Listed
- For use on copper conductors only
- Castings and bolts of high-strength copper alloy; spacer of ductile, high-conductivity copper alloy
- One-piece construction; contoured spacer is ringed and swings easily over the conductor

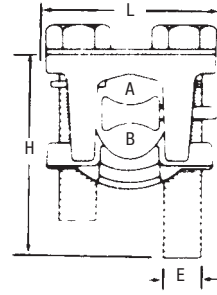

Cat. No.	Conductor Range (AWG or kcmil)				Conductor Diameter				Bolt Head (in.)	Dimensions (in.)		
	Main		Tap		A		B			L	H	E
	max.	min.	max.	min.	max.	min.	max.	min.				
<b>2B10W</b>	1/0 str.	2 str.	1/0 str.	10 sol.	0.373	0.292	0.373	0.102	1/2	1-5/16	1-5/8	5/16
<b>2B20W</b>	2/0 str.	2 str.	2/0 str.	8 sol.	0.419	0.292	0.419	0.128	1/2	1-5/16	1-5/8	5/16
<b>2B40W</b>	4/0 str.	1/0 str.	4/0 str.	6 sol.	0.528	0.368	0.528	0.162	9/16	1-23/32	2-1/8	3/8
<b>2B350W</b>	350 kcmil	4/0 str.	350 kcmil	4 sol.	0.681	0.522	0.681	0.204	3/4	2-1/8	2-1/2	1/2
<b>2B500W</b>	500 kcmil	350 kcmil	500 kcmil	4 sol.	0.813	0.679	0.813	0.204	3/4	2-1/4	2-3/4	1/2
<b>2B800W</b>	800 kcmil	600 kcmil	800 kcmil	2 sol.	1.031	0.891	1.031	0.258	3/4	2-1/2	3-1/4	1/2
<b>2B1000W</b>	1000 kcmil	750 kcmil	1000 kcmil	2 sol.	1.152	0.997	1.152	0.258	15/16	2-31/32	3-3/4	5/8

### Type 2BPW — One-Piece Two-Bolt Connectors with Spacer

- CSA Certified and UL Listed
- For use on copper, aluminum and ACSR conductors

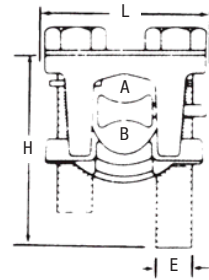

Cat. No.	Conductor Range (AWG or kcmil)				Conductor Diameter				Bolt Head (in.)	Dimensions (in.)		
	Main		Tap		A		B			L	H	E
	max.	min.	max.	min.	max.	min.	max.	min.				
<b>2B10PW</b>	1/0-2	1/0-6	1/0 str.-2 str.	1/0 str.-2 str.	0.398	0.292	0.398	0.102	1/2	1-5/16	1-5/8	5/16
<b>2B20PW</b>	2/0-2	2/0-6	2/0 str.-2 str.	1/0 str.-2 str.	0.447	0.292	0.447	0.128	1/2	1-5/16	1-5/8	5/16
<b>2B40PW</b>	4/0-1/0	4/0-6	4/0 str.-1/0 str.	4/0 str.-1/0 str.	0.563	0.368	0.563	0.162	9/16	1-23/32	2-1/8	3/8
<b>2B350PW</b>	350-4/0	350-4	350-4/0	350-4 sol.	0.680	0.522	0.680	0.204	3/4	2-1/8	2-1/2	1/2
<b>2B500PW</b>	397.5-336.4	397.5-4	500-350	500-4 sol.	0.813	0.679	0.813	0.204	3/4	2-1/4	2-3/4	1/2
<b>2B800PW</b>	666.6-397.5	666.6-2	800-600	800-2 sol.	1.031	0.891	1.031	0.258	3/4	2-1/2	3-1/4	1/2
<b>2B1000PW</b>	900-666.6	900-2	1000-750	1000-2 sol.	1.162	0.997	1.162	0.258	15/16	2-31/32	3-3/4	5/8

## AMT Connectors

### AMT Connectors

The high quality and built-in flexibility of the Blackburn® AMT Connectors reduce the cost of field installations on splices, taps, and terminations. They're easy and quick to install, and provide superior insulation that lasts the life of the connection.

#### Features and Benefits

- PVC insulation eliminates failures and reduces outage costs
- UV resistant material
- Compact design provides space efficiencies
- Dual-Rated for copper and aluminum conductors (CSA Certified and UL Listed, for 600V, 90°C).



Cat. No.	Figure	No. of Ports	Wire Range	Length (in.)	Width (in.)	Height (in.)	Hex Head Size	Std Pkg. Qty
<b>AMTSR10</b>	1	–	1/0–14 str.	3.25	0.94	1.63	3/16	4
<b>AMTSR250</b>	1	–	250 kcmil–6 str.	3.96	1.19	2.17	5/16	4
<b>AMTSR350</b>	1	–	350 kcmil–6 str.	4.43	1.31	2.62	5/16	2
<b>AMTSR500</b>	1	–	500 kcmil–4 str.	5.38	1.44	3.03	3/8	2
<b>AMTSR750</b>	1	–	750 kcmil–250 kcmil	7.25	1.75	3.16	1/2	2
<b>AMT Splices Offset</b>								
<b>AMTTC4</b>	3	2	4–14 str.	1.24	1.25	1.42	1/8	12
<b>AMTT10</b>	3	2	1/0–14 str.	1.63	1.63	1.63	3/16	6
<b>AMTT30</b>	3	2	3/0–6 str.	1.89	1.68	1.86	3/16	6
<b>AMT Multi-Port Connectors "Same Side"</b>								
<b>AMTS4142</b>	2	2	4–14 str.	1.24	1.22	1.42	1/8	12
<b>AMTS4143</b>	4	3	4–14 str.	1.70	1.22	1.42	1/8	12
<b>AMTS4144</b>	4	4	4–14 str.	2.16	1.22	1.42	1/8	6
<b>AMTS4145</b>	4	5	4–14 str.	2.61	1.22	1.42	1/8	6
<b>AMTS4146</b>	4	6	4–14 str.	3.07	1.22	1.42	1/8	6
<b>AMTS4147</b>	4	7	4–14 str.	3.53	1.22	1.42	1/8	4
<b>AMTS4148</b>	4	8	4–14 str.	3.99	1.22	1.42	1/8	4
<b>AMTS4149</b>	4	9	4–14 str.	4.45	1.22	1.42	1/8	4
<b>AMTS41410</b>	4	10	4–14 str.	4.90	1.22	1.42	1/8	4
<b>AMTS41411</b>	4	11	4–14 str.	5.36	1.22	1.42	1/8	3
<b>AMTS41412</b>	4	12	4–14 str.	5.82	1.22	1.42	1/8	3
<b>AMTS41413</b>	4	13	4–14 str.	6.28	1.22	1.42	1/8	2
<b>AMTS41414</b>	4	14	4–14 str.	6.74	1.22	1.42	1/8	2
<b>AMTS10142</b>	2	2	1/0–14 str.	1.67	1.53	1.63	3/16	12
<b>AMTS10143</b>	4	3	1/0–14 str.	2.29	1.53	1.63	3/16	12
<b>AMTS10144</b>	4	4	1/0–14 str.	2.92	1.53	1.63	3/16	6
<b>AMTS10145</b>	4	5	1/0–14 str.	3.54	1.53	1.63	3/16	6
<b>AMTS10146</b>	4	6	1/0–14 str.	4.17	1.53	1.63	3/16	6
<b>AMTS10147</b>	4	7	1/0–14 str.	4.79	1.53	1.63	3/16	4

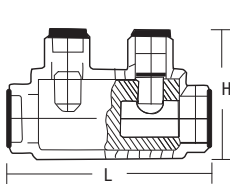

Fig. 1

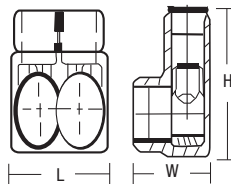

Fig. 2

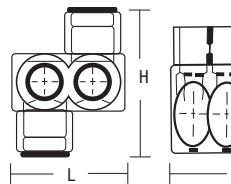

Fig. 3

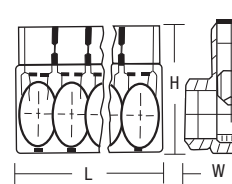

Fig. 4

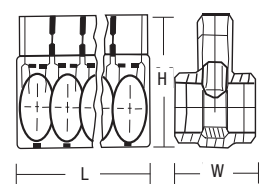

Fig. 5



Cat. No.	Figure	No. of Ports	Wire Range	Length	Width	Height	Hex Size	Std Pkg. Qty
<b>AMT Multi-Port Connectors "Same Side" (continued)</b>								
AMTS10148	4	8	1/0-14 str.	5.42	1.53	1.63	3/16	4
AMTS10149	4	9	1/0-14 str.	6.04	1.53	1.63	3/16	4
AMTS101410	4	10	1/0-14 str.	6.67	1.53	1.63	3/16	4
AMTS101411	4	11	1/0-14 str.	7.29	1.53	1.63	3/16	3
AMTS101412	4	12	1/0-14 str.	7.92	1.53	1.63	3/16	3
AMTS101413	4	13	1/0-14 str.	8.54	1.53	1.63	3/16	2
AMTS101414	4	14	1/0-14 str.	9.17	1.53	1.63	3/16	2
AMTS3062	2	2	3/0-6 str.	1.89	1.58	1.86	3/16	12
AMTS3063	4	3	3/0-6 str.	2.65	1.58	1.86	3/16	6
AMTS3064	4	4	3/0-6 str.	3.42	1.58	1.86	3/16	6
AMTS3065	4	5	3/0-6 str.	4.18	1.58	1.86	3/16	4
AMTS3066	4	6	3/0-6 str.	4.95	1.58	1.86	3/16	4
AMTS3067	4	7	3/0-6 str.	5.71	1.58	1.86	3/16	3
AMTS3068	4	8	3/0-6 str.	6.48	1.58	1.86	3/16	3
AMTS3069	4	9	3/0-6 str.	7.24	1.58	1.86	3/16	3
AMTS30610	4	10	3/0-6 str.	8.00	1.58	1.86	3/16	2
AMTS30611	4	11	3/0-6 str.	8.77	1.58	1.86	3/16	2
AMTS30612	4	12	3/0-6 str.	9.54	1.58	1.86	3/16	2
AMTS30613	4	13	3/0-6 str.	10.30	1.58	1.86	3/16	2
AMTS30614	4	14	3/0-6 str.	11.07	1.58	1.86	3/16	2
AMTS25062	4	2	250 kcmil-6 str.	2.17	1.91	2.17	5/16	6
AMTS25063	4	3	250 kcmil-6 str.	3.07	1.91	2.17	5/16	6
AMTS25064	4	4	250 kcmil-6 str.	3.96	1.91	2.17	5/16	6
AMTS25065	4	5	250 kcmil-6 str.	4.85	1.91	2.17	5/16	4
AMTS25066	4	6	250 kcmil-6 str.	5.75	1.91	2.17	5/16	4
AMTS25067	4	7	250 kcmil-6 str.	6.64	1.91	2.17	5/16	3
AMTS25068	4	8	250 kcmil-6 str.	7.53	1.91	2.17	5/16	3
AMTS25069	4	9	250 kcmil-6 str.	8.42	1.91	2.17	5/16	3
AMTS250610	4	10	250 kcmil-6 str.	9.32	1.91	2.17	5/16	2
AMTS250611	4	11	250 kcmil-6 str.	10.21	1.91	2.17	5/16	2
AMTS250612	4	12	250 kcmil-6 str.	11.10	1.91	2.17	5/16	2
AMTS250613	4	13	250 kcmil-6 str.	12.00	1.91	2.17	5/16	1
AMTS250614	4	14	250 kcmil-6 str.	12.89	1.91	2.17	5/16	1
AMTS35062	2	2	350 kcmil-6 str.	2.51	2.03	2.62	5/16	4
AMTS35063	4	3	350 kcmil-6 str.	3.56	2.03	2.62	5/16	4
AMTS35064	4	4	350 kcmil-6 str.	4.61	2.03	2.62	5/16	3
AMTS35065	4	5	350 kcmil-6 str.	5.66	2.03	2.62	5/16	3
AMTS35066	4	6	350 kcmil-6 str.	6.71	2.03	2.62	5/16	2
AMTS35067	4	7	350 kcmil-6 str.	7.76	2.03	2.62	5/16	2
AMTS35068	4	8	350 kcmil-6 str.	8.81	2.03	2.62	5/16	2
AMTS35069	4	9	350 kcmil-6 str.	9.86	2.03	2.62	5/16	2
AMTS350610	4	10	350 kcmil-6 str.	10.91	2.03	2.62	5/16	2
AMTS350611	4	11	350 kcmil-6 str.	11.96	2.03	2.62	5/16	1
AMTS350612	4	12	350 kcmil-6 str.	13.01	2.03	2.62	5/16	1
AMTS350613	4	13	350 kcmil-6 str.	14.06	2.03	2.62	5/16	1
AMTS350614	4	14	350 kcmil-6 str.	15.11	2.03	2.62	5/16	1
AMTS50042	2	2	500 kcmil-4 str.	2.97	2.28	3.04	3/8	3
AMTS50043	4	3	500 kcmil-4 str.	4.12	2.28	3.04	3/8	3
AMTS50044	4	4	500 kcmil-4 str.	5.28	2.28	3.04	3/8	3
AMTS50045	4	5	500 kcmil-4 str.	6.44	2.28	3.04	3/8	2
AMTS50046	4	6	500 kcmil-4 str.	7.59	2.28	3.04	3/8	2
AMTS50047	4	7	500 kcmil-4 str.	8.75	2.28	3.04	3/8	2
AMTS50048	4	8	500 kcmil-4 str.	9.90	2.28	3.04	3/8	2
AMTS50049	4	9	500 kcmil-4 str.	11.06	2.28	3.04	3/8	2
AMTS500410	4	10	500 kcmil-4 str.	12.22	2.28	3.04	3/8	1
AMTS500411	4	11	500 kcmil-4 str.	13.37	2.28	3.04	3/8	1

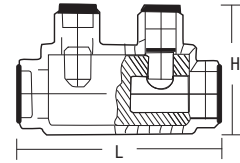

Fig. 1

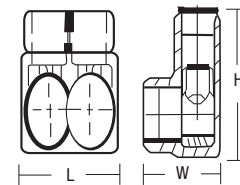

Fig. 2

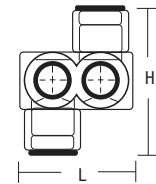

Fig. 3

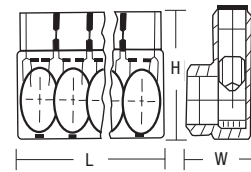

Fig. 4

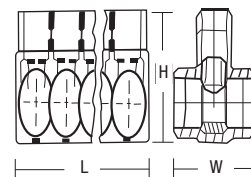

Fig. 5



## AMT Connectors



Cat. No.	Figure	No. of Ports	Wire Range	Length	Width	Height	Hex Size	Std Pkg. Qty
<b>AMT Multi-Port Connectors "Same Side" (continued)</b>								
AMTS500412	4	12	500 kcmil-4 str.	14.53	2.28	3.04	3/8	1
AMTS500413	4	13	500 kcmil-4 str.	15.68	2.28	3.04	3/8	1
AMTS500414	4	14	500 kcmil-4 str.	16.84	2.28	3.04	3/8	1
AMTS7502502	4	2	750 kcmil-250 kcmil	3.47	2.75	3.31	1/2	3
AMTS7502503	4	3	750 kcmil-250 kcmil	4.89	2.75	3.31	1/2	3
AMTS7502504	4	4	750 kcmil-250 kcmil	6.32	2.75	3.31	1/2	2
AMTS7502505	4	5	750 kcmil-250 kcmil	7.74	2.75	3.31	1/2	1
AMTS7502506	4	6	750 kcmil-250 kcmil	9.16	2.75	3.31	1/2	1
AMTS7502507	4	7	750 kcmil-250 kcmil	10.58	2.75	3.31	1/2	1
AMTS7502508	4	8	750 kcmil-250 kcmil	12.00	2.75	3.31	1/2	1
AMTS7502509	4	9	750 kcmil-250 kcmil	13.43	2.75	3.31	1/2	1
AMTS75025010	4	10	750 kcmil-250 kcmil	14.85	2.75	3.31	1/2	1
AMTS75025011	4	11	750 kcmil-250 kcmil	16.27	2.75	3.31	1/2	1
AMTS75025012	4	12	750 kcmil-250 kcmil	17.69	2.75	3.31	1/2	1
AMTS75025013	4	13	750 kcmil-250 kcmil	19.11	2.75	3.31	1/2	1
AMTS75025014	4	14	750 kcmil-250 kcmil	20.54	2.75	3.31	1/2	1
<b>AMT Multi-Port Connectors "Double" Both Sides</b>								
AMTD4142	5	2	4-14 str.	1.24	1.25	1.42	1/8	12
AMTD4143	5	3	4-14 str.	1.70	1.25	1.42	1/8	12
AMTD4144	5	4	4-14 str.	2.16	1.25	1.42	1/8	6
AMTD4145	5	5	4-14 str.	2.61	1.25	1.42	1/8	6
AMTD4146	5	6	4-14 str.	3.07	1.25	1.42	1/8	6
AMTD4147	5	7	4-14 str.	3.53	1.25	1.42	1/8	4
AMTD4148	5	8	4-14 str.	3.99	1.25	1.42	1/8	4
AMTD4149	5	9	4-14 str.	4.45	1.25	1.42	1/8	4
AMTD41410	5	10	4-14 str.	4.90	1.25	1.42	1/8	4
AMTD41411	5	11	4-14 str.	5.36	1.25	1.42	1/8	3
AMTD41412	5	12	4-14 str.	5.82	1.25	1.42	1/8	3
AMTD41413	5	13	4-14 str.	6.28	1.25	1.42	1/8	2
AMTD41414	5	14	4-14 str.	6.74	1.25	1.42	1/8	2
AMTD10142	5	2	1/0-14 str.	1.67	1.63	1.63	3/16	12
AMTD10143	5	3	1/0-14 str.	2.29	1.63	1.63	3/16	12
AMTD10144	5	4	1/0-14 str.	2.92	1.63	1.63	3/16	6
AMTD10145	5	5	1/0-14 str.	3.54	1.63	1.63	3/16	6
AMTD10146	5	6	1/0-14 str.	4.17	1.63	1.63	3/16	6
AMTD10147	5	7	1/0-14 str.	4.79	1.63	1.63	3/16	4
AMTD10148	5	8	1/0-14 str.	5.42	1.63	1.63	3/16	4
AMTD10149	5	9	1/0-14 str.	6.04	1.63	1.63	3/16	4
AMTD101410	5	10	1/0-14 str.	6.67	1.63	1.63	3/16	4
AMTD101411	5	11	1/0-14 str.	7.29	1.63	1.63	3/16	3
AMTD101412	5	12	1/0-14 str.	7.92	1.63	1.63	3/16	3
AMTD101413	5	13	1/0-14 str.	8.54	1.63	1.63	3/16	2
AMTD101414	5	14	1/0-14 str.	9.17	1.63	1.63	3/16	2
AMTD3062	5	2	3/0-6 str.	1.89	1.68	1.86	3/16	6
AMTD3063	5	3	3/0-6 str.	2.65	1.68	1.86	3/16	6
AMTD3064	5	4	3/0-6 str.	3.42	1.68	1.86	3/16	6
AMTD3065	5	5	3/0-6 str.	4.18	1.68	1.86	3/16	4
AMTD3066	5	6	3/0-6 str.	4.95	1.68	1.86	3/16	4
AMTD3067	5	7	3/0-6 str.	5.71	1.68	1.86	3/16	3
AMTD3068	5	8	3/0-6 str.	6.48	1.68	1.86	3/16	3
AMTD3069	5	9	3/0-6 str.	7.24	1.68	1.86	3/16	3
AMTD30610	5	10	3/0-6 str.	8.01	1.68	1.86	3/16	2
AMTD30611	5	11	3/0-6 str.	8.77	1.68	1.86	3/16	2
AMTD30612	5	12	3/0-6 str.	9.54	1.68	1.86	3/16	2
AMTD30613	5	13	3/0-6 str.	10.30	1.68	1.86	3/16	2
AMTD30614	5	14	3/0-6 str.	11.07	1.68	1.86	3/16	2

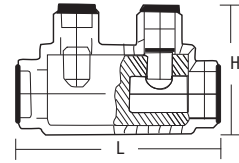

Fig. 1

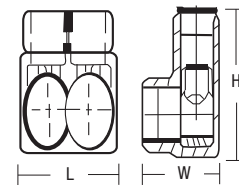

Fig. 2

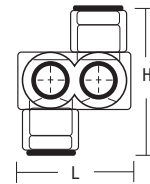

Fig. 3

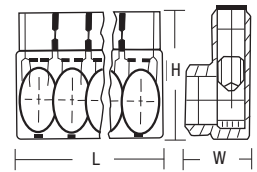

Fig. 4

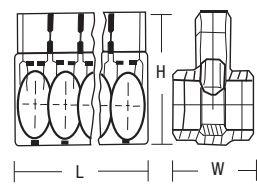
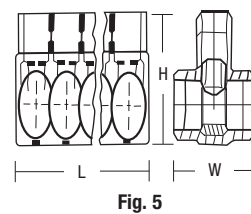
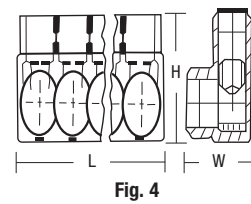
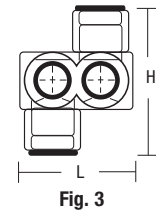
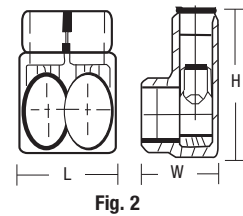
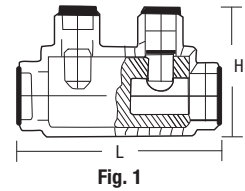

Fig. 5



Cat. No.	Figure	No. of Ports	Wire Range	Length	Width	Height	Hex Size	Std Pkg. Qty
<b>AMT Multi-Port Connectors "Double" Both Sides (continued)</b>								
AMTD25062	5	2	250 kcmil-6 str.	2.17	2.13	2.17	5/16	6
AMTD25063	5	3	250 kcmil-6 str.	3.07	2.13	2.17	5/16	6
AMTD25064	5	4	250 kcmil-6 str.	3.96	2.13	2.17	5/16	6
AMTD25065	5	5	250 kcmil-6 str.	4.85	2.13	2.17	5/16	4
AMTD25066	5	6	250 kcmil-6 str.	5.75	2.13	2.17	5/16	4
AMTD25067	5	7	250 kcmil-6 str.	6.64	2.13	2.17	5/16	3
AMTD25068	5	8	250 kcmil-6 str.	7.53	2.13	2.17	5/16	3
AMTD25069	5	9	250 kcmil-6 str.	8.42	2.13	2.17	5/16	3
AMTD250610	5	10	250 kcmil-6 str.	9.32	2.13	2.17	5/16	2
AMTD250611	5	11	250 kcmil-6 str.	10.21	2.13	2.17	5/16	2
AMTD250612	5	12	250 kcmil-6 str.	11.10	2.13	2.17	5/16	2
AMTD250613	5	13	250 kcmil-6 str.	12.00	2.13	2.17	5/16	1
AMTD250614	5	14	250 kcmil-6 str.	12.89	2.13	2.17	5/16	1
AMTD35062	5	2	350 kcmil-6 str.	2.51	2.25	2.62	5/16	4
AMTD35063	5	3	350 kcmil-6 str.	3.56	2.25	2.62	5/16	4
AMTD35064	5	4	350 kcmil-6 str.	4.61	2.25	2.62	5/16	3
AMTD35065	5	5	350 kcmil-6 str.	5.67	2.25	2.62	5/16	3
AMTD35066	5	6	350 kcmil-6 str.	6.71	2.25	2.62	5/16	2
AMTD35067	5	7	350 kcmil-6 str.	7.76	2.25	2.62	5/16	2
AMTD35068	5	8	350 kcmil-6 str.	8.81	2.25	2.62	5/16	2
AMTD35069	5	9	350 kcmil-6 str.	9.86	2.25	2.62	5/16	2
AMTD350610	5	10	350 kcmil-6 str.	10.91	2.25	2.62	5/16	2
AMTD350611	5	11	350 kcmil-6 str.	11.96	2.25	2.62	5/16	1
AMTD350612	5	12	350 kcmil-6 str.	13.01	2.25	2.62	5/16	1
AMTD350613	5	13	350 kcmil-6 str.	14.06	2.25	2.62	5/16	1
AMTD350614	5	14	350 kcmil-6 str.	15.11	2.25	2.62	5/16	1
AMTD50042	5	2	500 kcmil-4 str.	2.97	2.63	3.04	3/8	3
AMTD50043	5	3	500 kcmil-4 str.	4.12	2.63	3.04	3/8	3
AMTD50044	5	4	500 kcmil-4 str.	5.28	2.63	3.04	3/8	3
AMTD50045	5	5	500 kcmil-4 str.	6.44	2.63	3.04	3/8	2
AMTD50046	5	6	500 kcmil-4 str.	7.59	2.63	3.04	3/8	2
AMTD50047	5	7	500 kcmil-4 str.	8.75	2.63	3.04	3/8	2
AMTD50048	5	8	500 kcmil-4 str.	9.90	2.63	3.04	3/8	2
AMTD50049	5	9	500 kcmil-4 str.	11.06	2.63	3.04	3/8	2
AMTD500410	5	10	500 kcmil-4 str.	12.22	2.63	3.04	3/8	1
AMTD500411	5	11	500 kcmil-4 str.	13.37	2.63	3.04	3/8	1
AMTD500412	4	12	500 kcmil-4 str.	14.53	2.63	3.04	3/8	1
AMTD500413	4	13	500 kcmil-4 str.	15.68	2.63	3.04	3/8	1
AMTD500414	4	14	500 kcmil-4 str.	16.84	2.63	3.04	3/8	1
AMTD7502502	4	2	750 kcmil-250 kcmil	3.47	3.25	3.31	1/2	3
AMTD7502503	4	3	750 kcmil-250 kcmil	4.89	3.25	3.31	1/2	3
AMTD7502504	4	4	750 kcmil-250 kcmil	6.32	3.25	3.31	1/2	2
AMTD7502505	4	5	750 kcmil-250 kcmil	7.74	3.25	3.31	1/2	1
AMTD7502506	4	6	750 kcmil-250 kcmil	9.16	3.25	3.31	1/2	1
AMTD7502507	4	7	750 kcmil-250 kcmil	10.58	3.25	3.31	1/2	1
AMTD7502508	4	8	750 kcmil-250 kcmil	12.00	3.25	3.31	1/2	1
AMTD7502509	4	9	750 kcmil-250 kcmil	13.43	3.25	3.31	1/2	1
AMTD75025010	4	10	750 kcmil-250 kcmil	14.85	3.25	3.31	1/2	1
AMTD75025011	4	11	750 kcmil-250 kcmil	16.27	3.25	3.31	1/2	1
AMTD75025012	4	12	750 kcmil-250 kcmil	17.69	3.25	3.31	1/2	1
AMTD75025013	4	13	750 kcmil-250 kcmil	19.11	3.25	3.31	1/2	1
AMTD75025014	4	14	750 kcmil-250 kcmil	20.54	3.25	3.31	1/2	1



## AMT Connectors



Cat. No.	Figure	No. of Ports	Wire Range	Length	Width	Height	Hex Size	Std Pkg. Qty
<b>AMT Multi-Port Connectors "Double" Both sides (continued)</b>								
AMTDM3062	5	2	3/0-6 str.	3.42	1.68	1.86	3/16	6
AMTDM3063	5	3	3/0-6 str.	4.18	1.68	1.86	3/16	4
AMTDM3064	5	4	3/0-6 str.	4.95	1.68	1.86	3/16	4
AMTDM3065	5	5	3/0-6 str.	5.71	1.68	1.86	3/16	3
AMTDM3066	5	6	3/0-6 str.	6.48	1.68	1.86	3/16	3
AMTDM3067	5	7	3/0-6 str.	7.24	1.68	1.86	3/16	3
AMTDM3068	5	8	3/0-6 str.	8.01	1.68	1.86	3/16	2
AMTDM3069	5	9	3/0-6 str.	8.77	1.68	1.86	3/16	2
AMTDM30610	5	10	3/0-6 str.	9.54	1.68	1.86	3/16	2
AMTDM30611	5	11	3/0-6 str.	10.30	1.68	1.86	3/16	22644
AMTDM30612	5	12	3/0-6 str.	11.07	1.68	1.86	3/16	3
AMTDM25062	5	2	250 kcmil-6 str.	3.96	2.13	2.17	5/16	332
AMTDM25063	5	3	250 kcmil-6 str.	4.85	2.13	2.17	5/16	2
AMTDM25064	5	4	250 kcmil-6 str.	5.73	2.13	2.17	5/16	2
AMTDM25065	5	5	250 kcmil-6 str.	6.64	2.13	2.17	5/16	1
AMTDM25066	5	6	250 kcmil-6 str.	7.53	2.13	2.17	5/16	1
AMTDM25067	5	7	250 kcmil-6 str.	8.42	2.13	2.17	5/16	3
AMTDM25068	5	8	250 kcmil-6 str.	9.32	2.13	2.17	5/16	3
AMTDM25069	5	9	250 kcmil-6 str.	10.21	2.13	2.17	5/16	3
AMTDM250610	5	10	250 kcmil-6 str.	11.10	2.13	2.17	5/16	2
AMTDM250611	5	11	250 kcmil-6 str.	12.00	2.13	2.17	5/16	2
AMTDM250612	5	12	250 kcmil-6 str.	12.89	2.13	2.17	5/16	2
AMTDM35062	5	2	350 kcmil-6 str.	4.61	2.25	2.62	5/16	2
AMTDM35063	5	3	350 kcmil-6 str.	5.67	2.25	2.62	5/16	1
AMTDM35064	5	4	350 kcmil-6 str.	6.71	2.25	2.62	5/16	1
AMTDM35065	5	5	350 kcmil-6 str.	7.76	2.25	2.62	5/16	1
AMTDM35066	5	6	350 kcmil-6 str.	8.81	2.25	2.62	5/16	1
AMTDM35067	5	7	350 kcmil-6 str.	9.86	2.25	2.62	5/16	3
AMTDM35068	5	8	350 kcmil-6 str.	10.91	2.25	2.62	5/16	2
AMTDM35069	5	9	350 kcmil-6 str.	11.96	2.25	2.62	5/16	2
AMTDM350610	5	10	350 kcmil-6 str.	13.01	2.25	2.62	5/16	2
AMTDM350611	5	11	350 kcmil-6 str.	14.06	2.25	2.62	5/16	2
AMTDM350612	5	12	350 kcmil-6 str.	15.11	2.25	2.62	5/16	2
AMTDM50042	5	2	500 kcmil-4 str.	5.25	2.63	3.04	3/8	1
AMTDM50043	5	3	500 kcmil-4 str.	6.44	2.63	3.04	3/8	1
AMTDM50044	5	4	500 kcmil-4 str.	7.59	2.63	3.04	3/8	1
AMTDM50045	5	5	500 kcmil-4 str.	8.75	2.63	3.04	3/8	1
AMTDM50046	5	6	500 kcmil-4 str.	9.90	2.63	3.04	3/8	1
AMTDM50047	5	7	500 kcmil-4 str.	11.06	2.63	3.04	3/8	2
AMTDM50048	5	8	500 kcmil-4 str.	12.22	2.63	3.04	3/8	1
AMTDM50049	5	9	500 kcmil-4 str.	13.37	2.63	3.04	3/8	1
AMTDM500410	5	10	500 kcmil-4 str.	14.53	2.63	3.04	3/8	1
AMTDM500411	5	11	500 kcmil-4 str.	15.68	2.63	3.04	3/8	1
AMTDM500412	5	12	500 kcmil-4 str.	16.84	2.63	3.04	3/8	1
AMTDM7502502	5	2	750 kcmil-250 kcmil	6.32	3.25	3.31	1/2	2
AMTDM7502503	5	3	750 kcmil-250 kcmil	7.74	3.25	3.31	1/2	1
AMTDM7502504	5	4	750 kcmil-250 kcmil	9.16	3.25	3.31	1/2	1
AMTDM7502505	5	5	750 kcmil-250 kcmil	10.58	3.25	3.31	1/2	1
AMTDM7502506	5	6	750 kcmil-250 kcmil	12.00	3.25	3.31	1/2	1
AMTDM7502507	5	7	750 kcmil-250 kcmil	13.43	3.25	3.31	1/2	1
AMTDM7502508	5	8	750 kcmil-250 kcmil	14.85	3.25	3.31	1/2	1
AMTDM7502509	5	9	750 kcmil-250 kcmil	16.27	3.25	3.31	1/2	1
AMTDM75025010	5	10	750 kcmil-250 kcmil	17.69	3.25	3.31	1/2	1
AMTDM75025011	5	11	750 kcmil-250 kcmil	19.11	3.25	3.31	1/2	1
AMTDM75025012	5	12	750 kcmil-250 kcmil	20.54	3.25	3.31	1/2	1

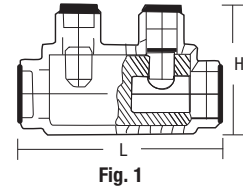

Fig. 1

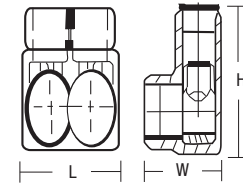

Fig. 2

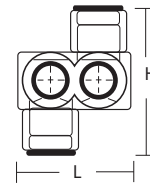

Fig. 3

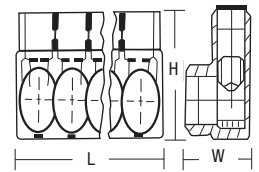

Fig. 4

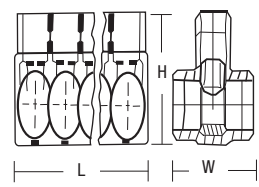

Fig. 5

## Features

- Insulated housing provides fast, clean, safe installation and controlled dielectric strength
- Grooved contact surfaces penetrate conductor oxides for best contact
- Easily installed and position-locked with DIN rail or screw mounting



Blackburn Power Distribution Blocks are suitable for all panel building applications and various terminal enclosure solutions; for extending or branching the cables or changing the conductor type.

## Specifications

- Max. Voltage: 600V
- Max. Temperature: 80°C
- Flammability Rating: V-2 (UL94)
- Standard & Testing: UL1059, Category XCFR2, File Numbers E66436; SFS 2663; VDE 0220, Teil 1/11.71, Teil 2/11.71, Sen 241510, SEN 245012; IEC 61238 class B

## Typical Applications

- Ideal for OEM use in electrical, electronics, panel, switchboard, switchgear, automation and control manufacturing
- Also suitable for industrial/commercial retrofit contractors, installation technicians, maintenance and service providers
- Used in distribution panels, control boxes, automation products, ESS centers and more

## Terminal Blocks

- One-pole feedthrough terminal blocks
- Three-pole version (Cat. No. PDS3610) supports three-phase systems
- Designed for connecting or extending both aluminum and copper conductors

## Tapping Blocks

- One pole, four identical terminals
- Suitable for extending or branching both aluminum and copper conductors



## Power Distribution Blocks

### Conductor Table

Conductors that can be used with the power Distribution Blocks: number, cross-section and type.

- Requirements of a specific apparatus may restrict the number of conductors
- Usually a maximum of three adjacent standard cross-sections in one space
- In general, the conductors connected to one conductor space of a connector must be of the same type
- Table values require careful installation
- We recommend use of ferrules when using fine-stranded conductors
- After installation, check that all conductors are pressed into a connection
- The nominal current of the power distribution blocks must not be exceeded
- According to some installation standards, each incoming and outgoing protection and neutral conductor in a panel must have its own separate power distribution block
- The conductor numbers below refer only to industrially installed power distribution blocks (internal connections in a panel)

Cross-sections of conductors (AWG/kcmil) and number of conductors/space.

Cat. No.	AWG/kcmil	8	6	4	3	2	1	1/0	2/0	3/0	4/0	250	300	350	400	500
PDS610	Al	1	1	1	1	1	1									
	Cu	1	1	1	1	1	1									
	Cu	2														
	Cu	3														
PDS3610	Al	1	1	1	1	1	1									
	Cu	1	1	1	1	1	1									
	Cu	2														
	Cu	3														
PDS440	Al		1	1	1	1	1	1	1	1	1					
	Cu		1	1	1	1	1	1	1	1	1					
	Cu		2	2	2	2										
	Cu		3													
PDS2300	Al				1	1	1	1	1	1	1	1	1	1		
	Cu				1	1	1	1	1	1	1	1	1	1		
	Cu				2	2	2									
	Cu				3											
PDS30500	Al								1	1	1	1	1	1	1	1
	Cu								1	1	1	1	1	1	1	1
	Cu				2	2	2	2								
	Cu				3	3	3									
PDS2610	Al	1	1	1	1	1	1									
	Cu	1	1	1	1	1	1									
	Cu	2														
	Cu	3														
PDS2440	Al		1	1	1	1	1	1	1	1	1					
	Cu		1	1	1	1	1	1	1	1	1					
	Cu		2	2	2	2										
	Cu		3													
PDS22300	Al				1	1	1	1	1	1	1	1	1			
	Cu				1	1	1	1	1	1	1	1	1			
	Cu				2	2	2									
	Cu				3											
PDS230500	Al								1	1	1	1	1	1	1	1
	Cu								1	1	1	1	1	1	1	1
	Cu				2	2	2	2								
	Cu				3	3	3									



## Power Distribution Blocks

Cat. No.	Wire Range	Max. Current	Tightening Torque	Allen Hex Socket Head Terminal Screw	Mounting	Dimensions W x H x D (in.)	Colour	Std. Pkg.
<b>Terminal Blocks</b>								
<b>PDS610</b>	1/0-6 AWG Cu or Al	150A Cu/ 120A Al	90 lb./in.	5 mm	Top Hat rail	0.7 x 1.9 x 1.7	Grey	30
<b>PDS610B</b>	1/0-6 AWG Cu or Al	150A Cu/ 120A Al	90 lb./in.	5 mm	Top Hat rail	0.7 x 1.9 x 1.7	Blue	30
<b>PDS610G</b>	1/0-6 AWG Cu or Al	150A Cu/ 120A Al	90 lb./in.	5 mm	Top Hat rail	0.7 x 1.9 x 1.7	Yellow - Green	30
<b>PDS3610</b>	1/0-6 AWG Cu or Al	150A Cu/ 120A Al	90 lb./in.	5 mm	Top Hat rail	1.9 x 1.9 x 1.7	Grey	30
<b>PDS440</b>	4/0-4 AWG Cu or Al	230A Cu/ 180A Al	126 lb./in.	5 mm	Top Hat rail or screw	0.9 x 3.4 x 1.7	Grey	30
<b>PDS440B</b>	4/0-4 AWG Cu or Al	230A Cu/ 180A Al	126 lb./in.	5 mm	Top Hat rail or screw	0.9 x 3.4 x 1.7	Blue	30
<b>PDS440G</b>	4/0-4 AWG Cu or Al	230A Cu/ 180A Al	126 lb./in.	5 mm	Top Hat rail or screw	0.9 x 3.4 x 1.7	Yellow - Green	30
<b>PDS2300</b>	300-2 AWG Cu or Al	285A Cu/ 230A Al	216 lb./in.	8 mm	Top Hat rail or screw	1.2 x 3.7 x 2.3	Grey	30
<b>PDS2300B</b>	300-2 AWG Cu or Al	285A Cu/ 230A Al	216 lb./in.	8 mm	Top Hat rail or screw	1.2 x 3.7 x 2.3	Blue	30
<b>PDS2300G</b>	300-2 AWG Cu or Al	285A Cu/ 230A Al	216 lb./in.	8 mm	Top Hat rail or screw	1.2 x 3.7 x 2.3	Yellow - Green	30
<b>PDS30500</b>	500-3/0 Cu or Al	380A Cu/ 310A Al	360 lb./in.	8 mm	Screw	1.5 x 5.1 x 2.6	Grey	30
<b>PDS30500B</b>	500-3/0 Cu or Al	380A Cu/ 310A Al	360 lb./in.	8 mm	Screw	1.5 x 5.1 x 2.6	Blue	30
<b>PDS30500G</b>	500-3/0 Cu or Al	380A Cu/ 310A Al	360 lb./in.	8 mm	Screw	1.5 x 5.1 x 2.6	Yellow - Green	30
<b>Tapping Blocks</b>								
<b>PDS2610</b>	1/0-6 AWG Cu or Al	150A Cu/ 120A Al	90 lb./in.	5 mm	Top Hat rail	1.2 x 1.9 x 1.7	Grey	30
<b>PDS2610B</b>	1/0-6 AWG Cu or Al	150A Cu/ 120A Al	90 lb./in.	5 mm	Top Hat rail	1.2 x 1.9 x 1.7	Blue	30
<b>PDS2610G</b>	1/0-6 AWG Cu or Al	150A Cu/ 120A Al	90 lb./in.	5 mm	Top Hat rail	1.2 x 1.9 x 1.7	Yellow - Green	30
<b>PDS2440</b>	1/0-6 AWG Cu or Al	150A Cu/ 120A Al	90 lb./in.	5 mm	Top Hat rail	1.7 x 3.4 x 1.9	Grey	30
<b>PDS2440B</b>	4/0-4 AWG Cu or Al	230A Cu/ 180A Al	126 lb./in.	5 mm	Top Hat rail or screw	1.7 x 3.4 x 1.9	Blue	30
<b>PDS2440G</b>	4/0-4 AWG Cu or Al	230A Cu/ 180A Al	126 lb./in.	5 mm	Top Hat rail or screw	1.7 x 3.4 x 1.9	Yellow - Green	30
<b>PDS22300</b>	4/0-4 AWG Cu or Al	230A Cu/ 180A Al	126 lb./in.	5 mm	Top Hat rail or screw	2 x 3.7 x 2.3	Grey	30
<b>PDS22300B</b>	300-2 AWG Cu or Al	285A Cu/ 230A Al	216 lb./in.	8 mm	Top Hat rail or screw	2 x 3.7 x 2.3	Blue	30
<b>PDS22300G</b>	300-2 AWG Cu or Al	285A Cu/ 230A Al	216 lb./in.	8 mm	Top Hat rail or screw	2 x 3.7 x 2.3	Yellow - Green	30
<b>PDS230500</b>	300-2 AWG Cu or Al	285A Cu/ 230A Al	216 lb./in.	8 mm	Top Hat rail or screw	2.5 x 5.1 x 2.6	Grey	30
<b>PDS230500B</b>	500-3/0 Cu or Al	380A Cu/ 310A Al	360 lb./in.	8 mm	Screw	2.5 x 5.1 x 2.6	Blue	30
<b>PDS230500G</b>	500-3/0 Cu or Al	380A Cu/ 310A Al	360 lb./in.	8 mm	Screw	2.5 x 5.1 x 2.6	Yellow - Green	30

## Copper Mechanical Connectors

### Type L — Single Conductor, One Hole Mount

- For copper conductors
- Screws are plated steel
- Compact design
- Add suffix P to catalogue number for tin plating
- One-piece construction for strength and durability
- Excellent for confined quarters
- Cat. Nos. L400 and L650 are cast from high strength bronze alloy
- Cat. Nos. L35, L70, L125 and L250 are cold forged from pure electrolytic copper. Other models are cast from high strength bronze alloy
- CSA Certified and UL Listed

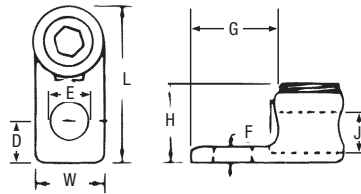

Cat. No.		Conductor Range		Dimensions (in.)							
Socket	Hex	max.	min.	L	W	H	F	D	J	E	G
L35*	—	8 str.	14 sol.	13/16	3/8	3/8	3/32	13/64	11/64	13/64	1/2
L70*	—	4 str.	14 sol.	1-1/8	17/32	35/64	3/32	9/32	9/32	9/32	21/32
L125**	L125H	1/0 str.	8 sol.	1-1/2	47/64	3/4	3/32	3/8	27/64	21/64	27/32
L250**	L250H	250 kcmil	6 str.	1-61/64	15/16	1-1/16	1/8	29/64	5/8	13/32	1-3/32
L400B**	L400H	500 kcmil	4/0 str.	3	1-13/32	1-15/32	9/32	5/8	7/8	9/16	1-5/8
L650**	L650H	1000 kcmil	500 kcmil	4	2	2-3/16	17/32	3/4	1-1/4	9/16	2

\* Sizes L35 and L70 have screwdriver slot head screws only.

\*\* Sizes L125 and up are Allen head screws.

### Type L — Single Conductor, Two Hole Mount

- Cast from high strength bronze alloy
- For use where large contact area is required to provide a more secure mounting
- CSA Certified and UL Listed

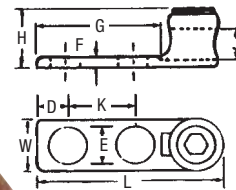

Cat. No.		Conductor Range		Dimensions (in.)								
Socket	Hex	max.	min.	L	W	H	F	D	K	E	G	J
L1252	L1252H	1/0 str.	4 str.	2-13/16	25/32	13/16	3/16	7/16	1	11/32	2	27/64
L2502	L2502H	250 kcmil	1/0 str.	3	3	1-1/32	15/64	7/16	1	13/32	1-7/8	5/8
L4002	L4002H	500 kcmil	4/0 str.	3-3/8	3-3/8	1-15/32	5/16	7/16	1	13/32	1-15/16	57/64
L6502	L6502H	1000 kcmil	500 kcmil	4-15/16	4-15/16	2	3/8	9/16	1-1/2	9/16	2-3/4	1-1/4

## Copper Mechanical Connectors

### Type TL — Two Conductors, Two Hole Mount

- Conveniently terminates parallel conductors
- For copper conductors
- Screws are plated steel
- Compact design
- Add suffix P to catalogue number for tin plating
- One-piece construction for strength and durability
- Excellent for confined quarters
- CSA Certified and UL Listed
- Cast from high strength bronze alloy

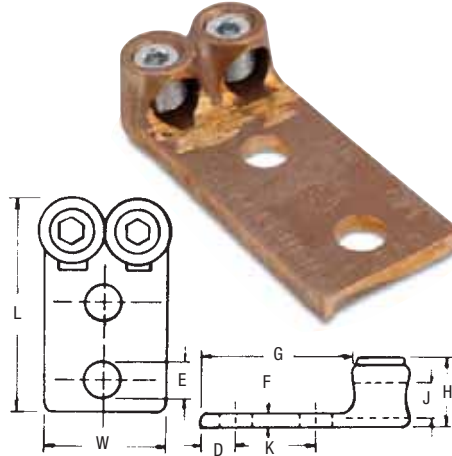

Cat. No.		Conductor Range		Dimensions (in.)								
Socket	Hex	max.	min.	L	W	H	F	K	E	D	G	J
TL250	TL250H	250 kcmil	1/0 str.	4-5/16	1-7/8	9/32	5/8	1-3/4	9/16	1-1/16	3-3/16	5/8
TL400	TL400H	500 kcmil	4/0 str.	4-3/4	2-9/16	13/32	11/16	1-3/4	9/16	1-9/16	3	7/8
TL650	TL650H	1000 kcmil	500 kcmil	5-9/16	3-1/4	9/16	5/8	1-3/4	9/16	2-3/16	3-3/8	1-1/4

Four hole NEMA tang on TL650.

### Type S — Copper End-to-End Splice Connectors

- Cast of high strength bronze alloy
- Plated steel socket head set screws
- For copper conductors
- Compact design
- Add suffix P to catalogue number for tin plating
- One-piece construction for strength and durability
- Excellent for confined quarters
- CSA Certified and UL Listed

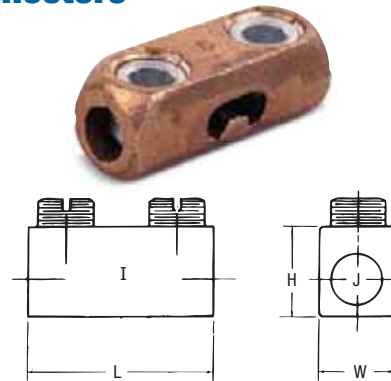

Cat. No.	Conductor Range		Dimensions (in.)				
	max.	min.	L	W	H	J	I
S100BB	1 str.	4 str.	1-11/16	5/8	11/16	3/8	15/16
S225BB*	4 str.	1 str.	2-3/16	27/32	31/32	9/16	1-3/16
S400BB	500 kcmil	4/0 str.	2-7/8	1-3/16	1-5/16	7/8	1-5/8

\* Not U.L. Listed.

## Copper Mechanical Connectors

### Type STC — Copper Single Conductor, One Hole Mount (Straight Tang)

- Uniquely designed pressure bar and notched v-bottom collar provide a vise-like grip between conductor and terminal
- CSA Certified and UL Listed for copper conductors
- Made of electrolytic seamless coppers
- Screws are zinc plated steel

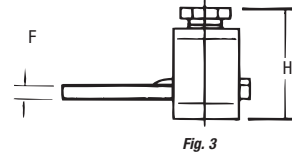
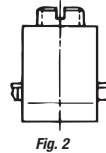
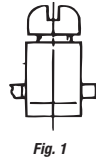
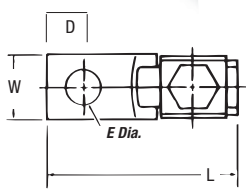

Cat. No.	Fig. No.	Conductor Range		Dimensions (in.)					
		max.	min.	L	W	H	F	E	D
<b>STC1014*</b>	1	10 AWG	14 AWG	1	5/16	1/2	5/64	5/32	3/16
<b>STC0614</b>	2	6 str.	14 AWG	1-9/64	3/8	11/16	5/64	13/64	7/32
<b>STC0414</b>	2	4 str.	14 AWG	1-1/4	1/2	37/32	3/32	17/64	1/4
<b>STC0208</b>	3	2 str.	8 str.	1-15/32	1/2	31/32	3/32	17/64	1/7
<b>STC1102</b>	3	1/0 str.	2 str.	1-15/16	5/8	1-1/4	1/8	17/64	7/16
<b>STC3104</b>	3	3/0 str.	4 str.	2-1/4	3/4	1-9/16	1/8	13/32	7/16
<b>STC4102</b>	3	4/0 str.	2 str.	2-3/8	1	1-21/32	1/8	11/32	1/2
<b>STC3511</b>	3	350 kcmil	1/0 str.	3-1/4	1	1-5/8	3/16	13/32	5/8
<b>STC5011</b>	3	500 kcmil	1/0 str.	3-7/8	1-1/2	1-13/16	3/16	13/32	15/16
<b>STC9960</b>	3	1000 kcmil	600 kcmil	5	2	2-5/8	1/4	17/32	1-1/8

\* CSA not applicable.



## Copper Mechanical Connectors

### Type BTC — Copper Single Conductor, One Hole Mount (Offset Tang)

- CSA Certified and UL Listed, tested for copper conductors
- Made of electrolytic seamless copper
- Screws are zinc plated steel

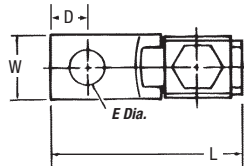
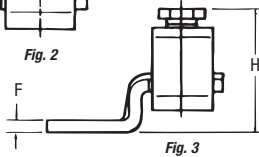
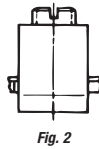
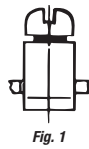

Cat. No.	Fig. No.	Conductor Range		Dimensions (in.)					
		max.	min.	L	W	H	F	E	D
<b>BTC1014*</b>	1	10 AWG	14 AWG	1	5/16	43/64	5/64	5/32	3/16
<b>BTC0614</b>	2	6 str.	14 AWG	1-3/32	3/8	25/32	5/64	13/64	7/32
<b>BTC0208</b>	2	2 str.	8 str.	1-15/32	1/2	27/32	3/32	17/64	1/4
<b>BTC1102</b>	3	1/0 str.	2 str.	1-25/32	5/8	1-13/32	1/8	17/64	7/16
<b>BTC3104</b>	3	3/0 str.	4 str.	2-3/64	3/4	1-9/16	1/8	13/32	7/16
<b>BTC4102</b>	3	4/0 str.	2 str.	2-9/16	1	1-61/64	1/8	11/32	1/2
<b>BTC3511</b>	3	350 kcmil	1/0 str.	3-1/4	1	2-1/2	3/16	13/32	5/8
<b>BTC5011</b>	3	500 kcmil	1/0 str.	4-1/4	1-1/2	2-21/32	3/16	13/32	15/16
<b>BTC9960</b>	3	1000 kcmil	600 kcmil	4-3/4	2	3-9/16	1/4	17/32	1-1/8

\* CSA not applicable.

## Dual-Rated Mechanical Connectors

### Type ADR-ALCÜL™ — Single Conductor, One Hole Mount

- For copper and aluminum conductors
- Easy installation—no special tools required
- Tin plated for low contact resistance
- CSA Certified and UL Listed, AL9CU, 600V Rated
- All aluminum bodies
- Slotted screw on lugs up through 2/0 str.; 5/16 socket screw on sizes 250 through 350 kcmil; 3/8 hex socket on sizes 500 kcmil and above

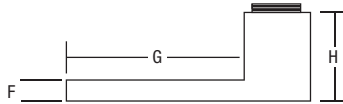
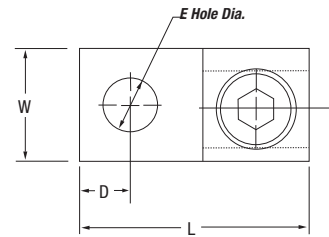

Cat. No.	Conductor Range		Dimensions (in.)						
	max.	min.	L	W	H	D	E	F	G
<b>Slotted Screw</b>									
<b>ADR6</b>	6 str.	14 AWG	1-3/64	1/2	31/64	15/64	1/4	5/64	43/64
<b>ADR2</b>	2 str.	14 AWG	1-5/32	1/2	9/16	19/64	1/4	7/64	11/16
<b>ADR11</b>	1/0 str.	14 AWG	1-15/32	5/8	25/32	7/16	1/4	3/16	27/32
<b>ADR21</b>	2/0 str.	14 AWG	1-15/32	5/8	25/32	7/16	1/4	3/16	27/32
<b>Socket Screw</b>									
<b>ADR25</b>	250 kcmil	6 str.	2	1	1-1/8	15/32	5/16	1/4	1
<b>ADR30</b>	300 kcmil	6 str.	2	1	1-1/8	15/32	5/16	1/4	1
<b>ADR35</b>	350 kcmil	6 str.	2-1/4	1-1/8	1-1/4	1/2	3/8	1/4	1-1/8
<b>ADR50</b>	500 kcmil	4 str.	2-13/16	1-1/2	1-9/16	3/4	3/8	5/16	1-19/32
<b>ADR60</b>	600 kcmil	2 str.	3-3/16	1-1/2	1-9/16	13/16	3/8	7/16	1-13/16
<b>ADR6004*</b>	600 kcmil (2) 250 kcmil	4 str. (2) 1/0 str.	2-13/16	1-3/8	1-13/16	5/8	3/8	5/16	1-1/2
<b>ADR80</b>	800 kcmil	300 kcmil	3-3/8	1-3/4	1-15/16	7/8	5/8	1/2	1-3/4
<b>ADR99</b>	1000 kcmil	500 kcmil	3-3/8	1-3/4	1-15/16	7/8	5/8	1/2	1-3/4

\* U.L. and CSA not applicable.

## Dual-Rated Mechanical Connectors

### Type ADR-ALCÜL™ — Single Conductor, Two Hole Mount\*

- For copper and aluminum conductors
- Easy installation—no special tools required
- Tin plated for low contact resistance
- CSA Certified and UL Listed
- All aluminum bodies



Fig. 1



Fig. 2

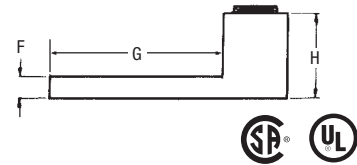
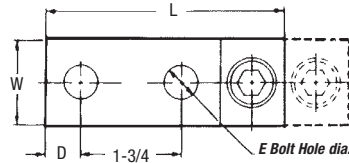

Cat. No.	Figure	Conductor Range (AL or CU)		Dimensions (in.)						
		max.	min.	L	W	H	D	E	F	G
<b>ADR35-12D</b>	1	350 kcmil	6 str.	4-1/4	1-1/4	1-3/8	5/8	1/2	5/16	3
<b>ADR60-12D</b>	2	600 kcmil	2 str.	5-5/16	1-1/2	1-1/2	5/8	1/2	3/8	3-1/16
<b>ADR80-12D</b>	2	800 kcmil	300 kcmil	6-3/16	1-3/4	1-7/8	5/8	1/2	9/16	3-7/16
<b>ADR99-12D</b>	2	1,000 kcmil	350 kcmil	6-3/16	1-3/4	1-7/8	5/8	1/2	9/16	3-7/16

\* NEMA spacing: 1-3/4" centers.  
Connectors accommodating conductors 600 kcmil and larger have double row of set screws (D suffix).

### Type ADR-ALCÜL™ — Single Conductor, Switchgear Mount\*

- For copper and aluminum conductors
- Easy installation—no special tools required
- Tin plated for low contact resistance
- CSA Certified and UL Listed
- All aluminum bodies

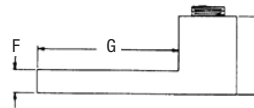
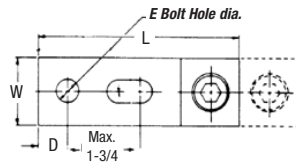
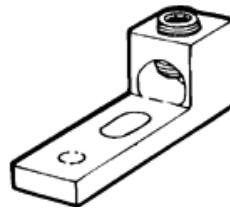

Cat. No.	Conductor Range (AL or CU)		Dimensions (in.)						
	max.	min.	L	W	H	D	E	F	G
<b>ADR25-12S</b>	250 kcmil	3/0 str.	3	1	13-16	1/2	3/8	1/4	2
<b>ADR35-12S</b>	350 kcmil	4 str.	4-11/16	1-1/4	1-9/16	23/32	1/2	7/16	3-5/16
<b>ADR50-12S</b>	500 kcmil	400 kcmil	4-11/16	1-1/4	1-9/16	23/32	1/2	7/16	3-5/16
<b>ADR80-12DS</b>	800 kcmil	300 kcmil	6-3/16	1-5/8	1-7/8	23/32	1/2	9/16	3-7/16
<b>ADR99-12DS</b>	1000 kcmil	350 kcmil	6-3/16	1-5/8	1-7/8	23/32	1/2	9/16	3-7/16

\* NEMA spacing: 1-3/4" centers except ADR25-12S: 1" centers.  
Connectors accommodating conductors 600 kcmil and larger have double row of set screws (D suffix).

**Dual-Rated Mechanical Connectors**

**Type ASL-ALCÜL™ — Two Conductors, One-Hole Mount**

- For copper and aluminum conductors
- Easy installation—no special tools required
- Tin plated for low contact resistance
- CSA Certified and UL Listed
- All aluminum bodies

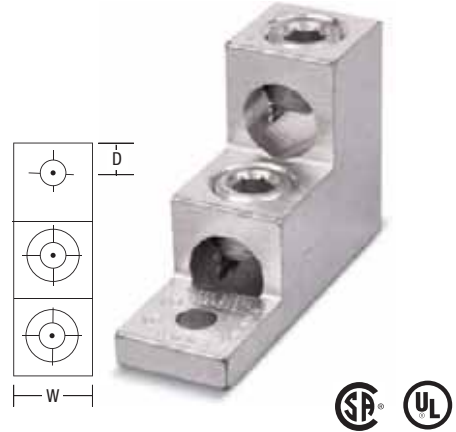
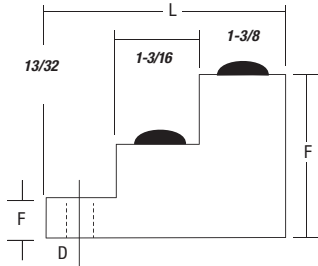

Cat. No.	Conductor Range		Dimensions (in.)					Mtg. Hole Dia.
	max.	min.	L	W	H	D	F	
<b>ASL30-21</b>	300 kcmil	6 str.	3	1-1/8	2	15/32	1/2	5/16

**Type ASL-ALCÜL™ — Two Conductors, Two-Hole Mount**

- For copper and aluminum conductors
- Easy installation—no special tools required
- Tin plated for low contact resistance
- CSA Certified and UL Listed
- All aluminum bodies

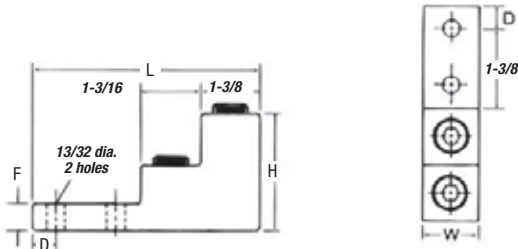

Cat. No.	Conductor Range		Dimensions (in.)				
	max.	min.	L	W	H	D	F
<b>ASL60-22</b>	600 kcmil	2 str.	4-29/32	1-1/2	3	3/4	3/8
<b>ASL75-22</b>	750 kcmil	3/0 str.	4-49/32	1-1/2	3	3/4	3/8

## Dual-Rated Mechanical Connectors

### Type ADR-ALCÜL™ — Two Conductor, One-Hole Mount

- For copper and aluminum conductors
- Easy installation—no special tools required
- Tin plated for low contact resistance
- CSA Certified and UL Listed
- All aluminum bodies

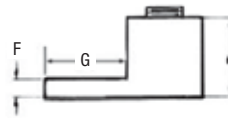
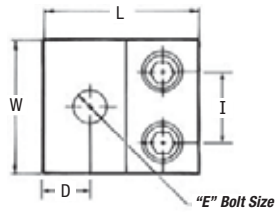

Cat. No.	Conductor Range		Dimensions (in.)							
	max.	min.	L	W	H	D	E	F	G	I
<b>ADR11-21</b>	1/0 str.	14 AWG	1-15/32	1-7/32	25/32	7/16	1/4	3/16	27/32	35/64
<b>ADR21-21*</b>	2/0 str.	14 AWG	1-15/32	1-1/4	25/32	27/64	1/4	3/16	27/32	21/32
<b>ADR25-21</b>	250 kcmil	6 str.	2-9/16	1-41/64	1-3/16	7/8	3/8	1/4	1-9/16	13/16
<b>ADR35-21</b>	350 kcmil	6 str.	2-7/8	1-59/64	1-1/4	7/8	1/2	1/4	1-3/4	61/64
<b>ADR60-21</b>	600 kcmil	2 str.	3-3/16	2-13/32	1-9/16	5/8	1/2	7/16	1-13/16	1-7/32
<b>ADR80-21</b>	800 kcmil	300 kcmil	3-3/8	3-3/16	1-15/16	7/8	5/8	1/2	1-3/4	1-5/8
<b>ADR99-21</b>	1000 kcmil	500 kcmil	3-3/8	3-3/16	1-15/16	7/8	5/8	1/2	1-3/4	1-5/8

\* CSA not applicable.

### Type ADR-ALCÜL™ — Two Conductor, Two-Hole Mount\*

- For copper and aluminum conductors
- Easy installation—no special tools required
- Tin plated for low contact resistance
- CSA Certified and UL Listed
- All aluminum bodies

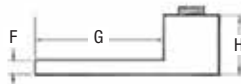
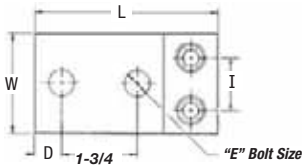

Fig. 1

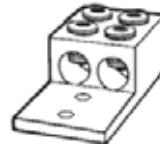

Fig. 2



Cat. No.	Figure	Conductor Range		Dimensions (in.)							
		max.	min.	L	W	H	D	E	F	G	I
<b>ADR35-22**</b>	1	350 kcmil	6 str.	4-1/4	2-19/64	1-3/8	5/8	1/2	5/16	3	1-7/32
<b>ADR60-22D</b>	2	600 kcmil	2 str.	5-5/16	2-3/4	1-1/2	5/8	1/2	3/8	3-1/16	1-7/16
<b>ADR80-22D</b>	2	800 kcmil	300 kcmil	6-3/16	3-1/2	1-7/8	5/8	1/2	9/16	3-7/16	1-13/16
<b>ADR99-22D</b>	2	1000 kcmil	350 kcmil	6-3/16	3-1/2	1-7/8	5/8	1/2	9/16	3-7/16	1-13/16

\* NEMA Spacing: 1-3/4" centers.

\*\* Not CSA Certified.

Connectors accommodating conductors 600 kcmil and larger have double row of set screws (D suffix).



## Dual-Rated Mechanical Connectors

### Type ASL-ALCÜL™ — Three Conductors, Two-Hole Mount

- For copper and aluminum conductors
- Easy installation—no special tools required
- Tin plated for low contact resistance
- CSA Certified and UL Listed
- All aluminum bodies

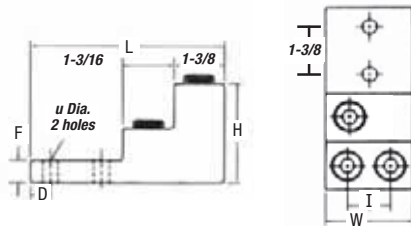

Cat. No.	Conductor Range		Dimensions (in.)								
	max.	min.	L	W	H	F	D	I	X2	X1	Y
<b>ASL60-32</b>	600 kcmil	2 str.	4-29/32	2-1/2	3	3/4	3/8	1-7/32	1.75	0.375	1.234

### Type ASL-ALCÜL™ — Four Conductors, Two-Hole Mount

- For copper and aluminum conductors
- Easy installation—no special tools required
- Tin plated for low contact resistance
- CSA Certified and UL Listed
- All aluminum bodies

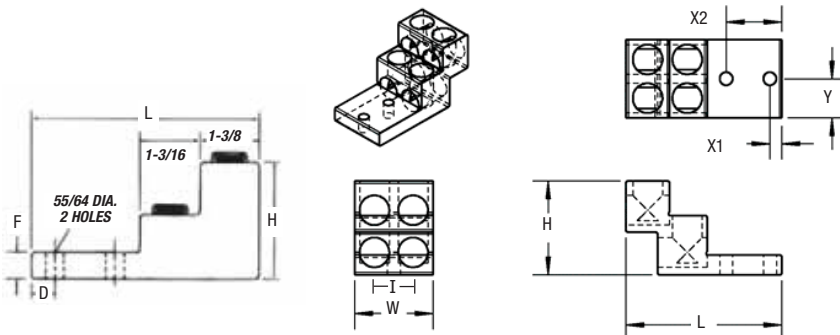

Cat. No.	Conductor Range		Dimensions (in.)								
	max.	min.	L	W	H	F	D	I	X2	X1	Y
<b>ASL60-42</b>	600 kcmil	2 str.	4-29/32	2-1/2	3	3/4	3/8	1-7/32	1.75	0.375	1.234
<b>ASL75-42</b>	750 kcmil	3/0 str.	4-49/32	2-27/21	3	3/4	3/8	1-5/16	1.75	0.375	1.31

## Dual-Rated Mechanical Connectors

### Type ADR-ALCÜL™ — Three Conductors, Two-Hole Mount\*\*

- For copper and aluminum conductors
- Easy installation—no special tools required
- Tin plated for low contact resistance
- CSA Certified and UL Listed
- All aluminum bodies

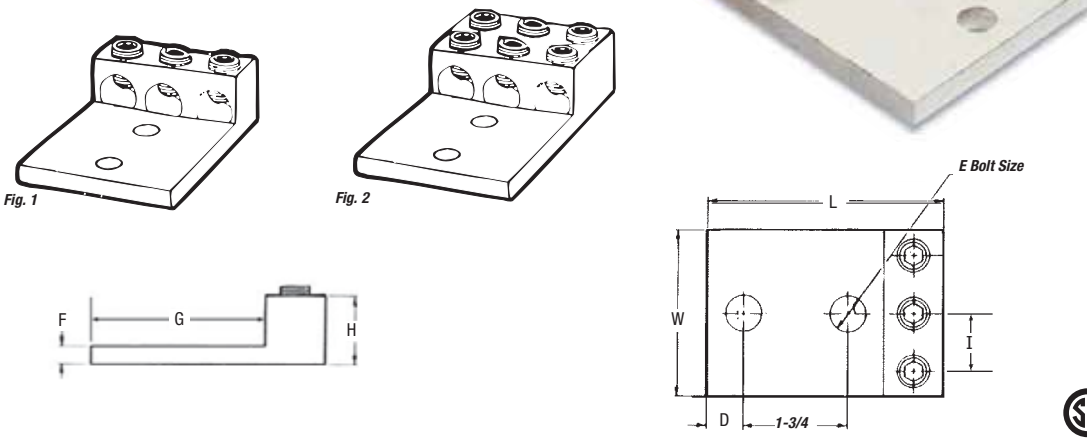

Cat. No.	Fig. No.	Conductor Range		Dimensions (in.)							
		max.	min.	L	W	H	D	E	F	G	I
ADR02-32	1	2 str.	14 AWG	2-3/16	1-5/8	5/8	11/32	5/16	3/16	1-11/16	9/16
ADR11-32	1	1/0 str.	14 AWG	2-29/32	2	7/8	11/32	3/8	1/4	2-5/32	45/64
ADR31-32	1	3/0 str.	6 str.	4	2-13/16	1-3/16	5/8	1/2	5/16	3	31/32
ADR25-32*	1	250 kcmil	6 str.	4-3/16	2-13/16	1-1/4	5/8	1/2	1/4	3-1/16	31/32
ADR35-32*	1	350 kcmil	6 str.	4-3/16	3-3/16	1-1/4	5/8	1/2	1/4	3-1/16	1-1/32
ADR50-32*	1	500 kcmil	4 str.	4-11/16	3-3/4	1-9/16	5/8	1/2	7/16	3-5/16	1-1/4
ADR60-32D	2	600 kcmil	2 str.	5-5/16	4-3/16	1-1/2	5/8	1/2	3/8	3-1/6	1-7/16
ADR80-32*	2	800 kcmil	300 kcmil	6-3/16	4-1/2	1-7/8	5/8	1/2	9/16	3-7/16	1-9/16
ADR99-32*	2	1000 kcmil	500 kcmil	6-3/16	4-3/4	1-7/8	5/8	1/2	9/16	3-7/16	1-41/64

\*\* NEMA Spacing: 1-3/4" centers except ADR02-32; 7/8" centers and ADR11-32; 1" centers. Connectors accommodating conductors 600 kcmil and larger have double row of set screws (D suffix).

## Dual-Rated Mechanical Connectors

Mechanical and Accessories

### Type ADR-ALCÜL™ — Three Conductors, Four-Hole Mount\*\*

- For copper and aluminum conductors
- Easy installation—no special tools required
- Tin plated for low contact resistance
- CSA Certified and UL Listed
- All aluminum bodies

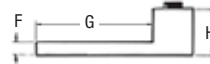
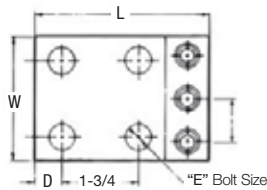
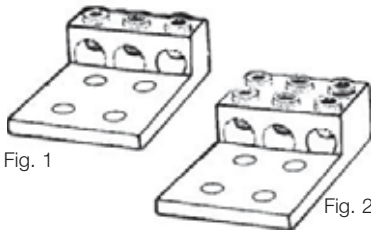

Cat. No.	Fig. No.	Conductor Range		Dimensions (in.)							
		max.	min.	L	W	H	D	E	F	G	I
ADR02-34	1	2 str.	14 AWG	2-3/16	1-5/8	5/8	11/32	5/16	3/16	1-11/16	9/16
ADR11-34	1	1/0 str.	14 AWG	2-29/32	2	7/8	11/32	3/8	1/4	2-5/32	45/64
ADR31-34	1	3/0 str.	6 str.	4	2-13/16	1-3/16	5/8	1/2	5/16	3	31/32
ADR25-34*	1	250 kcmil	6 str.	4-3/16	2-13/16	1-1/4	5/8	1/2	1/4	3-1/16	31/32
ADR35-34*	1	350 kcmil	6 str.	4-3/16	3-3/16	1-1/4	5/8	1/2	1/4	3-1/16	1-1/32
ADR50-34*	1	500 kcmil	4 str.	4-11/16	3-3/4	1-9/16	5/8	1/2	7/16	3-5/16	1-1/4
ADR60-34D	2	600 kcmil	2 str.	5-5/16	4-3/16	1-1/2	5/8	1/2	3/8	3-1/16	1-7/16
ADR80-34*	2	800 kcmil	300 kcmil	6-3/16	4-1/2	1-7/8	5/8	1/2	9/16	3-7/16	1-9/16
ADR99-34*	2	1000 kcmil	500 kcmil	6-3/16	4-3/4	1-7/8	5/8	1/2	9/16	3-7/16	1-41/64

\*\* NEMA Spacing: 1-3/4" centers except ADR02-34; 7/8" centers and ADR11-34; 1" centers.  
Connectors accommodating conductors 600 kcmil and larger have double row of set screws (D suffix).

### Type ADR-ALCÜL™ — Four Conductors, Four-Hole Mount\*

- For copper and aluminum conductors
- Easy installation—no special tools required
- Tin plated for low contact resistance
- CSA Certified and UL Listed
- All aluminum bodies



Cat. No.	Fig. No.	Conductor Range		Dimensions (in.)							
		max.	min.	L	W	H	D	E	F	G	I
ADR25-44	1	250 kcmil	6 str.	4	4-1/16	1-3/16	5/8	1/2	5/16	3	1-3/64
ADR35-44	1	350 kcmil	6 str.	4-1/4	4-23/32	1-3/8	5/8	1/2	5/16	3	1-7/32
ADR60-44D	2	600 kcmil	2 str.	5-5/16	5-5/8	1-1/2	5/8	1/2	3/8	3-1/16	1-7/16
ADR80-44D	2	800 kcmil	350 kcmil	6-3/16	7-1/8	1-7/8	5/8	1/2	9/16	3-7/16	1-13/16

\* NEMA Spacing: 1-3/4" centers.  
Connectors accommodating conductors 600 kcmil and larger have double row of set screws (D suffix).

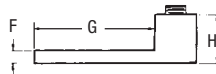
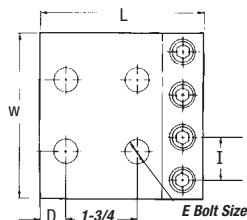

Fig. 2



## Dual-Rated Mechanical Connectors

### Type ASR-ALCÜL™ — Splice Reducers with Solid Barrier Wire Stop

- For copper and aluminum conductors
- Easy installation—no special tools required
- Tin plated for low contact resistance
- CSA Certified and UL Listed
- All aluminum bodies

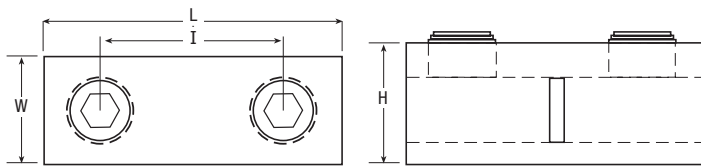

Cat. No.	Conductor Range (AL or CU)		Dimensions (in.)			
	max.	min.	L	W	H	I
<b>ASR0214*</b>	2 str.	14 AWG	1-1/4	33/64	39/64	21/32
<b>ASR1114*</b>	1/0 str.	14 AWG	1-1/2	39/64	23/32	51/64
<b>ASR2506</b>	250 kcmil	6 str.	2-1/8	55/64	31/32	1-7/64
<b>ASR3506</b>	350 kcmil	6 str.	2-3/8	1-1/32	1-1/8	1-1/4
<b>ASR7525**</b>	750 kcmil	250 kcmil	6-1/4	1-5/8	1-3/4	1-5/8

\* Slotted screws.

\*\* Two set screws per end. CSA not applicable.

### Type BX-ALCÜL™ — Rectangular Connectors

- Recognized component in accordance with U.L. 486B standard—90°C rating
- Anti-rotational boss
- For copper and aluminum conductors
- Easy installation—no special tools required
- Tin plated for low contact resistance
- CSA Certified and UL Listed
- All aluminum bodies

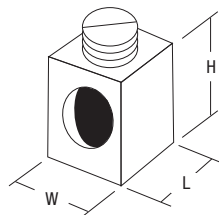

Cat. No.	Conductor Range		Style & Size of Boss	Boss Hole Tapped	Dimensions (in.)		
	max.	min.			L	W	H
<b>BX0214</b>	2	14CU 12AL	Square 0.229"	10-32	15/32	15/32	9/16
<b>BX1114</b>	1/0	14CU 12AL	Square 0.229"	10-32	5/8	17/32	39/64

**Dual-Rated Mechanical Connectors****Tightening Torque Values for Aluminum Dual-Rated Socket Screw Connectors**

AWG or Circular MII Size	Tightening Torque in (in.-lb)		AWG or Circular MII Size	Tightening Torque in (in.-lb)	
	Screwdriver	Wrench		Screwdriver	Wrench
12	20	75	4/0	–	200
10	20	75	250	–	250
8	20	75	350	–	250
6	35	100	500	–	300
4	35	100	600	–	300
2	50	125	700	–	300
1	50	125	750	–	300
1/0	50	150	800	–	300
2/0	50	150	1000	–	400
3/0	–	200	–	–	400



**Hardware**

**Type BB — Silicon Bronze Hardware Hex Head Bolts**

- For tin plated silicon bronze hardware, add suffix P to Catalogue Number
- Bolts 2" long or less have full thread; longer bolts have 2" of thread, except 1/4"-20 bolts have 1/4" min. thread



Cat. No. Diameter and Threads per inch				Length (in.)
1/4"-20	5/16"-18	3/8"-16	1/2"-13	
<b>25100BB-C</b>	<b>31100BB-C</b>	<b>37100BB-C</b>	<b>50100BB-C</b>	1
-	<b>31125BB-C</b>	<b>37125BB-C</b>	<b>50125BB-C</b>	1-1/4
-	<b>31150BB-C</b>	<b>37150BB-C</b>	<b>50150BB-C</b>	1-1/2
-	<b>31175BB-C</b>	<b>37175BB-C</b>	<b>50175BB-C</b>	1-3/4
-	<b>31200BB-C</b>	<b>37200BB-C</b>	<b>50200BB-C</b>	2
<b>25225BB-C</b>	<b>31225BB-C</b>	<b>37225BB-C</b>	<b>50225BB-C</b>	2-1/4
-	<b>31250BB-C</b>	<b>37250BB-C</b>	<b>50250BB-C</b>	2-1/2
-	<b>31275BB-C</b>	<b>37275BB-C</b>	<b>50275BB-C</b>	2-3/4
-	<b>31300BB-C</b>	<b>37300BB-C</b>	<b>50300BB-C</b>	3
-	-	<b>37325BB-C</b>	<b>50325BB-C</b>	3-1/4
-	-	<b>37350BB-C</b>	<b>50350BB-C</b>	3-1/2

**Type HN — Bronze Hex Nuts**



Cat. No.	Diameter and Threads per inch
<b>14010HN-C</b>	1/4-20
<b>31010HN-C</b>	5/16-18
<b>37010HN-C</b>	3/8-16
<b>50010HN-C</b>	1/2-13

**Type SW — Bronze Split Lockwashers**



Cat. No.	Bolt Size (in.)
<b>14030SW-C</b>	1/4
<b>31030SW-C</b>	5/16
<b>37030SW-C</b>	3/8
<b>50030SW-C</b>	1/2

**Type FW — Bronze Flat Washers**



Cat. No.	Bolt Size (in.)	O.D. (in.)	I.D. (in.)	Thickness (in.)
<b>14040FW-C</b>	1/4	11/16	0.260	0.040
<b>31040FW-C</b>	5/16	7/8	0.336	0.064
<b>37040FW-C</b>	3/8	1	0.395	0.064
<b>50040FW-C</b>	1/2	1-1/4	0.562	0.091

**Type BW — Belleville Washers  
301 Series Stainless Steel**



Cat. No.	Bolt Size (in.)	O.D. (in.)	I.D. (in.)	Thickness (in.)	Height (in.)
<b>50050BW-C</b>	1/2	1-1/8	17/32	0.062	1/8

## Compression Connectors — Quick Reference

### Type WR

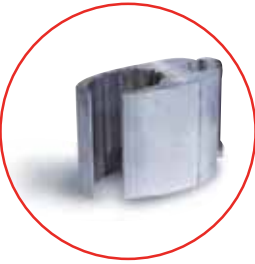

Wide Range  
Compression Connectors

pp. 38–44

### Type CF



Copper Compression  
Tap Connectors

p. 45

### Type C



Compression Tap  
Covers

p. 46

### Type CTL



Copper Short Barrel  
Connectors

p. 47

### Type CTL-L, LCN



Copper Long Barrel  
Connectors

pp. 48–50

### Type CU, CSP



Copper  
Compression Splices

pp. 51–52

### Type ATL



Aluminum  
Compression Connectors

pp. 53–54

### Type ASP



Aluminum Splices

p. 55

### Type PA

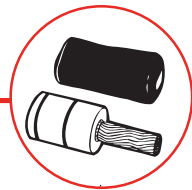

Pin Adapter  
Terminals

p. 56

### Wedge Clamps



p. 57

## Compression H-Taps Connectors

Compression Connectors

### Type WR — Wide Range Aluminum Tap Connectors

#### "O" and "D" Die Seven Connector Program

- For combinations of aluminum-aluminum and aluminum-copper conductors
- Pass the requirements of ANSI C119.4
- Standard compression tools and dies install all sizes
- Seven Connector Program provides superior connector performance, lower connection costs and simplified installation procedures
- Fold-in tabs provide positive tab interlock as tool closes
- Field-proven ribbed design provides unparalleled connector/conductor contact, without distorting the conductor's shape
- Made of 1350 aluminum alloy
- Pre-filled with an oxide inhibitor which is held captive in the rib/connection area
- For copper to copper combinations, use CF type shown on page 45.
- CSA Certified

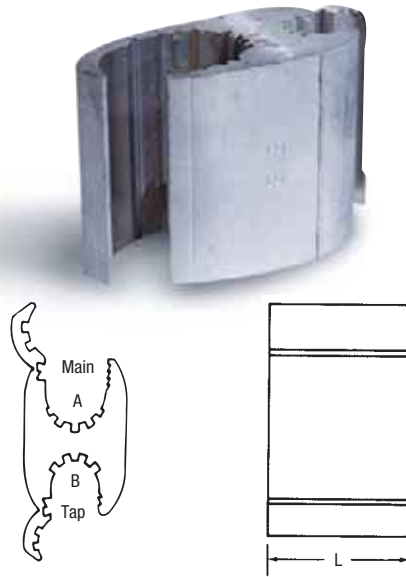

### Type WR — "O" and "D" Die Seven Connector Program



Cat. No.	Connector No.	Conductor Range												Connector Length L (in.)	Installation Information						
		Standard Conductor						Compact Conductor							Connector Die	No. Indents					
		Main			Tap			Main			Tap					Mech. Tool	Hyd. Tool				
ACSR	Str.	Sol.	ACSR	Str.	Sol.	ACSR	Str.	ACSR	Str.	max.	min.	max.	min.	max.	min.						
WR159	1	2	2	2	2	2	2	2	2	2	2	2	2	0.332	0.162	0.332	0.162	1-7/16	0	4	2
		3	3	3	3	3	3	3	3	3	3	3	3								
		4	4	4	4	4	4	4	4	4	4	4	4								
		6	6	6	6	6	6	6	6	6	6	6	6								
		1/0	2/0	3/0	2	1	1/0	2/0	2/0	1	1	0.419	0.266	0.332	0.162	1-11/16	0				
1	1/0	2/0	3	3	3	1/0	1/0	3	3												
2	1	1/0	4	4	4	1	1	4	4												
3	2	1	6	6	6	2	2	6	6												
1/0	2/0	3/0	2	1	1/0	2/0	2/0	1	1	0.470	0.398	0.332	0.162	1-13/16	D	5		2			
2	2	2	3	3	3	2	2	3	3												
3	3	3	4	4	4	3/0	3/0	4	4												
4	4	4	6	6	6	2/0	30	6	6												
2/0	3/0	4/0	2/0	3/0	3/0	3/0	3/0	3/0	3/0	0.470	0.336	0.470	0.36	1-13/16			D		5	2	
1/0	2/0	3/0	1/0	2/0	2/0	2/0	2/0	2/0	2/0												
1	1/0	2/0	1	1/0	2/0	1/0	1/0	1/0	1/0												
2	2	2	3	3	3	266-18/1	266	2	2	0.563	0.475	0.332	0.162	1-13/16	D	5		2			
3	3	3	4	4	4	250	250	3	3												
4	4	4	6	6	6	4/0	4/0	4	4												
6	6	6	266-18/1	266	266-18/1	266	266	6	6												
4/0	4/0	—	2/0	2/0	3/0	266-18/1	266	2/0	3/0	0.563	0.461	0.447	0.338	2-3/16			D		6	2	
3/0	3/0	—	1/0	1/0	2/0	4/0	250	1/0	2/0												
1	1	1	1	1	1	3/0	4/0	1/0	1/0												
4/0	4/0	—	4/0	4/0	—	266-18/1	266	266-18/1	266	0.563	0.461	0.563	0.461	2-7/16	D	7		3			
3/0	3/0	—	3/0	3/0	—	4/0	250	4/0	4/0												
1	1	1	1	1	1	3/0	4/0	3/0	4/0												
2	2	2	3	3	3	266-18/1	266	266-18/1	266												
3	3	3	4	4	4	4/0	250	4/0	4/0												

## Compression H-Taps Connectors

Compression Connectors

### Type WR — Wide Range Aluminum Tap Connectors

#### Supplemental "O" and "D" Die Seven Connector Program

- For combinations of aluminum-aluminum and aluminum-copper conductors
- Pass the requirements of ANSI C119.4
- Standard compression tools and dies install all sizes
- Seven Connector Program provides superior connector performance, lower connection costs and simplified installation procedures
- Fold-in tabs provide positive tab interlock as tool closes
- Field-proven ribbed design provides unparalleled connector/conductor contact, without distorting the conductor's shape
- Made of 1350 aluminum alloy
- Pre-filled with an oxide inhibitor which is held captive in the rib/connection area
- For copper to copper combinations, use CF type shown on page 45.

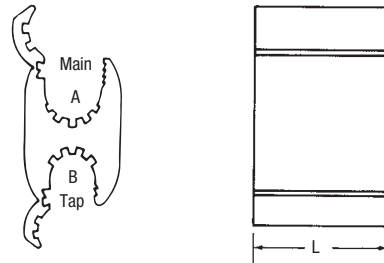

### Type WR — Supplemental "O" and "D" Die Connectors

Products on this page are not CSA Certified.

Cat. No.	Conductor Range														Connector Length L (in.)	Installation Information		
	Standard Conductor						Compact Conductor				Diameter (in.)					Connector Die	No. Indents	
	Main			Tap			Main		Tap		Main		Tap				Mech. Tool	Hyd. Tool
	ACSR	Str.	Sol.	ACSR	Str.	Sol.	ACSR	Str.	ACSR	Str.	max.	min.	max.	min.				
WR149		3	2		3	2		2	3	2	0.266	0.162	0.266	0.162	1-1/2	0	5	2
	4	4	3	4	4	3	4	4	4	3								
	6	6	6	6	6	6	6	6	6	6								
WR179	1/0	1/0	1	4	3	2	1/0	2/0	4	2	0.398	0.266	0.266	0.162	1-3/4	0	5	2
	1	1		6	4	3	1	1/0	1	3								
	2	2			6	4	2	2	2	4								
WR199	1/0	1/0	1	2	1	1/0	2/0	1	2	1	0.398	0.066	0.332	0.232	1-3/4	0	5	2
	1	1		3	2	1	1/0	2	2	2								
	2	2		4	3	2	2	1	1	3								
WR1010	1/0	2/0		1/0	2/0	2/0	2/0	2/0	2/0	2/0	0.419	0.232	0.419	0.232	1-3/4	0	4	2
	1	1/0		1	1/0	1/0	1/0	1	1/0	1								
	2	1	1	2	1	1	1	1	1	1								
	3	2	2	3	2	2	2	2	2	2								
WR259	1/0	2/0	-	1/0	2/0	2/0	2/0	2/0	2/0	2/0	0.419	0.326	0.412	0.292	1-7/8	D	5	2
	1	1/0		1	1/0	1/0	1/0	1/0	1/0	1/0								
WR299	2/0	3/0	-	4	3	3/0	3/0	4	2	2	0.470	0.398	0.266	0.162	1-1/2	D	4	2
	1/0	2/0		6	4	2/0	2/0	6	3	4								
					6	6			6	6								
WR219	1/0	1/0	-	1/0	1/0	1/0	2/0	1/0	2/0	1/0	0.398	0.324	0.398	0.316	1-7/8	D	5	2
	1	1		1	1		1/0	1/0	2/0	1/0								
				2	1													
WR239	2/0	2/0	-	2	1	2/0	4/0	1	2	1	0.447	0.365	0.332	0.236	1-7/8	D	5	2
	1/0	1/0		3	2	1/0	3/0	2	3	2								
				4	3			4	4	4								
WR229	2/0	3/0	-	1/0	1/0	3/0	3/0	1/0	2/0	1/0	0.470	0.410	0.398	0.316	1-7/8	D	5	2
		2/0		1	1	2/0	2/0	1	1/0	1/0								
				2														
WR269	2/0	2/0	-	2/0	2/0	2/0	3/0	2/0	3/0	2/0	0.447	0.410	0.447	0.336	1-7/8	D	5	2
				1/0	1/0			1/0	3/0	1/0								



## Compression H-Taps Connectors

Compression Connectors

### Type WR — Wide Range Aluminum Tap Connectors

#### Supplemental "O" and "D" Die seven Connector Program

- For combinations of aluminum-aluminum and aluminum-copper conductors
- Pass the requirements of ANSI C119.4
- Standard compression tools and dies install all sizes
- Seven Connector Program provides superior connector performance, lower connection costs and simplified installation procedures
- Fold-in tabs provide positive tab interlock as tool closes
- Field-proven ribbed design provides unparalleled connector/conductor contact, without distorting the conductor's shape
- Made of 1350 aluminum alloy
- Pre-filled with an oxide inhibitor which is held captive in the rib/connection area
- For copper to copper combinations, use CF type shown on page 45.

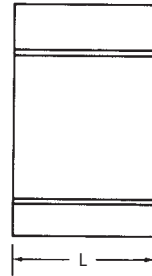
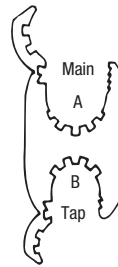

Products on this page are not CSA Certified.

Cat. No.	Conductor Range													Connector Length L (in.)	Installation Information			
	Standard Conductor*						Compact Conductor				Diameter (in.)				Connector Die	No. Indents		
	Main			Tap			Main		Tap		Main		Tap			Mech. Tool	Hyd. Tool	
	ACSR	Str.	Sol.	ACSR	Str.	Sol.	ACSR	Str.	ACSR	Str.	max.	min.	max.					min.
<b>WR319</b>	3/0	3/0	-	2 3 4	1 2 3 4	1 2	3/0	4/0	1 2 3 4	1 2	0.502	0.461	0.332	0.229	1-7/8	D	5	2
<b>WR339</b>	3/0	3/0	-	2/0 1/0 1	2/0 1/0	-	3/0	4/0	2/0 1/0	3/0 2/0 1/0	0.502	0.461	0.447	0.336	2-1/8	D	6	2
<b>WR359</b>	4/0 3/0	4/0 3/0	-	4 6	3 4 6	2 3 4 6	266 4/0 3/0	266 250 4/0	1/0 1 2	1/0 1 2	0.563	0.461	0.266	0.162	1-7/8	D	4	2
<b>WR369</b>	4/0 3/0	4/0 3/0	-	1 2 3 4	1/0 1 2 3	1	266 4/0 3/0	266 250 4/0	1/0 1 2	1/0 1 2	0.563	0.461	0.374	0.266	1-7/8	D	4	2
<b>WR369**</b>	4/0 3/0 2/0	4/0 3/0	-	1/0 1 2 3 4	1/0 1 2 3 4	1/0 1 2	266 4/0 3/0	266 250 4/0 3/0	1/0 1 2 4	1/0 1 2	0.63	0.423	0.3763	0.232	1-7/8	D	5	2
<b>WR389</b>	4/0 3/0	4/0 3/0	-	2/0 1/0	3/0 2/0	-	266 4/0 3/0	266 250 4/0	3/0 2/0	3/0 2/0	0.563	0.461	0.470	0.376	2-3/16	D	6	2
<b>WR389**</b>	4/0 3/0 2/0	4/0 3/0	-	2/0 1/0 1	3/0 2/0 1/0	-	266 4/0 3/0	266 250 4/0	3/0 2/0 1/0	3/0 2/0 1/0	0.563	0.423	0.470	0.336	2-3/16	D	6	2

\*Will accept conductors of these same wire sizes with a 3% reduction of diameter (compressed).  
 \*\*This range possible only when crimped with hydraulic tool TBM14M or JB12B.

## Compression H-Taps Connectors

### Type WR — Wide Range Aluminum Tap Connectors “N” Die for Hydraulic Tools, 12-Ton and Greater

- For combinations of aluminum-aluminum and aluminum-copper conductors
- Pass the requirements of ANSI C119.4
- Standard compression tools and dies install all sizes
- Seven Connector Program provides superior connector performance, lower connection costs and simplified installation procedures
- Fold-in tabs provide positive tab interlock as tool closes
- Field-proven ribbed design provides unparallel connector/conductor contact, without distorting the conductor's shape
- Made of 1350 aluminum alloy
- Pre-filled with an oxide inhibitor which is held captive in the rib/connection area
- For copper to copper combinations, use CF type shown on page 45.

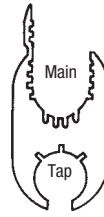

Fig. 1

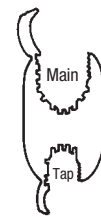
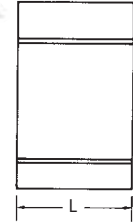

Fig. 2



Products on this page are not CSA Certified.

Compression Connectors

Cat. No.	Conductor Range												Connector Length L (in.)	Installation Information		
	Standard Conductor*						Compact Conductor				Diameter (in.)			For Use with Tool	No. of Indents	
	Main		Tap		Sol.	Main		Tap		max.	min.	max.				min.
	ACSR	Str.	ACSR	Str.		ACSR	Str.	ACSR	Str.							
WR715	397-18/1 336 300 266	400	2/0	2/0	3/0	477 397 336	500	2/0	3/0	0.753	0.520	0.447	0.162	2	TBM12, JB12B and Y-35	2
		397	1/0	1/0	2/0		477	1/0	1/0							
		350	1	1	1/0		477	1	1							
		336	2	2	2		397	2	2							
		300	3	3	3		336	3	3							
		266	4	4	4		350	4	4							
WR775	397-18/1 336 266 4/0	400	397-18/1	350	-	477 397 336 266	500	477	500	0.743	0.520	0.743	0.520	3	TBM12, JB12B and Y-35	3
		397	336	336			400	397	397							
		350	266	300			477	336	336							
		336	4/0	266			397	300	300							
		266	250	250			336	266	266							
		4/0	4/0	4/0			266	250	250							
WR815	477-18/1 397 336 266 4/0	556	2/0	2/0	3/0	556 477 397 350 336 266	500	2/0	3/0	0.858	0.520	0.447	0.162	2	TBM12, JB12B and Y-35	2
		500	1/0	1/0	2/0		477	1/0	2/0							
		400	1	1	1/0		397	1	1/0							
		397	2	2	1		350	2	1							
		336	3	3	2		336	3	2							
		266	4	4	3		266	4	3							
WR835	477-18/1 397 336 266 4/0	556	4/0	4/0	4/0	556 477 397 350 336 300 266 250	500	266	400	0.858	0.520	0.563	0.368	2	TBM12, JB12B and Y-35	2
		500	3/0	3/0	3/0		477	4/0	4/0							
		400	2/0	2/0	2/0		397	3/0	3/0							
		397	1/0	1/0	2/0		350	2/0	3/0							
		336					336									
		266					300									
WR875**	477-18/1 397 336 266 4/0	556				556 477 397 350 336 300 266 250	500	397	400	0.858	0.520	0.684	0.520	3	TBM12, JB12B and Y-35	3
		500					477	266	350							
		400					397		336							
		397					350		300							
		336					336		266							
		266					300		250							
WR885	477-18/1 397 336 266 4/0	500				556 477 397 350 336 300 266 250	500	556	556	0.814	0.520	0.814	0.520	3	TBM12, JB12B and Y-35	3
		400					477		477							
		397					397		397							
		350					350		350							
		336					336		336							
		266					300		300							

\* Will accept conductors of these same wire sizes with a 3% reduction of diameter (compressed).  
\*\* Not reversible (Fig. 2)

## Compression H-Taps Connectors

Compression Connectors

### Type WR — Wide Range Aluminum Tap Connectors “N” Die for Hydraulic Tools, 10-Ton and Greater

- For combinations of aluminum-aluminum and aluminum-copper conductors
- Pass the requirements of ANSI C119.4
- Standard compression tools and dies install all sizes
- Seven Connector Program provides superior connector performance, lower connection costs and simplified installation procedures
- Fold-in tabs provide positive tab interlock as tool closes
- Field-proven ribbed design provides unparalleled connector/conductor contact, without distorting the conductor's shape
- Made of 1350 aluminum alloy
- Pre-filled with an oxide inhibitor which is held captive in the rib/connection area
- For copper to copper combinations, use CF type shown on page 45.



Products on this page are not CSA Certified.

Cat. No.	Conductor Range													Connector Length L (in.)	Installation Information	
	Standard Conductor*					Compact Conductor				Diameter (in.)					For Use with Tool	No. of Indents
	Main		Tap			Main		Tap		Main		Tap				
	ACSR	Str.	ACSR	Str.	Sol.	ACSR	Str.	ACSR	Str.	max.	min.	max.	min.			
<b>WR699</b>	397-18/1 336 266		4 6	3 4 6	2 3 4 6			4 6	2 3 4 6	0.743	0.570	0.266	0.162	2	TBM12, JB12B and 13642M	2
<b>WR719</b>	397-18/1 336 266	400 397 350	2/0 1/0 1 2 3	2/0 1/0 1 2	3/0 2/0 1/0 1	477 397 350 336	477 397 350 300	2/0 1/0 1 2	3/0 2/0 1/0 1 2	0.743	0.570	0.447	0.289	2	TBM12, JB12B and 13642M	2
<b>WR739</b>	397-18/1 336 266	300 266 250	4/0 3/0 2/0 1/0	4/0 3/0 2/0	4/0			266 4/0 3/0	266 250 4/0	0.743	0.570	0.563	0.398	2	TBM12, JB12B and 13642M	2
<b>WR779</b>	397-18/1 336 266		397-18/1 336 266	400 397 350 336 266 250	477 397			477 397 336	477 397 336	0.743	0.570	0.743	0.570	3	TBM12, JB12B and 13642M	3
<b>WR799</b>	477-18/1 266	500 250	4 6	3 4 6	2 3 4 6	477-18/1 250	500 250	3 4 6	2 3 4 6	0.814	0.575	0.270	0.160	2	TBM12, JB12B and 13642M	2
<b>WR819</b>	477-18/1 397 336		2/0 1/0 1 2 3	2/0 1/0 1 2	3/0 2/0 1/0 1			2/0 1/0 1 2	3/0 2/0 1/0 2	0.858	0.659	0.477	0.289	2	TBM12, JB12B and 13642M	2
<b>WR839</b>	477-18/1 397 336	556 500 477 450 400 397 350 336	4/0 3/0 2/0	4/0 3/0	4/0	556 477 397	556 477 397	266 4/0 3/0	266 250 4/0	0.858	0.659	0.563	0.477	2	TBM12, JB12B and 13642M	2
<b>WR879**</b>	477-18/1 397 336		336-18/1 266	350 336 300 266	397			397 336	397 350 336	0.858	0.659	0.684	0.593	2	TBM12, JB12B and 13642M	3
<b>WR889</b>	477-18/1 397 336	500 400 397 350 336	477-18/1 397 336	500 400 397 350 336	-	556 477 397 336	556 477 397 350	556 477 397 336	556 477 397 350	0.814	0.666	0.814	0.666	2	TBM12, JB12B and 13642M	3

\*Will accept conductors of these same wire sizes with a 3% reduction of diameter (compressed).  
\*\*Not reversible (Fig. 2).

## Compression H-Taps Connectors

### Type WR — Wide Range Aluminum Tap Connectors “R” Die Seven Connector Program

- For combinations of aluminum-aluminum and aluminum-copper conductors
- Pass the requirements of ANSI C119.4
- Standard compression tools and dies install all sizes
- Seven Connector Program provides superior connector performance, lower connection costs and simplified installation procedures
- Fold-in tabs provide positive tab interlock as tool closes
- Field-proven ribbed design provides unparalleled connector/conductor contact, without distorting the conductor's shape
- Made of 1350 aluminum alloy
- Pre-filled with an oxide inhibitor which is held captive in the rib/connection area
- For copper to copper combinations, use CF type shown on page 45.

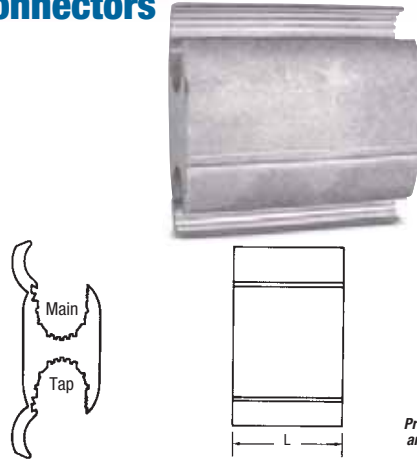

Products on this page are not CSA Certified.

Cat. No.	Conductor Range												Connector Length L (in.)	Installation Information		
	Standard Conductor				Compact Conductor				Diameter (in.)					For Use with Tool	Connector Die	No. of Indents
	Main		Tap		Main		Tap		Main		Tap					
	ACSR	Str.	ACSR	Str.	ACSR	Str.	ACSR	Str.	max.	min.	max.	min.				
WR909	556-18/1	600 400 556 550 500 477	336-1/81 266 4/0 3/0 2/0 1/0	350 336 266 250 4/0 3/0 2/0	636 556 477 397	700 636 556 500 477 450	397-1/2 350 336 300 266 250 4/0 3/0 2/0	397 350 336 300 266 250 4/0 3/0	0.893	0.666	0.684	0.398	4-3/4	TBM151 (15620)	R	4
WR949			336-18/1 266 4/0 3/0 2/0 1/0	350 336 266 250 4/0 3/0 2/0			397-18/1 350 336 300 266 250 4/0 3/0 2/0	397 350 336 300 266 250 4/0 3/0	1.108	0.883	0.684	0.398	4-3/4	TBM151 (15620)	R	4
WR969	795-26/7 715 666 636 606 556 477-30/7	900 874 800 795 750 715 700 636 600	556-18/1 477 397 336 300	600 556 550 500 477 450 400 397 350 336	954 874 795	1000 954 874 795	636 556 477 397	700 363 556 477 450	1.108	0.883	0.893	0.666	4-3/4	TBM151 (15620)	R	4
WR989			795-26/7 715 666 636 605 556 477-30/7	900 874 800 795 750 715 700 636 600			954 874 795	1000 954 874 795	1.108	0.883	1.108	0.883	4-3/4	TBM151 (15620)	R	4
WR999	954-45/7 900 874 795 715 666	1033 1000 900 874 800 795 715 750	954-45/7 900 874 7985 715 666	1033 1000 900 800 795 750	954 900	1000 900	954 900 874	1000 900	1.172	0.997	1.172	0.997	4-3/4	TBM151 (15620)	R	4

## Compression H-Taps Connectors

### Type WR — Street Lighting Compression Connectors

Compression Connectors

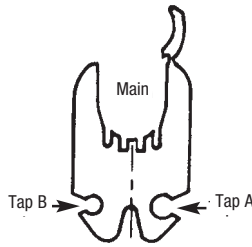

Fig. 1

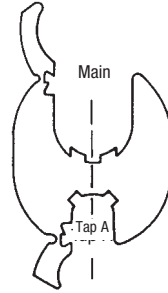
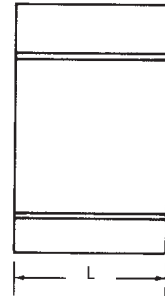

Fig. 2



Products on this page are not CSA Certified.

Cat. No.	Figure No.	Conductor Range												Connector Length L (in.)	Installation Information			
		Standard Conductor						Diameter (in.)							For Use with Tool	No. of Indents		
		Main		Tap A		Tap B		Main		Tap A		Tap B				Mech. Tool	Hyd. Tool	
		ACSR	Str.	Sol.	Str.	Sol.	Str.	Sol.	max.	min.	max.	min.	max.					min.
<b>WR9**</b>	2	3 4 6	2 3 4 6	1 2 3 4	8 10 12 14	8 10 12 14	-	-	0.292	0.184	0.146	0.064	-	-	13/16	5/8 BG	3	-
<b>WR139</b>	1	1/0 1 2 3 4	2/0 1/0 1 2 3	1 2	8 10	6 8 10	12 14	12 14	0.419	0.250	0.162	0.100	0.092	0.064	1-1/2	0	4	2
<b>WR502</b>	1	4/0 3/0	4/0 3/0	-	8 10	6 8 10	12 14	12 14	0.563	0.461	0.162	0.100	0.092	0.064	1-1/2	D	4	-
<b>WR502*</b>	1	4/0 3/0 2/0 1/0	4/0 3/0 2/0 1/0	-	8 10	6 8 10	12 14	12 14	0.563	0.365	0.162	0.100	0.092	0.064	1-1/2	D	-	2

Will accept conductors of these same wire sizes with a 3% reduction of diameter (compressed).  
 \* This range possible only when crimped with hydraulic tool TBM14M or JB12B.  
 \*\* CSA Certified.



## Compression H-Taps Connectors

### Type CF — Copper Compression Tap Connectors

- For tapping copper conductors to unbroken main copper conductors
- Extruded pure electrolytic copper
- Full length tab for easy installation
- Efficient design for lower crimping force
- Standard compression tools and dies
- Single and double tab designs

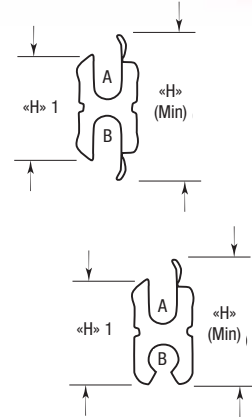

C o m p r e s s i o n  
C o n n e c t o r s

Cat. No.	Figure No.	Conductor Range								Dimensional Information			Installation Information						
		Standard Conductor				Diameter (in.)				H (min.)	H 1	Connector Length (in.)	Mechanical Tools***			Hydraulic Tools***			
		Main A		Tap B		Main A		Tap B					OD 58	Type 0	MD Series	JB12B	H Series	Y-35	TBM15/TBM15PF Y45/Y46
		ACSR	Str.	Sol.	Str.	max.	min.	max.	min.										
<b>CF44-1</b>	1	4 6	6	4 6 8	6	0.204	0.162	0.204	0.128	0.971	0.729	13/16	B, T 5/8	B, T 5/8	W-KB W-BG	BKT	B	BKT U-BG	BKT U-BG
<b>CFS44-1</b>	2	4 6	6	4 6 8	8	0.204	0.162	0.204	0.128	0.864	0.743	13/16	B, T 5/8	B, T 5/8	W-KB W-BG	BKT	BKT	BKT U-BG	BKT U-BG
<b>CF22-1</b>	1	2 4	4	2 4	4	0.258	0.204	0.258	0.204	1.162	0.813	13/16	K	K	W-KK	-	-	-	BKT
<b>CFS22-1</b>	2	2 4	4	2 6	6	0.258	0.204	0.258	0.162	1.017	0.842	13/16	K	K	W-KK	HBKC	BKT	BKT	BKT
<b>CF102-1</b>	1	-	1/0 1 2	2 4 6	4	0.373	0.292	0.258	0.162	1.540	1.100	27/32	-	-	-	0	0	0	0
<b>CF1010-1</b>	1	-	1/0 1 2	-	1/0 1 2	0.373	0.292	0.373	0.292	1.610	1.050	27/32	-	-	-	0	0	0	0
<b>CF202-1</b>	1	-	2/0 1/0	-	2/0 1/0 1 2	0.419	0.368	0.259	0.204	1.670	1.269	7/8	-	-	-	K-C	C	K-C	BK-C
<b>CF2020-1</b>	1	-	2/0 1/0	-	2/0 1/0 1 2	0.419	0.368	0.414	0.292	1.740	1.220	7/8	-	-	-	K-C	C	K-C	BK-C
<b>CF402-1</b>	1	-	4/0 3/0 2/0	2 4	4	0.528	0.414	0.259	0.204	1.983	1.423	1-1/8	-	-	-	D**	D**	D**	D**
<b>CF4010-1</b>	1	-	4/0 3/0 2/0	-	1/0 1 2	0.528	0.414	0.373	0.292	1.992	1.423	1-1/8	-	-	-	D**	D**	D**	D**
<b>CF4040-1</b>	1	-	4/0 3/0 2/0	-	4/0 3/0 2/0	0.528	0.414	0.528	0.414	2.252	1.483	1-1/8	-	-	-	D**	D**	D**	D**

\*Decimal dimensions are for conventional conductor, not Copperweld or Alumoweld.  
 \*\*Blackburn "D" dies.  
 \*\*\*Three indents with mechanical tools and one indent with hydraulic tools. 15-Ton/head use appropriate die adapters.

**Compression H-Taps Connectors**

**C  
o  
m  
p  
r  
e  
s  
s  
i  
o  
n  
  
C  
o  
n  
n  
e  
c  
t  
o  
r  
s**

**Type C — Compression Connectors Covers**

- Hinged polyethylene cover
- Installs easily, quickly—less expensive than taping
- Positive snap-locks fasten securely
- Drain ports prevent accumulation of corrosion-causing moisture
- Ultra-violet stabilized



Cat. No.	Capacity*	Dimensions (in.)		
		Height	Length	Width
<b>C2BB</b>	All 5/8" and O.D. Die taps, 2" long or less	1.10	4.00	1.05
<b>C5C</b>	All "O" Die taps, 1-3/4" long or less	1.60	3.75	1.25
<b>C7C</b>	All "D" Die taps, 2-1/2" long or less	1.80	5.00	1.45
<b>C9</b>	All "N" and "D" Die taps, up to 2" long	2.75	4.25	2.00
<b>C9L</b>	All "N" and "D" Die taps, up to 5" long	2.75	7.25	2.00

\* Before compression.

## Colour Coded Compression Connectors

C o m p r e s s i o n  
C o n n e c t o r s

### Type CTL — Copper Lugs, 1-Hole Mount, Short Barrel

#### Copper Compression Connectors

- For use with copper conductors: AWG stranded, flexible cable, welding cable and portable cord
- Specially designed for industrial and building applications
- Made of high conductivity seamless copper tubing
- Tin plated for corrosion resistance
- Specially chamfered barrel for ease of installation
- Colour coded for matching die identification
- Can be used for medium voltage application up to 35 kV provided proper insulation techniques are used
- CSA Certified and U.L. Listed for AWG conductors when installed with Blackburn, Burndy, T&B or Anderson tools, as specified by CSA
- Comply with Subpart 111.60-17 of Federal Register's Coast Guard Electrical Engineering Rules and Regulations

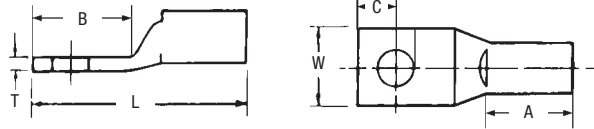

#### Short Barrel Connectors

- Short barrel connectors designed for regular duty applications
- Ideal for confined areas



Cat. No.	Conductor Size (CU)	Stud Size (in.)	Dimensions (in.)						Die Colour Code
			A	B	C	L	W	T	
CTL8-10	8 str.	10	13/32	1/2	7/32	1-5/32	3/8	1/16	Red
CTL8-14		1/4	13/32	19/32	1/4	1-3/16	7/16	1/16	
CTL8-516		5/16	13/32	5/8	9/32	1-5/16	9/16	1/16	
CTL6-10	6 str.	10	7/16	17/32	7/32	1-7/32	7/16	1/16	Blue
CTL6-14		1/4	7/16	17/32	7/32	1-7/32	7/16	1/16	
CTL6-516		5/16	7/16	21/32	9/32	1-13/32	19/32	1/16	
CTL6-38		3/8	7/16	21/32	9/32	1-13/32	19/32	1/16	
CTL4-10	4 str.	10	1/2	19/32	1/4	1-3/8	17/32	3/32	Grey
CTL4-14		1/4	1/2	19/32	1/4	1-3/8	17/32	3/32	
CTL4-516		5/16	1/2	21/32	5/16	1-13/32	19/32	1/16	
CTL4-38		3/8	1/2	21/32	5/16	1-13/32	19/32	1/16	
CTL2-14	2 + 3 str.	1/4	19/32	21/32	1/4	1-1/2	9/16	3/32	Brown
CTL2-516		5/16	19/32	7/8	3/8	1-23/32	9/16	3/32	
CTL2-38		3/8	19/32	29/32	3/8	1-3/4	9/16	3/32	
CTL2-12		1/2	19/32	1-1/16	1/2	1-29/32	3/4	1/16	
CTL1-14	1 str.	1/4	19/32	21/32	1/4	1-1/2	21/32	3/32	Green
CTL1-516		5/16	19/32	7/8	3/8	1-23/32	21/32	3/32	
CTL1-38		3/8	19/32	29/32	3/32	1-3/4	21/32	3/32	
CTL1-12		1/2	19/32	1-1/4	1/2	2-3/32	3/4	3/32	
CTL10-516	1/0 str.	5/16	11/16	7/8	3/8	1-13/16	3/4	1/8	Pink
CTL10-38		3/8	11/16	29/32	3/8	1-7/8	3/4	1/8	
CTL10-12		1/2	11/16	1-1/4	1/2	2-3/16	3/4	1/8	
CTL20-38	2/0 str.	3/8	13/16	29/32	3/8	2-1/32	13/16	1/8	Black
CTL20-12		1/2	13/16	1-1/4	1/2	2-11/32	13/16	1/8	
CTL30-38	3/0 str.	3/8	13/16	29/32	3/8	2-1/32	29/32	1/8	Orange
CTL30-12		1/2	13/16	1-1/4	1/2	2-11/32	29/32	1/8	
CTL40-38	4/0 str. or 3/0 weld	3/8	15/16	29/32	3/8	2-5/32	1-3/32	1/8	Purple
CTL40-12		1/2	15/16	1-1/4	1/2	2-1/2	1-1/32	1/8	
CTL250-12	250 kcmil or 4/0 weld	1/2	1-1/32	1-1/4	1/2	2-19/32	1-1/8	1/8	Yellow
CTL300-12	300 kcmil	1/2	1-1/32	1-1/4	1/2	2-25/32	1-3/16	5/32	White
CTL350-12	350 kcmil	1/2	1-1/32	1-1/4	1/2	2-25/32	1-11/32	5/32	Red
CTL400-12	400 kcmil	1/2	1-1/32	1-1/4	1/2	3-3/16	1-13/32	5/32	Blue
CTL400-58		5/8	1-1/32	1-9/16	5/8	3-1/2	1-13/32	5/32	
CTL500-12	500 kcmil	1/2	1-1/32	1-1/4	1/2	3-1/4	1-19/32	7/32	Brown
CTL500-58		5/8	1-1/32	1-9/16	5/8	3-9/16	1-19/32	7/32	
CTL600-58	600 kcmil	5/8	1-9/16	1-9/16	5/8	3-23/32	1-3/4	7/32	Green
CTL750-58	750 kcmil	5/8	1-1/2	1-9/16	5/8	3-25/32	1-29/32	1/4	Black
CTL1000-58	1000 kcmil	5/8	1-3/4	1-9/16	5/8	4-1/32	2-1/4	9/32	-

See pages 110-135 for more tool and die information.

## Colour Coded Compression Connectors

C  
o  
m  
p  
r  
e  
s  
s  
i  
o  
n  
  
C  
o  
n  
n  
e  
c  
t  
o  
r  
s

### Type CTL — Copper Lugs, 2-Hole Mount, Short Barrel

#### Copper Compression Connectors

- For use with copper conductors: AWG stranded, flexible cable, welding cable and portable cord
- Specially designed for industrial and building applications
- Made of high conductivity seamless copper tubing
- Tin plated for corrosion resistance
- Specially chamfered barrel for ease of installation
- Colour coded for matching die identification
- Can be used for medium voltage application up to 35 kV provided proper insulation techniques are used
- CSA Certified and U.L. Listed for AWG conductors when installed with Blackburn, Burndy, T&B or Anderson tools, as specified by CSA
- Comply with Subpart 111.60-17 of Federal Register's Coast Guard Electrical Engineering Rules and Regulations

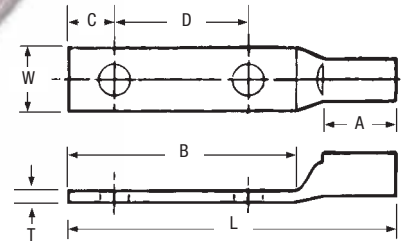

#### Short Barrel Connectors

- Short barrel connectors designed for regular duty applications
- Ideal for confined areas



Cat. No.	Conductor Size (CU)	Stud Size (in.)	Dimensions (in.)							Die Colour Code
			A	B	C	D	L	W	T	
CTL6-214	6 str.	1/4	1/2	1-1/4	1/4	5/8	1-31/32	13/32	1/16	Blue
CTL4-214	4 str.	1/4	1/2	1-1/4	1/4	5/8	2-1/32	1/2	3/32	Grey
CTL2-2516	2 + 3 str.	5/16	19/32	1-5/8	3/8	3/4	2-15/32	9/16	3/32	Brown
CTL1-2516	1 str.	5/16	19/32	1-3/4	3/8	7/8	2-19/32	21/32	3/32	Green
CTL10-2516	1/0 str.	5/16	11/16	1-3/4	3/8	7/8	2-11/16	3/4	1/8	Pink
CTL202	2/0 str.	1/2	13/16	2-13/16	1/2	1-3/4	3-13/16	13/16	1/8	Black
CTL302	3/0 str.	1/2	25/32	2-13/16	1/2	1-3/4	3-15/16	15/16	1/8	Orange
CTL402	4/0 str.	1/2	15/16	3	1/2	1-3/4	4-1/4	1-3/32	1/8	Purple
CTL2502	250 kcmil	1/2	1-1/32	3	1/2	1-3/4	4-11/32	1-1/8	5/32	Yellow
CTL3002	300 kcmil	1/2	1-1/32	3	1/2	1-3/4	4-17/32	1-3/16	5/32	White
CTL3502	350 kcmil	1/2	1-1/32	3	1/2	1-3/4	4-17/32	1-11/32	5/32	Red
CTL4002	400 kcmil	1/2	1-11/32	3	1/2	1-3/4	4-15/16	1-13/32	5/32	Blue
CTL5002	500 kcmil	1/2	1-3/8	3	1/2	1-3/4	5	1-17/32	7/32	Brown
CTL6002-38	600 kcmil	3/8	1-17/32	1-29/32	3/8	1-3/4	5-1/8	1-23/32	7/32	Green
CTL6002-12	600 kcmil	1/2	1-17/32	3	1/2	1-3/4	5-1/8	1-23/32	7/32	Green
CTL7502	750 kcmil	1/2	1-1/2	3	1/2	1-3/4	5-7/32	1-29/32	1/4	Black
CTL10002	1000 kcmil	1/2	1-3/4	3	1/2	1-3/4	5-7/16	2-1/4	9/32	-

See pages 110-135 for more tool and die information.

## Colour Coded Compression Connectors

### Type CTL — Copper Lugs, 1-Hole Mount, Long Barrel

#### Copper Compression Connectors

- For use with copper conductors: AWG stranded, flexible cable, welding cable and portable cord
- Specially designed for industrial and building applications
- Made of high conductivity seamless copper tubing
- Tin plated for corrosion resistance
- Specially chamfered barrel for ease of installation
- Colour coded for matching die identification
- Can be used for medium voltage application up to 35 kV provided proper insulation techniques are used
- CSA Certified and U.L. Listed for AWG conductors when installed with Blackburn, Burndy, T&B or Anderson tools, as specified by CSA
- Comply with Subpart 111.60-17 of Federal Register's Coast Guard Electrical Engineering Rules and Regulations

#### Long Barrel Connectors

- Ideal for industrial, oil rig, mining, welding and transportation electrical termination applications
- Heavy duty design which permits additional crimp for added - mechanical strength

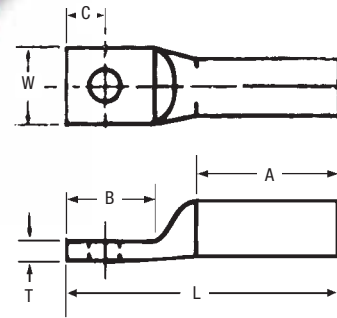

Cat. No.	Conductor Size (CU)	Flexible Conductor Size	Stranded	Stud Size (in.)	Dimensions (in.)						Die Colour Code
					A	B	C	L	W	T	
CTL8L-14	8 str.	1/4	37/24	1/4	25/32	5/8	1/4	1-5/8	13/32	1/16	Red
CTL6L-14	6 str.	1/4	61/24	1/4	25/32	5/8	1/4	1-5/8	13/32	1/16	Blue
CTL4L-14	4 str.	5/16	91/24	1/4	25/32	5/8	1/4	1-11/16	1/2	3/32	Grey
CTL2L-516	2 + 3 str.	5/16	125/24	5/16	7/8	7/8	3/8	2-1/32	9/16	3/32	Brown
CTL1L-516	1 str.	5/16	150/24	5/16	1-3/32	7/8	3/8	2-5/32	21/32	3/32	Green
CTL10L-516	1/0 str.	1/2	225/24	5/16	1-3/32	7/8	3/8	2-7/32	3/4	1/8	Pink
CTL20L-38	2/0 str.	1/2	275/24	3/8	1-3/32	29/32	3/8	2-1/4	13/16	1/8	Black
CTL30L-12	3/0 str.	1/2	325/24	1/2	1-1/8	1-1/4	1/2	2-11/16	29/32	1/8	Orange
CTL40L-12	4/0 str.	1/2	-	1/2	1-3/8	1-1/4	1/2	2-15/16	1-1/32	1/8	Purple
CTL250L-12	250 kcmil	1/2	450/24	1/2	1-19/32	1-1/4	1/2	3-1/8	1-1/8	1/8	Yellow
CTL300L-12	300 kcmil	1/2	550/24	1/2	1-25/32	1-1/4	1/2	3-17/32	1-3/16	1/8	White
CTL350L-12	350 kcmil	1/2	650/24	1/2	1-27/32	1-1/4	5/8	3-19/32	1-11/32	5/32	Red
CTL400L-58	400 kcmil	1/2	775/24	5/8	1-27/32	1-9/16	5/8	4-1/32	1-13/32	5/32	Blue
CTL500L-58	500 kcmil	3/8	925/24	5/8	2-11/32	1-9/16	5/8	4-1/2	1-19/32	3/16	Brown
CTL600L-58	600 kcmil	1/2	1100/24	5/8	2-1/8	1-9/16	5/8	4-5/16	1-23/32	7/32	Green
CTL750L-58	750 kcmil	1/2	1325/24	5/8	2-3/8	1-9/16	5/8	4-21/32	1-29/32	1/4	Black
CTL1000L-58	1000 kcmil	1/2	1600/24 1925/24	5/8	2-7/8	1-9/16	5/8	5-5/32	2-1/4	9/32	-

See pages 110-135 for more tool and die information.



## Colour Coded Compression Connectors

Compression Connectors

### Type LCN — Copper Lugs, 2-Hole Mount, Long Barrel

#### Copper Compression Connectors

- For use with copper conductors: AWG stranded, flexible cable, welding cable and portable cord
- Specially designed for industrial and building applications
- Made of high conductivity seamless copper tubing
- Tin plated for corrosion resistance
- Specially chamfered barrel for ease of installation
- Colour coded for matching die identification
- Can be used for medium voltage application up to 35 kV provided proper insulation techniques are used
- CSA Certified and U.L. Listed for AWG conductors when installed with Blackburn, Burndy, T&B or Anderson tools, as specified by CSA
- Comply with Subpart 111.60-17 of Federal Register's Coast Guard Electrical Engineering Rules and Regulations



#### Long Barrel Connectors

- Ideal for industrial, oil rig, mining, welding and transportation electrical termination applications
- Heavy duty design which permits additional crimp for added mechanical strength



Cat. No.	Conductor Size (CU)	Flexible Conductor Size	Stranded	Stud Size (in.)	Dimensions (in.)							Die Colour Code
					A	B	C	D	L	W	T	
LCN8-14	8 str.	8	37/24	1/4	25/32	1-3/16	1/4	5/8	2-1/8	15/32	1/16	Red
LCN6-14	6 str.	6	61/24	1/4	25/32	1-1/4	1/4	5/8	1-1/4	13/32	1/16	Blue
LCN6-12	6 str.	6	61/24	1/2	25/32	3	1/2	1-3/4	4-5/32	7/8	3/32	Blue
LCN4-14	4 str.	5	91/24	1/4	25/32	1-3/16	1/4	5/8	2-3/16	17/32	3/16	Grey
LCN4-12	4 str.	5	91/24	1/2	25/32	3	1/2	1-3/4	4-5/32	7/8	3/32	Grey
LCN2-516	2 + 3 str.	3	125/24	5/16	7/8	1-5/8	3/8	3/4	2-15/16	9/16	3/32	Brown
LCN2-12	2 str.	3	125/24	1/2	7/8	3	1/2	1-3/4	4-1/4	7/8	3/32	Brown
LCN1-516	1 str.	2	150/24	5/16	1-1/32	1-5/8	3/8	7/8	2-31/32	21/32	3/32	Green
LCN1-12	1 str.	2	150/24	1/2	1-1/32	3	1/2	1-3/4	4-13/32	7/8	3/32	Green
LCN10	1/0 str.	1	225/24	1/2	1-1/32	3	1/2	1-3/4	3-31/32	3/4	1/8	Pink
LCN20	2/0 str.	1/0	275/24	1/2	1-5/16	3	1/2	1-3/4	4-3/16	13/16	1/8	Black
LCN30	3/0 str.	2/0	325/24	1/2	1-1/8	2-15/16	1/2	1-3/4	4-7/16	15/16	1/8	Orange
LCN40	4/0 str.	—	—	1/2	1-3/8	3	1/2	1-3/4	4-11/16	1-1/32	1/8	Purple
LCN250	250 kcmil	3/0	450/24	1/2	1-19/32	3	1/2	1-3/4	4-29/32	1-1/16	1/8	Yellow
LCN300	300 kcmil	4/0	550/24	1/2	1-25/32	3	1/2	1-3/4	5-9/32	1-3/16	1/8	White
LCN350	350 kcmil	263	650/24	1/2	1-27/32	3	1/2	1-3/4	5-11/32	1-11/32	5/32	Red
LCN400	400 kcmil	313	775/24	1/2	1-27/32	3	1/2	1-3/4	5-7/16	1-13/32	5/32	Blue
LCN500	500 kcmil	373	925/24	1/2	2-11/32	3	1/2	1-3/4	5-15/16	1-19/32	3/16	Brown
LCN600	600 kcmil	444	1100/24	1/2	2-1/8	3	1/2	1-3/4	5-3/4	1-23/32	7/32	Green
LCN75	750 kcmil	535	1325/24	1/2	2-3/8	3	1/2	1-3/4	6-3/32	1-29/32	1/4	Black
LCN99	1000 kcmil	646 777	1600/24 1925/24	1/2	2-7/8	3	1/2	1-3/4	6-19/32	2-1/4	9/32	—

See pages 110-135 for more tool and die information.

## Colour Coded Compression Connectors

### Type CSP — Copper Splices, Short Barrel

#### Copper Compression Connectors

- For use with copper conductors: AWG stranded, flexible cable, welding cable and portable cord
- Specially designed for industrial and building applications
- Made of high conductivity seamless copper tubing
- Tin plated for corrosion resistance
- Specially chamfered barrel for ease of installation
- Colour coded for matching die identification
- Can be used for medium voltage application up to 35 kV provided proper insulation techniques are used
- CSA Certified and U.L. Listed for AWG conductors when installed with Blackburn, Burndy, T&B or Anderson tools, as specified by CSA
- Comply with Subpart 111.60-17 of Federal Register's Coast Guard Electrical Engineering Rules and Regulations

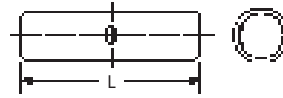

#### Short Barrel Connectors

- Short barrel connectors designed for regular duty applications
- Ideal for confined areas



Cat. No.	Conductor Size (CU)	Length L (In.)	Die Colour Code
<b>CSP8</b>	8 str.	1	Red
<b>CSP6</b>	6 str.	1	Blue
<b>CSP4</b>	4 str.	1	Grey
<b>CSP2</b>	2 + 3 str.	1-1/4	Brown
<b>CSP1</b>	1 str.	1-1/2	Green
<b>CSP10</b>	1/0 str.	1-5/8	Pink
<b>CSP20</b>	2/0 str.	1-3/4	Black
<b>CSP30</b>	3/0 str.	1-3/4	Orange
<b>CSP40</b>	4/0 str.	1-7/8	Purple
<b>CSP250</b>	250 kcmil	2-1/4	Yellow
<b>CSP300</b>	300 kcmil	1-1/8	White
<b>CSP350</b>	350 kcmil	2-1/4	Red
<b>CSP400</b>	400 kcmil	2-3/4	Blue
<b>CSP500</b>	500 kcmil	2-3/4	Brown
<b>CSP600</b>	600 kcmil	3	Green
<b>CSP750</b>	750 kcmil	3	Black
<b>CSP1000</b>	1000 kcmil	3-5/8	-

See pages 110-135 for more tool and die information.

## Colour Coded Compression Connectors

### Type CU — Copper Splices, Long Barrel

C o m p r e s s i o n  
C o n n e c t o r s

#### Copper Compression Connectors

- For use with copper conductors: AWG stranded, flexible cable, welding cable and portable cord
- Specially designed for industrial and building applications
- Made of high conductivity seamless copper tubing
- Tin plated for corrosion resistance
- Specially chamfered barrel for ease of installation
- Colour coded for matching die identification
- Can be used for medium voltage application up to 35 kV provided proper insulation techniques are used
- CSA Certified and U.L. Listed for AWG conductors when installed with Blackburn, Burndy, T&B or Anderson tools, as specified by CSA
- Comply with Subpart 111.60-17 of Federal Register's Coast Guard Electrical Engineering Rules and Regulations



#### Long Barrel Connectors

- Ideal for industrial, oil rig, mining, welding and transportation electrical termination applications
- Heavy duty design which permits additional crimp for added mechanical strength

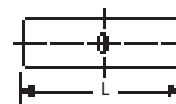

Cat. No.	Conductor Size (CU)	Flexible Conductor		Stud Size (in.)	Length L (in.)	Die Colour Code
		CMA	Stranded			
CU8	8 str.	8	37/24	1/4	1-3/4	Red
CU6	6 str.	6	61/24	1/4	1-3/4	Blue
CU4	4 str.	5	91/24	1/4	1-3/4	Grey
CU2	2 + 3 str.	3	125/24	5/16	1-7/8	Brown
CU1	1 str.	2	150/24	5/16	2	Green
CU10	1/0 str.	1	225/24	5/16	2	Pink
CU20	2/0 str.	1/2	275/24	3/8	2-1/8	Black
CU30	3/0 str.	2/0	325/24	1/2	2-1/4	Orange
CU40	4/0 str.	-	-	1/2	2-3/4	Purple
CU250	250 kcmil	3/0	450/24	1/2	3-3/8	Yellow
CU300	300 kcmil	4/0	550/24	1/2	3-1/2	White
CU350	350 kcmil	263	650/24	1/2	3-3/4	Red
CU400	400 kcmil	313	775/24	5/8	3-3/4	Blue
CU500	500 kcmil	373	925/24	5/8	4-3/4	Brown
CU600	600 kcmil	444	1100/24	5/8	4-1/4	Green
CU750	750 kcmil	535	1325/24	5/8	4-3/4	Black
CU1000	1000 kcmil	646 777	1600/24 1925/24	5/8	5-5/8	-

See pages 110-135 for more tool and die information.

## Colour Coded Compression Connectors

### Type ATL — Aluminum Lugs, 1-Hole

#### Aluminum Compression Connectors

- Specifically designed for use with aluminum conductors (concentric, compressed or compact)
- Also listed for use with copper conductors
- Made of high conductivity seamless aluminum tubing
- Tin plated for corrosion resistance
- Chamfered barrels for ease of installation
- Can be used for medium voltage applications up to 35 kV provided proper insulation techniques are used
- CSA Certified and U.L. Listed for AWG conductors when installed with Blackburn, Burndy, T&B or Anderson tools, as specified by CSA
- Colour coded for quick, easy die identification
- Pre-filled with oxide inhibiting compound

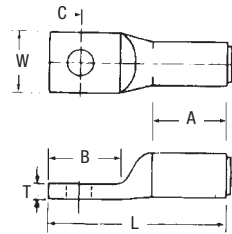

Cat. No.	Conductor Size		Stud Size (in.)	Dimensions (in.)						Die Colour Code
	(AL)	(CU)		A	B	C	L	W	T	
ATL8-10	8 str.	6 AWG	10	1/2	19/32	7/32	1-9/32	13/32	3/32	Blue
ATL8-14	8 str.	6 AWG	1/4	1/2	11/16	11/32	1-3/8	7/16	3/32	Blue
ATL6-10	6 str.	4 AWG	10	25/32	9/16	7/32	1-1/2	15/32	1/8	Grey
ATL6-14	6 str.	4 AWG	1/4	25/32	23/32	15/32	1-21/32	15/32	1/8	Grey
ATL6-38	6 str.	4 AWG	3/8	27/32	29/32	7/16	1-27/32	5/8	3/32	Grey
ATL4-14	4 str.	1 AWG	1/4	27/32	13/16	11/32	1-29/32	5/8	3/16	Green
ATL4-516	4 str.	1 AWG	5/16	27/32	1	7/16	2-1/16	5/8	3/16	Green
ATL4-38	4 str.	1 AWG	3/8	27/32	29/32	7/16	2	5/8	3/16	Green
ATL2-14	2 + 3 str.	1/0 AWG	1/4	27/32	25/32	11/32	1-15/16	23/32	3/16	Pink
ATL2-516	2 + 3 str.	1/0 AWG	5/16	27/32	7/8	7/16	2-11/32	3/4	3/16	Pink
ATL2-38	2 + 3 str.	1/0 AWG	3/5	27/32	29/32	7/16	2-1/16	23/32	3/16	Pink
ATL1-516	1 str.	-	5/16	27/32	7/8	7/16	2-1/32	23/32	3/16	Gold
ATL1-38	1 str.	-	3/8	27/32	29/32	7/16	2-3/8	3/4	3/16	Gold
ATL10-516	1/0 str.	-	5/16	1-5/32	1	7/16	2-17/32	7/8	3/16	Tan
ATL10-38	1/0 str.	-	3/8	1-5/32	1-1/16	7/16	2-19/32	7/8	3/16	Tan
ATL10-12	1/0 str.	-	1/2	1-5/32	1-3/8	11/16	2-15/16	15/16	3/16	Tan
ATL20-38	2/0 str.	-	3/8	1-3/16	1	7/16	2-5/8	31/32	7/32	Olive
ATL20-12	2/0 str.	-	1/2	1-3/16	1-3/8	11/16	3	1-1/32	7/32	Olive
ATL30-38	3/0 str.	-	3/8	1-11/32	1-1/16	7/16	2-13/16	1-1/16	7/32	Ruby
ATL30-12	3/0 str.	-	1/5	1-11/32	1-3/8	11/16	3-1/8	1-1/16	7/32	Ruby
ATL40-38	4/0 str.	300 kcmil	3/8	1-7/8	1-3/32	3/8	3-3/4	1-3/16	1/4	White
ATL40-12	4/0 str.	300 kcmil	1/2	1-7/8	1-1/4	1/2	3-7/8	1-3/16	1/4	White
ATL250-12	250 kcmil	350 kcmil	1/5	2-1/32	1-1/4	1/2	4-1/32	1-9/32	1/4	Red
ATL300-38	300 kcmil	400 kcmil	3/8	2	1-5/16	3/8	4-3/16	1-3/8	9/32	Blue
ATL300-12	300 kcmil	400 kcmil	1/2	2	1-5/16	1/2	4-3/16	1-3/8	9/32	Blue
ATL350-12	350 kcmil	500 kcmil	1/2	2-11/16	1-5/16	1/2	4-7/8	1-1/2	5/16	Brown
ATL400-58	400 kcmil	600 kcmil	5/8	2-11/16	1-1/4	1/2	4-15/16	1-5/8	3/8	Green
ATL500-12	500 kcmil	700 kcmil	1/2	2-11/16	1-1/4	1/2	4-15/16	1-25/32	3/8	Pink
ATL500-58	500 kcmil	700 kcmil	5/8	2-11/16	2	3/4	5-11/16	1-25/32	3/8	Pink
ATL600-12	-	600 kcmil	1/2	2-11/16	2	3/4	5-13/16	1-29/32	11/32	Black
ATL750-12	750 kcmil	900 kcmil	1/2	2-7/8	1-1/4	1/2	5-1/4	2-1/8	3/8	-
ATL750-58	750 kcmil	900 kcmil	5/8	2-7/8	2	3/4	6-1/32	2-1/8	3/8	-

See pages 110-135 for more tool and die information.

## Colour Coded Compression Connectors

Compression Connectors

### Type ATL — Aluminum Lugs, 2-Hole

#### Aluminum Compression Connectors

- Specifically designed for use with aluminum conductors (concentric, compressed or compact)
- Also listed for use with copper conductors
- Made of high conductivity seamless aluminum tubing
- Tin plated for corrosion resistance
- Chamfered barrels for ease of installation
- Can be used for medium voltage applications up to 35 kV provided proper insulation techniques are used
- Colour coded for quick, easy die identification
- Pre-filled with oxide inhibiting compound
- CSA Certified and U.L. Listed for AWG conductors when installed with Blackburn, Burndy, T&B or Anderson tools, as specified by CSA

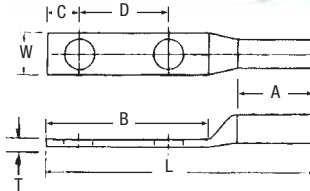

Cat. No.	Conductor Size		Stud Size (in.)	Dimensions (in.)							Die Colour Code
	(AL)	(CU)		A	B	C	D	L	W	T	
ATL102-38	1/0 str.	—	3/8	1-5/32	2-1/16	3/8	1	3-19/32	7/8	3/16	Tan
ATL102	1/0 str.	—	1/2	1-3/16	3	1/2	1-3/4	4-9/16	15/16	3/16	Tan
ATL202	2/0 str.	—	1/2	1-3/16	3-3/8	3/4	1-3/4	5	31/32	7/32	Olive
ATL302	3/0 str.	—	1/2	1-11/32	3-3/8	3/4	1-3/4	5-5/32	1-1/16	7/32	Ruby
ATL402	4/0 str.	300 kcmil	1/2	1-7/8	3	1/2	1-3/4	5-5/8	1-3/16	1/4	White
ATL2502	250 kcmil	350 kcmil	1/2	2-1/32	3	1/2	1-3/4	5-25/32	1-9/32	1/4	Red
ATL3002	300 kcmil	400 kcmil	1/2	2	3	1/2	1-3/4	5-7/8	1-3/8	9/32	Blue
ATL3502	350 kcmil	500 kcmil	1/2	2-11/16	3	1/2	1-3/4	6-9/16	1-1/2	5/16	Brown
ATL4002	400 kcmil	600 kcmil	1/2	2-11/16	3	1/2	1-3/4	6-11/16	1-5/8	3/8	Green
ATL5002	500 kcmil	700 kcmil	1/2	2-11/16	3	1/2	1-3/4	6-11/16	1-25/32	3/8	Pink
ATL6002	—	600 kcmil	1/2	2-11/16	3	1/2	1-3/4	6-13/16	1-29/32	11/32	Black
ATL7502	750 kcmil	900 kcmil	1/2	2-7/8	3	1/2	1-3/4	7-1/8	2-1/8	3/8	—

See pages 110–135 for more tool and die information.



## Colour Coded Compression Connectors

### Type ASP — Aluminum Splices

#### Aluminum Compression Connectors

- Specifically designed for use with aluminum conductors (concentric, compressed or compact)
- Also listed for use with copper conductors
- Made of high conductivity seamless aluminum tubing
- Tin plated for corrosion resistance
- Chamfered barrels for ease of installation
- Can be used for medium voltage applications up to 35 kV provided proper insulation techniques are used
- Colour coded for quick, easy die identification
- Pre-filled with oxide inhibiting compound
- CSA Certified and U.L. Listed when installed with Blackburn, Burndy, T&B or Anderson tools, as specified by CSA

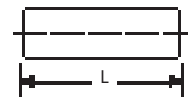

Cat. No.	Conductor Size		Length L (in.)	Die Colour Code
	(AL)	(CU)		
ASP8	8 str.	6 AWG	1-1/4	Blue
ASP6	6 str.	4 AWG	1-5/8	Grey
ASP4	4 str.	1 AWG	1-7/8	Green
ASP2	2 + 3 str.	1/0 AWG	1-7/8	Pink
ASP1	1 str.	–	2-3/8	Gold
ASP10	1/0 str.	–	2-3/8	Tan
ASP20	2/0 str.	–	2-1/2	Olive
ASP30	3/0 str.	–	2-7/8	Ruby
ASP40	4/0 str.	300 kcmil	3-3/4	White
ASP250	250 kcmil	350 kcmil	4	Red
ASP300	300 kcmil	400 kcmil	4	Blue
ASP350	350 kcmil	500 kcmil	3-7/8	Brown
ASP400	400 kcmil	600 kcmil	4-7/8	Green
ASP500	500 kcmil	700 kcmil	5	Pink
ASP600	–	600 kcmil	5-1/8	Black
ASP750	750 kcmil	900 kcmil	5-3/8	–
ASP1000	1000 kcmil	–	6	–

See pages 110–135 for more tool and die information.

## Colour Coded Compression Connectors

Compression Connectors

### Type PA — Pin Adapter Terminals

- Connector for aluminum conductors only; pigtail may be inserted into either aluminum or copper connectors
- Insulating cover included
- 90°C Rating per U.L. 486B
- Tin plated stranded copper wire pigtail
- Tin plated aluminum barrel pre-filled with oxide inhibitor and capped

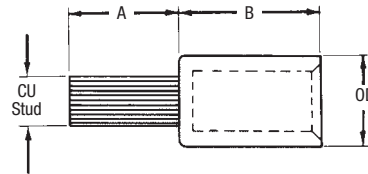
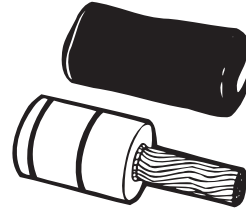

Cat. No.	Conductor Size (Al)	Copper Stud Size	Dimensions (in.)			Die Colour Code	Die #
			A	B	O.D.		
PA06	6 str.	8	7/8	1-11/32	0.640	Orange	50
PA04	4 str.	6	7/8	1-11/32	0.640	Orange	50
PA02	2 str.	4	7/8	1-11/32	0.640	Orange	50
PA01	1 str.	3	1	1-11/32	0.640	Orange	50
PA11	1/0 str.	2	1-1/4	1-19/32	0.906	Red	76
PA21	2/0 str.	1	1-1/4	1-19/32	0.906	Red	76
PA31	3/0 str.	1/0	1-3/8	1-7/8	0.906	Red	76
PA41	4/0 str.	2/0	1-3/8	1-7/8	0.906	Red	76
PA25	250 kcmil	3/0	1-1/2	2-1/16	1.155	Brown	87H
PA30	300 kcmil	4/0	1-5/8	2-1/16	1.155	Brown	87H
PA35	350 kcmil	4/0	1-5/8	2-1/16	1.155	Brown	87H
PA40	400 kcmil	250 kcmil	1-7/8	2-3/32	1.375	Black	106H
PA50	500 kcmil	350 kcmil	1-7/8	2-3/32	1.375	Black	106H
PA60	600 kcmil	350 kcmil	1-7/8	2-3/4	1.500	Yellow	115H
PA75	750 kcmil	500 kcmil	2	2-3/4	1.500	Yellow	115H

U.L. Listed AL9CU.  
Products on this page are not CSA Certified.

T&B Dies									
Alum. Wire Size	Die Code	UT3	UT5	TBM5	TBM6	TBM8	13642 12-Ton	TBM15 UT15	21920 20-Ton
#6 – #1	50	5/8	TU	Orange	–	–	–	15529	–
1/0 – 4/0	76 or 76H	–	TX	–	13472 Red 13476 Red	13467	11744	15512	11170
250 kcmil – 350 kcmil	87H	–	TH	–	–	13468	11746	15506	11176
400 kcmil – 500 kcmil	106H	–	–	–	–	–	11749	15515	11140
600 kcmil – 750 kcmil	115H	–	–	–	–	–	11753	15504	11157

## Service Wedge Clamps

### Type W — Stainless Steel Wedge Clamps

- For use on copper neutral
- Stainless Steel wedge and slider

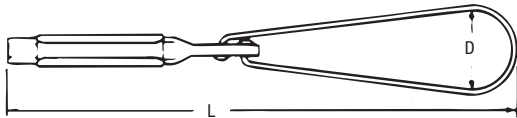

Cat. No.	Conductor Range			Dimensions (in.)		Typical Tensile Values	
	ACSR	AL	AAAC	D	L	Conductor	Value (lb.)
<b>W62D</b>	2-6	1 str. - 6 sol.	2-6	2-3/8 flex.	12	2 6 x 1 ACSR	1200

### Type W — Aluminum Service Wedge Clamps for use with ACSR, Aluminum, AAAC Conductors

- For dead-ending self-supporting drop wire
- Saves conductor—drop wire may be cut to exact length
- Can be attached to bare neutral at any point in the span
- Adjustments in drop wire sag are easily made
- Grips ACSR, AAAC, or aluminum conductors



"FC" Flexible Bail  
(Bail Length - 11-1/2")



Rigid Stainless Steel Bail  
(Bail Length - 6-1/2")

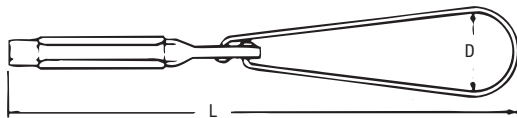

Cat. No.	Description	Conductor Range			Dimensions (in.)		Typical Tensile Values	
		ACSR	AL	AAAC	D	L	Conductor	Value (lb.)
<b>W62-1</b>	W-1 Series Aluminum Wedge and Slider	2-6	1 str. - 6 sol.	2-6	2-3/8 flex.	12, 17-1/2	2 6 x 1 ACSR	1200
<b>W62-1FC</b>	W-1 Series Aluminum Wedge and Slider	2-6	1 str. - 6 sol.	2-6	2-3/8 flex.	12, 17-1/2	2 6 x 1 ACSR	1200
<b>W20-1</b>	W-1 Series Aluminum Wedge and Slider	1/0-4	2/0 str. - 2 sol.	1/0-4	2-3/8 flex.	12-1/2, 18-1/2	1/0 6 x 1 ACSR	1800
<b>W20-1FC</b>	W-1 Series Aluminum Wedge and Slider	1/0-4	2/0 str. - 2 sol.	1/0-4	2-3/8 flex.	12-1/2, 18-1/2	1/0 6 x 1 ACSR	1800
<b>W40-1*</b>	W-1 Series Aluminum Wedge and Slider	4/0-2/0	4/0 str. - 2 sol.	4/0-2/0	2-3/8 flex.	12-3/4, 18-1/2	4/0 6 x 1 ACSR	1900
<b>W40-1FC*</b>	W-1 Series Aluminum Wedge and Slider	4/0-2/0	4/0 str. - 2 sol.	4/0-2/0	2-3/8 flex.	12-3/4, 18-1/2	4/0 6 x 1 ACSR	1900
<b>W62-1B</b>	W-1B Series for extremely corrosive areas. Iridited Aluminum Wedge and Slider	2-6	1 str. - 6 sol.	2-6	2-3/8 flex.	12, 17-1/2	2 6 x 1 ACSR	1200
<b>W62-1BFC</b>	W-1B Series for extremely corrosive areas. Iridited Aluminum Wedge and Slider	2-6	1 str. - 6 sol.	2-6	2-3/8 flex.	12, 17-1/2	2 6 x 1 ACSR	1200
<b>W20-1B</b>	W-1B Series for extremely corrosive areas. Iridited Aluminum Wedge and Slider	1/0-4	2/0 str. - 2 sol.	1/0-4	2-3/8 flex.	12-1/2, 18-1/2	1/0 6 x 1 ACSR	1800
<b>W20-1BFC</b>	W-1B Series for extremely corrosive areas. Iridited Aluminum Wedge and Slider	1/0-4	2/0 str. - 2 sol.	1/0-4	2-3/8 flex.	12-1/2, 18-1/2	1/0 6 x 1 ACSR	1800
<b>W40-1B*</b>	W-1B Series for extremely corrosive areas. Iridited Aluminum Wedge and Slider	4/0-2/0	4/0 str. - 2 sol.	4/0-2/0	2-3/8 flex.	12-3/4, 18-1/2	4/0 6 x 1 ACSR	1900
<b>W40-1BFC*</b>	W-1B Series for extremely corrosive areas. Iridited Aluminum Wedge and Slider	4/0-2/0	4/0 str. - 2 sol.	4/0-2/0	2-3/8 flex.	12-3/4, 18-1/2	4/0 6 x 1 ACSR	1900

\* W40 series clamps rated 850 lb ultimate tension for 1/0 ACSR, AL, or AAAC.

**Grounding Connectors and Accessories — Quick Reference**

**Grounding Connectors  
Quick Reference**

**Figure 6**



p. 65

**Figure 8**

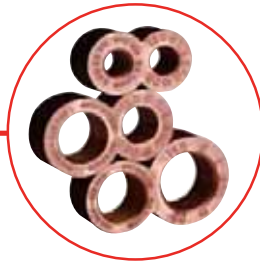

p. 65

**Figure 6-6**



p. 66

**Figure 6-8**



p. 66

**C-Taps**



pp. 67-68

**C-Crimp**



p. 69

**Type GR**



Pigtail Connectors

p. 69

**Grounding Studs**

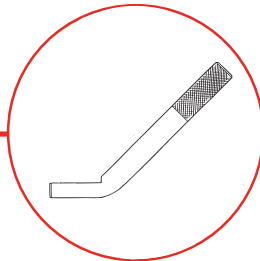

p. 70

**I-Beam Ground Clamps**



p. 71

## Grounding Connectors and Accessories — Quick Reference

### Cast Copper



Two-Way Cast Copper Connectors  
Heavy-Duty

p. 71

### Grounding Plates



p. 72

### Ground Bus



Bar Connectors

p. 73

### Types GRD, GG



Ground Grid  
Connectors

pp. 74–75

### Two Cables to Ground Rod



pp. 75–76

### Grounding Grid Connectors



Heavy-duty  
Cast Copper

p. 76

### Ground Clamps



p. 77

### Flat-Surface Ground Clamps



p. 77

### Grid-to-Fence Ground Clamps



p. 77



**Grounding Connectors and Accessories — Quick Reference**

**Grounding Connectors  
Quick Reference**

**Types JAB, G, JWR, GG, GGH**



Ground Rod Clamps

pp. 78–79

**Type GUV**



U-Bolt Ground Clamps

p. 80

**Ground Rods**

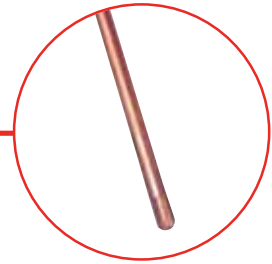

pp. 81–82

**Couplings**



p. 82

**Driving Studs**



p. 82

**Threadless Couplings**



p. 83

**Type DGC**



Drive-on Ground Clamps

p. 83

**Ground Rod Drivers**



For installing Ground Rods

p. 84

**Ground Electrode Boxes**



p. 85

## Grounding Connectors and Accessories — Quick Reference

### Metallic Gradient Control Mat

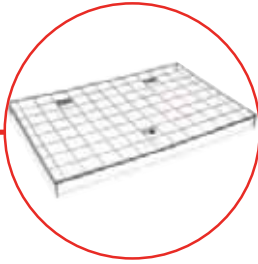

p. 85

### Type GP



Pole Bottom  
Ground Plates

p. 85

### Type PB



Bar Connectors

p. 85

### Type GTC



Tower Ground Clamps

p. 86

### CTG250

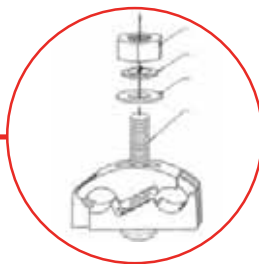

Wide Range Tower  
Ground Clamps

p. 86

### Types LL, CULL



Lay-in Lug  
Connectors

p. 87

### Parallel Connectors



p. 88

### Type DS

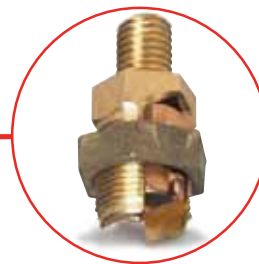

Service Post Connectors  
Short Stud

p. 89

### Type SP

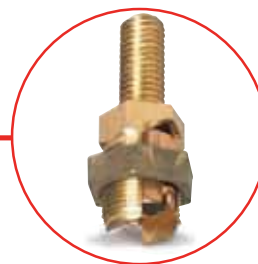

Service Post Connectors  
Long Stud

p. 90

**Grounding Connectors and Accessories — Quick Reference**

**Grounding Connectors  
Quick Reference**

**Type TTC**



Transformer Tank  
Grounding Connectors

p. 91

**Conduit Hubs**



p. 92

**Type FB**



Flexible Braid  
Connectors

pp. 93–100

**Clamps**



Die Cast Clamps

p. 101

**Waterpipe Ground Clamps**



p. 102

## Grounding Connectors

### Compression Method Grounding Connectors save 50 – 75% in time and labor costs.

- Eliminates exothermic welding
- Reduces time and labor costs
- Minimizes possibility of poor connections

Thomas & Betts introduces a method of compression to replace exothermic welding and its associated disadvantages. This compression method is designed to provide quick, reliable connections for grid grounding at significantly lower installed costs because compression connectors install in less time, in any weather, and are unaffected by moisture, reducing downtime. In addition, our compression connectors for grid grounding require no special training for installation. They are made of high-conductivity wrought and cast copper, and are used for connecting and tapping cross grid, loop lines and ground rods for direct burial or concrete embedded ground grid systems. The Thomas & Betts compression system uses standard electrical connector installation tools.



*This installation method results in a long-lasting low installed cost connection. You can install it and forget it.*

*Before compression, typical cable connector cross section of cable and connector consists of about 75% metal and 25% air. After Thomas & Betts method compression, the cross section shows 100% metal with virtually no air spaces.*

### Meets all applicable specifications

Thomas & Betts grid and ground rod connectors satisfy the requirements of CEC SECTION 10 for connecting to the Grounding Electrode System. They also meet the requirements of UL Std. 467, UL Std. 486, CSA Std. C22.2 No. 41 and CSA Std. C22.2 No. 65 being acceptable as grounding and bonding equipment suitable for direct burial. Thomas & Betts grid and ground rod connectors also satisfy the recommended practice for the selection of grounding connector joints described in IEEE 837 standard for qualifying permanent connections used in substation grounding.

The connectors conform to the following IEEE Standard 837 requirements:

- 350°C current cycling
- Freeze-thaw test
- Accelerated aging – nitric acid/salt spray
- Mechanical, tensile and electromagnetic force (EMF) criteria
- Install in any weather – cut downtime
- Enhance safety
- Easy to install – no special training



**TBM14M**  
(Suggested tool for E-Z-Ground® connectors to ground up to 5/8" diameter.)

### Reliable installations through compression connections

Dies that are used in Thomas & Betts hand and hydraulic tools contain the "die code" numbers which are engraved on the compression surface of the die. Under compression, this number becomes embossed on the completed connection for inspection purposes.

The inspector compares the die code number embossed on the connector with the die table to ensure that the proper connector was compressed with the correct die for that particular size conductor.

**Grounding Connectors**

Grounding

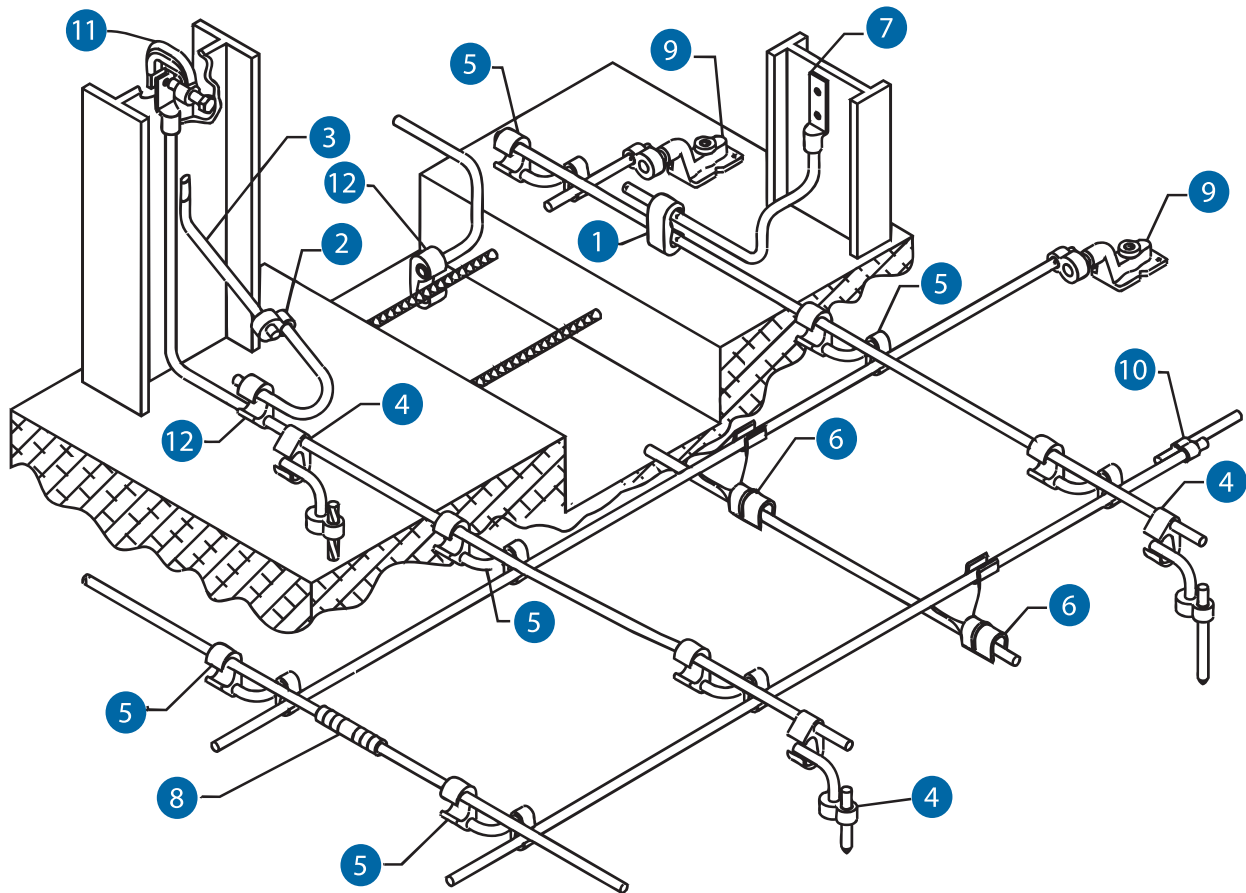

Thomas & Betts offers a complete line of grid-ground compression connectors. Our E-Z-Ground® connectors are designed for direct burial and offer a safe, efficient alternative to exothermic welding products. Grid ground installations do not require explosive charges, and can be installed in various climate conditions. These range-taking products will reduce the number of connectors and dies needed for your installation.

Thomas & Betts E-Z-Ground® products meet all applicable standards (IEEE837, UL467, CSA22.2). Connectors are prefilled with oxide inhibitors and sealed.

- |  |                                    |                               |
|--|------------------------------------|-------------------------------|
| <b>1</b> C-Tap                           | <b>5</b> Figure 6-6 Connectors     | <b>9</b> Ground Plates        |
| <b>2</b> Figure 8 Connector              | <b>6</b> Grid to Ground Connectors | <b>10</b> Figure 8 Connector  |
| <b>3</b> Steel Grounding Stud TBG Series | <b>7</b> Lug                       | <b>11</b> I-Beam Clamp        |
| <b>4</b> Figure 6-8 Connectors           | <b>8</b> Splice/Two-Way Connector  | <b>12</b> Figure 6 Connectors |



## Grounding Connectors

### Figure 6 — Compression Ground Tap Connectors

- Material: High conductivity copper
- Acceptable for direct burial

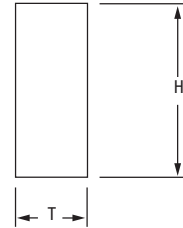
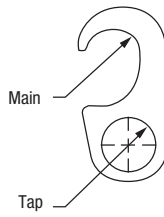

Cat. No.	Application		Cable to rebar application*		Dimensions in. (mm)		Dies for TBM14M, 13100A or TBM15I
	Main	Tap	Main	Tap	T	H	
54855	1/0 Str.–250 kcmil or 1/2"–5/8" Rod	#4 Sol.–#2 Str.	#3 Rebar 3/8 thru 1/2" #4 Rebar	#4 Sol.–#2 Str.	0.75 (19.1)	1.94 (49.3)	15G86R [1]
54860	1/0 Str.–250 kcmil or 1/2"–5/8" Rod	1/0 Str.–2/0 Str.	#3 Rebar 3/8 thru 1/2" #4 Rebar	1/0 Str.–2/0 Str.	0.75 (19.1)	2.19 (55.6)	15G86R [1]
54865-CK	1/0 Str.–250 kcmil or 1/2"–5/8" Rod	3/0 Str. – 250 kcmil	#3 Rebar 3/8 thru 1/2" #4 Rebar	3/0 Str. – 250 kcmil	0.75 (19.1)	2.19 (55.6)	15G86R [1]
54875	#6 Sol.–#2 Str.	#6 Sol.–#2 Str.	–	–	0.75 (19.1)	2.56 (65.0)	15501A [1]
54885	250 kcmil–500 kcmil or 5/8"–3/4" Rod	#4 Sol.–#2 Str.	#5 Rebar 5/8 thru 3/4" #6 Rebar	#4 Sol.–#2 Str.	0.75 (19.1)	1.94 (49.3)	15G126R [1]
54890	250 kcmil–500 kcmil or 5/8"–3/4" Rod	1/0 Str.–2/0 Str.	#5 Rebar 5/8 thru 3/4" #6 Rebar	1/0 Str.–2/0 Str.	0.75 (19.1)	2.13 (54.1)	15G126R [1]
54895	250 kcmil–500 kcmil or 5/8"–3/4" Rod	3/0 Str. – 250 kcmil	#5 Rebar 5/8 thru 3/4" #6 Rebar	3/0 Str. – 250 kcmil	0.75 (19.1)	2.19 (55.6)	15G126R [1]
54900	250 kcmil–500 kcmil or 5/8"–3/4" Rod	350 kcmil–500 kcmil	#5 Rebar 5/8 thru 3/4" #6 Rebar	350 kcmil–500 kcmil	1.38 (35.1)	2.44 (62.0)	15G121R [3]

Tin plated version of galvanized ground rods available. Add suffix-TP to catalogue number. Use 15500TB adaptor for 15-Ton Tool TBM15. \* CSA not applicable.

[ ] \* Number of crimps

### Figure 8 — Compression Ground Rod Tap Connectors

- Material: High conductivity copper
- Acceptable for direct burial

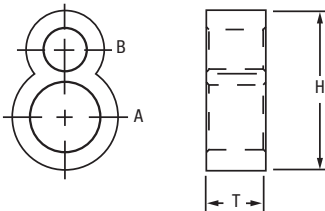

Cat. No.	A (in.) Ground Rod	B Cable Range	Dimensions in. (mm)		Dies for TBM14M, 13100A or TBM15I
			T	H	
GR12-202*	1/2	2 AWG–2/0 AWG	0.88 (22.4)	1.94 (49.3)	15G121R [2]
GR58-202*	5/8	2 AWG–2/0 AWG	0.88 (22.4)	1.97 (50.0)	15G121R [2]
GR34-202*	3/4	2 AWG–2/0 AWG	0.88 (22.4)	2.19 (55.6)	15G121R [2]
GR1-202	1	2 AWG–2/0 AWG	0.88 (22.4)	2.56 (65.0)	15G121R [2]
GR12-40250*	1/2	3/0 AWG–250 kcmil	0.88 (22.4)	1.94 (49.3)	15G121R [2]
GR58-40250*	5/8	3/0 AWG–250 kcmil	0.88 (22.4)	2.13 (54.1)	15G121R [2]
GR34-40250*	3/4	3/0 AWG–250 kcmil	0.88 (22.4)	2.19 (55.6)	15G121R [2]
GR1-40250	1	3/0 AWG–250 kcmil	0.88 (22.4)	2.44 (62.0)	15G121R [2]
GR58-300500*	5/8	300–500 kcmil	0.88 (22.4)	2.13 (54.1)	15G121R [2]
GR34-300500*	3/4	300–500 kcmil	0.88 (22.4)	2.44 (62.0)	15G121R [2]
GR1-300500	1	300–500 kcmil	0.88 (22.4)	2.69 (68.3)	15G121R [2]

\*Tin plated version of galvanized ground rods available. Add suffix-TP to catalogue number. Use 15500TB adaptor for or 15-Ton Tool TBM15. Optional Ground Rod Knurling die for 14-15 ton tool: 15508. Knurling tool: 240-31565-94 Tooling: pages 125–136

[ ] \* Number of crimps

## Grounding Connectors

### Figure 6 to 8 — Compression Ground Rod to Grid Connectors

Grounding

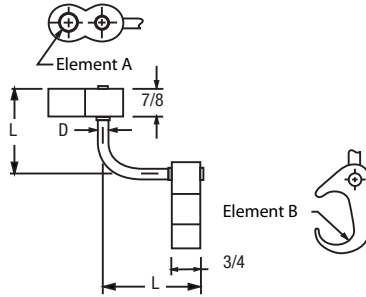

Cat. No.	A in. (mm) Ground Rod	B Cable Range	Dimensions in. (mm)		Dies for TBM14M, 13100A or TBM15I	
			D	L	Element A	Element B
54855LR12*	1/2 (12.7)	2 AWG–250 kcmil	0.31 (7.8)	2.50 (63.5)	15G121R	15G86R
54885LR12*	1/2 (12.7)	250 kcmil–500 kcmil	0.31 (7.8)	2.50 (63.5)	15G121R	15G126R
54865LR58*	5/8 (16.0)	2 AWG–250 kcmil	0.31 (7.8)	2.50 (63.5)	15G121R	15G86R
54895LR58*	5/8 (16.0)	250 kcmil–500 kcmil	0.31 (7.8)	2.50 (63.5)	15G121R	15G126R
54875LR34*	3/4 (19.1)	2 AWG–250 kcmil	0.50 (12.7)	2.63 (66.8)	15G121R	15G86R
54900LR34*	3/4 (19.1)	250 kcmil–500 kcmil	0.50 (12.7)	2.63 (66.8)	15G121R	15G126R
54910LR100	1 (25.4)	2 AWG–250 kcmil	0.50 (12.7)	2.63 (66.8)	15G121R	15G86R
54920LR100	1 (25.4)	250 kcmil–500 kcmil	0.50 (12.7)	2.63 (66.8)	15G121R	15G126R

\*Tin plated version of galvanized ground rods available. Add suffix-TP to catalogue number.

### Figure 6 to 6 — Compression Ground Rod to Grid Connectors

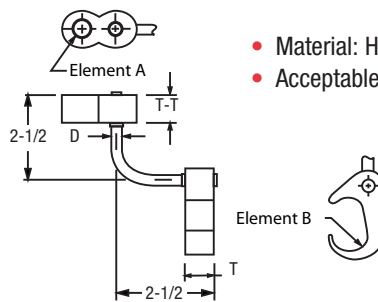

- Material: High conductivity copper
- Acceptable for direct burial



Cat. No.	Element A	Element B	Element A to Ground Rod (po)	*Element B to Rebar (po)	Dimensions in. (mm)			Die Selection for TBM14M, 13100A or TBM15I	
	Cable to Cable				D	T	T-T	A	B
54855L	#6 sol.–#2 str.	#6 sol.–#2 str.	–	–	0.88 (22.4)	0.75 (19.1)	0.75 (19.1)	15501A	15501A
54865L	#1 Str.–250 kcmil	#6 sol.–#2 str.	1/2 – 5/8	3/8 – 1/2 #3–#4 Rebar	0.88 (22.4)	0.75 (19.1)	0.75 (19.1)	15501A	15G86R
54875L	#2 Str.–250 kcmil	#2 str.–250 kcmil	1/2 – 5/8	3/8 – 1/2 #3–#4 Rebar	0.88 (22.4)	0.75 (19.1)	0.75 (19.1)	15G86R	15G86R
54885L	250 kcmil–500 kcmil	#6 sol.–#2 str.	5/8 – 3/4	5/8 – 3/4 #5–#6 Rebar	0.88 (22.4)	0.75 (19.1)	0.75 (19.1)	15501A	15G126R
54895L	250 kcmil–500 kcmil	#2 Str.–250 kcmil	5/8 – 3/4	5/8 – 3/4 #5–#6 Rebar	0.88 (22.4)	0.75 (19.1)	0.75 (19.1)	15G86R	15G126R
54900L	250 kcmil–500 kcmil	250 kcmil–500 kcmil	5/8 – 3/4	5/8 – 3/4 #5–#6 Rebar	0.88 (22.4)	1.13 (28.7)	1.13 (28.7)	15G121R	15G121R

Tooling: pages 125–136.  
Die Selector Chart: pages 121–123.  
\*CSA not applicable.  
Use 15500TB adaptor for 15-Ton Tool TBM15I.

☐ Number of crimps

## Grounding Connectors

### C-Taps

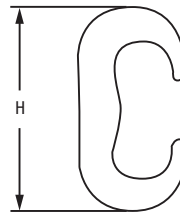
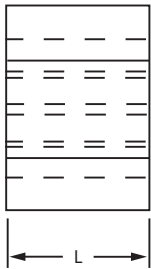

Grounding

Cat. No.	Main	Tap	Dimensions in. (mm)		Dies for TBM14M, 13100A or TBM15I*	Crimps
			H	L		
<b>CTP22</b>	#6 sol.-#2 str.	#6 sol.-#2 str.**	1.16 (29.5)	0.75 (19.1)	HBKC	1
<b>CTP202</b>	#1 str.-2/0 str.	#6 sol.-#2 str.**	1.41 (35.8)	0.75 (19.1)	15501A	1
<b>CTP2020</b>	#1 str.-2/0 str.	#1 str.-2/0 str.	1.54 (39.1)	0.75 (19.1)	15501A	1
<b>CTP25020</b>	3/0 str.-250 kcmil	#6 sol.-2/0 AWG**	1.97 (50.0)	0.75 (19.1)	15G86R	1
<b>CTP250250</b>	3/0 str.-250 kcmil	3/0 str.-250 kcmil	2.06 (52.3)	0.88 (22.4)	15G86R	1
<b>CTP50020</b>	300-500 kcmil	#6 sol.-2/0 AWG**	2.42 (61.5)	0.88 (22.4)	15G121R	2
<b>CTP500250</b>	300-500 kcmil	3/0 str.-250 kcmil	2.67 (67.8)	0.88 (22.4)	15G121R	2
<b>CTP500500</b>	300-500 kcmil	300-500 kcmil	2.91 (73.9)	1.10 (27.9)	15G121R	3

Material: High-Conductivity Copper.

\* Cat. No. 15500TB adaptor required if using TBM15I and 155XX Dies Series.

\*\* #6 AWG branch must be doubled.

### C-Taps — Small Size

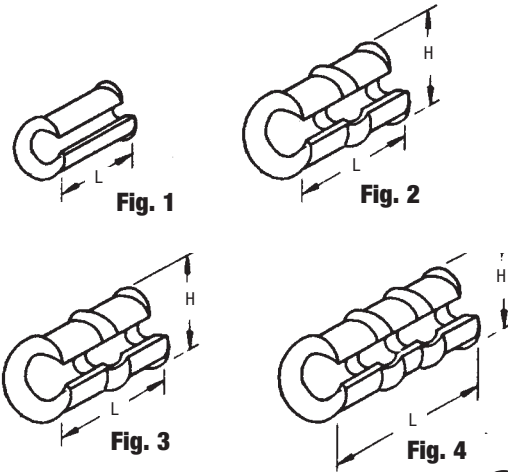

Cat. No.	Code Wire Comb. Cir. Mils Area Range		Die			Group 2	Group 3	Insulation Choice		Dimensions in. (mm)		Colour Code
	Main	Branch 1	Group 1	TBM62BSCR	Smart			Adhesive	Shrink Tubing	L	H	
54705	12	14	6TON21	TBM6221	-	↑ Accommodates this range ↓	↑ Accommodates this entire range ↓	AC5X3	HS12-6	0.31 (7.9)	0.31 (7.9)	Red
	14	16								0.56 (14.2)	0.44 (11.2)	Blue
54710	10	10	6TON24	TBM6224	-					0.56 (14.2)	0.63 (16.0)	Grey
	8	12								1.16 (29.5)	0.69 (17.5)	Brown
54715	6	10, 12	6TON29	TBM6229	-					1.16 (29.5)	0.81 (20.6)	Green
	8	8, 10, 12								1.16 (29.5)	0.84 (21.3)	Pink
54720	4 or 5	8, 10, 12	6TON33	TBM6233	TBM8-750C20					0.06 (1.5)	0.88 (22.4)	Black
	6	6, 8								1.69 (42.9)	0.97 (24.6)	Orange
54725	3	6, 8, 10, 12***	6TON37	TBM6237	TBM8-750C2530					1.69 (42.9)	1.06 (26.9)	Purple
	4 or 5	6, 5								1.69 (42.9)	1.19 (30.2)	Yellow
54730	2	6, 8, 10, 12	6TON42	TBM6242	TBM8-750C2530							
	3	5										
54735	4	3	6TON45	TBM6245	TBM8-750C3540							
	1	4, 5, 6, 8, 10, 12										
54740	2	4, 5	6TON50	TBM6250	TBM8-750C3540							
	3	3, 4										
54745	1/0	4, 5, 6, 8, 10, 12	6TON54	TBM6254	TBM8-750C4550							
	1	2, 3										
54750	2/0	3, 4, 5, 6, 8, 10, 12	6TON62	TBM6262	TBM8-750C-4550							
	1	1, 3										
54750	3/0	2, 3, 4, 5, 6, 8, 10, 12										
	2/0	1, 2										
54750	1/0	1/0, 1										

\*\*\* When using 3 AWG on main and 12 AWG on branch with Smart tools and dies, 12 AWG wire must be doubled (hair-pinned) and placed on branch for crimping.  
 Group 1 = TBM6H, TBM6BSCR.  
 Group 2 = TBM25S, TBM21E (require 2 compressions within each crimp area).  
 Group 3 = TBM4/4S, TBM5/5S, TBM6/6S, TBM8/8S, TBM6H (require 1 compression within each crimp area).

## Grounding Connectors

### Copper C-Crimps Wire Combinations\*\*

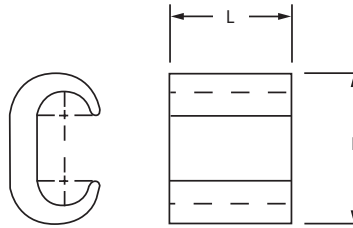

Grounding

Cat. No.	Run	Tap	Die Index	Manual Tool OD Series	Installing Die 14 and 15-Ton Tools	Dimensions in. (mm)	
						L	H
<b>BC48</b>	6 sol.-4 str.	8 sol.-8 str.	BG or 5/8	BY31	B58CR	0.64 (16.3)	0.56 (14.2)
<b>BC46-BB</b>	6 sol.-4 str.	6 sol.-6 str.	BG or 5/8	BY31	B58CR	0.64 (16.3)	0.75 (19.1)
<b>BC44</b>	6 sol.-4 str.	4 sol.-4 str.	BG or 5/8	BY31	B58CR	0.64 (16.3)	0.80 (20.3)
<b>BC24</b>	2 sol.-2 str.	8 sol.-4 str.	C	BY33	HBKC	0.75 (19.1)	0.98 (24.9)
<b>BC22</b>	2 sol.-2 str.	2 sol.-2 str.	C	BY33	HBKC	0.75 (19.1)	1.05 (26.7)
<b>BC202</b>	1/0 sol.-2/0 str.	8 sol.-2 str.	E or O	-	HO	0.94 (23.9)	1.31 (33.3)
<b>BC2020-BB</b>	1/0 sol.-2/0 str.	1/0 str.-2/0 str.	E or O	-	HO	0.94 (23.9)	1.34 (34.0)
<b>BC402</b>	3/0 str.-4/0 str.	6 sol.-2 str.	F or D3	-	HD	1.06 (26.9)	1.63 (41.4)
<b>BC4020</b>	3/0 str.-4/0 str.	1/0 sol.-2/0 str.	F or D3	-	HD	1.06 (26.9)	1.63 (41.4)
<b>BC4040</b>	3/0 str.-4/0 str.	3/0 sol.-4/0 str.	F or D3	-	HD	1.06 (26.9)	1.63 (41.4)

\*\*Do not meet IEEE837  
Tooling: pages 125-136  
Die Selector Chart: pages 111-120

### Hex Compression Intimately Bonds Directly to copper clad ground rod

#### Pigtail Figure 8 Connectors



When connecting cable to copper clad ground rod for direct burial or embedding in concrete, the connector shall be wrought copper with a minimum conductivity of 99% IACS such as Thomas & Betts series GR-120b. Hex compression with die code embossing shall be used.

Cat. No.	Cable Range	Copper clad Ground Rod (in.)	Die Code for TBM14M, TBM15, 13100A or TBM15I	Die
<b>GR12-306</b>	One Cable: 3/0 to 6 AWG Two Cables: 2 to 6 AWG	1/2	87H	15506 [2]
<b>GR58-406</b>	One Cable: 4/0 to 6 AWG Two Cables: 2 to 6 AWG	5/8	87H	15506 [2]
<b>GR34-4010</b>	One Cable: 4/0 to 1/0 AWG	3/4	99H	15506 [2]

\* [2] Number of crimps



Knurling ensures excellent mechanical pullout and electrical continuity

### Type TBGS Structural Grounding Studs

- Easily welded to steel structures with minimal construction welding equipment
- Connect to grounding conductors with appropriate Thomas & Betts grounding connectors
- Knurled portion of stud resists pullout and provides electrical continuity to ensure the integrity of the grounding circuit
- Constructed of high-strength steel and coated with corrosion-resistant copper cyanide

Cat. No.	Rod Size (in.)
TBGS-14	0.25
TBGS-38	0.38
TBGS-58	0.63
TBGS-34	0.75

Grounding

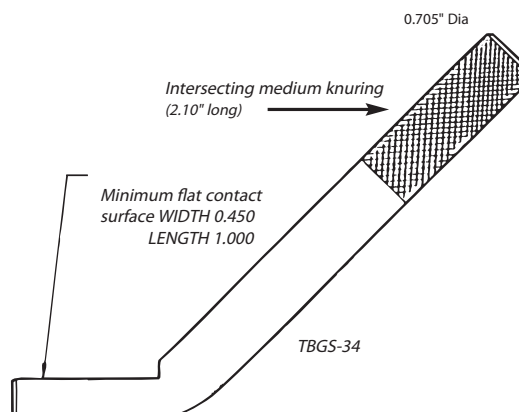
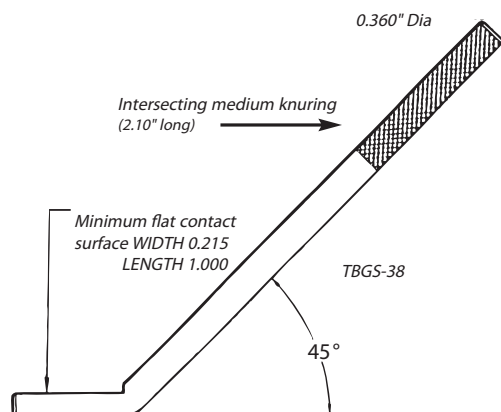
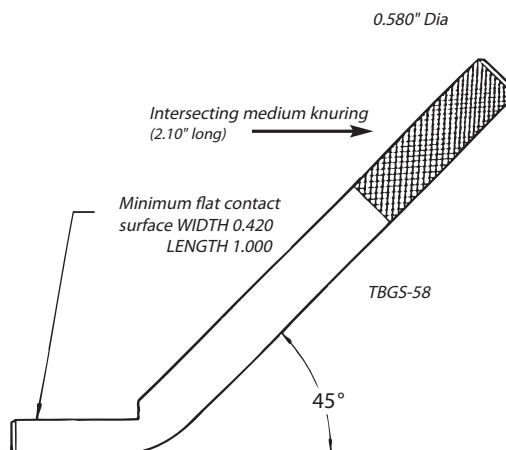
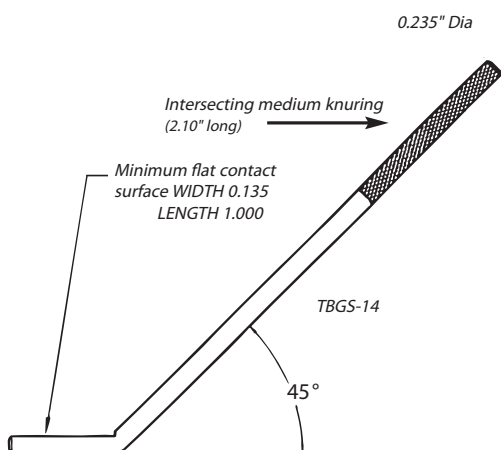

## Grounding Connectors

Connect ground cable to I-Beam or any 1" maximum structural steel member without welding or drilling

### I-Beam Ground Clamps

- Breakaway bolt head shears at predetermined torque to ensure tight connection
- Heavy-duty compression lug provides excellent current carrying capabilities
- Surface of steel must be cleaned in accordance with installation instruction sheet provided with product
- Connector made of high-conductivity cast copper bright dip
- Clamp made of drop-forged high-grade steel, zinc plated



MEETS  
**IEEE**  
837 REQUIREMENTS

Grounding

Cat. No.	Wire Range	TBM15I, TBM15 Installing Tool, Die Code	Die Cat. No.
<b>IBG2-10</b>	2 thru 1/0 AWG	66H	15534 [2]
<b>IBG20-40</b>	2/0 thru 4/0 AWG	87H	15506 [2]
<b>IBG350-500</b>	350 kcmil thru 500 kcmil	115H	15504 [2]

Hydraulic tooling with hex crimp dies.  
Use 15500TB adaptor for T&B 15-Ton Tools.

[\*] Number of crimps

### Cast Copper Two-Way Connectors — Heavy-Duty

- Made from high-conductivity cast copper
- Electro-tin plated finish



Cat. No.	Cable Size	Die Code	Die Colour	Hydraulic Tooling with hex dies	
				13642M	21940
<b>53504</b>	8 AWG	29	Grey	111734	11401
<b>53505</b>	6 AWG	29	Grey	111734	11401
<b>53506</b>	4 AWG	29	Grey	111734	11401
<b>53507</b>	2 AWG	45	Black	11738	11405
<b>53508</b>	1 AWG	45	Black	11738	11405
<b>53509</b>	1/0 AWG	45	Black	11738	11405
<b>53510</b>	2/0 AWG	66	White	11742	11409
<b>53511</b>	3/0 AWG	66	White	11742	11409
<b>53512</b>	4/0 AWG	66	White	11742	11409
<b>53513</b>	250 kcmil	76	Blue	11744	11410
<b>53515</b>	350 kcmil	99	Pink	11744	11410
<b>53518</b>	500 kcmil	99	Pink	11748	11424
<b>53523</b>	750 kcmil	112	Purple	11751	11426

**Grounding Connectors**

**Ground Plates**



MEETS  
**IEEE**  
837 REQUIREMENTS

Grounding



Cat. No.	Fig.	Cable Range	H in. (mm)	Die Code for 14 and 15-Ton Tools
<b>GP2250-2</b>	1	2-250 kcmil	3.63 (92.2)	15G86R [1]
<b>GP2250-4</b>	2	2-250 kcmil	4.22 (107.2)	15G121R [2]
<b>GP250500-2</b>	1	250-500 kcmil	3.63 (92.2)	15G86R [1]
<b>GP250500-4</b>	2	250-500 kcmil	4.22 (107.2)	15G121R [2]

\* Number of crimps

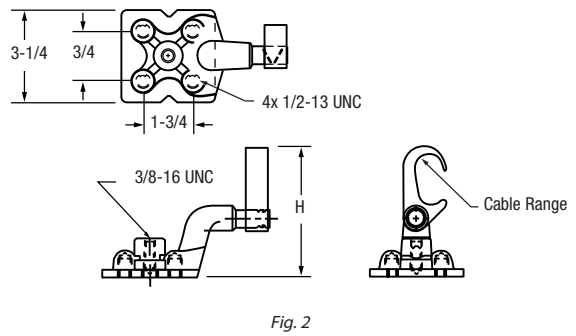
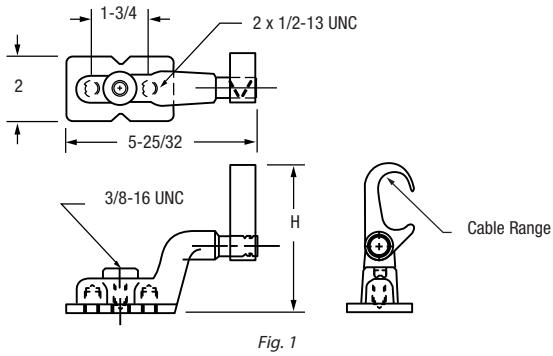

## Grounding Connectors

Cuts installation time in half – with results superior to conventional connectors

### E-Z-Ground® Bus Bar Connectors

- Unique
- Fast and easy installation
- Superior low-resistance, high-conductivity connections
- Installs with conventional compression tools
- Produces a permanent connection with any combination of copper from #6 to #2 solid or stranded conductors, to 1/4 in. copper bus bar
- Made from pure wrought copper and prefilled with oxide inhibitor
- CSA certified and UL Listed
- Installed with die HDF

E-Z-Ground® Bus Bar Connectors install in less than 2 minutes with one easy crimp! The connector attaches directly to the bus, saving the labor-intensive process of drilling and tapping. The unique jaw interface of the E-Z-Ground® Bus Bar Connector grips the copper bus, resulting in a low-resistance, high-conductivity connection.

The E-Z-Ground® Bus Bar Connector can be used in OEM applications or telecom applications – Cellular, PCS and others. It provides a continuous ground to the copper bus bar, making it ideal for tower applications. The design enables installation in virtually any position, horizontal or vertical, and is suitable for inside and outside plant use. Installation can be completed using any T&B 12, 14 or 15 ton compression tool that accepts U-shaped die sets.

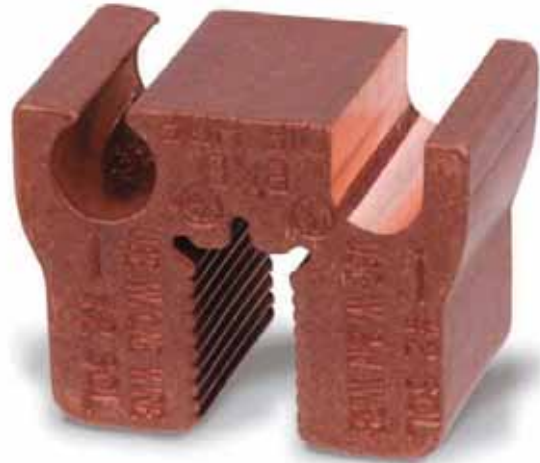

Grounding



Cat. No.	Die Cat. No.	Ground Cable Range (in.)	Conductor Range	Std. Pkg. Qty.
<b>GBBC22</b>	HDF	1/4	#2 AWG–#2 AWG	1
<b>GBBC26</b>	HDF	1/4	#6 AWG–#2 AWG	1

Use this side of the connector when using only one wire.

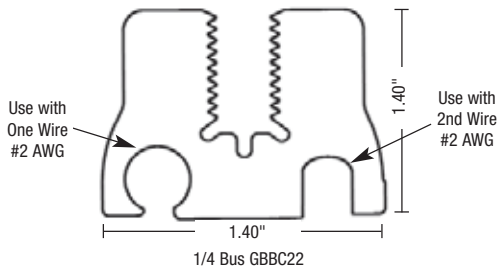

Use this side of the connector only when using two wires.

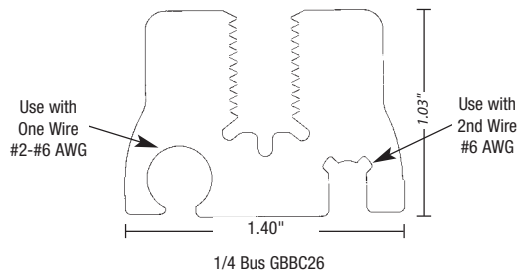

## Grounding Connectors

One-piece construction  
for cable-to-cable, cable-to-rod,  
“T” and “X” connections

### Cable-to-Cable or Cable-to-Rod Connectors

- Suitable for direct burial or in concrete
- Replaces exothermic welds
- Made from high-conductivity wrought copper

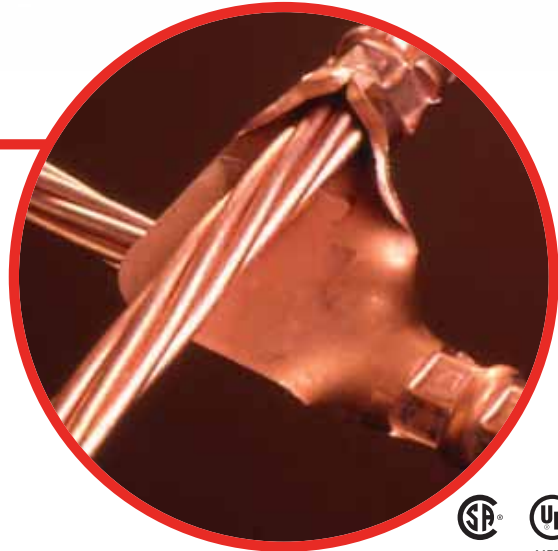

Grounding

Cat. No.	Cable to Cable Range						Rod to Cable range							
	Main	Die Code	TBM14 and 15 Die Cat. No.	Branch	Die Code	TBM14 and 15 Die Cat. No.	Ground Rod (in.)	Die Code	TBM14 and 15 Die Cat. No.	Cable	Die Code	TBM14 and 15 Die Cat. No.		
GG21-21	#2 or #1	45	15526	2	#2 or #1	45	15526	2	-	-	-	-	-	-
GG10-10	1/0	54	15511	2	1/0	54	15511	2	-	-	-	-	-	-
GG2030-21	2/0 or 3/0	60	15532	2	#2 or #1	50-45	15526 15530	2	-	-	-	-	-	-
GG2030-10	2/0 or 3/0	60	15532	2	1/0	54H	15511	2	-	-	-	-	-	-
GG2030-2030	2/0 or 3/0	60	15532	2	2/0-3/0	60	15532	2	-	-	-	-	-	-
GG40250-21	4/0 or 250 kcmil	71H	15514-CK	2	#2	45 50	15526 15530	2	1/2 5/8	71 80H	15514-CK 15517	#2 or #1 #2 or #1	45 50	15526 15530
GG40250-10	4/0 or 250 kcmil	71H	15514-CK	2	1/0 kcmil	54H	15511	2	1/2 5/8	71 80H	15514-CK 15517	1/0	54	15511
GG40250-2030	4/0 or 250 kcmil	71H	15514-CK	2	2/0 or 3/0	60	15532-CK	2	1/2 5/8	71 80H	15514-CK 15517	2/0 or 3/0 2/0 or 3/0	60 60	15532 15532
GG40250-40250	4/0 or 250 kcmil	71H	15514-CK	2	4/0 or 250 kcmil	71H	15514-CK	2	1/2 5/8	71 80H	15514-CK 15517	4/0 or 250 4/0 or 250	71H 71H	15514-CK 15514-CK
GG500-40250	500 kcmil	87H	15506	2	4/0 or 250 kcmil	71H	15514-CK	2	3/4 5/8	87H	15506	4/0 or 250	71H	15514-CK
GG500-500	500 kcmil	87H	15506	2	500 kcmil	87H	15506	2	3/4 5/8	87H	15506	500	87H	15506
GG500-350	500 kcmil	87H	15506	2	350 kcmil	80H	15606	2	3/4 5/8	87H	15506	350	80H	15606
GG500-2030	500 kcmil	87H	15506	2	2/0 or 3/0	60	15532-CK	2	3/4 5/8	87H		2/0 or 3/0	60	15532CK
GG350-350	350 kcmil	80H	15606	2	350 kcmil	80H	15606	2						

Tooling: pages 125-136.  
Use 15500TB adaptor for 15-ton hyphen ton tools.  
Optional ground rod knurling die for TBM14 and 15 tools: 15508.  
Optional ground rod knurling tool: 240-31565-94.

\* Number of crimps.



## Grounding Connectors

For copper cable-to-cable ground-grid connections

### Cable-to-Cable Connectors

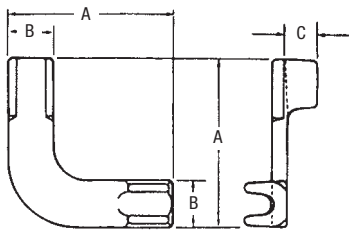

Cat. No.	Conductor Size								Ground Rod	Installation Information			Dimensions in. (mm)		
	Main				Tap					Hyd. Tool	Die	No. Crimps	A	B	C
	Max.	Min.	Max. (mm <sup>2</sup> )	Min. (mm <sup>2</sup> )	Max.	Min.	Max. (mm <sup>2</sup> )	Min. (mm <sup>2</sup> )							
GRD20	2/0	1/0	67.4	53	2/0	1/0	67.4	53	–	TBM14M	B10CH	1	3.00 (76.2)	0.81 (20.6)	0.88 (22.4)
GRD420	250 kcmil	4/0	126.6	107	2/0	1/0	67.4	53	0.63	TBM14M	B12CH	2	3.63 (92.2)	0.69 (17.5)	0.81 (20.6)
GRD40	250 kcmil	4/0	126.6	107	250 kcmil	4/0	126.6	107	0.63	TBM14M	B12CH	2	3.63 (92.2)	0.69 (17.5)	0.81 (20.6)

For connecting perpendicular runs of stranded copper cable to ground rod

### Two Cables to Ground Rod

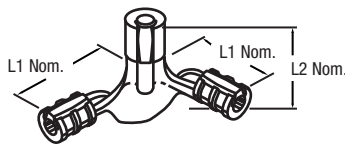

Cat. No.	Cable Size		Ground Rod Dia.	Installing Dies for TBM14 and 15				Overall Dimensions in. (mm)	
	Main	Tap		Ground Cable		Ground Rod		L1	L2
				Die Code	Cat. No.	Die Code	Cat. No.		
53065-58GR	250 or 4/0	250 or 4/0	5/8 and 1/2	87H	15506 [2]	87H	15506 [2]	4.94 (125.5)	3.25 (82.6)
53065-34GR	250 or 4/0	250 or 4/0	3/4	87H	15515-CK [2]	106H	15515 [2]	4.94 (125.5)	3.25 (82.6)

Use T&B hydraulic tools with hex crimp dies.

Optional ground rod knurling die for TBM14 and 15 Tools: 15508.

Optional ground rod knurling Tool: 240-31565-94.

Use 15500TB adapter for T&B 15-Ton tools.

\* Number of crimps

## Grounding Connectors

### Copperweld\* Conductors and Rebar For Use with Cast Copper Connectors

Grounding

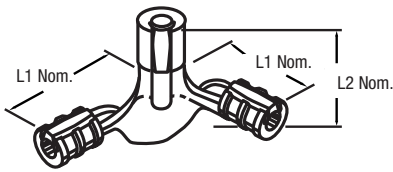

Cable Size	Reinforcing Rod Size	Copperweld Conductor Size
2, 1 AWG	–	3 #8 or 3 #6
1/0, 2/0 AWG	#3	3/8 (7 #8) or 7/16 (7 #7)
4/0, 250 kcmil	#4	7/16 (19 #9) or (7 #5)
300–350	#5	21/32 (19 #8) or 5/8 (7 #4)
500 kcmil	#6	13/16 (19 #6)

\*Reg. Trademark Copperweld Corporation.  
UL Listed for use with cast copper connectors.  
Tooling: see pages 125–136.

### Grounding Grid Connectors Heavy-duty Cast Copper\*\*

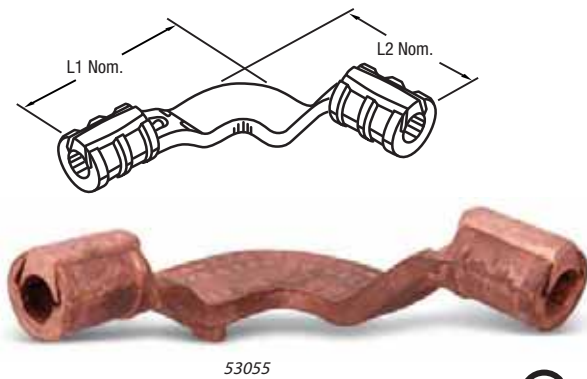

Cat. No.	Rod to Cable Range		Cable to Cable Range		Rod and Cable Installing Die Code for TBM14 or TBM15				Overall Dimensions in. (mm)			
	Rod Size (in.)	Cable Range	Main	Branch	Rod Die Code	Rod Cat. No.	Cable Die Code	Cable Cat. No.	L1	L2		
53055	–	–	1/0–2/0 AWG	1/0–2/0 AWG	–	–	66	15534	1	3.88 (98.6)	3.88 (98.6)	
53059*	1/2–5/8	2–1 AWG	4/0–250 kcmil	2–1 AWG	87H	15506	2	54H	15511	2	4.16 (105.7)	4.56 (115.8)
53060*	1/2–5/8	1/0–2/0 AWG	4/0–250 kcmil	1/0–2/0 AWG	87H	15506	2	87H	15506	2	4.44 (112.8)	4.44 (112.8)
53065*	1/2–5/8	4/0–250 kcmil	4/0–250 kcmil	4/0–250 kcmil	87H	15506	2	87H	15506	2	4.44 (112.8)	4.44 (112.8)
53069*	3/4	1/0–2/0 AWG	300–350 kcmil	1/0–2/0 AWG	106H	15515-CK	2	66	15534	1	4.59 (116.6)	4.59 (116.6)
53071*	3/4	4/0–250 kcmil	300–350 kcmil	4/0–250 kcmil	106H	15515-CK	2	106H	15515-CK	2	5.25 (133.4)	4.78 (121.4)
53073*	1	1/0–2/0 AWG	500 kcmil	1/0–2/0 AWG	125H	15603	3	66	15534	1	4.81 (122.2)	4.88 (124.0)
53075*	1	4/0–250 kcmil	500 kcmil	4/0–250 kcmil	125H	15603	3	87H	15506	2	6.56 (166.6)	5.00 (127.0)
53080*	1	500 kcmil	500 kcmil	500 kcmil	125H	15603	3	125H	15603	3	5.19 (131.8)	5.19 (131.8)

Cat. No. 15500TB adaptor is required for all 15500 Series dies, not for 15600 Series, crimp with 15-Ton Tools.  
\*4/0–250 kcmil wire barrels suitable for 1/2" and 5/8" rod; 300–500 kcmil wire barrels suitable for 3/4" rods; 500 kcmil wire barrels suitable for 1" rods  
Hydraulic tools only.  
\*\*Do not meet IEEE837.

☐ Number of crimps

## Grounding Connectors

For permanent, reliable connection

### Ground Clamps

- Crimps to cable
- Clamps to ground rod and rebar
- Uses standard Color-Keyed® hand and hydraulic tools
- Colour coded for easy installation die selection
- Made from high-conductivity wrought copper
- Furnished with stainless steel hardware, 1/4" washers, bolts and nuts



Grounding

Cat. No.	Wire Size	Ground Rod Diameter (in.)	Rebar (in.)	Bolt Size (in.)	Die Code and Colour
CC2C-45R	#2-#3 AWG	1/2 or 5/8	0.80	0.25	33 Brown
CC1C-45R	#1 AWG	1/2 or 5/8	0.80	0.25	37 Green
CC10C-56R	1/0 AWG	5/8 or 3/4	0.83	0.38	42 Pink
CC20C-56R	2/0 AWG	5/8 or 3/4	0.83	0.38	45 Black
CC40C-56R	4/0 AWG	5/8 or 3/4	0.83	0.38	54 Purple

UL467-Approved for direct burial.

Terminates or connects continuous runs of copper cable to flat surfaces

### Flat-Surface Ground Clamps

- Captive "Keeper bar" design extends cable range and helps hold cable prior to crimping, facilitating installation
- Saddles marked with conductor size and die code
- Conductor can be assembled to saddle with standard dies and hydraulic tools
- Made from high-conductivity cast copper

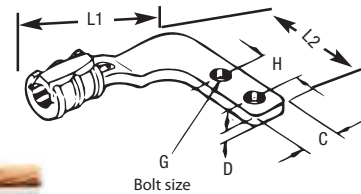

Cat. No.	Wire Range	G Bolt Hole (in.)	Die Code No.	Wt. Per 100	Hex Die		Dimensions in. (mm)				
					Cat. No.	Die Code No.	L1	L2	D	C	H
53055FL	1/0-2/0 AWG	3/8	66	75	15534*	66	4.09 (103.9)	3.66 (93.0)	0.28 (7.1)	1.38 (35.1)	1.00 (25.4)
53065FL	4/0-250 kcmil	3/8	87H	112	15506**	87H	4.50 (114.3)	4.09 (103.9)	0.31 (7.9)	1.38 (35.1)	1.00 (25.4)

\* TBM14M, 13100A, TBM15I with hex crimp dies.

\*\* TBM15I with hex crimp dies only.

### Grid-to-Fence Ground Clamps



- Bonds copper conductors to steel or aluminum fence posts
- Top rail of round fence posts
- Provide quick, dependable installation at low installed cost
- Use no incendiary materials
- Body made from cast copper alloy with steel U-bolt



Cat. No.	Ground Cable Range	Die Code	Steel and Aluminum Line Post Range (in)
FG2040R2	2/0-3/0-4/0	76	2.00
FG2040R25	2/0-3/0-4/0	76	2.50
FG2040R3	2/0-3/0-4/0	76	3.00
FG210R2	2-1-1/0	66	2.00
FG210R25	2-1-1/0	66	2.50
FG210F3	2-1-1/0	66	3.00

Install with hydraulic tooling with hex crimp dies.

## Ground Rod Clamps and Accessories

### Type JAB — Ground Rod Clamps

- Cast of high strength corrosion resistant copper alloy
- Both hex head and socket set screws available
- Long bearing surface of clamp on ground wire secures ground connection
- Listed for direct burial

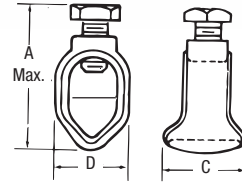

Cat. No.		Nominal Rod Dia.		Wire Range				Dimensions (in.)					
Socket Set Screw	Hex Head Bolt	(in.)	(mm)	max.	min.	max. (mm <sup>2</sup> )	min. (mm <sup>2</sup> )	A (max.) Socket Screw	A (max.) Hex Bolt	Screw Thread Size UNC-2A	B	C	D
JAB12*	JAB12H	1/2	12.7	2 str.	10 sol.	33.6	5.2	1-19/32	2-3/32	7/16-14	27/32	7/8	19/32
JAB58	JAB58H	5/8	15.8	1/0 str.	8 sol.	53.4	8.3	1-27/32	2-13/64	7/16-14	29/32	1	11/16
JAB34	JAB34H	3/4	19.0	1/0 str.	8 sol.	53.4	8.3	2	2-11/32	7/16-14	11/16	1	51/64
-	JAB34C	3/4 + 5/8	15.8 to 19.0	4/0 str.	8 sol.	95.0	8.3	-	2-11/32	7/16-14	1-1/8	1-1/32	13/16
JAB1	JAB1H	1	25.0	4/0 str.	8 sol.	107.1	8.3	2-1/4	3	7/16-14	1-11/32	1-1/16	1

\* CSA not applicable.  
Add suffix P to Cat. No. for tin plated clamp.

### Type G — Budget Line Ground Clamps

- A dependable ground connection offered at a substantial saving
- Cast of high strength corrosion-resistant copper alloy
- Hex head bolts
- Simplified compact design will make a lasting, trouble-free connection
- Listed for direct burial

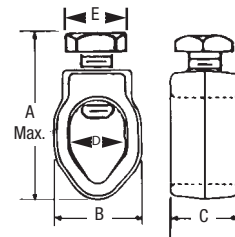

Cat. No.	Nominal Rod Dia.		Wire Range				Dimensions (in.)					
	(in.)	(mm)	max.	min.	max. (mm <sup>2</sup> )	min. (mm <sup>2</sup> )	A (max.) Bolt	Screw Thread Size UNC-2A	B	C	D	E
G3	3/8	9.5	4 str.	10 sol.	21.1	5.2	1-3/8	5/16-18	11/16	1/2	27/64	3/8
G4	1/2	12.7	2 str.	10 sol.	33.6	5.2	-	3/8-16	27/32	3/8	37/64	1/2
G5	5/8	15.8	2 str.	10 sol.	33.6	5.2	-	3/8-16	29/32	3/8	43/64	1/2
G6	3/4	19.0	2 str.	10 sol.	33.6	5.2	-	3/8-16	1-1/16	3/8	13/16	1/2

Add suffix P to Cat. No. for tin plated clamp.

## Ground Rod Clamps and Accessories

### Type JWR — Wide-Range Ground Rod Clamps

- Listed for direct burial in earth/concrete
- Constructed from bronze alloy and high-performance stainless steel bolt
- Provides wide range of connection sizes
- More than 300 lb. torque capacity

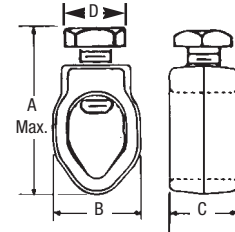

Cat. No.	Nominal Rod Dia.		Wire Range				Dimensions (in.)			
	(in.)	(mm)	max.	min.	max. (mm <sup>2</sup> )	min. (mm <sup>2</sup> )	A (max.) Bolt	B	C	D
<b>JWR</b>	3/8*	9.5	1/0 str.	10 sol.	53.4	5.2	1.535	1.050	0.812	0.652
	1/2	12.7	1/0 str.	10 sol.	53.4	5.2	1.535	1.050	0.812	0.652
	5/8	15.8	1/0 str.	10 sol.	53.4	5.2	1.535	1.050	0.812	0.652
	3/4	19.0	1/0 str.	10 sol.	53.4	8.3	1.535	1.050	0.812	0.652

\* 3/8" rod CSA not applicable/listed by UL.

### Types GG and GGH — Heavy Duty Ground Rod Clamps

- Cast of high strength corrosion-resistant copper alloy; two types of screws available
- Type GG has a socket set screw
- Type GGH has a hex head bolt
- Floating pressure bar distributes pressure evenly over a large area of the ground wire
- Axial groove keeps wire and rod in perfect alignment

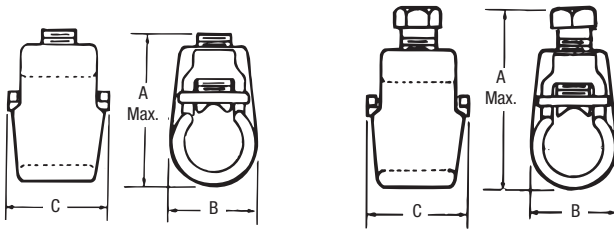

Cat. No.		Nominal Rod Dia.		Wire Range				Dimensions (in.)				
Socket Set Screw	Hex Head Bolt	(in.)	(mm)	max.	min.	max. (mm <sup>2</sup> )	min. (mm <sup>2</sup> )	A (max.) Socket Screw	A (max.) Hex Bolt	Screw Thread Size UNC-2A	B	C
<b>GG12</b>	<b>GG12H</b>	1/2	12.7	2 str.	8 sol.	33.6	8.3	1-13/64	1-13/16	7/16-14	27/32	15/16
<b>GG58</b>	<b>GG58H</b>	5/8	15.8	2/0 str.	8 sol.	53.6	8.3	1-51/64	2-7/32	7/16-14	61/64	15/16
—	<b>GG34H**</b>	3/4	19.0	4/0 str.	8 sol.	120.6	8.3	—	3	1/2-14	1-3/8	1-1/4

Add suffix P to catalogue number for tin plated clamp.  
GG34H has no pressure bar or axial groove.  
\*\* CSA not applicable.



## Ground Rod Clamps and Accessories

### Type GUV — U-Bolt Clamps

Grounding

- Listed for direct burial
- For connecting copper or copper clad steel grounding conductor to ground rod or pipe
- Excellent for connecting multiple electrodes with a single cable as in substation grounding
- All components are cast or forged from copper alloy
- Specially designed spacer provides proper alignment between cable and electrode and affords more positive contact area

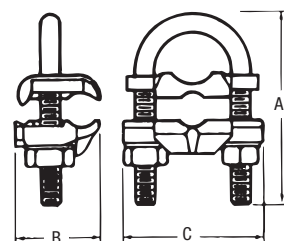

Cat. No.	Conductor Range (CU)		Nominal Rod Size (in.)		IPS Pipe Size (in.)		Dimensions (in.)		
	max.	min.	max.	min.	max.	min.	A	B	C
<b>GUV584</b>	4	8	3/4	5/8	3/8	—	2-13/16	1-9/16	2-1/4
<b>GUV5821</b>	2/0	4	3/4	5/8	3/8	—	2-13/16	1-9/16	2-1/4
<b>GUV5825</b>	250	2/0	3/4	5/8	3/8	—	2-13/16	1-9/16	2-1/4
<b>GUV784</b>	4	8	1	7/8	3/4	1/2	2-3/4	1-9/16	2-5/8
<b>GUV7821</b>	2/0	4	1	7/8	3/4	1/2	2-3/4	1-9/16	2-5/8
<b>GUV7825</b>	250	2/0	1	7/8	3/4	1/2	2-3/4	1-9/16	2-5/8
<b>GUV1184</b>	4	8	1-1/4	1-1/8	1	—	3-5/16	1-9/16	2-3/4
<b>GUV11821</b>	2/0	4	1-1/4	1-1/8	1	—	3-5/16	1-9/16	2-3/4
<b>GUV1384</b>	4	8	1-1/2	1-3/8	1-1/4	—	3-7/16	1-9/16	2-15/16
<b>GUV13821</b>	2/0	4	1-1/2	1-3/8	1-1/4	—	3-7/16	1-9/16	2-15/16
<b>GUV13825</b>	250	2/0	1-1/2	1-3/8	1-1/4	—	3-7/16	1-9/16	2-15/16
<b>GUV1584</b>	4	8	1-7/8	1-5/8	1-1/2	—	3-15/16	1-9/16	3-3/16
<b>GUV15821</b>	2/0	4	1-7/8	1-5/8	1-1/2	—	3-15/16	1-9/16	3-3/16
<b>GUV15825</b>	250	2/0	1-7/8	1-5/8	1-1/2	—	3-15/16	1-9/16	3-3/16
<b>GUV204</b>	4	8	2-3/8	2	2	—	4-7/16	1-9/16	3-11/16
<b>GUV2021</b>	2/0	4	2-3/8	2	2	—	4-7/16	1-9/16	3-11/16
<b>GUV2025</b>	250	2/0	2-3/8	2	2	—	4-7/16	1-9/16	3-11/16
<b>GUV21221</b>	2/0	4	2-7/8	2-1/2	2-1/2	—	4-15/16	1-9/16	4-3/16
<b>GUV21225</b>	250	2/0	2-7/8	2-1/2	2-1/2	—	4-15/16	1-9/16	4-3/16
<b>GUV3021</b>	2/0	4	3-1/2	3	3	—	5-9/16	1-9/16	4-13/16
<b>GUV3025</b>	250	2/0	3-1/2	3	3	—	5-9/16	1-9/16	4-13/16
<b>GUV31221</b>	2/0	4	4	3-1/2	3-1/2	—	6-1/16	1-9/16	5-1/2
<b>GUV4021</b>	2/0	4	4-1/2	4	4	—	6-5/16	1-9/16	5-11/16
<b>GUV4025</b>	250	2/0	4-1/2	4	4	—	6-5/16	1-9/16	5-11/16

For tin plating, add suffix TP to Catalogue number.

## Grounding Electrodes and Accessories

### Galvanized Ground Rods

- Made of high strength quality cold drawn steel, (1035) hot dip galvanized
- Meet ANSI C135.30-1979 requirements
- Stainless steel rods are also available (for more detailed information, contact your T&B regional sales office)



Cat. No.	Trade Size		Rod Size (nominal diameter x length)		Plating Thickness	Standard Packaging	Weight per 100	
	in.	ft.	mm	m			lb.	kg
<b>GR5006</b>	1/2	6	12.7	1.8	4 mils	10	410	186
<b>GR6256</b>	5/8	6	15.8	1.8	4 mils	5	600	272
<b>GR6258</b>	5/8	8	15.8	2.4	4 mils	5	800	363
<b>GR6250</b> (0.543 – 0.555)	5/8	10	15.8	3.0	4 mils	5	1000	454
<b>GR6260</b> (0.625 – 0.640)	5/8	10	15.8	3.0	4 mils	5	1000	454
<b>GR6250B*</b> (0.618 – 0.623)	5/8	10	15.8	3.0	4 mils	5	1000	454
<b>GR7506</b>	3/4	6	15.8	1.8	4 mils	5	700	318
<b>GR7508</b>	3/4	8	19.0	2.4	4 mils	5	1200	545
<b>GR7510</b>	3/4	10	19.0	3.0	4 mils	5	1500	681

\* B suffix denotes black iron bare steel ground rod (CSA not applicable).  
CSA lists rods 1/2 in. and larger, 10 ft and longer.

### Copper Bonded Steel Ground Rods

- All Blackburn® ground rods have a heavy uniform covering of electrolytic copper bonded to a rigid steel core
- Copper ions are forced electrically to join with the steel core, establishing a corrosion-resistant bond between the copper and the steel



Cat. No.	Trade Size		Rod Size (nominal diameter x length)		Plating Thickness	Standard Packaging	Weight per 100	
	in.	ft.	mm	m			lb.	kg
<b>5005</b>	1/2	5	12.7	1.8	5 mils	10	305	138
<b>5006</b>	1/2	6	15.8	1.8	5 mils	5	370	168
<b>5008</b>	1/2	8	15.8	2.4	5 mils	5	545	247
<b>5010</b>	1/2	10	15.8	3.0	5 mils	5	611	277
<b>6256</b>	5/8	6	15.8	3.0	5 mils	5	508	230
<b>6258*</b>	5/8	8	15.8	3.0	10 mils	5	678	308
<b>6260*</b>	5/8	10	15.8	1.8	10 mils	5	847	384
<b>7508*</b>	3/4	8	19.0	2.4	10 mils	5	992	450
<b>7510*</b>	3/4	10	19.0	3.0	10 mils	5	1240	462
<b>1010*</b>	1	10	25.4	3.0	10 mils	1	2248	1020

\* Ground rods are UL listed (425H), except for regular rods shorter than 8 ft or less than 1/2 inch.  
CSA lists rods 1/2 in. and larger, 10 ft and longer.

## Grounding Electrodes and Accessories

### Sectional Copper Bonded Steel Ground Rods

- Sectional type ground rods have the same high quality as regular copper bonded steel ground rods, and are threaded top and bottom



Cat. No.	Trade Size		Rod Size (nominal diameter x length)		Plating Thickness	Thread Size	Standard Packaging	Weight per 100	
	in.	ft.	mm	m				lb.	kg
5008LS	5/8	6	15.8	1.8	10 mils	9/16-12	5	546	248
5010LS	5/8	8	15.8	2.4	10 mils	9/16-12	5	682	309
6258S	5/8	8	15.8	3.0	10 mils	5/8-11	5	670	308
6260S	5/8	10	15.8	3.0	10 mils	5/8-11	5	837	384
7506S	3/4	6	15.8	1.8	5 mils	3/4-10	5	774	160
7508S	3/4	8	19.0	2.4	10 mils	3/4-10	5	992	450
7510S	3/4	10	19.0	3.0	10 mils	3/4-10	5	1040	562
1010S	1	10	25.4	3.0	10 mils	8-1	1	2248	1020

CSA lists rods 1/2\* in. and larger, 10 ft and longer.

### Couplings

- Threaded couplings are made of high strength, corrosion resistant alloy. Streamlined design reduces driving friction. Couplings are tapped for use on all standard threaded sectional rods



Cat. No.	Rod Size Diameter (in.)	Thread Size	Standard Packaging	Weight Per 100 (lb.)
50LC	1/2	9/16" - 12 UNS	25	17
60C	5/8	5/8" - 11 UNS	25	25
70C	3/4	3/4" - 10 UNS	25	38
80C	1	1" - 8 UNS	10	75

### Driving Studs

- Driving Studs of high strength steel may be used with all standard threaded couplings



Cat. No.	Rod Size Diameter (in.)	Thread Size	Standard Packaging	Weight Per 100 (lb)
50LDS*	1/2	9/16" - 12 UNS	10	16
60DS*+	5/8	5/8" - 11 UNS	25	23
70DS*	3/4	3/4" - 10 UNS	5	35
80DS	1	1" - 8 UNS	10	75

\* UL Listed.  
+ CSA Listed.

## Grounding Electrodes and Accessories

### Threadless Couplings and Driving Caps for Standard Copper Bonded Ground Rods

#### Threadless Couplings

- For joining non-threaded, sectional, copper bonded, steel ground rods
- Coupling is manufactured of a high strength, corrosion resistant, silicone bronze

#### Threadless Driving Caps

- Prevent “mushrooming” of ground rod while driving to insure proper fit of coupling
- Driving cap is manufactured of high strength, hardened steel



Cat. No.	Size (in.)	Dimensions (in.)		Standard Packaging	Weight Per 100 (lb.)
		Length	Diameter		
<b>Threadless couplings</b>					
<b>50CNT*</b>	1/2	3.0	0.78	25	34
<b>60CNT2*</b>	5/8	2.5	0.69	25	34
<b>70CNT*</b>	3/4	3.0	0.97	25	31
<b>Driving Caps</b>					
<b>60DSNT</b>	5/8	4.0	0.88	10	43

\* UL Listed.

### Type DGC — Drive-On Ground Clamps

- Drive-on design provides easy tool free installation, high reliability compression fit connection, and room for one or two ground leads
- High-strength copper alloy provides increased tensile strength and long-term corrosion resistance for direct burial applications
- U.L. 486A and U.L. 467 Listed



Cat. No.	Ground Rod Size in. (mm)	Ground Wire Size
<b>DGC58-44*</b>	5/8 (0.555–0.565)	1 or 2-#4 sol.
<b>DGC58-66*</b>	5/8 (0.555–0.565)	1 or 2-#4 sol. 1-#4 sol.
<b>DGC58-46</b>	5/8 (0.555–0.565)	1-#6 sol.

\* RUS Listed.

## Grounding Electrodes and Accessories

Grounding

### Ground Rod Drivers

For installing ground rods, there's no safer, simpler or more effective tool than the Thomas & Betts Ground Rod Driver. It can be used on all types of ground rods including copper-bonded, galvanized and stainless steel.

Integral inserts prevent the driver from slipping off the rod near ground level. The inserts are 5/8" and 3/4", and are interchangeable with the standard driver body. The convenient retaining collar holds the insert in the tool when not in use.

Thomas & Betts Ground Rod Drivers have a heavy-duty steel construction that allows maximum force for driving ground rods, while the efficient design ensures that minimal lifting force is required. The ground rod end is designed for high impact applications to ensure quality connections.

- Unique design allows installation of 10-foot rods from ground level
- Heavy-duty steel construction
- Ergonomic grip provides ease and comfort with increased safety
- Complete with interchangeable parts that are range-taking for different diameter ground rods
- Two interchangeable inserts allow the same tool to be used with all sizes of rods
- Completely self-contained and easy to store



Photo includes ground rod driver and insert

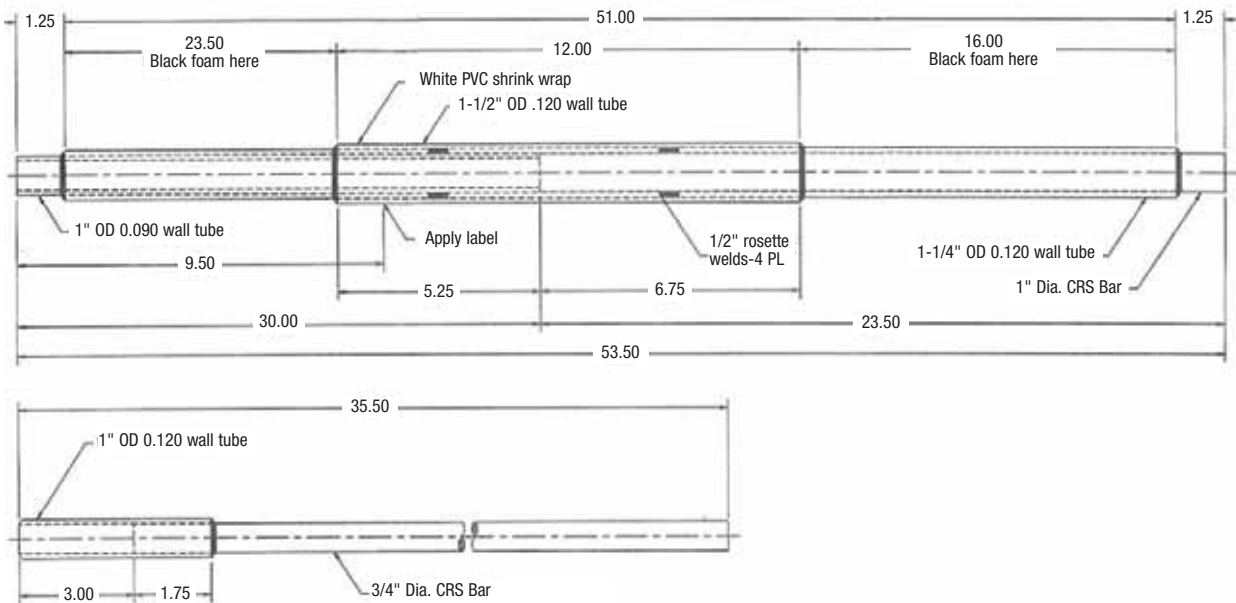

Cat. No.	Description	Weight (lb.)	Maximum Rod Diameter (in.)	Std. Pkg.
TBRD58	5 ft. Ground Rod Driver with 5/8" insert	25	0.63	1
TBRD34	5 ft. Ground Rod Driver with 3/4" insert	25	0.75	1
TBS58	Replacement 5/8" insert	4	0.63	1
TBS34	Replacement 3/4" insert	4	0.75	1



## Grounding Electrodes and Accessories

### Galvanized Grounding Plates

- Made of high quality steel, hot dip galvanized
- Major time and cost saving vs ground rods

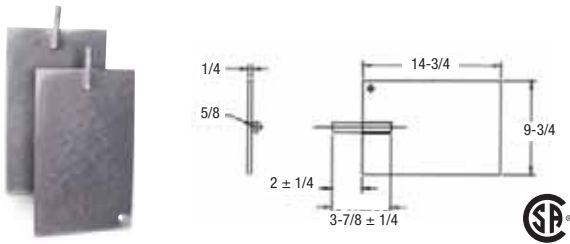

Cat. No.	Description	Wire Range	Std. Pkg.
<b>1016TB</b>	Galvanized grounding plate	—	1
<b>1016BTB</b>	Galvanized grounding plate complete with JAB34C connector	8 sol. to 4/0 str.	1
<b>1016TB-NG*</b>	Grounding plate (not galvanized)	8 sol. to 4/0 str.	1
<b>1016BTB-NG*</b>	Grounding plate (not galvanized) (complete with ground rod clamp)	8 sol. to 4/0 str.	1

\* CSA not applicable.

### Ground Electrode Boxes

Cat. No.	Description
<b>51628</b>	Pregalvanized Steel
<b>51629</b>	Hot dip galvanized

14 gauge steel 10 inch diameter, 12 inch depth.



### Metallic Gradient Control Mats

- To reduce risk and prevent build up of dangerous potential differences between high voltage equipment or structures and the user standing on the ground surface. CEC Rule 36-308



Cat. No.	Description	Std. Pkg.	Wt/100	
			lb.	kg
<b>64663</b>	Mat with connectors	1	3000	1363

4 ft x 6 ft hot dip galvanized mat is made from 6" x 6" welded mesh, 1/4" diameter. With hardware 3-1/2 x 1-1/2 galvanized bolts, 3 gal. washers and 3 gal. nuts.

### Type GP — Copper Pole Bottom Ground Plates for Multigrounded Neutral Construction

- More efficient than butt wrapping poles
- Made of electrolytic sheet copper
- Built-in high pressure connector for ground lead, or supplied with #6 AWG copper pigtail pre-attached
- Plates are grooved for trapping moisture



Cat. No.	Pigtail Wire Range				Diameter of Plate	
	min.	max.	min. (mm²)	max. (mm²)	(in.)	(mm)
<b>GP100</b>	8	2 sol.	6.3	25.6	7-1/2	191
<b>GP110</b>					10	254
<b>GP114</b>					14	356
<b>GP1003</b>			#6 AWG solid CU Pigtail with 18" conductor	—	—	7-1/2 191
<b>GP1008</b>			#6 AWG solid CU Pigtail with 18" conductor	—	—	7-1/2 191
<b>GP1108</b>			#6 AWG solid CU Pigtail with 18" conductor	—	—	7-1/2 254

### Type PB — Copper Pole Ground Plates

- Installed on butt end of utility poles to provide an economical, low resistance neutral ground
- Installed cost considerably less than butt-wrapped poles. Plate portion fabricated of .025" pure copper
- PBGW connector is eye-bolt type, cast of corrosion resistant aluminum bronze alloy, with silicon bronze nut and lock washer. Riveted all copper terminal lug is an integral part of the PBH, and provides the means of connection to the grounding conductor



Cat. No.	Wire Range		Finished Size (in.)	Surface Area sq. in.
	max.	min.		
<b>PBGW</b>	2/0 str.	10 sol.	7 x 7-5/8	56
<b>PBH*</b>	4 str.	14 sol.	7 x 7-3/8	56

\* RUS Listed.

## Mechanical Grounding Connectors

Grounding

### Type GTC — Tower Ground Clamps

- Bolt has square shank to prevent turning and allow clamp to be tightened with one wrench
- GTC 23 and 24 are two-piece clamps for connecting ground lead cable to flat metal surface; ideal for grounding substations on tower footings
- Castings are of high strength, corrosion resistant copper alloy
- GTC 13 and 14 are economical one-piece clamps which perform the same function as two-piece clamps except the under pad support is omitted and conductor is connected directly to tower
- Add suffix L to Cat. No. for 1/2" channel thickness

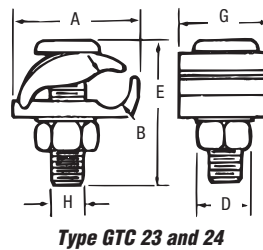
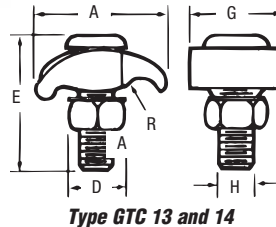

Cat. No.	Conductor Range				Channel Thickness	Dimensions (in.)						
	max.	min.	max. (mm <sup>2</sup> )	min. (mm <sup>2</sup> )		A	B	D	E	G	H	R
<b>GTC13</b>	2/0 str.	4 sol.	67.4	21.1	1/4	1-15/32	—	9/16	1-21/32	13/32	3/8	7/32
<b>GTC14</b>	250 kcmil	2/0 str.	126.6	67.4	1/4	1-15/16	—	3/4	1-15/16	1-13/32	1/2	5/16
<b>GTC23</b>	2/0 str.	4 sol.	67.4	21.1	1/4	1-41/64	7/16	9/16	2-21/32	1-3/32	3/8	—
<b>GTC24</b>	250 kcmil	2/0 str.	126.6	21.1	1/4	1-61/64	5/8	3/4	1-15/16	1-3/8	1/2	—

### CTG250 Wide Range Tower Ground Clamps

- For use with aluminum or copper conductors and in aluminum or galvanized steel cable tray.
- Ribbed neck on the bolt prevents rotation during tightening if 0.440 dia. hole is used



Cat. No.	Wide Range (2 sides)	Height	Width	Depth	Nut (Flats)
<b>CTG250</b>	#2 sol. (0.258 Dia.), 250 kcmil (0.575 Dia.)	1.95	2.00	1.13	0.560

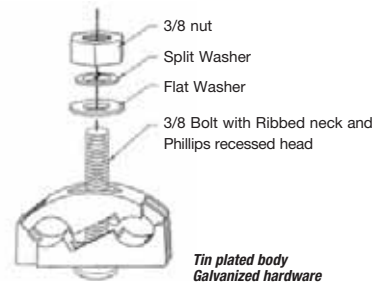

## Mechanical Grounding Connectors

### Copper Lay-In Lug Connectors

- Ideal for swimming pool grounding applications
- Carries “DB” marking for direct burial
- Open-faced design enables installer to quickly lay-in grounding conductor as jumper to multiple conduits with no break in ground conductor

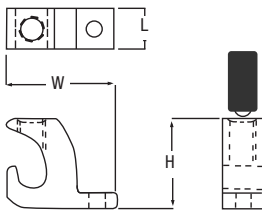

Figure 1



Cat. No.	Conductor Range		Stud Size		Dimensions					
	in.	AWG mm <sup>2</sup>	in.	mm	H		W		L	
					in.	mm	in.	mm	in.	mm
<b>CULL414</b>	4-14	16-1.5	0.22	5.59	0.78	19.81	0.38	9.65	1.07	27.18
<b>CULL414TP*</b>	4-14	16-1.5	0.22	5.59	0.78	19.81	0.38	9.65	1.07	27.18

90°C Rating.  
\* Tin plated.

### Lay-In Lug Connectors

These grounding connectors are manufactured with high strength 6061-T6 aluminum alloy to insure both maximum strength and conductivity. Dual-rated for both copper and aluminum conductor. The open-faced design allows the installer to quickly lay-in the grounding conductor as a jumper to multiple conduits with no break in the ground conductor.



Cat. No.	Fig. No.	Conductor Range		Stud Size		Dimensions					
		AWG in.	AWG mm <sup>2</sup>	in.	mm <sup>2</sup>	H		W		L	
						in.	mm	in.	mm	in.	mm
<b>LL414</b>	1	4-14	16-1.5	0.22	5.59	0.78	19.81	0.38	9.65	1.07	27.18
<b>LL1014</b>	1	1/0-14	50-1.5	0.27	6.86	1.17	29.72	0.60	15.24	1.50	38.10
<b>LL306</b>	2	3/0-6	70-16	0.33	8.38	1.56	39.62	0.80	20.32	2.00	50.80
<b>LL2506</b>	2	250-6	120-16	0.33	8.38	1.79	45.47	0.80	20.32	2.20	55.88

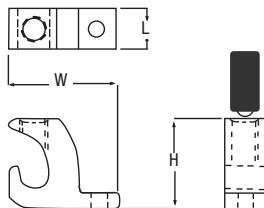

Figure 1



Figure 2

## Mechanical Grounding Connectors

### SnapTap® Parallel Connectors

- Designed for bonding and grounding applications using copper, steel stranded and ground rod
- Easily installed with channel locks or pliers
- Made from high-strength aluminum alloy with tin plating
- Offers excellent electrical and mechanical characteristics
- UL467 tested – exceed performance requirements
- CSA Std C22.2 No 41 for 1/2" ground rods to 2-#6 AWG sol.

With the SnapTap® Connectors, you can achieve an electrically superior, pressure-fit connection in seconds without expensive tooling. The connector is also easy to disassemble, requiring only a flat-head screwdriver to release the connected body. A one-piece design keeps parts together, minimizing loss of components prior to assembly. Simply separate the pieces and snap them in place for installation. An audible "Snap" indicates that the connection is complete and properly installed.



Cat. No.	Conductor Description		Packaging		Std. Order Qty
	Main	Branch	Inner Pack	Outer Pack	
JP62*	#2 AWG Sol. Copper	#6 AWG Sol. Copper	20	200	200
JP66-TB*	#2 AWG Sol. Copper	#6 AWG Sol. Copper	20	200	200
JP146	1/4" Steel Stranded	#6 AWG Sol. Copper	20	200	200
JP5166	5/8" Steel Stranded	#6 AWG Sol. Copper	20	200	200
JP386	3/8" Steel Stranded	#6 AWG Sol. Copper	20	200	200
JP126	1/2" Steel Stranded	#6 AWG Sol. Copper	20	200	200
JP126G	1/2" Ground Rod	#6 AWG Sol. Copper	20	200	200
JP2614	1/4" Steel Stranded	2-#6 AWG Sol. Copper	20	200	200
JP26516	5/16" Steel Stranded	2-#6 AWG Sol. Copper	20	200	200
JP2638	3/8" Steel Stranded	2-#6 AWG Sol. Copper	20	200	200
JP2612G*	1/2" Ground Rod	2-#6 AWG Sol. Copper	20	200	200

NOTE: All Toolless Connectors are UL Listed. Only items with (\*) are CSA listed.

#### General Usage Instructions

##### Separate

No special tools required. Use ordinary parallel jaw pliers to separate the connector into two parts. Hold one side of connector with pliers and bend opposite side back and forth until parts separate (see **Fig. 1**).

Caution: Be careful not to pinch fingers or thumb when separating parts. Keep fingers out of bend part when bending part against plier jaws.

##### Installation

1. Strip the insulation from each conductor. Be careful not to nick the conductor. Clean the conductor ends with a wire brush or emery cloth if necessary.
2. Place each conductor into the grooves in BODY piece. Press conductors with pliers to align and seat into grooves (see **Fig. 2**).
3. Hold the conductors and BODY piece until it closes. Use parallel jaw pliers and grip the SNAP and BODY pieces as shown (see **Fig. 3**). Apply pressure until connector "snaps" into place. Visually inspect snap to verify full insertion. The connection is now complete (see **Fig. 4**).

##### Removal

The connector can be disassembled using a flat-head screwdriver to pry the SNAP piece from BODY piece.

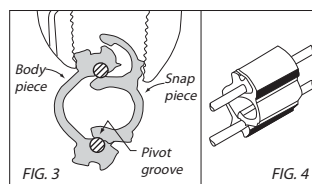
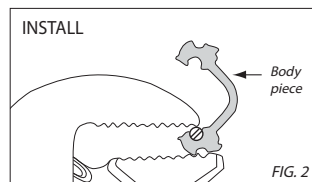
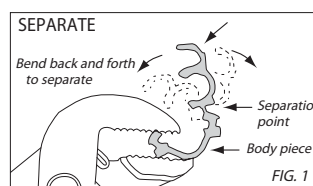

## Mechanical Grounding Connectors

### Type DS — Service Post Connectors, Short Stud

#### Application

The Blackburn® line of Service Post Connectors is designed for applications including steel structure, fence post or transformer grounding involving one or two cables. Service Posts can also be used to tap one or two cables from bus bar.

#### Construction & Ratings

Bolts used in the Service Post are machined from high conductivity bronze alloy while the nuts are cold-formed from high strength, corrosion resistant copper alloy. Pressure bars are copper through 4/0 size, while copper alloy is used for 350 kcmil size and above. Bolts and nuts are of the traditional Blackburn® hex design for easy installation.

Service Post Connectors are available in sizes accommodating AWG copper conductor ranges of #12 – 500 kcmil stranded (4 mm<sup>2</sup> - 240 mm<sup>2</sup>) and #12-#2 solid (4 mm<sup>2</sup> - 35 mm<sup>2</sup>).

The line includes both short and long stud versions for single conductor and double conductor connectors.

- For copper to copper connections
- For grounding of steel structures, fence posts or transformers using one or two cables
- For tapping one or two cables from bus bar
- Hex design bolts are machined from high conductivity bronze alloy
- Nuts and pressure bars are cold-formed from high-strength copper or copper alloy



Cat. No.		Conductor Range Stranded (AWG/mm <sup>2</sup> )		Conductors Range Solid (AWG/mm <sup>2</sup> )		Maximum Diameter Range (in.)	Stud Size (in.)
Double Conductor	Single Conductor	max.	min.	max.	min.		
<b>SP0DS</b>	<b>SP0SS</b>	8 6 mm <sup>2</sup>	12 4 mm <sup>2</sup>	8 6 mm <sup>2</sup>	12 4 mm <sup>2</sup>	0.146–0.080	1/4–20 x 1/2
<b>SP1DS</b>	<b>SP1SS</b>	7 10 mm <sup>2</sup>	10 6 mm <sup>2</sup>	6 10 mm <sup>2</sup>	10 6 mm <sup>2</sup>	0.170–0.102	1/4–20 x 1/2
<b>SP2DS</b>	<b>SP2SS</b>	5 16 mm <sup>2</sup>	10 6 mm <sup>2</sup>	4 16 mm <sup>2</sup>	10 6 mm <sup>2</sup>	0.217–0.102	5/16–18 x 5/8
<b>SP3DS</b>	<b>SP3SS</b>	3 25 mm <sup>2</sup>	10 6 mm <sup>2</sup>	2 35 mm <sup>2</sup>	10 6 mm <sup>2</sup>	0.271–0.102	3/8–16 x 5/8
<b>SP4DS</b>	<b>SP4SS</b>	1 35 mm <sup>2</sup>	8 6 mm <sup>2</sup>	2 35 mm <sup>2</sup>	8 10 mm <sup>2</sup>	0.332–0.128	3/8–16 x 5/8
<b>SP5DS</b>	<b>SP5SS</b>	1/0 50 mm <sup>2</sup>	2 35 mm <sup>2</sup>	2 35 mm <sup>2</sup>	—	0.385–0.259	1/2–13 x 3/4
<b>SP6DS</b>	<b>SP6SS</b>	2/0 70 mm <sup>2</sup>	2 35 mm <sup>2</sup>	2 35 mm <sup>2</sup>	—	0.443–0.258	1/2–13 x 3/4
<b>SP8DS</b>	<b>SP8SS</b>	4/0 95 mm <sup>2</sup>	1 35 mm <sup>2</sup>	—	—	0.570–0.289	5/8–11 x 1
<b>SP9DS</b>	<b>SP9SS</b>	350 150 mm <sup>2</sup>	1/0 70 mm <sup>2</sup>	—	—	0.715–0.373	5/8–11 x 1
<b>SP10DS</b>	<b>SP10SS</b>	500 240 mm <sup>2</sup>	3/0 95 mm <sup>2</sup>	—	—	0.840–0.464	3/4–10 x 1-1/4

Physical dimensions can be found on page 10.



## Mechanical Grounding Connectors

### Type SP — Service Post Connectors, Long Stud

Grounding

- For copper to copper connections
- For grounding of steel structures, fence posts, transformers using one or two cables
- For tapping one or two cables from bus bar
- Hex design bolts are machined from high conductivity bronze alloy
- Nuts and pressure bars are cold-formed from high-strength copper or copper alloy
- Pressure bars are copper through 4/0 size; copper alloy is used for 350 kcmil size and above
- Available in sizes accommodating AWG copper conductor ranges of #12–500 kcmil stranded (4mm<sup>2</sup>–240mm<sup>2</sup>) and #12–#2 solid (4mm<sup>2</sup>–35mm<sup>2</sup>)
- Line includes single conductor and double conductor connectors



Cat. No.		Conductors Range Stranded (AWG/mm <sup>2</sup> )		Conductors Range Solid (AWG/mm <sup>2</sup> )		Maximum Diameter Range (in.)	Stud Size (in.)
Double Conductor	Single Conductor	max.	min.	max.	min.		
<b>SP0DL</b>	<b>SP0SL</b>	8 6 mm <sup>2</sup>	12 4 mm <sup>2</sup>	8 6 mm <sup>2</sup>	12 4 mm <sup>2</sup>	0.146–0.080	1/4–20 x 1/2
<b>SP1DL</b>	<b>SP1SL</b>	7 10 mm <sup>2</sup>	10 6 mm <sup>2</sup>	6 10 mm <sup>2</sup>	10 6 mm <sup>2</sup>	0.170–0.102	1/4–20 x 1/2
<b>SP2DL</b>	<b>SP2SL</b>	5 16 mm <sup>2</sup>	10 6 mm <sup>2</sup>	4 16 mm <sup>2</sup>	10 6 mm <sup>2</sup>	0.217–0.102	5/16–18 x 5/8
<b>SP3DL</b>	<b>SP3SL</b>	3 25 mm <sup>2</sup>	10 6 mm <sup>2</sup>	2 35 mm <sup>2</sup>	10 6 mm <sup>2</sup>	0.271–0.102	3/8–16 x 5/8
<b>SP4DL</b>	<b>SP4SL</b>	1 35 mm <sup>2</sup>	8 6 mm <sup>2</sup>	2 35 mm <sup>2</sup>	8 10 mm <sup>2</sup>	0.332–0.128	3/8–16 x 5/8
<b>SP5DL</b>	<b>SP5SL</b>	1/0 50 mm <sup>2</sup>	2 35 mm <sup>2</sup>	2 35 mm <sup>2</sup>	–	0.385–0.259	1/2–13 x 3/4
<b>SP6DL</b>	<b>SP6SL</b>	2/0 70 mm <sup>2</sup>	2 35 mm <sup>2</sup>	2 35 mm <sup>2</sup>	–	0.443–0.258	1/2–13 x 3/4
<b>SP8DL</b>	<b>SP8SL</b>	4/0 95 mm <sup>2</sup>	1 35 mm <sup>2</sup>	–	–	0.570–0.289	5/8–11 x 1
<b>SP9DL</b>	<b>SP9SL</b>	350 150 mm <sup>2</sup>	1/0 70 mm <sup>2</sup>	–	–	0.715–0.373	5/8–11 x 1
<b>SP10DL</b>	<b>SP10SL</b>	500 240 mm <sup>2</sup>	3/0 95 mm <sup>2</sup>	–	–	0.840–0.464	3/4–10 x 1-1/4

Physical dimensions can be found on page 11.

## Mechanical Grounding Connectors

### Type TTC — Transformer Tank Ground Connectors

- Transformer Grounding Connectors are cast of high conductivity bronze; 1/2"–13 stud fits all standard EEI-NEMA distribution transformers
- Eye bolt on TTC2 rotates to accommodate cable in either vertical or horizontal direction
- One size connector to handle full range of grounding conductors from #8 through 2/0 str.
- No special tools required



Grounding

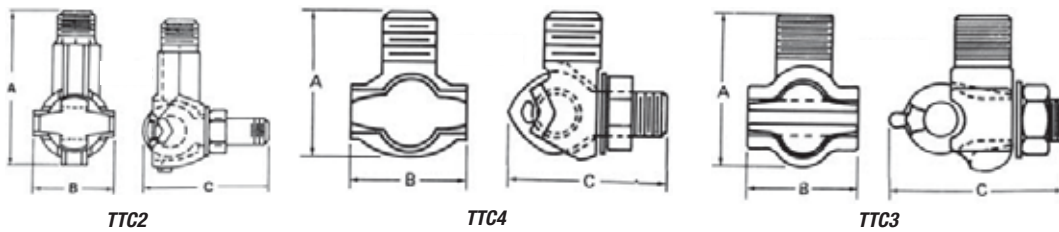

Cat. No.	Conductor Range				Stud Thread Size UNC-2A	Dimensions (in.)		
	max.	min.	max. (mm <sup>2</sup> )	min. (mm <sup>2</sup> )		A	B	C
<b>TTC2</b>	2/0 str.	8 sol.	67.4	8.3	1/2"–13	1-51/64	1-9/64	1-21/32
<b>TTC3</b>	1 str.	10 sol.	42.4	5.2	1/2"–13	1-3/8	1-3/64	1-9/16
<b>TTC4</b>	1 str.	10 sol.	42.4	5.2	1/2"–13	1-1/4	7/8	1-3/8
<b>TTC2P</b>	2/0 str.	8 sol.	67.4	8.3	1/2"–13	1-51/64	1-9/64	1-21/32
<b>TTC3P*</b>	1 str.	10 sol.	42.4	5.2	1/2"–13	1-3/8	1-3/64	1-9/16
<b>TTC4P*</b>	1 str.	10 sol.	42.4	5.2	1/2"–13	1-1/4	7/8	1-3/8

\* Tin Plated.

## Mechanical Grounding Connectors

### Conduit Hubs



Cat. No.	Ground Wire Size AWG	Conduit/Wire Size
3930	#8 to #2	1/2" Conduit
3940	#8 to #2	3/4" Conduit
3950	#8 to #3/0	1" Conduit
3951	#8 to #4/0	1-1/4" Conduit
3960	#8 to #4	Armored Wire

Material: Malleable iron.



### Type CH — Bronze Conduit Hubs

- Rugged cast bronze threaded hubs
- Provide positive connection between rigid conduit and water system in conjunction with "J" clamp



Cat. No.	Conduit Size (in.)	Conductor Range	
		max.	min.
CH12	1/2	6 sol.	10 sol.
CH34	3/4	2/0 str.	10 sol.
CH1	1	3/0 str.	10 sol.



## Mechanical Grounding Connectors

### Flexible Braids for Continuous current, Grounding and Bonding Applications (i.e.: Cable Tray)

Standard construction using 30 AWG individual wires are suitable for medium duty applications. If needed, all constructions and/or configurations in this Guide, can be supplied using 36 AWG for extra flexibility.

#### Rating of the Connectors

It is important to note that the Ampere ratings in this Guide are suggested for use as a reference only. If needed, we can certify ampacity of all connectors in our top of the line automatic heat cycle laboratory using CEI60694 standards. Performance certificate gives you the assurance that our connectors are suitable for your application. Actual values used for a given application will depend on such factors as temperature rise, number of braids, voltage ratings and other conditions of service needs to be verified by application engineers.



#### Length of the assemblies

All braid lengths are measured in inches and are measured from end to end. The last digits of the part numbers determine the length of the connector. (i.e.: FBD12, "12" = 12 inches)



#### Ferrules and Plating

Ferrules are made of high conductivity seamless 99.9% pure copper that are electro-tin plated prior to forming on each end of the assembly. This procedure is important to eliminate surface corrosion between the inside of the ferrule and the braids before compression can affect the connector's performance.

For increased pad conductivity, 30, 50 or 100 micron silver plated ferrules are available. Nickel plating or bare copper also available upon request.



#### Options

For special requests, provide a copy of your drawing with your specific requirements so we can design and build the flexible connectors to your exact specifications.

If needed, a wide range of insulation products are available depending on the application, voltage and temperature ratings.

## Mechanical Grounding Connectors

Grounding

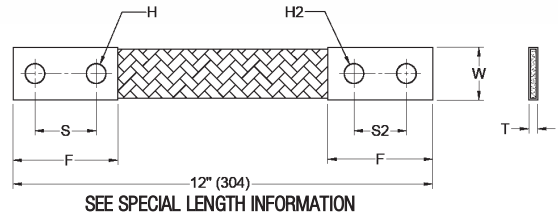
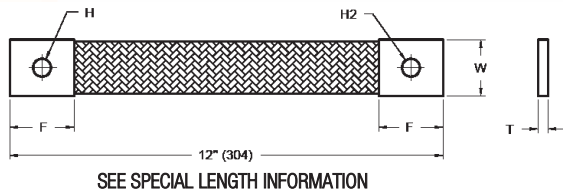

Cat. No.	Circular Mils	Bolt Hole (H or H2)	No. of Braids in Ferrule	Dimensions in. (mm)			
				(T) Thickness	(W) Width	(F) Ferrule Length	(S or S2) Distance Ctr. to Ctr
FBB12-1*	24000	1/4	1	0.140 (3.6)	0.625 (15.9)	0.750 (19.1)	N/A
FBC12-1*	48000	7/16	1	0.148 (3.8)	1.000 (25.4)	1.300 (33.0)	N/A
FBD12-1*	76800	7/16	1	0.200 (5.1)	1.000 (25.4)	1.300 (33.0)	N/A
FBD12*	76800	7/16	1	0.200 (5.1)	1.000 (25.4)	2.500 (63.5)	1.25 (31.8)
FB2D12-1*	153600	7/16	2	0.250 (6.4)	1.250 (31.8)	1.500 (38.1)	N/A
FB2D12*	153600	7/16	2	0.250 (6.4)	1.250 (31.8)	2.500 (63.5)	1.25 (31.8)
FB3D12-1*	230400	7/16	3	0.350 (8.9)	1.250 (31.8)	1.500 (38.1)	N/A
FB3D12*	230400	7/16	3	0.350 (8.9)	1.250 (31.8)	2.500 (63.5)	1.25 (31.8)
FBXD12-1*	105600	9/16	1	0.250 (6.4)	1.250 (31.8)	1.500 (38.1)	N/A
FBXD12*	105600	9/16	1	0.250 (6.4)	1.250 (31.8)	2.500 (63.5)	1.25 (31.8)
FB2XD12-1*	211200	9/16	2	0.350 (8.9)	1.250 (31.8)	1.500 (38.1)	N/A
FB2XD12*	211200	9/16	2	0.350 (8.9)	1.250 (31.8)	2.500 (63.5)	1.25 (31.8)
FB3XD12-1*	316800	9/16	3	0.400 (10.2)	1.250 (31.8)	1.500 (38.1)	N/A
FB3XD12*	316800	9/16	3	0.400 (10.2)	1.250 (31.8)	2.500 (63.5)	1.25 (31.8)
FBE12-1*	168000	9/16	1	0.500 (12.7)	1.250 (31.8)	2.500 (63.5)	N/A
FBE12*	168000	9/16	1	0.250 (6.4)	1.250 (31.8)	3.500 (88.9)	1.75 (44.5)
FB2E12-1*	336000	9/16	1	0.500 (12.7)	1.250 (31.8)	2.500 (63.5)	N/A
FB2E12*	336000	9/16	2	0.500 (12.7)	1.250 (31.8)	3.500 (88.9)	1.75 (44.5)
FB3E12	504000	9/16	3	0.750 (19.1)	1.250 (31.8)	3.500 (88.9)	1.75 (44.5)
FB4E12	672000	9/16	4	1.000 (25.4)	1.250 (31.8)	3.500 (88.9)	1.75 (44.5)
FBF12	230400	9/16	1	0.300 (7.6)	1.500 (38.1)	3.500 (88.9)	1.75 (44.5)
FB2F12	460800	9/16	2	0.450 (11.4)	1.500 (38.1)	3.500 (88.9)	1.75 (44.5)
FB3F12	691200	9/16	3	0.600 (15.2)	1.625 (41.2)	3.500 (88.9)	1.75 (44.5)
FB4F12	921600	9/16	4	0.750 (19.1)	1.625 (41.2)	3.500 (88.9)	1.75 (44.5)
FBG12	307200	9/16	1	0.380 (9.7)	1.500 (38.1)	3.500 (88.9)	1.75 (44.5)
FB2G12	614400	9/16	2	0.630 (16.0)	1.625 (41.2)	3.500 (88.9)	1.75 (44.5)
FB3G12	921600	9/16	3	0.850 (21.6)	1.625 (41.2)	3.500 (88.9)	1.75 (44.5)
FB4G12	1228800	9/16	4	1.000 (25.4)	1.880 (47.9)	3.500 (88.9)	1.75 (44.5)

\* Listed UL 467 and 486A, certified CSA C22.2 No. 41 as Grounding and Bonding Equipment. Special lengths offered in 6, 18, 24, 30 and 36 inches (end to end). Change the 12 in the above catalogue numbers to the desired length. (-1) indicates 1 bolt hole per ferrule. S2 and H2 measurements are used for customized braids only.

### Flexible Braids in a roll (10 feet minimum)











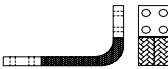

Cat. No.	Circular Mils	Thickness in. (mm)	Width in. (mm)
FBBRL	24000	0.140 (3.6)	0.625 (15.9)
FBCRL	48000	0.148 (3.8)	1.000 (25.4)
FBDRL	76800	0.200 (5.1)	1.000 (25.4)
FBXDRL	105600	0.250 (6.4)	1.250 (31.8)

Ferrules or lugs not included. Add suffix for desired length, i.e.: FBCRL "-10" for 10' roll.



## Mechanical Grounding Connectors

### Technical Specifications















Configuration	Type	Ind. Wire Gauge Size	Width Range (in.)	Rating Range (Amps)	Comments
<b>Extra-flexible Links for Heavy-Duty Application</b>					
	<b>FBEXA</b>	36 AWG	1-1/2 – 1-5/8	350 – 1000 A	Extra Flexible 1 hole NEMA Boreal's Top of the line
	<b>FBEXB</b>	36 AWG	1-1/2 – 1-5/8	400 – 2000 A	Extra Flexible 2 hole NEMA Boreal's top of the line
	<b>FBEXG</b>	36 AWG	1-3/4 – 2	900 – 1650 A	Extra Flexible Transformer Link
	<b>FBEXH</b>	36 AWG	3 – 4	1400 – 4000 A	Extra Flexible 4 hole NEMA Boreal's top of the line
	<b>FBEXJ</b>	36 AWG	3-1/4 – 3-3/4	2300 – 3600 A	Extra Flexible 90° 4 hole NEMA Boreal's top of the line
<b>Standard flexible Links for Medium-Duty Application</b>					
	<b>FBB**-1 FBC**-1 FBD**-1</b>	30 AWG	1-1/4 – 1-3/4	350 – 1000 A	NEMA std. Grounding Connectors
	<b>FBD** FB2D** FB3D** FBXD** FB2XD**</b>	30 AWG	1-1/2 – 1-5/8	400 – 2000 A	Same as EXB with 30 AWG wires
		30 AWG	1-1/2 – 2	700 – 1750 A	Standard Transformer Link
	<b>FBSWB</b>	30 AWG	1-1/2 – 2	700 – 1750 A	Same construction as SWB with different hole pattern
	<b>FBSWC</b>	30 AWG	3	1300 – 2350 A	4 hole pads also available in wider configuration, refer to EXH, SWD and LTL series
	<b>FBSWC</b>	30 AWG	3	1300 – 2350 A	Same construction as SWC Type A with different hole configuration
	<b>FBSWC</b>	30 AWG	3	1300 – 2350 A	Same construction as SWC Type A with different hole configuration
	<b>FBSWC</b>	30 AWG	3	1300 – 2350 A	Same construction as SWC Type A with different hole configuration

\*\* Specify desired length.

## Mechanical Grounding Connectors





### Technical Specifications

Grounding

Configuration	Type	Ind. Wire Gauge Size	Width Range (in.)	Rating Range (Amps)	Comments
<b>Standard Flexible Links for Medium-Duty Application</b>					
	FBSWC	30 AWG	3	1300 – 2350 A	Same construction as SWC with different hole configuration
	FBSWC	30 AWG	3	1300 – 2350 A	Same construction as SWC with different hole configuration
	FBSWC	30 AWG	3	1300 – 2350 A	Same construction as SWC with different hole configuration
	FBSWC	30 AWG	3	1300 – 2350 A	Same construction as SWC with different hole configuration
	FBSWC	30 AWG	2 – 4	600 – 1850 A	Same construction as SWC with different hole configuration
	FBSWD	30 AWG	3-3/4 – 4-3/4	1600 – 2100 A	4 hole Transformer Link
	FBSWC	30 AWG	3	1300 – 2100 A	1 to 4 hole Transformer Link
	FBSWD	30 AWG	3-3/4 – 4-3/4	1300 – 2100 A	1 to 4 hole Transformer Link
	FBSWD	30 AWG	3-3/4 – 4-3/4	1600 – 2100 A	2 to 4 hole Transformer Link
	FBSWD	30 AWG	3-3/4 – 4-3/4	1600 – 2100 A	3 to 4 hole Transformer Link
	FBSWE	30 AWG	3	1400 – 1600 A	6 to 4 hole Transformer Link
	FBSWF	30 AWG	3-3/4 – 4-3/4	1700 – 2300 A	6 to 4 hole Transformer Link
	FBSWE	30 AWG	3	1400 – 1600 A	6 hole Transformer Link
	FBSWF	30 AWG	3-3/4 – 4-3/4	1700 – 2300 A	6 hole Transformer Link

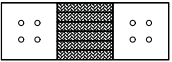
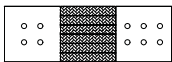

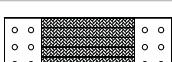
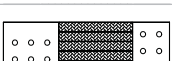



## Mechanical Grounding Connectors

### Technical Specifications

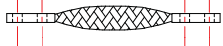
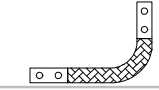
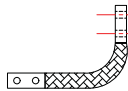
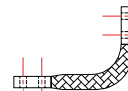
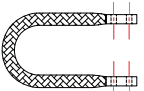
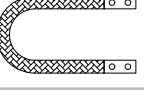
Configuration	Type	Ind. Wire Gauge Size	Width Range (in.)	Rating Range (Amps)	Comments
<b>Large Transformer Links</b>					
	FBLTL	30 AWG	6 – 6-3/8	2500 – 4000 A	4 hole Transformer Link
	FBLTL	30 AWG	6 – 6-3/8	2500 – 4000 A	4 to 6 hole Transformer Link
	FBLTL	30 AWG	6 – 6-3/8	2500 – 4000 A	4 to 6 hole Transformer Link
	FBLTL	30 AWG	6 – 6-3/8	2500 – 4000 A	6 hole Transformer Link
	FBLTL	30 AWG	6 – 6-3/8	2500 – 4000 A	6 hole Transformer Link
	FBLTL	30 AWG	6 – 6-3/8	2500 – 4000 A	6 hole Transformer Link

### Miscellaneous Configurations and Shapes

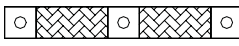
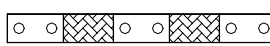
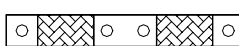
The following sketches represent the most popular configurations and shapes. For other non standard flexible links and/or dimensions, send us a copy of your drawing with your specific requirements so that we can design and build the flexible connectors to your exact specification.

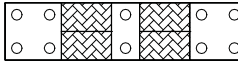
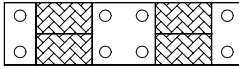
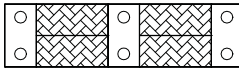
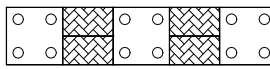
	Model FBBI Type A		Model FBBI Type B		Model FBBL Type A
	Model FBBL Type B		Model FBBL Type C		Model FBBLU Type A
	Model FBBLU Type B		Model FBBLU Type C		Model FBBIY Type A
	Model FBBIY Type B		Model FBBE Type A		Model FBBE Type B
	Model FBBE Type C		Model FBBE Type D		Model FBBE Type E
	Model FBBE Type F		Model FBBE Type G		Model FBBE Type H

## Mechanical Grounding Connectors

Grounding

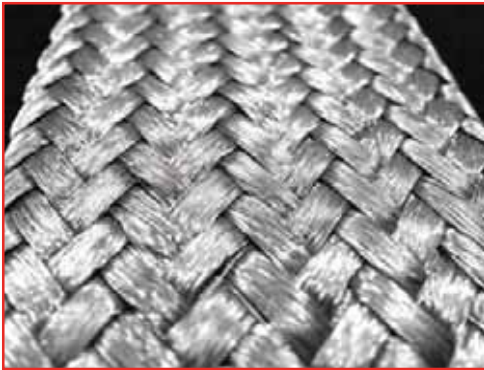

### Conductors

Strands are soft-drawn bare or tinned copper.

### Construction

Strands are woven into a tubular braid and rolled flat.

### Application

For bonding, grounding or connecting moving parts.

### Specification

ASTM-B33

### Assemblies

Factory Installed molded connectors also available.

*The following listing represents the most popular flat braid constructions used in specialized electrical industry applications. For other constructions, contact a T&B sales representative or your regional T&B sales office.*

Cat. No.	AWG Size	Circular Mil Area	Numbers and Size of Wires	Construction	Nominal Width (in.)	Nominal Thick. (in.)	Approx. Weight (lb./m)
<b>FB-4243230-1*</b>	300 kcmil	307,200	3,072 / 30	4 x (24 x 32/30)	1-3/8	0.420	1,110
<b>FB-1485230-1</b>	250 kcmil	249,600	2,496 / 30	48 x 52/30	2-1/2	0.190	900
<b>FB-3243230-1</b>	4/0	230,400	2,304 / 30	3 x (24 x 32/30)	1-1/4	0.375	825
<b>FB-2243230-1</b>	3/0	153,600	1,536 / 30	2 x (24 x 32/30)	1-1/8	0.250	560
<b>FBXDRL</b>	1/0	105,600	1,056 / 30	24 x 44/30	1	0.135	365
<b>FB-1482230-1</b>	1/0	105,600	1,056 / 30	48 x 22/30	1-3/8	0.120	365
<b>FB-1488436-1</b>	1/0	100,800	4,032 / 36	48 x 84/36	1-5/8	0.080	360
<b>FBDRL</b>	1	76,800	768 / 30	24 x 32/30	1	0.125	200
<b>FB-12412036-1</b>	2	72,000	2,880 / 36	24 x 120/36	1	0.135	240
<b>FB-1485036-1</b>	2	60,000	2,400 / 36	48 x 50/36	1-1/4	0.090	205
<b>FBCRL</b>	3	48,000	480 / 30	24 x 20/30	3/4	0.110	170
<b>FB-1484036-1</b>	3	48,000	1,920 / 36	48 x 40/36	1	0.090	160
<b>FB-1488640-1</b>	4	41,280	4,128 / 40	48 x 86/40	1	0.060	140
<b>FB-1246736-1</b>	4	40,200	1,608 / 36	24 x 67/36	3/4	0.090	135
<b>FB-1241630-1</b>	4	38,400	384 / 30	24 x 16/30	5/8	0.085	125
<b>FBBRL</b>	6	24,000	210 / 30	24 x 10/30	1/2	0.080	83
<b>FB-1244036-1</b>	6	24,000	960 / 36	24 x 40/36	1/2	0.090	80
<b>FB-14810644-2</b>	7	20,350	5,088 / 44	48 x 106/44	5/8	0.050	68
<b>FB-1480836-1</b>	10	9,600	384 / 36	48 x 8/36	1/2	0.030	39
<b>FB-1241636-1</b>	10	9,600	384 / 36	24 x 16/36	3/8	0.060	39
<b>FB-1480636-1</b>	12	7,200	288 / 36	48 x 6/36	3/8	0.030	28
<b>FB-1481036-1</b>	12	6,000	240 / 36	24 x 10/36	1/4	0.030	23

\* The suffix "-1" denotes tinned copper braid. For bare copper braid, replace "-1" with "-2".  
NOTE: Dimensions shown are only approximate due to the extreme flexibility of braided cables.

## Mechanical Grounding Connectors

### Conductors

Strands are soft-drawn bare or tinned copper.

### Construction

Strands are woven into a tubular braid.

### Application

For bonding, grounding or connecting moving parts.

### Specification

ASTM-B33, QQ-B-375

### Shield Coverage

Braid is formed to maintain coverages of 90% shielding over the nominal diameters specified.



Grounding

*The following listing represents the most popular tubular braid constructions used in today's electrical and electronic industries. For other constructions, contact a T&B sales representative or your regional T&B sales office.*

Cat. No.	Nominal I.D. when Rounded	Nominal Circular Mil Area	AWG Size Equivalent	Number and Size of Wires	Construction	Approx. Weight (lb./m)
<b>TB - 481630</b>	2-1/4	77,180	1	768 / 30	48 x 16 / 30	260
<b>TB - 481430*</b>	2	67,540	2	672 / 30	48 x 14 / 30	230
<b>TB - 481230*</b>	1-1/2	57,890	3	576 / 30	48 x 12 / 30	200
<b>TB - 481130*</b>	1-3/8	53,060	3	528 / 30	48 x 11 / 30	185
<b>TB - 481030</b>	1-1/4	48,240	3	480 / 30	48 x 10 / 30	168
<b>TB - 480930*</b>	1-1/8	43,420	4	432 / 30	48 x 9 / 30	155
<b>TB - 480830*</b>	1	38,600	4	384 / 30	48 x 8 / 30	140
<b>TB - 480730*</b>	7/8	33,770	5	336 / 30	48 x 7 / 30	123
<b>TB - 481234</b>	13/16	22,896	7	576 / 34	48 x 12 / 34	85
<b>TB - 481836*</b>	25/32	21,600	7	864 / 36	48 x 18 / 36	79
<b>TB - 480734*</b>	1/2	13,356	9	336 / 34	48 x 7 / 34	53
<b>TB - 481136*</b>	1/2	13,200	9	528 / 36	48 x 11 / 36	53
<b>TB - 240730*</b>	3/8	16,880	8	168 / 30	24 x 7 / 30	62
<b>TB - 480836*</b>	3/8	9,600	10	384 / 36	48 x 8 / 36	40
<b>TB - 240834</b>	3/8	7,632	11	192 / 34	24 x 8 / 34	30
<b>TB - 241336*</b>	13/64	7,800	11	312 / 36	24 x 13 / 36	31
<b>TB - 240734</b>	1/4	6,678	12	168 / 34	24 x 7 / 34	26
<b>TB - 240536*</b>	1/8	3,000	15	120 / 36	24 x 5 / 36	13
<b>TB - 240436*</b>	7/64	2,400	16	96 / 36	24 x 4 / 36	11

\* Denotes QQ-B-575 construction.

NOTE: Because Tubular Braid is very pliable, the I.D.'s are approximate.



## Mechanical Grounding Connectors

### Flexible Braids Selection Guide

#### Minimum Size Flexible Braid for Continuous Current Applications



Cat. No.	Circular Mills	Amperage Capacity
FBB12-1	24000	95
FBC12-1	48000	145
FBD12-1	76800	190
FBD12	76800	190
FB2D12-1	153600	330
FB2D12	153600	630
FB3D12-1	230400	470
FB312	230400	470
FBXD12-1	105600	235
FBXD12	105600	235
FB2XD12-1	211200	400
FB2XD12	211200	400
FB3XD12-1	316800	600
FB3XD12	316800	600

Cat. No.	Circular Mills	Amperage Capacity
FBE12-1	168000	340
FBE12	168000	340
FB2E12-1	336000	530
FB2E12	336000	530
FB3E12	504000	700
FB4E12	672000	805
FBF12	230400	360
FB2F12	460800	600
FB3F12	691200	820
FB4F12	921600	1000
FBG12	307200	415
FB2G12	614400	700
FB3G12	921600	760
FB4G12	1228800	1200

### Grounding and Bonding Information

#### Minimum Size Conductors for Bonding Raceways and Equipment

Rating or Setting of overcurrent Device in Circuit Ahead of Equipment, Conduit, etc. Not Exceeding – Amperes	Copper Wire Circular Mills
200	26 240 (6 AWG)
300	41 740 (4 AWG)
400	52 620 (3 AWG)
500	66 360 (2 AWG)
600	83 690 (1 AWG)
800	105 600 (1/0)
1000	133 100 (2/0)
1200	167 800 (3/0)
1600	211 600 (4/0)
2000	250 000
2500	350 000
3000	400 000
4000	500 000
5000	700 000
6000	800 000

Based on table 16 C.E.C.

#### Minimum Size of Bare Copper Grounding Conductors

Maximum Available Short Circuit Current Amperes	Maximum Fault Duration with Exothermic Weld, Compression or Bolted Joint	
	0.5 Second Circular Mills	1.0 Second Circular Mills
5000	26 240	41 740
10 000	52 620	83 690
15 000	83 690	105 600
20 000	105 600	167 800
25 000	133 100	211 600
35 000	211 600	250 000
40 000	211 600	300 000
50 000	250 000	350 000
60 000	30 000	500 000
70 000	350 000	600 000
80 000	400 000	600 000
90 000	500 000	700 000
100 000	500 000	700 000

Based on table 51 C.E.C.  
Size calculated in accordance with IEEE No. 80.

## Mechanical Grounding Connectors

### Aluminum Water Pipe Clamps

- For connecting grounding conductor to either steel or copper pipe, rod or tubing
- Tin plated for corrosion resistance
- For use with copper or aluminum conductors

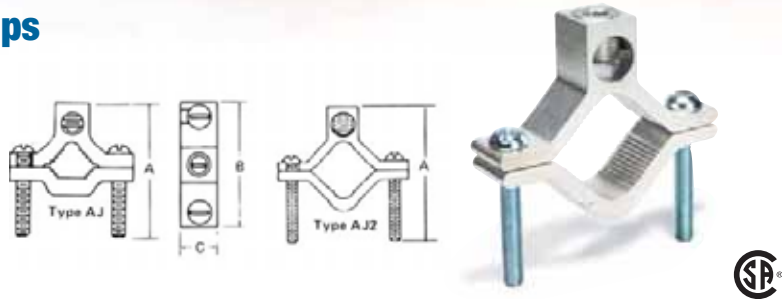

Grounding

Cat. No.	Water Pipe Size (in.)	Conductor Range		Dimensions (in.)			Steel Clamp Screw	Aluminum Wire Screw
		max.	min.	A	B	C		
<b>AJ</b>	1/2-1	1/0 str.	#14 sol.	2-1/2	2-1/4	5/8	1/4-20	7/16-20 slot
<b>AJ2</b>	1-1/2-2	250 kcmil	#6	3-7/8	3-3/4	7/8	5/16-18	11/16-20 socket
<b>AJ-2124</b>	2-1/2-4	250 kcmil	#6	5-9/16	6-5/16	7/8	3/8-16	11/16-20 socket

For both copper and aluminum conductors to steel pipe and copper water tubing.

### Budget Price Cast Bronze Clamp

- For connecting grounding conductor to either steel or copper pipe, rod or tubing
- For use with copper conductors only



Cat. No.	Water Pipe Size (in.)	Conductor Range		Dimensions (in.)		
		max.	min.	A	B	C
<b>JJR</b>	1/2-1	#4 str.	#10 sol.	2-15/32	25/32	17/32

Lay-in feature reduces installation time for difficult bends or continuous loops of ground wire.

### Type JDLI — Direct Burial Ground Clamp

- UL Listed for direct burial in earth/concrete.
- UL Listed for connection to ground rod, pipe or rebar up to 1".
- Constructed from bronze alloy and high-performance stainless steel bolts.
- Designed for easy installation or difficult bends or continuous loops.

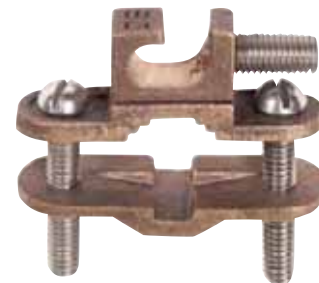

Cat. No.	Pipe Size	Rebar Size	Ground Rod Size	Conductor Range	Mech. Conn./Splice (UL Listed)
<b>JDLI</b>	1/2"-1"	3/8"-1"	1/4"-1"	#10 sol.-#2 Str.	(2) #8 sol.

## Mechanical Grounding Connectors

### Waterpipe Ground Clamps

Grounding



Cat. No.	Ground Wire Size	Water Pipe Size
<b>2-TB</b>	#6, #4, #2	1/2", 3/4", 1" or rebar 4-10
<b>3-TB</b>	#6, #4, #2	1-1/4", 1-1/2" or 2"
<b>4</b>	#6, #4, #2	2-1/2", 3" or 3-1/2"
<b>5-TB</b>	#6, #4, #2	4", 4-1/2" or 5"
<b>6</b>	#6, #4, #2	6"

Malleable iron crossbar, steel U-Bolt c/w copper cable clamp with serrations.



Cat. No.	Ground Wire Size	Water Pipe Size
<b>3902</b>	#4-4/0 AWG	1/2"-1"
<b>3903</b>	#4-4/0 AWG	1-1/4"-2"
<b>3904</b>	#4-4/0 AWG	2-1/2"-3-1/2"
<b>3905-TB</b>	#4-4/0 AWG	4"-5"
<b>3906-TB</b>	#4-4/0 AWG	6"
<b>3907</b>	#4-4/0 AWG	8"
<b>3908</b>	#4-4/0 AWG	10"
<b>3909-TB</b>	#4-4/0 AWG	12"

Material: Steel U-bolt and nut c/w bronzed aluminum cap and crossbar cadmium plated plus gold chromate finish.



Cat. No.	Ground Wire Size	Water Pipe Size
<b>3902BU*</b>	#4-4/0 AWG	1/2"-1"
<b>3903BU*</b>	#4-4/0 AWG	1-1/4"-2"
<b>3904BU*</b>	#4-4/0 AWG	2-1/2"-3-1/2"
<b>3905BU*</b>	#4-4/0 AWG	4"-5"
<b>3906BU*</b>	#4-4/0 AWG	6"
<b>3907BU*</b>	#4-4/0 AWG	8"
<b>3908BU*</b>	#4-4/0 AWG	10"
<b>3909BU*</b>	#4-4/0 AWG	12"

Material: Bronze U-bolt and nut c/w bronzed aluminum cap and crossbar with a bright dip finish.  
\*UL Listed for Direct Burial.

**Installation Dies and Tools — Quick Reference**

**Die Kits**



Metal cases of assorted Die Kits  
pp. 106–108

Introduction .....109  
 Warranty .....110  
 Tool Die Selection Chart ...111–112  
 Tool and Die Index for Copper Compression Connectors ...113–117  
 Installing Dies .....118–124  
 Tools .....125–138

**TBM4BB**



p. 125

**TBM4S**



p. 125

**JB12B**



12-Ton Manual Hydraulic Crimp Tool  
p. 126

**TBM14MC**



14-Ton Compact Manual Hydraulic Crimp Tool  
p. 126

**TBM840**



Crimp Tool  
p. 126

**OD581**



Manual Compression Tool  
p. 127

**TBM6H**



6-Ton Hydraulic Crimping Head  
p. 128

**Installation Dies and Tools — Quick Reference**

**13100A**



14-Ton Hydraulic Crimping Head

p. 129

**TBM8-750 and TBM8-750M**



12-Ton Smart® Tools

pp. 130–131

**CSR750**



Cable Cutter

p. 132

**368-CK**



Cable Stripper

p. 132

**CTR-1**



C-Tap Removal Tool

p. 132

**HM-250-TOOL**



Single Indent Dieless Crimper

p. 133

**Allen Wrench**



p. 133

**TBM14BSCR**



Hermetically Sealed 14-Ton Battery-Powered Compression Tool

p. 134

**TBM6BSCR**



6-Ton Battery Compression Tool

p. 134



## Installation Dies and Tools — Quick Reference

### REC-630 and REC-750



ROBO CRIMP™, 6-Ton  
Battery Powered Dieless  
Crimping Tool Kits  
p. 134

### TBM15BSCR



Hermetically Sealed  
15-Ton Battery-Powered  
Compression Tool  
p. 135

### TBM54BSCT and TBM54BSCTS



Battery-Powered  
Cutters  
p. 135

### TBM58BSCT



Battery-Powered  
Cutter  
p. 136

### TBM0DBSCR



6-Ton  
Battery-Powered  
Compression Tool  
p. 136

### Replacement Battery



pp. 137–138

### Sealants and Lubricants



pp. 139–140

## Assorted Blackburn® Die Kits

### EZ-CK DIEKIT — Die sets Kit

All the Thomas & Betts dies you need to crimp the complete T&B E-Z-Ground® connector offering, presented in a two sided metal carrying case. The reverse side of this kit allows you to keep all your colour coded Blackburn® crimping dies in one convenient location. A cable vs die reference chart inside each cover lets you sort and organize all your Blackburn® compression connector dies for either copper or aluminum conductors. Additional compartments for cutting dies and adaptors round off this great package.



Cat. No.: EZ-CK DIEKIT

	Die Cat. No.	Qty	Die Colour	Copper	Aluminum
BKB	B75CH	1	Brown	2 AWG	n/a
	B05CH	1	Green	1 AWG	4 AWG
	B06CH1	1	Pink	1/0 AWG	2 AWG
	B72CH	1	Black	2/0 AWG	1 AWG (Gold)
	B08CH	1	Orange	3/0 AWG	1/0 AWG (Tan)
	B09CH	1	Purple	4/0 AWG	2/0 AWG (Olive)
	B26CH	1	Yellow	250 kcmil	n/a
	B10CH1	1	White	300 kcmil	4/0 AWG
	B11CH	1	Red	350 kcmil	250 kcmil
	B12CH	1	Brown	500 kcmil	350 kcmil
	B39CH	1	Black	750 kcmil	650 kcmil
	15G121R	1			
	15G86R	1			
	15501A	1			
	15G126	1			
	CTB8	1			
	COLCHA2-E	1			
	GRNDIESEL-E	1			



## Assorted Blackburn® Die Kits

### OD-TOOL-KIT and OD-TOOL-KIT-I

These kits are offered in a metal carrying case with heavy duty handle and sturdy closures. The best way to carry the connectors and tools you need for commercial and residential hook-ups.

Cat. No.	Kit includes	Qty
OD-TOOL-KIT-I	Metallic carrying case	1
	ODB1 – Blackburn® Compression Tool	1
	ODH1 Insulating Heat Cover ( <i>installed on ODB1</i> )	1
	WR159 – Compression connectors	18
	WR189 – Compression connectors	12
	WR289 – Compression connectors	5
	WR379 – Compression connectors	5
	WR419 – Compression connectors	5
	C5C – Insulating covers	30
	C7C – Insulating covers	15



Cat. No.	Kit includes	Qty
OD-TOOL-KIT	Metallic carrying case	1
	ODB – Blackburn® Compression Tool	1
	WR159 – Compression connectors	18
	WR189 – Compression connectors	12
	WR289 – Compression connectors	5
	WR379 – Compression connectors	5
	WR419 – Compression connectors	5
	C5C – Insulating covers	30
	C7C – Insulating covers	15



**Assorted Blackburn® Die Kits**

Installation Dies  
and Tools

**TBM4BB-KIT — Die set Kit**

Comes in a metal carrying case with heavy duty handle and sturdy closures.



Cat. No.	Kit includes
TBM4BB-KIT	(1) TBM4BB – Colour Coded Comfort Crimp™ Installation Tool
	(25) CU2 – Long Brown Barrel #2 str. Splice
	(25) CU4 – Long Grey Barrel #4 str. Splice
	(25) CU6 – Long Blue Barrel #6 str. Splice
	(25) CU8 – Long Red Barrel #8 str. Splice
	(25) CTL2-14 – One Hole Brown Lug #2 str.
	(50) CTL4-14 – One Hole Grey Lug #4 str.
	(50) CTL6-14 – One Hole Blue Lug #6 str.
	(50) CTL8-10 – One Hole Red Lug #8 str.

## **Introduction**

### **An Unbeatable Tool Selection**

---

Thomas & Betts offers a complete range of tools for industrial electrical applications. This catalogue provides a look at our extensive tool offering including manual, hydraulic, and battery-operated compression tools. You'll also find a comprehensive die selection chart that makes matching dies to tools fast and easy.

Whatever the application or budget, there's a Thomas & Betts tool that will help you get the job done faster and more efficiently.

## **Warranty and Service Providers**

---

### **Thomas & Betts Tool Service**

---

Thomas & Betts Tool Service has a staff of highly trained, experienced and dedicated technicians and application specialists to support our customers in every aspect of their tooling needs.

The Tool Service Department is capable of repairing all Thomas & Betts tools, from small tools to large hydraulic pumps and crimping heads. The department is also responsible for warranty repairs and will supply a loaner tool when necessary.

For customers capable of repairing their own tools, Tool Service also sells the component parts. In addition, they can provide the technical data and information required.

Other services include the calibration or certification of tools to meet applicable standards including "in house" certification of tools for larger OEMs in conjunction with the ISO 9000 programs.

#### **Corporate Thomas & Betts Tool Service**

8735 Hamilton Road, Southaven, MS 3867  
Tel.: 662-342-1545 ext. 3930  
1-800-284-8665  
Fax: 662-393-3929

#### **Centre de réparation hydraulique Uptown Ltée**

464 St-Hubert  
Laval, Quebec H7G 2Y9  
Tel.: 514-387-6143  
Fax: 450-667-8335

#### **Trydor Industries Ltd.**

1201 Franklin Street  
Vancouver, British Columbia V6A 1L2  
Tel.: 604-254-1695  
1-800-567-8558  
Fax: 604-254-6666



## Warranty and Service Providers

### Limited Warranty

---

Thomas & Betts manufactures its tools to be free of defects in material and workmanship for the time specified below. Should any defect occur during the specified time period, Thomas & Betts will repair or replace the tool at its option.

### Limitations and Exclusions

---

This Warranty is in lieu of all other representations and expressed and implied warranties (including the implied warranties of merchantability and fitness for use) and under no circumstances shall Thomas & Betts be liable for any incidental or consequential property damages or losses.

**This warranty is non-transferable and replacement of defective parts must be made at a facility designated by the manufacturer.**

#### 90 DAYS

---

- Electronically operated tools (printers, testers)
- Individual dies

#### 1 YEAR

---

- Pneumatic tools
- Cable cutters, strippers
- ID printers

#### 2 YEARS

---

- Mechanical hand tools with ratchet or Shure-Stake® mechanism
- Hydraulic pumps (battery operated tools included)

#### 5 YEARS

---

- Mechanical hand tools without ratchet or Shure-Stake® mechanism
- Hydraulic tools (self-contained and remote heads)

Direct all inquiries to the Thomas & Betts Regional Sales Office in your area.

## Tool Die Selection Chart

This chart does not apply to catalogue series 61905-61975, 61102-61178, IBG2-10, IBG20-40, 63105-63180, 53000, 52000 and 15kV copper and aluminum connectors.

For installation die information, see pages illustrating these connector series. On some sizes, for special flexible strandings, consult your Regional Sales Office.

All colour coded die series require die adapter 15500TB for TBM15 tools only.



Connector Size		Die Colour Code	TBM48B	TBM4S	TBM840	TBM8-750/-1	OD58	JB12B
Copper	AL						Die Cat. No.	Die Cat. No.
8 AWG	10 AWG	Red	↕	↕	↕	↕	BY15C	B71CH
6 AWG	8 AWG	Blue					BY17C	B73CH
4 AWG	6 AWG	Grey	↕	↕	↕	↕	BY19C	B74CH
2 AWG		Brown					BY21C	B75CH
1 AWG	4 AWG	Green					BY53C	B05CH
1/0	2 AWG	Pink					BY23C	B06CH1
2/0		Black					BY28C	B72CH
3/0		Orange					BY25C	B08CH
4/0		Purple					BY31C	B09CH
250 kcmil		Yellow						B26CH
	1 AWG	Gold						
	1/0	Tan						
	2/0	Olive						B09CH
	3/0	Ruby						
300 kcmil	4/0	White						B10CH1
350 kcmil	250 kcmil	Red						B11CH
400 kcmil	300 kcmil	Blue						B11CH
925/24		Black						
500 kcmil	350 kcmil	Brown						B12CH
600 kcmil	400 kcmil	Green						B36CH
		Green						
700 kcmil	500 kcmil	Pink						B76CH
750 kcmil	650 kcmil	Black						B39CH
800 kcmil		Orange						
	700 kcmil	Purple						
900 kcmil	750 kcmil	Yellow						6024 AH
1000 kcmil	800 kcmil							
	1000 kcmil							6030 H

## Tool Die Selection Chart



Connector Size		Die Colour Code	TBM6BSCR/6H		TBM14BCSR/14M/13100A		*TBM15BSCR		21940 (40-TON)	
Copper	AL		Die Cat. No.	Die Code No.	Die Cat. No.	Die Code No.	Die Cat. No.	Die Code No.	Die Cat. No.	Die Code No.
8 AWG	10 AWG	Red	6TON21	21	B71CH	21	B71CH	21		21
6 AWG	8 AWG	Blue	6TON24	24	B73CH	24	B73CH	24		24
4 AWG	6 AWG	Grey	6TON29	29	B74CH	29	B74CH	29	11401	29
2 AWG		Brown	6TON33	33	B75CH	33	B75CH	33	11402	33
1 AWG	4 AWG	Green	6TON37	37	B05CH	37	B05CH	37	11333	37
1/0	2 AWG	Pink	6TON42	42	B06CH	42	B06CH1	42	11334	42
2/0		Black	6TON45	45	B72CH	45	B72CH	45	11405	45
3/0		Orange	6TON50	50	B08CH	50	B08CH	50	11406	50
4/0		Purple	6TON54	54	B09CH	54	B09CH	54H	11407	54H
250 kcmil		Yellow	6TON62	62	B26CH	62	B26CH	62	297-31669-7	62
	1 AWG	Gold	6TON45	45	B72CH	45	B72CH	45	11405	45
	1/0	Tan	6TON50	50	B08CH	50	B08CH	50	11406	50
	2/0	Olive	6TON54	54	B08CH	54	B09CH	54	11407	54
	3/0	Ruby	6TON60	60		60		60	11408	60
300 kcmil	4/0	White	6TON66	66H	B10CH1	66H	B10CH1	66H	11409	66
350 kcmil	250 kcmil	Red	6TON71	71H	B11CH	71H	B11CH	71H	11363	71
400 kcmil	300 kcmil	Blue	6TON76	76H	B11CH	76H	B11CH	76H	11410	76
925/24		Black	6TON80	80H		80H		80H		
		Black						80		
500 kcmil	350 kcmil	Brown	6TON87	87H	B12CH	87H	B12CH	87H	11423	87
600 kcmil	400 kcmil	Green	6TON94	94H			B36CH	94H	11364	94
		Green						94H		
700 kcmil	500 kcmil	Pink		99H			B76CH	99H	11424	99
750 kcmil	650 kcmil	Black		106H	B39CH		B39CH	106H	74506	106
800 kcmil		Orange		107H				107H	11425	107
	700 kcmil	Purple		112H				112H	11426	112
900 kcmil	750 kcmil	Yellow		115H				115H	11308	115
1000 kcmil	800 kcmil							125H	11416	125
	1000 kcmil							140H	11418	140
								150H	11419	150

\*Colour coded dies require 15500TB adapter when used with TBM15BSCR tool.

## Tool and Die Index for Copper Compression Connectors

Installation Dies  
and Tools

### Short Barrel — Types CTL, CTL-2 and CSP

Stranded Copper Wire Size	Die Colour Code	Blackburn Tools						Burdny Tools				T&B Tools					Anderson Tools				
		Mech. OD58	Crimps per End	Mech. per HM-250 TOOL	Crimps per End	Hyd. per JB12B	Crimps per End	Mech. MY29-3	Crimps per End	Hyd. Y35, Y39, Y46	Crimps per End	Mech. TBM5S	Crimps per End	Mech. TBM8S	Crimps per End	Hyd. TBM15	Crimps per End	CU Wire Range	VC6† VC6†	VC7† VC7†	VC8††
8	Red	7/32	3	**	1	B71CH	1	**	1		13454	2	13461	2	21	2					
		J																			
6	Blue	1/4	3	**	1	B73CH	1	**	1	U5CRT	2	13454	2	13461	2	24	2				
4	Grey	5/16	3	**	1	B74CH	1	**	1	U4CRT	2	13454	2	13461	2	29	2				
3	White			**	2			**	2	U3CRT	2										
2	Brown	3/8	4	**	2	B75CH	1	**	2	U2CRT	2	13454	2	13461	2	33	2	6-2	1*	2	
1	Green	P	4	**	2	B05CH	1	**	2	U1CRT	2	13455	3	13462	3	37	2	6-1	1	2	
1/0	Pink	1/2	4	**	2	B06CHI	2	**	2	U25RT	2	13455	3	13462	3	42H	3	6-1/0	1	2	
2/0	Black	17/32	4	**	2	B72CH	1	**	2	U26RT	2	13455	3	13462	3	45	2	4-2/0	1	2	
3/0	Orange	9/16	4	**	2	B08CH	1	**	2	U27RT	2	13455	4	13462	4	50	2	2-3/0	2	2	
4/0	Purple	5/8-1	4	**	2	B09CH	2	**	2	U28RT	2	13456	4	13463	4	54H	3	1-4/0	2	2	
250	Yellow	11/16	4	**	2	B26CH	2	**	2	U29RT	2	13456	4	13463	4	62	2	1/0-250†	2	2	
300	White					B10CHI															
						B10CH	2			U30RT	2			13465	4	66	2	2/0-300†	2	2	
350	Red					B11CH	2			U31RT	2			13465	4	71H	3	3/0-350†	2	3	
400	Blue					B11CH	2			U32RT	3			13467	4	76	2	4/0-400†	2	3	
500	Brown					B12CHI															
						B12CH	2			U34RT	3			13468	5	87H	3	4/0-500†	2	3	
600	Green					B36CH <sup>1</sup>	3			U36RT <sup>3</sup>	3					94H	3	250-600		3	
																					VC7FT only
750	Black					B39CH <sup>1</sup>															
							3														
							1			U39RT <sup>3</sup>	3					106H	3	500-750		4	
																					VC7FT only
1000	—						1			P44RT <sup>4</sup>	4					125H	4	750-1000		2	

\* CSA Listed range 4-2 with YC6 and VC6FT.  
 \*\* Adjustable Indent Tool. No insert dies required.  
 1 HCT7508-12, HCT1239, HCT7508H only.  
 3 Y39, Y46 only.  
 4 Y46 only.  
 † Users of VC6 and VC7 tools must strip off an extra 1-5/8" of insulation from end of cable to permit removal of tool over conductor sizes 250 kcmil and larger on CSP connectors.  
 †† Also use VC8 tool with aluminum nibs.

## Tool and Die Index for Copper Compression Connectors

### Long Barrel — Types CTL-L, LCN and CU

Stranded Copper Wire Size	Die Colour Code	Blackburn Tools						Burdny Tools				T&B Tools				Anderson Tools						
		Mech. 0058	Crimps per End	Mech. HM-250 TOOL	Crimps per End	Hyd. JB12B	Crimps per End	Mech. MY29-3	Crimps per End	Hyd. Y35, Y39, Y46	Crimps per End	Mech. TBM5S	Crimps per End	Mech. TBM8S	Crimps per End	Hyd. TBM15	Crimps per End	CU Wire Range	VC6† VC6F†	VC7† VC7F†	VC8††	
8	Red	7/32	4	**	2	B71CH	2	**	2		13454	2	13461	2	21	3						
		J																				
6	Blue	1/4	4	**	2	B73CH	2	**	2	U5CRT	2	13454	2	13461	2	24	3					
4	Grey	5/16	4	**	2	B74CH	2	**	2	U4CRT	2	13454	2	13461	2	29	3					
3	White			**	3			**	2	U3CRT	2											
2	Brown	3/8	5	**	3	B75CH	2	**	3	U2CRT	2	13454	2	13461	2	33	3	6-2	2	4		
1	Green	P	5	**	3	B05CH	2	**	3	U1CRT	2	13455	4	13462	3	37	3	6-1	2	5		
1/0	Pink	1/2	5	**	3	B06CHI	2	**	3	U25RT	2	13455	4	13462	4	42H	4	6-1/0	2	5		
2/0	Black	17/32	5	**	3	B72CH	2	**	3	U26RT	2	13455	4	13462	4	45	3	4-2/0	2	5		
3/0	Orange	9/16	5	**	4	B08CH	2	**	4	U27RT	3	13455	6	13462	6	50	3	2-3/0	3	6		
4/0	Purple	5/8-1	6	**	4	B09CH	3	**	4	U28RT	3	13456	6	13463	6	54H	5	1-4/0	3	6		
250	Yellow	11/16	6	**	4	B26CH	3	**	4	U29RT	3	13456	6	13463	6	62	3	1/0-250	3	6		
300	White					B10CHI																
						B10CH	3			U30RT	3			13465	6	66	3	2/0-300	3	6		
350	Red					B11CH	3			U31RT	4			13465	6	71H	4	3/0-350	3	6		
400	Blue					B11CH	4			U32RT	4			13467	6	76	3	4/0-400	3	6		
500	Brown					B12CHI																
						B12CH	4			U34RT	5			13468	8	87H	4	4/0-500	3	6	2†††	
600	Green					B36CH <sup>1</sup>	6			U36RT <sup>3</sup>	5					94H	4	250-600		8		
																					VC7FT only	3††††
750	Black					B39CH <sup>1</sup>																
							6															
							2			U39RT <sup>3</sup>	6					106H	6	500-750		9		
																						VC7FT only
4	1000	—					2			P44RT <sup>4</sup>	6					125H	5	750-1000				2

\*\* Adjustable Indent Tool. No insert dies required.

<sup>1</sup> HCT7508-12, HCT1239, HCT7508H only.

<sup>3</sup> Y39, Y46 only.

<sup>4</sup> Y46 only.

† Users of VC6 and VC7 tools must strip off an extra 1-5/8" of insulation from end of cable to permit removal of tool over conductor sizes 250 kcmil and larger on CU connectors.

†† Also use VC8 tool with aluminum nibs.

††† VC8 tool crimps 500 kcmil only.

†††† VC8 tool crimps 500-600 kcmil only.



## Tool and Die Index for Copper Compression Connectors

For Flexible Rope Stranded or Flexible Stranded Tinned Copper Locomotive Conductor Welding Cable and Portable Cord

Short Barrel — Types CTL, CTL-2 and CSP

Conductor Type						Blackburn Tools		Burdny Tools			T&B Tools		Anderson Tools				
Flex Stranded Size	Locomotive Stranding	Welding Cable	Portable Cord	Stranded CU AWG Size	Die Colour Code	Hyd. JB12B	Crimps per End	Mech. MY29-11	Crimps per End	Hyd. Y35 Y39 Y46	Crimps per End	Hyd. TBM15	Crimps per End	CU Wire Range for Locomotive Cable	VC6 <sup>†</sup> VC6FT	VC7 <sup>††</sup> VC7FT Crimps per End	VC8C <sup>†††</sup>
6	37/24	—	8	8	Red	B71CH	1	**	1	—	—	21	2				
6	61/24	6	6	6	Blue	B73CH	1	**	1	U5CD-1 Y34PR <sup>3</sup>	1	24	2				
5	91/24			4	Grey	B74CH	1	**	1	U4CD-1 Y34PR	1	29	2				
4	105/24	4	4	3	White			**	2	U3CD-1 Y34PR	1						
3	125/24	3	3	2	Brown	B75CH	1	**	2	U2CD-1 Y34PR	1	33	2	4-3	1	2	
2	150/24	2	2	1	Green	B05CH	1	**	2	U1CD-1 Y34PR	1	37	2	4-2	1	2	
1	225/24	1	1	1/0	Pink	B06CHI	2	**	2	U250-1 Y34PR	1	42H	3	4-1	1	2	
1/0	275/24	1/0	1/0	2/0	Black	B72CH	1	**	2	U26CD-1 Y34PR	1	45	2	4-1/0	1	2	
2/0	325/24	2/0	2/0	3/0	Orange	B08CH	1	**	2	U270-1 Y34PR	2	50	2	2-2/0	2	2	
—	—	3/0	3/0	4/0	Purple	B09CH	2	**	2	U280-1 Y34PR	2	54H	3				
3/0	450/24	4/0		250	Yellow	B26CH	2	**	2	U290-1 Y34PR <sup>3</sup>	2	62	2	1/0-3/0 <sup>†</sup>	2	2	
4/0	550/24		4/0	300	White	B12CHI B12CH	2			U300-1 Y34PR <sup>3</sup>	2	66	2	2/0-4/0 <sup>†</sup>	2		
263	650/24			300	Red	B11CH	2			U310-1 Y34PR <sup>3</sup>	2	71H	3	3/0-263 <sup>†</sup>	2	3	
313	775/24			400	Blue	B11CH	2			Y320-1 Y34PR <sup>3</sup>	2	76	2	4/0-313 <sup>†</sup>	2	3	
373	925/24			500	Brown	B10CHI B10CH	2			U340-1 Y34PR <sup>3</sup>		87H	3	4/0-373 <sup>†</sup>	2	3	2 <sup>†††</sup>
444	1100/24			600	Green	B36CH	3			C360 Y46PR <sup>4</sup>	2	94H	3	262-444		3 VC7FT Only	2 <sup>†††</sup>
535	1325/24			750	Black	B39CH <sup>1</sup>	1			C390 Y46PR <sup>4</sup>	2	106H	3	373-535		4 VC7FT Only	2
646 777	1600/24 1925/24			1000	—		1			C440 Y46PR <sup>4</sup>	2	125H	4	535-777			2

\*\* Adjustable Indent Tool. No insert dies required.  
 1 HCT7508-12, HCT1239, HCT7508H only.  
 3 Y39 only.  
 4 Y48B only.  
 † User of VC6 and VC7 tools must strip off an extra 1-5/8" of insulation from end of cable to permit removal of tool over conductor sizes 250 kcmil and larger on CSP connectors.  
 †† Also use VC8 tool with aluminum nibs.  
 ††† VC8 tool crimps 500 kcmil only.

## Tool and Die Index for Copper Compression Connectors

### Long Barrel — Types CTL-L, LNC and CU

Conductor Type						Blackburn Tools		Burdny Tools			T&B Tools		Anderson Tools					
Locomotive Size	Locomotive Stranding	Welding Cable	Portable Cord	Stranded CU AWG Size	Die Colour Code	Hyd. JB12B	Crimps per End	Mech. MY29-11	Crimps per End	Hyd. Y35 Y39 Y46	Crimps per End	Hyd. TBM15	Crimps per End	CU Wire Range for Locomotive Cable	VC6† VC6F†	VC7† VC7F† Crimps per End	VC8††	
8	37/24	—	8	8	Red	B71CH	2	**	2	—	—	21	3					
6	61/24	6	6	6	Blue	B73CH	2	**	2	U5CD-1 Y34PR <sup>3</sup>	2	24	3					
5	91/24			4	Grey	B74CH	2	**	2	U4CD-1 Y34PR	2	29	3					
4	105/24	4	4	3	White			**	3	U3CD-1 Y34PR	2							
3	125/24	3	3	2	Brown	B75CH	2	**	3	U2CD-1 Y34PR	2	33	3	4-2	2	4		
2	150/24	2	2	1	Green	B05CH	2	**	3	U1CD-1 Y34PR	2	37	3	4-2	2	5		
1	225/24	1	1	1/0	Pink	B06CHI	3	**	3	U250-1 Y34PR	2	42H	4	4-1	2	5		
1/0	275/24	1/0	1/0	2/0	Black	B72CH	2	**	3	U26CD-1 Y34PR	2	45	3	4-1/0	2	5		
2/0	325/24	2/0	2/0	3/0	Orange	B08CH	2	**	4	U270-1 Y34PR	2	50	3	2-2/0	3	6		
—	—	3/0	3/0	4/0	Purple	B09CH	3	**	4	U280-1 Y34PR	3	54H	5					
3/0	450/24	4/0		250	Yellow	B26CH	3	**	4	U290-1 Y34PR <sup>3</sup>	3	62	3	1/0-3/0†	3	6		
4/0	550/24		4/0	300	White	B12CHI B12CH	3			U300-1 Y34PR <sup>3</sup>	3	66	3	2/0-4/0†	3	6		
263	650/24			350	Red	B11CH	3			U310-1 Y34PR <sup>3</sup>	3	71H	4	3/0-263†	3	6		
313	775/24			400	Blue	B11CH	2			Y320-1 Y34PR <sup>3</sup>	3	76	3	4/0-313†	3	6		
373	925/24			500	Brown	B2CHI B12CH	4			U340-1 Y34PR <sup>3</sup>		87H	3	4/0-373†	3	6	3†††	
444	1100/24			600	Green	B36CH	6			C360 Y46PR <sup>4</sup>	2	94H	4	262-444		8 VC7FT Only	3†††	
535	1325/24			750	Black	B39CH <sup>1</sup>	2			C390 Y48PR <sup>4</sup>	2	106H	6	373-535		9 VC7FT Only	4	
646	1600/24																	
777	1925/24			1000	—		2			C440 Y46PR <sup>4</sup>	2	125H	5	535-777			4	
1111	2750/24			1500	—		2			C460 Y46PR <sup>4</sup>	2	—	—	1111	—	—	4	

\*\* Adjustable Indent Tool. No insert dies required.

1 HCT7508-12, HCT1239, HCT7508H only.

3 Y39 only.

4 Y48B only.

† Users of VC6 and VC7 tools must strip off an extra 1-5/8" of insulation from end of cable to permit removal of tool over conductor sizes

250 kcmil and larger on CU connectors.

†† Also use VC8 tool with aluminum nibs.

††† VC8 tool crimps 500 kcmil only.

## Tool and Die Index for Copper Compression Connectors

### One and two hole Lugs, Splices — Types ATL and ASP

Stranded AL Wire Size	Stranded CU Wire Size	Die Colour Code	Blackburn Tools						Burdny Tools				T&B Tools					Anderson Tools			
			Mech. OD58	Crimps per End	Mech. HM-250 TOOL	Crimps per End	Hyd. JB12B	Crimps per End	Mech. MY29-3	Crimps per End	Hyd. Y35 Y39	Crimps per End	Mech. TBM5S	Crimps per End	Mech. TBM8S	Crimps per End	Hyd. TBM15	Crimps per End	Stranded AL or CU Wire Range	VC6† VC6FT Crimps per End	VC8C
8	6	Blue	1/4	2	**	1	B73CH	1	**	1	U8CABT	1	13454	2	13461	2	24	2			
6	4	Grey	5/16	2	**	1	B74CH	1	**	1	U6CABT	2	13454	2	13461	2	29	2			
4	1	Green	P	3	**	2	B05CH	1	**	2	U4CABT	2	13455	2	13462	2	37	2			
2	1/0	Pink	1/2	4	**	2	B06CHI	2	**	2	U2CABT	2	13455	3	13462	3	42H	3	6-2	2	
1		Gold	1/2-1	3	**	2	B06CHI	2	**	2	U1CABT	2	13455	3	13464	3	45	2	4-1	2	
1/0		Tan	9/16	4	**	2	B08CH	2	**	2	U25ART	2	13457	3	13464	3	50	2	6-1/0	2	
2/0		Olive	5/8-1	4	**	2	B09CH	2	**	2	U26ART	2	13457	3	13464	3	54H	3	4-2/0	2	
3/0		Ruby	688	5	**	2	B26CH	2	**	2	U27ART	2	13457	3	13464	3	60	2	4-3/0	2	
4/0	300	White	781	5	**	2	B10CHI	2	**	2	U28ART	2	13457	3	13465	4	66	3	2-4/0	2	
250	350	Red	781	5	**		B11CH	3	**	2	U29ART	2	13473	4	13466	5	71H	4	1/0-250†	2	
300	400	Blue	840				B11CH	3			U30ART	2				76	2	1/0-300†			
350	500	Brown					B12CHI	4			U31ART	2			13468	7	87H	4	2/0-350†	2	
400	600	Green					B36CH	6			U32ART	4				94	2	3/0-400†	2		
500	700	Pink					B76CH	4			U34ART	4				99H	4	4/0-500†	2		
600		Black					B39CH	2			U36ART	4				106	2	350-600 AL 350-600 CU	3††		
750	900						6024AH <sup>1</sup>	1			U39RT <sup>2</sup>	4	U39ART-2 <sup>3</sup>	4			125H	5	500-750 AL 600 CU	2†††	
1000		—					6030AH <sup>1</sup>	2			P44ART <sup>2</sup>	3					150H	5	750-1000 AL	2†††	

\*\* Adjustable Indent Tool. No insert dies required.

<sup>1</sup> HCT7508-12, HCT1239, HCT7508H only.

<sup>2</sup> Y46 only.

<sup>3</sup> Y39 only.

† Users of VC6 and VC7 tools must strip off an extra 1-5/8" of insulation from end of cable to permit removal of tool over conductor sizes

250 kcmil and larger on ASP connectors.

†† VC6FT tool only.

††† With AL nibs for VC8C.

### Gauging Information for Standard Hex Dies

Die Code	TBM6H	Blackburn and T&B 12, 14- & 15-Ton Tools Colour Coded Dies	21940 Dies	Hex Gaging
Red	6 ton 21	B71CH	—	.191-.207
Blue	6 ton 24	B73CH	—	.222-.234
27	—	—	11330	.262-.268
Grey	6 ton 29	B74CH	11401	.282-.294
32	—	—	11332	.329-.335
Brown	6 ton 33	B75CH	11402	.326-.337
35	—	—	*11403	.353-.359
Green	6 ton 37	B05CH	11333	.369-.383
40	—	—	*11404	.397-.403
42	—	15508F	11334	.409-.423
Pink	6 ton 42	B06CHI	—	.409-.423
Black	6 ton 45	B08CH	11405	.445-.459
Orange	6 ton 50	B09CH	11406	.494-.506
Olive	—	B09CH	11407	.535-.553
Purple	6 ton 54	B09CH	—	.535-.553
57	—	—	—	.585-.591
58	—	—	11338	.585-.591
60	6 ton 60	—	11408	.587-.605
Yellow	6 ton 62	B06CH	11340	.613-.631
White	6 ton 66	B10CHI	11409	.657-.675
66H	—	—	—	.657-.675
Red	—	B11CH	11363	.707-.725
Red	6 ton 71	B11CH	—	.707-.725
Blue	6 ton 76	B11CH	11410	.751-.769
76H	—	—	—	.751-.769
78	—	—	11306	.751-.769
80	6 ton 80	—	11411	.790-.802
—	—	—	15517	.790-.802
83	—	—	*11370	.825-.831

\* Obsolete, consult your Regional Sales Office for availability.  
Gauges may be ordered from T&B Tool Service.

### Gauging Information for Standard Hex Dies

Die Code	TBM6H	T&B 14- & 15-Ton Tools Dies	21940 Dies	Hex Gaging
87	—	—	11423	.861-.879
Brown	6 ton 87	B12CH	—	.861-.879
94	—	—	11364	.935-.953
94H	—	—	—	.935-.953
96	—	—	11304	.959-.977
96H	—	—	—	.959-.977
99	—	—	11424	.979-.997
99H	—	—	—	.979-.997
100	—	—	11365	1.005-1.011
106A	—	—	—	1.049-1.071
Black	—	B39CH	—	1.049-1.071
107	—	—	11425	1.064-1.076
107H	—	—	—	1.064-1.076
112	—	—	11426	1.118-1.131
112H	—	—	—	1.118-1.131
115	—	—	11308	1.141-1.163
115H	—	—	—	1.141-1.163
125	—	—	11416	1.239-1.261
125H	—	—	—	1.239-1.261
126	—	—	11443	1.247-1.253
130	—	—	11417	1.299-1.305
138	—	—	11366	1.377-1.383
140	—	—	11418	1.369-1.391
140H	—	—	—	1.369-1.391
150	—	—	11419	1.459-1.481
150H	—	—	—	1.459-1.481
160	—	—	11442	1.609-1.615
161	—	—	11420	1.609-1.615
168	—	—	11447	1.684-1.690
175	—	—	11421	1.752-1.744
204	—	—	11448	2.037-2.043
212	—	—	11449	2.120-2.126
214	—	—	11337	2.140-2.146

Gauges may be ordered from T&B Tool Service.

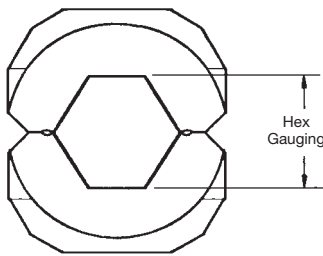

Fig. 2

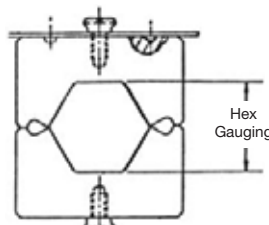

Fig. 1

## Installing Dies

### Insert Dies for TBM6H Hydraulic Head and Type OD Tools



Cat. No.	Description or Colour Codes	Cat. No.	Description or Colour Codes
<b>OJB</b>	0	<b>BY37</b>	840 (EEI 11A)
<b>DBL</b>	D	<b>BY55</b>	Wire Cutter (2/0 max.)
<b>BY39</b>	510 Hex (non-bow)	<b>BY63</b>	Orange (Nicopress)
<b>BY41</b>	635 Hex (non-bow)	<b>BY65</b>	Plum
<b>BY43</b>	747 Hex (non-bow)	<b>BY15C*</b>	7/32 Red
<b>BY45</b>	T	<b>BY17C*</b>	1/4 Blue
<b>BY47</b>	K	<b>BY19C*</b>	5/16 Grey
<b>BY49</b>	B	<b>BY21C*</b>	3/8 Brown
<b>BY51</b>	J	<b>BY23C*</b>	1/2 Pink
<b>BY53</b>	P	<b>BY24C*</b>	1/2-1 Gold
<b>BY13</b>	3/16	<b>BY25C*</b>	9/16 Tan/Orange
<b>BY15*</b>	7/32 (EEI-1 index 236)	<b>BY27C*</b>	11/16 Yellow
<b>BY17</b>	1/4	<b>BY31C*</b>	5/8-1 Olive/Purple
<b>BY19</b>	5/16 (index 161.242)	<b>BY32C*</b>	Ruby
<b>BY21</b>	3/8	<b>BY35C*</b>	781 White
<b>BY23</b>	1/2 (index 163)	<b>BY37C*</b>	840 Red
<b>BY25</b>	9/16	<b>BY28C*</b>	17/32 Black
<b>BY27</b>	11/16	<b>BY53C*</b>	P Green
<b>BY29</b>	19/32	<b>BG1</b>	Canvas Bag for OD58
<b>BY31</b>	5/8-1 (index 165)	<b>ODH1</b>	Insulating Head Cover
<b>BY33</b>	737		
<b>BY35</b>	781		

\*Can also be used with OD58 tool.



### Insert Dies for Hydraulic Heads\* JB12B, 13100A, TBM14M, TBM14MC, TBM14BSCR, TBM14RH, TBM15I, TBM15BSCR, BPLT14BSCR, BPLT15BSCR



Cat. No.	Description or Colour Codes
<b>B58CS</b>	5/8 Die Set
<b>HO</b>	"O" Die Set
<b>HD</b>	"D" Die Set
<b>HN</b>	"N" Die Set
<b>HU</b>	"U" Die Set
<b>HBKC</b>	BKC
<b>HBKT</b>	BKT
<b>B24EA</b>	EEl 8A
<b>B30EA</b>	EEl 9A
<b>B39EA</b>	EEl 10A
<b>B49EA</b>	EEl 11A (840)
<b>B61EA</b>	EEl 12A
<b>B80EA</b>	EEl 13A
<b>B20AH</b>	EEl14A
<b>B71AH</b>	-
<b>B72AH</b>	-
<b>B73AH</b>	-
<b>B74AH</b>	-

Cat. No.	Description or Colour Codes
<b>B75AH</b>	-
<b>B76AH</b>	-
<b>B76SH</b>	-
<b>B06CHI</b>	Pink/Gold 1/0 AWG CU – 2 AWG AL
<b>B08CH</b>	Tan/Orange 3/0 AWG CU – 1 AWG AL
<b>B09CH</b>	Olive/Purple 4/0 AWG CU – 2/0 AWG AL
<b>B11CH</b>	Red/Blue 350/400 kcmil CU – 250-300 kcmil AL
<b>B10SH</b>	-
<b>B05CH</b>	Green #1 AWG CU – 4 AWG AL
<b>B26CH</b>	Ruby/Yellow 250 kcmil CU, 3/0 AWG AL
<b>B71CH</b>	Red #8 AWG CU – 10 AWG AL
<b>B72CH</b>	Black 2/0 AWG CU
<b>B73CH</b>	Blue #6 AWG CU – 8 AWG AL
<b>B74CH</b>	Grey #4 AWG CU – 6 AWG AL
<b>B75CH</b>	Brown #2 AWG CU
<b>B76CH</b>	Pink 700 kcmil CU – 500 kcmil AL
<b>B10CHI</b>	White 300 kcmil CU – 4/0 AWG AL
<b>B12CHI</b>	Brown 500 kcmil CU – 350 kcmil AL
<b>B36CH</b>	Green 600 kcmil CU – 400 kcmil AL
<b>B39CH</b>	Black 750 kcmil CU – 600 kcmil AL
<b>6024AH</b>	Yellow 900 kcmil CU – 750 kcmil AL
<b>6030H</b>	No colour 1000 kcmil AL only

\*Adaptor 15500-TB required with T&B 15-ton tools.

## Installing Dies

### Dies for Figure 6 to 6 — Ground Connectors

Cat. No.	Cable Element A	To Cable Element B	To Ground Rod Element A	To Rebar Element B	Die Selection	
					Element A	Element B
54855L	#6 sol. - #2 str.	#6 sol. - #2 str.	-	-	15501A	15501A
54865L	#1 str. - 250 kcmil				15501A	15G86R
54875L	#2 str. - 250 kcmil	#2 str. - 250 kcmil	1/2" - 5/8" Rod	3/8" - 1/2" #3 - #4 Rebar	15G86R	15G86R
54885L	250 kcmil - 500 kcmil	#6 sol. - #2 str.	5/8" - 3/4" Rod	5/8" - 3/4" #3 - #4 Rebar	15501A	15G126R
54895L		#2 str. - 250 kcmil			15G86R	15G126R
54900L		#2 str. - 250 kcmil			15G121R	15G121R

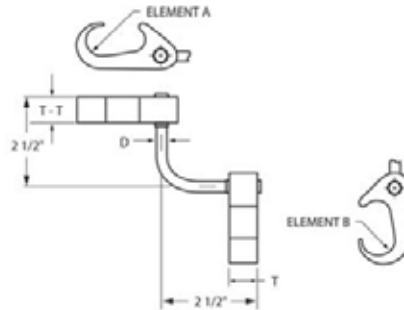

### Dies for Figure 6 to 6 – Ground Connectors and Cross Reference

Cat. No.	Dies for T&B 14- and 15-Ton Tools				Burdny Tools and dies											
	Element A		Element B		Y750				Y45				Y46			
	*	*	*	*	A	*	B	*	A	*	B	*	A	*	B	*
54900L	15G121R	3	15G121R	3	U1011	3	U1011	3	S1011	3	S1011	3	P1011	3	P1011	3
54895L	15G86R	1	15G126R	1	PU998 or PU998	1	U997	1	S998 or PU998	1	U997	1	P998	1	U-0	1
54885L	15501A	1	15G126R	1		1	U-0 or PU998	1	S998	1	U-0	1		1	1	U-0
54875L	15G86R	1	15G86R	1	U997	1	U997	1	U997	1	U997	1	U997	1	U997	1
54865L	15501A	1	15G86R	1		1	U-0	1	U-0	1	U-0	1		1	1	U-0
54855L	15501A	1	15501A	1	U-0	1	U-0	1	U-0	1	U-0	1	U-0	1	U-0	1

Use 15500-TB adaptor for T&B 15-ton tools.

\* = Number of crimps

### Die Adapters

Cat. No.	Description
15500TB	To be used with TBM15I tool only

### Installation Dies for Figure 6 and Figure 8 — Ground Connectors

Cat. No.	Cable Element A	To Cable Element B	To Ground Rod Element B	To Rebar Element B	Die Selection	
					Element A	Element B
54855L	#6 Sol. - #2 Str.	#6 Sol. - #2 Str.	-	-	15501A	15501A
54865L	#1 Str. - 250 kcmil	#6 Sol. - #2 Str.	1/2" - 5/8" Rod	3/8" - 1/2" #3 - #4 Rebar	15G86R	15501A
54875L	#2 Str. - 250 kcmil	#2 Str. - 250 kcmil	1/2" - 5/8" Rod	3/8" - 1/2" #3 - #4 Rebar	15G86R	15G86R
54885L	250 kcmil - 500 kcmil	#6 Sol. - #2 Str.	5/8" - 3/4" Rod	5/8" - 3/4" #5 - #6 Rebar	15G126R	15501A
54895L	250 kcmil - 500 kcmil	#2 Str. - 250 kcmil	5/8" - 3/4" Rod	5/8" - 3/4" #5 - #6 Rebar	15G126R	15G86R
54900L	250 kcmil - 500 kcmil	#2 Str. - 250 kcmil	5/8" - 3/4" Rod	5/8" - 3/4" #5 - #6 Rebar	15G121R	15G121R

### Dies for Figure 6 — Ground Connectors and Cross Reference

Cat. No.	Dies for T&B 14- and 15-Ton Tools *	Burndy Tools and dies			
		Y750 *	Y45 *	Y46 *	
54900	15G121R 3	U1011 3	S1011 3	P1011 3	
54895	15G126R 1	PU998 1	PU996 or S998 1	PU996 or S998 1	
54890					
54885	15501A 1	U0 1	U0 1	U0 1	
54875					
54865CK	15G86R 1	997 1	U997 1	U997 1	
54860					
54855	15G86R 1				

Use 15500-TB adaptor for T&B 15-ton tools.

\* = Number of crimps

### Dies for Figure 8 — Ground Connectors and Cross Reference

Cat. No.	Cable Range	Dies for T&B 14- and 15-Ton Tools *	Burndy Tools and dies		
			Y750 *	Y45 *	Y46 *
GR1-300500*	300-500 kcmil		U1011 2	S1011	P1011 2
GR34-300500 & TP*			PU998 1	S1012 or PU998 2 1	P1011 2 or PU998 1
GR58-30050 & TP					
GR1-40250*	4/0 AWG-250 kcmil	15G121R 2	U1011 2	S1011 2 S1012 or PU998 2 1	P1011 2 or PU998 1
GR34-40250 & TP*			PU998 1	S1012 or PU998 2 1	
GR58-40250 & TP					
GR12-40250 & TP					
GR1-202*	2 AWG-2/0 AWG		U1011 2	S1011 2 S1012 or PU998 2 1	
GR34-202 & TP			PU998 1	S1012 or PU998 2 1	
GR58-202 & TP					
GR12-202 & TP					

Optional ground rod knurling die for TBM 14- and 15-ton tools: 15508.

Use 15500-TB adaptor for T&B 15-ton tools.

Optional ground rod knurling tool: 240-31565-94.

\*Use 15-ton tool only.

\* = Number of crimps

### Dies for Figure 6 to 8 — Ground Connectors and Cross Reference

Cat. No.	Dies for T&B 14- and 15-Ton Tools		Burdly Tools and dies								
	Element A *	Element B *	Y750			Y45			Y46		
			A *	B *		A *	B *		A *	B *	
54920LR100	15G121R	15G126R [1]		U1011 or PU998 [2] [1]			U1011 or PU998 [2] [1]				U1011 or PU998 [2] [1]
54910LR100	15G121R	15G86R [1]		U997 [1]			U997 [1]				U997 [1]
54900L34 & TP	15G121R	115G126R [1]		U1011 or PU998 [2] [1]			U1011 or PU998 [2] [1]				U1011 or PU998 [2] [1]
54875L34 & TP	15G121R	15G86R [1]	U1011 or PU998 [2] [1]	U997 [1]	S1011 or PU998 [2] [1]		U997 [1]		P1011 or PU998 [2] [1]		U997 [1]
54895LR58 & TP	15G121R	15G126R [1]					S998 or PU998 [1] [1]				P998 or PU998 [1] [1]
54865L58 & TP	15G121R	15G86R [1]					U997 [1]				U997 [1]
54885LR12 & TP	15G121R	15G126R [1]		U1011 or PU998 [2] [1]			S998 or PU998 [1] [1]				P998 or PU998 [1] [1]
54855LR12 & TP	15G121R	15G86R [0]					U997 [1]				U997 [1]

Optional ground rod knurling die for TBM 14- and 15-ton tools: 15508.  
Use 15500-TB adaptor for T&B 15-ton tools.  
Optional ground rod knurling tool: 240-31565-94.

\* = Number of crimps

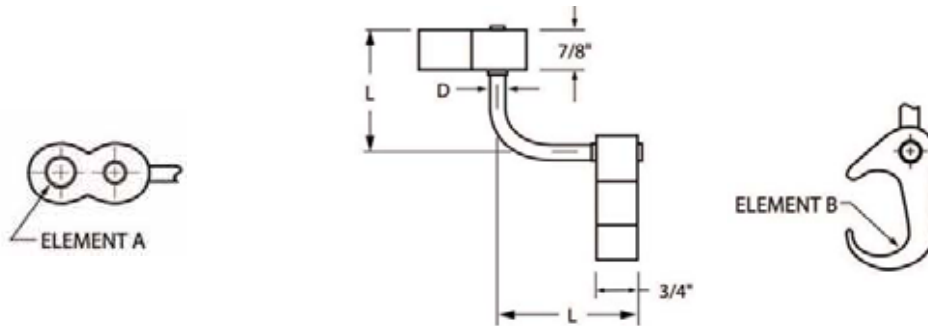

### Dies for E-Z-Ground® C-Taps and Cross Reference

Cat. No.	Dies for T&B 14- and 15-Ton Tools *		Burdly Tools and dies					
		*	Y750	*	Y45	*	Y46	*
CTP500500	15G121R	[3]	U1011	[3]	S1011	[3]	P1011	[3]
CTP500250	15G121R	[2]	U1011	[2]	S1011	[2]	P1011	[2]
CTP50020								
CTP250250	15G86R	[1]	U997	[1]	U997	[1]	U997	[1]
CTP25020								
CTP2020	15501A	[1]	U-0	[1]	U-0	[1]	U-0	[1]
CTP202								
CTP22*	HBKC	[1]	U-C	[1]	U-C	[1]	U-C	[1]

Cat. No. 15500-TB adaptor required if using T&B 15-ton tools with 155XX dies series.  
\*#6 AWG branch must be doubled.

\* = Number of crimps

## Installing Dies

### Cable Slicing Die Sets



- Cut copper and aluminum insulated cable sizes from #8 AWG through 500 kcmil
- Produce clean, squared-end cuts which eliminates extra trimming of conductor strands

Cat. No.	Maximum Cable Size	Tools	Pkg. Qty
<b>BY55</b>	2/0	TBM6H, BPLT6BSCR, BPLT6500BSCR	1
<b>40CS</b>	4/0	TBM14M, 13100A and TBM14BSC	
<b>156CS</b>	500 kcmil	TBM15I and TBM15BSCR	

Installation Dies and Tools

### Knurling Tool

Cat. No.	Description
<b>240-31565-94</b>	Hand knurling tool for all ground rods



Hand knurling Tool for all Ground Rods

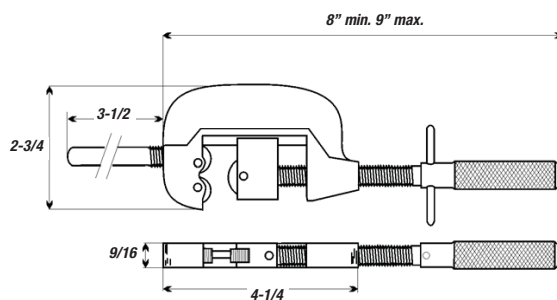



## Installation Tools

### TBM4BB Crimp Tool

- Installs lugs and splices over a wire range of #8 to #2 copper and #10 to #6 aluminum
- Also installs up to the green colour coded C-Taps and MD2 Series motor disconnect
- A colour coded die wheel is rotated into position and each die has die code embossing
- Shure Stake® tool

	Conductor Size					
	#10	#8	#6	#4	#2	#1
<b>Copper</b>						
One hole, short		CTL8-10 CTL8-14 CTL8-516 54132	CTL6-10 CTL6-14 CTL6-516 CTL6-38	CTL4-10 CTL4-14 CTL4-516 CTL4-38	CTL2-14 CTL2-516 CTL2-38 CTL2-12	
Two hole, short		54204	CTL6-214	CTL4-214	54207	
Splice, short		CSP8	CSP6	CSP4	CSP2	
One hole, long		CTL8L-14	CTL6L-14	CTL4L-14	54942BE	
Two hole, short		LCN8-14	LCN6-14	LCN4-14	LCN2-516	
Splice, long		CU8	CU6	CU4	CU2	
Cable Joints			54610	54615	54620	
Narrow Tongue				55112	55116	
C-Taps		54705	54710	54715	54720	54725
Motor Disconnects		MD8 Series	MD6 Series	MD4 Series	MD2 Series	
<b>Aluminum</b>						
One hole	60096 60099	ATL8-10 ATL8-14 60103 60104	ATL6-10 ATL6-14 60108 60109			
Splices	60500	ASP8	ASP6			
Bi-Pins		61905A	61910A			
Equipment Lugs		61102	61107			



#### Gauging Procedure

1. Rotate wheel to the desired nest.
2. Squeeze handles with 5 to 15 lb. force.
3. Holding handles tightly closed, insert GO, NO-GO gauge into nest. GO gauge should enter freely. NO-GO gauge may enter partially, but not pass completely through the length of the nest area.
4. Equivalent to TBM25S.

Cat. No.	Colour Code	Gauging Nom. – Tol.
TBM4BB	Red	0.183 ± 0.006
	Blue	0.220 ± 0.008
	Grey	0.273 ± 0.008
	Brown	0.332 ± 0.008
	Green	0.414 ± 0.008

### TBM4S Dieless Crimp Tool

- Wide range of #8 to 250 kcmil for copper lugs and #8 to 4/0 for aluminum lugs
- Adjustable indenter eliminates the need to buy and maintain numerous individual dies
- Shure-Stake® mechanism ensures a properly completed crimp each time
- Easily adjusted by turning knurled adjusting wheel and aligning pointer with proper terminal size
- Dieless adjustable crimper for Color-Keyed® compression connectors



Creates Indent-style crimp



Cat. No.	Description	Pkg. Qty
TBM4S	Dieless crimp tool with Shure-Stake® mechanism for #8–250 kcmil copper and #8–4/0 aluminum lugs	1

### JB12B — 12-Ton Manual Hydraulic Crimp Tool

- Self-contained hydraulic crimping tool for copper, aluminum and ACSR connectors
- Two-stage, rapid-ram advance mechanism for fast installation
- 180° head rotation
- Accepts all U-type dies used for Alcoa, Burndy, Thomas & Betts and Blackburn tools of equivalent tonnage
- Uses standard T&B Color-Keyed® 15500 dies Series (refer to pages 111–117)

#### Specifications

- Installing Range:
  - Up to 750 kcmil copper lugs & splices
  - Up to 650 kcmil aluminum lugs & splices
  - CHT814-10 to CHT2502-6 copper H-taps
  - 63105 to 63148 aluminum H-taps
  - 54755 to 54770 C-taps
- Output Force: 12 tons
- Dimensions (L x W x H): 22-3/4" x 2-1/2" x 4-7/8"
- Weight without Dies: 13 lb.



Creates Hex-style crimp



Cat. No.	Description	Pkg. Qty
JB12B	12-Ton Compression Tool	1

### TBM14M C 14-Ton Compact Manual Hydraulic Crimp Tool

- Improved ergonomic design requires less force
- 180° rotating head for use in tight spaces
- 1.65" jaw opening accommodates large compression terminals and joints
- Dual-speed action pump offers fast advancing speed for approach of die to connector and slower, more powerful speed for crimping
- Built-in safety valve bypasses oil supply at maximum pressure
- Pressure-release system can be activated at any stage of compression
- Uses standard T&B Blackburn® and Color-Keyed® 15500 dies series (refer to pages 112–117)



Creates Hex-style crimp



#### Specifications

- Installing Range:
  - Up to 900 kcmil copper lugs & splices
  - Up to 750 kcmil aluminum lugs & splices
- Output Force: 14 tons
- Length: 20-1/2"
- Weight without Dies: 14 lb.
- TBM14MG—Gauge and testing dies in carrying case

Cat. No.	Description	Pkg. Qty
TBM14MC	14-Ton Compact Hydraulic Crimp Tool	1

### TBM840 Crimp Tool

- Wide range of #8 to 4/0 for copper connectors and splices
- Installs Blackburn® and Thomas & Betts lugs and splices
- 8-position colour coded rotatable die
- Comfort hand grip
- Die index embossed for permanent inspectability



#### Specifications

- Overall length: 23-3/4"
- Handle length: 16-1/2"
- Weight: 8.8 lb.

Cat. No.	Description	Pkg. Qty
TBM840	Crimp Tool for #8 to 4/0 Copper Lugs c/w Rotating Colour Coded Die Wheel	1

## Installation Tools

### OD581 Manual Compression Tool

- Integral self-gauging system in tool head assures proper adjustment before each crimp
- Improved design reduces force to crimp by as much as 20%
- Teflon over bronze bearings greatly reduce wear at linkage and pins; far superior to steel bearing surfaces
- All standard insert dies available for OD58 tool: "O" and "D", 840, etc., 5/8" fixed die in nose
- ODF tool has fixed "O" and "D" dies
- ODB tool has fixed "O" and "D" dies; accepts standard insert dies designed for MD6 tool
- Distribution of weight over tool length gives better balance, results in easier handling and positioning
- Optional fiberglass handles for greater strength, lighter weight, better insulating properties and lower moisture absorption rate
- ODF and ODB tools with insulated heads available as an option
- Lever action tool with hot stick handles of Glastrux Fiberglass, rated and tested for 100kV/ft/5 minutes
- Lever action results in minimum applied force to crimp



Cat. No.	Description	Handle Length (in.)	Weight (lb.)
<b>OD58</b>	Manual Tool with 5/8" Nose Die and Insert Die Cavity Straight Wooden handles	-	6.5
<b>OD581</b>	Manual Tool with 5/8" Nose Die and Insert Die Cavity Straight Fiberglass handles	-	6.0
<b>OD583</b>	Manual Tool with 5/8" Nose Die and Insert Die Cavity Curved Wooden handles	-	6.5
<b>ODF1</b>	Manual Tool with fixed O & D dies Fiberglass handles	-	6.0
<b>ODB</b>	Manual Tool with fixed O & D dies "D" die cavity accepts MD6 tool insert dies Straight Wooden handles	-	-
<b>ODB1</b>	Manual Tool with fixed O & D dies "D" die cavity accepts MD6 tool insert dies Fiberglass handles	-	6.0
<b>ODB3</b>	Manual Tool with fixed O & D dies "D" die cavity accepts MD6 tool insert dies Curved Wooden handles	-	6.5
<b>OD58L72</b>	Manual Tool with 5/8" Nose Die and Insert Die Cavity Hot Stick Handles - 1.5" x 72"	72	10.5
<b>ODBL72</b>	Manual Tool with 5/8" Nose Die and Insert Die Cavity Accepts MD6 tool insert dies Hot Stick Handles - 1.5" x 72"	-	-
<b>BG1-BB</b>	Canvas bag for OD58	-	1.00
<b>ODH1</b>	Insulating head cover	-	0.40

*For Hand Tool with insulated head, add suffix 5 to catalogue number.*

### TBM6H — 6-Ton Hydraulic Crimping Head

- Lightweight design – weighs less than 7 lb., including dies
- Embosses die code on connection for easy inspection
- Uses 6-TON Series and Blackburn “O” & “D” dies Series and colour coded insert dies for easy matching with Blackburn® and Color-Keyed® connectors (refer to page 118)



Creates Hex-style crimp



#### Specifications

- Installing Range:
  - Up to 600 kcmil copper lugs & splices
  - Up to 400 kcmil aluminum lugs & splices
  - CHT814-10 to CHT214-9 copper H-taps
  - 63105 to 63148 aluminum H-taps
  - 54705 to 54750 C-taps
- Output Force: 6 tons
- Dimensions (L x W x H): 12" x 2-1/4" x 3-9/16"
- Battery: Ni-MH 14.4V 3.0Ah
- Weight: 6.5 lb.

Cat. No.	Description	Pkg. Qty
<b>TBM6H</b>	6-Ton Hydraulic Head with Steel Case	1
<b>TBM6HD-1</b>	Die Set for #8 thru 500 kcmil (6-TON21 thru 6-TON87)	

### TBM6H — Application Information Connector Dies

Connector Size		TBM6H Hydraulic Head		BKB Die No.	Colour Code
Copper	Aluminum	Color-Keyed Die Cat. No.	Die Code		
8 AWG	10 AWG	6TON21	21	BY15C	Red
6 AWG	8 AWG	6TON24	24	BY17C	Blue
4 AWG	6 AWG	6TON29	29	BY19C	Grey
2 AWG		6TON33	33	BY21C	Brown
1 AWG	4 AWG	6TON37	37		Green
1/0 AWG	2 AWG	6TON42	42H	BY23C	Pink
2/0 AWG	1 AWG	6TON45	45	BY24C	Black/Gold
3/0 AWG	1/0 AWG	6TON50	50	BY25C	Orange/Tan
4/0 AWG	2/0 AWG	6TON54	54H	BY31C	Purple/Olive
	3/0 AWG	6TON60	60	BY32C	Ruby
250 kcmil		6TON62	62	BY27C	Yellow
300 kcmil	4/0 AWG	6TON66	66	BY35C	White
350 kcmil	250 kcmil	6TON71	71H	BY37C	Red
400 kcmil	300 kcmil	6TON76	76		Blue
925/24		6TON80	80	BY28C	Black
500 kcmil	350 kcmil	6TON87	87H		Brown

Consult Connector Stuffer Sheets for series 61900, 61100 & 61300.  
Consult Connector Stuffer Sheets for Wire Ranges.

## Installation Tools

### 13100A — 14-Ton Hydraulic Crimping Head

- Rugged design, made to last in field or on bench
- C-yoke provides maximum flexibility for crimping
- Uses standard T&B Color-Keyed® Series 15500 dies (refer to pages 111–112)
- Operates on 10,000 psi hydraulic pumps

#### Specifications

- Installing Range:
  - Up to 900 kcmil copper lugs & splices
  - Up to 750 kcmil aluminum lugs & splices
  - CHT814-10 to CHT2502-6 copper H-taps
  - 63105 to 63148 aluminum H-taps
  - 54755 to 54775 C-taps
- Output Force: 14 tons
- Operating Pressure: 10,000 psi nominal
- Dimensions (L x W x H): 11-1/2" x 2-1/2" x 4-1/4"
- Weight: 10 lb.

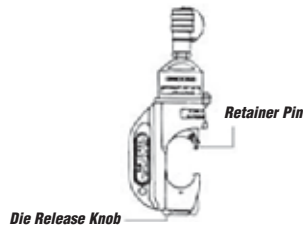

Creates Hex-style crimp



Cat. No.	Description	Pkg. Qty
13100A	14-Ton Hydraulic Head with Steel Case	1

#### Installation Range for Connectors

	Lugs	Splices
Copper	#8 AWG to 900 kcmil	#8 AWG to 900 kcmil
Aluminum	#10 AWG to 750 kcmil	#10 AWG to 750 kcmil



## Smart® Tools From T&B to Crimp 17 Blackburn® Connector Sizes with No Die Changes



TBM8-750M-1



TBM8-750



Wire Barrel Before Compression



After Compression—the connector and conductor are formed into a solid mass.

### Rugged Hydraulic Tool Gives You Uniform Dependable Connections — Lower Installed Costs

The new Smart® Tools are designed to give you uniform, high quality compression connections over a wide connector range. It easily installs copper and aluminum lugs and two-way connectors from #8 AWG through 750 kcmil—without changing dies. For the specified wire range, all you need is one hydraulic tool and one set of dies. You always have the right die size selection; mistakes are virtually eliminated. Productivity will be greatly improved, especially when installing a variety of connector sizes or types. Initial investment is low and requires only a minimum tool/die inventory. These benefits add up to lower installed cost.

### How It Works

The tool, which operates from a 9,800 psi hydraulic pump, has an engineered, built-in “intelligence\*.” The tool will sense the connector barrel diameter and apply just the right amount of compression force. This eliminates virtually all air spaces and forms the connector and conductor strands into a solid mass resulting in a high quality, low resistance connection. In addition, the tool clearly embosses “T&B” with each compression for positive verification that the correct tool was used.

\* System Novopress

## Installation Tools

### “C”-Type Yoke Offers Installation Convenience

The “C”-type yoke configuration and the large die spacing allows the tool to slip directly over the connector. This means added speed and convenience when installing 2-way connectors, especially in confined spaces.

### Rugged Construction

These ruggedly built tools are made from forged steel, and are well suited for both field and bench work. Their C-shaped heads, light weight, and compact size make them easy to use just about anywhere.

### Specifications

#### TBM8-750

##### Remote Head tool

Weight: 9 lb. (approx.)  
 Height: 14-1/2 in.  
 Width: 4-7/32 in.  
 Depth: 2-9/16 in.  
 Wire Range: #8 AWG through 750 kcmil copper and aluminum  
 Operating Pressure: 9,800 psi  
 Output Pressure: 12 tons  
 Coupler: Pioneer, female

#### TBM8-750M-1

##### Self-Contained Tool

Weight: 13 lb. (approx.)  
 Height: 21-1/2 in.  
 Width: 4-7/32 in.  
 Wire Range: #8 AWG through 750 kcmil copper and aluminum  
 Operating Pressure: 9,800 psi  
 Output Pressure: 12 tons

### Smart® Tool Range Taking Features

The following size copper Blackburn® lugs and 2-way connectors, when crimped with the Smart® Tools, Cat. Nos. TBM8-750 and TBM8-750-M1, produce these range taking capabilities:

Copper		Aluminum	
Standard Wire Size	Range Taking	Standard Wire Size	Range Taking
1/0-AWG	#6-1/0 AWG	1/0-AWG	#6-1/0 AWG
2/0-AWG	#1-2/0 AWG	2/0-AWG	#1-2/0 AWG
4/0-AWG	#2-4/0 AWG	4/0-AWG	#2-4/0 AWG
300 kcmil	#2/0-300 kcmil	300 kcmil	#2/0-300 kcmil
350 kcmil	250-350 kcmil	350 kcmil	250-350 kcmil
500 kcmil	250-500 kcmil	500 kcmil	4/0-500 kcmil
750 kcmil	500-750 kcmil	750 kcmil	500-750 kcmil



## Installation Tools

### TBM8-750M-1 — 12-Ton Dieless Manual Hydraulic SMART® Tool



Creates  
Indent-style crimp



TBM8-750M-1

#### Specifications

- Installing Range:  
Up to 900 kcmil copper lugs & splices  
Up to 750 kcmil aluminum lugs & splices
- Output Force: 12 tons
- Dimensions (L x W): 21-1/2" x 4-7/32"

### TBM8-750 — 12-Ton Dieless SMART® Hydraulic Head



Creates  
Indent-style crimp



TBM8-750

#### Specifications

- Installing Range:  
Up to 900 kcmil copper lugs & splices  
Up to 750 kcmil aluminum lugs & splices
- Output Force: 12 tons
- Operating Pressure: 10,000 psi nominal
- Dimensions (L x W x H):  
14-1/2" x 4-7/32" x 2-9/16"
- Weight: 9 lb

### Hydraulic Smart® Tool

Cat. No.	Description
TBM8-750	Remote Head installs Blackburn® #8 AWG through 750 kcmil aluminum and copper lugs, 2 way connectors, and "D" through "M" bare Sta-Kon® terminals with no die change; the only additional die sets required are for "H" and "C" type compression taps; the tool weighs only 9 lb. and is 13 in. long; operates on standard 10,000 psi electric and manual pumps. UL and CSA Listed for T&B connectors and uninsulated terminals.
TBM8-750M-1	Self-contained head installs same connectors as above tool; "C" Head swivels 90° for easy crimp positioning in confined spaces
TBM8-750G	Field compression gauging kit for both above tools
TBM8-750C20	Die set installs Cat. No. 54720 copper "C" taps
TBM8-750C2530	Die set installs Cat. Nos. 54735, 54730 copper "C" taps
TBM8-750C3540	Die set installs Cat. Nos. 54735, 54740 copper "C" taps
TBM8-750C4550	Die set installs Cat. Nos. 54745, 54750 copper "C" taps
TBM8-750CL	Die set installs Cat. No. 54755 through 54775 copper "C" taps
TBM8-750HG	Die set installs Cat. No. 63110 through 63118 and 63125 "H" taps
TBM8-750HB	Die set installs Cat. No. 63140 through 63148 "H" taps
297-31804-6	TBM8-750 with insulated head
297-31804-4	TBM8-750M-1 with insulated head

### Gauging Procedure

1. Insert the test bar in the die opening; allow 3/4" from the end of the bar or the last crimp to prevent poor crimping.
2. Start the pump, holding pressure on the tool until full pressure is shown on the gauge.
3. Release the pressure.
4. Measure the crimped area of the test bar with a Vernier Caliper as shown in the sketch.
5. Accept the tool if the crimped bar is within the listed dimension and no leaks or functional problems are observed.
6. Tools not crimping the test bar to specification, that leak or have a functional problem should be returned to T&B Tool Service.

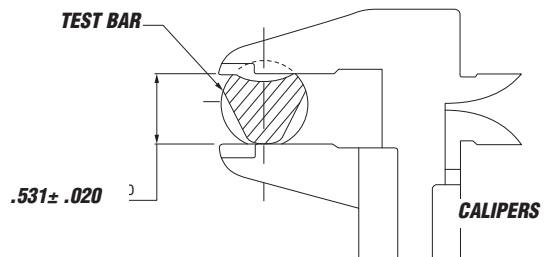

## Installation Tools

### CSR750 Cable Cutter

- Special advance stroke mechanism requires less handle force
- Cuts copper or aluminum cables up to 750 kcmil
- Short handles (only 10" long) enable use in tight spaces



Contact Tool Service for replacement blades.

Cat. No.	Description	Pkg. Qty
CSR750	Cutter for up to 750 kcmil copper or aluminum	1

### 368-CK Cable Stripper



Cat. No.	Description	Pkg. Qty
368-CK	Cable stripper for #1 to 1,000 kcmil	1

### CTR-1 — C-Tap Removal Tool



Cat. No.	Description	Pkg. Qty
CTR-1	C-Tap Removal Tool	1

### HM-250 TOOL — Mechanical Single Indent Dieless Crimper

- Manually operated single-indent compression tool
- For copper wire #8 to 250 kcmil
- For aluminum wire #8 to 4/0



Cat. No.	Description	Pkg. Qty
HM-250 TOOL	Mechanical Single Indent Dieless Crimper	1

### Blackburn® Allen Wrench



PVC dipped handle

Cat. No.	Description	Pkg. Qty
WA 516	PVC dipped handle – Hex size 5/16	1
WA 38	PVC dipped handle – Hex size 3/8	

## Battpac™ Battery-Powered Compression and Cutting Tools

Balanced, Inline Design for Better Handling and Greater Control.

### 4-Ton Battery-Powered Crimping Tool

This new 4-Ton Battery-Powered Crimping Tool weighs only 6.4 lb — including battery — but yields 4 tons of output force for crimping T&B service entry connectors and lugs or splices up to 300 kcmil copper or 4/0 AWG aluminum. The jaws automatically return to the open position after the completion of a crimp, but you can stop the automatic jaw return at any time for ease of positioning in confined spaces.

- Offers extremely quiet operation with minimal vibration
- Equipped with maximum pressure valve for safety
- Durable molded body offers high resistance to wear and damage in tough field conditions.
- Fixed 5/8" BG and D grooves; accepts all W style dies
- Includes 0 die insert
- Crimps select Homac®, Blackburn® and Color-Keyed® connectors



#### Specifications

- Installing Range:  
Up to 300 kcmil copper or 4/0 AWG aluminum lugs and splices
- Output Force: 4 tons
- Dimensions (L x W x H): 17.7" x 2.6" x 4.7"
- Battery: Ni-MH 9.6V 3.0Ah
- Weight with Battery: 6.4 lb

Cat. No.	Description	Pkg. Qty
BP4UCR	Includes tool, 0 die insert, two batteries, charger and durable plastic carrying case.	1

**Battpac™ Battery-Powered Compression and Cutting Tools**

**Battpac™ TBM14BSCR Hermetically Sealed 14-Ton Battery-Powered Compression Tool**

The TBM14BSCR is a self-contained battery operated 14-ton compression tool. The large jaw opening, 1.65 inches, accepts mid-span copper and aluminum splices and cables up to 750 kcmil. When the splices are compressed, they can be removed through the large jaw. This tool accepts T&B and Blackburn® shell type dies.

A built-in, pre-set 10,000 psi bypass cartridge will audibly kick out when the 14-ton pressure is achieved.

Portability and handling is easy because the TBM14BSCR system is self-contained and compact. There is no tool set-up time or extra power source needed. Makes splicing a breeze. And with one finger trigger operation, fatigue and muscle related strains are nearly eliminated. Safer work habits result from using this tool.



Creates Hex-style crimp

Cat. No.	Description	Pkg. Qty
TBM14BSCR	Hermetically sealed unit. Includes carrying case, charger, two batteries, carry strap	1

NOTE: When ordering the Smart® battery, add suffix "-SM" (Example: TBM14BSCR-SM). Suggested replacement oil T&B Cat. No. 21061 or any light weight hydraulic fluid or automatic transmission fluid is recommended. Do not use silicon based fluids.

**6-Ton Battery Compression Tool**

The TBM6BSCR is designed to crimp commonly used lugs, splices, service entrance connectors, H and C-taps. It can be easily carried and used in limited access areas because of its swivel head and compact design. The unique open yoke is also advantageous for C-tap, H-tap and splicing applications. Its six-ton output is equal to any comparable hand-held, hydraulic compression tool and far exceeds any mechanical crimper.

A built-in factory pre-set 10,000 psi by-pass cartridge assures a complete compression every time. Consult your Regional Sales Office for proper die/connector combinations or read the information on the connector package. Accepts standard T&B six-ton dies and Blackburn® OD58 dies Series.



Cat. No.	Description	Pkg. Qty
TBM6BSCR	6-Ton Battery Powered Compression Tool	1

**ROBO\*CRIMP™ 6-Ton Dieless, Battery-Powered Crimping Tool Kits**

Both kits include:

- (1) Battery powered tool
- (1) Carrying strap
- (1) Carrying case
- (1) BP-70R battery
- (1) CH-3TR 15 minute AC charger

Cat. No.	Description	Pkg. Qty
REC-630	#10 AWG – 500 kcmil	1
REC-750	#6 AWG – 750 kcmil	

ROBO\*CRIMP™ is a registered trademark of Huskies Tools.





## Battpac™ Battery-Powered Compression and Cutting Tools

### Battpac™ TBM15BSCR Hermetically Sealed 15-Ton Battery-Powered Compression Tool

- Weather-resistant, non-ventilated body for use in the most corrosive environments
- High grade forged steel head rotates 180°
- Rapid jaw-advance feature allows the operator quicker compression cycles
- 75kV live line rated
- 20-minute rapid battery charger
- Approx. 60 crimps per battery charge (based of 3/0 AWG cable)
- Uses Series 15600 dies ; can also use Series 15500 and Blackburn® dies with 15500-TB adaptor (refer to pages 112–118)
- The only tool that can be used with all Thomas & Betts connectors



 Creates Hex-style crimp

#### Specifications

- Installing Range:
  - Up to 1500 kcmil copper lugs & splices
  - Up to 1000 kcmil aluminum lugs & splices
  - CHT814-10 to CHT750-350-1F copper H-taps
  - 63105 to 63180 aluminum H-taps
  - 54755 to 54790 C-taps
- Output Force: 15 tons
- Dimensions (L x W x H): 21" x 3-1/2" x 11"
- Battery: 14.4V 3.0Ah Ni-Cd
- Weight with Battery: 23.75 lb.

Cat. No.	Description	Pkg. Qty
<b>TBM15BSCR</b>	15-Ton Battery Powered Compression Tool. Hermetically sealed unit. Includes carrying case, charger, two batteries, carry strap	1
<b>15500-TB</b>	Die adaptor for 15500 series and Blackburn dies	

Suggested replacement oil T&B Cat. No. 21061 or any light weight hydraulic fluid or automatic transmission fluid is recommended. Do not use silicon based fluids.

### Battpac™ TBM54BSCT and TBM54BSCTS Battery Powered Cutters

#### Guide to Cutting Cycles

This guide indicates the number of cutting cycles that the TBM54BSCT and TBM54BSCTS can be expected to perform when the battery is fully charged. These figures are approximate and will vary according to the charging and other operating conditions, such as temperature, humidity and battery condition.

- One-handed control of blade advancement and retraction
- TBM54BSCTS cuts up to 750 kcmil copper, 2-1/8" O.D. aluminum and 636 kcmil ACSR
- TBM54BSCT cuts up to 1,500 kcmil copper and 2-1/8" O.D. aluminum (not for use on ACSR)

#### Specifications

- Battery: 14.4V DC
- Dimensions (L x W x H): 16" x 4" x 4.5"
- Weight with Battery: 7.2 lb.
- Approx. 25 cuts per battery charge

Cat. No.	Conductor	Approx. Cutting Cycles
		CRCTBPI and CRCTBP
<b>TBM54BSCTS</b>	750 kcmil Cu, 2-1/8" Al	35
	636 kcmil ACSR	50
<b>TBM54BSCT</b>	1,000 kcmil Cu	45
	1,500 kcmil Cu; 2-1/8" Al	30

#### Battery Unit: CRCTBP

Battery Type: Sealed Nickel Cadmium  
Voltage: 14.4V DC  
Rated Current: 1.9Ah  
Dimensions: 3.5" L x 2.7" W x 5.3" H  
Weight: 1.6 lb.

#### Battery Charger: CRCTQC

Input Voltage: 120V AC Single Phase  
Charging Capacity: 20V AC  
Charging Time: 15 min. CRCTBP and CRCTBPI  
Dimensions: 7.5" L x 3.7" W x 3.5" H  
Weight: 4 lb.

#### Optional Accessories:

Battery Cartridge: CRCTBPI or CRCTBP  
DC Charger: CRCTQC  
(refer to page 137)



Cat. No.	Description	Pkg. Qty
<b>TBM54BSCTS</b>	Battery powered cutter for up to 750 kcmil Cu, 2-1/8" O.D. Al and 636 kcmil ACSR	1
<b>TBM54BSCT</b>	Battery powered cutter for up to 1,500 kcmil Cu, 2-1/8" O.D. Al (not for use on ACSR)	

Contact Tool Service for replacement blades.

## Battpac™ Battery-Powered Compression and Cutting Tools

### Battpac™ TBM58BSCT Battery-Powered Cutter

- To operate, simply remove pin latch, place over cable, re-insert pin and cut
- Built-in bypass pops off if material is beyond cutter's capacity
- Cuts ACSR, aluminum and copper cables up to 1-1/2", regular guy wires and ground rods up to 5/8"
- Approx. 25 cuts per battery charge

*NOTE: Not recommended for use on hardened steel.*

#### Specifications

- Output Force: 6 tons
- Max. Cutting Capacity:  
Soft steel bolts: 1-1/16" (17mm)  
Rebar & ground rod: 5/8" (16mm)  
ACSR : 1-1/2" (40mm) CU & AL  
Strands: 1-1/2" (40mm)  
Standard guy wire: 5/8" (16mm)  
Wire rope: 3/4" (20mm)
- Dimensions (H x W x D): 17" x 12" x 3"
- Weight with battery: 14 lb.



**Standard Battpac™ Kit Includes:**  
1 battery-powered tool  
1 carrying strap  
1 carrying case  
2 CRCTBP batteries  
1 CRCTQC 15-minute AC charger

Cat. No.	Description	Pkg. Qty
TBM58BSCT	Battery-Powered Cutter	1

Contact Tool Service for replacement blades.

### TBMODBSCT — 6-Ton Battery-Powered Compression Tool

- Versatile battery-powered crimp tool combines the features of an open yoke tool with the weight and balance of a closed yoke tool
- Reduces stress for operator when crimping connectors
- Ideal for industrial, commercial, telecom and utility applications
- Accepts T&B Color-Keyed® 6-TON and Blackburn® "O" and "D" dies (refer to pages 112–120)



#### Specifications

- Installing Range:  
Up to 4/0 aluminum H-taps  
Standard C-taps
- Approx. 200 crimps per battery charge
- Output Force: 6 tons
- Dimensions (L x W x H):  
12" x 3" x 13"
- Battery: Ni-MH 14.4V 3.0 Ah
- Weight with Battery: 8 lb.

Cat. No.	Description	Pkg. Qty
TBMODBSCT	Battery-Powered 6-Ton Crimping Tool – Includes Shoulder Strap, Charger, Carrying Case, Battery Cartridge and Owner's Manual	1



## Battpac™ Battery-Powered Compression and Cutting Tools

### Standard Replacement Battery

The CRCTBP is a standard replacement battery. The battery's life expectancy is approximately 600 recharges.

Cycles per charge will vary depending on the type and size of the material being cut or compressed.



Cat. No.	Description	Pkg. Qty
CRCTBP	Standard Replacement Battery	1

### Smart® Replacement Battery

The CRCTBPI Smart® battery is the same as the standard CRCTBP with the addition of an L.E.D. display that will indicate its power capabilities for you. The 14.4 volt battery is interchangeable with all T&B Battpac® products. It is self evaluating which allows the user to monitor the status of the battery's life and power between charges.

To check battery recharge cycles, depress "check" button once, release, depress again while L.E.D. lights are on, and hold approximately 10 seconds until L.E.D. pattern is displayed.



The battery's capacity is shown with an L.E.D. indicator of five red lights on its side. Different light patterns will give the user specific battery information. For instance, when the bottom red light begins to flash, it is a warning that only 10% of the battery power remains and it must be recharged soon. You'll know that the battery is fully charged if you push the "check" button and all five lights turn on.

Note: All L.E.D. lights will flash if the battery has internal problems. If this occurs, battery must be returned to factory for evaluation.

Recycling: T&B will gladly accept any used Ni-Cd batteries for recycling. Please call your Regional Sales Office for more details.

Cat. No.	Description	Pkg. Qty
CRCTBPI	Smart® Replacement Battery	1

### Standard 15-Minute Quick Charger

One hour standard battery charger for CRCTBP and CRCTBPI Battpac® batteries.

Do not use the charger for any other devices.



Cat. No.	Description	Pkg. Qty
CRCTQC	Standard 15-minute Quick Charger	1

## Battpac™ Battery-Powered Compression and Cutting Tools

### Battpac™ Die Information

Connector Size		TBM6BSCR	TBM6H	TBM14BSCR / TBM15BSCR	
Copper	Aluminum	Cat. No. Dies	Cat. No. Dies	Cat. No. Dies	Die Code
8 AWG	10 AWG	6TON21	BY15C	B71CH	Red
6 AWG	8 AWG	6TON24	BY17C	B73CH	Blue
4 AWG	6 AWG	6TON29	BY19C	B74CH	Grey
2 AWG	-	6TON33	BY21C	B75CH	Brown
1 AWG	4 AWG	6TON37		B05CH	Green
1/0 AWG	2 AWG	6TON42	BY23C	B06CH1	Pink
2/0 AWG	1 AWG	6TON45	BY24C	B72CH	Black/Gold
3/0 AWG	1/0 AWG	6TON50	BY25C	B08CH	Orange
4/0 AWG	2/0 AWG	6TON54	BY31C	B09CH	Purple/Olive
250 kcmil	-	6TON62	BY27C	B26CH	Yellow
-	1		BY24C	B72CH	Black/Gold
	1/0		BY25C	B08CH	Tan
	2/0		BY31C	B09CH	Purple/Olive
	3/0 AWG	6TON60	BY32C	-	Ruby
300 kcmil	4/0 AWG	6TON66	BY35C	B10CH1	White
350 kcmil	250 kcmil	6TON71	BY37C	B11CH	Red
400 kcmil	300 kcmil	6TON76		-	Blue
925/24	-	6TON80		-	Black
500 kcmil	350 kcmil	6TON87		B12CH	Brown
600 kcmil	400 kcmil			B36CH	Green
700 kcmil	500 kcmil			15505	Pink
750 kcmil	600 kcmil		BY28C	B39CH	Black
				-	Orange
	700 kcmil			-	Purple
	750 kcmil			-	Yellow
1000 kcmil				125H	
	1000 kcmil			140H	

### Cable Slicing Die Sets

Cat. No.	Maximum Cable Size	Tools
<b>BY55</b>	2/0	TBM6H, BPLT6BSCR and BPLT6500BSCR
<b>40CS</b>	4/0	TBM14M, 13100A and TBM14BSC
<b>156CS</b>	500 kcmil	TBM15I and TBM15BSCR

## Sealants and Lubricants

### Type CT — CONTAX™ Oxide Inhibiting Compound

- Seals electrical connections from oxygen and moisture
- Non-water soluble, non-petroleum based polymer grease
- Nontoxic, will not irritate the skin
- Service temperature to 238 °C (460 °F) can be applied in -18 °C (0 °F) weather



Cat. No.	Description
CTA	1/2 oz. Package
CTB	4 oz. Plastic Bottle
CTB8	8 oz. Plastic Bottle
CTQ	Quart Can
CTG	Gallon Can

### Type WW — Wire Bristle Brush

- Removes oxides from conductor surfaces
- Easy-grip handle with guard to prevent rubber-glove puncture
- Replaceable long-life brushes can be rotated
- Handle and guard coated with durable, nonconductive plastic for safety



Cat. No.	Description	Pkg. Qty
WWB1	Complete Brush with Handle	1
WRB1	Brush Replacement	

## Sealants and Lubricants

### Type DX — Duct Seal

- Seals around junction boxes, flashings, service mast entries, service cable entries and countless other applications
- Easy to use, forms around irregular surfaces and configurations
- Highly resistant to cracking, drying and shrinking
- Cuts and trims easily
- Can be painted immediately after application
- Grey colour
- No unpleasant odor
- -6.7 °C to 100 °C (20 °F to 212 °F) workable temperature range
- -40 °C to 121 °C (-40 °F to 250 °F) service temperature range
- Contains no asbestos



Cat. No.	Description
DX-1	1 lb Slug
DX-5	5-1 lb Slugs
DX-5S	5 lb Slug

U.L. Classified R13335.



### Silicone Lubricant for High Voltage Electrical Work

Cat. No.	Description	Pkg. Qty
2012	2 grams	250 tubes
2015	5 grams	100 tubes
SL5	5 oz./142 grams	12 tubes



## Competitive Cross Reference

### Mechanical Connectors

#### Split Bolts

##### Type H — High Strength Split-Bolt Connector

Blackburn	Penn Union	Burndy	IlSCO/Utilco	Anderson	Joslyn	Dossert	Eritech
9H	S-10	KS90	IK-10	C-10	J3657	DS-09F	ESB10
8H	S-8	KS15	IK-8	C-8	J3608	DS-1F	ESB8
8H3	SEL-8		SEL8S	C-8-L			
6H	S-6	KS17	IK-6	C-6	J3606	DS-2F	ESB6
6H3	SEL-6	KS17-3	SEL6S	C-6-L	J3608	DS-2-3	
4H	S-4	KS20	IK-4	C-4	J3604	DS-3F	ESB4
4H3	SEL-4	KS20-3	SEL4S	C-4-L	J3604	DS-3-3	
3H							ESB3
3H3							
2H	S-3	KS22	IK-3	C-2	J3602	DS-5F	ESB2
2H3	SEL-3	KS22-3		C-2-L	J3602	DS-5-3	
1H	S-2	KS23	IK-2	C-1		DS-6F	
1H3	SEL-2		SEL-2S	C-1-L		DS-6-3	
10H	S-1/0	KS25	IK-1/0	C-1/0	J3610	DS-10F	ESB1/0
20H	S-2/0	KS26	IK-2/0	C-2/0		DS-13F	ESB2/0
30H	S-3/0	KL27	IK-3/0	C-3/0		DS-17	ESB4/0
40H	S-4/0-250	KS29	IK-250	C-4/0	J3640	DS-25C	ESB250
350M	S-350	KS31	IK-350	C-350	J3635	DS-35	ESB350
500M	S-500	KS34	IK-500	C-500	J2650	DS-50	ESB500
750M	S-750	KS39	IK-750	C-750	J3675	DS-75	ESB750
1000M	S-1000	KS44	IK-1000	C-1000	J3679	DS-100	

##### Type HPS — Plated Split-Bolt Connector

Blackburn	Penn Union	Burndy	IlSCO/Utilco	Dossert	Eritech
9HPS	SW-1				
8HPS	SW-2				ESBP8
6HPS	SW-3	KSU17	SK-6	DSNS2	ESBP9
4HPS	SW-4	KSU20	SK-4	DSNS3F	ESBP6
2HPS	SW-5	KSU22	SK-3	DSNS5F	ESBP2
1HPS	SW-6	KSO23	SK-2	DSNS6F	
10HPS	SW-7	KSU25	SK-1/0	DSNS10F	ESBP1/0
20HPS	SW-8	KSU26	SK-2/0	DSNS13F	ESBP2/0
40HPS	SW-9A	KSU27	SK-3/0	DSNS25C	ESBP4/0
350HPS	SW-11	KSU31	SK-350	DSNS35	ESBP350
500HPS	SW-12	KSU34	SK-500	DSNS50	ESBP500
750HPS	SW-13			DSNS75	
1000HPS	SW-14			DSNS100	

##### Type APS — Aluminum Dual-Rated Split-Bolt

Blackburn	Penn Union	Burndy	IlSCO	Eritech
APS06		KSA-6	AK-6	ASBP6
APS04		KSA-4	AK-4	ASBP4
APS02	SW-6	KSA-2	AK-2	ASBP2
APS11	SW-7	KSA-1/0	AK-1/0	ASBP1/0
APS21	SW-8	KSA-2/0	AK-2/0	ASBP2/0
APS41	SW-9	KSA-4/0	AK-4/0	ASBP4/0
APS350	SW-11	KSA-350	AK-350	
APS500	SW-12	KSA-500	AK-500	



**Mechanical Connectors**

**Service Post Connectors**

**Type SP — Service Post Connector**

Blackburn	Penn Union	Burndy
SP0DL	SCS-0A1	K2C15B1
SP1DL	SCS-1A1	K2C17B1
SP2DL	SCS-2A1	K2C20B1
SP3DL	SCS-3A1	K2C22B1
SP4DL	SCS-4A1	K2C23B1
SP5DL	SCS-5A1	K2C25B1
SP6DL	SCS-6A1	K2C26B1
SP8DL	SCS-8A1	K2C28B1
SP9DL	SCS-9A1	K2C31B1
SP10DL	SCS-10A1	K2C34B1
SP0SL	SSS-0A1	KC15B1
SP1SL	SSS-1A1	KC17B1
SP2SL	SSS-2A1	KC20B1
SP3SL	SSS-3A1	KC22B1
SP4SL	SSS-4A1	KC23B1
SP5SL	SSS-5A1	KC25B1
SP6SL	SSS-6A1	KC26B1
SP8SL	SSS-8A1	KC28B1
SP9SL	SSS-9A1	KC31B1
SP10SL	SSS-10A1	KC34B1

**Insulated Conductor Connectors**

**Type IPC — Talon™ Insulation Piercing Connectors**

Blackburn	IlSCO	Kupler
IPC1102	IPC-1/0-2	130001
IPC4111	IPC-4/0-1/0	130003
IPC4141	IPC-4/0-4/0	130004
IPC5041	IPC-500-4/0	130005
IPC3535	IPC-350-350	130012
IPC3541	IPC-350-4/0	130013

## Competitive Cross Reference

### Mechanical Connectors

#### Two-Bolt Connectors

##### Type 2B — Two-Bolt Connector without Spacer

Blackburn	Penn Union	Burndy	IlSCO	Kearney	Anderson	Chance	Dossert
2B10	VT-0			17280	K-1		DSU10
2B20BB	VT-1	KVS26		16369	K-2	00UC	DSU13
2B40	VT-2	KVS28	IKB-4/0		K-3		DSU21
2B350	VT-3	KVS31	IKB-350	16371	K-4	35UC	DSU35
2B500	VT-4	KVS34	IKB-500	16372	K-5	50UC	DSU50
2B800	VT-5	KVS40	IKB-800		K-6	75UC	DSU80
2B1000	VT-6	KVS44	IKB-1000	16374	K-7	100UC	DSU100

##### Type 2BX — One-Piece Two-Bolt Connector without Spacer

Blackburn	Penn Union
2B10X	VT-0L
2B20X	VT-1L
2B40X	VT-2L
2B350X	VT-3L
2B500X	VT-4L
2B800X	VT-5L
2B1000X	VT-6L

##### Type 2BPW — Plated Two-Bolt Connector with Spacer

Blackburn	Penn Union	Burndy	IlSCO	Anderson	Dossert
2B10PW	VTA-0			KR-1TP	DSUN10
2B20PW	VTA-1	KVSU26		KR-2TP	DSUN13
2B40PW	VTA-2	KVSU28	IKS-4/0	KR-3TP	DSUN21
2B350PW	VTA-3	KVSU31	IKS-350	KR-4TP	DSUN35
2B500PW	VTA-4	KVSU34	IKS-500	KR-5TP	DSUN50
2B800PW	VTA-5	KVSU40	IKS-800	KR-6TP	DSUN80
2B1000PW	VTA-6	KVSU44	IKS-1000	KR-7TP	DSUN100

##### Type 2BW — One-Piece Two-Bolt Connector with Spacer

Blackburn	Penn Union	Burndy	Anderson	Dossert
2B10W	VTW-0		KR-1	DSUS10
2B20W	VTW-1	KVSW26	KR-2	DSUS13
2B40W	VTW-2	KVSW28	KR-3	DSUS21
2B350W	VTW-3	KVSW31	KR-4	DSUS35
2B500W	VTW-4	KVSW34	KR-5	DSUS50
2B800W	VTW-5	KVSW40	KR-6	DSUS80
2B1000W	VTW-6	KVSW44	KR-7	DSUS100

### Mechanical Connectors

#### AMT Mechanical Connector

Blackburn	Ilco*	Burndy	NSI
AMTC4	N/A	BIT-4	IT-4
AMTTC4	N/A	BITO-4	ITO-4
AMT20	N/A	BIT-2/0	IT-1/0
AMTT20	PCT-2-2/0	BITO-2/0	ITO-1/0
AMT250	PCT-2-4/0	BIT-250	IT-250
AMTT250	N/A	BITO-250	ITO-250
AMT350	PCT-2-350	BIT-350	IT-350
AMT500	PCT-2-600	BIT-500	N/A
AMTD250103	N/A	BIBD-250-3	IPLD-250-3
AMTD250104	PCT-4-4/0	BIBD-250-4	IPLD-250-4
AMTSR10	N/A	BISR-1/0	ISR-1/0
AMTSR250	N/A	BISR-250	ISR-250
AMTSR350	N/A	BISR-350	ISR-350
AMTSR500	N/A	BISR-500	ISR-500
AMTS414	N/A	BISR-4-4	IPL4-4
AMTS250108	PCT-8-4/0	BISR-250-8	IPL250-8
AMTS350103	N/A	BISR-350-3	IPL350-3
AMTS350104	PED-4-350-CPZ	BISR-350-4	IPL350-4
AMTS350105	N/A	BISR-350-5	IPL350-5
AMTS350106	PED-6-350-CPZ	BISR-350-6	IPL350-6
AMTD250105	N/A	BIBD-250-5	IPLD250-5
AMTD250106	PCT-6-4/0	BIBD-250-6	IPLD250-6
AMTD350103	N/A	BIBD-350-3	IPLD350-3
AMTD350104	PCT-4-350	BIBD-350-4	IPLD350-4
AMTD350105	N/A	BIBD-350-5	IPLD350-5
AMTD350106	PCT-6-350	BIBD-350-6	IPLD350-6
AMTD50063	N/A	BIBD-500-3	IPLD500-3
AMTD50064	PCT-4-500	BIBD-500-4	IPLD500-4
AMTD50065	N/A	BIBD-500-5	IPLD500-5
AMTD50066	PCT-6-500	BIBD-500-6	IPLD500-6

\* Not an exact match. Closest proximities of wire size and types.  
It would be necessary to disclose the T&B product specifications to the customer to avoid discrepancies.

## Competitive Cross Reference

### Mechanical Connectors

#### Copper Mechanical Connectors

##### Types L and LH — Copper Mechanical Connectors, Single Conductor, One Hole Mount

Blackburn	Penn Union	Burndy	IlSCO	T&B	Anderson	Dossert	Gedney
L35	PNL-8	KA8C	SLU-35	31003	LU-08	D-35	SL081
L70	PNL-4	KA4C	SLU-70	31005	LU-04	D-70	SL041
L125	PNL-1/0	KA25	LO-0	31007	LU-1/0	D-10	SL211
L250	PNL-250	KA28	LO-250	31011		D-25	SL241
L400	PNL-500	KA34	LO-500	31015	LU-500	D-50	SL501
L650	PNL-1000	QA44B	LO-1000	31019	LU-1000	D-100	SL921

##### Types L and LH — Copper Mechanical Connectors, Single Conductor, Two Hole Mount

Blackburn	Penn Union	Burndy	IlSCO	T&B	Gedney
L1252	PNL-1/0-2	QA1C-2B	E-125	32007	SL212
L2502	PNL-250-2	QA28-2B	E-225	32011	SL242
L4002	PNL-500-2	QA35-2B	E-400	32015	S1502
L6502	PNL-1000-2	QA44-2B	E-650	32019	SL922

##### Types TL and TLH — Copper Mechanical Connectors, Two Conductor, Two Hole Mount

Blackburn	Penn Union	Burndy	IlSCO	T&B	Anderson	Dossert	Gedney
TL250		Q2A31-2N	LU-4	32013BD		D2-25	SLL302
TL400	SLL504	Q2A34-2N		32015BD	LU2-500-2N	D2-50	SLL504
TL650		Q2A44-2N		32019BD		D2-100	SLL924

##### Type STC — Copper Single Conductor, One Hole Mount, Straight Tang

Blackburn	Burndy	IlSCO
STC1014		SLS25
STC0614	KPA8CUP	SLS35
STC0414	KPA4CUP	SAS70
STC0208		SLS70
STC1102	KPA25UP	SLS125
STC3104		SLS175
STC4102	KPA28UP	SLS225
STC3511		SLS300
STC5011	KPA34UP	SLS400
STC9960		SLS650

##### Type BTC — Copper Single Conductor, One Hole Mount, Offset Tang

Blackburn	Penn Union	Burndy	IlSCO	Dossert
BTC1014	SLU-25		SLU-25	
BTC0614	SLU-35	KPA8C	SLU-35	G-35-1
BTC0208	SLU-70	KPA4C	SLU-70	G-70-1
BTC1102	SLU-125	KPA25	SLU-125	G-125-1
BTC3104	SLU-175		SLU-175	
BTC4102	SLU-225	KPA28	SLU-225	G-225-1
BTC3511	SLU-300		SLU-300	
BTC5011	SLU-400	KPA34	SLU-400	G-400-1
BTC9960	SLU-650		SLU-650	G-650-1

### Mechanical Connectors

#### Dual-Rated Mechanical Connectors

##### Type ADR ALCÜL™ — Aluminum Dual-Rated Connectors, Single Conductor, One-Hole Mount

Blackburn	Penn Union	Burndy	IlSCO
ADR6	LA-6	KA6U	TA-6-S
ADR2	LA-2	KA2U	TA-2
ADR11	LA-0	KA-26U	TA-0
ADR21	LA-2/0	KA26U	TA-2/0
ADR25	LA-250	KA29U	TA-250
ADR30		KA30U	TA-300
ADR35	LA-350	KA31U	TA-350
ADR50	LA-500	KA34U	TA-500
ADR60	LA-600	KA36U	TA-600
ADR6004			TA-500S
ADR80	LA-800	KA40U	TA-800
ADR99	LA-1000	KA44U	TA-1000

##### Type ADR ALCÜL™ — Aluminum Dual-Rated Connectors, Two Conductor, One-Hole Mount

Blackburn	Penn Union	Burndy	IlSCO
ADR11-21	L2A-0	K2A25U	AU-0
ADR21-21		K2A28U	AU-2/0
ADR25-21	L2A-250	K2A29U	AU-250
ADR35-21	L2A-350	K2A31U	AU-350
ADR60-21	L2A-600	K2A36U	AU-600
ADR80-21	L2A-800	K2A40U	AU-800

##### Type ADR ALCÜL™ — Aluminum Dual-Rated Connectors, Three Conductor, Two-Hole Mount

Blackburn	Penn Union	Burndy	IlSCO
ADR02-32		K3A20-2	T3A2-2
ADR11-32		K3A25U2	T3A2-0
ADR31-32		K3A27-2N	T3A2-3/0
ADR25-32	L3A-250-2	K3A29U-2N	T3A2-250
ADR35-32	L3A-350-2	K3A31U-2N	T3A2-350
ADR50-32	L3A-500-2	K3A36U-2N	T3A2-500
ADR60-32D		KK3A-36U-2N	T3A2-600N
ADR80-32	L3A-800-2	K3A40U-2N	T3A2-800N
ADR99-32		KK3A-44U2N	T3A2-1000N

##### Type ADR ALCÜL™ — Aluminum Dual-Rated Connectors, Four Conductors, Four-Hole Mount

Blackburn	Penn Union	Burndy	IlSCO
ADR25-44	LA4M4-250	K4A29U-4N	T4A4-250N
ADR35-44	LA4M4-350	K4A31U-4N	T4A4-350N
ADR60-44D	LA4M4-600	KK4A36U-4N	T4A4-600N
ADR80-44D	LA4M4-800	KK4A40U-4N	T4A4-800N

##### Type ASL ALCÜL™ — Aluminum Dual-Rated Panelboard Lug, Two Conductors, One-Hole Mount

Blackburn	Penn Union	Burndy	IlSCO
ASL30-21	PB2-300	K11A30U	PB2300

##### Type ASL ALCÜL™ — Aluminum Dual-Rated Panelboard Lug, Two Conductors, Two-Hole Mount

Blackburn	IlSCO	Burndy
ASL60-22	PB2-600	K11A-36U-2
ASL75-22	PB2-750	



## Competitive Cross Reference

### Mechanical Connectors

#### Type ASL ALCÜL™ — Aluminum Dual-Rated Panelboard Lug, Three Conductor, Two-Hole Mount

Blackburn	IlSCO	Burndy
ASL60-32	PB3-600	K21A36U-2
ASL75-32		

#### Type ASR ALCÜL™ — Splice Reducer with Solid Barrier Wire Stop

Blackburn	IlSCO
ASR0214	SPA-2
ASR1114	SPA-0
ASR2506	SPA-250
ASR3506	SPA-350
ASR7525	SPA-750

#### Flexible Braid

T&B	Burndy	Penn-Union
FB2D12	B2D12N	FXB2A-12-Q
FB2E12	B2E12N	FXB2C-12N-Q
FB2F12	B2F12N	FXB2D-12N-Q
FB3D12	B3D12N	FXB3A-12-Q
FB3E12	B3E12N	FXB3C-12N-Q
FB3F12	B3F12N	
FB3XD12	B4D12N	
FB4E12	B4E12N	FXB4C-12N-Q
FB4F12	B4F12N	FXB4D-12N-Q
FBD12	BD12N	FXBA-12-Q
FBD18		FXBA-18-Q
FBD24		FXBA-24-Q
FBE12	BE12N	FXBB-12N-Q
FBF12	BF12N	FXBD-12N-Q
FBG12		FXBE-12N-Q
FBG18		FXBE-18S-Q
FBG24		FXBE-24S-Q

## Competitive Cross Reference

### Compression Connectors

### Compression H-Tap Connectors

#### Type WR "O" and "D" — Dies Seven Connector Program

Blackburn	Penn Union	Burndy	Homac	Kearney
WR159	KO-R06	YHO100, YHO1	OB44	506-82
WR189	KO-R08	YHO150, YHO2	OB101	508-82
WR289	KD-R02	YHD200, YHD3	DB202	502-82
WR279	KD-R04	YHD300, YHD4	DB2020	504-82
WR379	KD-R03	YHD250, YHD5	DB404	503-82
WR399	KD-R05	YHD350, YHD6	DB4020	505-82
WR419	KD-R28	YHD400, YHD7	DB4040	507-82

#### Type WR — Supplemental "O" and "D" Die Connectors

Blackburn	Penn Union	Burndy	Kearney	Anderson	Homac
WR149	KO-R33	YNO125	333-81	VCP44	
WR179	KO-R08	YC25A2	325-81		
WR199	KO-R08	YP26AU2 (ALT)	329-81		
WR1010		YHO2-ONE			OB1010D
WR259	KD-R04	YC25A25			
WR299	KD-R02	YHD200			
WR219	KD-R26		326-81		
WR239					
WR229	KD-R30				
WR269	KD-R27				
WR319					
WR339	KD-R96				
WR359	KD-R49		349-81		
WR369	KD-R94		394-81		
WR389	KD-R95		395-8		

#### Type WR — Wide Range "N" Die Tap Connectors for Hydraulic Tools, 12-Ton and Greater

Blackburn	Penn Union	Burndy	Homac
WR715	KN-1		NB50040
WR775		YHN450	
WR815		YHN500	
WR835	KN-R2		
WR875			
WR885		YHN525	NB500

#### Type WR — Wide Range "N" Die Tap Connectors for Hydraulic Tools, 10-Ton and Greater

Blackburn	Penn Union	Burndy	Kearney	Homac
WR699	KN-0		480	
WR719			481	
WR739	KN-R2	YHN550	482-81	
WR779	KN-4	YHN600	483	
WR799	KN-R5		485-81	
WR819	KN-R6	YC33R26	486-81	NB60020
WR839	KN-R7		487-81	
WR879	KN-8		488	
WR889				

#### Type WR — Wide Range "R" Die Tap Connectors

Blackburn	Penn Union	Burndy	Homac	Kearney
WR909	KR-R03	YHR700		603-82
WR929	KR-R04	YHR750	ZB-954	604-82
WR949	KR-R05	YHR800		605-82
WR969	KR-R06	YHR850	ZB-954	606-82
WR989	KR-R07	YHR900	ZB954	607-82
WR999				

## Competitive Cross Reference

### Compression Connectors

#### Type WR — Street Lighting Compression Connectors

Blackburn	Penn Union	Burndy	Kearney
WR9	KO-R22	YP2A9U	421-8
WR139	KO-R24	YPC26R8U	
WR502			

#### Type CF — Copper Compression Taps

Blackburn	Penn Union	Kearney
CF44-1	CDT-399-8	399-8
CFS44-1	CDT-301	
CF22-1	CDT-398-8	398-8
CFS22-1	CDT-302	
CF102-1	CDT-304-8	304-8
CF1010-1	CDT-303-8	303-8
CF202-1		
CF2020-1	CDT-305-8	305-8
CF402-1	CDT-309-8	309-8
CF4010-1	CDT-308-8	308-8
CF4040-1	CDT-307-8	307-8

#### Type C — Compression Connector Covers

Blackburn	Burndy	Homac	Kearney	Anderson
C2BB		CO20B	48480	SEC-4
C5-BB	CCO	CO20B	601O	PTC-1
C7	CCD	CD40B	601D	PTC-2
C9	CCN	CN600B		
C9L	CCNL	CN600B		

### Compression Connectors

#### Colour Coded Compression Connectors

Type CTL — Copper Lugs, 1-Hole Mount, Short Barrel

Blackburn	Penn Union	Burndy	Ilco	T&B	Anderson	Dossert	Panduit	3M
CTL8-10	BLU-8S14		CRA-8	54104				
CTL8-14	BLU-8S15			54130				
CTL8-516	BLU-8S16			54131				
CTL6-10	BLU-6S	YA6C	B131C	54134	VHCS-6-10/8	DPLS2-1-18	LCA6-10	30014
CTL6-14	BLU-6S1	YA6C-L1	B132C	54105	VHCS-6-14	DPLS2-1	LCA6-14	30015
CTL6-516	BLU-6S2	YA6C-L3		54135	VHCS-6-516	DPLS2-1-31	LCA6-56	30016
CTL6-38								
CTL4-10	BLU-4S	YA4C-L1	B133C	54138	VHCS-4-10/8	DPLS4-1-18	LCA4-10	30018
CTL4-14	BLU-4S1	YA4C-L	B134C	54106	VHCS-4-14	DPLS4-1	LCA4-14	30019
CTL4-516	BLU-4S10	YA4C-L3		54139	VHCS-4-516	DPLS4-2	LCA4-56	
CTL4-38	BLU-4S2	YA4CL4		54140	VHCS-4-38	DPLS4-1-38	LCA4-38	30021
CTL2-14	BLU-2S	YA2C-L2	CRA-2	54107	VHCS-2-14	DPLS6-1-125	LCA2-14	30022
CTL2-516	BLU-2S1	YA2C-L	CRB-2	54142	VHCS-2-516	DPLS6-1	LCA2-56	30023
CTL2-38	BLU-2S2	YA2C-L4		54143	VHCS-2-38	DPLS6-1-38	LCA2-38	30024
CTL2-12								
CTL1-14	BLU-1S9			54108	VHCS-1-14		LCA1-14	
CTL1-516	BLU-1S	YA1C-L	CRA-1	54147	VHCS-1-516	DPLS8-1	LCA1-56	30027
CTL1-38	BLU-1S1	YA1C-L4		54148	VHCS-1-38	DPLS8-2	LCA1-38	30028
CTL1-12								
CTL10-516	BLU-1/0S	YA25-L	CRA-0	54153	VHCS-1/0-516	DPLS10-1	LCA1/0-56	30031
CTL10-38	BLU-1/0S1	YA25-L4	CRB-0	54109	VHCS-Y0-38	DPLS10-1-38	LCA1/0-38	30032
CTL10-12								
CTL20-38	BLU-2/0S	YA26-L	CRA-2/0	54110	VHCS-2/0-38	DPLS31-1	LCA2/0-37	30036
CTL20-12	BLU-2/0S4	YA26-L6		54160	VHCS-2/0-12		LCA2/0-12	
CTL30-38	BLU-3/0S	YA27-L4	CRA-3/0	54111	VHCS-3/0-38	DPLS17-1-38	LCA3/0-38	
CTL30-12	BLU-3/0S1	YA27-L	CRB-3/0	54165	VHCS-3/0-12	DPLS17-1	LCA3/0-12	30041
CTL40-38	BLU-4/0S	YA28-L4	CRA-4/0	54112	VHCS-4/0-38	DPLS21-1-38	LCA4/0-38	
CTL40-12	BLU-4/0S1	YA28-L	CRB-4/0	54170	VHCS-4/0-12	DPLS21-1	LCA4/0-12	30045
CTL250-12	BLU-025S	YA29-L	CRA-250	54113	VHCS-250-12	DPLS25-1	LCA250-12	
CTL300-12	BLU-030S	YA30-L	CRA-300	54114	VHCS-300-12	DPLS30-1	LCA300-12	
CTL350-12	BLU-035S	YA31-L	CRA-350	54115	VHCS-350-12	DPLS35-1	LCA350-12	
CTL400-12	BLU-040S	YA32-L	CRA-400	54185	VHCS-400-12			
CTL400-58	BLU-4/0S	YA32-L						
CTL500-12	BLU-050S	YA34-L	CRA-500	54187	VHCS-500-12		LCA500-12	
CTL500-58							LCA500-58-6	
CTL600-58		YA36-L	CRA-600					
CTL750-58		YA39-L						
CTL1000-58								

## Competitive Cross Reference

### Compression Connectors

#### Type CTL — Copper Lugs, 2-Hole Mount, Short Barrel

Blackburn	Penn Union	Burndy	IlSCO	T&B	Anderson
CTL6-214		YA6CL2TC14 , YA6C2L		54205	
CTL4-214				54206	
CTL2-2516					VHCS-2-516
CTL1-2516		YA1C-2L			
CTL10-2516				54255	
CTL202				54260	
CTL302				54265	
CTL402	BLU-3/0D	YA27-2LN	CRA-4/0L2	54270	
CTL2502	BLU-4/0D	YA28-2LN	CRA-350L2	54275	
CTL3002	BLU-025D	YA29-2LN	CRA-300L2	54280	
CTL3502	BLU-030D	YA30-2LN	CRA-350L2	54282	
CTL4002	BLU-035D	YA31-2LN	CRA-400L2		
CTL5002	BLU-040D	YA32-2LN	CRA-500L2	54286	VHCS-500-12BN, VHCS-500-12B VHCS-600-38B
CTL6002-38					
CTL6002-12					
CTL7502	BLU-060D	YA36-2LN	CRA-750L2	54223	
CTL10002	BLU-075D	YA39-2LN	CRA-1000L2	54223	

#### Type CTL — Copper Lugs, 1-Hole Mount, Long Barrel

Blackburn	Penn Union	Burndy	IlSCO	T&B
CTL8L-14				54930BE
CTL6L-14	BBLU-6S		CRB-6L	54905BE
CTL4L-14	BBLU-4S	YA4C	CRB-4L	54906BE
CTL2L-516	BBLU-2S	YA2C		54942BE
CTL1L-516	BBLU-1S	YA1C	CRA-1L	54947BE
CTL10L-516	BBLU-1/0S	YA25	CRA-1/0L	
CTL20L-38	BBLU-2/0S	YA26	CRA-2/0L	54910BE
CTL30L-12	BBLU-3/0S	YA27	CRB-3/0L	54965BE
CTL40L-12	BBLU-4/0S	YA28	CRB-4/0B	54970BE
CTL250L-12	BBLU-025S		CRA-250L	54913BE

#### Type CTL — Copper Lugs, 1-Hole Mount, Long Barrel

Blackburn	Penn Union	Burndy	IlSCO	T&B
CTL300L-12	BBLU-030S	YA30	CRA-300L	54914BE
CTL350L-12	BBLU-035S	YA31	CRA-350L	54915BE
CTL400L-58	BBLU-040S	YA32	CRA-400L	
CTL500L-58	BBLU-050S	YA34	CRA-500L	
CTL600L-58	BBLU-060S	YA36	CRA-600L	54920BE
CTL750L-58	BBLU-075S	YA39	CRA-750L	54923BE
CTL1000L-58	BBLU-100S	YA44	CRA-1000L	54928BE

### Compression Connectors

#### Type LCN — Copper Lugs, 2-Hole Mount, Long Barrel

Blackburn	Penn Union	Burndy	IlSCO	T&B	Anderson	Dossert	3M
LCN8-14				54850BE			
LCN6-14	BBLU-6D	YA6C-2TC14	CRB-6L2	54852BE			
LCN6-12		YA6C-2N					
LCN4-14	BBLU-4D	YA4C-2TC14	CRB-4L2	54854BE			
LCN4-12		YA4C-2N	CRC-4L2				
LCN2-516	BBLU-2D		CRB-2L2	54856BE			
LCN2-12		YA2C-2N	CRC-2L2				
LCN1-516	BBLU-1D		CRA-1L2	54858BE			
LCN1-12		YA1C-2N					
LCN10	BBLU-1/0D	YA25-2	CRA-1/0L2	54860BE		DPL10-2	
LCN20	BBLU-2/0D	YA26-2N	CRA-2/0L2	54862BE	VHCL-2/0-12BN	DPL13-2N	
LCN30	BBLU-3/0D	YA27-2N	CRB-3/0L2	54864BE	VHCL-3/0-12BN	DPL17-2N	
LCN40	BBLU-4/0D	YA28-2N	CRA-4/0L2	54866BE	VHCL-4/0-12BN	DPL21-2N	31145
LCN250	BBLU-025D	YA29-2N	CRA-250L2	54868BE	VHCL-250-12BN	DPL25-2N	31149
LCN300	BBLU-030D	YA32-2N					
LCN350	BBLU-035D	YA31-2N	CRA-350L2	54872BE	VHCL-350-12BN	DPL35-2N	31156
LCN400	BBLU-040D						
LCN500	BBLU-050D	YA34-2N	CRA-500L2	54876BE	VHCL-500-12BN	DPL50-2N	31166
LCN600	BBLU-0600D						
LCN75	BBLU-075D						
LCN99	BBLU-100D						

#### Type CU — Copper Splices, Long Barrel

Blackburn	Penn Union	Burndy	IlSCO	T&B	Homac	Kearney	Anderson	Dossert	Panduit	3M
CU8		YS8C		54804						
CU6	BBCU-6	YS6C	LTL-6	54805						
CU4	BBCU-4	YS4C	LTL-4	54806						
CU2	BBCU-2	YS2C	LTL-2	54807						
CU1	BBCU-1	YS1C	LTL-1	54809						
CU10	BBCU-1/0	YS25	CTL-1/0	54809	C1/0	136700-010	VHS-1/0	DPC-10	SCL1/0	
CU20	BBCU-2/0	YS26	CTL-2/0	54810	C2/0	136700-020	VHS-2/0	DPC-13	SCL2/0	11006
CU30	BBCU-3/0	YS27	CTL-3/0	54811			VHS-3/0	DPC-17	SCL3/0	11007
CU40	BBCU-4/0	YS28	CTL-4/0	54812	C4/0	136700-040	VHS-4/0	DPC-21	SCL4/0	11008
CU250	BBCU-025	YS29	CTL-250	54813	C250	136700-250	VHS-250	DPC-25	SCL250	11009
CU300	BBCU-030	YS30								
CU350	BBCU-035	YS31	CTL-350	54815	C350		VHS-350	DPC-35	SCL350	11011
CU400	BBCU-040	YS32								
CU500	BBCU-050	YS34	CTL-500	54818	C500	136700-500	VHS-500	DPC-50	SCL500	11014
CU600	BBCU-060	YS36								
CU750	BBCU-075	YS39	CTL-750	54823	C750	136700-750	VHS-750	DPC-75	SCL750	11019
CU1000	BBCU-100	YS44	CTL-1000	54828	C1000	136700-1000	VHS-1000	DPC-100	SCL1000	11024

#### Type CSP — Copper Splices, Short Barrel

Blackburn	Penn Union	Burndy	IlSCO	T&B	Anderson	Dossert	Panduit	3M
CSP8	BCU-8		CT-8	54504			SCS8	
CSP6	BCU-6	YS6C-L	CT-6	54505	VHSS-6	DPCS-2	SCS6	10001
CSP4	BCU-4	YS4C-L	CT-4	54506	VHSS-4	DPCS-4	SCS4	10002
CSP2	BCU-2	YS2C-L	CT-2	54507	VHSS-2	DPCS-6	SCS2	10003
CSP1	BCU-1	YS1C-L	CT-1	54508	VHSS-1	DPCS-8	SCS1	10004
CSP10	BCU-1/0	YS25-L	CT-1/0	54509	VHSS-1/0	DPCS-10	SCS1/0	10005
CSP20	BCU-2/0	YS26-L	CT-2/0	54510	VHSS-2/0	DPCS-13	SCS2/0	10006
CSP30	BCU-3/0	YS27-L	CT-3/0	54511	VHSS-3/0	DPCS-17	SCS3/0	10007
CSP40	BCU-4/0	YS28-L	CT-4/0	54512	VHSS-4/0	DPCS-21	SCS4/0	10008
CSP250	BCU-025	YS29-L	CT-250	54513	VHSS-250	DPCS-25	SCS250	10009
CSP300	BCU-030	YS30-L	CT-300	54514	VHSS-300	DPCS-30	SCS300	10010
CSP350	BCU-035	YS31-L	CT-350	54515	VHSS-350	DPCS-35	SCS350	10011
CSP400	BCU-040	YS32-L	CT-400	54516	VHSS-400	DPCS-40	SCS400	
CSP500	BCU-050	YS34-L	CT-500	54518	VHSS-500	DPCS-50	SCS500	10014
CSP600								
CSP750	BCU-075	YS39-L	CT-750	54523	VHSS-750	DPCS-75	SCS750	10019
CSP1000	BCU-100	YS44-L	CT-1000	54528	VHSS-1000	DPCS-100	SCS1000	10024



## Competitive Cross Reference

### Compression Connectors

#### Type ATL — Aluminum Lugs, 1-Hole

Blackburn	Penn Union	Burndy	IlSCO	T&B	Anderson	Dossert	Panduit	3M
ATL8-10		YA8CA1	ACN-8	60101	VACL-8-10			
ATL8-14	BLUA-8S	YA8C-A3	ACL-8	60102	VACL-8-14	DPL-1-1-AA		
ATL6-10				60106	VACL-6-10			
ATL6-14	BLUA-6S	YA6C-A1	ACL-6	60107	VACL-6-14	DPL2-1-AA	LAA46-14	
ATL6-38								
ATL4-14	BLUA-4S3	YA4C-A1	ACL-4	60112	VACL-4-14		LAA4-14	
ATL4-516	BLUA-4S2	YA4C-A3	ACN-4	60113	VACL-4-516	DPL-4-1-AA	LAA4-56	40020
ATL4-38		YA4CA6			VACL-4-38		LAA4-38	
ATL2-14	BLUA-2S3		ACL-2	60116	VACL-2-14		LAA2-14	
ATL2-516	BLUA-2S4	YA2C-A1	ACN-2	60117	VACL-2-516		LAA2-56	
ATL2-38	BLUA-2S	YA2C-A3		60118	VACL-2-38	DPL-6-1-AA	LAA2-38	40024
ATL1-516	BLUA-1S3			60123			LAA1-56	
ATL1-38	BLUA-1S	YA1C-A1		60124	VACL-1-38	DPL-8-1-AA	LAA1-38	40028
ATL10-516	BLUA-1/0S3	YA25-A1	ACN-1/0	60129	VACL-1/0-516		LAA1/0-56	
ATL10-38	BLUA-1/0S	YA25-A3	ACL-1/0	60130	VACL-1/0-38	DPL-10-1-AA	LAA1/0-38	40032
ATL10-12								
ATL20-38	BLUA-2/0S6	YA26-A6	ACL-2/0	60136	VACL-2/0-38		LAA2/0-38	
ATL20-12	BLUA-2/0S	YA26-A1	ACN-2/0	60138	VACL-2/0-12	DPL-13-1-AA	LAA2/0-12	40037
ATL30-38	BLUA-3/0S2	YA27-A1	ACL-3/0	60142	VACL-3/0-38		LAA3/0-38	
ATL30-12	BLUA-3/0S	YA27A3	ACN-3/0	60144	VACL-3/0-12	DPL-17-1-AA	LAA3/0-12	40041
ATL40-38	BLUA-4/0S2	YA28-A1	ACL-4/0	60148	VACL-4/0-38		LAA4/0-38	
ATL40-12	BLUA-4/0S	YA28-A3		60150	VACL-4/0-12	DPL-21-1-AA	LAA4/0-12	40045
ATL250-12	BLUA-025S	YA29-A1	ACL-250	60156	VACL-250-12		LAA250-12	40049
ATL300-38								
ATL300-12								
ATL350-12	BLUA-035S	YA31A1	ACL-350	60166	VACL-350-12		LAA350-12	40056
ATL400-58								
ATL500-12	BLUA-050S2	YA34A1	ACL-500	60171	VACL-500-12		LAA500-12	
ATL500-58								
ATL600-12								
ATL750-12								
ATL750-58	BLUA-075S1	YA39A3	ACL-750	60178	VACL-750-58		LAA750-58	40073

#### Type ATL — Aluminum Lugs, 2-Hole

Blackburn	Penn Union	Burndy	IlSCO	T&B	Anderson	Dossert	Panduit	3M
ATL102-38	BLUA-1/0D1	YA25A5	2ACL-1/0	60230	VACL-1/0-38B		LAB1/0-38	40132
ATL102								
ATL202	BLUA-2/0D	YA26-A3	2ACL-2/0	60238	VACL-2/0-12BN	DPL-13-2N-AA	LAB2/0-12	40137
ATL302	BLUA-3/0D	YA27A5	2ACL-3/0	60244	VACL-3/0-12BN	DPL-17-2N-AA	LAB3/0-12	40141
ATL402	BLUA-4/0D	YA28-A5	2ACL-4/0	60250	VACL-4/0-12VN	DPL-21-2N-AA	LAB4/0-12	40145
ATL2502	BLUA-025D	YA29-A3	2ACL-250	60256	VACL-250-12BN	DPL-25-2N-AA	LAB250-12	
ATL3002								
ATL3502	BLUA-035D	YA31-A1	2ACL-350	60267	VACL-350-12BN	DPL-35-2N-AA	LAB350-12	40156
ATL4002								
ATL5002	BLUA-050D2	YA34A3	2ACL-750	60273	VACL-500-12BN	DPL-50-2N-AA	LAB500-12	40166
ATL6002								
ATL7502	BLUA-075D1	YA39-A5	2ACL-750	60278	VACL-750-12BN	DPL-75-2N-AA	LAB750-12	40172

### Compression Connectors

#### Type ASP — Aluminum Splices

Blackburn	Penn Union	Burndy	IlSCO	T&B	Anderson	Dossert	Panduit	3M
ASP8		YS8CA1	AS-8	60501	VACS-8			
ASP6	BCUA-6	YS6CA1	AS-6	60507	VACS-6	DPC-2-AA	SA6	20001
ASP4	BCUA-4	YS4CA1	AS-4	60512	VACS-4	DPC-4-AA	SA4	20002
ASP2	BCUA-2	YS2CA1	AS-2	60516	VACS-2	DPC-6-AA	SA2	20003
ASP1	BCUA-1	YS1CA1	AS-1	60522	VACS-1	DPC-8-AA	SA1	20004
ASP10	BCUA-1/0	YS25A1	AS-1/0	60530	VACS-1/0	DPC-10-AA	SA1/0	20005
ASP20	BCUA-2/0	YS26A1	AS-2/0	60536	VACS-2/0	DPC-13-AA	SA2/0	20006
ASP30	BCUA-3/0	YS27A1	AS-3/0	60542	VACS-3/0	DPC-17-AA	SA3/0	20007
ASP40	BCUA-4/0	YS28A1	AS-4/0	60548	VACS-4/0	DPC-21-AA	SA4/0	20008
ASP250	BCUA-025	YS29A1	AS-250	60554	VACS-250	DPC-25-AA	SA250	20009
ASP300								
ASP350	BCUA-035	YS31A1	AS-350	60565	VACS-350	DPC-35-AA	SA350	20011
ASP400								
ASP500	BCUA-050	YS34A1	AS-500	60571	VACS-500	DPC-50-AA	SA500	20014
ASP600								
ASP750	BCUA-075	YS39A1	AS-750	60578	VACS-750	DPC-75-AA	SA750	20019
ASP1000	BCUA-100	YS44A1	AS-1000	60584	VACS-1000	DPC-100-AA	SA1000	20024

#### Type PA — Pin Adapter Terminals

Blackburn	Penn Union	Burndy	IlSCO
PA06	TP-6	AYP-6	ACM-6
PA04	TP-4	AYP-4	ACM-4
PA02	TP-2	AYP-2	ACM-2
PA01	TP-1	AYP-1	ACM-1
PA11	TP-1/0	AYP-1/0	ACM-1/0
PA21	TP-2/0	AYP-2/0	ACM-2/0
PA31	TP-3/0	AYP-3/0	ACM-3/0
PA41	TP-4/0	AYP-4/0	ACM-4/0
PA25	TP-250	AYP-250	ACM-250
PA30	TP-300	AYP-300	ACM-300
PA35	TP-350	AYP-350	ACM-350
PA40	TP-400	AYP-400	ACM-400
PA50	TP-500	AYP-500	ACM-500
PA60	TP-600	AYP-600	ACM-600
PA75	TP-750	AYP-750	ACM-750

### Wedge Clamps

#### Type W — Aluminum Service Wedge Clamps for use with ACSR, Aluminum, AAAC Conductors

Blackburn	Reliable
W62-1	7195
W62-1FC	7195F
W20-1	7187
W20-1FC	7187F
W40-1	7197
W40-1FC	7187F
W62-1B	7195I
W62-1BFC	7195FI
W20-1B	7187I
W20-1BFC	7187FI
W40-1B	7187I
W40-1BFC	7187FI

## Competitive Cross Reference

### Ground Connectors

**Figure 6 — Compression Ground Tap Connectors**

E-Z-Ground	Burndy	IlSCO
54855	YGHP29C2	GGC-2
54860	YGHP29C26	GGC-3
54865	YGHP29C29	GGC-4
54875	YGHP2C2	GGC-1
54885	YGHP34C2	GGC-5
54890	YGHP34C26	GGC-6
54895	YGHP34C29	GGC-7
54900	YGHP34C34	GGC-8

**Figure 6 to Figure 6 — Compression Ground Grid Connectors**

E-Z-Ground	Burndy	IlSCO
54855L	YGL2C2	
54855LR12	YGLR29C12	
54865L	YGL29C2	GGA-2
54865LR58	YGLR29C58	
54875L	YGL29C29	GGA-3
54875LR34	YGLR29C34	
54885L	YGL34C2	GGA-4
54885LR12	YGLR34C12	
54895L	YGL34C29	GGA-5
54895LR58	YGLR34C58	
54900L	YGL34C34	GGA-6
54900LR34	YGLR34C34	
54910LR100	YGLR29C100	
54920LR100	YGLR34C100	

#### C-Crimp Series BC

E-Z-Ground	Burndy	IlSCO
BC202	YC26C2	
BC2020-BB	YC26C26	
BC22	YC2C2	ULT-7-Z
BC24	YC2C4	ULT-6-Z
BC402	YC28C2	
BC4020	YC28C26	
BC4040	YC28C28	ULT-12-Z
BC44	YC4C4	ULT-5-Z
BC46-BB	YC4C6	ULT-4-Z
BC48	YC4C8	

#### C-Taps

E-Z-Ground	Burndy	IlSCO
CTG250	GCM28CG3	
CTP202	YGHC26C2	ELT-4
CTP2020	YGHC26C26	ELT-2
CTP22	YGHC2C2	ELT-1
CTP25020	YGHC29C26	
CTP250250	YGHC29C29	ELT-3
CTP50020	YGHC34C26	
CTP500250	YGHC34C29	ELT-6
CTP500500	YGHC34C34	

### Ground Connectors

#### Ground Plates

E-Z-Ground	Burndy
GP2250-2	YGF29-2N
GP2250-4	YGF29-4N
GP250500-2	YGF34-2N
GP250500-4	YGF34-4N

#### Figure 8 — Compression Tap Connectors for Copper Ground Rods

E-Z-Ground	Burndy
GR1-202	YGHR26C100
GR12-202	YGHR26C12
GR12-40250	YGHR29C12
GR1-300500	YGHR34C100

#### Figure 8 — Compression Tap Connectors for Copper Ground Rods

E-Z-Ground	Burndy
GR1-202	YGHR26C100
GR12-202	YGHR26C12
GR12-40250	YGHR29C12
GR1-300500	YGHR34C100
GR1-40250	YGHR29C100
GR34-202	YGHR26C34
GR34-300500	YGHR34C34
GR34-40250	YGHR29C34
GR58-202	YGHR26C58
GR58-300500	YGHR34C58
GR58-40250	YGHR29C58

#### Type TBGS — Structural Grounding Studs

E-Z-Ground	Burndy
TBGS14	GSTUD14HY
TBGS34	GSTUD34HY
TBGS38	GSTUD38HY
TBGS58	GSTUD916HY

#### Type JAB — Ground Rod Clamps

Blackburn	Penn Union	Burndy	IlSCO	Eritech	Anderson	Joslyn	Dossert
JAB12	CAB-1	GRC12	CGRC48	HDC12		J8391AB	GNA50
JAB58	CAB-2	GRC58	CGRC58			J8392AB	GNA62
JAB34	CAB-3			HDC34		J8393AB	GNA75
JAB34C		GRC3426	CGRC68				
JAB1							
JAB12H	CAB-1			HDC12	GC-103-01	J8491AB	GN-50
JAB58H	CAB-2			HDC58R	GC-103-02	A8393AB	GN-62
JAB34H	CAB-3			HDC34	GC-103-03	J8493AB	GN-75
JAB1H							

#### Type G — Budget Line Ground Rod Clamps

Blackburn	Penn Union	Burndy	IlSCO	Eritech	Anderson	Dossert
G3	CAB-1	GRC12		CP38		
G4	CEB-1	GRC-12	GRC-48	CP12	GC-4	GNL50
G5	CEB-2	GRC-58	GRC-58	CP58	GC-5	GNL62
G6	CEB-3	GRC34	GRC-68	CP34	GC-6	GNL75

## Competitive Cross Reference

### Ground Connectors

#### Type GUV — U-Bolt Clamps

Blackburn	Penn Union	Burndy
GUV4021		GAR2226
GUV4025		GAR2229

#### Type GUV — U-Bolt Clamps

Blackburn	Penn Union	Burndy
GUV584		GAR644C
GUV5821		GAR6426
GUV5825		GAR6429
GUV784	GPL-8	GAR144C
GUV7821	GPL-9	GAR1426
GUV7825	GPL-10	GAR1429
GUV1184	GPL-14	GAR154C
GUV11821	GPL-15	GAR1526
GUV1384	GPL-20	GAR164C
GUV13821		GAR1626
GUV13825	GPL-22	GAR1629
GUV1584	GPL-26	GAR174C
GUV15821	GPL-27	GAR1726
GUV15825	GPL-28	GAR1729
GUV204	GPL-32	GAR184C
GUV2021	GPL-33	GAR1826
GUV2025	GPL-34	GAR1829
GUV21221	GPL-39	GAR1926
GUV21225	GPL-40	GAR1929
GUV3021	GPL-45	GAR2026
GUV3025	GPL-46	GAR2029
GUV31221	GPL-51	GAR2126

#### Type GTC — Tower Ground Clamps

Blackburn	Penn Union	Burndy	Anderson	Dossert
GTC13	GMS-2	GBM26	GC140-01	GFM-13
GTC14	GMS-3	GBM29	GC-140-02	GFM-25
GTC23	GM-2	GB26	GC141-01	GF13
GTC24	GM-3	GB29		GF25

#### Type TTC — Transformer Tank Ground Connectors

Blackburn	Penn Union	Burndy	Anderson	Dossert	Eritech
TTC2	HGSE-020	EQC632C	GTCL-34A		TGC210
TTC3	HGSE-C1		GTCL-23A	TGC8-50	
TTC4					
TTC2P					
TTC3P	GSE-C1TN		GTC23A-TP	TGC8-50SN	
TTC4P					

#### Type GP — Copper Pole Bottom Ground Plates

Blackburn	Eritech	Homac
GP100	EGP100	5575

### Die Cross Reference

Die Designation	Blackburn/T&B		Mechanical	Burndy	Hydraulic	Alcoa/ Other	EEI
	Mechanical OD58 Series & TBM6H Hydraulic Head (Except as Noted)	Hydraulic JB12B, TBM14M 13100A, TBM15					
5/8	BY31 13474/13477* (Orange/Tan Nest)	B58CS	W-BG		U-BG	G, TU, Peach	
840	BY37 13474/13477* (Red/Blue Nest)	B49EA 15512	W-K840		U-K840 U-249	TX	
O	OJB 13470*	HO 15501-A	W-O		U-O	B11AH	
D	DBL 13471*	HD 15502			U-D	BD	
N		HN 15612**			U-N	BN	
R		15620**			U-R		
B, T, BKT	BY45, BY49	HBKT	W-KB W-BG				
K	BY47	HBKT	W-KK				
C	BY33	HBKC	W-C		U-C		
KC		B39EA	W-247		U-247 U-167		
J, 5/16	BY19 BY51	B73AH	W161 W-242		U-161 U-242	TP	
P, 3/8	BY21 BY53	B71AH 15513	W-162		U-162	TK TL, TN, TB	
1/2, 510, 500	BY23	B17EA 15526 B72AH	W-163		U-163	B06AH TQ, TS	6A
5/8-1, 620	BY31	B24EA	W-BG W-165 W-243		U-BG, U-165 U-243	B08AH TU	8A
635	BY41	B30EA	W-245 W-687		U-245	TWTY B09AH	9A
737 747	BY33	B39EA 15534	W-C W-247 W-167 W-694 W-702		U-247 U-167 U-694	B10AH TV	10A
781	BY35	B74AH	W-247		U-247 U-659		
840, 845	BY37	B49EA 15514 15512	W-249		U-249 U-658 U-168	TX B11AH	11A
1		B75AH 15506 B61EA			U-251 U654	TH B12AH	12A
1 1/8-1		B80EA B20AH 15536 15505			U-321 U-490, U-317 U468, U426 U547, U-655	B13AH	13A 14A
1 5/16		B76AH B78AH B20AH 15515			U-318, U-327 U-261 U-788	B14AH	14A

All Blackburn and Alcoa "B" Series Dies and Burndy "U" Dies fit the T&B/Blackburn Hydraulic Tools listed.  
 Adapter 15500TB required with TBM15.  
 \* Fit TBM6, 6S, and TBM6ORS. (Same as Homac UT5 and "H" dies Series.  
 \*\* Fit TBM15 only.  
 For reference only. Connectors may require a specific die for proper application.



## Tool Cross Reference

Tool Type	Blackburn/T&B	Burndy	Kearny	Anderson/ Huskie	Homac	Alcoa
Mechanical	OD58, OD581 ODF, ODF1, ODF3 ODB, ODB1, ODB3	MD5, MD6, MD7 Series	OS49, OS50 061, 062, 063 068 Series	ND Series	UT5	
	TBM-250 TOOL	MY28, MY29 Series			UT3	
	TBM5, 5S, 6, 6S, 8, 8S, TBM60RS (For Colour Coded Copper & Aluminum series only except as noted on die chart)	MD5, MD6, MD7 Series (Only to 4/0)			UT5	
Self-Contained Hydraulic	JB12B, TBM14M	Y35, Y39, Y750	WH2 WH3	EP Series		12A 12AC
Remote Hydraulic	13100A, TBM15, TBM6H	Y35BH, Y39BH, Y750BH, Y45, Y46	PH13-10 PH14	EP Series	UT15	12HA 12HAC
Battpac™ Battery-Powered Compression and Cutting	TBM6BSCR TBM62BSCR TBM14BSCR TBM15BSCR BATCUT  Y700DC-1B	BAT500 BCT500 BAT35 BAT750 TBM58BSCT TBM40BSCT TBM54BSCT 13650A				

*Tools may have limits on connector range capabilities. Consult your T&B Regional Sales Office if necessary.  
All Hydraulic heads listed are for 10,000 psi systems only.  
TBM8-750 and TBM8-750M-1 are dieless, indent type crimp hydraulic tools equivalent to the Anderson Versa-Crimp tools and the Burndy Y644.  
Consult your T&B Regional Sales Office for application if necessary.*

### Bare Conductor Information AWG or kcmil

Conductor Diameter (in.)	ACSR or All Aluminum	Rated Breaking Strength	Aluminum Alloy (5005-6201)	Rated Breaking Strength	Compacted ACSR or All Aluminum	Rated Breaking Strength	AWAC	Rated Breaking Strength	Copper or Copperweld Copper Composite	Rated Breaking Strength
.162	#6, Solid	474.0							#6, Solid	1,280
.169					#6, 7W	528				
.174									91½2D	1,743
.179									8C	1,362
.182	#5, Solid	597.7			#6, 6/1	1,170			#5, Solid	1,591
.184	#6, 7W	560							#6, 7W	1,228
.198	#6, 6/1	1,170	#6, 7W	555						
.199									8A	2,233
.201			#6, 3W	915						
.202									#6, 3W	1,204
.204	#4, Solid	753.9							#4, Solid	1,970
.206									#5, 7W	1,542
.213					#4, 7W	826				
.219									8D	3,256
.223	#5, 6/1	1,460							7A	2,754
.225									6C	2,143
.226									#5, 3W	1,516
.229	#3, Solid	929.9			#4, 6/1	1,830			#3, Solid	2,439
.230									6A	2,585
.232	#4, 7W	915							#4, 7W	1,938
.236					#4, 7/1	2,288				
.245							#4, 6/1	1,783		
.246									7D	4,022
.250	#4, 6/1	1,830	#4, 7W	875						
.257	#4, 7/1	2,290								
.258	#2, Solid	1,172.6			#3, 6/1	2,250			#2, Solid; 5A	3,003; 3,193
.260	#3, 7W	1,100							#3, 7W	2,433
.261							#4, 5/2	2,830		
.268					#2, 7W	1,266				
.276									6D	4,942
.281	#3, 6/1	2,250					#4, 4/3	4,305		
.286									#3, 3W	2,359
.289									#1, Solid	3,688
.290					#2, 6/1	2,790			4A	3,938
.292	#2, 7W	1,340							#2, 7W	3,045
.298					#2, 7/1	3,525				
.301					#1, 7W	1,537				
.307							#4, 3/4	6,325		
.308									2F	4,233
.309							#2, 6/1	2,760		
.310									5D	6,035
.316	#2, 6/1	2,790	#2, 7W	2,195						
.320									#2, 3W	2,913
.325	#2, 7/1	3,525							1/0, Solid	4,517
.326					#1, 6/1	3,480			5P	9,311
.327									2G	5,626
.328	#1, 7W	1,620							#1, 7W; 4N	3,804; 8,460
.330							#2, 5/2	4,436		
.332	#1, 19W	1,685							#1, 19W	3,899
.338					1/0, 7W	1,865				
.340					1/0, 19W	2,090	#4, 2/5	9,314		
.346									1F	5,266

## Conductor Reference

### Bare Conductor Information AWG or kcmil — continued

Conductor Diameter (in.)	ACSR or All Aluminum	Rated Breaking Strength	Aluminum Alloy (5005-6201)	Rated Breaking Strength	Compacted ACSR or All Aluminum	Rated Breaking Strength	AWAC	Rated Breaking Strength	Copper or Copperweld Copper Composite	Rated Breaking Strength
.348									4D	7,340
.349									2J	7,322
.355	#1, 6/1	3,480					#2, 4/3	6,785		
.360									#1, 3W	3,620
.365					1/0, 6/1	4,280			2/0, Solid	5,519
.366									2A; 4P	5,876; 11,420
.367	80, 8/1	5,200							1G	6,956
.368	1/0, 7W	1,970							1/0, 7W; 3N	4,750; 10,390
.372									1/0, 19W	4,901
.373	1/0, 19W	2,090								
.377									2K	9,730
.381					2/0, 7W	2,350				
.382					2/0, 19W	2,586				
.386							#2, 3/4	9,793		
.388									1/0F	6,536
.390							1/0, 6/1	4,246	1/0, 12W	4,841
.392									1J	9,000
.398	1/0, 6/1	4,280	1/0, 7W	3,405						
.410					2/0, 6/1	5,345				
.411									3P	13,910
.412									1/0G	8,563
.413									2N	12,680
.414	2/0, 7W	2,485							2/0, 7W	5,927
.416							1/0, 5/2	6,712		
.419	2/0, 19W	2,586							2/0, 19W	6,152
.423									1K	11,900
.426					3/0, 7W	2,845				
.428					3/0, 19W	3,200				
.429							#2, 2/5	14,060		
.436									2/0F	8,094
.438							2/0, 6/1	5,135	2/0, 12W	6,048
.440									1/0J	10,970
.447	2/0, 6/1	5,345	2/0, 7W	4,230			1/0, 4/3	10,020		
.461	101.8, 12/7	9,860			3/0, 6/1	6,675				
.462									2P	16,870
.463									2/0G	10,510
.464	3/0, 7W	3,005							3/0, 7W; IN	7,366; 15,410
.467							2/0, 5/2	8,040		
.470	3/0, 19W	3,200							3/0, 19W	7,698
.475									1/0K	14,490
.480					4/0, 7W	3,590				
.481	110.8, 12/7	10,730			4/0, 19W	3,890				
.487							1/0, 3/4	14,006		
.492									3/0, 12W	7,556
.494									2/0J	13,430
.502	3/0, 6/1	6,675	3/0, 7W	4,965			2/0, 4/3	12,000		
.517					4/0, 6/1	8,420				
.522	4/0, 7W	3,590							4/0, 7W	9,154
.523					250, 19W	4,506				
.528	4/0, 19W	3,980							4/0, 19W	9,617
.530	134.6, 12/7	12,920								
.534									2/0K	17,600
.537					266.8, 7W	4,775				
.540					266.8, 19W	4,800				
.541							1/0, 2/5	20,030		
.550									4/0F	12,290

### Bare Conductor Information AWG or kcmil — continued

Conductor Diameter (in.)	ACSR or All Aluminum	Rated Breaking Strength	Aluminum Alloy (5005-6201)	Rated Breaking Strength	Compacted ACSR or All Aluminum	Rated Breaking Strength	AWAC	Rated Breaking Strength	Copper or Copperweld Copper Composite	Rated Breaking Strength
.552							4/0, 6/1	7,685	4/0, 12W	9,483
.559					266.8, 18/1	7,100				
.563	4/0, 6/1	8,420	4/0, 7W	6,265						
.571									4/0EK	15,370
.573					300, 19W	5,301				
.574	250, 19W								250, 19W	11,360
.575	250, 37W	4,860					4/0, 15/4	10,870	250, 37W	11,560
.576	159, 12/7	15,200								
.583									4/0G	15,640
.586	266.8, 7W	4,780								
.593	266.8, 19W	4,810			300, 18/1	7,990				
.594	266.8, 37W									
.600									250, 12W	11,130
.603					336.4, 7W	5,885				
.607	176.9, 12/7	16,440			336.4, 19W	5,940				
.609	266.8, 18/1	7,100								
.613									4/0E	20,730
.618					350, 19W	6,185				
.621									250EK	17,840
.628	300, 19W	5,890			336.4, 18/1	8,950			300, 19W	13,510
.630	300, 37W	5,830							300, 37W	13,870
.631	190.8, 12/7	17,730								
.633	266.8, 6/7	9,645								
.642	266.8, 26/7	11,250	266.8, 19W	8,180						
.657									300, 12W	13,170
.660					397.5, 19W	6,880				
.664	211.3, 12/7	19,640								
.666	336.4, 19W	5,945							250E	23,920
.678									350, 19W	15,590
.679	350, 19W	6,180					336.4, 18/1	8,650		
.680	300, 26/7	12,650							300EK	20,960
.681	350, 37W	6,680							350, 37W	16,060
.682					397.5, 18/1	10,040				
.684	336.4, 18/1	8,950								
.700	300, 30/7	15,430								
.710									350, 12W	15,140
.714	203.2, 16/19	27,500								
.721	336.4, 26/7	14,050								
.722					477, 19W	8,090				
.724	397.5, 19W	6,885								
.726									400, 19W	17,560
.728	400, 37W	7,350							400, 37W	18,320
.729									300E	27,770
.735									350EK	23,850
.739					500, 19W	8,480				
.741	336.4, 30/7	17,040								
.742					477, 18/1	11,870				
.743	397.5, 18/1	10,400								
.770									450, 19W	19,750
.772	450, 37W	8,110							450, 37W	20,450
.780					556, 19W	9,440				
.782			397.5, 19W	11,840						
.783	397.5, 26/7	16,190								
.788									350E	32,420
.793	477, 19W	8,090								
.795	477, 37W	8,600								

**Conductor Reference**

**Bare Conductor Information AWG or kcmil — continued**

Conductor Diameter (in.)	ACSR or All Aluminum	Rated Breaking Strength	Aluminum Alloy (5005-6201)	Rated Breaking Strength	Compacted ACSR or All Aluminum	Rated Breaking Strength	AWAC	Rated Breaking Strength	Copper or Copperweld Copper Composite	Rated Breaking Strength
.801					556.5, 18/1	13,850				
.806	397.5, 30/7	19,980								
.811	500, 19W	9,425							500, 19W	21,950
.813	500, 37W	9,010							500, 37W	22,510
.814	477, 18/1	12,300								
.834					636, 19W	10,790				
.846	477, 24/7	17,200								
.853									550, 37W	24,760
.855	500, 61W	10,490							550, 61W	25,230
.856	556, 19W	9,440								
.858	477, 26/7	19,430	477, 19W	13,450						
	556.5, 37W	9,835								
.862					636, 18/1	15,830				
.879	556.5, 18/1	14,300								
.883	477, 30/7	23,300								
.891									600, 37W	27,020
.893	600, 61W	11,450							600, 61W	27,530
.904	500, 30/7	24,450								
.914	556.5, 24/7	9,925								
.918	636, 37W	11,240								
.927	556.5, 26/7	19,850	556.5, 19W	15,680						
.928									650, 37W	29,130
.929	650, 61W	11,940							650, 61W	29,770
.932					795, 19W	16,540				
.940	636, 18/1	16,400								
.953	556.5, 30/7	27,200								
.953	605, 24/7	21,500								
.953	605, 54/7	22,500								
.962									700, 37W	31,170
.964	700, 61W	12,860							700, 61W	31,820
.966	605, 26/7	24,100								
.974	715.5, 37W	12,640								
.975	715.5, 61W	13,150								
.977	636, 24/7	22,600								
.977	636, 54/7	23,600								
.981										
.990	636, 26/7	25,000	636, 37W	19,110	874.5, 37W	14,830				
.994	605, 30/19	30,000			874.5, 36/1	17,900				
.997	750, 37W	14,430							750, 37W	33,400
.998	750, 61W	13,510							750, 61W	34,090
1.000	666.6, 24/7	23,700								
1.000	666.6, 54/7	24,500								
1.019	636, 30/19	30,500								
1.024					954, 37W	16,180				
1.026	795, 37W	13,770								
1.028	795, 61W	14,330								
1.029									800, 37W	35,120
1.031	800, 61W	14,410							800, 61W	36,360
1.039					954, 36/1	19,520				
1.040	795, 36/1	10,000								
1.051	715.5, 26/7	28,100								
1.061									850, 37W	37,310
1.062									850, 61W	38,270
1.063	795, 45/7	22,900								
1.077	874.5, 37W	14,840								
1.078	874.5, 61W	15,760								

**Bare Conductor Information AWG or kcmil — continued**

Conductor Diameter (in.)	ACSR or All Aluminum	Rated Breaking Strength	Aluminum Alloy (5005-6201)	Rated Breaking Strength	Compacted ACSR or All Aluminum	Rated Breaking Strength	AWAC	Rated Breaking Strength	Copper or Copperweld Copper Composite	Rated Breaking Strength
1.081	715.5, 30/19	34,600								
1.092									900, 37W	39,510
1.093	795, 54/7	28,500								
1.094	900, 61W	15,900							900, 61W	40,520
1.108	795, 26/7	31,200	795, 37W	23,590						
1.124	954, 37W	16,180								
1.126	954, 61W	16,860								
1.140	795, 30/19	38,400								
1.146	874.5, 54/7	31,400								
1.151	1,000, 37W								1,000, 37W	43,830
1.152	1,000, 61W	17,670							1,000, 61W	45,030
1.162	900, 54/7	32,300								
1.165	954, 45/7	26,900								
1.170	1,033.5, 37W	17,530								
1.172	1,033.5, 61W	18,260								
1.196	954, 54/7	34,200								
1.213	1,033.5, 45/7	28,900								
1.216	1,113, 61W	19,670								
1.246	1,033.5, 54/7	37,100								
1.258	1,192.5, 61W	21,070								
1.259	1,113, 45/7	30,900								
1.288						1,468 36/1		30,000		
1.293	1,113, 54/19	40,200								
1.300	1,272, 61W	22,030								
1.302	1,192.5, 45/7	33,200								
1.333	1,192.5, 54/19	43,100								
1.340	1,351.5, 61W	23,400								
1.345	1,272, 45/7	35,400								
1.379	1,431, 61W	23,400								
1.382	1,272, 54/19	44,800								
1.417	1,510.5, 61W	25,630								
1.424	1,351.5, 54/19	47,600								
1.427	1,431, 45/7	39,800								
1.443	1,431, 54/19,	50,400								
	1,590, 61W	26,970								
1.454	1,590, 91W	28,100								
1.465	1,431, 54/19	50,400								
1.504	1,590, 45/7	43,800								
1.506	1,510.5, 54/19	53,300								
1.545	1,590, 54/19	56,000								
1.602	1,780, 84/19	53,600								
1.630	2,000, 91W	34,640								
1.823	2,500, 91W	42,410								
1.996	3,000, 127W	50,890								
2.158	3,500, 127W	59,380								



## Conductor Reference

### AWG/kcmil vs. Metric Wire Sizes — Option 1

Circ. Mils Typical	AWG Size	Metric Wire Size mm <sup>2</sup>	Equivalent Circ. Mils	Stranding/Wire Diameter per Strand		Approximate Overall Diameter	
				in.	mm	in.	mm
		0.50	987	1/.032	1/.813	.032	0.81
1020	20			7/.0121	7/.307	.036	0.91
		0.75	1480	1/.039	1/.991	.039	0.99
1620	18			1/.0403	1/1.02	.040	1.02
1620	18			7/.0152	7/.386	.046	1.16
		1.0	1974	1/.045	1/1.14	.045	1.14
		1.0	1974	7/.017	7/.432	.051	1.30
2580	16			1/.0508	1/1.29	.051	1.29
2580	16			7/.0192	7/.488	.058	1.46
		1.5	2960	1/.055	1/1.40	.055	1.40
		1.5	2960	7/.021	7/5.33	.063	1.60
4110	14			1/.0641	1/1.63	.064	1.63
4110	14			7/.0242	7/.615	.073	1.84
		2.5	4934	1/.071	1/1.80	.071	1.80
		2.5	4934	7/.027	7/.686	.081	2.06
6530	12			1/.0808	1/2.05	.081	2.05
6530	12			7/.0305	7/.775	.092	2.32
		4	7894	1/.089	1/2.26	.089	2.26
		4	7894	7/.034	7/.864	.102	2.59
10380	10			1/.1019	1/2.59	.102	2.59
10380	10			7/.0385	7/.978	.116	2.93
		6	11840	1/.109	1/2.77	.109	2.77
		6	11840	7/.042	7/.107	.126	3.21
13090	9			1/.1144	1/2.91	.1144	2.91
13090	9			7/.0432	7/1.10	.130	3.30
16510	8			1/.1285	1/3.26	.128	3.26
16510	8			7/.0486	7/1.23	.146	3.70
		10	19740	1/.141	1/3.58	.141	3.58
		10	19740	7/.054	7/1.37	.162	4.12
20820	7			1/.1443	1/3.67	.144	3.67
20820	7			7/.0545	7/1.38	.164	4.15
26240	6			1/.162	1/4.11	.162	4.11
26240	6			7/.0612	7/1.55	.184	4.66
		16	31580	7/.068	7/1.73	.204	5.18
33090	5			7/.0688	7/1.75	.206	5.24
41740	4			7/.0772	7/1.96	.232	5.88
		25	49340	7/.085	7/2.16	.255	6.48
		25	49340	19/.052	19/1.32	.260	6.60
52620	3			7/.0867	7/2.20	.260	6.61
66360	2			7/.0974	7/2.47	.292	7.42
		35	69070	7/.100	7/2.54	.300	7.62
		35	69070	19/.061	19/1.55	.305	7.75

### AWG/kcmil vs. Metric Wire Sizes — Option 1 — Continued

Circ. Mils Typical	AWG Size	Metric Wire Size mm <sup>2</sup>	Equivalent Circ. Mils	Stranding/Wire Diameter per Strand		Approximate Overall Diameter	
				in.	mm	in.	mm
83690	1			19/.0664	19/1.69	.332	8.43
		50	98680	19/.073	19/1.85	.365	9.27
105600	1/0			19/.0745	19/1.89	.373	9.46
133100	2/0			19/.0837	19/2.13	.419	10.6
		70	138100	19/.086	19/2.18	.430	10.9
167800	3/0			19/.094	19/2.39	.470	11.9
167800	3/0			37/.0673	37/1.71	.471	12.0
		95	187500	19/.101	19/2.57	.505	12.8
		95	187500	37/.072	37/1.83	.504	12.8
211600	4/0			19/.1055	19/2.68	.528	13.4
		120	237.8 kcmil	37/.081	37/2.06	.567	14.4
250 kcmil				37/.0822	37/2.09	.575	14.6
300 kcmil		150		37/.090	37/2.29	.630	16.0
350 kcmil				37/.0973	37/2.47	.681	17.3
		185	365.1 kcmil	37/.100	37/2.54	.700	17.8
400 kcmil				37/.104	37/2.64	.728	18.5
		240	473.6 kcmil	37/.114	37/2.90	.798	20.3
		240	473.6 kcmil	61/.089	61/2.26	.801	20.3
500 kcmil				37/.1162	37/2.95	.813	20.7
500 kcmil				61/.0905	61/2.30	.814	20.7
		300	592.1 kcmil	61/.099	61/2.51	.891	22.6
600 kcmil				61/.0992	61/2.52	.893	22.7
700 kcmil				61/.1071	61/2.72	.964	24.5
750 kcmil				61/.1109	61/2.82	.998	25.4
750 kcmil				91/.0908	91/2.31	.999	25.4
		400	789.4 kcmil	61/.114	61/2.90	1.026	26.1
800 kcmil				61/.1145	61/2.91	1.031	26.2
800 kcmil				91/.0938	91/2.38	1.032	26.2
1000 kcmil		500	986.8 kcmil	61/.1280	61/3.25	1.152	29.3
1000 kcmil				91/.1048	91/2.66	1.153	29.3
		625	1233.7 kcmil	91/.117	91/2.97	1.287	32.7
1250 kcmil				91/.1172	91/2.98	1.289	32.7
1250 kcmil				127/.0992	127/2.52	1.290	32.8
1500 kcmil				91/.1284	91/3.26	1.412	35.9
1500 kcmil				127/.1087	127/2.76	1.413	35.9
		800	1578.8 kcmil	91/.132	91/3.35	1.452	36.9
		1000	1973.5 kcmil	91/.147	91/3.73	1.617	41.1
2000 kcmil				127/.1255	127/3.19	1.632	41.5
2000 kcmil				169/.1088	169/2.76	1.632	41.5

## Conductor Reference

### AWG/kcmil vs. Metric Wire Sizes — Option 2

Approximate Overall Diameter		Circ. Mils	AWG Size	Metric Wire Size mm <sup>2</sup>	Equivalent Circ. Mils	Stranding/ Wire Diameter per Strand	
in.	mm					in.	mm
.032	0.81			0.50	987	1/.032	1/.813
.036	0.91	1020	20			7/.0121	7/.307
.039	0.99			0.75	1480	1/.039	1/.991
.040	1.02	1620	18			1/.0403	1/1.02
.046	1.16	1620	18			7/.0152	7/.386
.045	1.14			1.0	1974	1/.045	1/1.14
.051	1.30			1.0	1974	7/.017	7/.432
.051	1.29	2580	16			1/.0508	1/1.29
.058	1.46	2580	16			7/.0192	7/.488
.055	1.40			1.5	2960	1/.055	1/1.40
.063	1.60			1.5	2960	7/.021	7/5.33
.064	1.63	4110	14			1/.0641	1/1.63
.073	1.84	4110	14			7/.0242	7/.615
.071	1.80			2.5	4934	1/.071	1/1.80
.081	2.06			2.5	4934	7/.027	7/.686
.081	2.05	6530	12			1/.0808	1/2.05
.092	2.32	6530	12			7/.0305	7/.775
.089	2.26			4	7894	1/.089	1/2.26
.102	2.59			4	7894	7/.034	7/.864
.102	2.59	10380	10			1/.1019	1/2.59
.116	2.93	10380	10			7/.0385	7/.978
.109	2.77			6	11840	1/.109	1/2.77
.126	3.21			6	11840	7/.042	7/1.07
.1144	2.91	13090	9			1/.1144	1/2.91
.130	3.30	13090	9			7/.0432	7/1.10
.128	3.26	16510	8			1/.1285	1/3.26
.146	3.70	16510	8			7/.0486	7/1.23
.141	3.58			10	19740	1/.141	1/3.58
.162	4.12			10	19740	7/.054	7/1.37
.144	3.67	20820	7			1/.1443	1/3.67
.164	4.15	20820	7			7/.0545	7/1.38
.162	4.11	26240	6			1/.162	1/4.11
.184	4.66	26240	6			7/.0612	7/1.55
.204	5.18			16	31580	7/.068	7/1.73
.206	5.24	33090	5			7/.0688	7/1.75
.232	5.88	41740	4			7/.0772	7/1.96
.255	6.48			25	49340	7/.085	7/2.16
.260	6.60			25	49340	19/.052	19/1.32
.260	6.61	52620	3			7/.0867	7/2.20
.292	7.42	66360	2			7/.0974	7/2.47
.300	7.62			35	69070	7/.100	7/2.54
.305	7.75			35	69070	19/.061	19/1.55

**AWG/kcmil vs. Metric Wire Sizes — Option 2 (continued)**

Approximate Overall Diameter		Circ. Mils	AWG Size	Metric Wire Size mm <sup>2</sup>	Equivalent Circ. Mils	Stranding/ Wire Diameter per Strand	
in.	mm					in.	mm
.332	8.43	83690	1			19/.0664	19/1.69
.365	9.27			50	98680	19/.073	19/1.85
.373	9.46	105600	1/0			19/.0745	19/1.89
.419	10.6	133100	2/0			19/.0837	19/2.13
.430	10.9			70	138100	19/.086	19/2.18
.470	11.9	167800	3/0			19/.094	19/2.39
.471	12.0	167800	3/0			37/.0673	37/1.71
.505	12.8			95	187500	19/.101	19/2.57
.504	12.8			95	187500	37/.072	37/1.83
.528	13.4	211600	4/0			19/.1055	19/2.68
.567	14.4			120	237.8 kcmil	37/.081	37/2.06
.575	14.6	250 kcmil				37/.0822	37/2.09
.630	16.0	300 kcmil		150		37/.090	37/2.29
.681	17.3	350 kcmil				37/.0973	37/2.47
.700	17.8			185	365.1 kcmil	37/.100	37/2.54
.728	18.5	400 kcmil				37/.104	37/2.64
.798	20.3			240	473.6 kcmil	37/.114	37/2.90
.801	20.3			240	473.6 kcmil	61/.089	61/2.26
.813	20.7	500 kcmil				37/.1162	37/2.95
.814	20.7	500 kcmil				61/.0905	61/2.30
.891	22.6			300	592.1 kcmil	61/.099	61/2.51
.893	22.7	600 kcmil				61/.0992	61/2.52
.964	24.5	700 kcmil				61/.1071	61/2.72
.998	25.4	750 kcmil				61/.1109	61/2.82
.999	25.4	750 kcmil				91/.0908	91/2.31
1.026	26.1			400	789.4 kcmil	61/.114	61/2.90
1.031	26.2	800 kcmil				61/.1145	61/2.91
1.032	26.2	800 kcmil				91/.0938	91/2.38
1.152	29.3	1000 kcmil		500	986.8 kcmil	61/.1280	61/3.25
1.153	29.3	1000 kcmil				91/.1048	91/2.66
1.287	32.7			625	1233.7 kcmil	91/.117	91/2.97
1.289	32.7	1250 kcmil				91/.1172	91/2.98
1.290	32.8	1250 kcmil				127/.0992	127/2.52
1.412	35.9	1500 kcmil				91/.1284	91/3.26
1.413	35.9	1500 kcmil				127/.1087	127/2.76
1.452	36.9			800	1578.8 kcmil	91/.132	91/3.35
1.617	41.1			1000	1973.5 kcmil	91/.147	91/3.73
1.632	41.5	2000 kcmil				127/.1255	127/3.19
1.632	41.5	2000 kcmil				169/.1088	169/2.76







## Alphanumerical Index

Cat. No.	Page	Cat. No.	Page	Cat. No.	Page
4	102	10HPS	7	37175BB-C	35
6	102	10HPW	7	37200BB-C	35
80	82	13100A	129	37225BB-C	35
1010	81	14010HN-C	35	37250BB-C	35
2012	140	14030SW-C	35	37275BB-C	35
2015	140	14040FW-C	36	37300BB-C	35
3902	102	15500-TB	121	37325BB-C	35
3903	102	156CS	124, 138	37350BB-C	35
3904	102	1AAW	9	3902BU	102
3907	102	1H	6	3903BU	102
3908	02	1H3	6	3904BU	102
3930	92	1HPS	7	3905BU	102
3940	92	1HPW	7	3905-TB	102
3950	92	20H	6	3906BU	102
3951	92	20HPS	7	3906-TB	102
3960	92	20HPW	7	3907BU	102
5005	81	240-31565-91	124	3908BU	102
5006	81	25100BB-C	35	3909BU	102
5008	81	25225BB-C	35	3909-TB	102
5010	81	297-31804-4	131	3H	6
6256	81	297-31804-6	131	3H3	6
6258	81	2AAW	9	3-TB	102
6260	81	2B10	13	40AAW	9
7508	81	2B1000	13	40CS	124, 138
7510	81	2B1000PW	14	40H	6
51628	85	2B1000W	14	40HPS	7
51629	85	2B1000X	13	40HPW	7
53055	76	2B10PW	14	4AAW	9
53059	76	2B10W	14	4H	6
53060	76	2B10X	13	4H3	6
53065	76	2B20BB	13	4HPS	7
53069	76	2B20PW	14	4HPW	7
53071	76	2B20W	14	50010HN-C	35
53073	76	2B20X	13	50030SW-C	35
53075	76	2B350	13	50040FW-C	36
53080	76	2B350PW	14	50050BW-C	36
53504	71	2B350W	14	5008LS	82
53505	71	2B350X	13	500HPS	7
53506	71	2B40	13	500M	6
53507	71	2B40PW	14	50100BB-C	35
53508	71	2B40W	14	5010LS	82
53509	71	2B40X	13	50125BB-C	35
53510	71	2B500	13	50150BB-C	35
53511	71	2B500PW	14	50175BB-C	35
53512	71	2B500W	14	50200BB-C	35
53513	71	2B500X	13	50225BB-C	35
53515	71	2B800	13	50250BB-C	35
53518	71	2B800PW	14	50275BB-C	35
53523	71	2B800W	14	50300BB-C	35
54705	68	2B800X	13	50325BB-C	35
54710	68	2H	6	50350BB-C	35
54715	68	2H3	6	50CNT	83
54720	68	2HPS	7	50LC	82
54725	68	2HPW	7	50LDS	82
54730	68	2-TB	102	53055FL	77
54735	68	30H	6	53065-34GR	75
54740	68	31010HN-C	35	53065-58GR	75
54745	68	31030SW-C	35	53065FL	77
54750	68	31040FW-C	36	54855L	66, 121
54855	65, 122	31100BB-C	35	54855LR12	66, 123
54860	65, 122	31125BB-C	35	54865-CK	65, 122
54875	65, 122	31150BB-C	35	54865L	66, 121
54885	65, 122	31175BB-C	35	54865LR58	66, 123
54890	65, 122	31200BB-C	35	54875L	66, 121
54895	65, 122	31225BB-C	35	54875LR34	66, 123
54900	65, 122	31250BB-C	35	54885L	66, 121
64660	85	31275BB-C	35	54885LR12	66, 123
64663	85	31300BB-C	35	54895L	66, 121
1000HPS	7	350HPS	7	54895LR58	66, 123
1000M	6	350M	6	54900L	66, 121
1010S	82	368-CK	132	54900LR34	66, 123
1016BTB	85	37010HN-C	35	54910LR100	66, 123
1016BTB-NG	85	37030SW-C	35	54920LR100	66, 123
1016TB	85	37040FW-C	36	5-TB	102
1016TB-NG	85	37100BB-C	35	60C	82
10AAW	9	37125BB-C	35	60CNT2	83
10H	6	37150BB-C	35	60DS	82

## Alphanumerical Index

Cat. No.	Page
60DSNT	.83
6258S	.82
6260S	.82
6AAW	.9
6H	.6
6H3	.6
6HPS	.7
6HPW	.7
70C	.82
70CNT	.83
70DS	.82
7506S	.82
7508S	.82
750HPS	.7
750M	.6
7510S	.82
80C	.82
80DS	.82
8H	.6
8H3	.6
8HPS	.7
9H	.6
9HPS	.7
ADR02-32	.31
ADR02-34	.32
ADR11	.26
ADR11-21	.29
ADR11-32	.31
ADR11-34	.32
ADR2	.26
ADR21	.26
ADR21-21	.29
ADR25	.26
ADR25-12S	.27
ADR25-21	.29
ADR25-32	.31
ADR25-34	.32
ADR25-44	.32
ADR30	.26
ADR31-32	.31
ADR31-34	.32
ADR35	.26
ADR35-21	.29
ADR35-12D	.27
ADR35-12S	.27
ADR35-22	.29
ADR35-32	.31
ADR35-34	.32
ADR35-44	.32
ADR50	.26
ADR50-12S	.27
ADR50-32	.31
ADR50-34	.32
ADR6	.26
ADR60	.26
ADR6004	.26
ADR60-12D	.27
ADR60-21	.29
ADR60-22D	.29
ADR60-32D	.31
ADR60-34D	.32
ADR60-44D	.32
ADR80	.26
ADR80-12D	.27
ADR80-12DS	.27
ADR80-21	.29
ADR80-22D	.29
ADR80-32	.31
ADR80-34	.32
ADR80-44D	.32
ADR99	.26
ADR99-12D	.27
ADR99-12DS	.27
ADR99-21	.29
ADR99-22D	.29
ADR99-32	.31
ADR99-34	.32

Cat. No.	Page
AJ	.101
AJ2	.101
AJ-2124	.101
AMTD101410	.17
AMTD101411	.17
AMTD101412	.17
AMTD101413	.17
AMTD101414	.17
AMTD10142	.17
AMTD10143	.17
AMTD10144	.17
AMTD10145	.17
AMTD10146	.17
AMTD10147	.17
AMTD10148	.17
AMTD10149	.17
AMTD250610	.18
AMTD250611	.18
AMTD250612	.18
AMTD250613	.18
AMTD250614	.18
AMTD25062	.18
AMTD25063	.18
AMTD25064	.18
AMTD25065	.18
AMTD25066	.18
AMTD25067	.18
AMTD25068	.18
AMTD25069	.18
AMTD30610	.17
AMTD30611	.17
AMTD30612	.17
AMTD30613	.17
AMTD30614	.17
AMTD3062	.17
AMTD3063	.17
AMTD3064	.17
AMTD3065	.17
AMTD3066	.17
AMTD3067	.17
AMTD3068	.17
AMTD3069	.17
AMTD350610	.18
AMTD350611	.18
AMTD350612	.18
AMTD350613	.18
AMTD350614	.18
AMTD35062	.18
AMTD35063	.18
AMTD35064	.18
AMTD35065	.18
AMTD35066	.18
AMTD35067	.18
AMTD35068	.18
AMTD35069	.18
AMTD41410	.17
AMTD41411	.17
AMTD41412	.17
AMTD41413	.17
AMTD41414	.17
AMTD4142	.17
AMTD4143	.17
AMTD4144	.17
AMTD4145	.17
AMTD4146	.17
AMTD4147	.17
AMTD4148	.17
AMTD4149	.17
AMTD500410	.18
AMTD500411	.18
AMTD500412	.18
AMTD500413	.18
AMTD500414	.18
AMTD50042	.18
AMTD50043	.18
AMTD50044	.18
AMTD50045	.18

Cat. No.	Page
AMTD50046	.18
AMTD50047	.18
AMTD50048	.18
AMTD50049	.18
AMTD75025010	.18
AMTD75025011	.18
AMTD75025012	.18
AMTD75025013	.18
AMTD75025014	.18
AMTD7502502	.18
AMTD7502503	.18
AMTD7502504	.18
AMTD7502505	.18
AMTD7502506	.18
AMTD7502507	.18
AMTD7502508	.18
AMTD7502509	.18
AMTDM250610	.19
AMTDM250611	.19
AMTDM250612	.19
AMTDM25062	.19
AMTDM25063	.19
AMTDM25064	.19
AMTDM25065	.19
AMTDM25066	.19
AMTDM25067	.19
AMTDM25068	.19
AMTDM25069	.19
AMTDM30610	.19
AMTDM30611	.19
AMTDM30612	.19
AMTDM3062	.19
AMTDM3063	.19
AMTDM3064	.19
AMTDM3065	.19
AMTDM3066	.19
AMTDM3067	.19
AMTDM3068	.19
AMTDM3069	.19
AMTDM350610	.19
AMTDM350611	.19
AMTDM350612	.19
AMTDM35062	.19
AMTDM35063	.19
AMTDM35064	.19
AMTDM35065	.19
AMTDM35066	.19
AMTDM35067	.19
AMTDM35068	.19
AMTDM35069	.19
AMTDM500410	.19
AMTDM500411	.19
AMTDM500412	.19
AMTDM50042	.19
AMTDM50043	.19
AMTDM50044	.19
AMTDM50045	.19
AMTDM50046	.19
AMTDM50047	.19
AMTDM50048	.19
AMTDM50049	.19
AMTDM75025010	.19
AMTDM75025011	.19
AMTDM75025012	.19
AMTDM7502502	.19
AMTDM7502503	.19
AMTDM7502504	.19
AMTDM7502505	.19
AMTDM7502506	.19
AMTDM7502507	.19
AMTDM7502508	.19
AMTDM7502509	.19
AMTS101410	.16
AMTS101411	.16
AMTS101412	.16
AMTS101413	.16
AMTS101414	.16

## Alphanumerical Index

Cat. No.	Page
AMTS10142	15
AMTS10143	15
AMTS10144	15
AMTS10145	15
AMTS10146	15
AMTS10147	15
AMTS10148	16
AMTS10149	16
AMTS250610	16
AMTS250611	16
AMTS250612	16
AMTS250613	16
AMTS250614	16
AMTS25062	16
AMTS25063	16
AMTS25064	16
AMTS25065	16
AMTS25066	16
AMTS25067	16
AMTS25068	16
AMTS25069	16
AMTS30610	16
AMTS30611	16
AMTS30612	16
AMTS30613	16
AMTS30614	16
AMTS3062	16
AMTS3063	16
AMTS3064	16
AMTS3065	16
AMTS3066	16
AMTS3067	16
AMTS3068	16
AMTS3069	16
AMTS350610	16
AMTS350611	16
AMTS350612	16
AMTS350613	16
AMTS350614	16
AMTS35062	16
AMTS35063	16
AMTS35064	16
AMTS35065	16
AMTS35066	16
AMTS35067	16
AMTS35068	16
AMTS35069	16
AMTS41410	15
AMTS41411	15
AMTS41412	15
AMTS41413	15
AMTS41414	15
AMTS4142	15
AMTS4143	15
AMTS4144	15
AMTS4145	15
AMTS4146	15
AMTS4147	15
AMTS4148	15
AMTS4149	15
AMTS500410	16
AMTS500411	16
AMTS500412	17
AMTS500413	17
AMTS500414	17
AMTS50042	16
AMTS50043	16
AMTS50044	16
AMTS50045	16
AMTS50046	16
AMTS50047	16
AMTS50048	16
AMTS50049	16
AMTS75025010	17
AMTS75025011	17
AMTS75025012	17
AMTS75025013	17

Cat. No.	Page
AMTS75025014	17
AMTS7502502	17
AMTS7502503	17
AMTS7502504	17
AMTS7502505	17
AMTS7502506	17
AMTS7502507	17
AMTS7502508	17
AMTS7502509	17
AMTSR10	15
AMTSR250	15
AMTSR350	15
AMTSR500	15
AMTSR750	15
AMTT10	15
AMTT30	15
AMTTC4	15
APS02	8
APS04	8
APS06	8
APS11	8
APS21	8
APS350	8
APS41	8
APSS500	8
ASL30-21	28
ASL60-22	28
ASL60-32	30
ASL60-42	30
ASL75-22	28
ASL75-42	30
ASP1	55
ASP10	55
ASP1000	55
ASP2	55
ASP20	55
ASP250	55
ASP30	55
ASP300	55
ASP350	55
ASP4	55
ASP40	55
ASP400	55
ASP500	55
ASP6	55
ASP600	55
ASP750	55
ASP8	55
ASR0214	33
ASR1114	33
ASR2506	33
ASR3506	33
ASR7525	33
ATL10-12	53
ATL102	54
ATL102-38	54
ATL10-38	53
ATL10-516	53
ATL1-38	53
ATL1-516	53
ATL20-12	53
ATL202	54
ATL20-38	53
ATL2-14	53
ATL2-38	53
ATL250-12	53
ATL2502	54
ATL2-516	53
ATL300-12	53
ATL3002	54
ATL300-38	53
ATL30-12	53
ATL302	54
ATL30-38	53
ATL350-12	53
ATL3502	54
ATL4002	54

Cat. No.	Page
ATL400-58	53
ATL40-12	53
ATL402	54
ATL40-38	53
ATL4-14	53
ATL4-38	53
ATL4-516	53
ATL500-12	53
ATL5002	54
ATL500-58	53
ATL600-12	53
ATL6002	54
ATL6-10	53
ATL6-14	53
ATL6-38	53
ATL750-12	53
ATL7502	54
ATL750-58	53
ATL8-10	53
ATL8-14	53
B05CH	120
B06CH	120
B08CH	120
B09CH	120
B10CH	120
B10SH	120
B11CH	120
B12CH	120
B20AH	120
B24EA	120
B26CH	120
B30EA	120
B36CH	120
B39CH	120
B39EA	120
B49EA	120
B58CS	120
B61EA	120
B71AH	120
B71CH	120
B72AH	120
B72CH	120
B73AH	120
B73CH	120
B74AH	120
B74CH	120
B75AH	120
B75CH	120
B76AH	120
B76CH	120
B76SH	120
B80EA	120
BC202	69
BC2020-BB	69
BC22	69
BC24	69
BC402	69
BC4020	69
BC4040	69
BC44	69
BC46-BB	69
BC48	69
BG1	119
BG1-BB	127
BTC0208	25
BTC0614	25
BTC1014	25
BTC1102	25
BTC3104	25
BTC3511	25
BTC4102	25
BTC5011	25
BTC9960	25
BX0214	33
BX1114	33
BY13	119
BY15	119

## Alphanumerical Index

Cat. No.	Page
BY15C	119
BY17	119
BY17C	119
BY19	119
BY19C	119
BY21	119
BY21C	119
BY23	119
BY23C	119
BY24C	119
BY25	119
BY25C	119
BY27	119
BY27C	119
BY28C	119
BY29	119
BY31	119
BY31C	119
BY32C	119
BY33	119
BY35	119
BY35C	119
BY37	119
BY37C	119
BY39	119
BY41	119
BY43	119
BY45	119
BY47	119
BY49	119
BY51	119
BY53	119
BY53C	119
BY55	119, 124, 138
BY63	119
BY65	119
C2BB	46
C5C	46
C7C	46
C9	46
C9L	46
CC10C-56R	77
CC1C-45R	77
CC20C-56R	77
CC2C-45R	77
CC40C-56R	77
CF1010-1	45
CF102-1	45
CF2020-1	45
CF202-1	45
CF22-1	45
CF4010-1	45
CF402-1	45
CF4040-1	45
CF44-1	45
CFS22-1	45
CFS44-1	45
CH1	92
CH12	92
CH34	92
CRCTBP	137
CRCTBPI	137
CRCTQC	137
CSP1	51
CSP10	51
CSP1000	51
CSP2	51
CSP20	51
CSP250	51
CSP30	51
CSP300	51
CSP350	51
CSP4	51
CSP40	51
CSP400	51
CSP500	51
CSP6	51

Cat. No.	Page
CSP600	51
CSP750	51
CSP8	51
CSR750	132
CTA	139
CTB	139
CTB8	139
CTG	139
CTG250	86
CTL10002	48
CTL1000L-58	49
CTL1000-58	47
CTL10-12	47
CTL10-2516	48
CTL10-38	47
CTL10-516	47
CTL10L-516	49
CTL1-12	47
CTL1-14	47
CTL1-2516	48
CTL1-38	47
CTL1-516	47
CTL1L-516	49
CTL20-12	47
CTL202	48
CTL20-38	47
CTL20L-38	49
CTL2-12	47
CTL2-14	47
CTL2-2516	48
CTL2-38	47
CTL250-12	47
CTL2502	48
CTL250L-12	49
CTL2-516	47
CTL2L-516	49
CTL300-12	47
CTL3002	48
CTL300L-12	49
CTL30-12	47
CTL302	48
CTL30-38	47
CTL30L-12	49
CTL30L-12	47
CTL40-12	47
CTL402	48
CTL40-38	47
CTL40L-12	49
CTL4-10	47
CTL4-14	47
CTL4-214	48
CTL4-38	47
CTL4-516	47
CTL4L-14	49
CTL500-12	47
CTL5002	48
CTL500-58	47
CTL500L-58	49
CTL6002-12	48
CTL6002-38	48
CTL600-58	47
CTL600L-58	49
CTL6-10	47
CTL6-14	47
CTL6-214	48
CTL6-38	47
CTL6-516	47
CTL6L-14	49
CTL7502	48
CTL750-58	47
CTL750L-58	49

Cat. No.	Page
CTL8-10	47
CTL8-14	47
CTL8-516	47
CTL8L-14	49
CTP202	67, 123
CTP2020	67, 123
CTP22	67, 123
CTP25020	67, 123
CTP250250	67, 123
CTP50020	67, 123
CTP500250	67, 123
CTP500500	67, 123
CTR-1	132
CU1	52
CU10	52
CU1000	52
CU2	52
CU20	52
CU250	52
CU30	52
CU300	52
CU350	52
CU4	52
CU40	52
CU400	52
CU500	52
CU6	52
CU600	52
CU750	52
CU8	52
CULL414	87
CULL414TP	87
DBL	119
DGC58-44	83
DGC58-46	83
DGC58-66	83
DX-1	140
DX-5	140
DX-5S	140
EZ-CK DIEKIT	106
FB-12412036-1	98
FB-1241630-1	98
FB-1241636-1	98
FB-1244036-1	98
FB-1246736-1	98
FB-1480636-1	98
FB-1480836-1	98
FB-1481036-1	98
FB-14810644-2	98
FB-1482230-1	98
FB-1484036-1	98
FB-1485036-1	98
FB-1485230-1	98
FB-1488436-1	98
FB-1488640-1	98
FB-2243230-1	98
FB2D12	94, 100
FB2D12-1	94, 100
FB2E12	94, 100
FB2E12-1	94, 100
FB2F12	94, 100
FB2G12	94, 100
FB2XD12	94, 100
FB2XD12-1	94, 100
FB3D12	94, 100
FB-3243230-1	98
FB3D12-1	94, 100
FB3E12	94, 100
FB3F12	94, 100
FB3G12	94, 100
FB3XD12	94, 100
FB3XD12-1	94, 100
FB-4243230-1	98
FB4E12	94, 100
FB4F12	94, 100
FB4G12	94, 100
FBB12-1	94, 100

## Alphanumerical Index

Cat. No.	Page
FBBRL	94, 98
FBC12-1	94, 100
FBCRL	94, 98
FBD12	94, 100
FBD12-1	94, 100
FBDRL	94, 98
FBE12	94, 100
FBE12-1	94, 100
FBF12	94, 100
FBG12	94, 100
FBXD12	94, 100
FBXD12-1	94, 100
FBXDRL	94, 98
FG2040R2	77
FG2040R25	77
FG2040R3	77
FG210F3	77
FG210R2	77
FG210R25	77
G3	78
G4	78
G5	78
G6	78
GBBC22	73
GBBC26	73
GG10-10	74
GG12	79
GG12H	79
GG2030-10	74
GG2030-2030	74
GG2030-21	74
GG21-21	74
GG34H	79
GG350-350	74
GG40250-10	74
GG40250-2030	74
GG40250-21	74
GG40250-40250	74
GG500-2030	74
GG500-350	74
GG500-40250	74
GG500-500	74
GG58	79
GG58H	79
GP100	85
GP1003	85
GP1008	85
GP110	85
GP1108	85
GP114	85
GP2250-2	72
GP2250-4	72
GP250500-2	72
GP250500-4	72
GR1-202	65
GR12-202	65
GR12-306	69
GR12-40250	65, 122
GR1-300500	65, 122
GR1-40250	65, 122
GR34-202	65, 122
GR34-300500	65, 122
GR34-4010	69
GR34-40250	65, 122
GR5006	81
GR58-202	65, 122
GR58-300500	65, 122
GR58-40250	65, 122
GR58-406	69
GR6250	81
GR6250B	81
GR6256	81
GR6258	81
GR6260	81
GR7506	81
GR7508	81
GR7510	81

Cat. No.	Page
GRD20	75
GRD40	75
GRD420	75
GTC13	86
GTC14	86
GTC23	86
GTC24	86
GUV11821	80
GUV1184	80
GUV13821	80
GUV13825	80
GUV1384	80
GUV15821	80
GUV15825	80
GUV1584	80
GUV2021	80
GUV2025	80
GUV204	80
GUV21221	80
GUV21225	80
GUV3021	80
GUV3025	80
GUV31221	80
GUV4021	80
GUV4025	80
GUV5821	80
GUV5825	80
GUV584	80
GUV7821	80
GUV7825	80
GUV784	80
HBKC	120
HBKT	120
HD	120
HM-250 TOOL	132
HN	120
HO	120
HU	120
IBG20-40	71
IBG2-10	71
IBG350-500	71
IPC1102	12
IPC3535	12
IPC3541	12
IPC4111	12
IPC4141	12
IPC5041	12
JAB1	78
JAB12	78
JAB12H	78
JAB1H	78
JAB34	78
JAB34C	78
JAB34H	78
JAB58	78
JAB58H	78
JB12B	126
JDLI	101
JJR	101
JP126	88
JP126G	88
JP146	88
JP2612G	88
JP2614	88
JP2638	88
JP26516	88
JP386	88
JP5166	88
JP62	88
JP66-TB	88
JWR	79
L125	22
L1252	22
L1252H	22
L125H	22
L250	22
L2502	22

Cat. No.	Page
L2502H	22
L250H	22
L35	22
L4002	22
L4002H	22
L400B	22
L400H	22
L650	22
L6502	22
L6502H	22
L650H	22
L70	22
LCN10	50
LCN1-12	50
LCN1-516	50
LCN20	50
LCN2-12	50
LCN250	50
LCN2-516	50
LCN30	50
LCN300	50
LCN350	50
LCN40	50
LCN400	50
LCN4-12	50
LCN4-14	50
LCN500	50
LCN600	50
LCN6-12	50
LCN6-14	50
LCN75	50
LCN8-14	50
LCN99	50
LL1014	87
LL2506	87
LL306	87
LL414	87
OD58	127
OD581	127
OD583	127
OD58L72	127
ODB	127
ODB1	127
ODB3	127
ODBL72	127
ODF1	127
ODH1	119, 127
OD-TOOL-KIT	107
OD-TOOL-KIT-1	107
OJB	119
PA01	56
PA02	56
PA04	56
PA06	56
PA11	56
PA21	56
PA25	56
PA30	56
PA31	56
PA35	56
PA40	56
PA41	56
PA50	56
PA60	56
PA75	56
PBGW	85
PBH	85
PDS22300	20, 21
PDS22300B	21
PDS22300G	21
PDS2300	20, 21
PDS2300B	21
PDS2300G	21
PDS230500	20, 21
PDS230500B	21
PDS230500G	21
PDS2440	20, 21



## Alphanumerical Index

Cat. No.	Page
PDS2440B	21
PDS2440G	21
PDS2610	20, 21
PDS2610B	21
PDS2610G	21
PDS30500	20, 21
PDS30500B	21
PDS30500G	21
PDS3610	20, 21
PDS440	20, 21
PDS440B	21
PDS440G	21
PDS610	20, 21
PDS610B	21
PDS610G	21
REC-630	134
REC-750	134
S100BB	23
S225BB	23
S400BB	23
SL5	140
SP0DL	11, 90
SP0DS	10, 89
SP0SL	11, 90
SPOSS	10, 89
SP10DL	11, 90
SP10DS	10, 89
SP10SL	11, 90
SP10SS	10, 89
SP1DL	11, 90
SP1DS	10, 89
SP1SL	11, 90
SP1SS	10, 89
SP2DL	11, 90
SP2DS	10, 89
SP2SL	11, 90
SP2SS	10, 89
SP3DL	11, 90
SP3DS	10, 89
SP3SL	11, 90
SP3SS	10, 89
SP4DL	11, 90
SP4DS	10, 89
SP4SL	11, 90
SP4SS	10, 89
SP5DL	11, 90
SP5DS	10, 89
SP5SL	11, 90
SP5SS	10, 89
SP6DL	11, 90
SP6DS	10, 89
SP6SL	11, 90
SP6SS	10, 89
SP8DL	11, 90
SP8DS	10, 89
SP8SL	11, 90
SP8SS	10, 89
SP9DL	11, 90
SP9DS	10, 89
SP9SL	11, 90
SP9SS	10, 89
STC0208	24
STC0414	24
STC0614	24
STC1014	24
STC1102	24
STC3104	24
STC3511	24
STC4102	24
STC5011	24
STC9960	24
TB-240436	99
TB-240536	99
TB-240730	99
TB-240734	99
TB-240834	99
TB-241336	99

Cat. No.	Page
TB-480730	99
TB-480734	99
TB-480830	99
TB-480836	99
TB-480930	99
TB-481030	99
TB-481130	99
TB-481136	99
TB-481230	99
TB-481234	99
TB-481430	99
TB-481630	99
TB-481836	99
TBM14BSCR	134
TBM14MC	126
TBM15BSCR	135
TBM4BB	125
TBM4BB-KIT	108
TBM4S	125
TBM54BSCT	135
TBM54BSCTS	135
TBM58BSCT	136
TBM6BSCR	134
TBM6H	128
TBM6HD-1	128
TBM840	126
TBM8-750	130, 131
TBM8-750C20	131
TBM8-750C2530	131
TBM8-750C3540	131
TBM8-750C4550	131
TBM8-750CL	131
TBM8-750G	131
TBM8-750HB	131
TBM8-750HG	131
TBM8-750M-1	130, 131
TBM0DBSCR	136
TBGS-14	70
TBGS-34	70
TBGS-38	70
TBGS-58	70
TBRD34	84
TBRD58	84
TBS34	84
TBS58	84
TL250	23
TL250H	23
TL400	23
TL400H	23
TL650	23
TL650H	23
TTC2	91
TTC2P	91
TTC3	91
TTC3P	91
TTC4	91
TTC4P	91
W20-1	57
W20-1B	57
W20-1BFC	57
W20-1FC	57
W40-1	57
W40-1B	57
W40-1BFC	57
W40-1FC	57
W62-1	57
W62-1B	57
W62-1BFC	57
W62-1FC	57
W62D	57
WA 38	132
WA 516	132
WR1010	39
WR139	44
WR149	39
WR159	38
WR179	39

Cat. No.	Page
WR189	38
WR199	39
WR219	39
WR229	39
WR239	39
WR259	39
WR269	39
WR279	38
WR289	38
WR299	39
WR319	40
WR339	40
WR359	40
WR369	40
WR379	38
WR389	40
WR399	38
WR419	38
WR502	44
WR699	42
WR715	41
WR719	42
WR739	42
WR775	41
WR779	42
WR799	42
WR815	41
WR819	42
WR835	41
WR839	42
WR875	41
WR879	42
WR885	41
WR889	42
WR9	44
WR909	43
WR929	43
WR949	43
WR969	43
WR989	43
WR999	43
WRB1	139
WWB1	139