

Receptacle Control Solutions

Receptacle Control Solutions

Energy Codes now require automatic shut-off controls for plug loads and lighting in many spaces.

With the increase in lighting control requirements and new lighting technologies like LED fixtures, plug load equipment has increased as a percentage of electrical power in many spaces. Research data has shown that plug loads have grown as a percentage of electricity usage from 15% to almost 50% in high efficiency offices today.

Additional energy savings can be captured by implementing receptacle or plug load control to automatically ensure that the plug loads are turned OFF when the space is vacant. Receptacle control has been added to the latest energy codes as a requirement in many spaces.

What is plug load control?

Plug Load or Receptacle Control is now required in ASHRAE 90.1-2010 and California's Title 24 2013. ASHRAE 90.1-2010 is the minimum building standard for the Department of Energy, several states currently have building codes that comply with or exceed ASHRAE 90.1-2010.

- ASHRAE 90.1-2010 requires automatic receptacle control of 50% of the 15 and 20 Amp receptacles, including those found in modular partitions, located in private offices, open offices and computer classrooms. Plug-in strips and devices can no longer be used for automatic receptacle control; the receptacle itself must be controlled.
- Title 24 2013 requires controlled 120v receptacles in all buildings. Applicable areas include private offices, open office areas, conference rooms, kitchenettes and more. Plug-in strips and devices can no longer be used for automatic receptacle control; the receptacle itself must be controlled.

How can we control plug loads?

There are two strategies for providing automatic plug load or receptacle control.

- Occupancy based control: Occupancy or Vacancy sensors constantly monitor if the space is occupied. When the space is vacant the sensor will ensure the receptacles are automatically turned OFF either directly or by sending a signal to the lighting control system.
- Schedule based control: The lighting control system or some other time clock device ensures the receptacles are automatically turned OFF based on user defined time.

Cooper Lighting

by **EAT•N**

Eaton's Lighting Systems Solutions

Eaton's Lighting Systems provides multiple solutions to control receptacle or plug loads including simple occupancy based control, room based controls, schedule based controls, centralized relay controls and DALI based controls.

Occupancy Sensor Solution:

- Automatic receptacle control based on occupancy

What do we need to order:

- Occupancy or vacancy sensor (OAC-*, VAC-*)
- Receptacle rated switchpack (SP-R-20-120)
- Manual switch (GMDS-W)

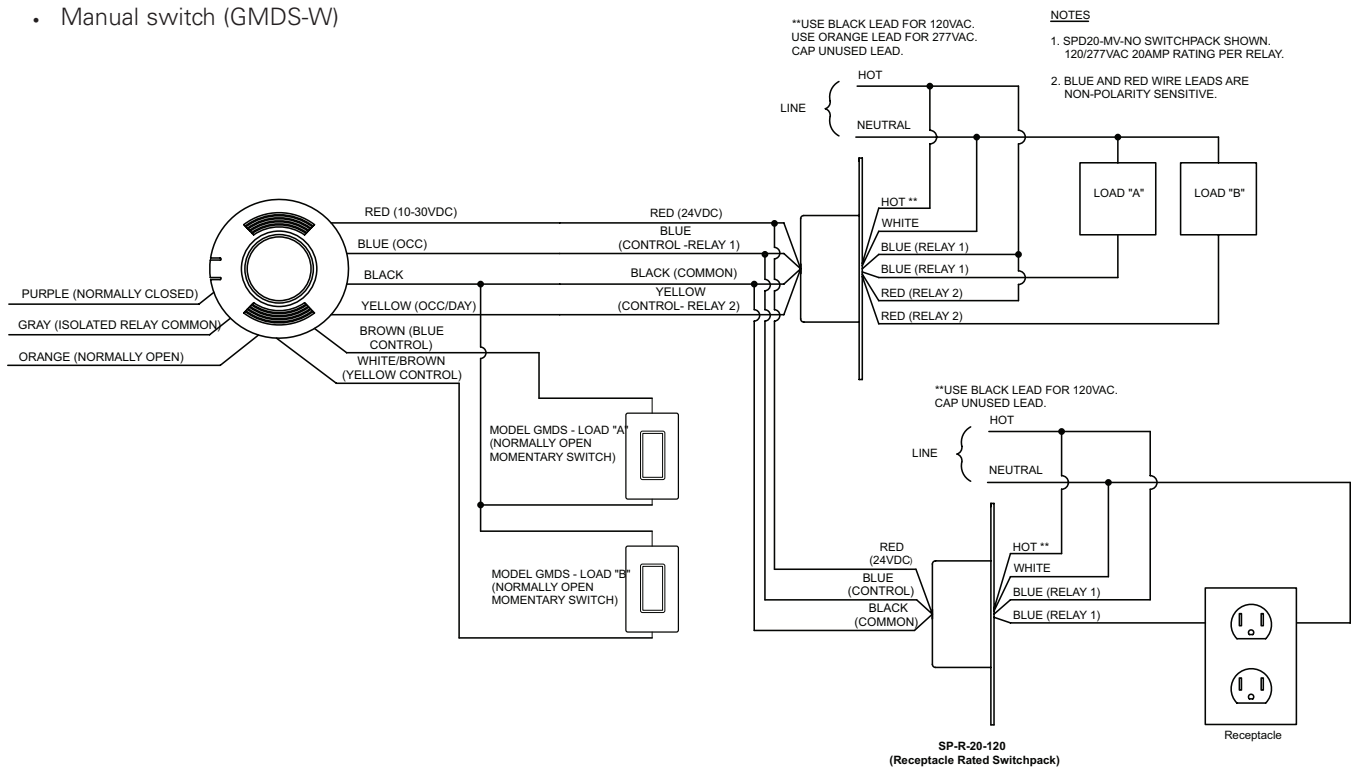

Room Controller Solution

- Automatic receptacle control based on room occupancy
- Exclusive Automatic On receptacle event in Vacancy Mode
- Out-of-the-box functionality

What do we need to order:

- Room Controller (RC3, RC3D, RC3DE, RC3DEHC)
- Receptacle rated switchpack (SPRC-R-20-120)
- Occupancy sensor (Any Greengate Sensor)
- Wallstation (Any Room Controller Wallstation)

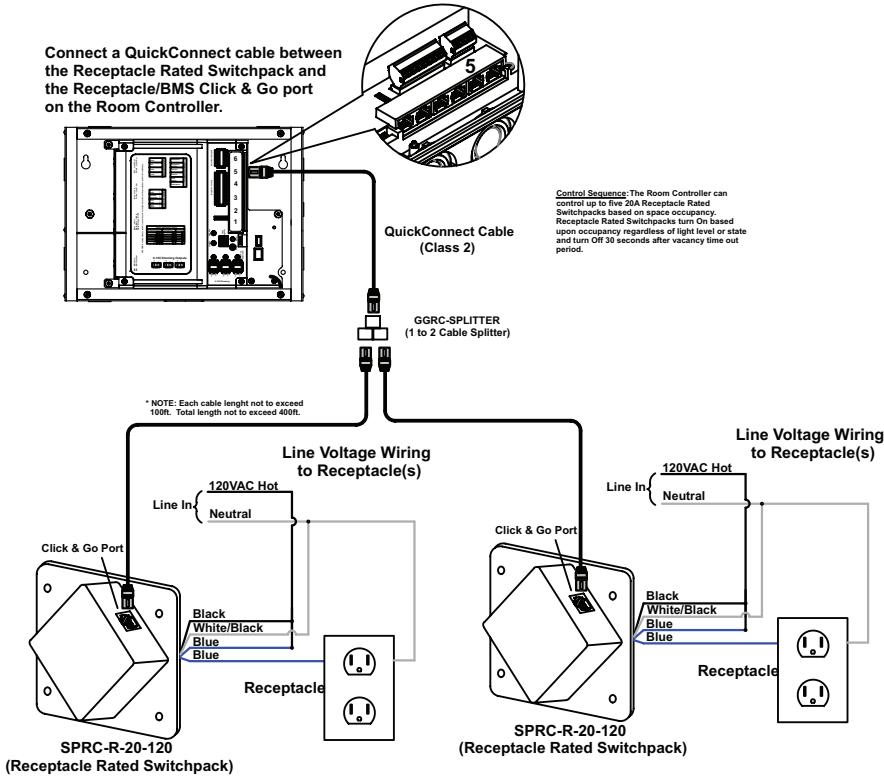

Schedule Based and Centralized Solution

Schedule Based and Centralized Solution

- Automatic receptacle control based on room occupancy
- Contractor friendly installation
- Built-in astronomical time clock
- Controlled via low voltage inputs, occupancy or BMS input

What do we need to order:

- Any lighting control relay panel that uses the Latching Relay Module (CKT, CKM, LK, SCRCP)
- Occupancy sensor (Any Greengate Sensor)
- Wallstation (Any compatible low voltage wallstation)

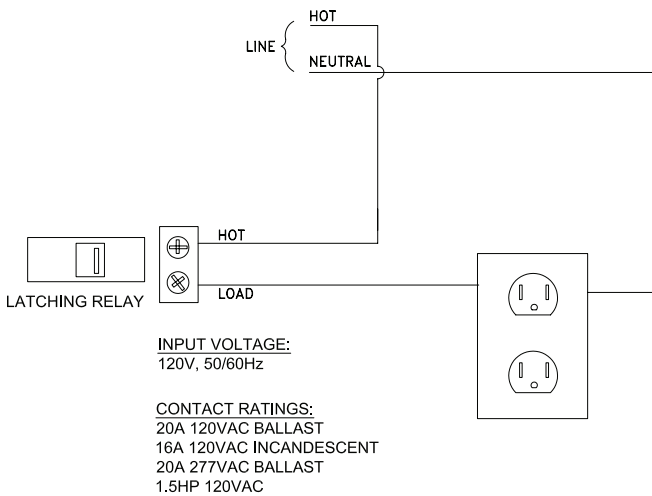
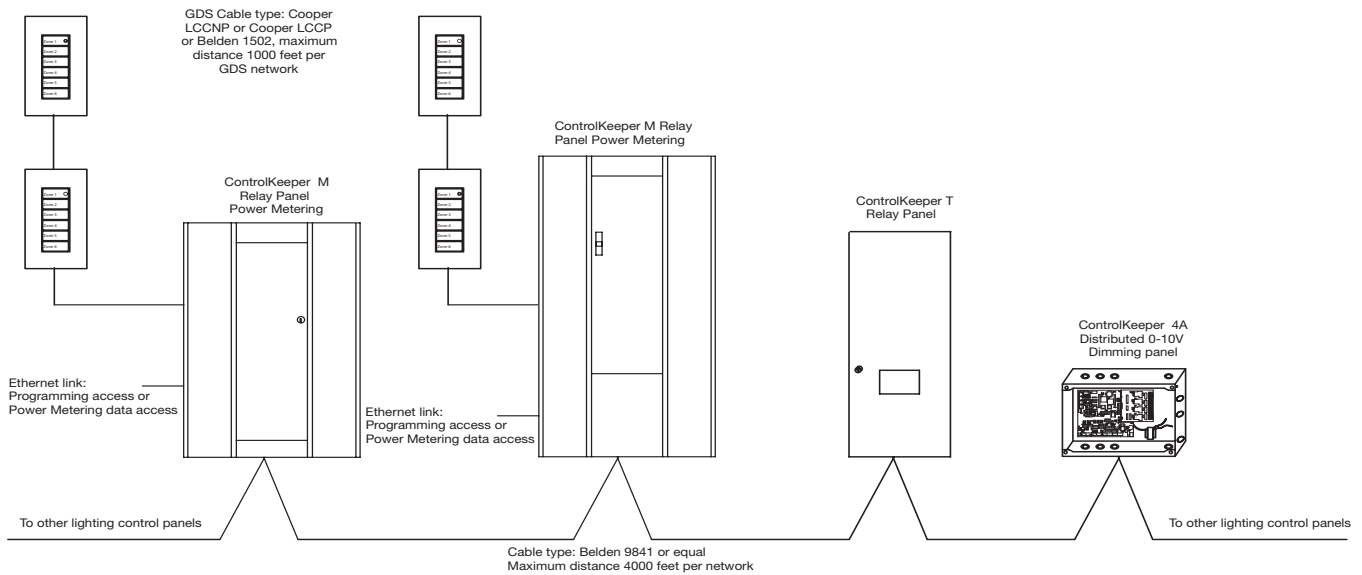

DALI Based Controls

- Automatic receptacle control based on room occupancy
- Contractor friendly installation
- Controlled via low voltage inputs, occupancy or schedule

What do we need to order:

- Fifth Light LCP (LCP-*)
- DALI Multi-Sensor (FLT-MTS12-DALI)
- DALI Field Relay (FLT-HPRS-DALI)

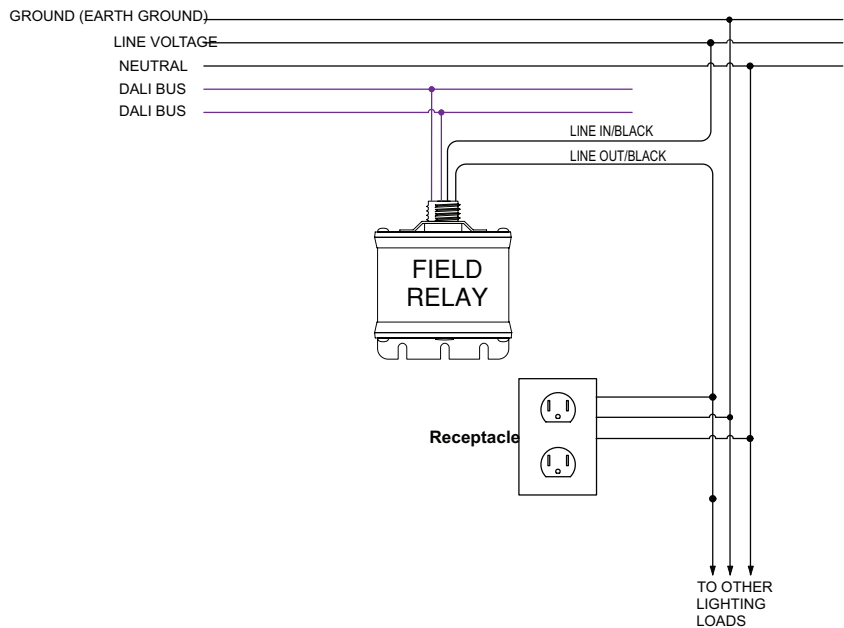
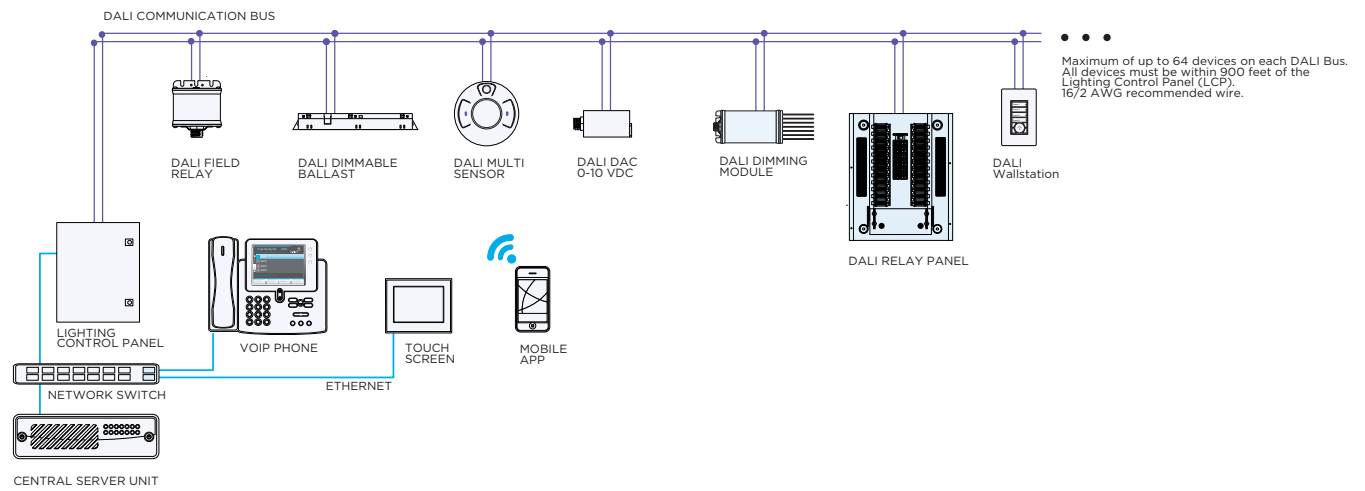

What's next:

Automatic Receptacle Control requirements are continuing to expand in future versions of building energy codes. Both ASHRAE 90.1-2013 and Title 24 version 2016 include automatic receptacle control requirements in more spaces.

Conclusion:

Lighting and receptacle controls continue to play a vital role in meeting energy code requirements that also help meet your operating budgets and our national energy conservation goals. The automatic receptacle control methods outlined in this document help reduce plug loads as a percentage of electricity used in spaces when not occupied.

Eaton
1000 Eaton Boulevard
Cleveland, OH 44122
United States
Eaton.com

Eaton's Cooper Controls Business
203 Cooper Circle
Peachtree City, GA 30269
coopercontrol.com

© 2014 Eaton
All Rights Reserved
Printed in USA
Publication No. ACC141030

Eaton is a registered trademark.

All trademarks are property
of their respective owners.