

Distributed by: **BEST MATERIALS LLC**
Ph: 800-474-7570, 602-272-8128 Fax: 602-272-8014
www.BestMaterials.com Email: Sales@BestMaterials.com

CATALOG CONTENTS

Page 2	Ladder Safety Information
Page 3-10	Sunset Ladder Products
Page 11-12	Wood Ladders
Page 13	Ladder Accesories
Page 8-16	Wing Enterprises "Little Giant Ladders"
Page 17-24	Steel Scaffolding
Page 25	Scaffold Safety Information
Page 25	Sunset Aluminum Hook Decks
Page 26-35	Aluminum Scaffolding
Page 36-37	Advantage Kit Scaffolds
Page 38-39	Sunset Utility Scaffold
Page 40	Aluminum Stages
Page 41	Stage Handrails and Extension Planks
Page 42	Sunset Aluminum Planks and Stages
Page 43-44	Stinson Planks and Ladder Jacks
Page 45-51	Steel Rolling Ladders and Access Ladders
Page 52-54	Safety Harnesses and Lanyards

SAFETY INFORMATION

Concerning OSHA Requirements



OSHA sets minimum national requirements for the use of ladders in business and industry. In addition, many states have their own regulations under the Occupational Safety and Health Act that may be even more stringent. The state codes will supersede the national OSHA standards within their own state. Users should check with their own state OSHA representative for the appropriate requirements.

The adequacy of ladders and the work practices followed by employees using them are regulated by OSHA in four sections: Portable Wood (1910.25), Portable Metal (1910.26), Fixed Ladders (1910.27) and ladders used in Construction Industry (1926.1053). These sections specify the standards to which all portable ladders must be manufactured, care and placement of ladders in the workplace and the safe use of ladders on the job.

Concerning ANSI Requirements



Depending on the material and type of ladder, different ANSI safety codes apply. The ANSI codes are as follows:

Wood Ladder	ANSI A14.1
Metal Ladder	ANSI A14.2
Fixed Ladder	ANSI A14.3
Fiberglass Ladder	ANSI A14.5

ANSI codes also have an established Duty Rating. This rating identifies which portable Ladder is intended for the conditions under which the ladder can be safely used. The Duty Rating system is as follows:

Type	Capable of Supporting	Rated Use
TYPE 1A	300 lbs.	Extra Heavy Duty Industrial
TYPE 1	250 lbs.	Heavy Duty Industrial
TYPE II	225 lbs.	Medium Duty Commercial
TYPE III	200 lbs.	Light Duty Household

Extensive testing and design requirements determine the appropriate Duty Rating for each ladder model. The rated load capacity includes the combined weight of the user, clothing, tools and any materials on the ladder. The tests requirements have been specified with a safety factor of four to ensure the ability of the ladder to meet the Duty Rating. However, the ratings assume proper use of the ladder (especially relating to the placement angle) in order to support the specified load.

General Ladder Safety

A ladder is a tool like any other. If it is used properly and according to safety guidelines, it will give many years of trouble free service. However, if proper cautions are not taken, a ladder can be involved in an accident. Please read and follow all instructions and labels accompanying each ladder.

Two factors that deserve particular attention are proper ladder selection and electrical shock precautions:

Pay close attention to the Duty Rating of the ladder and the combined weight of the user and materials. Select a ladder with the proper capacity. Also, be sure to select a ladder of proper height to reach the work area without overextending.

Be aware of wires, electrical devices and live electrical circuits. Metal ladders conduct electricity and can create a danger of electrocution. Failure to read and follow instructions regarding electrical safety could result in serious personal injury or death.

Inspection Before Each Use

1. Inspect upon receipt and before each use. Never climb a damaged, bent or broken ladder all working parts must be in good working order.
2. Make sure all rivets and joints, nuts and bolts are tight; feet, steps and rungs are secure; spreaders and pail shelf function properly (on step ladders); and rung locks, rope and pulley are in good condition (on extension ladders).
3. Keep ladder clean, free from grease, oil, mud, snow, wet paint and other slippery material. Keep your shoes clean. Leather soles should not be used.
4. Never make temporary repairs of damaged or missing parts.
5. Destroy ladder if damaged, worn or if exposed to fire or chemical corrosion.

General Precautions Before Each Use

1. Read the instructions printed on the ladder and follow them. Ladders are designed for one person. Exceptions are Double Front Step Ladders, which may be used by two people, one on each side. Duty Ratings still apply for each side and should be carefully observed.
2. Never leave a ladder set up and unattended. Special care should be taken to keep children away from all ladders.
3. If you anticipate the use of chemicals or other possibly corrosive materials, the ladder manufacturer should be consulted before use.
4. If you are in poor health, subject to fainting spells, have physical handicap that would impair your climbing ability, or if you are under the influence of any drugs or alcohol (including legal drugs that may cause drowsiness), you should not use a ladder.

5. Do not use in high winds or during a storm.
6. Stay focused on safety whenever you are on the ladder, and keep your body weight between the rails.

Proper Care & Storage of Ladders

1. Store ladders in a safe, dry place.
2. Hang ladders on racks, at intervals of 6 feet for support.
3. Properly secure and support ladders while in transit.
4. Keep ladders clean and free of foreign materials.
5. Never store materials on ladders.

Step Ladders - Proper Set Up

1. **DANGER! Metal Conducts Electricity!** Do not let ladders of any material come in contact with live electrical wires.
2. Make sure ladder is fully open, spreaders secure, and pail shelf in position.
3. Place on firm level surface with a secure footing. Do not use on slippery surfaces. Do not place on boxes, unstable bases or scaffolds to gain additional height. Do not place in front of door opening toward ladder.

Proper Climbing & Use

1. Face ladder when climbing up or down, keep body centered between side rails.
2. Maintain a firm grip. Use both hands in climbing.
3. Never climb a ladder from the side unless ladder is secure against side wise motion, or climb from one ladder to another.
4. Do not over reach, move ladder when needed.
5. Do not "walk" or "jog" ladder when standing on it.
6. Do not stand climb or sit on ladder top, pail shelf, braces, or back section.
7. Do not overload, ladders are meant for one person. Do not use as a brace, platform or plank.
8. Keep ladder close to work, avoid pushing or pulling off the side of ladders.

Extension Ladders - Proper Set Up

1. **DANGER! Metal Conducts Electricity!** Do not let ladders of any material come in contact with live electrical wires.
2. Secure base when raising extension and never set up ladder when it is extended.
3. Set single or extension ladder at proper 75-1/2 degree angle by bracing ladder base a distance of 1/4 total working length of ladder away from base of vertical support. If distance is less than 3 ft. place base of ladder a minimum of 3 ft. from vertical support.
4. Set ladder on firm ground. Do not lean sideways. Do not use on ice or snow or slippery or slippery surface without non-skid device or securing feet.
5. Erect ladder with minimum 3 ft. extending above roof line or working surface, the top at support points.
6. Extend top section only from ground, never by "bouncing" or from the roof.
7. Do not overextend - maintain maximum required overlap of sections as follows:
Ladder size up to and including 32' - 3' overlap
Ladder size over 32' up to and including 36' - 4' overlap
Ladder size over 36' up to and including 48' - 5' overlap
Ladder size over 48' - 6' overlap
8. Place on a firm surface and secure footing. Do not use on slippery surfaces. Do not place on boxes, unstable bases or scaffolds to gain additional height.
9. Do not place in front of door opening toward ladder.
10. Where possible, use second person to hold ladder.

Proper Climbing & Use

1. Securely engage ladder rung locks before climbing. Check that top and bottom ends of ladder rails are firmly supported.
2. Face ladder when climbing up or down; keep body centered between rails.
3. Maintain a firm grip. Use both hands in climbing.
4. Never climb a ladder from the side unless ladder is secured against side wise motion, or climb from one ladder to another.
5. Do not stand closer than 3 ft. from the top. Never climb above the top support.
6. Do not use ladder in high winds.
7. Never use ladder as a platform, plank or hoist. Never use ladder as a scaffold.
8. Do not overload. Ladders are meant for one person.
9. Keep ladder close to work; avoid pushing or pulling off to the side of ladders.
10. Never drop or apply an impact load to ladder.
11. Do not "walk" or "shift" ladder when standing on it.

SUNSET TYPE 1 - 250 LB. DUTY RATED FIBERGLASS STEPLADDERS

"The Mesa"

SUNSET F100 SERIES

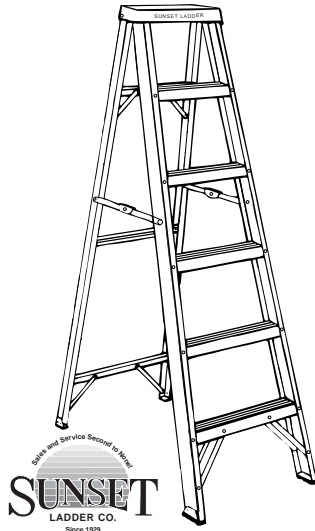

- Yellow Plastic Top With Tool Tray
- Yellow Full Channel Side Rails
- All Steel Rivet Construction
- Heavy Duty Steel Braces
- Gold Toned Steel Hardware
- Heavy Duty Steel External Spreaders

MODEL	SIZE	STEP SIZE	BOTTOM WIDTH	APPROX SPREAD	APPROX WEIGHT
F104	4'	3"	16 ¹ / ₂ "	23 ¹ / ₄ "	11.5
F105	5'	3"	18"	30 ¹ / ₄ "	14
F106	6'	3"	19 ³ / ₄ "	36"	17.5
F108	8'	3"	22 ³ / ₄ "	48 ³ / ₄ "	23

- Metal Top With Tool Tray
- Yellow Full Channel Side Rails
- All Steel Rivet Construction
- Heavy Duty Steel Braces
- Gold Toned Steel Hardware
- Heavy Duty Steel External Spreaders

"The Tempe"

SUNSET FY100 SERIES

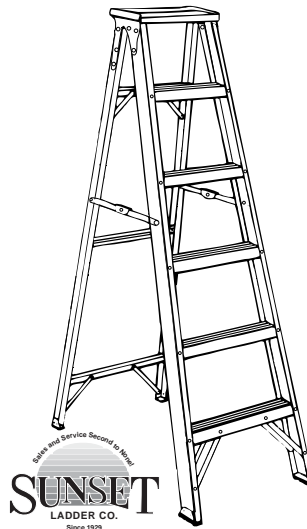

MODEL	SIZE	STEP SIZE	BOTTOM WIDTH	APPROX SPREAD	APPROX WEIGHT
FY104	4'	3"	16 ¹ / ₂ "	23 ¹ / ₄ "	12.5
FY105	5'	3"	18"	30 ¹ / ₄ "	14.5
FY106	6'	3"	19 ³ / ₄ "	36"	18
FY108	8'	3"	29 ³ / ₄ "	48 ³ / ₄ "	24

"The Biltmore"

SUNSET FD100 SERIES DOUBLE STEP



- Massive Steel Top Plates
- Yellow Side Rails
- All Steel Rivet Construction
- Heavy Duty Steel Braces
- Gold Toned Steel Hardware
- Heavy Duty Steel Spreaders

MODEL	SIZE	STEP SIZE	BOTTOM WIDTH	APPROX SPREAD	APPROX WEIGHT
FD104	4'	3"	19 ¹ / ₂ "	37"	19
FD105	5'	3"	22 ¹ / ₂ "	44 ¹ / ₂ "	20
FD106	6'	3"	23"	51"	25
FD108	8'	3"	25 ¹ / ₂ "	65"	35
FD110	10'	3"	28"	78"	42
FD112	12'	3"	31"	90"	54

Distributed by: **BEST MATERIALS LLC**
 Ph: 800-474-7570, 602-272-8128 Fax: 602-272-8014
www.BestMaterials.com Email: Sales@BestMaterials.com

SUNSET TYPE 1A -300 LB. DUTY RATED FIBERGLASS STEPLADDERS

"The Phoenix"

SUNSET F1A SERIES

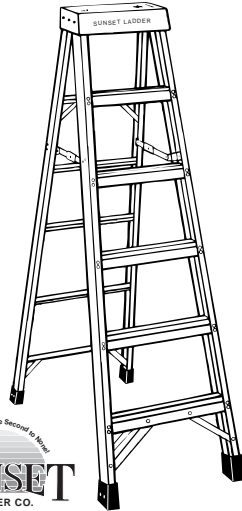

- Molded Top Cap With Tool Tray
- Orange Side Rails
- All Steel Rivet Construction
- Heavy Duty Steel Braces
- Gold Toned Steel Hardware
- Heavy Duty Interior Spreaders
- Molded Slip On Boots Prevent Rails From Splitting

MODEL	SIZE	STEP SIZE	BOTTOM WIDTH	APPROX SPREAD	APPROX WEIGHT
F1A03	3'	3"	15 ³ / ₄ "	18"	12.5
F1A04	4'	3"	17 ¹ / ₄ "	24"	14.5
F1A05	5'	3"	18 1/2"	30"	18
F1A06	6'	3"	20"	37"	19
F1A07	7'	3"	21 ¹ / ₂ "	44"	22
F1A08	8'	3"	23 ¹ / ₄ "	49"	25
F1A10	10'	3"	26"	62 ¹ / ₂ "	34
F1A12	12'	3"	29 ¹ / ₄ "	77"	46

- Metal Top Cap With Tool Tray
- Yellow Side Rails
- All Steel Rivet Construction
- Heavy Duty Steel Braces
- Gold Toned Steel Hardware
- Heavy Duty Interior Spreaders

"The Tucson"

SUNSET FY1A SERIES

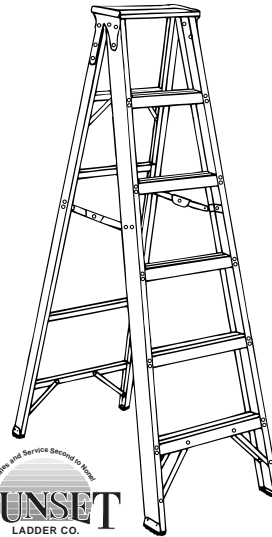

MODEL	SIZE	STEP SIZE	BOTTOM WIDTH	APPROX SPREAD	APPROX WEIGHT
FY1A03	3'	3"	15 ³ / ₄ "	18"	14
FY1A04	4'	3"	17 ¹ / ₄ "	24"	16
FY1A05	5'	3"	18 1/2"	30"	20
FY1A06	6'	3"	20"	37"	22
FY1A07	7'	3"	21 ³ / ₄ "	44"	25
FY1A08	8'	3"	23 ¹ / ₄ "	49"	29
FY1A10	10'	3"	26"	62 ¹ / ₂ "	35
FY1A12	12'	3"	29 ¹ / ₄ "	77"	46

"The Flagstaff"

SUNSET FY1AFB SERIES

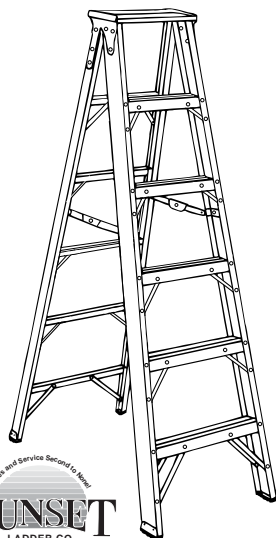

- Metal Top Cap With Tool Tray
- Yellow Side Rails
- All Steel Rivet Construction
- Heavy Duty Steel Braces Throughout
- Gold Toned Steel Hardware
- Heavy Duty Interior Spreaders

MODEL	SIZE	STEP SIZE	BOTTOM WIDTH	APPROX SPREAD	APPROX WEIGHT
FY1A03FB	3'	3"	15 ³ / ₄ "	18"	16
FY1A04FB	4'	3"	17 ¹ / ₄ "	24"	19
FY1A05FB	5'	3"	18 1/2"	30"	24
FY1A06FB	6'	3"	20"	37"	28
FY1A07FB	7'	3"	22"	34"	32
FY1A08FB	8'	3"	23 ¹ / ₄ "	49"	37
FY1A10FB	10'	3"	26"	62 ¹ / ₂ "	48
FY1A12FB	12'	3"	29 ¹ / ₄ "	77"	61

SUNSET TYPE 1AA -375 LB. DUTY RATED FIBERGLASS STEPLADDERS

“The Flagstaff - EHD”

**SUNSET
FY1AAFB SERIES**

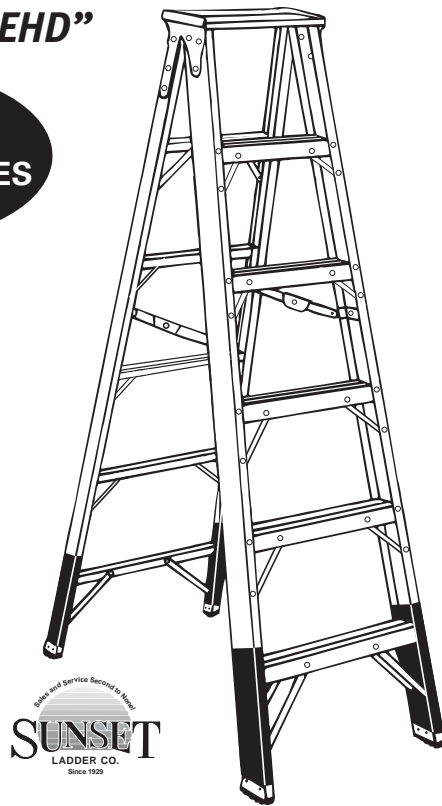

- Metal Top Cap With Tool Tray
- Yellow Side Rails
- All Steel Rivet Construction
- Heavy Duty Steel Braces Throughout
- Gold Toned Steel Hardware
- Heavy Duty Interior Spreaders
- Reinforced Rail Shields

MODEL	SIZE	STEP SIZE	BOTTOM WIDTH	APPROX SPREAD	APPROX WEIGHT
FY1AA03FB	3'	3"	15 ³ / ₄ "	18"	18
FY1AA04FB	4'	3"	17 ¹ / ₄ "	24"	20
FY1AA05FB	5'	3"	18 1/2"	30"	25
FY1AA06FB	6'	3"	20"	37"	27
FY1AA07FB	7'	3"	22"	34"	30
FY1AA08FB	8'	3"	23 ¹ / ₄ "	49"	33.5
FY1AA10FB	10'	3"	26 ¹ / ₂ "	63"	39.5
FY1AA12FB	12'	3"	29 ³ / ₄ "	77 ¹ / ₂ "	52

SUNSET TYPE 1AA- 375 LB. DUTY RATED FIBERGLASS DOUBLE STEP

- Massive Steel Top Plates
- Orange Side Rails
- All Steel Rivet Construction
- Heavy Duty Steel Braces
- Gold Toned Steel Hardware
- Heavy Duty Steel Interior Spreaders
- Spreader Brace Backup Plate
- Reinforced Rail Shields

“The SCOTTSDALE - EHD”

**SUNSET
FD1AA SERIES
DOUBLE STEP**

MODEL	SIZE	STEP SIZE	BOTTOM WIDTH	APPROX SPREAD	APPROX WEIGHT
FD1AA03	3'	3"	15 ³ / ₄ "	23"	18
FD1AA04*	4'	3"	17 ¹ / ₄ "	30"	22
FD1AA05*	5'	3"	18 3/4"	37 ³ / ₄ "	26
FD1AA06*	6'	3"	20"	44 ¹ / ₂ "	30
FD1AA07	7'	3"	21 ¹ / ₂ "	44 ¹ / ₂ "	34
FD1AA08*	8'	3"	23"	58 ¹ / ₂ "	38
FD1AA10	10'	3"	26 ¹ / ₄ "	71"	48
FD1AA12	12'	3"	29"	86"	62
FD1AA14	14'	3"	32"	104"	85
FD1AA16	16'	3"	35"	106 ¹ / ₄ "	100



*Center Pull Spreaders

SUNSET TYPE 1A- 300 LB. DUTY RATED FIBERGLASS DOUBLE STEP

"The SCOTTSDALE"

**SUNSET
FD1A SERIES
DOUBLE STEP**



SUNSET
LADDER CO.
Since 1929

Special Order Type IAA 375 lb.
FULLY BRACED Model FD1AFB
Available at Additional Cost.

- Massive Steel Top Plates
- Orange Side Rails
- All Steel Rivet Construction
- Heavy Duty Steel Braces
- Gold Toned Steel Hardware
- Heavy Duty Steel Interior Spreaders
- Spreader Brace Backup Plate

MODEL	SIZE	STEP SIZE	BOTTOM WIDTH	APPROX SPREAD	APPROX WEIGHT
FD1A03	3'	3"	15 ³ / ₄ "	23"	16.5
FD1A04*	4'	3"	17 ¹ / ₄ "	30"	20.5
FD1A05*	5'	3"	18 ³ / ₄ "	37 ³ / ₄ "	21.5
FD1A06*	6'	3"	20"	44 ¹ / ₂ "	26
FD1A07	7'	3"	21 ¹ / ₂ "	44 ¹ / ₂ "	30.5
FD1A08*	8'	3"	23"	58 ¹ / ₂ "	37.5
FD1A10	10'	3"	26 ¹ / ₄ "	71"	47
FD1A12	12'	3"	29"	86"	56.5
FD1A14	14'	3"	32"	104"	81
FD1A16	16'	3"	35"	106 ¹ / ₄ "	97.5

*Center Pull Spreaders

**SUNSET
FIBERGLASS
SHELF LADDERS**

SHELF LADDER FEATURES

- Type 1A -300 lb. Duty Rating
- Non-Conductive Fiberglass
- Slip Resistant Feet
- Rubber Bumper

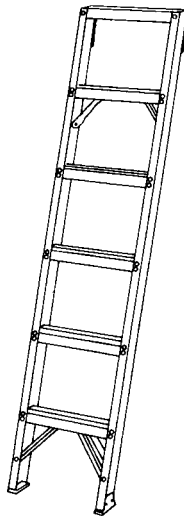

MODEL	SIZE	APPROX WEIGHT
FSH1A04	4'	8
FSH1A05	5'	9
FSH1A06	6'	11.5
FSH1A08	8'	14
FSH1A10	10'	17.5
FSH1A12	12'	21
FSH1A14	14'	24.5

SUNSET FIBERGLASS PLATFORM LADDER

"The Prescott"

**SUNSET
FP1A SERIES**



SUNSET
LADDER CO.
Since 1929

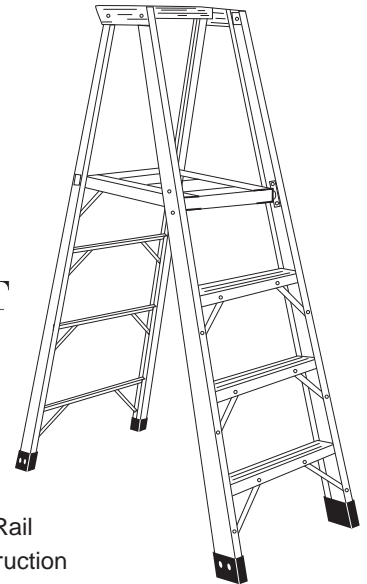

FEATURES

- Slip Resistant Platform
- Full Channel Fiberglass Rail
- Double-Rivet Step Construction
- Top Rail Guard
- Heavy Gusset Bracing

MODEL	SIZE	STEP SIZE	BOTTOM WIDTH	APPROX SPREAD	APPROX WEIGHT
FP1A03	3'	3"	22- ³ / ₄ "	38"	17.5
FP1A04	4'	3"	22- ¹ / ₄ "	44"	20
FP1A05	5'	3"	25- ³ / ₄ "	50"	24.5
FP1A06	6'	3"	27- ¹ / ₄ "	56"	31.5
FP1A08	8'	3"	30- ¹ / ₄ "	68"	39.5
FP1A10	10'	3"	33- ¹ / ₄ "	80"	50
FP1A12	12'	3"	36- ¹ / ₄ "	92"	59.5

SUNSET TYPE 1-250 LB. DUTY RATED ALUMINUM DOUBLE STEP

"The Kingman"

**SUNSET
AD1 SERIES
DOUBLESTEP**

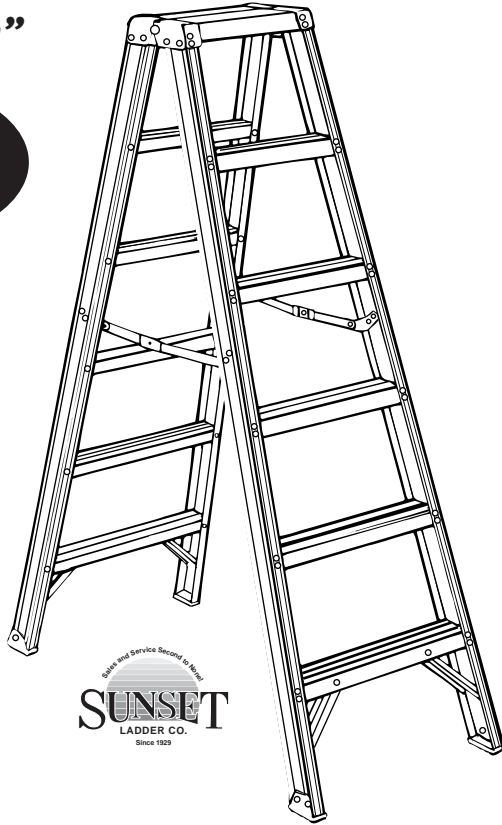

- Massive Steel Top Plates
- Unique Side Rail Design
- All Steel Rivet Construction
- Heavy Duty Steel Braces
- Gold Toned Steel Hardware
- Heavy Duty Steel Interior Spreaders

MODEL	SIZE	STEP SIZE	BOTTOM WIDTH	APPROX SPREAD	APPROX WEIGHT
AD102	2'	3"	16 ¹ / ₂ "	23"	11
AD103	3'	3"	18"	30"	17
AD104	4'	3"	19 ¹ / ₂ "	37"	19
AD105	5'	3"	21 ¹ / ₂ "	44 ¹ / ₂ "	21
AD106	6'	3"	23"	51"	24
AD108	8'	3"	25 ¹ / ₂ "	65"	30
AD110	10'	3"	28 ¹ / ₂ "	78"	38

SUNSET TYPE 1A- 300 LB. DUTY RATED ALUMINUM DOUBLE STEP

"The Winslow"

**SUNSET
AD1A SERIES
DOUBLESTEP**

- Massive Steel Top Plates
- Unique Side Rail Design
- All Steel Rivet Construction
- Heavy Duty Steel Braces
- Gold Toned Steel Hardware
- Heavy Duty Steel Interior Spreaders

MODEL	SIZE	STEP SIZE	BOTTOM WIDTH	APPROX SPREAD	APPROX WEIGHT
AD1A03	3'	3"	18"	30"	16
AD1A04*	4'	3"	19 ³ / ₄ "	37"	22
AD1A05*	5'	3"	21 ¹ / ₄ "	44 ¹ / ₂ "	25
AD1A06*	6'	3"	22 ¹ / ₄ "	51 ¹ / ₂ "	29
AD1A07*	7'	3"	24 ¹ / ₄ "	59 ¹ / ₂ "	32
AD1A08*	8'	3"	25 ¹ / ₂ "	65 ¹ / ₂ "	36
AD1A10	10'	3"	28 ¹ / ₂ "	78"	47
AD1A12	12'	3"	31 ¹ / ₂ "	93"	61
AD1A14	14'	3"	34 ¹ / ₂ "	104 ¹ / ₄ "	70
AD1A16	16'	3"	37 ¹ / ₂ "	116 ¹ / ₂ "	80

*Center Pull Spreader



SUNSET ALUMINUM SAWHORSE

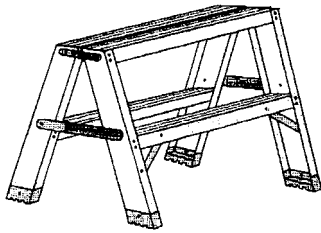

FEATURES

- Heavy Duty Aluminum Extrusion
- Solid Rivet Construction
- Non-Slip Rubber Boot
- Heavy-Duty Spreaders For Long Trouble-Free Use
- Folding Compact Design For Easy Transportation

MODEL	SIZE	STEP SIZE	BOTTOM WIDTH	APPROX SPREAD	APPROX WEIGHT
SAS 24	24"	3"	33"	21"	10
SAS 30	30"	3"	34"	25"	13
SAS 36	36"	3"	35"	29"	15
SAS 48	48"	3"	36"	36"	20

SUNSET TYPE 1-250 LB. DUTY RATED ALUMINUM STEPLADDERS

"The Yuma"

SUNSET AS100 SERIES

- Molded Top Cap With Tool Tray
- Unique Side Rail Design
- All Steel Rivet Construction
- Heavy Duty Steel Braces
- Gold Toned Steel Hardware
- Heavy Duty Steel Interior Spreaders

MODEL	SIZE	STEP SIZE	BOTTOM WIDTH	APPROX SPREAD	APPROX WEIGHT
AS102	2'	3"	16 ¹ / ₂ "	20 ³ / ₄ "	7
AS103	3'	3"	18"	26"	9 ¹ / ₂
AS104	4'	3"	19 ¹ / ₂ "	30"	12
AS105	5'	3"	21 ¹ / ₂ "	37 ¹ / ₂ "	14
AS106	6'	3"	23"	43"	17 ¹ / ₂
AS108	8'	3"	25 ¹ / ₂ "	57 ¹ / ₂ "	23
AS110	10'	3"	28 ¹ / ₂ "	68 ¹ / ₂ "	32

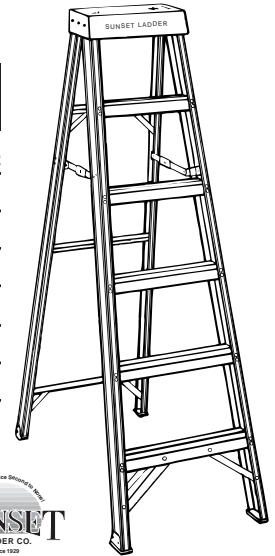

SUNSET TYPE 1A- 300 LB. DUTY RATED ALUMINUM STEPLADDERS

- Molded Top Cap With Tool Tray
- Unique Side Rail Design
- All Steel Rivet Construction
- Heavy Duty Steel Braces
- Gold Toned Steel Hardware
- Heavy Duty Steel Interior Spreaders

"The Sedona"

SUNSET AS1A SERIES

MODEL	SIZE	STEP SIZE	BOTTOM WIDTH	APPROX SPREAD	APPROX WEIGHT
AS1A03	3'	3"	18"	26"	14
AS1A04	4'	3"	19 ³ / ₄ "	30"	16
AS1A05	5'	3"	21 ¹ / ₄ "	36"	19
AS1A06	6'	3"	22 ³ / ₄ "	42 ¹ / ₄ "	22
AS1A07	7'	3"	24 ¹ / ₄ "	47"	25
AS1A08	8'	3"	25 ³ / ₄ "	52 ³ / ₄ "	28
AS1A10	10'	3"	28 ¹ / ₂ "	65 ¹ / ₂ "	36
AS1A12	12'	3"	31 ¹ / ₂ "	77 ¹ / ₄ "	46

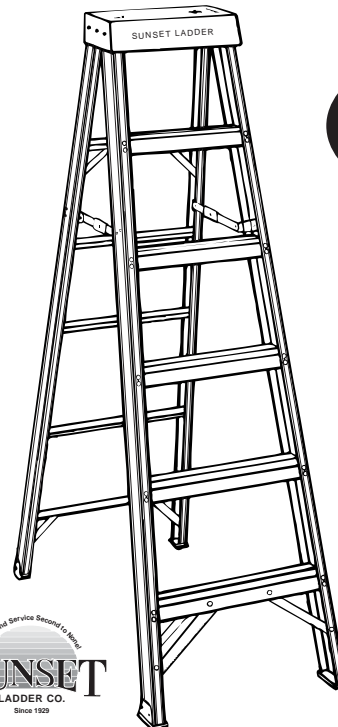

Distributed by: [BEST MATERIALS LLC](http://BESTMATERIALS.LLC)
 Ph: 800-474-7570, 602-272-8128 Fax: 602-272-8014
www.BestMaterials.com Email: Sales@BestMaterials.com

SUNSET FIBERGLASS SINGLES & EXTENSION LADDERS

- Plate and Rung Assembly are Riveted at Four Points to Each Side Rail to Allow for Rung Replacement
- Durable Rail Shield and Shoe Bracket Protect Rail From Damage
- Mar-resistant Molded End Caps
- Guides at Top of Base
- Rugged Gravity Spring Locks Operate Smoothly
- Heavy Duty Metal Pulley with Rope
- Internal Guides on Bottom of Fly Section Securely Interlock Rails
- Slip-resistant Round Serrated Rungs
- Interlocking Side Rails
- Steel Shoe with Slip-resistant Pad and Ice Pick

FE1AA SERIES EXTENSION TYPE 1AA 375

MODEL	SIZE	EXTENDED LENGTH	APPROX WEIGHT
FE1AA16	16'	13'	38
FE1AA20	20'	17'	46
FE1AA24	24'	21'	54
FE1AA28	28'	25'	61
FE1AA32	32'	29'	75

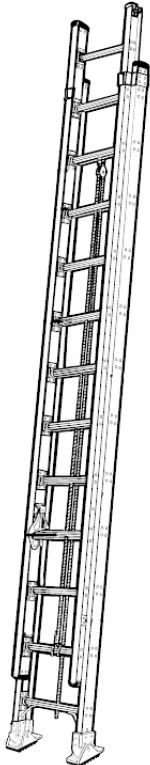

OPTIONAL COMBINATION POLE GRIP & CABLE HOOK
A rigid plated "V" shaped pole grip covered with rubber tread, combined with cable hook assembly.

FE1A SERIES EXTENSION TYPE 1A 300

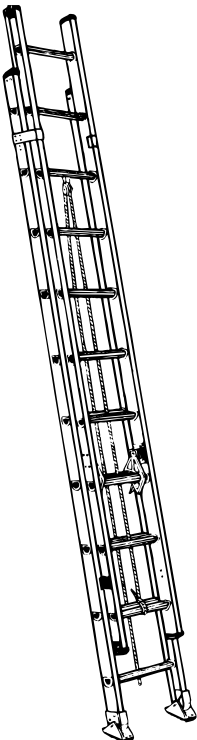

- "D" Rung Construction
- Orange Side Rails
- Steel Swivel Shoes
- Heavy Duty Steel Braces

MODEL	SIZE	EXTENDED LENGTH	APPROX WEIGHT
FE1A16	16'	13'	35
FE1A20	20'	17'	43
FE1A24	24'	21'	50
FE1A28	28'	25'	57
FE1A32	32'	29'	72
FE1A36*	36'	32'	82
FE1A40*	40'	35'	90

*Denotes 250 LB Type 1 Duty Rating



FS1A SERIES SINGLE TYPE 1A 300

- "D" Rung Construction
- Orange Side Rails
- Steel Swivel Shoes
- Heavy Duty Steel Braces

MODEL	SIZE	APPROX WEIGHT
FS1A08	8'	22
FS1A10	10'	25
FS1A12	12'	29
FS1A14	14'	33
FS1A16	16'	40
FS1A18	18'	44
FS1A20	20'	48



SUNSET ALUMINUM SINGLES & EXTENSION LADDERS

ASL1A SERIES SINGLE TYPE 1A 300

- Modified "I Beam" Construction
- "D" Shaped Rungs
- Swivel Safety Shoes
- Non-Marring End Caps



MODEL	HEIGHT	APPROX WEIGHT
ASL1A08	8'	15
ASL1A10	10'	17 ^{1/2}
ASL1A12	12'	22 ^{1/2}
ASL1A14	14'	28
ASL1A16	16'	33
ASL1A18	18'	39
ASL1A20	20'	45

AE200 SERIES EXTENSION TYPE II 225

- Modified "I Beam" Construction
- "D" Shaped Rungs
- Swivel Safety Shoes
- Non-Marring End Caps
- Cast Double Rung Locks
- Rope & Pulley 20' & Up

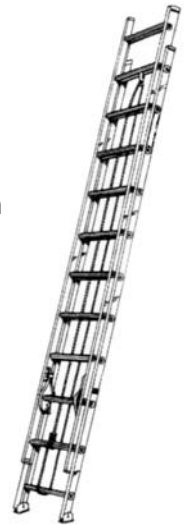

MODEL	SIZE	MAX WORKING LENGTH	APPROX WEIGHT
AE216	16'	13'	26
AE220	20'	17'	30
AE224	24'	21'	35
AE228	28'	25'	50
AE232	32'	29'	58
AE236	36'	32'	73
AE240	40'	35'	78

AE100 SERIES EXTENSION TYPE 1 250

- Modified "I Beam" Construction
- "D" Shaped Rungs
- Swivel Safety Shoes
- Non-Marring End Caps
- Cast Double Rung Locks
- Rope & Pulley 20' & Up

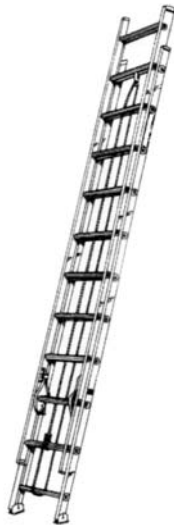

MODEL	SIZE	MAX WORKING LENGTH	APPROX WEIGHT
AE116	16'	13'	26
AE120	20'	17'	30
AE124	24'	21'	35
AE128	28'	25'	50
AE132	32'	29'	58
AE136	36'	32'	73
AE140	40'	35'	78

AE1A SERIES EXTENSION TYPE 1A 300

- Modified "I Beam" Construction
- "D" Shaped Rungs
- Swivel Safety Shoes
- Non-Marring End Caps
- Cast Double Rung Locks
- Rope & Pulley 20' & Up



MODEL	SIZE	MAX WORKING LENGTH	APPROX WEIGHT
AE1A16	16'	13'	29
AE1A20	20'	17'	35
AE1A24	24'	21'	45
AE1A28	28'	25'	58
AE1A32	32'	29'	67
AE1A36	36'	32'	80
AE1A40	40'	35'	90

SUNSET TYPE 1-250 LB. DUTY RATED INDUSTRIAL WOOD LADDERS

SUNSET W100 SERIES



Rail Dimensions

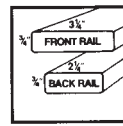

Front and back rails with radiused edges and grooved steps with flush front edges. Side rails are 3/4" x 3-1/4" in front and 3/4" x 2-1/4" in back.

Heavy Top Hinge

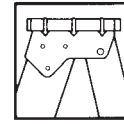

Heavy duty plated steel hinge connects front rails and rear legs for rigidity and durability. Wraparound feature adds strength and protects top.



MODEL	SIZE	STEP SIZE	BOTTOM WIDTH	APPROX SPREAD	APPROX WEIGHT
W103	3'	3 1/2"	17 ³ / ₈ "	23"	14
W104	4'	3 1/2"	18 ⁷ / ₈ "	29"	17
W105	5'	3 1/2"	20 ³ / ₈ "	35"	22
W106	6'	3 1/2"	21 ⁷ / ₈ "	41"	26
W108	8'	3 1/2"	24 ⁷ / ₈ "	54"	35
W110	10'	3 1/2"	27 ⁷ / ₈ "	66"	44
W112	12'	3 1/2"	30 ⁷ / ₈ "	78"	58

SUNSET TYPE 1A- 300 LB. DUTY RATED INDUSTRIAL WOOD LADDERS

SUNSET W1A SERIES

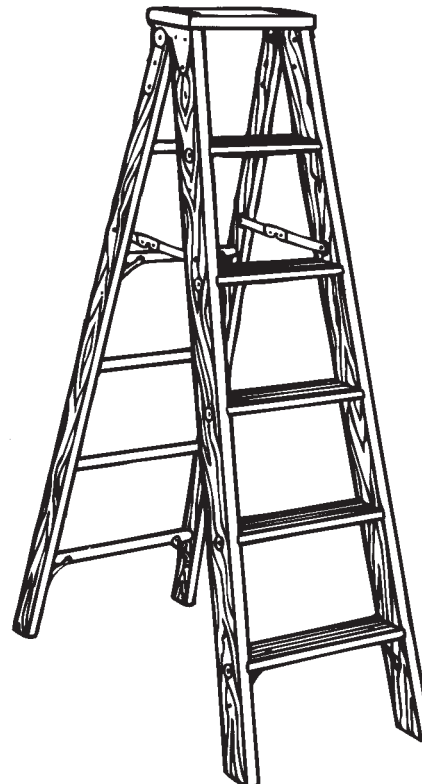

Rail Dimensions

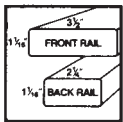

Front and back rails with radiused edges and grooved steps with flush front edges to hold up under daily use. Side rails are 1-1/16" x 3-1/2" in front and 1-1/16" x 2-1/4" in back.

Extra Heavy Top Hinge

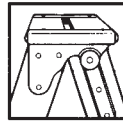

Extra heavy duty plated steel metal-to-metal hinge connects front rails and rear legs for rigidity and durability. Wraparound feature adds strength and protects top.

MODEL	SIZE	STEP SIZE	BOTTOM WIDTH	APPROX SPREAD	APPROX WEIGHT
W1A03	3'	3 1/2"	17 ³ / ₈ "	23"	17
W1A04	4'	3 1/2"	18 ⁷ / ₈ "	29"	22
W1A05	5'	3 1/2"	20 ³ / ₈ "	35"	24
W1A06	6'	3 1/2"	21 ⁷ / ₈ "	41"	33
W1A08	8'	3 1/2"	24 ⁷ / ₈ "	54"	44
W1A10	10'	3 1/2"	27 ⁷ / ₈ "	66"	55
W1A12	12'	3 1/2"	30 ⁷ / ₈ "	78"	65
W1A14	14'	3 1/2"	33 ⁷ / ₈ "	90"	76
W1A16	16'	3 1/2"	36 ⁷ / ₈ "	102"	87



SUNSET TYPE 1-250 LB. DUTY RATED INDUSTRIAL WOOD LADDERS

SUNSET 5P SERIES

Rail Dimensions

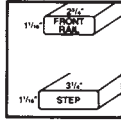

Front and back rails with radiused edges and serrated 1" X 3" steps. Side rails are 1-1/16" X 2-3/4". All steps are trussed & braced.

Extra Heavy Duty Top Hinge

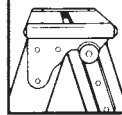

Extra heavy plated steel metal-to-metal hinge. Wrap-around feature adds strength and protects top.



MODEL	SIZE	STEP SIZE	BOTTOM WIDTH	APPROX SPREAD	APPROX WEIGHT
5P-3	3'	3"	18"	29 1/2"	16
5P-4	4'	3"	19 1/2"	35 1/2"	20
5P-5	5'	3"	21"	44"	24
5P-6	6'	3"	22 1/2"	52 1/2"	29
5P-8	8'	3"	26"	68 1/2"	40
5P-10	10'	3"	32 1/2"	85"	51
5P-12	12'	3"	36"	98 1/2"	64
5P-14	14'	3"	37 1/2"	113"	85
5P-16	16'	3"	39"	121"	97



SUNSET TYPE 1A-300 LB. DUTY RATED WOOD EXTENSION TRESTLE LADDERS

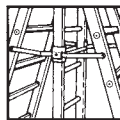
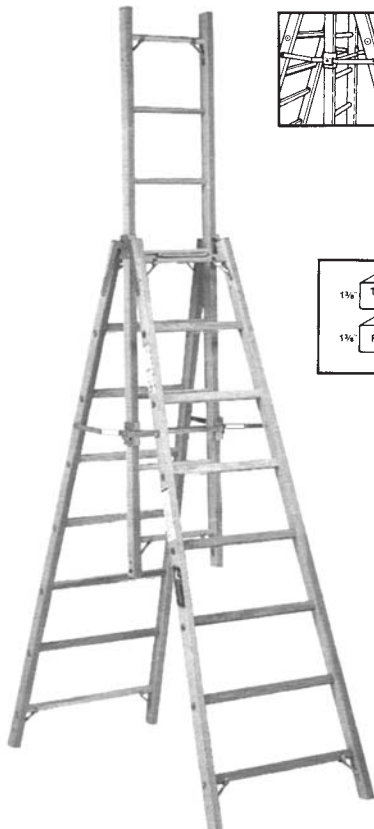

Slide Guides & Spreader Braces

Plated steel spreader braces interlock with the bottom pair of fly section slide guides.

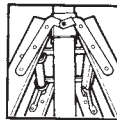

Heavy Trestle Top Hinge

Extra heavy plated steel strap hinges form top of trestle and support slide guides for the fly section.

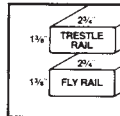

Rail Dimensions

Trestle front and back legs and fly section rails are constructed of 1-3/8" x 2-3/4" hemlock.

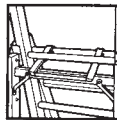

Locking Bail

Hinged steel bail provides easy to use solution for locking the fly section in place. Fly section can be raised or lowered in 12" increments without closing the trestle.

SUNSET WX1000 SERIES



MODEL	MAX STEP	EXT.	APPROX WEIGHT
WX1008	8'	12' 6"	65
WX1010	10'	15' 6"	85
WX1012	12'	19' 6"	105
WX1014	14'	22' 6"	125
WX1016	16'	26' 6"	145

Distributed by: **BEST MATERIALS LLC**
 Ph: 800-474-7570, 602-272-8128 Fax: 602-272-8014
www.BestMaterials.com Email: Sales@BestMaterials.com

ACCESSORIES

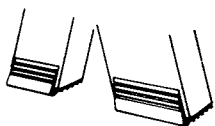

EXTRUDED RUBBER FEET

An extremely fine, step ladder, easily installed. Non-marking. Furnished in sets of four.

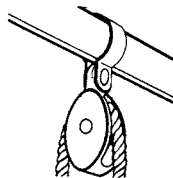

ROPE & PULLEY

All aluminum 1-1/4" pulley with 5/16" non-rotting polypropylene rope for all weather performance.

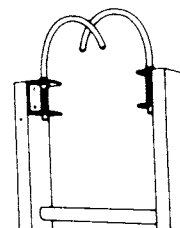

FOLDING STEEL LADDER HOOK

Bolts to ends of extension and single ladders. Folds inside ladder rails when not in use. Approximately 6" opening. Two hooks per set. Steel, 5 lbs. pr.

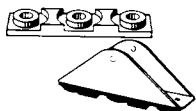

HEAVY DUTY SHOES 1-3/8"

For single and extension ladders

HEAVY DUTY SHOES 15/16"

For step ladders

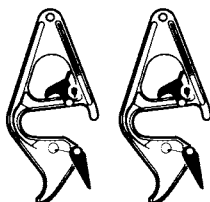

RUNG LOCK REPLACEMENT KIT

Pairs Only

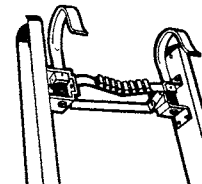

COMBINATION POLE GRIP & CABLE HOOK

A rigid plated "V" shaped pole grip covered with rubber tread, combined with cable hook assembly.

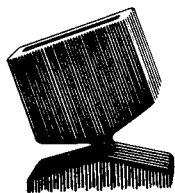

SLIP-ON BOOTS

Heavy all rubber non-skid shoes.

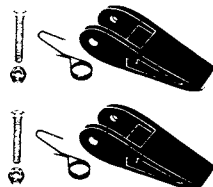

REPLACEMENT PLASTIC FLIPPER KIT

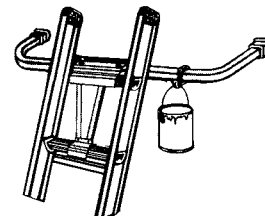

QUICKCLICK™ STABILIZER



EXTENSION SHOE

Reinforced neoprene. Ladder rail must be shaped to fit. Furnished in pairs. 1" and 1-1/4" width. Specify width when ordering.

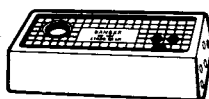

STEPLADDER TOP



MANUAL ADJUSTING LEVELLERS

Manually - operated ladder levellers can be field mounted on most types of extension ladders. Features include a safety guard and 11" adjustment.



STEPLADDER SPREADER BRACES

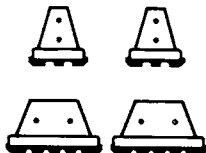

STEP LADDER SHOE KITS

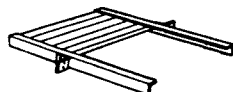

OPTIONAL SHELF FOR FIBERGLASS AND ALUMINUM STEPLADDERS

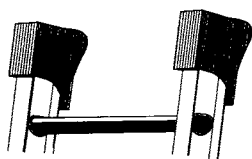

LADMIT

Prevents ladder marks. Fits most wood and aluminum ladders.

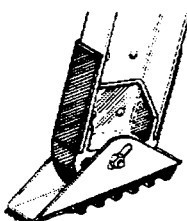

EXTENSION AND SINGLE LADDER SWIVEL SHOES

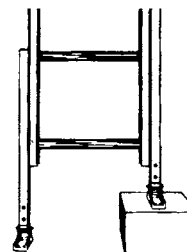

AUTOMATIC - ADJUSTING LEVELLER (FIBERGLASS & ALUMINUM LADDERS ONLY)

Leveller keeps ladder stabilized in perpendicular position on uneven terrain. Adjustable up to a 9" height differential.

Little Giant Ladder Systems®

The Little Giant Ladder Systems® are durable, portable and versatile. They are small, compact and one ladder can do the job of many conventional ladders.

“One Ladder Does It All.”®

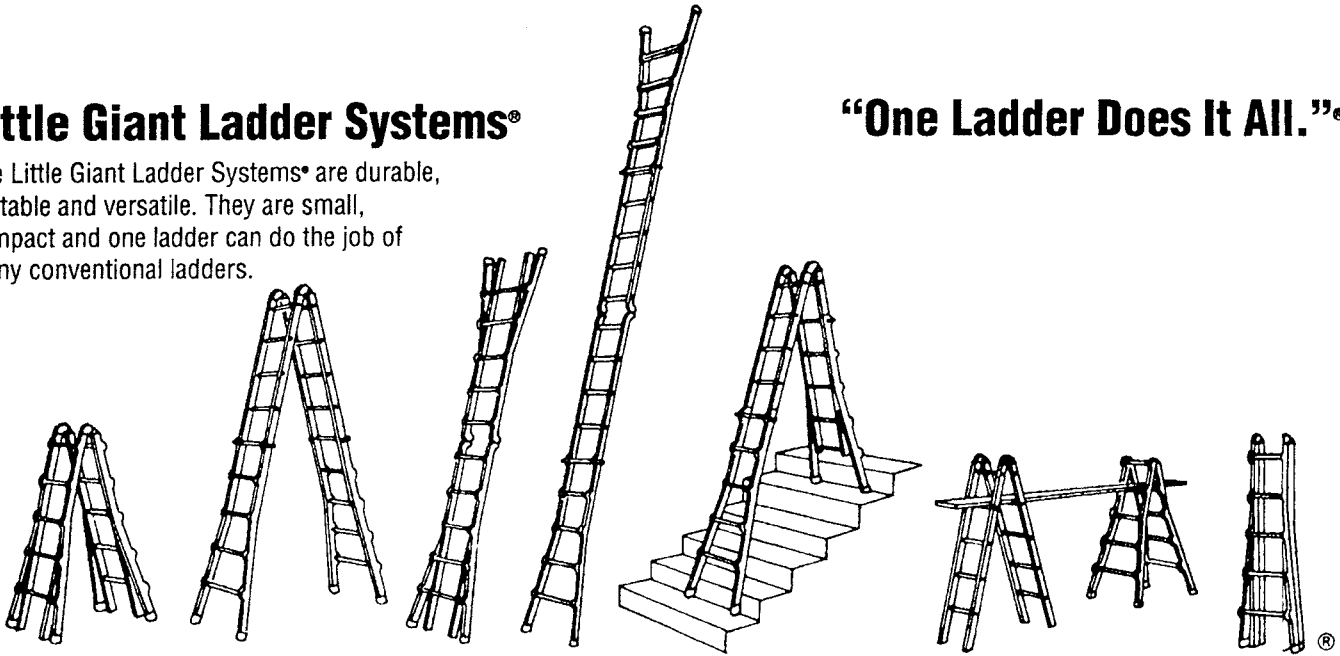

Little Giant Aluminum Ladder System – Type IA – 300 lbs.

Model	Size	Extension Height	Stepladder Height	Scaffolding Height	Storage Height	Weight
10101	13 ft.	7 ft. to 11 ft.	3 ft. to 5 ft.	3 ft.	3' 7"	26 lbs.
10102	17 ft.	9 ft. to 15 ft.	4 ft. to 7 ft.	4 ft.	4' 7"	35 lbs.
10103	22 ft.	11 ft. to 19 ft.	5 ft. to 9 ft.	5 ft.	5' 7"	42 lbs.
10126	26 ft.	13 ft. to 23 ft.	6 ft. to 11 ft.	6 ft.	6' 7"	54 lbs.

TYPE IA
HEAVY DUTY
INDUSTRIAL
300 lbs.

Little Giant Aluminum Ladder System – Type I – 250 lbs.

Model	Size	Extension Height	Stepladder Height	Scaffolding Height	Storage Height	Weight
10301	13 ft.	7 ft. to 11 ft.	3 ft. to 5 ft.	3 ft.	3' 7"	25 lbs.
10302	17 ft.	9 ft. to 15 ft.	4 ft. to 7 ft.	4 ft.	4' 7"	30 lbs.
10303	22 ft.	11 ft. to 19 ft.	5 ft. to 9 ft.	5 ft.	5' 7"	39 lbs.

TYPE I
COMMERCIAL
250 lbs.



Leg Leveler

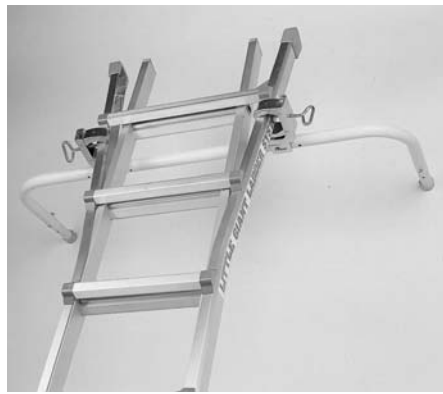

Wall Standoff



Work Platform

Accessories For The Little Giant Ladder System

- Model No. 10106 Leg Leveler for Aluminum Ladder System – Attaches easily to either ladder rail
- Model No. 10111ST Wall Standoff – Positions ladder away from working surfaces
- Model No. 10104 Work Platform
- Model No. 10606 Leg Leveler for Fiberglass Ladder System – Attaches easily to either ladder rail

MXZ Ladder System



The extra tall Little Giant MXZ Telescoping A-Frame Ladder replaces several sizes of stepladders. The ladder may be adjusted to fit safely on stairs and other uneven surfaces, and stores in half of its fully extended A-frame height. Ideal for areas with high ceilings, tight storage, and narrow entries. It comes with skid resistant feet and flared legs for improved stability.

LITTLE GIANT LADDER SYSTEMS



"ONE LADDER DOES IT ALL."



5 Year Warranty

SPECIFICATIONS

Model no.	Size	Stepladder height	Storage height	Model no.	Weight
10109	15'	8'0" TO 15'0"	8'7"	66 lbs.	
10110	17'	9'0" TO 17'0"	9'7"	79 lbs.	
10121	21'	11'0" TO 21'0"	11'7"	103 lbs.	

UL LISTED
OSHA/ANSI TYPE 1A ACCORDING
TO ANSI 14.2 SAFETY CODE

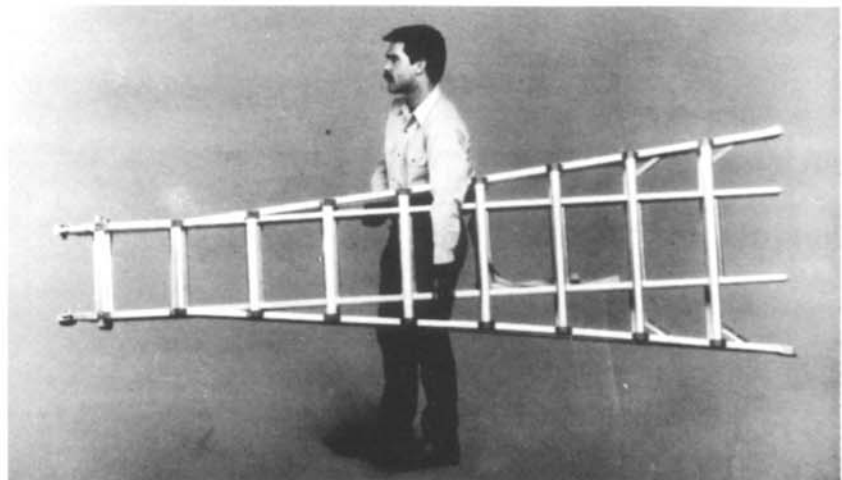

Made in U.S.A.

Distributed by: [BEST MATERIALS LLC](http://BESTMATERIALS.LLC)
Ph: 800-474-7570, 602-272-8128 Fax: 602-272-8014
www.BestMaterials.com Email: Sales@BestMaterials.com



LITTLE GIANT® ULTRA-LITE LADDERS

Little Giant® Ultra-Lite Fiberglass Type 1A Specifications

Model Number	Description Type 1A	Extension Height	Stepladder Height	Scaffolding Height	Storage Height	Weight
10717	Model 17	9'-15'	4'-7"	4'	47"	39 lbs.
10722	Model 22	11'-19'	5'-9"	5'	57"	47 lbs.



The Little Giant® Ultra-Lite ladder is a truly progressive ladder. The ladder is the only ladder on the market that is made from a special resin that is non-conductive and allows the ladder to be lighter and stronger than conventional fiberglass material. The Little Giant® Ultra-Lite ladder is a type 1A ladder that is rated at 300 lbs. The Ultra-Lite comes in 17-foot and 22-foot models. This ladder will cover any job from changing a light bulb to heavy-duty commercial use. The Little Giant® Ultra-Lite ladder has a one-year warranty on workmanship and materials.

The all new solid hinge design on the Little Giant® Ultra-lite ladder is revolutionary. The design has evolved from five generations of Little Giant® hinges. The continuation of material makes it the most solid and strongest hinge to date. This new design makes it the safest and most technically advanced hinge on any ladder in the market today. Patents pending



Little JUMBO™ SAFETY STEP



Little Jumbo Two-Step Little Jumbo Three-Step Little Jumbo Four-Step

Little Jumbo Specifications

Model Number	Description Little Jumbo	Height Top Step	Folded Height	Folded Width	Weight
10210	2 Step	18"	31.5"	2.8"	10 lbs.
10210B	2 Step w/Bar	18"	31.5"	4.7"	15 lbs.
10310	3 Step	27"	44"	2.8"	15 lbs.
10310B	3 Step w/Bar	27"	44"	4.7"	20 lbs.
10410	4 Step	36"	56"	2.8"	20 lbs.
10410B	4 Step w/Bar	36"	56"	4.7"	25 lbs.

SAFETY BAR
Available for all three models. Provides added security for all jobs.

LOCKING SYSTEM
Smooth action, sturdy locking system for easy, safe set-up.

LIGHT-WEIGHT ALUMINUM
Rugged, corrosion resistant, built to last.

SLIP-RESISTANT STEP TREADS
Wide slip-resistant steps provide maximum stability.

TIP-N-PULL WHEELS
Designed for ease of mobility.



SLIP-RESISTANT FEET
Ladder legs have slip-resistant feet for solid dependability.



SNAP-ON locking devices standard on all SUNSET Rolling Tower scaffolding frames.

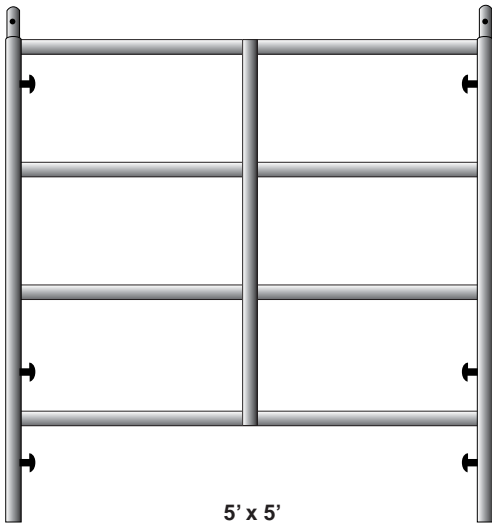
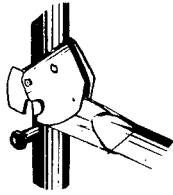

5' x 5'
DOUBLE LADDER BOX
SLC55DB

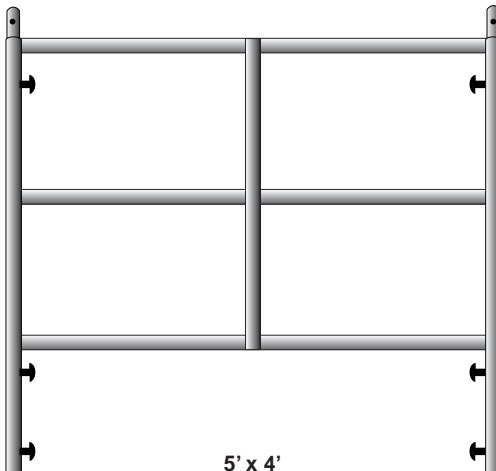

5' x 4'
DOUBLE LADDER BOX
SLD548DB

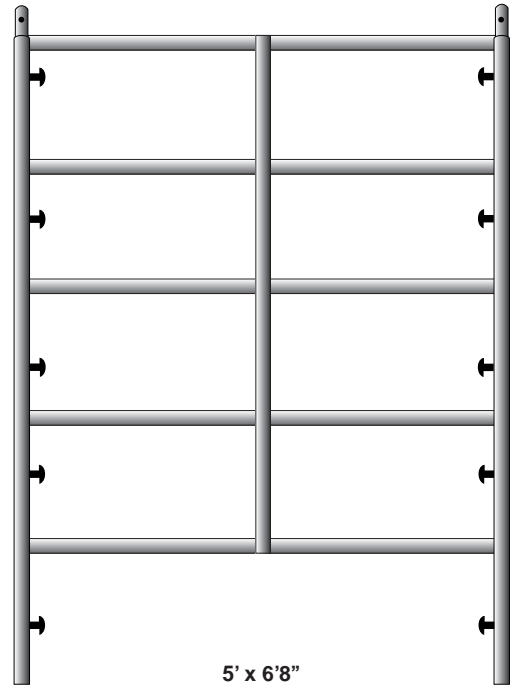

5' x 6'8"
DOUBLE LADDER BOX
SCL568DB

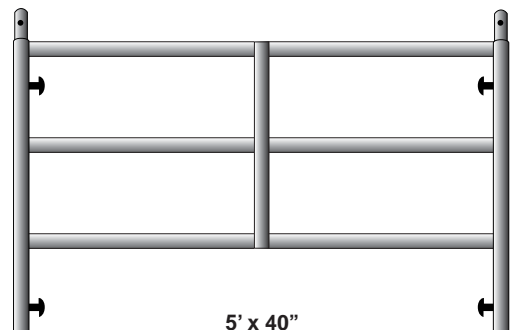

5' x 40"
DOUBLE LADDER BOX
SLC540DB

– ALL FRAMES AVAILABLE IN SINGLE LADDER STYLE FOR MASONS –

PLASTER SCAFFOLD END FRAMES

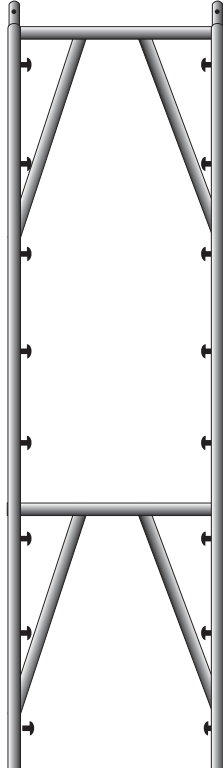

Description: 3' x 10'8" Apartment
Weight: 57 lbs.

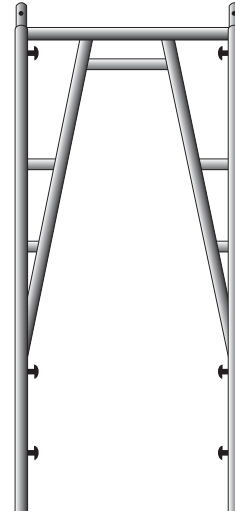

Description: 3' x 6'8" Walk Thru
Weight: 36 lbs.



Description: 3' x 5' Walk Thru
Weight: 31 lbs.

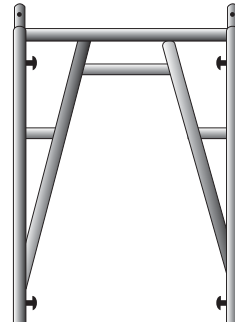

Description: 3' x 4' Walk Thru
Weight: 27 lbs.

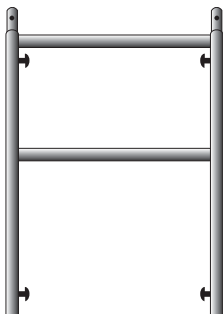

Description: 3' x 4' Ladder
Weight: 24 lbs.

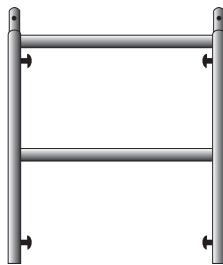

Description: 3' x 40" Ladder
Weight: 21 lbs.

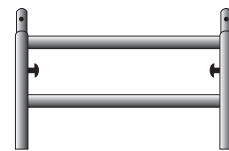

Description: 3' x 20" Ladder
Weight: 17 lbs.

ACCESSORIES

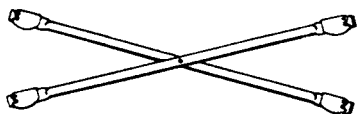

**SNAP-ON
CROSS BRACES**
5 x 32
7 x 32
7 x 4
10 x 32
10 x 4
*Can be manufactured
to any size*

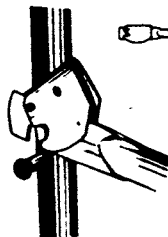

**SNAP-ON
GUARD RAILS**
3'
5'
7'
10'
*Can be manufactured
to any size*

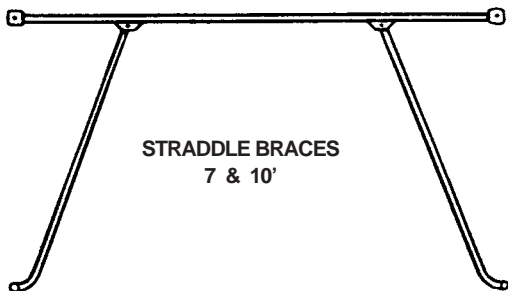

STRADDLE BRACES
7 & 10'

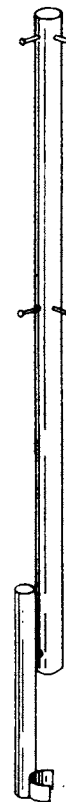

GUARD RAIL POST

GOOSERS
7 & 10'
10' x 5'
7' x 5'
*Can be manufactured
to any size*

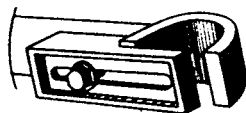

COUPLING PIN
With 1/8" Collar



COUPLING PIN
With 1" Collar



COUPLING PIN
No Collar

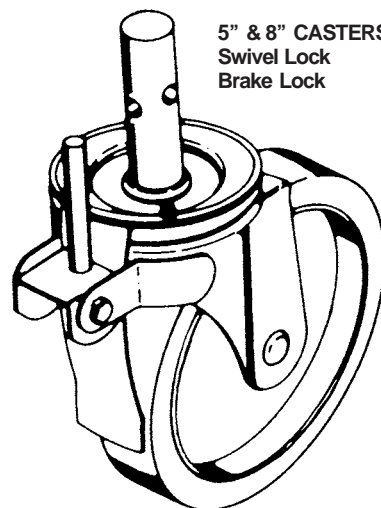
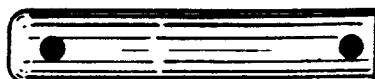

5" & 8" CASTERS
Swivel Lock
Brake Lock

ACCESSORIES

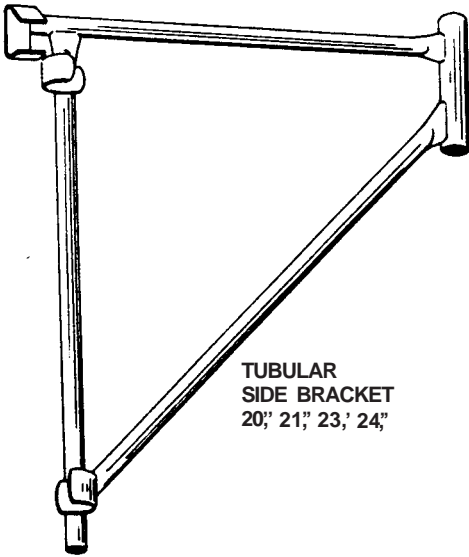

TUBULAR
SIDE BRACKET
20", 21", 23", 24"

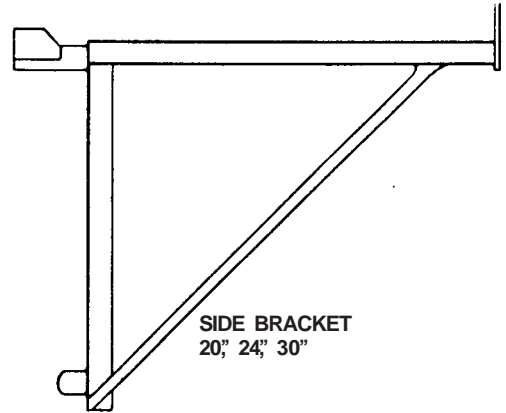

SIDE BRACKET
20", 24", 30"

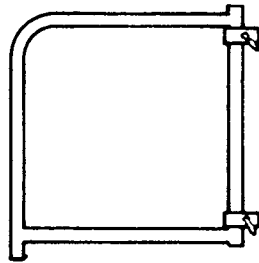

ROLLING TOWER
OUTRIGGER

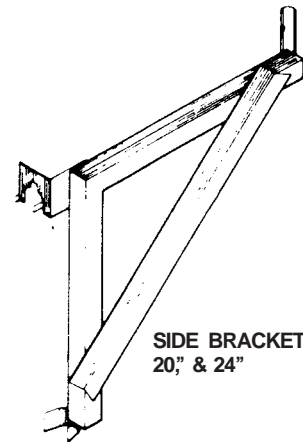

SIDE BRACKET
20" & 24"

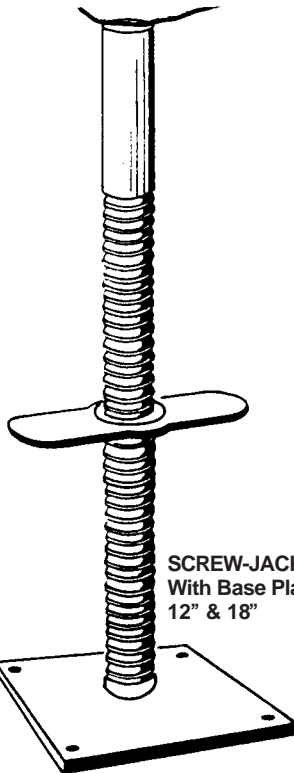

SCREW-JACK
With Base Plate
12" & 18"

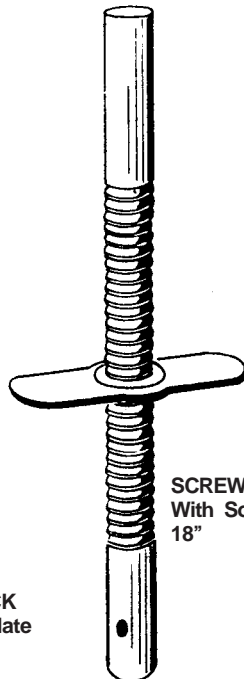

SCREW-JACK
With Socket
18"

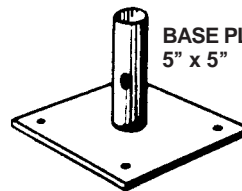

BASE PLATE
5" x 5"

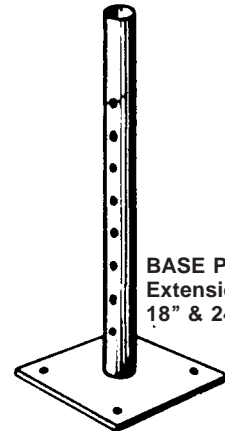

BASE PLATES
Extension Base Plate
18" & 24"

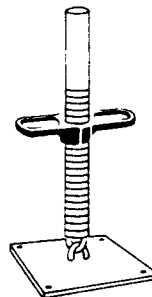

SWIVEL SCREW JACK

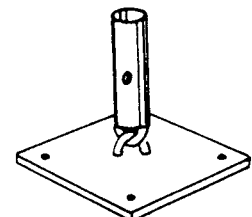

SWIVEL BASE PLATE

ACCESSORIES

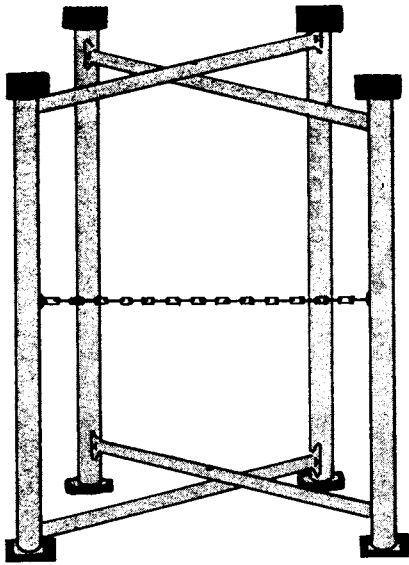

MORTAR BOARD STANDS
 20" x 30"
 20" x 30" Double Chain
 60" x 30"
 60" x 30" Double Chain

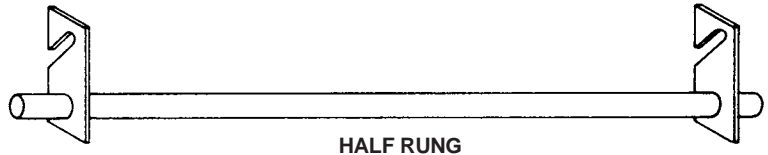

HALF RUNG



**GRAVITY LOCK PIN
 (Pig Tail)**



TOGGLE PIN

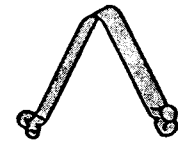

SPRING RETAINER

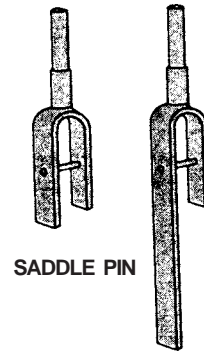
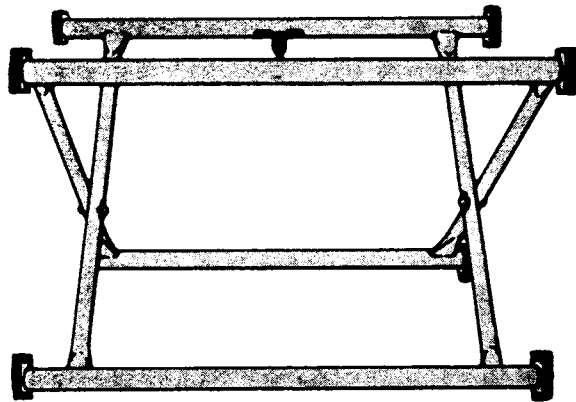

SADDLE PIN

RIGHT ANGLE CLAMP

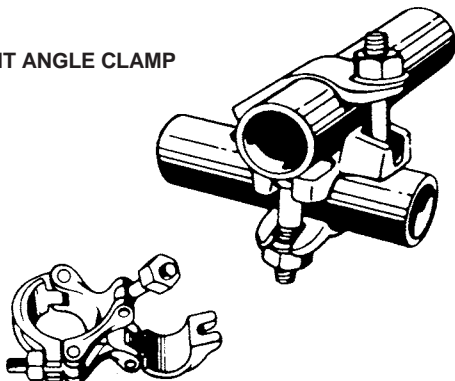

SWIVEL CLAMP

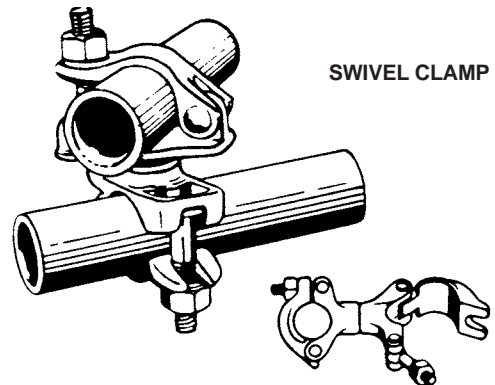

ACCESSORIES



TRUSSES
8' & 12' Straight Trusses
16' & 22' Trusses with Belly
*Trusses can be manufactured
to your specifications*

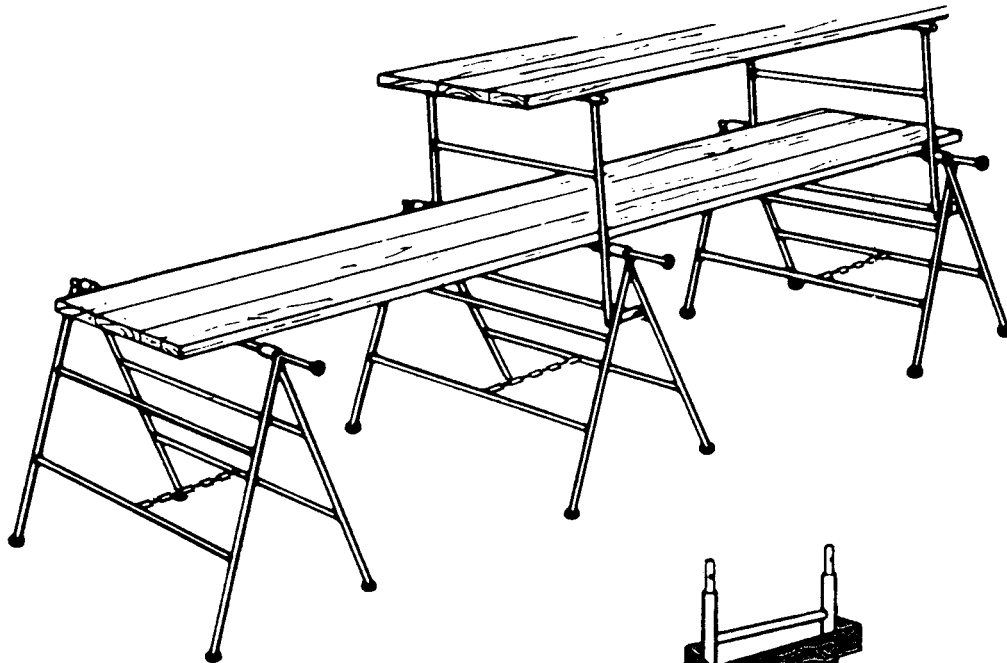
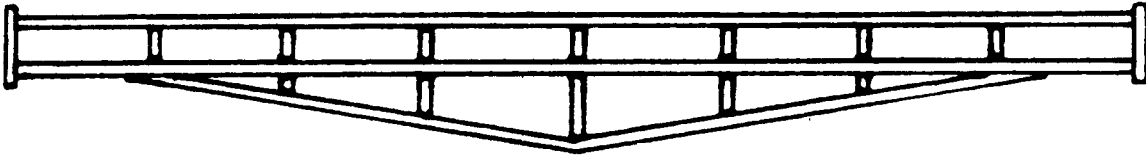

FOLDING TRESTLES
2', 3', 4' & 6'
Folding Trestle
Extensions
2' & 3'

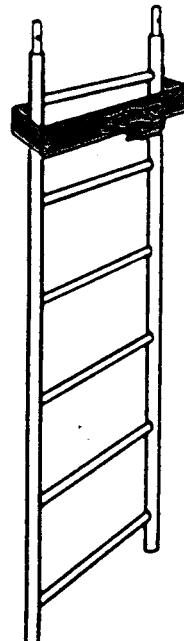

ACCESS LADDER

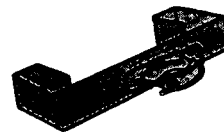

ACCESS LADDER
STARTER BRACKET

ACCESSORIES

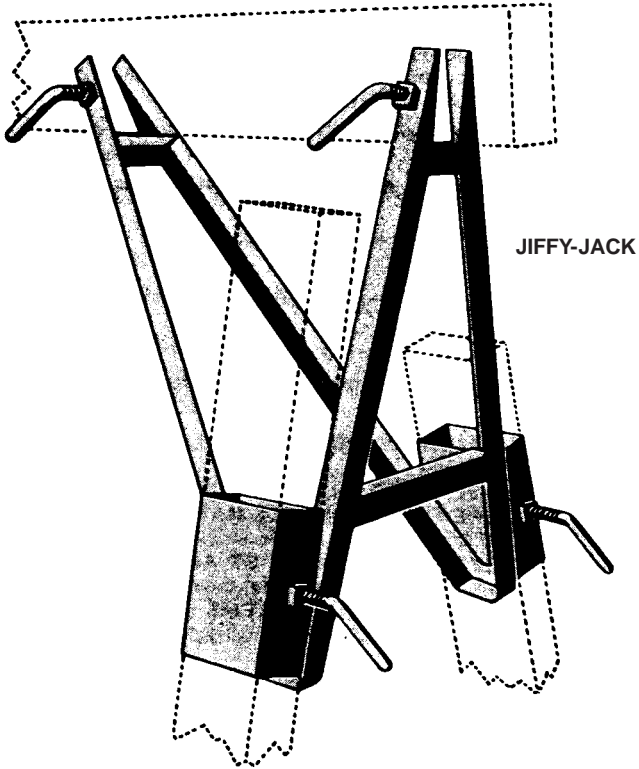

JIFFY-JACK



DRYWALL CART

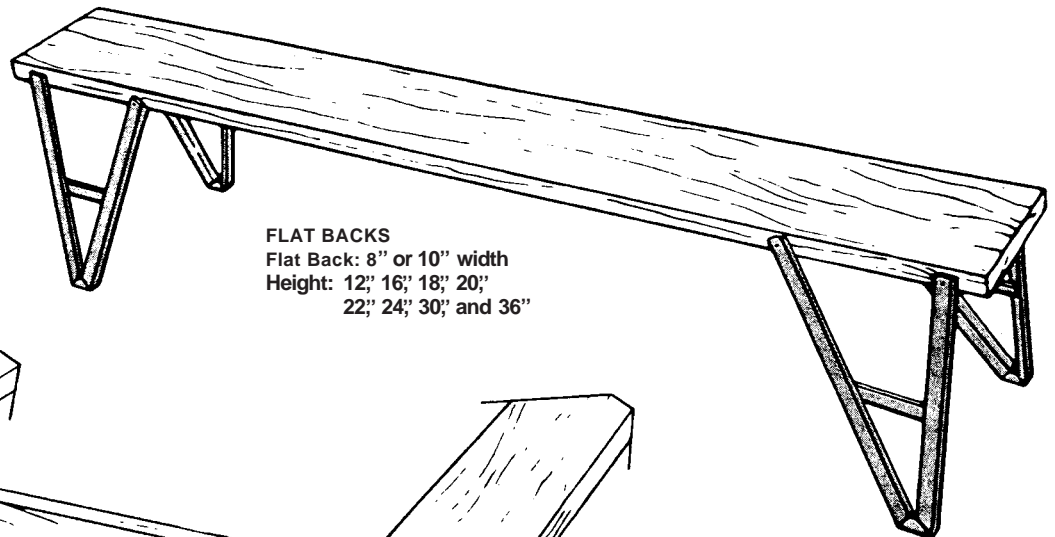

FLAT BACKS
Flat Back: 8" or 10" width
Height: 12", 16", 18", 20",
22", 24", 30", and 36"

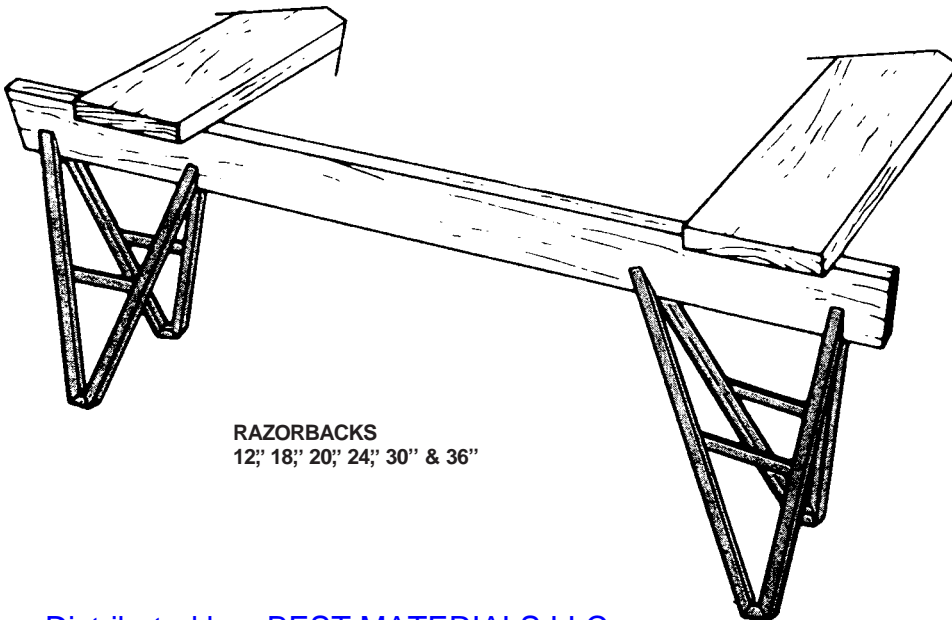

RAZORBACKS
12", 18", 20", 24", 30" & 36"



Distributed by: [BEST MATERIALS LLC](http://BESTMATERIALS.LLC)
Ph: 800-474-7570, 602-272-8128 Fax: 602-272-8014
www.BestMaterials.com Email: Sales@BestMaterials.com

MODEL AP 7500 SERIES



Plywood and Aluminum decks for steel scaffolds available for construction or general maintenance work. May be used end to end in continuous lengths or as single units.

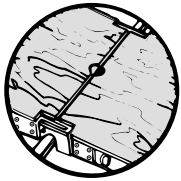

The plywood deck is notched in the center for easy installation around vertical post.

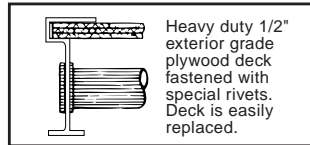
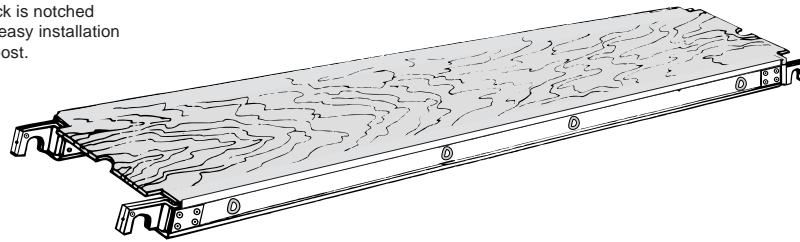

Heavy duty 1/2" exterior grade plywood deck fastened with special rivets. Deck is easily replaced.

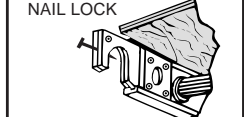

Heavy duty Hook Reinforcement plates help withstand abusive loads
Hook Lock Clamp... Fits easily in place, makes erection easier. Offsets hooks allow in-line installation.

Model	Duty Rating Lbs. per sq.ft.	Width	Length	Rail Size	Approx. Wt. Lbs.
AP7507	75	19"	7 ft.	4"	25
AP7508	50	19"	8 ft.	4"	28
AP7510	50	19"	10 ft.	4"	35

MODEL AA 7500 SERIES



All Aluminum decks for steel scaffolds are available for construction or general maintenance work. May be used end to end in continuous lengths or as single units.

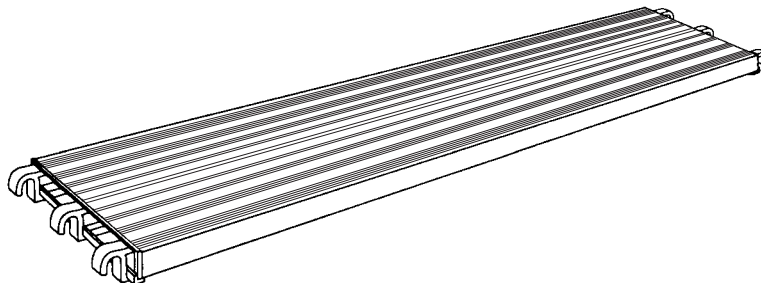

Model	Duty Rating Lbs. per sq.ft.	Width	Length	Rail Size	Approx. Wt. Lbs.
AA7507	75	19-1/16"	7 ft.	2"	31
AA7508	50	19-1/16"	8 ft.	2"	35
AA7510	50	19-1/16"	10 ft.	2"	40

SCAFFOLDING SAFETY RULES

As Recommended by SCAFFOLDING AND SHORING INSTITUTE (See Separate Shoring Safety Rules)

Following are some common sense rules designed to promote safety in the use of steel scaffolding. These rules are illustrative and suggestive only, and are intended to deal only with some of many practices and conditions encountered in the use of scaffolding. The rules do not purport to be all-inclusive or to supplant or replace other additional safety and precautionary measures to cover usual or unusual conditions. They are not intended to conflict with, or supersede, any state, local, or federal statute or regulation; reference to such specific provisions should be made by the user. (See Rule II.)

- I. **POST THESE SCAFFOLDING SAFETY RULES** in a conspicuous place and be sure that all persons who erect, dismantle or use scaffolding are aware of them.
 - II. **FOLLOW ALL STATE, LOCAL AND FEDERAL CODES, ORDINANCES AND REGULATIONS** pertaining to scaffolding.
 - III. **INSPECT ALL EQUIPMENT BEFORE USING** – Never use any equipment that is damaged or deteriorated in any way.
 - IV. **KEEP ALL EQUIPMENT IN GOOD REPAIR.**
 - V. **INSPECT ERECTED SCAFFOLDS REGULARLY** to be sure that they are maintained in safe condition.
 - VI. **CONSULT YOUR SCAFFOLDING SUPPLIER WHEN IN DOUBT** – scaffolding is his business. **NEVER TAKE CHANCES.**
- A. **PROVIDE ADEQUATE SILLS** for scaffold post and use base plates.
 - B. **USE ADJUSTING SCREWS** instead of blocking to adjust to uneven grade conditions.
 - C. **PLUMB AND LEVEL ALL SCAFFOLDS** as the erection proceeds. Do not force braces to fit - level the scaffold until proper fit can be made easily.
 - D. **FASTEN ALL BRACES SECURELY.**
 - E. **DO NOT CLIMB CROSS BRACES.** An access (climbing) ladder, access steps, frame designed to be climbed or equivalent safe access to the scaffold shall be used.
 - F. **ON WALL SCAFFOLDS PLACE AND MAINTAIN ANCHORS** securely between structure and scaffold at least every 30' of length and 25' of height.
 - G. **WHEN SCAFFOLDS ARE TO BE PARTIALLY OR FULLY ENCLOSED**, specific precautions must be taken to assure frequency and adequacy of ties attaching the scaffolding to the building due to increased load conditions resulting from effects of wind and weather. The scaffolding components to which the ties are attached must also be checked for additional loads.
 - H. **FREE STANDING SCAFFOLD TOWERS MUST BE RE-STRAINED FROM TIPPING** by guying or other means.
 - I. **EQUIP ALL PLANKED OR STAGED AREAS** with proper guardrails, midrails and toeboards along all open sides and ends of scaffold platforms.
 - J. **POWER LINES NEAR SCAFFOLDS** are dangerous - use caution and consult the power service company for advice.
 - K. **DO NOT USE** ladders or makeshift devices on top of scaffolds to increase the height.
 - L. **DO NOT OVERLOAD SCAFFOLDS.**
 - M. **PLANKING:**
 1. Use only lumber that is properly inspected and graded as scaffold plank.
 2. Planking shall have at least 12" of overlap and extend 6" beyond center of support, or be cleated at both ends to prevent sliding of supports.
 3. Fabricated scaffold planks and platforms unless cleated or restrained by hooks shall extend over their end supports not less than 6" nor more than 12".
 4. Secure plank to scaffold when necessary.
 - N. **FOR ROLLING SCAFFOLD THE FOLLOWING ADDITIONAL RULES APPLY:**
 1. **DO NOT RIDE ROLLING SCAFFOLDS.**
 2. **SECURE OR REMOVE ALL MATERIAL AND EQUIPMENT** from platform before moving scaffold.
 3. **CASTER BRAKES MUST BE APPLIED** at all times when scaffolds are not being moved.
 4. **CASTERS WITH PLAIN STEMS** shall be attached to the panel or adjustment screw by pins or other suitable means.
 5. **DO NOT ATTEMPT TO MOVE A ROLLING SCAFFOLD WITHOUT SUFFICIENT HELP** – watch out for holes in floor and overhead obstructions.
 6. **DO NOT EXTEND ADJUSTING SCREWS ON ROLLING SCAFFOLDS MORE THAN 12".**
 7. **USE HORIZONTAL DIAGONAL BRACING** near the bottom and at 20' intervals measured from rolling surface.
 8. **DO NOT USE BRACKETS ON ROLLING SCAFFOLDS** without consideration of overturning effect.
 9. **THE WORKING PLATFORM HEIGHT OF A ROLLING SCAFFOLD** must not exceed four times the smallest base dimension unless guyed or otherwise stabilized.
 - O. **For "PUTLOGS" and "TRUSSES"** the following additional rules apply:
 1. **DO NOT CANTILEVER OR EXTEND PUTLOGS /TRUSSES** as side brackets without thorough consideration for loads to be applied.
 2. **PUTLOGS/TRUSSES SHOULD EXTEND AT LEAST 6"** beyond point of support.
 3. **PLACE PROPER BRACING BETWEEN PUTLOGS/TRUSSES** when the span of putlog/truss is more than 12".
 - P. **ALL BRACKETS** shall be seated correctly with side brackets parallel to the frames and end brackets at 90 degrees to the frames. Brackets (except mobile brackets designed to carry materials) are to be used as work platforms only and shall not be used for storage of material or equipment.
 - Q. **ALL SCAFFOLDING ACCESSORIES** shall be used and installed in accordance with the manufacturers recommended procedure. Accessories shall not be altered in the field. Scaffolds, frames and their components, manufactured by different companies shall not be intermixed.



Choosing the Best System

Werner's Aluminum scaffolding is now available to order in three convenient ways:

- Towers
- Sections
- Components

Werner's complete line of scaffold products is now available as completed scaffold towers in various heights for easy ordering, scaffold sections for added convenience, and in individual component form for total versatility. As always, Werner's aluminum scaffolding is lightweight, durable, and narrow span scaffolding easily fits through doorways.

Towers, Sections, Components:

Towers: Werner's scaffold towers are easy and convenient to order. Available in standard 6', 8', and 10' lengths with platform heights up to 23', these are available as 29" wide Narrow Span towers, 4-1/2' wide Wide Span towers, and as Stairway towers. Each of these towers is shipped complete with outriggers, guard rails, toe boards, and planks with access doors which allow the user to climb the tower from the inside.

Sections: Scaffold sections allow the user to easily add height to an existing scaffold tower. Available in standard 6', 8', and 10' lengths and as 29" wide Narrow Span sections, 4-1/2' wide Wide Span sections, and Stairway sections. Each section is shipped complete with all necessary components.

Components: Individual scaffold components provide the most flexibility during installation by allowing the user to easily convert to different lengths or heights. All components are available separately for 29" wide Narrow Span scaffolds, 4-1/2' wide Wide Span scaffolds and for Stairway scaffolds.

Where Are Scaffolds Used?

Scaffold Towers are used for many applications, including the following:

- Painting
- Window and Facade Cleaning
- Remodeling
- Drywall Installation
- Rental Yards
- Schools and Hospitals
- Theatrical and Entertainment
- Building Maintenance

Which Scaffold Is Right For Me?

Ask yourself the following questions to consider your scaffold needs:

1. **How much working surface do I need?**

Choose the 4-1/2' wide Wide Span scaffold when space permits and the 29" wide Narrow Span scaffold when space is limited. Both are available in 6', 8', and 10' lengths.

2. **Will the scaffold I'm working on have to straddle anything?**

If the answer is yes, choose a hi-clearance base section.

3. **Could I benefit from having stairway access inside my scaffold?**

If the answer is yes, choose a stairway scaffold.

4. **How high do I need to reach?**

Remember that the maximum platform height is equal to 4x the smaller base section dimension of the scaffold or installed outrigger in most states except California, Oregon, Ohio, Montana, and Maine which require 3x and Washington which requires 3-1/2x. EXAMPLE: If you have a 4-1/2' x 6' base section, and work in California, your maximum platform height would be 13-1/2'. Please check your state and local codes for your particular specifications. Outriggers will be required for added height.

5. **When do I need guard rails and toe boards?**

The use of fall protection equipment is always recommended. Safety codes require guard rails and toe boards on all open sides when the platform height is 10' or more, and may be required at lower heights, depending on the application and jurisdiction. Check applicable ANSI, OSHA, state and local codes for specific requirements.

6. **How heavy a load do I need to support?**

If 25 lbs. per square foot or 500 lbs. maximum per deck and scaffold, choose any scaffold. If 25 lbs. per square foot or 500 lbs. maximum per deck and 1000 lbs. maximum per scaffold, choose a wide span scaffold. If 50 lbs. per square foot or 1300 lbs. maximum per scaffold, choose a stairway scaffold (except STHCB-U which is 650 lbs. maximum per scaffold).



Outstanding Aluminum Scaffold Features

Swedge-Master® Scaffold Joint Process & Snap-Hook Frame Lock:

Swedge-Master® Scaffold Joint Process:

- Provides consistently strong and tight internal and external joints
 - Allows easier inspection than welded joints
 - Standard on all vertical, diagonal and horizontal scaffold connections*
- *4000 Series Stairway joints are welded

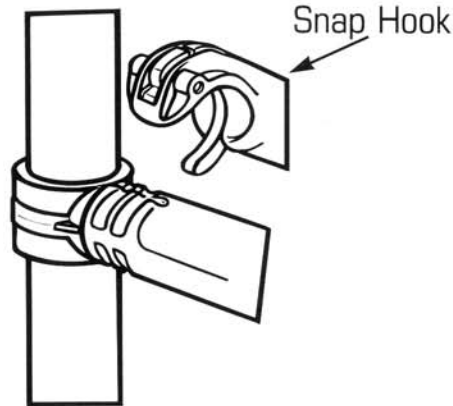

Snap-Hook Frame Lock:

- Spring-loaded hook snaps on easily
- Releases manually
- Goes 3/4 of the way around the brace it hooks onto for increased stability

Interlock Pin Assembly:

Interlock Pin Assembly:

- Aluminum stacking pin securely joins upper and lower sections
- Slip-resistant strap keeps pin with scaffold

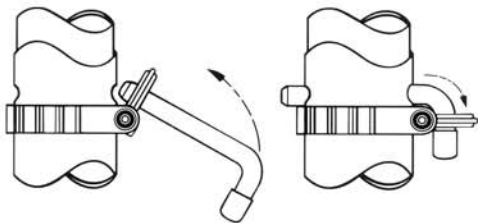

Snap-Up® Locking Mechanism:

Snap-Up® Locking Mechanism:

- Automatically locks when fully extended; easily unlocks by pushing on thumb release
- Corrosion-resistant "elbow latches"

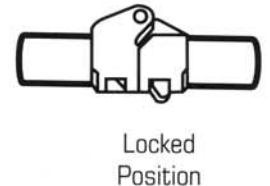

Double Locking Leg:

Double Locking Leg:

- Provides quick and easy adjustment up to 9-1/2"
- Standard on all base sections

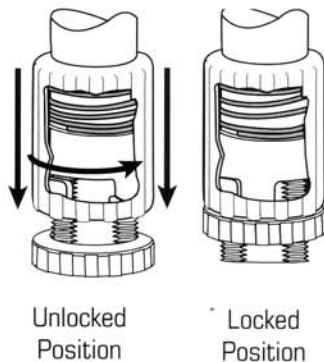

5" Ball Bearing Caster:

5" Ball Bearing Caster with 2-Way Lock:

- 2-way lock prevents rolling and swiveling
- Aldek® caster is rust resistant
- 8" caster (Kit #40-1) also available

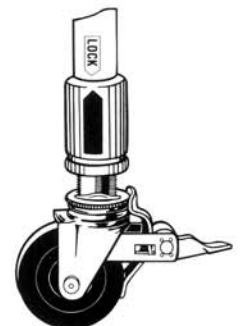



Aluminum Scaffold Towers

Narrow Span: 12' Platform Height

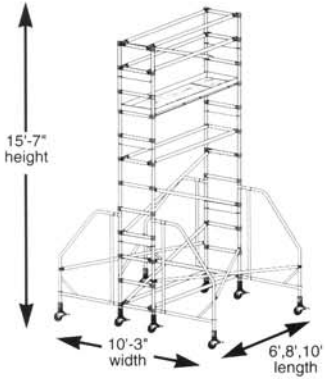

<u>Model Number</u>	<u>Platform Length</u>	<u>Platform Height</u>
4101-12	6'	12'
4102-12	8'	12'
4103-12	10'	12'

Wide Span*: 12' Platform Height

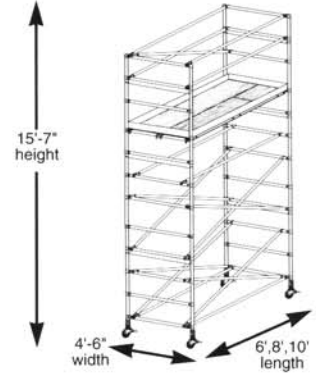

<u>Model Number</u>
4201-12
4202-12
4203-12

Narrow Span: 18' Platform Height

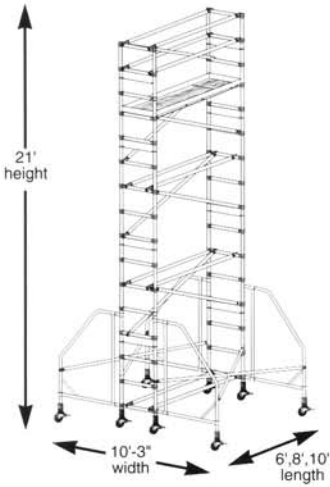

<u>Model Number</u>	<u>Platform Length</u>	<u>Platform Height</u>
4101-18	6'	17'6"
4102-18	8'	17'6"
4103-18	10'	17'6"

Wide Span: 18' Platform Height

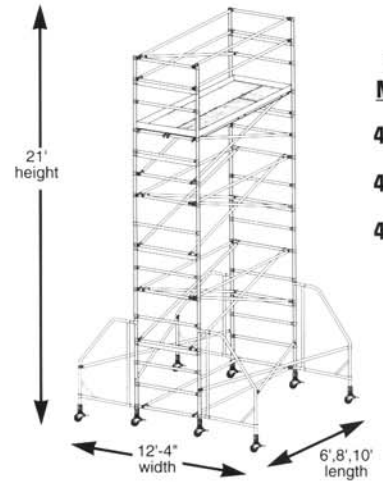

<u>Model Number</u>
4201-18
4202-18
4203-18

Narrow Span: 23' Platform Height

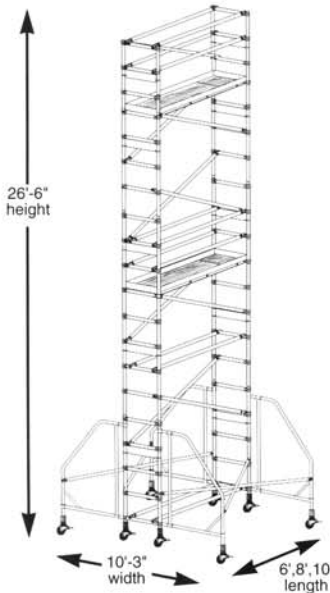

<u>Model Number</u>	<u>Platform Length</u>	<u>Platform Height</u>
4101-23	6'	23'
4102-23	8'	23'
4103-23	10'	23'

Wide Span: 23' Platform Height

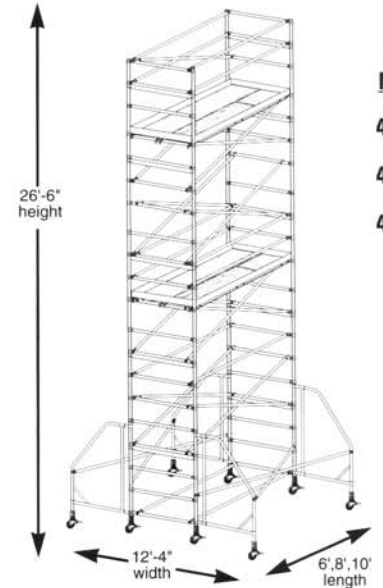

<u>Model Number</u>
4201-23
4202-23
4203-23

Load Capacity: 25 lbs. per sq. ft. or 500 lbs. maximum per deck & scaffold.

Load Capacity: 25 lbs. per sq. ft. or maximum per scaffold.

Includes guard rails, outriggers*, toe boards, and planks with access doors to allow for climbing inside the scaffold.
 Maximum platform height for all Werner scaffold towers (except Model Nos. 4201-23 and 4101-23) is equal to 4x smaller base section dimension. The toe board height for all Werner scaffold towers is 4". Check state and local codes.
 All individual narrow & wide-span planks are 22" wide. All individual stairway boards are 24" wide.

Stairway*: 13' Platform Height

Platform Length	Platform Height
6'	12'
8'	12'
10'	12'

* 12' Wide Span Scaffold Tower does not require outriggers

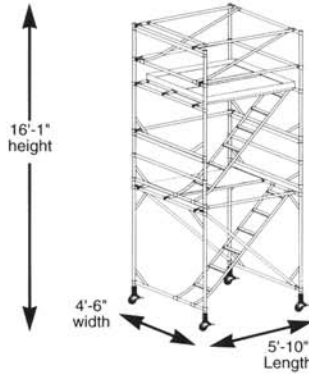

Model Number	Platform Length	Platform Height
4001-13	5'4"	13'

* 13' Stairway Scaffold Tower does not require outriggers

Stairway: 19' Platform Height

Platform Length	Platform Height
6'	17'6"
8'	17'6"
10'	17'6"

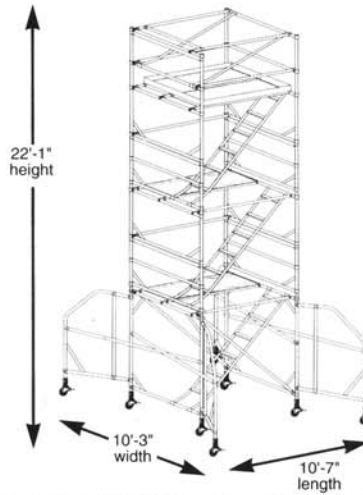

Model Number	Platform Length	Platform Height
4001-19	5'4"	19'

Stairway: 25' Platform Height

Platform Length	Platform Height
6'	23'
8'	23'
10'	23'

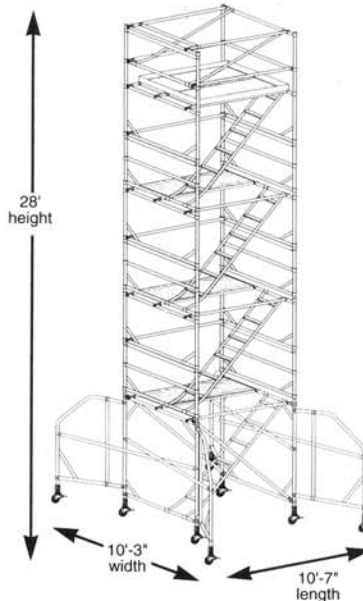

Model Number	Platform Length	Platform Height
4001-25	5'4"	25'

500 lbs. per deck and 1,000lbs.

Load Capacity: 50 lbs. per sq. ft. or 1300 lbs. maximum per scaffold.



Aluminum **Narrow** Span Scaffold Sections

Completed Scaffold Tower:

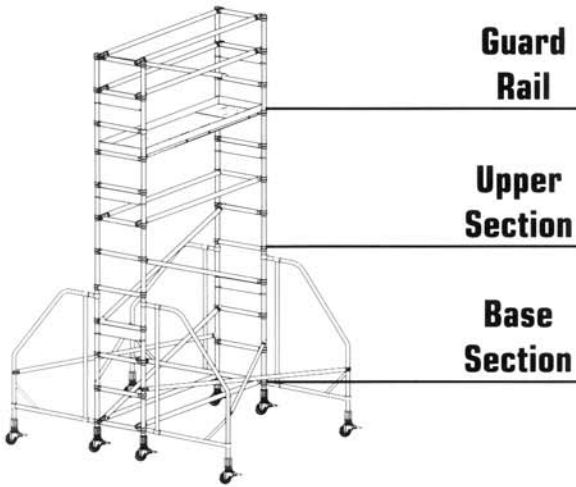

Guard Rail

Upper Section

Base Section

4100 Series bases include Horizontal-Diagonal braces. (Not Shown)

Guard Rail:

Choose a Guard Rail:

- Match in length to base chosen
- Each designed for use with either Standard, Snap-Up® Folding, or Hi-Clearance Scaffolds

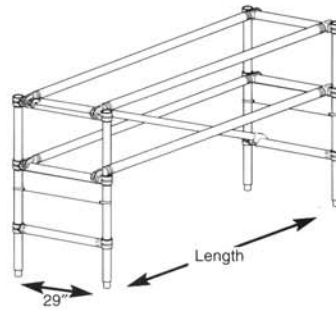

3-1/2' High Guard Rail Narrow Span Guard Rail

MODEL	Length	Wt. #
4110	6'	44.0
4111	8'	48.0
4112	10'	52.0

Guard rails are required when platform height is 10' or more.

Upper Section:

Choose an Upper Section:

- Each designed for use with either Standard, Snap-Up® Folding, or Hi-Clearance Scaffolds
- Match in length to base chosen

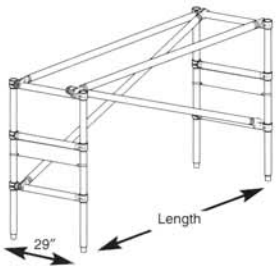

4' High Upper Section

MODEL	Length	Wt. #
4107	6'	47.0
4108	8'	51.0
4109	10'	55.0

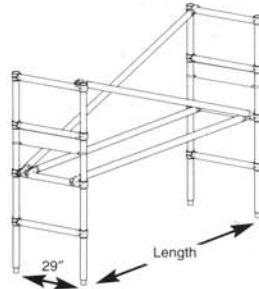

5-1/2' High Upper Section

MODEL	Length	Wt. #
4104	6'	53.0
4105	8'	58.0
4106	10'	62.0

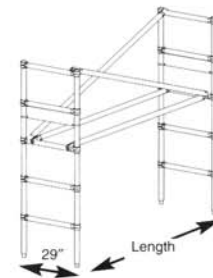

6-3/4' High Upper Section

MODEL	Length	Wt. #
4127	6'	60.0
4128	8'	65.0
4129	10'	68.0

Load Capacity: 25 lbs. per sq. ft. or 500 lbs. maximum per deck & scaffold.

Base Section: (does not include outriggers)

Choose a Base Section: Standard, Snap-Up® Folding, or Hi-Clearance Scaffolds

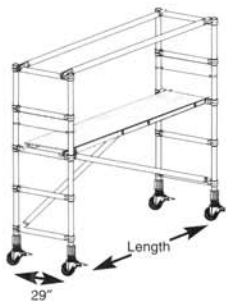

6'8" - 7'5" High Adjustable Base Section

MODEL	Length	Wt. #
4101	6'	123.0
4102	8'	133.0
4103	10'	145.0



6'8" - 7'5" High Snap-Up

MODEL	Length	Wt. #
SNB-6U	6'	127.0
SNB-8U	8'	139.0

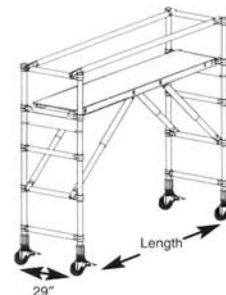

6'8" - 7'5" High Hi-Clearance Section

MODEL	Length	Wt. #
4113	6'	121.0
4114	8'	139.0
4115	10'	151.0

4100 Series bases include Horizontal-Diagonal braces. (Not Shown)

Outriggers may be required if more than the base section is used.



Aluminum Wide Span Scaffold Sections

Completed Scaffold Tower:

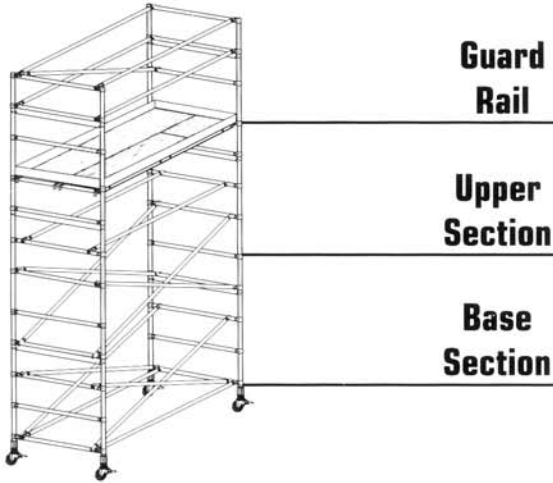

4200 Series bases include Horizontal-Diagonal braces. (Not Shown)

Guard Rail:

Choose a Guard Rail:

- Match in length to base chosen
- Each designed for use with either Standard, or Snap-Up® Scaffolds

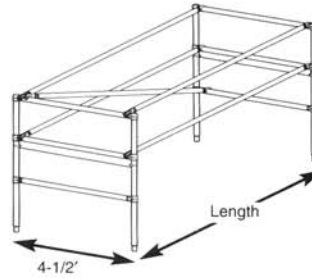

3-1/2' High Guard Rail Wide Span Guard Rail

MODEL	Length	Wt. #
4210	6'	55.0
4211	8'	60.0
4212	10'	65.0

Guard rails are required when platform height is 10' or more.

Upper Section:

Choose an Upper Section:

- Each designed for use with either Standard, or Snap-Up® Folding Scaffolds

- Match in length to base chosen

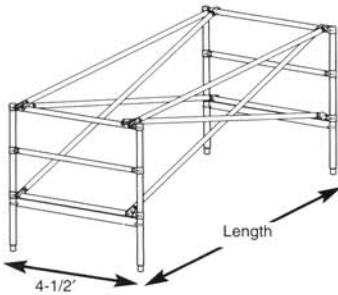

4' Upper Section Wide Span 3 Rung Upper

MODEL	Length	Wt. #
4207	6'	62.0
4208	8'	68.0
4209	10'	73.0

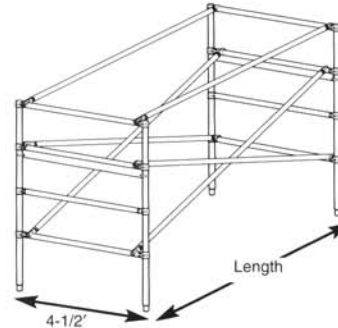

5-1/2' Upper Section Wide Span 4 Rung Upper

MODEL	Length	Wt. #
4204	6'	71.0
4205	8'	76.0
4206	10'	81.0

Load Capacity: 25 lbs. per sq. ft. or 500 lbs. per deck and 1,000 lbs. maximum per scaffold.

Base Section: (does not include outriggers)

Choose a Base Section: Standard, or Snap-Up® Folding Scaffolds

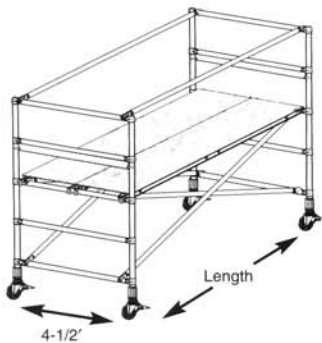

6'8" - 7'5" High Adjustable Base Section

MODEL	Length	Wt. #
4201	6'	167.0
4202	8'	188.0
4203	10'	208.0

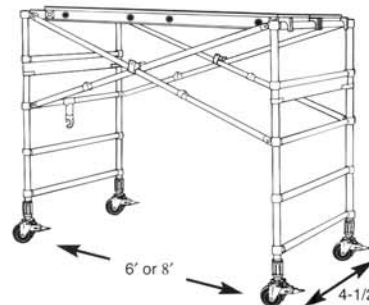

6'8" - 7'5" High Snap-Up

MODEL	Length	Wt. #
SWB-6U	6'	163.0
SWB-8U	8'	181.0

4200 Series bases include Horizontal-Diagonal braces. (Not Shown)
Outriggers may be required if more than the base section is used.



Aluminum **Narrow Span Individual Scaffold Components**

Guard Rail:

Upper Section:

**3-1/2' High Guard Rail
Narrow Span**

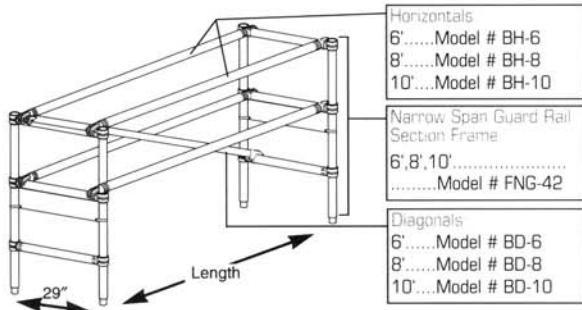

**4' High Upper Section
Narrow Span 3 Rung Upper**

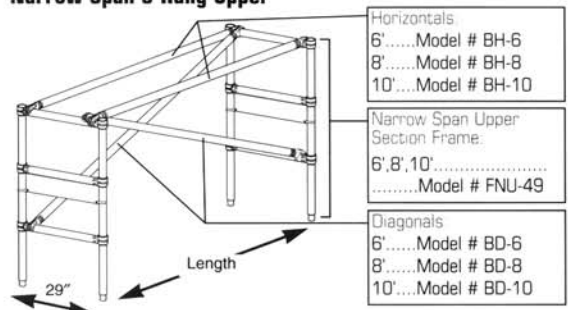

Guard rails are required when platform height is 10' or more.

**5-1/2' High Upper Section
Narrow Span 4 Rung Upper**

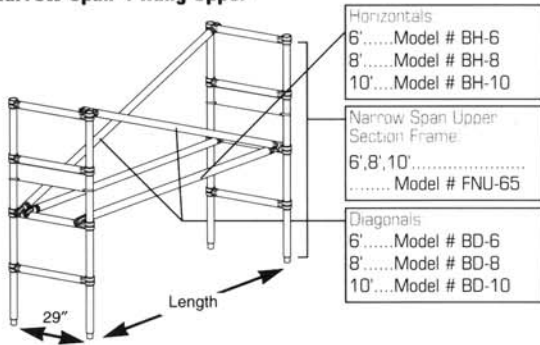

**6'9" High Upper Section
Narrow Span 5 Rung Upper**

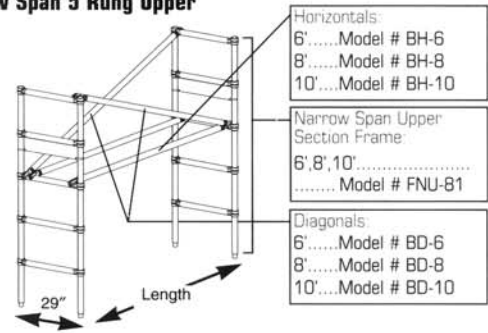

Load Capacity: 25 lbs. per sq. ft. or 500 lbs. maximum per deck & scaffold.

Base Section: (does not include outriggers)

**Base Section
Narrow Span Base**

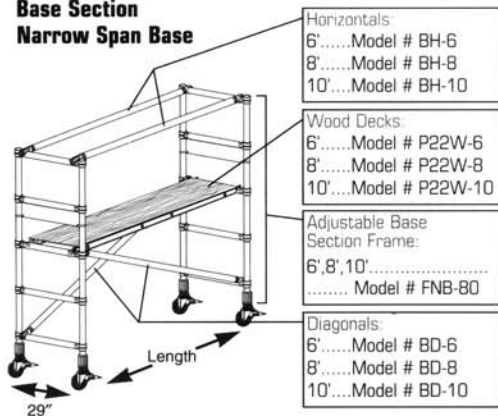

**Base Section
Narrow Span Hi-Clearance Base**

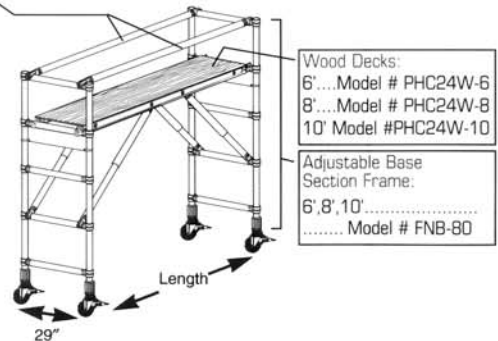

Horizontals - Diagonals:
6'.....Model # BN-6
8'.....Model # BN-8
10'.....Model # BN-10

NOT SHOWN

Outriggers may be required if more than the base section is used.



Aluminum Wide Span Individual Scaffold Components & Outriggers

Guard Rail Components:

**3-1/2' High Guard Rail
Wide Span**

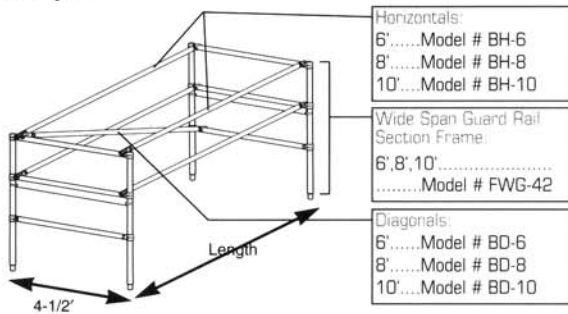

Upper Section Components:

**4' Upper Section
Wide Span 3 Rung Upper**

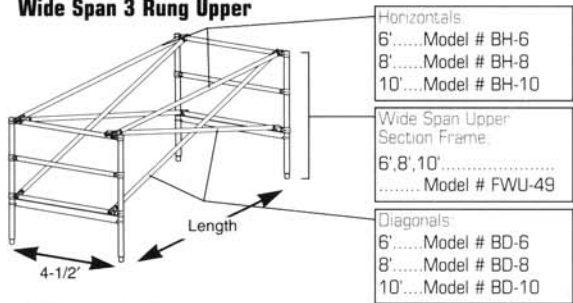

**5-1/2' Upper Section
Wide Span 4 Rung Upper**

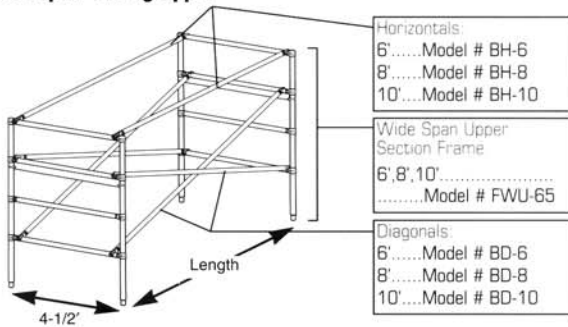

**Load Capacity: 25 lbs. per sq. ft. or 500 lbs. per deck
and 1,000 lbs. maximum per scaffold.**

Base Section Components:

**Base Section
Wide Span Base**

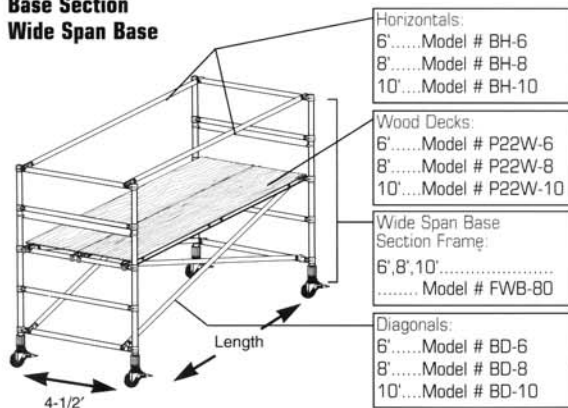

Horizontals - Diagonals:
6'.....Model # BW-6
8'.....Model # BW-8
10'.....Model # BW-10

NOT SHOWN

Outriggers:

Outrigger for Use with Stairway Scaffolds

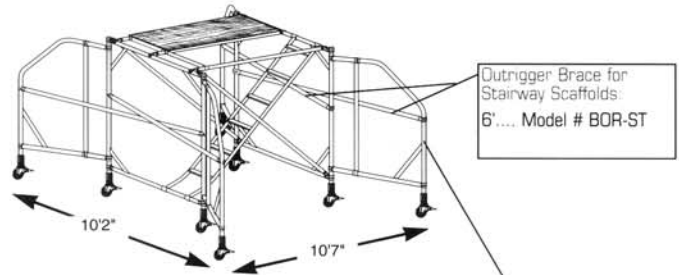

Outriggers for use with 2-sided system

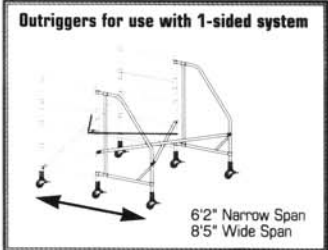
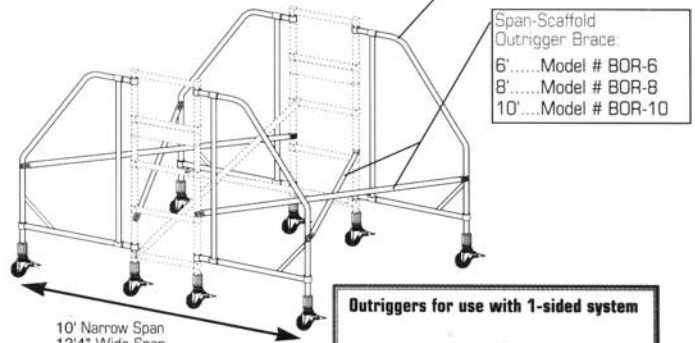

Adjustable Knee Type Outrigger

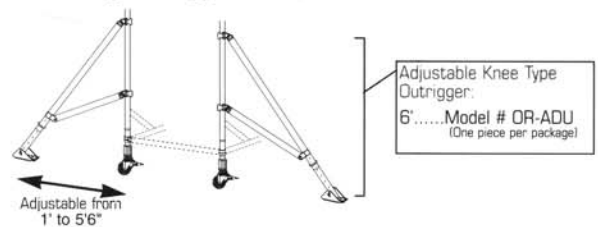



Stairway & High Clearance Scaffold Sections

Completed Scaffold Tower:

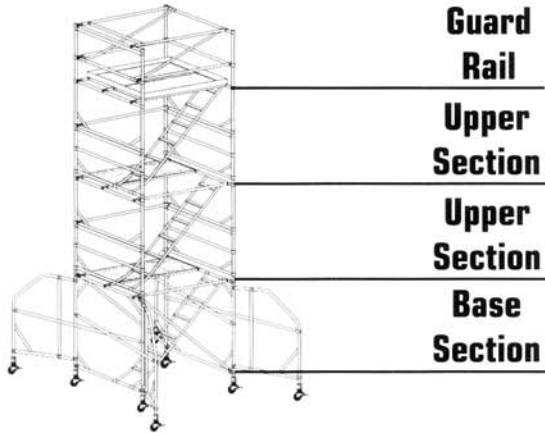

Guard Rail:

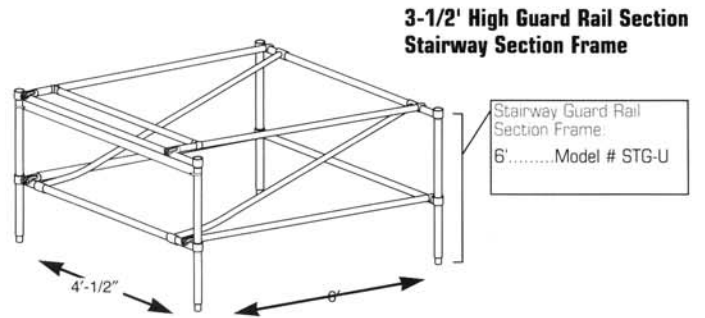

Upper Section:

Upper Section

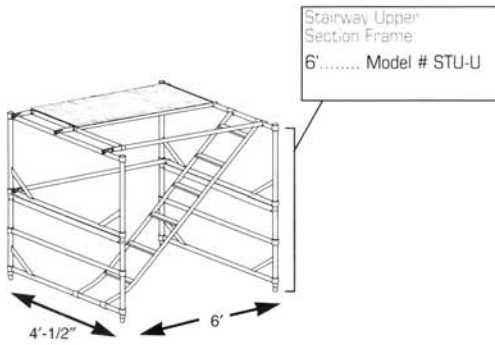

Base Section:

(does not include outriggers)

Base Section Adjustable Stairway Scaffold

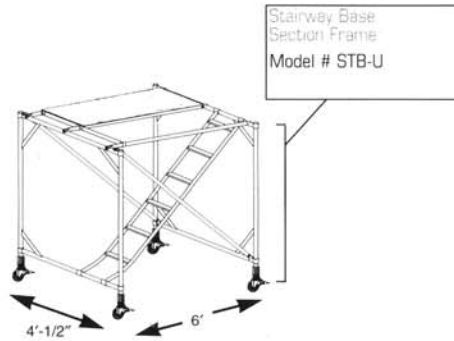

Base Section Adjustable Hi-Clearance Scaffold

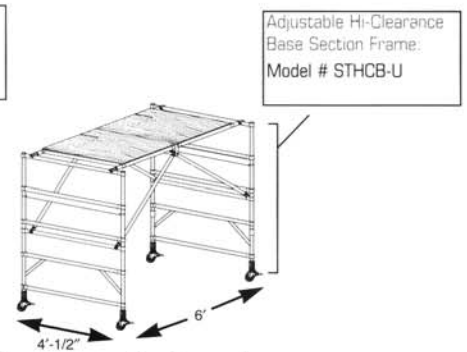

Outriggers may be required if more than the base section is used.

Load Capacity: 50 lbs. per sq. ft. or 1300 lbs. maximum per scaffold.*

* Except model STHCB-U: Load Capacity - 25 lbs. per sq. ft. or 650 lbs. maximum per scaffold.

Rules & Regulations:

- Maximum Scaffold platform height is equal to 4x the smaller base section dimension of the scaffold or installed outrigger in most states except California, Oregon, Ohio, Montana, Maine, which require 3x and Washington which requires 3-1/2x. Check your state and local codes.
- Guard rails are required when platform height is 10' or more.
- Outriggers may be required if more than the base section is used.





Scaffold Accessory Conversion Chart

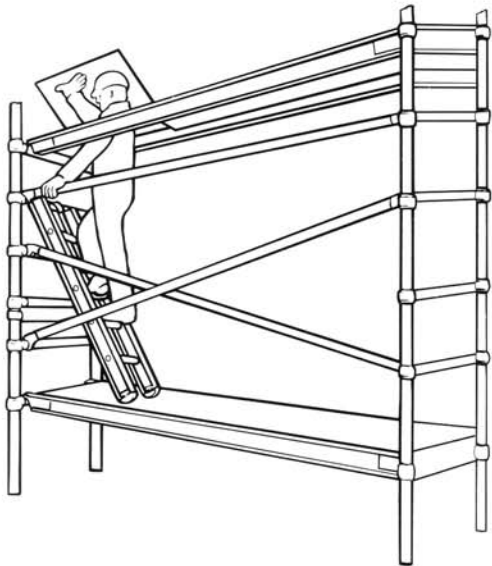

Snap-In Scaffold Ladder

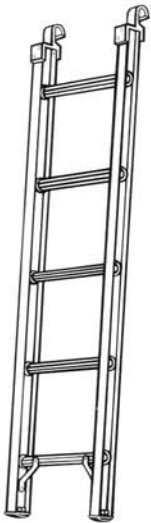

Access Door Platform Board

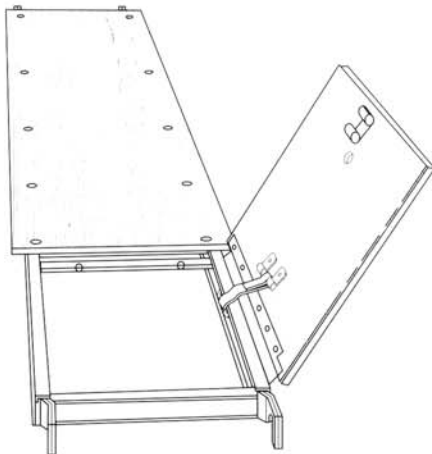

Toe board

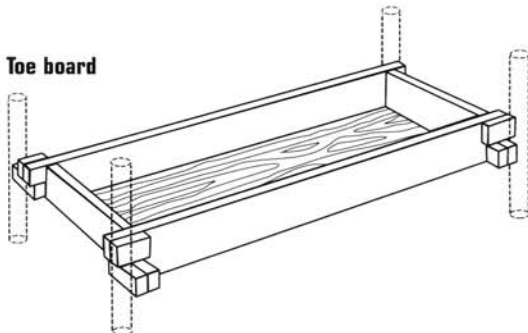

Check local codes for toe board height.

Previous Model Numbers	New Components Model Numbers	Description
45-1.....	LSIS-60.....	5'8" Snap-In Scaffold Ladder
45-2.....	LSIS-92.....	7'8" Snap-In Scaffold Ladder
D22-1W.....	PD22W-6.....	22" Wide Access Door Wood Deck - 6'
D22-2W.....	PD22W-8.....	22" Wide Access Door Wood Deck - 8'
D22-3W.....	PD22W-10.....	22" Wide Access Door Wood Deck - 10'
T4000-4.....	TST4-U.....	Toe Board for Stairway Scaffold
T4101-4.....	TN4-6U.....	4" Toe Board for Narrow Span - 6'
T4102-4.....	TN4-8U.....	4" Toe Board for Narrow Span - 8'
T4103-4.....	TN4-10U.....	4" Toe Board for Narrow Span - 10'
T4101-6.....	TN6-6U.....	6" Toe Board for Narrow Span - 6'
T4102-6.....	TN6-8U.....	6" Toe Board for Narrow Span - 8'
T4103-6.....	TN6-10U.....	6" Toe Board for Narrow Span - 10'
T4201-4.....	TW4-6U.....	4" Toe Board for Wide Span - 6'
T4202-4.....	TW4-8U.....	4" Toe Board for Wide Span - 8'
T4203-4.....	TW4-10U.....	4" Toe Board for Wide Span - 10'
T4202-6.....	TW6-6U.....	6" Toe Board for Wide Span - 6'
T4202-6.....	TW6-8U.....	6" Toe Board for Wide Span - 8'
T4203-6.....	TW6-10U.....	6" Toe Board for Wide Span - 10'
40-1.....		8" Caster Accessory Kit
41-1.....		Swivel Base Plate Accessory Kit
50-3.....		Plywood Enclosure Accessory Kit
43-1.....		Handrail Holder Accessory Kit
22-1A.....	P22A-6.....	22" Wide Aluminum Deck Board - 6'
22-2A.....	P22A-8.....	22" Wide Aluminum Deck Board - 8'
22-3A.....	P22A-10.....	22" Wide Aluminum Deck Board - 10'
24-1W.....	P24W-6.....	24" Wide Wood Deck Board - 6'
24-2W.....	P24W-8.....	24" Wide Wood Deck Board - 8'
24-3W.....	P24W-10.....	24" Wide Wood Deck Board - 10'
24-1A.....	P24A-6.....	24" Wide Aluminum Deck Board - 6'
24-2A.....	P24A-8.....	24" Wide Aluminum Deck Board - 8'
24-3A.....	P24A-10.....	24" Wide Aluminum Deck Board - 10'



BKE-BU6

ADVANTAGE

UTILITY SCAFFOLDS

FEATURES :

- Square, steel tubular frames are 29" wide and available in 6' and 8' lengths.



BKE-BU6



BKA-GU6

- Braces are designed to allow movement over lower obstacles.
- Guard rail system designed to stay at platform level at all times.
- Convenient locking system allows for quick and easy height adjustment.
- Plywood deck is reinforced with two steel supports underneath and surrounded with a steel frame.
- Compatible with other brands of utility scaffold.
- Packages are provided for ordering convenience and to meet specific job requirements.
- Units can be stacked for increased working heights.



BKA-DU6

- Platform adjusts in 4" increments. Each end can adjust separately to be used on both level surfaces and stairs.

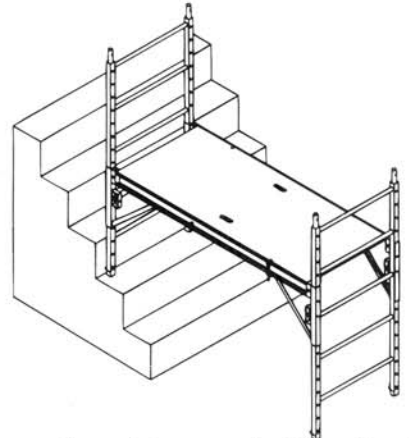

Do not use this product in areas where user can come in contact with live power. The manufacturer reserves the right to modify product specifications without prior notice. Follow all applicable OSHA and ANSI Regulations and Codes for the use of this equipment. All photos and line drawings are used for illustration purposes only.

ADVANTAGE

UTILITY SCAFFOLDS



BKE-BU6
BKA-BU8

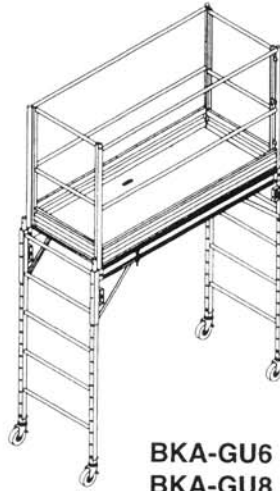

BKA-GU6
BKA-GU8

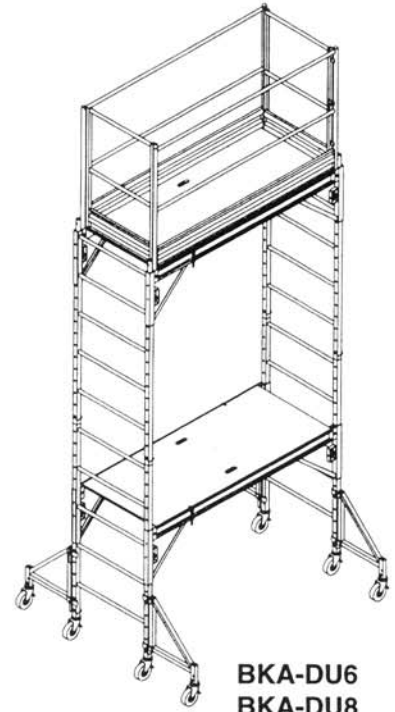

BKA-DU6
BKA-DU8

Part No.	Description	Wt.#
6' Packages Units		
BKE-BU6	6'L Advantage w/4 - 5" casters - 6'H	150
BKA-GU6	6'L Advantage w/casters & guard rail - 6'H	222
BKA-DU6	6'L Dbl. Advantage w/casters, guard rail & outriggers	374
8' Packages Units		
BKA-BU8	8'L Advantage w/4-5" casters - 6'H	200
BKA-GU8	8'L Advantage w/casters, guard rail - 6'H	296
BKA-DU8	8'L Dbl. Advantage w/casters, guard rail & outriggers	500
6' and 8' Component Packages		
BKA-AU6-6	69" Advantage Addl. Ht. Unit w/out walkboard - 6' L	96
BKA-AU6-8	69" Advantage Addl. Ht. Unit w/out walkboard - 8' L	128
BKA-AU3-6	42" Advantage Addl. Ht. Unit w/out walkboard - 6' L	66
BKA-AU3-8	42" Advantage Addl. Ht. Unit w/out walkboard - 8' L	88
BKA-GP6	6'L Complete Guardrail System w/6' steel toeboard (Protects All 4 Sides, Complies with OSHA)	72
BKA-GP8	8'L Complete Guardrail System w/8' steel toeboard (Protects All 4 Sides, Complies with OSHA)	96
BKA-OPN	Narrow Outrigger - 18" Wide (Set of 4)	32
BKA-OPW	Wide Outrigger - 46" Wide (Set of 4)	100



BKA-AU6-6
BKA-AU6-8



BKA-AU3-6
BKA-AU3-8



BKA-GP6
BKA-GP8

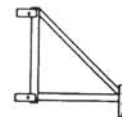

BKA-OPN
(set of 4)

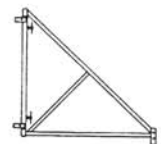

BKA-OPW
(set of 4)

SUNSET UTILITY SCAFFOLD



SLCUT06



SLCUT06D

MODEL	UTILITY SCAFFOLD	WT.
SLCUT06	29" X 6' UTILITY SCAFFOLD COMPLETE	152
SLCUT06G	29" X 6' UTILITY SCAFF. COMP. W/GUARD RAIL	285
SLCUT06D	29" X 12' UTILITY SCAFF. COMP. W/G.R. & OUTRIGGERS	376
SLCUT12C	29" X 6' UTILITY SCAFFOLD COMPLETE	528
SLCUT15C	29" X 15' UTILITY SCAFFOLD COMPLETE	610
SLCUT18C	29" X 18' UTILITY SCAFFOLD COMPLETE	610

MODEL	INDIVIDUAL COMPONENT PARTS LIST	WT.
SLC72FR	72" TALL UTILITY ADD-ON FRAME	28
SLC42FR	39" TALL UTILITY ADD-ON FRAME	18
SLC6TR	6" UTILITY SCAFFOLD ARM BRACE	21
SLCUTGR	6' UTILITY SCAFFOLD G. RAIL KIT	65
SLCUTWOR	WIDE UTILITY OUTRIGGER	25
SLCUTNOR	NARROW UTILITY OUTRIGGER	14
SLC5	5" UTILITY SCAFFOLD CASTER	2.5
SLCPLT	6' UTILITY SCAFFOLD PLATFORM	27

SUNSET UTILITY SCAFFOLD



MODEL	BI-FOLD MINI SCAFFOLDS	WT.
SLCMF4	4' TALL BI-FOLD SCAFFOLD W/2-PLANKS AND WORK TRAY	60
SLCMF6	6' TALL BI-FOLD SCAFFOLD W/3 PLANKS	105



Task-Master® Stages

Ideal for ladder jack applications, swing stages, or catwalks

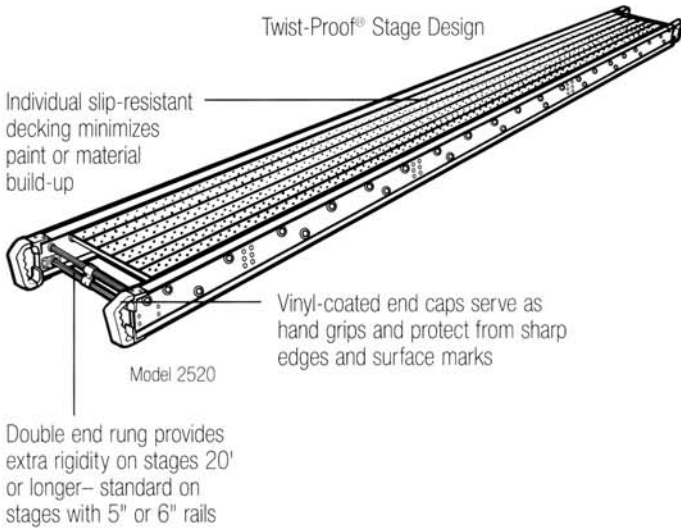

DECORATOR PLANKS

1 Person – 250 Lbs. Rated

Model No.	Width	Side Rail Length	Side Rail Depth	Side Rail Flange	Approx. Shipping Wt. Lbs.
2008	12"	8'	4"	1-3/8"	25
2012	12"	12'	4"	1-3/8"	36
2016	12"	16'	4"	1-3/8"	48
2020	12"	20'	5"	1-3/8"	65
2024	12"	24'	5"	1-3/8"	78
2108	20"	8'	4"	1-3/8"	33
2112	20"	12'	4"	1-3/8"	48
2116	20"	16'	4"	1-3/8"	64
2120	20"	20'	5"	1-3/8"	87
2124	20"	24'	5"	1-3/8"	104

SCAFFOLD PLANKS

2 Person – 500 Lbs. Rated

Model No.	Width	Side Rail Length	Side Rail Depth	Side Rail Flange	Approx. Shipping Wt. Lbs.
2316	12"	16'	4"	1-3/8"	48
2320	12"	20'	6"	1-3/8"	79
2324	12"	24'	6" Heavy Duty	1-3/8"	112
2328	12"	28'	6" Heavy Duty	1-3/8"	131
2330	12"	30'	6" Heavy Duty	1-3/8"	140
2332	12"	32'	6" Heavy Duty	1-3/8"	149
2408	14"	8'	4"	1-3/8"	27
2412	14"	12'	4"	1-3/8"	40
2416	14"	16'	5"	1-3/8"	58
2420	14"	20'	6"	1-3/8"	85
2424	14"	24'	6"	2"	109
2428	14"	28'	6"	2"	127
2430	14"	30'	6" Heavy Duty	2"	171
2432	14"	32'	6" Heavy Duty	2"	182

STAGE PLATFORMS

2 Person – 500 Lbs. Rated

Model No.	Width	Side Rail Length	Side Rail Depth	Side Rail Flange	Approx. Shipping Wt. Lbs.
2508	20"	8'	4"	1-3/8"	33.0
2512	20"	12'	4"	1-3/8"	48.0
2516	20"	16'	5"	1-3/8"	70.0
*2520	20"	20'	6"	1-3/8"	102.0
*2524	20"	24'	6"	1-3/8"	121.0
*2528	20"	28'	6"	2"	157.0
*2530	20"	30'	6"	2"	168.0
*2532	20"	32'	6"	2"	179.0
*2536	20"	36'	6" Heavy Duty	2"	243.0
*2539	20"	39'	6" Heavy Duty	2"	264.0
2608	24"	8'	4"	1-3/8"	38.0
2612	24"	12'	4"	1-3/8"	56.0
2616	24"	16'	5"	1-3/8"	81.0
*2620	24"	20'	6"	1-3/8"	115.0
*2624	24"	24'	6"	1-3/8"	138.0
*2628	24"	28'	6"	2"	168.0
*2630	24"	30'	6"	2"	180.0
*2632	24"	32'	6"	2"	191.0
*2636	24"	36'	6" Heavy Duty	2"	258.0
*2639	24"	39'	6" Heavy Duty	2"	280.0
2708	28"	8'	4"	1-3/8"	41
2712	28"	12'	4"	1-3/8"	60
2716	28"	16'	5"	1-3/8"	87
*2720	28"	20'	6"	1-3/8"	124
*2724	28"	24'	6"	1-3/8"	147
*2728	28"	28'	6"	2"	187
*2730	28"	30'	6"	2"	200
*2732	28"	32'	6"	2"	213
*2736	28"	36'	6" Heavy Duty	2"	282
*2739	28"	39'	6" Heavy Duty	2"	307

3 Person – 750 Lbs. Rated

3008	20"	8'	4"	2"	40
3012	20"	12'	4"	2"	59
3016	20"	16'	5"	2"	86
*3020	20"	20'	6"	2"	107
*3024	20"	24'	6"	2"	135
*3028	20"	28'	6" Heavy Duty	2"	189
*3030	20"	30'	6" Heavy Duty	2"	206
*3032	20"	32'	6" Heavy Duty	2"	219
3108	24"	8'	4"	2"	43
3112	24"	12'	4"	2"	64
3116	24"	16'	5"	2"	92
*3120	24"	20'	5"	2"	115
*3124	24"	24'	6"	2"	145
*3128	24"	28'	6" Heavy Duty	2"	204
*3130	24"	30'	6" Heavy Duty	2"	222
*3132	24"	32'	6" Heavy Duty	2"	236
*3136	24"	36'	6" Heavy Duty	2"	323
*3139	24"	39'	6" Heavy Duty	2"	365
3208	28"	8'	4"	2"	48
3212	28"	12'	4"	2"	71
3216	28"	16'	5"	2"	103
3220	28"	20'	5"	2"	128
*3224	28"	24'	6"	2"	161
*3228	28"	28'	6" Heavy Duty	2"	220
*3230	28"	30'	6" Heavy Duty	2"	236
*3232	28"	32'	6" Heavy Duty	2"	251
3236	28"	36'	6" Heavy Duty	2"	344
3239	28"	39'	6" Heavy Duty	2"	388

* Includes set of double rungs at the end of stage.

* Includes reinforcing channel

Modular Systems for Aluminum Stages

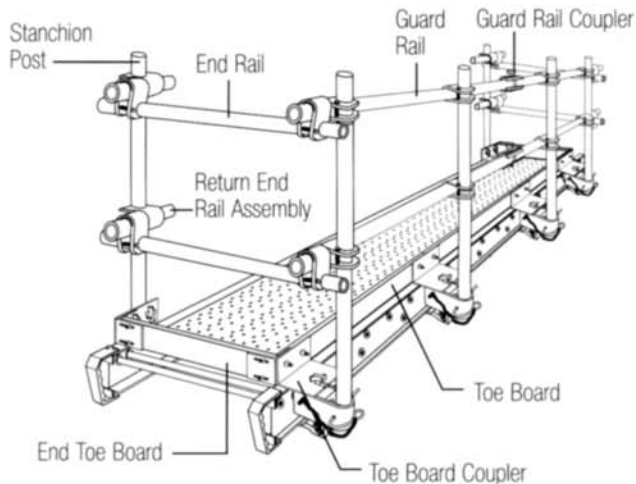

GUARD RAIL SYSTEMS

	Kit No.	Length	Package Quantity	Approx. Shipping Wt. Lbs.
Stanchion Post Assembly	SP2-1	---	2	16.0
	SP3-1	---	3	24.0
End Rail Assembly	ER28-1	28"	4	14.0
	ER34-1	34"	4	15.5
	ER40-1	40"	4	17.0
Return End Rail Assembly	RR24-1	---	4	6.5
Guard Rail	GR06-1	6"	1	5.0
	GR08-1	8"	1	5.0
	GR12-1	12"	1	5.0
Guard Rail Coupler Assembly	RC-1	---	1	1.5

To specify modular guard rail system, order Werner's Modular Guard Rail/Modular Toe Board System Slide Chart (GM6338) or contact your local Werner Sales Representative.

TOE BOARD SYSTEMS

	Kit No.	Length	Package Quantity	Approx. Shipping Wt. Lbs.
Toe Board Coupler Assembly	TBC-1	---	2	2.0
	TBC-1	---	3	3.0
Toe Board	TB05-1	5'	1	4.0
	TB06-1	6'	1	5.0
	TB07-1	7'	1	6.0
	TB08-1	8'	1	7.0
End Toe Board Assembly	ETB12-1	12"	2	3.0
	ETB14-1	14"	2	3.0
	ETB20-1	20"	2	4.0
	ETB24-1	24"	2	5.0
	ETB28-1	28"	2	6.0
Independent Toe Board Bracket Assembly	ITB2-1**	---	2	5.0
	ITB3-1**	---	3	7.0

To specify modular toe board system, order Werner's Modular Guard Rail/Modular Toe Board System Slide Chart (GM6338) or contact your local Werner Sales Representative.

Medium Duty Telescoping Plank

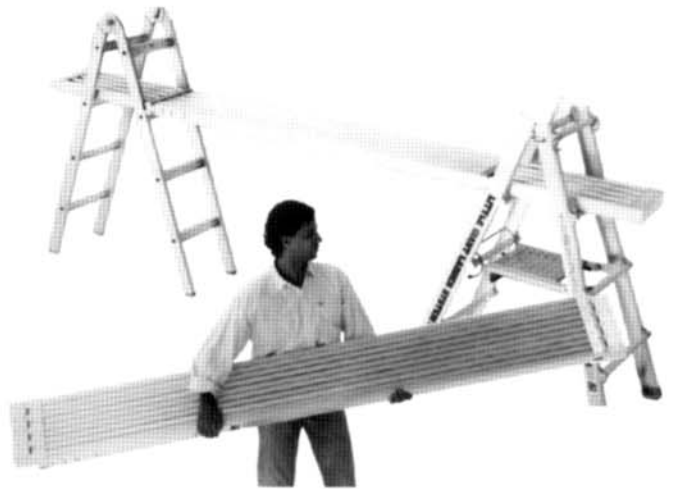

The Little Giant Medium-Duty Telescoping Plank is available in 9, 13 and 16-foot sizes (fully extended). The plank is manufactured with heavy wall aluminum tubing to prevent the twisting and flexing common to most other planks. The built-in, skid-resistant surface reduces slips. It stores and transports in approximately half of its fully extended length and fits perfectly in the Little Giant Ladder System scaffolding set up.

The telescoping plank has the strength to do the job safely and the compactness to store easily after the work is done.



SPECIFICATIONS

Model No.	Description	Standard Extension	Width	Weight
10069	Plank 9'	6'0" to 9'0"	12 1/4"	32 lbs.
10813	Plank 13'	8'0" to 13'0"	12 1/4"	42 lbs.
11016	Plank 16'	10'0" to 16'0"	12 1/4"	53 lbs.



Made in U.S.A.

SUNSET - ALUMINIUM PLANKS & STAGES

ALUMINUM PLANKS, STAGES & MODULAR HANDRAIL/TOEBOARD SYSTEM

Sunset scaffold Planks and Stage Platforms are used with and without modular toe board and handrail systems or in conjunction with extension ladders and ladder jacks. Stage platforms have multiple applications as swing stages, bridges and catwalks.

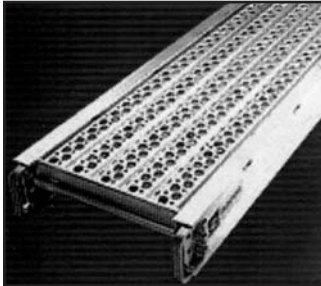

Raised Tread & Open Pattern deck Design provides slip-resistant surface that reduces buildup of solids and liquids.

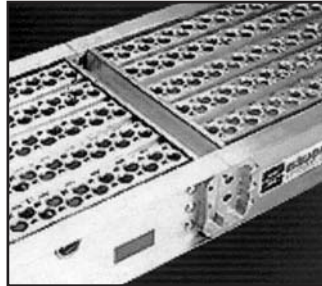

Interlocking handles permit continuous end-to-end positioning for easier and extended access.

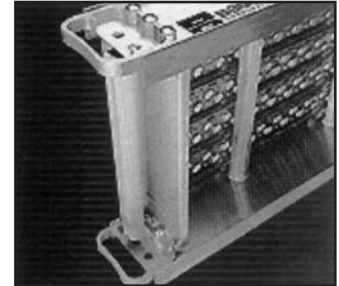

Rail Ends handles - Full Width End Rung Grips provide for easy lifting and carrying.

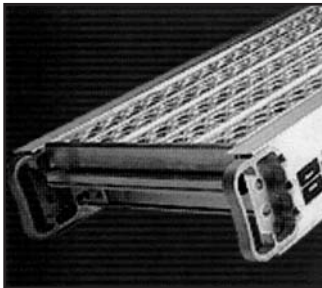

Rigid I-Beams Side Rails provide best strength, weight and cost relationship.

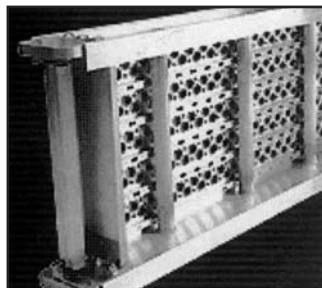

Round Rung Cross Braces on top and bottom

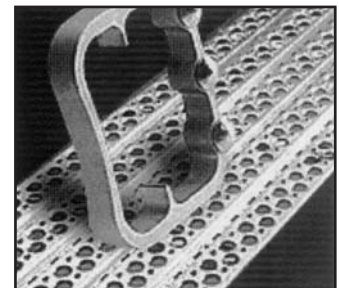

Handles & Individual Deck Strips designed for easy replacement.

Important Design Features Make Sunset Aluminum Planks and Stage Systems More Durable, Flexible and Productive for Reaching Work

Modular Safety Handrail & Toeboard System is easy to install.

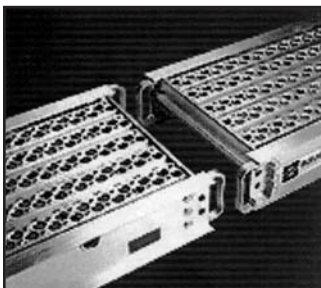

Style	Load Capacity*	Widths	Length
1-Man System	250 Lbs.	12", 14", 20"	8 ft. - 24 ft.
2-Man System	500 Lbs.	12", 14", 20", 24", 28"	8 ft. - 32 ft.
3-Man System	750 Lbs.	20", 24", 28"	8 ft. - 32 ft.

*Load Capacity includes the weight of the person and his tools.



OVER 40 YEARS

STINSON

STINSON PLANKS ARE THE PREFERRED PLANK OF THOUSANDS OF CONTRACTORS

RATED 500#

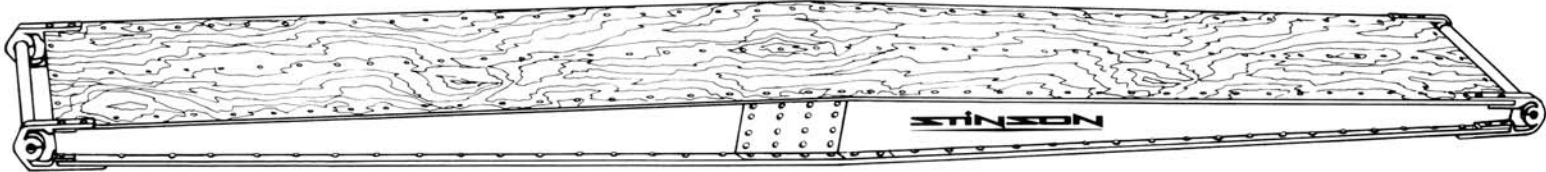

35 MODELS

7 LENGTHS FROM 8' to 32'

5 WIDTHS 12" to 24"

- LIGHT WEIGHT — UP TO 40% LESS THAN LIKE-RATED ALL-ALUMINUM PLANKS.
- STIFFER THAN STRAIGHT CHANNELED ALL-ALUMINUM PLANKS
- COMFORT OF WOOD WORKING SURFACES, ESPECIALLY IN TEMPERATURE EXTREMES.

QUALITY. PLANK AFTER PLANK.

STINSON PLANK SIZES

Width	Model Number	Length	Weight Lbs.	Width	Model Number	Length	Weight Lbs.
12"	P08HB	08'0"	16	20"	P08VHB	08'0"	30
	P12HB	11'9"	32		P12VHB	11'9"	51
	P16HB	15'9"	45		P16VHB	15'9"	66
	P20HB	19'6"	55		P20VHB	19'6"	84
	P24HB	23'6"	69		P24VHB	23'6"	110
	P28HB	27'3"	102		P28VHB	27'3"	125
	P32HB*	31'3"	135		P32VHB*	31'3"	148
14"	P08JHB	08'0"	19	24"	P08XHB	08'0"	35
	P12JHB	11'9"	35		P12XHB	11'9"	62
	P16JHB	15'9"	47		P16XHB	15'9"	77
	P20JHB	19'6"	61		P20XHB	19'6"	95
	P24JHB	23'6"	74		P24XHB	23'6"	126
	P28JHB	27'3"	108		P28XHB	27'3"	157
	P32JHB*	31'3"	139		P32XHB*	31'3"	175
18"	P08QHB	08'0"	27	*Come standard with armor ply surfaces			
	P12QHB	11'9"	42	Stinson support systems... the lightweights being used by			
	P16QHB	15'9"	60	successful painters, maintenance workers, carpenters, elec-			
	P20QHB	19'6"	76	tricians, siding applicators, structural ironworkers, concrete			
	P24QHB	23'6"	99	finishers, sheet metal workers, builders and contractors.			
	P28QHB	27'3"	112	NOTE: Do not use planks in connection with swing			
	P32QHB*	31'3"	142	staging or suspended scaffold. Please notify manufactur-			

*Come standard with armor ply surfaces

Stinson support systems... the lightweights being used by successful painters, maintenance workers, carpenters, electricians, siding applicators, structural ironworkers, concrete finishers, sheet metal workers, builders and contractors.

NOTE: Do not use planks in connection with swing staging or suspended scaffold. Please notify manufacturer if you have any questions about proper use.

— All Products Meet OSHA Requirements —

MEMBER
SCAFFOLD
INDUSTRY
ASSOCIATION **SIA**

Complies with
OSHA
Requirements

STINSON

LADDER JACKS – INDUSTRY RATED AT 250#

LIGHT WEIGHT ALUMINUM LADDER JACKS

SHORT BODY

MODEL JACK SFL
SPANS 2 RUNGS

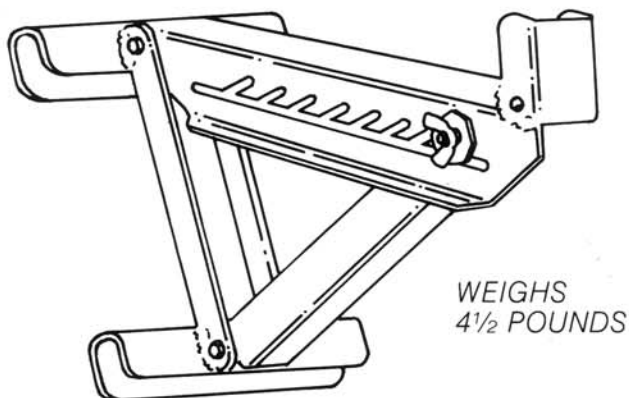

**Complies with
OSHA
Requirements**

LONG BODY

MODEL JACK XFL
SPANS 3 RUNGS

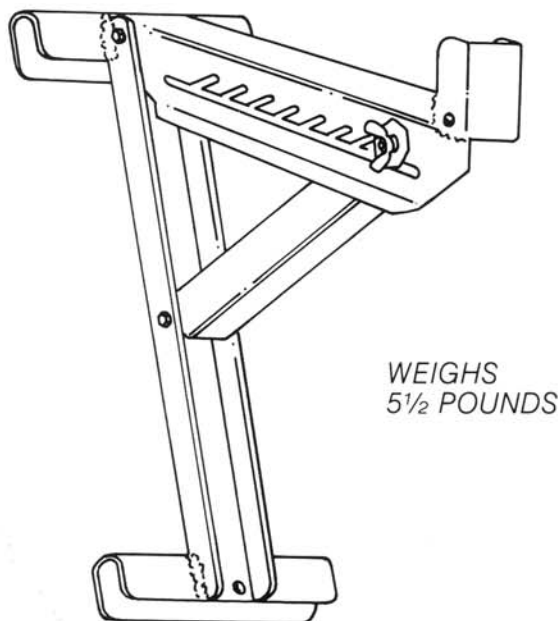

DURA-JACK®

MODEL JACK SDR
TOUGH ALL-STEEL CONSTRUCTION
SHORT BODY LADDER JACK

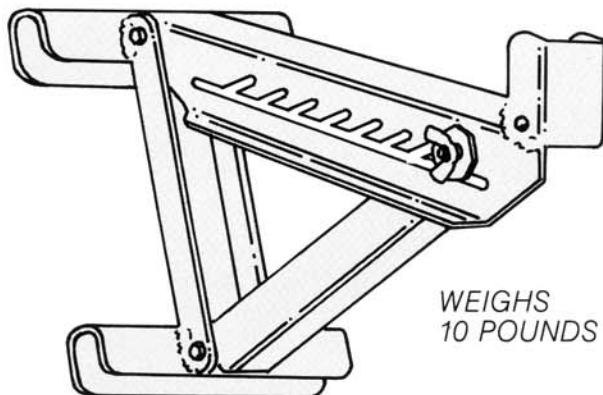

FULLY ASSEMBLED

- Rated 250# Per Ladder Jack
- No Busted Knuckles or Pinched Fingers
- Lightweight for Easy Handling
- Fits Inside and Outside Face of Ladder
- Will Accommodate up to 18" Plank
- To Be Used With Type I or IA Ladders

(Product's occupational use must conform with safe practices and federal, state and city codes).

*The ultimate in safety,
 appearance & construction*

MOBILE LADDER STAND

- 1" dia. steel tube construction
- Ruggedly braced and reinforced
- Standard 12" deep top platform
- Solid mig welded construction
- BIG non-skid, non-marking shoes
- Safety green enamel finish
- 42" tall guardrails on 6-step and larger
- Meets CAL/OSHA requirements
- Meets Federal OSHA/ANSI requirements

Optional Features:

- Guard chain with snap for entry-exit on any side of platform
- Fold down shelves
- Narrow aisle models
- Custom handrail arrangement or height
- Extra deep platform in multiples of 12"

*Custom designs available
 to meet your needs!*

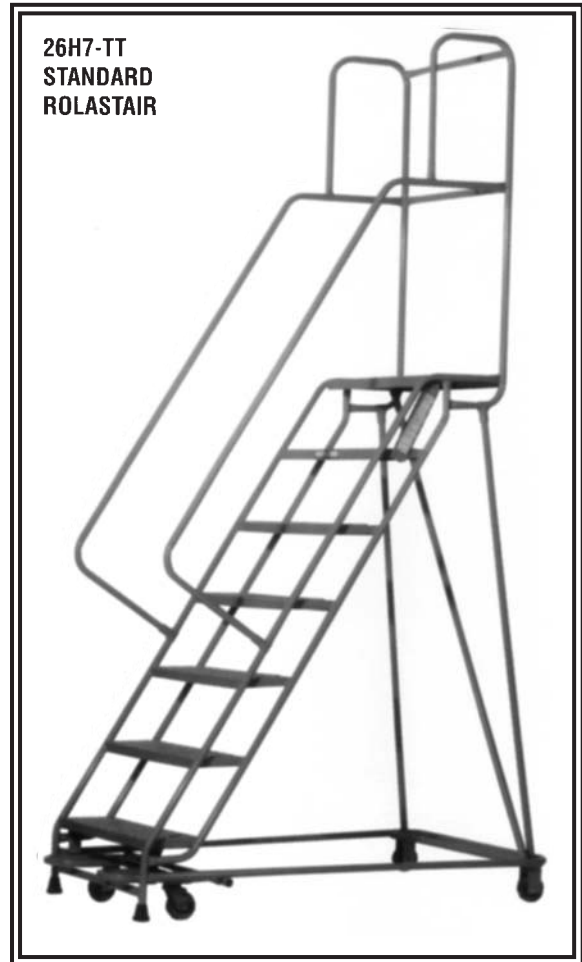

Traction Tread (Standard Step)

Designed and manufactured to provide the optimum in safety, strength and appearance. Provides greater non-slip protection than diamond plate.



Diamond Plate (Optional Step)

Provides anti-slip protection through use of raised diamond shaped ribs on a fully closed step surface.



Safety Grating (Optional Step)

Provides maximum non-skid protection in wet and/or dry conditions.

Select the best unit for your application based on the required platform height.

Custom sizes are available.

STEPS	DESCRIPTION	MODEL	PLATFORM HEIGHT	TOP WIDTH	OVERALL HEIGHT	BASE		WEIGHT
						WIDTH	DEPTH	
1	No Handrails Attractive and very handy in the office, library, vault, stockroom, machine shop, etc.	20-1	12"	20"	12"	20"	16"	15 lbs.
		26-1	12"	26"	12"	26"	16"	20 lbs.
2	All models equipped with 4 each 2" dia. spring loaded casters and 4 each large, non-skid rubber shoes to grip the floor when in use.	20-2	19"	20"	19"	21"	21"	22 lbs.
		26-2	19"	26"	19"	27"	21"	28 lbs.
3		20-3	28.5"	20"	28.5"	22"	29"	31 lbs.
		26-3	28.5"	26"	28.5"	28"	29"	35 lbs.

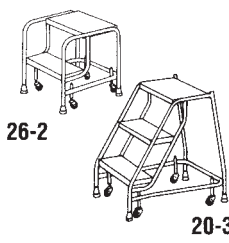

STEPS	DESCRIPTION	MODEL	PLATFORM HEIGHT	TOP WIDTH	OVERALL HEIGHT	BASE		WEIGHT
						WIDTH	DEPTH	
2	2 step has 22" handrails 3-5 step has 32" tall handrails All models equipped with 4 each 2" dia. spring loaded casters and 4 each large non-skid rubber shoes to grip the floor when in use.	20H2	19"	20"	41"	21"	21"	32 lbs.
		26H2	19"	26"	41"	27"	21"	36 lbs.
3		20H3	28.5"	20"	60.5"	22"	29"	42 lbs.
		26H3	28.5"	26"	60.5"	28"	29"	46 lbs.
4		20H4	38"	20"	70"	24"	35"	50 lbs.
		26H4	38"	26"	70"	30"	35"	56 lbs.
5		20H5	47.5"	20"	79.5"	25.5"	41.5"	57 lbs.
		26H5	47.5"	26"	79.5"	31.5"	41.5"	66 lbs.

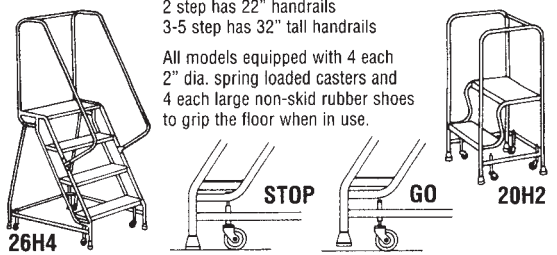

STEPS	DESCRIPTION	MODEL	PLATFORM HEIGHT	TOP WIDTH	OVERALL HEIGHT	BASE		WEIGHT
						WIDTH	DEPTH	
6	42" tall guardrail around platform StepJack foot controlled casters and floor lock assembly assures dependable "stop and go" safety on all ladders in this group. All StepJack mechanisms are equipped with two 3.5" swivel casters.	20H6	57"	20"	99"	27"	48.5"	81 lbs.
		26H6	57"	26"	99"	33"	48.5"	90 lbs.
7	Six through 10-step models have two 3.5" rigid casters under the platform end. Eleven through 15-step models are equipped with 5" rigid casters. Thirteen-step units and larger are equipped with 4" kick plate and are provided with a folded base for ease and economy in shipping.	20H7	66.5"	20"	108.5"	28.5"	55.5"	85 lbs.
		26H7	66.5"	26"	108.5"	35"	55.5"	106 lbs.
8		26H8	76"	26"	118"	36"	62"	116 lbs.
9		26H9	85.5"	26"	127.5"	36"	69"	126 lbs.
10		26H10	95"	26"	137"	36"	76"	135 lbs.
11		26H11	104.5"	26"	146.5"	39"	82.5"	146 lbs.
12		26H12	114"	26"	156"	42"	89"	158 lbs.
13		26H13	123.5"	26"	165.5"	45"	96"	190 lbs.
14		26H14	133"	26"	175"	48"	103"	232 lbs.
15		26H15	142.5"	26"	184.5"	52"	110"	243 lbs.

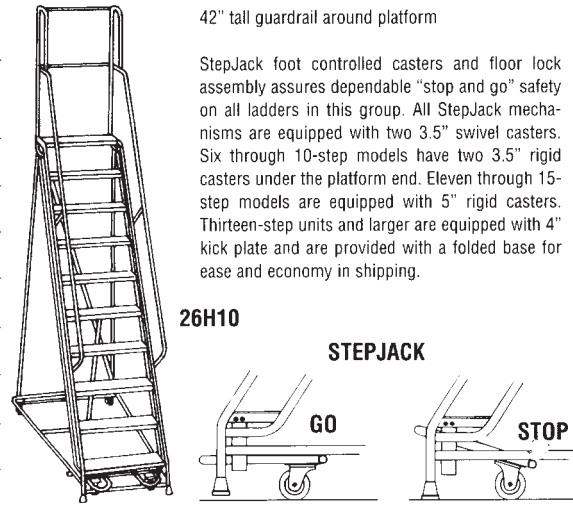

FOLDING ROLASTAIR



MOBILE LADDER STAND

- Knock-down base and handrails
- Safety green enamel finish
- Standard 12" deep top platform
- Large 2" dia. non-skid, non-marking rubber shoes
- 1" dia. steel tube construction
- 42" tall guardrails on all models
- Meets CAL/OSHA requirements
- Meets Federal OSHA/ANSI requirements

Optional Features:

- Extra deep platform in 12" multiples
- See standard Rolastair options

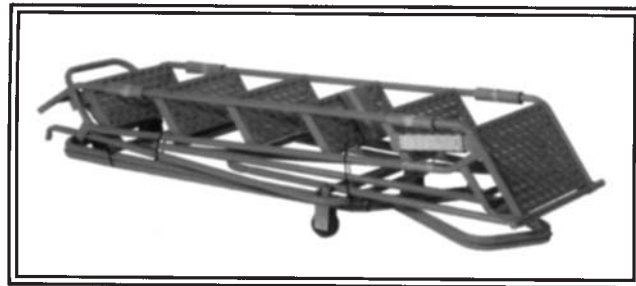

1



2

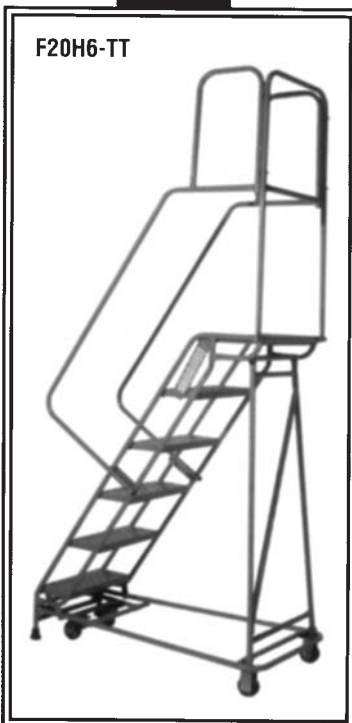
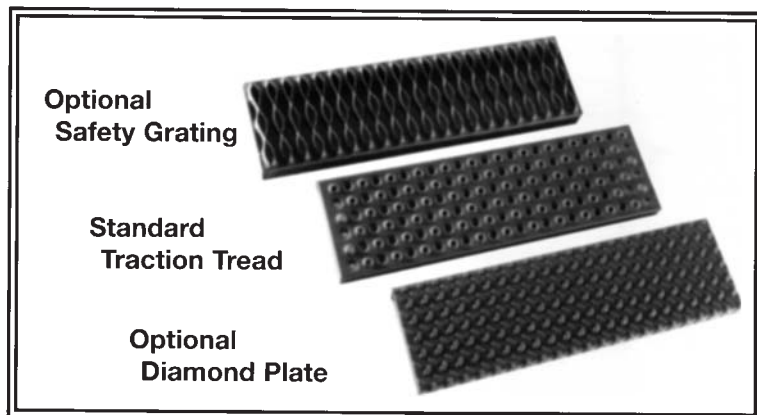

F20H6-TT

3

STEPS	DESCRIPTION	MODEL	PLATFORM HEIGHT	TOP WIDTH	OVERALL HEIGHT	BASE		WEIGHT
						WIDTH	DEPTH	
6	All of these models are shipped fully folded to reduce shipping cost.	F20H6	57"	18"	99"	26"	46"	82 lbs.
		F26H6	57"	26"	99"	31"	46"	92 lbs.
7	All are provided with StepJack foot controlled caster and floor lock assembly. 3.5" swivel casters are mounted on the StepJack.	F20H7	66.5"	18"	108.5"	26"	53"	89 lbs.
		F26H7	66.5"	26"	108.5"	31"	53"	108 lbs.
8	3.5" rigid casters are used under platform.	F26H8	76"	26"	118"	30"	60"	122 lbs.
9		F26H9	85.5"	26"	127.5"	33"	66"	135 lbs.
10		F26H10	95"	26"	137"	36"	73"	142 lbs.
11		F26H11	104.5"	26"	146.5"	39"	80"	151 lbs.
12		F26H12	114"	26"	156"	42"	87"	181 lbs.
13		F26H13	123.5"	26"	165.5"	45"	94"	207 lbs.
14		F26H14	133"	26"	175"	48"	100"	232 lbs.
15	All of these models have 5" rigid casters located under the platform.	F26H15	142.5"	26"	184.5"	52"	107"	242 lbs.
16		F26H16	152"	26"	194"	55"	114"	274 lbs.
17		F26H17	161.5"	26"	203.5"	58"	121"	292 lbs.
18		F26H18	171"	26"	213"	61"	128"	312 lbs.
19		F26H19	180.5"	26"	222.5"	64"	135"	327 lbs.

EZ-CLIMB ROLASTAIR



MOBILE LADDER STAND – *designed for forward descent*

- 45 degree angle of climb
- 9-1/2" rise and run per step
- 9-1/2"x 24" wide steps
- 1" diameter steel tube frame
- Standard 19" extra-deep top platform
- Diamond plate steps
- 3-4-5 step units have spring loaded casters
- 6 step & larger have StepJack
- 3-4-5 step units have 32" tall guardrail
- 6 step & larger have 42" tall guardrail
- 6 step & larger have K-D base
- Large 2" diameter rubber shoes
- Safety green enamel finish

Optional Features:

- Safety grating steps and platform
- Extra-deep top platforms
- StepJack on 3-4-5 step units



Standard
Diamond Plate

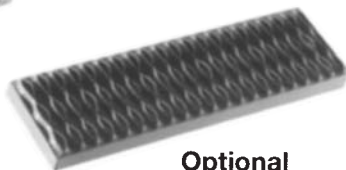

Optional
Safety Grating

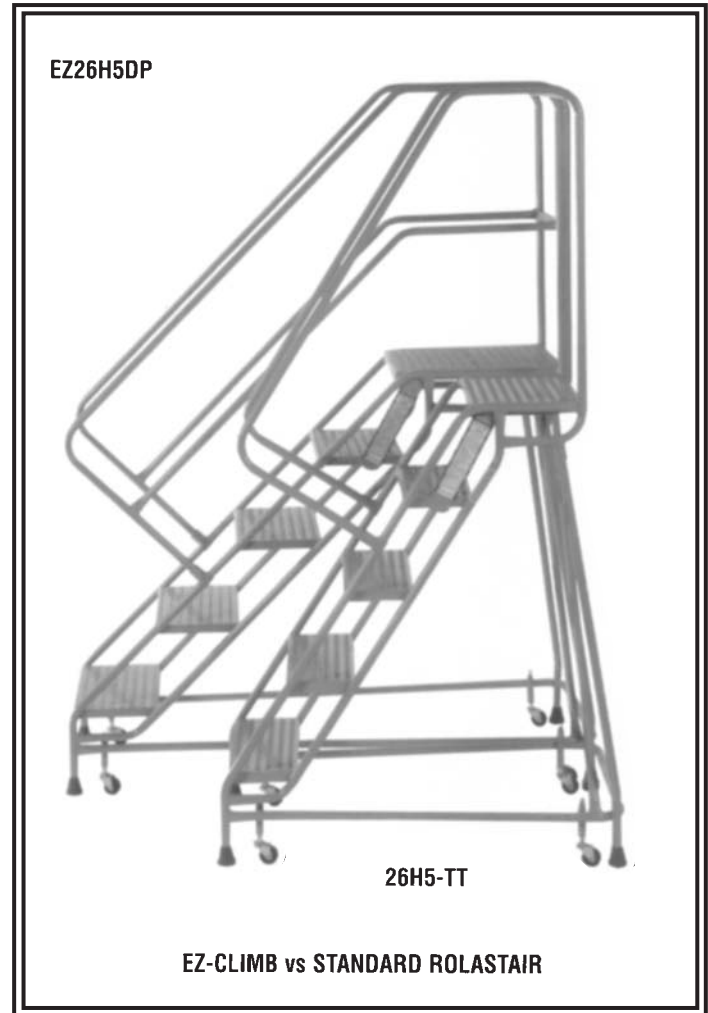

No. of STEPS	MODEL	PLATFORM HEIGHT	OVERALL HEIGHT	BASE		ESTIMATED WEIGHT
				WIDTH	DEPTH	
3	EZ26H3DP	28.5"	60.5"	28"	40"	59 lbs.
4	EZ26H4DP	38"	70"	30"	50"	72 lbs.
5	EZ26H5DP	47.5"	79.5"	31.5"	60"	89 lbs.
6	EZ26H6DP	57"	99"	33"	70.5"	114 lbs.
7	EZ26H7DP	66.5"	108.5"	35"	80.5"	131 lbs.
8	EZ26H8DP	76"	118"	36"	90.5"	148 lbs.
9	EZ26H9DP	85.5"	127.5"	36"	100.5"	165 lbs.
10	EZ26H10DP	95"	137"	36"	111"	182 lbs.

HEAVY DUTY STEEL ROLLING WAREHOUSE LADDERS / GSX2400 SERIES (Knocked Down)



ALL SIZES MEET OR EXCEED THE REQUIREMENTS OF ANSI A14.7 AND OSHA 1910.29 STANDARDS WITH A **350 LB. LOAD RATING**

GSX2409 with option #X09 shown



Super heavy duty ladders constructed for the most demanding requirements. Large ball bearing casters facilitate easy maneuvering. All models equipped with large swivel caster in front and rigid casters in the rear. Step on bottom step to activate and lock rubber tipped feet in down position. Step on unlocking pedal to unlock.



Forward Descent
50 degree climbing angle meets ANSI requirements for forward descent.



Tubular Construction
Massive 2" x 1" rectangular tubing base designed to reduce abusive damage.



Wide Steps
The 17" top step and large 8-1/2" steps make climbing and working easier.

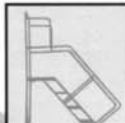

Handrail & Guardrail
All units come standard with 1-1/16" OD high strength steel tube handrails and guardrails.



Bottom Landing Step
The 10" bottom step gives a larger surface to engage the locking mechanism.

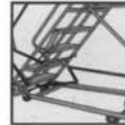

Accessory: Unique Easy-Turn™ Design (#X09)
Louisville's exclusive Easy-Turn™ feature includes five strategically placed casters for easier mobility and maneuverability. The design allows the user to spin the entire platform on a dime.



Non Marring/Marking Casters
Each model is equipped with 4 ball bearing casters. The caster's material will not mark or mar the working surface.

NEW LLG MODEL	STEPS	STEP WIDTH	PLATFORM HEIGHT	OVERALL HEIGHT	OVERALL DEPTH	OVERALL WIDTH	APPROX. CUBE	WEIGHT
GSX2404	4	24"	40"	76"	49"	28"	37.50	113
GSX2405	5	24"	50"	86"	58"	28"	42.70	126
GSX2406	6	24"	60"	96"	66"	34"	51.11	146
GSX2407	7	24"	70"	106"	74"	34"	56.66	159
GSX2408	8	24"	80"	116"	82"	34"	62.22	200
GSX2409	9	24"	90"	126"	91"	34"	67.77	232
GSX2410	10	24"	100"	136"	99"	34"	73.33	248
GSX2411	11	24"	110"	146"	107"	34"	78.88	264
GSX2412	12	24"	120"	156"	116"	34"	84.44	280
GSX2413	13	24"	130"	166"	124"	39"	92.22	356
GSX2414	14	24"	140"	176"	133"	39"	97.77	369
GSX2415	15	24"	150"	186"	141"	39"	103.33	392

*GSX spare parts are listed below



HEAVY DUTY STEEL ROLLING WAREHOUSE LADDERS / GSX1600 SERIES (Knocked Down)



ALL SIZES MEET OR EXCEED THE REQUIREMENTS OF ANSI A14.7 AND OSHA 1910.29 STANDARDS WITH A **350 LB. LOAD RATING**



This super heavy duty ladder is constructed for the most demanding requirements, yet it is only 16" wide—the number one choice for narrow spaced industrial applications.



Tubular Construction
Massive 2" x 1" rectangular tubing base designed to reduce abusive damage.



Non Marring/Marking Casters
Each model is equipped with 4 ball bearing casters. The caster's material will not mark or mar the working surface.



Bottom Landing Step
The 10" bottom step gives a larger surface to engage the locking mechanism.



Forward Descent
50 degree climbing angle meets ANSI requirements for forward descent.

GSX REPLACEMENT PARTS

MODEL	DESCRIPTION	SIZE
999844A	Step Lock Spring	3'-15'
601054A	2" Rubber Pad	3'-15'
921004A	4" Swivel Caster	3'-7'
921007A	4" Rigid Caster w/Stud	3'-7'
921009A	5" Swivel Caster	8'-15'
921008A	5" Rigid Caster w/Stud	8'-15'

*GSX parts are not interchangeable with SX parts

NEW LLG MODEL	STEPS	STEP WIDTH	PLATFORM HEIGHT	OVERALL HEIGHT	OVERALL DEPTH	OVERALL WIDTH	APPROX. CUBE	WEIGHT
NO HANDRAILS								
GSX1602	2	16"	20"	20"	33"	23"	9.02	35
HANDRAILS								
GSX1603	3	16"	30"	66"	41"	23"	27.98	75
GSX1604	4	16"	40"	76"	49"	23"	32.50	91
GSX1605	5	16"	50"	86"	58"	23"	37.01	104
GSX1606	6	16"	60"	96"	66"	27"	41.52	118
GSX1607	7	16"	70"	106"	74"	27"	46.04	132



STEEL ROLLING WAREHOUSE LADDERS GSW SERIES (Knocked Down)



Louisville Ladder steel rolling warehouse ladders are considered one of the best on the market. Ladder equipped with ball bearing casters allowing easy movement to any area. Rugged all steel construction. Sturdy handrails, easy 56 degree climbing angle, "Sure Grip" tread, 7" deep steps and 10" deep top platform provide quality features for the everyday user.

ALL SIZES MEET OR EXCEED THE REQUIREMENTS OF ANSI A14.7 AND OSHA 1910.29 STANDARDS WITH A **350 LB. LOAD RATING**



Spring Loaded Casters (standard on 2-step to 5-step models) Four spring loaded casters on 2-5 step models. Casters retract when load is placed on the ladder, setting the ladder firmly in place on rubber tips. When the load is removed, springs push down the casters enabling the ladder to move about freely.

Locking Device (standard on 6-step to 15-step models) Models 6-step and taller come equipped with a large 4" swivel caster in front and rigid casters in the rear. Stepping on bottom step activates the locking mechanism, locking rubber tipped feet in down position. To move the ladder, just step on the unlocking pedal.



No Forward Descent
56 degree climbing angle does not meet ANSI requirements for forward descent.



Toeboard (standard on 12-step to 15-step models) The top platform on models 12-step and taller is surrounded on three sides by a 4" high toeboard. *Can be added as an option to smaller size models. (W05)*



Premium Powder Paint
Baked-on finish is durable and provides superior scratch and scuff resistance. Attractive, even coverage with no drips or runs.

NEW LLG MODEL	STEPS	PLATFORM WIDTH	PLATFORM HEIGHT	OVERALL HEIGHT	OVERALL DEPTH	OVERALL WIDTH	APPROX. CUBE	WEIGHT
NO HANDRAILS								
GSW1601	1	16"	12"	12"	17"	19"	2.24	16
GSW1601-W04	1	16"	12"	12"	17"	19"	2.24	16
GSW1602	2	16"	20"	20"	19"	20"	6.66	24
GSW2402	2	24"	20"	20"	19"	28"	8.33	30
GSW1603	3	16"	30"	30"	27"	20"	13.54	34
GSW2403	3	24"	30"	30"	27"	28"	13.54	41
GSW1604	4	16"	40"	40"	35"	23"	18.05	47
GSW2404	4	24"	40"	40"	35"	31"	20.83	55
HANDRAILS								
GSW1603-W03	3	16"	30"	66"	27"	20"	25.83	46
GSW2403-W03	3	24"	30"	66"	27"	28"	32.29	56
GSW1604-W03	4	16"	40"	76"	35"	23"	30.00	58
GSW2404-W03	4	24"	40"	76"	35"	31"	40.00	66
GSW1605	5	16"	50"	86"	42"	23"	34.16	67
GSW2405	5	24"	50"	86"	42"	31"	45.55	79
GSW2406	6	24"	60"	96"	50"	34"	51.11	109
GSW2407	7	24"	70"	106"	57"	34"	56.66	121
GSW2408	8	24"	80"	116"	63"	34"	62.22	151
GSW2409	9	24"	90"	126"	70"	34"	67.77	170
GSW2410	10	24"	100"	136"	77"	34"	73.33	198
GSW2411	11	24"	110"	146"	83"	34"	78.88	214
GSW2412	12	24"	120"	156"	90"	34"	84.44	228
GSW2413	13	24"	130"	166"	97"	39"	92.22	289
GSW2414	14	24"	140"	176"	104"	39"	97.77	298
GSW2415	15	24"	150"	186"	110"	39"	103.33	311

GSW REPLACEMENT PARTS

MODEL	DESCRIPTION	SIZE
999844A	Step Lock Spring	6'-15'
601054A	2" Rubber Pad	6'-15'
921016	Caster	1'-5'
999928A	Front Crutch Tip	1'-5'
999928B	Back Crutch Tip	1'-5'
921004A	4" Swivel Caster	6'-15'
921007A	4" Rigid Caster w/Stud	6'-15'

*GSW parts are not interchangeable with SW parts

OPTIONS & ACCESSORIES



Extra Deep Top
Standard top platform is 10" deep. 16" and 24" wide models can also be manufactured with an extra deep top platform measuring 20" or 30".
Accessory # W01 (20")
Accessory # W02 (30")



Spring Loaded Casters
(option for 1-step model only)
1-step model comes standard with four rubber tipped legs for stability. Also available with spring loaded casters like those used on 2-5 step models.
Accessory # W04



Handrail & Guardrail
Models 5-step and taller come standard with 30" handrails and 36" guard-rails on back. Also available on 3-4 step models.
Accessory #W03



Handrail and Outrigger
Required when local codes require 3:1 height to base ratio. (CAL OSHA)

GSW Series	GSX Series
5 Step (16" wide)	3 to 7 Step (16" wide)
5 to 9 Step (24" wide)	4 to 9 Step (24" wide)
10 to 12 Step (24" wide)	10 to 12 Step (24" wide)
13 to 15 Step (24" wide)	13 to 15 Step (24" wide)



GSW2410



GSW2405



GSW1601

ACCESS LADDERS

INDUSTRIAL • ALL STEEL ALL WELDED

Construction:

- 3/8" x 2 1/2" flat bar side rails
- 3/4" diameter round rungs
- 1 1/2" diameter round - 42" tall boarding rail
- Stand-off brackets on maximum 72" centers
- Heavy duty flat bar cage
- See back cover for available colors.
- Standard 18 inch wide rungs on 12 inch centers

Standard Installation Considerations: (As required by code)

- Cages are required on all access ladders of more than 20 feet to a maximum unbroken length of 30 feet
- Intermediate platforms or landings must be used at 30 foot intervals or fraction there of, when overall height exceeds 30 feet
- When intermediate platforms are used adjacent ladder sections are to be off-set.
- When exiting to the side at the top of the access ladder the ladder rungs will continue 4 feet above the platform.
- When exiting to the front at the top of the access ladder boarding rails shall extend 42 inches above the top rungs.

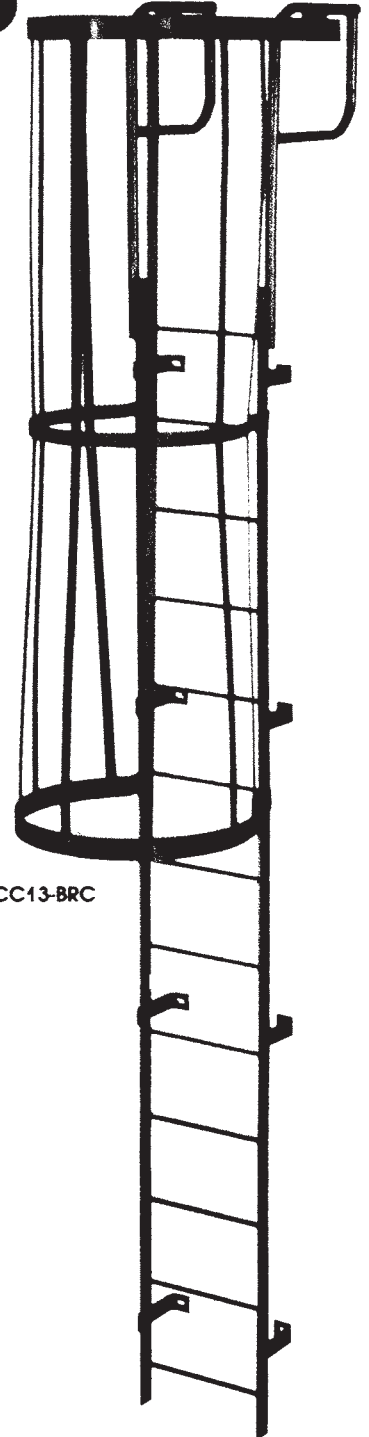

ACC13-BRC

CREATE YOUR OWN MODEL NUMBER!

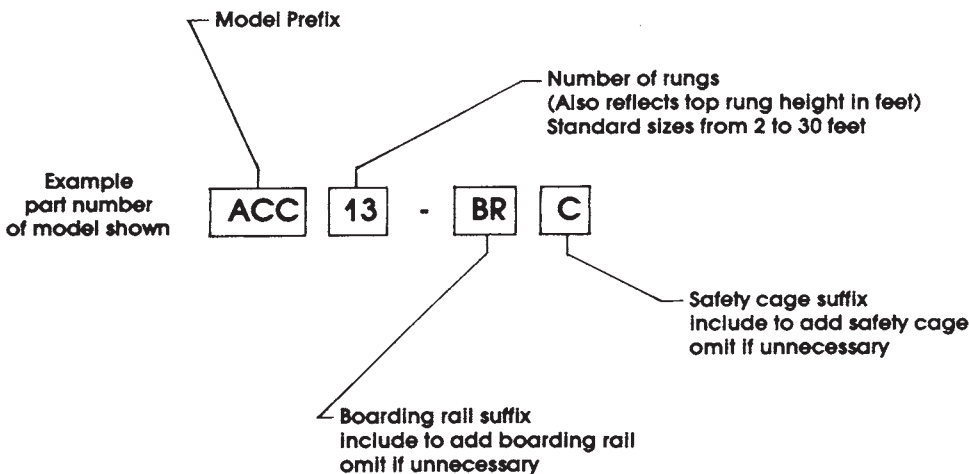

Available options:

- 36" x 36" intermediate platform
- Security door
- Split stand-off brackets
- Cage bottom security hatch
- All aluminum access ladders
- Flat diamond plate treads
- Hot dipped galvanized finish

ELK RIVER LANYARDS, BELTS, & HARNESSES



ConstructionPlus™ Harness

One D-ring ConstructionPlus™ Harness Sliding D-ring at center of back, Parachute-mating buckles on leg straps, Made of polyester.
Available Sizes: One Size
Part Number: 48103 (01809)

All Universal Series Full Body Harnesses include these Standard features and benefits:

Features	Benefits
1. Sliding back D-ring	Allows 100% tie off ground to ground
2. Full-strength chest strap	Increases reliability and safety
3. Seat strap	Provides maximum support
4. One size fits most workers	Reduces inventory requirements

CSA Classifications

Full body harnesses shall be classified as follows:

Group A	Group D	Group E
Fall Arresting	Controlled Descent	Confined Entry & Exit

Group L
Ladder Climbing

Group P
Worker Positioning

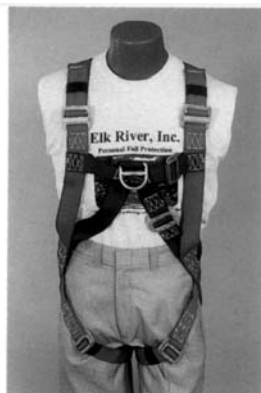

TowerMate LE Harness

Two D-ring TowerMate Harness
Sliding D-ring at center of back, Chest-high front D-ring.
Available Sizes: S-L, L-XL
Part Numbers: 56222 & 56224

Group A
Group L



Lanyards

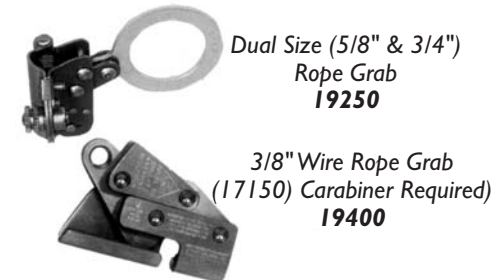
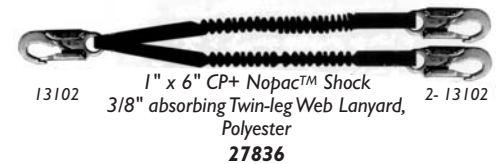
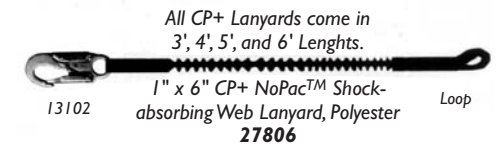
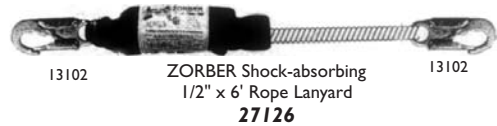

NightHawk™ Roofer's Kit

NightHawk™ Roofer's Kit contains NightHawk™ Harness, 50' Hawkline Lifeline with Rope Grab and 2' ZORBER Shock-absorbing lanyard, single use anchor with fasteners, packaged in a five-gallon bucket.
Available Sizes: One Size Fits Most
Part Number 05003



Group A



Retractable Lanyards

Retractable Lanyards can be used in a wide range of work situations where extra mobility is required. Typically the mechanical device is anchored to an approved overhead anchorage to eliminate interference with ladders and vertical work areas.

Care should be taken to address the "pendulum" or "swing" action of the Fall Arrest (FA) when Retractable Lanyards are in use. **NOTE: All Retractable Lanyards require carabiners.**

Retractable Lanyards feature an internal sealed spring mechanism that allows normal controlled movement away from the device. The inertial disc brake system is activated by any sudden movement, accidental slip or fall. It functions much like a seat belt, once activated it stops the action of the fall. An energy absorber is built into the braking system and will stop a fall in less than one foot.

Some Retractable Lanyards are equipped with built-in retrieval systems and are designed to be used in rescue situations. They are **NOT** to be used as a winch. Once a unit has been used as a retrieval system, it must be recertified.

All units have a safe work load of 350 pounds total weight and are proof tested prior to being shipped from the factory. Any unit which fails a field test or is subjected to an actual fall arrest must be removed from service immediately and returned to the factory for recertification. No annual recertification is required for retractable lanyards.

**Annual Recertification Not Required
for Retractable Lanyards**

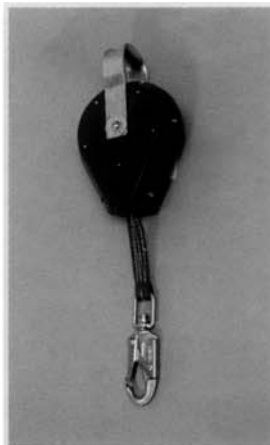
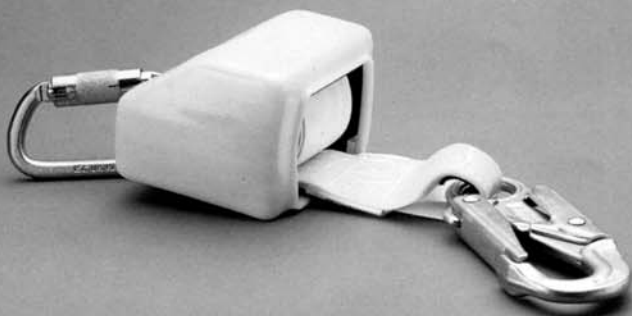

**Web Retractable Lanyard,
1' x 25', Available with
stainless aircraft cable.**

Part Number: 21225



**Galvanized Aircraft Cable
Retractable Lanyard,
3/16" x 25' Available with
stainless aircraft cable.**

Part Number: 21402



**Galvanized Aircraft Cable
Recovery Retractable
Lanyard, 3/16" x 50'**

Part Number: 21803

RETRACTAMAN Retractable Lanyard, 1-7/8" x 9', includes 17150 carabiner. RETRACTAMAN Retractable Lanyards are rated for Fall Arrest (FA), but once used in a fall must be retired from service. RETRACTAMAN Retractable Lanyards are NOT recertifiable.

Part Number: 21210

Portable Anchorage Connectors



D-ring Anchorage Eyebolt

Part Number: 13020



I-Beam Slider,
fits 3.5" to 12" wide beams,
horizontal only

Part Number: 13025



I-Beam Trolley Anchors

Fits 2-5/8" x 5-1/16" beam
Part Number: 13060
Fits 5-1/16" x 7-1/2" beam
Part Number: 13065



Elk River Roof Anchor: Reusable roof
peak anchor, Hinged at D-ring for
variable roof pitch applications, 32 -
2" x #10 wood screws included.

Part Number: 13050

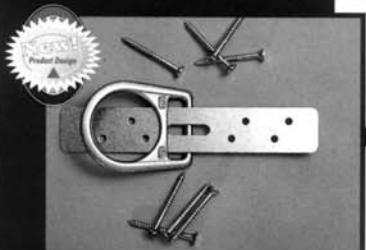

Elk River Roof Anchor Single Use.
Eight wood screws included.

Part Number: 13055

Pipe Anchor Hooks

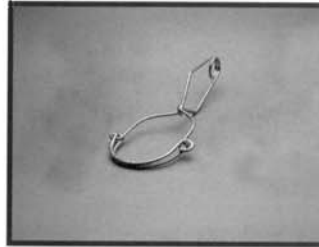

Pipe Anchor Hook, 3-1/4"

Part Number: 13500



Pipe Anchor Hook, 4-1/2"

Part Number: 13501



Pipe Anchor Hook, 5-3/4"

Part Number: 13502

Tie-off Slings

Tie-off slings are available in 12"
increments. See Price List.
3' and 6' lengths are the
most popular.



EZE-MAN Tie-off sling 12"

Part Number: 26770

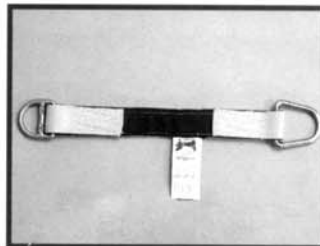

EZE-MAN Tie-off sling 18"

Part Number: 26771

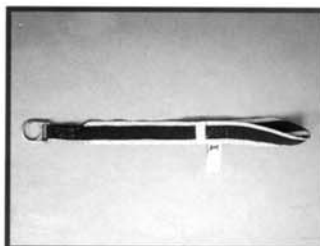

EZE-MAN Tie-off sling, 3'

Part Number: 26793