

Hi-lume™ A-Series Driver Overview Forward-Phase Control

Hi-lume™ A-Series Driver is a high-performance LED driver that provides smooth, continuous 1% dimming for virtually any LED fixture, whether it requires constant-current or constant-voltage. It is the most versatile LED driver offered today due to its compatibility with a wide variety of LED arrays, multiple form factors, and numerous control options.

Features

- Continuous, flicker-free dimming from 100% to 1%.
- Guaranteed compatibility with selected Maestro Wireless®, RadioRA® 2, HomeWorks® QS, GRAFIK Eye® QS, GRAFIK Systems™, Quantum®, and C•L® dimmers. Please see **Compatible Controls** chart or contact Lutron for details regarding compatible controls.
- QwikFig™ compatible. For more information please refer to Lutron® P/N 041473 (K and M case only).
- 100% performance tested at factory.
- A rated lifetime of 50,000 hours @ $t_c = 149^\circ\text{F}$ (65°C).
- UL® recognized and listed options for United States and Canada.
- Type TL Rated.
- FCC Part 15 compliant for commercial and residential (UL® Listed only) applications at 120 V~.
- Pulse width modulation (PWM) or constant-current reduction (CCR) dimming methods available. See Application Note #360 for details.
- RoHS Compliant
- For more information please go to: www.lutron.com/HilumeLED

Stickbulb note:
For dimming info, go to pages 32-34

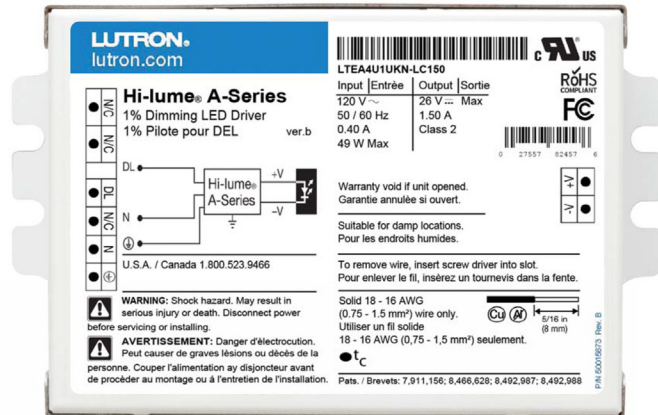

Hi-lume™ A-Series, case type K

3.00 in (76 mm) W x 1.00 in (25 mm) H x
4.90 in (124 mm) L



Hi-lume™ A-Series, case type M

1.18 in (30 mm) W x 1.00 in (25 mm) H x
14.25 in (362 mm) L



Hi-lume™ A-Series, case type KL

K-case mounted on a 4.00 in (102 mm) W x
1.50 in (38 mm) H x 4.00 in (102 mm) L junction
box to provide UL® listed wiring compartment

LUTRON® SPECIFICATION SUBMITTAL

Job Name:	Model Numbers:	
<input type="text"/>	<input type="text"/>	<input type="text"/>
Job Number:	<input type="text"/>	<input type="text"/>

Specifications

Regulatory Approvals

- Meets ANSI C62.41 category A surge protection standards up to and including 4 kV.
- FCC Part 15 compliant for commercial and residential (UL® Listed only) applications.
- Manufacturing facilities employ ESD reduction practices that comply with the requirements of ANSI/ESD S20.20.
- Lutron® Quality Systems registered to ISO 9001.2008.
- UL® 8750 recognized.
- UL® 8750 listed form factor available.
- Class 2 output available.
- Models available to meet LED Driver requirements for Energy Star 1.1.
- Type TL Rated.

UL® 8750 Listed Option

- cULus® for United States and Canada available for certain operating regions.
- Pre-wired and installation ready.
- See **KL Case: Case Dimensions** page for more specific details regarding UL® listed option.

Environmental

- Sound Rating: Inaudible in 27 dB ambient.
- Relative Humidity: Maximum 90% non-condensing.
- Minimum operating ambient temperature (t_a) = 32 °F (0 °C).

Performance

- Dimming Range: 100% to 1%.
- Operating Voltage: 120 V~ at 50/60 Hz
- Requires Forward Phase Control; please see **Compatible Controls** chart.
- A rated lifetime of 50,000 hours @ $t_c = 149$ °F (65 °C).
 - For rated warranty, t_c not to exceed the maximum rated temperatures.¹
- Patented thermal foldback protection.
- LEDs turn on to any dimmed level without going to full brightness.
- Non-volatile memory restores all driver settings after power failure.
- Power Factor: >0.90 at 40 W.
- Total Harmonic Distortion (THD): <20% at 40 W.
- Inrush Current: < 2 A.
- Inrush Current Limiting Circuitry: eliminates circuit breaker tripping, switch arcing and relay failure.
- Open circuit protected.
- Short circuit protected.
- Turn-on time: ≤ 1.5 seconds.²
- PWM Dimming Frequency: 550 Hz.

Driver Wiring & Mounting

- Driver is grounded by a mounting screw to the grounded fixture (or by terminal connection on the K case).
- Terminal blocks on the driver accept one solid wire per terminal from 18 AWG to 16 AWG (0.75 mm² to 1.5 mm²).
- Fixture must be grounded in accordance with local and national electrical codes.
- For maximum driver-to-LED light engine wire length, see charts in **Driver Leads** section at the end of the document.

¹ Installer is responsible for ensuring that the driver case temperature does not exceed the maximum rated temperature.

² Models available with turn-on time ≤ 1 second.

Job Name: <input style="width: 90%; height: 20px;" type="text"/>	Model Numbers: <input style="width: 60%; height: 20px;" type="text"/> <input style="width: 35%; height: 20px;" type="text"/>	
Job Number: <input style="width: 150px; height: 20px;" type="text"/>	<input style="width: 250px; height: 20px;" type="text"/>	<input style="width: 250px; height: 20px;" type="text"/>

How to Build a Model Number: Hi-lume™ A-Series LTE

LTEA4U1U -

Case Size:

K = Compact
M = Stick

Case Style:

S = Studded
(K case only)
N = Non-Studded
L = UL® Listed
(K case only)

Example: LTEA4U1UKS-HC070

For further assistance selecting your model number, contact our LED Center of Excellence at 1.877.346.5338 or LEDs@lutron.com

Current Level (for Constant-Current):

020 = 0.20 A; 021 = 0.21 A...070 = 0.70 A...210 = 2.10 A

Voltage Level (for Constant-Voltage):

100 = 10.0 V; 105 = 10.5 V...600 = 60.0 V

Driver Output:

C = Constant-current driver
with pulse width modulation (PWM) dimming
A = Constant-current driver
with constant-current reduction (CCR) dimming
V = Constant-voltage driver
with pulse width modulation (PWM) dimming

LED Load Output Range (see the following pages for more detail):

Class 2 Constant-Voltage

A = 10.0 V–12.0 V
B = 12.5 V–20.0 V*
C = 20.5 V–24.0 V*
D = 24.5 V–38.0 V*

Isolated Non-Class 2 Constant-Voltage

X = 38.5 V–60.0 V*

Class 2 Constant-Current

E = 0.20 A–0.50 A 30 V–54 V
F = 0.51 A–1.00 A 30 V–54 V*
G = 0.20 A–0.70 A 8 V–20 V
H = 0.20 A–0.70 A 15 V–38 V
I = 0.71 A–1.05 A 8 V–20 V
J = 0.71 A–1.05 A 15 V–38 V
K = 1.06 A–1.50 A 8 V–20 V
L = 1.06 A–1.50 A 15 V–38 V*
M = 1.51 A–2.10 A 8 V – 19.9 V*

Isolated Non-Class 2 Constant-Current

Y = 0.20 A–0.50 A 30 V–60 V
Z = 0.51 A–1.00 A 30 V–60 V*

* Output parameter is power-limited for these output ranges. Consult detailed specifications on the following pages for each range.

Job Name: <input style="width: 90%; height: 20px;" type="text"/>	Model Numbers: <input style="width: 90%; height: 20px;" type="text"/>	
Job Number: <input style="width: 150px; height: 20px;" type="text"/>	<input style="width: 90%; height: 20px;" type="text"/>	<input style="width: 90%; height: 20px;" type="text"/>

How to Build a Bulk Model Number (For use with Lutron® QwikFig™ technology): Hi-lume™ A-Series LTE

LTEA4U1U - BLK

Case Size:

K = Compact
M = Stick

Case Style:¹

S = Studded
(K-case only)
N = Non-Studded
(All M-case models)

Bulk Models:

Coverage based on “LED Load Output Range” from standard non-configurable models shown in the **How to Build a Model Number** section. Example Standard Model Number: LTEA4U1UKS-**H**C070 has LED load output range = H

K-case and M-case

1A = Covers “LED Load Output Range” Y and Z
2A = Covers “LED Load Output Range” M
3A = Covers “LED Load Output Range” E and F (CCR dimming only)

K-case only

2G = Covers “LED Load Output Range” G
2H = Covers “LED Load Output Range” H
2R = Covers “LED Load Output Range” I and K
2S = Covers “LED Load Output Range” J and L

M-case only

2B = Covers “LED Load Output Range” H, J, and L
2C = Covers “LED Load Output Range” G, I, and K

Note: Only the model numbers falling into the structure listed above can be configured with QwikFig™. Standard model numbers configured at Lutron will not be capable of being reconfigured at another facility.

¹ QwikFig™ bulk drivers are only available as UL® recognized.

Job Name: <input type="text"/>	Model Numbers: <input type="text"/>	
Job Number: <input type="text"/>	<input type="text"/>	<input type="text"/>

“A” Output Range, Voltage Driver Models

Driver Type	Output Dimming Method	Output Voltage	Output Current	Output Power	Standards Recognition	UL® Listed Option (KL case)
Constant-Voltage Driver (Class 2)	Pulse Width Modulation (PWM)	10.0–12.0 V PWM	0.42–3.3 A	5–40 W		Yes

Voltage Driver Operation Range:

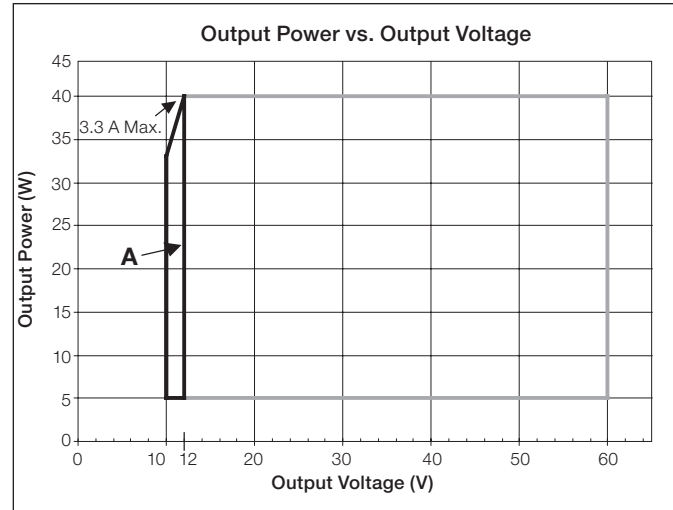
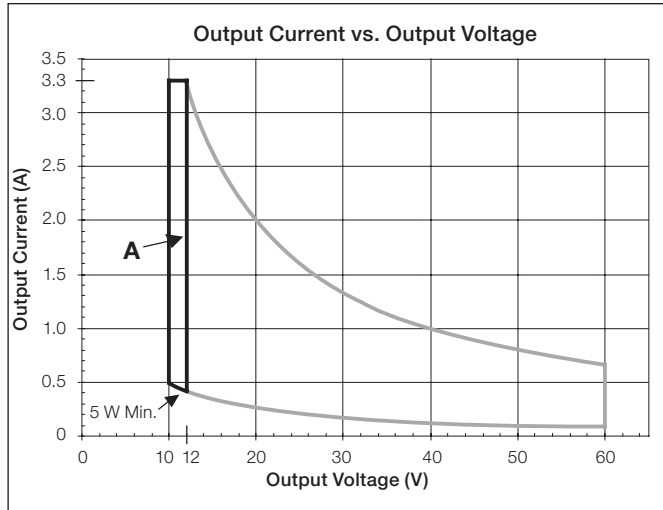

Typical Performance Specifications:

Parameter	Value	Test Conditions
Input Current	410 mA	$t_a = 25\text{ }^\circ\text{C}$, 12.0 V 40 W load, Maximum Light Output, K case 120 V~ without a dimmer
Power Factor	0.98	
THD	16%	
Driver Efficiency	79%	

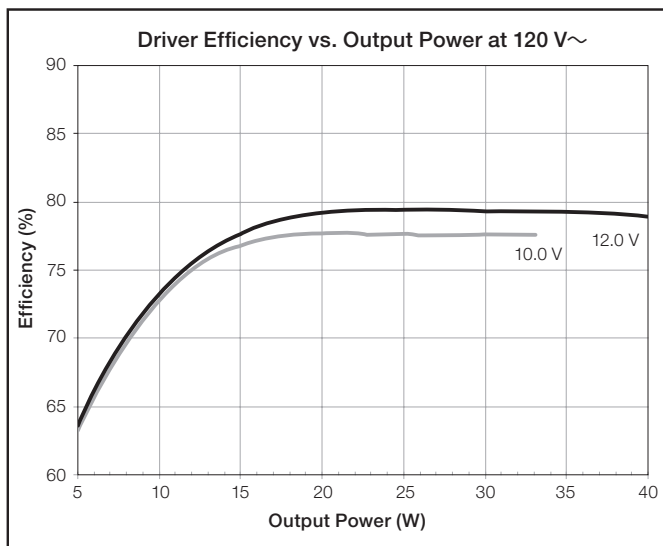

Job Name: <input style="width: 90%; height: 20px;" type="text"/>	Model Numbers: <input style="width: 95%; height: 20px;" type="text"/>
Job Number: <input style="width: 80%; height: 20px;" type="text"/>	<input style="width: 95%; height: 20px;" type="text"/>

“B” Output Range, Voltage Driver Models

Driver Type	Output Dimming Method	Output Voltage	Output Current	Output Power	Standards Recognition	UL® Listed Option (KL case)
Constant-Voltage Driver (Class 2)	Pulse Width Modulation (PWM)	12.5–20.0 V PWM	0.25–3.2 A	5–40 W		Yes

Voltage Driver Operation Range:

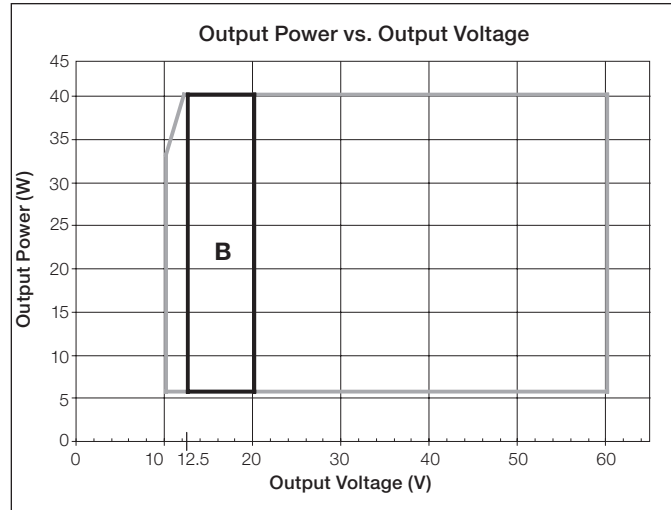
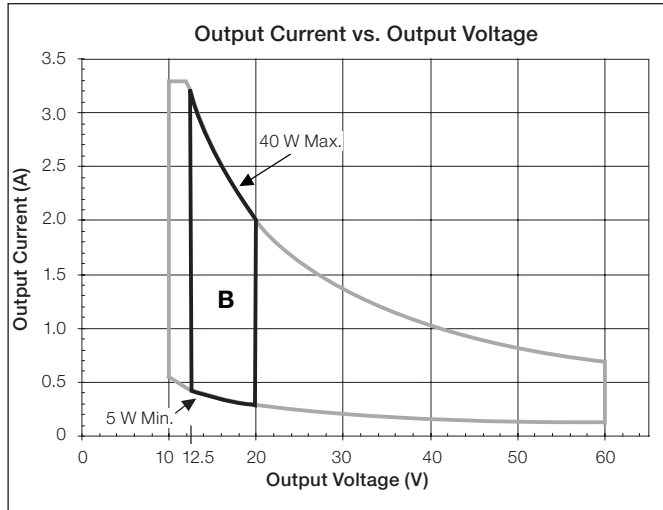

Typical Performance Specifications:

Parameter	Value	Test Conditions
Input Current	400 mA	$t_a = 25\text{ }^\circ\text{C}$, 20.0 V 40 W load, Max. Light Output, K case 120 V~ without a dimmer
Power Factor	0.99	
THD	9%	
Driver Efficiency	83%	

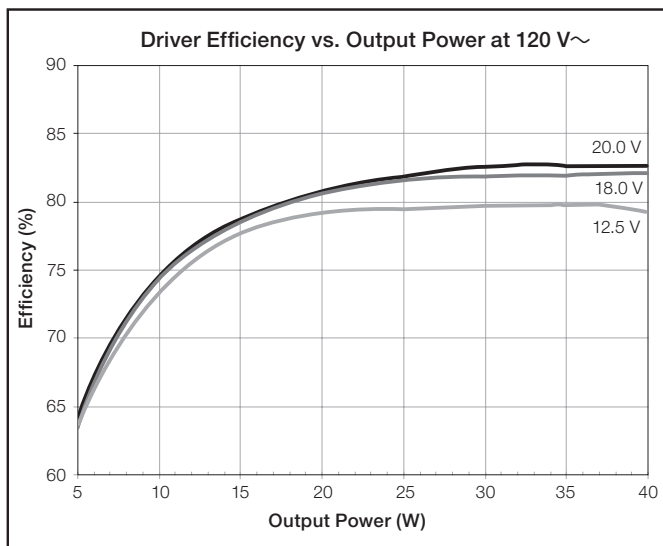

Job Name: <input style="width: 90%; height: 20px;" type="text"/>	Model Numbers: <input style="width: 95%; height: 20px;" type="text"/>
Job Number: <input style="width: 80%; height: 20px;" type="text"/>	<input style="width: 95%; height: 20px;" type="text"/>

“C” Output Range, Voltage Driver Models

Driver Type	Output Dimming Method	Output Voltage	Output Current	Output Power	Standards Recognition	UL® Listed Option (KL case)
Constant-Voltage Driver (Class 2)	Pulse Width Modulation (PWM)	20.5–24.0 V PWM	0.21–1.95 A	5–40 W		Yes

Voltage Driver Operation Range:

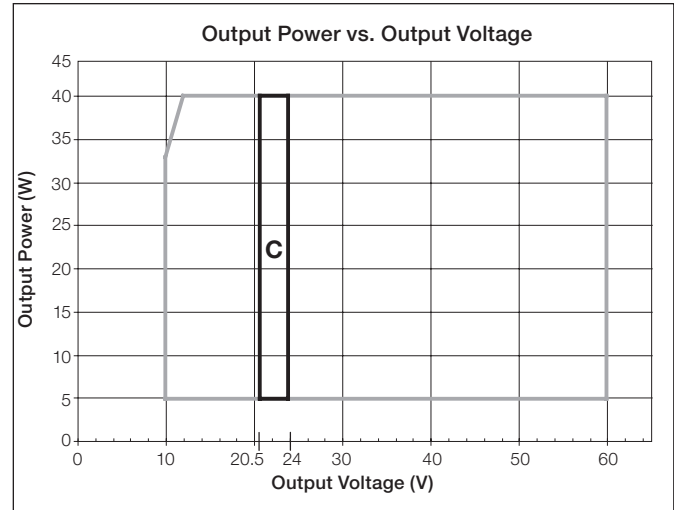
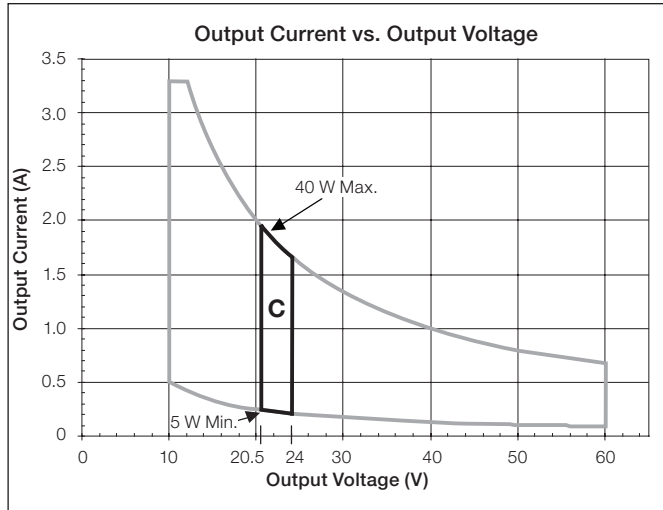

Typical Performance Specifications:

Parameter	Value	Test Conditions
Input Current	370 mA	$t_a = 25\text{ }^\circ\text{C}$, 24.0 V 40 W load, Maximum Light Output, K case 120 V~ without a dimmer
Power Factor	0.99	
THD	10%	
Driver Efficiency	84%	

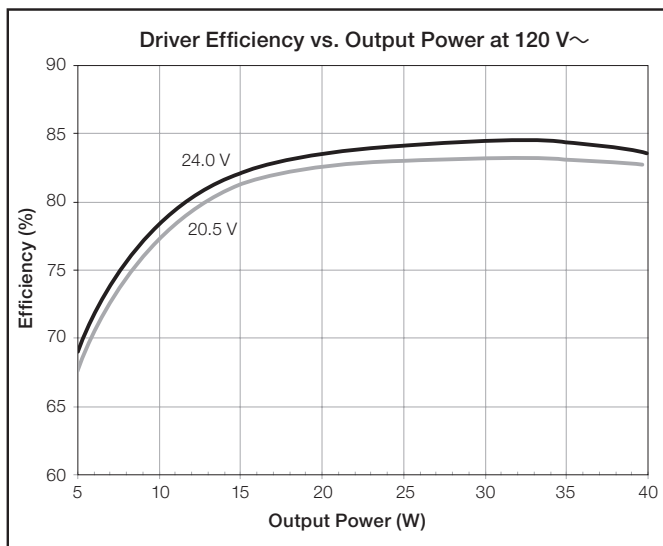

Job Name: <input style="width: 90%; height: 20px;" type="text"/>	Model Numbers: <input style="width: 95%; height: 20px;" type="text"/>
Job Number: <input style="width: 80%; height: 20px;" type="text"/>	<input style="width: 95%; height: 20px;" type="text"/>

“D” Output Range, Voltage Driver Models

Driver Type	Output Dimming Method	Output Voltage	Output Current	Output Power	Standards Recognition	UL® Listed Option (KL case)
Constant-Voltage Driver (Class 2)	Pulse Width Modulation (PWM)	24.5–38.0 V PWM	0.13–1.63 A	5–40 W		Yes

Voltage Driver Operation Range:

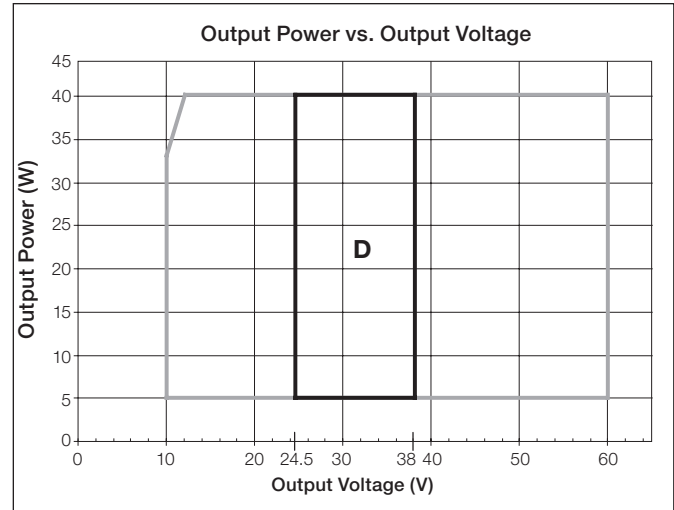
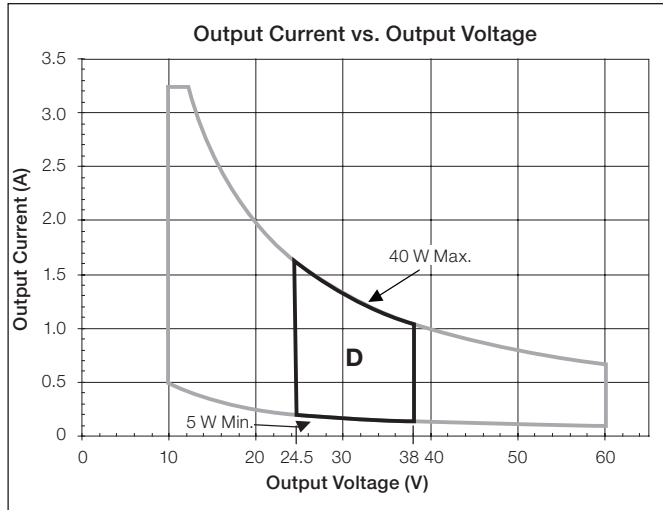

Typical Performance Specifications:

Parameter	Value	Test Conditions
Input Current	380 mA	$t_a = 25\text{ }^\circ\text{C}$, 38.0 V 40 W load, Maximum Light Output, K case 120 V~ without a dimmer
Power Factor	0.99	
THD	7%	
Driver Efficiency	86%	

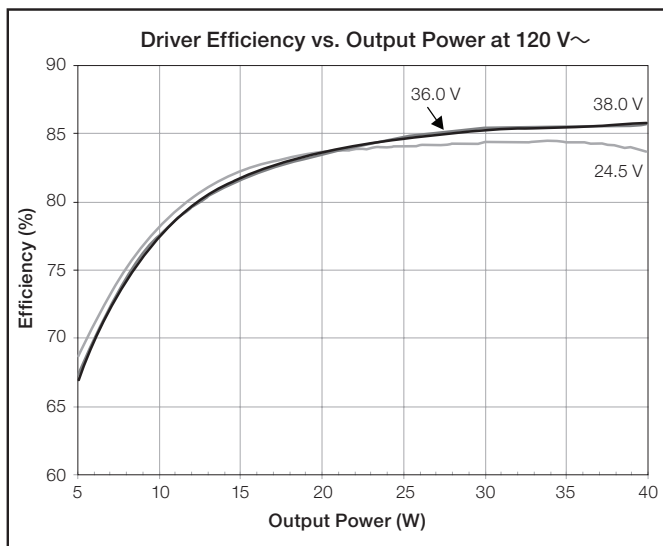

Job Name: <input style="width: 90%; height: 20px;" type="text"/>	Model Numbers: <input style="width: 95%; height: 20px;" type="text"/>
Job Number: <input style="width: 80%; height: 20px;" type="text"/>	<input style="width: 95%; height: 20px;" type="text"/>

“E” Output Range, Current Driver Models

Driver Type	Output Dimming Method	Output Voltage	Output Current	Output Power	Standards Recognition	UL® Listed Option (KL case)
Constant-Current Driver (Class 2)	Constant-Current Reduction (CCR)	30–54 V $\overline{\text{=}}$	0.20–0.50 A	6–27 W	 Type TL 82 °/74 °C - K-case Type TL 86 °/72 °C - M-case	Yes

When using QwikFig™ technology, these models can be built from the following bulk units:

K-case - LTEA4U1UKx-3ABLK*; M-case - LTEA4U1UMN-3ABLK

* x = studded (S) or non-studded (N)

Current Driver Operation Range:

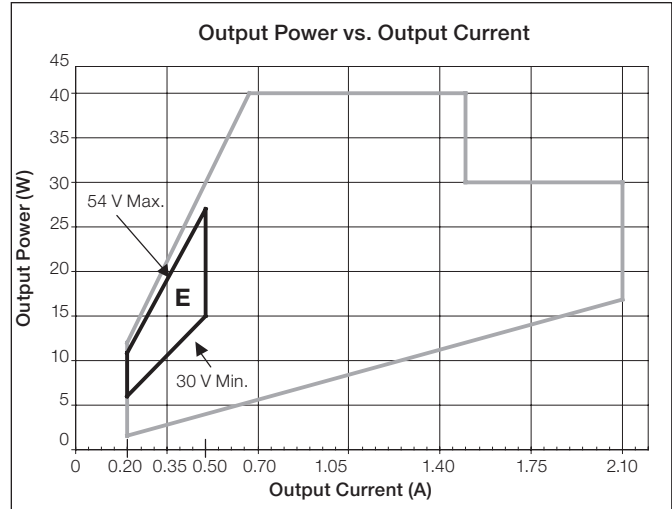
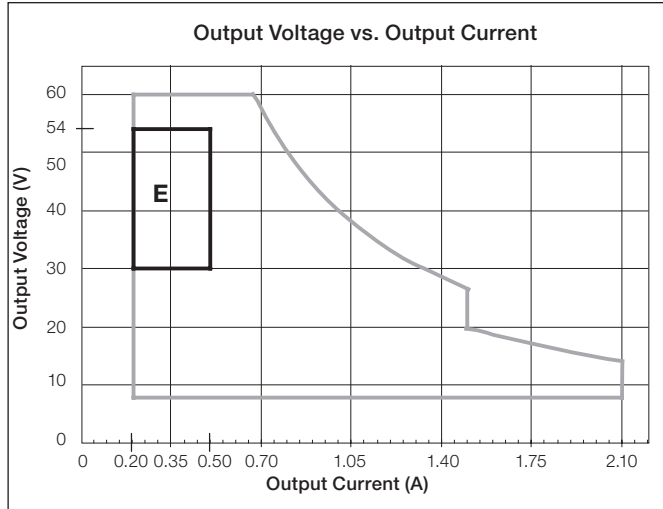

Typical Performance Specifications:

Parameter	Value	Test Conditions
Input Current	260 mA	$t_a = 25\text{ }^\circ\text{C}$,
Power Factor	0.99	0.50 A 27 W load,
THD	10%	Maximum Light Output,
Driver Efficiency	83%	K case
		120 V \sim without a dimmer

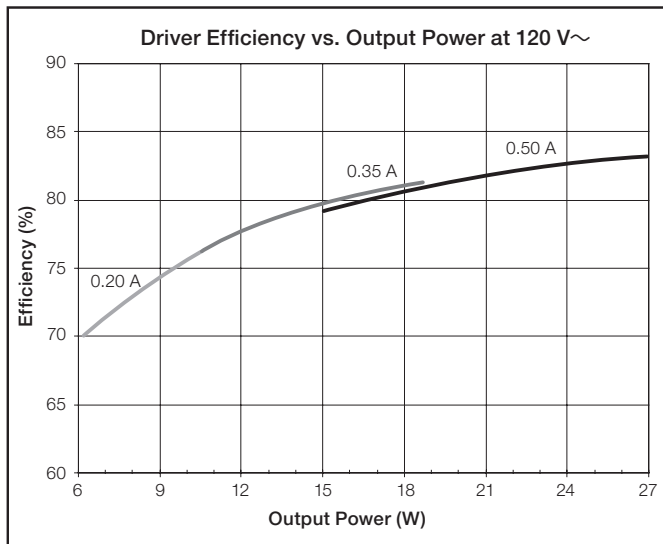

Job Name:	Model Numbers:	
<input style="width: 90%;" type="text"/>	<input style="width: 30%;" type="text"/>	<input style="width: 30%;" type="text"/>
Job Number:	<input style="width: 30%;" type="text"/>	<input style="width: 30%;" type="text"/>

“F” Output Range, Current Driver Models

Driver Type	Output Dimming Method	Output Voltage	Output Current	Output Power	Standards Recognition	UL® Listed Option (KL case)
Constant-Current Driver (Class 2)	Constant-Current Reduction (CCR)	30–54 V $\overline{=}$	0.51–1.00 A	15–40 W	 Type TL 82 °/74 °C - K-case Type TL 86 °/72 °C - M-case	Yes

When using QwikFig™ technology, these models can be built from the following bulk units:

K-case - LTEA4U1UKx-3ABLK*; M-case - LTEA4U1UMN-3ABLK

* x = studded (S) or non-studded (N)

Current Driver Operation Range:

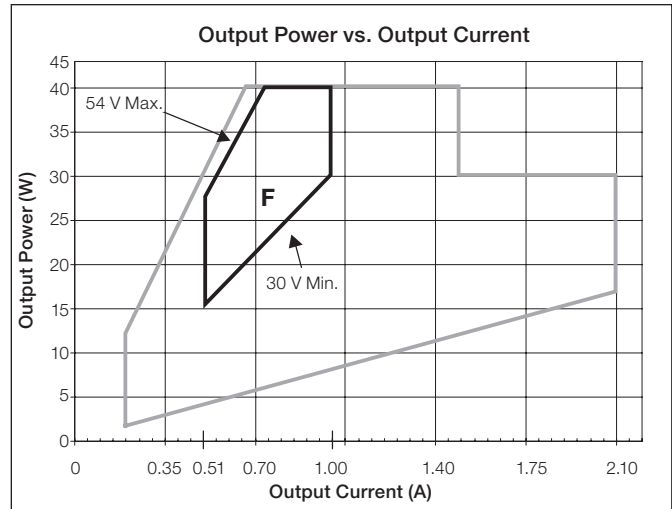
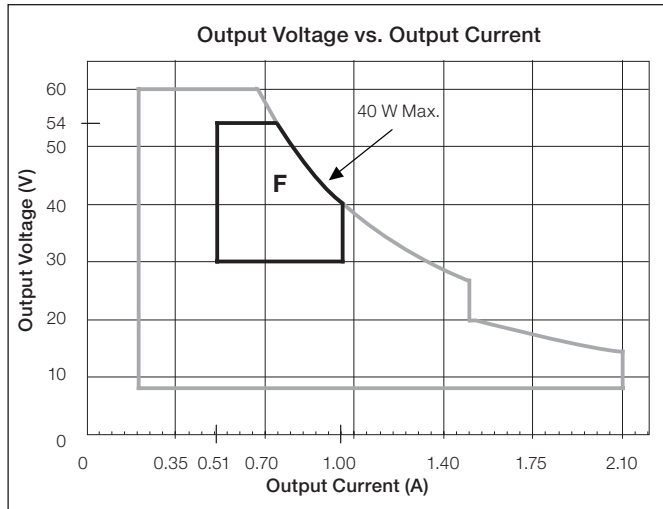

Typical Performance Specifications:

Parameter	Value	Test Conditions
Input Current	390 mA	$t_a = 25\text{ }^\circ\text{C}$,
Power Factor	0.99	1.00 A 40 W load,
THD	7%	Maximum Light Output,
Driver Efficiency	82%	K case 120 V \sim without a dimmer

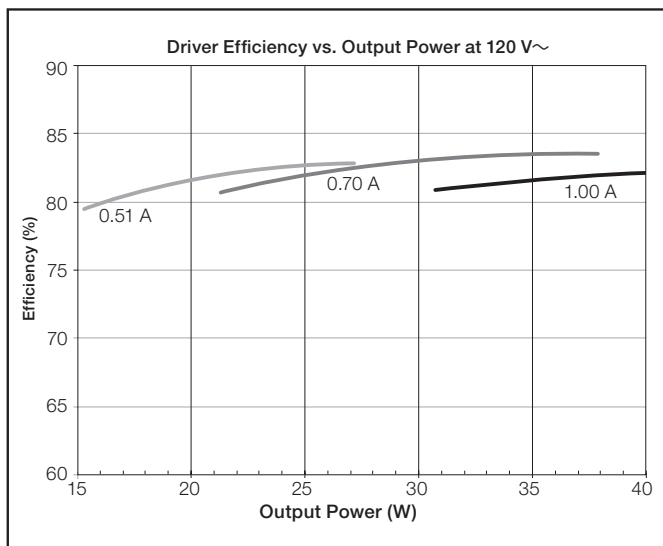

Job Name: <input style="width: 90%;" type="text"/>	Model Numbers: <input style="width: 60%;" type="text"/> <input style="width: 40%;" type="text"/>	
Job Number: <input style="width: 150px;" type="text"/>	<input style="width: 300px;" type="text"/>	<input style="width: 200px;" type="text"/>

“G” Output Range, Current Driver Models

Driver Type	Output Dimming Method	Output Voltage	Output Current	Output Power	Standards Recognition	UL® Listed Option (KL case)
Constant-Current Driver (Class 2)	Pulse Width Modulation (PWM)	8–20 V PWM	0.20–0.70 A	2–14 W	 Type TL 86 °/57 °C - K-case Type TL 90 °/69 °C - M-case	Yes
	Constant-Current Reduction (CCR)	8–20 V \sim				

When using QwikFig™ technology, these models can be built from the following bulk units:

K-case - LTEA4U1UKx-2GBLK*; M-case - LTEA4U1UMN-2CBLK

* x = studded (S) or non-studded (N)

Current Driver Operation Range:

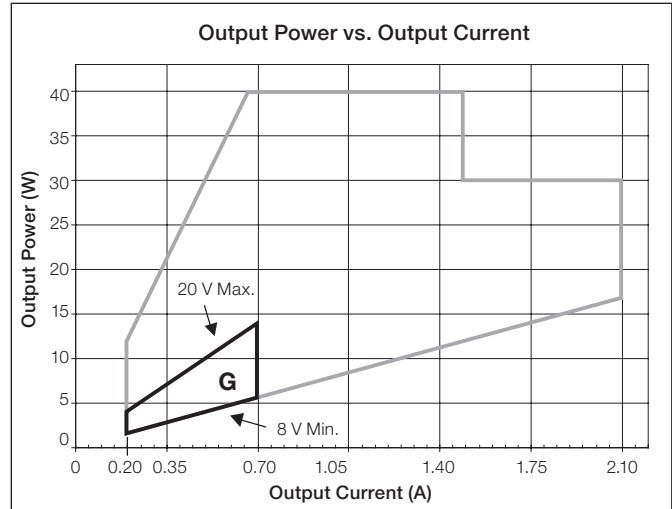
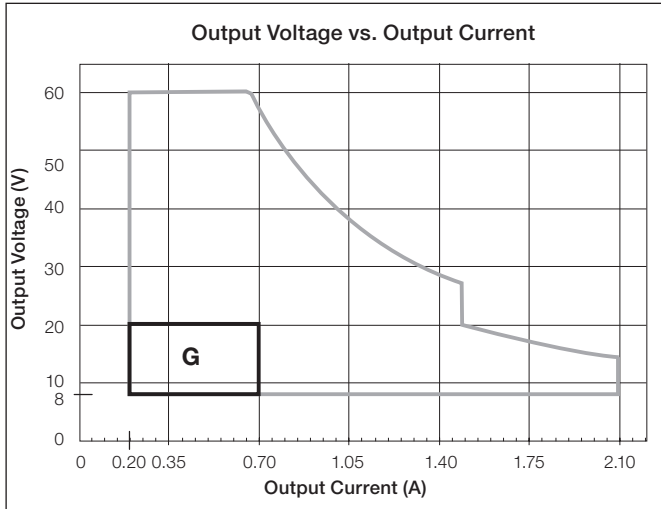

Typical Performance Specifications:

Parameter	Value	Test Conditions
Input Current	140 mA	t _a = 25 °C, 0.70 A 14 W load, Maximum Light Output, K case 120 V \sim without a dimmer
Power Factor	0.99	
THD	12%	
Driver Efficiency	76%	

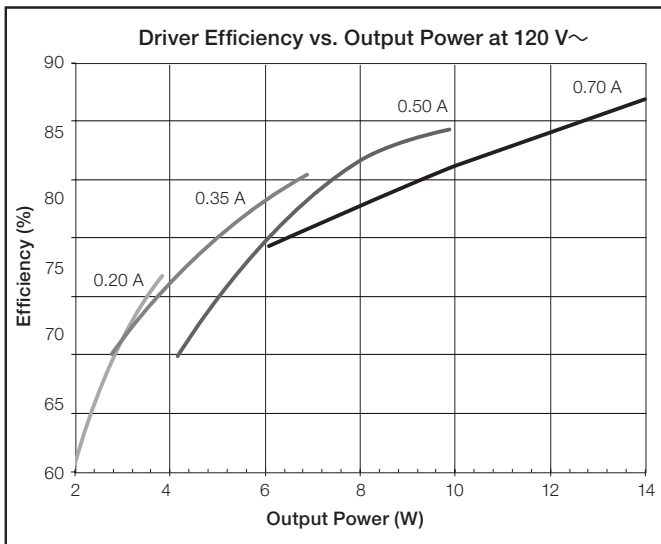

Job Name: <input style="width: 90%; height: 20px;" type="text"/>	Model Numbers: <input style="width: 95%; height: 20px;" type="text"/>
Job Number: <input style="width: 80%; height: 20px;" type="text"/>	<input style="width: 95%; height: 20px;" type="text"/>

“H” Output Range, Current Driver Models

Driver Type	Output Dimming Method	Output Voltage	Output Current	Output Power	Standards Recognition	UL® Listed Option (KL case)
Constant-Current Driver (Class 2)	Pulse Width Modulation (PWM)	15–38 V PWM	0.20–0.70 A	3–26.6 W	 Type TL 84 °/62 °C - K-case Type TL 86 °/78 °C - M-case	Yes
	Constant-Current Reduction (CCR)	15–38 V=				

When using QwikFig™ technology, these models can be built from the following bulk units:

K-case - LTEA4U1UKx-2HBLK*; M-case - LTEA4U1UMN-2BBLK

* x = studded (S) or non-studded (N)

Current Driver Operation Range:

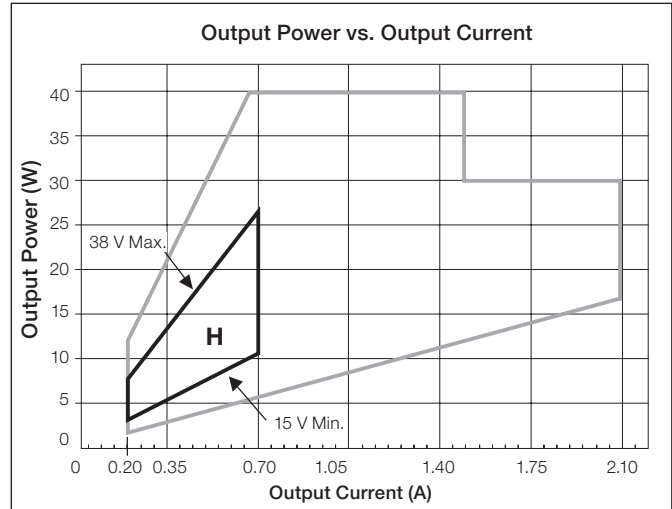
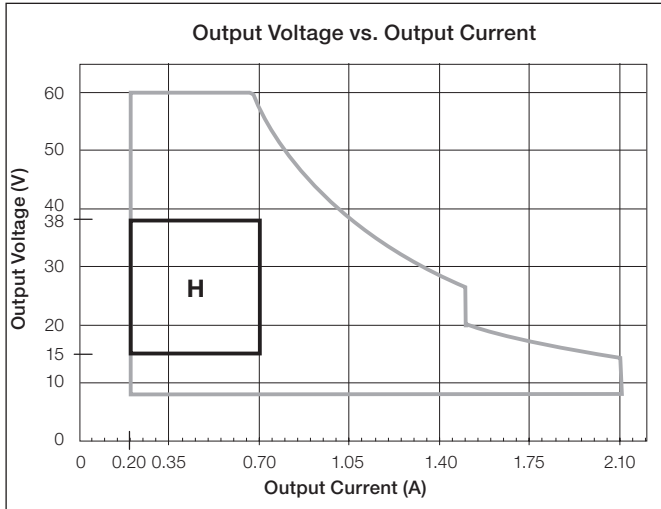

Typical Performance Specifications:

Parameter	Value	Test Conditions
Input Current	260 mA	t _a = 25 °C, 0.70 A 26 W load, Maximum Light Output, K case 120 V~ without a dimmer
Power Factor	0.99	
THD	8%	
Driver Efficiency	83%	

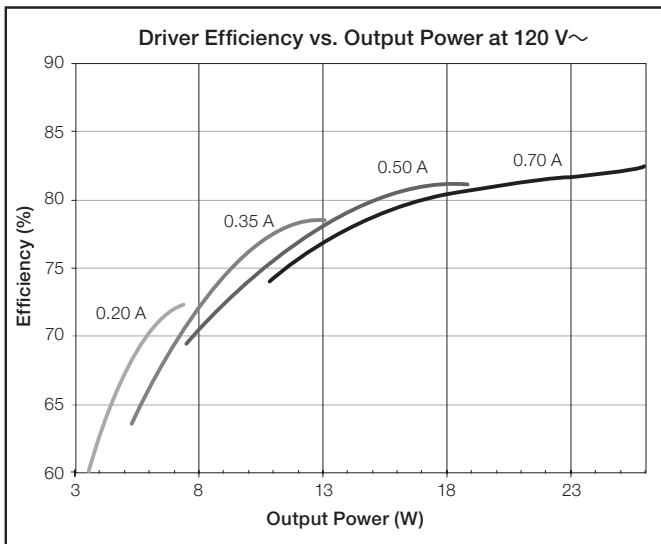

Job Name: <input style="width: 90%; height: 20px;" type="text"/>	Model Numbers: <input style="width: 95%; height: 20px;" type="text"/>
Job Number: <input style="width: 80%; height: 20px;" type="text"/>	<input style="width: 95%; height: 20px;" type="text"/>

“I” Output Range, Current Driver Models

Driver Type	Output Dimming Method	Output Voltage	Output Current	Output Power	Standards Recognition	UL® Listed Option (KL case)
Constant-Current Driver (Class 2)	Pulse Width Modulation (PWM)	8–20 V PWM	0.71–1.05 A	6–21 W	 Type TL 80 °/74 °C - K-case Type TL 90 °/69 °C - M-case	Yes
	Constant-Current Reduction (CCR)	8–20 V $\overline{\text{---}}$				

When using QwikFig™ technology, these models can be built from the following bulk units:

K-case - LTEA4U1UKx-2RBLK*; M-case - LTEA4U1UMN-2CBLK

* x = studded (S) or non-studded (N)

Current Driver Operation Range:

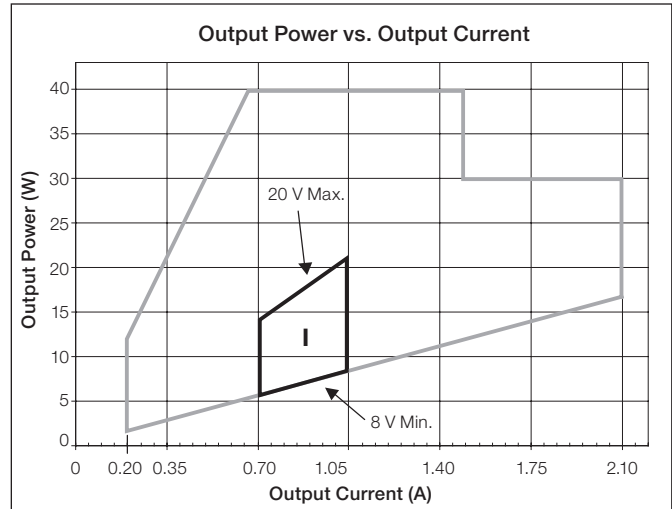
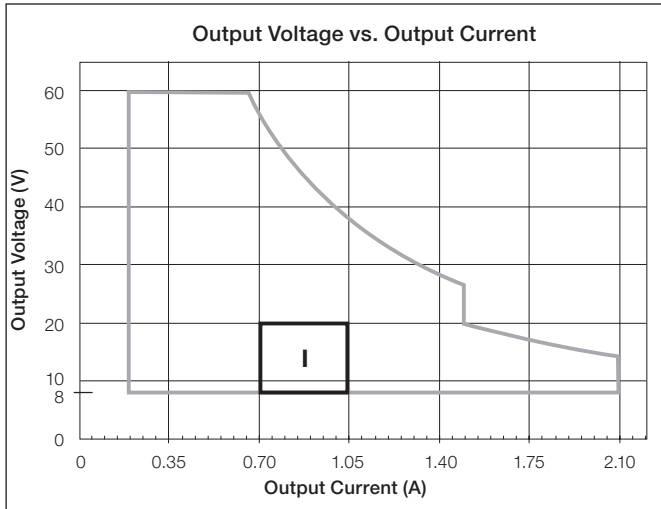

Typical Performance Specifications:

Parameter	Value	Test Conditions
Input Current	200 mA	$t_a = 25\text{ }^\circ\text{C}$,
Power Factor	0.99	1.05 A 21 W load,
THD	11%	Maximum Light Output,
Driver Efficiency	79%	K case 120 V \sim without a dimmer

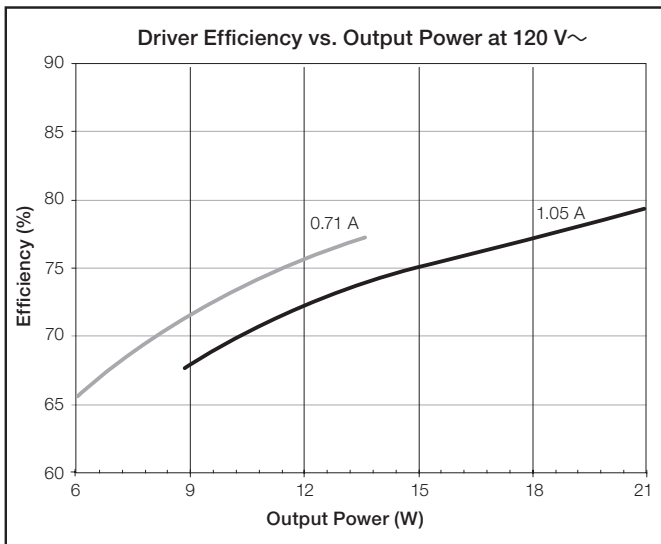

Job Name: <input style="width: 90%; height: 20px;" type="text"/>	Model Numbers: <input style="width: 95%; height: 20px;" type="text"/>
Job Number: <input style="width: 80%; height: 20px;" type="text"/>	<input style="width: 95%; height: 20px;" type="text"/>

“J” Output Range, Current Driver Models

Driver Type	Output Dimming Method	Output Voltage	Output Current	Output Power	Standards Recognition	UL® Listed Option (KL case)
Constant-Current Driver (Class 2)	Pulse Width Modulation (PWM)	15–38 V PWM	0.71–1.05 A	11–40 W	 Type TL 82 °/68 °C - K-case Type TL 86 °/78 °C - M-case	Yes
	Constant-Current Reduction (CCR)	15–38 V \sim				

When using QwikFig™ technology, these models can be built from the following bulk units:

K-case - LTEA4U1UKx-2SBLK*; M-case - LTEA4U1UMN-2BBLK

* x = studded (S) or non-studded (N)

Current Driver Operation Range:

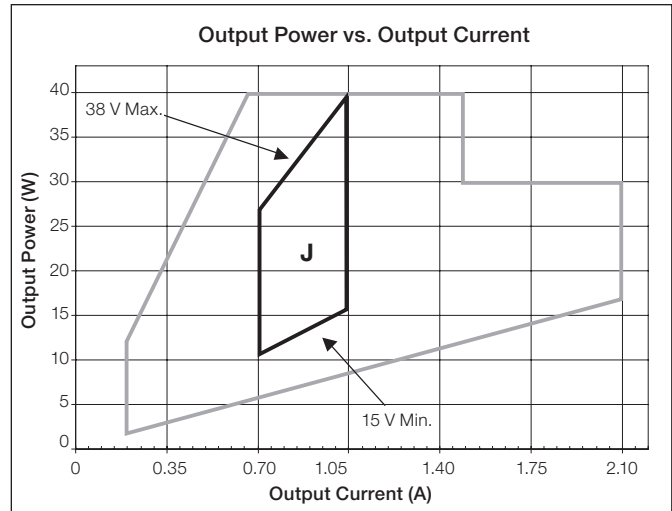
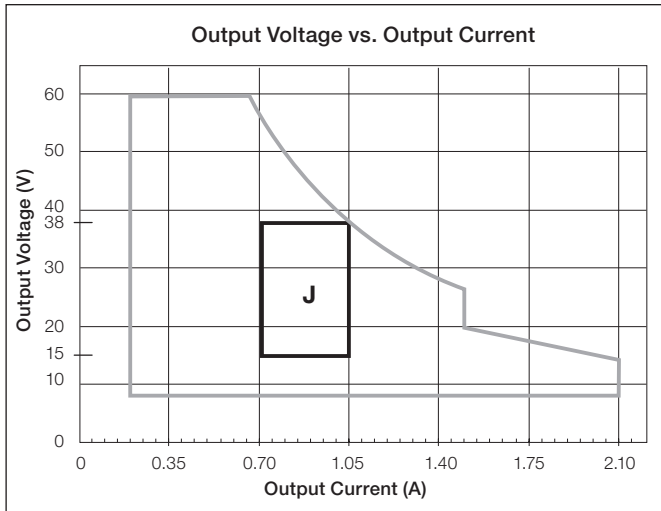

Typical Performance Specifications:

Parameter	Value	Test Conditions
Input Current	390 mA	t _a = 25 °C, 1.05 A 40 W load, Maximum Light Output, K case 120 V \sim without a dimmer
Power Factor	0.99	
THD	7%	
Driver Efficiency	84%	

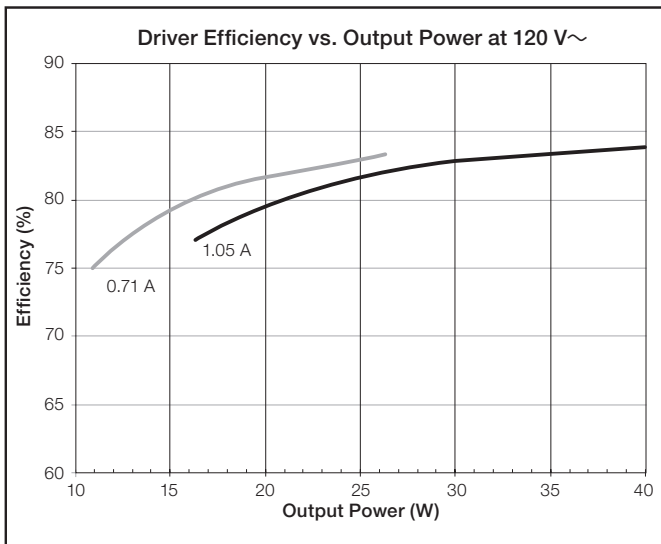

Job Name: <input style="width: 90%; height: 20px;" type="text"/>	Model Numbers: <input style="width: 95%; height: 20px;" type="text"/>
Job Number: <input style="width: 80%; height: 20px;" type="text"/>	<input style="width: 95%; height: 20px;" type="text"/>

“K” Output Range, Current Driver Models

Driver Type	Output Dimming Method	Output Voltage	Output Current	Output Power	Standards Recognition	UL® Listed Option (KL case)
Constant-Current Driver (Class 2)	Pulse Width Modulation (PWM)	8–20 V PWM	1.06–1.50 A	9–30 W	 Type TL 80 °/74 °C - K-case Type TL 90 °/69 °C - M-case	Yes
	Constant-Current Reduction (CCR)	8–20 V $\overline{\text{=}}$				

When using QwikFig™ technology, these models can be built from the following bulk units:

K-case - LTEA4U1UKx-2RBLK*; M-case - LTEA4U1UMN-2CBLK

* x = studded (S) or non-studded (N)

Current Driver Operation Range:

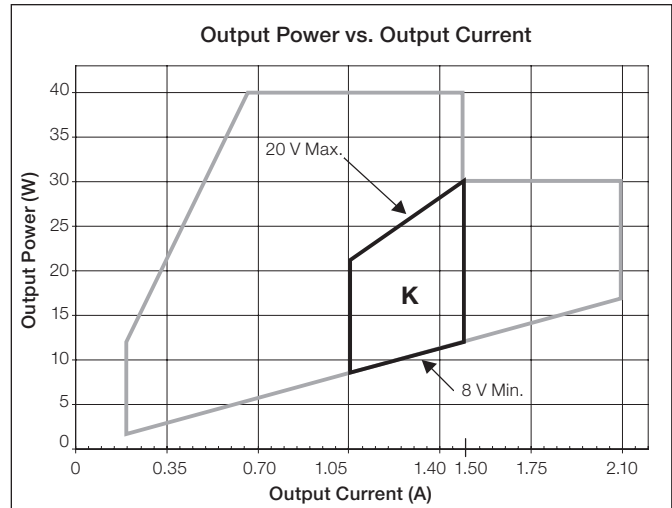
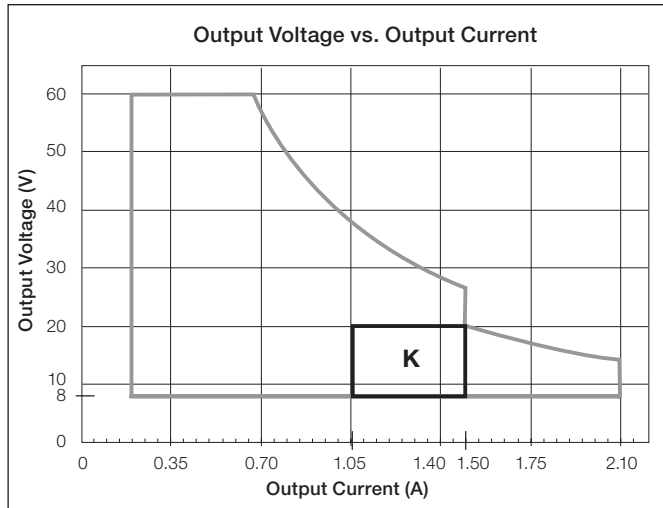

Typical Performance Specifications:

Parameter	Value	Test Conditions
Input Current	280 mA	$t_a = 25\text{ }^\circ\text{C}$, 1.50 A 30 W load, Maximum Light Output, K case 120 V \sim without a dimmer
Power Factor	0.99	
THD	12%	
Driver Efficiency	79%	

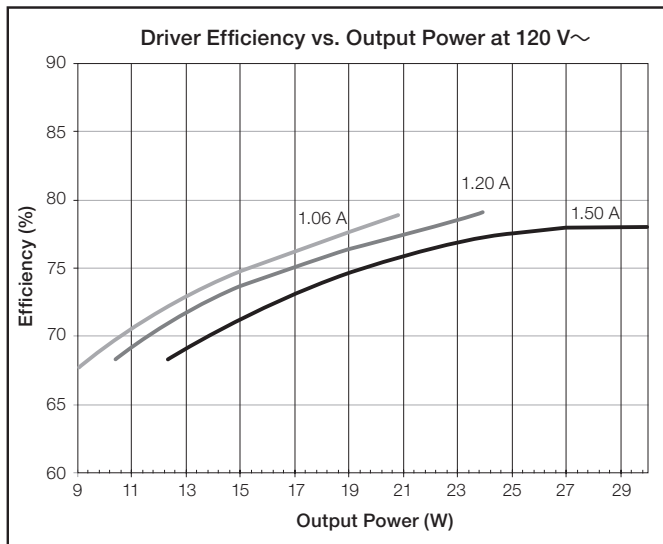

Job Name:	Model Numbers:	
<input type="text"/>	<input type="text"/>	<input type="text"/>
Job Number:	<input type="text"/>	<input type="text"/>

“L” Output Range, Current Driver Models

Driver Type	Output Dimming Method	Output Voltage	Output Current	Output Power	Standards Recognition	UL® Listed Option (KL case)
Constant-Current Driver (Class 2)	Pulse Width Modulation (PWM)	15–38 V PWM	1.06–1.50 A	16–40 W	 Type TL 82 °/68 °C - K-case Type TL 86 °/78 °C - M-case	Yes
	Constant-Current Reduction (CCR)	15–38 V=				

When using QwikFig™ technology, these models can be built from the following bulk units:

K-case - LTEA4U1UKx-2SBLK*; M-case - LTEA4U1UMN-2BBLK

* x = studded (S) or non-studded (N)

Current Driver Operation Range:

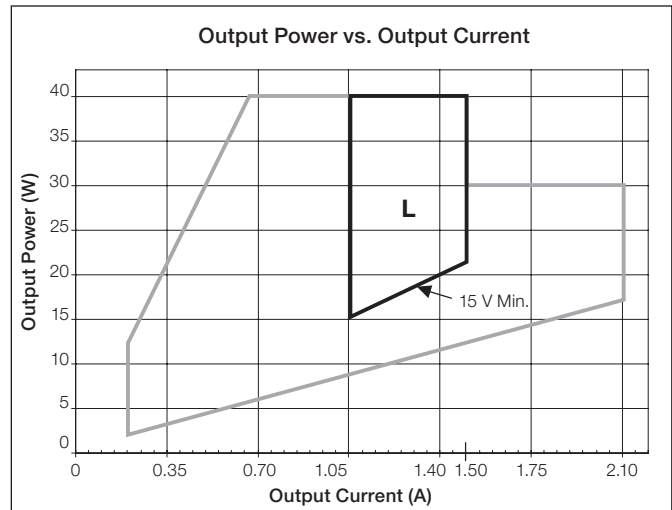
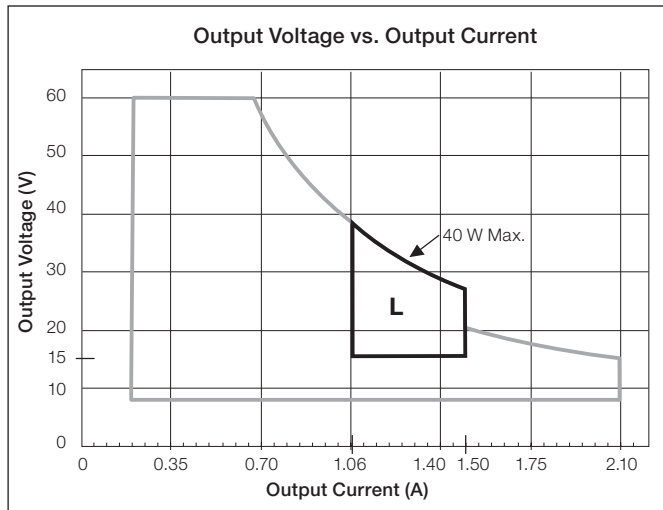

Typical Performance Specifications:

Parameter	Value	Test Conditions
Input Current	410 mA	$t_a = 25\text{ }^\circ\text{C}$,
Power Factor	0.99	1.50 A 40 W load,
THD	9%	Maximum Light Output,
Driver Efficiency	82%	K case
		120 V~ without a dimmer

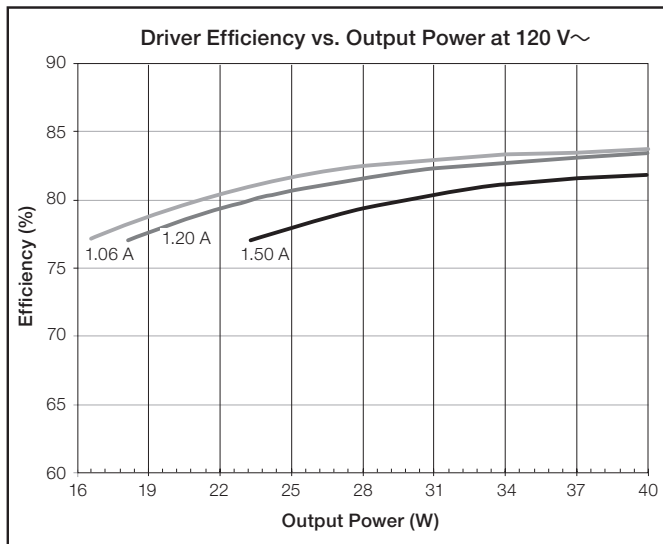

Job Name: <input style="width: 90%; height: 20px;" type="text"/>	Model Numbers: <input style="width: 95%; height: 20px;" type="text"/>
Job Number: <input style="width: 80%; height: 20px;" type="text"/>	<input style="width: 95%; height: 20px;" type="text"/>

“M” Output Range, Current Driver Models

Driver Type	Output Dimming Method	Output Voltage	Output Current	Output Power	Standards Recognition	UL® Listed Option (KL case)
Constant-Current Driver (Class 2)	Pulse Width Modulation (PWM)	8–19.9 V PWM	1.51–2.10 A	12–30 W	 Type TL 87 °/72 °C - K-case Type TL 90 °/73 °C - M-case	Yes
	Constant-Current Reduction (CCR)	8–19.9 V				

When using QwikFig™ technology, these models can be built from the following bulk units:

K-case - LTEA4U1UKx-2ABLK*; M-case - LTEA4U1UMN-2ABLK

* x = studded (S) or non-studded (N)

Current Driver Operation Range:

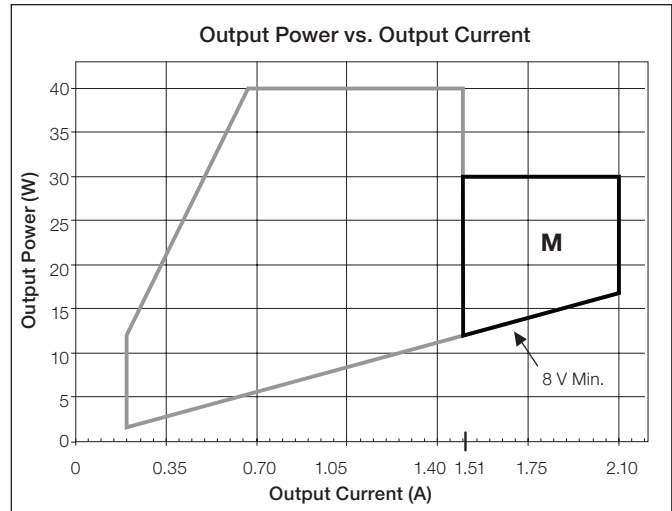
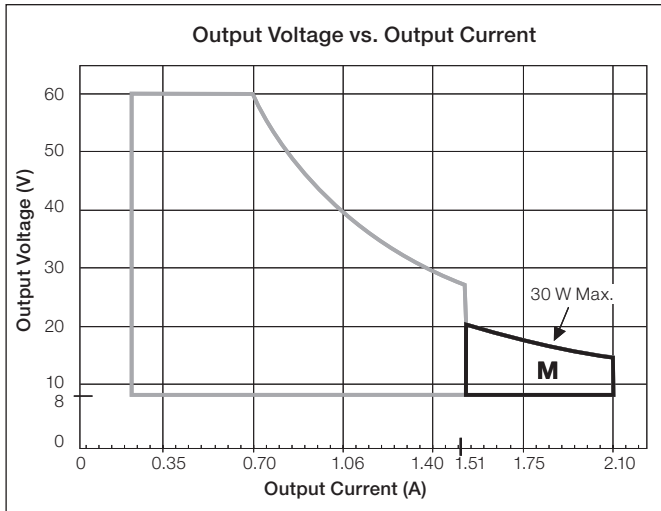

Typical Performance Specifications:

Parameter	Value	Test Conditions
Input Current	310 mA	t _a = 25 °C, 2.10 A 30 W load, Maximum Light Output, K case 120 V~ without a dimmer
Power Factor	0.99	
THD	14%	
Driver Efficiency	76%	

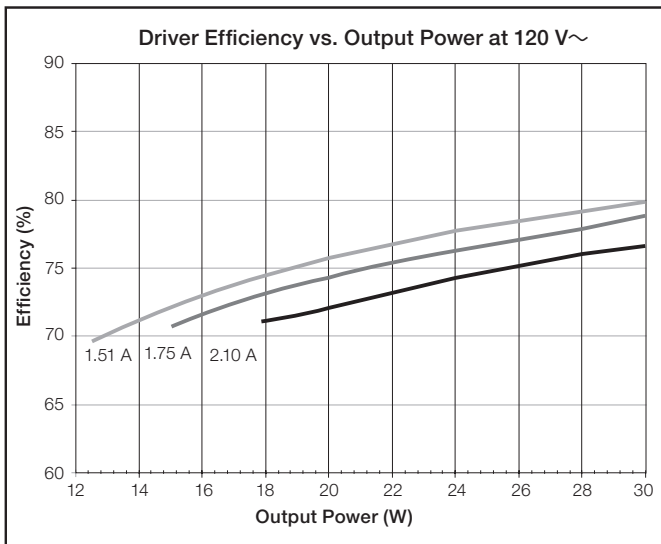

Job Name: <input style="width: 90%; height: 20px;" type="text"/>	Model Numbers: <input style="width: 95%; height: 20px;" type="text"/>
Job Number: <input style="width: 80%; height: 20px;" type="text"/>	<input style="width: 95%; height: 20px;" type="text"/>

“X” Output Range, Voltage Driver Models

Driver Type	Output Dimming Method	Output Voltage	Output Current	Output Power	Standards Recognition	UL® Listed Option (KL case)
Constant-Voltage Driver (Isolated, Non-Class 2)	Pulse Width Modulation (PWM)	38.5–60.0 V PWM	0.08–1.04 A	5–40 W		No

Voltage Driver Operation Range:

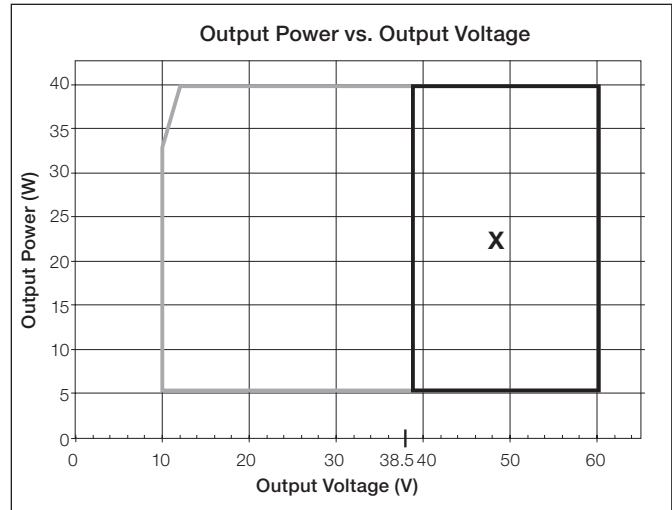
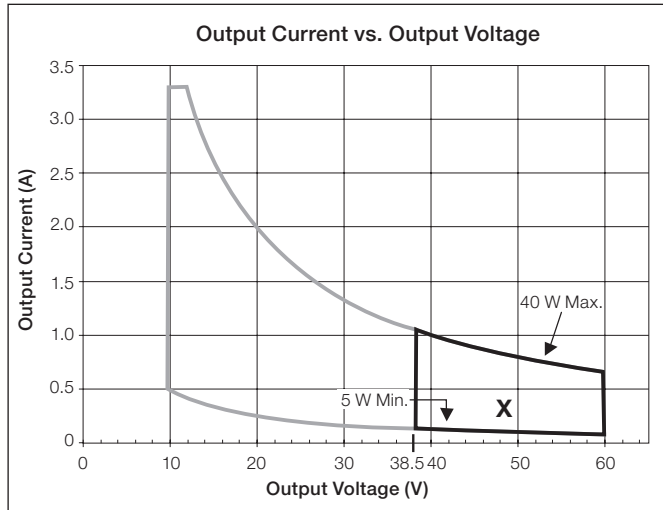

Typical Performance Specifications:

Parameter	Value	Test Conditions
Input Current	390 mA	$t_a = 25\text{ }^\circ\text{C}$, 60.0 V 40 W load, Maximum Light Output, K case 120 V~ without a dimmer
Power Factor	0.99	
THD	10%	
Driver Efficiency	86%	

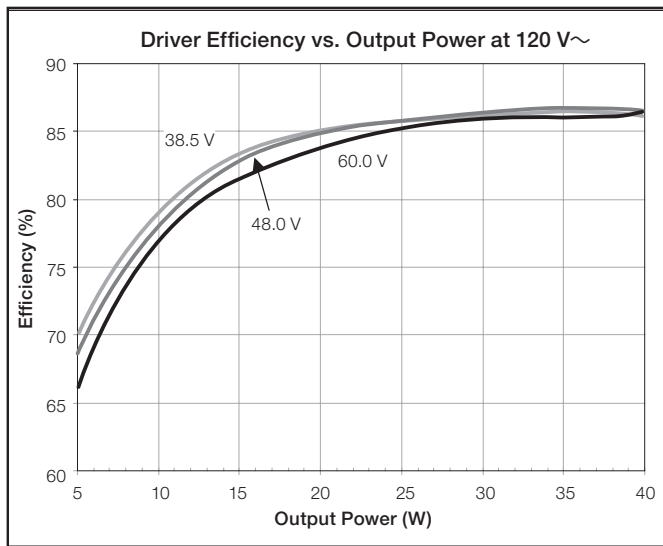

Job Name: <input style="width: 90%; height: 20px;" type="text"/>	Model Numbers: <input style="width: 95%; height: 20px;" type="text"/>
Job Number: <input style="width: 80%; height: 20px;" type="text"/>	<input style="width: 95%; height: 20px;" type="text"/>

“Y” Output Range, Current Driver Models

Driver Type	Output Dimming Method	Output Voltage	Output Current	Output Power	Standards Recognition	UL® Listed Option (KL case)
Constant-Current Driver (Isolated, Non-Class 2)	Pulse Width Modulation (PWM)	30–60 V PWM	0.20–0.50 A	6–30 W	 Type TL 80 °/72 °C - K-case Type TL 89 °/74 °C - M-case	No
	Constant-Current Reduction (CCR)	30–60 V \sim				

When using QwikFig™ technology, these models can be built from the following bulk units:

K-case - LTEA4U1UKx-1ABLK*; M-case - LTEA4U1UMN-1ABLK

* x = studded (S) or non-studded (N)

Current Driver Operation Range:

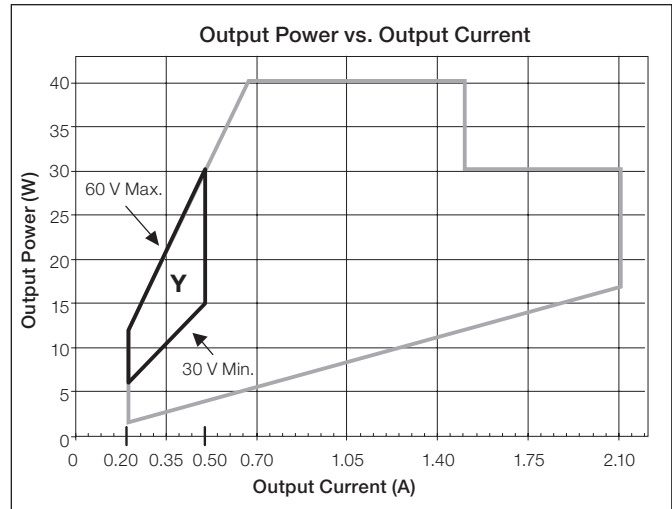
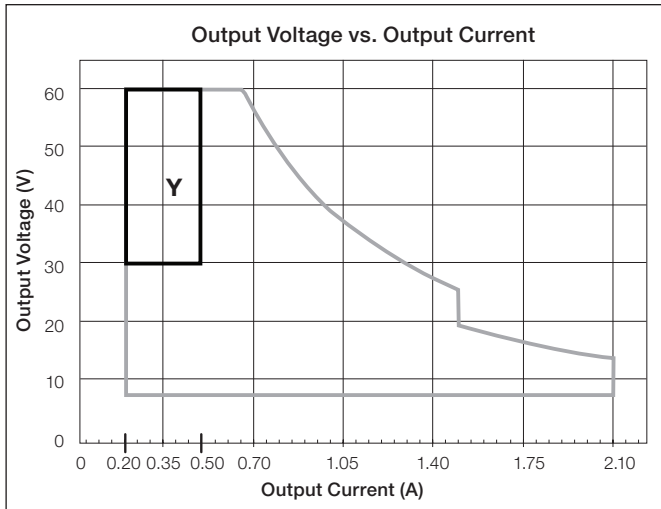

Typical Performance Specifications:

Parameter	Value	Test Conditions
Input Current	290 mA	t _a = 25 °C, 0.50 A 30 W load, Maximum Light Output, K case 120 V \sim without a dimmer
Power Factor	0.99	
THD	11%	
Driver Efficiency	84%	

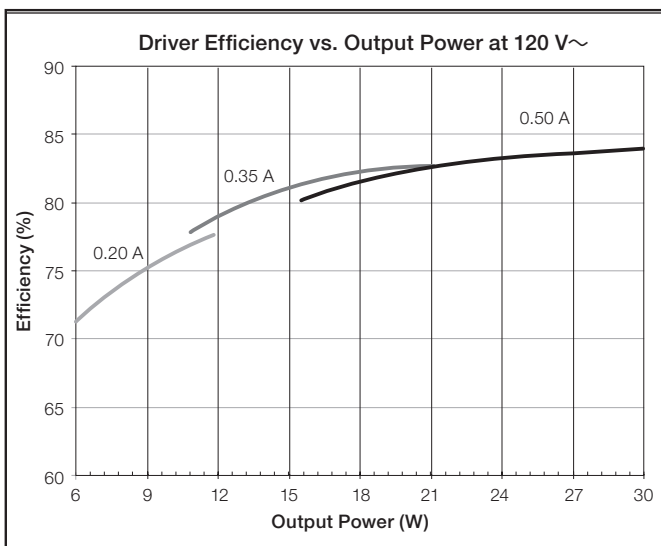

Job Name: <input style="width: 90%; height: 20px;" type="text"/>	Model Numbers: <input style="width: 95%; height: 20px;" type="text"/>
Job Number: <input style="width: 80%; height: 20px;" type="text"/>	<input style="width: 95%; height: 20px;" type="text"/>

“Z” Output Range, Current Driver Models

Driver Type	Output Dimming Method	Output Voltage	Output Current	Output Power	Standards Recognition	UL® Listed Option (KL case)
Constant-Current Driver (Isolated, Non-Class 2)	Pulse Width Modulation (PWM)	30–60 V PWM	0.51–1.00 A	16–40 W	 Type TL 80 °/72 °C - K-case Type TL 89 °/74 °C - M-case	No
	Constant-Current Reduction (CCR)	30–60 V=				

When using QwikFig™ technology, these models can be built from the following bulk units:

K-case - LTEA4U1UKx-1ABLK*; M-case - LTEA4U1UMN-1ABLK

* x = studded (S) or non-studded (N)

Current Driver Operation Range:

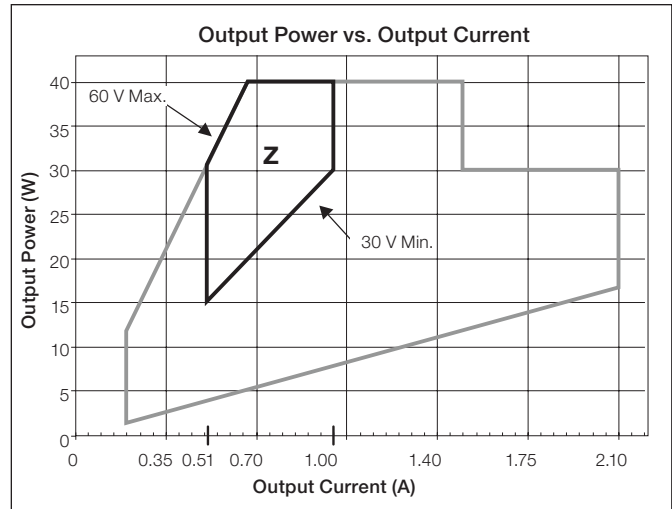
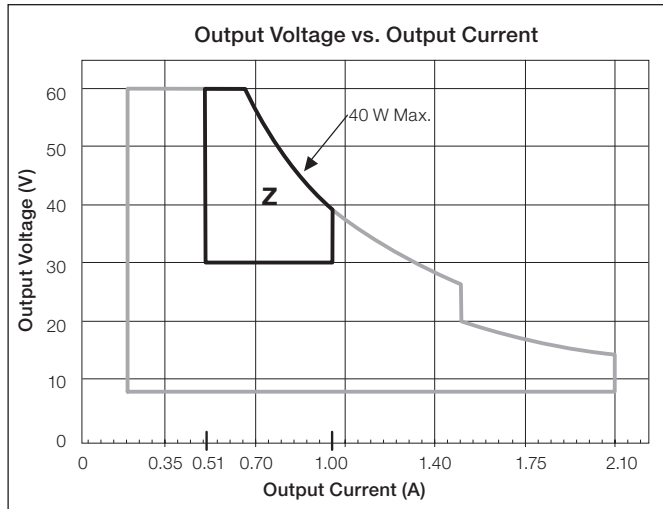

Typical Performance Specifications:

Parameter	Value	Test Conditions
Input Current	410 mA	t _a = 25 °C, 1.00 A 40 W load, Maximum Light Output, K case 120 V~ without a dimmer
Power Factor	0.99	
THD	8%	
Driver Efficiency	83%	

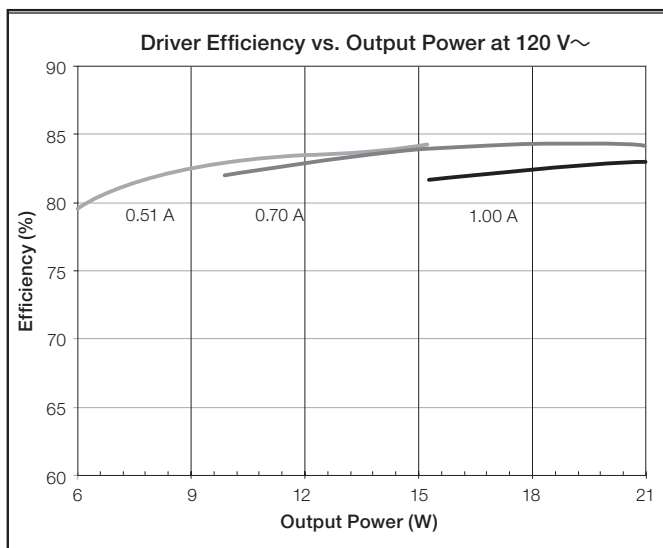

Job Name: <input style="width: 90%; height: 20px;" type="text"/>	Model Numbers: <input style="width: 95%; height: 20px;" type="text"/>
Job Number: <input style="width: 80%; height: 20px;" type="text"/>	<input style="width: 95%; height: 20px;" type="text"/>

Bulk Model Coverage - K-Case Model Numbers For use with Lutron® QwikFig™ technology

3ABLK Operation Range:

Bulk Model	Driver Type	Output Dimming Method	Output Voltage	Output Current	Output Power	Standards Recognition
3ABLK	Constant-Current Driver (Class 2)	Constant-Current Reduction (CCR)	30–54 V _{DC}	0.20–1.00 A	6–40 W	 Type TL 82 °/74 °C

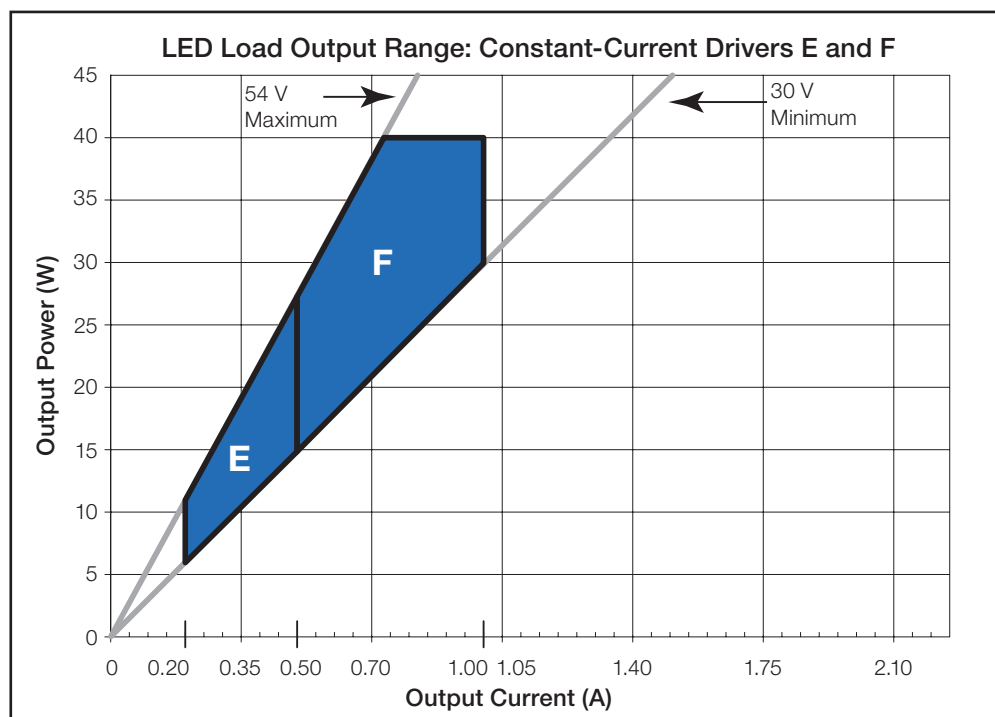



3A = Covers “LED Load Output Range” E and F (CCR dimming only)

Job Name: <input style="width: 90%;" type="text"/>	Model Numbers: <input style="width: 60%;" type="text"/> <input style="width: 40%;" type="text"/>	
Job Number: <input style="width: 80%;" type="text"/>	<input style="width: 100%;" type="text"/>	<input style="width: 100%;" type="text"/>

Bulk Model Coverage - K-Case Model Numbers (continued)
 For use with Lutron® QwikFig™ technology

2HBLK and 2SBLK Operation Range:

Bulk Model	Driver Type	Output Dimming Method	Output Voltage	Output Current	Output Power	Standards Recognition
2HBLK	Constant-Current Driver (Class 2)	Pulse Width Modulation (PWM)	15–38 V PWM	0.20–0.70 A	3–26.6 W	 Type TL 84 °/62 °C
		Constant-Current Reduction (CCR)	15–38 V=			
2SBLK	Constant-Current Driver (Class 2)	Pulse Width Modulation (PWM)	15–38 V PWM	0.71–1.50 A	11–40 W	 Type TL 82 °/68 °C
		Constant-Current Reduction (CCR)	15–38 V=			

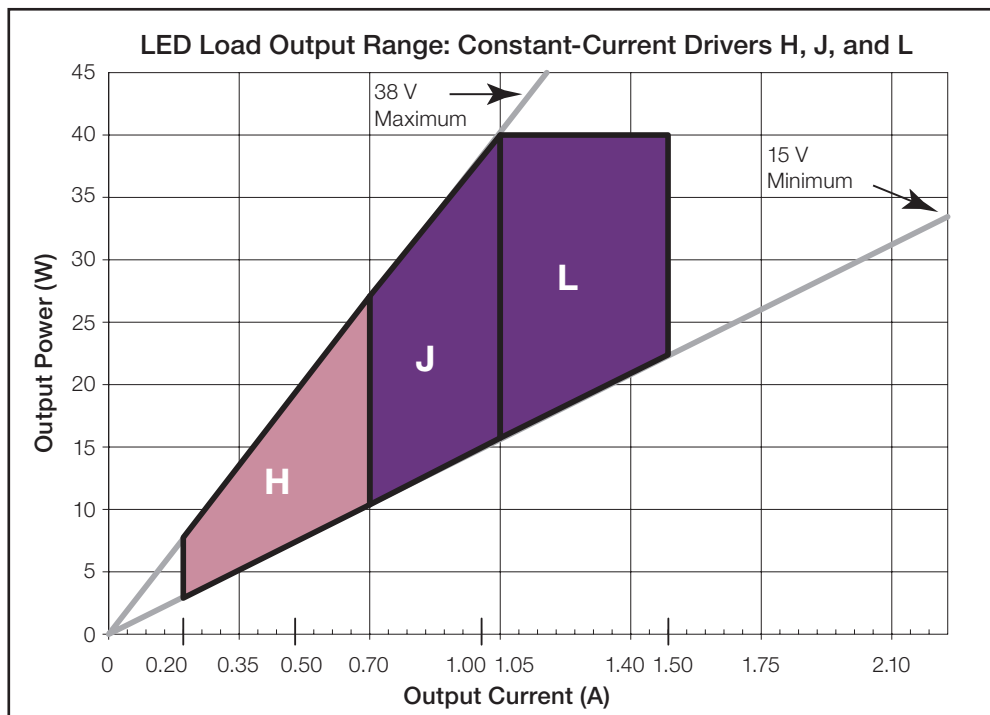



2H = Covers “LED Load Output Range” H
 2S = Covers “LED Load Output Range” J and L

Job Name: <input style="width: 90%; height: 20px;" type="text"/>	Model Numbers: <input style="width: 60%; height: 20px;" type="text"/> <input style="width: 35%; height: 20px;" type="text"/>	
Job Number: <input style="width: 80%; height: 20px;" type="text"/>	<input style="width: 30%; height: 20px;" type="text"/>	<input style="width: 30%; height: 20px;" type="text"/>

Bulk Model Coverage - K-Case Model Numbers (continued)

For use with Lutron® QwikFig™ technology

2GBLK, 2RBLK, and 2ABLK Operation Range:

Bulk Model	Driver Type	Output Dimming Method	Output Voltage	Output Current	Output Power	Standards Recognition
2GBLK	Constant-Current Driver (Class 2)	Pulse Width Modulation (PWM)	8–20 V PWM	0.20–0.70 A	2–14 W	 Type TL 86 °/57 °C
		Constant-Current Reduction (CCR)	8–20 V==			
2RBLK	Constant-Current Driver (Class 2)	Pulse Width Modulation (PWM)	8–20 V PWM	0.71–1.50 A	6–30 W	 Type TL 80 °/74 °C
		Constant-Current Reduction (CCR)	8–20 V==			
2ABLK	Constant-Current Driver (Class 2)	Pulse Width Modulation (PWM)	8–19.9 V PWM	1.51–2.10 A	12–30 W	 Type TL 87 °/72 °C
		Constant-Current Reduction (CCR)	8–19.9 V==			

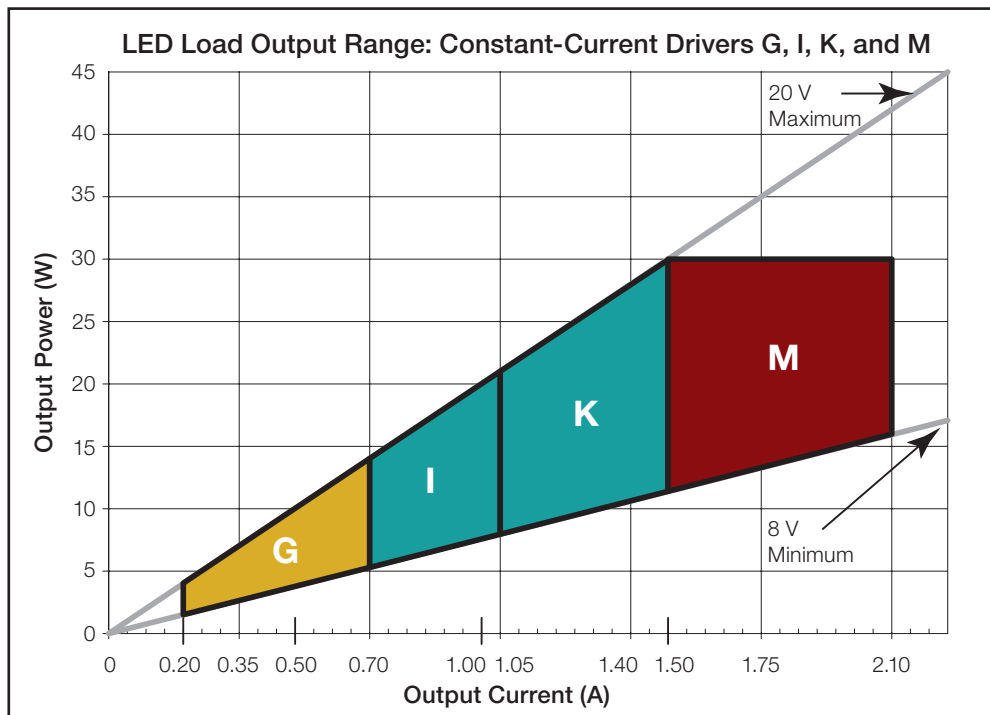

- 2G = Covers “LED Load Output Range” G
- 2R = Covers “LED Load Output Range” I and K
- 2A = Covers “LED Load Output Range” M

Job Name: <input style="width: 90%; height: 20px;" type="text"/>	Model Numbers: <input style="width: 95%; height: 20px;" type="text"/>
Job Number: <input style="width: 80%; height: 20px;" type="text"/>	<input style="width: 95%; height: 20px;" type="text"/>

Bulk Model Coverage - K-Case Model Numbers *(continued)*

For use with Lutron® QwikFig™ technology

1ABLK Operation Range:

Bulk Model	Driver Type	Output Dimming Method	Output Voltage	Output Current	Output Power	Standards Recognition
1ABLK	Constant-Current Driver (Isolated, Non-Class 2)	Pulse Width Modulation (PWM)	30–60 V PWM	0.20–1.00 A	6–40 W	 Type TL 80 °/72 °C
		Constant-Current Reduction (CCR)	30–60 V=			

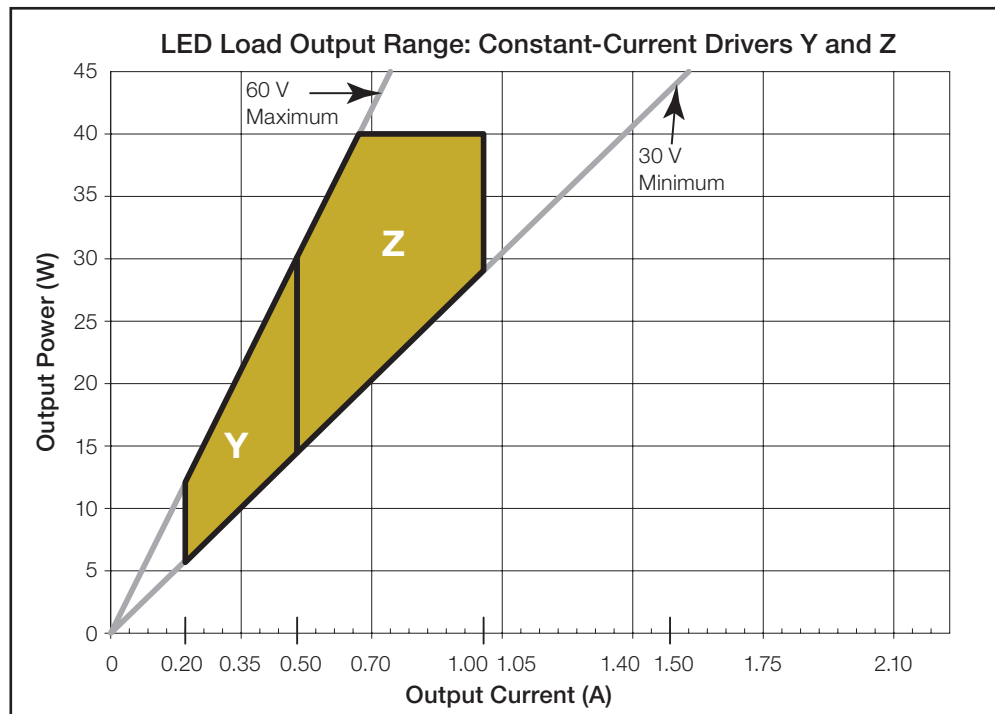

1A = Covers “LED Load Output Range” Y and Z

Job Name: <input style="width: 90%; height: 20px;" type="text"/>	Model Numbers: <input style="width: 60%; height: 20px;" type="text"/> <input style="width: 35%; height: 20px;" type="text"/>	
Job Number: <input style="width: 80%; height: 20px;" type="text"/>	<input style="width: 30%; height: 20px;" type="text"/>	<input style="width: 35%; height: 20px;" type="text"/>

Bulk Model Coverage - M-Case Model Numbers For use with Lutron® QwikFig™ technology

3ABLK Operation Range:

Bulk Model	Driver Type	Output Dimming Method	Output Voltage	Output Current	Output Power	Standards Recognition
3ABLK	Constant-Current Driver (Class 2)	Constant-Current Reduction (CCR)	30–54 V _{DC}	0.20–1.00 A	6–40 W	 Type TL 86 °/72 °C

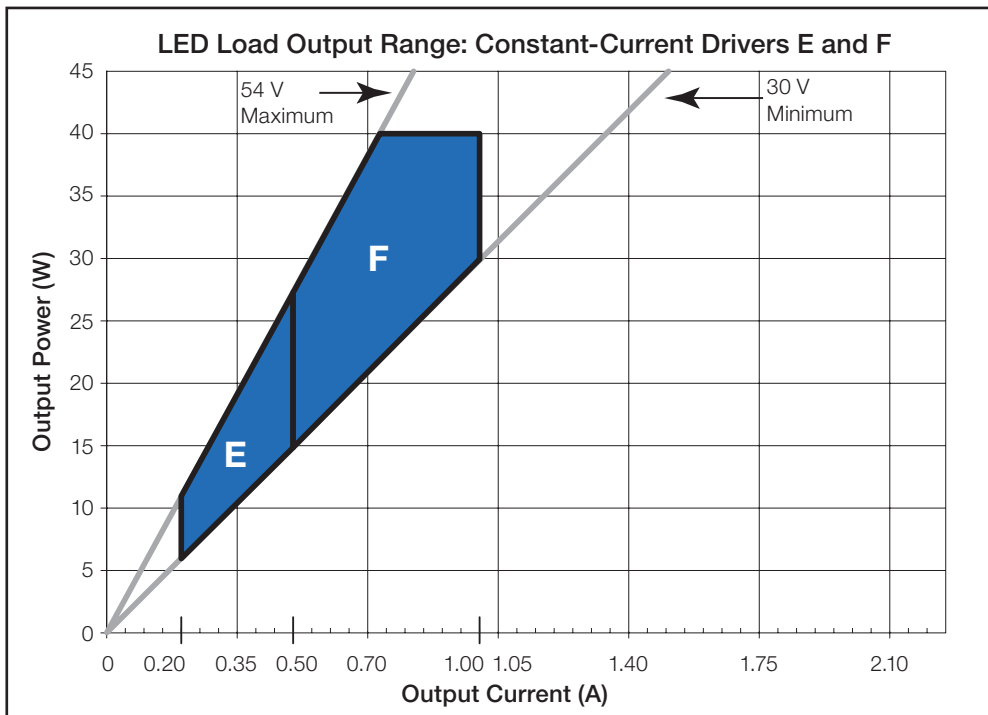

3A = Covers “LED Load Output Range” E and F (CCR dimming only)

Job Name: <input style="width: 90%; height: 20px;" type="text"/>	Model Numbers: <input style="width: 60%; height: 20px;" type="text"/> <input style="width: 35%; height: 20px;" type="text"/>	
Job Number: <input style="width: 80%; height: 20px;" type="text"/>	<input style="width: 30%; height: 20px;" type="text"/> <input style="width: 35%; height: 20px;" type="text"/>	

Bulk Model Coverage - M-Case Model Numbers (continued)

For use with Lutron® QwikFig™ technology

2BBLK Operation Range:

Bulk Model	Driver Type	Output Dimming Method	Output Voltage	Output Current	Output Power	Standards Recognition
2BBLK	Constant-Current Driver (Class 2)	Pulse Width Modulation (PWM)	15–38 V PWM	0.20–1.50 A	3–40 W	 Type TL 86 °/78 °C
		Constant-Current Reduction (CCR)	15–38 V=			

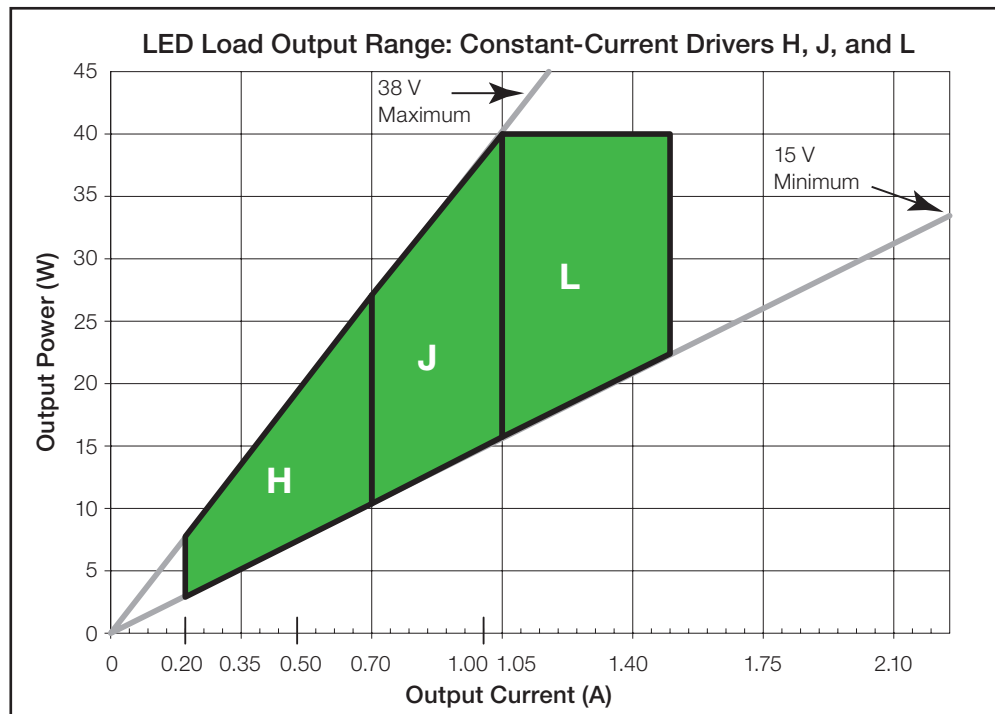



2B = Covers “LED Load Output Range” H, J, and L

Job Name: <input style="width: 90%;" type="text"/>	Model Numbers: <input style="width: 60%;" type="text"/> <input style="width: 40%;" type="text"/>	
Job Number: <input style="width: 150px;" type="text"/>	<input style="width: 300px;" type="text"/>	<input style="width: 300px;" type="text"/>

Bulk Model Coverage - M-Case Model Numbers *(continued)*

For use with Lutron® QwikFig™ technology

2CBLK and 2ABLK Operation Range:

Bulk Model	Driver Type	Output Dimming Method	Output Voltage	Output Current	Output Power	Standards Recognition
2CBLK	Constant-Current Driver (Class 2)	Pulse Width Modulation (PWM)	8–20 V PWM	0.20–1.50 A	2–30 W	 Type TL 90 °/69 °C
		Constant-Current Reduction (CCR)	8–20 V===			
2ABLK	Constant-Current Driver (Class 2)	Pulse Width Modulation (PWM)	8–19.9 V PWM	1.51–2.10 A	12–30 W	 Type TL 90 °/73 °C
		Constant-Current Reduction (CCR)	8–19.9 V===			

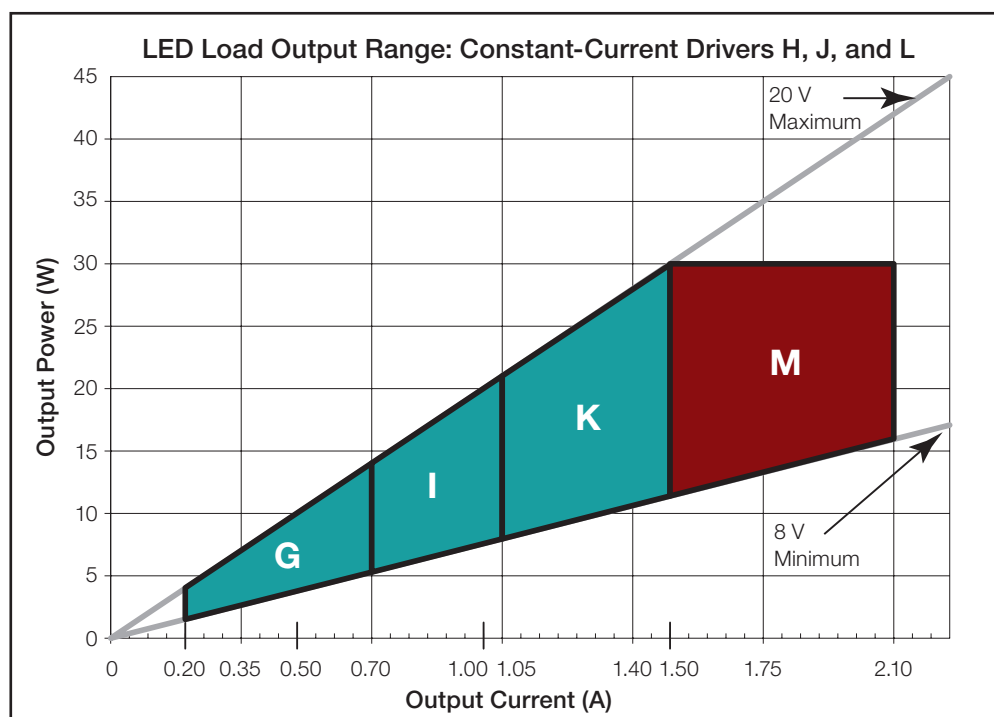

2C = Covers “LED Load Output Range” G, I, and K

2A = Covers “LED Load Output Range” M

Job Name: <input style="width: 90%; height: 20px;" type="text"/>	Model Numbers: <input style="width: 60%; height: 20px;" type="text"/> <input style="width: 30%; height: 20px;" type="text"/>	
Job Number: <input style="width: 80%; height: 20px;" type="text"/>	<input style="width: 30%; height: 20px;" type="text"/>	<input style="width: 30%; height: 20px;" type="text"/>

Bulk Model Coverage - M-Case Model Numbers (continued)

For use with Lutron® QwikFig™ technology

1ABLK Operation Range:

Bulk Model	Driver Type	Output Dimming Method	Output Voltage	Output Current	Output Power	Standards Recognition
1ABLK	Constant-Current Driver (Isolated, Non-Class 2)	Pulse Width Modulation (PWM)	30–60 V PWM	0.20–1.00 A	6–40 W	 Type TL 89 °/74 °C
		Constant-Current Reduction (CCR)	30–60 V=			

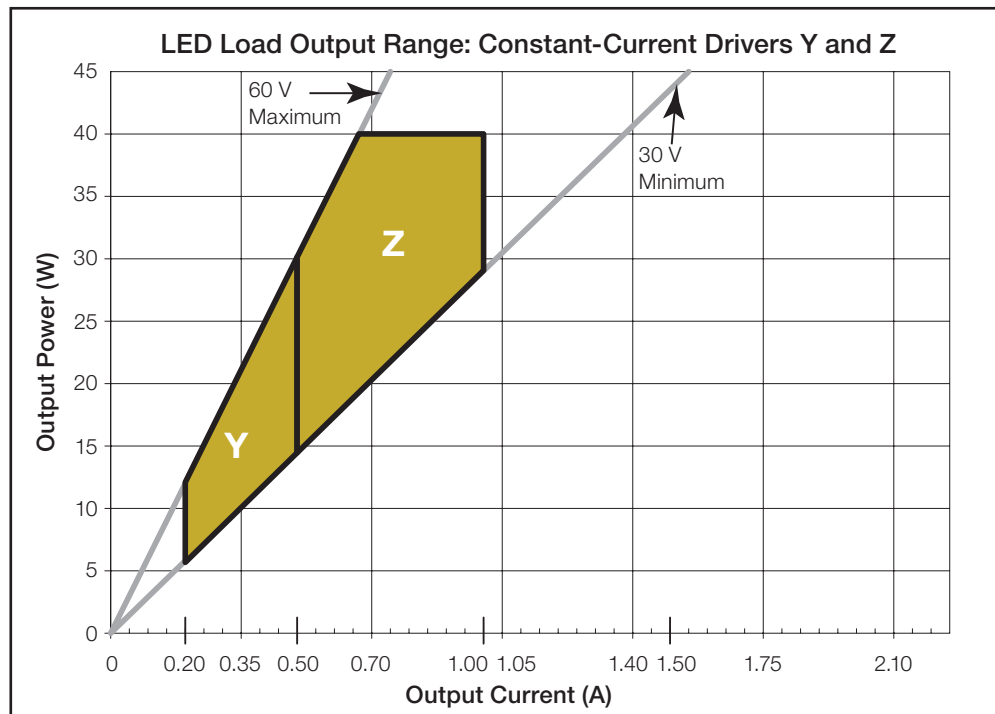

1A = Covers “LED Load Output Range” Y and Z

Job Name: <input style="width: 90%; height: 20px;" type="text"/>	Model Numbers: <input style="width: 95%; height: 20px;" type="text"/>
Job Number: <input style="width: 80%; height: 20px;" type="text"/>	<input style="width: 95%; height: 20px;" type="text"/>

K Case: Case Dimensions

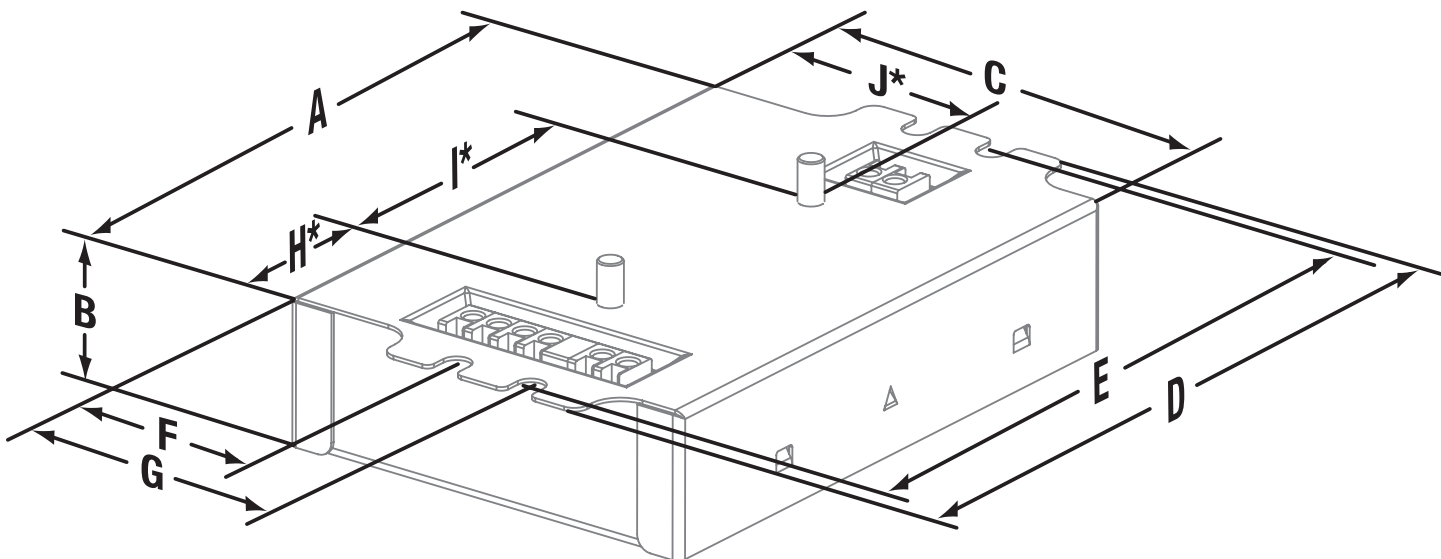

K Case: Connector Location Dimensions

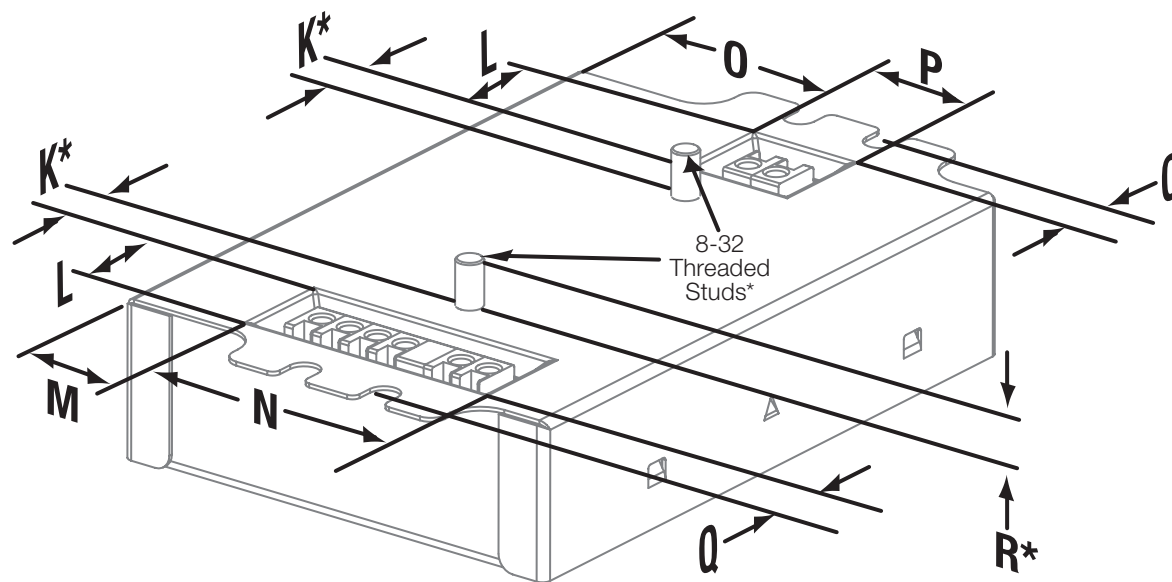

A	4.20 in (107 mm)	F	1.42 in (36 mm)	K*	0.33 in (8.3 mm)	P	0.74 in (19 mm)
B	1.00 in (25 mm)	G	1.99 in (51 mm)	L	0.65 in (16.5 mm)	Q	0.32 in (8 mm)
C	3.00 in (76 mm)	H*	1.11 in (28 mm)	M	0.75 in (19 mm)	R*	0.29 in (7 mm)
D	4.90 in (124 mm)	I*	2.00 in (51 mm)	N	1.73 in (44 mm)		
E	4.60 in (117 mm) (mounting center)	J*	1.60 in (41 mm)	O	1.33 in (34 mm)		

* Applies to studded K case only.

Job Name:	Model Numbers:	
<input type="text"/>	<input type="text"/>	<input type="text"/>
Job Number:	<input type="text"/>	<input type="text"/>

K Case: Side Entry Connector Location Dimensions (Non-Studded)

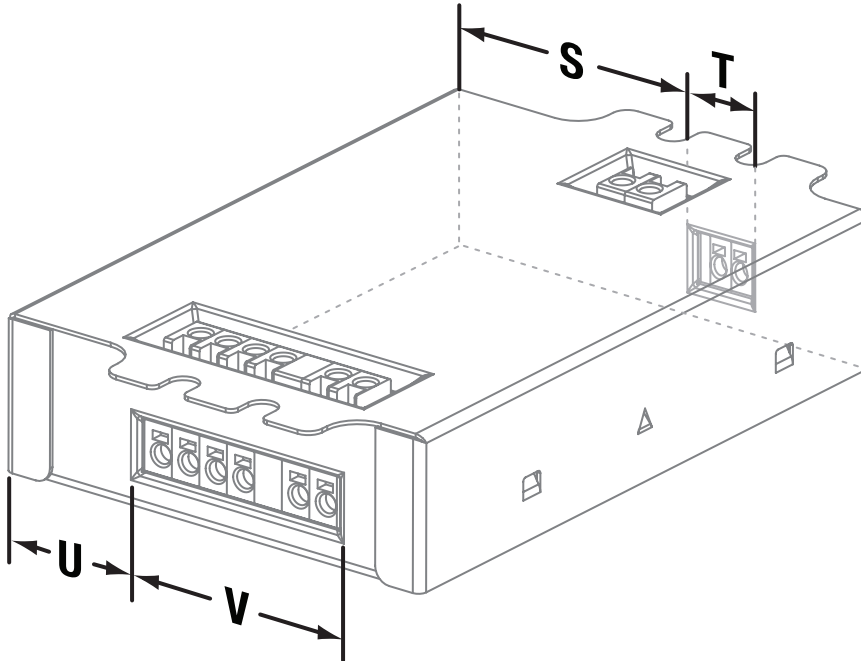

- S 1.38 in (35 mm)
- T 0.64 in (16 mm)
- U 0.88 in (22 mm)
- V 1.53 in (39 mm)

M Case: Case Dimensions

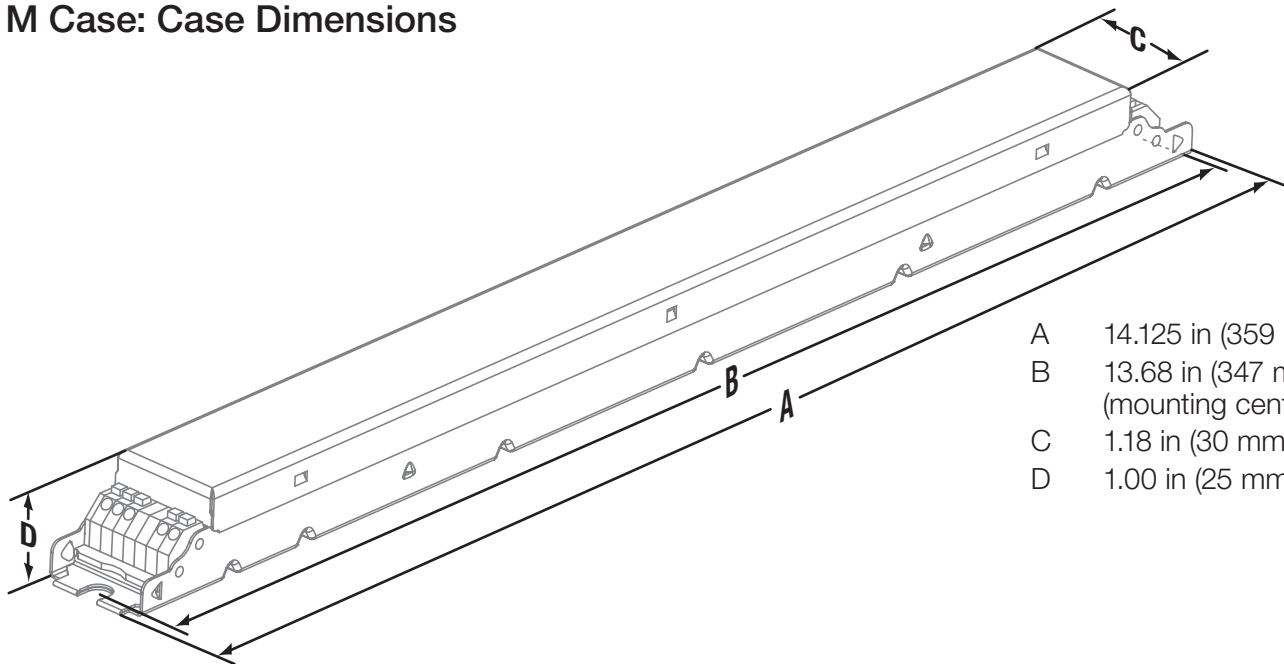

- A 14.125 in (359 mm)
- B 13.68 in (347 mm)
(mounting center)
- C 1.18 in (30 mm)
- D 1.00 in (25 mm)

Job Name: <input type="text"/>	Model Numbers: <input type="text"/>	<input type="text"/>
Job Number: <input type="text"/>	<input type="text"/>	<input type="text"/>

KL Case: Case Dimensions

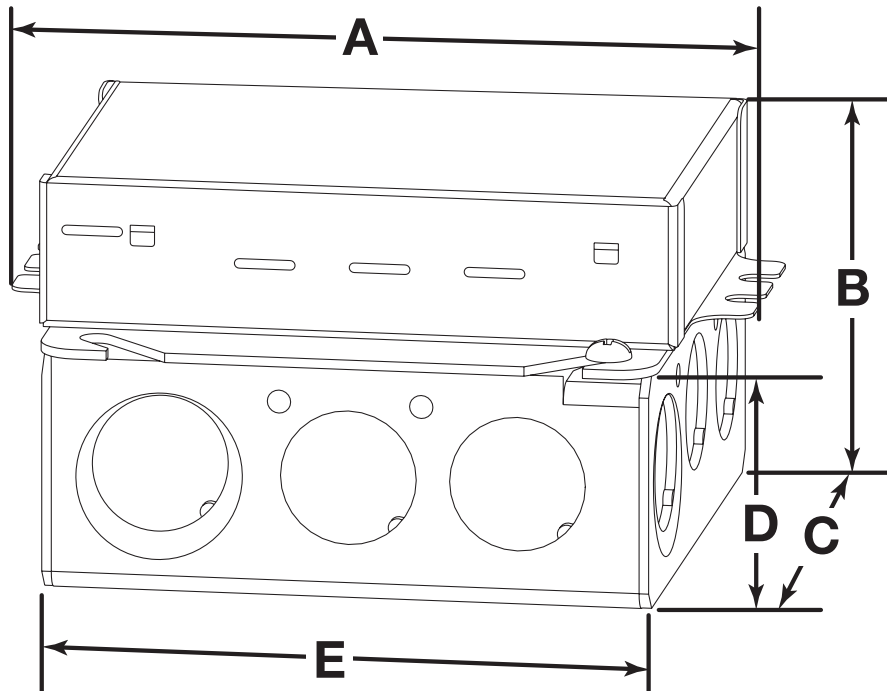

A	4.89 in (124 mm)
B	2.62 in (66 mm)
C	4.00 in (102 mm)
D	1.62 in (41 mm)
E	4.00 in (102 mm)

KL case includes a 4 in (102 mm) square junction box which complies with NEMA® OS 1-2008 Figure 112.

Knockouts

- Sides
 - 8 locations: 0.5 in (13 mm)
 - 4 locations: 0.5/0.75 in (13/19 mm)
- Bottom
 - 2 locations: 0.5 in (13 mm)
 - 2 locations: 0.5/0.75 in (13/19 mm)

Driver Wiring and Mounting

- Driver is grounded by the green ground wire connection on the enclosure or by the ground lug terminal in the junction box
- Driver and junction box must be grounded in accordance with local and national electrical codes
- All wire connections must be made in the junction box to maintain UL® listing
- 4 in (102 mm) square junction box is 1.5 in (38 mm) deep with 22.0 in³ (360.5 cm³) capacity and complies with NEMA® OS 1-2008 Figure 112
- Driver is pre-wired with 6 in (152 mm), 18 AWG (0.75 mm²) solid copper leads in all terminal blocks

Job Name: <input type="text"/>	Model Numbers: <input type="text"/>	
Job Number: <input type="text"/>	<input type="text"/>	<input type="text"/>

Wiring

Controls Requiring Neutral

Note: Colors shown correspond to terminals on driver.

Stickbulb note:
for more dimming info,
see pages 33-34

Wiring Diagram

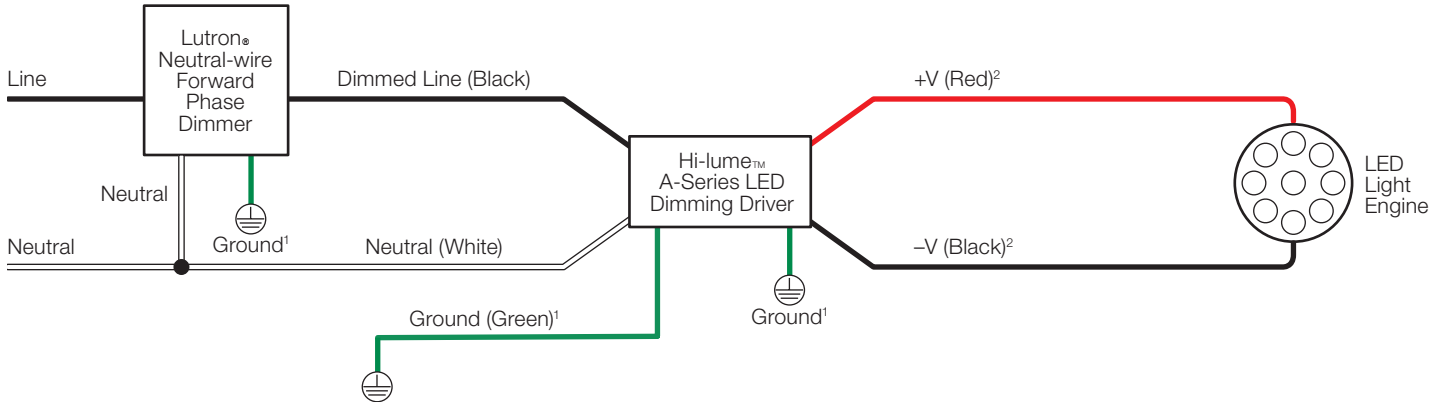

¹Ground wire connection available on K case models only. Fixture and driver case must be grounded in accordance with local and national electrical codes.

²For maximum driver-to-LED light engine wire length, see charts in **Driver Leads** section at the end of the document.

Compatible Controls: Lutron® Neutral-wire Dimmers

Guaranteed performance specifications with the controls listed in the chart below.

For assistance selecting controls, contact our LED Center of Excellence at 1.877.346.5338 or LEDs@lutron.com

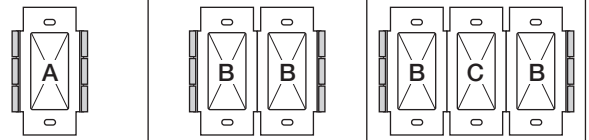

Product	Part Number	Low-End Setting/Load-Type Setting*	Drivers per Control		
			A: Not Ganged	B: End of Gang	C: Middle of Gang
Maestro Wireless® 600 W dimmer	MRF2-6ND-120-	Trim low-end per APM App Note (Lutron® P/N 048370)	1-8	1-8	1-8
Maestro Wireless® 1000 W dimmer	MRF2-10ND-120-	Trim low-end per APM App Note (Lutron® P/N 048370)	1-13	1-13	1-13
Caséta® Wireless Pro 1000 W dimmer	PD-10NXD-	Trim low-end per instructions at www.casetawireless.com/lowend	1-13	1-13	1-13
GRAFIK™ C•L® dimmer	GT-250M-GTJ-250M-	Set low-end trim per dimmer installation instructions	1-10	1-10	1-10
HomeWorks® QS adaptive dimmer	HQRD-6NA-	LED Lutron® A-Series 2-Wire	1-8	1-8	1-8
HomeWorks® QS 600 W dimmer	HQRD-6ND-	LED Lutron® A-Series 2-Wire	1-8	1-8	1-8
HomeWorks® QS 1000 W dimmer	HQRD-10ND-	LED Lutron® A-Series 2-Wire	1-13	1-13	1-13
RadioRA® 2 adaptive dimmer	RRD-6NA-	Hi-lume® A-Series LTE LED Driver 2-Wire	1-8	1-8	1-8
RadioRA® 2 1000 W dimmer	RRD-10ND-	Set Device type to "INC/MLV Neutral Dimmer"; Set High-End Trim to 99%; Set Low-End Trim to 35%	1-13	1-13	1-13

* Setting the low-end trim and load type is necessary to ensure optimal performance and 1% dimming capability.

Note: For information about Legacy Product use in existing control application, contact LEDs@lutron.com

Job Name: <input style="width: 90%;" type="text"/>	Model Numbers: <input style="width: 95%;" type="text"/>
Job Number: <input style="width: 80%;" type="text"/>	<input style="width: 95%;" type="text"/>

Wiring (continued)

Controls Requiring Neutral (continued)

Note: Colors shown correspond to terminals on driver.

Stickbulb note:
for more dimming info,
see pages 32 and 34

Wiring Diagram

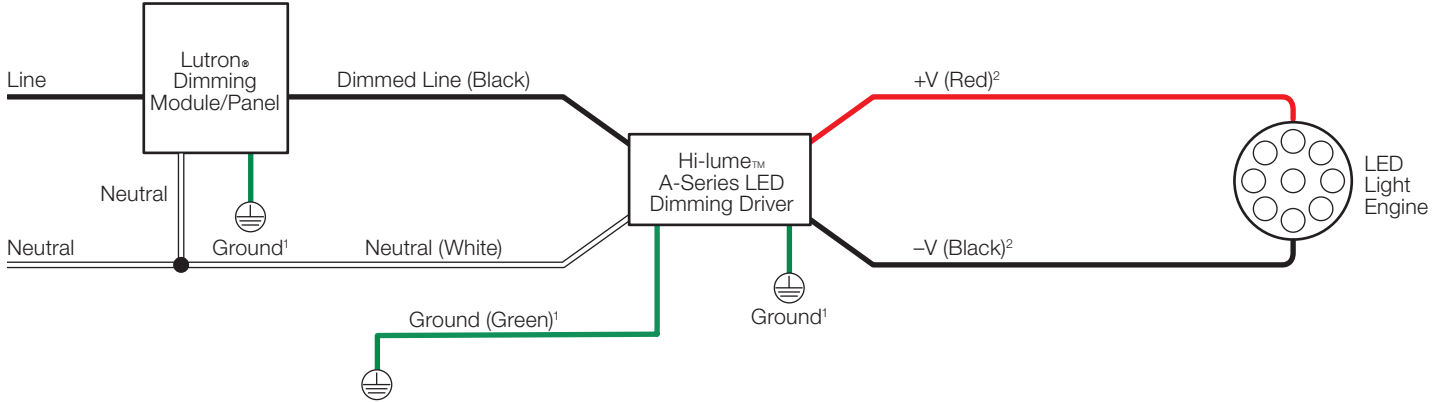

¹ Ground wire connection available on K case models only. Fixture and driver case must be grounded in accordance with local and national electrical codes.

² For maximum driver-to-LED light engine wire length, see charts in **Driver Leads** section at the end of the document.

Compatible Controls: Lutron® Dimming Modules/Panels

Guaranteed performance specifications with the controls listed in the chart below.

For assistance selecting controls, contact our LED Center of Excellence at 1.877.346.5338 or LEDs@lutron.com

Product	Part Number	Drivers per Control	Low-End Setting/Load-Type Setting*
myRoom™ DIN power module	MQSE-4A1-D	1–6 (per output); 1 A maximum driver input current	LED Lutron® A-Series 2-Wire
HomeWorks® QS DIN power module	LQSE-4A1-D	1–6 (per output); 1 A maximum driver input current	LED Lutron® A-Series 2-Wire
HomeWorks® QS wallbox power module	HQRJ-WPM-6D-120	2–10 (per output); 26 total per module	LED Lutron® A-Series 2-Wire
HomeWorks® wallbox power module	HWI-WPM-6D-120	2–10 (per output); 26 total per module	Set load type to “GRX-FDBI or GRX-TVI”
GRAFIK Eye® QS control unit	QSGR-, QSGRJ-	2–10 (per output); 26 total per unit	Set load type to “Fluorescent Module”
GRAFIK Eye® 3000 control unit	GRX-3100-, GRX-3500-	2–10 (per output); 26 total per module	Set load type to “GRX-FDBI or GRX-TVI”
RPM-4U module (LCP, HomeWorks® QS, GRAFIK Systems™, Quantum®)	HW-RPM-4U-120, LP-RPM-4U-120	2–26 (per output); 26 total per module	LED Lutron® A-Series 2-Wire Set load type to “2-1”
RPM-4A module (LCP, HomeWorks® QS, GRAFIK Systems™, Quantum®)	HW-RPM-4A-120, LP-RPM-4A-120	1–13 (per output); 26 total per module	LED Lutron® A-Series 2-Wire Set load type to “2-1”
GP dimming panels	Various	1–26	Set load type to “2-1”

*Setting the low-end trim and load type is necessary to ensure optimal performance and 1% dimming capability.

Job Name:	Model Numbers:	
<input type="text"/>	<input type="text"/>	<input type="text"/>
Job Number:	<input type="text"/>	<input type="text"/>

Wiring (continued)

Controls Not Requiring Neutral

Note: Colors shown correspond to terminals on driver.

Stickbulb note:
for more dimming info,
see pages 32-33

Wiring Diagram

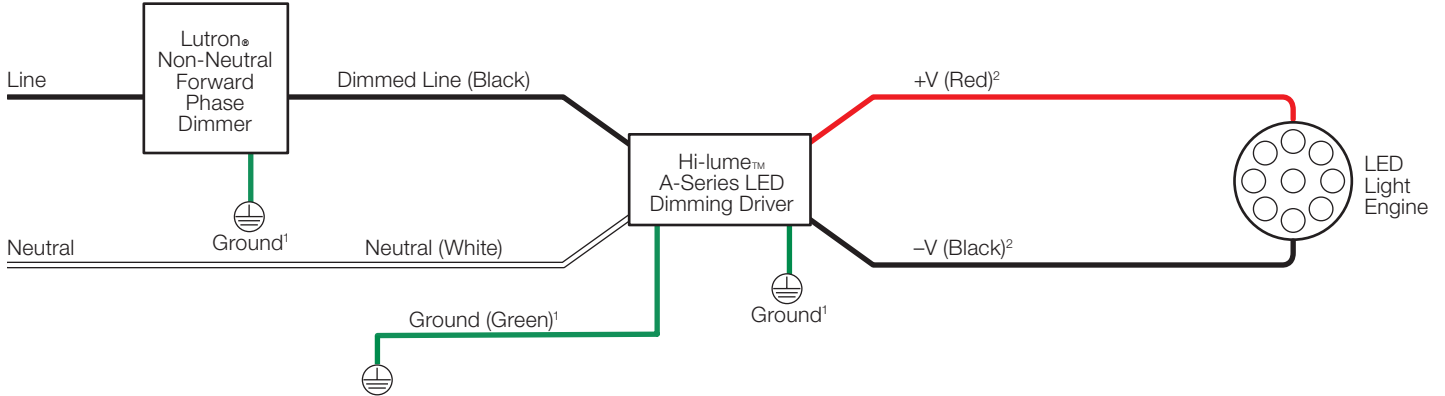

¹ Ground wire connection available on K case models only. Fixture and driver case must be grounded in accordance with local and national electrical codes.

² For maximum driver-to-LED light engine wire length, see charts in **Driver Leads** section at the end of the document.

Compatible Controls: Lutron® Non-Neutral Dimmers

Guaranteed performance specifications with the controls listed in the chart below.

For assistance selecting controls, contact our LED Center of Excellence at 1.877.346.5338 or LEDs@lutron.com

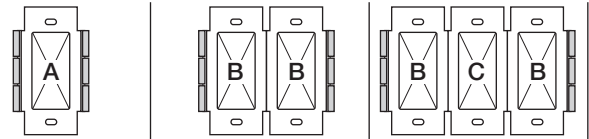

Product	Part Number	Low-End Setting/ Load-Type Setting*	Drivers per Control		
			A: Not Ganged	B: End of Gang	C: Middle of Gang
Ariadni® C•L® 250 W dimmer	AYCL-253P-	Set low-end trim dial to 1 o'clock. Adjust slightly if needed. See Figure 1 under 'Dimmer Range Adjustment' section in the Dimmer Installation Guide for how to adjust low-end trim	1-8	1-8	1-8
Diva® C•L® 250 W dimmer	DVCL-253P- DVSCCL-253P-	Set low-end trim dial to 10 o'clock. Adjust slightly if needed. See Figure 1 under 'Dimmer Range Adjustment' section in the Dimmer Installation Guide for how to adjust low-end trim	1-8	1-8	1-8
Nova T★® C•L® 250 W dimmer	NTCL-250-	Set low-end trim per dimmer installation instructions	1-10	1-10	1-10

*Setting the low-end trim and load type is necessary to ensure optimal performance and 1% dimming capability.

Note: For information about Legacy Product use in existing control application, contact LEDs@lutron.com

Job Name: <input style="width: 90%; height: 20px;" type="text"/>	Model Numbers: <input style="width: 95%; height: 20px;" type="text"/>
Job Number: <input style="width: 80%; height: 20px;" type="text"/>	<input style="width: 95%; height: 20px;" type="text"/>

ELECTRICIANS AND CONTRACTORS

Driver Leads

Maximum driver-to-LED light engine wire length for

Constant-Current Drivers:

Wire Gauge	Maximum Lead Length		
	200 mA to 700 mA	710 mA to 1.50 A	1.51 A to 2.10 A
18 AWG (0.75 mm ²)	30 ft (9 m)	15 ft (4.5 m)	10 ft (3 m)
16 AWG (1.5 mm ²)	35 ft (10.5 m)	25 ft (7.5 m)	15 ft (4.5 m)
14 AWG (2.5 mm ²)	50 ft (15 m)	40 ft (12 m)	25 ft (7.5 m)
12 AWG (4.0 mm ²)	100 ft (30 m)	60 ft (18 m)	40 ft (12 m)

Maximum driver-to-LED light engine wire length for

Constant-Voltage Drivers:

Wire Gauge	Maximum Lead Length		
	10 to 20 V $\overline{=}$	20.5 to 40 V $\overline{=}$	40.5 to 60 V $\overline{=}$
18 AWG (0.75 mm ²)	10 ft (3 m)	15 ft (4.5 m)	30 ft (9 m)
16 AWG (1.5 mm ²)	15 ft (4.5 m)	25 ft (7.5 m)	50 ft (15 m)
14 AWG (2.5 mm ²)	25 ft (7.5 m)	40 ft (12 m)	75 ft (22.5 m)
12 AWG (4.0 mm ²)	40 ft (12 m)	60 ft (18 m)	100 ft (30 m)

Wiring and Grounding

Driver and lighting fixture must be grounded.

Drivers must be installed per national and local electrical codes.

LED Load Replacement

For Class 2 rated drivers, the LED load can be changed while the driver is installed and powered.

Maximum Driver Operating Temperature

Driver case temperature (t_c) must not exceed UL® conditions of acceptability in end product.

For 50,000 hour lifetime, driver case temperature (t_c) must not exceed 65 °C.

FACILITIES MANAGERS

SERVICE

Warranty

For warranty information, please visit www.lutron.com/BallastDriverWarranty.pdf

Replacement Parts

When ordering Lutron® replacement parts please provide the full model number. Consult Lutron® Technical Support if you have any questions.

Further Information

For further information, please visit us at www.lutron.com/hilumeLED or contact our LED Control Center of Excellence at 1.877.346.5338 or LEDs@lutron.com

Job Name: <input type="text"/>	Model Numbers: <input type="text"/>	
Job Number: <input type="text"/>	<input type="text"/>	<input type="text"/>