

VERSION 14

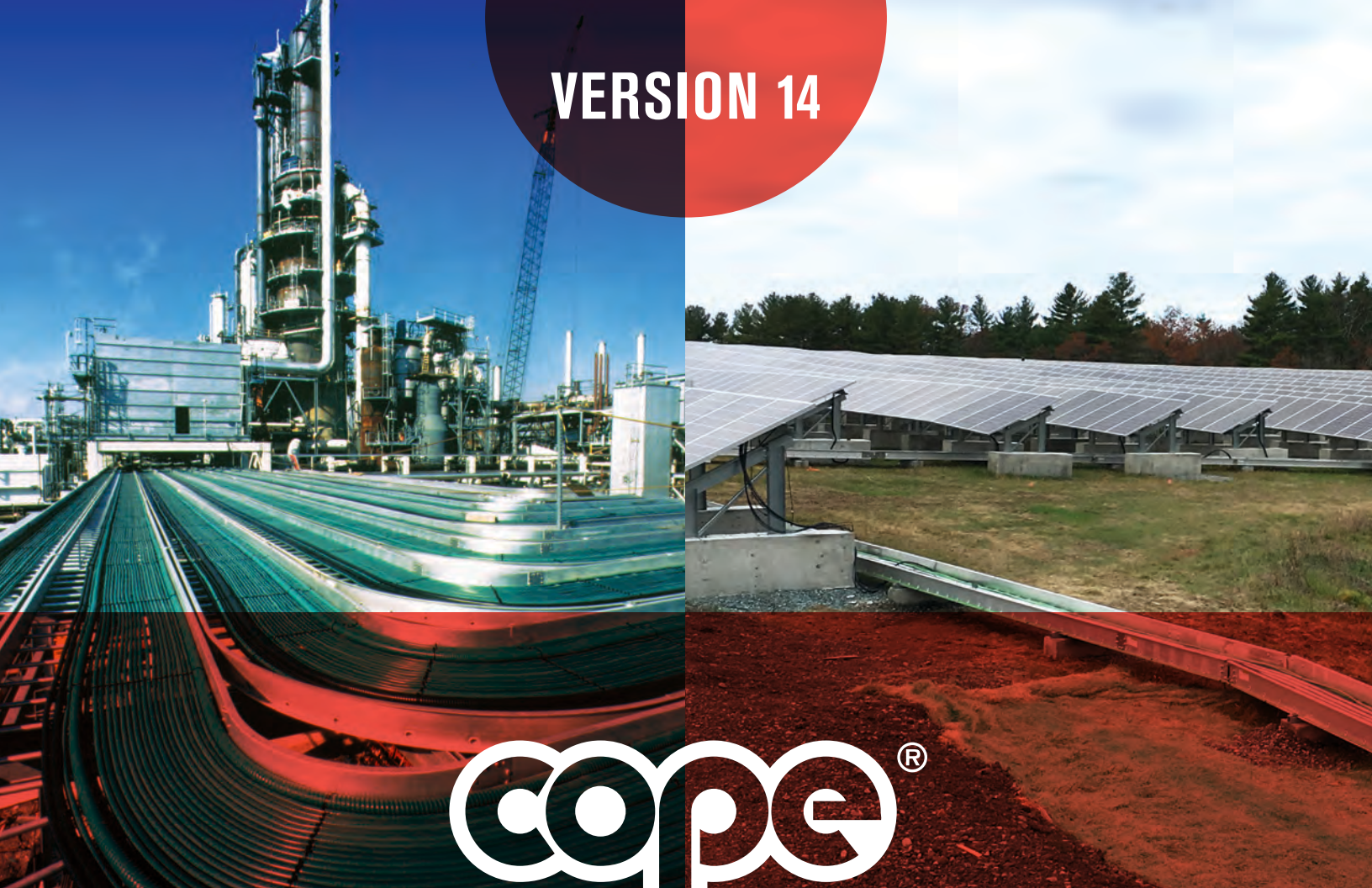

CABLE MANAGEMENT SOLUTIONS



A PART OF



CABLE TRAY SYSTEMS

COPE® CABLE TRAY SOLUTIONS FOR YOUR INFRASTRUCTURE REQUIREMENTS

Welcome to our new products catalog. For the first time we offer our complete line of Cope cable tray products in a single catalog. This complete catalog is designed for ease of use and to provide the basic information needed to select the proper cable tray system for your needs.

The first section of the catalog provides comprehensive product information, definitions, and technical data needed to select the proper tray. The second section provides industry standards and guidelines for the manufacture and installation of cable tray.

Cope's I-BEAM™ tray provides a heavy duty welded cable tray for clients requiring I-BEAM side rails. It is perfect for long span locations, heavy loads, and will interface with existing "I" Beam configuration trays.

Cope's Swaged Ladder tray uses our patented swaging system of rung attachment. This system of attachment provides a very rigid tray without welding that is easy to handle and install. The flange out design provides the maximum access to your cables, even in narrow or divided cable trays.

Cope's Hat Rung tray provides a flange in alternative for those instances where space is critical. With the flanges turned inward, this tray can be fitted into confined spaces. Slotted rungs provide excellent cable tie down capability.

Cope Trof provides the ultimate in cable support for your small diameter, flexible cable. With 1" ribs located every 2" on center, drooping of cable is virtually eliminated.



Cope Channel provides an excellent support system for those applications where only a few cables are needed. It can also be used for separation of services in ladder or trof trays.

CAT TRAY™ wire basket provides the superior flexibility and ease of installation required by data-com installations. The exclusive

Kwik-Latch system speeds cable tray installation.

Cope Glas™ fiberglass cable tray provides the answer to many adverse environments. Life cycle costs, long span capability and easy field modification make Cope Glas™ an ideal choice for industrial, chemical, and petro-chemical facilities.

Our customer service team is available to assist with questions about application, installation, and availability of our products.

Thank you for considering Cope for your cable tray requirements.

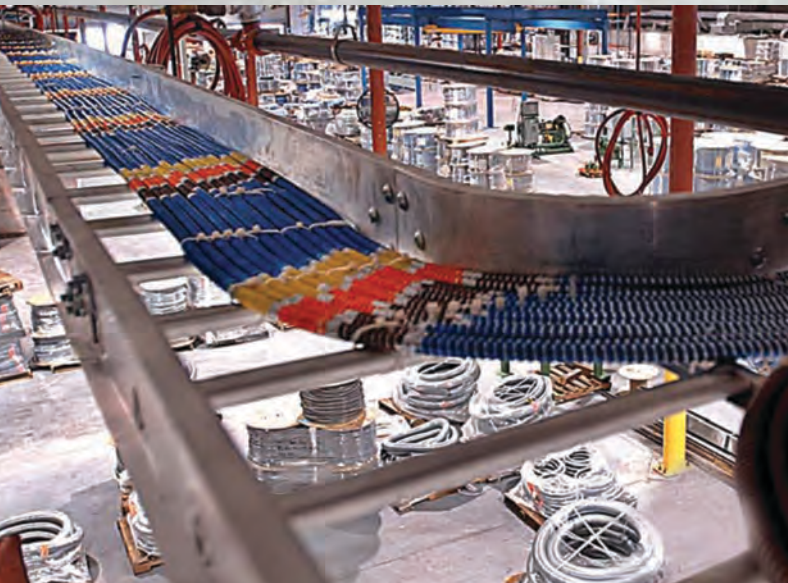

Thomas Jefferson Cope founded T.J. Cope in Philadelphia, Pennsylvania in 1887. At that time, T.J. Cope's primary business was designing and manufacturing cable installation/pulling equipment for overhead and underground applications.

In 1948, T.J. Cope introduced the first modular Cable Tray System. The tray system was fabricated from sheet metal with the edges turned up forming a trof shape. This type of installation offered a more flexible and economical alternative to the traditional use of conduit.

In 1957, T.J. Cope was purchased by the Rome Cable Corporation, which in turn, was purchased by Alcoa in 1959. The Cyprus Mines Corporation purchased T. J. Cope six years later when the U. S. Justice Department forced Alcoa to divest its holdings of the Rome Cable Company.

T.J. Cope was merged into Allied Tube & Conduit Corporation in 1996. The Cope brand is owned by Allied Tube & Conduit Corporation and is part of the Electrical and Support Division. Allied Tube & Conduit Corporation is a world leading manufacturer of galvanized steel tubing, including electrical conduit; its affiliate, AFC Cable Systems, provides AC/MC cable and flexible conduits; and its other affiliate, Unistrut International Corporation, provides Power-Strut and Unistrut metal framing systems. Allied Tube & Conduit Corporation, a part of Atkore International, serves the electrical, mechanical, and construction markets worldwide.

Headquarters:

Atkore International
16100 S. Lathrop Avenue
Harvey, IL 60426
Tel: 708-339-1610
Fax: 708-339-0615
Toll Free: 800-825-5433









Manufacturing:

Atkore International
11500 Norcom Road
Philadelphia, PA 19154
Tel: 215-961-2570
Fax: 215-961-2580

Atkore International
11539 North Houston Rosslyn Road
Houston, TX 77088
Tel: 281-445-2900
Fax: 281-931-9324



INTRODUCTION/CONTENT

| | | | |
|------------------|--------------------------------------|---|----------------------|
| SECTION 1 | FEATURES & TECHNICAL DATA |  | Cutaway - Cope Swage |
| SECTION 2 | LADDER |  | |
| SECTION 3 | I-BEAM |  | |
| SECTION 4 | HAT |  | |
| SECTION 5 | TROF |  | |
| SECTION 6 | CHANNEL |  | |
| SECTION 7 | GLAS |  | |
| SECTION 8 | WIRE BASKET |  | |
| SECTION 9 | REFERENCE DATA | | |

Intro

LADDER

I-BEAM

HAT

TROF

CHANNEL

COPE-GLAS™

WIREBASKET

Reference



A PART OF **atkore**
INTERNATIONAL

COPE® Quotation Check List

PROJECT INFORMATION

| | | | |
|--------------|--|-----------|--|
| Name: | | Date: | |
| Contractor: | | Location: | |
| Distributor: | | | |
| Contact: | | | |
| Email/Phone: | | | |

| | | | | |
|------------|----------------------------------|--------------------------------------|------------------------------------|-------------------------------------|
| TRAY TYPE: | <input type="checkbox"/> Ladder | <input type="checkbox"/> Marine Rung | <input type="checkbox"/> Vent Trof | <input type="checkbox"/> Solid Trof |
| | <input type="checkbox"/> Channel | <input type="checkbox"/> Wire Basket | <input type="checkbox"/> I-Beam | |

| | | | | |
|----------------|--|--|---------------------------------------|--------------|
| TRAY MATERIAL: | <input type="checkbox"/> Aluminum | <input type="checkbox"/> Steel, Pre-Galvanized | <input type="checkbox"/> Steel, HDGAF | Other, _____ |
| | <input type="checkbox"/> 304 Stainless Steel | <input type="checkbox"/> 316 Stainless Steel | <input type="checkbox"/> Fiberglass | |

| | | | |
|-------------------------------------|------------------------------------|--------------------------------------|--|
| TRAY MATERIAL: (Fiberglass Only) | <input type="checkbox"/> Polyester | <input type="checkbox"/> Vinyl Ester | |
|-------------------------------------|------------------------------------|--------------------------------------|--|

| | | | | | |
|--------------|------------------------------|------------------------------|------------------------------|------------------------------|------------------------------|
| TRAY LENGTH: | <input type="checkbox"/> 10' | <input type="checkbox"/> 12' | <input type="checkbox"/> 20' | <input type="checkbox"/> 24' | <input type="checkbox"/> 30' |
|--------------|------------------------------|------------------------------|------------------------------|------------------------------|------------------------------|

| | | | | |
|-------------|------------------------------|------------------------------|------------------------------|---|
| TRAY WIDTH: | <input type="checkbox"/> 6" | <input type="checkbox"/> 9" | <input type="checkbox"/> 12" | <input type="checkbox"/> 18" |
| | <input type="checkbox"/> 24" | <input type="checkbox"/> 30" | <input type="checkbox"/> 36" | <input type="checkbox"/> 42" or 48" <small>Note: Ladder Tray Only, not NEMA Standard</small> |

| | | | | | | | | | |
|-----------------------------------|-----------------------------|-----------------------------|-----------------------------|-----------------------------|------------------------------|------------------------------|------------------------------|------------------------------|------------------------------|
| TRAY WIDTH: (Wire basket Only) | <input type="checkbox"/> 2" | <input type="checkbox"/> 4" | <input type="checkbox"/> 6" | <input type="checkbox"/> 8" | <input type="checkbox"/> 12" | <input type="checkbox"/> 16" | <input type="checkbox"/> 18" | <input type="checkbox"/> 20" | <input type="checkbox"/> 24" |
|-----------------------------------|-----------------------------|-----------------------------|-----------------------------|-----------------------------|------------------------------|------------------------------|------------------------------|------------------------------|------------------------------|

| | | | | |
|---------------|-----------------------------|-----------------------------|------------------------------|------------------------------|
| RUNG SPACING: | <input type="checkbox"/> 6" | <input type="checkbox"/> 9" | <input type="checkbox"/> 12" | <input type="checkbox"/> 18" |
|---------------|-----------------------------|-----------------------------|------------------------------|------------------------------|

| | | | | | |
|-------------|-----------------------------|-----------------------------|-----------------------------|-----------------------------|-----------------------------|
| LOAD DEPTH: | <input type="checkbox"/> 2" | <input type="checkbox"/> 3" | <input type="checkbox"/> 4" | <input type="checkbox"/> 5" | <input type="checkbox"/> 6" |
|-------------|-----------------------------|-----------------------------|-----------------------------|-----------------------------|-----------------------------|

| | | | |
|-----------------|------------------------------|------------------------------|------------------------------|
| FITTING RADIUS: | <input type="checkbox"/> 12" | <input type="checkbox"/> 24" | <input type="checkbox"/> 36" |
|-----------------|------------------------------|------------------------------|------------------------------|

| | | | | |
|---|------------------------------|------------------------------|------------------------------|-------------------------------|
| STRUCTURAL REQUIREMENTS: (NEMA CLASS) OR, | <input type="checkbox"/> 8A | <input type="checkbox"/> 8B | <input type="checkbox"/> 8C | |
| | <input type="checkbox"/> 12A | <input type="checkbox"/> 12B | <input type="checkbox"/> 12C | |
| | <input type="checkbox"/> 16A | <input type="checkbox"/> 16B | <input type="checkbox"/> 16C | |
| | <input type="checkbox"/> 20A | <input type="checkbox"/> 20B | <input type="checkbox"/> 20C | <input type="checkbox"/> 20C+ |

| | |
|---------------------------|--|
| CABLE WEIGHT SUPPORT SPAN | |
|---------------------------|--|

| | |
|-----------------------|--|
| SPECIAL REQUIREMENTS: | |
|-----------------------|--|

| | |
|------------------------|--|
| DELIVERY REQUIREMENTS: | |
|------------------------|--|

All tray widths and lengths listed are not available for every tray type. See Cope catalog for dimensions.

Customer Service
16100 S. Lathrop Ave. • Harvey, IL 60426
Phone: 800-882-5543 • Fax: 708-339-7814

www.copecabletray.com

Confidential Information

COP-L-1005-1404

COPE® QUICK SHIP PROGRAM

The Cope Quick Ship program is designed to ship our most popular cable tray straights, wire basket, fittings and hardware **SAME DAY/NEXT DAY!**
The items below are in stock at our **PHILADELPHIA** facility.

| CABLE TRAY STRAIGHTS AND FITTINGS | | | | | | | |
|--|---|---|--------------------------------------|--|---|---|--|
| 90° Inside/Outside Vertical Elbows | 12" Radius 248-069I-12 248-129I-12 248-189I-12 248-249I-12 248-069O-12 248-129O-12 248-189O-12 248-249O-12 | 24" Radius 248-069I-24 248-129I-24 248-189I-24 248-249I-24 248-069O-24 248-129O-24 248-189O-24 248-249O-24 | Ladder Straights NEMA | 12B 12' Long 9"RS 1B48-06SL-12-09 1B48-12SL-12-09 1B48-18SL-12-09 1B48-24SL-12-09 | Horizontal Cross | 248-06FC-12 248-12FC-12 248-18FC-12 248-24FC-12 | |
| | Barrier Strips | 5A-01SB-10 4A-01SB-12 | | 90° Horizontal Elbows | 12" Radius 248-069F-12 248-129F-12 248-189F-12 248-249F-12 | 24" Radius 248-069F-24 248-129F-24 248-189F-24 248-249F-24 | Universal Curvilinear Connector |
| NEMA 12B Ladder Tray System • 1B48 System • 248 Fittings • 5-1/4" Side Rail • 4" Load Depth | | | Horizontal Tee | 12" Radius 248-06FT-12 248-12FT-12 248-18FT-12 248-24FT-12 | Hold-Down Clamp | 9131A | |
| WIRE BASKET AND ACCESSORIES | | | | Products packaged and shipped Same Day/Next Day! A PART OF | | | |
| Wire Basket | CAT4-12SL-120 CAT4-18SL-120 CAT2-12SL-120 CAT2-06SL-120 CAT2-04SL-120 CAT2-02SL-120 | Hardware | CH1 CH2 CH3 T-BAR SPLICE | | | | |
| Trapeze Hangers | CAT-HSB-120 CAT-USB-120 | Contact your local sales representative for more information! 708-225-2070 copecabletray.com | | | | | |

©2016 Atkore International, Inc. All rights reserved. COP-I-1009-1606

COPE® QUICK SHIP PROGRAM

The Cope Quick Ship program is designed to ship our most popular cable tray straights, wire basket, fittings and hardware **SAME DAY/NEXT DAY!**
The items below are in stock at our **HOUSTON** facility.

| CABLE TRAY STRAIGHTS AND FITTINGS | | | | | | | |
|--|--|--|--------------------------------------|--|---|--|--------------------------|
| 90° Inside/Outside Vertical Elbows | 12" Radius Inside 249-069I-12 249-129I-12 249-189I-12 249-249I-12 | 24" Radius Inside 458-069I-24 458-129I-24 458-189I-24 458-249I-24 458-369I-24 | Ladder Straights NEMA | 12B 12' Long 9"RS 1B48-06SL-12-09 1B48-12SL-12-09 1B48-18SL-12-09 1B48-24SL-12-09 | 20C 20' Long 9"RS 7D58-06SL-20-09 7D58-12SL-20-09 7D58-18SL-20-09 7D58-24SL-20-09 7D58-36SL-20-09 | Universal Curvilinear Connector | 58-02RC 48-02RC |
| | Outside 248-069O-12 248-129O-12 248-189O-12 248-249O-12 | Outside 458-069O-24 458-129O-24 458-189O-24 458-249O-24 458-369O-24 | 90° Horizontal Elbows | 12" Radius 248-069F-12 248-129F-12 248-189F-12 248-249F-12 | 24" Radius 458-069F-24 458-129F-24 458-189F-24 458-249F-24 458-369F-24 | Hold-Down Clamp | 9131A |
| NEMA 20C Ladder Tray System • 7D58 System • 458 Fittings • 5-1/4" Side Rail • 5" Load Depth | | NEMA 12B Ladder Tray System • 1B48 System • 248 Fittings • 5-1/4" Side Rail • 4" Load Depth | | Horizontal Tee | 12" Radius 248-06FT-12 248-12FT-12 248-18FT-12 248-24FT-12 | Barrier Strips | 5A-01SB-10 4A-01SB-12 |
| WIRE BASKET AND ACCESSORIES | | | | Products packaged and shipped Same Day/Next Day! A PART OF | | | |
| Wire Basket | CAT4-12SL-120 CAT4-18SL-120 CAT2-12SL-120 CAT2-06SL-120 CAT2-04SL-120 CAT2-02SL-120 | Hardware | CH1 CH2 CH3 T-BAR SPLICE | | | | |
| Trapeze Hangers | CAT-HSB-120 CAT-USB-120 | Contact your local sales representative for more information! 708-225-2070 copecabletray.com | | | | | |

©2016 Atkore International, Inc. All rights reserved. COP-I-1008-1602

CABLE TRAY SYSTEMS

PRODUCT FEATURES

SELECTING A COPE® CABLE TRAY SYSTEM

A number of factors must be considered when selecting the proper cable tray system and planning the installation:

- Material and Finish
- Types of Cable Tray
- NEMA Class
- Cavity Size - Load/Depth/Width of Tray
- Length of Straight Sections
- Rung Spacing
- Radius of Fittings
- Cable Tray Support Locations
- Electrical Grounding

CABLE TRAY SYSTEM DRAWING LEGEND

- 1 Straight Section, Ladder (SL)
- 2 Horizontal Elbow, 90°, Ladder Type (9F)
- 3 Horizontal Elbow, 30° (3F), 45° (4F) or 60° (6F)
- 4 Horizontal Cross, Ladder Type (FC)
- 5 Horizontal Tee, Ladder Type (FT)
- 6 Vertical Elbow, Outside, 90° (9O)
- 7 Vertical Elbow, Outside & Inside, 30° (3O, 3I), 45° (4O, 4I), or 60° (6O, 6I)
- 8 Vertical Tee, Solid Bottom Trof Type (VT)
- 9 Straight Section, Solid Bottom Trof (SL)
- 10 Flanged Solid Cover (FS)
- 11 Barrier Strip-Straight Section (SB)
- 12 Barrier Strip-Flexible-Horizontal Fitting (FB)
- 13 Straight Section, Channel (SL)
- 14 Blind End (BE)
- 15 Box Connector (BC)
- 16 Angle Connector (CA)
- 17 Reducing Connector (CO)
- 18 Universal Curvilinear Connector (RC)

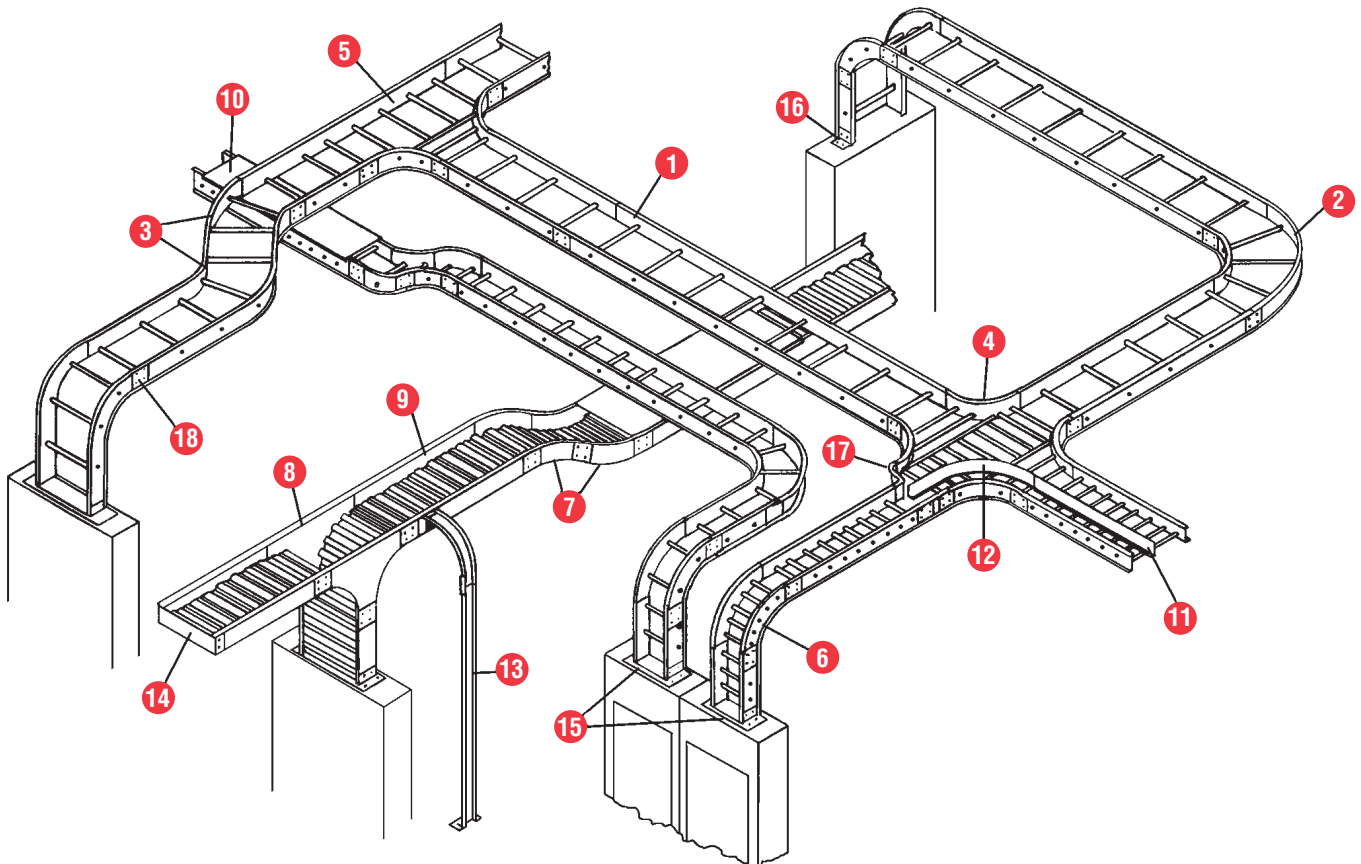

TYPES OF CABLE TRAY

Any assembly of cable tray straight sections, fittings and accessories that form a rigid system to support cables is a cable tray. The different types of tray designs are described below.

Ladder

A prefabricated metal structure consisting of two side rails connected by individual transverse members or rungs. Ladder tray is the most common and the most economical type of tray. It also provides maximum ventilation for cabling.

I-Beam

Cope I-Beam cable tray system provides long span capability and versatility. Cope I-Beam interfaces with existing "I" Beam configurations.

Ventilated Trof

A prefabricated metal structure with clear openings no greater than 4".

Trof cable trays are the best choice for smaller cables. Ventilated trofs offer some air-flow while completely eliminating cable sagging.

Solid Trof

A prefabricated metal structure consisting of a bottom with no openings within the cable bearing surface. Solid bottom cable trays completely eliminate cable sagging and offer the most protection for the cables.

Channel

A prefabricated metal structure consisting of a one-piece ventilated or solid bottom channel section not exceeding 6" in width.

Cope-Glas

Fiberglass cable tray provides the answer to many adverse environments. Life cycle costs, long span capability and easy field modification make Cope Glas™ an ideal choice for industrial, chemical, and petro-chemical facilities.

Wire Basket

Provides the superior flexibility and ease of installation required by power and data-com installations. The exclusive Kwik- Latch system speeds cable tray installation. A1008 steel, with an electro galv finish, ASTM B633 TYPE III, SC3

MATERIALS AND FINISH

The material selection is based on the environmental conditions and economic considerations for the project.

Steel - Pre-Galvanized

Hot Dip Mill-Galvanized steel (ASTM-A-653-G90 CS) is zinc coated by a hot dip process. Steel strip from a coil is fed through a continuous zinc coater which cleans, fluxes and coats the steel with molten zinc. After cooling, the steel is recoiled. The pre-galvanized coating provides a total weight of 0.90 oz. of zinc for both sides of one square foot of material.

Mill galvanized ladder is made of pre-galvanized steel and generally used indoors or in locations not exposed to the elements or corrosives.

Steel - Hot Dip Galvanized After Fabrication

In hot dip galvanizing after fabrication (HDGAF), the finished part is immersed in a bath of molten zinc (ASTM 123). This method results in complete zinc coverage and a thicker coating than pregalvanized or electro-plated steel.

The zinc coating is typically 2.6 MIL or 1.5 oz./sq. ft. of surface area.

This is the coating of choice for applications where protection from severe corrosion is a design factor.

Stainless Steel

Type 304 and Type 316 stainless steel material in accordance with ASTM-A-240.

Aluminum

Aluminum material in accordance with AA-6063-T6. Aluminum trays are suitable for most outdoor applications and offer reductions in total installed costs.

Fiberglass

For extremely corrosive areas, Cope offers the most complete line of Fiberglass cable trays available. For a complete Cope "Cope-Glas™" catalog, please contact the factory or the Cope representative in your area.

Special Finishes

For extremely corrosive areas Cope can supply a PVC (polyvinyl chloride) coating over aluminum or uncoated steel. This is applied using the fluidized bed process to a nominal thickness of 12 mils.

Weathering steel is also available; contact factory for availability.

PRODUCT FEATURES

ASSOCIATED PRODUCTS

POWER-STRUT® METAL FRAMING SYSTEM

Trapeze Support System

Power-Strut metal framing is ideal for electrical and mechanical pipe support applications.

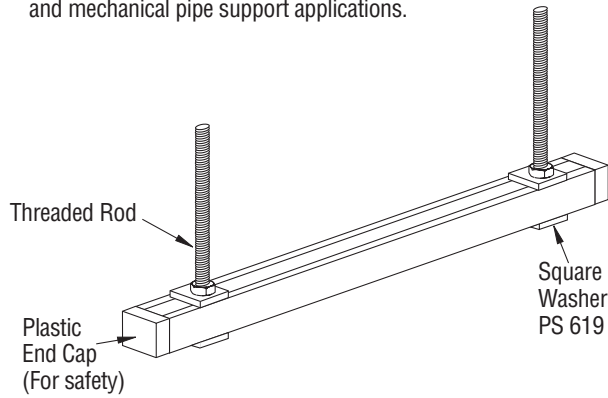

Acceptable Methods to Hang Channels

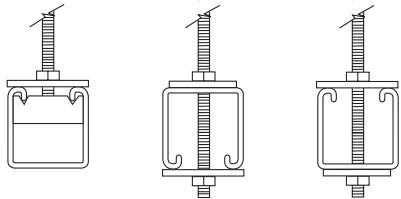

Pre-slotted channel allow through channel connections

Overhead Multi-Use Support Systems Using Channel Attached to "I" Beams

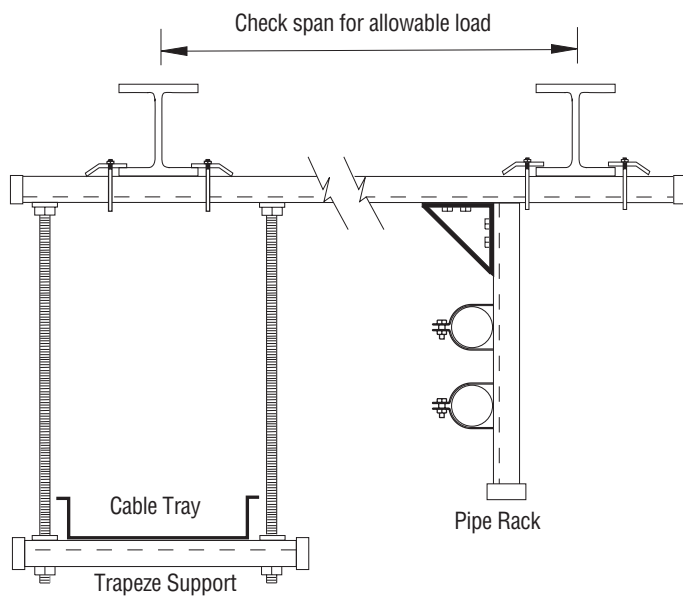

Standard Channel and Fitting Assembly

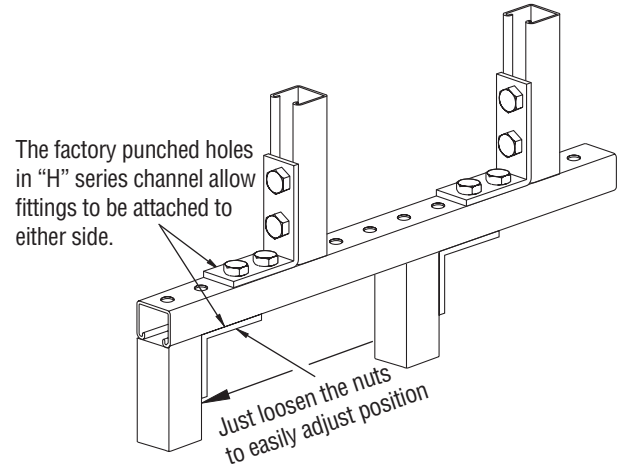

Ganged Pipe Support

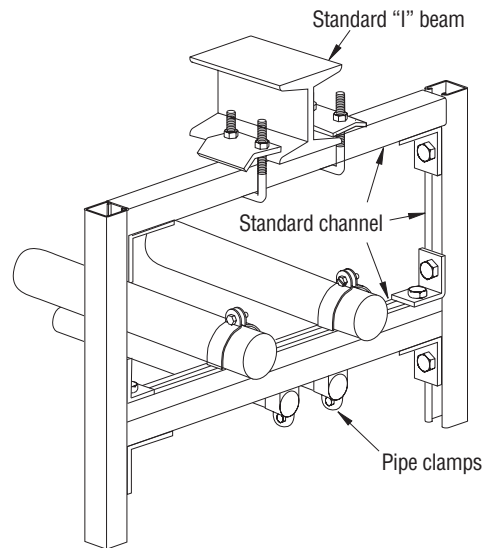

Stock brackets are available in lengths from 6" to 36"

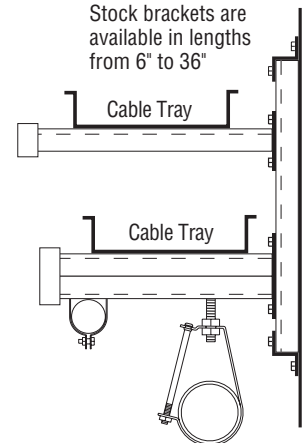

*Reference your Power-Strut Catalog, or Power-Strut.us for more information

CABLE TRAY FITTINGS

Fittings are used to change the size or direction of the cable tray. A wide variety of standard fittings are offered to simplify installation of a tray system. Horizontal or vertical bends are offered for each tray width and with angles of 30°, 45°, 60° or 90°. The radius of the bend, whether horizontal or vertical, can be 12", 24", 36", or even greater on a custom basis. Specification of the radius of the bend involves a trade-off between available space, minimum bending radius of cables, ease of cable pulling, and cost. The most common radius is 24 in. Fittings are not subject to NEMA/CSA load ratings and the diagrams below illustrate how the tray should be supported near the fittings.

When a standard angle will not work, field fittings or adjustable elbows can be used. Refer to NEMA VE2 Installation Guidelines for suggested support locations for these situations.

Support for Flat Fittings

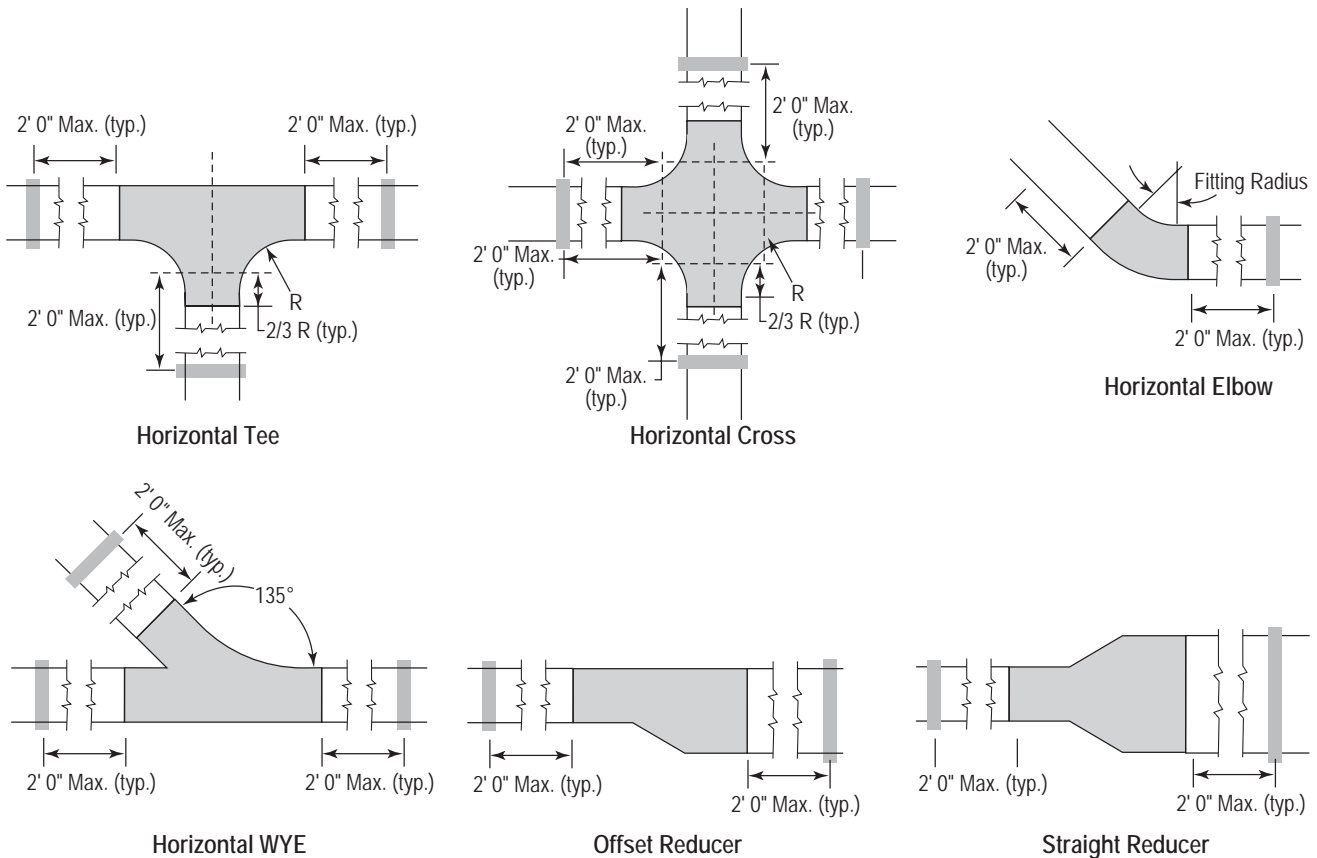

Support for Vertical Fittings

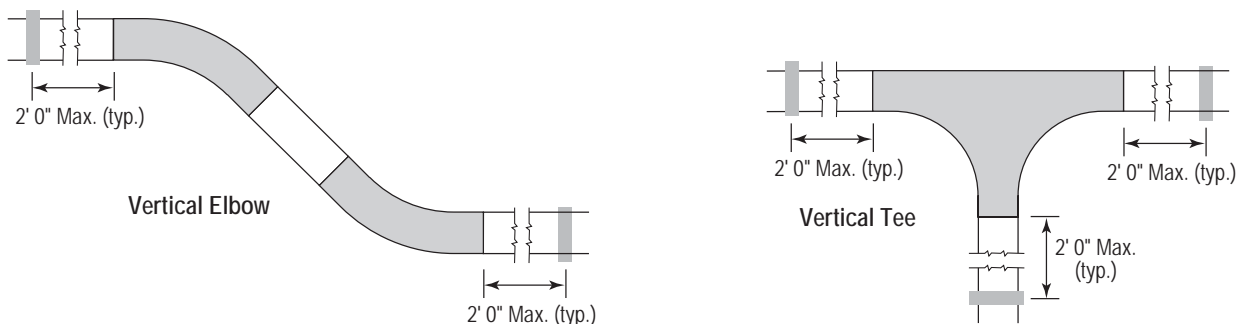

NOTES

2

LADDER

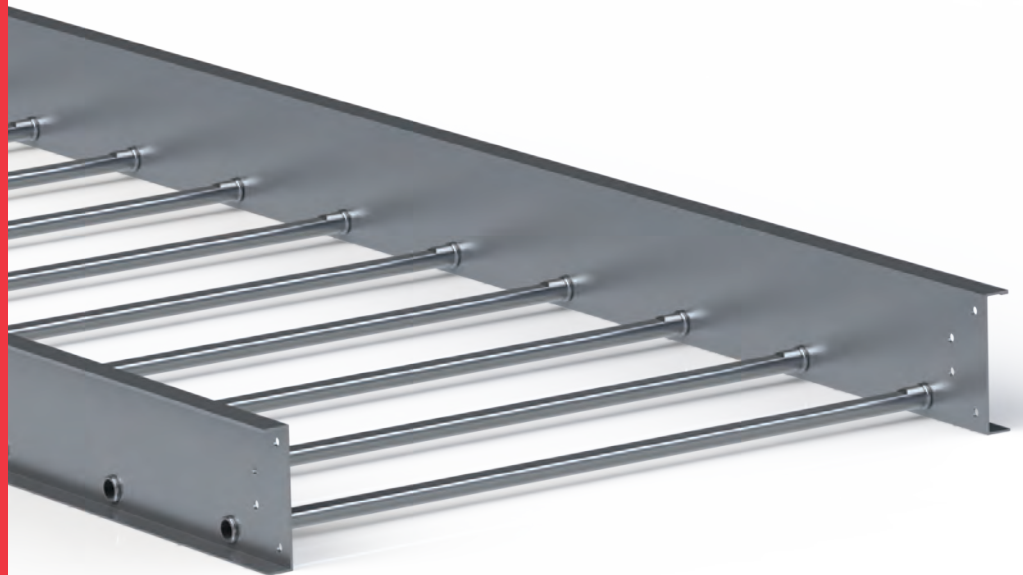

Cable Ladder System for Power, Control,
Instrumentation Cable & Pneumatic Tubing

LADDER CABLE TRAY SYSTEM

CONTENTS

GENERAL & TECHNICAL INFORMATION

| | |
|--|---------|
| Selection Chart: Cope Ladder - Aluminum..... | 14 - 15 |
| Selection Chart: Cope Ladder - Steel..... | 16 - 17 |
| Overview..... | 18 - 19 |
| Ordering Information..... | 20 |
| Straight Length..... | 21 |
| Electrical Grounding Chart..... | 22 |
| CSA Ordering Information..... | 23 |
| CSA Selection Chart: Aluminum/Steel..... | 24 |
| Fittings..... | 25 |

COPE LADDER FITTINGS

| | |
|---------------------------------------|---------|
| Horizontal Elbows | |
| 90° & 60°..... | 26 |
| 45° & 30°..... | 27 |
| Horizontal Tee..... | 28 |
| Horizontal Cross..... | 29 |
| Horizontal Tapped Tee..... | 30 - 31 |
| Horizontal Tapped Cross..... | 32 - 33 |
| Left and Right Hand Reducers..... | 34 |
| Straight Reducers..... | 35 |
| Adjustable Elbow..... | 36 |
| 45° "Y" Branch..... | 36 |
| Vertical Elbows (Inside and Outside) | |
| 90° & 60°..... | 37 |
| 45° & 30°..... | 38 |
| 90° Vertical Cable Support Elbow..... | 39 |
| Vertical Tee..... | 39 |

CONNECTORS & HARDWARE

| | |
|---|----|
| Universal Curvilinear Connector, Expansion, Mid Span Splice Plate | |
| Horiz. and Vert. Adjustable, Reducing and 90° Connector..... | 40 |
| General Hardware..... | 41 |

COVERS

| | |
|--|----|
| Covers..... | 42 |
| Cover Attachments (Hold down clamps, elevated and peaked cover connectors)..... | 43 |

ACCESSORIES

| | |
|---|---------|
| Blind End, Drop Out, Bonding Jumper, Box Connector | |
| Cable Tray Ground Clamp, Ground Cable Retainer Clamp..... | 44 |
| Conduit Clamp, Wall Sleeve..... | 45 |
| Barrier Strips and Barrier Strip Clamps..... | 46 |
| Hold Down Clamp and Expansion Guide, Cable Clamp, Seismic Hold Down..... | 47 |
| Support Brackets..... | 48 - 49 |
| Tray Hangers, Tray Brackets..... | 50 |
| Hanger Support, Trapeze Hanger Support..... | 50 |

SPECIFICATION INFORMATION

| | |
|---------------------------------|----|
| Electrical Grounding Chart..... | 51 |
| Typical Specification..... | 51 |
| Quick Ship Program..... | 52 |

STRAIGHT LENGTH

Page 21

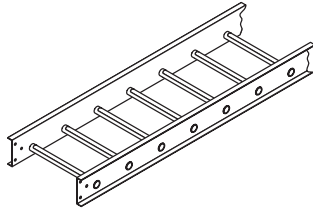

VERTICAL ELBOWS

Pages 37 - 38

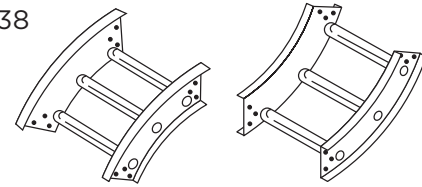

HORIZONTAL ELBOWS

Pages 26 - 27

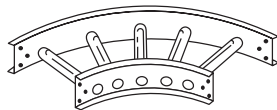

90° VERTICAL CABLE SUPPORT ELBOW

Page 39

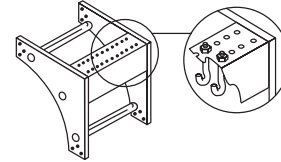

HORIZONTAL TEE & CROSS

Pages 28 - 29

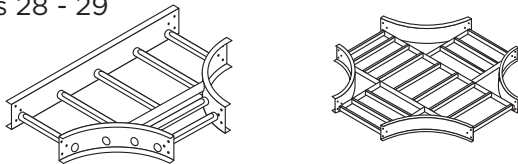

VERTICAL TEE

Page 39

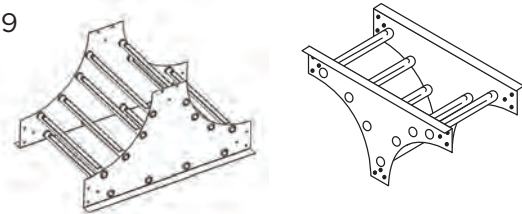

HORIZONTAL TAPPED TEE & CROSS

Pages 30 - 33

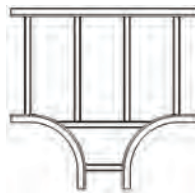

CONNECTORS

Page 40



REDUCERS

Pages 34 - 35

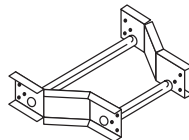

COVERS

Page 42

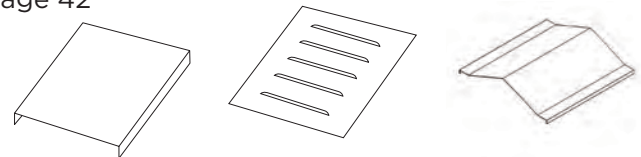

ADJUSTABLE ELBOWS

Page 36

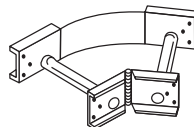

COVER ATTACHMENTS

Page 43

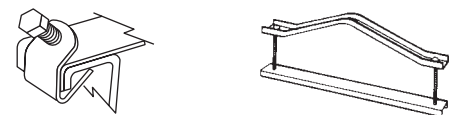

45° "Y" BRANCH

Page 36

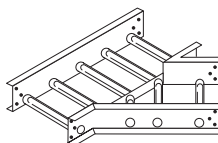

BARRIER STRIPS & ACCESSORIES

Page 46

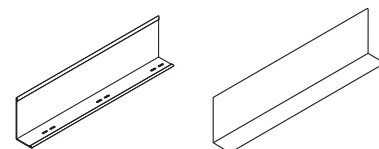

LADDER CABLE TRAY SYSTEM

ALUMINUM TRAY

SELECTION CHART

NEMA CLASS, PHYSICAL AND STRUCTURAL PROPERTIES

| NEMA Standard VE-1 Load/ Span Class | NEMA Ld/Span | Cope System Number | Cope Systems Certified By CSA (See pg. 3-9) | Actual Load Depth | Side Rail Height | Flange Width (in.) | Sect. Mod. of 2 Rails Sx (in. ³) | Moment of Inertia for 2 Rails Ix (in. ⁴) | Min X-Sect. Area of 2 Rails per NEC 392.7 (in. ²) |
|--|-------------------------|--------------------------|--|----------------------|---------------------|--------------------------|---|--|---|
| 8A-12A | 50 lb./ft. 12' span | 1B38 | 1B38 | 3" (76mm) | 4 1/4" (108mm) | 1 3/16" | 0.898 | 1.822 | .60 |
| | | 1B48 | 1B48 | 4" (102mm) | 5 1/4" (133mm) | 1 3/16" | 1.142 | 2.872 | .60 |
| | | 3B58 | — | 5" (127mm) | 6 1/4" (159mm) | 1 3/16" | 1.614 | 4.720 | 1.00 |
| | | 1B68 | — | 6" (152mm) | 7 1/4" (184mm) | 1 3/16" | 1.874 | 6.568 | 1.00 |
| 12B | 75 lb./ft. 12' span | 3B38 | — | 3" (76mm) | 4 1/4" (108mm) | 1 3/16" | 1.148 | 2.270 | .60 |
| | | 1B48 | 1B48 | 4" (102mm) | 5 1/4" (133mm) | 1 3/16" | 1.142 | 2.872 | .60 |
| | | 3B58 | — | 5" (127mm) | 6 1/4" (159mm) | 1 3/16" | 1.614 | 4.720 | 1.00 |
| | | 1B68 | — | 6" (152mm) | 7 1/4" (184mm) | 1 3/16" | 1.874 | 6.568 | 1.00 |
| 12C | 100 lb./ft 12' span | 5B38 | — | 3" (76mm) | 4 1/4" (108mm) | 1 3/16" | 1.646 | 3.350 | 1.00 |
| | | 3B48 | — | 4" (102mm) | 5 1/4" (133mm) | 1 3/16" | 1.522 | 3.734 | 1.00 |
| | | 5B58 | — | 5" (127mm) | 6 1/4" (159mm) | 1 3/16" | 1.944 | 5.866 | 1.00 |
| | | 5B68 | — | 6" (152mm) | 7 1/4" (184mm) | 1 3/16" | 2.576 | 9.032 | 1.00 |
| 16A | 50 lb./ft. 16' span | 5B38 | — | 3" (76mm) | 4 1/4" (108mm) | 1 3/16" | 1.646 | 3.350 | 1.00 |
| | | 7448 | 7448 | 4" (102mm) | 5 1/4" (133mm) | 1 1/4" | 2.396 | 6.292 | 1.50 |
| | | 1D58 | 1D58 | 5" (127mm) | 6 1/4" (159mm) | 1 1/4" | 2.378 | 7.202 | 1.00 |
| | | 5D68 | 5D68 | 6" (152mm) | 7 1/4" (184mm) | 1 1/4" | 4.874 | 17.188 | 2.00 |
| 16B | 75 lb./ft. 16' span | 3D38 | 3D38 | 3" (76mm) | 4 1/4" (108mm) | 1 1/4" | 2.242 | 4.406 | 1.50 |
| | | 7448 | 7448 | 4" (102mm) | 5 1/4" (133mm) | 1 1/4" | 2.396 | 6.292 | 1.50 |
| | | 1D58 | 1D58 | 5" (127mm) | 6 1/4" (159mm) | 1 1/4" | 2.378 | 7.202 | 1.00 |
| | | 5D68 | 5D68 | 6" (152mm) | 7 1/4" (184mm) | 1 1/4" | 4.874 | 17.188 | 2.00 |
| 16C | 100 lb./ft. 16' span | 5D38 | 5D38 | 3" (76mm) | 4 1/4" (108mm) | 1 1/4" | 2.782 | 5.738 | 1.50 |
| | | 3D48 | 3D48 | 4" (102mm) | 5 1/4" (133mm) | 1 1/4" | 3.434 | 8.746 | 2.00 |
| | | 5D58 | 5D58 | 5" (127mm) | 6 1/4" (159mm) | 1 1/4" | 3.542 | 10.748 | 2.00 |
| | | 5D68 | 5D68 | 6" (152mm) | 7 1/4" (184mm) | 1 1/4" | 4.874 | 17.188 | 2.00 |
| 20A | 50 lb./ft. 20' span | 3D38 | 3D38 | 3" (76mm) | 4 1/4" (108mm) | 1 1/4" | 2.242 | 4.406 | 1.50 |
| | | 7448 | 7448 | 4" (102mm) | 5 1/4" (133mm) | 1 1/4" | 2.396 | 6.292 | 1.50 |
| | | 1D58 | — | 5" (127mm) | 6 1/4" (159mm) | 1 1/4" | 2.378 | 7.202 | 1.00 |
| | | 5D68 | 5D68 | 6" (152mm) | 7 1/4" (184mm) | 1 1/4" | 4.874 | 17.188 | 2.00 |
| 20B | 75 lb./ft. 20' span | 3D48 | — | 4" (102mm) | 5 1/4" (133mm) | 1 1/4" | 3.434 | 8.746 | 2.00 |
| | | 5D58 | 5D58 | 5" (127mm) | 6 1/4" (159mm) | 1 1/4" | 3.542 | 10.748 | 2.00 |
| | | 5D68 | 5D68 | 6" (152mm) | 7 1/4" (184mm) | 1 1/4" | 4.874 | 17.188 | 2.00 |
| 20C | 100 lb./ft. 20' span | 7D38 | — | 3" (102mm) | 4 1/4" (133mm) | 1 1/4" | 3.512 | 6.956 | 2.00 |
| | | 5D48 | — | 4" (102mm) | 5 1/4" (133mm) | 1 1/4" | 3.910 | 10.020 | 2.00 |
| | | 7D58 | 7D58 | 5" (127mm) | 6 1/4" (159mm) | 1 1/4" | 4.186 | 12.024 | 2.00 |
| | | 5D68 | 5D68 | 6" (152mm) | 7 1/4" (184mm) | 1 1/4" | 4.874 | 17.188 | 2.00 |
| EXTRA HEAVY DUTY - VERY LONG SPAN TRAYS- 6", 9" OR 12" RUNG SPACING | | | | | | | | | |
| 20C+ | | 9D58 | — | 5" (127mm) | 6 1/4" (159mm) | 1 1/4" | 5.130 | 15.700 | 2.00 |
| | | 7G58 | — | 5" (127mm) | 6 1/4" (159mm) | 2" | 5.804 | 17.456 | 2.00 |

NOTE: Indicates items included in our Quick Ship Program. Consult factory for lead times on other systems.

NOTE: Special Applications Available. Please Contact Factory.

LOAD AND DEFLECTION DATA FOR ALUMINUM LADDER
 Working (Allowable) Load Capacity, Evenly Distributed-Tested per NEMA Standard VE-1,
 Simple Beam - SAFETY FACTOR 1.5

| Cope System Numbers | 6 Ft. Span | | | 8 Ft. Span | | | 10 Ft. Span | | | 12 Ft. Span | | | 16 Ft. Span | | | 20 Ft. Span | | | 24 Ft. Span | | | 25 Ft. Span | | | | |
|---------------------|------------|-----|------|------------|-----|------|-------------|------|------|-------------|------|------|-------------|------|------|-------------|------|------|-------------|------|------|-------------|------|------|---|---|
| | w | d | k | w | d | k | w | d | k | w | d | k | w | d | k | w | d | k | w | d | k | w | d | k | w | d |
| 1B38 | 222 | .35 | .002 | 125 | .63 | .005 | 80 | .99 | .012 | 55 | 1.42 | .026 | | | | | | | | | | | | | | |
| 1B48 | 324 | .33 | .001 | 173 | .56 | .003 | 117 | .87 | .007 | 77 | 1.26 | .016 | | | | | | | | | | | | | | |
| 3B58 | 359 | .22 | † | 191 | .37 | .002 | 115 | .55 | .005 | 75 | .74 | .010 | | | | | | | | | | | | | | |
| 1B68 | 416 | .18 | † | 221 | .31 | .001 | 133 | .46 | .003 | 87 | .62 | .007 | | | | | | | | | | | | | | |
| 3B38 | 354 | .45 | .001 | 191 | .76 | .004 | 117 | 1.14 | .010 | 78 | 1.57 | .020 | | | | | | | | | | | | | | |
| 1B48 | 324 | .33 | .001 | 182 | .59 | .003 | 117 | .87 | .007 | 77 | 1.26 | .016 | | | | | | | | | | | | | | |
| 3B58 | 359 | .22 | † | 191 | .37 | .002 | 115 | .55 | .005 | 75 | .74 | .010 | | | | | | | | | | | | | | |
| 1B68 | 416 | .18 | † | 221 | .31 | .001 | 133 | .46 | .003 | 87 | .62 | .007 | | | | | | | | | | | | | | |
| 5B38 | 448 | .39 | † | 251 | .69 | .003 | 161 | 1.08 | .007 | 112 | 1.55 | .014 | | | | | | | | | | | | | | |
| 3B48 | 394 | .31 | † | 222 | .55 | .002 | 142 | .86 | .006 | 100 | 1.24 | .012 | | | | | | | | | | | | | | |
| 5B58 | 480 | .24 | † | 257 | .40 | .002 | 156 | .60 | .004 | 102 | .81 | .008 | | | | | | | | | | | | | | |
| 5B68 | 540 | .17 | † | 286 | .29 | .001 | 172 | .43 | .003 | 111 | .57 | .005 | | | | | | | | | | | | | | |
| 5B38 | | | | 251 | .69 | .003 | 161 | 1.08 | .007 | 112 | 1.55 | .014 | 51 | 2.26 | .044 | 25 | 2.75 | .110 | | | | | | | | |
| 7448 | | | | 349 | .51 | .001 | 223 | .80 | .004 | 155 | 1.15 | .007 | 79 | 1.85 | .023 | 51 | 2.89 | .057 | | | | | | | | |
| 1D58 | | | | 380 | .49 | .001 | 222 | .69 | .003 | 154 | 1.00 | .006 | 78 | 1.61 | .021 | 50 | 2.51 | .050 | | | | | | | | |
| 5D68 | | | | | | | | | | 316 | .86 | .003 | 161 | 1.38 | .009 | 103 | 2.16 | .021 | | | | | | | | |
| 3D38 | | | | 342 | .72 | .002 | 219 | 1.12 | .005 | 152 | 1.61 | .011 | 82 | 2.74 | .033 | 52 | 4.27 | .082 | | | | | | | | |
| 7448 | | | | 349 | .51 | .001 | 223 | .80 | .004 | 155 | 1.15 | .007 | 79 | 1.85 | .023 | 51 | 2.89 | .057 | | | | | | | | |
| 1D58 | | | | 380 | .49 | .001 | 222 | .69 | .003 | 154 | 1.00 | .006 | 78 | 1.61 | .021 | 50 | 2.51 | .050 | | | | | | | | |
| 5D68 | | | | | | | | | | 316 | .86 | .003 | 161 | 1.38 | .009 | 103 | 2.16 | .021 | | | | | | | | |
| 5D38 | | | | 444 | .71 | .002 | 284 | .70 | .002 | 188 | 1.53 | .008 | 106 | 2.73 | .026 | 65 | 4.07 | .063 | | | | | | | | |
| 3D48 | | | | 525 | .55 | .001 | 336 | .86 | .003 | 233 | 1.24 | .005 | 119 | 2.01 | .017 | 76 | 3.14 | .041 | | | | | | | | |
| 5D58 | | | | | | | | | | 229 | 1.00 | .004 | 116 | 1.60 | .014 | 75 | 2.50 | .033 | | | | | | | | |
| 5D68 | | | | | | | | | | 316 | .86 | .003 | 161 | 1.38 | .009 | 103 | 2.16 | .021 | | | | | | | | |
| 3D38 | | | | | | | | | | 152 | 1.61 | .011 | 82 | 2.74 | .033 | 52 | 4.27 | .082 | | | | | | | | |
| 7448 | | | | | | | | | | 155 | 1.15 | .007 | 79 | 1.85 | .023 | 51 | 2.89 | .057 | | | | | | | | |
| 1D58 | | | | | | | | | | 154 | 1.00 | .006 | 78 | 1.61 | .021 | 50 | 2.51 | .050 | | | | | | | | |
| 5D68 | | | | | | | | | | 316 | .86 | .003 | 161 | 1.38 | .009 | 103 | 2.16 | .021 | | | | | | | | |
| 3D48 | | | | | | | | | | 233 | 1.24 | .005 | 119 | 2.01 | .017 | 76 | 3.14 | .041 | | | | | | | | |
| 5D58 | | | | | | | | | | 229 | 1.00 | .004 | 116 | 1.60 | .014 | 75 | 2.50 | .033 | | | | | | | | |
| 5D68 | | | | | | | | | | 316 | .86 | .003 | 161 | 1.38 | .009 | 103 | 2.16 | .021 | | | | | | | | |
| 7D38 | | | | | | | | | | 277 | 2.03 | .007 | 156 | 3.61 | .023 | 100 | 5.64 | .056 | | | | | | | | |
| 5D48 | | | | | | | | | | 290 | 1.35 | .005 | 156 | 2.30 | .015 | 100 | 3.59 | .036 | | | | | | | | |
| 7D58 | | | | | | | 404 | .76 | .002 | 281 | 1.09 | .004 | 158 | 1.94 | .012 | 101 | 3.02 | .030 | | | | | | | | |
| 5D68 | | | | | | | | | | 316 | .86 | .003 | 161 | 1.38 | .009 | 103 | 2.16 | .021 | | | | | | | | |
| 9D58 | | | | | | | | | | 412 | 1.22 | .003 | 214 | 2.00 | .009 | 131 | 3.01 | .023 | 68 | 3.23 | .048 | | | | | |
| 7G58 | | | | | | | | | | 451 | 1.20 | .003 | 253 | 2.14 | .008 | 162 | 3.35 | .020 | 112 | 4.79 | .043 | 104 | 5.24 | .050 | | |

NOTE: To convert 1.5 safety factor to 2.0 multiply w, d, k by 0.75.

NOTE: █ Indicates items included in our Quick Ship Program. Consult factory for lead times on other systems.

W=Pounds per linear foot

Metric: for kg/m multiply w by 1.48

d=Deflection (inches)

k= Deflection (in.) for each pound of load

†= Denotes k is less than .001 inch

LADDER CABLE TRAY SYSTEM

STEEL TRAY

SELECTION CHART

NEMA CLASS, PHYSICAL AND STRUCTURAL PROPERTIES

| NEMA Standard VE-1 Class | NEMA Load/Span | Mill Galv. System Number | HDGAF System Number | Type 304 SS System Number | Actual Load Depth | Side Rail Height | Flange Width (in.) | Section Modulus of 2 Rails Sx (in. ³) | Moment of Inertia for 2 Rails Ix (in. ⁴) | Min. X-Sect. Area of 2 Rails per NEC 392-7 (in. ²) |
|--|-------------------------|--------------------------------|---------------------------|------------------------------------|----------------------|---------------------|--------------------------|--|---|---|
| 8A-12B | 75 lb./ft. 12' span | 8B36 | 6237 | 8B3T | 3" (76mm) | 4 1/4" (108mm) | 1 3/16" | 0.678 | 1.370 | .40 |
| | | 8246 | 6247 | 824T | 4" (102mm) | 5 1/4" (133mm) | 1 3/16" | 0.816 | 2.142 | .40 |
| | | 8256 | 6257 | 825T | 5" (127mm) | 6 1/4" (159mm) | 1 3/16" | 1.072 | 3.352 | .70 |
| | | 8B66 | 6B67 | 8B6T | 6" (152mm) | 7 1/4" (184mm) | 1 3/16" | 1.574 | 5.516 | .70 |
| 12C | 100 lb./ft. 12' span | 8B36 | 6B37 | 8B3T | 3" (76mm) | 4 1/4" (108mm) | 1 3/16" | 0.834 | 1.690 | .70 |
| | | 8B46 | 6B47 | 8B4T | 4" (102mm) | 5 1/4" (133mm) | 1 3/16" | 0.924 | 2.324 | .40 |
| | | 6256 | 6257 | 625T | 5" (127mm) | 6 1/4" (159mm) | 1 3/16" | 1.330 | 4.158 | .70 |
| | | 8B66 | 6267 | 8B6T | 6" (152mm) | 7 1/4" (184mm) | 1 3/16" | 1.574 | 5.516 | .70 |
| 16A | 50 lb./ft. 16' span | 8D36 | 6D37 | 8D3T | 3" (76mm) | 4 1/4" (108mm) | 1 1/4" | 0.852 | 1.736 | .40 |
| | | 8D46 | 6447 | 8D4T | 4" (102mm) | 5 1/4" (133mm) | 1 1/4" | 1.146 | 2.894 | .70 |
| | | 8456 | 6457 | 845T | 5" (127mm) | 6 1/4" (159mm) | 1 1/4" | 1.330 | 4.156 | .70 |
| | | 6466 | 6467 | 646T | 6" (152mm) | 7 1/4" (184mm) | 1 1/4" | 2.062 | 7.478 | 1.00 |
| 16B | 75 lb./ft. 16' span | 6D36 | 6D37 | 6D3T | 3" (76mm) | 4 1/4" (108mm) | 1 1/4" | 1.056 | 2.152 | .70 |
| | | 8D46 | 6447 | 8D4T | 4" (102mm) | 5 1/4" (133mm) | 1 1/4" | 1.146 | 2.894 | .70 |
| | | 6456 | 6457 | 645T | 5" (127mm) | 6 1/4" (159mm) | 1 1/4" | 1.652 | 5.160 | 1.00 |
| | | 6466 | 6467 | 646T | 6" (152mm) | 7 1/4" (184mm) | 1 1/4" | 2.062 | 7.478 | 1.00 |
| 16C | 100 lb./ft. 16' span | 4D36 | 4D37 | 4D3T | 3" (76mm) | 4 1/4" (108mm) | 1 1/4" | 1.298 | 2.652 | 1.00 |
| | | 6446 | 6447 | 644T | 4" (102mm) | 5 1/4" (133mm) | 1 1/4" | 1.280 | 3.360 | .70 |
| | | 6456 | 6457 | 645T | 5" (127mm) | 6 1/4" (159mm) | 1 1/4" | 1.652 | 5.160 | 1.00 |
| | | 8D66 | 6D67 | 8D6T | 6" (152mm) | 7 1/4" (184mm) | 1 1/4" | 1.814 | 6.370 | .70 |
| 20A | 50 lb./ft. 20' span | 6D36 | 6D37 | 6D3T | 3" (76mm) | 4 1/4" (108mm) | 1 1/4" | 1.056 | 2.152 | .70 |
| | | 6446 | 6447 | 644T | 4" (102mm) | 5 1/4" (133mm) | 1 1/4" | 1.280 | 3.360 | .70 |
| | | 6456 | 6457 | 645T | 5" (127mm) | 6 1/4" (159mm) | 1 1/4" | 1.652 | 5.160 | 1.00 |
| | | 6466 | 6467 | 646T | 6" (152mm) | 7 1/4" (184mm) | 1 1/4" | 2.062 | 7.478 | 1.00 |
| 20B | 75 lb./ft. 20' span | 2D36 | 2D37 | 2D3T | 3" (76mm) | 4 1/4" (108mm) | 1 1/4" | 1.758 | 3.604 | 1.00 |
| | | 4D46 | 4D47 | 4D4T | 4" (102mm) | 5 1/4" (133mm) | 1 1/4" | 1.744 | 4.418 | 1.00 |
| | | 6D56 | 6D57 | 6D5T | 5" (127mm) | 6 1/4" (159mm) | 1 1/4" | 1.814 | 5.486 | 1.00 |
| | | 6D66 | 6D67 | 6D6T | 6" (152mm) | 7 1/4" (184mm) | 1 1/4" | 2.246 | 7.902 | 1.00 |
| 20C | 100 lb./ft. 20' span | 2D46 | 2D47 | 2D4T | 4" (102mm) | 5 1/4" (133mm) | 1 1/4" | 2.370 | 6.026 | 1.50 |
| | | 4D56 | 4D57 | 4D5T | 5" (127mm) | 6 1/4" (159mm) | 1 1/4" | 2.240 | 6.778 | 1.00 |
| | | 4466 | 4467 | 446T | 6" (152mm) | 7 1/4" (184mm) | 1 1/4" | 2.556 | 9.264 | 1.00 |
| EXTRA HEAVY DUTY - VERY LONG SPAN TRAYS- 6", 9" OR 12" RUNG SPACING | | | | | | | | | | |
| 20C+ | | 2D56 | 2D57 | 2D5T | 5" (127mm) | 6 1/4" (159mm) | 1 1/4" | 3.052 | 9.270 | 1.50 |
| | | 11D56 | 11D57 | 11D5T | 5" (127mm) | 6 1/4" (159mm) | 1 1/4" | 3.536 | 10.630 | 1.50 |

NOTE: All steel available in 316 upon request.

LOAD AND DEFLECTION DATA FOR STEEL LADDER
Working (Allowable) Load Capacity, Evenly Distributed-Tested per NEMA Standard VE-1,
Simple Beam - SAFETY FACTOR 1.5

| Cope System Numbers | 6 Ft. Span | | | 8 Ft. Span | | | 10 Ft. Span | | | 12 Ft. Span | | | 16 Ft. Span | | | 20 Ft. Span | | | 24 Ft. Span | | | 25 Ft. Span | | |
|---------------------|------------|------|---|------------|------|-------|-------------|------|------|-------------|-----|------|-------------|-----|-------|-------------|-----|-------|-------------|------|-------|-------------|------|-------|
| | w | d | k | w | d | k | w | d | k | w | d | k | w | d | k | w | d | k | w | d | k | w | d | k |
| 8B36/6237/8B3T | 360 | 0.26 | † | 198 | 0.46 | 0.002 | 124 | 0.70 | 0.01 | 84 | 1.0 | 0.01 | | | | | | | | | | | | |
| 8246/6247/824T | 383 | 0.18 | † | 210 | 0.31 | 0.001 | 127 | 0.46 | 0.00 | 83 | 0.6 | 0.01 | | | | | | | | | | | | |
| 8256/6257/825T | 357 | 0.11 | † | 194 | 0.18 | † | 119 | 0.28 | 0.00 | 79 | 0.4 | 0.01 | | | | | | | | | | | | |
| 8B66/6B67/8B6T | 680 | 0.12 | † | 328 | 0.19 | † | 182 | 0.26 | 0.00 | 107 | 0.3 | 0.00 | | | | | | | | | | | | |
| 6B36/6B37/6B3T | 453 | 0.27 | † | 249 | 0.47 | 0.002 | 156 | 0.71 | 0.01 | 106 | 1.0 | 0.01 | | | | | | | | | | | | |
| 8B46/6B47/8B4T | 456 | 0.20 | † | 244 | 0.33 | 0.001 | 152 | 0.51 | 0.00 | 103 | 0.7 | 0.01 | | | | | | | | | | | | |
| 6256/6257/625T | 460 | 0.11 | † | 250 | 0.19 | † | 154 | 0.29 | 0.00 | 103 | 0.4 | 0.00 | | | | | | | | | | | | |
| 8B66/6267/8B6T | 680 | 0.12 | † | 328 | 0.19 | † | 182 | 0.26 | 0.00 | 107 | 0.3 | 0.00 | | | | | | | | | | | | |
| 8D36/6D37/8D3T | | | | 290 | 0.53 | 0.002 | 182 | 0.81 | 0.00 | 126 | 1.2 | 0.01 | 65 | 1.9 | 0.029 | | | | | | | | | |
| 8D46/6447/8D4T | | | | 382 | 0.42 | 0.001 | 245 | 0.66 | 0.00 | 170 | 0.9 | 0.01 | 86 | 1.5 | 0.018 | | | | | | | | | |
| 8456/6457/845T | | | | 268 | 0.20 | † | 166 | 0.31 | 0.00 | 111 | 0.4 | 0.00 | 58 | 0.7 | 0.012 | | | | | | | | | |
| 6466/6467/646T | | | | 372 | 0.20 | † | 238 | 0.24 | 0.00 | 178 | 0.4 | 0.00 | 93 | 0.6 | 0.007 | | | | | | | | | |
| 6D36/8D37/6D3T | | | | 381 | 0.56 | 0.001 | 244 | 0.88 | 0.00 | 169 | 1.3 | 0.01 | 88 | 2.1 | 0.024 | | | | | | | | | |
| 8D46/6447/8D4T | | | | 382 | 0.42 | 0.001 | 245 | 0.66 | 0.00 | 170 | 0.9 | 0.01 | 86 | 1.5 | 0.018 | | | | | | | | | |
| 6456/6457/645T | | | | 574 | 0.35 | † | 367 | 0.55 | 0.00 | 245 | 0.8 | 0.00 | 123 | 1.2 | 0.01 | | | | | | | | | |
| 6466/6467/646T | | | | 372 | 0.20 | † | 238 | 0.24 | 0.00 | 178 | 0.4 | 0.00 | 93 | 0.6 | 0.007 | | | | | | | | | |
| 4D36/4D37/4D3T | | | | 487 | 0.58 | 0.001 | 312 | 0.91 | 0.00 | 216 | 1.3 | 0.01 | 113 | 2.2 | 0.019 | | | | | | | | | |
| 6446/6447/644T | | | | 444 | 0.42 | † | 273 | 0.63 | 0.00 | 186 | 0.9 | 0.01 | 100 | 1.5 | 0.015 | | | | | | | | | |
| 6456/6457/645T | | | | 574 | 0.35 | † | 367 | 0.55 | 0.00 | 245 | 0.8 | 0.00 | 123 | 1.2 | 0.01 | | | | | | | | | |
| 8D66/6D67/8D6T | | | | 504 | 0.25 | † | 306 | 0.37 | 0.00 | 202 | 0.5 | 0.00 | 101 | 0.8 | 0.008 | | | | | | | | | |
| 6D36/6D37/6D3T | | | | | | | | | | 169 | 1.3 | 0.01 | 88 | 2.1 | 0.024 | 52 | 3.0 | 0.057 | | | | | | |
| 6446/6447/644T | | | | | | | | | | 186 | 0.9 | 0.01 | 100 | 1.5 | 0.015 | 53 | 1.9 | 0.037 | | | | | | |
| 6456/6457/645T | | | | | | | | | | 245 | 0.8 | 0.00 | 123 | 1.2 | 0.01 | 66 | 1.6 | 0.024 | | | | | | |
| 6466/6467/646T | | | | | | | | | | 178 | 0.4 | 0.00 | 93 | 0.6 | 0.007 | 55 | 0.9 | 0.017 | | | | | | |
| 2D36/2D37/2D3T | | | | | | | | | | 304 | 1.4 | 0.00 | 159 | 2.2 | 0.014 | 94 | 3.2 | 0.034 | | | | | | |
| 4D46/4D47/4D4T | | | | | | | | | | 280 | 1.0 | 0.00 | 145 | 1.7 | 0.012 | 85 | 2.4 | 0.028 | | | | | | |
| 6D56/6D57/6D5T | | | | | | | | | | 269 | 0.8 | 0.00 | 139 | 1.3 | 0.009 | 81 | 1.8 | 0.022 | | | | | | |
| 6D66/6D67/6D6T | | | | | | | | | | 291 | 0.6 | 0.00 | 148 | 1.0 | 0.006 | 85 | 1.3 | 0.016 | | | | | | |
| 2D46/2D47/2D4T | | | | | | | | | | 395 | 1.1 | 0.00 | 206 | 1.7 | 0.008 | 121 | 2.5 | 0.021 | | | | | | |
| 4D56/4D57/4D5T | | | | | | | | | | 296 | 0.8 | 0.00 | 152 | 1.3 | 0.008 | 105 | 1.9 | 0.018 | | | | | | |
| 4466/4467/446T | | | | | | | | | | 379 | 0.7 | 0.00 | 191 | 1.1 | 0.005 | 102 | 1.4 | 0.013 | | | | | | |
| 2D56/2D57/2D5T | | | | | | | | | | 490 | 0.9 | 0.00 | 254 | 1.4 | 0.006 | 149 | 2.0 | 0.013 | 79 | 1.91 | 0.024 | 73 | 2.38 | 0.033 |
| 11D56/11D57/11D5T | | | | | | | | | | 434 | 0.7 | † | 244 | 1.2 | 0.005 | 156 | 1.8 | 0.012 | 108 | 2.62 | 0.024 | 100 | 2.85 | 0.029 |

NOTE: To convert 1.5 safety factor to 2.0 multiply w, d, k by 0.75.

W=Pounds per linear foot

Metric: for kg/m multiply w by 1.48

d=Deflection (inches)

k= Deflection (in.) for each pound of load

†= Denotes k is less than .001 inch

LADDER CABLE TRAY SYSTEM

OVERVIEW

SWAGE LADDER is a structure consisting of two side rails, connected by individual rungs and is manufactured in accordance with NEMA Standard VE-1. Cope rungs are fastened to the side members by an exclusive swaging process. This assembly method insures a superior mechanical and electrical connection.

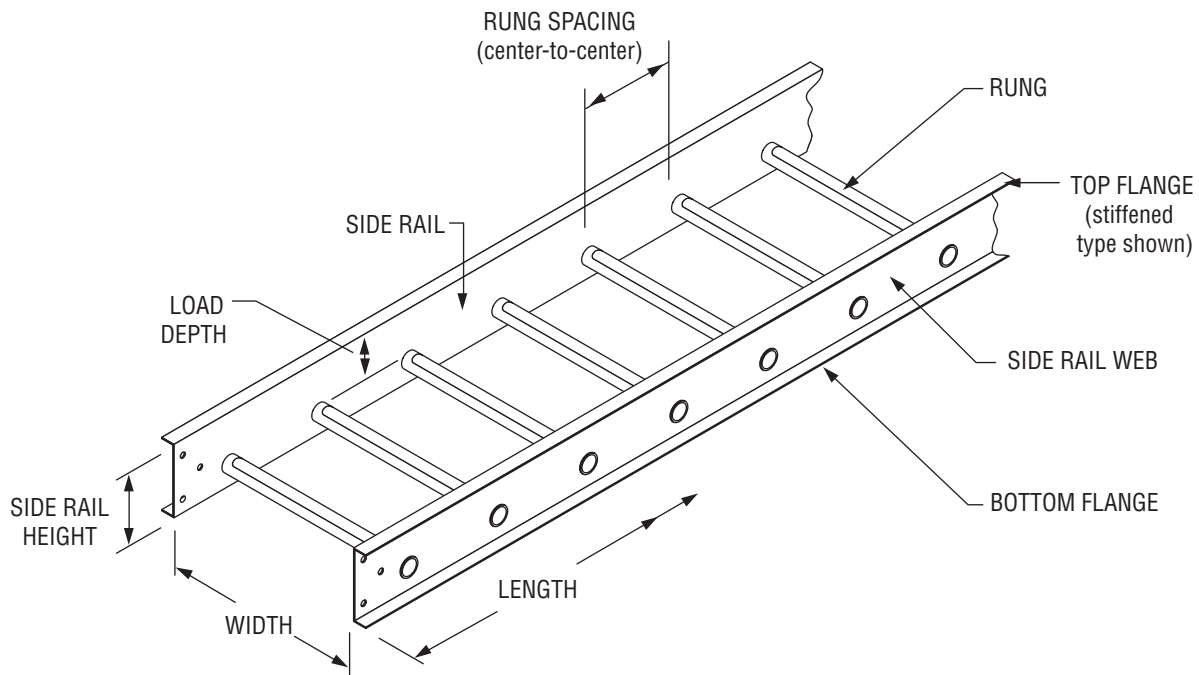

Side Members - Cope side members are designed with top and bottom flanges turned outward. This simplifies fastening the cable tray to the supports. Cable tray with outward facing flanges allows complete access within the cable loading area and eliminates the possibility of cable damage from sharp edges within the cable area. The return on the top flange strengthens the side member and allows cable to be smoothly dropped over the side.

Rung - Cope ladder rungs are 1.00" diameter tubing flattened on top to provide a cable bearing surface. This construction allows cable to drop out anywhere without contacting a sharp edge.

Rung Spacing - The interval at which rungs are swaged to the side member. This is measured from centerline of rung to centerline of rung. Cope manufactures straight lengths with four standard rung spacings; 6", 9", 12", and 18". Rung spacing selected is generally determined by size and type of cable being supported. When in doubt, 9" rung spacing is a generally accepted compromise. : 18" rung spacing not available on widths 24" or greater.

Length - The longitudinal dimensions of standard Cope Cable Ladder are 10', 12', 20' or 24'. Custom lengths may be available upon request.

Width - The transverse dimensions of Cope Cable Ladder are measured inside, (from side member web to side member web), and are furnished in seven standard widths: 6", 9", 12", 18", 24", 30", or 36". 42" and 48" available upon request.*

Overall Width - Overall ladder width is equal to the inside or nominal width plus the width of side member flanges.

Load Depth - Measured from top surface of rung to top of side member. This is not to be confused with overall height. Cope manufactures four loading depths: 3", 4", 5", 6", and 2" Nominal* in accordance with NEMA Standard VE-1. All Cope part numbers refer to the load depth of the tray.

Overall Height - Ladder Tray overall height is equal to the loading depth plus 1-1/4".

Fittings - For changing direction horizontally and vertically, Cope manufactures elbows, tees and crosses in all widths and loading depths. Fittings are available in three standard radii; 12", 18"* , 24", 36" and 48"* . Cope maintains a nominal 9" rung spacing through the centerline of all fittings.

* Available upon request, not recognized by NEMA Standards

COPE CABLE LADDER FEATURES IMPORTANT INDUSTRY-LEADING FEATURES:

1. Universal Curvilinear Splice Plate System

The splice plates for rigid connections have a slight curve so they can be used on straight sections or fittings. Tightening of the fastener pulls the plate flush with the side rail. The fasteners are snug and the joint is superior structurally and electrically. Even when tightened by hand, there is pressure on the fastener to hold it securely.

NOTE: Heavy Duty, Mid Span Splice Plates available upon request.

2. Zero Tangent Fittings

Tangent as referred to on cable tray fittings is the straight at the end of the curve to accommodate a flat splice plate. Zero Tangent Fittings facilitates installation when parallel cable trays must be located at minimum distances from each other, such as motor control centers and switch gear centers. ZERO TANGENT FITTINGS CAN SAVE UP TO A MINIMUM OF 6" PER ROW OF TRAY.

3. Swage Rung Cable Ladder System Process

The heart of the Cope design is the tubular rung and its connection to the side rail by cold swaging... a process where special machinery compresses and locks the tubular rung material around both the inside and outside of the cable tray side rails. This connection is made without the use of heat, which can potentially disturb the molecular structure of the metal and weaken it.

The tubular rung is flattened during the swaging process to ensure a proper cable bearing surface.

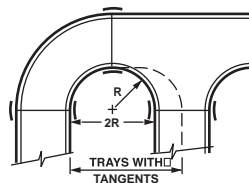

Testing - The superior strength of the swaged ladder tray system has been verified in independent testing conducted by the Pittsburgh Testing Laboratory.

Pullout loads of 2500 lbs. were reached. Other tests show the same type rungs, when welded, had a 35% lower pullout load. The strength of the swage also maintains the 90° relationship of the rungs to the side rail. The tubular rungs, which are very stiff, transmit the cable loads to the side rails resulting in much less deflection than in a similar system with welded rungs.

For a copy of the independent test results, please contact the factory.

Swage Advantages -

Cold swaging allows for the side rails to be turned outward, simplifying cable installation, and provides 100% access to the cables. The cold swaging yields the most rigid tray system in the industry.

The swaged rung connection resists stresses in all directions; up or down, side to side, or in and out. The swaged ladder also resists the camber and warping effects encountered in a typical welded system.

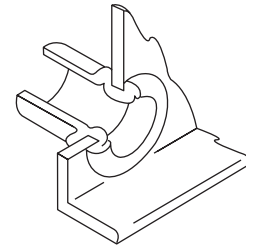

The increased rigidity means that a 24' section of tray can be lifted on one end with little or no twisting or bending of the tray section. This rigid construction makes the trays safer for field personnel to handle and reduces shipping damage.

Electrical Properties - Electrically, the 106 tons of pressure in the swaging process virtually eliminates the interstices and a homogenous electrical path results:

Resistance of Cope Aluminum Swaged Tray: 31 microhms

Resistance of Cope Steel Swaged Tray: 37.3 microhms

Resistance of Popular Aluminum Welded Tray: 101 microhms

Conclusion - Cold swaging yields a very strong, efficient and aesthetically pleasing system that has stood the test of time and offers installation savings due to its ease of handling.

LADDER CABLE TRAY SYSTEM

PART NUMBERING SYSTEM:

Please pay careful attention to the part numbering structure. Example: Catalog No. 1B48-06SL-12-09 is a 4" load depth aluminum ladder with a 13/16" flange, 6 inches wide, straight length 12 feet long, rungs on 9" centers. Please make sure to use the system numbers from pages 26 through 29 when ordering.

STRAIGHT LENGTH

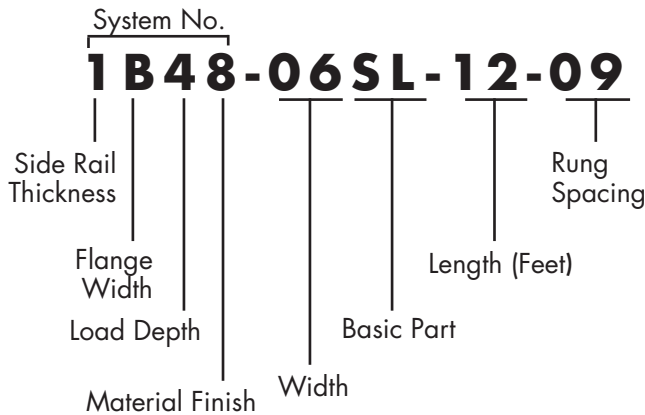

SYSTEM NUMBER (STRAIGHT SECTION ONLY) -

The first four digits make up the system number which identifies the structural, dimensional and material characteristics of the straight length. It is made up of the side rail digits indicating the side rail thickness and flange width, the load depth (inside, in inches), and material finish (galvanized, aluminum or coated).

PREFIX NUMBER (FITTINGS ONLY) - Fittings are ordered using the 3-digit prefix number given in the charts on the fitting pages. Fittings do not have stiffened upper flanges.

WIDTH - Identifies the inside width of the tray in inches. *NOTE:* Sizes 42" and 48" are not recognized by NEMA

BASIC PART NUMBER - Identifies the straight length, fitting or accessory.

| Thickness Steel (Ga.) | Flange Width | Load Depth | Material Finish |
|-----------------------|-------------------|------------|-----------------|
| 8 - 18 ga. | 2 - 13/16" (21mm) | 3" (76mm) | 6 - Mill-Galv. |
| 6 - 16 ga. | 4 - 1 1/4" (32mm) | 4" (102mm) | 7 - HDGAF |
| 4 - 14 ga. | 5 - 1 1/2" (38mm) | 5" (127mm) | 8 - Aluminum |
| 2 - 12 ga. | 6 - 1 3/4" (45mm) | 6" (152mm) | T - 304SS |
| 11 - 11 ga. | 7 - 2" (51mm) | | |
| Thickness Alum (in.) | | | |
| 1 - Thinner | B - 13/16" (21mm) | | |
| 3 - | D - 1 1/4" (32mm) | | |
| 5 - ** | E - 1 1/2" (38mm) | | |
| 7 - | F - 1 3/4" (45mm) | | |
| 9 - Thicker | G - 2" (51mm) | | |

**Alum. extruded side rails are individually engineered to loads and spans.

*** Contact factory for 42" and 48" width tray (not NEMA Standard)

FITTINGS

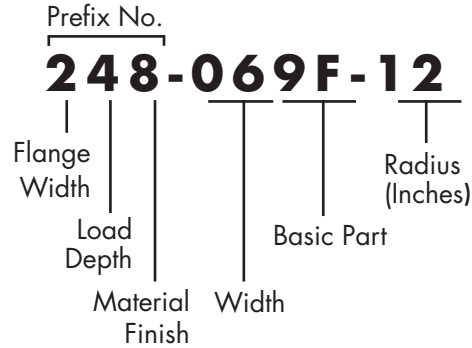

SECONDARY DIMENSION NUMBER - Identifies the length of a straight section in feet, the radius of a fitting in inches, or the second width of a reducer in inches.

RUNG SPACING - Identifies the center-to-center distance between rungs on straight length. Nominal 9" (229mm) rung spacing maintained through center line of all fittings.

| Description | | | |
|------------------|--------------------------------|-----------------|------------------|
| Width (in.) *** | Basic Part Number | Length | Rung Spacing |
| -06=6" (152mm) | SL (Straight Len.) | - 10' (3m, CSA) | 06=6" (152mm) |
| -09=9" (229mm) | 9F (90° Horiz. El.) | - 12' (3.7m) | 09=9" (229mm) |
| -12=12" (305mm) | 6F (60° Horiz. El.) | - 20' (6m, CSA) | 12=12" (305mm) |
| -18=18" (457mm) | 4F (45° Horiz. El.) | - 24' (7.3m) | 18=18" (457mm) |
| -24=24" (610mm) | 3F (30° Horiz. El.) | | |
| -30=30" (762mm) | 90 (90° Out. Vert. El.) | | |
| -36=36" (914mm) | 60 (60° Out. Vert. El.) | | |
| -42=42" (1067mm) | 40 (45° Out. Vert. El.) | | |
| -48=48" (1219mm) | 30 (30° Out. Vert. El.) | | |
| | 91 (90° In. Vert. El.) | | |
| | 61 (60° In. Vert. El.) | | |
| | 41 (45° In. Vert. El.) | | |
| | 31 (30° In. Vert. El.) | | |
| | FT (Horiz. Tee) | | |
| | FC (Horiz. Cross) | | |
| | TT (Horiz. Tapped Tee) | | |
| | TC (Horiz. Tapped Cross) | | |
| | VT (Vert. Tee) | | |
| | SR (Vert. Cable Support Elbow) | | |
| | ST (Straight Reducer) | | |
| | RH (Right Hand Reducer) | | |
| | LH (Left Hand Reducer) | | |
| | AF (Adjustable Elbow) | | |
| | LY (45° Left "Y" Branch) | | |
| | RY (45° Right "Y" Branch) | | |
| | | | Radius (in.) |
| | | | -12=12" (205mm) |
| | | | -18=18" (457mm) |
| | | | -24=24" (610mm) |
| | | | -36=36" (914mm) |
| | | | -48=48" (1219mm) |

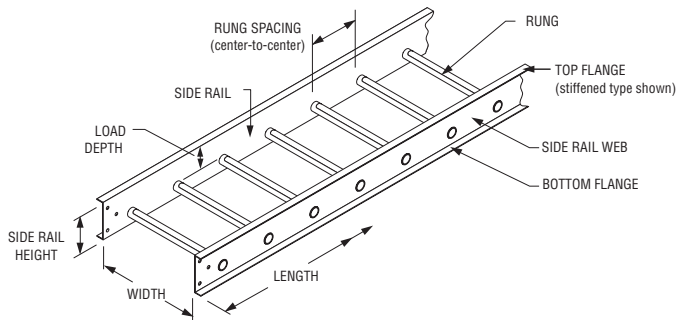

COPE LADDER is manufactured in 10' (CSA), 12', 20' (CSA), and 24' lengths; 6", 9", 12", 18", 24", 30", and 36" widths; and, 3", 4", 5", and 6" load depths. Rungs are 1" diameter tubes with a 7/8" flattened cable support surface. 6", 9", 12", and 18" rung spacings are available. Fittings have nominal 9" rung spacing through center line. Dimensions given are inside. For overall widths add two flange widths of the system selected (see Selection Charts). Some systems have stiffened upper (top) flanges to obtain rigidity required (see Selection Charts).

Rungs are assembled to side rails by Cope's exclusive cold swaging process. Outward facing flanges allow full unobstructed access to contents of tray in width and depth.

Materials: Aluminum, Hot Dip Mill-Galvanized (pre galvanized) to ASTM A-653, Hot Dip Galvanized After Fabrication (HDGAF) to ASTM A-123, Stainless Steel (Type 304 and 316). Sufficient connectors are supplied to assemble straight sections and fittings for each order. Connectors for field cuts to be ordered separately (see Connectors).

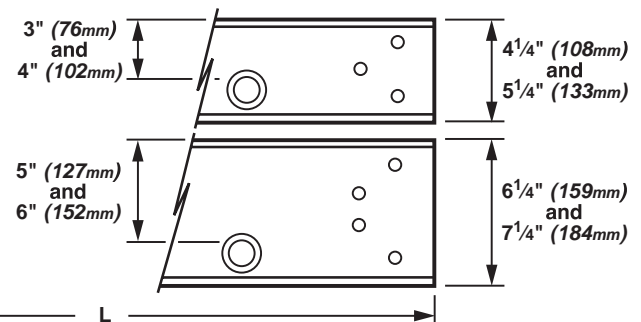
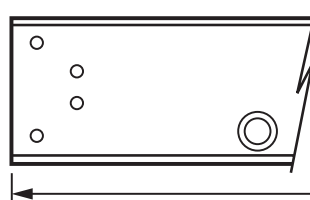
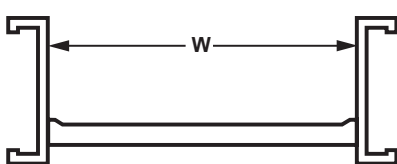

MATERIAL & FINISH SPECIFICATIONS (Ladder Cable Tray)

| | Pre-Galvanized Steel | Hot-Dip Galvanized after Fabrication ASTM A-123 | Aluminum | Type 304 Stainless Steel |
|---------------------|--|---|---|---|
| Siderails | ASTM A-653-G90 CS (18 & 16 Gage) ASTM A-653-G90 CS (14 & 12 Gage) | ASTM A-1008 (18 & 16 Gage) ASTM A-1011 (14 & 12 Gage) | AA-6063-T6 Extruded | ASTM A-240; Type 304 |
| Rungs | ASTM A-653-G90 CS | ASTM A-1008 | AA-6063-T6 Extruded* AA-6063-T832 Extruded* AA-6063-T52 Extruded* | ASTM A-269; Type 304 |
| Splice Plate Finish | ASTM A-1011 ASTM A-591 Class C | ASTM A-1011 ASTM A-123 Grade 65 | AA-5052-H34 | ASTM A-240; Type 304 2B Finish (Typical) |
| Connector Bolts | SAE J429 Grade 1 (ASTM A-307 Grade A) | SAE J429 Grade 1 (ASTM A-307 Grade A) | SAE J429 Grade 1 (ASTM A-307 Grade A) | AISI Type 304 Stainless Steel |
| Bolt Plating | ASTM B-633.0002" Zinc | ASTM B-633.0002" Zinc | ASTM B-633.0002" Zinc | |
| Covers | ASTM A-653-G90 CQ | ASTM A-653-G90 CQ | AA-3003 H14 or 3150 H14 | ASTM A-240; Type 304 |

CATALOG NUMBER

| System | Width | Basic No. | Length | Rung Spacing |
|--------|---------------------|-----------|-------------|-----------------|
| | -06=6" (152mm) | SL | NEMA | -06=6" (152mm) |
| | -09=9" (229mm) | | 12' (3.7m)* | -09=9" (229mm) |
| | -12=12" (305mm) | | 24' (7.3m)* | -12=12" (305mm) |
| See | -18=18" (457mm) | | 10' (3m)* | |
| Pages | -24=24" (610mm) | | 20' (6m)* | |
| 25-29 | -30=30" (762mm) | | CSA | |
| | -36=36" (914mm) | | -10' (3m) | -18=18" (457mm) |
| | -42=42"*** (1067mm) | | -20' (6m) | |
| | -48=48"*** (1219mm) | | | |

* 10' & 12' all NEMA Classes, 20' & 24' NEMA Classes 16A, 16B, 16C, 20A, 20B, 20C.

** not NEMA standard width

Example: Catalog No. 1B48-06SL-12-09 is a 4-inch load depth aluminum ladder with a 13/16" flange, 6 inches wide, straight length 12 feet long, on 9" centers.

CONVERSION TABLE

| | CSA | | | | | | | | | | |
|-------------|-----|-----|-----|-----|-----|-----|-----|------|------|-----|-----|
| English | 6" | 9" | 12" | 18" | 24" | 30" | 36" | 12' | 24' | 10' | 20' |
| Metric (mm) | 152 | 229 | 305 | 457 | 610 | 762 | 914 | 3.7m | 7.3m | 3m | 6m |

LADDER CABLE TRAY SYSTEM

ELECTRICAL GROUNDING CHART

Table 1 below provides the Minimum Cross Sectional area for two side rails. Using the Fitting Prefix Number (248), the proper value is determined by the Material (column 3), the Flange Width (column 1), and Load Depth (column 2). Locate the line containing the Load Depth (column 1) and follow it to the right to the appropriate Flange Width and Material.

TABLE 1

| Fitting Prefix Number | | | Min. X-Sect for 2 Rails (NEC® Table 392.7B) | | | |
|-----------------------|------------|--------------|--|-------------------------|--------------------------|-------------------------|
| | | | Aluminum | | Steel | |
| | | | $\frac{13}{16}$ " Flange | $\frac{11}{4}$ " Flange | $\frac{13}{16}$ " Flange | $\frac{11}{4}$ " Flange |
| Flange | Load Depth | Material | X-Sect Area | X-Sect Area | X-Sect Area | X-Sect Area |
| 2 - $\frac{13}{16}$ " | 3" | 6 - Mill Gal | 0.60 | 0.60 | 0.40 | 0.70 |
| 4 - $\frac{11}{4}$ " | 4" | 7 - HDGAF | 0.60 | 0.60 | 0.40 | 0.70 |
| | 5" | 8 - Alum. | 0.60 | 1.00 | 0.70 | 0.70 |
| | 6" | | 0.60 | 1.00 | 0.70 | 1.00 |

Find that value in Table 2, follow it to the right to the Material column to determine the Maximum Ground Fault Amperage.

TABLE 2

| Maximum Ground Fault Amperage (in Amps) | | |
|---|----------|-------|
| X-Sect Area | Material | |
| | Aluminum | Steel |
| .40 sq in | - | 100 |
| .60 sq in | 1000 | - |
| .70 sq in | - | 200 |
| 1.00 sq in | 1200 | 400 |

For Example:

If the fitting prefix is 248, the Flange is $\frac{13}{16}$ " , the Load Depth is 4", and the Material is Aluminum. The Minimum Cross Sectional Area (X-Sect Area) is 0.60 sq. in. The Amperage is 1000.

TYPICAL SPECIFICATIONS

By specifying the NEMA class designation, you will use the simplest, clearest, and most complete method of specification available and automatically incorporate support span in feet, working (allowable) load in pounds per linear foot, a safety factor of 1.5, a concentrated load, if present; and, all other design, manufacturing, and test standards including electrical continuity.

All you need to do is add the desired load depth, rung spacing, radius of fittings, metal, and finish. You may add accessory information pursuant to your project. Here is a typical specification for an outdoor tray system where the working (allowable) load has been determined to be approximately 75 pounds per foot on support spans of 12'-0".

SPECIFICATION ALUMINUM COPE LADDER SYSTEM

Ladder Cable Tray shall be manufactured by a company regularly engaged in the manufacture of metal cable trays and shall be a member of NEMA. Trays shall conform to NEMA Metal Cable Tray Standard Publication VE-1 (latest issue).

- Ladder Cable Tray shall be NEMA Classification 12B of the widths indicated.
- Material shall be aluminum alloy with side rails and rungs of 6063.
- Finish shall be natural.
- Inside load depth to be NEMA Standard 3".
- Fittings shall be 12" radius for control cables and 24" radius for power cables. (This must be commensurate with the cable manufacturer's recommended minimum bending radius.)
- All top level trays in stacks and single runs to have raised, peaked aluminum ventilated covers with heavy duty hold down clamps every 3'-0".
- Install expansion connectors, expansion guides, and hold down clamps per NEMA Standard VE-1.
- Where slopes or horizontal bends of trays are not at the Standard NEMA angles, use adjustable connectors. If the angle is too great for cable bending radius, use combinations of fitting and adjustable connectors.
- Separate all cables of different voltages in the same tray using the manufacturer's standard barriers and barrier hold down system.
- The Ladder Cable Tray system will be used as an equipment grounding conductor.
- To save space fittings shall have no tangents. To facilitate field installation, use one pair of universal type connector plates for rigid joints.
- Ladder Cable Tray shall have outward facing side rails with tubular rungs assembled into side rails by cold swaging. Cable support surface on top of rungs to be flattened. Inside of tray shall not have flanges or other projections. Full access to the contents of the Ladder Cable Tray shall be available.
- Trays shall be Cope Ladder Cable Tray System Number 3B38 as manufactured by Cope Cable Tray®.

COPE CSA STANDARDS C22-2 CABLE TROF LADDER TYPE

HOW TO ORDER: Explanation of Cope's Canadian Standards cable tray catalog numbers is described below. Use the system numbers given in selection charts for straight sections, or the fitting prefix numbers given in fitting tables. Be sure to follow system number or the fitting prefix with the item "description" number. The list below gives the CSA certified item carrying the CSA label.

STRAIGHT LENGTH

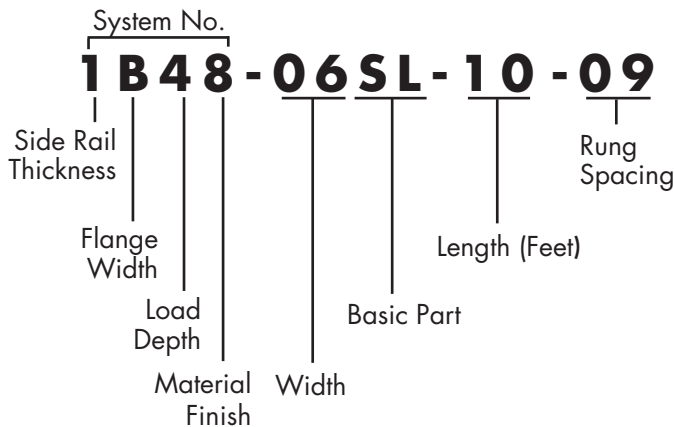

SYSTEM NUMBER (STRAIGHT SECTION ONLY) -

The first four digits make up the system number which identifies the structural, dimensional, and material characteristics of the straight length. It is made up of the side rail digits indicating the side rail thickness and flange width, the load depth (inside, in inches), and material finish (galvanized, aluminum or coated).

PREFIX NUMBER (FITTINGS ONLY) - Fittings are ordered using the 3-digit prefix number given in the charts on the fitting pages. Fittings do not have stiffened upper flanges.

WIDTH - Identifies the inside width of the tray in inches.

BASIC PART NUMBER - Identifies the straight length, fitting, or accessory.

| Thickness Steel (Ga.) | Flange Width | Load Depth | Material/ Finish |
|-----------------------------|--------------------|------------|------------------|
| 8 - 18 ga. | 2 - 13/16" (21mm) | 3" (76mm) | 7 - HDGAF |
| 6 - 16 ga. | 4 - 1 1/4" (32mm) | 4" (102mm) | CSA Class 1 |
| 4 - 14 ga. | 6 - 1 3/4" (45mm) | 5" (127mm) | 8 - Aluminum |
| | *B - 13/16" (21mm) | 6" (152mm) | Plain Finish |
| Thickness Alum (in.) | *D - 1 1/4" (32mm) | | |
| 1 - Thinner | | | |
| 3 - | | | |
| 5 - ** | | | |
| 7 - Thicker | | | |

*Stiffened Upper Flange

**Alum. extruded side rails are individually engineered to loads and spans



FITTINGS

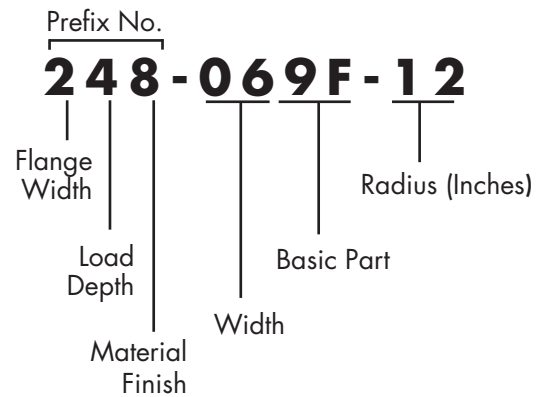

SECONDARY DIMENSION NUMBER - Identifies the length of a straight section in feet, the radius of a fitting in inches, or the second width of a reducer in inches.

RUNG SPACING - Identifies the center-to-center distance between rungs on straight length. Nominal 9" (229mm) rung spacing maintained through center line of all fittings.

DESCRIPTIONS

| Width (in.) *** | Basic Part Number | Length | Rung Spacing |
|------------------|--------------------------------|-----------------|-----------------|
| -06=6" (152mm) | SL (Straight Len.) | - 10' (3m, CSA) | 06=6" (152mm) |
| -09=9" (229mm) | 9F (90° Horiz. El.) | - 12' (3.7m) | 09=9" (229mm) |
| -12=12" (305mm) | 6F (60° Horiz. El.) | - 20' (6m, CSA) | 12=12" (305mm) |
| -18=18" (457mm) | 4F (45° Horiz. El.) | - 24' (7.3m) | 18=18" (457mm) |
| -24=24" (610mm) | 3F (30° Horiz. El.) | | |
| -30=30" (762mm) | 90 (90° Out. Vert. El.) | | |
| -36=36" (914mm) | 60 (60° Out. Vert. El.) | | |
| -42=42" (1067mm) | 40 (45° Out. Vert. El.) | | |
| -48=48" (1219mm) | 30 (30° Out. Vert. El.) | | |
| | | | Radius (in.) |
| | 9I (90° In. Vert. El.) | | -12=12" (205mm) |
| | 6I (60° In. Vert. El.) | | -24=24" (610mm) |
| | 4I (45° In. Vert. El.) | | -36=36" (914mm) |
| | 3I (30° In. Vert. El.) | | |
| | FT (Horiz. Tee) | | |
| | FC (Horiz. Cross) | | |
| | TT (Horiz. Tapped Tee) | | |
| | TC (Horiz. Tapped Cross) | | |
| | VT (Vert. Tee) | | |
| | SR (Vert. Cable Support Elbow) | | |
| | ST (Straight Reducer) | | |
| | RH (Right Hand Reducer) | | |
| | LH (Left Hand Reducer) | | |
| | AF (Adjustable Elbow) | | |
| | RY & LY (45° "Y" Branch) | | |

LADDER CABLE TRAY SYSTEM

CSA SYSTEM SELECTION CHART

COPE LADDER - TYPE CABLE TROF



Certified Ladder Cable Tray Systems That Meet Performance Class CSA Std.C22.2

| Certified CSA Load Class | Cope System | Load Depth | Side Rail | Flange Width | Max. Load Kg/m (lb/ft) | Maximum Support Span | Deflection at Max Support Span | Meets CSA Elec. Tests |
|--|-------------|------------|-------------|--------------|------------------------|----------------------|--------------------------------|-----------------------|
| ALUMINUM LADDER TRAY - Safety Factor: 1.5 | | | | | | | | |
| C | 1B38 | 3" (76mm) | 4¼" (108mm) | ⅜" (21mm) | 97 (65) | 3m | 25.1mm | Yes |
| D | 3D38 | 3" (76mm) | 4¼" (108mm) | 1¼" (32mm) | 67 (45) | 6m (1) | 108.5mm | Yes |
| 16C | 5D38 | 3" (76mm) | 4¼" (108mm) | 1¼" (32mm) | 149 (100) | 4.9m | 69.3mm | Yes |
| C | 1B48 | 4" (102mm) | 5¼" (133mm) | ⅜" (21mm) | 97 (65) | 3m | 22.1mm | Yes |
| 20A | 7448 | 4" (102mm) | 5¼" (133mm) | 1¼" (32mm) | 74 (50) | 6m (1) | 73.4mm | Yes |
| 20B | 3D48 | 4" (102mm) | 5¼" (133mm) | 1¼" (32mm) | 112 (75) | 6m (1) | 79.8mm | Yes |
| 20A | 1D58 | 5" (127mm) | 6¼" (159mm) | 1¼" (32mm) | 74 (50) | 6m (1) | 63.8mm | Yes |
| 20B | 5D58 | 5" (127mm) | 6¼" (159mm) | 1¼" (32mm) | 112 (75) | 6m (1) | 54.9mm | Yes |
| E | 3658 | 5" (127mm) | 6¼" (159mm) | 1¼" (45mm) | 112 (75) | 6m (1) | 64.8mm | Yes |
| 20C | 7D58 | 5" (127mm) | 6¼" (159mm) | 1¼" (32mm) | 149 (100) | 6m (1) | 76.7mm | Yes |
| 20C | 5D68 | 6" (152mm) | 7¼" (184mm) | 1¼" (32mm) | 149 (100) | 6m (1) | 54.9mm | Yes |
| Mil Gal STEEL LADDER TRAY - Safety Factor: 1.5 | | | | | | | | |
| C | 8B36 | 3" (76mm) | 4¼" (108mm) | ⅜" (21mm) | 97 (65) | 3m | 17.8mm | Yes |
| 20A | 6456 | 5" (127mm) | 6¼" (159mm) | 1¼" (32mm) | 74 (50) | 6m (1) | 40.4mm | Yes |
| E | 6D56 | 5" (127mm) | 6¼" (159mm) | 1¼" (32mm) | 112 (75) | 6m (1) | 46.2mm | Yes |
| 20C | 4D56 | 5" (127mm) | 6¼" (159mm) | 1¼" (32mm) | 149 (100) | 6m (1) | 48.5mm | Yes |
| 12B | 8B66 | 6" (152mm) | 7¼" (184mm) | ⅜" (21mm) | 112 (75) | 3.7m | 24.9mm | Yes |
| 20A | 6466 | 6" (152mm) | 7¼" (184mm) | 1¼" (32mm) | 74 (50) | 6m (1) | 23.1mm | Yes |
| 20B | 6D66 | 6" (152mm) | 7¼" (184mm) | 1¼" (32mm) | 112 (75) | 6m (1) | 33.8mm | Yes |
| HDGAF STEEL LADDER TRAY - Safety Factor: 1.5 | | | | | | | | |
| C | 8B37 | 3" (76mm) | 4¼" (108mm) | ⅜" (21mm) | 97 (65) | 3m | 17.8mm | Yes |
| 20A | 6457 | 5" (127mm) | 6¼" (159mm) | 1¼" (32mm) | 74 (50) | 6m (1) | 40.4mm | Yes |
| E | 6D57 | 5" (127mm) | 6¼" (159mm) | 1¼" (32mm) | 112 (75) | 6m (1) | 46.2mm | Yes |
| 12B | 8B67 | 6" (152mm) | 7¼" (184mm) | ⅜" (21mm) | 112 (75) | 3.7m | 24.9mm | Yes |
| 20A | 6467 | 6" (152mm) | 7¼" (184mm) | 1¼" (32mm) | 74 (50) | 6m (1) | 23.1mm | Yes |
| 20B | 6D67 | 6" (152mm) | 7¼" (184mm) | 1¼" (32mm) | 112 (75) | 6m (1) | 33.8mm | Yes |

*Also recommended for 3 meter support spans

NOTE: ■ Indicates items included in our Quick Ship Program. Consult factory for lead times on other systems.

CSA LOADS

Identify the desired load designation needed for your project from the chart below. Both CSA Class and NEMA designations are listed by load capability and span. Then select the CSA Certified Cope System from the table above. Where CSA C22.2 is not mandatory, you may want to consider other Cope systems offered on the selection charts (page 25 thru 29).

| Load, kg/m (lb/ft) | Span, m (ft) | | | | |
|--------------------|--------------|----------|----------|----------|----------|
| | 2.4 (8) | 3.0 (10) | 3.7 (12) | 4.9 (16) | 6.0 (20) |
| 37 (25) | - | A | - | - | - |
| 67 (45) | - | - | - | - | D |
| 74 (50) | 8A | - | 12A | 16A | 20A |
| 97 (65) | - | C | - | - | - |
| 112 (75) | 8B | - | 12B | 16B | E or 20B |
| 149 (100) | 8C | - | 12C | 16C | 20C |
| 179 (120) | - | D | - | - | - |
| 299 (200) | - | E | - | - | - |

NOTE: 8A/B/C, 12A/B/C, 16A/B/C, and 20A/B/C have been NEMA designations. A, B, C, D and E have been CSA designations

RECEIVING, INSTALLING, AND MAINTENANCE

The proper care and handling of cable trays by the receiver and installers is very important to insure a safe installation that will meet the intended service life. Cope has an installation guide available to assist the installers and those who will maintain the installed system.

DIMENSIONS AND STRUCTURAL PROPERTIES: COPE CSA SYSTEMS

The performance of the Cope cable trays systems certified by CSA is given above. Structural properties of straight sections, though not required to be listed, are given in the Cope NEMA selection charts, in English units. Dimensions of straight sections and certified fittings are furnished in English and metric units for use in layout and/or entry into computerized systems.

NOTE: For other CSA approved systems please contact the factory.

| ALUMINUM | | MILL-GALV | | HDGAF | |
|---------------|----------------|---------------|----------------|---------------|----------------|
| SYSTEM NUMBER | FITTING PREFIX | SYSTEM NUMBER | FITTING PREFIX | SYSTEM NUMBER | FITTING PREFIX |
| 1B38 | 238 | 8236 | 236 | 6257 | 257 |
| 1B48 | 248 | 8246 | 246 | 6D37 | 437 |
| 3B58 | 258 | 8256 | 256 | 4D37 | 437 |
| 1B68 | 268 | 8266 | 266 | 6447 | 447 |
| 3B38 | 238 | 8B36 | 236 | 6457 | 457 |
| 5B38 | 238 | 8B66 | 266 | 6467 | 467 |
| 3B48 | 248 | 8B46 | 246 | 4D47 | 447 |
| 5B58 | 258 | 6256 | 256 | 6D57 | 457 |
| 5B68 | 268 | 8D36 | 436 | 6D67 | 467 |
| 7448 | 448 | 8D46 | 446 | 4D57 | 457 |
| 1D58 | 458 | 8D56 | 456 | 4467 | 467 |
| 1D68 | 468 | 8466 | 466 | 4B37 | 237 |
| 3D38 | 438 | 6D36 | 436 | 6B47 | 247 |
| 5D38 | 438 | 4D36 | 436 | 4B47 | 247 |
| 3D48 | 448 | 6446 | 446 | 2D37 | 437 |
| 3658 | 458 | 6456 | 456 | 2D47 | 447 |
| 5E38 | 438 | 8D66 | 466 | 2D57 | 457 |
| 5D48 | 448 | 6466 | 466 | 11D57 | 457 |
| 7D58 | 458 | 4D46 | 446 | | |
| 9D58 | 458 | 6D56 | 456 | | |
| 7G58 | 758 | 6D66 | 466 | | |
| 5D58 | 458 | 4D56 | 456 | | |
| 5D68 | 468 | 4466 | 466 | | |
| | | 4B36 | 236 | | |
| | | 6B46 | 246 | | |
| | | 4B46 | 246 | | |
| | | 2D36 | 436 | | |
| | | 2D46 | 446 | | |
| | | 2D56 | 456 | | |
| | | 11D56 | 456 | | |

NOTE: Indicates items included in our Quick Ship Program. Consult factory for lead times on other systems.

Intro

LADDER

I-BEAM

HAT

TROF

CHANNEL

COPE-GLAS™

WIREBASKET

Reference

LADDER CABLE TRAY SYSTEM

90° HORIZONTAL ELBOW [9F]

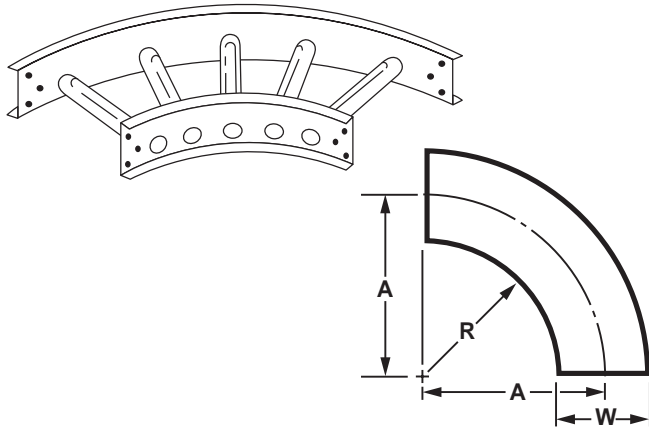

CSA CERTIFIED FOR CSA SYSTEMS

| Radius - R | Width - W | "A" Dimension |
|----------------|--------------|------------------|
| 12" (305mm) | 6" (152mm) | 15" (381mm) |
| | 9" (229mm) | 16 1/2" (419mm) |
| | 12" (305mm) | 18" (457mm) |
| | 18" (457mm) | 21" (533mm) |
| | 24" (610mm) | 24" (610mm) |
| | 30" (762mm) | 27" (686mm) |
| | 36" (914mm) | 30" (762mm) |
| | 42" (1067mm) | 33" (838mm) |
| 24" (610mm) | 48" (1219mm) | 36" (914mm) |
| | 6" (152mm) | 27" (686mm) |
| | 9" (229mm) | 28 1/2" (724mm) |
| | 12" (305mm) | 30" (762mm) |
| | 18" (457mm) | 33" (838mm) |
| | 24" (610mm) | 36" (914mm) |
| | 30" (762mm) | 39" (991mm) |
| | 36" (914mm) | 42" (1067mm) |
| 36" (914mm) | 42" (1067mm) | 45" (1143mm) |
| | 48" (1219mm) | 48" (1219mm) |
| | 6" (152mm) | 39" (991mm) |
| | 9" (229mm) | 40 1/2" (1029mm) |
| | 12" (305mm) | 42" (1067mm) |
| | 18" (457mm) | 45" (1143mm) |
| | 24" (610mm) | 48" (1219mm) |
| | 30" (762mm) | 51" (1295mm) |
| 48" (1219mm) | 36" (914mm) | 54" (1372mm) |
| | 42" (1067mm) | 57" (1448mm) |
| | 48" (1219mm) | 60" (1524mm) |

Example: 238-129F-12

NOTE: Indicates items included in our Quick Ship Program. Consult factory for lead times on other systems.

Use Adjustable Connectors for odd angles. Nominal 9" rung spacing maintained through centerline of all fittings. Quickship items with 248 or 458 prefix

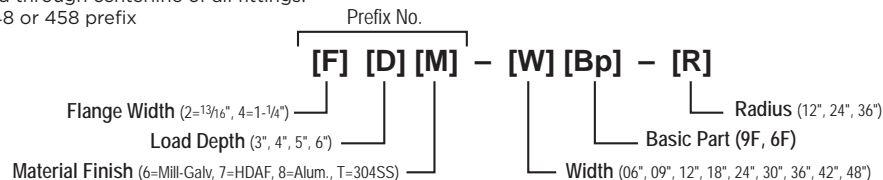

See Page 50
for Electrical
Grounding Chart

60° HORIZONTAL ELBOW [6F]

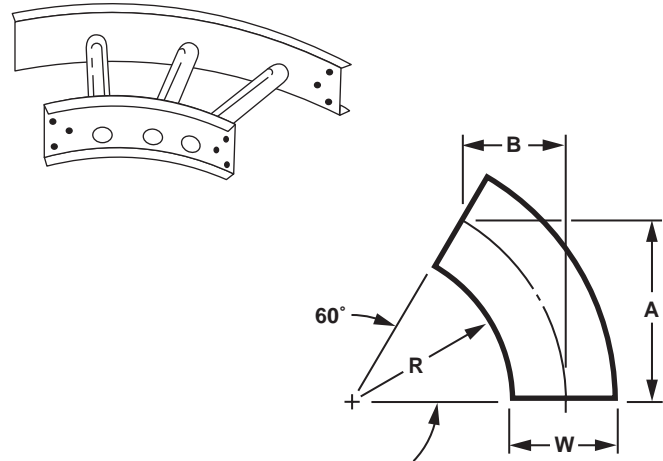

CSA CERTIFIED FOR CSA SYSTEMS

| Radius - R | Width - W | "A" Dimension | "B" Dimension |
|----------------|--------------|--------------------|-----------------|
| 12" (305mm) | 6" (152mm) | 13" (330mm) | 7 1/2" (191mm) |
| | 9" (229mm) | 14 1/4" (362mm) | 8 1/4" (210mm) |
| | 12" (305mm) | 15 5/8" (397mm) | 9" (229mm) |
| | 18" (457mm) | 18 1/4" (464mm) | 10 1/2" (267mm) |
| | 24" (610mm) | 20 3/4" (527mm) | 12" (305mm) |
| | 30" (762mm) | 23 3/8" (594mm) | 13 1/2" (343mm) |
| | 36" (914mm) | 26" (660mm) | 15" (381mm) |
| | 42" (1067mm) | 28 9/16" (725mm) | 16 1/2" (419mm) |
| 24" (610mm) | 48" (1219mm) | 31 1/8" (791mm) | 18" (457mm) |
| | 6" (152mm) | 23 3/8" (594mm) | 13 1/2" (343mm) |
| | 9" (229mm) | 24 3/4" (629mm) | 14 1/4" (362mm) |
| | 12" (305mm) | 26" (660mm) | 15" (381mm) |
| | 18" (457mm) | 28 5/8" (727mm) | 16 1/2" (416mm) |
| | 24" (610mm) | 31 1/4" (794mm) | 18" (457mm) |
| | 30" (762mm) | 33 3/4" (857mm) | 19 1/2" (495mm) |
| | 36" (914mm) | 36 3/8" (924mm) | 21" (533mm) |
| 36" (914mm) | 42" (1067mm) | 38 15/16" (989mm) | 22 1/2" (572mm) |
| | 48" (1219mm) | 41 9/16" (1056mm) | 24" (610mm) |
| | 6" (152mm) | 33 3/4" (857mm) | 19 1/2" (495mm) |
| | 9" (229mm) | 35 1/8" (892mm) | 20 1/4" (514mm) |
| | 12" (305mm) | 36 3/8" (924mm) | 21" (533mm) |
| | 18" (457mm) | 39" (991mm) | 22 1/2" (572mm) |
| | 24" (610mm) | 41 5/8" (1057mm) | 24" (610mm) |
| | 30" (762mm) | 44 1/8" (1121mm) | 25 1/2" (648mm) |
| 48" (1219mm) | 36" (914mm) | 46 3/4" (1187mm) | 27" (686mm) |
| | 42" (1067mm) | 49 5/16" (1253mm) | 28 1/2" (724mm) |
| | 48" (1219mm) | 51 15/16" (1319mm) | 30" (762mm) |

Example: 238-126F-12

45° HORIZONTAL ELBOW [4F]

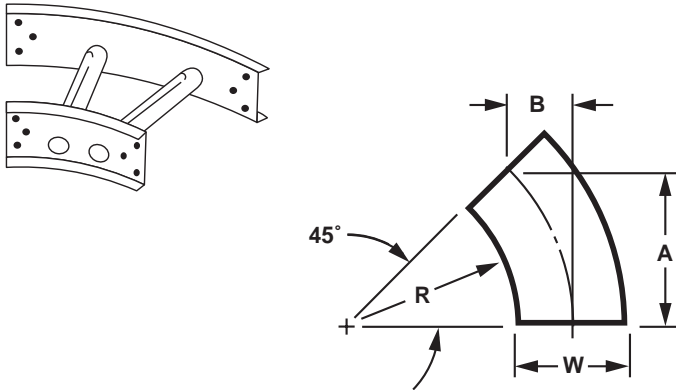

30° HORIZONTAL ELBOW [3F]

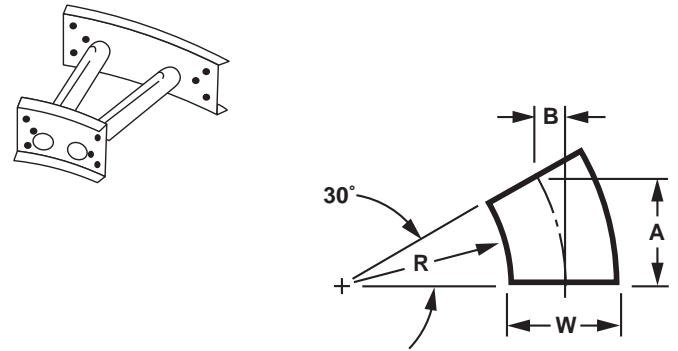

CSA CERTIFIED FOR CSA SYSTEMS

| Radius - R | Width - W | "A" Dimension | "B" Dimension |
|----------------|--------------|--|--|
| 12" (305mm) | 6" (152mm) | 10 ⁵ / ₈ " (270mm) | 4 ³ / ₈ " (111mm) |
| | 9" (229mm) | 11 ⁵ / ₈ " (295mm) | 4 ⁷ / ₈ " (124mm) |
| | 12" (305mm) | 12 ³ / ₄ " (324mm) | 5 ¹ / ₄ " (133mm) |
| | 18" (457mm) | 14 ⁷ / ₈ " (378mm) | 6 ¹ / ₈ " (156mm) |
| | 24" (610mm) | 17" (432mm) | 7" (178mm) |
| | 30" (762mm) | 19 ⁷ / ₈ " (486mm) | 7 ⁷ / ₈ " (200mm) |
| | 36" (914mm) | 21 ¹ / ₄ " (540mm) | 8 ³ / ₄ " (222mm) |
| | 42" (1067mm) | 23 ⁵ / ₁₆ " (592mm) | 9 ⁵ / ₈ " (244mm) |
| 24" (610mm) | 48" (1219mm) | 25 ⁷ / ₁₆ " (646mm) | 10 ¹ / ₂ " (267mm) |
| | 6" (152mm) | 19 ¹ / ₈ " (486mm) | 7 ⁷ / ₈ " (200mm) |
| | 9" (229mm) | 20 ¹ / ₈ " (511mm) | 8 ³ / ₈ " (213mm) |
| | 12" (305mm) | 21 ¹ / ₄ " (540mm) | 8 ³ / ₄ " (222mm) |
| | 18" (457mm) | 23 ³ / ₈ " (594mm) | 9 ⁵ / ₈ " (244mm) |
| | 24" (610mm) | 25 ¹ / ₂ " (648mm) | 10 ¹ / ₂ " (267mm) |
| | 30" (762mm) | 27 ⁵ / ₈ " (702mm) | 11 ¹ / ₂ " (292mm) |
| | 36" (914mm) | 29 ³ / ₄ " (756mm) | 12 ³ / ₈ " (314mm) |
| 36" (914mm) | 42" (1067mm) | 31 ¹³ / ₁₆ " (808mm) | 13 ¹ / ₈ " (333mm) |
| | 48" (1219mm) | 33 ¹³ / ₁₆ " (862mm) | 14" (356mm) |
| | 6" (152mm) | 27 ⁵ / ₈ " (702mm) | 11 ¹ / ₂ " (292mm) |
| | 9" (229mm) | 28 ⁵ / ₈ " (727mm) | 11 ⁷ / ₈ " (302mm) |
| | 12" (305mm) | 29 ³ / ₄ " (756mm) | 12 ³ / ₈ " (314mm) |
| | 18" (457mm) | 31 ¹ / ₈ " (810mm) | 13 ¹ / ₄ " (337mm) |
| | 24" (610mm) | 34" (864mm) | 14 ¹ / ₈ " (359mm) |
| | 30" (762mm) | 36 ¹ / ₈ " (918mm) | 15" (381mm) |
| 48" (1219mm) | 36" (914mm) | 38 ¹ / ₄ " (972mm) | 15 ⁷ / ₈ " (403mm) |
| | 42" (1067mm) | 40 ¹ / ₄ " (1022mm) | 16 ¹¹ / ₁₆ " (424mm) |
| | 48" (1219mm) | 42 ³ / ₈ " (1076mm) | 17 ¹ / ₈ " (446mm) |

Example: 238-124F-12

NOTE: Use Adjustable Connectors for odd angles. Nominal 9" rung spacing maintained through centerline of all fittings.

CSA CERTIFIED FOR CSA SYSTEMS

| Radius - R | Width - W | "A" Dimension | "B" Dimension |
|----------------|--------------|--|---|
| 12" (305mm) | 6" (152mm) | 7 ¹ / ₂ " (191mm) | 2" (51mm) |
| | 9" (229mm) | 8 ¹ / ₄ " (210mm) | 2 ¹ / ₄ " (57mm) |
| | 12" (305mm) | 9" (229mm) | 2 ³ / ₈ " (60mm) |
| | 18" (457mm) | 10 ¹ / ₂ " (267mm) | 2 ⁷ / ₈ " (73mm) |
| | 24" (610mm) | 12" (305mm) | 3 ¹ / ₄ " (83mm) |
| | 30" (762mm) | 13 ¹ / ₂ " (343mm) | 3 ⁵ / ₈ " (92mm) |
| | 36" (914mm) | 15" (381mm) | 4" (102mm) |
| | 42" (1067mm) | 16 ¹ / ₂ " (419mm) | 4 ³ / ₈ " (111mm) |
| 24" (610mm) | 48" (1219mm) | 18" (457mm) | 4 ¹³ / ₁₆ " (122mm) |
| | 6" (152mm) | 13 ¹ / ₂ " (343mm) | 3 ⁵ / ₈ " (92mm) |
| | 9" (229mm) | 14 ¹ / ₄ " (362mm) | 3 ⁷ / ₈ " (98mm) |
| | 12" (305mm) | 15" (381mm) | 4" (102mm) |
| | 18" (457mm) | 16 ¹ / ₂ " (419mm) | 4 ³ / ₈ " (111mm) |
| | 24" (610mm) | 18" (457mm) | 4 ⁷ / ₈ " (124mm) |
| | 30" (762mm) | 19 ¹ / ₂ " (495mm) | 5 ¹ / ₄ " (133mm) |
| | 36" (914mm) | 21" (533mm) | 5 ⁵ / ₈ " (143mm) |
| 36" (914mm) | 42" (1067mm) | 22 ¹ / ₂ " (572mm) | 6" (152mm) |
| | 48" (1219mm) | 24" (610mm) | 6 ³ / ₈ " (162mm) |
| | 6" (152mm) | 19 ¹ / ₂ " (495mm) | 5 ¹ / ₄ " (133mm) |
| | 9" (229mm) | 20 ¹ / ₄ " (514mm) | 5 ¹ / ₂ " (140mm) |
| | 12" (305mm) | 21" (533mm) | 5 ⁵ / ₈ " (143mm) |
| | 18" (457mm) | 22 ¹ / ₂ " (572mm) | 6" (152mm) |
| | 24" (610mm) | 24" (610mm) | 6 ¹ / ₂ " (165mm) |
| | 30" (762mm) | 25 ¹ / ₂ " (648mm) | 6 ⁷ / ₈ " (175mm) |
| 48" (1219mm) | 36" (914mm) | 27" (686mm) | 7 ¹ / ₄ " (184mm) |
| | 42" (1067mm) | 28 ¹ / ₂ " (724mm) | 7 ⁵ / ₈ " (194mm) |
| | 48" (1219mm) | 30" (762mm) | 8" (203mm) |

Example: 238-123F-12

Prefix No.
[F] [D] [M] - [W] [Bp] - [R]

Flange Width (2=1³/₁₆", 4=1-1/4")

Load Depth (3", 4", 5", 6")

Material Finish (6=Mill-Galv, 7=HDAF, 8=Alum., T=304SS)

Radius (12", 24", 36")

Basic Part (4F, 3F)

Width (06", 09", 12", 18", 24", 30", 36", 42", 48")

See Page 50
for Electrical
Grounding Chart

LADDER CABLE TRAY SYSTEM

HORIZONTAL TEE [FT]

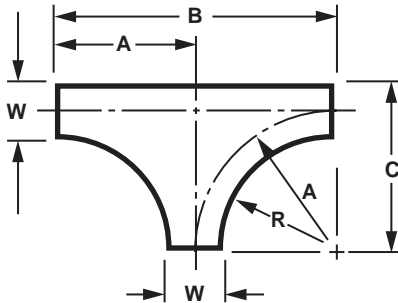
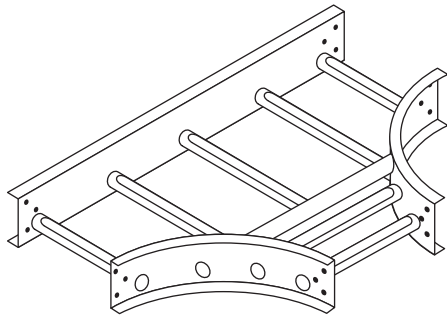

CSA CERTIFIED FOR CSA SYSTEMS

| Radius - R | Width - W | "A" Dimension | "B" Dimension | "C" Dimension |
|----------------|--------------|------------------|---------------|---------------|
| 12" (305mm) | 6" (152mm) | 15" (381mm) | 30" (762mm) | 18" (457mm) |
| | 9" (229mm) | 16 1/2" (419mm) | 33" (838mm) | 21" (533mm) |
| | 12" (305mm) | 18" (457mm) | 36" (914mm) | 24" (610mm) |
| | 18" (457mm) | 21" (533mm) | 42" (1067mm) | 30" (762mm) |
| | 24" (610mm) | 24" (610mm) | 48" (1219mm) | 36" (914mm) |
| | 30" (762mm) | 27" (686mm) | 54" (1372mm) | 42" (1067mm) |
| | 36" (914mm) | 30" (762mm) | 60" (1524mm) | 48" (1219mm) |
| | 42" (1067mm) | 33" (838mm) | 66" (1676mm) | 54" (1372mm) |
| 24" (610mm) | 48" (1219mm) | 36" (914mm) | 72" (1829mm) | 60" (1524mm) |
| | 6" (152mm) | 27" (686mm) | 54" (1372mm) | 30" (762mm) |
| | 9" (229mm) | 28 1/2" (724mm) | 57" (1448mm) | 33" (838mm) |
| | 12" (305mm) | 30" (762mm) | 60" (1524mm) | 36" (914mm) |
| | 18" (457mm) | 33" (838mm) | 66" (1676mm) | 42" (1067mm) |
| | 24" (610mm) | 36" (914mm) | 72" (1829mm) | 48" (1219mm) |
| | 30" (762mm) | 39" (991mm) | 78" (1981mm) | 54" (1372mm) |
| | 36" (914mm) | 42" (1067mm) | 84" (2134mm) | 60" (1524mm) |
| 36" (914mm) | 42" (1067mm) | 45" (1143mm) | 90" (2286mm) | 66" (1676mm) |
| | 48" (1219mm) | 48" (1219mm) | 96" (2438mm) | 72" (1829mm) |
| | 6" (152mm) | 39" (991mm) | 78" (1981mm) | 42" (1067mm) |
| | 9" (229mm) | 40 1/2" (1029mm) | 81" (2057mm) | 45" (1143mm) |
| | 12" (305mm) | 42" (1067mm) | 84" (2134mm) | 48" (1219mm) |
| | 18" (457mm) | 45" (1143mm) | 90" (2286mm) | 54" (1372mm) |
| | 24" (610mm) | 48" (1219mm) | 96" (2438mm) | 60" (1524mm) |
| | 30" (762mm) | 51" (1295mm) | 102" (2591mm) | 66" (1676mm) |
| 36" (914mm) | 54" (1372mm) | 108" (2743mm) | 72" (1829mm) | |
| 42" (1067mm) | 57" (1448mm) | 114" (2896mm) | 78" (1981mm) | |
| 48" (1219mm) | 60" (1524mm) | 120" (3048mm) | 84" (2134mm) | |

Example: 238-12FT-12

NOTE: Indicates items included in our Quick Ship Program. Consult factory for lead times on other systems.

Nominal 9" rung spacing maintained through centerline of all fittings.

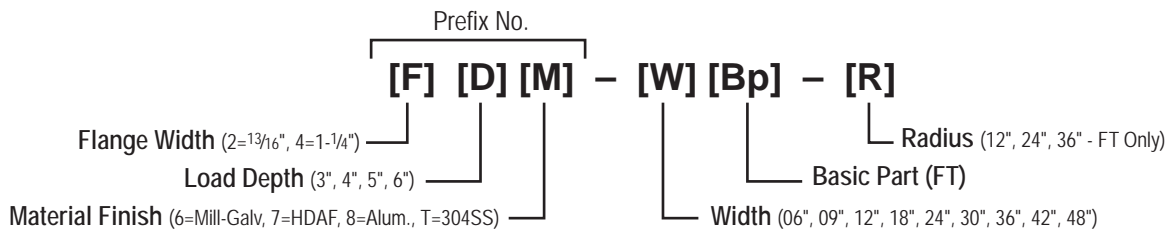

See Page 50
for Electrical
Grounding Chart

HORIZONTAL CROSS [FC]

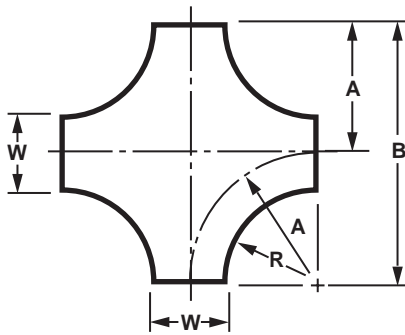
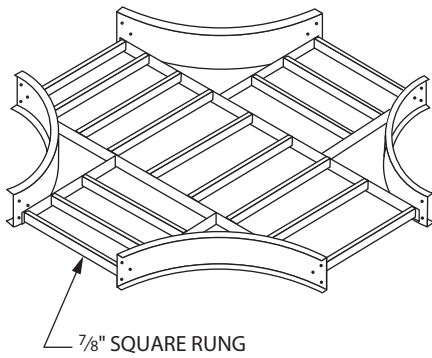

CSA CERTIFIED FOR CSA SYSTEMS

| Radius - R | Width - W | "A" Dimension | "B" Dimension |
|-----------------------|--------------|---------------|---------------|
| 12" (305mm) | 6" (152mm) | 15" (381mm) | 30" (762mm) |
| | 9" (229mm) | 16½" (419mm) | 33" (838mm) |
| | 12" (305mm) | 18" (457mm) | 36" (914mm) |
| | 18" (457mm) | 21" (533mm) | 42" (1067mm) |
| | 24" (610mm) | 24" (610mm) | 48" (1219mm) |
| | 30" (762mm) | 27" (686mm) | 54" (1372mm) |
| | 36" (914mm) | 30" (762mm) | 60" (1524mm) |
| | 42" (1067mm) | 33" (838mm) | 66" (1676mm) |
| 24" (610mm) | 48" (1219mm) | 36" (914mm) | 72" (1829mm) |
| | 6" (152mm) | 27" (686mm) | 54" (1372mm) |
| | 9" (229mm) | 28½" (724mm) | 57" (1448mm) |
| | 12" (305mm) | 30" (762mm) | 60" (1524mm) |
| | 18" (457mm) | 33" (838mm) | 66" (1676mm) |
| | 24" (610mm) | 36" (914mm) | 72" (1829mm) |
| | 30" (762mm) | 39" (991mm) | 78" (1981mm) |
| | 36" (914mm) | 42" (1067mm) | 84" (2134mm) |
| 36" (914mm) | 42" (1067mm) | 45" (1143mm) | 90" (2286mm) |
| | 48" (1219mm) | 48" (1219mm) | 96" (2438mm) |
| | 6" (152mm) | 39" (991mm) | 78" (1981mm) |
| | 9" (229mm) | 40½" (1029mm) | 81" (2057mm) |
| | 12" (305mm) | 42" (1067mm) | 84" (2134mm) |
| | 18" (457mm) | 45" (1143mm) | 90" (2286mm) |
| | 24" (610mm) | 48" (1219mm) | 96" (2438mm) |
| | 30" (762mm) | 51" (1295mm) | 102" (2591mm) |
| 36" (914mm) | 54" (1372mm) | 108" (2743mm) | |
| 42" (1067mm) | 57" (1448mm) | 114" (2896mm) | |
| 48" (1219mm) | 60" (1524mm) | 120" (3048mm) | |

Example: 238-12FC-12

NOTE: Indicates items included in our Quick ShipProgram. Consult factory for lead times on other systems.
Nominal 9" rung spacing maintained through centerline of all fittings.

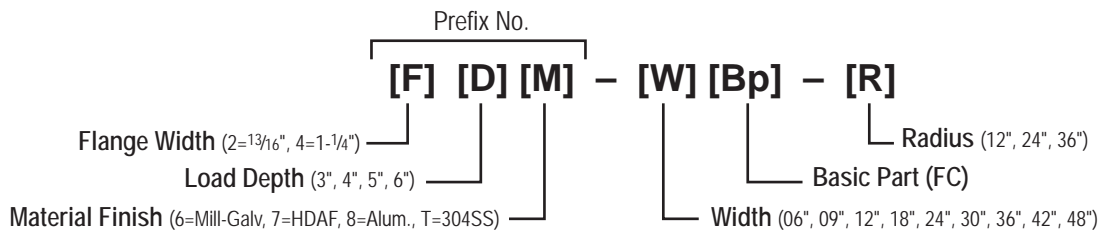

See Page 50
for Electrical
Grounding Chart

LADDER CABLE TRAY SYSTEM

HORIZONTAL TAPPED TEE [TT]

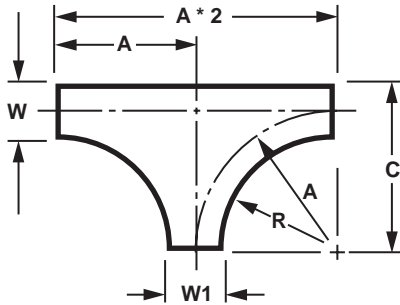
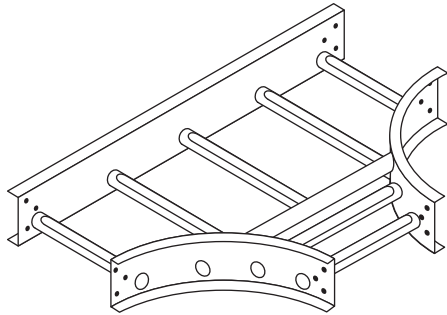

CSA CERTIFIED FOR CSA SYSTEMS

| R Radius | W Width | W1 Width | "A" Dimension | "C" Dimension | | | | | | |
|----------------|-----------------|----------------|------------------|------------------|-----------------|----------------|-----------------|------------|-------------|----------------|
| 12" (305mm) | 48" (1219mm) | 42" (1067mm) | 33" (838mm) | 60" (1524mm) | | | | | | |
| | | 36" (914mm) | 30" (762mm) | | | | | | | |
| | | 30" (762mm) | 27" (686mm) | | | | | | | |
| | | 24" (610mm) | 24" (610mm) | | | | | | | |
| | | 18" (457mm) | 21" (533mm) | | | | | | | |
| | | 12" (305mm) | 18" (457mm) | | | | | | | |
| | | 9" (229mm) | 16 1/2" (419mm) | | | | | | | |
| 12" (305mm) | 42" (1067mm) | 36" (914mm) | 30" (762mm) | 54" (1372mm) | | | | | | |
| | | 30" (762mm) | 27" (686mm) | | | | | | | |
| | | 24" (610mm) | 24" (610mm) | | | | | | | |
| | | 18" (457mm) | 21" (533mm) | | | | | | | |
| | | 12" (305mm) | 18" (457mm) | | | | | | | |
| | | 9" (229mm) | 16 1/2" (419mm) | | | | | | | |
| | | 6" (152mm) | 15" (381mm) | | | | | | | |
| 12" (305mm) | 36" (914mm) | 30" (762mm) | 27" (686mm) | 48" (1219mm) | | | | | | |
| | | 24" (610mm) | 24" (610mm) | | | | | | | |
| | | 18" (457mm) | 21" (533mm) | | | | | | | |
| | | 12" (305mm) | 18" (457mm) | | | | | | | |
| | | 9" (229mm) | 16 1/2" (419mm) | | | | | | | |
| | | 6" (152mm) | 15" (381mm) | | | | | | | |
| | | 12" (305mm) | 30" (762mm) | | 24" (610mm) | 24" (610mm) | 42" (1067mm) | | | |
| 18" (457mm) | 21" (533mm) | | | | | | | | | |
| 12" (305mm) | 18" (457mm) | | | | | | | | | |
| 9" (229mm) | 16 1/2" (419mm) | | | | | | | | | |
| 6" (152mm) | 15" (381mm) | | | | | | | | | |
| 12" (305mm) | 24" (610mm) | | | 18" (457mm) | 21" (533mm) | 36" (914mm) | | | | |
| | | | | 12" (305mm) | 18" (457mm) | | | | | |
| | | 9" (229mm) | 16 1/2" (419mm) | | | | | | | |
| | | 6" (152mm) | 15" (381mm) | | | | | | | |
| | | 12" (305mm) | 18" (457mm) | 12" (305mm) | 18" (457mm) | | 30" (762mm) | | | |
| | | | | 9" (229mm) | 16 1/2" (419mm) | | | | | |
| | | | | 6" (152mm) | 15" (381mm) | | | | | |
| 12" (305mm) | 12" (305mm) | | | 9" (229mm) | 16 1/2" (419mm) | 24" (610mm) | | | | |
| | | | | 6" (152mm) | 15" (381mm) | | | | | |
| | | | | 12" (305mm) | 9" (229mm) | | | 6" (152mm) | 15" (381mm) | 21" (533mm) |

Example: 238-12TT-09-12

NOTE: Nominal 9" rung spacing maintained through centerline of all fittings.
Expanding taps available upon request

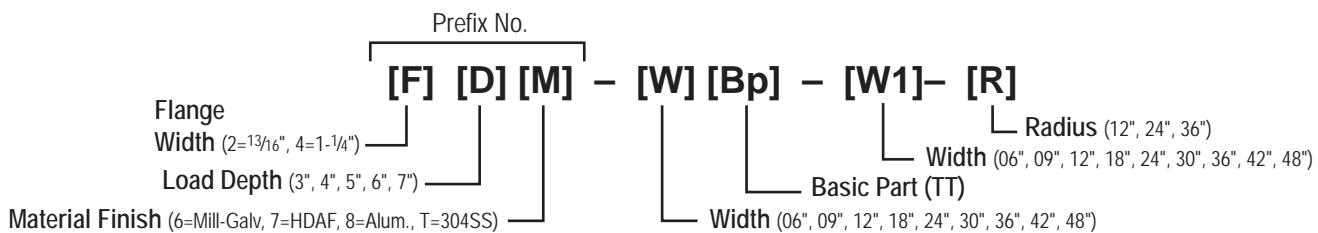

See Page 50
for Electrical
Grounding Chart

HORIZONTAL TAPPED TEE [TT] continued

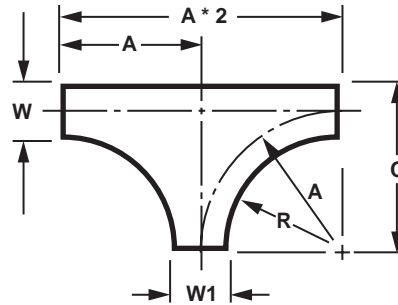

See Page 50
for Electrical
Grounding Chart

CSA CERTIFIED FOR CSA SYSTEMS

| R Radius | W Width | W1 Width | "A" Dimension | "C" Dimension | |
|------------------------|-----------------------|-------------|------------------|------------------|---------|
| 48" (1219mm) | 42" | (1067mm) | 45" | (1143mm) | |
| | 36" | (914mm) | 42" | (1067mm) | |
| | 30" | (762mm) | 39" | (991mm) | |
| | 24" | (610mm) | 36" | (914mm) | |
| | 18" | (457mm) | 33" | (838mm) | |
| | 12" | (305mm) | 30" | (762mm) | |
| | 9" | (229mm) | 28½" | (724mm) | |
| | 6" | (152mm) | 27" | (686mm) | |
| 42" (1067mm) | 36" | (914mm) | 42" | (1067mm) | |
| | 30" | (762mm) | 39" | (991mm) | |
| | 24" | (610mm) | 36" | (914mm) | |
| | 18" | (457mm) | 33" | (838mm) | |
| | 12" | (305mm) | 30" | (762mm) | |
| | 9" | (229mm) | 28½" | (724mm) | |
| | 6" | (152mm) | 27" | (686mm) | |
| | 36" (914mm) | 30" | (762mm) | 39" | (991mm) |
| 24" | | (610mm) | 36" | (914mm) | |
| 18" | | (457mm) | 33" | (838mm) | |
| 12" | | (305mm) | 30" | (762mm) | |
| 9" | | (229mm) | 28½" | (724mm) | |
| 6" | | (152mm) | 27" | (686mm) | |
| 30" (762mm) | | 24" | (610mm) | 36" | (914mm) |
| | | 18" | (457mm) | 33" | (838mm) |
| | 12" | (305mm) | 30" | (762mm) | |
| | 9" | (229mm) | 28½" | (724mm) | |
| | 6" | (152mm) | 27" | (686mm) | |
| 24" (610mm) | 18" | (457mm) | 33" | (838mm) | |
| | 12" | (305mm) | 30" | (762mm) | |
| | 9" | (229mm) | 28½" | (724mm) | |
| | 6" | (152mm) | 27" | (686mm) | |
| 18" (457mm) | 12" | (305mm) | 30" | (762mm) | |
| | 9" | (229mm) | 28½" | (724mm) | |
| | 6" | (152mm) | 27" | (686mm) | |
| 12" (305mm) | 9" | (229mm) | 28½" | (724mm) | |
| | 6" | (152mm) | 27" | (686mm) | |
| 9" (229mm) | 6" | (152mm) | 27" | (686mm) | |

CSA CERTIFIED FOR CSA SYSTEMS

| R Radius | W Width | W1 Width | "A" Dimension | "C" Dimension | |
|------------------------|-----------------------|-------------|------------------|------------------|----------|
| 48" (1219mm) | 42" | (1067mm) | 57" | (1448mm) | |
| | 36" | (914mm) | 54" | (1372mm) | |
| | 30" | (762mm) | 51" | (1295mm) | |
| | 24" | (610mm) | 48" | (1219mm) | |
| | 18" | (457mm) | 45" | (1143mm) | |
| | 12" | (305mm) | 42" | (1067mm) | |
| | 9" | (229mm) | 40½" | (1029mm) | |
| | 6" | (152mm) | 39" | (991mm) | |
| 42" (1067mm) | 36" | (914mm) | 54" | (1372mm) | |
| | 30" | (762mm) | 51" | (1295mm) | |
| | 24" | (610mm) | 48" | (1219mm) | |
| | 18" | (457mm) | 45" | (1143mm) | |
| | 12" | (305mm) | 42" | (1067mm) | |
| | 9" | (229mm) | 40½" | (1029mm) | |
| | 6" | (152mm) | 39" | (991mm) | |
| | 36" (914mm) | 30" | (762mm) | 51" | (1295mm) |
| 24" | | (610mm) | 48" | (1219mm) | |
| 18" | | (457mm) | 45" | (1143mm) | |
| 12" | | (305mm) | 42" | (1067mm) | |
| 9" | | (229mm) | 40½" | (1029mm) | |
| 6" | | (152mm) | 39" | (991mm) | |
| 30" (762mm) | | 24" | (610mm) | 48" | (1219mm) |
| | | 18" | (457mm) | 45" | (1143mm) |
| | 12" | (305mm) | 42" | (1067mm) | |
| | 9" | (229mm) | 40½" | (1029mm) | |
| | 6" | (152mm) | 39" | (991mm) | |
| 24" (610mm) | 18" | (457mm) | 45" | (1143mm) | |
| | 12" | (305mm) | 42" | (1067mm) | |
| | 9" | (229mm) | 40½" | (1029mm) | |
| | 6" | (152mm) | 39" | (991mm) | |
| 18" (457mm) | 12" | (305mm) | 42" | (1067mm) | |
| | 9" | (229mm) | 40½" | (1029mm) | |
| | 6" | (152mm) | 39" | (991mm) | |
| 12" (305mm) | 9" | (229mm) | 40½" | (1029mm) | |
| | 6" | (152mm) | 39" | (991mm) | |
| 9" (229mm) | 6" | (152mm) | 39" | (991mm) | |

LADDER CABLE TRAY SYSTEM

HORIZONTAL TAPPED CROSS [TC]

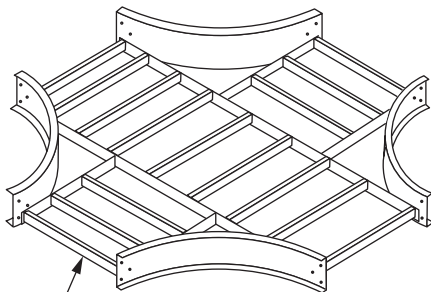

7/8" SQUARE RUNG

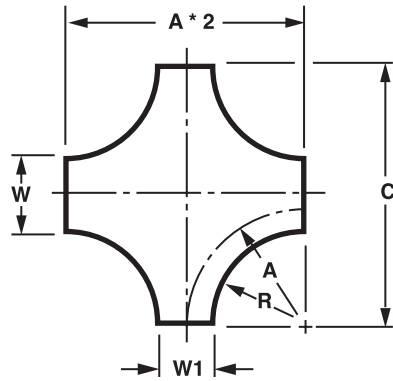

CSA CERTIFIED FOR CSA SYSTEMS

| R Radius | W Width | W1 Width | "A" Dimension | "C" Dimension | | | |
|-----------------|----------------|-------------|------------------|------------------|-----------------|---------|-----------------|
| 48" (1219mm) | 42" | (1067mm) | 33" | (838mm) | 72" (1829mm) | | |
| | 36" | (914mm) | 30" | (762mm) | | | |
| | 30" | (762mm) | 27" | (686mm) | | | |
| | 24" | (610mm) | 24" | (610mm) | | | |
| | 18" | (457mm) | 21" | (533mm) | | | |
| | 12" | (305mm) | 18" | (457mm) | | | |
| | 9" | (229mm) | 16 1/2" | (419mm) | | | |
| 42" (1067mm) | 36" | (914mm) | 30" | (762mm) | 66" (1676mm) | | |
| | 30" | (762mm) | 27" | (686mm) | | | |
| | 24" | (610mm) | 24" | (610mm) | | | |
| | 18" | (457mm) | 21" | (533mm) | | | |
| | 12" | (305mm) | 18" | (457mm) | | | |
| | 9" | (229mm) | 16 1/2" | (419mm) | | | |
| | 6" | (152mm) | 15" | (381mm) | | | |
| 12" (305mm) | 36" | (914mm) | 30" | (762mm) | 60" (1524mm) | | |
| | 30" | (762mm) | 27" | (686mm) | | | |
| | 24" | (610mm) | 24" | (610mm) | | | |
| | 18" | (457mm) | 21" | (533mm) | | | |
| | 12" | (305mm) | 18" | (457mm) | | | |
| | 9" | (229mm) | 16 1/2" | (419mm) | | | |
| | 6" | (152mm) | 15" | (381mm) | | | |
| 30" (762mm) | 24" | (610mm) | 24" | (610mm) | 54" (1372mm) | | |
| | 18" | (457mm) | 21" | (533mm) | | | |
| | 12" | (305mm) | 18" | (457mm) | | | |
| | 9" | (229mm) | 16 1/2" | (419mm) | | | |
| | 6" | (152mm) | 15" | (381mm) | | | |
| | 24" (610mm) | 18" | (457mm) | 21" | | (533mm) | 48" (1219mm) |
| | | 12" | (305mm) | 18" | | (457mm) | |
| 9" | | (229mm) | 16 1/2" | (419mm) | | | |
| 6" | | (152mm) | 15" | (381mm) | | | |
| 18" (457mm) | 12" | (305mm) | 18" | (457mm) | 42" (1067mm) | | |
| | 9" | (229mm) | 16 1/2" | (419mm) | | | |
| | 6" | (152mm) | 15" | (381mm) | | | |
| 12" (305mm) | 9" | (229mm) | 16 1/2" | (419mm) | 36" (914mm) | | |
| | 6" | (152mm) | 15" | (381mm) | | | |
| 9" (229mm) | 6" | (152mm) | 15" | (381mm) | 33" (838mm) | | |

Example: 238-36TC-18-12

NOTE: Nominal 9" rung spacing maintained through centerline of all fittings.
Expanding taps available upon request

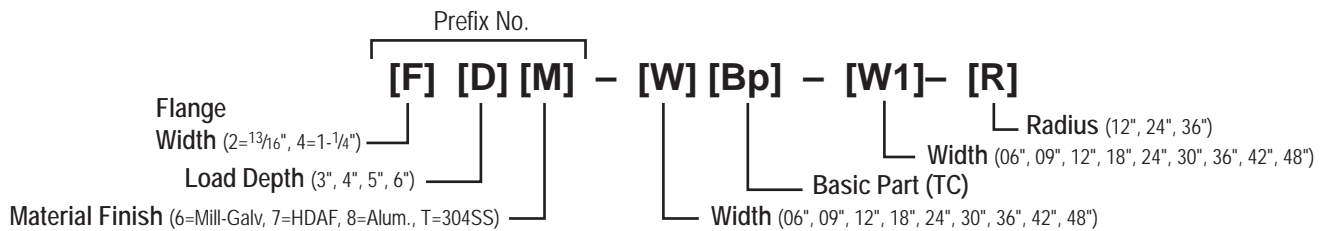

See Page 50
for Electrical
Grounding Chart

HORIZONTAL TAPPED CROSS [TC] continued

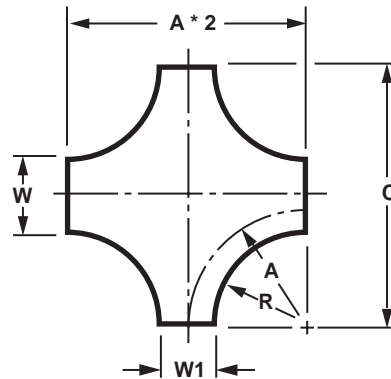

See Page 50
for Electrical
Grounding Chart

CSA CERTIFIED FOR CSA SYSTEMS

| R Radius | W Width | W1 Width | "A" Dimension | "C" Dimension |
|----------------|-----------------|--------------|------------------|------------------|
| 24" (610mm) | 48" (1219mm) | 42" (1067mm) | 45" (1143mm) | 96" (2438mm) |
| | | 36" (914mm) | 42" (1067mm) | |
| | | 30" (762mm) | 39" (991mm) | |
| | | 24" (610mm) | 36" (914mm) | |
| | | 18" (457mm) | 33" (838mm) | |
| | | 12" (305mm) | 30" (762mm) | |
| | | 9" (229mm) | 28½" (724mm) | |
| | 6" (152mm) | 27" (686mm) | | |
| | 42" (1067mm) | 36" (914mm) | 42" (1067mm) | 90" (2286mm) |
| | | 30" (762mm) | 39" (991mm) | |
| 24" (610mm) | | 36" (914mm) | | |
| 18" (457mm) | | 33" (838mm) | | |
| 12" (305mm) | | 30" (762mm) | | |
| 9" (229mm) | | 28½" (724mm) | | |
| 6" (152mm) | | 27" (686mm) | | |
| 36" (914mm) | 30" (762mm) | 39" (991mm) | 84" (2134mm) | |
| | 24" (610mm) | 36" (914mm) | | |
| | 18" (457mm) | 33" (838mm) | | |
| | 12" (305mm) | 30" (762mm) | | |
| | 9" (229mm) | 28½" (724mm) | | |
| | 6" (152mm) | 27" (686mm) | | |
| | 30" (762mm) | 24" (610mm) | | 36" (914mm) |
| 18" (457mm) | | 33" (838mm) | | |
| 12" (305mm) | | 30" (762mm) | | |
| 9" (229mm) | | 28½" (724mm) | | |
| 6" (152mm) | | 27" (686mm) | | |
| 24" (610mm) | 18" (457mm) | 33" (838mm) | 72" (1829mm) | |
| | 12" (305mm) | 30" (762mm) | | |
| | 9" (229mm) | 28½" (724mm) | | |
| | 6" (152mm) | 27" (686mm) | | |
| 18" (457mm) | 12" (305mm) | 30" (762mm) | 66" (1676mm) | |
| | 9" (229mm) | 28½" (724mm) | | |
| | 6" (152mm) | 27" (686mm) | | |
| 12" (305mm) | 9" (229mm) | 28½" (724mm) | 60" (1524mm) | |
| | 6" (152mm) | 27" (686mm) | | |
| 9" (229mm) | 6" (152mm) | 27" (686mm) | 57" (1448mm) | |

CSA CERTIFIED FOR CSA SYSTEMS

| R Radius | W Width | W1 Width | "A" Dimension | "C" Dimension |
|-----------------|-----------------|---------------|------------------|------------------|
| 48" (1219mm) | 48" (1219mm) | 42" (1067mm) | 57" (1448mm) | 120" (3048mm) |
| | | 36" (914mm) | 54" (1372mm) | |
| | | 30" (762mm) | 51" (1295mm) | |
| | | 24" (610mm) | 48" (1219mm) | |
| | | 18" (457mm) | 45" (1143mm) | |
| | | 12" (305mm) | 42" (1067mm) | |
| | | 9" (229mm) | 40½" (1029mm) | |
| | 6" (152mm) | 39" (991mm) | | |
| | 42" (1067mm) | 36" (914mm) | 54" (1372mm) | 114" (2896mm) |
| | | 30" (762mm) | 51" (1295mm) | |
| 24" (610mm) | | 48" (1219mm) | | |
| 18" (457mm) | | 45" (1143mm) | | |
| 12" (305mm) | | 42" (1067mm) | | |
| 9" (229mm) | | 40½" (1029mm) | | |
| 6" (152mm) | | 39" (991mm) | | |
| 36" (914mm) | 30" (762mm) | 51" (1295mm) | 108" (2743mm) | |
| | 24" (610mm) | 48" (1219mm) | | |
| | 18" (457mm) | 45" (1143mm) | | |
| | 12" (305mm) | 42" (1067mm) | | |
| | 9" (229mm) | 40½" (1029mm) | | |
| | 6" (152mm) | 39" (991mm) | | |
| | 30" (762mm) | 24" (610mm) | | 48" (1219mm) |
| 18" (457mm) | | 45" (1143mm) | | |
| 12" (305mm) | | 42" (1067mm) | | |
| 9" (229mm) | | 40½" (1029mm) | | |
| 6" (152mm) | | 39" (991mm) | | |
| 24" (610mm) | 18" (457mm) | 45" (1143mm) | 96" (2438mm) | |
| | 12" (305mm) | 42" (1067mm) | | |
| | 9" (229mm) | 40½" (1029mm) | | |
| | 6" (152mm) | 39" (991mm) | | |
| 18" (457mm) | 12" (305mm) | 42" (1067mm) | 90" (2286mm) | |
| | 9" (229mm) | 40½" (1029mm) | | |
| | 6" (152mm) | 39" (991mm) | | |
| 12" (305mm) | 9" (229mm) | 40½" (1029mm) | 84" (2134mm) | |
| | 6" (152mm) | 39" (991mm) | | |
| 9" (229mm) | 6" (152mm) | 39" (991mm) | 81" (2057mm) | |

LADDER CABLE TRAY SYSTEM

LEFT HAND [LH] & RIGHT HAND [RH] REDUCER

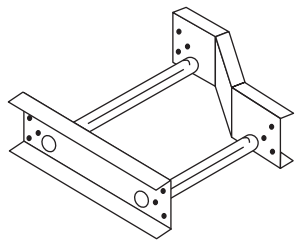

RIGHT HAND (RH)

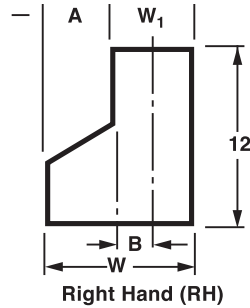

Right Hand (RH)

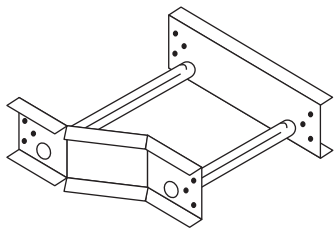

LEFT HAND (LH)

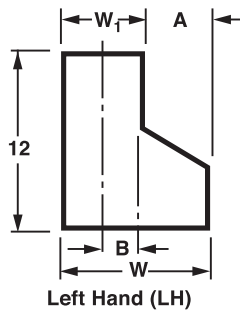

Left Hand (LH)

CSA CERTIFIED FOR CSA SYSTEMS

| Width - W | "W1" Dim. | "A" Dim. | "B" Dim. |
|------------------------|--------------|--------------|----------------|
| 48" (1219mm) | 42" (1067mm) | 6" (152mm) | 21" (533mm) |
| | 36" (914mm) | 12" (305mm) | 18" (457mm) |
| | 30" (762mm) | 18" (457mm) | 15" (381mm) |
| | 24" (610mm) | 24" (610mm) | 12" (305mm) |
| | 18" (457mm) | 30" (762mm) | 9" (229mm) |
| | 12" (305mm) | 36" (914mm) | 6" (152mm) |
| | 9" (229mm) | 39" (991mm) | 4 1/2" (114mm) |
| | 6" (152mm) | 42" (1067mm) | 3" (76mm) |
| 42" (1067mm) | 36" (914mm) | 6" (152mm) | 18" (457mm) |
| | 30" (762mm) | 12" (305mm) | 15" (381mm) |
| | 24" (610mm) | 18" (457mm) | 12" (305mm) |
| | 18" (457mm) | 24" (610mm) | 9" (229mm) |
| | 12" (305mm) | 30" (762mm) | 6" (152mm) |
| | 9" (229mm) | 33" (838mm) | 4 1/2" (114mm) |
| 36" (914mm) | 30" (762mm) | 6" (152mm) | 15" (381mm) |
| | 24" (610mm) | 12" (305mm) | 12" (305mm) |
| | 18" (457mm) | 18" (457mm) | 9" (229mm) |
| | 12" (305mm) | 24" (610mm) | 6" (152mm) |
| | 9" (229mm) | 27" (686mm) | 4 1/2" (114mm) |
| | 6" (152mm) | 30" (762mm) | 3" (76mm) |
| 30" (762mm) | 24" (610mm) | 6" (152mm) | 12" (305mm) |
| | 18" (457mm) | 12" (305mm) | 9" (229mm) |
| | 12" (305mm) | 18" (457mm) | 6" (152mm) |
| | 9" (229mm) | 21" (533mm) | 4 1/2" (114mm) |
| | 6" (152mm) | 24" (610mm) | 3" (76mm) |
| 24" (610mm) | 18" (457mm) | 6" (152mm) | 9" (229mm) |
| | 12" (305mm) | 12" (305mm) | 6" (152mm) |
| | 9" (229mm) | 15" (381mm) | 4 1/2" (114mm) |
| | 6" (152mm) | 18" (457mm) | 3" (76mm) |
| 18" (457mm) | 12" (305mm) | 6" (152mm) | 6" (152mm) |
| | 9" (229mm) | 9" (229mm) | 4 1/2" (114mm) |
| | 6" (152mm) | 12" (305mm) | 3" (76mm) |
| 12" (305mm) | 9" (229mm) | 3" (76mm) | 4 1/2" (114mm) |
| | 6" (152mm) | 6" (152mm) | 3" (76mm) |
| 9" (229mm) | 6" (152mm) | 3" (76mm) | 3" (76mm) |

Example: 238-12LH-06

NOTE: Nominal 9" rung spacing maintained through centerline of all fittings.
Expanding taps available upon request

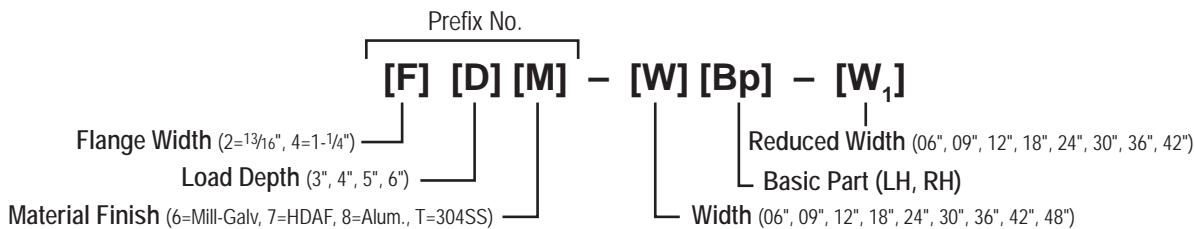

See Page 50
for Electrical
Grounding Chart

STRAIGHT REDUCER [ST]

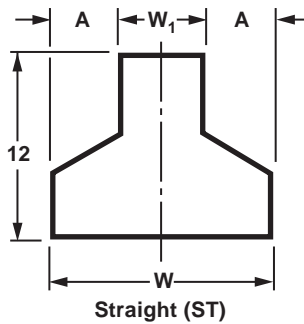
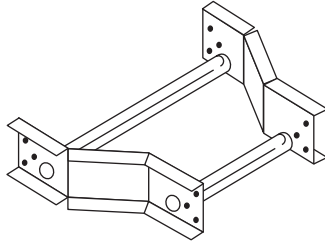

CSA CERTIFIED FOR CSA SYSTEMS

| Width - W | Width - W1 | "A" Dimension | |
|------------------------|--------------|---------------|---------|
| 48" (1219mm) | 42" (1067mm) | 3" | (76mm) |
| | 36" (914mm) | 6" | (152mm) |
| | 30" (762mm) | 9" | (229mm) |
| | 24" (610mm) | 12" | (305mm) |
| | 18" (457mm) | 15" | (381mm) |
| | 12" (305mm) | 18" | (457mm) |
| | 9" (229mm) | 19½" | (495mm) |
| | 6" (152mm) | 21" | (533mm) |
| 42" (1067mm) | 36" (914mm) | 3" | (76mm) |
| | 30" (762mm) | 6" | (152mm) |
| | 24" (610mm) | 9" | (229mm) |
| | 18" (457mm) | 12" | (305mm) |
| | 12" (305mm) | 15" | (381mm) |
| | 9" (229mm) | 16½" | (419mm) |
| 36" (914mm) | 30" (762mm) | 3" | (76mm) |
| | 24" (610mm) | 6" | (152mm) |
| | 18" (457mm) | 9" | (229mm) |
| | 12" (305mm) | 12" | (305mm) |
| | 9" (229mm) | 13½" | (343mm) |
| | 6" (152mm) | 15" | (381mm) |
| 30" (762mm) | 24" (610mm) | 3" | (76mm) |
| | 18" (457mm) | 6" | (152mm) |
| | 12" (305mm) | 9" | (229mm) |
| | 9" (229mm) | 10½" | (267mm) |
| | 6" (152mm) | 12" | (304mm) |
| 24" (610mm) | 18" (457mm) | 3" | (76mm) |
| | 12" (305mm) | 6" | (152mm) |
| | 9" (229mm) | 7½" | (191mm) |
| | 6" (152mm) | 9" | (229mm) |
| 18" (457mm) | 12" (305mm) | 3" | (76mm) |
| | 9" (229mm) | 4½" | (114mm) |
| | 6" (152mm) | 6" | (152mm) |
| 12" (305mm) | 9" (229mm) | 1½" | (38mm) |
| | 6" (152mm) | 3" | (76mm) |
| 9" (229mm) | 6" (152mm) | 1½" | (38mm) |

Example: 238-12ST-06

NOTE: Nominal 9" rung spacing maintained through centerline of all fittings.

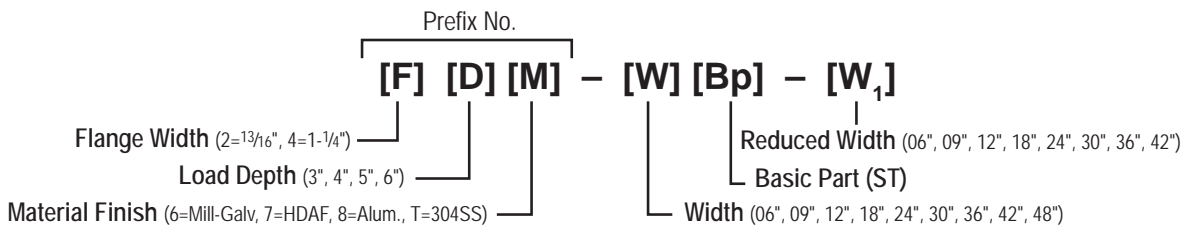

See Page 50
for Electrical
Grounding Chart

LADDER CABLE TRAY SYSTEM

45° "Y" BRANCH LEFT HAND [LY] & RIGHT HAND [RY]

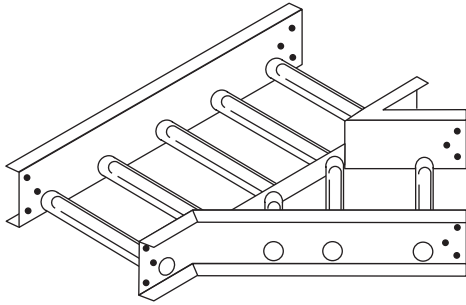

| Width - W | "A" Dim. | "B" Dim. | "C" Dim. | "D" Dim. |
|--------------|---|---|---|---|
| 6" (152mm) | 22 ¹ / ₂ " (571mm) | 16 ¹ / ₄ " (413mm) | 9 ¹ / ₄ " (235mm) | 11 ¹ / ₈ " (283mm) |
| 9" (229mm) | 26 ³ / ₄ " (679mm) | 21 ³ / ₈ " (543mm) | 9 ¹³ / ₁₆ " (249mm) | 13 ³ / ₄ " (349mm) |
| 12" (305mm) | 31" (787mm) | 26 ¹ / ₂ " (673mm) | 10 ¹ / ₂ " (267mm) | 16 ¹ / ₄ " (412mm) |
| 18" (457mm) | 39 ¹ / ₂ " (1003mm) | 36 ³ / ₄ " (933mm) | 11 ³ / ₄ " (298mm) | 21 ³ / ₈ " (543mm) |
| 24" (610mm) | 48" (1219mm) | 47" (1193mm) | 13" (330mm) | 26 ¹ / ₂ " (673mm) |
| 30" (762mm) | 56 ³ / ₈ " (1432mm) | 57 ¹ / ₄ " (1454mm) | 14 ¹ / ₈ " (359mm) | 31 ⁵ / ₈ " (803mm) |
| 36" (914mm) | 65" (1651mm) | 67 ¹ / ₂ " (1714mm) | 15 ¹ / ₂ " (394mm) | 36 ³ / ₄ " (933mm) |
| 42" (1067mm) | 73 ³ / ₈ " (1864mm) | 77 ⁵ / ₈ " (1972mm) | 16 ³ / ₄ " (425mm) | 41 ³ / ₄ " (1060mm) |
| 48" (1219mm) | 81 ⁷ / ₈ " (2080mm) | 87 ⁷ / ₈ " (2232mm) | 18" (457mm) | 46 ⁷ / ₈ " (1191mm) |

Example: 238-12LY

RIGHT HAND (RY) SHOWN

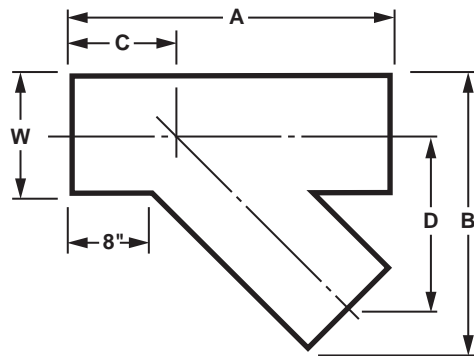

ADJUSTABLE ELBOW [AF]

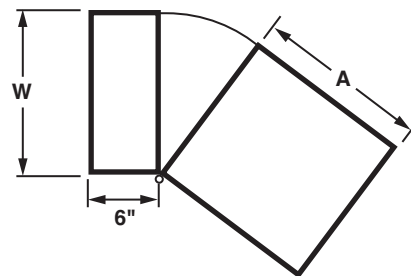
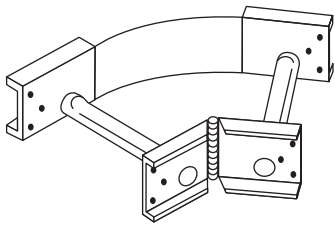

| Width - W | "A" Dimension |
|--------------|---------------|
| 6" (152mm) | 8" (203mm) |
| 9" (229mm) | 11" (279mm) |
| 12" (305mm) | 14" (356mm) |
| 18" (457mm) | 20" (508mm) |
| 24" (610mm) | 26" (660mm) |
| 30" (762mm) | 32" (813mm) |
| 36" (914mm) | 38" (965mm) |
| 42" (1067mm) | 44" (1118mm) |
| 48" (1219mm) | 50" (1270mm) |

Example: 238-12AF

NOTE: Nominal 9" rung spacing maintained through centerline of all fittings.

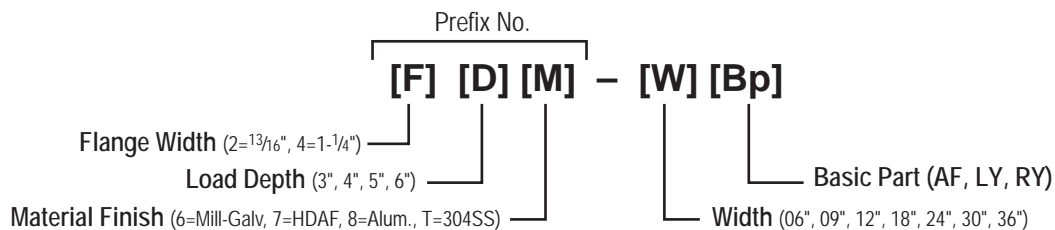

90° VERTICAL ELBOW OUTSIDE [90] & INSIDE [9I]

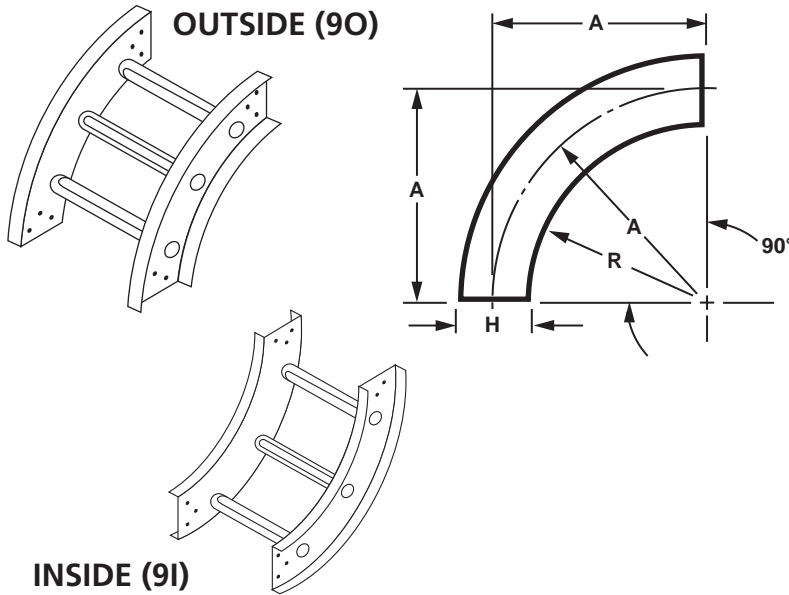

CSA Certified for CSA Systems

| Radius - R | "H" Dim. | "A" Dim. |
|----------------|----------------|------------------|
| 12" (305mm) | 4 1/4" (108mm) | 14 1/8" (359mm) |
| | 5 1/4" (133mm) | 14 5/8" (372mm) |
| | 6 1/4" (159mm) | 15 1/8" (384mm) |
| 24" (610mm) | 4 1/4" (108mm) | 26 1/8" (664mm) |
| | 5 1/4" (133mm) | 26 5/8" (676mm) |
| | 6 1/4" (159mm) | 27 1/8" (689mm) |
| 36" (914mm) | 4 1/4" (108mm) | 38 1/8" (969mm) |
| | 5 1/4" (133mm) | 38 5/8" (981mm) |
| | 6 1/4" (159mm) | 39 1/8" (994mm) |
| | 7 1/4" (184mm) | 39 5/8" (1007mm) |

Example: 238-1290-12

NOTE: Indicates items included in our Quick Ship Program. Consult factory for lead times on other systems.

60° VERTICAL ELBOW OUTSIDE [60] & INSIDE [6I]

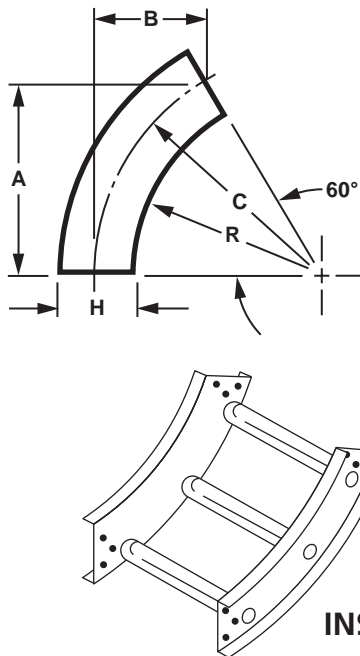

CSA Certified for CSA Systems

| Radius - R | "H" Dim. | "A" Dim. | "B" Dim. | "C" Dim. |
|----------------|----------------|-----------------|-----------------|------------------|
| 12" (305mm) | 4 1/4" (108mm) | 12 1/4" (311mm) | 7 1/8" (181mm) | 14 1/8" (359mm) |
| | 5 1/4" (133mm) | 12 5/8" (321mm) | 7 3/8" (187mm) | 14 5/8" (372mm) |
| | 6 1/4" (159mm) | 13 1/8" (334mm) | 7 5/8" (194mm) | 15 1/8" (384mm) |
| | 7 1/4" (184mm) | 13 1/2" (343mm) | 7 7/8" (200mm) | 15 5/8" (397mm) |
| 24" (610mm) | 4 1/4" (108mm) | 22 5/8" (575mm) | 13 1/8" (334mm) | 26 1/8" (664mm) |
| | 5 1/4" (133mm) | 23 1/8" (588mm) | 13 3/8" (340mm) | 26 5/8" (676mm) |
| | 6 1/4" (159mm) | 23 1/2" (597mm) | 13" (330mm) | 27 1/8" (689mm) |
| | 7 1/4" (184mm) | 24" (610mm) | 17 5/8" (353mm) | 27 5/8" (702mm) |
| 36" (914mm) | 4 1/4" (108mm) | 33" (838mm) | 19 1/8" (486mm) | 38 1/8" (969mm) |
| | 5 1/4" (133mm) | 33 1/2" (851mm) | 19 3/8" (492mm) | 38 5/8" (981mm) |
| | 6 1/4" (159mm) | 33 7/8" (861mm) | 19 5/8" (499mm) | 39 1/8" (994mm) |
| | 7 1/4" (184mm) | 34 3/8" (873mm) | 19 7/8" (505mm) | 39 5/8" (1007mm) |

Example: 238-1260-12

NOTE: Use Adjustable Connectors for odd angles. Nominal 9" rung spacing maintained through centerline of all fittings.

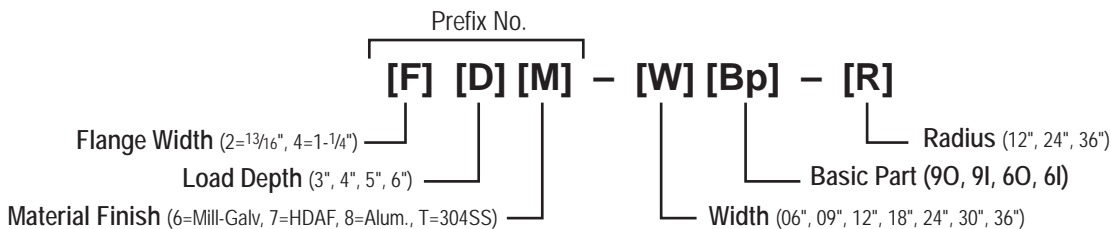

See Page 50 for Electrical Grounding Chart

LADDER CABLE TRAY SYSTEM

45° VERTICAL ELBOW OUTSIDE [40] & INSIDE [41]

OUTSIDE (40)

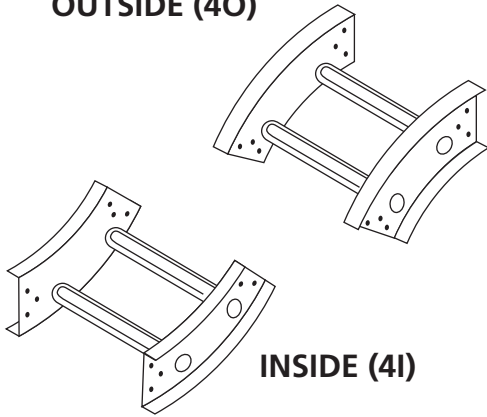

INSIDE (41)

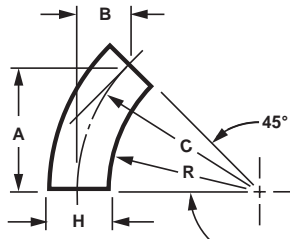

CSA CERTIFIED FOR CSA SYSTEMS

| Radius - R | "H" Dim. | "A" Dim. | "B" Dim. | "C" Dim. |
|-----------------------|---|--|--|---|
| 12" (305mm) | 4 ¹ / ₄ " (108mm) | 10" (254mm) | 4 ¹ / ₈ " (105mm) | 14 ¹ / ₈ " (359mm) |
| | 5 ¹ / ₄ " (133mm) | 10 ³ / ₈ " (264mm) | 4 ¹ / ₄ " (108mm) | 14 ⁵ / ₈ " (372mm) |
| | 6 ¹ / ₄ " (159mm) | 10 ³ / ₄ " (273mm) | 4 ¹ / ₂ " (114mm) | 15 ¹ / ₈ " (384mm) |
| | 7 ¹ / ₄ " (184mm) | 11 ¹ / ₈ " (283mm) | 4 ⁵ / ₈ " (118mm) | 15 ¹ / ₈ " (397mm) |
| 24" (610mm) | 4 ¹ / ₄ " (108mm) | 18 ¹ / ₂ " (470mm) | 7 ⁵ / ₈ " (194mm) | 26 ¹ / ₈ " (664mm) |
| | 5 ¹ / ₄ " (133mm) | 18 ⁷ / ₈ " (480mm) | 7 ⁷ / ₈ " (200mm) | 26 ⁵ / ₈ " (676mm) |
| | 6 ¹ / ₄ " (159mm) | 19 ¹ / ₄ " (489mm) | 8" (203mm) | 27 ¹ / ₈ " (689mm) |
| | 7 ¹ / ₄ " (184mm) | 19 ¹ / ₂ " (495mm) | 8 ⁷ / ₈ " (207mm) | 27 ⁵ / ₈ " (702mm) |
| 36" (914mm) | 4 ¹ / ₄ " (108mm) | 27" (686mm) | 11 ¹ / ₈ " (283mm) | 38 ¹ / ₈ " (969mm) |
| | 5 ¹ / ₄ " (133mm) | 27 ³ / ₈ " (695mm) | 11 ³ / ₈ " (289mm) | 38 ⁵ / ₈ " (981mm) |
| | 6 ¹ / ₄ " (159mm) | 27 ⁵ / ₈ " (702mm) | 11 ¹ / ₂ " (292mm) | 39 ¹ / ₈ " (994mm) |
| | 7 ¹ / ₄ " (184mm) | 8" (711mm) | 11 ⁵ / ₈ " (295mm) | 39 ⁵ / ₈ " (1007mm) |

Example: 238-1240-12

NOTE: Use Adjustable Connectors for odd angles. Nominal 9" rung spacing maintained through centerline of all fittings.

30° VERTICAL ELBOW OUTSIDE [30] & INSIDE [31]

OUTSIDE (30)

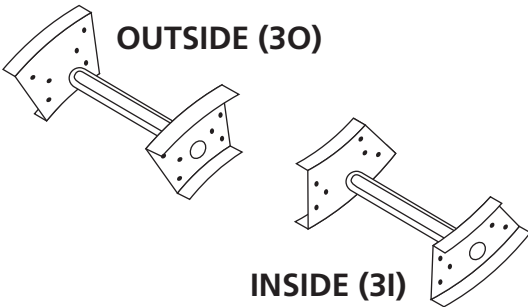

INSIDE (31)

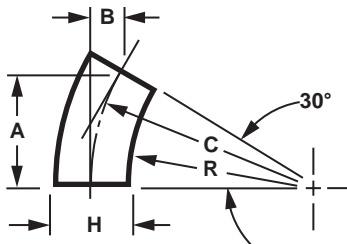

CSA CERTIFIED FOR CSA SYSTEMS

| Radius - R | "H" Dim. | "A" Dim. | "B" Dim. | "C" Dim. |
|-----------------------|---|--|---|---|
| 12" (305mm) | 4 ¹ / ₄ " (108mm) | 7 ¹ / ₈ " (181mm) | 1 ⁷ / ₈ " (48mm) | 14 ¹ / ₈ " (359mm) |
| | 5 ¹ / ₄ " (133mm) | 7 ³ / ₈ " (187mm) | 2" (51mm) | 14 ⁵ / ₈ " (372mm) |
| | 6 ¹ / ₄ " (159mm) | 7 ⁵ / ₈ " (194mm) | 2" (51mm) | 15 ¹ / ₈ " (384mm) |
| | 7 ¹ / ₄ " (184mm) | 7 ⁷ / ₈ " (200mm) | 2 ¹ / ₈ " (54mm) | 15 ⁵ / ₈ " (397mm) |
| 24" (610mm) | 4 ¹ / ₄ " (108mm) | 13 ¹ / ₈ " (334mm) | 3 ¹ / ₂ " (89mm) | 26 ¹ / ₈ " (664mm) |
| | 5 ¹ / ₄ " (133mm) | 13 ³ / ₈ " (340mm) | 3 ⁵ / ₈ " (92mm) | 26 ⁵ / ₈ " (676mm) |
| | 6 ¹ / ₄ " (159mm) | 13 ⁵ / ₈ " (346mm) | 3 ⁵ / ₈ " (92mm) | 27 ¹ / ₈ " (689mm) |
| | 7 ¹ / ₄ " (184mm) | 13 ⁷ / ₈ " (353mm) | 3 ³ / ₄ " (95mm) | 27 ⁵ / ₈ " (702mm) |
| 36" (914mm) | 4 ¹ / ₄ " (108mm) | 19 ¹ / ₈ " (486mm) | 5 ¹ / ₈ " (130mm) | 38 ¹ / ₈ " (969mm) |
| | 5 ¹ / ₄ " (133mm) | 19 ³ / ₈ " (492mm) | 5 ¹ / ₄ " (133mm) | 38 ⁵ / ₈ " (981mm) |
| | 6 ¹ / ₄ " (159mm) | 19 ⁵ / ₈ " (499mm) | 5 ¹ / ₄ " (133mm) | 39 ¹ / ₈ " (994mm) |
| | 7 ¹ / ₄ " (184mm) | 19 ⁷ / ₈ " (505mm) | 5 ³ / ₈ " (137mm) | 39 ⁵ / ₈ " (1007mm) |

Example: 238-1230-12

NOTE: Use Adjustable Connectors for odd angles. Nominal 9" rung spacing maintained through centerline of all fittings.

Prefix No.

[F] [D] [M] - [W] [Bp] - [R]

Flange Width (2=1³/₁₆", 4=1-¹/₄")

Load Depth (3", 4", 5", 6")

Material Finish (6=Mill-Galv, 7=HDAF, 8=Alum., T=304SS)

Radius (12", 24", 36")

Basic Part (40, 41, 30, 31)

Width (06", 09", 12", 18", 24", 30", 36")

See Page 50
for Electrical
Grounding Chart

90° VERTICAL CABLE SUPPORT ELBOW [SR]

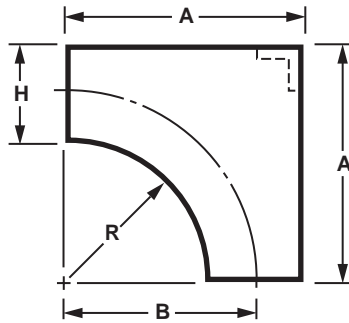
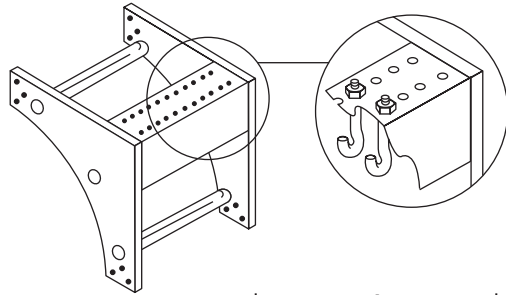

CSA CERTIFIED FOR CSA SYSTEMS

| Radius - R | "H" Dim. | "A" Dim. | "B" Dim. |
|-----------------------|----------------|------------------|------------------|
| 12" (305mm) | 4 1/4" (108mm) | 16 1/4" (413mm) | 14 1/8" (359mm) |
| | 5 1/4" (133mm) | 17 1/4" (438mm) | 14 5/8" (371mm) |
| | 6 1/4" (159mm) | 18 1/4" (464mm) | 15 1/8" (384mm) |
| | 7 1/4" (814mm) | 19 1/4" (489mm) | 15 5/8" (397mm) |
| 24" (610mm) | 4 1/4" (108mm) | 28 1/4" (718mm) | 26 1/8" (664mm) |
| | 5 1/4" (133mm) | 29 1/4" (743mm) | 26 5/8" (676mm) |
| | 6 1/4" (159mm) | 30 1/4" (768mm) | 27 1/8" (689mm) |
| | 7 1/4" (814mm) | 31 1/4" (794mm) | 27 5/8" (702mm) |
| 36" (914mm) | 4 1/4" (108mm) | 40 1/4" (1022mm) | 38 1/8" (968mm) |
| | 5 1/4" (133mm) | 41 1/4" (1048mm) | 38 5/8" (981mm) |
| | 6 1/4" (159mm) | 42 1/4" (1073mm) | 39 1/8" (994mm) |
| | 7 1/4" (814mm) | 43 1/4" (1099mm) | 39 5/8" (1006mm) |

Example: 238-12SR-12

NOTE: Use Adjustable Connectors for odd angles. Nominal 9" rung spacing maintained through centerline of all fittings.

VERTICAL TEE - DOWN [VT] & UP [OT]

VERTICAL TEE - DOWN (VT)

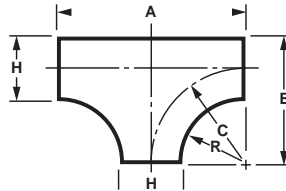
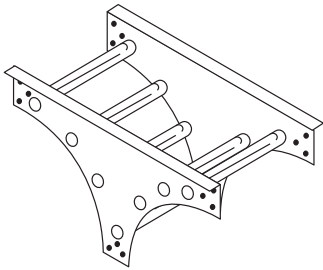

CSA CERTIFIED FOR CSA SYSTEMS

| Radius - R | "H" Dimension | "A" Dimension | "B" Dimension |
|-----------------------|----------------|------------------|------------------|
| 12" (305mm) | 4 1/4" (108mm) | 16 1/4" (413mm) | 14 1/8" (359mm) |
| | 5 1/4" (133mm) | 17 1/4" (438mm) | 14 5/8" (371mm) |
| | 6 1/4" (159mm) | 18 1/4" (464mm) | 15 1/8" (384mm) |
| | 7 1/4" (814mm) | 19 1/4" (489mm) | 15 5/8" (397mm) |
| 24" (610mm) | 4 1/4" (108mm) | 28 1/4" (718mm) | 26 1/8" (664mm) |
| | 5 1/4" (133mm) | 29 1/4" (743mm) | 26 5/8" (676mm) |
| | 6 1/4" (159mm) | 30 1/4" (768mm) | 27 1/8" (689mm) |
| | 7 1/4" (814mm) | 31 1/4" (794mm) | 27 5/8" (702mm) |
| 36" (914mm) | 4 1/4" (108mm) | 40 1/4" (1022mm) | 38 1/8" (968mm) |
| | 5 1/4" (133mm) | 41 1/4" (1048mm) | 38 5/8" (981mm) |
| | 6 1/4" (159mm) | 42 1/4" (1073mm) | 39 1/8" (994mm) |
| | 7 1/4" (814mm) | 43 1/4" (1099mm) | 39 5/8" (1006mm) |

Example: 238-12VT-12

NOTE: Use Adjustable Connectors for odd angles. Nominal 9" rung spacing maintained through centerline of all fittings.

VERTICAL TEE - UP (OT)

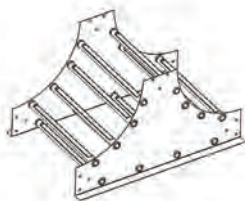

Prefix No.
[F] [D] [M] - [W] [Bp] - [R]

Flange Width (2=13/16", 4=1-1/4")

Load Depth (3", 4", 5", 6")

Material Finish (6=Mill-Galv, 7=HDAF, 8=Alum., T=304SS)

Radius (12", 24", 36")

Basic Part (SR, VT, OT)

Width (06", 09", 12", 18", 24", 30", 36")

See Page 50
for Electrical
Grounding Chart

LADDER CABLE TRAY SYSTEM

CONNECTOR PLATES

TRAY CONNECTORS

| Load Depth | Finish (LADDER) | Basic No. |
|------------|-----------------|----------------|
| 3" | 6 (Mill Galv.) | -02RC |
| 4" | 7 (HDGAF) | -02CE |
| 5" | 8 (Alum.) | -02CV |
| 6" | T (304SS) | -02CH -02CA |

Example: 38-02RC for 3" load depth, aluminum, universal curvilinear connector.

NOTE: Hole patterns match corresponding tray. Three-hole pattern illustrated.

UNIVERSAL CURVILINEAR CONNECTOR [RC]

NOTE: Sold in pairs

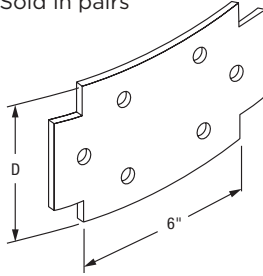

11 Gage Steel, 0.125" Aluminum
3/8"-16 spline bolts & flange nuts furnished.

EXPANSION CONNECTOR [CE]

NOTE: Sold in pairs

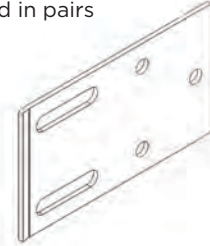

11 Gage Steel, 0.125" Aluminum
3/8"-16 cap screws & Nylok nuts furnished and
3/8"-16 spline bolts & flange nuts furnished.

NOTE: Bonding Jumpers are required and are sold separately.

HORIZONTAL ADJUSTABLE CONNECTOR [CH]

NOTE: Sold in pairs – inner & outer

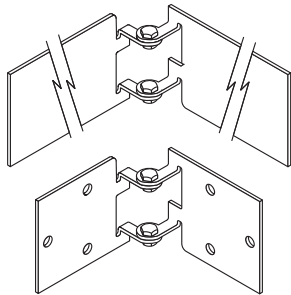

11 Gage Steel, 0.125" Aluminum
3/8"-16 spline bolts & flange nuts furnished.

NOTE: Bonding Jumpers are required and are sold separately.

VERTICAL ADJUSTABLE CONNECTOR [CV]

NOTE: Sold in pairs

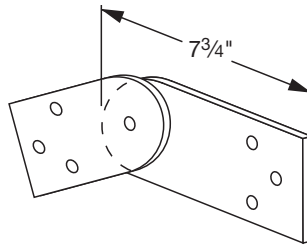

11 Gage Steel, 0.125" Aluminum
3/8"-16 spline bolts & flange nuts furnished.

NOTE: Bonding Jumpers are required and are sold separately.

MID-SPAN SPLICE PLATE [RC]

Catalog Number: 58-02RC-MID

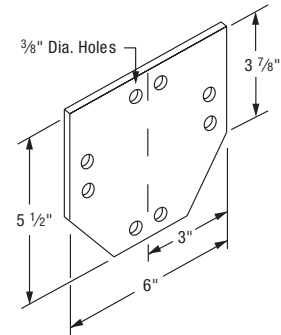

3/8" - Aluminum
For use with 7D58 and 7G58 Systems.

REDUCING CONNECTOR [CO]

NOTE: Not sold in pairs

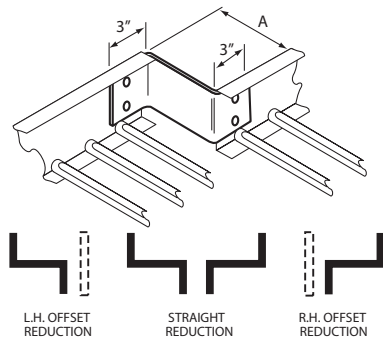

12 Gage Steel, 0.125" Aluminum

For offset reductions – use 1 of above with standard connector plate.

For straight reductions– use 2 (of 1/2 reduction dim.). 3/8"-16 spline bolts and flange nuts furnished.

Example: 38-03CO for 3" load depth, aluminum, 3" Reducer Connector.

Typical Use: 9" to 6", or use 2 for 12" to 6", etc.

Catalog Number

| Load Depth | Finish (LADDER) | Finish (HAT & TROF) | Basic Number | "A" Dimension |
|------------|-----------------|---------------------|--------------|-----------------|
| 3" | 6 (Mill Galv.) | 2 (Mill Galv.) | -30CO | 30" (762mm) |
| 4" | 7 (HDGAF) | 3 (HDGAF) | -27CO | 27" (686mm) |
| 5" | 8 (Alum.) | 4 (Alum.) | -24CO | 24" (610mm) |
| 6" | T (304SS) | U (304SS) | -21CO | 21" (533mm) |
| | | | -18CO | 18" (457mm) |
| | | | -15CO | 15" (381mm) |
| | | | -13CO | 13 1/2" (343mm) |
| | | | -12CO | 12" (305mm) |
| | | | -10CO | 10 1/2" (267mm) |
| | | | -09CO | 9" (229mm) |
| | | | -07CO | 7 1/2" (191mm) |
| | | | -06CO | 6" (152mm) |
| | | | -04CO | 4 1/2" (114mm) |
| | | | -03CO | 3" (76mm) |
| | | | -01CO | 1 1/2" (38mm) |

90° ANGLE CONNECTOR [CA]

NOTE: Sold in pairs

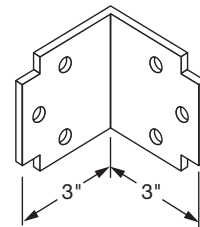

11 Gage Steel, 0.125" Aluminum
3/8"-16 spline bolts & flange nuts furnished.

MID-SPAN EXPANSION PLATE [CE-MID]

Catalog Number: 58-02CE-MID

NOTE: Sold in pairs

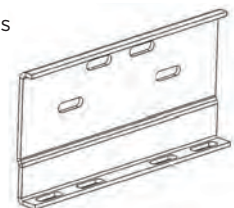

For Use with 5" Load Depth Systems
3/8"-16 spline bolts & flange nuts furnished

MATERIAL/FINISH

Electrogalvanized finish standard. Other finishes available; consult factory.

*Use following suffix when applicable - use only where indicated.

NO SUFFIX Electrogalvanized carbon steel only

-SS 302/304 Stainless Steel

-S1 316 Stainless Steel (check factory for availability)

Example: PS 6024 3/8" x 1 1/2" SS, 3/8" x 1 1/2" hex head bolt, 304 stainless steel

CONNECTOR HARDWARE

(Case-hardened steel electrogalvanized)

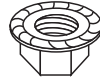
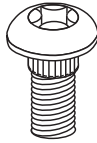

Part No. 5009-1
3/8"-16 hex-flanged nut with serrated washer face.

Part No. 5003-1
3/8"-16 x 1" spline bolt

COVER SCREW [EM]

Part No. EM-CC (electrogalv. steel)
Part No. EM-CC-SS (stainless steel)

No. 10 x 5/8" long, self drilling-self tapping hex head plated steel screw.

Suggested spacing:
Indoor: 8 per 12';
Outdoor: 10 per 12'

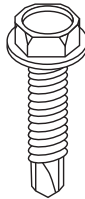

CONTINUOUS THREADED ROD [PS 146]

| Cat. No. | Size (Diameter x Length) |
|----------|-----------------------------|
| PS 146* | 1/4" x 10' |
| PS 146* | 3/8" x 10' |
| PS 146* | 1/2" x 10' |
| PS 146* | 5/8" x 10' |
| PS 146* | 3/4" x 10' |

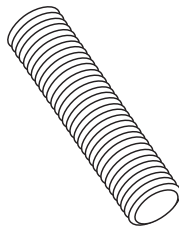

(Hot Dip Galvanized not available)

HEX NUTS [PS 83]

| Cat. No. | Size |
|----------|------|
| PS 83* | 1/4" |
| PS 83* | 3/8" |
| PS 83* | 1/2" |
| PS 83* | 5/8" |
| PS 83* | 3/4" |

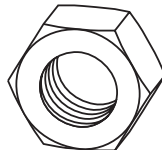

SQUARE NUTS [PS 6108]

| Cat. No. | Size |
|----------|------|
| PS 6108* | 1/4" |
| PS 6108* | 3/8" |
| PS 6108* | 1/2" |
| PS 6108* | 5/8" |
| PS 6108* | 3/4" |

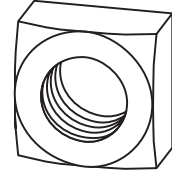

FLAT WASHERS [PS 209]

| Cat. No. | Size |
|----------|------|
| PS 209* | 1/4" |
| PS 209* | 3/8" |
| PS 209* | 1/2" |
| PS 209* | 5/8" |
| PS 209* | 3/4" |

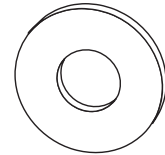

SPLIT-LOCK WASHERS [PS 211]

| Cat. No. | Size |
|----------|------|
| PS 211* | 1/4" |
| PS 211* | 3/8" |
| PS 211* | 1/2" |
| PS 211* | 5/8" |
| PS 211* | 3/4" |

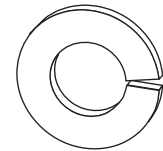

FENDER WASHERS [PS 230]

| Cat. No. | Size (I.D. x O.D.) |
|----------|--------------------|
| PS 230* | 1/4" x 1 1/4" O.D. |
| PS 230* | 3/8" x 1 1/2" O.D. |
| PS 230* | 1/2" x 2" O.D. |

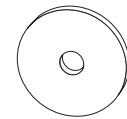

HEX HEAD CAP SCREW / ROUND HEAD, SLOTTED CAP SCREW [PS 6024]

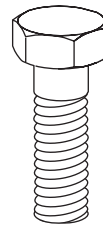

Catalog No. PS 6024

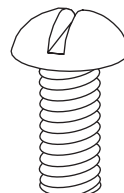

Catalog No. PS 6072

| Hex Head Cap Screw Cat. No. | Round Head Cap Screw Cat. No. | Size (Dia. x Len.) |
|-----------------------------|-------------------------------|--------------------|
| PS 6024* | PS 6072* | 1/4" x 1" |
| PS 6024* | PS 6072* | 1/4" x 1 1/2" |
| PS 6024* | PS 6072* | 3/8" x 1" |
| PS 6024* | PS 6072* | 3/8" x 1 1/2" |
| PS 6024* | PS 6072* | 3/8" x 3" |
| PS 6024* | PS 6072* | 1/2" x 1" |
| PS 6024* | PS 6072* | 1/2" x 1 1/2" |
| PS 6024* | PS 6072* | 1/2" x 2" |
| PS 6024* | PS 6072* | 1/2" x 2 1/2" |
| PS 6024* | PS 6072* | 1/2" x 3" |
| PS 6024* | PS 6072* | 1/2" x 3 1/2" |
| PS 6024* | PS 6072* | 5/8" x 1 1/2" |
| PS 6024* | PS 6072* | 5/8" x 2" |
| PS 6024* | PS 6072* | 5/8" x 3" |
| PS 6024* | PS 6072* | 5/8" x 4" |
| PS 6024* | PS 6072* | 3/4" x 2" |
| PS 6024* | PS 6072* | 3/4" x 3" |
| PS 6024* | PS 6072* | 3/4" x 4" |

LADDER CABLE TRAY SYSTEM

COVERS - LADDER, HAT, AND TROF

COVERS for straight sections shown. Standard fitting covers are flat solid type (NF). Aluminum covers are fabricated from 0.040" aluminum AA-3150-H14; steel covers are fabricated from 20 gage ASTM A-653-G90 CQ, mill-galvanized steel.

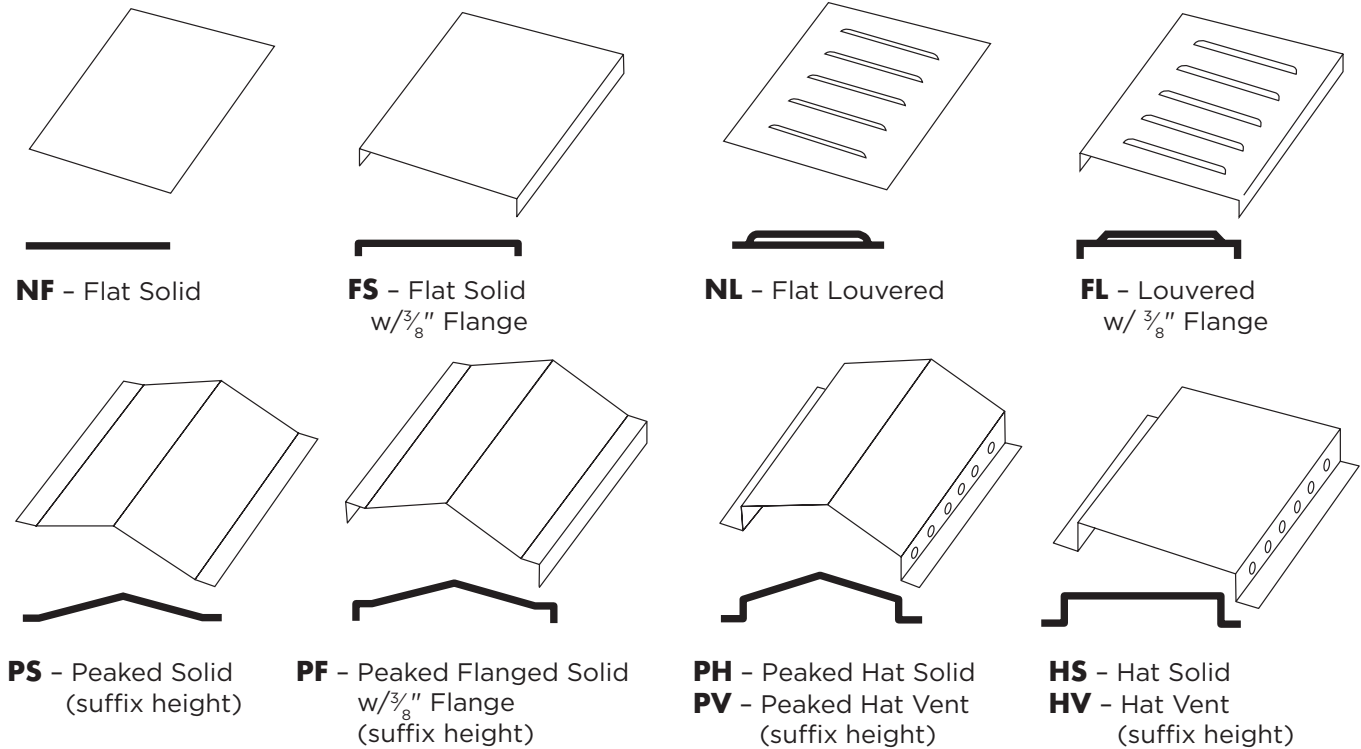

NOTE: Use EM-CC Cover Screws (see pg. 57) to attach PH, PV, HS & HV covers.

Hot dip covers - straights only 6'

Cover Catalog Number – Straight Sections

| Type | Flange | Finish | Basic No. (Width) | Length | Height* |
|---------|-----------------------|----------------|---------------------|--------|---------|
| HS, HV, | 2 - $1\frac{3}{16}$ " | 6 - Mill Galv. | -06SL = 6" (152mm) | -06' | -2* |
| FL, FS, | 4 - $1\frac{1}{4}$ " | 7 - HDGAF | -09SL = 9" (229mm) | -10' | |
| NF, NL, | 5 - $1\frac{1}{2}$ " | 8 - Alum. | -12SL = 12" (305mm) | -12' | |
| PS, PF, | 6 - $1\frac{3}{4}$ " | T - 304SS | -18SL = 18" (457mm) | | |
| PH, PV | 7 - 2" | | -24SL = 24" (610mm) | | |
| | | | -30SL = 30" (762mm) | | |
| | | | -36SL = 36" (914mm) | | |

*peak and hat only, 2" height standard. Consult factory for other heights.

Example: NL46-09SL-10 is a flat louvered mill-galv. steel cover for a 9" wide mill galvanized ladder 10' long with a $1\frac{1}{4}$ " flange.

Cover Catalog Number – Fittings

| Type | Flange | Load Depth | Finish | Width/Basic No. | Radius |
|------|-----------------------|------------|----------------|-----------------|--------|
| NF | 2 - $1\frac{3}{16}$ " | 3 | 6 - Mill Galv. | -06 XX ** | 12" |
| FS | 4 - $1\frac{1}{4}$ " | 4 | 7 - HDGAF | -09 XX ** | 24" |
| | | 5 | 8 - Alum.* | -12 XX ** | 36" |
| | | 6 | T - 304SS | -18 XX ** | |
| | | | | -24 XX ** | |
| | | | | -30 XX ** | |
| | | | | -36 XX ** | |

* Load depth for outside riser or vertical tee only.

** XX from fitting selection page 32

Example: NF26-369F-24 is a mill galvanized non-flanged solid cover for a 36" wide horizontal 90° elbow with a 24" radius.

JOINT PLATE

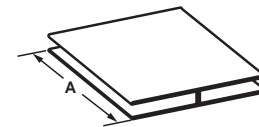

Joint plate is black PVC and is offered in 10' lengths to be field cut to desired length, or in pre-cut lengths for specified covers (e.g., PJ-06 is a joint plate for 6" wide tray).

| Part No. | Tray Size | Part No. | Tray Size |
|----------|-------------|----------|-------------------|
| JP-06 | 6" (152mm) | JP-24 | 24" (610mm) |
| JP-09 | 9" (229mm) | JP-30 | 30" (762mm) |
| JP-12 | 12" (305mm) | JP-36 | 36" (914mm) |
| JP-18 | 18" (457mm) | JP-120 | 10' for field cut |

STAINLESS STEEL COVER CLIP [CCS-SS]

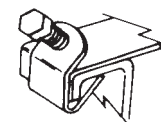

$\frac{1}{4}$ " - 28 stainless steel cone point machine screw.
Use with any width tray and cover. Not sold in pairs.

Indoor use only. Suggest spacing 6' max.

COVER ACCESSORIES - LADDER, HAT, AND TROF

DOUBLE CLAMP CONNECTOR [(W) DC]

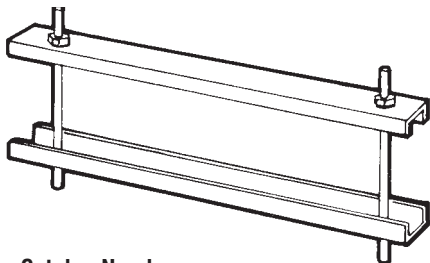

Catalog Number

| Flange | Load Depth | Finish | Width | Type |
|------------------------------------|------------|--------------|-------|------|
| 2=1 ³ / ₁₆ " | 3 | 6=Mill Galv. | -06 | DC |
| 4=1 ¹ / ₄ " | 4 | 7=HDGAF | -09 | |
| 5=1 ¹ / ₂ " | 5 | 8=Alum. | -12 | |
| 6=1 ³ / ₄ " | 6 | T=304SS | -18 | |
| 7=2" | | | -24 | |
| | | | -30 | |
| | | | -36 | |

Example: 238-12DC for 3" load depth, 1³/₁₆" flange, aluminum, Double Clamp Connector

For all covers except hat & peak type. Furnished with: (2) 1/4"-20 all-thread rods

(4) hex nuts, flat washers and lock washers

Suggested spacing:
Indoor: 2 per 12'
Outdoor: 3 per 12'
High Wind: 5 per 12'

ELECTRO-GALV. STEEL COVER CLIP [PS 135X]

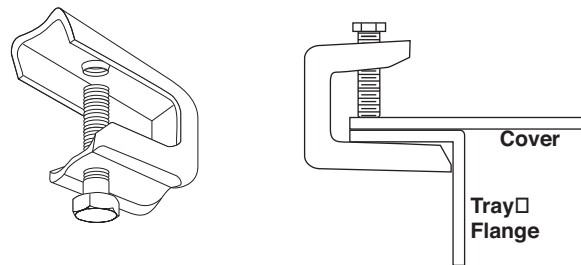

Use with any width tray. Not sold in pairs.

Indoor use only. Suggest spacing 6' max.

COVER CONNECTOR [CC]

NOTE: For all covers except hat & peak type

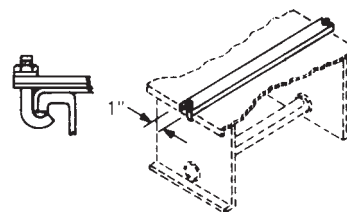

Catalog Number

| Flange | Finish | Width | Type |
|------------------------------------|--------------|-------|------|
| 2=1 ³ / ₁₆ " | 6=Mill Galv. | -06 | CC |
| 4=1 ¹ / ₄ " | 7=HDGAF | -09 | |
| 5=1 ¹ / ₂ " | 8=Alum. | -12 | |
| 6=1 ³ / ₄ " | T=304SS | -18 | |
| 7=2" | | -24 | |
| | | -30 | |
| | | -36 | |

Example: 28-12CC for aluminum, 12" wide Cover Connector

PEAK COVER CONNECTOR [PC]

NOTE: For PS & PF Covers

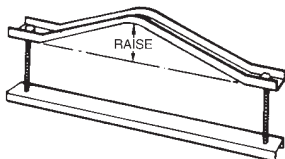

Suggested spacing:
Indoor: 2 per 12'
Outdoor: 3 per 12'
High Wind: 5 per 12'

Catalog Number

| Flange | Load Depth | Finish | Width | Type | Raise (in)* |
|------------------------------------|------------|--------------|-------|------|-------------|
| 2=1 ³ / ₁₆ " | 3 | 6=Mill Galv. | -06 | PC | -2 |
| 4=1 ¹ / ₄ " | 4 | 7=HDGAF | -09 | | |
| 5=1 ¹ / ₂ " | 5 | 8=Alum. | -12 | | |
| 6=1 ³ / ₄ " | 6 | T=304SS | -18 | | |
| 7=2" | | | -24 | | |
| | | | -30 | | |
| | | | -36 | | |

*2" standard raise. Consult factory for other peak heights.

Example: 238-12PC-2 for 3" load depth, 1³/₁₆" flange, aluminum, 12" wide, Peak Cover Connector with 2" peak.

ELEVATED COVER CONNECTORS [EM-CC]

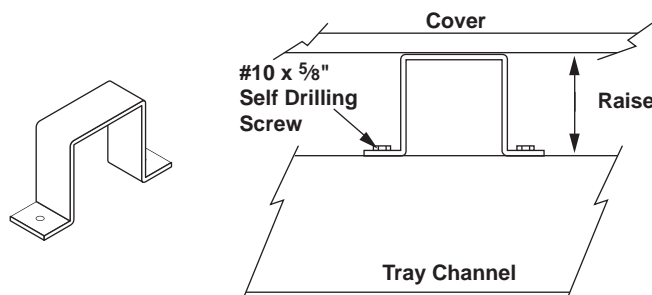

Catalog Number

| Finish | Type | Height* |
|--------------|-------|----------------|
| 6=Mill Galv. | EM-CC | - Raise* (in.) |
| 7=HDGAF | | |
| 8=Alum. | | |
| T=304SS | | |

*1", 2" or 3" standard.

Example: 7-EM-CC-2 for hot dipped galvanized, Elevated Cover Connector with a 2" raise

Includes:
(3) #10 x 5/8 Self drilling screws.
Suggested spacing:
Indoor: 3/Side
(6 tot.) per 12';

PEAK VENT COVER CONNECTOR [VC]

NOTE: For PV Covers

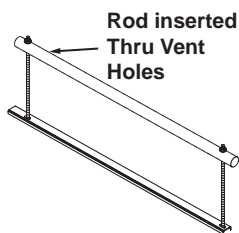

Catalog Number

| Flange | Load Depth | Finish | Width | Type |
|------------------------------------|------------|--------------|-------|------|
| 2=1 ³ / ₁₆ " | 3 | 6=Mill Galv. | -06 | VC |
| 4=1 ¹ / ₄ " | 4 | 7=HDGAF | -09 | |
| 5=1 ¹ / ₂ " | 5 | 8=Alum. | -12 | |
| 6=1 ³ / ₄ " | 6 | T=304SS | -18 | |
| 7=2" | | | -24 | |
| | | | -30 | |
| | | | -36 | |

Example: 238-12VC for 3" load depth, 1³/₁₆" flange, aluminum, 12" wide, Peak Vented Cover Connector

LADDER CABLE TRAY SYSTEM

ACCESSORIES - LADDER, HAT, AND TROF

BOX CONNECTOR [CB]

14 Gage Steel, .080" Aluminum.

NOTE: ¼"-20 carriage bolts, flat washers, hex nuts furnished

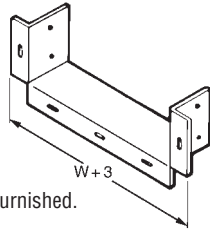

.080" Aluminum

Note: ¼"-20 carriage bolts, flat washers, hex nuts furnished.

Catalog Number

| Load Depth | Finish | Width |
|------------|----------------|---------------------|
| 3 | 6 (Mill Galv.) | -06CB = 6" (152mm) |
| 4 | 7 (HDGAF) | -09CB = 9" (229mm) |
| 5 | 8 (Alum.) | -12CB = 12" (305mm) |
| 6 | T (304SS) | -18CB = 18" (457mm) |
| | | -24CB = 24" (610mm) |
| | | -30CB = 30" (762mm) |
| | | -36CB = 36" (914mm) |

Example: 38-12CB for 3" load depth, aluminum, 12" wide, Box Connector.

BLIND END [BE]

22 Gage Steel, .040" Aluminum

NOTE: ⅜"-16 spline bolts and flange nuts furnished.

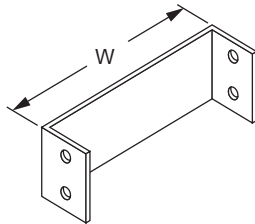

Catalog Number

| Load Depth | Finish | Width |
|------------|----------------|---------------------|
| 3 | 6 (Mill Galv.) | -06BE = 6" (152mm) |
| 4 | 7 (HDGAF) | -09BE = 9" (229mm) |
| 5 | 8 (Alum.) | -12BE = 12" (305mm) |
| 6 | T (304SS) | -18BE = 18" (457mm) |
| | | -24BE = 24" (610mm) |
| | | -30BE = 30" (762mm) |
| | | -36BE = 36" (914mm) |

Example: 38-12BE for 3" load depth, aluminum, 12" wide Blind End.

CABLE TRAY GROUND CLAMP [9156]

Extruded Alum. with ElectroGalvanized Hex Head Screws

Capacity: #6 AWG to 250 kcmil

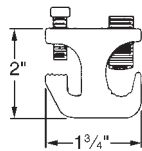
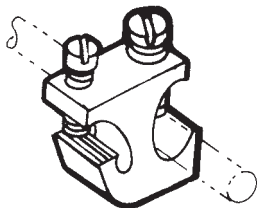

UL Listed E-24264

SP Certified File No. LR 9795

DROP OUT [DO]

14 Gage Steel, .080" Aluminum.

NOTE: (2) #10 x ⅝" self tapping screws furnished.

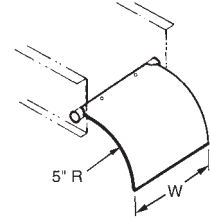

Catalog Number

| Basic Finish | Width |
|----------------|---------------------|
| 6 (Mill Galv.) | -06DO = 6" (152mm) |
| 7 (HDGAF) | -09DO = 9" (229mm) |
| 8 (Alum.) | -12DO = 12" (305mm) |
| T (304SS) | -18DO = 18" (457mm) |
| | -24DO = 24" (610mm) |
| | -30DO = 30" (762mm) |
| | -36DO = 36" (914mm) |

Example: 8-12DO for aluminum, 12" wide, Drop Out.

BONDING JUMPER [CBJ]

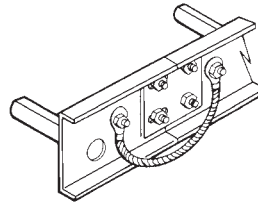

NOTE: No hardware supplied
For hardware kit add -HDW:

Ex: CBJ-C-HDW includes
2ea CBJ-C
4ea 5003-1
4ea 5009-1

| Catalog No. | Dimensional Data | Amperes as Equipment Ground |
|-------------|--|-----------------------------|
| CBJ-C | AWG 1/0 copper wire 15½" long overall | 800 amperes |
| CBJ-4C | AWG 4/0 copper wire 15½" long overall | 1,600 amperes |
| CBJ-250C | 250 MCM copper wire 15½" long overall | 2,000 amperes |

GROUND CABLE RETAINER CLAMP

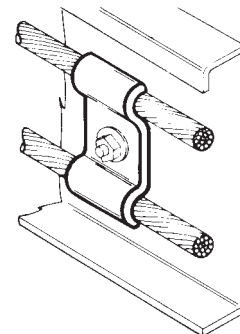

| Catalog No. | Capacity | Metal & Finish | Dimensions |
|-------------|-------------|---------------------|-----------------|
| 9056-EP | 1/0 2/0 3/0 | Electro-Galv. Steel | 1" w x 2" long |
| 9057-EP | 4/0 250 MCM | | 1" w x 2⅜" long |
| 9056-SS | 1/0 2/0 3/0 | Stainless Steel | 1" w x 2" long |
| 9057-SS | 4/0 250 MCM | | 1" w x 2⅜" long |

ACCESSORIES - LADDER, HAT, AND TROF

CONDUIT CLAMP BRACKET

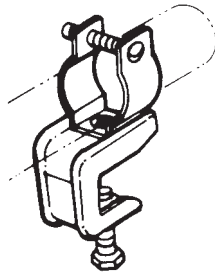

| Catalog No. | Size-Rigid | Size-EMT |
|-------------|--------------|----------|
| CCB-050 | 3/8" to 1/2" | 1/2" |
| CCB-075 | 3/4" | 3/4" |
| CCB-100 | 1" | 1" |
| CCB-125 | - | 1 1/4" |
| CCB-150 | 1 1/4" | 1 1/2" |
| CCB-200 | 2" | 2" |

CONDUIT-TO-CABLE TRAY CLAMP SWIVEL TYPE

Malleable iron hub and steel "U" bolt. For connecting and grounding rigid conduit to tray at any angle within 90° arc. U.L. listed as a grounding means.

| Catalog No. | Size | Std. Pkg. |
|-------------|-----------|-----------|
| TB6209 | 1/2"-3/4" | 10 |
| TB6211 | 1"-1 1/4" | 10 |
| TB6214 | 1 1/2"-2" | 5 |
| TB6216 | 2 1/2"-3" | 5 |
| TB6218 | 3 1/2"-4" | 2 |

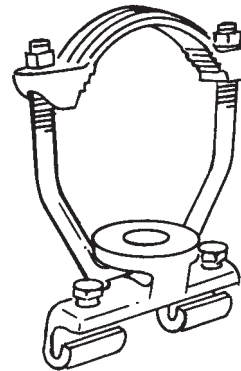

WALL PENETRATING SLEEVE ASSEMBLY

Part No. SS89042(W)*

W = Tray Width
 * = Fitting 3-Digit Prefix

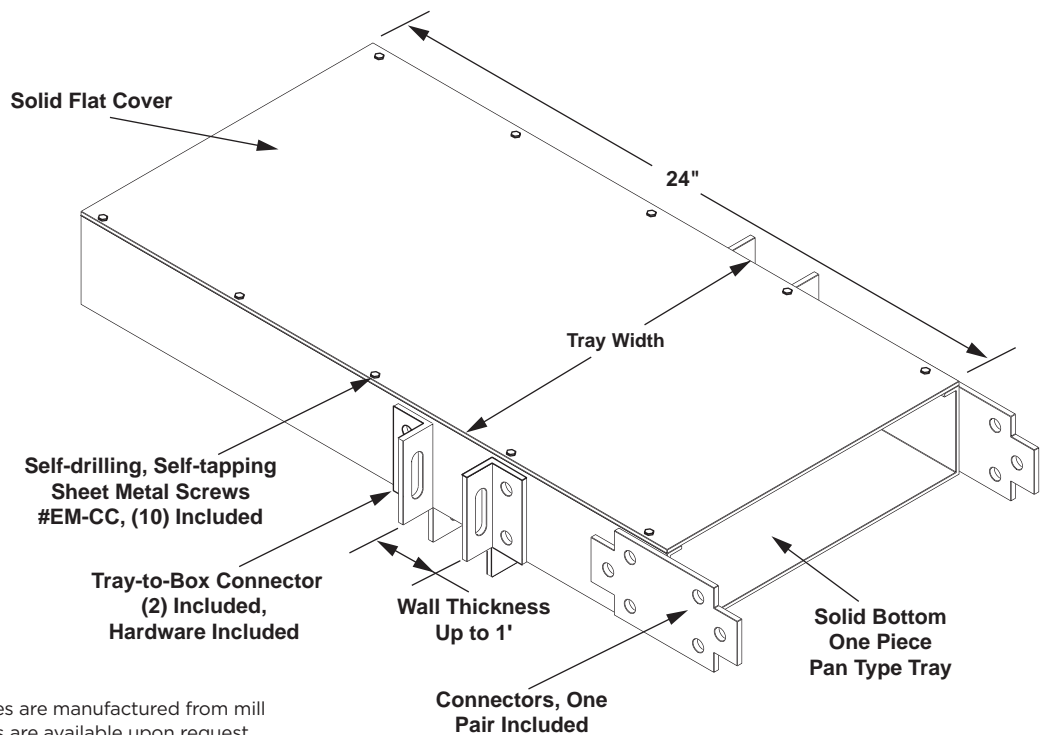

NOTE: Standard penetration sleeves are manufactured from mill galvanized steel. Aluminum sleeves are available upon request.

LADDER CABLE TRAY SYSTEM

BARRIER STRIPS - LADDER, HAT, AND TROF

UNIVERSAL ALUMINUM BARRIER STRIP - STRAIGHT SECTION [SB]

| Catalog Number | | |
|----------------|-----------|----------------------|
| Load Depth | Finish | Basic No. 12' Length |
| 3 | A (Alum.) | -01SB-12 |
| 4 | | |
| 5 | | |
| 6 | | |

Example: 3A-01SB-12 for 3" load depth, aluminum straight barrier, 12' long.

Furnished with 8 self tapping screws.

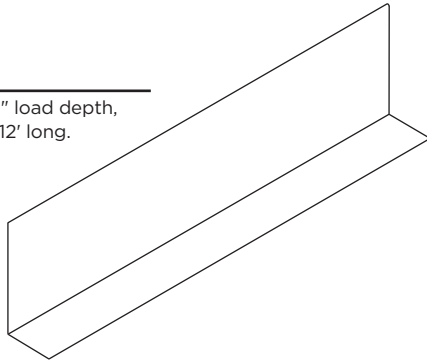

BARRIER STRIP - STRAIGHT SECTION [SB]

Catalog Number

| Load Depth | Finish | Basic No. 12' Length |
|------------|----------------|----------------------|
| 3 | 6 (Mill Galv.) | -01SB-12 |
| 4 | 7 (HDGAF) | |
| 5 | 8 (Alum.) * | |
| 6 | T (304 SS) | |

Example: 46-01SB-12 for 4" load depth, mill galvanized straight barrier, 12' long.

Furnished with 4 barrier strip clamps and necessary hardware. (SB-HDW)

* Long lead time item - See Universal aluminum barrier strip to the left

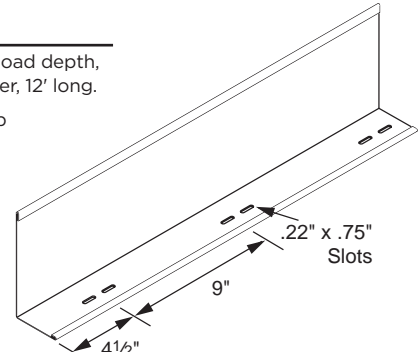

BARRIER STRIP - HORIZONTAL FITTING [FB]

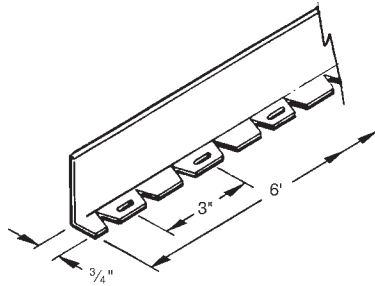

Furnished with 4 barrier strip clamps and necessary hardware.

Catalog Number

| Load Depth | Finish | Basic No. 6' Length |
|------------|----------------|---------------------|
| 3 | 6 (Mill Galv.) | -01FB-06 |
| 4 | 7 (HDGAF) | |
| 5 | 8 (Alum.) | |
| 6 | T (304 SS) | |

Example: 38-01FB-06 for 3" load depth, aluminum fitting barrier, 6' long.

BARRIER STRIP CLAMP [SB-HDW]

Includes: (1) U-Bolt 707981505
(2) Acorn Nuts 707671500

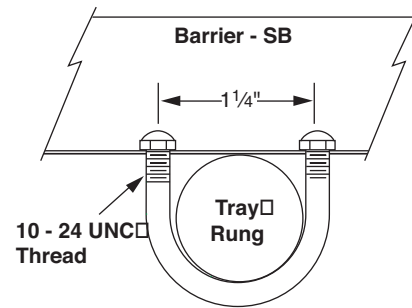

BARRIER STRIP VERTICAL ELBOW OUTSIDE [OB] & INSIDE [IB] (OB SHOWN)

Furnished with sufficient clamp assemblies for installation. Additional clamp assemblies may be ordered separately.

Barrier Strip Clamp Ass'y (Fitting System No.)-50735 Mill-Galv. & Alum. only

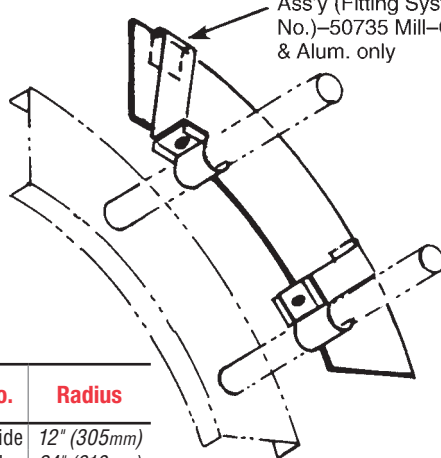

Catalog Number

| Load Depth | Finish | Bend (deg.) | Basic No. | Radius |
|------------|----------------|-------------|--------------|-------------|
| 3 | 6 (Mill Galv.) | 90 | OB = Outside | 12" (305mm) |
| 4 | 7 (HDGAF) | 60 | IB = Inside | 24" (610mm) |
| 5 | 8 (Alum.) | 45 | | 36" (914mm) |
| 6 | T (304 SS) | 30 | | |

Example: 38-90OB-12 for 3" load depth, aluminum 90° outside vertical barrier with 12" radius.

NYLON BARRIER SPLICE & PROTECTOR [BSP-L]

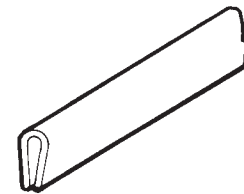

Catalog Number

| Prefix | Length (L) |
|--------|-----------------------|
| BSP | -5 (5' Splice) |
| | -144 (144" Protector) |
| | -1200 (100' Roll) |

Example: BSP-1200 for 100' roll

ACCESSORIES - LADDER, HAT, AND TROF

COMBINATION HOLD-DOWN CLAMP & EXPANSION GUIDE [9131]

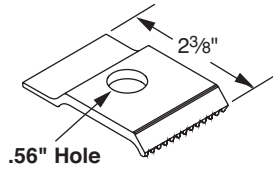

| Catalog No. | Material |
|-------------|--------------------------|
| 9131 | Hot-Dipped Galvanized |
| 9131L | 316 Type Stainless Steel |
| 9131A | Aluminum |

Hardware purchased separately to suit support system.

NOTE: ■ Indicates items included in our Quick Ship Program. Consult factory for lead times on other systems.

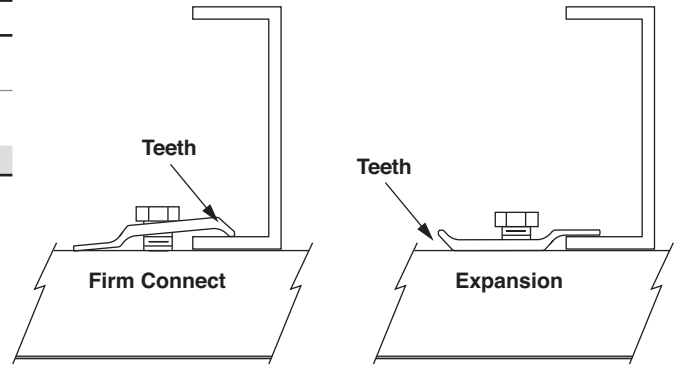

Catalog No. 9131-HDW (Complete Hardware Kit)

Hardware list:

- (2) Combination hold-down clamp & expansion guide
- (2) 1/2" - 13 x 1 1/4" Cap Screw
- (2) 1/2" Flat Washer
- (2) Clamping Nut (Strut Nut)

COMBINATION HOLD-DOWN / EXPANSION GUIDE [9053] (LADDER ONLY)

Universal Guide: for either side of ladder. Use when tray is mounted on I-beams or channels. No drilling required.

NOTE: Use set screws for firm hold down

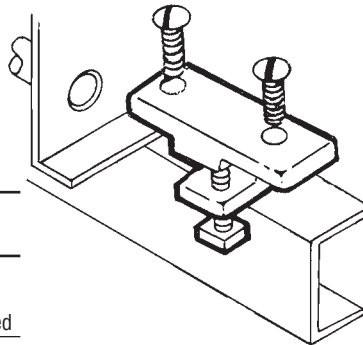

| Type | Catalog No. | Finish |
|-------------------|-------------|-----------------------|
| Combination Guide | 6-9053 | Hot-Dipped Galvanized |
| Combination Guide | 8-9053 | Aluminum |

NOTE: Electroplated set screws included

CABLE CLAMP

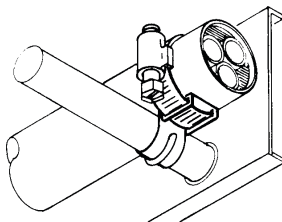

Galvanized Steel – Part No. GCC

| Catalog No. | Clamp Min. | Dia. (in.) Max. |
|-------------|------------|-----------------|
| GCC-300 | 1 | 3 1/2 |
| GCC-400 | 1 | 4 1/2 |
| GCC-450 | 1 | 5 |
| GCC-650 | 1 | 7 |
| GCC-850 | 1 | 9 |
| GCC-100 | 1 | 10 1/2 |
| GCC-115 | 1 | 12 |
| GCC-135 | 1 | 14 |

Stainless Steel – Part No. SCC

| Catalog No. | Clamp Min. | Dia. (in.) Max. |
|-------------|------------|-----------------|
| SCC-150 | 3/4 | 1 1/2 |
| SCC-250 | 1 5/8 | 2 1/2 |
| SCC-400 | 2 1/2 | 4 |
| SCC-450 | 2 3/4 | 4 1/2 |
| SCC-600 | 4 1/4 | 6 |

ISOLATION PAD [9131-IP]

The Isolation pad provides protection from galvanic corrosion when Aluminum tray is mounted on steel supports.

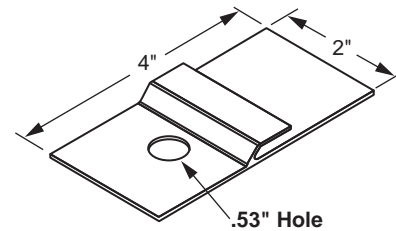

NOTE: For use with the 9131A shown above.
Hardware purchased separately

SEISMIC HOLD-DOWN [9132]

NOTE: Preferred for seismic applications or other bolted connections.

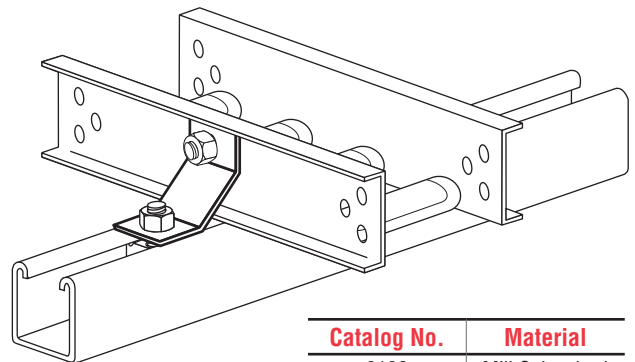

| Catalog No. | Material |
|-------------|-----------------|
| 9132 | Mill Galvanized |
| 9133 | Stainless Steel |

Hardware purchased separately to suit support system.

LADDER CABLE TRAY SYSTEM

SUPPORTS - LADDER, HAT, AND TROF

VERTICAL SUPPORTS

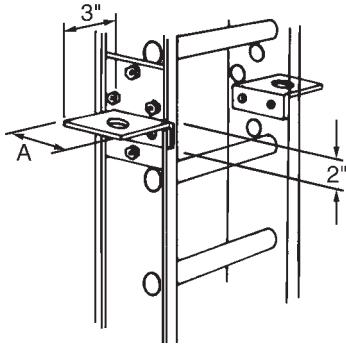

| Catalog No. | For Use With |
|-------------|---|
| 9043-37 | 4 1/4" Overall Height Side Members |
| 9043 | 5 1/4" Overall Height Side Members |
| 9025-98 | 6 1/4" & 7 1/4" Overall Height Side Members |

Ladder Supports can be bolted anywhere along the straight runs. They can be bolted directly onto the coupler plates at splices of straight runs and riser fittings, or they can be bolted at any place in the run by field-drilling side rails. Ladder supports are used with either 3/8" or 1/2" hanger rods. Finish is Hot-Dipped Galvanized.

GUSSET-TYPE SUPPORTS

For use with all types of Cope Ladder and Trof systems. Finish is electro-galvanized. Order hardware separately.

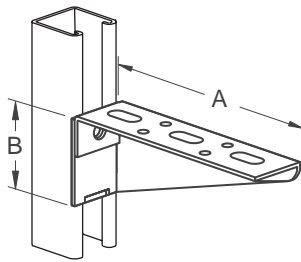

| Catalog No. | Ladder Width | Dimension | | Uniform-Load Rating |
|-------------|--------------|-----------|----------|---------------------|
| | | A | B | |
| PS 838R-6 | - | 6" | 1 15/16" | 275 lbs. |
| PS 838R-8 | - | 8" | 2 7/16" | 275 lbs. |
| PS 838R-10 | - | 10" | 2 15/16" | 275 lbs. |
| PS 838R-12 | 6" | 12" | 3 7/16" | 275 lbs. |
| PS 838R-16 | 9" | 16" | 4 7/16" | 275 lbs. |
| PS 838R-18 | 12" | 18" | 4 15/16" | 275 lbs. |
| PS 838R-24 | 18" | 24" | 6 7/16" | 275 lbs. |
| PS 838R-30 | 24" | 30" | 7 15/16" | 275 lbs. |

CHANNEL-TYPE SUPPORTS

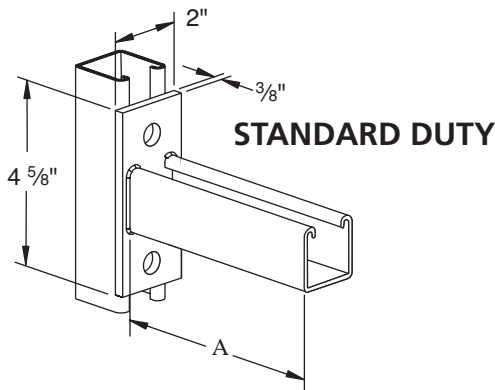

For use with all types of Cope Ladder and Trof systems. Finish is electro-galvanized. Order hardware separately.

| Standard Duty for Lighter Loads. | | | |
|----------------------------------|--------------|-------------|----------------------|
| Catalog No. | Ladder Width | Dimension A | Uniform-Load Rating* |
| PS 651-6 | - | 6" | 1,200 lbs. |
| PS 651-12 | 6" | 12" | 600 lbs. |
| PS 651-15 | 9" | 15" | 480 lbs. |
| PS 651-18 | 12" | 18" | 400 lbs. |
| PS 651-24 | 18" | 24" | 300 lbs. |
| PS 651-30 | 24" | 30" | 240 lbs. |
| PS 651-36 | 30" | 36" | - |

* Mounted on 12 Ga. Channel.

DOUBLE CHANNEL-TYPE SUPPORTS

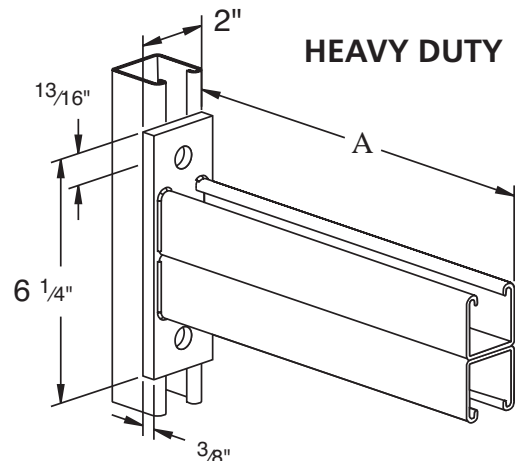

For use with all types of Cope Ladder and Trof systems. Finish is electro-galvanized. Order hardware separately.

| Heavy Duty for Heavier Loads | | | |
|------------------------------|--------------|-------------|----------------------|
| Catalog No. | Ladder Width | Dimension A | Uniform-Load Rating* |
| PS 809-12 | 6" | 12" | 2,000 lbs. |
| PS 809-15 | 9" | 15" | 1,600 lbs. |
| PS 809-18 | 12" | 18" | 1,330 lbs. |
| PS 809-24 | 18" | 24" | 1,000 lbs. |
| PS 809-30 | 24" | 30" | 800 lbs. |
| PS 809-36 | 30" | 36" | 660 lbs. |
| PS 809-42 | 36" | 42" | 570 lbs. |

* Mounted on 12 Ga. Channel.

SUPPORT BRACKETS & TRAY HANGERS - LADDER, HAT, AND TROF

WALL SUPPORT BRACKETS

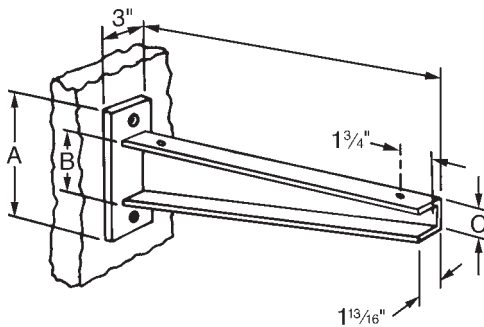

| Catalog Number | Ladder Width | Length "L" | Dimensions | | | End-Load Rating* |
|----------------|--------------|------------|------------|-----|--------|------------------|
| | | | "A" | "B" | "C" | |
| 9037-12 | 6" | 12 1/4" | 10" | 6" | 2" | 2000 lbs. |
| 9037-18 | 12" | 18 1/4" | 11" | 7" | 2 1/2" | 2000 lbs. |
| 9037-24 | 18" | 24 1/4" | 11" | 7" | 2 1/2" | 1600 lbs. |
| 9037-30 | 24" | 30 1/4" | 12" | 8" | 4" | 1300 lbs. |
| 9037-36 | 30" | 36 1/4" | 12" | 8" | 4" | 1100 lbs. |
| 9037-42 | 36" | 42 1/4" | 12" | 8" | 4" | 900 lbs. |

*Uniform load rating is normally twice the end-load rating.
Finish is hot-dip galvanized after fabrication.
Order hardware separately

STRUCTURAL SUPPORT BRACKET

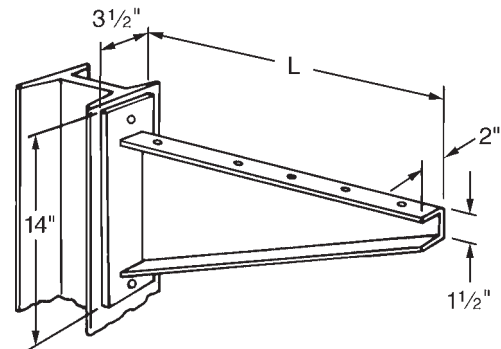

| Catalog No. | Ladder Width | Length "L" | End-Load Rating* |
|-------------|--------------|------------|------------------|
| 9036-31 | 24" | 31 1/4" | 2000 lbs. |
| 9036-37 | 30" | 37 1/4" | 1800 lbs. |
| 9036-45 | 36" | 45 1/4" | 1500 lbs. |

*Uniform load rating is normally twice the end-load rating.
For use with Cope Ladder 24" or wider. May be welded or bolted to building steel.
Finish is hot-dip galvanized after fabrication.
Order hardware separately.

SINGLE LADDER HANGERS

Cope Ladder Hangers are sized according to the side rail height and flange dimensions of various Cope ladders. The 17/32" holes accommodate either 3/8" or 1/2" diameter threaded rod.

Order hardware separately.
Finish is Mill-Galv., HDGAF, or Aluminum.

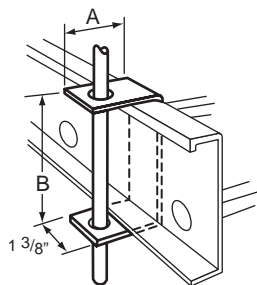

| Catalog No. | | | | | | |
|-------------|------|---------------|-------|----------------|----------|----------|
| Basic No. | M.G. | Finish H.D.G. | Alum. | Side Rail | "A" Dim. | "B" Dim. |
| 9038- | 236 | 237 | 238 | 4 1/4 X 1 3/16 | 2" | 4 5/16" |
| 9038- | 246 | 247 | 248 | 5 1/4 X 1 3/16 | 2" | 5 5/16" |
| 9038- | 256 | 257 | 258 | 6 1/4 X 1 3/16 | 2" | 6 5/16" |
| 9038- | 266 | 267 | 268 | 7 1/4 X 1 3/16 | 2" | 7 5/16" |
| 9038- | 436 | 437 | 438 | 4 1/4 X 1 1/4 | 2 9/16" | 4 5/16" |
| 9038- | 446 | 447 | 448 | 5 1/4 X 1 1/4 | 2 9/16" | 5 5/16" |
| 9038- | 456 | 457 | 458 | 6 1/4 X 1 1/4 | 2 9/16" | 6 5/16" |
| 9038- | 466 | 467 | 468 | 7 1/4 X 1 1/4 | 2 9/16" | 7 5/16" |

POWER-PIER ROOFTOP SUPPORT SYSTEM

The Power-Pier Rooftop support system provides a simple and versatile way to support and manage pipe, tubing, conduit, HVAC systems, and the like. The Power-Pier system supports without roof surface penetration and allows the parts to remain off the surface.

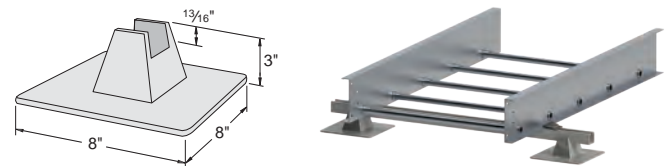

| Part Number | Power-Pier Bases Qty. | Ladder Width | Description |
|--------------|-----------------------|--------------|---|
| PS PP | 4 | - | Power-Pier Base Only (4 Bases & Hardware) |
| PS-SPSS-10HG | 4 | 6" | PS PP + 4 Pcs PS 500 EH HG @ 10" Long for 4" to 8" Pipe |
| PS-MPDS-13HG | 4 | 9" | PS PP + 2 Pcs PS 200 EH HG @ 13" Long for Trapeze |
| PS-MPDS-16HG | 4 | 12" | PS PP + 2 Pcs PS 200 EH HG @ 16" Long for Trapeze |
| PS-MPDS-22HG | 4 | 18" | PS PP + 2 Pcs PS 200 EH HG @ 22" Long for Trapeze |
| PS-MPDS-28HG | 4 | 24" | PS PP + 2 Pcs PS 200 EH HG @ 28" Long for Trapeze |
| PS-MPDS-34HG | 4 | 30" | PS PP + 2 Pcs PS 200 EH HG @ 34" Long for Trapeze |
| PS-MPDS-40HG | 4 | 36" | PS PP + 2 Pcs PS 200 EH HG @ 40" Long for Trapeze |

LADDER CABLE TRAY SYSTEM

TRAY HANGERS & SUPPORTS - LADDER, HAT, AND TROF

SINGLE ROD HANGER SUPPORT

| Catalog Number | | | | | | |
|----------------|-----------------|-------------------------|---------------------|----------------------|------------------------|-----------------|
| Assy. Type | Channel Length* | Channel Finish** | Rod Diameter | Rod Length | Beam Clamp | |
| P200 | 14" (356mm) | GV (Pre-Galv) | 38=3/8" (9.53mm) | 000 - No Rod | A - Bridgeport | |
| | 17" (432mm) | | | | | |
| | 20" (508mm) | | | | | |
| | 26" (661mm) | HG (Hot Dipped Galv) | 12=1/2" (12.7mm) | 036 - 36" (914mm) | B - P2622 | |
| | 32" (813mm) | | | | | |
| | 38" (966mm) | | | | | |
| | 44" (1118mm) | | | | | |
| | | | | | 072 - 72" (1828mm) | O - No Clamp |
| | | | | | 120 - 120" (3048mm) | R - Rod Coupler |
| | | | | | 144 - 144" (3658mm) | S - Special |

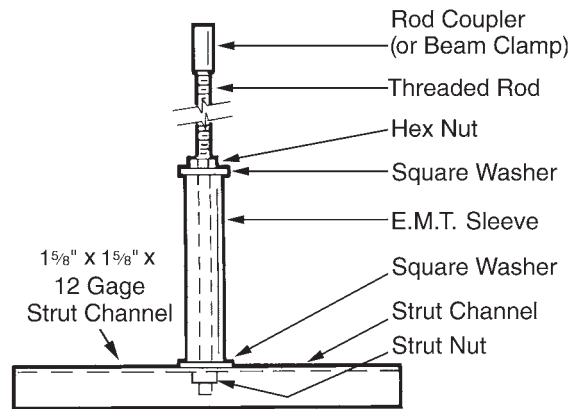

Example:

P20020GV12036B is a Single 20" pre-galvanized channel with 1/2" x 36" drop rod and P2622 clamp.

NOTE:

- *Order channel length 8" longer than tray width. For example, 44" channel for 36" tray.
- ** Other channel types and finishes available upon request. Contact factory.
- To order hardware only:
3/8" - PGV380000
1/2" - PGV120000

TRAPEZE HANGER SUPPORT

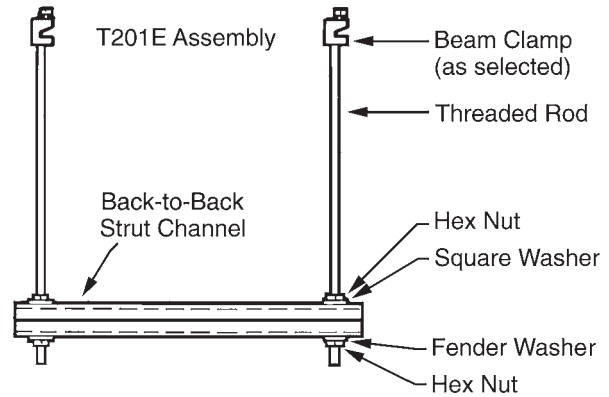
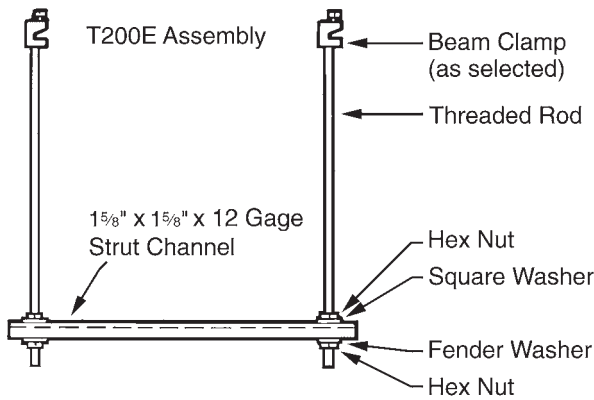

| Catalog Number | | | | | | | |
|----------------|-----------------|----------------------|---------------------|------------------------|-----------------|--|--|
| Assy. Type | Channel Length* | Channel Finish** | Rod Diameter | Rod Length | Beam Clamp | | |
| T200E | 16" (407mm) | GV (Pre-Galv) | 38=3/8" (9.53mm) | 000 - No Rod | A - PS 85 | | |
| T201E | 19" (483mm) | HG (Hot Dipped Galv) | 12=1/2" (12.7mm) | 036 - 36" (914mm) | B - P2622 | | |
| | 22" (559mm) | | | 072 - 72" (1828mm) | O - No Clamp | | |
| | 28" (712mm) | | | 120 - 120" (3048mm) | R - Rod Coupler | | |
| | 34" (864mm) | | | 144 - 144" (3658mm) | S - Special | | |
| | 40" (1017mm) | | | | | | |
| | 46" (1169mm) | | | | | | |

Example:

T200E22GV12036B is a Single 22" pre-galvanized channel with 1/2" x 36" drop rod and P2622 clamp.

NOTE:

- *Order channel length 10" longer than tray width. For example, 46" channel for 36" tray.
- ** Other channel types and finishes available upon request. Contact factory.
- To order hardware only:
3/8" - PGV380000
1/2" - PGV120000

ELECTRICAL GROUNDING CHART

Table 1 below provides the Minimum Cross Sectional area for two side rails. Using the Fitting Prefix Number (248), the proper value is determined by the Material (column 3), the Flange Width (column 1), and Load Depth (column 2). Locate the line containing the Load Depth (column 1) and follow it to the right to the appropriate Flange Width and Material.

TABLE 1

| | | | Min. X-Sect for 2 Rails (NEC® Table 392.7B) | | | |
|-------------------------------------|------------|--------------|--|--|--|--|
| | | | Aluminum | | Steel | |
| Fitting Prefix Number | | | ¹³ / ₁₆ " Flange | 1 ¹ / ₄ " Flange | ¹³ / ₁₆ " Flange | 1 ¹ / ₄ " Flange |
| Flange | Load Depth | Material | X-Sect Area | X-Sect Area | X-Sect Area | X-Sect Area |
| 2 - ¹³ / ₁₆ " | 3" | 6 - Mill Gal | 0.60 | 0.60 | 0.40 | 0.70 |
| 4 - 1 ¹ / ₄ " | 4" | 7 - HDGAF | 0.60 | 0.60 | 0.40 | 0.70 |
| | 5" | 8 - Alum. | 0.60 | 1.00 | 0.70 | 0.70 |
| | 6" | | 0.60 | 1.00 | 0.70 | 1.00 |

Find that value in Table 2, follow it to the right to the Material column to determine the Maximum Ground Fault Amperage.

TABLE 2

| X-Sect Area | Maximum Ground Fault Amperage (in Amps) | |
|-------------|---|-------|
| | Material | |
| | Aluminum | Steel |
| .40 sq in | - | 100 |
| .60 sq in | 1000 | - |
| .70 sq in | - | 200 |
| 1.00 sq in | 1200 | 400 |

For Example:

If the fitting prefix is 248, the Flange is ¹³/₁₆" the Load Depth is 4", and the Material is Aluminum. The Minimum Cross Sectional Area (X-Sect Area) is 0.60 sq. in. The Amperage is 1000.

TYPICAL SPECIFICATIONS

By specifying the NEMA class designation, you will use the simplest, clearest, and most complete method of specification available and automatically incorporate support span in feet, working (allowable) load in pounds per linear foot, a safety factor of 1.5, a concentrated load, if present; and, all other design, manufacturing, and test standards including electrical continuity.

All you need to do is add the desired load depth, rung spacing, radius of fittings, metal, and finish. You may add accessory information pursuant to your project. Here is a typical specification for an outdoor tray system where the working (allowable) load has been determined to be approximately 75 pounds per foot on support spans of 12'-0".

SPECIFICATION ALUMINUM COPE LADDER SYSTEM

Ladder Cable Tray shall be manufactured by a company regularly engaged in the manufacture of metal cable trays and shall be a member of NEMA. Trays shall conform to NEMA Metal Cable Tray Standard Publication VE-1 (latest issue).

- Ladder Cable Tray shall be NEMA Classification 12B of the widths indicated.
- Material shall be aluminum alloy with side rails and rungs of 6063.
- Finish shall be natural.
- Inside load depth to be NEMA Standard 3".
- Fittings shall be 12" radius for control cables and 24" radius for power cables. (This must be commensurate with the cable manufacturer's recommended minimum bending radius.)
- All top level trays in stacks and single runs to have raised, peaked aluminum ventilated covers with heavy duty hold down clamps every 3'-0".
- Install expansion connectors, expansion guides, and hold down clamps per NEMA Standard VE-1











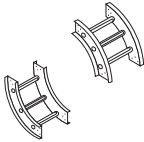

- Where slopes or horizontal bends of trays are not at the Standard NEMA angles, use adjustable connectors. If the angle is too great for cable bending radius, use combinations of fitting and adjustable connectors.
- Separate all cables of different voltages in the same tray using the manufacturer's standard barriers and barrier hold down system.
- The Ladder Cable Tray system will be used as an equipment grounding conductor.
- To save space fittings shall have no tangents. To facilitate field installation, use one pair of universal type connector plates for rigid joints.
- Ladder Cable Tray shall have outward facing side rails with tubular rungs assembled into side rails by cold swaging. Cable support surface on top of rungs to be flattened. Inside of tray shall not have flanges or other projections. Full access to the contents of the Cable Ladder shall be available.
- Trays shall be Cope Ladder Cable Tray System Number 3B38 as manufactured by Cope Cable Tray.

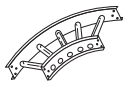
LADDER CABLE TRAY SYSTEM

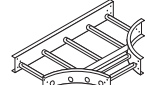
QUICK SHIP PROGRAM

COPE® QUICK SHIP PROGRAM









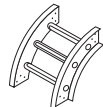
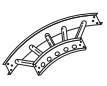

The Cope Quick Ship program is designed to ship our most popular cable tray straights, wire basket, fittings and hardware **SAME DAY/NEXT DAY!**
The items below are in stock at our **PHILADELPHIA** facility.

| CABLE TRAY STRAIGHTS AND FITTINGS | | | | | | | |
|--|---|--|---|--|--|---|---|
| 90° Inside/Outside Vertical Elbows  | 12" Radius 248-069I-12 248-129I-12 248-189I-12 248-249I-12 248-069O-12 248-129O-12 248-189O-12 248-249O-12 | 24" Radius 248-069I-24 248-129I-24 248-189I-24 248-249I-24 248-069O-24 248-129O-24 248-189O-24 248-249O-24 | Ladder Straights NEMA  | 12B 12' Long 9"RS 1B48-06SL-12-09 1B48-12SL-12-09 1B48-18SL-12-09 1B48-24SL-12-09 | Horizontal Cross  | 248-06FC-12 248-12FC-12 248-18FC-12 248-24FC-12 | |
| | Barrier Strips  | NEMA 12B Ladder Tray System <ul style="list-style-type: none"> • 1B48 System • 248 Fittings • 5-1/4" Side Rail • 4" Load Depth | | 90° Horizontal Elbows  | 12" Radius 248-069F-12 248-129F-12 248-189F-12 248-249F-12 | 24" Radius 248-069F-24 248-129F-24 248-189F-24 248-249F-24 | Universal Curvilinear Connector  |
| NEMA 12B Ladder Tray System <ul style="list-style-type: none"> • 1B48 System • 248 Fittings • 5-1/4" Side Rail • 4" Load Depth | | | Horizontal Tee  | 12" Radius 248-06FT-12 248-12FT-12 248-18FT-12 248-24FT-12 | Hold-Down Clamp  | 9131A | |
| WIRE BASKET AND ACCESSORIES | | | | | | | |
| Wire Basket  | CAT4-12SL-120 CAT4-18SL-120 CAT2-12SL-120 CAT2-06SL-120 CAT2-04SL-120 CAT2-02SL-120 | Hardware  | CH1 CH2 CH3 T-BAR SPUCE | Products packaged and shipped Same Day/Next Day! Contact your local sales representative for more information! 708-225-2070 copecabletray.com | | |  A PART OF  |
| Trapeze Hangers  | CAT-HSB-120 CAT-USB-120 | | | | | | |

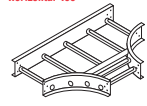
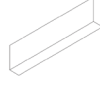
©2016 Atkore International, Inc. All rights reserved. COP-L-1009-1606

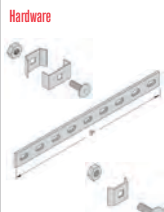
COPE® QUICK SHIP PROGRAM

The Cope Quick Ship program is designed to ship our most popular cable tray straights, wire basket, fittings and hardware **SAME DAY/NEXT DAY!**
The items below are in stock at our **HOUSTON** facility.

| CABLE TRAY STRAIGHTS AND FITTINGS | | | | | | | | | | | |
|--|--|--|--|--|---|---|--|---|--|--|--------------------------|
| 90° Inside/Outside Vertical Elbows  | 12" Radius Inside 248-069I-12 248-129I-12 248-189I-12 248-249I-12 | 24" Radius Inside 458-069I-24 458-129I-24 458-189I-24 458-249I-24 458-369I-24 | Ladder Straights NEMA  | 12B 12' Long 9"RS 1B48-06SL-12-09 1B48-12SL-12-09 1B48-18SL-12-09 1B48-24SL-12-09 | 20C 20' Long 9"RS 7D58-06SL-20-09 7D58-12SL-20-09 7D58-18SL-20-09 7D58-24SL-20-09 7D58-36SL-20-09 | Universal Curvilinear Connector  | 58-02RC 48-02RC | | | | |
| |  | 12" Radius Outside 248-069O-12 248-129O-12 248-189O-12 248-249O-12 | 24" Radius Outside 458-069O-24 458-129O-24 458-189O-24 458-249O-24 458-369O-24 | 90° Horizontal Elbows  | 12" Radius 248-069F-12 248-129F-12 248-189F-12 248-249F-12 | 24" Radius 458-069F-24 458-129F-24 458-189F-24 458-249F-24 458-369F-24 | Hold-Down Clamp  | 9131A | | | |
| NEMA 20C Ladder Tray System <ul style="list-style-type: none"> • 7D58 System • 458 Fittings • 6-1/4" Side Rail • 5" Load Depth | | | NEMA 12B Ladder Tray System <ul style="list-style-type: none"> • 1B48 System • 248 Fittings • 5-1/4" Side Rail • 4" Load Depth | | | | Horizontal Tee  | 12" Radius 248-06FT-12 248-12FT-12 248-18FT-12 248-24FT-12 | 24" Radius 458-06FT-24 458-12FT-24 458-18FT-24 458-24FT-24 458-36FT-24 | Barrier Strips  | 5A-01SB-10 4A-01SB-12 |
| WIRE BASKET AND ACCESSORIES | | | | | | | | | | | |
| Wire Basket  | CAT4-12SL-120 CAT4-18SL-120 CAT2-12SL-120 CAT2-06SL-120 CAT2-04SL-120 CAT2-02SL-120 | Hardware  | CH1 CH2 CH3 T-BAR SPUCE | Products packaged and shipped Same Day/Next Day! Contact your local sales representative for more information! 708-225-2070 copecabletray.com | | |  A PART OF  | | | | |
| Trapeze Hangers  | CAT-HSB-120 CAT-USB-120 | | | | | | | | | | |

©2016 Atkore International, Inc. All rights reserved. COP-L-1008-1602

3



I-BEAM

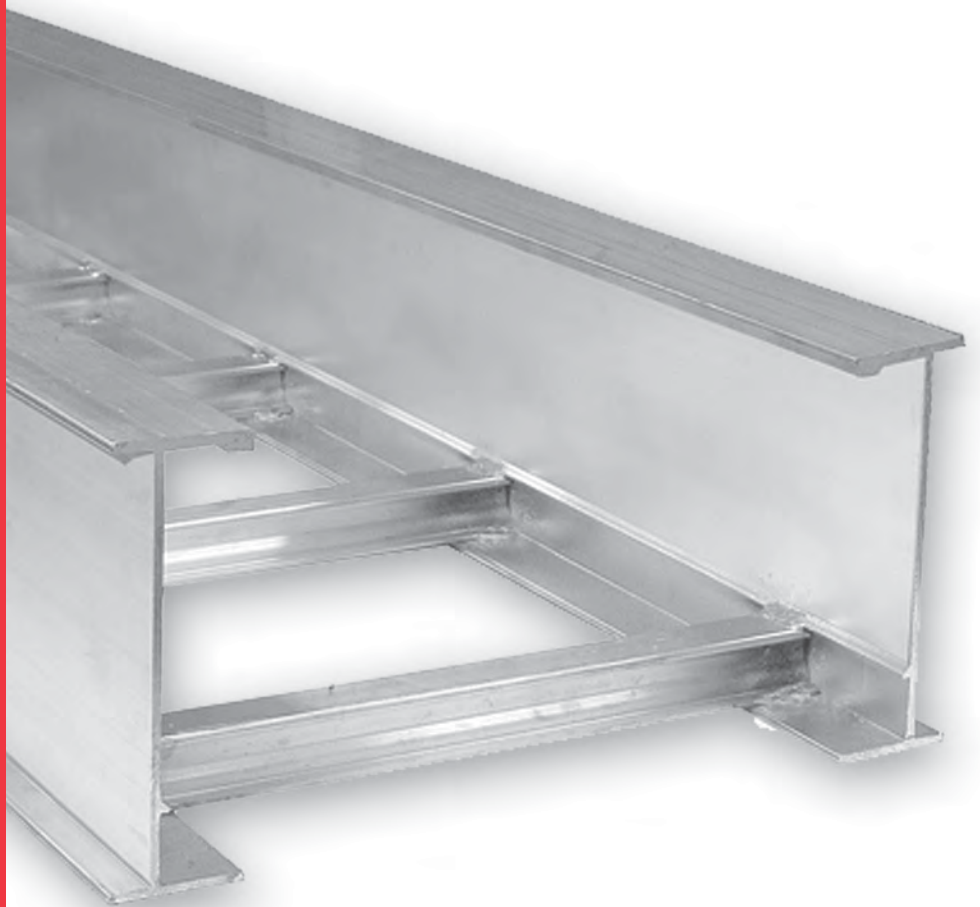

I-BEAM CABLE TRAY SYSTEM

CONTENTS

GENERAL & TECHNICAL INFORMATION

| | |
|--|---------|
| Pictorial Index | 55 |
| Selection Chart, Straight Length, Load information | 56 - 57 |
| Straight Length & Ordering Information | 58 |

COPE I-BEAM FITTINGS

| | |
|--|----|
| Horizontal Elbows | |
| 90° | 59 |
| 60° | 60 |
| 45° | 61 |
| 30° | 62 |
| Horizontal Tee | 63 |
| Horizontal Tapped Tee | 64 |
| Horizontal Cross | 65 |
| Horizontal Tapped Cross | 66 |
| Straight Reducers | 67 |
| Left and Right Hand Reducers | 67 |
| 45°"Y" Branch | 68 |
| Vertical Elbows (Inside and Outside) | |
| 90° | 69 |
| 60° | 70 |
| 45° | 71 |
| 30° | 72 |
| 90° Vertical Cable Support Elbow | 73 |
| Vertical Tee | 73 |

CONNECTORS & HARDWARE

| | |
|---|---------|
| Horizontal Adjustable Connector, Expansion Connector, Universal Connector, Reducing Connector, Mid-Span Splice Plate | 74 - 75 |
| Vertical Hanger Splice Plate, Hold Down Brackets, Adjustable Vertical Connectors | 76 |
| Hold Down Clamp and Expansion Guide, Cable Clamp, Isolation Pad, Box Splice Plates..... | 76 |
| General Hardware, Threaded Rod | 77 |

COVERS

| | |
|--|----|
| Covers, Joint Plate..... | 78 |
| Cover Attachments (Hold Down Clamps, Elevated and Peaked Cover Connectors, Steel Cover Clip)..... | 79 |

ACCESSORIES

| | |
|--|----|
| Blind End, Drop Out, Bonding Jumper, Box Connector | |
| Cable Tray Ground Clamp, Ground Cable Retainer Clamp | 80 |
| Conduit & Pipe Clamps, Wall Sleeve Assembly..... | 81 |
| Barrier Strips and Barrier Strip Clamps..... | 82 |
| Support Brackets | 83 |
| Tray Brackets, Rooftop Support System..... | 84 |
| Hanger Support, Trapeze Hanger Support | 85 |

SPECIFICATION INFORMATION

| | |
|---------------------------------|----|
| Electrical Grounding Chart..... | 86 |
| Typical Specification..... | 86 |

STRAIGHT LENGTH

Pages 58

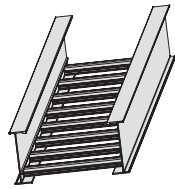

HORIZONTAL ELBOWS

Pages 59 - 62

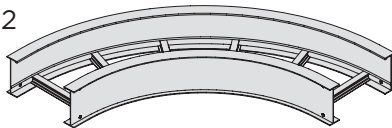

HORIZONTAL TEE

Page 63

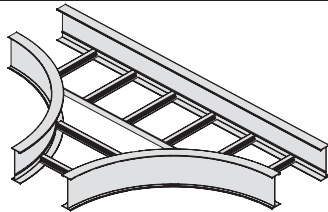

HORIZONTAL CROSS

Pages 65

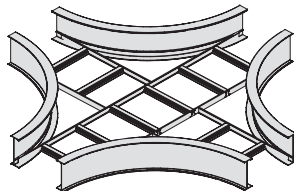

REDUCERS

Page 65

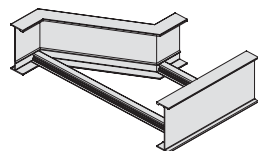

45° "Y" BRANCH

Page 67

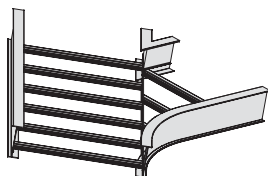

VERTICAL ELBOWS

Pages 69 - 72

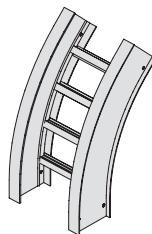

VERTICAL TEE & 90° VERTICAL SUPPORT ELBOW

Page 73

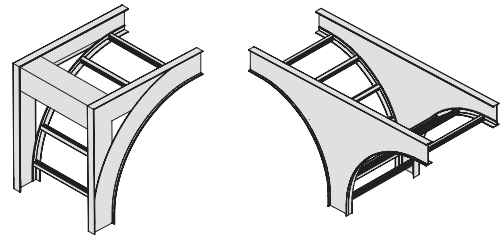

CONNECTORS & HARDWARE

Pages 74 - 77

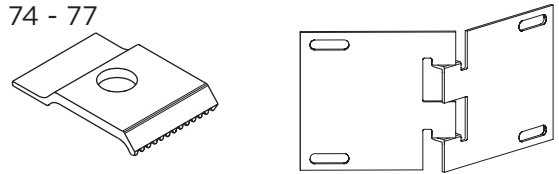

COVERS

Page 78

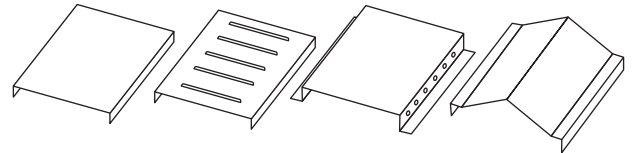

COVER ATTACHMENTS

Page 79

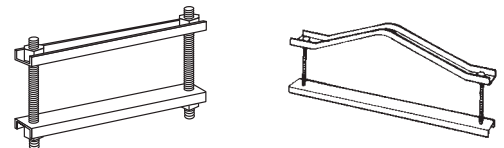

ACCESSORIES

Pages 80 - 81

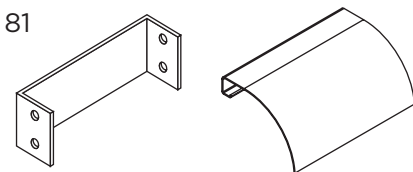

BARRIER STRIPS & ACCESSORIES

Page 82 - 83

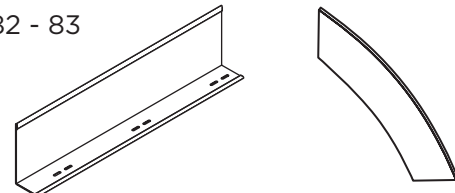

BRACKETS & HANGERS

Pages 84 - 85

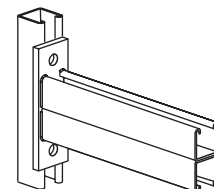

I-BEAM CABLE TRAY SYSTEM

ALUMINUM TRAY

SELECTION CHART

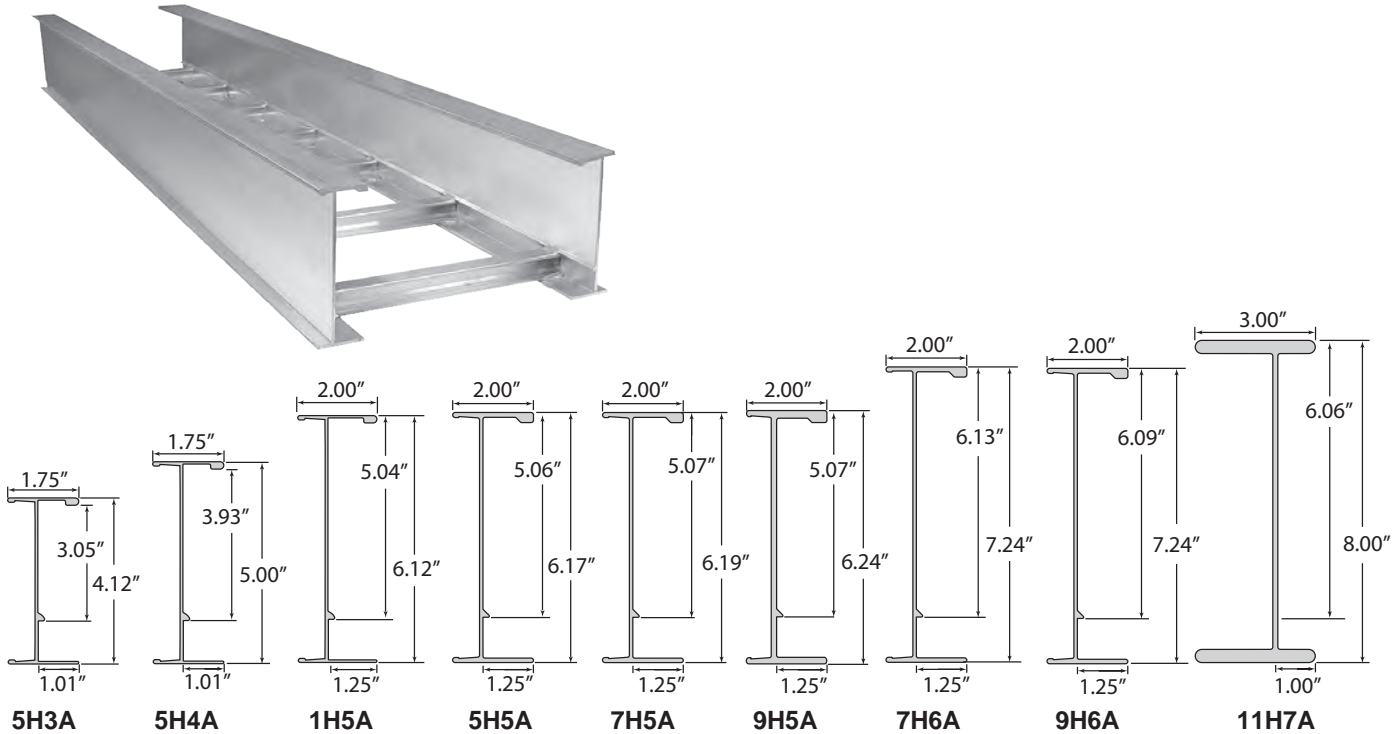

NEMA CLASS, PHYSICAL AND STRUCTURAL PROPERTIES

| NEMA Standard VE-1 Load/ Span Class | NEMA Ld/Span | Cope System Number | Actual Load Depth | Side Rail Height | Flange Width (in.) | Sect. Mod. of 2 Rails Sx (in. ³) | Moment of Inertia for 2 Rails Ix (in. ⁴) | Min X-Sect. Area of 2 Rails per NEC 392.7 (in. ²) |
|---|----------------------|--------------------------|----------------------|---------------------|--------------------------|--|---|--|
| 12C | 100 lb./ft. 12' span | 5H3A | 3.05" (77mm) | 4.12" (105mm) | 1 3/4 | 1.48 | 3.10 | 1.18 |
| 12C | 100 lb./ft. 12' span | 5H4A | 3.93" (100mm) | 5" (127mm) | 1 3/4 | 1.93 | 4.90 | 1.30 |
| 16A | 50 lb./ft. 16' span | 5H3A | 3.05" (77mm) | 4.12" (105mm) | 1 3/4 | 1.48 | 3.10 | 1.18 |
| 16A | 50 lb./ft. 16' span | 5H4A | 3.93" (100mm) | 5" (127mm) | 1 3/4 | 1.93 | 4.90 | 1.30 |
| 16B | 75 lb./ft. 16' span | 1H5A | 5.04" (128mm) | 6.12" (155mm) | 2 | 2.53 | 7.92 | 1.41 |
| 16C | 100 lb./ft. 16' span | 5H5A | 5.06" (129mm) | 6.17" (157mm) | 2 | 3.36 | 10.85 | 1.81 |
| 20A | 50 lb./ft. 20' span | 1H5A | 5.04" (128mm) | 6.12" (155mm) | 2 | 2.53 | 7.92 | 1.41 |
| 20B | 75 lb./ft. 20' span | 5H5A | 5.06" (129mm) | 6.17" (157mm) | 2 | 3.36 | 10.85 | 1.81 |
| 20C | 100 lb./ft. 20' span | 7H5A | 5.07" (129mm) | 6.19" (157mm) | 2 | 3.85 | 12.44 | 2.00 |
| 20C | 100 lb./ft. 20' span | 7H6A | 6.13" (156mm) | 7.24" (184mm) | 2 | 4.94 | 17.88 | 2.38 |
| 20C+ | 100 lb./ft. 24' span | 9H5A | 5.07" (129mm) | 6.24" (158mm) | 2 | 5.34 | 17.52 | 2.00 |
| 20C+ | 100 lb./ft. 24' span | 9H6A | 6.09" (155mm) | 7.24" (184mm) | 2 | 6.10 | 22.91 | 3.04 |
| 30C | 100 lb./ft. 30' span | 11H7A | 6.06" (154mm) | 8" (203mm) | 3 | 16.17 | 64.69 | 5.67 |

Note: Special Applications Available. Please Contact Factory.

MATERIAL & FINISH SPECIFICATIONS (I-BEAM™ Cable Tray)

| Item | Aluminum | Item | Aluminum |
|-----------|---|---------------------|--|
| Siderails | AA-6063-T6 Extruded | Splice Plate Finish | AA-5052-H34 |
| Rungs | AA-6063-T6 Extruded* AA-6063-T832 Extruded* AA-6063-T52 Extruded* | Connector Bolts | SAE J429 Grade 1 (ASTM A-307 Grade A) |
| Covers | AA-3003 H14 or 3150 H14 | Bolt Plating | ASTM B-633.0002" Zinc |

*Special High Strength 32 ksi Minimum Yield

LOAD AND DEFLECTION DATA FOR ALUMINUM LADDER
 Working (Allowable) Load Capacity, Evenly Distributed-Tested per NEMA Standard VE-1,
 Simple Beam - SAFETY FACTOR 1.5

| Cope System No. | NEMA | CLASSIFIED | CLASSIFIED | | SPAN | | | | | | | | | | | |
|-----------------|-----------|----------------|----------------|---|-------|------|--------|-------|------|--------|-------|------|-------|-------|------|-------|
| | | | | | 6 Ft | | | 8 Ft | | | 10 Ft | | | 12 Ft | | |
| | | | | | w | d | k | w | d | k | w | d | k | w | d | k |
| 5H3A | 16A & 12C | ✓ | | | 455 | 0.52 | 0.001 | 256 | 0.93 | 0.004 | 164 | 1.46 | 0.009 | 114 | 2.10 | 0.018 |
| 5H4A | 16A & 12C | ✓ | | | 505 | 0.33 | 0.001 | 284 | 0.58 | 0.002 | 182 | 0.91 | 0.005 | 126 | 1.31 | 0.010 |
| 1H5A | 16B & 20A | ✓ | ✓ | | 555 | 0.21 | 0.0004 | 319 | 0.36 | 0.001 | 204 | 0.57 | 0.003 | 142 | 0.85 | 0.006 |
| 5H5A | 16C & 20B | ✓ | ✓ | | 917 | 0.25 | 0.0003 | 527 | 0.44 | 0.001 | 337 | 0.69 | 0.002 | 233 | 1.00 | 0.004 |
| 7H5A | 20C | ✓ | ✓ | ✓ | 1,178 | 0.27 | 0.0002 | 663 | 0.47 | 0.001 | 424 | 0.74 | 0.002 | 294 | 1.07 | 0.004 |
| 9H5A | 20C+ | ✓ | ✓ | ✓ | 1,889 | 0.32 | 0.0002 | 1,063 | 0.57 | 0.001 | 680 | 0.89 | 0.001 | 472 | 1.28 | 0.003 |
| 7H6A | 20C | ✓ | ✓ | | 1,105 | 0.18 | 0.0002 | 622 | 0.32 | 0.001 | 398 | 0.50 | 0.001 | 276 | 0.72 | 0.003 |
| 9H6A | 20C+ | ✓ | ✓ | | 1,656 | 0.21 | 0.0001 | 932 | 0.37 | 0.0004 | 596 | 0.58 | 0.001 | 413 | 0.84 | 0.002 |

NOTE: Contact your Cope representative for loading information on the 11H7A system

To convert 1.5 safety factor to 2.0 multiply w, d, k by .75

w = Pounds per linear foot

d = Deflections (inches)

k = Deflection (in.) for each pound of load

t = Denotes k is less than .001 inch

| Cope System No. | NEMA | CLASSIFIED | CLASSIFIED | | SPAN (cont.) | | | | | | | | | | | |
|-----------------|-----------|----------------|----------------|---|--------------|------|-------|-------|------|-------|-------|------|-------|-------|------|-------|
| | | | | | 16 Ft | | | 20 Ft | | | 24 Ft | | | 25 Ft | | |
| | | | | | w | d | k | w | d | k | w | d | k | w | d | k |
| 5H3A | 16A & 12C | ✓ | | | 64 | 3.73 | 0.058 | - | - | - | - | - | - | - | - | - |
| 5H4A | 16A & 12C | ✓ | | | 71 | 2.33 | 0.033 | - | - | - | - | - | - | - | - | - |
| 1H5A | 16B & 20A | ✓ | ✓ | | 80 | 1.52 | 0.019 | 51 | 2.30 | 0.045 | - | - | - | - | - | - |
| 5H5A | 16C & 20B | ✓ | ✓ | | 131 | 1.83 | 0.014 | 84 | 2.77 | 0.033 | - | - | - | - | - | - |
| 7H5A | 20C | ✓ | ✓ | ✓ | 166 | 1.89 | 0.011 | 106 | 2.96 | 0.028 | 73 | 4.20 | 0.058 | - | - | - |
| 9H5A | 20C+ | ✓ | ✓ | ✓ | 266 | 2.27 | 0.009 | 170 | 3.55 | 0.021 | 117 | 5.04 | 0.043 | 108 | 5.48 | 0.51 |
| 7H6A | 20C | ✓ | ✓ | | 156 | 1.28 | 0.008 | 100 | 2.01 | 0.020 | 69 | 2.88 | 0.042 | - | - | - |
| 9H6A | 20C+ | ✓ | ✓ | | 233 | 1.49 | 0.006 | 149 | 2.38 | 0.016 | 103 | 3.40 | 0.033 | 95 | 3.61 | 0.038 |

NOTE: Contact your Cope representative for loading information on the 11H7A system

To convert 1.5 safety factor to 2.0 multiply w, d, k by .75

w = Pounds per linear foot

d = Deflections (inches)

k = Deflection (in.) for each pound of load

t = Denotes k is less than .001 inch

I-BEAM CABLE TRAY SYSTEM

PART NUMBERING SYSTEM:

Please pay careful attention to the part numbering structure. Example: Catalog No. 5H4A-06SL-12-09 is a 4" load depth aluminum ladder with an I-Beam flange, 6 inches wide, straight length 12 feet long, rungs on 9" centers. Please make sure to use the system numbers from pages 66 and 67 when ordering.

STRAIGHT LENGTH

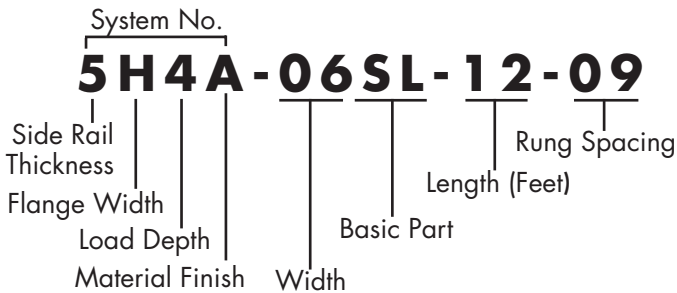

FITTINGS

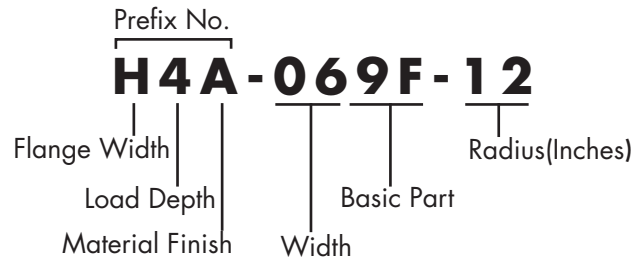

SYSTEM NUMBER (STRAIGHT SECTION ONLY) -

The first four digits make up the system number which identifies the structural, dimensional and material characteristics of the straight length. It is made up of the side rail digits indicating the side rail thickness and flange design, the load depth (inside, in inches) and material finish (aluminum).

- 1H5A:** 3 Thick, I-Beam Rail, 5" Load Depth, Aluminum
- 5H3A:** 5 Thick, I-Beam Rail, 3" Load Depth, Aluminum
- 5H4A:** 5 Thick, I-Beam Rail, 4" Load Depth, Aluminum
- 5H5A:** 5 Thick, I-Beam Rail, 5" Load Depth, Aluminum
- 7H5A:** 7 Thick, I-Beam Rail, 5" Load Depth, Aluminum
- 7H6A:** 7 Thick, I-Beam Rail, 6" Load Depth, Aluminum
- 9H5A:** 9 Thick, I-Beam Rail, 5" Load Depth, Aluminum
- 9H6A:** 9 Thick, I-Beam Rail, 6" Load Depth, Aluminum
- 11H7A:** 11 Thick, I-Beam Rail, 7" Load Depth, Aluminum

PREFIX NUMBER (FITTINGS ONLY) - Fittings are ordered using the 3-digit prefix number given in the charts on the fitting pages.

- H3A:** I-Beam Rail, 3" Load Depth, Aluminum
- H4A:** I-Beam Rail, 4" Load Depth, Aluminum
- H5A:** I-Beam Rail, 5" Load Depth, Aluminum
- H6A:** I-Beam Rail, 6" Load Depth, Aluminum
- H7A:** I-Beam Rail, 7" Load Depth, Aluminum

WIDTH - The inside width of the tray.

- 06:** 6" Width (152mm)
- 09:** 9" Width (229mm)
- 12:** 12" Width (305mm)
- 18:** 18" Width (457mm)
- 24:** 24" Width (610mm)
- 30:** 30" Width (762mm)
- 36:** 36" Width (914mm)

Length (STRAIGHT SECTION ONLY) - The length of the tray in feet.

- 12:** 12' Length (3.7m)
- 20:** 20' Length (6.1m)
- 24:** 24' Length (7.3m)
- 30:** 30' Length (9.1m)

BASIC PART NUMBER - Identifies the straight length, fitting, or accessory.

- SL:** Straight Length
- 9F:** 90° Horizontal Elbow
- 6F:** 60° Horizontal Elbow
- 4F:** 45° Horizontal Elbow
- 3F:** 30° Horizontal Elbow
- 9O:** 90° Vertical Outside Elbow
- 6O:** 60° Vertical Outside Elbow
- 4O:** 45° Vertical Outside Elbow
- 3O:** 30° Vertical Outside Elbow
- 9I:** 90° Vertical Inside Elbow
- 6I:** 60° Vertical Inside Elbow
- 4I:** 45° Vertical Inside Elbow
- 3I:** 30° Vertical Inside Elbow
- FT:** Horizontal Tee
- TT:** Horizontal Tapped Tee
- FC:** Horizontal Cross
- TC:** Horizontal Tapped Cross
- VT:** Vertical Tee
- SR:** Vertical Cable Support Elbow
- ST:** Straight Reducer
- RH:** Right Hand Reducer
- LH:** Left Hand Reducer
- RY:** 45°"Y" Right Hand Branch
- LY:** 45°"Y" Left Hand Branch

RUNG SPACING - The center-to-center distance between rungs on straight length. Rung spacing is maintained through centerline of all fittings.

- 09:** 9" Nominal (229mm) rung spacing

Radius (FITTINGS ONLY) - The radius of bend.

- 12:** 12" Length (305mm)
- 24:** 24" Length (610mm)
- 36:** 36" Length (914mm)

90° HORIZONTAL ELBOW [9F]

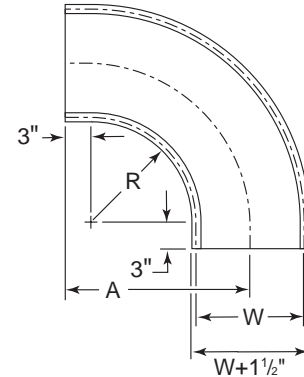
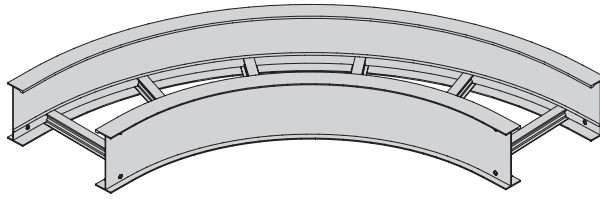

| Radius - R | Width - W | "A" Dimension |
|-----------------------|-------------|------------------|
| 12" (305mm) | 6" (152mm) | 18" (457mm) |
| | 9" (229mm) | 19 1/2" (495mm) |
| | 12" (305mm) | 21" (533mm) |
| | 18" (457mm) | 24" (610mm) |
| | 24" (610mm) | 27" (686mm) |
| | 30" (762mm) | 30" (762mm) |
| | 36" (914mm) | 33" (838mm) |
| 24" (610mm) | 6" (152mm) | 30" (762mm) |
| | 9" (229mm) | 31 1/2" (800mm) |
| | 12" (305mm) | 33" (838mm) |
| | 18" (457mm) | 36" (914mm) |
| | 24" (610mm) | 39" (991mm) |
| | 30" (762mm) | 42" (1067mm) |
| | 36" (914mm) | 45" (1143mm) |
| 36" (914mm) | 6" (152mm) | 42" (1067mm) |
| | 9" (229mm) | 43 1/2" (1105mm) |
| | 12" (305mm) | 45" (1143mm) |
| | 18" (457mm) | 48" (1219mm) |
| | 24" (610mm) | 51" (1295mm) |
| | 30" (762mm) | 54" (1372mm) |
| | 36" (914mm) | 57" (1448mm) |

Example: H4A-129F-12

NOTE: Nominal 9" rung spacing maintained through centerline of all fittings.

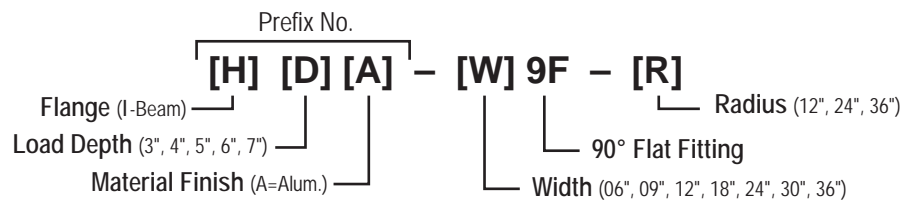

See Page 86
for Electrical
Grounding Chart

I-BEAM CABLE TRAY SYSTEM

60° HORIZONTAL ELBOW [6F]

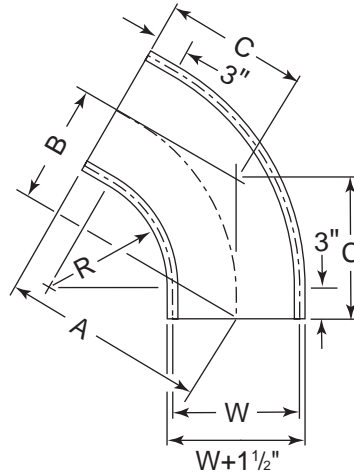
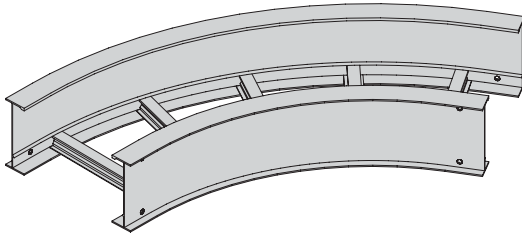

| Radius - R | Width - W | "A" Dimension | "B" Dimension | "C" Dimension |
|----------------|-------------|--------------------|-----------------|-------------------|
| 12" (305mm) | 6" (152mm) | 17 1/2" (445mm) | 10 1/8" (257mm) | 11 1/16" (297mm) |
| | 9" (229mm) | 18 13/16" (478mm) | 10 7/8" (276mm) | 12 1/2" (318mm) |
| | 12" (305mm) | 20 1/16" (510mm) | 11 5/8" (295mm) | 13 3/8" (340mm) |
| | 18" (457mm) | 22 11/16" (576mm) | 13 1/8" (333mm) | 15 1/8" (384mm) |
| | 24" (610mm) | 25 5/16" (643mm) | 14 5/8" (371mm) | 16 7/8" (429mm) |
| | 30" (762mm) | 27 7/8" (708mm) | 16 1/8" (410mm) | 18 9/16" (471mm) |
| | 36" (914mm) | 30 1/2" (775mm) | 17 5/8" (448mm) | 20 5/16" (516mm) |
| 24" (610mm) | 6" (152mm) | 27 7/8" (708mm) | 16 1/8" (410mm) | 18 9/16" (471mm) |
| | 9" (229mm) | 29 3/16" (741mm) | 16 7/8" (429mm) | 19 7/16" (494mm) |
| | 12" (305mm) | 30 1/2" (775mm) | 17 5/8" (448mm) | 20 5/16" (516mm) |
| | 18" (457mm) | 33 1/16" (840mm) | 19 1/8" (486mm) | 22 1/16" (560mm) |
| | 24" (610mm) | 35 11/16" (906mm) | 20 5/8" (524mm) | 23 13/16" (605mm) |
| | 30" (762mm) | 38 1/4" (972mm) | 22 1/8" (562mm) | 25 1/2" (648mm) |
| | 36" (914mm) | 40 7/8" (1038mm) | 23 5/8" (600mm) | 27 1/4" (692mm) |
| 36" (914mm) | 6" (152mm) | 38 1/4" (972mm) | 22 1/8" (562mm) | 25 1/2" (648mm) |
| | 9" (229mm) | 39 9/16" (1005mm) | 22 7/8" (581mm) | 26 3/8" (670mm) |
| | 12" (305mm) | 40 7/8" (1038mm) | 23 5/8" (600mm) | 27 1/4" (692mm) |
| | 18" (457mm) | 43 1/2" (1105mm) | 25 1/8" (638mm) | 29" (737mm) |
| | 24" (610mm) | 46 1/16" (1170mm) | 26 5/8" (676mm) | 30 11/16" (779mm) |
| | 30" (762mm) | 48 11/16" (1237mm) | 28 1/8" (714mm) | 32 7/16" (824mm) |
| | 36" (914mm) | 51 1/4" (1302mm) | 29 5/8" (752mm) | 34 3/16" (868mm) |

Example: H4A-126F-12

NOTE: Nominal 9" rung spacing maintained through centerline of all fittings.

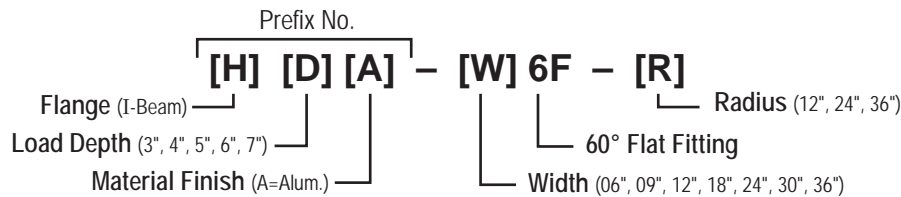

See Page 86
for Electrical
Grounding Chart

45° HORIZONTAL ELBOW [4F]

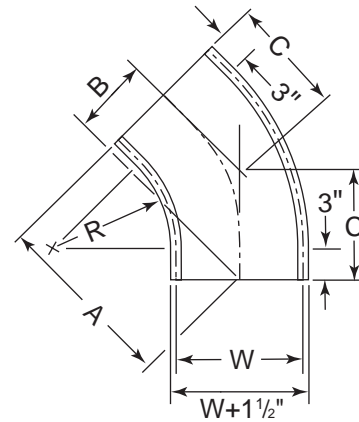
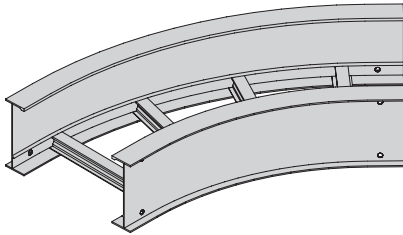

| Radius - R | Width - W | "A" Dimension | "B" Dimension | "C" Dimension |
|-----------------------|-------------------|-------------------|-------------------|-------------------|
| 12" (305mm) | 6" (152mm) | 15 3/4" (400mm) | 6 1/2" (165mm) | 9 3/16" (233mm) |
| | 9" (229mm) | 16 13/16" (427mm) | 6 15/16" (176mm) | 9 13/16" (249mm) |
| | 12" (305mm) | 17 7/8" (454mm) | 7 3/8" (187mm) | 10 7/16" (265mm) |
| | 18" (457mm) | 20" (508mm) | 8 1/4" (210mm) | 11 1/16" (297mm) |
| | 24" (610mm) | 22 1/16" (560mm) | 9 9/8" (232mm) | 12 15/16" (329mm) |
| | 30" (762mm) | 24 3/16" (614mm) | 10" (254mm) | 14 3/16" (360mm) |
| 36" (914mm) | 26 5/16" (668mm) | 10 15/16" (278mm) | 15 7/16" (392mm) | |
| 24" (610mm) | 6" (152mm) | 24 3/16" (614mm) | 10" (254mm) | 14 3/16" (360mm) |
| | 9" (229mm) | 25 1/4" (641mm) | 10 1/2" (267mm) | 14 13/16" (376mm) |
| | 12" (305mm) | 26 5/16" (668mm) | 10 15/16" (278mm) | 15 7/16" (392mm) |
| | 18" (457mm) | 28 7/16" (722mm) | 11 13/16" (300mm) | 16 1/16" (424mm) |
| | 24" (610mm) | 30 9/16" (776mm) | 12 1/16" (322mm) | 17 15/16" (456mm) |
| | 30" (762mm) | 32 1/16" (830mm) | 13 3/16" (344mm) | 19 1/8" (486mm) |
| 36" (914mm) | 34 13/16" (884mm) | 14 7/16" (367mm) | 20 3/8" (518mm) | |
| 36" (914mm) | 6" (152mm) | 32 1/16" (830mm) | 13 9/16" (344mm) | 19 1/8" (486mm) |
| | 9" (229mm) | 33 3/4" (857mm) | 14" (356mm) | 19 3/4" (502mm) |
| | 12" (305mm) | 34 13/16" (884mm) | 14 7/16" (367mm) | 20 3/8" (518mm) |
| | 18" (457mm) | 36 15/16" (938mm) | 15 5/16" (389mm) | 21 5/8" (549mm) |
| | 24" (610mm) | 39 7/16" (992mm) | 16 3/16" (411mm) | 22 7/8" (581mm) |
| | 30" (762mm) | 41 3/16" (1046mm) | 17 1/16" (433mm) | 24 1/8" (613mm) |
| 36" (914mm) | 43 5/16" (1100mm) | 17 15/16" (456mm) | 25 3/8" (645mm) | |

Example: H4A-124F-12

NOTE: Nominal 9" rung spacing maintained through centerline of all fittings.



See Page 86
for Electrical
Grounding Chart

I-BEAM CABLE TRAY SYSTEM

30° HORIZONTAL ELBOW [3F]

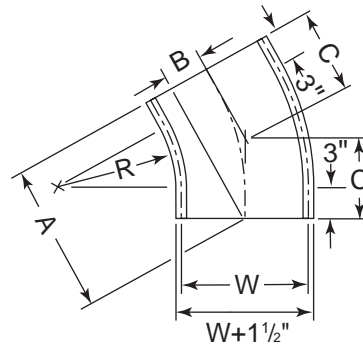
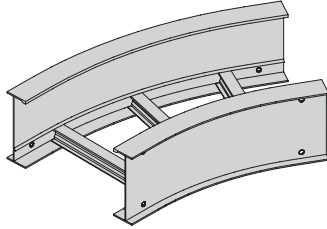

| Radius - R | Width - W | "A" Dimension | "B" Dimension | "C" Dimension |
|----------------|-------------|-----------------|------------------|-------------------|
| 12" (305mm) | 6" (152mm) | 13 1/8" (333mm) | 3 1/2" (89mm) | 7" (178mm) |
| | 9" (229mm) | 13 7/8" (352mm) | 3 11/16" (94mm) | 7 7/16" (189mm) |
| | 12" (305mm) | 14 5/8" (371mm) | 3 15/16" (100mm) | 7 13/16" (198mm) |
| | 18" (457mm) | 16 1/8" (410mm) | 4 5/16" (110mm) | 8 5/8" (219mm) |
| | 24" (610mm) | 17 5/8" (448mm) | 4 11/16" (119mm) | 9 7/16" (240mm) |
| | 30" (762mm) | 19 1/8" (486mm) | 5 1/8" (130mm) | 10 1/4" (260mm) |
| | 36" (914mm) | 20 5/8" (524mm) | 5 1/2" (140mm) | 11 1/16" (281mm) |
| 24" (610mm) | 6" (152mm) | 19 1/8" (486mm) | 5 1/8" (130mm) | 10 1/4" (260mm) |
| | 9" (229mm) | 19 7/8" (505mm) | 5 5/16" (135mm) | 10 5/8" (270mm) |
| | 12" (305mm) | 20 5/8" (524mm) | 5 1/2" (140mm) | 11 1/16" (281mm) |
| | 18" (457mm) | 22 1/8" (562mm) | 5 15/16" (151mm) | 11 13/16" (300mm) |
| | 24" (610mm) | 23 5/8" (600mm) | 6 5/16" (160mm) | 12 5/8" (321mm) |
| | 30" (762mm) | 25 1/8" (638mm) | 6 3/4" (171mm) | 13 7/16" (341mm) |
| | 36" (914mm) | 26 5/8" (676mm) | 7 1/8" (181mm) | 14 1/4" (362mm) |
| 36" (914mm) | 6" (152mm) | 25 1/8" (638mm) | 6 3/4" (171mm) | 13 7/16" (341mm) |
| | 9" (229mm) | 25 7/8" (657mm) | 6 15/16" (176mm) | 13 7/8" (352mm) |
| | 12" (305mm) | 26 5/8" (676mm) | 7 1/8" (181mm) | 14 1/4" (362mm) |
| | 18" (457mm) | 28 1/8" (714mm) | 7 1/2" (191mm) | 15 1/16" (383mm) |
| | 24" (610mm) | 29 5/8" (752mm) | 7 15/16" (202mm) | 15 7/8" (403mm) |
| | 30" (762mm) | 31 1/8" (791mm) | 8 5/16" (211mm) | 16 1/16" (424mm) |
| | 36" (914mm) | 32 5/8" (829mm) | 8 3/4" (222mm) | 17 1/2" (445mm) |

Example: H4A-123F-12

NOTE: Nominal 9" rung spacing maintained through centerline of all fittings.



See Page 86
for Electrical
Grounding Chart

HORIZONTAL TEE [FT]

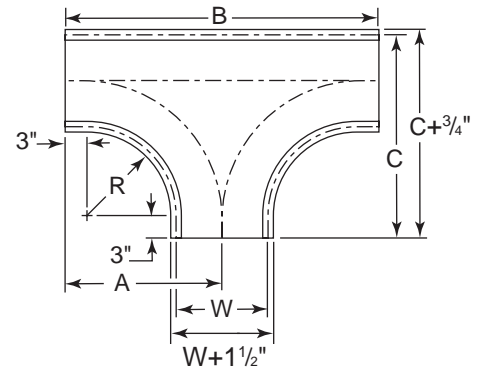
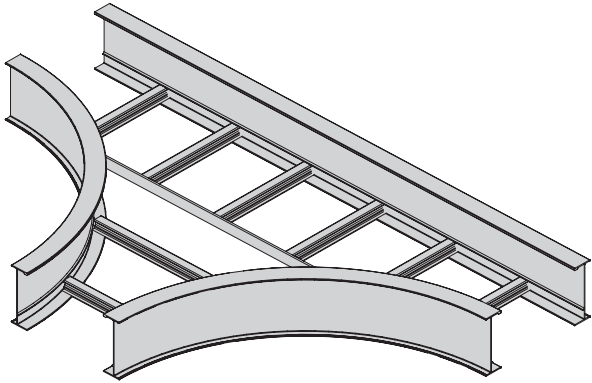

| Radius - R | Width - W | "A" Dimension | "B" Dimension | "C" Dimension |
|-----------------------|-------------|------------------|---------------|---------------|
| 12" (305mm) | 6" (152mm) | 18" (457mm) | 36" (914mm) | 21" (533mm) |
| | 9" (229mm) | 19 1/2" (495mm) | 39" (991mm) | 24" (610mm) |
| | 12" (305mm) | 21" (533mm) | 42" (1067mm) | 27" (686mm) |
| | 18" (457mm) | 24" (610mm) | 48" (1219mm) | 33" (838mm) |
| | 24" (610mm) | 27" (686mm) | 54" (1372mm) | 39" (991mm) |
| | 30" (762mm) | 30" (762mm) | 60" (1524mm) | 45" (1143mm) |
| | 36" (914mm) | 33" (838mm) | 66" (1676mm) | 51" (1295mm) |
| 24" (610mm) | 6" (152mm) | 30" (762mm) | 60" (1524mm) | 33" (838mm) |
| | 9" (229mm) | 31 1/2" (800mm) | 63" (1600mm) | 36" (914mm) |
| | 12" (305mm) | 33" (838mm) | 66" (1676mm) | 39" (991mm) |
| | 18" (457mm) | 36" (914mm) | 72" (1829mm) | 45" (1143mm) |
| | 24" (610mm) | 39" (991mm) | 78" (1981mm) | 51" (1295mm) |
| | 30" (762mm) | 42" (1067mm) | 84" (2134mm) | 57" (1448mm) |
| | 36" (914mm) | 45" (1143mm) | 90" (2286mm) | 63" (1600mm) |
| 36" (914mm) | 6" (152mm) | 42" (1067mm) | 84" (2134mm) | 45" (1143mm) |
| | 9" (229mm) | 43 1/2" (1105mm) | 87" (2210mm) | 48" (1219mm) |
| | 12" (305mm) | 45" (1143mm) | 90" (2286mm) | 51" (1295mm) |
| | 18" (457mm) | 48" (1219mm) | 96" (2438mm) | 57" (1448mm) |
| | 24" (610mm) | 51" (1295mm) | 102" (2591mm) | 63" (1600mm) |
| | 30" (762mm) | 54" (1372mm) | 108" (2743mm) | 69" (1753mm) |
| | 36" (914mm) | 57" (1448mm) | 114" (2896mm) | 75" (1905mm) |

Example: H4A-12FT-12

NOTE: Nominal 9" rung spacing maintained through centerline of all fittings.

Prefix No. **[H] [D] [A] - [W] FT - [R]**

Flange (H=I-Beam) ————

Load Depth (3", 4", 5", 6", 7") ————

Material Finish (A=Alum.) ————

Radius (12", 24", 36")

Flat "Tee" Fitting

Width (06", 09", 12", 18", 24", 30", 36")

See Page 86
for Electrical
Grounding Chart

I-BEAM CABLE TRAY SYSTEM

HORIZONTAL TAPPED TEE [TT]

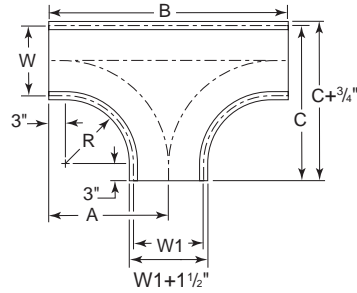
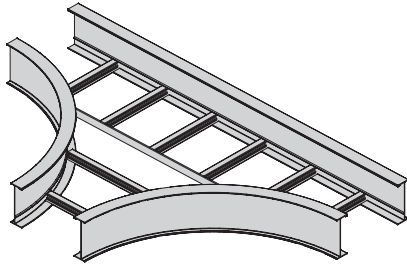

| R Radius | W Width | W1 Width | "A" Dimension | "C" Dimension |
|----------------|-------------|-------------|------------------|------------------|
| 12" (305mm) | 36" (914mm) | 30" (762mm) | 27" (686mm) | 48" (1219mm) |
| | 36" (914mm) | 24" (610mm) | 24" (610mm) | 48" (1219mm) |
| | 36" (914mm) | 18" (457mm) | 21" (533mm) | 48" (1219mm) |
| | 36" (914mm) | 12" (305mm) | 18" (457mm) | 48" (1219mm) |
| | 36" (914mm) | 9" (229mm) | 16 1/2" (419mm) | 48" (1219mm) |
| | 36" (914mm) | 6" (152mm) | 15" (381mm) | 48" (1219mm) |
| | 30" (762mm) | 24" (610mm) | 24" (610mm) | 42" (1067mm) |
| | 30" (762mm) | 18" (457mm) | 21" (533mm) | 42" (1067mm) |
| | 30" (762mm) | 12" (305mm) | 18" (457mm) | 42" (1067mm) |
| | 30" (762mm) | 9" (229mm) | 16 1/2" (419mm) | 42" (1067mm) |
| | 30" (762mm) | 6" (152mm) | 15" (381mm) | 42" (1067mm) |
| | 24" (610mm) | 18" (457mm) | 21" (533mm) | 36" (914mm) |
| | 24" (610mm) | 12" (305mm) | 18" (457mm) | 36" (914mm) |
| | 24" (610mm) | 9" (229mm) | 16 1/2" (419mm) | 36" (914mm) |
| | 24" (610mm) | 6" (152mm) | 15" (381mm) | 36" (914mm) |
| | 18" (457mm) | 12" (305mm) | 18" (457mm) | 30" (762mm) |
| | 18" (457mm) | 9" (229mm) | 16 1/2" (419mm) | 30" (762mm) |
| | 18" (457mm) | 6" (152mm) | 15" (381mm) | 30" (762mm) |
| | 12" (305mm) | 9" (229mm) | 16 1/2" (419mm) | 24" (610mm) |
| | 12" (305mm) | 6" (152mm) | 15" (381mm) | 24" (610mm) |
| 9" (229mm) | 6" (152mm) | 15" (381mm) | 21" (533mm) | |
| 24" (610mm) | 36" (914mm) | 30" (762mm) | 39" (991mm) | 60" (1524mm) |
| | 36" (914mm) | 24" (610mm) | 36" (914mm) | 60" (1524mm) |
| | 36" (914mm) | 18" (457mm) | 33" (838mm) | 60" (1524mm) |
| | 36" (914mm) | 12" (305mm) | 30" (762mm) | 60" (1524mm) |
| | 36" (914mm) | 9" (229mm) | 28 1/2" (724mm) | 60" (1524mm) |
| | 36" (914mm) | 6" (152mm) | 27" (686mm) | 60" (1524mm) |
| | 30" (762mm) | 24" (610mm) | 36" (914mm) | 54" (1372mm) |
| | 30" (762mm) | 18" (457mm) | 33" (838mm) | 54" (1372mm) |
| | 30" (762mm) | 12" (305mm) | 30" (762mm) | 54" (1372mm) |
| | 30" (762mm) | 9" (229mm) | 28 1/2" (724mm) | 54" (1372mm) |
| | 30" (762mm) | 6" (152mm) | 27" (686mm) | 54" (1372mm) |

| R Radius | W Width | W1 Width | "A" Dimension | "C" Dimension |
|---------------------------|-------------|------------------|------------------|------------------|
| 24" (610mm) (Cont.) | 24" (610mm) | 18" (457mm) | 33" (838mm) | 48" (1219mm) |
| | 24" (610mm) | 12" (305mm) | 30" (762mm) | 48" (1219mm) |
| | 24" (610mm) | 9" (229mm) | 28 1/2" (724mm) | 48" (1219mm) |
| | 24" (610mm) | 6" (152mm) | 27" (686mm) | 48" (1219mm) |
| | 18" (457mm) | 12" (305mm) | 30" (762mm) | 42" (1067mm) |
| | 18" (457mm) | 9" (229mm) | 28 1/2" (724mm) | 42" (1067mm) |
| | 18" (457mm) | 6" (152mm) | 27" (686mm) | 42" (1067mm) |
| | 12" (305mm) | 9" (229mm) | 28 1/2" (724mm) | 36" (914mm) |
| | 12" (305mm) | 6" (152mm) | 27" (686mm) | 36" (914mm) |
| | 9" (229mm) | 6" (152mm) | 27" (686mm) | 33" (838mm) |
| 36" (914mm) | 36" (914mm) | 30" (762mm) | 51" (1295mm) | 72" (1829mm) |
| | 36" (914mm) | 24" (610mm) | 48" (1219mm) | 72" (1829mm) |
| | 36" (914mm) | 18" (457mm) | 45" (1143mm) | 72" (1829mm) |
| | 36" (914mm) | 12" (305mm) | 42" (1067mm) | 72" (1829mm) |
| | 36" (914mm) | 9" (229mm) | 40 1/2" (1029mm) | 72" (1829mm) |
| | 36" (914mm) | 6" (152mm) | 39" (991mm) | 72" (1829mm) |
| | 30" (762mm) | 24" (610mm) | 48" (1219mm) | 66" (1676mm) |
| | 30" (762mm) | 18" (457mm) | 45" (1143mm) | 66" (1676mm) |
| | 30" (762mm) | 12" (305mm) | 42" (1067mm) | 66" (1676mm) |
| | 30" (762mm) | 9" (229mm) | 40 1/2" (1029mm) | 66" (1676mm) |
| | 30" (762mm) | 6" (152mm) | 39" (991mm) | 66" (1676mm) |
| | 24" (610mm) | 18" (457mm) | 45" (1143mm) | 60" (1524mm) |
| | 24" (610mm) | 12" (305mm) | 42" (1067mm) | 60" (1524mm) |
| | 24" (610mm) | 9" (229mm) | 40 1/2" (1029mm) | 60" (1524mm) |
| | 24" (610mm) | 6" (152mm) | 39" (991mm) | 60" (1524mm) |
| 18" (457mm) | 12" (305mm) | 42" (1067mm) | 54" (1372mm) | |
| 18" (457mm) | 9" (229mm) | 40 1/2" (1029mm) | 54" (1372mm) | |
| 18" (457mm) | 6" (152mm) | 39" (991mm) | 54" (1372mm) | |
| 12" (305mm) | 9" (229mm) | 40 1/2" (1029mm) | 48" (1219mm) | |
| 12" (305mm) | 6" (152mm) | 39" (991mm) | 48" (1219mm) | |
| 9" (229mm) | 6" (152mm) | 39" (991mm) | 45" (1143mm) | |

NOTE: Nominal 9" rung spacing maintained through centerline of all fittings.

Standing tees available upon request.

Prefix No. **[H] [D] [A] - [W] TT - [W1] - [R]**

Flange (H=I-Beam) ———

Load Depth (3", 4", 5", 6", 7") ———

Material Finish (A=Alum.) ———

Radius (12", 24", 36")

Width (06", 09", 12", 18", 24", 30", 36")

Tapped Tee

Width (06", 09", 12", 18", 24", 30", 36")

See Page 86
for Electrical
Grounding Chart

HORIZONTAL CROSS [FC]

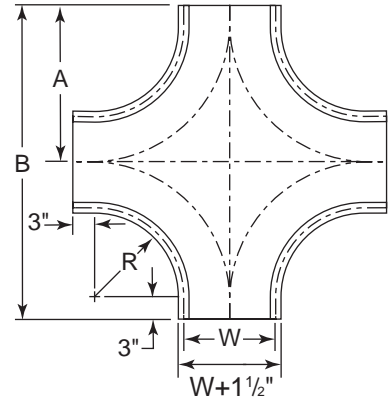
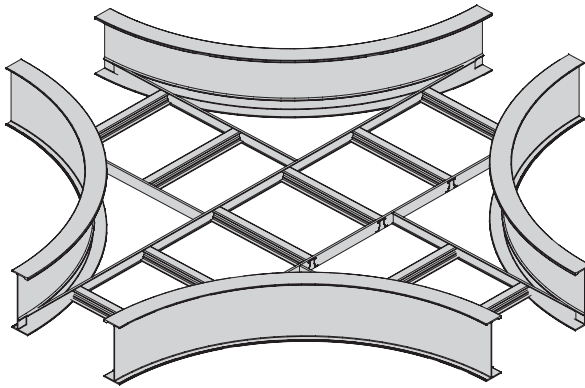

| Radius - R | Width - W | "A" Dimension | "B" Dimension |
|----------------|--------------|------------------|---------------|
| 12" (305mm) | 6" (152mm) | 18" (457mm) | 36" (914mm) |
| | 9" (229mm) | 19 1/2" (495mm) | 39" (991mm) |
| | 12" (305mm) | 21" (533mm) | 42" (1067mm) |
| | 18" (457mm) | 24" (610mm) | 48" (1219mm) |
| | 24" (610mm) | 27" (686mm) | 54" (1372mm) |
| | 30" (762mm) | 30" (762mm) | 60" (1524mm) |
| 24" (610mm) | 6" (152mm) | 30" (762mm) | 60" (1524mm) |
| | 9" (229mm) | 31 1/2" (800mm) | 63" (1600mm) |
| | 12" (305mm) | 33" (838mm) | 66" (1676mm) |
| | 18" (457mm) | 36" (914mm) | 72" (1829mm) |
| | 24" (610mm) | 39" (991mm) | 78" (1981mm) |
| | 30" (762mm) | 42" (1067mm) | 84" (2134mm) |
| 36" (914mm) | 6" (152mm) | 42" (1067mm) | 84" (2134mm) |
| | 9" (229mm) | 43 1/2" (1105mm) | 87" (2210mm) |
| | 12" (305mm) | 45" (1143mm) | 90" (2286mm) |
| | 18" (457mm) | 48" (1219mm) | 96" (2438mm) |
| | 24" (610mm) | 51" (1295mm) | 102" (2591mm) |
| | 30" (762mm) | 54" (1372mm) | 108" (2743mm) |
| 36" (914mm) | 57" (1448mm) | 114" (2896mm) | |

Example: H4A-12FC-12

NOTE: Nominal 9" rung spacing maintained through centerline of all fittings.

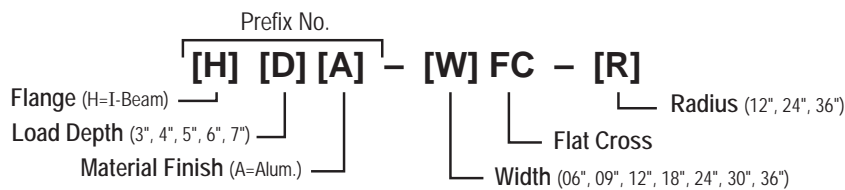

See Page 86
for Electrical
Grounding Chart

I-BEAM CABLE TRAY SYSTEM

HORIZONTAL TAPPED CROSS [TC]

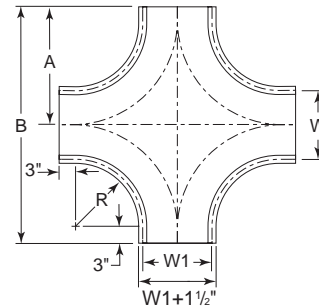
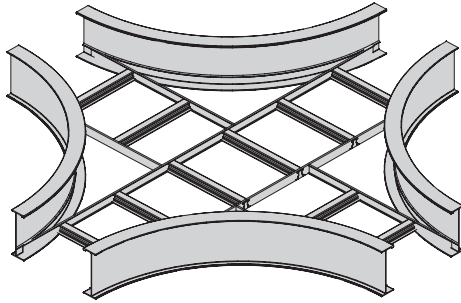

| R Radius | W Width | W1 Width | "A" Dimension | "C" Dimension |
|----------------|-------------|-------------|------------------|------------------|
| 12" (305mm) | 36" (914mm) | 30" (762mm) | 27" (686mm) | 60" (1524mm) |
| | 36" (914mm) | 24" (610mm) | 24" (610mm) | 60" (1524mm) |
| | 36" (914mm) | 18" (457mm) | 21" (533mm) | 60" (1524mm) |
| | 36" (914mm) | 12" (305mm) | 18" (457mm) | 60" (1524mm) |
| | 36" (914mm) | 9" (229mm) | 16 1/2" (419mm) | 60" (1524mm) |
| | 36" (914mm) | 6" (152mm) | 15" (381mm) | 60" (1524mm) |
| | 30" (762mm) | 24" (610mm) | 24" (610mm) | 54" (1372mm) |
| | 30" (762mm) | 18" (457mm) | 21" (533mm) | 54" (1372mm) |
| | 30" (762mm) | 12" (305mm) | 18" (457mm) | 54" (1372mm) |
| | 30" (762mm) | 9" (229mm) | 16 1/2" (419mm) | 54" (1372mm) |
| | 30" (762mm) | 6" (152mm) | 15" (381mm) | 54" (1372mm) |
| | 24" (610mm) | 18" (457mm) | 21" (533mm) | 48" (1219mm) |
| | 24" (610mm) | 12" (305mm) | 18" (457mm) | 48" (1219mm) |
| | 24" (610mm) | 9" (229mm) | 16 1/2" (419mm) | 48" (1219mm) |
| | 24" (610mm) | 6" (152mm) | 15" (381mm) | 48" (1219mm) |
| | 18" (457mm) | 12" (305mm) | 18" (457mm) | 42" (1067mm) |
| | 18" (457mm) | 9" (229mm) | 16 1/2" (419mm) | 42" (1067mm) |
| | 18" (457mm) | 6" (152mm) | 15" (381mm) | 42" (1067mm) |
| | 12" (305mm) | 9" (229mm) | 16 1/2" (419mm) | 36" (914mm) |
| | 12" (305mm) | 6" (152mm) | 15" (381mm) | 36" (914mm) |
| 9" (229mm) | 6" (152mm) | 15" (381mm) | 33" (838mm) | |
| 24" (610mm) | 36" (914mm) | 30" (762mm) | 39" (991mm) | 84" (2134mm) |
| | 36" (914mm) | 24" (610mm) | 36" (914mm) | 84" (2134mm) |
| | 36" (914mm) | 18" (457mm) | 33" (838mm) | 84" (2134mm) |
| | 36" (914mm) | 12" (305mm) | 30" (762mm) | 84" (2134mm) |
| | 36" (914mm) | 9" (229mm) | 28 1/2" (724mm) | 84" (2134mm) |
| | 36" (914mm) | 6" (152mm) | 27" (686mm) | 84" (2134mm) |
| | 30" (762mm) | 24" (610mm) | 36" (914mm) | 78" (1981mm) |
| | 30" (762mm) | 18" (457mm) | 33" (838mm) | 78" (1981mm) |
| | 30" (762mm) | 12" (305mm) | 30" (762mm) | 78" (1981mm) |
| | 30" (762mm) | 9" (229mm) | 28 1/2" (724mm) | 78" (1981mm) |
| | 30" (762mm) | 6" (152mm) | 27" (686mm) | 78" (1981mm) |

| R Radius | W Width | W1 Width | "A" Dimension | "C" Dimension |
|---------------------------|-------------|------------------|------------------|------------------|
| 24" (610mm) (Cont.) | 24" (610mm) | 18" (457mm) | 33" (838mm) | 72" (1829mm) |
| | 24" (610mm) | 12" (305mm) | 30" (762mm) | 72" (1829mm) |
| | 24" (610mm) | 9" (229mm) | 28 1/2" (724mm) | 72" (1829mm) |
| | 24" (610mm) | 6" (152mm) | 27" (686mm) | 72" (1829mm) |
| | 18" (457mm) | 12" (305mm) | 30" (762mm) | 66" (1676mm) |
| | 18" (457mm) | 9" (229mm) | 28 1/2" (724mm) | 66" (1676mm) |
| | 18" (457mm) | 6" (152mm) | 27" (686mm) | 66" (1676mm) |
| | 12" (305mm) | 9" (229mm) | 28 1/2" (724mm) | 60" (1524mm) |
| | 12" (305mm) | 6" (152mm) | 27" (686mm) | 60" (1524mm) |
| | 9" (229mm) | 6" (152mm) | 27" (686mm) | 57" (1448mm) |
| 36" (914mm) | 36" (914mm) | 30" (762mm) | 51" (1295mm) | 108" (2743mm) |
| | 36" (914mm) | 24" (610mm) | 48" (1219mm) | 108" (2743mm) |
| | 36" (914mm) | 18" (457mm) | 45" (1143mm) | 108" (2743mm) |
| | 36" (914mm) | 12" (305mm) | 42" (1067mm) | 108" (2743mm) |
| | 36" (914mm) | 9" (229mm) | 40 1/2" (1029mm) | 108" (2743mm) |
| | 36" (914mm) | 6" (152mm) | 39" (991mm) | 108" (2743mm) |
| | 30" (762mm) | 24" (610mm) | 48" (1219mm) | 102" (2591mm) |
| | 30" (762mm) | 18" (457mm) | 45" (1143mm) | 102" (2591mm) |
| | 30" (762mm) | 12" (305mm) | 42" (1067mm) | 102" (2591mm) |
| | 30" (762mm) | 9" (229mm) | 40 1/2" (1029mm) | 102" (2591mm) |
| | 30" (762mm) | 6" (152mm) | 39" (991mm) | 102" (2591mm) |
| | 24" (610mm) | 18" (457mm) | 45" (1143mm) | 96" (2438mm) |
| | 24" (610mm) | 12" (305mm) | 42" (1067mm) | 96" (2438mm) |
| | 24" (610mm) | 9" (229mm) | 40 1/2" (1029mm) | 96" (2438mm) |
| | 24" (610mm) | 6" (152mm) | 39" (991mm) | 96" (2438mm) |
| | 18" (457mm) | 12" (305mm) | 42" (1067mm) | 90" (2286mm) |
| | 18" (457mm) | 9" (229mm) | 40 1/2" (1029mm) | 90" (2286mm) |
| | 18" (457mm) | 6" (152mm) | 39" (991mm) | 90" (2286mm) |
| 12" (305mm) | 9" (229mm) | 40 1/2" (1029mm) | 84" (2134mm) | |
| 12" (305mm) | 6" (152mm) | 39" (991mm) | 84" (2134mm) | |
| 9" (229mm) | 6" (152mm) | 39" (991mm) | 81" (2057mm) | |

NOTE: Nominal 9" rung spacing maintained through centerline of all fittings.

Expanding cross available upon request.



See Page 86 for Electrical Grounding Chart

LEFT HAND [LH] & RIGHT HAND [RH] REDUCER

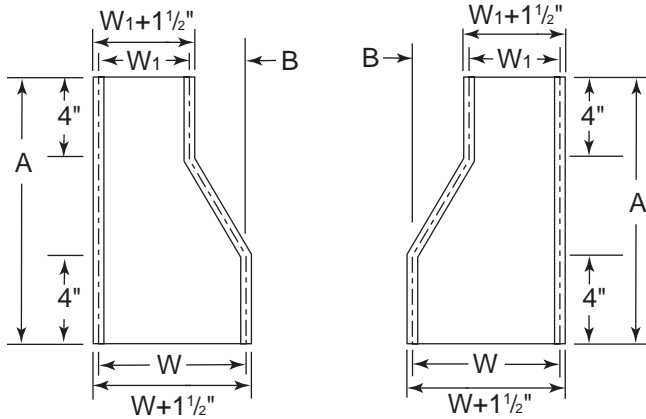
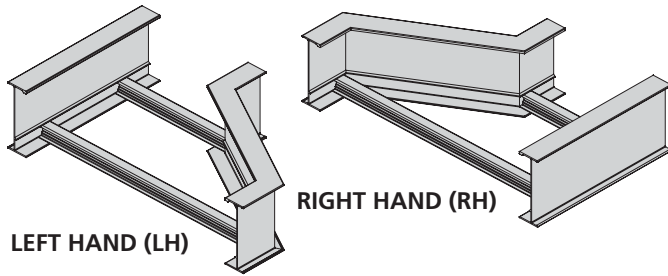

STRAIGHT REDUCER [ST]

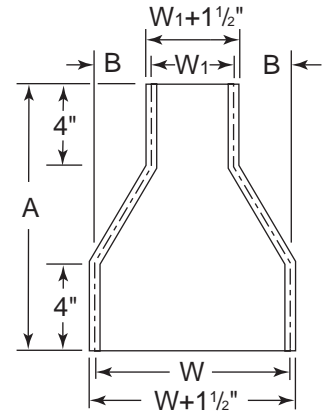
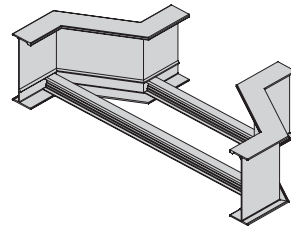

| W | W1 | "A" Dimension | "B" Dimension |
|-------------|-------------|-------------------|---------------|
| 9" (229mm) | 6" (152mm) | 9 3/4" (248mm) | 3" (76mm) |
| 12" (305mm) | 6" (152mm) | 11 7/16" (291mm) | 6" (152mm) |
| | 9" (229mm) | 9 3/4" (248mm) | 3" (76mm) |
| 18" (457mm) | 6" (152mm) | 14 15/16" (379mm) | 12" (305mm) |
| | 9" (229mm) | 13 3/16" (335mm) | 9" (229mm) |
| | 12" (305mm) | 11 7/16" (291mm) | 6" (152mm) |
| 24" (610mm) | 6" (152mm) | 18 3/8" (467mm) | 18" (457mm) |
| | 9" (229mm) | 16 11/16" (424mm) | 15" (381mm) |
| | 12" (305mm) | 14 15/16" (379mm) | 12" (305mm) |
| | 18" (457mm) | 11 7/16" (291mm) | 6" (152mm) |
| 30" (762mm) | 6" (152mm) | 21 7/8" (556mm) | 24" (610mm) |
| | 9" (229mm) | 20 7/8" (511mm) | 21" (533mm) |
| | 12" (305mm) | 18 3/8" (467mm) | 18" (457mm) |
| | 18" (457mm) | 14 15/16" (379mm) | 12" (305mm) |
| | 24" (610mm) | 11 7/16" (291mm) | 6" (152mm) |
| 36" (914mm) | 6" (152mm) | 25 5/16" (643mm) | 30" (762mm) |
| | 9" (229mm) | 23 9/16" (598mm) | 27" (686mm) |
| | 12" (305mm) | 21 7/8" (556mm) | 24" (610mm) |
| | 18" (457mm) | 18 3/8" (467mm) | 18" (457mm) |
| | 24" (610mm) | 14 15/16" (379mm) | 12" (305mm) |
| | 30" (762mm) | 11 7/16" (291mm) | 6" (152mm) |

Example: H4A-12LH-06

NOTE: Nominal 9" rung spacing maintained through centerline of all fittings.

| W | W1 | "A" Dimension | "B" Dimension |
|-------------|-------------|-------------------|-----------------|
| 9" (229mm) | 6" (152mm) | 8 7/8" (225mm) | 1 1/2" (38mm) |
| 12" (305mm) | 6" (152mm) | 9 3/4" (248mm) | 3" (76mm) |
| | 9" (229mm) | 8 7/8" (225mm) | 1 1/2" (38mm) |
| 18" (457mm) | 6" (152mm) | 11 7/16" (291mm) | 6" (152mm) |
| | 9" (229mm) | 10 5/8" (270mm) | 4 1/2" (114mm) |
| | 12" (305mm) | 9 3/4" (248mm) | 3" (76mm) |
| 24" (610mm) | 6" (152mm) | 13 3/16" (335mm) | 9" (229mm) |
| | 9" (229mm) | 12 5/16" (313mm) | 7 1/2" (191mm) |
| | 12" (305mm) | 11 7/16" (291mm) | 6" (152mm) |
| | 18" (457mm) | 9 3/4" (248mm) | 3" (76mm) |
| 30" (762mm) | 6" (152mm) | 14 15/16" (379mm) | 12" (305mm) |
| | 9" (229mm) | 14 1/16" (357mm) | 10 1/2" (267mm) |
| | 12" (305mm) | 13 3/16" (335mm) | 9" (229mm) |
| | 18" (457mm) | 11 7/16" (291mm) | 6" (152mm) |
| | 24" (610mm) | 9 3/4" (248mm) | 3" (76mm) |
| 36" (914mm) | 6" (152mm) | 16 11/16" (424mm) | 15" (381mm) |
| | 9" (229mm) | 15 13/16" (402mm) | 13 1/2" (343mm) |
| | 12" (305mm) | 14 15/16" (379mm) | 12" (305mm) |
| | 18" (457mm) | 13 3/16" (335mm) | 9" (229mm) |
| | 24" (610mm) | 11 7/16" (291mm) | 6" (152mm) |
| | 30" (762mm) | 9 3/4" (248mm) | 3" (76mm) |

Example: H4A-12ST-06

Prefix No. [H] [D] [A] - [W] [Bp] - [W1]

Flange (H=I-Beam) [H]
 Load Depth (3", 4", 5", 6", 7") [D]
 Material Finish (A=Alum.) [A]

Reduced Width (06", 09", 12", 18", 24", 30") [W]
 Basic Part (LH, RH, ST) [Bp]
 Width (06", 09", 12", 18", 24", 30", 36") [W1]

See Page 86 for Electrical Grounding Chart

I-BEAM CABLE TRAY SYSTEM

45°"Y" BRANCH LEFT HAND [LY] & RIGHT HAND [RY]

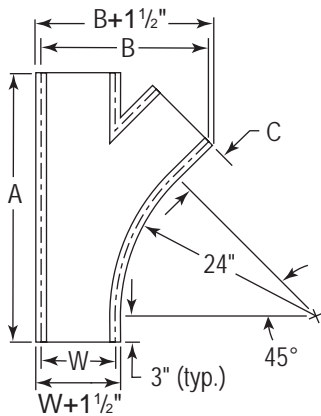
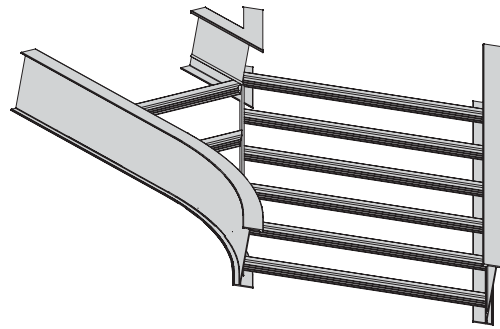
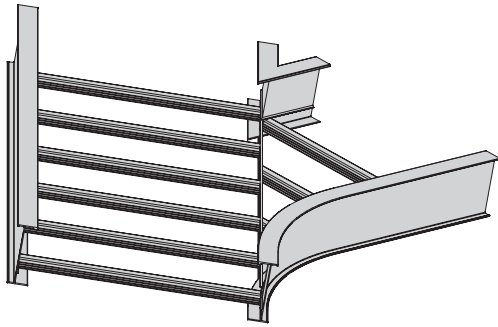

RIGHT HAND (RY)

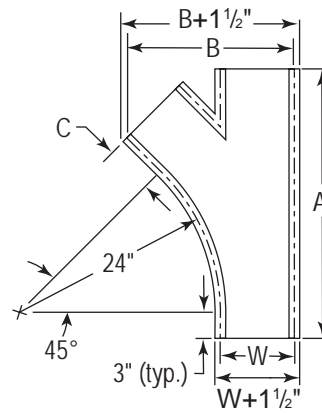

LEFT HAND (LY)

| W | "A" Dimension | "B" Dimension | "C" Dimension |
|-------------|---|---|---|
| 6" (152mm) | 28 ⁷ / ₁₆ " (722mm) | 15 ³ / ₁₆ " (386mm) | 3 ¹ / ₁₆ " (78mm) |
| 9" (229mm) | 32 ¹¹ / ₁₆ " (830mm) | 20 ⁵ / ₁₆ " (516mm) | 6 ¹ / ₁₆ " (154mm) |
| 12" (305mm) | 36 ¹⁵ / ₁₆ " (938mm) | 25 ⁷ / ₁₆ " (646mm) | 9 ¹ / ₁₆ " (230mm) |
| 18" (457mm) | 45 ³ / ₈ " (1153mm) | 35 ¹³ / ₁₆ " (910mm) | 15 ¹ / ₁₆ " (383mm) |
| 24" (610mm) | 53 ⁷ / ₈ " (1368mm) | 45 ¹⁵ / ₁₆ " (1167mm) | 21 ¹ / ₁₆ " (535mm) |
| 30" (762mm) | 62 ³ / ₈ " (1584mm) | 56 ³ / ₁₆ " (1427mm) | 27 ¹ / ₁₆ " (687mm) |
| 36" (914mm) | 70 ¹³ / ₁₆ " (1799mm) | 66 ⁷ / ₁₆ " (1688mm) | 33 ¹ / ₁₆ " (840mm) |

Example: H4A-12LY

NOTE: Nominal 9" rung spacing maintained through centerline of all fittings.

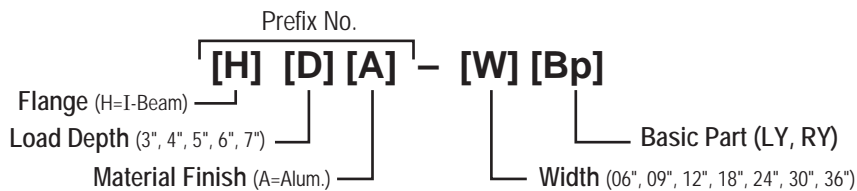

See Page 86
for Electrical
Grounding Chart

90° VERTICAL ELBOW OUTSIDE [90] & INSIDE [91]

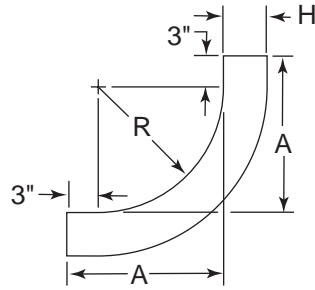
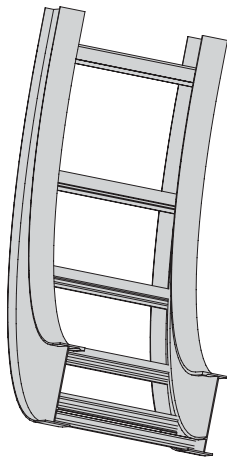

INSIDE (91)

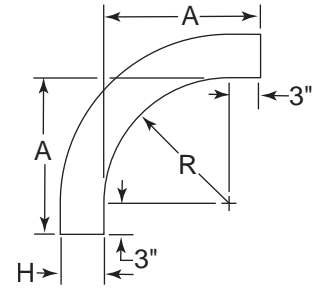
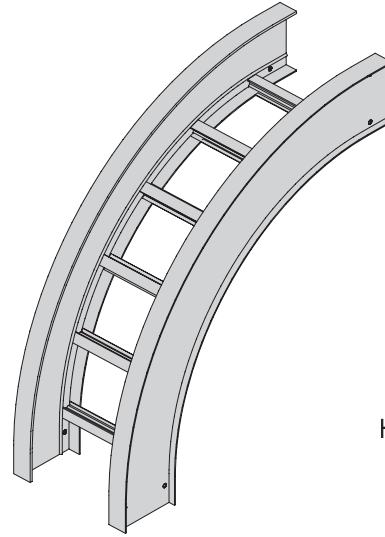

OUTSIDE (90)

| Radius - R | Load Depth | "H" Dimension | A (Outside 90) | A (Inside 91) |
|-----------------------|-------------|----------------|----------------|------------------|
| 12" (305mm) | 3" (76mm) | 4 1/8" (105mm) | 15" (381mm) | 19 1/8" (486mm) |
| | 4" (102mm) | 5" (127mm) | 15" (381mm) | 20" (508mm) |
| | 5" (127mm) | 6 1/4" (159mm) | 15" (381mm) | 21 1/4" (540mm) |
| | 6" (152mm) | 7 1/4" (184mm) | 15" (381mm) | 22 1/4" (565mm) |
| | 7" (179mm) | 8" (203mm) | 15" (381mm) | 23" (584mm) |
| 24" (610mm) | 3" (76mm) | 4 1/8" (105mm) | 27" (686mm) | 31 1/8" (791mm) |
| | 4" (102mm) | 5" (127mm) | 27" (686mm) | 32" (813mm) |
| | 5" (127mm) | 6 1/4" (159mm) | 27" (686mm) | 33 1/4" (845mm) |
| | 6" (152mm) | 7 1/4" (184mm) | 27" (686mm) | 34 1/4" (870mm) |
| | 7" (1579mm) | 8" (203mm) | 27" (686mm) | 35" (889mm) |
| 36" (914mm) | 3" (76mm) | 4 1/8" (105mm) | 39" (991mm) | 43 1/8" (1095mm) |
| | 4" (102mm) | 5" (127mm) | 39" (991mm) | 44" (1118mm) |
| | 5" (127mm) | 6 1/4" (159mm) | 39" (991mm) | 45 1/4" (1149mm) |
| | 6" (152mm) | 7 1/4" (184mm) | 39" (991mm) | 46 1/4" (1175mm) |
| | 7" (179mm) | 8" (203mm) | 39" (991mm) | 47" (1194mm) |

Example: H4A-129O-12

NOTE: Nominal 9" rung spacing maintained through centerline of all fittings.

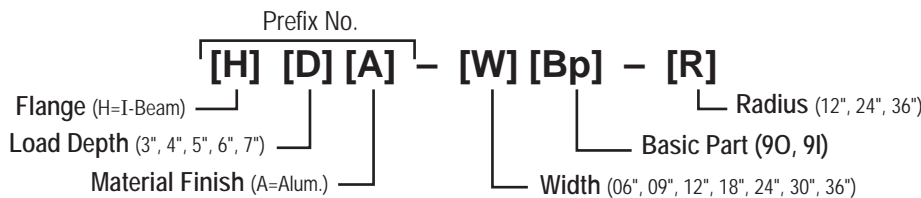

See Page 86 for Electrical Grounding Chart

I-BEAM CABLE TRAY SYSTEM

60° VERTICAL ELBOW OUTSIDE [60] & INSIDE [6I]

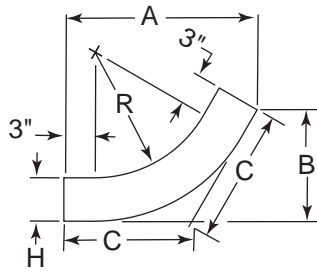
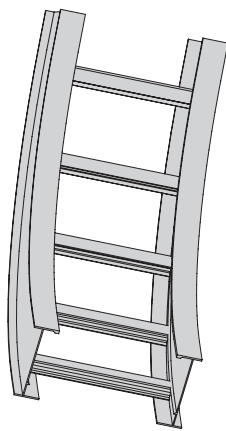

INSIDE (6I)

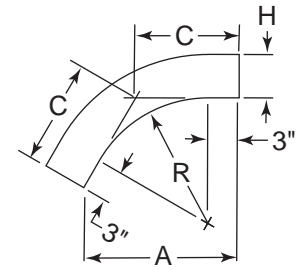
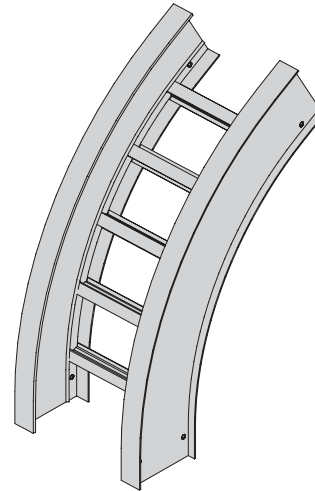

OUTSIDE (60)

| Radius R | Load Depth | H | Outside (60) | | | Inside (6I) | | |
|----------------|---------------|----------------|----------------------|--------------------|----------------------|--------------------|-------------------|-------------------|
| | | | A | B | C | A | B | C |
| 12" (305mm) | 3" (76mm) | 4 1/8" (105mm) | 14 7/8" (378mm) | 8 5/8" (219mm) | 9 15/16" (252mm) | 18 7/16" (468mm) | 10 11/16" (271mm) | 12 5/8" (313mm) |
| | 4" (102mm) | 5" (127mm) | | | | 19 1/4" (489mm) | 11 1/8" (283mm) | 12 13/16" (325mm) |
| | 5" (127mm) | 6 1/4" (159mm) | | | | 20 5/16" (516mm) | 11 3/4" (298mm) | 13 9/16" (344mm) |
| | 6" (152mm) | 7 1/4" (184mm) | | | | 21 3/16" (538mm) | 12 1/4" (311mm) | 14 1/8" (359mm) |
| | 7" (179mm) | 8" (203mm) | | | | 21 13/16" (554mm) | 12 5/8" (321mm) | 14 9/16" (370mm) |
| 24" (610mm) | 3" (76mm) | 4 1/8" (105mm) | 25 5/16" (643mm) | 14 5/8" (371mm) | 16 7/8" (429mm) | 28 7/8" (733mm) | 16 11/16" (424mm) | 19 1/4" (489mm) |
| | 4" (102mm) | 5" (127mm) | | | | 29 5/8" (752mm) | 17 1/8" (435mm) | 19 3/4" (502mm) |
| | 5" (127mm) | 6 1/4" (159mm) | | | | 30 11/16" (779mm) | 17 3/4" (451mm) | 20 7/16" (519mm) |
| | 6" (152mm) | 7 1/4" (184mm) | | | | 31 9/16" (802mm) | 18 1/4" (464mm) | 21 1/16" (535mm) |
| | 7" (179mm) | 8" (203mm) | | | | 32 3/16" (818mm) | 18 5/8" (473mm) | 21 1/2" (546mm) |
| 36" (914mm) | 3" (76mm) | 4 1/8" (105mm) | 35 11/16" (906mm) | 20 5/8" (524mm) | 23 13/16" (605mm) | 39 1/4" (997mm) | 22 11/16" (576mm) | 26 3/16" (665mm) |
| | 4" (102mm) | 5" (127mm) | | | | 40" (1016mm) | 23 7/8" (587mm) | 26 11/16" (678mm) |
| | 5" (127mm) | 6 1/4" (159mm) | | | | 41 1/16" (1043mm) | 23 3/4" (603mm) | 27 3/8" (695mm) |
| | 6" (152mm) | 7 1/4" (184mm) | | | | 41 15/16" (1065mm) | 24 1/4" (616mm) | 28" (711mm) |
| | 7" (179mm) | 8" (203mm) | | | | 42 5/8" (1083mm) | 24 5/8" (625mm) | 28 3/8" (721mm) |

Example: H4A-126O-12

NOTE: Nominal 9" rung spacing maintained through centerline of all fittings.

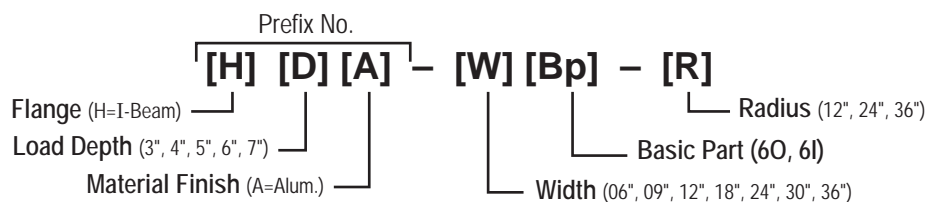

See Page 86
for Electrical
Grounding Chart

45° VERTICAL ELBOW OUTSIDE [40] & INSIDE [4I]

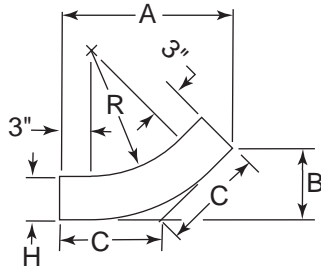
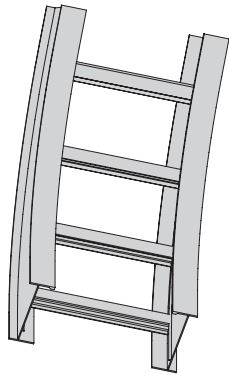

INSIDE (4I)

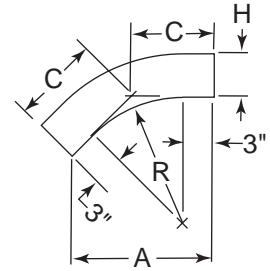
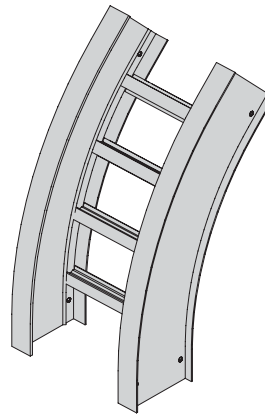

OUTSIDE (4O)

| Radius R | Load Depth | H | Outside (4O) | | | Inside (4I) | | |
|-----------------------|---------------|----------------|---------------------|---------------------|----------------------|------------------|-------------------|-------------------|
| | | | A | B | C | A | B | C |
| 12" (305mm) | 3" (76mm) | 4 1/8" (105mm) | 13 5/8" (346mm) | 5 5/8" (143mm) | 8" (203mm) | 16 1/2" (419mm) | 6 7/8" (175mm) | 9 11/16" (246mm) |
| | 4" (102mm) | 5" (127mm) | | | | 17 1/8" (435mm) | 7 1/8" (181mm) | 10 1/16" (256mm) |
| | 5" (127mm) | 6 1/4" (159mm) | | | | 18" (457mm) | 7 7/16" (189mm) | 10 9/16" (268mm) |
| | 6" (152mm) | 7 1/4" (184mm) | | | | 18 3/4" (476mm) | 7 3/4" (197mm) | 11" (279mm) |
| | 7" (179mm) | 8" (203mm) | | | | 19 1/4" (489mm) | 8" (203mm) | 11 5/16" (287mm) |
| 24" (610mm) | 3" (76mm) | 4 1/8" (105mm) | 22 1/16" (560mm) | 9 1/8" (232mm) | 12 15/16" (329mm) | 25" (635mm) | 10 3/8" (264mm) | 14 5/8" (371mm) |
| | 4" (102mm) | 5" (127mm) | | | | 25 5/8" (651mm) | 10 5/8" (270mm) | 15" (381mm) |
| | 5" (127mm) | 6 1/4" (159mm) | | | | 26 1/2" (673mm) | 11" (279mm) | 15 1/2" (394mm) |
| | 6" (152mm) | 7 1/4" (184mm) | | | | 27 3/16" (691mm) | 11 1/4" (286mm) | 15 15/16" (405mm) |
| | 7" (179mm) | 8" (203mm) | | | | 27 3/4" (705mm) | 11 1/2" (292mm) | 16 1/4" (413mm) |
| 36" (914mm) | 3" (76mm) | 4 1/8" (105mm) | 30 9/16" (776mm) | 12 1/16" (322mm) | 17 15/16" (456mm) | 33 1/2" (851mm) | 13 7/8" (352mm) | 19 5/8" (498mm) |
| | 4" (102mm) | 5" (127mm) | | | | 34 1/8" (867mm) | 14 1/8" (359mm) | 20" (508mm) |
| | 5" (127mm) | 6 1/4" (159mm) | | | | 35" (889mm) | 14 1/2" (368mm) | 20 1/2" (521mm) |
| | 6" (152mm) | 7 1/4" (184mm) | | | | 35 1/16" (906mm) | 14 13/16" (376mm) | 20 15/16" (532mm) |
| | 7" (179mm) | 8" (203mm) | | | | 36 1/4" (921mm) | 15" (381mm) | 21 1/4" (540mm) |

Example: H4A-1240-12

NOTE: Nominal 9" rung spacing maintained through centerline of all fittings.



See Page 86 for Electrical Grounding Chart

I-BEAM CABLE TRAY SYSTEM

30° VERTICAL ELBOW OUTSIDE [30] & INSIDE [31]

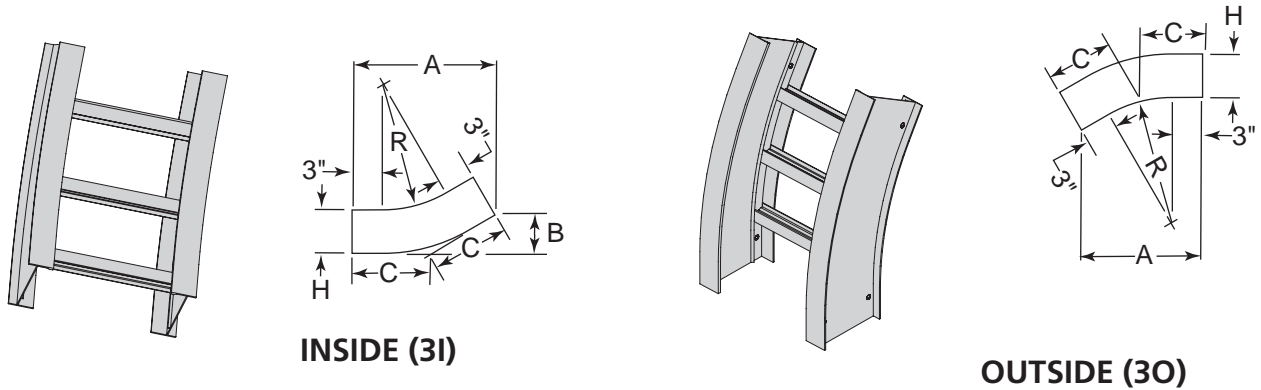

INSIDE (31)

OUTSIDE (30)

| Radius - R | Load Depth | H | Outside (30) | | | Inside (31) | | |
|-----------------------|---------------|----------------|-----------------|------------------|-----------------|-------------------|------------------|-------------------|
| | | | A | B | C | A | B | C |
| 12" (305mm) | 3" (76mm) | 4 1/8" (105mm) | | | | 13 11/16" (348mm) | 3 11/16" (94mm) | 7 5/16" (186mm) |
| | 4" (102mm) | 5" (127mm) | | | | 14 1/8" (359mm) | 3 3/4" (95mm) | 7 9/16" (192mm) |
| | 5" (127mm) | 6 1/4" (159mm) | 11 5/8" (295mm) | 3 1/8" (79mm) | 6 3/16" (157mm) | 14 3/4" (375mm) | 3 15/16" (100mm) | 7 7/8" (200mm) |
| | 6" (152mm) | 7 1/4" (184mm) | | | | 15 1/4" (387mm) | 4 1/16" (103mm) | 8 3/16" (208mm) |
| | 7" (179mm) | 8" (203mm) | | | | 15 5/8" (397mm) | 4 3/16" (106mm) | 8 3/8" (213mm) |
| 24" (610mm) | 3" (76mm) | 4 1/8" (105mm) | | | | 19 11/16" (500mm) | 5 1/4" (133mm) | 10 9/16" (268mm) |
| | 4" (102mm) | 5" (127mm) | | | | 20 1/8" (511mm) | 5 3/8" (137mm) | 10 3/4" (273mm) |
| | 5" (127mm) | 6 1/4" (159mm) | 17 5/8" (448mm) | 4 11/16" (119mm) | 9 7/16" (240mm) | 20 3/4" (527mm) | 5 9/16" (141mm) | 11 1/8" (283mm) |
| | 6" (152mm) | 7 1/4" (184mm) | | | | 21 1/4" (540mm) | 5 11/16" (144mm) | 11 3/8" (289mm) |
| | 7" (179mm) | 8" (203mm) | | | | 21 5/8" (549mm) | 5 13/16" (148mm) | 11 9/16" (294mm) |
| 36" (914mm) | 3" (76mm) | 4 1/8" (105mm) | | | | 25 1/16" (652mm) | 6 7/8" (175mm) | 13 3/4" (349mm) |
| | 4" (102mm) | 5" (127mm) | | | | 26 1/8" (664mm) | 7" (178mm) | 14" (356mm) |
| | 5" (127mm) | 6 1/4" (159mm) | 23 5/8" (600mm) | 6 5/16" (160mm) | 12 5/8" (321mm) | 26 3/4" (679mm) | 7 3/16" (183mm) | 14 5/16" (364mm) |
| | 6" (152mm) | 7 1/4" (184mm) | | | | 27 1/4" (692mm) | 7 5/16" (186mm) | 14 9/16" (376mm) |
| | 7" (179mm) | 8" (203mm) | | | | 27 5/8" (702mm) | 7 3/8" (187mm) | 14 13/16" (370mm) |

Example: H4A-123I-12

NOTE: Nominal 9" rung spacing maintained through centerline of all fittings.

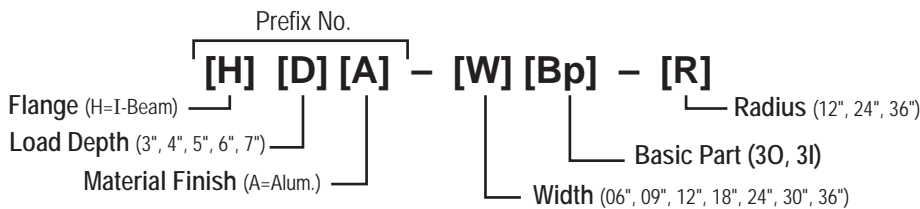

See Page 86
for Electrical
Grounding Chart

90° VERTICAL CABLE SUPPORT ELBOW [SR]

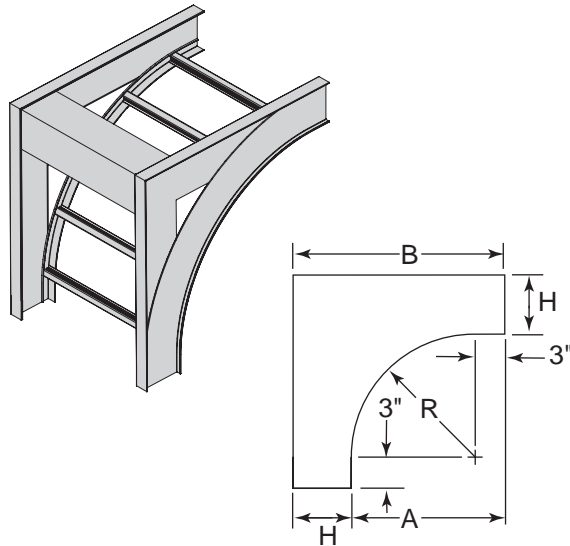

| Radius - R | Load Depth | H | A | B |
|----------------|------------|----------------|----------------|------------------|
| 12" (305mm) | 3" (76mm) | 4 1/8" (105mm) | 15" (381mm) | 19 1/8" (486mm) |
| | 4" (102mm) | 5" (127mm) | | 20" (508mm) |
| | 5" (127mm) | 6 1/4" (159mm) | | 21 1/4" (540mm) |
| | 6" (152mm) | 7 1/4" (184mm) | | 22 1/4" (565mm) |
| | 7" (179mm) | 8" (203mm) | | 23" (584mm) |
| 24" (610mm) | 3" (76mm) | 4 1/8" (105mm) | 27" (686mm) | 21 1/8" (537mm) |
| | 4" (102mm) | 5" (127mm) | | 32" (813mm) |
| | 5" (127mm) | 6 1/4" (159mm) | | 33 1/4" (845mm) |
| | 6" (152mm) | 7 1/4" (184mm) | | 34 1/4" (870mm) |
| | 7" (179mm) | 8" (203mm) | | 35" (889mm) |
| 36" (914mm) | 3" (76mm) | 4 1/8" (105mm) | 39" (991mm) | 43 1/8" (1095mm) |
| | 4" (102mm) | 5" (127mm) | | 44" (1118mm) |
| | 5" (127mm) | 6 1/4" (159mm) | | 45 1/4" (1149mm) |
| | 6" (152mm) | 7 1/4" (184mm) | | 46 1/4" (1175mm) |
| | 7" (179mm) | 8" (203mm) | | 47" (1194mm) |

Example: H4A-12SR-12

VERTICAL TEE DOWN [VT] & UP [OT]

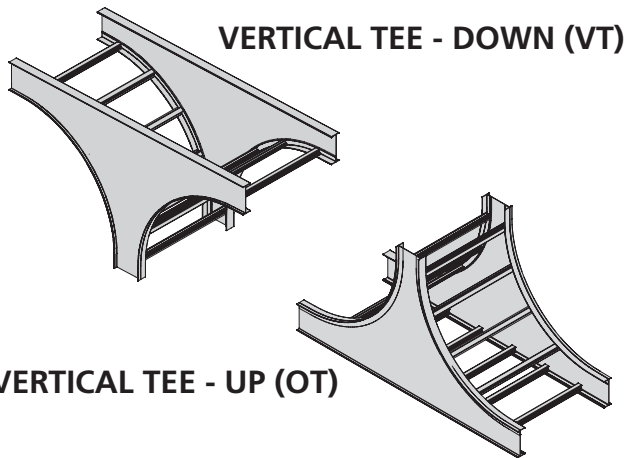

| Radius - R | Load Depth | H | A | B |
|----------------|------------|----------------|----------------|------------------|
| 12" (305mm) | 3" (76mm) | 4 1/8" (105mm) | 15" (381mm) | 34 1/8" (867mm) |
| | 4" (102mm) | 5" (127mm) | | 35" (889mm) |
| | 5" (127mm) | 6 1/4" (159mm) | | 36 1/4" (921mm) |
| | 6" (152mm) | 7 1/4" (184mm) | | 37 1/4" (946mm) |
| | 7" (179mm) | 8" (203mm) | | 38" (965mm) |
| 24" (610mm) | 3" (76mm) | 4 1/8" (105mm) | 27" (686mm) | 58 1/8" (1476mm) |
| | 4" (102mm) | 5" (127mm) | | 59" (1499mm) |
| | 5" (127mm) | 6 1/4" (159mm) | | 60 1/4" (1530mm) |
| | 6" (152mm) | 7 1/4" (184mm) | | 61 1/4" (1556mm) |
| | 7" (179mm) | 8" (203mm) | | 62" (1575mm) |
| 36" (914mm) | 3" (76mm) | 4 1/8" (105mm) | 39" (991mm) | 82 1/8" (2086mm) |
| | 4" (102mm) | 5" (127mm) | | 83" (2108mm) |
| | 5" (127mm) | 6 1/4" (159mm) | | 84 1/4" (2140mm) |
| | 6" (152mm) | 7 1/4" (184mm) | | 85 1/4" (2165mm) |
| | 7" (179mm) | 8" (203mm) | | 86" (2184mm) |

Example: H4A-12VT-12

NOTE: Nominal 9" rung spacing maintained through centerline of all fittings.

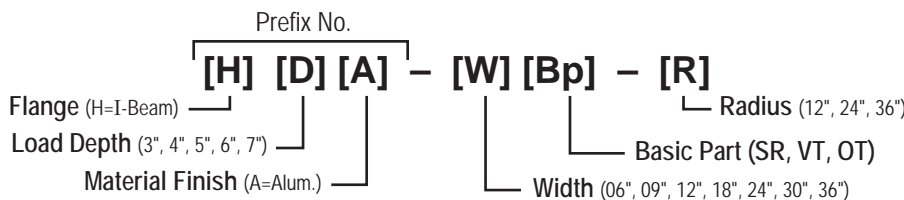

See Page 86 for Electrical Grounding Chart

I-BEAM CABLE TRAY SYSTEM

CONNECTOR PLATES

TRAY CONNECTORS

Catalog Number (Aluminum)

| Part | Load Depth | Basic No. |
|------|------------|-----------|
| H3A | 3" | -02RC |
| H4A | 4" | -02CE |
| H5A | 5" | -02CV |
| H6A | 6" | -02CH |
| H7A | 7" | -02CA |

Example: H3A -02RC for I-Beam flange, 3" load depth, aluminum, universal connector.

NOTE: Hole patterns match corresponding tray. Three-hole pattern illustrated.

UNIVERSAL CONNECTOR [RC]

Note: Sold in pairs

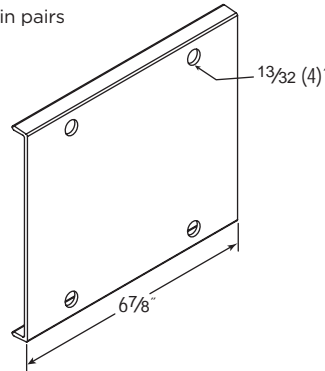

11 Gage Steel, 0.125" Aluminum
3/8"-16 spline bolts & flange nuts furnished.

EXPANSION CONNECTOR [CE]

Note: Sold in pairs

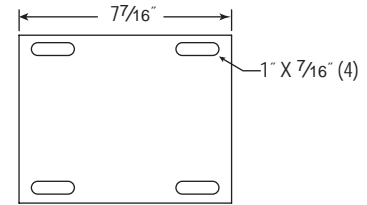

11 Gage Steel, 0.125" Aluminum
3/8"-16 cap screws & Nylok nuts furnished and
3/8"-16 spline bolts & flange nuts furnished.

NOTE: Bonding Jumpers are required and are sold separately.

MID-SPAN SPLICE PLATE [RC]

3/8" - Aluminum

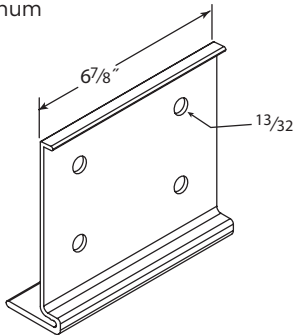

CATALOG NUMBER

| Part | Use With System |
|--------------|-----------------|
| H5A-02RC-MID | 7H5A, 9H5A |
| H6A-02RC-MID | 7H6A, 9H6A |

HORIZONTAL ADJUSTABLE CONNECTOR [CH]

NOTE: Sold in pairs - inner & outer

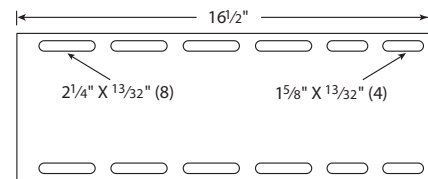
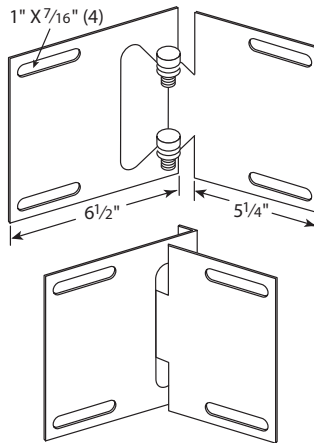

0.125" Aluminum
Horizontal Adjustable Splice Plate to be used with HCH hinge
3/8"-16 spline bolts and flange nuts furnished.

MID-SPAN SPLICE PLATE [RC]

Catalog Number: 58-02RC-MID

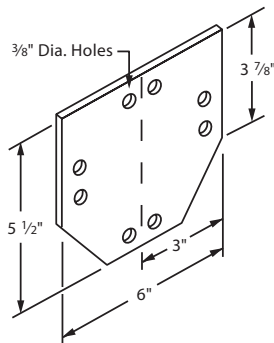

3/8" - Aluminum
For use with 11H7A Systems.

See Page 86
for Electrical
Grounding Chart

REDUCING CONNECTOR [CO]

NOTE: Not sold in pairs

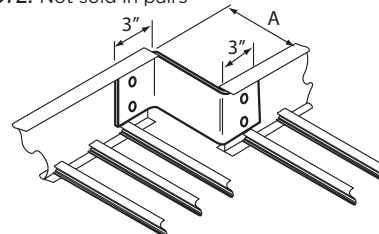

0.125" Aluminum

For offset reductions - use 1 of above with standard connector plate.

For straight reductions- use 2 (of 1/2 reduction dim.).

3/8"-16 spline bolts and flange nuts furnished.

CATALOG NUMBER (ALUMINUM)

| Part | Load Depth | Basic Number | "A" Dimension |
|------|------------|--------------|-----------------|
| H3A | 3" | -30CO | 30" (762mm) |
| H4A | 4" | -27CO | 27" (686mm) |
| H5A | 5" | -24CO | 24" (610mm) |
| H6A | 6" | -21CO | 21" (533mm) |
| H7A | 7" | -18CO | 18" (457mm) |
| | | -15CO | 15" (381mm) |
| | | -13CO | 13 1/2" (343mm) |
| | | -12CO | 12" (305mm) |
| | | -10CO | 10 1/2" (267mm) |
| | | -09CO | 9" (229mm) |
| | | -07CO | 7 1/2" (191mm) |
| | | -06CO | 6" (152mm) |
| | | -04CO | 4 1/2" (114mm) |
| | | -03CO | 3" (76mm) |
| | | -01CO | 1 1/2" (38mm) |

Example: H3A-03CO for I-Beam flange, 3" load depth, aluminum, 3" Reducer Connector. Typical Use: 9" to 6", or use 2 for 12" to 6", etc.

CONNECTOR PLATES

VERTICAL ADJUSTABLE CONNECTOR [CV]

11 Gage Steel, 0.125" Aluminum
 3/8"-16 spline bolts & flange nuts furnished.

Note: Sold in pairs

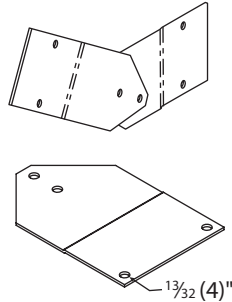

HEAVY DUTY HOLD DOWN BRACKET [7-HDHDB]

2 - 3/8" Holes & 2 - 1/2" Holes.

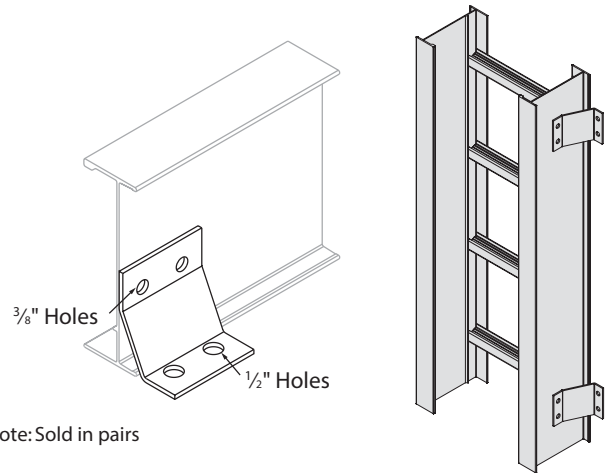

Note: Sold in pairs

VERTICAL ADJ. BRANCH PIVOT CONNECTOR [BPC]

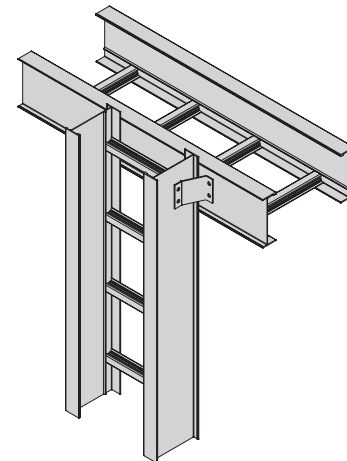
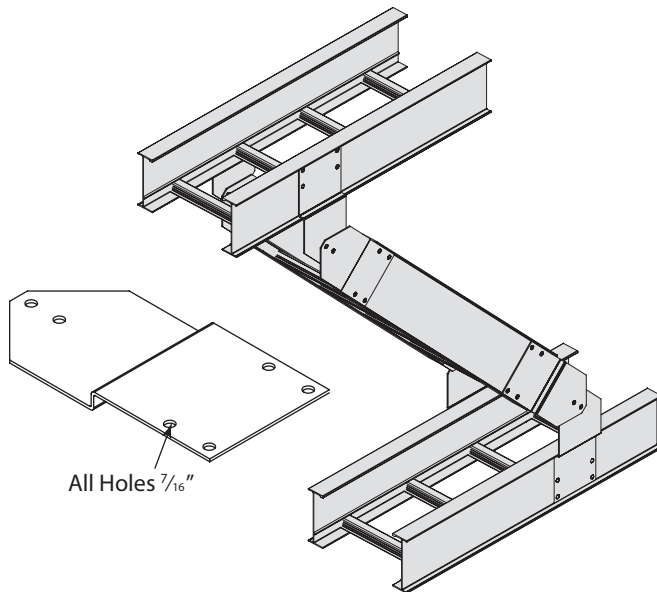

VERTICAL HANGER SPlice PLATE [VH]

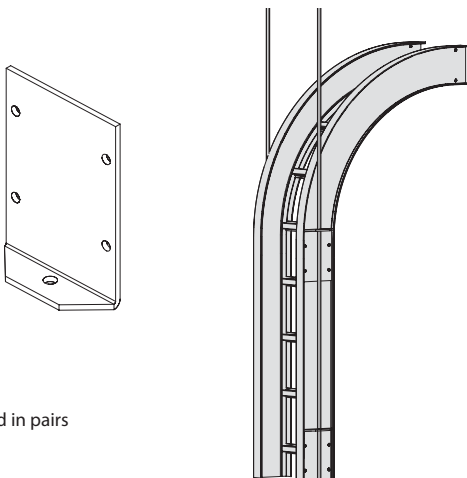

Note: Sold in pairs

| Catalog No. | For Use With Cope System Number |
|-------------|---------------------------------|
| H-9043-412 | 5H3A |
| H-9043-500 | 5H4A |
| H-9043-619 | 7H5A |
| H-9043-724 | 7H6A |
| H-9043-624 | 9H5A |
| H-9043-724 | 9H6A |
| H-9043-800 | 11H7A |

I-Beam Supports can be bolted anywhere along the straight runs. They can be bolted directly onto the coupler plates at splices of straight runs and riser fittings, or they can be bolted at any place in the run by field-drilling side rails. I-Beam supports are used with either 3/8" or 1/2" hanger rods. Finish is aluminum.

Intro

LADDER

I-BEAM

HAT

TROF

CHANNEL

COPE-GLAS™

WIREBASKET

Reference

I-BEAM CABLE TRAY SYSTEM

ACCESSORIES

COMBINATION HOLD-DOWN CLAMP & EXPANSION GUIDE [9131]

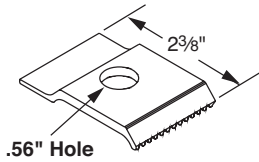

9131A

| Catalog No. | Material |
|-------------|--------------------------|
| 9131A | Aluminum |
| 9131L | Stainless Steel Type 316 |

Hardware purchased separately to suit support system.

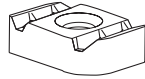

PS NS

Catalog No. 9131A-HDW (Complete Hardware Kit)

Hardware list:

- (2) 9131A Combination hold-down clamp & expansion guides
- (2) PS 6024 - 1/2" - 13 x 1 1/4" Cap Screw
- (2) PS 209 - 1/2" Flat Washer
- (2) PS NS - Clamping Nut (Strut Nut)

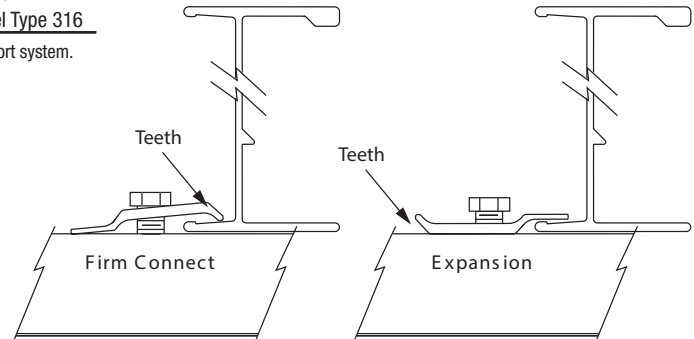

COMBINATION HOLD-DOWN / EXPANSION GUIDE [9053]

Universal Guide: for either side of ladder. Use when tray is mounted on I-beams or channels. No drilling required.

Note: Use set screws for firm hold down

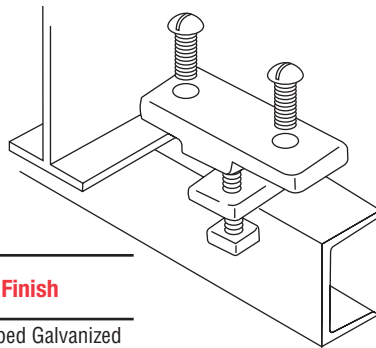

| Type | Catalog No. | Finish |
|-------------------|-------------|-----------------------|
| Combination Guide | 6-9053 | Hot-dipped Galvanized |
| | 8-9053 | Cast. Alum |

NOTE: Electroplated set screws included

ISOLATION PAD [9131-IP]

The Isolation pad provides protection from galvanic corrosion when Aluminum tray is mounted on steel supports.

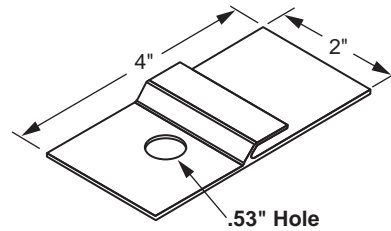

NOTE: For use with the 9131A-HDW shown above. Hardware purchased separately

BOX SPLICE PLATE [CA]

Note: Sold in pairs

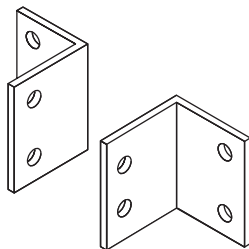

Use to attach the end of a cable tray to a distribution box or control panel.

| Catalog Number | | | |
|----------------|------------|-----------|-----------|
| Part | Load Depth | Finish | Basic No. |
| H3A | 3" | A - Alum. | -02CA |
| H4A | 4" | | |
| H5A | 5" | | |
| H6A | 6" | | |
| H7A | 7" | | |

Example: H4A -02CA for 4" load depth, aluminum Box Splice Plate.

HOLD-DOWN [9132]

NOTE: For seismic applications or other bolted connections is preferred.

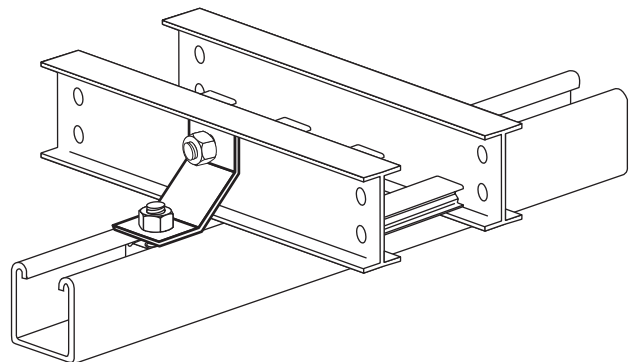

| Catalog No. | Material |
|-------------|-----------------|
| 9132 | Mill Galvanized |
| 9133 | Stainless Steel |

Hardware purchased separately to suit support system.

MATERIAL/FINISH

Electroplated finish standard. Other finishes available; consult factory.

*Use following suffix when applicable - use only where indicated.

NO SUFFIX Electroplated carbon steel only

-SS 302/304 Stainless Steel

-S1 316 Stainless Steel (check factory for availability)

Example: PS 6024 3/8" x 1 1/2" SS, 3/8" x 1 1/2" hex head bolt, 304 stainless steel

CONNECTOR HARDWARE

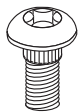

Spline Bolt



Hex-Flanged Nut with Serrated Washer Face

| Catalog Number | Item | Size | Material |
|----------------|-------------|----------------|-----------------------------------|
| 5003-1 | Spline Bolt | 3/8" - 16 x 1" | Case-Hardened Steel electroplated |
| 5003-2-S1 | Spline Bolt | 1/2" - 13 x 1" | Stainless Steel |
| 5009-1 | Hex Nut | 3/8" - 16 | Case-Hardened Steel electroplated |
| 5009-2-S1 | Hex Nut | 1/2" - 13 | Stainless Steel |

COVER SCREW [EM]

Part No. EM-CC (electroplated steel)

Part No. EM-CC-SS (stainless steel)

No. 10 x 5/8" long, self drilling-self tapping hex head plated steel screw.

Suggested spacing:

Indoor: 8 per 12';

Outdoor: 10 per 12'

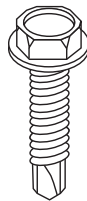

CONTINUOUS THREADED ROD [PS 146]

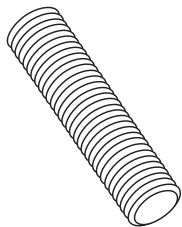

| Cat. No. | Size (Diameter x Length) |
|----------|--------------------------|
| PS 146* | 1/4" x 10' |
| PS 146* | 3/8" x 10' |
| PS 146* | 1/2" x 10' |
| PS 146* | 5/8" x 10' |
| PS 146* | 3/4" x 10' |

(Hot Dip Galvanized not available)

ROD COUPLER [PS 135]

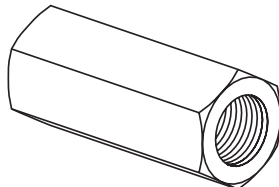

| Cat. No. | Size |
|----------|------|
| PS 135* | 1/4" |
| PS 135* | 3/8" |
| PS 135* | 1/2" |
| PS 135* | 5/8" |
| PS 135* | 3/4" |

HEX NUTS [PS 83]



| Cat. No. | Size |
|----------|------|
| PS 83* | 1/4" |
| PS 83* | 3/8" |
| PS 83* | 1/2" |
| PS 83* | 5/8" |
| PS 83* | 3/4" |

SQUARE NUTS [PS 6108]

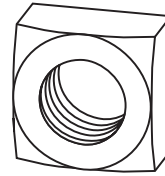

| Cat. No. | Size |
|----------|------|
| PS 6108* | 1/4" |
| PS 6108* | 3/8" |
| PS 6108* | 1/2" |
| PS 6108* | 5/8" |
| PS 6108* | 3/4" |

FLAT WASHERS [PS 209]

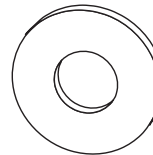

| Cat. No. | Size |
|----------|------|
| PS 209* | 1/4" |
| PS 209* | 3/8" |
| PS 209* | 1/2" |
| PS 209* | 5/8" |
| PS 209* | 3/4" |

SPLIT-LOCK WASHERS [PS 211]

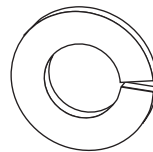

| Cat. No. | Size |
|----------|------|
| PS 211* | 1/4" |
| PS 211* | 3/8" |
| PS 211* | 1/2" |
| PS 211* | 5/8" |
| PS 211* | 3/4" |

FENDER WASHERS [PS 230]

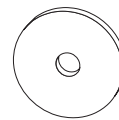

| Cat. No. | Size (I.D. x O.D.) |
|----------|--------------------|
| PS 230* | 1/4" x 1 1/4" O.D. |
| PS 230* | 3/8" x 1 1/2" O.D. |
| PS 230* | 1/2" x 2" O.D. |

HEX HEAD CAP SCREW / ROUND HEAD, SLOTTED CAP SCREW [PS 6024]

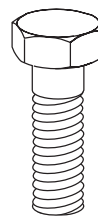

Catalog No. PS 6024

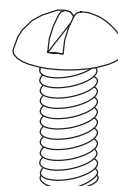

Catalog No. PS 6072

| Hex Head Cap Screw Cat. No. | Round Head Cap Screw Cat. No. | Size (Dia. x Len.) |
|-----------------------------|-------------------------------|--------------------|
| PS 6024* | PS 6072* | 1/4" x 1" |
| PS 6024* | PS 6072* | 1/4" x 1 1/2" |
| PS 6024* | PS 6072* | 3/8" x 1" |
| PS 6024* | PS 6072* | 3/8" x 1 1/2" |
| PS 6024* | PS 6072* | 3/8" x 3" |
| PS 6024* | PS 6072* | 1/2" x 1" |
| PS 6024* | PS 6072* | 1/2" x 1 1/2" |
| PS 6024* | PS 6072* | 1/2" x 2" |
| PS 6024* | PS 6072* | 1/2" x 2 1/2" |
| PS 6024* | PS 6072* | 1/2" x 3" |
| PS 6024* | PS 6072* | 1/2" x 3 1/2" |
| PS 6024* | PS 6072* | 5/8" x 1 1/2" |
| PS 6024* | PS 6072* | 5/8" x 2" |
| PS 6024* | PS 6072* | 5/8" x 3" |
| PS 6024* | PS 6072* | 5/8" x 4" |
| PS 6024* | PS 6072* | 3/4" x 2" |
| PS 6024* | PS 6072* | 3/4" x 3" |
| PS 6024* | PS 6072* | 3/4" x 4" |

I-BEAM CABLE TRAY SYSTEM

COVERS

COVERS for straight sections shown. Standard fitting covers are flat solid type (NF). Aluminum covers are fabricated from 0.040" aluminum AA-3150-H14.

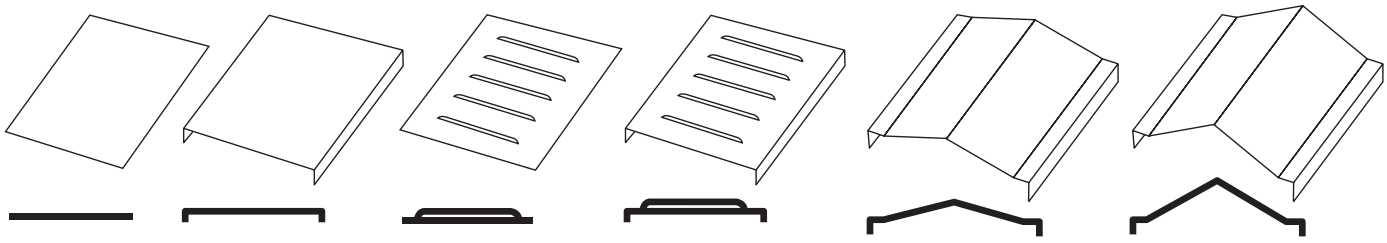

NFHA – Flat Solid

FSHA – Flat Solid
w/ 3/8" Flange

NLHA – Flat
Louvered

FLHA – Flat Louvered
w/ 3/8" Flange

PFHA – Peaked Flanged
Solid w/ 3/8" Flange
(suffix height)

PPHA – Peaked 2 to 3 Pitch
Flanged Solid
w/ 3/8" Flange

NOTE: Use EM-CC Cover Screws (see pg. 57) to attach PH, PV & covers.

COVER CATALOG NUMBER – STRAIGHT SECTIONS (ALUMINUM)

| Type | Basic No. (Width) | Length | Height* |
|------|---------------------|--------|---------|
| NFHA | -06SL = 6" (152mm) | -12' | -2" |
| FSHA | -09SL = 9" (229mm) | -10' | |
| NLHA | -12SL = 12" (305mm) | -06' | |
| FLHA | -18SL = 18" (457mm) | | |
| PFHA | -24SL = 24" (610mm) | | |
| PPHA | -30SL = 30" (762mm) | | |
| | -36SL = 36" (914mm) | | |

*PF only, 2" height standard. Consult factory for other heights.

Example: NLHA-09SL-12 is a flat louvered aluminum cover for a 9" wide I-Beam 12' long

COVER CATALOG NUMBER – FITTINGS (ALUMINUM)

| Type | Load Depth | Width/Basic No. | Radius |
|------|------------|-----------------|--------|
| NFHA | 3" | -06 XX ** | 12" |
| FSHA | 4" | -09 XX ** | 24" |
| | 5" | -12 XX ** | 36" |
| | 6" | -18 XX ** | |
| | | -24 XX ** | |
| | | -30 XX ** | |
| | | -36 XX ** | |

* Load depth for outside riser or vertical tee only.

** XX from fitting selection page 68

Example: NFHA-369-24 is a non-flanged solid cover for a 36" wide horizontal 90° elbow with a 24" radius

JOINT PLATE

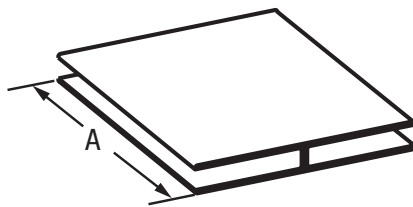

Joint plate is black PVC and is offered in 10' lengths to be field cut to desired length, or in pre-cut lengths for specified covers.

JP-120 is joint plate in 10' lengths.

Joint plate for specified covers is specified as follows.

Tray Width "A"

| | |
|-------------|---------|
| JP-06 = 6" | (152mm) |
| JP-09 = 9" | (229mm) |
| JP-12 = 12" | (305mm) |
| JP-18 = 18" | (457mm) |
| JP-24 = 24" | (610mm) |
| JP-30 = 30" | (762mm) |
| JP-36 = 36" | (914mm) |

Example: JP-06 is a joint plate for 6" wide tray.

COVER ACCESSORIES

DOUBLE CLAMP CONNECTOR [DC]

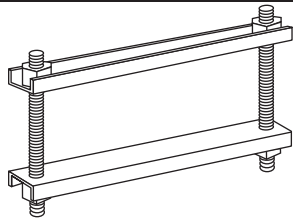

Catalog Number (Aluminum Clamp)

| Part | Load Depth | Width | Type |
|------|------------|-------|------|
| H3A | 3" | -06 | DC |
| H4A | 4" | -09 | |
| H5A | 5" | -12 | |
| H6A | 6" | -18 | |
| H7A | 7" | -24 | |
| | | -30 | |
| | | -36 | |

For all covers except peaked. Furnished with:
 (2) 1/4"-20 all-thread rods
 (4) hex nuts, flat washers and lock washers
 Suggested spacing:
 Indoor: 2 per 12'
 Outdoor: 3 per 12'
 High Wind: 5 per 12'

Example: H4A-12DC for 4" load depth, I-Beam flange, aluminum, Double Clamp Connector

PEAK COVER CONNECTOR [PC]

NOTE: For PF Covers

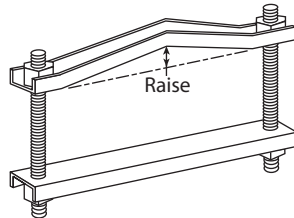

CATALOG NUMBER (ALUMINUM CLAMP)

| Part | Load Depth | Width | Type | Raise (in)* |
|------|------------|----------|------|-------------|
| H3A | 3" | -06, -09 | PC | -2 |
| H4A | 4" | -12, -18 | | |
| H5A | 5" | -24, -30 | | |
| H6A | 6" | -36 | | |
| H7A | 7" | | | |

*2" standard raise. Consult factory for other peak heights.

Example: H4A-12PC-2 for 4" load depth, I-Beam flange, aluminum, 12" wide, Peak Cover Connector with 2" peak.

PEAK PITCH COVER CONNECTOR [PP]

Note: For PP Covers

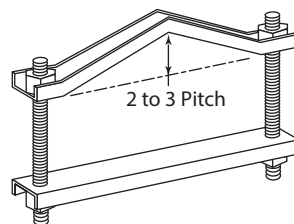

CATALOG NUMBER (ALUMINUM)

| Part | Load Depth | Width | Type |
|------|------------|----------|------|
| H3A | 3" | -06, -09 | PP |
| H4A | 4" | -12, -18 | |
| H5A | 5" | -24, -30 | |
| H6A | 6" | -36 | |
| H7A | 7" | | |

NOTE: 2 to 3 standard pitch.
Example: H4A-12PP for 4" load depth, I-Beam flange, aluminum, 12" wide, Pitched Peak Cover

ELEVATED COVER CONNECTORS [EM-CC]

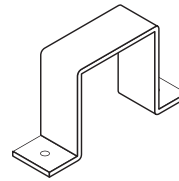

Includes:
 (3) #10 x 5/8" Self drilling screws.
 Suggested spacing:
 Indoor: 3/Side (6 tot.) per 12';

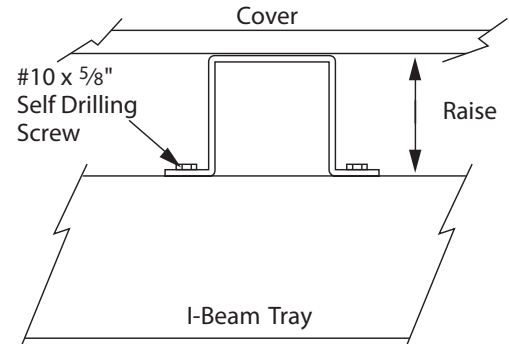

| Finish | Type | Height* |
|---------|-------|----------------|
| 8=Alum. | EM-CC | - Raise* (in.) |

*1", 2" or 3" standard.

Example: 8-EM-CC-2 for aluminum, Elevated Cover Connector with a 2" raise

ELECTRO-GALV. STEEL COVER CLIP [PS 135X]

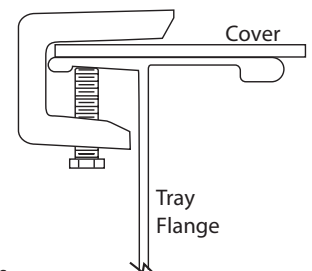
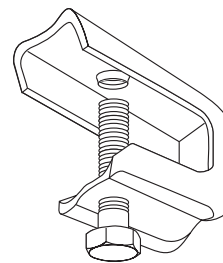

Use with any width tray. Not sold in pairs.
 Indoor use only. Suggest spacing 6' max.

I-BEAM CABLE TRAY SYSTEM

ACCESSORIES

BOX CONNECTOR [CB]

.080" Aluminum.

NOTE: ¼"-20 carriage bolts, flat washers, hex nuts furnished

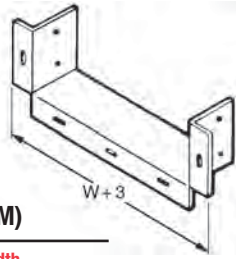

CATALOG NUMBER (ALUMINUM)

| Part | Load Depth | Width |
|------|------------|---------------------|
| H3A | 3" | -06CB = 6" (152mm) |
| H4A | 4" | -09CB = 9" (229mm) |
| H5A | 5" | -12CB = 12" (305mm) |
| H6A | 6" | -18CB = 18" (457mm) |
| H7A | 7" | -24CB = 24" (610mm) |
| | | -30CB = 30" (762mm) |
| | | -36CB = 36" (914mm) |

Example: H4A-12CB for I-Beam flange, 4" load depth, aluminum, 12" wide, Box Connector.

DROP OUT [DO]

.080" Aluminum.

NOTE: (2) #10 x 5/8" self tapping screws furnished.

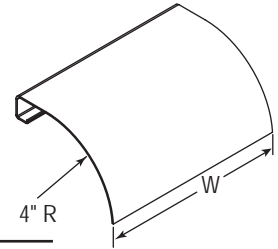

| Basic Finish | Width |
|--------------|---------------------|
| A - Alum. | -06DO = 6" (152mm) |
| | -09DO = 9" (229mm) |
| | -12DO = 12" (305mm) |
| | -18DO = 18" (457mm) |
| | -24DO = 24" (610mm) |
| | -30DO = 30" (762mm) |
| | -36DO = 36" (914mm) |

Example: A-12DO for aluminum, 12" wide, Drop Out

BLIND END [BE]

.040" Aluminum

NOTE: 3/8"-16 spline bolts and flange nuts furnished.

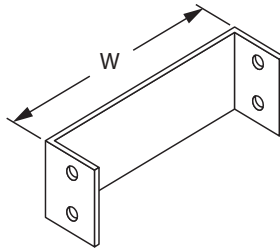

| Part | Load Depth | Width |
|------|------------|---------------------|
| H3A | 3" | -06BE = 6" (152mm) |
| H4A | 4" | -09BE = 9" (229mm) |
| H5A | 5" | -12BE = 12" (305mm) |
| H6A | 6" | -18BE = 18" (457mm) |
| H7A | 7" | -24BE = 24" (610mm) |
| | | -30BE = 30" (762mm) |
| | | -36BE = 36" (914mm) |

Example: H4A-12BE for I-Beam flange, 4" load depth, aluminum, 12" wide, Box Connector.

CABLE TRAY GROUND CLAMP [9156]

Extruded Alum. with ElectroGalvanized Hex Head Screws

Capacity: #6 AWG to 250 kcmil

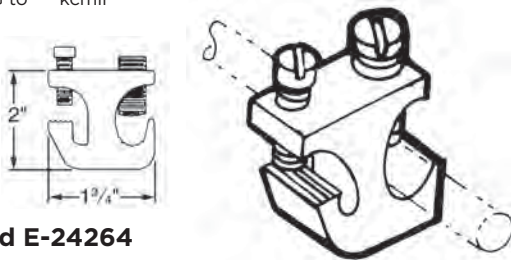

UL Listed E-24264
Certified File No. LR 9795

BONDING JUMPER [CBJ]

NOTE: No hardware supplied

For hardware kit add -HDW:

Ex: CBJ-C-HDW includes
 2ea CBJ-C
 4ea 5003-1
 4ea 5009-1

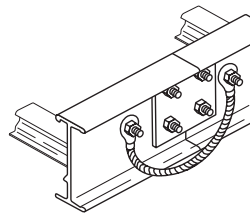

| Catalog No. | Dimensional Data | Amperes as Equipment Ground |
|-------------|---------------------------------------|-----------------------------|
| CBJ-C | AWG 1/0 copper wire 15½" long overall | 800 amperes |
| CBJ-4C | AWG 4/0 copper wire 15½" long overall | 1,600 amperes |
| CBJ-250C | 250 MCM copper wire 15½" long overall | 2,000 amperes |

GROUND CABLE RETAINER CLAMP

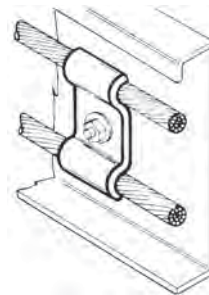

| Catalog No. | Capacity | Metal & Finish | Dimensions |
|-------------|-------------|---------------------|--------------------|
| 9056-EP | 1/0 2/0 3/0 | Electro-Galv. Steel | 1" w x 2" long |
| 9057-EP | 4/0 250 MCM | Electro-Galv. Steel | 1" w x 2 3/8" long |
| 9056-SS | 1/0 2/0 3/0 | Stainless Steel | 1" w x 2" long |
| 9057-SS | 4/0 250 MCM | Stainless Steel | 1" w x 2 3/8" long |

MUSTANG UNIVERSAL ONE-PIECE PIPE, CONDUIT (GRC, EMT & IMC) AND TUBING CLAMPS [PS MU]

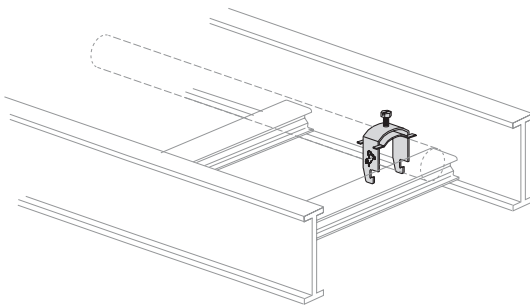

NOTE:
Available in 14 ga. Electro-galvanized steel

| Part No. | Nominal Trade Size | OD | | Height Above Channel "H" | |
|-------------|--------------------|--------|--------|--------------------------|--------|
| | | Min | Max | Min | Max. |
| PS MU-1/4 | 1/4" | 0.250" | 0.540" | 1 3/4" | 2" |
| PS MU-3/8 | 3/8" | 0.500" | 0.675" | 1 7/8" | 2 1/8" |
| PS MU-1/2 | 1/2" | 0.625" | 0.840" | 2" | 2 1/4" |
| PS MU-3/4 | 3/4" | 0.875" | 1.050" | 2 1/4" | 2 1/2" |
| PS MU-1 | 1" | 1.125" | 1.315" | 2 1/2" | 2 3/4" |
| PS MU-1-1/4 | 1 1/4" | 1.375" | 1.660" | 2 3/4" | 3 1/8" |
| PS MU-1-1/2 | 1 1/2" | 1.625" | 1.900" | 3" | 3 3/8" |
| PS MU-2 | 2" | 2.000" | 2.375" | 3 1/2" | 3 7/8" |
| PS MU-2-1/2 | 2 1/2" | 2.500" | 2.875" | 4 1/4" | 4 5/8" |
| PS MU-3 | 3" | 3.000" | 3.500" | 4 7/8" | 5 3/8" |
| PS MU-3-1/2 | 3 1/2" | 3.625" | 4.000" | 5 3/8" | 5 7/8" |
| PS MU-4 | 4" | 4.125" | 4.500" | 5 7/8" | 6 3/8" |

CONDUIT CLAMP BRACKET [CCB]

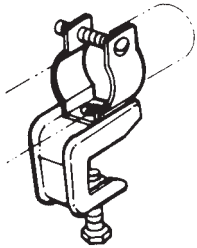

| Catalog No. | Size-Rigid | Size-EMT |
|-------------|--------------|----------|
| CCB-050 | 3/8" to 1/2" | 1/2" |
| CCB-075 | 3/4" | 3/4" |
| CCB-100 | 1" | 1" |
| CCB-125 | - | 1 1/4" |
| CCB-150 | 1 1/4" | 1 1/2" |
| CCB-200 | 2" | 2" |

CONDUIT-TO-CABLE TRAY CLAMP SWIVEL TYPE (TB)

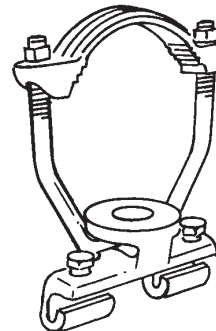

Malleable iron hub and steel "U" bolt. For connecting and grounding rigid conduit to tray at any angle within 90° arc. U.L. listed as a grounding means.

| Catalog No. | Size | Std. Pkg. |
|-------------|-----------|-----------|
| TB6209 | 1/2"-3/4" | 10 |
| TB6211 | 1"-1 1/4" | 10 |
| TB6214 | 1 1/2"-2" | 5 |
| TB6216 | 2 1/2"-3" | 5 |
| TB6218 | 3 1/2"-4" | 2 |

WALL PENETRATING SLEEVE ASSEMBLY

Part No. SS89042(W)*

W = Tray Width
* = Fitting 3-Digit Prefix

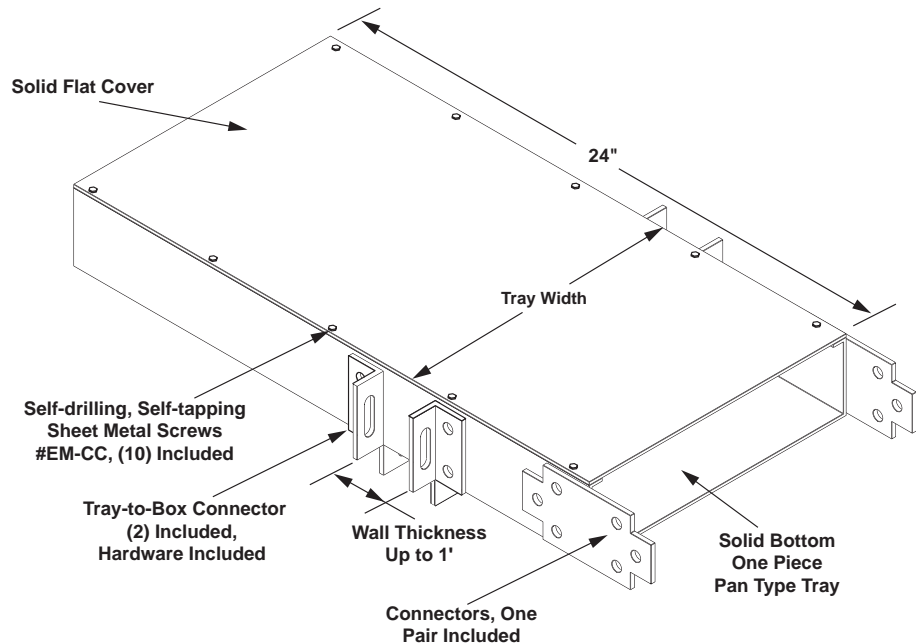

NOTE: Standard penetration sleeves are manufactured from mill galvanized steel. Aluminum sleeves are available upon request.

I-BEAM CABLE TRAY SYSTEM

BARRIER STRIP

UNIVERSAL ALUMINUM BARRIER STRIP - STRAIGHT SECTION [SB]

Catalog Number (Aluminum)

| Part | Load Depth | Basic No. - Length |
|------|------------|--------------------|
| 3A | 3" | -01SB-10 = 10' |
| 4A | 4" | -01SB-12 = 12' |
| 5A | 5" | |
| 6A | 6" | |
| 7A | 7" | |

Example: 4A-01SB-12 for I-Beam flange, 4" load depth, aluminum straight barrier 12' long.

Furnished with 8 self tapping screws.

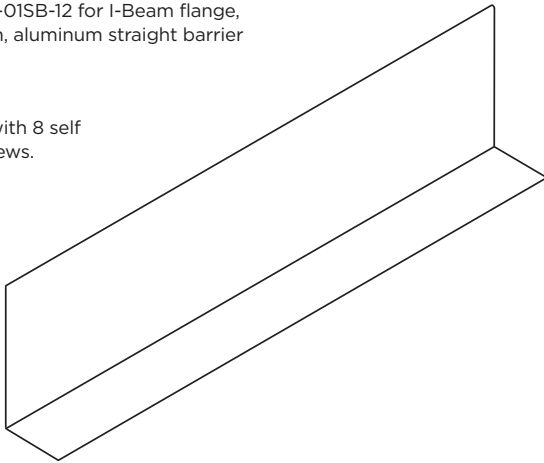

BARRIER STRIP VERTICAL ELBOW OUTSIDE [OB] & INSIDE [IB]

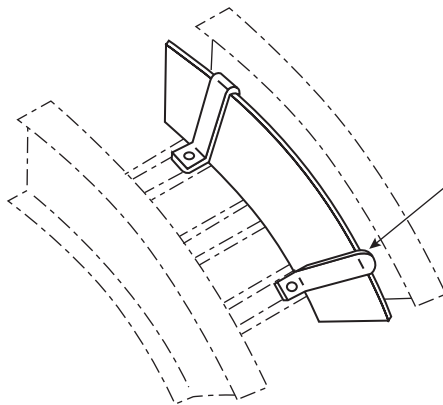

Barrier Strip Clamp
Part No. 50172
Furnished with vertical
elbow barriers

CATALOG NUMBER (ALUMINUM)

| Part | Load Depth | Bend (deg.) | Basic No. | Radius |
|------|------------|-------------|--------------|-------------|
| 3A | 3" | 90 | OB = Outside | 12" (305mm) |
| 4A | 4" | 60 | IB = Inside | 24" (610mm) |
| 5A | 5" | 45 | | 36" (914mm) |
| 6A | 6" | 30 | | |
| 7A | 7" | | | |

Example: 3A-90OB-12 for I-Beam flange, 3" load depth, aluminum 90° outside vertical barrier with 12" radius. (OB Vert. Elbow outside shown) Furnished with sufficient clamp assemblies for installation. Additional clamp assemblies may be ordered separately.

BARRIER STRIP - HORIZONTAL FITTING [FB]

Catalog Number (Aluminum)

| Part | Load Depth | Basic No. 6' Length |
|------|------------|---------------------|
| 3A | 3" | -01FB-06 |
| 4A | 4" | |
| 5A | 5" | |
| 6A | 6" | |
| 7A | 7" | |

Example: 4A-01FB-06 for I-Beam flange, 4" load depth, aluminum fitting barrier, 6' long.

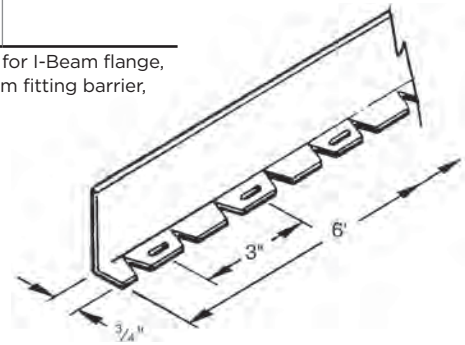

NYLON BARRIER SPLICE & PROTECTOR [BSP-L]

CATALOG NUMBER

| Prefix | Length |
|--------|-----------------------|
| | -5 (5" Splice) |
| BSP | -144 (144" Protector) |
| | -1200 (100' Roll) |

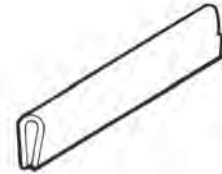

Example: BSP-1200 for 100' roll

BARRIER STRIP CLAMP (OPTIONAL) [50172]

No. 10 bolt, nut, washer and lock washer furnished.

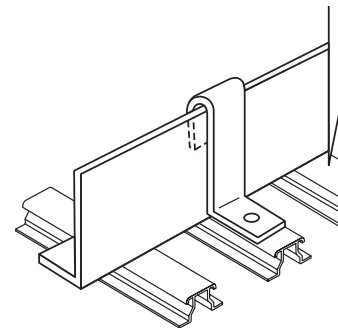

CATALOG NUMBER (ALUMINUM)

| Part | Load Depth | Basic No. |
|------|------------|-----------|
| H3A | 3" | -50172 |
| H4A | 4" | |
| H5A | 5" | |
| H6A | 6" | |
| H7A | 7" | |

Example: H3A-5072 for I-Beam flange, 3" load depth, aluminum clamp.

GUSSET-TYPE SUPPORTS

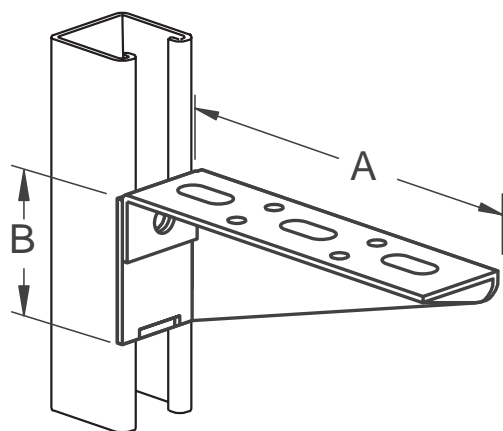

For use with all types of Cope I-Beam systems.
Finish is electro-galvanized.
Order hardware separately.

| Catalog No. | I-Beam Width | Dimension | | Uniform-Load Rating |
|-------------|--------------|-----------|-----------------------------------|---------------------|
| | | Dim. A | Dim. B | |
| PS 838R-12 | 6" | 12" | 3 ⁷ / ₁₆ " | 275 lbs. |
| PS 838R-16 | 9" | 16" | 4 ⁷ / ₁₆ " | 275 lbs. |
| PS 838R-18 | 12" | 18" | 4 ¹⁵ / ₁₆ " | 275 lbs. |
| PS 838R-24 | 18" | 24" | 6 ⁷ / ₁₆ " | 275 lbs. |
| PS 838R-30 | 24" | 30" | 7 ¹⁵ / ₁₆ " | 275 lbs. |

CHANNEL-TYPE SUPPORTS

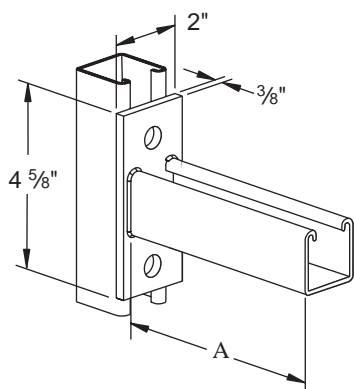

STANDARD DUTY

For use with all types of Cope I-Beam systems.
Finish is electro-galvanized.
Order hardware separately.

Standard Duty for Lighter Loads.

| Catalog No. | I-Beam Width | Dimension A | Uniform-Load Rating* |
|-------------|--------------|-------------|----------------------|
| PS 651-12 | 6" | 12" | 600 lbs. |
| PS 651-15 | 9" | 15" | 480 lbs. |
| PS 651-18 | 12" | 18" | 400 lbs. |
| PS 651-24 | 18" | 24" | 300 lbs. |
| PS 651-30 | 24" | 30" | 240 lbs. |

* Mounted on 12 Ga. Channel.

DOUBLE CHANNEL-TYPE SUPPORTS

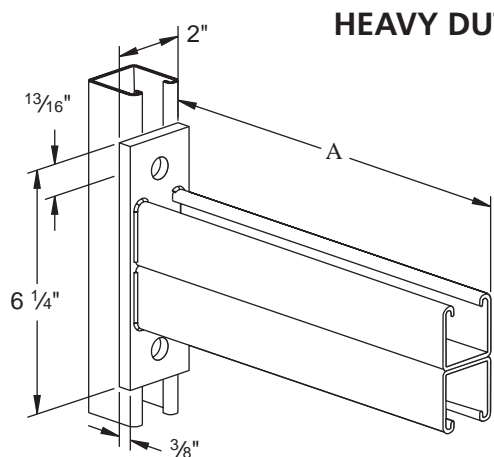

HEAVY DUTY

For use with all types of Cope I-Beam systems.
Finish is electro-galvanized.
Order hardware separately.

Heavy Duty for Heavier Loads

| Catalog No. | I-Beam Width | Dimension A | Uniform-Load Rating* |
|-------------|--------------|-------------|----------------------|
| PS 809-12 | 6" | 12" | 2,000 lbs. |
| PS 809-15 | 9" | 15" | 1,600 lbs. |
| PS 809-18 | 12" | 18" | 1,330 lbs. |
| PS 809-24 | 18" | 24" | 1,000 lbs. |
| PS 809-30 | 24" | 30" | 800 lbs. |
| PS 809-36 | 30" | 36" | 660 lbs. |
| PS 809-42 | 36" | 42" | 570 lbs. |

* Mounted on 12 Ga. Channel.

I-BEAM CABLE TRAY SYSTEM

SUPPORT BRACKETS & TRAY HANGERS

WALL SUPPORT BRACKETS

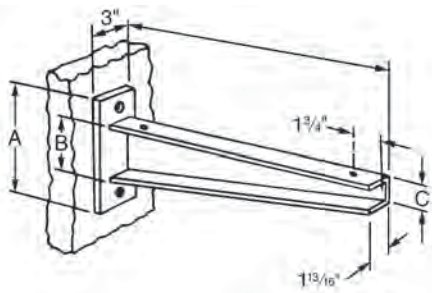

STRUCTURAL SUPPORT BRACKET

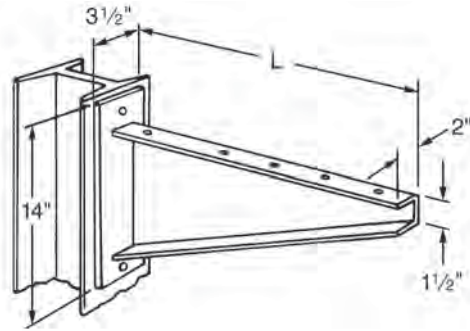

| Catalog Number | Ladder Width | Length "L" | Dimensions | | | End-Load Rating* |
|----------------|--------------|------------|------------|-----|--------|------------------|
| | | | "A" | "B" | "C" | |
| 9037-12 | 6" | 12 1/4" | 10" | 6" | 2" | 2000 lbs. |
| 9037-18 | 12" | 18 1/4" | 11" | 7" | 2 1/2" | 2000 lbs. |
| 9037-24 | 18" | 24 1/4" | 11" | 7" | 2 1/2" | 1600 lbs. |
| 9037-30 | 24" | 30 1/4" | 12" | 8" | 4" | 1300 lbs. |
| 9037-36 | 30" | 36 1/4" | 12" | 8" | 4" | 1100 lbs. |
| 9037-42 | 36" | 42 1/4" | 12" | 8" | 4" | 900 lbs. |

*Uniform load rating is normally twice the end-load rating.
Finish is hot-dip galvanized after fabrication.
Order hardware separately

| Catalog No. | Ladder Width | Length "L" | End-Load Rating* |
|-------------|--------------|------------|------------------|
| 9036-31 | 24" | 31 1/4" | 2000 lbs. |
| 9036-37 | 30" | 37 1/4" | 1800 lbs. |
| 9036-45 | 36" | 45 1/4" | 1500 lbs. |

*Uniform load rating is normally twice the end-load rating.
For use with Cope I-Beam 24" or wider. May be welded or bolted to building steel.
Finish is hot-dip galvanized after fabrication.
Order hardware separately.

POWER-PIER ROOFTOP SUPPORT SYSTEM

The Power-Pier Rooftop support system provides a simple and versatile way to support and manage pipe, tubing, conduit, HVAC systems, and the like. The Power-Pier system supports without roof surface penetration and allows the parts to remain off the surface.

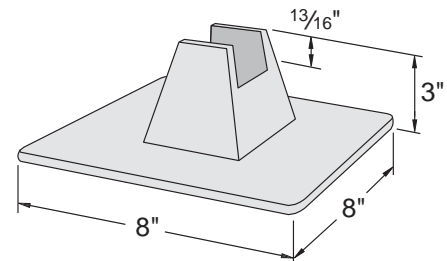

| Part Number | Power-Pier Bases Qty. | I-Beam Width | Description |
|--------------|-----------------------|--------------|---|
| PS PP | 4 | - | Power-Pier Base Only (4 Bases & Hardware) |
| PS-SPSS-10HG | 4 | 6" | PS PP + 4 Pcs PS 500 EH HG @ 10" Long for 4" to 8" Pipe |
| PS-MPDS-13HG | 4 | 9" | PS PP + 2 Pcs PS 200 EH HG @ 13" Long for Trapeze |
| PS-MPDS-16HG | 4 | 12" | PS PP + 2 Pcs PS 200 EH HG @ 16" Long for Trapeze |
| PS-MPDS-22HG | 4 | 18" | PS PP + 2 Pcs PS 200 EH HG @ 22" Long for Trapeze |
| PS-MPDS-28HG | 4 | 24" | PS PP + 2 Pcs PS 200 EH HG @ 28" Long for Trapeze |
| PS-MPDS-34HG | 4 | 30" | PS PP + 2 Pcs PS 200 EH HG @ 34" Long for Trapeze |
| PS-MPDS-40HG | 4 | 36" | PS PP + 2 Pcs PS 200 EH HG @ 40" Long for Trapeze |

TRAY HANGER & SUPPORTS

SINGLE ROD HANGER SUPPORT

| Catalog Number | | | | | |
|----------------|-----------------|-------------------------|---------------------|------------------------|-----------------|
| Assy. Type | Channel Length* | Channel Finish** | Rod Diameter | Rod Length | Beam Clamp |
| P200 | 14" (356mm) | GV (Pre-Galv) | 38=3/8" (9.53mm) | 000 - No Rod | A - Bridgeport |
| | 17" (432mm) | | | 036 - 36" (914mm) | B - P2622 |
| | 20" (508mm) | | | 072 - 72" (1828mm) | O - No Clamp |
| | 26" (661mm) | HG (Hot Dipped Galv) | 12=1/2" (12.7mm) | 120 - 120" (3048mm) | R - Rod Coupler |
| | 32" (813mm) | | | 144 - 144" (3658mm) | S - Special |
| | 38" (966mm) | | | | |
| | 44" (1118mm) | | | | |

Example:

P20020GV12036B is a Single 20" pre-galvanized channel with 12" x 36" drop rod and P2622 clamp.

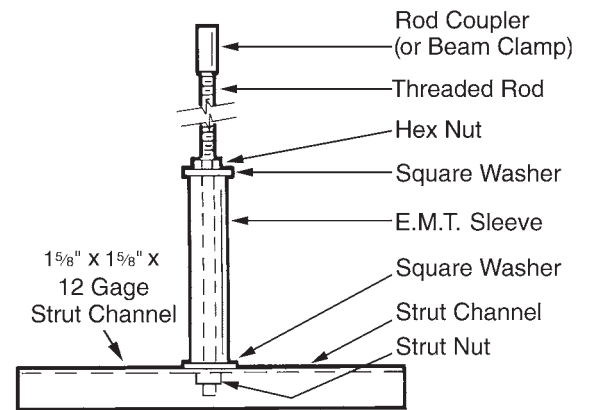

NOTE:

*Order channel length 8" longer than tray width. For example, 44" channel for 36" tray.

** Other channel types and finishes available upon request. Contact factory.

To order hardware only:
3/8" - PGV380000
1/2" - PGV120000

TRAPEZE HANGER SUPPORT

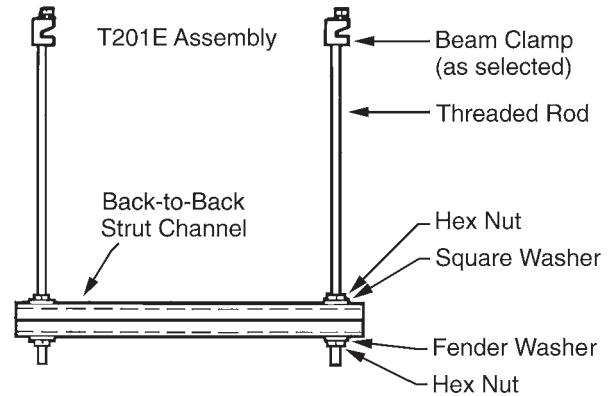
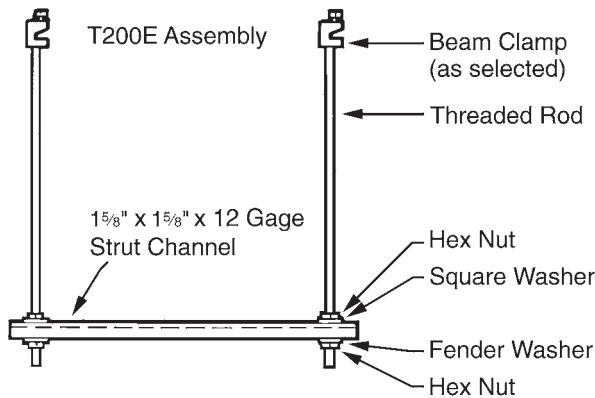

Catalog Number

| Assy. Type | Channel Length* | Channel Finish** | Rod Diameter | Rod Length | Beam Clamp |
|------------|-----------------|----------------------|---------------------|------------------------|-----------------|
| T200E | 16" (407mm) | GV (Pre-Galv) | 38=3/8" (9.53mm) | 000 - No Rod | A - PS 85 |
| T201E | 19" (483mm) | | | 036 - 36" (914mm) | B - P2622 |
| | 22" (559mm) | HG (Hot Dipped Galv) | 12=1/2" (12.7mm) | 072 - 72" (1828mm) | O - No Clamp |
| | 28" (712mm) | | | 120 - 120" (3048mm) | R - Rod Coupler |
| | 34" (864mm) | | | 144 - 144" (3658mm) | S - Special |
| | 40" (1017mm) | | | | |
| | 46" (1169mm) | | | | |

Example: T200E22GV12036B is a Single 22" pre-galvanized channel with 12" x 36" drop rod and P2622 clamp.

NOTE: *Order channel length 10" longer than tray width. For example, 46" channel for 36" tray.

** Other channel types and finishes available upon request. Contact factory.

To order hardware only:
3/8" - PGV380000
1/2" - PGV120000

I-BEAM CABLE TRAY SYSTEM

ELECTRICAL GROUNDING CHART

| Fitting Prefix Number | | Min. X-Sect for 2 Rails (NEC Table 392.7B) Aluminum I-Beam X-Sect Area | Maximum Ground Fault Amperage (in Amps) Aluminum |
|-----------------------|------------|---|---|
| System | Load Depth | | |
| 5H3A | 3" | 1.00 | 1,200 |
| 5H4A | 4" | 1.00 | 1,200 |
| 1H5A | 5" | 1.50 | 1,600 |
| 5H5A | 5" | 1.50 | 1,600 |
| 7H5A | 5" | 2.00 | 2,000 |
| 9H5A | 5" | 2.00 | 2,000 |
| 7H6A | 6" | 2.00 | 2,000 |
| 9H6A | 6" | 2.00 | 2,000 |
| 11H7A | 7" | 2.00 | 2,000 |

The table to the left provides the Minimum Cross Sectional area for two side rails. Using the Fitting Prefix Number (H4A), the proper value is determined by the Material (column 3), the Flange (column 1) and Load Depth (column 2). Locate the line containing the Load Depth (column 1) and follow it to the right to the appropriate Flange and Material.

Find that value in Maximum Ground Fault (column 4), follow it to the right to the Material column to determine the Maximum Ground Fault Amperage.

For Example:

If the fitting prefix is H4A, the Flange is I-Beam, the Load Depth is 4", and the Material is Aluminum. The Minimum Cross Sectional Area (X-Sect Area) is 1.00 sq. in. The Amperage is 1,200.

TYPICAL SPECIFICATIONS

By specifying the NEMA class designation, you will use the simplest, clearest, and most complete method of specification available and automatically incorporate support span in feet, working (allowable) load in pounds per linear foot, a safety factor of 1.5, a concentrated load if present; and, all other design, manufacturing and test standards including electrical continuity.

All you need to do is add the desired load depth, rung spacing, radius of fittings, metal and finish. You may add accessory information pursuant to your project. Here is a typical specification for an outdoor tray system where the working (allowable) load has been determined to be approximately 75 pounds per foot on support spans of 12'-0".

SPECIFICATION ALUMINUM COPE I-BEAM SYSTEM

Cable I-Beam shall be manufactured by a company regularly engaged in the manufacture of metal cable trays and shall be a member of NEMA. Trays shall conform to NEMA Metal Cable Tray Standard Publication VE-1 (latest issue).

- Cable I-Beam shall be NEMA Classification 12B of the widths indicated.
- Material shall be aluminum alloy with side rails and rungs of 6063.
- Finish shall be natural.
- Inside load depth to be NEMA Standard 4".
- Fittings shall be 12" radius for control cables and 24" radius for power cables. (This must be commensurate with the cable manufacturers' recommended minimum bending radius.)
- All top level trays in stacks, and single runs to have raised peaked, aluminum ventilated covers with heavy duty hold down clamps every 3'-0".
- Install expansion connectors, expansion guides, and hold down clamps per NEMA Standard VE-1.
- Where slopes or horizontal bends of trays are not at the Standard NEMA angles, use adjustable connectors. If the angle is too great for cable bending radius, use combinations of fitting and adjustable connectors.
- Separate all cables of different volt ages in the same tray using the manufacturer's standard barriers and barrier hold down system.
- The Cable I-Beam system will be used as an equipment grounding conductor.
- To save space fittings shall have 3" tangents. To facilitate field installation use one pair of universal type connector plates for rigid joints.
- Trays shall be Cope Cable I-Beam System Number 5H4A as manufactured by Allied Tube & Conduit® Corporation.

4



HAT

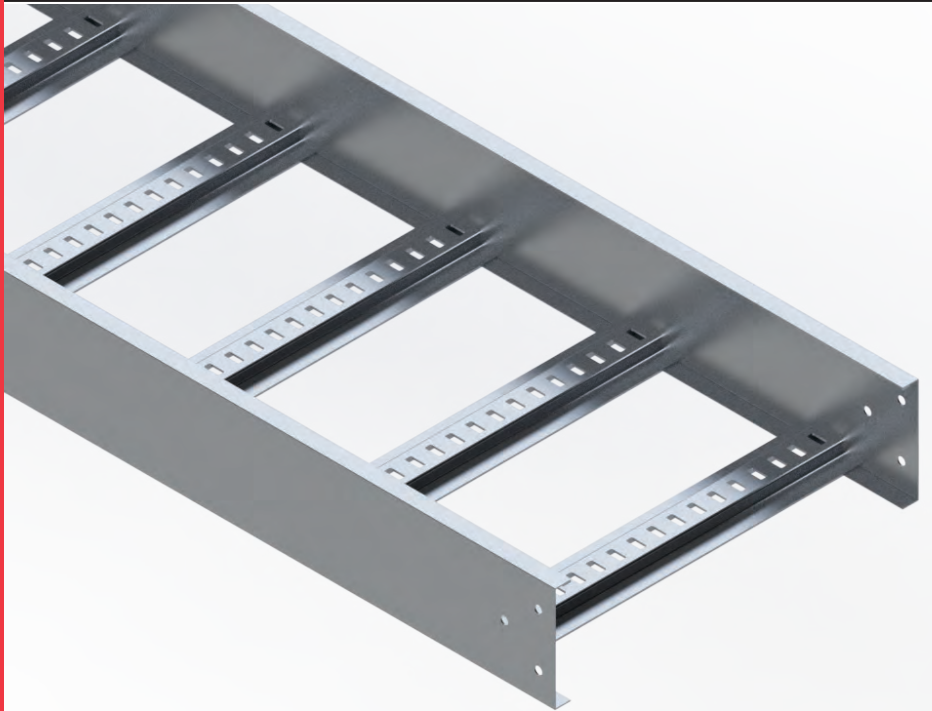

Economical Flange in Welded Cable Ladder/Trof System for Electrical, Telephone, Computer Control & Instrumentation Cable

Slotted or **Solid Rungs** available on all widths.

HAT CABLE TRAY SYSTEM

CONTENTS

GENERAL & TECHNICAL INFORMATION

| | |
|--|---------|
| Selection Chart: Cope Hat - Aluminum | 90 - 91 |
| Selection Chart: Cope Hat - Steel..... | 92 - 93 |
| Overview | 94 - 95 |
| Ordering Information..... | 96 |
| Straight Length..... | 96 -97 |

COPE HAT FITTINGS

| | |
|--|-----------|
| Horizontal Elbows | |
| 90° | 98 |
| 60° | 98 |
| 45° | 99 |
| 30° | 99 |
| Horizontal Tee | 100 |
| Horizontal Cross | 101 |
| Horizontal Tapped Tee | 102 |
| Horizontal Tapped Cross..... | 103 - 104 |
| Straight Reducers | 105 |
| Left and Right Hand Reducers | 105 |
| Adjustable Elbow | 106 |
| 45° "Y" Branch | 106 |
| Vertical Elbows (Inside and Outside) | |
| 90° | 107 |
| 60° | 107 |
| 45° | 108 |
| 30° | 108 |
| 90° Vertical Cable Support Elbow | 109 |
| Vertical Tee | 109 |
| Connector Plates..... | 110 |
| Hardware | 111 |
| Covers..... | 112 |
| Cover Accessories..... | 113 |
| Accessories..... | 114 - 115 |
| Barrier Strips..... | 116 - 117 |
| Support Brackets | 118 |
| Tray Hangers & Supports | 119 |
| Electrical Grounding Chart..... | 120 |
| Typical Specification..... | 120 |

PICTORIAL INDEX

STRAIGHT LENGTH

Page 96 - 97

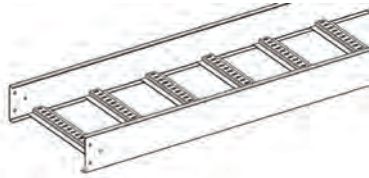

VERTICAL ELBOWS

Pages 107 - 108

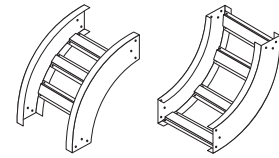

HORIZONTAL ELBOWS

Pages 98 - 99

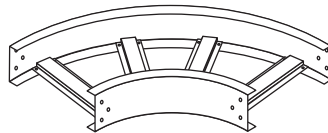

90° VERTICAL CABLE SUPPORT ELBOW

Page 109

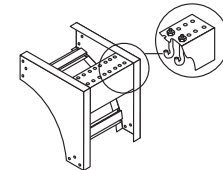

HORIZONTAL TEE

Pages 100, 102

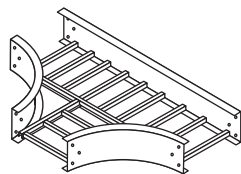

VERTICAL TEE

Page 109

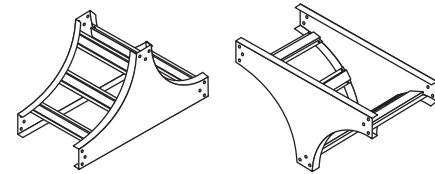

HORIZONTAL CROSS

Pages 101, 103 - 104

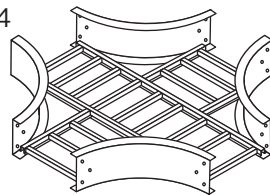

SPLICE PLATES

Pages 110

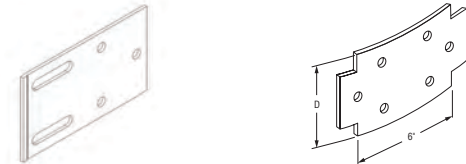

REDUCERS

Page 105

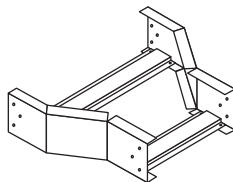

COVERS

Page 112

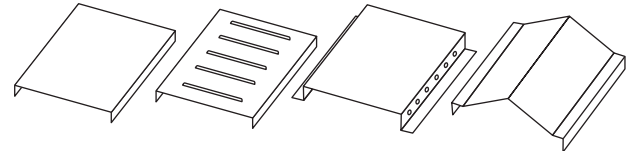

ADJUSTABLE ELBOWS

Page 106

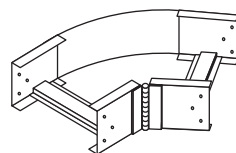

COVER ATTACHMENT

Page 113

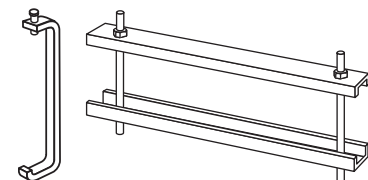

45° "Y" BRANCH

Page 106

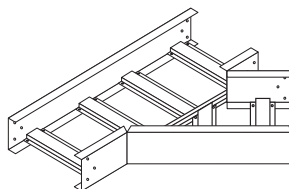

BARRIER STRIPS AND ACCESSORIES

Page 116 - 117

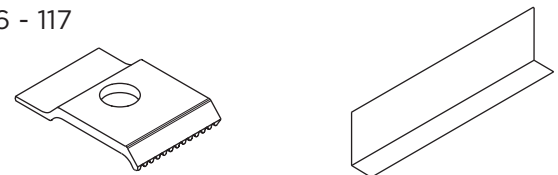

Intro

LADDER

I-BEAM

HAT

TROF

CHANNEL

COPE-GLAS™

WIREBASKET

Reference

HAT CABLE TRAY SYSTEM

ALUMINUM TRAY

SELECTION CHART

NEMA CLASS, PHYSICAL AND STRUCTURAL PROPERTIES

| NEMA Standard VE-1 Load/Span Class | Actual NEMA Load/Span | Cope System Number | Nominal Load Depth | Side Rail Height | Flange Width (in.) | Section Modulus of 2 Rails Sx (in. ³) | Moment of Inertia for 2 Rails Ix (in. ⁴) | Min X-Sect. Area of 2 Rails per NEC 392.7 (in. ²) |
|--|-------------------------|--------------------|--------------------|------------------|--------------------|---|--|---|
| 8A-12A | 50 lb./ft. 12' span | 523A | 3" (76mm) | 3 ½" (89mm) | ⅜" | 0.800 | 1.400 | 0.60 |
| | | 1B4A | 4" (102mm) | 4 ¼" (108mm) | ⅜" | 1.898 | 1.822 | 0.60 |
| | | 1B5A | 5" (127mm) | 5 ¼" (133mm) | ⅜" | 1.142 | 2.872 | 0.60 |
| | | 3B6A | 6" (152mm) | 6 ¼" (159mm) | ⅜" | 1.614 | 4.720 | 1.00 |
| 12B | 75 lb./ft. 12' span | 3B4A | 4" (102mm) | 4 ¼" (108mm) | ⅜" | 1.148 | 2.316 | 0.60 |
| | | 1B5A | 5" (127mm) | 5 ¼" (133mm) | ⅜" | 1.142 | 2.872 | 0.60 |
| | | 3B6A | 6" (152mm) | 6 ¼" (159mm) | ⅜" | 1.614 | 4.720 | 0.60 |
| 12C | 100 lb./ft 12' span | 5B4A | 4" (102mm) | 4 ¼" (108mm) | ⅜" | 1.646 | 3.058 | 1.00 |
| | | 3B5A | 5" (127mm) | 5 ¼" (133mm) | ⅜" | 1.522 | 3.734 | 1.00 |
| | | 5B6A | 6" (152mm) | 6 ¼" (159mm) | ⅜" | 1.944 | 5.866 | 1.00 |
| 16A | 50 lb./ft. 16' span | 5B4A | 4" (102mm) | 4 ¼" (108mm) | ⅜" | 1.646 | 3.058 | 1.00 |
| | | 745A | 5" (127mm) | 5 ¼" (133mm) | 1 ¼" | 2.396 | 6.292 | 1.50 |
| | | 1D6A | 6" (152mm) | 6 ¼" (159mm) | 1 ¼" | 2.378 | 7.202 | 1.00 |
| 16B | 75 lb./ft. 16' span | 3D4A | 4" (102mm) | 4 ¼" (108mm) | 1 ¼" | 2.242 | 4.406 | 1.00 |
| | | 745A | 5" (127mm) | 5 ¼" (133mm) | 1 ¼" | 2.396 | 6.292 | 1.50 |
| | | 1D6A | 6" (152mm) | 6 ¼" (159mm) | 1 ¼" | 2.378 | 7.202 | 1.00 |
| 16C | 100 lb./ft. 16' span | 5D4A | 4" (102mm) | 4 ¼" (108mm) | 1 ¼" | 2.782 | 5.738 | 1.50 |
| | | 3D5A | 5" (127mm) | 5 ¼" (133mm) | 1 ¼" | 3.434 | 8.746 | 2.00 |
| | | 7D6A | 6" (152mm) | 6 ¼" (159mm) | 1 ¼" | 4.186 | 12.024 | 2.00 |
| 20A | 50 lb./ft. 20' span | 3D4A | 4" (102mm) | 4 ¼" (108mm) | 1 ¼" | 2.242 | 4.406 | 1.00 |
| | | 745A | 5" (127mm) | 5 ¼" (133mm) | 1 ¼" | 2.396 | 6.292 | 1.50 |
| | | 1D6A | 6" (152mm) | 6 ¼" (159mm) | 1 ¼" | 2.378 | 7.202 | 1.00 |
| 20B | 75 lb./ft. 20' span | 3D5A | 5" (127mm) | 5 ¼" (133mm) | 1 ¼" | 3.434 | 8.746 | 2.00 |
| | | 7D6A | 6" (152mm) | 6 ¼" (159mm) | 1 ¼" | 4.186 | 12.024 | 2.00 |
| 20C | 100 lb./ft. 20' span | 7D4A | 4" (127mm) | 4 ¼" (108mm) | 1 ¼" | 3.512 | 6.956 | 2.00 |
| | | 5D5A | 5" (127mm) | 5 ¼" (108mm) | 1 ¼" | 3.910 | 10.020 | 2.00 |
| | | 7D6A | 6" (152mm) | 6 ¼" (133mm) | 1 ¼" | 4.1860 | 12.024 | 2.00 |
| EXTRA HEAVY DUTY - VERY LONG SPAN TRAYS- 4", 6" OR 9" RUNG SPACING | | 9D6A | 6" (152mm) | 6 ¼" (159mm) | 1 ¼" | 5.130 | 15.700 | 2.00 |
| | | 7G6A | 6" (152mm) | 6 ¼" (159mm) | 2" | 5.804 | 17.456 | 2.00 |

NOTE: Slotted or Solid Rungs available on all widths.

SELECTION CHART

**LOAD AND DEFLECTION DATA FOR ALUMINUM HAT WORKING (ALLOWABLE) LOAD CAPACITY,
EVENLY DISTRIBUTED-TESTED PER NEMA STANDARD VE-1,
SIMPLE BEAM - SAFETY FACTOR 1.5**

| Cope Sys. No. | 6 Ft. Span | | | 8 Ft. Span | | | 10 Ft. Span | | | 12 Ft. Span | | | 16 Ft. Span | | | 20 Ft. Span | | | 24 Ft. Span | | | 25 Ft. Span | | | |
|--|------------|-----|------|------------|-----|------|-------------|------|------|-------------|------|------|-------------|------|------|-------------|------|------|-------------|------|------|-------------|------|------|--|
| | w | d | k | w | d | k | w | d | k | w | d | k | w | d | k | w | d | k | w | d | k | w | d | k | |
| 523A | 207 | .43 | .002 | 117 | .77 | .007 | 75 | 1.20 | .016 | 52 | 1.73 | .033 | | | | | | | | | | | | | |
| 1B4A | 222 | .35 | .002 | 125 | .63 | .005 | 80 | .99 | .012 | 55 | 1.42 | .026 | | | | | | | | | | | | | |
| 1B5A | 324 | .33 | .001 | 182 | .59 | .003 | 117 | .87 | .007 | 77 | 1.26 | .016 | | | | | | | | | | | | | |
| 3B6A | 359 | .22 | † | 191 | .37 | .002 | 115 | .55 | .005 | 75 | .74 | .010 | | | | | | | | | | | | | |
| 3B4A | 354 | .45 | .001 | 191 | .76 | .004 | 117 | 1.14 | .010 | 78 | 1.57 | .020 | | | | | | | | | | | | | |
| 1B5A | 324 | .33 | .001 | 182 | .59 | .003 | 117 | .87 | .007 | 77 | 1.26 | .016 | | | | | | | | | | | | | |
| 3B6A | 359 | .22 | † | 191 | .37 | .002 | 115 | .55 | .005 | 75 | .74 | .010 | | | | | | | | | | | | | |
| 5B4A | 362 | .32 | † | 251 | .69 | .003 | 161 | 1.08 | .007 | 112 | 1.55 | .014 | | | | | | | | | | | | | |
| 3B5A | 394 | .31 | † | 222 | .55 | .002 | 142 | .86 | .006 | 100 | 1.24 | .012 | | | | | | | | | | | | | |
| 5B6A | 480 | .24 | † | 257 | .40 | .002 | 156 | .60 | .004 | 102 | .81 | .008 | | | | | | | | | | | | | |
| 5B4A | | | | 251 | .69 | .003 | 161 | 1.08 | .007 | 112 | 1.55 | .014 | 51 | 2.26 | .044 | 25 | 2.75 | .110 | | | | | | | |
| 745A | | | | 349 | .51 | .001 | 223 | .80 | .004 | 155 | 1.15 | .007 | 79 | 1.85 | .023 | 51 | 2.89 | .057 | | | | | | | |
| 1D6A | | | | 380 | .49 | .001 | 222 | .69 | .003 | 154 | 1.00 | .006 | 78 | 1.61 | .021 | 50 | 2.51 | .050 | | | | | | | |
| 3D4A | | | | 342 | .72 | .002 | 219 | 1.12 | .005 | 152 | 1.61 | .011 | 82 | 2.74 | .033 | 52 | 4.27 | .082 | | | | | | | |
| 745A | | | | 349 | .51 | .001 | 223 | .80 | .004 | 155 | 1.15 | .007 | 79 | 1.85 | .023 | 51 | 2.89 | .057 | | | | | | | |
| 1D6A | | | | 380 | .49 | .001 | 222 | .69 | .003 | 154 | 1.00 | .006 | 78 | 1.61 | .021 | 50 | 2.51 | .050 | | | | | | | |
| 5D4A | | | | 444 | .71 | .002 | 284 | .70 | .002 | 188 | 1.53 | .008 | 106 | 2.73 | .026 | 65 | 4.07 | .063 | | | | | | | |
| 3D5A | | | | 525 | .55 | .001 | 336 | .86 | .003 | 233 | 1.24 | .005 | 119 | 2.01 | .017 | 76 | 3.14 | .041 | | | | | | | |
| 7D6A | | | | | | | | | | 229 | 1.00 | .004 | 116 | 1.60 | .014 | 75 | 2.50 | .033 | | | | | | | |
| 3D4A | | | | | | | | | | 152 | 1.61 | .011 | 82 | 2.74 | .033 | 52 | 4.27 | .082 | | | | | | | |
| 745A | | | | | | | | | | 155 | 1.15 | .007 | 79 | 1.85 | .023 | 51 | 2.89 | .057 | | | | | | | |
| 1D6A | | | | | | | | | | 154 | 1.00 | .006 | 78 | 1.61 | .021 | 50 | 2.51 | .050 | | | | | | | |
| 3D5A | | | | | | | | | | 233 | 1.24 | .005 | 119 | 2.01 | .017 | 76 | 3.14 | .041 | | | | | | | |
| 7D6A | | | | | | | | | | 229 | 1.00 | .004 | 116 | 1.60 | .014 | 75 | 2.50 | .033 | | | | | | | |
| 7D4A | | | | | | | | | | 277 | 2.03 | .007 | 156 | 3.61 | .023 | 100 | 5.64 | .056 | | | | | | | |
| 5D5A | | | | | | | | | | 290 | 1.35 | .005 | 156 | 2.30 | .015 | 100 | 3.59 | .036 | | | | | | | |
| 7D6A | | | | | | | | | | 284 | 1.09 | .004 | 158 | 1.94 | .012 | 101 | 3.02 | .030 | | | | | | | |
| EXTRA HEAVY DUTY - VERY LONG SPAN TRAYS- 4", 6" OR 9" RUNG SPACING | | | | | | | | | | | | | | | | | | | | | | | | | |
| 9D6A | | | | | | | | | | 412 | 1.22 | .003 | 214 | 2.00 | .009 | 131 | 3.01 | .023 | 68 | 3.23 | .048 | | | | |
| 7G6A | | | | | | | | | | 451 | 1.20 | .003 | 253 | 2.14 | .008 | 162 | 3.35 | .020 | 112 | 4.79 | .043 | 104 | 5.24 | .050 | |

NOTE: To convert 1.5 safety factor to 2.0 multiply w,d,k by .75.

W=Pounds per linear foot

Metric: for kg/m multiply w by 1.48

d=Deflection (inches)

k= Deflection (in.) for each pound of load

†= Denotes k is less than .001 inch

HAT CABLE TRAY SYSTEM

STEEL TRAY

SELECTION CHART

NEMA CLASS, PHYSICAL AND STRUCTURAL PROPERTIES

| NEMA Standard VE-1 Load/Span Class | NEMA Load/ Span | Mill Galv. System Number | HDGAF System Number | Type 304 SS System Number | Nominal Load Depth | | Side Rail Height | | Flange Width (in.) | Section Modulus of 2 Rails Sx (in. ³) | Moment of Inertia for 2 Rails Ix (in. ⁴) | Min. X-Sect. Area of 2 Rails per NEC 392-7 (in. ²) |
|--|----------------------|--------------------------|---------------------|---------------------------|--------------------|---------|------------------|---------|--------------------|---|--|--|
| 8A-12A | 50 lb./ft. 12' span | 823P | 623G | 823S | 3" | (76mm) | 3 1/2" | (89mm) | 13/16" | 0.444 | 0.778 | .40 |
| | | 824P | 624G | 824S | 4" | (102mm) | 4 1/4" | (108mm) | 13/16" | 0.592 | 1.258 | .40 |
| | | 825P | 625G | 825S | 5" | (127mm) | 5 1/4" | (133mm) | 13/16" | 0.816 | 2.142 | .40 |
| | | 826P | 626G | 826S | 6" | (152mm) | 6 1/4" | (159mm) | 13/16" | 1.072 | 3.352 | .70 |
| 12B | 75 lb./ft. 12' span | 423P | 423G | 423S | 3" | (76mm) | 3 1/2" | (89mm) | 13/16" | 0.674 | 1.180 | .70 |
| | | 8B4P | 6B4G | 8B4S | 4" | (102mm) | 4 1/4" | (108mm) | 13/16" | 0.678 | 1.370 | .40 |
| | | 825P | 625G | 825S | 5" | (127mm) | 5 1/4" | (133mm) | 13/16" | 0.816 | 2.142 | .40 |
| | | 826P | 626G | 826S | 6" | (152mm) | 6 1/4" | (159mm) | 13/16" | 1.072 | 3.352 | .70 |
| 12C | 100 lb./ft. 12' span | 6B4P | 6B4G | 6B4S | 4" | (102mm) | 4 1/4" | (108mm) | 13/16" | 0.834 | 1.690 | .70 |
| | | 6B5P | 6B5G | 6B5S | 5" | (127mm) | 5 1/4" | (133mm) | 13/16" | 1.140 | 2.872 | .70 |
| | | 626P | 626G | 626S | 6" | (152mm) | 6 1/4" | (159mm) | 13/16" | 1.330 | 4.158 | .70 |
| 16A | 50 lb./ft. 16' span | 8D4P | 6D4G | 8D4S | 4" | (102mm) | 4 1/4" | (108mm) | 13/16" | 0.852 | 1.736 | .40 |
| | | 645P | 645G | 645S | 5" | (127mm) | 5 1/4" | (133mm) | 1 1/4" | 1.280 | 3.360 | .70 |
| | | 646P | 646G | 646S | 6" | (152mm) | 6 1/4" | (159mm) | 1 1/4" | 1.652 | 5.160 | .70 |
| 16B | 75 lb./ft. 16' span | 6D4P | 6D4G | 6D4S | 4" | (102mm) | 4 1/4" | (108mm) | 1 1/4" | 1.056 | 2.152 | .70 |
| | | 645P | 645G | 645S | 5" | (127mm) | 5 1/4" | (133mm) | 1 1/4" | 1.280 | 3.360 | .70 |
| | | 646P | 646G | 646S | 6" | (152mm) | 6 1/4" | (159mm) | 1 1/4" | 1.652 | 5.160 | .70 |
| 16C | 100 lb./ft. 16' span | 4D4P | 4D4G | 4D4S | 4" | (102mm) | 4 1/4" | (108mm) | 1 1/4" | 1.298 | 2.652 | 1.00 |
| | | 645P | 645G | 645S | 5" | (127mm) | 5 1/4" | (133mm) | 1 1/4" | 1.280 | 3.360 | .70 |
| | | 646P | 646G | 646S | 6" | (152mm) | 6 1/4" | (159mm) | 1 1/4" | 1.652 | 5.160 | .70 |
| 20A | 50 lb./ft. 20' span | 6D4P | 6D4G | 6D4S | 4" | (102mm) | 4 1/4" | (108mm) | 1 1/4" | 1.056 | 2.152 | .70 |
| | | 645P | 645G | 645S | 5" | (127mm) | 5 1/4" | (133mm) | 1 1/4" | 1.280 | 3.360 | .70 |
| | | 646P | 646G | 646S | 6" | (152mm) | 6 1/4" | (159mm) | 1 1/4" | 1.652 | 5.160 | 1.00 |
| 20B | 75 lb./ft. 20' span | 2D4P | 2D4G | 2D4S | 4" | (102mm) | 4 1/4" | (108mm) | 1 1/4" | 1.758 | 3.604 | 1.00 |
| | | 4D5P | 4D5G | 4D5S | 5" | (127mm) | 5 1/4" | (133mm) | 1 1/4" | 1.744 | 4.418 | 1.00 |
| | | 6D6P | 6D6G | 6D6S | 6" | (152mm) | 6 1/4" | (159mm) | 1 1/4" | 1.814 | 5.486 | 1.00 |
| 20C | 100 lb./ft. 20' span | 2D5P | 2D5G | 2D5S | 5" | (127mm) | 5 1/4" | (133mm) | 1 1/4" | 2.370 | 6.026 | 1.50 |
| | | 4D6P | 4D6G | 4D6S | 6" | (143mm) | 6 1/4" | (159mm) | 1 1/4" | 2.240 | 6.778 | 1.00 |
| EXTRA HEAVY DUTY - VERY LONG SPAN TRAYS- 4", 6" OR 9" RUNG SPACING | | 2D6P | 2D6G | 2D6S | 6" | (152mm) | 6 1/4" | (159mm) | 1 1/4" | 3.052 | 9.270 | 1.50 |
| | | 11D6P | 11D6G | 11D6S | 6" | (152mm) | 6 1/4" | (159mm) | 1 1/4" | 3.536 | 10.630 | 1.50 |

NOTE: Slotted or Solid Rungs available on all widths.

**LOAD AND DEFLECTION DATA FOR STEEL HAT
WORKING (ALLOWABLE) LOAD CAPACITY, EVENLY DISTRIBUTED-TESTED PER NEMA STANDARD VE-1,
SIMPLE BEAM - SAFETY FACTOR 1.5**

| Cope Sys. No. | 6 Ft. Span | | | 8 Ft. Span | | | 10 Ft. Span | | | 12 Ft. Span | | | 16 Ft. Span | | | 20 Ft. Span | | | 24 Ft. Span | | | 25 Ft. Span | | |
|--|------------|-----|------|------------|-----|------|-------------|-----|------|-------------|------|------|-------------|------|------|-------------|------|------|-------------|------|------|-------------|------|------|
| | w | d | k | w | d | k | w | d | k | w | d | k | w | d | k | w | d | k | w | d | k | w | d | k |
| 823P/G/S | 230 | .30 | .001 | 126 | .52 | .004 | 79 | .79 | .010 | 53 | 1.11 | .021 | | | | | | | | | | | | |
| 824P/G/S | 292 | .23 | † | 164 | .42 | .003 | 103 | .63 | .006 | 69 | .89 | .013 | | | | | | | | | | | | |
| 825P/G/S | 383 | .18 | † | 210 | .31 | .001 | 127 | .46 | .004 | 83 | .62 | .007 | | | | | | | | | | | | |
| 826P/G/S | 357 | .11 | † | 194 | .18 | † | 119 | .28 | .002 | 79 | .38 | .005 | | | | | | | | | | | | |
| 423P/G/S | 358 | .30 | † | 197 | .53 | .003 | 124 | .81 | .007 | 83 | 1.13 | .014 | | | | | | | | | | | | |
| 8B4P/G/S | 360 | .26 | † | 198 | .46 | .002 | 124 | .70 | .006 | 84 | .98 | .012 | | | | | | | | | | | | |
| 825P/G/S | 383 | .18 | † | 210 | .31 | .001 | 127 | .46 | .004 | 83 | .62 | .007 | | | | | | | | | | | | |
| 826P/G/S | 357 | .11 | † | 194 | .18 | † | 119 | .28 | .002 | 79 | .38 | .005 | | | | | | | | | | | | |
| 6B4P/G/S | 453 | .27 | † | 249 | .47 | .002 | 156 | .71 | .005 | 106 | 1.00 | .009 | | | | | | | | | | | | |
| 6B5P/G/S | 591 | .21 | † | 325 | .36 | .001 | 203 | .55 | .003 | 137 | .77 | .006 | | | | | | | | | | | | |
| 626P/G/S | 460 | .11 | † | 250 | .19 | † | 154 | .29 | .002 | 103 | .40 | .004 | | | | | | | | | | | | |
| 8D4P/G/S | | | | 290 | .53 | .002 | 182 | .81 | .004 | 126 | 1.17 | .009 | 65 | 1.91 | .029 | | | | | | | | | |
| 645P/G/S | | | | 444 | .42 | † | 273 | .63 | .002 | 186 | .89 | .005 | 100 | 1.51 | .015 | | | | | | | | | |
| 646P/G/S | | | | 574 | .42 | † | 367 | .55 | .001 | 245 | .76 | .003 | 123 | 1.22 | .010 | | | | | | | | | |
| 6D4P/G/S | | | | 381 | .56 | .001 | 244 | .88 | .004 | 169 | 1.27 | .008 | 88 | 2.08 | .024 | | | | | | | | | |
| 645P/G/S | | | | 444 | .42 | † | 273 | .63 | .002 | 186 | .89 | .005 | 100 | 1.51 | .015 | | | | | | | | | |
| 646P/G/S | | | | 574 | .42 | † | 367 | .55 | .001 | 245 | .76 | .003 | 123 | 1.22 | .010 | | | | | | | | | |
| 4D4P/G/S | | | | 487 | .58 | .001 | 312 | .91 | .003 | 216 | 1.31 | .006 | 113 | 2.16 | .019 | | | | | | | | | |
| 645P/G/S | | | | 444 | .42 | † | 273 | .63 | .002 | 186 | .89 | .005 | 100 | 1.51 | .015 | | | | | | | | | |
| 646P/G/S | | | | 574 | .42 | † | 367 | .55 | .001 | 245 | .76 | .003 | 123 | 1.22 | .010 | | | | | | | | | |
| 6D4P/G/S | | | | | | | | | | 169 | 1.27 | .008 | 88 | 2.08 | .024 | 52 | 2.98 | .057 | | | | | | |
| 645P/G/S | | | | | | | | | | 186 | .89 | .005 | 100 | 1.51 | .015 | 53 | 1.94 | .037 | | | | | | |
| 646P/G/S | | | | | | | | | | 245 | .76 | .003 | 123 | 1.22 | .010 | 66 | 1.59 | .024 | | | | | | |
| 2D4P/G/S | | | | | | | | | | 304 | 1.36 | .004 | 159 | 2.24 | .014 | 94 | 3.23 | .034 | | | | | | |
| 4D5P/G/S | | | | | | | | | | 280 | 1.02 | .004 | 145 | 1.67 | .012 | 85 | 2.40 | .028 | | | | | | |
| 6D6P/G/S | | | | | | | | | | 269 | .80 | .003 | 139 | 1.28 | .009 | 81 | 1.82 | .022 | | | | | | |
| 2D5P/G/S | | | | | | | | | | 395 | 1.05 | .003 | 206 | 1.74 | .008 | 121 | 2.50 | .021 | | | | | | |
| 4D6P/G/S | | | | | | | | | | 296 | .79 | .003 | 152 | 1.28 | .008 | 105 | 1.91 | .018 | | | | | | |
| EXTRA HEAVY DUTY - VERY LONG SPAN TRAYS- 4", 6" OR 9" RUNG SPACING | | | | | | | | | | | | | | | | | | | | | | | | |
| 2D6P/G/S | | | | | | | | | | 300 | .85 | .002 | 221 | 1.40 | .006 | 149 | 2.00 | .013 | 79 | 1.91 | .024 | 73 | 2.38 | .033 |
| 11D6P/G/S | | | | | | | | | | 434 | .66 | † | 244 | 1.17 | .005 | 156 | 1.82 | .012 | 108 | 2.62 | .024 | 100 | 2.85 | .029 |

NOTE: To convert 1.5 safety factor to 2.0 multiply w,d,k by.75.
W=Pounds per linear foot
Metric: for kg/m multiply w by 1.48
d=Deflection (inches)
k= Deflection (in.) for each pound of load
†= Denotes k is less than .001 inch

Intro

LADDER

I-BEAM

HAT

TROF

CHANNEL

COPE-GLAS™

WIREBASKET

Reference

HAT CABLE TRAY SYSTEM

OVERVIEW

COPE HAT is a prefabricated metal structure consisting of reinforced hat-shaped rungs, arc-welded to the side rails, and is manufactured to NEMA Standard VE-1. The rungs of Cope Hat allow for increased surface area for cable loading. The low profile design of the hat rungs reduce the total height needed for the cable tray. This allows for the cable tray to be used in tight or narrow applications where standard ladder type cable tray with the same fill area is not applicable.

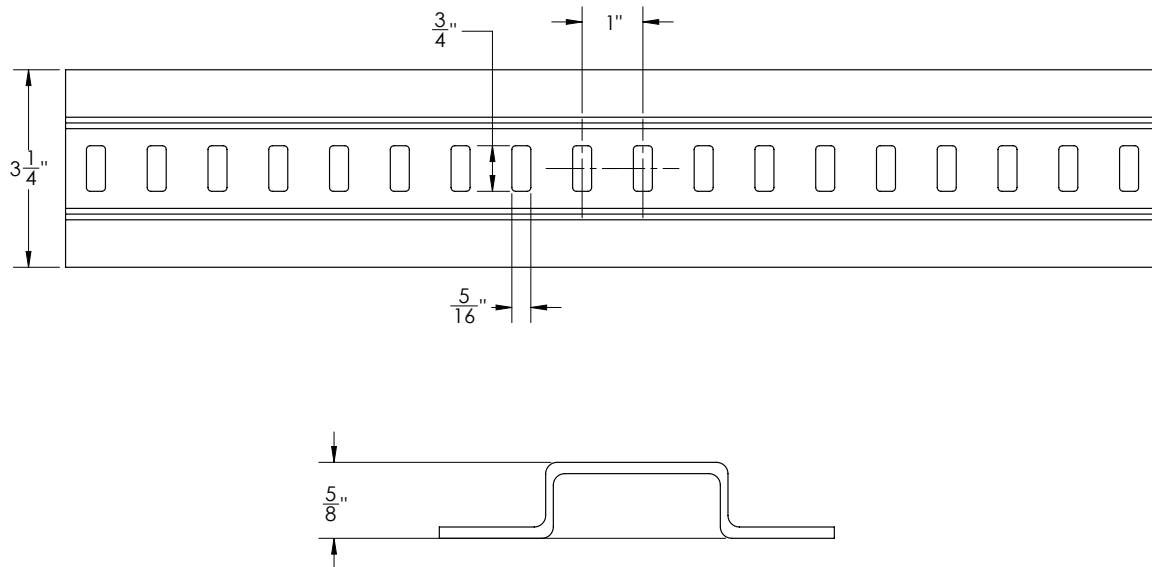

Side Members - Cope Hat side members are designed with top and bottom flanges turned inward. This minimizes the space requirements of the cable tray system, and allows a very low side rail height for each NEMA Standard VE-1 load depth.

Rungs - Cope Hat provides for hat shaped rungs.

Solid Rungs — are offered as a special order. Please contact Cope for more information

Slotted Rungs — Slotted Hat shaped Rungs are standard on all tray widths.

Slotted Hat Rungs for Steel trays are Hat shaped, 2 1/4" wide and provide for a 7/8" cable bearing surface.

Slotted Hat Rungs for Aluminum trays are Hat shaped, 3 1/4" wide and provide for a 1 1/2" cable bearing surface.

Rung Spacing - Cope manufactures straight lengths with four standard rung spacings; 6", 9", 12", and 18". The 6" rung spacing results in a 3 3/4" opening between rungs allowing the tray to be classified as a ventilated tray per NEMA Standard VE-1.

Length - The longitudinal dimensions of standard Cope Hat cable tray are 10', 12', 20', and 24'.

Width - The transverse dimensions of Cope Hat cable tray are measured inside, (from side member web to side member web), and are furnished in seven standard widths: 6", 9", 12", 18", 24", 30" and 36".

Overall Width - Overall tray width is equal to the inside or nominal width plus the thickness of the two side rail webs.

Overall Tray Width = Nominal + 3/16" Width

Load Depth - Measured from the top surface of the rungs to the top of the side member. Cope manufactures four loading depths; 2 7/8", 3 5/8", 4 5/8", and 5 5/8" corresponding to the four nominal loading depths in NEMA Standard VE-1; 3", 4", 5" and 6".

Overall Height - Cope Hat cable tray overall height is equal to the loading depth plus 5/8".

Fittings - For changing direction both horizontally and vertically, Cope manufactures elbows, tees, and crosses in all widths and loading depths. Fittings are available in three standard radii; 12", 24", and 36". Standard fittings maintain a nominal 9" rung spacing through the centerline of the fitting. Cope manufactures all standard fittings with zero tangents.

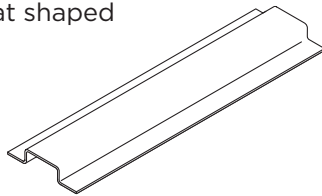

COPE HAT CABLE TRAY WITH Four IMPORTANT INDUSTRY-LEADING FEATURES:

1. Compact Economical System -

Cope Hat cable tray is an extremely compact economical flange in cable tray system which allows the designer to utilize this cable tray in tight locations. The extremely low profile Hat Rungs ($\frac{5}{8}$ " high) minimize the required side rail height while maintaining NEMA Standard VE-1 nominal load depths. Overall system height is only $\frac{5}{8}$ " greater than the actual loading depth.

2. Universal Curvilinear Splice Plate System -

The splice plates for rigid connections have a slight curve so they can be used on straight sections or fittings. Tightening of the fastener pulls the plate flush with the side rail. The fasteners are snug and the joint is superior structurally and electrically. Even when hand-tightened, there is pressure on the fastener to hold it securely.

NOTE: Heavy Duty, Mid Span Splice Plates available upon request.

3. Zero Tangent Fittings -

Tangent as referred to on cable tray fittings is the straight at the end of the curve to accommodate a flat splice plate. This wastes space in tightly packed areas, such as spreader rooms, where the heat of thousands of cables accumulate. Eliminating tangents allow more tray runs to distribute the heat.

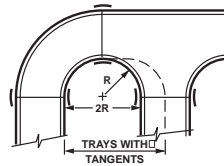

COPE ZERO TANGENT FITTINGS CAN SAVE UP TO 12" PER ROW OF TRAY.

BONUS: Inspection for proper installation of splice plate is visual. If the plate is bowed away from the rail, nuts must be tightened.

4. The Exclusive Auto MIG-Arc-Welded Assembly System -

Cope Hat rungs on straight sections are assembled to the side rails using an automatic, self indexing MIGArc- welding system fusing a $\frac{1}{2}$ " diameter zone. These welds are 700% larger and stronger than the common resistance (spot) weld in use today. Electrical properties of the assembly are unequaled; are well within the NEMA requirements due to the continuous electrical path. The mechanical strength of this welded assembly withstands the rigors of shipping, handling, installation, and service. The size of the weld keeps the vertical axis of the side rail from sloping inward under load. The weld maintains the 90° angle between the side rail and bottom. This allows full use of the section properties. Spot welds do not permit this. Also, stresses on spot welds (barely $\frac{1}{8}$ " in diameter) are so severe that breakage often occurs during shipping and installation. Cope Hat fittings are also assembled by MIG-arc welding.

See page 120
for Grounding
Chart Reference

HAT CABLE TRAY SYSTEM

PART NUMBERING SYSTEM:

STRAIGHT LENGTH

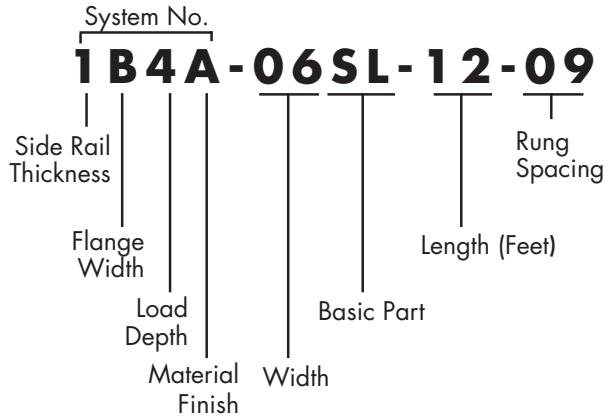

SYSTEM NUMBER (STRAIGHT SECTION ONLY)

The first four digits make up the system number which identifies the structural, dimensional, and material characteristics of the straight length. It is made up of the side rail digits indicating the side rail thickness and flange width, the load depth (inside, in inches) and material finish (galvanized, aluminum or coated).

PREFIX NUMBER (FITTINGS ONLY) - Fittings are ordered using the 3-digit prefix number given in the charts on the fitting pages. Fittings do not have stiffened upper flanges.

| Thickness Steel (Ga.) | Flange Width | Load Depth | Material Finish |
|-----------------------|-------------------------------|------------|-----------------|
| 8 - 18 ga. | 2 - $1\frac{13}{16}$ " (21mm) | 3" (76mm) | P - Mill-Galv. |
| 6 - 16 ga. | 4 - 1 $\frac{1}{4}$ " (32mm) | 4" (102mm) | G - HDGAF |
| 4 - 14 ga. | 7 - 2" (51mm) | 5" (127mm) | A - Aluminum |
| 2 - 12 ga. | 6 - 1 $\frac{3}{4}$ " (152mm) | | S - 304SS |
| 11 - 11 ga. | | | |
| Thickness Alum (in.) | | | |
| 1 - Thinner | B - $1\frac{13}{16}$ " (21mm) | | |
| 3 - | D - 1 $\frac{1}{4}$ " (32mm) | | |
| 5 -** | G - 2" (51mm) | | |
| 7 - | | | |
| 9 - Thicker | | | |

**Alum. extruded side rails are individually engineered to loads and spans.

NOTE:

Slotted or **Solid Rungs** available on all widths.

FITTINGS

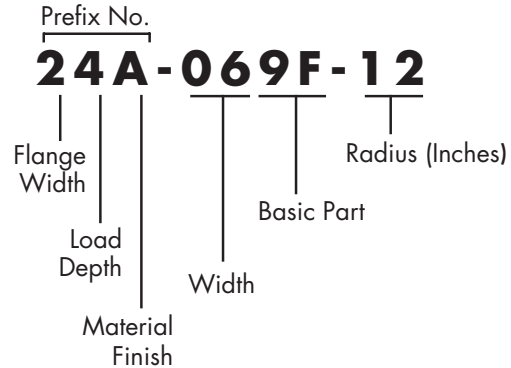

WIDTH - Identifies the inside width of the tray in inches.

BASIC PART NUMBER - Identifies the straight length, fitting, or accessory.

SECONDARY DIMENSION NUMBER - Identifies the length of a straight section in feet, the radius of a fitting in inches, or the second width of a reducer in inches.

RUNG SPACING - Identifies the center-to-center distance between rungs on straight length. Nominal 9" (229mm) rung spacing maintained through centerline of all fittings.

| Width (in.) | Basic Part Number | Length | Rung Spacing |
|-----------------|--------------------------------|--------------|-----------------|
| -06=6" (152mm) | SL (Straight Len.) | - 12' (3.7m) | 06=6" (152mm) |
| -09=9" (229mm) | 9F (90° Horiz. El.) | - 24' (7.3m) | 09=9" (229mm) |
| -12=12" (305mm) | 6F (60° Horiz. El.) | - 10' (3m) | 12=12" (305mm) |
| -18=18" (457mm) | 4F (45° Horiz. El.) | - 20' (6m) | 18=18" (457mm) |
| -24=24" (610mm) | 3F (30° Horiz. El.) | | |
| -30=30" (762mm) | 90 (90° Out. Vert. El.) | | |
| -36=36" (914mm) | 60 (60° Out. Vert. El.) | | |
| | 40 (45° Out. Vert. El.) | | |
| | 30 (30° Out. Vert. El.) | | |
| | 9I (90° In. Vert. El.) | | |
| | 6I (60° In. Vert. El.) | | |
| | 4I (45° In. Vert. El.) | | |
| | 3I (30° In. Vert. El.) | | |
| | FT (Horiz. Tee) | | |
| | FC (Horiz. Cross) | | |
| | VT (Vert. Tee) | | |
| | SR (Vert. Cable Support Elbow) | | |
| | ST (Straight Reducer) | | |
| | RH (Right Hand Reducer) | | |
| | LH (Left Hand Reducer) | | |
| | AF (Adjustable Elbow) | | |
| | RY & LY (45° "Y" Branch) | | |
| | | | Radius (in.) |
| | | | -12=12" (205mm) |
| | | | -24=24" (610mm) |
| | | | -36=36" (914mm) |

STRAIGHT LENGTH [SL]

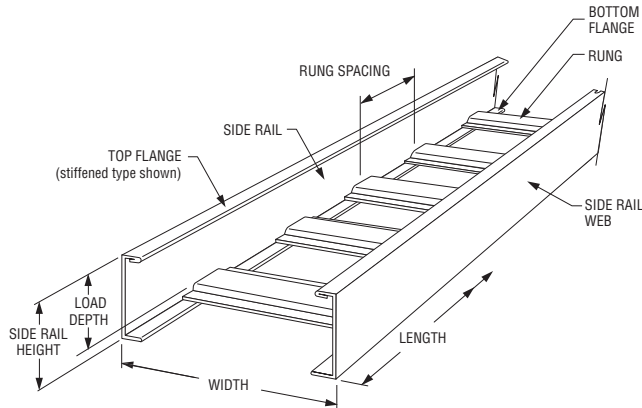

Cope Hat cable tray is manufactured in 10', 12', 20' and 24' lengths; 6", 9", 12", 18", 24", 30" and 36" widths and 3", 4", 5", and 6" nominal load depths. Sufficient connectors are supplied to assemble straight sections and fittings for each other. Connectors for field cuts must be ordered separately.

CATALOG NUMBER

| SYSTEM | BASIC WIDTH | BASIC NO. | LENGTH (FT.) | RUNG SPACING |
|---------------------|-------------|-----------|--------------|--------------|
| See Pages 102 – 105 | -06 | SL | -10 | -04 |
| | -09 | | -12 | -06 |
| | -12 | | -20 | -09 |
| | -18 | | -24 | -12 |
| | -24 | | | -18 |
| | -30 | | | |
| | -36 | | | |

Example: 1B4A-06SL-12-09 is a 4" load depth aluminum Hat with a 1³/₁₆" flange, 6" wide, 12' long, with 9" rung spacing.

CONVERSION TABLE

| English | 6" | 9" | 12" | 18" | 24" | 30" | 36" | 12' | 24' | 10' | 20' |
|-------------|-----|-----|-----|-----|-----|-----|-----|------|------|-----|-----|
| Metric (mm) | 152 | 229 | 305 | 457 | 610 | 762 | 914 | 3.7m | 7.3m | 3m | 6m |

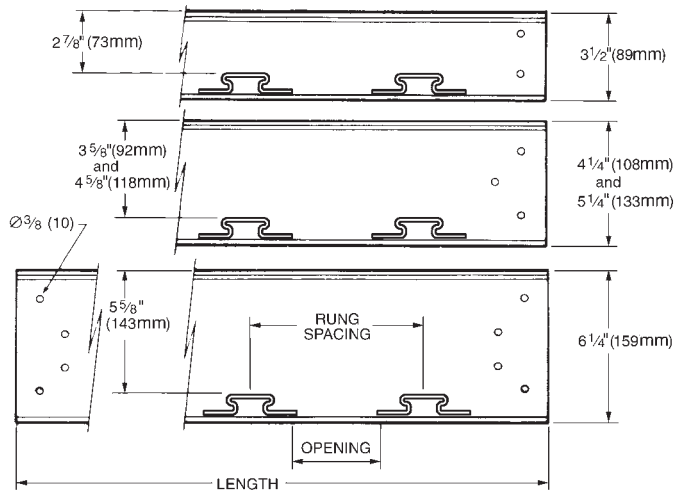
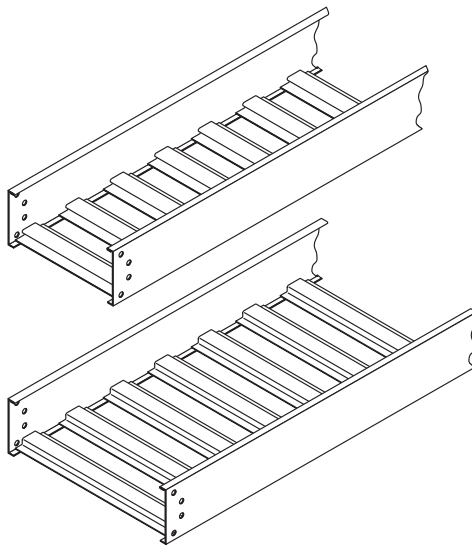

MATERIAL & FINISH SPECIFICATIONS (HAT CABLE TRAY)

| | Pre-Galvanized Steel | Hot-Dip Galvanized after Fabrication ASTM A-123 | Aluminum | Type 304 Stainless Steel |
|---------------------|---|---|---------------------------------------|--|
| Siderails | ASTM A-653-G90 CS (18 & 16 Gage) ASTM A-653-G90 CS (14 & 12 Gage) | ASTM A-1008 (18 & 16 Gage) ASTM A-1011 (14 & 12 Gage) | AA-6063-T6 Extruded | ASTM A-240; Type 304 |
| Rungs | ASTM A-653-G90 CS | ASTM A-1008 | AA-6063-H34 | ASTM A-269; Type 304 |
| Splice Plate Finish | ASTM A-1011 ASTM A-591 Class C | ASTM A-1011 ASTM A-123 Grade 65 | AA-5052-H34 | ASTM A-240; Type 304 2B Finish (Typical) |
| Connector Bolts | SAE J429 Grade 1 (ASTM A-307 Grade A) | SAE J429 Grade 1 (ASTM A-307 Grade A) | SAE J429 Grade 1 (ASTM A-307 Grade A) | AISI Type 304 Stainless Steel |
| Bolt Plating | ASTM B-633.0002" Zinc | ASTM B-633.0002" Zinc | ASTM B-633.0002" Zinc | |
| Covers | ASTM A-653-G90 CQ | ASTM A-653-G90 CQ | AA-3003 H14 or 3150 H14 | ASTM A-240; Type 304 |

HAT CABLE TRAY SYSTEM

90° HORIZONTAL ELBOW [9F]

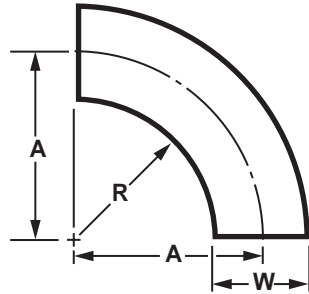
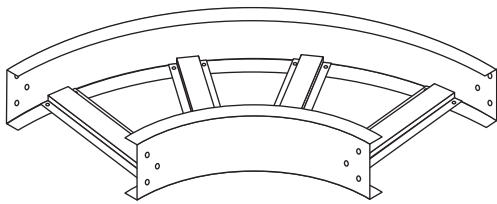

CSA CERTIFIED FOR CSA SYSTEMS

| Radius - R | Width - W | "A" Dimension | Part Number |
|----------------|-------------|------------------|-------------|
| 12" (305mm) | 6" (152mm) | 15" (381mm) | XXX-069F-12 |
| | 9" (229mm) | 16 1/2" (419mm) | XXX-099F-12 |
| | 12" (305mm) | 18" (457mm) | XXX-129F-12 |
| | 18" (457mm) | 21" (533mm) | XXX-189F-12 |
| | 24" (610mm) | 24" (610mm) | XXX-249F-12 |
| | 30" (762mm) | 27" (686mm) | XXX-309F-12 |
| | 36" (914mm) | 30" (762mm) | XXX-369F-12 |
| 24" (610mm) | 6" (152mm) | 27" (686mm) | XXX-069F-24 |
| | 9" (229mm) | 28 1/2" (724mm) | XXX-099F-24 |
| | 12" (305mm) | 30" (762mm) | XXX-129F-24 |
| | 18" (457mm) | 33" (838mm) | XXX-189F-24 |
| | 24" (610mm) | 36" (914mm) | XXX-249F-24 |
| | 30" (762mm) | 39" (991mm) | XXX-309F-24 |
| | 36" (914mm) | 42" (1067mm) | XXX-369F-24 |
| 36" (914mm) | 6" (152mm) | 39" (991mm) | XXX-069F-36 |
| | 9" (229mm) | 40 1/2" (1029mm) | XXX-099F-36 |
| | 12" (305mm) | 42" (1067mm) | XXX-129F-36 |
| | 18" (457mm) | 45" (1143mm) | XXX-189F-36 |
| | 24" (610mm) | 48" (1219mm) | XXX-249F-36 |
| | 30" (762mm) | 51" (1295mm) | XXX-309F-36 |
| | 36" (914mm) | 54" (1372mm) | XXX-369F-36 |

Example: 24A-129F-12

60° HORIZONTAL ELBOW [6F]

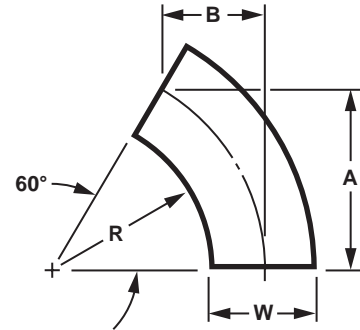
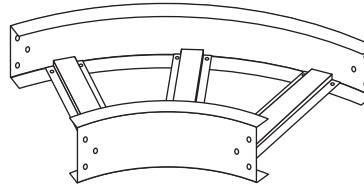

CSA CERTIFIED FOR CSA SYSTEMS

| Radius - R | Width - W | "A" Dimension | "B" Dimension | Part Number |
|----------------|-------------|------------------|-----------------|-------------|
| 12" (305mm) | 6" (152mm) | 13" (330mm) | 7 1/2" (191mm) | XXX-066F-12 |
| | 9" (229mm) | 14 1/4" (362mm) | 8 1/4" (210mm) | XXX-096F-12 |
| | 12" (305mm) | 15 5/8" (397mm) | 9" (229mm) | XXX-126F-12 |
| | 18" (457mm) | 18 1/4" (464mm) | 10 1/2" (267mm) | XXX-186F-12 |
| | 24" (610mm) | 20 3/4" (527mm) | 12" (305mm) | XXX-246F-12 |
| | 30" (762mm) | 23 3/8" (594mm) | 13 1/2" (343mm) | XXX-306F-12 |
| | 36" (914mm) | 26" (660mm) | 15" (381mm) | XXX-366F-12 |
| 24" (610mm) | 6" (152mm) | 23 3/8" (594mm) | 13 1/2" (343mm) | XXX-066F-24 |
| | 9" (229mm) | 24 3/4" (629mm) | 14 1/4" (362mm) | XXX-096F-24 |
| | 12" (305mm) | 26" (660mm) | 15" (381mm) | XXX-126F-24 |
| | 18" (457mm) | 28 3/8" (727mm) | 16 1/2" (416mm) | XXX-186F-24 |
| | 24" (610mm) | 31 1/4" (794mm) | 18" (457mm) | XXX-246F-24 |
| | 30" (762mm) | 33 3/4" (857mm) | 19 1/2" (495mm) | XXX-306F-24 |
| | 36" (914mm) | 36 3/8" (924mm) | 21" (533mm) | XXX-366F-24 |
| 36" (914mm) | 6" (152mm) | 33 3/4" (857mm) | 19 1/2" (495mm) | XXX-066F-36 |
| | 9" (229mm) | 35 1/8" (892mm) | 20 1/4" (514mm) | XXX-096F-36 |
| | 12" (305mm) | 36 3/8" (924mm) | 21" (533mm) | XXX-126F-36 |
| | 18" (457mm) | 39" (991mm) | 22 1/2" (572mm) | XXX-186F-36 |
| | 24" (610mm) | 41 3/8" (1057mm) | 24" (610mm) | XXX-246F-36 |
| | 30" (762mm) | 44 1/8" (1121mm) | 25 1/2" (648mm) | XXX-306F-36 |
| | 36" (914mm) | 46 3/4" (1187mm) | 27" (686mm) | XXX-366F-36 |

Example: 24A-126F-12

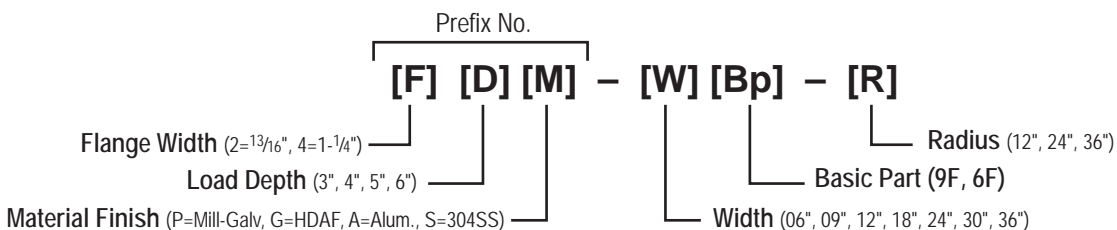

See page 120
for Grounding
Chart Reference

45° HORIZONTAL ELBOW [4F]

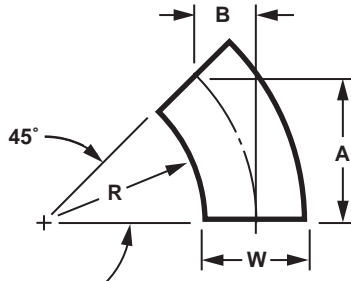
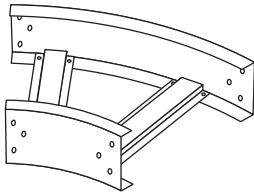

CSA CERTIFIED FOR CSA SYSTEMS

| Radius - R | Width - W | "A" Dimension | "B" Dimension | Part Number |
|-------------|-------------|-----------------|-----------------|-------------|
| 12" (305mm) | 6" (152mm) | 10 5/8" (270mm) | 4 3/8" (111mm) | XXX-064F-12 |
| | 9" (229mm) | 11 5/8" (295mm) | 4 7/8" (124mm) | XXX-094F-12 |
| | 12" (305mm) | 12 3/4" (324mm) | 5 1/4" (133mm) | XXX-124F-12 |
| | 18" (457mm) | 14 7/8" (378mm) | 6 1/8" (156mm) | XXX-184F-12 |
| | 24" (610mm) | 17" (432mm) | 7" (178mm) | XXX-244F-12 |
| | 30" (762mm) | 19 7/8" (486mm) | 7 7/8" (200mm) | XXX-304F-12 |
| | 36" (914mm) | 21 1/4" (540mm) | 8 3/4" (222mm) | XXX-364F-12 |
| 24" (610mm) | 6" (152mm) | 19 1/8" (486mm) | 7 7/8" (200mm) | XXX-064F-24 |
| | 9" (229mm) | 20 1/8" (511mm) | 8 3/8" (213mm) | XXX-094F-24 |
| | 12" (305mm) | 21 1/4" (540mm) | 8 3/4" (222mm) | XXX-124F-24 |
| | 18" (457mm) | 23 3/8" (594mm) | 9 5/8" (244mm) | XXX-184F-24 |
| | 24" (610mm) | 25 1/2" (648mm) | 10 1/2" (267mm) | XXX-244F-24 |
| | 30" (762mm) | 27 5/8" (702mm) | 11 1/2" (292mm) | XXX-304F-24 |
| | 36" (914mm) | 29 3/4" (756mm) | 12 3/8" (314mm) | XXX-364F-24 |
| 36" (914mm) | 6" (152mm) | 27 5/8" (702mm) | 11 1/2" (292mm) | XXX-064F-36 |
| | 9" (229mm) | 28 5/8" (727mm) | 11 7/8" (302mm) | XXX-094F-36 |
| | 12" (305mm) | 29 3/4" (756mm) | 12 3/8" (314mm) | XXX-124F-36 |
| | 18" (457mm) | 31 7/8" (810mm) | 13 1/4" (337mm) | XXX-184F-36 |
| | 24" (610mm) | 34" (864mm) | 14 1/8" (359mm) | XXX-244F-36 |
| | 30" (762mm) | 36 1/8" (918mm) | 15" (381mm) | XXX-304F-36 |
| | 36" (914mm) | 38 1/4" (972mm) | 15 7/8" (403mm) | XXX-364F-36 |

Example: 24A-124F-12

30° HORIZONTAL ELBOW [3F]

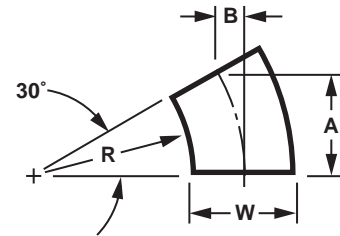
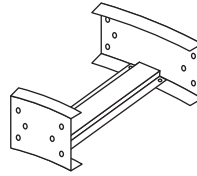

CSA CERTIFIED FOR CSA SYSTEMS

| Radius - R | Width - W | "A" Dimension | "B" Dimension | Part Number |
|-------------|-------------|-----------------|----------------|-------------|
| 12" (305mm) | 6" (152mm) | 7 1/2" (191mm) | 2" (51mm) | XXX-063F-12 |
| | 9" (229mm) | 8 1/4" (210mm) | 2 1/4" (57mm) | XXX-093F-12 |
| | 12" (305mm) | 9" (229mm) | 2 5/8" (60mm) | XXX-123F-12 |
| | 18" (457mm) | 10 1/2" (267mm) | 2 7/8" (73mm) | XXX-183F-12 |
| | 24" (610mm) | 12" (305mm) | 3 1/4" (83mm) | XXX-243F-12 |
| | 30" (762mm) | 13 1/2" (343mm) | 3 5/8" (92mm) | XXX-303F-12 |
| | 36" (914mm) | 15" (381mm) | 4" (102mm) | XXX-363F-12 |
| 24" (610mm) | 6" (152mm) | 13 1/2" (343mm) | 3 5/8" (92mm) | XXX-063F-24 |
| | 9" (229mm) | 14 1/4" (362mm) | 3 7/8" (98mm) | XXX-093F-24 |
| | 12" (305mm) | 15" (381mm) | 4" (102mm) | XXX-123F-24 |
| | 18" (457mm) | 16 1/2" (419mm) | 4 3/8" (111mm) | XXX-183F-24 |
| | 24" (610mm) | 18" (457mm) | 4 7/8" (124mm) | XXX-243F-24 |
| | 30" (762mm) | 19 1/2" (495mm) | 5 1/4" (133mm) | XXX-303F-24 |
| | 36" (914mm) | 21" (533mm) | 5 5/8" (143mm) | XXX-363F-24 |
| 36" (914mm) | 6" (152mm) | 19 1/2" (495mm) | 5 1/4" (133mm) | XXX-063F-36 |
| | 9" (229mm) | 20 1/4" (514mm) | 5 1/2" (140mm) | XXX-093F-36 |
| | 12" (305mm) | 21" (533mm) | 5 5/8" (143mm) | XXX-123F-36 |
| | 18" (457mm) | 22 1/2" (572mm) | 6" (152mm) | XXX-183F-36 |
| | 24" (610mm) | 24" (610mm) | 6 1/2" (165mm) | XXX-243F-36 |
| | 30" (762mm) | 25 1/2" (648mm) | 6 7/8" (175mm) | XXX-303F-36 |
| | 36" (914mm) | 27" (686mm) | 7 1/4" (184mm) | XXX-363F-36 |

Example: 24A-123F-12

Prefix No.

[F] [D] [M] - [W] [Bp] - [R]

Flange Width (2=13/16", 4=1-1/4")

Load Depth (3", 4", 5", 6")

Material Finish (P=Mill-Galv, G=HDAF, A=Alum., S=304SS)

Radius (12", 24", 36")

Basic Part (4F, 3F)

Width (06", 09", 12", 18", 24", 30", 36")

See page 120
for Grounding
Chart Reference

HAT CABLE TRAY SYSTEM

HORIZONTAL TEE [FT]

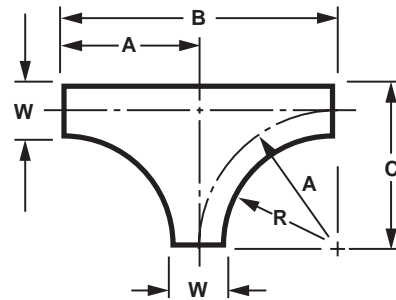
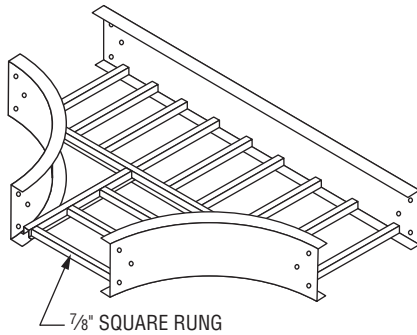

CSA CERTIFIED FOR CSA SYSTEMS

| Radius - R | Width - W | "A" Dimension | "B" Dimension | "C" Dimension | Part Number |
|----------------|--------------|------------------|---------------|---------------|-------------|
| 12" (305mm) | 6" (152mm) | 15" (381mm) | 30" (762mm) | 18" (457mm) | XXX-06FT-12 |
| | 9" (229mm) | 16 1/2" (419mm) | 33" (838mm) | 21" (533mm) | XXX-09FT-12 |
| | 12" (305mm) | 18" (457mm) | 36" (914mm) | 24" (610mm) | XXX-12FT-12 |
| | 18" (457mm) | 21" (533mm) | 42" (1067mm) | 30" (762mm) | XXX-18FT-12 |
| | 24" (610mm) | 24" (610mm) | 48" (1219mm) | 36" (914mm) | XXX-24FT-12 |
| | 30" (762mm) | 27" (686mm) | 54" (1372mm) | 42" (1067mm) | XXX-30FT-12 |
| 24" (610mm) | 6" (152mm) | 27" (686mm) | 54" (1372mm) | 30" (762mm) | XXX-06FT-24 |
| | 9" (229mm) | 28 1/2" (724mm) | 57" (1448mm) | 33" (838mm) | XXX-09FT-24 |
| | 12" (305mm) | 30" (762mm) | 60" (1524mm) | 36" (914mm) | XXX-12FT-24 |
| | 18" (457mm) | 33" (838mm) | 66" (1676mm) | 42" (1067mm) | XXX-18FT-24 |
| | 24" (610mm) | 36" (914mm) | 72" (1829mm) | 48" (1219mm) | XXX-24FT-24 |
| | 30" (762mm) | 39" (991mm) | 78" (1981mm) | 54" (1372mm) | XXX-30FT-24 |
| 36" (914mm) | 6" (152mm) | 39" (991mm) | 78" (1981mm) | 42" (1067mm) | XXX-06FT-36 |
| | 9" (229mm) | 40 1/2" (1029mm) | 81" (2057mm) | 45" (1143mm) | XXX-09FT-36 |
| | 12" (305mm) | 42" (1067mm) | 84" (2134mm) | 48" (1219mm) | XXX-12FT-36 |
| | 18" (457mm) | 45" (1143mm) | 90" (2286mm) | 54" (1372mm) | XXX-18FT-36 |
| | 24" (610mm) | 48" (1219mm) | 96" (2438mm) | 60" (1524mm) | XXX-24FT-36 |
| | 30" (762mm) | 51" (1295mm) | 102" (2591mm) | 66" (1676mm) | XXX-30FT-36 |
| 36" (914mm) | 54" (1372mm) | 108" (2743mm) | 72" (1829mm) | XXX-36FT-36 | |

Example: 24A-12FT-12

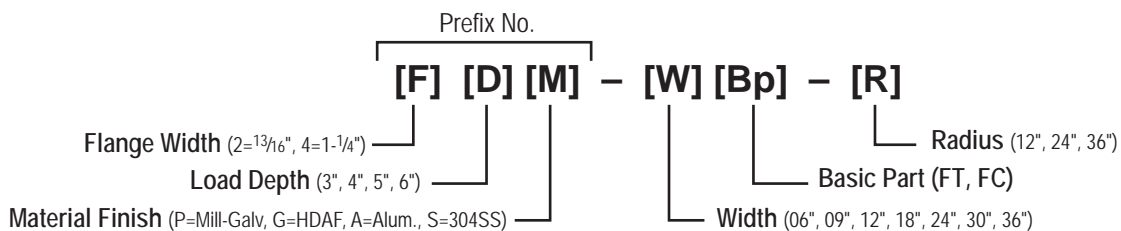

See page 120
for Grounding
Chart Reference

HORIZONTAL CROSS [FC]

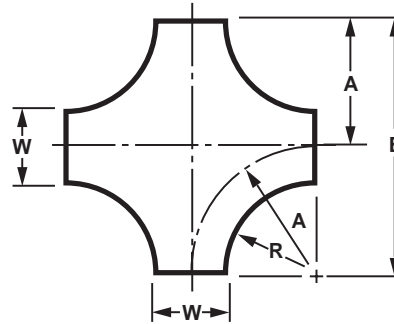
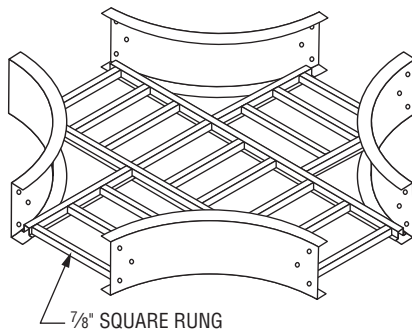

CSA CERTIFIED FOR CSA SYSTEMS

| Radius - R | Width - W | "A" Dimension | "B" Dimension | Part Number |
|----------------|--------------|------------------|---------------|-------------|
| 12" (305mm) | 6" (152mm) | 15" (381mm) | 30" (762mm) | XXX-06FC-12 |
| | 9" (229mm) | 16 1/2" (419mm) | 33" (838mm) | XXX-09FC-12 |
| | 12" (305mm) | 18" (457mm) | 36" (914mm) | XXX-12FC-12 |
| | 18" (457mm) | 21" (533mm) | 42" (1067mm) | XXX-18FC-12 |
| | 24" (610mm) | 24" (610mm) | 48" (1219mm) | XXX-24FC-12 |
| | 30" (762mm) | 27" (686mm) | 54" (1372mm) | XXX-30FC-12 |
| 24" (610mm) | 6" (152mm) | 27" (686mm) | 54" (1372mm) | XXX-06FC-24 |
| | 9" (229mm) | 28 1/2" (724mm) | 57" (1448mm) | XXX-09FC-24 |
| | 12" (305mm) | 30" (762mm) | 60" (1524mm) | XXX-12FC-24 |
| | 18" (457mm) | 33" (838mm) | 66" (1676mm) | XXX-18FC-24 |
| | 24" (610mm) | 36" (914mm) | 72" (1829mm) | XXX-24FC-24 |
| | 30" (762mm) | 39" (991mm) | 78" (1981mm) | XXX-30FC-24 |
| 36" (914mm) | 6" (152mm) | 39" (991mm) | 78" (1981mm) | XXX-06FC-36 |
| | 9" (229mm) | 40 1/2" (1029mm) | 81" (2057mm) | XXX-09FC-36 |
| | 12" (305mm) | 42" (1067mm) | 84" (2134mm) | XXX-12FC-36 |
| | 18" (457mm) | 45" (1143mm) | 90" (2286mm) | XXX-18FC-36 |
| | 24" (610mm) | 48" (1219mm) | 96" (2438mm) | XXX-24FC-36 |
| | 30" (762mm) | 51" (1295mm) | 102" (2591mm) | XXX-30FC-36 |
| 36" (914mm) | 54" (1372mm) | 108" (2743mm) | XXX-36FC-36 | |

Example: 24A-12FC-12

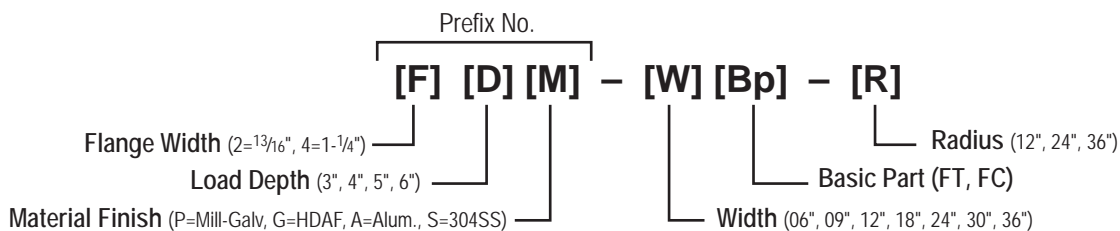

See page 120
for Grounding
Chart Reference

HAT CABLE TRAY SYSTEM

HORIZONTAL TAPPED TEE [TT]

CSA CERTIFIED FOR CSA SYSTEMS

| R Radius | W Width | W1 Width | "A" Dimension | "C" Dimension | Part Number | | |
|----------------|----------------|----------------|-----------------|-----------------|-----------------|----------------|----------------|
| 12" (305mm) | 36" (914mm) | 30" (762mm) | 27" (686mm) | 48" (1219mm) | XXX-36TT-30-12 | | |
| | | 24" (610mm) | 24" (610mm) | | XXX-36TT-24-12 | | |
| | | 18" (457mm) | 21" (533mm) | | XXX-36TT-18-12 | | |
| | | 12" (305mm) | 18" (457mm) | | XXX-36TT-12-12 | | |
| | | 9" (229mm) | 16 1/2" (419mm) | | XXX-36TT-09-12 | | |
| | | 6" (152mm) | 15" (381mm) | | XXX-36TT-06-12 | | |
| | 30" (762mm) | 24" (610mm) | 24" (610mm) | 42" (1067mm) | XXX-30TT-24-12 | | |
| | | 18" (457mm) | 21" (533mm) | | XXX-30TT-18-12 | | |
| | | 12" (305mm) | 18" (457mm) | | XXX-30TT-12-12 | | |
| | | 9" (229mm) | 16 1/2" (419mm) | | XXX-30TT-09-12 | | |
| | | 6" (152mm) | 15" (381mm) | | XXX-30TT-06-12 | | |
| | | 24" (610mm) | 18" (457mm) | | 21" (533mm) | 36" (914mm) | XXX-24TT-18-12 |
| | 12" (305mm) | | 18" (457mm) | XXX-24TT-12-12 | | | |
| | 9" (229mm) | | 16 1/2" (419mm) | XXX-24TT-09-12 | | | |
| | 6" (152mm) | | 15" (381mm) | XXX-24TT-06-12 | | | |
| | 18" (457mm) | | 12" (305mm) | 18" (457mm) | 30" (762mm) | | XXX-18TT-12-12 |
| | | | 9" (229mm) | 16 1/2" (419mm) | | | XXX-18TT-09-12 |
| | | 6" (152mm) | 15" (381mm) | XXX-18TT-06-12 | | | |
| | 12" (305mm) | 9" (229mm) | 16 1/2" (419mm) | 24" (610mm) | XXX-12TT-09-12 | | |
| | | 6" (152mm) | 15" (381mm) | | XXX-12TT-06-12 | | |
| | 9" (229mm) | 6" (152mm) | 15" (381mm) | 21" (533mm) | XXX-09TT-06-12 | | |
| | 24" (610mm) | 36" (914mm) | 30" (762mm) | 39" (991mm) | 60" (1524mm) | XXX-36TT-30-24 | |
| | | | 24" (610mm) | 36" (914mm) | | XXX-36TT-24-24 | |
| | | | 18" (457mm) | 33" (838mm) | | XXX-36TT-18-24 | |
| 12" (305mm) | | | 30" (762mm) | XXX-36TT-12-24 | | | |
| 9" (229mm) | | | 28 1/2" (724mm) | XXX-36TT-09-24 | | | |
| 6" (152mm) | | | 27" (686mm) | XXX-36TT-06-24 | | | |
| 30" (762mm) | | 24" (610mm) | 36" (914mm) | 54" 1372mm | XXX-30TT-24-24 | | |
| | | 18" (457mm) | 33" (838mm) | | XXX-30TT-18-24 | | |
| | | 12" (305mm) | 30" (762mm) | | XXX-30TT-12-24 | | |
| | | 9" (229mm) | 28 1/2" (724mm) | | XXX-30TT-09-24 | | |
| | | 6" (152mm) | 27" (686mm) | | XXX-30TT-06-24 | | |
| | | 24" (610mm) | 18" (457mm) | | 33" (838mm) | 48" 1219mm | XXX-24TT-18-24 |
| 12" (305mm) | | | 30" (762mm) | XXX-24TT-12-24 | | | |
| 9" (229mm) | | | 28 1/2" (724mm) | XXX-24TT-09-24 | | | |
| 6" (152mm) | | | 27" (686mm) | XXX-24TT-06-24 | | | |
| 18" (457mm) | | | 12" (305mm) | 30" (762mm) | 42" 1067mm | | XXX-18TT-12-24 |
| | | | 9" (229mm) | 28 1/2" (724mm) | | | XXX-18TT-09-24 |
| | | 6" (152mm) | 27" (686mm) | XXX-18TT-06-24 | | | |
| 12" (305mm) | | 9" (229mm) | 28 1/2" (724mm) | 36" 914mm | XXX-12TT-09-24 | | |
| | | 6" (152mm) | 27" (686mm) | | XXX-12TT-06-24 | | |
| 9" (229mm) | | 6" (152mm) | 27" (686mm) | 33" 838mm | XXX-09TT-06-24 | | |

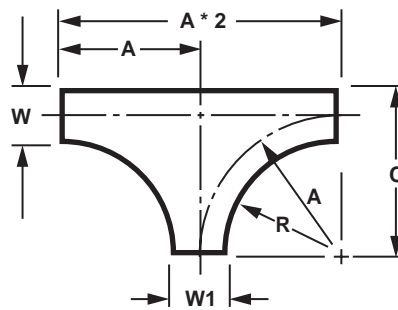
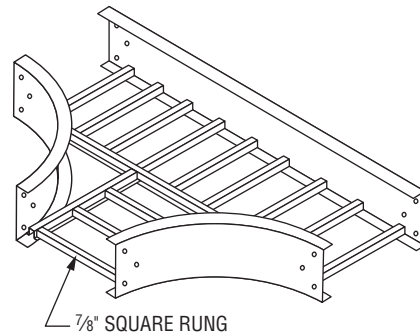

| | | | | | | |
|----------------|----------------|------------------|------------------|-----------------|-----------------|----------------|
| 36" (914mm) | 30" (762mm) | 51" (1295mm) | 72" (1829mm) | XXX-36TT-30-36 | | |
| | 24" (610mm) | 48" (1219mm) | | XXX-36TT-24-36 | | |
| | 18" (457mm) | 45" (1143mm) | | XXX-36TT-18-36 | | |
| | 12" (305mm) | 42" (1067mm) | | XXX-36TT-12-36 | | |
| | 9" (229mm) | 40 1/2" (1029mm) | | XXX-36TT-09-36 | | |
| | 6" (152mm) | 39" (991mm) | | XXX-36TT-06-36 | | |
| 30" (762mm) | 24" (610mm) | 48" (1219mm) | 66" (1676mm) | XXX-30TT-24-36 | | |
| | 18" (457mm) | 45" (1143mm) | | XXX-30TT-18-36 | | |
| | 12" (305mm) | 42" (1067mm) | | XXX-30TT-12-36 | | |
| | 9" (229mm) | 40 1/2" (1029mm) | | XXX-30TT-09-36 | | |
| | 6" (152mm) | 39" (991mm) | | XXX-30TT-06-36 | | |
| | 24" (610mm) | 18" (457mm) | | 45" (1143mm) | 60" (1524mm) | XXX-24TT-18-36 |
| 12" (305mm) | | 42" (1067mm) | XXX-24TT-12-36 | | | |
| 9" (229mm) | | 40 1/2" (1029mm) | XXX-24TT-09-36 | | | |
| 6" (152mm) | | 39" (991mm) | XXX-24TT-06-36 | | | |
| 18" (457mm) | | 12" (305mm) | 42" (1067mm) | 54" (1372mm) | | XXX-18TT-12-36 |
| | | 9" (229mm) | 40 1/2" (1029mm) | | | XXX-18TT-09-36 |
| | 6" (152mm) | 39" (991mm) | XXX-18TT-06-36 | | | |
| 12" (305mm) | 9" (229mm) | 40 1/2" (1029mm) | 48" (1219mm) | XXX-12TT-09-36 | | |
| | 6" (152mm) | 39" (991mm) | | XXX-12TT-06-36 | | |
| 9" (229mm) | 6" (152mm) | 39" (991mm) | 45" (1143mm) | XXX-09TT-06-36 | | |

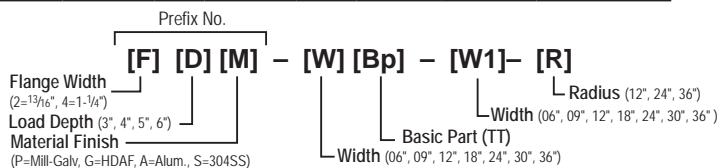

See page 120
for Grounding
Chart Reference

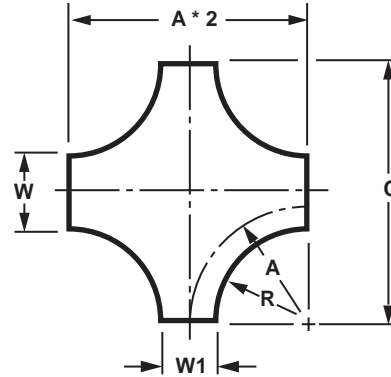
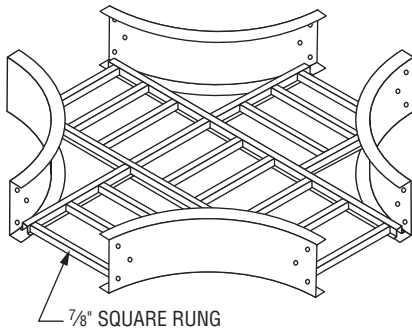

CSA CERTIFIED FOR CSA SYSTEMS

| R Radius | W Width | W1 Width | "A" Dimension | "C" Dimension | Part Number | | |
|----------------|----------------|----------------|-----------------|-----------------|----------------|---------------|----------------|
| 12" (305mm) | 36" (914mm) | 30" (762mm) | 27" (686mm) | 60" 1524mm | XXX-36TC-30-12 | | |
| | | 24" (610mm) | 24" (610mm) | | XXX-36TC-24-12 | | |
| | | 18" (457mm) | 21" (533mm) | | XXX-36TC-18-12 | | |
| | | 12" (305mm) | 18" (457mm) | | XXX-36TC-12-12 | | |
| | | 9" (229mm) | 16 1/2" (419mm) | | XXX-36TC-09-12 | | |
| | | 6" (152mm) | 15" (381mm) | | XXX-36TC-06-12 | | |
| | 30" (762mm) | 24" (610mm) | 24" (610mm) | 54" 1372mm | XXX-30TC-24-12 | | |
| | | 18" (457mm) | 21" (533mm) | | XXX-30TC-18-12 | | |
| | | 12" (305mm) | 18" (457mm) | | XXX-30TC-12-12 | | |
| | | 9" (229mm) | 16 1/2" (419mm) | | XXX-30TC-09-12 | | |
| | | 6" (152mm) | 15" (381mm) | | XXX-30TC-06-12 | | |
| | | 24" (610mm) | 18" (457mm) | | 21" (533mm) | 48" 1219mm | XXX-24TC-18-12 |
| | 12" (305mm) | | 18" (457mm) | XXX-24TC-12-12 | | | |
| | 9" (229mm) | | 16 1/2" (419mm) | XXX-24TC-09-12 | | | |
| | 6" (152mm) | | 15" (381mm) | XXX-24TC-06-12 | | | |
| | 18" (457mm) | | 12" (305mm) | 18" (457mm) | 42" 1067mm | | XXX-18TC-12-12 |
| | | | 9" (229mm) | 16 1/2" (419mm) | | | XXX-18TC-09-12 |
| | | 6" (152mm) | 15" (381mm) | XXX-18TC-06-12 | | | |
| | 12" (305mm) | 9" (229mm) | 16 1/2" (419mm) | 36" 914mm | XXX-12TC-09-12 | | |
| | | 6" (152mm) | 15" (381mm) | | XXX-12TC-06-12 | | |
| | 9" (229mm) | 6" (152mm) | 15" (381mm) | 33" 838mm | XXX-09TC-06-12 | | |

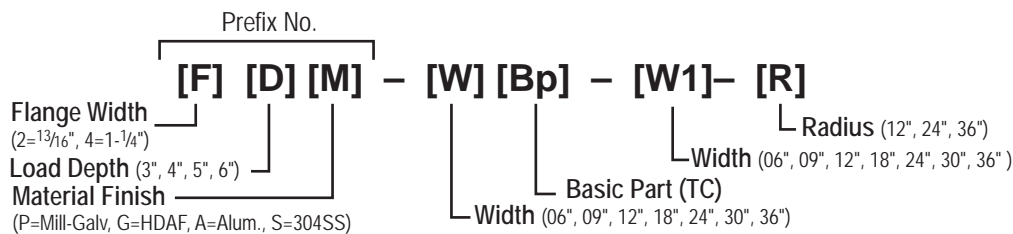

See page 120 for Grounding Chart Reference

HAT CABLE TRAY SYSTEM

HORIZONTAL TAPPED CROSS [TC] [PAGE 2 OF 2]

CSA CERTIFIED FOR CSA SYSTEMS

| R Radius | W Width | W1 Width | "A" Dimension | "C" Dimension | Part Number | | |
|----------------|----------------|----------------|------------------|------------------|----------------|----------------|----------------|
| 24" (610mm) | 36" (914mm) | 30" (762mm) | 39" (991mm) | 84" 2134mm | XXX-36TC-30-24 | | |
| | | 24" (610mm) | 36" (914mm) | | XXX-36TC-24-24 | | |
| | | 18" (457mm) | 33" (838mm) | | XXX-36TC-18-24 | | |
| | | 12" (305mm) | 30" (762mm) | | XXX-36TC-12-24 | | |
| | | 9" (229mm) | 28 1/2" (724mm) | | XXX-36TC-09-24 | | |
| | | 6" (152mm) | 27" (686mm) | | XXX-36TC-06-24 | | |
| | 30" (762mm) | 24" (610mm) | 36" (914mm) | 78" 1981mm | XXX-30TC-24-24 | | |
| | | 18" (457mm) | 33" (838mm) | | XXX-30TC-18-24 | | |
| | | 12" (305mm) | 30" (762mm) | | XXX-30TC-12-24 | | |
| | | 9" (229mm) | 28 1/2" (724mm) | | XXX-30TC-09-24 | | |
| | | 6" (152mm) | 27" (686mm) | | XXX-30TC-06-24 | | |
| | | 24" (610mm) | 18" (457mm) | | 33" (838mm) | 72" 1829mm | XXX-24TC-18-24 |
| | 12" (305mm) | | 30" (762mm) | XXX-24TC-12-24 | | | |
| | 9" (229mm) | | 28 1/2" (724mm) | XXX-24TC-09-24 | | | |
| | 6" (152mm) | | 27" (686mm) | XXX-24TC-06-24 | | | |
| | 18" (457mm) | | 12" (305mm) | 30" (762mm) | 66" 1676mm | | XXX-18TC-12-24 |
| | | | 9" (229mm) | 28 1/2" (724mm) | | | XXX-18TC-09-24 |
| | | 6" (152mm) | 27" (686mm) | XXX-18TC-06-24 | | | |
| | 12" (305mm) | 9" (229mm) | 28 1/2" (724mm) | 60" 1524mm | XXX-12TC-09-24 | | |
| | | 6" (152mm) | 27" (686mm) | | XXX-12TC-06-24 | | |
| | | 9" (229mm) | 27" (686mm) | | XXX-09TC-06-24 | | |
| | 36" (914mm) | 36" (914mm) | 30" (762mm) | 51" (1295mm) | 108" 2743mm | XXX-36TC-30-36 | |
| | | | 24" (610mm) | 48" (1219mm) | | XXX-36TC-24-36 | |
| | | | 18" (457mm) | 45" (1143mm) | | XXX-36TC-18-36 | |
| 12" (305mm) | | | 42" (1067mm) | XXX-36TC-12-36 | | | |
| 9" (229mm) | | | 40 1/2" (1029mm) | XXX-36TC-09-36 | | | |
| 6" (152mm) | | | 39" (991mm) | XXX-36TC-06-36 | | | |
| 30" (762mm) | | 24" (610mm) | 48" (1219mm) | 102" 2591mm | XXX-30TC-24-36 | | |
| | | 18" (457mm) | 45" (1143mm) | | XXX-30TC-18-36 | | |
| | | 12" (305mm) | 42" (1067mm) | | XXX-30TC-12-36 | | |
| | | 9" (229mm) | 40 1/2" (1029mm) | | XXX-30TC-09-36 | | |
| | | 6" (152mm) | 39" (991mm) | | XXX-30TC-06-36 | | |
| | | 24" (610mm) | 18" (457mm) | | 45" (1143mm) | 96" 2438mm | XXX-24TC-18-36 |
| 12" (305mm) | | | 42" (1067mm) | XXX-24TC-12-36 | | | |
| 9" (229mm) | | | 40 1/2" (1029mm) | XXX-24TC-09-36 | | | |
| 6" (152mm) | | | 39" (991mm) | XXX-24TC-06-36 | | | |
| 18" (457mm) | | | 12" (305mm) | 42" (1067mm) | 90" 2286mm | | XXX-18TC-12-36 |
| | | | 9" (229mm) | 40 1/2" (1029mm) | | | XXX-18TC-09-36 |
| | | 6" (152mm) | 39" (991mm) | XXX-18TC-06-36 | | | |
| 12" (305mm) | | 9" (229mm) | 40 1/2" (1029mm) | 84" 2134mm | XXX-12TC-09-36 | | |
| | | 6" (152mm) | 39" (991mm) | | XXX-12TC-06-36 | | |
| | | 9" (229mm) | 6" (152mm) | | 39" (991mm) | 81" 2057mm | XXX-09TC-06-36 |

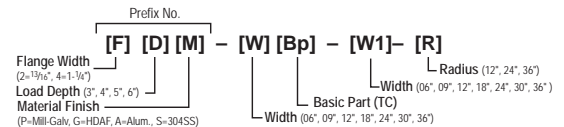
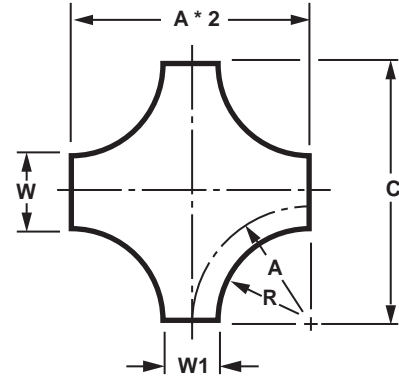

See page 120
for Grounding
Chart Reference

STRAIGHT REDUCER [ST]

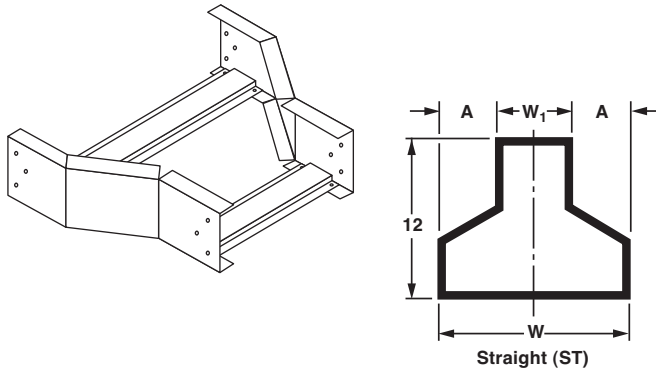

LEFT HAND [LH] & RIGHT HAND [RH] REDUCER

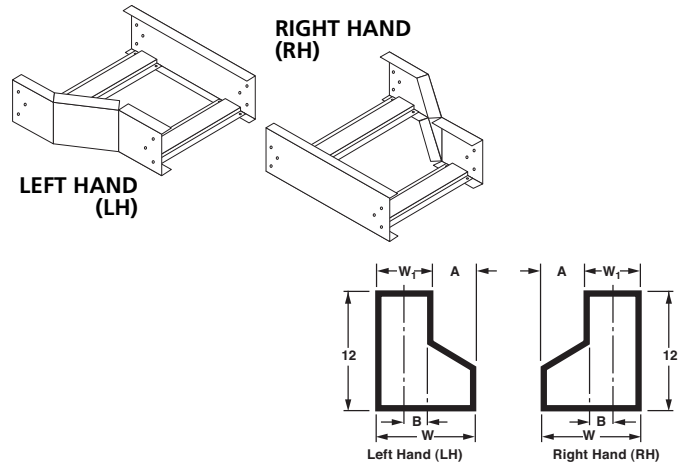

CSA CERTIFIED FOR CSA SYSTEMS

| Width - W | Width - W1 | "A" Dimension | Part Number |
|----------------|-------------|-----------------|-------------|
| 36" (914mm) | 30" (762mm) | 3" (76mm) | XXX-36ST-30 |
| | 24" (610mm) | 6" (152mm) | XXX-36ST-24 |
| | 18" (457mm) | 9" (229mm) | XXX-36ST-18 |
| | 12" (305mm) | 12" (305mm) | XXX-36ST-12 |
| | 9" (229mm) | 13 1/2" (343mm) | XXX-36ST-09 |
| | 6" (152mm) | 15" (381mm) | XXX-36ST-06 |
| 30" (762mm) | 24" (610mm) | 3" (76mm) | XXX-30ST-24 |
| | 18" (457mm) | 6" (152mm) | XXX-30ST-18 |
| | 12" (305mm) | 9" (229mm) | XXX-30ST-12 |
| | 9" (229mm) | 10 1/2" (267mm) | XXX-30ST-09 |
| | 6" (152mm) | 12" (304mm) | XXX-30ST-06 |
| 24" (610mm) | 18" (457mm) | 3" (76mm) | XXX-24ST-18 |
| | 12" (305mm) | 6" (152mm) | XXX-24ST-12 |
| | 9" (229mm) | 7 1/2" (191mm) | XXX-24ST-09 |
| | 6" (152mm) | 9" (229mm) | XXX-24ST-06 |
| 18" (457mm) | 12" (305mm) | 3" (76mm) | XXX-18ST-12 |
| | 9" (229mm) | 4 1/2" (114mm) | XXX-18ST-09 |
| | 6" (152mm) | 6" (152mm) | XXX-18ST-06 |
| 12" (305mm) | 9" (229mm) | 1 1/2" (38mm) | XXX-12ST-09 |
| | 6" (152mm) | 3" (76mm) | XXX-12ST-06 |
| 9" (229mm) | 6" (152mm) | 1 1/2" (38mm) | XXX-09ST-06 |

Example: 24A-12ST-06

CSA CERTIFIED FOR CSA SYSTEMS

| Width - W | "W1" Dim. | "A" Dim. | "B" Dim. | Part Number |
|----------------|-------------|-------------|----------------|------------------|
| 36" (914mm) | 30" (914mm) | 6" (152mm) | 15" (381mm) | XXX-36(LH/RH)-30 |
| | 24" (610mm) | 12" (305mm) | 12" (305mm) | XXX-36(LH/RH)-24 |
| | 18" (457mm) | 18" (457mm) | 9" (229mm) | XXX-36(LH/RH)-18 |
| | 12" (305mm) | 24" (610mm) | 6" (152mm) | XXX-36(LH/RH)-12 |
| | 9" (229mm) | 27" (686mm) | 4 1/2" (114mm) | XXX-36(LH/RH)-09 |
| | 6" (152mm) | 30" (762mm) | 3" (76mm) | XXX-36(LH/RH)-06 |
| 30" (762mm) | 24" (610mm) | 6" (152mm) | 12" (305mm) | XXX-30(LH/RH)-24 |
| | 18" (457mm) | 12" (305mm) | 9" (229mm) | XXX-30(LH/RH)-18 |
| | 12" (305mm) | 18" (457mm) | 6" (152mm) | XXX-30(LH/RH)-12 |
| | 9" (229mm) | 21" (533mm) | 4 1/2" (114mm) | XXX-30(LH/RH)-09 |
| | 6" (152mm) | 24" (610mm) | 3" (76mm) | XXX-30(LH/RH)-06 |
| 24" (610mm) | 18" (457mm) | 6" (152mm) | 9" (229mm) | XXX-24(LH/RH)-18 |
| | 12" (305mm) | 12" (305mm) | 6" (152mm) | XXX-24(LH/RH)-12 |
| | 9" (229mm) | 15" (381mm) | 4 1/2" (114mm) | XXX-24(LH/RH)-09 |
| | 6" (152mm) | 18" (457mm) | 3" (76mm) | XXX-24(LH/RH)-06 |
| 18" (457mm) | 12" (305mm) | 6" (152mm) | 6" (152mm) | XXX-18(LH/RH)-12 |
| | 9" (229mm) | 9" (229mm) | 4 1/2" (114mm) | XXX-18(LH/RH)-09 |
| | 6" (152mm) | 12" (305mm) | 3" (76mm) | XXX-18(LH/RH)-06 |
| 12" (305mm) | 9" (229mm) | 3" (76mm) | 4 1/2" (114mm) | XXX-12(LH/RH)-09 |
| | 6" (152mm) | 6" (152mm) | 3" (76mm) | XXX-12(LH/RH)-06 |
| 9" (229mm) | 6" (152mm) | 3" (76mm) | 3" (76mm) | XXX-09(LH/RH)-06 |

Example: 238-12LH-06

Prefix No.

[F] [D] [M] - [W] [Bp] - [W₁]

Flange Width (2=13/16", 4=1-1/4")

Load Depth (3", 4", 5", 6")

Material Finish (P=Mill-Galv, G=HDAF, A=Alum., S=304SS)

Reduced Width (06", 09", 12", 18", 24", 30")

Basic Part (ST, LH, RH)

Width (06", 09", 12", 18", 24", 30", 36")

See page 120
for Grounding
Chart Reference

HAT CABLE TRAY SYSTEM

ADJUSTABLE ELBOW [AF]

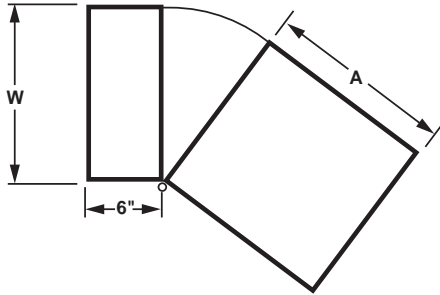
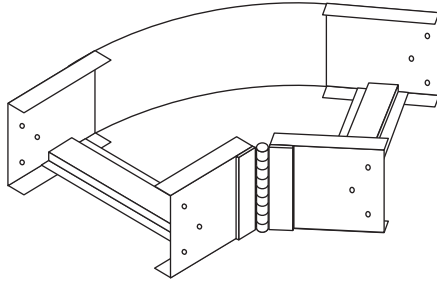

| Width - W | | "A" Dim. | | Part Number |
|-----------|---------|----------|---------|-------------|
| 6" | (152mm) | 8" | (203mm) | XXX-06AF |
| 9" | (229mm) | 11" | (279mm) | XXX-09AF |
| 12" | (305mm) | 14" | (356mm) | XXX-12AF |
| 18" | (457mm) | 20" | (508mm) | XXX-18AF |
| 24" | (610mm) | 26" | (660mm) | XXX-24AF |
| 30" | (762mm) | 32" | (813mm) | XXX-30AF |
| 36" | (914mm) | 38" | (965mm) | XXX-36AF |

Both rails at hinge break to be bonded if fitting is used as equipment grounding conductor.

Example: 24A-12AF

45° "Y" BRANCH LEFT [LY] & RIGHT [RY]

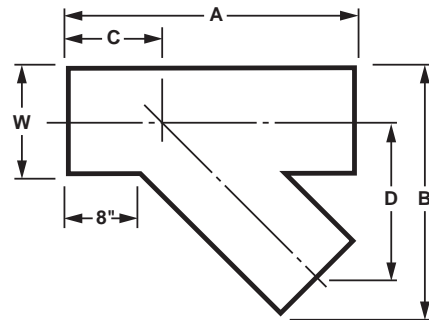
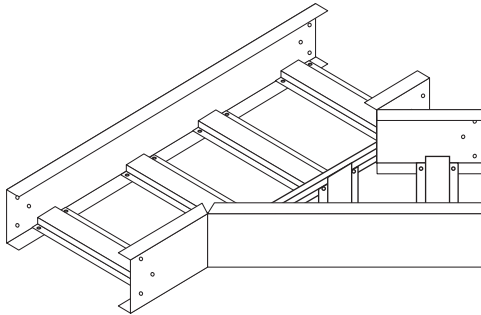

**RIGHT SIDE [RY]
SHOWN**

CSA CERTIFIED FOR CSA SYSTEMS

| Width - W | | "A" Dim. | | "B" Dim. | | "C" Dim. | | "D" Dim. | | Part Number |
|-----------|---------|----------|----------|----------|----------|----------|---------|----------|---------|--------------|
| 6" | (152mm) | 22 1/2" | (571mm) | 16 1/4" | (413mm) | 9 1/4" | (289mm) | 11 1/8" | (283mm) | XXX-06(LY/R) |
| 9" | (229mm) | 26 3/4" | (679mm) | 21 3/8" | (543mm) | 9 13/16" | (330mm) | 13 3/4" | (349mm) | XXX-09(LY/R) |
| 12" | (305mm) | 31" | (787mm) | 26 1/2" | (673mm) | 10 1/2" | (375mm) | 16 1/4" | (412mm) | XXX-12(LY/R) |
| 18" | (457mm) | 39 1/2" | (1003mm) | 36 3/4" | (933mm) | 11 3/4" | (460mm) | 21 3/8" | (543mm) | XXX-18(LY/R) |
| 24" | (610mm) | 48" | (1219mm) | 47" | (1193mm) | 13" | (546mm) | 26 1/2" | (673mm) | XXX-24(LY/R) |
| 30" | (762mm) | 56 3/8" | (1432mm) | 57 1/4" | (1454mm) | 14 1/8" | (629mm) | 31 5/8" | (803mm) | XXX-30(LY/R) |
| 36" | (914mm) | 65" | (1651mm) | 67 1/2" | (1714mm) | 15 1/2" | (718mm) | 36 3/4" | (933mm) | XXX-36(LY/R) |

Example: 24A-12RY

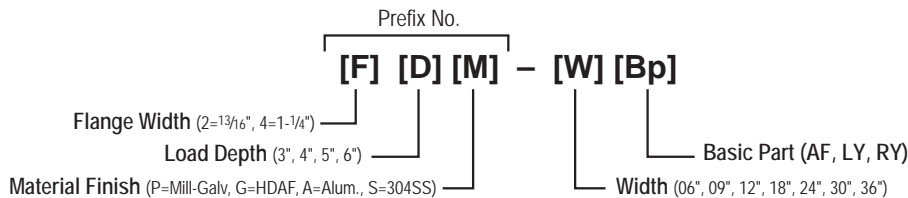

See page 120
for Grounding
Chart Reference

90° VERTICAL ELBOW OUTSIDE [90] & INSIDE [9I]

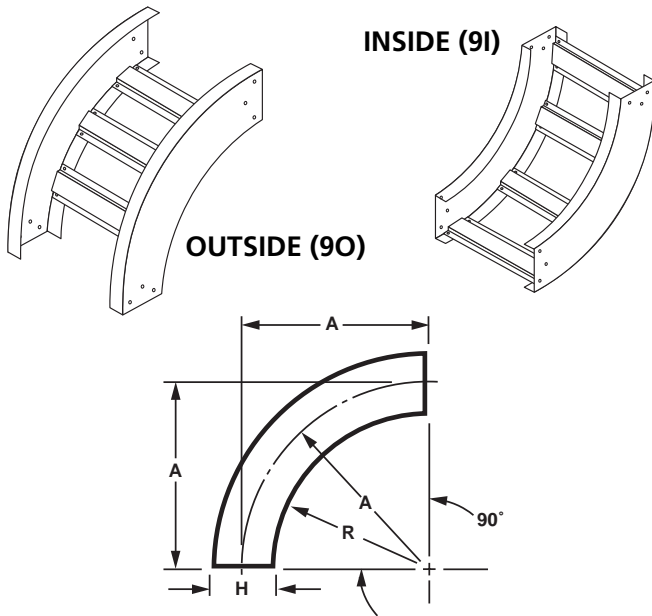

CSA CERTIFIED FOR CSA SYSTEMS

| Radius - R | "H" Dim. | "A" Dim. | Part Number |
|----------------|----------------|-----------------|------------------|
| 12" (305mm) | 3 1/2" (89mm) | 13 3/4" (349mm) | X3X-WW(90/9I)-12 |
| | 4 1/4" (108mm) | 14 1/8" (359mm) | X4X-WW(90/9I)-12 |
| | 5 1/4" (133mm) | 14 5/8" (372mm) | X5X-WW(90/9I)-12 |
| | 6 1/4" (159mm) | 15 1/8" (384mm) | X6X-WW(90/9I)-12 |
| 24" (610mm) | 3 1/2" (89mm) | 25 3/4" (349mm) | X3X-WW(90/9I)-24 |
| | 4 1/4" (108mm) | 26 1/8" (664mm) | X4X-WW(90/9I)-24 |
| | 5 1/4" (133mm) | 26 5/8" (676mm) | X5X-WW(90/9I)-24 |
| | 6 1/4" (159mm) | 27 1/8" (689mm) | X6X-WW(90/9I)-24 |
| 36" (914mm) | 7 1/4" (184mm) | 37 3/4" (702mm) | X3X-WW(90/9I)-36 |
| | 4 1/4" (108mm) | 38 1/8" (969mm) | X4X-WW(90/9I)-36 |
| | 5 1/4" (133mm) | 38 5/8" (981mm) | X5X-WW(90/9I)-36 |
| | 6 1/4" (159mm) | 39 1/8" (994mm) | X6X-WW(90/9I)-36 |

Example: 24A-129O-12

60° VERTICAL ELBOW OUTSIDE [60] & INSIDE [6I]

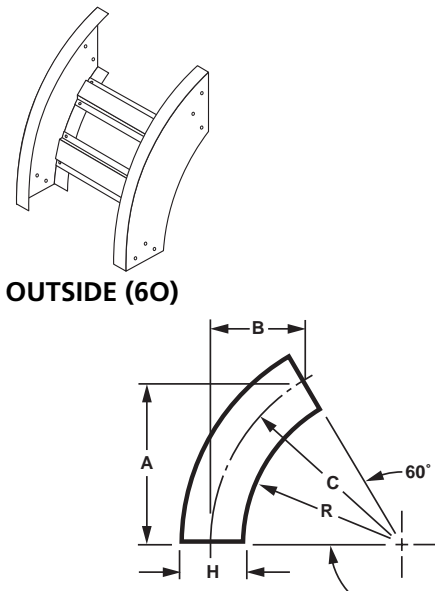

CSA CERTIFIED FOR CSA SYSTEMS

| Radius - R | "H" Dim. | "A" Dim. | "B" Dim. | "C" Dim. | Part Number |
|----------------|----------------|-----------------|-----------------|-----------------|------------------|
| 12" (305mm) | 3 1/2" (89mm) | 11 7/8" (302mm) | 6 7/8" (175mm) | 13 3/4" (349mm) | X3X-WW(60/6I)-12 |
| | 4 1/4" (108mm) | 12 1/4" (311mm) | 7 1/8" (181mm) | 14 1/8" (359mm) | X4X-WW(60/6I)-12 |
| | 5 1/4" (133mm) | 12 5/8" (321mm) | 7 3/8" (187mm) | 14 5/8" (372mm) | X5X-WW(60/6I)-12 |
| | 6 1/4" (159mm) | 13 1/8" (334mm) | 7 5/8" (194mm) | 15 1/8" (384mm) | X6X-WW(60/6I)-12 |
| 24" (610mm) | 3 1/2" (89mm) | 22 1/4" (565mm) | 12 7/8" (327mm) | 25 3/4" (654mm) | X3X-WW(60/6I)-24 |
| | 4 1/4" (108mm) | 22 5/8" (575mm) | 13 1/8" (334mm) | 26 1/8" (664mm) | X4X-WW(60/6I)-24 |
| | 5 1/4" (133mm) | 23 1/8" (588mm) | 13 3/8" (340mm) | 26 5/8" (676mm) | X5X-WW(60/6I)-24 |
| | 6 1/4" (159mm) | 23 1/2" (597mm) | 13" (330mm) | 27 1/8" (689mm) | X6X-WW(60/6I)-24 |
| 36" (914mm) | 3 1/2" (89mm) | 32 3/4" (832mm) | 18 7/8" (480mm) | 37 3/4" (959mm) | X3X-WW(60/6I)-36 |
| | 4 1/4" (108mm) | 33" (838mm) | 19 1/8" (486mm) | 38 1/8" (969mm) | X4X-WW(60/6I)-36 |
| | 5 1/4" (133mm) | 33 1/2" (851mm) | 19 3/8" (492mm) | 38 5/8" (981mm) | X5X-WW(60/6I)-36 |
| | 6 1/4" (159mm) | 33 7/8" (861mm) | 19 5/8" (499mm) | 39 1/8" (994mm) | X6X-WW(60/6I)-36 |

Example: 24A-126O-12

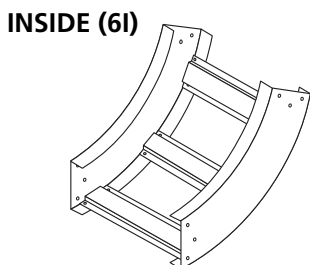

Prefix No. **[F] [D] [M] - [W] [Bp] - [R]**

Flange Width (2=13/16", 4=1-1/4")

Load Depth (3", 4", 5", 6")

Material Finish (P=Mill-Galv, G=HDAF, A=Alum., S=304SS)

Radius (12", 24", 36")

Basic Part (90, 9I, 60, 6I)

Width (06", 09", 12", 18", 24", 30", 36")

See page 120
for Grounding
Chart Reference

HAT CABLE TRAY SYSTEM

45° VERTICAL ELBOW OUTSIDE [40] & INSIDE [4I]

OUTSIDE (40)

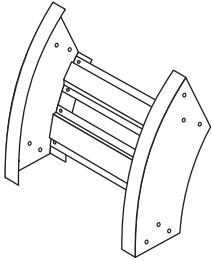

INSIDE (4I)

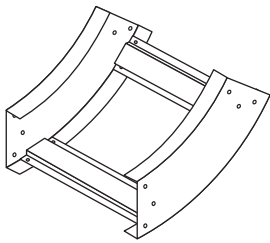

CSA CERTIFIED FOR CSA SYSTEMS

| Radius - R | "H" Dim. | "A" Dim. | "B" Dim. | "C" Dim. | Part Number |
|----------------|----------------|-----------------|-----------------|-----------------|------------------|
| 12" (305mm) | 3 1/2" (89mm) | 9 3/4" (248mm) | 4" (102mm) | 13 3/4" (349mm) | X3X-WW(40/4I)-12 |
| | 4 1/4" (108mm) | 10" (254mm) | 4 1/8" (105mm) | 14 1/8" (359mm) | X4X-WW(40/4I)-12 |
| | 5 1/4" (133mm) | 10 5/8" (264mm) | 4 1/4" (108mm) | 14 5/8" (372mm) | X5X-WW(40/4I)-12 |
| | 6 1/4" (159mm) | 10 3/4" (273mm) | 4 1/2" (114mm) | 15 1/8" (384mm) | X6X-WW(40/4I)-12 |
| 24" (610mm) | 4 1/4" (108mm) | 18 1/2" (470mm) | 7 5/8" (194mm) | 26 1/8" (664mm) | X3X-WW(40/4I)-24 |
| | 5 1/4" (133mm) | 18 7/8" (480mm) | 7 7/8" (200mm) | 26 5/8" (676mm) | X4X-WW(40/4I)-24 |
| | 6 1/4" (159mm) | 19 1/4" (489mm) | 8" (203mm) | 27 1/8" (689mm) | X5X-WW(40/4I)-24 |
| | 3 1/2" (89mm) | 18 1/4" (464mm) | 7 1/2" (191mm) | 25 3/4" (654mm) | X6X-WW(40/4I)-24 |
| 36" (914mm) | 3 1/2" (89mm) | 9 3/4" (248mm) | 4" (102mm) | 13 3/4" (349mm) | X3X-WW(40/4I)-36 |
| | 4 1/4" (108mm) | 27" (686mm) | 11 1/8" (283mm) | 38 1/8" (969mm) | X4X-WW(40/4I)-36 |
| | 5 1/4" (133mm) | 27 5/8" (695mm) | 11 3/8" (289mm) | 38 5/8" (981mm) | X5X-WW(40/4I)-36 |
| | 6 1/4" (159mm) | 27 5/8" (702mm) | 11 1/2" (292mm) | 39 1/8" (994mm) | X6X-WW(40/4I)-36 |

Example: 24A-1240-12

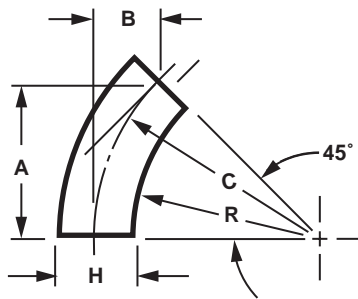

30° VERTICAL ELBOW OUTSIDE [30] & INSIDE [3I]

OUTSIDE (30)

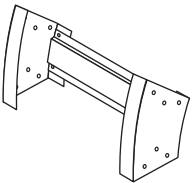

INSIDE (3I)

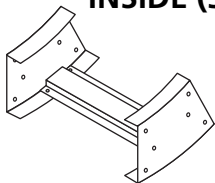

CSA CERTIFIED FOR CSA SYSTEMS

| Radius - R | "H" Dim. | "A" Dim. | "B" Dim. | "C" Dim. | Part Number |
|----------------|----------------|-----------------|----------------|-----------------|------------------|
| 12" (305mm) | 3 1/2" (89mm) | 6 7/8" (175mm) | 1 7/8" (48mm) | 13 3/4" (349mm) | X3X-WW(30/3I)-12 |
| | 4 1/4" (108mm) | 7 1/8" (181mm) | 1 7/8" (48mm) | 14 1/8" (359mm) | X4X-WW(30/3I)-12 |
| | 5 1/4" (133mm) | 7 5/8" (187mm) | 2" (51mm) | 14 5/8" (372mm) | X5X-WW(30/3I)-12 |
| | 6 1/4" (159mm) | 7 5/8" (194mm) | 2" (51mm) | 15 1/8" (384mm) | X6X-WW(30/3I)-12 |
| 24" (610mm) | 3 1/2" (89mm) | 12 1/8" (327mm) | 3 1/2" (89mm) | 24 3/4" (654mm) | X3X-WW(30/3I)-24 |
| | 4 1/4" (108mm) | 13 1/8" (334mm) | 3 1/2" (89mm) | 26 1/8" (664mm) | X4X-WW(30/3I)-24 |
| | 5 1/4" (133mm) | 13 3/8" (340mm) | 3 5/8" (92mm) | 26 5/8" (676mm) | X5X-WW(30/3I)-24 |
| | 6 1/4" (159mm) | 13 5/8" (346mm) | 3 5/8" (92mm) | 27 1/8" (689mm) | X6X-WW(30/3I)-24 |
| 36" (914mm) | 3 1/2" (89mm) | 18 7/8" (480mm) | 5 1/8" (130mm) | 37 3/4" (959mm) | X3X-WW(30/3I)-36 |
| | 4 1/4" (108mm) | 19 1/8" (486mm) | 5 1/8" (130mm) | 38 1/8" (969mm) | X4X-WW(30/3I)-36 |
| | 5 1/4" (133mm) | 19 3/8" (492mm) | 5 1/4" (133mm) | 38 5/8" (981mm) | X5X-WW(30/3I)-36 |
| | 6 1/4" (159mm) | 19 5/8" (499mm) | 5 1/4" (133mm) | 39 1/8" (994mm) | X6X-WW(30/3I)-36 |

Example: 24A-1230-12

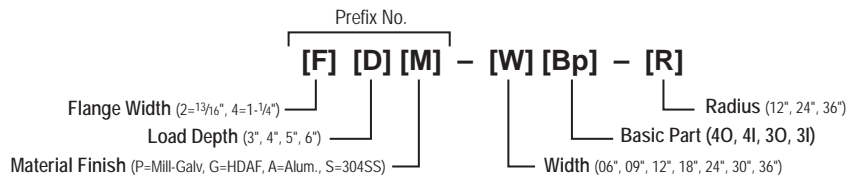
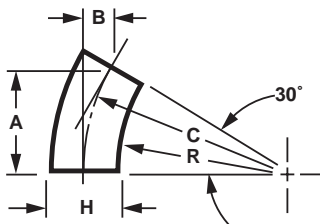

See page 120
for Grounding
Chart Reference

90° VERTICAL CABLE SUPPORT ELBOW (SR)

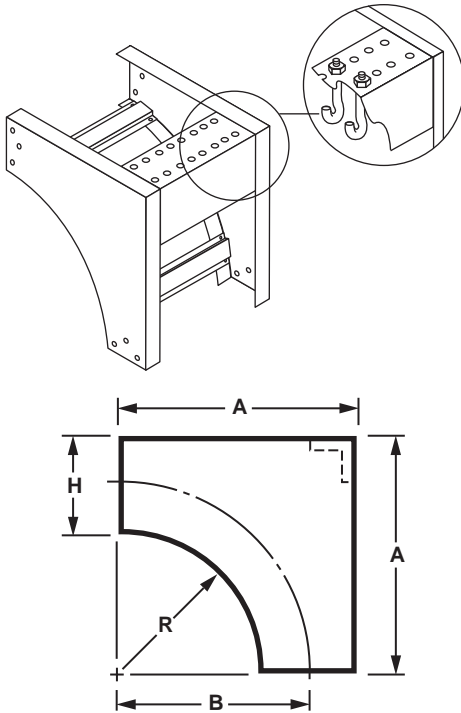

CSA CERTIFIED FOR CSA SYSTEMS

| Radius - R | "H" Dim. | "A" Dim. | "B" Dim. | Part Number |
|----------------|----------------|------------------|-----------------|-------------|
| 12" (305mm) | 3 1/2" (89mm) | 15 1/2" (394mm) | 13 3/4" (349mm) | X3X-WWSR-12 |
| | 4 1/4" (108mm) | 16 1/4" (413mm) | 14 1/8" (359mm) | X4X-WWSR-12 |
| | 5 1/4" (133mm) | 17 1/4" (438mm) | 14 5/8" (371mm) | X5X-WWSR-12 |
| | 6 1/4" (159mm) | 18 1/4" (464mm) | 15 1/8" (384mm) | X6X-WWSR-12 |
| 24" (610mm) | 3 1/2" (89mm) | 27 1/2" (699mm) | 25 3/4" (654mm) | X3X-WWSR-24 |
| | 4 1/4" (108mm) | 28 1/4" (718mm) | 26 1/8" (664mm) | X4X-WWSR-24 |
| | 5 1/4" (133mm) | 29 1/4" (743mm) | 26 5/8" (676mm) | X5X-WWSR-24 |
| | 6 1/4" (159mm) | 30 1/4" (768mm) | 27 1/8" (689mm) | X6X-WWSR-24 |
| 36" (914mm) | 3 1/2" (89mm) | 39 1/2" (1003mm) | 37 3/4" (959mm) | X3X-WWSR-36 |
| | 4 1/4" (108mm) | 40 1/4" (1022mm) | 38 1/8" (968mm) | X4X-WWSR-36 |
| | 5 1/4" (133mm) | 41 1/4" (1048mm) | 38 5/8" (981mm) | X5X-WWSR-36 |
| | 6 1/4" (159mm) | 42 1/4" (1073mm) | 39 1/8" (994mm) | X6X-WWSR-36 |

Example: 24A-12SR-12

VERTICAL TEE DOWN [VT] & UP [OT]

CSA CERTIFIED FOR CSA SYSTEMS

| Radius - R | "H" Dim. | "A" Dim. | "C" Dim. | "C" Dim. | Part Number |
|----------------|----------------|------------------|------------------|-----------------|------------------|
| 12" (305mm) | 3 1/2" (89mm) | 27 1/2" (718mm) | 15 1/2" (394mm) | 13 3/4" (349mm) | X3X-WW(VT/OT)-12 |
| | 4 1/4" (108mm) | 28 1/4" (743mm) | 16 1/4" (413mm) | 14 1/8" (359mm) | X4X-WW(VT/OT)-12 |
| | 5 1/4" (133mm) | 29 1/4" (768mm) | 17 1/4" (438mm) | 14 5/8" (371mm) | X5X-WW(VT/OT)-12 |
| | 6 1/4" (159mm) | 30 1/4" (794mm) | 18 1/4" (464mm) | 15 1/8" (384mm) | X6X-WW(VT/OT)-12 |
| 24" (610mm) | 3 1/2" (89mm) | 51 1/2" (1327mm) | 27 1/2" (699mm) | 25 3/4" (654mm) | X3X-WW(VT/OT)-24 |
| | 4 1/4" (108mm) | 52 1/4" (1353mm) | 28 1/4" (718mm) | 26 1/8" (664mm) | X4X-WW(VT/OT)-24 |
| | 5 1/4" (133mm) | 53 1/4" (1378mm) | 29 1/4" (743mm) | 26 5/8" (676mm) | X5X-WW(VT/OT)-24 |
| | 6 1/4" (159mm) | 54 1/4" (1403mm) | 30 1/4" (768mm) | 27 1/8" (689mm) | X6X-WW(VT/OT)-24 |
| 36" (914mm) | 3 1/2" (89mm) | 75 1/2" (1937mm) | 39 1/2" (1003mm) | 37 3/4" (959mm) | X3X-WW(VT/OT)-36 |
| | 4 1/4" (108mm) | 76 1/4" (1962mm) | 40 1/4" (1022mm) | 38 1/8" (968mm) | X4X-WW(VT/OT)-36 |
| | 5 1/4" (133mm) | 77 1/4" (1988mm) | 41 1/4" (1048mm) | 38 5/8" (981mm) | X5X-WW(VT/OT)-36 |
| | 6 1/4" (159mm) | 78 1/4" (2013mm) | 42 1/4" (1073mm) | 39 1/8" (994mm) | X6X-WW(VT/OT)-36 |

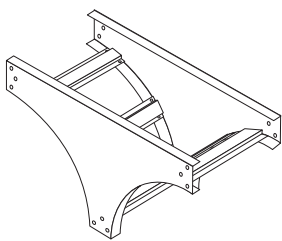

VERTICAL TEE - UP (OT)

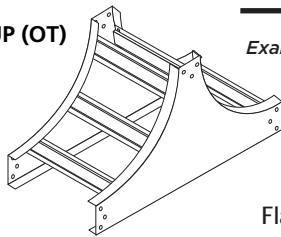

Example: 24A-12VT-12

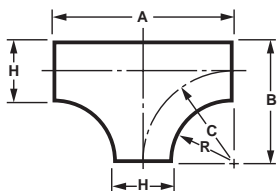

Prefix No.

[F] [D] [M] - [W] [Bp] - [R]

Flange Width (2=13/16", 4=1-1/4")

Load Depth (3", 4", 5", 6")

Material Finish (P=Mill-Galv, G=HDAF, A=Alum., S=304SS)

Width (06", 09", 12", 18", 24", 30", 36")

Radius (12", 24", 36")

Basic Part (SR, VT, OT)

See page 120
for Grounding
Chart Reference

HAT CABLE TRAY SYSTEM

CONNECTOR PLATES

TRAY CONNECTORS

CATALOG NUMBER

| Load Depth | Finish | Basic No. |
|------------|----------------|----------------|
| 3" | 2 (Mill Galv.) | -02RC |
| 4" | 3 (HDGAF) | -02CE |
| 5" | 4 (Alum.) | -02CV |
| 6" | U (304SS) | -02CH -02CA |

Example: 34 -02RC for 3" load depth, aluminum, universal curvilinear connector.

Note: Hole patterns match corresponding tray. Three-hole pattern illustrated.

UNIVERSAL CURVILINEAR CONNECTORS [RC]

NOTE: Sold in pairs

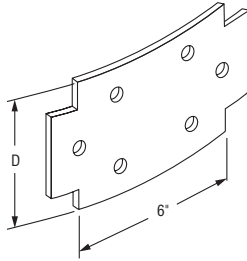

11 Gage Steel, 0.125" Aluminum
3/8"-16 spline bolts & flange nuts furnished.

EXPANSION CONNECTORS [CE]

NOTE: Sold in pairs

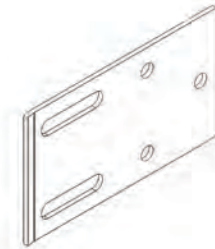

11 Gage Steel, 0.125" Aluminum
3/8"-16 cap screws & Nylok nuts furnished and
3/8"-16 spline bolts & flange nuts furnished.

Note: Bounding jumpers are required and are sold separately.

HORIZONTAL ADJUSTABLE CONNECTORS [CH]

NOTE: Sold in pairs - inner & outer

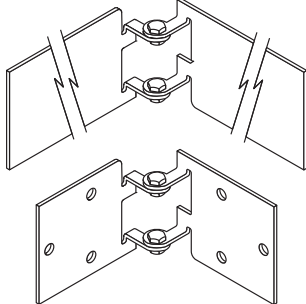

11 Gage Steel, 0.125" Aluminum
3/8"-16 spline bolts & flange nuts furnished.

Note: Bounding jumpers are required and are sold separately.

VERTICAL ADJUSTABLE CONNECTORS [CV]

NOTE: Sold in pairs

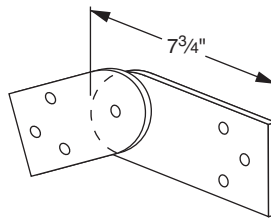

11 Gage Steel, 0.125" Aluminum
3/8"-16 spline bolts & flange nuts furnished.

Note: Bounding jumpers are required and are sold separately.

90° ANGLE CONNECTORS [CA]

NOTE: Sold in pairs

11 Gage Steel, 0.125" Aluminum

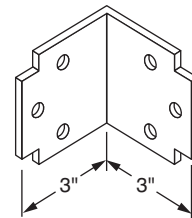

3/8"-16 spline bolts and flange nuts furnished.

REDUCING CONNECTORS [CO]

NOTE: Not sold in pairs

12 Gage Steel, 0.125" Aluminum

For offset reductions - use 1 of above with standard connector plate.

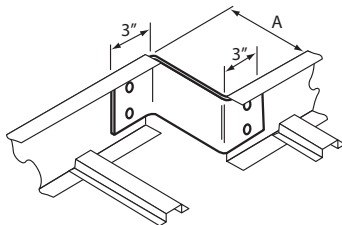

L.H. OFFSET REDUCTION



STRAIGHT REDUCTION



R.H. OFFSET REDUCTION

For straight reductions- use 2 (of 1/2 reduction dim.).
3/8"-16 spline bolts and flange nuts furnished.

CATALOG NUMBER

| Load Depth | Finish | Basic No. | "A" Dimension |
|------------|----------------|-----------|-----------------|
| 3" | 2 (Mill Galv.) | -30CO | 30" (762mm) |
| 4" | 3 (HDGAF) | -27CO | 27" (686mm) |
| 5" | 4 (Alum.) | -24CO | 24" (610mm) |
| 6" | U (304SS) | -21CO | 21" (533mm) |
| | | -18CO | 18" (457mm) |
| | | -15CO | 15" (381mm) |
| | | -13CO | 13 1/2" (343mm) |
| | | -12CO | 12" (305mm) |
| | | -10CO | 10 1/2" (267mm) |
| | | -09CO | 9" (229mm) |
| | | -07CO | 7 1/2" (191mm) |
| | | -06CO | 6" (152mm) |
| | | -04CO | 4 1/2" (114mm) |
| | | -03CO | 3" (76mm) |
| | | -01CO | 1 1/2" (38mm) |

Example: 34-03CO for 3" load depth, aluminum, 3" Reducer Connector.
Typical Use: 9" to 6", or use 2 for 12" to 6", etc.

MATERIAL/FINISH

Electrogalvanized finish standard. Other finishes available; consult factory.

*Use following suffix when applicable - use only where indicated.

No Suffix Electrogalvanized carbon steel only

-SS..... 302/304 Stainless Steel

-S1 316 Stainless Steel (check factory for availability)

Example: PS 6024-SS, 3/8" x 1 1/2" hex head bolt, 304 stainless steel

CONNECTOR HARDWARE [5003]

(Case-hardened steel electrogalvanized)

Part No. 5003-1

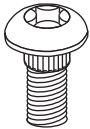

3/8"-16 x 1" spline bolt



3/8"-16 hex-flanged nut with serrated washer face.

Part No. 5009-1

COVER SCREW [EM]

Part No. EM-CC (electrogalv. steel)
Part No. EM-CC-SS (stainless steel)

No. 10 x 3/8" long, self drilling-self tapping hex head plated steel screw.

Suggested spacing:
Indoor: 8 per 12'

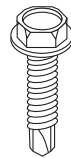

CONTINUOUS THREADED ROD [PS 146]

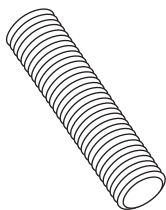

| Cat. No. | Size (Diameter x Length) |
|----------|--------------------------|
| PS 146* | 1/4" x 10' |
| PS 146* | 3/8" x 10' |
| PS 146* | 1/2" x 10' |
| PS 146* | 5/8" x 10' |
| PS 146* | 3/4" x 10' |

(Hot Dip Galvanized not available)

ROD COUPLER [PS 135]

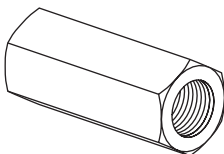

| Cat. No. | Size |
|----------|------|
| PS 135* | 1/4" |
| PS 135* | 3/8" |
| PS 135* | 1/2" |
| PS 135* | 5/8" |
| PS 135* | 3/4" |

HEX NUTS [PS 83]



| Cat. No. | Size |
|----------|------|
| PS 83* | 1/4" |
| PS 83* | 3/8" |
| PS 83* | 1/2" |
| PS 83* | 5/8" |
| PS 83* | 3/4" |

SQUARE NUTS [PS 6108]

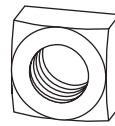

| Cat. No. | Size |
|----------|------|
| PS 6108* | 1/4" |
| PS 6108* | 3/8" |
| PS 6108* | 1/2" |
| PS 6108* | 5/8" |
| PS 6108* | 3/4" |

FLAT WASHERS [PS 209]

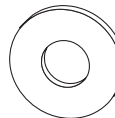

| Cat. No. | Size |
|----------|------|
| PS 209* | 1/4" |
| PS 209* | 3/8" |
| PS 209* | 1/2" |
| PS 209* | 5/8" |
| PS 209* | 3/4" |

SPLIT-LOCK WASHERS [PS 211]

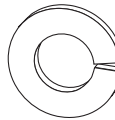

| Cat. No. | Size |
|----------|------|
| PS 211* | 1/4" |
| PS 211* | 3/8" |
| PS 211* | 1/2" |
| PS 211* | 5/8" |
| PS 211* | 3/4" |

FENDER WASHERS [PS 230]

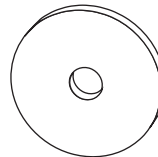

| Cat. No. | Size (I.D. x O.D.) |
|----------|--------------------|
| PS 230* | 1/4" x 1 1/4" O.D. |
| PS 230* | 3/8" x 1 1/2" O.D. |
| PS 230* | 1/2" x 2" O.D. |

HEX HEAD CAP SCREW [PS 6024] / ROUND HEAD SLOTTED CAP SCREWS [PS 6072]

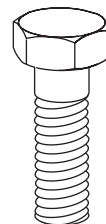

Catalog No. PS 6024

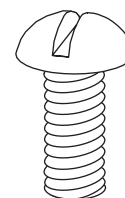

Catalog No. PS 6072

| Hex Head Cap Screw Cat. No. | Round Head Cap Screw Cat. No. | Size (Dia. x Len.) |
|-----------------------------|-------------------------------|--------------------|
| PS 6024* | PS 6072* | 1/4" x 1" |
| PS 6024* | PS 6072* | 1/4" x 1 1/2" |
| PS 6024* | PS 6072* | 3/8" x 1" |
| PS 6024* | PS 6072* | 3/8" x 1 1/2" |
| PS 6024* | PS 6072* | 3/8" x 3" |
| PS 6024* | PS 6072* | 1/2" x 1" |
| PS 6024* | PS 6072* | 1/2" x 1 1/2" |
| PS 6024* | PS 6072* | 1/2" x 2" |
| PS 6024* | PS 6072* | 1/2" x 2 1/2" |
| PS 6024* | PS 6072* | 1/2" x 3" |
| PS 6024* | PS 6072* | 1/2" x 3 1/2" |
| PS 6024* | PS 6072* | 5/8" x 1 1/2" |
| PS 6024* | PS 6072* | 5/8" x 2" |
| PS 6024* | PS 6072* | 5/8" x 3" |
| PS 6024* | PS 6072* | 5/8" x 4" |
| PS 6024* | PS 6072* | 3/4" x 2" |
| PS 6024* | PS 6072* | 3/4" x 3" |
| PS 6024* | PS 6072* | 3/4" x 4" |

HAT CABLE TRAY SYSTEM

COVERS

COVERS for straight sections shown. Standard fitting covers are flat solid type (NF). Aluminum covers are fabricated from 0.040" aluminum AA-3150-H14; steel covers are fabricated from 20 gage ASTM A-653-G90 CQ, mill-galvanized steel.

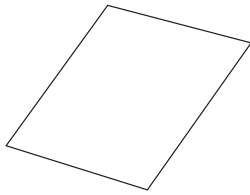

NF - Flat Solid

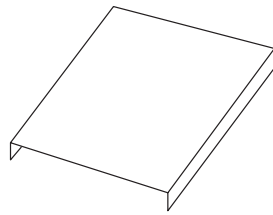

FS - Flat Solid
w/3/8" Flange

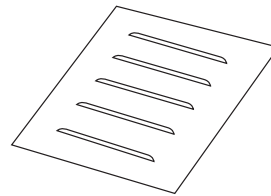

NL - Flat Louvered

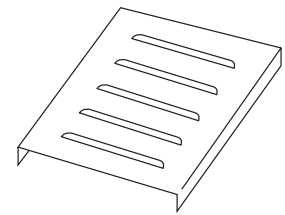

FL - Louvered
w/3/8" Flange

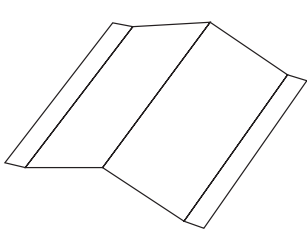

PS - Peaked Solid
(suffix height)

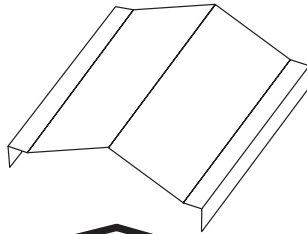

PF - Peaked Flanged Solid
(suffix height)

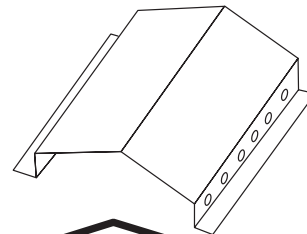

PV - Peaked Hat Vent
PH - Peaked Hat Solid
(suffix height)

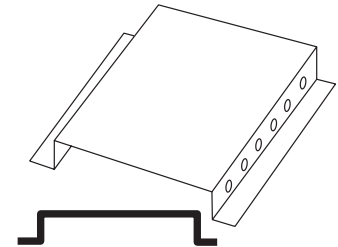

HS - Hat Solid
HV - Hat Vent
(suffix height)

NOTE: Use EM-CC Cover Screws (see pg. 123) to attach PH, PV, HS & HV covers.

HDGAF straights only available in 6' sections.

COVER CATALOG NUMBER – STRAIGHT SECTIONS

| Type | Finish | Basic No. (Width) | Length | Height* |
|---------|----------------|---------------------|--------|---------|
| HS, HV, | 2 - Mill Galv. | -06SL = 6" (152mm) | -12' | -2* |
| FL, FS, | 3 - HDGAF | -09SL = 9" (229mm) | -10' | |
| NF, NL, | 4 - Alum. | -12SL = 12" (305mm) | -06' | |
| PS, PF, | U - 304SS | -18SL = 18" (457mm) | | |
| PH, PV | | -24SL = 24" (610mm) | | |
| | | -30SL = 30" (762mm) | | |
| | | -36SL = 36" (914mm) | | |

*Peak and hat only, 2" height standard. Consult factory for other heights.

Example: NL2-09SL-12 is a flat louvered mill-galv. steel cover for a 9" wide mill galvanized hat 12' long.

COVER CATALOG NUMBER – FITTINGS

| Type | Load Depth | Finish | Width/Basic No. | Radius |
|------|------------|----------------|-----------------|--------|
| NF | 3 | 2 - Mill Galv. | -06 XX** | 12" |
| FS | 4 | 3 - HDGAF | -09 XX** | 24" |
| | 5 | 4 - Alum. | -12 XX** | 36" |
| | 6 | U - 304SS | -18 XX** | |
| | | | -24 XX** | |
| | | | -30 XX** | |
| | | | -36 XX** | |

*Load depth for outside riser or vertical tee only.

**XX from fitting selection page 108

Example: NF2-369F-24 is a mill galvanized non-flanged solid cover for a 36" wide horizontal 90° elbow with a 24" radius.

JOINT PLATE

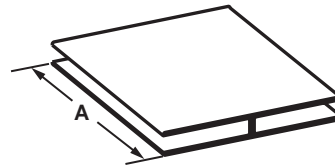

Joint plate is black PVC and is offered in 10' lengths to be field cut to desired length, or in precut lengths for specified covers.

JP-120 is joint plate in 10' lengths.

Joint plate for specified covers is specified as follows.

| Tray Width | Flange Type |
|---------------------|------------------|
| JP-06 = 6" (152mm) | |
| JP-09 = 9" (229mm) | |
| JP-12 = 12" (305mm) | -2=13/16" Flange |
| JP-18 = 18" (457mm) | -4=1 1/4" Flange |
| JP-24 = 24" (610mm) | -7=2" Flange |
| JP-30 = 30" (762mm) | |
| JP-36 = 36" (914mm) | |

Example: JP-06 is a joint plate for 6" wide tray with a 13/16" Flange.

SINGLE SIDE CONNECTOR [01CC]



Furnished with 1/4"-28 stainless steel cone point machine screw.

For use with any width tray.

Not sold in pairs.

Suggested spacing:
Indoor Use Only;
4 per 12' section

CATALOG NUMBER [BASIC NO -01CC]

| Flange | Load Depth | Finish |
|------------|------------|----------------|
| 2 - 13/16" | 3 | 2 - Mill Galv. |
| 4 - 1 1/4" | 4 | 3 - HDGAF |
| 5 - 1 1/2" | 5 | 4 - Alum. |
| 7 - 2" | 6 | U - 304SS |

Example: 234-01CC for 3" load depth, aluminum single side connector.

DOUBLE CLAMP CONNECTOR [(W)DC]

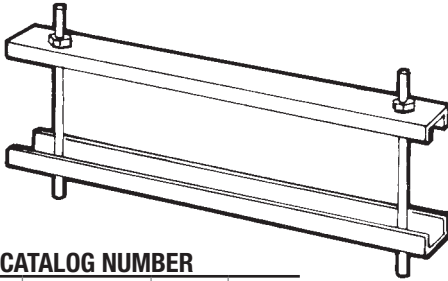

CATALOG NUMBER

| Load Depth | Finish | Width | Type |
|------------|----------------|-------|------|
| 3 | 2 - Mill Galv. | -06 | DC |
| 4 | 3 - HDGAF | -09 | |
| 5 | 4 - Alum. | -12 | |
| 6 | U - 304SS | -18 | |
| | | -24 | |
| | | -30 | |
| | | -36 | |

For all covers except hat & peak type. Furnished with:
(2) 1/4"-20 all-thread rods
(4) hex nuts, flat washers and lock washers

Suggested spacing:
Indoor: 2 per 12'
Outdoor: 3 per 12'
High Wind: 5 per 12'

Example: 34-12DC for 3" load depth, aluminum, Double Clamp Connector

PEAK COVER CONNECTOR [PC]

NOTE: For PS & PF Cover

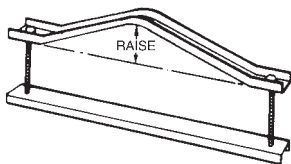

CATALOG NUMBER

| Load Depth | Finish | Width | Type | Raise (in)* |
|------------|----------------|-------|------|-------------|
| 3 | 2 - Mill Galv. | -06 | PC | -2 |
| 4 | 3 - HDGAF | -09 | VC | |
| 5 | 4 - Alum. | -12 | | |
| 6 | U - 304SS | -18 | | |
| | | -24 | | |
| | | -30 | | |
| | | -36 | | |

*2" standard raise. Consult factory for other peak heights.
Example: 34-12VC-2 for 3" load depth, aluminum, 12" wide, Peak Cover Connector (vented cover) with 2" peak.

COVER ACCESSORIES

PEAK VENT CONNECTOR [VC]

NOTE: For PV Covers

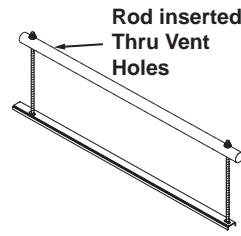

CATALOG NUMBER

| Flange | Load Depth | Finish | Width | Type |
|----------|------------|--------------|-------|------|
| 2=13/16" | 3 | 2=Mill Galv. | -06 | VC |
| 4=1 1/4" | 4 | 3=HDGAF | -09 | |
| 5=1 1/2" | 5 | 4=Alum. | -12 | |
| 6=1 3/4" | 6 | U=304SS | -18 | |
| | | | -24 | |
| | | | -30 | |
| | | | -36 | |

Example: 238-12VC for 3" load depth, 13/16" flange, aluminum, 12" wide, Peak Vented Cover Connector

COVER CONNECTOR [CC]

NOTE: For all covers except hat & peak type

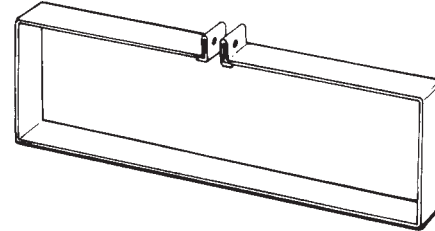

CATALOG NUMBER

| Load Depth | Finish | Width | Type |
|------------|----------------|-------|------|
| 3 | 2 - Mill Galv. | -06 | CC |
| 4 | 3 - HDGAF | -09 | |
| 5 | 4 - Alum. | -12 | |
| 6 | U - 304SS | -18 | |
| | | -24 | |
| | | -30 | |
| | | -36 | |

Example: 34-12CC for aluminum, 12" wide Connector

ELEVATED COVER CONNECTOR [EM-CC]

HDGAF for Outdoor Use
Includes:

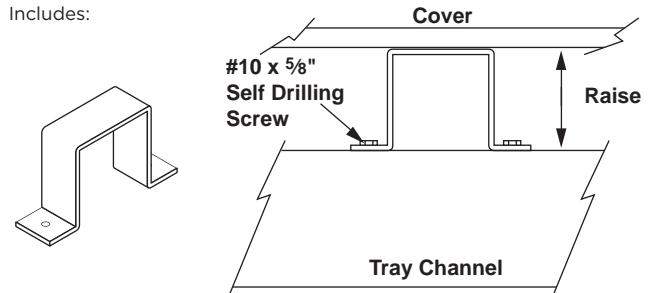

CATALOG NUMBER

| Finish | Type | Height* |
|----------------|-------|----------------|
| 2 - Mill Galv. | EM-CC | - Raise* (in.) |
| 3 - HDGAF | | |
| 4 - Alum. | | |
| U - 304SS | | |

(3) #10 x 5/8" Self drilling screws.
Suggested spacing:
Indoor: 3/Side (6 tot.) per 12';

*1", 2" or 3" standard.
Example: 3-EM-CC-2 for hot dipped galvanized, Elevated Cover Connector with a 2" raise

HAT CABLE TRAY SYSTEM

ACCESSORIES

DROP OUT [DO]

14 Gage Steel, .080" Aluminum

NOTE: (2) #10 x 5/8" self tapping screws furnished.

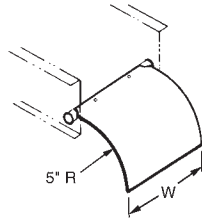

Catalog Number

| Basic Finish | Width | |
|----------------|-------------|---------|
| 2 (Mill Galv.) | -06DO = 6" | (152mm) |
| 3 (HDGAF) | -09DO = 9" | (229mm) |
| 4 (Alum.) | -12DO = 12" | (305mm) |
| U (304SS) | -18DO = 18" | (457mm) |
| | -24DO = 24" | (610mm) |
| | -30DO = 30" | (762mm) |
| | -36DO = 36" | (914mm) |

Example: 4-12DO for aluminum, 12" wide, Drop Out.

BOX CONNECTOR [CB]

14 Gage Steel
.080" Aluminum

NOTE: 1/4"-20 carriage bolts, flat washers, hex nuts furnished.

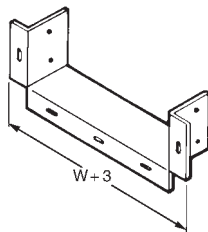

Catalog Number

| Load Depth | Finish | Width | |
|------------|----------------|-------------|---------|
| 3 | 2 (Mill Galv.) | -06CB = 6" | (152mm) |
| 4 | 3 (HDGAF) | -09CB = 9" | (229mm) |
| 5 | 4 (Alum.) | -12CB = 12" | (305mm) |
| 6 | U (304SS) | -18CB = 18" | (457mm) |
| | | -24CB = 24" | (610mm) |
| | | -30CB = 30" | (762mm) |
| | | -36CB = 36" | (914mm) |

Example: 34-12CB for 3" load depth, aluminum, 12" wide, Box Connector.

CABLE TRAY GROUND CLAMP [9156]

Extruded Alum. with ElectroGalvanized Hex Head Screws

Capacity: #6 AWG to 250 kcmil

UL Listed, CSA Certified for grounding means

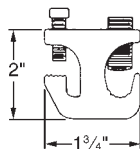
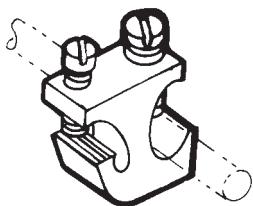

BLIND END [BE]

22 Gage Steel, .040" Aluminum

NOTE: 3/8"-16 spline bolts and flange nuts furnished.

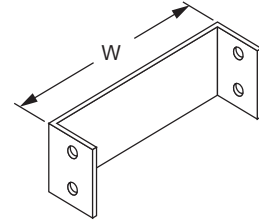

Catalog Number

| Load Depth | Finish | Width | |
|------------|----------------|-------------|---------|
| 3 | 2 (Mill Galv.) | -06BE = 6" | (152mm) |
| 4 | 3 (HDGAF) | -09BE = 9" | (229mm) |
| 5 | 4 (Alum.) | -12BE = 12" | (305mm) |
| 6 | U (304SS) | -18BE = 18" | (457mm) |
| | | -24BE = 24" | (610mm) |
| | | -30BE = 30" | (762mm) |
| | | -36BE = 36" | (914mm) |

Example: 34-12BE for 3" load depth, aluminum, 12" wide Blind End.

BONDING JUMPER [CBJ]

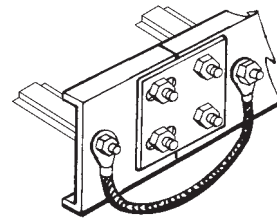

| Catalog No. | Dimensional Data | Amperes as Equipment Ground |
|-------------|---|-----------------------------|
| CBJ-C | AWG 1/0 copper wire 15 1/2" long overall | 800 amperes |
| CBJ-4C | AWG 4/0 copper wire 15 1/2" long overall | 1,600 amperes |
| CBJ-250C | 250 MCM copper wire 15 1/2" long overall | 2,000 amperes |

NOTE:

No hardware supplied

For hardware kit add -HDW:

Ex: CBJ-C-HDW includes
2ea CBJ-C
4ea 5003-1
4ea 5009-1

GROUND CABLE RETAINER CLAMP

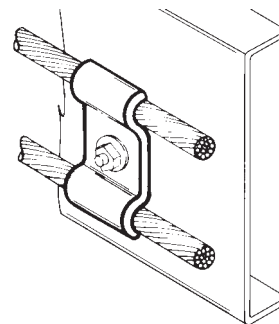

| Catalog No. | Capacity | Metal & Finish | Dimensions |
|-------------|-------------|---------------------|--------------------|
| 9056-EP | 1/0 2/0 3/0 | Electro-Galv. Steel | 1" w x 2" long |
| 9057-EP | 4/0 250 MCM | | 1" w x 2 3/8" long |
| 9056-SS | 1/0 2/0 3/0 | Stainless Steel | 1" w x 2" long |
| 9057-SS | 4/0 250 MCM | | 1" w x 2 3/8" long |

CONDUIT CLAMP BRACKET

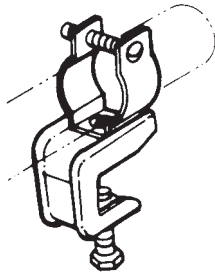

| Catalog No. | Size-Rigid | Size-EMT |
|-------------|--------------|----------|
| CCB-050 | 3/8" to 1/2" | 1/2" |
| CCB-075 | 3/4" | 3/4" |
| CCB-100 | 1" | 1" |
| CCB-125 | - | 1 1/4" |
| CCB-150 | 1 1/4" | 1 1/2" |
| CCB-200 | 2" | 2" |

CONDUIT-TO-CABLE TRAY CLAMP - SWIVEL TYPE

Malleable iron hub and steel "U" bolt. For connecting and grounding rigid conduit to tray at any angle within 90° arc. UL listed as a grounding means.

| Catalog No. | Size | Std. Pkg. |
|-------------|-----------|-----------|
| TB6209 | 1/2"-3/4" | 10 |
| TB6211 | 1"-1 1/4" | 10 |
| TB6214 | 1 1/2"-2" | 5 |
| TB6216 | 2 1/2"-3" | 5 |
| TB6218 | 3 1/2"-4" | 2 |

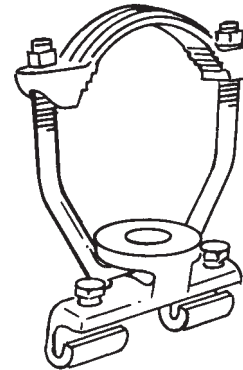

WALL PENETRATING SLEEVE ASSEMBLY [SS89042 (W)*]

W = Tray Width
 *=Fitting 3-Digit Prefix

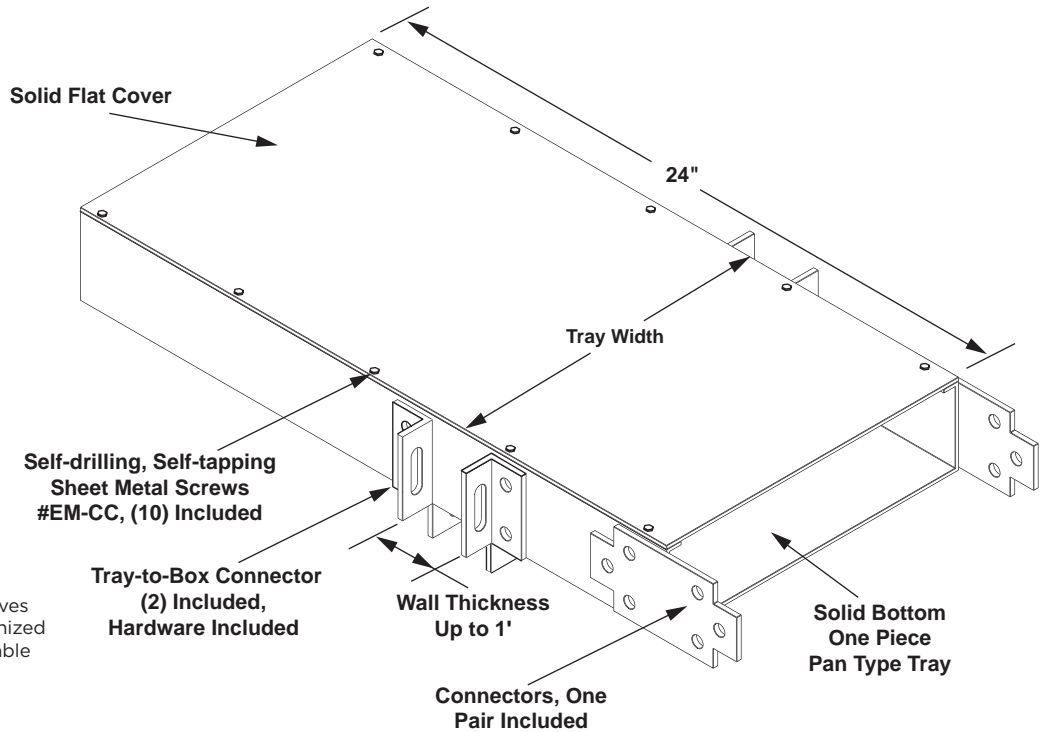

NOTE: Standard penetration sleeves are manufactured from mill galvanized steel. Aluminum sleeves are available upon request.

HAT CABLE TRAY SYSTEM

BARRIER STRIPS

UNIVERSAL ALUMINUM BARRIER STRIP - STRAIGHT SECTION [SB]

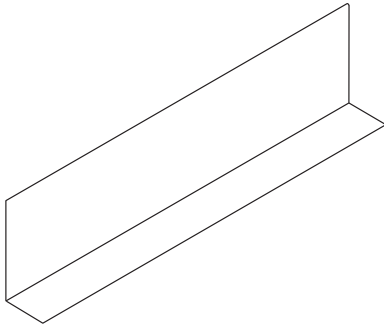

Furnished with 8 self tapping screws.

CATALOG NUMBER

| Load Depth | Finish | Basic No. 12' Length |
|------------|-----------|----------------------|
| 3 | A (Alum.) | -01SB-12 |
| 4 | | |
| 5 | | |
| 6 | | |

Example: 3A-01SB-12 for 3" load depth, aluminum straight barrier, 12' long.

BARRIER STRIP - HORIZONTAL SECTION [FB]

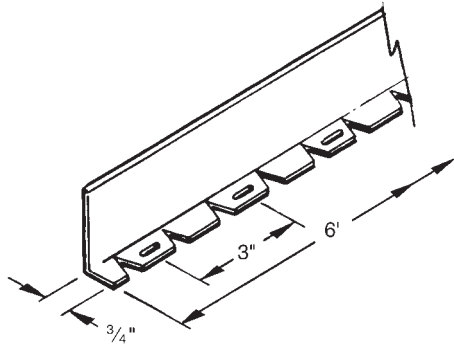

CATALOG NUMBER

| Load Depth | Finish | Basic No. 6' Length |
|------------|----------------|---------------------|
| 3 | 2 (Mill Galv.) | -01FB-06 |
| 4 | 3 (HDGAF) | |
| 5 | 4 (Alum.) | |
| 6 | U (304 SS) | |

Example: 34-01FB-06 for 3" load depth, aluminum fitting barrier, 6' long.
Furnished with 4 self tapping screws.

BARRIER STRIP - VERTICAL ELBOW OUTSIDE [OB] & INSIDE [IB]

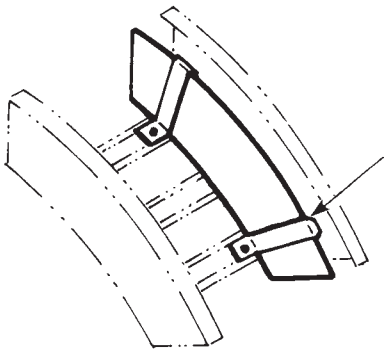

Barrier Strip Clamp
Part No. 50172
Furnished with vertical
elbow barriers

CATALOG NUMBER

| Load Depth | Finish | Bend (deg.) | Basic No. | Radius |
|------------|----------------|-------------|--------------|-------------|
| 3 | 2 (Mill Galv.) | 90 | OB = Outside | 12" (305mm) |
| 4 | 3 (HDGAF) | 60 | IB = Inside | 24" (610mm) |
| 5 | 4 (Alum.) | 45 | | 36" (914mm) |
| 6 | U (304 SS) | 30 | | |

Example: 34-90OB-12 for 3" load depth, aluminum 90° outside vertical barrier with 12" radius. (OB Vert. Elbow outside shown)
Furnished with sufficient clamp assemblies for installation.
Additional clamp assemblies may be ordered separately.

NYLON BARRIER SPLICE & PROTECTOR - [BSP-L]

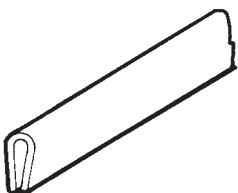

CATALOG NUMBER

| Prefix | Length (L) |
|--------|-----------------------|
| | -5 (5" Splice) |
| BSP | -144 (144" Protector) |
| | -1200 (100' Roll) |

Example: BSP-1200 for 100' roll

COVER SCREW

Part No. EM-CC (electro galv. steel)
Part No. EM-CC-SS (stainless steel)

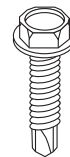

No. 10 x 5/8" long, self drilling-self tapping hex head plated steel screw.
Suggested spacing: Indoor: 8 per 12'; Outdoor: 10 per 12'

BARRIER CLAMP - OPTIONAL [50172]

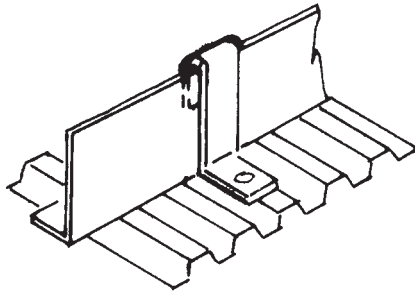

No. 10 bolt, nut, washer and lock washer furnished.

| CATALOG NUMBER | | |
|----------------|----------------|-----------|
| Load Depth | Finish | Basic No. |
| 3 | 2 (Mill Galv.) | -50172 |
| 4 | 3 (HDGAF) | |
| 5 | 4 (Alum.) | |
| 6 | U (304 SS) | |

Example: 34-5072 for 3" load depth, aluminum clamp.

HOLD-DOWN [9132]

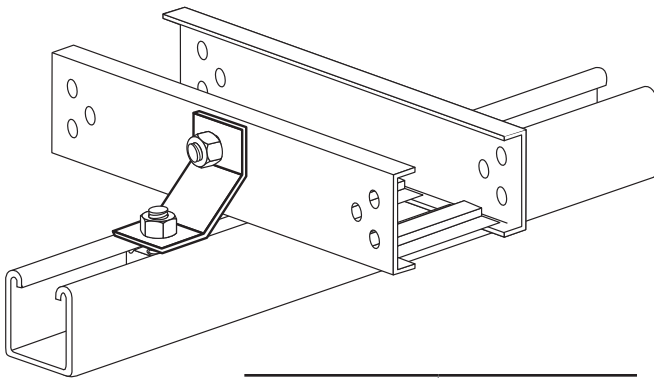

| Catalog No. | Material |
|-------------|-----------------|
| 9132 | Mill Galvanized |
| 9133 | Stainless Steel |

Hardware purchased separately to suit support system.

Note: For seismic applications or other bolted connections is preferred.

4" wide and 4" tall

Made from 11 gauge material

HOLD-DOWN CLAMP & EXPANSION GUIDE

(For expansion guide clamp, add suffix "EX" to catalog number.)

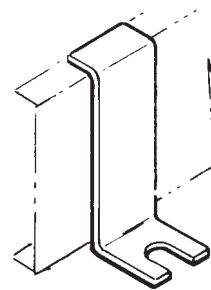

CATALOG NUMBER

| Load Depth | Basic No. |
|------------|---------------------------|
| 3 | -9039 (Aluminum) |
| 4 | -9040 (ElectroGalv.Steel) |
| 5 | -9041 (HDGAF) |
| 6 | -9042 (316SS) |

Example: 3-9039-EX for 3" load depth, expansion guide. Hardware purchased separately to suit support system.

Complete Kit add "-HDW" to Part Number above.

Hardware Kit List:

- (2) Hold-Down Clamps
- (2) 1/2" - 13 x 1 1/2" Cap Screws
- (2) 1/2" Flat Washer
- (2) Clamping Nut (Strut Nut)

ISOLATION PAD [PVC-PAD]

The Isolation pad provides protection from galvanic corrosion when Aluminum tray is mounted on steel supports.

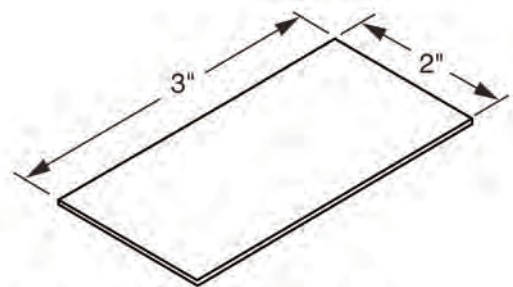

Note: For use with the 9039 series of Hold-Down Clamp & Expansion Guide.

Hardware purchased separately

HAT CABLE TRAY SYSTEM

SUPPORT BRACKETS

GUSSET-TYPE SUPPORTS

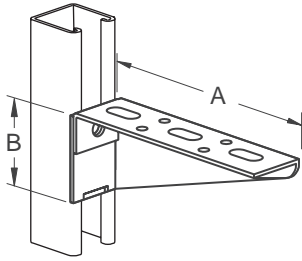

For use with all types of Cope Ladder and Trof systems.
Finish is electro-galvanized.
Order hardware separately.

| Catalog No. | Ladder Width | Dimension | | Uniform-Load Rating |
|-------------|--------------|-----------|----------|---------------------|
| | | A | B | |
| PS 838R-6 | - | 6" | 1 15/16" | 275 lbs. |
| PS 838R-8 | - | 8" | 2 7/16" | 275 lbs. |
| PS 838R-10 | - | 10" | 2 15/16" | 275 lbs. |
| PS 838R-12 | 6" | 12" | 3 7/16" | 275 lbs. |
| PS 838R-16 | 9" | 16" | 4 7/16" | 275 lbs. |
| PS 838R-18 | 12" | 18" | 4 15/16" | 275 lbs. |
| PS 838R-24 | 18" | 24" | 6 7/16" | 275 lbs. |
| PS 838R-30 | 24" | 30" | 7 15/16" | 275 lbs. |

CHANNEL-TYPE SUPPORTS

For use with all types of Cope Ladder and Trof systems.
Finish is electro-galvanized.
Order hardware separately.

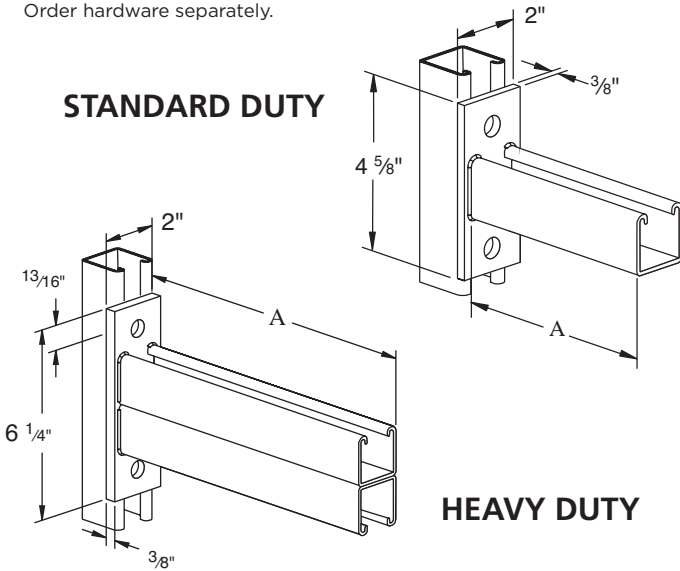

STANDARD DUTY FOR LIGHTER LOADS.

| Catalog No. | Ladder Width | Dimension A | Uniform-Load Rating* |
|-------------|--------------|-------------|----------------------|
| PS 651-6 | - | 6" | 1,200 lbs. |
| PS 651-12 | 6" | 12" | 600 lbs. |
| PS 651-15 | 9" | 15" | 480 lbs. |
| PS 651-18 | 12" | 18" | 400 lbs. |
| PS 651-24 | 18" | 24" | 300 lbs. |
| PS 651-30 | 24" | 30" | 240 lbs. |

* Mounted on 12 Ga. Channel.

HEAVY DUTY FOR HEAVIER LOADS

| Catalog No. | Ladder Width | Dimension A | Uniform-Load Rating* |
|-------------|--------------|-------------|----------------------|
| PS 809-12 | 6" | 12" | 2,000 lbs. |
| PS 809-15 | 9" | 15" | 1,600 lbs. |
| PS 809-18 | 12" | 18" | 1,330 lbs. |
| PS 809-24 | 18" | 24" | 1,000 lbs. |
| PS 809-30 | 24" | 30" | 800 lbs. |
| PS 809-36 | 30" | 36" | 660 lbs. |
| PS 809-42 | 36" | 42" | 570 lbs. |

* Mounted on 12 Ga. Channel.

WALL SUPPORT BRACKETS

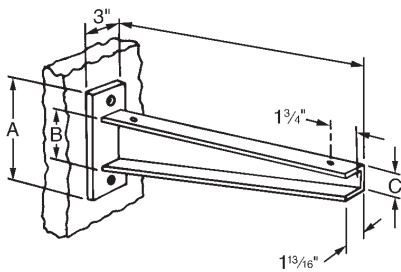

| Catalog No. | Tray Width | Length "L" | Dimensions | | | End-Load Rating* |
|-------------|------------|------------|------------|-----|--------|------------------|
| | | | "A" | "B" | "C" | |
| 9037-12 | 6" | 12 1/4" | 10" | 6" | 2" | 2000 lbs. |
| 9037-18 | 12" | 18 1/4" | 11" | 7" | 2 1/2" | 2000 lbs. |
| 9037-24 | 18" | 24 1/4" | 11" | 7" | 2 1/2" | 1600 lbs. |
| 9037-30 | 24" | 30 1/4" | 12" | 8" | 4" | 1300 lbs. |
| 9037-36 | 30" | 36 1/4" | 12" | 8" | 4" | 1100 lbs. |
| 9037-42 | 36" | 42 1/4" | 12" | 8" | 4" | 900 lbs. |

*Uniform load rating is normally twice the end-load rating.
Finish is hot-dip galvanized after fabrication. Order hardware separately.

STRUCTURAL SUPPORT BRACKET

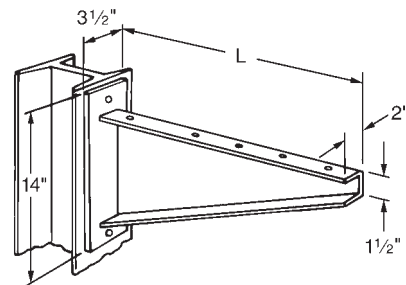

| Catalog No. | Tray Width | Length "L" | End-Load Rating* |
|-------------|------------|------------|------------------|
| 9036-31 | 24" | 31 1/4" | 2000 lbs. |
| 9036-37 | 30" | 37 1/4" | 1800 lbs. |
| 9036-45 | 36" | 45 1/4" | 1500 lbs. |

*Uniform load rating is normally twice the end-load rating.
For use with Trof 24" or wider. May be welded or bolted to building steel.
Finish is hot-dip galvanized after fabrication. Order hardware separately.

TRAY HANGER & SUPPORTS

VERTICAL SUPPORTS

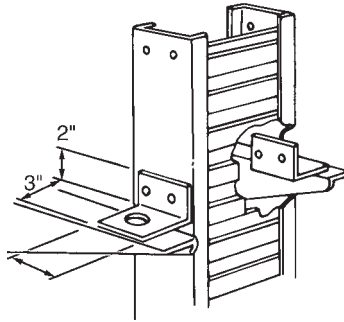

| Cat. No. | For Use With |
|----------|---|
| 9045 | 3 1/4" Overall Height Side Members |
| 9043-37 | 4 1/4" Overall Height Side Members |
| 9043 | 5 1/4" Overall Height Side Members |
| 9025-98 | 6 1/4" & 7 1/4" Overall Height Side Members |

Tray Supports can be bolted anywhere along the straight runs. They can be bolted directly onto the coupler plates at splices of straight runs and riser fittings, or they can be bolted at any place in the run by field-drilling side rails. TROF supports are used with either 3/8" or 1/2" hanger rods. Finish is electrogalvanized.

SINGLE ROD HANGER SUPPORT

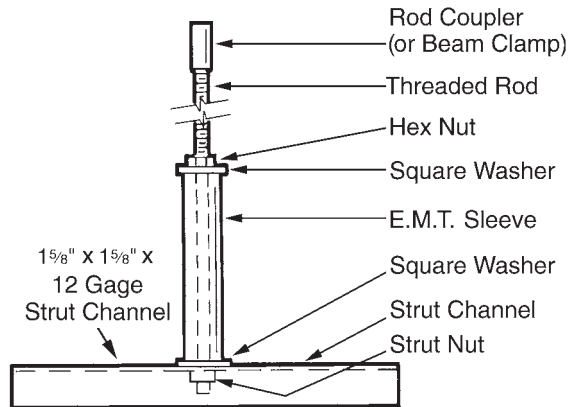

CATALOG NUMBER

| Assy. Type | Channel Length* | Channel Finish** | Rod Diameter | Rod Length | Beam Clamp |
|------------|-----------------|----------------------|--------------------|---------------------|-----------------|
| P200 | 14" (356mm) | GV (Pre-Galv) | 38 = 3/8" (9.53mm) | 000 - No Rod | A - PS 85 |
| | 17" (432mm) | HG (Hot Dipped Galv) | 12 = 1/2" (12.7mm) | 036 - 36" (914mm) | B - P2622 |
| | 20" (508mm) | | | 072 - 72" (1828mm) | O - No Clamp |
| | 26" (661mm) | | | 120 - 120" (3048mm) | R - Rod Coupler |
| | 32" (813mm) | | | 144 - 144" (3658mm) | S - Special |
| | 38" (966mm) | | | | |
| | 44" (1118mm) | | | | |

Example: P20020GV12036B is a Single 20" pre-galvanized channel with 1/2" x 36" drop rod and P2622 clamp.

NOTE: *Order channel length 8" longer than tray width. For example, 44" channel for 36" tray.
** Other channel types and finishes available upon request. Contact factory.
To order hardware only: 3/8" - PGV380000, 1/2" - PGV120000

TRAPEZE HANGER SUPPORT

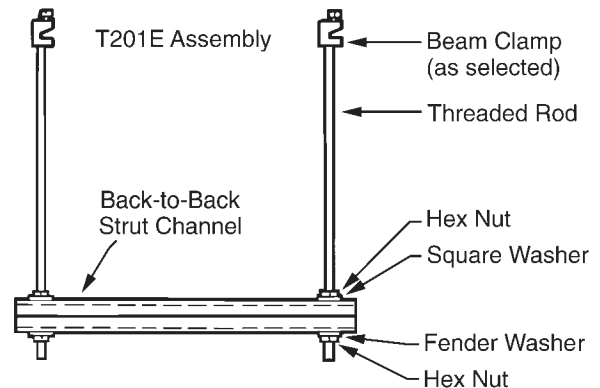
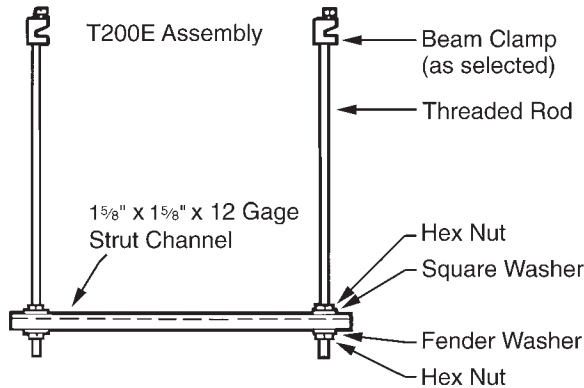

CATALOG NUMBER

| Assy. Type | Channel Length* | Channel Finish** | Rod Diameter | Rod Length | Beam Clamp |
|------------|-----------------|----------------------|--------------------|---------------------|-----------------|
| T200E | 16" (407mm) | GV (Pre-Galv) | 38 = 3/8" (9.53mm) | 000 - No Rod | A - PS 85 |
| T201E | 19" (483mm) | HG (Hot Dipped Galv) | 12 = 1/2" (12.7mm) | 036 - 36" (914mm) | B - P2622 |
| | 22" (559mm) | | | 072 - 72" (1828mm) | O - No Clamp |
| | 28" (712mm) | | | 120 - 120" (3048mm) | R - Rod Coupler |
| | 34" (864mm) | | | 144 - 144" (3658mm) | S - Special |
| | 40" (1017mm) | | | | |
| | 46" (1169mm) | | | | |

Example: T200E22GV12036B is a Single 22" pre-galvanized channel with 1/2" x 36" drop rod and P2622 clamp.

NOTE: *Order channel length 10" longer than tray width. For example, 46" channel for 36" tray.
** Other channel types and finishes available upon request. Contact factory.
To order hardware only: 3/8" - PGV380000, 1/2" - PGV120000

HAT CABLE TRAY SYSTEM

ELECTRICAL GROUNDING CHART

Table 1 below provides the Minimum Cross Sectional area for two side rails. Using the Fitting Prefix Number (24A), the proper value is determined by the Material (column 3), the Flange Width (column 1) and Load Depth (column 2). Locate the line containing the Load Depth (column 1) and follow it to the right to the appropriate Flange Width and Material.

TABLE 1

| | | | Min. X-Sect for 2 Rails (NEC® Table 392.60(A)) | | | |
|-------------------------------------|------------|--------------|---|-------------|--|-------------|
| | | | Aluminum | | Steel | |
| Fitting Prefix Number | | | ¹³ / ₁₆ " Flange | 1 ¼" Flange | ¹³ / ₁₆ " Flange | 1 ¼" Flange |
| Flange | Load Depth | Material | X-Sect Area | X-Sect Area | X-Sect Area | X-Sect Area |
| 2 - ¹³ / ₁₆ " | 3" | 6 - Mill Gal | 0.60 | 0.60 | 0.40 | 0.70 |
| 4 - 1 ¼" | 4" | 7 - HDGAF | 0.60 | 0.60 | 0.40 | 0.70 |
| | 5" | 8 - Alum. | 0.60 | 1.00 | 0.70 | 0.70 |
| | 6" | | 0.60 | 1.00 | 0.70 | 1.00 |

Find that value in Table 2, follow it to the right to the Material column to determine the Maximum Ground Fault Amperage.

TABLE 2

| Maximum Ground Fault Amperage (in Amps) | | |
|---|----------|-------|
| X-Sect Area | Material | |
| | Aluminum | Steel |
| .40 sq in | - | 100 |
| .60 sq in | 1000 | - |
| .70 sq in | - | 200 |
| 1.00 sq in | 1200 | 400 |

For Example:

If the fitting prefix is 24A, the Flange is ¹³/₁₆", the Load Depth is 4", and the Material is Aluminum. The Minimum Cross Sectional Area (X-Sect Area) is 0.60 sq. in. The Amperage is 1000.

TYPICAL SPECIFICATIONS

By specifying the NEMA class designation, you will use the simplest, clearest, and most complete method of specification available and automatically incorporate support span in feet, working (allowable) load in pounds per linear foot, a safety factor of 1.5, a concentrated load if present, and, all other design, manufacturing, and test standards including electrical continuity.

All you need to do is add the desired load depth, rung spacing, radius of fittings, metal and finish. You may add accessory information pursuant to your project. Here is a typical specification for an outdoor tray system where the working (allowable) load has been determined to be approximately 75 pounds per foot on support spans of 12'-0".

SPECIFICATION - COPE HAT LADDER SYSTEM

Cable Hat Ladder shall be manufactured by a company regularly engaged in the manufacture of metal cable trays and shall be a member of NEMA. Trays shall conform to NEMA Metal Cable Tray Standard Publication VE-1 (latest issue).

1. Cable ladder shall be NEMA Classification 12B of the widths indicated.
2. Material shall be aluminum alloy 6063-T6 for side rails and 5052-H34 for rungs.
3. Finish shall be natural.
4. Inside load depth to be NEMA Standard 4".
5. Fittings shall be 12" radius for control cables and 24" radius for power cables. (This must be commensurate with the cable manufacturer's recommended minimum bending radius.)
6. All top level trays in stacks, and single runs to have raised peaked, aluminum ventilated covers with heavy duty hold down clamps every 3'-0"
7. Install expansion connectors, expansion guides, and hold down clamps per NEMA Standard VE-1.
8. Where slopes or horizontal bends of trays are not at the Standard NEMA angles, use adjustable connectors.

If the angle is too great for cable bending radius, use combinations of fitting and adjustable connectors.

9. Separate all cables of different voltages in the same tray using the manufacturer's standard barriers and barrier hold down system.
10. The Cable Hat Ladder system will be used as an equipment grounding conductor.
11. To save space, fittings shall have no tangents. To facilitate field installation use one pair of universal type connector plates for rigid joints.
12. Cable Ladder to have hat type rungs arc welded to side rails. Rungs shall not protrude below side rails. Outside depth shall not exceed inside depth by more than ⁵/₈". Side rails to have flanges facing in. Trays shall be Cope Hat Ladder System No. 3B4A as manufactured by Cope.

5



TROF



Corrugated Bottom Cable TROF System for Power, Control, Instrumentation Cable, & Pneumatic Tubing

TROF CABLE TRAY SYSTEM

CONTENTS

GENERAL & TECHNICAL INFORMATION

| | |
|---|-----------|
| Selection Chart: Cope Trof - Aluminum | 124 - 125 |
| Selection Chart: Cope Trof - Steel | 126 - 127 |
| Overview | 128 |
| Ordering Information..... | 129 |
| CSA Ordering Information..... | 130 |
| CSA Selection Chart: Aluminum/Steel | 131 |
| Straight Length..... | 132 |

COPE TROF FITTINGS

| | |
|--|----------------|
| Horizontal Elbows | |
| 90° | 133 |
| 60° | 133 |
| 45° | 134 |
| 30° | 134 |
| Horizontal Tee | 135, 136 - 137 |
| Horizontal Cross | 135, 138 - 139 |
| Straight Reducers | 140 |
| Left and Right Hand Reducers | 140 |
| Adjustable Elbow | 141 |
| 45° "Y" Branch | 141 |
| Vertical Elbows (Inside and Outside) | |
| 90° | 142 |
| 60° | 142 |
| 45° | 143 |
| 30° | 143 |
| 90° Vertical Cable Support Elbow | 144 |
| Vertical Tee..... | 144 |

COPE TROF FITTINGS

| | |
|--|-----------|
| Blind End, Drop Out, Bonding Jumper, Box Connector, Cable Tray | |
| Ground Clamp, Ground Cable Retainer Clam | 149 |
| Conduit Clamp, Wall Sleeve | 150 |
| Barrier Strips, Nylon Protector | 151 |
| Hold Down Clamp & Expansion Guide, Seismic Hold Down, Barrier | |
| Strip Clamps..... | 152 |
| Channel Supports, Tray Brackets, Support Brackets | 153 - 154 |
| Hanger Support, Trapeze Hanger Support, Vertical Supports..... | 154 - 155 |

SPECIFICATION INFORMATION

| | |
|--|-----|
| Typical Specification..... | 156 |
| Electrical Grounding Information | 120 |

STRAIGHT LENGTH

Page 132

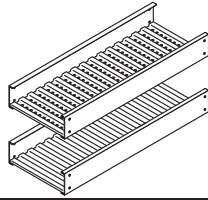

VERTICAL ELBOWS

Pages 142 - 143

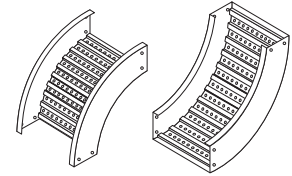

HORIZONTAL ELBOWS

Pages 133 - 134

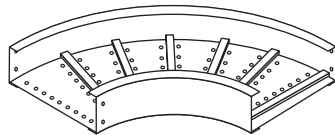

90° VERTICAL CABLE SUPPORT ELBOW

Page 144

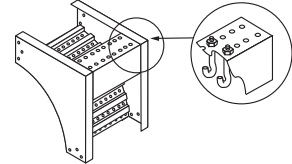

HORIZONTAL TEE

Pages 135, 136 - 137

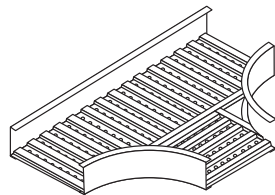

VERTICAL TEE

Page 144

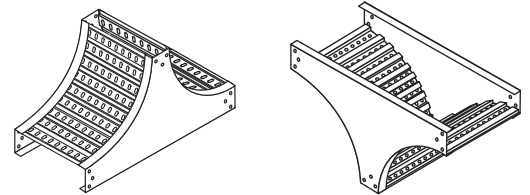

HORIZONTAL CROSS

Pages 135, 138 - 139

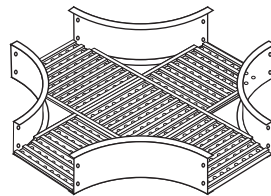

SPLICE PLATES

Pages 145



REDUCERS

Page 140

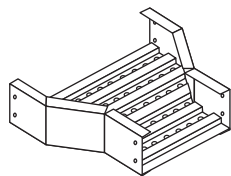

COVERS

Page 147

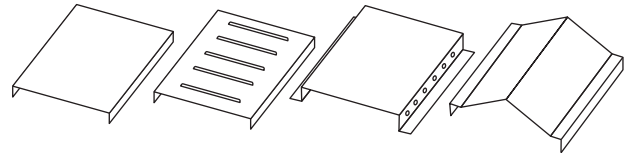

ADJUSTABLE ELBOWS

Page 141

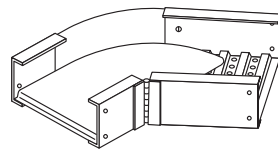

COVER ATTACHMENT

Page 148

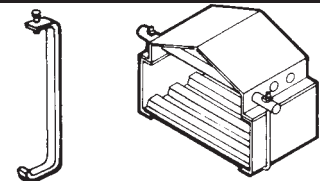

45° "Y" BRANCH

Page 141

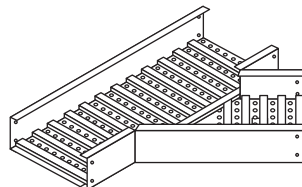

BARRIER STRIPS AND ACCESSORIES

Page 151

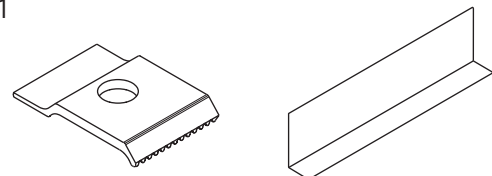

Intro

LADDER

I-BEAM

HAT

TROF

CHANNEL

COPE-GLAS™

WIREBASKET

Reference

TROF CABLE TRAY SYSTEM

ALUMINUM TRAY

SELECTION CHART

NEMA CLASS, PHYSICAL AND STRUCTURAL PROPERTIES

| NEMA Standard VE-1 Load/Span Class | NEMA Load/Span | Cope System Number | Cope Systems Certified by CSA | Nominal Load Depth | Side Rail Height | Flange Width (in.) | Section Modulus of 2 Rails S _x (in. ³) | Moment of Inertia for 2 Rails I _x (in. ⁴) | Min X-Sect. Area of 2 Rails per NEC 392.7 (in. ²) |
|---|-------------------------|--------------------|-------------------------------|--------------------|------------------|--------------------|---|--|---|
| 8A-12A | 50 lb./ft. 12' span | 5234 | - | 3" (76mm) | 3 ½" (89mm) | ⅜" | 0.800 | 1.400 | .60 |
| | | 1B44 | 1B44 | 4" (102mm) | 4 ¼" (108mm) | ⅜" | 0.898 | 1.822 | .60 |
| | | 1B54 | 1B54 | 5" (127mm) | 5 ¼" (133mm) | ⅜" | 1.142 | 2.872 | .60 |
| | | 3B64 | - | 6" (152mm) | 6 ¼" (159mm) | ⅜" | 1.614 | 4.720 | 1.00 |
| 12B | 75 lb./ft. 12' span | 3B44 | - | 4" (102mm) | 4 ¼" (108mm) | ⅜" | 1.148 | 2.316 | .60 |
| | | 1B54 | 1B54 | 5" (127mm) | 5 ¼" (133mm) | ⅜" | 1.142 | 2.872 | .60 |
| | | 3B64 | - | 6" (152mm) | 6 ¼" (159mm) | ⅜" | 1.614 | 4.720 | .60 |
| 12C | 100 lb./ft. 12' span | 5B44 | - | 4" (102mm) | 4 ¾" (108mm) | ⅜" | 1.646 | 3.058 | 1.00 |
| | | 3B54 | - | 5" (127mm) | 5 ¼" (133mm) | ⅜" | 1.522 | 3.734 | 1.00 |
| | | 5B64 | - | 6" (152mm) | 6 ¼" (159mm) | ⅜" | 1.944 | 5.866 | 1.00 |
| 16A | 50 lb./ft. 16' span | 5B44 | - | 4" (102mm) | 4 ¼" (108mm) | ⅜" | 1.646 | 3.058 | 1.00 |
| | | 7454 | 7454 | 5" (127mm) | 5 ¼" (133mm) | 1 ¼" | 2.396 | 6.292 | 1.50 |
| | | 1D64 | 1D64 | 6" (152mm) | 6 ¼" (159mm) | 1 ¼" | 2.378 | 7.202 | 1.00 |
| 16B | 75 lb./ft. 16' span | 3D44 | 3D44 | 4" (102mm) | 4 ¼" (108mm) | 1 ¼" | 2.242 | 4.406 | 1.00 |
| | | 7454 | 7454 | 5" (127mm) | 5 ¼" (133mm) | 1 ¼" | 2.396 | 6.292 | 1.50 |
| | | 1D64 | 1D64 | 6" (152mm) | 6 ¼" (159mm) | 1 ¼" | 2.378 | 7.202 | 1.00 |
| 16C | 100 lb./ft. 16' span | 5D44 | 5D44 | 4" (102mm) | 4 ¼" (108mm) | 1 ¼" | 2.782 | 5.738 | 1.50 |
| | | 3D54 | 3D54 | 5" (127mm) | 5 ¼" (133mm) | 1 ¼" | 3.434 | 8.746 | 2.00 |
| | | 7D64 | - | 6" (152mm) | 6 ¼" (159mm) | 1 ¼" | 4.186 | 12.024 | 2.00 |
| 20A | 50 lb./ft. 20' span | 3D44 | - | 4" (102mm) | 4 ¼" (108mm) | 1 ¼" | 2.242 | 4.406 | 1.00 |
| | | 7454 | 7454 | 5" (127mm) | 5 ¼" (133mm) | 1 ¼" | 2.396 | 6.292 | 1.50 |
| | | 1D64 | 1D64 | 6" (152mm) | 6 ¼" (159mm) | 1 ¼" | 2.378 | 7.202 | 1.00 |
| 20B | 75 lb./ft. 20' span | 3D54 | 3D54 | 5" (127mm) | 5 ¼" (133mm) | 1 ¼" | 3.434 | 8.746 | 2.00 |
| | | 7D64 | 7D64 | 6" (152mm) | 6 ¼" (159mm) | 1 ¼" | 4.186 | 12.024 | 2.00 |
| 20C | 100 lb./ft. 20' span | 7D44 | 7D44 | 4" (102mm) | 4 ¼" (108mm) | 1 ¼" | 3.512 | 6.956 | 2.00 |
| | | 5D54 | - | 5" (127mm) | 5 ¼" (133mm) | 1 ¼" | 3.910 | 10.020 | 2.00 |
| | | 7D64 | 7D64 | 6" (152mm) | 6 ¼" (159mm) | 1 ¼" | 4.186 | 12.024 | 2.00 |
| EXTRA HEAVY DUTY - VERY LONG SPAN TRAYS - SOLID OR VENTILATED BOTTOMS | | | | | | | | | |
| | | 9D64 | - | 6" (152mm) | 6 ¼" (159mm) | 1 ¼" | 5.130 | 15.700 | 2.00 |
| | | 7G64 | - | 6" (152mm) | 6 ¼" (159mm) | 2" | 5.804 | 17.456 | 2.00 |

LOAD AND DEFLECTION DATA FOR ALUMINUM TROF

WORKING (ALLOWABLE) LOAD CAPACITY, EVENLY DISTRIBUTED - TESTED PER NEMA STANDARD VE-1

SPAN (FT.) - SIMPLE BEAM - SAFETY FACTOR: 1.5

| Cope Sys. No. | 6 Ft. Span | | | 8 Ft. Span | | | 10 Ft. Span | | | 12 Ft. Span | | | 16 Ft. Span | | | 20 Ft. Span | | | 24 Ft. Span | | | 25 Ft. Span | | |
|---|------------|-----|------|------------|-----|------|-------------|------|------|-------------|------|------|-------------|------|------|-------------|------|------|-------------|------|------|-------------|------|------|
| | w | d | k | w | d | k | w | d | k | w | d | k | w | d | k | w | d | k | w | d | k | w | d | k |
| 5234 | 207 | .43 | .002 | 117 | .77 | .007 | 75 | 1.20 | .016 | 52 | 1.73 | .033 | | | | | | | | | | | | |
| 1B44 | 222 | .35 | .002 | 125 | .63 | .005 | 80 | .99 | .012 | 55 | 1.42 | .026 | | | | | | | | | | | | |
| 1B54 | 324 | .33 | .001 | 182 | .59 | .003 | 117 | .87 | .007 | 77 | 1.26 | .016 | | | | | | | | | | | | |
| 3B64 | 359 | .22 | † | 191 | .37 | .002 | 115 | .55 | .005 | 75 | .74 | .010 | | | | | | | | | | | | |
| 3B44 | 354 | .45 | .001 | 191 | .76 | .004 | 117 | 1.14 | .010 | 78 | 1.57 | .020 | | | | | | | | | | | | |
| 1B54 | 324 | .33 | .001 | 182 | .59 | .003 | 117 | .87 | .007 | 77 | 1.26 | .016 | | | | | | | | | | | | |
| 3B64 | 359 | .22 | † | 191 | .37 | .002 | 115 | .55 | .005 | 75 | .74 | .010 | | | | | | | | | | | | |
| 5B44 | 362 | .32 | † | 251 | .69 | .003 | 161 | 1.08 | .007 | 112 | 1.55 | .014 | | | | | | | | | | | | |
| 3B54 | 394 | .31 | † | 222 | .55 | .002 | 142 | .86 | .006 | 100 | 1.24 | .012 | | | | | | | | | | | | |
| 5B64 | 480 | .24 | † | 257 | .40 | .002 | 156 | .60 | .04 | 102 | .81 | .008 | | | | | | | | | | | | |
| 5B44 | | | | 251 | .69 | .003 | 161 | 1.08 | .007 | 112 | 1.55 | .014 | 51 | 2.26 | .044 | 25 | 2.75 | .110 | | | | | | |
| 7454 | | | | 349 | .51 | .001 | 223 | .80 | .004 | 155 | 1.15 | .007 | 79 | 1.85 | .023 | 51 | 2.89 | .057 | | | | | | |
| 1D64 | | | | 380 | .49 | .001 | 222 | .69 | .003 | 154 | 1.00 | .006 | 78 | 1.61 | .021 | 50 | 2.51 | .050 | | | | | | |
| 3D44 | | | | 342 | .72 | .002 | 219 | 1.12 | .005 | 152 | 1.61 | .011 | 82 | 2.74 | .033 | 52 | 4.27 | .082 | | | | | | |
| 7454 | | | | 349 | .51 | .001 | 223 | .80 | .004 | 155 | 1.15 | .007 | 79 | 1.85 | .023 | 51 | 2.89 | .057 | | | | | | |
| 1D64 | | | | 380 | .49 | .001 | 222 | .69 | .003 | 154 | 1.00 | .006 | 78 | 1.61 | .021 | 50 | 2.51 | .050 | | | | | | |
| 5D44 | | | | 444 | .71 | .002 | 284 | 1.10 | .004 | 188 | 1.53 | .008 | 106 | 2.73 | .026 | 65 | 4.07 | .063 | | | | | | |
| 3D54 | | | | 525 | .55 | .001 | 336 | .86 | .003 | 233 | 1.24 | .005 | 119 | 2.01 | .017 | 76 | 3.14 | .041 | | | | | | |
| 7D64 | | | | | | | 404 | .76 | .002 | 281 | 1.09 | .004 | 158 | 1.94 | .012 | 101 | 3.02 | .030 | | | | | | |
| 3D44 | | | | | | | | | | 152 | 1.61 | .011 | 82 | 2.74 | .033 | 52 | 4.27 | .082 | | | | | | |
| 7454 | | | | | | | | | | 155 | 1.15 | .007 | 79 | 1.85 | .023 | 51 | 2.89 | .057 | | | | | | |
| 1D64 | | | | | | | | | | 154 | 1.00 | .006 | 78 | 1.61 | .021 | 50 | 2.51 | .050 | | | | | | |
| 3D54 | | | | | | | | | | 233 | 1.24 | .005 | 119 | 2.01 | .017 | 76 | 3.14 | .041 | | | | | | |
| 7D64 | | | | | | | | | | 281 | 1.09 | .004 | 158 | 1.94 | .012 | 101 | 3.02 | .030 | | | | | | |
| 7D44 | | | | | | | | | | 277 | 2.03 | .007 | 156 | 3.61 | .023 | 100 | 5.64 | .056 | | | | | | |
| 5D54 | | | | | | | | | | 290 | 1.35 | .005 | 156 | 2.30 | .015 | 100 | 3.59 | .036 | | | | | | |
| 7D64 | | | | | | | | | | 281 | 1.09 | .004 | 158 | 1.94 | .012 | 101 | 3.02 | .030 | | | | | | |
| EXTRA HEAVY DUTY - VERY LONG SPAN TRAYS - SOLID OR VENTILATED BOTTOMS | | | | | | | | | | | | | | | | | | | | | | | | |
| 9D64 | | | | | | | | | | 412 | 1.22 | .003 | 214 | 2.00 | .009 | 131 | 3.01 | .023 | 68 | 3.23 | .048 | | | |
| 7G64 | | | | | | | | | | 451 | 1.20 | .003 | 253 | 2.14 | .008 | 162 | 3.35 | .020 | 112 | 4.79 | .043 | 104 | 5.24 | .050 |

NOTE: To convert 1.5 safety factor to 2.0 multiply w, d, k by .75
 w = Pounds per linear foot
 Metric: for kg/m multiply w by 1.48
 d = Deflection (inches)
 k = Deflection (in.) for each pound of load
 † = Denotes k is less than .001 inch

TROF CABLE TRAY SYSTEM

STEEL TRAY

SELECTION CHART

NEMA CLASS, PHYSICAL AND STRUCTURAL PROPERTIES

| NEMA Standard VE-1 Load/Span Class | NEMA Load/Span | Mill Galv. System No. | HDGAF System No. | Type 304 SS System No. | Cope HDGAF Systems Certified by CSA | Nominal Load Depth | Side Rail Height | Flange Width (in.) | Section Modulus of 2 Rails Sx (in. ³) | Moment of Inertia for 2 Rails Ix (in. ⁴) | Minimum X-Sect. Area of 2 Rails per NEC 392.7 (in. ²) |
|---|-------------------------|--------------------------------|------------------------|---------------------------------|---|-----------------------|---------------------|--------------------------|---|---|---|
| 8A - 12A | 50 lb./ft. 12' span | 8232 | 6233 | 823U | - | 3" (76mm) | 3 1/2" (89mm) | 13/16" | 0.444 | 1.378 | .40 |
| | | 8242 | 6243 | 824U | 8242/3 | 4" (102mm) | 4 1/4" (108mm) | 13/16" | 0.592 | 1.258 | .40 |
| | | 8252 | 6253 | 825U | - | 5" (127mm) | 5 1/4" (133mm) | 13/16" | 0.816 | 2.142 | .40 |
| | | 8262 | 6263 | 826U | 8262/3 | 6" (152mm) | 6 1/4" (159mm) | 13/16" | 1.072 | 3.352 | .70 |
| 12B | 75 lb./ft. 12' span | 4232 | 4233 | 423U | - | 3" (76mm) | 3 1/2" (89mm) | 13/16" | 0.674 | 1.180 | .70 |
| | | 8B42 | 6B43 | 8B4U | - | 4" (102mm) | 4 1/4" (108mm) | 13/16" | 0.678 | 1.370 | .40 |
| | | 8252 | 6253 | 825U | - | 5" (127mm) | 5 1/4" (133mm) | 13/16" | 0.816 | 2.142 | .40 |
| | | 8262 | 6263 | 826U | 8262/3 | 6" (152mm) | 6 1/4" (159mm) | 13/16" | 1.072 | 3.352 | .70 |
| 12C | 100 lb./ft. 12' span | 6B42 | 6B43 | 6B4U | - | 4" (102mm) | 4 1/4" (108mm) | 13/16" | 0.834 | 1.690 | .70 |
| | | 6B52 | 6B53 | 6B5U | - | 5" (127mm) | 5 1/4" (133mm) | 13/16" | 1.140 | 2.872 | .70 |
| | | 6262 | 6263 | 626U | - | 6" (152mm) | 6 1/4" (159mm) | 13/16" | 1.330 | 4.158 | .70 |
| 16A | 50 lb./ft. 16' span | 8D42 | 6D43 | 8D4U | - | 4" (102mm) | 4 1/4" (108mm) | 1 1/4" | 0.852 | 1.736 | .40 |
| | | 6452 | 6453 | 645U | 6452/3 | 5" (127mm) | 5 1/4" (133mm) | 1 1/4" | 1.280 | 3.360 | .70 |
| | | 6462 | 6463 | 646U | 6462/3 | 6" (152mm) | 6 1/4" (159mm) | 1 1/4" | 1.652 | 5.160 | .70 |
| 16B | 75 lb./ft. 16' span | 6D42 | 6D43 | 6D4U | - | 4" (102mm) | 4 1/4" (108mm) | 1 1/4" | 1.056 | 2.152 | .70 |
| | | 6452 | 6453 | 645U | 6452/3 | 5" (127mm) | 5 1/4" (133mm) | 1 1/4" | 1.280 | 3.360 | .70 |
| | | 6462 | 6463 | 646U | 6462/3 | 6" (152mm) | 6 1/4" (159mm) | 1 1/4" | 1.652 | 5.160 | .70 |
| 16C | 100 lb./ft. 16' span | 4D42 | 4D43 | 4D4U | - | 4" (102mm) | 4 1/4" (108mm) | 1 1/4" | 1.298 | 2.652 | 1.00 |
| | | 6452 | 6453 | 645U | 6452/3 | 5" (127mm) | 5 1/4" (133mm) | 1 1/4" | 1.280 | 3.360 | .70 |
| | | 6462 | 6463 | 646U | 6462/3 | 6" (152mm) | 6 1/4" (159mm) | 1 1/4" | 1.652 | 5.160 | .70 |
| 20A | 50 lb./ft. 20' span | 6D42 | 6D43 | 6D4U | - | 4" (102mm) | 4 1/4" (108mm) | 1 1/4" | 1.056 | 2.152 | .70 |
| | | 6452 | 6453 | 645U | 6452/3 | 5" (127mm) | 5 1/4" (133mm) | 1 1/4" | 1.280 | 3.360 | .70 |
| | | 6462 | 6463 | 646U | 6462/3 | 6" (152mm) | 6 1/4" (159mm) | 1 1/4" | 1.652 | 5.160 | 1.00 |
| 20B | 75 lb./ft. 20' span | 2D42 | 2D43 | 2D4U | - | 4" (102mm) | 4 1/4" (108mm) | 1 1/4" | 1.758 | 3.604 | 1.00 |
| | | 4D52 | 4D53 | 4D5U | 4D52/3 | 5" (127mm) | 5 1/4" (133mm) | 1 1/4" | 1.744 | 4.418 | 1.00 |
| | | 6D62 | 6D63 | 6D6U | - | 6" (152mm) | 6 1/4" (159mm) | 1 1/4" | 1.814 | 5.486 | 1.00 |
| 20C | 100 lb./ft. 20' span | 2D52 | 2D53 | 2D5U | - | 5" (127mm) | 5 1/4" (133mm) | 1 1/4" | 2.370 | 6.026 | 1.50 |
| | | 4D62 | 4D63 | 4D6U | 4D62/3 | 6" (152mm) | 6 1/4" (159mm) | 1 1/4" | 2.240 | 6.778 | 1.00 |
| EXTRA HEAVY DUTY - VERY LONG SPAN TRAYS - SOLID OR VENTILATED BOTTOMS | | | | | | | | | | | |
| | | 2D62 | 2D63 | 2D6U | - | 6" (152mm) | 6 1/4" (159mm) | 1 1/4" | 3.056 | 9.270 | 1.50 |
| | | 11D62 | 11D63 | 11D6U | - | 6" (152mm) | 6 1/4" (159mm) | 1 1/4" | 3.536 | 10.630 | 1.50 |

**LOAD AND DEFLECTION DATA FOR STEEL TROF
WORKING (ALLOWABLE) LOAD CAPACITY, EVENLY DISTRIBUTED-TESTED PER NEMA STANDARD VE-1
SPAN (FT.) - SIMPLE BEAM - SAFETY FACTOR: 1.5**

| Cope Sys. No. | 6 Ft. Span | | | 8 Ft. Span | | | 10 Ft. Span | | | 12 Ft. Span | | | 16 Ft. Span | | | 20 Ft. Span | | | 24 Ft. Spa | | | 25 Ft. Span | | |
|---|------------|-----|------|------------|-----|------|-------------|-----|------|-------------|------|------|-------------|------|------|-------------|------|------|------------|------|------|-------------|------|------|
| | w | d | k | w | d | k | w | d | k | w | d | k | w | d | k | w | d | k | w | d | k | w | d | k |
| 8232/3/U | 230 | .30 | .001 | 126 | .52 | .004 | 79 | .79 | .010 | 53 | 1.11 | .021 | | | | | | | | | | | | |
| 8242/3/U | 292 | .23 | † | 164 | .42 | .003 | 103 | .63 | .006 | 69 | .89 | .013 | | | | | | | | | | | | |
| 8252/3/U | 383 | .18 | † | 210 | .31 | .001 | 127 | .46 | .004 | 83 | .62 | .007 | | | | | | | | | | | | |
| 8262/3/U | 357 | .11 | † | 194 | .18 | † | 119 | .28 | .002 | 79 | .38 | .005 | | | | | | | | | | | | |
| 4232/3/U | 358 | .30 | † | 197 | .53 | .003 | 124 | .81 | .007 | 83 | 1.13 | .014 | | | | | | | | | | | | |
| 8B42/3/U | 360 | .26 | † | 198 | .46 | .002 | 124 | .70 | .006 | 84 | .98 | .012 | | | | | | | | | | | | |
| 8252/3/U | 383 | .18 | † | 210 | .31 | .001 | 127 | .46 | .004 | 83 | .62 | .007 | | | | | | | | | | | | |
| 8262/3/U | 357 | .11 | † | 194 | .18 | † | 119 | .28 | .002 | 79 | .38 | .005 | | | | | | | | | | | | |
| 6B42/3/U | 453 | .27 | † | 249 | .47 | .002 | 156 | .71 | .005 | 106 | 1.00 | .009 | | | | | | | | | | | | |
| 6B52/3/U | 591 | .21 | † | 325 | .36 | .001 | 203 | .55 | .003 | 137 | .77 | .006 | | | | | | | | | | | | |
| 6262/3/U | 460 | .11 | † | 250 | .19 | † | 154 | .29 | .002 | 103 | .40 | .004 | | | | | | | | | | | | |
| 8D42/3/U | | | | 290 | .53 | .002 | 182 | .81 | .004 | 126 | 1.17 | .009 | 65 | 1.91 | .029 | | | | | | | | | |
| 6452/3/U | | | | 444 | .42 | † | 273 | .63 | .002 | 186 | .89 | .005 | 100 | 1.51 | .015 | | | | | | | | | |
| 6462/3/U | | | | 574 | .42 | † | 367 | .55 | .001 | 245 | .76 | .003 | 123 | 1.22 | .010 | | | | | | | | | |
| 6D42/3/U | | | | 381 | .56 | .001 | 244 | .88 | .004 | 169 | 1.27 | .008 | 88 | 2.08 | .024 | | | | | | | | | |
| 6452/3/U | | | | 444 | .42 | † | 273 | .63 | .002 | 186 | .89 | .005 | 100 | 1.51 | .015 | | | | | | | | | |
| 6462/3/U | | | | 574 | .42 | † | 367 | .55 | .001 | 245 | .76 | .003 | 123 | 1.22 | .010 | | | | | | | | | |
| 4D42/3/U | | | | 487 | .58 | .001 | 312 | .91 | .003 | 216 | 1.31 | .006 | 113 | 2.16 | .019 | | | | | | | | | |
| 6452/3/U | | | | 444 | .42 | † | 273 | .63 | .002 | 186 | .89 | .005 | 100 | 1.51 | .015 | | | | | | | | | |
| 6462/3/U | | | | 574 | .42 | † | 367 | .55 | .001 | 245 | .76 | .003 | 123 | 1.22 | .010 | | | | | | | | | |
| 6D42/3/U | | | | | | | | | | 169 | 1.27 | .008 | 88 | 2.08 | .024 | 52 | 2.98 | .057 | | | | | | |
| 6452/3/U | | | | | | | | | | 186 | .89 | .005 | 100 | 1.51 | .015 | 53 | 1.94 | .037 | | | | | | |
| 6462/3/U | | | | | | | | | | 245 | .76 | .003 | 123 | 1.22 | .010 | 66 | 1.59 | .024 | | | | | | |
| 2D42/3/U | | | | | | | | | | 304 | 1.36 | .004 | 159 | 2.24 | .014 | 94 | 3.23 | .034 | | | | | | |
| 4D52/3/U | | | | | | | | | | 280 | 1.02 | .004 | 145 | 1.67 | .012 | 85 | 2.40 | .028 | | | | | | |
| 6D62/3/U | | | | | | | | | | 269 | .80 | .003 | 139 | 1.28 | .009 | 81 | 1.82 | .022 | | | | | | |
| 2D52/3/U | | | | | | | | | | 395 | 1.05 | .003 | 206 | 1.74 | .008 | 121 | 2.50 | .021 | | | | | | |
| 4D62/3/U | | | | | | | | | | 296 | .79 | .003 | 152 | 1.28 | .008 | 105 | 1.91 | .018 | | | | | | |
| EXTRA HEAVY DUTY - VERY LONG SPAN TRAYS - SOLID OR VENTILATED BOTTOMS | | | | | | | | | | | | | | | | | | | | | | | | |
| 2D62/3/U | | | | | | | | | | 390 | .85 | .002 | 221 | 1.40 | .006 | 149 | 2.00 | .013 | 79 | 1.91 | .024 | 73 | 2.38 | .033 |
| 11D62/3/U | | | | | | | | | | 434 | .66 | † | 244 | 1.17 | .005 | 156 | 1.82 | .012 | 108 | 2.62 | .024 | 100 | 2.85 | .029 |

NOTE: To convert 1.5 safety factor to 2.0 multiply w, d, k by .75
w = Pounds per linear foot
Metric: for kg/m multiply by 1.48
d = Deflection (inches)
k = Deflection (in.) for each pound of load
† = Denotes k is less than .001 inch

Intro

LADDER

I-BEAM

HAT

TROF

CHANNEL

COPE-GLAS™

WIREBASKET

Reference

TROF CABLE TRAY SYSTEM

OVERVIEW

COPE TROF is a prefabricated metal structure consisting of ventilated or solid bottoms, welded to the side rails, and are manufactured and tested to NEMA Standard VE-1. Straight sections, fittings (elbows, tees, crosses, reducers, etc.) and a full line of matching and interfacing accessories are available. Corrugations give great lateral rigidity to the bottom transmitting the load to the side rails. Lateral (transverse) deflection is nearly eliminated compared to rung type trofs where the rails are not continuously braced by the bottom.

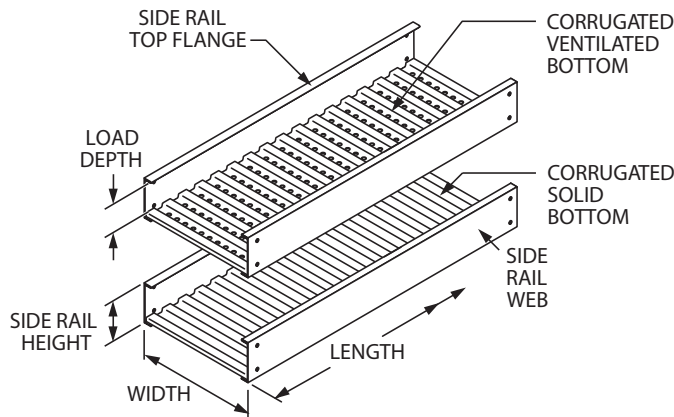

STRAIGHT SECTION

Cope Corrugated bottoms do NOT limit the tray load capacity. Corrugated bottoms have 1" wide ribs on 2" centers. Ventilation holes in the valleys of the corrugations are $\frac{1}{8}$ " diameter on one inch (1") centers. Free passage of air through the openings results in a 68% open area at the elevated cable support surface on top of ribs. Solid Trof have the same corrugations but have no holes.

NOTE: Where drain holes are required, one can be placed in the center of each valley, if specified.

COPE TROF WITH Three IMPORTANT INDUSTRY-LEADING FEATURES:

1. New Universal Curvilinear Splice Plate System

The splice plates for rigid connections have a slight curve so they can be used on straight sections or fittings. Tightening of the fastener pulls the plate flush with the side rail. The fasteners are snug and the joint is structurally and electrically superior. Even when hand-tightened, there is pressure on the fastener to hold it securely.

Note: Heavy Duty, Mid Span Splice Plates available upon request.

2. Zero Tangent Fittings

Tangent as referred to on cable tray fittings is the straight at the end of the curve to accommodate a flat splice plate. This wastes space in tightly packed areas, such as spreader rooms, where the heat of thousands of cables accumulate. Eliminating tangents allow more tray runs to distribute the heat. COPE ZERO TANGENT FITTINGS CAN SAVE UP TO 12" PER ROW OF TRAY.

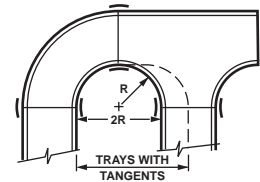

BONUS: Inspection for proper installation of splice plate is visual. If the plate is bowed away from the rail, nuts must be tightened.

3. The Exclusive Auto Arc-Welded Assembly System

Corrugated bottoms on straight sections are assembled to the side rails using an automatic, self indexing MIGarc-welding system fusing a $\frac{1}{2}$ " diameter zone. These welds are 700% larger and stronger than the common resistance (spot) weld in use today. Electrical properties of the assembly are unequalled; are well within the NEMA requirements due to the continuous electrical path. The mechanical strength of this welded assembly withstands the rigors of shipping, handling, installation and service. The size of the weld keeps the vertical axis of the side rail from sloping inward under load. The weld maintains the 90° angle between the side rail and bottom. This allows full use of the section properties. Spot welds do not permit this. Also, stresses on spot welds (barely $\frac{1}{8}$ " in diameter) are so severe that breakage often occurs during shipping and installation. Cope Trof fittings are also assembled by MIG-arc-welding.

USES OF COPE TROF

Generally, Cope Trof is optimum for ANY size cable. It offers continuous support with or without ventilation. The bottom design offers safety and security from unauthorized personnel. The vent holes may be bushed with a grommet for dropping out communication cables (Cat. DOG-2).

PART NUMBERING SYSTEM:

Please pay careful attention to the part numbering structure. Example: Catalog No. 1B44-06SL-12-V is a 4 inch load depth aluminum ladder with $\frac{13}{16}$ " flange, 6 inches wide, straight length 12 feet long, with ventilated bottom. Please make sure you use the system numbers from pages 136 through 139.

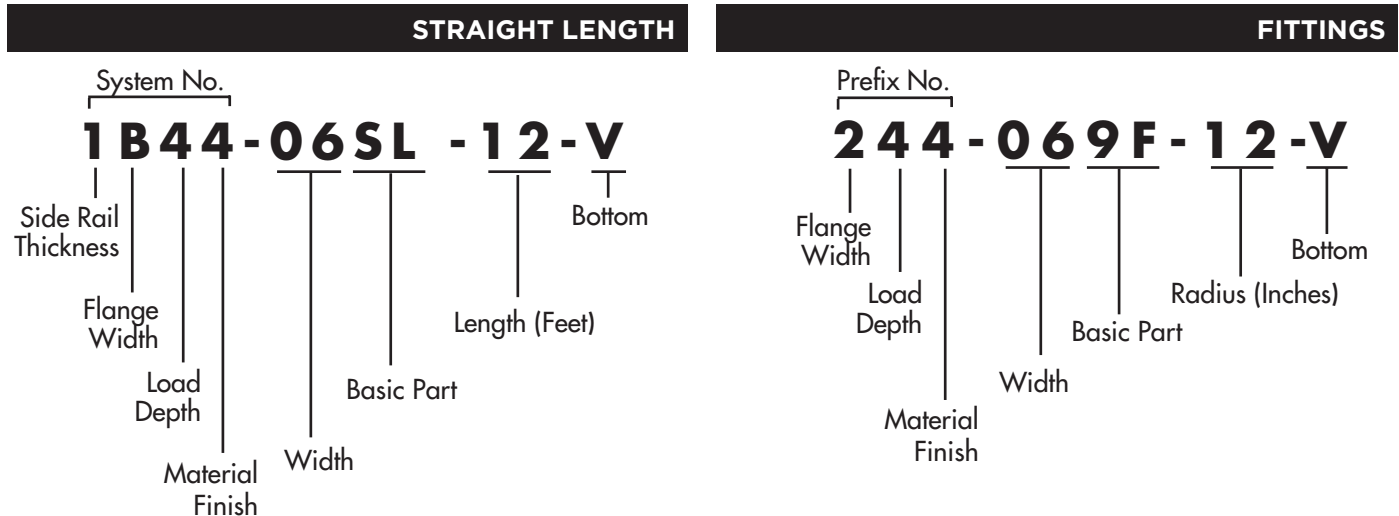

SYSTEM NUMBER (STRAIGHT SECTION ONLY)-

The first four digits make up the system number which identifies the structural, dimensional, and material characteristics of the straight length. It is made up of the side rail digits indicating the side rail thickness and flange width, the load depth (inside, in inches), and material finish (galvanized, aluminum or coated).

PREFIX NUMBER (FITTINGS ONLY) - Fittings are ordered using the 3-digit prefix number given in the charts on the fitting pages. Fittings do not have stiffened upper flanges.

WIDTH - Identifies the inside width of the tray in inches.

BASIC PART NUMBER - Identifies the straight length, fitting, or accessory.

SECONDARY DIMENSION NUMBER - Identifies the length of a straight section in feet, the radius of a fitting in inches, or the second width of a reducer in inches.

BOTTOM TYPE- Identifies the type bottom: V (Ventilated) or S (Solid). Example: 1B44-06SL-12-V is a 4" load depth aluminum Trof with a $\frac{13}{16}$ " flange, 6" wide, straight length 12' long with a ventilated bottom.

| Thickness Steel (Ga.) | Flange Width | Load Depth | Material Finish |
|-----------------------|------------------------------|------------|-----------------|
| 8 - 18 ga. | 2 - $\frac{13}{16}$ " (21mm) | 3" (76mm) | 2 - Mill-Galv. |
| 6 - 16 ga. | 4 - 1 $\frac{1}{4}$ " (32mm) | 4" (102mm) | 3 - HDGAF |
| 4 - 14 ga. | 5 - 1 $\frac{1}{2}$ " (38mm) | 5" (127mm) | 4 - Aluminum |
| 2 - 12 ga. | 7 - 2" (51mm) | 6" (152mm) | U - 304SS |
| 11 - 11 ga. | | | |
| Thickness Alum (in.) | | | |
| 1 - Thinner | B - $\frac{13}{16}$ " (21mm) | | |
| 3 - | D - 1 $\frac{1}{4}$ " (32mm) | | |
| 5 -** | E - 1 $\frac{1}{2}$ " (38mm) | | |
| 7 - | G - 2" (51mm) | | |
| 9 - Thicker | | | |

**Alum. extruded side rails are individually engineered to loads and spans.

Slotted Rungs or Solid Rungs available on all widths.

| Description | | | |
|----------------|--------------------------------|-----------------|-----------------|
| Width (in.) | Basic Part Number | Length | Bottom |
| 06=6" (152mm) | SL (Straight Len.) | - 12' (3.7m) | -V (ventilated) |
| 09=9" (229mm) | 9F (90° Horiz. El.) | - 24' (7.3m) | -S (solid) |
| 12=12" (305mm) | 6F (60° Horiz. El.) | - 10' (3m, CSA) | |
| 18=18" (457mm) | 4F (45° Horiz. El.) | - 20' (6m, CSA) | |
| 24=24" (610mm) | 3F (30° Horiz. El.) | | |
| 30=30" (762mm) | 90 (90° Out. Vert.El.) | | |
| 36=36" (914mm) | 60 (60° Out. Vert. El.) | | |
| | 40 (45° Out. Vert. El.) | | |
| | 30 (30° Out. Vert. El.) | | |
| | 9I (90° In. Vert. El.) | | Radius (in.) |
| | 6I (60° In. Vert. El.) | | 12=12" (305mm) |
| | 4I (45° In. Vert. El.) | | 24=24" (610mm) |
| | 3I (30° In. Vert. El.) | | 36=36" (914mm) |
| | FT (Horiz. Tee) | | |
| | FC (Horiz. Cross) | | |
| | VT (Vert. Tee) | | |
| | SR (Vert. Cable Support Elbow) | | |
| | ST (Straight Reducer) | | |
| | RH (Right Hand Reducer) | | |
| | LH (Left Hand Reducer) | | |
| | AF (Adjustable Elbow) | | |
| | RY & LY (45° "Y" Branch) | | |

TROF CABLE TRAY SYSTEM

CSA ORDERING INFORMATION

COPE CSA STANDARDS C22-2 CABLE TROF VENTILATED & SOLID BOTTOM TYPE

HOW TO ORDER:

Explanation of Cope's Canadian Standards cable tray catalog numbers is described below. Use the system numbers given in selection charts for straight sections, or the fitting prefix numbers given in fitting tables. Be sure to follow system number or the fitting prefix with the item "description" number.

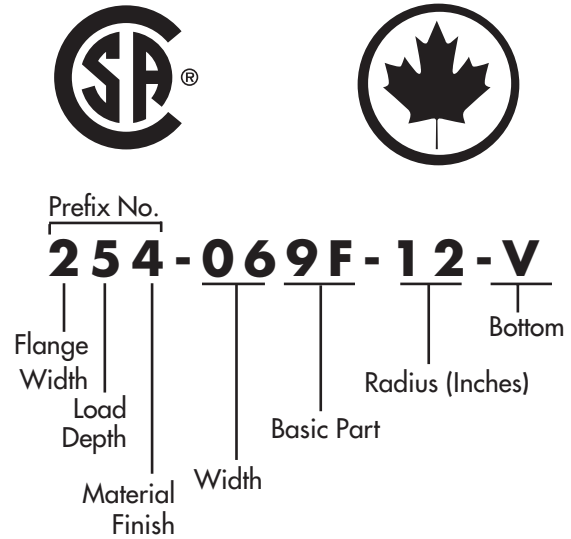
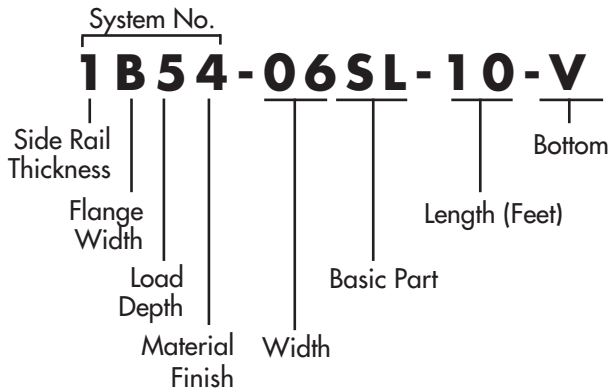

SYSTEM NUMBER (STRAIGHT SECTION ONLY) -

The first four digits make up the system number which identifies the structural, dimensional, and material characteristics of the straight length. It is made up of the side rail digits indicating the side rail thickness and flange width, the load depth (inside, in inches), and material finish (galvanized, aluminum or coated).

PREFIX NUMBER (FITTINGS ONLY) - Fittings are ordered using the 3-digit prefix number given in the charts on the fitting pages. Fittings do not have stiffened upper flanges.

WIDTH - Identifies the inside width of the tray (in inches).

BASIC PART NUMBER - Identifies the straight length, fitting, or accessory.

SECONDARY DIMENSION NUMBER - Identifies the length of a straight section (in feet), the radius of a fitting (in inches), or the second width of a reducer (in inches).

BOTTOM TYPE - Identifies the type bottom: V (Ventilated) or S (Solid)

CSA STRAIGHT LENGTH SYSTEM NUMBER

| Thickness Steel (Ga.) | Flange Width | Load Depth | Material Finish |
|------------------------|--|------------|---------------------------|
| 8 - 18 ga. | 2 - 1 ³ / ₁₆ " (21mm) | 4" (102mm) | 2 - Mill Galv |
| 6 - 16 ga. | 4 - 1 1/4" (32mm) | 5" (127mm) | 3 - HDGAF, CSA Class 1 |
| 4 - 14 ga. | | 6" (152mm) | 4 - Aluminum Plain Finish |
| Thickness Alum (in.)** | | | |
| 1 - thinner | *B - 1 ³ / ₁₆ " (21mm) | | |
| 3 - | *D - 1 1/4" (32mm) | | |
| 5 - ** | *E - 1 1/2" (38mm) | | |
| 7 - | | | |
| 9 - thicker | | | |

* Stiffened Upper Flange

**Alum. extruded side rails are individually engineered to loads and spans.

DESCRIPTION FITTINGS

| Width (in.) | Basic Part No. | Length | Bottom |
|----------------|--------------------------------|----------------|------------------|
| 06=6" (152mm) | SL (Straight Length) | 10-10' (3.05m) | -V (ventilated) |
| 09=9" (229mm) | 9F (90° Horiz. Elbow) | 20-20' (6.10m) | -S (solid) |
| 12=12" (305mm) | 6F (60° Horiz. Elbow) | | |
| 18=18" (457mm) | 4F (45° Horiz. Elbow) | | |
| 24=24" (610mm) | 3F (30° Horiz. Elbow) | | |
| 30=30" (762mm) | 90 (90° Out. Vert. Elbow) | | |
| 36=36" (914mm) | 60 (60° Out. Vert. Elbow) | | |
| | 40 (45° Out. Vert. Elbow) | | |
| | 30 (30° Out. Vert. Elbow) | | |
| | 9I (90° In. Vert. Elbow) | | |
| | 6I (60° In. Vert. Elbow) | | |
| | 4I (45° In. Vert. Elbow) | | |
| | 3I (30° In. Vert. Elbow) | | |
| | FT (Horiz. Tee) | | |
| | FC (Horiz. Cross) | | |
| | VT (Vert. Tee) | | |
| | SR (Vert. Cable Support Elbow) | | |
| | ST (Straight Reducer) | | |
| | RH (Right Hand Reducer) | | |
| | LH (Left Hand Reducer) | | |
| | AF (Adjustable Elbow) | | |
| | RY & LY (45° "Y" Branch) | | |
| | AF (Adjustable Elbow) | | |
| | RY & LY (45° "Y" Branch) | | |
| | | | Radius (in.) |
| | | | 12 = 12" (305mm) |
| | | | 24 = 24" (610mm) |
| | | | 36 = 36" (915mm) |

The list below gives the CSA certified items carrying the CSA label.



CERTIFIED COPE SYSTEMS THAT MEET PERFORMANCE CLASS CSA STD.C22.2

| CSA Class | Cope System | Load Depth | Side Rail | Flange Width | Max. Load Kg/m (lb/ft) | Maximum Support Span | Deflection at Max Support Span | Meets CSA Elec. Tests |
|--|-------------|---------------|----------------|----------------|------------------------|----------------------|--------------------------------|-----------------------|
| ALUMINUM TROF TRAY - Safety Factor: 1.5 | | | | | | | | |
| C | 1B44 | 4" (102mm) | 4 1/4" (108mm) | 1 3/16" (21mm) | 97 (65) | 3m | 25.1mm | Yes |
| 20A | 3D44 | 4" (102mm) | 4 1/4" (108mm) | 1 1/4" (32mm) | 74 (50) | 6m (1) | 108.5mm | Yes |
| 16C | 5D44 | 4" (102mm) | 4 1/4" (108mm) | 1 1/4" (32mm) | 149 (100) | 4.9m | 71.4mm | Yes |
| 20C | 5E44 | 4" (102mm) | 4 1/4" (108mm) | 1 1/2" (38mm) | 149 (100) | 6m (1) | 121.7mm | Yes |
| C | 1B54 | 5" (127mm) | 5 1/4" (133mm) | 1 3/16" (21mm) | 97 (65) | 3m | 22.1mm | Yes |
| 20A | 7454 | 5" (127mm) | 5 1/4" (133mm) | 1 1/4" (32mm) | 74 (50) | 6m (1) | 73.4mm | Yes |
| 20B | 3D54 | 5" (127mm) | 5 1/4" (133mm) | 1 1/4" (32mm) | 112 (75) | 6m (1) | 78.7mm | Yes |
| 20A | 1D64 | 6" (152mm) | 6 1/4" (159mm) | 1 1/4" (32mm) | 74 (50) | 6m (1) | 63.8mm | Yes |
| 20C | 7D64 | 6" (152mm) | 6 1/4" (159mm) | 1 1/4" (32mm) | 149 (100) | 6m (1) | 76.7mm | Yes |
| Mil Gal STEEL TROF TRAY Safety Factor: 1.5 | | | | | | | | |
| C | 8242 | 3 3/4" (95mm) | 4 1/4" (108mm) | 1 3/16" (21mm) | 97 (65) | 3m | 16.0mm | Yes |
| 20A | 6452 | 5" (127mm) | 5 1/4" (133mm) | 1 1/4" (32mm) | 74 (50) | 6m (1) | 49.3mm | Yes |
| 20B | 4D52 | 5" (127mm) | 5 1/4" (133mm) | 1 1/4" (32mm) | 112 (75) | 6m (1) | 61.0mm | Yes |
| 12B | 8262 | 6" (152mm) | 6 1/4" (159mm) | 1 3/16" (21mm) | 112 (75) | 3.7m | 9.7mm | Yes |
| 20A | 6462 | 6" (152mm) | 6 1/4" (159mm) | 1 1/4" (32mm) | 74 (50) | 6m (1) | 40.4mm | Yes |
| 20C | 4D62 | 6" (152mm) | 6 1/4" (159mm) | 1 1/4" (32mm) | 149 (100) | 6m | 48.5mm | Yes |
| HDGAF STEEL TROF TRAY Safety Factor: 1.5 | | | | | | | | |
| C | 8243 | 3 3/4" (95mm) | 4 1/4" (108mm) | 1 3/16" (21mm) | 97 (65) | 3m | 16.0mm | Yes |
| 20A | 6453 | 5" (127mm) | 5 1/4" (133mm) | 1 1/4" (32mm) | 74 (50) | 6m (1) | 49.3mm | Yes |
| 20B | 4D53 | 5" (127mm) | 5 1/4" (133mm) | 1 1/4" (32mm) | 112 (75) | 6m (1) | 61.0mm | Yes |
| 12B | 8263 | 6" (152mm) | 6 1/4" (159mm) | 1 3/16" (21mm) | 112 (75) | 3.7m | 9.7mm | Yes |
| 20A | 6463 | 6" (152mm) | 6 1/4" (159mm) | 1 1/4" (32mm) | 74 (50) | 6m (1) | 40.4mm | Yes |
| 20C | 4D63 | 6" (152mm) | 6 1/4" (159mm) | 1 1/4" (32mm) | 149 (100) | 6m | 48.5mm | Yes |

NOTES: (1) Also recommended for 3 meter support spans

NOTE: indicates most common systems. Consult factory for lead times on other systems.

CSA Loads

Identify the desired load designation needed for your project from the chart below. Both CSA Class and NEMA designations are listed by load capability and span. Then, select the CSA Certified Cope System from the table above. Where CSA C22.2 is not mandatory, you may want to consider one of the other Cope systems offered on the selection charts (page 142 thru 143).

HISTORICAL LOAD/SPAN CLASS DESIGNATION

| Load, kg/m (lb/ft) | Span, m (ft) | | | | |
|--------------------|--------------|----------|----------|----------|----------|
| | 2.4 (8) | 3.0 (10) | 3.7 (12) | 4.9 (16) | 6.0 (20) |
| 37 (25) | - | A | - | - | - |
| 67 (45) | - | - | - | - | D |
| 74 (50) | 8A | - | 12A | 16A | 20A |
| 97 (65) | - | C | - | - | - |
| 112 (75) | 8B | - | 12B | 16B | E or 20B |
| 149 (100) | 8C | - | 12C | 16C | 20C |
| 179 (120) | - | D | - | - | - |
| 299 (200) | - | E | - | - | - |

NOTE: 8A/B/C, 12A/B/C, 16A/B/C, and 20A/B/C have been NEMA designations. A, B, C, D and E have been CSA designations

Receiving, Installing, and Maintenance

The proper care and handling of cable Trofs by the receiver and installers is very important to insure a safe installation that will meet the intended service life. Cope has an installation guide available to assist the installers and those who will maintain the installed system.

Dimensions and Structural Properties: Cope CSA Systems

The performance of the Cope cable Trof systems certified by CSA is given above. Structural properties of straight sections, though not required to be listed, are given in the Cope NEMA selection charts, in English units. Dimensions of straight sections and certified fittings are furnished in English and metric units for use in layout and/or entry into computerized systems.

Note: For other CSA approved systems please contact the factory.

TROF CABLE TRAY SYSTEM

STRAIGHT LENGTH [SL]

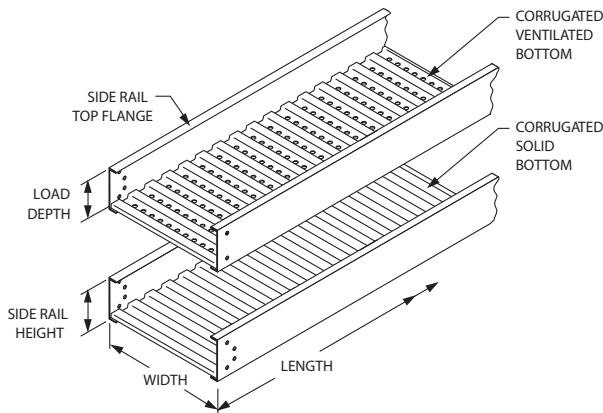

COPE TROF is manufactured in 10' (CSA), 12', 20' (CSA) and 24' lengths; 6", 9", 12", 18", 24", 30" and 36" widths; and, 3", 4", 5", and 6" nominal load depths. A complete line of fittings and accessories are available.

Corrugated bottoms have 1" wide ribs on 2" centers. Ventilation holes in the valleys of the corrugations are 1/8" diameter on one inch (1") centers. Free passage of air through the openings results in a 68% open area. Corrugations give great lateral rigidity to the bottom transmitting the load to the side rails.

Solid Trof have the same corrugations but have no holes. Materials: Aluminum, Hot Dip-Mill galvanized (pre-galvanized) to ASTM A-924, Hot Dip Galvanized after Fabrication (HDGAF) to ASTM A-123.

Sufficient connectors are supplied to assemble straight sections and fittings for each order. Connectors for field cuts to be ordered separately.

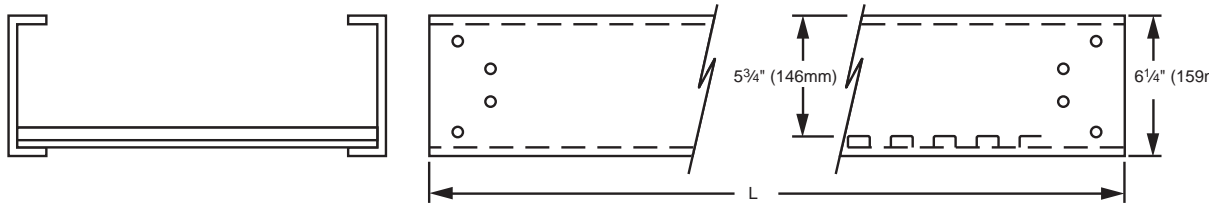

CATALOG NUMBER

| System | Width | Basic No. | Length | Bottom Type | |
|----------------------|-----------------|-----------|-------------|-----------------|--|
| See Pages 136 to 139 | -06=6" (152mm) | SL | NEMA | -S (solid) | |
| | -09=9" (229mm) | | | -V (ventilated) | |
| | -12=12" (305mm) | | 12' (3.7m)* | | |
| | -18=18" (457mm) | | 24' (7.3m)* | | |
| | -24=24" (610mm) | | 10' (3m)* | | |
| | -30=30" (762mm) | | 20' (6m)* | | |
| | -36=36" (914mm) | | CSA | -10' (3m) | |
| | | | | -20' (6m) | |

*10', 12' all NEMA Classes, 20', 24' NEMA Classes 16A, 16B, 16C, 20A, 20B, 20C.

Example: 1B44-06SL-12-V is a 4" load depth aluminum Trof with 1/8" flange, 6" wide, 12' long, with ventilated bottom.

CONVERSION TABLE

| English | 6" | 9" | 12" | 18" | 24" | 30" | 36" | 12'-0" | 24'-0" | 10'-0" | 20'-0" |
|-------------|-----|-----|-----|-----|-----|-----|-----|--------|--------|--------|--------|
| Metric (mm) | 152 | 229 | 305 | 457 | 610 | 762 | 914 | 3658 | 7316 | 3048 | 6096 |

MATERIAL & FINISH SPECIFICATIONS (COPE TROF)

| | Pre-Galvanized Steel | Hot-Dip Galvanized after Fabrication ASTM A-123 | Aluminum | Type 304 Stainless Steel |
|----------------------------|--|--|-------------------------|-------------------------------|
| Siderails | ASTM A-653-G90 CS (18 & 16 Gage) ASTM A-653-G90 CS (14 & 12 Gage) | ASTM A-1008 (18 & 16 Gage) ASTM A-1011 (14 & 12 Gage) | AA-6063-T6 Extruded | ASTM A-240; Type 304 |
| Bottom | ASTM A-653-G90 CS | ASTM A-1008 | AA-6063-H34 | ASTM A-269; Type 304 |
| Splice Plate Finish | ASTM A-1011 | ASTM A-1011 | AA-5052-H34 | ASTM A-240; Type 304 |
| | ASTM A-591 Class C | ASTM A-123 Grade 65 | 2B Finish (Typical) | |
| Connector | SAE J429 Grade 1 | SAE J429 Grade 1 | SAE J429 Grade 1 | |
| Bolts | (ASTM A-307 Grade A) | (ASTM A-307 Grade A) | (ASTM A-307 Grade A) | AISI Type 304 Stainless Steel |
| Bolt Plating | ASTM B-633.0002" Zinc | ASTM B-633.0002" Zinc | ASTM B-633.0002" Zinc | |
| Covers | ASTM A-653-G90 CQ | ASTM A-653-G90 CQ | AA-3003 H14 or 3150 H14 | ASTM A-240; Type 304 |

90° HORIZONTAL ELBOW [9F]

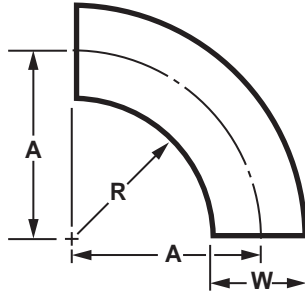
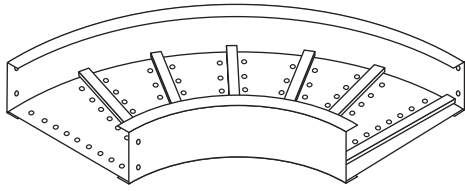

CSA CERTIFIED FOR CSA SYSTEMS

| Radius - R | Width - W | "A" Dimension | Part Number |
|----------------|-------------|------------------|---------------|
| 12" (305mm) | 6" (152mm) | 15" (381mm) | XXX-069F-12-X |
| | 9" (229mm) | 16 1/2" (419mm) | XXX-099F-12-X |
| | 12" (305mm) | 18" (457mm) | XXX-129F-12-X |
| | 18" (457mm) | 21" (533mm) | XXX-189F-12-X |
| | 24" (610mm) | 24" (610mm) | XXX-249F-12-X |
| | 30" (762mm) | 27" (686mm) | XXX-309F-12-X |
| | 36" (914mm) | 30" (762mm) | XXX-369F-12-X |
| 24" (610mm) | 6" (152mm) | 27" (686mm) | XXX-069F-24-X |
| | 9" (229mm) | 28 1/2" (724mm) | XXX-099F-24-X |
| | 12" (305mm) | 30" (762mm) | XXX-129F-24-X |
| | 18" (457mm) | 33" (838mm) | XXX-189F-24-X |
| | 24" (610mm) | 36" (914mm) | XXX-249F-24-X |
| | 30" (762mm) | 39" (991mm) | XXX-309F-24-X |
| | 36" (914mm) | 42" (1067mm) | XXX-369F-24-X |
| 36" (914mm) | 6" (152mm) | 39" (991mm) | XXX-069F-36-X |
| | 9" (229mm) | 40 1/2" (1029mm) | XXX-099F-36-X |
| | 12" (305mm) | 42" (1067mm) | XXX-129F-36-X |
| | 18" (457mm) | 45" (1143mm) | XXX-189F-36-X |
| | 24" (610mm) | 48" (1219mm) | XXX-249F-36-X |
| | 30" (762mm) | 51" (1295mm) | XXX-309F-36-X |
| | 36" (914mm) | 54" (1372mm) | XXX-369F-36-X |

*Add Suffix -V (vented) or -S (solid) to catalog number.

Example: 234-129F-12-V

NOTE: When small or in-between angles are needed, use Cope's Adjustable Connectors.

60° HORIZONTAL ELBOW [6F]

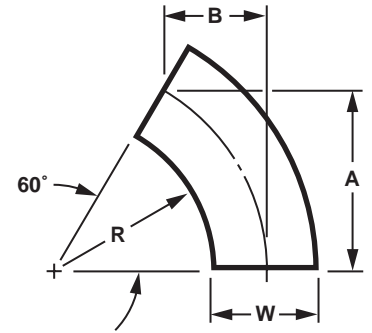
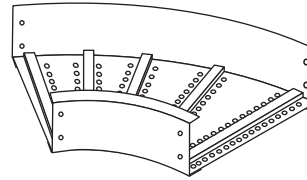

CSA CERTIFIED FOR CSA SYSTEMS

| Radius - R | Width - W | "A" Dimension | "B" Dimension | Part Number |
|----------------|-------------|------------------|-----------------|---------------|
| 12" (305mm) | 6" (152mm) | 13" (330mm) | 7 1/2" (191mm) | XXX-066F-12-X |
| | 9" (229mm) | 14 1/4" (362mm) | 8 1/4" (210mm) | XXX-096F-12-X |
| | 12" (305mm) | 15 5/8" (397mm) | 9" (229mm) | XXX-126F-12-X |
| | 18" (457mm) | 18 1/4" (464mm) | 10 1/2" (267mm) | XXX-186F-12-X |
| | 24" (610mm) | 20 3/4" (527mm) | 12" (305mm) | XXX-246F-12-X |
| | 30" (762mm) | 23 3/8" (594mm) | 13 1/2" (343mm) | XXX-306F-12-X |
| | 36" (914mm) | 26" (660mm) | 15" (381mm) | XXX-366F-12-X |
| 24" (610mm) | 6" (152mm) | 23 3/8" (594mm) | 13 1/2" (343mm) | XXX-066F-24-X |
| | 9" (229mm) | 24 3/4" (629mm) | 14 1/4" (362mm) | XXX-096F-24-X |
| | 12" (305mm) | 26" (660mm) | 15" (381mm) | XXX-126F-24-X |
| | 18" (457mm) | 28 5/8" (727mm) | 16 1/2" (416mm) | XXX-186F-24-X |
| | 24" (610mm) | 31 1/4" (794mm) | 18" (457mm) | XXX-246F-24-X |
| | 30" (762mm) | 33 3/4" (857mm) | 19 1/2" (495mm) | XXX-306F-24-X |
| | 36" (914mm) | 36 3/8" (924mm) | 21" (533mm) | XXX-366F-24-X |
| 36" (914mm) | 6" (152mm) | 33 3/4" (857mm) | 19 1/2" (495mm) | XXX-066F-36-X |
| | 9" (229mm) | 35 1/8" (892mm) | 20 1/4" (514mm) | XXX-096F-36-X |
| | 12" (305mm) | 36 3/8" (924mm) | 21" (533mm) | XXX-126F-36-X |
| | 18" (457mm) | 39" (991mm) | 22 1/2" (572mm) | XXX-186F-36-X |
| | 24" (610mm) | 41 5/8" (1057mm) | 24" (610mm) | XXX-246F-36-X |
| | 30" (762mm) | 44 1/8" (1121mm) | 25 1/2" (648mm) | XXX-306F-36-X |
| | 36" (914mm) | 46 3/4" (1187mm) | 27" (686mm) | XXX-366F-36-X |

*Add suffix -V (vented) or -S (solid) to catalog number .

Example: 234-126F-12-V

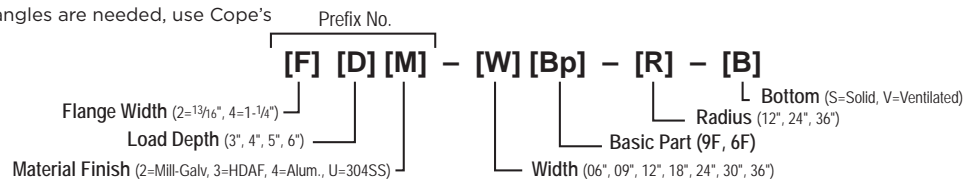

TROF CABLE TRAY SYSTEM

45° HORIZONTAL ELBOW [4F]

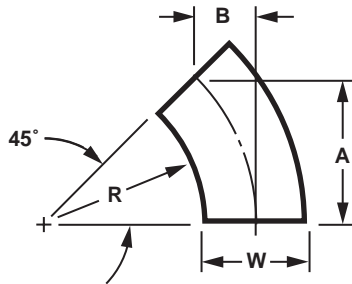
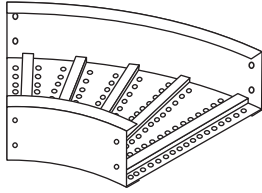

CSA CERTIFIED FOR CSA SYSTEMS

| Radius - R | Width - W | "A" Dimension | "B" Dimension | Part Number |
|----------------|-------------|-----------------|-----------------|---------------|
| 12" (305mm) | 6" (152mm) | 10 5/8" (270mm) | 4 3/8" (111mm) | XXX-064F-12-X |
| | 9" (229mm) | 11 5/8" (295mm) | 4 7/8" (124mm) | XXX-094F-12-X |
| | 12" (305mm) | 12 3/4" (324mm) | 5 1/4" (133mm) | XXX-124F-12-X |
| | 18" (457mm) | 14 7/8" (378mm) | 6 1/8" (156mm) | XXX-184F-12-X |
| | 24" (610mm) | 17" (432mm) | 7" (178mm) | XXX-244F-12-X |
| | 30" (762mm) | 19 1/8" (486mm) | 7 7/8" (200mm) | XXX-304F-12-X |
| | 36" (914mm) | 21 1/4" (540mm) | 8 3/4" (222mm) | XXX-364F-12-X |
| 24" (610mm) | 6" (152mm) | 19 1/8" (486mm) | 7 7/8" (200mm) | XXX-064F-24-X |
| | 9" (229mm) | 20 1/8" (511mm) | 8 3/8" (213mm) | XXX-094F-24-X |
| | 12" (305mm) | 21 1/4" (540mm) | 8 3/4" (222mm) | XXX-124F-24-X |
| | 18" (457mm) | 23 3/8" (594mm) | 9 5/8" (244mm) | XXX-184F-24-X |
| | 24" (610mm) | 25 1/2" (702mm) | 10 1/2" (267mm) | XXX-244F-24-X |
| | 30" (762mm) | 27 5/8" (702mm) | 11 1/2" (292mm) | XXX-304F-24-X |
| | 36" (914mm) | 29 3/4" (756mm) | 12 3/8" (314mm) | XXX-364F-24-X |
| 36" (914mm) | 6" (152mm) | 27 5/8" (702mm) | 11 1/2" (292mm) | XXX-064F-36-X |
| | 9" (229mm) | 28 5/8" (727mm) | 11 7/8" (302mm) | XXX-094F-36-X |
| | 12" (305mm) | 29 3/4" (756mm) | 12 3/8" (314mm) | XXX-124F-36-X |
| | 18" (457mm) | 31 7/8" (810mm) | 13 1/4" (337mm) | XXX-184F-36-X |
| | 24" (610mm) | 34" (864mm) | 14 1/8" (359mm) | XXX-244F-36-X |
| | 30" (762mm) | 36 1/8" (918mm) | 15" (381mm) | XXX-304F-36-X |
| | 36" (914mm) | 38 1/4" (972mm) | 15 7/8" (403mm) | XXX-364F-36-X |

*Add suffix -V (vented) or -S (solid) to catalog number.
Example: 234-124F-12-V
NOTE: When small or in-between angles are needed, use Cope's Adjustable Connectors.

30° HORIZONTAL ELBOW [3F]

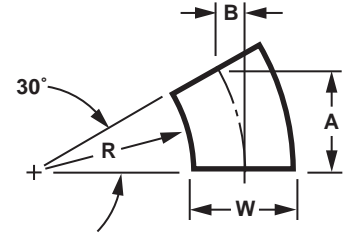
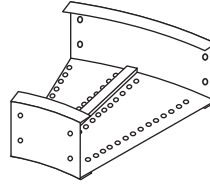

CSA CERTIFIED FOR CSA SYSTEMS

| Radius - R | Width - W | "A" Dimension | "B" Dimension | Part Number |
|----------------|-------------|-----------------|----------------|---------------|
| 12" (305mm) | 6" (152mm) | 7 1/2" (191mm) | 2" (51mm) | XXX-063F-12-X |
| | 9" (229mm) | 8 1/4" (210mm) | 2 1/4" (57mm) | XXX-093F-12-X |
| | 12" (305mm) | 9" (229mm) | 2 5/8" (60mm) | XXX-123F-12-X |
| | 18" (457mm) | 10 1/2" (267mm) | 2 7/8" (73mm) | XXX-183F-12-X |
| | 24" (610mm) | 12" (305mm) | 3 1/4" (83mm) | XXX-243F-12-X |
| | 30" (762mm) | 13 1/2" (343mm) | 3 5/8" (92mm) | XXX-303F-12-X |
| | 36" (914mm) | 15" (381mm) | 4" (102mm) | XXX-363F-12-X |
| 24" (610mm) | 6" (152mm) | 13 1/2" (343mm) | 3 5/8" (92mm) | XXX-063F-24-X |
| | 9" (229mm) | 14 1/4" (362mm) | 3 7/8" (98mm) | XXX-093F-24-X |
| | 12" (305mm) | 15" (381mm) | 4" (102mm) | XXX-123F-24-X |
| | 18" (457mm) | 16 1/2" (419mm) | 4 3/8" (111mm) | XXX-183F-24-X |
| | 24" (610mm) | 18" (457mm) | 4 7/8" (124mm) | XXX-243F-24-X |
| | 30" (762mm) | 19 1/2" (495mm) | 5 1/4" (133mm) | XXX-303F-24-X |
| | 36" (914mm) | 21" (533mm) | 5 5/8" (143mm) | XXX-363F-24-X |
| 36" (914mm) | 6" (152mm) | 19 1/2" (495mm) | 5 1/4" (133mm) | XXX-063F-36-X |
| | 9" (229mm) | 20 1/4" (514mm) | 5 1/2" (140mm) | XXX-093F-36-X |
| | 12" (305mm) | 21" (533mm) | 5 5/8" (143mm) | XXX-123F-36-X |
| | 18" (457mm) | 22 1/2" (572mm) | 6" (152mm) | XXX-183F-36-X |
| | 24" (610mm) | 24" (610mm) | 6 1/2" (165mm) | XXX-243F-36-X |
| | 30" (762mm) | 25 1/2" (648mm) | 6 7/8" (175mm) | XXX-303F-36-X |
| | 36" (914mm) | 27" (686mm) | 7 1/4" (184mm) | XXX-363F-36-X |

*Add suffix -V (vented) or -S (solid) to catalog number.
Example: 234-123F-12-V

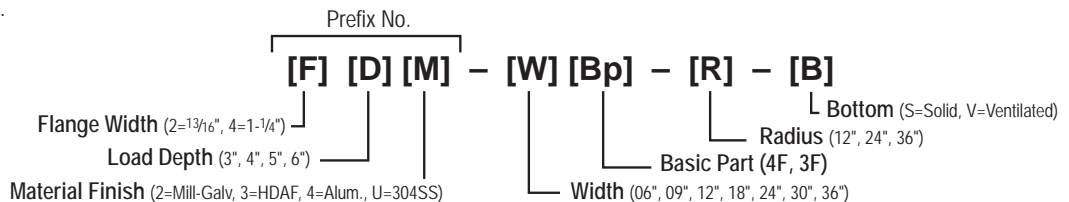

HORIZONTAL TEE [FT]

CSA CERTIFIED FOR CSA SYSTEMS

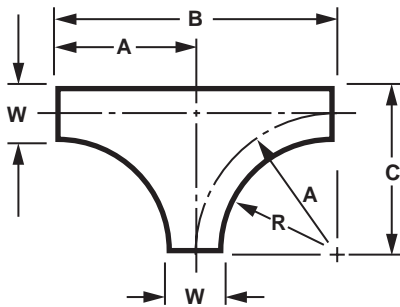
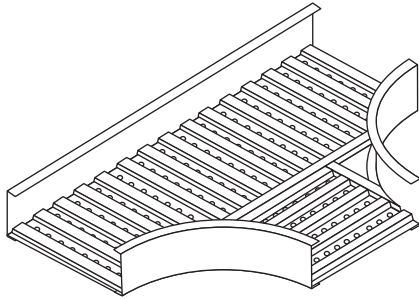

| Radius - R | Width - W | "A" Dimension | "B" Dimension | "C" Dimension | Part Number |
|----------------|--------------|------------------|---------------|---------------|---------------|
| 12" (305mm) | 6" (152mm) | 15" (381mm) | 30" (762mm) | 18" (457mm) | XXX-06FT-12-X |
| | 9" (229mm) | 16 1/2" (419mm) | 33" (838mm) | 21" (533mm) | XXX-09FT-12-X |
| | 12" (305mm) | 18" (457mm) | 36" (914mm) | 24" (610mm) | XXX-12FT-12-X |
| | 18" (457mm) | 21" (533mm) | 42" (1067mm) | 30" (762mm) | XXX-18FT-12-X |
| | 24" (610mm) | 24" (610mm) | 48" (1219mm) | 36" (914mm) | XXX-24FT-12-X |
| | 30" (762mm) | 27" (686mm) | 54" (1372mm) | 42" (1067mm) | XXX-30FT-12-X |
| 24" (610mm) | 6" (152mm) | 27" (686mm) | 54" (1372mm) | 30" (762mm) | XXX-06FT-24-X |
| | 9" (229mm) | 28 1/2" (724mm) | 57" (1448mm) | 33" (838mm) | XXX-09FT-24-X |
| | 12" (305mm) | 30" (762mm) | 60" (1524mm) | 36" (914mm) | XXX-12FT-24-X |
| | 18" (457mm) | 33" (838mm) | 66" (1676mm) | 42" (1067mm) | XXX-18FT-24-X |
| | 24" (610mm) | 36" (914mm) | 72" (1829mm) | 48" (1219mm) | XXX-24FT-24-X |
| | 30" (762mm) | 39" (991mm) | 78" (1981mm) | 54" (1372mm) | XXX-30FT-24-X |
| 36" (914mm) | 6" (152mm) | 42" (1067mm) | 84" (2134mm) | 60" (1524mm) | XXX-06FT-36-X |
| | 9" (229mm) | 40 1/2" (1029mm) | 81" (2057mm) | 45" (1143mm) | XXX-09FT-36-X |
| | 12" (305mm) | 42" (1067mm) | 84" (2134mm) | 48" (1219mm) | XXX-12FT-36-X |
| | 18" (457mm) | 45" (1143mm) | 90" (2286mm) | 54" (1372mm) | XXX-18FT-36-X |
| | 24" (610mm) | 48" (1219mm) | 96" (2438mm) | 60" (1524mm) | XXX-24FT-36-X |
| | 30" (762mm) | 51" (1295mm) | 102" (2591mm) | 66" (1676mm) | XXX-30FT-36-X |
| 36" (914mm) | 54" (1372mm) | 108" (2743mm) | 72" (1829mm) | XXX-36FT-36-X | |

* Add suffix -V (vented) or -S (solid) to catalog number. - Example: 234-12FT-12-V

HORIZONTAL CROSS [FC]

CSA CERTIFIED FOR CSA SYSTEMS

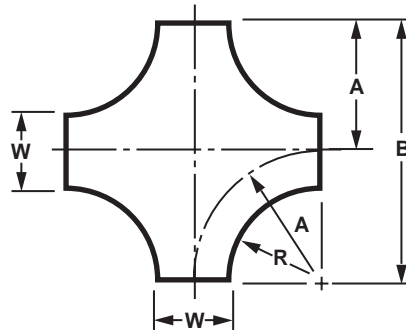
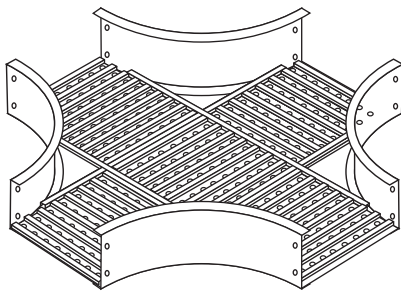

| Radius - R | Width - W | "A" Dimension | "B" Dimension | Part Number |
|----------------|--------------|------------------|---------------|---------------|
| 12" (305mm) | 6" (152mm) | 15" (381mm) | 30" (762mm) | XXX-06FC-12-X |
| | 9" (229mm) | 16 1/2" (419mm) | 33" (838mm) | XXX-09FC-12-X |
| | 12" (305mm) | 18" (457mm) | 36" (914mm) | XXX-12FC-12-X |
| | 18" (457mm) | 21" (533mm) | 42" (1067mm) | XXX-18FC-12-X |
| | 24" (610mm) | 24" (610mm) | 48" (1219mm) | XXX-24FC-12-X |
| | 30" (762mm) | 27" (686mm) | 54" (1372mm) | XXX-30FC-12-X |
| 24" (610mm) | 6" (152mm) | 27" (686mm) | 54" (1372mm) | XXX-06FC-24-X |
| | 9" (229mm) | 28 1/2" (724mm) | 57" (1448mm) | XXX-09FC-24-X |
| | 12" (305mm) | 30" (762mm) | 60" (1524mm) | XXX-12FC-24-X |
| | 18" (457mm) | 33" (838mm) | 66" (1676mm) | XXX-18FC-24-X |
| | 24" (610mm) | 36" (914mm) | 72" (1829mm) | XXX-24FC-24-X |
| | 30" (762mm) | 39" (991mm) | 78" (1981mm) | XXX-30FC-24-X |
| 36" (914mm) | 6" (152mm) | 42" (1067mm) | 84" (2134mm) | XXX-06FC-36-X |
| | 9" (229mm) | 40 1/2" (1029mm) | 81" (2057mm) | XXX-09FC-36-X |
| | 12" (305mm) | 42" (1067mm) | 84" (2134mm) | XXX-12FC-36-X |
| | 18" (457mm) | 45" (1143mm) | 90" (2286mm) | XXX-18FC-36-X |
| | 24" (610mm) | 48" (1219mm) | 96" (2438mm) | XXX-24FC-36-X |
| | 30" (762mm) | 51" (1295mm) | 102" (2591mm) | XXX-30FC-36-X |
| 36" (914mm) | 54" (1372mm) | 108" (2743mm) | XXX-36FC-36-X | |

*Add suffix -V (vented) or -S (solid) to catalog number.

Example: 234-12FC-12-V

NOTE: Nominal 9" rung spacing maintained through centerline of all fittings.

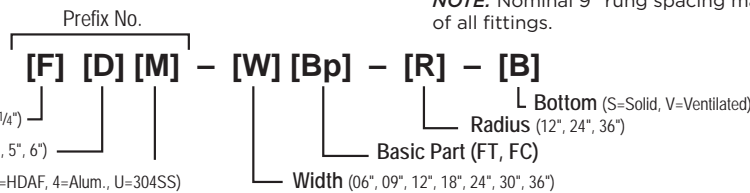

TROF CABLE TRAY SYSTEM

HORIZONTAL TAPPED TEE [TT]

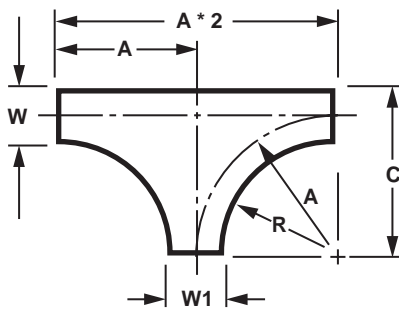
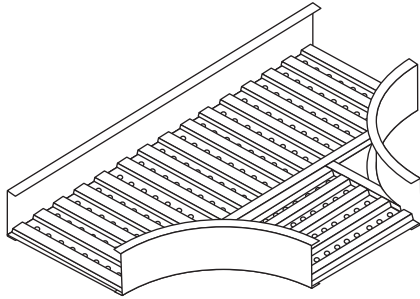

CSA CERTIFIED FOR CSA SYSTEMS

| R Radius | W Width | W1 Width | "A" Dimension | "C" Dimension | Part Number | | | |
|----------------|-----------------|----------------|-----------------|------------------|------------------|----------------|----------------|------------------|
| 12" (305mm) | 36" (914mm) | 30" (762mm) | 27" (686mm) | 48" (1219mm) | XXX-36TT-30-12-X | | | |
| | | 24" (610mm) | 24" (610mm) | | XXX-36TT-24-12-X | | | |
| | | 18" (457mm) | 21" (533mm) | | XXX-36TT-18-12-X | | | |
| | | 12" (305mm) | 18" (457mm) | | XXX-36TT-12-12-X | | | |
| | | 9" (229mm) | 16 1/2" (419mm) | | XXX-36TT-09-12-X | | | |
| | | 6" (152mm) | 15" (381mm) | | XXX-36TT-06-12-X | | | |
| 12" (305mm) | 30" (762mm) | 24" (610mm) | 24" (610mm) | 42" (1067mm) | XXX-30TT-24-12-X | | | |
| | | 18" (457mm) | 21" (533mm) | | XXX-30TT-18-12-X | | | |
| | | 12" (305mm) | 18" (457mm) | | XXX-30TT-12-12-X | | | |
| | | 9" (229mm) | 16 1/2" (419mm) | | XXX-30TT-09-12-X | | | |
| | | 6" (152mm) | 15" (381mm) | | XXX-30TT-06-12-X | | | |
| | | 12" (305mm) | 24" (610mm) | | 18" (457mm) | 21" (533mm) | 36" (914mm) | XXX-24TT-18-12-X |
| 12" (305mm) | 18" (457mm) | | | XXX-24TT-12-12-X | | | | |
| 9" (229mm) | 16 1/2" (419mm) | | | XXX-24TT-09-12-X | | | | |
| 6" (152mm) | 15" (381mm) | | | XXX-24TT-06-12-X | | | | |
| 12" (305mm) | 18" (457mm) | | | 12" (305mm) | 18" (457mm) | 30" (762mm) | | XXX-18TT-12-12-X |
| | | | | 9" (229mm) | 16 1/2" (419mm) | | | XXX-18TT-09-12-X |
| | | 6" (152mm) | 15" (381mm) | XXX-18TT-06-12-X | | | | |
| 12" (305mm) | 12" (305mm) | 9" (229mm) | 16 1/2" (419mm) | 24" (610mm) | XXX-12TT-09-12-X | | | |
| | | 6" (152mm) | 15" (381mm) | | XXX-12TT-06-12-X | | | |
| 12" (305mm) | 9" (229mm) | 6" (152mm) | 15" (381mm) | 21" (533mm) | XXX-09TT-06-12-X | | | |

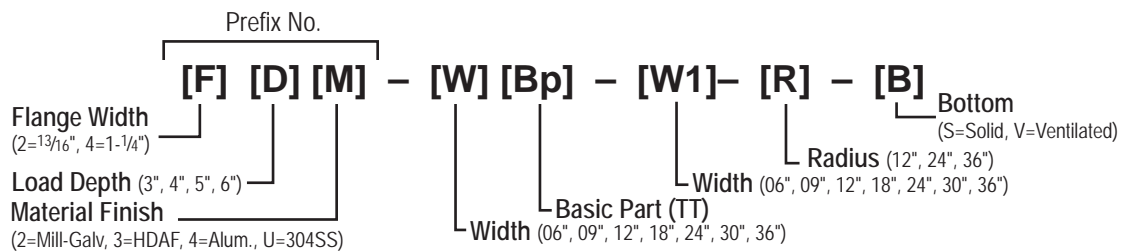

HORIZONTAL TAPPED TEE [TT] (CONT.)

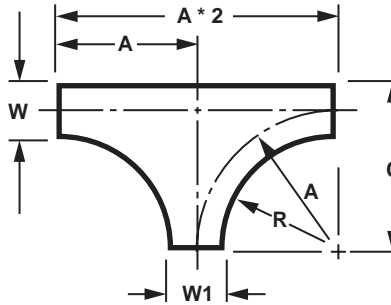

CSA CERTIFIED FOR CSA SYSTEMS

| R Radius | W Width | W1 Width | "A" Dimension | "C" Dimension | Part Number | | |
|----------------|----------------|----------------|-----------------|------------------|------------------|-----------------|------------------|
| 24" (610mm) | 36" (914mm) | 30" (762mm) | 39" (991mm) | 60" (1524mm) | XXX-36TT-30-24-X | | |
| | | 24" (610mm) | 36" (914mm) | | XXX-36TT-24-24-X | | |
| | | 18" (457mm) | 33" (838mm) | | XXX-36TT-18-24-X | | |
| | | 12" (305mm) | 30" (762mm) | | XXX-36TT-12-24-X | | |
| | | 9" (229mm) | 28 1/2" (724mm) | | XXX-36TT-09-24-X | | |
| | | 6" (152mm) | 27" (686mm) | | XXX-36TT-06-24-X | | |
| | 30" (762mm) | 24" (610mm) | 36" (914mm) | 54" (1372mm) | XXX-30TT-24-24-X | | |
| | | 18" (457mm) | 33" (838mm) | | XXX-30TT-18-24-X | | |
| | | 12" (305mm) | 30" (762mm) | | XXX-30TT-12-24-X | | |
| | | 9" (229mm) | 28 1/2" (724mm) | | XXX-30TT-09-24-X | | |
| | | 6" (152mm) | 27" (686mm) | | XXX-30TT-06-24-X | | |
| | | 24" (610mm) | 18" (457mm) | | 33" (838mm) | 48" (1219mm) | XXX-24TT-18-24-X |
| | 12" (305mm) | | 30" (762mm) | XXX-24TT-12-24-X | | | |
| | 9" (229mm) | | 28 1/2" (724mm) | XXX-24TT-09-24-X | | | |
| | 6" (152mm) | | 27" (686mm) | XXX-24TT-06-24-X | | | |
| | 18" (457mm) | | 12" (305mm) | 30" (762mm) | 42" (1067mm) | | XXX-18TT-12-24-X |
| | | | 9" (229mm) | 28 1/2" (724mm) | | | XXX-18TT-09-24-X |
| | | 6" (152mm) | 27" (686mm) | XXX-18TT-06-24-X | | | |
| | 12" (305mm) | 9" (229mm) | 28 1/2" (724mm) | 36" (914mm) | XXX-12TT-09-24-X | | |
| | | 6" (152mm) | 27" (686mm) | | XXX-12TT-06-24-X | | |
| | 9" (229mm) | 6" (152mm) | 27" (686mm) | 33" (838mm) | XXX-09TT-06-24-X | | |

CSA CERTIFIED FOR CSA SYSTEMS

| R Radius | W Width | W1 Width | "A" Dimension | "C" Dimension | Part Number | | |
|----------------|----------------|----------------|------------------|------------------|------------------|-----------------|------------------|
| 36" (914mm) | 36" (914mm) | 30" (762mm) | 51" (1295mm) | 72" (1829mm) | XXX-36TT-30-36-X | | |
| | | 24" (610mm) | 48" (1219mm) | | XXX-36TT-24-36-X | | |
| | | 18" (457mm) | 45" (1143mm) | | XXX-36TT-18-36-X | | |
| | | 12" (305mm) | 42" (1067mm) | | XXX-36TT-12-36-X | | |
| | | 9" (229mm) | 40 1/2" (1029mm) | | XXX-36TT-09-36-X | | |
| | | 6" (152mm) | 39" (991mm) | | XXX-36TT-06-36-X | | |
| | 30" (762mm) | 24" (610mm) | 48" (1219mm) | 66" (1676mm) | XXX-30TT-24-36-X | | |
| | | 18" (457mm) | 45" (1143mm) | | XXX-30TT-18-36-X | | |
| | | 12" (305mm) | 42" (1067mm) | | XXX-30TT-12-36-X | | |
| | | 9" (229mm) | 40 1/2" (1029mm) | | XXX-30TT-09-36-X | | |
| | | 6" (152mm) | 39" (991mm) | | XXX-30TT-06-36-X | | |
| | | 24" (610mm) | 18" (457mm) | | 45" (1143mm) | 60" (1524mm) | XXX-24TT-18-36-X |
| | 12" (305mm) | | 42" (1067mm) | XXX-24TT-12-36-X | | | |
| | 9" (229mm) | | 40 1/2" (1029mm) | XXX-24TT-09-36-X | | | |
| | 6" (152mm) | | 39" (991mm) | XXX-24TT-06-36-X | | | |
| | 18" (457mm) | | 12" (305mm) | 42" (1067mm) | 54" (1372mm) | | XXX-18TT-12-36-X |
| | | | 9" (229mm) | 40 1/2" (1029mm) | | | XXX-18TT-09-36-X |
| | | 6" (152mm) | 39" (991mm) | XXX-18TT-06-36-X | | | |
| | 12" (305mm) | 9" (229mm) | 40 1/2" (1029mm) | 48" (1219mm) | XXX-12TT-09-36-X | | |
| | | 6" (152mm) | 39" (991mm) | | XXX-12TT-06-36-X | | |
| | 9" (229mm) | 6" (152mm) | 39" (991mm) | 45" (1143mm) | XXX-09TT-06-36-X | | |

Note: Nominal 9" rung spacing maintained through centerline of all fittings.

TROF CABLE TRAY SYSTEM

HORIZONTAL TAPPED CROSS [TC]

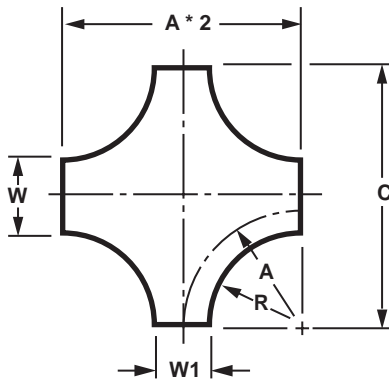
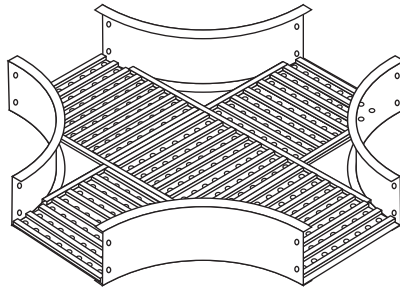

CSA CERTIFIED FOR CSA SYSTEMS

| R Radius | W Width | W1 Width | "A" Dimension | "C" Dimension | Part Number |
|----------------|----------------|-----------------|------------------|------------------|------------------|
| 12" (305mm) | 36" (914mm) | 30" (762mm) | 27" (686mm) | 60" (1524mm) | XXX-36TC-30-12-X |
| | | 24" (610mm) | 24" (610mm) | | XXX-36TC-24-12-X |
| | | 18" (457mm) | 21" (533mm) | | XXX-36TC-18-12-X |
| | | 12" (305mm) | 18" (457mm) | | XXX-36TC-12-12-X |
| | | 9" (229mm) | 16 1/2" (419mm) | | XXX-36TC-09-12-X |
| | | 6" (152mm) | 15" (381mm) | | XXX-36TC-06-12-X |
| | 30" (762mm) | 24" (610mm) | 24" (610mm) | 54" (1372mm) | XXX-30TC-24-12-X |
| | | 18" (457mm) | 21" (533mm) | | XXX-30TC-18-12-X |
| | | 12" (305mm) | 18" (457mm) | | XXX-30TC-12-12-X |
| | | 9" (229mm) | 16 1/2" (419mm) | | XXX-30TC-09-12-X |
| | 24" (610mm) | 18" (457mm) | 21" (533mm) | 48" (1219mm) | XXX-24TC-18-12-X |
| | | 12" (305mm) | 18" (457mm) | | XXX-24TC-12-12-X |
| 9" (229mm) | | 16 1/2" (419mm) | XXX-24TC-09-12-X | | |
| 6" (152mm) | | 15" (381mm) | XXX-24TC-06-12-X | | |
| 18" (457mm) | 12" (305mm) | 18" (457mm) | 42" (1067mm) | XXX-18TC-12-12-X | |
| | 9" (229mm) | 16 1/2" (419mm) | | XXX-18TC-09-12-X | |
| | 6" (152mm) | 15" (381mm) | | XXX-18TC-06-12-X | |
| 12" (305mm) | 9" (229mm) | 16 1/2" (419mm) | 36" (914mm) | XXX-12TC-09-12-X | |
| | 6" (152mm) | 15" (381mm) | | XXX-12TC-06-12-X | |
| 9" (229mm) | 6" (152mm) | 15" (381mm) | 33" (838mm) | XXX-09TC-06-12-X | |

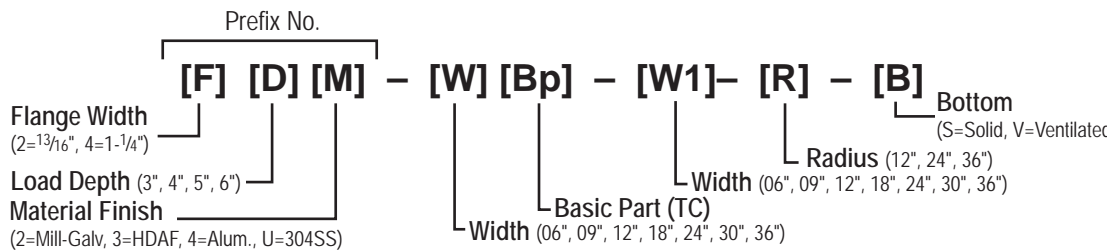

HORIZONTAL TAPPED CROSS [TC] (CONT.)

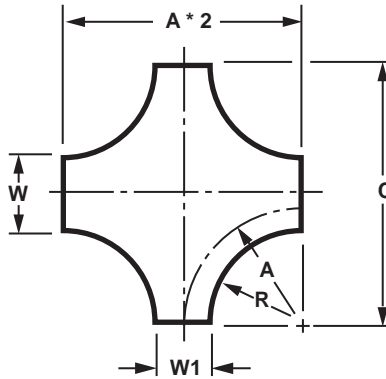

CSA CERTIFIED FOR CSA SYSTEMS

| R Radius | W Width | W1 Width | "A" Dimension | "C" Dimension | Part Number |
|----------------|----------------|----------------|-----------------|------------------|------------------|
| 24" (610mm) | 36" (914mm) | 30" (762mm) | 39" (991mm) | 84" (2134mm) | XXX-36TC-30-24-X |
| | | 24" (610mm) | 36" (914mm) | | XXX-36TC-24-24-X |
| | | 18" (457mm) | 33" (838mm) | | XXX-36TC-18-24-X |
| | | 12" (305mm) | 30" (762mm) | | XXX-36TC-12-24-X |
| | | 9" (229mm) | 28 1/2" (724mm) | | XXX-36TC-09-24-X |
| | | 6" (152mm) | 27" (686mm) | | XXX-36TC-06-24-X |
| | 30" (762mm) | 24" (610mm) | 36" (914mm) | 78" (1981mm) | XXX-30TC-24-24-X |
| | | 18" (457mm) | 33" (838mm) | | XXX-30TC-18-24-X |
| | | 12" (305mm) | 30" (762mm) | | XXX-30TC-12-24-X |
| | | 9" (229mm) | 28 1/2" (724mm) | | XXX-30TC-09-24-X |
| | | 6" (152mm) | 27" (686mm) | | XXX-30TC-06-24-X |
| | | 24" (610mm) | 18" (457mm) | | 33" (838mm) |
| | 12" (305mm) | | 30" (762mm) | XXX-24TC-12-24-X | |
| | 9" (229mm) | | 28 1/2" (724mm) | XXX-24TC-09-24-X | |
| | 6" (152mm) | | 27" (686mm) | XXX-24TC-06-24-X | |
| | 18" (457mm) | 12" (305mm) | 30" (762mm) | 66" (1676mm) | XXX-18TC-12-24-X |
| | | 9" (229mm) | 28 1/2" (724mm) | | XXX-18TC-09-24-X |
| | | 6" (152mm) | 27" (686mm) | | XXX-18TC-06-24-X |
| | 12" (305mm) | 9" (229mm) | 28 1/2" (724mm) | 60" (1524mm) | XXX-12TC-09-24-X |
| | | 6" (152mm) | 27" (686mm) | | XXX-12TC-06-24-X |
| | 9" (229mm) | 6" (152mm) | 27" (686mm) | 57" (1448mm) | XXX-09TC-06-24-X |

CSA CERTIFIED FOR CSA SYSTEMS

| R Radius | W Width | W1 Width | "A" Dimension | "C" Dimension | Part Number |
|----------------|----------------|----------------|------------------|------------------|------------------|
| 36" (914mm) | 36" (914mm) | 30" (762mm) | 51" (1295mm) | 108" (2743mm) | XXX-36TC-30-36-X |
| | | 24" (610mm) | 48" (1219mm) | | XXX-36TC-24-36-X |
| | | 18" (457mm) | 45" (1143mm) | | XXX-36TC-18-36-X |
| | | 12" (305mm) | 42" (1067mm) | | XXX-36TC-12-36-X |
| | | 9" (229mm) | 40 1/2" (1029mm) | | XXX-36TC-09-36-X |
| | | 6" (152mm) | 39" (991mm) | | XXX-36TC-06-36-X |
| | 30" (762mm) | 24" (610mm) | 48" (1219mm) | 102" (2591mm) | XXX-30TC-24-36-X |
| | | 18" (457mm) | 45" (1143mm) | | XXX-30TC-18-36-X |
| | | 12" (305mm) | 42" (1067mm) | | XXX-30TC-12-36-X |
| | | 9" (229mm) | 40 1/2" (1029mm) | | XXX-30TC-09-36-X |
| | | 6" (152mm) | 39" (991mm) | | XXX-30TC-06-36-X |
| | | 24" (610mm) | 18" (457mm) | | 45" (1143mm) |
| | 12" (305mm) | | 42" (1067mm) | XXX-24TC-12-36-X | |
| | 9" (229mm) | | 40 1/2" (1029mm) | XXX-24TC-09-36-X | |
| | 6" (152mm) | | 39" (991mm) | XXX-24TC-06-36-X | |
| | 18" (457mm) | 12" (305mm) | 42" (1067mm) | 90" (2286mm) | XXX-18TC-12-36-X |
| | | 9" (229mm) | 40 1/2" (1029mm) | | XXX-18TC-09-36-X |
| | | 6" (152mm) | 39" (991mm) | | XXX-18TC-06-36-X |
| | 12" (305mm) | 9" (229mm) | 40 1/2" (1029mm) | 84" (2134mm) | XXX-12TC-09-36-X |
| | | 6" (152mm) | 39" (991mm) | | XXX-12TC-06-36-X |
| | 9" (229mm) | 6" (152mm) | 39" (991mm) | 81" (2057mm) | XXX-09TC-06-36-X |

TROF CABLE TRAY SYSTEM

STRAIGHT REDUCER [ST]

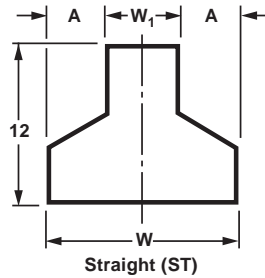
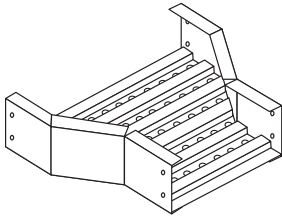

LEFT HAND [LH] & RIGHT HAND [RH] REDUCER

LEFT HAND (LH)

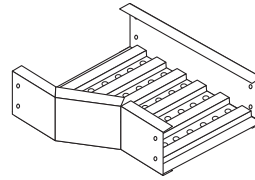

RIGHT HAND (RH)

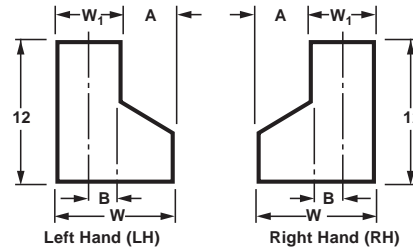
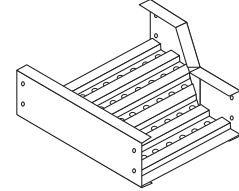

CSA CERTIFIED FOR CSA SYSTEMS

| Width - W | Width - W1 | "A" Dimension | Part Number |
|----------------|-------------|-----------------|---------------|
| 36" (914mm) | 30" (762mm) | 3" (76mm) | XXX-36ST-30-X |
| | 24" (610mm) | 6" (152mm) | XXX-36ST-24-X |
| | 18" (457mm) | 9" (229mm) | XXX-36ST-18-X |
| | 12" (305mm) | 12" (305mm) | XXX-36ST-12-X |
| | 9" (229mm) | 13 1/2" (343mm) | XXX-36ST-09-X |
| | 6" (152mm) | 15" (381mm) | XXX-36ST-06-X |
| 30" (762mm) | 24" (610mm) | 3" (76mm) | XXX-30ST-24-X |
| | 18" (457mm) | 6" (152mm) | XXX-30ST-18-X |
| | 12" (305mm) | 9" (229mm) | XXX-30ST-12-X |
| | 9" (229mm) | 10 1/2" (267mm) | XXX-30ST-09-X |
| | 6" (152mm) | 12" (304mm) | XXX-30ST-06-X |
| 24" (610mm) | 18" (457mm) | 3" (76mm) | XXX-24ST-18-X |
| | 12" (305mm) | 6" (152mm) | XXX-24ST-12-X |
| | 9" (229mm) | 7 1/2" (191mm) | XXX-24ST-09-X |
| | 6" (152mm) | 9" (229mm) | XXX-24ST-06-X |
| 18" (457mm) | 12" (305mm) | 3" (76mm) | XXX-18ST-12-X |
| | 9" (229mm) | 4 1/2" (114mm) | XXX-18ST-09-X |
| | 6" (152mm) | 6" (152mm) | XXX-18ST-06-X |
| 12" (305mm) | 9" (229mm) | 1 1/2" (38mm) | XXX-12ST-09-X |
| | 6" (152mm) | 3" (76mm) | XXX-12ST-06-X |
| 9" (229mm) | 6" (152mm) | 1 1/2" (38mm) | XXX-09ST-06-X |

CSA CERTIFIED FOR CSA SYSTEMS

| Width - W | "W1" Dim. | "A" Dim. | "B" Dim. | Part Number |
|----------------|-------------|-------------|----------------|--------------------|
| 36" (914mm) | 30" (914mm) | 6" (152mm) | 15" (381mm) | XXX-36(LH/RH)-30-X |
| | 24" (610mm) | 12" (305mm) | 12" (305mm) | XXX-36(LH/RH)-24-X |
| | 18" (457mm) | 18" (457mm) | 9" (229mm) | XXX-36(LH/RH)-18-X |
| | 12" (305mm) | 24" (610mm) | 6" (152mm) | XXX-36(LH/RH)-12-X |
| | 9" (229mm) | 27" (686mm) | 4 1/2" (114mm) | XXX-36(LH/RH)-09-X |
| | 6" (152mm) | 30" (762mm) | 3" (76mm) | XXX-36(LH/RH)-06-X |
| 30" (762mm) | 24" (610mm) | 6" (152mm) | 12" (305mm) | XXX-30(LH/RH)-24-X |
| | 18" (457mm) | 12" (305mm) | 9" (229mm) | XXX-30(LH/RH)-18-X |
| | 12" (305mm) | 18" (457mm) | 6" (152mm) | XXX-30(LH/RH)-12-X |
| | 9" (229mm) | 21" (533mm) | 4 1/2" (114mm) | XXX-30(LH/RH)-09-X |
| | 6" (152mm) | 24" (610mm) | 3" (76mm) | XXX-30(LH/RH)-06-X |
| 24" (610mm) | 18" (457mm) | 6" (152mm) | 9" (229mm) | XXX-24(LH/RH)-18-X |
| | 12" (305mm) | 12" (305mm) | 6" (152mm) | XXX-24(LH/RH)-12-X |
| | 9" (229mm) | 15" (381mm) | 4 1/2" (114mm) | XXX-24(LH/RH)-09-X |
| | 6" (152mm) | 18" (457mm) | 3" (76mm) | XXX-24(LH/RH)-06-X |
| 18" (457mm) | 12" (305mm) | 6" (152mm) | 6" (152mm) | XXX-18(LH/RH)-12-X |
| | 9" (229mm) | 9" (229mm) | 4 1/2" (114mm) | XXX-18(LH/RH)-09-X |
| | 6" (152mm) | 12" (305mm) | 3" (76mm) | XXX-18(LH/RH)-06-X |
| 12" (305mm) | 9" (229mm) | 3" (76mm) | 4 1/2" (114mm) | XXX-12(LH/RH)-09-X |
| | 6" (152mm) | 6" (152mm) | 3" (76mm) | XXX-12(LH/RH)-06-X |
| 9" (229mm) | 6" (152mm) | 3" (76mm) | 3" (76mm) | XXX-09(LH/RH)-06-X |

*Add suffix -V (vented) or -S (solid) to catalog number.

Example: 234-36ST-12-V

Left Hand [LH] & Right Hand [RH] Reducer

*Add suffix -V (vented) or -S (solid) to catalog number.

Example: 234-36LH-12-V

Note: COPE FITTINGS are offered in 12", 24", and 36" radius.

When small or in-between angles are needed, use Cope's Adjustable Connectors.

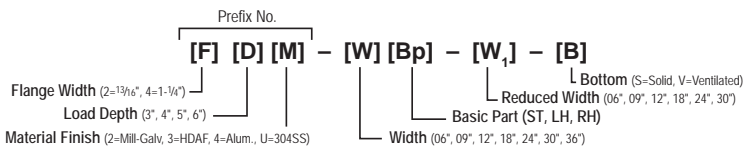

ADJUSTABLE ELBOW [AF]

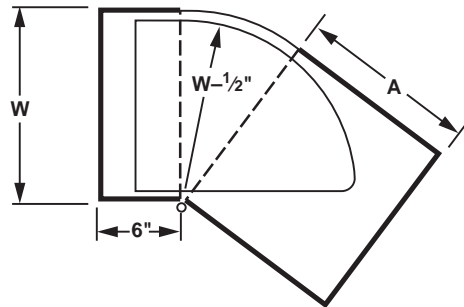
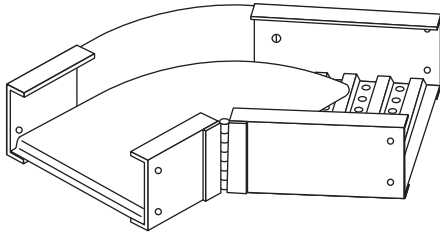

CSA CERTIFIED FOR CSA SYSTEMS

| Width - W | "A" Dimension | Part Number |
|-------------|---------------|-------------|
| 6" (152mm) | 8" (203mm) | XXX-06AF-X |
| 9" (229mm) | 11" (279mm) | XXX-09AF-X |
| 12" (305mm) | 14" (356mm) | XXX-12AF-X |
| 18" (457mm) | 20" (508mm) | XXX-18AF-X |
| 24" (610mm) | 26" (660mm) | XXX-24AF-X |
| 30" (762mm) | 32" (813mm) | XXX-30AF-X |
| 36" (914mm) | 38" (965mm) | XXX-36AF-X |

Both rails at hinge break to be bonded if fitting is used as equipment grounding conductor. * Add suffix-V (vented) or -S (solid) to catalog number. Example: 234-12AF-V

45° "Y" BRANCH LEFT [LY] & RIGHT [RY]

RIGHT HAND [RY] SHOWN

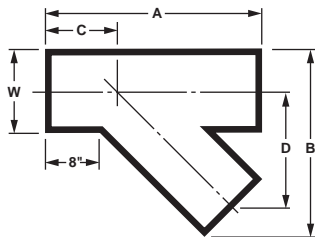
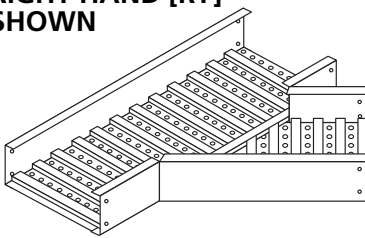

CSA CERTIFIED FOR CSA SYSTEMS

| Width - W | "A" Dim. | "B" Dim. | "C" Dim. | "D" Dim. | Part Number |
|-------------|------------------|------------------|-----------------|-----------------|-----------------|
| 6" (152mm) | 22 1/2" (571mm) | 16 1/4" (413mm) | 11 3/8" (289mm) | 11 1/8" (283mm) | XXX-06(LY/Ry)-X |
| 9" (229mm) | 26 3/4" (679mm) | 21 3/8" (543mm) | 13" (330mm) | 13 3/4" (349mm) | XXX-09(LY/Ry)-X |
| 12" (305mm) | 31" (787mm) | 26 1/2" (673mm) | 14 3/4" (375mm) | 16 1/4" (412mm) | XXX-12(LY/Ry)-X |
| 18" (457mm) | 39 1/2" (1003mm) | 36 3/4" (933mm) | 18 1/8" (460mm) | 21 3/8" (543mm) | XXX-18(LY/Ry)-X |
| 24" (610mm) | 48" (1219mm) | 47" (1193mm) | 21 1/2" (546mm) | 26 1/2" (673mm) | XXX-24(LY/Ry)-X |
| 30" (762mm) | 56 3/8" (1432mm) | 57 1/4" (1454mm) | 24 3/4" (629mm) | 31 3/8" (803mm) | XXX-30(LY/Ry)-X |
| 36" (914mm) | 65" (1651mm) | 67 1/2" (1714mm) | 28 1/4" (718mm) | 36 3/4" (933mm) | XXX-36(LY/Ry)-X |

*Add suffix -V (vented) or -S (solid) to catalog number.
Example: 234-12RY-V

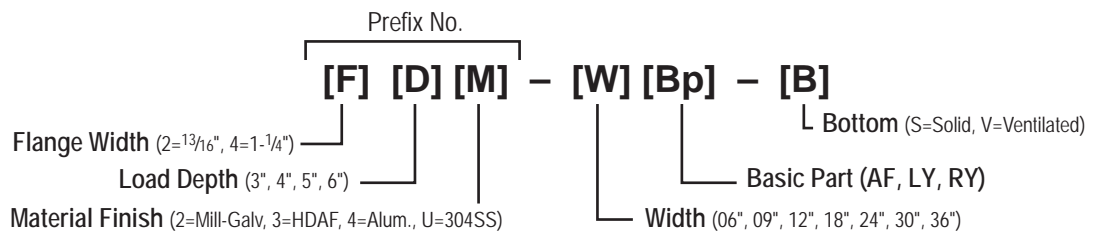

TROF CABLE TRAY SYSTEM

90° VERTICAL ELBOW OUTSIDE [90] & INSIDE [9I]

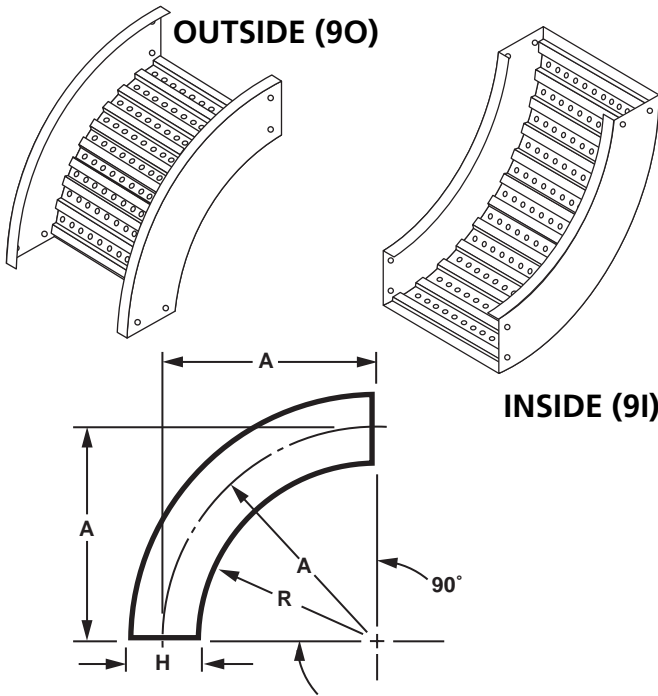

CSA CERTIFIED FOR CSA SYSTEMS

| Radius - R | "H" Dim. | "A" Dim. | Part Number |
|----------------|----------------|-----------------|--------------------|
| 12" (305mm) | 3 1/2" (89mm) | 13 3/4" (349mm) | X3X-WW(90/9I)-12-X |
| | 4 1/4" (108mm) | 14 1/8" (359mm) | X4X-WW(90/9I)-12-X |
| | 5 1/4" (133mm) | 14 5/8" (372mm) | X5X-WW(90/9I)-12-X |
| | 6 1/4" (159mm) | 15 1/8" (384mm) | X6X-WW(90/9I)-12-X |
| 24" (610mm) | 3 1/2" (89mm) | 25 3/4" (654mm) | X3X-WW(90/9I)-24-X |
| | 4 1/4" (108mm) | 26 1/8" (664mm) | X4X-WW(90/9I)-24-X |
| | 5 1/4" (133mm) | 26 5/8" (676mm) | X5X-WW(90/9I)-24-X |
| | 6 1/4" (159mm) | 27 1/8" (689mm) | X6X-WW(90/9I)-24-X |
| 36" (914mm) | 3 1/2" (89mm) | 37 3/4" (959mm) | X3X-WW(90/9I)-36-X |
| | 4 1/4" (108mm) | 36 1/8" (969mm) | X4X-WW(90/9I)-36-X |
| | 5 1/4" (133mm) | 36 5/8" (981mm) | X5X-WW(90/9I)-36-X |
| | 6 1/4" (159mm) | 39 1/8" (994mm) | X6X-WW(90/9I)-36-X |

*Add suffix -V (vented) or -S (solid) to catalog number.
Example: 234-129O-12-V

60° VERTICAL ELBOW OUTSIDE [60] & INSIDE [6I]

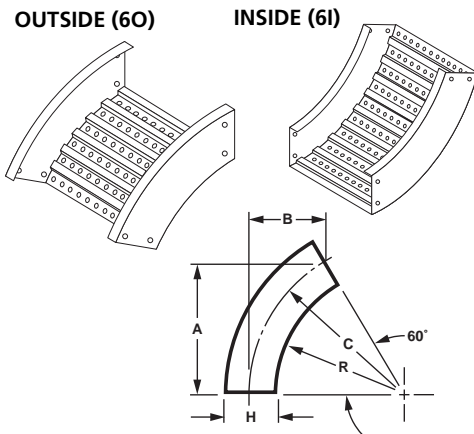

CSA CERTIFIED FOR CSA SYSTEMS

| Radius - R | "H" Dim. | "A" Dim. | "B" Dim. | "C" Dim. | Part Number |
|----------------|----------------|-----------------|-----------------|-----------------|--------------------|
| 12" (305mm) | 3 1/2" (89mm) | 11 7/8" (302mm) | 6 7/8" (175mm) | 13 3/4" (349mm) | X3X-WW(60/6I)-12-X |
| | 4 1/4" (108mm) | 12 1/4" (311mm) | 7 7/8" (181mm) | 14 1/8" (359mm) | X4X-WW(60/6I)-12-X |
| | 5 1/4" (133mm) | 12 5/8" (321mm) | 7 3/8" (187mm) | 14 5/8" (372mm) | X5X-WW(60/6I)-12-X |
| | 6 1/4" (159mm) | 13 1/8" (334mm) | 7 5/8" (194mm) | 15 1/8" (384mm) | X6X-WW(60/6I)-12-X |
| 24" (610mm) | 3 1/2" (89mm) | 22 1/4" (565mm) | 12 7/8" (327mm) | 25 3/4" (654mm) | X3X-WW(60/6I)-24-X |
| | 4 1/4" (108mm) | 22 5/8" (575mm) | 13 1/8" (334mm) | 26 1/8" (664mm) | X4X-WW(60/6I)-24-X |
| | 5 1/4" (133mm) | 23 1/8" (588mm) | 13 3/8" (340mm) | 26 5/8" (676mm) | X5X-WW(60/6I)-24-X |
| | 6 1/4" (159mm) | 23 1/2" (597mm) | 13" (330mm) | 27 1/8" (689mm) | X6X-WW(60/6I)-24-X |
| 36" (914mm) | 3 1/2" (89mm) | 32 3/4" (832mm) | 18 7/8" (480mm) | 37 3/4" (959mm) | X3X-WW(60/6I)-36-X |
| | 4 1/4" (108mm) | 33" (838mm) | 19 1/8" (486mm) | 38 1/8" (969mm) | X4X-WW(60/6I)-36-X |
| | 5 1/4" (133mm) | 33 1/2" (851mm) | 19 3/8" (492mm) | 38 5/8" (981mm) | X5X-WW(60/6I)-36-X |
| | 6 1/4" (159mm) | 33 7/8" (861mm) | 19 5/8" (499mm) | 39 1/8" (994mm) | X6X-WW(60/6I)-36-X |

*Add suffix -V (vented) or -S (solid) to catalog number.

Example: 234-126O-12-V 90° Vertical Elbow Outside [90] & Inside [9I]

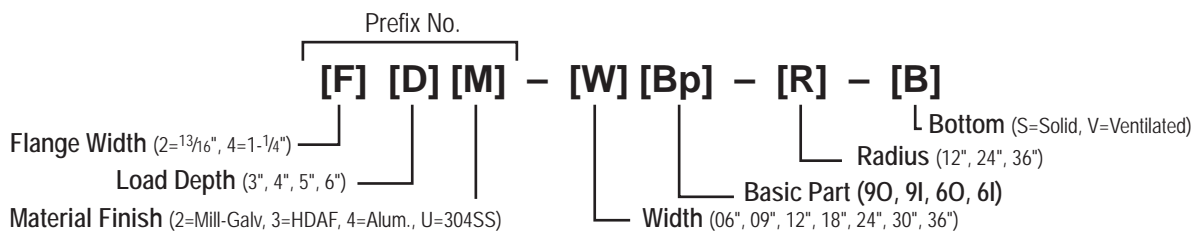

45° VERTICAL ELBOW OUTSIDE [40] & INSIDE [4I]

OUTSIDE (40)

INSIDE (4I)

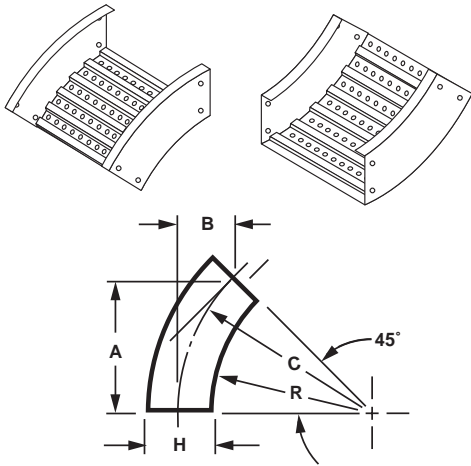

CSA CERTIFIED FOR CSA SYSTEMS

| Radius - R | "H" Dim. | "A" Dim. | "B" Dim. | "C" Dim. | Part Number |
|----------------|----------------|-----------------|-----------------|-----------------|--------------------|
| 12" (305mm) | 3 1/2" (89mm) | 9 3/4" (248mm) | 4" (102mm) | 13 3/4" (349mm) | X3X-WW(40/4I)-12-X |
| | 4 1/4" (108mm) | 10" (254mm) | 4 1/8" (105mm) | 14 1/8" (359mm) | X4X-WW(40/4I)-12-X |
| | 5 1/4" (133mm) | 10 3/8" (264mm) | 4 1/4" (108mm) | 14 5/8" (372mm) | X5X-WW(40/4I)-12-X |
| | 6 1/4" (159mm) | 10 3/4" (273mm) | 4 1/2" (114mm) | 15 1/8" (384mm) | X6X-WW(40/4I)-12-X |
| 24" (610mm) | 3 1/2" (89mm) | 18 1/4" (464mm) | 7 1/2" (191mm) | 25 3/4" (654mm) | X3X-WW(40/4I)-24-X |
| | 4 1/4" (108mm) | 18 1/2" (470mm) | 7 5/8" (194mm) | 26 1/8" (664mm) | X4X-WW(40/4I)-24-X |
| | 5 1/4" (133mm) | 18 7/8" (480mm) | 7 7/8" (200mm) | 26 5/8" (676mm) | X5X-WW(40/4I)-24-X |
| | 6 1/4" (159mm) | 19 1/4" (489mm) | 8" (203mm) | 27 1/8" (689mm) | X6X-WW(40/4I)-24-X |
| 36" (914mm) | 3 1/2" (89mm) | 26 3/4" (679mm) | 11 1/8" (283mm) | 37 3/4" (959mm) | X3X-WW(40/4I)-36-X |
| | 4 1/4" (108mm) | 27" (686mm) | 11 1/8" (283mm) | 38 1/8" (969mm) | X4X-WW(40/4I)-36-X |
| | 5 1/4" (133mm) | 27 3/8" (695mm) | 11 3/8" (289mm) | 38 5/8" (981mm) | X5X-WW(40/4I)-36-X |
| | 6 1/4" (159mm) | 27 5/8" (702mm) | 11 1/2" (292mm) | 39 1/8" (994mm) | X6X-WW(40/4I)-36-X |

*Add suffix -V (vented) or -S (solid) to catalog number.
 Example: 234-1241-12-V

30° VERTICAL ELBOW OUTSIDE [30] & INSIDE [3I]

OUTSIDE (30)

INSIDE (3I)

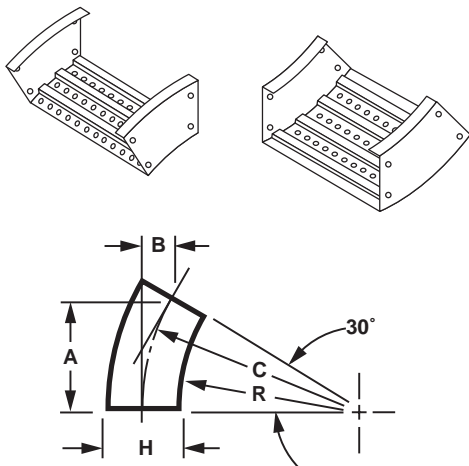

CSA CERTIFIED FOR CSA SYSTEMS

| Radius - R | "H" Dim. | "A" Dim. | "B" Dim. | "C" Dim. | Part Number |
|----------------|----------------|-----------------|----------------|-----------------|--------------------|
| 12" (305mm) | 3 1/2" (89mm) | 6 7/8" (175mm) | 1 7/8" (48mm) | 13 3/4" (349mm) | X3X-WW(30/3I)-12-X |
| | 4 1/4" (108mm) | 7 1/8" (181mm) | 1 7/8" (48mm) | 14 1/8" (359mm) | X4X-WW(30/3I)-12-X |
| | 5 1/4" (133mm) | 7 3/8" (187mm) | 2" (51mm) | 14 5/8" (372mm) | X5X-WW(30/3I)-12-X |
| | 6 1/4" (159mm) | 7 5/8" (194mm) | 2" (51mm) | 15 1/8" (384mm) | X6X-WW(30/3I)-12-X |
| 24" (610mm) | 3 1/2" (89mm) | 12 7/8" (327mm) | 3 1/2" (89mm) | 25 3/4" (654mm) | X3X-WW(30/3I)-24-X |
| | 4 1/4" (108mm) | 13 1/8" (334mm) | 3 1/2" (89mm) | 26 1/8" (664mm) | X4X-WW(30/3I)-24-X |
| | 5 1/4" (133mm) | 13 3/8" (340mm) | 3 3/8" (92mm) | 26 5/8" (676mm) | X5X-WW(30/3I)-24-X |
| | 6 1/4" (159mm) | 13 5/8" (346mm) | 3 5/8" (92mm) | 27 1/8" (689mm) | X6X-WW(30/3I)-24-X |
| 36" (914mm) | 3 1/2" (89mm) | 18 7/8" (480mm) | 5 1/8" (130mm) | 37 3/4" (959mm) | X3X-WW(30/3I)-36-X |
| | 4 1/4" (108mm) | 19 3/8" (486mm) | 5 1/8" (130mm) | 38 1/8" (969mm) | X4X-WW(30/3I)-36-X |
| | 5 1/4" (133mm) | 19 3/8" (492mm) | 5 1/4" (133mm) | 38 5/8" (981mm) | X5X-WW(30/3I)-36-X |
| | 6 1/4" (159mm) | 19 5/8" (499mm) | 5 1/4" (133mm) | 39 1/8" (994mm) | X6X-WW(30/3I)-36-X |

*Add suffix -V (vented) or -S (solid) to catalog number.
 Example: 234-1231-12-V

Prefix No.

[F] [D] [M] - [W] [Bp] - [R] - [B]

Flange Width (2=13/16", 4=1-1/4")

Load Depth (3", 4", 5", 6")

Material Finish (2=Mill-Galv, 3=HDAF, 4=Alum., U=304SS)

Width (06", 09", 12", 18", 24", 30", 36")

Bottom (S=Solid, V=Ventilated)

Radius (12", 24", 36")

Basic Part (40, 4I, 30, 3I)

TROF CABLE TRAY SYSTEM

VERTICAL TEE DOWN [VT] & UP [OT]

VERTICAL TEE - DOWN (VT)

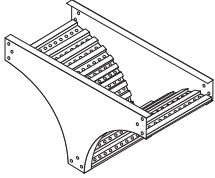

VERTICAL TEE - UP (OT)

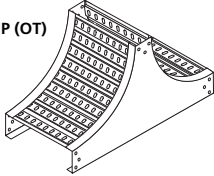

CSA CERTIFIED FOR CSA SYSTEMS

| Radius-R | "H" Dim. | "A" Dimension | "B" Dimension | "C" Dimension | Part Number |
|----------------|----------------|------------------|------------------|-----------------|--------------------|
| 12" (305mm) | 3 1/2" (89mm) | 27 1/2" (699mm) | 15 1/2" (394mm) | 13 3/4" (349mm) | X3X-WW(VT/OT)-12-X |
| | 4 1/4" (108mm) | 28 1/4" (718mm) | 16 1/4" (413mm) | 14 1/8" (359mm) | X4X-WW(VT/OT)-12-X |
| | 5 1/4" (133mm) | 29 1/4" (743mm) | 17 1/4" (438mm) | 14 5/8" (371mm) | X5X-WW(VT/OT)-12-X |
| | 6 1/4" (159mm) | 30 1/4" (768mm) | 18 1/4" (464mm) | 15 1/8" (384mm) | X6X-WW(VT/OT)-12-X |
| 24" (610mm) | 3 1/2" (89mm) | 51 1/2" (1308mm) | 27 1/2" (699mm) | 25 3/4" (654mm) | X3X-WW(VT/OT)-24-X |
| | 4 1/4" (108mm) | 52 1/4" (1327mm) | 28 1/4" (718mm) | 26 1/8" (664mm) | X4X-WW(VT/OT)-24-X |
| | 5 1/4" (133mm) | 53 1/4" (1353mm) | 29 1/4" (743mm) | 26 5/8" (676mm) | X5X-WW(VT/OT)-24-X |
| | 6 1/4" (159mm) | 54 1/4" (1378mm) | 30 1/4" (768mm) | 27 1/8" (689mm) | X6X-WW(VT/OT)-24-X |
| 36" (914mm) | 3 1/2" (89mm) | 75 1/2" (1918mm) | 39 1/2" (1003mm) | 37 3/4" (959mm) | X3X-WW(VT/OT)-36-X |
| | 4 1/4" (108mm) | 76 1/4" (1937mm) | 40 1/4" (1022mm) | 38 1/8" (968mm) | X4X-WW(VT/OT)-36-X |
| | 5 1/4" (133mm) | 77 1/4" (1962mm) | 41 1/4" (1048mm) | 38 5/8" (981mm) | X5X-WW(VT/OT)-36-X |
| | 6 1/4" (159mm) | 78 1/4" (1988mm) | 42 1/4" (1073mm) | 39 1/8" (994mm) | X6X-WW(VT/OT)-36-X |

*Add suffix -V (vented) or -S (solid) to catalog number.
Example: 234-12VT-12-V

90° VERTICAL CABLE SUPPORT ELBOW [SR]

*"J" hooks not included.
 Order separately (Cat. No. 75170).

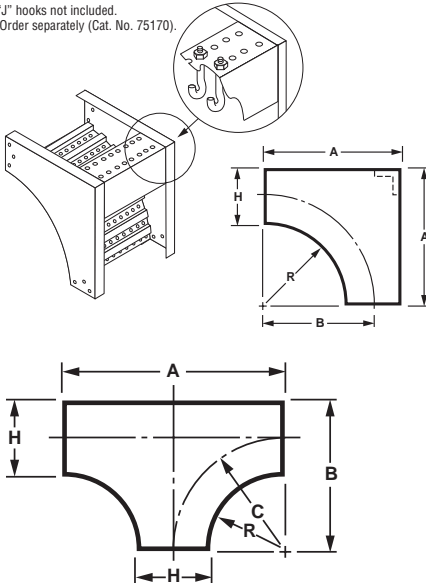

CSA CERTIFIED FOR CSA SYSTEMS

| Radius-R | "H" Dim. | "A" Dimension | "B" Dimension | Part Number |
|----------------|----------------|------------------|-----------------|---------------|
| 12" (305mm) | 3 1/2" (89mm) | 15 1/2" (394mm) | 13 3/4" (349mm) | X3X-WWSR-12-X |
| | 4 1/2" (108mm) | 16 1/4" (413mm) | 14 1/8" (359mm) | X4X-WWSR-12-X |
| | 5 1/4" (133mm) | 17 1/4" (438mm) | 14 5/8" (371mm) | X5X-WWSR-12-X |
| | 6 1/4" (159mm) | 18 1/4" (464mm) | 15 1/8" (384mm) | X6X-WWSR-12-X |
| 24" (610mm) | 3 1/2" (89mm) | 27 1/2" (699mm) | 25 3/4" (654mm) | X3X-WWSR-24-X |
| | 4 1/4" (108mm) | 28 1/4" (718mm) | 26 1/8" (664mm) | X4X-WWSR-24-X |
| | 5 1/4" (133mm) | 29 1/4" (743mm) | 26 5/8" (676mm) | X5X-WWSR-24-X |
| | 6 1/4" (159mm) | 30 1/4" (768mm) | 27 1/8" (689mm) | X6X-WWSR-24-X |
| 36" (914mm) | 3 1/2" (89mm) | 39 1/2" (1003mm) | 37 3/4" (959mm) | X3X-WWSR-36-X |
| | 4 1/4" (108mm) | 40 1/4" (1022mm) | 38 1/8" (968mm) | X4X-WWSR-36-X |
| | 5 1/4" (133mm) | 41 1/4" (1048mm) | 38 5/8" (981mm) | X5X-WWSR-36-X |
| | 6 1/4" (159mm) | 42 1/4" (1073mm) | 39 1/8" (994mm) | X6X-WWSR-36-X |

*Add suffix -V (vented) or -S (solid) to catalog number
Example: 234-12SR-12-V

Prefix No. **[F] [D] [M] - [W] [Bp] - [R] - [B]**

Flange Width (2=13/16", 4=1-1/4")

Load Depth (3", 4", 5", 6")

Material Finish (2=Mill-Galv, 3=HDAF, 4=Alum., U=304SS)

Width (06", 09", 12", 18", 24", 30", 36")

Bottom (S=Solid, V=Ventilated)

Radius (12", 24", 36")

Basic Part (SR, VT, OT)

TRAY CONNECTORS

| Catalog No. | | |
|-------------|----------------|-----------|
| Load Depth | Finish | Basic No. |
| 3" | 2 (Mill Galv.) | -02RC |
| 4" | 3 (HDGAF) | -02CE |
| 5" | 4 (Alum.) | -02CV |
| 6" | U (304SS) | -02CH |
| | | -02CA |

Example: 34 -02RC for 3" load depth, aluminum, universal curvilinear connector. Part Nos. CE, CH, and CV to be bonded if used as equipment grounding conductor.

Note: Hole patterns match corresponding tray. 3-hole pattern illustrated.

Heavy Duty, Mid Span Splice Plates available upon request.

UNIVERSAL CURVILINEAR CONNECTOR [RC]

NOTE: Sold in pairs

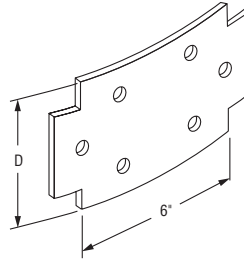

11 Gage Steel, 0.125" Aluminum
 $\frac{3}{8}$ "-16 spline bolts & flange nuts furnished.

EXPANSION CONNECTORS [CE]

NOTE: Sold in pairs

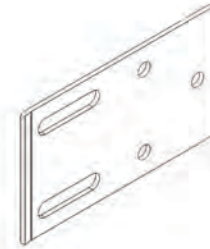

11 Gage Steel, 0.125" Aluminum
 $\frac{3}{8}$ "-16 cap screws & Nylok nuts furnished and
 $\frac{3}{8}$ "-16 spline bolts & flange nuts furnished.
Note: Bonding Jumpers are required and are sold separately.

HORIZONTAL ADJUSTABLE CONNECTORS [CH]

NOTE: Sold in pairs

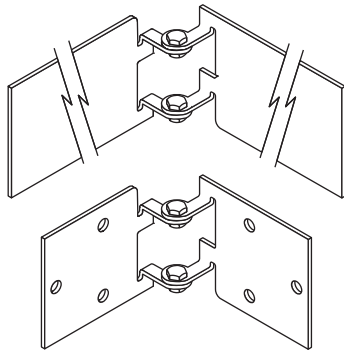

11 Gage Steel, 0.125" Aluminum
 $\frac{3}{8}$ "-16 cap screws & Nylok nuts furnished and
 $\frac{3}{8}$ "-16 spline bolts & flange nuts furnished.

Note: Bonding Jumpers are required and are sold separately.

VERTICAL ADJUSTABLE CONNECTORS [CV]

NOTE: Sold in pairs

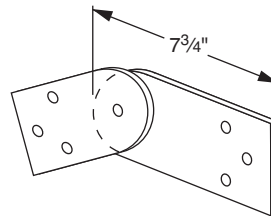

11 Gage Steel, 0.125" Aluminum
 $\frac{3}{8}$ "-16 cap screws & Nylok nuts furnished and
 $\frac{3}{8}$ "-16 spline bolts & flange nuts furnished.

Note: Bonding Jumpers are required and are sold separately.

90° ANGLE CONNECTORS [CA]

NOTE: Sold in pairs

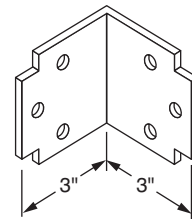

11 Gage Steel, 0.125" Aluminum
 $\frac{3}{8}$ "-16 spline bolts and flange nuts furnished.

REDUCING CONNECTORS [CO]

NOTE: Sold in pairs

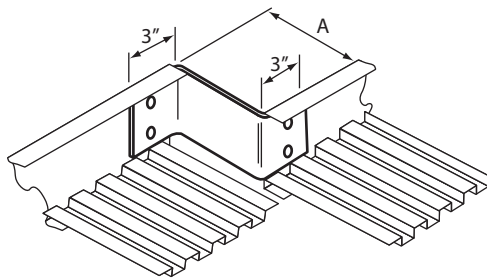

CATALOG NUMBER

| Load Depth | Finish | Basic No. | "A" Dimension |
|------------|----------------|-----------|-----------------|
| 3" | 2 (Mill Galv.) | -30CO | 30" (762mm) |
| 4" | 3 (HDGAF) | -27CO | 27" (686mm) |
| 5" | 4 (Alum.) | -24CO | 24" (610mm) |
| 6" | U (304SS) | -21CO | 21" (533mm) |
| | | -18CO | 18" (457mm) |
| | | -15CO | 15" (381mm) |
| | | -13CO | 13 1/2" (343mm) |
| | | -12CO | 12" (305mm) |
| | | -10CO | 10 1/2" (267mm) |
| | | -09CO | 9" (229mm) |
| | | -07CO | 7 1/2" (191mm) |
| | | -06CO | 6" (152mm) |
| | | -04CO | 4 1/2" (114mm) |
| | | -03CO | 3" (76mm) |
| | | -01CO | 1 1/2" (38mm) |

Example: 34-03CO for 3" load depth, aluminum, 3" Reducer Connector. Typical Use: 9" to 6", or use 2 for 12" to 6", etc.

TROF CABLE TRAY SYSTEM

HARDWARE

Material/Finish

Electrogalvanized finish standard. Other finishes available; consult factory. *Use following suffix when applicable - use only where indicated.

No Suffix Electrogalvanized carbon steel only

-SS 302/304 Stainless Steel

-S1 316 Stainless Steel (check factory for availability)

Example: PS 6024-SS, $\frac{3}{8}$ " x 1 $\frac{1}{2}$ " hex head bolt, 304 stainless steel

CONNECTOR HARDWARE BOLT [5003], NUT [5009]

(Case-hardened steel electrogalvanized)

Part No. 5003-1

$\frac{3}{8}$ "-16 x 1" spline bolt

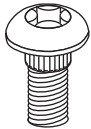

Part No. 5009-1

$\frac{3}{8}$ "-16 hex-flanged nut with serrated washer face.

COVER SCREWS [EM]

Part No. EM-CC (electrogalv. steel)

Part No. EM-CC-SS (stainless steel)

No. 10 x $\frac{5}{8}$ " long, self drilling-self tapping hex head plated steel screw.

Suggested spacing:

Indoor: 8 per 12'

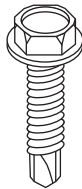

CONTINUOUS THREADED ROD [PS 146]

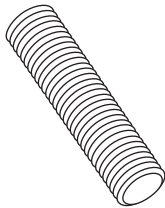

| Cat. No. | Size (Diameter x Length) |
|----------|--------------------------|
| PS 146* | $\frac{1}{4}$ " x 10' |
| PS 146* | $\frac{3}{8}$ " x 10' |
| PS 146* | $\frac{1}{2}$ " x 10' |
| PS 146* | $\frac{5}{8}$ " x 10' |
| PS 146* | $\frac{3}{4}$ " x 10' |

(Hot Dip Galvanized not available.)

ROD COUPLER [PS 135]

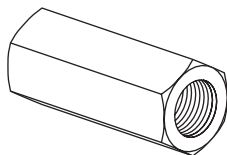

| Cat. No. | Size |
|----------|-----------------|
| PS 135* | $\frac{1}{4}$ " |
| PS 135* | $\frac{3}{8}$ " |
| PS 135* | $\frac{1}{2}$ " |
| PS 135* | $\frac{5}{8}$ " |
| PS 135* | $\frac{3}{4}$ " |

HEX NUTS [PS 83]



| Cat. No. | Size |
|----------|-----------------|
| PS 83* | $\frac{1}{4}$ " |
| PS 83* | $\frac{3}{8}$ " |
| PS 83* | $\frac{1}{2}$ " |
| PS 83* | $\frac{5}{8}$ " |
| PS 83* | $\frac{3}{4}$ " |

SQUARE NUTS [PS 6108]

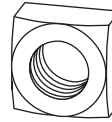

| Cat. No. | Size |
|----------|-----------------|
| PS 6108* | $\frac{1}{4}$ " |
| PS 6108* | $\frac{3}{8}$ " |
| PS 6108* | $\frac{1}{2}$ " |
| PS 6108* | $\frac{5}{8}$ " |
| PS 6108* | $\frac{3}{4}$ " |

FLAT WASHERS [PS 209]

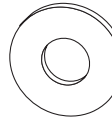

| Cat. No. | Size |
|----------|-----------------|
| PS 209* | $\frac{1}{4}$ " |
| PS 209* | $\frac{3}{8}$ " |
| PS 209* | $\frac{1}{2}$ " |
| PS 209* | $\frac{5}{8}$ " |
| PS 209* | $\frac{3}{4}$ " |

SPLIT-LOCK WASHERS [PS 211]

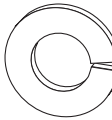

| Cat. No. | Size |
|----------|-----------------|
| PS 211* | $\frac{1}{4}$ " |
| PS 211* | $\frac{3}{8}$ " |
| PS 211* | $\frac{1}{2}$ " |
| PS 211* | $\frac{5}{8}$ " |
| PS 211* | $\frac{3}{4}$ " |

FENDER WASHERS [PS 230]

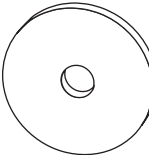

| Cat. No. | Size (I.D. x O.D.) |
|----------|--|
| PS 230* | $\frac{1}{4}$ " x 1 $\frac{1}{4}$ " O.D. |
| PS 230* | $\frac{3}{8}$ " x 1 $\frac{1}{2}$ " O.D. |
| PS 230* | $\frac{1}{2}$ " x 2" O.D. |

HEX HEAD CAP SCREW [PS 6024], ROUND HEAD, SLOTTED CAP SCREW [PS 6072]

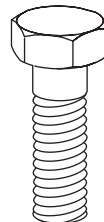

Catalog No.
PS 6024

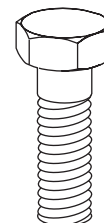

Catalog No.
PS 6072

| Hex Head Cap Screw | Round Head Cap Screw | Size (Dia. x Len.) |
|--------------------|----------------------|-------------------------------------|
| PS 6024* | PS 6072* | $\frac{1}{4}$ " x 1" |
| PS 6024* | PS 6072* | $\frac{1}{4}$ " x 1 $\frac{1}{2}$ " |
| PS 6024* | PS 6072* | $\frac{3}{8}$ " x 1" |
| PS 6024* | PS 6072* | $\frac{3}{8}$ " x 1 $\frac{1}{2}$ " |
| PS 6024* | PS 6072* | $\frac{3}{8}$ " x 3" |
| PS 6024* | PS 6072* | $\frac{1}{2}$ " x 1" |
| PS 6024* | PS 6072* | $\frac{1}{2}$ " x 1 $\frac{1}{2}$ " |
| PS 6024* | PS 6072* | $\frac{1}{2}$ " x 2" |
| PS 6024* | PS 6072* | $\frac{1}{2}$ " x 2 $\frac{1}{2}$ " |
| PS 6024* | PS 6072* | $\frac{1}{2}$ " x 3" |
| PS 6024* | PS 6072* | $\frac{1}{2}$ " x 3 $\frac{1}{2}$ " |
| PS 6024* | PS 6072* | $\frac{5}{8}$ " x 1 $\frac{1}{2}$ " |
| PS 6024* | PS 6072* | $\frac{5}{8}$ " x 2" |
| PS 6024* | PS 6072* | $\frac{5}{8}$ " x 3" |
| PS 6024* | PS 6072* | $\frac{5}{8}$ " x 4" |
| PS 6024* | PS 6072* | $\frac{3}{4}$ " x 2" |
| PS 6024* | PS 6072* | $\frac{3}{4}$ " x 3" |
| PS 6024* | PS 6072* | $\frac{3}{4}$ " x 4" |

NOTE: Standard finish is electrogalvanized. Refer to finishes above for specifications of alternate finish or material.

COVERS for straight sections shown. Standard fitting covers are flat solid type (NF). Aluminum covers are fabricated from 0.040" aluminum AA-3150-H14; steel covers are fabricated from 20 gage ASTM A-653-G90 CQ, mill-galvanized steel.

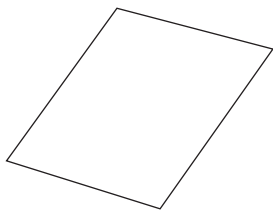

NF – Flat Solid

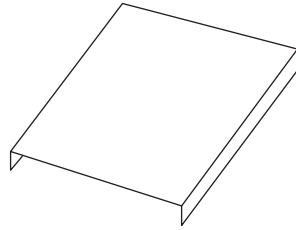

FS – Flat Solid
w/3/8" Flange

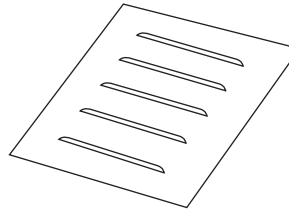

NL – Flat Louvered

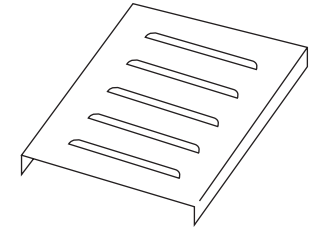

FL – Louvered
w/3/8" Flange

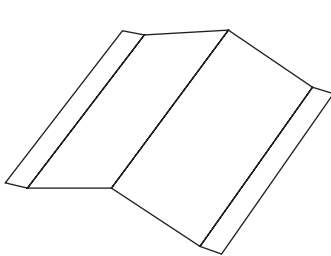

PS – Peaked Solid
(suffix height)

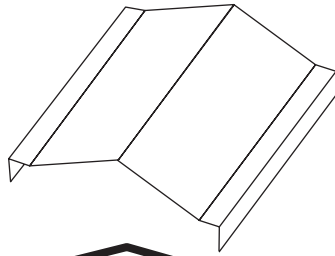

PF – Peaked Flanged Solid
(suffix height)

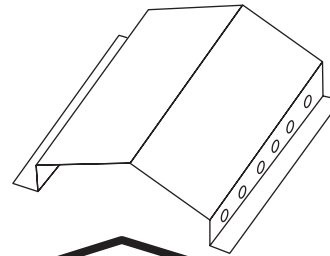

PV – Peaked Hat Vent
PH – Peaked Hat Solid
(suffix height)

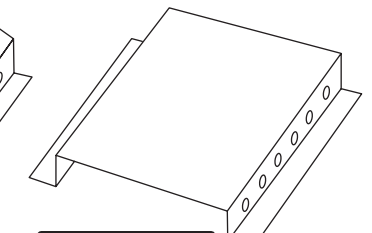

HS – Hat Solid
HV – Hat Vent
(suffix height)

NOTE: Use EM-CC Cover Screws (see pg. 158) to attach PH, PV, HS & HV covers.
HDGAF straights only available in 6' sections.

COVER CATALOG NUMBER – STRAIGHT SECTIONS

| Type | Finish | Basic No. (Width) | Length | Height* |
|---------|----------------|---------------------|--------|---------|
| HS, HV, | 2 - Mill Galv. | -06SL = 6" (152mm) | -12' | -2" |
| FL, FS, | 3 - HDGAF | -09SL = 9" (229mm) | -10' | |
| NF, NL, | 4 - Alum. | -12SL = 12" (305mm) | -06' | |
| PS, PF, | U - 304SS | -18SL = 18" (457mm) | | |
| PH, PV | | -24SL = 24" (610mm) | | |
| | | -30SL = 30" (762mm) | | |
| | | -36SL = 36" (914mm) | | |

* Peak and hat only, 2" height standard. Consult factory for other heights.

Example: NL2-09SL-12 is a flat louvered mill-galv. steel cover for a 9" wide mill galvanized TROF 12' long.

COVER CATALOG NUMBER – FITTINGS

| Type | Load Depth | Finish | Width/Basic No. | Radius |
|------|------------|----------------|-----------------|--------|
| NF | 3 | 2 - Mill Galv. | -06 XX** | 12" |
| FS | 4 | 3 - HDGAF | -09 XX** | 24" |
| | 5 | 4 - Alum. | -12 XX** | 36" |
| | 6 | U - 304SS | -18 XX** | |
| | | | -24 XX** | |
| | | | -30 XX** | |
| | | | -36 XX** | |

*Load depth for outside riser or vertical tee only.

**XX from fitting selection page 141.

JOINT PLATE

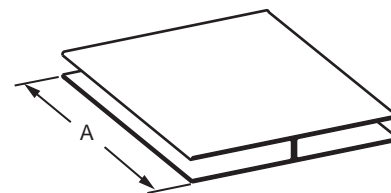

Joint plate is black PVC and is offered in 10' lengths to be field cut to desired length, or in precut lengths for specified covers.

JP-120 is joint plate in 10' lengths.

Joint plate for specified covers is specified as follows.

| Tray Width | Flange Type |
|---------------------|--------------------|
| JP-06 = 6" (152mm) | |
| JP-09 = 9" (229mm) | -2 = 1/16" Flange |
| JP-12 = 12" (305mm) | -4 = 1 1/4" Flange |
| JP-18 = 18" (457mm) | -7 = 2" Flange |
| JP-24 = 24" (610mm) | |
| JP-30 = 30" (762mm) | |
| JP-36 = 36" (914mm) | |

Example: JP-06-2 is a joint plate for 6" wide tray with a 1/16" flange.

TROF CABLE TRAY SYSTEM

COVER ACCESSORIES

SINGLE SIDE CONNECTOR [01CC]



Furnished with 1/4"-28 stainless steel cone point machine screw.

For use with any width tray.

Not sold in pairs.

Suggested spacing:
Indoor Use Only;
4 per 12' section

CATALOG NUMBER [BASIC NO -01CC]

| Flange | Load Depth | Finish |
|------------|------------|----------------|
| 2 - 13/16" | 3 | 2 - Mill Galv. |
| 4 - 1 1/4" | 4 | 3 - HDGAF |
| 5 - 1 1/2" | 5 | 4 - Alum. |
| 7 - 2" | 6 | U - 304SS |

Example: 234-01CC for 3" load depth, aluminum single side connector.

PEAK VENT COVER CONNECTOR [VC]

NOTE: For PV Covers

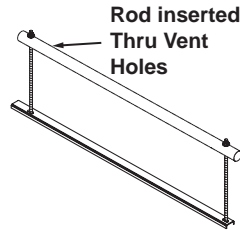

CATALOG NUMBER

| Flange | Load Depth | Finish | Width | Type |
|------------|------------|--------------|-------|------|
| 2 = 13/16" | 3 | 2=Mill Galv. | -06 | VC |
| 4 = 1 1/4" | 4 | 3=HDGAF | -09 | |
| 5 = 1 1/2" | 5 | 4=Alum. | -12 | |
| 6 = 1 3/4" | 6 | U=304SS | -18 | |
| | | | -24 | |
| | | | -30 | |
| | | | -36 | |

Example: 238-12VC for 3" load depth, 13/16" flange, aluminum, 12" wide, Peak Vented Cover Connector

DOUBLE CLAMP CONNECTOR [(W)DC]

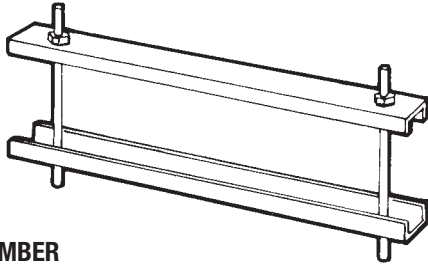

CATALOG NUMBER

| Load Depth | Finish | Width | Type |
|------------|----------------|-------|------|
| 3 | 2 - Mill Galv. | -06 | DC |
| 4 | 3 - HDGAF | -09 | |
| 5 | 4 - Alum. | -12 | |
| 6 | U - 304SS | -18 | |
| | | -24 | |
| | | -30 | |
| | | -36 | |

Example: 34-12DC for 3" load depth, 13/16" flange, aluminum, Double Clamp Connector.

For all covers except hat & peak type. Furnished with:
(2) 1/4"-20 all-thread rods
(4) hex nuts, flat washers and lock washers

Suggested spacing:

Indoor: 2 per 12'
Outdoor: 3 per 12'
High Wind: 5 per 12'

COVER CONNECTOR [CC]

NOTE: For all covers except hat & peak type

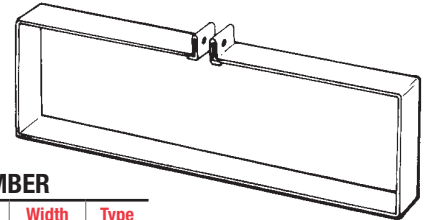

CATALOG NUMBER

| Load Depth | Finish | Width | Type |
|------------|----------------|-------|------|
| 3 | 2 - Mill Galv. | -06 | CC |
| 4 | 3 - HDGAF | -09 | |
| 5 | 4 - Alum. | -12 | |
| 6 | U - 304SS | -18 | |
| | | -24 | |
| | | -30 | |
| | | -36 | |

Example: 34-12CC for 13/16" flange, 3" load depth, aluminum, 12" wide connector.

PEAK COVER CONNECTOR [PC]

NOTE: For PS & PF Cover

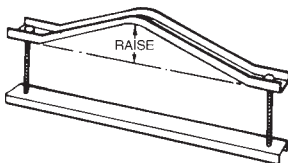

CATALOG NUMBER

| Load Depth | Finish | Width | Type | Raise (in)* |
|------------|----------------|-------|------|-------------|
| 3 | 2 - Mill Galv. | -06 | PC | -2 |
| 4 | 3 - HDGAF | -09 | | |
| 5 | 4 - Alum. | -12 | | |
| 6 | U - 304SS | -18 | | |
| | | -24 | | |
| | | -30 | | |
| | | -36 | | |

*2" standard raise. Consult factory for other peak heights.

Example: 34-12-VC-3 for 3" load depth, aluminum, 12" wide, Peak Cover Connector (vented cover) with 2" peak.

ELEVATED COVER CONNECTOR [EM-CC]

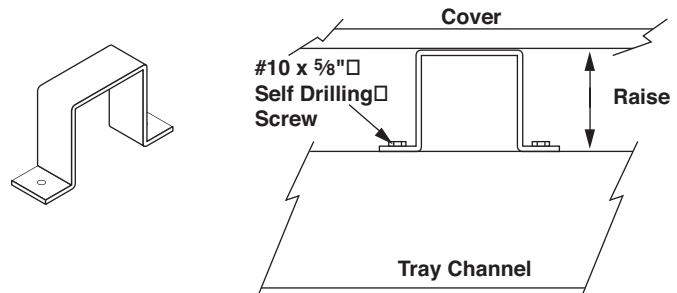

CATALOG NUMBER

| Finish | Type | Height* |
|----------------|-------|----------------|
| 2 - Mill Galv. | EM-CC | - Raise* (in.) |
| 3 - HDGAF | | |
| 4 - Alum. | | |
| U - 304SS | | |

*1", 2" or 3" standard.

Example: 3-EM-CC-2 for hot dipped galvanized, Elevated Cover Connector with a 2" raise.

Includes:
(3) #10 x 5/8" Self drilling screws.

Suggested spacing:
Indoor: 3/Side (6 tot.) per 12';

DROP OUT [DO]

14 Gage Steel, .080" Aluminum

NOTE: (2) #10 x 3/8" self tapping screws furnished.

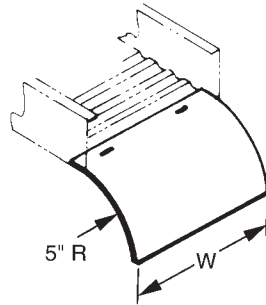

CATALOG NUMBER

| Basic Finish | Width |
|----------------|---------------------|
| 2 (Mill Galv.) | -06DO = 6" (152mm) |
| 3 (HDGAF) | -09DO = 9" (229mm) |
| 4 (Alum.) | -12DO = 12" (305mm) |
| U (304SS) | -18DO = 18" (457mm) |
| | -24DO = 24" (610mm) |
| | -30DO = 30" (762mm) |
| | -36DO = 36" (914mm) |

Example: 4-12DO for aluminum, 12" wide, Drop Out.

BOX CONNECTOR [CB]

14 Gage Steel

.080" Aluminum

NOTE: 1/4"-20 carriage bolts, flat washers, hex nuts furnished.

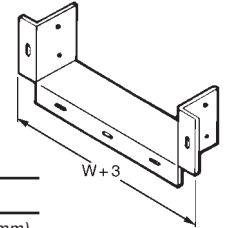

CATALOG NUMBER

| Load Depth | Finish | Width |
|------------|------------------|---------------------|
| 3 | 2 - (Mill Galv.) | -06CB = 6" (152mm) |
| 4 | 3 - (HDGAF) | -09CB = 9" (229mm) |
| 5 | 4 - (Alum.) | -12CB = 12" (305mm) |
| 6 | U - (304SS) | -18CB = 18" (457mm) |
| | | -24CB = 24" (610mm) |
| | | -30CB = 30" (762mm) |
| | | -36CB = 36" (914mm) |

Example: 34-12CB for 3" load depth, aluminum, 12" wide, Box Connector.

BLIND END [BE]

22 Gage Steel, .040" Aluminum

Note: 3/8"-16 spline bolts and flange nuts furnished.

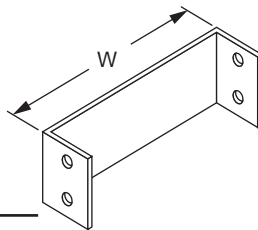

CATALOG NUMBER

| Load Depth | Finish | Width |
|------------|----------------|---------------------|
| 3 | 2 (Mill Galv.) | -06BE = 6" (152mm) |
| 4 | 3 (HDGAF) | -09BE = 9" (229mm) |
| 5 | 4 (Alum.) | -12BE = 12" (305mm) |
| 6 | U (304SS) | -18BE = 18" (457mm) |
| | | -24BE = 24" (610mm) |
| | | -30BE = 30" (762mm) |
| | | -36BE = 36" (914mm) |

Example: 34-12BE for 3" load depth, aluminum, 12" wide Blind End.

BONDING JUMPER [CBJ]

NOTE:

No hardware supplied

For hardware kit add -HDW:

Ex: CBJ-C-HDW includes
2ea CBJ-C
4ea 5003-1
4ea 5009-1

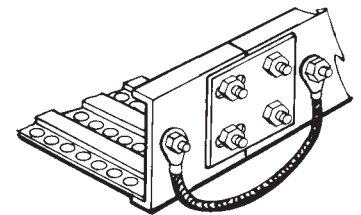

| Catalog No. | Dimensional Data | Amperes as Equipment Ground |
|-------------|---|-----------------------------|
| CBJ-C | AWG 1/0 copper wire 15 1/2" long overall | 800 amperes |
| CBJ-4C | AWG 4/0 copper wire 15 1/2" long overall | 1,600 amperes |
| CBJ-250C | 250 MCM copper wire 15 1/2" long overall | 2,000 amperes |

CABLE TRAY GROUND CLAMP [9156]

Extruded Alum. with Electro-Galvanized Steel Hex Head Screws.

Capacity: #6 AWG to 250 kcmil

UL Listed and CSA Certified for grounding

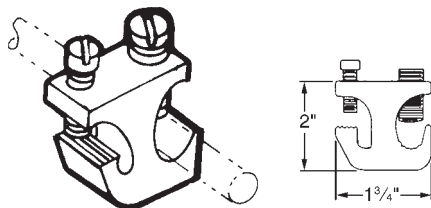

GROUND CABLE RETAINER CLAMP

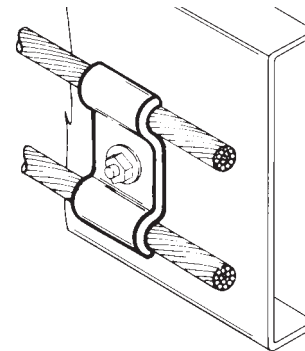

| Catalog No. | Capacity | Metal & Finish | Dimensions |
|-------------|-------------|---------------------|--------------------|
| 9056-EP | 1/0 2/0 3/0 | Electro-Galv. Steel | 1" w x 2" long |
| 9057-EP | 4/0 250 MCM | Electro-Galv. Steel | 1" w x 2 3/8" long |
| 9056-SS | 1/0 2/0 3/0 | Stainless Steel | 1" w x 2" long |
| 9057-SS | 4/0 250 MCM | Stainless Steel | 1" w x 2 3/8" long |

TROF CABLE TRAY SYSTEM

ACCESSORIES

CONDUIT CLAMP BRACKETS

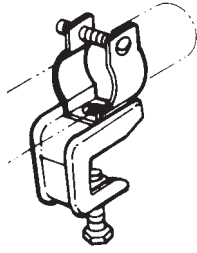

| Catalog No. | Size Rigid | Size EMT |
|-------------|--------------|----------|
| CCB-050 | 3/8" to 1/2" | 1/2" |
| CCB-075 | 3/4" | 3/4" |
| CCB-100 | 1" | 1" |
| CCB-125 | - | 1 1/4" |
| CCB-150 | 1 1/4" | 1 1/2" |
| CCB-200 | 2" | 2" |

CONDUIT-TO-CABLE TRAY CLAMP - SWIVEL TYPE

Malleable iron hub and steel "U" bolt.

For connecting and grounding rigid conduit to tray at any angle within 90° arc. UL listed as a grounding means.

| Catalog No. | Size | Std. Pkg. |
|-------------|-------------|-----------|
| TB6209 | 1/2" - 3/4" | 10 |
| TB6211 | 1" - 1 1/4" | 10 |
| TB6214 | 1 1/2" - 2" | 5 |
| TB6216 | 2 1/2" - 3" | 5 |
| TB6218 | 3 1/2" - 4" | 2 |

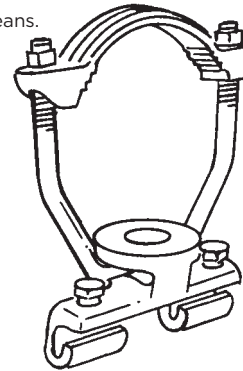

WALL PENETRATING SLEEVE ASSEMBLY [SS89042W*]

Note: W = Tray Width

* = Fitting 3-Digit Prefix

NOTE: Standard penetration sleeves are manufactured from mill galvanized steel. Aluminum sleeves are available upon request.

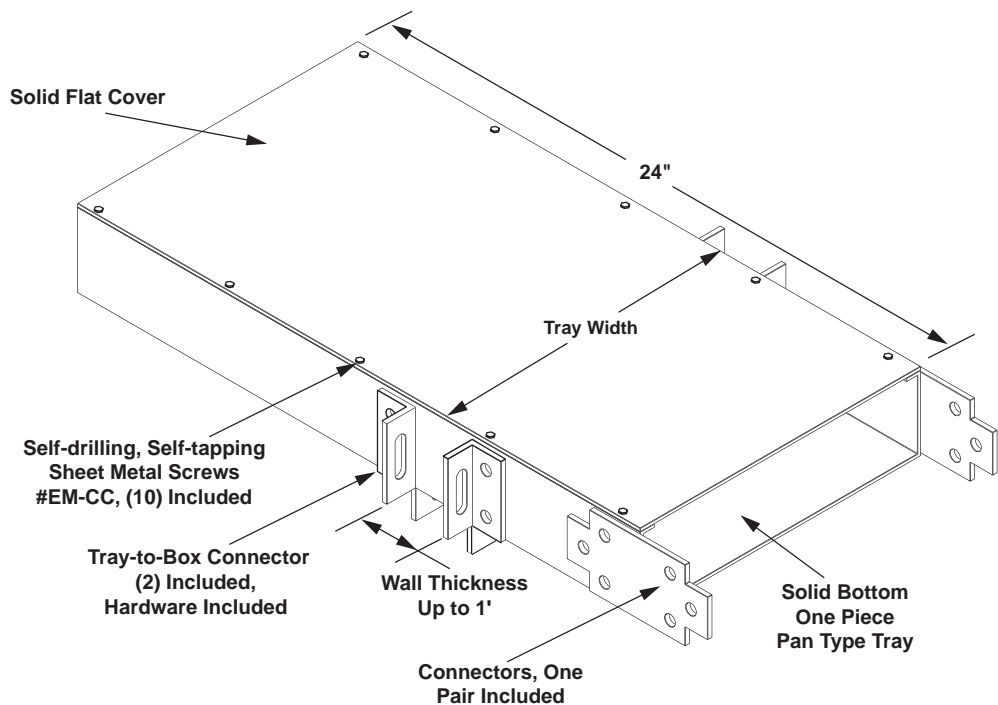

UNIVERSAL ALUMINUM BARRIER STRIP - STRAIGHT SECTION [SB]

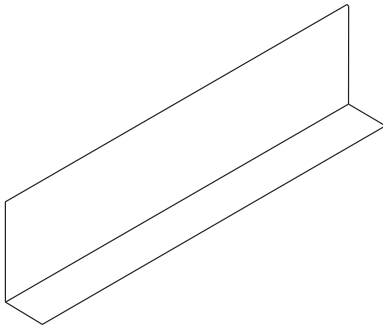

Furnished with 8 self tapping screws.

CATALOG NUMBER

| Load Depth | Finish | Basic No. 12' Length |
|------------|-----------|----------------------|
| 3 | A (Alum.) | -01SB-12 |
| 4 | | |
| 5 | | |
| 6 | | |

Example: 3A-01SB-12 for 3" load depth, aluminum straight barrier, 12' long.

BARRIER STRIP - HORIZONTAL FITTING [FB]

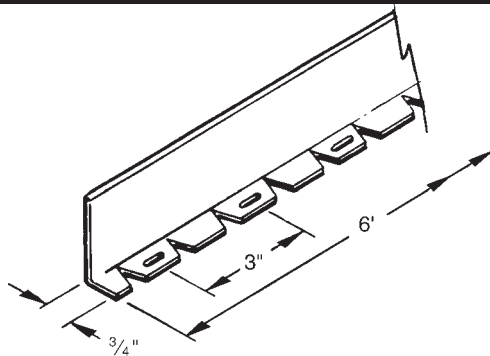

CATALOG NUMBER

| Load Depth | Finish | Basic No. - Length |
|------------|----------------|--------------------|
| 3 | 2 (Mill Galv.) | -01FB-06 |
| 4 | 3 (HDGAF) | |
| 5 | 4 (Alum.) | |
| 6 | U (304 SS) | |

Example: 34-01FB-06 for 3" load depth, aluminum fitting barrier, 6' long. Furnished with 4 self tapping screws.

BARRIER STRIP VERTICAL ELBOW OUTSIDE [OB] & INSIDE [IB]

(OB Vert. Elbow outside shown).

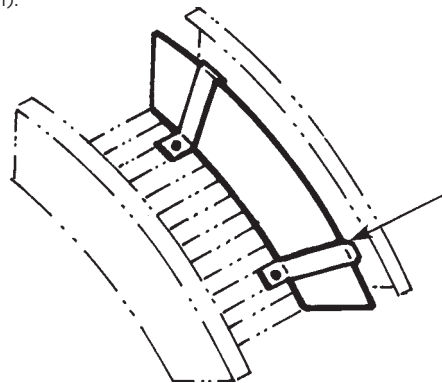

Furnished with sufficient clamp assemblies for installation. Additional clamp assemblies may be ordered separately.

CATALOG NUMBER

| Load Depth | Finish | Bend (deg.) | Basic No. | Radius |
|------------|----------------|-------------|--------------|-------------|
| 3 | 2 (Mill Galv.) | 90° | OB = Outside | 12" (305mm) |
| 4 | 3 (HDGAF) | 60° | IB = Inside | 24" (610mm) |
| 5 | 4 (Alum.) | 45° | | 36" (914mm) |
| 6 | U (304 SS) | 30° | | |

Example: 34-90OB-12 for 3" load depth, aluminum 90° outside vertical barrier with 12" radius.

NYLON CARRIER SPLICE & PROTECTOR [BSP-L]

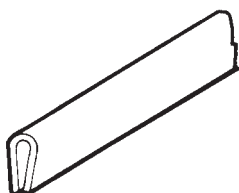

CATALOG NUMBER

| Prefix | Length (L) |
|--------|-----------------------|
| | -5 (5" Splice) |
| BSP | -144 (144" Protector) |
| | -1200 (100' Roll) |

Example: BSP-1200 for 100' roll

COVER SCREW

Part No. EM-CC (electro galv. steel)
 Part No. EM-CC-SS (stainless steel)
 No. 10 x 5/8" long, self drilling-self tapping hex head plated steel screw.
 Suggested spacing:
 Indoor: 8 per 12";
 Outdoor: 10 per 12"

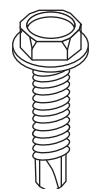

TROF CABLE TRAY SYSTEM

ACCESSORIES

HOLD-DOWN CLAMP & EXPANSION GUIDE

(For expansion guide clamp, add suffix "EX" to catalog number.)

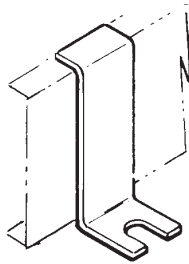

CATALOG NUMBER

| Load Depth | Basic No. |
|------------|----------------------------|
| 3 | -9039 (Aluminum) |
| 4 | -9040 (ElectroGalv. Steel) |
| 5 | -9041 (HDGAF) |
| 6 | -9042 (316SS) |

Example: 3-9039-EX for 3" load depth, expansion guide. Hardware purchased separately to suit support system. Complete Kit add "-HDW" to Part No. Above

- Hardware Kit List:
 (2) Hold-Down Clamps
 (2) ½" - 13 x 1 ¼" Cap Screw
 (2) ½" Flat Washer
 (2) Clamping Nut (Strut Nut)

BARRIER STRIP CLAMP [50172] (OPTIONAL)

No. 10 bolt, nut, washer and lock washer furnished.

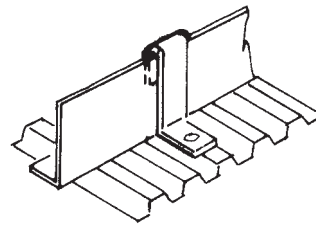

CATALOG NUMBER

| Load Depth | Finish | Basic Number |
|------------|----------------|--------------|
| 3 | 2 (Mill Galv.) | -50172 |
| 4 | 3 (HDGAF) | |
| 5 | 4 (Alum.) | |
| 6 | U (304 SS) | |

Example: 34-5072 for 3" load depth, aluminum clamp.

ISOLATION PAD [PVC-PAD]

The Isolation pad provides protection from galvanic corrosion when Aluminum tray is mounted on steel supports.

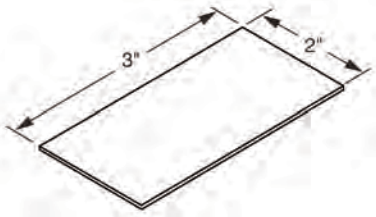

NOTE: For use with the 9039 series of Hold-Down Clamp & Expansion Guide. Hardware purchased separately

SEISMIC HOLD-DOWN [9132]

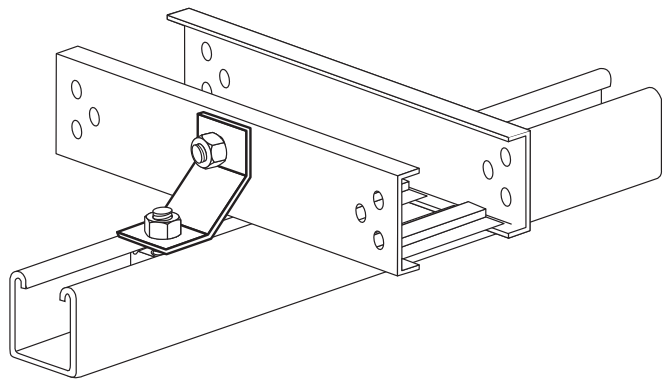

| Catalog No. | Material |
|-------------|-----------------|
| 9132 | Mill Galvanized |
| 9133 | Stainless Steel |

Hardware purchased separately to suit support system.

NYLON DROPOUT GROMMET [DOG-1]

Use at cable dropouts, or thru vent holes.
 Furnished in 12' lengths. Cut to length in field.

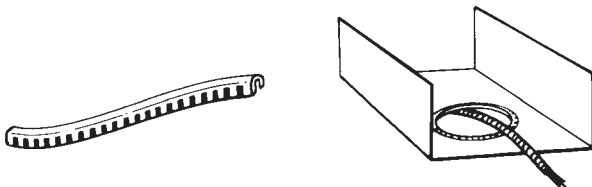

Note: For seismic applications other bolted connections is preferred. 4" wide and 4" tall and made from 11 gauge material

SUPPORT BRACKETS

GUSSET-TYPE SUPPORT

For use with all types of Cope Ladder and Trof systems. Finish is electro-galvanized. Order hardware separately.

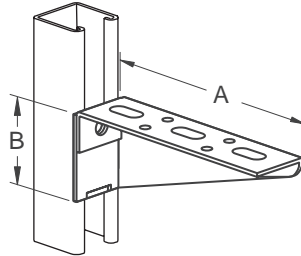

| Catalog No. | Ladder Width | Dimension | | Uniform-Load Rating |
|-------------|--------------|-----------|----------|---------------------|
| | | A | B | |
| PS 838R-6 | - | 6" | 1 15/16" | 275 lbs. |
| PS 838R-8 | - | 8" | 2 7/16" | 275 lbs. |
| PS 838R-10 | - | 10" | 2 15/16" | 275 lbs. |
| PS 838R-12 | 6" | 12" | 3 7/16" | 275 lbs. |
| PS 838R-16 | 9" | 16" | 4 7/16" | 275 lbs. |
| PS 838R-18 | 12" | 18" | 4 15/16" | 275 lbs. |
| PS 838R-24 | 18" | 24" | 6 7/16" | 275 lbs. |
| PS 838R-30 | 24" | 30" | 7 15/16" | 275 lbs. |

CHANNEL-TYPE SUPPORT

For use with all types of Cope Ladder and Trof systems. Finish is electro-galvanized. Order hardware separately.

STANDARD DUTY

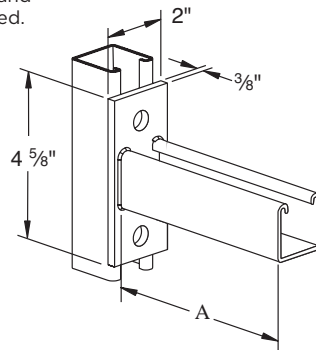

STANDARD DUTY FOR LIGHTER LOADS.

| Catalog No. | Ladder Width | Dimension A | Uniform-Load Rating* |
|-------------|--------------|-------------|----------------------|
| PS 651-6 | - | 6" | 1,200 lbs. |
| PS 651-12 | 6" | 12" | 600 lbs. |
| PS 651-15 | 9" | 15" | 480 lbs. |
| PS 651-18 | 12" | 18" | 400 lbs. |
| PS 651-24 | 18" | 24" | 300 lbs. |
| PS 651-30 | 24" | 30" | 240 lbs. |

* Mounted on 12 Ga. Channel.

HEAVY DUTY

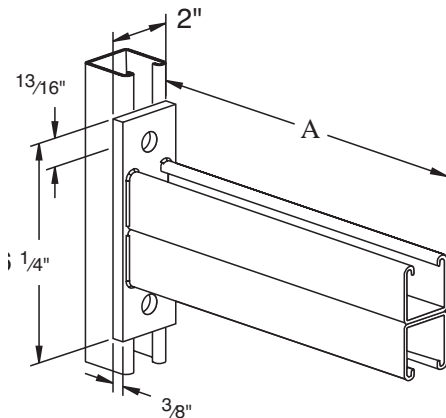

HEAVY DUTY FOR HEAVIER LOADS

| Catalog No. | Ladder Width | Dimension A | Uniform-Load Rating* |
|-------------|--------------|-------------|----------------------|
| PS 809-12 | 6" | 12" | 2,000 lbs. |
| PS 809-15 | 9" | 15" | 1,600 lbs. |
| PS 809-18 | 12" | 18" | 1,330 lbs. |
| PS 809-24 | 18" | 24" | 1,000 lbs. |
| PS 809-30 | 24" | 30" | 800 lbs. |
| PS 809-36 | 30" | 36" | 660 lbs. |
| PS 809-42 | 36" | 42" | 570 lbs. |

* Mounted on 12 Ga. Channel.

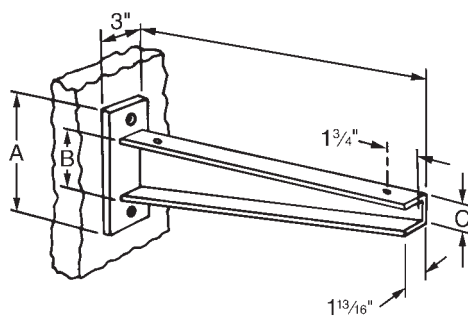

| Catalog No. | Trof Width | Length "L" | Dimensions | | | End-Load Rating* |
|-------------|------------|------------|------------|-----|--------|------------------|
| | | | "A" | "B" | "C" | |
| 9037-12 | 6" | 12 1/4" | 10" | 6" | 2" | 2000 lbs. |
| 9037-18 | 12" | 18 1/4" | 11" | 7" | 2 1/2" | 2000 lbs. |
| 9037-24 | 18" | 24 1/4" | 11" | 7" | 2 1/2" | 1600 lbs. |
| 9037-30 | 24" | 30 1/4" | 12" | 8" | 4" | 1300 lbs. |
| 9037-36 | 30" | 36 1/4" | 12" | 8" | 4" | 1100 lbs. |
| 9037-42 | 36" | 42 1/4" | 12" | 8" | 4" | 900 lbs. |

*Uniform load rating is normally twice the end-load rating. Finish is hot-dip galvanized after fabrication. Order hardware separately.

TROF CABLE TRAY SYSTEM

TRAY HANGER & SUPPORTS

STRUCTURAL SUPPORT BRACKET

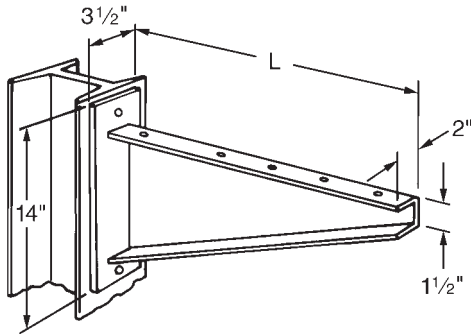

VERTICAL SUPPORT

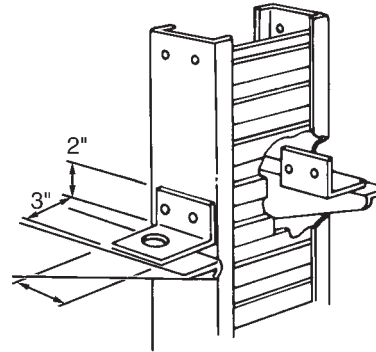

| Catalog No. | Trof Width | Length "L" | End-Load Rating* |
|-------------|------------|------------|------------------|
| 9036-31 | 24" | 31 1/4" | 2000 lbs. |
| 9036-37 | 30" | 37 1/4" | 1800 lbs. |
| 9036-45 | 36" | 45 1/4" | 1500 lbs. |

*Uniform load rating is normally twice the end-load rating.
For use with Cope Trof 24" or wider. May be welded or bolted to building steel.
Finish is hot-dip galvanized after fabrication.
Order hardware separately.

| Cat. No. | For Use With |
|----------|---|
| 9045 | 3 1/4" Overall Height Side Members |
| 9043-37 | 4 1/4" Overall Height Side Members |
| 9043 | 5 1/4" Overall Height Side Members |
| 9025-98 | 6 1/4" & 7 1/4" Overall Height Side Members |

Tray Supports can be bolted anywhere along the straight runs. They can be bolted directly onto the coupler plates at splices of straight runs and riser fittings, or they can be bolted at any place in the run by field-drilling side rails. TROF supports are used with either 3/8" or 1/2" hanger rods.
Finish is electrogalvanized.

SINGLE ROD HANGER SUPPORT

CATALOG NUMBER

| Assy. Type | Channel Length* | Channel Finish** | Rod Diameter | Rod Length | Beam Clamp |
|------------|-----------------|----------------------|---------------------|---------------------|-----------------|
| P200 | 14" (356mm) | GV (Pre-Galv) | 3/8 = 3/8" (9.53mm) | 000 - No Rod | A - Bridgeport |
| | 17" (432mm) | | 1/2 = 1/2" (12.7mm) | 036 - 36" (914mm) | B - P2622 |
| | 20" (508mm) | HG (Hot Dipped Galv) | | 072 - 72" (1828mm) | O - No Clamp |
| | 26" (661mm) | | | 120 - 120" (3048mm) | R - Rod Coupler |
| | 32" (813mm) | | | 144 - 144" (3658mm) | S - Special |
| | 38" (966mm) | | | | |
| | 44" (1118mm) | | | | |

Example:

P20020GV12036B is a Single 20" pre-galvanized channel with 1/2" x 36" drop rod and P2622 clamp.

Note:

*Order channel length 8" longer than tray width.
For example, 44" channel for 36" tray.

** Other channel types and finishes available upon request. Contact factory.

To order hardware only:

3/8" - PGV380000

1/2" - PGI200000

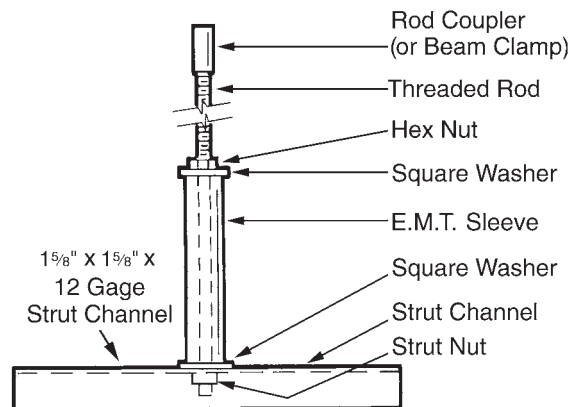

ELECTRICAL GROUNDING & SUPPORTS

TRAPEZE HANGER SUPPORT

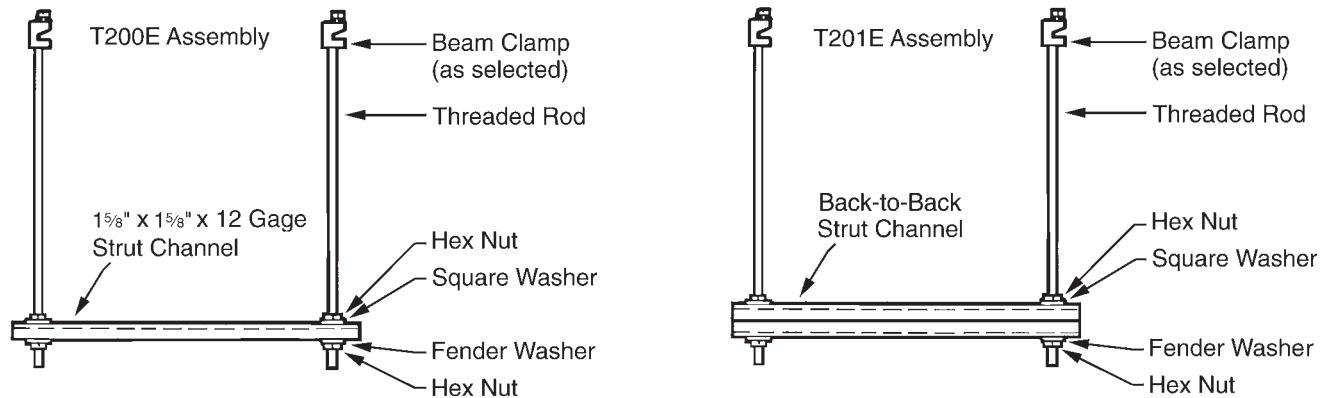

CATALOG NUMBER

| Assy. Type | Channel Length* | Channel Finish** | Rod Diameter | Rod Length | Beam Clamp |
|------------|-----------------|----------------------|---------------|---------------------|-----------------|
| T200E | 16" (407mm) | GV (Pre-Galv) | 3/8" (9.53mm) | 000 - No Rod | A - PS 85 |
| T201E | 19" (483mm) | HG (Hot Dipped Galv) | 1/2" (12.7mm) | 036 - 36" (914mm) | B - P2622 |
| | 22" (559mm) | | | 072 - 72" (1828mm) | O - No Clamp |
| | 28" (712mm) | | | 120 - 120" (3048mm) | R - Rod Coupler |
| | 34" (864mm) | | | 144 - 144" (3658mm) | S - Special |
| | 40" (1017mm) | | | | |
| | 46" (1169mm) | | | | |

Example: T200E22GV12036B is a Single 22" pre-galvanized channel with 1/2" x 36" drop rod and P2622 clamp.

Note: *Order channel length 10" longer than tray width. For example, 46" channel for 36" tray.

** Other channel types and finishes available upon request. Contact factory.

To order hardware only:

3/8" - PGV380000

1/2" - PGV120000

ELECTRICAL GROUNDING CHART

Table 1 below provides the Minimum Cross Sectional area for two side rails. Using the Fitting Prefix Number (244), the proper value is determined by the Material (column 3), the Flange Width (column 1) and Load Depth (column 2). Locate the line containing the Load Depth (column 1) and follow it to the right to the appropriate Flange Width and Material.

Find that value in Table 2, follow it to the right to the Material column to determine the Maximum Ground Fault Amperage.

Table 1

| Fitting Prefix Number | | | Min. X-Sect for 2 Rails (NEC Table 392.60(A)) | | | |
|-----------------------|------------|--------------|---|---------------|----------------|---------------|
| | | | Aluminum | | Steel | |
| | | | 1 3/16" Flange | 1 1/4" Flange | 1 3/16" Flange | 1 1/4" Flange |
| Flange | Load Depth | Material | X-Sect Area | X-Sect Area | X-Sect Area | X-Sect Area |
| 2 - 1 3/16" | 3" | 2 - Mill Gal | 0.60 | - | 0.40 | - |
| 4 - 1 1/4" | 4" | 3 - HDGAF | 0.60 | 0.60 | 0.40 | 0.70 |
| | 5" | 4 - Alum. | 0.60 | 1.00 | 0.70 | 0.70 |
| | 6" | | 0.60 | 1.00 | 0.70 | 1.00 |

Table 2

| X-Sect Area | Maximum Ground Fault Amperage (in Amps) | |
|-------------|---|-------|
| | Material | |
| | Aluminum | Steel |
| .40 sq in | - | 100 |
| .60 sq in | 1000 | - |
| .70 sq in | - | 200 |
| 1.00 sq in | 1200 | 400 |

For Example:

If the fitting prefix is 244, the Flange is 1 3/16", the Load Depth is 4", and the Material is Aluminum. The Minimum Cross Sectional Area (X-Sect Area) is 0.60 sq.in. The Amperage is 1000.

TYPICAL SPECIFICATIONS

By Specifying the NEMA class designation, you will use the simplest, clearest, and most complete method of specification available and automatically incorporate support span in feet, working (allowable) load in pounds per linear foot, a safety factor or 1.5, a concentrated load if present; and, all other design, manufacturing and test standards including electrical continuity.

All you need to add is inside depth, desired radius of fittings (to protect from cable damage), metal and finish. You can add accessory information pursuant to your project. Here is a typical specification for an outdoor tray system where the working (allowable) load has been determined to be approximately 75 pounds per foot on support spans of 12'-0".

SPECIFICATION - ALUMINUM COPE TROF

Cable Trof type tray shall be manufactured by a company regularly engaged in the manufacture of metal cable trays and shall be a member of NEMA. Trays shall conform to NEMA Metal Cable Tray Standard Publication VE-1 (latest issue).

1. Cable Trof shall be NEMA Classification 12B of the widths indicated.
2. Material shall be aluminum alloy with side rails of 6063 and bottoms of 5052 alloy.
3. Finish shall be natural.
4. Inside load depth to be NEMA Standard 3".
5. Fittings shall be 12" radius for control cables and 24" radius for power cables. (This must be commensurate with the cable manufacturer's recommended minimum bending radius.)
6. All top level trays in stacks and single runs to have raised peaked aluminum ventilated covers with heavy duty hold down clamps every 3'-0".
7. Install expansion connectors, expansion guides, and hold down clamps per NEMA Standard VE-1.
8. Where slopes or horizontal bends of trays are not at the Standard NEMA angles use adjustable connectors. If the angle is too great for cable bending radius, use combinations of fitting and adjustable connectors.
9. Separate all cables of different voltages in the same tray using the manufacturer's standard barriers and barrier hold down system.
10. The cable Trof system will be used as an equipment grounding conductor.
11. To save space, fittings shall have no tangents. To facilitate field installation, use one pair of universal type connector plates for rigid joints.
12. Cable Trof shall be three (3) piece construction with corrugated bottoms having 1" wide ribs on 2" centers arc welded to 3 1/2", high side rails. Ventilating holes, 1 1/16" diameter on 1" centers, shall be provided across valleys of the corrugations. Welds shall be MIG-arc type with approximately 1/2" diameter fused zone for rigidity to resist the rigors of shipping, installation, and service.
13. Trays shall be Cope Trof as manufactured by Cope.

6



CHANNEL

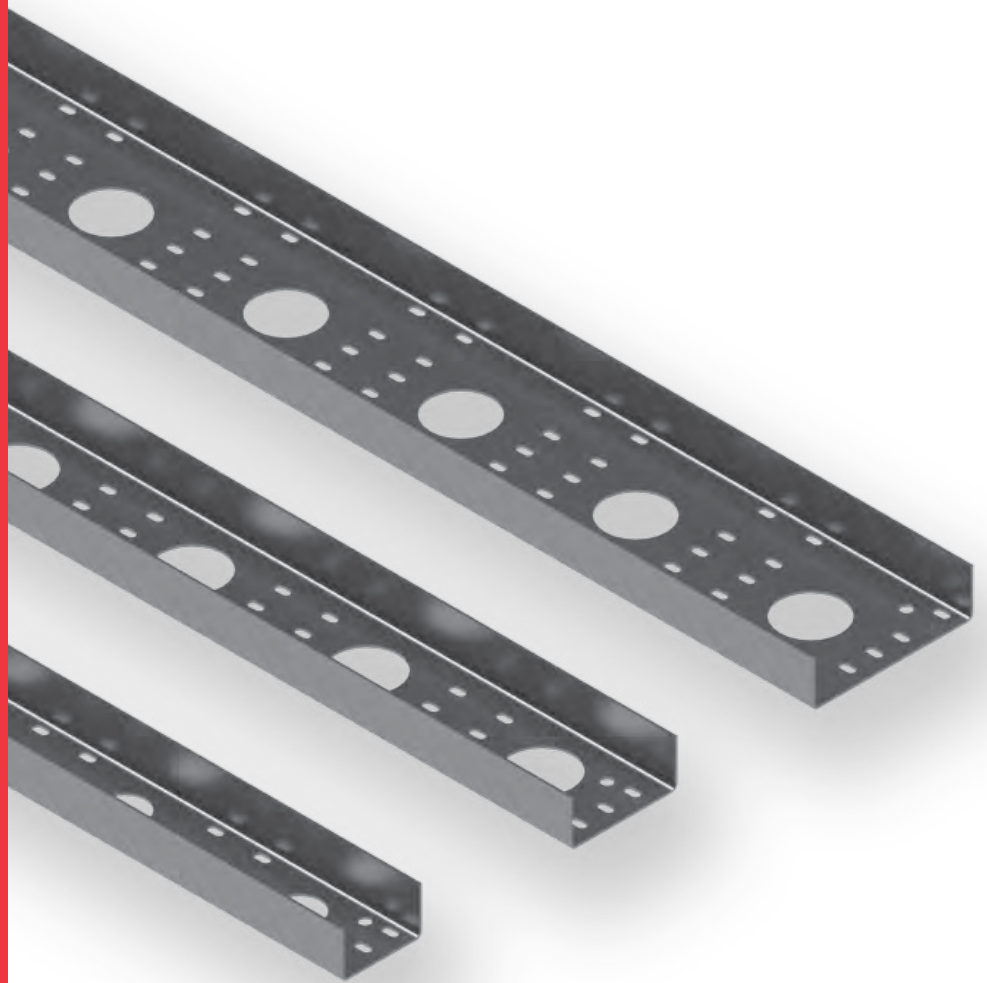

Cable Tray for Branch Power Circuits,
Control, Signal & Tubing Systems.

CHANNEL CABLE TRAY SYSTEM

CONTENTS

GENERAL & TECHNICAL INFORMATION

| | |
|----------------------|-----|
| Pictorial Index..... | 159 |
| Straight Length..... | 160 |

COPE CHANNEL FITTINGS

| | |
|--------------------------------------|-----------|
| Horizontal Elbows | |
| 90° | 161 |
| 60° | 161 |
| 45°..... | 161 |
| 30° | 162 |
| Vertical Elbows (Inside and Outside) | |
| 90° | 162 |
| 60° | 163 |
| 45° | 163 - 164 |
| 30° | 164 |
| Horizontal Tee..... | 165 |
| Horizontal Cross | 165 |

ACCESSORIES

| | |
|--|-----|
| Blind End | 166 |
| End Drop Out..... | 166 |
| Nylon Dropout Grommet | 166 |
| Channel to Box or Wall Connector | 166 |
| Standard Connector..... | 166 |
| Expansion Connector | 167 |
| Channel Hold Down Clamp | 167 |
| Adjustable Horizontal Connector | 167 |
| Adjustable Riser Connector | 167 |
| Cover Connector | 167 |
| Interconnections..... | 167 |
| Channel Hangers | 168 |

STRAIGHT LENGTH

Page 160

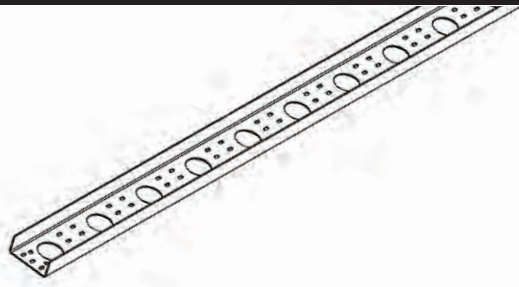

HORIZONTAL CROSS

Page 165

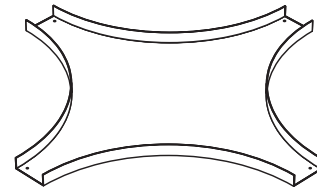

HORIZONTAL ELBOWS

Pages 161 - 162



BARRIER STRIPS & ACCESSORIES

Page 166

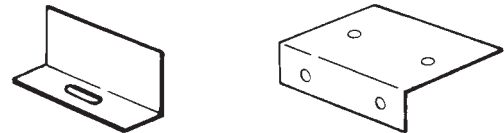

VERTICAL INSIDE ELBOW

Pages 162 - 164

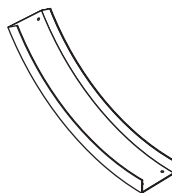

COVER ATTACHMENTS

Page 161

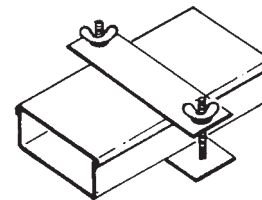

VERTICAL OUTSIDE ELBOW

Pages 164



ADJUSTABLE CONNECTORS

Page 167

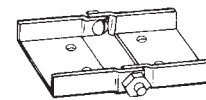

HORIZONTAL TEE

Page 165

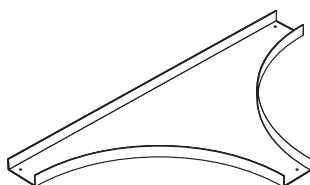

CHANNEL HANGERS

Page 168

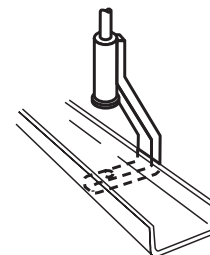

CHANNEL CABLE TRAY SYSTEM

INTRODUCTION

COPE® CHANNEL

New pre-punched holes allow the secure attachment of cables to the inside of the channel without the need to drill holes, reducing labor and speeding up installation.

Cope Channel supports single branches of power or multiconductor control cable or instrument tubing. Ideal for communication, fire alarm, or call station and clock cabling.

A complete line of devices are available for interfacing with Cope Ladders and Cope Trops. Compatible with any cable tray system. Cope Channel is more economical than conduit.

Cope Channel is offered in both aluminum and steel, either hot dip mill galvanized (ASTM A 525), or hot dip galvanized after fabrication (ASTM A 386). Covers are available in aluminum and mill galvanized steel. Connectors are furnished with all straight sections and fittings. Other accessories must be ordered separately.

Cope Channel is offered ventilated or solid. Basic units are 3", 4", or 6" wide and are 1 3/4" high. Standard lengths are 12' (3.7m) and 24' (7.4m) long. A load chart is furnished to give you guidance on how often you should support the system. Fitting radii available are 12", 24", and 36". Cope Channel meets NEMA VE-1 standards for cable tray.

ORDERING

For ordering, specify by catalog number using the following prefix to specify the material and finish.

FEATURES AND BENEFITS OF SLOTTED CHANNEL

- Secure cables easily using the pre-punched holes
- Saves time and labor by eliminating the need to drill holes
- Allows easy inspection of cables
- Available in aluminum, mill-galvanized steel, or hot-dip galvanized steel
- 3 sizes available: 3", 4" and 6"

| Catalog Number Prefix | | | |
|-----------------------|-------------------|------------------------------------|--------|
| Finish | Straight Sections | Fittings, Accessories & Connectors | Covers |
| Aluminum | 1124 | 24 | FS24 |
| Mill-Galv. Steel | 6122 | 22 | FS22 |
| Hot-Dip Galv. Steel | 6123 | 23 | -- |

| Loads and Deflection | | | | | | | |
|---|------------------------|----------------|--------------|-----------------|---------------|-----------------|---------------|
| Width | Cope Channel Basic No. | 8' Span (2.4m) | | 10' Span (3.0m) | | 12' Span (3.7m) | |
| | | #/Lin Ft* | Deflection | #/Lin Ft* | Deflection | #/Lin Ft* | Deflection |
| Aluminum-Plain Finish | | | | | | | |
| 3" (76mm) | 1124-03SL | 8 | .21" (5.3mm) | 5 | .33" (8.4mm) | 3 | .40" (10.6mm) |
| 4" (102mm) | 1124-04SL | 13 | .34" (8.6mm) | 9 | .57" (14.5mm) | 6 | .79" (20.2mm) |
| 6" (152mm) | 1124-06SL | 15 | .37" (9.4mm) | 10 | .61" (15.5mm) | 6 | .76" (19.3mm) |
| Hot Dip Mill-Galvanized Steel (ASTM A-525) | | | | | | | |
| 3" (76mm) | 6122-03SL | 8 | .13" (3.3mm) | 5 | .20" (5.1mm) | 3 | .25" (6.4mm) |
| 4" (102mm) | 6122-04SL | 13 | .21" (5.3mm) | 9 | .35" (8.9mm) | 6 | .48" (12.2mm) |
| 6" (152mm) | 6122-06SL | 15 | .23" (5.8mm) | 10 | .37" (9.4mm) | 6 | .46" (11.7mm) |
| Hot Dip Galvanized Steel (ASTM A-386), Covers Mill-Galvanized Only | | | | | | | |
| 3" (76mm) | 6123-03SL | 8 | .13" (3.3mm) | 5 | .20" (5.1mm) | 3 | .25" (6.4mm) |
| 4" (102mm) | 6123-04SL | 13 | .21" (5.3mm) | 9 | .35" (8.9mm) | 6 | .48" (12.2mm) |
| 6" (152mm) | 6123-06SL | 15 | .23" (5.8mm) | 10 | .37" (9.4mm) | 6 | .46" (11.7mm) |

Straight Section and Flanged Cover

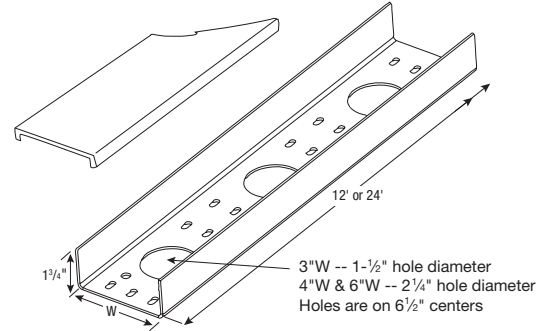

| Catalog Number – Straight Section | | | |
|-----------------------------------|------------|---------------------|------------|
| Finish | Width | Length | Type |
| 1124 - Alum. | 3" (76mm) | SL-12 = 12' (3.65m) | V - Vented |
| 6122 - Mill Galv. | 4" (102mm) | SL-24 = 24' (7.3m) | S - Solid |
| 6123 - HDGAF | 6" (152mm) | | |

Example: 1124-04SL-12-V is a 4" wide, vented, 12' aluminum tray.

| Catalog Number – Flanged Cover | | |
|--------------------------------|------------|---------------------|
| Finish | Width | Length |
| FS24 - Alum. | 3" (76mm) | SL-12 = 12' (3.65m) |
| FS22 - Mill Galv. | 4" (102mm) | |
| | 6" (152mm) | |

Example: FS24-04SL-12 is a 4" wide, 12' aluminum cover.
NOTE: 24' length not available.

| Catalog Number – Flanged Fitting Covers | | |
|---|------------------|--------|
| Finish | Width/Basic No. | Radius |
| FS24 - Alum. | -03 XX * (76mm) | 12" |
| FS22 - Mill Galv. | -04 XX * (102mm) | 24" |
| | -06 XX * (152mm) | 36" |

Example: FS24-034F-12 is a 3" wide, 45° Horizontal Elbow, 12" Radius fitting cover.

* XX from fitting selection base part number

90° HORIZONTAL ELBOW [9F]

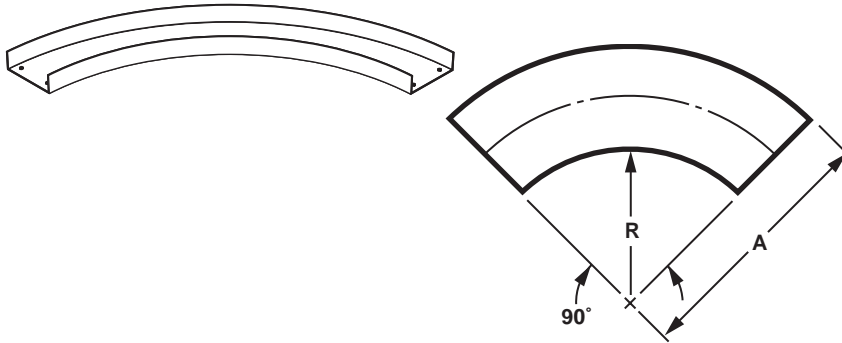

| Radius - R | Width - W | "A" Dim. |
|----------------|------------|--------------|
| 12" (305mm) | 3" (76mm) | 15" (381mm) |
| | 4" (102mm) | 16" (406mm) |
| | 6" (152mm) | 18" (457mm) |
| 24" (610mm) | 3" (76mm) | 17" (432mm) |
| | 4" (102mm) | 28" (711mm) |
| | 6" (152mm) | 30" (762mm) |
| 36" (914mm) | 3" (76mm) | 39" (991mm) |
| | 4" (102mm) | 40" (1016mm) |
| | 6" (152mm) | 42" (1067mm) |

60° HORIZONTAL ELBOW [6F]

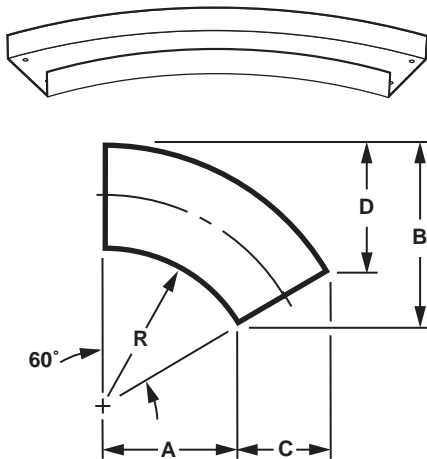

| Radius-R | Width - W | "A" Dim. | "B" Dim. | "C" Dim. | "D" Dim. |
|----------------|------------|-----------------|-------------|----------------|-----------------|
| 12" (305mm) | 3" (76mm) | 10 3/8" (264mm) | 9" (229mm) | 2 5/8" (66mm) | 7 1/2" (191mm) |
| | 4" (102mm) | 10 3/8" (264mm) | 10" (254mm) | 3 1/2" (88mm) | 8" (203mm) |
| | 6" (152mm) | 10 3/8" (264mm) | 12" (305mm) | 5 1/4" (132mm) | 9" (229mm) |
| 24" (610mm) | 3" (76mm) | 20 3/4" (528mm) | 15" (381mm) | 2 5/8" (66mm) | 13 1/2" (343mm) |
| | 4" (102mm) | 20 3/4" (528mm) | 16" (406mm) | 3 1/2" (88mm) | 14" (356mm) |
| | 6" (152mm) | 20 3/4" (528mm) | 18" (457mm) | 5 1/4" (132mm) | 15" (381mm) |
| 36" (914mm) | 3" (76mm) | 31 1/4" (792mm) | 21" (533mm) | 2 5/8" (66mm) | 19 1/2" (495mm) |
| | 4" (102mm) | 31 1/4" (792mm) | 22" (559mm) | 3 1/4" (88mm) | 20" (508mm) |
| | 6" (152mm) | 31 1/4" (792mm) | 24" (610mm) | 5 1/4" (132mm) | 21" (553mm) |

45° HORIZONTAL ELBOW [4F]

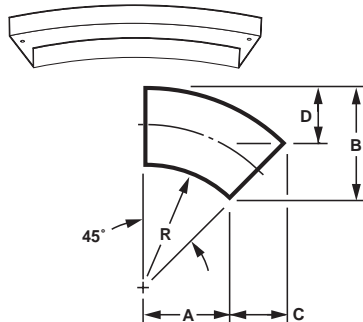

| Radius-R | Width - W | "A" Dim. | "B" Dim. | "C" Dim. | "D" Dim. |
|----------------|------------|-----------------|-----------------|----------------|-----------------|
| 12" (305mm) | 3" (76mm) | 8 1/2" (216mm) | 6 1/2" (165mm) | 2 1/8" (54mm) | 4 3/8" (112mm) |
| | 4" (102mm) | 8 1/2" (216mm) | 7 1/2" (191mm) | 2 5/8" (71mm) | 4 3/4" (119mm) |
| | 6" (152mm) | 8 1/2" (216mm) | 9 1/2" (241mm) | 4 1/4" (108mm) | 5 3/4" (134mm) |
| 24" (610mm) | 3" (76mm) | 17 1/8" (431mm) | 10 1/8" (255mm) | 2 1/8" (54mm) | 7 7/8" (201mm) |
| | 4" (102mm) | 17 1/8" (431mm) | 11 1/8" (280mm) | 2 5/8" (71mm) | 8 1/4" (208mm) |
| | 6" (152mm) | 17 1/8" (431mm) | 13 1/8" (331mm) | 4 1/4" (108mm) | 8 3/4" (223mm) |
| 36" (914mm) | 3" (76mm) | 25 1/2" (647mm) | 13 5/8" (344mm) | 2 1/8" (54mm) | 11 1/2" (291mm) |
| | 4" (102mm) | 25 1/2" (647mm) | 14 5/8" (370mm) | 2 5/8" (71mm) | 11 3/4" (298mm) |
| | 6" (152mm) | 25 1/2" (647mm) | 16 5/8" (421mm) | 4 1/4" (108mm) | 12 5/8" (313mm) |

ORDERING INFORMATION

Prefix No.

[M] - [W] [Bp] - [R] [B]

Material Finish
(22=Mill-Galv Steel,
23=Hot-Dip-Galv Steel,
24=Aluminum)

Width (03", 04", 06")

Basic Part (9F, 6F, 4F)

Radius (12", 24", 36")

Bottom (S=Solid)

Note: All Channel Cable Fittings come in solid bottom only

CHANNEL CABLE TRAY SYSTEM

FITTINGS

30° HORIZONTAL ELBOW [3F]

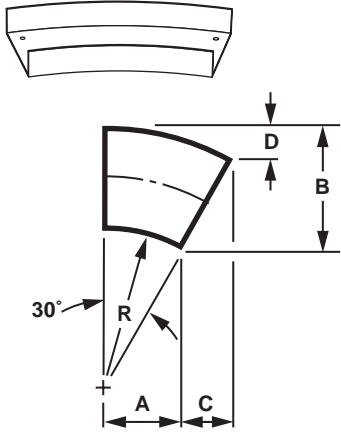

| Radius - R | Width - W | "A" Dim. | "B" Dim. | "C" Dim. | "D" Dim. | Part Number |
|-------------|------------|-----------------|-------------|----------------|-----------------|-------------|
| 12" (305mm) | 3" (76mm) | 10 3/8" (264mm) | 9" (229mm) | 2 5/8" (66mm) | 7 1/2" (191mm) | M-039F-12-B |
| | 4" (102mm) | 10 3/8" (264mm) | 10" (254mm) | 3 1/2" (887mm) | 8" (203mm) | M-049F-12-B |
| | 6" (152mm) | 10 3/8" (264mm) | 12" (305mm) | 5 1/4" (132mm) | 9" (229mm) | M-069F-12-B |
| 24" (610mm) | 3" (76mm) | 20 3/4" (528mm) | 15" (381mm) | 2 5/8" (66mm) | 13 1/2" (343mm) | M-039F-24-B |
| | 4" (102mm) | 20 3/4" (528mm) | 16" (406mm) | 3 1/2" (88mm) | 14 1/2" (356mm) | M-049F-24-B |
| | 6" (152mm) | 20 3/4" (528mm) | 18" (457mm) | 5 1/4" (132mm) | 15" (381mm) | M-069F-24-B |
| 36" (914mm) | 3" (76mm) | 31 1/4" (792mm) | 21" (533mm) | 2 5/8" (66mm) | 19 1/2" (495mm) | M-039F-36-B |
| | 4" (102mm) | 31 1/4" (792mm) | 22" (559mm) | 3 1/2" (88mm) | 20" (508mm) | M-049F-36-B |
| | 6" (152mm) | 31 1/4" (792mm) | 24" (610mm) | 5 1/4" (132mm) | 21" (553mm) | M-069F-36-B |

90° VERTICAL INSIDE ELBOW [9I]

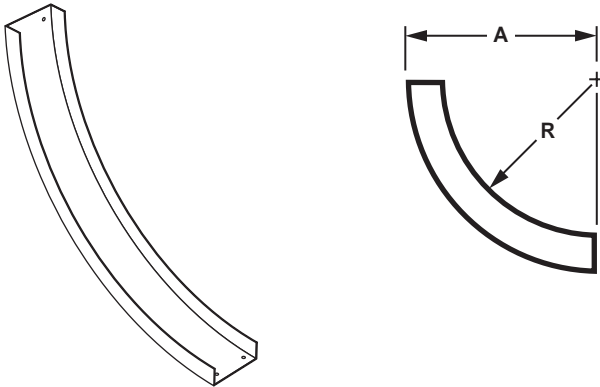

| Radius - R | Width - W | "A" Dimension |
|-------------|------------|---------------|
| 12" (305mm) | 3" (76mm) | 12" (305mm) |
| | 4" (102mm) | 12" (305mm) |
| | 6" (152mm) | 12" (305mm) |
| 24" (610mm) | 3" (76mm) | 24" (610mm) |
| | 4" (102mm) | 24" (610mm) |
| | 6" (152mm) | 24" (610mm) |
| 36" (914mm) | 3" (76mm) | 36" (914mm) |
| | 4" (102mm) | 36" (914mm) |
| | 6" (152mm) | 36" (914mm) |

90° VERTICAL OUTSIDE ELBOW [9O]

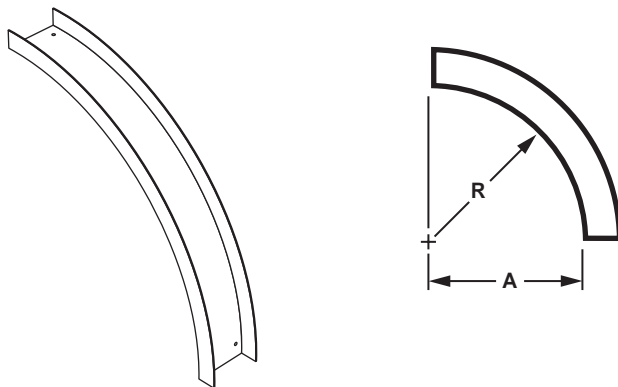

| Radius - R | Width - W | "A" Dim. | Part Number |
|-------------|------------|-----------------|-------------|
| 12" (305mm) | 3" (76mm) | 13 3/4" (349mm) | M-0390-12-B |
| | 4" (102mm) | 13 3/4" (349mm) | M-0490-12-B |
| | 6" (152mm) | 13 3/4" (349mm) | M-0690-12-B |
| 24" (610mm) | 3" (76mm) | 25 3/4" (654mm) | M-0390-24-B |
| | 4" (102mm) | 25 3/4" (654mm) | M-0490-24-B |
| | 6" (152mm) | 25 3/4" (654mm) | M-0690-24-B |
| 36" (914mm) | 3" (76mm) | 37 3/4" (959mm) | M-0390-36-B |
| | 4" (102mm) | 37 3/4" (959mm) | M-0490-36-B |
| | 6" (152mm) | 37 3/4" (959mm) | M-0690-36-B |

ORDERING INFORMATION

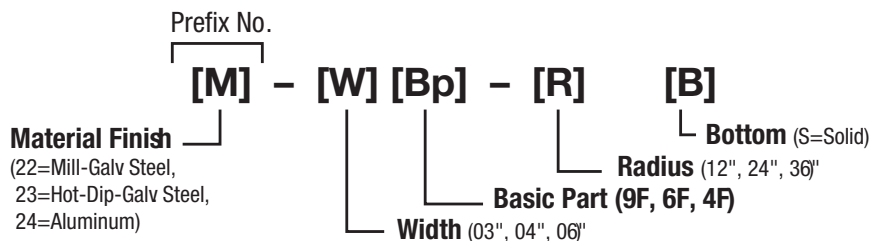

Note: All Channel Cable Fittings come in solid bottom only

60° VERTICAL INSIDE ELBOW [6I]

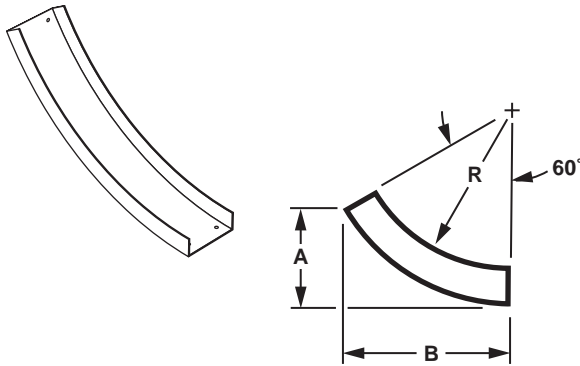

| Radius - R | Width - W | "A" Dim. | "B" Dim. |
|----------------|------------|-----------------|-----------------|
| 12" (305mm) | 3" (76mm) | 6 7/8" (175mm) | 11 1/8" (302mm) |
| | 4" (102mm) | 6 7/8" (175mm) | 11 1/8" (302mm) |
| | 6" (152mm) | 6 7/8" (175mm) | 11 1/8" (302mm) |
| 24" (610mm) | 3" (76mm) | 12 7/8" (327mm) | 22 1/4" (567mm) |
| | 4" (102mm) | 12 7/8" (327mm) | 22 1/4" (567mm) |
| | 6" (152mm) | 12 7/8" (327mm) | 22 1/4" (567mm) |
| 36" (914mm) | 3" (76mm) | 18 7/8" (479mm) | 32 3/4" (830mm) |
| | 4" (102mm) | 18 7/8" (479mm) | 32 3/4" (830mm) |
| | 6" (152mm) | 18 7/8" (479mm) | 32 3/4" (830mm) |

60° VERTICAL OUTSIDE ELBOW [6O]

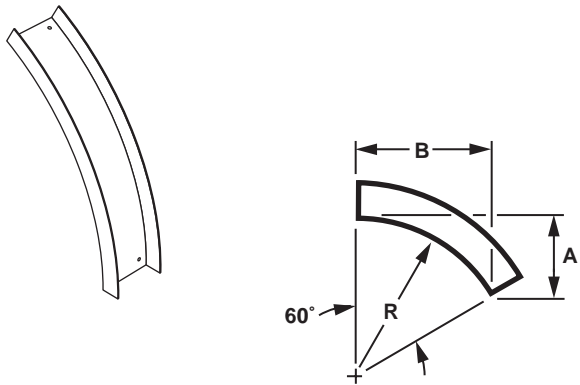

| Radius - R | Width - W | "A" Dim. | "B" Dim. |
|----------------|------------|-------------|-----------------|
| 12" (305mm) | 3" (76mm) | 6" (152mm) | 10 3/8" (264mm) |
| | 4" (102mm) | 6" (152mm) | 10 3/8" (264mm) |
| | 6" (152mm) | 6" (152mm) | 10 3/8" (264mm) |
| 24" (610mm) | 3" (76mm) | 12" (305mm) | 20 3/4" (528mm) |
| | 4" (102mm) | 12" (305mm) | 20 3/4" (528mm) |
| | 6" (152mm) | 12" (305mm) | 20 3/4" (528mm) |
| 36" (914mm) | 3" (76mm) | 18" (457mm) | 31 1/4" (792mm) |
| | 4" (102mm) | 18" (457mm) | 31 1/4" (792mm) |
| | 6" (152mm) | 18" (457mm) | 31 1/4" (792mm) |

45° VERTICAL INSIDE ELBOW [4I]

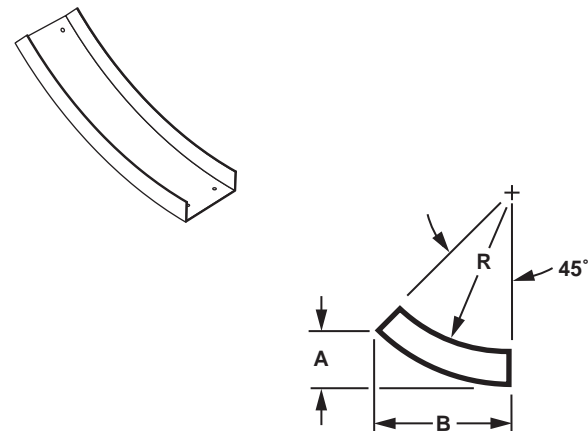

| Radius - R | Width - W | "A" Dim. | "B" Dim. |
|----------------|------------|-----------------|-----------------|
| 12" (305mm) | 3" (76mm) | 4 1/8" (102mm) | 9 3/4" (247mm) |
| | 4" (102mm) | 4 1/8" (102mm) | 9 3/4" (247mm) |
| | 6" (152mm) | 4 1/8" (102mm) | 9 3/4" (247mm) |
| 24" (610mm) | 3" (76mm) | 7 1/2" (191mm) | 18 1/4" (463mm) |
| | 4" (102mm) | 7 1/2" (191mm) | 18 1/4" (463mm) |
| | 6" (152mm) | 7 1/2" (191mm) | 18 1/4" (463mm) |
| 36" (914mm) | 3" (76mm) | 11 1/8" (281mm) | 26 3/4" (678mm) |
| | 4" (102mm) | 11 1/8" (281mm) | 26 3/4" (678mm) |
| | 6" (152mm) | 11 1/8" (281mm) | 26 3/4" (678mm) |

ORDERING INFORMATION

Prefix No. [M] - [W] [Bp] - [R] [B]

Material Finish
 (22=Mill-Galv Steel,
 23=Hot-Dip-Galv Steel,
 24=Aluminum)

Width (03", 04", 06")

Basic Part (9F, 6F, 4F)

Radius (12", 24", 36")

Bottom (S=Solid)

Note: All Channel Cable Fittings come in solid bottom only

CHANNEL CABLE TRAY SYSTEM

FITTINGS

45° VERTICAL OUTSIDE ELBOW [40]

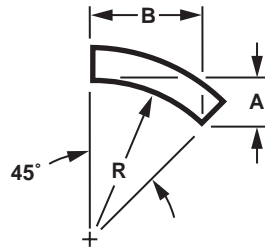
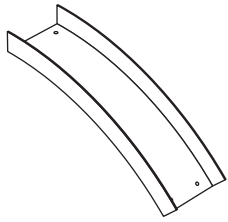

| Radius - R | Width - W | "A" Dim. | "B" Dim. |
|----------------|------------|-----------------|-----------------|
| 12" (305mm) | 3" (76mm) | 3 1/2" (89mm) | 8 1/2" (216mm) |
| | 4" (102mm) | 3 1/2" (89mm) | 8 1/2" (216mm) |
| | 6" (152mm) | 3 1/2" (89mm) | 8 1/2" (216mm) |
| 24" (610mm) | 3" (76mm) | 7 1/8" (179mm) | 17 1/8" (431mm) |
| | 4" (102mm) | 7 1/8" (179mm) | 17 1/8" (431mm) |
| | 6" (152mm) | 7 1/8" (179mm) | 17 1/8" (431mm) |
| 36" (914mm) | 3" (76mm) | 10 1/2" (268mm) | 25 1/8" (646mm) |
| | 4" (102mm) | 10 1/2" (268mm) | 25 1/8" (646mm) |
| | 6" (152mm) | 10 1/2" (268mm) | 25 1/8" (646mm) |

30° VERTICAL INSIDE ELBOW [3I]

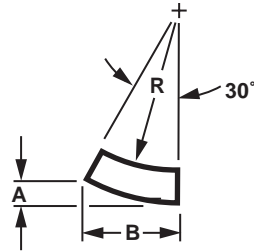
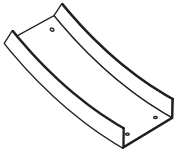

| Radius - R | Width - W | "A" Dim. | "B" Dim. |
|----------------|------------|----------------|-----------------|
| 12" (305mm) | 3" (76mm) | 1 7/8" (47mm) | 6 7/8" (175mm) |
| | 4" (102mm) | 1 7/8" (47mm) | 6 7/8" (175mm) |
| | 6" (152mm) | 1 7/8" (47mm) | 6 7/8" (175mm) |
| 24" (610mm) | 3" (76mm) | 3 1/2" (87mm) | 12 7/8" (327mm) |
| | 4" (102mm) | 3 1/2" (87mm) | 12 7/8" (327mm) |
| | 6" (152mm) | 3 1/2" (87mm) | 12 7/8" (327mm) |
| 36" (914mm) | 3" (76mm) | 5 1/8" (129mm) | 18 7/8" (479mm) |
| | 4" (102mm) | 5 1/8" (129mm) | 18 7/8" (479mm) |
| | 6" (152mm) | 5 1/8" (129mm) | 18 7/8" (479mm) |

30° VERTICAL OUTSIDE ELBOW [3O]

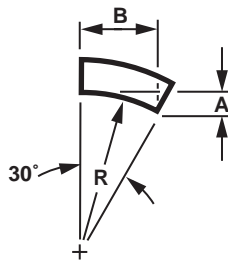
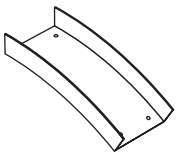

| Radius - R | Width - W | "A" Dim. | "B" Dim. |
|----------------|------------|----------------|-------------|
| 12" (305mm) | 3" (76mm) | 1 5/8" (40mm) | 6" (152mm) |
| | 4" (102mm) | 1 5/8" (40mm) | 6" (152mm) |
| | 6" (152mm) | 1 5/8" (40mm) | 6" (152mm) |
| 24" (610mm) | 3" (76mm) | 3 1/4" (82mm) | 12" (305mm) |
| | 4" (102mm) | 3 1/4" (82mm) | 12" (305mm) |
| | 6" (152mm) | 3 1/4" (82mm) | 12" (305mm) |
| 36" (914mm) | 3" (76mm) | 4 7/8" (122mm) | 18" (457mm) |
| | 4" (102mm) | 4 7/8" (122mm) | 18" (457mm) |
| | 6" (152mm) | 4 7/8" (122mm) | 18" (457mm) |

ORDERING INFORMATION

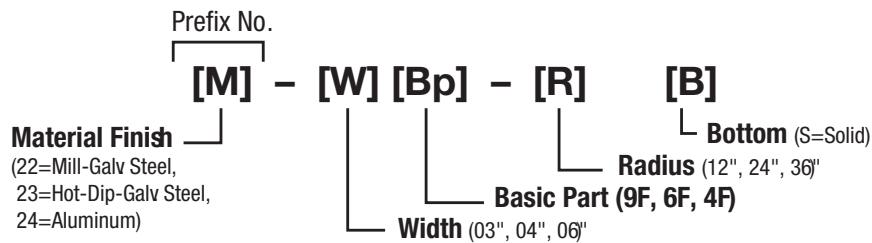

Note: All Channel Cable Fittings come in solid bottom only

HORIZONTAL TEE [FT]

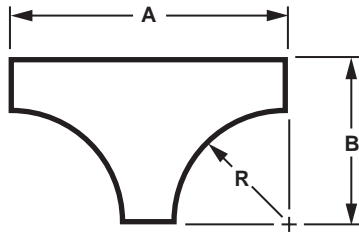
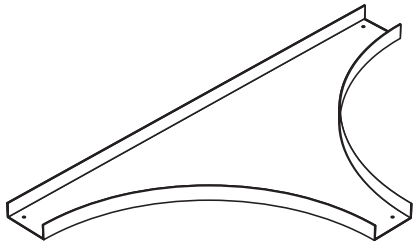

| Radius - R | Width - W | "A" Dim. | "B" Dim. |
|----------------|------------|--------------|--------------|
| 12" (305mm) | 3" (76mm) | 27" (686mm) | 15" (381mm) |
| | 4" (102mm) | 28" (711mm) | 16" (406mm) |
| | 6" (152mm) | 30" (762mm) | 18" (457mm) |
| 24" (610mm) | 3" (76mm) | 51" (1275mm) | 27" (686mm) |
| | 4" (102mm) | 52" (1321mm) | 28" (711mm) |
| | 6" (152mm) | 54" (1372mm) | 30" (762mm) |
| 36" (914mm) | 3" (76mm) | 75" (1905mm) | 39" (991mm) |
| | 4" (102mm) | 76" (1930mm) | 40" (1016mm) |
| | 6" (152mm) | 78" (1981mm) | 42" (1067mm) |

HORIZONTAL CROSS [FC]

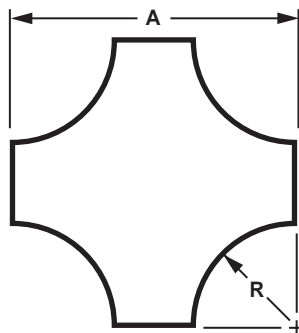
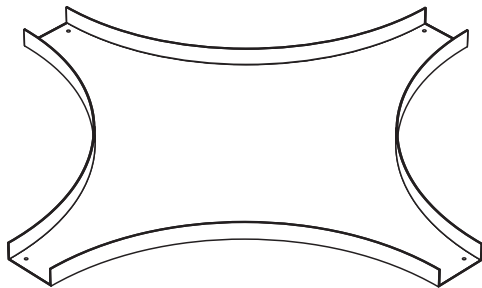

| Radius - R | Width - W | Catalog No. | "A" Dim. |
|----------------|------------|----------------|--------------|
| 12" (305mm) | 3" (76mm) | Prefix-03FC-12 | 27" (686mm) |
| | 4" (102mm) | Prefix-04FC-12 | 28" (711mm) |
| | 6" (152mm) | Prefix-06FC-12 | 30" (762mm) |
| 24" (610mm) | 3" (76mm) | Prefix-03FC-24 | 51" (1295mm) |
| | 4" (102mm) | Prefix-04FC-24 | 52" (1321mm) |
| | 6" (152mm) | Prefix-06FC-24 | 54" (1372mm) |
| 36" (914mm) | 3" (76mm) | Prefix-03FC-36 | 75" (1905mm) |
| | 4" (102mm) | Prefix-04FC-36 | 76" (1930mm) |
| | 6" (152mm) | Prefix-06FC-36 | 78" (1981mm) |

ORDERING INFORMATION



Note: All Channel Cable Fittings come in solid bottom only

CHANNEL CABLE TRAY SYSTEM

ACCESSORIES

BLIND END [BE]

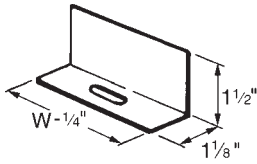

| W | Catalog No. |
|------------|-------------|
| 3" (76mm) | Prefix-03BE |
| 4" (102mm) | Prefix-04BE |
| 6" (152mm) | Prefix-06BE |

Steel Plated, Furnished with one set 1/4" x 3/4" bolt, nut and washer.

END DROPOUT [DO]

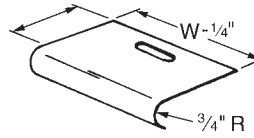

| W | Catalog No. |
|------------|-------------|
| 3" (76mm) | Prefix-03DO |
| 4" (102mm) | Prefix-04DO |
| 6" (152mm) | Prefix-06DO |

Prefixes:

- 22 = Mill-Galv. Steel,
- 23 = Hot-Dip Galv. Steel,
- 24 = Aluminum

Steel plated, Furnished with one set 1/4" x 3/4" bolt, nut and washer.

CHANNEL TO BOX OR WALL CONNECTOR [CB]

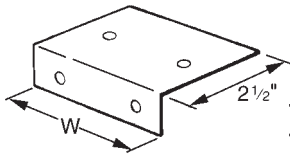

| W | Catalog No. |
|------------|-------------|
| 3" (76mm) | Prefix-03CB |
| 4" (102mm) | Prefix-04CB |
| 6" (152mm) | Prefix-06CB |

Prefixes:

- 22 = Mill-Galv. Steel,
- 23 = Hot-Dip Galv. Steel,
- 24 = Aluminum

Furnished with two sets 3/8" x 3/4" bolt, nut and washer. Steel plated.

NYLON DROPOUT GROMMET [DOG-1]

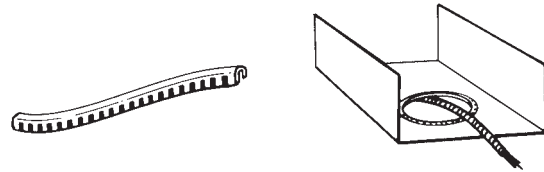

Use at cable dropouts, over sides or thru vent holes.

Furnished in 12' lengths. Cut to length in field.

STANDARD CONNECTOR [CS]

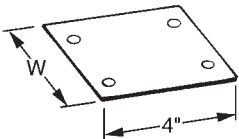

| W | Catalog No. |
|------------|-------------|
| 3" (76mm) | Prefix-03CS |
| 4" (102mm) | Prefix-04CS |
| 6" (152mm) | Prefix-06CS |

Prefixes:

- 22 = Mill-Galv. Steel,
- 23 = Hot-Dip Galv. Steel,
- 24 = Aluminum

Hardware: 3/8" x 3/4" Bolt and flanged nut
Steel plated incl. (4-sets)

EXPANSION CONNECTOR [CE]

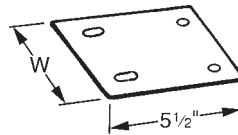

| W | Catalog No. |
|------------|-------------|
| 3" (76mm) | Prefix-03CE |
| 4" (102mm) | Prefix-04CE |
| 6" (152mm) | Prefix-06CE |

Prefixes:

- 22 = Mill-Galv. Steel,
- 23 = Hot-Dip Galv. Steel,
- 24 = Aluminum

Hardware: 3/8" x 3/4" Bolt and flanged nut
Steel plated incl. (4-sets)

ORDERING INFORMATION

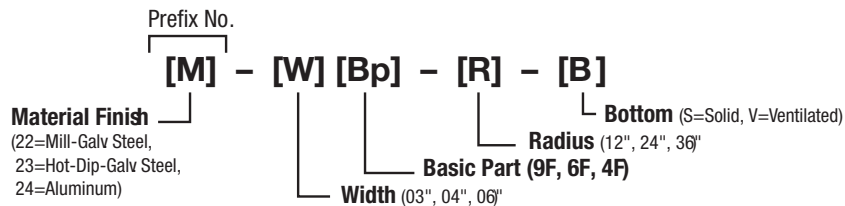

ACCESSORIES, INTERCONNECTIONS

ADJUSTABLE HORIZONTAL CONNECTOR [CH]

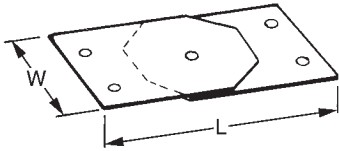

| W | L | Catalog No. |
|------------|-----------------|-------------|
| 3" (76mm) | 7 1/2" (191mm) | Prefix-03CH |
| 4" (102mm) | 8 1/2" (216mm) | Prefix-04CH |
| 6" (152mm) | 10 1/2" (267mm) | Prefix-06CH |

Prefixes:

- 22 = Mill-Galv. Steel,
- 23 = Hot-Dip Galv. Steel,
- 24 = Aluminum

Hardware: 3/8" x 3/4" Bolt and flanged nut
Steel plated incl. (4-sets)

ADJUSTABLE RISER CONNECTOR [CV]

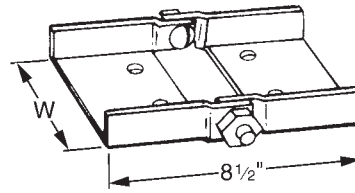

| W | Catalog No. |
|------------|-------------|
| 3" (76mm) | Prefix-03CV |
| 4" (102mm) | Prefix-04CV |
| 6" (152mm) | Prefix-06CV |

Prefixes:

- 22 = Mill-Galv. Steel,
- 23 = Hot-Dip Galv. Steel,
- 24 = Aluminum

Hardware: 1/4" x 2 1/4" Machine screw and wing nut. Steel plated incl. (2-sets)

COVER CONNECTOR [CC]

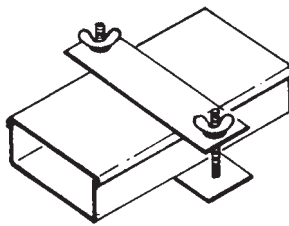

| W | Catalog No. |
|------------|-------------|
| 3" (76mm) | Prefix-03CC |
| 4" (102mm) | Prefix-04CC |
| 6" (152mm) | Prefix-06CC |

Prefixes:

- 22 = Mill-Galv. Steel,
- 23 = Hot-Dip Galv. Steel,
- 24 = Aluminum

Hardware: 3/8" x 3/4" Bolt and flanged nut
Steel plated incl. (4-sets)

CHANNEL HOLDDOWN CLAMP (STAINLESS STEEL)[9079]

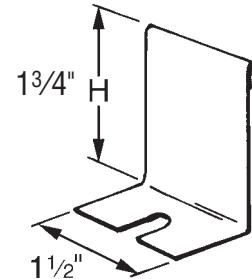

For use with steel or aluminum systems.

(No hardware included.)

INTERCONNECTIONS

9019-1 (3/4" L)

5/16" Dia.

Bolt, Nut, & Washer

70620
Conduit Clamp
Bracket

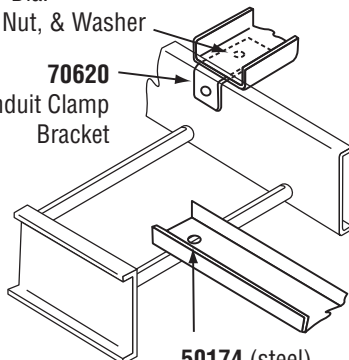

50174 (steel)

50174 (Alum.)

Rung Clamp with Hardware

70620
Conduit Clamp
Bracket with
Mounting
Hardware

9019-1

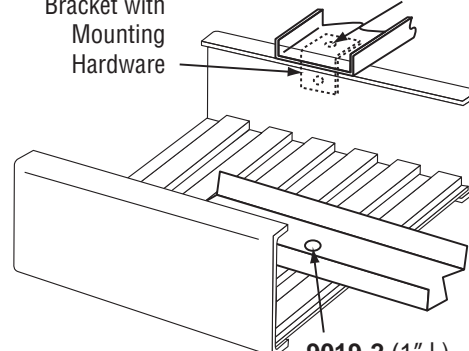

9019-2 (1" L)

5/16" Dia.

Bolt, Nut & Washer

CHANNEL CABLE TRAY SYSTEM

HANGERS

CHANNEL HANGERS

For 3"-, 4"- or 6"- wide Cope Channel raceways. Pipe sleeve accommodates either $\frac{3}{8}$ " or $\frac{1}{2}$ " diameter rods. Finish is hot-dip galvanized after fabrication. Order hardware separately.

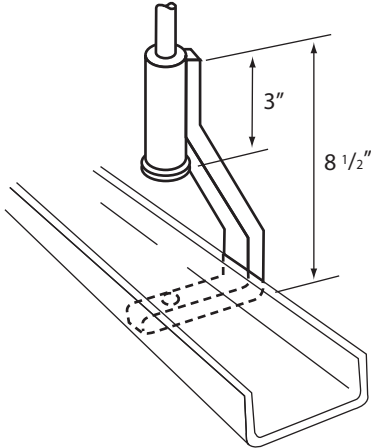

SINGLE CHANNEL HANGER

| Catalog No. | Use With |
|-------------|-----------------------|
| 9013 | 3"- & 4"-wide channel |
| 9013-1 | 6"-wide channel |

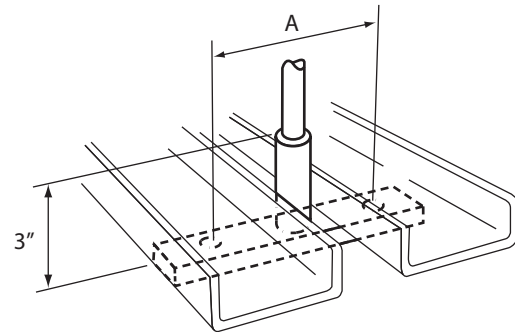

DOUBLE CHANNEL HANGER

| Catalog No. | Use With | Dimension "A" |
|-------------|-----------------------|---------------|
| 9014 | 3"- & 4"-wide channel | 5" |
| 9014-1 | 6"-wide channel | 7" |

7

COPE-GLAS™

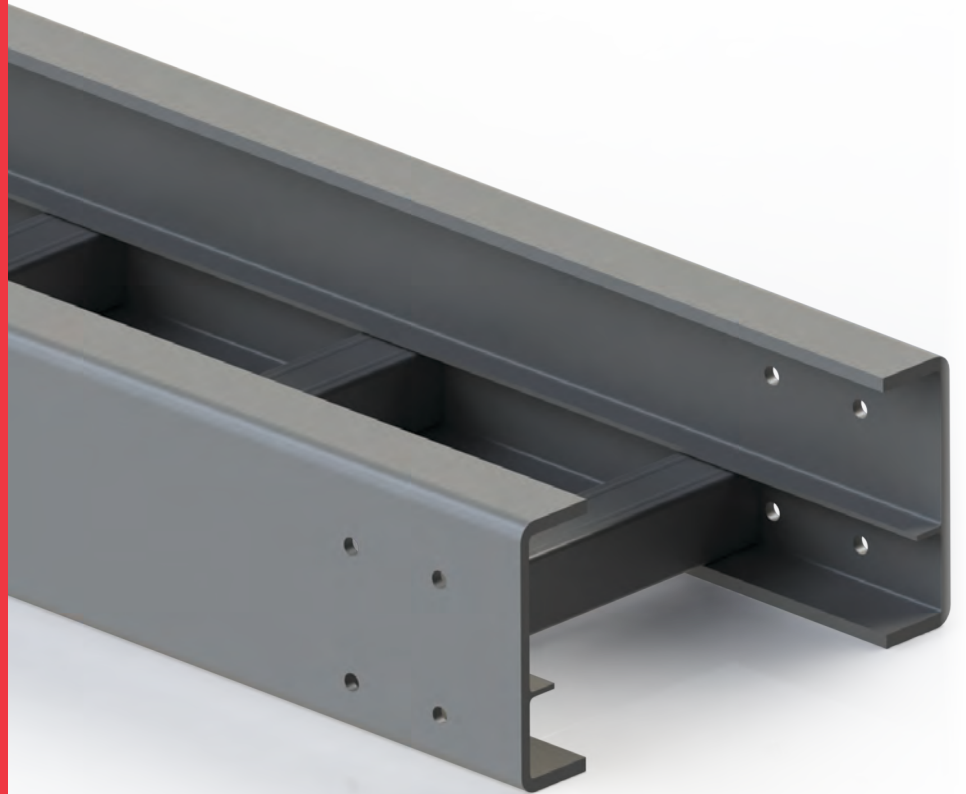

Fiberglass Cable Tray System

CONTENTS

GENERAL & TECHNICAL INFORMATION

| | |
|---|-----------|
| Advantages of COPE-GLAS™ Cable Tray | 172 - 173 |
| Fiberglass Cable Tray Standards..... | 174 |
| COPE-GLAS™ Cable Tray and AICKINSTRUT® Specifications | 175 |

CABLE TRAY DESIGN AND APPLICATION

| | |
|---|-----------|
| Construction and Physical Properties..... | 176 - 177 |
| Application Environments | 178 - 179 |
| COPE-GLAS™ Structural Designs | 180 |
| COPE-GLAS™ Selection Guide..... | 180 |
| Installation Procedures | 181 - 185 |

PRODUCT INFORMATION

| | |
|--------------------------------------|-----------|
| Straight Sections..... | 186 - 187 |
| Covers..... | 188 |
| Vertical Elbows (Inside and Outside) | |
| 90° | 189 |
| 45° | 190 |
| Adjustable (VAB) | 191 |
| Vertical Tee..... | 192 |
| Horizontal Elbows | |
| 90° | 193 |
| 45° | 193 |
| Adjustable (HAB)..... | 194 |
| Horizontal Tee | 195 |
| Horizontal Cross | 196 |
| Straight Reducers | 197 |
| Left and Right Hand Reducers | 197 |

ACCESSORIES

| | |
|-------------------------------------|-----------|
| Splice Plates | 199 - 200 |
| Accessories..... | 201 - 202 |
| AICKINSTRUT® Support Systems..... | 203 - 206 |
| COPE-GLAS™ Fiberglass Channel | 207 - 210 |

COPE-GLAS CABLE TRAY IS UL LISTED

Cope-Glas Fiberglass Cable Tray as manufactured by Cope (a part of Atkore International) is now UL listed. This UL Listing guarantees the customer that they will receive a quality product that meets the rigid standards of Underwriters Laboratories. Furthermore, it ensures the customer that the product they receive will meet the required UL and NEMA FG1 performance criteria in the following areas:

- Low Temperature
- High Temperature
- Flame resistance
- Loading & Deflection
- Dielectric Strength
- Volume Resistivity
- Thermogravimetric Analysis
- Infrared Analysis
- UV Exposure
- Water Exposure & Immersion

In order to maintain the UL Listing, Cope must continually undergo follow-up testing with Underwriters Laboratories. This further assures the customer that Cope is maintaining its quality with respect to raw materials, production and fabrication. This UL Listing demonstrates Cope's commitment to developing and providing its customers with the highest quality fiberglass cable tray products available in the industry.

PICTORIAL INDEX

STRAIGHT LENGTH

Pages 186 - 187

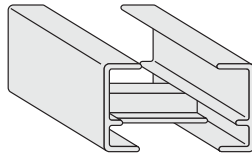

HORIZONTAL CROSS

Page 195

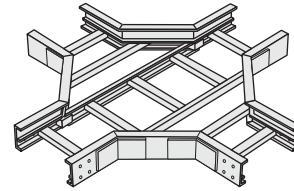

COVERS

Page 188

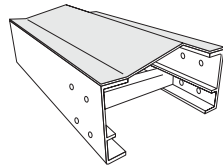

REDUCERS

Page 197

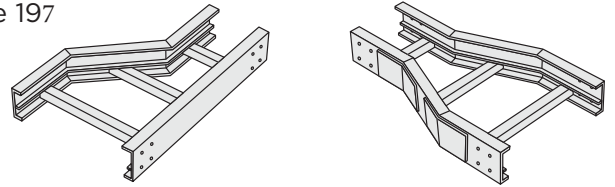

VERTICAL BENDS (INSIDE & OUTSIDE)

Pages 189 - 190

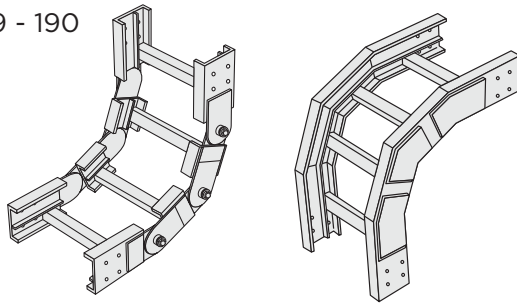

SPLICE PLATES

Pages 199 - 200

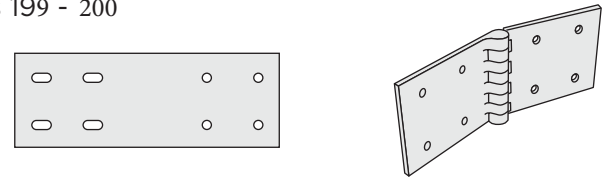

VERTICAL TEES

Page 192

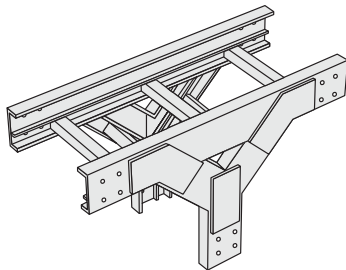

ACCESSORIES

Pages 201 - 202

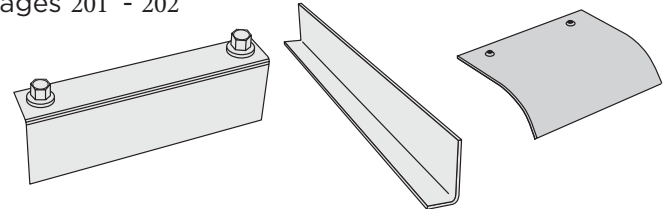

HORIZONTAL ELBOWS

Pages 193 - 194

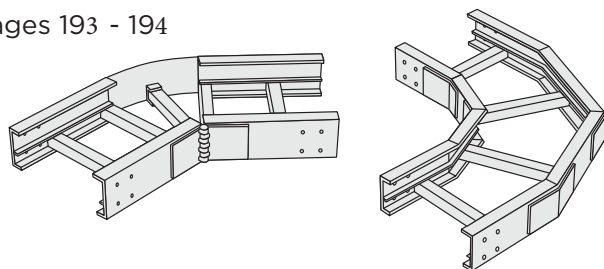

AICKINSTRUT SUPPORT SYSTEM

Pages 203 - 206

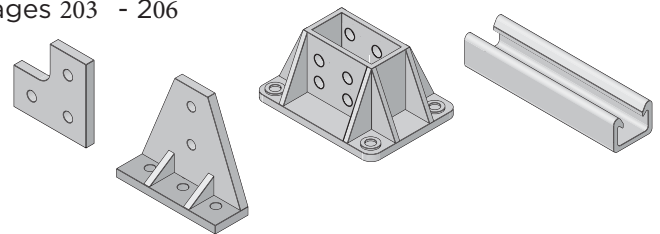

COPE FIBERGLASS CHANNEL SYSTEM

Pages 207-210

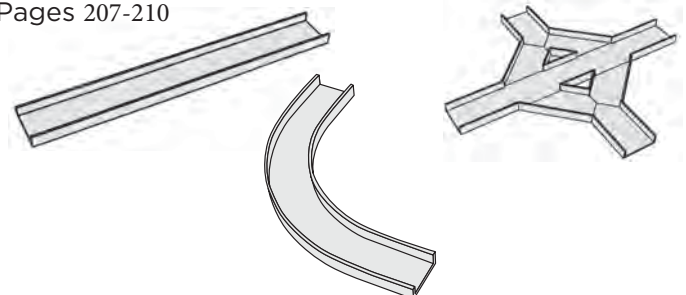

HORIZONTAL TEES

Page 195

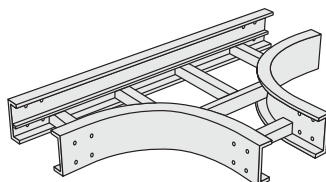

ADVANTAGES OF COPE-GLAS™ CABLE TRAY

COPE-GLAS™

Systems Advantages

Engineers, designers, contractors, installers and end users have many reasons to choose COPE-GLAS cable tray for their power, signal and control distribution support requirements. Here are some specific advantages that COPE-GLAS systems provide:

Corrosion Resistance

The inherent chemical resistance of COPE-GLAS cable tray makes it desirable for severely corrosive environments. Life cycle costs of tray installations can be dramatically reduced by the extended life expectancy of this product. Many original installations have been in service for nearly twenty-five years and are providing reliable service.

Versatile

COPE-GLAS cable tray systems are available in a variety of sizes and styles. A standard or special design can be fabricated for any indoor or outdoor application regardless of size.

Easy Installation

COPE-GLAS cable tray is strong and lightweight, allowing this durable system to be installed quickly and easily. Because there are no sharp edges or burrs, long runs of armored cable can be installed with less chance for cable damage.

Tray System Advantages Over Other Wiring Methods

Cable tray systems in general provide the following advantages over other wiring methods:

Full Ventilation

Power cables need not be derated in a ventilated cable tray system. Explosive gases cannot be trapped or transmitted as in totally enclosed wiring systems.

Long Support Spans

COPE-GLAS cable tray systems are designed for up to twenty foot support spans, longer than most other wiring methods. Fewer supports reduce both installation time and cost.

Installation Labor Reduced

COPE-GLAS cable tray can be installed after concrete and major building steel and mechanical piping are complete. Crews can start later and finish sooner.

Space Efficiency

COPE-GLAS cable tray systems can carry more cable in less space than other wiring methods.

Fully Compatible with Other Wiring Methods

COPE-GLAS cable tray is often used in main runs when other wiring methods are employed in branch circuits.

Simple Field Modifications

Modifications can be made easily using standard metalworking tools without extensive re-engineering.

Accessibility for the Future

New cable can be easily added, replaced or repaired. Circuits can be visually traced, minimizing startup and trouble shooting.

ADVANTAGES OF COPE-GLAS™ CABLE TRAY

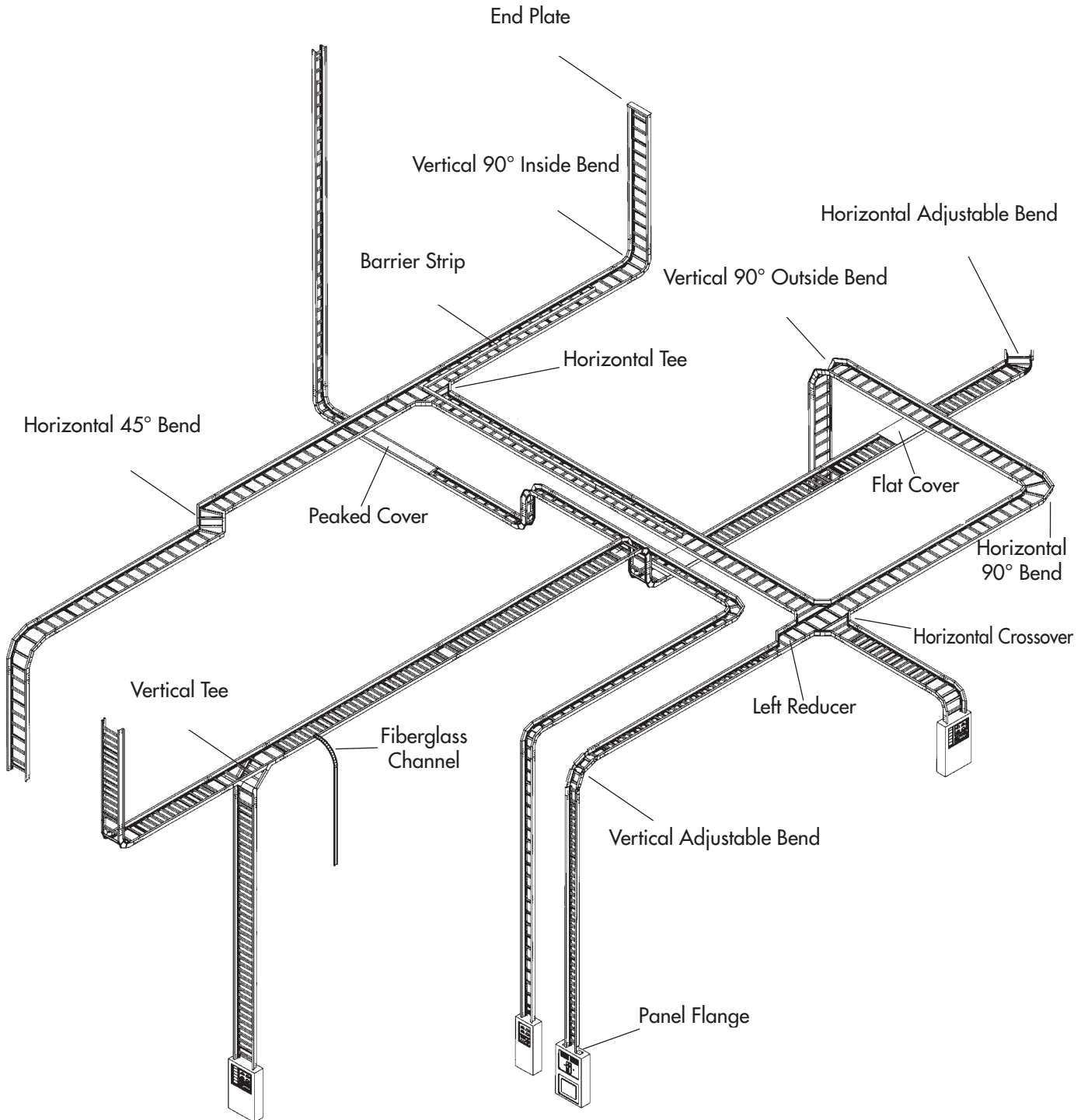

Intro

LADDER

I-BEAM

HAT

TROF

CHANNEL

COPE-GLAS™

WIREBASKET

Reference

STANDARDS

The standards commonly referenced in specifying cable tray are the National Electric Code, Article 392-Cable trays; NEMA Standards Publication NO. FG 1, Fiberglass Cable Tray Systems; Canadian Standards Association CAN/CSA-C22.2 No. 126-M91, Cable Tray Systems and Underwriters Laboratories Inc. Standard UL-568, CYOV Non-Metallic Cable Trays. ASTM and UL standards are also referenced to characterize the materials used to construct the fiberglass cable tray.

ASTM standards define physical properties tests for the materials used to pultrude the cable tray. The specific ASTM test methods for mechanical, thermal and flammability properties are identified in the Construction and Physical Properties Section. UL flammability standards applied to fiberglass cable tray materials are also identified in the same section. ASTM and UL standard material properties for fiberglass channel and strut are identical to those of the cable tray because they are pultruded from the same materials.

Load Standards

Section 3 of NEMA FG 1 provides the performance standards and class designations for fiberglass cable tray systems. Based on a twenty foot support span, three working load classifications are recognized:

LOAD STANDARDS

| Load Class | Allowable Working Load |
|------------|------------------------|
| A | 50 lbs./linear ft. |
| B | 75 lbs./linear ft. |
| C | 100 lbs./linear ft. |

COPE-GLAS "Z" Style standard tray is available in one load classification. The standard four inch fill depth cable tray is designated as type "CZ" for the respective NEMA class. The deep tray, which provides six inches of cable fill depth, is designated as Type "CZD" for

its respective NEMA class. The style "E" tray is available in two load classes, which are designated as Type "BE" and Type "CE" for the respective NEMA classes. All COPE-GLAS tray styles have a 1.5 safety factor and exceed the NEMA FG 1 requirement for the allowable working load.

The Low Profile Cable Tray, Type "LC", is not yet included in the NEMA Standard; however, it has been designed and tested to comply with the intent of NEMA FG 1. A safety factor 1.5 times the Type "LC" working load of 50 lbs./linear foot for a 12 foot length has been confirmed by NEMA FG 1 test methods.

Type "LC" cable tray meets the requirements of Class C1 in the CAN/CSA-C22.2 No. 126-M91 standard.

Considerations for Cable Tray Deflection

Cable Tray load testing as specified by NEMA Standard FG 1 requires the test article to be a single length of tray simply supported at each end (referred to as a "simple beam" configuration - see diagram below). This requirement was established to standardize testing and because it is impractical to test large tray system assemblies to destruction. Most actual tray installations consist of multiple lengths of connected tray with multiple supports (referred to as a "continuous beam" configuration). The most significant difference between a continuous versus simple beam configuration is that for continuous beam, the presence of adjacent lengths of tray affect the deflection of the tray in the section of interest.

With the same loading and support span, the maximum deflection is dramatically less for continuous compared to simple beam. For example, in the NEMA FG 1 simple beam test, COPE-GLAS Class CE fiberglass cable tray deflects approximately 3.75" at the mid-point of a 20' support span while carrying its rated load of 100 pounds per foot. In continuous beam, the maximum mid-span deflection would be only 0.8" or 20% of that for simple beam.

Tray Splice Joint Locations vs. Support Locations

In a continuous beam configuration, the bending moment in the tray side rails becomes zero at points located approximately 1/4 of the span from each tray support (referred to as "quarter span points" or just "quarter points"). For example, if the support span is 10 feet, the quarter point is 2.5 feet from the support. Quarter points are ideal locations for spliced tray connections because joints are subjected to minimum bending stresses (see diagram below).

EFFECT OF TEMPERATURE

| Temp. in °F | Approximate % of Strength | |
|-------------|---------------------------|-------------------|
| | Polyester Resin | Vinyl Ester Resin |
| 75° | 100 | 100 |
| 100° | 90 | 100 |
| 125° | 78 | 100 |
| 150° | 68 | 90 |
| 175° | 60 | 90 |
| 200° | 52 | 75 |

Note: Consult the manufacturer when temperatures above 200° F are encountered. Cope-Glas™ is not adversely affected by below freezing temperatures.

Effect of Temperature

When continuously exposed to elevated temperatures, the strength properties of reinforced fiberglass are reduced. Working loads shall be reduced based on the following table..

Chemical Resistance

is used because of its superior corrosion resistance; therefore, corrosion resistance data for specific environments are very important. The corrosion resistance guide in the Application Environments Section offers performance data in the most common environments. If information for a specific environment is not shown in the guide, please consult the factory.

Installation/Application

Guidance for cable tray installation, supports and support locations and thermal expansion/contraction is provided in NEMA FG 1. The installation instructions for supports and support locations contained in the Installation Procedures Section of this catalog are based on the Application Information Section of NEMA FG 1.

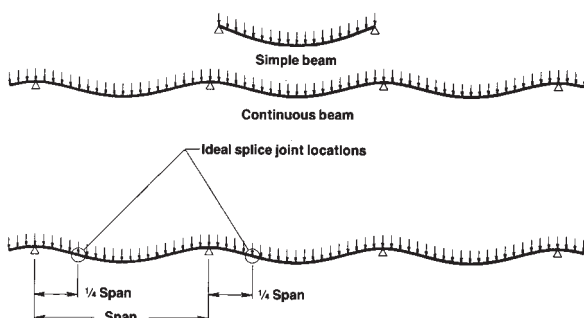

COPE-GLAS™ CABLE TRAY SYSTEM

1. Material

1.1 Cable tray shall be of pultruded glass reinforced polyester or vinyl ester resin having physical property values as listed in the Design and Application Section of this catalog.

2. Composition

2.1 Glass reinforced components shall have a synthetic NEXUS® veil applied on exterior surfaces to improve weatherability and inhibit ultraviolet degradation.* An ultraviolet stabilizer shall be incorporated in the resin formulation to further inhibit ultraviolet degradation.

3. Structural Design

3.1 Cable tray shall be of ladder type design having "E" or "Z" shaped side rails.

3.2 Rungs shall be of the same material as the side rail and shall be secured in place to prevent roll-over when cables are pulled into the tray.

3.3 Cable tray sections shall be 10' or 20' in length (+ or - 1/8"). Each straight section and fitting shall be furnished with pre-punched holes to accept the splice plate fastener.

3.4 Tray system design shall meet or exceed allowable working loads in accordance with the appropriate standard, i.e. NEMA FG 1, CAN/CSA-22.2 No. 126-M91 or UL-568.

3.5 Cable trays shall exceed NEMA FG 1 load requirements.

3.6 The tray loaded to the allowable working load shall be capable of supporting an additional 200 lb. concentrated static load at midspan without failure or permanent deflection.

3.7 Tray system design shall meet all the requirements set forth in Underwriters Laboratories Fiberglass Cable Tray Standard, UL-568. The tray system design shall be tested by UL and be issued the appropriate certified UL listing.

*Due to process limitations, compression molded parts do not incorporate surface veil.

4. General

4.1 Cable trays shall be furnished as a system including all necessary fasteners, hold-down clips, splice plates, support systems, barrier strips, covers, hinged horizontal and vertical splice plates, elbows, reducers, tees, crosses, etc.

4.2 Standard cable tray fittings shall be assembled by the manufacturer. Adjustable fittings may require some field adjustment.

4.3 Splice plate fasteners shall be fiberglass encapsulated stainless steel. Fasteners shall be designed to prevent encroachment of liquids or vapors on the metal threads when fully assembled and tightened. Fasteners must be capable of withstanding a torque of 10 ft./lbs. without damage to the threads of encapsulated coating.

4.4 Manufacturer shall provide certified test data to verify compliance with above loading and deflection data when requested by the purchaser.

4.5 Witness tests may be specified by the customer and shall be scheduled at the time of purchase. Documentation shall also be specified at the time of purchase.

4.6 Special non-standard tests, if requested, shall be specified at the time of purchase.

AICKINSTRUT® SPECIFICATIONS

1. Scope

1.1 This specification covers the requirements for the Aickinstrut Non-Metallic Channel Framing System.

2. Material

2.1 FRP channel shall be of pultruded glass reinforced polyester or vinyl ester resin having the physical property values listed in this catalog.

2.2 PVC channel shall be of extruded polyvinyl chloride having the physical property values listed in this catalog.

2.3 Some accessories shall be of injection molded, 40% long glass fiber reinforced polyurethane, polypropylene or nylon.

3. Composition

3.1 Glass reinforced channel shall have a synthetic surfacing veil applied on exterior surfaces to improve weatherability and inhibit ultraviolet degradation.

3.2 PVC channel shall be manufactured from a UV stabilized resin and incorporate dark gray pigment to improve weatherability and inhibit ultraviolet degradation.

4. Structural Design

4.1 Channel shall incorporate Aickinstrut's patented flange profile design which

allows full and positive interlocking contact of channel accessories and prohibits premature flange failure from torqued accessories.

4.2 Channel profile dimensions shall be: 1 5/8" X 1 5/8" X 1/4", and 1 1/2" x 1 1/8" x 1/8".

4.3 All 1 5/8" x 1 5/8" channel profiles shall have a minimum pull out resistance of 1000 pounds when load is applied over a 3/8" long section of the inside flanges.

4.4 Channel section lengths shall be supplied in 10' or 20' lengths (+ or - 1/8").

4.5 Universal Pipe Clamps shall have full interlocking contact with interior channel flanges to maximize pull-out resistance and be adjustable to accommodate a minimum 3/4" variance in piping or conduit O.D. sizes.

5. Standards

5.1 Glass reinforced and PVC channels covered in this specification shall have a flame spread rating of 25 or less when tested per ASTM E84 and meet the requirements of UL 94V0 thereby qualifying them as Class 1 material in the Uniform Building Code.

5.2 Glass reinforced channels covered in this specification shall comply with the

requirements of ASTM D 3917 and ASTM D 4385 which govern the dimensional tolerances and visual defects of pultruded shapes.

6. General

6.1 Aickinstrut Non-Metallic Framing Channel shall be furnished as a system which includes all the necessary fasteners, channel splice plates, brackets, sealants, hangers, pipe clamps, etc.

6.2 Non-Metallic fasteners shall be manufactured from long glass fiber reinforced polyurethane to ensure maximum strength and corrosion resistance.

6.3 All components of the Aickinstrut Framing System shall be nonmetallic except where 316 stainless steel hardware is used as part of the assembly.

6.4 Aickinstrut® is manufactured by Aickinstrut, a subsidiary of Allied Tube & Conduit® Corporation, Harvey, IL, 1-800-825-5433.

6.5 The manufacturer shall not have had less than 10 years experience in manufacturing strut systems.

6.6 Products are manufactured in the United States of America.

CONSTRUCTION AND PHYSICAL PROPERTIES

The Pultrusion Process

The pultruded structural component is made by reinforcing a polymer resin (usually polyester or vinyl ester resin) with multiple strands of glass filament and alternating layers of glass mat.

The glass is drawn through the liquid resin, which coats and saturates the fibers. The combination of resin and glass is then continuously guided and pulled (pultruded) through a heated die that determines the shape of the component.

In the die, the resin is cured to form a permanent, reinforced part which can be cut to a specific

length. Since the hardened fiberglass pultrusion is reinforced with an internal arrangement of permanently bonded continuous glass fibers, it possesses great strength. In addition to strength, pultruded fiberglass components exhibit exceptional corrosion resistance. This attribute makes fiberglass the material of choice for many harsh industrial applications.

Resin Systems

Polyester and vinyl ester resin systems are available. The vinyl ester resin system is somewhat stronger and is applied in severe corrosive applications.

Both resin systems are flame retardant, conforming to ASTM E84, Class 1 flame rating and are self extinguishing per the requirements of UL94V-0.

Consult the corrosion resistance guide on pages 190 - 191 to determine the correct resin system for your application.

| Typical Properties | Typical Value Test Method | Typical Value Direction | Unit | Polyester | Vinyl Ester |
|-------------------------------------|------------------------------|----------------------------|-------------|-----------------------|-----------------------|
| Mechanical | | | | | |
| Ultimate Tensile Strength | ASTM D-638 | Longitudinal | PSI | 30,000 | 35,000 |
| | ASTM D-638 | Transverse | PSI | 7,000 | 10,000 |
| Tensile Modulus | ASTM D-638 | Longitudinal | PSI | 2.5 x 10 ⁶ | 3.0 x 10 ⁶ |
| | ASTM D-638 | Transverse | PSI | 0.8 x 10 ⁶ | 1.0 x 10 ⁶ |
| Ultimate Compressive Strength | ASTM D-695 | Longitudinal | PSI | 30,000 | 35,000 |
| | ASTM D-695 | Transverse | PSI | 15,000 | 20,000 |
| Compressive Modulus | ASTM D-695 | Longitudinal | PSI | 2.5 x 10 ⁶ | 2.5 x 10 ⁶ |
| | ASTM D-695 | Transverse | PSI | 1.0 x 10 ⁶ | 1.2 x 10 ⁶ |
| Ultimate Flexural Strength | ASTM D-790 | Longitudinal | PSI | 30,000 | 35,000 |
| | ASTM D-790 | Transverse | PSI | 10,000 | 14,000 |
| Flexural Modulus | ASTM D-790 | Longitudinal | PSI | 1.6 x 10 ⁶ | 2.0 x 10 ⁶ |
| | ASTM D-790 | Transverse | PSI | 0.8 x 10 ⁶ | 1.0 x 10 ⁶ |
| Shear Strength Short Beam | ASTM D-2344 | Longitudinal or | PSI | 5,500 | 7,000 |
| | | Transverse | PSI | 5,500 | 6,000 |
| Impact Strength-Izod | ASTM D-256 | Longitudinal | ft.-lb./in. | 25 | 30 |
| | | Transverse | ft.-lb./in. | 4 | 5 |
| Hardness-Barcol | ASTM D-2583 | Perpendicular | | 50 | 50 |
| Electrical | | | | | |
| Electric Strength Short Time-in oil | ASTM D-149 | Perpendicular | Volts/mil. | 200 | 200 |
| | | Parallel | KV/in. | 35 | 35 |
| Dielectric Constant | ASTM D-150 | Perpendicular | F/M | 5.0 | 5.0 |
| Dissipation Factor | ASTM D-150 | Perpendicular | | 0.03 | 0.03 |
| Arc Resistance | ASTM D-495 | Longitudinal or | Seconds | 80 | 120 |
| | | Transverse | Seconds | 80 | 120 |

CONSTRUCTION AND PHYSICAL PROPERTIES

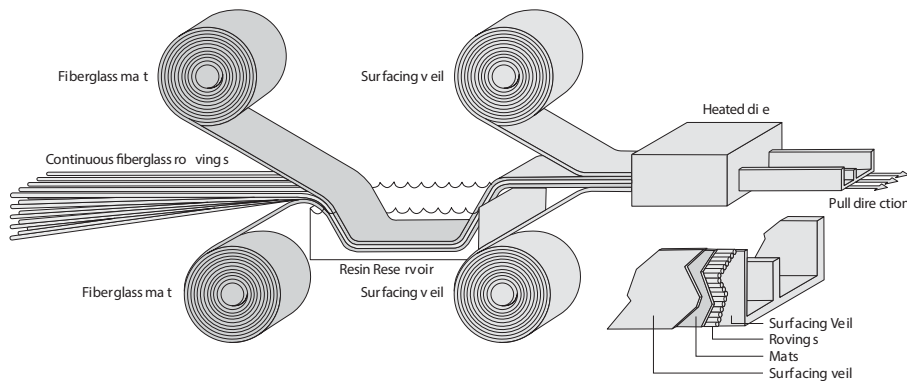

COPE-GLAS Material Properties (Continued from previous page)

Glass Roving and Mat Reinforced Polyester and Vinyl Ester Fiberglass Components

| Typical Properties Mechanical | Typical Value Test Method | Typical Value | | | |
|----------------------------------|------------------------------|---------------|------------------------|----------------------|----------------------|
| | | Direction | Unit | Polyester | Vinyl Ester |
| Other | | | | | |
| Thermal Coefficient of Expansion | ASTM D-696 | Longitudinal | in./in./°F | 5 x 10 ⁻⁶ | 5 x 10 ⁻⁶ |
| Thermal Conductivity | | Longitudinal | BTU/Hr. sq. ft./in./°F | 4 | 4 |
| Water Absorption 24 hours | ASTM D-570 | Longitudinal | % | 1 | 1 |
| Density | ASTM D-792 | Longitudinal | lbs./cu.in. | 0.062 | 0.062 |
| Color (Standard) | | | | Dark Gray | Beige |
| Flammability | UL94 | | Classification: | V-0 | V-0 |
| Flammability | ASTME84 | | Rating: | 25 | 25 |

The foregoing list of properties was derived from laboratory data using coupon test specimens cut from pultruded sections. Such information should only be used as a general guide in design. Many actual components (such as cable tray side rail) take advantage of the flexibility of the pultrusion process and are selectively reinforced to enhance performance in a particular load axis. The factory should be contacted for specific information on any given component.

Aickinstruct Fiberglass Threaded Rod Material Properties Threaded rod is a proprietary combination of fiberglass and Class I vinyl ester flame retardant resin.

AICKINSTRUT FIBERGLASS THREADED ROD MATERIAL PROPERTIES

Threaded rod is a proprietary combination of fiberglass and Class I vinyl ester flame retardant resin.

| Properties | ¾ -16 UNC | ½ -13 UNC | ¾ -11 UNC |
|---|--------------------------------|-----------------------|-----------------------|
| Thread shear strength using fiberglass nut in tensile (lbs.) | 1,250 | 2,500 | 3,800 |
| Transverse shear on threaded rod-double shear ASTM-B-565 (load lb.) | 4,200 | 7,400 | 11,600 |
| Transverse shear on threaded rod-single shear (load lb.) | 1,600 | 2,600 | 3,800 |
| Compressive strength-longitudinal ASTM-D-695 (psi) | 55,000 | 55,000 | 55,000 |
| Flexural strength ASTM-D-790 (psi) | 60,000 | 60,000 | 60,000 |
| Flexural modulus ASTM-D-790 (psi x 10 ⁶) | 2.0 x 10 ⁶ | 2.0 x 10 ⁶ | 2.0 x 10 ⁶ |
| Torque strength using fiberglass nut lubricated with SAE IOW30 motor oil (ft./lbs.) | 8 | 15 | 33 |
| Dielectric strength ASTM-D-149 (kw/in.) | 40 | 40 | 40 |
| Water absorption 24 hour immersion-threaded ASTM-D-570 (%) | 1 | 1 | 1 |
| Coefficient of thermal expansion-longitudinal (in./in./°F) | 5 x 10 ⁻⁶ | 5 x 10 ⁻⁶ | 5 x 10 ⁻⁶ |
| Max recommended operation temp, based on 50% retention of ultimate thread shear strength (°F) | 200 | 200 | 200 |
| Stud weight (lb./ft.) | .076 | .129 | .209 |
| Flammability | Self extinguishing per UL94V-0 | | |

APPLICATION ENVIRONMENTS

Corrosion Resistance

In most applications COPE-GLAS cable tray is used because of its superior corrosion resistance. The following corrosion resistance guide offers performance recommendations for the most common environments.

Additional data for less common environments are also available from the factory.

Corrosion Resistance Guide

The general guidelines presented in this table take into consideration the normal applications of cable tray products and accessories where exposure to harsh chemicals is limited to fumes or vapors and occasional splashes at ambient temperatures. This information is provided as a guide only since it is impossible to anticipate every conceivable application. For specific applications, which may fall outside the scope of these guidelines, it is recommended that the factory be consulted directly.

Special applications may require a screening test of material samples in the chemical environment of interest.

Notes:

- S - indicates satisfactory performance.
- NR - indicates not recommended for use. However, acceptable performance may be provided if fumes are not highly concentrated.
- NA - indicates information not available.

| Chemical Environment | COPE-GLAS Performance | | Chemical Environment | COPE-GLAS Performance | |
|----------------------------|-----------------------|-------------|----------------------------|-----------------------|-------------|
| | Polyester | Vinyl Ester | | Polyester | Vinyl Ester |
| Acetic Acid | S | S | Chlorinated Paraffin | S | S |
| Acetone | NR | NR | Chlorine, dry gas | S | S |
| Acrylic Acid | NR | S | Chlorine, wet gas | NR | S |
| Aluminum Chloride | S | S | Chlorine, liquid | NR | NR |
| Aluminum Chlorohydroxide | S | S | Chlorine Dioxide | NR | S |
| Aluminum Citrate | S | S | Chlorine Water | S | S |
| Aluminum Hydroxide | S | S | Chlorobenzene | NR | NR |
| Aluminum Nitrate | S | S | Chromic Acid | NR | S |
| Aluminum Potassium Sulfate | S | S | Chromous Sulfate | S | S |
| Aluminum Sulfate | S | S | Citric Acid | S | S |
| Ammonia, dry gas | S | S | Coconut Oil | S | S |
| Ammonia, liquid | NR | NR | Copper Acetate | S | S |
| Ammonium Acetate | NR | S | Copper Chloride | S | S |
| Ammonium Carbonate | NR | S | Copper Cyanide | S | S |
| Ammonium Chloride | S | S | Copper Nitrate | S | S |
| Ammonium Citrate | S | S | Copper Sulfate | S | S |
| Ammonium Hydroxide | NR | S | Cresylic Acid Fumes | NR | NR |
| Ammonium Nitrate | S | S | Cresol | NR | NA |
| Ammonium Phosphate | S | S | Crude Oil (Sour) | S | S |
| Ammonium Sulfate | S | S | Cyclohexane | NR | S |
| Ammonium Sulfide | NR | NA | Diallylphthalate | S | S |
| Ammonium Sulfite | NR | S | Diammonium Phosphate | NR | S |
| Ammonium Thiosulfate | NR | S | Dibutyl Ether | NR | S |
| Amyl Acetate | NR | NR | Dibutyl Phthalate | S | S |
| Amyl Alcohol | S | S | Diesel Fuel | S | S |
| Amyl Chloride | NR | NA | Diethylene Glycol | S | S |
| Aniline Sulfate | S | S | Dimethyl Phthalate | NR | S |
| Barium Acetate | S | S | Dimethyl Sulfoxide | NR | NA |
| Barium Carbonate | S | S | Diphenyl Ether | NR | S |
| Barium Chloride | S | S | Dipropylene Glycol | S | S |
| Barium Sulfate | S | S | Esters, Fatty Acid | S | S |
| Benzene | S | NR | Ethyl Alcohol | NR | S |
| Benzoic Acid | S | S | Ethylene Chlorohydrin | NR | S |
| Benzyl Alcohol | NR | NR | Ethylene Glycol | S | S |
| Borax | S | S | Fatty Acids | S | S |
| Boric Acid | S | S | Ferric Chloride | S | S |
| Brine | S | S | Ferric Nitrate | S | S |
| Bromine, dry gas | NR | S | Ferric Sulfate | S | S |
| Bromine, wet gas | NR | S | Ferrous Chloride | S | S |
| Bromine, liquid | NR | NR | Ferrous Nitrate | S | S |
| Butyl Acetate | NR | NR | Ferrous Sulfate | S | S |
| Butyl Alcohol, normal | S | S | Fluoboric Acid | S | S |
| Butyl Cellosolve | S | NR | Fluosilicic Acid | NR | S |
| Butylene Glycol | S | S | Formic Acid, vapor | S | S |
| Butyric Acid | S | S | Fuel Oil | S | S |
| Calcium Bisulfite | S | S | Furfural | NR | NR |
| Calcium Carbonate | S | S | Gasoline, Aviation | S | S |
| Calcium Chlorate | S | S | Gasoline, Ethyl | S | S |
| Calcium Chloride | S | S | Gluconic Acid | S | S |
| Calcium Nitrate | S | S | Glucose | S | S |
| Calcium Sulfate | S | S | Glycerine | S | S |
| Caprylic Acid | S | S | Hexachlorocyclopentadienl | NR | NA |
| Carbon Dioxide, gas | S | S | Hydrochloric Acid | S | S |
| Carbon Disulfide | NR | NR | Hydrofluoric Acid | NR | |
| Carbonic Acid | S | NA | Hydrogen Bromide, dry gas | S | S |
| Carbon Monoxide, gas | S | S | Hydrogen Chloride, dry gas | S | S |
| Carbon Tetrachloride | NR | NR | Hydrogen Chloride, wet gas | S | S |
| Chloracetic Acid | NR | S | Hydrogen Fluoride, vapor | NR | S |

APPLICATION ENVIRONMENTS

| Chemical Environment | COPE-GLAS Performance | | Chemical Environment | COPE-GLAS Performance | | Chemical Environment | COPE-GLAS Performance | |
|----------------------------|-----------------------|-------------|-----------------------------|-----------------------|-------------|------------------------------|-----------------------|-------------|
| | Polyester | Vinyl Ester | | Polyester | Vinyl Ester | | Polyester | Vinyl Ester |
| Hydrogen Peroxide | NR | S | Potassium Permanganate | NR | S | Toluene | NR | S |
| Hydrogen Sulfide, dry gas | S | S | Potassium Persulfate | NR | S | Toluene Di-isocyanate fumes | NR | NA |
| Hydrogen Sulfide, wet gas | S | S | Potassium Sulfate | S | S | Trichlorethylene, fumes | NR | NR |
| Hydroiodic Acid | NR | NA | Propylene Glycol | S | S | Trichloroacetic Acid | NR | S |
| Hypochlorous Acid | NR | S | Silicic Acid | S | NA | Trimethylamine Hydrochloride | S | S |
| sodecanol | S | S | Silver Nitrate | S | S | Triphenyl Phosphite | NR | S |
| Isopropyl Palmitate | S | S | Sodium Acetate | S | S | Trisodium Phosphate | NR | S |
| Jet Fuel (JP-4) | S | S | Sodium Benzoate | S | S | Turpentine, Pure Gum | NR | S |
| Kerosene | S | S | Sodium Bicarbonate | | | Urea | S | S |
| Lactic Acid | S | S | Saturated | S | S | Vinegar | S | S |
| Lead Acetate | S | S | Sodium Bisulfate | S | S | Water, Cooling Tower | S | S |
| Lime Slurry | S | S | Sodium Borate | S | S | Water, Demineralized | S | S |
| Linseed Oil | S | S | Sodium Bromide | S | S | Water, Distilled | S | S |
| Lithium Bromide | S | S | Sodium Carbonate | NR | S | Water, Mine | S | S |
| Lithium Chloride | S | S | Sodium Chlorate | NR | S | Water, Sea | S | S |
| Magnesium Bicarbonate | S | S | Sodium Chloride | S | S | Water, Steam Condensate | S | S |
| Magnesium Carbonate | S | S | Sodium Chloride | | | Water, Tap | S | S |
| Magnesium Chloride | S | S | Saturated Chlorine | NR | S | Xylene | NR | S |
| Magnesium Nitrate | S | S | Sodium Chlorite | NR | S | Zinc Chloride | S | S |
| Magnesium Sulfate | S | S | Sodium Cyanide | S | S | Zinc Nitrate | S | S |
| Mercuric Chloride | S | S | Sodium Dichromate | NR | S | Zinc Sulfate | S | S |
| Mercurous Chloride | S | S | Sodium Di-phosphate | S | S | | | |
| Mercury | S | S | Sodium Ferricyanide | S | S | | | |
| Methyl Alcohol | S | NR | Sodium Ferrocyanide | S | S | | | |
| Methyl Ethyl Ketone | NR | NR | Sodium Fluoride | NR | S | | | |
| Milk Waste | S | S | Sodium Hydroxide | NR | S | | | |
| Mineral Oils | S | S | Sodium Hypochlorite | NR | S | | | |
| Monochlorobenzene | NR | NR | Sodium Hyposulfite | S | NA | | | |
| Naptha | S | S | Sodium Mono-phosphate | S | S | | | |
| Napthalene | S | S | Sodium Nitrate | S | S | | | |
| Nickel Chloride | S | S | Sodium Nitrite | S | S | | | |
| Nickel Nitrate | S | S | Sodium Silicate, pH<12 | NR | S | | | |
| Nickel Sulfate | S | S | Sodium Silicate, pH>12 | NR | S | | | |
| Nickel Sulfonate Plating | | | Sodium Sulfate | S | S | | | |
| Solution | S | S | Sodium Sulfide | NR | S | | | |
| Nitric Acid | NR | S | Sodium Sulfite | NR | S | | | |
| Oleic Acid | S | S | Sodium Tetraborate | S | S | | | |
| Olive Oils | S | S | Sodium Thiosulfate | S | S | | | |
| Oxalic Acid | S | S | Sodium Xylene Sulfonate | NR | S | | | |
| Palmitic Acid | S | S | Sorbitol Solutions | S | S | | | |
| Perchlorethylene | NR | S | Sour Crude Oil | S | S | | | |
| Perchloric Acid | NR | S | Soya Oil | S | S | | | |
| Phenol | NR | NR | Stannous Chloride | S | S | | | |
| Phosphoric Acid | S | S | Stearic Acid | S | S | | | |
| Photographic Solutions | S | NA | Styrene | NR | NR | | | |
| Phthalic Anhydride | S | S | Sulfated Detergents | S | S | | | |
| Pickling Liquids, Acid | S | S | Sulfonated Detergents | NR | S | | | |
| Pickling Liquids, Alkaline | NR | NA | Sulfonyl Chloride, Aromatic | NR | NA | | | |
| Picric Acids | NR | NA | Sulfur Dioxide, dry gas | S | S | | | |
| Potassium Aluminum Sulfate | S | S | Sulfur Dioxide, wet gas | S | S | | | |
| Potassium Bicarbonate | S | S | Sulfuric Acid, vapor | S | S | | | |
| Potassium Bromide | S | S | Sulfurous Acid | NR | S | | | |
| Potassium Carbonate | NR | S | Tannic Acid | S | S | | | |
| Potassium Chloride | S | S | Tartaric Acid | S | S | | | |
| Potassium Ferricyanide | S | S | Tetrachloroethylene | NR | S | | | |
| Potassium Ferrocyanide | S | S | Tetrapotassium | | | | | |
| Potassium Hydroxide | NR | S | Pyrophosphate | NR | S | | | |
| Potassium Nitrate | S | S | Tetrasodium Pyrophosphate | NR | S | | | |

Intro

LADDER

I-BEAM

HAT

TROF

CHANNEL

COPE-GLAS™

WIREBASKET

Reference

STRUCTURAL DESIGNS

COPE-GLAS™ Cable Tray Styles

COPE-GLAS cable tray systems are available in flange-out and flange-in styles. Standard tray, Type CZ and Type CZD deep tray are flange-out designs. Type LC Low Profile tray and standard tray Types BE and CE are flange-in designs.

The "Z" siderail profiles allow for easier cable loading and cover attachment or removal. COPE-GLAS basic "Z" rail profiles provide four inches of cable fill depth and are available in one load classification: CZ.

COPE-GLAS "Deep Z" profile tray, Type CZD, provides six inches of cable fill depth and is only available in NEMA load class "C".

COPE-GLAS Style "E" siderail profiles are flange-in designs that

are especially useful when space is a consideration, such as on closely spaced parallel runs or flush wall mountings. COPE-GLAS "E" rail profile provides four inches of cable fill depth and is available in NEMA load classes "C" as BE and CE.

The Low Profile cable tray, Type LC, is an "E" siderail profile that has a three inch cable loading depth. Type LC cable tray is ideal for control wiring and lighter cable runs that do

not require numerous circuits.

All COPE-GLAS cable trays have a 1.5 safety factor that meets the NEMA FG 1 safety factor requirement of 1.5 times the allowable working load.

COPE-GLAS cable tray is also available with a solid bottom upon request. Solid bottom tray consists of a standard ladder tray with a flat fiberglass cover material bonded to the bottom of the tray.

PERFORMANCE STANDARDS AND CLASS DESIGNATIONS

| Tray Type | Class | Working Load (20' Span) | Safety Factor |
|----------------|-------|-------------------------|---------------|
| LC Low Profile | A | 50 lbs./ft. (12' span) | 1.5 |
| BE Standard | C | 100 lbs./ft. | 1.5 |
| CZ Standard | C+ | 133 lbs./ft. | 1.5 |
| CE Standard | C+ | 133 lbs./ft. | 2.0 |
| CZD Deep | C+ | 133 lbs./ft. | 1.5 |

SELECTION GUIDE

Several criteria must be considered in selecting COPE-GLAS cable tray for your application. Factors include load capacity and safety factor; support spans; deflection; cable diameter and tray fill capacity; application environment; space restrictions; fire resistance; future expansion and cost.

Article 392 of the National Electric Code provides cable size and cable fill information. NEMA Standards Publication No. FG 1, Fiberglass Cable Tray Systems, specifies manufacturing standards, performance standards, load class designation specifications and application information such as support span guidelines and temperature deflection information.

The following guidelines will assist you in your selection of COPE-GLAS cable tray:

Step 1:

Determine the resin system required based on the application, location, and environment (consult the corrosion resistance guide in the Application Environments section). COPE-GLAS cable tray is available in polyester and vinyl ester resin systems. Vinyl ester provides more corrosion resistance than polyester in some environments.

Step 2 :

Determine tray loading depth and width. Depending on the size and number of cables needed, use the guidelines in NEC Article 392-8 through -12 to determine tray loading depth and width.

Step 3 :

Determine rung spacing. The smallest cable or wire bundle determines the rung spacing for ladder type trays. In general, use eighteen inch rung spacing for 2" O.C. or larger, nine or twelve inch rung spacing for cables from 1" to 2" O.D., six inch run spacing for cables from 1/2" to 1" O.D. and fiberglass channel type trays for smaller cables.

Step 4 :

Determine the cable load. Calculate in pounds per linear foot the load of the cables to be supported. Consider any extraneous loads such as ice, snow, wind, etc. and add this value to the cable load.

Step 5 :

Determine the tray style. COPE-GLAS offers two side rail configurations; "E" and "Z".

Refer to the Structural Designs section of this catalog to determine tray style.

Step 6 :

Determine the support spacing. Normally, cable tray systems are supported at eight foot to twenty foot intervals. Tray may be supported by wall mount brackets, trapeze suspensions, supports from existing structures or it may be floor mounted to minimize deflection.

Splice joints should be placed at or near the quarter point of the span. This guideline should be rigidly followed and non-compliance granted only after careful engineering analysis because of high cable tray stresses which can be generated.

Step 7:

Determine the NEMA or CSA load class. The cable tray system should be determined by the combination of cable load (Step 4) and support spacing (Step 5). Consult the Structural Design section of this catalog or NEMA FG 1 to assist you in the selection of a tray system that meets your requirements.

| NEMA Class | Working Load* |
|------------|-------------------|
| A | 50 lbs./lin. ft. |
| B | 75 lbs./lin. ft. |
| C | 100 lbs./lin. ft. |

* Working load classifications based on 20 foot support spans. Chart not applicable for channel tray.

INSTALLATION PROCEDURES

The following information shall be used as a guideline for installing COPE-GLAS cable tray.

Special Considerations

With few exceptions, the installation of fiberglass cable tray does not differ from that of metal tray. All standard installation practices and procedures apply. In general, special handling is not required.

Tools Required

Fiberglass tray is easy to cut and drill. For most installations, standard tools are sufficient; however, for large jobs where many sections require cutting and drilling, high speed steel tools may become dull due to the abrasiveness of glass. In such installations, the use of carbide tipped drills and abrasive (grit) saw blades is recommended.

Cutting Tray in the Field

Tray may be easily cut in the field using a standard hacksaw. If some type of power saw is used, abrasive grit-blades work best. When using a power saw, dust filter masks should be worn. Gloves and long sleeve clothing are also recommended.

Sealing Edges

All cut edges should be sealed. In harsh environments, proper sealing insures against future migration of corrosive elements into the cut sections.

Drilling Holes for Splice Plates

When drilling holes for splice plates, a $\frac{1}{32}$ " drill bit will provide a properly sized hole. Clamp a splice plate (using a C-clamp) to the side of the tray and use this plate as a drilling template. The plate should be positioned to allow a $\frac{1}{16}$ " gap between joined side rails or fittings.

Use of Encapsulated Hardware

Tray sections should be joined using COPE-GLAS fiberglass encapsulated stainless steel nuts and bolts (Part #FECNBSS). For maximum protection in extremely harsh environments, apply a generous amount of FIBER-SEAL to the nut and bolt (inside surfaces and threads) just prior to assembly. Assembled splice joints should be tightened to approximately 12 ft/lbs.

Locating Splice Joints

When possible, splice joints should be placed at or near the quarter point of any given support span. This is the point of least mechanical stress. For example: with a section of tray resting on supports spaced 20 feet apart, the splice plate joints should be located 5 feet from supports (support span divided by 4).

Splice plate joints should be located as close as possible to the quarter point of the support span.

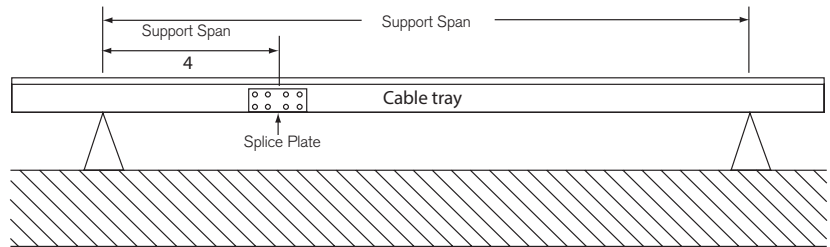

Expansion Splice Plates

Each COPE-GLAS expansion splice plate allows $\frac{5}{8}$ " total expansion or contraction under varying temperature conditions. A complete table showing expansion plate placement intervals appears in the COPE-GLAS Accessories section of this catalog.

Clamping & Securing Cable Tray

COPE-GLAS provides a special hold down clamp (Part #HD4AB which grips the bottom flange of the tray and prevents lateral movement. This clamp is commonly used to prevent lateral tray movement when long runs rest on I-Beams or other horizontal support members.

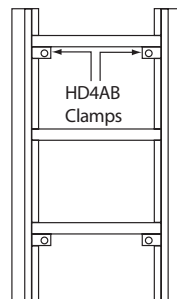
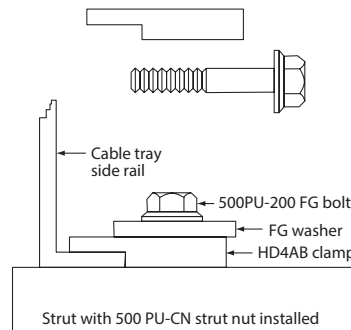

The HD4AB may also be used to secure tray against a vertical wall or bulkhead. In such applications, the clamp should be located adjacent to and below a rung for extra support. When securing tray to a flat vertical bulkhead, it is also acceptable to drill

and bolt directly through the bottom flange of the tray. Holes should be centered in the flange and kept as small as possible ($\frac{3}{8}$ " diameter max).

Wall Brackets

COPE-GLAS fiberglass wall brackets may be used to support cable tray adjacent to a vertical wall. Wall brackets are rated at 750 pounds total weight bearing capacity with a safety factor of 3.0.

Bracket spacing may be determined by dividing 750 lbs. by the tray load (in pounds per foot). Example: With a cable tray loading of 100 lbs./ft., divide 750 lbs. by 100 lbs./ft. = 7.5 feet. One bracket will be required every $7\frac{1}{2}$ feet.

Tray may be secured to the bracket with HD-4 clamps. Note that the brackets are fabricated using Aickinstrut as the main horizontal support member.

Aickinstrut provides a channel nut (Part #500PU-CN) which fits the interior of the strut. This nut, used in conjunction with a fiberglass bolt (Part #500PU-200), washer (Part #WR500) and HD4AB hold down clamp, forms a complete clamping system. Over-torquing should be avoided (3 ft/lbs max).

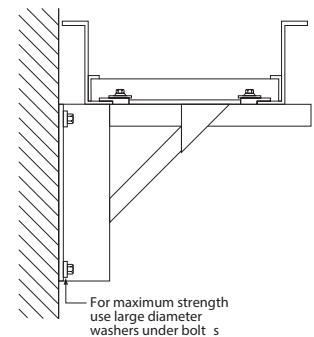

INSTALLATION PROCEDURES

Trapeze Hanging Systems

The fiberglass trapeze hanging system pictured below may be used to support tray in areas where tray cannot be placed on I-beams or other existing structures. Trapeze hangers are assembled in the field using components from this catalog. Care should be taken to configure the hanger as shown.

When properly assembled, the hanger, pictured below, can support 1000 lbs. with a safety factor of 4 (assuming a balanced load). For NEMA Class C Tray rated at 100 lbs./ft., we recommend a minimum of one hanger for every 10 feet of tray (1000 lbs. divided by 100 lbs./ft. = 10 ft.).

As with the fiberglass wall bracket, HD-4 clamps and associated hardware may be used with these Trapeze Systems.

When trapeze hangers are suspended from I-beams using polyurethane beam clamps, it is imperative that the fiberglass all-thread rod be screwed completely into the clamp until it "bottoms out". Achieving full pull out strength requires total thread engagement. Care should be taken not to over torque the rod.

COPE-GLAS Cover Installation Procedure

Nylon Drive Rivets (Part #NDR1) are the most economical method to fasten cable tray covers, but they require 1/4" field drilled holes on 24" centers along both siderails.

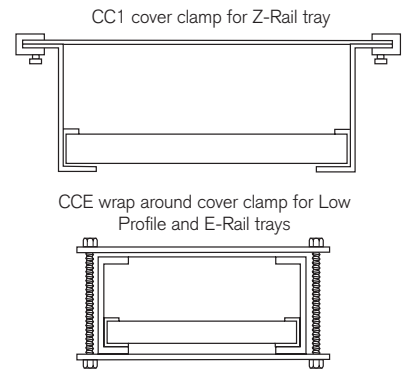

If cover removal or high winds are a concern, either the CC1 or CCE cover clamp may be desired. The CC1 clamp is designed for use on "Z" Style siderail tray and fittings. This PVC coated steel cover clamp requires no field drilling and is easily removed to allow ready access to the inside tray and cables. Six CC1 clamps are recommended for each ten foot length of cable tray cover.

The CCE clamp is designed for use with flat cover on Low Profile and "E" Style siderail trays and fittings. The CCE clamp is constructed entirely of fiberglass components and is available in either polyester or vinyl ester resin. Two CCE clamps are recommended for each ten foot length of cable tray cover.

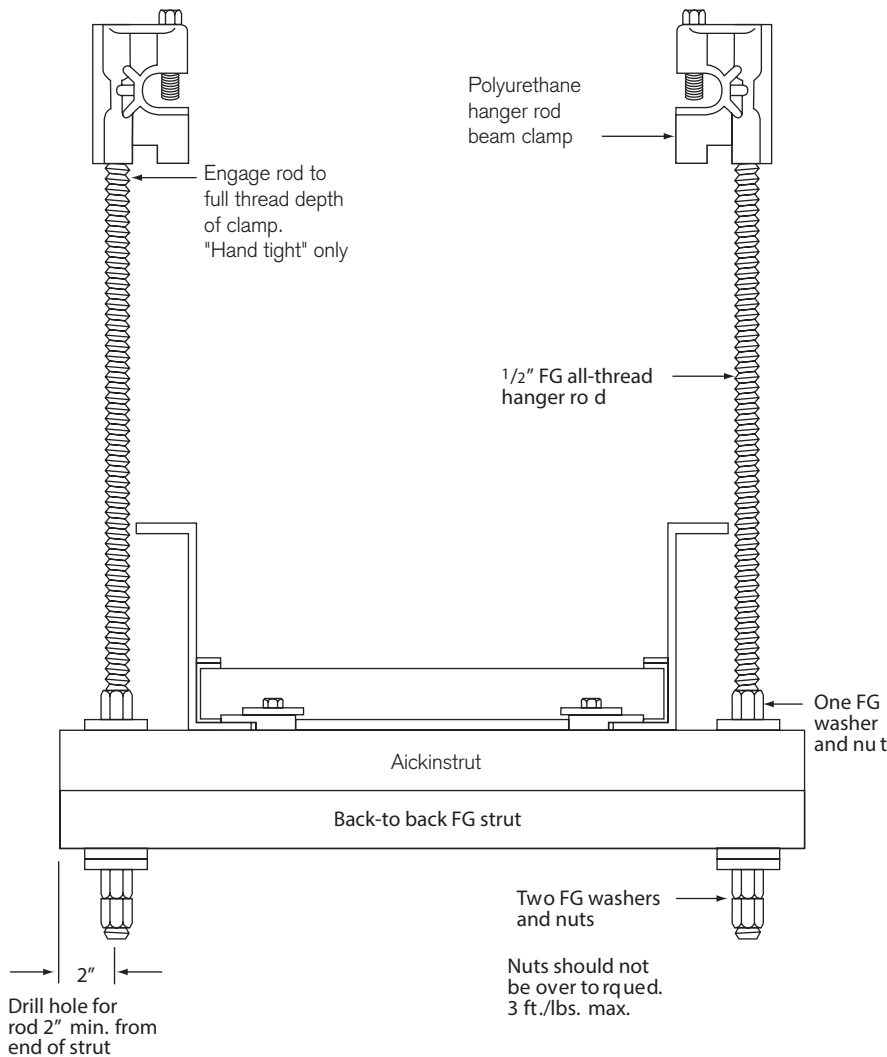

Cover stand-off SO 200

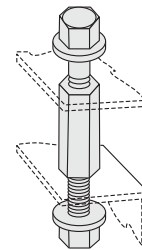

Cover stand-offs secure cable tray cover while providing a ventilation gap for cables. The SO200 requires field drilling. Five pairs of clamps are recommended per ten foot length of cable tray cover.

INSTALLATION PROCEDURES

Installation Guidelines:
Fiberglass Trapeze Hanging Systems
The COPE-GLAS cable tray system

offers three types of fiberglass trapeze hanging systems: back to back strut trapeze, single strut with open end down trapeze,

and single strut with open end up trapeze. The specifications associated with each trapeze type are shown below.

Back-to-Back Bonded Strut

1. Fiberglass nuts should not be over-torqued. A snug 3 to 4 ft./lbs. is sufficient.
2. When supporting a 100 lb./ft. load, the spacing between each trapeze should not exceed ten feet. Under these conditions, each trapeze will be supporting 1000 lbs., thus yielding a support system safety factor of 2.
3. When using beam clamps, only COPE-GLAS RGBC series clamps are acceptable. This clamp provides more thread engagement than clamps designed for steel rod and load ratings are dependent on the extra thread engagement. Care should be taken to insure that the rod is fully engaged in the clamp nut, but not over torqued (5 ft./lbs. max.).
4. Material being supported should “fit” the trapeze system as closely as possible. The spacing between the all-thread rod and the material being supported should not exceed 1”.

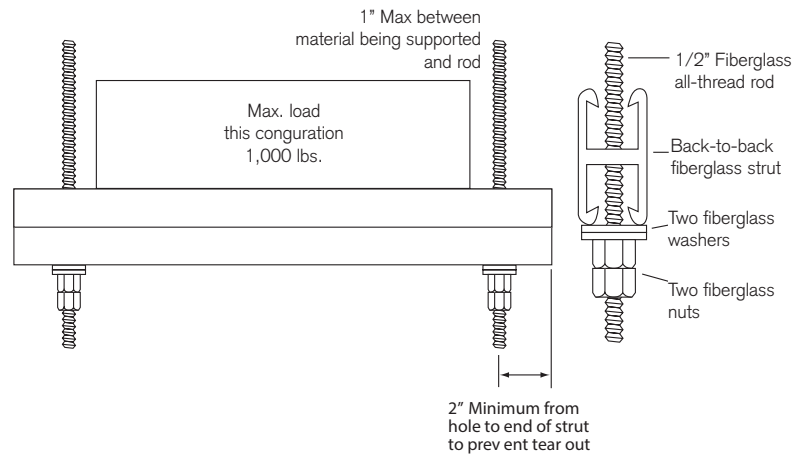

Single Strut With Open End Down

1. When supporting a 100 lb./ft. load, the spacing between each trapeze should not exceed five feet. Under these conditions, each trapeze will be supporting 500 lbs., thus yielding a support system safety factor of 2.
2. When using beam clamps, only COPE-GLAS RGBC series clamps are acceptable. This clamp provides more thread engagement than clamps designed for steel rod and load ratings are dependent on the extra thread engagement. Care should be taken to insure that the rod is fully engaged in the clamp nut, but not over torqued (5 ft./lbs. max.).
3. Material being supported should “fit” the trapeze system as closely as possible. The spacing between the all-thread rod and the material being supported should not exceed 1”.

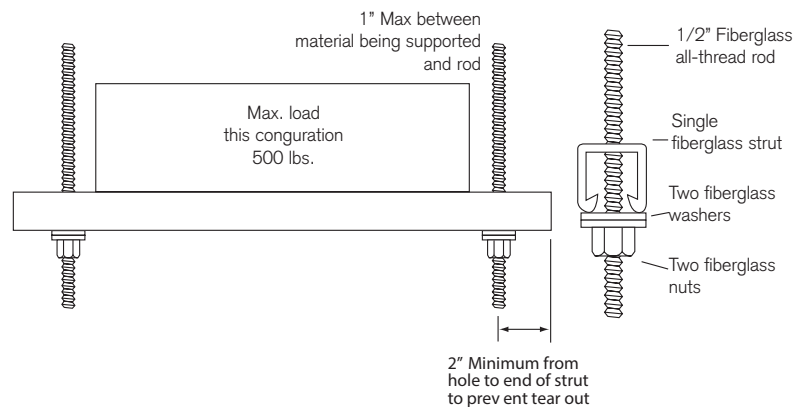

Single Strut With Open-End Up

1. To maintain a safety factor of 2, the load for this configuration should not exceed 400 lbs.
2. When using beam clamps, only COPE-GLAS RGBC series clamps are acceptable. This clamp provides more thread engagement than clamps designed for steel rod and load ratings are dependent on the extra thread engagement. Care should be taken to insure that the rod is fully engaged in the clamp nut, but not over-torqued (5 ft./lbs. max.).
3. Material being supported should “fit” the trapeze system as closely as possible. The spacing between the all-thread rod and the material being supported should not exceed 1”.

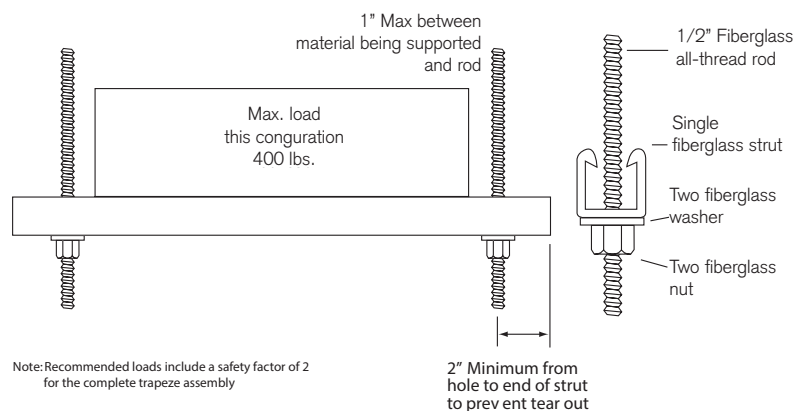

Note: Recommended loads include a safety factor of 2 for the complete trapeze assembly

INSTALLATION PROCEDURES

Aickinstrut® Strut Loading

Aickinstrut is used to hang loads from ceilings where it is common practice to use pipe straps or strut nuts to fasten the loads. The limiting factor in such loading applications is the strength of the non-metallic pipe clamp. Guidelines for these applications are shown at right.

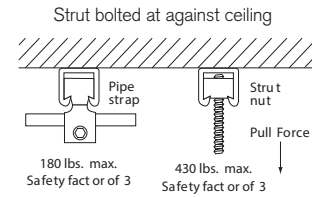

Fiberglass Strut Recommended Loads

(Based on a Safety Factor of 3)

Aickinstrut Light Duty*

1 1/2" x 1 1/8"

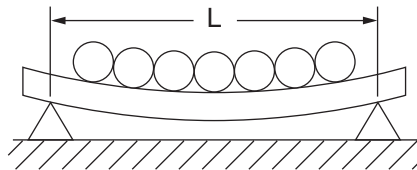
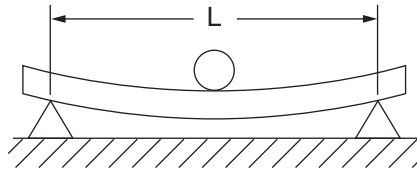

CONCENTRATED LOAD

| L | Max. Load | Deflection |
|----|-----------|------------|
| 2' | 407 lbs. | 0.48" |
| 3' | 271 lbs. | 1.08" |
| 4' | 203 lbs. | 1.92" |
| 5' | 163 lbs. | 3.01" |

DISTRIBUTED LOAD

| L | Max. Load | Deflection |
|----|-----------|------------|
| 2' | 815 lbs. | 0.605" |
| 3' | 543 lbs. | 1.36" |
| 4' | 407 lbs. | 2.41" |
| 5' | 326 lbs. | 3.77" |

Aickinstrut Heavy Duty*

1 5/8" x 1 5/8"

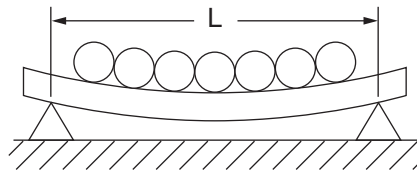
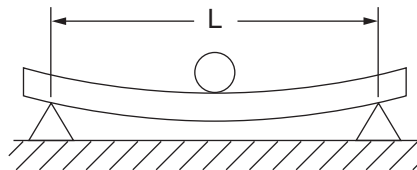
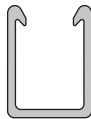

CONCENTRATED LOAD

| L | Max. Load | Deflection |
|----|-----------|------------|
| 2' | 890 lbs. | 0.328" |
| 3' | 593 lbs. | 0.737" |
| 4' | 445 lbs. | 1.304" |
| 5' | 356 lbs. | 2.04" |

DISTRIBUTED LOAD

| L | Max. Load | Deflection |
|----|-----------|------------|
| 2' | 1781 lbs. | 0.410" |
| 3' | 1187 lbs. | 0.922" |
| 4' | 890 lbs. | 1.63" |
| 5' | 712 lbs. | 2.56" |

Aickinstrut Heavy Duty Strut bolted at against ceiling*

3 1/4" x 1 5/8"

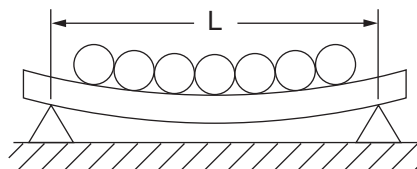
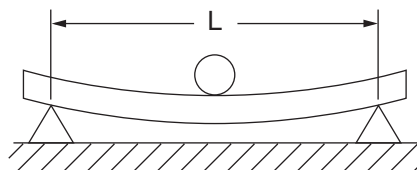
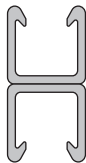

CONCENTRATED LOAD

| L | Max. Load | Deflection |
|----|-----------|------------|
| 2' | 1390 lbs. | 0.09" |
| 3' | 926 lbs. | 0.203" |
| 4' | 695 lbs. | 0.361" |
| 5' | 556 lbs. | 0.566" |

DISTRIBUTED LOAD

| L | Max. Load | Deflection |
|----|-----------|------------|
| 2' | 2780 lbs. | 0.113" |
| 3' | 1853 lbs. | 0.254" |
| 4' | 1390 lbs. | 0.452" |
| 5' | 1112 lbs. | 0.707" |

* See Aickinstrut catalog for part numbers

INSTALLATION PROCEDURES

COPE-GLAS Fiberglass Components and Associated Hardware Loads

The maximum recommended loads and associated safety factors of various fiberglass components are shown here. The recommended support locations for the cable tray fittings are shown below.

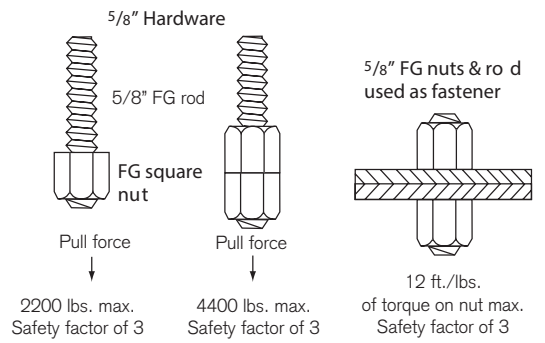
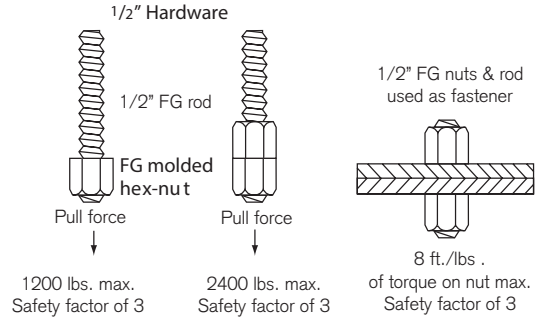
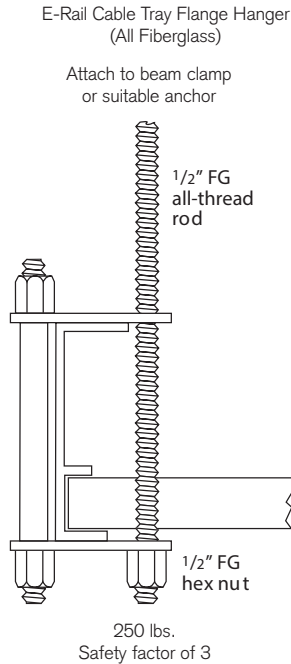
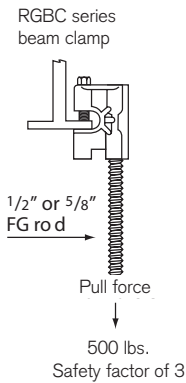

Support Locations for Cable Tray Fittings

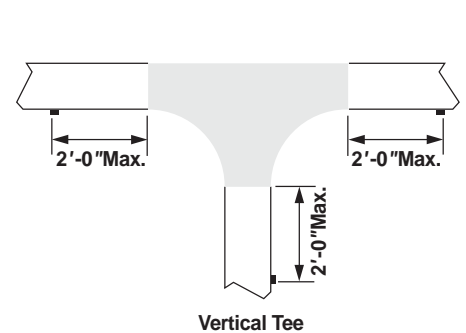
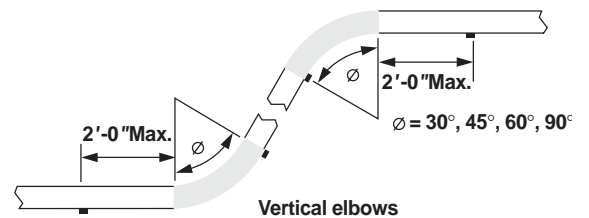
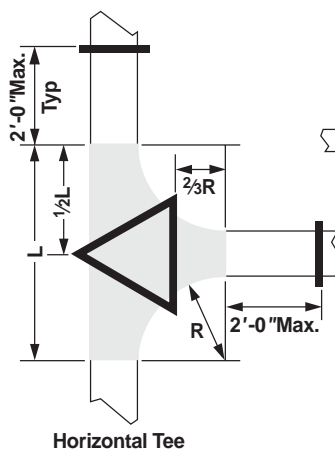
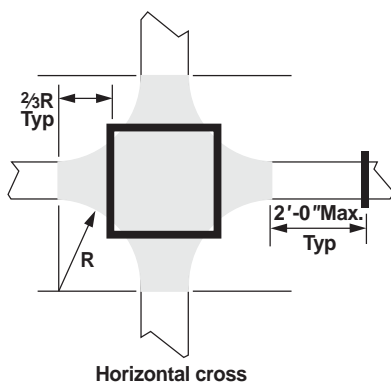
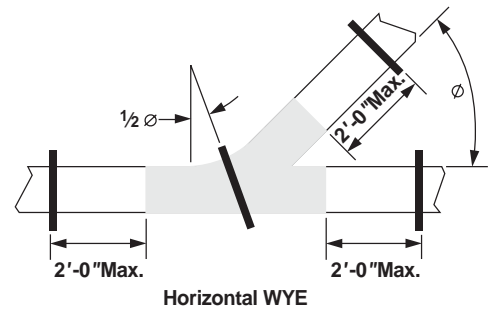
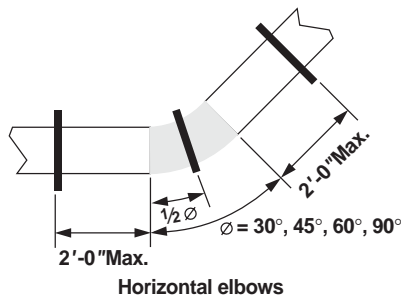
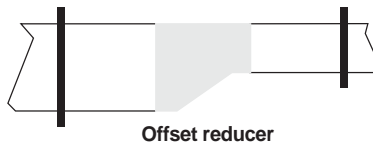
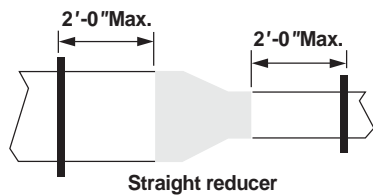

COPE-GLAS™ CABLE TRAY SYSTEM

STRAIGHT SECTIONS

PART NUMBERING SYSTEM

All cable tray straight sections are available in polyester or vinyl ester resin. Standard tray lengths are 10' and 20'. Special tray lengths are available upon request.

Cable tray sections, except for Low Profile Type LC, can be provided with fiberglass strut substituted as alternating rungs upon request at no additional cost. Solid bottom cable tray sections are available,

but require special quotation.

All cable tray sections are supplied pre-drilled to accept splice plate fasteners.

Note: Connector plates and hardware are not included and must be ordered separately.

TYPE LC STRAIGHT SECTION - C PROFILE* [LC]

Low Profile Tray

NEMA Class 12A

(100 lbs./ft. Working Load - 10' Length)

(50 lbs./ft. Working Load - 12' Length)

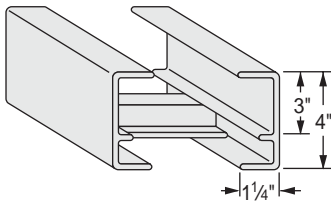

10 FOOT LENGTH PART NUMBERS (TYPE LC)

| Rung Spacing | Section Width | | | | | | |
|--------------|---------------|-------------|-------------|-------------|-------------|-------------|-------------|
| | 06" (152mm) | 09" (229mm) | 12" (305mm) | 18" (457mm) | 24" (610mm) | 30" (762mm) | 36" (914mm) |
| 06" | LC060610 | LC090610 | LC120610 | LC180610 | LC240610 | LC300610 | LC360610 |
| 09" | LC060910 | LC090910 | LC120910 | LC180910 | LC240910 | LC300910 | LC360910 |
| 12" | LC061210 | LC091210 | LC121210 | LC181210 | LC241210 | LC301210 | LC361210 |

12 FOOT LENGTH PART NUMBERS (TYPE LC)

| Rung Spacing | Section Width | | | | | | |
|--------------|---------------|-------------|-------------|-------------|-------------|-------------|-------------|
| | 06" (152mm) | 09" (229mm) | 12" (305mm) | 18" (457mm) | 24" (610mm) | 30" (762mm) | 36" (914mm) |
| 06" | LC060612 | LC090612 | LC120612 | LC180612 | LC240612 | LC300612 | LC360612 |
| 09" | LC060912 | LC090912 | LC120912 | LC180912 | LC240912 | LC300912 | CE360912 |
| 12" | LC061212 | LC091212 | LC121212 | LC181212 | LC241212 | LC301212 | LC361212 |

TYPE BE STRAIGHT SECTION - E PROFILE [BE]

NEMA Class 20C

(100 lbs./ft. Working Load - 20' Length)

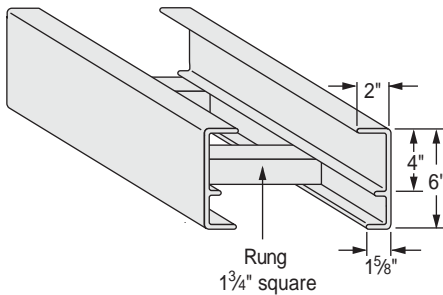

10 FOOT LENGTH PART NUMBERS (TYPE BE)

| Rung Spacing | Section Width | | | | | | |
|--------------|---------------|-------------|-------------|-------------|-------------|-------------|-------------|
| | 06" (152mm) | 09" (229mm) | 12" (305mm) | 18" (457mm) | 24" (610mm) | 30" (762mm) | 36" (914mm) |
| 06" | BE060610 | BE090610 | BE120610 | BE180610 | BE240610 | BE300610 | BE360610 |
| 09" | BE060910 | BE090910 | BE120910 | BE180910 | BE240910 | BE300910 | BE360910 |
| 12" | BE061210 | BE091210 | BE121210 | BE181210 | BE241210 | BE301210 | BE361210 |

20 FOOT LENGTH PART NUMBERS (TYPE BE)

| Rung Spacing | Section Width | | | | | | |
|--------------|---------------|-------------|-------------|-------------|-------------|-------------|-------------|
| | 06" (152mm) | 09" (229mm) | 12" (305mm) | 18" (457mm) | 24" (610mm) | 30" (762mm) | 36" (914mm) |
| 06" | BE060620 | BE090620 | BE120620 | BE180620 | BE240620 | BE300620 | BE360620 |
| 09" | BE060920 | BE090920 | BE120920 | BE180920 | BE240920 | BE300920 | CE360920 |
| 12" | BE061220 | BE091220 | BE121220 | BE181220 | BE241220 | BE301220 | BE361220 |

Ordering Information:

[S][W][R][L] [V]* [SR]*

Tray Style (LC, BE, CE, CZ, CZD) ————
 Width (6", 9", 12", 18", 24", 30", 36") ————
 Rung Spacing (6", 9", 12", 18") ————

Length (10', 20')

Suffix

SR=Strut as Alternating Rungs
 MR=Marine Rungs
 Vinyl Ester Resin

Example: CZ181220VSR
 CZ Style Tray, 18" Wide, 12" Rung Spacing, 20' Long
 Vinyl Ester Resin, with Alternating Strut Rungs.

* Add suffix "V" to specify vinyl ester resin, add "SR" to specify strut as alternating rungs, add "MR" for marine rungs
 Note: See page 200 for cable tray straight section cover options and part numbers.

STRAIGHT SECTIONS

TYPE CE STRAIGHT SECTION - E PROFILE [CE]

NEMA Class 20C+
(133 lbs./ft. Working Load -
20' length)

See ordering information on previous page

* 2:1 Safety Factor

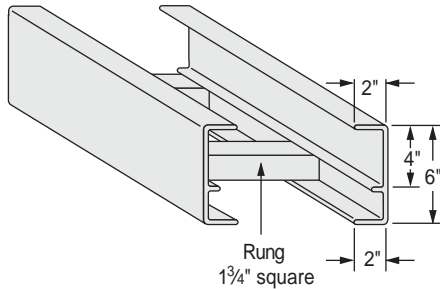

10 FOOT LENGTH PART NUMBERS (TYPE CE)

| Rung Spacing | Section Width | | | | | | |
|--------------|----------------|----------------|----------------|----------------|----------------|----------------|----------------|
| | 06" (152mm) | 09" (229mm) | 12" (305mm) | 18" (457mm) | 24" (610mm) | 30" (762mm) | 36" (914mm) |
| 06" | CE060610 | CE090610 | CE120610 | CE180610 | CE240610 | CE300610 | CE360610 |
| 09" | CE060910 | CE090910 | CE120910 | CE180910 | CE240910 | CE300910 | CE360910 |
| 12" | CE061210 | CE091210 | CE121210 | CE181210 | CE241210 | CE301210 | CE361210 |
| 18" | CE061810 | CE091810 | CE121810 | CE181810 | CE241810 | CE301810 | CE361810 |

20 FOOT LENGTH PART NUMBERS (TYPE CE)

| Rung Spacing | Section Width | | | | | | |
|--------------|----------------|----------------|----------------|----------------|----------------|----------------|----------------|
| | 06" (152mm) | 09" (229mm) | 12" (305mm) | 18" (457mm) | 24" (610mm) | 30" (762mm) | 36" (914mm) |
| 06" | CE060620 | CE090620 | CE120620 | CE180620 | CE240620 | CE300620 | CE360620 |
| 09" | CE060920 | CE090920 | CE120920 | CE180920 | CE240920 | CE300920 | CE360920 |
| 12" | CE061220 | CE091220 | CE121220 | CE181220 | CE241220 | CE301220 | CE361220 |
| 18" | CE061820 | CE091820 | CE121820 | CE181820 | CE241820 | CE301820 | CE361820 |

TYPE CZ STRAIGHT SECTION - Z PROFILE [CZ]

NEMA Class 20C+
(133 lbs./ft. Working Load -
20' length)

See ordering information on previous page

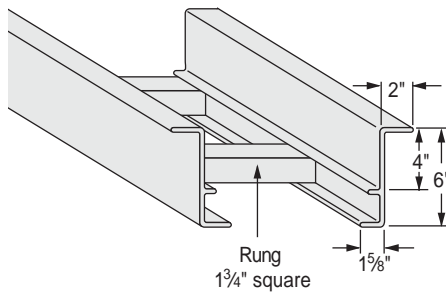

10 FOOT LENGTH PART NUMBERS (TYPE CZ)

| Rung Spacing | Section Width | | | | | | |
|--------------|----------------|----------------|----------------|----------------|----------------|----------------|----------------|
| | 06" (152mm) | 09" (229mm) | 12" (305mm) | 18" (457mm) | 24" (610mm) | 30" (762mm) | 36" (914mm) |
| 06" | CZ060610 | CZ090610 | CZ120610 | CZ180610 | CZ240610 | CZ300610 | CZ360610 |
| 09" | CZ060910 | CZ090910 | CZ120910 | CZ180910 | CZ240910 | CZ300910 | CZ360910 |
| 12" | CZ061210 | CZ091210 | CZ121210 | CZ181210 | CZ241210 | CZ301210 | CZ361210 |
| 18" | CZ061810 | CZ091810 | CZ121810 | CZ181810 | CZ241810 | CZ301810 | CZ361810 |

20 FOOT LENGTH PART NUMBERS (TYPE CZ)

| Rung Spacing | Section Width | | | | | | |
|--------------|----------------|----------------|----------------|----------------|----------------|----------------|----------------|
| | 06" (152mm) | 09" (229mm) | 12" (305mm) | 18" (457mm) | 24" (610mm) | 30" (762mm) | 36" (914mm) |
| 06" | CZ060620 | CZ090620 | CZ120620 | CZ180620 | CZ240620 | CZ300620 | CZ360620 |
| 09" | CZ060920 | CZ090920 | CZ120920 | CZ180920 | CZ240920 | CZ300920 | CZ360920 |
| 12" | CZ061220 | CZ091220 | CZ121220 | CZ181220 | CZ241220 | CZ301220 | CZ361220 |
| 18" | CZ061820 | CZ091820 | CZ121820 | CZ181820 | CZ241820 | CZ301820 | CZ361820 |

TYPE CZD STRAIGHT SECTION - DEEP Z PROFILE [CZD]

NEMA Class 20C+
(133 lbs./ft. Working Load -
20' length)

See ordering information on previous page

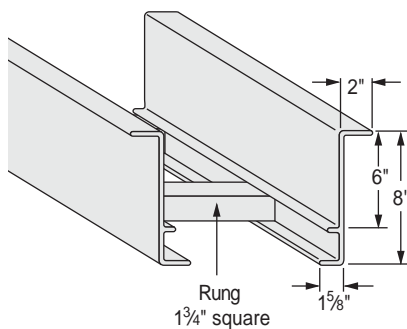

10 FOOT LENGTH PART NUMBERS (TYPE CZD)

| Rung Spacing | Section Width | | | | | | |
|--------------|----------------|----------------|----------------|----------------|----------------|----------------|----------------|
| | 06" (152mm) | 09" (229mm) | 12" (305mm) | 18" (457mm) | 24" (610mm) | 30" (762mm) | 36" (914mm) |
| 06" | CZD060610 | CZD090610 | CZD120610 | CZD180610 | CZD240610 | CZD300610 | CZD360610 |
| 09" | CZD060910 | CZD090910 | CZD120910 | CZD180910 | CZD240910 | CZD300910 | CZD360910 |
| 12" | CZD061210 | CZD091210 | CZD121210 | CZD181210 | CZD241210 | CZD301210 | CZD361210 |
| 18" | CZD061810 | CZD091810 | CZD121810 | CZD181810 | CZD241810 | CZD301810 | CZD361810 |

20 FOOT LENGTH PART NUMBERS (TYPE CZD)

| Rung Spacing | Section Width | | | | | | |
|--------------|----------------|----------------|----------------|----------------|----------------|----------------|----------------|
| | 06" (152mm) | 09" (229mm) | 12" (305mm) | 18" (457mm) | 24" (610mm) | 30" (762mm) | 36" (914mm) |
| 06" | CZD060620 | CZD090620 | CZD120620 | CZD180620 | CZD240620 | CZD300620 | CZD360620 |
| 09" | CZD060920 | CZD090920 | CZD120920 | CZD180920 | CZD240920 | CZD300920 | CZD360920 |
| 12" | CZD061220 | CZD091220 | CZD121220 | CZD181220 | CZD241220 | CZD301220 | CZD361220 |
| 18" | CZD061820 | CZD091820 | CZD121820 | CZD181820 | CZD241820 | CZD301820 | CZD361820 |

COPE-GLAS™ CABLE TRAY SYSTEM

COVERS

COPE-GLAS CABLE TRAY COVERS

Covers are used where cable protection is necessary or desired. Two COPE-GLAS cover designs, flat and peaked, are offered. The flat cover suits most applications and is more widely used; however, where the accumulation of snow or other particulate is likely, the peak cover will help shed excessive loads on the cable tray system. Flat covers are available in polyester or vinyl ester resin and are offered in ten foot lengths. To specify vinyl ester resin, add the suffix "V" to the part number. Peaked covers are made from polypropylene and are supplied in black. Peaked covers are not available for COPE-GLAS fittings.

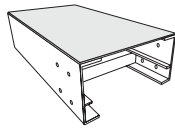

Flat Cover

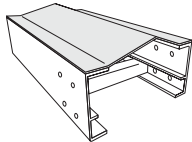

Peaked Cover
Note: 5' Lengths only

Installation procedures for covers are located in the Installation Procedures Section of this catalog.

FLAT COVER FOR "Z" SHAPED PROFILE SIDERAIL

| Tray Width | Polyester Resin | Vinyl Ester Resin | Wt./ Ft. |
|------------|-----------------|-------------------|----------|
| 06" | CTC06 | CTC06V | 0.8 |
| 09" | CTC09 | CTC09V | 1 |
| 12" | CTC12 | CTC12V | 1.2 |
| 18" | CTC18 | CTC18V | 1.6 |
| 24" | CTC24 | CTC24V | 2.1 |
| 30" | CTC30 | CTC30V | 2.6 |
| 36" | CTC36 | CTG36V | 3 |

FLAT COVER FOR "E" SHAPED PROFILE SIDERAILS

| Tray Width | Polyester Resin | Vinyl Ester Resin | Wt./ Ft. |
|------------|-----------------|-------------------|----------|
| 06" | CTCE06 | CTCE06V | 0.7 |
| 09" | CTCE09 | CTCE09V | 0.9 |
| 12" | CTCE12 | CTCE12V | 1.1 |
| 18" | CTCE18 | CTCE18V | 1.5 |
| 24" | CTCE24 | CTCE24V | 2 |
| 30" | CTCE30 | CTCE30V | 2.5 |
| 36" | CTCE36 | CTCE36V | 2.9 |

PEAKED COVER FOR "Z" SHAPED PROFILE SIDERAIL

| Tray Width | PVC | Wt./Ft. |
|------------|-------|---------|
| 06" | PTK06 | 0.9 |
| 09" | PTK09 | 1.1 |
| 12" | PTK12 | 1.3 |
| 18" | PTK18 | 1.8 |
| 24" | PTK24 | 2.3 |
| 30" | PTK30 | 2.9 |
| 36" | PTK36 | 3.3 |

PEAKED COVER FOR "E" SHAPED PROFILE SIDERAILS

| Tray Width | PVC | Wt./Ft. |
|------------|--------|---------|
| 06" | PTKE06 | 1 |
| 09" | PTKE09 | 1.2 |
| 12" | PTKE12 | 1.7 |
| 18" | PTKE18 | 1.8 |
| 24" | PTKE24 | 2.2 |
| 30" | PTKE30 | 2.8 |
| 36" | PTKE36 | 3.3 |

FITTINGS

All types and widths of tray are available as fittings with the COPE-GLAS Cable Tray System. All fittings are pre-drilled at the factory to accept splice plate fasteners. Rung spacing specified in the tray straight sections does not necessarily apply to fittings.

Molded Fittings

Type LC Low Profile and Type "BE" & "CE" tray fitting side rails are resin transfer molded with smooth radius corners. Smooth radius fittings are compact and the curved rail shape is an aid for cable pulling. The following fittings are available in smooth radius:

Type LC Smooth Radius Fittings

90° Inside Vertical Assemblies
90° Outside Vertical Assemblies
90° Horizontal Bend Assembly,
All 12" width, 12" radius
Vertical Tee Assemblies
Horizontal Tee Assemblies
Horizontal Cross Assemblies

Type BE and CE Smooth Radius Fittings

90° Inside Vertical Assemblies,
12" & 24" radius
90° Outside Vertical Assemblies,
12" & 24" radius
90° Horizontal Bend Assemblies
24" & 36" width, 12" radius
06", 09", 12", 18", & 24" width,
24" radius
Vertical Tee Assemblies
12" & 24" radius
Horizontal Tee Assemblies
12" & 24" radius
Horizontal Cross Assemblies
12" & 24" radius

Type CZ, 24" Radius Molded Fittings

Type CZ tray 24" radius fittings are compression molded with a NEMA Load Class C rating. All 24" radius fittings will be molded unless otherwise specified. Molded fittings are stocked for quick shipment. They are also dimensionally consistent to assure a precise fit at the job site.
90° Inside & Outside Vertical
90° Horizontal
90° Horizontal Tee
Horizontal Cross

Mitered Fittings

All 12" and 36" radius assemblies and reducing assemblies for CZ and CZD trays are fabricated from cut and mitered side rail sections. All BE and CE tray, 36" radius fittings and horizontal bends (with the exception of those listed in the molded fittings text) will also be mitered.

Custom Fittings

Factory engineering support will help with your special requirements; 30° and 60° bends along with other special fittings are available upon request.

Cable Tray Fitting Part Numbering System

With each fitting drawing, there is an example of how to create the correct part number for the fittings and its cover. Alternating strut and rungs can be provided by using the suffix "SR".

90° VERTICAL INSIDE BENDS [V90I]

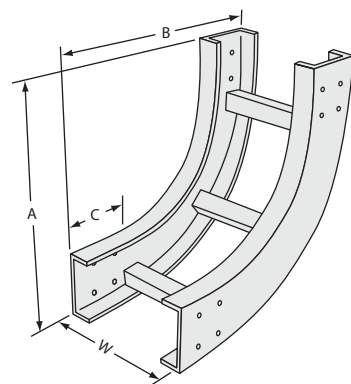
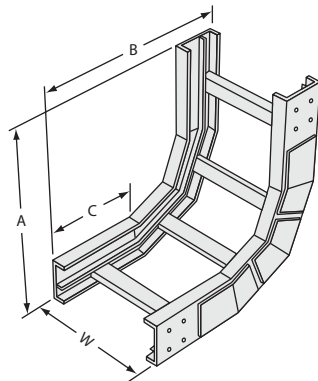

90° VERTICAL OUTSIDE BENDS - MITERED

| Tray Style | Radius | A or B | C (Straight) | Close-Coupled Inside & Outside Fittings | |
|-----------------|-------------|--|---|---|---|
| | | | | Rise | Length |
| CZ | 12" (305mm) | 30" (762mm) | 13 ³ / ₁₆ " (346mm) | 52 ¹ / ₁₆ " (1322mm) | 52" (1321mm) |
| CZD | 12" (305mm) | 32" (813mm) | 13 ³ / ₁₆ " (346mm) | 52 ¹ / ₁₆ " (1322mm) | 52" (1321mm) |
| CZ | 24" (610mm) | 27 ¹⁵ / ₁₆ " (710mm) | 4 ⁵ / ₁₆ " (110mm) | 49 ¹³ / ₁₆ " (1265mm) | 49 ³ / ₄ " (1264mm) |
| CZD | 24" (610mm) | 44" (1118mm) | 13 ³ / ₁₆ " (346mm) | 76 ¹ / ₁₆ " (1932mm) | 76" (1930mm) |
| CZ, CZD, BE, CE | 36" (914mm) | 54" (1372mm)* | 13 ³ / ₁₆ " (346mm) | 100 ¹ / ₁₆ " (2542mm) | 100" (2540mm) |

90° VERTICAL OUTSIDE BENDS - SMOOTH RADIUS

| Tray Style | Radius | A or B | C (Straight) | Close-Coupled Inside & Outside Fittings | |
|------------|-------------|--|--------------|---|---|
| | | | | Rise | Length |
| LC | 12" (305mm) | 20" (508mm) | 5" (127mm) | 36 ¹ / ₁₆ " (916mm) | 36" (914mm) |
| LC | 24" (610mm) | 32" (813mm) | 5" (127mm) | 60 ¹ / ₁₆ " (1526mm) | 60" (1524mm) |
| BE, CE | 12" (305mm) | 21 ¹⁵ / ₁₆ " (557mm) | 6" (152mm) | 37 ¹⁵ / ₁₆ " (964mm) | 37 ⁷ / ₈ " (914mm) |
| BE, CE | 24" (610mm) | 33 ¹⁵ / ₁₆ " (862mm) | 6" (152mm) | 61 ¹⁵ / ₁₆ " (1574mm) | 61 ⁷ / ₈ " (1524mm) |

90° VERTICAL OUTSIDE BENDS [V90O]

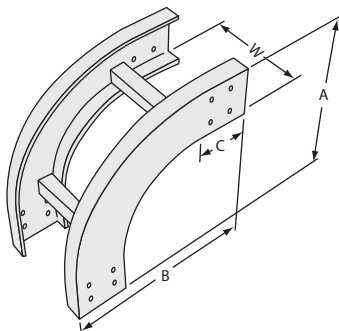
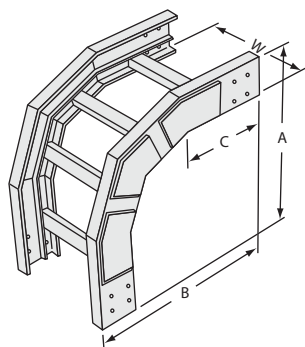

90° VERTICAL INSIDE BENDS - SMOOTH RADIUS

| Tray Style | Radius | A or B | C (Straight) | Close-Coupled Inside & Outside Fittings | |
|------------|-------------|--|--------------|---|---|
| | | | | Rise | Length |
| LC | 12" (305mm) | 20" (508mm) | 5" (127mm) | 36 ¹ / ₁₆ " (916mm) | 36" (914mm) |
| LC | 24" (610mm) | 32" (813mm) | 5" (127mm) | 60 ¹ / ₁₆ " (1526mm) | 60" (1524mm) |
| BE, CE | 12" (305mm) | 21 ¹⁵ / ₁₆ " (557mm) | 6" (152mm) | 37 ¹⁵ / ₁₆ " (964mm) | 37 ⁷ / ₈ " (914mm) |
| BE, CE | 24" (610mm) | 33 ¹⁵ / ₁₆ " (862mm) | 6" (152 mm) | 61 ¹⁵ / ₁₆ " (1574mm) | 61 ⁷ / ₈ " (1524mm) |

90° VERTICAL INSIDE BENDS - MITERED

| Tray Style | Radius | A or B | C (Straight) | Close-Coupled Inside & Outside Fittings | |
|------------|-------------|--|---|---|---|
| | | | | Rise | Length |
| CZ | 12" (305mm) | 28" (711mm) | 13 ¹ / ₁₆ " (335mm) | 52 ¹ / ₁₆ " (1322mm) | 52" (1321mm) |
| CZD | 12" (305mm) | 28" (711mm) | 12 ¹ / ₁₆ " (325mm) | 52 ¹ / ₁₆ " (1322mm) | 52" (1321mm) |
| CZ | 24" (610mm) | 27 ¹⁵ / ₁₆ " (710mm) | 4 ⁵ / ₁₆ " (110mm) | 49 ¹³ / ₁₆ " (1265mm) | 49 ³ / ₄ " (1264mm) |
| CZD | 24" (914mm) | 40" (1016mm) | 12 ¹ / ₁₆ " (325mm) | 76 ¹ / ₁₆ " (1932mm) | 76" (1930mm) |
| CZ, BE, CE | 36" (914mm) | 52" (1321mm) | 13 ³ / ₁₆ " (335mm) | 100 ¹ / ₁₆ " (2542mm) | 100" (2540mm) |
| CZD | 36" (914mm) | 52" (1321mm) | 12 ¹ / ₁₆ " (325mm) | 100 ¹ / ₁₆ " (2542mm) | 100" (2540mm) |

Intro

LADDER

I-BEAM

HAT

TROF

CHANNEL

COPE-GLAS™

WIREBASKET

Reference

FITTINGS

45° VERTICAL INSIDE BENDS [V45I]

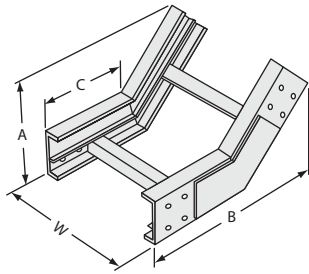

45° VERTICAL INSIDE BENDS [V45I]

| Tray Style | A | B | C (Straight) | Close-Coupled Inside & Outside Fittings | |
|------------|--|--|--|---|--|
| | | | | Rise | Length |
| LC | 11¼" (286mm) | 20 ¹⁵ / ₁₆ " (517mm) | 11 ¹⁵ / ₁₆ " (304mm) | 15¾" (399mm) | 37 ⁷ / ₈ " (963mm) |
| CZ, BE, CE | 14½" (368mm) | 24¾" (629mm) | 12" (305mm) | 18¾" (476mm) | 45¼" (1149mm) |
| CZD | 15 ¹⁵ / ₁₆ " (405mm) | 24¾" (629mm) | 11 ¹⁵ / ₁₆ " (284mm) | 18¾" (476mm) | 45¼" (1149mm) |

45° VERTICAL OUTSIDE BENDS [V45O]

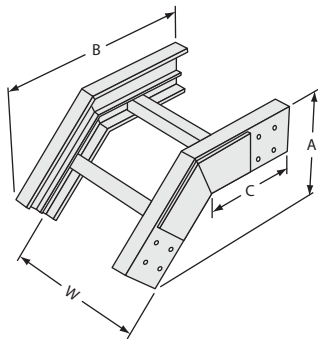

45° VERTICAL OUTSIDE BENDS [V45O]

| Tray Style | A | B | C (Straight) | Close-Coupled Inside & Outside Fittings | |
|-----------------|---------------|--|--|---|--|
| | | | | Rise | Length |
| LC | 11¼" (286mm) | 20 ¹⁵ / ₁₆ " (517mm) | 11 ¹⁵ / ₁₆ " (304mm) | 15¾" (399mm) | 37 ⁷ / ₈ " (963mm) |
| CZ, BE, CE, CZD | 14½" (368mm)* | 24¾" (629mm) | 12" (305mm) | 18¾" (476mm) | 45¼" (1149mm) |
| CZD | 16½" (419mm) | 26 ¹ / ₈ " (664mm) | 12" (305mm) | 18¾" (476mm) | 45¼" (1149mm) |

Vertical inside/Outside Bends - Part Numbering System

The following information will help you order vertical bends for your application. Special fittings are available upon request. Strut as rungs can be provided every other rung at no additional cost. Solid bottom fittings are available through special quotation. Smooth radius vertical bends are available for Type LC, BE, and CE cable trays in 12" and 24" radius. All Type CZ and CZD fittings will be mitered as will BE and CE 36" radius fittings.

Ordering Information Fittings:

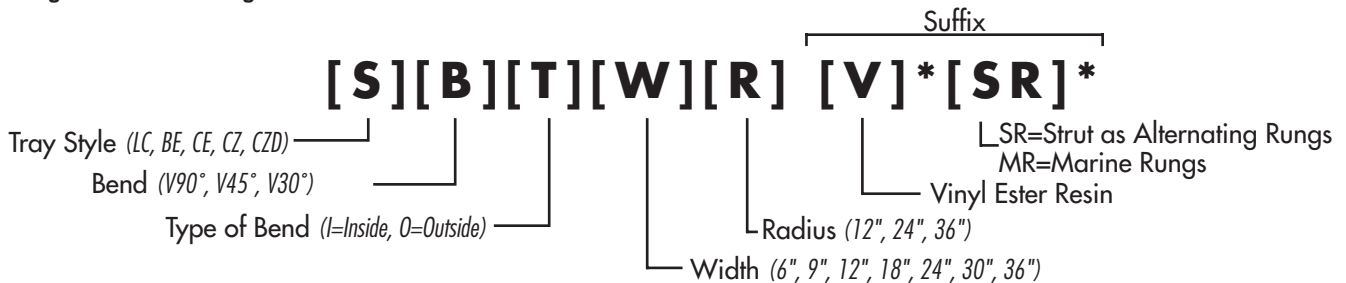

Example: CZV90I2412VSR

CZ Style Tray, 90° Inside Vertical Bend, 24" Wide, 12" Radius, Vinyl Ester Resin, With Alternating Strut Rungs.

* Add suffix "V" to specify vinyl ester resin, add "SR" to specify strut as alternating rungs, add "MR" to specify Marine Rungs

Ordering Information Covers:



Example: ZV90I2412V

Cover Style Z, 90° Inside Vertical Bend, 24" Wide, 12" Radius, Vinyl Ester Resin.

* Add suffix "V" to specify vinyl ester resin

0° THRU 90° VERTICAL ADJUSTABLE BENDS [VAB]

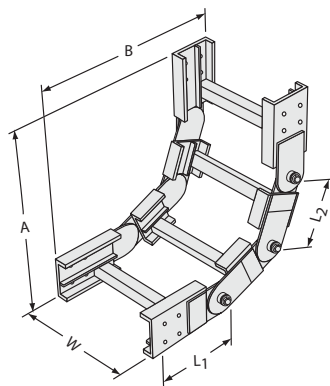
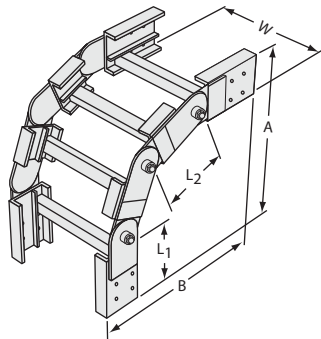

| Tray Style | Radius | A or B (@90°) | Leg L1 | Leg L2 |
|-----------------|-------------|---|--|---|
| LC | 12" (305mm) | 26 ¹ / ₈ " (664mm) | 11 ¹ / ₄ " (286mm) | 9 ⁷ / ₈ " (251mm) |
| LC | 24" (610mm) | 38 ¹ / ₁₆ " (967mm) | 11 ¹ / ₄ " (286mm) | 19" (483mm) |
| CZ, CZD, BE, CE | 12" (305mm) | 28" (711mm) | 12 ¹ / ₈ " (308mm) | 9 ⁷ / ₈ " (251mm) |
| CZ, CZD, BE, CE | 24" (610mm) | 39 ¹⁵ / ₁₆ " (1014mm) | 12 ¹ / ₈ " (308mm) | 19" (483mm) |
| CZ, CZD, BE, CE | 36" (914mm) | 51 ¹⁵ / ₁₆ " (1319mm) | 12 ¹ / ₈ " (308mm) | 28 ³ / ₁₆ " (716mm) |

Vertical Adjustable Bends - Part Number System

This versatile fitting is fully adjustable from 0° to 90° and can accommodate either an inside or outside bend. Strut rungs can be provided every other rung at no additional cost.

Ordering Information Fittings:



Example: CZVAB2412VSR
 CZ Style Tray, Vertical Adjustable Bend, 24" Wide, 12" Radius, Vinyl Ester Resin, with Alternating Strut Rungs.

* Add suffix "V" to specify vinyl ester resin, add "SR" to specify strut as alternating rungs, add "MR" to specify Marine rungs

Ordering Information Covers:



Example: ZVAB2412V
 Z Style Cover, Vertical Adjustable Bend, 24" Wide, 12" Radius, Vinyl Ester Resin.

* Add suffix "V" to specify vinyl ester resin

FITTINGS

VERTICAL TEES [VT]

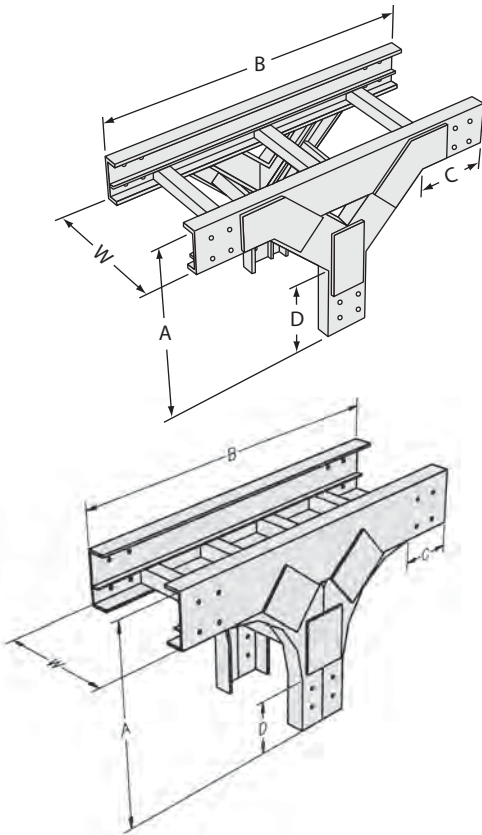

VERTICAL TEES-MITERED

| Tray Style | Radius | A | B | C (Straight) | D (Straight) |
|------------|-------------|--|--------------|---|---|
| CZ | 12" (305mm) | 25 ⁷ / ₈ " (657mm) | 44" (1118mm) | 10 ¹ / ₈ " (257mm) | 11" (279mm) |
| CZD | 12" (305mm) | 29 ³ / ₄ " (756mm) | 46" (1169mm) | 8 ¹ / ₄ " (210mm) | 11" (279mm) |
| CZ | 24" (610mm) | 35" (889mm) | 64" (1626mm) | 14 ¹ / ₂ " (368mm) | 14 ¹ / ₂ " (368mm) |
| CZD | 24" (610mm) | 37" (940mm) | 66" (1676mm) | 14 ¹ / ₂ " (368mm) | 14 ¹ / ₂ " (368mm) |
| CZ, BE, CE | 36" (914mm) | 47" (1194mm) | 88" (2235mm) | 18 ³ / ₁₆ " (478mm) | 18 ³ / ₁₆ " (478mm) |
| CZD | 36" (914mm) | 49" (1245mm) | 90" (2286mm) | 18 ³ / ₁₆ " (478mm) | 18 ³ / ₁₆ " (478mm) |

VERTICAL TEES-SMOOTH RADIUS

| Tray Style | Radius | A | B | C (Straight) |
|------------|-------------|--|---|--------------|
| LC | 12" (305mm) | 20" (508mm) | 36" (914mm) | 5" (127mm) |
| LC | 24" (610mm) | 32" (813mm) | 60" (1524mm) | 5" (127mm) |
| BE, CE | 12" (305mm) | 21 ¹⁵ / ₁₆ " (557mm) | 37 ⁷ / ₈ " (962mm) | 6" (152mm) |
| BE, CE | 24" (610mm) | 33 ¹⁵ / ₁₆ " (862mm) | 61 ⁷ / ₈ " (1572mm) | 6" (152mm) |

Vertical Tee - Part Number System

This assembly can be provided with strut rungs at no additional cost. Solid bottom fittings are available through special quotation. Smooth radius vertical tees are available for type LC, BE, and CE cable trays in 12" and 24" radius. All type CZ and CZD fittings will be mitered as will type BE and CE 36" radius fittings.

Ordering Information Fittings:

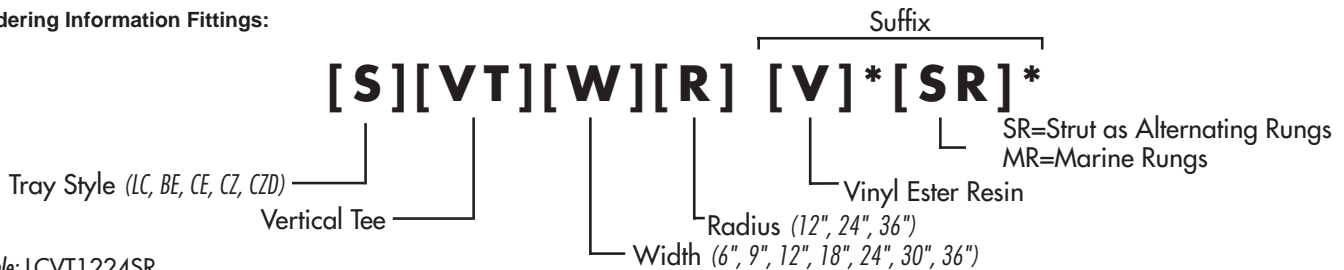

Example: LCVT1224SR
 LC Style Tray, Vertical Tee, 12" Wide, 24" Radius,
 Polyester Resin, with Alternating Strut Rungs.

* Add suffix "V" to specify vinyl ester resin, add "SR" to specify strut as alternating rungs, add "MR" to specify Marine rungs

Ordering Information Covers:



Example: ZVT1224
 Z Style Cover, Vertical Tee, 12" Wide, 24" Radius, Polyester Resin.

* Add suffix "V" to specify vinyl ester resin

90° HORIZONTAL BENDS [H90]

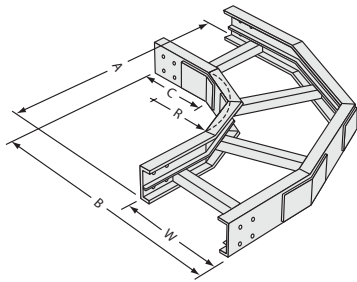

90° HORIZONTAL BENDS-MITERED

| Tray Style | Radius | A or B (W Tray Width) | C (Straight) | Close-Coupled 90° Fittings | |
|-----------------|-------------|--|--|--|--|
| | | | | Offset | Length |
| LC | 12" (305mm) | 23 ³ / ₈ " (594mm)+W | 11 ¹ / ₄ " (286mm) | 46 ⁹ / ₁₆ " (1183mm)+W | 46 ¹ / ₂ " (1181 mm)+W |
| LC | 24" (610mm) | 35 ³ / ₈ " (899mm)+W | 11 ¹ / ₄ " (286mm) | 70 ⁷ / ₈ " (1794mm)+W | 70 ⁹ / ₁₆ " (1772mm)+W |
| CZ, CZD, BE, CE | 12" (305mm) | 25" (635mm)+W* | 12 ¹⁵ / ₁₆ " (329mm)** | 50 ¹ / ₁₆ " (1272mm)+W | 50" (1270mm)+W |
| CZ | 24" (610mm) | 36 ³ / ₄ " (933mm)+W | 16 ⁷ / ₈ " (429mm) | 70 ¹ / ₁₆ " (1780mm)+W | 70" (1778mm)+W |
| CZD, BE, CE | 24" (610mm) | 37" (940mm)+W* | 12 ¹⁵ / ₁₆ " (329mm)** | 74 ¹ / ₁₆ " (1881mm)+W | 74" (1880mm)+W |
| CZ, CZD, BE, CE | 36" (914mm) | 49" (1245mm)+W* | 12 ¹⁵ / ₁₆ " (329mm)** | 98 ¹ / ₁₆ " (2491mm)+W | 98" (2489mm)+W |

*For "Z" style siderail add 2" (51 mm) to accommodate the upper flange
 **For "Z" style siderail use 12⁵/₈" (321 mm)

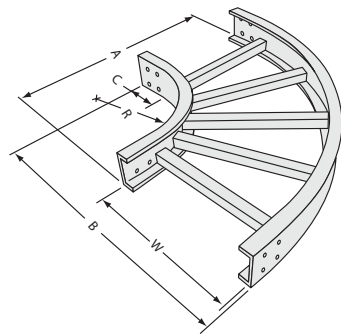

90° HORIZONTAL BENDS-SMOOTH RADIUS

| Tray Style | Width | Radius | A or B (W Tray Width) | C (Straight) | Close-Coupled 90° Fittings | |
|------------|-------------|-------------|--|---|--|----------------|
| | | | | | Offset | Length |
| LC | 12" (305mm) | 12" (305mm) | 17 ¹ / ₈ " (435mm)+W | 5 ¹⁵ / ₁₆ " (127mm) | 34 ¹ / ₁₆ " (865mm)+W | 34" (864mm)+W |
| BE, CE | 24" (610mm) | 12" (305mm) | 18 ¹ / ₄ " (464mm)+W | 6" (152mm) | 60 ¹ / ₁₆ " (1526mm)+W | 60" (1524mm)+W |
| BE, CE | 36" (914mm) | 12" (305mm) | 18 ¹ / ₄ " (464mm)+W | 6" (152mm) | 60 ¹ / ₁₆ " (1526mm)+W | 60" (1524mm)+W |
| BE, CE | 6" (152mm) | 24" (610mm) | 30 ³ / ₄ " (768mm)+W | 6" (152mm) | 72 ¹ / ₁₆ " (1830mm)+W | 72" (1829mm)+W |
| BE, CE | 9" (229mm) | 24" (610mm) | 30 ³ / ₄ " (768mm)+W | 6" (152mm) | 72 ¹ / ₁₆ " (1830mm)+W | 72" (1829mm)+W |
| BE, CE | 12" (305mm) | 24" (610mm) | 30 ³ / ₄ " (768mm)+W | 6" (152mm) | 72 ¹ / ₁₆ " (1830mm)+W | 72" (1829mm)+W |
| BE, CE | 18" (457mm) | 24" (610mm) | 30 ³ / ₄ " (768mm)+W | 6" (152mm) | 72 ¹ / ₁₆ " (1830mm)+W | 72" (1829mm)+W |
| BE, CE | 24" (610mm) | 24" (610mm) | 30 ³ / ₄ " (768mm)+W | 6" (152mm) | 72 ¹ / ₁₆ " (1830mm)+W | 72" (1829mm)+W |

45° HORIZONTAL BENDS [H45]

45° HORIZONTAL BENDS [45H]

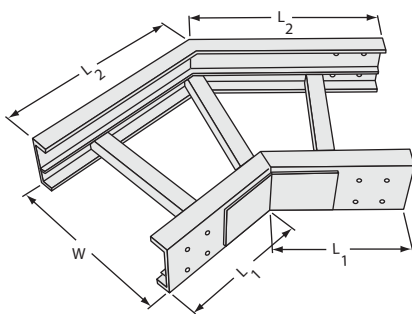

| Tray Style | Tray Widths | L1 | L2 | Close-Coupled 45° Fittings | |
|-----------------|-------------|--|--|--|---|
| | | | | Offset | Length |
| LC | 6" (152mm) | 10 ⁵ / ₈ " (270mm) | 12 ¹ / ₁₆ " (323mm) | 16 ³ / ₁₆ " (411mm) | 39" (991mm) |
| LC | 9" (229mm) | 10 ⁵ / ₈ " (270mm) | 13 ¹⁵ / ₁₆ " (354mm) | 17 ¹ / ₁₆ " (434mm) | 41 ¹ / ₈ " (1045mm) |
| LC | 12" (305mm) | 10 ⁵ / ₈ " (270mm) | 15 ³ / ₁₆ " (386mm) | 17 ¹⁵ / ₁₆ " (456mm) | 43 ³ / ₄ " (1099mm) |
| LC | 18" (457mm) | 10 ⁵ / ₈ " (270mm) | 17 ¹ / ₁₆ " (449mm) | 19 ¹ / ₁₆ " (500mm) | 47 ¹ / ₂ " (1207mm) |
| LC | 24" (610mm) | 10 ⁵ / ₈ " (270mm) | 20 ³ / ₁₆ " (512mm) | 21 ¹ / ₁₆ " (545mm) | 51 ¹ / ₄ " (1314mm) |
| LC | 30" (762mm) | 10 ⁵ / ₈ " (270mm) | 22 ⁵ / ₈ " (575mm) | 23 ³ / ₄ " (591mm) | 56" (1422mm) |
| LC | 36" (914mm) | 10 ⁵ / ₈ " (270mm) | 25 ¹ / ₈ " (638mm) | 25" (635mm) | 60 ³ / ₄ " (1530mm) |
| CZ, BE, CE, CZD | 6" (152mm) | 13" (330mm) | 15 ¹ / ₂ " (394mm) | 20 ¹ / ₁₆ " (513mm) | 48 ¹ / ₁₆ " (1237mm) |
| CZ, BE, CE, CZD | 9" (229mm) | 13" (330mm) | 16 ³ / ₄ " (425mm) | 21 ¹ / ₁₆ " (535mm) | 50 ³ / ₁₆ " (1291mm) |
| CZ, BE, CE, CZD | 12" (305mm) | 13" (330mm) | 18" (457mm) | 21 ¹⁵ / ₁₆ " (557mm) | 52 ¹⁵ / ₁₆ " (1345mm) |
| CZ, BE, CE, CZD | 18" (457mm) | 13" (330mm) | 20 ¹ / ₁₆ " (519mm) | 23 ¹ / ₁₆ " (602mm) | 57 ¹ / ₁₆ " (1453mm) |
| CZ, BE, CE, CZD | 24" (610mm) | 13" (330mm) | 22 ¹⁵ / ₁₆ " (583mm) | 25 ¹ / ₁₆ " (646mm) | 61 ³ / ₈ " (1559mm) |
| CZ, BE, CE, CZD | 30" (762mm) | 13(330mm) | 25 ¹ / ₁₆ " (646mm) | 27 ¹ / ₁₆ " (691mm) | 65 ³ / ₈ " (1667mm) |
| CZ, BE, CE, CZD | 36" (914mm) | 13(330mm) | 27 ¹⁵ / ₁₆ " (710mm) | 29" (737mm) | 69 ¹ / ₈ " (1775mm) |

FITTINGS

HORIZONTAL BENDS - PART NUMBER SYSTEM

The following information will help you order horizontal bends for your application. Special fittings are available upon request. Strut rungs can be provided every other rung at no additional cost. Solid bottom fittings are available through special quotation. Smooth radius bends are available in the following tray sizes:

- LC** 90° Horizontal Bend, 12" width, 12" radius
- BE & CE** 90° Horizontal Bend, 24" and 36" width, 12" radius
- BE & CE** 90° Horizontal Bend, 6", 9", 12", 18", 24", and 30" width, 24" radius

Ordering Information Fittings:

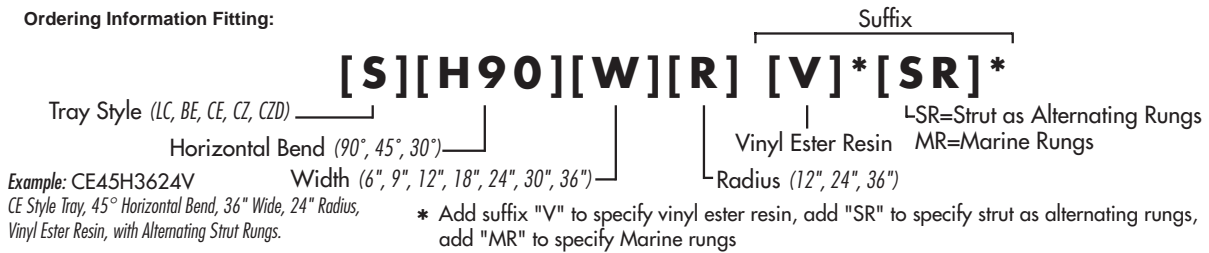

Ordering Information Covers:

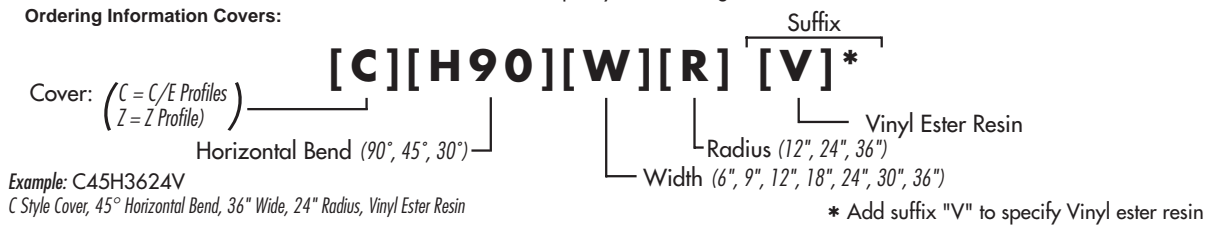

HORIZONTAL ADJUSTABLE BENDS [HAB]

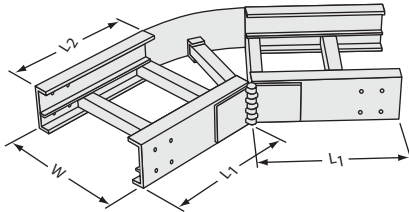

HORIZONTAL ADJUSTABLE BENDS [HAB]

| Tray style | Angle Adjustment Range | Leg L1 | Leg L2 |
|-----------------|------------------------|------------------|------------------|
| LC | 25°-65° | 16 1/16" (408mm) | 16 1/16" (408mm) |
| LC | 60°-100° | 16 1/16" (408mm) | 16 1/16" (408mm) |
| CZ, CZD, BE, CE | 25°-65° | 18" (457mm) | 18" (457mm) |
| CZ, CZD, BE, CE | 60°-100° | 18" (457mm) | 18" (457mm) |

Horizontal Adjustable Bends Part Number System

This versatile fitting is offered in two designs to accommodate a full range of adjustment.

Style "A" design is adjustable from 25° to 65°.

Style "B" design is adjustable from 60° to 100°

The range of adjustment must be specified when ordering this fitting. Strut rungs can be provided every other rung at no additional cost. Horizontal adjustable bends are available in all tray widths except 6".

Ordering Information Fittings:

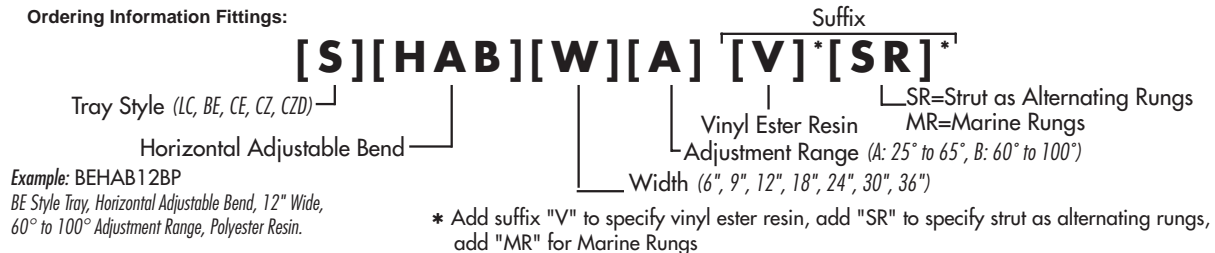

Ordering Information Covers:



HORIZONTAL TEES [T]

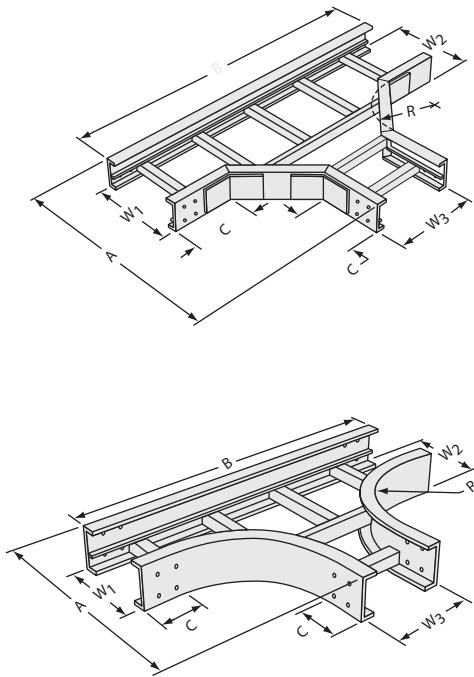

HORIZONTAL TEES-MITERED

| Tray Style | Radius | A (W=Tray Width) | B | C (Straight) |
|-----------------|-------------|-------------------------|-----------------|--|
| CZ, CZD | 12" (305mm) | 27" (686mm)+W1 or W2 | 50" (1270mm)+W3 | 12 ³ / ₁₆ " (310mm) |
| CZ | 24" (610mm) | 26" (660mm)+W1 or W2 | 48" (1219mm)+W3 | 6 ¹ / ₈ " (156mm) |
| CZD | 24" (610mm) | 39" (991 mm)+W1 or W2 | 74" (1880mm)+W3 | 12 ³ / ₁₆ " (310mm) |
| CZ, CZD, BE, CE | 36" (914mm) | 49" (1245mm)+W1* or W2* | 98" (2489mm)+W3 | 12 ⁵ / ₁₆ " (329mm)* |

t For Reducing Tees use wider of W1 or W2
 *For "Z" style siderail add 2" (51 mm) to accommodate the upper flange
 *For "Z" style siderail use 12⁵/₁₆" (310mm)

HORIZONTAL TEES-SMOOTH RADIUS

| Tray Style | Radius | At (W=Tray Width) | B | C (Straight) |
|------------|-------------|--|-----------------|--------------|
| LC | 12" (305mm) | 17 ¹ / ₈ " (435mm)+W1 or W2 | 34" (864mm)+W3 | 5" (127mm) |
| LC | 24" (610mm) | 41 ¹ / ₈ " (1095mm)+W1 or W2 | 58" (1473mm)+W3 | 5" (127mm) |
| BE, CE | 12" (305mm) | 18 ¹ / ₄ " (464mm)+W1 or W2 | 36" (914mm)+W3 | 6" (152mm) |
| BE, CE | 24" (610mm) | 30 ³ / ₄ " (786mm)+W1 or W2 | 60" (1524mm)+W3 | 6" (152mm) |

For Reducing Tees use wider of W1 or W2

Horizontal Tees - Part Number System

This assembly is commonly provided with equal width legs for standard tees but can also be provided with reduced width legs. Strut as rungs can be provided every other rung at no additional cost. Solid bottom fittings and reducing tees are available through special quotation. Smooth radius horizontal tees are available for type LC, BE and CE cable trays in 12" and 24" radius. All type CZ, and CZD fittings will be mitered as will type BE and CE 36" radius fittings.

Ordering Information Fittings:

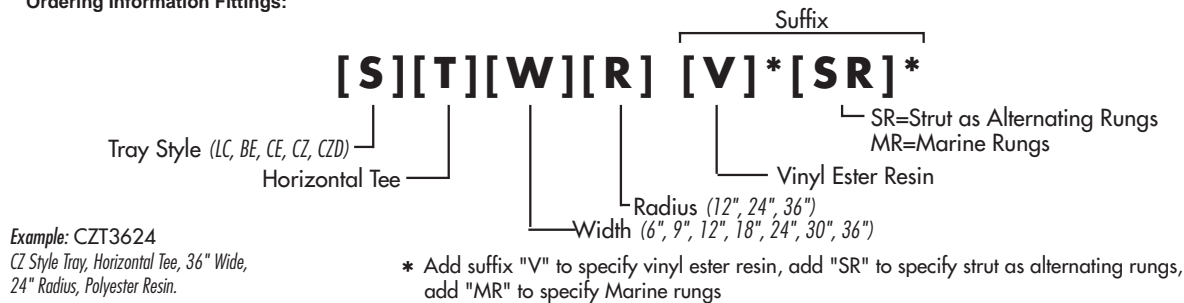

Ordering Information Covers:

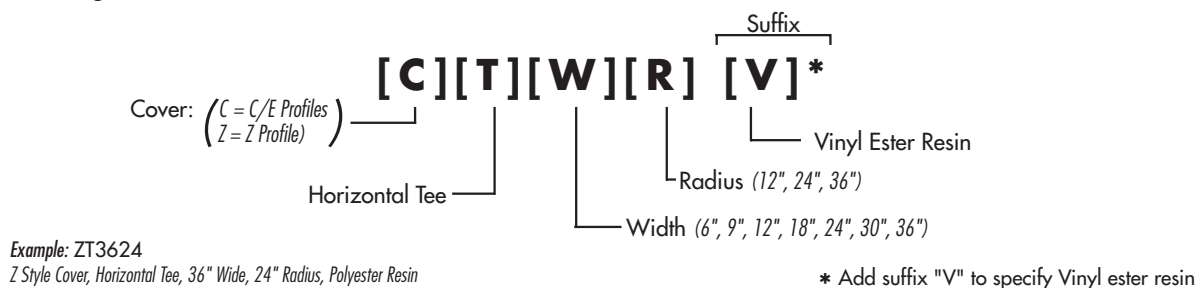

HORIZONTAL CROSSOVERS [X]

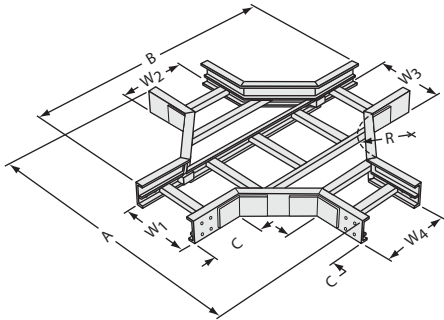

HORIZONTAL CROSSOVERS-MITERED

| Tray Style | Radius | A (W=Tray Width) | B | C (Straight) |
|-----------------|-------------|-----------------------|-----------------------|--|
| CZ, CZD | 12" (305mm) | 50" (1270mm)+W1 or W3 | 50" (1270mm)+W2 or W4 | 12 ³ / ₁₆ " (310mm) |
| CZ | 24" (610mm) | 48" (1219mm)+W1 or W3 | 48" (1219mm)+W2 or W4 | 6 ¹ / ₈ " (156mm) |
| CZD | 24" (610mm) | 74" (1880mm)+W1 or W3 | 74" (1880mm)+W2 or W4 | 12 ³ / ₁₆ " (310mm) |
| CZ, CZD, BE, CE | 36" (914mm) | 98" (2489mm)+W1 or W3 | 98" (2489mm)+W2 or W4 | 12 ⁵ / ₁₆ " (329mm)* |

For Reducing Crossovers use wider of W1 or W3
 For Reducing Crossovers use wider of W2 or W4
 *For "Z" style siderail use 12³/₁₆" (310mm)

HORIZONTAL CROSSOVERS-SMOOTH RADIUS

| Tray Style | Radius | A (W=Tray Width) | B | C (Straight) |
|------------|-------------|-----------------------|-----------------------|--------------|
| LC | 12" (305mm) | 34" (864mm)+W1 or W3 | 34" (864mm)+W1 or W3 | 5" (127mm) |
| LC | 24" (610mm) | 58" (1473mm)+W1 or W3 | 58" (1473mm)+W1 or W3 | 5" (127mm) |
| BE, CE | 12" (305mm) | 36" (914mm)+W1 or W3 | 36" (914mm)+W1 or W3 | 6" (152mm) |
| BE, CE | 24" (610mm) | 60" (1524mm)+W1 or W3 | 60" (1524mm)+W1 or W3 | 6" (152mm) |

For Reducing Crossovers use wider of W1 or W3
 For Reducing Crossovers use wider of W2 or W4

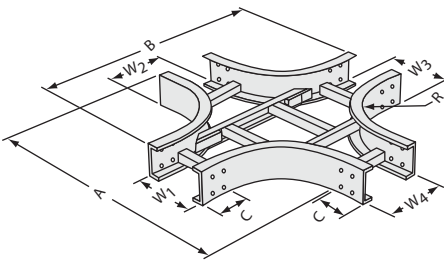

Horizontal Cross - Part Number System

This assembly is commonly provided with equal width legs for standard crosses but can also be provided with reduced width legs. Strut as rungs can be provided every other rung at no additional cost. Solid bottom fittings and reducing tees are available through special quotation. Smooth radius horizontal tees are available for type LC, BE, and CE cable trays in 12" and 24" radius. All type CZ, and CZD fittings will be mitered as will type BE and CE 36" radius fittings.

Ordering Information Fittings:

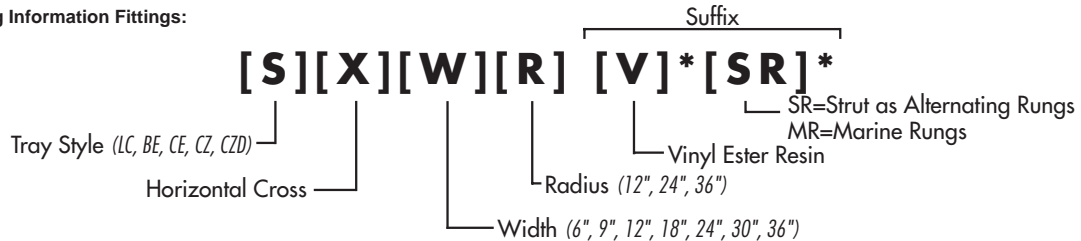

Example: BEX1812
 BE Style Tray, Horizontal Cross, 18" Wide,
 12" Radius, Polyester Resin.

* Add suffix "V" to specify vinyl ester resin, add "SR" to specify strut as alternating rungs, add "MR" to specify Marine rungs

Ordering Information Covers:



Example: CX1812
 C Style Cover, Horizontal Cross, 18" Wide, 12" Radius, Polyester Resin

* Add suffix "V" to specify Vinyl ester resin

STRAIGHT REDUCERS [RS]

STRAIGHT REDUCERS

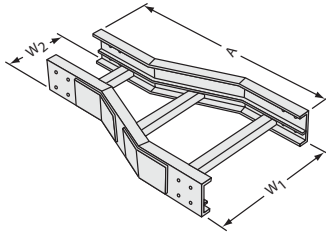

STRAIGHT REDUCERS [RS]

| Part Number | W1* | W2* | LC Tray Style A | CZ, BE, CE, CZD Tray Style A |
|-------------|----------------|-------------|-----------------|--|
| RS0906 | 09" (229mm) | 06" (152mm) | 21" (533mm) | 33 ³ / ₁₆ " (852mm) |
| RS1206 | 12" (305mm) | 06" (152mm) | 30" (762mm) | 41 ¹ / ₁₆ " (1043mm) |
| RS1209 | 12" (305mm) | 09" (229mm) | 21" (533mm) | 33 ³ / ₁₆ " (852mm) |
| RS1806 | 18" (457mm) | 06" (152mm) | 30" (762mm) | 40 ¹ / ₂ " (1029mm) |
| RS1809 | | 09" (229mm) | | 36 ⁷ / ₁₆ " (937mm) |
| RS1812 | | 12" (305mm) | | 41 ¹ / ₁₆ " (1043mm) |
| RS2406 | 24" (610mm) | 06" (152mm) | 30" (762mm) | 47 ³ / ₄ " (1213mm) |
| RS2409 | | 09" (229mm) | | 44 ¹ / ₈ " (1121 mm) |
| RS2412 | | 12" (305mm) | | 40 ¹ / ₂ " (1029mm) |
| RS2418 | 24" (610mm) | 18" (457mm) | 30" (762mm) | 41 ¹ / ₁₆ " (1043mm) |
| RS3006 | 30" (762mm) | 06" (152mm) | 30" (762mm) | 55" (1397mm) |
| RS3009 | 30" (762mm) | 09" (229mm) | 30" (762mm) | 51 ³ / ₈ " (1305mm) |
| RS3012 | 30" (762mm) | 12" (305mm) | 30" (762mm) | 47 ³ / ₄ " (1213mm) |
| RS3018 | | 18" (457mm) | | 40 ¹ / ₂ " (1029mm) |
| RS3024 | | 24" (610mm) | | 41 ¹ / ₁₆ " (1043mm) |
| RS3606 | 36" (914mm) | 06" (152mm) | 30" (762mm) | 62 ³ / ₁₆ " (1580mm) |
| RS3609 | | 09" (229mm) | | 58 ³ / ₁₆ " (1487mm) |
| RS3612 | | 12" (305mm) | | 55" (1397mm) |
| RS3618 | 36" (914mm) | 18" (457mm) | 30" (762mm) | 47 ³ / ₄ " (1213mm) |
| RS3624 | | 24" (610mm) | | 40 ¹ / ₂ " (1029mm) |
| RS3630 | | 30" (762mm) | | 41 ¹ / ₁₆ " (1043mm) |

For "Z" style siderail add 4 (102mm) to accommodate the upper flange.

RIGHT & LEFT REDUCERS [RR] OR [RL]

RIGHT REDUCERS

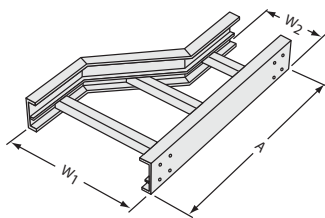

LEFT REDUCERS

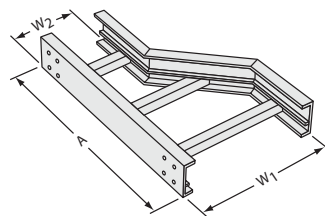

RIGHT & LEFT REDUCERS [RR] OR [RL]

| Part Number | W1* | W2* | LC Tray Style A | CZ, BE, CE, CZD Tray Style A |
|------------------|----------------|-------------|-----------------|---|
| RR0906 or RL0906 | 09" (229mm) | 06" (152mm) | 30" (762mm) | 33 ³ / ₄ " (845mm) |
| RR1206 or RL1206 | 12" (305mm) | 06" (152mm) | | 40 ¹ / ₂ " (1029mm) |
| RR1209 or RL1209 | 12" (305mm) | 09" (229mm) | | 33 ³ / ₄ " (845mm) |
| RR1806 or RL1806 | 18" (457mm) | 06" (152mm) | 30" (762mm) | 38" (965mm) |
| RR1809 or RL1809 | | 09" (229mm) | | 35" (889mm) |
| RR1812 or RL1812 | | 12" (305mm) | | 40 ¹ / ₂ " (1029mm) |
| RR2406 or RL2406 | 24" (610mm) | 06" (152mm) | 39" (991mm) | 44" (1118mm) |
| RR2409 or RL2409 | | 09" (229mm) | 39" (991mm) | 41" (1041mm) |
| RR2412 or RL2412 | | 12" (305mm) | 30" (762mm) | 38" (965mm) |
| RR2418 or RL2418 | 24" (610mm) | 18" (457mm) | 30" (762mm) | 40 ¹ / ₂ " (1029mm) |
| RR3006 or RL3006 | 30" (762mm) | 06" (152mm) | 45" (1143mm) | 50" (1270mm) |
| RR3009 or RL3009 | 30" (762mm) | 09" (229mm) | 39" (991 mm) | 47" (1194mm) |
| RR3012 or RL3012 | 30" (762mm) | 12" (305mm) | 39" (991 mm) | 44" (1118mm) |
| RR3018 or RL3018 | | 18" (457mm) | 30" (762mm) | 38" (965mm) |
| RR3024 or RL3024 | | 24" (610mm) | 30" (762mm) | 40 ¹ / ₂ " (1029mm) |
| RR3606 or RL3606 | 36" (914mm) | 06" (152mm) | 48" (1219mm) | 56" (1422mm) |
| RR3609 or RL3609 | | 09" (229mm) | 45" (1143mm) | 53" (1346mm) |
| RR3612 or RL3612 | | 12" (305mm) | 45" (1143mm) | 50" (1270mm) |
| RR3618 or RL3618 | 36" (914mm) | 18" (457mm) | 39" (991mm) | 44" (1118mm) |
| RR3624 or RL3624 | | 24" (610mm) | 30" (762mm) | 38" (965mm) |
| RR3630 or RL3630 | | 30" (762mm) | 30" (762mm) | 40 ¹ / ₂ " (1029mm) |

For "Z" style siderail add 4" (102mm) to accommodate the upper flange

FITTINGS / SPLICE PLATES

Reducers - Part Number System

Reducers are available in three styles:

- Straight
- Left Hand Offset
- Right Hand Offset

Strut rungs can be provided at every other run location at no additional cost. Solid bottom fittings are available through special quotation

Ordering Information Fittings:

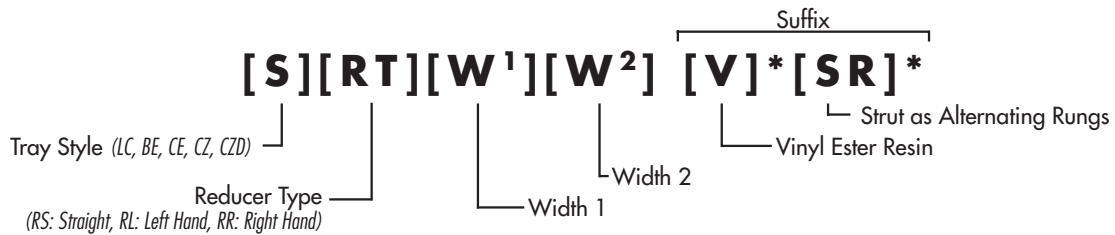

Example: BERS2412
 BE Style Tray, Straight Reducer, 24" Width,
 12" Width, Polyester Resin.

* Add suffix "V" to specify vinyl ester resin, add "SR" to specify strut as alternating rungs

Ordering Information Covers:



Example: CRS2412
 C Style Cover, Straight Reducer, 24" Width, 12" Width, Polyester Resin

* Add suffix "V" to specify Vinyl ester resin

SPLICE PLATES

The COPE-GLAS Cable Tray System offers a full line of fiberglass accessories to suit any application. All accessories must be ordered individually to complete the system.

Splice Plates

Splice plates for system assembly come in six variations designed for specific applications: straight, expansion straight, fixed angle horizontal, fixed angle vertical, horizontal adjustable and vertical adjustable. Low Profile (LC) splice plates require six 3/8-inch fasteners while splice plates for standard and deep tray require eight 3/8-inch fasteners. Splice plates and fasteners are sold separately and

are not provided with straight sections or fittings. The part numbers shown are for polyester splice plates. To specify vinyl ester splice plates, add the suffix "V" to the part number. All Low Profile splice plate part numbers are designated with an "L" prefix.

Example: LS12

Splice plates are shown on the next page.

STRAIGHT SPLICE PLATES

Used for tray-to-tray or tray-to-fitting connections.

Mid Span (Part Numbers: S12-MID)

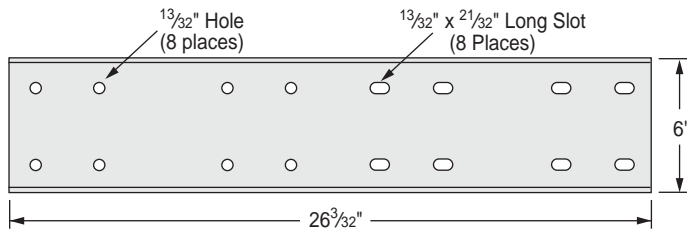

Note: The S12-MID is for use with BE and CE Style Fiberglass Cable Tray

Standard (Part Numbers: S12)

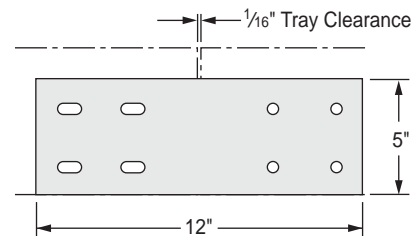

Low Profile (Part Numbers: LS12)

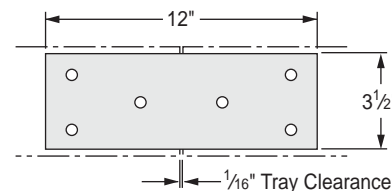

EXPANSION SPLICE PLATES

Used to accommodate thermal expansion/contraction of extended straight tray runs. The following table should be used as a guideline in determining the number of expansion splice plates needed for your application.

EXPANSION SPLICE PLATES

| Temperature Differential Deg. F | Tray Length for 1" Expansion | Max Distance Between Expansion Splices |
|---------------------------------|------------------------------|--|
| 25° | 667 ft. | 417 ft. |
| 50° | 333 ft. | 208 ft. |
| 75° | 222 ft. | 139 ft. |
| 100° | 167 ft. | 104 ft. |
| 125° | 133 ft. | 83 ft. |
| 150° | 111 ft. | 69 ft. |
| 175° | 95 ft. | 59 ft. |

The 1 inch slotted holes in each expansion connector allow 3/8" total expansion or contraction.

Standard (Part Numbers: ES12)

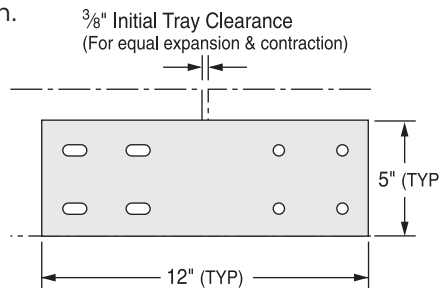

Low Profile (Part Numbers: LES12)

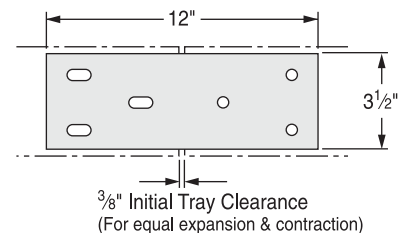

FIXED ANGLE HORIZONTAL SPLICE PLATES

Often field situations necessitate unplanned changes in the horizontal or vertical direction of a cable tray run. Fixed angle and adjustable splice plates provide a means to make horizontal and vertical direction changes in the field. These splice plates may also be used to fabricate special fittings.

Used for 90°, 45°, and 22.5° horizontal direction changes.

Standard (Part Numbers: H90, H45, H22.5)

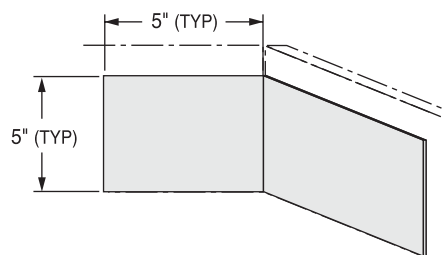

Low Profile (Part Numbers: LH90, LH45, LH22.5)

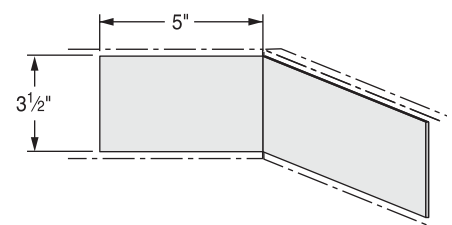

SPLICE PLATES & HARDWARE

FIXED ANGLE VERTICAL SPLICE PLATES

Used for 90°, 45°, and 22.5° vertical direction changes.

Standard (Part Numbers: V90, V45, V22.5)

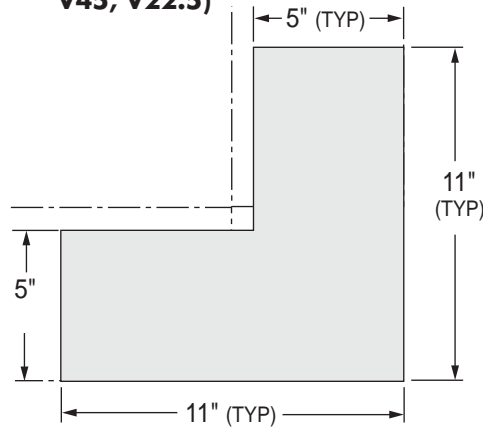

Low Profile (Part Numbers: LV90, LV45, LV22.5)

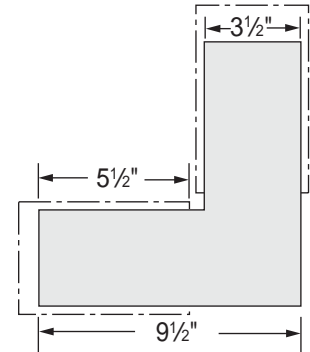

ADJUSTABLE HORIZONTAL SPLICE PLATES

Used for variable horizontal direction changes.

Standard (Part Number: H12)

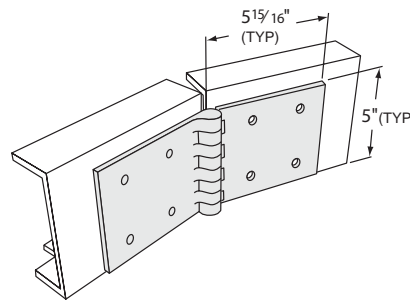

Low Profile (Part Number: LH12)

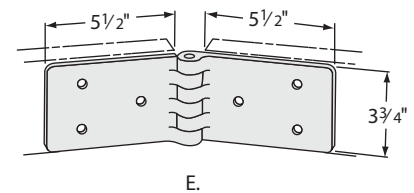

ADJUSTABLE VERTICAL SPLICE PLATES

Used for variable vertical direction changes.

Standard (Part Number: V12)

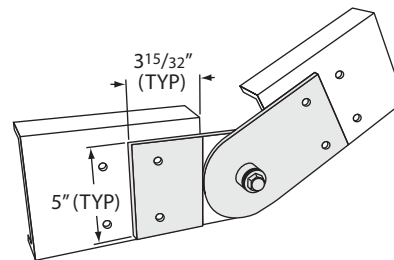

Low Profile (Part Number: LV12)

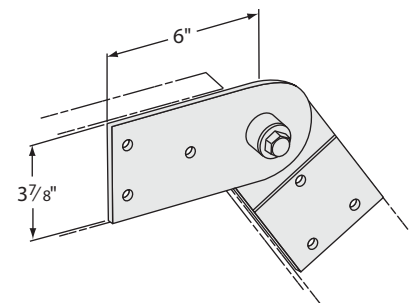

CABLE TRAY HARDWARE

The COPE-GLAS cable tray system offers four types of splice plate fasteners; Fiberglass Encapsulated 316 Stainless Steel, Standard 316 Stainless Steel, Silicon Bronze and Monel. Each bolt set with the exception of the fiberglass encapsulated hardware includes one bolt, one nut, and two washers. The fiberglass encapsulated hardware includes molded collars which act as washers and provide a smooth sealing surface. It is recommended that all splice plate fasteners be installed with a hex head socket wrench and torqued to a maximum 15 ft./lbs.

CABLE TRAY HARDWARE

| Part Numbers | Size | Type |
|--------------|-------------|-------------------------|
| FECNBSS | 3/8-16 x 1" | Fiberglass Encapsulated |
| SSNBW2-316 | 3/8-16 x 1" | 316 Stainless Steel |
| SBNBW2 | 3/8-16 x 1" | Silicon Bronze |
| MONBW2 | 3/8-16 x 1" | Monel |

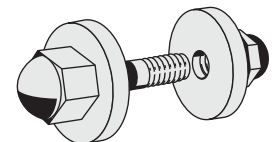

TRAY COVERS AND ACCESSORIES

RIVET [NDR1]

Nylon Drive Rivet is used to secure cover or barrier strip to tray.

Part Number: NDR1

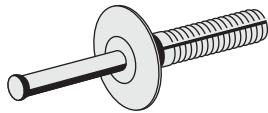

COVER CLAMP [CC1]

PVC coated steel cover clamp designed for use with "Z" profile tray and fittings.

Part Number: CC1

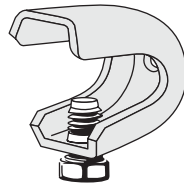

COVER CLAMP [CCE]

Fiberglass cover clamp designed for use with all "E" profile trays and fittings. Available in polyester or vinyl ester. To specify vinyl ester, add suffix "V" to part number.

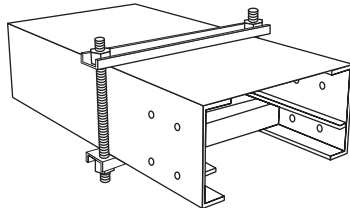

| Part No. | Tray Width | Part No. | Tray Width |
|----------|------------|----------|------------|
| CCE06 | 06" | CCE24 | 24" |
| CCE09 | 09" | CCE30 | 30" |
| CCE12 | 12" | CCE36 | 36" |
| CCE18 | 18" | | |

FIBERGLASS BOLT

½-13 x 2 vinyl ester hex head bolt for use with hold down clamps.

Part Number: 500PU-200

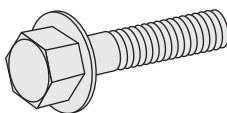

HOLD DOWN PACKAGE

The Hold Down Package consists of the necessary components for securing COPE-GLAS tray to strut or wall brackets. The Hold Down Package includes one each of the following items; HD4AB (hold down clamp), 500PU-200 (½"-13 x 2 fiberglass bolt) and 500PU-CN (1½" strut nut). The components are also available individually. Installation procedures are located in the installation Procedures Section of this catalog.

Part Number: HDBLTNT

Combination Hold-Down Clamp and Expansion Guide

Hold-Down side secures and prevents lateral movement of cable tray while expansion side allows for thermal expansion and contraction of cable tray.

Part Number: HD4AB

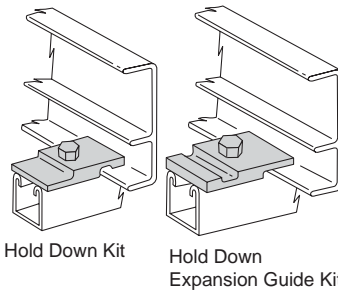

END PLATES

To order appropriate End Plate, see chart. To specify vinyl ester, add suffix "V" to part number (hardware not included).

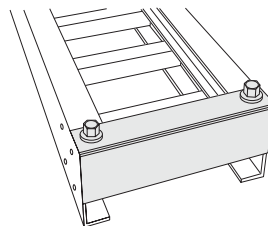

| Tray Width | "LC" | "CZ" | "BE/CE" |
|------------|-------|-------|---------|
| 06" | EPL06 | EPZ07 | EPE06 |
| 09" | EPL09 | EPZ09 | EPE09 |
| 12" | EPL12 | EPZ12 | EPE12 |
| 18" | EPL18 | EPZ18 | EPE18 |
| 24" | EPL24 | EPZ24 | EPE24 |
| 30" | EPL30 | EPZ30 | EPE30 |
| 36" | EPL36 | EPZ36 | EPE36 |

FLOOR & PANEL FLANGE

Available in polyester and vinyl ester resin. To specify vinyl ester, add suffix "V" to part number.

Part Numbers: LF400, F400

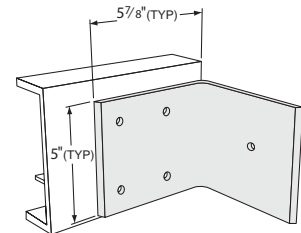

BARRIER STRIP

Barrier strip is supplied in ten foot lengths and is intended for field installation unless otherwise indicated. For securing barrier strip to tray, we recommend the use of Nylon Drive Rivets (Part #NDR1) which require field drilling or Adjustable Divider Clamps (Part ADC1). Barrier strip is available in polyester and vinyl ester resin types. To specify vinyl ester, add suffix "V" to part number.

Example: RGBS4V

| Tray Style | Part Number | Dimensions |
|-------------|-------------|--------------|
| Low Profile | RGBS3 | 3" x 2" x ¾" |
| Basic | RGBS4 | 4" x 2" x ¾" |
| Deep | RGBS6 | 6" x 2" x ¾" |

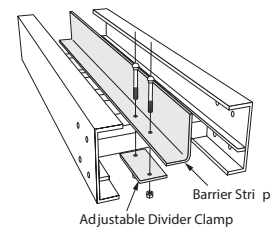

ADJUSTABLE DIVIDER CLAMP

The Adjustable Divider Clamp makes locating the barrier strip a snap. The ADC is available in polyester and vinyl ester resin. To specify vinyl ester, add suffix "V" to part number. Two clamps per ten foot section of barrier strip are recommended.

| Tray Style | Part Number |
|-------------|-------------|
| Low Profile | LADC1 |
| Basic | ADC1 |
| Deep | ADC1 |

COPE-GLAS™ CABLE TRAY SYSTEM

ACCESSORIES

DROP OUTS

Drop Outs are easily fastened to tray rungs with two Nylon Drive Rivets (NDR1). Nylon Drive Rivets are separate order items. To specify vinyl ester, add suffix "V" to part number.

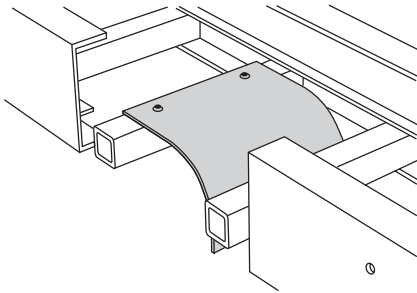

| Tray Width | Part Number |
|------------|-------------|
| 06" | D006 |
| 09" | D009 |
| 12" | D012 |
| 18" | D018 |
| 24" | D024 |
| 30" | D030 |
| 36" | D036 |

COVER STAND-OFFS

Cover Stand-Offs secure cable tray cover to tray or fittings while providing a ventilation gap for cables. The S0200 is designed to be used with all "Z" and "E" profile cable trays. It is supplied with a threaded fiberglass stand-off and two 3/8" diameter, non-metallic bolts (375PU-125). The S0200 requires field drilling. Five pairs of clamps are recommended per ten foot length of cable tray cover.

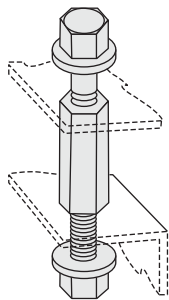

CONDUIT TO CABLE TRAY CLAMP

The Cope-Glas Conduit to Cable Tray Clamp allows a smooth transition for electrical conduits to Cope-Glas Cable Tray. The clamp is available in either polyester or vinyl ester and is adjustable to accommodate any entry angle. This clamp will work with all Cope-Glas tray styles. To order, specify the correct conduit size. For vinyl ester, add the suffix "V" to the part number.

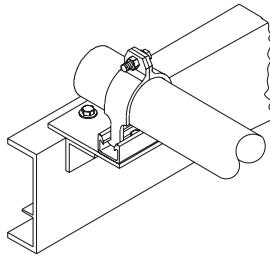

| Conduit Size | Part Number | Conduit Size | Part Number |
|--------------|-------------|--------------|-------------|
| 1/2" | CG-CCB-050 | 2" | CG-CCB-200 |
| 3/4" | CG-CCB-075 | 2 1/2" | CG-CCB-250 |
| 1" | CG-CCB-100 | 3" | CG-CCB-300 |
| 1 1/4" | CG-CCB-125 | 4" | CG-CCB-400 |
| 1 1/2" | CG-CCB-150 | | |

TRAY FLANGE HANGER

THE COPE-GLAS Flange Hanger is recommended when space requirements make conventional tray hanging and supporting methods impractical. Flange Hanger has a 375 lb. Load rating with a 2.0 safety factor. To specify vinyl ester, add suffix "V" to part number.

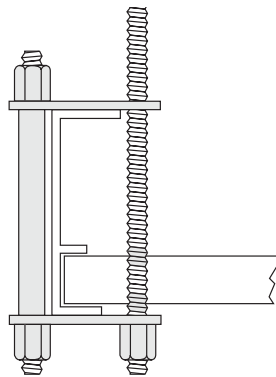

| Part Number | Tray Style |
|-------------|-------------|
| RGFH1 | Low Profile |
| RGFH2 | E Profile |

WALL SUPPORT BRACKETS

Constructed of Aickinstrut fiberglass components, Wall Support Brackets are an alternative tray hanging system. The Aickinstrut product line offers a complete line of fasteners that can be used with the wall brackets in many different tray clamping schemes. Installation guidelines for wall brackets are located in the installation Procedures Section of this catalog. To specify vinyl ester, add suffix "V" to part number.

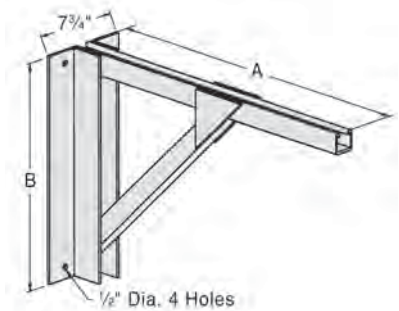

| Part No. | Tray Width | Dim. A | Dim. B |
|----------|------------|-------------|------------|
| CTB06A | 06" | 11"(279mm) | 10"(254mm) |
| CTB09A | 09" | 14"(356mm) | 12"(305mm) |
| CTB12A | 12" | 17"(432mm) | 13"(330mm) |
| CTB18A | 18" | 23"(584mm) | 16"(406mm) |
| CTB24A | 24" | 29"(737mm) | 19"(483mm) |
| CTB30A | 30" | 35"(889mm) | 22"(559mm) |
| CTB36A | 36" | 41"(1041mm) | 25"(635mm) |

MARINE RUNG

The marine rung may be specified for several tray components by adding MR to the part number. The marine rung is shown below.

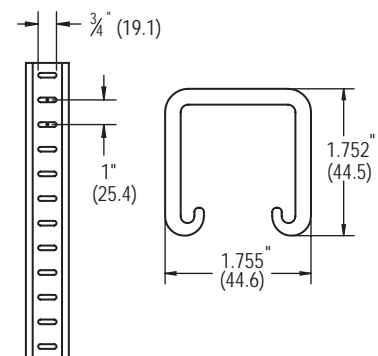

For complete Aickinstrut offering go to copecabletray.com

AICKINSTRUT® SUPPORT SYSTEMS

AICKINSTRUT® CHANNEL

Aickinstrut is commonly used as a support system for cable tray, structural piping and electrical conduit. Aickinstrut is available in three profiles (light duty, heavy duty, and back-to-back), and can be supplied in either polyester or vinyl ester resin. Aickinstrut heavy duty and light duty channels are also available slotted (1" long x 3/8" diameter). The standard channel lengths are ten and twenty feet but special lengths are available upon request. For load/deflection information and installation guidelines, refer to the Installation Procedures Section of this catalog.

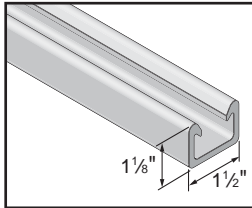

LIGHT DUTY CHANNEL

| Part Number | Design | Resin System |
|-------------|---------|--------------|
| 20P-1000 | Solid | Polyester |
| 20V-1000 | Solid | Vinyl Ester |
| 20P-1200 | Slotted | Polyester |
| 20V-1200 | Slotted | Vinyl Ester |

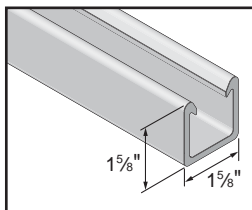

HEAVY DUTY CHANNEL

| Part Number | Design | Resin System |
|-------------|---------|--------------|
| 20P-2000 | Solid | Polyester |
| 20V-2000 | Solid | Vinyl Ester |
| 20P-2200 | Slotted | Polyester |
| 20V-2200 | Slotted | Vinyl Ester |

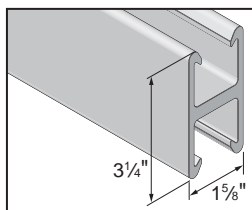

BACK-TO-BACK CHANNEL*

| Part Number | Resin System |
|-------------|--------------|
| 20P-2100 | Polyester |
| 20V-2100 | Vinyl Ester |

*Add "-SL" to the part number for slotted strut.

FIBERGLASS ALL-THREAD ROD

Fiberglass all-thread rods are an excellent choice for hanging and fastening Aickinstrut Channel. Aickinstrut all-thread rods are available in five sizes: 3/8", 1/2", 5/8", 3/4", and 1". All Aickinstrut all-thread rods are manufactured from pultruded vinyl ester resin and are gray in color. The standard rod lengths are four and eight feet.

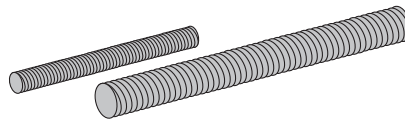

FOUR FOOT LENGTHS

| Part Number | Size (in.) |
|-------------|---------------|
| 200-3827 | 3/8 - 16 x 48 |
| 20V-2100 | 1/2 - 13 x 48 |
| 200-3829 | 5/8 - 11 x 48 |
| 200-3830 | 3/4 - 10 x 48 |
| 200-3831 | 1 - 8 x 48 |

EIGHT FOOT LENGTHS

| Part Number | Size (in.) |
|-------------|---------------|
| 200-3827-96 | 3/8 - 16 x 96 |
| 200-3828-96 | 1/2 - 13 x 96 |
| 200-3829-96 | 5/8 - 11 x 96 |
| 200-3830-96 | 3/4 - 10 x 96 |
| 200-3831-96 | 1 - 8 x 96 |

AICKINSTRUT® ROD COUPLERS

Rod couplers are an excellent means for extending Aickinstrut FRP all-thread rods beyond their standard lengths. All Aickinstrut rod couplers are manufactured from glass-reinforced polyurethane and are colored gray.

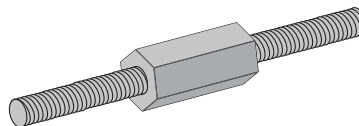

| Part Number | Size (in.) | Length (in.) | Shear (lbs.)* |
|-------------|------------|--------------|---------------|
| 200-3840 | 3/8 - 16 | 2 1/4 | 800 |
| 200-3841 | 1/2 - 13 | | 870 |
| 200-3842 | 5/8 - 11 | | 1500 |
| 200-3843 | 3/4 - 10 | | 1500 |

*Thread shear values shown represent a 3:1 safety factor.

ALL-THREAD HEX FLANGE NUTS

Hex flange nuts are manufactured from glass-reinforced polyurethane resin and are available in four sizes.

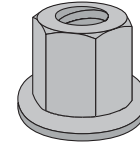

| Part Number | Size (in.) | Thread Shear (lbs)* | Torque |
|--------------|------------|---------------------|------------|
| 375PU-FN-000 | 3/8 - 16 | 500 | 10 in/lbs. |
| 500PU-FN-000 | 1/2 - 13 | 1200 | 3 ft/lbs. |
| 625PU-FN-000 | 5/8 - 11 | 2200 | 8 ft/lbs. |
| 750PU-FN-000 | 3/4 - 10 | 2900 | 12 ft/lbs. |

*Thread shear values shown represent a 3:1 safety factor.

ALL-THREAD WASHERS

COPE-GLAS All-Thread Washers are flat fiberglass washers for use with FRP all-thread rods. All-thread rod washers are 1/4" thick with a 1/e" diameter and are available in polyester or vinyl ester resin. To order vinyl ester, add the suffix "V" to the part number.

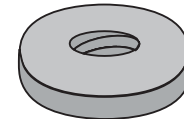

| Part Number | All-Thread Rod Size (in.) |
|-------------|---------------------------|
| WR375 | 3/8 |
| WR500 | 1/2 |
| WR625 | 5/8 |
| WR750 | 3/4 |

*Add "-SL" to the part number for slotted strut.

CHANNEL CAPPING STRIP

Channel capping strip is made from PVC and is provided in 10 foot lengths. Part Number 20E-5000

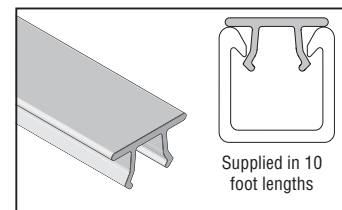

Supplied in 10 foot lengths

COPE-GLAS™ CABLE TRAY SYSTEM

AICKINSTRUT® SUPPORT SYSTEMS

AICKINSTRUT® CHANNEL NUTS

Aickinstrut Channel Nuts can be used to attach pipe straps, channel fittings or COPEGLAS holdown clamps to Aickinstrut Channel. The standard duty channel nuts are designed for applications where high thread shear values are not required. The heavy duty channel nuts are designed for applications that require high thread shear and torque values.

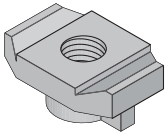

STANDARD DUTY

| Part Number | Size (in.) | Thread Shear (lbs.)* | Torque (ft./lbs) |
|-------------|------------|----------------------|------------------|
| 375PU-CN | 3/8 - 16 | 460 | 2 |
| 500PU-CN | 1/2 | 460 | 3 |

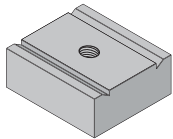

HEAVY DUTY

| Part Number | Size (in.) | Thread Shear (lbs.)* | Torque (ft./lbs) |
|-------------|------------|----------------------|------------------|
| 375PU-CNHD | 3/8 - 16 | 1400 | 8 |
| 375PU-CNHD | 1/2 - 13 | 1400 | 8 |

*Thread shear values shown a 3:1 safety represent factor.

HANGER ROD BEAM CLAMPS

COPE-GLAS Hanger Rod Beam Clamps are molded from glass-reinforced polyurethane and are available in three sizes: 3/8", 1/2" and 5/8".

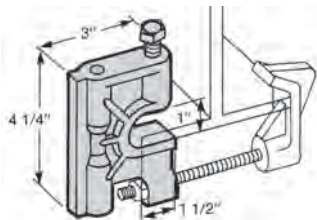

| Part Number | Size (in.) | Thread Shear (lbs.)* | Torque (ft./lbs) |
|-------------|------------|----------------------|------------------|
| RGBC-1 | 3/8 | 500 | 10 |
| RGBC-2 | 1/2 | 500 | 10 |
| RGBC-3 | 5/8 | 500 | 10 |

*Thread shear values shown represent a 3:1 safety factor.

FIBERFAST BOLTS

Fiberfast bolts are available in three diameters (3/16", 3/8" & 1/2") and are injection molded from glass-reinforced polyurethane resin.

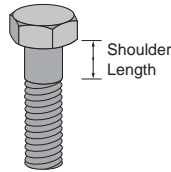

| Part Number | Size (in.) | Thread Shear (lbs.)* | Shank Shear (lbs.) | Torque (ft./lbs) |
|-------------|--------------|----------------------|--------------------|------------------|
| 300PU-100 | 3/16 x 1 | 225 | 450 | 3 |
| 300PU-125 | 3/16 x 1 1/4 | 225 | 450 | 3 |
| 300PU-150 | 3/16 x 1 1/2 | 225 | 450 | 3 |
| 375PU-125 | 3/8 x 1 1/4 | 250 | 470 | 3 |
| 375PU-150 | 3/8 x 1 1/2 | 250 | 470 | 3 |
| 375PU-200 | 3/8 x 2 | 250 | 470 | 3 |
| 375PU-250 | 3/8 x 2 1/2 | 250 | 470 | 3 |
| 375PU-300 | 3/8 x 3 | 250 | 470 | 3 |
| 500PU-125 | 1/2 x 1 1/4 | 450 | 870 | 8 |
| 500PU-200 | 1/2 x 2 | 450 | 870 | 8 |
| 500PU-250 | 1/2 x 2 1/2 | 450 | 870 | 8 |
| 500PU-300 | 1/2 x 3 | 450 | 870 | 8 |

*Thread shear and shank shear values shown represent a 3:1 safety factor.

NON-METALLIC U-BOLTS

Non-metallic U-Bolts are injection molded from glass-reinforced polyurethane and are available in sizes from 1/2" - 4" diameter.

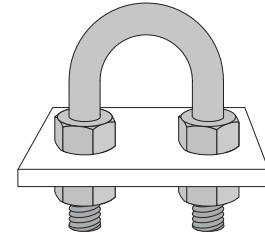

| Part Number | Size (in.) | Load (lbs.)* | Torque (ft./lbs) |
|-------------|------------|--------------|------------------|
| UB-050 | 1/2 | 135 | 40 |
| UB-075 | 3/4 | 135 | 40 |
| UB-100 | 1 | 135 | 40 |
| UB-125 | 1 1/4 | 135 | 40 |
| UB-150 | 1 1/2 | 135 | 40 |
| UB-200 | 2 | 135 | 80 |
| UB-250 | 2 1/2 | 135 | 80 |
| UB-300 | 3 | 135 | 80 |
| UB-350 | 3 1/2 | 153 | 80 |
| UB-400 | 4 | 135 | 80 |

*Torque and load values shown represent a 3:1 safety factor.

K. RIGID PIPE CLAMPS

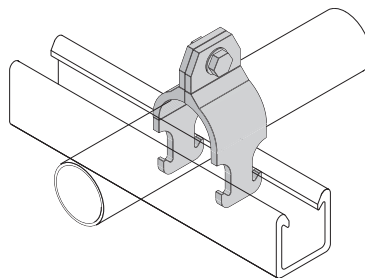

Aickinstrut Rigid Pipe Clamps resemble the more traditional style of pipe clamps. These clamps are made from glass reinforced polyurethane and are sized based on the pipe inside diameter or nominal size.

| Part Number | Nominal Size (in.) | PVC Sch. 80 and Rigid Metal | Design Load (lbs.)* | | FRP Bolt Size (in.) | Torque |
|-------------|--------------------|-----------------------------|---------------------|--------|---------------------|----------|
| | | | Type 1 | Type 2 | | |
| PCR-050 | 1/2 | .840 | 180 | 25 | 1/4 x 1 | 5in/lbs |
| PCR-075 | 3/4 | 1.050 | 180 | 25 | 1/4 x 1 | 5in/lbs |
| PCR-100 | 1 | 1.315 | 180 | 25 | 1/4 x 1 | 5in/lbs |
| PCR-125 | 1 1/4 | 1.660 | 180 | 25 | 1/4 x 1 | 5in/lbs |
| PCR-150 | 1 1/2 | 1.900 | 180 | 25 | 1/4 x 1 | 5in/lbs |
| PCR-200 | 2 | 2.375 | 180 | 25 | 1/4 x 1 | 5in/lbs |
| PCR-300 | 3 | 3.500 | 220 | 50 | 3/8 x 1 1/4 | 3 ft/lbs |
| PCR-400 | 4 | 4.500 | 250 | 100 | 3/8 x 1 1/4 | 3 ft/lbs |
| PCR-600 | 6 | 6.625 | 250 | 100 | 3/8 x 1 1/4 | 3 ft/lbs |

*Design loads shown represent a safety factor 3:1

For complete Aickinstruct offering go to copecabletray.com

Aickinstruct Channel Fittings Legend: P Series Fittings are Gray Polyester, V Series Fittings are Beige Vinyl Ester, PU Series Fittings are Gray Polyurethane,

Note: All fittings are provided with 1/8" holes which accommodate 3/8" hardware

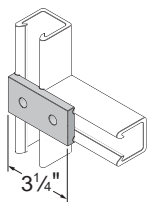
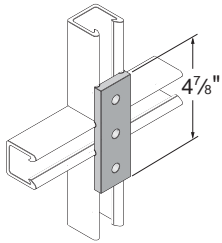
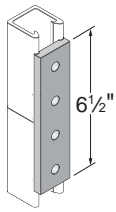
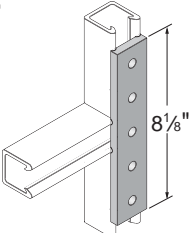
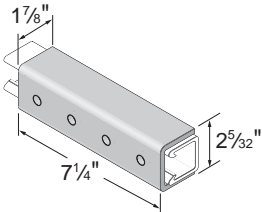
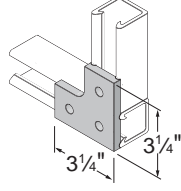
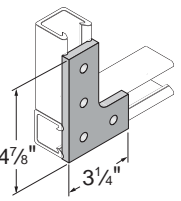
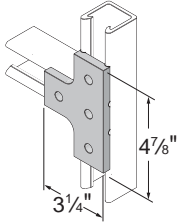
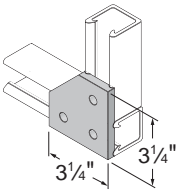
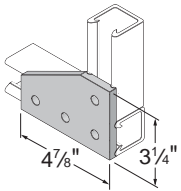
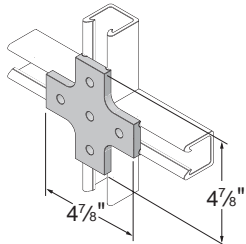
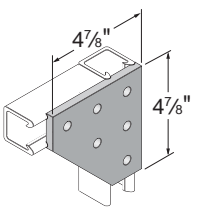
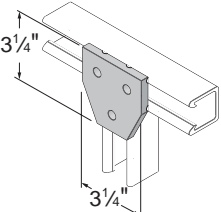
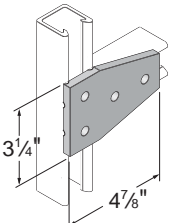
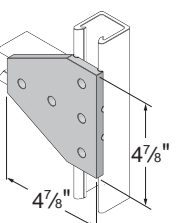
| | | |
|---|---|---|
| <p>Part Number 20P-2500 20V-2500</p>  | <p>Part Number 20P-2502 20V-2502</p>  | <p>Part Number 20P-2504 20V-2504</p>  |
| <p>Part Number 20P-2506 20V-2506</p>  | <p>Part Number 50PU-2616</p>  | <p>Part Number 20P-2508 20V-2508</p>  |
| <p>Part Number 20P-2510 20V-2510</p>  | <p>Part Number 20P-2512 20V-2512</p>  | <p>Part Number 20P-2514 20V-2514</p>  |
| <p>Part Number 20P-2516 20V-2516</p>  | <p>Part Number 20P-2518 20V-2518</p>  | <p>Part Number 20P-2520 20V-2520</p>  |
| <p>Part Number 20P-2522 20V-2522</p>  | <p>Part Number 20P-2524 20V-2524</p>  | <p>Part Number 20P-2526 20V-2526</p>  |

Intro

LADDER

I-BEAM

HAT

TROF

CHANNEL

COPE-GLAS™

WIREBASKET

Reference

COPE-GLAS™ CABLE TRAY SYSTEM

AICKINSTRUT® SUPPORT SYSTEMS

For complete Aickinstrut offering go to copecabletray.com

Aickinstrut Channel Fittings Legend: P Series Fittings are Gray Polyester, V Series Fittings are Beige Vinyl Ester, PU Series Fittings are Gray Polyurethane,

Note: All fittings are provided with $\frac{1}{32}$ " holes which accommodate $\frac{3}{8}$ " hardware

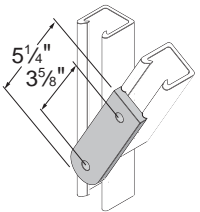
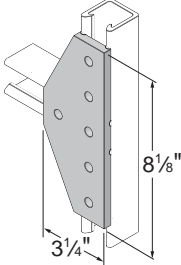
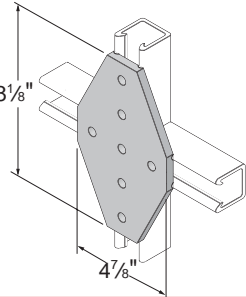
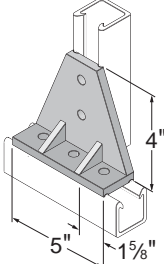
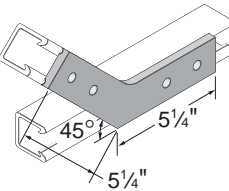
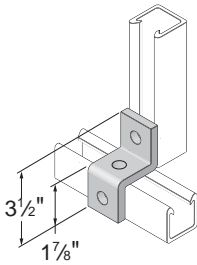
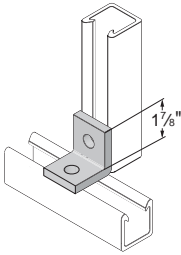
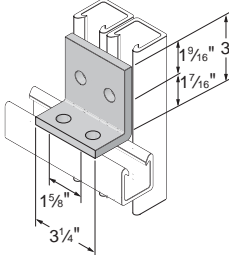
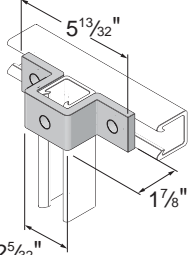
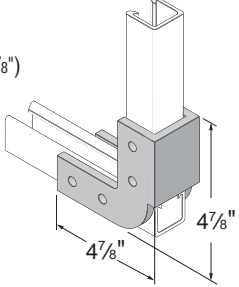
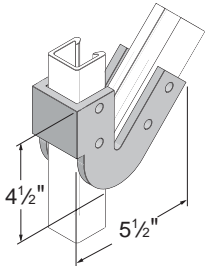
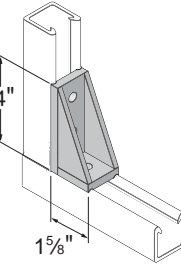
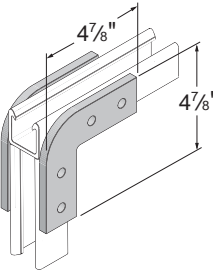
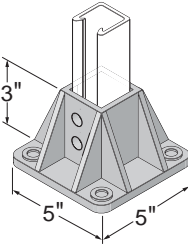
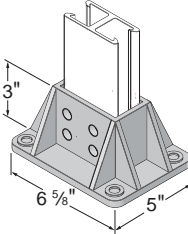
| | | |
|---|--|--|
| <p>Part Number 20P-2528 20V-2528</p>  | <p>Part Number 20P-2530 20V-2530</p>  | <p>Part Number 20P-2534 20V-2534</p>  |
| <p>Part Number 50PU-2538</p>  | <p>Part Number 20P-2540 20V-2540</p>  | <p>Part Number 50PU-2611</p>  |
| <p>Part Number 50PU-2611-SP</p>  | <p>Part Number 20P-2542 20V-2542</p>  | <p>Part Number 50PU-2613</p>  |
| <p>Part Number 50PU-2008 (1 5/8")</p>  | <p>Part Number 50PU-2045 (1 5/8")</p>  | <p>Part Number 50PU-2636¹ (Flat, without splines) 50PU-2636A² (Splines on long side) 50PU-2636B³ (Splines on short side) 50PU-2936⁴ (Splines on both sides)</p>  |
| <p>Part Number 50PU-2090 (1 5/8")</p>  | <p>Part Number 20PU-5853 (1 5/8") 20PU-5855 (1 1/8")</p>  | <p>Part Number 20PU-5903 (3 1/4") 20PU-5905 (2 1/4")</p>  |

FIBERGLASS CHANNEL

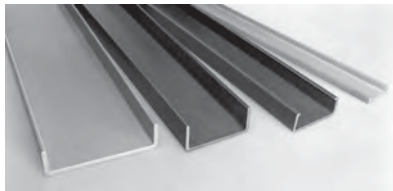

Fiberglass channel is designed to carry light wiring or tubing loads where a transition from cable tray to individual control points are required. All straight sections are offered in solid or punched construction and are supplied in ten and twenty foot lengths. COPE-GLAS Channel is available in polyester or vinyl ester resin. Contact factory for vinyl ester channel pricing. Channel fittings are supplied completely assembled from the factory. Special channel fittings that are not standard catalog items are available upon request. Channel splice plates and fasteners are separate order items.

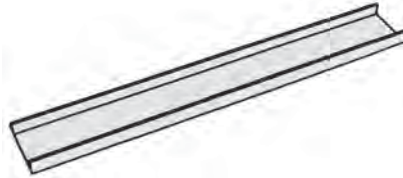
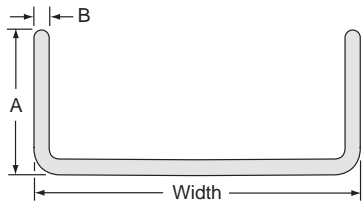

SOLID AND PUNCHED STRAIGHT CHANNEL (10FT. & 20FT. LENGTH)

| Solid | Punched | Width | "A" | "B" |
|---------|-------------|-------------|-----------------|-------------|
| CH2-(L) | -Not Avail- | 2" (51mm) | 1 13/16" (31mm) | 1/8" (3mm) |
| CH3-(L) | CH3-(L)P | 3" (76mm) | 7/8" (22mm) | 1/4" (6mm) |
| CH4-(L) | CH4-(L)P | 4" (102 mm) | 1 3/8" (35mm) | 3/16" (5mm) |
| CH6-(L) | CH6-(L)P | 6" (152mm) | 1 5/8" (41mm) | 1/4" (6mm) |
| CH8-(L) | CH8-(L)P | 8" (203mm) | 2 3/16" (56mm) | 1/4" (6mm) |

Punched channel consists of two rows of 1/2" diameter holes on 12" centers.

CHANNEL FITTINGS [CH]

Solid and punched Channel Fittings are available for all channel widths except 2" (2" punched channel fittings are not available). All fittings are preassembled and do not include splice plates and hardware. Contact factory for dimensional information on 45° Channel Fitting bends.

Unless specified otherwise, smooth radius channel fittings will be supplied wherever possible for all 4" (102mm) and 6" (152mm) widths.

Ordering Information

To create a part number, first insert the fitting type from key shown below. Then substitute the appropriate number for "W", the desired radius for "R" and the degree of bend for "D". Add a "P" suffix to the "W" designation to specify punched channel fittings. Channel Fittings are available in polyester or vinyl ester resin. Polyester is standard, to specify vinyl ester resin, add the suffix "V" to the part number.

Ordering Information:

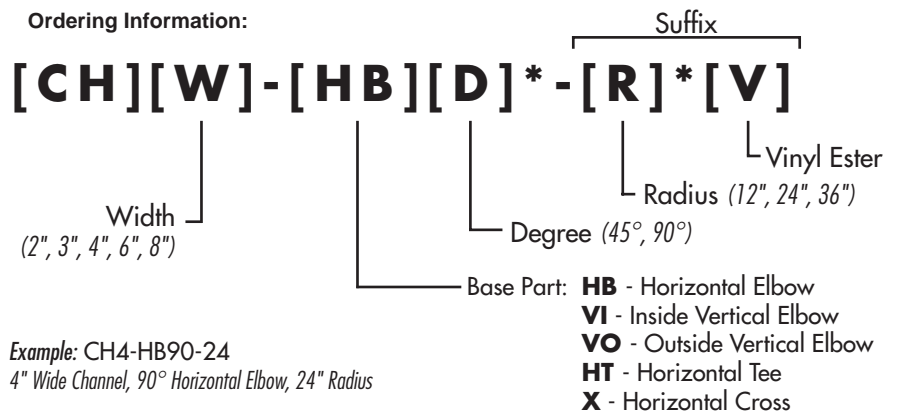

Example: CH4-HB90-24
 4" Wide Channel, 90° Horizontal Elbow, 24" Radius

* Radius and degree designations do not apply to tees and crosses.

Note: Connector plates and hardware are not included and must be ordered separately.

FIBERGLASS CHANNEL

COVERS [C]

Covers are used where cable protection is necessary or desired. Covers are available in polyester or vinyl ester resin and are offered in ten foot lengths. To specify vinyl ester resin, add the suffix "V" to the part number.



Cover Ordering Information:

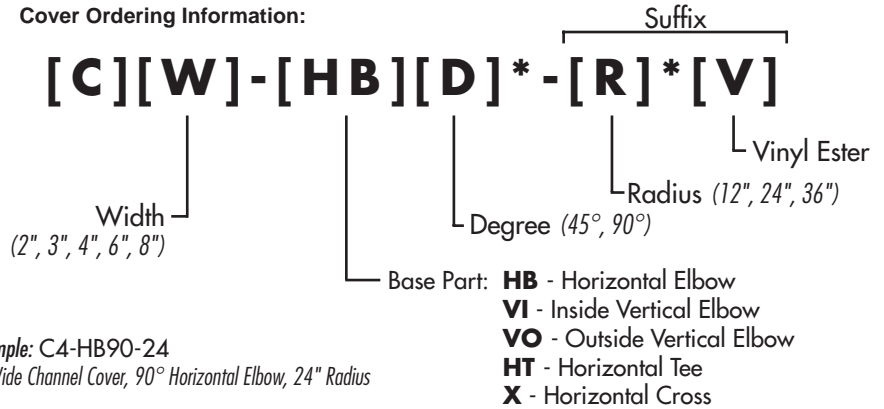

Example: C4-HB90-24
4" Wide Channel Cover, 90° Horizontal Elbow, 24" Radius

* Radius and degree designations do not apply to tees and crosses.

Note: Connector plates and hardware are not included and must be ordered separately.

HORIZONTAL ELBOWS [HB]

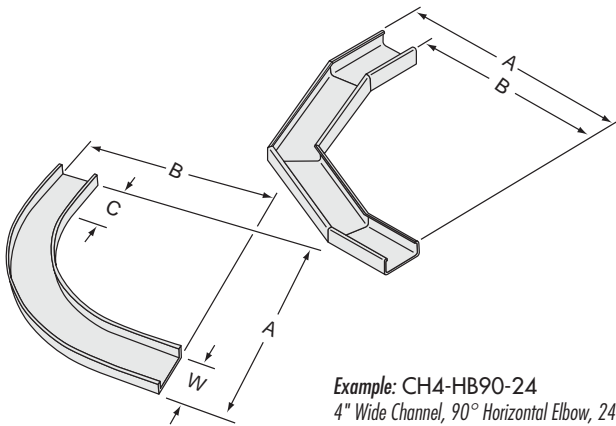

Example: CH4-HB90-24
4" Wide Channel, 90° Horizontal Elbow, 24" Radius

MITERED RADIUS DIMENSIONS

| Radius | A | B |
|-------------|----------------|--------------|
| 12" (305mm) | 17" (432mm)+W | 17" (432mm) |
| 24" (610mm) | 29" (737mm)+W | 29" (737mm) |
| 36" (914mm) | 41" (1041mm)+W | 41" (1041mm) |

SMOOTH RADIUS (AVAILABLE ONLY IN 4" AND 6" DIMENSIONS)

| Radius | W | A or B | C (straight) |
|-------------|---------|-------------|--------------|
| 12" (305mm) | 4" | 20" (508mm) | 5" |
| 24" (610mm) | (102mm) | 32" (813mm) | (127mm) |
| 12" (305mm) | 6" | | |
| 24" (610mm) | (152mm) | | |

FIBERGLASS CHANNEL

INSIDE VERTICAL ELBOW [VI]

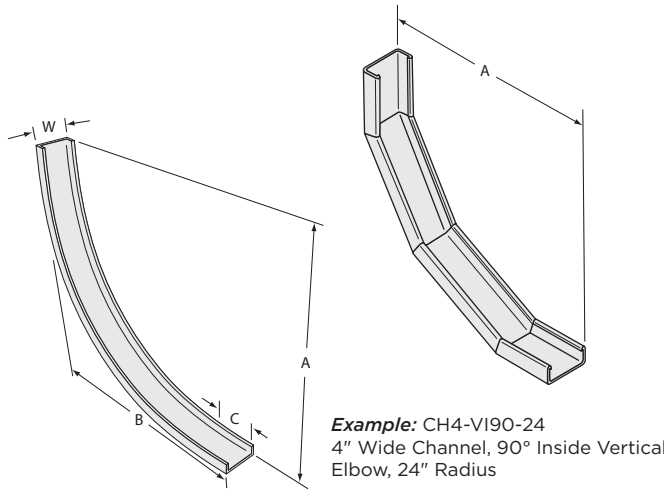

MITERED RADIUS DIMENSIONS

| Radius | A |
|-------------|--------------|
| 12" (305mm) | 17" (432mm) |
| 24" (610mm) | 29" (737mm) |
| 36" (914mm) | 41" (1041mm) |

SMOOTH RADIUS (AVAILABLE ONLY IN 4" & 6" WIDTHS)

| Radius | W | A or B | C (Straight) |
|-------------|------------|--------------|--------------|
| 12" (305mm) | 4" (102mm) | 29½" (740mm) | 5" (127mm) |
| 24" (610mm) | | | |
| 12" (305mm) | 6" (152mm) | | |
| 24" (610mm) | | | |

OUTSIDE VERTICAL ELBOW [VO]

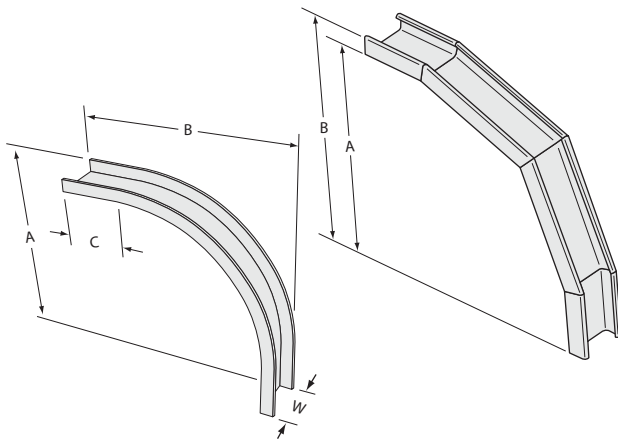

MITERED RADIUS DIMENSIONS

| Radius | A | B |
|-------------|--------------|------------------------------|
| 12" (305mm) | 17" (432mm) | 17" (432mm) + Flange Height |
| 24" (610mm) | 29" (737mm) | 29" (737mm) + Flange Height |
| 36" (914mm) | 41" (1041mm) | 41" (1041mm) + Flange Height |

SMOOTH RADIUS (AVAILABLE ONLY IN 4" WIDTHS)

| Radius | Channel Width | A or B | C (Straight) |
|-------------|---------------|--------------|--------------|
| 12" (305mm) | 4" (102mm) | 18½" (460mm) | 5" (127mm) |
| 24" (610mm) | | | |
| 12" (305mm) | 6" (152mm) | | |
| 24" (610mm) | | | |

HORIZONTAL TEE [HT]

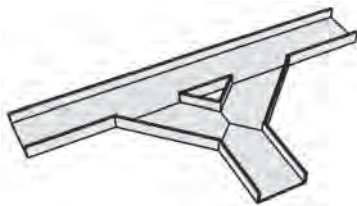

Horizontal Tees and Crosses are available as part of the COPE-GLAS Channel System. Contact factory for dimensional information.

HORIZONTAL CROSS [X]

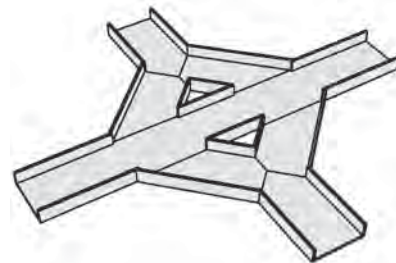

FIBERGLASS CHANNEL - CHANNEL SPLICE PLATES

Channel splice plates are available in seven styles and are made from polyester or vinyl ester resin. All splice plates are pre-drilled and do not include assembly fasteners.

STRAIGHT SPLICE PLATES [CHSP]



| Channel Width | Part Number |
|---------------|-------------|
| 2" | CHSP |
| 3" | CHSP |
| 4" | CHSP |
| 6" | CHSP |
| 8" | CHSP |

HORIZONTAL ELBOW SPLICE PLATES [SPH]

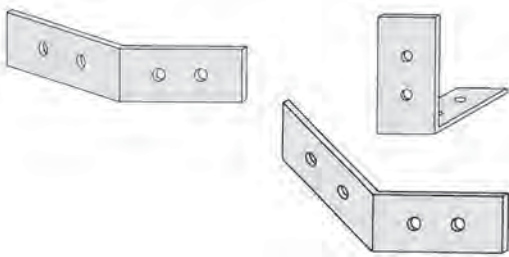

| Channel Width | Part Numbers for Given Angle | | |
|---------------|------------------------------|-----------|-----------|
| | 90° | 45° | 22½° |
| 2" | CH2-SPH90 | CH2-SPH45 | CH2-SPH22 |
| 3" | CH3-SPH90 | CH3-SPH45 | CH3-SPH22 |
| 4" | CH4-SPH90 | CH4-SPH45 | CH4-SPH22 |
| 6" | CH6-SPH90 | CH6-SPH45 | CH6-SPH22 |
| 8" | CH8-SPH90 | CH8-SPH45 | CH8-SPH22 |

VERTICAL ELBOW SPLICE PLATES [SPV]

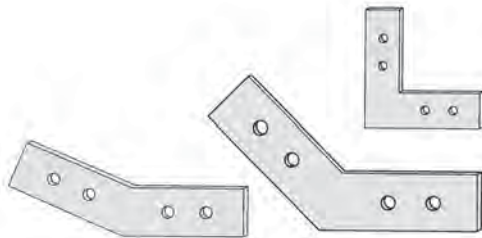

| Channel Width | Part Numbers for Given Angle | | |
|---------------|------------------------------|-----------|-----------|
| | 90° | 45° | 22½° |
| 2" | CH2-SPV90 | CH2-SPV45 | CH2-SPV22 |
| 3" | CH3-SPV90 | CH3-SPV45 | CH3-SPV22 |
| 4" | CH4-SPV90 | CH4-SPV45 | CH4-SPV22 |
| 6" | CH6-SPV90 | CH6-SPV45 | CH6-SPV22 |
| 8" | CH8-SPV90 | CH8-SPV45 | CH8-SPV22 |

CHANNEL SPLICE PLATE HARDWARE

Assembly hardware sets include:
 (1) 316 stainless steel ¼-20 x ¾" bolt,
 (1) 316 stainless steel ¼-20 nut and
 (2) 316 stainless steel flat washers.

Assembly hardware is sold individually and not provided with channel straight sections or fittings. Four sets are required for each splice plate.

Part Number: 252075

8



WIRE BASKET

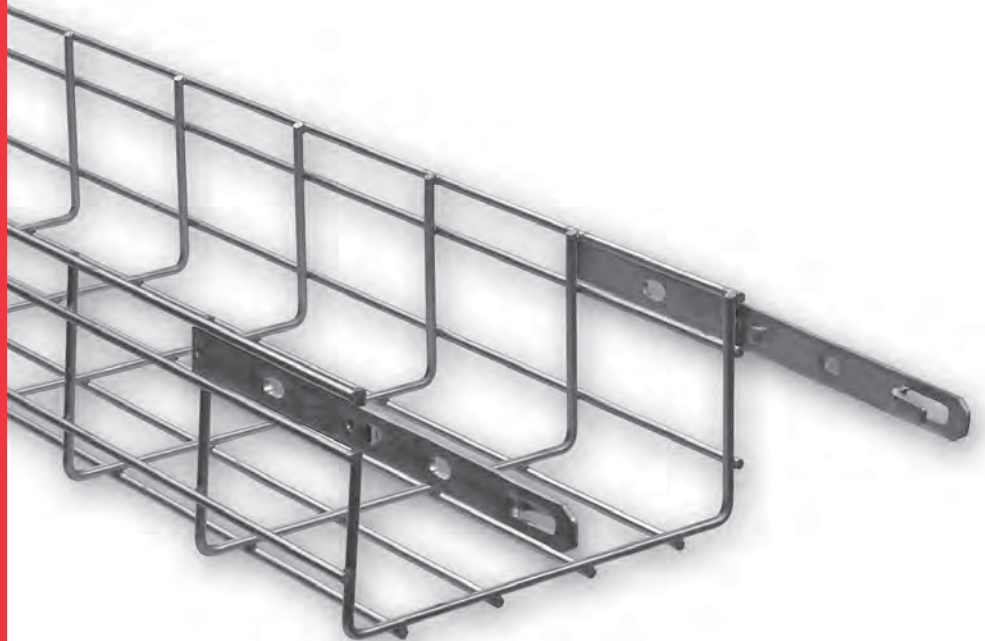

WIRE BASKET SYSTEM

CONTENTS

GENERAL & TECHNICAL INFORMATION

| | |
|---------------|-----|
| Overview..... | 215 |
| Assembly..... | 216 |

WIRE BASKET TRAY

| | |
|-------------------------------|-----------|
| Straight Length | |
| 2" Load Depth..... | 217 |
| 4" Load Depth..... | 218 |
| 6" Load Depth..... | 219 |
| Bar Connectors..... | 220 |
| Connection Hardware Kits..... | 221 - 222 |
| Support Brackets..... | 223 |
| Drop Rod Clips..... | 224 |
| Wall & Ceiling Mounts..... | 225 |
| Zed Bracket..... | 226 |
| Cantilevers..... | 226 |
| Hangers..... | 227 |
| Pendants..... | 228 |
| Hanging Brackets..... | 228 - 230 |
| Pedestal Brackets..... | 231 |

COVERS

| | |
|-------------|-----|
| Covers..... | 232 |
|-------------|-----|

ACCESSORIES

| | |
|--------------------|-----|
| Drop Outs..... | 232 |
| Tray Dividers..... | 232 |
| Blind Ends..... | 233 |
| Box Connector..... | 233 |
| Brackets..... | 234 |
| Wall Sleeve..... | 235 |
| Cutting Tool..... | 236 |

FITTINGS

| | |
|-----------------------------|-----------|
| 90° Long Radius Bends..... | 237 |
| 90° Short Radius Bends..... | 238 - 239 |
| Standard Tee..... | 240 |
| Cross..... | 240 |
| Reducer..... | 241 |
| Offset..... | 241 |
| Risers..... | 241 |

GROUNDING & HARDWARE

| | |
|--------------------------------|-----------|
| Grounding Clips and Clamp..... | 242 |
| General Hardware..... | 243 - 245 |

STRAIGHT LENGTH

Pages 217 - 219

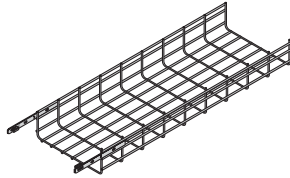

BAR CONNECTORS & HARDWARE

Pages 220 - 222

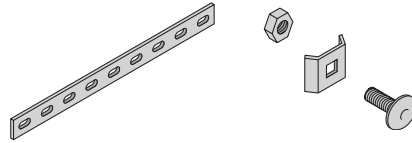

SUPPORT BRACKETS

Page 223

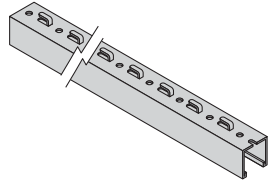

DROP ROD CLIPS

Page 224

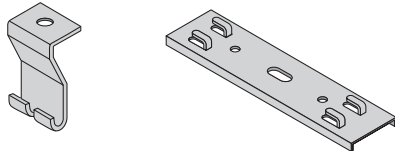

WALL & CEILING MOUNTS

Page 225

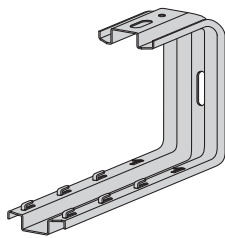

CANTILEVER & ZED BRACKETS

Page 226

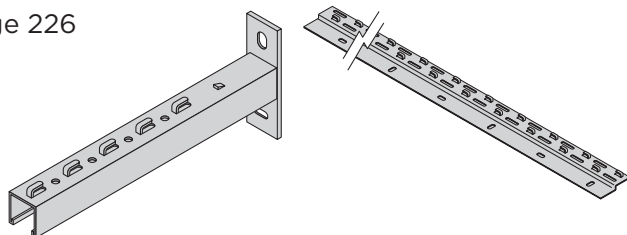

HANGERS & HANGING BRACKETS

Pages 227 - 230

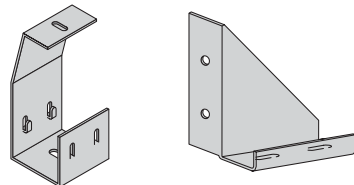

PENDENTS

Page 228

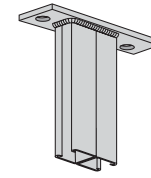

PEDESTAL BRACKETS

Page 231

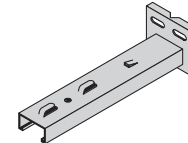

COVERS

Page 232

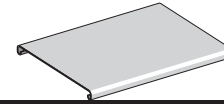

TRAY DIVIDERS AND DROP OUTS

Page 232

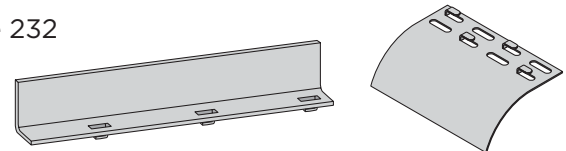

ACCESSORIES

Pages 233 - 236

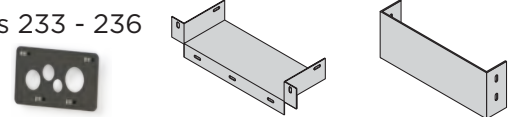

LONG & SHORT RADIUS BANDS

Pages 237 - 239

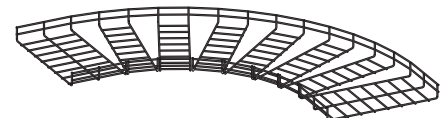

CROSS & TEE FITTINGS

Page 240

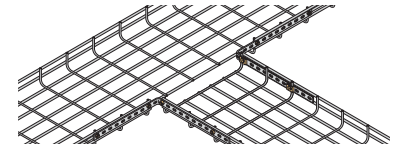

RISER, REDUCER & OFFSET FITTINGS

Page 241



GROUNDING & HARDWARE

Pages 242 - 245

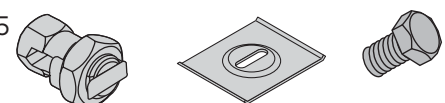

Intro

LADDER

I-BEAM

HAT

TROF

CHANNEL

COPE-GLAS™

WIREBASKET

Reference

SAMPLE SPECIFICATION

1.0 ACCEPTABLE MANUFACTURER

Provide Cope® Wire Basket type of cable management system as manufactured by Atkore International or engineered approved equal.

All cable trays shall be installed in a neat uniform fashion. Installing contractor shall field modify tray system to accommodate the exact routing requirements.

2.0 MATERIAL/FINISHES

Wire basket tray to be fabricated from high strength steel wires.

2.1 Acceptable finishes;

2.1.a Standard Finish

EG – Electro-Galvanized Steel in accordance with ASTM 633 Type I SC3.

2.1.b Special Finishes

HD – Hot dipped Galvanized Steel in accordance with ASTM 123.

ZD – Electro- Galvanized Steel with a Yellow Dichromate applied over the Standard EG finish per ASTM633 type II, SC3.

EP – Epoxy Coated Steel.

SS – AISI 304L stainless or AISI 316L stainless steel.

3.0 - STRAIGHT SECTIONS

Straight sections shall be manufactured from high strength steel wires forming 2" X 4" openings and shall conform to the following dimensions

3.1 Length

Straight sections shall be supplied in 10' lengths

3.2 Width

Widths shall be 2", 4", 6", 8", 12", 16", 18", 20", or 24" as called out on drawings.

3.3 - Load depths

The load depths shall include 2", 4", & 6" as required.

4.0 SPLICES

All straight sections shall be supplied with pre-installed, auto-locking, splices plates, where possible, as per Cope® brand. Trays design shall allow for a snap together type connection and shall require no nut and bolt assembly.

5.0 FITTINGS

All fittings shall be fabricated in the field as required, per manufacturer's recommendations. Radius of the fittings shall be based on the "minimum bending" radius of the cables being installed.

6.0 ACCESSORIES

Accessories such as blind ends, dropouts, and barriers, etc... shall be installed as specified on drawings.

7.0 SUPPORTS

Supports shall include, but are not limited to, center type, trapeze type, wall supports and floor supports.

7.1 Auto Locking

All supports shall be supplied with an Auto locking feature, requiring no special tools for attachment of the trays.

7.2 Finish

All supports, including threaded rod and associated hardware shall be electro-galvanized coated to ASTM B633 SC1 or ASTM B633 SC3.

PRODUCT DESCRIPTION

Wire basket tray is a welded wire mesh cable management system produced from high strength steel wires. Wire basket tray is produced by first welding a net, forming the channel, and then finishing after fabrication. The 2" x 4" mesh permits continuous airflow to help prevent heat buildup. In addition, this unique open design prevents the buildup of dust, contaminants and bacterial proliferation.

Wire basket tray is produced in standard 10' lengths and is supplied in three channel depths: 2", 4", and 6".

Wire basket tray is offered in nine different widths:

- 2" (50 mm), 4" (100mm),
- 6" (150mm), 8" (200mm),
- 12" (300mm), 16" (400mm),
- 18" (450mm), 20" (500mm), and
- 24" (550mm).

Special sizes are available to meet your unique requirements.

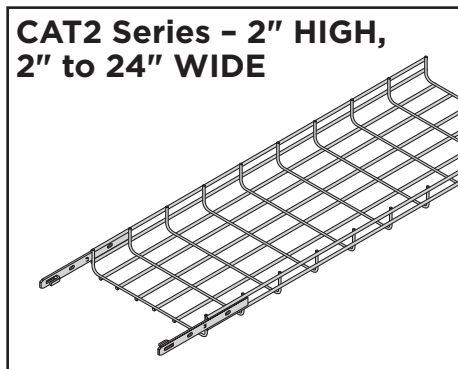

STANDARD FINISH

EG – ELECTRO-PLATED ZINC GALVANIZED - (ASTM B633 TYPE III, SC3 • Thickness: .000472" (12µm))

Electrodeposited zinc coating is suitable for most indoor applications and may be used outdoors in mild environmental conditions.

SPECIAL ORDER FINISHES

HG – HOT DIP GALVANIZED - (ASTM A123 GRD.55 • Thickness: .0002165" (55µm))

Provided by immersing the product in a molten zinc bath. This treatment is most suitable for outdoor applications or situations where increased corrosion resistance is desired.

SS – 304 TYPE STAINLESS STEEL

Corrosive resistant stainless steel with no additional surface treatment. This material option provides the best corrosion resistance available. Stainless steel is used primarily in marine environments or food processing facilities.

OTHER - Powder Coating - Standard colors black, white, red. Custom colors available upon request.

HOW TO ORDER

Part numbers shown in the catalog are for the standard electro-galvanized finish. For special order finishes, add the finish code as a suffix.

EXAMPLE -

CAT2-12SL-120 is electro-galvanized
 CAT2-12SL-120-SS is stainless steel

WIRE BASKET SYSTEM

ASSEMBLY

SELF-SPICING STRAIGHT LENGTHS

The Quick-Latch splicing system makes connecting wire basket tray fast and simple. The Quick-Latch, or self splicing bars which come pre-installed on wire basket tray systems, eliminates the need for a typical nut and bolt type connection. For proper grounding of wire basket tray please refer to page 242.

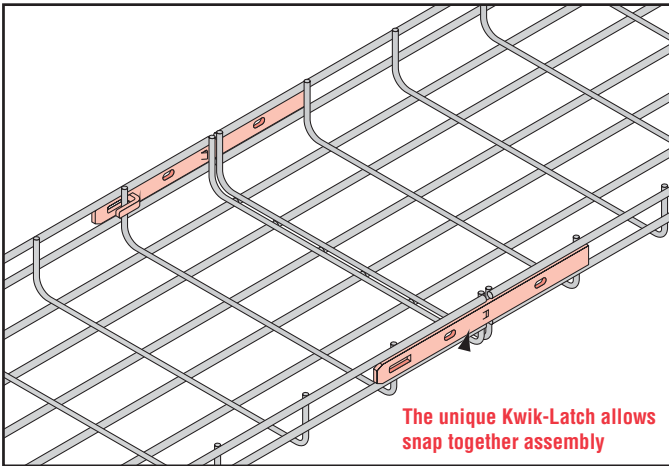

WIRE BASKET ASSEMBLY - CAT2, CAT4, CAT6

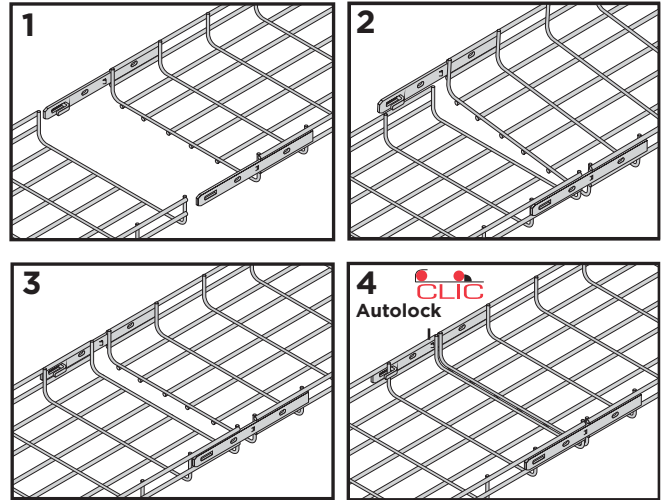

Step 1 Align the trays as shown.

Step 2 While raising the rear edge of the male connection, slide the tray forward, but do not engage the locking clip.

Step 3 Push the rear locking clip over the back edge of the tray.

Step 4 Slide the tray forward to engage both front and rear locking clips

ACCESSORY ASSEMBLY

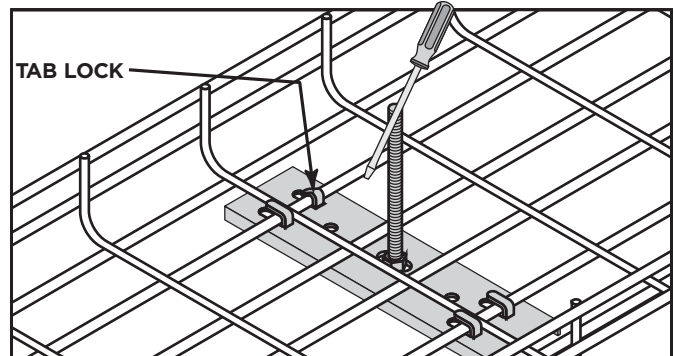
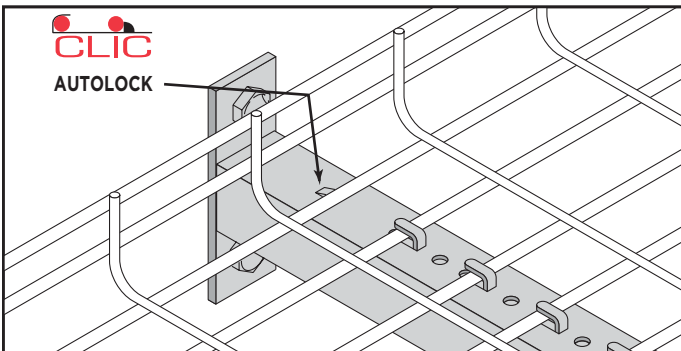

Many of the wire basket accessories feature the unique Autolock. Just slide the tray under the tabs and then push down to engage the Autolock. No tools, bending, or attachments are required for a secure connection.

For accessories which use the tab lock, the tray is secured by using a screw driver to gently bend one of the tabs down over the tray.

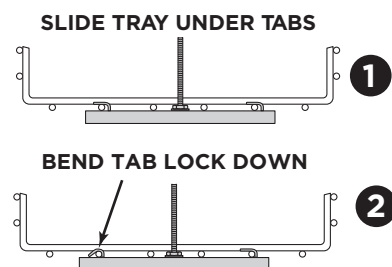
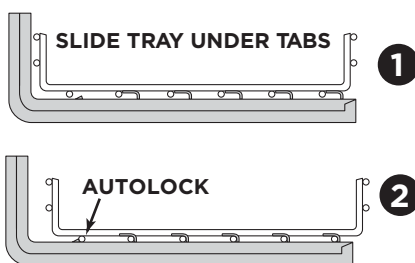

DOUBLE ROD REINFORCED TRAY (2" DEPTH)

DOUBLE ROD REINFORCED TRAY (2" DEPTH) [CAT2-(W)SL-120]

- Double rod reinforced tray is 2" high
- Standard length of tray is 10'
- Standard finish is electro-galvanized (EG)
- No hardware is necessary to connect straight sections
- For continuous grounding use CAT-GC (See page 242)

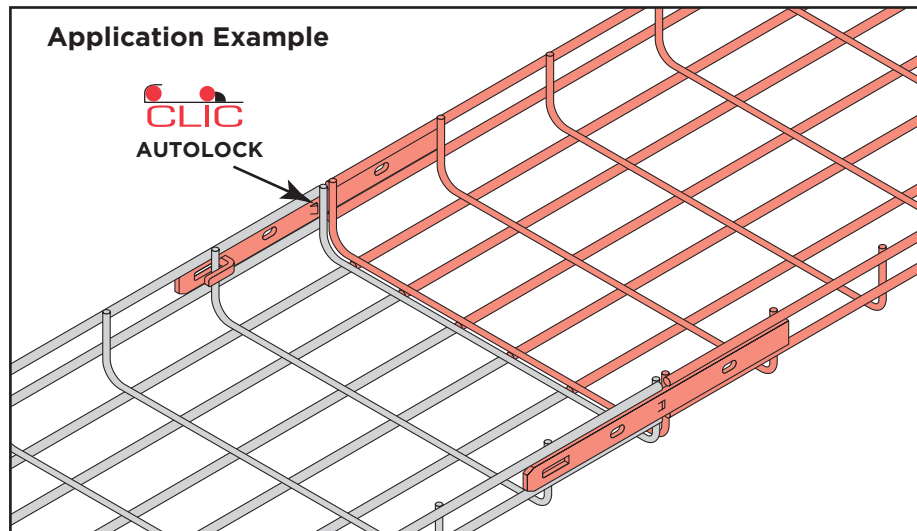
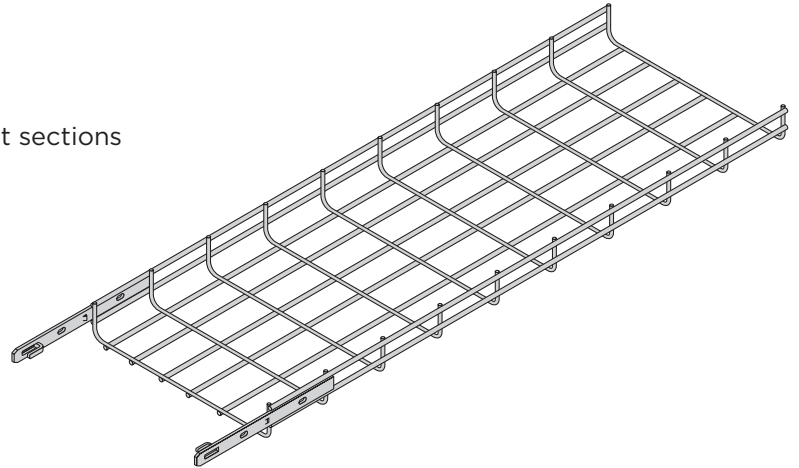

| Approvals | | Part Description | Width Nominal | Dimensions Wire Dia (in.) | Wt. (piece) | Loading (lb/ft) | | | |
|------------------|------------------|------------------|---------------|---------------------------|-------------|-----------------|---------|---------|---------|
| UL | cUL | | | | | 5' Span | 6' Span | 8' Span | 9' Span |
| | CLASSIFIED UL | CAT2-02SL-120 | 2" (50mm) | 0.177 | 4.6 | 60 | 42 | 23 | 19 |
| | CLASSIFIED UL | CAT2-04SL-120 | 4" (100mm) | 0.177 | 6.8 | 60 | 42 | 23 | 19 |
| | CLASSIFIED UL | CAT2-06SL-120 | 6" (150mm) | 0.177 | 8.0 | 60 | 42 | 23 | 19 |
| CLASSIFIED UL | CLASSIFIED UL | CAT2-08SL-120 | 8" (200mm) | 0.197 | 9.3 | 89 | 62 | 35 | 27 |
| CLASSIFIED UL | CLASSIFIED UL | CAT2-12SL-120 | 12" (300mm) | 0.197 | 14.5 | 89 | 62 | 35 | 27 |
| CLASSIFIED UL | CLASSIFIED UL | CAT2-16SL-120 | 16" (400mm) | 0.236 | 25.3 | 149 | 103 | 58 | 46 |
| CLASSIFIED UL | CLASSIFIED UL | CAT2-18SL-120 | 18" (450mm) | 0.236 | 27.6 | 149 | 103 | 58 | 46 |
| CLASSIFIED UL | CLASSIFIED UL | CAT2-20SL-120 | 20" (500mm) | 0.236 | 29.8 | 149 | 103 | 58 | 46 |
| CLASSIFIED UL | CLASSIFIED UL | CAT2-24SL-120 | 24" (600mm) | 0.236 | 34.3 | 149 | 103 | 58 | 46 |

Load Values are determined by NEMA VE1 testing. Copies of load tests available upon request.
Safety Factor 1.5

Denotes Quick Ship Items

WIRE BASKET SYSTEM

TRIPLE ROD REINFORCED TRAY (4" DEPTH)

TRIPLE ROD REINFORCED TRAY (4" DEPTH) [CAT4-(W)SL-120]

- Triple rod reinforced tray is 4" high
- Standard length of tray is 10'
- Standard finish is electro-galvanized (EG)
- No hardware is necessary to connect straight sections
- For continuous grounding use CAT-GC (See page 242)

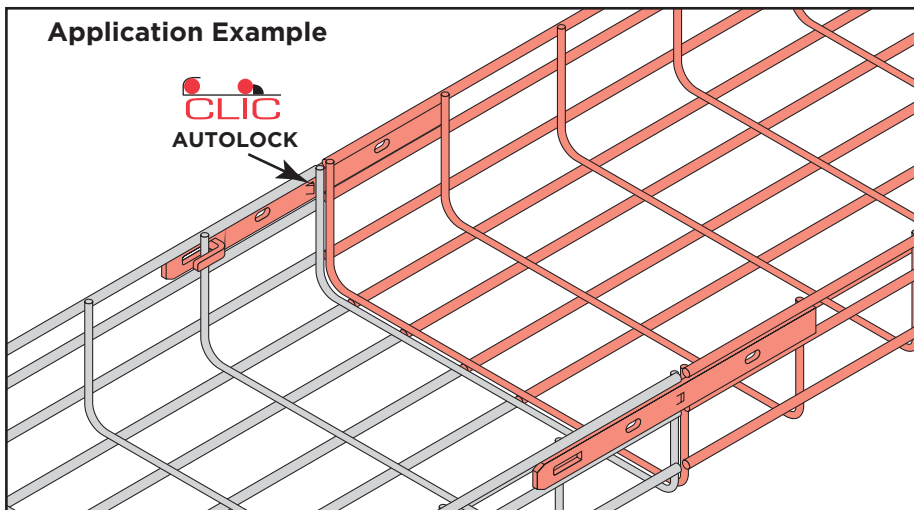
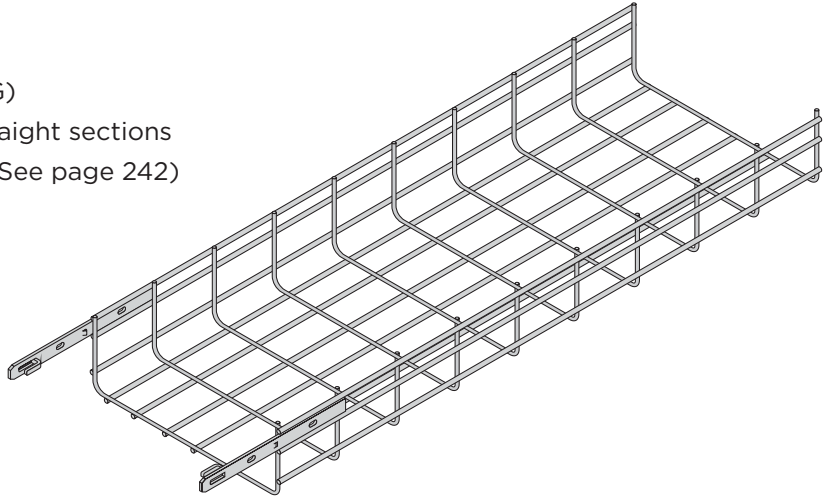

| Approvals | | Part Description | Width Nominal | Dimensions Wire Dia (in.) | Wt. (piece) | Loading (lb/ft) | | | | |
|-----------|-----|------------------|---------------|---------------------------|-------------|-----------------|---------|---------|---------|----|
| UL | cUL | | | | | 5' Span | 6' Span | 8' Span | 9' Span | |
| | | | CAT4-04SL-120 | 4" (100mm) | 0.197 | 9.3 | 108 | 75 | 42 | 33 |
| | | | CAT4-08SL-120 | 8" (200mm) | 0.197 | 14.5 | 108 | 75 | 42 | 33 |
| | | | CAT4-12SL-120 | 12" (300mm) | 0.236 | 25.3 | 182 | 127 | 71 | 56 |
| | | | CAT4-16SL-120 | 16" (400mm) | 0.236 | 29.8 | 182 | 127 | 71 | 56 |
| | | | CAT4-18SL-120 | 18" (450mm) | 0.236 | 32.0 | 182 | 127 | 71 | 56 |
| | | | CAT4-20SL-120 | 20" (500mm) | 0.236 | 34.3 | 182 | 127 | 71 | 56 |
| | | | CAT4-24SL-120 | 24" (600mm) | 0.236 | 38.8 | 182 | 127 | 71 | 56 |

Load Values are determined by NEMA VE1 testing. Copies of load tests available upon request.
Safety Factor 1.5

Denotes Quick Ship Items

QUADRUPLE ROD REINFORCED TRAY (6" DEPTH)

QUADRUPLE ROD REINFORCED TRAY (6" DEPTH) [CAT6-(W)SL-120]

- Quadruple rod reinforced tray is 6" high
- Standard length of tray is 10'
- Standard finish is electro-galvanized (EG)
- No hardware is necessary to connect straight sections
- For continuous grounding use CAT-GC (See page 242)

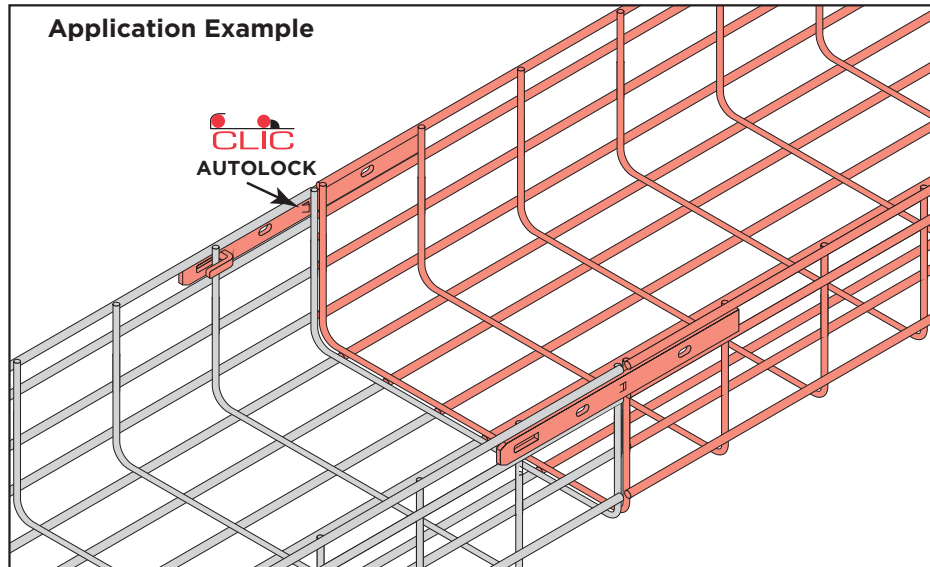
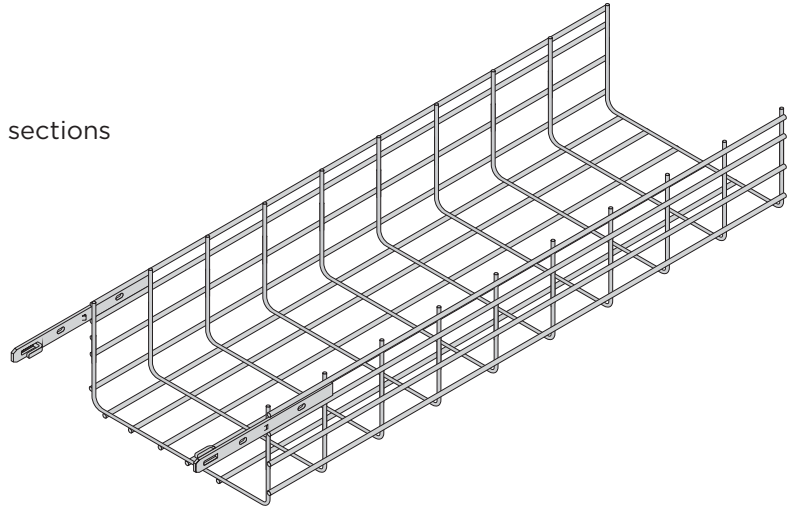

| Approvals | | Part Description | Width Nominal | Dimensions Wire Dia (in.) | Wt. (piece) | Loading (lb/ft) | | | | |
|------------------|------------------|------------------|---------------|---------------------------|-------------|-----------------|---------|---------|---------|----|
| UL | cUL | | | | | 5' Span | 6' Span | 8' Span | 9' Span | |
| | CLASSIFIED UL | | CAT6-06SL-120 | 6" (150mm) | 0.177 | 8.0 | 60 | 42 | 23 | 19 |
| CLASSIFIED UL | CLASSIFIED UL | | CAT6-08SL-120 | 8" (200mm) | 0.236 | 25.3 | 235 | 163 | 92 | 73 |
| CLASSIFIED UL | CLASSIFIED UL | | CAT6-12SL-120 | 12" (300mm) | 0.236 | 29.8 | 235 | 163 | 92 | 73 |
| CLASSIFIED UL | CLASSIFIED UL | | CAT6-16SL-120 | 16" (400mm) | 0.236 | 34.3 | 235 | 163 | 92 | 73 |
| CLASSIFIED UL | CLASSIFIED UL | | CAT6-18SL-120 | 18" (450mm) | 0.236 | 36.4 | 235 | 163 | 92 | 73 |
| CLASSIFIED UL | CLASSIFIED UL | | CAT6-20SL-120 | 20" (500mm) | 0.236 | 38.8 | 235 | 163 | 92 | 73 |
| CLASSIFIED UL | CLASSIFIED UL | | CAT6-24SL-120 | 24" (600mm) | 0.236 | 48.4 | 235 | 163 | 92 | 73 |

Load Values are determined by NEMA VE1 testing. Copies of load tests available upon request.
Safety Factor 1.5

WIRE BASKET SYSTEM

STANDARD BAR CONNECTOR

SPLICE

Weight: .29/each

- Splice bar connector is $\frac{3}{4}$ x 9" long
- Standard finish is electro-galvanized (EG)
- Connect using CH3 (sold separately)
- Bend 90° for use as an angle connector

NOTES:

1. Always place nut on outside of tray
2. For use with CAT2, CAT4, & CAT6 tray
3. The splice connector is used to connect remnant sections of tray cut from standard lengths and to field fabricate fittings.

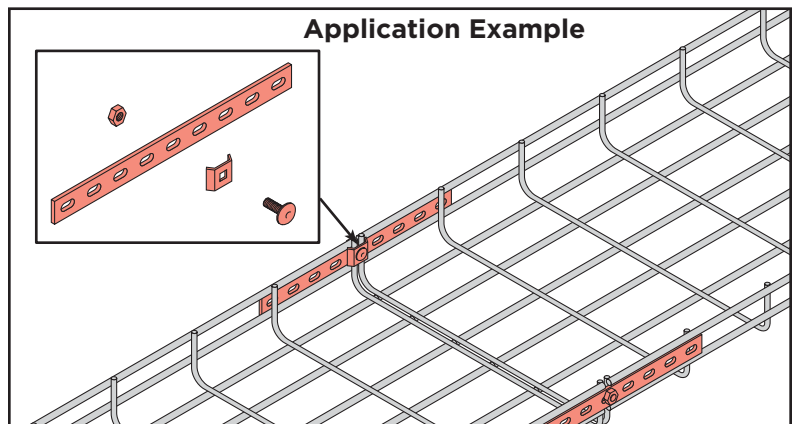
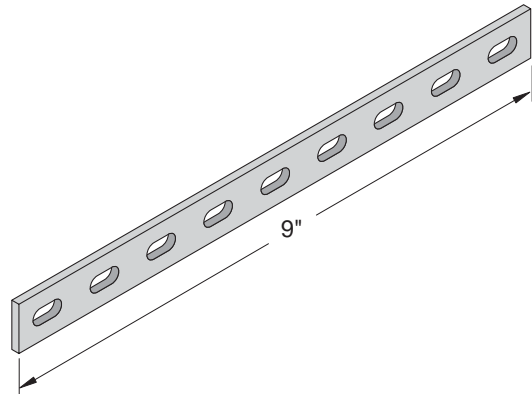

Application Example

BEND & INTERSECTION BARS

T-BAR

Weight: 1.43/each

- T-Bar connector is $\frac{3}{4}$ x 44" long
- Connect using CH3 (sold separately)
- Bend 90° for use as an angle connector

T-BAR-22

Weight: .715/each

- T-Bar connector is $\frac{3}{4}$ x 22" long
- Connect using CH3 (sold separately)

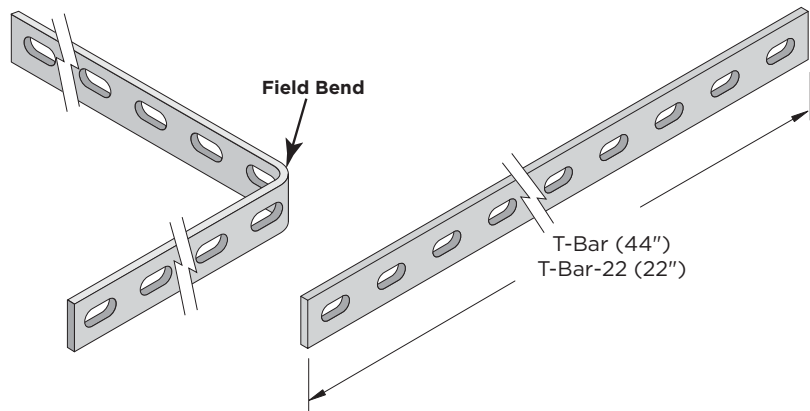

NOTES:

1. Always place nut on outside of tray
2. For use with CAT2, CAT4, & CAT6 tray
3. Used for tees which require a heavier support
4. These bars are normally cut to appropriate length

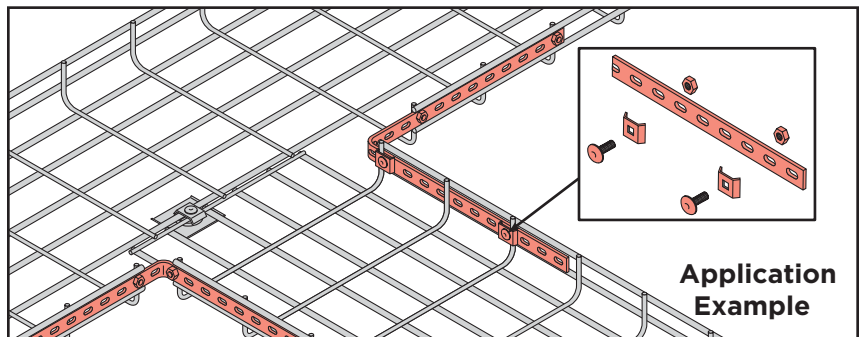

Application Example

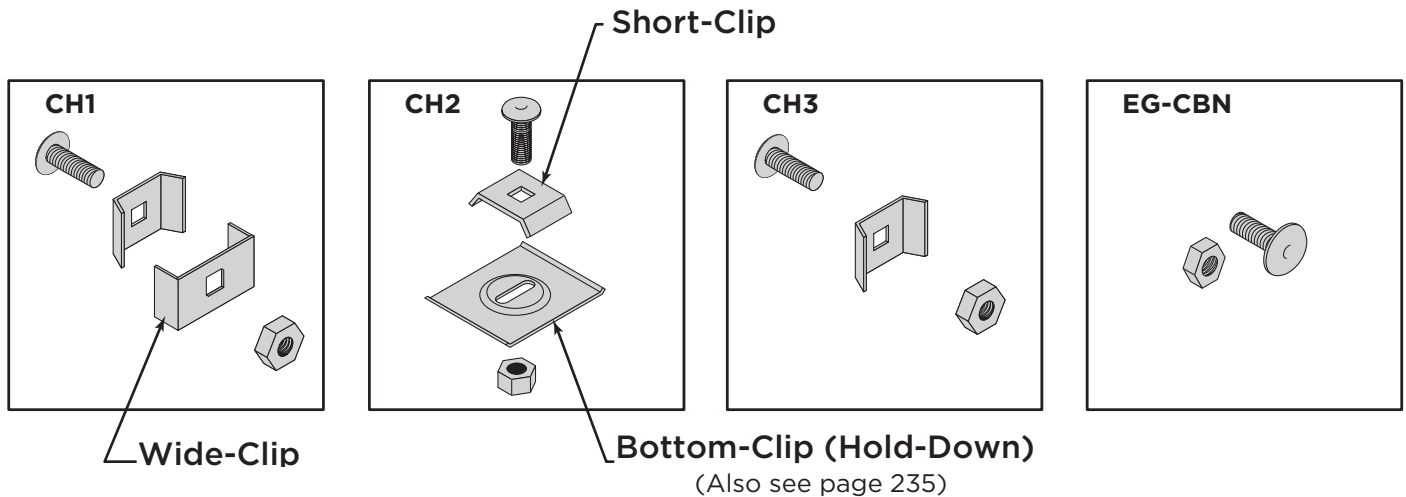

| Part Kit | Weight | No./ Pkg |
|----------|--------|----------|
| CH1 | 0.70 | 10 |
| CH2 | 1.16 | 10 |
| CH3 | 0.44 | 10 |
| EG-CBN | 0.20 | 10 |

| Single Part | WEIGHT | NO./ PKG |
|-------------|--------|----------|
| Short-Clip | 0.20 | 10 |
| Wide-Clip | 0.31 | 10 |
| Bottom-Clip | 0.92 | 10 |

CONNECTOR KIT [CH1]

- Standard bar connector is 1 $\frac{3}{16}$ x 1 $\frac{1}{16}$ "
- Standard finish is electro-galvanized (EG)
- Sold in packs of 10
(EG-CBN connector hardware included)

NOTE: Always place nut on outside of tray

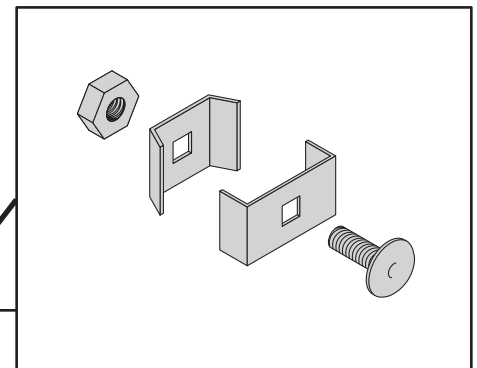
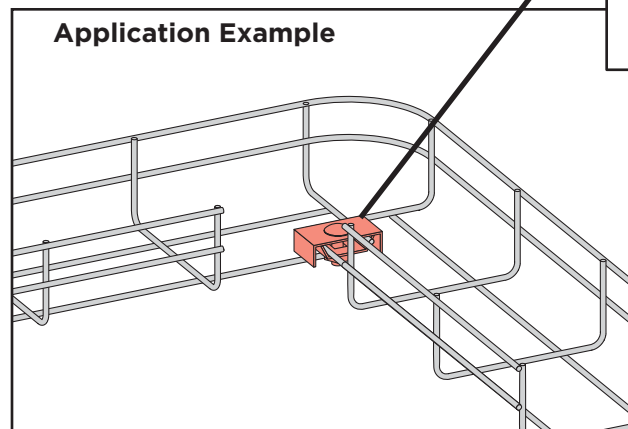

WIRE BASKET SYSTEM

CONNECTOR HARDWARE KITS

CONNECTOR KIT [CH2]

- Bottom connector is $2 \times 2\frac{3}{8}$ "
- Standard finish is electro-galvanized (EG)
- Sold in packs of 10
(EG-CBN connector hardware included)

NOTE: Always place nut on outside of tray

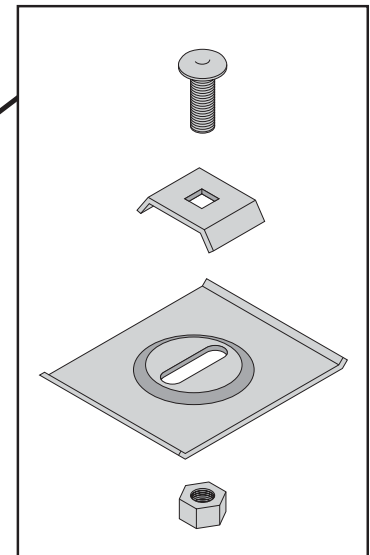
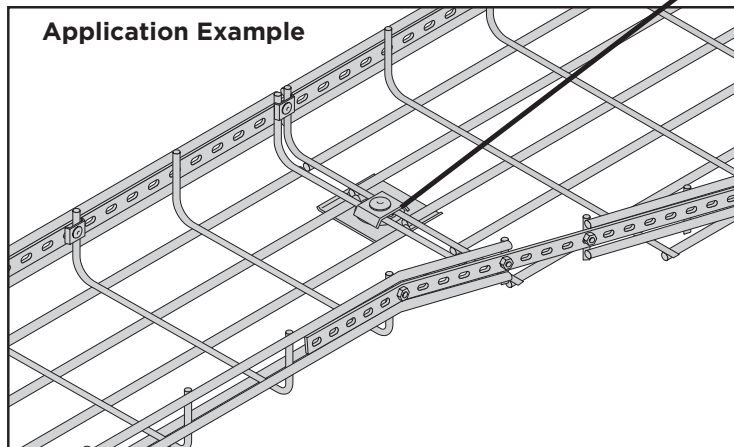

CONNECTOR KIT [CH3]

- Universal connector is $1\frac{1}{16} \times 1\frac{1}{16}$ "
- Standard finish is electro-galvanized (EG)
- Sold in packs of 10
(EG-CBN connector hardware included)

NOTE: Always place nut on outside of tray

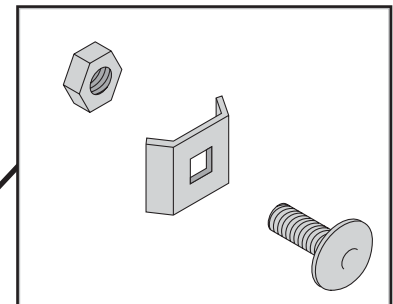
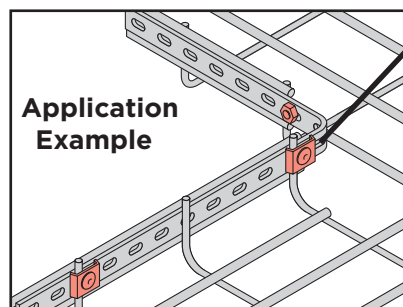

CONNECTOR HARDWARE [EG-CBN]

- $\frac{1}{4}$ -20 x $\frac{3}{4}$ " Carriage bolt
- $\frac{1}{4}$ -20 Hex head nut
- Standard finish is electro-galvanized (EG)
- Sold in packs of 10 each

NOTE: Always place nut on outside of tray

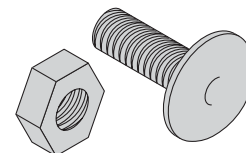

SUPPORT BRACKETS

U SUPPORT BRACKET [CAT-USB-120]

Weight: 6.83 lb/each

- U support bracket $1\frac{5}{16} \times 1\frac{5}{16}$ " channel
- Standard finish is pregalvanized (PG)
- Support is 10' long, customer cuts to size as needed
- Cut lengths 6" wider than tray width for trapeze
Cut lengths 1" shorter than tray width for single rod support
- Unique grip system requires only a push of a screwdriver to fasten the tray to the supports

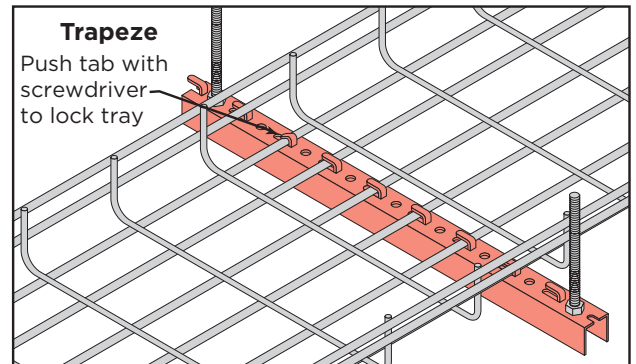
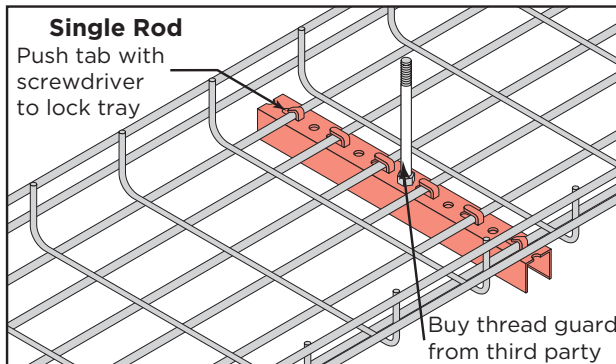
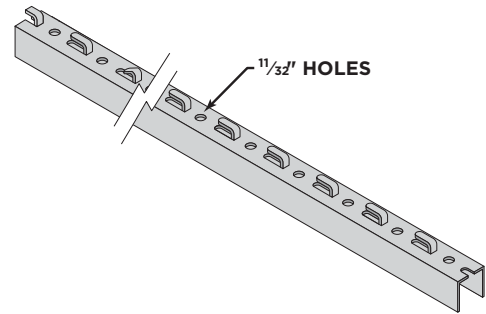

SUPPORT BRACKET MEDIUM [CAT-MSB-120] & HEAVY [CAT-HSB-120]

- Heavy support bracket is $1\frac{5}{8} \times 1\frac{5}{8}$ " strut, Medium support bracket is $1\frac{5}{8} \times 1\frac{3}{16}$ " strut
- Standard finish is pregalvanized (PG)
- Support is 10' long, customer cuts to size as needed
- Cut lengths 6" wider than tray width for trapeze
Cut lengths 1" shorter than tray width for single rod support
- Unique grip system requires only a push of a screwdriver to fasten the tray to the supports

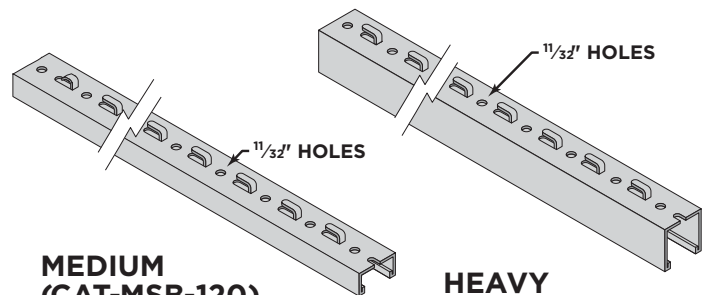

Weight 11.9 lb/each

Weight: 16.53 lb/each

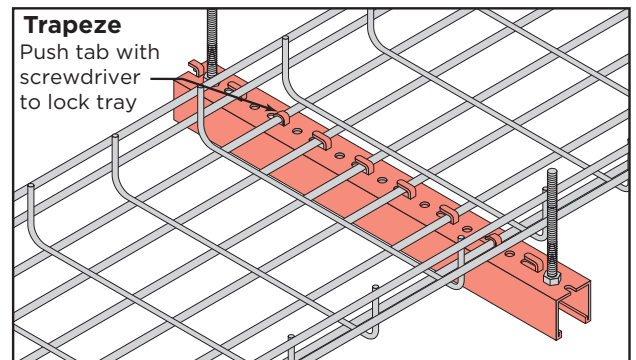
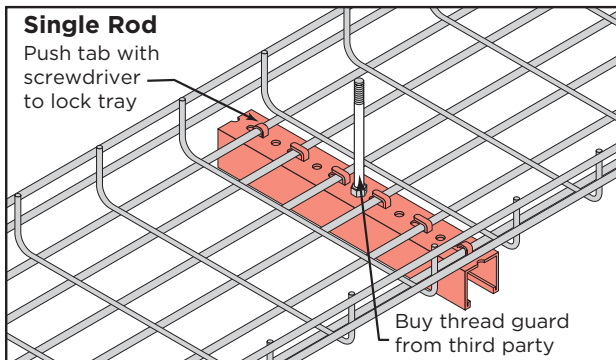

WIRE BASKET SYSTEM

DROP ROD CLIP

DROP ROD CLIP [CAT-SIDE-HC]

Weight: .13 lb/each

- Standard finish pregalvanized (PG)
- .08" Bracket thickness
- For all widths of tray

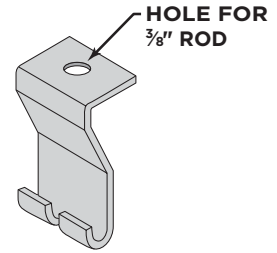
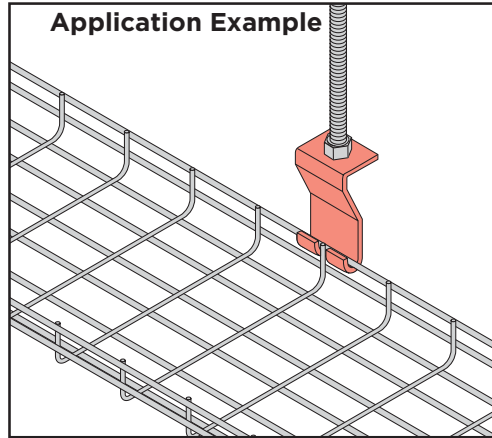

DROP ROD CLIP [CAT-1X6-HC]

Weight: .12 lb/each

- Standard finish pregalvanized (PG)
- .08" Bracket thickness
- For all 4" w & 6" w tray

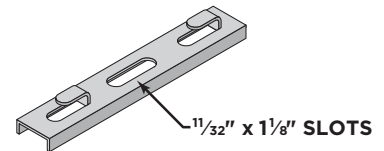
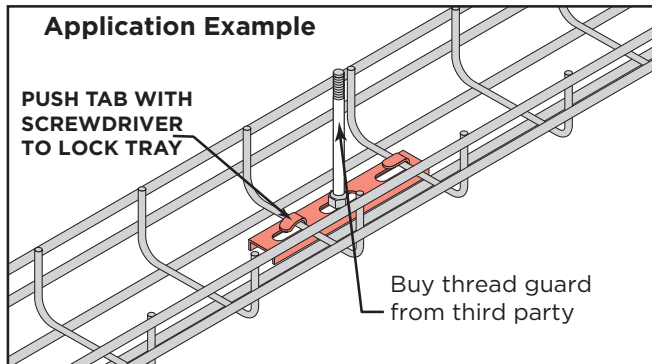

DROP ROD CLIP [CAT-2X8-HC]

Weight: .40 lb/each

- Standard finish pregalvanized (PG)
- .08" Bracket thickness
- For all 8" w & 12" w tray

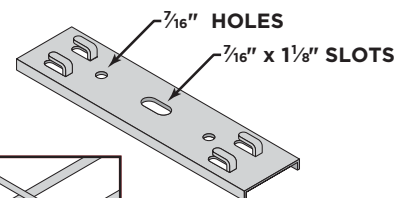
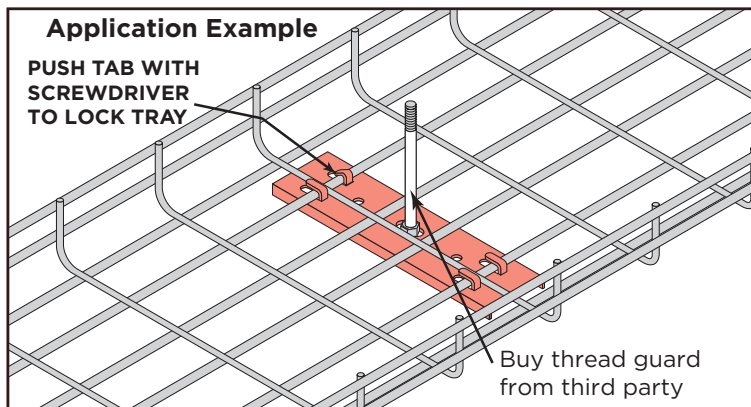

WALL & CEILING MOUNTS

CEILING CLIP [CAT-CCA-(W)]

- For attaching tray to ceiling
- Standard finish pregalvanized (PG)
- Easy mounting of the cable tray using grips and autolock

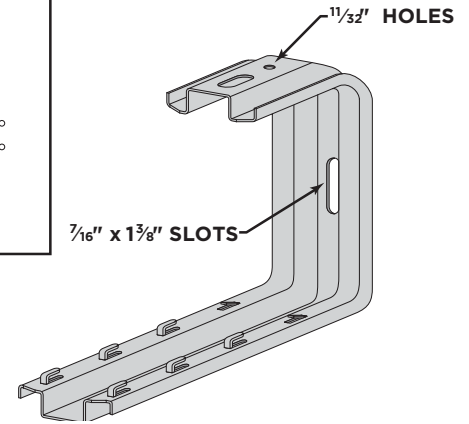
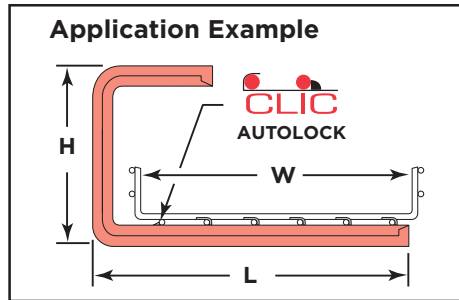

Ceiling Clip [CAT-CCA-(W)]

| Part No. | Tray Size(W) | Height(H) | Length(L) | Wt(Lbs) | Load(Lbs) |
|------------|--------------|-----------|-----------|---------|-----------|
| CAT-CCA-04 | 4" | 7" | 6" | 1.3 | 270 |
| CAT-CCA-06 | 6" | 7" | 8" | 1.5 | 225 |
| CAT-CCA-08 | 8" | 7" | 10" | 1.7 | 202 |
| CAT-CCA-12 | 12" | 7" | 14" | 2 | 180 |
| CAT-CCA-16 | 16" | 7" | 18" | 2.3 | 90 |

WALL CLIP [CAT-CPA-(W)]

- For attaching tray to wall
- Standard finish pregalvanized (PG)
- Easy mounting of the cable tray using grips and autolock

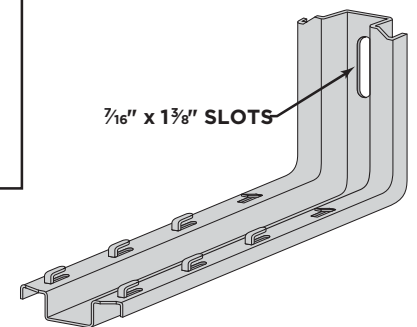
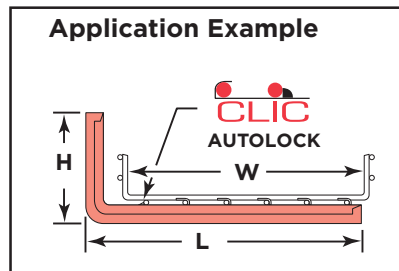

Wall Clip [CAT-CPA-(W)]

| Part No. | Tray Size(W) | Height(H) | Length(L) | Wt(Lbs) | Load(Lbs) |
|------------|--------------|-----------|-----------|---------|-----------|
| CAT-CPA-06 | 6" | 5" | 8" | 1 | 337 |
| CAT-CPA-08 | 8" | 5" | 10" | 1.1 | 225 |
| CAT-CPA-12 | 12" | 5" | 14" | 1.5 | 202 |
| CAT-CPA-16 | 16" | 5" | 18" | 1.8 | 90 |

PENDANT [CAT-PPA-(H)]

- Standard finish is pregalvanized (PG)
- For attaching tray to ceiling. Used with wall clip CAT-CPA Series

Pendant [CAT-PPA-(H)]

| Part No. | Height(H) | Length(L) | Wt(Lbs) |
|------------|-----------|-----------|---------|
| CAT-PPA-06 | 6" | 5" | 0.7 |
| CAT-PPA-10 | 10" | 5" | 1.1 |
| CAT-PPA-14 | 14" | 5" | 1.3 |
| CAT-PPA-18 | 18" | 5" | 1.7 |
| CAT-PPA-22 | 22" | 5" | 2.0 |
| CAT-PPA-26 | 26" | 5" | 2.3 |

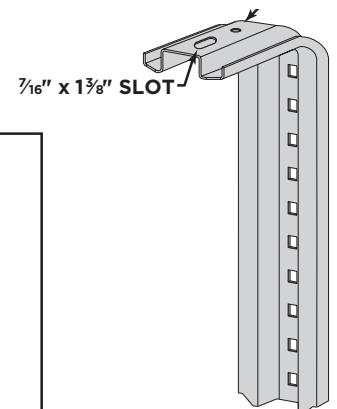
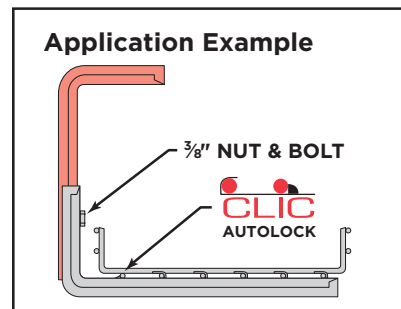

WIRE BASKET SYSTEM

CANTILEVER & ZED BRACKETS

ZED [CAT-ZBAR-120]

Weight: 11.24 lb/each 1/4" x 1 3/8" SLOTS

- ZED floor or wall mounted support is 1/2 x 3 1/2
- Standard finish pregalvanized (PG)
- Support is 10' long, customer cuts to size as needed
- Unique grip system requires only a push of a screwdriver to fasten the tray to the supports

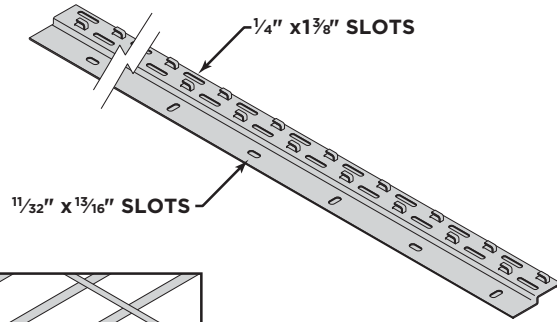

Application Example

PUSH TAB WITH SCREWDRIVER TO LOCK TRAY

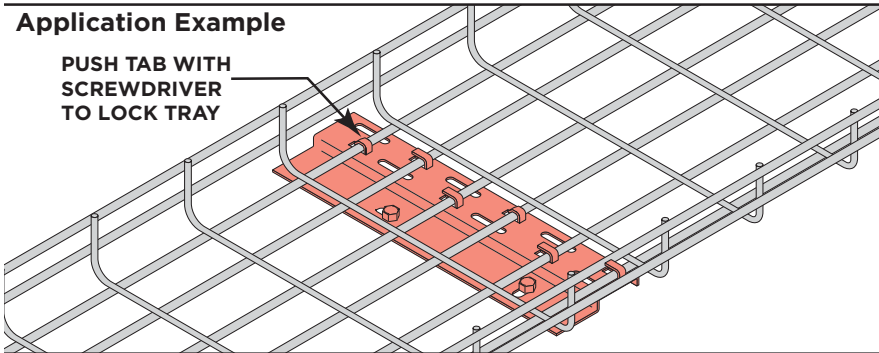

CANTILEVER MEDIUM [CAT-MWSB-(W)] & HEAVY [CAT-HWSB-(W)]

- Standard finish is hot-dipped galvanized (HG)
- Cantilever arm support 1 5/8 x 1 5/8" or 1 5/8 x 1 3/16" strut
- Unique Auto-Lock system requires no hardware to fasten the tray to the supports
- Use Strut Profile to support other items below the support bracket using strut hardware

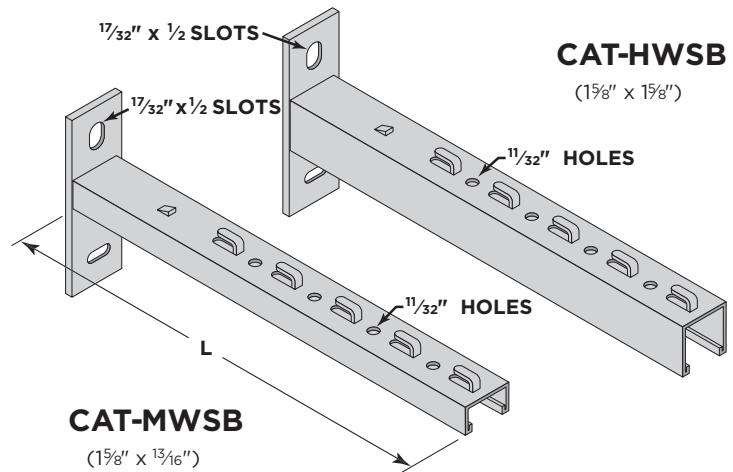

| Cantilever Medium [CAT-MWSB-(W)] & HEAVY [CAT-HWSB-(W)] | | | | | |
|---|------------------|----------------|------------|----------|------------|
| Part No. | Channel Size | Tray Width (W) | Length (L) | Wt (Lbs) | Load (Lbs) |
| CAT-MWSB-06 | 1 5/8" x 1 3/16" | 6" | 8" | 1.3 | 270 |
| CAT-MWSB-08 | 1 5/8" x 1 3/16" | 8" | 10" | 1.5 | 225 |
| CAT-MWSB-12 | 1 5/8" x 1 3/16" | 12" | 14" | 1.9 | 157 |
| CAT-HWSB-08 | 1 5/8" x 1 5/8" | 8" | 10" | 1.9 | 562 |
| CAT-HWSB-12 | 1 5/8" x 1 5/8" | 12" | 14" | 2.5 | 450 |
| CAT-HWSB-18 | 1 5/8" x 1 5/8" | 18" | 18" | 3 | 337 |
| CAT-HWSB-20 | 1 5/8" x 1 5/8" | 20" | 22" | 3.6 | 292 |
| CAT-HWSB-24 | 1 5/8" x 1 5/8" | 24" | 26" | 4.1 | 247 |

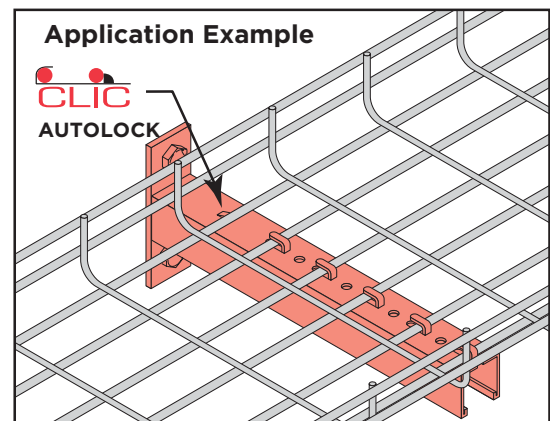

HANGERS

HANGER [CAT-HGR-2]

- Standard finish is pregalvanized (PG)
- Ceiling or center hung with threaded rod

NOTE: For use with CAT2-02 only

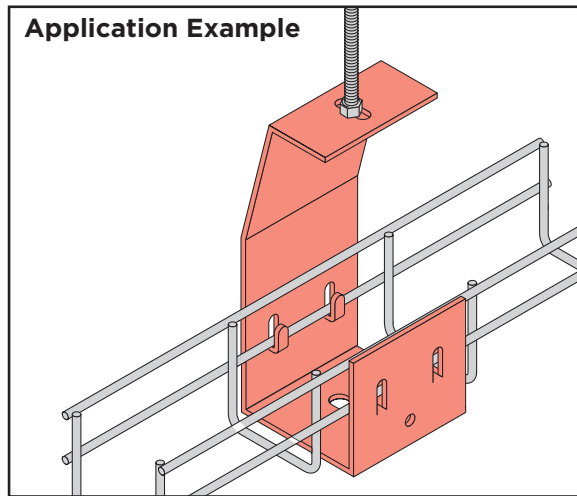

HANGER [CAT-HGR-4]

- Standard finish is pregalvanized (PG)
- Ceiling or center hung with threaded rod

NOTE: For use with CAT2-02 only

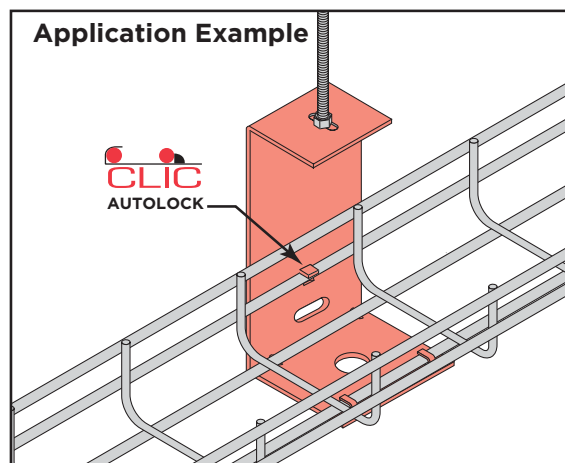

WALL BRACKET [CAT-WC-2]

- Standard finish is pregalvanized (PG)

NOTE: For use with CAT2-02 only

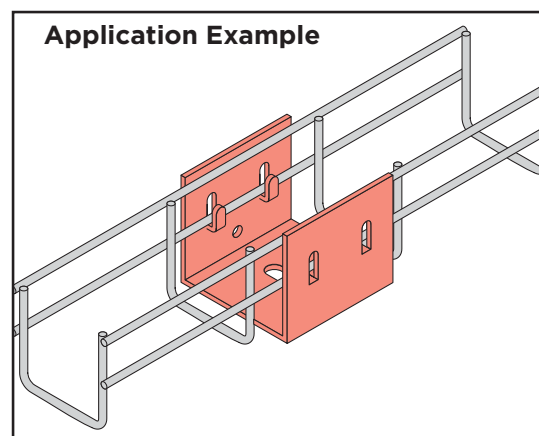

Intro

LADDER

I-BEAM

HAT

TROF

CHANNEL

COPE-GLAS™

WIREBASKET

Reference

WIRE BASKET SYSTEM

HANGING BRACKET & PENDENTS

SINGLE CHANNEL PENDANT [PS 651-(L)]

- Standard finish is electro-galvanized (EG)

| Single Channel Pendant [PS 651-(L)] | | | |
|-------------------------------------|-----------|--------------|---------|
| Part No. | Length(L) | Uniform Load | Weight" |
| PS651-06 | 6" | 1,200 | 1.85 |
| PS651-12 | 12" | 600 | 2.93 |
| PS651-18 | 18" | 400 | 4.01 |
| PS651-24 | 24" | 300 | 5.09 |

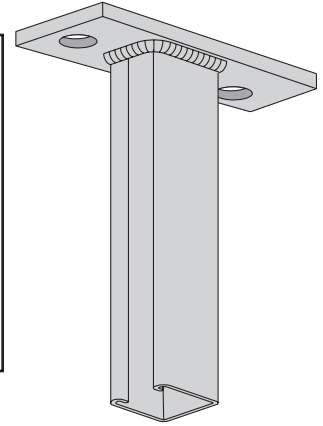
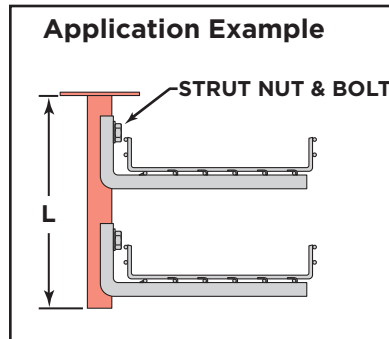

BACK-TO-BACK CHANNEL PENDANT [PS 809-(L)]

- Standard finish is electro-galvanized (EG)

| Back-to-Back Channel Pendant [PS 809-(L)] | | | |
|---|-----------|--------------|--------|
| Part No. | Length(L) | Uniform Load | Weight |
| PS809-12 | 12" | 2,000 | 5.02 |
| PS809-18 | 18" | 1,300 | 6.92 |
| PS809-24 | 24" | 1,000 | 8.82 |
| PS809-30 | 30" | 800 | 10.72 |
| PS809-36 | 36" | 650 | 12.62 |

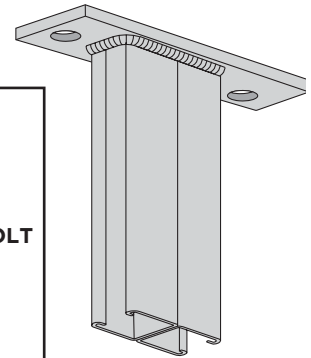
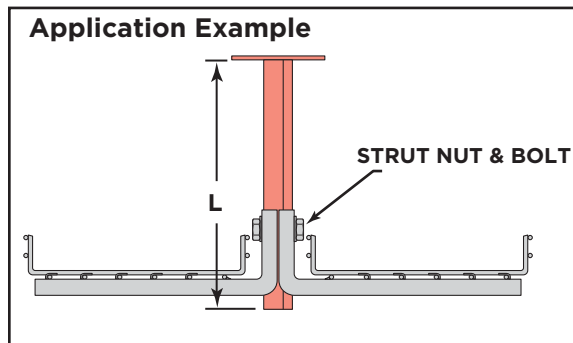

HANGING BRACKET [CAT-CB-USB]

Weight: .8 lb/each

- Standard finish is pregalvanized (PG)
- For Use with CAT-USB-120 Style Support Bracket Channel

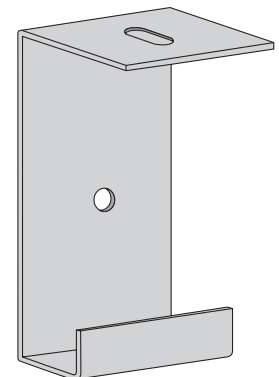
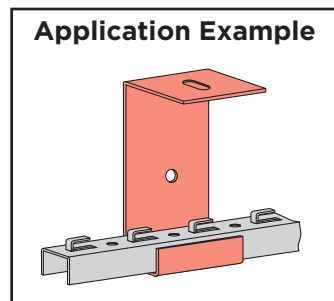
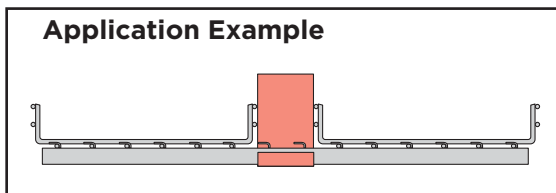

HANGING BRACKETS

HANGING BRACKET [CAT-AB-USB]

Weight: .53 lb/each

- Standard finish is pregalvanized (PG)
- For use with CAT-USB-120 Support Bracket Channel

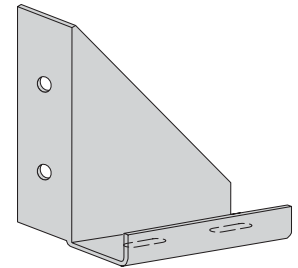
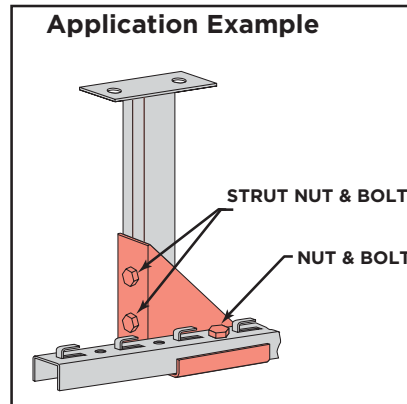
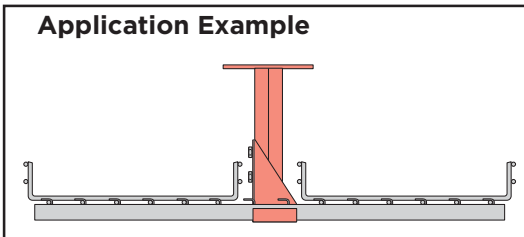

HANGING BRACKET [CAT-AB-HSB]

Weight: .62 lb/each

- Standard finish is hot-dipped galvanized (HG)
- For Use with:
 - CAT-MSB-10 Medium Support Bracket Strut
 - CAT-HSB-10 Heavy Support Bracket Strut

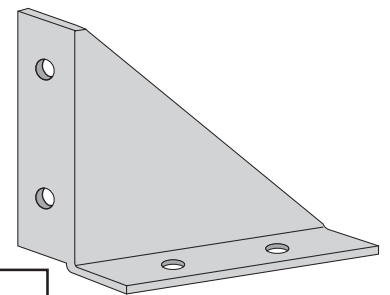
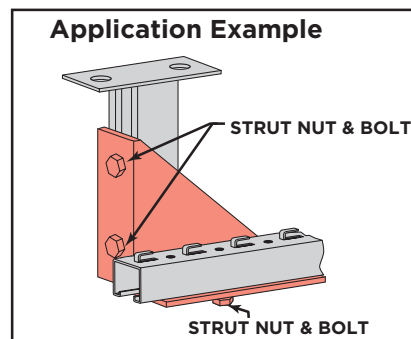
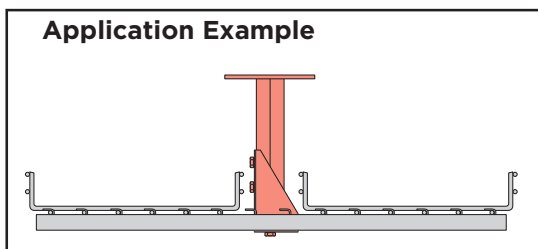

HANGING BRACKET [CAT-CB-MSB]

Weight: 1.46 lb/each

- Standard finish is pregalvanized (PG)
- For Use with:
 - CAT-MSB-10 Medium Support Bracket Strut

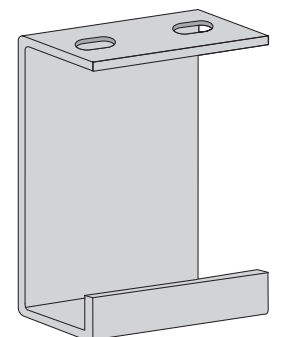
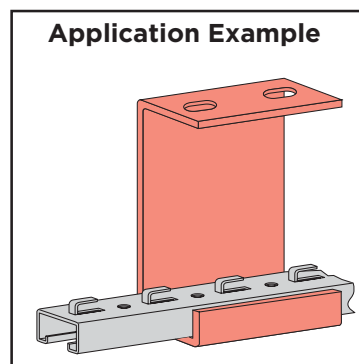
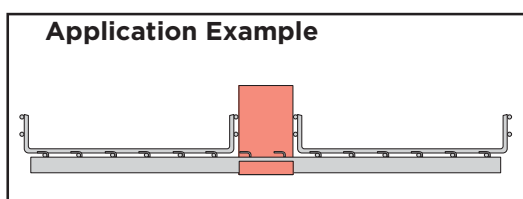

WIRE BASKET SYSTEM

HANGING BRACKETS

HANGING BRACKET [CAT-CB-HSB]

Weight: 2.98 lb/each

- Available in pregalvanized (PG) or hot-dipped galvanized (HG)
- For Use with:
CAT-MSB-10 Medium Support Bracket Strut
CAT-HSB-10 Heavy Support Bracket Strut

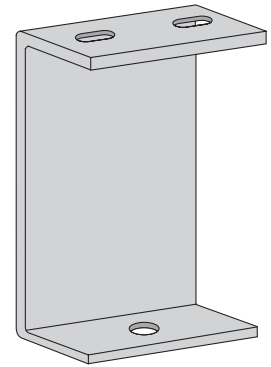
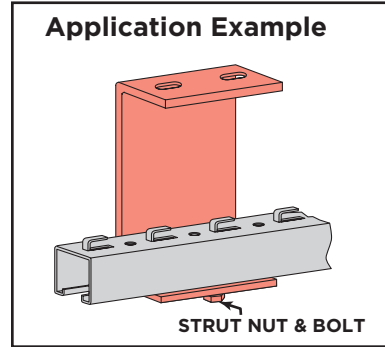
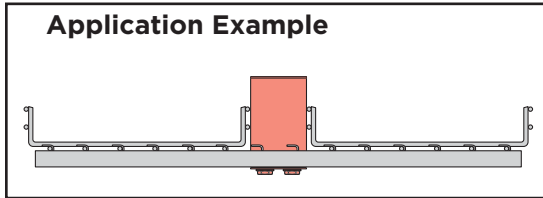

BRACKET [CAT-CMA-(W)]

- Standard finish is pregalvanized (PG)
- Mounted on cantilever arms or channels
- Easy mounting of the bracket using grips and autolock
- Designed for use with new/existing 158" strut framing

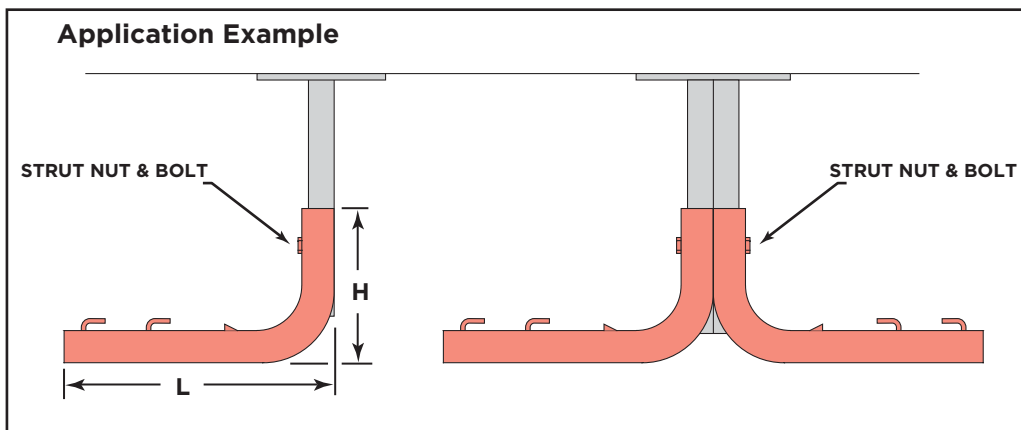
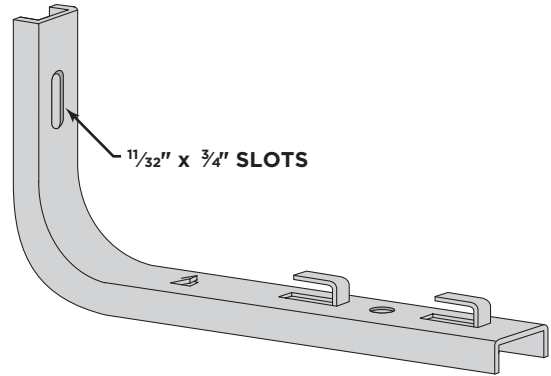

Bracket [CAT-CMA-(W)]

| Part No. | Tray Width (W) | Height (H) | Length (L) | Wt (Lbs) | Load (Lbs) |
|------------|----------------|------------|------------|----------|------------|
| CAT-CMA-04 | 4" | 4.7" | 5" | 0.8 | 360 |
| CAT-CMA-06 | 6" | 4.7" | 7" | 1.0 | 270 |
| CAT-CMA-08 | 8" | 4.7" | 9" | 1.1 | 180 |
| CAT-CMA-12 | 12" | 4.7" | 13" | 1.5 | 135 |

PEDESTAL BRACKETS

PEDESTAL BRACKETS [CAT-PED-06] & [CAT-PED-12]

- Channel use on pedestal for raised floor
- Attach to pedestal using U-Bolt & nuts (included)

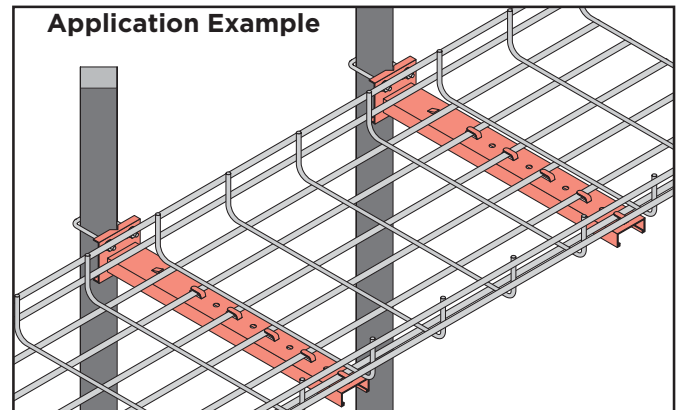
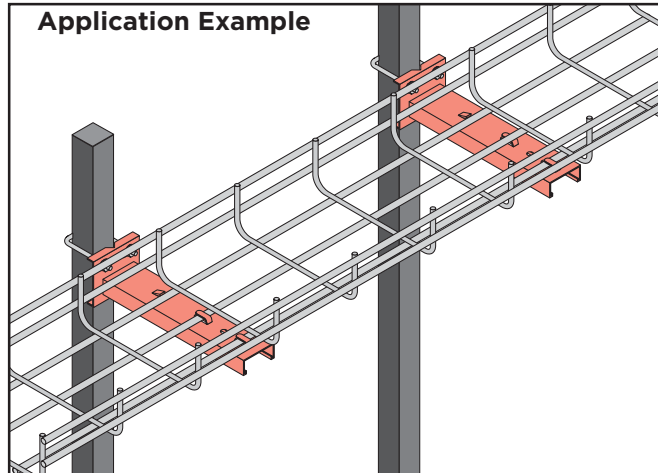
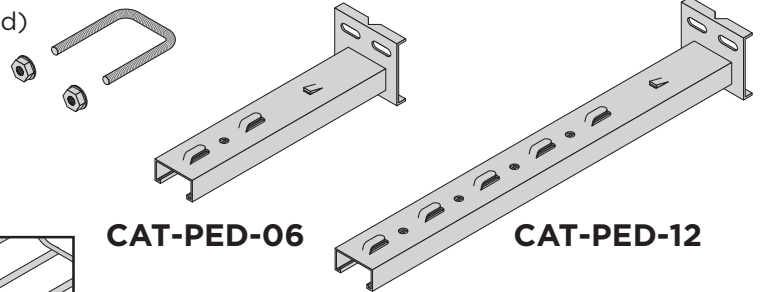

PEDESTAL KIT [CAT-PED-KIT]

- Channel use on pedestal for raised floor
- Attach to pedestal using U-Bolt & nuts (included)

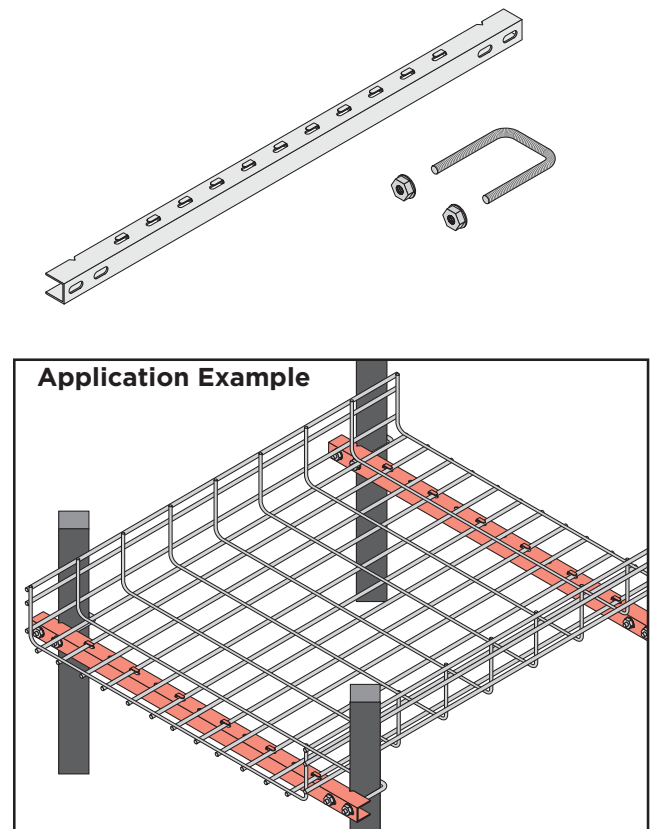
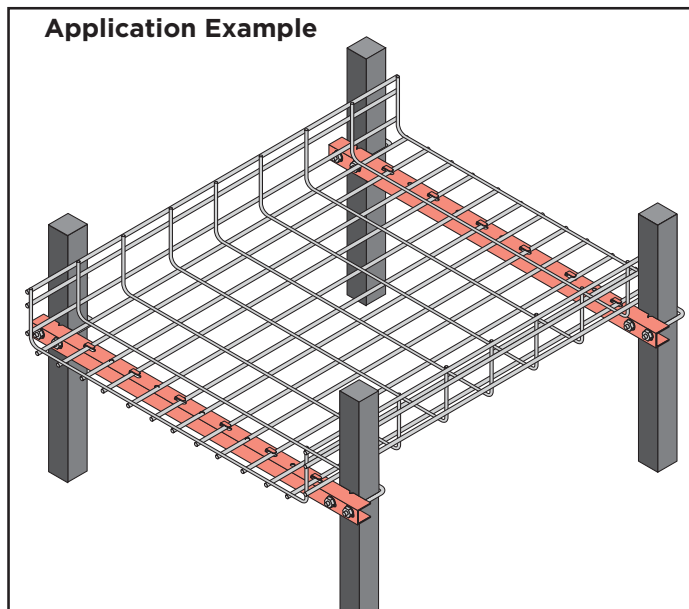

WIRE BASKET SYSTEM

ACCESSORIES

COVER [CAT-CVR-(W)]

- Standard finish is pregalvanized (PG)
- Length is 10'

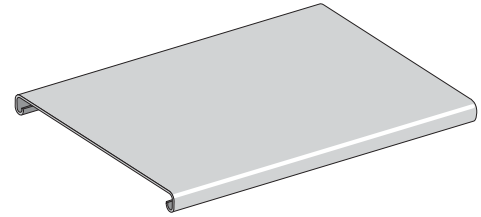

| Part | Weight (lb) |
|------------|-------------|
| CAT-CVR-02 | 5.29 |
| CAT-CVR-04 | 7.93 |
| CAT-CVR-06 | 10.58 |
| CAT-CVR-08 | 13.22 |
| CAT-CVR-12 | 18.52 |
| CAT-CVR-16 | 35.71 |
| CAT-CVR-18 | 39.68 |
| CAT-CVR-20 | 43.65 |
| CAT-CVR-24 | 51.53 |

Application Example

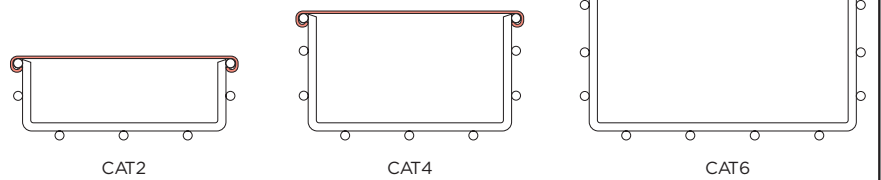

TRAY DIVIDERS [CAT2-01SB-120], [CAT4-01SB-120], & [CAT6-01SB-120]

- Standard finish is pregalvanized (PG)
- Locks into tray with auto-lock tabs (no hardware required)
- Cut "V" notches into bottom flange to make barriers for flat fittings

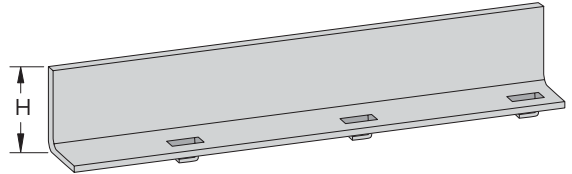

Application Example

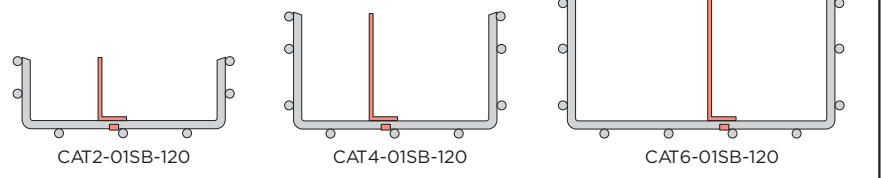

DROP OUT [CAT-(W)DO]

- Standard finish is pregalvanized (PG)
- CAT-UNI-DO can be used in any 2" x 4" mesh opening or as a "side-out"

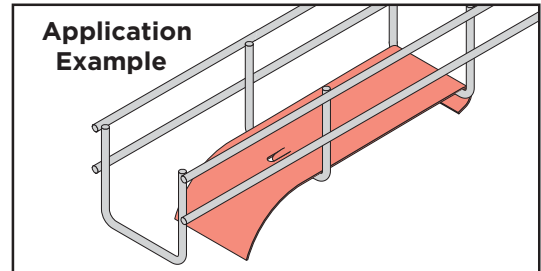
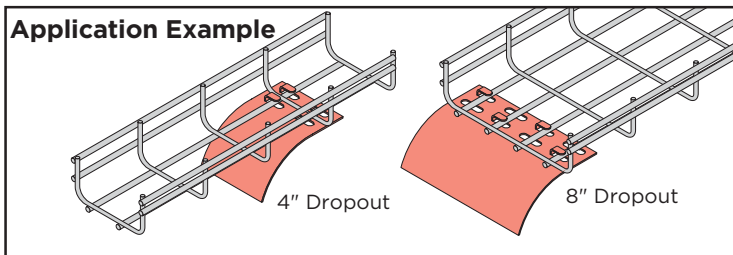
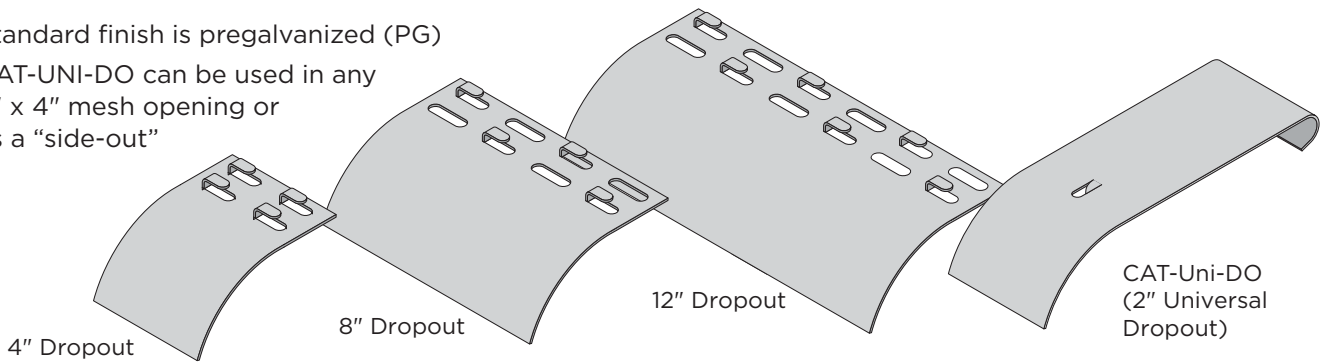

BLIND END [CAT(H)-(W)BE]

- Standard finish is pregalvanized (PG)
- Standard use per blind end is:
(2 pc) CH3 (sold separately)

NOTES:

1. Always place nut on outside of tray

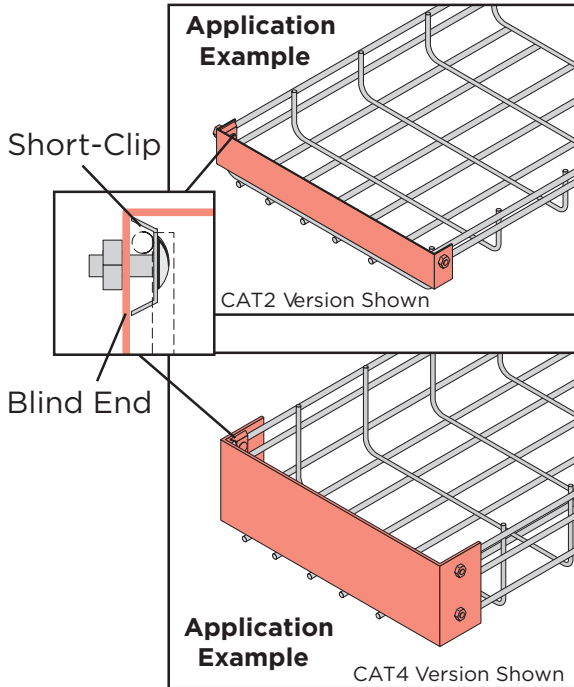

| Part | WEIGHT (lb) |
|-----------|-------------|
| CAT2-04BE | 0.18 |
| CAT2-06BE | 0.22 |
| CAT2-08BE | 0.28 |
| CAT2-12BE | 0.40 |
| CAT2-16BE | 0.50 |
| CAT2-18BE | 0.57 |
| CAT2-20BE | 0.64 |
| CAT2-24BE | 0.70 |

| Part | WEIGHT (lb) |
|-----------|-------------|
| CAT4-04BE | 0.52 |
| CAT4-08BE | 0.64 |
| CAT4-12BE | 0.76 |
| CAT4-16BE | 0.96 |
| CAT4-18BE | 1.08 |
| CAT4-20BE | 1.20 |
| CAT4-24BE | 1.44 |

| Part | WEIGHT (lb) |
|-----------|-------------|
| CAT6-08BE | 0.82 |
| CAT6-12BE | 1.12 |
| CAT6-16BE | 1.42 |
| CAT6-18BE | 1.57 |
| CAT6-20BE | 1.72 |
| CAT6-24BE | 2.10 |

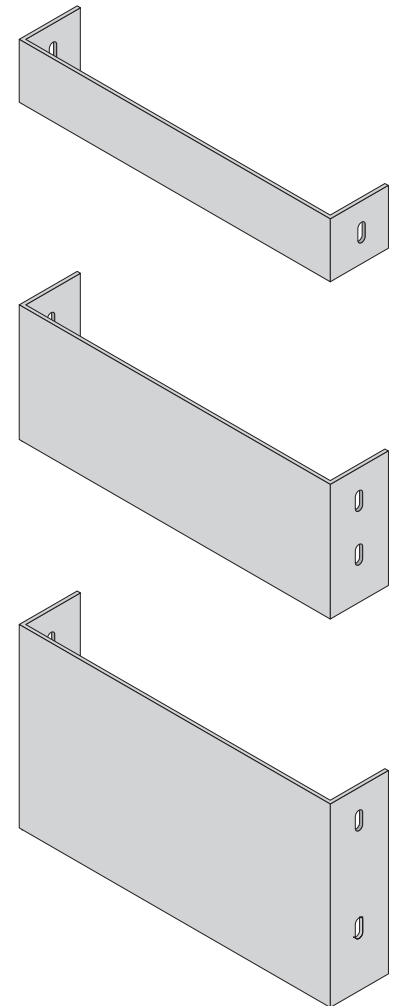

BOX CONNECTOR [CAT(H)-(W)CB]

- Standard finish is pregalvanized (PG)
- Standard use per box connector is:
(2 pc) CH3
(5 pc) EG-CBN
(both sold separately)

NOTES:

1. Always place nut on outside of tray
2. For use with CAT2, CAT4 & CAT6 tray only

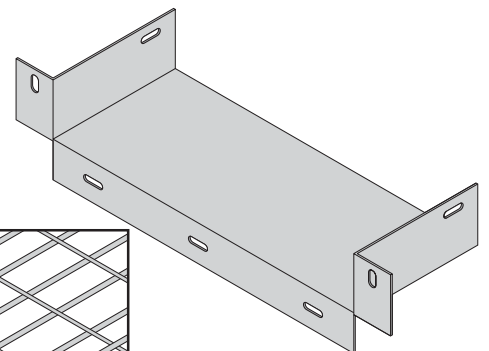
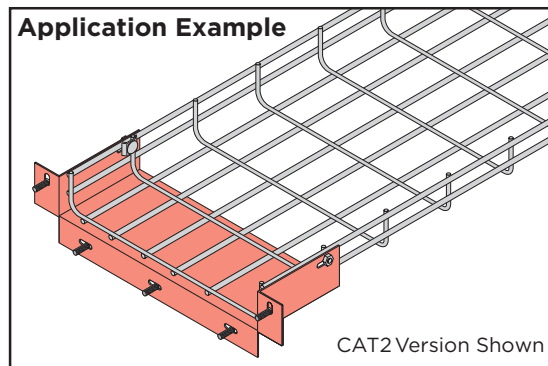

WIRE BASKET SYSTEM

ACCESSORIES

CONDUIT TO BASKET CLIP [CAT-EMT-.5-1.25]

- Two different latching configurations built into every clip
- - Configuration 1: accommodates 1/2", 3/4" and 1" EMT Connectors
- - Configuration 2: accommodates 1/2", 3/4" and 1-1/4" EMT Connectors
- Bottom mounting for all load depth
- Can be side mounted to 4" and 6" load depth wire baskets

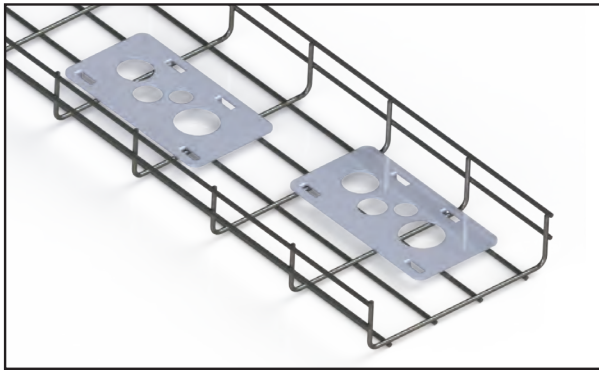

LIGHTING BRACKET [CAT-HLT]

- Standard finish is pregalvanized (PG)

Application Example

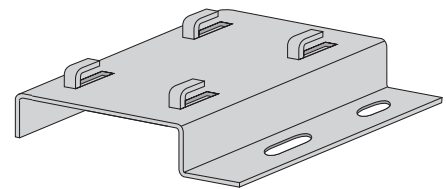
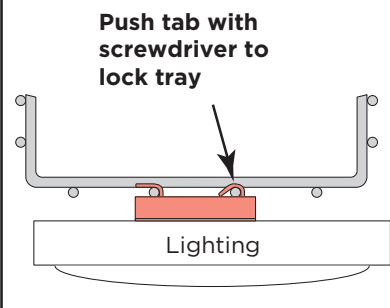

ELECTRICAL BOX BRACKET [CAT-EBC]

- Standard finish is pregalvanized (PG)

Application Example

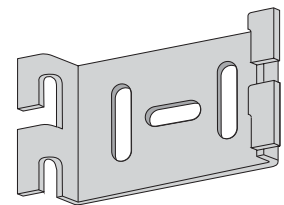
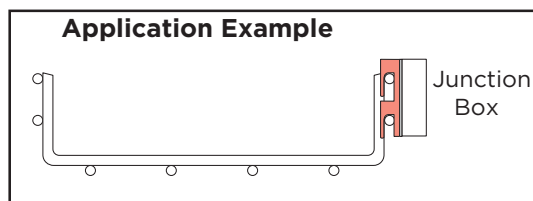

WALL SLEEVE [CAT(H)-(W)WS]

- Standard finish is pregalvanized (PG)
- Standard use per wall sleeve is:
 - (4 pc) CH3 (5 pc) 6112-0
 - (4 pc) 5003-1 (4 pc) 5009-1
 - (8 pc) EM -CC
 - (all sold separately)

NOTES:

1. Always place nut on outside of tray
2. Example CAT2-12WS

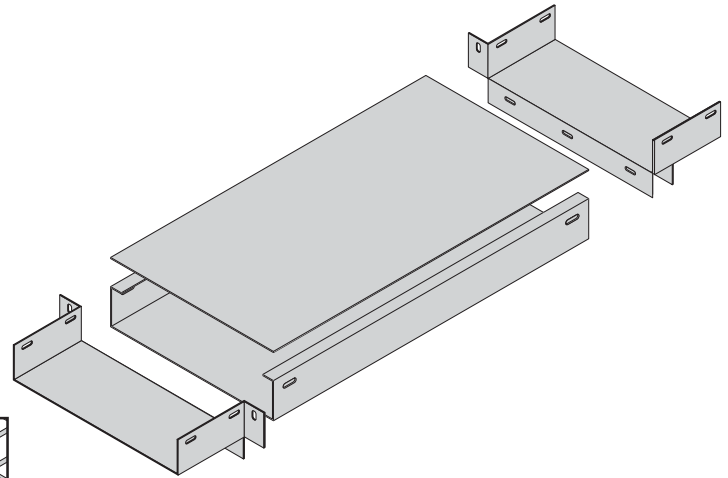
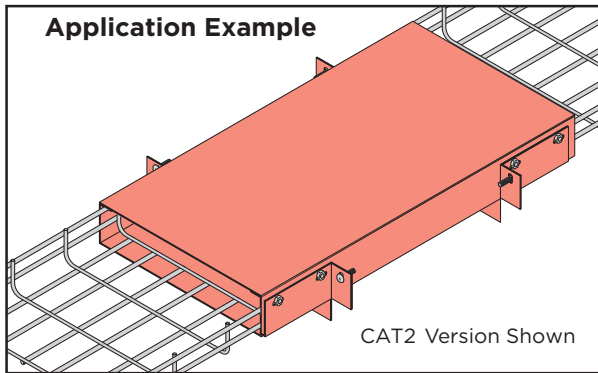

Intro

LADDER

I-BEAM

HAT

TROF

CHANNEL

COPE-GLAS™

WIREBASKET

Reference

WIRE BASKET SYSTEM

FITTINGS OVERVIEW

FITTINGS OVERVIEW

Fittings are typically fabricated on the job. However, prefabricated fittings are available upon request. Please contact factory.

To determine the fitting hardware required to create a set of fittings, please consult our online calculator. [Choose Wire basket tray from the Products menu on the front page of www.copecabletray.com.]

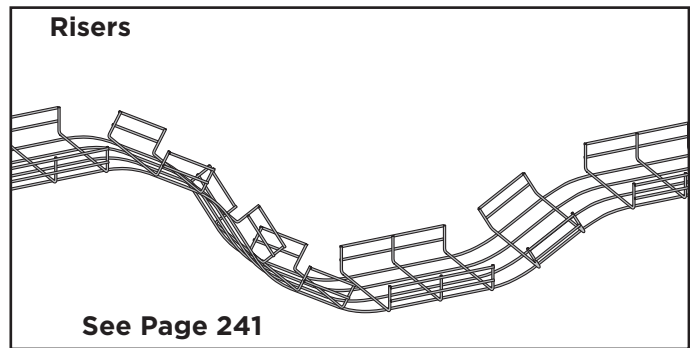
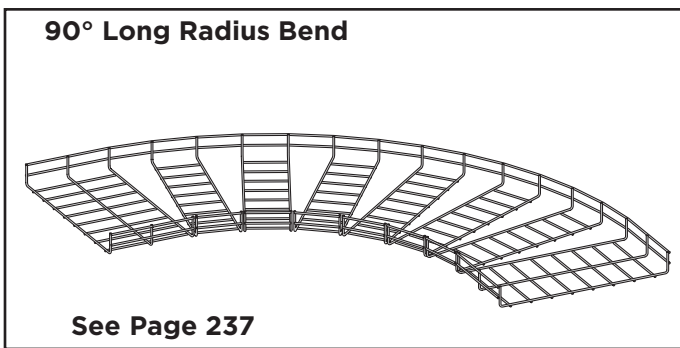
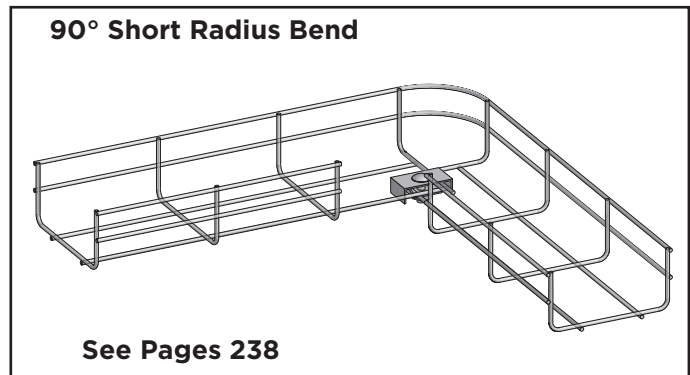
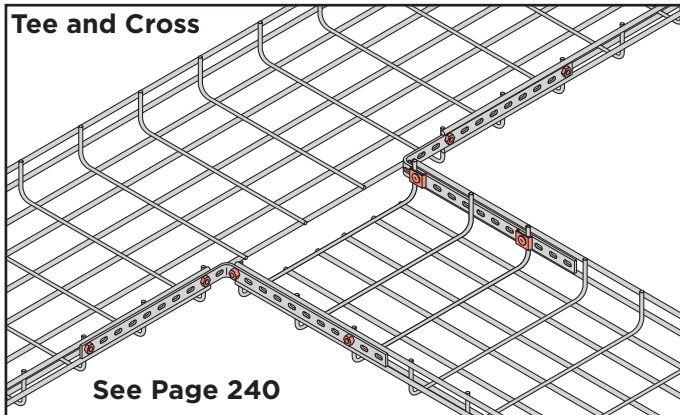

CUTTING TOOL [CAT-CUT]

Fittings can be formed easily on-site by cutting the bottom and side wires. Cut the tray bars on an angle as shown in the illustration.

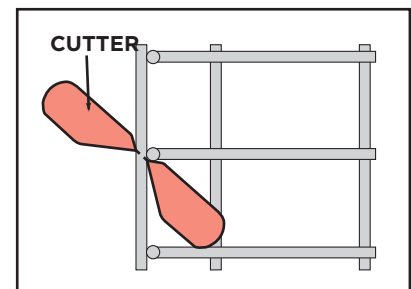
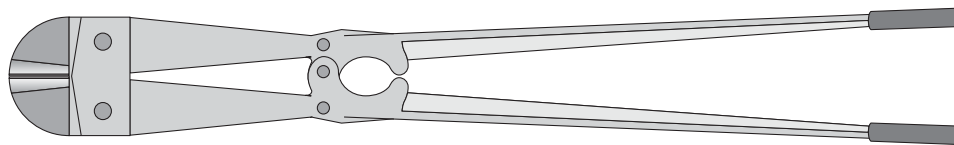

NOTE: When cutting, keep the remaining sharp edge away from the inside of the tray.

1 CUT THE BOTTOM AND SIDE WIRES

To form 90° bends in the tray, cut out the number of sections shown below based on the width of the tray used

2 ASSEMBLE USING APPROPRIATE HARDWARE

- Standard hardware is shown with each bend size.

Advantages:

- Use as bonding jumper
- Vertical support of standing sections
- Adjustable radius allowances

NOTE: Always place nut on outside of tray

| | | |
|--|-----------------------------------|--|
| <p>Cut Out 4 Sections of Mesh as Shown</p> | <p>(1) T-Bar (5 pcs) CH3</p> | <p>CAT2-04 16" Inside Radius</p> <p>CAT2-06 12" Inside Radius</p> <p>CAT2-08 12" Inside Radius</p> |
| <p>Cut Out 6 Sections of Mesh as Shown</p> | <p>(1) T-Bar (7 pcs) CH3</p> | <p>CAT2-12 17" Inside Radius</p> |
| <p>Cut Out 7 Sections of Mesh as Shown</p> | <p>(1) T-Bar (8 pcs) CH3</p> | <p>CAT2-16 18" Inside Radius</p> <p>CAT2-18 18" Inside Radius</p> |
| <p>Cut Out 9 Sections of Mesh as Shown</p> | <p>(1) T-Bar (10 pcs) CH3</p> | <p>CAT2-20 24" Inside Radius</p> <p>CAT2-24 24" Inside Radius</p> |

WIRE BASKET SYSTEM

90° SHORT RADIUS BENDS

90° BENDS - FORMING INSTRUCTIONS

To form 90° bends in the tray, cut the wires shown in the color shaded area of the drawing which corresponds to the width of the tray used.

1 CUT THE BOTTOM AND SIDE WIRES

Bends can be formed easily on-site by cutting the bottom and side wires. The shaded areas indicated should be cut and removed. Then, simply bend Wire basket tray cable tray to form a 90° angle and you are ready to install. Make sure you use the appropriate hardware.

2 ASSEMBLE USING APPROPRIATE HARDWARE

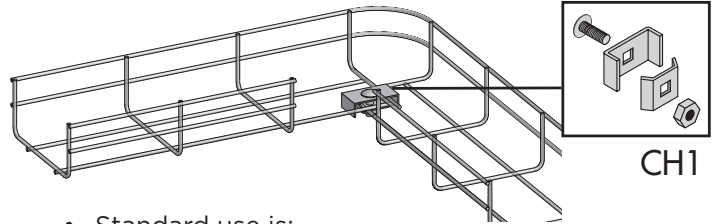

- Standard use is:
Sizes 4" - 12" (1 pc) CH1
Sizes 16" - 24" (2 pc) CH1

NOTE: Always place nut on outside of tray

90° BENDS - CUTTING DIAGRAMS

4" (100mm)

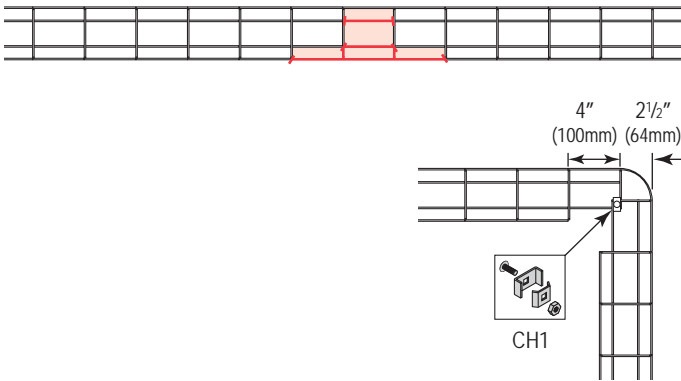

6" (150mm)

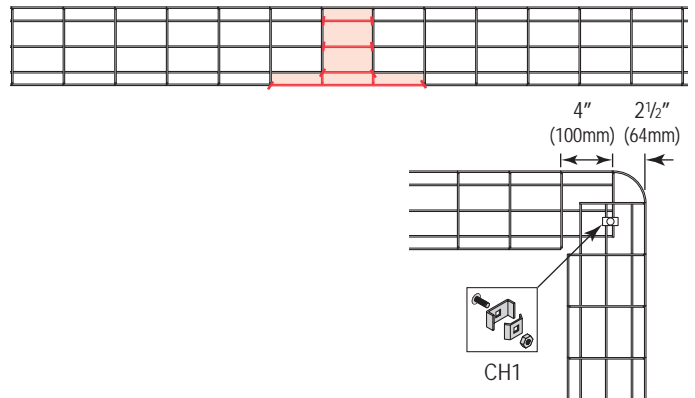

8" (200mm)

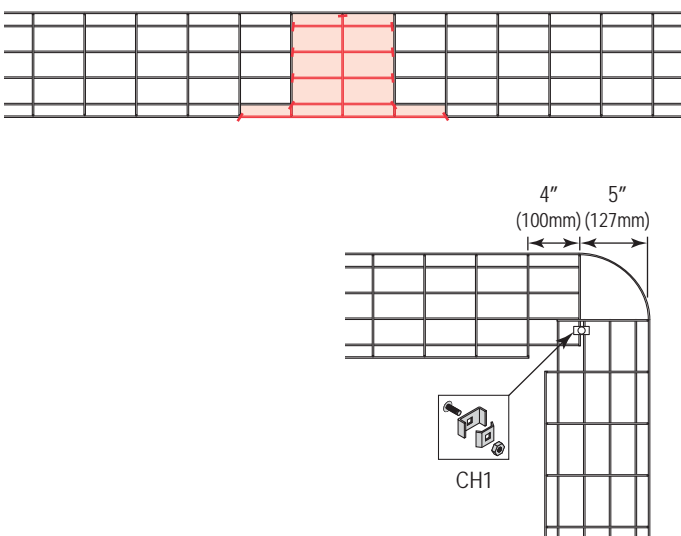

12" (300mm)

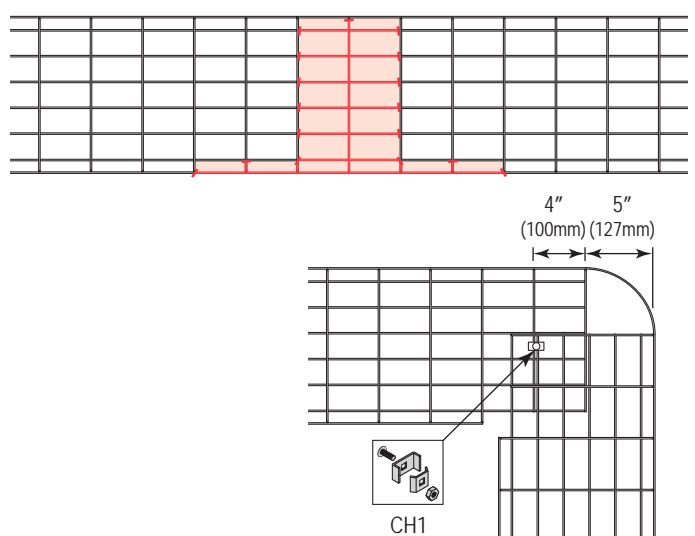

90° SHORT RADIUS BENDS

90° BENDS - CUTTING DIAGRAMS

16" (400mm)

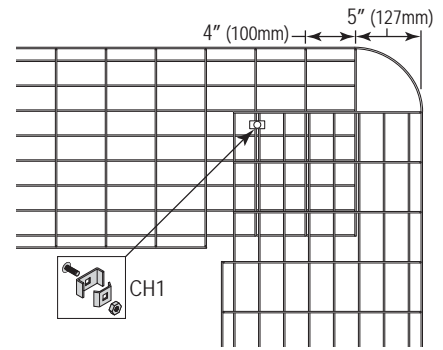
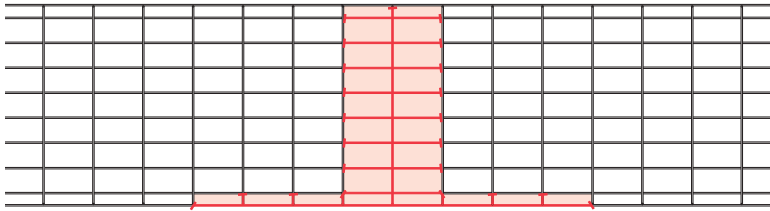

18" (450mm)

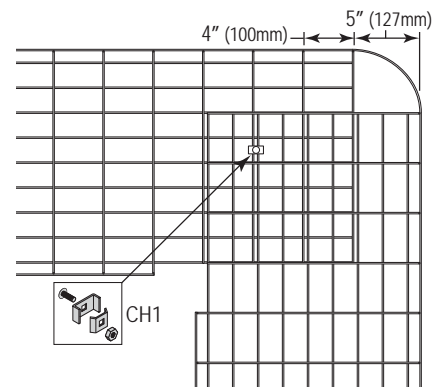
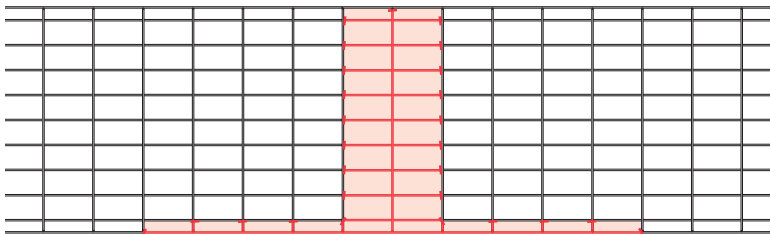

20" (500mm)

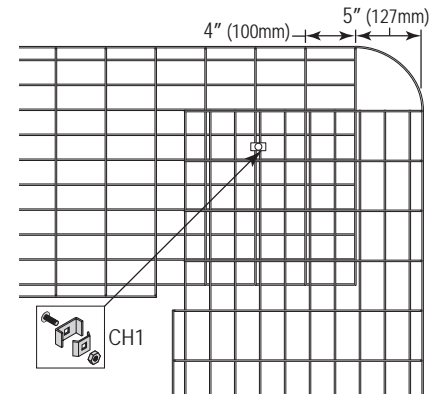
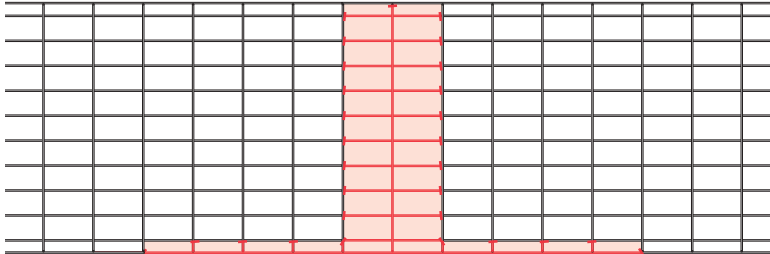

24" (600mm)

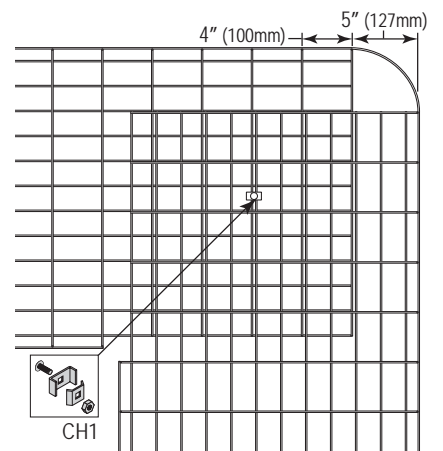
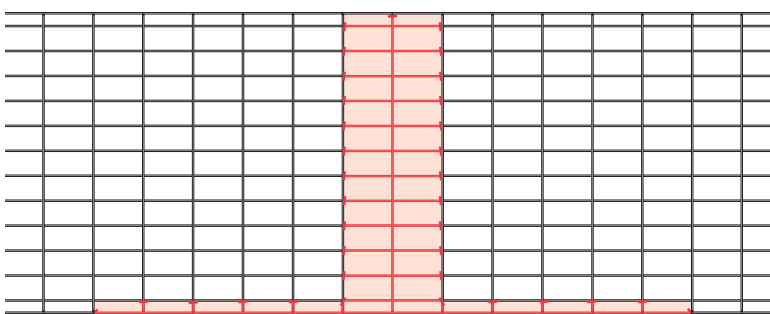

WIRE BASKET SYSTEM

CROSS & TEE FITTINGS

STANDARD TEE

- Standard use per tee is:
(2 pc) T-Bar-22 or (1 pc) T-Bar cut in half
(8 pc) CH3

NOTE: Always place nut on outside of tray

To form a tee, cut the wires marked in red.

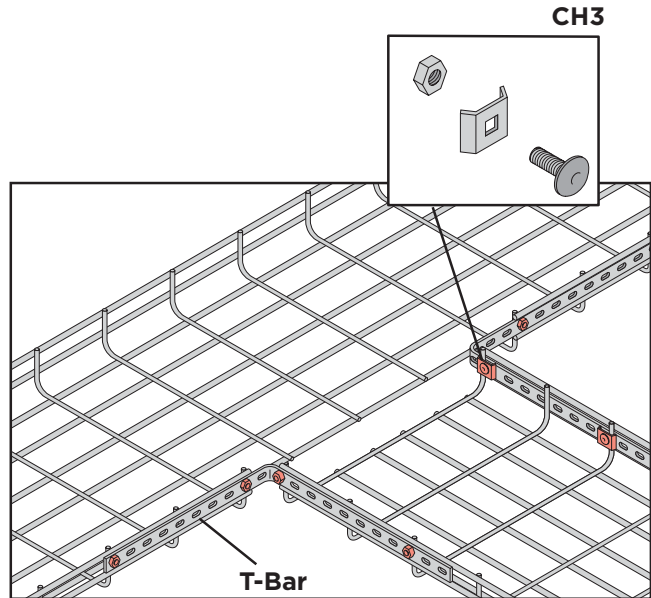
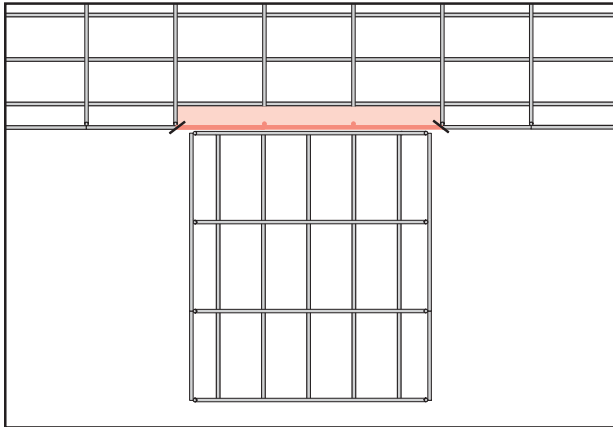

CROSS

- Standard use per cross is:
(4 pc) T-Bar-22 or (2 pc) T-Bar cut in half
(16 pc) CH3

NOTE: Always place nut on outside of tray

To form a cross, cut the wires marked in red.

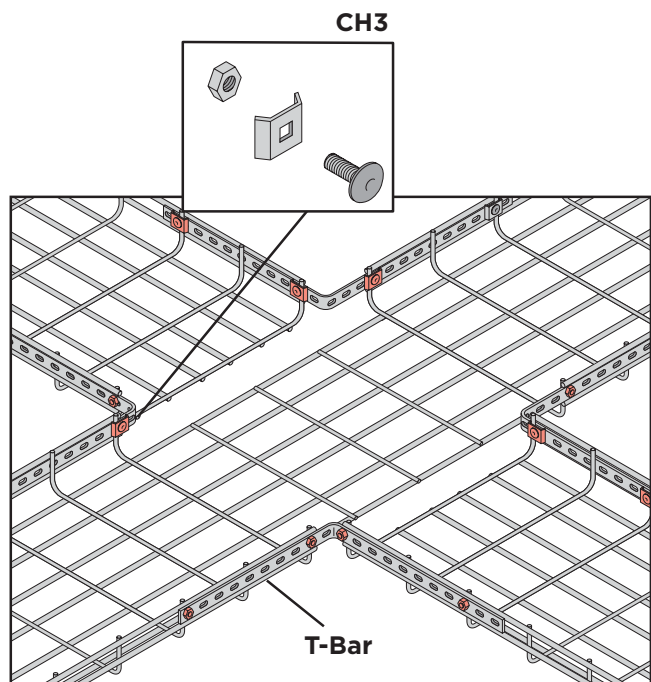
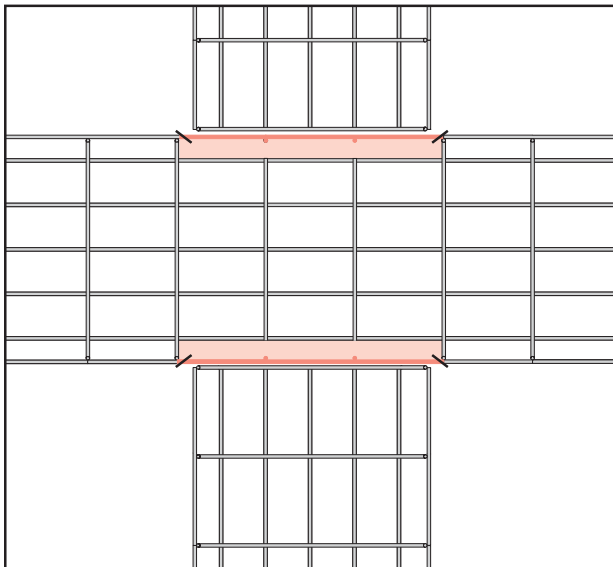

RISER, REDUCER & OFFSET FITTINGS

REDUCER

- Standard use per reducer is:
 (2 pc) T-bar
 (8 pc) CH3
 (1 pc) CH2

NOTE: Always place nut on outside of tray

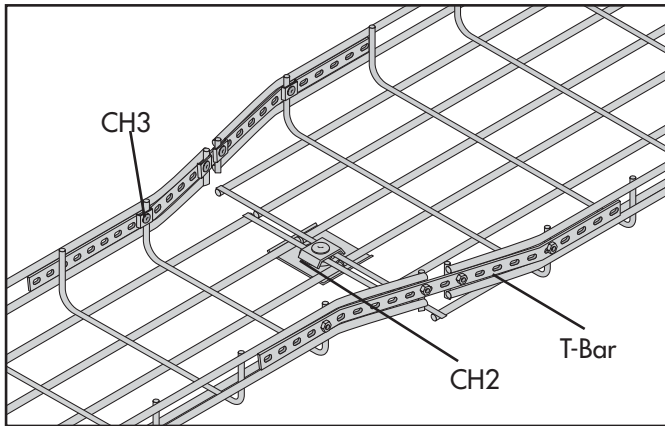
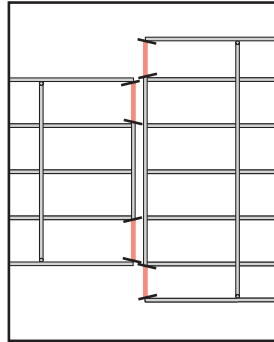

OFFSET

- Standard use per reducer is:
 (2 pc) T-bar
 (8 pc) CH3
 (1 pc) CH2

NOTE: Always place nut on outside of tray

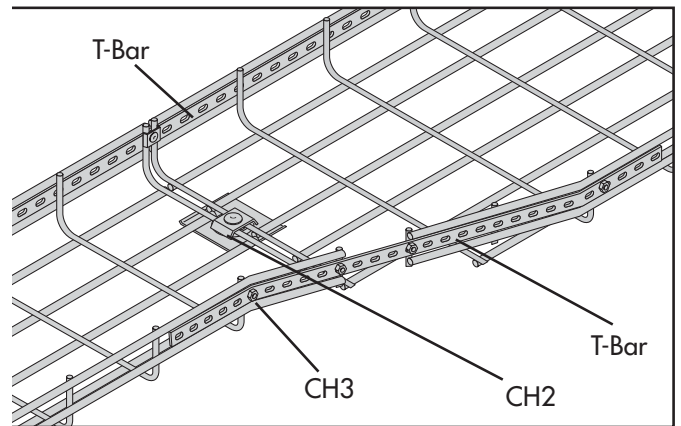
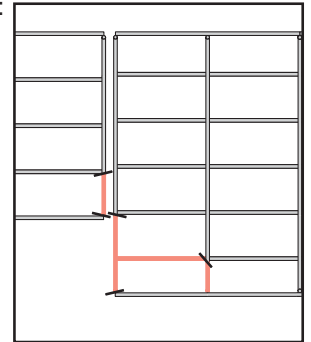

RISER

Risers and drops can be created to avoid different obstacles in the job path. Simply cut out the required number of side mesh sections and bend a vertical riser or drop to fit the application.

Cut out 4 side sections of mesh for a soft 90° bend.

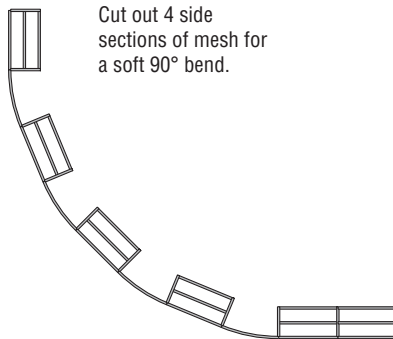

Cut out 3 side sections of mesh for a 90° bend.

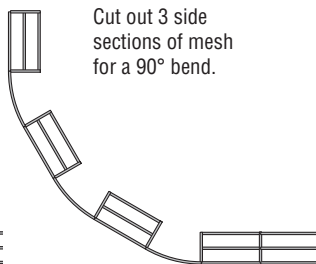

Cut out 2 side sections of mesh for a 90° bend.

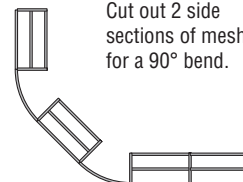

Cut out 1 side sections of mesh for a hard 90° bend.

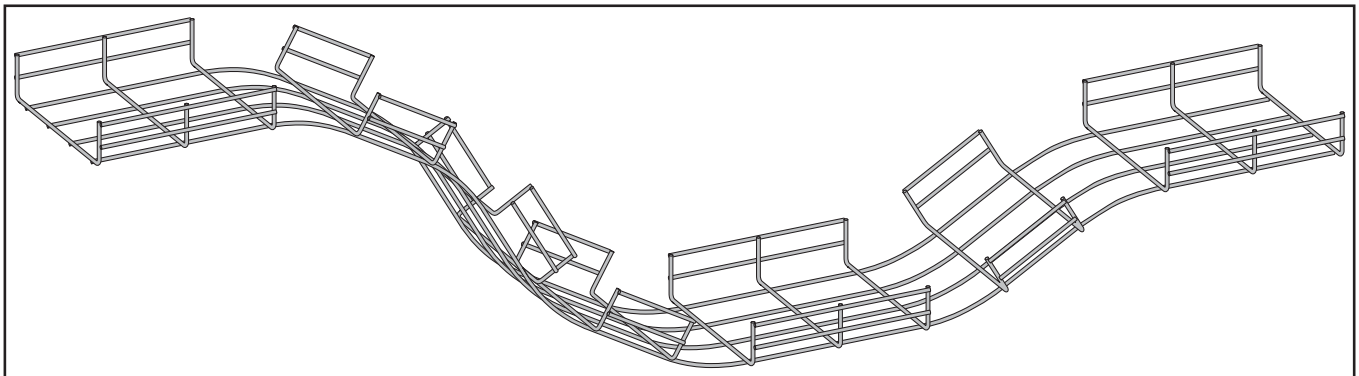
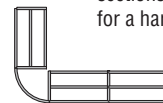

WIRE BASKET SYSTEM

GROUNDING

GROUNDING

UL CLASSIFIED SYSTEMS

Cope® Wire Basket systems meet the UL Classification.

NOTES: Cope® recommends use of a separate ground wire for equipment grounding.

Any non-conductive coating to wire basket must be removed by the contractor/end-user to maintain electrical continuity.

STRAIGHT SECTIONS - The grounding of two straight sections requires the use of (2) CAT-GC's and (2) EG-CBN's.

These items consist of grounding clips and the appropriate hardware, for connecting to the trays. One clip should be placed on both sides of the tray, attached at the self-splicing bar.

FITTINGS - Grounding of fittings requires special attention. Typically, fittings are fabricated in the field by cutting straight sections, thus altering the cross sectional area of the tray. A bonding jumper, and/or a T-Bar Splice, along with the appropriate hardware must be used on either side of the fitting to ensure electrical continuity.

Straights

2 pcs of CAT-GC
2 pcs of EG-CBN

EG-CBN

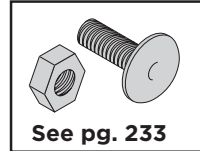

Application Example

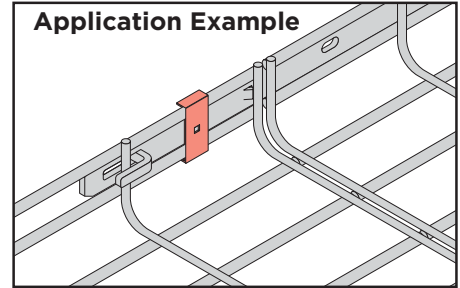

Fittings

T-Bar and
CH3s

Application Example

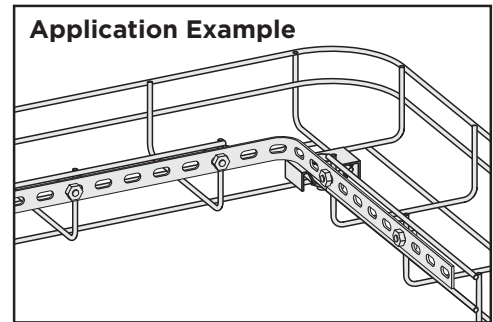

GROUNDING CLIP [CAT-GC]

- Standard finish is pregalvanized (PG)
- Sold in packs of 10
- Connection to splice bars requires a nut and bolt assembly (EG-CBN) purchased separately
- Use on both sides of tray

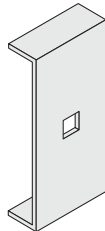

NOTE: Always place nut on outside of tray

CAT-GC's must be utilized if the tray is to be utilized as an equipment ground conductor.

GROUNDING CLAMP/SPLIT BOLT [SPLIT-BOLT]

- Split bolts are utilized for the attachment of a separate ground wire.
- Use with #6 AWG Ground Conductor

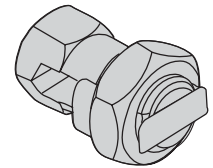

NOTE: Always place nut on outside of tray

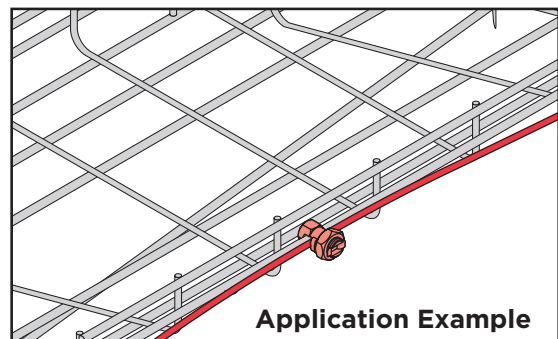

BOTTOM CLIP [BOTTOM-CLIP]

- Bottom-clip used a hold-down clip

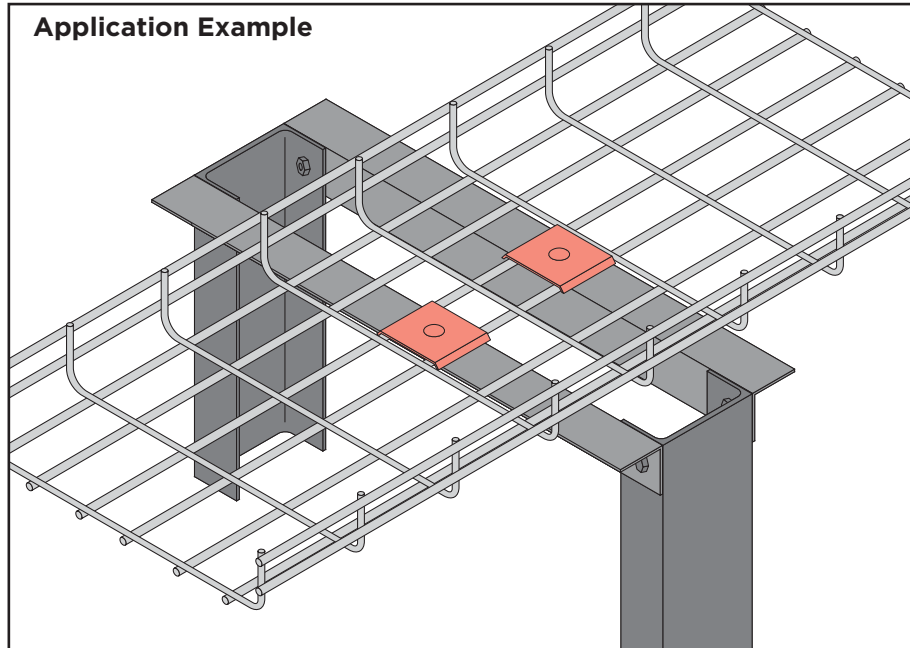
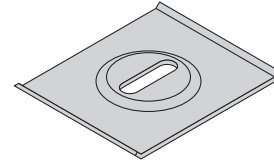

Drill hole in aluminum angle of relay rack.
Use bottom-clip to hold Wire basket tray to relay rack using $\frac{1}{4}$ "-20 round head machine screw and bolt and washer.

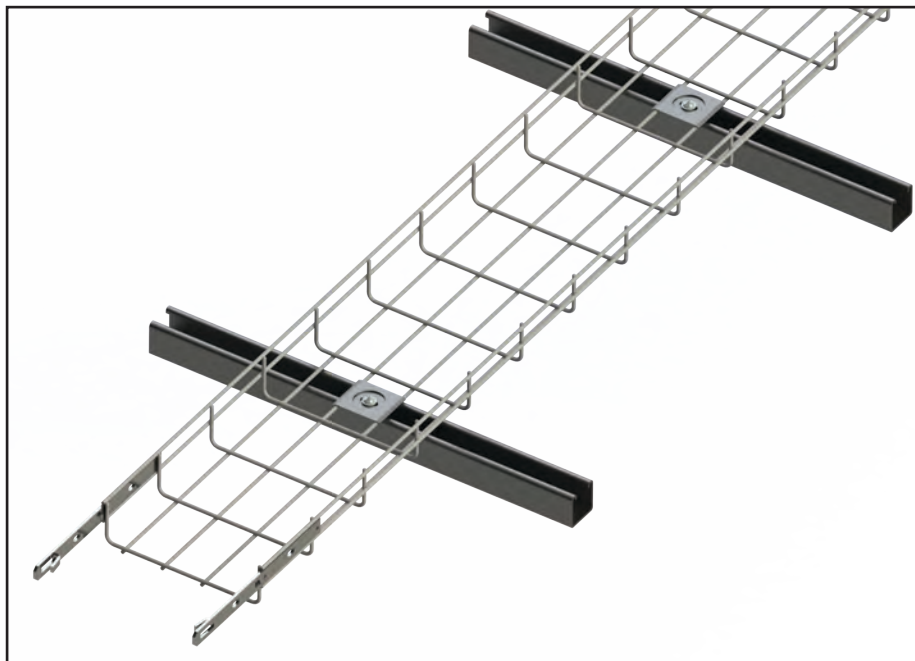

WIRE BASKET SYSTEM

HARDWARE

HEX HEAD CAP SCREWS

- Standard finish is electro-galvanized (EG)

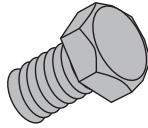

| Part No. | Description |
|----------|-----------------------|
| PS 6024 | 1/4"-20 x 1" Long |
| PS 6024 | 1/4"-20 x 1-1/2" Long |
| PS 6024 | 3/8"-16 x 5/8" Long |
| PS 6024 | 3/8"-16 x 1" Long |
| PS 6024 | 3/8"-16 x 1-1/2" Long |
| PS 6024 | 3/8"-16 x 2" Long |

ROUND HEAD MACHINE SCREWS

- Standard finish is electro-galvanized (EG)



| Part No. | Description |
|----------|-----------------------|
| PS 6072 | 1/4"-20 x 1" Long |
| PS 6072 | 1/4"-20 x 1-1/2" Long |
| PS 6072 | 3/8"-16 x 5/8" Long |
| PS 6072 | 3/8"-16 x 1" Long |
| PS 6072 | 3/8"-16 x 1-1/2" Long |
| PS 6072 | 3/8"-16 x 2" Long |

HEX NUTS

- Standard finish is electro-galvanized (EG)



| Part No. | Description |
|----------|-------------|
| PS 83 | 1/4"-20 |
| PS 83 | 3/8"-16 |
| PS 83 | 1/2"-13 |

SQUARE NUTS

- Standard finish is electro-galvanized (EG)

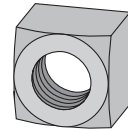

| Part No. | Description |
|----------|-------------|
| PS 6108 | 1/4" - 20 |
| PS 6108 | 3/8" - 16 |
| PS 6108 | 1/2" - 13 |

FLAT WASHERS

- Standard finish is electro-galvanized (EG)

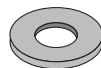

| Part No. | Description |
|----------|-------------|
| PS 209 | 1/4" |
| PS 209 | 3/8" |
| PS 209 | 1/2" |

LOCK WASHERS

- Standard finish is electro-galvanized (EG)



| Part No. | Description |
|----------|-------------|
| PS 211 | 1/4" |
| PS 211 | 3/8" |
| PS 211 | 1/2" |

STRUT NUTS

- Standard finish is electro-galvanized (EG)

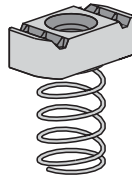

| Part No. | Description |
|----------|-------------|
| PSRS-1/4 | 1/4" - 20 |
| PSRS-3/8 | 3/8" - 16 |
| PSRS-1/2 | 1/2" - 13 |

SQUARE STRUT WASHERS

- Standard finish is electro-galvanized (EG)

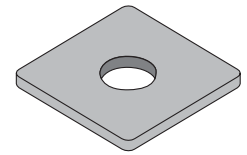

| Part No. | Description |
|----------|-------------|
| PS 619 | 1/4" hole |
| PS 619 | 3/8" hole |
| PS 619 | 1/2" hole |

TRAY CLIPS (SEE PAGES 221 - 222 FOR CONNECTOR KITS)

- Standard finish is electro-galvanized (EG)

| Single Part | Weight | No./ Pkg. |
|-------------|--------|-----------|
| Short-Clip | 0.2 | 10 |
| Wide-Clip | 0.31 | 10 |
| Bottom-Clip | 0.92 | 10 |

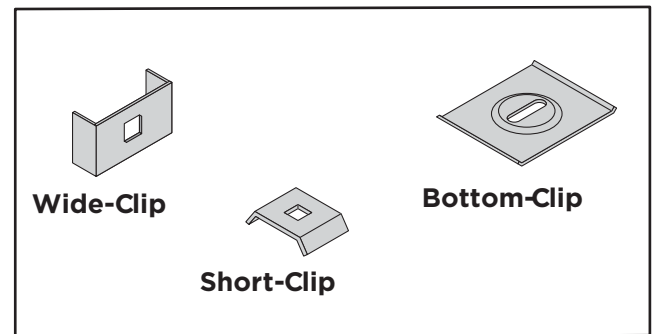

THREADED ROD

- Standard finish is electro-galvanized (EG)

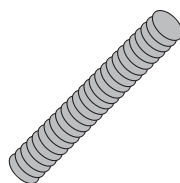

| Part No. | Description | Weight | | |
|----------|-------------|------------|-------------|-------------|
| | | 6' Lengths | 10' Lengths | 12' Lengths |
| PS 146 | 1/4" - 20 | 73 | 121 | 146 |
| PS 146 | 3/8" - 16 | 175 | 292 | 350 |
| PS 146 | 1/2" - 13 | 319 | 531 | 638 |

9



REFERENCE DATA

COPE® QUOTATION CHECKLIST



A PART OF **atkore**
INTERNATIONAL

COPE® Quotation Check List

PROJECT INFORMATION

| | | | |
|---------------------|--|------------------|--|
| Name: | | Date: | |
| Contractor: | | Location: | |
| Distributor: | | | |
| Contact: | | | |
| Email/Phone: | | | |

| | | | | |
|-------------------|----------------------------------|--------------------------------------|------------------------------------|-------------------------------------|
| TRAY TYPE: | <input type="checkbox"/> Ladder | <input type="checkbox"/> Marine Rung | <input type="checkbox"/> Vent Trof | <input type="checkbox"/> Solid Trof |
| | <input type="checkbox"/> Channel | <input type="checkbox"/> Wire Basket | <input type="checkbox"/> I-Beam | |

| | | | | |
|-----------------------|--|--|---------------------------------------|---------------------------------------|
| TRAY MATERIAL: | <input type="checkbox"/> Aluminum | <input type="checkbox"/> Steel, Pre-Galvanized | <input type="checkbox"/> Steel, HDGAF | <input type="checkbox"/> Other, _____ |
| | <input type="checkbox"/> 304 Stainless Steel | <input type="checkbox"/> 316 Stainless Steel | <input type="checkbox"/> Fiberglass | |

| | | | |
|--|------------------------------------|--------------------------------------|--|
| TRAY MATERIAL: (Fiberglass Only) | <input type="checkbox"/> Polyester | <input type="checkbox"/> Vinyl Ester | |
|--|------------------------------------|--------------------------------------|--|

| | | | | | |
|---------------------|------------------------------|------------------------------|------------------------------|------------------------------|------------------------------|
| TRAY LENGTH: | <input type="checkbox"/> 10' | <input type="checkbox"/> 12' | <input type="checkbox"/> 20' | <input type="checkbox"/> 24' | <input type="checkbox"/> 30' |
|---------------------|------------------------------|------------------------------|------------------------------|------------------------------|------------------------------|

| | | | | |
|--------------------|------------------------------|------------------------------|------------------------------|--|
| TRAY WIDTH: | <input type="checkbox"/> 6" | <input type="checkbox"/> 9" | <input type="checkbox"/> 12" | <input type="checkbox"/> 18" |
| | <input type="checkbox"/> 24" | <input type="checkbox"/> 30" | <input type="checkbox"/> 36" | <input type="checkbox"/> 42" or <input type="checkbox"/> 48" <small>Note: Ladder Tray Only, not NEMA Standard</small> |

| | | | | | | | | | |
|--|-----------------------------|-----------------------------|-----------------------------|-----------------------------|------------------------------|------------------------------|------------------------------|------------------------------|------------------------------|
| TRAY WIDTH: (Wire basket Only) | <input type="checkbox"/> 2" | <input type="checkbox"/> 4" | <input type="checkbox"/> 6" | <input type="checkbox"/> 8" | <input type="checkbox"/> 12" | <input type="checkbox"/> 16" | <input type="checkbox"/> 18" | <input type="checkbox"/> 20" | <input type="checkbox"/> 24" |
|--|-----------------------------|-----------------------------|-----------------------------|-----------------------------|------------------------------|------------------------------|------------------------------|------------------------------|------------------------------|

| | | | | |
|----------------------|-----------------------------|-----------------------------|------------------------------|------------------------------|
| RUNG SPACING: | <input type="checkbox"/> 6" | <input type="checkbox"/> 9" | <input type="checkbox"/> 12" | <input type="checkbox"/> 18" |
|----------------------|-----------------------------|-----------------------------|------------------------------|------------------------------|

| | | | | | |
|--------------------|-----------------------------|-----------------------------|-----------------------------|-----------------------------|-----------------------------|
| LOAD DEPTH: | <input type="checkbox"/> 2" | <input type="checkbox"/> 3" | <input type="checkbox"/> 4" | <input type="checkbox"/> 5" | <input type="checkbox"/> 6" |
|--------------------|-----------------------------|-----------------------------|-----------------------------|-----------------------------|-----------------------------|

| | | | |
|------------------------|------------------------------|------------------------------|------------------------------|
| FITTING RADIUS: | <input type="checkbox"/> 12" | <input type="checkbox"/> 24" | <input type="checkbox"/> 36" |
|------------------------|------------------------------|------------------------------|------------------------------|

| | | | | |
|--|------------------------------|------------------------------|------------------------------|--|
| STRUCTURAL REQUIREMENTS: (NEMA CLASS) OR, | <input type="checkbox"/> 8A | <input type="checkbox"/> 8B | <input type="checkbox"/> 8C | |
| | <input type="checkbox"/> 12A | <input type="checkbox"/> 12B | <input type="checkbox"/> 12C | |
| | <input type="checkbox"/> 16A | <input type="checkbox"/> 16B | <input type="checkbox"/> 16C | |
| | <input type="checkbox"/> 20A | <input type="checkbox"/> 20B | <input type="checkbox"/> 20C | |

| | |
|-----------------------------------|--|
| CABLE WEIGHT SUPPORT SPAN: | |
|-----------------------------------|--|

| | |
|------------------------------|--|
| SPECIAL REQUIREMENTS: | |
|------------------------------|--|

| | |
|-------------------------------|--|
| DELIVERY REQUIREMENTS: | |
|-------------------------------|--|

All tray widths and lengths listed are not available for every tray type. See Cope catalog for dimensions.

Customer Service
16100 S. Lathrop Ave. • Harvey, IL 60426
Phone: 800-882-5543 • Fax: 708-339-7814

www.copecabletray.com

Confidential Information

COP-L-1005-1404

CABLE TRAY/WIRE BASKET LOADINGS REFERENCE

NEMA (VE-1) Loadings¹

| Tray/Load Designation | Class A | Class B | Class C |
|-----------------------|---------|---------|---------|
| lbs/ft | 50 | 75 | 100 |

Power Cables^{1,2}

| Tray Dimension | 36" Wide | 30" Wide | 24" Wide | 18" Wide | 12" Wide | 9" Wide | 6" Wide |
|-------------------|----------|----------|----------|----------|----------|---------|---------|
| Cable Fill Weight | 140 | 115 | 90 | 70 | 45 | 35 | 25 |

Data/Communication Cables^{1,3,4}

| Tray Size | 36" Wide | 30" Wide | 24" Wide | 18" Wide | 12" Wide | 9" Wide | 6" Wide |
|-----------|----------|----------|----------|----------|----------|---------|---------|
| 6" Depth | 89 | 74 | 59 | 45 | 30 | 23 | 15 |
| 5" Depth | 74 | 62 | 49 | 37 | 25 | 19 | 13 |
| 4" Depth | 59 | 49 | 40 | 30 | 20 | 15 | 10 |
| 3" Depth | 45 | 37 | 30 | 23 | 15 | 12 | 8 |
| 2" Depth | 30 | 25 | 20 | 15 | 10 | 8 | 5 |

Note:

1. All Cable Weight/Loads are in Lbs/ft unless otherwise noted.
2. Larger diameter cables used in weight estimation.
3. Max 50% fill ratio used in calculations for Data/Communication Cables
4. CAT6/CAT6E cables, O.D. = 0.25" nominal, weight = 0.040 lbs/ft

CORROSION RESISTANCE GUIDE

The symbols to the right have been used throughout the table in order to provide an indication about the suitability of a potential candidate material for a specific chemical environment.

NOTE: These tables should be regarded only as GUIDES to anticipated performance because of possible contributions from temperature, pollutant (contaminant) species, etc.

SYMBOLS:

| | |
|-----|--|
| ++ | First choice; very low corrosion rate, typically <5 mpy, or <0.005 Inch/year, (1 mil = 1/1000 inch). |
| + | Good choice; low corrosion rate, typically <20 mpy, or <0.02 lpy. |
| - | Can use; corrosion rate up to 50 mpy (0.05 lpy); some limitations may apply. |
| X | Not recommended. |
| (-) | Brackets indicate probable limitations, E.G., At higher temperatures, [symbol "T"]; at higher concentrations, [symbol "C"]; due to pitting, [symbol "P"]; due to local grain boundary attack in the metal - intergranular corrosion, [symbol "I"]; due to stress corrosion cracking, [symbol "S"]. |
| nd | No available data |

| Corrosion Resistance Guide | | | |
|----------------------------|-------------------|-----------|--------------------|
| Chemical Species | Aluminum | HDG/Steel | 316SS |
| Acetaldehyde | ++ | + | ++ |
| Acetic acid - aerated | (+) ^{TC} | X | (++) ^T |
| Acetic acid - not aerated | (+) ^{TC} | X | (++) ^T |
| Acetone | ++ | ++ | ++ |
| Acetylene | ++ | nd | ++ |
| Allyl alcohol | + | nd | ++ |
| Aluminum chloride - dry | + | nd | (+) ^{TP} |
| Aluminum chloride - wet | X | X | (-) ^P |
| Aluminum sulfate - satd. | X | nd | + |
| Ammonia - anhydrous | ++ | ++ | ++ |
| Ammonia - gas | - | + | (+) ^T |
| Ammonium acetate | + | nd | + |
| Ammonium bicarbonate | - | nd | (+) ^T |
| Ammonium carbonate - satd. | + | X | + |
| Ammonium chloride - 28% | X | X | (+) ^{PS} |
| Ammonium chloride - 50% | X | X | X |
| Ammonium hydroxide | + | + | (++) ^C |
| Ammonium nitrate | + | X | (++) ^S |
| Ammonium phosphate - 40% | X | nd | + |
| Ammonium sulfate - to 30% | X | - | + |
| Amyl acetate | ++ | ++ | ++ |
| Asphalt | ++ | + | + |
| Beer | ++ | X | ++ |
| Benzene (benzol) | ++ | + | (+) ^P |
| Benzoic acid | + | nd | + |
| Benzol - see benzene | | | |
| Boric acid (boracic acid) | ++ | nd | (++) ^{TP} |
| Bromine - wet | X | X | X |
| Butadiene (butylene) | + | + | + |
| Butyl alcohol (butanol) | ++ | ++ | ++ |
| Butyric acid | + | X | + |
| Cadmium sulfate | + | nd | ++ |

| Corrosion Resistance Guide | | | |
|--|---------------------|-----------|--------------------|
| Chemical Species | Aluminum | HDG/Steel | 316SS |
| Calcium carbonate | - | nd | + |
| Calcium chloride - satd. | + | X | (+) ^S |
| Calcium hydroxide - satd. | X | nd | + |
| Calcium hypochlorite - satd. | X | X | (-) ^P |
| Carbon dioxide - wet | ++ | + | + |
| Carbon disulfide (bisulfide) | ++ | + | ++ |
| Carbon tetrachloride | X | + | (++) ^{PS} |
| Carbolic acid - see phenol | | | |
| Carbonic acid - see carbon dioxide | | | |
| Caustic potash - see potassium hydroxide | X | ++ | (-) ^{PS} |
| Caustic soda - see sodium hydroxide | | | |
| Chlorine gas - wet | | | |
| Chloroform | (+) ^{dry} | + | (+) ^{TS} |
| Chromic acid | + | nd | (+) ^P |
| Citric acid - dilute | (+) ^{TC} | X | (++) ^P |
| Copper chloride | X | X | (-) ^P |
| Copper nitrate | X | nd | ++ |
| Copper sulfate | X | - | + |
| Cresol | + | + | + |
| Crude oil | ++ | ++ | ++ |
| Diethylamine | + | ++ | ++ |
| Dimethyl ketone - see acetone | | | |
| Ethyl acetate | (++) ^{dry} | ++ | + |
| Ethyl alcohol (ethanol) | ++ | ++ | ++ |
| Ethylene dichloride | (-) ^{dry} | ++ | (+) ^{PS} |
| Ethylene glycol (glycol) | ++ | ++ | ++ |
| Ferric chloride | X | X | X |
| Ferric nitrate - 10% | X | nd | + |
| Ferrous sulfate | + | nd | (+) ^P |
| Formaldehyde (methanal) | (+) ^P | ++ | (++) ^{TC} |
| Fluorine gas - moist | X | X | X |
| Formalin - see formaldehyde | | | |
| Formic acid (methanoic acid) - 10% | (+) ^T | X | (+) ^{PC} |
| Furfural (furfuraldehyde) | + | nd | + |

CORROSION RESISTANCE GUIDE

| Corrosion Resistance Guide | | | |
|-----------------------------------|-------------------|-----------|-------------------|
| Chemical Species | Aluminum | HDG/Steel | 316SS |
| Furol - see furfural Gelatin | ++ | + | ++ |
| Glycerine (glycerol) | ++ | ++ | ++ |
| Hexamine - 80% | ++ | nd | ++ |
| Hydrobromic acid | X | X | X |
| Hydrochloric acid (muriatic acid) | X | X | X |
| Hydrocyanic acid - dilute | + | nd | + |
| Hydrocyanic acid - conc | X | nd | + |
| Hydrofluoric acid | X | X | X |
| Hydrogen chloride gas - dry | X | X | (++) ^S |
| Hydrogen chloride gas - wet | X | X | + |
| Hydrogen fluoride | (-) ^T | nd | + |
| Hydrogen peroxide - to 40% | ++ | nd | + |
| Hydrogen sulfide - wet | (+) ^P | nd | (+) ^{PS} |
| Hypo - see sodium thiosulfate | | | |
| Hypochlorous acid | X | X | X |
| Iodine solution - satd | X | X | X |
| Lactic acid | (+) ^T | nd | (+) ^{PI} |
| Latex | ++ | - | ++ |
| Lithium chloride - to 30% | X | nd | ++ |
| Linseed oil | + | nd | ++ |
| Magnesium chloride - 50% | X | X | (+) ^{PS} |
| Magnesium hydroxide | + | nd | ++ |
| Magnesium sulfate | + | X | + |
| Maleic acid (maleinic acid) - 20% | + | nd | + |
| Methyl alcohol (methanol) | ++ | ++ | ++ |
| Methyl ethyl ketone | + | ++ | + |
| Milk | ++ | X | ++ |
| Molasses | + | nd | ++ |
| Naptha | + | + | + |
| Natural fats | ++ | ++ | ++ |
| Nickel chloride | X | nd | (+) ^{PS} |
| Nickel sulfate | X | nd | + |
| Nitric acid | X | X | (++) |
| IOleic acid | (++) ^T | nd | ++ |
| Oxalic acid - dilute | - | nd | + |
| Oxalic acid - saturated | (+) ^T | X | X |
| Paraformaldehyde - to 30% | + | nd | ++ |
| Perchloroethylene | + | X | (++) |
| PPhenol (carbolic acid) | + | + | ++ |
| Phosphoric acid - dilute | X | X | ++ |
| Phosphoric acid - 50% | X | X | (++) |
| IPicric acid | ++ | nd | + |
| Potassium bicarbonate - 30% | X | nd | ++ |
| Potassium carbonate | X | nd | ++ |
| Potassium chloride - to 25% | X | X | (++) ^P |

| Corrosion Resistance Guide | | | |
|-------------------------------------|---------------------|-----------|--------------------|
| Chemical Species | Aluminum | HDG/Steel | 316SS |
| Potassium dichromate - 30% | (++) ^T | X | ++ |
| Potassium hydroxide | X | nd | (+) ^S |
| Potassium nitrate | ++ | ++ | + |
| Potassium sulfate | ++ | ++ | ++ |
| Propionic acid (propanoic acid) | (+) ^T | X | (+) ^T |
| Propyl alcohol (propane) | ++ | ++ | ++ |
| Prussic acid - see hydrocyanic acid | | | |
| Pyridine | + | nd | ++ |
| Soaps | + | - | + |
| Sodium bicarbonate - 20% | + | nd | ++ |
| Sodium bisulfate | X | X | (+) ^T |
| Sodium bisulfite | X | X | + |
| Sodium chloride - to 30% | X | X | (+) ^{PS} |
| Sodium cyanide | X | nd | (+) ^T |
| Sodium hydroxide - 10-30% | X | X | (+) ^S |
| Sodium hydroxide - 50% | X | X | (++) ^S |
| Sodium hydroxide - conc | X | X | ++ |
| Sodium hypochlorite - conc | X | + | (-) ^{PS} |
| Sodium nitrate | ++ | X | ++ |
| Sodium peroxide - 10% | + | nd | + |
| Sodium silicate | ++ | nd | ++ |
| Sodium sulfate | (++) ^{30%} | X | ++ |
| Sodium sulfide - to 50% | X | nd | (+) ^T |
| Sodium thiosulfate | + | nd | ++ |
| Steam | (+) ^P | ++ | ++ |
| Stearic acid | + | nd | ++ |
| Sorbital (hexahydric alcohol) | ++ | + | ++ |
| Sulfur dioxide - dry | + | + | ++ |
| Sulfur dioxide - wet | X | X | (+) ^T |
| Sulfuric acid - to 80% | X | X | X |
| Sulfuric acid - 80-90% | X | X | (-) ^I |
| Sulfuric acid - 98% | X | X | (+) ^I |
| Tannic acid (tannin) | X | X | + |
| Tartaric acid - to 50% | (+) ^T | nd | ++ |
| Toluene (Toluol; methyl benzene) | ++ | ++ | ++ |
| Trichloroethylene | (++) ^T | + | (+) ^P |
| Turpentine | + | ++ | ++ |
| Water - acid, mine | X | - | (++) ^P |
| Water - potable | + | + | ++ |
| Water - sea | + | + | ++ |
| Xylene | ++ | nd | ++ |
| Zinc chloride - dilute | ++ | nd | (++) ^{PS} |

NOTE: These tables should be regarded only as GUIDES to anticipated performance because of possible contributions from temperature, pollutant (contaminant) species, etc.

Intro

LADDER

I-BEAM

HAT

TROF

CHANNEL

COPE-GLAS™

WIREBASKET

Reference

TABLE OF CONVERSIONS

| English to Metric | | | Metric to English | | |
|--|--------------------------------------|--------------|--------------------------------------|--|--------------------|
| To Convert From | To | Multiply By | To Convert From | To | Multiply By |
| Length | | | | | |
| Inch [in] | Millimeter [mm] | 25.400 000 | Millimeter [mm] | Inch [in] | 0.039 370 |
| Foot [ft] | Meter [m] | 0.304 800 | Meter [m] | Foot [ft] | 3.280 840 |
| Yard [yd] | Meter [m] | 0.914 400 | Meter [m] | Yard [yd] | 1.093 613 |
| Mile (U.S. Statute) [mi] | Kilometer [km] | 1.609 347 | Kilometer [km] | Mile (U.S. Statute) [mi] | 0.621 370 |
| Area | | | | | |
| Square Inch [in ²] | Square Millimeter [mm ²] | 645.16 | Square Millimeter [mm ²] | Square Inch [in ²] | 0.001550 |
| Square Foot [ft ²] | Square Meter [m ²] | 0.092 903 | Square Meter [m ²] | Square Foot [ft ²] | 10.763 915 |
| Square Yard [yd ²] | Square Meter [m ²] | 0.836 127 | Square Meter [m ²] | Square Yard [yd ²] | 1.195 991 |
| Square Mile [mi ²] (U.S. Statute) | Square Kilometer [km ²] | 2.589 998 | Square Kilometer [km ²] | Square Mile [mi ²] (U.S. Statute) | 0.386 101 |
| Acre | Square Meter [m ²] | 4.046 873 | Square Meter [m ²] | Acre | 0.000 247 |
| Acre | Hectare | 0.404 687 | Hectare | Acre | 2.471 046 |
| Volume | | | | | |
| Cubic Inch [in ³] | Cubic Millimeter [mm ³] | 16,387.06 | Cubic Millimeter [mm ³] | Cubic Inch [in ³] | 0.000061 |
| Cubic Foot [ft ³] | Cubic Meter [m ³] | 0.028 317 | Cubic Meter [m ³] | Cubic Foot [ft ³] | 35.314 662 |
| Cubic Yard [yd ³] | Cubic Meter [m ³] | 0.764 555 | Cubic Meter [m ³] | Cubic Yard [yd ³] | 1.307 950 |
| Gallon (U.S. Liquid) [gal] | Litre [l] | 3.785 412 | Litre [l] | Gallon (U.S. Liquid) [gal] | 0.264 172 |
| Quart (U.S. Liquid) [qt] | Litre [l] | 0.946 353 | Litre [l] | Quart (U.S. Liquid) [qt] | 1.056 688 |
| Mass | | | | | |
| Ounce (Avoirdupois) [oz] | Gram [g] | 28.349 520 | Gram [g] | Ounce (Avoirdupois) [oz] | 0.035 274 |
| Pound (Avoirdupois) [lb] | Kilogram [kg] | 0.453 592 | Kilogram [kg] | Pound (Avoirdupois) [lb] | 2.204 624 |
| Short Ton | Kilogram [kg] | 907.185 | Kilogram [kg] | Short Ton | 0.00110 |
| Force | | | | | |
| Ounce-Force | Newton [N] | 0.278 014 | Newton [N] | Ounce-Force | 3.596 941 |
| Pound-Force [lbf] | Newton [N] | 4.448 222 | Newton [N] | Pound-Force [lbf] | 0.224 809 |
| Bending Moment | | | | | |
| Pound-Force-Inch [lbf-in] | Newton-Meter [N-m] | 0.112 985 | Newton-Meter [N-m] | Pound-Force-Inch [lbf-in] | 8.850 732 |
| Pound-Force-Foot [lbf-ft] | Newton-Meter [N-m] | 1.355 818 | Newton-Meter [N-m] | Pound-Force-Foot [lbf-ft] | 0.737 562 |
| Pressure, Stress | | | | | |
| Pound-Force per Square Inch [lbf/in ²] | Kilopascal [kPa] | 6.894 757 | Kilopascal [kPa] | Pound-Force per Square Inch [lbf/in ²] | 0.145 038 |
| Foot of Water (39.2 F) | Kilopascal [kPa] | 2.988 980 | Kilopascal [kPa] | Foot of Water (39.2 F) | 0.334 562 |
| Inch of Mercury (32 F) | Kilopascal [kPa] | 3.386 380 | Kilopascal [kPa] | Inch of Mercury (32 F) | 0.295 301 |
| Energy, Work, Heat | | | | | |
| Foot-Pound-Force [ft-lbf] | Joule [J] | 1.355 818 | Joule [J] | Foot-Pound-Force [ft-lbf] | 0.737 562 |
| British Thermal Unit [Btu] | Joule [J] | 1,055.056 | Joule [J] | British Thermal Unit [Btu] | 0.000948 |
| Calorie [cal] | Joule [J] | 4.186 800 | Joule [J] | Calorie [cal] | 0.238 846 |
| Kilowatt Hour [kW-h] | Joule [J] | 3,600,000 | Joule [J] | Kilowatt Hour [kW-h] | 2.78 ⁻⁷ |
| Power | | | | | |
| Foot-Pound-Force /Second [ft-lbs/s] | Watt [W] | 1.355 818 | Watt [W] | Foot-Pound-Force /Second [ft-lbs/s] | 0.737 562 |
| British Thermal Unit /Hour [Btu/h] | Watt [W] | 0.293 071 | Watt [W] | British Thermal Unit /Hour [Btu/h] | 3.412 142 |
| Horsepower (550 Ft. Lbf/s) [hp] | Kilowatt [kW] | 0.745 700 | Kilowatt [kW] | Horsepower (550 Ft. Lbf/s) [hp] | 1.341 022 |
| Angle | | | | | |
| Degree | Radian [rad] | 0.017 453 | Radian [rad] | Degree | 57.295 788 |
| Temperature | | | | | |
| Degree Fahrenheit [F] | Degree Celsius [C] | (F° -32)/1.8 | Degree Celsius [C] | Degree Fahrenheit [F] | 1.8x C° +32 |

FRACTIONS & DECIMAL EQUIVALENTS

| | | | | | |
|------|-------|----------|-------|-------|----------|
| | 1/64 | 0.015625 | | 33/64 | 0.515625 |
| | 1/32 | 0.03125 | | 17/32 | 0.53125 |
| | 3/64 | 0.046875 | | 35/64 | 0.546875 |
| 1/16 | | 0.0625 | 9/16 | | 0.5625 |
| | 5/64 | 0.078125 | | 37/64 | 0.578125 |
| | 3/32 | 0.09375 | | 19/32 | 0.59375 |
| | 7/64 | 0.109375 | | 39/64 | 0.609375 |
| 1/8 | | 0.125 | 5/8 | | 0.625 |
| | 9/64 | 0.140625 | | 41/64 | 0.640625 |
| | 5/32 | 0.15625 | | 21/32 | 0.65625 |
| | 11/64 | 0.171875 | | 43/64 | 0.671875 |
| 3/16 | | 0.1875 | 11/16 | | 0.6875 |
| | 13/64 | 0.203125 | | 45/64 | 0.703125 |
| | 7/32 | 0.21875 | | 23/32 | 0.71875 |
| | 15/64 | 0.234375 | | 47/64 | 0.734375 |
| 1/4 | | 0.25 | 3/4 | | 0.75 |
| | 17/64 | 0.265625 | | 49/64 | 0.765625 |
| | 9/32 | 0.28125 | | 25/32 | 0.78125 |
| | 19/64 | 0.296875 | | 51/64 | 0.796875 |
| 5/16 | | 0.3125 | 13/16 | | 0.8125 |
| | 21/64 | 0.328125 | | 53/64 | 0.828125 |
| | 11/32 | 0.34375 | | 27/32 | 0.84375 |
| | 23/64 | 0.359375 | | 55/64 | 0.859375 |
| 3/8 | | 0.375 | 7/8 | | 0.875 |
| | 25/64 | 0.390625 | | 57/64 | 0.890625 |
| | 13/32 | 0.40625 | | 29/32 | 0.90625 |
| | 27/64 | 0.421875 | | 59/64 | 0.921875 |
| 7/16 | | 0.4375 | 15/16 | | 0.9375 |
| | 29/64 | 0.453125 | | 61/64 | 0.953125 |
| | 15/32 | 0.46875 | | 31/32 | 0.96875 |
| | 31/64 | 0.484375 | | 63/64 | 0.984375 |
| 1/2 | | 0.5 | 1 | | 1. |

Intro

LADDER

I-BEAM

HAT

TROF

CHANNEL

COPE-GLAS™

WIREBASKET

Reference

INDEX

LADDER - PART NUMBER INDEX

| Part Number..... | Page | Part Number..... | Page | Part Number..... | Page |
|------------------|------|------------------|------|------------------|-------|
| 06BE..... | 44 | 9131-HDW..... | 47 | P200..... | 50 |
| 06CB..... | 44 | 9131-IP..... | 47 | PC..... | 43 |
| 06DO..... | 44 | 9131L..... | 47 | PF..... | 42 |
| 06SL..... | 42 | 9131..... | 47 | PH..... | 42 |
| 09BE..... | 44 | 9132..... | 47 | PS..... | 42 |
| 09CB..... | 44 | 9133..... | 47 | PS 135X..... | 43 |
| 09DO..... | 44 | 9156..... | 44 | PS 146..... | 41 |
| 09SL..... | 42 | 9F..... | 26 | PS 209..... | 41 |
| 12BE..... | 44 | 9I..... | 37 | PS 211..... | 41 |
| 12CB..... | 44 | 90..... | 37 | PS 230..... | 41 |
| 12DO..... | 44 | AF..... | 36 | PS 6024..... | 41 |
| 12SL..... | 42 | BE..... | 44 | PS 6072..... | 41 |
| 18BE..... | 44 | BSP..... | 46 | PS 6108..... | 41 |
| 18CB..... | 44 | BSP-L..... | 46 | PS 651-12..... | 48 |
| 18DO..... | 44 | CA..... | 40 | PS 651-15..... | 48 |
| 18SL..... | 42 | CB..... | 44 | PS 651-18..... | 48 |
| 24BE..... | 44 | CBJ..... | 44 | PS 651-24..... | 48 |
| 24CB..... | 44 | CBJ-250C..... | 80 | PS 651-30..... | 48 |
| 24DO..... | 44 | CBJ-4C..... | 80 | PS 651-36..... | 48 |
| 24SL..... | 42 | CBJ-C..... | 80 | PS 651-6..... | 48 |
| 30BE..... | 44 | CC..... | 43 | PS 809-12..... | 48 |
| 30CB..... | 44 | CCB-050..... | 45 | PS 809-15..... | 48 |
| 30DO..... | 44 | CCB-075..... | 45 | PS 809-18..... | 48 |
| 30S..... | 42 | CCB-100..... | 45 | PS 809-24..... | 48 |
| 36BE..... | 44 | CCB-125..... | 45 | PS 809-30..... | 48 |
| 36CB..... | 44 | CCB-150..... | 45 | PS 809-36..... | 48 |
| 36DO..... | 44 | CCB-175..... | 45 | PS 809-42..... | 48 |
| 36SL..... | 42 | CCB-200..... | 45 | PS 83..... | 41 |
| 3F..... | 27 | CCS-SS..... | 42 | PS 838R-10..... | 48 |
| 3I..... | 37 | CE..... | 40 | PS 838R-12..... | 48 |
| 3O..... | 38 | CE-MID..... | 40 | PS 838R-16..... | 48 |
| 4F..... | 27 | CH..... | 40 | PS 838R-18..... | 48 |
| 4I..... | 38 | CO..... | 40 | PS 838R-24..... | 48 |
| 4O..... | 38 | CV..... | 40 | PS 838R-30..... | 48 |
| 58-02CE-MID..... | 40 | DC..... | 43 | PS 838R-6..... | 48 |
| 58-02RC-MID..... | 40 | DO..... | 44 | PS 838R-8..... | 48 |
| 6-9053..... | 47 | EM..... | 41 | PS PP..... | 41 |
| 6F..... | 26 | EM-CC..... | 43 | PV..... | 42 |
| 6I..... | 37 | EM-CC-SS..... | 43 | RC..... | 40 |
| 6O..... | 37 | FB..... | 108 | RH..... | 34 |
| 8-9053..... | 47 | FC..... | 29 | RY..... | 36 |
| 9025-98..... | 48 | FL..... | 42 | SB..... | 46 |
| 9036-31..... | 49 | FS..... | 42 | SB-HDW..... | 46 |
| 9036-37..... | 49 | FT..... | 28 | SR..... | 39 |
| 9036-45..... | 49 | HS..... | 42 | ST..... | 35 |
| 9037-12..... | 49 | HV..... | 42 | T200E..... | 50 |
| 9037-18..... | 49 | IB..... | 46 | T201E..... | 50 |
| 9037-24..... | 49 | JP-06..... | 42 | TB6209..... | 45 |
| 9037-30..... | 49 | JP-09..... | 42 | TB6210..... | 45 |
| 9037-36..... | 49 | JP-12..... | 42 | TB6211..... | 45 |
| 9037-42..... | 49 | JP-120..... | 42 | TB6214..... | 45 |
| 9038..... | 49 | JP-18..... | 42 | TB6216..... | 45 |
| 9043..... | 48 | JP-24..... | 42 | TB6218..... | 45 |
| 9043-37..... | 48 | JP-30..... | 42 | TC..... | 32-33 |
| 9053..... | 47 | JP-36..... | 42 | TT..... | 30-31 |
| 9056-EP..... | 44 | LH..... | 34 | VC..... | 43 |
| 9056-SS..... | 44 | LY..... | 36 | VT..... | 39 |
| 9057-EP..... | 44 | NF..... | 42 | | |
| 9057-SS..... | 44 | NL..... | 42 | | |
| 9131A..... | 47 | OB..... | 46 | | |
| 9131-DC..... | 47 | OT..... | 39 | | |

LADDER - KEYWORD INDEX

| Description..... | Page | Description..... | Page |
|---|-------|--|-------|
| 30° Horizontal Elbow (3F) | 27 | Overview | 19 |
| 30° Vertical Elbow Inside | 38 | Peak Cover Connector..... | 43 |
| 30° Vertical Elbow Outside..... | 38 | Reducing Connector..... | 40 |
| 45° Horizontal Elbow (4F) | 27 | Right Hand Reducer | 34 |
| 45° Vertical Elbow Inside | 38 | Rod Coupler..... | 50 |
| 45° Vertical Elbow Outside..... | 38 | Seismic Hold-Down | 47 |
| 45° Y Branch Left Hand | 36 | Single Ladder Hangers..... | 49 |
| 45° Y Branch Right Hand | 36 | Single Rod Hanger Support..... | 50 |
| 45° Y System..... | 48 | Split-Lock Washers..... | 41 |
| 60° Horizontal..... | 41 | Stainless Steel Cover Clip | 42 |
| 60° Vertical Elbow Inside | 37 | Straight Length (SL)..... | 21 |
| 60° Vertical Elbow Outside..... | 37 | Straight Reducer..... | 35 |
| 60° Vertical Support..... | 48 | Structural Support Bracket..... | 49 |
| 90° Angle Connector..... | 40 | Support Brackets | 49 |
| 90° Vertical Cable Support Elbow..... | 39 | Supports..... | 48-50 |
| 90° Vertical Elbow Inside | 37 | Tray Connectors | 40 |
| 90° Vertical Outside | 37 | Tray Hanger | 50 |
| Adjustable Elbow | 36 | Tray Hanger & Supports | 50 |
| Barrier Strip - Straight | 49 | Universal Aluminum Barrier Strip - Straight Section..... | 46 |
| Barrier Strip Clamp | 46 | Universal Curvilinear Connector | 40 |
| Barrier Strip Vertical Elbow Inside | 46 | Vertical Adjustable Connector..... | 40 |
| Barrier Strip Vertical Elbow outside | 46 | Vertical Tee-Down..... | 39 |
| Barrier Strips | 49 | Vertical Tee-Up | 36 |
| Blind End | 44 | | |
| Bonding Jumper | 44 | | |
| Box Connector | 44 | | |
| Cable Tray Grounding Clamp | 44 | | |
| Combination Hold-Down Clamp | 47 | | |
| Combination Hold-Down Expansion Guide | 47 | | |
| Conduit-to-Cable Tray Clamp Swivel Type | 45 | | |
| Connector Plates..... | 41 | | |
| Cope Swage | 49 | | |
| Cover Accessories..... | 43 | | |
| Cover Connector | 43 | | |
| Cover Screw | 41 | | |
| Covers | 42 | | |
| CSA System..... | 49 | | |
| Double Clamp Connector (W) | 43 | | |
| Drop Out..... | 44 | | |
| Electrical Grounding Chart | 51 | | |
| Electro-Galv Steel Cover Clip..... | 43 | | |
| Elevated Cover Connectors | 43 | | |
| Expansion Connector | 40 | | |
| Fender Washers..... | 41 | | |
| Flat Washers..... | 41 | | |
| Hardware..... | 41 | | |
| Horizontal Adjustable Connector..... | 40 | | |
| Horizontal Cross..... | 29 | | |
| Horizontal Tapped Cross..... | 32-33 | | |
| Horizontal Tapped Tee | 30-31 | | |
| Horizontal Tee | 27 | | |
| How To | 23 | | |
| Isolation Pad | 47 | | |
| Left Hand Reducer | 34 | | |
| Mid-Span Expansion Plate | 40 | | |
| Mid-Span Splice Plate..... | 40 | | |
| Nylon Barrier..... | 46 | | |
| Ordering information..... | 20 | | |

Intro

LADDER

I-BEAM

HAT

TROF

CHANNEL

COPE-GLAS™

WIREBASKET

Reference

INDEX

I-BEAM - PART NUMBER INDEX

| Part Number..... | Page | Part Number..... | Page | Part Number..... | Page |
|------------------|------|-------------------|------|-------------------|------|
| 01CO..... | 74 | 9037-12..... | 84 | OT..... | 73 |
| 01FB-06..... | 82 | 9037-18..... | 84 | PC..... | 79 |
| 01SB-10..... | 82 | 9037-24..... | 84 | PF..... | 78 |
| 01SB-12..... | 82 | 9037-30..... | 84 | PFHA..... | 78 |
| 02CA..... | 74 | 9037-36..... | 84 | PP..... | 79 |
| 02CE..... | 74 | 9037-42..... | 84 | PPHA..... | 78 |
| 02CH..... | 74 | 9053..... | 76 | PS 135..... | 77 |
| 02CV..... | 74 | 9056-EP..... | 80 | PS 135X..... | 79 |
| 02RC..... | 74 | 9056-SS..... | 80 | PS 146..... | 77 |
| 03CO..... | 74 | 9057-EP..... | 80 | PS 209..... | 77 |
| 04CO..... | 74 | 9057-SS..... | 80 | PS 211..... | 77 |
| 06BE..... | 80 | 9131A..... | 76 | PS 230..... | 77 |
| 06CB..... | 80 | 9131A-HDW..... | 76 | PS 6024..... | 77 |
| 06CO..... | 74 | 9131-IP..... | 76 | PS 6072..... | 77 |
| 06DO..... | 80 | 9131L..... | 76 | PS 6108..... | 77 |
| 06SL..... | 78 | 9132..... | 76 | PS 651..... | 83 |
| 07CO..... | 74 | 9132..... | 76 | PS 809..... | 83 |
| 09BE..... | 80 | 9133..... | 76 | PS 83..... | 77 |
| 09CB..... | 80 | 9156..... | 80 | PS 838R..... | 83 |
| 09CO..... | 74 | 9F..... | 59 | PS MU..... | 81 |
| 09DO..... | 80 | 9I..... | 69 | PS MU-1..... | 81 |
| 09SL..... | 78 | 90..... | 69 | PS MU-1/2..... | 81 |
| 10CO..... | 74 | BE..... | 80 | PS MU-1/4..... | 81 |
| 12BE..... | 80 | BPC..... | 75 | PS MU-1-1/2..... | 81 |
| 12CB..... | 80 | BSP-L..... | 82 | PS MU-1-1/4..... | 81 |
| 12CO..... | 74 | CA..... | 76 | PS MU-2..... | 81 |
| 12DO..... | 80 | CB..... | 80 | PS MU-2-1/2..... | 81 |
| 12SL..... | 78 | CBJ..... | 80 | PS MU-3..... | 81 |
| 13CO..... | 74 | CBJ-250C..... | 80 | PS MU-3/4..... | 81 |
| 15CO..... | 74 | CBJ-4C..... | 80 | PS MU-38..... | 81 |
| 18BE..... | 80 | CBJ-C..... | 80 | PS MU-3-1/2..... | 81 |
| 18CB..... | 80 | CCB..... | 81 | PS MU-4..... | 81 |
| 18CO..... | 74 | CE..... | 74 | PS PP..... | 84 |
| 18DO..... | 80 | CH..... | 74 | PS-MPDS-13HG..... | 84 |
| 18SL..... | 78 | CO..... | 74 | PS-MPDS-16HG..... | 84 |
| 21CO..... | 74 | CV..... | 75 | PS-MPDS-22HG..... | 84 |
| 24BE..... | 80 | DC..... | 79 | PS-MPDS-28HG..... | 84 |
| 24CB..... | 80 | DO..... | 80 | PS-MPDS-34HG..... | 84 |
| 24CO..... | 74 | EM..... | 77 | PS-MPDS-40HG..... | 84 |
| 24DO..... | 80 | EM-CC..... | 79 | PS-SPSS-10HG..... | 84 |
| 24SL..... | 78 | EM-CC-SS..... | 77 | RC..... | 74 |
| 27CO..... | 74 | FB..... | 82 | RH..... | 67 |
| 30BE..... | 80 | FC..... | 65 | RY..... | 68 |
| 30CB..... | 80 | FL..... | 78 | SB..... | 82 |
| 30CO..... | 74 | FLHA..... | 78 | SR..... | 73 |
| 30DO..... | 80 | FS..... | 78 | SS89042..... | 81 |
| 30SL..... | 78 | FS..... | 78 | ST..... | 67 |
| 36BE..... | 80 | FSHA..... | 78 | T200E..... | 85 |
| 36CB..... | 80 | FT..... | 63 | T201E..... | 85 |
| 36DO..... | 80 | H6A-02RC-MID..... | 74 | TB..... | 81 |
| 36SL..... | 78 | H7A-02RC-MID..... | 74 | TB6209..... | 81 |
| 3F..... | 62 | H-9043..... | 75 | TB6211..... | 81 |
| 3I..... | 72 | HDHDB..... | 75 | TB6214..... | 81 |
| 30..... | 72 | IB..... | 82 | TB6216..... | 81 |
| 4F..... | 61 | JP-06..... | 78 | TB6218..... | 81 |
| 4I..... | 71 | JP-09..... | 78 | TC..... | 66 |
| 40..... | 71 | JP-12..... | 78 | TT..... | 64 |
| 5003-1..... | 77 | JP-120..... | 78 | VH..... | 75 |
| 5003-2-S1..... | 77 | JP-18..... | 78 | VT..... | 73 |
| 5009-1..... | 77 | JP-24..... | 78 | | |
| 5009-2-S1..... | 77 | JP-30..... | 78 | | |
| 50172..... | 82 | JP-36..... | 78 | | |
| 6F..... | 60 | LH..... | 67 | | |
| 6I..... | 70 | LY..... | 68 | | |
| 60..... | 70 | NF..... | 78 | | |
| 8-9053..... | 76 | NFHA..... | 78 | | |
| 9036-31..... | 84 | NL..... | 78 | | |
| 9036-37..... | 84 | NLHA..... | 78 | | |
| 9036-45..... | 84 | OB..... | 82 | | |

I-BEAM - KEYWORD INDEX

| Description..... | Page | Description..... | Page |
|--|------|--|-------|
| (GRC, EMT & IMC) and Tubing Clamps [PS MU]..... | 81 | Horizontal Cross [FC] | 65 |
| 30° Horizontal Elbow [3F] | 62 | Horizontal Tapped Cross [TC] | 66 |
| 30° Vertical Elbow Inside [3I] | 72 | Horizontal Tapped Tee [TT] | 64 |
| 30° Vertical Elbow Outside [3O] | 72 | Horizontal Tee [FT] | 63 |
| 45° "Y" Branch Left Hand [LY] | 68 | How to Order | 58 |
| 45° "Y" Branch Right Hand [RY]..... | 68 | I-Beam™ Fittings | 58 |
| 45° Horizontal Elbow [4F] | 61 | Isolation Pad [9131-IP]..... | 76 |
| 45° Vertical Elbow Inside [4I] | 71 | Joint Plate | 78 |
| 45° Vertical Elbow Outside [4O] | 71 | Left Hand Reducer [LH]..... | 67 |
| 60° Horizontal Elbow [6F] | 60 | Material / Finish | 56 |
| 60° Vertical Elbow Inside [6I] | 70 | Mid-Span Splice Plate [RC] | 74 |
| 60° Vertical Elbow Outside [6O] | 70 | Mustang Universal One-Piece Pipe, Conduit..... | 81 |
| 90° Horizontal Elbow [9F] | 59 | Nylon Barrier Splice & Protector [BSP-L] | 82 |
| 90° Vertical Cable Support Elbow [SR] | 72 | Ordering Information | 58 |
| 90° Vertical Elbow Inside [9I] | 69 | Peak Cover Connector [PC] | 79 |
| 90° Vertical Elbow Outside [9O] | 69 | Peak Pitch Cover Connector [PP]..... | 79 |
| Barrier Strip - Horizontal Fitting [FB] | 82 | Power-Pier Rooftop Support System | 84 |
| Barrier Strip Clamp (Optional) [50172] | 82 | Reducing Connector [CO] | 74 |
| Barrier Strip Vertical Elbow Outside [OB] & Inside [IB]..... | 82 | Right Hand Reducer [RH] | 67 |
| Barrier Strips | 82 | Rod Coupler [PS 135]..... | 77 |
| Blind End [BE]..... | 80 | Selection Chart | 56 |
| Bonding Jumper [CBJ]..... | 80 | Single Rod Hanger Support..... | 85 |
| Box Connector [CB]..... | 80 | Specification Aluminum Cope I-Beam System | 86 |
| Box Splice Plate [CA] | 76 | Split-Lock Washers [PS 211]..... | 77 |
| Cable Tray Ground Clamp [9156]..... | 80 | Square Nuts [PS 6108] | 77 |
| Channel-Type Supports..... | 83 | Standard Duty..... | 83 |
| Combination Hold-Down / Expansion Guide [9053] | 76 | Straight Length..... | 58 |
| Combination Hold-Down Clamp & Expansion Guide [9131A] | 76 | Straight Reducer [ST]..... | 67 |
| Conduit Clamp Bracket [CCB]..... | 81 | Structural Support Bracket..... | 84 |
| Conduit-to-Cable Tray Clamp Swivel Type [TB] | 81 | Support Brackets & Tray Hangers..... | 84 |
| Connector Hardware | 77 | Supports | 83-84 |
| Connector Plates..... | 74 | Trapeze Hanger Support..... | 85 |
| Continuous Threaded Rod [PS 146]..... | 77 | Tray Connectors | 74 |
| Cover Accessories..... | 79 | Tray Hanger & Supports | 85 |
| Cover Screw [EM] | 77 | Typical Specifications | 86 |
| Covers | 78 | Universal Aluminum Barrier Strip - Straight Section [SB] | 82 |
| Cross Connection Bracket [CCB] | 81 | Universal Connector [RC] | 74 |
| Double Channel-Type Supports | 83 | Vertical Adj Branch Pivot Connector [BPC] | 75 |
| Double Clamp Connector [DC]..... | 79 | Vertical Adjustable Connector [CV] | 75 |
| Drop Out [DO] | 80 | Vertical Hanger Splice Plate [VH]..... | 75 |
| Electrical Grounding Chart | 86 | Vertical Tee - Down (VT)..... | 73 |
| Electro-Galv Steel Cover Clip [PS 135X] | 79 | Vertical Tee - UP (OT) | 73 |
| Elevated Cover Connectors [EM-CC]..... | 79 | Vertical Tee Down [VT] & Up [OT] | 73 |
| Expansion Connector [CE] | 74 | Wall Penetrating Sleeve Assembly..... | 81 |
| Fender Washers [PS 230]..... | 77 | Wall Support Brackets..... | 84 |
| Flat Washers [PS 209]..... | 77 | | |
| Ground Cable Retainer Clamp | 80 | | |
| Gusset-Type Supports..... | 83 | | |
| Hardware | 77 | | |
| Heavy Duty | 75 | | |
| Heavy Duty Hold Down Bracket [HDHDB] | 75 | | |
| Hex Head Cap Screw / Round Head, Slotted Cap Screw [PS 6024] | 77 | | |
| Hex Nuts [PS 83]..... | 77 | | |
| Hold-Down [9132] | 76 | | |
| Horizontal Adjustable Connector [CH] | 74 | | |

Intro

LADDER

I-BEAM

HAT

TROF

CHANNEL

COPE-GLAS™

WIREBASKET

Reference

INDEX

HAT - PART NUMBER INDEX

| Part Number..... | Page | Part Number..... | Page | Part Number..... | Page |
|------------------|------|------------------|------|------------------|---------|
| SL..... | 97 | PS 6072 | 111 | CBJ-4C..... | 114 |
| 6F..... | 98 | PS 6108 | 111 | CBJ-C..... | 114 |
| 9F..... | 98 | PS 83 | 111 | DO..... | 114 |
| 3F..... | 99 | FL..... | 112 | CCB-050..... | 115 |
| 4F..... | 99 | FS..... | 112 | CCB-075..... | 115 |
| FT..... | 100 | HS..... | 112 | CCB-100..... | 115 |
| FC..... | 101 | HV..... | 112 | CCB-125..... | 115 |
| TT..... | 102 | JP-06 | 112 | CCB-150..... | 115 |
| LH..... | 105 | JP-09 | 112 | CCB-175..... | 115 |
| RH..... | 105 | JP-12 | 112 | CCB-200..... | 115 |
| ST..... | 105 | JP-120 | 112 | TB6209 | 115 |
| AF..... | 106 | JP-18 | 112 | TB6210 | 115 |
| LY..... | 106 | JP-24 | 112 | TB6211 | 115 |
| RY..... | 106 | JP-30 | 112 | TB6214 | 115 |
| 6I..... | 107 | JP-36 | 112 | TB6216 | 115 |
| 6O..... | 107 | NF..... | 112 | TB6218 | 115 |
| 9I..... | 107 | NL..... | 112 | 01FB-06 | 116 |
| 9O..... | 107 | PF..... | 112 | 01SB-12..... | 116 |
| 3I..... | 108 | PH..... | 112 | 09BE | 114 |
| 3O..... | 108 | PS..... | 112 | 09CB | 114 |
| 4I..... | 108 | PV..... | 112 | 50172..... | 117 |
| 4O..... | 108 | [(W) DC]..... | 113 | BSP..... | 116 |
| SR..... | 109 | 01CC..... | 113 | BSP-L..... | 116 |
| VT..... | 109 | 01-CC..... | 113 | FB..... | 116 |
| 01CO..... | 110 | CC..... | 113 | IB..... | 116 |
| 02CA..... | 110 | DC..... | 113 | OB..... | 116 |
| 02CE..... | 110 | EM..... | 111 | SB..... | 116 |
| 02CH..... | 110 | EM-CC..... | 113 | 9039..... | 117 |
| 02CV..... | 110 | EM-CC-SS | 111 | 9040..... | 117 |
| 02RC..... | 110 | PC..... | 113 | 9041..... | 117 |
| 03CO..... | 110 | VC..... | 113 | 9042..... | 117 |
| 04CO..... | 110 | 06BE..... | 114 | 9132..... | 117 |
| 06CO..... | 110 | 06CB..... | 114 | 9133..... | 117 |
| 07CO..... | 110 | 06DO..... | 114 | 9025-98..... | 119 |
| 09CO..... | 110 | 09DO..... | 114 | 9043..... | 119 |
| 10CO..... | 110 | 12BE..... | 114 | 9043-37 | 119 |
| 12CO..... | 110 | 12CB..... | 114 | PS 651 | 118 |
| 13CO..... | 110 | 12DO..... | 114 | PS 809 | 118 |
| 15CO..... | 110 | 18BE..... | 114 | PS 838R | 118 |
| 18CO..... | 110 | 18CB..... | 114 | 9036-31 | 118 |
| 21CO..... | 110 | 18DO..... | 114 | 9036-37 | 118 |
| 24CO..... | 110 | 24BE..... | 114 | 9036-45..... | 118 |
| 27CO..... | 110 | 24CB..... | 114 | 9037-12..... | 118 |
| 30CO..... | 110 | 24DO..... | 114 | 9037-18..... | 118 |
| CA..... | 110 | 30BE..... | 114 | 9037-24..... | 118 |
| CE..... | 110 | 30CB..... | 114 | 9037-30..... | 118 |
| CH..... | 110 | 30DO..... | 114 | 9037-36..... | 118 |
| CO..... | 110 | 36BE..... | 114 | 9037-42 | 118 |
| CV..... | 110 | 36CB..... | 114 | T200E..... | 119 |
| RC..... | 110 | 36DO..... | 114 | T201E..... | 119 |
| 5003..... | 111 | 9056-EP..... | 114 | TC..... | 103-104 |
| 5003-1..... | 111 | 9056-SS..... | 114 | OT..... | 109 |
| 5009-1..... | 111 | 9057-EP | 114 | | |
| PS 135 | 111 | 9057-SS..... | 114 | | |
| PS 146 | 111 | 9156..... | 114 | | |
| PS 209 | 111 | BE..... | 114 | | |
| PS 211 | 111 | CB..... | 114 | | |
| PS 230 | 111 | CBJ..... | 114 | | |
| PS 6024 | 111 | CBJ-250C..... | 114 | | |

HAT - KEYWORD INDEX

| Description..... | Page | Description..... | Page |
|---|------|--|---------|
| Slotted Rungs | 94 | Square Nuts [PS 6108] | 111 |
| Solid Rungs | 94 | Covers | 112 |
| Ordering information..... | 95 | Joint Plate | 112 |
| Straight Length [SL]..... | 97 | Cover Accessories..... | 113 |
| 60° Horizontal Elbow [6F] | 98 | Cover Connector [CC]..... | 113 |
| 90° Horizontal Elbow [9F] | 98 | Double Clamp Connector [(W) DC]..... | 113 |
| 30° Horizontal Elbow [3F] | 99 | Elevated Cover Connectors [EM-CC]..... | 113 |
| 45° Horizontal Elbow [4F] | 99 | Peak Cover Connector [PC, VC]..... | 113 |
| Horizontal Tee [FT] | 100 | Single Side Connector [01-CC]..... | 113 |
| Horizontal Cross [FC] | 101 | Blind End [BE]..... | 114 |
| Horizontal Tapped Tee [TT] | 102 | Bonding Jumper [CBJ] | 114 |
| Left Hand Reducer (LH)..... | 105 | Box Connector [CB]..... | 114 |
| Right Hand Reducer (RH)..... | 105 | Cable Tray Ground Clamp [9156]..... | 114 |
| Straight Reducer [ST]..... | 105 | Channel-Type Supports..... | 118 |
| 45° "Y" Branch Left [LY] | 106 | Drop Out [DO] | 114 |
| 45° "Y" Branch Right [RY]..... | 106 | Ground Cable Retainer Clamp | 114 |
| Adjustable Elbow [AF] | 106 | Conduit-to-Cable Tray Clamp | 115 |
| 60° Vertical Elbow Inside [6I] | 107 | Conduit-to-Cable Tray Clamp - Swivel Type..... | 115 |
| 60° Vertical Elbow Outside [6O] | 107 | Wall Penetrating Sleeve Assembly [SS89042(W)*]..... | 115 |
| 90° Vertical Elbow Inside [9I] | 107 | Barrier Strip Clamp (Optional) [50172] | 117 |
| 90° Vertical Elbow Outside [9O] | 107 | Barrier Strip Vertical Elbow Inside [IB] | 116 |
| INSIDE (6I) | 107 | Barrier Strip Vertical Elbow Outside [OB] | 116 |
| INSIDE (9I) | 107 | Barrier Strip—Horizontal Fitting [FB] | 116 |
| OUTSIDE (6O)..... | 107 | Barrier Strips | 116 |
| OUTSIDE (9O)..... | 107 | Barrier Strip—Straight Section [SB]..... | 116 |
| 30° Vertical Elbow Inside [3I] | 108 | Nylon Barrier Splice & Protector [BSP-L] | 116 |
| 30° Vertical Elbow Outside [3O] | 108 | Universal Aluminum Barrier Strip - Straight Section [SB] | 116 |
| 45° Vertical Elbow Inside [4I] | 108 | Hold-Down [9132] | 117 |
| 45° Vertical Elbow Outside [4O] | 108 | Hold-Down Clamp & Expansion Guide..... | 117 |
| INSIDE (3I) | 108 | Isolation Pad [PVC-PAD] | 117 |
| INSIDE (4I) | 108 | Conduit Clamp Bracket | 115 |
| OUTSIDE (3O)..... | 108 | Gusset-Type Supports..... | 118 |
| OUTSIDE (4O)..... | 108 | Single Rod Hanger Support..... | 119 |
| 90° Vertical Cable Support Elbow (SR) | 109 | Structural Support Bracket..... | 118 |
| Vertical Tee - Down (VT)..... | 109 | Support Brackets | 118 |
| Vertical Tee - Up (OT) | 109 | Wall Support Brackets..... | 118 |
| 90° Angle Connectors [CA]..... | 110 | Trapeze Hanger Support..... | 119 |
| Expansion Connectors [CE] | 110 | Tray Hanger & Supports | 119 |
| Horizontal Adjustable Connectors [CH] | 110 | Selection Chart | 90-93 |
| Reducing Connector [CO]..... | 110 | Overview | 94 |
| Tray Connectors..... | 110 | Horizontal Tapped Cross [TC] | 103-104 |
| Universal Curvilinear Connectors [RC] | 110 | | |
| Vertical Adjustable Connectors [CV]..... | 110 | | |
| Connector Hardware [5003]..... | 111 | | |
| Connector Plates..... | 111 | | |
| Continuous Threaded Rod [PS 146]..... | 111 | | |
| Cover Screw [EM] | 111 | | |
| Fender Washers [PS 230]..... | 111 | | |
| Flat Washers [PS 209]..... | 111 | | |
| Hardware..... | 111 | | |
| Hex Head Cap Screw [PS 6024] | 111 | | |
| Hex Nuts [PS 83]..... | 111 | | |
| Rod Coupler [PS 135]..... | 111 | | |
| Round Head, Slotted Cap Screw [PS 6072] | 111 | | |
| Split-Lock Washers [PS 211]..... | 111 | | |

Intro

LADDER

I-BEAM

HAT

TROF

CHANNEL

COPE-GLAS™

WIREBASKET

Reference

INDEX

TROF - PART NUMBER INDEX

| Part Number..... | Page | Part Number..... | Page | Part Number..... | Page |
|------------------|------|------------------|------|------------------|---------|
| 5003..... | 146 | 40..... | 143 | JP-06..... | 147 |
| 5009..... | 146 | 5003-1..... | 146 | JP-09..... | 147 |
| 9039..... | 152 | 5009-1..... | 146 | JP-12..... | 147 |
| 9040..... | 152 | 6F..... | 133 | JP-120..... | 147 |
| 9041..... | 152 | 6I..... | 142 | JP-18..... | 147 |
| 9042..... | 152 | 6O..... | 142 | JP-24..... | 147 |
| 9043..... | 154 | 9025-98..... | 154 | JP-30..... | 147 |
| 9132..... | 152 | 9036-31..... | 154 | JP-36..... | 147 |
| 9133..... | 152 | 9036-37..... | 154 | LH..... | 140 |
| 9156..... | 149 | 9036-45..... | 154 | LY..... | 141 |
| 50172..... | 152 | 9037-12..... | 153 | NF..... | 147 |
| 01CC..... | 148 | 9037-18..... | 153 | NL..... | 147 |
| 01CO..... | 145 | 9037-24..... | 153 | OB..... | 151 |
| 01FB-06..... | 151 | 9037-30..... | 153 | OT..... | 144 |
| 01SB-12..... | 151 | 9037-36..... | 153 | PC..... | 148 |
| 02CA..... | 145 | 9037-42..... | 153 | PF..... | 147 |
| 02CE..... | 145 | 9043-37..... | 154 | PH..... | 147 |
| 02CH..... | 145 | 9056-EP..... | 149 | PS..... | 147 |
| 02CV..... | 145 | 9056-SS..... | 149 | PS 135..... | 146 |
| 02RC..... | 145 | 9057-EP..... | 149 | PS 146..... | 146 |
| 03CO..... | 145 | 9057-SS..... | 149 | PS 209..... | 146 |
| 04CO..... | 145 | 9F..... | 133 | PS 211..... | 146 |
| 06BE..... | 149 | 9I..... | 142 | PS 230..... | 146 |
| 06CB..... | 149 | 9O..... | 142 | PS 6024..... | 146 |
| 06CO..... | 145 | AF..... | 141 | PS 6072..... | 146 |
| 06DO..... | 149 | BE..... | 149 | PS 6108..... | 146 |
| 07CO..... | 145 | BSP..... | 151 | PS 651..... | 153 |
| 09BE..... | 149 | BSP-L..... | 151 | PS 809..... | 153 |
| 09CB..... | 149 | CA..... | 145 | PS 83..... | 146 |
| 09CO..... | 145 | CB..... | 149 | PS 838R-10..... | 153 |
| 09DO..... | 149 | CBJ..... | 149 | PS 838R-12..... | 153 |
| 10CO..... | 145 | CBJ-250C..... | 149 | PS 838R-16..... | 153 |
| 12BE..... | 149 | CBJ-4C..... | 149 | PS 838R-18..... | 153 |
| 12CB..... | 149 | CBJ-C..... | 149 | PS 838R-24..... | 153 |
| 12CO..... | 145 | CC..... | 148 | PS 838R-30..... | 153 |
| 12DO..... | 149 | CCB-050..... | 150 | PS 838R-6..... | 153 |
| 13CO..... | 145 | CCB-075..... | 150 | PS 838R-8..... | 153 |
| 15CO..... | 145 | CCB-100..... | 150 | PV..... | 147 |
| 18BE..... | 149 | CCB-125..... | 150 | RC..... | 145 |
| 18CB..... | 149 | CCB-150..... | 150 | RH..... | 140 |
| 18CO..... | 145 | CCB-175..... | 150 | RY..... | 141 |
| 18DO..... | 149 | CCB-200..... | 150 | SB..... | 151 |
| 21CO..... | 145 | CE..... | 145 | SL..... | 132 |
| 24BE..... | 149 | CH..... | 145 | SR..... | 144 |
| 24CB..... | 149 | CO..... | 145 | ST..... | 140 |
| 24CO..... | 145 | CV..... | 145 | T200E..... | 155 |
| 24DO..... | 149 | DC..... | 148 | T201E..... | 155 |
| 27CO..... | 145 | DO..... | 149 | TB6209..... | 150 |
| 30BE..... | 149 | DOG-1..... | 152 | TB6210..... | 150 |
| 30CB..... | 149 | EM..... | 148 | TB6211..... | 150 |
| 30CO..... | 145 | EM-CC..... | 148 | TB6214..... | 150 |
| 30DO..... | 149 | EM-CC-SS..... | 151 | TB6216..... | 150 |
| 36BE..... | 149 | FB..... | 151 | TB6218..... | 150 |
| 36CB..... | 149 | FC..... | 135 | TC..... | 138-139 |
| 36DO..... | 145 | FL..... | 147 | TT..... | 136-137 |
| 3F..... | 134 | FS..... | 147 | VT..... | 144 |
| 3I..... | 143 | FT..... | 135 | | |
| 3O..... | 143 | HS..... | 147 | | |
| 4F..... | 134 | HV..... | 147 | | |
| 4I..... | 143 | IB..... | 151 | | |

TROF - KEYWORD INDEX

| Description..... | Page |
|--|---------|
| 30° Horizontal Elbow [3F] | 134 |
| 30° Vertical Elbow Inside [3I] | 143 |
| 30° Vertical Elbow Outside [3O] | 143 |
| 45° “Y” Branch Left [LY]..... | 141 |
| 45° “Y” Branch Right [RY]..... | 141 |
| 45° Horizontal Elbow [4F] | 134 |
| 45° Vertical Elbow Inside [4I] | 143 |
| 45° Vertical Elbow Outside [4O] | 143 |
| 60° Horizontal Elbow [6F] | 133 |
| 60° Vertical Elbow Inside [6I] | 142 |
| 60° Vertical Elbow Outside [6O] | 142 |
| 90° Angle Connector [CA] | 145 |
| 90° Horizontal Elbow [9F] | 133 |
| 90° Vertical Cable Support Elbow [SR] | 144 |
| 90° Vertical Elbow Inside [9I] | 142 |
| 90° Vertical Elbow Outside [9O] | 142 |
| Adjustable Elbow [AF] | 141 |
| Barrier Strip - Horizontal Fitting [FB] | 151 |
| Barrier Strip - Straight Section [SB]..... | 151 |
| Barrier Strip Clamp [50172] (optional) | 152 |
| Barrier Strip Vertical Elbow Inside [IB] | 151 |
| Barrier Strip Vertical Elbow Outside [OB] | 151 |
| Barrier Strips | 151 |
| Blind End [BE] | 149 |
| Bonding Jumper [CBJ]..... | 149 |
| Box Connector [CB]..... | 149 |
| Cable Tray Ground Clamp [9156]..... | 149 |
| Channel-Type Supports..... | 153 |
| Conduit Clamp Bracket | 150 |
| Conduit-to-Cable Tray Clamp | 150 |
| Connector Hardware Bolt [5003] | 146 |
| Connector Hardware Nut [5009]..... | 146 |
| Connectors | 145 |
| Continuous Threaded Rod [PS 146]..... | 146 |
| Cope CSA Standards C22-2 Cable Trof Ventilated & | 130 |
| Cover Accessories..... | 148 |
| Cover Connector [CC]..... | 148 |
| Cover Screw [EM] | 146 |
| Covers | 147 |
| CSA Ordering Information | 130 |
| CSA System Selection Chart..... | 131 |
| Double Clamp Connector (W) DC..... | 148 |
| Drop Out [DO] | 149 |
| Electrical Grounding Chart | 165 |
| Elevated Cover Connectors [EM-CC]..... | 148 |
| Expansion Connector [CE]..... | 145 |
| Fender Washers [PS 230]..... | 146 |
| Flat Washers [PS 209]..... | 146 |
| Ground Cable Retainer Clamp | 149 |
| Gusset-Type Supports..... | 153 |
| Hardware..... | 146 |
| Hex Head Cap Screw [PS 6024] | 146 |
| Hex Nuts [PS 83]..... | 146 |
| Hold-Down Clamp & Expansion Guide..... | 152 |
| Horizontal Adjustable Connectors [CH] | 145 |
| Horizontal Cross [FC] | 135 |
| Horizontal Tapped Cross [TC] | 138-139 |
| Horizontal Tapped Tee [TT] | 136-137 |
| Horizontal Tee [FT] | 135 |

| Description..... | Page |
|--|---------|
| How to Order | 129 |
| Inside [3I] | 143 |
| Inside [4I] | 143 |
| Inside [6I] | 142 |
| Inside [9I] | 142 |
| Isolation Pad [PVC-PAD] | 152 |
| Joint Plate | 147 |
| Left Hand Reducer [LH] | 140 |
| Nylon Barrier Splice & Protector [BSP-L] | 151 |
| Nylon Dropout Grommet [DOG-1] | 152 |
| Ordering Information | 129 |
| Outside [3O] | 143 |
| Outside [4O] | 143 |
| Outside [6O] | 142 |
| Outside [9O] | 142 |
| Overview | 128 |
| Peak Cover Connector [PC, VC]..... | 148 |
| Reducing Connector [CO] | 145 |
| Right Hand Reducer [RH] | 140 |
| Rod Coupler [PS 135]..... | 146 |
| Round Head, Slotted Cap Screw [PS 6072] | 146 |
| Seismic Hold-Down [9132] | 152 |
| Selection Chart: | 124-127 |
| Single Rod Hanger Support..... | 154 |
| Single Side Connector [01CC] | 148 |
| Solid Bottom Type..... | 129 |
| Split-Lock Washers [PS 211]..... | 146 |
| Square Nuts [PS 6108] | 146 |
| Straight Length [SL] | 132 |
| Straight Reducer [ST]..... | 140 |
| Structural Support Bracket..... | 154 |
| Support Brackets..... | 153 |
| Trapeze Hanger Support..... | 155 |
| Tray Connectors..... | 145 |
| Tray Hanger & Supports | 154 |
| Universal Aluminum Barrier Strip - Straight Section [SB] | 151 |
| Universal Curvilinear Connector [RC] | 145 |
| Vertical Adjustable Connectors [CV]..... | 145 |
| Vertical Supports | 154 |
| Vertical Tee - DOWN (VT)..... | 144 |
| Vertical Tee - UP (OT) | 144 |
| Wall Penetrating Sleeve Assembly [SS89042W*] | 150 |
| Wall Support Brackets..... | 153 |

Intro

LADDER

I-BEAM

HAT

TROF

CHANNEL

COPE-GLAS™

WIREBASKET

Reference

INDEX

CHANNEL - PART NUMBER & KEYWORD INDEX

| Part Number..... | Page | Description..... | Page |
|------------------|------|---|---------|
| 9013..... | 168 | 30° Horizontal Elbow [3F] | 162 |
| 9014..... | 168 | 30° Vertical Inside Elbow [3I] | 164 |
| 9079..... | 167 | 30° Vertical Outside Elbow [3O] | 164 |
| 50174..... | 167 | 45° Horizontal Elbow [4F] | 161 |
| 70620..... | 167 | 45° Vertical Inside Elbow [4I] | 163 |
| 03BE | 166 | 45° Vertical Outside Elbow [4O] | 164 |
| 03CB | 166 | 60° Horizontal Elbow [6F] | 161 |
| 03CC | 167 | 60° Vertical Inside Elbow [6I] | 163 |
| 03CE | 166 | 60° Vertical Outside Elbow [6O] | 163 |
| 03CH | 167 | 90° Horizontal Elbow [9F] | 161 |
| 03CS | 166 | 90° Vertical Inside Elbow [9I] | 162 |
| 03CV | 167 | 90° Vertical Outside Elbow [9O] | 162 |
| 03DO | 166 | Accessories | 165-168 |
| 04BE | 166 | Adjustable Horizontal Connector [CH] | 167 |
| 04CB | 166 | Adjustable Riser Connector [CV] | 167 |
| 04CC | 167 | Blind End [BE]..... | 166 |
| 04CE | 166 | Channel Hangers | 168 |
| 04CH | 167 | Channel Holddown Clamp (Stainless Steel) [9079] | 167 |
| 04CS | 166 | Channel to Box or Wall Connector [CB]..... | 166 |
| 04CV | 167 | Cope Channel | 160 |
| 04DO | 166 | Cover Connector [CC]..... | 167 |
| 06BE | 166 | End Dropout [DO]..... | 166 |
| 06CB | 166 | Expansion Connector [CE]..... | 166 |
| 06CC | 167 | Fittings | 161-164 |
| 06CE | 166 | Hangers..... | 168 |
| 06CH | 167 | Horizontal Cross [FC] | 165 |
| 06CS | 166 | Horizontal Tee [FT] | 165 |
| 06CV | 167 | Interconnections | 167 |
| 06DO | 166 | Introduction | 160 |
| 3F..... | 162 | Nylon Dropout Grommet [DOG-1] | 166 |
| 3I..... | 164 | Ordering | 160 |
| 3O | 164 | Standard Connector [CS]..... | 166 |
| 4F..... | 161 | | |
| 4I..... | 163 | | |
| 4O | 164 | | |
| 6F..... | 161 | | |
| 6I..... | 163 | | |
| 6O | 163 | | |
| 9013-1 | 168 | | |
| 9014-1 | 168 | | |
| 9019-1 | 167 | | |
| 9019-2 | 167 | | |
| 9F..... | 161 | | |
| 9I..... | 162 | | |
| 9O | 162 | | |
| BE | 166 | | |
| CB | 166 | | |
| CC | 167 | | |
| CE | 166 | | |
| CH | 167 | | |
| CS | 166 | | |
| CV | 167 | | |
| DO | 166 | | |
| DOG-1 | 166 | | |
| FC..... | 165 | | |
| FT..... | 165 | | |

COPE-GLAS™ - PART NUMBER INDEX

| Part Number..... | Page | Part Number..... | Page | Part Number..... | Page |
|-----------------------------|------|-------------------|----------|-----------------------|------|
| 252075..... | 210 | 375PU-150..... | 204 | BE240620..... | 186 |
| 200-3827 thru 200-3843..... | 203 | 375PU-200..... | 204 | BE240910..... | 186 |
| 20P-1000..... | 203 | 375PU-250..... | 204 | BE240920..... | 186 |
| 20P-1200..... | 203 | 375PU-300..... | 204 | BE241210..... | 186 |
| 20P-2000..... | 203 | 375PU-CN..... | 204 | BE241220..... | 186 |
| 20P-2100..... | 203 | 375PU-CNJHD..... | 204 | BE300610..... | 186 |
| 20P-2200..... | 203 | 375PU-FN-000..... | 203 | BE300620..... | 186 |
| 20P-2500..... | 205 | 45H..... | 193 | BE300910..... | 186 |
| 20P-2502..... | 205 | 500PLJ-CN..... | 204 | BE300920..... | 186 |
| 20P-2504..... | 205 | 500PU-125..... | 204 | BE301210..... | 186 |
| 20P-2506..... | 205 | 500PU-200..... | 201, 204 | BE301220..... | 186 |
| 20P-2508..... | 205 | 500PU-250..... | 204 | BE360610..... | 186 |
| 20P-2510..... | 205 | 500PU-300..... | 204 | BE360620..... | 186 |
| 20P-2512..... | 205 | 500PU-CN..... | 201 | BE360910..... | 186 |
| 20P-2514..... | 205 | 500PU-CNHD..... | 204 | BE360920..... | 186 |
| 20P-2516..... | 205 | 500PU-FN-000..... | 203 | BE361210..... | 186 |
| 20P-2518..... | 205 | 50PU-2008..... | 206 | BE361220..... | 186 |
| 20P-2520..... | 205 | 50PU-2045..... | 206 | CC1..... | 201 |
| 20P-2522..... | 205 | 50PU-2090..... | 206 | CCE..... | 201 |
| 20P-2524..... | 205 | 50PU-2538..... | 206 | CCE06 thru CCE36..... | 201 |
| 20P-2526..... | 205 | 50PU-2611..... | 206 | CE..... | 187 |
| 20P-2528..... | 206 | 50PU-2611-SP..... | 206 | CE060610..... | 187 |
| 20P-2530..... | 206 | 50PU-2613..... | 206 | CE060620..... | 187 |
| 20P-2534..... | 206 | 50PU-2616..... | 205 | CE060910..... | 187 |
| 20P-2540..... | 206 | 50PU-2636..... | 206 | CE060920..... | 187 |
| 20P-2542..... | 206 | 50PU-2636A..... | 206 | CE061210..... | 187 |
| 20PU-5853..... | 206 | 50PU-2636B..... | 206 | CE061220..... | 187 |
| 20PU-5855..... | 206 | 50PU-2936..... | 206 | CE061810..... | 187 |
| 20PU-5903..... | 206 | 625PU-FN-000..... | 203 | CE061820..... | 187 |
| 20PU-5905..... | 206 | 750PU-FN-000..... | 203 | CE090610..... | 187 |
| 20V-1000..... | 203 | 90H..... | 193 | CE090620..... | 187 |
| 20V-1200..... | 203 | ADC1..... | 201 | CE090910..... | 187 |
| 20V-2000..... | 203 | BE..... | 186 | CE090920..... | 187 |
| 20V-2100..... | 203 | BE060610..... | 186 | CE091210..... | 187 |
| 20V-2200..... | 203 | BE060620..... | 186 | CE091220..... | 187 |
| 20V-2500..... | 205 | BE060910..... | 186 | CE091810..... | 187 |
| 20V-2502..... | 205 | BE060920..... | 186 | CE091820..... | 187 |
| 20V-2504..... | 205 | BE061210..... | 186 | CE120610..... | 187 |
| 20V-2506..... | 205 | BE061220..... | 186 | CE120620..... | 187 |
| 20V-2508..... | 205 | BE090610..... | 186 | CE120910..... | 187 |
| 20V-2510..... | 205 | BE090620..... | 186 | CE120920..... | 187 |
| 20V-2512..... | 205 | BE090910..... | 186 | CE121210..... | 187 |
| 20V-2514..... | 205 | BE090920..... | 186 | CE121220..... | 187 |
| 20V-2516..... | 205 | BE091210..... | 186 | CE121810..... | 187 |
| 20V-2518..... | 205 | BE091220..... | 186 | CE121820..... | 187 |
| 20V-2520..... | 205 | BE120610..... | 186 | CE180610..... | 187 |
| 20V-2522..... | 205 | BE120620..... | 186 | CE180620..... | 187 |
| 20V-2524..... | 205 | BE120910..... | 186 | CE180910..... | 187 |
| 20V-2526..... | 205 | BE120920..... | 186 | CE180920..... | 187 |
| 20V-2528..... | 206 | BE121210..... | 186 | CE181210..... | 187 |
| 20V-2530..... | 206 | BE121220..... | 186 | CE181220..... | 187 |
| 20V-2534..... | 206 | BE180610..... | 186 | CE181810..... | 187 |
| 20V-2540..... | 206 | BE180620..... | 186 | CE181820..... | 187 |
| 20V-2542..... | 206 | BE180910..... | 186 | CE240610..... | 187 |
| 300PU-100..... | 204 | BE180920..... | 186 | CE240620..... | 187 |
| 300PU-125..... | 204 | BE181210..... | 186 | CE240910..... | 187 |
| 300PU-150..... | 204 | BE181220..... | 186 | CE240920..... | 187 |
| 375PU-125..... | 204 | BE240610..... | 186 | CE241210..... | 187 |

Intro

LADDER

I-BEAM

HAT

TROF

CHANNEL

COPE-GLAS™

WIREBASKET

Reference

INDEX

COPE-GLAS™ - PART NUMBER INDEX (CONT.)

| Part Number..... | Page | Part Number..... | Page | Part Number..... | Page |
|--------------------------------------|------|----------------------|------|------------------|------|
| CE241220..... | 187 | CTC12, CTC12V..... | 188 | CZ301220..... | 187 |
| CE241810..... | 187 | CTC18, CTC18V..... | 188 | CZ301810..... | 187 |
| CE241820..... | 187 | CTC24, CTC24V..... | 188 | CZ301820..... | 187 |
| CE300610..... | 187 | CTC30, CTC30V..... | 188 | CZ360610..... | 187 |
| CE300620..... | 187 | CTC36, CTC36V..... | 188 | CZ360620..... | 187 |
| CE300910..... | 187 | CTCE06, CTCE06V..... | 188 | CZ360910..... | 187 |
| CE300920..... | 187 | CTCE09, CTCE09V..... | 188 | CZ360920..... | 187 |
| CE301210..... | 187 | CTCE12, CTCE12V..... | 188 | CZ361210..... | 187 |
| CE301220..... | 187 | CTCE18, CTCE18V..... | 188 | CZ361220..... | 187 |
| CE301810..... | 187 | CTCE24, CTCE24V..... | 188 | CZ361810..... | 187 |
| CE301820..... | 187 | CTCE30, CTCE30V..... | 188 | CZ361820..... | 187 |
| CE360610..... | 187 | CTCE36, CTCE36V..... | 188 | CZD..... | 187 |
| CE360620..... | 187 | CZ..... | 187 | CZD060610..... | 187 |
| CE360910..... | 187 | CZ060610..... | 187 | CZD060620..... | 187 |
| CE360920..... | 187 | CZ060620..... | 187 | CZD060910..... | 187 |
| CE361210..... | 187 | CZ060910..... | 187 | CZD060920..... | 187 |
| CE361220..... | 187 | CZ060920..... | 187 | CZD061210..... | 187 |
| CE361810..... | 187 | CZ061210..... | 187 | CZD061220..... | 187 |
| CE361820..... | 187 | CZ061220..... | 187 | CZD061810..... | 187 |
| CG-CCB-050 thru CG-CCB-400..... | 202 | CZ061810..... | 187 | CZD061820..... | 187 |
| CH2-10..... | 207 | CZ061820..... | 187 | CZD090610..... | 187 |
| CH2-SP..... | 210 | CZ090610..... | 187 | CZD090620..... | 187 |
| CH2-SPH22..... | 210 | CZ090620..... | 187 | CZD090910..... | 187 |
| CH2-SPH45..... | 210 | CZ090910..... | 187 | CZD090920..... | 187 |
| CH2-SPH90..... | 210 | CZ090920..... | 187 | CZD091210..... | 187 |
| CH2-SPV22..... | 210 | CZ091210..... | 187 | CZD091220..... | 187 |
| CH2-SPV45..... | 210 | CZ091220..... | 187 | CZD091810..... | 187 |
| CH2-SPV90..... | 210 | CZ091810..... | 187 | CZD091820..... | 187 |
| CH3-10..... | 207 | CZ091820..... | 187 | CZD120610..... | 187 |
| CH3-10P..... | 207 | CZ120610..... | 187 | CZD120620..... | 187 |
| CH3-SP..... | 207 | CZ120620..... | 187 | CZD120910..... | 187 |
| CH3-SPH22, CH3-SPH45, CH3-SPH90..... | 210 | CZ120910..... | 187 | CZD120920..... | 187 |
| CH3-SPV22, CH3-SPV45, CH3-SPV90..... | 210 | CZ120920..... | 187 | CZD121210..... | 187 |
| CH4-10, CH4-10P..... | 207 | CZ121210..... | 187 | CZD121220..... | 187 |
| CH4-HB90-24..... | 208 | CZ121220..... | 187 | CZD121810..... | 187 |
| CH4-HT..... | 209 | CZ121810..... | 187 | CZD121820..... | 187 |
| CH4-SP..... | 210 | CZ121820..... | 187 | CZD180610..... | 187 |
| CH4-SPH22, CH4-SPH45, CH4-SPH90..... | 210 | CZ180610..... | 187 | CZD180620..... | 187 |
| CH4-SPV22, CH4-SPV45, CH4-SPV90..... | 210 | CZ180620..... | 187 | CZD180910..... | 187 |
| CH4-VI90-24, CH4-VO90-24..... | 209 | CZ180910..... | 187 | CZD180920..... | 187 |
| CH4-X..... | 209 | CZ180920..... | 187 | CZD181210..... | 187 |
| CH6-10, CH6-10P..... | 207 | CZ181210..... | 187 | CZD181220..... | 187 |
| CH6-SP..... | 210 | CZ181220..... | 187 | CZD181810..... | 187 |
| CH6-SPH22, CH6-SPH45, CH6-SPH90..... | 210 | CZ181810..... | 187 | CZD181820..... | 187 |
| CH6-SPV22, CH6-SPV45, CH6-SPV90..... | 210 | CZ181820..... | 187 | CZD240610..... | 187 |
| CH8-10, CH8-10P..... | 208 | CZ240610..... | 187 | CZD240620..... | 187 |
| CH8-SP..... | 210 | CZ240620..... | 187 | CZD240910..... | 187 |
| CH8-SPH22, CH8-SPH45, CH8-SPH90..... | 210 | CZ240910..... | 187 | CZD240920..... | 187 |
| CH8-SPV22, CH8-SPV45, CH8-SPV90..... | 210 | CZ240920..... | 187 | CZD241210..... | 187 |
| CTB06A..... | 202 | CZ241210..... | 187 | CZD241220..... | 187 |
| CTB09A..... | 202 | CZ241220..... | 187 | CZD241810..... | 187 |
| CTB12A..... | 202 | CZ241810..... | 187 | CZD241820..... | 187 |
| CTB18A..... | 202 | CZ241820..... | 187 | CZD300610..... | 187 |
| CTB24A..... | 202 | CZ300610..... | 187 | CZD300620..... | 187 |
| CTB30A..... | 202 | CZ300620..... | 187 | CZD300910..... | 187 |
| CTB36A..... | 202 | CZ300910..... | 187 | CZD300920..... | 187 |
| CTC06, CTC06V..... | 188 | CZ300920..... | 187 | CZD301210..... | 187 |
| CTC09, CTC09V..... | 188 | CZ301210..... | 187 | CZD301220..... | 187 |

COPE-GLAS™ - PART NUMBER INDEX (CONT.)

| Part Number..... | Page | Part Number..... | Page | Part Number..... | Page |
|-----------------------|------|-------------------------------|------|-------------------------|----------|
| CZD301810..... | 187 | LC300910..... | 186 | RR3006..... | 197 |
| CZD301820..... | 187 | LC300912..... | 186 | RR3009..... | 197 |
| CZD360610..... | 187 | LC301210..... | 186 | RR3012..... | 197 |
| CZD360620..... | 187 | LC301212..... | 186 | RR3018..... | 197 |
| CZD360910..... | 187 | LC360610..... | 186 | RR3024..... | 197 |
| CZD360920..... | 187 | LC360612..... | 186 | RR3606..... | 197 |
| CZD361210..... | 187 | LC360910..... | 186 | RR3609..... | 197 |
| CZD361220..... | 187 | LC360912..... | 186 | RR3612..... | 197 |
| CZD361810..... | 187 | LC361210..... | 186 | RR3618..... | 197 |
| CZD361820..... | 187 | LC361212..... | 186 | RR3624..... | 197 |
| D006 thru D036..... | 202 | LES12..... | 199 | RR3630..... | 197 |
| EPE06 thru EPE36..... | 201 | LF400..... | 201 | RS..... | 197 |
| EPL06 thru EPL36..... | 201 | LH12..... | 200 | RS0906..... | 197 |
| EPZ07 thru EPZ36..... | 201 | LH22 5, LH45, LH90..... | 199 | RS1206..... | 197 |
| ES12..... | 199 | LS12..... | 199 | RS1209..... | 197 |
| F400..... | 201 | LV12, LV22 5, LV45, LV90..... | 200 | RS1806..... | 197 |
| FECNBSS..... | 200 | MONBW2..... | 200 | RS1809..... | 197 |
| H12..... | 200 | NDR1..... | 201 | RS1812..... | 197 |
| H22 5, H45, H90..... | 199 | PCR-050 hru PCR-600..... | 204 | RS2406..... | 197 |
| HAB..... | 194 | PTK06 thru PTK36..... | 188 | RS2409..... | 197 |
| HB..... | 208 | PTKE06 thru PTKE36..... | 188 | RS2412..... | 197 |
| HD4AB..... | 201 | RGBC-1 thru RGBC-3..... | 204 | RS2418..... | 197 |
| HDBLTNT..... | 201 | RGBS3 thru RGBS6..... | 201 | RS3006..... | 197 |
| HT..... | 209 | RGFH1..... | 202 | RS3009..... | 197 |
| LADC1..... | 201 | RGFH2..... | 202 | RS3012..... | 197 |
| LC..... | 186 | RL..... | 197 | RS3018..... | 197 |
| LC060610..... | 186 | RL0906..... | 197 | RS3024..... | 197 |
| LC060612..... | 186 | RL1206..... | 197 | RS3606..... | 197 |
| LC060910..... | 186 | RL1209..... | 197 | RS3609..... | 197 |
| LC060912..... | 186 | RL1806..... | 197 | RS3612..... | 197 |
| LC061210..... | 186 | RL1809..... | 197 | RS3618..... | 197 |
| LC061212..... | 186 | RL1812..... | 197 | RS3624..... | 197 |
| LC090610..... | 186 | RL2406..... | 197 | RS3630..... | 197 |
| LC090612..... | 186 | RL2409..... | 197 | S0200..... | 202 |
| LC090910..... | 186 | RL2412..... | 197 | S12..... | 199 |
| LC090912..... | 186 | RL2418..... | 197 | S12-MID..... | 199 |
| LC091210..... | 186 | RL3006..... | 197 | SBNBW2..... | 200 |
| LC091212..... | 186 | RL3009..... | 197 | SP..... | 210 |
| LC120610..... | 186 | RL3012..... | 197 | SPH..... | 210 |
| LC120612..... | 186 | RL3018..... | 197 | SPV..... | 210 |
| LC120910..... | 186 | RL3024..... | 197 | SSNBW2-316..... | 200 |
| LC120912..... | 186 | RL3606..... | 197 | T..... | 195 |
| LC121210..... | 186 | RL3609..... | 197 | UB-050 thru UB-400..... | 204 |
| LC121212..... | 186 | RL3612..... | 197 | V12, V22 5, V45..... | 200 |
| LC180610..... | 186 | RL3618..... | 197 | V45I, V450..... | 190 |
| LC180612..... | 186 | RL3624..... | 197 | V90..... | 189 |
| LC180910..... | 186 | RL3630..... | 197 | V90I, V900..... | 189 |
| LC180912..... | 186 | RR..... | 197 | VAB..... | 191 |
| LC181210..... | 186 | RR0906..... | 197 | VI, VO..... | 209 |
| LC181212..... | 186 | RR1206..... | 197 | VT..... | 192 |
| LC240610..... | 186 | RR1209..... | 197 | WR375 thru WR750..... | 203 |
| LC240612..... | 186 | RR1806..... | 197 | X..... | 196, 209 |
| LC240910..... | 186 | RR1809..... | 197 | | |
| LC240912..... | 186 | RR1812..... | 197 | | |
| LC241210..... | 186 | RR2406..... | 197 | | |
| LC241212..... | 186 | RR2409..... | 197 | | |
| LC300610..... | 186 | RR2412..... | 197 | | |
| LC300612..... | 186 | RR2418..... | 197 | | |

Intro

LADDER

I-BEAM

HAT

TROF

CHANNEL

COPE-GLAS™

WIREBASKET

Reference

INDEX

COPE-GLAS™ - KEYWORD INDEX

| Description..... | Page |
|---|---------|
| 0° thru 90° Vertical Adjustable Bends [VAB] | 191 |
| 45° Horizontal Bends [45H]..... | 193 |
| 45° Vertical Inside Bends [V45I] | 190 |
| 45° Vertical Outside Bends [V45O] | 190 |
| 90° Horizontal Bends [90H]..... | 193 |
| 90° Vertical Inside Bends [V90I] | 189 |
| 90° Vertical Outside Bends [V90O] | 189 |
| Accessories | 202 |
| Additional Related Products..... | 210 |
| Adjustable Divider Clamp | 201 |
| Adjustable Horizontal Splice Plates | 200 |
| Adjustable Vertical Splice Plates..... | 200 |
| Advantages of COPE-GLAS™ Cable Tray..... | 172-173 |
| Aickinstruct® Channel | 203 |
| Aickinstruct® Channel Nuts | 204 |
| Aickinstruct® Rod Couplers..... | 203 |
| Aickinstruct® Support Systems..... | 203-206 |
| All-Thread Hex Flange Nuts..... | 203 |
| All-Thread Washers..... | 203 |
| Application Environments..... | 178-179 |
| Barrier Strip | 201 |
| Cable Tray Hardware..... | 200 |
| Channel Capping Strip | 203 |
| Channel Fittings [CH] | 207 |
| Channel Splice Plate Hardware | 210 |
| Channel Splice Plates | 210 |
| Conduit to Cable Tray Clamp | 202 |
| Construction and Physical Properties | 176-177 |
| COPE-GLAS Cable Tray Covers | 188 |
| Cover Clamp [CC1] | 201 |
| Cover Clamp [CCE]..... | 201 |
| Cover Stand-Offs | 202 |
| Covers..... | 188 |
| Drop Outs | 202 |
| End Plates | 201 |
| Expansion Splice Plates | 199 |
| Fiberfast Bolts..... | 204 |
| Fiberglass All-Thread Rod | 203 |
| Fiberglass Bolt..... | 201 |
| Fiberglass Channel | 207-210 |
| Fittings | 188-198 |
| Fittings / Splice Plates..... | 198 |
| Fixed Angle Horizontal Splice Plates..... | 199 |
| Fixed Angle Vertical Splice Plates | 200 |
| Floor & Panel Flange..... | 201 |
| Hanger Rod Beam Clamps | 204 |
| Hold Down Package..... | 201 |
| Horizontal Adjustable Bends [HAB] | 194 |
| Horizontal Cross [X] | 209 |
| Horizontal Crossovers [X] | 196 |
| Horizontal Elbow Splice Plates [SPH]..... | 210 |
| Horizontal Elbows [HB]..... | 208 |
| Horizontal Tee [HT]..... | 209 |
| Horizontal Tees [T] | 195 |
| Inside Vertical Elbow [VI]..... | 209 |
| Installation Procedures..... | 181-186 |

| Description..... | Page |
|---|---------|
| K Rigid Pipe Clamps..... | 204 |
| Left Reducers | 197 |
| Marine Rung | 202 |
| Non-Metallic U-Bolts..... | 204 |
| Outside Vertical Elbow [VO] | 209 |
| Right & Left Reducers [RR] or [RL] | 197 |
| Right Reducers | 197 |
| Rivet [NDR1] | 201 |
| Selection Guide..... | 180 |
| Specifications | 175 |
| Splice Plates..... | 198-199 |
| Splice Plates & Hardware..... | 200 |
| Standards | 174 |
| Straight Reducers | 197 |
| Straight Reducers [RS]..... | 197 |
| Straight Sections | 186-187 |
| Straight Splice Plates..... | 199 |
| Straight Splice Plates [CHSP] | 210 |
| Structural Designs | 180 |
| Tray Covers and Accessories..... | 201 |
| Tray Flange Hanger | 202 |
| Type BE Straight Section - E Profile [BE] | 186 |
| Type CE Straight Section - E Profile [CE] | 187 |
| Type CZ Straight Section - Z Profile [CZ] | 187 |
| Type CZD Straight Section - Deep Z Profile [CZD]..... | 187 |
| Type LC Straight Section - C Profile* [LC]..... | 186 |
| Vertical Elbow Splice Plates [SPV] | 210 |
| Vertical Tees [VT] | 192 |
| Wall Support Brackets..... | 202 |

WIRE BASKET TRAY - PART NUMBER INDEX

| Part Number..... | Page | Part Number..... | Page | Part Number..... | Page |
|---------------------|------|----------------------|------|-------------------|------|
| BOTTOM-CLIP..... | 243 | CAT6-16SL-120..... | 219 | CAT-PED-06..... | 231 |
| CAT(H)-(W)BE..... | 233 | CAT6-18BE..... | 233 | CAT-PED-12..... | 231 |
| CAT(H)-(W)CB..... | 233 | CAT6-18SL-120..... | 219 | CAT-PED-KIT..... | 231 |
| CAT(H)-(W)WS..... | 235 | CAT6-20BE..... | 233 | CAT-PPA-(H)..... | 225 |
| CAT-(W)DO..... | 232 | CAT6-20SL-120..... | 219 | CAT-PPA-06..... | 225 |
| CAT-1x6-HC..... | 224 | CAT6-24BE..... | 233 | CAT-PPA-10..... | 225 |
| CAT2-(W)SL-120..... | 217 | CAT6-24SL-120..... | 219 | CAT-PPA-14..... | 225 |
| CAT2-01SB-120..... | 232 | CAT-AB-HSB..... | 229 | CAT-PPA-18..... | 225 |
| CAT2-02SL-120..... | 217 | CAT-AB-USB..... | 229 | CAT-PPA-22..... | 225 |
| CAT2-04..... | 237 | CAT-CB-HSB..... | 230 | CAT-PPA-26..... | 225 |
| CAT2-04BE..... | 233 | CAT-CB-MSB..... | 230 | CAT-SIDE-HC..... | 224 |
| CAT2-04SL-120..... | 217 | CAT-CB-USB..... | 228 | CAT-UNI-DO..... | 233 |
| CAT2-06..... | 237 | CAT-CCA-(W)..... | 225 | CAT-USB-120..... | 223 |
| CAT2-06BE..... | 233 | CAT-CCA-04..... | 225 | CAT-WC-2..... | 227 |
| CAT2-06SL-120..... | 217 | CAT-CCA-06..... | 225 | CAT-ZBAR-120..... | 226 |
| CAT2-08..... | 237 | CAT-CCA-08..... | 225 | CH1..... | 221 |
| CAT2-08BE..... | 233 | CAT-CCA-12..... | 225 | CH2..... | 222 |
| CAT2-08SL-120..... | 217 | CAT-CCA-16..... | 225 | CH3..... | 222 |
| CAT2-12..... | 237 | CAT-CMA-(W)..... | 230 | EG-CBN..... | 222 |
| CAT2-12BE..... | 233 | CAT-CMA-04..... | 230 | PS 146..... | 245 |
| CAT2-12SL-120..... | 217 | CAT-CMA-06..... | 230 | PS 209..... | 244 |
| CAT2-16..... | 237 | CAT-CMA-08..... | 230 | PS 211..... | 244 |
| CAT2-16BE..... | 233 | CAT-CMA-12..... | 230 | PS 6024..... | 244 |
| CAT2-16SL-120..... | 217 | CAT-CPA-(W)..... | 225 | PS 6072..... | 244 |
| CAT2-18..... | 237 | CAT-CPA-06..... | 225 | PS 6108..... | 244 |
| CAT2-18BE..... | 233 | CAT-CPA-08..... | 225 | PS 619..... | 245 |
| CAT2-18SL-120..... | 217 | CAT-CPA-12..... | 225 | PS 651-(L)..... | 228 |
| CAT2-20..... | 237 | CAT-CPA-16..... | 225 | PS 809-(L)..... | 228 |
| CAT2-20BE..... | 233 | CAT-CUT..... | 236 | PS 83..... | 244 |
| CAT2-20SL-120..... | 217 | CAT-CVR-(W)..... | 232 | PSRS-1/2..... | 245 |
| CAT2-24..... | 237 | CAT-CVR-02..... | 232 | PSRS-1/4..... | 245 |
| CAT2-24BE..... | 233 | CAT-CVR-04..... | 232 | PSRS-3/8..... | 245 |
| CAT2-24SL-120..... | 217 | CAT-CVR-06..... | 232 | Short-Clip..... | 245 |
| CAT-2x8-HC..... | 224 | CAT-CVR-08..... | 232 | SPLIT-BOLT..... | 242 |
| CAT4-(W)SL-120..... | 218 | CAT-CVR-12..... | 232 | T-BAR..... | 220 |
| CAT4-01SB-120..... | 232 | CAT-CVR-16..... | 232 | T-BAR-22..... | 220 |
| CAT4-04BE..... | 233 | CAT-CVR-18..... | 232 | Wide-Clip..... | 245 |
| CAT4-04SL-120..... | 218 | CAT-CVR-20..... | 232 | | |
| CAT4-08BE..... | 233 | CAT-CVR-24..... | 232 | | |
| CAT4-08SL-120..... | 218 | CAT-EBC..... | 234 | | |
| CAT4-12BE..... | 233 | CAT-EMT-.5-1.25..... | 234 | | |
| CAT4-12SL-120..... | 218 | CAT-GC..... | 242 | | |
| CAT4-16BE..... | 233 | CAT-HGR-2..... | 227 | | |
| CAT4-16SL-120..... | 218 | CAT-HGR-4..... | 227 | | |
| CAT4-18BE..... | 233 | CAT-HLT..... | 234 | | |
| CAT4-18SL-120..... | 218 | CAT-HSB-10..... | 229 | | |
| CAT4-20BE..... | 233 | CAT-HSB-120..... | 223 | | |
| CAT4-20SL-120..... | 218 | CAT-HWSB-(W)..... | 226 | | |
| CAT4-24BE..... | 233 | CAT-HWSB-08..... | 226 | | |
| CAT4-24SL-120..... | 218 | CAT-HWSB-12..... | 226 | | |
| CAT6-(W)SL-120..... | 219 | CAT-HWSB-18..... | 226 | | |
| CAT6-01SB-120..... | 232 | CAT-HWSB-20..... | 226 | | |
| CAT6-06BE..... | 233 | CAT-HWSB-24..... | 226 | | |
| CAT6-06SL-120..... | 219 | CAT-MSB-10..... | 229 | | |
| CAT6-08BE..... | 233 | CAT-MSB-120..... | 223 | | |
| CAT6-08SL-120..... | 219 | CAT-MWSB-(W)..... | 226 | | |
| CAT6-12BE..... | 233 | CAT-MWSB-06..... | 226 | | |
| CAT6-12SL-120..... | 219 | CAT-MWSB-08..... | 226 | | |
| CAT6-16BE..... | 233 | CAT-MWSB-12..... | 226 | | |

Intro

LADDER

I-BEAM

HAT

TROF

CHANNEL

COPE-GLAS™

WIREBASKET

Reference

INDEX

WIRE BASKET TRAY - KEYWORD INDEX

| Description..... | Page |
|---|---------|
| 90° Bends - Cutting Diagrams | 238-239 |
| 90° Bends - Forming Instructions | 238 |
| 90° Bends - Long Radius | 237 |
| 90° Long Radius Bend | 237-238 |
| 90° Short Radius Bend | 238 |
| Accessories | 233-236 |
| Accessory Assembly | 216 |
| Assembly | 216 |
| Back-to-Back Channel Pendant [PS 809-(L)] | 228 |
| Bar Connectors & Hardware | 220 |
| Bend & Intersection Bars | 220 |
| Blind End [CAT(H)-(W)BE] | 233 |
| Bottom Clip [BOTTOM-CLIP] | 243 |
| Box Connector [CAT(H)-(W)CB] | 233 |
| Bracket [CAT-CMA-(W)] | 230 |
| Cantilever & Zed Brackets | 226 |
| Cantilever Medium [CAT-MWSB-(W)] & Heavy [CAT-HWSB-(W)] | 226 |
| Ceiling Clip [CAT-CCA-(W)] | 225 |
| Conduit to Basket Clip [CAT-EMT-.5-1.25] | 234 |
| Connector Hardware [EG-CBN] | 222 |
| Connector Hardware Kits | 222 |
| Connector Hardware Overview | 221 |
| Connector Kit [CH1] | 221 |
| Connector Kit [CH2], [CH3] | 222 |
| Contents | 212 |
| Cover [CAT-CVR-(W)] | 232 |
| Covers | 232 |
| Cross | 240 |
| Cross & Tee Fittings | 240 |
| Cutting Tool [CAT-CUT] | 236 |
| Double Rod Reinforced Tray (2" Depth) [CAT2-(W)SL-120] | 217 |
| Drop Out [CAT-(W)DO] | 232 |
| Drop Rod Clip [CAT-1x6-HC], [CAT-2x8-HC], [CAT-SIDE-HC] | 224 |
| EG-CBN | 222 |
| Electrical Box Bracket [CAT-EBC] | 234 |
| Fittings Overview | 236 |
| Flat Washers | 244 |
| General & Technical Information | 214 |
| Grounding | 242 |
| Grounding & Hardware | 242 |
| Grounding Clamp/Split Bolt [SPLIT-BOLT] | 242 |
| Grounding Clip [CAT-GC] | 242 |
| Hanger [CAT-HGR-2] | 227 |
| Hanger [CAT-HGR-4] | 227 |
| Hangers | 227 |
| Hanging Bracket & Pendants | 228 |
| Hanging Bracket [CAT-AB-HSB], [CAT-AB-USB] | 229 |
| Hanging Bracket [CAT-CB-HSB] | 230 |
| Hanging Bracket [CAT-CB-MSB] | 229 |
| Hanging Bracket [CAT-CB-USB] | 228 |
| Hanging Brackets | 228-231 |
| Hardware | 243-245 |
| Hex Head Cap Screws | 244 |
| Hex Nuts | 244 |
| Lighting Bracket [CAT-HLT] | 234 |

| Description..... | Page |
|---|------|
| Lock Washers | 244 |
| Offset | 241 |
| Overview | 215 |
| Pedestal Brackets [CAT-PED-06] & [CAT-PED-12] | 231 |
| Pedestal Kit [CAT-PED-KIT] | 231 |
| Pendant [CAT-PPA-(H)] | 225 |
| Pendants | 228 |
| Pictorial Index | 213 |
| Product Description | 215 |
| Quadruple Rod Reinforced Tray (6" Depth) [CAT6-(W)SL-120] | 219 |
| Reducer | 241 |
| Riser | 241 |
| Risers | 241 |
| Round Head Machine Screws | 244 |
| Sample Specification | 214 |
| Self-Splicing Straight Lengths | 216 |
| Single Channel Pendant [PS 651-(L)] | 228 |
| Special Order Finishes | 215 |
| Specification Information | 214 |
| Splice | 220 |
| Square Nuts | 244 |
| Square Strut Washers | 245 |
| Standard Bar Connector | 220 |
| Standard Finish | 215 |
| Standard Tee | 240 |
| Straight Length | 216 |
| Strut Nuts | 245 |
| Support Bracket Heavy [CAT-HSB-120] | 223 |
| Support Bracket Medium [CAT-MSB-120] | 223 |
| Tee and Cross | 240 |
| Threaded Rod | 245 |
| Tray Clips (See Page 221-222 for Connector Kits) | 245 |
| Tray Dividers [CAT2-01SB-120], [CAT4-01SB-120], & [CAT6-01SB-120] | 232 |
| Triple Rod Reinforced Tray (4" Depth) [CAT4-(W)SL-120] | 218 |
| U Support Bracket [CAT-USB-120] | 223 |
| Wall & Ceiling Mounts | 225 |
| Wall Bracket [CAT-WC-2] | 227 |
| Wall Clip [CAT-CPA-(W)] | 225 |
| Wall Sleeve [CAT(H)-(W)WS] | 235 |
| Wire Basket Tray Assembly - CAT2, CAT4, & CAT6 | 216 |
| ZED [CAT-ZBAR-120] | 226 |

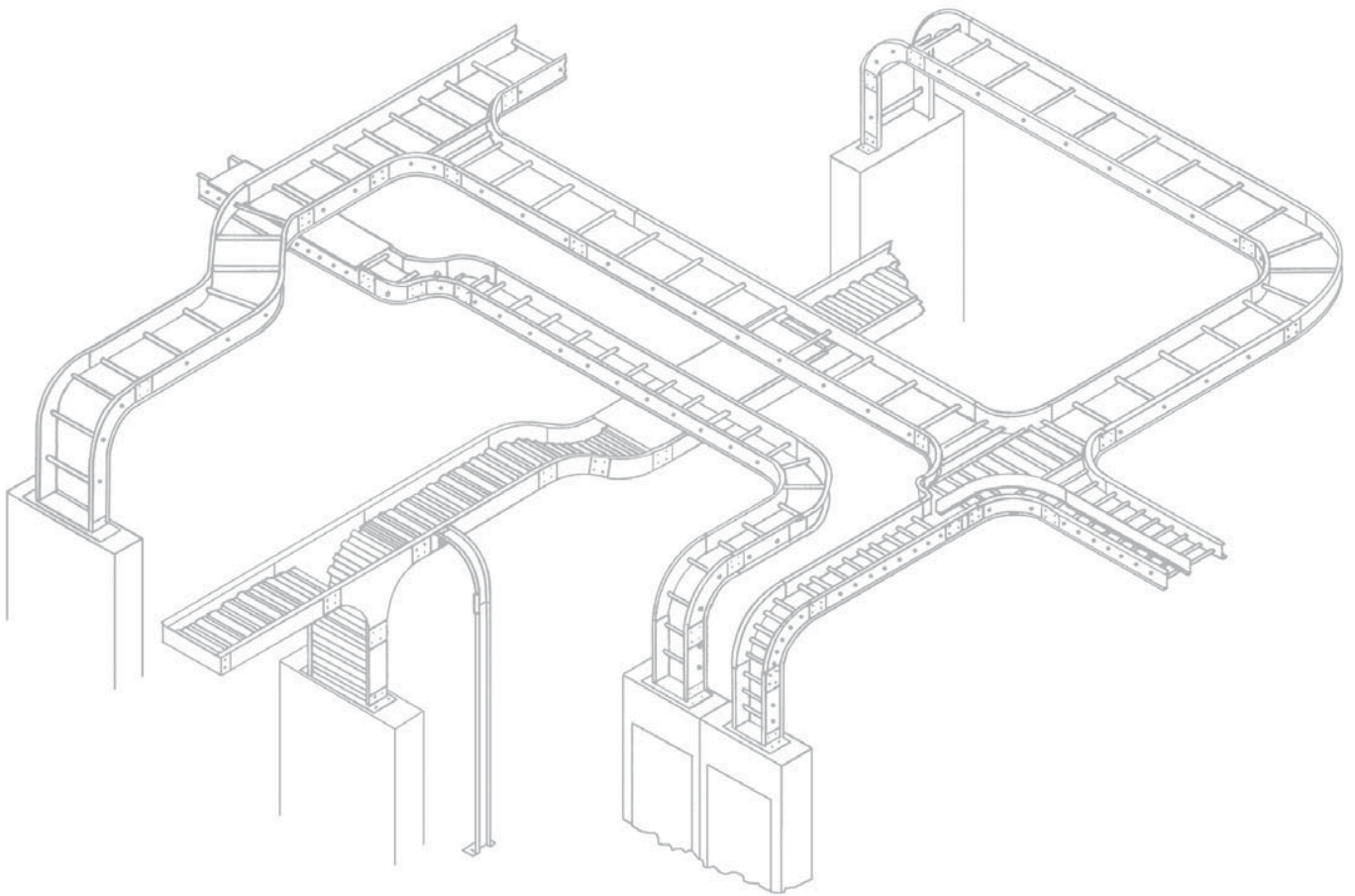

Intro

LADDER

I-BEAM

HAT

TROUGH

CHANNEL

COPE-GLAS™

WIREBASKET

Reference

INDEX

Cope® uses a unique manufacturing process called “cold swaging” to attach rung to rail. Compared to welded products, Cope cold swaged cable tray offers double the pull out strength, provide stiffer overall rigidity, freer access to cables and look better installed. This unique manufacturing process is extremely efficient which quickens production and improves product availability.

APPLICATION SPOTLIGHT: WIND TURBINES
Renewable Energy is a growing and important segment to the energy industry. The wind power industry is developing into an important player in that mix. Cope cold swaged cable tray has proven to be a vital component in the construction of the thousands of wind towers that have been built in recent years.

Wind turbines vibrate intensely during operation. This can cause welded tray to become brittle and snap after a relatively short period of time. Cope cold swaged tray has proven durable even in this extreme dynamic state environment. This reliable performance under extreme conditions is the basis for prominent manufacturers incorporating Cope products into their wind tower designs.

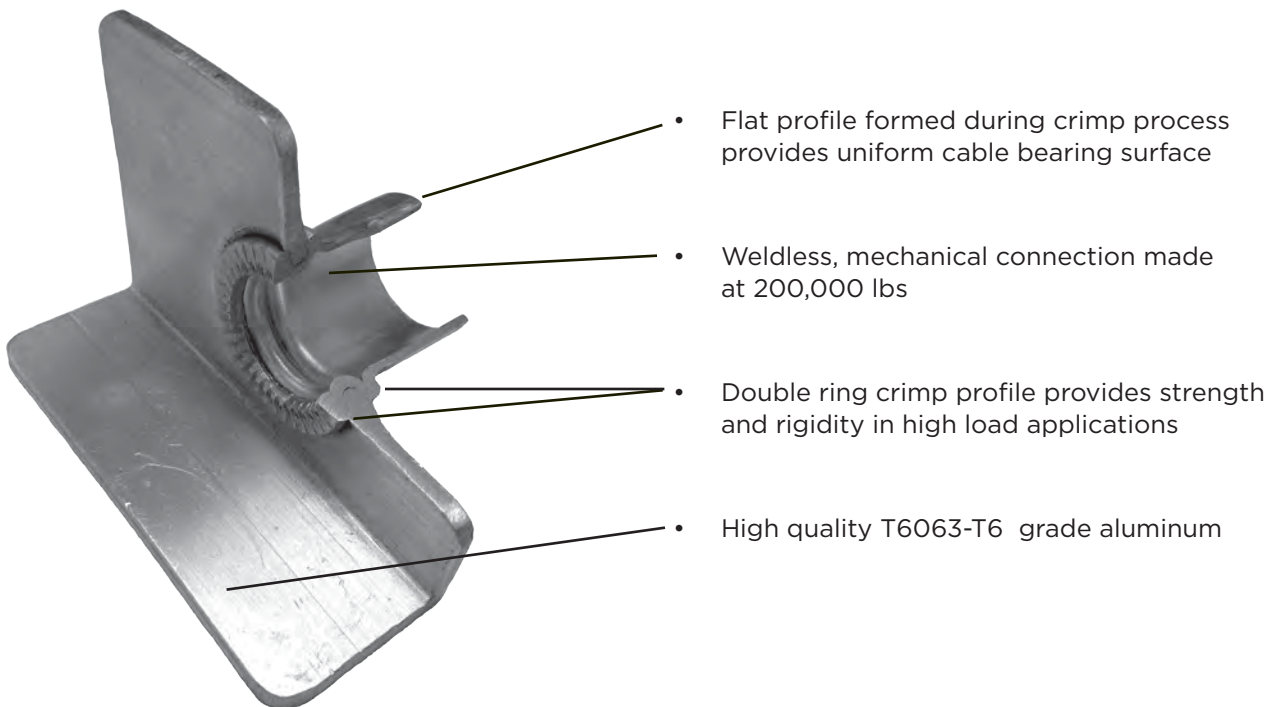

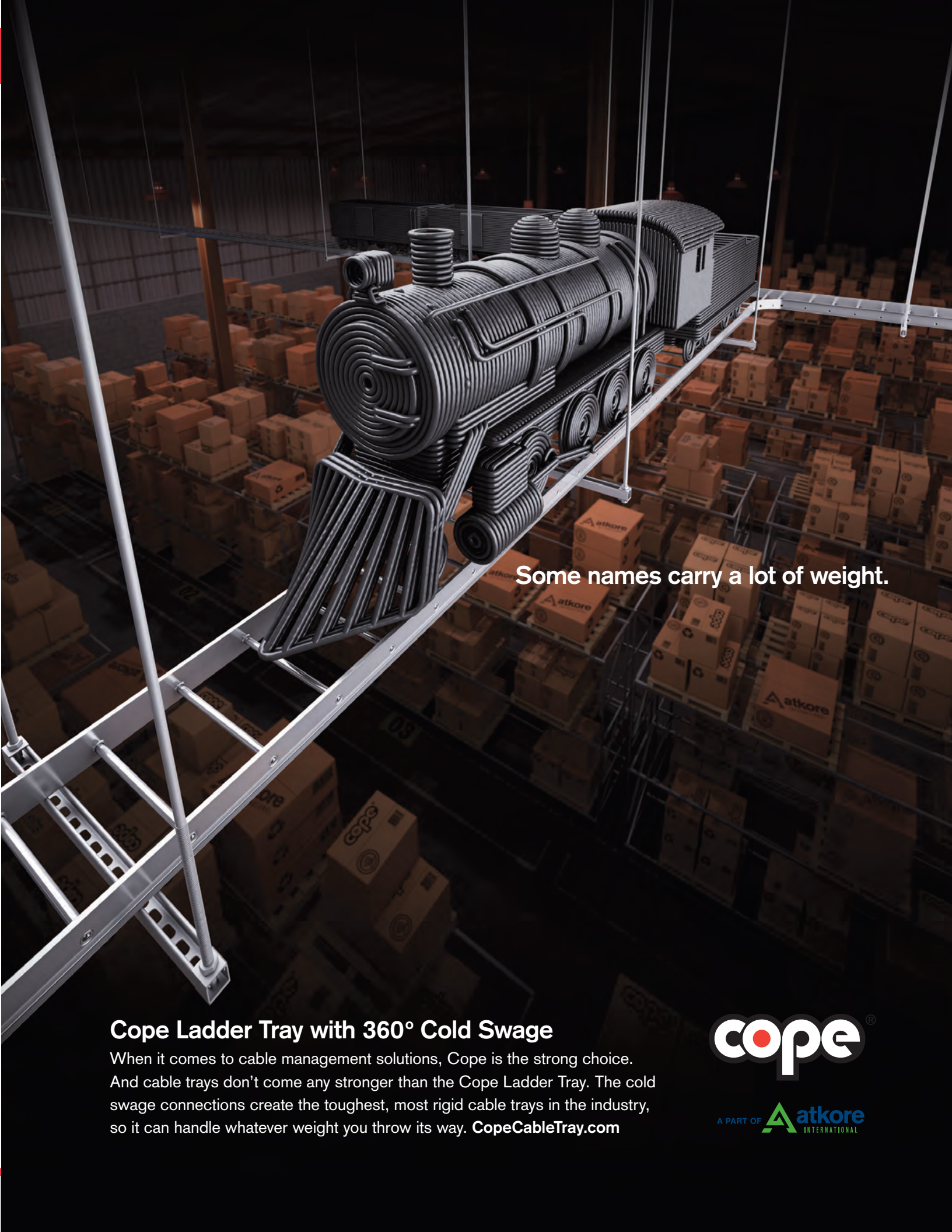

Some names carry a lot of weight.

Cope Ladder Tray with 360° Cold Swage

When it comes to cable management solutions, Cope is the strong choice. And cable trays don't come any stronger than the Cope Ladder Tray. The cold swage connections create the toughest, most rigid cable trays in the industry, so it can handle whatever weight you throw its way. CopeCableTray.com

COPE[®]

A PART OF **Atkore**
INTERNATIONAL

Corporate Headquarters:

16100 S. Lathrop Ave.
Harvey, IL 60426
PHONE / 708-339-1610
TOLL FREE / 800-882-5543

www.copecabletray.com

Manufacturing Locations:

11539 North Houston Rosslyn Rd
Houston, Texas 77088

11500 Norcom Road
Philadelphia, PA, 19154



UNISTRUT



Columbia-MBF

