

Master Catalog

Solutions for the Electrical Industry



 **BURNDY**[®]

Experience. Technology. Answers.[™]



Customer Service Department

7 Aviation Park Drive
Londonderry, NH 03053
1-800-346-4175
1-603-647-5299 (International)

Canada

1-800-361-6975 (Quebec)
1-800-387-6487 (All other provinces)

Mexico

011-52-722-265-4400

Brazil

011-55-11-5515-7200

Tool Repair Center

Littleton Industrial Park
Littleton, NH 03561
1-800-426-8720

From the Ground Up

With Over 85 Years of Experience

Since 1924, BURNDY® has been at the forefront of technological innovation for the telecommunications, data, industrial, instrumentation, and energy industries. As a result, we offer one of most widely used and reliable product lines available.

But as times change, we don't forget where we've been. It's our ongoing commitment to our customers and our products that propel us forward. All our products come with the guarantee of the BURNDY® Engineered System. Our coordinating dies, connectors, and tools are designed to work together—today and in the future. When improving our products or debuting new ones, we're committed to ensuring they continue to work with the BURNDY® pieces you already have.

As you look through our catalog and consider how we can work together, look for:

- **The Grounding Superstore™** BURNDY® offers three versatile grounding system choices, you can choose from mechanical grounding connectors, BURNDYWeld® exothermic products, and the HYGROUND® Irreversible Compression Grounding System.
- **Installation Tooling.** Our mechanical, hydraulic, and battery-powered tools and accessories are designed to work where you work—regardless of weather or access to a power supply.
- **Resources for the future.** BURNDY® devotes significant resources to developing and offering state-of-the-art wind and solar technology.

Our trained and experienced factory sales force can further help you get the products that are right for your job. In fact, as you tell us what you need, our advanced engineering support teams can custom build connectors specifically for your needs.

Make the connection. Call today.

www.burndy.com | 1-800-346-4175



Item # 591717

Experience. Technology. Answers.™

		INSTALLATION TOOLING SYSTEM												
Conductor		LUGS & SPLICES One & Two HOLE				TAPS Thin-Wall C-taps Run=Tap, AWG only			TAPS Heavy Duty C-Taps Run=Tap			TAPS H-Taps Run=Tap		
		Die	Color	Index	T&B Index Code (Flex)	Die	Color	Index	Die	Color	Index	Die	Color	Index
AWG	FLEX	Die	Color	Index	T&B Index Code (Flex)	Die	Color	Index	Die	Color	Index	Die	Color	Index
#8/#6 sol	#8	W8CVT U8CRT	RED	49	21	W4CVT	GRAY	8	U240	RED	240	U11T-1	GREEN	11
#6	#6	W5CVT U5CRT	BLUE	7	24	W2CVT	BROWN	10	UC	BROWN	C	UBGRT	ORANGE	BG
#4	#4	W4CVT U4CRT	GRAY	8	29	W25VT	PINK	12	UC	BROWN	C	UC	BROWN	C
#3/#2 sol		W3CRT U3CRT	WHITE	9		W26VT	BLACK	13	UC	BROWN	C	UC	BROWN	C
#2	#2	W2CVT U2CRT	BROWN	10	33	W27VT	ORANGE	14	UC	BROWN	C	UC	BROWN	C
#1	#1	W1CVT U1CRT-1	GREEN	11		W28VT	PURPLE	15	U997	ORANGE	997	U654	PURPLE	654
1/0	1/0	W25VT U25RT	PINK	12	42 (45)	W29VT	YELLOW	16	U997	ORANGE	997	U654	PURPLE	654
2/0	2/0	W26VT U26RT	BLACK	13	45 (50)		REFER TO CATALOG		U997	ORANGE	997	U654	PURPLE	654
3/0	3/0	W27VT U27RT	ORANGE	14					U997	ORANGE	997	U654	PURPLE	654
4/0	4/0	W28VT U28RT	PURPLE	15	54 (62)	-	-	-	U997	ORANGE	997	U654	PURPLE	654
250	4/0/ 250 class G & H	W29VT U29RT	YELLOW	16		-	-	-	U997	ORANGE	997	U654	PURPLE	654
300	262/ 250 class I, K & M	W30VT U30RT	WHITE	17		-	-	-	U1104	BROWN	1104	U1104	BROWN	1104
350	313	W31VT U31RT	RED	18	71	-	-	-	U1104	BROWN	1104	U1104	BROWN	1104
	350/ 373	W32VT U32RT	BLUE	19		-	-	-	U1104	BROWN	1104	U1104	BROWN	1104
500	444	W34VT U34RT	BROWN	20	87	-	-	-	U1104	BROWN	1104	U1104	BROWN	1104
	500/ 535	U38XRT	PINK	L99		-	-	-	P1103	BLUE	1103	PYFR	YELLOW	KR
600		U36RT	GREEN	22	(99)	-	-	-	P1103	BLUE	1103	PYFR	YELLOW	KR
700		U38RT	PINK	400		-	-	-	P1103	BLUE	1103	PYFR	YELLOW	KR
750	646	U39RT	BLACK	24	106	-	-	-	P1103	BLUE	1103	PYFR	YELLOW	KR
	750/ 777	U44XRT P44XRT-1	YELLOW	L115										
800		P40RT	ORANGE	25	(115)	-	-	-	P1102	WHITE	1102	PYFR	YELLOW	KR
1000		P44RT	WHITE	27		-	-	-	P1102	WHITE	1102	PYFR	YELLOW	KR



Customer Service Department

7 Aviation Park Drive
Londonderry, NH 03053
1-800-346-4175
1-603-647-5299 (International)

Canada

1-800-361-6975 (Quebec)
1-800-387-6487 (All other provinces)

Mexico

011-52-722-265-4400

Brazil

011-55-11-5515-7200

Tool Repair Center

Littleton Industrial Park
Littleton, NH 03561
1-800-426-8720

Experience

- Founded July 19, 1924 in New York City under the name of BURNDY® Engineering Company.
- Over 85 years of experience in engineering and manufacturing of quality connectors and tooling to the electrical industry.
- Headquartered in Manchester, New Hampshire.

Technology

- Our lab tests connectors and tooling to the following standards: ANCE, ANSI, ASTM, CSA, IEC, IEEE, NEMA, UL, NUPIC, OSHA, SAE, and Military.
- Quickly and efficiently create virtually any model that our customers desire using the Dimension 1200 Series rapid prototype machine.

Answers

- BURNDY® is the recognized leader in innovation in engineering and manufacturing of high quality compression connectors, grounding products and installation tooling.
- Supplying products and services that span the entire scope the energy industry.
- A trained and experienced factory sales force that is available to assist you with choosing the right BURNDY® connector and tooling solution for your specific application.



Experience. Technology. Answers.™

Trust the BURNDY® Engineered System

Since 1924, BURNDY® has been at the forefront of technological innovation for the telecommunications, data, industrial, instrumentation, and energy industries. As a result, we offer one of most widely used and reliable product lines available.

Our trained and experienced factory sales force can further help you get the products that are right for your job. In fact, as you tell us what you need, our advanced engineering support teams can custom build specifically for your needs.



The SmartCart® and BURNDY® Wire Caddies













Tooling: Designed to BURNDY® Specifications

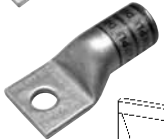

Die Sets: Die Embossment with Color Match System

Experience. Technology. Answers.™

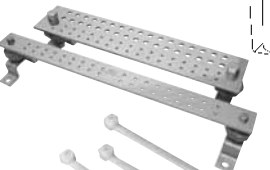
What's New

	<p>POWER DISTRIBUTION BLOCKS U-BLOK™ A-39 - A-40</p>
	<p>CONNECTORS Ferrules, Bare and Insulated B-5 - B-9</p>
	<p>CONNECTORS Heat Shrink Terminals B-10 - B-11</p>
	<p>CONNECTORS Heat Shrink Fully Loaded Rack B-12</p>
	<p>CONNECTORS Heat Shrink Kit B-13</p>
	<p>CONNECTORS BREAK-AWAY™ Lugs C-11 - C-13</p>
	<p>CONNECTORS Narrow Tongue C-21 - C-22, C-34 - C-35, C-47 - C-48, C-59 - C-60, C-66 - C-67</p>
	<p>CONNECTORS YAG-L-TC, Flex with No Inspection Window C-49 - C-50</p>
	<p>CONNECTORS YSR Reducer In-Line Splice Kits C-90 - C-99</p>
	<p>GROUNDING BusBars E-57 - E-58</p>
	<p>CABLE TIES Universal Cable Ties G-8</p>
	<p>TRANSMISSION IMPLO™ I-53 - I-68</p>

(Continued on next page)

What's New



DIE KITS

U-Die Kits..... N-5



YF TOOLS

Ferrule Installation Tools N-8



MRC840AL

Mechanical Crimping Tool N-15



MD6-K

Hand Operated Crimping Tool
(Accepts KEARNEY™ Dies)..... N-19



PATRIOT® HIGH PERFORMANCE PAT750XT-18V

Battery Actuated Crimping Tool N-34



PATRIOT® PAT750K-18V

Battery Actuated Crimping Tool
(Accepts KEARNEY™ Dies)..... N-35



PATRIOT® IN-LINE® PATMD6K-14V

Battery Actuated IN-LINE® Crimping Tool
(Accepts KEARNEY™ Dies)..... N-40



PATRIOT® PATHCC10-18V SERIES

Battery Actuated Cutting Tool N-59



ENFORCER™ HIW716ENF

Low Pressure Hydraulic Impact Wrench N-75



WIRE MANAGEMENT

SmartCart®..... N-97 - N-99



WIRE MANAGEMENT

Wire Caddies N-100 - N-106

Mechanical	A
Small Terminals	B
Compression Connectors	C
Hardware	D
Grounding	E
Accessories	F
Cable Ties	G
Overhead	H
Transmission	I
Wedge	J
Underground	K
Substation — Bolted	L
Substation — Welded/EHV	M
Tooling — Crimpers	N
Tooling — Cutters	N
Tooling — Hydraulic Pumps and LPHT	N
Tooling — Knockouts	N
Tooling — Benders	N
Tooling — Wire Management	N
Reference and Index	0

TABLE OF CONTENTS

Types ^{HN} KS, KS-3 & SC . . . A-4	Type HFB-P1 A-22	Type BIPC A-37
Type ^{HN} KSU A-5	Type HFB-N A-23	TERMINAL BLOCKS . . A-38
Type KSA A-6	Types KA-U, KKA-U . . . A-24	U-BLOK™ A-39
Types ^{HN} KVS, KVSU A-7	Type K2A-U A-25	U-BLOK™ PLATFORMS A-40
Types ^{HN} KVSW, KVS-A . . . A-8	Types ^{HN} K3A-U, KK3A-U A-26, A-27	SPEC-BLOK™ . . A-41, A-42
Type ^{HN} QPX A-9	Types ^{HN} K4A-U, KK4A, K11A-U, K21A, K22A A-28	SPEC-BLOK™ PLATFORMS A-43
Type ^{HN} QPX-Y A-10	Type KAU-KIT A-29	Types BDA, BDB, BDC A-45, A-46, A-47, A-48, A-49
Type KPA A-11	Type AMS A-30	Types BIT, BISR A-50
Type KPA-UP A-12	Type AGSKIT A-31	Types BIT, BISR A-50
Type KLU A-13	Type UGSKIT A-31	Type BIBS A-51
Types KA, EA A-14	Type UGSKIT8 A-32	Type BIBD A-52
Types ^{HN} BGBL, CL50-1 . . A-15	Type UGS350ULDB . . . A-32	Types BIBS-MT, BIBD-MT A-53
Types ^{HN} QA, QQA A-16	Type BISR-DB A-33	Type 1PL A-54
Types ^{HN} Q2A, Q3A A-17	Type QGFL A-34	
Types ^{HN} QB, Q2B A-18	Type FCB A-35	
Types ^{HN} QDA & QR A-19	Types ^{HN} KPU-AC, UCU-AC A-36	
Types ^{HN} VT, E-C-G A-20		
Types ^{HN} VA, VVA A-21		

^{HN} Complies with NFPA 78-86 Ordinary Structures.
^{HN} Complies with NFPA 78-86 Heavy Duty Stacks
(order: LD for Lead Plating for Heavy Duty Stacks applications.)

⚡ LIGHTNING PROTECTION INFO.

Basic rules for selection are:

- | | | |
|--|--|--|
| <ol style="list-style-type: none"> 1 Must be like material to the conductor (Flexitap out due to steel bolts!). 2 Two bolts to ground rod — minimum. 3 Cable to cable connections can be anything — one bolt, two bolt, compression, etc. 4 Cable to steel structure must have 8 square inch contact with steel. | <ol style="list-style-type: none"> 5. Heavy duty stacks — mechanical only. 6. On all connectors with heavy duty stack rating, we must offer 1/16" thick lead plating as an option. Reason is closest 25 ft. to stack opening must use lead coated product. | <p>⚡
⚡⚡</p> <p>Complies with NFPA 78-86 Ordinary Structures.
Complies with NFPA 78-86 Heavy Duty Stacks
(order: LD for Lead Plating for Heavy Duty Stack applications)</p> |
|--|--|--|

SPECIAL FEATURES

Other features are also available for products listed in price book such as undrilled or special drilling, 45° or 90° pad angles, belling for extra flexible cable, smooth or special

threaded studs, special labeling or packaging, extra long braid, and nuclear certification. REFER TO FACTORY.

**ALL OTHERS
REFER TO FACTORY**

1-800-346-4175

Blue highlighted items are industry standard and most frequently ordered.

**REVOLUTIONARY
BURNDY® DESIGN
MEETS STRICT
UL486B STANDARDS**

**. . . and puts the bite on
aluminum connections
forever!**

For use on all combinations

- Aluminum to aluminum
- Aluminum to copper
- Copper to copper

Patented

**Unique “bite and grip”
TRITAP™ SERVIT® contact
delivers safe, long-term
reliability—even without
scratch brushing . . .
without oxide inhibiting
compounds.†**

Available in sizes from #10 through 500 kcmil.

Spacer provides built-in
separation to retard
galvanic corrosion.

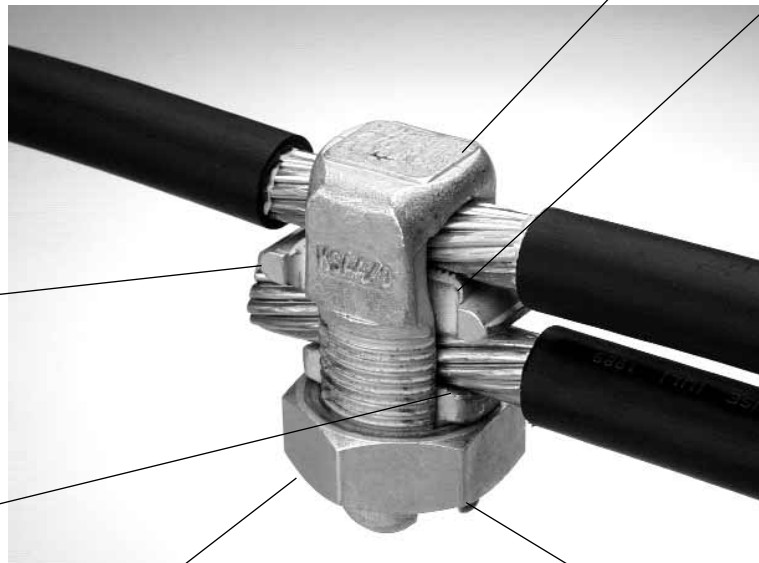

Triangular edges bite into
cable to break through
surface oxides:

- provide low contact
resistance.
- produces gas tight seal.

Tin-plated contact
surface inhibits
oxide formation.

Special heat-treated hard, aluminum alloy.

Anti-galling, high efficiency threaded
components result in high contact
force. Easily installed using standard,
everyday wrenches.



†When used in NEC applications of insulated cables only.

Blue highlighted items are industry standard and most frequently ordered.

TYPES KS & KS-3

SERVIT®

For Copper, Copperweld

Compact, high strength, high copper alloy SERVIT® split-bolt has free-running threads and easy to grip wrench flats. Highly resistant to season cracking and corrosion, the SERVIT® provides maximum pressure and assures a secure connection on all combinations of run and tap conductors. Type KS-3 accommodates 3 maximum size conductors.

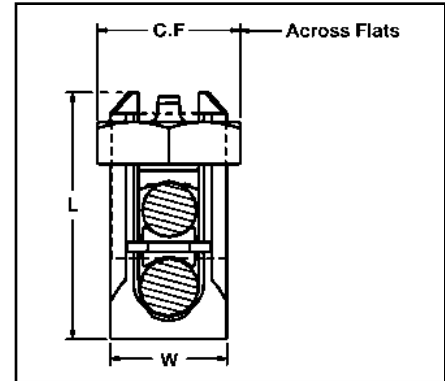

Catalog Number	Cross Flats	L	W	Conductor						▲ Recommended Tightening Torque in-lb
				Copper		Copperweld				
				Range for Equal Run and Tap	Min. Tap with Max. Run	Maximum Run and Tap		Type A	Type D	
† KS90	.50	.85	.38	12 Str. - 10 Str.	16 Str.	#10	—	—	—	80
† KS15	.50	.85	.38	10 Str. - 8 Str.	14 Str.	#8	—	—	—	80
† KS17	.63	1.14	.45	8 Str. - 6 Sol.	14 Str.	#6	3 #12	8A	9-1/2D	165
* KS17-3				8 Str. - 6 Sol.	16 Str.	#6	3 #12	8A	9-1/2D	
† KS20	.69	1.20	.51	8 Str. - 4 Sol.	14 Str.	#4	3 #10	6A	8D	
* KS20-3				8 Str. - 4 Sol.	14 Str.	#4	3 #10	6A	8D	275
† KS22	.75	1.50	.60	6 Str. - 2 Sol.	14 Str.	#2	3 #8	4A	6D	
* KS22-3				6 Str. - 2 Sol.	14 Str.	#2	3 #8	4A	6D	
† KS23	.82	1.54	.62	6 Str. - 2 Str.	14 Str.	#1	3 #7	3A	5D	385
† KS25	.94	1.77	.73	4 Str. - 1/0 Str.	14 Str.	2/0	3 #5	2A	4D	
† KS26	1.05	1.94	.82	2 Str. - 2/0 Str.	14 Str.	3/0	7 #7	—	—	
† KS27	1.36	1.86	1.17	1 Str. - 3/0 Str.	8 Sol.	—	—	—	—	500
† KS29	1.36	2.07	1.17	1 Str. - 250	8 Str.	4/0	7 #5	—	—	650
† KS31	1.70	2.51	1.41	1/0 Str. - 350	1/0 Str.	—	19 #8	—	—	
† KS34	1.82	2.79	1.48	2/0 Str. - 500	2/0 Str.	—	19 #6	—	—	825
KS39	2.31	3.29	1.94	4/0 Str. - 750	4/0 Str.	—	19 #5	—	—	1000
KS44	2.56	3.73	2.19	300 - 1000	4/0 Str.	—	—	—	—	1100

▲ Listed torque values are for maximum conductor combinations accommodated. Consult UL486 Tables 7-4, 7-5, 7-6 for smaller conductor combinations.

See note page A-2

* Not UL Listed or CSA Certified.

† In addition to UL Listed for wire connectors and CSA Certified, these items are also UL rated for direct burial.

TYPE SC

SERVIT® COVER

HUG-A-BUG

Used indoors or outdoors, this compact, one-piece plastic SERVIT® cover saves time and material, **eliminates costly taping of split-bolts**. Positive latch snaps easily and quickly over connector, ideal for tight quarters. Self-positioning plastic fingers wrap around wires fully insulating joint. UL Listed for 600 volt indoor application with type KS. Three Covers accommodate a range of 6 SERVIT® sizes through 2/0 Str.



SERVIT® and cover combination can be ordered as follows:

CKS4 KS20 with cover

For other combinations, please contact factory.



Catalog Number	For Use With
SC4	KS17, KS17-3, KS20 KSU17, KSU20
SC2	KS22, KS20-3, KS23, KS22-3, KSA6, KSA4, KSU22, KSU23
SC2/0	KS25, KS26, KSA2, KSA 1/0 KSU25, KSU26

Blue highlighted items are industry standard and most frequently ordered.

TYPE KSU

UNIVERSAL SERVIT®

For All Combinations of Copper, Aluminum, ACSR, AAAC, 5005, and Steel

Tin-plated, high strength copper alloy SERVIT® with spacer. Spacer separates dissimilar conductors and provides long contact length that prevents high pressure point contacts between run and tap conductors.

Use of PENETROX™ joint compound recommended with Aluminum and ACSR.

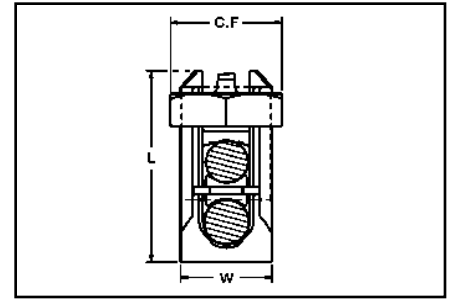
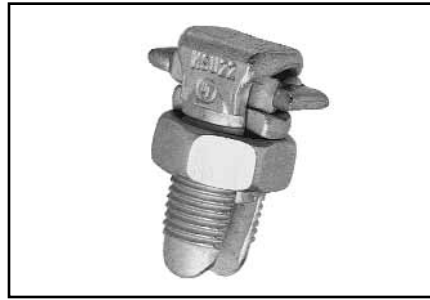

Catalog Number	Fig.	Cross Flat	L	W	Conductor								Recommended Tightening Torque in-lb.			
					Run				Tap					Maximum Conductor		
					Copper & Aluminum	ACSR AAAC 5005	Copper & Aluminum	ACSR † AAAC 5005	Sol. BWG	3 Str. BWG	Nom Dia.	Steel				
KSU17	2	.62	.92	.42	12 Sol. - 6 Sol.	8 (6-1)	12 Sol. - 6 Sol.	8 (6-1)	8	—	5/32	165				
KSU20	2	.69	1.05	.48	10 Sol. - 4 Sol.	6 (6-1)	10 Sol. - 4 Sol.	6 (6-1)	6	8	7/32					
KSU22	2	.74	1.25	.57	10 Sol. - 2 Sol.	6 (6-1) - 4 (7-1)	10 Sol. - 2 Sol.	6 (6-1) - 4 (7-1)	4	6	1/4	275				
KSU23	2	.81	1.48	.59	8 Str. - 2 Str.	3 (6-1) - 2 (6-1)	8 Sol. - 2 Str.	6 (6-1) - 2 (6-1)	—	4	5/16	275				
KSU25	2	.93	1.77	.70	2 Str. - 1/0 Str.	3 (6-1) - 1 (6-1)	10 Str. - 1/0 Str.	6 (6-1) - 1 (6-1)	—	—	3/8	385				
KSU26	2	1.04	1.93	.79	1/0 Str. - 2/0 Str.	1 (6-1) - 1/0 (6-1)	8 Str. - 2/0 Str.	6 (6-1) - 1/0 (6-1)	—	—	7/16	385				
KSU27	1	1.38	2.34	1.12	1 Str. - 3/0 Str.	1 (6-1) - 2/0 (6-1)	8 Sol. - 3/0 Str.	8 (6-1) - 2/0 (6-1)	—	—	1/2	500				
KSU29	1	1.38	2.50	1.14	1 Str. - 250	2/0 (6-1) - 4/0 (6-1)	8 Str. - 250	6 (6-1) - 4/0 (6-1)	—	—	1/2	650				
KSU31	1	1.69	2.88	1.36	4/0 Str. - 350	3/0 (6-1) - 4/0 (6-1)	4 Str. - 350	4 (6-1) - 4/0 (6-1)	—	—	5/8	650				
KSU34	1	2.00	3.12	1.47	400 - 500	336 (30-7) - 477 (18-1)	2 Str. - 500	2 (6-1) - 477 (18-1)	—	—	—	825				

Accommodates compressed conductors within conductor ranges.

See note page A-2

Blue highlighted items are industry standard and most frequently ordered.

TYPE KSA

TRITAP™ SERVIT®

For All Combinations of Aluminum to Aluminum, Aluminum to Copper and Copper to Copper, Aluminum Alloy Tin Plated

PATENTED TRIANGULAR PENETRATION TECHNOLOGY CONTACT

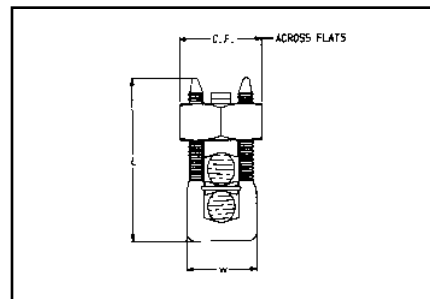
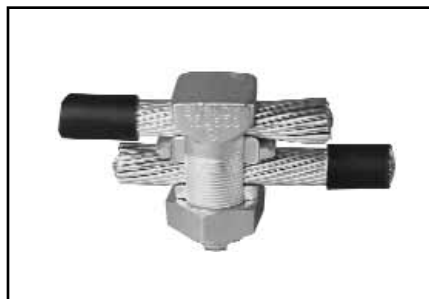

Features and Benefits

- No scratch brushing required.
- No oxide inhibitor required.
- Orients the conductor.
- Provides maximum pressure and assures a secure connection of run and tap conductors.
- Facilitates piercing the aluminum conductor surface oxides.
- UL 486B listed, 90°C rated.
- Provides a low contact resistance.
- Provides equal coefficient of expansion
- Inhibits the reformation of oxides by producing a gas-tight seal.
- Provides improved retention of minimum to maximum conductor combinations.



Catalog Number	Cross Flats	L	W	Alum. to Alum., Alum. to Copper, Copper to Copper Conductors						Recommended ▲ Tightening Torque in-lb
				Max. Run to Max. Tap		Min. Run to Min. Tap		Max. Run to Min. Tap		
KSA6	.75	1.28	.56	#6 Str. (.184)	#6 Str. (.184)	#10 Sol. (.102)	#10 Sol. (.102)	#6 Str. (.184)	#10 Sol. (.102)	165
KSA4	.81	1.38	.62	#4 Str. (.232)	#4 Str. (.232)	#8 Sol. (.129)	#10 Sol. (.102)	#4 Str. (.232)	#10 Sol. (.102)	165
KSA2	.94	1.58	.69	#2 Str. (.292)	#2 Str. (.292)	#6 Sol. (.169)	#8 Str. (.146)	#2 Str. (.292)	#8 Sol. (.146)	275
KSA 1/0	1.00	1.92	.75	#1/0 Str. (.373)	#1/0 Str. (.373)	#2 Str. Compact (.268)	#8 Sol. (.129)	#1/0 Str. (.373)	#8 Sol. (.129)	385
KSA 2/0	1.12	1.92	.88	#2/0 Str. (.418)	#2/0 Str. (.418)	#2 Str. Compact (.268)	#8 Str. (.146)	#2/0 Str. (.418)	#8 Str. (.146)	385
KSA 4/0	1.49	2.54	1.13	#4/0 Str. (.528)	#4/0 Str. (.528)	#2 Str. Compact (.268)	#6 Str. (.184)	#4/0 Str. (.528)	#6 Str. (.184)	500
*KSA 350	1.69	3.24	1.50	350 kcmil (.681)	350 kcmil (.681)	#1/0 Str. Compact (.336)	#4 Str. (.232)	#350 kcmil (.681)	#4 Str. (.232)	650
*KSA 500	2.00	3.62	1.73	500 kcmil (.813)	500 kcmil (.813)	400 kcmil Compact (.659)	#2 Str. Compact (.268)	#500 kcmil (.813)	#2 Str. Compact (.268)	825

▲ Listed torque values are for maximum conductor combinations accommodated. Consult UL486 Tables 7-4, 7-5, 7-6 for smaller conductor combinations.

* Not CSA Certified.

** No scratch brushing or oxide inhibiting compounds required for insulated 90° C max. rated conductor for N.E.C. applications.

Blue highlighted items are industry standard and most frequently ordered.

TYPE KVS

OKLIP™

Mechanical Connector
For Copper & Copperweld



Compact, two-piece, high strength, high copper alloy BURNDY® OKLIP™ recommended for heavy duty connections. Neoprene rings hold DURIUUM™ bolts in place during installation. Installed with ordinary wrench.

Catalog Number	Conductor					Recommended ▲ Tightening Torque in-lb
	Copper		Copperweld			
	Run	Tap	Max. Run and Tap			
			Sol.	Str.	Type V	
KVS26	2 Str. - 2/0 Str.	6 Sol. - 2/0 Str.	3/0	7 #8	—	180
KVS28	1/0 Str. - 4/0 Str.	10 Str. - 4/0 Str.	4/0	7 #6	V3/0	250
KVS31	250 - 350 kcmil	10 Str. - 350 kcmil	—	19 #8	V250	325
KVS34	400 - 500 kcmil	10 Str. - 500 kcmil	—	19 #6	V350	375
KVS40	400 - 800 kcmil	3/0 Str. - 800 kcmil	—	19 #5	—	500
KVS44	500 - 1000 kcmil	3/0 Str. - 1000 kcmil	—	—	—	500

▲ Listed torque values are for maximum conductor combinations accommodated. Consult UL486 Tables 7-4, 7-5, 7-6 for smaller conductor combinations.

↗ See note page A-2

TYPE KVSU

UNIVERSAL OKLIP™

Mechanical Connector
For All Combinations
of Copper, Aluminum,
ACSR, AAAC & 5005

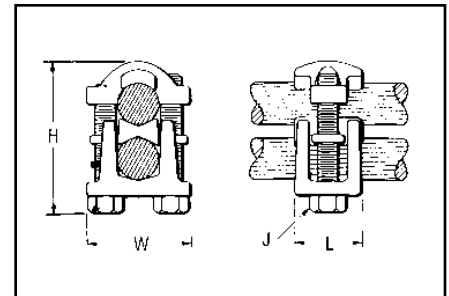

Compact, high strength, tin plated copper alloy two-piece connector with spacer and tin-plated silicon bronze DURIUUM™ hardware. Recommended for heavy duty connections. Spacer separates dissimilar conduc-

tors and provides long contact length. Neoprene ring prevents loss of shorter bolt during installation. Longer peened bolt permits swivel action for easier installation.

Use of PENETROX™ joint compound recommended with aluminum and ACSR.

Catalog Number	Conductor								H	J	L	W	Recommended Tightening Torque in-lb
	Run		Tap		Run		Tap						
	Copper & Alum.	ACSR, AAAC, & 5005	Copper & Alum.	ACSR, AAAC, & 5005	Copper Sol., Copperweld Sol.,	Steel Nom. Dia.	Copper Sol., Copperweld Sol.,	Steel Nom. Dia.					
KVSU26	2 Str. - 2/0 Str.	3 - 2/0	6 Str. - 2/0 Str.	6 - 2/0	1 - 3/0	5/16 - 7/16	#6 - 3/0	3/16 - 7/16	2	5/16	1	1-1/2	180
KVSU28	1/0 Str. - 4/0 Str.	1/0 - 4/0	6 Str. - 4/0 Str.	6 - 4/0	2/0 - 4/0	3/8 - 1/2	#6 - 4/0	5/32 - 1/2	2-3/8	3/8	1-1/8	1-3/4	250
KVSU31	250 - 350 kcmil	4/0 - 300	AWG 6 - 350 kcmil	6 - 300	—	9/16 - 5/8	#6 - 4/0	3/16 - 5/8	2-5/8	1/2	1-3/8	2-1/8	325
KVSU34	400 - 500 kcmil	336.4 - 397.5	AWG 4 - 500 kcmil	5 - 397.5	—	3/4 - 3/4	#4 - 4/0	7/32 - 3/4	3	1/2	1-1/2	2-1/4	375
KVSU40	400 - 800 kcmil	4/0 - 800	AWG 4/0 - 800 kcmil	3/0 - 715.5	—	3/4 - 1	—	1/2 - 1	3-1/2	1/2	1-5/8	2-1/2	500
KVSU44	500 - 1000 kcmil	4/0 - 1000	AWG 4/0 - 1000 kcmil	4/0 - 900	—	7/8 - 1-1/8	—	1/2 - 1-1/8	4	3/8	2	3	500

Accommodations compressed conductors within diameter range.

↗ See note page A-2

Blue highlighted items are industry standard and most frequently ordered.

TYPE KVS

OKLIP™

Mechanical Connector
For Copper and Copperweld.

Similar to OKLIP™ Type KVS except for a high copper alloy spacer that separates run and tap conductors. Provides high contact pressure, confines conductor strands, and assures vibration-proof connection. Longer peened bolt, permits swivel action for easier installation. Silicon bronze DURIMUM™ hardware.



Catalog Number	Conductor		Recommended Tightening Torque in-lb
	Run	Tap	
KVSW26	2 Str. - 2/0 Str.	6 Sol. - 2/0 Str.	180
KVSW28	1/0 Str. - 4/0 Str.	6 Sol. - 4/0 Str.	250
KVSW31	250 - 350 kcmil	4 Sol. - 350 kcmil	325
KVSW34	400 - 500 kcmil	4 Str. - 500 kcmil	375
KVSW40	400 - 800 kcmil	AWG 4/0 - 800 kcmil	500
KVSW44	500 - 1000 kcmil	250 - 1000 kcmil	500

See note page A-2

TYPE KVS-A

ALUMINUM OKLIP™

Mechanical Connector
For All Combinations of
Copper, Aluminum†, ACSR†,
AAAC and 5005

Three-piece, high-conductivity, non-copper bearing aluminum alloy connector with thick spacer and aluminum hardware. Hardware in KVS26A and KVS28A is stainless steel. Recommended for heavy duty dissimilar metal applications. Spacer separates conductors and provides long contact length. Belled entrances prevent chafing, permit easier assembly of conductors. Longer peened bolt permits swivel action for easier installation. Neoprene ring prevents loss of shorter bolt. PENETROX™ joint compound recommended with aluminum and ACSR.

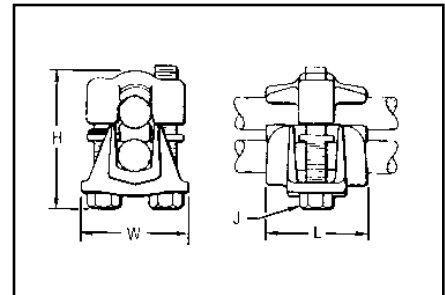

Catalog Number	Conductor				Recommended Tightening Torque in-lb
	Run		Tap		
	Copper, & Alum.†	ACSR†, AAAC, & 5005	Copper, & Alum.†	ACSR†, AAAC & 5005	
KVS26A	2 Str. - 2/0 Str.	AWG 4 - 2/0	10 Str. - 2/0 Str.	6 - 2/0	180
KVS28A	1/0 Str. - 4/0 Str.	AWG 1/0 - 4/0	10 Str. - 4/0 Str.	6 - 4/0	240
KVS31A	250 - 350 kcmil	AWG 4/0 - 336.4	6 Str. - 350 kcmil	6 - 336.4	300
KVS34A	400 - 500 kcmil	336.4 - 397.5	4 Str. - 500 kcmil	5 - 397.5	300
KVS40A	400 - 800 kcmil	336.4 - 715.5	3/0 Str. - 800 kcmil	3/0 - 715.5	300
KVS44A	500 - 1000 kcmil	397.5 - 900	3/0 Str. - 1000 kcmil	3/0 - 900	480

† Accommodates compressed conductors within diameter range.

See note page A-2

**THESE CONNECTORS
CAN ACCOMMODATE
ACSR CONDUCTORS
OVER ARMOR ROD WITHIN
THE DIAMETER RANGE
INDICATED.**

APPLICATION OVER
ARMOR ROD

Catalog Number	Conductor Range by Diameter			H	J	L	W
	Min. Run Dia.	Min. Tap Dia.	Max. Run & Tap Dia.				
KVS26A	.281	.116	.447	2-1/4	5/16	1-1/4	1-5/8
KVS28A	.360	.116	.564	3	3/8	1-5/8	2-1/16
KVS31A	.565	.184	.681	3-1/16	1/2	1-15/16	2-7/16
KVS34A	.728	.216	.814	3-9/16	1/2	2-5/16	2-5/8
KVS40A	.728	.470	1.036	4-1/16	1/2	2-7/16	2-7/8
KVS44A	.806	.470	1.162	4-7/8	5/8	2-1/2	3-1/8

Blue highlighted items are industry standard and most frequently ordered.

TYPE QPX

VERSITAP™

Parallel Clamp For Copper, Copperweld, Copperweld-Copper

The VERSITap™ Type QPX is recommended for Tee, Cross, Parallel, Butt and Tap connections. Range-taking, only 10 connectors required to accommodate conductor sizes from #6 Str. to 1000 kcmil. Edges are rounded for easy taping. Made of high strength, high-conductivity copper alloy and silicon bronze DURIUM™ hardware.

* For various configurations, see page A-10.

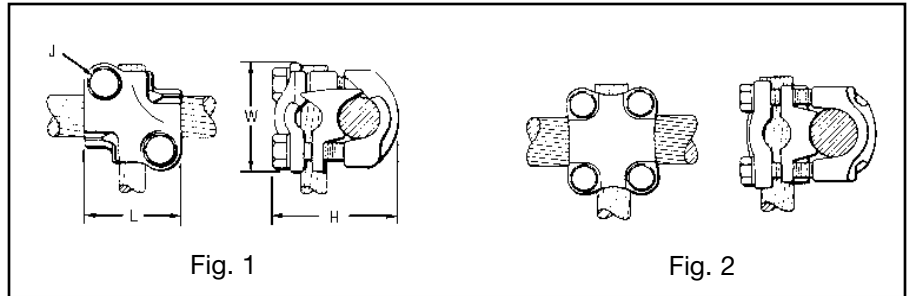
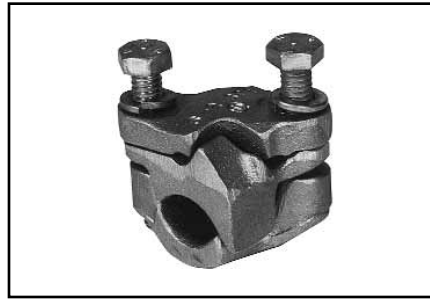

Catalog Number	Copper Conductor		Fig. No.	H	J	L	W	Recommended Tightening Torque in-lb ▲
	Run	Tap						
QPX2C2C	6 Str. - 2 Str.	6 Str. - 2 Str.	1	1-1/2	5/16	1-5/16	1-3/8	150
QPX282C	1 Str. - 4/0 Str.	6 Str. - 2 Str.		2-1/16			1-9/16	
QPX2828		1 Str. - 4/0 Str.		3/8	1-13/16	1-13/16		
QPX342C	250 - 500 kcmil	6 Str. - 2 Str.			2-3/8	5/16	1-3/8	
QPX3428		1 Str. - 4/0 Str.	3/8	1-3/4	2-1/16			
QPX3434		250 - 500 kcmil		2	3	2-1/16	2-3/16	
QPX442C	500 - 1000 kcmil	6 Str. - 2 Str.	1	2-11/16	5/16	1-3/8	2-1/4	500
QPX4428		1 Str. - 4/0 Str.		2-7/8			1-13/16	
QPX4434		250 - 500 kcmil	2	3-1/16	3/8	2-1/16	2-5/8	
QPX4444		500 - 1000 kcmil		3-7/16				

▲ Listed torque values are for maximum conductor combinations accommodated. Consult UL486 Tables 7-4, 7-5, 7-6 for smaller conductor combinations.

↗ See note page A-2.

Catalog Number	Conductor			
	Run		Tap	
	Copperweld	Copperweld - Copper	Copperweld	Copperweld - Copper
QPX2C2C	5 Sol. - 3 #7	8A - 4A	5 Sol. - 3 #7	8A - 4A
QPX282C	7 #9 - 7 #5	3A - 3/0 V	5 Sol. - 3 #7	8A - 4A
QPX2828	7 #9 - 7 #5	3A - 3/0 V	7 #9 - 7 #5	3A - 3/0 V
QPX342C	19 #9 - 19 #6	4/0 EK	5 Sol. - 3 #7	8A - 4A
QPX3428			7 #9 - 7 #5	3A - 3/0 V
QPX3434			19 #9 - 19 #6	4/0 EK
QPX442C			5 Sol. - 3 #7	8A - 4A
QPX4428	19 #6	—	7 #9 - 7 #5	3A - 3/0 V
QPX4434			19 #9 - 19 #6	4/0 EK
QPX4444			19 #6	

Blue highlighted items are industry standard and most frequently ordered.

TYPE QPX-Y

UNIVERSAL VERSITAP™

Universal Parallel Clamp For Copper and Aluminum

High copper alloy cast connector, tin-plated for use with copper or aluminum cable. Makes parallel, tap, tee, cross or end-to-end connections. Edges rounded for easy taping. PENETROX™ joint compound recommended.

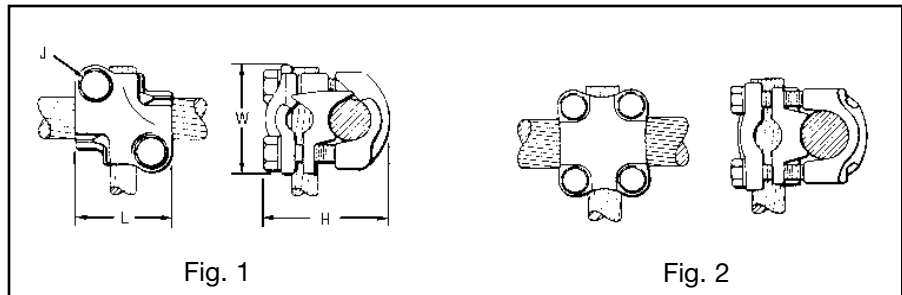

Catalog Number	Conductor		Fig. No.	H	J	L	W	Recommended Tightening Torque in-lb ▲
	Aluminum or Copper							
	Run	Tap						
QPX2C2C-Y	6 Str. - 2 Str.	6 Str. - 2 Str.	1	1-5/8	5/16	1-1/2	1-5/8	150
QPX282C-Y	1/0 Str. - 4/0 Str.	6 Str. - 2 Str.		1-7/8			1-7/8	
QPX2828-Y	1/0 Str. - 4/0 Str.	1/0 Str. - 4/0 Str.	1	2	3/8	2	2-1/8	250
QPX342C-Y	250 - 500 kcmil	6 Str. - 2 Str.		2-1/4			5/16	
QPX3428-Y		1/0 Str. - 4/0 Str.	2	2-1/2	3/8	2	2-1/2	375
QPX3434-Y	200 - 500 kcmil	200 - 500 kcmil		2-7/8			2-1/2	
QPX4444-Y	750 - 1000 kcmil	750 - 1000 kcmil	2	3-7/8	1/2	3-1/2	3-1/2	500

▲ Listed torque values are for maximum conductor combinations accommodated. Consult UL486 Tables 7-4, 7-5 7-6 for smaller conductor combinations.
 ✎ See note page A-2.

APPLICATION VARIATIONS

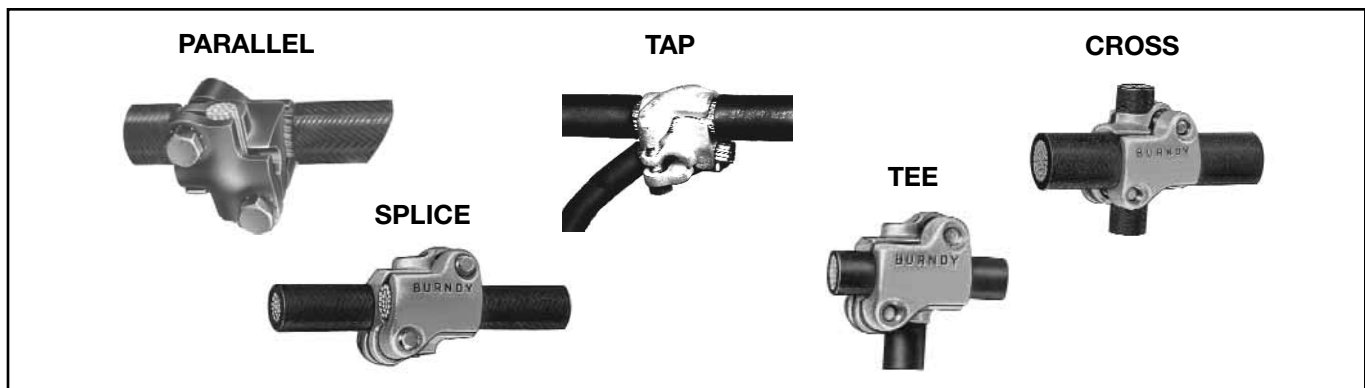

Blue highlighted items are industry standard and most frequently ordered.

TYPE KPA

SCRULUG™

For Copper Cable

High copper alloy tin-plated terminal for joining a wide range of cable to equipment pads or terminal blocks. Especially good in light industrial applications. The tongue and body are a one-piece design. The pressure bar equalizes pressure over the conductor and prevents the screw from cutting into the cable.

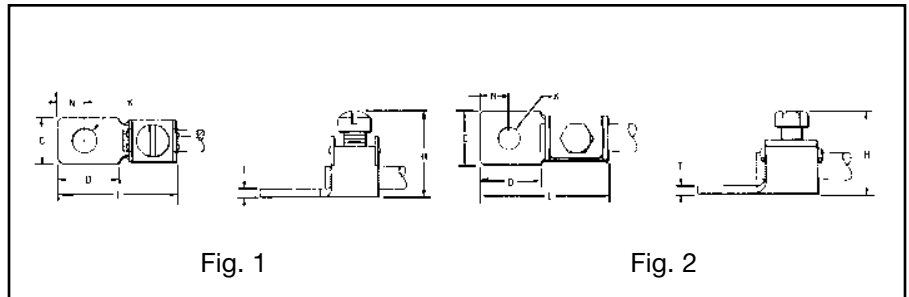

Catalog Number	Wire Range	Fig. No.	C	D	H	K	Stud Hole Size	L	N	T	Recommended Tightening Torque in-lb
KPA8C	14 Sol. - 8 Str.	1	.38	.47	.72	.21	.10	.95	.22	.06	12
KPA4C	14 Sol. - 4 Str.	1	.50	.59	.94	.27	1/4	1.20	.30	.06	45
KPA25	4 Str. - 1/0 Str.	2	.75	.81	1.25	.33	5/16	1.70	.41	.10	180
KPA28	1/0 Str. - 4/0 Str.	2	.97	1.12	1.66	.40	3/8	2.29	.53	.13	250
KPA34	4/0 Str. - 500 kcmil	2	1.38	1.38	2.44	.54	1/2	3.14	.75	.20	375

NOTE: For unplated version add "UNPL" suffix.

Blue highlighted items are industry standard and most frequently ordered.

TYPE KPA-UP

SCRULUG™

For Copper Cable

High copper alloy terminal for joining a wide range of cable to equipment pads or terminal blocks. Plain copper finish.

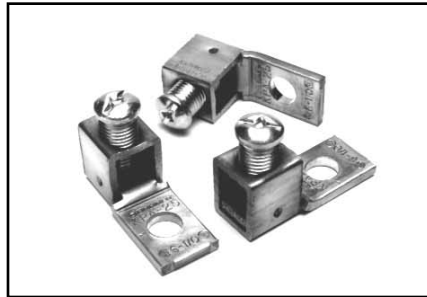

Features and Benefits

- One piece design.
 - ◇ Superior torque and pull out performance.
- Convenient range taking design.
 - ◇ Reduces catalog numbers. One catalog number accommodates several conductor sizes.
- High conductivity copper alloy.
 - ◇ Long lasting, reliable contact.
- Compact design.
 - ◇ Easy to use.
- Slot Robertson screw, hex head, hex socket bolt.
 - ◇ No special installation tools required. Eliminates over-torquing/potential conductor damage.

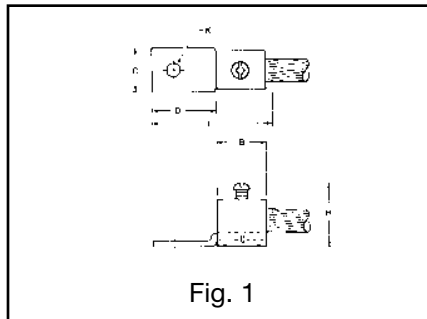

Catalog Number	Wire Range	Fig. No.	C	D	H	K	Stud Hole Size	L	N	T	Hardware	Recommended Tightening Torque in-lb
KPA8CUP	14 Sol. - 6 Str.	1	0.38	0.51	0.81	0.20	#10	1.01	0.24	0.07	1/4 Dia. Slot Robertson	35
KPA4CUP	14 Sol. - 4 Str.		0.50	0.71	1.00	0.28	1/4	1.28	0.33	0.07	5/16 Dia. Slot Robertson	45

NOTE: For tin plating drop "-UP" suffix and add "-TP" suffix (example: KPA4CTP).
For use in grounding applications with a green screw, contact factory. Listed for grounding per UL467.

Blue highlighted items are industry standard and most frequently ordered.

TYPE KLU

SCRULUG™

For Copper Cable —
Offset Tongue — Non-Plated

High copper alloy terminal with offset tongue for joining a wide range of cable to equipment pads or bar. Easy to install with screwdriver or wrench. Connector is reusable. Plain copper finish.



Features and Benefits

- Convenient range-taking design.
 - ◇ Reduces catalog numbers.
 - One conductor accommodates several conductor sizes.
- High conductivity copper alloy.
 - ◇ Long lasting reliable contact.
- Compact design.
 - ◇ Easy to use. Reduces labor time.
- Slot Robertson screw, hex head/hex socket bolt.
 - ◇ No special installation tools required.
 - Eliminates over-torquing/potential conductor damage.

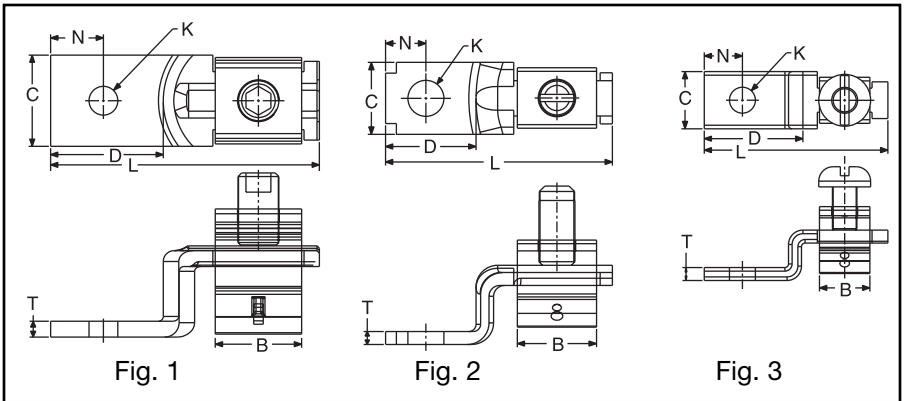

① Catalog Number	Conductor	Fig. No.	B (MM/IN)	C (MM/IN)	K (MM/IN)	L (MM/IN)	N (MM/IN)	T (MM/IN)	Recommended Tightening Torque in Lbs.	Hardware	Stud Hole Size	Quantity/Package	Strip Length (In.)
KLU25	14 Sol. 1.63 (0.64) Dia. to	3	6.4	8.0	3.6	26.0	6.3	1.9	20	No. 8 - 32 Slotted Round Machine Screw	#6	100	7/16
KLU25TP	10 Sol. 2.60 (1.02) Dia. Cu		.26	.31	.14	1.02	.21	.07					
KLU35	14 Sol. 1.63 (.0641) Dia. to	2	8.4	10.0	6.0	31.6	5.6	1.8	45	1/4 UNF Slotted Set Screw	#10	100	5/8
KLU35TP	6 Str. 4.67 (.184) Dia. Cu		.33	.39	.20	1.24	.22	.07					
KLU70	8 Sol. 3.28 (.129) Dia. to		11.8	12.0	6.7	39.6	6.4	2.1	50	5/16 UNF Slotted Set Screw	1/4	100	3/4
KLU70TP	2 Str. 7.42 (.292) Dia. Cu		.46	.47	.26	1.56	.25	.08					
KLU125	2 Str. 7.42 (.292) Dia. to	1	16.9	16.9	6.5	50.5	10.8	2.7	50	3/8 UNF Slotted Set Screw	1/4	25	15/16
KLU125TP	1/0 Str. 9.44 (.372) Dia. Cu		.63	.63	.26	1.99	.43	.11					
KLU175	4 Str. 5.89 (.232) Dia. to	1	18.0	19.0	10.0	66.0	11.0	4.0	124	3/8 UNF Socket/Hex Screw	3/8	12	1
KLU175TP	3/0 Str. 11.94 (.470) Dia. Cu		.71	.75	.39	2.20	.43	.16					
KLU225	2 Str. 7.42 (.292) Dia. to		19.6	26.2	8.5	65.0	13.0	3.1					
KLU225TP	4/0 Str. 13.4 (.528) Dia. Cu	.77	.99	.33	2.56	.51	.12						
KLU300	1/0 Str. 9.44 (.372) Dia. to	1	25.2	26.2	10.0	72.0	13.1	3.1	325	5/8 UNF Socket/Hex Screw	3/8	6	1-5/8
KLU300TP	350 kcmil 17.30 (.681) Dia. Cu		1.0	.99	.39	2.83	.52	.12					
KLU400	1/0 Str. 9.44 (.372) Dia. to		29.6	38.0	10.0	104.0	23.0	4.5					
KLU400TP	500 kcmil 207 (.813) Dia Cu	1.16	1.60	.39	4.09	.91	.18						

NOTES:
 ① Suffix "-TP" on catalog number denotes tin plate (example: KLU400TP).
 2 Material: Copper alloy.

Blue highlighted items are industry standard and most frequently ordered.

TYPE KA

KA-LUG™

For Copper Cable

Compact, economical, high copper alloy terminal for joining a wide range of cable to equipment pads or terminal blocks.

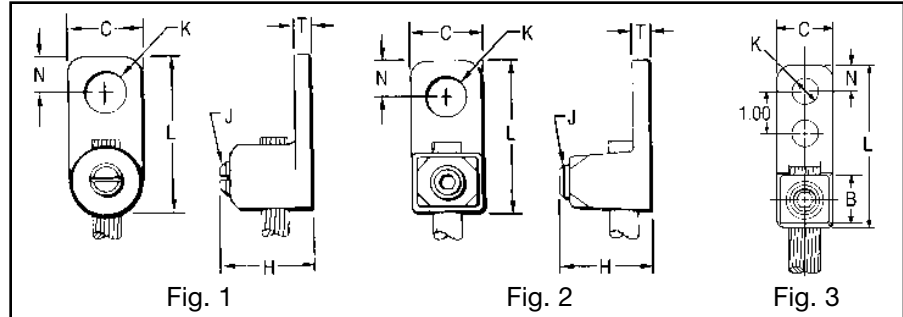
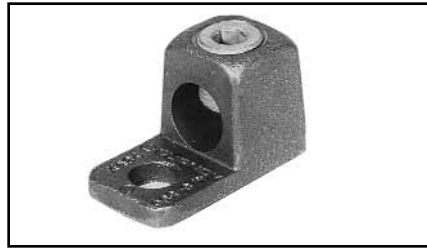

Catalog Number	Conductor	Fig. No.	C	H	J	K	Stud Hole Size	L	N	T	Recommended Tightening Torque in-lb
KA8C	14 Sol. - 8 Str.	1	3/8	5/8	#12	7/32	#10	13/16	3/16	3/32	25
KA4C	14 Sol. - 4 Str.		9/16	3/4	5/16	9/32	1/4	1-1/8	1/4	7/64	45
KA25	4 Str. - 1/0 Str.	2	3/4	15/16	1/2	27/64	3/8	1-11/16	3/8	1/8	200
KA25-2TC 38	4 Str. - 1/0 Str.	3	3/4	15/16	1/2	27/64	3/8	2-13/16	3/8	1/8	200
KA28	1 Str. - 4/0 Str.	2	15/16	1-1/4	5/8	27/64	3/8	1-15/16	7/16	3/16	275
KA34	4/0 Str. - 500 kcmil		1-3/8	2-3/32	13/16	9/16	1/2	2-9/16	9/16	9/32	375

▲ Listed torque values are for maximum conductor sizes accommodated. Consult UL486 Tables 7-4, 7-5, 7-6 for smaller conductor sizes.

TYPE EA

VERSILUG™

For Copper Cable

Compact, high copper alloy terminal for joining a wide range of cable to equipment pads or bar. **Clamping element adjustable to several angles.** One-wrench installation.

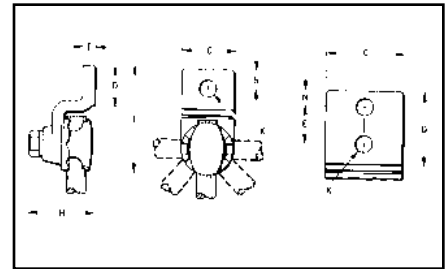

Catalog Number	Conductor	No. of Holes in Pad	C	D	E	H	K	Stud Hole Size	L	N	T	Recommended Tightening Torque in-lb
EA2C	8 Sol. - 2 Str.	1	13/16	1-1/16	—	1-3/8	7/16	3/8	2-1/2	13/32	1/4	150
EA25	2 Str. - 1/0 Str.	1	7/8	1-1/8	—	1-7/16		3/8	2-11/16	7/16		180
EA28	1/0 Str. - 4/0 Str.	1	1-1/16	1-3/8	—	1-3/4	9/16	3/8	3-3/16	17/32	5/16	250
EA28-2N		2 NEMA		3-5/8	1-3/4			1/2	5-1/8	5/8		
EA34	250 - 500 kcmil	1	1-3/8	1-5/8	—	2-1/4	9/16	1/2	4	13/16	3/8	375
EA34-2N		2 NEMA		3-5/8	1-3/4			1/2	5-5/8	5/8		

* "N" indicates NEMA standard stud holes.

▲ Listed torque values are for maximum conductor sizes accommodated. Consult UL486 Tables 7-4, 7-5, 7-6 for smaller conductor sizes.

Blue highlighted items are industry standard and most frequently ordered.

TYPE BGBL

LAY-IN QIKLUG™

*UL Listed 90° C, 600 V

The Lay-In QIKLUG™, Type BGBL is manufactured from high strength 6061-T6 aluminum, and is ideally suited for grounding and bonding applications accommodating both copper and aluminum conductor sizes #14 AWG to 250 kcmil.

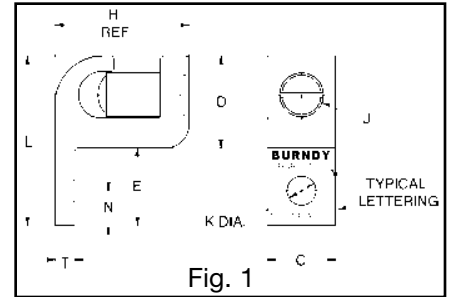

Features and Benefits

- * UL486B listed, AL9CU rated.
 - ◇ For copper and aluminum conductor combinations up to 90° C, 600 Volt applications.
- UL Recognized for grounding and bonding.
 - ◇ Ensures reliability.
- Electro-tin plated.
 - ◇ Provides low contact resistance.
- Lay-in feature.
 - ◇ Eases installation.

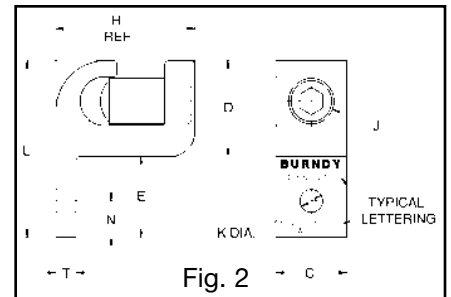

Catalog Number	Fig. No.	Conductor Range	Dimensions									Hex Size
			C	D	E	H Ref.	Bolt Size J	K Dia.	L	N	T	
BGBL-4	1	AWG 14 - 4	.39 [10]	.62 [16]	.48 [12]	.79 [20]	1/4 - 28	.22 [6]	1.10 [28]	.20 [5]	.13 [3]	SLOT
BGBL-1/0	1	AWG 14 - 1/0	.63 [16]	.80 [20]	.83 [21]	1.16 [29]	3/8 - 24	.28 [7]	1.63 [41]	.44 [11]	.19 [5]	SLOT
BGBL-250	2	AWG 6 - 250 kcmil	.88 [22]	1.18 [30]	1.00 [30]	1.72 [44]	7/16 - 18	.28 [7]	2.18 [55]	.45 [11]	.25 [6]	7/32

NOTE: PEN-A PENETROX™ inhibitor is recommended for all aluminum terminations.

TYPE CL50-1

COPPER LAY-IN QIKLUG™ FOR COPPER

The Lay-In QIKLUG™ is manufactured from high strength pure electrolytic copper to ensure maximum strength and conductivity. UL467 Listed for direct burial in earth or concrete. The open-faced design allows for fast lay-in of the conductor without the need for cutting or breaking.

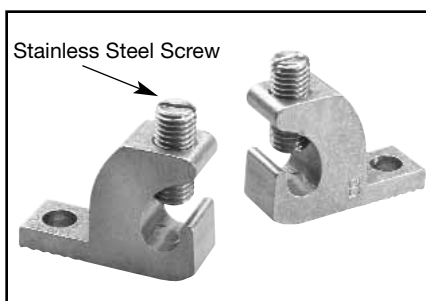

Catalog Number	Wire Range Copper	Stud Hole
CL50-1	#14 - #4 Cu	#10
CL50-1TN*	#14 - #4 Cu	#10

*-TN version is tin plated. Commonly used for solar panel grounding

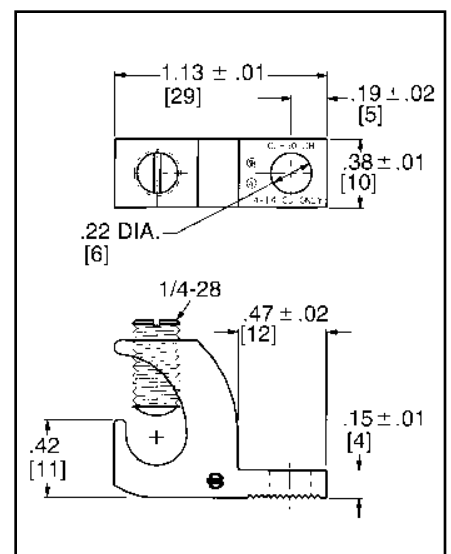

Blue highlighted items are industry standard and most frequently ordered.

TYPES QA, QQA

QIKLUG™

For Copper Cable

Type QA heavy duty, compact, high copper alloy terminal for joining a wide range of cable to equipment pads or bar. Fast one-wrench installation. Type QQA heavy duty, high copper alloy terminal for joining cable to equipment pads or bar. Twin clamping elements secure joint vibration and flexing. One-wrench installation.

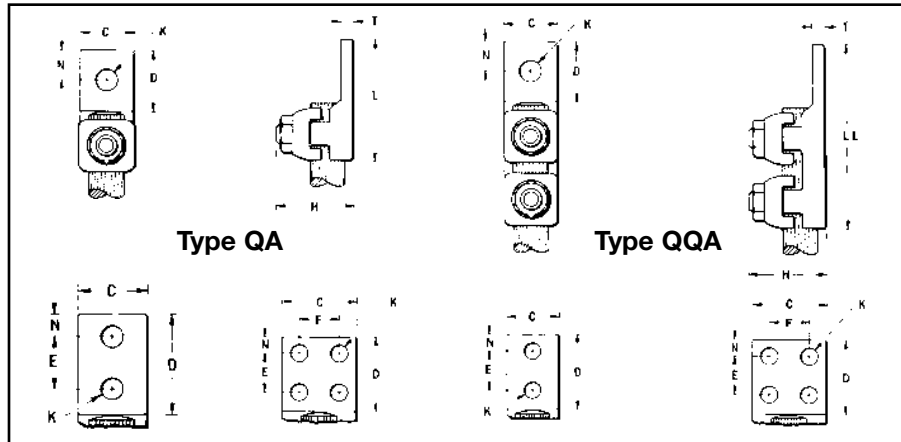
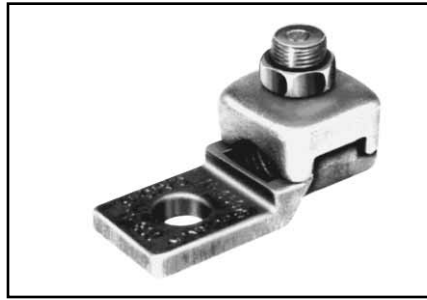

Catalog Number*		Conductor		No. of Holes in Pad	C	D	E & F	H	K	Stud Hole Size	L	LL	N	T	Recommended Tightening Torque in-lb
Type QA	Type QQA	Commercial	Navy												
QA8C-B		14 Sol. - 8 Str.	4 - 14	1	9/16	9/16	—	11/16	7/32	#10	1-3/8	2-5/16	9/32	5/32	75
QA8C-2B				2		1-1/4	5/8				5/16				
QA4C-B	QQA4C	8 Str. - 4 Str.	23 - 40	1	5/8	5/8	—	3/4	9/32	1/4	1-7/16	2-3/8	5/16	3/16	110
QA4C-2B	QQA4C-2			2		1-3/16	5/8				2	2-15/16			
QA1C-B	QQA1C	4 Str. - 1 Str.	50 - 75	1	5/8	3/4	—	1	11/32	5/16	1-3/4	2-13/16	11/32	7/32	150
QA1C-2B	QQA1C-2			2		1-9/16	7/8				2-9/16	3-5/8			
QA26-B	QQA26	1/0 Str. - 2/0 Str.	100 - 125	1	13/16	1	—	1-3/16	13/32	3/8	2	3-3/16	7/16	7/32	180
QA26-2B	QQA26-2			2		1-15/16	1				3	4-3/16			
QA28-B	QQA28	3/0 Str. - 4/0 Str.	150 - 200	1	1	1-1/16	—	1-5/16	13/32	3/8	2-1/4	3-9/16	17/32	1/4	250
QA28-2B				2		2	1				3-9/16	—			
QA28-2N*	QQA28-2N*			2 NEMA		3-1/8	1-3/4		9/16	1/2	4-5/16	5-5/8	5/8		
QA31-B	QQA31	250 - 350 kcmil	250 - 350	1	1-3/16	1-3/8	—	1-11/16	17/32	1/2	2-11/36	4-1/8	11/16	5/16	325
QA31-2B				2		1-31/32	1				7/16	3/8	3-3/8		
QA31-2N*	QQA31-2N*			2 NEMA		3	1-3/4		9/16	1/2	4-7/16	5-7/8	5/8		
QA34-B	QQA34	400 - 500 kcmil	400 - 500	1	1-3/8	1-5/8	—	2	17/32	1/2	3-3/16	4-7/8	13/16	5/16	375
QA34-2B				2		2	—				13/32	3/8	3-9/16		
QA34-4B				4	1-7/8	1-15/16	1		7/16	3/8	3-1/2	—	7/16		
QA34-2N*	QQA34-2N*			2 NEMA	1-3/8	3-3/32	1-3/4		9/16	1/2	4-11/16	6-9/32	5/8		
QA40-B		600 - 800 kcmil	650 - 800	1	1-5/8	1-7/8	—	2-7/16	11/16	5/8	3-11/16	—	27/32	3/8	500
QA40-2N*	QQA40-2N*			2 NEMA		3	3				1-3/4	4-14/16	7-3/32		
	QQA40-4N			4 NEMA	3	—	—		9/16	1/2	—	—	5/8		
QA44-B		850 - 1000 kcmil	1000	1	1-7/8	2	—	2-3/4	11/16	5/8	3-15/16	—	1	1/2	600
QA44-2N*	QQA44-2N			2 NEMA		3	3				1-3/4	9/16	1/2		
QA44-4N*				4 NEMA	3	3-1/16	—		9/16	1/2	—	—	5/8		
QA46-B		1100 - 1500 kcmil	1300	1	2-1/8	2-1/8	—	3-1/8	13/16	3/4	4-3/8	—	1-1/16	9/16	600
QA46-2N*				2 NEMA		3	1-3/4				9/16	1/2	5-1/4		

* "N" indicates NEMA standard stud holes.
All 4N items ✓ See note page A-2

Blue highlighted items are industry standard and most frequently ordered.

TYPE Q2A

QIKLUG™

For Copper Cable

Compact, high copper alloy terminal for joining two cables to equipment pads or bars. Each element accommodates a wide range of cable. One-wrench installation.

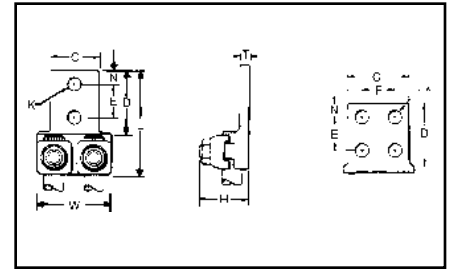

Catalog Number*	Conductor	No. of Holes in Pad	C	D	E & F	H	K	Stud Hole Size	L	N	T	W	Recommended Tightening Torque in-lb ▲		
Q2A1C-2	4 Str. - 1 Str.	2	1-1/2	1-7/8	1	1-1/16	7/16	3/8	2-7/8	7/16	7/32	1-13/16	150		
Q2A26-2N	1/0 Str. - 2/0 Str.	2 NEMA	1-5/8	3-1/8	3/4	1-3/16	9/16	1/2	4-3/16	5/8	7/32	1-15/16	180		
Q2A28-2N	3/0 Str. - 4/0 Str.	2 NEMA	1-7/8						4-3/8					1-15/16	250
Q2A28-4N		4 NEMA	3												
Q2A31-2N	250 - 350 kcmil	2 NEMA	2-3/8						4-1/2					2-1/8	325
Q2A31-4N		4 NEMA	3	5/16	3										
Q2A34-2N	400 - 500 kcmil	2 NEMA	2-1/2			4-11/16	3	375							
Q2A34-4N		4 NEMA	3	3/8	3-3/4										
Q2A40-2N	600 - 800 kcmil	2 NEMA	3			5	7/16	500							
Q2A40-4N		4 NEMA		3-1/4	4-11/32										
Q2A44-4N	850 - 1000 kcmil	4 NEMA	3-1/4			3-1/4	2-3/4	5-1/4	1/2	4-11/32	11/16	5	600		
Q2A46-4N	1100 - 1500 kcmil	4 NEMA	3-1/2	3-1/8	5-1/2										

* "N" indicates NEMA standard stud holes. All 4N items ✓ See note page A-2

TYPE Q3A

QIKLUG™

For Copper Cable

Compact, high copper alloy terminal for joining three cables to equipment pads or bar. Each element accommodates a wide range of cable. One-wrench installation.

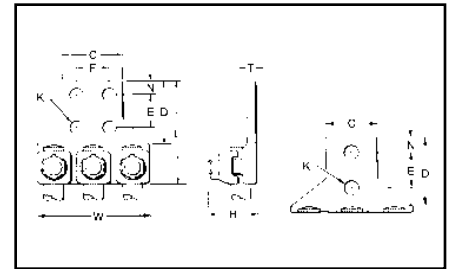

Catalog Number*	Conductor	No. of Holes in Pad	C	D	E & F	H	K	Stud Hole Size	L	N	T	W	Recommended Tightening Torque in-lb			
Q3A28-2N	3/0 Str. - 4/0 Str.	2 NEMA	1-7/8	3-1/8	1-3/4	1-3/8	9/16	1/2	4-5/16	5/8	1/4	3-3/16	250			
Q3A28-4N		4 NEMA	3						4-3/8							
Q3A31-2N	250 - 350 kcmil	2 NEMA	2-3/8											4-7/16	5/16	4-1/16
Q3A31-4N		4 NEMA	3													
Q3A34-2N	400 - 500 kcmil	2 NEMA	2-1/2	3	1-15/16	9/16	1/2	4-3/4	5/8	3/8	4-9/16	375				
Q3A34-4N		4 NEMA	3													
Q3A40-4N	600 - 800 kcmil	4 NEMA	3-1/4	3-1/4	2-7/16	9/16	1/2	5	7/16	5-13/16	500					
Q3A44-4N	850 - 1000 kcmil	4 NEMA										3-1/4	2-3/4	5-1/4	1/2	6-5/8
Q3A46-4N	1100 - 1500 kcmil	4 NEMA	3-1/2	3-1/8	5-1/2	11/16	7-7/8	600								

* "N" indicates NEMA standard stud holes.

Blue highlighted items are industry standard and most frequently ordered.

TYPE QB

QIKLUG™

For Copper Cable

Compact, high copper alloy side entrance terminal for joining a range of cable at right angles to terminal blocks. One-wrench installation.

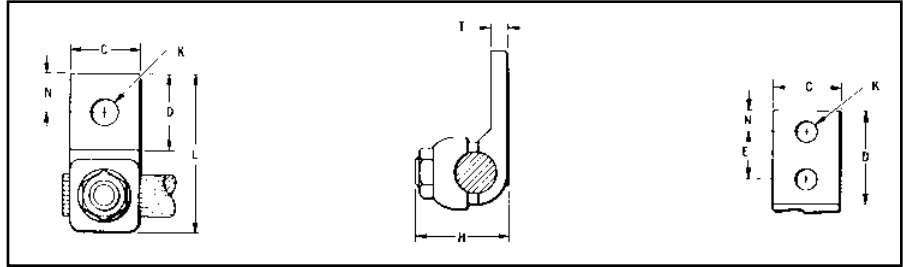

Catalog Number*	Conductor	No. of Holes in Pad	C	D	E	H	K	Stud Hole Size	L	N	T	Recommended Tightening Torque in-lb ▲
QB8C	14 Sol. - 8 Str.	1	9/16	9/16	—	7/8	7/32	#10	1-1/8	9/32	5/32	75
QB4C	8 Str. - 4 Str.	1	11/16	27/32	—	13/16	9/32	1/4	1-3/8	11/32	1/4	110
QB1C	4 Str. - 1 Str.	1		13/16	—	1			7/32		150	
QB26	1/0 Str. - 2/0 Str.	1	13/16	1	—	1-1/32	13/32	3/8	1-13/16	7/16	7/32	180
QB28	3/0 Str. - 4/0 Str.	1	1	1-1/16	—	1-5/16			2-1/16	17/32	1/4	250
QB31-2N	250 - 350 kcmil	2 NEMA	13/16	3-1/4	1-3/4	1-11/16	9/16	1/2	4-1/2	5/8	5/16	325

*"N" indicates NEMA standard stud holes.

TYPE Q2B

QIKLUG™

For Copper Cable

Compact, high copper alloy terminal for joining two cables at right angles to a single terminal block. Each element accommodates a range of cable. One-wrench installation.

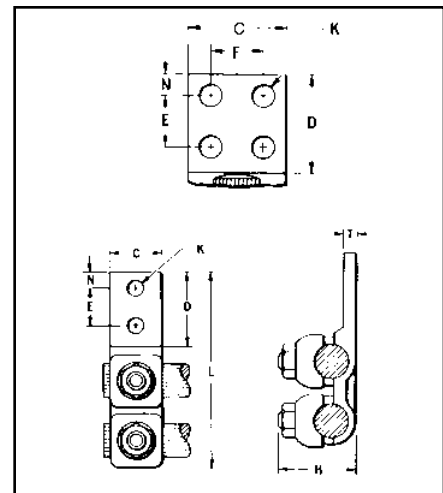

Catalog Number*	Conductor	No. of Holes in Pad	C	D	E & F	H	K	Stud Hole Size	L	N	T	Recommended Tightening Torque in-lb
Q2B28-2N	3/0 Str. - 4/0 Str.	2 NEMA	1-7/8	3-1/8	1-3/4	1-3/8	9/16	3/8	5-3/16	5/8	1/4	250
Q2B31-2N	250 - 350 kcmil	2 NEMA	2-3/8	3-3/16	1-11/16	1-3/8		1/2	5-7/8		5/16	325
Q2B40-4N	600 - 800 kcmil	4 NEMA	3	3-1/16	1-3/8	2-5/16		1	6-11/16		7/16	500

*"N" indicates NEMA standard stud holes.
All 4N items ✓ See note page A-2

Blue highlighted items are industry standard and most frequently ordered.

TYPE QDA

QIKLUG™

For Copper Cable

Compact, high copper alloy terminal for joining a wide range of cable to equipment studs. Provides low contact resistance when gripped between two contact nuts. One-wrench installation.

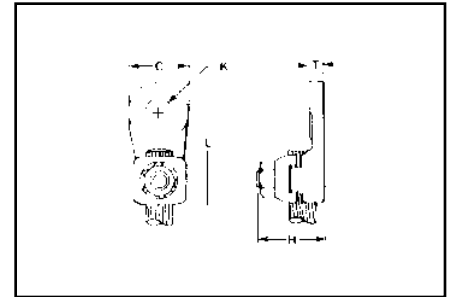

Catalog Number	Conductor		C	H	K	Stud Hole Size	L	T	Recommended Tightening Torque in-lb
	Commercial	Navy							
QDA8C	14 Sol. - 8 Str.	3 - 14	1	11/16	7/16	3/8	1-7/8	3/16	75
QDA4C	8 Str. - 4 Str.	23 - 40		3/4				7/32	110
QDA1C	4 Str. - 1 Str.	50 - 75		1				9/32	150
QDA26	1/0 Str. - 2/0 Str.	100 - 125	1-1/4	1-3/16	9/16	1/2	2-1/2	5/16	180
QDA28	3/0 Str. - 4/0 Str.	150 - 200		1-5/16					250
QDA31	250 - 350 kcmil	250 - 350	1-1/2	1-11/16	11/16	5/8	3	5/16	325
QDA34	400 - 500 kcmil	400 - 500	1-7/8	2	13/16	3/4	3-5/8	3/8	375
QDA40	600 - 800 kcmil	650 - 800	2-1/8	2-5/16	1-1/16	1	4-3/16	3/8	500

TYPE QR QIKLINK™

SPLICE OR REDUCER

For Copper Cable to Cable

High copper alloy splicer/reducer for joining a range of cable end to end. Neat, compact easy to tape installation. One-wrench installation.

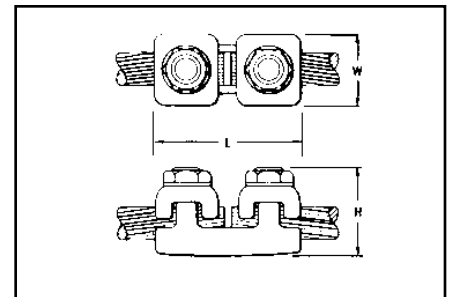

Catalog Number	Conductor Either Size	H	L	W	Recommended Tightening Torque in-lb
QR4C	8 Str. - 4 Str.	3/4	1-11/16	5/8	110
QR1C	4 Str. - 1 Str.	1-1/16	1-15/16	11/16	150
QR26	1/0 Str. - 2/0 Str.	1-3/16	2-1/8	13/16	180
QR28	3/0 Str. - 4/0 Str.	1-3/8	2-3/8	1	250
QR31	250 - 350 kcmil	1-11/16	2-5/8	1-1/4	325
QR34	400 - 500 kcmil	1-15/16	3-1/16	1-7/16	375
QR40	600 - 800 kcmil	2-7/16	3-5/8	1-7/8	500

See note page A-2.

Blue highlighted items are industry standard and most frequently ordered.

TYPE VT

VARITAP™ T-CONNECTOR

For Copper Cable to Cable

High copper alloy T-connector for cable run, cable tap. V-bolt clamping elements accommodate large range of cable and are particularly suited for extra flexible cable. One-wrench installation.

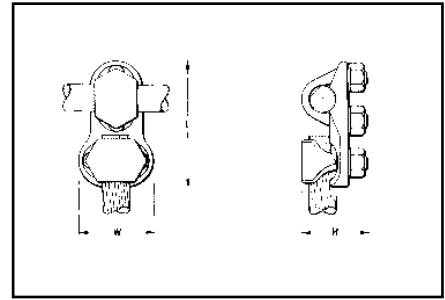
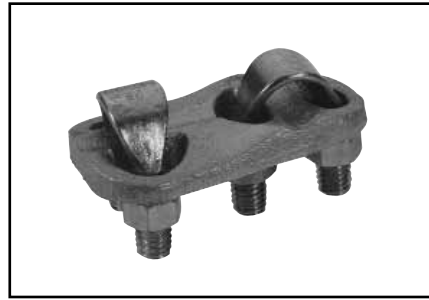

Catalog Number	Conductor		H	L	W	Recommended Tightening Torque in-lb	
	Run	Tap				Run	Tap
VT2C2C	8 Sol. - 2 Str.	8 Sol. - 2 Str.	1-5/16	2-5/16	1-5/16	275	275
VT2525	6 Sol. - 1/0 Str.	6 Sol. - 1/0 Str.	1-5/8	2-5/8	1-7/16	385	385
VT2825	1/0 Str. - 4/0 Str.	6 Sol. - 1/0 Str.		3-1/8	1-1/4	250	385
VT2828		1/0 Str. - 4/0 Str.	1-11/16	1-11/16	250	250	
VT3025	1/0 Str. - 300 kcmil	6 Sol. - 1/0 Str.	1-7/8	3-3/8	1-3/8	325	385
VT3030		1/0 Str. - 300		3-5/16	1-15/16	325	325
VT3425	300 - 500 kcmil	6 Sol. - 1/0 Str.	2-5/16	3-11/16	1-1/2	375	385
VT3428		1/0 Str. - 4/0 Str.		3-1/2	1-11/16	375	250
VT3430		1/0 Str. - 300		3-5/8	1-15/16	375	325
VT3434		300 - 500		3-3/4	2-1/4	375	375
VT4040	500 - 800 kcmil	500 - 800	2-9/16	4-1/2	2-5/8	500	500
VT4425	750 - 1000 kcmil	6 Sol. - 1/0 Str.	2-7/8	4-5/16	2	500	385
VT4428		1/0 Str. - 4/0 Str.		4-1/8	2	500	250
VT4834	1500 - 2000 kcmil	300 - 500	4-1/4	5-1/4	5	600	375

✎ See note page A-2

TYPE E-C-G

TRANSFORMER TAP ADAPTER

For Copper

Multi-tap, range-taking cast copper alloy connector designed to take 2, 3 or 4 conductors from a single secondary transformer outlet.

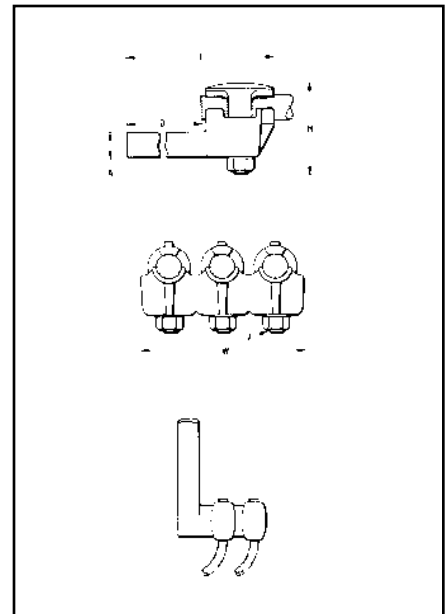

Catalog Number	No. of Conductors	Conductor Size	A Dia.	D	H	J	L	W	Recommended Tightening Torque in-lb
E2C34G1	2	1/0 Sol. - 500 kcmil	.78	3-3/4	2-7/8	1/2-13	6-1/4	3-1/2	480
E3C34G1	3							5-1/4	
E4C34G1	4							6-7/8	

Blue highlighted items are industry standard and most frequently ordered.

TYPES VA, VVA

VARILUG™

For Copper Cable

High copper alloy terminal for joining a wide range of cable to equipment pads or bar. Particularly suitable for use on extra flexible cable. One-wrench installation. Type VVA, twin elements secure joint against vibration and flexing. Particularly recommended for use on extra flexible cables. One-wrench installation.

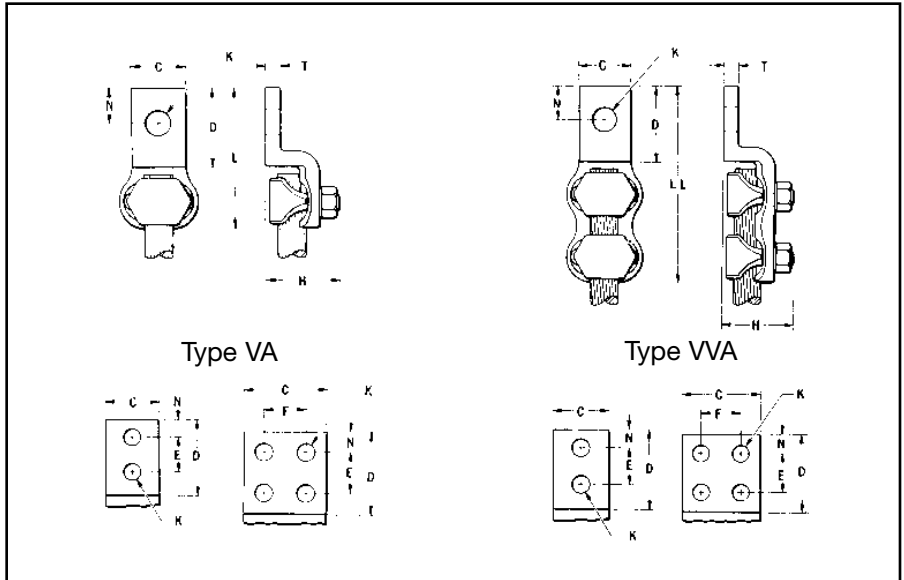

Catalog Number*		Conductor	No. of Holes in Pad	C	D	E & F	H	K	Stud Hole Size	L	LL	N	T	Recommended Tightening Torque in-lb
Type VA	Type VVA													
VA2C	VVA2	8 Sol. - 2 Str.	1	13/16	1-1/4	—	1-1/2	7/16	3/8	2-3/4	4-1/16	13/32	1/4	275
VA25	VVA25	6 Sol. - 1/0 Str.		7/8	1-5/16	—	1-7/8			2-7/8	4-5/16	7/16		385
VA28	VVA28	1/0 Str. - 4/0 Str.	1	1-1/16	1-1/2	—	2-1/4	7/16	1/2	2-7/8	4-1/8	17/32	5/16	250
VA28-2N	VVA28-2N		2 NEMA		3-1/2	1-3/4		9/16		4-15/16	6-3/6	5/8		
VA30	VVA30	1/0 Str. - 300 kcmil	1	1-1/8	1-5/8	—	2-3/16	7/16	3/8	3-1/4	4-5/8	5/8	5/16	325
VA30-2N	VVA30-2N		2 NEMA		3-9/16	1-3/4		5-3/16		6-9/16	5/8			
VA34	VVA34	300 - 500 kcmil	1	1-3/8	2	—	3-11/32	9/16	1/2	3-13/16	5-5/16	13/16	3/8	375
VA34-2N	VVA34-2N		2 NEMA		3-5/8	1-3/4				5-3/8	6-7/8	5/8		
VA34-4N	VVA34-4N		4 NEMA		3	3-5/8				1-3/4	5-3/8	6-7/8		
VA40	VVA40	500 - 800 kcmil	1	1-5/8	2-5/16	—	2-7/8	11/16	5/8	4-1/2	6-3/8	15/16	3/8	500
VA40-2N	VVA40-2N		2 NEMA		3-5/8	1-3/4		9/16		5-13/16	7-11/16	5/8		
VA40-4N	VVA40-4N		4 NEMA		3	2-5/8		1-3/4		9/16	5-13/16	7-11/16		

*"N" indicates NEMA standard stud holes.
All 4N items See note page A-2

Blue highlighted items are industry standard and most frequently ordered.

TYPE HFB-P1

BAR CLAMP ASSEMBLY COMPONENTS

For Copper Bar

To build your own high strength clamp assembly for multiple flat bar using type HFB-P1 bar clamps and clamping hardware, the following tables have been provided. The clamp assembly eliminates the need for drilling the flat bar and is used in indoor and outdoor applications.

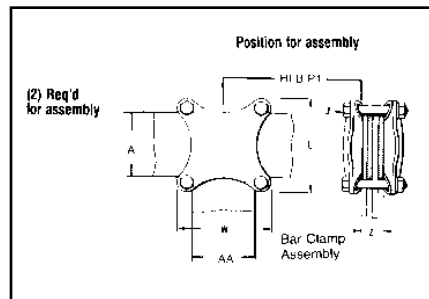

One Clamp Half							
Bar Clamp Bar			"J" Bolt Dia.	L	W	Z	Recommended Tightening Torque in-lb
Catalog Number	Run 'A'	Tap 'AA'					
HFB22P1	2.00	2.00	3/8	4.38	4.38	*	240
HFB33P1	3.00	3.00	3/8	4.38	4.38	*	240
HFB42P1	4.00	2.00	3/8	5.75	5.75	*	240
HFB44P1	4.00	4.00	1/2	5.75	5.75	*	480
HFB63P1	6.00	3.00	1/2	7.75	4.75	*	480
HFB66P1	6.00	6.00	5/8	8.12	8.12	*	660
HFB88P1	8.00	8.00	3/4	10.50	10.50	*	1990

*Z=Space between the bar clamp contact surfaces

Bar Clamp Assembly Components †									
Copper Bus Bar Width (Inches)		Silicon Bronze Clamping Hardware							
		Bar Clamp		Bolts		Nuts		Split Lock Washers	
Run-A	Tap-AA	Qty.	Cat. No.	Qty.	Cat. No.	Qty.	Cat. No.	Qty.	Cat. No.
2	2	2	HFB22P1	4	38 X (*) HEB	4	38CHEN	4	38SW
3	3	2	HFB33P1	4	38 X (*) HEB	4	38CHEN	4	38SW
4	2	2	HFB42P1	4	38 X (*) HEB	4	38CHEN	4	38SW
4	4	2	HFB44P1	4	50 X (*) HEB	4	50CHEN	4	50SW
6	3	2	HFB63P1	4	50 X (*) HEB	4	50CHEN	4	50SW
6	6	2	HFB66P1	4	62 X (*) HEB	4	62CHEN	4	62SW
8	8	2	HFB88P1	4	75 X (*) HEB	4	75CHEN	4	75SW

† Ordered separately from BURNDY®.

* See table below when ordering assembly clamping bolts to specify correct bolt length in Cat. #.

Bolt Length									
Clamp Number	"J" Bolt Dia.	When Z = 1.25	When Z = 1.50	When Z = 1.75	When Z = 2.00	When Z = 2.25	When Z = 2.50	When Z = 2.75	When Z = 3.00
HFB22P1	3/8 (-16)	3.00	3.25	3.50	4.00	4.00	4.50	4.50	5.00
HFB33P1	3/8 (-16)	3.00	3.25	3.50	4.00	4.00	4.50	4.50	5.00
HFB42P1	3/8 (-16)	3.00	3.25	3.50	4.00	4.00	4.50	4.50	5.00
HFB44P1	1/2 (-13)	3.25	3.50	3.75	4.00	4.50	4.50	5.00	5.00
HFB63P1	1/2 (-13)	3.25	3.50	3.75	4.00	4.50	4.50	5.00	5.00
HFB66P1	5/8 (-11)	3.50	4.00	4.00	4.50	4.50	5.00	5.00	5.50
HFB88P1	3/4 (-10)	3.75	4.00	4.50	4.50	5.00	5.00	5.50	5.50

NOTE: When ordering assembly bolts specify correct bolt length in catalog number as indicated in table.

Blue highlighted items are industry standard and most frequently ordered.

TYPE HFB-N

**BAR CLAMP
TAP PAD ADAPTER**

For Copper Bar

High conductivity copper, tap pad adapter provides a NEMA drilled contact pad when assembled to the HFB-P1 clamps. Tap connections can be made from copper bus bar(s) without drilling, by bolting standard mechanical or compression terminal pads directly to the pre-drilled tap pad

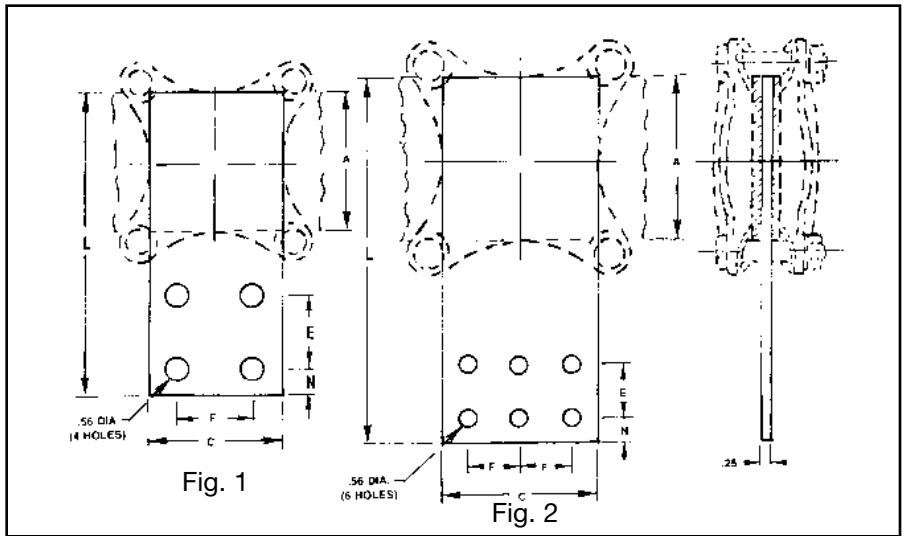

Catalog Number	Fig. No.	A-C	E & F	L	N	Use with 'H' Clamp Catalog Number ①
HFB33-4N	1	3.00	1.75	7.00	.62	HFB33P1
HFB44-4N	1	4.00	1.75	9.12	1.12	HFB44P1
HFB66-6N	2	6.00	1.75	11.31	1.12	HFB66P1

① 'H' Clamp (two required per assembly) and hardware (as shown) not included with bar clamp tap pad, order separately.

Blue highlighted items are industry standard and most frequently ordered.

TYPES KA-U, KKA-U

UNIVERSAL TERMINAL

(One Conductor)
For Aluminum and
Copper Conductors

These dual-rated one-conductor lugs are constructed from high strength aluminum alloy and electro tin-plated to provide low contact resistance.



AL9CU

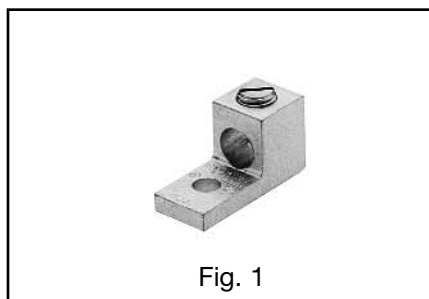

Fig. 1

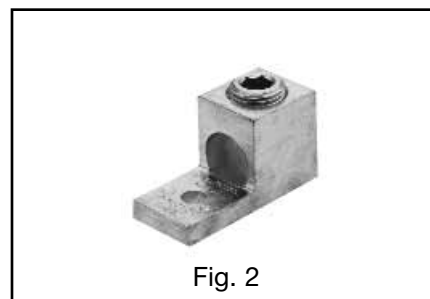

Fig. 2

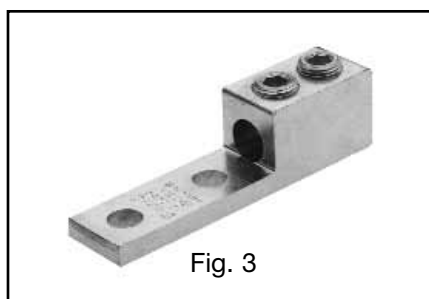

Fig. 3

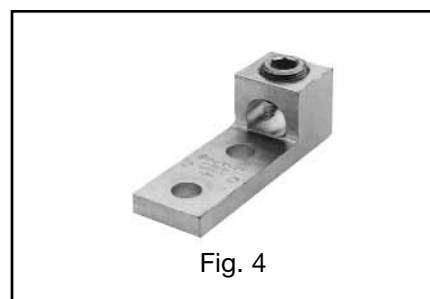
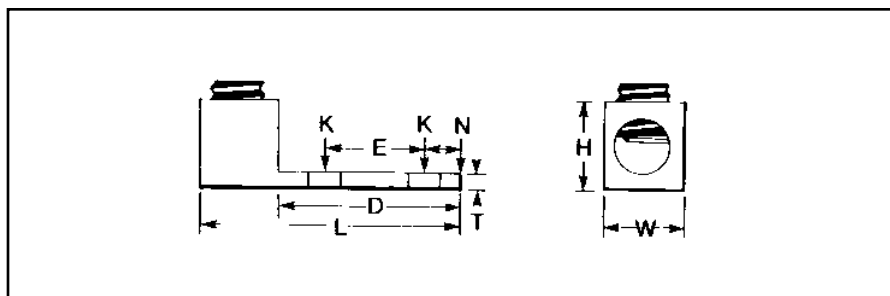

Fig. 4



Catalog Number*	Fig. No.	Wire Range Aluminum or Copper	Stud Hole Size	Dimensions							Recommended Tightening ▲ Torque in-lb
				D	L	N	** W	E	T	** H	
KA6U	1	14 Str. - 6 Str.	1/4	.63	1.06	.25	.50	—	.09	.50	45
KA2U	1	14 Str. - 2 Str.		.63	1.16	.31	.50	—	.10	.55	50
KA25U	1	14 Str. - 1/0 Str.		.81	1.50	.44	.63	—	.19	.80	50
KA26U	2	6 Str. - 2/0 Str.		.81	1.47	.47	.63	—	.19	.80	120
KA29U	2	6 Str. - 250 kcmil	5/16	.94	2.00	.50	1.00	—	.25	1.13	275
KA30U	2	6 Str. - 300 kcmil		.94	2.00	.50	1.00	—	.25	1.12	275
KA31U	2	6 Str. - 350 kcmil	3/8	1.03	2.25	.88	1.13	—	.25	1.25	275
KA34U	2	4 Str. - 500 kcmil		1.50	2.81	.88	1.51	—	.31	1.58	500
KA36U	2	2 Str. - 600 kcmil		1.72	3.19	.78	1.50	—	.44	1.56	500
KA40U	2	300 - 800 kcmil	1/2	1.69	3.38	.88	1.75	—	.50	1.94	550
KA44U	2	500 - 1000 kcmil		1.69	3.38	.88	1.75	—	.50	1.94	550
KKA31U-2N	3	6 Str. - 350 kcmil	1/2	3.16	5.50	.63	1.25	1.75	.38	1.50	275
KA36U-2N	4	2 Str. - 600 kcmil		3.22	4.69	.63	1.50	1.75	.44	1.57	500
KA40U-2N	4	300 - 800 kcmil		3.03	4.75	.63	1.75	1.75	.50	1.94	500
KA44U-2N	4	500 - 1000 kcmil		3.03	4.75	.63	1.75	1.75	.50	1.94	550

* "N" indicates NEMA standard stud holes.

▲ Listed torque values are for maximum conductor sizes accommodated. Consult UL486 Tables 7-4, 7-5, 7-6 for smaller conductor sizes.

** Maximum dimension.

Blue highlighted items are industry standard and most frequently ordered.

TYPE K2A-U

UNIVERSAL TERMINAL

(Two Conductor)
For Aluminum and
Copper Conductors

These dual-rated two-conductor lugs are constructed from high strength aluminum alloy and electro tin-plated to provide low contact resistance.

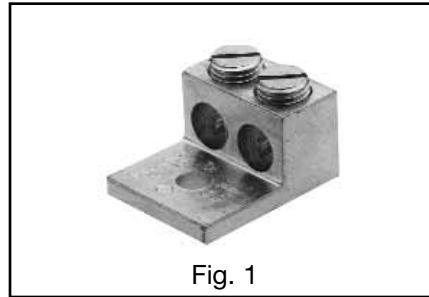

Fig. 1

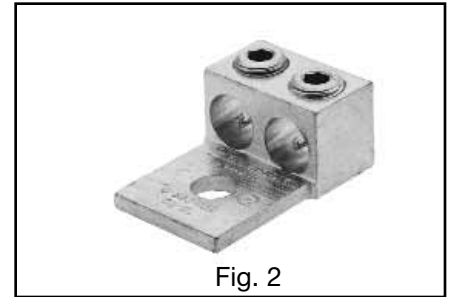

Fig. 2

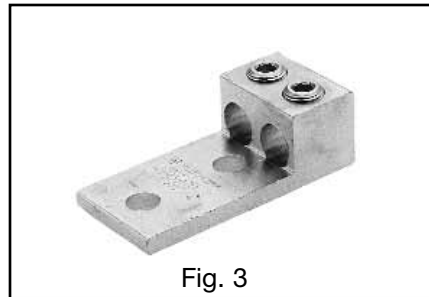
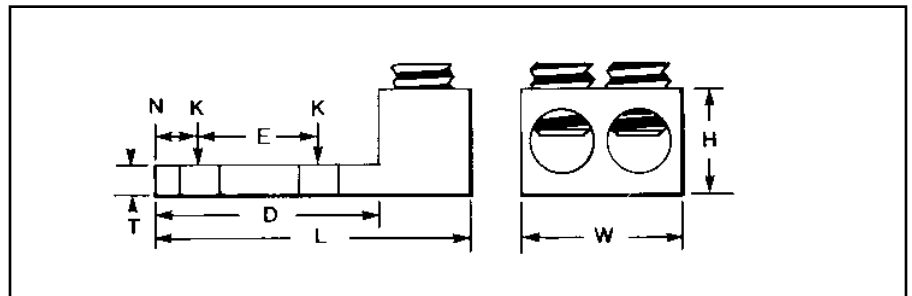

Fig. 3



Catalog Number*	Fig. No.	Wire Range Aluminum or Copper	Stud Hole Size	Dimensions						Recommended Tightening ▲ Torque in-lb	
				D	L	N	** W	E	T		** H
K2A25U	1	Two: 14 Str. - 1/0 Str.	1/4	.81	1.47	.44	1.13	—	.19	.79	50
K2A26U	2	Two: 14 Str. - 2/0 Str.		.81	1.47	.44	1.25	—	.19	.79	120
K2A29U	2	Two: 6 Str. - 250 kcmil	3/8	1.50	2.56	.50	1.66	—	.25	1.20	275
K2A31U	2	Two: 6 Str. - 350 kcmil	1/2	1.69	2.88	.88	1.94	—	.25	1.25	275
K2A36U	2	Two: 2 Str. - 600 kcmil		1.75	3.20	.63	2.41	—	.44	1.58	375
K2A40U	2	Two: 300 - 800 kcmil	5/8	1.66	3.38	.88	3.19	—	.50	1.94	550
K2A44U	2	Two: 500 - 1000 kcmil		1.66	3.50	.88	3.52	—	.50	1.94	550
K2A31U-2N	3	Two: 6 Str. - 350 kcmil	1/2	3.00	4.50	.63	2.31	1.75	.31	1.38	275
K2A36U-2N	3	Two: 2 Str. - 600 kcmil		3.22	4.69	.63	2.41	1.75	.44	1.56	375
K2A40U-2N	3	Two: 300 - 800 kcmil		3.03	4.75	.63	3.19	1.75	.50	1.94	375
K2A44U-2N	3	Two: 500 - 1000 kcmil		3.03	4.75	.63	3.19	1.75	.50	1.94	375

* "N" indicates NEMA standard stud holes.

▲ Listed torque values are for maximum conductor sizes accommodated. Consult UL486 Tables 7-4, 7-5, 7-6 for smaller conductor sizes.

** Maximum dimension.

Blue highlighted items are industry standard and most frequently ordered.

TYPES K3A-U, KK3A-U

UNIVERSAL TERMINAL

(Three Conductor)
For Aluminum and
Copper Conductors

Dual-rated three-conductor lugs are constructed from high strength aluminum alloy and electro tin-plated to provide low contact resistance.



AL9CU

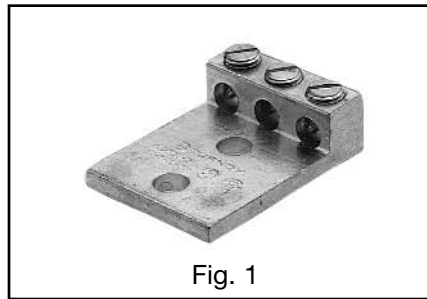

Fig. 1

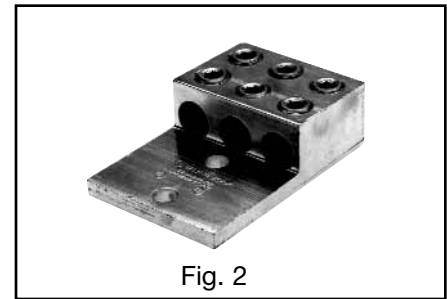

Fig. 2

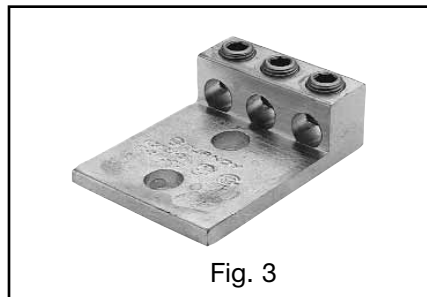
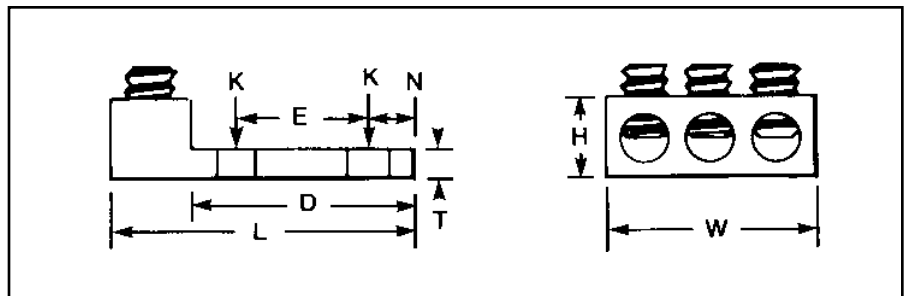

Fig. 3



Catalog Number*	Fig. No.	Wire Range Aluminum or Copper	K	Stud Hole Size	Dimensions						Recommended Tightening ▲ Torque in-lb	
					D	L	N	W	E	T		H
K3A2U-2*	1	Three: 14 Str. - 2 Str.	11/32	5/16	1.63	2.19	.34	1.59	.88	.19	.62	50
K3A25U-2*	1	Three: 14 Str. - 1/0 Str.	7/16	3/8	2.09	2.91	.34	1.94	1.00	.25	.88	
K3A26U-2N	3	Three: 14 Str. - 2/0 Str.	9/16	1/2	3.06	3.75	.63	1.95	1.75	.19	1.79	275
K3A27U-2N	3	Three: 6 Str. - 3/0 Str.			3.00	3.88	.63	2.81		.31	1.12	
K3A29U-2N	3	Three: 6 Str. - 250 kcmil			3.00	4.00	.63	2.81		.31	1.19	
K3A31U-2N	3	Three: 6 Str. - 350 kcmil			3.52	4.31	.63	3.00		.31	1.38	
K3A36U-2N	3	Three: 2 Str. - 600 kcmil			3.22	4.69	.63	3.63		.44	1.56	
KK3A36U-2N	2	Three: 2 Str. - 600 kcmil			3.00	5.63	.56	4.22		.44	1.69	
KK3A40U-2N	2	Three: 300 - 800 kcmil			3.03	5.69	.63	4.81		.50	1.94	
KK3A44U-2N	2	Three: 500 - 1000 kcmil	3.34	6.19	.63	4.75	.56	1.88	375			

* Slotted screw.

** "N" indicates NEMA standard stud holes.

▲ Listed torque values are for maximum conductor sizes accommodated.
Consult UL486 Tables 7-4, 7-5, 7-6 for smaller conductor sizes. All 4N items See note page A-2

Blue highlighted items are industry standard and most frequently ordered.

TYPES K3A-U, KK3A-U

(Continued)

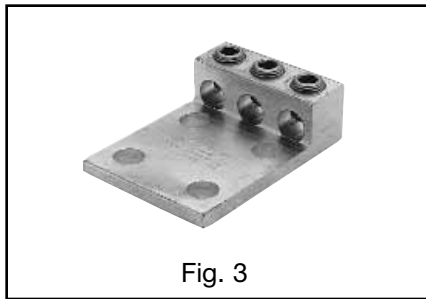

Fig. 3

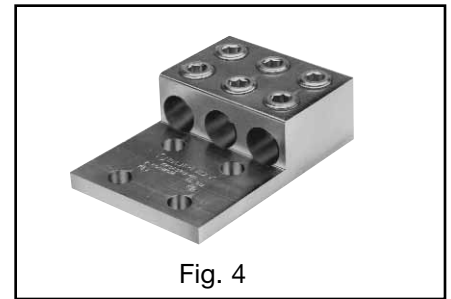
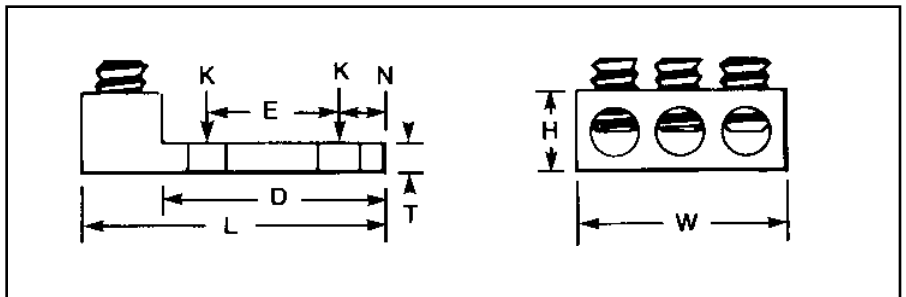

Fig. 4



Catalog Number**	Fig. No.	Wire Range Aluminum or Copper	K	Stud Hole Size	Dimensions							Recommended Tightening ▲ Torque in-lb
					D	L	N	W	E	T	H	
K3A2U-4*	3	Three: 14 Str. - 2 Str.	11/32	5/16	1.63	2.19	.34	1.59	.88	.19	.62	50
K3A25U-4*	3	Three: 14 Str. - 1/0 Str.	7/16	3/8	2.09	2.91	.34	1.94	1.00	.25	.88	
K3A27U-4N	3	Three: 6 Str. - 3/0 Str.	9/16	1/2	3.00	3.88	.63	2.81	1.75	.31	1.12	275
K3A29U-4N	3	Three: 6 Str. - 250 kcmil			3.00	4.00		2.81		.31	1.19	
K3A31U-4N	3	Three: 6 Str. - 350 kcmil			3.00	4.31		3.00		.31	1.38	
K3A36U-4N	3	Three: 2 Str. - 600 kcmil			3.22	4.69		3.63		.44	1.56	
K3A40U-4N	3	Three: 300 - 800 kcmil			3.03	4.75		4.81		.50	1.94	375
KK3A36U-4N	4	Three: 2 Str. - 600 kcmil			3.00	5.63		4.22		.44	1.69	
KK3A40U-4N	4	Three: 350 - 800 kcmil			3.34	6.19		5.34		.56	1.88	275
KK3A44U-4N	4	Three: 500 - 1000 kcmil			3.34	6.19		4.75		.56	1.88	375

* Slotted screw
 ** "N" indicates NEMA standard stud holes.
 ▲ Listed torque values are for maximum conductor sizes accommodated. Consult UL486 Tables 7-4, 7-5, 7-6 for smaller conductor sizes.
 All 4N items See note page A-2

Blue highlighted items are industry standard and most frequently ordered.

TYPES K4A-U, KK4A-U

UNIVERSAL TERMINAL

(Four Conductor)
For Aluminum and
Copper Conductors

These dual-rated four conductor lugs are constructed from high strength aluminum alloy and electro tin-plated to provide low contact resistance.

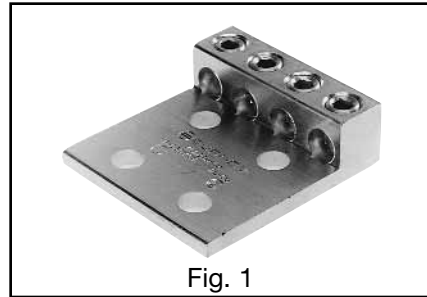

Fig. 1

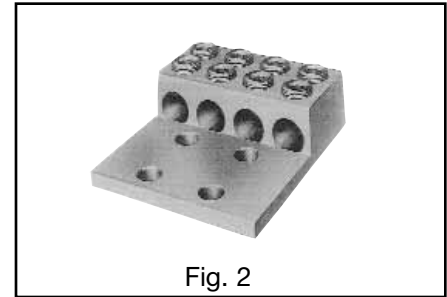
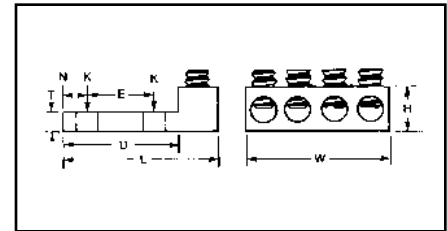

Fig. 2



Catalog Number*	Fig. No.	Wire Range Aluminum or Copper	Stud Hole Size	Dimensions							Recommended Tightening ▲ Torque in-lb
				D	L	N	W	E	T	H	
K4A29U-4N	1	Four: 6 Str. - 250 kcmil	1/2	3	4	.63	3.69	1.75	.31	1.19	275
K4A31U-4N	1	Four: 6 Str. - 350 kcmil		3	4.31		5.04		.31	1.38	
KK4A36U-4N	2	Four: 2 Str. - 600 kcmil		3.34	5.63		5		.44	1.69	
KK4A40U-4N	2	Four: 300 - 800 kcmil		3	6.19		6		.56	1.88	375

* "N" indicates NEMA standard stud holes.
All 4N items See note page A-2

TYPES K11A-U, K21A-U, K22A-U

UNIVERSAL TERMINAL

For Aluminum and
Copper Conductors

Dual-rated panelboard lugs are constructed from high strength extruded aluminum alloy and electro tin-plated to provide low contact resistance.

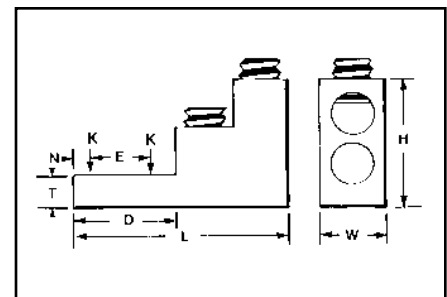
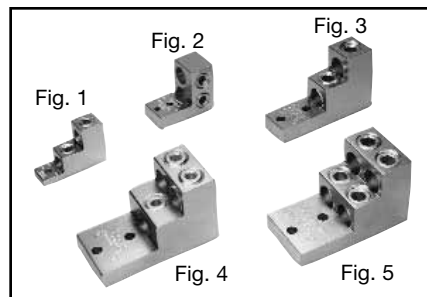

Catalog Number	Fig. No.	Wire Range Aluminum or Copper	Stud Hole Size	Dimensions							Recommended Tightening ▲ Torque in-lb
				D	L	N	W	E	T	H	
K11A30U	1	Two: 6 Str. - 300 kcmil	5/16	.94	3.00	.47	1.00	—	.31	2.00	275
K11A34U-2	2	Two: 4/0 Str. - 500 kcmil	1/4	2.31	4.91	.38	1.50	.69	.63	2.38	375
K11A36U-2	3	Two: 2 Str. - 600 kcmil									
K21A36U-2	4	Three: 2 Str. - 600 kcmil	3/8	2.31	4.91	.38	2.50	1.38	.75	3.00	
K22A36U-2	5	Four: 2 Str. - 600 kcmil					2.50				
K11A39U-2	3	Two: 1/0 Str. - 750 kcmil					1.69				
K22A39U-2	5	Four: 1/0 Str. - 750 kcmil				3.06					

▲ Listed torque values are for maximum conductor sizes accommodated. Consult UL486 Tables 7-4, 7-5, 7-6 for smaller conductor sizes.

Blue highlighted items are industry standard and most frequently ordered.

TYPE KAU-KIT

TRANSFORMER LUG KIT

These dual-rated lugs are constructed from high strength aluminum alloy and electro tinned to provide low contact resistance. Lugs and mounting hardware packaged together in these kits.

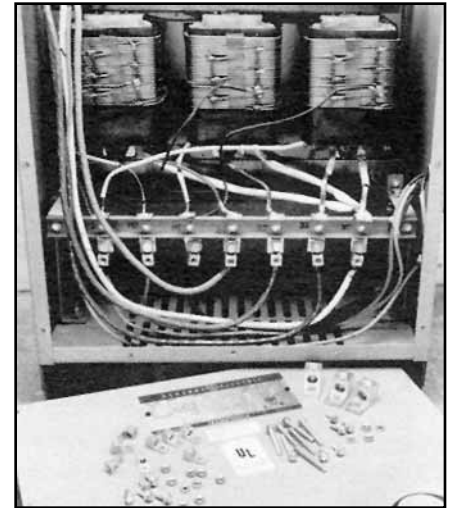
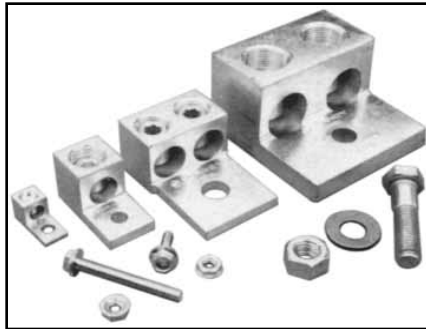

Features and Benefits

- UL listed AL9CU dual rated set screw terminals and CSA certified.
 - ◇ Ensure the transformer feeders and taps are terminated properly.
- Plated steel cap screws and hex nuts with captive conical washers or individual Belleville washers.
 - ◇ Terminal to bus connections are made using proper hardware resulting in true torque to pressure performance. Compensates for dissimilar metal expansion and contraction.
- Hardware packed in plastic bag.
 - ◇ No lost hardware prior to installation.
- Larger 800 kcmil lugs in KIT3 and KIT4.
 - ◇ Accommodates common 750 kcmil tap conductors in larger transformers.

Catalog Number	Transformer KVA Rating		Terminals		Wire Range Aluminum or Copper	Hardware					
			Qty.	Catalog Number		Qty.	Bolt Size	Qty.	Nut	Qty.	Washer
KAU-KIT1	15 - 37.5	1Ø	8	KA2U	#14 - 2	8	1/4-20 × 3/4 HH	8	1/4 × 20 HN	—	Captive to Nut
	15 - 45	3Ø	4	KA29U	#6 - 250 kcmil						
KAU-KIT2	50 - 75	1Ø	12	KA29U	#6 - 250 kcmil	8	1/4-20 × 3/4 HH	16	1/4 × 20 HN	—	Captive to Nut
	75 - 112.5	3Ø				8	1/4-20 × 2 HH				
KAU-KIT3	100 - 167	1Ø	6	K2A31U	#6 - 350 kcmil	5	1/2-13 × 3 HH	11	1/2-13 HN	22	1/2 FW
	150 - 300	3Ø	7	K2A40U	300 - 800 kcmil	6	1/2-13 × 2-1/2 HH			11	1/2 Belleville
KAU-KIT4	400 - 500	3Ø	15	K2A40U	300 - 800 kcmil	7	1/2-13 × 2	11	1/2-13 HN	22	1/2 FW
						4	1/2-13 × 2-1/2			11	1/2 Belleville

Blue highlighted items are industry standard and most frequently ordered.

TYPE AMS

DUAL RATED SPLICER/REDUCER

For Copper and
Aluminum Cable

All splicer/reducers are dual rated for use with aluminum and copper conductors and are constructed from high strength, tin plated aluminum. PENTROX™ oxide inhibiting joint compounds are recommended for all aluminum applications.

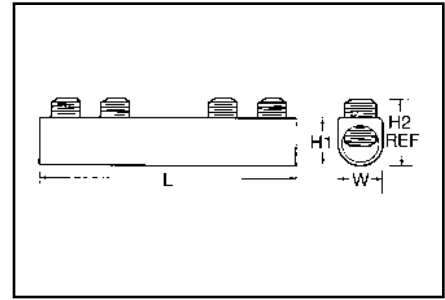

Features and Benefits

- All connectors are tin-plated.
 - ◇ Provide low contact resistance and prevents galvanic corrosion.
- Connectors feature rounded bottoms.
 - ◇ Facilitates taping.
- Solid center barrier.
 - ◇ Prevents contact of dissimilar metals.
- Large screw diameters.
 - ◇ Ensures greater surface contact with wires for maximum pullout force.
- Large cable ranges.
 - ◇ Each splice is also an effective reducing connector.

Catalog Number	Wire Range		L	W	H1	H2 Max.	No. of Screws	Screw Dia.	Hex Size
	Max.	Min.							
AMS-2*	AWG 2	AWG 14	1-19/32	9/16	9/16	.79	2	3/8	S
AMS-0*	AWG 1/0	AWG 14	1-29/32	3/4	3/4	.86	2	7/16	S
AMS-4/0	AWG 4/0	AWG 6	2-5/16	1	1-3/32	1.28	2	9/16	5/16
AMS-250	250 kcmil	AWG 6	4-3/32	1	1-3/32	1.29	4	5/8	5/16
AMS-350	350 kcmil	AWG 6	4-11/32	1	1-3/32	1.30	4	11/16	5/16
AMS-500	500 kcmil	AWG 3/0	4-25/32	1-1/4	1-3/8	1.48	4	13/16	3/8
AMS-750	750 kcmil	250 kcmil	6-1/16	1-7/16	1-5/8	1.98	4	15/16	1/2
AMS-1000	1000 kcmil	500 kcmil	8-11/16	1-21/32	1-7/8	2.34	6	1-1/8	9/16

* Slotted Screws. H2 measured with maximum conductors, reference only.

✓ Complies with NFPA 78-86.

Blue highlighted items are industry standard and most frequently ordered.

TYPE AGSKIT

ABOVE GRADE SPLICE KITS

For All Aluminum or Copper/Aluminum Combinations

Type AGS Above Grade Splice Kit consists of a standard AMS splice/reducer and a heavy wall heat-shrink sleeve. The AMS Splice is dual rated for use with aluminum and copper conductors and are constructed from high strength, tin plated aluminum that provides low contact resistance and reduces the effects of galvanic corrosion. Connector is installed with common installation tools. The heavy wall heat shrink sleeve is lined with adhesive material, providing a positive seal against moisture egress. Heat shrink sleeve is installed with standard propane torch, or electric heat gun.



Fig. 1



Fig. 2



Catalog Number	Figure Number	Wire Range	
		Maximum	Minimum
AGSKIT2	1	2	8
AGSKIT250	2	250	1

TYPE UGSKIT

WATERTIGHT/ UNDERGROUND SPLICE KITS

For all Aluminum or Copper/Aluminum Combinations

Type UGS Watertight Underground Splice Kit consists of a standard AMS splice/reducer and two heavy wall heat-shrink sleeves. The AMS Splice is dual rated for use with aluminum and copper conductors and are constructed from high strength, tin plated aluminum that provides low contact resistance and reduces the effects of galvanic corrosion. Connector installed with common installation tools. Both heavy wall heat shrink sleeves are lined with adhesive material, providing a watertight splice that can withstand abrasions that may occur during direct burial applications. Heat shrink sleeve installed with standard propane torch, or electric heat gun.



Fig. 1



Fig. 2



Catalog Number	Figure Number	Wire Range	
		Maximum	Minimum
UGSKIT2*	1	2	8
UGSKIT250*	2	250	1

*UL486D Listed for Direct Burial

Blue highlighted items are industry standard and most frequently ordered.

TYPE UGSKIT8

UF DIRECT BURIAL SPLICE KIT

Type UGS UF Splice Kit consists of a UF splice connector and a heavy wall heat-shrink sleeve. The UF splice connector can accommodate up to four UF conductors and is installed with common installation tools. The heavy wall heat shrink sleeve is lined with an adhesive material, providing a water-tight splice that can withstand abrasions that may occur during direct burial applications. Heat shrink sleeve installed with standard propane torch, or electric heat gun.



Catalog Number	Wire Range
	Copper
UGSKIT8*	8 AWG – 14 AWG

*UL486D Listed for Direct Burial.

TYPE UGS350ULDB

IN-LINE SPLICE/REDUCER

For Direct Burial

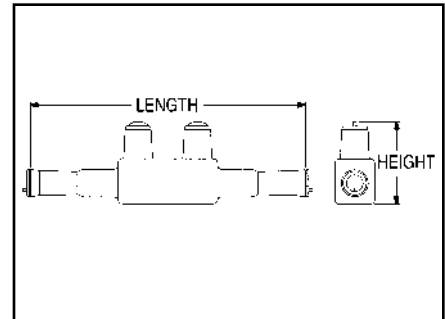

Features and Benefits

- EPDM rubber covered 6061-T6 aluminum connector.
- Dual rated AL9CU for copper or aluminum conductor.
- UL Listed and CSA Certified for Direct Burial.
- Broad range taking capability.
- Low installation cost.

Catalog Number	Wire Range	Length In. [mm]	Height In. [mm]	Hex Size	Torque (In. Lbs.)
UGS350ULDB	AWG 12 - 350 kcmil	8.50 [216]	2.81 [71.4]	5/16"	350

Dimensions in brackets [] are in millimeters.

Blue highlighted items are industry standard and most frequently ordered.

**BURNDY® UNITAP™
THE MOLE™**

For Direct Burial

600V, 90°C

Designed specifically for direct burial applications, the MOLE™ inline splice/reducer is made with a specialized plastisol material that forms a rugged weathertight connection.



Features and Benefits

- UL486D Listed for direct burial.
- AL9CU Dual-rated for copper and aluminum applications. 600V 90°C.
- Plastisol covered AL6061-T6 aluminum body saves time by eliminating the need for heat shrink.
- Oxide inhibitor pre-installed preventing moisture and contaminants from entering contact area.
- Range-taking capability reduces the number of connectors carried in inventory.

Catalog Number	Number of Ports	Wire Range (AWG/kcmil)	Dimensions (Inches)			Hex Key (Torque) (In.-lbs.)	Wire Strip Length
			L	W	H		
BISR4-DB	2	#6 - 4 AWG	4.30	0.80	1.28	1/8 (50)	7/8"
BISR1-DB	2	#2 - 1 AWG	6.30	0.93	1.59	5/32 (130)	1-3/32"
BISR3/0-DB	2	1/0 - 3/0 AWG	6.25	0.99	1.84	3/16 (220)	1-3/32"
BISR250-DB	2	4/0 - 250 kcmil	6.70	1.18	2.03	5/16 (360)	1-5/16"

BISR-DB = BURNDY Inline Splice/Reducer Direct Burial.
UNITAP™ rated for code conductor only.

Blue highlighted items are industry standard and most frequently ordered.

TYPE QGFL

BARTAP™

For Copper Cable To Flat

High copper alloy BARTAP™ for joining a range of cable to bar or pad. One-wrench installation.

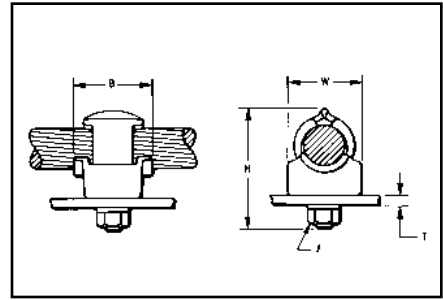
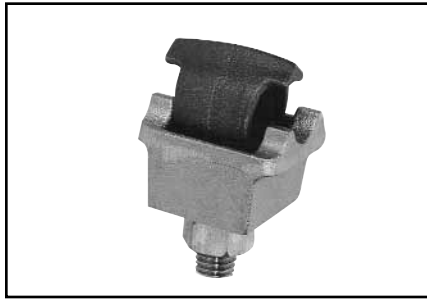

Catalog Number	Copper Conductor	B	H	J	T (Max.)	W					
QGFL1CB1	10 Sol. - 1 Str.	1-1/8	1-7/8	3/8	1/4	1					
QGFL1CB1T6			2-3/8		3/4						
QGFL26B1	8 Sol. - 2/0 Str.	1-1/4	2-1/8		1/2	1/4	1-1/8				
QGFL26B1T6			2-5/8			3/4					
QGFL26B2*			2-1/2	1/4							
QGFL26B2T6*			2-1/8	3/4							
QGFL29B1*	6 Str. - 250 kcmil	1-1/2	2-5/8	1/2		1/4	1-3/8				
QGFL29B1T6*			3-1/8			3/4					
QGFL31B1*	2 Sol. - 350 kcmil	1-5/8	2-7/8			1/2	1/4	1-5/8			
QGFL31B1T6*			3-1/4				3/4				
QGFL34B1	1/0 Sol. - 500 kcmil	1-3/4	3-1/8		1/2		1/4	1-3/4			
QGFL34B1T6			3-5/8				3/4				
QGFL39B1	350 - 750 kcmil	2	3-1/4				1/2		1/4	1-3/4	
QGFL39B1T6			3-5/8						3/4		
QGFL44B1	750 - 1000 kcmil	2-1/4	3-3/8					1/2	1/4	2-1/8	
QGFL44B1T6			4-1/8						3/4		
QGFL46B1	1000 - 1500 kcmil		2-1/4	4					1/2	1/4	2-1/2
QGFL46B1T6				4-1/2						3/4	
QGFL48B1	1500 - 2000 kcmil	5-1/4		1/4						3	

* Can be installed side by side or in-line on NEMA drilled bar.

Blue highlighted items are industry standard and most frequently ordered.

TYPE FCB

**TRANSFORMER
TAP ADAPTER**

For Copper and Aluminum

Silver brazed 101% conductivity copper transformer tap adapter designed to accommodate from 1 to 6 NEMA drilled copper or aluminum terminal taps from a single secondary transformer outlet. Tin-plated. Order mounting hardware & tap terminals separately.

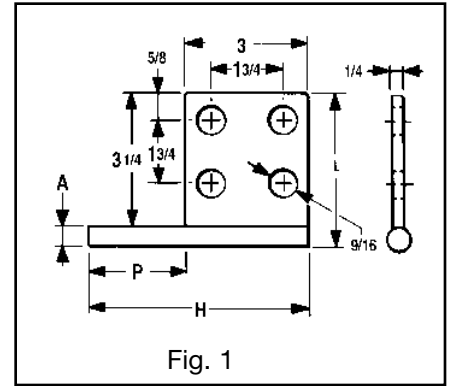
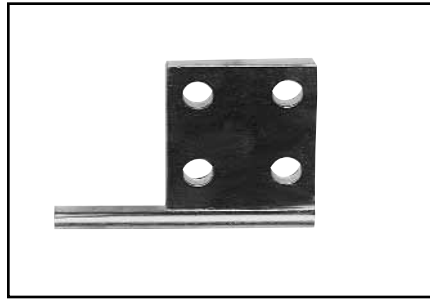

Fig. 1

Fig. No.	Catalog Number	A Dia.	H Ref.	L	P
1	FCB63-4N	.50	5.25	3.75	2.25
2	FCB63-6N	.50	5.25	5.50	2.25
1	FCB64-4N	.75	5.75	4.00	2.75
2	FCB64-6N	.75	5.75	5.75	2.75
1	FCB65-4N	1.00	7.00	4.25	4.00
Not Shown	FCB63-2NP300	.50	5.00	3.50	3.00
	FCB64-44NP50	.75	9.00	5.00	5.00

NOTE: All pads are NEMA drilled.

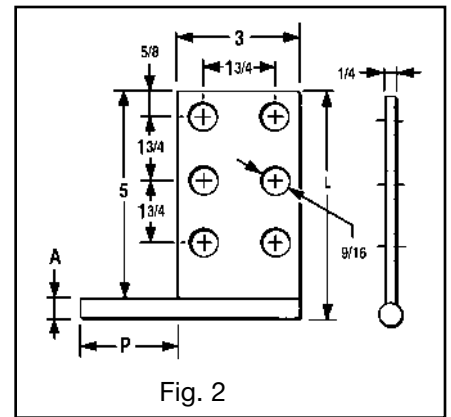

Fig. 2

Blue highlighted items are industry standard and most frequently ordered.

TYPE KPU-AC

POLYTAP™

Insulated Gutter Tap for All Copper and Aluminum Combinations

Wide range-taking tin-plated aluminum parallel clamp and insulating cover assembly for industrial and multiple story structure applications. Only six connectors cover the entire 14 Sol.-750 kcmil range. Covers having flexible fingers that conform to conductor, fully insulating the connection. UL486B listed for 600 volts maximum 90° C service. Cover and connector are packaged together. No taping required.

600 Volt Max. 90° C

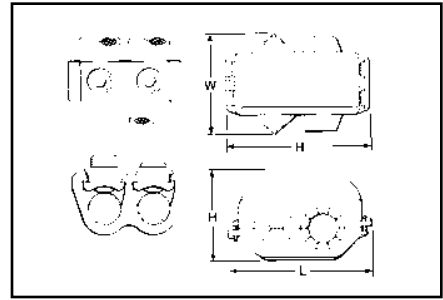
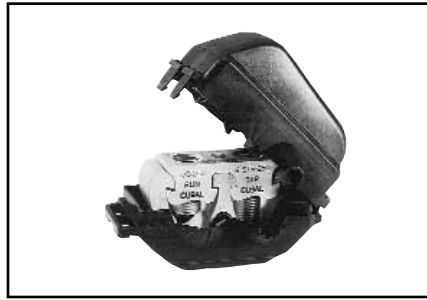

Catalog Number	Conductor Copper or Aluminum		W	H	L	Recommended Tightening Torque in-lb
	Run	Tap				
KPU29A26AC	1/0 Str. - 250 kcmil	14 Sol. - 2/0 Str.	3-1/8	3-3/8	4-1/4	375
KPU29A29AC	1/0 Str. - 250 kcmil	6 Str. - 250 kcmil				
KPU34A26AC	4/0 Str. - 500 kcmil	14 Sol. - 2/0 Str.	3-1/2	3-1/2	4-5/8	450
KPU34A34AC	4/0 Str. - 500 kcmil	6 Str. - 500 kcmil				
KPU39A26AC	500 - 750 kcmil	14 Sol. - 2/0 Str.	3-1/2	3-7/8	5-1/16	600
KPU39A39AC	500 - 750 kcmil	1/0 Str. - 750 kcmil				

▲ Listed torque values are for maximum conductor combinations accommodated. Consult UL486 Tables 7-4, 7-5, 7-6 for smaller combinations.

✓ See note page A-2.

TYPE UCU-AC

RISER TAP

Parallel-groove riser tap and insulation cover for copper and aluminum. Wide range-taking assembly for apartment house and light industrial applications. Cover and connector are packaged together. Covers having insulating fingers that conform to conductors, fully insulating the connection. UL486B Listed for 600 volts max. 90° C service.

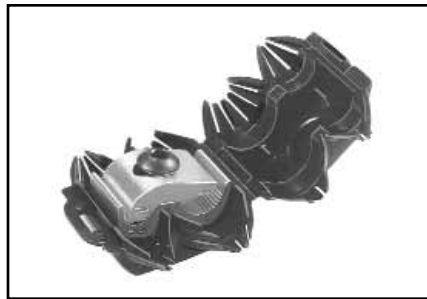

600 Volt Max. 90° C Max.

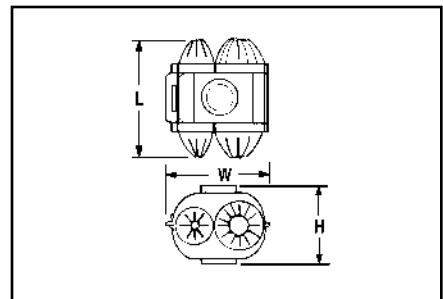
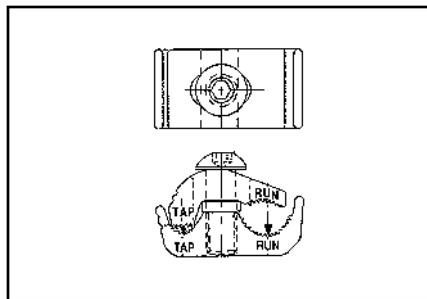

Catalog Number	Conductor		W	H	L	Recommended Tightening ▲ Torque in-lb
	Run	Tap				
UCU28AC	2 Str. - 4/0 Str.	10 Sol. - 2 Str.	2-1/4	1-13/16	2-5/8	120

▲ Listed torque values are for maximum conductor combinations accommodated. Consult UL486 Tables 7-4, 7-5, 7-6 for smaller combinations.

Blue highlighted items are industry standard and most frequently ordered.

TYPE BIPC

UL Listed 90° C, *600 Volt

The Type BIPC, **B**urndy **I**nsulation **P**iercing **C**onnectors are ideally suited for splicing and tapping aluminum and copper conductor wire sizes: #10 AWG to 500 kcmil.



Features and Benefits

- Insulation piercing capability.
 - ◇ Eliminates the need for conductor insulation stripping.
- UL486B listed, AL9CU rated.
 - ◇ For copper and aluminum conductor combinations up to 90° *600 Volt applications.
- Insulation piercing design.
 - ◇ Eliminates the need for taping.
- Easy snap-out tabs.
 - ◇ Eases installation, protects connection from dirt and debris.
- Simple bolt-on connection.
 - ◇ Eases installation.

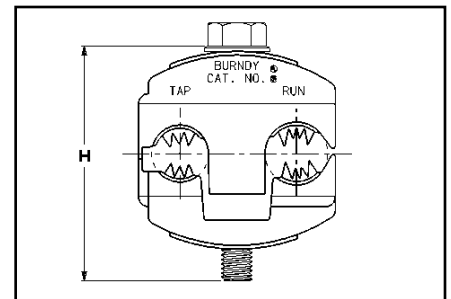
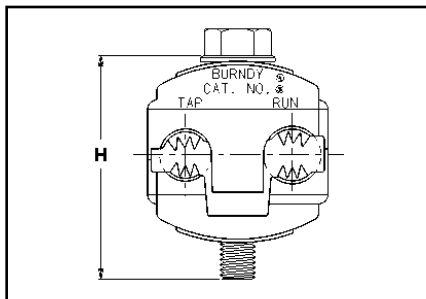
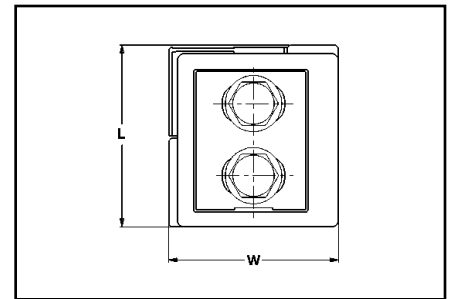
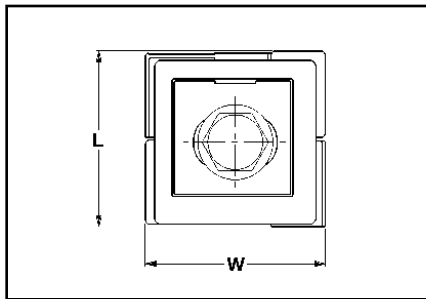
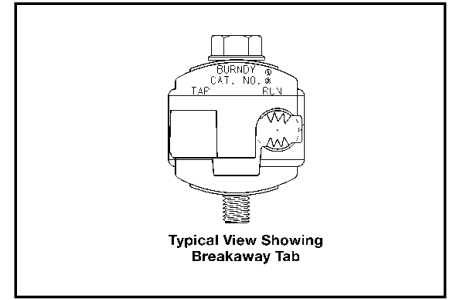

Fig. 1

Fig. 2

Catalog Number	Conductor Range		Bolt Size	Socket Size	Fig. No.	Dimensions			Recommended Torque (N,m)	Max. Voltage Rating
	Run	Tap				H	L	W		
BIPC1/0-2	1/0 - 8 AWG [50 - 6 mm ²]	2 - 8 AWG [35 - 6 mm ²]	5/16-18	1/2	1	2.00 [51]	1.53 [39]	2.56 [65]	180 in. lbs. [20.3 N.m]	600V
BIPC4/0-6	4/0 - 1/0 AWG [95 - 50 mm ²]	1/0 - 6 AWG [50 - 16 mm ²]	5/16-18	1/2	2	2.50 [64]	2.12 [54]	2.00 [51]	250 in. lbs. [28.3 N.m]	300V
BIPC4/0-1/0	4/0 - 1/0 AWG [95 - 50 mm ²]	4/0 - 1/0 AWG [95 - 50 mm ²]	5/16-18	1/2	2	2.50 [64]	2.12 [2.12]	2.06 [52]	250 in. lbs. [28.3 N.m]	300V
BIPC350-4/0	350 - 4/0 AWG [185 - 95 mm ²]	4/0 - 10 AWG [95 - 6 mm ²]	3/8-16	9/16	1	3.00 [76]	1.59 [40]	2.50 [64]	375 in. lbs. [42.4 N.m]	300V
BIPC350-350	350 - 4/0 AWG [185 - 95 mm ²]	350 - 4/0 AWG [185 - 95 mm ²]	3/8-16	9/16	2	3.00 [76]	2.62 [67]	2.75 [70]	300 in. lbs. [33.9 N.m]	300V
BIPC500-4/0	500 - 350 kcmil [240 - 185 mm ²]	4/0 - 4 AWG [95 - 25 mm ²]	3/8-16	9/16	1	3.25 [83]	1.59 [40]	2.62 [67]	400 in. lbs. [45.2 N.m]	600V

Blue highlighted items are industry standard and most frequently ordered.

MISCELLANEOUS ACCESSORIES

TERMINAL BLOCKS

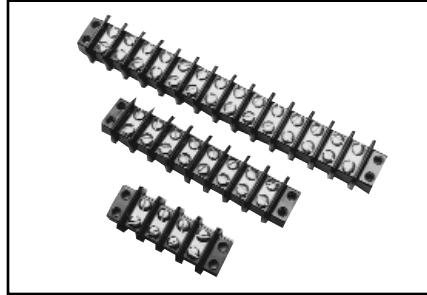

Meets UL component requirements:

CLASS B:

Commercial Equipment 300 V RMS

CLASS C:

General Industrial 300 V RMS

Withstands volts, Vdc 10,500

Steel nickel plated screws

Number of Circuits	Overall Length	General Description	Catalog Number
2	2-3/32"	Molded General Purpose Phenolic Base 30 amps, #10 studs	RK149-2
2	3-7/32"		RK150-2
6	4-11/32"		RK225-2
8	5-15/32"	1 piece, per card 300-volt rating	RK151-2
10	6-19/32"		RK152-2
12	7-23/32"		RK226-2
14	8-27/32"		RK153-2
16	9-31/32"		RK227-2

For bulk pack contact factory.

Blue highlighted items are industry standard and most frequently ordered.

U-BLOK™ POWER DISTRIBUTION BLOCKS

For Junction Box Applications

The U-BLOK™ system is a modern, state-of-the-art approach to multi-load power distribution applications. Among typical uses are multi-story or multi-unit buildings, HVAC, refrigeration, control panels, motor control, switch gear, elevator systems and materials-handling equipment. U-BLOK™ is UL Listed for Copper or Aluminum conductors and rated for 600-volt applications. U-BLOK™ can be mounted on bases for use in troughs or bolted directly to junction boxes. AL9CU rated.



FT4B500

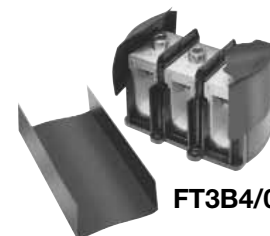

FT3B4/0

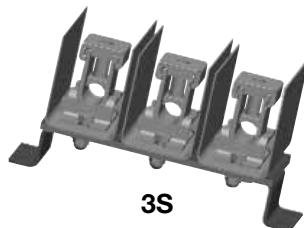

3S

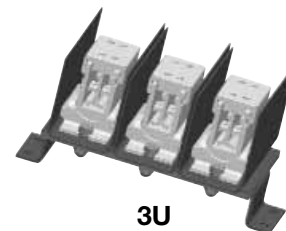

3U

Features and Benefits

- Connector top slides OFF/ON for quick cable lay-in.
 - ◊ Labor savings. Easy access for installation, modifications or retrofit.
- Electro-tin plated connectors in each pole.
 - ◊ Durability. High-conductivity and resistance to corrosion.
- Compact size.
 - ◊ Requires less space than traditional connection methods.
- Trough installations can be mounted on raised platforms.
 - ◊ Passage of cables under block means through-cables need not be terminated.
- Insulating covers and mounting blocks rated 94-VO.
 - ◊ Saves costly taping, time and material. Conforms to or exceeds building codes.
- Connectors accommodate a wide range of wire sizes.
 - ◊ Reduces parts inventory requirements.
- Feeder conductors can be cut or fed through on a continuous run.
 - ◊ Ease of installation.

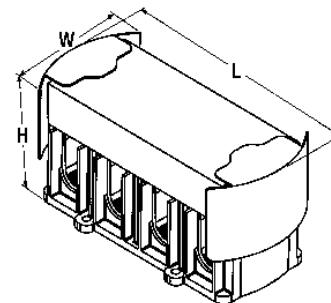

3 WIRE POWER DISTRIBUTION BLOCKS

Catalog Number	Maximum Number of Wires per Phase		Al or Cu Wire Range *		W	L	H	Weight Each	Allen Wrench Size	Torque (in-lb)	Strip Length	
			Run	Tap							Run	Tap
FT3B4/0	2		3/0 - 4/0	6 - 4/0	3-7/8"	5-7/8"	4-1/8"	1-1/4 lbs.	1/4"	200	1-1/2"	
FT3B500			400 - 500	6 - 500							2-5/16"	
3S	2		250-350	6 - 350	3-5/8"	9-3/4"	4-7/8"	3 lbs.	1/4"	200	1-3/4"	
3U	Run	Tap	3/0-500	6 - 1/0	4-3/4"	9-3/4"	5-1/2"	3 lbs.	5/32"	110	Run	Tap
											1	8

4 WIRE POWER DISTRIBUTION BLOCKS

Catalog Number	Maximum Number of Wires per Phase		Al or Cu Wire Range *		W	L	H	Weight Each	Allen Wrench Size	Torque (in-lb)	Strip Length	
			Run	Tap							Run	Tap
FT4B4/0	2		3/0 - 4/0	6 - 4/0	3-7/8"	7-7/8"	4-1/8"	2 lbs.	1/4"	200	1-1/2"	
FT4B500			400 - 500	6 - 500							2-5/16"	
4S	2		250-350	6 - 350	3-5/8"	11-3/4"	4-7/8"	3-1/2 lbs.	1/4"	200	1-3/4"	
4U	Run	Tap	3/0-500	6 - 1/0	4-3/4"	11-3/4"	5-1/2"	3-1/2 lbs.	5/32"	110	Run	Tap
											1	8

PENETROX™ inhibitor is recommended for all aluminum wire connections. For two wire tap range is 8 through 1/0.

* Aluminum and copper conductors cannot be assembled under the same pressure plate or t-bar.

Blue highlighted items are industry standard and most frequently ordered.

U-BLOK™ MOUNTING PLATFORMS

For Trough Applications

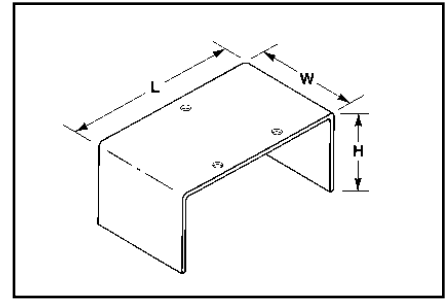
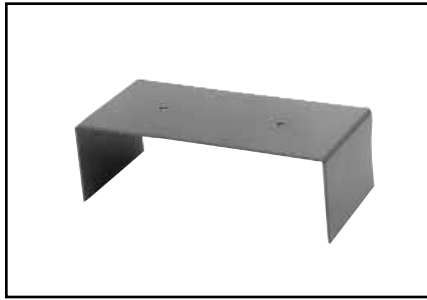

CATALOG NUMBER	W	L	H	GUTTER SIZE	WEIGHT EACH
TBPT-6*	4-1/4"	5-7/8"	1-1/2"	6"	3/4 lb.
TBPT-8	4-1/4"	7-7/8"	3-1/2"	8"	1-1/4 lb.
TBPT-10	4-1/4"	9-7/8"	4"	10"	1-1/2 lb.
TBPT-12	4-1/4"	11-7/8"	4"	12"	1-3/4 lb.

Hole pattern shown is for reference only.

* Supercedes TBPT4/0-6 and TBPT350/500-6.

FLEXI-TAP™

ALLOWABLE AMPACITIES OF INSULATED CONDUCTOR, 60° TO 90° C **

Size AWG kcmil	Copper			Al or Copper Clad Al		
	60 deg. C	75 deg. C	90 deg. C	60 deg. C	75 deg. C	90 deg. C
12	25	25	30	20	20	25
10	30	35	40	25	30	35
8	40	50	55	30	40	45
6	55	65	75	40	50	60
4	70	85	95	55	65	75
3	85	100	110	65	75	85
2	95	115	130	75	90	100
1	110	130	150	85	100	115
1/0	125	150	170	100	120	135
2/0	145	175	195	115	135	150
3/0	165	200	225	130	155	175
4/0	195	230	260	150	180	205
250	215	255	290	170	205	230
300	240	285	320	190	230	255
350	260	310	350	210	250	280
400	280	335	380	225	270	305
500	320	380	430	260	310	350
600	355	420	475	285	340	385
700	385	460	520	310	375	420
750	400	475	535	320	385	435

** NOTE: Values referenced from Article 310 of the National Electric Code, Table 310-16, 1996. The above chart is to be used for REFERENCE ONLY. Please consult Table 310-16 of the National Electric Code (latest revision) for information regarding insulation type, voltage range, and conductor housings/surroundings. U-TAP™, U-BLOK™, and SPEC-BLOK™ connectors are rated for 90 deg. C by Underwriters' Laboratories. Use of 60 deg. C and 75 deg. C conductor(s) is valid, though only as determined by the National Electric Code.

Blue highlighted items are industry standard and most frequently ordered.

SPEC-BLOK™ POWER DISTRIBUTION CONNECTORS

Unique, modular, made-to-order, power-distribution assemblies accommodate any number of supply and load conductors in any number of poles. Capacity matches the conductors accommodated and SPEC-BLOK™ assures uniform loading.

Adjacent poles are separated by easy-to-handle, wrap-around insulating covers which eliminate taping and reduce heat build-up by allowing air to flow freely around connectors. SPEC-BLOK™ is UL Listed for copper or aluminum conductors for 600 volts. (AL9CU) Assemblies are mounted on platforms suitable for easy installation in wireway or junction box.

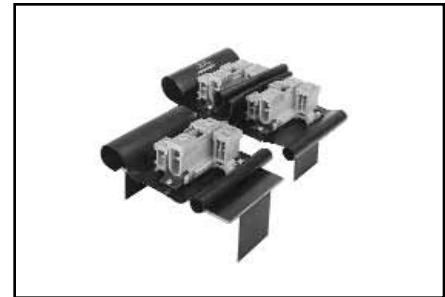
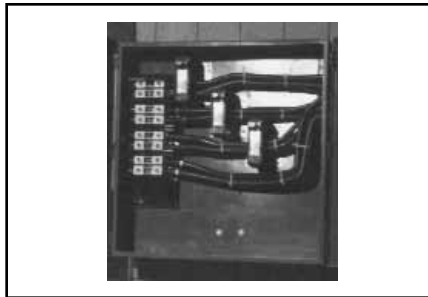
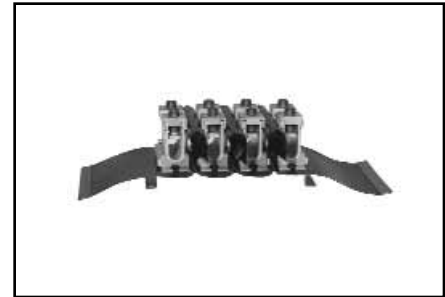
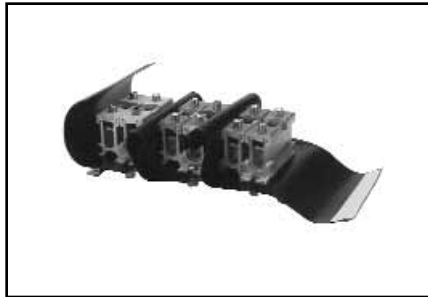

Features and Benefits

- Accommodate unlimited conductors.
 - ◇ Fits wide range of applications. Eliminates need for non-UL-listed improvisation.
- Connector elements tin-plated.
 - ◇ Provides high reliability, low-resistance connections.
- User friendly, space-saving design.
 - ◇ Easy to install. Saves labor.
- 94-VO rated insulation folds into place insulating the components.
 - ◇ Saves time and material. Allows easy installation.
- Connector caps removable for easy cable lay-in.
 - ◇ Saves labor. Makes installation easier. Allows installation or straight-through conductors. Eases retrofit.
- Belleville washers built-in on pressure screw assemblies, except in assemblies installed with a 5/32" Allen wrench.
 - ◇ Provides high-integrity connections.
- Conductors can be cut or fed straight through.
 - ◇ Straight through installation ideal for riser applications.

**Contact BURNDY® or Technical Services: 1-800-451-4956,
or BURNDY® Customer Service: 1-800-346-4175**

Blue highlighted items are industry standard and most frequently ordered.

SPEC-BLOK™

Features and Benefits

- The SPEC-BLOK™ system includes 12 connector elements
 - ◇ A wide variety of conductor sizes can be accommodated
- Each element can be bolted together in parallel
 - ◇ Provides an efficient flow of current from one element to another
- AL9CU rated for Copper or Aluminum conductors
 - ◇ Dual-rated system, with UL486B's highest temperature rating
- 2 Wire (series), 4 (parallel), and Multi-Tap versions available
 - ◇ Nearly any conductor combination can be terminated
- Tin-plated Aluminum Alloy Construction
 - ◇ High-strength, corrosion-resistant connector elements
- All SPEC-BLOKs™ are custom made for nearly any Power Distribution system requirement
 - ◇ Time savings — pre-assembled in our factory for immediate installation!

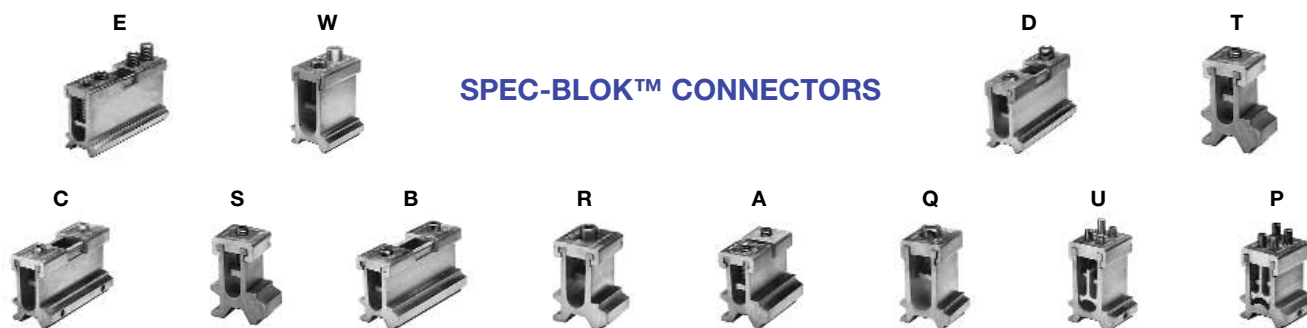

SPEC-BLOK™ CONNECTORS

Catalog Designation (Maximum Conductor)		Number of Conductors Accommodated		AL or CU Wire Range Under Each Cap		Dimensions				Allen Wrench Size
4 Conductor	2 Conductor	4 Conductor	2 Conductor	First Conductors MUST Be	Second Conductor (if required) May Be	Height On Max Conductors	Width	Length Without Insulator		
								4 Conductor	2 Conductor	
A	Q	1 to 4 (0, 1 or 2 per cap)	1 or 2 per cap	1/0-2/0	#12-2/0	2-9/16"	1-1/2"	2-1.8"	7/8"	5/32"
(2/0)				3/0-250	#6-250	3-1/8"	1-11/16"	4-1/4"	1-3/8"	1/4"
B	R			250-350	#6-350	3-5/16"	1-13/16"	4-5/8"	1-1/2"	
(250)				400-500	#6-500	4-1/16"	2"	5-5/8"	1-3/4"	3/8"
C	S			600-750	3/0-750	4-7/8"	2-1/4"	7-1/4"	2-5/8"	
(350)										
D	T									
(500)										
E	W									
(750)										

Catalog Designation (Maximum Conductor)	Number of Conductors Accommodated	Large Groove	Small Grooves**	Height On Maximum Conductors	Width	Length Without Insulator	Allen Wrench Size
P (1/0)	1 to 8 (0, 1 or 2 under each screw)	—	6-1/0	3-1/2"	2"	1-3/4"	5/32"
U (1/0 & 500)	2 to 9 (0, 1 or 2 under each screw plus one large conductor)	3/0-500	6-1/0	4-1/8"	2"		

** This range may be expanded to include #8 provided two conductors are being installed in that particular element.

Blue highlighted items are industry standard and most frequently ordered.

SPEC-BLOK™

MOUNTING PLATFORMS

SPEC-BLOK™ Mounting Platforms are rigid steel construction with a black finish. They can be supplied for junction box mounting or wireway construction allowing trough conductors to pass underneath the assemblies.

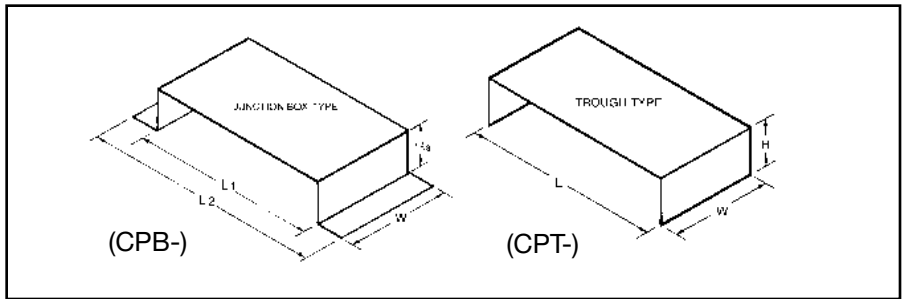

Catalog Number	L (Nominal)	L (Overall)	W (Overall)
CPB6	6"	7-3/4"	2-1/2"
CPB8	8"	9-3/4"	2-1/2"
CPB10	10"	11-3/4"	2-1/2"
CPB12	12"	13-3/4"	3-1/2"
CPB14	14"	15-3/4"	3-1/2"
CPB16-5/8	16-5/8"	18-3/8"	3-1/2"
CPB21-1/4	21-1/4"	23"	3-1/2"

Catalog Number	L	W	H
CPT6	5-7/8"	2-1/2"	2-1/4"
CPT8	7-7/8"	3-1/2"	3"
CPT10	9-7/8"	3-1/2"	3-1/2"
CPT12	11-7/8"	3-1/2"	4"
CPT16	15-7/8"	3-1/2"	4"

SPEC-BLOK™ catalog numbers describe exactly how the distribution block is assembled:

5DR-NDST-GQP-12
(assembly pictured)

- 5 Total number of poles in the completed assembly
- DR One 'D' unit and one 'R' unit, bolted in parallel, forming each phase pole (3 phase poles)
- N Denotes the beginning of the neutral pole (where required)
- DST One 'D' unit, one 'S' unit, and on 'T' unit, bolted in parallel, forming the neutral pole
- G Denotes the beginning of the ground pole description (where required)
- QP One 'Q' unit and on 'P' unit, bolted in parallel, forming the ground pole.
- 12 Size (inches) of the wireway or trough that is needed to enclose the assembly. If a junction box enclosure is used, no number is used to denote the size of the enclosure.



SPEC-BLOK™ IS A SYSTEM THAT CAN SOLVE MOST POWER DISTRIBUTION APPLICATIONS!

Blue highlighted items are industry standard and most frequently ordered.

QUESTIONNAIRE
 FOR SPEC-BLOK™
 OR ELECTRO-RAIL™
 APPLICATIONS

What is the total capacity of the system? _____ amps

How many poles in the system

(3-wire, 4-wire, single phase, etc.)? _____ poles

Are neutral conductors (when required) different sizes (AWG/kcmil) than the phase conductors?

_____ the same size _____ different size

Is a ground connection required? Yes No

What are the **quantities, sizes** (AWG/kcmil) and material (Al/Cu) of the incoming line conductors and outgoing load conductors?

		QUANTITY	SIZE	CONDUCTOR TYPE (Cu/Al)
PER PHASE	LINE			
	LOAD			
PER NEUTRAL	LINE			
	LOAD			
PER GROUND	LINE			
	LOAD			

Are any conductors continuous? Yes No

If yes, which ones? _____

What kind of enclosure is connection assembly being mounted into and what are inside space dimensions?

Trough size _____

Box, panel, cabinet, other size _____

When is a quotation required? Date: _____

When is the material required? Date: _____

Is there a preference for a particular BURNDY® distributor? Yes No

If yes, give name, location & telephone Number:

Name: _____

Address: _____

Phone #: _____

Blue highlighted items are industry standard and most frequently ordered.

VERSI-POLE™

POWER DISTRIBUTION BLOCKS

VERSI-POLE™ Power Distribution Blocks are designed to provide modular solutions to power distribution applications. Each connector element is made from a high conductivity aluminum alloy which is insulated with a high strength polymer housing. One, two, and three pole versions available. “Add” a pole (snap-together) blocks are also available for wire sizes up to 500 kcmil. For use with Cu or Al. 600 V, AL9CU rated.

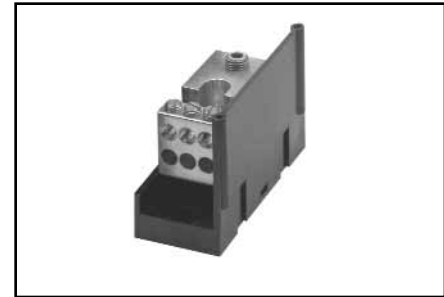

Features and Benefits

- “Add” a pole feature available.
 - ◇ Provides capability to create as many poles as required.
- Up to 30 tap conductors accommodated.
 - ◇ Ideal for current distribution to multiple locations.
- Single or dual run connections.
 - ◇ Allows user to minimize the number of connectors needed to do the job.
- Suitable for use with aluminum or copper conductors.
 - ◇ Provides maximum versatility.
- 600 V, AL9CU rated.*
 - ◇ Meets or exceeds industry standard requirements.
- Dead-front covers available
 - ◇ Provides user protection – one cover per pole.

* BDB-430-500-1 not UL recognized or CSA certified

VERSI-POLE™ Snap-Together Blocks

Catalog Number	Connector		Run	Tap	Ampere Rating per Pole	Number of Poles
	Run	Tap	Wire Range AL9CU	Wire Range AL9CU		
BDA-112-350			AWG 6 - 350 kcmil	AWG 14 - 4	310	ADDER
BDA-16-350			AWG 6 - 350 kcmil	AWG 14 - 2/0	310	ADDER
BDA-16-500			AWG 4 - 500 kcmil	AWG 4 - 2/0	380	ADDER
BDA-26-350			AWG 6 - 350 kcmil	AWG 14 - 2/0	620	ADDER
BDA-212-500			AWG 4 - 500 kcmil	AWG 14 - 4	760	ADDER
BDA-26-500			AWG 4 - 500 kcmil	AWG 14 - 2/0	760	ADDER
BDA-24-500			AWG 4 - 500 kcmil	AWG 6 - 4/0	760	ADDER
BDA-11-500			AWG 4 - 500 kcmil	AWG 4 - 500 kcmil	380	ADDER
BDA-22-350			AWG 6 - 350 kcmil	AWG 6 - 350 kcmil	620	ADDER
BDA-22-500			AWG 4 - 500 kcmil	AWG 4 - 500 kcmil	760	ADDER

NOTES:
 1. Order Optional BDB COVER1 per pole if desired.
 2. Snap-together blocks can also be assembled to 1, 2, 3 pole blocks to create multi-pole distribution blocks.

Blue highlighted items are industry standard and most frequently ordered.

VERSI-POLE™

VERSI-POLE™ 1, 2, 3 Pole Distribution Blocks



Catalog Number	Connector		Run	Tap	Ampere Rating per Pole	Number of Poles	Optional Cover Order 1 per Pole
	Run	Tap	Wire Range AL9CU	Wire Range AL9CU			
BDB-16-2/0-1 BDB-16-2/0-2 BDB-16-2/0-3			AWG 12 - 2/0	AWG 14 - 4	175	1 2 3	BDBCORDER2
BDB-26-2/0-1 BDB-26-2/0-2 BDB-26-2/0-3			AWG 14 - 2/0	AWG 14 - 2	350	1 2 3	BDBCORDER2
BDB-112-350-1 BDB-112-350-2 BDB-112-350-3			AWG 6 - 350 kcmil	AWG 14 - 4	310	1 2 3	BDBCORDER1
BDB-16-350-1 BDB-16-350-2 BDB-16-350-3			AWG 6 - 350 kcmil	AWG 14 - 2/0	310	1 2 3	BDBCORDER1
BDB-14-500-1 BDB-14-500-2 BDB-14-500-3			AWG 4 - 500 kcmil	AWG 14 - 2/0	380	1 2 3	BDBCORDER2
BDB-16-500-1 BDB-16-500-2 BDB-16-500-3			AWG 4 - 500 kcmil	AWG 14 - 2/0	380	1 2 3	BDBCORDER1
BDB-162-500-1 BDB-162-500-2 BDB-162-500-3			AWG 4 - 500 kcmil	AWG 14 - 2	380	1 2 3	BDBCORDER2
BDB-26-350-1 BDB-26-350-2 BDB-26-350-3			AWG 6 - 350 kcmil	AWG 14 - 2/0	620	1 2 3	BDBCORDER1
BDB-212-500-1 BDB-212-500-2 BDB-212-500-3			AWG 4 - 500 kcmil	AWG 14 - 4	760	1 2 3	BDBCORDER1
BDB-26-500-1 BDB-26-500-2 BDB-26-500-3			AWG 4 - 500 kcmil	AWG 14 - 2/0	760	1 2 3	BDBCORDER1
BDB-24-500-1 BDB-24-500-2 BDB-24-500-3			AWG 4 - 500 kcmil	AWG 6 - 4/0	760	1 2 3	BDBCORDER1

Blue highlighted items are industry standard and most frequently ordered.

VERSI-POLE™



**VERSI-POLE™ 1, 2, 3
Splice/Reducer Blocks**

Catalog Number	Connector		Run	Tap	Ampere Rating per Pole	Number of Poles	Optional Cover Order 1 per Pole
	Run	Tap	Wire Range AL9CU	Wire Range AL9CU			
BDB-11-2/0-1 BDB-11-2/0-2 BDB-11-2/0-3			AWG 14 - 2/0	AWG 14 - 2/0	175	1 2 3	BDBC0VER2
BDB-11-350-1 BDB-11-350-2 BDB-11-350-3			AWG 6 - 350 kcmil	AWG 6 - 350 kcmil	310	1 2 3	BDBC0VER2
BDB-11-500-1 BDB-11-500-2 BDB-11-500-3			AWG 6 - 500 kcmil	AWG 6 - 500 kcmil	380	1 2 3	BDBC0VER1
BDB-22-2/0-1 BDB-22-2/0-2 BDB-22-2/0-3			AWG 14 - 2/0	AWG 14 - 2/0	350	1 2 3	BDBC0VER2
BDB-22-350-1 BDB-22-350-2 BDB-22-350-3			AWG 6 - 350 kcmil	AWG 6 - 350 kcmil	620	1 2 3	BDBC0VER1
BDB-22-500-1 BDB-22-500-2 BDB-22-500-3			AWG 4 - 500 kcmil	AWG 4 - 500 kcmil	760	1 2 3	BDBC0VER1

**SNAP TOGETHER
SPLICE/REDUCER
BLOCKS**



Catalog Number	Connector		Run	Tap	Ampere Rating per Pole	Number of Poles	Optional Cover Order 1 per Pole
	Run	Tap	Wire Range AL9CU	Wire Range AL9CU			
BDC-14-2/0-1			AWG 14 - 2/0	AWG 14 - 4	175	1	BDBC0VER3
BDA-14-2/0-1			AWG 14 - 2/0	AWG 14 - 4	175	ADDER	BDBC0VER3
BDC-11-2/0-1			AWG 14 - 2/0	AWG 14 - 2/0	175	1	BDBC0VER3
BDA-11-2/0-1			AWG 14 - 2/0	AWG 14 - 2/0	175	ADDER	BDBC0VER3

Blue highlighted items are industry standard and most frequently ordered.

VERSI-POLE™

(Continued)



VERSI-POLE™ 1, 2, 3 Splice/Reducer Blocks

These tables and illustrations refer to VERSI-POLE™ Power Distribution Blocks listed on pages A-48 through A-50.

The Figure to the Lower Right is Applicable to the Following:

Catalog Number	Number of Poles	Catalog Number	Number of Poles
BDA-11-500	1 (adder)	BDB-16-500-3	3
BDA-112-350	1 (adder)	BDB-212-500-1	1
BDA-16-350	1 (adder)	BDB-212-500-2	2
BDA-16-500	1 (adder)	BDB-212-500-3	3
BDA-212-500	1 (adder)	BDB-22-350-1	1
BDA-22-350	1 (adder)	BDB-22-350-2	2
BDA-22-500	1 (adder)	BDB-22-350-3	3
BDA-24-500	1 (adder)	BDB-22-500-1	1
BDA-26-350	1 (adder)	BDB-22-500-2	2
BDA-26-500	1 (adder)	BDB-22-500-3	3
BDB-11-500-1	1	BDB-24-500-1	1
BDB-11-500-2	2	BDB-24-500-2	2
BDB-11-500-3	3	BDB-24-500-3	3
BDB-112-350-1	1	BDB-26-350-1	1
BDB-112-350-2	2	BDB-26-350-2	2
BDB-112-350-3	3	BDB-26-350-3	3
BDB-16-350-1	1	BDB-26-500-1	1
BDB-16-350-2	2	BDB-26-500-2	2
BDB-16-350-3	3	BDB-26-500-3	3
BDB-16-500-1	1	BDB-430-500-1	1
BDB-16-500-2	2		

No. of Poles	Dimensions A Inches
Adder	2.50
1	2.81
2	5.31
3	7.81
N	(2.50 X N) + .31

Example for 10 poles:
A = (2.50 X 10) + .31 = 25

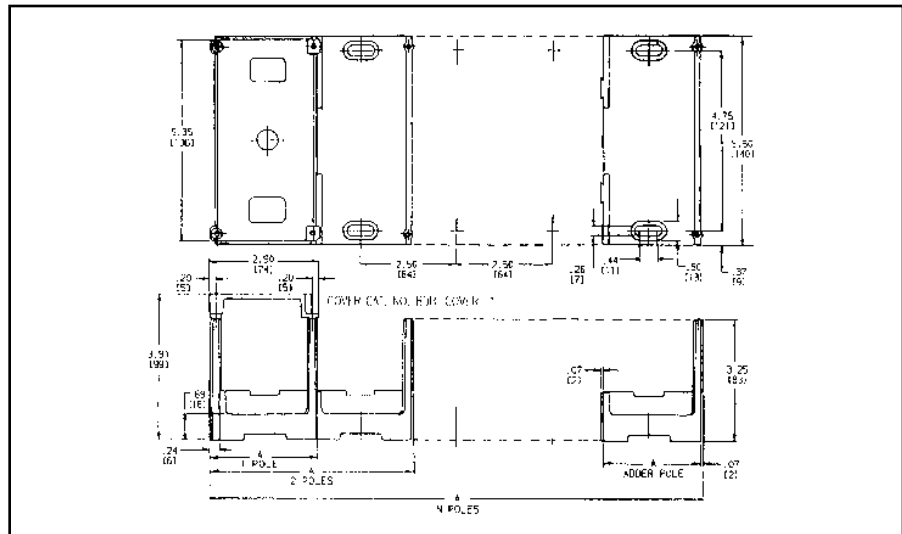

Blue highlighted items are industry standard and most frequently ordered.

VERSI-POLE™

(Continued)



**VERSI-POLE™ 1, 2, 3
Splice/Reducer Blocks**

These tables and illustrations refer to VERSI-POLE™ Power Distribution Blocks listed on pages A-41 through A-55.

The Figure to the Right is Applicable to the Following:	
Catalog Number	Number of Poles
BDB-11-2/0-1	1
BDB-11-2/0-2	2
BDB-11-2/0-3	3
BDB-11-350-1	1
BDB-11-350-2	2
BDB-11-350-3	3
BDB-14-500-1	1
BDB-14-500-2	2
BDB-14-500-3	3
BDB-16-2/0-1	1
BDB-16-2/0-2	2
BDB-16-2/0-3	3
BDB-162-500-1	1
BDB-162-500-2	2
BDB-162-500-3	3
BDB-22-2/0-1	1
BDB-22-2/0-2	2
BDB-22-2/0-3	3
BDB-26-2/0-1	1
BDB-26-2/0-2	2
BDB-26-2/0-3	3

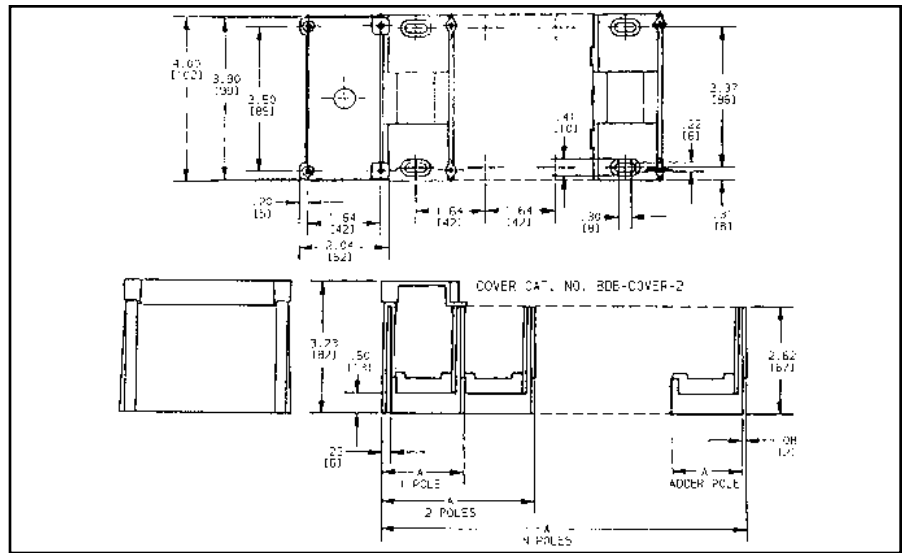

No. of Poles	Dimensions A Inches
Adder	1.64
1	1.94
2	3.57
3	5.20
N	(1.64 X N) + .30

Example for 10 poles:
A = (1.64 X 10) + .30 = 16.20

Applicable VERSI-POLE™ Items	
Catalog Number	Number of Poles
BDA-14-2/0-1	1 (adder)
BDC-14-2/0-1	1
BDA-11-2/0-1	1 (adder)
BDC-11-2/0-1	1

No. of Poles	Dimensions A Inches
Adder	.81
1	1.08
2	1.89
3	2.70
N	(.81 X N) + .27

Example for 10 poles:
A = (.81 X 10) + .27 = 8.37

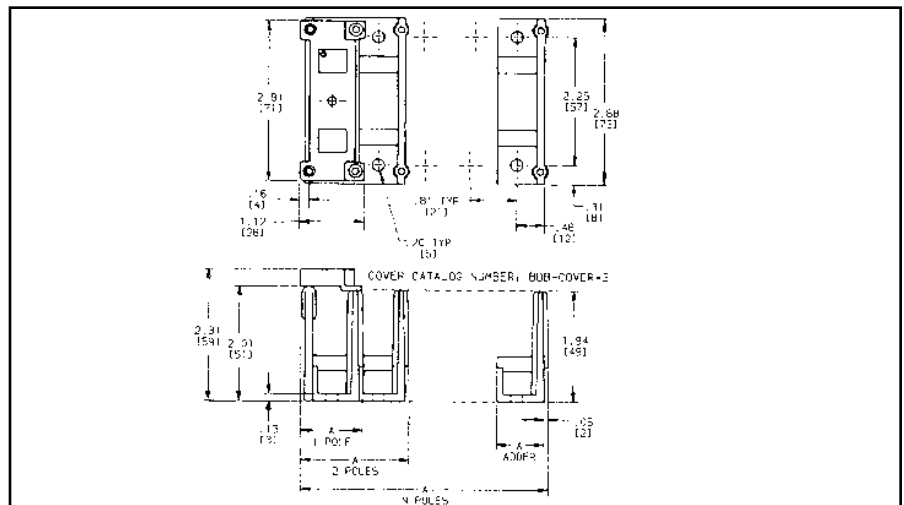

Blue highlighted items are industry standard and most frequently ordered.

BURNDY® UNITAP™

TYPES BIT, BISR

Clear Insulated Multiple Tap Connectors

Tap connections and in-line splice/reductions are made quickly and easily with the UNITap™ line of connectors. UL486B Listed. Dual-rated AL9CU for any stranded copper or stranded aluminum applications. 600 Volt, 90° C.



Features and Benefits

- Clear Plastisol covered AL6061-T6 aluminum body.
 - ◇ Saves time, lowers installation costs, eliminates taping.
- Clear Plastisol.
 - ◇ Allows visual confirmation that conductor is properly inserted.
- Oxide inhibitor pre-installed.
 - ◇ Inhibits moisture and contaminants from entering the contact area.
- Range-taking.
 - ◇ Reduces number of connectors carried in inventory.

2 Port, 1 or 2 Sided Entry

Catalog Number	# of Ports	Wire Range (AWG/kcmil)	L	W	H	Hex Key	Fig. No.
BIT4	2	#14 - #4	1.16	1.16	1.25	1/8	1
BIT04	2	#14 - #4	1.16	1.50	1.25	1/8	2
BIT2/0	2	#14 - 2/0	1.52	1.40	1.38	3/16	1
BIT02/0	2	#14 - 2/0	1.52	1.56	1.38	3/16	2
BIT250	2	#10 - 250	2.03	2.07	2.13	5/16	1
BIT0250	2	#10 - 250	2.03	2.64	2.13	5/16	2
BIT350	2	#10 - 350	2.22	2.32	2.50	5/16	1
BIT0350	2	#10 - 350	2.22	3.00	2.50	5/16	2
BIT600	2	#4 - 600	2.72	2.38	2.75	3/8	1
BIT0600	2	#4 - 600	2.72	3.00	2.75	3/8	2
BIT750*	2	#2 - 750	2.87	2.70	3.00	3/8	1
BIT0750*	2	#2 - 750	2.87	3.38	3.00	3/8	2

* Not UL Listed.
UNITAP™ rated for code conductor only.

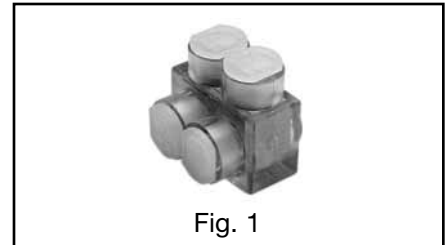

Fig. 1

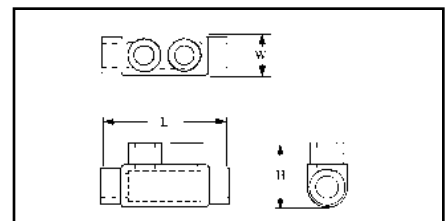

Fig. 2

In-Line Splicer/Reducer

Catalog Number	Wire Range (AWG/kcmil)	L	W	H	Hex Key
BISR2	#14 - 2	2.38	0.75	1.22	5/32
BISR1/0	#14 - 1/0	2.91	0.91	1.38	3/16
BISR250	#10 - 250	4.01	1.19	2.10	5/16
BISR350	#10 - 350	4.63	1.34	2.35	5/16
BISR500	#6 - 500	5.00	1.62	2.62	3/8

UNITAP™ rated for code conductor only.



Blue highlighted items are industry standard and most frequently ordered.

BURNDY® UNITAP™



MULTI-PORT
Single-Sided Entry

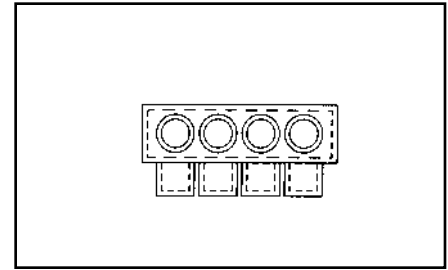
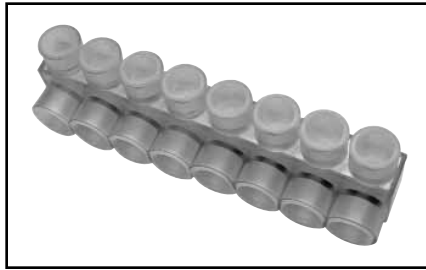

Catalog Number	# of Ports	Wire Range (AWG/kcmil)	L	W	H	Hex Key
BIBS4-3	3	#14 - 4	1.59	1.25	1.25	1/8
BIBS4-4	4	#14 - 4	2.03	1.25	1.25	1/8
BIBS4-5	5	#14 - 4	2.47	1.25	1.25	1/8
BIBS4-6	6	#14 - 4	2.91	1.25	1.25	1/8
BIBS4-8	8	#14 - 4	3.78	1.25	1.25	1/8
BIBS2/0-3	3	#14 - 2/0	2.19	1.31	1.38	3/16
BIBS2/0-4	4	#14 - 2/0	2.86	1.31	1.38	3/16
BIBS2/0-5	5	#14 - 2/0	3.53	1.31	1.38	3/16
BIBS2/0-6	6	#14 - 2/0	4.20	1.31	1.38	3/16
BIBS2/0-8	8	#14 - 2/0	5.55	1.31	1.38	3/16
BIBS2/0-10	10	#14 - 2/0	6.89	1.31	1.38	3/16
BIBS2/0-12	12	#14 - 2/0	8.24	1.31	1.38	3/16
BIBS2/0-14	14	#14 - 2/0	9.58	1.31	1.38	3/16
BIBS250-3	3	#10 - 250	2.97	2.07	2.13	5/16
BIBS250-4	4	#10 - 250	3.91	2.07	2.13	5/16
BIBS250-5	5	#10 - 250	4.84	2.07	2.13	5/16
BIBS250-6	6	#10 - 250	5.78	2.07	2.13	5/16
BIBS250-8	8	#10 - 250	7.66	2.07	2.13	5/16
BIBS250-10	10	#10 - 250	9.53	2.07	2.13	5/16
BIBS250-12	12	#10 - 250	11.41	2.07	2.13	5/16
BIBS250-14	14	#10 - 250	13.29	2.07	2.13	5/16
BIBS350-3	3	#10 - 350	3.13	2.32	2.50	5/16

Catalog Number	# of Ports	Wire Range (AWG/kcmil)	L	W	H	Hex Key
BIBS350-4	4	#10 - 350	4.04	2.32	2.50	5/16
BIBS350-5	5	#10 - 350	4.95	2.32	2.50	5/16
BIBS350-6	6	#10 - 350	5.86	2.32	2.50	5/16
BIBS350-8	8	#10 - 350	7.68	2.32	2.50	5/16
BIBS350-10	10	#10 - 350	9.50	2.32	2.50	5/16
BIBS350-12	12	#10 - 350	11.32	2.32	2.50	5/16
BIBS350-14	14	#10 - 350	13.14	2.32	2.50	5/16
BIBS600-3	3	#4 - 600	4.00	2.38	2.75	3/8
BIBS600-4	4	#4 - 600	5.28	2.38	2.75	3/8
BIBS600-5	5	#4 - 600	6.56	2.38	2.75	3/8
BIBS600-6	6	#4 - 600	7.84	2.38	2.75	3/8
BIBS600-8	8	#4 - 600	10.41	2.38	2.75	3/8
BIBS600-10	10	#4 - 600	12.97	2.38	2.75	3/8
BIBS600-12	12	#4 - 600	15.53	2.38	2.75	3/8
BIBS600-14	14	#4 - 600	18.09	2.38	2.75	3/8
BIBS750-3*	3	#2 - 750	4.25	2.70	3.00	3/8
BIBS750-4*	4	#2 - 750	5.63	2.70	3.00	3/8
BIBS750-6*	6	#2 - 750	8.37	2.70	3.00	3/8
BIBS750-8*	8	#2 - 750	11.13	2.70	3.00	3/8
BIBS750-10*	10	#2 - 750	13.87	2.70	3.00	3/8
BIBS750-12*	12	#2 - 750	16.63	2.70	3.00	3/8
BIBS750-14*	14	#2 - 750	19.37	2.70	3.00	3/8

* Not UL Listed.
UNITAP™ rated for code conductor only.

Blue highlighted items are industry standard and most frequently ordered.

BURNDY® UNITAP™

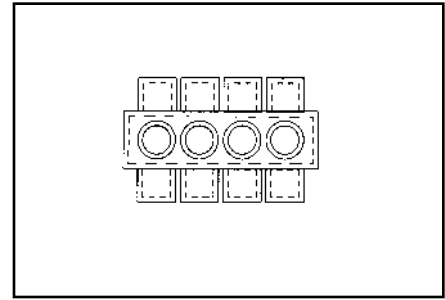
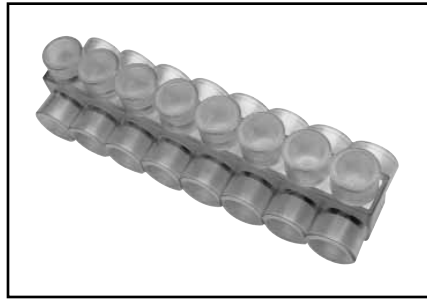
MULTI-PORT
Double-Sided Entry

Catalog Number	# of Ports	Wire Range (AWG/kcmil)	L	W	H	Hex Key
BIBD4-2	2	#14 - #4	1.16	1.50	1.25	1/8
BIBD4-3	3	#14 - #4	1.59	1.50	1.25	1/8
BIBD4-4	4	#14 - #4	2.03	1.50	1.25	1/8
BIBD4-5	5	#14 - #4	2.47	1.50	1.25	1/8
BIBD4-6	6	#14 - #4	2.91	1.50	1.25	1/8
BIBD4-8	8	#14 - #4	3.78	1.50	1.25	1/8
BIBD2/0-2	2	#14 - 2/0	1.52	1.56	1.25	3/16
BIBD2/0-3	3	#14 - 2/0	2.19	1.56	1.25	3/16
BIBD2/0-4	4	#14 - 2/0	2.86	1.56	1.25	3/16
BIBD2/0-5	5	#14 - 2/0	3.53	1.56	1.25	3/16
BIBD2/0-6	6	#14 - 2/0	4.20	1.56	1.25	3/16
BIBD2/0-8	8	#14 - 2/0	5.55	1.56	1.25	3/16
BIBD2/0-10	10	#14 - 2/0	6.89	1.56	1.25	3/16
BIBD2/0-12	12	#14 - 2/0	8.24	1.56	1.25	3/16
BIBD2/0-14	14	#14 - 2/0	9.58	1.56	1.25	3/16
BIBD250-2	2	#10 - 250	2.03	2.64	2.13	5/16
BIBD250-3	3	#10 - 250	2.97	2.64	2.13	5/16
BIBD250-4	4	#10 - 250	3.91	2.64	2.13	5/16
BIBD250-5	5	#10 - 250	4.84	2.64	2.13	5/16
BIBD250-6	6	#10 - 250	5.78	2.64	2.13	5/16
BIBD250-8	8	#10 - 250	7.66	2.64	2.13	5/16
BIBD250-10	10	#10 - 250	9.53	2.64	2.13	5/16
BIBD250-12	12	#10 - 250	11.41	2.64	2.13	5/16
BIBD250-14	14	#10 - 250	13.29	2.64	2.13	5/16
BIBD350-2	2	#10 - 350	2.22	3.00	2.50	5/16

Catalog Number	# of Ports	Wire Range (AWG/kcmil)	L	W	H	Hex Key
BIBD350-3	3	#10 - 350	3.13	3.00	2.50	5/16
BIBD350-4	4	#10 - 350	4.04	3.00	2.50	5/16
BIBD350-5	5	#10 - 350	4.95	3.00	2.50	5/16
BIBD350-6	6	#10 - 350	5.86	3.00	2.50	5/16
BIBD350-8	8	#10 - 350	7.68	3.00	2.50	5/16
BIBD350-10	10	#10 - 350	9.50	3.00	2.50	5/16
BIBD350-12	12	#10 - 350	11.32	3.00	2.50	5/16
BIBD350-14	14	#10 - 350	13.14	3.00	2.50	5/16
BIBD600-2	2	#4 - 600	2.56	3.00	2.75	3/8
BIBD600-3	3	#4 - 600	3.77	3.00	2.75	3/8
BIBD600-4	4	#4 - 600	4.97	3.00	2.75	3/8
BIBD600-5	5	#4 - 600	6.17	3.00	2.75	3/8
BIBD600-6	6	#4 - 600	7.37	3.00	2.75	3/8
BIBD600-8	8	#4 - 600	9.78	3.00	2.75	3/8
BIBD600-10	10	#4 - 600	12.97	3.00	2.75	3/8
BIBD600-12	12	#4 - 600	15.53	3.00	2.75	3/8
BIBD600-14	14	#4 - 600	18.09	3.00	2.75	3/8
BIBD750-2*	2	#2 - 750	2.87	3.38	3.00	3/8
BIBD750-3*	3	#2 - 750	4.25	3.38	3.00	3/8
BIBD750-4*	4	#2 - 750	5.63	3.38	3.00	3/8
BIBD750-6*	6	#2 - 750	8.37	3.38	3.00	3/8
BIBD750-8*	8	#2 - 750	11.13	3.38	3.00	3/8
BIBD750-10*	10	#2 - 750	13.87	3.38	3.00	3/8
BIBD750-12*	12	#2 - 750	16.63	3.38	3.00	3/8
BIBD750-14*	14	#2 - 750	19.37	3.38	3.00	3/8

NOTE: Only 1 conductor per port allowed.

* Not UL Listed.

UNITAP™ rated for code conductor only.

Blue highlighted items are industry standard and most frequently ordered.

BURNDY® UNITAP™

TYPES BIBS-MT, BIBD-MT

Clear Insulated
Multiple Tap Connectors

Mounting Version



The BIBS-MT and BIBD-MT series UNITAP™ offer the same multi-port capabilities as the standard UNITAP™ connectors except these -MT types are provided with two isolated mounting holes at both ends of the connector for direct mounting to a trough, gutter or wireway. They will accommodate up to standard 1/4" hardware.

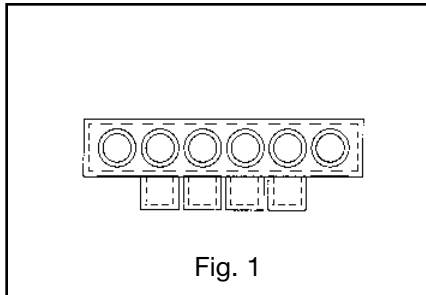

Fig. 1

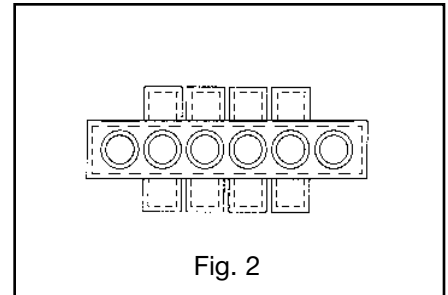

Fig. 2

**MULTI-PORT
Single-Sided Entry**

Catalog Number	Fig #	# of Ports	Wire Range (AWG/Kcmil)	L	W	H	Hex Key
BIBS2/04MT	1	4	#14-2/0	3.95	1.31	1.38	3/16
BIBS2/06MT	1	6	#14-2/0	5.29	1.31	1.38	3/16
BIBS2/08MT	1	8	#14-2/0	6.64	1.31	1.38	3/16
BIBS2/010MT	1	10	#14-2/0	7.98	1.31	1.38	3/16
BIBS2/012MT	1	12	#14-2/0	9.33	1.31	1.38	3/16
BIBS2504MT	1	4	#10-250	5.53	2.07	2.13	5/16
BIBS2506MT	1	6	#10-250	7.40	2.07	2.13	5/16
BIBS2508MT	1	8	#10-250	9.28	2.07	2.13	5/16
BIBS25010MT	1	10	#10-250	11.16	2.07	2.13	5/16
BIBS25012MT	1	12	#10-250	13.03	2.07	2.13	5/16
BIBS3504MT	1	4	#10-350	5.61	2.32	2.50	5/16
BIBS3506MT	1	6	#10-350	7.43	2.32	2.50	5/16
BIBS3508MT	1	8	#10-350	9.25	2.32	2.50	5/16
BIBS35010MT	1	10	#10-350	11.07	2.32	2.50	5/16
BIBS35012MT	1	12	#10-350	12.89	2.32	2.50	5/16
BIBS6004MT	1	4	#4-600	7.59	2.38	2.75	3/8
BIBS6006MT	1	6	#4-600	10.16	2.38	2.75	3/8
BIBS6008MT	1	8	#4-600	12.72	2.38	2.75	3/8
BIBS60010MT	1	10	#4-600	15.28	2.38	2.75	3/8
BIBS60012MT	1	12	#4-600	17.84	2.38	2.75	3/8

UNITAP™ rated for code conductor only.

**MULTI-PORT
Double-Sided Entry**

Catalog Number	Fig #	# of Ports	Wire Range (AWG/Kcmil)	L	W	H	Hex Key
BIBD2/04MT	2	4	#14-2/0	3.95	1.56	1.38	3/16
BIBD2/06MT	2	6	#14-2/0	5.29	1.56	1.38	3/16
BIBD2/08MT	2	8	#14-2/0	6.64	1.56	1.38	3/16
BIBD2/010MT	2	10	#14-2/0	7.98	1.56	1.38	3/16
BIBD2/012MT	2	12	#14-2/0	9.33	1.56	1.38	3/16
BIBD2504MT	2	4	#10-250	5.53	2.64	2.13	5/16
BIBD2506MT	2	6	#10-250	7.40	2.64	2.13	5/16
BIBD2508MT	2	8	#10-250	9.28	2.64	2.13	5/16
BIBD25010MT	2	10	#10-250	11.16	2.64	2.13	5/16
BIBD25012MT	2	12	#10-250	13.03	2.64	2.13	5/16
BIBD3504MT	2	4	#10-350	5.61	3.00	2.50	5/16
BIBD3506MT	2	6	#10-350	7.43	3.00	2.50	5/16
BIBD3508MT	2	8	#10-350	9.25	3.00	2.50	5/16
BIBD35010MT	2	10	#10-350	11.07	3.00	2.50	5/16
BIBD35012MT	2	12	#10-350	12.89	3.00	2.50	5/16
BIBD6004MT	2	4	#4-600	7.59	3.00	2.75	3/8
BIBD6006MT	2	6	#4-600	10.16	3.00	2.75	3/8
BIBD6008MT	2	8	#4-600	12.72	3.00	2.75	3/8
BIBD60010MT	2	10	#4-600	15.28	3.00	2.75	3/8
BIBD60012MT	2	12	#4-600	17.84	3.00	2.75	3/8

UNITAP™ rated for code conductor only.

Blue highlighted items are industry standard and most frequently ordered.

UV RATED BLACK UNITAP™

600V, 90°C

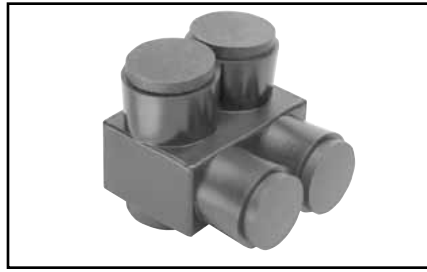

Features and Benefits

- UV Rated Plastisol covered AL6061-T6 aluminum body saves time by eliminating the need for taping.
- Oxide inhibitor pre-installed inhibits moisture and contaminants from entering the contact area.
- Range-taking capability reduces the number of connectors carried in inventory.
- UL486B Listed, AL9CU, 600V 90°C

Catalog Number	Number of Ports	Wire Range (AWG/kcmil)	Dimensions (Inches)			Hex Key (Torque) (In.-lbs.)
			L	W	H	
1PL42	2	#14 - 4	1.16	1.16	1.25	1/8 (45)
1PLO42	2	#14 - 4	1.16	1.50	1.25	1/8 (45)
1PL2/02	2	#14 - 2/0	1.52	1.40	1.38	3/16 (120)
1PLO2/02	2	#14 - 2/0	1.52	1.56	1.38	3/16 (120)
1PL2502	2	#10 - 250	2.03	2.07	2.13	5/16 (275)
1PLO2502	2	#10 - 250	2.03	2.64	2.13	5/16 (275)
1PL3502	2	#10 - 350	2.22	2.32	2.50	5/16 (275)
1PL6002	2	#4 - 600	2.72	2.38	2.75	3/8 (375)
1PLO6002	2	#4 - 600	2.72	3.00	2.75	3/8 (375)
1PBS2	2	#14 - 2	2.38	0.75	1.22	5/32 (45)
1PBS1/0	2	#14 - 1/0	2.91	0.91	1.38	3/16 (120)
1PBS250	2	#10 - 250	4.01	1.19	2.10	5/16 (120)
1PBS350	2	#10 - 350	4.63	1.34	2.35	5/16 (275)
1PBS500	2	#6 - 500	5.00	1.62	2.62	3/8 (375)
1PL43	3	#14 - 4	1.59	1.25	1.25	1/8 (45)
1PL44	4	#14 - 4	2.03	1.25	1.25	1/8 (45)
1PL2/03	3	#14 - 2/0	2.19	1.31	1.38	3/16 (120)
1PL2503	3	#10 - 250	2.97	2.07	2.13	5/16 (275)
1PLD43	3	#14 - 4	1.59	1.50	1.25	1/8 (45)
1PLD44	4	#14 - 4	2.03	1.50	1.25	1/8 (45)
1PLD2/02	2	#14 - 2/0	1.52	1.56	1.25	3/16 (120)
1PLD2/03	3	#14 - 2/0	2.19	1.56	1.25	3/16 (120)
1PLD2/04	4	#14 - 2/0	2.86	1.56	1.25	3/16 (120)
1PLD2/06	6	#14 - 2/0	4.20	1.56	1.25	3/16 (120)
1PLD2502	2	#10 - 250	2.03	2.64	2.13	5/16 (275)
1PLD2503	3	#10 - 250	2.97	2.64	2.13	5/16 (275)
1PLD2504	4	#10 - 250	3.91	2.64	2.13	5/16 (275)
1PLD2506	6	#10 - 250	5.78	2.64	2.13	5/16 (275)
1PLD3502	2	#10 - 350	2.22	3.00	2.50	5/16 (375)
1PLD3503	3	#10 - 350	3.13	3.00	2.50	5/16 (375)
1PLD3504	4	#10 - 350	4.04	3.00	2.50	5/16 (375)
1PLD3506	6	#10 - 350	5.86	3.00	2.50	5/16 (375)
1PLD3508	8	#10 - 350	7.68	3.00	2.50	5/16 (375)
1PLD6002	2	#4 - 600	2.56	3.00	2.75	3/8 (375)
1PLD6003	3	#4 - 600	3.77	3.00	2.75	3/8 (375)
1PLD6004	4	#4 - 600	4.97	3.00	2.75	3/8 (375)
1PLD6005	5	#4 - 600	6.17	3.00	2.75	3/8 (375)
1PLD6006	6	#4 - 600	7.37	3.00	2.75	3/8 (375)
1PLD6008	8	#4 - 600	9.78	3.00	2.75	3/8 (375)

1PL = 2 Port Single Sided Entry
1PLO = 2 Port Offset Entry
1PBS = In-line Splice/Reducer

1PL = Multi-Port Single Sided Entry
1PLD = Multi-Port Double Sided Entry
UNITAP™ rated for code conductor only.

TABLE OF CONTENTS

General Information	B-2, B-3	Types YAV-T-F BOX & YAV-T-F	B-35
MIL. SPEC. Equivalent Tables	B-4	Types YAV-H-F BOX, YAV-H-F	
Bare Ferrules		& YAV-Z	B-36
Type YF	B-5, B-6	Types TN-F & YAES-F	B-37
Insulated Ferrules		Types YAE-N-F BOX & YAE-N-F	B-38
Type YFI	B-7, B-8	Types TP-F & BA-EF	B-39
Types YF & YFI Twin Ferrules	B-9	Types YAE-Z BOX & YAE-Z	B-40
Heat Shrink		Types TP-Z & BA-EZ	B-41
Type YHS Ring and		Types TP-LF & BA-EL	B-42
Fork Tongue Terminals.....	B-10	Type Q-F	B-43
Type YHS Butt Splices and		Type QP-F	B-43
Quick Disconnects.....	B-11	Type QN-F	B-44
Type HSSHRACK	B-12	Type QM	B-44
Type HSKIT	B-13	Type QP-M	B-45
Terminals		Type QN-M	B-45
Types T & YAD	B-14	Types PGP & PGN	B-46
Types TP & BA	B-15	Types FQN-F & FQN-M	B-47
Types TN & YAES	B-16	Type FL	B-48
Type YAE-G BOX	B-17	Uninsulated Splices	B-49
Types YAE-N BOX & YAE-N	B-18	Types YSV, YSV-H & YSV-L	B-49
Type YAES-K	B-19, B-20	Type YSV-L	B-50
Types YAV BOX & YAV	B-21, B-22	Type YSM	B-51
Types YAV-L BOX & YAV-L	B-23, B-24	Type YSCM	B-52
Types YAV-H BOX & YAV-H	B-25	Types YSES-K	B-53
Type YBM	B-26	Types SP & BS	B-54
Types YAEV & YAEV-L	B-27, B-28	Insulated Splices	B-55
Type YAEV-H	B-29, B-30	Types SN, YSE-HN	B-55
Types YAV-R & YAV-RS	B-31	Types SNM, YSE BOX, YSES,	
Type YAEV-RS	B-32	YSE-H BOX, YSE & YSE-H	B-56
Type YAEV-RH	B-33	Types YSV & YRV-L	B-57
Types T-F & YAD-F	B-34	Types YQE & RK	B-58

Blue highlighted items are industry standard and most frequently ordered.

Performance

The terminals and splices in this catalog are approved, per SAE-AS7928 and/or UL486, where indicated. Table 1 shows the performance requirements for terminals used in military and commercial equipment. The voltage drops listed are maximum allowable values taken at currents well above rated current for the wires. Tensile values assure that the wires will not become separated from the terminals under reasonably expected stresses. UL tensile values are chosen to reflect the severest expected duty. MIL Specification tensile values apply only to crimp terminations and reflect minimum values that are obtained in good crimp joints. Actual performance of BURNDY® terminals exceeds the requirements of Table 1. Typical values are shown in Figs. 1-5. For High Temperature application BURNDY® YAV series with nickel plating “-NK” suffix provide for continuous operation to 650° F and 750° F intermittent service.

Table 1

Performance Requirements — Terminals for Copper Wire					
Wire Size	Per SAE-AS7928			Per UL486	
	Test Current (Amps)	Maximum Voltage Drop (Mv.)	Minimum Tensile Strength (Lbs.)	Minimum Tensile Strength (Lbs.)	Test Current For Max. 50°C Rise (Amps)
26	3	8	7	—	—
24	4.5	8	10	—	—
22	9	7	15	8	—
20	11	6	19	13	—
18	16	5	38	20	—
16	22	7	50	30	—
14	32	6	70	50	15
12	41	5	110	70	20
10	55	5	150	80	30
8	73	5	225	90	50
6	101	5	300	100	65
4	135	5	400	140	85
2	181	5	550	180	115
1	211	5	650	200	130
0	245	5	700	250	150
00	283	5	750	300	175
000	320	5	825	350	200
0000	380	5	875	450	230

Fig 1. Tensile strength of YAD HYLUG™ after axial rotation stresses.

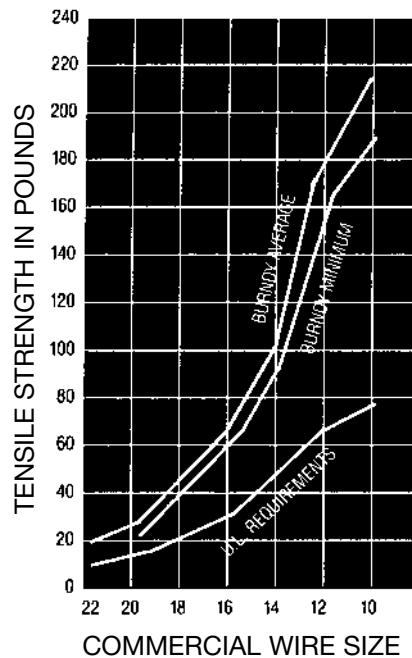
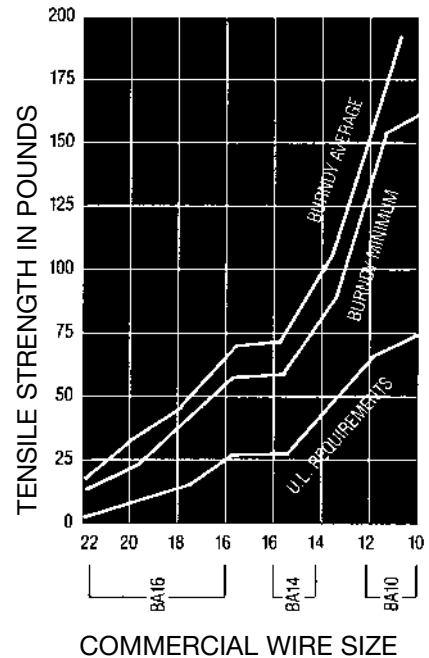

Fig 2. Tensile strength of BA VINYLUG™ after axial rotation stresses.



Blue highlighted items are industry standard and most frequently ordered.

GENERAL INFORMATION

(Continued)

Fig 3. Tensile strength of YAES INSULUG™ after vibration.

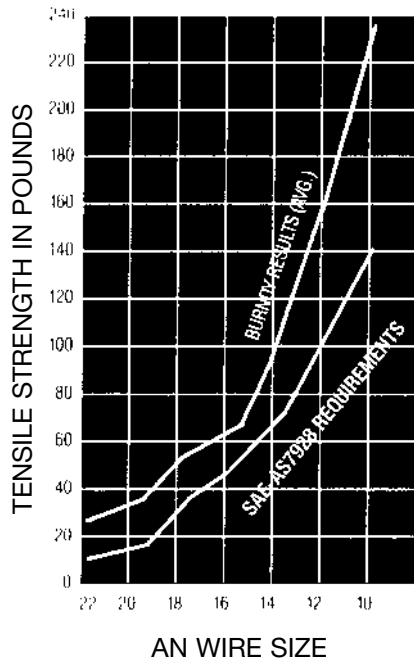

Fig 5. Voltage drops of YAES at currents per Table 1 after vibration.

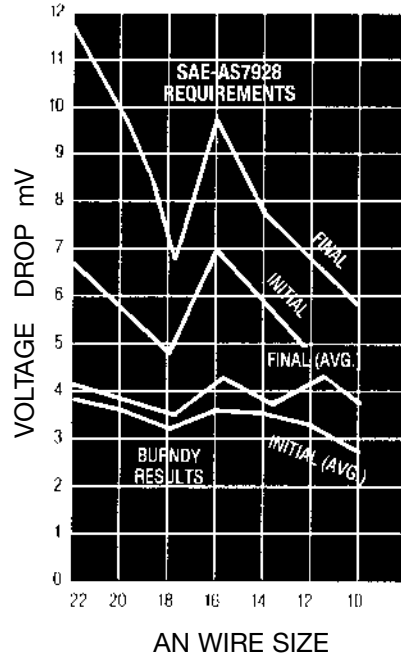
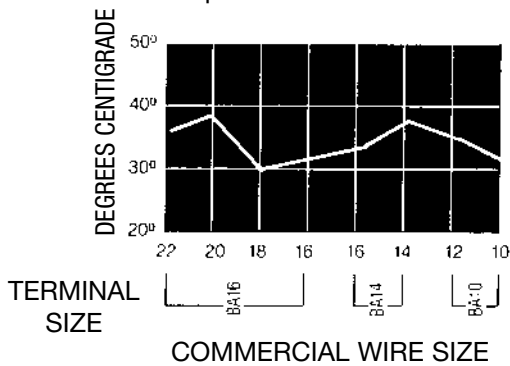

Fig 4. Temperature rise of BA VINYLUG™ at currents per Table 1.



Blue highlighted items are industry standard and most frequently ordered.

EQUIVALENT TABLES

MILITARY SPECIFICATIONS

Terminals

BURNDY® Equivalents to SAE-AS25036 in accordance with Specification SAE-AS7928

Terminals

BURNDY® Equivalents to SAE-AS20659 in accordance with Specification SAE-AS7928

AS25036 Dash No.	Catalog Number	Class 1	Class 2	Cage Code*	AS25036 Dash No.	Catalog Number	Class 1	Class 2	Cage Code*	AS20659 Dash No.	Catalog Number	Class 1	Class 2	Cage Code*	AS20659 Dash No.	Catalog Number	Class 1	Class 2	Cage Code*
101	YAES18-N1	X	X	1NJK8	124	YAEV4C-L4	X		1NJK8	105	YAV10	X	X	1NJK8	134	YAV1C-L3	X		1NJK8
	YAE18-G43		X		125	YAEV4C-L2	X	X	1NJK8	106	YAV10-T2	X	X	1NJK8	135	YAV25-L3	X		1NJK8
102	YAES18-N2	X	X	1NJK8	126	YAEV2C-L1	X	X	1NJK8	107	YAV8C-L	X		1NJK8	136	YAV26-L3	X	X	1NJK8
	YAE18-N21		X		127	YAEV2C-L	X		1NJK8	108	YAV8C-L2	X		1NJK8	137	YAV28-L54	X		1NJK8
103	YAES18-N3	X	X	1NJK8	128	YAEV2C-L4	X	X	1NJK8	109	YAV6C-L	X	X	1NJK8	140	YAV8C-L14	X		1NJK8
	YAE18N		X		129	YAEV1C-L1	X		1NJK8	110	YAV6C-L2	X		1NJK8	141	YAV8C-L1	X	X	1NJK8
104	YAES18-N4	X	X	1NJK8	130	YAEV1C-L	X	X	1NJK8	111	YAV4C-L	X	X	1NJK8	142	YAV8C-L4	X		1NJK8
	YAE18-N3		X		131	YAEV1C-L3	X		1NJK8	112	YAV4C-L2	X		1NJK8	143	YAV6C-L10	X		1NJK8
105	YAES18-N5	X	X	1NJK8	132	YAEV25-L1	X		1NJK8	113	YAV2C-L1	X		1NJK8	144	YAV4C-L3	X		1NJK8
	YAE18-N15		X		133	YAEV25-L	X	X	1NJK8	114	YAV2C-L	X		1NJK8	145	YAV4C-L5	X		1NJK8
106	YAES14-N6	X	X	1NJK8	134	YAEV25-L3	X		1NJK8	115	YAV1C-L1	X	X	1NJK8	146	YAV2C-L3	X		1NJK8
	YAE14-N43		X		135	YAEV26-L2	X		1NJK8	116	YAV1C-L	X		1NJK8	147	YAV2C-L2	X	X	1NJK8
107	YAES14-N7	X	X	1NJK8	136	YAEV26-L	X		1NJK8	117	YAV25-L1	X		1NJK8	148	YAV2C-L11	X		1NJK8
108	YAES14-N8	X	X	1NJK8	137	YAEV26-L3	X		1NJK8	118	YAV25-L	X	X	1NJK8	149	YAV1C-L2	X		1NJK8
	YAE14N		X		143	YAE22-G18		X	1NJK8	119	YAV26-L2	X		1NJK8	150	YAV1C-L4	X		1NJK8
109	YAES14-N9	X	X	1NJK8	144	YAE22-G16		X	1NJK8	120	YAV26-L	X		1NJK8	151	YAV25-L2	X		1NJK8
	YAE14-N3		X		145	YAE22-G13		X	1NJK8	121	YAV27-L	X	X	1NJK8	152	YAV25-L16	X		1NJK8
110	YAES14-N10	X		1NJK8	146	YAE22-G14		X	1NJK8	122	YAV27-L1	X		1NJK8	153	YAV26-L1	X		1NJK8
	YAE14-N4		X		147	YAE22-G15		X	1NJK8	123	YAV28-L	X		1NJK8	154	YAV26-L16	X		1NJK8
111	YAES10-N11	X	X	1NJK8	148	YAES18-N48	X	X	1NJK8	124	YAV28-L12	X	X	1NJK8	155	YAV27-L20	X		1NJK8
	YAE10-N5		X		149	YAES18-N49	X	X		1NJK8	129	YAV8C-L3	X		1NJK8	157	YAV28-L56	X	
112	YAES10-N12	X	X	1NJK8	149	YAE18N1	X		1NJK8		130	YAV6C-L1	X		1NJK8	158	YAV28-L60	X	
	YAE10N		X		150	YAES18-N50	X	X		1NJK8	131	YAV6C-L4	X		1NJK8	159	YAV28-L13	X	
113	YAES10-N13	X	X	1NJK8	150	YAE18-N2	X		1NJK8		132	YAV4C-L4	X		1NJK8	160	YAV28-L14	X	
	YAE10-N2		X		152	YAES14-N52	X	X		1NJK8	133	YAV2C-L4	X		1NJK8	165	YAV10-T7	X	X
114	YAES10-N14	X		1NJK8	153	YAES14-N53	X	X	1NJK8										
115	YAEV8C-L	X	X		154	YAE14-N1	X			1NJK8									
116	YAEV8C-L1	X		1NJK8	154	YAES14-N54	X	X	1NJK8										
117	YAEV8C-L2	X		1NJK8		YAE14-N2	X												
118	YAEV8C-L3	X		1NJK8	155	YAES14-N54	X	X	1NJK8										
119	YAEV6C-L1M	X	X	1NJK8	156	YAES10-N56	X	X	1NJK8										
120	YAEV6C-LM	X		1NJK8		YAE10-N11	X												
121	YAEV6C-L4M	X		1NJK8	157	YAES10-N57	X	X	1NJK8										
122	YAEV6C-L2M	X		1NJK8		YAE10-N3	X												
123	YAEV4C-L	X		1NJK8	158	YAES10-N58	X	X	1NJK8										

* Main Office Cage Code Number

Notes:

For factory cage code numbers, please contact your local BURNDY® Sales Representative or the Headquarters phone number below.
SAE stands for the Society of Automotive Engineering, which has replaced the Military Specifications.

Blue highlighted items are industry standard and most frequently ordered.

TYPE YF

BARE FERRULES

For Use On Copper Conductor

Wire ferrules are also known as cord end terminals or bootlace ferrules. These are electrical connectors used to terminate stranded wires. These terminals are made of electrolytically tin plated copper, uninsulated ferrules are designed to form neat end terminations to multi-strand cables or wires. Smooth funnel entry assists in wire insertion. Specifically designed to aid in termination of extra flexible

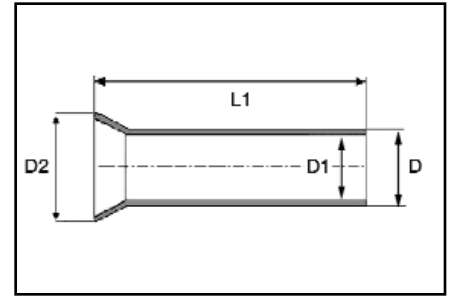

fine stranded conductor, provides enhanced flexibility relating to wire termination and management. A positive contact surface helps ensure system integrity.

Features and Benefits

- Made of electrolytic copper, tin plated
- Seamless barrels
- Smooth funnel entry to make wire insertion easier
- RoHS compliant

Catalog Number	Wire Size		Dimensions in Inches				Bag Qty.	Recommended Tooling
	AWG	mm ²	L1	D	D1	D2		
YF2807UI	28	.14	.276	.035	.027	.063	1000	YF3206TOOL
YF2605UI	26	.25	.196	.043	.031	.059	1000	
YF2607UI	26	.25	.276	.043	.031	.059	1000	YF3206TOOL
YF2405UI	24	.34	.196	.047	.031	.059	1000	YF2610TOOL
YF2407UI	24	.34	.276	.047	.031	.059	1000	
YF2206UI	22	.50	.236	.051	.039	.059	1000	
YF2208UI	22	.50	.315	.051	.039	.067	1000	
YF2210UI	22	.50	.394	.051	.039	.067	1000	
YF2212UI	22	.50	.472	.051	.039	.067	1000	
YF2006UI	20	.75	.236	.059	.047	.067	1000	
YF2010UI	20	.75	.394	.059	.047	.075	1000	
YF2012UI	20	.75	.472	.059	.047	.075	1000	
YF1806UI	18	1.00	.236	.067	.055	.075	1000	
YF1808UI	18	1.00	.315	.067	.055	.087	1000	
YF1810UI	18	1.00	.394	.067	.055	.087	1000	YF3206TOOL
YF1812UI	18	1.00	.472	.067	.055	.087	1000	YF2610TOOL
YF1607UI	16	1.50	.276	.079	.067	.087	1000	YF2214TOOL
YF1608UI	16	1.50	.315	.079	.067	.098	1000	YF2210TOOL
YF1610UI	16	1.50	.394	.079	.067	.098	1000	
YF1612UI	16	1.50	.472	.079	.067	.098	1000	
YF1618UI	16	1.50	.709	.079	.067	.098	1000	
YF1407UI	14	2.50	.276	.102	.091	.130	1000	
YF1408UI	14	2.50	.315	.102	.091	.130	1000	
YF1410UI	14	2.50	.394	.102	.091	.130	1000	
YF1412UI	14	2.50	.472	.102	.091	.130	1000	
YF1418UI	14	2.50	.709	.102	.091	.130	1000	
YF1209UI	12	4.00	.354	.126	.110	.154	1000	
YF1212UI	12	4.00	.472	.126	.110	.154	1000	YF3206TOOL
YF1215UI	12	4.00	.591	.126	.110	.154	1000	YF2610TOOL
YF1218UI	12	4.00	.709	.126	.110	.154	1000	YF2210TOOL
YF1010UI	10	6.00	.394	.154	.138	.185	250	YF3206TOOL
YF1012UI	10	6.00	.472	.154	.138	.185	250	YF2610TOOL
YF1015UI	10	6.00	.591	.154	.138	.185	250	YF2210TOOL
YF1018UI	10	6.00	.709	.154	.138	.185	250	YF1006TOOL
YF0812UI	8	10.00	.472	.193	.177	.228	250	
YF0815UI	8	10.00	.591	.193	.177	.228	250	
YF0818UI	8	10.00	.709	.193	.177	.228	250	YF3206TOOL
YF0612UI	6	16.00	.472	.244	.228	.283	250	YF1006TOOL
YF0615UI	6	16.00	.591	.244	.228	.283	250	YF0801TOOL
YF0618UI	6	16.00	.709	.244	.228	.283	250	
YF0625UI	6	16.00	.984	.244	.228	.283	250	

Blue highlighted items are industry standard and most frequently ordered.

TYPE YF (Continued)

BARE FERRULES

For Use On Copper Conductor

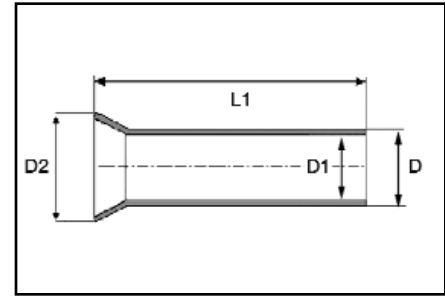

Catalog Number	Wire Size		Dimensions in Inches				Bag Qty.	Recommended Tooling
	AWG	mm ²	L1	D	D1	D2		
YF0412UI	4	25.00	.472	.311	.295	.358	100	YF0801TOOL YF0401TOOL
YF0415UI	4	25.00	.591	.311	.295	.358	100	
YF0418UI	4	25.00	.709	.311	.295	.358	100	
YF0420UI	4	25.00	.787	.311	.295	.358	100	
YF0425UI	4	25.00	.984	.311	.295	.358	100	
YF0432UI	4	25.00	1.260	.311	.295	.358	100	
YF0215UI	2	35.00	.591	.343	.327	.402	100	
YF0220UI	2	35.00	.787	.343	.327	.402	100	
YF0225UI	2	35.00	.984	.343	.327	.402	100	
YF0232UI	2	35.00	1.260	.343	.327	.402	100	
YF0122UI	1	50.00	.866	.429	.406	.500	50	
YF0125UI	1	50.00	.984	.429	.406	.500	50	
YF0132UI	1	50.00	1.260	.429	.406	.500	50	
YF2/022UI	2/0	70.00	.866	.563	.531	.622	50	
YF2/025UI	2/0	70.00	.984	.563	.531	.622	50	
YF2/032UI	2/0	70.00	1.260	.563	.531	.622	50	
YF3/025UI	3/0	95.00	.984	.614	.583	.681	50	YF1/03/0T00L
YF3/030UI	3/0	95.00	1.180	.614	.583	.681	50	
YF3/032UI	3/0	95.00	1.260	.614	.583	.681	50	
YF4/032UI	4/0	120.00	1.260	.697	.657	.795	25	
YF4/034UI	4/0	120.00	1.390	.697	.657	.795	25	YF4/0250T00L
YF4/040UI	4/0	120.00	1.570	.697	.657	.795	25	
YF25032UI	250	150.00	1.260	.811	.722	.906	25	Y644HSXT
YF25040UI	250	150.00	1.570	.811	.722	.906	25	
YF35032UI	350	185.00	1.260	.843	.795	.941	25	
YF35040UI	350	185.00	1.570	.843	.795	.941	25	

Blue highlighted items are industry standard and most frequently ordered.

TYPE YF-I FERRULES

INSULATED FERRULES

For Use On Copper Conductor
Offered in Series D, T & W

Ferrules are electrical connectors used to terminate stranded wires, creating a quality, reliable connection by ensuring each wire strand conducts current when properly crimped. Especially useful when multiple reconnections could be necessary within terminal blocks or other similar devices. No breakage of wire strands when wire is bent, under stress or in a vibration environment. Twin ferrule designs allow two individual stranded conductors to be connected to the same termination, most beneficial in jumpering or other similar applications. Both styles (single and twin) offer the same features and benefits. The YF-TOOL series has been designed to crimp both the bare (type YF-UI) and insulated (type YF-I) ferrules.

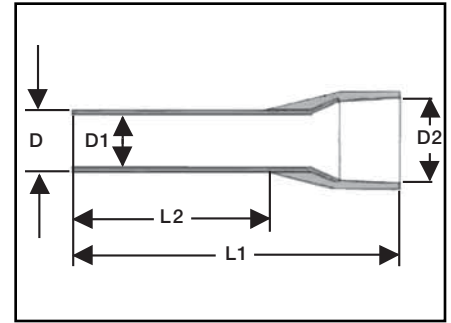
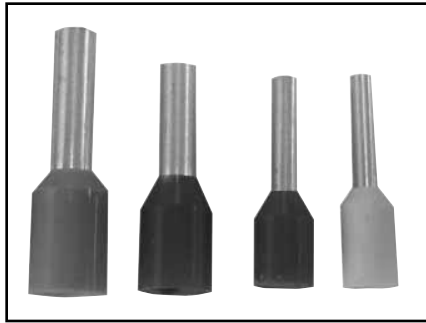

Features & Benefits

- Made of electrolytic copper, tin plated
- Smooth funnel entry to make wire insertion easier
- Secure contacting even after multiple reconnections
- Long-term contact resistance
- No fraying of strands
- No breakage of wire strands when wire is bent, under stress or in vibration environment
- RoHS compliant

Catalog Number*	Wire Size		Dimensions in Inches					Bag Qty.	Tooling
	AWG	mm ²	L1 (in.)	L2 (in.)	D (in.)	D1 (in.)	D2 (in.)		
YF2806I	28	.14	.409	.236	.037	.031	.043	500	YF3206TOOL
YF2808I	28	.14	.488	.315	.037	.031	.043	500	
YF2606I	26	.25	.409	.236	.043	.031	.075	500	YF3206TOOL YF2610TOOL
YF2608I	26	.25	.488	.315	.043	.031	.075	500	
YF2406I	24	.34	.409	.236	.043	.031	.075	500	YF3206TOOL YF2610TOOL YF2214TOOL YF2210TOOL
YF2408I	24	.34	.488	.315	.043	.031	.075	500	
YF2205I	22	.50	.433	.197	.051	.039	.102	500	
YF2206I	22	.50	.472	.236	.051	.039	.102	500	
YF2208I	22	.50	.551	.315	.051	.039	.102	500	
YF2210I	22	.50	.630	.394	.051	.039	.102	500	
YF2212I	22	.50	.709	.472	.051	.039	.102	500	
YF2006I	20	.75	.472	.236	.059	.047	.110	500	
YF2008I	20	.75	.551	.315	.059	.047	.110	500	
YF2010I	20	.75	.630	.394	.059	.047	.110	500	
YF2012I	20	.75	.709	.472	.059	.047	.110	500	
YF2018I	20	.75	.957	.709	.059	.047	.110	500	
YF1806I	18	1.00	.472	.236	.067	.055	.118	500	
YF1808I	18	1.00	.551	.315	.067	.055	.118	500	
YF1810I	18	1.00	.630	.394	.067	.055	.118	500	
YF1812I	18	1.00	.709	.472	.067	.055	.118	500	
YF1818I	18	1.00	.957	.709	.067	.055	.118	500	
YF1606I	16	1.50	.484	.236	.079	.067	.138	500	
YF1608I	16	1.50	.551	.315	.079	.067	.138	500	
YF1610I	16	1.50	.630	.394	.079	.067	.138	500	
YF1612I	16	1.50	.709	.472	.079	.067	.138	500	
YF1615I	16	1.50	.839	.591	.079	.067	.138	500	
YF1618I	16	1.50	.945	.709	.079	.067	.138	500	
YF1408I	14	2.50	.591	.315	.098	.087	.165	500	
YF1410I	14	2.50	.685	.394	.098	.087	.165	500	
YF1412I	14	2.50	.709	.472	.098	.087	.165	500	
YF1418I	14	2.50	.945	.709	.098	.087	.165	500	
YF1425I	14	2.50	.984	.709	.098	.087	.165	500	

* Insert series letter for complete catalog number:
(example: YF2806IW).

Blue highlighted items are industry standard and most frequently ordered.

TYPE YF-I FERRULES

(Continued)

INSULATED FERRULES

For Use On Copper Conductor
Offered in Series D, T & W

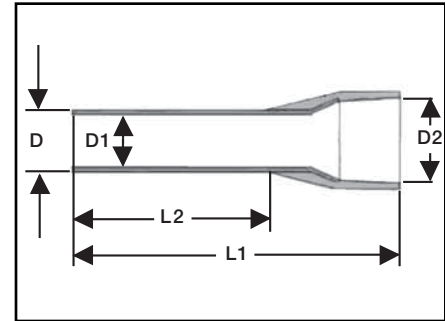

Catalog Number*	Wire Size		Dimensions in Inches					Bag Qty.	Tooling
	AWG	mm ²	L1 (in.)	L2 (in.)	D (in.)	D1 (in.)	D2 (in.)		
YF1209I	12	4.00	.646	.315	.126	.110	.189	500	YF3206TOOL YF2610TOOL YF2210TOOL
YF1210I	12	4.00	.699	.394	.126	.110	.189	500	
YF1212I	12	4.00	.787	.472	.126	.110	.189	500	
YF1218I	12	4.00	1.020	.709	.126	.110	.189	500	YF3206TOOL YF2610TOOL YF2210TOOL YF1006TOOL
YF1010I	10	6.00	.728	.394	.154	.138	.248	100	
YF1012I	10	6.00	.787	.472	.154	.138	.248	100	
YF1018I	10	6.00	1.020	.709	.154	.138	.138	100	YF3206TOOL YF1006TOOL YF0801TOOL
YF0812I	8	10.00	.866	.472	.193	.177	.299	100	
YF0815I	8	10.00	.929	.591	.193	.177	.299	100	
YF0818I	8	10.00	1.10	.709	.193	.177	.299	100	YF3206TOOL YF1006TOOL YF0801TOOL
YF0612I	6	16.00	.945	.472	.244	.228	.346	100	
YF0618I	6	16.00	1.10	.709	.244	.228	.346	100	
YF0412I	4	25.00	.945	.472	.303	.287	.441	100	YF0801TOOL YF0401TOOL
YF0415I	4	25.00	1.06	.591	.303	.287	.441	100	
YF0416I	4	25.00	1.10	.630	.303	.287	.441	100	
YF0418I	4	25.00	1.18	.709	.303	.287	.441	100	
YF0422I	4	25.00	1.42	.866	.303	.287	.441	100	
YF0425I	4	25.00	1.45	.984	.303	.287	.441	100	
YF0216I	2	35.00	1.18	.630	.343	.327	.500	100	
YF0218I	2	35.00	1.26	.709	.343	.327	.500	100	
YF0222I	2	35	1.15	.709	.343	.327	.50	100	
YF0225I	2	35	1.53	.984	.343	.327	.50	100	
YF0112I	1	50	1.10	.472	.429	.406	.591	50	
YF0116I	1	50	1.26	.630	.429	.406	.591	50	
YF0120I	1	50	1.417	.787	.429	.406	.591	50	
YF0122I	1	50	1.50	.866	.429	.406	.591	50	
YF0125I	1	50	1.58	.984	.429	.406	.591	50	
YF0130I	1	50	1.81	1.18	.429	.406	.591	50	
YF2/020ID	2/0	70	1.48	.787	.563	.531	.631	25	YF1/03/0TOOL
YF2/025ID	2/0	70	1.654	.984	.563	.531	.631	25	
YF2/027ID	2/0	70	1.73	1.06	.563	.531	.631	25	
YF3/025ID	3/0	95	1.73	.984	.614	.583	.725	25	
YF3/030ID	3/0	95	1.95	1.18	.614	.583	.725	25	
YF4/027ID	4/0	120	1.87	1.06	.697	.657	.799	25	YF4/0250TOOL
YF4/030ID	4/0	120	2.09	1.18	.697	.657	.799	25	
YF4/032ID	4/0	120	2.07	1.26	.697	.657	.799	25	
YF4/034ID	4/0	120	2.15	1.34	.697	.657	.799	25	
YF25025ID	250	150	1.99	.984	.811	.772	.921	25	
YF25027ID	250	150	2.07	1.06	.811	.772	.921	25	
YF25032ID	250	150	2.27	1.26	.811	.772	.921	25	
YF25038ID	250	150	2.50	1.50	.811	.772	.921	25	

* Insert series letter for complete Catalog Number:
(example: YF2806IW).
** Note that 2/0 size and above only available in D Series.

Blue highlighted items are industry standard and most frequently ordered.

TYPES YF, YF-I FERRULES

INSULATED TWIN FERRULES

For Use On Copper Conductor



Ferrules are electrical connectors used to terminate stranded wires, creating a quality, reliable connection by ensuring each wire strand conducts current when properly crimped. Especially useful when multiple reconnections could be necessary within terminal blocks or other similar devices. No breakage of wire strands when wire is bent, under stress or in a vibration environment. Twin ferrule designs allow two individual stranded conductors to be connected to the same termination, most beneficial in jumpering or other similar applications. Both styles (single and twin) offer the same features and benefits. The YF-TOOL series has been designed to crimp both the bare (type YF) and insulated (type YF-I) ferrules.

Features & Benefits

- Made of electrolytic copper, tin plated
- Smooth funnel entry to make wire insertion easier
- Secure contacting even after multiple reconnections
- Long-term contact resistance
- No fraying of strands
- No breakage of wire strands when wire is bent, under stress or in vibration environment
- RoHS compliant

Catalog Number*	Wire Size		Dimensions in Inches				Bag Qty.	Tooling
	AWG	mm ²	L1 (in.)	D (in.)	D1 (in.)	D2 (in.)		
YFTW0614_	6	16.00	1.230"	0.343"	0.327"	0.748"	100	YF2210TOOL
YFTW0814_	8	10.00	1.050"	0.272"	0.256"	0.496"	100	
YFTW1014_	10	6.00	1.030"	0.209"	0.193"	0.374"	100	
YFTW1212_	12	4.00	0.909"	0.165"	0.150"	0.346"	100	
YFTW1410_	14	2.5	0.728"	0.130"	0.114"	0.315"	500	
YFTW1413_	14	2.5	0.846"	0.130"	0.114"	0.315"	500	
YFTW1608_	16	1.5	0.610"	0.102"	0.091"	0.252"	500	
YFTW1612_	16	1.5	0.768"	0.102"	0.091"	0.252"	500	
YFTW1808_	18	1.00	0.594"	0.094"	0.083"	0.217"	500	
YFTW1810_	18	1.00	0.673"	0.094"	0.083"	0.217"	500	
YFTW2008_	20	.75	0.579"	0.083"	0.071"	0.217"	500	
YFTW2010_	20	.75	0.657"	0.083"	0.071"	0.217"	500	
YFTW2208_	22	.50	0.571"	0.071"	0.059"	0.197"	500	

* Insert series number after Catalog Number (example: YFTW0614W is the W series).

Blue highlighted items are industry standard and most frequently ordered.

TYPE YHS

HYDENT™ HEAT SHRINK RING AND FORK TONGUE TERMINALS

For Use On Copper Conductor

Features and Benefits

- Made from pure copper, annealed for maximum strength
- Color-coded, imprinted with wire size
- Serrated barrels offer maximum wire contact and tensile strength
- Electro tin plated for corrosion resistance
- Wire Strip Length 5/16"

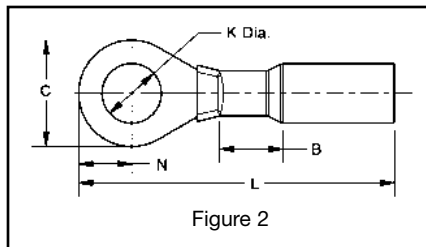

Figure 2

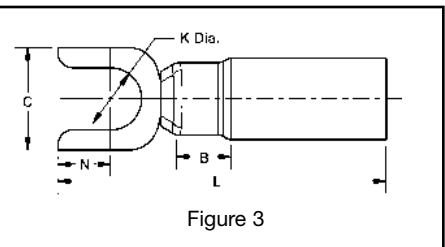

Figure 3

Catalog No. (100/bag)	Catalog No. (20/bag)	Fig. No.	Stud Size	Conductor Size	Tongue Type	Dimensions					Tongue Thickness
						B	C	K	L	N	
YHSA18K6	YHSA18K6RK	2	#6	22 - 18 AWG	Ring	0.22"	0.29"	0.14"	1.18"	0.14"	0.03"
YHSA18K8	YHSA18K8RK	2	#8	22 - 18 AWG	Ring	0.22"	0.32"	0.17"	1.18"	0.17"	0.03"
YHSA18K10	YHSA18K10RK	2	#10	22 - 18 AWG	Ring	0.22"	0.32"	0.20"	1.18"	0.33"	0.03"
YHSA18K14	YHSA18K14RK	2	1/4	22 - 18 AWG	Ring	0.22"	0.47"	0.27"	1.40"	0.38"	0.03"
YHSA18K38	YHSA18K38RK	2	3/8	22 - 18 AWG	Ring	0.22"	0.56"	0.40"	1.45"	0.28"	0.03"
YHSA14K8	YHSA14K8RK	2	#8	16 - 14 AWG	Ring	0.22"	0.32"	0.17"	1.18"	0.16"	0.03"
YHSA14K10	YHSA14K10RK	2	#10	16 - 14 AWG	Ring	0.22"	0.32"	0.20"	1.18"	0.17"	0.03"
YHSA14K14	YHSA14K14RK	2	1/4	16 - 14 AWG	Ring	0.22"	0.47"	0.26"	1.40"	0.23"	0.03"
YHSA14K38	YHSA14K38RK	2	3/8	16 - 14 AWG	Ring	0.22"	0.56"	0.40"	1.45"	0.28"	0.03"
YHSA10K10	YHSA10K10RK	2	#10	12 - 10 AWG	Ring	0.22"	0.34"	0.20"	1.15"	0.18"	0.04"
YHSA10K14	YHSA10K14RK	2	1/4	12 - 10 AWG	Ring	0.22"	0.56"	0.26"	1.45"	0.15"	0.04"
YHSA10K38	YHSA10K38RK	2	3/8	12 - 10 AWG	Ring	0.22"	0.56"	0.40"	1.45"	0.28"	0.04"
YHSA10K12	YHSA10K12RK	2	1/2	12 - 10 AWG	Ring	0.22"	0.69"	0.53"	1.69"	0.36"	0.04"
YHSA18K10F	YHSA18K10FRK	3	#10	22 - 18 AWG	Fork	0.22"	0.31"	0.20"	1.18"	0.27"	0.03"
YHSA14K10F	YHSA14K10FRK	3	#10	16 - 14 AWG	Fork	0.22"	0.34"	0.21"	1.17"	0.27"	0.03"
YHSA10K10F	YHSA10K10FRK	3	#10	12 - 10 AWG	Fork	0.22"	0.37"	0.21"	1.16"	0.27"	0.04"

Recommended Tooling MR22.

Blue highlighted items are industry standard and most frequently ordered.

TYPE YHS

HYDENT™ HEAT SHRINK BUTT SPLICES AND QUICK DISCONNECTS

For Use On Copper Conductor

Features and Benefits

- Made from pure copper, annealed for maximum strength
- Color-coded, imprinted with wire size
- Serrated barrels offer maximum wire contact and tensile strength
- Electro tin plated for corrosion resistance
- Wire strip length 5/16"

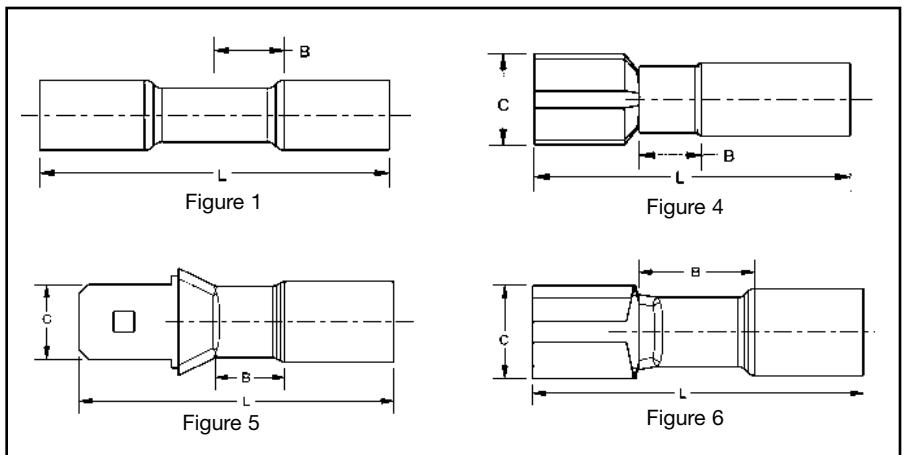

Catalog No. (100/bag)	Catalog No. (20/bag)	Fig. No.	Conductor Size	Connector Type	Dimensions		
					B	C	L
YHSS18	YHSS18RK	1	22 - 18 AWG	Butt Splice	0.25"	—	1.50"
YHSS14	YHSS14RK	1	16 - 14 AWG	Butt Splice	0.25"	—	1.50"
YHSS10	YHSS10RK	1	12 - 10 AWG	Butt Splice	0.25"	—	1.60"
YHSQ18F25X03	YHSQ18F25X03RK	4	22 - 18 AWG	Female Quick Disconnect	0.22"	0.30"	1.27"
YHSQ18M25X03	YHSQ18M25X03RK	5	22 - 18 AWG	Male Quick Disconnect	0.22"	0.25"	1.25"
YHSQ14F25X03	YHSQ14F25X03RK	4	16 - 14 AWG	Female Quick Disconnect	0.22"	0.30"	1.27"
YHSQ14M25X03	YHSQ14M25X03RK	5	16 - 14 AWG	Male Quick Disconnect	0.22"	0.25"	1.25"
YHSQ10F25X03	YHSQ10F25X03RK	4	12 - 10 AWG	Female Quick Disconnect	0.22"	0.30"	1.27"
YHSQ10M25X03	YHSQ10M25X03RK	5	12 - 10 AWG	Male Quick Disconnect	0.22"	0.25"	1.19"
YHSFQ18F25X03	YHSFQ18F25X03RK	6	22 - 18 AWG	Fully Insulated Female Quick Disconnect	0.22"	0.38"	1.28"
YHSFQ14F25X03	YHSFQ14F25X03RK	6	16 - 14 AWG	Fully Insulated Female Quick Disconnect	0.22"	0.38"	1.28"
YHSFQ10F25X03	YHSFQ10F25X03RK	6	12 - 10 AWG	Fully Insulated Female Quick Disconnect	0.22"	0.38"	1.34"

Recommended Tooling MR22.

Blue highlighted items are industry standard and most frequently ordered.

TYPE HSSHRACK

HYDENT™ HEAT SHRINK FULLY LOADED RACK

For Use On Copper Conductor

Standard crimp terminals leave the wire exposed allowing in moisture or other contaminants which can result in corrosion. Corrosion reduces the amount of current the wire can carry safely. The integrity of the electrical system can be compromised when unsealed electrical connections are utilized. Heat shrink terminals provide a durable seal blocking out contaminants ensuring a better connection.

Features and Benefits

- Made from pure copper, annealed for maximum strength
- Color-coded, imprinted with wire size
- Serrated barrels offer maximum wire contact and tensile strength
- Electro tin plated for corrosion resistance
- Wire strip length 5/16"



List of Items Included in HSSHRACK

Quantity of Bags included in rack (20 pieces per bag)	Catalog Number	Stud Size	Conductor Size	Description
5	YHSS18RK	—	22 - 18 AWG	Butt Splice
5	YHSS14RK	—	16 - 14 AWG	Butt Splice
5	YHSS10RK	—	12 - 10 AWG	Butt Splice
5	YHSA18K10RK	#10	22 - 18 AWG	Ring Tongue Terminal
5	YHSA14K10RK	#10	16 - 14 AWG	Ring Tongue Terminal
5	YHSA10K10RK	#10	12 - 10 AWG	Ring Tongue Terminal
5	YHSA18K10FRK	#10	22 - 18 AWG	Fork Tongue Terminal
5	YHSA14K10FRK	#10	16 - 14 AWG	Fork Tongue Terminal
5	YHSA10K10FRK	#10	12 - 10 AWG	Fork Tongue Terminal
5	YHSFQ18F25X03RK	—	22 - 18 AWG	Fully Insulated Female Quick Disconnect
5	YHSFQ14F25X03RK	—	16 - 14 AWG	Fully Insulated Female Quick Disconnect
5	YHSFQ10F25X03RK	—	12 - 10 AWG	Fully Insulated Female Quick Disconnect
—	—	—	—	Durable Cardboard Rack Display

Recommended Tooling MR22.

Blue highlighted items are industry standard and most frequently ordered.

TYPE HSKIT

HYDENT™ HEAT SHRINK CONNECTORS AND INSTALLATION TOOL

For Use On Copper Conductor

Standard crimp terminals leave the wire exposed allowing in moisture or other contaminants which can result in corrosion. Heat shrink terminals provide a durable seal, blocking out contaminants, ensuring a better connection.

Features and Benefits

- Made from pure copper, annealed for maximum strength
- Color-coded, imprinted with wire size
- Serrated barrels offer maximum wire contact and tensile strength
- Electro tin plated for corrosion resistance
- Wire strip length 5/16"



List of Items Included in HSKIT							
Quantity of Pieces included in kit	Description	Conductor Size	Stud Size	Quantity of Pieces included in kit	Description	Conductor Size	Stud Size
50	Butt Splice	22 - 18 AWG	—	10	Fork Terminal	22 - 18 AWG	#6
50	Butt Splice	16 - 14 AWG	—	10	Fork Terminal	22 - 18 AWG	#8
30	Butt Splice	12 - 10 AWG	—	10	Fork Terminal	22 - 18 AWG	#10
15	Butt Splice	#8 AWG	—	10	Fork Terminal	16 - 14 AWG	#6
10	Ring Terminal	22 - 18 AWG	#6	10	Fork Terminal	16 - 14 AWG	#8
10	Ring Terminal	22 - 18 AWG	#8	10	Fork Terminal	16 - 14 AWG	#10
10	Ring Terminal	22 - 18 AWG	#10	10	Fork Terminal	12 - 10 AWG	#6
10	Ring Terminal	22 - 18 AWG	5/16"	10	Fork Terminal	12 - 10 AWG	#8
10	Ring Terminal	22 - 18 AWG	1/4"	10	Fork Terminal	12 - 10 AWG	#10
10	Ring Terminal	22 - 18 AWG	3/8"	15	Fork Terminal	#8 AWG	3/8"
10	Ring Terminal	16 - 14 AWG	#8	50 (25 ea)	Male & Female Quick Disc.	22 - 18 AWG	—
10	Ring Terminal	16 - 14 AWG	#10	50 (25 ea)	Male & Female Quick Disc.	16 - 14 AWG	—
10	Ring Terminal	16 - 14 AWG	5/16"	50 (25 ea)	Male & Female Quick Disc.	12 - 10 AWG	—
10	Ring Terminal	16 - 14 AWG	1/4"	30 (15 ea)	Male & Female Bullet	16 - 14 AWG	—
10	Ring Terminal	16 - 14 AWG	3/8"	20 (10 ea)	Male & Female Ins. Quick Disc.	22 - 18 AWG	—
10	Ring Terminal	16 - 14 AWG	#6	20 (10 ea)	Male & Female Ins. Quick Disc.	16 - 14 AWG	—
10	Ring Terminal	12 - 10 AWG	#8	20 (10 ea)	Male & Female Ins. Quick Disc.	12 - 10 AWG	—
10	Ring Terminal	12 - 10 AWG	#10	10	Step Down Butt Splice	16 - 14 to 22 - 18 AWG	—
10	Ring Terminal	12 - 10 AWG	5/16"	10	Step Down Butt Splice	12 - 10 to 16 - 14 AWG	—
10	Ring Terminal	12 - 10 AWG	1/4"	1	Ratchet Crimp Tool	—	—
10	Ring Terminal	12 - 10 AWG	3/8"	1	Metal Case with Dividers	—	—
15	Ring Terminal	#8 AWG	#10				

Blue highlighted items are industry standard and most frequently ordered.

TYPES T AND YAD

HYLUG™

Uninsulated Compression Terminal, Ring Tongue

The Type T uninsulated terminals are constructed of pure electrolytic copper. Designed with a long brazed seam barrel, standard neck, deep V groove inner serrations and electro-tin plated. The terminals are ideal for control wiring and other standard duty applications.

The ring tongue provides a secure termination under the screw head that cannot be removed without the complete removal of the screw. Two or more terminals can easily be stacked on a common stud.

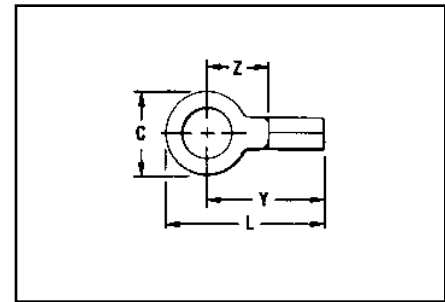
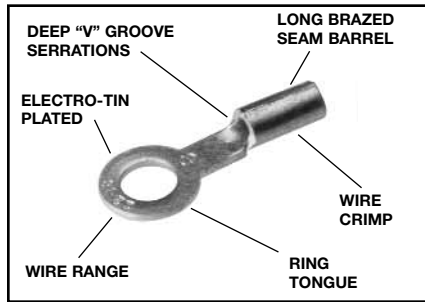

Features and Benefits

- Constructed of pure electrolytic copper.
 - ◇ Provides maximum conductivity, low resistance and ductility for excellent crimp forming properties.
- Long brazed seam barrel and deep V groove inner serrations.
 - ◇ Provides optimum conductivity reliability and holding power after crimping.
- Electro-tin plated.
 - ◇ Provides durable long-lasting corrosion resistance.
- Wire range is clearly marked on terminal.
 - ◇ Provides easy identification.
- Inspection hole.
 - ◇ Provides an easy visual check of wire insertion.
- Long neck terminal.
 - ◇ Permits easy bending and stacking of several terminals on a common stud.



Catalog Number	Wire Range	Stud Size	Dimensions				Bulk Catalog Number*	Installation Tooling	Tape Mounted Catalog Number 2000/Reel	Installation Tooling	Wire Strip Length
			C	L Max.	Y Max.	Z Min.					
T18-4	22-18	3, 4	.25	.65	.53	.24	YAD18-4	YAD18-4M YAD18-6M YAD18-8M YAD18-10M YAD18-14M	TFM with DFM6D1 Die	9/32"	
T18-6		4-6	.25	.65	.53	.24	YAD18-6				
T18-8		6-8	.31	.77	.61	.33	YAD18-8				
T18-10		8-10	.31	.77	.61	.33	YAD18-10				
T18-14		1/4	.45	.96	.73	.44	YAD18-14				
T18-516		5/16	.45	.96	.73	.44	YAD18-516				
T18-38		3/8	.53	1.05	.78	.49	YAD18-38				
T14-4	20-14	3, 4	.25	.67	.55	.26	YAD14-4	YAD14-4M YAD14-6M YAD14-8M YAD14-10M YAD14-14M — YAD14-38M	TFM with DFM5D1 Die	9/32"	
T14-6		4-6	.25	.67	.55	.26	YAD14-6				
T14-8		6-8	.31	.77	.61	.33	YAD14-8				
T14-10		8-10	.31	.77	.61	.33	YAD14-10				
T14-14		1/4	.45	.96	.73	.44	YD14-14				
T14-516		5/16	.45	.96	.73	.44	YAD14-516				
T14-38		3/8	.53	1.05	.78	.49	YAD14-38				
T10-6	12-10*	4-6	.37	.83	.64	.29	YAD10-6	— •YAD10-8M — *YAD10-14M *YAD10-516M *YAD10-38M	TFM with DFM4D1 Die	11/32"	
T10-8		6-8	.37	.83	.64	.29	YAD10-8				
T10-10		8-10	.37	.83	.64	.29	YAD10-10				
T10-14		1/4	.46	.97	.74	.39	YAD10-14				
T10-516		5/16	.53	1.02	.76	.41	YAD10-516				
T10-38		3/8	.58	1.08	.79	.44	YAD10-38				

* NOTE: UL Listed for 14-10 when installed with MR8G98 and Y8MRB-1 tools only.
• 1000 pcs/reel.

Blue highlighted items are industry standard and most frequently ordered.

TYPES TP AND BA

VINYLUTM

Terminal – Polyvinylchloride Insulated, Ring Tongue

600 Volts Max., 105° C Max.

VINYLUTM Type TP is designed for commercial and light duty industrial control and power circuit applications. Supplied with an expanded polyvinyl chloride (PVC) insulation shroud, many tongue variations and rated 600V makes TP terminals versatile and economical.

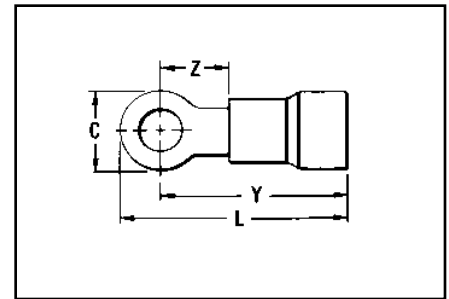
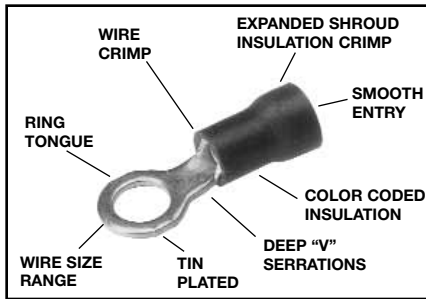

Features and Benefits

- Expanded insulation support accepts standard and large wire diameters.
 - ◇ Lowers inventory requirements, permits greater flexibility and provides insulation support.
- Funnel entry.
 - ◇ Easy wire insertion.
- Manufactured of pure electrolytic copper.
 - ◇ Provides maximum conductivity, low resistance and ductility for excellent crimp forming properties.
- Deep V groove serrations in the inner barrel.
 - ◇ Provides added holding strength and better conductivity.
- Electro-tin plated.
 - ◇ Provides durable long-lasting corrosion resistance.

Catalog Number	Wire Range	Stud Size	Dimensions				Bulk Catalog Number*	Installation Tooling	Tape Mounted Catalog Number 2000/Reel	Installation Tooling	Wire Strip Length
			C	L	Y	Z					
TP16-4	22-16 Max. Insul. Dia. Accom.: .145 Color Code: Red	3-4	.22	.71	.61	.17	BA16E4	Plier Type: Y10-22, Y10D or Ratchet Tool: MR8-89-1, MR8-G96, MR15	BA16E4M	TFM with DFM3D-1 Die	13/64"
TP16-6		4-6	.25	.74	.62	.18	BA16E6		BA16E6M		
TP16-8		6-8	.31	.85	.70	.26	BA16E8		BA16E8M		
TP16-10		8-10	.31	.85	.70	.26	BA16E10		BA16E10M		
TP16-14		12, 1/4	.40	.99	.79	.36	BA16E14		BA16E14M		
TP16-38		3/8	.53	1.15	.88	.45	BA16E38		BA16E38M		
TP14-4	16-14 Max. Insul. Dia. Accom.: .180 Color Code: Blue	3-4	.22	.71	.61	.17	BA14E4	Plier Type: Y10-22, Y10D or Ratchet: MR8-89-1, MR8-G96, MR15	BA14E4M	TFM with DFM2D-1 Die	13/64"
TP14-6		4-6	.25	.74	.62	.18	BA14E6		BA14E6M		
TP14-8		6-8	.31	.85	.70	.26	BA14E8		BA14E8M		
TP14-10		8-10	.31	.85	.70	.26	BA14E10		BA14E10M		
TP14-14		12, 1/4	.40	.99	.79	.36	BA14E14		BA14E14M		
TP14-516		5/16	.53	1.15	.88	.45	BA14E516		BA14E516M		
TP14-38	3/8	.53	1.15	.88	.45	BA14E38	—				
TP10-6	12-10 Max. Insul. Dia. Accom.: .260 Color Code: Yellow	4-6	.31	.91	.75	.20	BA10E6	Plier Type: Y10-22, Y10D or Ratchet: MR8-89-1, MR15, M8ND w/N10HET-23	*BA10E6M	TFM with DFM1D5 Die	19/64"
TP10-8		6-8	.36	1.00	.81	.26	BA10E8		*BA10E8M		
TP10-10		8-10	.36	1.00	.81	.26	BA10E10		*BA10E10M		
TP10-14		12, 1/4	.53	1.22	.95	.40	BA10E14		*BA10E14M		
TP10-38		3/8	.53	1.27	1.00	.45	BA10E38		*BA10E38M		

* 1000/Reel

Blue highlighted items are industry standard and most frequently ordered.

TYPES TN AND YAES

INSULUG™

Terminal – Nylon Insulated, Ring-Tongue

300 Volts Max., 105°C Max.

INSULUG™ type TN Nylon-insulated terminals are designed for heavy duty industrial, utility and military power and control-circuit applications for wire sizes 26 AWG through 10 AWG. They offer high dielectric strength and stability in oily conditions and meet military CLASS 1 and CLASS 2 requirements per SAE-AS25036 and the requirements of military specifications SAE-AS7928.

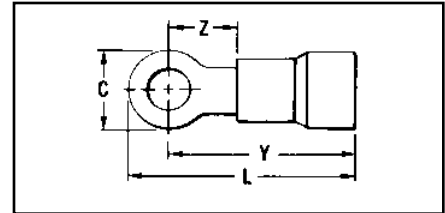
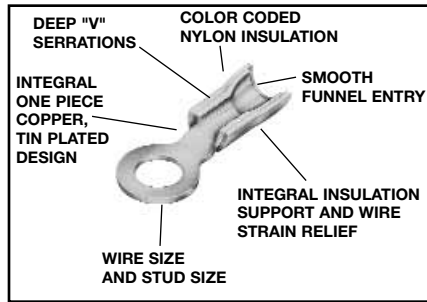

Features and Benefits

- An integral one-piece copper barrel /insulation grip and wire strain relief design.
 - ◇ Provides improved physical strength characteristics over a multi-piece design.
- Manufactured of pure electrolytic copper.
 - ◇ Provides maximum conductivity, low resistance and ductility for excellent crimp forming properties.
- Brazed seam.
 - ◇ Provides a stronger barrel design to minimize any possible splitting and eliminates folding.
- Deep inner barrel serrations.
 - ◇ Provides excellent electrical conductivity and pullout strength values.
- Smooth funnel entry.
 - ◇ Easy wire insertion.
- The insulation is locked in place.
 - ◇ Will not twist off, thereby maintains proper dielectric values.
- Electro-tin plated.
 - ◇ Provides durable long-lasting resistance to corrosion.
- Color-coded and clearly marked.
 - ◇ Provides quick, easy wire size identification.
- Ring Tongue.
 - ◇ Provides a secure termination under the screw head that can not be removed without complete removal of the screw.
- Two or more terminals may be stacked on a common stud easily.
 - ◇ Provides flexibility and versatility.

Catalog Number	Wire Range	Stud Size	SAE-25036	Dimensions				Bulk ▲ Catalog Number	Installation Tooling	Wire Strip Length
				C	L Max.	Y Max.	Z Max.			
TN18-4	22-18 Max. Insul. Dia. Accom.: .120 Color Code: Red	3-4	-148	.23	.76	.64	.20	YAES18N48	Non-Ratchet: Y10D, Y1022 Ratchet: MR8-83	7/32"
TN18-6		4-6	-101	.25	.76	.64	.20	YAES18N1		
TN186G1		4-6	-102	.25	.87	.74	.49	YAES18N2		
TN18-8		6-8	-149	.31	.91	.76	.29	YAES18N49		
TN18-10		8-10	-103	.31	.91	.76	.29	YAES18N3		
TN18-14		12, 1/4	-150	.46	1.09	.87	.41	YAES18N50		
TN18-516		5/16	-104	.46	1.09	.87	.41	YAES18N4		
TN18-38	3/8	-105	.53	1.17	.91	.45	YAES18N5			
TN14-4	16-14 Max. Insul. Dia. Accom.: .153 Color Code: Blue	3-4	-152	.25	.79	.67	.24	YAES14N52		7/32"
TN14-6		4-6	-106	.25	.79	.67	.24	YAES14N6		
TN146G1		4-6	-107	.30	.91	.76	.51	YAES14N7		
TN14-8		6-8	-153	.31	.89	.74	.31	YAES14N53		
TN14-10		8-10	-108	.31	.89	.74	.31	YAES14N8		
TN14-14		12, 1/4	-154	.45	1.08	.86	.43	YAES14N54		
TN1412G1		1/2	-155	.71	1.32	.97	.72	YAES14N55		
TN14-516		5/16	-109	.45	1.08	.86	.43	YAES14N9		
TN14-38		3/8	-110	.53	1.16	.90	.47	YAES14N10		
TN10-6		12-10 Max. Insul. Dia. Accom.: .210 Color Code: Yellow	4-6	-111	.37	1.12	.94	.26	YAES10N11	
TN10-8	6-8		-156	.37	1.12	.94	.26	YAES10N56		
TN10-10	8-10		-112	.37	1.12	.94	.26	YAES10N12		
TN10-14	12, 1/4		-157	.53	1.32	1.06	.37	YAES10N57		
TN10-516	5/16		-113	.53	1.32	1.06	.37	YAES10N13		
TN10-38	3/8		-114	.58	1.34	1.05	.40	YAES10N14		

▲ Class 1 and class 2. Meets the requirement of aerospace specification SAE-AS7928.

Blue highlighted items are industry standard and most frequently ordered.

TYPES YAE-G AND YAE-N

INSULUG™

Terminal – Nylon Insulated, Ring-Tongue Multi-Finger Insulation Grip

300 Volts Max., 105° C Max.

INSULUG™ Types YAE-G and YAE-N nylon insulated terminals are designed with a multi-finger insulation grip for paper, EPR and other elastic or hard to grip insulations. The metal fingers firmly grip the insulation providing superior holding characteristics, cable support and strain relief. Types YAE-G and YAE-N terminals are rated 105° C and meet military standard AS25036 Class 2 and SAE-AS7928 requirements.

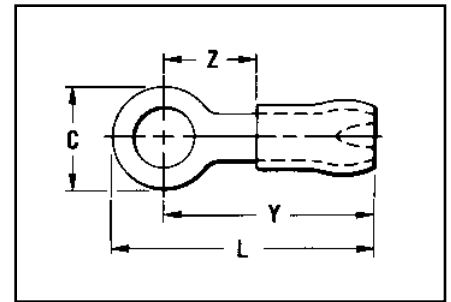
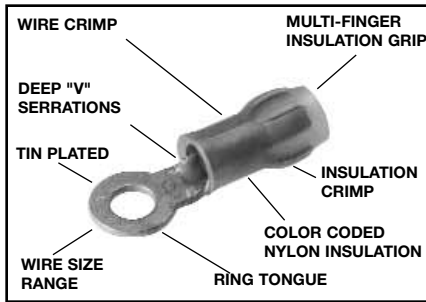

Features and Benefits

- Multi-finger insulation grip.
 - ◇ Provides superior insulation holding characteristics, especially on EPR and other elastic-type insulations.
- Brazed seam.
 - ◇ Provides stronger more durable termination.
- Manufactured of pure electrolytic copper.
 - ◇ Provides maximum conductivity, low resistance and ductility for excellent crimp forming properties.
- Deep V groove, inner barrel serrations.
 - ◇ Provide optimum conductivity, reliability, and holding power.
- Smooth funnel entry.
 - ◇ Easy wire insertion.

Catalog Number	Wire Range	Stud Size	** SAE-AS25036	Dimensions				Bulk Catalog Number*	Installation Tooling	Tape Mounted Catalog Number 2000/Reel	Installation Tooling	Wire Strip Length
				C	L Max.	Y Max.	Z Max.					
YAE22G18 BOX•	26-20	1.2	-148	.15	.70	.62	.22	YAE22G18•	M8ND with N14HET-25V1 Die MR8-1A	YAE22G18M•	TFM with DFM11D1 Die	5/32"
YAE22G12 BOX•	Max. Insul.	1.2	—	.25	.75	.62	.22	YAE22G12•		—		
YAE22G16 BOX•	Dia. Accom.:	3.4	-144	.18	.75	.62	.22	YAE22G16•		YAE22G16M•		
YAE22G13 BOX•	.098	4-6	-145	.25	.75	.62	.22	YAE22G13•		YAE22G13M•		
YAE22G14 BOX•	Color Code:	6-8	-146	.32	.83	.67	.27	YAE22G14•		—		
YAE22G15 BOX•	Amber	8-10	-147	.32	.83	.67	.27	YAE22G15•		—		

• Not UL recognized or Listed.
 * 1000/Box
 ** Class 2

Blue highlighted items are industry standard and most frequently ordered.

TYPES YAE-G AND YAE-N
(Continued)

INSULUG™

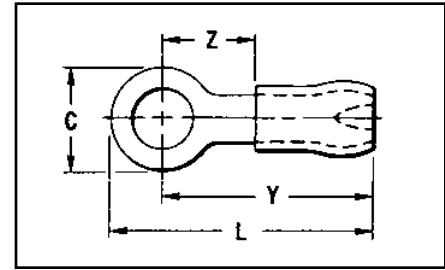

Catalog Number	Wire Range	Stud Size	**SAE-AS25036	Dimensions				Bulk Catalog Number	Installation Tooling	Tape Mounted Catalog Number 2000/Reel	Installation Tooling	Wire Strip Length
				C	L Max.	Y Max.	Z Min.					
YAE18N29 BOX	22-16 † Max. Insul. Dia. Accom.: .125 Color Code: Red	1-2	—	.14	.75	.68	.19	YAE18N29	MR8-1A, MR8-33T-1 (no extra dies required) M8ND with one of following dies: N14HET-25V1 N10ET-9 N14HET-15 N10ET-23 or Y10D Y10-22	YAE18N29M	TFM with DFM10D1 die	3/16"
YAE18N27 BOX		2	—	.19	.77	.66	.19	YAE18N27		YAE18N27M		
—		4	—	.25	.80	.68	.19	YAE18-N7		YAE18-N7M		
—		4	-148	.25	.80	.68	.19	YAE18N17		—		
—		4	—	.23	.78	.68	.19	YAE18N26		YAE18N26M		
YAE18N21 BOX		4-6	-102	.25	.89	.77	.28	YAE18N21		YAE18N21M		
—		4-6	—	.22	.79	.68	.19	YAE18N25		YAE18N25M		
YAE18G43 BOX		4-6	-101	.25	.90	.68	.19	YAE18G43		YAE18G43M		
YAE18N24 BOX		6-8	—	.28	.92	.77	.28	YAE18N24		YAE18N24M		
YAE18N1 BOX		6-8	-149	.31	.92	.77	.28	YAE18N1		YAE18N1M		
YAE18N BOX		8-10	-103	.31	.92	.77	.28	YAE18N		YAE18NM		
YAE18N2 BOX		12, 1/4	-150	.45	1.11	.88	.40	YAE18N2		YAE18N2M		
YAE18N3 BOX		5/16	-104	.45	1.11	.88	.40	YAE18N3		YAE18N3M		
YAE18N15 BOX		3/8	-105	.53	1.19	.93	.43	YAE18N15		YAE18N15M		
YAE14N43 BOX	16-14 Max. Insul. Dia. Accom.: .156 Color Code: Blue	4-6	-106	.25	.82	.69	.20	YAE14N43	YAE14N43M	TFM with DFM9D1 die	3/16"	
YAE14N1 BOX		6-8	-153	.31	.92	.75	.28	YAE14N1	YAE14N1M			
YAE14N BOX		8-10	-108	.31	.92	.75	.28	YAE14N	YAE14NM			
YAE14N2 BOX		1/4	-154	.45	1.11	.88	.40	YAE14N2	YAE14N2M			
YAE14N3 BOX	5/16	-109	.45	1.11	.88	.40	YAE14N3	YAE14N3M				
YAE14N4 BOX	3/8	-110	.53	1.19	.93	.44	YAE14N4	YAE14N4M				
—	14-12 Max. Insul. Dia. Accom.: .180 Color Code: Green	10	—	.31	1.06	.93	.29	YAE12N7	—	TFM with DFM7D1 die	21/64"	
YAE12N9 BOX		6-8	—	.31	1.06	.90	.28	YAE12N9	YAE12N9M			
YAE12N1 BOX		6-8	—	.31	1.06	.90	.28	YAE12N1	YAE12N1M			
YAE12N BOX		8-10	—	.31	1.06	.90	.28	YAE12N	YAE12NM			
YAE12N2 BOX	1/4	—	.46	1.25	1.02	.40	YAE12N2	YAE12N2M				
YAE10N5 BOX	12-10 Max. Insul. Dia. Accom.: .209 Color Code: Yellow	4-6	-111	.38	1.15	.96	.28	YAE10N5	* YAE10N5M	TFM with DFM7D1 die	3/8"	
YAE10N11 BOX		6-8	-156	.38	1.17	.98	.30	YAE10N11	* YAE10N11M			
YAE10N BOX		8-10	-112	.38	1.15	.96	.28	YAE10N	* YAE10NM			
YAE10N3 BOX		1/4	-157	.54	1.39	1.12	.44	YAE10N3	* YAE10N3M			
YAE10N2		5/16	-113	.54	1.39	1.12	.44	YAE10N2	* YAE10N2M			
YAE10N4		3/8	-114	.54	1.39	1.12	.44	YAE10N4	* YAE10N4M			

* 1000/Reel
** Class 2
† Use Y10D or Y10-22 only when crimping #16 AWG.

Blue highlighted items are industry standard and most frequently ordered.

TYPE YAES-K

INSULUG™

NUCLEAR TERMINALS AND SPLICES

Radiation Resistant Insulated Terminals, Ring Tongue

Polyvinylidene (PVF₂) Insulated 200 Megarads, -60° through 150° C, 600 Volts

The type YAES-K, radiation resistant KYNAR® insulated terminals are designed and have been tested to meet the requirements for class 1E critical circuits as set by the Nuclear Regulatory Commission (NRC). Additional testing for compatibility under loss of coolant accident (LOCA) conditions with cross-link polyethylene (XLP) and HYPALON® insulations was completed successfully. Compatibility with ethylene propylene rubber (EPR) insulation was determined by analysis. Each terminal is manufactured of pure electrolytic copper per QQ-C 576 and bright tin-plated per MIL-T-10727 and meets or exceeds SAE-AS7928 using stranded copper AWG wire. The KYNAR® insulation offers 200 megarad radiation resistance.

The Type YAES-K radiation resistant KYNAR® - insulated terminals are suitable for class 1E critical circuits and non-critical nuclear associated applications.

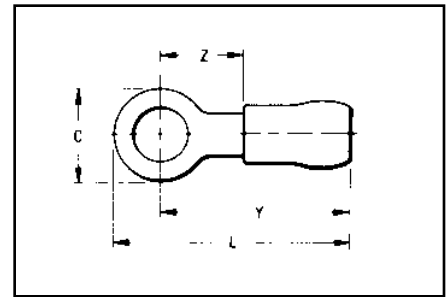
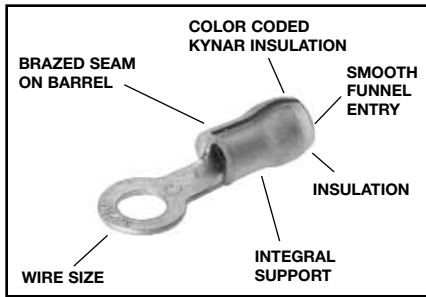

Features and Benefits

- KYNAR® insulation.
 - ◇ Provides 200 megarad radiation resistance plus successfully tested for insulation compatibility.
- An integral one-piece copper barrel/insulation grip and wire strain relief design.
 - ◇ Provides improved physical strength characteristics over a multi-piece design.
- The KYNAR® insulation is locked in place.
 - ◇ The insulation will not move or twist off, thereby maintains proper dielectric values.
- Manufactured from pure electrolytic copper.
 - ◇ Provides maximum conductivity, low resistance and ductility for excellent crimp forming properties.
- Bright tin-plated per MIL-T-10727.
 - ◇ Provides durable long-lasting resistance to corrosion.
- Deep inner barrel serrations.
 - ◇ Provides excellent electrical conductivity and tensile strength values.
- Brazed seam.
 - ◇ Provides a stronger barrel design to minimize any possible splitting and eliminates folding.
- Smooth funnel entry.
 - ◇ Easy wire insertion.
- Color coded terminals.
 - ◇ Provides easy wire size identification and inspection.
- Coded raised dots in the die area of the connection after compression.
 - ◇ Provides visual identification that the correct tool and die were used for proper installation.
- Inspection hole.
 - ◇ Permits visual check for proper wire insertion.
- Ring tongue design.
 - ◇ Provides a secure termination under screw head that cannot be removed without the complete removal of the screw.
- Multiple terminals may be stacked on a common stud easily.
 - ◇ Provides flexibility and versatility.

KYNAR - is a registered trademark of the Pennwalt Corp. for Polyvinylidene Fluoride (PVF₂)

HYPALON - Is a registered trademark of the E.I. DuPont deNemours & Co., Inc.

Blue highlighted items are industry standard and most frequently ordered.

TYPE YAES-K

(Continued)

INSULUG™

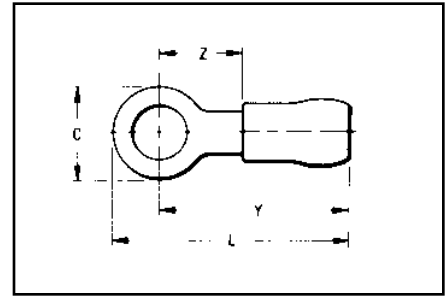

Catalog Number	Wire Range	Stud Size	Dimensions				Installation Tooling	Wire Strip Length
			C	L Max.	Y Max.	Z Min.		
YAES18K48	22-18 AWG str. Max. Insul. Dia. Accom.: .120 Color Code: Red	4	.23	.76	.64	.20	Ratchet Tool: MR10G6 Crimp Mark: (1) Small Dot Red Groove Calibration Gauge: PG-373-1	7/32"
YAES18K-1		6	.23	.76	.64	.20		
YAES18K-2		6	.25	.87	.74	.29		
YAES18K-49		8	.31	.91	.76	.29		
YAES18K-3		10	.31	.91	.76	.29		
YAES18K-50		1/4	.46	1.09	.86	.41		
YAES18K-4		5/16	.46	1.09	.86	.41		
YAES18K-5		3/8	.53	1.18	.91	.45		
YAES14K-6		16-14 AWG str. Max. Insul. Dia. Accom.: .153 Stock Thickness: .032 Color Code: Blue	6	.25	.77	.65		
YAES14K-7	6		.31	.91	.76	.29		
YAES14K-53	8		.31	.91	.76	.29		
YAES14K-8	10		.31	.91	.76	.29		
YAES14K-54	1/4		.46	1.09	.86	.41		
YAES14K-9	5/16		.46	1.09	.86	.41		
YAES10K-10	12-10 AWG str. Max. Insul. Dia. Accom.: .210 Stock Thickness: .040 Color Code: Yellow	3/8	.53	1.18	.91	.45	Ratchet Tool: MR10G6 Crimp Mark: (1) Large Dot Calibration Gauge: PG-372-1	3/8"
YAES10K-11		6	.38	1.12	.94	.26		
YAES10K-11T1		6	.31	1.09	.94	.26		
YAES10K-56		8	.38	1.12	.94	.26		
YAES10K-12		10	.38	1.12	.94	.26		
YAES10K-57		1/4	.53	1.32	1.06	.37		
YAES10K-13		5/16	.53	1.32	1.06	.37		
YAES10K-14		3/8	.58	1.34	1.05	.40		
YAES10K-58	1/2	.72	1.41	1.06	.45			

Blue highlighted items are industry standard and most frequently ordered.

TYPES YAV BOX AND YAV

HYLUG™

Seamless Uninsulated Compression Heavy Duty Ring Tongue Terminal

#22-10 Stranded and Solid Copper

HYLUG™ type YAV is a seamless, heavy duty uninsulated compression ring tongue terminal manufactured from pure electrolytic copper tubing and is for use on copper commercial (code) cable, type AN aircraft cable and extra flexible conductors. Because of its seamless design, the YAV HYLUG™ also accommodates solid conductors.

The seamless tubing produces a double thick tongue and a strong connector for demanding applications that require high reliability. Applications include industrials, hospitals, electric utilities, aircraft, shipboard and marine, computers, steel mills, mining equipment and other equipment that is subject to vibration or requiring dependable electrical performance.

The YAV-HYLUG™ terminals meet the requirements of SAE-AS7928.

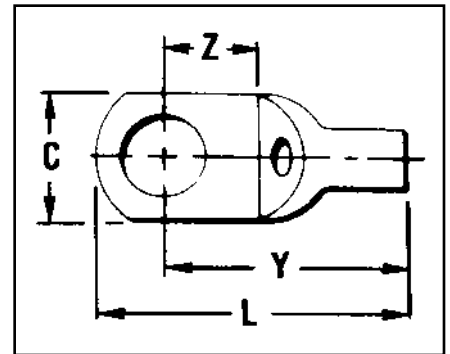
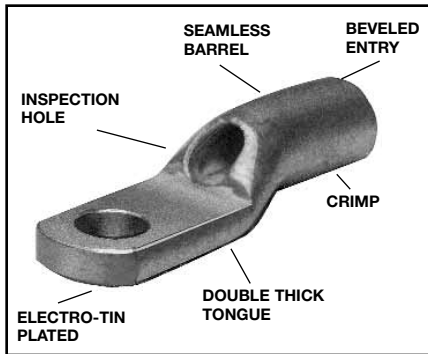

(See table on following page for specifications)

Features and Benefits

- Manufactured from seamless pure electrolytic copper tubing.
 - ◊ Provides maximum conductivity, low resistance and excellent ductility for crimping.
- Seamless tubular crimp barrel design.
 - ◊ No seams to split resulting in a very high quality electrical connection. Also can be used on solid conductor.
- Double thick tongue.
 - ◊ Provides a very strong terminal tongue.
- Produced from tubular copper.
 - ◊ Extra copper material assures the compression connector will operate cooler than the conductors it connects.
- Internally bevelled barrel.
 - ◊ Provides easy cable entry, especially for flexible conductors.
- Inspection hole.
 - ◊ Provides easy visual check for proper conductor insertion.
- Electro-tin plated.
 - ◊ Provides long lasting durable corrosion resistance.
- Nickel plating available, add "NK" suffix."
 - ◊ Nickel plated HYLUGs™ provide high temperature applications up to 650° F continuous service and 750° F intermittent service.

Blue highlighted items are industry standard and most frequently ordered.

TYPES YAV BOX AND YAV

HYLUG™

Seamless Uninsulated
Compression Heavy Duty
Ring Tongue Terminal

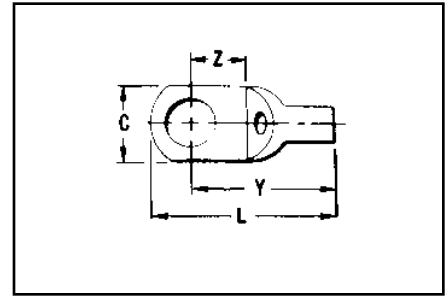

Catalog Number	Wire Range	Stud Size	Dimensions				Bulk Catalog Number	Installation Tooling	Wire Strip Length
			C	L Max.	Y Max.	Z Min.			
YAV18-T4 BOX	22-18 Str. and Sol.	3, 4	.19	.62	.54	.16	YAV18-T4	Non-Ratchet: Y10D, Y10-22 Ratchet: MR8G98, MR8-9Q, Y8MRB-1, MR20	9/32"
YAV18-L33 BOX		4-6	.25	.67	.55	.18	YAV18-L33		
YAV18-T5 BOX		4-6	.31	.76	.61	.24	YAV18-T5		
YAV18-T1 BOX		6-8	.31	.76	.61	.24	YAV18-T1		
YAV18 BOX		8-10	.31	.76	.61	.24	YAV18		
YAV14-L33 BOX	20-14 Str.	4-6	.25	.71	.59	.18	YAV14-L33	Non-Ratchet: Y10D, Y10-22 Ratchet: MR8G98, MR8-9Q, Y8MRB-1, MR20	9/32"
YAV14-T5 BOX		4-6	.31	.79	.64	.24	YAV14-T5		
YAV14-T1 BOX		6-8	.31	.79	.64	.24	YAV14-T1		
YAV14-L36 BOX	20-12 Sol.	8-10	.29	.74	.59	.18	YAV14-L36	Non-Ratchet: Y10D, Y10-22 Ratchet: MR8G98, MR8-9Q, Y8MRB-1, MR20	9/32"
YAV14 BOX		8-10	.31	.79	.64	.24	YAV14		
YAV14-T2 BOX		1/4	.42	.99	.75	.32	YAV14-T2		
YAV14-T3 BOX		5/16	.44	.99	.75	.32	YAV14-T3		
YAV12-G2 BOX ■	14-12 Str.	8-10	.30	.82	.67	.24	YAV12-G2	Y10D, Y8MRB-1 M8ND w/N14HT	9/32"
YAV12-G3 BOX ■		1/4	.36	1.00	.76	.34	YAV12-G3		
YAV10-T7 BOX	†14 Str. 12-10 Str. and Sol.	4-6	.30	.93	.78	.24	YAV10-T7 *	Non-Ratchet: Y10D, Y10-22 Ratchet: MR8G98, MR8-9Q, Y8MRB-1, MR20, N10HT, N10HT-24	7/16"
YAV10-T11 BOX		6-8	.38	.97	.79	.26	YAV10-T11		
YAV10-L36 BOX		8-10	.29	.86	.71	.23	YAV10-L36		
YAV10 BOX		8-10	.38	.97	.79	.26	YAV10 *		
YAV10-T3 BOX		1/4	.47	1.10	.87	.32	YAV10-T3		
YAV10-T2 BOX		5/16	.53	1.13	.87	.31	YAV10-T2 *		
YAV10-T4 BOX		3/8	.56	1.18	.90	.35	YAV10-T4 *		
YAV9C-L36 BOX	10-9 Str.	8-10	.31	.97	.83	.15	YAV9C-L36	Ratchet: MR8-9Q, Y8MRB-1	7/16"
YAV9C-T9 BOX		1/4	.44	1.19	.95	.31	YAV9C-T9		
YAV9C-T4 BOX		5/16	.52	1.27	1.02	.36	—		

■ Use #14 groove
† UL Listed for 14 Str. to #10 Sol. & Str. when installed with MR8G98 and Y8MRB-1 tools only.
* Class 1 & 2 connectors.

Blue highlighted items are industry standard and most frequently ordered.

TYPES YAV-L BOX AND YAV-L

HYLUG™

Large Size Uninsulated Compression Terminals
Seamless Uninsulated Compression Ring Tongue Terminal

#8-4/0 Str. Copper

HYLUG™ Type YAV is a seamless, heavy duty uninsulated compression terminal manufactured from electrolytic copper and is for use on Type AN aircraft cable, extra flexible conductors and commercial (code) conductors. The seamless tubing produces a double thick tongue and seamless barrel design

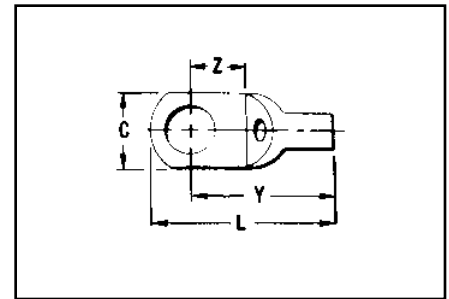
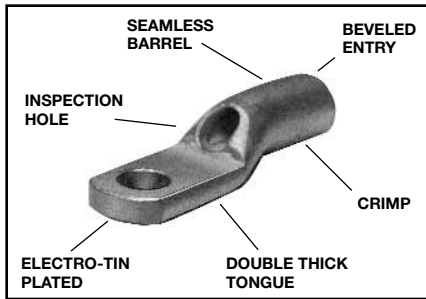

provides a strong connector for demanding applications requiring high reliability.

Applications include aircraft, industrials, hospitals, electric utilities, marine, computers, and other equipment subject to vibration or requiring dependable electrical performance.

The YAV HYLUG™ terminals meet the requirements of SAE-AS7928 and are listed per AS20659 for use with copper aircraft cable per MIL-W-5086

The benefits of YAV-L connectors are the same as YAV connectors for stranded conductors.

Catalog Number	Wire Range	Stud Size	MS20659 Dash No.†	Dimensions (Inches)				Bulk Catalog Number	Installation Tooling				Wire Strip Length
				C	L Max.	Y Max.	Z Min.		HYTOOL™ ■	Die Index	HYPRESS™		
											Y29B, Y29NC	Y35, Y39, Y750 ▲	
—	8 Aircraft AN 8 Flex	6-8	-140	.41	1.15	.94	.28	YAV8C-L14 •	Non-Ratchet: MY29-11 Ratchet: MR4C, MR8-9Q, Y8MRB-1, M8ND w/ N8CT Die Set	38	DV8L-1 Nest Y29PL Indentor (1) Crimp	UV8L Nest Y34PL Indentor (1) Crimp	1/2"
YAV8C-L BOX		8-10	-107	.41	1.15	.94	.28	YAV8C-L •					
YAV8C-L1 BOX		1/4	-141	.46	1.22	.99	.32	YAV8C-L1 •					
YAV8C-L2 BOX		5/16	-108	.57	1.30	1.01	.34	YAV8C-L2 •					
YAV8C-L3 BOX		3/8	-129	.57	1.30	1.01	.34	YAV8C-L3 •					
YAV8C-L4 BOX		1/2	-142	.73	1.52	1.14	.48	YAV8C-L4 •					
—	5 & 6 Aircraft AN 5 & 6 Flex	8-10	-130	.48	1.31	1.06	.29	YAV6C-L1 •	Non-Ratchet: MY28, MY29-11 Ratchet: MR4C	39	DV6L Nest Y29PL Indentor (1) Crimp	UV6L Nest Y34PLA Indentor (1) Crimp	1/2"
YAV6C-L BOX		1/4	-109	.48	1.31	1.06	.29	YAV6C-L •					
YAV6C-L4 BOX		5/16	-131	.60	1.43	1.13	.35	YAV6C-L4 •					
YAV6C-L2 BOX		3/8	-110	.60	1.43	1.13	.35	YAV6C-L2 •					
YAV6C-L10 BOX		1/2	-143	.73	1.64	1.26	.49	YAV6C-L10					
—		4 Aircraft AN 4 Flex	8-10	-144	.55	1.37	1.11	.28					
YAV4C-L BOX	1/4		-111	.55	1.37	1.11	.28	YAV4C-L					
YAV4C-L4 BOX	5/16		-132	.63	1.48	1.17	.33	YAV4C-L4 •					
YAV4C-L2 BOX	3/8		-112	.63	1.48	1.17	.33	YAV4C-L2 •					
YAV4C-L5 BOX	1/2		-145	.73	1.68	1.30	.47	YAV4C-L5					
—	2 Aircraft AN 2 Flex		8-10	-146	.69	1.72	1.37	.35	YAV2C-L3	Non-Ratchet: MY28, MY29-11	41	DV2L Nest Y29PL Indentor (1) Crimp	UV2L Nest Y34PLA Indentor (1) Crimp
YAV2C-L1 BOX		1/4	-113	.69	1.72	1.37	.35	YAV2C-L1 •					
YAV2C-L2 BOX		5/16	-147	.69	1.72	1.37	.35	YAV2C-L2 •					
YAV2C-L BOX		3/8	-114	.69	1.72	1.37	.35	YAV2C-L •					
YAV2C-L4 BOX		1/2	-133	.77	1.89	1.49	.46	YAV2C-L4					

† Class 1.
• Available in (90°) right angle design. Suffix "RS" Replaces Suffix "L".
▲ Use Y35P3 Indentor Adapter with Y35 and Y39 Tool.

■ Bench Mount Adapter - Cat. BMY-BCH-MT is available for Type "MY" HYTOOLS™. Add "NK" suffix for nickel plated HYLUGs™ for high temperature applications up to 650° F continuous service and 750° intermittent service.

Blue highlighted items are industry standard and most frequently ordered.

TYPES YAV-L BOX AND YAV-L
(Continued)

HYLUG™

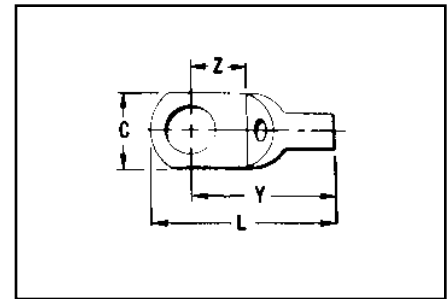
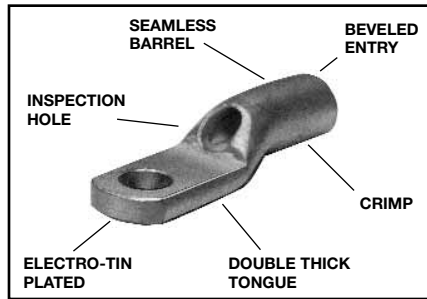

Catalog Number	Wire Range	Stud Size	MS20659 Dash No.†	Dimensions (Inches)				Bulk Catalog Number	Installation Tooling				
				C	L Max.	Y Max.	Z Min.		■ HYTOOL™	Die Index	HYPRESS™		Wire Strip Length
											Y29B, Y29NC	Y35, Y39, Y750 ▲	
—	1 Aircraft AN 1 Flex	8-10	—	.76	1.67	1.32	.25	Non-Ratchet: MY28, MY29-11	42	DV1L Nest Y29PL Indentor (1) Crimp	UV1L Nest Y34PLA Indentor (1) Crimp	5/8"	
YAV1C-L1 BOX		1/4	-115	.76	1.84	1.45	.38						YAV1C-L1•
YAV1C-L2 BOX		5/16	-149	.76	1.84	1.45	.38						YAV1C-L2•
YAV1C-L BOX		3/8	-116	.76	1.84	1.45	.38						YAV1C-L
YAV1C-L3 BOX	1/2	-134	.86	1.97	1.54	.46	YAV1C-L3						
YAV25-L1 BOX	1/0 Aircraft AN 1/0 Flex	1/4	-117	.83	2.01	1.61	.43		YAV25-L1	43	DV25L Nest Y29PR Indentor (1) Crimp	UV25L Nest Y34PA Indentor (1) Crimp	11/16"
YAV25-L2 BOX		5/16	-151	.83	2.01	1.61	.43		YAV25-L2				
YAV25-L BOX		3/8	-118	.83	2.01	1.61	.43		YAV25-L•				
YAV25-L3 BOX		1/2	-135	.88	2.09	1.64	.46		YAV25-L3•				
YAV25-L4 BOX	5/8	—	.88	2.31	1.80	.62	YAV25-L4						
YAV26-L1 BOX	2/0 Aircraft AN 2/0 Flex	1/4	-153	.93	2.32	1.85	.48		YAV26-L1	44	DV26L Nest Y29PR Indentor (1) Crimp	UV26L Nest Y34PA Indentor (1) Crimp	13/16"
YAV26-L2 BOX		5/16	-119	.93	2.32	1.85	.48		YAV26-L2				
YAV26-L BOX		3/8	-120	.93	2.32	1.85	.48		YAV26-L•				
YAV26-L3 BOX		1/2	-136	.93	2.32	1.85	.48		YAV26-L3•				
YAV26-L12 BOX	5/8	—	.93	2.52	1.99	.62	YAV26-L12						
YAV27-L BOX	3/0 Aircraft AN 3/0 Flex	3/8	-121	1.03	2.45	1.93	.52		YAV27-L•	45	—	UV27L Nest Y34PA Indentor (1) Crimp	13/16"
YAV27-L1 BOX		1/2	-122	1.03	2.45	1.93	.52	YAV27-L1					
YAV27-L15 BOX	5/8	—	1.03	2.60	2.04	.62	YAV27-L15						
YAV28-L BOX	4/0	3/8	-123	1.12	2.72	2.16	.60	YAV28-L	46	—	UV28L Nest Y34PA Indentor (1) Crimp	7/8"	
YAV28-L12 BOX	1/2	-124	1.12	2.72	2.16	.60	YAV28-L12						
YAV28-L13 BOX	5/8	-159	1.12	2.72	2.16	.60	YAV28-L13						
YAV28-L14 BOX	3/4	-160	1.23	2.95	2.33	.78	YAV28-L14						

† Class 1.
• Available in (90°) right angle design. Suffix "RS" replaces suffix "L".
▲ Use Y35P3 Indentor Adapter with Y35 and Y39 tool.

■ Bench Mount Adapter - Cat. BMY-BCH-MT is available for Type "MY" HYTOOLS™. Add "NK" suffix for nickel plated HYLUGs™ for high temperature applications up to 650° F continuous service and 750° intermittent service.

Blue highlighted items are industry standard and most frequently ordered.

TYPES YAV-H BOX AND YAV-H

HYLUG™

Seamless Uninsulated Compression Ring Tongue Terminal With Shroud

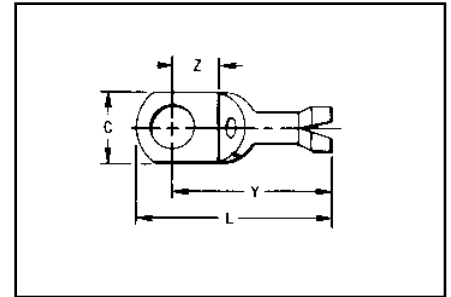

The type YAV-H HYLUG™ is a seamless heavy duty uninsulated compression ring tongue terminal with a shroud for an insulation grip and cable support. They are manufactured from pure electrolytic copper tubing for use on copper commercial (code) cable, Type AN aircraft cable and extra flexible conductors.

The seamless design produces a double thick tongue and the seamless barrel provides a strong highly reliable connection.

Meets the requirements of SAE-AS7928. The benefits of the Type YAV apply to the YAV-H HYLUG™.

Features and Benefits

- Shroud/insulation grip cable support and strain relief.
 - ◇ Protects the wire against breaking under vibration or flexing conditions.



Catalog Number	Wire Range	Stud Size	Max. Insul. Dia. Accom.	Dimensions				Bulk Catalog Number	Installation Tooling	Dies	Wire Strip Length
				C	L Max.	Y Max.	Z Min.				
YAV18-H BOX	22-18	8-10	.120"	.31	.91	.76	.24	YAV18-H	Plier: Y10D*, Y10-22*	M8ND, with N14HT, N14HT-5 Die	9/32"
YAV14-H1 BOX	20-14	6-8	.150"	.31	.95	.80	.24	YAV14-H1			Ratchet: MR8-G98, MR8-9Q, Y8MRB-1*, MR20*, M8ND
YAV14-H BOX		8-10		.31	.95	.80	.24	YAV14-H			
YAV14-H2 BOX		1/4		.42	1.14	.90	.32	YAV14-H2			
YAV10-H25 BOX	12-10	6-8	.192"	.31	1.04	.90	.24	YAV10-H25	MR8-9Q, Y8MRB-1*, MR20*, M8ND	M8ND, N10HT-24	7/16"
YAV10-H BOX		8-10		.38	1.09	.91	.24	YAV10-H			
YAV10-H3 BOX		1/4		.47	1.22	.99	.32	YAV10-H3			

* For conductor crimp only.

Blue highlighted items are industry standard and most frequently ordered.

TYPE YBM

HYLUG™

Flag-Type
Ring-Tongue Terminals

Made of pure electrolytic copper for maximum conductivity and ductility. Seamless extrusion tin plated to resist corrosion.

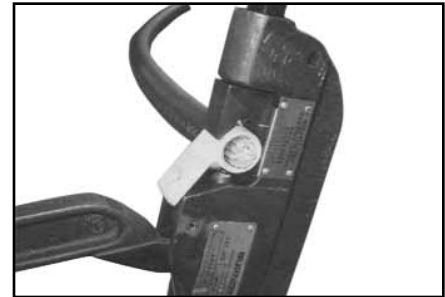
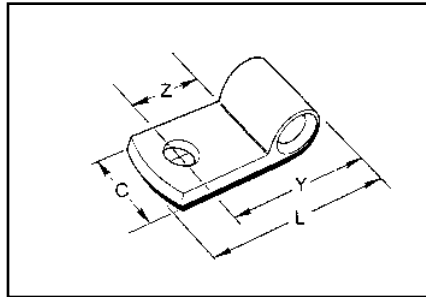

Catalog* Number	Wire Range		Stud Size	Dimensions in Inches				HYTOOL™	**Installation Tooling HYPRESS™ Y29NC, Y29B, Y35, Y750		Wire Strip Length
	Flex	Code		C	Z Min.	Y Max.	L Max.		Nest	Indenter	
YBM8C	8 Class I, K, DLO (37/24) MIL-W-5086	8	8-10	0.44	0.34	0.77	1.01	MY28	DV8B	Y29PBL	7/16"
YBM8C-T2			1/4	0.50	0.37	0.80	1.07				1/2"
YBM8CT4			3/8	0.62	0.52	0.83	1.35				9/16"
YBM6C-L9	6 Class I, DLO (81/24) 5086 MIL	6	8-10	0.50	0.37	0.85	1.09		DV6BL-1		1/2"
YBM6C-L			1/4	0.50	0.37	0.85	1.12				9/16"
YBM6C-L2			5/16	0.56	0.43	0.91	1.21				5/8"
YBM6C-L3	3/8	0.62	0.52	0.88	1.21						
YBM4C-L4	4 Class I, DLO (105/24) MIL-W-5086	4	8-10	0.50	0.37	0.99	1.18		DV4BL	Y29PBL	1/2"
YBM4C-L			1/4	0.50	0.37	0.94	1.21				9/16"
YBM4C-L1			5/16	0.56	0.43	1.00	1.30				5/8"
YBM4C-L2	3/8	0.62	0.52	0.97	1.30						
YBM2C-L1	2 Class I, DLO (150/24) MIL-W-5086	2	1/4	0.62	0.37	1.01	1.29		DV2BL	Y29PL	5/8"
YBM2C-L2			5/16	0.62	0.43	1.07	1.38				
YBM2C-L			3/8	0.62	0.37	1.01	1.35				
YBM1C-L3	1 Class I, DLO (225/24) MIL-W-5086	1	1/2	0.88	0.71	1.29	1.74	DV1BL		1"	
YBM1C-L			3/8	0.62	0.50	1.19	1.53			5/8"	
YBM25-L1	1/0 Class I, DLO (275/24) MIL-W-5086	—	1/4	0.69	0.52	1.19	1.83	DV25BL-1		3/4"	
YBM25-L2			5/16	0.69	0.46	1.25	1.56				
YBM25-L			3/8	0.69	0.58	1.26	1.59				
YBM26-L	2/0 Class I, DLO (325/24) MIL-W-5086	—	3/8	0.81	0.51	1.37	1.72	DV26L	Y29PR	13/16"	
YBM28-1/4	4/0 Class I, DLO (550/24) MIL-W-5086	—	1/4	.95	.72	1.66	2.09	DV28L		1"	

* Lead Plated available, contact factory.

** See top illustration for recommended connector insertion into tools.

Blue highlighted items are industry standard and most frequently ordered.

TYPES YAEV AND YAEV-L

INSULUG™

Terminal — Nylon Insulated — Ring-Tongue

300 Volts Max., 105° C Max.

The INSULUG™ type YAEV is designed for very demanding high vibration applications encountered in aircraft and aboard ships as well as motor lead applications in hospitals, industrials and generating plants. The nylon insulated seamless, electrolytic copper barrel with double thick tongue provides an extra strong insulated connection. The terminal is rated 105°C and meets SAE-AS7928 requirements.

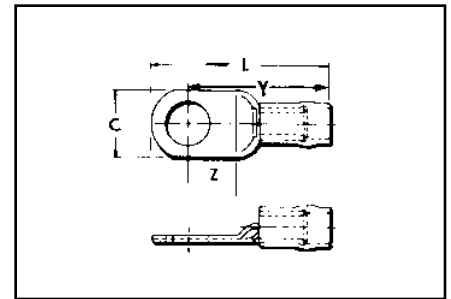
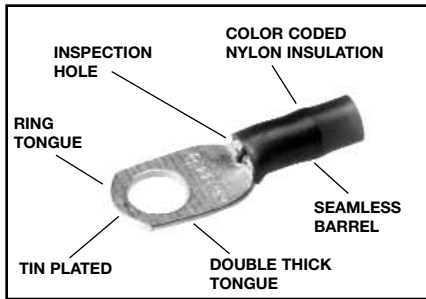

Features and Benefits

- Double thick tongue.
 - ◇ Provides maximum reliability and electrical capacity plus an extra strong terminal tongue.
- Manufactured from one-piece pure electrolytic copper.
 - ◇ Provides high conductivity, low resistance with no seams to split plus ductility for excellent crimp forming properties.
- Electro-tin plated.
 - ◇ Provides long-lasting corrosion resistance.
- Nylon insulation is locked in place.
 - ◇ Insulation will not move or twist off.
- 300 volt nylon insulation.
 - ◇ High dielectric strength and stability in demanding oily environmental conditions.
- Color Coded.
 - ◇ Provides quick, easy wire size connector selection.

Catalog Number	Wire Range AWG AN Aircraft	Stud Size	AS25036-Dash No.	Dimensions				Bulk Catalog Number	Installation Tooling	Wire Strip Length
				C	Z Min.	Y Max.	L Max.			
YAEV18 BOX	22-18 Max. Insul. Dia. Accom.: .125 Color Code: Red	8-10	—	.31	.24	.77	.91	YAEV18	Ratchet: MR8D94	1/4"
YAEV14 BOX	18-14 Max. Insul. Dia. Accom.: .154 Color Code: Blue	8-10	—	.31	.24	.88	.94	YAEV14	Ratchet: MR8D94	1/4"
YAEV10-T7 BOX	12-10 Max. Insul. Dia. Accom.: .209 Color Code: Yellow	4-5	—	.30	.24	.95	1.09	YAEV10-T7	Ratchet: MR8D94 MR8-33-T1 M8ND with N10ET-9 Die MR4 10M MR18*	5/16"
YAEV10-T11 BOX		6-8	—	.37	.26	.97	1.14	YAEV10-T11		
YAEV10 BOX		8-10	—	.37	.26	.97	1.14	YAEV10		
YAEV10-L36 BOX		8-10	—	.30	.18	.89	1.04	YAEV10-L36		
YAEV10-T3 BOX		1/4	—	.47	.38	1.12	1.30	YAEV10-T3		
YAEV10-T2 BOX		5/16	—	.53	.31	1.12	1.30	YAEV10-T2		
YAEV10-T4 BOX		3/8	—	.56	.35	1.12	1.35	YAEV10-T4		

* #10 wire only.

Blue highlighted items are industry standard and most frequently ordered.

TYPES YAEV AND YAEV-L

(Continued)

INSULUG™

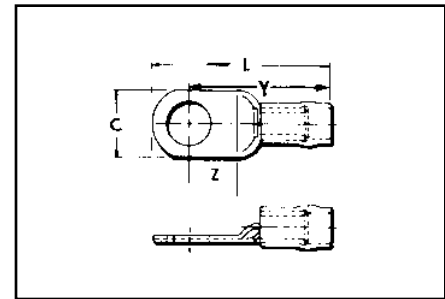
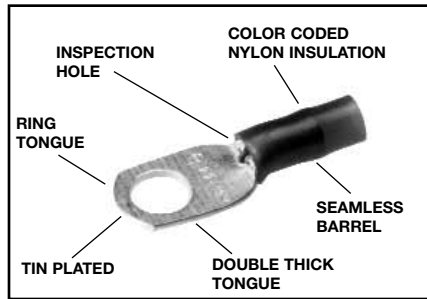

Catalog Number	Wire Range	Stud Size †	AS25036 Dash No.	Dimensions				Bulk Catalog Number	Installation Tooling	HYPRESS™ Y29NC		Wire Strip Length
				C	Z Min.	Y Max.	L Max.			Nest	Indenter	
YAEV8C-L14 BOX	8 Str. Max. Insul. Dia. Accom.: .258 Color Code: Red	6-8	—	.41	.28	1.20	1.40	YAEV8C-L14	Ratchet: M8ND with N8CET-2 Die Non-Ratchet: MY28-6* Hydraulic: Y35, Y39 with U8CET Die Set	DEV8L	Y29PLE-1 Y29PLE-1	7/16"
YAEV8C-L BOX		8-10	-115	.41	.28	1.20	1.40	YAEV8C-L				
YAEV8C-L1 BOX		1/4	-116	.46	.33	1.24	1.47	YAEV8C-L1				
YAEV8C-L2 BOX		5/16	-117	.57	.35	1.28	1.55	YAEV8C-L2				
YAEV8C-L3 BOX		3/8	-118	.57	.35	1.39	1.55	YAEV8C-L3				
YAEV8C-L4 BOX		1/2	—	.73	.47	1.39	1.75	YAEV8C-L4				
—	6 Str. Max. Insul. Dia. Accom.: .313 Color Code: Blue	8-10	-119**	.48	.29	1.33	1.56	YAEV6C-L1**	Non-Ratchet: MY28-6* Hydraulic: Y35, Y39 with U6CET Die Set	DEV6L	Y29PLE-1 Y29PLE-1	1/2"
—		1/4	-120**	.48	.29	1.33	1.56	YAEV6C-L**				
—		5/16	-121**	.60	.36	1.39	1.68	YAEV6C-L4**				
—		3/8	-122**	.60	.36	1.39	1.68	YAEV6C-L2**				
—	4 Str. Max. Insul. Dia. Accom.: .374 Color Code: Yellow	8-10	—	.55	.28	1.40	1.62	YAEV4C-L3	Non-Ratchet: MY28-6* Hydraulic: Y35, Y39 with U4CET Die Set	DEV4L	Y29PLE-1 Y29PLE-1	1/2"
—		1/4	-123	.55	.28	1.37	1.62	YAEV4C-L				
—		5/16	-124	.63	.34	1.43	1.74	YAEV4C-L4				
—		3/8	-125	.63	.34	1.43	1.74	YAEV4C-L2				
—	2 Str. Max. Insul. Dia. Accom.: .459 Color Code: Red	10	—	.69	.35	1.72	2.03	YAEV2C-L3	Non-Ratchet: MY28-6* Hydraulic: Y35, Y39 with U2CET Die Set	DEV2L	Y29PLE-1 Y29PLE-1	5/8"
—		1/4	-126	.69	.35	1.61	2.03	YAEV2C-L1				
—		5/16	—	.69	.35	1.68	2.03	YAEV2C-L2				
—		3/8	-127	.69	.35	1.69	2.03	YAEV2C-L				
—	1 Str. Max. Insul. Dia. Accom.: .516 Color Code: White	1/4	-129	.76	.38	1.63	2.14	YAEV1C-L1	Non-Ratchet: MY28-6* Hydraulic: Y35, Y39 with U1CET Die Set	DV26L	Y29PLE-1 Y29PLE-1	5/8"
—		5/16	—	.76	.38	1.71	2.14	YAEV1C-L2				
—		3/8	-130	.76	.38	1.72	2.14	YAEV1C-L				
—		1/2	-131	.86	.47	1.86	2.27	YAEV1C-L3				
—	1/0 Str. Max. Insul. Dia. Accom.: .564 Color Code: Blue	1/4	-132	.83	.43	1.97	2.40	YAEV25-L1	Non-Ratchet: MY28-6* Hydraulic: Y35, Y39 with U25ET Die Set	DEV25L	Y29PLE-1 Y29PLE-1	11/16"
—		5/16	—	.83	.43	1.97	2.40	YAEV25-L2				
—		3/8	-133	.83	.43	1.97	2.40	YAEV25-L				
—		1/2	-134	.88	.47	2.02	2.46	YAEV25-L3				
—	2/0 Str. Max. Insul. Dia. Accom.: .628 Color Code: Yellow	5/8	—	.88	.63	2.17	2.67	YAEV25-L4	Non-Ratchet: MY28-6* Hydraulic: Y35, Y39, Y750 with U26ET Die Set	DEV26L	Y29PLE-1 Y29PLE-1	13/16"
—		1/4	—	.93	.49	2.19	2.72	YAEV26-L1				
—		5/16	-135	.93	.49	2.19	2.72	YAEV26-L2				
—		3/8	-136	.93	.49	2.19	2.72	YAEV26-L				
—	1/2	-137	.93	.49	2.27	2.72	YAEV26-L3					

† Additional terminal stud sizes available.
 * BMY, BNCH-MT bench mount adapter available.
 ** NOTE: Add suffix "M" to cat. number to conform to AS25036 - standard for these items only (example: YAEV6C-L1M).
 See above. Contact BURNDY® for UL Listed products.

Blue highlighted items are industry standard and most frequently ordered.

TYPE YAEV-H

INSULUG™

Ring-Tongue Terminals

Nylon-Insulated
For Expanded Insulation

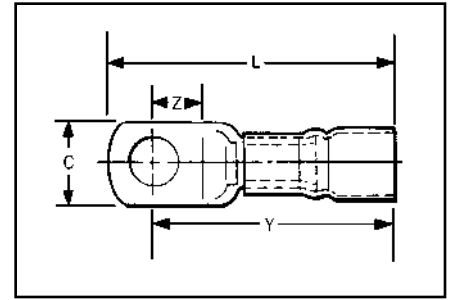

Designed to accommodate larger conductor insulation diameters. Made of one piece tin plated pure electrolytic seamless copper tubing for maximum conductivity and ductility. Color-coded insulating sleeves are locked into position. Inspection hole permits visual check of wire insertion. Meets requirements of SAE-AS7928.

Bulk Catalog Number	Wire Range	Stud Size	C	Z Min.	Y Max.	L Max.	Installation Tooling		Wire Strip Length	
							HYTOOL™ HYPRESS™	Y29NC, Y29BH		
								Nest		Indenter
YAEV8C-H14	8 Max. Insul. Dia.: .30" Sleeve Color: Red	6-8	.41	.25	1.32	1.54	M8ND with N8CET-2 Die MY28-6* Y35, Y39 with U8CET Die	DEV8L	Y29PLE-1	7/16"
YAEV8C-H		8-10	.41	.25	1.34	1.54				
YAEV8C-H1		1/4	.46	.28	1.37	1.61				
YAEV8C-H2		5/16	.57	.33	1.39	1.68				
YAEV8C-H3		3/8	.57	.33	1.39	1.68				
YAEV8C-H4		1/2	.73	.47	1.52	1.91				
YAEV6C-H1	6 Max. Insul. Dia.: .38" Sleeve Color: Blue	8-10	.48	.28	1.48	1.73	MY28-6* Y35, Y39 with U6CET Die Set	DEV6L	Y29PLE-1	1/2"
YAEV6C-H		1/4	.48	.28	1.48	1.73				
YAEV6C-H4		5/16	.60	.33	1.54	1.85				
YAEV6C-H2		3/8	.60	.34	1.54	1.85				
YAEV6C-H10		1/2	.73	.47	1.68	2.06				
YAEV4C-H3	4 Max. Insul. Dia.: .44" Sleeve Color: Yellow	8-10	.55	.28	1.60	1.87	MY28-6* Y35, Y39 with U4CET	DEV4L	Y29PLE-1	1/2"
YAEV4C-H		1/4	.55	.28	1.60	1.87				
YAEV4C-H4		5/16	.62	.34	1.66	1.98				
YAEV4C-H2		3/8	.62	.34	1.66	1.98				
YAEV4C-H5		1/2	.73	.47	1.79	2.18				
YAEV2C-H3	2 Max. Insul. Dia.: .52" Sleeve Color: Red	8-10	.69	.35	1.98	2.34	MY28-6* Y35, Y39 with U2CET Die	DEV2L	Y29PLE	5/8"
YAEV2C-H1		1/4	.69	.35	1.98	2.34				
YAEV2C-H2		5/16	.69	.35	1.98	2.34				
YAEV2C-H		3/8	.69	.35	1.98	2.34				
YAEV2C-H4		1/2	.77	.47	2.10	2.49				
YAEV1C-H1	1 Max. Insul. Dia.: .58" Sleeve Color: White	1/4	.76	.38	2.10	2.49	MY28-6* Y35, Y39 with U1CET Die	DV26L	Y29PLE	5/8"
YAEV1C-H2		5/16	.76	.38	2.10	2.49				
YAEV1C-H		3/8	.76	.38	2.10	2.49				
YAEV1C-H3		1/2	.86	.47	2.10	2.62				

* BMV BNCH-MT bench mount adapter available.

Blue highlighted items are industry standard and most frequently ordered.

TYPE YAEV-H

(Continued)

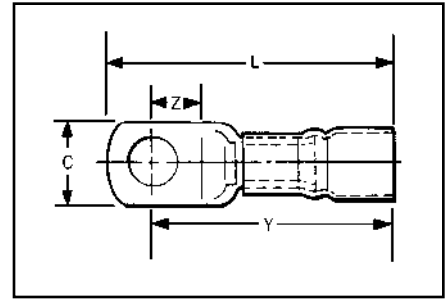

Bulk Catalog Number	Wire Range	Stud Size	C	Z Min.	Y Max.	L Max.	Installation Tooling			Wire Strip Length
							HYTOOL™ HYPRESS™	Y29NC, Y29BH		
								Nest	Indentor	
YAEV25-H1	1/0	1/4	.83	.43	2.39	2.82	MY28-6* Y35, Y39 with U25ET Die Set	DEV25L	Y29PLE	11/16"
YAEV25-H2	Max. Insul.	5/16	.83	.43	2.39	2.82				
YAEV25-H	Dia.: .66"	3/8	.83	.43	2.39	2.82				
YAEV25-H3	Sleeve	1/2	.88	.47	2.43	2.88				
YAEV25-H4	Color: Blue	5/8	.88	.62	2.59	3.10	MY28-6* Y35, Y39 with U26ET Die Set	DEV26L	Y29PLE	13/16"
YAEV26-H1	2/0	1/4	.94	.48	2.65	3.13				
YAEV26-H2	Max. Insul.	5/16	.94	.48	2.65	3.13				
YAEV26-H	Dia.: .73"	3/8	.94	.48	2.65	3.13				
YAEV26-H3	Sleeve Color:	1/2	.94	.48	2.65	3.13				
YAEV26-H12	Yellow	5/8	.94	.62	2.70	3.33				

* BMY BNCH-MT bench mount adapter available.

Blue highlighted items are industry standard and most frequently ordered.

TYPES YAV-R, YAV-RS

HYLUG™

Heavy Duty Right-Angle Terminals

Factory formed right angle HYLUG™ connectors made of seamless pure copper tubing. These rugged terminals withstand the most severe applications. Inspection hole in barrel permits visual check of wire insertion. Tin plated to resist corrosion. Meets requirements of SAE-AS7928.

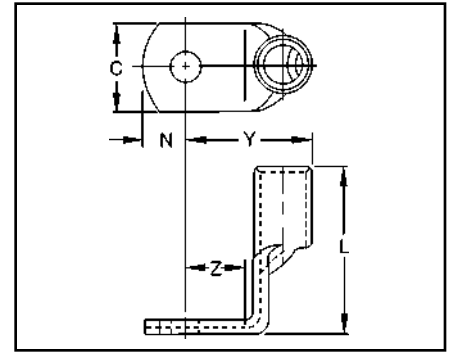

Catalog Number	Wire Range	Stud Size	Dimensions					Installation Tooling	Wire Strip Length
			C	L Max.	Y Max.	Z Min.	N		
YAV18-R	22-18	8-10	.31	.35	.54	.25	.16	Non-Ratchet: Y10D Ratchet: Y8MRB-1, MR20, MR8-G98, MR8-9Q	1/4
YAV14-RL33	20-14	4-6	.25	.37	.45	.21	.12		
YAV14-R		8-10	.31	.38	.57	.25	.16		
YAV10-R	12-10	8-10	.38	.55	.58	.25	.19	5/16	
YAV10-R3 BOX		1/4	.47	.57	.60	.28	.23		

Bulk Catalog Number	Wire	Stud	Dimensions in Inches					Installation Tooling		Wire Strip Length	Tool ▲ Index Number				
			C	L Max.	Y Max.	Z Min.	N	HYTOOL™	HYPRESS™ Y29NC, Y29BH						
									Nest			Indentor			
YAV8C-RS	8	8-10	.41	1.00	.75	.25	.20	MY28 MY29-11	DV8L*	Y29PL	7/16"	38			
YAV8C-RS1		1/4	.41	1.00	.79	.28	.20								
YAV8C-RS3		3/8	.56	1.00	.85	.34	.20								
YAV6C-RS1	6	8-10	.50	1.02	.81	.28	.25		MY28 MY29-11	DV6L	Y29PL	1/2"	39		
YAV6C-RS		1/4	.50	1.02	.81	.28	.25								
YAV6C-RS4		5/16	.59	1.02	.89	.34	.31								
YAV6C-RS2	3/8	.59	1.02	.89	.34	.31									
YAV4C-RS3	4	8-10	.53	1.04	.87	.28	.25			MY28 MY29-11	DV4L	Y29PL	1/2"	40	
YAV4C-RS		1/4	.53	1.04	.87	.28	.25								
YAV4C-RS4		5/16	.62	1.04	.95	.34	.31								
YAV4C-RS2	3/8	.62	1.04	.95	.34	.31									
YAV2C-RS1	2	1/4	.68	1.27	1.05	.34	.33	MY28 MY29-11			DV2L	Y29PL	5/8"	41	
YAV2C-RS2		5/16	.68	1.27	1.05	.34	.33								
YAV2C-RS	3/8	.68	1.27	1.05	.34	.33									
YAV1C-RS1	1	1/4	.73	1.35	1.15	.34	.33		MY28 MY29-11		DV1L	Y29PR	5/8"	42	
YAV1C-RS2		5/16	.73	1.35	1.15	.34	.33								
YAV25-RS	1/0	3/8	.82	1.51	1.29	.43	.39				MY28 MY29-11	DV25L	Y29PR	11/16"	43
YAV25-RS3		1/2	.88	1.51	1.32	.47	.44								
YAV26-RS	2/0	3/8	.92	1.63	1.40	.47	.39			MY28 MY29-11		DV26L	Y29PR	13/16"	44
YAV26-RS3		1/2	.92	1.63	1.40	.47	.39								
YAV27-RS	3/0	3/8	1.02	1.65	1.54	.47	.48					—	—	7/8"	45
YAV28-RS	4/0	3/8	1.13	1.80	1.54	.47	.48								

* For aircraft applications (Flexible Cable) use die DV8L-1.
▲ See Present Installation Tool Index starting on page O-35.

Blue highlighted items are industry standard and most frequently ordered.

TYPES YAEV-RS

INSULUG™

Nylon-Insulated
Right-Angle Terminals

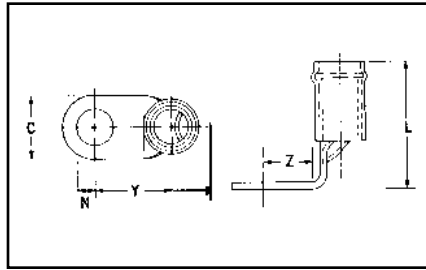

Factory formed right angle INSULUG™ connectors made of seamless pure copper tubing. These rugged terminals withstand the most severe applications. Inspection hole in barrel permits visual check of wire insertion. Meets requirements of SAE-AS7928.



Catalog Number	Wire Size	Stud Size	N	C	Z Min.	Y Max.	L Max.	Installation Tooling			Length		
								HYTOOL™	HYPRESS™ Y29NC, Y29BH				
									Nest	Indentor			
YAEV8C-RS	8 Max. Insul. Dia.: .258" Sleeve Color: Red	8-10	.20	.41	.25	.82	1.25	A	DEV8L	Y29PLE-1	7/16"		
YAEV8C-RS1		1/4	.25	.41	.28	.84	1.25						
YAEV6C-RS1	6 Max. Insul. Dia.: .313" Sleeve Color: Blue	8-10	.25	.50	.28	.88	1.28	B	DEV6L		Y29PLE	1/2"	
YAEV6C-RS		1/4	.25	.50	.28	.88	1.20						
YAEV4C-RS	4 Max. Insul. Dia.: .374" Sleeve Color: Yellow	1/4	.25	.53	.28	.95	1.28	C	DEV4L			Y29PLE	1/2"
YAEV4C-RS2		3/8	.31	.62	.34	1.02	1.28						
YAEV2C-RS1	2 Max. Insul. Dia.: .459" Sleeve Color: Red	1/4	.33	.68	.34	1.13	1.62	D	DEV2L	Y29PLE	5/8"		
YAEV2C-RS		3/8	.33	.68	.34	1.13	1.62						
YAEV1C-RS2	1 Max. Insul. Dia.: .516" Sleeve Color: White	5/16	.33	.73	.34	1.22	1.65	E	DV26L		Y29PLE	5/8"	
YAEV1C-RS		3/8	.33	.73	.34	1.22	1.65						
YAEV25-RS	1/0 Max. Insul. Dia.: .564" Sleeve Color: Blue	3/8	.39	.81	.43	1.46	1.88	F	DEV25L			Y29PLE	11/16"
YAEV26-RS	2/0 Max. Insul. Dia.: .628" Sleeve Color: Yellow	3/8	.39	.92	.47	1.48	2.06	G	DEV26				13/16"

A	B	C	D	E	F	G
Ratchet: M8ND with N8CET-2 Die Non-Ratchet: MY28-6†† Hydraulic: Y35, Y39 with U8CET Die Set	Non-Ratchet: MY28-6†† Hydraulic: Y35, Y39 with U6CET Die Set	Non-Ratchet: MY28-6†† Hydraulic: Y35, Y39 with U4CET Die Set	Non-Ratchet: MY28-6†† Hydraulic: Y35, Y39 with U2CET Die Set	Non-Ratchet: MY28-6†† Hydraulic: Y35, Y39 with U1CET Die Set	Non-Ratchet: MY28-6†† Hydraulic: Y35, Y39 with U25ET Die Set	Non-Ratchet: MY28-6†† Hydraulic: Y35, Y39 with U26ET Die Set

†† BMY BNCH-MT bench mount adapter available.

Blue highlighted items are industry standard and most frequently ordered.

TYPE YAEV-RH

INSULUG™

Nylon-Insulated
Right-Angle Terminals

Designed to Accommodate
Larger Conductor
Insulation Diameters

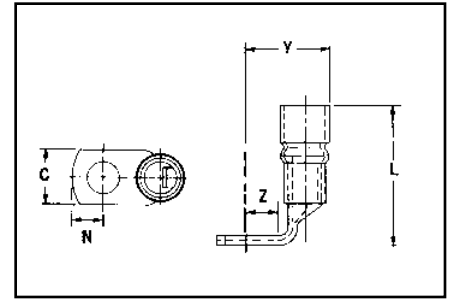

Factory formed right angle INSULUG™ connectors made of seamless pure copper tubing. These rugged terminals withstand the most severe applications. Inspection hole in barrel permits visual check of wire insertion. Tin plated to resist corrosion. Meets requirements of SAE-AS7928.

Catalog Number	Wire Size	Stud Size	N	C	Z Min.	Y Max.	L Max.	Installation Tooling			Length
								HYTOOL™	HYPRESS™ Y29NC, Y29BH		
									Nest	Indentor	
YAEV8C-RH	8 Max. Insul. Dia.: .30" Sleeve Color: Red	8-10	.20	.41	.25	.87	1.38	A	DEV8L	Y29PLE-1	7/16"
YAEV8C-RH1		1/4	.25	.41	.28	.90	1.38				
YAEV6C-RH1	6 Max. Insul. Dia.: .38" Sleeve Color: Blue	8-10	.25	.50	.28	.97	1.43	B	DEV6L		1/2"
YAEV6C-RH		1/4	.25	.50	.28	.97	1.43				
YAEV4C-RH	4 Max. Insul. Dia.: .44" Sleeve Color: Yellow	1/4	.25	.53	.28	1.04	1.53	C	DEV4L	1/2"	
YAEV4C-RH2		3/8	.31	.62	.34	1.11	1.53				
YAEV2C-RH1	2 Max. Insul. Dia.: .52" Sleeve Color: White	1/4	.33	.67	.34	1.22	1.88	D	DEV2L	Y29PLE	5/8"
YAEV2C-RH		3/8	.33	.67	.34	1.22	1.88				
YAEV1C-RH2	1 Max. Insul. Dia.: .52" Sleeve Color: White	5/16	.33	.73	.34	1.32	1.99	E	DV26L		5/18"
YAEV1C-RH		3/8	.33	.73	.34	1.32	1.99				
YAEV25-RH	1/0 Max. Insul. Dia.: .66" Sleeve Color: Blue	3/8	.39	.81	.43	1.50	2.29	F	DEV25L	11/16"	
YAEV26-RH	2/0 Max. Insul. Dia.: .73" Sleeve Color: Yellow	3/8	.39	.92	.47	1.60	2.42	G	DEV26L	13/16"	

A	B	C	D	E	F	G
Ratchet: M8ND with N8CET-2 Die Non-Ratchet: MY28-6†† Hydraulic: Y35, Y39 with U8CET Die Set	Non-Ratchet: MY28-6†† Hydraulic: Y35, Y39 with U6CET Die Set	Non-Ratchet: MY28-6†† Hydraulic: Y35, Y39 with U4CET Die Set	Non-Ratchet: MY28-6†† Hydraulic: Y35, Y39 with U2CET Die Set	Non-Ratchet: MY28-6†† Hydraulic: Y35, Y39 with U1CET Die Set	Non-Ratchet: MY28-6†† Hydraulic: Y35, Y39 with U25ET Die Set	Non-Ratchet: MY28-6†† Hydraulic: Y35, Y39 with U26ET Die Set

†† BMY BNCH-MT bench mount adapter available.

Blue highlighted items are industry standard and most frequently ordered.

TYPES T-F AND YAD-F

HYLUG™

Uninsulated Compression Terminal, Fork Tongue

Type T-F is constructed in the same manner as the type "T" and employs a fork tongue.

The fork permits rapid installation of the terminal under a screw head without completely removing the screw. Two or more terminals may be stacked easily on a common stud.

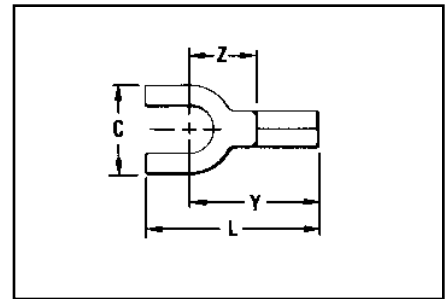
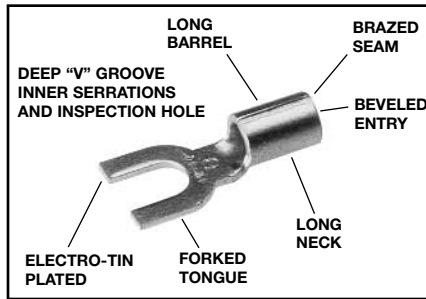

Catalog Number	Wire Range	Stud Size	Dimensions				Bulk Catalog Number	Installation Tooling	Wire Strip Length
			C	L Max.	Y Max.	Z Min.			
T18-6F	22-18	4-6	.28	.68	.55	.25	YAD18-6F	Non-Ratchet: Y10D, Y10-22 Ratchet: MR8G98 Y8MRB-1, MR20	9/32"
T18-8F		6-8	.31	.74	.57	.27	YAD18-8F		
T18-10F		8-10	.37	.74	.58	.29	—		
T18-14F			.47	.92	.69	.39	YAD18-14F		
T14-6F	20-14	4-6	.28	.68	.55	.25	YAD14-6F	Non-Ratchet: Y10D, Y10-22 Ratchet: MR8G98, Y8MRB-1, MR20	9/32"
T14-8F		6-8	.31	.74	.57	.27	YAD14-8F		
T14-10F		8-10	.37	.74	.58	.29	YAD14-10F		
T14-14F			.47	.92	.69	.39	YAD14-14F		
T10-6F	12-10	4-6	.28	.74	.61	.25	YAD10-6F	Non-Ratchet: Y10D, Y10-22 Ratchet: MR8G98, Y8MRB-1, MR20	11/32"
T10-8F		6-8	.31	.80	.63	.27	YAD10-8F		
T10-10F		8-10	.41	.87	.68	.32	YAD10-10F		
T10-14F			.50	1.00	.75	.39	—		

Blue highlighted items are industry standard and most frequently ordered.

TYPES YAV-T-F BOX AND YAV-T-F

HYLUG™

Seamless Uninsulated Compression Fork Tongue Terminal

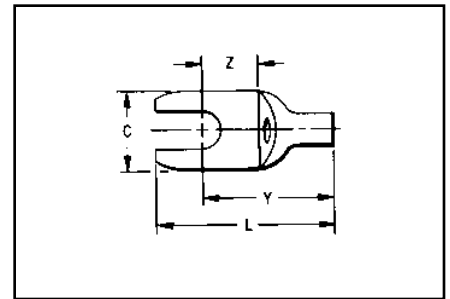
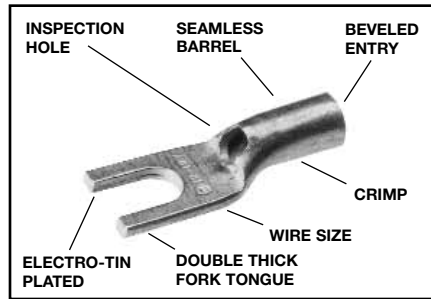

The type YAV-T-F HYLUG™ is a seamless heavy duty uninsulated compression fork-tongue terminal manufactured from electrolytic copper for use on copper commercial (code) cable, Type AN aircraft cable and extra flexible conductors.

The seamless design produces a double thick tongue and the seamless barrel provides a strong highly reliable connection.

All the benefits of the Type YAV apply for the same wire sizes.

Features and Benefits

- Fork tongue.
 - ◇ Allows installation of compression terminal under screw head without complete removal of the screw.



Catalog Number	Wire Range	Stud Size	Dimensions				Bulk Catalog Number	Installation Tooling	Wire Strip Length
			C	L Max.	Y Max.	Z Min.			
YAV18-T19F BOX	22-18	4-6	.31	.80	.55	.25	YAV18-T19F	Non-Ratchet: Y10D, Y10-22 Ratchet: MR8-G98, MR8-9Q, MR20, Y8MRB-1	9/32"
YAV18-T21F BOX		8-10	.37	.80	.55	.25	YAV18-T21F		9/32"
YAV14-T32F BOX	20-14	4-6	.31	.80	.57	.25	YAV14-T32F		7/16"
YAV14-T34F BOX		8-10	.37	.82	.60	.26	YAV14-T34F		
YAV10-T21F BOX	12-10	8-10	.38	.91	.69	.26	YAV10-21F		
YAV10-T23F BOX		1/4"	.47	1.00	.75	.34	YAV10T23F		

Blue highlighted items are industry standard and most frequently ordered.

TYPES YAV-H-F BOX, YAV-H-F AND YAV-Z

HYLUG™

Uninsulated Compression Terminal Fork Tongue With Seamless Shroud

The type "YAV-H-F" HYLUG™ is a seamless heavy duty uninsulated compression fork tongue terminal with a shroud for an insulation grip and cable support. Manufactured from electrolytic copper tubing for use on copper commercial (code) cable, Type "AN" aircraft and extra flexible conductors.

The seamless tubing produces a double thick tongue while the seamless barrel design provides a very strong connector for very demanding applications that require highly reliable connections.

In addition to the benefits described for the YAV box series of connectors the YAVH-F Box and YAV-Z terminals provide the following benefits.

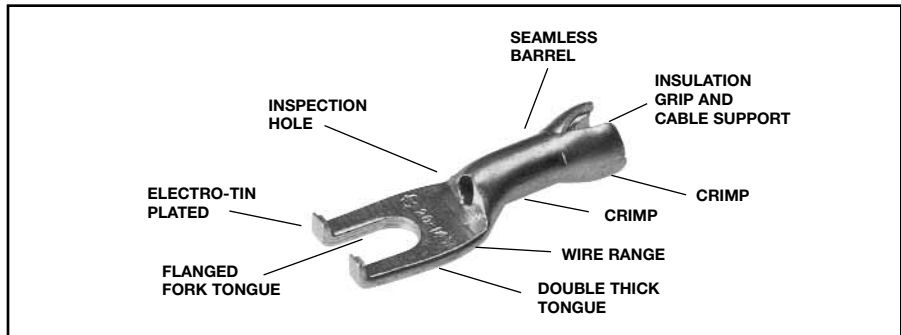

Features and Benefits

- Fork tongue.
 - ◇ Allows installation of compression terminal under screw head without complete removal of the screw thereby lowering installation costs.
- Flanged fork tongue.
 - ◇ Allows installation of compression terminal under screw head without complete removal of the screw plus aids in maintaining the terminal on the stud should the screw loosen slightly.

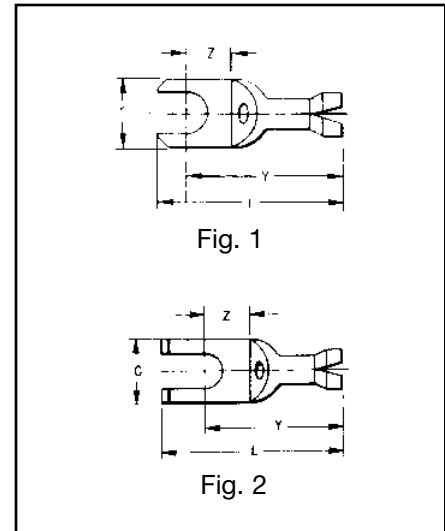

Catalog Number	Fig.	Wire Range	Stud Size	Max. Insul. Dia. Accom.	Dimensions				Bulk Catalog Number	Installation Tooling	Wire Strip Length
					C	L Max.	Y Max.	Z Min.			
YAV18-H6F BOX	1	22-18	4-6	.120	.25	.89	.80	.19	YAV18-H6F	Non-Ratchet: Y10D*, Y14MV, Y10-22* Ratchet: MR8-G98, MR8-9Q, Y8MRB-1*, MR20, and M8ND with N14HT-5 Die or N14HT	1/4"
YAV18-H19 BOX	1		4-6	.120	.30	.97	.75	.21	YAV18-H19F		
YAV18-H21F BOX	1		8-10	.120	.37	.97	.76	.22	YAV18-H21F		
YAV14-Z5 BOX	2	20-14	4-6	.150	.31	.89	.69	.13	YAV14-Z5		
YAV14-H32F BOX	1		4-6	.150	.30	.96	.78	.23	YAV14-H32F		
YAV14-H56F BOX	1		6-8	.150	.30	.96	.78	.23	YAV14-H56F		
YAV14-H34F BOX	1		8-10	.150	.37	.96	.78	.23	YAV14-H34F		
YAV14-HF BOX	1		8-10	.150	.31	.93	.78	.23	YAV14-HF		
YAV14-Z6 BOX	2		8-10	.150	.37	1.04	.78	.21	YAV14-Z6		
YAV10-HF BOX	1		12-10	8-10	.192	.38	1.07	.92	.24	YAV10-HF	N10HT-24

* Crimps conductor crimp only.

Blue highlighted items are industry standard and most frequently ordered.

TYPES TN-F AND YAES-F

INSULUG™

Terminal — Nylon Insulated, Fork Tongue

300 Volts Max., 105° C Max.

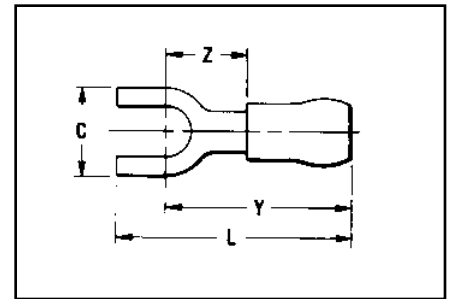
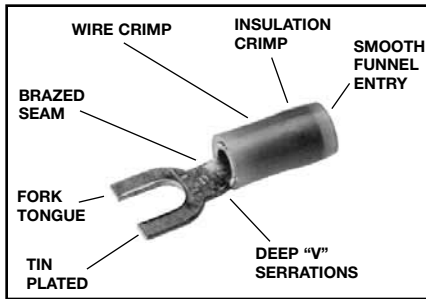

The type TN-F, nylon insulated fork tongue terminal has the same high quality as the TN. It is designed to meet the heavy-duty requirements of industrial and utility applications.

Used on both power and control circuits for wire sizes #26 AWG through #10 AWG. The TN-F provides high dielectric strength and stability in oily conditions.

The TN-F is identical to the TN with the addition of a fork tongue which allows installation without complete removal of its supporting screw.

Features and Benefits

- Fork tongue.
 - ◇ Provides faster and easier installation by permitting insertion under the screw head without completely removing it.



Catalog Number	Wire Range	Stud Sizes	Dimensions				Bulk Catalog Number	Installation Tooling	Wire Strip Length
			C	L Max.	Y Max.	Z Min.			
TN20-2F*	26-20 Max. Insul. Dia. Accom.: .098 Color Code: Amber	1-2	.18	.76	.65	.24	—	M8ND with N14HET-25V1 Die Set	3/16"
TN20-6F*		4-6	.28	.80	.70	.28	—		
TN18-6F	22-18 Max. Insul. Dia. Accom.: .120 Color Code: Red	4-6	.28	.79	.65	.24	YAES18N1F	Non-Ratchet: Y10D, Y10-22	7/32"
TN18-8F		6-8	.31	.84	.67	.26	—		
TN18-10F		8-10	.37	.84	.68	.27	YAES18N3F		
TN18-14F		1/4	.47	1.03	.79	.38	—		
TN14-6F	16-14 Max. Insul. Dia. Accom.: .153 Color Code: Blue	4-6	.28	.79	.65	.24	YAES14N6F		7/32"
TN14-8F		6-8	.31	.84	.67	.26	YAES14N53F		
TN14-10F		8-10	.37	.84	.68	.27	YAES14N8F		
TN14-14F		1/4	.47	1.03	.79	.38	YAES14N54F		
TN10-6F	12-10 Max. Insul. Dia. Accom.: .209 Color Code: Yellow	4-6	.28	.96	.82	.24	YAES10N11F	Ratchet: MR8-83**, MR18	11/32"
TN10-8F		6-8	.31	1.01	.84	.26	YAES10N56F		
TN10-10F		8-10	.41	1.09	.89	.31	YAES10N12F		
TN10-14F		1/4	.50	1.21	.96	.38	YAES10N57F		

* These sizes not UL Listed.
** Or other tool conforming to military specification AS25036 or AS90413

Blue highlighted items are industry standard and most frequently ordered.

TYPES YAE-N-F BOX AND YAE-N-F

INSULUG™

Terminal — Nylon Insulated, Fork Tongue

Multi-Finger Insulation Grip

300 Volts Max., 105° C Max.

INSULUG™ type YAE-N-F nylon insulated terminals are designed with a Multi-Finger Insulation grip, are rated 105° C and are supplied with a fork tongue for easy terminal insertion and removal.

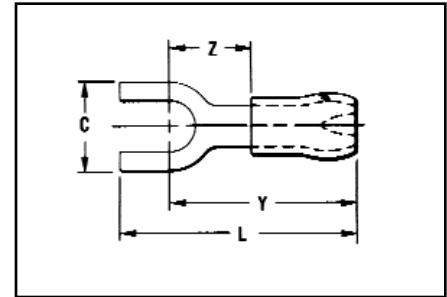
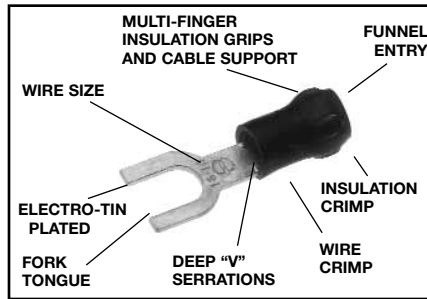

Features and Benefits

- Fork tongue.
 - ◇ Permits rapid easy installation of the terminal under the screw head without complete removal of the screw.



Catalog Number	Wire Range	Stud Size	Dimensions			Bulk Catalog Number	Installation Tooling	Tape Mounted Catalog Number 2000/Reel	Installation Tooling	Wire Strip Length	
			C	L Max.	Y Max.						Z Min.
YAE22N65F BOX•	24 - 20 Max. Insul. Dia.: .098" Sleeve Color: Amber	1 - 2	.18	.73	.65	.24	Ratchet: M8ND N14HET25V1 Die	YAE22N65FM•	TFM with DFM11D1 Die	5/32"	
YAE22N66F BOX•		4 - 6	.28	.80	.70	.28		YAE22N66FM•			
YAE18N60F BOX	22 - 16 Max. Insul. Dia.: .125" Sleeve Color: Red	4	.21	.92	.73	.24	Non-Ratchet: Y10D or Y10-22 Ratchet: MR8-33T-1, M8ND With one of the following Dies: N14HET-25V1, N10ET-9, N14HET-15, N10ET-23	YAE18G60FM	TFM with DFM10D1 Die	3/16"	
YAE18G43F BOX		4 - 6	.25	.78	.68	.19		YAE18G43F			
—			.28	.83	.76	.23		YAE18N56F			
YAE18N57F BOX		6 - 8	.31	.96	.78	.29		YAE18N57F			
—	16 - 14 Max. Insul. Dia.: .156" Sleeve Color: Blue	4 - 6	.28	.87	.76	.26	YAE14N76FM	YAE14N76FM	TFM with DFM9D1 Die	3/16"	
YAE14N77F BOX		6 - 8	.31	.96	.78	.29					YAE14N77F
YAE14N78F BOX		8 - 10	.36	1.01	.83	.34					YAE14N78F

• Not UL recognized.

Blue highlighted items are industry standard and most frequently ordered.

TYPES TP-F AND BA-EF

VINYLUTM

Terminal — Polyvinylchloride Insulated, Fork Tongue

600 Volts Max., 105° C Max.

The Type TP-F is a fork tongue variation of the TP design and makes installation easier.

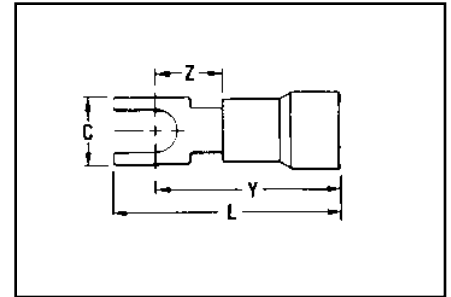
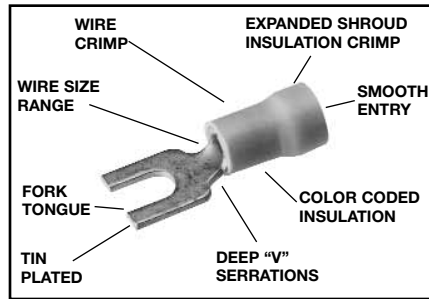

Features and Benefits

- Fork tongue design.
 - ◇ Faster installation-screw needs only to be loosened for termination.



Catalog Number	Wire Range	Stud Size	Dimensions				Bulk Catalog Number •	Installation Tooling	Tape Mounted Catalog Number 2000/Reel	Installation Tooling	Wire Strip Length
			C	L Max.	Y Max.	Z Min.					
TP16-2F	22-16	1-2	.17	.75	.66	.23	BA16EF2	Plier Type: Y10-22	BA16EF2M	TFM with DFM3D-1 Die	13/64"
TP16-6F	Max. Insul.	4-6	.28	.80	.66	.23	BA16EF6		BA16EF6M		
TP16-8F	Dia. Accom.: .145	6-8	.31	.86	.69	.26	BA16EF8		BA16EF8M		
TP16-10F	Color Code: Red	8-10	.41	.95	.75	.31	BA16EF10		BA16EF10M		
TP14-2F	16-14	1-2	.17	.75	.66	.23	BA14EF2	Ratchet Tool: MR8-89-1	—	TFM with DFM2D-1 Die	13/64"
TP14-6F	Max. Insul.	4-6	.28	.80	.66	.23	BA14EF6		—		
TP14-8F	Dia. Accom.: .180	6-8	.31	.86	.69	.26	BA14EF8		BA14EF8M		
TP14-10F	Color Code: Blue	8-10	.41	.95	.75	.31	BA14EF10		BA14EF10M		
TP10-6F	12-10	4-6	.28	.95	.81	.26	BA10EF6	MR15, M8ND with N10ET-23	*BA10EF6M	TFM with DFM1D5 Die	19/64"
TP10-8F	Max. Insul.	6-8	.31	.98	.81	.26	BA10EF8		*BA10EF8M		
TP10-10F	Dia. Accom.: .260	8-10	.41	1.07	.87	.31	BA10EF10		*BA10EF10M		

• UL Listed and CSA Certified with MR8-89-1 and MR15.
* 1000/Reel.

Blue highlighted items are industry standard and most frequently ordered.

TYPES YAE-Z BOX AND YAE-Z

INSULUG™

Terminal —
Nylon Insulated, Flanged Fork
Multi-Finger Insulation Grip
300 Volts Max., 105° C Max.

INSULUG™ type YAE-Z is identical to type YAE-N and employs a flanged fork tongue for faster installation while maintaining security if supporting screw becomes loose.

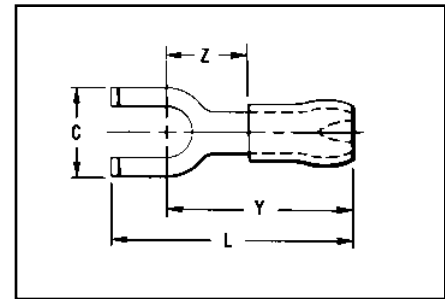
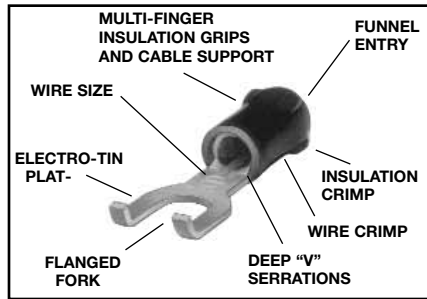

Features and Benefits

- Flanged fork.
 - ◊ Permits rapid, easy installation of the terminal under the screw head without complete removal of the screw. Additionally, it may not be removed with only a slight loosening of the screw.

Catalog Number	Wire Range	Stud Size	Dimensions				Bulk Catalog Number	Installation Tooling
			C	Z Max.	Y Max.	L Max.		
YAE2221 BOX	26-20 Max. Insul.	1-2	.18	.24	.65	.75	—	MR8-33T-1, M8ND with one of the following Dies:
YAE2222 BOX	Dia.: .098"	4-6	.28	.28	.70	.83	YAE2222	
YAE2223 BOX	Sleeve Color: Amber	6-8	.31	.30	.72	.92	YAE2223	
YAE1821 BOX	22-16 Max. Insul.	1-2	.18	.22	.73	.83	YAE1821	N14HET-15, N10ET-9, N10ET-23, N14HET-25V1, Y10D, Y10-22
YAE1822 BOX	Dia. Accom.: (125)	4-6	.28	.26	.76	1.00	YAE1822	
YAE1823 BOX	Color Code: Red	6-8	.31	.29	.78	1.00	YAE1823	
YAE1824 BOX		8-10	.36	.34	.83	1.08	YAE1824	
YAE1422 BOX	16-14 Max. Insul.	4-6	.28	.26	.76	.90	YAE1422	MR833T-1, M8ND with N12HET-1, Y10D, Y10-22
YAE1423 BOX	Dia. Accom.: (156)	6-8	.31	.29	.78	1.00	YAE1423	
YAE1424 BOX	Color Code: Blue	8-10	.36	.34	.83	1.08	YAE1424	
YAE1222 BOX	14-12 Max. Insul.	4-6	.28	.27	.90	1.04	YAE1222	
YAE1223 BOX	Dia. Accom.: (180)	6-8	.31	.32	.96	1.16	YAE1223	
YAE1224 BOX	Color Code: Green	8-10	.36	.35	1.00	1.23	YAE1224	

Blue highlighted items are industry standard and most frequently ordered.

TYPES TP-Z AND BA-EZ

VINYLUG™

Terminal — Polyvinylchloride Insulated, Flanged Fork Tongue
600 Volts Max., 105° C Max.

VINYLUG™ Type TP-Z is a variation of the Type TP and employs a flanged fork tongue for fast installation and security.

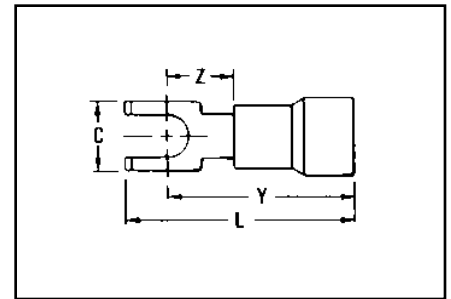
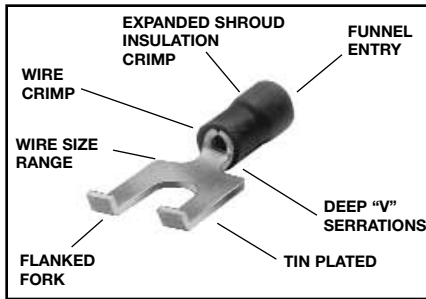

Features and Benefits

- Flange fork tongue design.
 - ◊ Allows fast installation—screw only has to be loosened for termination.
- The flanges on the end of the fork terminal aid in preventing a slightly loose terminal from becoming fully disconnected from the screw.
 - ◊ Flanges make re-securing a loose terminal easier.

Catalog Number	Wire Range	Stud Size	Dimensions				Bulk Catalog Number	Installation Tooling
			C	L Max.	Y Max.	Z Min.		
TP16-2Z	22-16	1-2	.17	.78	.66	.23	BA16EZ2	Plier Type: Y10-22
TP16-6Z	Max. Insul.	4-6	.28	.83	.66	.23	BA16EZ6	
TP16-8Z	Dia. Accom.: .145	6-8	.31	.88	.69	.26	BA16EZ8	
TP16-10Z	Color Code: Red	8-10	.41	.96	.75	.31	BA16EZ10	
TP14-2Z	16-14	1-2	.17	.78	.66	.23	BA14EZ2	Ratchet Tool: MR8-89-1
TP14-6Z	Max. Insul.	4-6	.28	.83	.66	.23	BA14EZ6	
TP14-8Z	Dia. Accom.: .180	6-8	.31	.88	.69	.26	BA14EZ8	
TP14-10Z	Color Code: Blue	8-10	.41	.96	.75	.31	BA14EZ10	
TP10-6Z	12-10 Max. Insul.	4-6	.28	.99	.81	.26	BA10EZ6	MR15, M8ND with N10ET-23
TP10-8Z	Dia. Accom.: .260	6-8	.31	1.01	.81	.26	BA10EZ8	
TP10-10Z	Color Code: Yellow	8-10	.41	1.09	.81	.31	BA10EZ10	

Blue highlighted items are industry standard and most frequently ordered.

TYPES TP-LF AND BA-EL

VINYLUTM

Terminal —
Polyvinylchloride Insulated,
Locking Fork Tongue

600 Volts Max., 105° C Max.

Type TP-LF is a variation of the Type TP design and employs a locking fork tongue for fast installation and security.

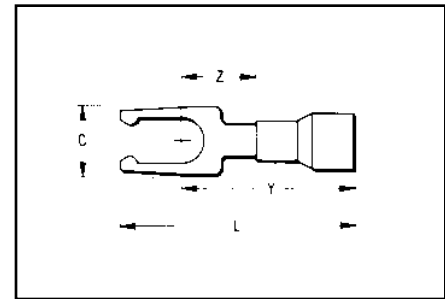
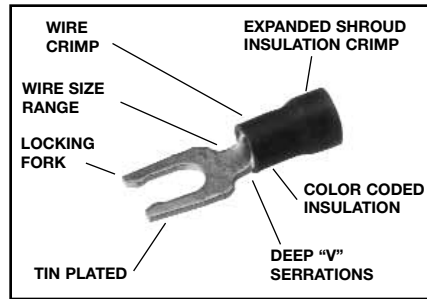

Features and Benefits

- Locking fork tongue design.
 - ◇ Allows fast installation—screw only has to be loosened for termination.
- Internal configuration of the fork.
 - ◇ Prevents the terminal from coming off the screw without applying a pulling force.
- Locking fork is made from a copper alloy.
 - ◇ Permits many installations while maintaining proper spring retention of forks.

Catalog Number	Wire Range	Stud Size	Dimensions				Bulk Catalog Number •	Installation Tooling	Tape Mounted Catalog Number 2000/Reel	Installation Tooling	Wire Strip Length
			C	L Max.	Y Max.	Z Min.					
TP16-6LF	22-16 Max. Insul. Dia. Accom.: .145 Color Code: Red	4-6	.28	.80	.66	.23	BA16EL6	Plier Type: Y10-22	BA16EL6M	TFM with DFM3D-1 Die	13/64"
TP16-8LF		6-8	.31	.86	.69	.26	BA16EL8		BA16EL8M		
TP16-10LF		8-10	.41	.95	.75	.31	BA16EL10		BA16EL10M		
TP14-6LF	16-14 Max. Insul. Dia. Accom.: .180 Color Code: Blue	4-6	.28	.80	.66	.23	BA14EL6	Ratchet Tool: MR8-89-1, MR15	BA14EL6M	TFM with DFM2D-1 Die	13/64"
TP14-8LF		6-8	.31	.86	.69	.26	BA14EL8		BA14EL8M		
TP14-10LF		8-10	.41	.95	.75	.31	BA14EL10		BA14EL10M		
TP10-6LF	12-10 Max. Insul. Dia. Accom.: .260 Color Code: Yellow	4-6	.28	.95	.81	.26	BA10EL6	Ratchet Tool: MR8-89-1, M8ND with N10ET-23	* BA10EL6M	TFM with DFM1D5 Die	19/64"
TP10-8LF		6-8	.31	.98	.81	.26	BA10EL8		* BA10EL8M		
TP10-10LF		8-10	.41	1.07	.87	.31	BA10EL10		* BA10EL10M		

• UL Listed and CSA Certified with MR8-89-1 and MR15.
* 1000/Reel.

Blue highlighted items are industry standard and most frequently ordered.

TYPE Q-F FINGRIP™

NON-INSULATED FEMALE QUICK DISCONNECTS

Material: Tin-Plated Brass

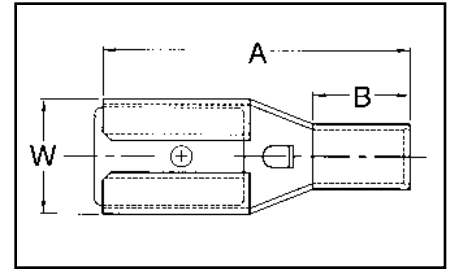
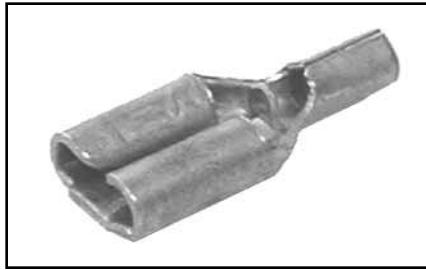

Features and Benefits

- Butted seam.
- Chamfered barrel opening.
 - ◇ Assures quick and easy wire insertion.
- Dimpled female socket detent.
 - ◇ Ensures firm grip.

FEMALE BARE DISCONNECT TERMINAL

(Mates with Type Q-M male disconnects)

Standard Catalog Number	Std. Pkg. Qty.	Wire Range	NEMA Tab Size	Dimensions			Bulk Catalog Number	Bulk Qty.	Installation Tool*
				A	B	W			
Q18F18X02D	100	18-22	.187 × .020	0.58	0.17	0.23	Q18F18X02B	1000	MR20, Y10D
Q18F25X03D			.250 × .032	0.62	0.17	0.29	Q18F25X03B		
Q14F11X02D	100	14-16	.110 × .020	0.55	0.17	0.14	Q14F11X02B		
Q14F18X02D			.187 × .020	0.58	0.17	0.20	Q14F18X02B		
Q14F25X03D			.250 × .032	0.62	0.17	0.29	Q14F25X03B		

* For UL Listed applications consult BURNDY® factory.

TYPE QP-F FINGRIP™

VINYL INSULATED FEMALE QUICK DISCONNECTS

Material: Tin-Plated Brass
600 Volts Max., 105° C Max.

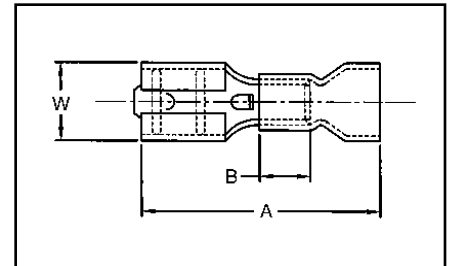

Features and Benefits

- Butted seam.
- Insulated connectors.
 - ◇ Eliminate the need for post installation insulation.
- Funnel entry barrel opening.
 - ◇ Assures quick and easy wire insertion.
- Dimpled female socket detent.
 - ◇ Ensures firm grip.

FEMALE VINYL DISCONNECT TERMINAL

(Mates with Type QP-M male disconnects)

Standard Catalog Number	Std. Pkg. Qty.	Wire Range	NEMA Tab Size	Dimensions			Bulk Catalog Number	Bulk Pkg. Qty.	Installation Tool*
				A	B	W			
QP18F110X02D	100	18-22	.110 × .020	0.77	0.24	0.11	—	1000	Y10D
QP18F18X02D			.187 × .020	0.86	0.20	0.22	QP18F18X02B		
QP18F25X03D			.250 × .032	0.91	0.20	0.29	QP18F25X03B		
QP14F110X02D	100	14-16	.110 × .020	0.77	0.24	0.11	—		
QP14F18X02D			.187 × .020	0.87	0.20	0.23	QP14F18X02B		
QP14F25X03D			.250 × .032	0.92	0.20	0.29	QP14F25X03B		
QP10F25X03D			10-12	.250 × .032	0.97	0.23	0.29	QP10F25X03B	

* For UL Listed applications consult BURNDY® factory.

Blue highlighted items are industry standard and most frequently ordered.

TYPE QN-F FINGRIP™

NYLON INSULATED FEMALE QUICK DISCONNECTS

Material: Tin-Plated Brass
300 Volts Max., 105°C Max.

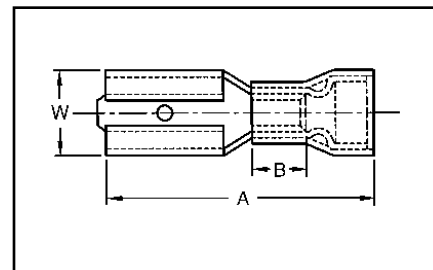

Features and Benefits

- Sleeved barrel.
- Insulated connectors.
 - ◇ Eliminate the need for post installation insulation.
- Funnel entry barrel opening.
 - ◇ Assures quick and easy wire insertion.
- Dimpled female socket detent.
 - ◇ Ensures firm grip.



FEMALE NYLON DISCONNECT TERMINAL

(Mates with Type QN-M male disconnects)

Standard Catalog Number	Std. Pkg. Qty.	Wire Range	NEMA Tab Size	Dimensions			Bulk Catalog Number	Bulk Pkg. Qty.	Installation Tool*
				A	B	W			
QN18F18X02D	100	18-22	.187 × .020	0.86	0.23	0.22	QN18F18X02B	1000	Y10D
QN18F25X03D			.250 × .032	0.91	0.23	0.29	QN18F25X03B		
QN14F18X02D	100	14-16	.187 × .020	0.87	0.23	0.23	QN14F18X02B		
QN14F25X03D			.250 × .032	0.92	0.23	0.29	QN14F25X03B		
QN10F25X03D		12-10	.250 × .032	0.97	0.23	0.25	QN10F25X03B		

* For UL Listed applications consult BURNDY® factory.

TYPE Q-M FINGRIP™

NON-INSULATED MALE QUICK DISCONNECTS

Material: Tin-Plated Brass

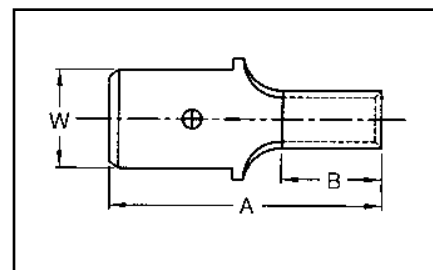

Features and Benefits

- Butted seam.
- Chamfered barrel opening.
 - ◇ Assures quick and easy wire insertion.
- Mates with dimpled female socket detent.
 - ◇ Ensures firm grip.



MALE BARE DISCONNECT TERMINAL

(Mates with Type Q-F female disconnects)

Standard Catalog Number	Std. Pkg. Qty.	Wire Range	NEMA Tab Size	Dimensions			Bulk Catalog Number	Bulk Pkg. Qty.	Installation Tool*
				A	B	W			
Q18M18X02D	100	18-22	.187 × .020	0.55	0.17	0.19	Q18M18X02B	1000	MR20, Y10D
Q18M25X03D			.250 × .032	0.67	0.17	0.25	Q18M25X03B		
Q14M18X02D	100	14-16	.187 × .020	0.55	0.17	0.19	Q14M18X02B		
Q14M25X03D			.250 × .032	0.67	0.17	0.25	Q14M25X03B		

* For UL Listed applications consult BURNDY® factory.

Blue highlighted items are industry standard and most frequently ordered.

**TYPE QP-M
FINGRIP™**

**VINYL INSULATED MALE
QUICK DISCONNECTS**

Material: Tin-Plated Brass
600 Volts Max., 105° C Max.

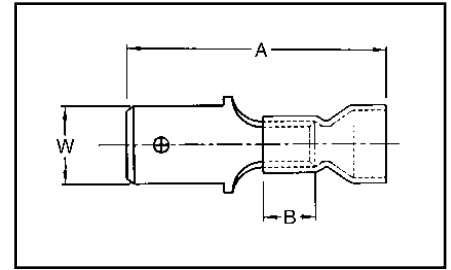
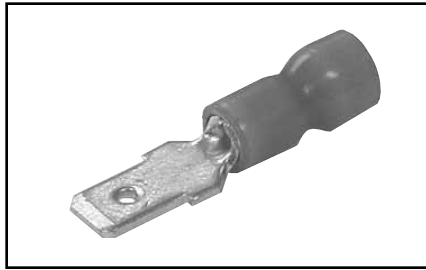

Features and Benefits

- Butted seam.
- Funnel entry barrel opening.
 - ◇ Assures quick and easy wire insertion.
- Mates with dimpled female socket detent.
 - ◇ Ensures firm grip.



MALE VINYL DISCONNECT TERMINAL

(Mates with Type QP-F female disconnects)

Standard Catalog Number	Std. Pkg. Qty.	Wire Range	NEMA Tab Size	Dimensions			Bulk Catalog Number	Bulk Pkg. Qty.	Installation Tool*
				A	B	W			
QP18M18X02D	100	18-22	.187 × .020	0.83	0.17	0.19	QP18M18X02B	1000	Y10D
QP18M25X03D			.250 × .032	0.95	0.17	0.25	QP18M25X03B		
QP14M18X02D	100	14-16	.187 × .020	0.83	0.17	0.19	QP14M18X02B	1000	
QP14M25X03D			.250 × .032	0.95	0.17	0.25	QP14M25X03B		

* For UL Listed applications consult BURNDY® factory.

**TYPE QN-M
FINGRIP™**

**NYLON INSULATED MALE
QUICK DISCONNECTS**

Material: Tin-Plated Brass
300 Volts Max., 105° C Max.

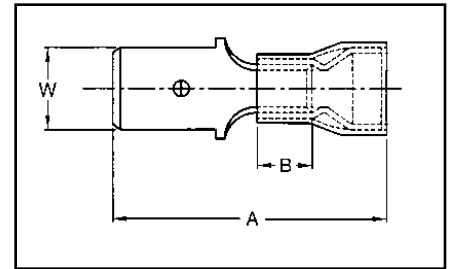
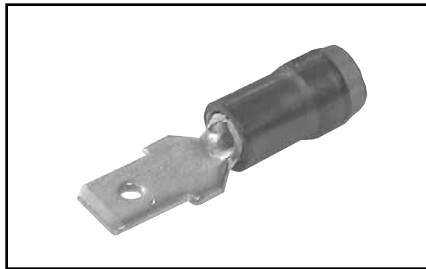

Features and Benefits

- Sleeved barrel.
- Funnel entry barrel opening.
 - ◇ Assures quick and easy wire insertion.
- Mates with dimpled female socket detent.
 - ◇ Ensures firm grip.



MALE NYLON DISCONNECT TERMINAL

(Mates with Type QN-F female disconnects)

Standard Catalog Number	Std. Pkg. Qty.	Wire Range	NEMA Tab Size	Dimensions			Bulk Catalog Number	Bulk Pkg. Qty.	Installation Tool*
				A	B	W			
QN18M18X02D	100	18-22	.187 × .020	0.82	0.17	0.19	QN18M18X02B	1000	Y10D
QN18M25X03D			.250 × .032	0.91	0.17	0.25	—		
QN14M18X02D	100	14-16	.187 × .020	0.84	0.17	0.19	QN14M18X02B	1000	
QN14M25X03D			.250 × .032	0.91	0.17	0.25	QN14M25X03B		

* For UL Listed applications consult BURNDY® factory.

Blue highlighted items are industry standard and most frequently ordered.

TYPES PGP, AND PGN FINGRIP™

MALE/FEMALE COMBINATION QUICK DISCONNECTS

Material: Tin-Plated Brass

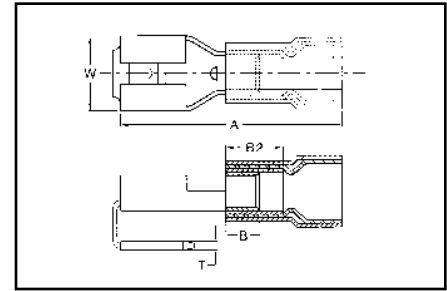
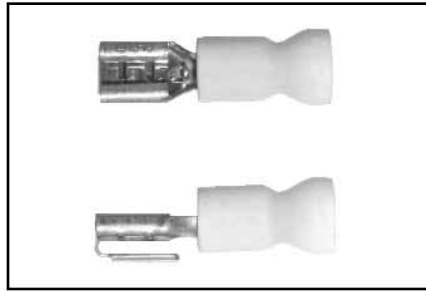

Features and Benefits

- Sleeved barrel.
- Combination connector.
 - ◇ Allows for more than one connection to a circuit.
- Funnel entry barrel opening.
 - ◇ Assures quick and easy wire insertion.
- Dimpled female socket detent.
 - ◇ Ensures firm grip.



VINYL COMBINATION DISCONNECT TERMINAL

600 Volts Max. 105° C Max.

Standard Catalog Number	Std. Pkg. Qty.	Wire Range	NEMA Tab Size	Dimensions			Bulk Catalog Number	Bulk Pkg. Qty.	Installation Tool*
				A	B	W			
PGP1825X03D	100	18-22	.250 × .032	0.91	0.17	0.30	PGP1825X03B	1000	Y10D
PGP1425X03D	100	14-16	.250 × .032	0.91	0.17	0.30	PGP1425X03B	1000	

NYLON COMBINATION DISCONNECT TERMINAL

300 Volts Max. 105° C Max.

Standard Catalog Number	Std. Pkg. Qty.	Wire Range	NEMA Tab Size	Dimensions			Bulk Catalog Number	Bulk Pkg. Qty.	Installation Tool*
				A	B	W			
PGN1825X03D	100	18-22	.250 × .032	0.90	0.17	0.30	PGN1825X03B	1000	Y10D
PGN1425X03D	100	14-16	.250 × .032	0.90	0.17	0.30	PGN1425X03B	1000	

* For UL Listed applications consult BURNDY® factory.

Blue highlighted items are industry standard and most frequently ordered.

TYPES FQN-F AND FQN-M FINGRIP™

NYLON FULLY INSULATED FEMALE AND MALE QUICK DISCONNECTS

Material: Tin-Plated Brass
300 Volts Max., 105° C Max.

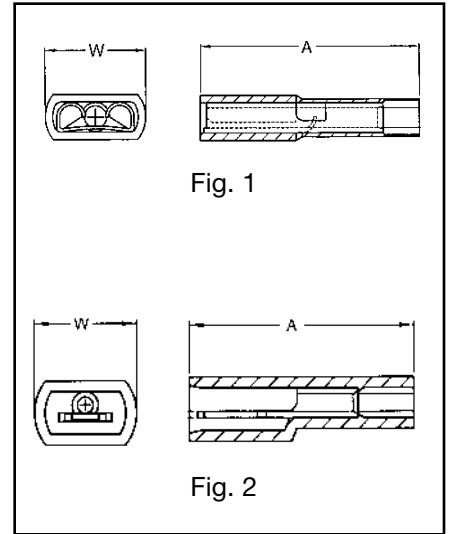
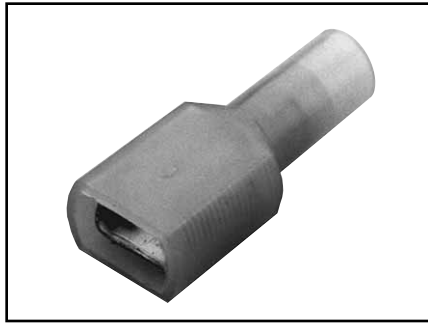

Features and Benefits

- Fully insulated connectors.
 - ◇ Eliminate the need for post installation insulation.
- Funnel entry barrel opening.
 - ◇ Assures quick and easy wire insertion.
- Dimpled female socket detent.
 - ◇ Ensures firm grip.



FULLY INSULATED FEMALE NYLON DISCONNECT TERMINAL (Fig. 1)

Standard Catalog Number	Std. Pkg. Qty.	Wire Range	NEMA Tab Size	Dimensions		Bulk Catalog Number	Bulk Pkg. Qty.	Installation Tool*
				A	W			
FQN18F25X03D	50	18-22	.250 × .032	0.98	0.40	FQN18F25X03B	1000	Y10D
FQN14F25X03D	50	14-16	.250 × .032	0.96	0.40	FQN14F25X03B	1000	
FQN10F25X03D	25	10-12	.250 × .032	0.99	0.41	FQN10F25X03B	500	

FULLY INSULATED MALE NYLON DISCONNECT TERMINAL (Fig. 2)

Standard Catalog Number	Std. Pkg. Qty.	Wire Range	NEMA Tab Size	Dimensions		Bulk Catalog Number	Bulk Pkg. Qty.	Installation Tool*
				A	W			
FQN18M25X03D	50	18-22	.250 × .032	1.05	0.48	FQN18M25X03B	1000	Y10D
FQN14M25X03D	50	14-16	.250 × .032	1.03	0.48	FQN14M25X03B	1000	
FQN10M25X03D	25	10-12	.250 × .032	1.03	0.48	FQN10M25X03B	500	

* For UL Listed applications consult BURNDY® factory.

** For Mylar tape reels consult BURNDY® factory.

Blue highlighted items are industry standard and most frequently ordered.

B-48

TYPE FL FINGRIP™

FLAG-STYLE FEMALE QUICK DISCONNECT

Material: Tin-Plated Brass

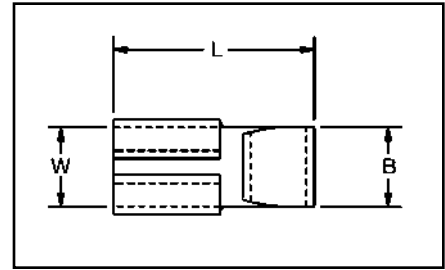
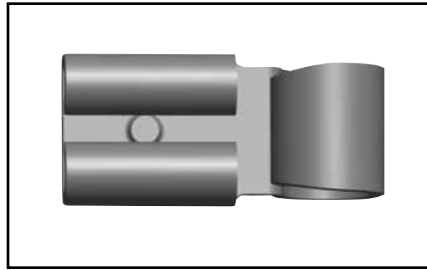

Features and Benefits

- Dimpled female socket detent.
 - ◇ Ensures firm grip.

FEMALE BARE DISCONNECT TERMINAL

Standard Catalog Number	Std. Pkg. Qty.	Wire Range	NEMA Tab Size	Dimensions			Bulk Catalog Number	Bulk Pkg. Qty.	Installation Tool*
				L	B	W			
FL1825X03D	100	18-22	.250 × .032	0.67	0.17	0.25	FL1825X03B	1000	Consult Factory
FL1425X03D	100	14-16	.250 × .032	0.67	0.17	0.25	FL1425X03B	1000	
FL1025X03D *	50	10-12	.250 × .032	0.67	0.17	0.25	—	—	

* Not UL Listed or CSA Approved.

Blue highlighted items are industry standard and most frequently ordered.

UNINSULATED SPLICES

BURNDY® manufactures several designs of uninsulated butt splices. Each type is designed to meet specific application requirements and provide a high quality, electrical splice connection that is easily installed. The following features and benefits apply to all BURNDY® uninsulated splices.

Features and Benefits

- Manufactured from seamless tubing.
 - ◇ A high quality design with no seams to split.
- Electrolytic copper.
 - ◇ Provides maximum conductivity, low resistance and ductility for excellent crimp forming properties.
- Electro-tin plated.
 - ◇ Provides durable long lasting resistance to corrosion.
- Positive center wire stops.
 - ◇ Provides proper depth of wire insertion.
- Marked with wire size.
 - ◇ Provides easy wire size identification.
- The HYLINK™ splice connectors have inspection holes.
 - ◇ Provides easy visual inspection for proper wire insertion.

TYPES YSV, YSV-H AND YSV-L

HYLINK™

Uninsulated Butt Splice
600 Volts Maximum

HYLINK™ type YSV seamless splice connector is used to splice stranded and solid copper conductors in virtually all heavy duty industrial and general purpose applications.

The type YSV-H HYLINK™ seamless splice connector has the added benefit of an insulation support and cable strain relief.

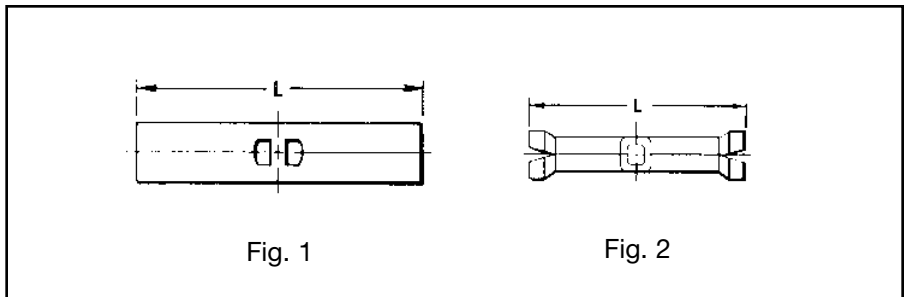
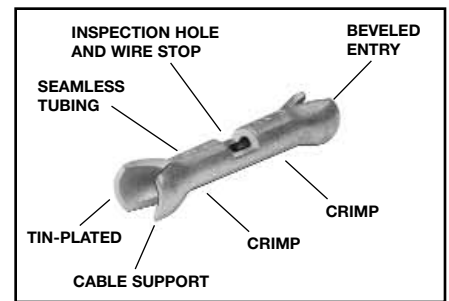
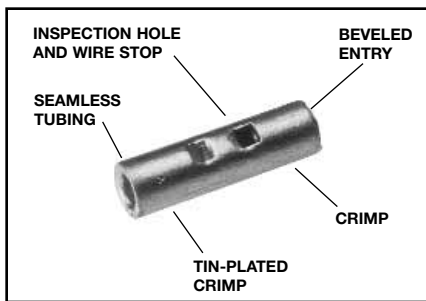

Catalog Number	Wire Range Code AWG Str. and Sol. Aircraft-AN	Fig.	Dimensions		Bulk Catalog Number	Installation Tooling HYTOOL™	Wire Strip Length
			L	Max. Dia.			
YSV18 BOX	22-18	1	.62	—	YSV18	Non-Ratchet: Y10D, Y1022 Ratchet: MR20, Y8MRB-1, MR8-9Q*, MR8-G98	1/4"
YSV18-H BOX	Str. & Sol.	2	.89	.120	YSV18-H		
YSV14 BOX	20-14 Str.	1	.64	—	YSV14		
YSV14-H BOX	20-12 Sol.	2	.94	.150	YSV14-H		
YSV10 BOX	12-10	1	.75	—	YSV10	5/16"	
YSV10-H BOX	Str. & Sol.	2	1.06	.192	YSV10-H		
YSV9C-L BOX	9 Str.	1	.75	—	YSV9C-L	Non-Ratchet: MY28, MY29-3, MY29-11 Ratchet: Y8MRB-1†, MR8-9Q*, Y1MRTC ▲	5/16"
YSV8C-L BOX	8 Str.	1	1.00	—	YSV8C-L		7/16"

* Remove stop plate.
▲ Y1MRTC for 8 Str. only
† Use #10 groove
Note: Use MR8 series tools for (-H) series.

Blue highlighted items are industry standard and most frequently ordered.

TYPE YSV-L

HYLINK™

Uninsulated Butt Splice
600 Volts Maximum
#8 Through 4/0 Copper

HYLINK™ type YSV-L seamless splice connector is used to splice Type AN aircraft cables plus commercial stranded and solid AWG conductors. Suitable for aircraft, light duty industrial and general purpose applications.

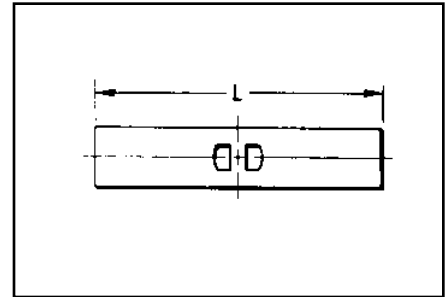
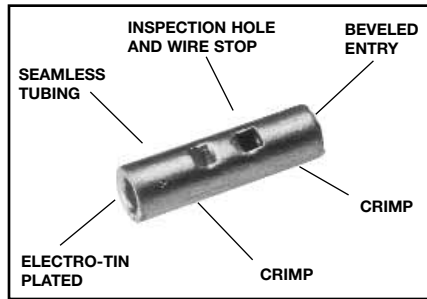

Catalog Number	Wire Range Aircraft-AN" Comm'I-AWG Str. & Sol.	Dimensions L	Bulk Catalog Number	Installation Tooling				Y34PA Wire Strip Length
				Ratchet	HYTOOL™ **	HYPRESS™• H35, Y35BH, Y39, Y39BH*		
						Nest	Indenter	
YSV8C-L BOX	8	1.00	YSV8C-L	MR89Q, Y8MRB-1, Y1MRTC	Type AH Aircraft Cable: MY28	UV8L-1	Y34PL	7/16"
YSV6C-L BOX	6	1.12	YSV6C-L	Y1MRTC, MR4C		UV6L	Y34PLA	1/2"
YSV4C-L BOX	4	1.12	YSV4C-L	Y1MRTC, MR4C		UV4L		5/8"
YSV2C-L BOX	2	1.41	YSV2C-L	Y1MRTC		UV2L		5/8"
YSV1C-L BOX	1	1.46	YSV1C-L	—	All Others:	UV1L	5/8"	
YSV25-L BOX	1/0	1.53	YSV25-L	—	MY29-3,	UV25L	Y34PA	11/16"
YSV26-L BOX	2/0	1.78	YSV26-L	—	MY29-11	UV26L		13/16"
YSV27-L BOX	3/0	1.81	YSV27-L	—	1 Crimp	UV27L		13/16"
YSV28-L BOX	4/0	1.94	YSV28-L	—		UV28L		7/8"

* Remove stop plate
 • Use Y35P3 Indenter Adaptor.
 ** Bench Mount Adaptor - Cat. No. BMY-BCH-MT is available for Type MY HYTOOLS™.

Blue highlighted items are industry standard and most frequently ordered.

TYPE YSM

HYLINK™

Uninsulated Parallel Splice

HYLINK™ type YSM seamless parallel splice connector permits wires to be laid parallel inside the connector and spliced together with BURNDY's compression HYTOOL™. Each YSM connector accommodates a wide combination of round, square, and rectangular copper conductors that have a total combined circular mil area listed in the table below. The conductors to be spliced must physically fit within title splice without being forced.

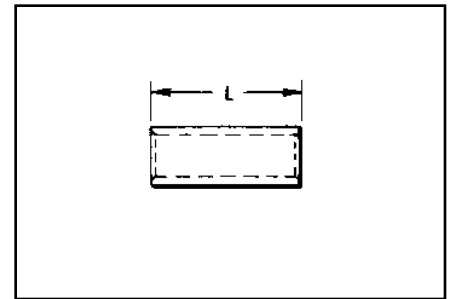
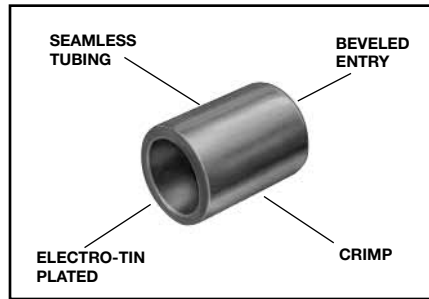

Catalog Number	Circular Mil. Range		Dimensions L	Installation Tooling				Wire Strip Length
				Ratchet	Mechanical HYTOOL™	HYPRESS™• Y35BH, Y39BH*		
						Nest	Indentor	
YSM18	300	1,909	.25	MR8-9Q*	—	—	—	5/16"
YSM14	477	4,107	.25	MR8-9Q*	—	—	—	5/16"
YSM10	4,107	10,380	.36	MR8-9Q*, MR4CQ	—	—	—	7/16"
YSM8C	6,088	16,864	.41	MR4CQ Y1MRTC	MY29-11 or MY28 (1) Crimp	UV8L-1	Y29PQ	1/2"
YSM6C	10,380	26,813	.44			UV6L		1/2"
YSM4C	26,813	42,613	.50			UV4L	9/16"	
YSM2C	42,613	66,832	.62	Y1MRTC		UV2L	11/16"	
YSM1C	66,832	81,807	.62	—		UV1L	11/16"	
YSM25	81,807	104,110	.69	—		UV25L	Y29PQ-6	3/4"
YSM26	104,110	133,650	.81	—		UV26L		7/8"
YSM27	133,650	167,332	.81	—		UV27L		7/8"
YSM28	167,332	211,954	.88	—		UV28L		15/16"

* Remove stop plate.
 • Use Y35P indentor adapter, with Y35BH and Y39BH HYPRESSES.

Wire Size	Area Cir. Mils.	Solid Wire Dia. (In.)	Concentric Str. Max. Dia. (In.)	Flex. Bunch or Rope Lay Dia. (In Approx.)
30	100.5	.010003	.012	
29	126.7	.01126	-	
28	159.8	.01264	.015	
27	201.5	.01420	-	
26	254.1	.01594	.019	
25	320.4	.01790	-	
24	404.0	.02010	.024	
23	509.5	.02257	-	
22	642.4	.02535	.030	
21	810.1	.02845	-	
20	1022	.03196	.038	
19	1288	.03589	-	
18	1624	.04030	.0460	
17	2048	.04526	-	
16	2583	.05082	.0585	
15	3257	.05707	-	
14	4107	.06408	.0735	

Wire Size	Area Cir. Mils.	Solid Wire Dia. (In.)	Concentric Str. Max. Dia. (In.)	Flex. Bunch or Rope Lay Dia. (In Approx.)
13	5178	.07196	-	-
12	6530	.08081	.0931	.101
11	8234	.09074	-	-
10	10380	.1019	.117	.126
9	13090	.1144	.132	.146
8	16510	.1285	.148	.157-.162
7	20820	.1433	.166	.179-.196
6	26250	.1620	.186	.207-.215
5	33100	.1819	.209	.235-.240
4	41740	.2043	.235	.263-.269
3	52640	.2294	.264	.219-.305
2	66370	.2576	.297	.319-.337
1	83690	.2893	.333	.367-.376
1/0	105500	.3249	.374	.441-.423
2/0	133100	.3648	.420	.500-.508
3/0	167800	.4096	.472	.549-.576
4/0	211600	.4600	.530	.613-.645

Blue highlighted items are industry standard and most frequently ordered.

TYPE YSCM

HYLINK™

Color-Coded Uninsulated Parallel Splice

Type YSCM HYLINK™ seamless parallel splice connectors permit stranded wires to be laid parallel inside the connector and spliced together with BURNDY® compression tools. Each YSCM connector accommodates a wide range of conductors and is color-coded to ensure proper tool and die match. YSCM connectors are UL486A Listed for applications up to 600V and CSA Listed.

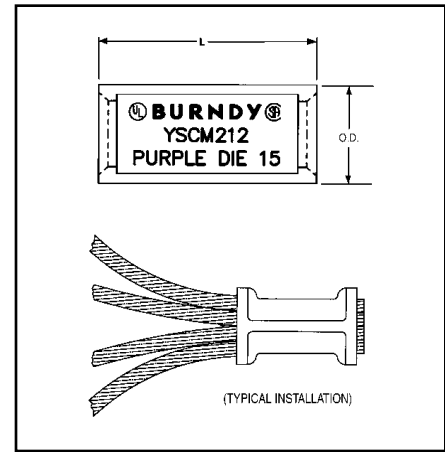
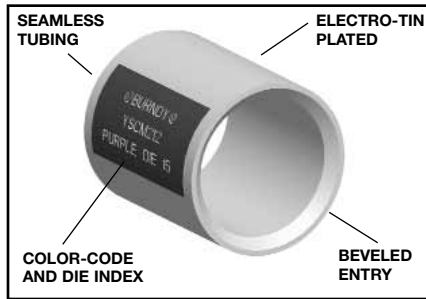

Catalog Number	Conductor Range Cable ⑤		Dimensions Inches [mm]		Color Code	Die Index	Recommended Installation Tooling		Wire Strip Length ④
	Circular Mils		L ±.03	O.D. ±.01			OUR840, Y500CTHS, PAT60018V Series	Y35, Y750, PAT750 Series	
	Min.	Max.							
YSCM17	13,060	16,910	.50 [13]	.27 [7]	Red	49	X8CRT, W8CRT	U8CRT	11/16"
YSCM27	16,910	26,890	.50 [13]	.31 [8]	Blue	7	X5CRT, W5CRT	U5CRT	11/16"
YSCM42	29,970	41,520	.50 [13]	.38 [10]	Gray	8	X4CRT, W4CRT	U4CRT	11/16"
YSCM66	42,750	66,040	.62 [16]	.47 [12]	Brown	10	X2CRT, W2CRT	U2CRT	3/4"
YSCM80	67,980	80,020	.62 [16]	.52 [13]	Green	11	X1CRT, W1CRT	U1CRT-1	3/4"
YSCM104	82,870	103,630	.69 [18]	.57 [14]	Pink	12	X25RT, W25RT	U25RT	15/16"
YSCM133	104,960	133,220	.81 [21]	.64 [16]	Black	13	X26RT, W26RT	U26RT	1-1/16"
YSCM167	134,340	166,560	.81 [21]	.70 [18]	Orange	14	X27RT, W27RT	U27RT	1-1/16"
YSCM212	167,380	211,820	.88 [22]	.78 [20]	Purple	15	X28RT, W28RT	U28RT	1-1/16"
YSCM231	—	230,800	1.05 [27]	.81 [21]	Yellow	16	X29RT, W29RT	U29RT	1-1/16"

Size		ASTM Strandings	
Stranded		Class	Cable Diameter Inches
Circular Mils	AWG		
1,022	20	B	0.036
1,624	18	B	0.045
2,583	16	B	0.057
4,107	14	B	0.072
6,530	12	B	0.091
10,380	10	B	0.116
13,090	9	B	0.130
16,510	8	B	0.146
20,820	7	B	0.164
26,250	6	B	0.184
33,100	5	B	0.206
41,740	4	AA	0.254
41,740	4	B&A	0.232
52,630	3	AA	0.285

Size		ASTM Strandings	
Stranded		Class	Cable Diameter Inches
Circular Mils	AWG		
52,630	3	B&A	0.260
66,370	2	AA	0.320
66,370	2	B&A	0.292
83,690	1	AA	0.360
83,690	1	A	0.328
83,690	1	B	0.332
105,500	1/0	A&A	0.368
105,500	1/0	—	0.390
105,500	1/0	B	0.373
133,100	2/0	A&A	0.414
133,100	2/0	—	0.438
133,100	2/0	B	0.419
167,800	3/0	A&A	0.464
167,800	3/0	—	0.492
167,800	3/0	B	0.470
211,600	4/0	A&A	0.522
211,600	4/0	—	0.522
211,600	4/0	B	0.528

1. Material: Copper per ASTM B75.
2. Finish: Tin plated. For nickel plating, add suffix "NK" to the Catalog Number.
3. Dimensions in brackets [] are in millimeters rounded off to the nearest millimeter, unless otherwise noted, and are for reference only.

④ Recommended strip length. Strip length dependant on size, no. of wires and insulation thickness.

⑤ Refer to Circular Mil Table per ASTM B8 for total Class B Circular Mil calculations.

TYPE YSES-K

INSULINK™

Radiation Resistant Insulated Butt Splice

Polyvinylidene Flouride (PVF₂) Insulated

200 Megarads - 60° C
Through 150° C, 600 Volts

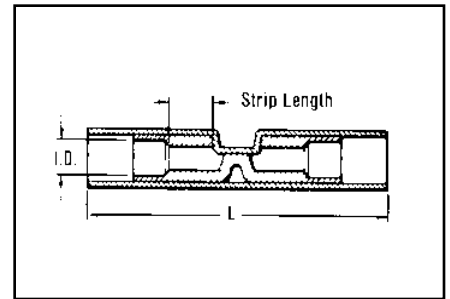
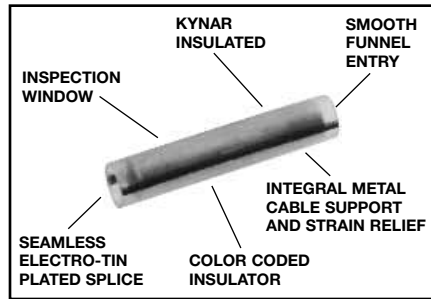

The type YSES-K radiation resistant KYNAR® insulated splices are suitable for class 1E applications plus non critical nuclear associated applications. The splice is manufactured from pure electrolytic copper seamless tubing which eliminates potential splitting of seams. A color code stripe is used for wire size identification and a window is provided for inspection of proper wire insertion.

Catalog Number	Wire Range	Color Stripe	Dimensions Max. Insul. Dia. Accom.	L Max.	Installation Tooling	Wire Strip Length
YSES18K	22-18	Red	.112	1.00	Ratchet Tool: MR10G8 Red Groove Calibration Gauge: PG-373-1 Crimp ID. Mark: (1) Small Dot	3/16"
YSES14K	16-14	Blue	.153	1.00	Ratchet Tool: MR10G8 Blue Groove Calibration Gauge: PG-371-1 Crimp ID. Mark: (2) Small Dot	3/16"
YSES10K	12-10	Yellow	.210	1.38	Ratchet Tool: MR10G8 Yellow Groove Calibration Gauge: PG-372-1 Crimp ID. Mark: (1) Large Dot	7/16"

KYNAR® is the registered trademark for Pennwalt Corp. for Polyvinylidene Flouride (PVF₂)

Blue highlighted items are industry standard and most frequently ordered.

TYPES SP AND BS

VINYLINK™

Splice, Polyvinylchloride Insulated

600 Volts, 105° C

The type SP VINYLINK™ is a PVC insulated seamless butt splice. Type SP VINYLINK™ is designed to accommodate a broad range of 600 volt cables.

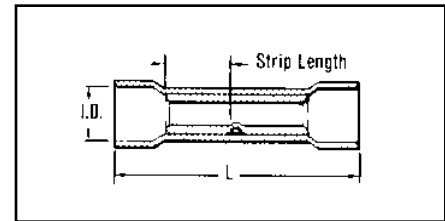
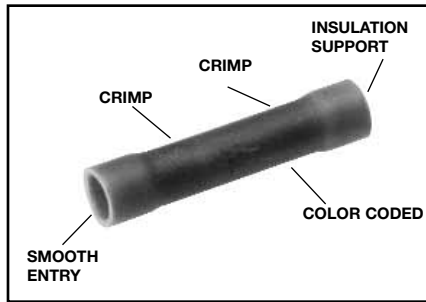

Features and Benefits

- Manufactured from seamless electrolytic copper tubing.
 - ◇ Provides maximum conductivity and tensile strength, in a high quality design with NO seams to split.
- Funnel entry.
 - ◇ Provides easy wire insertion.
- Electro-tin plated.
 - ◇ Provides durable long lasting resistance to corrosion.
- Expanded insulation support.
 - ◇ Lower inventory requirements.
- Red wire range of 22-16.
 - ◇ Lower inventory requirements.
- Vinyl insulator.
 - ◇ Economical means of providing high dielectric values and cable insulation support.

Catalog Number	Wire Range	Color Code	Bulk Catalog Number	Dimensions (Inches)		Installation Tooling	Wire Strip Length
				L Max. Insul.	Max. Dia.		
SP16	22-16	Red	BS16	1.00	.145	Non-Ratchet: Y10-22, Y10D Ratchet: MR8G-98, MR15, MR8-89-1	1/4"
SP14	16-14	Blue	BS14	1.00	.180		1/4"
SP10	12-10	Yellow	BS10	1.23	.260		21/64"

Blue highlighted items are industry standard and most frequently ordered.

INSULATED SPLICES

BURNDY® manufactures several designs of insulated butt splices. Each type is designed to meet specific application requirements and provide a high quality electrically pre-insulated splice that is easily installed. The following features and benefits apply to all BURNDY® pre-insulated butt splices.

Features and Benefits

- Manufactured from seamless tubing.
 - ◇ A high quality design with no seams to split.
- Pure electrolytic copper.
 - ◇ Provides maximum conductivity, low resistance and ductility for excellent crimp forming properties.
- Electro-tin plated.
 - ◇ Provides durable long-lasting resistance to corrosion.
- Positive center wire stops.
 - ◇ Provides for proper depth of wire insertion.
- Color-coded in red, blue and yellow.
 - ◇ Provides easy wire size identification.

TYPES SN AND YSE-HN

INSULINK™

Butt Splice, Nylon Insulated

600 Volts Maximum,
105° C Maximum

The type SN INSULINK™ is a high quality nylon-insulated butt splice designed to meet heavy duty application requirements.

Meets the functional requirements of MIL-T-7928 (ASG) and conforms to the requirements of NAS1388.



600 Volts, 105° C
(1000 Volts, Max. Inside Sign or Fixture)

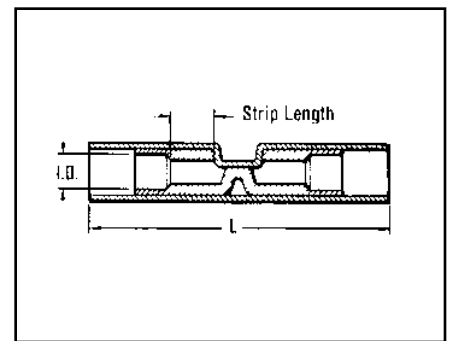
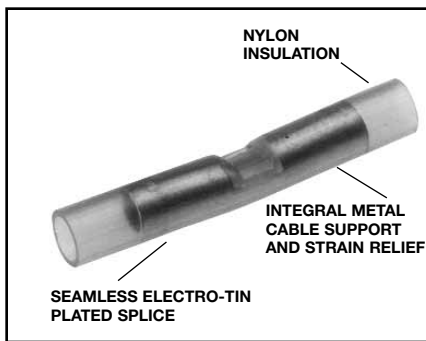

Features and Benefits

- Manufactured from one-piece tin-plated seamless copper tubing with an integral barrel/insulation grip.
 - ◇ Provides maximum tensile strength, plus excellent cable support and strain relief and eliminates failures due to vibration.
- Smooth funnel entry.
 - ◇ Provides easy wire insertion.
- Window position locator for full cycle ratchet tool crimp.
 - ◇ Provides proper tool/connector alignment for correct crimp.
- Nylon insulation offers high dielectric strength and stability in oily environmental conditions.
 - ◇ Maintains a high quality connection in demanding applications.
- The nylon is locked into position.
 - ◇ The connector will not move.

Catalog Number	Wire Range	Color Code	Bulk Catalog Number	Dimensions (Inches)		Installation Tooling	Wire Strip Length
				L Max. Insul.	Max. Dia.		
SN18	22-18	Red	YSE18HN	1.25	.115	Plier: Y10D Ratchet: MR8-85, MR18	15/64"
SN14	16-14	Blue	YSE14HN	1.25	.150		7/32"
SN10	12-10	Yellow	YSE10HN	1.64	.220		3/8"

Blue highlighted items are industry standard and most frequently ordered.

TYPES SNM AND YSES

INSULINK™

Butt Splice, Nylon Insulated

MS25181, Class 1 Splice
300 Volts, 105° C

The type SNM INSULINK™ is a high quality nylon insulated butt splice designed to meet military MS25181, class 1 requirements.

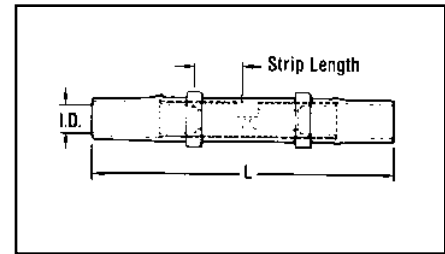
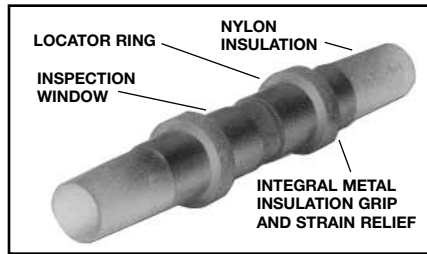

Features and Benefits

- Manufactured from tin plated, seamless copper tubing with an integral barrel/insulation grip.
 - ◇ Provides maximum tensile strength, plus excellent cable support and strain relief.
- Smooth funnel entry.
 - ◇ Provides easy wire insertion.
- Transparent nylon insulation.
 - ◇ Permits easy wire inspection.
- External ring locator.
 - ◇ Provides proper tool alignment for correct crimp.

Catalog Number	Wire Range	Color Code	Bulk Catalog Number	MS25181 Dash No.	Dimensions		Installation Tooling	Wire Strip Length
					L Max.	Max. Dia. Insul.		
SNM18	22-18	Red	YSES18-1	-1	1.53	.120	Plier: Y10D Ratchet: MR8-83 or MR8-85 MS25037 TOOL	7/32"
SNM14	16-14	Blue	YSES14-2	-2	1.53	.150		7/32"

TYPES YSE BOX, YSE-H BOX, YSE, YSES AND YSE-H

INSULINK™

600 Volts, 105° C

The types YSE and YSE-H INSULINK™ are high quality nylon insulated butt splices designed for splicing aircraft and commercial flexible cables.

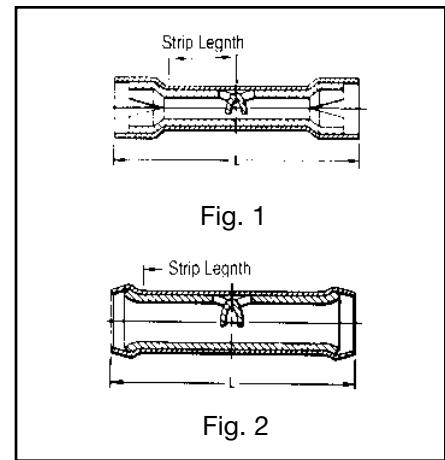
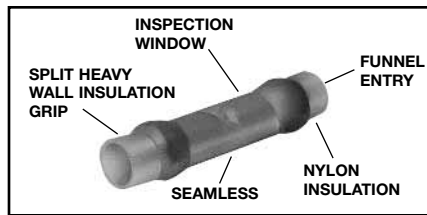

Features and Benefits

- Manufactured from tin plated, seamless electrolytic copper tubing with integral barrel/insulation grip.
 - ◇ Provides maximum conductivity and tensile strength, plus excellent cable support and strain relief.
- Split heavy wall insulation grip.
 - ◇ Provides stronger insulation grip and strain relief.
- Smooth funnel entry.
 - ◇ Provides easy wire insertion.
- Transparent nylon insulation.
 - ◇ Permits easy wire inspection.



600 Volts 105°C

Wire Range Catalog Number	Fig.	Wire Code AWG Aircraft AN	Color Code	Bulk Catalog Number	Dimensions		Installation Tooling	Wire Strip Length
					L Max. Insul.	Max. Dia.		
YSE18H-BOX	1	22-18	Red	YSE18H	1.220	.115	Y10D	9/32"
YSE14H-BOX	1	16-14	Blue	YSE14H	1.36	.150	Ratchet:	11/32"
YSE10-BOX	2	12-10	Yellow	YSE10	1.15	.209	MR8-33S-1	23/64"

Blue highlighted items are industry standard and most frequently ordered.

TYPES YSV, YRV-L

HYREDUCER™

Reducer Butt Splice

The HYREDUCER™ is a connector for splicing two different size wires. The larger conductor is inserted first and butts against the center of the connector where the smaller barrel begins. Constructed of pure electrolytic copper tubing for maximum conductivity, tin plated to resist corrosion, the HYREDUCER™ accommodates a wide range of cable sizes.

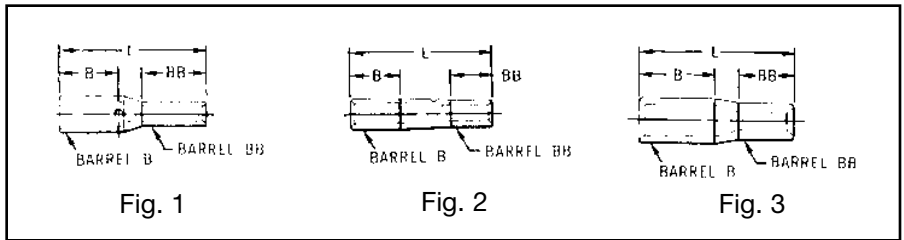

Dimensional information may be found in Table 1. Table 2 is a comprehensive tooling index for these connectors.

TABLE 1

Bulk Catalog Number	Total Wire Range	Fig. No.	B Barrel*		Tool Index	BB Barrel*		Tool Index	"L" Max.
			Wire Size	B Dim.		Wire Size	BB Dim.		
YSV1418	22 - 14	1	20 - 14	.27	1	22 - 18	.27	2	.64
YSV1214-G1	16 - 12	2	12	.31	4	16 - 14	.27	1	.83
YSV1014-G2	20 - 10	2	12 - 10	.31	4	20 - 14	.27	1	.83
YRV8CV14-L	20 - 8	3	8	.44	5	20 - 14	.39	1	1
YRV8CV10-L	12 - 8	3	8	.44	5	12 - 10	.53	4	1.18
YRV6CV10-L	12 - 6	3	6	.50	6	12 - 10	.53	4	1.28
YRV6CV8C-L	8 - 6	3	6	.50	6	8	.53	5	1.21
YRV4CV6C-L	6 - 4	3	4	.50	7	6	.54	6	1.27
YRV2CV6C-L	6 - 2	3	2	.62	8	6	.51	6	1.63

* B and BB dimensions are wire strip lengths.

TABLE 2 TOOL INDEX

Index Number	Hand Tools	Tools With Dies	
		Y29NC	
1	MR8G98 Y8MRB-1 MR8-90† MR20	—	
2	MR8G98 Y8MRB-1 MR8-90† MR20	—	
4	MR8G98 Y8MRB-1 MR8-90† MR20	—	
5	Y8MRB-1 MY28 MR4C Y1MRTC	Nest	Indentor
		DV8L-1*	Y29PL
6	MY28 Y1MRTC MR4C	DV6L	Y29PL
7	MY28 Y1MRTC MR4C	DV4L	Y19PL
8	Y1MRTC MY28	DV2L	Y29PL

* For aircraft applications (flexible cables).

Blue highlighted items are industry standard and most frequently ordered.

BURCAP TYPES YQE, RK

PIGTAIL SPLICE, NYLON-INSULATED

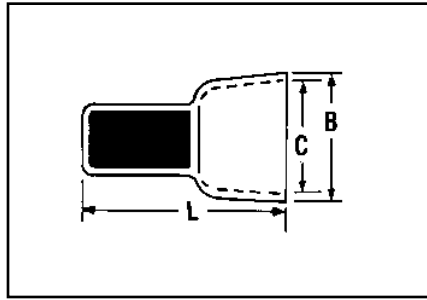

Rated at 600 volts for building wire and 1000 volts for fixtures and signs, the BURCAP is designed to splice a wide range of different cable sizes.

Catalog Number	Wire Combinations	Total Area Circular Mils	Dimensions in Inches			Installation Tools	Wire Strip Length
			L	B	C	Die Set	
						M8ND, Y8ND	
YQE-91†	1 #16 & 1 #18	4,205	.76	.30	.24	N150WT	5/16"
	2 #18	3,250					
*RK141-2	RK141ABOX100	500 5,180	.607 (16, 4)	.311 (7, 9)	.269 (8, 6)		
	RK142ABOX100						
*RK142-2	6 1 1 1 2 1 1	2,400 13,100	.722 (18, 3)	.440 (11, 2)	.384 (9, 8)		
	5 1 1 1 1 1 1						
	4 2 1 1 1 1 1						
	4 1 2 1 1 1 1						
	3 2 3 1 1 1 1						
	3 2 1 1 1 1 1						
	3 3 1 1 1 1 1						
	2 3 2 2 1 1 1						
	2 2 1 3 1 1 1						
	1 4 2 2 2 1 1						
	1 2 1 1 1 1 1						
	1 1 1 1 1 1 1						
	4 2 1 1 1 1 1						
	3 1 3 1 1 1 1						
	2 2 4 1 1 1 1						
	2 1 1 2 1 1 1						
	1 2 2 2 1 1 1						
	1 1 3 2 1 1 1						
	3 2 1 1 1 1 1						
	2 1 3 1 1 1 1						
	3 1 1 1 1 1 1						
	5 1 1 1 1 1 1						

NOTE: * Convenience Package. For Box quantity, order RK141ABOX100 and RK142ABOX100 respectively.
† This item is UL Listed

Blue highlighted items are industry standard and most frequently ordered.

INTRODUCTION

MEDIUM AND LARGE HYDENT™

Copper and aluminum compression terminals and splices for terminating conductors from #8 AWG through 2000 kcmil.

The medium and large HYDENT™ line is designed for terminating and splicing medium and large conductors in electrical power applications.

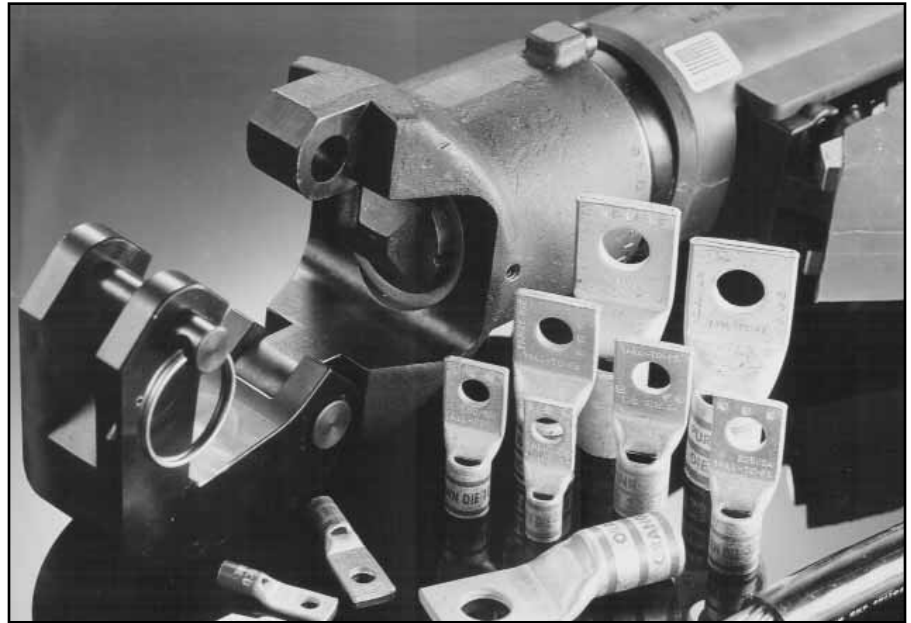

C-1

HYLUG™

UNINSULATED COPPER COMPRESSION TERMINALS

UL Listed 90° C,
600 Volts to 35 kV ◆

BURNDY's HYLUG™ terminals, types YA, YA-TC, YA-L, YA-L-TC, YA-2N, YA-2TC, YA-L-TC-FX, YA-L-2TC, and YA-2LN are designed for terminating copper conductors in a wide variety of electrical connections, including heavy-duty industrial, utility, commercial, and telecommunications applications.

The HYLUG™ terminals require simple cable preparation for an easily installed permanent and inspectable cable termination. The terminals are listed by UL (UL STD. 486A) and CSA certified to 600 volts, when applied with the proper tool and die combination. The terminals may be used in applications to 35KV. See each catalog page for UL 35kV listings.

Features and Benefits

- Manufactured from seamless high conductivity electrolytic copper tubing with heavy duty wall thickness.
 - ◇ Provides maximum conductivity, low resistance and ductility for an excellent combination of electrical and crimp forming properties.
- Barrel diameter closely matches commercial (code) cable and Navy cable diameters.
 - ◇ Provides an excellent relationship of the conductor/connector combination to produce a high quality electrical connection with the recommended tooling.
- Electro-tin plated. Electro-lead plated. Burndy's proprietary brite finish.
 - ◇ Provides durable long-lasting corrosion resistance.
- Internally beveled barrel end.
 - ◇ Provides easy cable insertion.
- Each connector is clearly marked with the wire size and type, die index, and color coding.
 - ◇ Provides easy identification and proper tooling recommendation.
- Marked with the proper number and location of crimps.
 - ◇ Lowers installed costs. Provides for proper installations.
- Proper compression systems forms a homogeneous mass.
 - ◇ The result is an excellent electrical connection.
- Use up to 35 kV as indicated.
 - ◇ Suitable for high voltage applications.
- Expanded wire ranges when using Y644 HYPRESS™ Dieless 1 Crimp.
 - ◇ Provides ability to complete emergency repairs when connector and wire size do not match.
- Crimp areas clearly marked.
 - ◇ Provides correct number and location of crimps for proper installation.
- Hydraulic and Battery tooling crimp embossment.
 - ◇ Provides permanent die index number embossment on completed crimp for inspection purposes.

Blue highlighted items are industry standard and most frequently ordered.

**HYLUG™
TABLE OF CONTENTS**

BURNDY® Die Sets & Die Index Chart
 12 Ton U-Dies **C-9**
 W-Dies **C-9**
 Index Chart **C-10**

BREAK-AWAY™ HYLUG™ C-11

Blank Tongue HYLUG™ C-14

One Hole HYLUG™ – Code Conductor
 Standard Barrel **C-17**
 Standard Barrel – Narrow Tongue **C-21**
 Long Barrel **C-23**
 Long Barrel – With Inspection Window. **C-27**

Two Hole HYLUG™ – Code Conductor
 Standard Barrel **C-30**
 Standard Barrel – Narrow Tongue **C-34**
 Long Barrel **C-36**
 Long Barrel – With Inspection Window. **C-39**

Four Hole HYLUG™ – Code Conductor
 Long Barrel **C-43**

One Hole HYLUG™ – Flex Conductor
 Standard Barrel **C-44**
 Standard Barrel – Narrow Tongue **C-47**
 Standard Barrel **C-49**
 Standard Barrel – Belled End **C-51**
 Long Barrel – With Inspection Window. **C-52**
 Long Barrel – Belled End **C-54**
 Standard Barrel – Lead Plated **C-68**

Two Hole HYLUG™ – Flex Conductor
 Standard Barrel **C-56**
 Standard Barrel – Narrow Tongue **C-59**
 Long Barrel – With Inspection Window. **C-61**
 Long Barrel – Belled End **C-63**
 Long Barrel – Narrow Tongue **C-66**
 Standard Barrel – Lead Plated **C-71**
 Double Barrel. **C-74**

One Hole HYLUG™
 Non-Insulated Copper Terminals **C-75**

E-Line HYLUG™ – Equipment Line
 Type YAE Compression Terminals. . . . **C-80**

HYLINK™
 Splices. **C-82**

HYSPLICE™ and HYREDUCER™
 In-Line Splice Kits **C-89**

Copper Taps
 C-Taps. **C-100**
 H-Taps. **C-103**
 Covers for H-Taps. **C-106**

H-CRIMPIT™
 Copper Connectors. **C-100**

T Connectors
 Copper. **C-108**

HYPLUG™
 Copper Connectors. **C-110**

HYSTACK™
 Copper Terminals **C-113**

Aluminum HYLUG™
 Terminals **C-114**

Transformer Lug Kits
 Aluminum or Copper. **C-117**

HYPLUG™
 Aluminum and Copper Connectors . . **C-118**

HYLINK™
 Aluminum Splices **C-120**
 Aluminum to Copper Splices **C-123**
 Insulating Covers. **C-125**

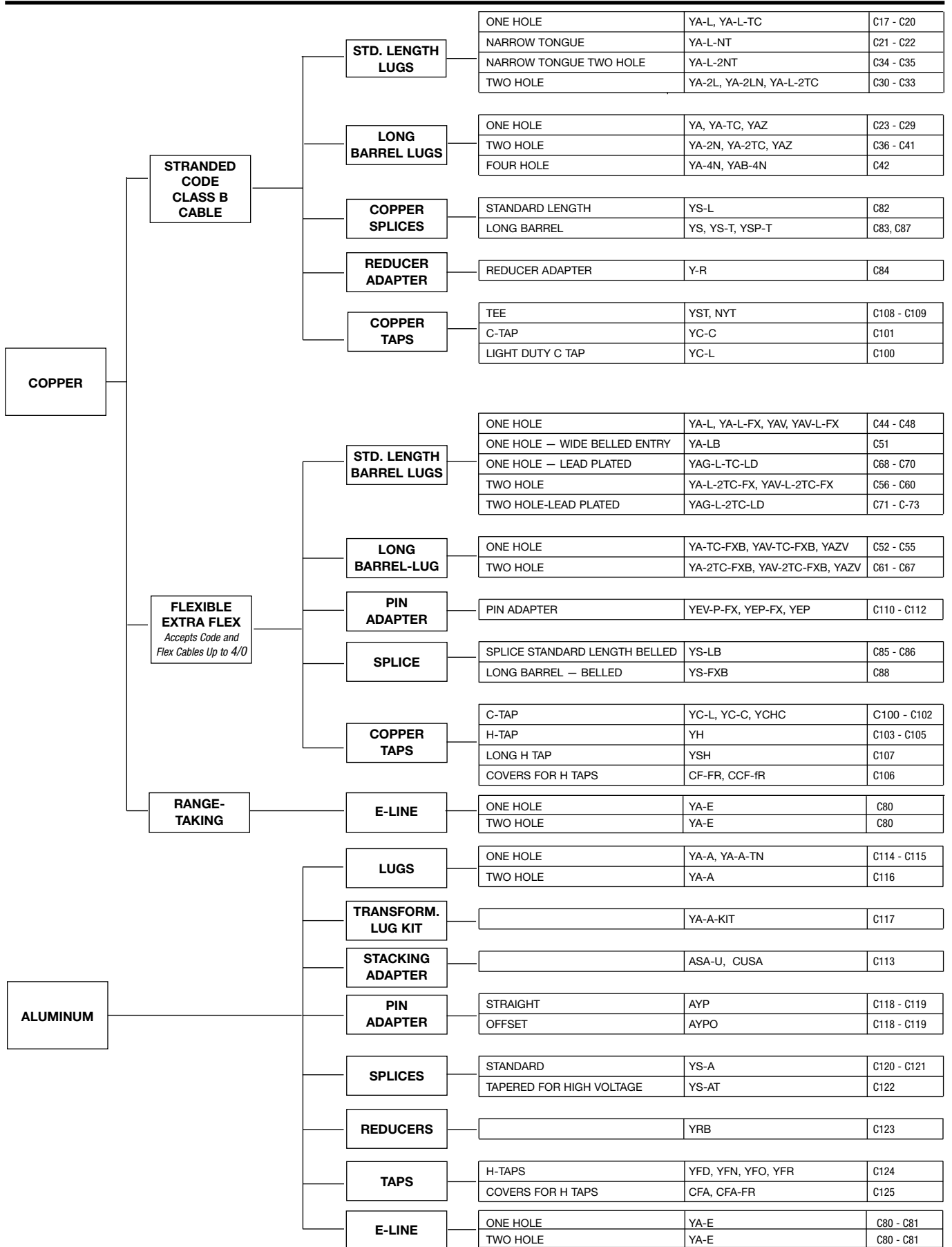

COMPRESSION CONNECTORS

BURNDY's compression connectors are designed for reliable and controllable electrical connections. The complete installation is fully inspectable. They are high conductivity copper and operate cooler than the wire on which they are installed. The connectors withstand a wide range of electrical and environmental conditions, including current surges, temperatures, corrosion and vibrations, for a wide variety of applications. These features mean a consistently high quality connection at a low installed cost.

Copper compression connectors are manufactured from high-conductivity electrolytic copper. The connectors are normally tinned, lead-plated, or plated with proprietary BURNDY® brite finish to provide durable long-lasting corrosion resistance. The connector design has been matched to the cable size to provide the necessary physical strength requirements for reliable electrical performance.

Aluminum compression connectors are manufactured from high conductivity, high purity wrought aluminum. They are designed with sufficient mass and are electro-tin plated to minimize corrosion due to galvanic action between dissimilar metals. The connector barrels are pre-filled with PENETROX®, BURNDY's oxide inhibiting compound.

PENETROX® contains homogeneously suspended metallic particles which penetrate the wire's oxides to establish excellent continuity between the individual strands and the connector barrel for a low-resistance connection. PENETROX® maintains an air-tight connection. Each barrel end is covered with a color-coded plastic dust cap which prevents foreign matter from entering the connector before it is used. The connector design has been engineered to match the cable size to provide the necessary physical strength requirements for reliable electrical performance.

SELECTION AND USE

Copper compression connectors are recommended for use on copper conductors. Aluminum compression connectors are recommended for use on aluminum conductors. Dual-rated aluminum compression connectors may be used on both copper and aluminum conductors.

Two basic compression designs are available: Circumferential and indent.

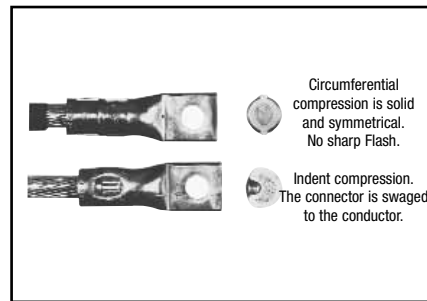

After compression, virtually all the air is removed leaving a tight homogeneous mass of connector and conductor.

The circumferential crimp design is recommended for color coded connectors in low and high voltage applications. Die index number embossment provides an easy inspection where required to verify the use of the proper connector/die combination. It is also recommended for insulated connectors and for terminating flexible and welding cables.

The circumferential crimp design dies compress cable strands into polygonal shapes forming intimate contact with each other and the connector barrel. This compression forms a tight homogeneous mass with virtually no air pockets. The circumferential crimp provides an excellent electrical connection with high pull-out values. The circumferential crimp is ideal for high voltage applications leaving the connector barrel symmetrical, which is easier to insulate.

The indent type crimp can be used in virtually any application except polyvinylchloride (PVC) insulated terminals and splices. It is an excellent means of terminating flexible, extra flexible and welding cables. The indentor compresses the cable strands to form intimate contact with each other and the connector barrel. The result is an excellent electrical connection with high pull-out strength. Laboratory work testing curves established the proper depth and shape of indent for each type of connector and wire combination.

TOOLING

Tooling systems are essential for proper installation of a compression connector. Since connectors and dies are designed as a unit for specific wire sizes, only the recommended tools and dies should be used. Most aluminum and copper HYLUG™ terminals and HYLINK™ splices are marked with a die index number and are color-coded to identify the correct installation die. Dies marked with the matching die index number and color can be used to install the connector.

BURNDY® tooling installs a wide range of connectors, is reliable, cost effective, and precision engineered for durable, long-lasting service and quality connections. The tools include small plier types, full cycle ratchet designs and hydraulically-powered HYPRESS™ heads and new Battery Actuated Tools. Some have permanent die grooves or adjustable dies, while others require a change of die sets or nest die for each connector size. BURNDY's recommended tools achieve crimp performance consistent with UL and other industry standards. Since several tools are suitable for most connectors, the most economical and practical tool can be chosen for each application.

INDUSTRY STANDARDS

BURNDY's compression terminals, splices and tap connectors requiring third party testing and approval are listed by Underwriters' Laboratories, Inc. Many have also received CSA approval and are approved under MIL-T-7928 and other military standards. All conform to applicable sections of the National Electrical Code.

BURNDY® also offers connectors and splices which meet the (LOCA Seismic and Aging) requirements of IEEE standards 323, 383 and 344 for class 1E critical circuits for use in Nuclear Utility Applications. Certification to 10CFR50 and 10CFR21 available.

Detail catalog listings should be consulted to obtain the appropriate standards for each connector and splice.

Blue highlighted items are industry standard and most frequently ordered.

**BURNDY®
Telecommunications
Connectors...**

**The industry's first choice in
compression connections...**

BURNDY® provides a complete selection of one and two hole compression's terminals, H-taps, C-taps, and other compression connection products specifically engineered to meet the demanding applications of both the Central Office and Wireless communications markets.

All of BURNDY's compression products are designed for reliable and controllable electrical connections. All connectors are made from high conductivity electrolytic copper and operate at cooler temperatures than the conductor on which they are installed. The connectors are normally tin-plated, lead-plated, or plated with a proprietary BURNDY® brite finish to provide the industry standard in long-lasting corrosion resistance.

The complete installation is fully inspectable and UL Listed when installed with BURNDY® dies. Every die in the system is color-coded and provides die index embossment for complete inspectability.

The Circumferential Crimp...



Circumferential compression is solid and symmetrical. No sharp Flash.

BURNDY's circumferential crimp provides a solid, homogenous connection, with high pull out values and is rated for high voltage applications, more than sufficient for the 48 V DC operating voltage common in the telecom market. In addition the circumferential crimp doesn't require the removal of the copper flash produced by other die systems. This not only saves time in installation but removes a potential safety hazard from the job.

All of the dies in the system are color-coded to match the connectors and feature die index and die number matching to the connector for ease of installation.

**BURNDY® Tooling...
the right choice for the job**

BURNDY® tooling installs a wide range of connectors, is reliable, cost effective, and precision engineered for durable, long-lasting service and quality connections. BURNDY's compression tooling system ranges from full cycle ratchet hand tools to 12 and 15 ton hydraulically-powered HYPRESS™ heads. Hydraulic tools are available in self-contained, battery powered, and AC service electrically powered pump and remote head designs to meet all possible installation situations.

Industry Standards

BURNDY's compression terminals, splices and tap connectors requiring third party testing and approval are listed by Underwriters Laboratories, Inc. Many have also received CSA approval, and all conform to the applicable sections of the National Electric Code.

Blue highlighted items are industry standard and most frequently ordered.

EXPANDED RANGES

The following connectors are range taking when crimped onto code conductor using Y644HS family of tools:



COPPER

ALUMINUM

Copper HYLUG™ & HYLINK™ Connectors Types YA, YA-L, YAB, YS, YS-L, YST, YS-T, YSP-T			
Catalog No.		Standard Wire Size	Expanded Wire Range
Terminal*	Splice**		
YA6C-	YS6C-	#6 AWG	#6 AWG
YA5C-	YS5C-	#5 AWG	#5 - #6 AWG
YA4C-	YS4C-	#4 AWG	#4 - #6 AWG
YA3C-	YS3C-	#3 AWG	#3 - #6 AWG
YA2C-	YS2C-	#2 AWG	#2 - #6 AWG
YA1C-	YS1C-	#1 AWG	#1 - #6 AWG
YA25-	YS25-	1/0 AWG	1/0 - #6 AWG
YA26-	YS26-	2/0 AWG	2/0 - #4 AWG
YA27-	YS27-	3/0 AWG	3/0 - #2 AWG
YA28-	YS28-	4/0 AWG	4/0 - #1 AWG
YA29-	YS29-	250 kcmil	250 kcmil - 1/0 AWG
YA30-	YS30-	300 kcmil	300 kcmil - 2/0 AWG
YA31-	YS31-	350 kcmil	350 kcmil - 3/0 AWG
YA32-	YS32-	400 kcmil	400 kcmil - 4/0 AWG
YA34-	YS34-	500 kcmil	500 kcmil - 4/0 AWG
YA36-	YS36-	600 kcmil	600 - 250 kcmil
YA39-	YS39-	750 kcmil	750 - 500 kcmil
YA40-	YS40-	800 kcmil	800 - 500 kcmil
YA44-	YS44-	1000 kcmil	1000 - 750 kcmil

Aluminum HYLUG™ & HYLINK™ Connectors Types YA-A & YS-A			
Catalog No.		Standard Wire Size	Expanded Wire Range
Terminal*	Splice**		
YA6CA-	YS6CA-	#6 AWG	#6 AWG
YA4CA-	YS4CA-	#4 AWG	#4 - #6 AWG
YA2CA-	YS2CA-	#2 AWG	#2 - #6 AWG
YA1CA-	YS1CA-	#1 AWG	#1 - #2 AWG
YA25A-	YS25A-	1/0 AWG	1/0 - #1 AWG
YA26A-	YS26A-	2/0 AWG	2/0 - #1 AWG
YA27A-	YS27A-	3/0 AWG	3/0 - #1 AWG
YA28A-	YS28A-	4/0 AWG	4/0 - #1 AWG
YA29A-	YS29A-	250 kcmil	250 kcmil - 1/0 AWG
YA30A-	YS30A-	300 kcmil	300 kcmil - 2/0 AWG
YA31A-	YS31A-	350 kcmil	350 kcmil - 3/0 AWG
YA32A-	YS32A-	400 kcmil	400 kcmil - 4/0 AWG
YA34A-	YS34A-	500 kcmil	500 kcmil - 4/0 AWG
YA36A-	YS36A-	600 kcmil	600 - 250 kcmil
YA39A-	YS39A-	750 kcmil	750 - 500 kcmil
YA40A-	YS40A-	800 kcmil	800 - 500 kcmil
YA44A-	YS44A-	1000 kcmil	1000 - 750 kcmil

* 1 Crimp
** 1 Crimp per side

* 1 Crimp
** 1 Crimp per side

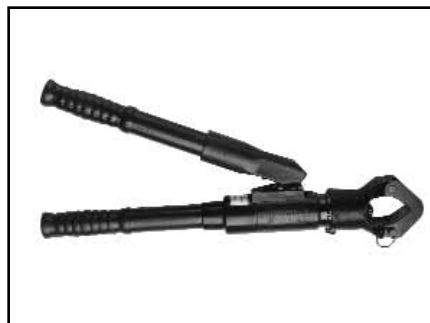

Blue highlighted items are industry standard and most frequently ordered.

EXPANDED RANGES

The following connectors are range taking when crimped onto code & flex conductor using 4-POINT™ family of tools:



C-7

ALUMINUM CONNECTORS

Aluminum & Copper Conductor (Code & Compact)				
Conductor		Connector		
Wire Size	Expanded Range	Terminal	Splice	# Crimps
#8 AWG	#8 AWG	YA8CA-	YS8CA-	1
#6 AWG	#6 AWG	YA6CA-	YS6CA-	1
#4 AWG	#6 - #4 AWG	YA4CA-	YS4CA-	1
#2 AWG	#6 - #2 AWG	YA2CA-	YS2CA-	2
#1 AWG	#6 - #1 AWG	YA1CA-	YS1CA-	2
1/0 AWG	#6 - 1/0 AWG	YA25A-	YS25A-	2
2/0 AWG	#4 - 2/0 AWG	YA26A-	YS26A-	2
3/0 AWG	#2 - 3/0 AWG	YA27A-	YS27A-	2
4/0 AWG	#1 - 4/0 AWG	YA28A-	YS28A-	2
250 kcmil	1/0 - 250	YA29A-	YS29A-	2
300 kcmil	2/0 - 300	YA30A-	YS30A-	2
350 kcmil	3/0 - 350	YA31A-	YS31A-	3
400 kcmil	4/0 - 400	YA32A-	YS32A-	4
500 kcmil	4/0 - 500	YA34A-	YS34A-	4
600 kcmil	250 - 600	YA36A-	YS36A-	4
750 kcmil	500-750	YA39A-	YS39A-	4

AYP/AYPO CONNECTORS

(Aluminum and Copper — Code & Compact)				
Wire Size	Expanded Range	Pin		# Crimps
		Straight	Offset	
#6 AWG	#6 AWG	AYP6	—	1
#4 AWG	#4 AWG	AYP4	—	1
#2 AWG	#4 - #2 AWG	AYP2	—	1
#1 AWG	#2 - #1 AWG	AYP1	—	1
1/0 AWG	#2 - 1/0 AWG	AYP1/0	—	1
2/0 AWG	#1 - 2/0 AWG	AYP2/0	AYPO2/0	2
3/0 AWG	1/0 - 3/0 AWG	AYP3/0	AYPO3/0	2
4/0 AWG	2/0 - 4/0 AWG	AYP4/0	AYPO4/0	2
250 kcmil	3/0 - 250 kcmil	AYP250	AYPO250	2
300 kcmil	4/0 - 300 kcmil	AYP300	AYPO300	2
350 kcmil	250 - 350 kcmil	AYP350	AYPO350	2
400 kcmil	350 - 500 kcmil	AYP400	AYPO400	2
500 kcmil	350 - 500 kcmil	AYP500	AYPO500	2
600 kcmil	400 - 600 kcmil	AYP600	AYPO600	3
750 kcmil	500 - 750 kcmil	AYP750	AYPO750	3

COPPER CONNECTORS

Copper Conductor (Code & Compact)							
Conductor		Standard Barrel			Long Barrel		
Wire Size	Expanded Range	Terminal	Splice	# of Crimps*	Terminal	Splice	# of Crimps*
#8 AWG	#8 AWG	YA8CL-	YS8CL-	1	YA8C-	YS8C-	1
#6 AWG	#6 AWG	YA6CL-	YS6CL-	1	YA6C-	YS6C-	1
#4 AWG	#6 - #4	YA4CL-	YS4CL-	1	YA4C-	YS4C-	1
#2 AWG	#6 - #2	YA2CL-	YS2CL-	1	YA2C-	YS2C-	2
#1 AWG	#6 - #1	YA1CL-	YS1CL-	1	YA1C-	YS1C-	2
1/0 AWG	#6 - 1/0	YA25L-	YS25L-	1	YA25-	YS25-	2
2/0 AWG	#4 - 2/0	YA26L-	YS26L-	1	YA26-	YS26-	2
3/0 AWG	#2 - 3/0	YA27L-	YS27L-	2	YA27-	YS27-	2
4/0 AWG	#1 - 4/0	YA28L-	YS28L-	2	YA28-	YS28-	2
250 kcmil	1/0 - 250	YA29L-	YS29L-	2	YA29-	YS29-	2
300 kcmil	2/0 - 300	YA30L-	YS30L-	2	YA30-	YS30-	3
350 kcmil	3/0 - 350	YA31L-	YS31L-	2	YA31-	YS31-	3
400 kcmil	4/0 - 400	YA32L-	YS32L-	2	YA32-	YS32-	3
500 kcmil	4/0 - 500	YA34L-	YS34L-	2	YA34-	YS34-	4
600 kcmil	250 - 600	YA36L-	YS36L-	2	YA36-	YS36-	4
700 kcmil	350-700	YA38L-	YS38L-	3	YA38-	YS38-	4
750 kcmil	500-750	YA39L-	YS39L-	3	YA39-	YS39-	4
800 kcmil	500-800	YA40L-	YS40L-	3	YA40-	YS40-	4
1000 kcmil	750-1000	YA44L-	YS44L-	3	YA44-	YS44-	4

*Same number of recommended crimps for both Standard and Expanded wire ranges

Blue highlighted items are industry standard and most frequently ordered.

EXPANDED RANGES

The following connectors are range taking when crimped onto code & flex conductor using 4-POINT™ family of tools:



COPPER CONNECTORS

Copper Conductor (Flex Only)								
Nominal Flex Wire Size	Standard Barrel				Long Barrel			
	Expanded Range	Terminal	Splice	# of Crimps	Expanded Range	Terminal	Splice	# of Crimps
#8 AWG	#8 AWG	YAV8CL-	YSV8CL-	1	#8 AWG	YAV8C-	YSV8C-	1
#6 AWG	#6 AWG	YAV6CL-	YSV6CL-	1	#6 AWG	YAV6C-	YSV6C-	1
#4 AWG	#6 - #4 AWG	YAV4CL-	YSV4CL-	1	#6 - #4 AWG	YAV4C-	YSV4C-	1
#2 AWG	#6 - #2 AWG	YAV2CL-	YSV2CL-	1	#6 - #2 AWG	YAV2C-	YSV2C-	1
#1 AWG	#4 - #1 AWG	YAV1CL-	YSV1CL-	1	#4 - #1 AWG	YAV1C-	YSV1C-	1
1/0 AWG	#4 - 1/0 AWG	YAV25L-	YSV25L-	1	#6 - 1/0 AWG	YAV25-	YSV25-	2
2/0 AWG	#2 - 2/0 AWG	YAV26L-	YSV26L-	1	#4 - 2/0 AWG	YAV26-	YSV26-	2
3/0 AWG	#1 - 3/0 AWG	YAV27L-	YSV27L-	1	#2 - 3/0 AWG	YAV27-	YSV27-	2
4/0 AWG	1/0 - 4/0 AWG	YAV28L-	YSV28L-	1	#1 - 4/0 AWG	YAV28-	YSV28-	2
250 kcmil	3/0 - 250	YAV29L-	YSV29L-	1	1/0 - 250	YAV29-	YS29-	2
300 kcmil	4/0 - 313.1	YA32L-	YS32L-	1	2/0 - 313.1	YA32-	YS32-	2
350 kcmil	250 - 373.7	YA34L-	YS34L-	1	3/0 - 373.7	YA34-	YS34-	2
450 kcmil	250 - 444.4	YA36L-	YS36L-	1	4/0 - 444.4	YA36-	YS36-	2
500 kcmil	373.7 - 535.3	YA38L-	YS38L-	1	4/0 - 535.3	YA38-	YS38-	2
600 kcmil	373.7 - 600	YA39L-	YS39L-	2	250 - 600	YA39-	YS39-	3
650 kcmil	444.4 - 646	YA40L-	YS40L-	2	373.3 - 646	YA40-	YS40-	3
750 kcmil	535.3 - 777.7	YA44L-	YS44L-	2	535.3 - 777.7	YA44-	YS44-	3

COPPER CONNECTORS

E-Line Connectors							
Wire Size	Expanded Wire Range	Aluminum			Copper		
		Offset Cat. No.	Centerformed Cat. No.	No. of Crimps	Offset Cat. No.	Centerformed Cat. No.	No. of Crimps
#8 AWG	#8 AWG	YA8CA-T-E		1			
#6 AWG	#6 AWG						
#4 AWG	#6 - #4						
#2 AWG	#6-#2	YA2CA-T-E	YAC2CA-T-E	1			
#1 AWG	#6-#1						
1/0 AWG	#6-1/0	YA25A-T-E		1	YA25L-T-E	YAC25L-T-E	1
2/0 AWG	#4 - 2/0	YA26A-T-E		2	YA26L-T-E	YAC26L-T-E	1
3/0 AWG	#2 - 3/0	YA27A-T-E	YAC27A-T-E	2			
4/0 AWG	#1 - 4/0	YA28A-T-E		2			
250 kcmil	1/0 - 250						
300 kcmil	2/0 - 300	YA30A-T-E		2	YA30L-T-E	YAC30L-T-E	2
350 kcmil	3/0 - 350	YA31A-T-E	YAC31A-T-E	2			
400 kcmil	4/0 - 400	YA32A-T-E		4			
500 kcmil	4/0 - 500	YA34A-T-E		4	YA34L-T-E		2
500 kcmil	4/0-500				YA342L-T-E		2
600 kcmil	250 - 600	YA36A-T-E		4	YA36L-T-E		2
600 kcmil	250-600				YA362L-T-E		2
700 kcmil	350-700						
750 kcmil	500-750	YA39A-T-E		4	YA39L-T-E		2
750 kcmil	500-750				YA392L-T-E		2
800 kcmil	500-800						
1000 kcmil	750-1000						

*Same number of recommended crimps for both Standard and Expanded wire ranges

Blue highlighted items are industry standard and most frequently ordered.

12-TON U DIES*

BURNDY® Die Sets

**Fits Y35, Y39, Y750 Series,
PAT750-18V Series,
PAT46-18V, Y46
(W/PUADP-1 Adapter)**

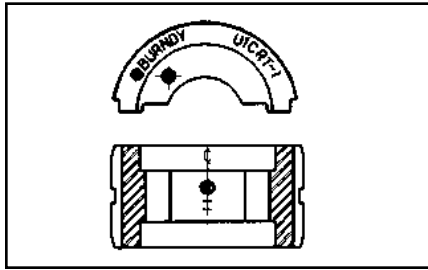

U die case Part# **PT29291**, holds up to 15 dies

	Wire Size	Copper	Aluminum
Small	#8	U8CRT	U8CABT
	#6	U5CRT	U6CABT
	#4	U4CRT	U4CABT
	#3	U3CRT	N/A
	#2	U2CRT	U2CABT
	#1	U1CRT-1	U1CART
	1/0	U25RT	U25ART
	2/0	U26RT	U26ART
	3/0	U27RT	U27ART
	4/0	U28RT	U28ART
	250 kcmil	U29RT	U29ART
	300 kcmil	U30RT	U30ART
	350 kcmil	U31RT	U31ART
	400 kcmil	U32RT	U32ART
500 kcmil	U34RT	U34ART	
535 Flex kcmil	U38XRT	N/A	
600 kcmil	U36RT	U36ART	
750 kcmil	U39RT	U39ART-2	
Large	777 Flex	U44XRT	N/A

* Non-tension U-type 12-ton dies for YA, YS, YA-A, YS-A style connectors.
NOTE: N/A = not applicable.

W DIES

BURNDY® Die Sets

**Fits Tools MD6, MD7,
Y500CTHS, PAT600-18V,
PATMD6**

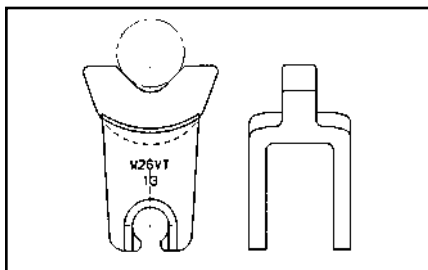

W die case Part# **CASEWDIES**, holds up to 24 dies

	Wire Size	Copper	Copper	Aluminum
Small	#8	W8CVT	W8CRT	X8CART
	#6	W5CVT	W5CRT	W161
	#4	W4CVT	W4CRT	W162
	#3	W3CRT	W3CRT	N/A
	#2	W2CVT	W2CRT	W239
	#1	W1CVT	W1CRT	W163
	1/0	W25VT	W25CRT	W241
	2/0	W26VT	W26CRT	W245
	3/0	W27VT	W27CRT	W166
	4/0	W28VT	W28CRT	W660
	250	*W29VT	W29CRT	N/A
	300	*W30VT	W30CRT	N/A
	350	*W31VT	W31CRT	*W31ART
	400	*W32VT	W32CRT	N/A
450	W33VT	W33CRT	N/A	
500	*W34VT	W34CRT	N/A	
Large	600	**W36RT	W36CRT	N/A

* These sizes (250-500) for Y5000CTHS, MD7-34(R), BAT500, BCT500HS only.

** For PAT600-18V only.

NOTE: N/A = not applicable.
Suitable for use on YA, YS, YA-A, YS-A type non-tension connectors.

Blue highlighted items are industry standard and most frequently ordered.

C-10

Conductor		Installation Tooling System											Taps H-Taps Run=Tap		
		Lugs & Splices One & Two Hole				T&B Index*	Taps Thin-Wall C-taps Run=Tap, AWG only			Taps Heavy Duty C-Taps Run=Tap					
		Die	Color	Index	Code (Flex)		Die	Color	Index	Die	Color	Index			
#8/#6 sol	#8	W8CVT U8CRT	RED	49	21	W4CVT	GRAY	8	U240	RED	240	U11T-1	GREEN	11	
#6	#6	W5CVT U5CRT	BLUE	7	24	W2CVT	BROWN	10	UC	BROWN	C	UBGRT	ORANGE	BG	
#4	#4	W4CVT U4CRT	GRAY	8	29	W25VT	PINK	12	UC	BROWN	C	UC	BROWN	C	
#3/#2 sol		W3CRT U3CRT	WHITE	9	29	W26VT	BLACK	13	UC	BROWN	C	UC	BROWN	C	
#2	#2	W2CVT U2CRT	BROWN	10	33	W27VT	ORANGE	14	UC	BROWN	C	UC	BROWN	C	
#1	#1	W1CVT U1CRT-1	GREEN	11	33 (37)	W28VT	PURPLE	15	U997	ORANGE	997	U654	PURPLE	654	
1/0	1/0	W25VT U25RT	PINK	12	37 (42)	W29VT	YELLOW	16	U997	ORANGE	997	U654	PURPLE	654	
2/0	2/0	W26VT U26RT	BLACK	13	42 (45)		REFER TO CATALOG		U997	ORANGE	997	U654	PURPLE	654	
3/0	3/0	W27VT U27RT	ORANGE	14	45 (50)				U997	ORANGE	997	U654	PURPLE	654	
4/0	4/0	W28VT U28RT	PURPLE	15	50 (54)	-	-	-	U997	ORANGE	997	U654	PURPLE	654	
250	4/0/250 class G & H	W29VT U29RT	YELLOW	16	62	-	-	-	U997	ORANGE	997	U654	PURPLE	654	
300	262/250 class I, K & M	W30VT U30RT	WHITE	17	62	-	-	-	U1104	BROWN	1104	U1104	BROWN	1104	
350	313	W31VT U31RT	RED	18	66	-	-	-	U1104	BROWN	1104	U1104	BROWN	1104	
	350/ 373	W32VT U32RT	BLUE	19	(76)	-	-	-	U1104	BROWN	1104	U1104	BROWN	1104	
500	444	W34VT U34RT	BROWN	20	76 (87)	-	-	-	U1104	BROWN	1104	U1104	BROWN	1104	
	500/ 535	U38XRT	PINK	L99	(99)	-	-	-	P1103	BLUE	1103	PYFR	YELLOW	KR	
600		U36RT	GREEN	22	87	-	-	-	P1103	BLUE	1103	PYFR	YELLOW	KR	
700		U38RT	PINK	400	99	-	-	-	P1103	BLUE	1103	PYFR	YELLOW	KR	
750	646	U39RT	BLACK	24	(106)	-	-	-	P1103	BLUE	1103	PYFR	YELLOW	KR	
	750/ 777	U44XRT	YELLOW	L115	(115)										
800		P40RT	ORANGE	25	106	-	-	-	P1102	WHITE	1102	PYFR	YELLOW	KR	
1000		P44RT	WHITE	27		-	-	-	P1102	WHITE	1102	PYFR	YELLOW	KR	

* Die set with a dash CK are not UL Listed. Please consult factory for further information.

Bolt Equivalent	
Unified Inch Hole Size	Metric Equivalent
1/4"	M6
5/16"	M8
3/8"	M10
1/2"	M12
5/8"	M16

Blue highlighted items are industry standard and most frequently ordered.

TYPES YBA, YBA-FX, YBAV-FX and YBA-A

BREAK-AWAY™ HYLUG™

Copper and Aluminum Compression Terminals

UL Listed 90° C, 600 Volts to 35 kV

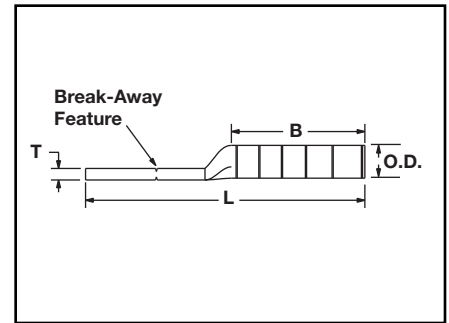
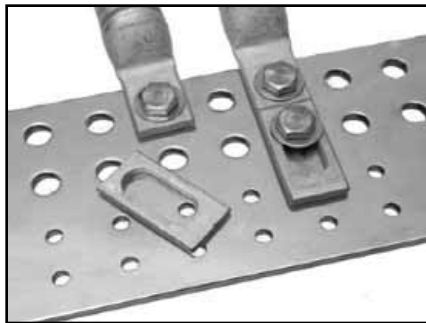

The BREAK-AWAY™ line of Copper and Aluminum HYLUG™ terminals are designed to provide maximum field flexibility by allowing the installer (using the BREAK-AWAY feature) to easily convert two-hole terminals to one-hole terminals to suit the application.

The BREAK-AWAY™ line of terminals encompasses a wide range of features that affords the installer the flexibility in meeting the requirements for challenging projects.



Features and Benefits

- BREAK-AWAY feature allows for field modification of the terminal from a two-hole design to a one-hole design and the terminal still retains its UL Listing and CSA Certification.
- Field modification of the terminal does not require specialized tooling or training.
- Stud size is 1/2" (12 mm²) on the first stud as well as the slotted second stud.
- Slotted second stud provides built in flexibility for the terminal to conform to various bus bar dimensions. With the slotted second stud, the terminal can be used on two-hole spacing ranging from 1.00" to 1.75" for 1/2" stud hole sizes and 0.63" to 1.00" for 1/4" stud hole size.
- Narrow tongue design allows for the terminal to fit into tight spaces.
- Accommodates a wide range of conductor combinations (AWG, Compact, DLO, Flex as well as Metric).
- The BREAK-AWAY™ line of terminals can be installed with standard BURNDY® tooling (example: PAT750XT-18V) and U-dies.
- Terminals are range taking when installed with Y644 tooling platforms.

Copper Conductor

Catalog Number	Conductor Size	mm ²	Dimensions					Installation Tooling (# of crimps)						
			Stud Hole Spacing	Stud Hole Size	Tongue Width	B	T	L	Dieless	MD6, MD7, MD7-34R platforms OUR840**	Y500CTHS, PAT60018V, PATMD6 platform	Y35, Y39, Y750, *Y46, PAT750, *PAT46 platforms	Color Code	Die Index
YBAV25FX14	1/0 Flex (275/24); 1/0 AWG	50	.63" to 1.08"	1/4" [6]	.73"	1.50"	.13"	3.69"	MY29 (MY29 platform tools can only be used on Code Conductor), PAT644- & Y644-platforms (1) 4-POINT® Y81K, PAT81K, Y4PC PAT4PC-platforms (2)	W25VT (4) X25RT (4) W25RT (4)	W25VT (4) X25RT (4) W25RT (4)	U25RT (2)	Pink	12 or 348
YBAV26FX14	2/0 Flex (325/24); 2/0 AWG	70	.63" to 1.08"	1/4" [6]	.89"	1.50"	.13"	3.74"		W26VT (4) X26RT (4) W26RT (4)	W26VT (4) X26RT (4) W26RT (4)	U26RT (2)	Black	13
YBAV27FX14	3/0 Flex (450/24); 3/0 AWG	95	.63" to 1.08"	1/4" [6]	.87"	1.50"	.14"	3.78"		W27VT (4) X27RT (4) W27RT (4)	W27VT (4) X27RT (4) W27RT (4)	U27RT (4)	Orange	14
YBAV28FX	4/0 Flex (550/24); 4/0 AWG	120	1" to 1.75"	1/2" [12]	.94"	1.62"	.14"	5.24"		X28RT (6) W28RT (4) W28VT (4)	X28RT (6) W28RT (4) W28VT (4)	U28RT (2)	Purple	15
YBA29	250 kcmil (Class A & B)	—	1" to 1.75"	1/2" [12]	.96"	1.62"	.16"	5.21"	PAT644 & Y644 platforms (1), 4-POINT® Y81K, PAT81K, Y4PC, PAT4PC platforms (2) for YBA29, (3) for YBA31FX & YBA32FX, (4) for YBA34FX	W29RT (4) W29VT (4)	W29RT (4) W29VT (4)	U29RT (2)	Yellow	16
YBA31FX	250 kcmil (Class I, K & M)	150	1" to 1.75"	1/2" [12]	.96"	2.00"	.18"	5.68"		W30VT (4) W30RT (4)	W30VT (4) W30RT (4)	U30RT (4)	White	17 or 298
YBA32FX	313.1 kcmil Flex (775/24)	185	1" to 1.75"	1/2" [12]	.96"	2.12"	.19"	5.85"		W31VT (4) W31RT (4)	W31VT (4) W31RT (4)	U31RT (4)	Red	18 or 324
YBA34FX	373.7 kcmil Flex (775/24)	240	1" to 1.75"	1/2" [12]	.96"	2.25"	.23"	6.08"		W32VT (4) W32RT (4)	W34VT (6) W34RT (6)	U32RT (4)	Blue	19 or 470

* Y46 and PAT46 platforms require PUADP-1 adaptor to use U dies.

** OUR840 can use X-style dies only.

Blue highlighted items are industry standard and most frequently ordered.

C-12

TYPES YBA, YBA-FX, YBAV-FX and YBA-A

BREAK-AWAY™ HYLUG™
(Continued)

Copper and Aluminum
Compression Terminals

UL Listed 90° C,
600 Volts to 35 kV

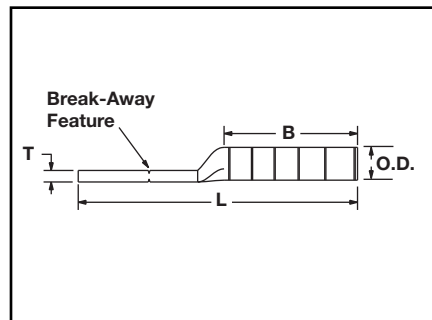

Copper Conductor (Continued)

Catalog Number	Conductor Size	mm ²	Dimensions						Installation Tooling (# of crimps)			
			Stud Hole Spacing	Stud Hole Size	Tongue Width	B	T	L	Dieless	Y35, Y39, Y750, *Y46, PAT750, *PAT46 Platforms	Color Code	Die Index
YBA36FX	440 kcmil Flex	—	1" to 1.75"	1/2" [12]	1.47"	2.69"	.27"	6.59"	Y644, PAT644 (1), Y81K, PAT81K (2)	U34RT (4)	Brown	20 or 299
YBA36FX58	444.4 kcmil (1100/24)		1" to 1.75"	5/8" [16]								
YBA38FX	535.3 Flex (1325/24) 500 kcmil nom.	300	1" to 1.75"	1/2" [12]	1.62"	2.81"	.27"	6.76"		U38XRT (4)	Pink	L99
YBA39	750 kcmil (Code Class AA, A & B)	—	1" to 1.75"	1/2" [12]	1.63"	2.88"	.27"	6.87"		U39RT (4)	Black	24
YBA44FX	750 kcmil Flex (Class I);	500	1" to 1.75"	1/2" [12]	1.62"	3.00"	.32"	7.14"		U44XRT (4)	Yellow	L115
YBA44FX58	777.7 Flex (1925/24)		1" to 1.75"	5/8" [16]								

* Y46 and PAT46 platforms require PUADP-1 adaptor to use U dies.

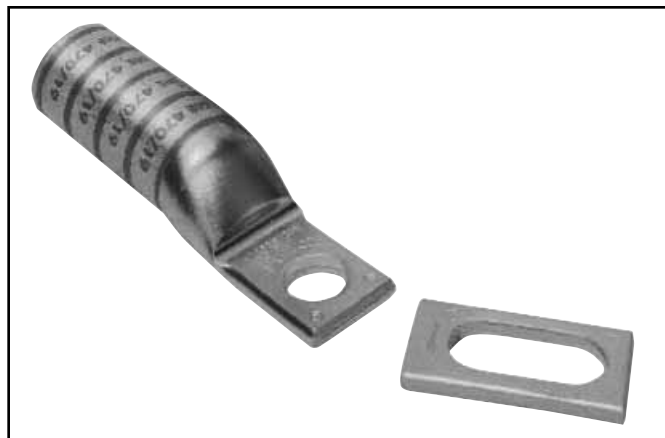

Blue highlighted items are industry standard and most frequently ordered.

TYPES YBA, YBA-FX, YBAV-FX and YBA-A

BREAK-AWAY™ HYLUG™
(Continued)

Copper and Aluminum
Compression Terminals

UL Listed 90° C,
600 Volts to 35 kV

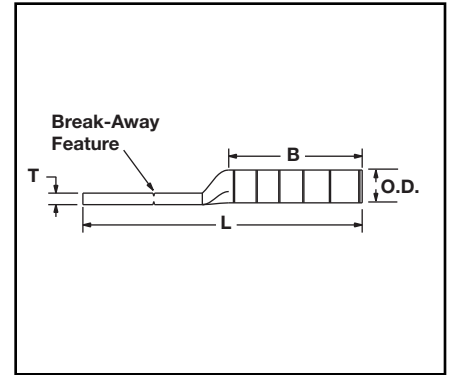
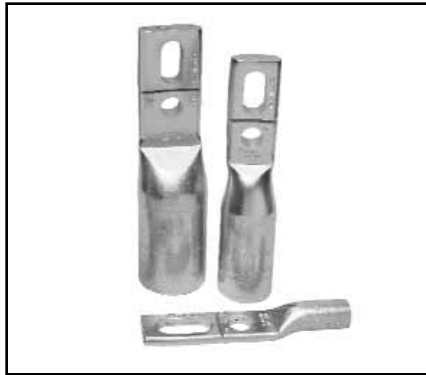

Aluminum Conductor

Catalog Number	Conductor Size (Concentric and Compact)	Dimensions						Installation Tooling (# of crimps)						
		Stud Hole Spacing	Stud Hole Size [mm]	Tongue Width	B	T	L	Dieless	MD6, MD7, MD7-34R platforms OUR840**	Y500C7HS, PAT60018V, PATMD6 platform	Y35, Y39, Y750, *Y46, PAT750, *PAT46 platforms	Color Code	Die Index	
YBA25A	1/0	1" to 1.75"	1/2" [12]	1.03"	1.05"	.17"	4.59"	MY29 (MY29 platform tools can only be used on Code Conductor), PAT644 & Y644 platforms (1), 4-POINT® Y81K, PAT81K, Y4PC, PAT4PC platforms (2)	W241 (2) X241 (4)	W241 (2)	U25ART (1)	Tan	296	
YBA26A	2/0	1" to 1.75"	1/2" [12]	1.03"	1.17"	.20"	4.78"		—	—	U26ART (2)	Olive	297	
YBA27A	3/0	1" to 1.75"	1/2" [12]	1.04"	1.31"	.26"	5.02"		—	—	U27ART (2)	Ruby	467	
YBA28A	4/0	1" to 1.75"	1/2" [12]	1.17"	1.39"	.30"	5.19"		W660 (4) X660 (8)	W660 (4)	U28ART (2)	White	298	
YBA29A	250 kcmil	1" to 1.75"	1/2" [12]	1.26"	1.45"	.33"	5.28"		—	—	U29ART (2)	Red	324	
YBA30A	300 kcmil	1" to 1.75"	1/2" [12]	1.38"	1.53"	.36"	5.64"		—	—	U30ART (2)	Blue	470	
YBA31A	350 kcmil	1" to 1.75"	1/2" [12]	1.52"	1.85"	.39"	6.07"		—	—	U31ART (2)	Brown	299	
YBA32A	400 kcmil	1" to 1.75"	1/2" [12]	1.62"	2.26"	.43"	6.16"		PAT644 & Y644 platforms (1), 4-POINT® Y81K, PAT81K, Y4PC, PAT4PC platforms (4)	—	—	U32ART (4)	Green	472
YBA34A	500 kcmil	1" to 1.75"	1/2" [12]	1.62"	2.34"	.46"	6.80"			—	—	U34ART (4)	Pink	300
YBA36A	600 kcmil	1" to 1.75"	1/2" [12]	1.31"	2.47"	.52"	7.09"			—	—	U36ART (4)	Black	473
YBA39A	700 & 750 kcmil	1" to 1.75"	1/2" [12]	1.62"	2.46"	.43"	7.07"	—		—	U39ART-2 (2)	Yellow	936	
YBA44A	1000 kcmil	1" to 1.75"	1/2" [12]	1.65"	2.74"	.55"	7.76"	Y644MBH (1)	—	—	P44ART† (4)	Brown	302	

† Can only be crimped with PAT46 or Y46 platform tools using the P44ART die.
* Y46 and PAT46 platforms require PUADP-1 adaptor to use U dies
** OUR840 can use X-style dies only.

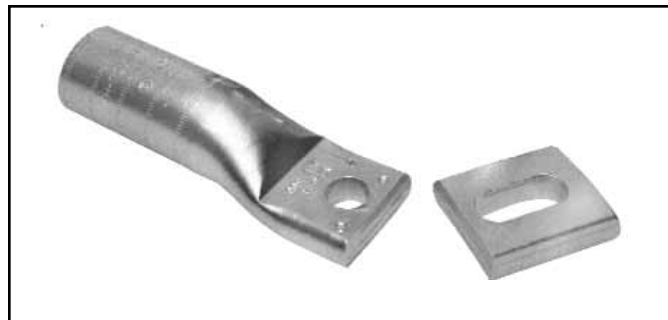

Blue highlighted items are industry standard and most frequently ordered.

C-14

TYPES YA-2NU, YA-4NU

Blank Tongue HYLUG™

The Blank Tongue line of Copper Code HYLUG™ terminals are designed to provide maximum field flexibility. Scored lines prevent the drill from walking when trying to drill in this area. This innovative design allows the installer to customize the tongue drilling to fit their specific application while maintaining UL Listing and CSA certification.

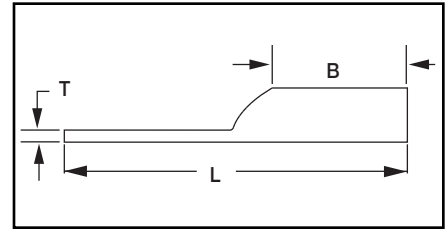

Features & Benefits

- Manufactured from seamless high-conductivity electrolytic copper tubing with heavy duty wall thickness.
- Internally beveled barrel end.
- Proper compression systems form a highly efficient electrical connection.
- Dimples located at each end of the scored line represent the location of the NEMA standard hole spacing.
- Scored line locates the center of the Tongue and prevents the drill from walking when trying to drill in this area.
- Offered in a wide range of code conductor sizes.



Catalog Number	Conductor		Min. Bolt Hole**	Tongue Width	Figure Dimensions			▲ Installation Tooling				Color Code	Die Index	Wire Strip Length
	AWG	*** MM ²			B	T	L	Dieless (# of crimps)	Mechanical	Hydraulic				
									MD6, OUR840, MD7-34R	BCT500HS, Y500CTHS	Y750, Y46*, PAT750			
YA8C2NU	#8 AWG	—	#10	.83"	0.81"	.12"	4.08"	Y1MRTC (2) MY29-11 (1)	W8CRT (1) W8CVT (1) X8CRT (2) W8CVT (1)	W8CRT (1)	U8CRT (1) U8CRT (1)	Red	49	7/8"
YA6C2NU	#6 AWG	—	#10	.83"	1.12"	.12"	4.40"	Y1MRTC (2) MY29-11 (2) MRC840 (2) Y81KFT (1) Y81KFTBMH (1) PAT81KFT-18V (1)	W5CVT (2) W5CRT (2) X5CRT (2) X8CART (2)	W5CVT (2) W5CRT (2) X5CRT (2) X8CART (2)	U5CRT (2) U8CABT (2)	Blue	7	1-3/16"
YA4C2NU	#4 AWG	—	#10	.83"	1.12"	.12"	4.45"	Y1MRTC (4) MY29-3 (2) MY29-11 (2) MRC840 (2) Y644HS (1) Y81KFT (1)	W4CVT (2) W4CRT (2) X4CRT (2)	W4CVT (2) W4CRT (2) X4CRT (2)	U4CRT (2) U6CABT (2)	Gray	8	1-3/16"
YA3C2NU	#3 AWG #2 Sol.	25	1/4	.83"	1.25"	.12"	4.62"	Y81KFTBMH (1) PAT81KFT-18V (1)	W3CRT (2)	W3CRT (2)	U3CRT (2)	White	9	1-5/16"
YA2C2NU	#2 AWG	35	1/4	.83"	1.25"	.12"	4.64"	Y1MRTC (4) MY29-3 (2) MY29-11 (2) MRC840 (2) Y644HS (1) Y81KFT (2) Y81KFTBMH (2) PAT81KFT-18V (2)	W2CVT (2) W2CRT (2) X2CRT (2)	W2CVT (2) W2CRT (2) X2CRT (2)	U2CRT (2)	Brown	10	1-5/16"

*** The MM² conductor sizes listed are the recommendations for Class 2 conductor.
* Use PUADP-1 adaptor with U -dies in Y46 HYPRESS™

‡ Requires Y60BHU HYPRESS™
** Minimum bolt hole size must be maintained for UL & CSA.

Blue highlighted items are industry standard and most frequently ordered.

TYPES YA-2NU, YA-4NU

Blank Tongue HYLUG™
(Continued)

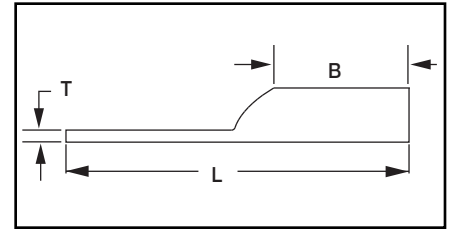

C-15

Catalog Number	Conductor		Min. Bolt Hole**	Tongue Width	Figure Dimensions			Dieless (# of crimps)	▲ Installation Tooling			Color Code	Die Index	Wire Strip Length
	AWG	*** MM ²			B	T	L		Mechanical	Hydraulic				
									MD6, OUR840, MD7-34R	BCT500HS, Y500CTS	Y750, Y46*, PAT750			
YA1C2NU	#1 AWG	50	1/4	.83"	1.38"	.12"	4.82"	Y1MRTC (4) MY29-3 (2) MY29-11 (2) MRC840 (2) Y644HS (1) Y81KFT (2) Y81KFTMBH (2) PAT81KFT-18V (2)	W1CVT (2) W1CRT-1 (2) X1CRT-1 (2)	W1CVT (2) W1CRT-1 (2) X1CRT-1 (2)	U1CRT-1 (2) U4CABT (2)	Green	11	1-7/16"
YA252NU	1/0 AWG	—	1/4	.83"	1.38"	.11"	4.81"	MY29-3 (2) MY29-11 (2) MRC840 (4) Y644HS (1) Y81KFT (2) Y81KFTMBH (2) PAT81KFT-18V (2)	W25VT (4) W25RT (4) X25RT (4)	W25VT (4) W25RT (4) X25RT (4)	U25RT (2) U2CABT (2)	Pink	12	1-7/16"
YA262NU	2/0 AWG	70	1/4	.83"	1.50"	.12"	4.97"		W26VT (4) W26RT (4) X26RT (4)	W26VT (4) W26RT (4) X26RT (4)	U26RT (2)	Black	13	1-9/16"
YA272NU	3/0 AWG	—	1/4	.91"	1.50"	.13"	5.01"		W27VT (4) W27RT (4) X27RT (6)	W27VT (4) W27RT (4) X27RT (6)	U27RT (2)	Orange	14	1-9/16"
YA282NU	4/0 AWG	—	1/4	1.02"	1.62"	.14"	5.17"		W28VT (4) W28RT (4) X28RT (6)	W28VT (4) W28RT (4) X28RT (6)	U28RT (2)	Purple	15	1-11/16"
YA292NU	250 kcmil	120	1/4	1.11"	1.62"	.16"	5.21"		W29VT (4) X29RT (8)	W29VT (4) W29RT (4) X29RT (8)	U29RT (2)	Yellow	16	1-11/16"
YA302NU	300 kcmil	150	1/4	1.20"	2.00"	.16"	5.64"	Y644HS (1) Y81KFT (3) Y81KFTMBH (3) PAT81KFT-18V (3)	W30VT (4)	W30VT (4) W30RT (4)	U30RT (4) U28ART (4)	White	17	2-1/16"
YA312NU	350 kcmil	185	1/4	1.29"	2.00"	.18"	5.68"		W31VT (4)	W31VT (4) W31RT (4)	U31RT (4) U29ART (4)	Red	18	2-1/16"
YA322NU	400 kcmil	—	3/8	1.40"	2.12"	.19"	5.85"		W32VT (4)	W32VT (4) W32RT (4)	U32RT (4) U30ART (4)	Blue	19	2-3/16"
YA342NU	500 kcmil	240	3/8	1.55"	2.25"	.22"	6.06"	Y644HS (1) Y81KFT (4) Y81KFTMBH (4) PAT81KFT-18V (4)	W34VT (4)	W34VT (4) W34RT (4)	U34RT (4) U31ART (4)	Brown	20	2-5/16"
YA362NU	600 kcmil	300	3/8	1.73"	2.69"	.26"	6.59"		U36RT (4) U32ART (4)	U36RT (4) U32ART (4)	Green	22	2-3/4"	
YA392NU	750 kcmil	—	3/8	1.91"	2.88"	.26"	6.87"	Y644HS (1) Y81KFT (3) Y81KFTMBH (3) PAT81KFT-18V (3)	—	—	P39RT (4)**	Black	24	2-15/16"
YA402NU	800 kcmil	400	3/8	1.98"	2.94"	.30"	6.95"				P40RT (4)	Orange	25	3"
YA442NU	1000 kcmil	500	3/8	2.18"	3.00"	.33"	7.14"				P44RT (4)**	White	27	3-1/16"
YA452NU	1250 kcmil	—	3/8	2.46"	3.19"	.38"	7.44"				P45RT (6)**	Yellow	29	3-1/4"
YA462NU	1500 kcmil	800	3/8	2.69"	3.19"	.40"	7.55"				P46RT (6)**	Green	31	3-1/4"
YA472NU‡	1750 kcmil	—	3/8	2.90"	3.44"	.42"	7.89"				‡	Gray	33	3-1/2"
YA482NU‡	2000 kcmil	1000	3/8	3.10"	3.44"	.46"	7.98"				‡	Brown	34	3-1/2"
YA444NU	1000 kcmil	500	3/8	3.00"	3.00"	.23"	7.14"				P44RT	White	27	3-1/16"
YA454NU	1250 kcmil	—	3/8	3.00"	3.19"	.30"	7.44"				P45RT	Yellow	29	3-1/4"
YA464NU	1500 kcmil	800	3/8	3.00"	3.19"	.34"	7.55"				P46RT	Green	31	3-1/4"

*** The MM² conductor sizes listed are the recommendations for Class 2 conductor.

* Use PUADP-1 adaptor with U -dies in Y46 HYPRESS™
‡ Requires Y608HU HYPRESS™

** Minimum bolt hole size must be maintained for UL & CSA.

Blue highlighted items are industry standard and most frequently ordered.

TYPES YBA-KIT, YA-KIT, YBAFX-KIT, YAFX-KIT

Copper and Aluminum Turbine Lug Kits

UL Listed 90°C,
600 Volts to 35 kV

Aiding in the staging and flow of material on a project, the BURNDY® Turbine Lug Kits are designed to meet the termination requirements for the standard 1.5 MW wind turbine, improving overall project efficiency. Each lug kit contains UL Listed and CSA Certified copper or aluminum lugs. Kits include the required number of lugs needed to terminate aluminum or copper conductors on the low voltage side of a base transformer or the down tower switchgear. There are four individual kits, two for aluminum, two for copper, they are all custom designed to handle any termination requirements.



Features & Benefits

- **YA44A3** (1000 kcmil aluminum) HYLUG™, 2-hole, narrow tongue aluminum compression terminal that is dual rated for both copper and aluminum.
- **YBA44A** (1000 kcmil, 1000 compact aluminum) BREAK-AWAY™ HYLUG™, 2-hole narrow tongue aluminum compression terminal that is dual rated for both copper and aluminum. The BREAK-AWAY™ feature allows for field modification of the terminal from a 2-hole to a 1-hole terminal and still retain UL Listing and CSA Certification.
- **YAZ442NNTFX** (777.7 Flex, 1925/24 str., 750 kcmil copper) HYLUG™, 2-hole, narrow tongue copper compression terminal that accommodates flex and AWG conductor.
- **YBA44FX** (777.7 Flex, 1925/24 str. [750 kcmil] nom. copper) BREAK-AWAY™ HYLUG™, 2-hole, narrow tongue copper compression terminal that accepts a wide range of conductor combinations (AWG, compact, DLO, flex, metric). The BREAK-AWAY™ feature allows field modification of the terminal from a 2-hole to 1-hole terminal and still retain UL Listing and CSA Certification.
- Both aluminum and copper low voltage turbine lug kits include **YA29-2N** (250 kcmil, copper, 2-hole) lugs for terminating grounding conductor.
- Aluminum kits are shipped with squeeze packets of PENETROX™ oxide inhibitor for terminating aluminum conductor.

Copper Kits

Catalog Number	Includes:
YBAFX15CLKIT	15 pcs YBA44FX (777.7 Flex Cu 2-hole NEMA lug); 3 pcs YA29-2N (250 kcmil Cu 2-hole NEMA lug)
YAFX15CLKIT	15 pcs YAZ442NNTFX (777.7 Flex Cu 2-hole NEMA lug); 3 pcs YA29-2N (250 kcmil Cu 2-hole NEMA lug)

Aluminum Kits

Catalog Number	Includes:
YBA15ALKIT	15 pcs YBA44A (1000 Al 2-hole NEMA lug); 3 pcs YA29-2N (250 kcmil Cu 2-hole NEMA lug); 1 squeeze tube (1/2 oz) of PENETROX™ oxide inhibitor
YA15ALKIT	15 pcs YA44A3 (1000 Al 2-hole NEMA lug); 3 pcs YA29-2N (250 kcmil Cu 2-hole NEMA lug); 1 squeeze tube (1/2 oz) of PENETROX™ oxide inhibitor



Heat shrink and mounting hardware sold separately.

Blue highlighted items are industry standard and most frequently ordered.

**ONE HOLE HYLUG™
CODE CONDUCTOR
STANDARD BARREL**

TYPES YA-L, YA-L-TC

**COPPER COMPRESSION
TERMINAL**

UL Listed 90° C,
600 Volts to 35 kV ◆

45° and 90° angles are available.
Please contact Customer Service to order:
1-800-346-4175

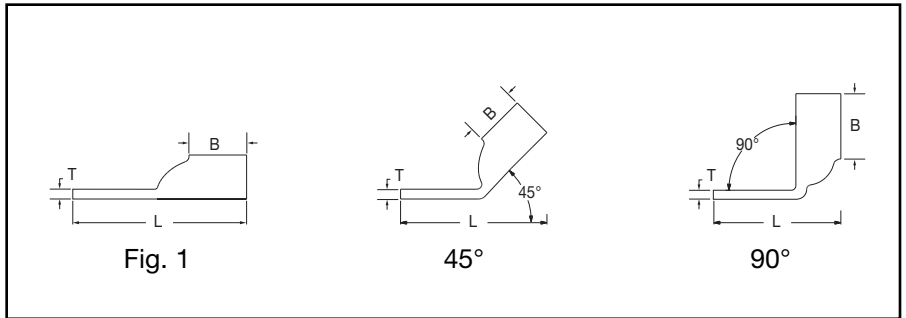
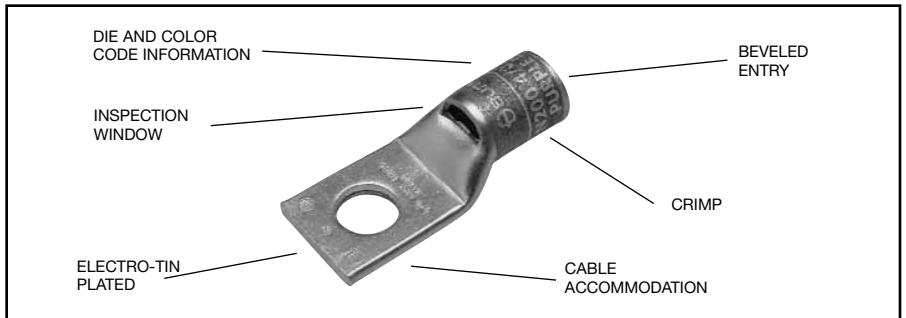

Catalog Number	Fig #	Conductor		Stud Hole Size	Tongue Width	Figure Dimensions			Dieless (# of crimps)	▲ Installation Tooling				Wire Strip Length	
		AWG	*** MM ²			(B)	(T)	(L)		Mechanical MD6, OUR840, MD7-34R	Hydraulic BCT500HS, Y500CTHS	Y35, Y39, Y750, Y46*, PAT750	Color Code		Die Index
YAV10-BOX	1	#14-#10 Str Sol	6	8-10	.38"	.405"	.058"	1.02"	Y8MRB-1 (1)	—	—	—	—	—	7/16"
YAV10R-BOX	3			1/4"	.47"	.405"	.047"	.83"							
YAV10R3-BOX	3			5/16"	.53"	.38"	.047"	1.12"							
YAV10T2-BOX	1			1/4"	.47"	.405"	.047"	1.10"							
YAV10T3-BOX	1			3/8"	.56"	.38"	.047"	1.18"							
YAV10T4-BOX	1			1/4"	.44"	.44"	.08"	1.26"							
YA8CL1-BOX	1	#8 AWG #8 Weld 37/24 #6 Solid	† 10	5/16"	.52"	.44"	.06"	1.38"	Y1MRTC (1) Y8MRB-1 (1) MY29-3 (1) MY29-11 (1) MRC840 (1) Y81KFT (1) Y81KFTMBH (1) PAT81KFT-18V (1)	W8CVT (1) W8CRT (1) X8CRT (1)	W8CVT (1) W8CRT (1) X8CRT (1)	U8CRT (1)	Red	49	7/16"
YA8CL2-BOX	1			3/8"	.58"	.44"	.06"	1.51"							
YA8CL3-BOX	1			1/2"	.71"	.44"	.05"	1.76"							
YA8CL4-BOX	1			8-10	.41"	.44"	.08"	1.16"							
YA8CL-BOX	1			1/4"	.45"	.54"	.08"	1.18"							
YA6CL-BOX	1	#6 AWG		8-10	.41"	.54"	.09"	.99"	Y1MRTC (1) MY29-3 (1) MY29-11 (1) MRC840 (1)	W5CVT (1) W5CRT (1) X5CRT (1) X8CART (1)	W5CVT (1) W5CRT (1) X5CRT (1) X8CART (1)	U5CRT (1)	Blue	7	5/8"
YA6CL1-BOX	1			5/16"	.52"	.54"	.07"	1.24"							
YA6CL3-BOX	1			3/8"	.63"	.54"	.06"	1.28"							
YA6CL4-BOX	1	#6 AWG		1/2"	.75"	.54"	.12"	1.60"	Y81KFT (1) Y81KFTMBH (1) PAT81KFT-18V (1)	W5CVT (1) W5CRT (1) X5CRT (1) X8CART (1)	W5CVT (1) W5CRT (1) X5CRT (1) X8CART (1)	U5CRT (1) UBCART (1)	Blue	7	5/8"
YA6CL6-BOX	1			1/4"	.44"	.81"	.07"	1.65"							
YA5CL-BOX	1	#5 AWG		1/4"	.44"	.81"	.07"	1.65"	W5CRT (1) W5CVT (1) X5CRT (1)	W5CVT (1) X5CRT (1) W5CVT (1)	U5CRT (1)	Blue	7	7/8"	

* Use PUADP-1 adapter with U dies in Y46 HYPRESS™.
 ** P-RT die sets for use in Y46 HYPRESS™ only, PUADP-1 adapter not required.
 *** The MM² conductor sizes listed are the recommendations for Class 2 conductor.

† The MM² conductor size listed is for both Class 2 and Class 5 conductor.
 ▲ See tooling section of this catalog for complete tool and die listings.

◆ For applications greater than 2000 Volts, consult cable manufacturer for voltage stress relief instructions.
 Note: All dimensions shown are for reference only.

Blue highlighted items are industry standard and most frequently ordered.

Compression Connections

BURNDY®

Copper Compression – Code

C-18

ONE HOLE HYLUG™ CODE CONDUCTOR STANDARD BARREL (Continued)

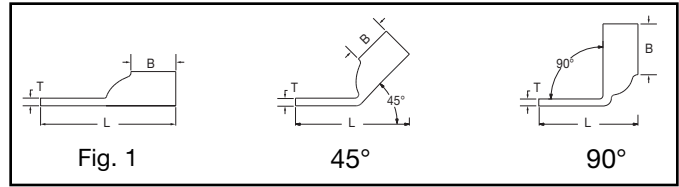

45° and 90° angles are available.

Please contact Customer Service to order:
1-800-346-4175



Catalog Number	Fig #	Conductor		Stud Hole Size	Tongue Width	Figure Dimensions			Dieless (# of crimps)	▲ Installation Tooling						
		AWG	*** MM²			(B)	(T)	(L)		Mechanical		Hydraulic		Color Code	Die Index	Wire Strip Length
										MD6, OUR840, MD7-34R	BCT500HS, Y500CTS	Y35, Y39, Y750, Y46*, PAT750				
YA4CL-BOX	1	#4 AWG		1/4"	.50"	.81"	.09"	1.74"	Y1MRTC (2) MY29-3 (1) MY29-11 (1) MRC840 (1) Y644HS (1) Y81KFT (1)	W4CVT (1) W4CRT (1) X4CRT (1)	W4CVT (1) W4CRT (1) X4CRT (1)	U4CRT (1) U6CABT (1)	Gray	8	7/8"	
YA4CL1-BOX	1			8-10	.50"	.81"	.09"	1.58"								
YA4CL3-BOX	1			5/16"	.58"	.81"	.08"	1.92"								
YA4CL4-BOX	1			3/8"	.58"	.81"	.08"	1.92"								
YA4CL6-BOX	1			1/2"	.71"	.81"	.06"	2.20"								
YA3CL	1	# 3 Str # 2 Sol	25	5/16"	.55"	.88"	.09"	1.88"	Y81KFTMBH (1) PAT81KFT-18V (1)	W3CRT (1)	W3CRT (1)	U3CRT (1)	White	9	15/16"	
YA2CL2-BOX	1	#2 AWG	35	1/4"	.61"	.88"	.11"	1.88"								
YA2CL-BOX	1			5/16"	.61"	.88"	.11"	1.93"								
YA2CL4-BOX	1			3/8"	.61"	.88"	.11"	2.06"								
YA2CL6-BOX	1			1/2"	.73"	.88"	.09"	2.32"								
YA1CL2	1	#1 AWG	50	1/4"	.68"	.88"	.10"	1.81"	Y81KFTMBH (1) PAT81KFT-18V (1)	W1CVT (1) W1CRT-1 (1) X1CRT-1 (1)	W1CVT (1) W1CRT-1 (1) X1CRT-1 (1)	U1CRT-1 (1) U4CABT (1)	Green	11	15/16"	
YA1CL-BOX	1			5/16"	.68"	.88"	.01"	1.94"								
YA1CL4-BOX	1			3/8"	.68"	.88"	.10"	2.06"								
YA1CL6-BOX	1			1/2"	.73"	.88"	.09"	2.37"								
YA25L2-BOX	1	1/0 AWG		1/4"	.75"	.88"	.12"	1.84"	MY29-3 (1) MY29-11 (1) MRC840 (2) Y644HS (1) Y81KFT (1)	W25VT (2) W25RT (2) X25RT (2)	W25VT (2) W25RT (2) X25RT (2)	U25RT (1) U2CABT (1)	Pink	12	15/16"	
YA25L4-BOX	1			3/8"	.75"	.88"	.12"	2.09"								
YA25L6-BOX	1			1/2"	.75"	.88"	.12"	2.34"								
YA25L-BOX	1			5/16"	.75"	.88"	.12"	1.96"								
YA26L2-BOX	1	2/0 AWG	70	1/4"	.83"	.94"	.12"	1.94"	Y81KFTMBH (1) PAT81KFT-18V (1)	W26VT (2) W26RT (2) X26RT (2)	W26VT (2) W26RT (2) X26RT (2)	U26RT (1)	Black	13	1"	
YA26L-BOX	1			3/8"	.83"	.94"	.12"	2.19"								
YA26L60	1			3/4"	.96"	.94"	.12"	2.96"								
YA26L6-BOX	1			1/2"	.83"	.94"	.12"	2.44"								
YA26LNT516	1			5/16"	.62"	.94"	.13"	2.62"								
YA27L3	1	3/0 AWG		5/16"	.91"	1.00"	.13"	2.16"	MY29-3 (1) MY29-11 (1) MRC840 (2) Y644HS (1) Y81KFT (2)	W27VT (2) W27RT (2) X27RT (3)	W27VT (2) W27RT (2) X27RT (3)	U27RT (1)	Orange	14	1-1/16"	
YA27L4-BOX	1			3/8"	.91"	1.00"	.13"	2.29"								
YA27L-BOX	1			1/2"	.91"	1.00"	.13"	2.54"								
YA27LNT38	1			3/8"	.76"	1.00"	.12"									
YA28L2-BOX	1	4/0 AWG		1/4"	1.02"	.88"	.14"	1.96"	Y81KFTMBH (2) PAT81KFT-18V (2)	W28VT (2) W28RT (2) X28RT (3)	W28VT (2) W28RT (2) X28RT (3)	U28RT (1)	Purple	15	1-1/8"	
YA28L3	1	4/0 AWG		5/16"	1.02"	.88"	.14"	2.08"	MY29-3 (1) MY29-11 (1) MRC840 (2) Y644HS (1) Y81KFT (2)	W28VT (2) W28RT (2) X28RT (2)	W28VT (2) W28RT (2) X28RT (3)	U28RT (1)	Purple	15	1-1/8"	
YA28L4-BOX	1			3/8"	1.02"	.88"	.14"	2.21"								
YA28L56	1			3/4"	1.05"	.88"	.13"	1.97"								
YA28L-BOX	1			1/2"	1.02"	.88"	.14"	2.46"								
YA28LNT38	1			3/8"	.76"	.88"	.16"	2.79"	Y81KFTMBH (2) PAT81KFT-18V (2)							

* Use PUADP-1 adapter with U dies in Y46 HYPRESS™.
** P-RT die sets for use in Y46 HYPRESS™ only, PUADP-1 adapter not required.

*** The MM² conductor sizes listed are the recommendations for Class 2 conductor.
▲ See tooling section of this catalog for complete tool and die listings.

Note: All dimensions shown are for reference only.

Blue highlighted items are industry standard and most frequently ordered.

**ONE HOLE HYLUG™
CODE CONDUCTOR
STANDARD BARREL**
(Continued)

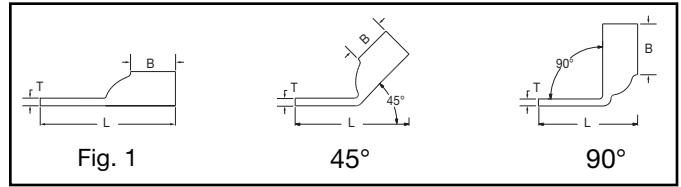

45° and 90° angles are available.
Please contact Customer Service to order:
1-800-346-4175



Catalog Number	Fig #	Conductor		Stud Hole Size	Tongue Width	Figure Dimensions			Dieless (# of crimps)	▲ Installation Tooling					Wire Strip Length
		AWG	MM²			(B)	(T)	(L)		Mechanical MD6, OUR840, MD7-34R	Hydraulic BCT500HS, Y500CTHS	Y35, Y39, Y750, Y46*, PAT750	Color Code	Die Index	
YA29L2	1	250 kcmil		1/4"	1.11"	1.06"	.16"	2.17"	MY29-3 (1) MY29-11 (1) Y644HS (1) Y81KFT (2) Y81KFTMBH (2) PAT81KFT-18V (2)	W29VT (2) X29RT (4)	W29VT (2) W29RT (2) X29RT (4)	U29RT (1)	Yellow	16	1-1/8"
YA29L4	1			3/8"	1.11"	1.06"	.16"	2.42"							
YA29L7	1			5/16"	1.11"	1.06"	.16"	2.30"							
YA29LTC78	1			7/8"	1.11"	1.06"	.14"	3.36"							
YA29LNT38	1			3/8"	.96"	1.06"	.16"	2.96"							
YA29L-BOX	1			1/2"	1.11"	1.06"	.16"	2.67"							
YA30L	1	300 kcmil	150	1/2"	1.20"	1.03"	.16"	2.69"	Y644HS (1) Y81KFT (2) Y81KFTMBH (2) PAT81KFT-18V (2)	W30VT (2)	W30VT (2) W30RT (2)	U30RT (2) U28ART (2)	White	17	1-1/16"
YA30L1	1			5/16"	1.20"	1.03"	.16"	2.31"							
YA30L24	1			3/8"	1.20"	1.03"	.16"	2.44"							
YA30L27	1			7/8"	1.20"	1.03"	.16"	3.37"							
YA30L28	1			3/4"	1.20"	1.03"	.16"	3.12"							
YA30L7	1			5/8"	1.20"	1.03"	.16"	2.94"							
YA31L	1	350 kcmil	185	1/2"	1.29"	1.06"	.18"	2.75"	Y644HS (1) Y81KFT (2) Y81KFTMBH (2) PAT81KFT-18V (2)	W31VT (2)	W31VT (2) W31RT (2)	U31RT (2) U29ART (2)	Red	18	1-3/16"
YA31L11	1			3/8"	1.29"	1.06"	.18"	2.50"							
YA31L36	1			7/8"	1.29"	1.06"	.18"	4.02"							
YA31L7	1			5/8"	1.29"	1.06"	.18"	3.00"							
YA31LNT38				3/8"	.96"	1.06"	.18"	3.37"							
YA32L	1	400 kcmil		5/8"	1.38"	1.19"	.19"	3.18"	Y644HS (1) Y81KFT (2) Y81KFTMBH (2) PAT81KFT-18V (2)	W32VT (2)	W32VT (2) W32RT (2)	U32RT (2) U30ART (2)	Blue	19	1-1/4"
YA32L1	1			1/2"	1.40"	1.19"	.19"	2.93"							
YA32L14	1			3/8"	1.38"	1.19"	.19"	2.68"							
YA32LTC78	1			7/8"	1.40"	1.19"	.19"	3.62"							
YA33L	1	450 kcmil		5/8"	1.48"	1.50"	.21"	3.57"							
YA34L	1	500 kcmil	240	5/8"	1.55"	1.27"	.23"	3.37"	Y644HS (1) Y81KFT (2) Y81KFTMBH (2) PAT81KFT-18V (2)	W34VT (2)	W34VT (2) W34RT (2)	U34RT (2) U31ART (2)	Brown	20	1-7/16"
YA34L20	1			1"	1.55"	1.27"	.23"	4.05"							
YA34L37	1			3/8"	1.55"	1.27"	.23"	2.87"							
YA34L6	1			1/2"	1.55"	1.27"	.23"	3.12"							
YA34L8	1			3/4"	1.55"	1.27"	.23"	3.55"							
YA34L9	1			7/8"	1.55"	1.27"	.23"	3.80"							
YA35L	1	550 kcmil		5/8"	1.65"	1.69"	.25"	3.81"			U35RT (2)	Yellow	21	1-3/4"	
YA36L11	1	600 kcmil	300	1/2"	1.74"	1.38"	.27"	3.29"	Y644HS (1) Y81KFT (2) Y81KFTMBH (2)			U36RT (2) U32ART (2)	Green	22	1-3/4"
YA36L	1			5/8"	1.74"	1.38"	.27"	3.72"							
YA36LTC78	1	600 kcmil	300	7/8"	1.74"	1.38"	.27"	3.97"							
YA37L	1	650 kcmil		5/8"	1.80"	1.39"	.27"	3.57"	Y644HS (1) Y81KFT (3) Y81KFTMBH (3) PAT81KFT-18V (3)			U37RT (2)	Orange	23	1-15/16"
YA37L1	1														
YA38L	1	700 kcmil		5/8"	1.84"	1.45"	.27"	3.66"				U38RT (2)	Pink	400	1-15/16"
YA39L	1	750 kcmil		5/8"	1.91"	1.42"	.27"	3.67"	Y644HS (1) Y81KFT (3) Y81KFTMBH (3) PAT81KFT-18V (3)			U39RT (2) P39RT (2) **	Black	24	1-15/16"
YA39L2	1			7/8"	1.91"	1.42"	.27"	4.10"							
YA39L9	1			1-1/4"	1.91"	1.42"	.27"	4.85"							
YA39LNT38				3/8"	1.12"	1.42"	.27"	4.70"							
YA39L6	1			1/2"	1.91"	1.42"	.27"	3.41"							

* Use PUADP-1 adapter with U dies in Y46 HYPRESS™.
** P-RT die sets for use in Y46 HYPRESS™ only, PUADP-1 adapter not required.

*** The MM² conductor sizes listed are the recommendations for Class 2 conductor.
▲ See tooling section of this catalog for complete tool and die listings.

◆ For applications greater than 2000 Volts, consult cable manufacturer for voltage stress relief instructions.
Note: All dimensions shown are for reference only.

Blue highlighted items are industry standard and most frequently ordered.

ONE HOLE HYLUG™ CODE CONDUCTOR STANDARD BARREL (Continued)

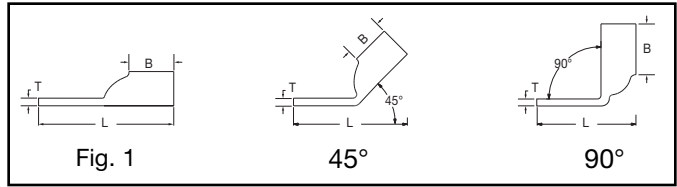

45° and 90° angles are available.

Please contact Customer Service to order:
1-800-346-4175



Catalog Number	Fig #	Conductor		Stud Hole Size	Tongue Width	Figure Dimensions			Dieless (# of crimps)	▲ Installation Tooling				Wire Strip Length	
		AWG	MM²			(B)	(T)	(L)		Mechanical	Hydraulic		Color Code		Die Index
										MD6, OUR840, MD7-34R	BCT500HS, Y500CTHS	Y35, Y39, Y750, Y46*, PAT750			
YA40L	1	800 kcmil	400	5/8"	1.98"	1.42"	.30"	3.81"	Y644HS (1)	—	—	P40RT(3) **	Orange	25	1-15/16"
YA41L	1	850 kcmil		5/8"	2.01"	1.88"	.31"	4.15"	Y81KFT (3)	—	—	—	Gold	26	1-15/16"
YA44L	1	1000 kcmil	500	5/8"	2.19"	1.65"	.33"	4.04"	Y81KFTMBH (3)	—	—	P44RT(3) **	White	27	1-15/16"
YA44L2	1			1/2"	2.49"	1.65"	.33"	3.98"	PAT81KFT-18V (3)						
YA44L23	1			1"	2.19"	1.65"	.33"	4.73"	Y644MBH (1) PAT644-18V (1)						
YA45L	1	1250 kcmil		3/4"	2.46"	2.00"	.38"	4.68"	—	—	P45RT(3) **	Yellow	29	2-1/16"	
YA453L	1	1300 kcmil		3/4"	2.53"	2.00"	.39"	4.71"	—	—	—	Orange	30	2-1/16"	
YA46L	1	1500 kcmil		3/4"	2.69"	2.00"	.40"	4.78"	—	—	P46RT(3) **	Green	31	2-1/16"	
YA48L	1	2000 kcmil		3/4"	3.10"	2.25"	.46"	5.19"	—	—	—	Brown	34	2-1/4"	

* Use PUADP-1 adapter with U dies in Y46 HYPRESS™.
** P-RT die sets for use in Y46 HYPRESS™ only, PUADP-1 adapter not required.

*** The MM² conductor sizes listed are the recommendations for Class 2 conductor.
▲ See tooling section of this catalog for complete tool and die listings.

u For applications greater than 2000 Volts, consult cable manufacturer for voltage stress relief instructions.
Note: All dimensions shown are for reference only.

Blue highlighted items are industry standard and most frequently ordered.

**ONE HOLE HYLUG™
CODE CONDUCTOR
STANDARD BARREL
NARROW TONGUE**

TYPE YA-L-NT

**COPPER COMPRESSION
NARROW TONGUE
TERMINAL**

UL Listed 90° C,
600 Volts to 35 kV ◆

45° and 90° angles are available.
Please contact Customer Service to order:
1-800-346-4175

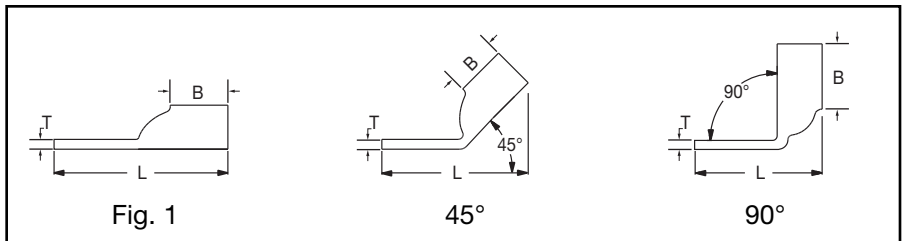
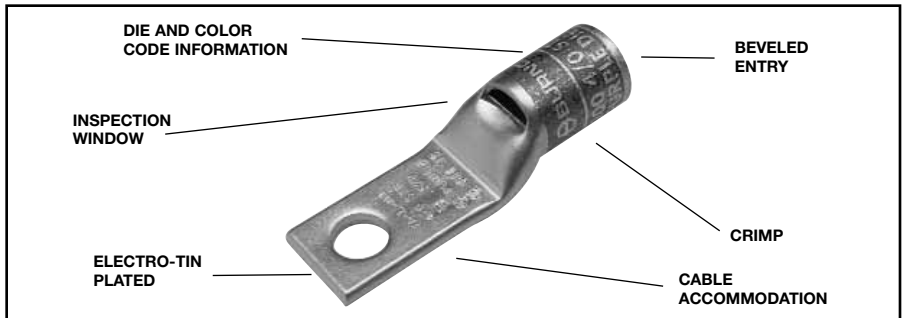

Catalog Number	Fig #	Conductor		Stud Hole Size	Tongue Width	Figure Dimensions			▲ Installation Tooling						Wire Strip Length	
		AWG	*** MM²			(B)	(T)	(L)	**** Dieless (# of crimps)	Mechanical		Hydraulic		Color Code		Die Index
										MD6, OUR840, MD7-34R	BCT500HS, Y500CTHS	Y35, Y39, Y750, Y46*, PAT750				
YA8CLNT6	1	#8 AWG	** 10	6	.29"	.44"	.09"	1.08"	Y8MRB-1 (1) MY29-3 (1) MY29-11 (1) MRC840 (1) Y81KFT (1) Y81KFTMBH (1) PAT81KFT-18V (1)	W8CVT (1)	X8CRT (1)	U8CRT (1)	Red	49	1/2"	
YA8CLNT8	1		8	.33"	.44"	.09"	1.18"									
YA6CLNT6	1	#6 AWG	—	6	.29"	.54"	.09"	1.17"	Y1MRTC (1)	W5CVT (1)	X5CRT (1)	U5CRT (1)	Blue	7	7/8"	
YA4CLNT10	1	#4 AWG	—	# 10	.40"	.81"	.09"	1.73"	MY29-3 (1)	W4CVT (1)	X4CRT (1)	U4CRT (1)	Gray	8	7/8"	
YA3CLNT14	1	#3 AWG	25	# 10	1/4"	.41"	.88"	.09"	1.82"	MY29-11 (1) MRC840	W3CVT (1)	W3CVT (1)	U3CRT (1)	White	9	15/16"
YA3CLNT516	1	#2 Sol.			5/16"	.49"	.88"	.09"	1.80"							
YA2CLNT10	1	#2 AWG	35	# 10	.48"	.88"	.11"	1.80"	Y644HS (1) Y81KFT (1) Y81KFTMBH (1) PAT81KFT-18V (1)	W2CVT (1)	X2CRT (1)	U2CRT (1)	Brown	10	15/16"	
YA2CLNT14	1				1/4"	.50"	.88"	.11"								1.80"
YA2CLNT516	1				5/16"	.49"	.88"	.11"								1.82"
YA1CLNT10	1				#1 AWG	50	# 10	.50"								.88"
YA1CLNT14	1	1/4"	.50"	.88"				.10"	2.23"							
YA25LNT10	1	1/0 AWG	—	# 10	.62"	.88"	.12"	2.28"	Y644HS (1) Y81KFT (1) Y81KFTMBH (1) PAT81KFT-18V (1)	W25VT (2)	X25RT (2)	U25RT (1)	Pink	12	15/16"	
YA25LNT14	1				1/4"	.48"	.88"	.12"								1.93"
YA25LNT516	1				5/16"	.62"	.88"	.12"								2.28"
YA25LNT38	1				3/8"	.62"	.88"	.12"								2.18"
YA26LNT10	1	2/0 AWG	70	# 10	.62"	.94"	.13"	2.62"	Y81KFTMBH (1) PAT81KFT-18V (1)	W26VT (2)	X26RT (2)	U26RT (1)	Black	13	1"	
YA26LNT14	1				1/4"	.48"	.94"	.13"								2.02"
YA26LNT516	1				5/16"	.62"	.94"	.13"								2.62"
YA26LNT38	1				3/8"	.72"	.94"	.12"								2.48"

* Use PUADP-1 adapter with U dies in Y46 HYPRESS™.
** The MM² conductor size listed is for Class 2 and Class 5 conductor.
*** The MM² conductor sizes listed are the recommendations for Class 2 conductor.

**** Y644M is not recommended for standard barrel length #6 AWG HYLUG™.
▲ See tooling section of this catalog for complete tool and die listings. Use ONLY color-coded die recommendations for -FXconnectors. For nest/indenter system contact factory.

◆ For applications greater than 2000 Volts consult cable manufacturer for voltage stress relief instructions.
Note: All dimensions shown are for reference only.

Blue highlighted items are industry standard and most frequently ordered.

Compression Connections

BURNDY®

Copper Compression – Code – Narrow Tongue

C-22

ONE HOLE HYLUG™ CODE CONDUCTOR STANDARD BARREL NARROW TONGUE (Continued)

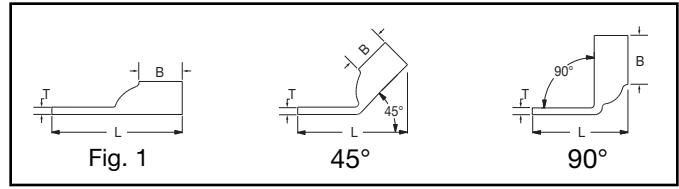

45° and 90° angles are available.
Please contact Customer Service to order:
1-800-346-4175



Catalog Number	Fig #	Conductor		Stud Hole Size	Tongue Width	Figure Dimensions			**** Dieless (# of crimps)	▲ Installation Tooling					Wire Strip Length						
		AWG	MM ²			(B)	(T)	(L)		Mechanical MD6, OUR840, MD7-34R	Hydraulic		Color Code	Die Index							
											BCT500HS, Y500CTHS	Y35, Y39, Y750, Y46*, PAT750									
YA27LNT14	1	3/0 AWG	—	1/4"	.76"	1.00"	.13"	2.10"	Y644HS (1) Y81KFT (2) Y81KFTMB (2) PAT81KFT-18V (2)	W27VT (2)	X27RT (3)	U27RT (1)	Orange	14	1-1/16"						
YA27LNT516	1			5/16"	.60"	1.00"	.12"	2.17"													
YA27LNT38	1			3/8"	.76"	1.00"	.12"	2.73"													
YA28LNT14	1	4/0 AWG	—	1/4"	.76"	.88"	.14"	2.60"		Y644HS (1) Y81KFT (2) Y81KFTMB (2) PAT81KFT-18V (2)	W28VT (2)	X28RT (3)	U28RT (1)	Purple	15	1-1/8"					
YA28LNT516	1			5/16"	.70"	.88"	.14"	2.09"													
YA28LNT38	1			3/8"	.76"	.88"	.14"	2.67"													
YA29LNT516	1	250 kcmil	—	5/16"	.76"	1.06"	.16"	2.48"			Y644HS (1) Y81KFT (2) Y81KFTMB (2) PAT81KFT-18V (2)	W29VT (2)	X29RT (4)	U29RT (1)	Yellow	16	1-1/8"				
YA29LNT38	1			3/8"	.96"	1.06"	.16"	2.96"													
YA29LNT38	1			3/8"	.96"	1.06"	.16"	2.96"													
YA30LNT14	1	300 kcmil	150	1/4"	.83"	1.03"	.16"	2.26"				Y644HS (1) Y81KFT (2) Y81KFTMB (2) PAT81KFT-18V (2)	W30VT (4)	—	U30RT (2)	White	17	1-1/8"			
YA30LNT38	1			3/8"	.96"	1.03"	.16"	2.97"													
YA31LNT38	1	350 kcmil	185	3/8"	.96"	1.06"	.18"	3.31"					Y644HS (1) Y81KFT (2) Y81KFTMB (2) PAT81KFT-18V (2)	W31VT (4)	—	U31RT (2)	Red	18	1-3/16"		
YA31LNT12	1			1/2"	.88"	1.06"	.18"	2.75"													
YA32LNT38	1	400 kcmil	—	3/8"	.96"	1.19"	.20"	3.21"	Y644HS (1) Y81KFT (2) Y81KFTMB (2) PAT81KFT-18V (2)					W32VT (4)	—	U32RT (2)	Blue	19 or 470	1-1/4"		
YA32LNT12	1			1/2"	.96"	1.19"	.19"	3.21"													
YA34LNT38	1	500 kcmil	240	3/8"	.96"	1.27"	.23"	3.65"		Y644HS (1) Y81KFT (2) Y81KFTMB (2) PAT81KFT-18V (2)				W34VT (4)	—	U34RT (2)	Brown	20 or 299	1-7/16"		
YA34LNT12	1			1/2"	.96"	1.27"	.23"	3.65"													
YA36LNT38	1	600 kcmil	300	3/8"	1.12"	1.38"	.27"	4.09"						Y644HS (1) Y81KFT (2) Y81KFTMB (2) PAT81KFT-18V (2)	—	—	U36RT (2)	Green	22	1-3/4"	
YA36LNT12	1			1/2"	1.00"	1.38"	.27"	3.29"													
YA39LNT38	1	750 kcmil	—	3/8"	1.12"	1.42"	.27"	4.24"			Y644HS (1) Y81KFT (2) Y81KFTMB (2) PAT81KFT-18V (2)				Y81KFT (3)	—	—	U39RT (2)	Black	24	1-15/16"
YA39LNT12	1			1/2"	1.63"	1.42"	.27"	4.24"													
YA39LNT58	1			5/8"	1.30"	1.42"	.27"	3.67"													

* Use PUADP-1 adapter with U dies in Y46 HYPRESS™.
** The MM² conductor size listed is for Class 2 and Class 5 conductor.
*** The MM² conductor sizes listed are the recommendations for Class 2 conductor.

**** Y644M is not recommended for standard barrel length #6 AWG HYLUG™.
▲ See tooling section of this catalog for complete tool and die listings. Use ONLY color-coded die recommendations for -FXconnectors. For nest/indenter system contact factory.

◆ For applications greater than 2000 Volts consult cable manufacturer for voltage stress relief instructions.
Note: All dimensions shown are for reference only.

Blue highlighted items are industry standard and most frequently ordered.

**ONE HOLE HYLUG™
CODE CONDUCTOR
LONG BARREL**

TYPES YA, YA-TC

**UNINSULATED COPPER
COMPRESSION TERMINAL**

UL Listed 90° C,
600 Volts to 35 kV ◆

45° and 90° angles are available.
Please contact Customer Service to order:
1-800-346-4175

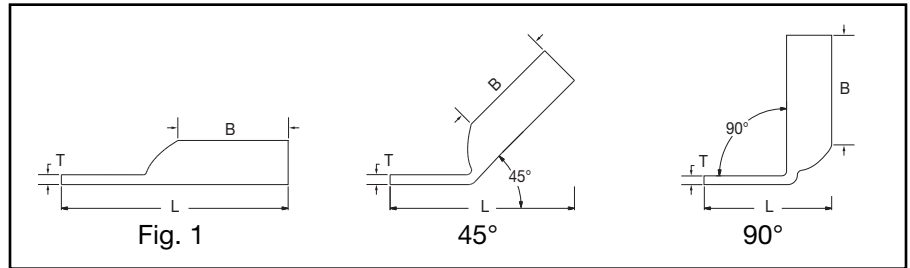
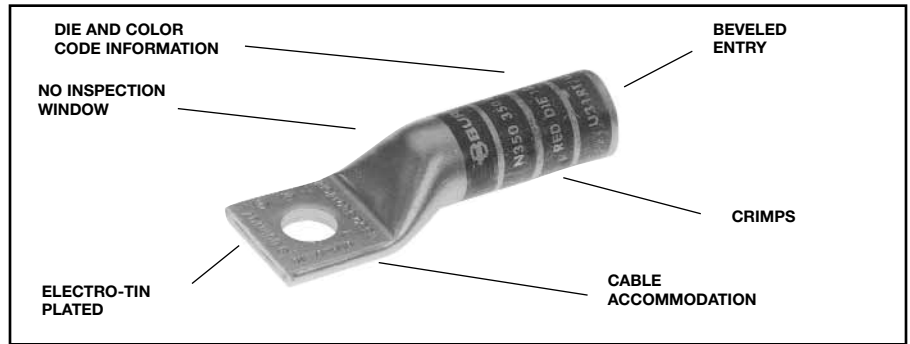

Catalog Number	Fig #	Conductor		Stud Hole Size	Tongue Width	Figure Dimensions			Dieless (# of crimps)	▲ Installation Tooling				Wire Strip Length	
		AWG	*** MM ²			(B)	(T)	(L)		Mechanical MD6, OUR840, MD7-34R	Hydraulic BCT500HS, Y500GTHS	Y35, Y39, Y750 Y46*, PAT750	Color Code		Die Index
YA8CTC10	1	#8 AWG	† 10	# 10	38"	.81"	.08"	1.57"	MRC840 (2) Y8MBR-1 (1)	W8CVT (2) W8CRT (2) X8CRT (2)	X8CRT (2) W8CVT (2) W8CRT (2)	U8CRT (2)	Red	49	1"
YA8CTC14	1	#8 Weld 37/24		1/4"	.41"	.81"	.08"	1.69"	Y1MRTC (2) Y81KFT (1)						
YA8CTC38	1	#6 Sol		3/8"	58"	.81"	.06"	1.88"	Y81KFTMBH (1) PAT81KFT-18V (1)						
YA6CTC10	1	#6 AWG	—	# 10	.41"	1.12"	.09"	1.89"	MRC840 (2) MY29-3 (2) MY29-11 (2)	W5CVT (2) W5CRT (2) X5CRT (2) X8CART (2)	W5CVT (2) W5CRT (2) X5CRT (2) X8CART (2)	U5CRT (2) U8CABT (2)	Blue	7	1-3/16"
YA6CN	1			1/2"	.83"	1.12"	.12"	2.64"	Y644HS (1) Y1MRTC (2) Y81KFT (1)						
YA6C	1			1/4"	.41"	1.12"	.09"	1.81"	Y81KFTMBH (1) PAT81KFT-18V (1)						
YA5C	1	#5 AWG	—	1/4"	.44"	1.12"	.07"	1.98"	Y1MRTC (2) MRC840 (2) MY29-3 (2) MY29-11 (2)	W5CVT (2) W5CRT (2) X5CRT (2)	W5CVT (2) W5CRT (2) X5CRT (2)	U5CRT (2)	Blue	7	1-3/16"
YA5CN	1			1/2"	.83"	1.12"	.12"	2.67"	Y644HS (1) Y81KFT (1) Y81KFTMBH (1) PAT81KFT-18V (1)						
YA4CTC10	1	#4 AWG	—	# 10	.49"	1.12"	.09"	1.94"	MRC840 (2) MY29-3 (2) MY29-11 (2)	W4CVT (2) W4CRT (2) X4CRT (2)	W4CVT (2) W4CRT (2) X4CRT (2)	U4CRT (2) U6CABT (2)	Gray	8	1-3/16"
YA4C	1			1/4"	.50"	1.12"	.09"	1.87"	Y644HS (1) Y81KFT (1) Y81KFTMBH (1) PAT81KFT-18V (1)						

* Use PUADP-1 adapter with U dies in Y46 HYPRESS™.
** P-RT die sets for use in Y46 HYPRESS™ only, PUADP-1 adapter not required.
*** The MM² conductor sizes listed are the recommendations for Class 2 conductor.

† The MM² conductor size listed is for Class 2 and Class 5 conductor.
▲ See tooling section of this catalog for complete tool and die listings. Use ONLY color coded die recommendations for -FX connectors. For nest/indenter system contact factory.

◆ Available undrilled. Add suffix U to catalog number (example: YA25U).
◆ For applications greater than 2000 Volts consult cable manufacturer for voltage stress relief instructions.
Note: All dimensions shown are for reference only.

Blue highlighted items are industry standard and most frequently ordered.

Compression Connections

BURNDY®

Copper Compression – Code – Long Barrel – No Inspection Window

C-24

ONE HOLE HYLUG™ CODE CONDUCTOR LONG BARREL (Continued)

UL Listed 90° C,
600 Volts to 35 kV ♦

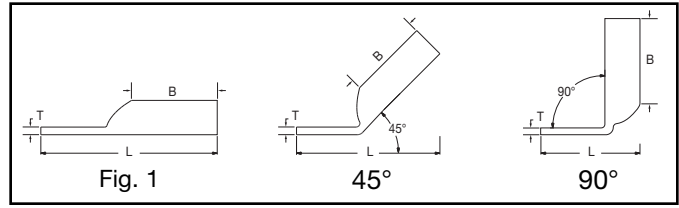

45° and 90° angles are available.
Please contact Customer Service to order:
1-800-346-4175



Catalog Number	Fig #	Conductor		Stud Hole Size	Tongue Width	Figure Dimensions			▲ Installation Tooling					Wire Strip Length		
		AWG	*** MM²			(B)	(T)	(L)	Dieless (# of crimps)	Mechanical	Hydraulic		Color Code		Die Index	
										MD6, OUR840, MD7-34R	BCT500HS, Y500CTHS	Y35, Y39, Y750, Y46*, PAT750				
YA4CTC38	1	#4 AWG	—	3/8"	.58"	1.12"	.08"	2.25"	MRC840 (2) MY29-3 (2) MY29-11 (2) Y644HS (1) Y1MRTC (4) Y81KFT (1) Y81KFTMBH (1) PAT81KFT-18V (1)	W4CVT (2) W4CRT (2) X4CRT (2)	W4CVT (2) W4CRT (2) X4CRT (2)	U4CRT (2) U6CABT (2)	Gray	8	1-3/16"	
YA4CN	1			1/2"	.83"	1.12"	.12"	2.69"								
YA3CTC14	1	#3 AWG #2 Solid	25	1/4"	.55"	1.25"	.09"	2.23"	MY29-3 (2) MY29-11 (2) Y644HS (1) Y81KFT (2)	W3CRT (2)	W3CRT (2)	U3CRT (2)	White	9	1-1/2"	
YA3C	1			5/16"	.55"	1.25"	.09"	2.30"	Y81KFTMBH (2)							
YA3CTC38	1			3/8"	.61"	1.25"	.08"	2.42"	PAT81KFT-18V (2)							
YA3CN	1			1/2"	.81"	1.25"	.12"	2.86"								
YA2CTC10	1	#2 AWG	35	# 10	.61"	1.25"	.11"	2.10"	Y1MRTC (4) MRC840 (2) MY29-3 (2) MY29-11 (2) Y644HS (1) Y81KFT (2)	W2CVT (2) W2CRT (2) X2CRT (2)	W2CVT (2) W2CRT (2) X2CRT (2)	U2CRT (2)	Brown	10	1-5/16"	
YA2CTC14	1			1/4"	.60"	1.25"	.11"	2.23"	Y81KFTMBH (2)							
YA2C	1			5/16"	.61"	1.25"	.11"	2.29"								
YA2CN	1			1/2"	.83"	1.25"	.12"	2.88"								
YA1CTC10	1	#1 AWG	50	# 10	.68"	1.38"	.10"	2.27"	PAT81KFT-18V (2) Y1MR (4) MRC840 (2) MY29-3 (2) MY29-11 (2) Y644HS (1) Y81KFT (2)	W1CVT (2) W1CRT-1 (2) X1CRT-1 (2)	W1CVT (2) W1CRT-1 (2) X1CRT-1 (2)	U1CRT-1 (2) U4CABT (2)	Green	11	1-7/16"	
YA1C	1			5/16"	.68"	1.38"	.10"	2.45"	Y81KFTMBH (2) PAT81KFT-18V (2)							
YA1CN	1			1/2"	.83"	1.38"	.12"	3.06"								
YA25TC10	1	1/0 AWG	—	# 10	.75"	1.38"	.12"	2.30"	MRC840 (4) MY29-3 (2) MY29-11 (2) Y644HS (1) Y81KFT (2)	W25VT (4) W25RT (4) X25RT (4)	W25VT (4) W25RT (4) X25RT (4)	U25RT (2) U2CABT (2)	Pink	12	1-7/16"	
YA25	1			5/16"	.75"	1.38"	.12"	2.48"	Y81KFTMBH (2) PAT81KFT-18V (2)							
YA25TC38	1			3/8"	.75"	1.38"	.12"	2.61"								

* Use PUADP-1 adapter with U dies in Y46 HYPRESS™.
** P-RT die sets for use in Y46 HYPRESS™ only, PUADP-1 adapter not required.

*** The MM² conductor sizes listed are the recommendations for Class 2 conductor.
▲ See tooling section of this catalog for complete tool and die listings. Use ONLY color coded die recommendations for -FX connectors. For nest/indentor system contact factory.

• Available undrilled. Add suffix U to catalog number (example: YA25U).
♦ For applications greater than 2000 Volts consult cable manufacturer for voltage stress relief instructions.
Note: All dimensions shown are for reference only.

Blue highlighted items are industry standard and most frequently ordered.

**ONE HOLE HYLUG™
CODE CONDUCTOR
LONG BARREL**
(Continued)

UL Listed 90° C,
600 Volts to 35 kV ◆

45° and 90° angles are available.
Please contact Customer Service to order:
1-800-346-4175

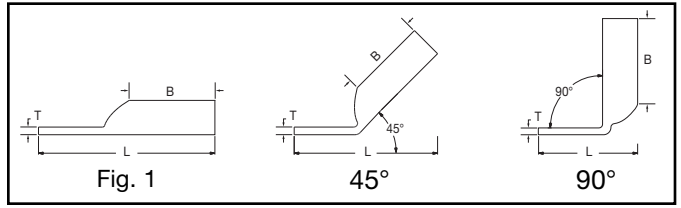

Catalog Number	Fig #	Conductor		Stud Hole Size	Tongue Width	Figure Dimensions			▲ Installation Tooling					Wire Strip Length	
		AWG	*** MM ²			(B)	(T)	(L)	Dieless (# of crimps)	Mechanical MD6, OUR840, MD7-34R	Hydraulic		Color Code		Die Index
											BCT500HS, Y500CTHS	Y35, Y39, Y750, Y46*, PAT750			
YA25N	1	1/0 AWG	—	1/2"	.81"	1.38"	.11"	3.05"	MRC840 (4) MY29-3 (2) MY29-11 (2) Y644HS (1) Y81KFT (2) Y81KFTMBH (2) PAT81KFT-18V (2)	W25VT (4) W25RT (4) X25RT (4)	W25VT (4) W25RT (4) X25RT (4)	U25RT (2) U2CABT (2)	Pink	12	1-7/16"
YA26	1	2/0 AWG	70	3/8"	.83"	1.50"	.12"	2.77"	MRC840 (4) MY29-3 (2) MY29-11 (2) Y644HS (1) Y81KFT (2) Y81KFTMBH (2) PAT81KFT-18V (2)	W26VT (4) W26RT (4) X26RT (4)	W26VT (4) W26RT (4) X26RT (4)	U26RT (2)	Black	13	1-9/16"
YA26N	1			1/2"	.83"	1.50"	.12"	3.21"							
YA27	1	3/0 AWG	—	1/2"	.91"	1.50"	.13"	3.06"	MRC840 (4) MY29-3 (2) MY29-11 (2) Y644HS (1) Y81KFT (2) Y81KFTMBH (2) PAT81KFT-18V (2)	W27VT (4) W27RT (4) X27RT (6)	W27VT (4) W27RT (4) X27RT (6)	U27RT (2)	Orange	14	1-9/16"
YA28TC38	1	4/0 AWG	—	3/8"	1.02"	1.62"	.14"	2.98"	MRC840 (4) MY29-3 (2) MY29-11 (2) Y644HS (1) Y81KFT (2) Y81KFTMBH (2) PAT81KFT-18V (2)	W28VT (4) W28RT (4) X28RT (6)	W28VT (4) W28RT (4) X28RT (6)	U28RT (2)	Purple	15	1-1/16"
YA28	1			1/2"				3.23"							
YA29	1	250 kcmil	—	1/2"	1.11"	1.62"	.16"	3.26"	MY29-3 (2) MY29-11 (2) Y644HS (1) Y81KFT (2) Y81KFTMBH (2) PAT81KFT-18V (2)	W29VT (4) X29RT (8)	W29VT (4) W29RT (4) X29RT (8)	U29RT (2)	Yellow	16	1-1/16"

* Use PUADP-1 adapter with U dies in Y46 HYPRESS™.
** P-RT die sets for use in Y46 HYPRESS™ only, PUADP-1 adapter not required.

*** The MM² conductor sizes listed are the recommendations for Class 2 conductor.
▲ See tooling section of this catalog for complete tool and die listings. Use ONLY color coded die recommendations for -FX connectors. For nest/indenter system contact factory.

• Available undrilled. Add suffix U to catalog number (example: YA25U).
◆ For applications greater than 2000 Volts consult cable manufacturer for voltage stress relief instructions.
Note: All dimensions shown are for reference only.

Blue highlighted items are industry standard and most frequently ordered.

Compression Connections

BURNDY®

Copper Compression – Code – Long Barrel – No Inspection Window

C-26

ONE HOLE HYLUG™ CODE CONDUCTOR LONG BARREL (Continued)

UL Listed 90° C,
600 Volts to 35 kV ◆

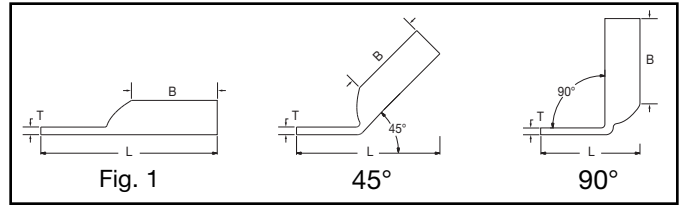

45° and 90° angles are available.
Please contact Customer Service to order:
1-800-346-4175



Catalog Number	Fig #	Conductor		Stud Hole Size	Tongue Width	Figure Dimensions			Dieless (# of crimps)	▲ Installation Tooling				Wire Strip Length	
		AWG	MM²			(B)	(T)	(L)		Mechanical MD6, OUR840, MD7-34R	Hydraulic BCT500HS, Y500CTHS		Y35, Y39, Y750, Y46*, PAT750		Color Code
YA30	1	300 kcmil	150	1/2"	1.20"	2.00"	.16"	3.69"	Y644HS (1) Y81KFT (3) Y81KFTMBH (3) PAT81KFT-18V (3)	W30VT (4)	W30VT (4) W30RT (4)	U30RT (4) U28ART (4)	White	17 or 298	2-1/16"
YA31	1	350 kcmil	185	1/2"	1.29"	2.00"	.18"	3.73"	Y644HS (1) Y81KFT (3) Y81KFTMBH (3) PAT81KFT-18V (3)	W31VT (4)	W31VT (4) W31RT (4)	U31RT (4) U29ART (4)	Red	18 or 324	2-1/16"
YA32N	1	400 kcmil	—	1/2"	1.38"	2.12"	.19"	4.09"	Y644HS (1) Y81KFT (3) Y81KFTMBH (3) PAT81KFT-18V (3)	W32VT (4)	W32VT (4) W32RT (4)	U32RT (4) U30ART (4)	Blue	19 or 470	2-3/16"
YA32	1			5/8"	1.38"	2.12"	.19"	4.15"							
YA33	1	450 kcmil	—	5/8"	1.48"	2.13"	.21"	4.24"	Y644HS (1) Y81KFT (4) Y81KFTMBH (4) PAT81KFT-18V (4)	W33VT (4)	W33VT (4) W33RT (4)	U33RT (4)	Gray	326 or 538	2-5/16"
YA33N	1			1/2"	1.48"	2.13"	.21"	4.17"							
YA34N	1	500 kcmil	240	1/2"	1.55"	2.25"	.23"	4.32"	Y644HS (1) Y81KFT (4) Y81KFTMBH (4) PAT81KFT-18V (4)	W34VT (4)	W34VT (4) W34RT (4)	U34RT (4) U31ART (4)	Brown	20 or 299	2-5/16"
YA34	1			5/8"	1.55"	2.25"	.23"	4.39"							
YA35	1	550 kcmil	—	5/8"	1.65"	2.63"	.25"	4.79"	Y644HS (1) Y81KFT (4) Y81KFTMBH (4) PAT81KFT-18V (4)	—	—	U35RT (4)	Yellow	21	2-11/16,
YA35N	1			1/2"	1.65"	2.63"	.25"	4.73"							
YA36N	1	600 kcmil	300	1/2"	1.69"	2.69"	.27"	4.83"	Y644HS (1) Y81KFT (4) Y81KFTMBH (4) PAT81KFT-18V (4)	—	—	U36RT (4) U32ART (4)	Green	22 or 472	2-3/4"
YA36	1			5/8"	1.69"	2.69"	.27"	4.90"							
YA37	1	650 kcmil	—	5/8"	1.80"	2.81"	.27"	5.05"	Y644HS (1) Y81KFT (4) Y81KFTMBH (4) PAT81KFT-18V (4)	—	—	U37RT (4)	Orange	23	2-7/8"
YA37N	1			1/2"	1.80"	2.81"	.27"	4.98"							
YA38	1	700 kcmil	—	5/8"	1.84"	2.81"	.27"	5.07"	Y644HS (1) Y81KFT (4) Y81KFTMBH (4) PAT81KFT-18V (4)	—	—	U38RT (4)	Pink	400	2-7/8"
YA38N	1			1/2"	1.84"	2.81"	.27"	5.01"							
YA39N	1	750 kcmil	—	1/2"	1.89"	2.88"	.27"	5.11"	Y644HS (1) Y81KFT (4) Y81KFTMBH (4) PAT81KFT-18V (4)	—	—	U39RT (4) P39RT (4) **	Black	24	2-15/16"
YA39	1			5/8"	1.89"	2.88"	.27"	5.17"							
YA40	1	800 kcmil	400	5/8"	1.98"	2.94"	.30"	5.25"	Y644HS (1) Y81KFT (4) Y81KFTMBH (4) PAT81KFT-18V (4)	—	—	P40RT (4) **	Orange	25	3"
YA41	1	850 kcmil	—	5/8"	2.01"	2.94"	.31"	5.26"	Y644HS (1) Y81KFT (4) Y81KFTMBH (4) PAT81KFT-18V (4)	—	—	—	Gold	26	3"
YA41N	1			1/2"	2.01"	2.91"	.31"	5.20"							
YA44	1	1000 kcmil	500	5/8"	2.17"	3.00"	.33"	5.45"	Y644HS (1) Y81KFT (4) Y81KFTMBH (4) PAT81KFT-18V (4)	—	—	P44RT (4) **	White	27	3-1/16"
YA44N	1			1/2"	2.19"	3.00"	.33"	5.38"							
YA45	1	1250 kcmil	—	3/4"	2.46"	3.19"	.38"	5.93"	Y644HS (1) Y81KFT (4) Y81KFTMBH (4) PAT81KFT-18V (4)	—	—	P45RT (6) **	Yellow	29	3-1/4"
YA46	1	1500 kcmil	—	3/4"	2.69"	3.19"	.40"	6.04"	Y644HS (1) Y81KFT (4) Y81KFTMBH (4) PAT81KFT-18V (4)	—	—	P46RT (6) **	Green	31	3-5/16"
YA46N	1			1/2"	2.69"	3.19"	.40"	5.79"							
YA47	1	1750 kcmil	—	3/4"	2.90"	3.44"	.42"	6.38"	Y644HS (1) Y81KFT (4) Y81KFTMBH (4) PAT81KFT-18V (4)	—	—	—	Gray	33	3-1/2"
YA47N	1			1/2"	2.90"	3.44"	.42"	6.13"							
YA48	1	2000 kcmil	—	3/4"	3.10"	3.44"	.46"	6.47"	Y644HS (1) Y81KFT (4) Y81KFTMBH (4) PAT81KFT-18V (4)	—	—	—	Brown	34	3-1/2"
YA48N	1			1/2"	3.10"	3.44"	.46"	6.22"							

* Use PUADP-1 adapter with U dies in Y46 HYPRESS™.
** P-RT die sets for use in Y46 HYPRESS™ only, PUADP-1 adapter not required.

*** The MM² conductor sizes listed are the recommendations for Class 2 conductor.
▲ See tooling section of this catalog for complete tool and die listings. Use ONLY color coded die recommendations for -FX connectors. For nest/indenter system contact factory.

• Available undrilled. Add suffix U to catalog number (example: YA25U).
◆ For applications greater than 2000 Volts consult cable manufacturer for voltage stress relief instructions.
Note: All dimensions shown are for reference only.

Blue highlighted items are industry standard and most frequently ordered.

**ONE HOLE HYLUG™
CODE CONDUCTOR
LONG BARREL WITH
INSPECTION WINDOW**

TYPE YAZ

**UNINSULATED COPPER
COMPRESSION TERMINAL**

UL Listed 90° C,
600 Volts to 35 kV ◆

45° and 90° angles are available.
Please contact Customer Service to order:
1-800-346-4175

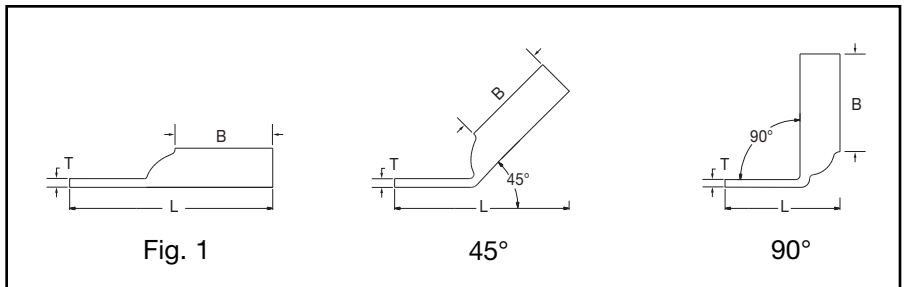
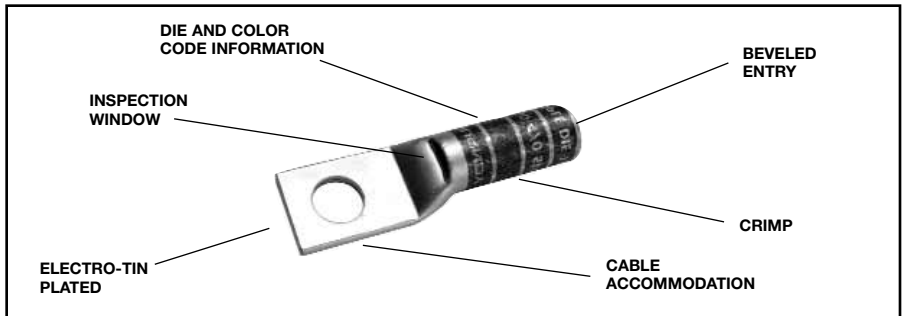

Catalog Number	Fig #	Conductor		Stud Hole Size	Tongue Width	Figure Dimensions			Dieless (# of crimps)	▲ Installation Tooling					Wire Strip Length
		AWG	MM ²			(B)	(T)	(L)		Mechanical MD6, OUR840, MD7-34R	Hydraulic BCT500HS, Y500CTHS	Y35, Y39, Y750, Y46*, PAT750	Color Code	Die Index	
YAZV10TC14	1	#14 - 10 Str #12 - 10 Sol	6	1/4"	.41"	.69"	.05"	1.54"	Y8MRB-1	—	—	—	—	—	3/4"
YAZ8CTC10	1	#8 AWG #8 Weld 37/24 #6 Sol	† 10	#10	.41"	.75"	.08"	1.58"	Y1MRTC (2) MY29-3 (2)	W8CVT (2) W8CRT (2) X8CRT (2)	W8CVT (2) W8CRT (2) X8CRT (2)	U8CRT (2)	Red	49	7/8"
YAZ8CTC14	1			1/4"	.44"	.75"	.08"	1.71"							
YAZ8CTC38	1			3/8"	.58"	.75"	.06"	1.89"							
YAZ6CTC14	1	#6 AWG	—	1/4"	.45"	1.12"	.08"	2.03"	MRC840 (2) Y644HS (1) Y81KFT (1)	W5CVT (2) W5CRT (2) X5CRT (2)	W5CVT (2) W5CRT (2) X5CRT (2)	U5CRT (2) U8CABT (2)	Blue	7 or 374	1-3/16"
YAZ6CTC38	1			3/8"	.58"	1.12"	.06"	2.22"							
YAZ6CTC12	1			1/2"	.83"	1.12"	.12"	2.65"							
YAZ5CTC12	1	#5 AWG	—	1/2"	.83"	1.12"	.12"	2.68"	Y81KFTMBH (1) PAT81KFT-18V (1)	W5CRT (2) W5CVT (2) X5CRT (2)	W5CVT (2) W5CRT (2) X5CRT (2)	U5CRT (2)	Blue	7 or 374	1-3/16"
YAZ4CTC14	1	#4 AWG	—	1/4"	.49"	1.12"	.09"	2.05"	Y1MRTC (4) MY29-3 (2) MY29-11 (2) MRC840 (2) Y644HS (1) Y81KFT (1)	W4CVT (2) W4CRT (2) X4CRT (2)	W4CVT (2) W4CRT (2) X4CRT (2)	U4CRT (2) U6CABT (2)	Gray	8 or 346	1-3/16"
YAZ4CTC38	1			3/8"	.58"	1.12"	.08"	2.23"							
YAZ4CTC12	1			1/2"	.73"	1.12"	.06"	2.50"							

* Use PUADP-1 adapter with U dies in Y46 HYPRESS™.
 ** P-RT die sets for use in Y46 HYPRESS™ only, PUADP-1 adapter not required.
 *** The MM² conductor sizes listed are the recommendations for Class 2 conductor.

† The MM² conductor size listed is for Class 2 and Class 5 conductor.
 ▲ See tooling section of this catalog for complete tool and die listings.

• Available undrilled. Add suffix U to catalog number (example: YA25U).
 ◆ For applications greater than 2000 Volts consult cable manufacturer for voltage stress relief instructions.
Note: All dimensions shown are for reference only.

Blue highlighted items are industry standard and most frequently ordered.

Compression Connections

BURNDY®

Copper Compression – Code – Long Barrel – Inspection Window

C-28

ONE HOLE HYLUG™ CODE CONDUCTOR LONG BARREL WITH INSPECTION WINDOW (Continued)

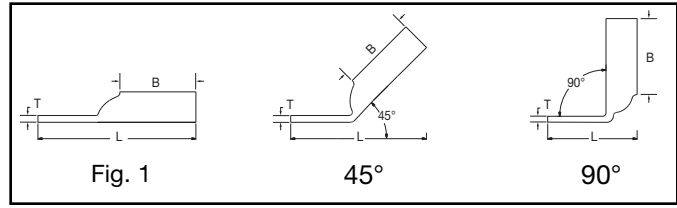

UL Listed 90° C,
600 Volts to 35 kV ◆

45° and 90° angles are available.
Please contact Customer Service to order:
1-800-346-4175



Catalog Number	Fig #	Conductor		Stud Hole Size	Tongue Width	Figure Dimensions			Dieless (# of crimps)	▲ Installation Tooling				Wire Strip Length	
		AWG	MM²			(B)	(T)	(L)		Mechanical MD6, OUR840, MD7-34R	Hydraulic		Color Code		Die Index
											BCT500HS, Y500CTHS	Y35, Y39, Y750, Y46*, PAT750			
YAZ3CTC14	1	#3 AWG #2 Sol	25	1/4"	.55"	1.25"	.09"	2.21"	Y1MRTC (4) MY29-3 (2) MY29-11 (2) MRC840 (2) Y644HS (1) Y81KFT (2) Y81KFTMBH (2) PAT81KFT-18V (2)	W3CRT (2)	W3CRT (2)	U3CRT (2)	White	9	1-5/16"
YAZ3CTC38	1			3/8"	.58"	1.25"	.08"	2.39"							
YAZ3CTC12	1			1/2"	.83"	1.25"	.07"	2.83"							
YAZ2CTC14	1	#2 AWG	35	1/4"	.60"	1.25"	.11"	2.23"	W2CVT (2) W2CRT (2) X2CRT (2)	W2CVT (2) W2CRT (2) X2CRT (2)	U2CRT (2)	Brown	10	1-5/16"	
YAZ2CTC38	1			3/8"	.60"	1.25"	.11"	2.41"							
YAZ2CTC12	1			1/2"	.83"	1.25"	.09"	2.85"							
YAZ1CTC14	1	#1 AWG	50	1/4"	.67"	1.38"	.10"	2.39"	W1CVT (2) W1CRT-1 (2) X1CRT-1 (2)	W1CVT (2) W1CRT-1 (2) X1CRT-1 (2)	U1CRT-1 (2) U4CABT (2)	Green	11 or 375	1-7/16"	
YAZ1CTC38	1			3/8"	.67"	1.38"	.10"	2.57"							
YAZ1CTC12	1			1/2"	.83"	1.38"	.09"	3.01"							
YAZ25TC14	1	1/0 AWG	—	1/4"	.75"	1.38"	.12"	2.42"	MY29-3 (2) MY29-11 (2) MRC840 (4) Y644HS (1) Y81KFT (2) Y81KFTMBH (2) PAT81KFT-18V (2)	W25VT (4) W25RT (4) X25RT (4)	W25VT (4) W25RT (4) X25RT (4)	U25RT (2) U2CABT (2)	Pink	12 or 348	1-7/16"
YAZ25TC516	1			5/16"	.75"	1.38"	.12"	2.47"							
YAZ25TC38	1			3/8"	.75"	1.38"	.12"	2.60"							
YAZ25TC12	1	2/0 AWG	70	1/2"	.83"	1.38"	.12"	3.04"	W26VT (4) W26RT (4) X26RT (4)	W26VT (4) W26RT (4) X26RT (4)	U26RT (2)	Black	13	1-9/16"	
YAZ26TC14	1			1/4"	.83"	1.50"	.12"	2.58"							
YAZ26TC38	1			3/8"	.83"	1.50"	.12"	2.76"							
YAZ26TC12	1	3/0 AWG	—	1/2"	.83"	1.50"	.12"	3.2"	W27RT (4) W27VT (4) X27RT (6)	W27RT (4) W27VT (4) X27RT (6)	U27RT (2)	Orange	14	1-9/16"	
YAZ27TC38	1			3/8"	.90"	1.50"	.12"	2.8"							
YAZ27TC12	1			1/2"	.91"	1.5"	0.12"	3.23"							
YAZ28TC38	1	4/0 AWG	—	3/8"	1.02"	1.62"	0.14"	2.99"	W28VT (4) W28RT (4) X28RT (6)	W28VT (4) W28RT (4) X28RT (6)	U28RT (2)	Purple	15	1-11/16"	
YAZ28TC12	1			1/2"	1.02"	1.62"	0.14"	3.40"							
YAZ29TC38	1	250 kcmil	—	3/8"	1.10"	1.62"	0.16"	2.99"	W29VT (4) X29RT (8)	W29VT (4) W29RT (4) X29RT (6)	U29RT (2)	Yellow	16	1-11/16"	
YAZ29TC12	1			1/2"	1.10"	1.62"	0.16"	3.43"							

* Use PUADP-1 adapter with U dies in Y46 HYPRESS™.
** P-RT die sets for use in Y46 HYPRESS™ only, PUADP-1 adapter not required.

*** The MM² conductor sizes listed are the recommendations for Class 2 conductor.
▲ See tooling section of this catalog for complete tool and die listings.

◆ Available undrilled. Add suffix U to catalog number (example: YA25U).
◆ For applications greater than 2000 Volts consult cable manufacturer for voltage stress relief instructions.
Note: All dimensions shown are for reference only.

Blue highlighted items are industry standard and most frequently ordered.

**ONE HOLE HYLUG™
CODE CONDUCTOR
LONG BARREL WITH
INSPECTION WINDOW**
(Continued)

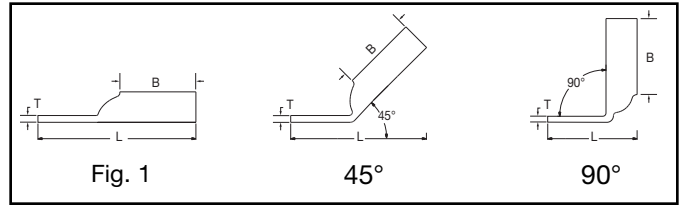

UL Listed 90° C,
600 Volts to 35 kV ◆



45° and 90° angles are available.
Please contact Customer Service to order:
1-800-346-4175

Catalog Number	Fig #	Conductor		Stud Hole Size	Tongue Width	Figure Dimensions			Dieless (# of crimps)	▲ Installation Tooling					Wire Strip Length	
		AWG	MM ²			(B)	(T)	(L)		Mechanical MD6, OUR840, MD7-34R	Hydraulic		Color Code	Die Index		
											BCT500HS, Y500C7HS	Y35, Y39, Y750, Y46*, PAT750				
YAZ30TC38	1	300 kcmil	150	3/8"	1.20"	2"	.16"	3.42"	Y644HS (1)	W30VT (4)	W30RT (4)	U30RT (4)	White	17 or 298	2-1/16"	
YAZ30TC12	1			1/2"	1.20"	2"	.16"	3.85"		W31VT (4)	W31RT (4)	U31RT (4)				
YAZ31TC38	1	350 kcmil	185	3/8"	1.29"	2"	0.18	3.45"	Y81KFT (3)	W31VT (4)	W31RT (4)	U31RT (4)	Red	18 or 324	2-1/16"	
YAZ31TC12	1			1/2"	1.29"	2"	0.18	3.89"								W32VT (4)
YAZ32TC38	1	400 kcmil	—	3/8"	1.40"	2.12"	.19"	3.62"	PAT81KFT-18V (3)	W32VT (4)	W32RT (4)	U32RT (4)	Blue	19 or 470	2-3/16"	
YAZ32TC12	1			1/2"	1.40"	2.12"	.19"	4.06"								W33VT (4)
YAZ33TC12	1	450 kcmil	—	1/2"	1.48"	2.12"	.21"	4.14"	Y644HS (1)	W33VT (4)	W33RT (4)	U33RT (4)	Gray	326 or 538	2-5/16"	
YAZ34TC38	1	500 kcmil	240	3/8"	1.55"	2.25"	.23"	3.85"	Y81KFT (4)	W34VT (4)	W34RT (4)	U34RT (4)	Brown	20 or 299	2-5/16"	
YAZ34TC12	1			1/2"	1.55"	2.25"	.23"	4.29"								W34RT (4)
YAZ35TC12	1	550 kcmil	—	1/2"	1.65"	2.62"	.25"	4.7"	Y81KFTMBH (4)	—	—	U35RT (4)	Yellow	21	2-11/16"	
YAZ36TC38	1	600 kcmil	300	3/8"	1.74"	2.69"	.26"	4.55"	PAT81KFT-18V (4)	—	—	U36RT (4)	Green	22 or 472	2-3/4"	
YAZ36TC12	1	600 kcmil	300	1/2"	1.74"	2.69"	.26"	4.80"	Y644HS (1) Y81KFT (4) Y81KFTMBH (4) PAT81KFT-18V (4)	—	—	U36RT (4)	Green	22 or 472	2-3/4"	
YAZ37TC12	1	650 kcmil	—	1/2"	1.80"	2.81"	.27"	4.95"		—	—	U37RT (4)	Orange	23	2-7/8"	
YAZ38TC12	1	700 kcmil	—	1/2"	1.84"	2.81"	.27"	4.97"		—	—	U38RT (4)	Pink	400	2-7/8"	
YAZ39TC38	1	750 kcmil	—	3/8"	1.91"	2.88"	.27"	4.82"		Y644HS (1) Y81KFT (4) Y81KFTMBH (4) PAT81KFT-18V (4)	—	—	U39RT (4) P39RT (4) **	Black	24	2-15/16"
YAZ39TC12	1			1/2"	1.91"	2.88"	.27"	5.07"								
YAZ39NT12	1			1/2"	1.63"	2.88"	.27"	5.07"								
YAZ40TC12	1	800 kcmil	400	1/2"	1.98"	2.94"	.30"	5.14"		—	—	P40RT (4) **	Orange	25	3"	
YAZ41TC12	1	850 kcmil	—	1/2"	2.01"	2.94"	.31"	5.16"		—	—	—	Gold	26	3"	
YAZ44TC38	1	1000 kcmil	500	3/8"	2.19"	3.00"	.33"	5.09"		—	—	P44RT (4) **	White	27	3-1/16"	
YAZ44TC12	1			1/2"	2.19"	3.00"	.33"	5.33"								
YAZ45TC12	1	1250 kcmil	—	1/2"	2.46"	3.19"	.38"	5.63"	—	—	P45RT (6) **	Yellow	29	3-1/4"		
YAZ453TC12	1	1300 kcmil	—	1/2"	2.53"	3.19"	.39"	5.66"	—	—	—	Orange	30	2-1/16"		
YAZ46TC12	1	1500 kcmil	—	1/2"	2.69"	3.19"	.40"	5.73"	—	—	P46RT (6) **	Green	31	3-5/16"		
YAZ47TC12	1	1750 kcmil	—	1/2"	2.90"	3.44"	.42"	6.07"	—	—	—	Gray	33	3-1/2"		
YAZ48TC12	1	2000 kcmil	—	1/2"	3.10"	3.44"	.46"	6.14"	—	—	—	Brown	34	3-1/2"		

* Use PUADP-1 adapter with U dies in Y46 HYPRESS™.
 ** P-RT die sets for use in Y46 HYPRESS™ only, PUADP-1 adapter not required.
 *** The MM² conductor sizes listed are the recommendations for Class 2 conductor.

▲ See tooling section of this catalog for complete tool and die listings.
 • Available undrilled. Add suffix U to catalog number (example: YA25U).

◆ For applications greater than 2000 Volts consult cable manufacturer for voltage stress relief instructions.
Note: All dimensions shown are for reference only.

Blue highlighted items are industry standard and most frequently ordered.

Compression Connections

BURNDY®

Copper Compression – Code – Inspection Window

C-30

TWO HOLE HYLUG™ CODE CONDUCTOR STANDARD BARREL

TYPES YAV-2TC, YA-L2L,
YA-2LN, AND YA-L-2TC

COPPER COMPRESSION
TERMINAL

UL Listed 90° C,
600 Volts to 35 kV ♦

45° and 90° angles are available.
Please contact Customer Service to order:
1-800-346-4175

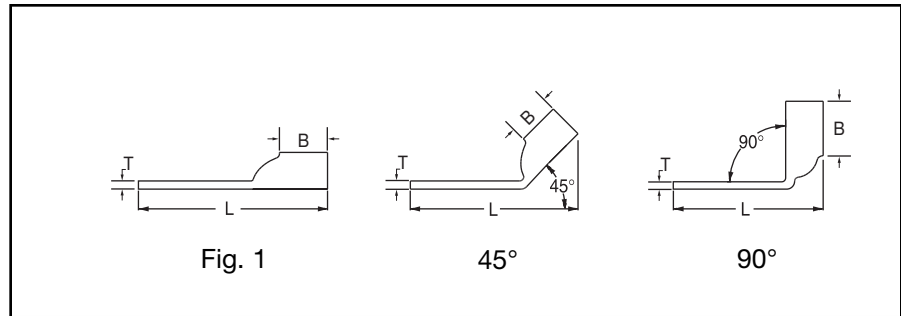
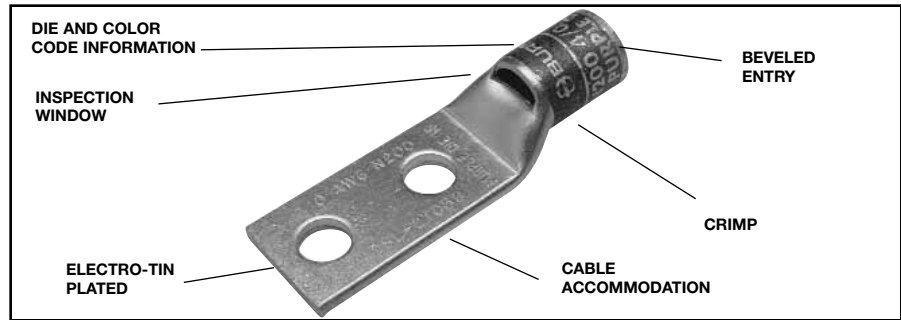

Catalog Number	Fig #	Conductor		Stud Hole Size	Stud Hole Spacing	Tongue Width	Figure Dimensions			▲ Installation Tooling					Wire Strip Length	
		AWG	MM ²				(B)	(T)	(L)	Dieless (# of crimps)	Mechanical	Hydraulic		Color Code		Die Index
											MD6, OUR840, MD7-34R	BCT500HS, Y500CTHS	Y35, Y39, Y750, Y46*, PAT750			
YAV10-2TC10	1	#14-10 Str. #12-10 Sol.	6	# 10	5/8"	.38"	.38"	.06"	1.72"	Y8MRB-1 (1)	—	—	—	—	—	7/16"
YAV10-2TC14	1			1/4"	5/8"	.47"	.38"	.06"	1.84"							
YAV10-2TC14E1	1			1/4"	1"	.47"	.38"	.05"	2.22"							
YAV10-2TC14E2	1			1/4"	3/4"	.47"	.38"	.05"	1.97"							
YAV10-2TC38	1			3/8"	1"	.56"	.38"	.04"	2.40"							
YA8CL-2TC10	1	#8 AWG #8 Weld 37/24 #6 Sol.	† 10	# 10	5/8"	.41"	.44"	.08"	1.83"	Y1MRTC (1)	W8CVT (1) W8CRT (1) X8CRT (1)	W8CVT (1) W8CRT (1) X8CRT (1)	U8CRT (1)	Red	49	1/2"
YA8CL-2TC10E2	1			# 10	3/4"	.41"	.44"	.08"	1.95"	Y8MRB-1 (1)						
YA8CL-2TC14	1			1/4"	5/8"	.44"	.44"	.08"	1.95"	MY29-3 (1)						
YA8CL-2TC14E1	1			1/4"	1"	.44"	.44"	.08"	2.33"	MY29-11 (1)						
YA8CL-2TC14E2	1			1/4"	3/4"	.44"	.44"	.08"	2.08"	MRC840 (1)						
YA8CL-2TC38	1			3/8"	1"	.57"	.44"	.06"	2.52"	Y81KFT (1)						
YA8C-2LN	1			1/2"	1-3/4"	.83"	.44"	.12"	3.75"	Y81KFTMBH (1)						
YA6C-2L	1			1/4"	5/8"	.45"	.54"	.08"	2.01"	PAT81KFT-18V (1)						
YA6C-2LN	1			1/2"	1-3/4"	.81"	.54"	.12"	3.87"							
YA6CL-2TC10	1			# 10	5/8"	.42"	.54"	.09"	1.94"	Y1MRTC (1)						
YA6CL-2TC14	1	1/4"	5/8"	.45"	.54"	.08"	2.07"	MY29-3 (1)								
YA6CL-2TC14E	1	1/4"	1/2"	.45"	.54"	.08"	1.94"	MY29-11 (1)								
YA6CL-2TC14E1	1	1/4"	1"	.45"	.54"	.08"	2.44"	MRC840 (1)								
YA6CL-2TC14E2	1	1/4"	3/4"	.44"	.54"	.08"	2.19"	MRC840 (1)								
YA6CL-2TC38	1	3/8"	1"	.63"	.54"	.06"	2.63"	Y81KFT (1)								
YA6C-2L51	1	# 10	1/2"	.42"	.54"	.09"	1.79"	Y81KFTMBH (1)								
YA6CL-2TC516	1	5/16"	1"	.52"	.54"	.07"	2.51"	PAT81KFT-18V (1)								
YA6CL-2TC516E2	1	5/16"	3/4"	.52"	.54"	.07"	2.26"									
YA6C-2L52	1	1/4"	1/2"	.45"	.54"	.08"	1.88"									
YA5C-2L	1	5 AWG	—	1/4"	5/8"	.44"	.81"	.07"	2.28"							7/8"

-- Color code not assigned.
* Use PUADP-1 adapter with U dies in Y46 HYPRESS™.
** P-RT die sets for use in Y46 HYPRESS™ only, PUADP-1 adapter not required.

*** The MM² conductor sizes listed are the recommendations for Class 2 conductor.
† The MM² conductor size referenced here is for both Class 2 and Class 5.

▲ See tooling section of this catalog for complete tool and die listings.
♦ For applications greater than 2000 volts consult cable manufacturer for voltage stress relief instructions.
Note: All dimensions shown are for reference only.

Blue highlighted items are industry standard and most frequently ordered.

**TWO HOLE HYLUG™
CODE CONDUCTOR
STANDARD BARREL**
(Continued)

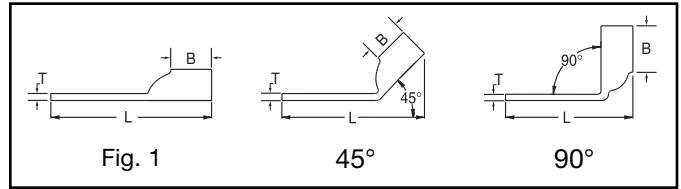

UL Listed 90° C,
600 Volts to 35 kV ◆

45° and 90° angles are available.
Please contact Customer Service to order:
1-800-346-4175



Catalog Number	Fig #	Conductor		Stud Hole Size	Stud Hole Spacing	Tongue Width	Figure Dimensions			▲ Installation Tooling						Wire Strip Length
		AWG	MM²				(B)	(T)	(L)	Dieless (# of crimps)	Mechanical MD6, OUR840, MD7-34R	Hydraulic		Color Code	Die Index	
												BCT500HS, Y500CTHS	Y35, Y39, Y750, Y46*, PAT750			
YA4C-2L	1	4 AWG	—	1/4"	5/8"	.49"	.81"	.09"	2.30"	Y1MRTC (2) MY29-3 (1) MY29-11 (1) MRC840 (1) Y644HS (1) Y81KFT (1) Y81KFTMBH (1) PAT81KFT-18V (1)	W4CVT (1) W4CRT (1) X4CRT (1)	W4CVT (1) W4CRT (1) X4CRT (1)	U4CRT (1) U6CABT (1)	Gray	8	7/8"
YA4CL-2TC14	1			1/4"	5/8"	.49"	.81"	.09"	2.36"							
YA4CL-2TC38	1			3/8"	1"	.58"	.81"	.08"	2.96"							
YA4CL-2TC14E1	1			1/4"	1"	.49"	.81"	.09"	2.74"							
YA4C-2LN	1	4 AWG	—	1/2"	1-3/4"	.83"	.81"	.12"	4.14"	Y1MRTC (2) MY29-3 (1) MY29-11 (1) MRC840 (1) Y644HS (1) Y81KFT (1) Y81KFTMBH (1) PAT81KFT-18V (1)	W4CVT (1)	X4CRT (1)	U4CRT (1)	Gray	8	7/8"
YA4CL-2TC14E2	1			1/4"	3/4"	.49"	.81"	.09"	2.49"							
YA4CL-2TC516	1			5/16"	1"	.52"	.81"	.09"	2.80"							
YA3CL-2TC14	1	3 AWG #2 Sol.	25	1/4"	5/8"	.55"	.81"	.09"	2.45"	Y1MRTC (2) MY29-3 (1) MY29-11 (1) MRC840 (1) Y644HS (1) Y81KFT (1) Y81KFTMBH (1) PAT81KFT-18V (1)	W3CRT (1)	W3CRT (1)	U3CRT (1)	White	9	15/16"
YA3C-2L	1			5/16"	5/8"	.55"	.88"	.09"	2.64"							
YA3CL-2TC38	1			3/8"	1"	.58"	.88"	.08"	3.06"							
YA2C-2L	1	2 AWG	35	5/16"	3/4"	.60"	.88"	.11"	2.67"	Y1MRTC (2) MY29-3 (1) MY29-11 (1) MRC840 (1) Y644HS (1) Y81KFT (1) Y81KFTMBH (1) PAT81KFT-18V (1)	W2CVT (1) W2CRT (1) X2CRT (1)	W2CVT (1) W2CRT (1) X2CRT (1)	U2CRT (1)	Brown	10	15/16"
YA2C-2LN	1			1/2"	1-3/4"	.83"	.88"	.11"	4.27"							
YA2CL-2TC14	1			1/4"	5/8"	.60"	.88"	.11"	2.47"							
YA2CL-2TC14E1	1			1/4"	1"	.60"	.88"	.11"	2.85"							
YA2CL-2TC14E2	1	1/4"	3/4"	.60"	.88"	.11"	2.60"	Y1MRTC (2) MY29-3 (1) MY29-11 (1) MRC840 (1) Y644HS (1) Y81KFT (1) Y81KFTMBH (1) PAT81KFT-18V (1)	W1CVT (1) W1CRT-1 (1) X1CRT-1 (1)	W1CVT (1) W1CRT-1 (1) X1CRT-1 (1)	U1CRT-1 (1) U4CABT (1)	Green	11	15/16"		
YA2CL-2TC38	1	3/8"	1"	.60"	.88"	.11"	3.03"									
YA2CL-2TC516	1	5/16"	1"	.60"	.88"	.11"	2.91"									
YA1C-2LN	1	1 AWG	50	1/2"	1-3/4"	.81"	.88"								.12"	4.32"
YA1C-2L	1			5/16"	7/8"	.68"	.88"	.10"	2.82"							
YA1CL-2TC14	1			1/4"	5/8"	.68"	.88"	.10"	2.51"							
YA1CL-2TC14E2	1			1/4"	3/4"	.68"	.88"	.10"	2.64"							
YA1CL-2TC38	1	—	—	3/8"	1	.68"	.88"	.10"	3.07"	Y1MRTC (2) MY29-3 (1) MY29-11 (1) MRC840 (1) Y644HS (1) Y81KFT (1) Y81KFTMBH (1) PAT81KFT-18V (1)	W1CVT (1)	X1CRT-1 (1)	U1CRT (1)	Green	11	15/16"
YA25-2L	1	5/16"	7/8"	.75"	.88"	.12"	2.85"									
YA25-2LN	1	1/2"	1-3/4"	.83"	.88"	.11"	4.29"									
YA25L-2TC14	1	1/4"	5/8"	.75"	.88"	.12"	2.64"									
YA25L-2TC14E1	1	1/4"	1"	.75"	.88"	.12"	3.01"	Y1MRTC (2) MY29-3 (1) MY29-11 (1) MRC840 (2) Y644HS (1) Y81KFT (1) Y81KFTMBH (1) PAT81KFT-18V (1)	W25VT (2) W25RT (2) X25RT (2)	W25VT (2) W25RT (2) X25RT (2)	U25RT (1) U2CABT (1)	Pink	12	15/16"		
YA25L-2TC14E2	1	1/4"	3/4"	.75"	.88"	.12"	2.66"									
YA25L-2TC38	1	3/8"	1"	.75"	.88"	.12"	3.10"									
YA26-2L	1	5/16"	7/8"	.83"	.94"	.12"	2.95"									
YA26-2LN	1	1/2"	1-3/4"	.83"	.94"	.12"	4.39"	Y1MRTC (2) MY29-3 (1) MY29-11 (1) MRC840 (2) Y644HS (1) Y81KFT (1) Y81KFTMBH (1) PAT81KFT-18V (1)	W26VT (2) W26RT (2) X26RT (2)	W26VT (2) W26RT (2) X26RT (2)	U26RT (1)	Black	13	1"		
YA26L-2TC14	1	1/4"	5/8"	.83"	.94"	.12"	2.64"									
YA26L-2TC14E1	1	1/4"	1"	.83"	.94"	.12"	3.01"									
YA26L-2TC14E2	1	1/4"	3/4"	.83"	.94"	.12"	2.76"									
YA26L-2TC38	1	3/8"	1"	.83"	.94"	.12"	3.20"	Y1MRTC (2) MY29-3 (1) MY29-11 (1) MRC840 (2) Y644HS (1) Y81KFT (1) Y81KFTMBH (1) PAT81KFT-18V (1)	W27VT (2) W27RT (2) X27RT (3)	W27VT (2) W27RT (2) X27RT (3)	U27RT (1)	Orange	14	1-1/16"		
YA27-2LN	1	1/2"	1-3/4"	.91"	1.00"	.13"	4.48"									
YA27L-2TC14E2	1	1/4"	3/4"	.91"	1.00"	.12"	2.86"									
YA27L-2TC38	1	3/8"	1"	.91"	1.00"	.12"	3.30"									

-- Color code not assigned.
▲ See tooling section of this catalog for complete tool and die listings.

◆ For applications greater than 2000 volts consult cable manufacturer for voltage stress relief instructions.
* Use PUADP-1 adapter with U dies in Y46 HYPRESS™.

** P-RT die sets for use in Y46 HYPRESS™ only, PUADP-1 adapter not required.
*** The MM² conductor sizes listed are the recommendations for Class 2 conductor.

Note: All dimensions shown are for reference only.

Blue highlighted items are industry standard and most frequently ordered.

Compression Connections

BURNDY®

Copper Compression – Code – Inspection Window

C-32

TWO HOLE HYLUG™ CODE CONDUCTOR STANDARD BARREL (Continued)

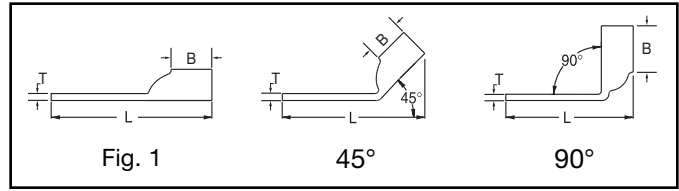

UL Listed 90° C,
600 Volts to 35 kV ♦

45° and 90° angles are available.
Please contact Customer Service to order:
1-800-346-4175



Catalog Number	Fig #	Conductor		Stud Hole Size	Stud Hole Spacing	Tongue Width	Figure Dimensions			Dieless (# of crimps)	▲ Installation Tooling					Wire Strip Length
		AWG	MM ²				(B)	(T)	(L)		Mechanical MD6, OUR840, MD7-34R	Hydraulic		Color Code	Die Index	
												BCT500HS, Y500CTHS	Y35, Y39, Y750, Y46*, PAT750			
YA28L-2NTC516	1	4/0 AWG	—	5/16"	1-3/4"	1.02"	.88"	.14"	3.84"	MY29-3 (1)	W28VT (2) W28RT (2) X28RT (3)	W28VT (2) W28RT (2) X28RT (3)	U28RT (1)	Purple	15	1-1/8"
YA28-2LN	1			1/2"	1-3/4"	1.02"	.88"	.14"	4.41"	MY29-11 (1)						
YA28L-2TC14E1	1			1/4"	1"	1.02"	.88"	.14"	3.03"	MRC840 (2)						
YA28L-2TC14E2	1			1/4"	3/4"	1.02"	.88"	.14"	2.78"	Y644HS (1)						
YA28L-2TC38E2	1			3/8"	3/4"	1.02"	.88"	.14"	2.97"	Y81KFT (1)						
YA28L-2TC38	1			3/8"	1"	1.02"	.88"	.14"	3.22"	Y81KFTMBH (1) PAT81KFT-18V (1)						
YA29-2LN	1	250 kcmil	—	1/2"	1-3/4"	1.11"	1.06"	.16"	4.62"	MY29-3 (1)	W29VT (2) X29RT (4)	W29VT (2) W29RT (2) X29RT (4)	U29RT (1)	Yellow	16	1-1/8"
YA29L-2TC38	1			3/8"	1"	1.11"	1.06"	.16"	3.45"	MY29-11 (1)						
YA30-2LN	1	300 kcmil	150	1/2"	1-3/4"	1.20"	1.03"	.16"	4.63"	Y644HS (1)	W30VT (2)	W30VT (2) W30RT (2)	U30RT (2) U28ART (2)	White	17	1"
YA30L-2TC-38	1			3/8"	1"	1.20"	1.03"	.16"	3.45"							
YA31-2LN	1	350 kcmil	185	1/2"	1-3/4"	1.29"	1.06"	.18"	4.70"	Y81KFT (1)	W31VT (2)	W31VT (2) W31RT (2)	U31RT (2) U29ART (2)	Red	18	1-1/8"
YA31L-2TC12	1			1/2"	1-1/4"	1.29"	1.06"	.18"	4.01"							
YA31L-2TC14E2	1			1/4"	3/4"	1.29"	1.06"	.18"	3.07"							
YA31L-2TC38	1			3/8"	1"	1.29"	1.06"	.18"	3.51"							
YA31L-2NTC516	1			5/16"	1-3/4"	1.29"	1.06"	.18"	4.13"							
YA32-2LN	1			1/2"	1-3/4"	1.38"	1.19"	.19"	4.88"							
YA32L-2TC38E5	1	400 kcmil	—	3/8"	1-1/16"	1.40"	1.19"	.19"	3.75"	Y81KFTMBH (1)	W32VT (2)	W32VT (2) W32RT (2)	U32RT (2) U30ART (2)	Blue	19	1-1/4"
YA32L-2TC38	1			3/8"	1"	1.38"	1.19"	.19"	3.69"							
YA32-2L	1			3/8"	1"	1.40"	1.19"	.19"	3.75"							
YA33-2LN	1	450 kcmil	—	1/2"	1-3/4"	1.48"	1.50"	.21"	5.23"	Y81KFTMBH (1)	W33VT (2)	W33VT (2) W33RT (2)	U33RT (2)	Gray	326 or 538	1-9/16"
YA34-2LN	1	500 kcmil	240	1/2"	1-3/4"	1.52"	1.27"	.23"	5.06"	PAT81KFT-18V (1)	W34VT (2)	W34VT (2) W34RT (2)	U34RT (2) U31ART (2)	Brown	20	1-7/16"
YA34L-2TC12	1			1/2"	1-1/4"	1.52"	1.27"	.23"	4.38"							
YA34L-2TC14E2	1			1/4"	3/4"	1.52"	1.27"	.23"	3.44"							
YA34L-2TC38	1			3/8"	1"	1.52"	1.27"	.23"	3.88"							
YA34-2L	1			3/8"	1"	1.55"	1.27"	.23"	3.94"							
YA35-2L	1	550 kcmil	—	3/8"	1-1/8"	1.65"	1.69"	.25"	4.64"	—	—	—	U35RT (2)	Yellow	21	1-3/4"
YA35-2LN	1			1/2"	1-3/4"	1.65"	1.69"	.25"	—							
YA36-2LN	1			1/2"	1-3/4"	1.74"	1.38"	.27"	4.36"							
YA36L-2TC38	1	600 kcmil	300	3/8"	1"	1.73"	1.38"	.27"	4.23"	—	—	—	U36RT (2) U32ART (2)	Green	22	1-3/4"
YA37-2L	1			3/8"	1-1/8"	1.80"	1.39"	.27"	4.40"							
YA37-2LN	1	650 kcmil	—	1/2"	1-3/4"	1.80"	1.39"	.27"	5.27"	—	—	—	U37RT (2)	Orange	23	1-15/16"

-- Color code not assigned.
▲ See tooling section of this catalog for complete tool and die listings.
♦ For applications greater than 2000 volts consult cable manufacturer for voltage stress relief instructions.

* Use PUADP-1 adapter with U dies in Y46 HYPRESS™.
** P-RT die sets for use in Y46 HYPRESS™ only, PUADP-1 adapter not required.
*** The MM² conductor sizes listed are the recommendations for Class 2 conductor.
Note: All dimensions shown are for reference only.

Blue highlighted items are industry standard and most frequently ordered.

**TWO HOLE HYLUG™
CODE CONDUCTOR
STANDARD BARREL**
(Continued)

UL Listed 90° C,
600 Volts to 35 kV ◆

45° and 90° angles are available.
Please contact Customer Service to order:
1-800-346-4175

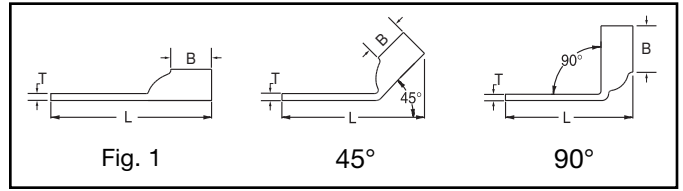

C-33



Catalog Number	Fig #	Conductor		Stud Hole Size	Stud Hole Spacing	Tongue Width	Figure Dimensions			Dieless (# of crimps)	▲ Installation Tooling					Wire Strip Length	
		AWG	MM²				(B)	(T)	(L)		Mechanical MD6, OUR840, MD7-34R	Hydraulic		Color Code	Die Index		
												BCT500HS, Y500CTHS	Y35, Y39, Y750, Y46*, PAT750				
YA38-2L	1	700 kcmil	—	3/8"	1-1/8"	1.84"	1.45"	.27"	4.48"	Y644HS (1)	—	—	U38RT (2)	Pink	400	1-15/16"	
YA38-2LN	1			1/2"	1-3/4"	1.81"	1.45"	.27"	5.35"	Y81KFT (1)							
YA38L-2TC12	1			1/2"	1-1/2"	1.81"	1.45"	.27"	4.67"	Y81KFTMBH (1)							
YA38L-2TC38	1			3/8"	1"	1.81"	1.45"	.27"	4.35"	PAT81KFT-18V (1)							
YA39-2L	1	750 kcmil	—	3/8"	1-1/8"	1.91"	1.42"	.27"	4.48"	Y644HS (1)	—	—	U39RT (2) P39RT (2) **	Black	24	1-15/16"	
YA39-2LN	1			1/2"	1-3/4"	1.89"	1.42"	.27"	5.36"								Y81KFT (2)
YA39L-2TC12E3	1			1/2"	1-1/2"	1.89"	1.42"	.27"	4.92"								PAT81KFT-18V (2)
YA39L-2TC38	1			3/8"	1"	1.89"	1.42"	.27"	4.36"								
YA39L-2TC58	1	800 kcmil	400	5/8"	1-1/2"	1.89"	1.42"	.27"	5.17"	Y81KFTMBH (2)	—	—	P40RT (3) **	Orange	25	1-15/16"	
YA40-2L	1			3/8"	1-1/8"	1.98"	1.42"	.30"	4.63"								
YA40-2LN	1			1/2"	1-3/4"	1.89"	1.42"	.30"	5.51"								
YA40L-2TC38	1	850 kcmil	—	3/8"	1"	1.95"	1.42"	.30"	4.51"	PAT81KFT-18V (2)	—	—	—	Gold	26	1-15/16"	
YA41-2L	1			3/8"	1-1/8"	2.01"	1.88"	.31"	4.97"								
YA44-2LN	1	1000 kcmil	500	1/2"	1-3/4"	2.17"	1.65"	.33"	5.74"	—	—	—	P44RT (3) **	White	27	1-15/16"	
YA44-2L	1			1/2"	1-1/4"	2.19"	1.65"	.33"	5.24"								
YA44L-2TC12	1			1/2"	1-1/4"	2.17"	1.65"	.33"	5.05"								

-- Color code not assigned.
▲ See tooling section of this catalog for complete tool and die listings.
◆ For applications greater than 2000 volts consult cable manufacturer for voltage stress relief instructions.
* Use PUADP-1 adapter with U dies in Y46 HYPRESS™.

** P-RT die sets for use in Y46 HYPRESS™ only, PUADP-1 adapter not required.
*** The MM² conductor sizes listed are the recommendations for Class 2 conductor.
Note: All dimensions shown are for reference only.

Blue highlighted items are industry standard and most frequently ordered.

Compression Connections

BURNDY®

Copper Compression – Code – Two Hole Narrow Tongue – Inspection Window

C-34

TWO HOLE HYLUG™ CODE CONDUCTOR STANDARD BARREL NARROW TONGUE

TYPES YA-L-2NT

COPPER COMPRESSION
TERMINAL

UL Listed 90° C,
600 Volts to 35 kV ◆

45° and 90° angles are available.

Please contact Customer Service to order:
1-800-346-4175

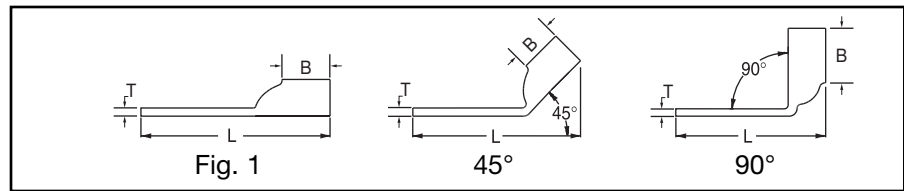
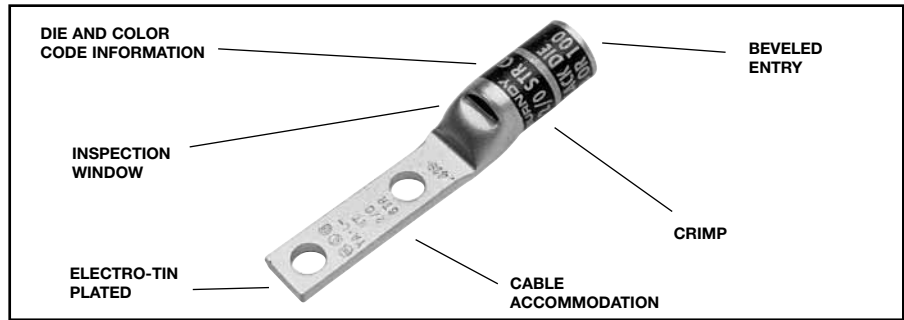

Catalog Number	Fig #	Conductor		Stud Hole Size	Stud Hole Spacing	Tongue Width	Figure Dimensions			Dieless (# of crimps)	▲ Installation Tooling				Wire Strip Length		
		AWG	MM ²				(B)	(T)	(L)		Mechanical		Hydraulic			Color Code	Die Index
											MD6, OUR840, MD7-34R	BCT500HS, Y500CTS	Y35, Y39, Y750, Y46*, PAT750				
YA2CL2NT14	1	#2 AWG	35	1/4"	5/8"	.48"	.88"	.11"	2.47"	W2CVT (1)	W2CVT (1)	U2CRT (1)	Brown	10	15/16"		
YA2CL2NT14E2	1			1/4"	3/4"	.48"	.88"	.11"	2.60"								
YA2CL2NT14E1	1			1/4"	1"	.48"	.88"	.11"	2.84"								
YA1CL2NT14	1	#1 AWG	50	1/4"	5/8"	.50"	.88"	.11"	2.55"	W1CVT (1)	W1CRT (1)	U1CRT (1)	Green	11	15/16"		
YA1CL2NT14E2	1			1/4"	3/4"	.50"	.88"	.10"	2.68"								
YA25L2NT14	1	1/0 AWG	—	1/4"	5/8"	.48"	.88"	.10"	2.56"	W25VT (2)	W25VT (2)	U25RT (1)	Pink	12	15/16"		
YA25L2NT14E1	1			1/4"	1"	.48"	.88"	.12"	3.28"								
YA26L2NT14	1	2/0 AWG	70	1/4"	5/8"	.48"	.94"	.12"	2.66"	W26VT (2)	W26VT (2) X26RT (2)	U26RT (1)	Black	13	1"		
YA26L2NT14E1	1			1/4"	1"	.48"	.94"	.12"	3.03"								

* Use PUADP-1 adapter with U dies in Y46 HYPRESS™.

*** The MM² conductor sizes listed are the recommendations for Class 2 conductor.

Note: All dimensions shown are for reference only.

Blue highlighted items are industry standard and most frequently ordered.

**TWO HOLE HYLUG™
CODE CONDUCTOR
STANDARD BARREL
NARROW TONGUE
(Continued)**

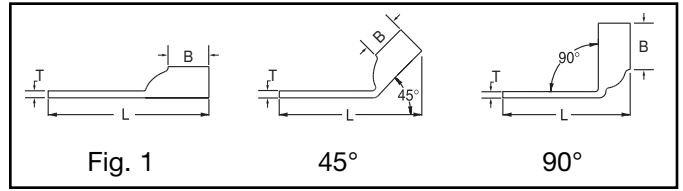
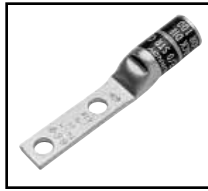

UL Listed 90° C,
600 Volts to 35 kV ◆

45° and 90° angles are available.
Please contact Customer Service to order:
1-800-346-4175



Catalog Number	Fig #	Conductor		Stud Hole Size	Stud Hole Spacing	Tongue Width	Figure Dimensions			▲ Installation Tooling					Wire Strip Length	
		AWG	*** MM²				(B)	(T)	(L)	Dieless (# of crimps)	Mechanical MD6, OUR840, MD7-34R	Hydraulic		Color Code		Die Index
												Y35, Y39, Y750, Y46*, PAT750				
YA27L2NT14	1	3/0 AWG	—	1/4"	5/8"	.76"	1.00"	.13"	2.73"	MY29-3 (1) MY29-11 (1)	W27VT (2) W27RT (2) X27RT (3)	W27VT (2) W27RT (2) X27RT (3)	U27RT (1)	Orange	14	1-1/16"
YA27L2NT38	1			3/8"	1"	.60"	1.00"	.13"	3.30"	MRC840 (2) Y644HS (1) Y81KFT (1)						
YA27LENT516	1			5/16"	1"	.60"	1.00"	.13"	3.11"	Y81KFTMBH (1) PAT81KFT-18V (1)						
YA28L2NT14	1	4/0 AWG	—	1/4"	5/8"	.76"	.88"	.13"	2.65"	Y81KFTMBH (1) PAT81KFT-18V (1)	W27RT (2)	W28RT (2) X28RT (3)	U28RT (1)	Purple	15	1-1/16"
YA29L2NT38	1	250 kcmil	—	3/8"	1"	.80"	1.00"	.16"	3.43"	MY29-3 (1) MY29-11 (1) Y644HS (1) Y81KFT (1)	W29VT (2) X29RT (2)	W29VT (2) W29RT (2) X29RT (2)	U29RT (1)	Yellow	16	1-1/8"
YA29L2NT38E16	1			3/8"	1-3/4"	.80"	1.06"	.16"	4.18"	Y81KFTMBH (1) PAT81KFT-18V (1)						
YA31L2NT38	1	350 kcmil	185	3/8"	1"	.96"	1.06"	.18"	3.51"	Y644HS (1) Y81KFT (1) Y81KFTMBH (1) PAT81KFT-18V (1)	W31VT (2)	W31VT (2) W31RT (2)	U31RT (2) U29ART (2)	Red	18	1-1/8"
YA31L2NT38E16	1			3/8"	1-3/4"	.88"	1.06"	.18"	4.26"							
YA34L2NT38	1	500 kcmil	240	3/8"	1"	.96"	1.27"	.23"	3.65"	Y644HS (1) Y81KFT (1) Y81KFTMBH (1) PAT81KFT-18V (1)	W34VT (4)	W34VT (4)	U34RT (2)	Brown	20 or 22	1-7/16"
YA34L2NT38E16	1			3/8"	1-3/4"	.96"	1.27"	.23"	4.63"							
YA34L2NTE1	1			1/2"	1"	.96"	1.27"	.23"	4.13"							
YA36L2NNT	1	600 kcmil	300	1/2"	1-3/4"	1.12"	1.38"	.27"	5.43"	—	—	U36RT (2)	Green	472	1-3/4"	
YA39L2NT38	1	750 kcmil	—	3/8"	1"	1.63"	1.42"	.27"	4.34"	—	—	U39RT (2)	Black	24	1-1/2"	
YA39L2NT38E16	1			3/8"	1-3/4"	1.30"	1.42"	.27"	5.11"							
YA39L2NT12E1	1	1/2"	1"	1.30"	1.42"	.27"	4.42"									

* Use PUADP-1 adapter with U dies in Y46 HYPRESS™.

*** The MM² conductor sizes listed are the recommendations for Class 2 conductor.

Note: All dimensions shown are for reference only.

Blue highlighted items are industry standard and most frequently ordered.

Compression Connections

BURNDY®

Copper Compression – Code – Long Barrel – No Inspection Window

C-36

TWO HOLE HYLUG™ CODE CONDUCTOR LONG BARREL

TYPES YA-2N, YA-2TC, YA-4N

UL Listed 90° C,
600 Volts to 35 kV ◆

45° and 90° angles are available.

Please contact Customer Service to order:
1-800-346-4175

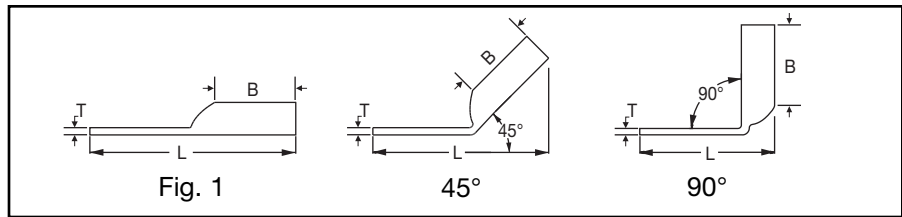
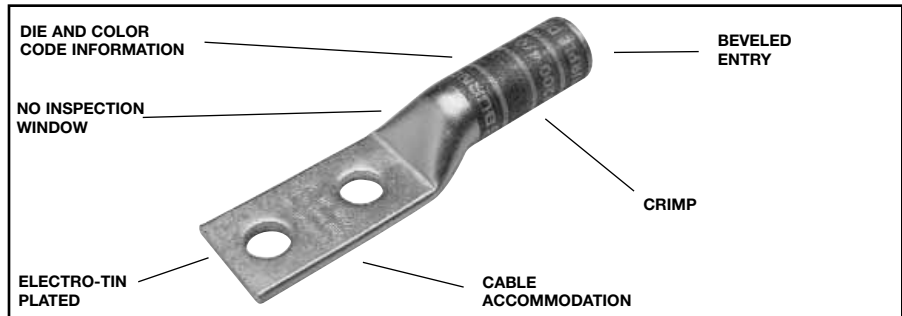

Catalog Number	Fig #	Conductor			Stud Hole Size	Stud Hole Spacing	Tongue Width	Figure Dimensions			Dieless (# of crimps)	▲ Installation Tooling				Wire Strip Length					
		AWG	MM ²	†				(B)	(T)	(L)		Mechanical MD6, OUR840, MD7-34R	Hydraulic		Color Code		Die Index				
													BCT500HS, Y500CTS	Y35, Y39, Y750, Y46*, PAT750							
YA8C2TC14	1	#8 Str. #6 Sol. 37/24	† 10	1/4"	5/8"	.40"	.81"	.08"	2.33"	Y8MRB-1 (2) MY29-3 (2) MY29-11 (2) MRC840 (2) Y81KFT (1) Y81KFTMBH (1) PAT81KFT-18V (1)	W8CVT (2) W8CRT (2) X8CRT (2)	W8CVT (2) W8CRT (2) X8CRT (2)	U8CRT (1)	Red	49	1"					
YA8C2TC14E2	1						1/4"	3/4"	.41"	.81"	.08"	2.45"									
YA8C2TC38	1						3/8"	1"	.73"	.81"	.06"	2.89"									
YA6C2N	1	#6 AWG	—	1/2"	1-3/4"	.81"	1.12"	.12"	4.40"	Y1MRTC (2)	W5CVT (2) W5CRT (2) X5CRT (2) X8CART (2)	W5CVT (2)	W5CVT (2)	U5CRT (2) U8CABT (2)	Blue	7	1-3/16"				
YA6C2TC14	1						1/4"	5/8"	.45"	1.12"		.08"	2.65"					MY29-3 (2)			
YA6C2TC14E1	1						1/4"	1"	.45"	1.12"		.08"	3.03"					MY29-11 (2)			
YA6C2TC14E2	1						1/4"	3/4"	.45"	1.12"		.08"	2.78"					MRC840 (2)			
YA6C2TC38	1						3/8"	1"	.63"	1.12"		.06"	3.22"					Y81KFT (1)			
YA6C2TC38E2	1						3/8"	3/4"	.63"	1.12"		.06"	2.97"					Y81KFTMBH (1)			
YA6C2TC38E6	1						3/8"	7/8"	.63"	1.12"		.06"	3.09"					PAT81KFT-18V (1)			
YA5C2N	1	#5 AWG	—	1/2"	1-3/4"	.83"	1.12"	.12"	4.43"	MY29-3 (2) MY29-1 (2) MRC840 (2) Y644HS (1) Y81KFT (1) Y81KFTMBH (1) PAT81KFT-18V (1)	W5CRT (2) W5CVT (2) X5CRT (2)	X5CRT (2) X5CVT (2) W5CRT (2)	U5CRT (2)	Blue	7	1-3/16"					
YA4C2N	1	#4 AWG	—	1/2"	1-3/4"	.81"	1.12"	.12"	4.45"	Y1MRTC (4)	W4CVT (2)	W4CVT (2)	U4CRT (2) U6CABT (2)	Gray	8	1-3/16"					
YA4C2TC14	1						1/4"	5/8"	.50"	1.12"	.09"	2.70"					MY29-3 (2)	W4CRT (2)	W4CRT (2)		
YA4C2TC14E2	1						1/4"	3/4"	.50"	1.12"	.09"	2.83"					MY29-11 (2)	X4CRT (2)	X4CRT (2)		
YA4C2TC38	1						3/8"	1"	.56"	1.12"	.08"	3.26"					MRC840 (2)				
YA3C2N	1						1/2"	1-3/4"	.81"	1.25"	.12"	4.62"					Y644HS (1)	W3CRT (2)	W3CRT (2)	U3CRT (2)	White
YA3C2TC14	1	#3 Str.	25	1/4"	5/8"	.55"	1.25"	.09"	2.87"	Y81KFT (1)											
YA3C2TC14E2	1	#3 AWG	1/4"	3/4"	.55"	1.25"	.09"	2.99"	Y81KFTMBH (1)												
YA3C2TC38	1	#2 Sol.	3/8"	1"	.58"	1.25"	.08"	3.43"	PAT81KFT-18V (1)												
YA3C2TC38E2	1	3/8"	3/4"	.58"	1.25"	.08"	3.18"														

▲ See tooling section of this catalog for complete tool and die listings.

* Use PUADP-1 adaptor with U -dies in Y46 HYPRESS™.

** P-RT die sets for use in Y46 HYPRESS™ only, PUADP-1 adaptor not required.

*** The MM² conductor sizes listed are the recommendations for Class 2 conductor.

† The MM² conductor size listed here is for Class 2 and Class 5 conductor.

Available undrilled. Add suffix U to catalog number (example: YA25U).

◆ For applications greater than 2000 Volts consult cable manufacturer for voltage stress relief instructions.

Note: All dimensions shown are for reference only.

Blue highlighted items are industry standard and most frequently ordered.

**TWO HOLE HYLUG™
CODE CONDUCTOR
LONG BARREL**
(Continued)

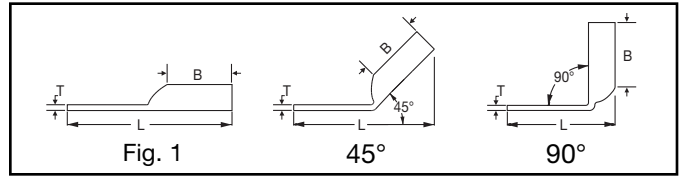
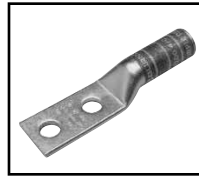

UL Listed 90° C,
600 Volts to 35 kV ◆

45° and 90° angles are available.
Please contact Customer Service to order:
1-800-346-4175



Catalog Number	Fig #	Conductor		Stud Hole Size	Stud Hole Spacing	Tongue Width	Figure Dimensions			Dieless (# of crimps)	▲ Installation Tooling					
		AWG	MM²				(B)	(T)	(L)		Mechanical MD6, OUR840, MD7-34R	Hydraulic		Color Code	Die Index	Wire Strip Length
												BCT500HS, Y500GTHS	Y35, Y39, Y750, Y46*, PAT750			
YA2C2N	1	#2 AWG	35	1/2"	1-3/4"	.81"	1.25"	.12"	4.64"	Y1MRTC (4) MY29-3 (2) MY29-11 (2) MRC840 (2) Y644HS (1) Y81KFT (2) Y81KFTMBH (2) PAT81KFT-18V (2)	W2CVT (2) W2CRT (2) X2CRT (2)	W2CVT (2) W2CRT (2) X2CRT (2)	U2CRT (2)	Brown	10	1-5/16"
YA2C2TC14	1			1/4"	5/8"	.60"	1.25"	.11"	2.86"							
YA2C2TC14E2	1			1/4"	3/4"	.60"	1.25"	.11"	2.98"							
YA2C2TC38E2	1			3/8"	3/4"	.60"	1.25"	.11"	3.17"							
YA2C2TC516E2	1			5/16"	3/4"	.60"	1.25"	.11"	3.05"							
YA2C2NTC38	1			3/8"	1-3/4"	.60"	1.25"	.11"	4.17"							
YA2C2TC38	1			3/8"	1"	.60"	1.25"	.11"	3.42"							
YA2C2TC38E6	1			3/8"	7/8"	.60"	1.25"	.11"	3.30"							
YA2C2TC516E2	1			5/16"	3/4"	.60"	1.25"	.11"	3.05"							
YA1C2N	1	#1 AWG	50	1/2"	1-3/4"	.81"	1.38"	.12"	4.82"	Y1MRTC (4) MY29-3 (2) MY29-11 (2) MRC840 (2) Y644HS (1) Y81KFT (2) Y81KFTMBH (2) PAT81KFT-18V (2)	W1CVT (2) W1CRT-1 (2) X1CRT-1 (2)	W1CVT (2) W1CRT-1 (2) X1CRT-1 (2)	U1CRT-1 (2) U4CABT (2)	Green	11	1-1/2"
YA1C2TC14	1			1/4"	5/8"	.68"	1.38"	.10"	3.03"							
YA1C2TC14E2	1			1/4"	3/4"	.75"	1.38"	.10"	3.15"							
YA1C2TC38	1			3/8"	1"	.68"	1.38"	.10"	3.59"							
YA252N	1	1/0 AWG	—	1/2"	1-3/4"	.81"	1.38"	.11"	4.81"	MY29-3 (2) MY29-11 (2) MRC840 (4) Y644HS (1) Y81KFT (2) Y81KFTMBH (2) PAT81KFT-18V (2)	W25VT (4) W25RT (4) X25RT (4)	W25VT (4) W25RT (4) X25RT (4)	U25RT (2) U2CABT (2)	Pink	12	1-7/16"
YA252TC14	1			1/4"	5/8"	.75"	1.38"	.12"	3.05"							
YA252TC14E2	1			1/4"	3/4"	.75"	1.38"	.12"	3.18"							
YA252TC38	1			3/8"	1"	.75"	1.38"	.12"	3.62"							
YA252TC516	1			5/16"	1"	.75"	1.38"	.12"	3.49"							
YA252NTC38	1			3/8"	1-3/4"	.75"	1.38"	.12"	4.37"							
YA262N	1	2/0 AWG	70	1/2"	1-3/4"	.83"	1.50"	.12"	4.97"	MY29-3 (2) MY29-11 (2) MRC840 (4) Y644HS (1) Y81KFT (2) Y81KFTMBH (2) PAT81KFT-18V (2)	W26VT (4) W26RT (4) X26RT (4)	W26VT (4) W26RT (4) X26RT (4)	U26RT (2)	Black	13	1-9/16"
YA262TC14	1			1/4"	5/8"	.83"	1.50"	.12"	3.22"							
YA262TC14E2	1			1/4"	3/4"	.83"	1.50"	.12"	3.34"							
YA262TC38	1			3/8"	1"	.83"	1.50"	.12"	3.78"							
YA272N	1	3/0 AWG	—	1/2"	1-3/4"	.91"	1.50"	.13"	5.01"	Y81KFTMBH (2) PAT81KFT-18V (2)	W27VT (4) W27RT (4) X27RT (6)	W27VT (4) W27RT (4) X27RT (6)	U27RT (2)	Orange	14	1-9/16"
YA272TC14E2	1			1/4"	3/4"	.91"	1.50"	.12"	3.38"							
YA272TC38	1			3/8"	1"	.90"	1.50"	.12"	3.82"							
YA282N	1	4/0 AWG	—	1/2"	1-3/4"	1.02"	1.62"	.14"	5.17"	MY29-3 (2) MY29-11 (2) Y644HS (1) Y81KFT (2) Y81KFTMBH (2) PAT81KFT-18V (2)	W28VT (4) W28RT (4) X28RT (6)	W28VT (4) W28RT (4) X28RT (6)	U28RT (2)	Purple	15	1-11/16"
YA282TC38	1			3/8"	1"	1.02"	1.62"	.14"	3.99"							
YA282TC14E2	1			1/4"	3/4"	1.02"	1.62"	.14"	3.55"							
YA282NTC38	1			3/8"	1-3/4"	1.02"	1.62"	.14"	4.74"							
YA292N	1	250 kcmil	—	1/2"	1-3/4"	1.11"	1.62"	.16"	5.21"	MY29-3 (2) MY29-11 (2) Y644HS (1) Y81KFT (2) Y81KFTMBH (2) PAT81KFT-18V (2)	W29VT (4) X29RT (8)	W29VT (4) W29RT (4) X29RT (8)	U29RT (2)	Yellow	16	1-11/16"
YA292TC38	1			3/8"	1"	1.10"	1.62"	.16"	4.02"							

▲ See tooling section of this catalog for complete tool and die listings.
* Use PUADP-1 adaptor with U -dies in Y46 HYPRESS™.

** P-RT die sets for use in Y46 HYPRESS™ only, PUADP-1 adaptor not required.
*** The MM² conductor sizes listed are the recommendations for Class 2 conductor.

Available undrilled. Add suffix U to catalog number (example: YA25U).
◆ For applications greater than 2000 Volts consult cable manufacturer for voltage stress relief instructions.
Note: All dimensions shown are for reference only.

Blue highlighted items are industry standard and most frequently ordered.

Compression Connections

BURNDY®

Copper Compression – Code – Long Barrel – No Inspection Window

C-38

TWO HOLE HYLUG™ CODE CONDUCTOR LONG BARREL (Continued)

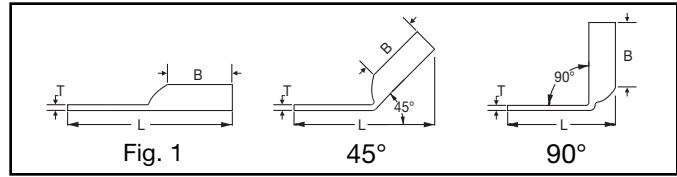
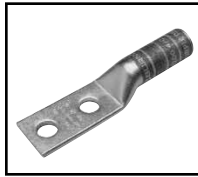

UL Listed 90° C,
600 Volts to 35 kV ◆

45° and 90° angles are available.
Please contact Customer Service to order:
1-800-346-4175



Catalog Number	Fig #	Conductor		Stud Hole Size	Stud Hole Spacing	Tongue Width	Figure Dimensions			Dieless (# of crimps)	▲ Installation Tooling					Wire Strip Length	
		AWG	MM²				(B)	(T)	(L)		Mechanical		Hydraulic		Color Code		Die Index
											MD6, OUR840, MD7-34R	BCT500HS, Y500CTS	Y35, Y39, Y750, Y46*, PAT750				
YA302TC38	1	300 kcmil	150	3/8"	1"	1.20"	2.00"	.16"	4.45"	Y644HS (1) Y81KFT (3) Y81KFTMBH (3) PAT81KFT-18V (3)	W30VT (4)	W30VT (4) W30RT (4)	U30RT (4) U28ART (4)	White	17	2"	
YA302N	1			1/2"	1-3/4"	1.20"	2.00"	.16"	5.64"								
YA312N	1	350 kcmil	185	1/2"	1-3/4"	1.29"	2.00"	.18"	5.68"	Y644HS (1) Y81KFT (4) Y81KFTMBH (4) PAT81KFT-18V (4)	W31VT (4)	W31VT (4) W31RT (4)	U31RT (4) U29ART (4)	Red	18	2-1/16"	
YA312TC14E2	1			1/4"	3/4"	1.29"	2.00"	.18"	4.05"								
YA312TC38	1			3/8"	1"	1.29"	2.00"	.18"	4.49"								
YA322N	1	400 kcmil	—	1/2"	1-3/4"	1.38"	2.12"	.19"	5.85"	Y644HS (1) Y81KFT (4) Y81KFTMBH (4) PAT81KFT-18V (4)	W32VT (4)	W32VT (4) W32RT (4)	U32RT (4) U30ART (4)	Blue	19	2-3/16"	
YA322TC38	1			3/8"	1"	1.38"	2.12"	.19"	4.66"								
YA332N	1	450 kcmil	—	1/2"	1-3/4"	1.48"	2.12"	.21"	5.93"	Y644HS (1) Y81KFT (4) Y81KFTMBH (4) PAT81KFT-18V (4)	W33VT (4)	W33VT (4) W33RT (4)	U33RT	Gray	326 or 538	2-3/16"	
YA342N	1	500 kcmil	240	1/2"	1-3/4"	1.55"	2.25"	.23"	6.06"	Y644HS (1) Y81KFT (4) Y81KFTMBH (4) PAT81KFT-18V (4)	W34VT (4)	W34VT (4) W34RT (4)	U34RT (4) U31ART (4)	Brown	20	2-1/2"	
YA342TC14E2	1			1/4"	3/4"	1.55"	2.25"	.23"	4.46"								
YA342TC38	1			3/8"	1"	1.55"	2.25"	.23"	4.90"								
YA352N	1	550 kcmil	—	1/2"	1-3/4"	1.65"	2.63"	.25"	6.49"	Y644HS (1) Y81KFT (4) Y81KFTMBH (4) PAT81KFT-18V (4)	—	—	U35RT (4)	Yellow	21	2-11/16"	
YA362N	1	600 kcmil	300	1/2"	1-3/4"	1.74"	2.69"	.27"	6.59"		—	—	U36RT (4) U32ART (4)	Green	22	2-3/4"	
YA362TC38	1			3/8"	1"	1.74"	2.69"	.26"	5.59"								
YA372N	1	650 kcmil	—	1/2"	1-3/4"	1.80"	2.81"	.27"	6.74"	Y644HS (1) Y81KFT (4) Y81KFTMBH (4) PAT81KFT-18V (4)	—	—	U37RT (4)	Orange	23	2-7/8"	
YA382N	1	700 kcmil	—	1/2"	1-3/4"	1.84"	2.81"	.27"	6.77"		—	—	U38RT (4)	Pink	400	2-7/8"	
YA382TC38	1			3/8"	1"	1.84"	2.81"	.27"	5.76"								
YA392N	1	750 kcmil	—	1/2"	1-3/4"	1.91"	2.88"	.27"	6.87"	Y644HS (1) Y81KFT (4) Y81KFTMBH (4) PAT81KFT-18V (4)	—	—	U39RT (4) P39RT (4) **	Black	24	2-3/4"	
YA392NT38	1			3/8"	1"	1.63"	2.88"	.27"	5.87"								
YA392TC38	1			3/8"	1"	1.91"	2.88"	.27"	5.87"								
YA402N	1	800 kcmil	400	1/2"	1-3/4"	1.95"	2.94"	.30"	6.95	Y644HS (1) Y81KFT (4) Y81KFTMBH (4) PAT81KFT-18V (4)	—	—	P40RT (4) **	Orange	25	3"	
YA412N	1	850 kcmil	—	1/2"	1-3/4"	2.01"	2.94"	.31"	6.96"		—	—	—	Gold	26	3"	
YA442N	1	1000 kcmil	500	1/2"	1-3/4"	2.17"	3.00"	.33"	7.14"		—	—	P44RT (4) **	White	27	3-1/16"	
YA442TC38	1			3/8"	1"	2.19"	3.00"	.33"	6.14"								
YA452N	1	1250 kcmil	—	1/2"	1-3/4"	2.46"	3.19"	.38"	7.44"	Y644HS (1) Y81KFT (4) Y81KFTMBH (4) PAT81KFT-18V (4)	—	—	P45RT (6) **	Yellow	29	3-1/4"	
YA4532N	1	1300 kcmil	—	1/2"	1-3/4"	2.53"	3.19"	.39"	7.48"		—	—	—	Orange	30	3-1/4"	
YA462N	1	1500 kcmil	—	1/2"	1-3/4"	2.67"	3.19"	.40"	7.55"		—	—	P46RT (6) **	Green	31	3-1/4"	
YA472N	1	1750 kcmil	—	1/2"	1-3/4"	2.90"	3.44"	.42"	7.89"	Y644HS (1) Y81KFT (4) Y81KFTMBH (4) PAT81KFT-18V (4)	—	—	—	Gray	33	3-1/2"	
YA482N	1	2000 kcmil	—	1/2"	1-3/4"	3.10"	3.44"	.46"	7.98"		—	—	—	Brown	34	3-1/2"	

▲ See tooling section of this catalog for complete tool and die listings.

* Use PUADP-1 adaptor with U -dies in Y46 HYPRESS™.

** P-RT die sets for use in Y46 HYPRESS™ only, PUADP-1 adaptor not required.

*** The MM² conductor sizes listed are the recommendations for Class 2 conductor.

Available undrilled. Add suffix U to catalog number (example: YA25U).

◆ For applications greater than 2000 Volts consult cable manufacturer for voltage stress relief instructions.

Note: All dimensions shown are for reference only.

Blue highlighted items are industry standard and most frequently ordered.

**TWO HOLE HYLUG™
CODE CONDUCTOR
LONG BARREL WITH
INSPECTION WINDOW**

**TYPES YAZ-2N, YAZ-2TC
COPPER COMPRESSION
TERMINAL**

UL Listed 90° C,
600 Volts to 35 kV ◆

45° and 90° angles are available.
Please contact Customer Service to order:
1-800-346-4175

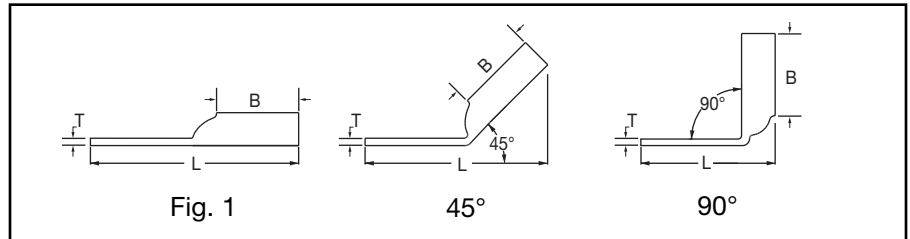
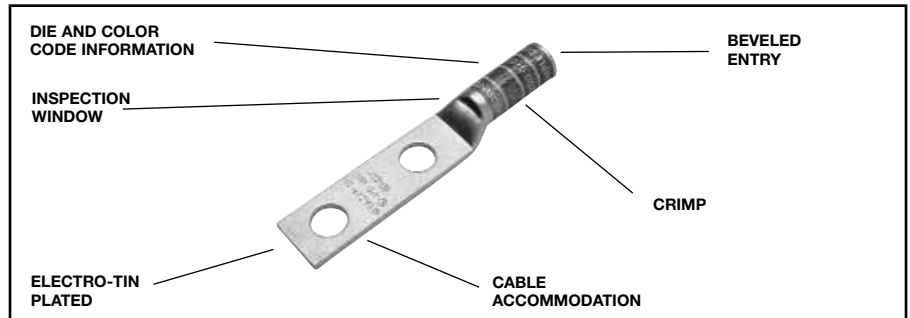

Catalog Number	Fig #	Conductor		Stud Hole Size	Stud Hole Spacing	Tongue Width	Figure Dimensions			Dieless (# of crimps)	▲ Installation Tooling					Wire Strip Length								
		AWG	MM²				(B)	(T)	(L)		Mechanical MD6, OUR840, MD7-34R	Hydraulic		Color Code	Die Index									
												BCT500HS, Y500GTHS	Y35, Y39, Y750, Y46*, PAT750											
YAZV10-2TC14	1	14-10 AWG	6	1/4"	5/8"	.41"	.69"	.05"	2.16"	Y8MRB-1 (2)	—	—	—	—	—	3/4"								
YAZV10-2TC14E2	1			1/4"	3/4"	.41"	.69"	.05"	2.28"		—	—	—	—	—	—	—							
YAZ8C-2TC10	1	#8 Str #6 Sol 37/24	† 10	#10	5/8"	.41"	.75"	.08"	2.20"	Y1MRTC (2)	W8CVT (2) W8CRT (2) X8CRT (2)	W8CVT (2) W8CRT (2) X8CRT (2)	U8CRT (2)	Red	49	7/8"								
YAZ8C-2TC10E2	1			#10	3/4"	.41"	.75"	.08"	2.33"	Y8MRB-1 (2)														
YAZ8C-2TC14	1			1/4"	5/8"	.44"	.75"	.08"	2.33"	MY29-3 (2)														
YAZ8C-2TC14E2	1			1/4"	3/4"	.44"	.75"	.08"	2.45"	MY29-11 (2)														
YAZ8C-2TC14E1	1			1/4"	1"	.44"	.75"	.08"	2.70"	MRC840 (2)														
YAZ8C-2TC38	1			3/8"	1"	.58"	.75"	.06"	2.89"	Y81KFT (1)														
YAZ6C-2N	1			#6 AWG	—	1/2"	1-3/4"	.83"	1.12"	.12"							4.40"	Y81KFTMBH (1)	W5CVT (2) W5CRT (2) X5CRT (2) X8CART (2)	W5CVT (2) W5CRT (2) X5CRT (2) X8CART (2)	U5CRT (2) U8CABT (2)	Blue	7 or 374	1-1/16"
YAZ6C-2TC10E2	1					#10	3/4"	.42"	1.12"	.09"							2.65"	PAT81KFT-18V (1)						
YAZ6C-2TC14	1	#6 AWG	—	1/4"	5/8"	.45"	1.12"	.08"	2.65"	Y1MRTC (2) MY29-3 (2) MY29-11 (2) MRC840 (2) Y644HS (2) Y81KFT (1) Y81KFTMBH (1) PAT81KFT-18V (1)	W5CVT (2) W5CRT (2) X5CRT (2) X8CART (2)	W5CVT (2) X5CRT (2) X5CRT (2) X8CART (2)	U5CRT (2) U8CABT (2)	Blue	7 or 374	1-1/16"								
YAZ6C-2TC14E2	1			1/4"	3/4"	.45"	1.12"	.08"	2.78"															
YAZ6C-2TC14E1	1			1/4"	1"	.45"	1.12"	.08"	3.03"															
YAZ6C-2TC38E2	1			3/8"	3/4"	.58"	1.12"	.06"	2.97"															
YAZ6C-2TC38E6	1			3/8"	7/8"	.58"	1.12"	.06"	3.09"															
YAZ6C-2TC38	1			3/8"	1"	.58"	1.12"	.06"	3.22"															
YAZ5C-2N	1	#5 AWG	—	1/2"	1-3/4"	.83"	1.12"	.12"	4.43"	Y81KFTMBH (1)	W5CRT (2) W5CVT (2) X5CRT (2)	W5CVT (2) W5CRT (2) X5CRT (2)	U5CRT (2)	Blue	7 or 374	1/16"								

▲ See tooling section of this catalog for complete tool and die listings.
* Use PUADP-1 adaptor with U -dies in Y46 HYPRESS™.
** P-RT die sets for use in Y46 HYPRESS™ only, PUADP-1 adaptor not required.

*** The MM² conductor sizes listed are the recommendations for Class 2 conductor.
† The MM² conductor size referred to here is for Class 2 and Class 5 conductor.

Available undrilled. Add suffix U to catalog number (example: YA25U).
◆ For applications greater than 2000 Volts consult cable manufacturer for voltage stress relief instructions.
Note: All dimensions shown are for reference only.

Blue highlighted items are industry standard and most frequently ordered.

Compression Connections

BURNDY®

Copper Compression – Code – Long Barrel – Inspection Window

C-40

TWO HOLE HYLUG™ CODE CONDUCTOR LONG BARREL WITH INSPECTION WINDOW (Continued)

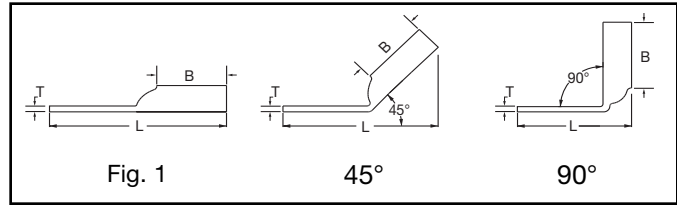

UL Listed 90° C,
600 Volts to 35 kV ◆

45° and 90° angles are available.
Please contact Customer Service to order:
1-800-346-4175



Catalog Number	Fig #	Conductor		Stud Hole Size	Stud Hole Spacing	Tongue Width	Figure Dimensions			Dieless (# of crimps)	▲ Installation Tooling					Wire Strip Length
		AWG	MM ²				(B)	(T)	(L)		Mechanical MD6, OUR840, MD7-34R	Hydraulic		Color Code	Die Index	
												BCT500HS, Y500CTHS	Y35, Y39, Y750, Y46*, PAT750			
YAZ4C-2N	1	#4 AWG	—	1/2"	1-3/4"	.83"	1.12"	.12"	4.42"	Y1MRTC (4) MY29-3 (2) MY29-11 (2) MRC840 (2) Y644HS (2) Y81KFT (1) PAT81KFT-18V (1)	W4CVT (2) W4CRT (2) X4CRT (2)	W4CVT (2) W4CRT (2) X4CRT (2)	U4CRT (2) U6CABT (2)	Gray	8 or 346	1-1/16"
YAZ4C-2TC10-E2	1			#10	3/4"	.49"	1.12"	.09"	2.67"							
YAZ4C-2TC14	1			1/4"	5/8"	.49"	1.12"	.09"	2.67"							
YAZ4C-2TC14E2	1			1/4"	3/4"	.49"	1.12"	.09"	2.80"							
YAZ4C-2TC38	1			3/8"	1"	.58"	1.12"	.08"	3.01"							
YAZ3C-2N	1	#3 AWG #2 Sol	25	1/2"	1-3/4"	.83"	1.25"	.12"	4.58"	Y1MRTC (4) MY29-3 (2) MY29-11 (2) MRC840 (2) Y644HS (2) Y81KFT (2) Y81KFTMBH (2) PAT81KFT-18V (2)	W3CRT (2)	W3CRT (2)	U3CRT (2)	White	9	1-5/16"
YAZ3C-2TC14	1			1/4"	5/8"	.55"	1.25"	.09"	2.83"							
YAZ3C-2TC14E2	1			1/4"	3/4"	.55"	1.25"	.09"	2.95"							
YAZ3C-2TC38E2	1			3/8"	3/4"	.58"	1.25"	.08"	3.14"							
YAZ3C-2TC38	1	#3 AWG #2 Sol	25	3/8"	1"	.58"	1.25"	.08"	3.39"		W3CRT (2)	W3CRT (2)	U3CRT (2)	White	9	1-5/16"
YAZ2C-2N	1	#2 AWG	35	1/2"	1-3/4"	.83"	1.25"	.12"	4.60"	Y1MRTC (4) MY29-3 (2) MY29-11 (2) MRC840 (2) Y644HS (1) Y81KFT (2) Y81KFTMBH (2) PATKFT-18V (2)	W2CVT (2) W2CRT (2) X2CRT (2)	W2CVT (2) W2CRT (2) X2CRT (2)	U2CRT (2)	Brown	10	1-5/16"
YAZ2C-2TC10E2	1			#10	3/4"	.60"	1.25"	.11"	2.85"							
YAZ2C-2TC14	1			1/4"	5/8"	.60"	1.25"	.11"	2.85"							
YAZ2C-2TC14E2	1			1/4"	3/4"	.60"	1.25"	.11"	2.97"							
YAZ2C-2TC14E1	1			1/4"	1"	.60"	1.25"	.11"	3.22"							
YAZ2C-2TC516E2	1			5/16"	3/4"	.60"	1.25"	.11"	3.03"							
YAZ2C-2TC38E2	1			3/8"	3/4"	.60"	1.25"	.11"	3.16"							
YAZ2C-2TC38E6	1			3/8"	7/8"	.60"	1.25"	.11"	3.28"							
YAZ2C-2TC38	1			3/8"	1"	.60"	1.25"	.11"	3.41"							
YAZ2C-2NTC38	1			3/8"	1-3/4"	.60"	1.25"	.11"	4.16"							
YAZ1C-2N	1	#1 AWG	50	1/2"	1-3/4"	.83"	1.38"	.12"	4.76"	W1CVT (2) W1CRT-1 (2) X1CRT-1 (2)	W1CVT (2) W1CRT-1 (2) X1CRT-1 (2)	U1CRT-1 (2) U4CABT (2)	Green	11 or 375	1-7/16"	
YAZ1C-2TC14	1			1/4"	5/8"	.67"	1.38"	.10"	3.01"							
YAZ1C-2TC14E2	1			1/4"	3/4"	.67"	1.38"	.10"	3.13"							
YAZ1C-2TC38	1			3/8"	1"	.67"	1.38"	.10"	3.57"							
YAZ25-2N	1	1/0 AWG	—	1/2"	1-3/4"	.83"	1.38"	.11"	4.79"	MY29-3 (2) MY29-11 (2) MRC840 (4) Y644HS (1) Y81KFT (2) Y81KFTMBH (2) PAT81KFT-18V (2)	W25RT (4) W25VT (4) X25RT (4)	W25VT (4) W25RT (4) W25RT (4)	U25RT (2) U2CABT (2)	Pink	12 or 348	1-7/16"
YAZ25-2TC14	1			1/4"	5/8"	.75"	1.38"	.12"	3.04"							
YAZ25-2TC14E2	1			1/4"	3/4"	.75"	1.38"	.12"	3.16"							
YAZ25-2TC14E1	1			1/4"	1"	.75"	1.38"	.12"	3.41"							
YAZ25-2TC516E6	1			5/16"	7/8"	.75"	1.38"	.12"	3.35"							
YAZ25-2TC516	1			5/16"	1"	.75"	1.38"	.12"	3.47"							
YAZ25-2TC38	1			3/8"	1"	.75"	1.38"	.12"	3.60"							
YAZ25-2NTC38	1			3/8"	1-3/4"	.75"	1.38"	.12"	4.35"							

▲ See tooling section of this catalog for complete tool and die listings.
* Use PUADP-1 adaptor with U -dies in Y46 HYPRESS™.
** P-RT die sets for use in Y46 HYPRESS™ only, PUADP-1 adaptor not required.

*** The MM² conductor sizes listed are the recommendations for Class 2 conductor.
Available undrilled. Add suffix U to catalog number (example: YA25U).

◆ For applications greater than 2000 Volts consult cable manufacturer for voltage stress relief instructions.
Note: All dimensions shown are for reference only.

Blue highlighted items are industry standard and most frequently ordered.

**TWO HOLE HYLUG™
CODE CONDUCTOR
LONG BARREL WITH
INSPECTION WINDOW**
(Continued)

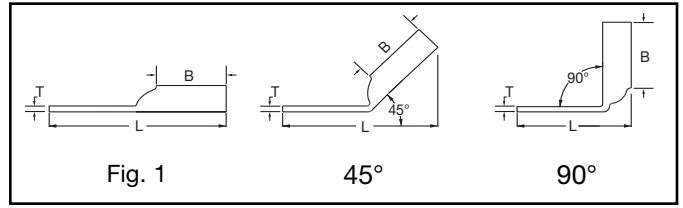

UL Listed 90° C,
600 Volts to 35 kV ◆



45° and 90° angles are available.
Please contact Customer Service to order:
1-800-346-4175

Catalog Number	Fig #	Conductor		Stud Hole Size	Stud Hole Spacing	Tongue Width	Figure Dimensions			Dieless (# of crimps)	▲ Installation Tooling					Wire Strip Length	
		AWG	MM²				(B)	(T)	(L)		Mechanical		Hydraulic		Color Code		Die Index
											MD6, OUR840, MD7-34R	BCT500HS, Y500CTS	Y35, Y39, Y750, Y46*, PAT750				
YAZ26-2N	1	2/0 AWG	70	1/2"	1-3/4"	.83"	1.50"	.12"	4.95"	MY29-3 (2) MY29-11 (2)	W26VT (4) W26RT (4) X26RT (4)	W26VT (4) W26RT (4) X26RT (4)	U26RT (2)	Black	13	1-9/16"	
YAZ26-2TC14	1			1/4"	5/8"	.83"	1.50"	.12"	3.20"								
YAZ26-2TC14E2	1			1/4"	3/4"	.83"	1.50"	.12"	3.32"								
YAZ26-2TC38	1			3/8"	1"	.83"	1.50"	.12"	3.76"								
YAZ27-2N	1	3/0 AWG	—	1/2"	1-3/4"	.91"	1.50"	.13"	4.98"	MRC840 (4) Y644HS (1) Y81KFT (2)	W27VT (4) W27RT (4) X27RT (6)	W27VT (4) W27RT (4) X27RT (6)	U27RT (2)	Orange	14	1-9/16"	
YAZ27-2TC14E2	1			1/4"	3/4"	.90"	1.50"	.12"	3.36"								
YAZ27-2TC38	1			3/8"	1"	.90"	1.50"	.12"	3.80"								
YAZ28-2N	1	4/0 AWG	—	1/2"	1-3/4"	1.02"	1.62"	.14"	5.15"	Y81KFTMBH (2) PAT81KFT-18V (2)	W28VT (4) W28RT (4) X28RT (6)	W28VT (4) W28RT (4) X28RT (6)	U28RT (2)	Purple	15	1-11/16"	
YAZ28-2TC14E2	1			1/4"	3/4"	1.02"	1.62"	.14"	3.55"								
YAZ28-2TC38	1			3/8"	1"	1.02"	1.62"	.14"	3.99"								
YAZ28-2NTC38	1			3/8"	1-3/4"	1.02"	1.62"	.14"	4.74"								
YAZ29-2N	1	250 kcmil	—	1/2"	1-3/4"	1.10"	1.62"	.16"	5.18"	MY29-3 (2) MY29-11(2) Y644HS (1) Y81KFT (2)	W29VT (4) X29RT (8)	X29RT (8) W29VT (4) W29RT (4)	U29RT (2)	Yellow	16	1-11/16"	
YAZ29-2TC38	1			3/8"	1"	1.10"	1.62"	.14"	3.99"								
YAZ30-2N	1	300 kcmil	150	1/2"	1-3/4"	1.20"	2.00"	.16"	5.60"	Y644HS (1) Y81KFT (3) PAT81KFT-18V (3)	W30VT (4)	W30VT (4) W30RT (4)	U30RT (4) U28ART (4)	White	17 or 298	2-1/16"	
YAZ30-2TC38	1			3/8"	1"	1.20"	2.00"	.16"	4.42"								
YAZ31-2N	1	350 kcmil	185	1/2"	1-3/4"	1.29"	2.00"	.18"	5.64"	Y81KFTMBH (3) PAT81KFT-18V (3)	W31VT (4)	W31VT (4) W31RT (4)	U31RT (4) U29ART (4)	Red	18 or 324	2-1/16"	
YAZ31-2TC14E2	1			1/4"	3/4"	1.29"	2.00"	.18"	4.02"								
YAZ31-2TC38	1			3/8"	1"	1.29"	2.00"	.18"	4.45"								
YAZ32-2N	1	400 kcmil	—	1/2"	1-3/4"	1.40"	2.12"	.19"	5.81"	PAT81KFT-18V (3)	W32VT (4)	W32VT (4) W32RT (4)	U32RT (4) U30ART (4)	Blue	19 or 470	2-1/16"	
YAZ32-2TC38	1			3/8"	1"	1.40"	2.12"	.19"	4.62"								
YAZ33-2N	1	450 kcmil	—	1/2"	1-3/4"	1.48"	2.13"	.21"	5.89"	W33VT (4)	W33VT (4) W33RT (4)	U33RT (4)	Gray	326 or 538	2-5/16"		
YAZ34-2N	1	500 kcmil	240	1/2"	1-3/4"	1.55"	2.25"	.23"	6.04"	Y644HS (1) Y81KFT (4)	W34VT (4)	W34VT (4) W34RT (4)	U34RT (4) U31ART (4)	Brown	20 or 299	2-5/16"	
YAZ34-2TC14E2	1			1/4"	3/4"	1.55"	2.25"	.23"	4.42"								
YAZ34-2TC38	1			3/8"	1"	1.55"	2.25"	.23"	4.85"								
YAZ35-2N	1	550 kcmil	—	1/2"	1-3/4"	1.65"	2.63"	.25"	6.45"	Y81KFTMBH (4)	—	—	U35RT (4)	Yellow	21	2-11/16"	
YAZ36-2N	1	600 kcmil	300	1/2"	1-3/4"	1.74"	2.69"	.27"	6.55"	PAT81KFT-18V (4)	—	—	U36RT (4) U32ART (4)	Green	22 or 472	2-3/4"	
YAZ36-2TC38	1			3/8"	1"	1.74"	2.69"	.26"	5.55"								
YAZ37-2N	1	650 kcmil	—	1/2"	1-3/4"	1.80"	2.81"	.27"	6.70"	—	—	U37RT (4)	Orange	23	2-7/8"		
YAZ38-2N	1	700 kcmil	—	1/2"	1-3/4"	1.84"	2.81"	.27"	6.72"	—	—	U38RT (4)	Pink	400	2-7/8"		

▲ See tooling section of this catalog for complete tool and die listings.
* Use PUADP-1 adaptor with U -dies in Y46 HYPRESS™.
** P-RT die sets for use in Y46 HYPRESS™ only, PUADP-1 adaptor not required.

*** The MM² conductor sizes listed are the recommendations for Class 2 conductor. Available undrilled. Add suffix U to catalog number (example: YA25U).

◆ For applications greater than 2000 Volts consult cable manufacturer for voltage stress relief instructions.
Note: All dimensions shown are for reference only.

Blue highlighted items are industry standard and most frequently ordered.

Compression Connections

BURNDY®

Copper Compression – Code – Long Barrel – Inspection Window

C-42

TWO HOLE HYLUG™ CODE CONDUCTOR LONG BARREL WITH INSPECTION WINDOW (Continued)

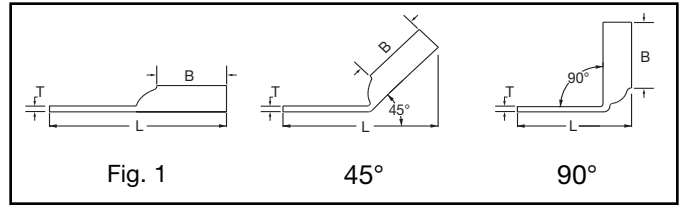

UL Listed 90° C,
600 Volts to 35 kV ◆



45° and 90° angles are available.

Please contact Customer Service to order:
1-800-346-4175

Catalog Number	Fig #	Conductor		Stud Hole Size	Stud Hole Spacing	Tongue Width	Figure Dimensions			▲ Installation Tooling													
		AWG	MM ²				(B)	(T)	(L)	Dieless (# of crimps)	Mechanical		Hydraulic		Color Code	Die Index	Wire Strip Length						
											MD6, OUR840, MD7-34R	BCT500HS, Y500CTS	Y35, Y39, Y750, Y46*, PAT750										
YAZ39-2N	1	750 kcmil	—	1/2"	1-3/4"	1.91"	2.88"	.27"	6.82"	Y644HS (1) Y81KFT (4) Y81KFTMBH (4) PAT81KFT-18V (4)	—	—	U39RT (4) P39RT (4) **	Black	24	2-15/16"							
YAZ39-2NT38	1			3/8"	1"	1.63"	2.88"	.27"	5.82"														
YAZ39-2TC38	1			3/8"	1"	1.91"	2.88"	.27"	5.82"														
YAZ39-2NNT	1			1/2"	1-3/4"	1.63"	2.88"	.27"	6.82"														
YAZ40-2N	1	800 kcmil	400	1/2"	1-3/4"	1.98"	2.94"	.30"	6.89"		—	—	P40RT (4) **	Orange	25	3"							
YAZ41-2N	1	850 kcmil	—	1/2"	1-3/4"	2.01"	2.94"	.31"	6.91"		—	—	—	Gold		3"							
YAZ44-2N	1	1000 kcmil	500	1/2"	1-3/4"	2.19"	3.00"	.33"	7.08"		Y644HS (1) Y81KFT (4) Y81KFTMBH (4) PAT81KFT-18V (4)	—	—	P44RT (4) **	White	27	3-1/16"						
YAZ44-2TC38	1			3/8"	1"	2.19"	3.00"	.33"	6.09"														
YAZ45-2N	1	1250 kcmil	—	1/2"	1-3/4"	2.46"	3.19"	.38"	7.38"									—	—	P45RT (6) **	Yellow	29	3-1/4"
YAZ453-2N	1	1300 kcmil	—	1/2"	1-3/4"	2.53"	3.19"	.39"	7.41"									—	—	—	Orange	30	2-1/16"
YAZ46-2N	1	1500 kcmil	—	1/2"	1-3/4"	2.69"	3.19"	.40"	7.48"			—	—	P46RT (6) **	Green	31	3-5/16"						
YAZ47-2N	1	1750 kcmil	—	1/2"	1-3/4"	2.90"	3.44"	.42"	7.82"			—	—	—	Gray	33	3-1/2"						
YAZ48-2N	1	2000 kcmil	—	1/2"	1-3/4"	3.10"	3.44"	.46"	7.89"	—		—	—	Brown	34	3-1/2"							

▲ See tooling section of this catalog for complete tool and die listings.

* Use PUADP-1 adaptor with U -dies in Y46 HYPRESS™.

** P-RT die sets for use in Y46 HYPRESS™ only, PUADP-1 adaptor not required.

*** The MM² conductor sizes listed are the recommendations for Class 2 conductor.

Available undrilled. Add suffix U to catalog number (example: YA25U).

◆ For applications greater than 2000 Volts consult cable manufacturer for voltage stress relief instructions.

Note: All dimensions shown are for reference only.

Blue highlighted items are industry standard and most frequently ordered.

**FOUR HOLE
HYLUG™
CODE CONDUCTOR**

TYPE YA

45° and 90° angles are available.
Please contact Customer Service to order:
1-800-346-4175

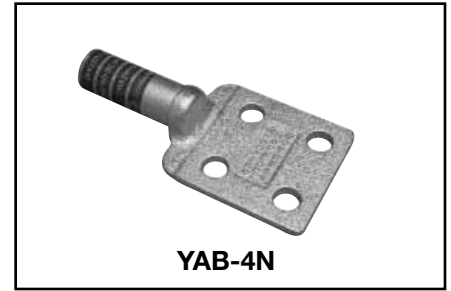
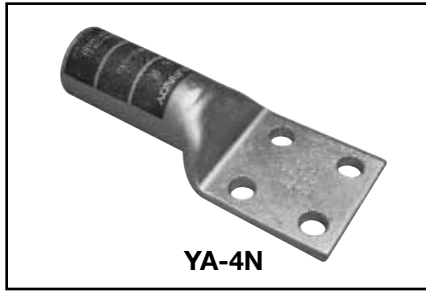

C-43

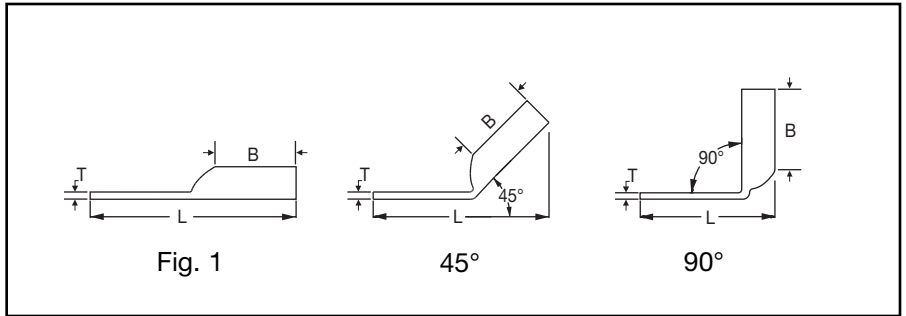

Catalog Number	Fig.#	Conductor		Stud Hole Size	Stud Hole Spacing	Tongue Width	Tongue Angle	Installation Tooling						Wire Strip Length
		AWG	*** MM ²					B	T	L	Hydraulic (Y35, Y39, Y750, Y46*)			
											**	Color Code	Die Index	
YA444N	1	1000 kcmil	500	1/2"	1.75"	3"	Straight	3.00"	.23"	7.14"	P44RT	White	27	3-1/16"
YA454N	1	1250 kcmil	—	1/2"	1.75"	3"	Straight	3.19"	.30"	7.44"	P45RT	Yellow	29	3-1/4"
YA464N	1	1500 kcmil	—	1/2"	1.75"	3"	Straight	3.19"	.34"	7.55"	P46RT	Green	31	3-1/4"
YA47N	1	1750 kcmil	—	1/2"	1.75"	3.10"	Straight	3.44"	.39"	7.89"	†L47RT	Gray	33	3-1/2"
YA484N	1	2000 kcmil	—	1/2"	1.75"	3.06"	Straight	3.44"	.46"	7.98"	†L48RT	Brown	34	3-1/2"
YA4864N	1	2500 kcmil	—	1/2"	1.75"	3.46"	Straight	4.69"	.52"	9.38"	†L486RT	—	—	4-3/4"
YAB344N	1	500 kcmil	—	1/2"	1.75"	3.00"	Straight	2.25"	.25"	6.33"	U36RT	Green	22	2-1/2"
YAB394N	1	750 kcmil	—	1/2"	1.75"	3.00"	Straight	2.88"	.25"	7.15"	U39RT	Black	24	2-15/16"

Available undrilled. Add suffix U to catalog number (example YA444NU).

* Use PUADP-1 adaptor with U dies in Y46 HYPRESS™.

** P dies for use with Y46 HYPRESS™ only. PUADP-1 adaptor not required.

*** The MM² conductor sizes listed are for Class 2 conductor. For applications greater than 2000 Volts, consult cable manufacturer for voltage stress relief instructions.

‡ Requires Y60BHU HYPRESS™

Note: All dimensions shown are for reference only.

Blue highlighted items are industry standard and most frequently ordered.

Compression Connections

BURNDY®

Copper Compression – Flex – Inspection Window

C-44

ONE HOLE HYLUG™ FLEX CONDUCTOR STANDARD BARREL

TYPES YA-L, YA-L-FX, YAV,
YAV-L-FX

COPPER COMPRESSION TERMINAL

UL Listed 90° C,
600 Volts to 35 kV ◆

45° and 90° angles are available.
Please contact Customer Service to order:
1-800-346-4175

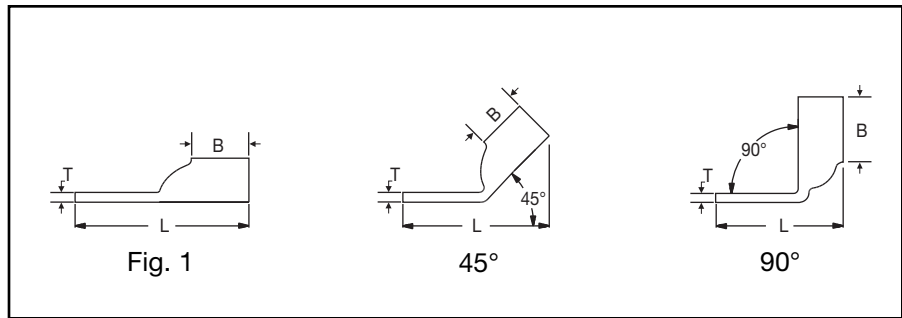
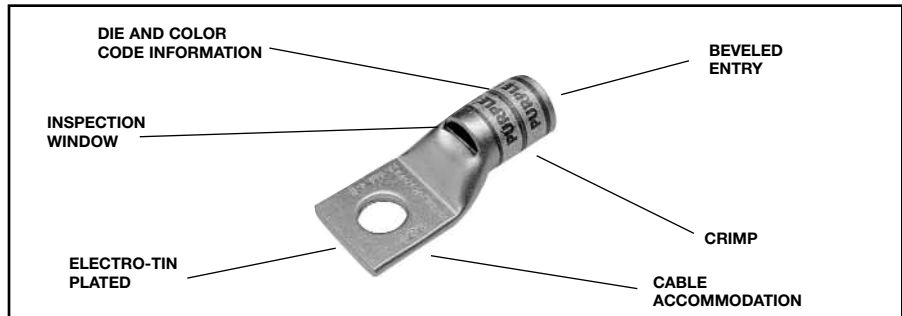

Catalog Number	Fig #	Conductor		Stud Hole Size	Tongue Width	Figure Dimensions			Dieless (# of crimps)	▲ Installation Tooling				Wire Strip Length	
		AWG	MM ²			(B)	(T)	(L)		Mechanical MD6, OUR840, MD7-34R	Hydraulic		Color Code		Die Index
											BCT500HS, Y500CTHS	Y35, Y39, Y750, Y46*, PAT750			
YA8CL-BOX	1	37/24 #8 Weld #8 AWG	10	8-10	.41"	.44"	.08"	1.16"	Y1MRTC (1)	W8CVT (1) W8CRT (1) X8CRT (1)	W8CVT (1) W8CRT (1) X8CRT (1)	U8CRT (1)	Red	49	7/16"
YA8C-L1-BOX	1			1/4"	.44"	.44"	.08"	1.26"	Y8MRB (1)						
YA8C-L2-BOX	1			5/16"	.52"	.44"	.08"	1.38"	MY29-11 (1) Y81KFT (1)						
YA8C-L3-BOX	1			3/8"	.58"	.44"	.08"	1.51"	Y81KFTMBH (1)						
YA8C-L4-BOX	1			1/2"	.71"	.44"	.08"	1.76"	PAT81KFT-18V (1)						
YAV6CL-TC10-FX	1	61/24 #6 Weld #6 AWG	16	8-10	.48"	.50"	.08"	1.30"	Y1MRTC (1)	W5CVT (1) W5CRT (1) X5CRT (1)	W5CVT (1) W5CRT (1) X5CRT (1)	U5CRT (1)	Blue	7	1/2"
YAV6CL-TC12-FX	1			1/2"	.75"	.50"	.12"	1.86"	MY29-11 (1)						
YAV6CL-TC14-FX	1			1/4"	.48"	.50"	.08"	1.43"	Y81KFT (1)						
YAV6CL-TC38-FX	1			3/8"	.60"	.50"	.06"	1.61"	Y81KFTMBH (1)						
YAV6CL-TC516-FX	1	5/16"	.60"	.50"	0.07"	1.49"									
YAV6CL-TC34-FX	1	61/24 #6 Weld #6 AWG	16	3/4"	1.05"	.50"	.13"	2.30"	MY29-11 (1) Y644HS (1) Y81KFT (1) Y81KFTMBH (1) PAT81KFT-18V (1)	W5CVT (1)	X5CRT (1)	U5CRT (1)	Blue	7	1/2"
YAV4CL-TC10-FX	1	91/24 105/24 #4 Weld #4 AWG	—	10-8	.55"	.50"	.09"	1.32"	Y1MRTC (2) MY29-11 (1) Y81KFT (1)	W4CVT (1) W4CRT (1) X4CRT (1)	W4CVT (1) W4CRT (1) X4CRT (1)	U4CRT (1)	Gray	8	1/2"
YAV4CL-TC12-FX	1			1/2"	.71"	.50"	.07"	1.92"							
YAV4CL-TC14-FX	1			1/4"	.55"	.50"	.09"	1.44"							
YAV4CL-TC38-FX	1			3/8"	.58"	.50"	.08"	1.67"							
YAV4CL-TC516-FX	1			5/16"	.55"	.50"	.09"	1.51"							
YAV2CL-TC10-FX	1	125/24 150/24 #2 Weld #2 AWG	35	# 10	.68"	.63"	.10"	1.50"	Y81KFTMBH (1) PAT81KFT-18V (1)	W2CVT (1) W2CRT (1) X2CRT (1)	W2CVT (1) W2CRT (1) X2CRT (1)	U2CRT (1)	Brown	10	11/16"
YAV2CL-TC12-FX	1			1/2"	.77"	.63"	0.09	2.12"							
YAV2CL-TC14-FX	1			1/4"	.68"	.63"	.10"	1.62"							
YAV2CL-TC38-FX	1			3/8"	.68"	.63"	.10"	1.81"							
YAV2CL-TC516-FX	1			5/16"	.68"	.63"	.10"	1.69"							

* Use PUADP-1 adapter with U dies in Y46 HYPRESS™.
** The MM² conductor size listed is for both Class 2 and Class 5 conductors.
*** The MM² conductor sizes listed are the recommendations for Class 5 conductor.

▲ See tooling section of this catalog for complete tool and die listings. Use ONLY color-coded die recommendations for -FX connectors. For nest/indenter system contact factory.

◆ For applications greater than 2000 Volts consult cable manufacturer for voltage stress relief instructions.
Note: All dimensions shown are for reference only.

Blue highlighted items are industry standard and most frequently ordered.

**ONE HOLE HYLUG™
FLEX CONDUCTOR
STANDARD BARREL**
(Continued)

UL Listed 90° C,
600 Volts to 35 kV ◆

45° and 90° angles are available.
Please contact Customer Service to order:
1-800-346-4175

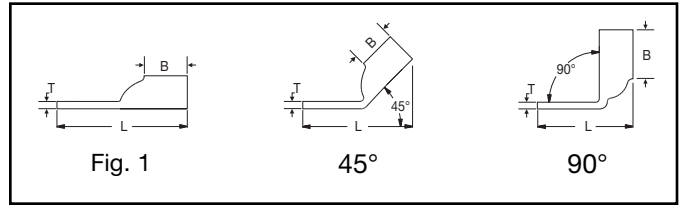

C-45

Catalog Number	Fig #	Conductor		Stud Hole Size	Tongue Width	Figure Dimensions			▲ Installation Tooling						Wire Strip Length
		AWG	*** MM²			(B)	(T)	(L)	Dieless (# of crimps)	Mechanical	Hydraulic		Color Code	Die Index	
										MD6, OUR840, MD7-34R	BCT500HS, Y500CTHS	Y35, Y39, Y750, Y46*, PAT750			
YAV1CL-TC10-FX	1	175/24	—	# 10	.75"	.69"	.12"	1.59"	MY29-11 (1) Y81KFT (1) Y81KFTMBH (1) PAT81KFT-18V (1)	W1CVT (1) W1CRT-1 (1) X1CRT-1 (1)	W1CVT (1) W1CRT-1 (1) X1CRT-1 (1)	U1CRT (1)	Green	11	11/16"
YAV1CL-TC12-FX	1	225/24		1/2"	.75"	.69"	.12"	2.15"							
YAV1CL-TC14-FX	1	#1 Weld		1/4"	.75"	.69"	.12"	1.71"							
YAV1CL-TC38-FX	1	#1 AWG		3/8"	.75"	.69"	.12"	1.90"							
YAV1CL-TC516-FX	1			5/16"	.75"	.69"	.12"	1.78"							
YAV25L-TC12-FX	1	275/24	50	1/2"	.83"	.69"	.12"	2.19"	MY29-11 (1) Y81KFT (1) Y81KFTMBH (1) PAT81KFT-18V (1)	W25VT (2) W25RT (2) X25RT (2)	W25VT (2) W25RT (2) X25RT (2)	U25RT (1)	Pink	12	11/16"
YAV25L-TC14-FX	1	1/0 Weld		1/4"	.83"	.69"	.12"	1.75"							
YAV25L-TC38-FX	1	1/0 AWG		3/8"	.83"	.69"	.12"	1.94"							
YAV25L-TC516-FX	1			5/16"	.83"	.69"	.12"	1.77"							
YAV26L-TC10-FX	1	325/24 2/0 Weld 2/0 AWG	70	# 10	.93"	.81"	.13"	1.80"	MY29-11 (1) Y644HS (1) Y81KFT (1) Y81KFTMBH (1) PAT81KFT-18V (1)	W26VT (2) W26RT (2) X26RT (2)	W26VT (2) W26RT (2) X26RT (2)	U26RT (1)	Black	13	13/16"
YAV26L-TC12-FX	1			1/2"	.93"	.81"	.13"	2.36"							
YAV26L-TC14-FX	1			1/4"	.93"	.81"	.13"	1.92"							
YAV26L-TC34-FX	1			3/4"	1.10"	.81"	.11"	2.89"							
YAV26L-TC38-FX	1			3/8"	.93"	.81"	.13"	2.11"							
YAV26L-TC516-FX	1			5/16"	.93"	.81"	.13"	1.98"							
YAV26L-TC58-FX	1	5/8"	.93"	.81"	.13"	2.61"									
YAV27L-TC10-FX	1	450/24 3/0 Weld 3/0 AWG	95	# 10	1.03"	1.00"	.14"	2.03"	MY29-11 (1) Y644HS (1) Y81KFT (1) Y81KFTMBH (1) PAT81KFT-18V (1)	W27VT (2) W27RT (2) X27RT (3)	W27VT (2) W27RT (2) X27RT (3)	U27RT (1)	Orange	14	1"
YAV27L-TC12-FX	1			1/2"	1.03"	1.00"	.14"	2.59"							
YAV27L-TC14-FX	1			1/4"	1.03"	1.00"	.14"	2.15"							
YAV27L-TC38-FX	1			3/8"	1.03"	1.00"	.14"	2.34"							
YAV27L-TC516-FX	1	5/16"	1.03"	1.00"	.14"	2.21"									
YAV28L-TC12-FX	1	550/24 4/0 Weld 4/0 AWG	120	1/2"	1.14"	1.03"	.15"	2.67"	MY29-11 (1) Y644HS (1) Y81KFT (1) Y81KFTMBH (1) PAT81KFT-18V (1)	W28VT (2) W28RT (2) X28RT (2)	W28VT (2) W28RT (2) X28RT (3)	U28RT (1)	Purple	15	1-1/16"
YAV28L-TC14-FX	1			1/4"	1.14"	1.03"	.15"	2.23"							
YAV28L-TC34-FX	1			3/4"	1.14"	1.03"	.15"	3.11"							
YAV28L-TC38-FX	1			3/8"	1.14"	1.03"	.15"	2.42"							
YAV28L-TC516-FX	1			5/16"	1.14"	1.03"	.15"	2.29"							
YAV28L-TC58-FX	1	5/8"	1.14"	1.03"	.15"	2.92"									
YAV29L-TC12-FX	1	550/24 4/0 Weld	—	1/2"	1.14"	1.03"	.16"	2.67"	MY29-11 (1) Y644HS (1) Y81KFT (1) Y81KFTMBH (1) PAT81KFT-18V (1)	W29VT (2) X29RT (4)	W29VT (2) W29RT (2) X29RT (4)	U29RT (1)	Yellow	16	1-1/16"
YAV29L-TC14-FX	1			1/4"	1.14"	1.03"	.16"	2.23"							
YAV29L-TC34-FX	1			3/4"	1.14"	1.03"	.16"	3.11"							
YAV29L-TC38-FX	1			3/8"	1.14"	1.03"	.16"	2.42"							
YAV29L-TC516-FX	1			5/16"	1.14"	1.03"	.16"	2.29"							
YAV29L-TC58-FX	1			5/8"	1.14"	1.03"	.16"	2.92"							
YA30L-TC516-FX	1	250 Flex	—	5/16"	1.20"	1.03"	.16"	2.31"	MY29-11 (1) Y644HS (1) Y81KFT (1) Y81KFTMBH (1) PAT81KFT-18V (1)	W29VT (2) X29RT (4)	W29VT (2) W29RT (2) X29RT (4)	U29RT (1)	Yellow	16	1-1/16"
YA30L-TC38-FX	1	CLASS G		3/8"	1.20"	1.03"	.16"	2.44"							
YA30L-TC12-FX	1	259 Str.		1/2"	1.20"	1.03"	.16"	2.69"							
YA30L-TC58-FX	1	CLASS H		5/8"	1.20"	1.03"	.16"	2.94"							
YA30L-TC34-FX	1	427 Str.		3/4"	1.20"	1.03"	.16"	3.12"							

* Use PUADP-1 adapter with U dies in Y46 HYPRESS™
 ** The 16 MM² is for both Class 2 and Class 5 conductors.
 *** The MM² conductor sizes listed are the recommendations for Class 5 conductor.

▲ See tooling section of this catalog for complete tool and die listings. Use ONLY color-coded die recommendations for -FX connectors. For nest/indenter system contact factory.

◆ For applications greater than 2000 Volts consult cable manufacturer for voltage stress relief instructions.
Note: All dimensions shown are for reference only.

Blue highlighted items are industry standard and most frequently ordered.

Compression Connections

BURNDY®

Copper Compression – Flex – Inspection Window

C-46

ONE HOLE HYLUG™ FLEX CONDUCTOR STANDARD BARREL (Continued)

UL Listed 90° C,
600 Volts to 35 kV ◆

45° and 90° angles are available.
Please contact Customer Service to order:
1-800-346-4175

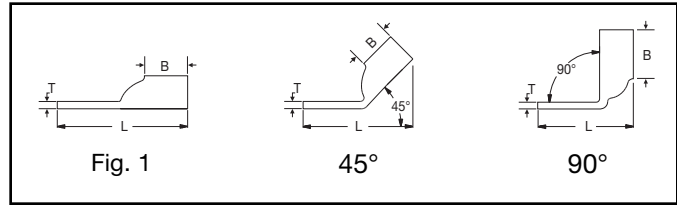

Catalog Number	Fig #	Conductor		Stud Hole Size	Tongue Width	Figure Dimensions			▲ Installation Tooling						
		AWG	*** MM ²			(B)	(T)	(L)	Dieless (# of crimps)	Mechanical MD6, OUR840, MD7-34R	Hydraulic BCT500HS, Y500CTHS	Y35, Y39, Y750, Y46*, PAT750	Color Code	Die Index	Wire Strip Length
YA31L-TC14-FX	1	250 Flex 637/24 CLASS I, K, M	150	1/4"	1.29"	1.06"	.18"	2.31"	Y644HS (1) Y81KFT (1) Y81KFTMBH (1) PAT81KFT-18V (1)	W30VT (2)	W30RT (2)	U30RT (2)	White	17	1-1/8"
YA31L-TC516-FX	1			5/16"	1.29"	1.06"	.18"	2.37"							
YA31L-TC38-FX	1			3/8"	1.29"	1.06"	.18"	2.50"							
YA31L-NT12-FX	1			1/2"	.96"	1.06"	.18"	2.75"							
YA31L-TC12-FX	1			1/2"	1.29"	1.06"	.18"	2.75"							
YA31L-TC58-FX	1			5/8"	1.29"	1.06"	.18"	3.00"							
YA31L-TC34-FX	1			3/4"	1.29"	1.06"	.18"	3.19"							
YA32L-TC38-FX	1			313.1 kcmil	185	3/8"	1.40"	1.19"							
YA32L-TC12-FX	1	775/24	1/2"	1.40"		1.19"	.19"	2.93"							
YA32L-TC58-FX	1	300 Flex	5/8"	1.40"		1.19"	.19"	3.18"							
YA34L-TC516-FX	1	373.7 kcmil 925/24 350 Flex	240	5/16"	1.55"	1.27"	.23"	2.74"	W32VT (2)	W32RT (2)	U32RT (2)	Blue	19	1-5/16"	
YA34L-TC38-FX	1			3/8"	1.55"	1.27"	.23"	2.87"							
YA34L-TC12-FX	1			1/2"	1.55"	1.27"	.23"	3.12"							
YA34L-TC58-FX	1			5/8"	1.55"	1.27"	.23"	3.37"							
YA36L-TC12-FX	1	444.4 kcmil 450 Flex	—	1/2"	1.74"	1.38"	.27"	3.29"	—	—	U34RT (2)	Brown	20	1-3/8"	
YA36L-TC58-FX	1	1100/24	—	5/8"	1.74"	1.38"	.27"	3.54"	W32VT (2)	W32RT (2)	U38XRT (2)	Pink	L99	1-7/16"	
YA38L-TC12-FX	1	535.3 kcmil 1325/24 500 Flex	300	1/2"	1.84"	1.45"	.27"	3.41"							
YA38L-TC58-FX	1			5/8"	1.84"	1.45"	.27"	3.66"							
YA38L-TC516-FX	1			5/16"	1.84"	1.45"	.27"	3.03"							
YA38L-TC38-FX	1			3/8"	1.84"	1.45"	.27"	3.34"							
YA40L-TC516-FX	1	646 kcmil 1600/24	400	5/16"	1.98"	1.42"	.30"	3.05"	Y644HS (1) Y81KFT (2) Y81KFTMBH (2) PAT81KFT-18V (2)	—	—	U39RT (2)	Black	24	1-5/16"
YA40L-TC38-FX	1			3/8"	1.98"	1.42"	.30"	3.38"							
YA40L-TC12-FX	1			1/2"	1.98"	1.42"	.30"	3.43"							
YA40L-TC58-FX	1			5/8"	1.98"	1.42"	.30"	3.68"							
YA44L-TC12-FX	1	777.7 kcmil 1925/24	500	1/2"	2.19"	1.65"	.33"	3.79"	—	—	U44XRT (2)	Yellow	L115	1-5/8"	
YA44L-TC58-FX	1			5/8"	2.19"	1.65"	.33"	4.04"							

* Use PUADP-1 adapter with U dies in Y46 HYPRESS™
 ** The 16 MM² is for both Class 2 and Class 5 conductors.
 *** The MM² conductor sizes listed are the recommendations for Class 5 conductor.

▲ See tooling section of this catalog for complete tool and die listings. Use ONLY color-coded die recommendations for -FX connectors. For nest/indenter system contact factory.

◆ For applications greater than 2000 Volts consult cable manufacturer for voltage stress relief instructions.
Note: All dimensions shown are for reference only.

Blue highlighted items are industry standard and most frequently ordered.

**ONE HOLE HYLUG™
FLEX CONDUCTOR
STANDARD BARREL
NARROW TONGUE**

TYPE YAV-L-NTFX

**COPPER COMPRESSION
NARROW TONGUE
TERMINAL**

UL Listed 90° C,
600 Volts to 35 kV ◆

45° and 90° angles are available.
Please contact Customer Service to order:
1-800-346-4175

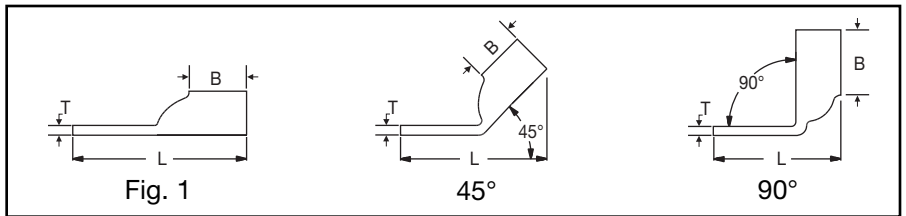
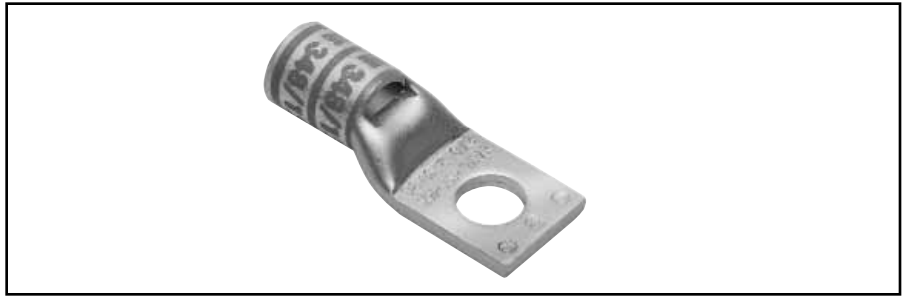

C-47



Catalog Number	Fig #	Conductor		Stud Hole Size	Tongue Width	Figure Dimensions			▲ Installation Tooling					Wire Strip Length	
		AWG	*** MM²			(B)	(T)	(L)	Dieless (# of crimps)	Mechanical	Hydraulic		Color Code		Die Index
										MD6, OUR840, MD7-34R	BCT500HS, Y500CTHS	Y35, Y39, Y750, Y46*, PAT750			
YAV4CLNT10FX	1	#4 AWG #4 Weld 91/24 105/24	—	#10	.41"	.50"	.09"	1.32"	MY29-11 (1) Y1MRTC (2) Y81KFT (1) Y81KFTMBH (1) PAT81KFT-18V (1)	W4CRT (1) X4CRT (1) W4CVT (1)	W4CRT (1) W4CVT (1) X4CRT (1)	U4CRT (1)	Gray	8	1/2"
YAV2CLNT14FX	1	#2 AWG #2 Weld 125/24	35	1/4"	.46"	.63"	.10"	1.71"	Y1MRTC (2) MY29-11 (1) Y81KFT (1) Y81KFTMBH (1) PAT81KFT-18V (1)	W2CVT (1) W2CRT (1) X2CRT (1)	W2CVT (1) W2CRT (1) X2CRT (1)	U2CRT (1)	Brown	10	11/16"
YAV2CLNT516FX	1	150/24	35	5/16"	.44"	.63"	.10"	1.78"	Y81KFT (1) Y81KFTMBH (1) PAT81KFT-18V (1)	W2CVT (1) W2CRT (1) X2CRT (1)	W2CVT (1) W2CRT (1) X2CRT (1)	U2CRT (1)	Brown	10	11/16"
YAV25LNT14FX	1	1/0 AWG	50	1/4"	.67"	.69"	.12"	1.75"	MY29-11 (1)	W25VT (2)	W25VT (2)	U25RT (1)	Pink	12	11/16"
YAV25LNT516FX	1	1/0 Weld		5/16"	.67"	.69"	.12"	1.81"	Y81KFT (1)	W25RT (2)	W25RT (2)				
YAV25LNT38FX	1	275/24		3/8"	.76"	.69"	.13"	1.94"	Y81KFTMBH (1) PAT81KFT-18V (1)	W25RT (2) X25RT (2)	W25RT (2) X25RT (2)				
YAV26LNT516FX	1	2/0 AWG	70	5/16"	.90"	.81"	.13"	1.98"	MY29-11 (1)	W26VT (2)	W26VT (2)	U26RT (1)	Black	13	13/16"
YAV26LNT38FX	1	2/0 Weld		3/8"	.90"	.81"	.13"	2.11"	Y644HS (1) Y81KFT (1)	W26RT (2) W26RT (2)	W26RT (2) W26RT (2)				
YAV26LNT12FX	1	325/24		1/2"	—	—	—	—	Y81KFTMBH (1) PAT81KFT-18V (1)	X26RT (2)	X26RT (2)				
YAV28LNT516FX	1	4/0 AWG	—	5/16"	.94"	1.03"	.15"	2.29"	MY29-11 (1)	W28VT (2)	W28VT (2)	U28RT (1)	Purple	15	1-1/16"
YAV28LNT38FX	1	4/0 Weld		3/8"	.94"	1.03"	.15"	2.42"	Y644HS (1) Y81KFT (1)	W28RT (2) W28RT (2)	W28RT (2) W28RT (2)				
YAV28LNT12FX	1	550/24		1/2"	.76"	1.03"	.15"	2.67"	Y81KFTMBH (1) PAT81KFT-18V (1)	X28RT (3)	X28RT (3)				
YA31LNT12FX	1	250 Flex 637/24 Class I,K,M	150	1/2"	.96"	1.06"	.18"	2.75"	Y644HS (1) Y81KFT (1) Y81KFTMBH (1) PAT81KFT-18V (1)	W30VT (2)	W30VT (2) W30RT (2)	U30RT (2)	White	17	1-1/8"

Consult cable manufacturers for stress relief instructions.
◆ For applications greater than 2000 Volts consult cable manufacturer for voltage stress relief instructions.

* Use PUADP-1 adaptor with U -dies in Y46 HYPRESS™.
▲ See tooling section of this catalog for complete tool and die listings. Use ONLY color-coded die recommendations for -FX connectors.

Note: All dimensions shown are for reference only.

Blue highlighted items are industry standard and most frequently ordered.

Compression Connections

BURNDY®

Copper Compression – Flex – Standard Barrel – Narrow Tongue

C-48

ONE HOLE HYLUG™ FLEX CONDUCTOR STANDARD BARREL NARROW TONGUE (Continued)

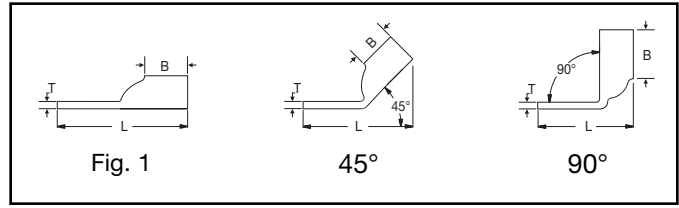

UL Listed 90° C,
600 Volts to 35 kV ◆



45° and 90° angles are available.
Please contact Customer Service to order:
1-800-346-4175

Catalog Number	Fig #	Conductor		Stud Hole Size	Tongue Width	Figure Dimensions			▲ Installation Tooling					Wire Strip Length	
		AWG	*** MM ²			(B)	(T)	(L)	Dieless (# of crimps)	Mechanical	Hydraulic		Color Code		Die Index
										MD6, OUR840, MD7-34R	BCT500HS, Y500CTHS	Y35, Y39, Y750, Y46*, PAT750			
YA32LNT516FX	1	313.1 kcmil	185	5/16"	.96"	1.19"	.19"	2.65"	Y644HS (1) Y81KFT (1) Y81KFTMBH (1) PAT81KFT-18V (1)	W31VT (2)	W31VT (2) W31RT (2)	U31RT (2)	Red	18	1-1/4"
YA32LNT38FX	1	775/24 300 Flex		3/8"	.96"	1.19"	.19"	2.68"							
YA38LNT12FX	1	535.3 kcmil	300	1/2"	1.63"	1.45"	.27"	3.41"	Y644HS (1) Y81KFT (1) Y81KFTMBH (1) PAT81KFT-18V (1)	—	—	U38XRT (2)	Pink	L99	1-7/16"
YA38LNTM20FX	1	1325/24 500 Flex		M20	1.63"	1.45"	.27"	3.84"							
YA44LNT38FX	1	777.7 kcmil	500	3/8"	1.50"	1.65"	.33"	3.79"	Y644HS (1) Y81KFT (2) Y81KFTMBH (2) PAT81KFT-18V (2)	—	—	U44XRT (2)	Yellow	L115	1-5/8"
YA44LNT12FX	1	1925/24 750 Flex		1/2"	1.62"	1.65"	.33"	3.98"							

Consult cable manufacturers for stress relief instructions.
◆ For applications greater than 2000 Volts consult cable manufacturer for voltage stress relief instructions.

* Use PUADP-1 adaptor with U -dies in Y46 HYPRESS™.
▲ See tooling section of this catalog for complete tool and die listings. Use ONLY color-coded die recommendations for -FX connectors.

Note: All dimensions shown are for reference only.

Blue highlighted items are industry standard and most frequently ordered.

**ONE HOLE HYLUG™
FLEX CONDUCTOR
STANDARD BARREL
NO INSPECTION
WINDOW**

TYPE YAG-L-TC

**COPPER COMPRESSION
TERMINAL**

UL Listed 90° C,
600 Volts to 35 kV



45° and 90° angles are available.
Please contact Customer Service
to order: 1-800-346-4175

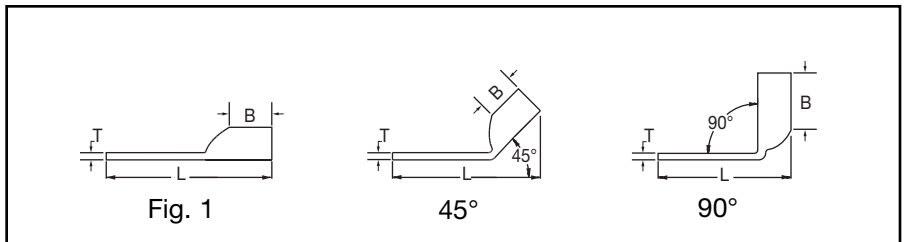
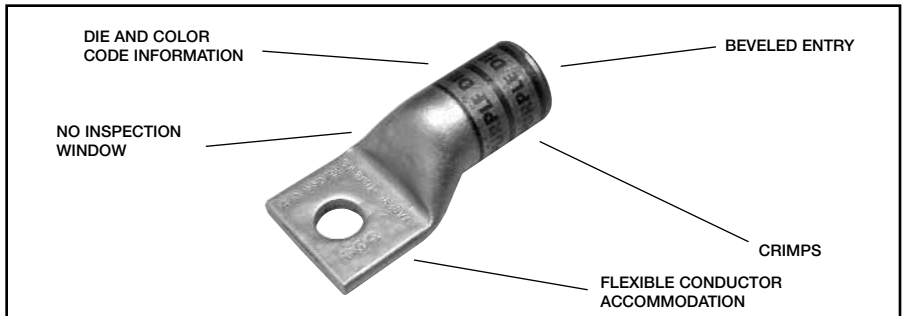

Catalog Number	Fig #	Conductor		Stud Hole Size	Tongue Width	Figure Dimensions			Dieless (# of crimps)	▲ Installation Tooling					Wire Strip Length
		AWG	*** MM²			(B)	(T)	(L)		Mechanical MD6, OUR840, MD7-34R	Hydraulic		Color Code	Die Index	
											BCT500HS, Y500GTHS	Y35, Y39, Y750, Y46*, PAT750			
YAG8CLTC14FX	1	37/24 #8	10	1/4"	.44"	.44"	.08"	1.32"	MY29-11 (1) Y1MRTC (1) Y81KFT (1)	W8CRT (1)	W8CRT (1)	U8CRT (1)	Red	49	7/16"
YAG8CLTC516FX	1	Weld 8		5/16"	.52"	.44"	.06"	1.38"		X8CRT (1)	X8CRT (1)				
YAG8CLTC12FX	1	AWG		1/2"	.72"	.44"	.05"	1.76"		W8CVT (1)	W8CVT (1)				
YAG6CLTC14FX	1	61/24 #6 Weld #6 AWG	16	1/4"	.48"	.50"	.05"	1.43"	Y81KFT (1) Y81KFTMBH (1) PAT81KFT-18V (1)	W5CRT (1)	W5CRT (1)	U5CRT (1)	Blue	7	1/2"
YAG6CLTC516FX	1			5/16"	.52"	.50"	.07"	1.49"		X5CRT (1)	W5CVT (1)				
YAG6CLTC38FX	1			3/8"	.58"	.50"	.06"	1.61"		W5CVT (1)	X5CRT (1)				
YAG6CLTC12FX	1	1/2"	.75"	.50"	.12"	1.86"									
YAG4CLTC14FX	1	91/24	—	1/4"	.55"	.50"	.09"	1.48"	MY29-11 (1) Y1MRTC (2) Y81KFT (1)	W4CRT (1)	W4CRT (1)	U4CRT (1)	Gray	8	1/2"
YAG4CLTC516FX	1	105/24		5/16"	.55"	.50"	.08"	1.55"		X4CRT (1)	W4CVT (1)				
YAG4CLTC38FX	1	#4 AWG		3/8"	.58"	.50"	.08"	1.67"		W4CVT (1)	X4CRT (1)				
YAG4CLTC12FX	1	#4 Weld	1/2"	.71"	.50"	.07"	1.92"								
YAG2CLTC14FX	1	#2 AWG	35	1/4"	.68"	.63"	.10"	1.52"	Y81KFTMBH (1) PAT81KFT-18V (1)	W2CVT (1)	W2CVT (1)	U2CRT (1)	Brown	10	11/16"
YAG2CLTC516FX	1	#2 Weld		5/16"	.68"	.63"	.10"	1.64"		W2CRT (1)	W2CRT (1)				
YAG2CLTC38FX	1	125/24		3/8"	.68"	.63"	.10"	1.70"		X2CRT (1)	X2CRT (1)				
YAG2CLTC12FX	1	150/24	1/2"	.77"	.63"	.10"	1.83"								
YAG1CLTC14FX	1	#1 AWG	—	1/4"	.75"	.69"	.12"	1.73"	MY29-11 (1) Y81KFT (1)	W1CVT (1)	W1CVT (1)	U1CRT-1 (1)	Green	11	11/16"
YAG1CLTC516FX	1	#1 Weld		5/16"	.75"	.69"	.12"	1.80"		W1CRT (1)	W1CRT (1)				
YAG1CLTC38FX	1	175/24		3/8"	.75"	.69"	.12"	1.92"		X1CRT (1)	X1CRT (1)				
YAG1CLTC12FX	1	225/24	1/2"	.75"	.69"	.12"	2.17"								
YAG25LTC14FX	1	1/0 AWG	50	1/4"	.83"	.69"	.12"	1.77"	Y81KFTMBH (1) PAT81KFT-18V (1)	W25VT (2)	W25VT (2)	U25RT (1)	Pink	12	11/16"
YAG25LTC516FX	1	1/0 Weld		5/16"	.83"	.69"	.12"	1.84"		W25RT (2)	W25RT (2)				
YAG25LTC38FX	1	275/24		3/8"	.83"	.69"	.12"	1.96"		X25RT (2)	X25RT (2)				
YAG25LTC12FX	1	1/2"	.83"	.69"	.12"	2.21"									
YAG26LTC14FX	1	2/0 AWG	70	1/4"	.93"	.81"	.13"	1.95"	MY29-11 (1) Y644HS (1) Y81KFT (1)	W26VT (2)	W26VT (2)	U26RT (1)	Black	13	13/16"
YAG26LTC516FX	1	2/0 Weld		5/16"	.93"	.81"	.13"	2.01"		W26RT (2)	W26RT (2)				
YAG26LTC38FX	1	325/24		3/8"	.93"	.81"	.13"	2.13"		X26RT (2)	X26RT (2)				
YAG26LTC12FX	1	1/2"	.93"	.81"	.13"	2.38"									
YAG27LTC14FX	1	3/0 AWG	95	1/4"	1.03"	1.00"	.14"	2.18"	Y81KFTMBH (1) PAT81KFT-18V (1)	W27VT (2)	W27VT (2)	U27RT (1)	Orange	14	1"
YAG27LTC516FX	1	3/0 Weld		5/16"	1.03"	1.00"	.14"	2.21"		W27RT (2)	W27RT (2)				
YAG27LTC38FX	1	450/24		3/8"	1.03"	1.00"	.14"	2.37"		X27RT (3)	X27RT (3)				
YAG27LTC12FX	1	1/2"	1.03"	1.00"	.14"	2.62"									
YAG28LTC14FX	1	4/0 AWG	—	1/4"	1.14"	1.03"	.15"	2.26"	MY29-11 (1) Y81KFT (1) Y81KFTMBH (1) PAT81KFT-18V (1)	W28VT (2)	W28VT (2)	U28RT (1)	Purple	15	1-1/16"
YAG28LTC516FX	1	4/0 Weld		5/16"	1.14"	1.03"	.15"	2.32"		W28RT (2)	W28RT (2)				
YAG28LTC38FX	1	550/24		3/8"	1.14"	1.03"	.15"	2.45"		X28RT (3)	X28RT (3)				
YAG28LTC12FX	1	1/2"	1.14"	1.03"	.15"	2.70"									

* Use PUADP-1 adapter with U dies in Y46 HYPRESS™.
** The MM² conductor size referenced here is for Class 5 conductor.

▲ See tooling section of this catalog for complete tool and die listings.
Note: All dimensions shown are for reference only.

Blue highlighted items are industry standard and most frequently ordered.

Compression Connections

BURNDY®

Copper Compression – Flex – Standard Barrel – No Inspection Window

C-50

ONE HOLE HYLUG™ FLEX CONDUCTOR STANDARD BARREL NO INSPECTION WINDOW (Continued)

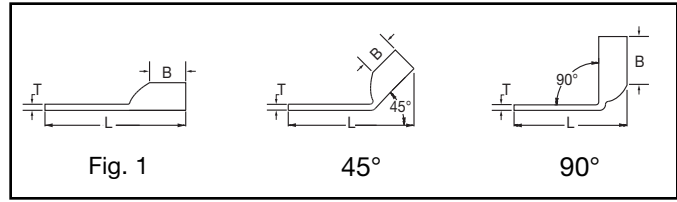

UL Listed 90° C,
600 Volts to 35 kV



45° and 90° angles are available.

Please contact Customer Service to order:

1-800-346-4175

Catalog Number	Fig #	Conductor		Stud Hole Size	Tongue Width	Figure Dimensions			Dieless (# of crimps)	▲ Installation Tooling					Wire Strip Length	
		AWG	*** MM ²			(B)	(T)	(L)		Mechanical		Hydraulic		Color Code		Die Index
										MD6, OUR840, MD7-34R	BCT500HS, Y500CTS	Y35, Y39, Y750, Y46*, PAT750				
YAG29LTC38FX	1	4/0 AWG	—	3/8"	1.14"	1.03"	.16"	2.45"	Y644HS (1) Y81KFT (1) Y81KFTMBH (1) PAT81KFT-18V (1)	W29VT (2) X29RT (4)	W29VT (2) W29RT (2) X29RT (4)	U29RT (1)	Yellow	16	1-1/16"	
YAG29LTC12FX	1	4/0 Weld	—	1/2"	1.14"	1.03"	.16"	2.70"								
YAG29LTC58FX	1	550/24	—	5/8"	1.14"	1.03"	.16"	3.14"								
YAG30LTC38FX	1	250 Flex	—	3/8"	1.20"	1.03"	.16"	2.47"	Y644HS (1) Y81KFT (1) Y81KFTMBH (1) PAT81KFT-18V (1)	W30VT (2)	W30VT (2) W30RT (2)	U30RT (2)	White	17	1-1/8"	
YAG30LTC12FX	1	Class G 259 Str.	—	1/2"	1.20"	1.03"	.16"	2.72"								
YAG30LTC58FX	1	Class H 427 Str.	—	5/8"	1.20"	1.03"	.16"	2.97"								
YAG31LTC14FX	1	250 Flex 637/24 Class I,K,M	150	1/4"	1.29"	1.06"	.18"	2.35"	Y644HS (1) Y81KFT (1) Y81KFTMBH (1) PAT81KFT-18V (1)	W31VT (2)	W31VT (2) W31RT (2)	U31RT (2)	Red	18	1-1/4"	
YAG31LTC516FX	1			5/16"	1.29"	1.06"	.18"	2.41"								
YAG31LTC38FX	1			3/8"	1.29"	1.06"	.18"	2.53"								
YAG31LTC12FX	1			1/2"	1.29"	1.06"	.18"	2.78"								
YAG31LTC58FX	1	5/8"	1.29"	1.06"	.18"	3.06"										
YAG32LTC12FX	1	313.1 kcmil 775/24	185	1/2"	1.40"	1.19"	.19"	2.97"	Y644HS (1) Y81KFT (1) Y81KFTMBH (1) PAT81KFT-18V (1)	W32VT (2)	W32VT (2) W32RT (2)	U32RT (2)	Blue	19	1-5/16"	
YAG32LTC58FX	1	300 Flex		5/8"	1.40"	1.19"	.19"	3.22"								
YAG34LTC516FX	1	373.7 kcmil 925/24 350 Flex	240	5/16"	1.55"	1.27"	.23"	2.78"	Y644HS (1) Y81KFT (1) Y81KFTMBH (1) PAT81KFT-18V (1)	W32VT (2)	W32VT (2) W32RT (2)	U32RT (2)	Blue	19	1-5/16"	
YAG34LTC38FX	1			3/8"	1.55"	1.27"	.23"	2.91"								
YAG34LTC12FX	1			1/2"	1.55"	1.27"	.23"	3.16"								
YAG34LTC58FX	1	5/8"	1.55"	1.27"	.23"	3.41"										
YAG36LTC38FX	1	444.4 kcmil 1100/24 450 Flex	—	3/8"	1.73"	1.38"	.27"	3.27"	—	—	U34RT (2)	Brown	20	1-7/16"		
YAG38LTC38FX	1	535.3 kcmil 1325/24 500 Flex	300	1/4"	1.84"	1.45"	.27"	3.02"	Y644HS (1) Y81KFT (2) Y81KFTMBH (2) PAT81KFT-18V (2)	—	—	U38XRT (2)	Pink	L99	1-7/16"	
YAG38LTC516FX	1			5/16"	1.84"	1.45"	.27"	3.08"								
YAG38LTC38FX	1			3/8"	1.84"	1.45"	.27"	3.39"								
YAG38LTC12FX	1			1/2"	1.84"	1.45"	.27"	3.46"								
YAG40LTC14FX	1	646 kcmil 1600/24 650 Flex	400	1/4"	1.96"	1.42"	.30"	3.04"	Y644HS (1) Y81KFT (2) Y81KFTMBH (2) PAT81KFT-18V (2)	—	—	U39RT (2)	Black	24	1-5/16"	
YAG40LTC516FX	1			5/16"	1.96"	1.42"	.30"	3.11"								
YAG40LTC38FX	1			3/8"	1.96"	1.42"	.30"	3.42"								
YAG40LTC12FX	1			1/2"	1.96"	1.42"	.30"	3.48"								
YAG44LTC516FX	1	777.7 kcmil	500	5/16"	2.18"	1.65"	.33"	3.50"	Y644HS (1) Y81KFT (2) Y81KFTMBH (2) PAT81KFT-18V (2)	—	—	U44XRT (2)	Yellow	L115	1-5/8"	
YAG44LTC38FX	1	1925/24		3/8"	2.18"	1.65"	.33"	3.81"								
YAG44LTC12FX	1	750 Flex		1/2"	2.18"	1.65"	.33"	3.85"								

* Use PUADP-1 adapter with U dies in Y46 HYPRESS™.

** The MM² conductor size referenced here is for Class 5 conductor.

▲ See tooling section of this catalog for complete tool and die listings.

Note: All dimensions shown are for reference only.

Blue highlighted items are industry standard and most frequently ordered.

**ONE HOLE HYLUG™
FLEX CONDUCTOR
STANDARD BARREL
BELLED END**

TYPE YA-LB

**COPPER COMPRESSION
TERMINAL**

UL Listed 90° C,
600 Volts to 35 kV ◆

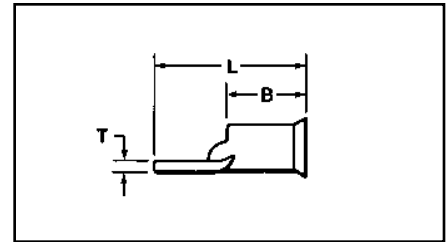
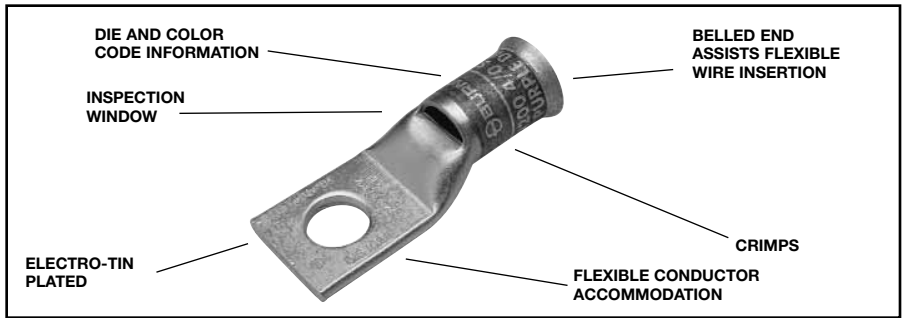

Catalog Number	Flexible Conductor Size AWG/kcmil	Stranding Class (Size of Strand)					Locomotive Cable	Bolt Size	Wire Strip Length	Installation Tooling Dieless (# of crimps)	Die Index ▲	Dimensions	
		G	H	I (#24 Str.)	Battery Cable K (#30 Str.)	Welding Cable M (#34 Str.)						B	L
YA8C-LB	8	49	133	41	168	420	37/24	10	7/16"	Y81KFT (1) Y81KFTMBH (1) PAT81KFT-18 (1)	1013	.41"	1.12"
YA5C-LB	6			63	266	665	61/24	1/4"	7/8"		1014	.44"	1.73"
YA4C-LB	5			84	336	836	91/24				1015	.50"	1.92"
YA3C-LB	4			105	420	1064	105/24	5/16"	5/16"		1016	.55"	1.94"
YA2C-LB	3			133	532	1323	125/24				1017	.61"	1.97"
YA1C-LB	2			161	665	1666	150/24				1018	.68"	2.02"
YA25-LB	1	210	836	2107	225/24	1019	.75"				2.26"		
YA26-LB	1/0	133	259	266	1064	2646	275/24	3/8"	1"		1020	.83"	2.61"
YA27-LB	2/0			342	1323	3325	325/24	1/2"	1-1/16"		1021	.91"	2.67"
YA28-LB	3/0			418	1666	4256	450/24				1022	1.02"	2.77"
YA29-LB	4/0			—	—	—	—				1023	1.11"	2.82"
YA30-LB	4/0			—	—	532	2107	5320	550/24		1-1/8"	1024	1.20"
	250	259	427	—	—	—	—	1025	1.29"	3.31"			
YA31-LB	250	—	—	—	—	—	—	1-3/16"	1026	1.40"	3.56"		
	262.2	—	—	637	2499	6384	650/24		1027	1.52"	3.83"		
YA32-LB	300	259	427	735	2989	7851	—	1-1/4"	1028	1.69"	4.31"		
	313.1	—	—	—	—	—	775/24		1029	1.81"	4.27"		
YA34-LB	350	—	—	—	3458	8806	—	1-7/16"	1030	1.89"	4.27"		
	373.7	—	—	—	—	—	925/24		1031	1.95"	4.27"		
YA36-LB	400	259	427	980	—	—	—	1-3/4"	1032	2.17"	4.5"		
	444.4	—	—	—	—	—	1100/24		1028	1.69"	4.31"		
YA38-LB	450	—	—	1127	4522	11396	—	5/8"	1029	1.81"	4.27"		
	500	—	—	—	—	—	12691		1030	1.89"	4.27"		
	535.3	427	703	1372	5054	—	1325/24		1031	1.95"	4.27"		
YA39-LB	550	—	—	—	—	—	—	1-15/16"	1032	2.17"	4.5"		
	550	427	703	—	—	—	—		1030	1.89"	4.27"		
YA40-LB	600	—	—	—	—	13664	—	Y81KFT (2) Y81KFTMBH (2) PAT81KFT-18 (2)	1031	1.95"	4.27"		
	—	—	703	1470	—	14945	1600/24		1032	2.17"	4.5"		
YA44-LB	650	—	—	—	5985	—	—		1032	2.17"	4.5"		
	750	427	703	—	—	—	—		1032	2.17"	4.5"		
	777.7	—	—	—	—	—	1925/24	1032	2.17"	4.5"			

Note: All dimensions shown are for reference only.

Blue highlighted items are industry standard and most frequently ordered.

Compression Connections

BURNDY®

Copper Compression – Flex – Long Barrel – Inspection Window

C-52

ONE HOLE HYLUG™ FLEX CONDUCTOR LONG BARREL WITH INSPECTION WINDOW

TYPES YAZ, YAZV

**COPPER COMPRESSION
TERMINAL**

UL Listed 90° C,
600 Volts to 35 kV ◆

45° and 90° angles are available.
Please contact Customer Service to order:
1-800-346-4175

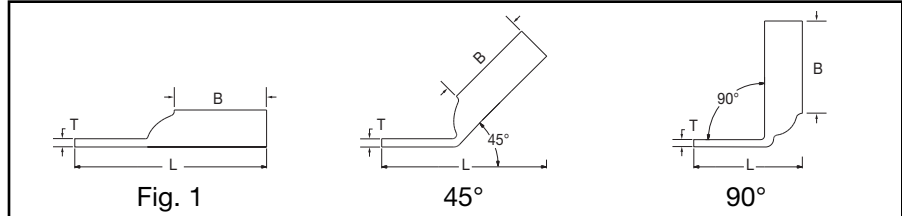
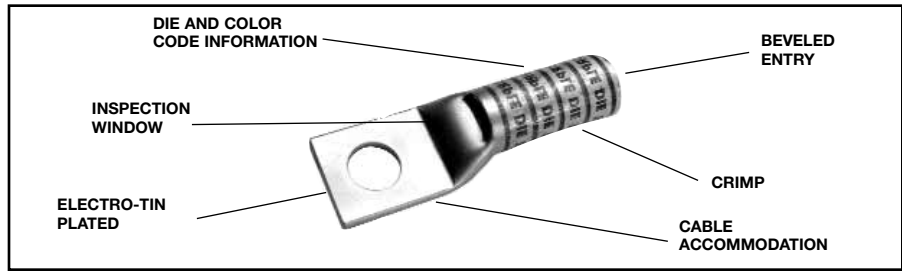

Catalog Number	Fig #	Conductor		Stud Hole Size	Tongue Width	Figure Dimensions			Dieless (# of crimps)	▲ Installation Tooling				Wire Strip Length	
		AWG	*** MM ²			(B)	(T)	(L)		Mechanical MD6, OUR840, MD7-34R	Hydraulic BC7500HS, Y500CTS	Y35, Y39, Y750, Y46*, PAT750	Color Code		Die Index
YAZ8CTC10	1	37/24 #8 Weld #8 AWG	10	# 10	.41"	.75"	.08"	1.58"	Y1MRTC (2) Y8MRB-1 (2) MY29-3 (2) MY29-11 (2) MRC840 (2) Y81KFT (1) Y81KFTMBH (1) PAT81KFT-18V (1)	W8CVT (2) W8CRT (2) X8CRT (2)	W8CVT (2) W8CRT (2) X8CRT (2)	U8CRT (2)	Red	49	7/16"
YAZ8CTC14	1			1/4"	.44"	.75"	.08"	1.58"							
YAZ8CTC38	1			3/8"	.58"	.75"	.06"	1.89"							
YAZV6CTC14FX	1	61/24 #6 Weld #6 AWG	16	1/4"	.48"	.75"	.08"	2.03"	Y1MRTC (2) MY29-3 (2) MY29-11 (2) MRC840 (2) Y644HS (1) Y81KFT (1) Y81KFTMBH (1) PAT81KFT-18V (1)	W5CVT (2) W5CRT (2) X5CRT (2)	W5CVT (2) W5CRT (2) X5CRT (2)	U5CRT (2)	Blue	7	1-3/16"
YAZV6CTC38FX	1			3/8"	.58"	.75"	.06"	1.77"							
YAZV4CTC14FX	1	91/24 105/24 #4 Weld #4 AWG	—	1/4"	.55"	1.25"	.09"	2.21"	Y1MRTC (4) MY29-3 (2) MY29-11 (2) MRC840 (2) Y644HS (1) Y81KFT (1) Y81KFTMBH (1) PAT81KFT-18V (1)	W4CVT (2) W4CRT (2) X4CRT (2)	W4CVT (2) W4CRT (2) X4CRT (2)	U4CRT (2)	Gray	8	1-5/16"
YAZV4CTC38FX	1			3/8"	.58"	1.25"	.08"	2.39"							
YAZV2CTC14FX	1	125/24 150/24 #2 Weld #2 AWG	35	1/4"	.68"	1.38"	.10"	2.39"	Y81KFT (1) Y81KFTMBH (1) PAT81KFT-18V (1)	W2CVT (2) W2CRT (2) X2CRT (2)	W2CVT (2) W2CRT (2) X2CRT (2)	U2CRT (2)	Brown	10	1-7/16"
YAZV2CTC38FX	1			3/8"	.68"	1.38"	.10"	2.57"							
YAZV2CTC12FX	1			1/2"	.83"	1.38"	.09"	3.01"							
YAZV1CTC14FX	1	175/24	—	1/4"	.75"	1.38"	.12"	2.42"	MY29-3 (2) MY29-11 (2) MRC840 (2) Y644HS (1) Y81KFT (1) Y81KFTMBH (1) PAT81KFT-18V (1)	W1CRT-1 (2) W1CVT (2) X1CRT-1 (2)	W1CRT-1 (2) W1CVT (2) X1CRT-1 (2)	U1CRT-1 (2)	Green	11	11/16"

* Use PUADP-1 adapter with U dies in Y46 HYPRESS™
 ** The MM² conductor size referenced here is for both Class 2 and Class 5 conductor.
 *** The MM² conductor sizes listed are the recommendations for Class 5 conductor.

▲ See tooling section of this catalog for complete tool and die listings. Use ONLY color-coded die recommendations for -FX connectors. For nest/indenter system contact factory.

◆ For applications greater than 2000 Volts consult cable manufacturer for voltage stress relief instructions.
Note: All dimensions shown are for reference only.

Blue highlighted items are industry standard and most frequently ordered.

**ONE HOLE HYLUG™
FLEX CONDUCTOR
LONG BARREL WITH
INSPECTION WINDOW**
(Continued)

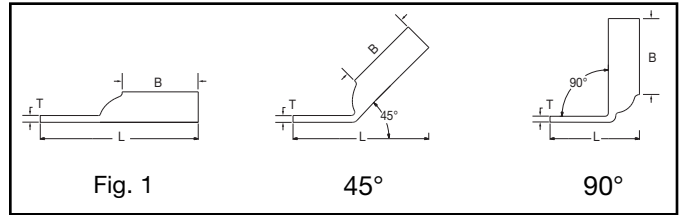

UL Listed 90° C,
600 Volts to 35 kV ◆

45° and 90° angles are available.
Please contact Customer Service to order:
1-800-346-4175



Catalog Number	Fig #	Conductor		Stud Hole Size	Tongue Width	Figure Dimensions			▲ Installation Tooling						Wire Strip Length
		AWG	MM ²			(B)	(T)	(L)	Dieless (# of crimps)	Mechanical	Hydraulic		Color Code	Die Index	
										MD6, OUR840, MD7-34R	BCT500HS, Y500CTHS	Y35, Y39, Y750, Y46*, PAT750			
YAZV1CTC516FX	1	225/24 #1 Weld	—	5/16"	.75"	1.38"	.12"	2.47"	Y644HS (1) Y81KFT (1) Y81KFTMBH (1) PAT81KFT-18V (1)	W1CRT-1 (2) W1CVT (2) X1CRT-1 (2)	W1CRT-1 (2) W1CVT (2) X1CRT-1 (2)	U1CRT-1 (2)	Green	11	1-7/16"
YAZV1CTC38FX	1	1/0 AWG	—	3/8"	.75"	1.38"	.12"	2.60"		MY29-11 (2) Y644HS (1) Y81KFT (2) Y81KFTMBH (2) PAT81KFT-18V (2)	W25VT (4) W25RT (4) X25RT (4)	W25VT (4) W25RT (4) X25RT (4)	U25RT (2)	Pink	12
YAZV25TC14FX	1	275/24 1/0 Weld	50	1/4"	.83"	1.50"	.12"	2.58"	MY29-11 (2) Y644HS (1) Y81KFT (2) Y81KFTMBH (2) PAT81KFT-18V (2)		W26VT (4) W26RT (4) X26RT (4)	W26VT (4) W26RT (4) X26RT (4)	U26RT (2)	Black	13
YAZV25TC38FX	1	1/0 AWG	—	1/2"	.83"	1.50"	.12"	3.20"		MY29-11 (2) Y644HS (1) Y81KFT (2) Y81KFTMBH (2) PAT81KFT-18V (2)	W26VT (4) W26RT (4) X26RT (4)	W26VT (4) W26RT (4) X26RT (4)	U26RT (2)	Black	13
YAZV26TC14FX	1	325/24 2/0 Weld	70	1/4"	.93"	1.50"	.13"	2.58"	MY29-11 (2) Y644HS (1) Y81KFT (2) Y81KFTMBH (2) PAT81KFT-18V (2)		W26VT (4) W26RT (4) X26RT (4)	W26VT (4) W26RT (4) X26RT (4)	U26RT (2)	Black	13
YAZV26TC38FX	1	2/0 AWG	—	1/2"	.93"	1.50"	.13"	3.20"		MY29-11 (2) Y644HS (1) Y81KFT (2) Y81KFTMBH (2) PAT81KFT-18V (2)	W26VT (4) W26RT (4) X26RT (4)	W26VT (4) W26RT (4) X26RT (4)	U26RT (2)	Black	13
YAZV27TC38FX	1	450/24 3/0 Weld	95	3/8"	1.03"	1.50"	.14"	2.80"	MY29-11 (2) Y644HS (1) Y81KFT (2) Y81KFTMBH (2) PAT81KFT-18V (2)		W27RT (4) W27VT (4) X27RT (4)	W27RT (4) W27VT (4) X27RT (4)	U27RT (2)	Orange	14
YAZV28NT38FX	1	550/24 4/0 Weld	120	3/8"	.94"	1.62"	.14"	2.96"		MY29-11 (2) Y644HS (1) Y81KFT (2) Y81KFTMBH (2) PAT81KFT-18V (2)	W28VT (4) W28RT (4) X28RT (6)	W28VT (4) W28RT (4) X28RT (6)	U28RT (2)	Purple	15
YAZV28TC38FX	1	4/0 AWG	—	1/2"	1.14"	1.62"	.14"	3.18"	MY29-11 (2) Y644HS (1) Y81KFT (2) Y81KFTMBH (2) PAT81KFT-18V (2)		W28VT (4) W28RT (4) X28RT (6)	W28VT (4) W28RT (4) X28RT (6)	U28RT (2)	Purple	15
YAZV28TC12FX	1	4/0 AWG	—	1/2"	1.14"	1.62"	.14"	3.18"		MY29-11 (2) Y644HS (1) Y81KFT (2) Y81KFTMBH (2) PAT81KFT-18V (2)	W29VT (4) X29RT (8)	W29RT (4) W29VT (4) X29RT (8)	U29RT (2)	Yellow	16
YAZV29NT516FX	1	550/24 4/0 Weld	—	5/16"	.96"	2.00"	.16"	2.87"	MY29-11 (2) Y644HS (1) Y81KFT (2) Y81KFTMBH (2) PAT81KFT-18V (2)		W29VT (4) X29RT (8)	W29RT (4) W29VT (4) X29RT (8)	U29RT (2)	Yellow	16
YAZ30TC38FX	1	250 Flex CLASS G 259 Str. CLASS H 427 Str	—	3/8"	1.20"	2.00"	.16"	3.42"		MY29-11 (2) Y644HS (1) Y81KFT (2) Y81KFTMBH (2) PAT81KFT-18V (2)	W29VT (4) X29RT (8)	W29RT (4) W29VT (4) X29RT (8)	U29RT (2)	Yellow	16
YAZ31TC38FX	1	262.2 Flex 637/24 CLASS I, K, M	150	3/8"	1.28"	2.00"	.18"	3.45"	MY29-11 (2) Y644HS (1) Y81KFT (2) Y81KFTMBH (2) PAT81KFT-18V (2)		W30VT (4)	W30VT (4) W30RT (4)	U30RT (4)	White	17
YAZ32TC38FX	1	775/24 313.1 kcmil 300 Flex	185	3/8"	1.55"	2.12"	.19"	3.62"		MY29-11 (2) Y644HS (1) Y81KFT (2) Y81KFTMBH (2) PAT81KFT-18V (2)	W31VT (4)	W31VT (4) W31RT (4)	U31RT (4)	Blue	19
YAZ34NT38FX	1	925/24 373.3 kcmil	240	3/8"	.96"	2.25"	.23"	3.85"	MY29-11 (2) Y644HS (1) Y81KFT (2) Y81KFTMBH (2) PAT81KFT-18V (2)		W32VT (4)	W32VT (4) W32RT (4)	U32RT (4)	Blue	19
YAZ34TC38FX	1	350 Flex	—	1/2"	1.52"	2.25"	.23"	4.29"		MY29-11 (2) Y644HS (1) Y81KFT (2) Y81KFTMBH (2) PAT81KFT-18V (2)	W32VT (4)	W32VT (4) W32RT (4)	U32RT (4)	Blue	19
YAZ34TC12FX	1	1100/24 444.4 kcmil 450 Flex	—	3/8"	1.72"	2.69"	.26"	4.55"	MY29-11 (2) Y644HS (1) Y81KFT (2) Y81KFTMBH (2) PAT81KFT-18V (2)		—	—	U34RT (4)	Brown	20
YAZ36TC38FX	1	1325/24 535.3 kcmil 500 Flex	300	3/8"	1.63"	2.81"	.27"	4.72"		MY29-11 (2) Y644HS (1) Y81KFT (2) Y81KFTMBH (2) PAT81KFT-18V (2)	—	—	U38XRT (4)	Pink	L99
YAZ38NT38FX	1	1325/24 535.3 kcmil	—	3/8"	1.81"	2.81"	.27"	4.72"	MY29-11 (2) Y644HS (1) Y81KFT (2) Y81KFTMBH (2) PAT81KFT-18V (2)		—	—	U38XRT (4)	Pink	L99
YAZ38TC38FX	1	500 Flex	—	1/2"	1.63"	2.81"	.27"	4.97"		MY29-11 (2) Y644HS (1) Y81KFT (2) Y81KFTMBH (2) PAT81KFT-18V (2)	—	—	U38XRT (4)	Pink	L99
YAZ38NT12FX	1	500 Flex	—	1/2"	1.81"	2.81"	.27"	4.97"	MY29-11 (2) Y644HS (1) Y81KFT (2) Y81KFTMBH (2) PAT81KFT-18V (2)		—	—	U38XRT (4)	Pink	L99
YAZ38TC12FX	1	500 Flex	—	1/2"	1.81"	2.81"	.27"	4.97"		MY29-11 (2) Y644HS (1) Y81KFT (2) Y81KFTMBH (2) PAT81KFT-18V (2)	—	—	U38XRT (4)	Pink	L99

* Use PUADP-1 adapter with U dies in Y46 HYPRESS™
 ** The 120 MM² referenced here is for both Class 2 and Class 5 conductor.
 *** The MM² conductor sizes listed are the recommendations for Class 5 conductor.

▲ See tooling section of this catalog for complete tool and die listings. Use ONLY color-coded die recommendations for -FX connectors. For nest/indenter system contact factory.

◆ For applications greater than 2000 Volts consult cable manufacturer for voltage stress relief instructions.
 Note: All dimensions shown are for reference only.

Blue highlighted items are industry standard and most frequently ordered.

Compression Connections

BURNDY®

Copper Compression – Flex – Long Barrel – Belled End – No Inspection Window

C-54

ONE HOLE HYLUG™ FLEX CONDUCTOR LONG BARREL BELLED END

**TYPES YA-TC-FXB,
YAV-TC-FXB**

UL Listed 90° C,
600 Volts to 35 kV ◆

45° and 90° angles are available.

Please contact
Customer Service
to order:
1-800-346-4175

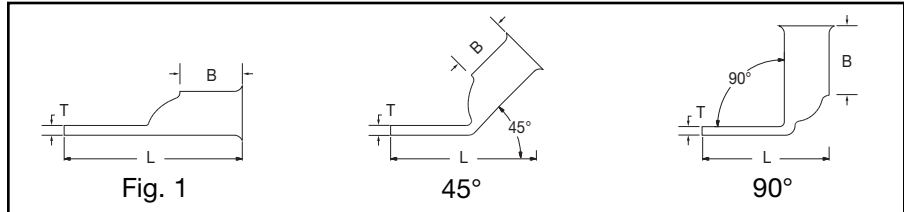
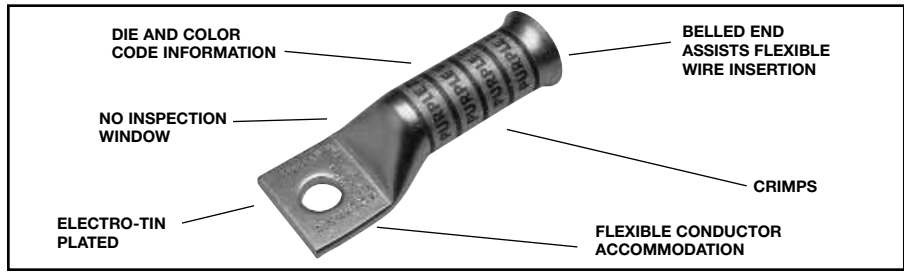

Catalog Number	Fig #	Conductor		Stud Hole Size	Tongue Width	Figure Dimensions			Dieless (# of crimps)	▲ Installation Tooling				Wire Strip Length	
		AWG	MM ²			(B)	(T)	(L)		Mechanical MD6, OUR840, MD7-34R	Hydraulic		Color Code		Die Index
											BCT500HS, Y500CTHS	Y35, Y39, Y750 Y46*, PAT750			
YA8C-TC14-FXB	1	37/24 #8 Weld 8 AWG	** 10	1/4"	.41"	.90"	.08"	1.76"	MRC840 (2) MY29-11 (2) Y1MRTC (2) Y81KFT (1) Y81KFTMBH (1) PAT81KFT-18V (1)	W8CVT (2)	W8CVT (2)	U8CRT (2)	Red	49	1"
YAV6C-TC10-FXB	1	61/24 #6 Weld #6 AWG	** 16	8-10	.48"	1.22"	.08"	1.90"	MY29-11 (2) Y1MRTC (2) Y644HS (1) Y81KFT (1)	W5CVT (2)	W5CVT (2)	U5CRT (2)	Blue	7	1-5/16"
YAV6C-TC14-FXB	1	91/24 #5 Str.	1/4"				2.11"	Y81KFTMBH (1) PAT81KFT-18V (1)							
YAV5C-TC14-FXB	1	#5 AWG		1/4"	.44"	1.22"	.07"	2.11"	MY29-11 (2) Y1MRTC (2) Y644HS (1) Y81KFT (1) Y81KFTMBH (1) PAT81KFT-18V (1)	W5CVT (2)	W5CVT (2)	U5CRT (2)	Blue	7	1-5/16"
YAV4C-TC10-FXB	1	91/24 105/24 #4 Weld #4 AWG		8-10	.55"	1.22"	.09"	2.03"	MY29-11 (2) Y1MRTC (4) Y644HS (1) Y81KFT (1)	W4CVT (2)	W4CVT (2)	U4CRT (2)	Gray	8	1-5/16"
YAV4C-TC14-FXB	1		1/4"	.55"	1.22"	.09"	2.16"	Y81KFTMBH (1) PAT81KFT-18V (1)							
YAV4C-TC516-FXB	1		5/16"	.63"	1.22"	.09"	2.22"								
YAV2C-TC10-FXB	1	125/24 150/24 #2 Weld #2 AWG	35	8-10	.67"	1.35"	.10"	2.23"	MY29-11 (2) Y1MRTC (4) Y644HS (1) Y81KFT (1)	W2CVT (2)	W2CVT (2)	U2CRT (2)	Brown	10	1-7/16"
YAV2C-TC516-FXB	1			5/16"				2.42"	Y81KFTMBH (1) PAT81KFT-18V (1)						
YAV1C-TC10-FXB	1	175/24 225/24 #1 Weld #1AWG		8-10	.69"	1.50"	.12"	2.40"	MY29-11 (2) Y644HS (1) Y81KFT (1)	W1CVT (2)	W1CVT (2)	U1CRT-1 (2)	Green	11	1-9/16"
YAV1C-TC516-FXB	1			5/16"				2.59"	Y81KFTMBH (1) PAT81KFT-18V (1)						

* Use PUADP-1 adapter with U dies in Y46 HYPRESS™
 ** The MM² conductor sizes referenced here are for both Class 2 and Class 5 conductor.
 *** The MM² conductor sizes listed are the recommendations for Class 5 conductor.

‡ P44RT for use with Y46 HYPRESS™ only. PUADP-1 adapter not required.
 ▲ See tooling section of this catalog for complete tool and die listings. Use ONLY color-coded die recommendations

for -FX connectors. For nest/indentor system contact factory.
 ◆ For applications greater than 2000 Volts consult cable manufacturer for voltage stress relief instructions.
Note: All dimensions shown are for reference only.

Blue highlighted items are industry standard and most frequently ordered.

**ONE HOLE HYLUG™
FLEX CONDUCTOR
LONG BARREL
BELLED END
(Continued)**

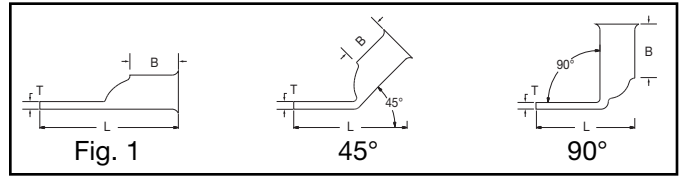
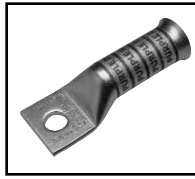

UL Listed 90° C,
600 Volts to 35 kV ◆

45° and 90° angles are available.
Please contact Customer Service to order:
1-800-346-4175



Catalog Number	Fig #	Conductor		Stud Hole Size	Tongue Width	Figure Dimensions			Dieless (# of crimps)	▲ Installation Tooling				Wire Strip Length		
		AWG	*** MM²			(B)	(T)	(L)		Mechanical MD6, OUR840, MD7-34R	Hydraulic BCT500HS, Y500CTHS	Y35, Y39, Y750 Y46*, PAT750	Color Code		Die Index	
YAV25-TC10-FXB	1	275/24 1/0 Weld 1/0 AWG	50	8-10	.83"	1.50"	.12"	2.44"	MY29-11 (2) Y644HS (1) Y81KFT (2) Y81KFTMBH (2) PAT81KFT-18V (2)	W25VT (4)	W25VT (4)	U25RT (2)	Pink	12	1-9/16"	
YAV25-TC516-FXB	1			5/16"				2.63"								
YAV25-TC38-FXB	1			3/8"				2.75"								
YAV25-TC12-FXB	1			1/2"				3.19"								
YAV26-TC38-FXB	1	352/24 2/0 Weld 2/0 AWG	70	3/8"	.93"	1.63"	.13"	2.94"	MY29-11 (2) Y644HS (1) Y81KFT (2) Y81KFTMBH (2) PAT81KFT-18V (2)	W26VT (4)	W26VT (4)	U26RT (2)	Black	13	1-13/16"	
YAV26-TC12-FXB	1			1/2"				3.37"								
YAV27-TC12-FXB	1	3/0 AWG 450/24 3/0 Weld	95	1/2"	1.10"	1.64"	.14"	3.43"	MY29-11 (2) Y644HS (1) Y81KFT (2) Y81KFTMBH (2) PAT81KFT-18V (2)	W27VT (4)	W27VT (4)	U27RT (2)	Orange	14	1-13/16"	
YAV28-TC38-FXB	1	550/24 4/0 Weld 4/0 AWG 250 Flex	120	3/8"	1.12"	1.77"	.14"	3.17"	MY29-11 (2) Y644HS (1) Y81KFT (2) Y81KFTMBH (2) PAT81KFT-18V (2)	W28VT (4)	W28VT (4)	U28RT (2)	Purple	15	1-7/8"	
YAV28-TC12-FXB	1			1/2"				3.61"								
YA30-TC12-FXB	1	Class G 259 str. Class H 427 str. 250 Flex		1/2"	1.20"	2.16"	.16"	4.02"	Y644HS (1) Y81KFT (2) Y81KFTMBH (2) PAT81KFT-18V (2)	W29VT (4)	W29VT (4)	U29RT (2)	Yellow	16	2-1/4"	
YA31-TC12-FXB	1	637/24 Class I,K,M	150	1/2"	1.28"	2.18"	.18"	4.08"	Y644HS (1) Y81KFT (2) Y81KFTMBH (2) PAT81KFT-18V (2)	W30VT (4)	W30VT (4)	U30RT (4)	White	17	2-1/4"	
YA32-TC12-FXB	1	313.1 kcmil	185	1/2"	1.38"	2.32"	.19"	4.28"	Y644HS (1) Y81KFT (2)	W31VT (4)	W31VT (4)	U31RT (4)	Red	18	2-1/4"	
YA34-TC12-FXB	1	373.7 kcmil 925/24	240	1/2"	1.50"	2.48"	.23"	4.54"		W32VT (4)	W32VT (4)	U32RT (4)	Blue	19	2-9/16"	
YA36-TC12-FXB	1	444.4 kcmil		1/2"	1.69"	2.95"	.26"	5.09"	Y81KFTMBH (2) PAT81KFT-18V (2)			U34RT (4)	Brown	20	3-1/16"	
YA36-TC58-FXB	1	1100/24		5/8"				5.15"								
YA38-TC58-FXB	1	535.3 kcmil 1325/24	300	5/8"	1.81"	3.08"	.27"	5.32"		—	—	U38XRT (4)	Pink	L99	3-3/16"	
YA40-TC58-FXB	1	646 kcmil - 1600/24	400	5/8"	1.95"	3.24"	.30"	5.53"	Y644HS (1) Y81KFT (3) Y81KFTMBH (3) PAT81KFT-18V (3)	—	—	U39RT (4)	Black	24	3-5/16"	
YA44-TC58-FXB	1	777.7 kcmil - 1925/24	500	5/8"	2.17"	3.33"	.33"	5.71"	Y644HS (1) Y81KFT (3) Y81KFTMBH (3) PAT81KFT-18V (3)	—	—	U44XRT (4)	Yellow	L115	3-7/16"	
YA46-TC58-FXB	1	1111 kcmil		5/8"	2.69"	3.58"	.39"	6.19"		—	—	**P45RT (4)	Yellow	29	3-11/16"	

* Use PUADP-1 adapter with U dies in Y46 HYPRESS™

** The 16 MM² and 120 MM² referenced here are for both Class 2 and Class 5 conductor.

*** The MM² conductor sizes listed are the recommendations for Class 5 conductor.

‡ P44RT for use with Y46 HYPRESS™ only. PUADP-1 adapter not required.

▲ See tooling section of this catalog for complete tool and die listings. Use ONLY color-coded die recommendations

for -FX connectors. For nest/indenter system contact factory.

◆ For applications greater than 2000 Volts consult cable manufacturer for voltage stress relief instructions.

Note: All dimensions shown are for reference only.

Blue highlighted items are industry standard and most frequently ordered.

Compression Connections

BURNDY®

Copper Compression – Flex – Inspection Window

C-56

TWO HOLE HYLUG™ FLEX CONDUCTOR STANDARD BARREL

TYPES YA-L-2TC, YA-L-2TC-FX, YAV-L-2TC-FX

COPPER COMPRESSION TERMINAL

UL Listed 90° C, 600 Volts to 35 kV ◆

45° and 90° angles are available. Please contact Customer Service to order: 1-800-346-4175

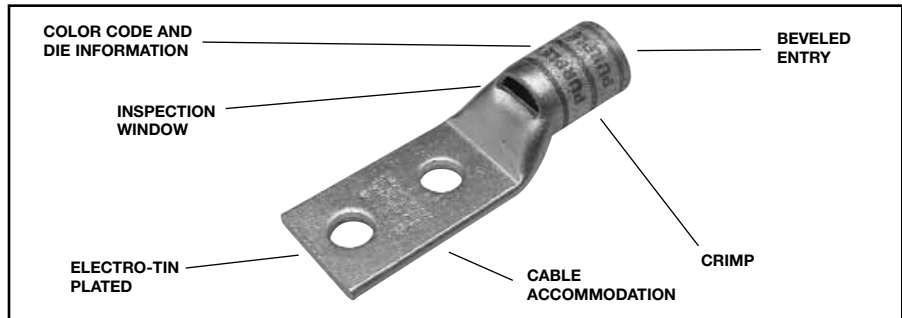

◆ For applications greater than 2000 Volts consult cable manufacturer for voltage stress relief instructions.

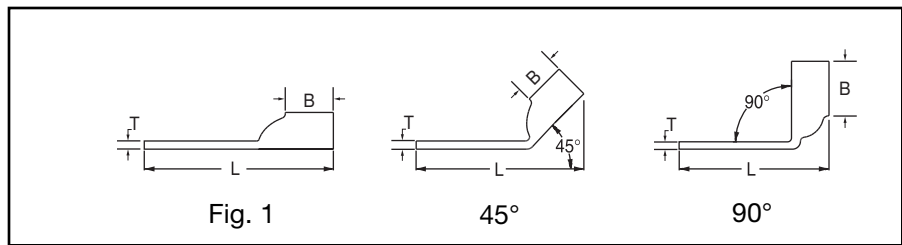

Catalog Number	Fig #	Conductor		Stud Hole Size	Stud Hole Spacing	Tongue Width	Figure Dimensions			Dieless (# of crimps)	▲ Installation Tooling				Wire Strip Length	
		AWG	MM ²				(B)	(T)	(L)		Mechanical MD6, OUR840, MD7-34R	Hydraulic BCT500HS, Y500CTHS		Y35, Y39, Y750, Y46*, PAT750		Color Code
YA8C-L2TC10	1	37/24 #8 Weld #8 AWG	** 10	# 10	5/8"	.41"	.44"	.08"	1.84"	MRC840 (1) MY29-3 (1) MY29-11 (1) Y8MRB-1 (1) Y1MRTC (1) Y81KFT (1) Y81KFTMBH (1) PAT81KFT-18V (1)	W8CVT (1) W8CRT (1) X8CRT (1)	W8CVT (1) W8CRT (1) X8CRT (1)	U8CRT (1)	Red	49	7/16"
YA8C-L2TC14	1			1/4"	5/8"	.44"	.44"	.08"	1.95"							
YA8C-L2TC14E1	1			1/4"	1"	.44"	.44"	.08"	2.33"							
YA8C-L2TC14E2	1			1/4"	3/4"	.44"	.44"	.08"	2.08"							
YA8C-L2TC38	1			3/8"	1"	.58"	.44"	.06"	2.52"							
YAV6C-L2TC10-FX	1	61/24 #6 Weld #6 AWG	** 16	# 10	5/8"	.44"	.50"	.07"	1.94"	MRC840 (1) MY29-11 (1) Y1MRTC (1) Y81KFT (1) Y81KFTMBH (1) PAT81KFT-18V (1)	W5CVT (1) W5CRT (1) X5CRT (1)	W5CVT (1) W5CRT (1) X5CRT (1)	U5CRT (1)	Blue	7	1/2"
YAV6C-L2TC10E2-FX	1			# 10	3/4"	.48"	.50"	.08"	2.06"							
YAV6C-L2TC10E4-FX	1			# 10	11/16"	.44"	.50"	.07"	2.00"							
YAV6C-L2TC10E9-FX	1			# 10	1/2"	.48"	.50"	.08"	1.81"							
YAV6C-L2TC14-FX	1	61/24 #6 Weld #6 AWG	** 16	1/4"	5/8"	.48"	.50"	.08"	2.06"	MY29-11 (1) Y1MRTC (1) Y81KFT (1) Y81KFTMBH (1) PAT81KFT-18V (1)	W5CVT (1) W5CRT (1) X5CRT (1)	W5CVT (1) W5CRT (1) X5CRT (1)	U5CRT (1)	Blue	7	7/16"
YAV6C-L2TC14E2-FX	1			1/4"	3/4"	.48"	.50"	.08"	2.19"							
YAV6C-L2TC14E1-FX	1			1/4"	1"	.48"	.50"	.08"	2.44"							
YAV6C-L2TC516-FX	1			5/16"	1"	.52"	.50"	.07"	2.50"							
YAV6C-L2TC38-FX	1			3/8"	1"	.58"	.50"	.06"	2.62"							
YAV6C-L2NTC-FX	1			1/2"	1-3/4"	.83"	.50"	.12"	3.81"							
YAV4C-L2NT10-FX	1			91/24 105/24 #4 Weld #4 AWG	-	# 10	5/8"	.41"	.50"							
YAV4C-L2NT10E1-FX	1	# 10	1"			.41"	.50"	.09"	2.33"							
YAV4C-L2TC14-FX	1	1/4"	5/8"			.55"	.50"	.09"	2.08"							
YAV4C-L2TC14E2-FX	1	1/4"	3/4"			.55"	.50"	.09"	2.20"							
YAV4C-L2TC14E1-FX	1	1/4"	1"			.55"	.50"	.09"	2.45"							
YAV4C-L2TC516-FX	1	5/16"	1"			.55"	.50"	.09"	2.52"							
YAV4C-L2TC38-FX	1	3/8"	1"			.58"	.50"	.08"	2.68"							
YAV4C-L2NTC-FX	1	1/2"	1-3/4"			.83"	.50"	.12"	3.87"							

* Use PUADP-1 adaptor with U dies in Y46 HYPRESS™.
 ** The MM² conductor size referenced here is for both Class 2 and Class 5 conductor.
 *** The MM² conductor sizes listed are the recommendations for Class 5 conductor.

▲ See tooling section of this catalog for complete tool and die listings. Use ONLY color-coded die recommendations for -FX connectors. For nest/indenter system contact factory.

◆ For applications greater than 2000 Volts consult cable manufacturer for voltage stress relief instructions.
Note: All dimensions shown are for reference only.

Blue highlighted items are industry standard and most frequently ordered.

**TWO HOLE HYLUG™
FLEX CONDUCTOR
STANDARD BARREL**
(Continued)

UL Listed 90° C,
600 Volts to 35 kV ◆

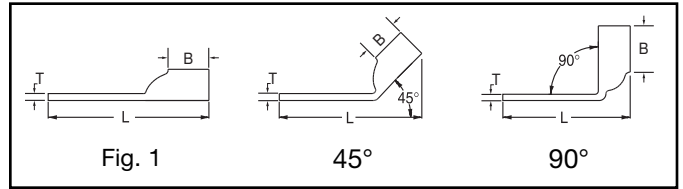

45° and 90° angles are available.
Please contact Customer Service to order:
1-800-346-4175



C-57

Catalog Number	Fig #	Conductor		Stud Hole Size	Stud Hole Spacing	Tongue Width	Figure Dimensions			Dieless (# of crimps)	▲ Installation Tooling					Wire Strip Length
		AWG	MM²				(B)	(T)	(L)		Mechanical MD6, OUR840, MD7-34R	Hydraulic		Color Code	Die Index	
												BCT500HS, Y500GTHS	Y35, Y39, Y750, Y46*, PAT750			
YAV2C-L2TC14-FX	1	125/24 150/24 #2 Weld #2 AWG	35	1/4"	5/8"	.68"	.63"	.10"	2.26"	MY29-11 (1) Y1MRTC (2) Y81KFT (1) Y81KFTMBH (1) PAT81KFT-18V (1)	W2CVT (1) W2CRT (1) X2CRT (1)	W2CVT (1) W2CRT (1) X2CRT (1)	U2CRT (1)	Brown	10	11/16"
YAV2C-L2TC14E2-FX	1			1/4"	3/4"	.68"	.63"	.10"	2.38"							
YAV2C-L2TC14E1-FX	1			1/4"	1"	.68"	.63"	.10"	2.63"							
YAV2C-L2TC516-FX	1			5/16"	1"	.68"	.63"	.10"	2.71"							
YAV2C-L2TC38-FX	1			3/8"	1"	.68"	.63"	.10"	2.82"							
YAV2C-L2NTC-FX	1	1/2"	1-3/4"	.83"	.63"	.08"	4.07"									
YAV1C-L2TC14-FX	1	175/24 225/24 #1 Weld #1 AWG	—	1/4"	5/8"	.75"	.69"	.12"	2.35"	MY29-11 (1) Y81KFT (1) Y81KFTMBH (1) PAT81KFT-18V (1)	W1CVT (1) W1CRT-1 (1) X1CRT-1 (1)	W1CVT (1) W1CRT-1 (1) X1CRT-1 (1)	U1CRT-1 (1)	Green	11	11/16"
YAV1C-L2TC14E1-FX	1			1/4"	1"	.75"	.69"	.12"	2.71"							
YAV1C-L2TC14E2-FX	1			1/4"	3/4"	.75"	.69"	.12"	2.47"							
YAV1C-L2TC516-FX	1			5/16"	1"	.75"	.69"	.12"	2.79"							
YAV1C-L2TC38-FX	1			3/8"	1"	.75"	.69"	.12"	2.91"							
YAV1C-L2NTC-FX	1	1/2"	1-3/4"	.83"	.69"	.11"	4.10"									
YAV25-L2TC14-FX	1	275/24 1/0 Weld 1/0 AWG	50	1/4"	5/8"	.83"	.69"	.12"	2.39"	MY29-11 (1) Y81KFT (1) Y81KFTMBH (1) PAT81KFT-18V (1)	W25VT (2) W25RT (2) X25RT (2)	W25VT (2) W25RT (2) X25RT (2)	U25RT (1)	Pink	12	11/16"
YAV25-L2TC14E2-FX	1			1/4"	3/4"	.83"	.69"	.12"	2.51"							
YAV25-L2TC516E2-FX	1			5/16"	3/4"	.83"	.69"	.12"	2.57"							
YAV25-L2TC516-FX	1			5/16"	1"	.83"	.69"	.12"	2.82"							
YAV25-L2TC38-FX	1			3/8"	1"	.83"	.69"	.12"	2.95"							
YAV25-L2TC12E1-FX	1	1/2"	1"	.83"	.69"	.12"	3.20"									
YAV25-L2NTC-FX	1	275/24 1/0 AWG 1/0 Weld	50	1/2"	1-3/4"	.83"	.69"	.12"	4.14"		W25VT (2)	W25VT (2)	U25RT (1)	Pink	12	11/16"
YAV26-L2TC14-FX	1	325/24 2/0 Weld 2/0 AWG	70	1/4"	5/8"	.93"	.81"	.13"	2.56"	MY29-11 (1) Y644HS (1) Y81KFT (1) Y81KFTMBH (1) PAT81KFT-18V (1)	W26VT (2) W26RT (2) X26RT (2)	W26VT (2) W26RT (2) X26RT (2)	U26RT (1)	Black	13	13/16"
YAV26-L2TC14E2-FX	1			1/4"	3/4"	.93"	.81"	.13"	2.68"							
YAV26-L2TC516-FX	1			5/16"	1"	.93"	.81"	.13"	2.99"							
YAV26-L2TC38-FX	1			3/8"	1"	.93"	.81"	.13"	3.12"							
YAV26-L2TC12E1-FX	1			1/2"	1"	.93"	.81"	.13"	3.37"							
YAV26-L2NTC-FX	1	1/2"	1-3/4"	.93"	.81"	.13"	4.31"									
YAV27-L2TC14-FX	1	450/24 3/0 Weld 3/0 AWG	95	1/4"	5/8"	1.03"	1.00"	.14"	2.83"	MY29-11 (1) Y644HS (1) Y81KFT (1) Y81KFTMBH (1) PAT81KFT-18V (1)	W27VT (2) W27RT (2) X27RT (3)	W27VT (2) W27RT (2) X27RT (3)	U27RT (1)	Orange	14	1"
YAV27-L2TC38-FX	1			3/8"	1"	1.03"	1.00"	.14"	3.35"							
YAV27-L2TC-FX	1			1/2"	1-3/4"	1.03"	1.00"	.14"	4.54"							
YAV28-L2TC14E2-FX	1	550/24 4/0 Weld 4/0 AWG	120	1/4"	3/4"	1.12"	1.03"	.15"	2.91"	MY29-11 (1) Y644HS (1) Y81KFT (1) Y81KFTMBH (1) PAT81KFT-18V (1)	W28VT (2) W28RT (2) X28RT (3)	W28VT (2) W28RT (2) X28RT (3)	U28RT (1)	Purple	15	1-1/16"
YAV28-L2TC14-FX	1			1/4"	5/8"	1.12"	1.03"	.15"	2.86"							
YAV28-L2TC516-FX	1			5/16"	1"	1.12"	1.03"	.15"	3.30"							
YAV28-L2TC38-FX	1			3/8"	1"	1.12"	1.03"	.15"	3.43"							
YAV28-L2NTC-FX	1			1/2"	1-3/4"	1.20"	1.03"	.15"	4.18"							
YAV28-L2TC14E2	1			1/4"	3/4"	1.14"	1.03"	.15"	2.99"							
YAV28-L2NT38-FX	1			3/8"	1"	.94"	1.03"	.15"	3.44"							
YAV28-LTC12E1-FX	1			1/2"	1"	1.14"	1.03"	.15"	3.68"							
YAV28-L2TC12-FX	1			1/2"	1-1/4"	1.14"	1.03"	.15"	3.93"							
YAV28-L2NTC-FX	1			1/2"	1-3/4"	1.14"	1.03"	.15"	4.62"							

* Use PUADP-1 adaptor with U dies in Y46 HYPRESS™.
** The 16 MM² referenced here is for both Class 2 and Class 5 conductor.
*** The MM² conductor sizes listed are the recommendations for Class 5 conductor.

▲ See tooling section of this catalog for complete tool and die listings. Use ONLY color-coded die recommendations for -FX connectors. For nest/indenter system contact factory.

◆ For applications greater than 2000 Volts consult cable manufacturer for voltage stress relief instructions.
Note: All dimensions shown are for reference only.

Blue highlighted items are industry standard and most frequently ordered.

Compression Connections

BURNDY®

Copper Compression – Flex – Inspection Window

C-58

TWO HOLE HYLUG™ FLEX CONDUCTOR STANDARD BARREL (Continued)

UL Listed 90° C,
600 Volts to 35 kV ◆

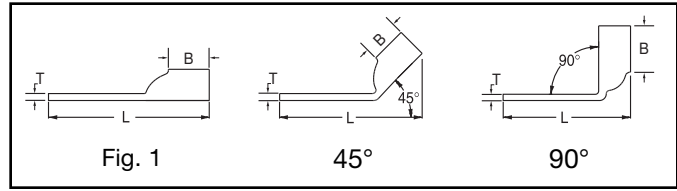
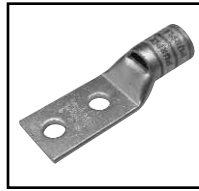

45° and 90° angles are available.
Please contact Customer Service to order:
1-800-346-4175



Catalog Number	Fig #	Conductor		Stud Hole Size	Stud Hole Spacing	Tongue Width	Figure Dimensions			Dieless (# of crimps)	▲ Installation Tooling					Wire Strip Length	
		AWG	*** MM ²				(B)	(T)	(L)		Mechanical		Hydraulic		Color Code		Die Index
											MD6, OUR840, MD7-34R	BCT500HS, Y500CTHS	Y35, Y39, Y750, Y46*, PAT750				
YAV29-L2TC14E2-FX	1	550/24 4/0 Weld	—	1/4"	3/4"	1.12"	1.03"	.16"	2.91"	W29VT (2) X29RT (4)	W29VT (2) W29RT (2) X29RT (4)	U29RT (1)	Yellow	16	1-1/16"		
YAV29-L2TC14-FX	1			1/4"	5/8"	1.12"	1.03"	.16"	2.86"								
YAV29-L2TC516-FX	1			5/16"	1"	1.12"	1.03"	.16"	3.30"								
YAV29-L2TC38-FX	1			3/8"	1"	1.12"	1.03"	.16"	3.43"								
YAV29-L2NTC-FX	1			1/2"	1-3/4"	1.20"	1.03"	.16"	4.18"								
YAV29-L2NT38-FX	1			3/8"	1"	.94"	1.03"	.16"	3.44"								
YAV29-LTC12E1-FX	1			1/2"	1"	1.14"	1.03"	.16"	3.68"								
YAV29-L2TC12-FX	1			1/2"	1-1/4"	1.14"	1.03"	.16"	3.93"								
YA30-L2TC38-FX	1			250 Flex CLASS G 259 Str. CLASS H 427 Str.	—	3/8"	1"	1.20"	1.03"							.16"	3.45"
YA30-L2TC12-FX	1	1/2"	1-1/4"			1.20"	1.03"	.16"	3.95"								
YA30-L2NTC-FX	1	1/2"	1-3/4"			1.20"	1.03"	.16"	4.63"								
YA31-L2TC38-FX	1	250 Flex 637/24 CLASS I, K, M	150	3/8"	1"	1.29"	1.06"	.18"	3.51"	W31VT (2)	W31VT (2) W31RT (2)	U31RT (2)	Red	18	1-1/4"		
YA31-L2TC12-FX	1			1/2"	1-1/4"	1.29"	1.06"	.18"	4.01"								
YA31-L2NTC-FX	1			1/2"	1-3/4"	1.29"	1.06"	.18"	4.70"								
YA31-L2NTC38-FX	1			3/8"	1-3/4"	1.29"	1.06"	.18"	4.26"								
YA32-L2TC38-FX	1	775/24 313.1 kcmil	185	3/8"	1"	1.38"	1.19"	.19"	3.69"	W32VT (2)	W32VT (2) W32RT (2)	U32RT (2)	Blue	19	1-5/16"		
YA32-L2NTC-FX	1			1/2"	1-3/4"	1.38"	1.19"	.19"	4.88"								
YA34-L2TC38-FX	1	373.7 kcmil 925/24 (360 kcmil Nom.)	240	3/8"	1"	1.52"	1.27"	.23"	3.88"	—	—	U34RT (2)	Brown	20	1-7/16"		
YA34-L2TC12-FX	1			1/2"	1-1/4"	1.52"	1.27"	.23"	4.38"								
YA34-L2NTC-FX	1			1/2"	1-3/4"	1.52"	1.27"	.23"	5.06"								
YA34-L2TC516-FX	1			5/16"	1"	1.55"	1.27"	.23"	3.75"								
YA34-L2NT38-FX	1			3/8"	1"	.96"	1.27"	.23"	3.88"								
YA34-L2NTC38-FX	1	3/8"	1-3/4"	1.55"	1.27"	.23"	4.63"										
YA36-L2TC38-FX	1	1100/24	—	3/8"	1"	1.72"	1.38"	.27"	4.24"	—	—	U38RT (2)	Purple	23	1-3/8"		
YA36-L2NTC-FX	1	444.4 kcmil	—	1/2"	1-3/4"	1.72"	1.38"	.27"	5.24"								
YA38-L2TC38-FX	1	535.3 kcmil 1325/24 (500 kcmil nom.)	300	3/8"	1"	1.81"	1.45"	.27"	4.35"	—	—	U38XRT (2)	Pink	L99	1-7/16"		
YA38-L2TC12-FX	1			1/2"	1-1/4"	1.81"	1.45"	.27"	4.67"								
YA38-L2NTC-FX	1			1/2"	1-3/4"	1.81"	1.45"	.27"	5.35"								
YA38-L2TC516-FX	1	535.3 kcmil 1325/24 (500 kcmil nom.)	300	5/16"	1"	1.84"	1.45"	.27"	4.04"	—	—	U39RT (2)	Black	24	1-5/16"		
YA38-L2NT38-FX	1			3/8"	1"	1.63"	1.45"	.27"	4.35"								
YA38-L2NNT-FX	1			1/2"	1-3/4"	1.63"	1.45"	.27"	5.35"								
YA39-L2NTC-FX	1	600 kcmil	—	1/2"	1-3/4"	1.91"	1.42"	.27"	5.36"	—	—	U44XRT (2)	Yellow	L115	1-5/8"		
YA40-L2NTC-FX	1	646 kcmil 1600/24	400	1/2"	1-3/4"	1.95"	1.42"	.30"	5.38"								
YA40-L2TC38-FX	1			3/8"	1"	1.98"	1.42"	.30"	4.28"								
YA40-L2NNT-FX	1			1/2"	1-3/4"	1.63"	1.42"	.30"	5.38"								
YA44-L2TC38-FX	1	777.7 kcmil 1925/24 (750 kcmil nom.)	500	3/8"	1"	2.19"	1.65"	.33"	4.74"	Y644HS (1) Y81KFT (2) Y81KFTMBH (2) PAT81KFT-18V (2)	—	—	—	—	—		
YA44-L2NTC-FX	1			1/2"	1-3/4"	2.19"	1.65"	.33"	5.74"								
YA44-L2TC58-FX	1			5/8"	1-1/2"	2.19"	1.65"	.33"	5.55"								
YA44-L2TC12-FX	1			1/2"	1-1/4"	2.19"	1.65"	.33"	5.05"								
YA44-L2TC12E3-FX	1			1/2"	1-1/2"	2.19"	1.65"	.33"	5.30"								
YA44-L2NT38-FX	1			3/8"	1"	1.63"	1.65"	.33"	4.74"								
YA44-L2NNT-FX	1			1/2"	1-3/4"	1.63"	1.65"	.33"	5.74"								

* Use PUADP-1 adaptor with U dies in Y46 HYPRESS™.
*** The MM² conductor sizes listed are the recommendations for Class 5 conductor.

▲ See tooling section of this catalog for complete tool and die listings. Use ONLY color-coded die recommendations for -FX connectors. For nest/indentor system contact factory.

◆ For applications greater than 2000 Volts consult cable manufacturer for voltage stress relief instructions.
Note: All dimensions shown are for reference only.

Blue highlighted items are industry standard and most frequently ordered.

**TWO HOLE HYLUG™
FLEX CONDUCTOR
STANDARD BARREL
NARROW TONGUE**

TYPE YAV-L-NTFX

**COPPER COMPRESSION
NARROW TONGUE TERMINAL**

UL Listed 90° C
600 Volts to 35 kV ◆

45° and 90° angles are available.
Please contact Customer Service to order:
1-800-346-4175

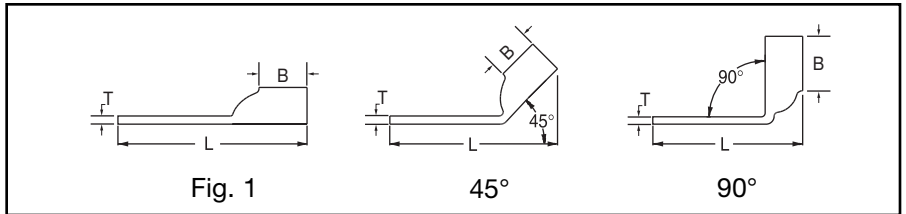
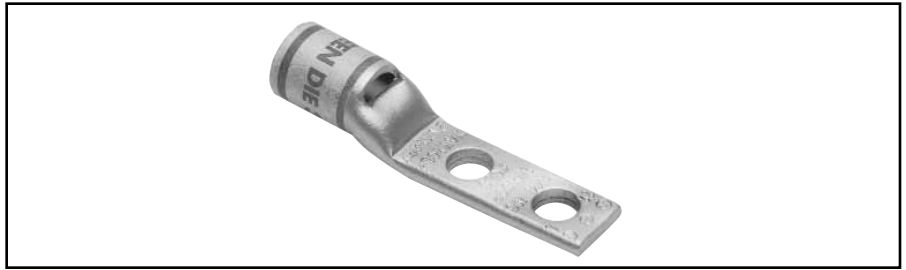

Catalog Number	Fig #	Conductor		Stud Hole Size	Stud Hole Spacing	Tongue Width	Figure Dimensions			Dieless (# of crimps)	▲ Installation Tooling				Wire Strip Length		
		AWG	*** MM²				(B)	(T)	(L)		Mechanical		Hydraulic			Color Code	Die Index
											MD6, OUR840, MD7-34R	BCT500HS, Y500CTHS	Y35, Y39, Y750, Y46*, PAT750				
YAV4CL2NT10E1FX	1	#4 AWG		#10	1.00"	0.41"	0.50"	0.09"	2.33"	MY29-11 (1) Y1MRTC (2)	W4CVT (1)	W4CVT (1)					
YAV4CL2NT10FX	1	#4 Weld 91/24	—		0.63"	0.41"	0.50"	0.09"	1.95"	Y81KFT (1)	W4CRT (1)	W4CRT (1)	U4CRT (1)	Gray	8	9/16"	
YAV4CL2NT14FX	1	105/24		1/4"	0.63"	0.45"	0.50"	0.09"	2.08"	Y81KFTMBH (1) PAT81KFT-18V (1)	X4CRT (1)	X4CRT (1)					
YAV2CL2NT10FX	1	#2 AWG		#10	0.63"	0.48"	0.63"	0.10"	2.14"	MY29-11 (1) Y1MRTC (2)	W2CVT (1)	W2CVT (1)					
YAV2CL2NT14E1FX	1	#2 Weld 125/24	35		1.00"	0.48"	0.63"	0.10"	2.63"	Y81KFT (1)	W2CRT (1)	W2CRT (1)	U2CRT (1)	Brown	10	11/16"	
YAV2CL2NT14FX	1	150/24		1/4"	0.63"	0.48"	0.63"	0.10"	2.26"	Y81KFTMBH (1) PAT81KFT-18V (1)	X2CRT (1)	X2CRT (1)					
YAV1CL2NT14FX	1	#1 AWG		1/4"	0.63"	0.50"	0.62"	0.12"	2.28"	MY29-11 (1) Y81KFT (1)	W1CVT (1)	W1CVT (1)					
YAV1CL2NT516FX	1	#1 Weld 175/24 225/24	—	5/16"	1.00"	0.58"	0.63"	0.12"	2.72"	Y81KFTMBH (1) PAT81KFT-18V (1)	W1CRT-1 (1) X1CRT-1 (1)	W1CRT-1 (1) X1CRT-1 (1)	U1CRT-1 (1)	Green	11	11/16"	
YAV25L2NT14E1FX	1	1/0 AWG		1/4"	1.00"	0.64"	0.69"	0.12"	2.76"	MY29-11 (1) Y81KFT (1)	W25VT (2)	W25VT (2)					
YAV25L2NT14FX	1	1/0 Weld 275/24	50		1/4"	0.63"	0.64"	0.12"	2.39"	Y81KFTMBH (1)	W25RT (2)	W25RT (2)	U25RT (1)	Pink	12	11/16"	
YAV25L2NT516FX	1			5/16"	1.00"	0.58"	0.69"	0.12"	2.82"	PAT81KFT-18V (1)	X25RT (2)	X25RT (2)					
YAV26L2NT14FX	1	2/0 AWG		1/4"	0.63"	0.76"	0.81"	0.13"	2.56"	MY29-11 (1) Y644HS (1)	W26VT (2)	W26VT (2)					
YAV26L2NT516FX	1	2/0 Weld 325/24	70		5/16"	1.00"	0.58"	0.13"	2.99"	Y81KFT (1)	W26RT (2)	W26RT (2)	U26RT (1)	Black	13	13/16"	
YAV26L2NT38FX	1			3/8"	1.00"	0.63"	0.81"	0.13"	3.23"	Y81KFTMBH (1) PAT81KFT-18V (1)	X26RT (2)	X26RT (2)					
YAV28L2ENT14FX	1	4/0 AWG		1/4"	0.63"	0.76"	1.03"	0.15"	2.86"	MY29-11 (1) Y644HS (1)	W28VT (2)	W28VT (2)					
YAV28L2NT38FX	1	4/0 Weld 550/24	—	3/8"	1.00"	0.94"	1.03"	0.15"	3.43"	Y81KFT (1) Y81KFTMBH (1) PAT81KFT-18V (1)	W28RT (2) X28RT (3)	W28RT (2) X28RT (3)	U28RT (1)	Purple	15	1-1/16"	

Consult cable manufacturers for stress relief instructions.
◆ For applications greater than 2000 Volts consult cable manufacturer for voltage stress relief instructions.

* Use PUADP-1 adaptor with U -dies in Y46 HYPRESS™.
▲ See tooling section of this catalog for complete tool and die listings. Use ONLY color-coded die recommendations for -FX connectors.

Note: All dimensions shown are for reference only.

Blue highlighted items are industry standard and most frequently ordered.

Compression Connections

BURNDY®

Copper Compression – Flex – Standard Barrel – Narrow Tongue

C-60

TWO HOLE HYLUG™ FLEX CONDUCTOR STANDARD BARREL NARROW TONGUE (Continued)

UL Listed 90° C,
600 Volts to 35 kV ◆

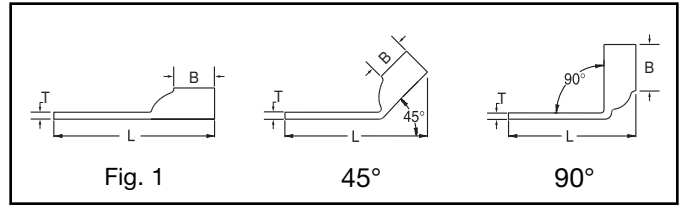

45° and 90° angles are available.
Please contact Customer Service to order:
1-800-346-4175



Catalog Number	Fig #	Conductor		Stud Hole Size	Stud Hole Spacing	Tongue Width	Figure Dimensions			Dieless (# of crimps)	▲ Installation Tooling				Wire Strip Length	
		AWG	*** MM ²				(B)	(T)	(L)		Mechanical MD6, OUR840, MD7-34R	Hydraulic		Color Code		Die Index
												BCT500HS, Y500CTHS	Y35, Y39, Y750, Y46*, PAT750			
YAV29L2NT38FX	1	4/0 AWG 4/0 Weld 550/24	—	3/8"	1.00"	0.94"	1.03"	0.16"	3.43"	Y644HS (1) Y81KFT (1) Y81KFTMBH (1) PAT81KFT-18V (1)	W29VT (2) X29RT (4)	W29VT (2) W29RT (2) X29RT (4)	U29RT (1)	Yellow	16	1-1/16"
YA31L2NT38FX	1	250 Flex 637/24 Class I,K,M	150	3/8"	1.00"	0.96"	1.06"	0.18"	3.51"	Y644HS (1) Y81KFT (1) Y81KFTMBH (1) PAT81KFT-18V (1)	W30VT (2)	W30VT (2) W30RT (2)	U30RT (2)	White	17	1-1/8"
YA32L2NT38FX	1	313.1 kcmil 775/24 300 Flex	185	3/8"	1.00"	0.96"	1.19"	0.20"	3.69"	Y644HS (1) Y81KFT (1) Y81KFTMBH (1) PAT81KFT-18V (1)	W31VT (2)	W31VT (2) W31RT (2)	U31RT (2)	Red	18	1-1/4"
YA34L2NT38FX	1	373.7 kcmil 925/24 350 Flex	240	3/8"	1.00"	0.96"	1.27"	0.23"	3.88"	Y644HS (1) Y81KFT (1) Y81KFTMBH (1) PAT81KFT-18V (1)	W32VT (2)	W32VT (2) W32RT (2)	U32RT (2)	Blue	19	1-5/16"
YA36L2NT38FX	1	444.4 kcmil 1100/24 450 Flex	—	3/8"	1.00"	1.63"	1.38"	0.27"	4.24"	Y644HS (1) Y81KFT (1) Y81KFTMBH (1) PAT81KFT-18V (1)	—	—	U34RT (2)	Brown	20	1-7/16"
YA38L2ENT38FX	1	535.3 kcmil	300	3/8"	1.00"	1.50"	1.45"	0.27"	4.35"	Y644HS (1) Y81KFT (1)	—	—	U38XRT (2)	Pink	L99	1-7/16"
YA38L2NT38FX	1	1325/24		3/8"	1.00"	1.63"	1.45"	0.27"	4.35"	Y81KFTMBH (1)						
YA38L2NNTFX	1	500 Flex		1/2"	1.75"	1.63"	1.45"	0.27"	5.35"	PAT81KFT-18V (1)						
YA40L2NNTFX	1	646 kcmil 1600/24 650 Flex	400	1/2"	1.75"	1.63"	1.42"	0.30"	5.38"	Y644HS (1) Y81KFT (2) Y81KFTMBH (2) PAT81KFT-18V (2)	—	—	U39RT (2)	Black	24	1-5/16"
YA44L2NNTFX	1	777.7 kcmil	500	1/2"	1.75"	1.63"	1.65"	0.33"	5.74"	Y644HS (1) Y81KFT (2)	—	—	U44XRT (2)	Yellow	L115	1-5/8"
YA44L2NT38FX	1	1925/24 750 Flex		3/8"	1.00"	1.63"	1.65"	0.33"	4.74"	Y81KFTMBH (2) PAT81KFT-18V (2)						
YA45L2NT38FX	1	929 kcmil 2300/24	—	3/8"	1.00"	1.70"	2.00"	0.38"	5.18"	—	—	—	P44RT(2)	White	27	2-1/16"

Consult cable manufacturers for stress relief instructions.
◆ For applications greater than 2000 Volts consult cable manufacturer for voltage stress relief instructions.

* Use PUADP-1 adaptor with U -dies in Y46 HYPRESS™.
▲ See tooling section of this catalog for complete tool and die listings. Use ONLY color-coded die recommendations for -FX connectors.

Note: All dimensions shown are for reference only.

Blue highlighted items are industry standard and most frequently ordered.

**TWO HOLE HYLUG™
FLEX CONDUCTOR
LONG BARREL WITH
INSPECTION WINDOW**

TYPE YAZ-FX

**COPPER COMPRESSION
TERMINAL**

UL Listed 90° C,
600 Volts to 35 kV ◆

45° and 90° angles are available.
Please contact Customer Service to order:
1-800-346-4175

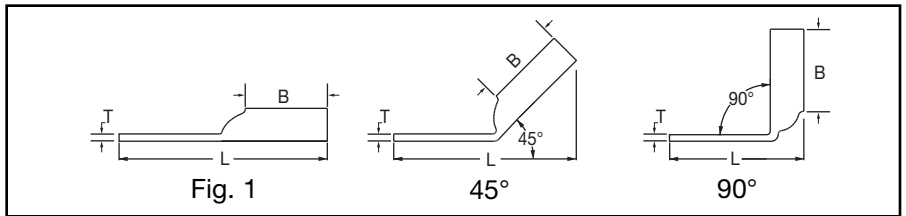
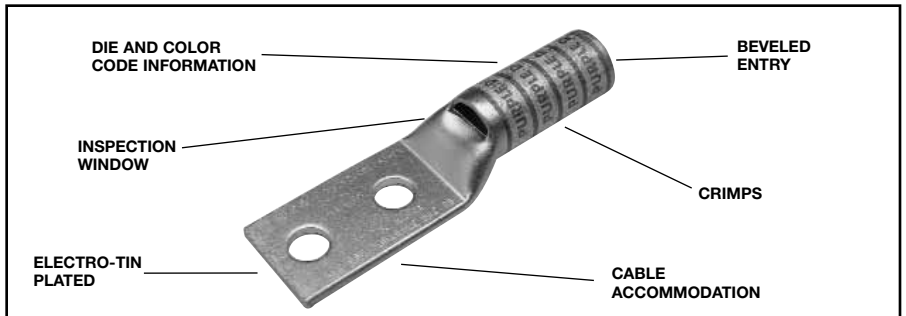

Catalog Number	Fig #	Conductor		Stud Hole Size	Stud Hole Spacing	Tongue Width	Figure Dimensions			Dieless (# of crimps)	▲ Installation Tooling				Wire Strip Length		
		AWG	MM²				(B)	(T)	(L)		Mechanical		Hydraulic			Color Code	Die Index
											MD6, OUR840, MD7-34R	BCT500HS, Y500CTHS	Y35, Y39, Y750, Y46*, PAT750				
YAZ8C2TC10FX	1	37/24 #8 Weld #3 AWG	10	# 10	5/8"	.41"	.75"	.08"	2.20"	Y8MRB-1 (1)	W8CVT (2) W8CRT (2) X8CRT (2)	W8CVT (2) W8CRT (2) X8CRT (2)	U8CRT (2)	Red	49	1"	
YAZ8C2TC10E2FX	1			# 10	3/4"	.41"	.75"	.08"	2.33"	MY29-11 (2)							
YAZ8C2TC14E1FX	1			1/4"	1"	.44"	.75"	.08"	2.70"	Y1MRTC (2)							
YAZ8C2TC14FX	1			1/4"	5/8"	.44"	.75"	.08"	2.32"	Y81KFT (1)							
YAZ8C2TC14E2FX	1			1/4"	3/4"	.44"	.75"	.08"	2.45"	Y81KFTMBH (1)							
YAZ8C2TC38FX	1			3/8"	1"	.58"	.75"	.06"	2.89"	PAT81KFT-18V (1)							
YAZV6C2TC10E2FX	1	61/24 #6 Weld #6 AWG	16	# 10	3/4"	.48"	.75"	.08"	2.64"	MY29-11 (2) Y644HS (1) Y1MRTC (2) Y81KFT (1) Y81KFTMBH (1) PAT81KFT-18V (1)	W5CVT (2) W5CRT (2) X5CRT (2)	W5CVT (2) W5CRT (2) X5CRT (2)	U5CRT (2)	Blue	7	1-3/16"	
YAZV6C2TC14FX	1			1/4"	5/8"	.48"	.75"	.08"	2.65"								
YAZV6C2TC14E2FX	1			1/4"	3/4"	.48"	.75"	.08"	2.78"								
YAZV6C2TC14E1FX	1			1/4"	1"	.48"	.75"	.08"	3.03"								
YAZV6C2TC38FX	1			3/8"	1"	.58"	.75"	.06"	3.22"								
YAZV6C2TC38E2FX	1			3/8"	3/4"	.58"	.75"	.06"	2.97"								
YAZV6C2TC38E6FX	1			3/8"	7/8"	.58"	.75"	.06"	3.09"								
YAZV4C2TC38E2-FX	1			3/8"	3/4"	.58"	1.25"	.08"	3.14"	Y1MRTC (4)							
YAZV4C2TC38FX	1	91/24-105/24 #4 Weld #4 AWG	—	3/8"	1"	.58"	1.25"	.08"	3.39"	MY29-11 (2) Y644HS (1)	W4CVT (2) W4CRT (2) X4CRT (2)	W4CVT (2) W4CRT (2) X4CRT (2)	U4CRT (2)	Gray	8	1-5/16"	
YAZV4C2TC14FX	1			1/4"	5/8"	.55"	1.25"	.09"	2.83"	Y81KFT (1)							
YAZV4C2TC14E2FX	1			1/4"	3/4"	.55"	1.25"	.09"	2.95"	Y81KFTMBH (1) PAT81KFT-18V (1)							
YAZV2C2TC14FX	1	125/24-150/24 #2 Weld #2 AWG	35	1/4"	5/8"	.68"	1.38"	.10"	3.01"	Y1MRTC (4)	W2CVT (2) W2CRT (2) X2CRT (2)	W2CVT (2) W2CRT (2) X2CRT (2)	U2CRT (2)	Brown	10	1-7/16"	
YAZV2C2TC14E2FX	1			1/4"	3/4"	.68"	1.38"	.10"	3.13"	MY29-11 (4)							
YAZV2C2TC38FX	1			3/8"	1"	.68"	1.38"	.10"	3.57"	Y644HS (1)							
YAZV2C2TNTCFX	1			1/2"	1-3/4"	.83"	1.38"	.10"	4.76"	Y81KFT (1)							
YAZV1C2TC14FX	1	175/24-225/24 #1 Weld #1 AWG	—	1/4"	5/8"	.75"	1.38"	.12"	3.04"	MY29-11 (2) Y644HS (1) Y81KFT (2) Y81KFTMBH (2) PAT81KFT-18V (2)	W1CVT (2) W1CRT-1 (2) X1CRT-1 (2)	W1CVT (2) W1CRT-1 (2) X1CRT-1 (2)	U1CRT-1 (2)	Green	11	1-7/16"	
YAZV1C2TC14E1FX	1			1/4"	1"	.75"	1.38"	.12"	3.41"								
YAZV1C2TC14E2FX	1			1/4"	3/4"	.75"	1.38"	.12"	3.16"								
YAZV1C2TC38FX	1			3/8"	1"	.75"	1.38"	.12"	3.60"								
YAZV1C2TC516E6FX	1			5/16"	7/8"	.75"	1.38"	.12"	3.35"								
YAZV1C2TC516FX	1			5/16"	1"	.75"	1.38"	.12"	3.47"								

* Use PUADP-1 adaptor with U -dies in Y46 HYPRESS™.
 ** The MM² conductor size referenced here is for both Class 2 and Class 5 conductor.
 *** The MM² conductor size listed are the recommendations for Class 5 conductor.

▲ See tooling section of this catalog for complete tool and die listings. Use ONLY color-coded die recommendations for -FX connectors. For nest/indenter system contact factory.

◆ For applications greater than 2000 Volts consult cable manufacturer for voltage stress relief instructions.
 Note: All dimensions shown are for reference only.

Blue highlighted items are industry standard and most frequently ordered.

Compression Connections

BURNDY®

Copper Compression – Flex – Long Barrel – Inspection Window

C-62

TWO HOLE HYLUG™ FLEX CONDUCTOR LONG BARREL WITH INSPECTION WINDOW (Continued)

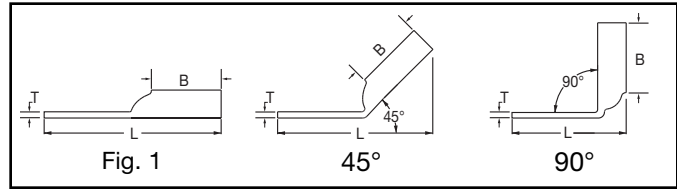

UL Listed 90° C,
600 Volts to 35 kV ◆

45° and 90° angles are available.
Please contact Customer Service to order:
1-800-346-4175



Catalog Number	Fig #	Conductor		Stud Hole Size	Stud Hole Spacing	Tongue Width	Figure Dimensions			Dieless (# of crimps)	▲ Installation Tooling				Wire Strip Length		
		AWG	MM²				(B)	(T)	(L)		Mechanical		Hydraulic			Color Code	Die Index
											MD6, OUR840, MD7-34R	BCT500HS, Y500CTHS	Y35, Y39, Y750, Y46*, PAT750				
YAZV252TC14FX	1	275/24 1/0 Weld 1/0 AWG	50	1/4"	5/8"	.83"	1.50"	.12"	3.20"	MY29-11 (2) Y644HS (1) Y81KFT (2) Y81KFTMBH (2) PAT81KFT-18V (2)	W25VT (4)	W25RT (4)	U25RT (2)	Pink	12	1-9/16"	
YAZV252TC14E2FX	1			1/4"	3/4"	.83"	1.50"	.12"	3.32"		W25RT (4)	W25RT (4)					
YAZV252TC38FX	1			3/8"	1"	.83"	1.50"	.12"	3.76"		X25RT (4)	X25RT (4)					
YAZV252NTCFX	1	325/24 2/0 Weld 2/0 AWG	70	1/4"	5/8"	.93"	1.50"	.13"	3.20"	MY29-11 (2) Y644HS (1) Y81KFT (2) Y81KFTMBH (2) PAT81KFT-18V (2)	W26VT (4)	W26RT (4)	U26RT (2)	Black	13	1-9/16"	
YAZV262TC14E2FX	1			1/4"	3/4"	.93"	1.50"	.13"	3.32"		W26RT (4)	W26RT (4)					
YAZV262TC38FX	1			3/8"	1"	.93"	1.50"	.13"	3.76"		X26RT (4)	X26RT (4)					
YAZV262NTCFX	1	450/24 3/0 Weld 3/0 AWG	95	1/4"	3/4"	1.03"	1.50"	.14"	3.36"	MY29-11 (2) Y644HS (1) Y81KFT (2) Y81KFTMBH (2) PAT81KFT-18V (2)	W27VT (4)	W27RT (4)	U27RT (2)	Orange	14	1-9/16"	
YAZV272TC14E2FX	1			1/4"	3/4"	1.03"	1.50"	.14"	3.36"		W27RT (4)	W27RT (4)					
YAZV272TC38FX	1			3/8"	1"	1.03"	1.50"	.14"	3.80"		X27RT (4)	X27RT (4)					
YAZV282TC14E2FX	1	550/24 4/0 Weld 4/0 AWG	120	1/4"	3/4"	1.14"	1.62"	.15"	3.52"	MY29-11 (2) Y644HS (1) Y81KFT (2) Y81KFTMBH (2) PAT81KFT-18V (2)	W28VT (4)	W28RT (4)	U28RT (2)	Purple	15	1-11/16"	
YAZV282NT38FX	1			3/8"	1"	.94"	1.62"	.15"	3.96"		W28RT (4)	W28RT (4)					
YAZV282TC38FX	1			3/8"	1"	1.14"	1.62"	.15"	3.96"		X28RT (6)	X28RT (6)					
YAZV282NTCFX	1	550/24 4/0 Weld	—	1/2"	1-3/4"	1.14"	1.62"	.15"	4.93"	MY29-11 (2) Y644HS (1) Y81KFT (2) Y81KFTMBH (2) PAT81KFT-18V (2)	W28VT (4)	W28RT (4)	U28RT (2)	Purple	15	1-11/16"	
YAZV292NT516FX	1			3/8"	1"	1.14"	1.62"	.15"	4.93"		X28RT (6)	X28RT (6)					
YAZ302TC38FX	1			250 Flex CLASS G 259 Str. CLASS H 427 Str.	—	3/8"	1"	1.20"	2.00"		.16"	4.42"	W29VT (4) X29RT (8)	W29RT (4) X29RT (8)	U29RT (2)		Yellow
YAZ312TC38FX	1	250 Flex 637/24 CLASS I, K, M	150	3/8"	1"	1.28"	2.00"	.18"	4.45"	MY29-11 (2) Y644HS (1) Y81KFT (2) Y81KFTMBH (2) PAT81KFT-18V (2)	W30VT (4)	W30RT (4)	U30RT (4)	White	17	2-1/16"	
YAZ312TC14E2FX	1			1/4"	3/4"	1.29"	2.00"	.18"	4.02"		W30RT (4)	W30RT (4)					
YAZ322TC38FX	1	775/24 313.1 kcmil	185	3/8"	1"	1.55"	2.12"	.19"	4.62"	MY29-11 (2) Y644HS (1) Y81KFT (2) Y81KFTMBH (2) PAT81KFT-18V (2)	W31VT (4)	W31RT (4)	U31RT (4)	Red	18	2-3/16"	
YAZ342TC14E2FX	1	373.3 kcmil 925/24 (350 kcmil nom.)	240	1/4"	3/4"	1.55"	2.25"	.23"	4.42"	MY29-11 (2) Y644HS (1) Y81KFT (2) Y81KFTMBH (2) PAT81KFT-18V (2)	W32VT (4)	W32RT (4)	U32RT (4)	Blue	19	2-5/16"	
YAZ342NT38FX	1			3/8"	1"	.96"	2.25"	.23"	4.85"		W32RT (4)	W32RT (4)					
YAZ342TC38FX	1			3/8"	1"	1.55"	2.25"	.23"	4.85"		W32RT (4)	W32RT (4)					
YAZ342NTCFX	1			1/2"	1-3/4"	1.55"	2.25"	.23"	6.04"		X32RT (4)	X32RT (4)					
YAZ362TC38FX	1	1100/24 444.4 kcmil	—	3/8"	1"	1.72"	2.69"	.27"	5.55"	MY29-11 (2) Y644HS (1) Y81KFT (2) Y81KFTMBH (2) PAT81KFT-18V (2)	—	—	U34RT (4)	Brown	20	2-3/4"	
YAZ382NT38FX	1	535.3 kcmil 1325/24 (500 kcmil nom.)	300	3/8"	1"	1.63"	2.81"	.27"	5.72"	MY29-11 (2) Y644HS (1) Y81KFT (2) Y81KFTMBH (2) PAT81KFT-18V (2)	—	—	U38XRT (4)	Pink	L99	2-7/8"	
YAZ382TC38FX	1			3/8"	1"	1.81"	2.81"	.27"	5.72"		—	—					
YAZ382NNTFX	1			1/2"	1-3/4"	1.63"	2.81"	.27"	6.72"		—	—					
YAZ382NTCFX	1			1/2"	1-3/4"	1.84"	2.81"	.27"	6.72"		X38RT (4)	X38RT (4)					
YAZ402NTCFX	1	646 kcmil 1600/24 650 kcmil Flex	—	1/2"	1-3/4"	1.93"	2.94"	.30"	6.89"	MY29-11 (2) Y644HS (1) Y81KFT (2) Y81KFTMBH (2) PAT81KFT-18V (2)	U39RT (4)	—	U39RT (4)	Black	24	3"	
YAZ442NT38FX	1	750 Flex 1925/24 Str. 777.7 kcmil	—	3/8"	1"	1.63"	3.00"	.33"	6.08"	MY29-11 (2) Y644HS (1) Y81KFT (2) Y81KFTMBH (2) PAT81KFT-18V (2)	—	—	U44XRT (4)	Yellow	L115	3-1/16"	

* Use PUADP-1 adaptor with U -dies in Y46 HYPRESS™.
** The MM² conductor size referenced here is for both Class 2 and Class 5 conductor.
*** The MM² conductor sizes listed are the recommendations for Class 5 conductor.

▲ See tooling section of this catalog for complete tool and die listings. Use ONLY color-coded die recommendations for -FX connectors. For nest/indenter system contact factory.

◆ For applications greater than 2000 Volts consult cable manufacturer for voltage stress relief instructions.
Note: All dimensions shown are for reference only.

Blue highlighted items are industry standard and most frequently ordered.

**TWO HOLE HYLUG™
FLEX CONDUCTOR
LONG BARREL
BELLED END**

**TYPES YA-2TC-FXB,
YAV-2TC-FXB**

**COPPER COMPRESSION
TERMINAL**

UL Listed 90° C,
600 Volts to 35 kV ◆

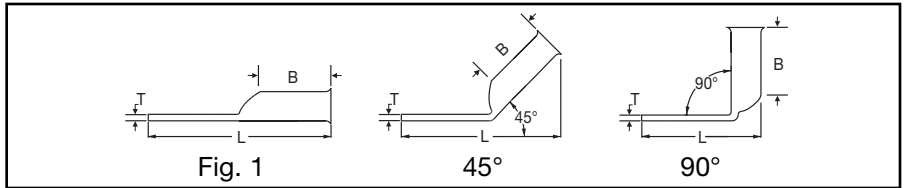
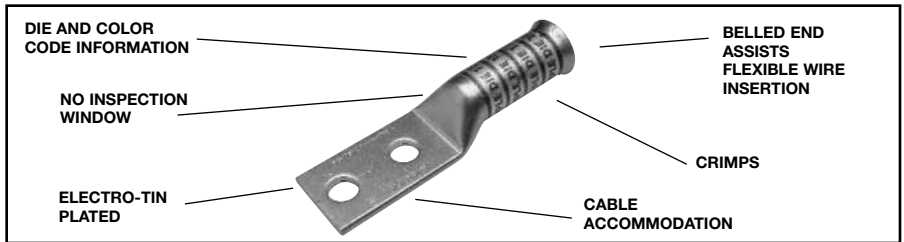

45° and 90° angles are available.
Please contact Customer Service to order:
1-800-346-4175



Catalog Number	Fig #	Conductor		Stud Hole Size	Stud Hole Spacing	Tongue Width	Figure Dimensions			Dieless (# of crimps)	▲ Installation Tooling					Wire Strip Length
		AWG	MM²				(B)	(T)	(L)		Mechanical MD6, OUR840, MD7-34R	Hydraulic BCT500HS, Y500CTHS		Y35, Y39, Y750, Y46*, PAT750	Color Code	
YA8C2TC14E2-FXB	1	37/24	**	1/4"	3/4"	.41"	.90"	.08"	2.54"	Y8MRB-1 (2) Y1MRTC (2) MY29-11 (2)	W8CRT (2) W8CVT (2) W8CRT (2) X8CRT (2)	W8CVT (2) W8CRT (2) X8CRT (2)	U8CRT (2)	Red	49	1"
YA8C2TC38-FXB	1	#8 Weld #8 AWG	10	3/8"	1"	.57"	.90"	.06"	2.98"	Y81KFT (1) Y81KFTMBH (1) PAT81KFT-18V (1)						
YAV6C2TC14E2-FXB	1	61/24 #6 Weld #6 AWG	**	1/4"	3/4"	.48"	1.22"	.08"	2.88"	Y1MRTC (2) MY29-11 (2)	W5CVT (2) W5CRT (2) W5CRT (2) X5CRT (2)	W5CVT (2) W5CRT (2) W5CRT (2) X5CRT (2)	U5CRT (2)	Blue	7	1-5/16"
YAV6C2TC14-FXB	1			1/4"	5/8"	.48"	1.22"	.08"	2.76"	Y644HS (1)						
YAV6C2TC38-FXB	1			3/8"	1"	.60"	1.22"	.06"	3.32"	Y81KFT (1) Y81KFTMBH (1)						
YAV6C2N-FXB	1			1/2"	1-3/4"	.77"	1.22"	.04"	4.51"	PAT81KFT-18V (1)						
YAV5C2TC14-FXB	1	#5 AWG	—	1/4"	5/8"	.44"	1.22"	.07"	2.76"	Y644HS (1) Y81KFT (1) Y81KFTMBH (1) PAT81KFT-18V (1)	W4CVT (2) W4CRT (2) W4CRT (2) X4CRT (2)	W4CVT (2) W4CRT (2) W4CRT (2) X4CRT (2)	U4CRT (2)	Gray	8	1-5/16"
YAV4C2TC14E2-FXB	1	91/24 - 105/24	—	1/4"	3/4"	.55"	1.22"	.09"	2.93"	Y1MRTC (4) MY29-11 (2)						
YAV4C2TC14-FXB	1	#4 Weld #4 AWG	—	1/4"	5/8"	.55"	1.22"	.09"	2.81"	Y644HS (1)	W3CRT (2)	W3CRT (2)	U3CRT (2)	White	9	1-9/16"
YAV4C2TC516-FXB	1			5/16"	1"	.55"	1.22"	.09"	3.24"	Y81KFT (1)						
YAV4C2TC38-FXB	1			3/8"	1"	.63"	1.22"	.09"	3.37"	Y81KFTMBH (1)						
YAV4C2N-FXB	1			1/2"	1-3/4"	.77"	1.22"	.09"	4.56"	PAT81KFT-18V (1)						
YA3C2TC516-FXB	1	105/24 - 125/24	—	5/16"	1"	.55"	1.48"	.09"	3.51"	MY29-11 (2) Y644HS (1)	W2CVT (2)	W2CVT (2)	U2CRT (2)	Brown	10	1-7/16"
YA3C2TC38-FXB	1	#3 Weld	—	3/8"	1"	.58"	1.48"	.09"	3.64"							
YA3C2N-FXB	1	#3 AWG	—	1/2"	1-3/4"	.77"	1.48"	.09"	4.83"	Y81KFTMBH (1) PAT81KFT-18V (1)	W1CVT (2) W1CRT-1 (2) X1CRT-1 (2)	W1CVT (2) W1CRT-1 (2) X1CRT-1 (2)	U1CRT-1 (2)	Green	11	1-9/16"
YAV2C2TC14-FXB	1	125/24 - 150/24 #2 Weld #2 AWG	35	1/4"	5/8"	.67"	1.35"	.10"	3.00"	Y81KFT (1)						
YAV2C2TC14E2-FXB	1			1/4"	3/4"	.67"	1.35"	.10"	3.13"	Y81KFT (1)						
YAV2C2TC14E1-FXB	1			1/4"	1"	.67"	1.35"	.10"	3.38"	Y81KFT (1)						
YAV2C2TC516-FXB	1			5/16"	1"	.67"	1.35"	.10"	3.44"	Y81KFT (1)						
YAV2C2TC38-FXB	1			3/8"	1"	.67"	1.35"	.10"	3.57"	Y81KFT (1)						
YAV2C2N-FXB	1			1/2"	1-3/4"	.77"	1.35"	.09"	4.76"	PAT81KFT-18V (1)						
YAV1C2TC38-FXB	1	175/24 - 225/24	—	3/8"	1"	.75"	1.50"	.12"	3.74"	Y81KFT (1) Y81KFTMBH (1) PAT81KFT-18V (1)	W1CVT (2) W1CRT-1 (2) X1CRT-1 (2)	W1CVT (2) W1CRT-1 (2) X1CRT-1 (2)	U1CRT-1 (2)	Green	11	1-9/16"
YAV1C2N-FXB	1	#1 Weld #1 AWG	—	1/2"	1-3/4"	.77"	1.50"	.12"	4.92"							

Consult cable manufacturers for stress relief instructions.
◆ For applications greater than 2000 Volts consult cable manufacturer for voltage stress relief instructions.
* Use PUADP-1 adaptor with U -dies in Y46 HYPRESS™.
** The MM² conductor sizes referenced here are for both Class 2 and Class 5 conductors.

*** The MM² conductor sizes listed are the recommendations for Class 5 conductor.
‡ P-RT die sets for use in Y46 HYPRESS™ only, PUADP-1 adaptor not required.
Note: All dimensions shown are for reference only.

▲ See tooling section of this catalog for complete tool and die listings. Use ONLY color-coded die recommendations for -FX connectors.
Consult shielded cable manufacturers for stress relief instructions.

Blue highlighted items are industry standard and most frequently ordered.

Compression Connections

BURNDY®

Copper Compression – Flex – Long Barrel – Belled End – No Inspection Window

C-64

TWO HOLE HYLUG™ FLEX CONDUCTOR LONG BARREL BELLED END (Continued)

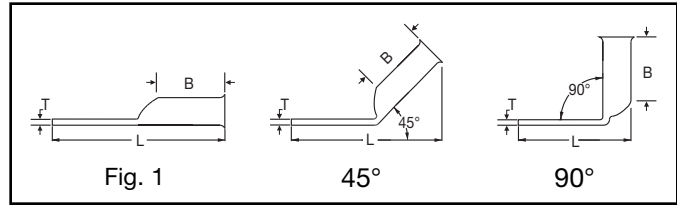

UL Listed 90° C,
600 Volts to 35 kV ◆

45° and 90° angles are available.
Please contact Customer Service to order:
1-800-346-4175



Catalog Number	Fig #	Conductor		Stud Hole Size	Stud Hole Spacing	Tongue Width	Figure Dimensions			Dieless (# of crimps)	▲ Installation Tooling					Wire Strip Length					
		AWG	MM²				(B)	(T)	(L)		Mechanical		Hydraulic		Color Code		Die Index				
											MD6, OUR840, MD7-34R	BCT500HS, Y500CTHS	Y35, Y39, Y750, Y46*, PAT750								
YAV252TC14-FXB	1	275/24	50	1/4"	5/8"	.83"	1.50"	.12"	3.21"	MY29-11 (2) Y644HS (1) Y81KFT (2) Y81KFTMBH (2) PAT81KFT-18V (2)	W25RT (4)	W25RT (4)	U25RT (2)	Pink	12	1-9/16"					
YAV252TC14E2-FXB	1	1/0 Weld		1/4"	3/4"	.83"	1.50"	.12"	3.34"		W25VT (4)	W25VT (4)									
YAV252TC38-FXB	1	1/0 AWG		3/8"	1"	.83"	1.50"	.12"	3.78"		X25RT (4)	X25RT (4)									
YAV252N-FXB	1		70	1/2"	1-3/4"	.83"	1.50"	.12"	4.96"	MY29-11 (2) Y644HS (1) Y81KFT (2) Y81KFTMBH (2) PAT81KFT-18V (2)	W26RT (4)	W26RT (4)	U26RT (2)	Black	13	1-13/16"					
YAV262TC14-FXB	1	325/24		1/4"	5/8"	.93"	1.63"	.13"	3.40"		W26VT (4)	W26VT (4)									
YAV262TC14E2-FXB	1	2/0 Weld		1/4"	3/4"	.93"	1.63"	.13"	3.52"		W26RT (4)	W26RT (4)									
YAV262TC38-FXB	1	2/0 AWG	95	3/8"	1"	.93"	1.63"	.13"	3.96"	MY29-11 (2) Y644HS (1) Y81KFT (2) Y81KFTMBH (2) PAT81KFT-18V (2)	X26RT (4)	X26RT (4)	U26RT (2)	Black	13	1-13/16"					
YAV262NTC38-FXB	1	2/0 AWG		3/8"	1-3/4"	.93"	1.63"	.13"	4.71"		W27RT (4)	W27RT (4)									
YAV262N-FXB	1	3/0 AWG		1/2"	1-3/4"	.93"	1.63"	.13"	5.15"		W27VT (4)	W27VT (4)									
YAV272TC14E2-FXB	1	450/24	120	1/4"	3/4"	1.02"	1.64"	.14"	3.58"	MY29-11 (2) Y644HS (1) Y81KFT (2) Y81KFTMBH (2) PAT81KFT-18V (2)	W27RT (4)	W27RT (4)	U27RT (2)	Orange	14	1-13/16"					
YAV272TC38-FXB	1	3/0 Weld		3/8"	1"	1.02"	1.64"	.14"	4.01"		W27VT (4)	W27VT (4)									
YAV272N-FXB	1	3/0 AWG		1/2"	1-3/4"	1.02"	1.64"	.14"	5.20"		X27RT (4)	X27RT (4)									
YAV282TC14E2-FXB	1	550/24	120	1/4"	3/4"	1.14"	1.77"	.14"	3.76"	MY29-11 (2) Y644HS (1) Y81KFT (2) Y81KFTMBH (2) PAT81KFT-18V (2)	W28RT (4)	W28RT (4)	U28RT (2)	Purple	15	1-7/8"					
YAV282NTC38-FXB	1	4/0 Weld		3/8"	1"	.75"	1.77"	.14"	4.20"		W28VT (4)	W28VT (4)									
YAV282N-FXB	1	4/0 AWG		3/8"	1"	1.14"	1.77"	.14"	4.20"		W28RT (4)	W28RT (4)									
YAV282NTC38-FXB	1	4/0 AWG	120	3/8"	1-3/4"	1.14"	1.77"	.14"	4.20"	MY29-11 (2) Y644HS (1) Y81KFT (2) Y81KFTMBH (2) PAT81KFT-18V (2)	X28RT (6)	X28RT (6)	U28RT (2)	Purple	15	1-7/8"					
YAV282N-FXB	1			1/2"	1-3/4"	1.14"	1.77"	.14"	5.39"		W29RT (4)	W29RT (4)									
YAV292TC14E2-FXB	1	550/24		120	1/4"	3/4"	1.14"	2.00"	.15"		3.76"	MY29-11 (2) Y644HS (1) Y81KFT (2) Y81KFTMBH (2) PAT81KFT-18V (2)					W29VT (4)	W29VT (4)	U29RT (2)	Yellow	16
YAV292NTC38-FXB	1	4/0 Weld	3/8"		1"	.75"	2.00"	.15"	4.20"	W29RT (4)	W29RT (4)										
YAV292N-FXB	1	4/0 AWG	3/8"		1-3/4"	1.14"	2.00"	.15"	4.20"	X29RT (6)	X29RT (6)										
YAV292NTC38-FXB	1	4/0 AWG	120	3/8"	1-3/4"	1.14"	2.00"	.15"	4.20"	MY29-11 (2) Y644HS (1) Y81KFT (2) Y81KFTMBH (2) PAT81KFT-18V (2)	W29VT (4)	W29VT (4)	U29RT (2)	Yellow	16	1-7/8"					
YAV292N-FXB	1			1/2"	1-3/4"	1.14"	2.00"	.15"	5.39"		X29RT (6)	X29RT (6)									
YAV292N-FXB	1			1/2"	1-3/4"	1.14"	2.00"	.15"	5.39"		W29VT (4)	W29VT (4)									
YA302N-FXB	1	250 Flex - CLASS G 259 Str. CLASS H 427 Str.	150	1/2"	1-3/4"	1.20"	2.12"	.16"	5.80"	Y644HS (1) Y81KFT (2) Y81KFTMBH (2) PAT81KFT-18V (2)	W30RT (4)	W30RT (4)	U30RT (4)	White	17	2-1/4"					
YA312TC38-FXB	1	250 Flex	150	3/8"	1"	1.29"	2.18"	.18"	4.66"		W30VT (4)	W30VT (4)									
YA312N-FXB	1	637/24 CLASS I, K, M	150	1/2"	1-3/4"	1.29"	2.18"	.18"	5.85"		W31RT (4)	W31RT (4)									
YA322TC38-FXB	1	775/24	185	3/8"	1"	1.40"	2.32"	.19"	4.85"	Y644HS (1) Y81KFT (2) Y81KFTMBH (2) PAT81KFT-18V (2)	W31VT (4)	W31VT (4)	U31RT (4)	Red	18	2-1/4"					
YA322N-FXB	1	313.1 kcmil		185	1/2"	1-3/4"	1.40"	2.32"	.19"		6.04"	W31VT (4)					W31VT (4)				
YA342TC38-FXB	1	925/24 373.7 kcmil	240	3/8"	1"	1.55"	2.48"	.23"	5.10"	Y644HS (1) Y81KFT (2) Y81KFTMBH (2) PAT81KFT-18V (2)	W32RT (4)	W32RT (4)	U32RT (4)	Blue	19	2-9/16"					
YA342N-FXB	1	(350 kcmil nom.)		240	1/2"	1-3/4"	1.55"	2.48"	.23"		6.29"	W32VT (4)					W32VT (4)				
YA362MFXB	1	1100/24 444.4 kcmil (450 nom.)	300	1/2"	1-3/4"	1.73"	2.95"	.26"	6.84"	Y644HS (1) Y81KFT (2) Y81KFTMBH (2) PAT81KFT-18V (2)	W34RT (4)	W34RT (4)	U34RT (4)	Brown	20	3-1/16"					
YA382TC38-FXB	1	1325/24	300	3/8"	1"	1.84"	3.08"	.26"	6.01"		Y644HS (1) Y81KFT (2) Y81KFTMBH (2) PAT81KFT-18V (2)	W38RT (4)					W38RT (4)	U38XRT (4)	Pink	L99	3-3/16"
YA382N-FXB	1	535.3 kcmil		300	1/2"	1-3/4"	1.84"	3.08"	.26"			7.01"					W38VT (4)				
YA382-FXBG2	1	(500 kcmil nom.)		300	3/8"	2"	1.84"	3.08"	.27"	6.82"		W38RT (4)	W38RT (4)								
YA382-FXBG3	1	(500 kcmil nom.)	300	1/2"	1-3/16"	1.84"	3.08"	.27"	6.26"	W38RT (4)	W38RT (4)										

Consult cable manufacturers for stress relief instructions.
◆ For applications greater than 2000 Volts consult cable manufacturer for voltage stress relief instructions.
* Use PUADP-1 adaptor with U -dies in Y46 HYPRESS™.
** The MM² conductor sizes referenced here are for both Class 2 and Class 5 conductors.

*** The MM² conductor sizes listed are the recommendations for Class 5 conductor.
‡ P-RT die sets for use in Y46 HYPRESS™ only, PUADP-1 adaptor not required.

▲ See tooling section of this catalog for complete tool and die listings. Use ONLY color-coded die recommendations for -FX connectors.
Note: All dimensions shown are for reference only.

Blue highlighted items are industry standard and most frequently ordered.

**TWO HOLE HYLUG™
FLEX CONDUCTOR
LONG BARREL
BELLED END
(Continued)**

UL Listed 90° C,
600 Volts to 35 kV ◆

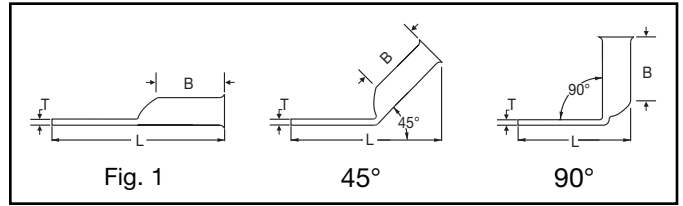

45° and 90° angles are available.
Please contact Customer Service to order:
1-800-346-4175



Catalog Number	Fig #	Conductor		Stud Hole Size	Stud Hole Spacing	Tongue Width	Figure Dimensions			Dieless (# of crimps)	▲ Installation Tooling				Wire Strip Length	
		AWG	*** MM ²				(B)	(T)	(L)		Mechanical MD6, OUR840, MD7-34R	Hydraulic		Color Code		Die Index
												BCT500HS, Y500GTHS	Y35, Y39, Y750, Y46*, PAT750			
YA402N-FXB	1	1600/24 646 kcmil	400	1/2"	1-3/4"	1.98"	3.24"	.30"	7.22"	—	—	U39RT (4)	Black	24	3-5/16"	
YA442TC38-FXB	1	1925/24	500	3/8"	1"	2.19"	3.33"	.33"	6.44"	Y644HS (1) Y81KFT (3) Y81KFTMBH (3) PAT81KFT-18V (3)	—	—	U44XRT (4)	Yellow	L115	3-7/16"
YA442N-FXB	1	777.7 kcmil (750 kcmil nom.)		1/2"	1-3/4"	2.19"	3.33"	.33"	7.44"							
YA462N-FXB	1	2750/24 1111 kcmil (1000 kcmil nom.)		—	1/2"	1-3/4"	2.69"	3.58"	.39"							

Consult cable manufacturers for stress relief instructions.
◆ For applications greater than 2000 Volts consult cable manufacturer for voltage stress relief instructions.
* Use PUADP-1 adaptor with U -dies in Y46 HYPRESS™.
** The MM² conductor sizes referenced here are for both Class 2 and Class 5 conductors.

*** The MM² conductor sizes listed are the recommendations for Class 5 conductor.
‡ P-RT die sets for use in Y46 HYPRESS™ only, PUADP-1 adaptor not required.

▲ See tooling section of this catalog for complete tool and die listings. Use ONLY color-coded die recommendations for -FX connectors.
Note: All dimensions shown are for reference only.

Blue highlighted items are industry standard and most frequently ordered.

Compression Connections

BURNDY®

Copper Compression – Flex – Long Barrel – Narrow Tongue

C-66

TWO HOLE HYLUG™ FLEX CONDUCTOR LONG BARREL NARROW TONGUE

TYPES YAZ-2-NTFX,
YAZV-2NTFX

COPPER COMPRESSION
NARROW TONGUE TERMINAL

UL Listed 90° C
600 Volts to 35 kV ◆

45° and 90° angles are available.

Please contact Customer Service to order:
1-800-346-4175

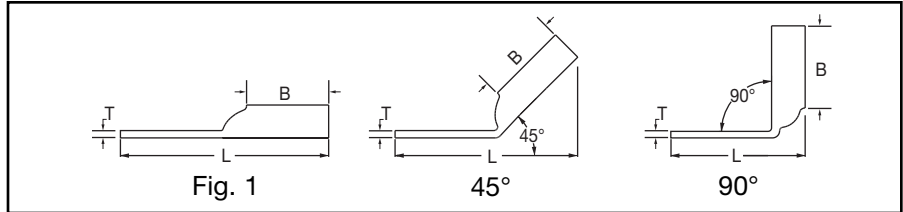
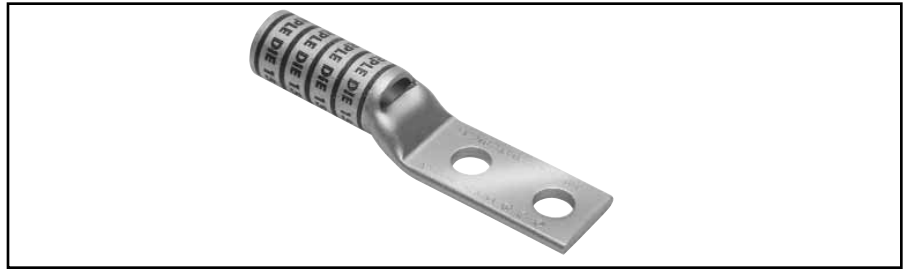

Catalog Number	Fig #	Conductor		Stud Hole Size	Stud Hole Spacing	Tongue Width	Figure Dimensions			▲ Installation Tooling					Wire Strip Length	
		AWG	*** MM²				(B)	(T)	(L)	Dieless (# of crimps)	Mechanical	Hydraulic		Color Code		Die Index
											MD6, OUR840, MD7-34R	BCT500HS, Y500C7HS	Y35, Y39, Y750, Y46*, PAT750			
YAZV4C2NT14E2FX	1	#4 AWG #4 Weld 91/24 105/24	—	1/4"	0.75"	0.44"	1.25"	0.09"	2.95"	Y1MRTC (4) MY29-11 (2) Y644HS (1) Y81KFT (1) Y81KFTMBH (1) PAT81KFT-18V (1)	W4CVT (2) W4CRT (2) X4CRT (2)	W4CVT (2) W4CRT (2) X4CRT (2)	U4CRT (2)	Gray	8	1-5/16"
YAZV2C2NT14E2FX	1	#2 AWG #2 Weld 125/24 150/24	35	1/4"	0.75"	0.50"	1.38"	0.10"	3.14"	Y1MRTC (4) MY29-11 (4) Y644HS (1) Y81KFT (1) Y81KFTMBH (1) PAT81KFT-18V (1)	W2CVT (2) W2CRT (2) X2CRT (2)	W2CVT (2) W2CRT (2) X2CRT (2)	U2CRT (2)	Brown	10	1-7/16"
YAZV282NT38FX	1	4/0 AWG 4/0 Weld 550/24	—	3/8"	1.00"	0.94"	1.62"	0.17"	3.96"	MY29-11 (2) Y644HS (1) Y81KFT (2) Y81KFTMBH (2) PAT81KFT-18V (2)	W28VT (4) W28RT (4) X28RT (6)	W28VT (4) W28RT (4) X28RT (6)	U28RT (2)	Purple	15	1-11/16"
YAZV292NT516FX	1	4/0 Flex Class I,K,M	—	5/16"	1.00"	0.96"	2.00"	0.16"	4.28"	Y644HS (1) Y81KFT (2) Y81KFTMBH (2) PAT81KFT-18V (2)	W29VT (4) X29RT (8)	W29RT (4) W29VT (4) X29RT (8)	U29RT (2)	Yellow	16	2-1/16"
YAZ342NT38FX	1	373.7 kcmil 925/24 350 Flex	240	3/8"	1.00"	0.96"	2.25"	0.23"	4.85"	Y644HS (1) Y81KFT (2) Y81KFTMBH (2) PAT81KFT-18V (2)	W32VT (4)	W32VT (4) W32RT (4)	U32RT (4)	Blue	19	2-5/16"
YAZ382ENT38FX	1	535.3 kcmil 1325/24 500 Flex	300	3/8"	1.00"	1.46"	2.81"	0.27"	5.72"	Y644HS (1) Y81KFT (2) Y81KFTMBH (2) PAT81KFT-18V (2)	—	—	U38XRT (4)	Pink	L99	2-7/8"

Consult cable manufacturers for stress relief instructions.
◆ For applications greater than 2000 Volts consult cable manufacturer for voltage stress relief instructions.

* Use PUADP-1 adaptor with U -dies in Y46 HYPRESS™.
▲ See tooling section of this catalog for complete tool and die listings. Use ONLY color-coded die recommendations for -FX connectors.

Note: All dimensions shown are for reference only.

Blue highlighted items are industry standard and most frequently ordered.

**TWO HOLE HYLUG™
FLEX CONDUCTOR
LONG BARREL
NARROW TONGUE
(Continued)**

UL Listed 90° C,
600 Volts to 35 kV ◆

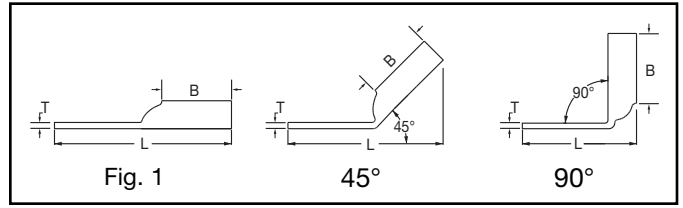

45° and 90° angles are available.
Please contact Customer Service to order:
1-800-346-4175



Catalog Number	Fig #	Conductor		Stud Hole Size	Stud Hole Spacing	Tongue Width	Figure Dimensions			▲ Installation Tooling					Wire Strip Length	
		AWG	*** MM ²				(B)	(T)	(L)	Dieless (# of crimps)	Mechanical MD6, OUR840, MD7-34R	Hydraulic		Color Code		Die Index
												BCT500HS, Y500GTHS	Y35, Y39, Y750, Y46*, PAT750			
YAZ382NNTFX	1	535.3 kcmil 1325/24 500 Flex	300	1/2"	1.75"	1.62"	2.81"	0.27"	6.72"	Y644HS (1) Y81KFT (2) Y81KFTMBH (2) PAT81KFT-18V (2)	—	—	U38XRT (4)	Pink	L99	2-7/8"
YAZ382NT38FX	1	535.3 kcmil 1325/24 500 Flex	300	3/8"	1.00"	1.62"	2.81"	0.27"	5.72"	Y644HS (1) Y81KFT (2) Y81KFTMBH (2) PAT81KFT-18V (2)	—	—	U38XRT (4)	Pink	L99	2-7/8"
YAZ442NT38FX	1	777.7 kcmil 1925/24 750 Flex	500	3/8"	1.00"	1.62"	3.00"	0.33"	6.09"	—	—	—	U44XRT (4)	Yellow	L115	3-1/16"

Consult cable manufacturers for stress relief instructions.
◆ For applications greater than 2000 Volts consult cable manufacturer for voltage stress relief instructions.

* Use PUADP-1 adaptor with U -dies in Y46 HYPRESS™.
▲ See tooling section of this catalog for complete tool and die listings. Use ONLY color-coded die recommendations for -FX connectors.

Note: All dimensions shown are for reference only.

Blue highlighted items are industry standard and most frequently ordered.

Compression Connections

BURNDY®

Copper Compression – Flex – Lead Plated – No Inspection Window

C-68

ONE HOLE HYLUG™ FLEX CONDUCTOR STANDARD BARREL LEAD PLATED

TYPE YAG-L-TC-LD

UL Listed 90° C,
600 Volts to 35 kV ◆

45° and 90° angles are available.
Please contact Customer Service to order:
1-800-346-4175

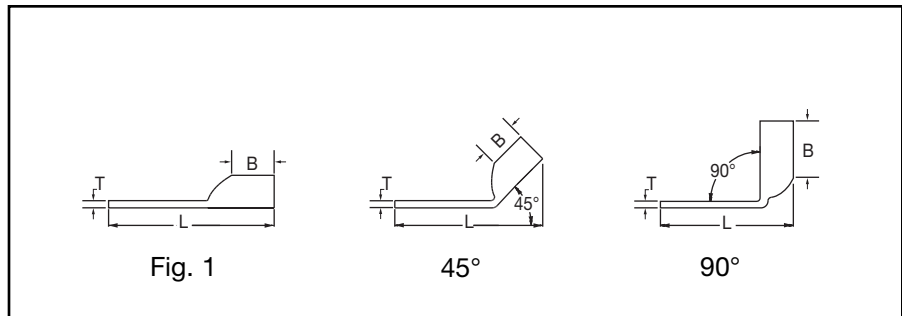
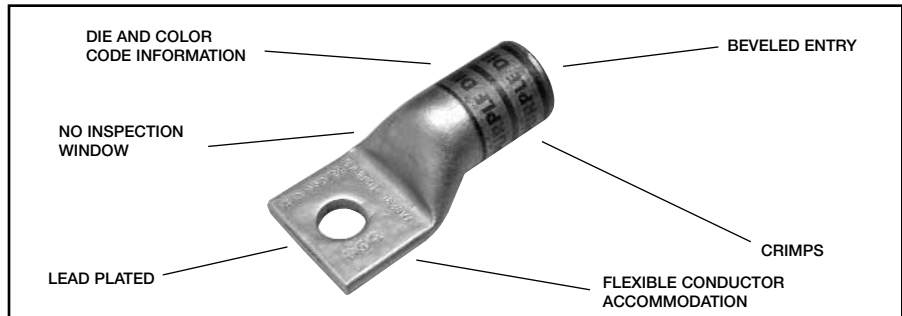

Catalog Number	Fig #	Conductor		Stud Hole Size	Tongue Width	Figure Dimensions			▲ Installation Tooling					Wire Strip Length				
		AWG	MM²			***	(B)	(T)	(L)	Dieless (# of crimps)	Mechanical	Hydraulic			Color Code	Die Index		
											MD6, OUR840, MD7-34R	BCT500HS, Y500CTS	Y35, Y39, Y750, Y46*, PAT750					
YAG18TC516LD	1	22-18 AWG			5/16"	.52"	.25"	.06"	1.42"	MR20 (1)							1/4"	
YAG8CLTC10LD	1	37/24 #8 Weld 8 AWG	10	**	#10	.41"	.44"	.08"	1.19"	MY29-11 (1)								
YAG8CLTC14LD	1				1/4"	.44"	.44"	.08"	1.32"	Y1MRTC (1)	W8CVT (1)	W8CVT (1)						
YAG8CLTC516LD	1				5/16"	.52"	.44"	.06"	1.38"	Y81KFT (1)	W8CRT (1)	W8CRT (1)	U8CRT (1)	Red	49	7/16"		
YAG8CLTC38LD	1				3/8"	.58"	.44"	.06"	1.51"	Y81KFTMBH (1)	X8CRT (1)	X8CRT (1)						
YAG8CLTC12LD	1				1/2"	.71"	.44"	.05"	1.76"	PAT81KFT-18V (1)								
YAG6CLTC10LD	1	61/24 #6 Weld #6 AWG	16	**	#10	.41"	.50"	.08"	1.30"	Y1MRTC (1)								
YAG6CLTC14LD	1				1/4"	.48"	.50"	.08"	1.43"	MY29-11 (1)	W5CVT (1)	W5CVT (1)						
YAG6CLTC516LD	1				5/16"	.52"	.50"	.07"	1.49"	Y81KFT (1)	W5CRT (1)	W5CRT (1)	U5CRT (1)	Blue	7	1/2"		
YAG6CLTC38LD	1				3/8"	.58"	.50"	.06"	1.61"	Y81KFTMBH (1)	X5CRT (1)	X5CRT (1)						
YAG6CLTC12LD	1				1/2"	.75"	.50"	.12"	1.86"	PAT81KFT-18V (1)								
YAG4CLTC10LD	1	91/24 - 105/24 #4 Weld 4 AWG	—	—	#10	.55"	.50"	.09"	1.36"	Y1MRTC (2)								
YAG4CLNT10LD	1				#10	.41"	.50"	.09"	1.36"	MY29-11 (1)	W4CVT (1)	W4CVT (1)						
YAG4CLTC14LD	1				1/4"	.55"	.50"	.09"	1.48"	Y81KFT (1)	W4CRT (1)	W4CRT (1)	U4CRT (1)	Gray	8	1/2"		
YAG4CLTC516LD	1				5/16"	.55"	.50"	.08"	1.55"	Y81KFTMBH (1)	X4CRT (1)	X4CRT (1)						
YAG4CLTC38LD	1				3/8"	.58"	.50"	.08"	1.67"	PAT81KFT-18V (1)								
YAG4CLTC12LD	1	1/2"	.71"	.50"	.07"	1.92"												
YAG2CLTC10LD	1	125/24 #2 Weld 2 AWG	35	—	#10	.68"	.63"	.10"	1.52"	Y1MRTC (2)								
YAG2CLTC14LD	1				1/4"	.68"	.63"	.10"	1.64"	MY29-11 (1)	W2CRT (1)	W2CRT (1)						
YAG2CLTC516LD	1				5/16"	.68"	.63"	.10"	1.70"	Y81KFT (1)	W2CVT (1)	W2CVT (1)	U2CRT (1)	Brown	10	11/16"		
YAG2CLTC38LD	1				3/8"	.68"	.63"	.10"	1.83"	Y81KFTMBH (1)	X2CRT (1)	X2CRT (1)						
YAG2CLTC12LD	1				1/2"	.73"	.63"	.10"	2.12"	PAT81KFT-18V (1)								
YAG1CLTC10LD	1	225/24 175/24 - #1 Weld 1 AWG	—	—	#10	.75"	.69"	.12"	1.61"	MY29-11 (1)								
YAG1CLTC14LD	1				1/4"	.75"	.69"	.12"	1.73"	Y81KFT (1)	W1CVT (1)	W1CVT (1)						
YAG1CLTC516LD	1				5/16"	.75"	.69"	.12"	1.80"	Y81KFTMBH (1)	W1CRT-1 (1)	W1CRT-1 (1)	U1CRT-1 (1)	Green	11	11/16"		
YAG1CLTC38LD	1				3/8"	.75"	.69"	.12"	1.92"	Y81KFTMBH (1)	X1CRT-1 (1)	X1CRT-1 (1)						
YAG1CLTC12LD	1				1/2"	.75"	.69"	.12"	2.17"	PAT81KFT-18V (1)								

* Use PUADP-1 adapter with U dies in Y46 HYPRESS™
 ** The MM² conductor size referenced here is for both Class 2 and Class 5 conductor.
 *** The MM² conductor sizes listed are the recommendations for Class 5 conductor.

▲ See tooling section of this catalog for complete tool and die listings.
 † Alternate Tooling includes Y8MRB-1, MY29-11

◆ For applications greater than 2000 Volts consult cable manufacturer for voltage stress relief instructions.
 Note: All dimensions shown are for reference only.

Blue highlighted items are industry standard and most frequently ordered.

**ONE HOLE HYLUG™
FLEX CONDUCTOR
STANDARD BARREL
LEAD PLATED
(Continued)**

UL Listed 90° C,
600 Volts to 35 kV ◆

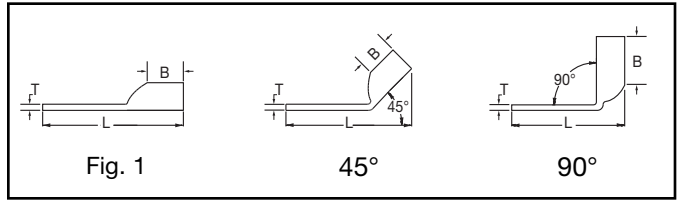

45° and 90° angles are available.
Please contact Customer Service to order:
1-800-346-4175



C-69

Catalog Number	Fig #	Conductor		Stud Hole Size	Tongue Width	Figure Dimensions			Dieless (# of crimps)	▲ Installation Tooling				Wire Strip Length							
		AWG	MM²			(B)	(T)	(L)		Mechanical MD6, OUR840, MD7-34R	Hydraulic BCT500HS, Y500GTHS		Y35, Y39, Y750, Y46*, PAT750		Color Code	Die Index					
YAG25LTC14LD	1	275/24 1/0 Weld 1/0 AWG	50	1/4"	.83"	.69"	.12"	1.77"	MY29-11 (1) Y81KFT (1) Y81KFTMBH (1) PAT81KFT-18V (1)	W25RT (2) W25VT (2) X25RT (2)	W25RT (2) W25VT (2) X25RT (2)	U25RT (1)	Pink	12	11/16"						
YAG25LTC516LD	1			5/16"	.83"	.69"	.12"	1.84"													
YAG25LTC38LD	1			3/8"	.83"	.69"	.12"	1.96"													
YAG25LTC12LD	1			1/2"	.83"	.69"	.12"	2.21"													
YAG26LTC10LD	1	325/24 2/0 Weld 2/0 AWG	70	#10	.93"	.81"	.13"	1.82"	MY29-11 (1) Y644HS (1) Y81KFT (1) Y81KFTMBH (1) PAT81KFT-18V (1)	W26VT (2) W26RT (2) X26RT (2)	W26VT (2) W26RT (2) X26RT (2)	U26RT (1)	Black	13	13/16"						
YAG26LTC14LD	1			1/4"	.93"	.81"	.13"	1.95"													
YAG26LTC516LD	1			5/16"	.93"	.81"	.13"	2.01"													
YAG26LTC38LD	1			3/8"	.93"	.81"	.13"	2.13"													
YAG26LTC12LD	1			1/2"	.93"	.81"	.13"	2.38"													
YAG26LTC58LD	1			5/8"	.93"	.81"	.13"	2.63"													
YAG26LTC34LD	1	3/4"	.93"	.81"	.11"	2.89"															
YAG27LTC10LD	1	450/24 3/0 Weld 3/0 AWG	95	#10	1.03"	1.00"	.14"	2.05"	MY29-11 (1) Y81KFT (1) Y81KFTMBH (1) PAT81KFT-18V (1)	W27VT (2) X27RT (3) W27RT (2)	W27VT (2) X27RT (3) W27RT (2)	U27RT (1)	Orange	14	1"						
YAG27LTC14LD	1			1/4"	1.03"	1.00"	.14"	2.18"													
YAG27LTC516LD	1			5/16"	1.03"	1.00"	.14"	2.24"													
YAG27LTC38LD	1			3/8"	1.03"	1.00"	.14"	2.37"													
YAG27LTC12LD	1			1/2"	1.03"	1.00"	.14"	2.62"													
YAG28LTC14LD	1	550/24 4/0 Weld 4/0 AWG	120	1/4"	1.14"	1.03"	.15"	2.26"	MY29-11 (1) Y644HS (1) Y81KFT (1) Y81KFTMBH (1) PAT81KFT-18V (1)	W28VT (2) X28RT (3) W28RT (2)	W28VT (2) X28RT (3) W28RT (2)	U28RT (1)	Purple	15	1-1/16"						
YAG28LTC516LD	1			5/16"	1.14"	1.03"	.15"	2.32"													
YAG28LTC516N66LD	1			5/16"	1.14"	1.03"	.15"	2.64"													
YAG28LTC38LD	1			3/8"	1.14"	1.03"	.15"	2.45"													
YAG28LTC12LD	1			1/2"	1.14"	1.03"	.15"	2.70"													
YAG28LTC58LD	1			5/8"	1.14"	1.03"	.15"	2.95"													
YAG29LTC516LD	1	550/24 4/0 Weld	—	5/16"	1.14"	1.03"	.16"	2.32"	Y644HS (1) Y81KFT (1) Y81KFTMBH (1) PAT81KFT-18V (1)	W29VT (2) X29RT (4)	W29VT (2) X29RT (4) W29RT (2)	U29RT (1)	Yellow	16	1-1/16"						
YAG29LTC38LD	1			3/8"	1.14"	1.03"	.16"	2.45"													
YAG29LTC12LD	1			1/2"	1.14"	1.03"	.16"	2.70"													
YAG29LTC34LD	1			3/4"	1.14"	1.03"	.16"	3.14"													
YAG30LTC58LD	1	250 Flex CLASS G - 259 Str. CLASS H - 427 Str.	—	5/8"	1.20"	1.03"	.16"	2.97"	Y644HS (1) Y81KFT (1) Y81KFTMBH (1) PAT81KFT-18V (1)	W30VT (2)	W30VT (2) W30RT (2)	U30RT (2)	White	17	1-1/8"						
YAG30LTC34LD	1	3/4"	1.20"	1.03"	.16"	3.16"															
YAG31LTC14LD	1	637/259 250 Flex CLASS I, K, M	150	1/4"	1.29"	1.06"	.18"	2.35"													
YAG31LTC516LD	1			5/16"	1.29"	1.06"	.18"	2.41"													
YAG31LTC38LD	1			3/8"	1.29"	1.06"	.18"	2.53"													
YAG31LTC12LD	1			1/2"	1.29"	1.06"	.18"	2.78"													
YAG31LNT12LD	1			1/2"	.96"	1.06"	.18"	2.78"													
YAG31LTC58LD	1			5/8"	1.29"	1.06"	.18"	3.03"													
YAG31LTC34LD	1	3/4"	1.29"	1.06"	.18"	3.22"															
YAG32LTC38LD	1	775/24-300 Flex	185	3/8"	1.40"	1.19"	.19"	2.72"								W31VT (2)	W31VT (2) W31RT (2)	U31RT (2)	Red	18	1-1/4"
YAG32LTC12LD	1	1/2"		1.40"	1.19"	.19"	2.97"														
YAG32LTC58LD	1	313.1 kcmil	—	5/8"	1.40"	1.19"	.19"	3.22"													

* Use PUADP-1 adapter with U dies in Y46 HYPRESS™
 *** The MM² conductor sizes listed are the recommendations for Class 5 conductor.
 ▲ See tooling section of this catalog for complete tool and die listings.

† Alternate Tooling includes Y8MRB-1, MY29-11
 ◆ For applications greater than 2000 Volts consult cable manufacturer for voltage stress relief instructions.
 Note: All dimensions shown are for reference only.

Blue highlighted items are industry standard and most frequently ordered.

Compression Connections

BURNDY®

Copper Compression – Flex – Lead Plated – No Inspection Window

C-70

ONE HOLE HYLUG™ FLEX CONDUCTOR STANDARD BARREL LEAD PLATED (Continued)

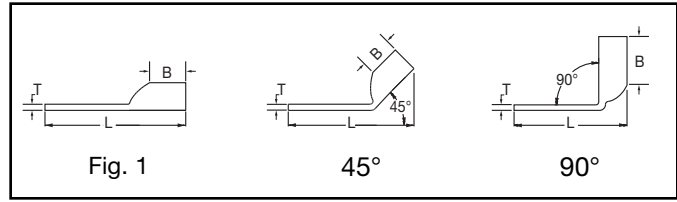

UL Listed 90° C,
600 Volts to 35 kV ◆

45° and 90° angles are available.
Please contact Customer Service to order:
1-800-346-4175



Catalog Number	Fig #	Conductor		Stud Hole Size	Tongue Width	Figure Dimensions			Dieless (# of crimps)	▲ Installation Tooling				Wire Strip Length	
		AWG	MM ²			(B)	(T)	(L)		Mechanical MD6, OUR840, MD7-34R	Hydraulic		Color Code		Die Index
											BCT500HS, Y500CTS	Y35, Y39, Y750, Y46*, PAT750			
YAG34LTC516LD	1	925/24-350 Flex 373.7 kcmil	240	5/16"	1.55"	1.27"	.23"	2.78"	Y644HS (1) Y81KFT (1) Y81KFTMBH (1) PAT81KFT-18V (1)	W32VT (2) W32RT (2)	W32VT (2) W32RT (2)	U32RT (2)	Blue	19	1-5/16"
YAG34LTC516N66LD	1			5/16"	1.55"	1.27"	.23"	3.09"							
YAG34LNT516N66LD	1			3/8"	.96"	1.27"	.23"	3.09"							
YAG34LTC38LD	1			3/8"	1.55"	1.27"	.23"	2.91"							
YAG34LTC12LD	1			1/2"	1.55"	1.27"	.23"	3.16"							
YAG34LTC58LD	1			5/8"	1.55"	1.27"	.23"	3.41"							
YAG36LTC12LD	1	1100/24-450 Flex 444.4 kcmil	300	1/2"	1.73"	1.38"	.27"	3.34"	Y644HS (1) Y81KFT (1) Y81KFTMBH (1) PAT81KFT-18V (1)	—	—	U34RT (2)	Brown	20	1-3/8"
YAG36LTC58LD	1	5/8"		1.73"	1.38"	.27"	3.59"								
YAG38LTC516LD	1	1325/24		5/16"	1.84"	1.45"	.27"	3.08"							
YAG38LTC38LD	1	500 Flex		3/8"	1.84"	1.45"	.27"	3.39"							
YAG38LTC12LD	1	535.3 kcmil		1/2"	1.84"	1.45"	.27"	3.46"							
YAG38LTC58LD	1	5/8"		1.84"	1.45"	.27"	3.71"								
YAG40LTC516LD	1	1600/24-646 kcmil	400	5/16"	1.96"	1.42"	.30"	3.11"	Y644HS (1) Y81KFT (2) Y81KFTMBH (2) PAT81KFT-18V (2)	—	—	U39RT (2)	Black	24	1-5/16"
YAG40LTC38LD	1	650 Flex		3/8"	1.96"	1.42"	.30"	3.42"							
YAG40LTC12LD	1	1/2"		1.96"	1.42"	.30"	3.48"								
YAG40LTC58LD	1	5/8"		1.96"	1.42"	.30"	3.73"								
YAG44LTC12LD	1	1925/24 750 Flex	500	1/2"	2.18"	1.65"	.33"	3.85"	Y644HS (1) Y81KFT (2) Y81KFTMBH (2) PAT81KFT-18V (2)	—	—	U44XRT (2)	Yellow	L115	1-5/8"
YAG44LTC58LD	1	777.7 kcmil		5/8"	2.18"	1.65"	.33"	4.10"							

* Use PUADP-1 adapter with U dies in Y46 HYPRESS™

*** The MM² conductor sizes listed are the recommendations for Class 5 conductor.

▲ See tooling section of this catalog for complete tool and die listings.

† Alternate Tooling includes Y8MRB-1, MY29-11

◆ For applications greater than 2000 Volts consult cable manufacturer for voltage stress relief instructions.

Note: All dimensions shown are for reference only.

Blue highlighted items are industry standard and most frequently ordered.

**TWO HOLE HYLUG™
FLEX CONDUCTOR
STANDARD BARREL
LEAD PLATED**

TYPE YAG-L-2TC-LD

**COPPER COMPRESSION
TERMINAL**

UL Listed 90° C,
600 Volts to 35 kV ◆

45° and 90° angles are available.
Please contact Customer Service to order:
1-800-346-4175

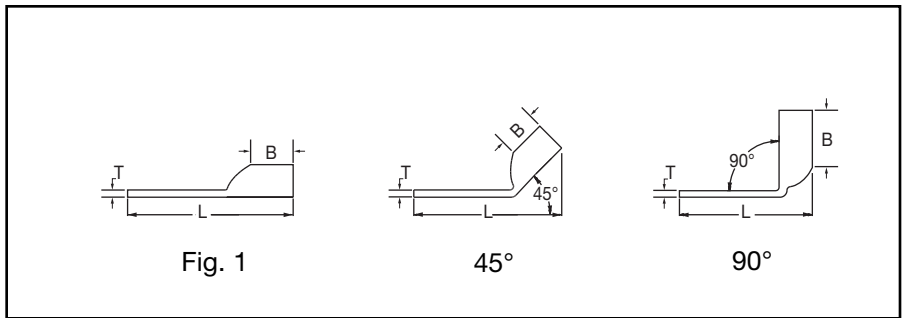
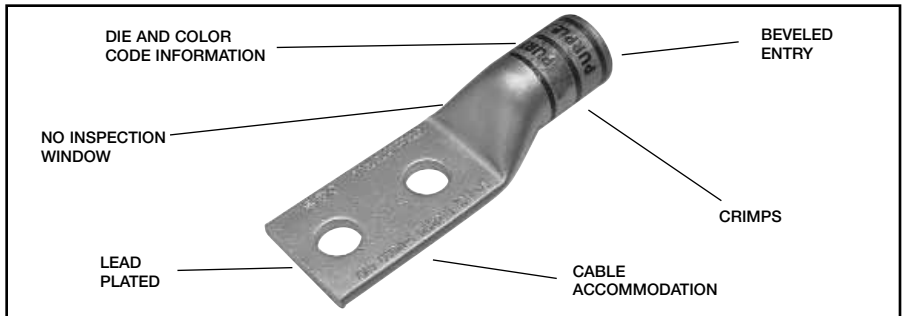

Catalog Number	Fig #	Conductor		Stud Hole Size	Stud Hole Spacing	Tongue Width	Figure Dimensions			Dieless (# of crimps)	▲ Installation Tooling					Wire Strip Length
		AWG	MM²				(B)	(T)	(L)		Mechanical MD6, OUR840, MD7-34R	Hydraulic		Color Code	Die Index	
												BCT500HS, Y500GTHS	Y35, Y39, Y750, Y46*, PAT750			
YAG8CL-2TC14-LD	1	#8 Weld 37/24 #8 AWG	10	1/4"	5/8"	.41"	.44"	.08"	1.95"	MRC840 (1) MY29-3 (1) MY29-11 (1) Y8MRB-1 (1) Y1MRTC (1) Y81KFT (1)	W8CVT	W8CVT	U8CRT	Red	49	1/2"
YAG8CL-2TC38-LD	1			3/8"	1"	.57"	.44"	.06"	2.52"	Y81KFTMBH (1) PAT81KFT-18V (1)	W8CVT (1) W8CRT (1) X8CRT (1)	W8CVT (1) W8CRT (1) X8CRT (1)	U8CRT (1)	Red	49	7/16"
YAG8CL-2TC10-LD	1			#10	5/8"	.41"	.44"	.08"	1.84"	Y81KFTMBH (1) PAT81KFT-18V (1)	W8CVT (1) W8CRT (1) X8CRT (1)	W8CVT (1) W8CRT (1) X8CRT (1)	U8CRT (1)	Red	49	7/16"
YAG8CL-2TC14E1-LD	1	#6 Weld 61/24 #6 AWG	16	1/4"	1"	.44"	.44"	.08"	2.33"	MY29-11 (1) Y1MRTC (1) Y81KFT (1) Y81KFTMBH (1) PAT81KFT-18V (1)	W5CVT (1) W5CRT (1) X5CRT (1)	W5CVT (1) W5CRT (1) X5CRT (1)	U5CRT (1)	Blue	7	1/2"
YAG8CL-2TC14E2-LD	1			1/4"	3/4"	.44"	.44"	.08"	2.08"							
YAG6CL-2TC10-LD	1			#10	5/8"	.44"	.50"	.07"	1.94"							
YAG6CL-2TC10E2-LD	1	#6 Weld 61/24 #6 AWG	16	#10	3/4"	.48"	.50"	.08"	2.06"	MY29-11 (1) Y1MRTC (1) Y81KFT (1) Y81KFTMBH (1) PAT81KFT-18V (1)	W5CVT (1) W5CRT (1) X5CRT (1)	W5CVT (1) W5CRT (1) X5CRT (1)	U5CRT (1)	Blue	7	1/2"
YAG6CL-2TC10E4-LD	1			#10	11/16"	.44"	.50"	.07"	2.00"							
YAG6CL-2TC10E-LD	1			#10	1/2"	.48"	.50"	.08"	1.81"							
YAG6CL-2TC14-LD	1	#4 Weld 91/24 105/24 #4 AWG	—	1/4"	5/8"	.48"	.50"	.08"	2.06"	MY29-11 (1) Y1MRTC (2) Y81KFT (1) Y81KFTMBH (1) PAT81KFT-18V (1)	W4CVT (1) W4CRT (1) X4CRT (1)	W4CVT (1) W4CRT (1) X4CRT (1)	U4CRT (1)	Gray	8	1/2"
YAG6CL-2TC14E1-LD	1			1/4"	1"	.48"	.50"	.08"	2.44"							
YAG6CL-2TC14E2-LD	1			1/4"	3/4"	.48"	.50"	.08"	2.18"							
YAG6CL-2TC516-LD	1	#2 Weld 125/24 150/24 #2 AWG	35	5/16"	1"	.52"	.50"	.07"	2.50"	MY29-11 (1) Y1MRTC (2) Y81KFT (1) Y81KFTMBH (1) PAT81KFT-18V (1)	W2CVT (1) W2CRT (1) X2CRT (1)	W2CVT (1) W2CRT (1) X2CRT (1)	U2CRT (1)	Brown	10	11/16"
YAG6CL-2TC38-LD	1			3/8"	1"	.58"	.50"	.06"	2.62"							
YAG6CL-2NTC-LD	1			1/2"	1-3/4"	.83"	.50"	.12"	3.81"							
YAG4CL-2NT10-LD	1	#4 Weld 91/24 105/24 #4 AWG	—	#10	5/8"	.41"	.50"	.09"	1.99"	MY29-11 (1) Y1MRTC (2) Y81KFT (1) Y81KFTMBH (1) PAT81KFT-18V (1)	W4CVT (1) W4CRT (1) X4CRT (1)	W4CVT (1) W4CRT (1) X4CRT (1)	U4CRT (1)	Gray	8	1/2"
YAG4CL-2NT10E1-LD	1			#10	1"	.41"	.50"	.09"	2.37"							
YAG4CL-2TC14-LD	1			1/4"	5/8"	.55"	.50"	.09"	2.11"							
YAG4CL-2TC14E2-LD	1	#2 Weld 125/24 150/24 #2 AWG	35	1/4"	3/4"	.55"	.50"	.09"	2.24"	MY29-11 (1) Y1MRTC (2) Y81KFT (1) Y81KFTMBH (1) PAT81KFT-18V (1)	W2CVT (1) W2CRT (1) X2CRT (1)	W2CVT (1) W2CRT (1) X2CRT (1)	U2CRT (1)	Brown	10	11/16"
YAG4CL-2TC14E1-LD	1			1/4"	1"	.55"	.50"	.09"	2.49"							
YAG4CL-2TC38-LD	1			3/8"	1"	.58"	.50"	.08"	2.68"							
YAG4CL-2TC516-LD	1	#2 Weld 125/24 150/24 #2 AWG	35	5/16"	1"	.55"	.50"	.09"	2.56"	MY29-11 (1) Y1MRTC (2) Y81KFT (1) Y81KFTMBH (1) PAT81KFT-18V (1)	W2CVT (1) W2CRT (1) X2CRT (1)	W2CVT (1) W2CRT (1) X2CRT (1)	U2CRT (1)	Brown	10	11/16"
YAG4CL-2NTC-LD	1			1/2"	1-3/4"	.83"	.50"	.12"	3.87"							
YAG2CL-2TC14-LD	1			1/4"	5/8"	.68"	.63"	.10"	2.28"							
YAG2CL-2TC14E1-LD	1	#2 Weld 125/24 150/24 #2 AWG	35	1/4"	1"	.68"	.63"	.10"	2.63"	MY29-11 (1) Y1MRTC (2) Y81KFT (1) Y81KFTMBH (1) PAT81KFT-18V (1)	W2CVT (1) W2CRT (1) X2CRT (1)	W2CVT (1) W2CRT (1) X2CRT (1)	U2CRT (1)	Brown	10	11/16"
YAG2CL-2TC14E2-LD	1			1/4"	3/4"	.68"	.63"	.10"	2.40"							
YAG2CL-2TC38-LD	1			3/8"	1"	.68"	.63"	.10"	2.84"							

* Use PUADP-1 adapter with U dies in Y46 Hypress™.
** The MM² conductor size referenced here is for both Class 2 and Class 5 conductor.

*** The MM² conductor sizes listed are the recommendations for Class 5 conductor.
◆ For applications greater than 2000 Volts consult cable manufacturer for voltage stress relief instructions.

Note: All dimensions shown are for reference only.

Blue highlighted items are industry standard and most frequently ordered.

Compression Connections

BURNDY®

Copper Compression – Flex – Lead Plated – No Inspection Window

C-72

TWO HOLE HYLUG™ FLEX CONDUCTOR STANDARD BARREL LEAD PLATED (Continued)

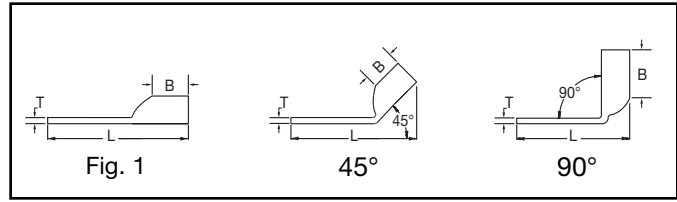

UL Listed 90° C,
600 Volts to 35 kV ◆

45° and 90° angles are available.
Please contact Customer Service to order:
1-800-346-4175



Catalog Number	Fig #	Conductor		Stud Hole Size	Stud Hole Spacing	Tongue Width	Figure Dimensions			Dieless (# of crimps)	▲ Installation Tooling				Wire Strip Length										
		AWG	MM²				(B)	(T)	(L)		Mechanical MD6, OUR840, MD7-34R	Hydraulic		Color Code		Die Index									
												BCT500HS, Y500CTHS	Y35, Y39, Y750, Y46*, PAT750												
YAG2CL-2TC516-LD	1	#2 Weld 125/24	35	5/16"	1"	.68"	.63"	.10"	2.71"	MY29-11 (1) Y1MRTC (2) Y81KFT (1) Y81KFTMBH (1) PAT81KFT-18V (1)	W2CVT (1) W2CRT (1) X2CRT (1)	W2CVT (1) W2CRT (1) X2CRT (1)	U2CRT (1)	Brown	10	11/16"									
YAG2CL-2NTC-LD	1	150/24 #2 AWG		1/2"	1-3/4"	.83"	.63"	.08"	4.03"																
YAG1CL-2TC14-LD	1	#1 Weld 175/24 225/24	—	1/4"	5/8"	.75"	.69"	.12"	2.37"	MY29-11 (1) Y81KFT (1) Y81KFTMBH (1) PAT81KFT-18V (1)	W1CVT (1) W1CRT-1 (1) X1CRT-1 (1)	W1CVT (1) W1CRT-1 (1) X1CRT-1 (1)	U1CRT-1 (1)	Green	11	11/16"									
YAG1CL-2TC14E2-LD	1			1/4"	3/4"	.75"	.69"	.12"	2.49"																
YAG1CL-2TC14E1-LD	1			1/4"	1"	.75"	.69"	.12"	2.73"																
YAG1CL-2TC516-LD	1			5/16"	1"	.75"	.69"	.12"	2.81"																
YAG1CL-2TC38-LD	1			3/8"	1"	.75"	.69"	.12"	2.93"																
YAG1CL-2NTC-LD	1			1/2"	1-3/4"	.83"	.69"	.11"	4.12"																
YAG25L-2TC14-LD	1	1/0 Weld 275/24	50	1/4"	5/8"	.83"	.69"	.12"	2.41"	MY29-11 (1) Y81KFT (1) Y81KFTMBH (1) PAT81KFT-18V (1)	W25VT (2) W25RT (2) X25RT (2)	W25VT (2) W25RT (2) X25RT (2)	U25RT (1)	Pink	12	11/16"									
YAG25L-2TC14E2-LD	1			1/4"	3/4"	.83"	.69"	.12"	2.53"																
YAG25L-2TC516E2-LD	1			5/16"	3/4"	.83"	.69"	.12"	2.60"																
YAG25L-2TC516-LD	1			5/16"	1"	.83"	.69"	.12"	2.85"																
YAG25L-2TC38-LD	1			3/8"	1"	.83"	.69"	.12"	2.97"																
YAG25L-2NTC-LD	1			1/2"	1-3/4"	.83"	.69"	.12"	4.16"																
YAG25L-2TC12E1-LD	1	1/2"	1"	.83"	.69"	.12"	3.22"																		
YAG26L-2TC14-LD	1	2/0 Weld 325/24	70	1/4"	5/8"	.93"	.81"	.13"	2.58"	MY29-11 (1) Y644HS (1) Y81KFT (1) Y81KFTMBH (1) PAT81KFT-18V (1)	W26RT (2) W26VT (2) X26RT (2)	W26RT (2) W26VT (2) X26RT (2)	U26RT (1)	Black	13	13/16"									
YAG26L-2TC14E2-LD	1			1/4"	3/4"	.93"	.81"	.13"	2.71"																
YAG26L-2TC516-LD	1			5/16"	1"	.93"	.81"	.13"	3.02"																
YAG26L-2TC38-LD	1			3/8"	1"	.93"	.81"	.13"	3.14"																
YAG26L-2NTC-LD	1			1/2"	1-3/4"	.93"	.81"	.13"	4.33"																
YAG27L-2TC14-LD	1			1/4"	5/8"	1.03"	1.00"	.14"	2.81"																
YAG27L-2TC14E2-LD	1	3/0 Weld 450/24	95	1/4"	3/4"	1.03"	1.00"	.14"	2.94"	MY29-11 (1) Y644HS (1) Y81KFT (1) Y81KFTMBH (1) PAT81KFT-18V (1)	W27VT (2) W27RT (2) X27RT (3)	W27VT (2) W27RT (2) X27RT (3)	U27RT (1)	Orange	14	1"									
YAG27L-2TC516-LD	1			5/16"	1"	1.03"	1.00"	.14"	3.25"																
YAG27L-2TC38-LD	1			3/8"	1"	1.03"	1.00"	.14"	3.38"																
YAG27L-2NTC-LD	1			1/2"	1-3/4"	1.03"	1.00"	.14"	4.56"																
YAG28L-2TC14-LD	1			4/0 Weld 550/24	120	1/4"	5/8"	1.14"	1.03"								.15"	2.90"	Y644HS (1) Y81KFT (1) Y81KFTMBH (1) PAT81KFT-18V (1)	W28VT (2) W28RT (2) X28RT (3)	W28VT (2) W28RT (2) X28RT (3)	U28RT (1)	Purple	15	1-1/16"
YAG28L-2TC14E2-LD	1					1/4"	3/4"	1.14"	1.03"								.15"	3.02"							
YAG28L-2TC516-LD	1	5/16"	1"			1.14"	1.03"	.15"	3.33"																
YAG28L-2TC38-LD	1	3/8"	1"			.94"	1.03"	.17"	3.48"																
YAG28L-2TC12E1-LD	1	1/2"	1"			1.14"	1.03"	.17"	3.71"																
YAG28L-2TC12-LD	1	1/2"	1-1/4"			1.14"	1.03"	.17"	3.96"																
YAG28L-2NTC-LD	1	1/2"	1-3/4"	1.14"	1.03"	.15"	4.65"																		
YAG29L-2TC14-LD	1	4/0 Weld 550/24	—	1/4"	5/8"	1.14"	1.03"	.16"	2.90"	Y644HS (1) Y81KFT (1) Y81KFTMBH (1) PAT81KFT-18V (1)	W29VT (2) X29RT (4)	W29VT (2) W29RT (2) X29RT (4)	U29RT (1)	Yellow	16	1-1/16"									
YAG29L-2TC14E2-LD	1			1/4"	3/4"	1.14"	1.03"	.16"	3.02"																
YAG29L-2TC516-LD	1			5/16"	1"	1.14"	1.03"	.16"	3.33"																
YAG29L-2TC38-LD	1			3/8"	1"	1.14"	1.03"	.16"	3.46"																
YAG29L-2NT38-LD	1	3/8"	1"	.94"	1.03"	.16"	3.48"																		

* Use PUADP-1 adapter with U dies in Y46 Hypress™.
** The 16 MM² referenced here is for both Class 2 and Class 5 conductor.

*** The MM² conductor sizes listed are the recommendations for Class 5 conductor.

◆ For applications greater than 2000 Volts consult cable manufacturer for voltage stress relief instructions.
Note: All dimensions shown are for reference only.

Blue highlighted items are industry standard and most frequently ordered.

**TWO HOLE HYLUG™
FLEX CONDUCTOR
STANDARD BARREL
LEAD PLATED
(Continued)**

UL Listed 90° C,
600 Volts to 35 kV ◆

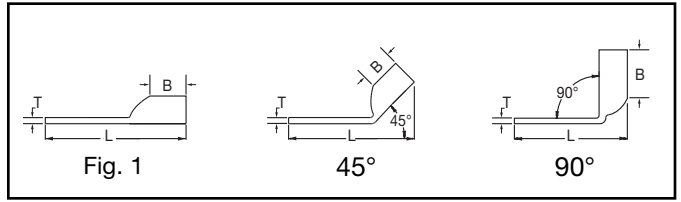

45° and 90° angles are available.
Please contact Customer Service to order:
1-800-346-4175



Catalog Number	Fig #	Conductor		Stud Hole Size	Stud Hole Spacing	Tongue Width	Figure Dimensions			Dieless (# of crimps)	▲ Installation Tooling					Wire Strip Length
		AWG	MM²				(B)	(T)	(L)		Mechanical MD6, OUR840, MD7-34R	Hydraulic		Color Code	Die Index	
												BC7500HS, Y500GTHS	Y35, Y39, Y750, Y46*, PAT750			
YAG29L-2TC12E1-LD	1	4/0 Weld 550/24	—	1/2"	1"	1.14"	1.03"	.16"	3.71"	Y644HS (1) Y81KFT (1) Y81KFTMBH (1) PAT81KFT-18V (1)	W29VT (2) X29RT (4)	W29VT (2) W29RT (2) X29RT (4)	U29RT (1)	Yellow	16	1-1/16"
YAG29L-2TC12-LD	1			1/2"	1-1/4"	1.14"	1.03"	.16"	3.96"							
YAG29L-2NTC-LD	1			1/2"	1-3/4"	1.14"	1.03"	.16"	4.65"							
YAG30L-2TC38-LD	1	250 kcmil CLASS G 259 Str. CLASS H 427 Str.	—	3/8"	1"	1.20"	1.03"	.16"	3.48"							
YAG30L-2TC12-LD	1			1/2"	1-1/4"	1.20"	1.03"	.16"	3.98"							
YAG30L-2NTC-LD	1			1/2"	1-3/4"	1.20"	1.03"	.16"	4.67"							
YAG31L-2TC38-LD	1	250 Weld 637/24 CLASS I,K,M	150	3/8"	1"	1.29"	1.06"	.18"	3.54"							
YAG31L-2NTC38-LD	1			3/8"	1-3/4"	1.29"	1.06"	.18"	4.30"							
YAG31L-2TC12-LD	1			1/2"	1-1/4"	1.29"	1.06"	.18"	4.04"							
YAG31L-2NTC-LD	1	1/2"	1-3/4"	1.29"	1.06"	.18"	4.73"									
YAG32L-2TC38-LD	1	775/24 313.1 kcmil	185	3/8"	1"	1.40"	1.19"	.19"	3.73"							
YAG32L-2NTC-LD	1			1/2"	1-3/4"	1.40"	1.19"	.19"	4.91"							
YAG34L-2TC516-LD	1	373.7 kcmil 925/24 350 kcmil CLASS I	240	5/16"	1"	1.55"	1.27"	.23"	3.79"							
YAG34L-2TC38-LD	1			3/8"	1"	1.55"	1.27"	.23"	3.92"							
YAG34L-2NT38-LD	1			3/8"	1-3/4"	.96"	1.27"	.23"	4.67"							
YAG34L-2TC12-LD	1			1/2"	1-1/4"	1.55"	1.27"	.23"	4.42"							
YAG34L-2NTC-LD	1	1/2"	1-3/4"	1.55"	1.27"	.23"	5.11"									
YAG36L-2TC38-LD	1	1100/24 444.4 kcmil	—	3/8"	1"	1.73"	1.38"	.27"	4.28"							
YAG36L-2NTC-LD	1			1/2"	1-3/4"	1.73"	1.38"	.27"	5.28"							
YAG38L-2TC516-LD	1	535.3 kcmil 1325/24 500 kcmil CLASS I	300	5/16"	1"	1.82"	1.45"	.27"	4.09"							
YAG38L-2NT38-LD	1			3/8"	1"	1.63"	1.45"	.27"	4.40"							
YAG38L-2TC38-LD	1			3/8"	1"	1.82"	1.45"	.27"	4.28"							
YAG38L-2TC12-LD	1			1/2"	1-1/4"	1.82"	1.45"	.27"	4.72"							
YAG38L-2NTC-LD	1	1/2"	1-3/4"	1.82"	1.45"	.27"	5.28"									
YAG39L-2NTC-LD	1	600 kcmil	—	1/2"	1-3/4"	1.90"	1.19"	.27"	5.29"							
YAG40L-2TC38-LD	1	646 kcmil 1600/24	400	3/8"	1"	1.98"	1.42"	.30"	4.33"							
YAG40L-2NNT-LD	1			1/2"	1-3/4"	1.63"	1.42"	.30"	5.43"							
YAG40L-2NTC-LD	1	1/2"	1-3/4"	1.98"	1.42"	.30"	5.43"									
YAG44L-2TC38-LD	1	777.7 kcmil 1925/24 750 kcmil CLASS I	500	3/8"	1"	2.18"	1.65"	.33"	4.80"							
YAG44L-2TC12-LD	1			1/2"	1-1/4"	2.18"	1.65"	.33"	5.11"							
YAG44L-2TC12E3-LD	1			1/2"	1-1/2"	2.18"	1.65"	.33"	5.36"							
YAG44L-2NTC-LD	1			1/2"	1-3/4"	2.18"	1.65"	.33"	5.80"							
YAG44L-2TC58-LD	1	5/8"	1-1/2"	2.18"	1.65"	.33"	5.61"									

* Use PUADP-1 adapter with U dies in Y46 HYPRESS™.
*** The MM² conductor sizes listed are the recommendations for Class 5 conductor.

◆ For applications greater than 2000 Volts consult cable manufacturer for voltage stress relief instructions.

Note: All dimensions shown are for reference only.

Blue highlighted items are industry standard and most frequently ordered.

Compression Connections

BURNDY®

Copper Compression – Flex

C-74

TYPE YAS-L-2TC-FX,60

**TWO HOLE HYLUG™ -
DOUBLE BARREL**

**COPPER COMPRESSION
TERMINAL**

UL Listed 90° C,
600 Volts to 35 kV ◆

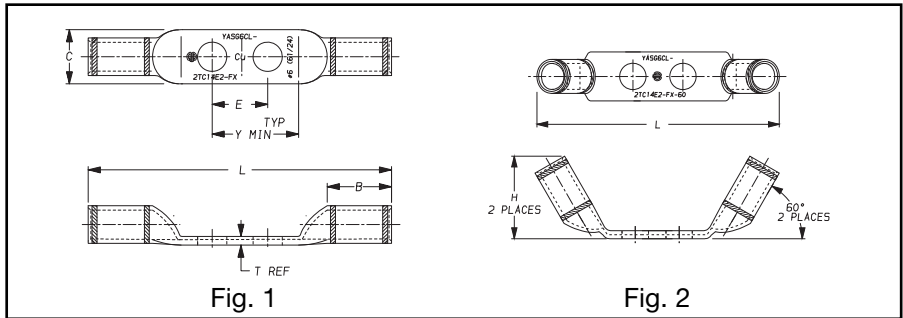

Catalog Number	Conductor			Bolt Size	Fig. No.	Dimensions							Die Index	Color Code	Installation Tooling			Wire Strip Length
	Flex	AWG	*** MM ²			B	C	E	H	L	T Ref.	Y Min.			Mechanical		Hydraulic	
															MD7-34 MD6 OUR840	Y1MRTC Y2MR Y8MRB-1		
YASG6CL-2TC14E2-FX	#6 Weld 61/24	#6 AWG	16	1/4"	1	.50 (13)	.48 (12)	.75 (19)	—	3.0 (78)	.08 (2)	1.14 (29)	7 or 374	Blue	W5CVT (1) W5CRT (1)	Y2MR (1) Y1MRTC (1)	U5CRT (1)	9/16"
YASV6CL-2TC14E2-FX**	#6 Weld 61/24	#6 AWG	16	1/4"	1	.50 (13)	.48 (12)	.75 (19)	—	3.0 (78)	.08 (2)	1.14 (29)	7 or 374	Blue	W5CVT (1) W5CRT (1)	Y2MR (1) Y1MRTC (1)	U5CRT (1)	9/16"
YASV6CL-2TC14E2-FX-60**					2				.68 (17)	2.9 (75)								

- ◆ For applications greater than 2000 Volts consult cable manufacturer for voltage stress relief instructions.
 - * Use PUADP-1 adapter with U dies in Y46 HYPRESS™.
 - ** Type YASV series have inspection hole.
 - *** The MM² conductor sizes listed are the recommendations for Class 2 and Class 5 conductor.
- Note:** All dimensions shown are for reference only.

Blue highlighted items are industry standard and most frequently ordered.

TYPE YAV

HYLUG™

**NON-INSULATED COPPER
TUBULAR TERMINALS
0.3 - 1000 mm²**

Made from electrolytic copper tube, electro tinned. Range of copper tube formed terminals taking wires from 0.3 - 1000 mm². Heat resistant up to +125° C.

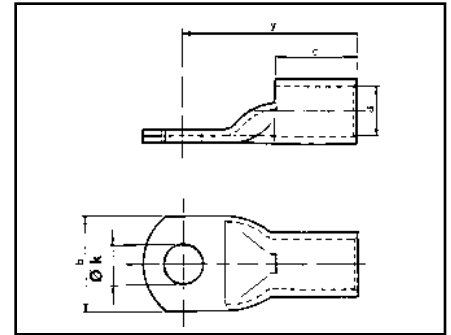

C-75

Catalog Number	mm ²	Stud Size	d	y	b	c	Øk	Pack Qty.	Mechanical Tools		Hydraulic Tools					
									Tooling Number	MRD29	Y29BH Y29NC	Y35BH, Y35, Y750, Y46*, PAT750	Y644M			
YAV18T4	0.3 - 1.2	3.0	1.4	13.7	4.8	6.9	3.1	100	Y10R4BY							
YAV18T5		3.5		15.5	6.1		3.7									
YAV18T1		4.0		15.5	8.0		4.3									
YAV18		5.0		15.5	8.0		5.1									
YAV025M6	1.5 - 2.5	6.0	2.3	16.7	10.4	6.9	6.4	100	Y10R4BY							
YAV14T3		8.0		17.9	11.1		8.4									
YAV04M6	2.5 - 4	6.0	2.6	16.7	9.1	6.9	6.4	100	Y10R4BY							
YAV06M35	4 - 6	3.5	3.3	17.9	7.0	9.5	3.7	50	Y10R4BY							
YAV06M4		4.0		19.4	8.0		4.3									
YAV06M5		5.0		19.9	10.0		5.3									
YAV06M6		6.0		20.9	11.0		6.4									
YAV06M8		8.0		23.4	13.0		8.4									
YAV10T38		10.0		22.5	14.2		10.5									
YAV06FM6	Flex 6	6.0	3.8	20.1	11.0	9.9	6.4	50	Y10R4BY	N	I	N	I	N	I	
YAV10M6	10	6.0	4.6	21.4	11.1	12.0	6.4	50	Y10R4BY MY2913GE2	50NC1	50PIO-25C	DV8L	Y29PL	U10C	Y35P1 + Y29PQS (Y29PQ10B1 UK)	Dieless
YAV10M8		8.0		23.4	14.3		8.4									
YAV10M10		10.0		25.4	14.3		10.5									
YAV10M12		12.0		28.4	18.5		12.3									
YAV16M6	16	6.0	5.7	23.9	12.7	14.0	6.4	50	MY2913GE2	50NC1	50PIO-25C	DV6L	Y29PL	U16C	Y35P1 + Y29PQS (Y29PQ10B1 UK)	Dieless
YAV16M8		8.0		25.9	15.0		8.4									
YAV16M10		10.0		27.9	15.0		10.5									
YAV16M12		12.0		30.9	18.5		13.2									
YAV25M6	25	6.0	7.2	25.7	13.9	15.0	6.4	50	MY2913GE2	50NC2	50PIO-25C	DV4L	Y29PL	U25C	Y35P1 + Y29PQS (Y29PQ10B1 UK)	Dieless
YAV25M8		8.0		27.7	15.9		8.4									
YAV25M10		10.0		29.7	15.9		10.5									
YAV25M12		12.0		32.7	18.5		13.2									

N = Nest die, I = Indentor

Note: All dimensions shown are for reference only.

* Use PUADP-1 adaptor with U dies in Y46 HYPRESS™.

Blue highlighted items are industry standard and most frequently ordered.

Compression Connections

BURNDY®

Copper Compression — Metric — Inspection Window

C-76

TYPE YAV

HYLUG™

NON-INSULATED COPPER
TUBULAR TERMINALS
0.3 - 1000 mm²
(Continued)

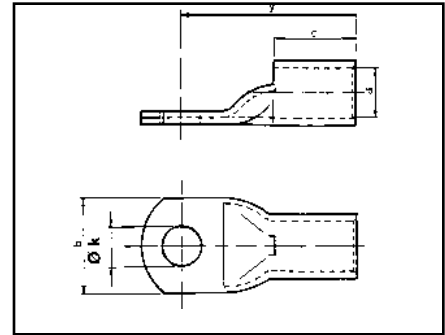

Catalog Number	mm ²	Stud Size	d	y	b	c	Øk	Pack Qty.	Mechanical Tools				Hydraulic Tools				Y644M
									Tooling Number	MRD29		Y29BH Y29NC		Y35BH, Y35, Y750, Y46*, PAT750		Y644M	
										N	I	N	I	N	I		
YAV35M5	35	5	8.5	27.4	15.9	17.0	5.3	50	MY2913GE2	50NC2	50P35-70C	DV2L	Y29PL	U35C	Y35P1 + Y29PQS (Y29PQ11B1 UK)	Dieless	
YAV35M6		6		28.4	15.9		6.4										
YAV35M8		8		30.4	15.9		8.4										
YAV35M10		10		32.4	15.9		10.5										
YAV35M12		12		35.4	19.8		13.2										
YAV50M5	50	5	9.5	30.9	18.2	20.0	5.3	50	MY2913GE2	50NC2	50P35-70C	DV1L	Y29PL	U50C	Y35P1 + Y29PQS (Y29PQ11B1 UK)	Dieless	
YAV50M6		6		31.9	18.2		6.4										
YAV50M8		8		33.9	18.2		8.4										
YAV50M10		10		35.9	18.2		10.5										
YAV50M12		12		38.9	19.8		13.2										
YAV50M14		14		38.9	21.5		15.0										
YAV50M16	16	41.9	22.4	17.0													
YAV50FM12	Flex 50	12	10.0	38.9	21.8	20.0	13.2	50	MY2913GE2	50NC12	50P35-70C	DV1L	Y29PL	U50C	Y35P1 + Y29PQS (Y29PQ11B1 UK)	Dieless	
YAV50FM14		14		38.9	21.8		15.0										
YAV70M5	70	5	11.3	32.4	21.4	21.0	5.3	25	MY2913GE2	50NC1 -2X	50P95-120C	DV25L	Y29PR	U70C	Y35P1 + Y29PQ6S (Y29PQ12B1 UK)	Dieless	
YAV70M6		6		33.4	21.4		6.4										
YAV70M8		8		35.4	21.4		8.4										
YAV70M10		10		37.4	21.4		10.5										
YAV70M12		12		40.4	22.4		13.2										
YAV70M14		14		40.4	22.4		15.0										
YAV70M16		16		43.4	22.4		17.0										
YAV70FM10	Flex 70	10	12.8	42.4	23.8	25.0	10.5	25	MY2913GE2	50NC1 - 2X	50P95-120C	DV26L	Y29PR	UV26D	Y35P1 + Y29PQ6S (Y29PQ12B1 UK)	Dieless	
YAV70FM12		12		45.4	13.2												
YAV95M10	95	10	13.4	43.4	25	25.0	10.5	25	MY2913GE2	50NC2 - 2X	50P95-120C	DV27L*	Y29PR	U95C	Y35P1 + Y29PQ6S (Y29PQ12B1 UK)	Dieless	
YAV95M12		12		46.4	13.2												

N = Nest die, I = Indentor

*DV27L - DV28L — only for Y29BH

Note: All dimensions shown are for reference only.

* Use PUADP-1 adaptor with U dies in Y46 HYPRESS™.

Blue highlighted items are industry standard and most frequently ordered.

TYPE YAV

HYLUG™

**NON-INSULATED COPPER
TUBULAR TERMINALS**
0.3 - 1000 mm²
(Continued)

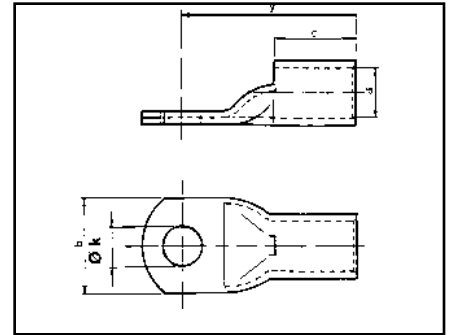

C-77

Catalog Number	mm ²	Stud Size	d	y	b	c	Øk	Pack Qty.	Mechanical Tools				Hydraulic Tools			
									Tooling Number	MRD29		Y29BH Y29NC		Y35BH, Y35, Y750 Y46*, PAT750		Y644M
										N	I	N	I	N	I	
YAV95FM12	Flex 95	12	14.2	46.4	25.0	25.0	13.2	25	MY2913GE2	50NC2 - 2X	50P95-120C	DV27L*	Y29PR	U95C	Y35P1 + Y29P06S (Y29P012B1 UK)	Dieless
YAV120M8	120	8	15.0	44.4	29.0	27.0	8.4	25	MY2913GE2	50NC1 - 2X		DV28L*		U120C		
YAV120M10		10		46.4			10.5									
YAV120M12		12		49.4			13.2									
YAV120M14		14		49.4			15.0									
YAV120M16		16		52.4			17.0									
YAV120M20		20		58.4			21.0									
YAV120FM10	Flex 120	10	15.9	46.4	29.0	27.0	10.5	25	MY2913GE2	50NC1 - 2X	DV28L*	U120C	Y35P1 + Y29P06S (Y29P012B1 UK)	Dieless		
YAV120FM12		12		49.4			13.2									
YAV120FM16		16		52.4			17.0									

N = Nest die, I = Indentor
 *DV27L - DV28L — only for Y29BH.
 Y260DBHM takes U-Dies with adaptor 26UADP.
 * Y46 takes U-Dies with adaptor PUADP-1.
Note: All dimensions shown are for reference only.

Blue highlighted items are industry standard and most frequently ordered.

Compression Connections

BURNDY®

Copper Compression – Metric – Inspection Window

C-78

TYPE YAV

HYLUG™

NON-INSULATED COPPER
TUBULAR TERMINALS
0.3 - 1000 mm²
(Continued)

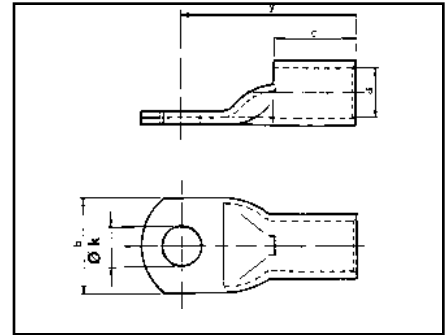

Catalog Number	mm ²	Stud Size	d	y	b	c	Øk	Pack Qty.	Hydraulic Tools							
									Y35BH, Y35, Y750, PAT750		Y260DBHM		Y46*		UK Y22BH	
									N	I	Y644M	N	I	N	I	N
YAV150M10	150	10	16.5	52.3	30.4	27.0	10.5	10	U150C	Dieless	Y644M	26M30D	26P30-34C	U150C	PUADP + Y35P3 + Y34PR	EDB1 + Y20PQ8
YAV150M12		12		55.3			13.2									
YAV150M14		14		55.3			15.0									
YAV150M16		16		58.3			17.0									
YAV150M20		20		64.3			21.0									
YAV150FM12	Flex 150 UK	12	17.8	58.9	32.8	28.6	13.2	10	U185C	26M31D	U185C	ED31BD				
YAV185M10	185	10	18.4	61.8	35.7	30.2	10.5	10	U32D	Dieless	Y644M	26M32D	26P30-34C	U32D	PUADP + Y35P3 + Y34PR	EDB1 + Y20PQ8
YAV185M12		12		64.8			13.2									
YAV185M14		14		64.8			15.0									
YAV185M16		16		67.8			17.0									
YAV185M20		20		73.8			21.0									
YAV185FM10	Flex 185 UK	10	19.4	61.8	35.7	30.2	10.5	10	U32D	26M32D	U32D	ED32BD				
YAV240M10	240	10	21.2	68.2	39.6	34.9	10.5	10	U240C	Dieless	Y644M	26M34D	26P30-34C	U240C	PUADP + Y35P3 + Y34PR	EDB1 + Y20PQ10
YAV240M12		12		71.2			13.2									
YAV240M14		14		71.2			15.0									
YAV240M16		16		74.2			17.0									
YAV240M20		20		80.2			21.0									
YAV240FM10	Flex 240 UK	10	22.0	73.4	41.0	36.0	10.5	10	U35BD	Dieless	Y644M	26M35BD	26P36C	U35BD	PUADP + Y35P3 + Y34PR	EDB1 + Y20PQ10
YAV240FM12		12		76.4			13.2									
YAV300M12	300	12	23.4	77.3	43.0	43.0	13.2	10	U300C	Dieless	Y644M	26M36D	26P36C	U300C	PUADP + Y35P3 + Y34PR	EDB1 + Y20PQ10
YAV300M14		14		78.3			15.0									
YAV300M16		16		80.3			17.0									
YAV300M20		20		86.3			21.0									
YAV300FM14	Flex 300 UK	14	24.2	82.4	45.0	43.0	15.0	10	U37BD	26M37BD	U37BD	ED37BD				

N = Nest die, I = Indentor
Y260DBHM takes U-Dies with adaptor 26UADP.
* Y46 takes U-Dies with adaptor PUADP-1.
Y22BH takes U-Dies with adaptor 22UADP.

Note: All dimensions shown are for reference only.

Blue highlighted items are industry standard and most frequently ordered.

TYPE YAV

HYLUG™

**NON-INSULATED COPPER
TUBULAR TERMINALS**
0.3 - 1000 mm²
(Continued)

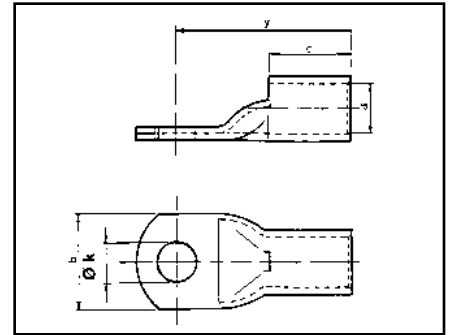

C-79

Catalog Number	mm ²	Stud Size	d	y	b	c	Øk	Pack Qty.	Hydraulic Tools										
									Y644M	Y260DBHM		Y46*		UK-Y22BH		Y530DBHM			
										N	I	N	I	N	I	N	I		
YAV375M12	375 (750 kcmil)	12	26.2	81.3	48.0	43.0	13.2	10	Dieless	26M39D	26P-36C	P39D	P44PR	ED448D	EDPB1 + Y20PQ10	53M39D	53P40-45C		
YAV375M16		16		84.3			17.0												
YAV375M20		20		90.3			21.0												
YAV500M12	500	12	29.8	87.8	55.1	47.7	13.2	10		26M44D	26P40-45C	P44D	P44PR	ED448D	EDPB1 + Y20PQ11	53M44D		53P40-45C	
YAV500M14		14		88.8			15.0												
YAV500M20		20		96.8			21.0												
YAV630FM20	Flex 630 UK	20	34.4	104.6	63.0	53.0	21.0	10		P45D	HEAD	P45D	P44PR	ED453BD	EDPB2 + Y22PQ12	53M45D			53P46-48C
YAV800M20*	800 (1500 kcmil)	20	38.0	113.6	67.5	52.0	21.0	10						ED466BD	EDPB2 + Y48PQ2	53M46D			
YA48L	1000 (2000 kcmil)	20	42.2	127.2	77.7	55.0	21.0	10						ED488D	EDPB2 + Y48PQ2	53M48D			

N = Nest die, I = Indentor

Y260DBHM takes U-Dies with adaptor 26UADP

* Y46 takes U-Dies with adaptor PUADP-1

Y22BH takes U-Dies with adaptor 22UADP

Y530DBHM takes U-Dies with adaptor 53UADP.

Note: All dimensions shown are for reference only.

Blue highlighted items are industry standard and most frequently ordered.

Compression Connections

BURNDY®

Copper and Aluminum Compression — Narrow Tongue — One and Two Hole

C-80

E-LINE HYLUG™ EQUIPMENT LINE

TYPE YA-E COPPER AND ALUMINUM COMPRESSION TERMINAL

UL Listed 90° C,
600 Volts to 35 kV ◆

YA-E Equipment terminals are designed to provide replacements for original equipment mechanical or other compression terminals. These narrow tongue terminals are specially designed to fit in tight areas. Whether you're

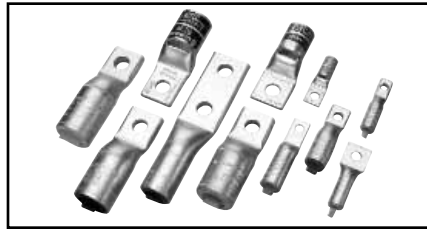

upgrading or replacing, YA-E connectors will provide for any of your cable termination needs. When installed with our dieless tool, these terminals can accommodate a range of conductor sizes.

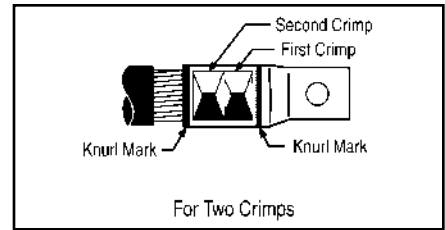
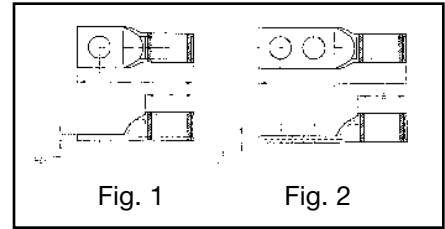

COPPER E-LINE HYLUG™ COMPRESSION TERMINALS

Catalog Number	Fig No.	Conductor Accommodations		Bolt Size	Bolt Hole Spacing	Tongue Width (max)	Dimensions			Dieless (number of crimps)	† Installation Tooling				
		Conventional Wire Size	Expanded Wire Range using Y644M				B	T	L		Mechanical		Color Code	Die Index	Wire Strip Length
											MD6, MD7 (number of crimps)	Hydraulic Y35, Y750, Y46*, PAT750 (number of crimps)			
YA25LN50T14E	1	1/0 AWG	#6 - 1/0 AWG	1/4	—	0.50	0.88	0.12	1.84	Y644HS (1)	W25RT (2)	U25RT (1)	Pink	12 348	15/16"
YA25LN64T516E	1			5/16	—	0.64	0.88	0.12	1.96	PAT644HS (1)	W25VT (2)	U2CABT (1)			
YA26LN50T14E	1	2/0 AWG	#4 - 2/0 AWG	1/4	—	0.50	0.94	0.12	1.94	Y81KFT (1) Y81KFTMBH (1) PAT81KFT-18V (1)	W26RT (2) W26VT (2)	U26RT (1)	Black	13	1"
YA30L24N100T38E	1	300 kcmil	2/0 AWG - 300 kcmil	3/8	—	1.00	1.03	0.16	2.44	Y644HS (1)	W30RT (2)	U30RT (2) U28ART (2)	White	17 298	1-1/16"
YA342LNN119T12E	2	500 kcmil	4/0 AWG - 500 kcmil	1/2	1.75	1.19	1.27	0.23	5.06	PAT644HS (1)	—	U34RT (2)	Brown	20 299	1-5/16"
YA342LNN131T12E	2			1/2	1.75	1.31	1.27	0.23	5.06	Y81KFT (2)					
YA34LGN131T12E	1			1/2	—	1.31	1.27	0.23	3.31	Y81KFTMBH (2)					
YA39LGN131T12E	1			1/2	—	1.31	1.42	0.27	3.61	PAT81KFT-18V (2)					
YA392LNN131T12E	2	750 kcmil	500 - 750 kcmil	1/2	1.745	1.31	1.42	0.27	5.37	—	U39RT (2)	Black	24	1-1/2"	

ALUMINUM E-LINE HYLUG™ COMPRESSION TERMINALS

Catalog Number	Fig No.	Conductor Accommodations		Bolt Size	Bolt Hole Spacing	Tongue Width (max)	Dimensions			Dieless (number of crimps)	† Installation Tooling				
		Aluminum Conventional Wire Size	Copper or Aluminum Expanded Wire Range using Y644M				B	T	L		Mechanical		Color Code	Die Index	Wire Strip Length
											MD6, MD7, Y500CT (number of crimps)	Hydraulic Y35, Y750, Y46*, PAT750 (number of crimps)			
YA8CA3S56T14E	1	#8 AWG	#8 AWG	1/4	—	0.56	0.62	0.09	1.65	Y644HS (1)	—	U8CABT (1)	Blue	374	11/16"
YA2CA5S53T14E	1	#2 AWG	#6 - #2 AWG	1/4	—	0.53	1.00	0.22	2.25	PAT644HS (1)	—	U2CABT (1)	Pink	348	1-3/16"
YA2CA1S9T1516E	1			5/16	—	0.91	1.12	0.16	2.50	Y81KFT (1)					
YA25A1S60T516E	1	1/0 AWG	#1 - 1/0 AWG	5/16	—	0.63	1.00	0.21	2.29	Y81KFTMBH (1)	—	U25ART (1)	Tan	296	1-1/8"
YA25A3N69T38E	1			3/8	—	0.69	1.05	0.21	2.38	PAT81KFT-18V (1)					
YA26A13N100T516E	1	2/0 AWG	#1 - 2/0 AWG	5/16	—	1.00	1.11	0.24	2.45	Y644HS (1) PAT644HS (1)	—	U26ART (2)	Olive	297	1-3/16"
YA26A6N100T38E	1			3/8	—	1.00	1.11	0.24	2.53						
YA27A10S76T516E	1	3/0 AWG	#1 - 3/0 AWG	5/16	—	0.76	1.11	0.26	2.58	Y644HS (1) PAT644HS (1)	—	U27ART (2)	Ruby	467	1-3/16"
YA28A14N100T516E	1	3/8	—	1.00	1.39	0.30	2.85								
YA28A1N100T38E	1	4/0 AWG	1/0 - 4/0 AWG	5/16	—	1.00	1.39	0.30	2.94	Y81KFT (2) Y81KFTMBH (2) PAT81KFT-18V (2)	—	U28ART (2)	White	298	1-7/16"
YA30A9N100T516E	1	5/16	—	1.00	1.53	0.36	3.12								
YA30A6N100T38E	1	300 kcmil	2/0 AWG - 300 kcmil	3/8	—	1.00	1.53	0.36	3.20	Y81KFT (2) Y81KFTMBH (2) PAT81KFT-18V (2)	—	U30ART (2)	Blue	470	1-5/8"
YA30A1N131T12E	1			1/2	—	1.31	1.53	0.35	3.57						
YA31A11N100T516E	1	350 kcmil	3/0 AWG - 350 kcmil	5/16	—	1.00	1.85	0.39	3.51	—	—	U31ART (2)	Brown	299	1-7/8"
YA31A9N100T38E	1			3/8	—	1.00	1.85	0.39	3.59						
YA32A8N106T516E	1	400 kcmil	4/0 AWG - 400 kcmil	5/16	—	1.06	2.26	0.43	3.92	—	U32ART (4)	Green	472	2-5/16"	

† A variety of BURNDY® installation tools are available and not all tools are listed. If you require additional tooling information, please feel free to call our customer service department for other recommendations.

* Use PUADP-1 adapter with U dies in Y46 HYPRESS™, P-RT die sets for use in Y46 HYPRESS™ only. PUADP-1 adapter not required.

Note: All dimensions shown are for reference only.
** 900 Compact Aluminum Cable not UL Listed. Tested with Y644HS and PAT644 dieless tools only.

**E-LINE HYLUG™
EQUIPMENT LINE**

**TYPE YA-E
COPPER AND ALUMINUM
COMPRESSION TERMINAL**
(Continued)

UL Listed 90° C,
600 Volts to 35 kV ◆

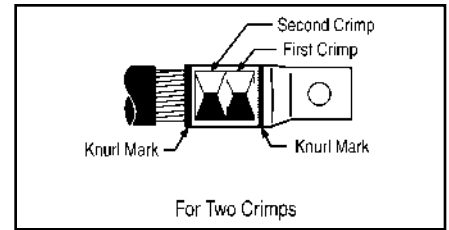
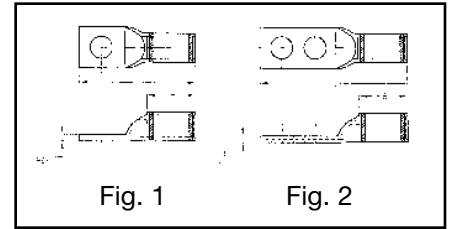
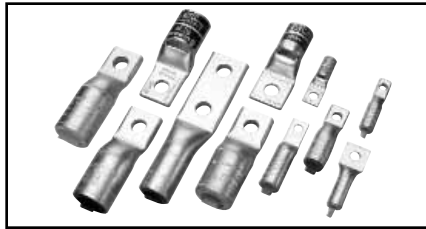

ALUMINUM E-LINE HYLUG™ COMPRESSION TERMINALS

Catalog Number	Fig No.	Conductor Accommodations		Bolt Size	Bolt Hole Spacing	Tongue Width (max)	Dimensions			† Installation Tooling					Wire Strip Length
		Aluminum Wire Size	Copper or Aluminum Expanded Wire Range using Y644M				B	T	L	Dieless (number of crimps)	Mechanical	Hydraulic	Color Code	Die Index	
											MD6, MD7, Y500CT (number of crimps)	Y35, Y750, Y46*, PAT750 (number of crimps)			
YA34A8N131T38E	1	500 kcmil	4/0 AWG - 500 kcmil	3/8	—	1.31	1.64	0.35	3.88	Y644HS (2) PAT644HS (2) Y81KFT (2) Y81KFTMBH (2) PAT81KFT-18V (2)	—	U34ART (4)	Pink	300	1-11/16"
YA34A3N131T12E	2			1/2	1.75	1.31	1.64	0.35	5.71						
YA34A7N131T12E	1			1/2	—	1.31	1.64	0.35	3.88						
YA36A9N131TD12E	1	600 kcmil	250 - 600 kcmil	1/2	—	1.31	1.64	0.39	3.98						
YA36A3N131TD38E	2			3/8	—	1.31	1.64	0.39	5.32						
YA36A3N131TD12E	2			1/2	1.75	1.31	1.64	0.39	5.71						
YA39A5N131TD12E	2	750 kcmil	500 - 900** kcmil Aluminum 500 kcmil Copper Only	1/2	1.75	1.31	1.86	0.31	6.09						
YA39A1N131TD12E	1			1/2	—	1.31	1.86	0.31	4.28						1-15/16"

† A variety of BURNDY® installation tools are available and not all tools are listed. If you require additional tooling information, please feel free to call our customer service department for other recommendations.

* Use PUADP-1 adapter with U dies in Y46 HYPRESS™, P-RT die sets for use in Y46 HYPRESS™ only. PUADP-1 adapter not required.

Note: All dimensions shown are for reference only.
** 900 Compact Aluminum Cable not UL Listed. Tested with Y644HS and PAT644 dieless tools only.

Blue highlighted items are industry standard and most frequently ordered.

Compression Connections

BURNDY®

Copper Compression — Code Splice

C-82

TYPE YS-L

HYLINK™ SPLICE STANDARD BARREL

COPPER COMPRESSION

UL Listed 90° C,
600 Volts to 35 kV ◆

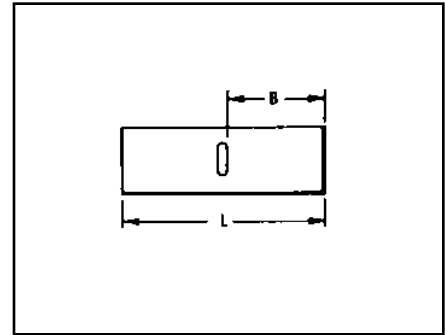

Features and Benefits

- Standard barrel length.
 - ◇ Ideal for limited space applications while providing ample barrel length for proper crimp.
- Four (4) center conductor stops.
 - ◇ Provides a center wire stop for proper conductor insertion.

Catalog Number	Conductor		Dimensions		Dieless (# of crimps)	Installation Tooling ▲					Wire Strip Length		
	AWG	*** MM ²	L	B		Mechanical			Y35, ■ Y39, Y750, Y46*			▲ Die Index & Embossment	
						Y1MRTC Y2MR	MD7-34R	MD6 OUR840	Die Number (# crimps)	Color Code			
YS8C-L-BOX	8 str.	10	1.00	.41	Y81KFT (1) Y81KFTMBH (1) PAT81KFT-18V (1)	Y1MRTC (1)	W8CVT (1)	X8CRT (1)	U8CRT (1)	Red	49	1/2"	
YS6C-L BOX	6 str.	—	1.75	.81			W5CVT (1)	X5CRT (1)	U5CRT (1)	Blue	7 or 374	7/8"	
YS5C-L BOX	5 str.	16	1.90	.81		Y1MRTC (2)	W4CVT (1)	X4CRT (1)	U4CRT (1)	Gray	8 or 346	7/8"	
YS4C-L BOX	4 str.	—	1.75	.81			—	—	U3CRT (1)	White	9	15/16"	
YS3C-L	3 str.	25	2.05	.88		Y1MRTC (2)	W2CVT (1)	X2CRT (1)	U2CRT (1)	Brown	10	15/16"	
YS2C-L BOX	2 str.	—	2.00	.88			W1CVT (1)	X1CRT (1)	U1CRT-1 (1)	Green	11 or 375	15/16"	
YS1C-L BOX	1 str.	50	2.06	.88		Y81KFT (2) Y81KFTMBH (2) PAT81KFT-18V (2)	—	W25VT (2)	X25RT (2)	U25RT (1)	Pink	12 or 348	15/16"
YS25-L BOX	1/0 str.	—	2.08	.88				W26VT (2)	X26RT (2)	U26RT (1)	Black	13	1"
YS26-L BOX	2/0 str.	70	2.17	.94				W27VT (2)	X27RT (2)	U27RT (1)	Orange	14	1-1/16"
YS27-L BOX	3/0 str.	95	2.30	1.00				W28VT (2)	X28RT (2)	U28RT (1)	Purple	15	1-1/16"
YS28-L BOX	4/0 str.	—	2.32	1.00	W29VT (2)			—	U29RT (1)	Yellow	16	1-1/8"	
YS29-L BOX	250 kcmil	120	2.46	1.06	W30VT (2)			—	U30RT (2)	White	17 or 298	1-1/8"	
YS30-L	300 kcmil	150	2.47	1.06	W31VT (2)			—	U31RT (2)	Red	18 or 324	1-3/16"	
YS31-L	350 kcmil	185	2.60	1.12	W32VT (2)			—	U32RT (2)	Blue	19 or 470	1-1/4"	
YS32-L	400 kcmil	—	2.74	1.19	W34VT (2)			—	U34RT (2)	Brown	20 or 299	1-7/16"	
YS34-L	500 kcmil	240	3.15	1.38	Y81KFT (3) Y81KFTMBH (3) PAT81KFT-18V (3)			—	U36RT (2)	Green	22 or 472	1-7/16"	
YS36-L	600 kcmil	300	3.22	1.38		U38RT (2)	Pink		400	1-7/16"			
YS38-L	700 kcmil	—	3.22	1.38		U39RT (2)	Black		24	1-11/16"			
YS39-L	750 kcmil	—	3.72	1.62		P44RT** (2)	White		27	1-15/16"			
YS44-L	1000 kcmil	500	4.28	1.88									

▲ See tooling section of this catalog for complete tool and die listings.

* Use PUADP-1 adaptor with U dies in Y46 HYPRESS™.

** P44RT for use with Y46 HYPRESS™ only. PUADP-1 adaptor not required.

*** The MM² conductor sizes listed are the recommendations for Class 2 conductor.

■ The maximum size for the Y35 is 400 kcmil insulated code cable.

◆ For applications greater than 2000 Volts consult cable manufacturer for voltage stress relief instructions.

Note: All dimensions shown are for reference only.

Blue highlighted items are industry standard and most frequently ordered.

TYPE YS

HYLINK™ SPLICE - LONG BARREL

COPPER COMPRESSION SPLICE

UL Listed 90° C, 600 Volts to 35 kV ◆

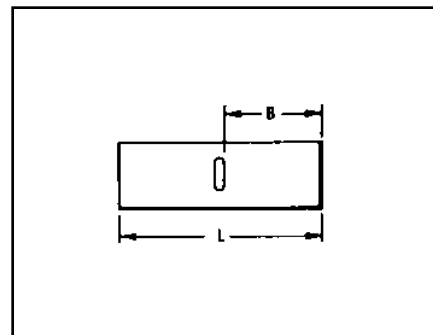
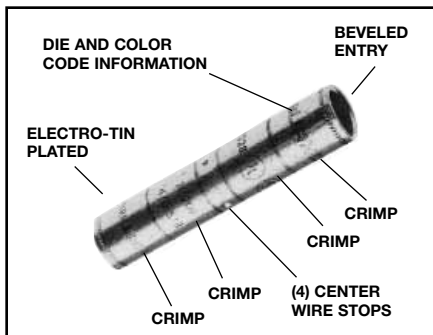

Features and Benefits

- Long barrel length.
 - ◆ Ideal for 600 volt heavy duty applications. Also may be used at higher voltages up to 35KV.
- Four (4) center conductor stops.
 - ◆ Provides a center wire stop for proper conductor insertion.
- High pull out force.
 - ◆ Provides added security for much greater mechanical and electrical properties.

Catalog Number	Conductor		Dimensions		Dieless (# of crimps)	Installation Tooling ▲					Wire Strip Length	
	AWG	*** MM ²	L	B		Mechanical			Y35 ■, Y39, Y750, Y46*			▲ Die Index & Embossment
						Y1MRTC Y2MR	MD7-34R	MD6 OUR840	Die Number (# crimps)	Color Code		
YS8C	8 str.	10	1.75	.78	Y81KFT (1) Y81KFTMBH (1) PAT81KFT-18V (1)	Y1MRTC (2)	W8CVT (2)	X8CRT (2)	U8CRT (2)	Red	49	7/8"
YS6C	6 str.	—	2.38	1.09		Y1MRTC (2)	W5CVT (2)	X5CRT (2)	U5CRT (2)	Blue	7 or 374	1-3/16"
YS5C	5 str.	16	2.55	1.09		Y1MRTC (4)	W4CVT (2)	X4CRT (2)	U4CRT (2)	Gray	8 or 346	1-3/16"
YS4C	4 str.	—	2.55	1.09	Y81KFT (2) Y81KFTMBH (2) PAT81KFT-18V (2)	Y1MRTC (4)	—	U3CRT (2)	—	White	9	1-5/16"
YS3C	3 str./2 sol.	25	2.80	1.22		Y1MRTC (4)	W2CVT/W2CRT	W2CVT/W2CRT	U2CRT (2)	Brown	10	1-5/8"
YR2C2WT	2 str. - 2 sol.	25	2.90	1.44		Y1MRTC (4)	W2CVT (2)	X2CRT (2)	U2CRT (2)	Brown	10	1-5/16"
YS2C	2 str.	35	2.82	1.22		Y1MRTC (4)	W1CVT (2)	X1CRT (2)	U1CRT-1 (2)	Green	11 or 375	1-7/16"
YS1C	1 str.	50	3.07	1.34		Y81KFT (3) Y81KFTMBH (3) PAT81KFT-18V (3)	W25VT (4)	X25RT (4)	U25RT (2)	Pink	12 or 348	1-7/16"
YS25	2/0 str.	—	3.06	1.34			W26VT (4)	X26RT (4)	U26RT (2)	Black	13	1-9/16"
YS26	2/0 str.	70	3.30	1.45			W27VT (4)	X27RT (4)	U27RT (2)	Orange	14	1-9/16"
YS27	3/0 str.	—	3.30	1.45			W28VT (4)	X28RT (4)	U28RT (2)	Purple	15	1-11/16"
YS28	4/0 str.	—	3.57	1.58			W29VT (4)	—	U29RT (2)	Yellow	16	1-11/16"
YS29	250 kcmil	120	3.58	1.58			W30VT (4)	—	U30RT (4)	White	17 or 298	2-1/16"
YS30	300 kcmil	150	4.34	1.95	W31VT (4)		—	U31RT (4)	Red	18 or 324	2-1/16"	
YS31	350 kcmil	185	4.35	1.95	W32VT (4)		—	U32RT (4)	Blue	19 or 470	2-3/16"	
YS32	400 kcmil	—	4.62	2.08	W34VT (4)	—	U34RT (4)	Brown	20 or 299	2-5/16"		
YS34	500 kcmil	240	4.91	2.20	Y81KFT (4) Y81KFTMBH (4) PAT81KFT-18V (4)	—	—	U36RT (4)	Green	22 or 472	2-3/4"	
YS36	600 kcmil	300	5.85	2.63		—	—	U39RT (4)	Black	24	2-15/16"	
YS39	750 kcmil	—	6.38	2.81		—	—	P44RT** (2)	White	27	3-1/16"	
YS44	1000 kcmil	500	6.95	2.94		—	—	P46RT** (6)	Green	31	3-1/4"	
YS46	1500 kcmil	—	7.01	3.13		—	—	L48RT (4)	Brown	34	3-3/8"	
YS48	2000 kcmil	—	7.57	3.27		—	—	—	—	—	—	—

① Not color coded.

* Use PUADP-1 adapter with U dies in Y46 HYPRESS™.

** P44RT for use with Y46 HYPRESS™ only. PUADP-1 adapter not required.

*** The MM² conductor sizes listed are the recommendations for Class 2 conductor.

■ The maximum size for the Y35 is 400 kcmil.

▲ See tooling section of this catalog for complete tool and die listings.

◆ For applications greater than 2000 Volts consult cable manufacturer for voltage stress relief instructions.

† Requires Y60BHU HYPRESS™ with L48RT die set.

Note: All dimensions shown are for reference only.

Blue highlighted items are industry standard and most frequently ordered.

C-84

TYPES Y-R

REDUCING ADAPTER

FOR COPPER

600 Volts to 35 kV◆

The Y-R reducing adapter has been designed to allow large size, long barrel, copper long barrel HYDENT™, HYSPLICE™ and HYTEE™ terminals, splices, and T taps to be used on smaller conductor sizes. To use, simply insert the reducer adapter into the barrel, insert the wire into the reducer adapter and crimp the outer barrel using its recommended tooling.

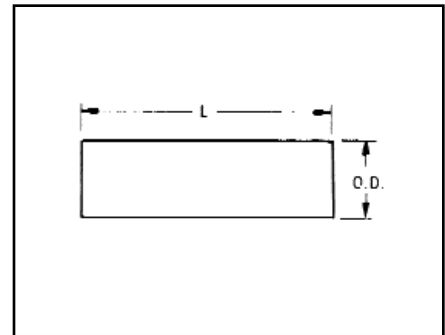
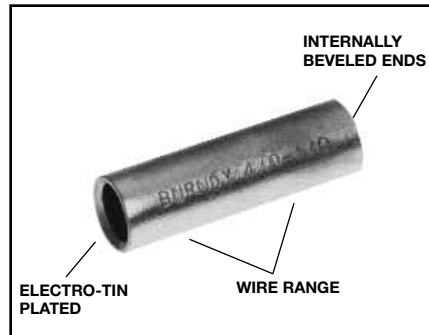

Features and Benefits

- Wide range of conductors are accommodated.
 - ◇ Lowers inventory requirements and affords maximum versatility.
- Same die set for all legs of the connection.
 - ◇ Permits the same tool and die combination normally used on the compression barrel.
- Length fits the long barrel connector design (YS, YA).
 - ◇ Can be used on all long barrel connectors. Field cut to fit shorter length compression barrels (YS-L, YA-L).
- Manufactured from high conductivity electrolytic copper and electro-tin plated.
 - ◇ Provides maximum conductivity low resistance and ductility for an excellent combination of electrical and crimp forming properties, and provides long lasting corrosion resistance.

Catalog Number	Wire Range		Dimensions	
	From	To	Max O.D.	L
Y286CR	4/0 str.	6, 8 str. 6 sol.	.534	1.75
Y284WR		4 sol.		
Y284CR		4 str.		
Y282CR		2 str.		
Y281CR		1 str.		
Y2825R		1/0 str.		
Y2826R		2/0 str.		
Y2827R		3/0 str.		
Y2928R	250 kcmil	4/0	.582	1.62
Y302CR	300 kcmil	2	.637	2.00
Y304CR		4		
Y3025R		1/0		
Y3026R		2/0		
Y3027R		3/0		
Y3028R		4/0		
Y3126R		2/0		
Y3128R	4/0			
Y3129R	250			
Y342CR	500 kcmil	2 str.	.821	2.50
Y3425R		1/0 str.		
Y3426R		2/0 str.		
Y3427R		3/0 str.		
Y3428R		4/0 str.		
Y3429R		250 kcmil		
Y3430R		300 kcmil		
Y3431R		350 kcmil		
Y3432R	400 kcmil	1.017	2.25	
Y3934R	500 kcmil			
Y3936R	600 kcmil			
Y4439R	1000 kcmil	750 kcmil	1.296	3.19

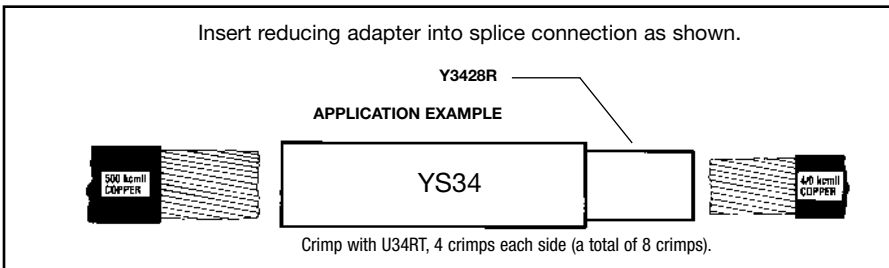

Contact Technical Support for other sizes not listed.
 ◆ For applications greater than 2000 Volts consult cable manufacturer for voltage stress relief instructions.

Note: All dimensions shown are for reference only.

Blue highlighted items are industry standard and most frequently ordered.

TYPE YS-LB

HYLINK™

**UNINSULATED
BELLED COPPER
COMPRESSION SPLICE**

**STANDARD LENGTH
BELLED BARREL**

UL Listed 90° C,
600 Volts to 35 kV◆

HYLINK™ type YS-LB splices are designed for flexible and extra flexible copper conductors used in mining machines, locomotives, welding cables and other flexible cable applications. The seamless, high conductivity copper, electro-tin plated belled barrel provides for easy insertion of flexible stranded conductors and the nest indenter die system provides an excellent electrical and mechanical connection.

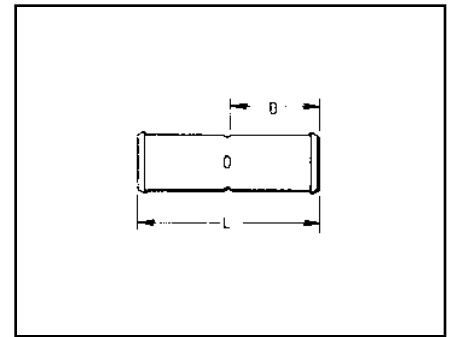
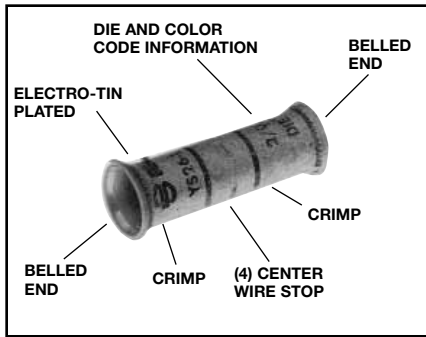

C-85

Features and Benefits

- Belled barrel ends.
 - ◇ Provides easy cable insertion into the splice barrel and smooth cable strain relief during cable flexing and movement.
- Standard length barrel.
 - ◇ Permits easy passage around pulleys yet is long enough for easy crimping.



Catalog Number	Copper Cables *											
	Code Cable Flex Cable	Navy Cable	Flexible and Extra Flexible Cables							Dimensions		
			Class G	Class H	Class I	Battery Cable Class K	Welding Cable Class M	Locomotive Cable	Metric Cable			
B	L											
YS5C-LB	—	—	—	—	—	—	—	—	—	—	.81	1.75
	6 Flex	—	#6 (49 str)	#6 (133 str)	#6 (63/24)	#6 (266/30)	#6 (665/34)	#6 (61/24)	—	—	.81	1.75
YS4C-LB	—	—	—	—	—	—	—	—	—	—	.81	1.75
	5 Flex	—	#5 (49 str)	#5 (133 str)	#5 (84/24)	#5 (336/30)	#5 (836/34)	#5 (91/24)	—	—	.81	1.75
YS3C-LB	—	—	—	—	—	—	—	—	—	—	.81	1.88
	4 Flex	—	#4 (49 str)	#4 (133 str)	#4 (105/24)	#4 (420/30)	#4 (1064/34)	#4 (105/24)	—	—	.81	1.88
YS2C-LB	—	—	—	—	—	—	—	—	—	—	.81	1.88
	3 Flex	—	#3 (49 str)	#3 (133 str)	#3 (133/24)	#3 (532/30)	#3 (1323/24)	#3 (125/24)	—	—	.81	1.88
YS1C-LB	—	—	—	—	—	—	—	—	—	—	.81	1.88
	2 Flex	—	#2 (49 str)	#2 (133 str)	#2 (161/24)	#2 (665/30)	#2 (1666/34)	#2 (150/24)	—	—	.81	1.88
YS25-LB	—	—	—	—	—	—	—	—	—	—	.81	1.88
	1 Flex	—	#1 (133 str)	#1 (259 str)	#1 (210/24)	#1 (836/30)	#1 (2107/34)	#1 (225/24)	—	—	.81	1.88
YS26-LB	—	—	—	—	—	—	—	—	—	—	.94	2.00
	1/0 Flex	—	1/0 (133 str)	1/0 (259 str)	1/0 (266/24)	1/0 (1064/30)	1/0 (2646/34)	1/0 (275/24)	—	—	.94	2.00
YS27-LB	—	—	—	—	—	—	—	—	—	—	1.00	2.13
	2/0 Flex	—	2/0 (133 str)	2/0 (259 str)	2/0 (342/24)	2/0 (1323/30)	2/0 (3325/34)	2/0 (325/24)	—	—	1.00	2.13
YS28-LB	—	—	—	—	—	—	—	—	—	—	1.00	2.13
	3/0 Flex	—	3/0 (133 str)	3/0 (259 str)	3/0 (418/24)	3/0 (1666/30)	—	3/0 (450/24)	—	—	1.00	2.13
YS29-LB	—	—	—	—	—	—	—	—	—	—	1.06	2.25
	4/0 Flex	—	4/0 (133 str)	4/0 (259 str)	—	—	—	—	—	—	1.06	2.25
YS30-LB	—	—	—	—	—	—	—	—	—	—	1.06	2.25
	4/0 - 250 Flex	—	250 kcmil (259 str)	250 kcmil (427 str)	4/0 (532/24)	4/0 (2107/30)	4/0 (5320/34)	4/0 (550/24)	—	—	1.06	2.25

◆ Contact BURNDY® for conductors not shown.
◆ For applications greater than 2000 Volts consult cable manufacturer for voltage stress relief instructions.
Note: All dimensions shown are for reference only.

Blue highlighted items are industry standard and most frequently ordered.

Compression Connections

BURNDY®

Copper Compression — Flex — Splice — Belled Ends

C-86

TYPE YS-LB

HYLINK™

UNINSULATED BELLED
COPPER COMPRESSION
SPLICE

STANDARD LENGTH
BELLED BARREL

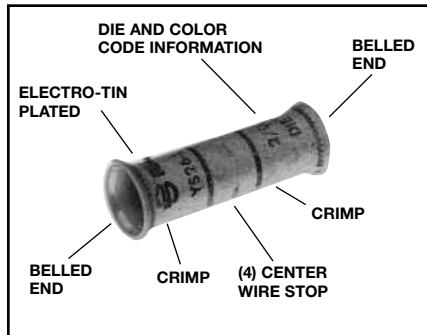

UL Listed 90° C,
600 Volts to 35 kV◆



(INSTALLATION TOOLING)

Catalog Number	Code Cable	Installation Tooling ▲						Wire Strip Length		
		Dieless (# of crimps)	Dieless HYTOOL™ (# of crimps)	Die Index	Color Code	Die Type	Hydraulic Tooling, Die Sets, (# of crimps) ▲			
							Y35†		Y39†, Y750†	Y46*†
① YS5C-LB	6 Flex	Y81KFT (1) Y81KFTMBH (1) PAT81KFT-18V (1)	MY29-11 (1) (1 Crimp/end)	1014	—	Nest Indentor	U6CD-1 (1) Y34PR (1)	U6CD-1 (1) Y34PR (1)	U6CD-1 (1) Y34PR (1)	7/8"
YS4C-LB	5 Flex			1015			U4CD-1 (1) Y34PR (1)	U4CD-1 (1) Y34PR (1)	U4CD-1 (1) Y34PR (1)	7/8"
YS3C-LB	4 Flex			1016			U3CD-1 (1) Y34PR (1)	U3CD-1 (1) Y34PR (1)	U3CD-1 (1) Y34PR (1)	15/16"
YS2C-LB	3 Flex			1017			U2CD-1 (1) Y34PR (1)	U2CD-1 (1) Y34PR (1)	U2CD-1 (1) Y34PR (1)	15/16"
YS1C-LB	2 Flex			1018			U1CD-1 (1) Y34PR (1)	U1CD-1 (1) Y34PR (1)	U1CD-1 (1) Y34PR (1)	15/16"
YS25-LB	1 Flex			1019			U25D-1 (1) Y34PR-2 (1)	U25D-1 (1) Y34PR-2 (1)	U25D-1 (1) Y34PR-2 (1)	15/16"
YS26-LB	1/0 Flex			1020			U26D-1 (1) Y34PR-2 (1)	U26D-1 (1) Y34PR-2 (1)	U26D-1 (1) Y34PR-2 (1)	1"
YS27-LB	2/0 Flex			1021			U27D-1 (1) Y34PR-2 (1)	U27D-1 (1) Y34PR-2 (1)	U27D-1 (1) Y34PR-2 (1)	1-1/16"
YS28-LB	3/0 Flex			1022			—	U28D-1 (1) Y34PR-2 (1)	U28D-1 (1) Y34PR-2 (1)	1-1/16"
YS29-LB	4/0 Flex			1023				U29D-1 (1) Y34PR-2 (1)	U29D-1 (1) Y34PR-2 (1)	1-1/16"
YS30-LB	4/0-250 Flex	1024	U30D-1 (1) Y34PR-2 (1)	U30D-1 (1) Y34PR-2 (1)	1-1/8"					

† Use Y35P3 adaptor with Y34PR indentor.
 * Use PUADP-1 adaptor with U-DIES in Y46 HYPRESSTM.
 ▲ See Tooling section in this catalog for complete tool and die listings.
 ① Not color coded.
 ◆ For applications greater than 2000 Volts consult cable manufacturer for voltage stress relief instructions.
Note: All dimensions shown are for reference only.

Blue highlighted items are industry standard and most frequently ordered.

TYPES YS-T AND YSP-T

HIGH-VOLTAGE HYLINKS™

UNINSULATED HIGH VOLTAGE COPPER COMPRESSION SPLICE

STANDARD BARREL - TAPERED ENDS

UL Listed 90° C, 600 Volts to 35 kV◆

Seamless types YS-T and YSP-T high conductivity copper electro-tin plated compression HYLINK™ high-voltage splices with standard barrel and tapered ends are ideally suited for higher voltage applications from 5KV through 35 KV.

Type YS-T splice connector has four center wire stops for proper conductor insertion.

Type YSP-T splice connector has a brazed in place center plug to prevent the passage of oil between two oil filled conductors or between conductors without oil and conductors with oil and acts as a center wire stop for proper conductor insertion.

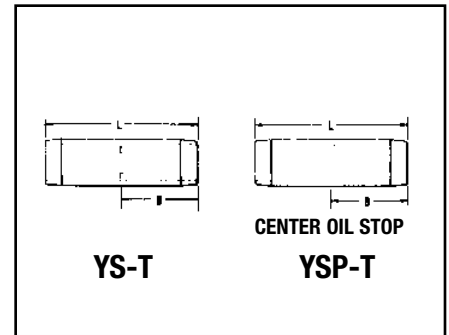
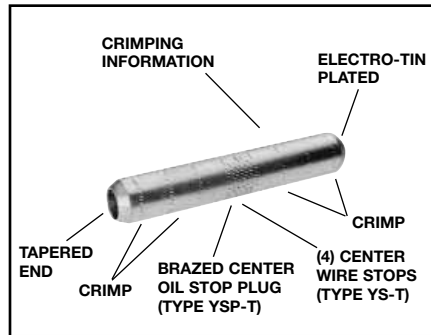

C-87

Features and Benefits

- Tapered connector ends per EEI standard TD160.
 - ◇ Suitable for use on voltages 5KV through 35KV to aid in preventing corona emission and simplify taping thus lowering installed cost.
- Type YS-T four center wire stops.
 - ◇ Provides a center wire stop for proper conductor insertion.
- Type YSP-T has a center plug permanently brazed in place.
 - ◇ Prevents oil within oil-filled conductors from passing through the splice connector and provides a center strip for proper conductor insertion.



Catalog Number		Code Conductors	Dimensions		Installation Tooling - Nest/Indentor ▲					Wire Strip Length
					Y34B Y34PR Indentor	Y35, Y39, Y750 Y34PR Indentor Y35P3 Adaptor	Y35, Y39, Y750 Y46*, PAT750 Die Number (# of crimps per end)	Die Index ▲	No. of Indent	
YS-T	YSP-T		B	L	Nest Die	Nest Die				
YS6C-T	—	6 str.	.90	2.16	B6CD	U6CD-1	U5CRT (2)	7	1	15/16"
YS4C-T	YSP4C-T	4 str.	.90	2.16	B4CD	U4CD-1	U4CRT (2)	8	1	15/16"
YS2C-T	YSP2C-T	2 str.	.98	2.34	B2CD	U2D-1	U2CRT (2)	10	1	1"
YS1C-T	YSP1C-T	1 str.	.97	2.31	B1CD	U1D-1	U1CRT-1 (2)	11	1	1"
YS25-T	YSP25-T	1/0 str.	.98	2.35	B25D	U25D-1	U25RT (2)	12	1	1-3/32"
YS26-T	YSP26-T	2/0 str.	1.04	2.47	B26D	U26D-1	U26RT (2)	13	1	1-3/32"
YS28-T	YSP28-T	4/0 str.	1.13	2.67	B28D	U28D-1	U28RT (2)	15	1	1-3/16"
YS29-T	YSP29-T	250 kcmil	1.21	2.85	B29D	U29D-1	U29RT (2)	16	1	1-3/32"
YS30-T	YSP30-T	300 kcmil	1.22	2.87	B30D	U30D-1	U30RT (4)	17	2	1-5/16"
YS31-T	YSP31-T	350 kcmil	1.32	3.09	B31D	U31D-1	U31RT (4)	18	2	1-3/5"
YS34-T	YSP34-T	500 kcmil	1.68	3.86	No Die Needed	U34D-1	U34RT (4)	20	2	1-3/4"
YS39-T	YSP39-T	750 kcmil	2.00	4.60	—	—	U39RT (4)	24	2	2-1/8"

* Use adapter PUADP-1 with U Dies in Y46 HYPRESS™. Y46 HYPRESS™ uses the same nest indentor and adaptor as the Y35, Y39 and Y750, but with the PUADP-1 adaptors.

■ The maximum size for the Y35 is 400 kcmil.
▲ See tooling section of this catalog for complete tool and die listings.

◆ For applications greater than 2000 Volts consult cable manufacturer for voltage stress relief instructions.

Note: All dimensions shown are for reference only.

Blue highlighted items are industry standard and most frequently ordered.

Compression Connections

BURNDY®

Copper Compression – Flex – Splice – Long Barrel – Belled Ends

C-88

TYPE YS-FXB

HYLINK™ - SPLICE - BELLED LONG BARREL

UL Listed 90° C,
600 Volts to 35 kV ◆



Features and Benefits

- Long barrel length.
 - ◇ High voltage terminations.
- Four (4) center conductor stops.
 - ◇ Provides a center wire stop for proper conductor insertion.
- High pull out force.
 - ◇ Provides added security for greater mechanical and electrical properties.
- Belled cable entry.
 - ◇ A funnel type entry provide easy insertion of extra flexible cables plus offers mechanical strain relief for individual strands.

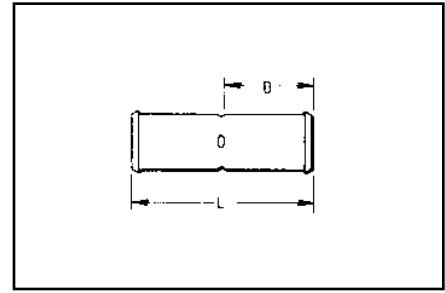

Catalog Number	Conductor		Dimensions		Installation Tooling ▲					Cable Strip Length	
	Flexible Cable Code	AWG	*** MM ²	L [mm]	B [mm]	Dieless (# of crimps/end)	Mechanical Y1MRTC Y2MR	Embossed Die Index	Color Code		Die Number (# of crimps/end)
YS8C-FXB	#8 Str. (37/24)	#8 AWG	10	1.99 [51]	.90 [23]	Y81KFT (1) Y81KFTMBH (1) PAT81KFT-18V (1)	Y2MR (2) Y1MR (2)	49	Red	U8CRT (2)	1" [25]
YSV6C-FXB	#6 Str. (61/24)	#6 AWG	16	2.62 [67]	1.22 [31]			7	Blue	U5CRT (2)	1-5/16" [33]
YSV4C-FXB	#4 Str. (91/24-105/24)	#4 AWG	—	2.62 [67]	1.22 [31]		Y2MR (4) Y1MR (4)	8	Gray	U4CRT (2)	1-5/16" [33]
YSV2C-FXB	#2 Str. (125/24-150/24)	#2 AWG	35	2.89 [73]	1.35 [34]			10	Brown	U2CRT (2)	1-7/16" [37]
YSV1C-FXB	#1 Str. (175/24-225/24)	#1 AWG	—	3.18 [81]	1.50 [38]		—	11	Green	U1CRT-1 (4)	1-9/16" [40]
YSV25-FXB	1/0 Str. (275/24)	1/0 AWG	50	3.18 [81]	1.50 [38]			12	Pink	U25RT (4)	1-9/16" [40]
YSV26-FXB	2/0 Str. (325/24)	2/0 AWG	70	3.44 [87]	1.63 [41]			13	Black	U26RT (4)	1-11/16" [43]
YSV27-FXB	3/0 Str. (450/24)	3/0 AWG	95	3.46 [88]	1.64 [42]			14	Orange	U27RT (4)	1-11/16" [43]
YSV28-FXB	4/0 Str. (550/24)	4/0 AWG	120	3.72 [94]	1.77 [45]			15	Purple	U28RT (4)	1-7/8" [48]
YS30-FXB	250 kcmil Flex Class G 259 Str. Class H 427 Str.	—	—	4.51 [115]	2.16 [55]			Y81KFT (2) Y81KFTMBH (2) PAT81KFT-18V (2)	16	Yellow	U29RT (4)
YS31-FXB	263 kcmil (650/24) 250 Flex Class I, K, M	150	4.54 [115]	2.18 [55]	17	White			U30RT (4)	2-1/4" [57]	
YS32-FXB	313.1 kcmil (775/24) 300 kcmil Nom.	185	4.82 [122]	2.32 [59]	18	Red			U31RT (4)	2-7/16" [62]	
YS34-FXB	373 kcmil (925/24) 350 kcmil Nom.	240	5.14 [131]	2.48 [63]	19	Blue	U32RT (4)		2-9/16" [65]		
YS36-FXB	444.4 kcmil (1100/24) 450 kcmil Nom.	300	6.09 [155]	2.95 [75]	20	Brown	U34RT (4)		3-1/16" [79]		
YS38-FXB	535.3 kcmil (1325/24) 500 kcmil Nom.	—	6.34 [161]	3.08 [78]	L99	Pink	U38XRT (4)		3-3/16" [81]		
YS40-FXB	646 kcmil (1600/24) 600 kcmil Nom.	400	6.66 [1.69]	3.24 [82]	Y81KFT (3) Y81KFTMBH (3) PAT81KFT-18V (3)	24	Black		U39RT (4)	3-5/16" [84]	
YS44-FXB	777.7 kcmil (1925/24) 750 kcmil Nom.	500	6.84 [174]	3.33 [85]		L115	Yellow		U44XRT (4)	3-7/16" [87]	

* Use PUADP-1 adapter with U dies in Y46 HYPRESS™.

** P44RT and P46RT dies sets are for use with Y46 HYPRESS™ only. PUADP-1 adapter not required.

*** The MM² conductor sizes listed are the recommendations for Class 5 conductor.

† 16 mm² and 120 mm² referenced are for both Class 2 and Class 5

■ The maximum size for the Y35 is 373.7 kcmil.

▲ See tooling section of this catalog for complete tool and die listings.

◆ For applications greater than 2000 Volts consult cable manufacturer for voltage stress relief instructions.

Note: All dimensions shown are for reference only.

Measurements in brackets [] are in metric dimensions.

Blue highlighted items are industry standard and most frequently ordered.

TYPE YS-TC

HYSPLICE™

In-line Splice Kits for Telecommunications Applications

YS-TC kits are for splicing cables and covering the connection with **clear** heat shrink. Splices are constructed from seamless, high conductivity electrolytic copper tubing for maximum conductivity and tin-plated to resist corrosion. Each YS-TC splice is provided with inspection holes and cable stops. The YS-TC family also features the BURNDY® color code system.

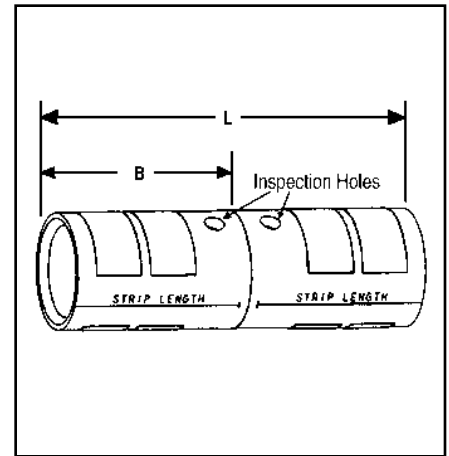
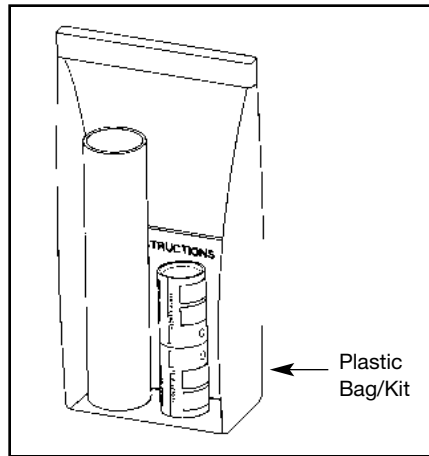

* Clear Heat Shrink Kit Catalog Number	Wire Size		Connector					Wire Strip Length
			Barrel Type	Dimensions		Color Code	Die Index	
				Barrel B	Length L			
YS44FXLTCKITC	750 kcmil Flex	500 mm ² Class 5	Standard	1.90	4.30	Yellow	L115	1.96
YS39LTCKITC	750 kcmil Code	—	Standard	1.62	3.68	Black	23	1.67
YS38FXLTCKITC	500 kcmil Flex	300 mm ² Class 5	Standard	1.71	3.87	Pink	L99	1.77
YS34LTCKITC	500 kcmil Code	240 mm ² Class 2	Standard	1.56	3.51	Brown	20	1.60
YS34FXLTCKITC	350 kcmil Flex	240 mm ² Class 5	Standard	1.56	3.51	Blue	19 or L80	1.60
YS31LTCKITC	350 kcmil Code	185 mm ² Class 2	Standard	1.39	3.10	Red	17	1.42
YS29FXLTCKITC	4/0 AWG Flex	—	Standard	1.36	2.98	Yellow	16	1.38
YS28LTCKITC	4/0 AWG Code	—	Standard	1.23	2.69	Purple	15	1.24
YS26LTCKITC	2/0 AWG Code	70 mm ²	Standard	1.16	2.62	Black	13	1.10
YS26FXLTCKITC	2/0 AWG Flex or Code	70 mm ² Class 5	Standard	1.09	2.41	Black	13	1.10
YS25LTCKITC	1/0 AWG Code	—	Standard	1.04	2.37	Pink	12	1.00
YS25FXLTCKITC	1/0 AWG Flex or Code	50 mm ² Class 5	Standard	1.04	2.18	Pink	12	1.00
YS2CLTCKITC	#2 AWG Code	35 mm ² Class 5	Standard	0.82	1.88	Brown	10	0.78
YS2CFXLTCKITC	#2 AWG Flex or Code	35 mm ² Class 5	Standard	0.82	1.73	Brown	10	0.78
YS4CFXLTCKITC	#4 AWG Flex or Code	—	Standard	0.74	1.69	Grey	8	0.71
YS6CFXLTCKITC	#6 AWG Flex or Code	16 mm ² Class 5 or Class 2	Standard	0.73	1.60	Blue	7 or 24	0.70
YS8CFXLTCKITC	#8 AWG Flex or Code	—	Standard	0.65	1.48	Red	49	0.62

* Clear Heatshrink – UL224 VW1 Listed – passes TELCORDIA GR-347-CORE Abrasion and Cut Test. (Up to 750 kcmil Class B code cable. Contact factory for 750 flex cable applications.)

Note: All dimensions shown are for reference only.

Blue highlighted items are industry standard and most frequently ordered.

C-90

TYPE YSR-TC

HYREDUCER™

In-line Reducer Splice Kits for Telecommunications Applications

YSR-TC reducing splice kits provide for splicing two different cable sizes with inspection holes. The larger conductor is inserted first and butts against the center of the connector where the smaller barrel begins. Constructed from seamless, high conductivity electrolytic copper tubing for maximum conductivity, and tin plated to resist corrosion. The YSR-TC family also features the BURNDY® color code system.

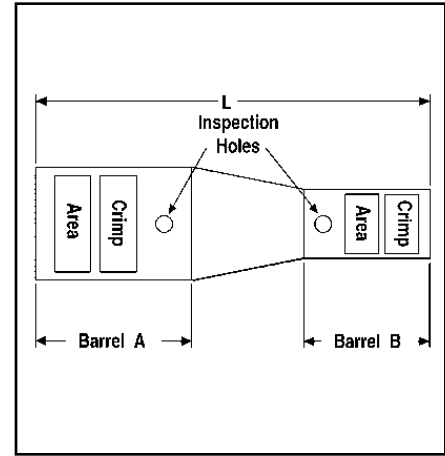
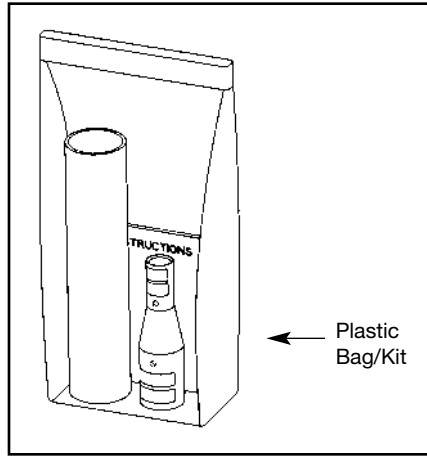

** Clear Heat Shrink Kit Catalog Number	Wire Range				Barrel Type	Connector							Wire Strip Length	
	Barrel A		Barrel B			Dimensions			Color Code		Die Index		Barrel A	Barrel B
	AWG	mm ²	AWG	mm ²		Barrel A	Barrel B	L	Barrel A	Barrel B	Barrel A	Barrel B	Barrel A	Barrel B
YSR44FX39LTCKITC	750 kcmil Flex	500 mm ² Class 5	750 kcmil Code	—	Standard	2.09	1.78	4.38	Yellow	Black	L115	24	1.96	1.67
YSR44FX38FLTCKITC			500 kcmil Flex	300 mm ²	Standard	2.09	1.60	4.61	Yellow	Pink	L115	L99	1.96	1.77
YSR44FX34LTCKITC			500 kcmil Code	240 mm ²	Standard	2.09	1.69	4.91	Yellow	Brown	L115	20	1.96	1.60
YSR44FX34FLTCKITC			350 kcmil Flex	240 mm ²	Standard	2.09	1.69	4.91	Yellow	Blue	L115	19 or L80	1.96	1.60
YSR44FX31LTCKITC			350 kcmil Code	185 mm ²	Standard	2.09	1.49	5.18	Yellow	Red	L115	18	1.96	1.41
YSR44FX30LTCKITC			300 kcmil Code	150 mm ²	Standard	2.09	1.30	5.01	Yellow	White	L115	17 or 298	1.96	1.24
YSR44FX29FLTCKITC			4/0 AWG Flex	120 mm ²	Standard	2.09	1.44	5.46	Yellow	Yellow	L115	16	1.96	1.24
YSR44FX28FLTCKITC			4/0 AWG Flex or Telco Flex	120 mm ²	Standard	2.09	1.43	5.21	Yellow	Purple	L115	15	1.96	1.38
YSR44FX28LTCKITC	4/0 AWG Code	—	Standard	2.09	1.30	5.27	Yellow	Purple	L115	15	1.96	1.36		
YSR3939LTCKITC	750 kcmil Code	—	750 kcmil Code	—	Standard	1.78	1.78	4.13	Black	Black	24	24	1.67	1.67
YSR3938FLTCKITC			500 kcmil Flex	300 mm ²	Standard	1.78	1.88	3.79	Black	Pink	24	L99	1.67	1.77
YSR3934LTCKITC			500 kcmil Code	240 mm ²	Standard	1.78	1.69	4.09	Black	Brown	24	20	1.67	1.60
YSR3934FLTCKITC			350 kcmil Flex	240 mm ²	Standard	1.78	1.69	4.09	Black	Blue	24	19 or L80	1.67	1.60
YSR3931LTCKITC			350 kcmil Code	185 mm ²	Standard	1.78	1.49	4.36	Black	Red	24	18	1.67	1.41
YSR3930LTCKITC			300 kcmil Code	150 mm ²	Standard	1.78	1.30	4.23	Black	White	24	17 or 298	1.67	1.24
YSR3929FLTCKITC			4/0 AWG Flex	120 mm ²	Standard	1.78	1.44	4.71	Black	Yellow	24	16	1.67	1.38
YSR3928FLTCKITC			4/0 AWG Flex or Telco Flex	120 mm ²	Standard	1.78	1.43	4.43	Black	Purple	24	15	1.67	1.36
YSR3928LTCKITC	4/0 AWG Code	—	Standard	1.78	1.30	4.65	Black	Purple	24	15	1.67	1.24		
YSR38FX34LTCKITC	500 kcmil Flex	300 mm ²	500 kcmil Code	240 mm ²	Standard	1.88	1.69	4.06	Pink	Brown	L99	20	1.77	1.60
YSR38FX34FLTCKITC			350 kcmil Flex	240 mm ²	Standard	1.88	1.69	4.06	Pink	Blue	L99	19 or L80	1.77	1.60
YSR38FX31LTCKITC			350 kcmil Code	185 mm ²	Standard	1.88	1.49	4.33	Pink	Red	L99	18	1.77	1.41
YSR38FX30LTCKITC			300 kcmil Code	150 mm ²	Standard	1.88	1.30	4.20	Pink	White	L99	17 or 298	1.77	1.24
YSR38FX29FLTCKITC			4/0 AWG Flex	120 mm ²	Standard	1.88	1.44	4.67	Pink	Yellow	L99	16	1.77	1.38
YSR38FX28FLTCKITC			4/0 AWG Flex or Telco Flex	120 mm ²	Standard	1.88	1.43	4.60	Pink	Purple	L99	15	1.77	1.36
YSR38FX28LTCKITC			4/0 AWG Code	—	Standard	1.88	1.30	4.62	Pink	Purple	L99	15	1.77	1.24
YSR38FX26FLTCKITC			2/0 AWG Flex or Code	70 mm ² Class 5	Standard	1.88	1.13	4.62	Pink	Black	L99	13	1.77	1.19
YSR3434FLTCKITC	500 kcmil Code	240 mm ²	350 kcmil Flex	240 mm ²	Standard	1.69	1.69	3.51	Brown	Blue	20	19 or L80	1.60	1.60
YSR3431LTCKITC			350 kcmil Code	185 mm ²	Standard	1.69	1.49	3.66	Brown	Red	20	18	1.60	1.41
YSR3429FLTCKITC			4/0 AWG Flex	120 mm ²	Standard	1.69	1.44	3.81	Brown	Yellow	20	16	1.60	1.38
YSR3428FLTCKITC			4/0 AWG Flex or Telco Flex	120 mm ²	Standard	1.69	1.43	3.78	Brown	Purple	20	15	1.60	1.36
YSR3428LTCKITC			4/0 AWG Code	—	Standard	1.69	1.30	3.93	Brown	Purple	20	15	1.60	1.24
YSR3425FLTCKITC			1/0 AWG Flex or Code	50 mm ²	Standard	1.69	1.04	4.01	Brown	Pink	20	12	1.60	1.00

† Provided with 2 heat shrink tubings. One will overlap the other. Install the smaller first and larger second.

** Clear Heatshrink – UL224 VW1 Listed – passes TELCORDIA GR-347-CORE Abrasion and Cut Test. (Up to 750 kcmil Class B code cable. Contact factory for 750 flex cable applications.)

Note 1: All dimensions shown are for reference only.

Note 2: Non-inspection window versions are available.

Please contact customer service.

Note 3: Installation Tooling Charts on pages C-94 - C-99.

Blue highlighted items are industry standard and most frequently ordered.

TYPE YSR-TC

HYREDUCER™

(Continued)

In-line Reducer Splice Kits for Telecommunications Applications

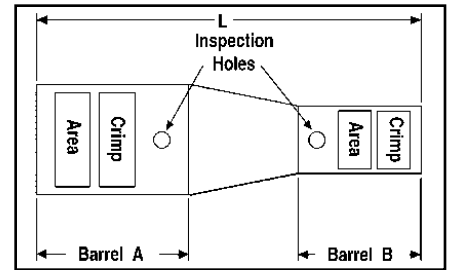
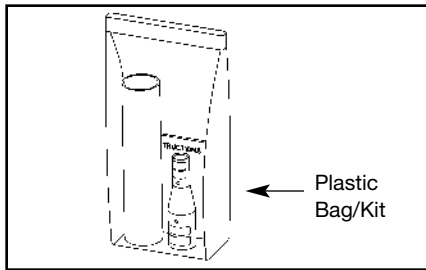

C-91

** Clear Heat Shrink Kit Catalog Number	Wire Range				Connector								Wire Strip Length	
	Barrel A		Barrel B		Barrel Type	Dimensions			Color Code		Die Index			
	AWG	mm ²	AWG	mm ²		Barrel A	Barrel B	L	Barrel A	Barrel B	Barrel A	Barrel B	Barrel A	Barrel B
YSR34FX31LTCKITC	350 kcmil Flex	240 mm ²	350 kcmil Code	185 mm ²	Standard	1.69	1.49	3.63	Blue	Red	19 or L80	18	1.60	1.41
YSR34FX29FXLTCKITC			4/0 AWG Flex	120 mm ²	Standard	1.69	1.44	3.81	Blue	Yellow	19 or L80	16	1.60	1.38
YSR34FX28FXLTCKITC			4/0 AWG Flex or Telco Flex	120 mm ²	Standard	1.69	1.43	3.86	Blue	Purple	19 or L80	15	1.60	1.36
YSR34FX28LTCKITC			4/0 AWG Code	—	Standard	1.69	1.30	3.95	Blue	Purple	19 or L80	15	1.60	1.24
YSR34FX26FXLTCKITC			2/0 AWG Flex or Code	70 mm ² Class 5	Standard	1.69	1.13	3.94	Blue	Black	19 or L80	13	1.60	1.09
YSR34FX25FXLTCKITC			1/0 AWG Flex or Code	50 mm ²	Standard	1.69	1.04	4.01	Blue	Pink	19 or L80	12	1.60	1.00
YSR34FX2CFXLTCKITC			#2 AWG Flex or Code	35 mm ²	Standard	1.69	0.82	4.02	Blue	Brown	19 or L80	10	1.60	0.78
YSR34FX4CFXLTCKITC			#4 AWG Flex or Code	—	Standard	1.69	0.74	4.11	Blue	Gray	19 or L80	8	1.60	0.71
YSR34FX6CFXLTCKITC			#6 AWG Flex or Code	16 mm ²	Standard	1.69	0.73	4.26	Blue	Blue	19 or L80	7	1.60	0.70
YSR32FX29FXLTCKITC	300 kcmil Flex	185 mm ² Class 2	4/0 AWG Flex	120 mm ²	Standard	1.57	1.44	3.50	Red	Yellow	19 or L80	16	1.48	1.38
YSR32FX28FXLTCKITC			4/0 AWG Flex or Telco Flex	120 mm ²	Standard	1.57	1.43	3.46	Red	Purple	19 or L80	15	1.48	1.36
YSR3129FXLTCKITC	350 kcmil Code	185 mm ² Class 2	4/0 AWG Flex	120 mm ²	Standard	1.49	1.44	3.13	Red	Yellow	18	16	1.41	1.38
YSR3128FXLTCKITC			4/0 AWG Flex or Telco Flex	120 mm ²	Standard	1.49	1.43	3.25	Red	Purple	19 or L80	15	1.41	1.36
YSR3128LTCKITC			4/0 AWG Code	—	Standard	1.49	1.30	3.27	Red	Purple	18	15	1.41	1.24
YSR3126FXLTCKITC			2/0 AWG Flex or Code	70 mm ² Class 5	Standard	1.49	1.16	3.24	Red	Black	18	13	1.41	1.10
YSR3125FXLTCKITC			1/0 AWG Flex or Code	50 mm ²	Standard	1.49	1.04	3.33	Red	Pink	18	12	1.41	1.00
YSR312CFXLTCKITC			#2 AWG Flex or Code	35 mm ²	Standard	1.49	0.82	3.37	Red	Brown	18	10	1.41	0.78
YSR314CFXLTCKITC			#4 AWG Flex or Code	—	Standard	1.49	0.74	3.43	Red	Gray	18	8	1.41	0.71
YSR316CFXLTCKITC			#6 AWG Flex or Code	16 mm ²	Standard	1.49	0.73	3.58	Red	Blue	18	7	1.41	0.70
YSR29FX28LTCKITC	4/0 AWG Flex	120 mm ²	4/0 AWG Code	—	Standard	1.44	1.30	3.00	Yellow	Purple	16	15	1.38	1.24
YSR29FX25FXLTCKITC			1/0 AWG Flex or Code	50 mm ²	Standard	1.44	1.04	3.07	Yellow	Pink	16	12	1.38	1.00
YSR29FX2CFXLTCKITC			#2 AWG Flex or Code	35 mm ²	Standard	1.44	0.82	3.11	Yellow	Brown	16	10	1.38	0.78

† Provided with 2 heat shrink tubings. One will overlap the other. Install the smaller first and larger second.

** Clear Heatshrink – UL224 VW1 Listed – passes TELCORDIA GR-347-CORE Abrasion and Cut Test. (Up to 750 kcmil Class B code cable. Contact factory for 750 flex cable applications.)

Note 1: All dimensions shown are for reference only.

Note 2: Non-inspection window versions are available. Please contact customer service.

Note 3: Installation Tooling Charts on pages C-94 - C-99.

(Table continued on next 2 pages)

Blue highlighted items are industry standard and most frequently ordered.

Compression Connections

BURNDY®

Copper Compression – Reducing Splice Kit – Code and Flex – Inspection Window

C-92

TYPE YSR-TC

HYREDUCER™

(Continued)

In-line Reducer Splice Kits for Telecommunications Applications

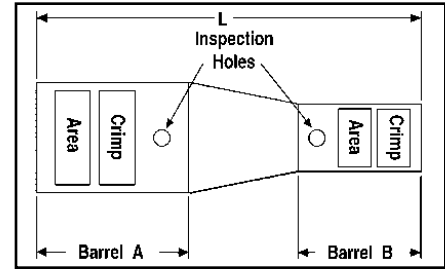
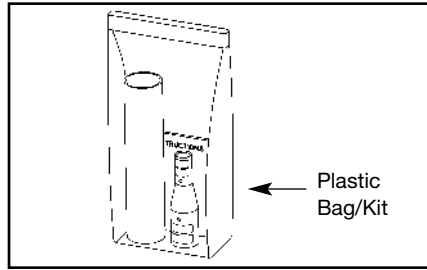

** Clear Heat Shrink Kit Catalog Number	Wire Range				Barrel Type	Dimensions			Connector				Wire Strip Length	
	Barrel A		Barrel B			Barrel A	Barrel B	L	Color Code		Die Index		Barrel A	Barrel B
	AWG	mm ²	AWG	mm ²					Barrel A	Barrel B	Barrel A	Barrel B		
YSR28FX28LTCKITC	4/0 AWG Flex or Telco Flex	120 mm ²	4/0 AWG Code	—	Standard	1.43	1.43	3.00	Purple	Purple	15	15	1.36	1.36
YSR28FX26FLTKITC			2/0 AWG Flex or Code	70 mm ² Class 5	Standard	1.43	1.13	2.94	Purple	Black	15	13	1.36	1.19
YSR28FX25FLTKITC			1/0 AWG Flex or Code	50 mm ²	Standard	1.43	1.04	2.94	Purple	Pink	15	12	1.36	1.00
YSR28FX2CFXLTCKITC			#2 AWG Flex or Code	35 mm ²	Standard	1.43	0.82	2.92	Purple	Brown	15	10	1.36	0.78
YSR28FX4CFXLTCKITC			#4 AWG Flex or Code	—	Standard	1.43	0.74	3.19	Purple	Gray	15	8	1.36	0.71
YSR2825FXLTCKITC	4/0 AWG Code	—	1/0 AWG Flex or Code	50 mm ²	Standard	1.30	1.04	2.66	Purple	Pink	15	12	1.24	1.00
YSR282CFXLTCKITC			#2 AWG Flex or Code	35 mm ²	Standard	1.30	0.82	2.70	Purple	Brown	15	10	1.24	0.78
YSR284CFXLTCKITC			#4 AWG Flex or Code	—	Standard	1.30	0.74	2.69	Purple	Gray	15	8	1.24	0.71
YSR286CFXLTCKITC			#6 AWG Flex or Code	16 mm ²	Standard	1.30	0.73	2.99	Purple	Blue	15	7	1.24	0.70
YSR26FX25FLTKITC	2/0 AWG Flex or Code	70 mm ²	1/0 AWG Flex or Code	50 mm ²	Standard	1.16	1.04	2.36	Black	Pink	13	12	1.10	1.00
YSR26FX2CFXLTCKITC			#2 AWG Flex or Code	35 mm ²	Standard	1.16	0.82	2.41	Black	Brown	13	10	1.10	0.78
YSR26FX4CFXLTCKITC			#4 AWG Flex or Code	—	Standard	1.16	0.74	2.47	Black	Gray	13	8	1.10	0.71
YSR26FX6CFXLTCKITC †			#6 AWG Flex or Code	16 mm ²	Standard	1.16	0.73	2.71	Black	Blue	13	7	1.10	0.70
YSR25FX2CFXLTCKITC	1/0 AWG Flex or Code	50 mm ²	#2 AWG Flex or Code	35 mm ²	Standard	1.04	0.82	2.12	Pink	Brown	12	10	1.00	0.78
YSR25FX4CFXLTCKITC			#4 AWG Flex or Code	—	Standard	1.04	0.74	2.18	Pink	Gray	12	8	1.00	0.71
YSR25FX6CFXLTCKITC †			#6 AWG Flex or Code	16 mm ²	Standard	1.04	0.73	2.42	Pink	Blue	12	7	1.00	0.70
YSR2CFX4CFXLTCKITC	#2 AWG Flex or Code	35 mm ²	#4 AWG Flex or Code	—	Standard	0.82	0.74	1.79	Brown	Gray	10	8	0.78	0.71
YSR2CFX6CFXLTCKITC			#6 AWG Flex or Code	16 mm ²	Standard	0.82	0.73	1.93	Brown	Blue	10	7	0.78	0.70
YSR2CFX8CFXLTCKITC			#8 AWG Flex or Code	10 mm ²	Standard	0.82	0.60	1.79	Brown	Red	10	49	0.78	0.57
YSR4CFX6CFXLTCKITC	#4 AWG Flex or Code	—	#6 AWG Flex or Code	16 mm ²	Standard	0.74	0.73	1.67	Gray	Blue	8	7	0.71	0.70
YSR4CFX8CFXLTCKITC			#8 AWG Flex or Code	10 mm ²	Standard	0.74	0.60	1.50	Gray	Red	8	49	0.71	0.57
YSR4CFX10CLTKITC			#10 AWG Flex or Code	6 mm ² Str. or 2.5 mm ² Flex	Standard	0.74	0.66	1.66	Gray	—	8	—	0.71	0.63

† Provided with 2 heat shrink tubings. One will overlap the other. Install the smaller first and larger second.

** Clear Heatshrink – UL224 VW1 Listed – passes TELCORDIA GR-347-CORE Abrasion and Cut Test. (Up to 750 kcmil Class B code cable. Contact factory for 750 flex cable applications.)

Note 1: All dimensions shown are for reference only.

Note 2: Non-inspection window versions are available. Please contact customer service.

Note 3: Installation Tooling Charts on pages C-94 - C-99.

(Table continued on next page)

Blue highlighted items are industry standard and most frequently ordered.

TYPE YSR-TC

HYREDUCER™

(Continued)

In-line Reducer Splice Kits for Telecommunications Applications

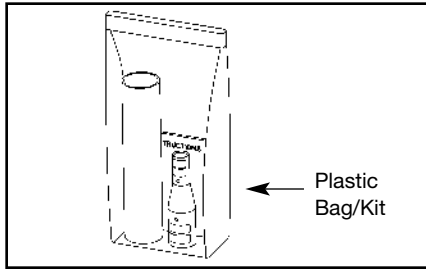

Plastic Bag/Kit

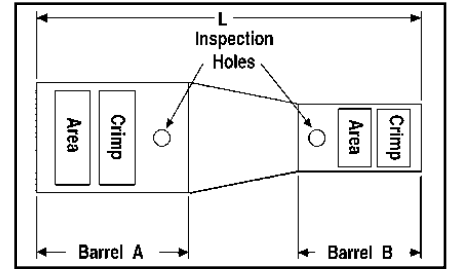

C-93

** Clear Heat Shrink Kit Catalog Number	Wire Range				Connector								Wire Strip Length	
	Barrel A		Barrel B		Barrel Type	Dimensions			Color Code		Die Index		Barrel A	Barrel B
	AWG	mm ²	AWG	mm ²		Barrel A	Barrel B	L	Barrel A	Barrel B	Barrel A	Barrel B		
YSR6CFX8CFXLTKITC	#6 AWG Flex or Code	16 mm ²	#8 AWG Flex or Code	10 mm ²	Standard	0.73	0.60	1.37	Blue	Red	7	49	0.70	0.57
YSR6CFX10CLTKITC			#10 AWG Flex or Code	6 mm ² Str. or 2.5 mm ² Flex	Standard	0.73	0.66	1.53	Blue	—	7	—	0.70	0.63
YSR8CFX10CLTKITC	#8 AWG Flex or Code	10 mm ²	#10 AWG Flex or Code	6 mm ² Str. or 2.5 mm ² Flex	Standard	0.60	0.66	1.41	Red	—	49	—	0.57	0.63
YSR8CFX14CLTKITC			#14 AWG Flex or Code	6 mm ² Str. or 2.5 mm ² Flex	Standard	0.60	0.66	1.41	Red	—	49	—	0.57	0.06
YSR10CFX12CLTKITC	#10 AWG Flex or Code	6 mm ² Str. or 2.5 mm ² Flex	#12 AWG Flex or Code	6 mm ² Str. or 2.5 mm ² Flex	Standard	0.66	0.66	1.45	—	—	—	—	0.63	0.63
YSR10CFX14CLTKITC		2.5 mm ² Flex	#14 AWG Flex or Code	6 mm ² Str. or 2.5 mm ² Flex	Standard	0.66	0.66	1.45	—	—	—	—	0.63	0.63

† Provided with 2 heat shrink tubings. One will overlap the other. Install the smaller first and larger second.

** Clear Heatshrink – UL224 VW1 Listed – passes TELCORDIA GR-347-CORE Abrasion and Cut Test. (Up to 750 kcmil Class B code cable. Contact factory for 750 flex cable applications.)

Note 1: All dimensions shown are for reference only.
Note 2: Non-inspection window versions are available. Please contact customer service.
Note 3: Installation Tooling Charts on pages C-94 - C-99.

Blue highlighted items are industry standard and most frequently ordered.

Compression Connections

BURNDY®

Copper Compression – Reducing Splice Kit – Code and Flex – Inspection Window

C-94

TYPE YSR-TC

INSTALLATION TOOLING CHART

In-line Reducer Splice Kits for Telecommunications Applications

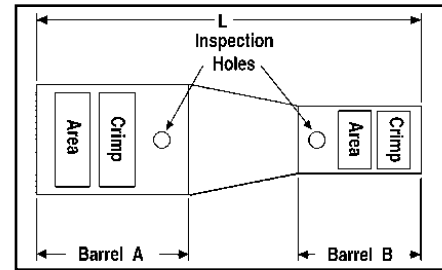
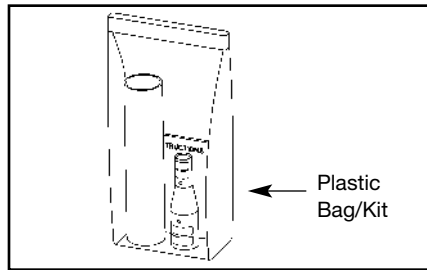

** Clear Heat Shrink Kit Catalog Number	Installation Tooling																	
	Wire Range				Color Code				Die Index		Hydraulic		Hydraulic		Mechanical		Dieless	
	Barrel A		Barrel B		Barrel A	Barrel B	Barrel A	Barrel B	Y750, Y35, Y46, PAT750, BAT750		BCT500HS, Y500THS		OUR840, MD7-34		Y/PAT644 Series, MY29-11			
	AWG	mm ²	AWG	mm ²					Barrel A	Barrel B	Barrel A	Barrel B	Barrel A	Barrel B	Barrel A	Barrel B		
YSR44FX39LTCKITC	750 kcmil Flex	500 mm ² Class 5	750 kcmil Code	—	Yellow	Black	L115	24	U44XRT (2)	U39RT (2) P39RT (2)	—	—	—	—	Y644M (1) PAT644M (1)	Y644M (1) PAT644M (1)		
YSR44FX38FLTKITC			500 kcmil Flex	300 mm ²	Yellow	Pink	L115	L99	U44XRT (2)	U38XRT (2)	—	—	—	—	Y644M (1) PAT644M (1)	Y644M (1) PAT644M (1)		
YSR44FX34LTCKITC			500 kcmil Code	240 mm ²	Yellow	Brown	L115	20	U44XRT (2)	U34RT (2) U31ART (2)	—	W34VT (2) W34RT (2)	—	W34VT (2) W34RT (2)	Y644M (1) PAT644M (1)	Y644M (1) PAT644M (1)		
YSR44FX34FLTKITC			350 kcmil Flex	240 mm ²	Yellow	Blue	L115	19 or L80	U44XRT (2)	U32RT (2)	—	W32VT (2) W32RT (2)	—	W32VT (2) W32RT (2)	Y644M (1) PAT644M (1)	Y644M (1) PAT644M (1)		
YSR44FX31LTCKITC			350 kcmil Code	185 mm ²	Yellow	Red	L115	18	U44XRT (2)	U31RT (2)	—	W31VT (2) W31RT (2)	—	W31VT (2) W31RT (2)	Y644M (1) PAT644M (1)	Y644M (1) PAT644M (1)		
YSR44FX30LTCKITC			300 kcmil Code	150 mm ²	Yellow	White	L115	17 or 298	U44XRT (2)	U30RT (2)	—	W30VT (2) W30RT (2)	—	W30VT (2) W30RT (2)	Y644M (1) PAT644M (1)	Y644M (1) PAT644M (1)		
YSR44FX29FLTKITC			4/0 AWG Flex	120 mm ²	Yellow	Yellow	L115	16	U44XRT (2)	U29RT (1)	—	W29VT (2) W29RT (2) X29RT (4)	—	W29VT (2) W29RT (2) X29RT (4)	Y644M (1) PAT644M (1)	Y644M (1) PAT644M (1)		
YSR44FX28FLTKITC			4/0 AWG Flex or Telco Flex	120 mm ²	Yellow	Purple	L115	15	U44XRT (2)	U28RT (1)	—	W28VT (2) W28RT (2) X28RT (3)	—	W28VT (2) W28RT (2) X28RT (3)	Y644M (1) PAT644M (1)	Y644M (1) PAT644M (1)		
YSR44FX28LTCKITC			4/0 AWG Code	—	Yellow	Purple	L115	15	U44XRT (2)	U28RT (1)	—	W28VT (2) W28RT (2) X28RT (3)	—	W28VT (2) W28RT (2) X28RT (3)	Y644M (1) PAT644M (1)	MY29-11 (1), Y644M (1), MRC840 (2) PAT644M (1)		
YSR3939LTCKITC	750 kcmil Code	—	750 kcmil Code	—	Black	Black	24	24	U39RT (2) P39RT (2)	U39RT (2) P39RT (2)	—	—	—	—	Y644M (1) PAT644M (1)	Y644M (1) PAT644M (1)		
YSR3938FLTKITC			500 kcmil Flex	300 mm ²	Black	Pink	24	L99	U39RT (2) P39RT (2)	U38XRT (2)	—	—	—	—	Y644M (1) PAT644M (1)	Y644M (1) PAT644M (1)		
YSR3934LTCKITC			500 kcmil Code	240 mm ²	Black	Brown	24	20	U39RT (2) P39RT (2)	U34RT (2) U31ART (2)	—	W34VT (2) W34RT (2)	—	W34VT (2) W34RT (2)	Y644M (1) PAT644M (1)	Y644M (1) PAT644M (1)		
YSR3934FLTKITC			350 kcmil Flex	240 mm ²	Black	Blue	24	19 or L80	U39RT (2) P39RT (2)	U32RT (2)	—	W32VT (2) W32RT (2)	—	W32VT (2) W32RT (2)	Y644M (1) PAT644M (1)	Y644M (1) PAT644M (1)		
YSR3931LTCKITC			350 kcmil Code	185 mm ²	Black	Red	24	18	U39RT (2) P39RT (2)	U31RT (2)	—	W31VT (2) W31RT (2)	—	W31VT (2) W31RT (2)	Y644M (1) PAT644M (1)	Y644M (1) PAT644M (1)		
YSR3930LTCKITC			300 kcmil Code	150 mm ²	Black	White	24	17 or 298	U39RT (2) P39RT (2)	U30RT (2)	—	W30VT (2) W30RT (2)	—	W30VT (2) W30RT (2)	Y644M (1) PAT644M (1)	Y644M (1) PAT644M (1)		
YSR3929FLTKITC			4/0 AWG Flex	120 mm ²	Black	Yellow	24	16	U39RT (2) P39RT (2)	U29RT (1)	—	W29VT (2) W29RT (2) X29RT (4)	—	W29VT (2) W29RT (2) X29RT (4)	Y644M (1) PAT644M (1)	Y644M (1) PAT644M (1)		
YSR3928FLTKITC			4/0 AWG Flex or Telco Flex	120 mm ²	Black	Purple	24	15	U39RT (2) P39RT (2)	U28RT (1)	—	W28VT (2) W28RT (2) X28RT (3)	—	W28VT (2) W28RT (2) X28RT (3)	Y644M (1) PAT644M (1)	Y644M (1) PAT644M (1)		
YSR3928LTCKITC			4/0 AWG Code	—	Black	Purple	24	15	U39RT (2) P39RT (2)	U28RT (1)	—	W28VT (2) W28RT (2) X28RT (3)	—	W28VT (2) W28RT (2) X28RT (3)	Y644M (1) PAT644M (1)	MY29-11 (1), Y644M (1), MRC840 (2) PAT644M (1)		

Note 1: All dimensions shown are for reference only.
 Note 2: Non-inspection window versions are available. Please contact customer service.

† Provided with 2 heat shrink tubings. One will overlap the other. Install the smaller first and larger second.
 ** Clear Heatshrink – UL224 VW1 Listed – passes TELCORDIA GR-347-CORE Abrasion and Cut Test.

(Up to 750 kcmil Class B code cable. Contact factory for 750 flex cable applications.)

(Installation Tooling Chart continued on next 5 pages)

Blue highlighted items are industry standard and most frequently ordered.

TYPE YSR-TC

INSTALLATION TOOLING CHART (Continued)

In-line Reducer Splice Kits for Telecommunications Applications

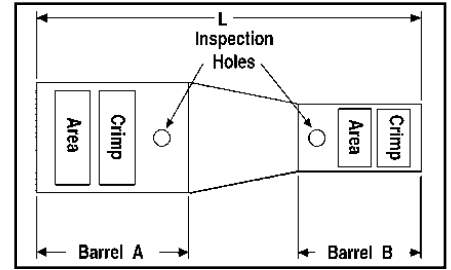
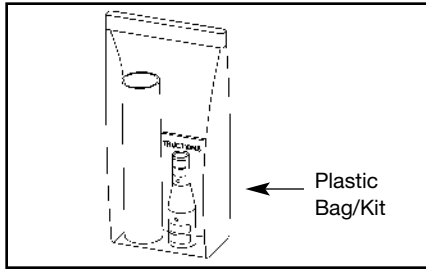

** Clear Heat Shrink Kit Catalog Number	Installation Tooling																	
	Wire Range				Color Code				Die Index		Hydraulic Y750, Y35, Y46, PAT750, BAT750		Hydraulic BCT500HS, Y500CTHS		Mechanical OUR840, MD7-34		Dieless Y/PAT644 Series, MY29-11	
	Barrel A		Barrel B		Barrel A	Barrel B	Barrel A	Barrel B	Barrel A	Barrel B	Barrel A	Barrel B	Barrel A	Barrel B	Barrel A	Barrel B		
	AWG	mm ²	AWG	mm ²														
YSR38FX34LTCKITC	500 kcmil Flex	300 mm ²	500 kcmil Code	240 mm ²	Pink	Brown	L99	20	U38XRT (2)	U34RT (2) U31ART (2)	—	W34VT (2) W34RT (2)	—	W34VT (2) W34RT (2)	Y644M (1), PAT644M (1)	Y644M (1), PAT644M (1)		
YSR38FX34FXLTCKITC			350 kcmil Flex	240 mm ²	Pink	Blue	L99	19 or L80	U38XRT (2)	U32RT (2)	—	W32VT (2) W32RT (2)	—	W32VT (2) W32RT (2)	Y644M (1), PAT644M (1)	Y644M (1), PAT644M (1)		
YSR38FX31LTCKITC			350 kcmil Code	185 mm ²	Pink	Red	L99	18	U38XRT (2)	U31RT (2)	—	W31VT (2) W31RT (2)	—	W31VT (2) W31RT (2)	Y644M (1), PAT644M (1)	Y644M (1), PAT644M (1)		
YSR38FX30LTCKITC			300 kcmil Code	150 mm ²	Pink	White	L99	17 or 298	U38XRT (2)	U30RT (2)	—	W30VT (2) W30RT (2)	—	W30VT (2) W30RT (2)	Y644M (1), PAT644M (1)	Y644M (1), PAT644M (1)		
YSR38FX26FXLTCKITC			2/0 AWG Flex or Code	70 mm ² Class 5	Pink	Black	L99	13	U38XRT (2)	U26RT (1)	—	W26VT (2) W26RT (2) X26RT (2)	—	W26VT (2) W26RT (2) X26RT (2)	Y644M (1), PAT644M (1)	Y644M (1), PAT644M (1)		
YSR38FX29FXLTCKITC			4/0 AWG Flex	120 mm ²	Pink	Yellow	L99	16	U38XRT (2)	U29RT (1)	—	W29VT (2) W29RT (2) X29RT (4)	—	W29VT (2) W29RT (2) X29RT (4)	Y644M (1), PAT644M (1)	Y644M (1), PAT644M (1)		
YSR38FX28FXLTCKITC			4/0 AWG Flex or Telco Flex	120 mm ²	Pink	Purple	L99	15	U38XRT (2)	U28RT (1)	—	W28VT (2) W28RT (2) X28RT (3)	—	W28VT (2) W28RT (2) X28RT (3)	Y644M (1), PAT644M (1)	Y644M (1), PAT644M (1)		
YSR38FX28LTCKITC			4/0 AWG Code	—	Pink	Purple	L99	15	U38XRT (2)	U28RT (1)	—	W28VT (2) W28RT (2) X28RT (3)	—	W28VT (2) W28RT (2) X28RT (3)	Y644M (1), PAT644M (1)	MY29-11 (1), Y644M (1), PAT644M (1) MRC840 (2)		
YSR3434FXLTCKITC	500 kcmil Code	240 mm ²	350 kcmil Flex	240 mm ²	Brown	Blue	20	19 or L80	U34RT (2) U31ART (2)	U32RT (2)	W34VT (2) W34RT (2)	W32VT (2) W32RT (2)	W34VT (2) W32RT (2)	W32VT (2) W32RT (2)	Y644M (1), PAT644M (1)	Y644M (1), PAT644M (1)		
YSR3431LTCKITC			350 kcmil Code	185 mm ²	Brown	Red	20	18	U34RT (2) U31ART (2)	U31RT (2)	W34VT (2) W34RT (2)	W31VT (2) W31RT (2)	W34VT (2) W31RT (2)	W31VT (2) W31RT (2)	Y644M (1), PAT644M (1)	Y644M (1), PAT644M (1)		
YSR3429FXLTCKITC			4/0 AWG Flex	120 mm ²	Brown	Yellow	20	16	U34RT (2) U31ART (2)	U29RT (1)	W34VT (2) W34RT (2)	W29VT (2) W29RT (2) X29RT (4)	W34VT (2) W34RT (2)	W29VT (2) W29RT (2) X29RT (4)	Y644M (1), PAT644M (1)	Y644M (1), PAT644M (1)		
YSR3428FXLTCKITC			4/0 AWG Flex or Telco Flex	120 mm ²	Brown	Purple	20	15	U34RT (2) U31ART (2)	U28RT (1)	W34VT (2) W34RT (2)	W28VT (2) W28RT (2) X28RT (3)	W34VT (2) W34RT (2)	W28VT (2) W28RT (2) X28RT (3)	Y644M (1), PAT644M (1)	Y644M (1), PAT644M (1)		
YSR3428LTCKITC			4/0 AWG Code	—	Brown	Purple	20	15	U34RT (2) U31ART (2)	U28RT (1)	W34VT (2) W34RT (2)	W28VT (2) W28RT (2) X28RT (3)	W34VT (2) W34RT (2)	W28VT (2) W28RT (2) X28RT (3)	Y644M (1), PAT644M (1)	MY29-11 (1), Y644M (1), PAT644M (1) MRC840 (2)		
YSR3425FXLTCKITC			1/0 AWG Flex or Code	50 mm ²	Brown	Pink	20	12	U34RT (2) U31ART (2)	U25RT (1)	W34VT (2) W34RT (2)	W25VT (2) W25RT (2) X25RT (2)	W34VT (2) W34RT (2)	W25VT (2) W25RT (2) X25RT (2)	Y644M (1), PAT644M (1)	MY29-11 (1), Y644M (1), PAT644M (1)		
YSR34FX31LTCKITC			350 kcmil Code	185 mm ²	Blue	Red	19 or L80	18	U32RT (2)	U31RT (2)	W32VT (2) W32RT (2)	W31VT (2) W31RT (2)	W32VT (2) W32RT (2)	W31VT (2) W31RT (2)	Y644M (1), PAT644M (1)	Y644M (1), PAT644M (1)		
YSR34FX29FXLTCKITC			4/0 AWG Flex	120 mm ²	Blue	Yellow	19 or L80	16	U32RT (2)	U29RT (1)	W32VT (2) W32RT (2)	W29VT (2) W29RT (2) X29RT (4)	W32VT (2) W32RT (2)	W29VT (2) W29RT (2) X29RT (4)	Y644M (1), PAT644M (1)	Y644M (1), PAT644M (1)		

Note 1: All dimensions shown are for reference only.
 Note 2: Non-inspection window versions are available. Please contact customer service.

† Provided with 2 heat shrink tubings. One will overlap the other. Install the smaller first and larger second.
 ** Clear Heatshrink – UL224 VW1 Listed – passes TELCORDIA GR-347-CORE Abrasion and Cut Test.

(Up to 750 kcmil Class B code cable. Contact factory for 750 flex cable applications.)

(Installation Tooling Chart continued on next 4 pages)

Blue highlighted items are industry standard and most frequently ordered.

Compression Connections

BURNDY®

Copper Compression – Reducing Splice Kit – Code and Flex – Inspection Window

C-96

TYPE YSR-TC

INSTALLATION TOOLING CHART (Continued)

In-line Reducer Splice Kits for Telecommunications Applications

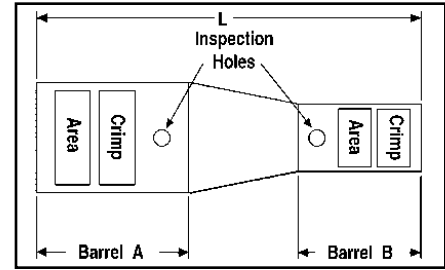
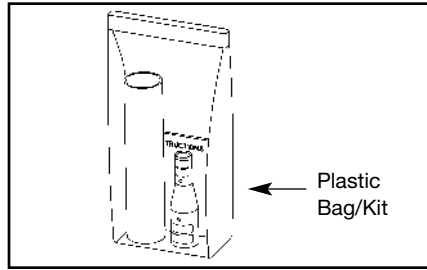

Installation Tooling																
** Clear Heat Shrink Kit Catalog Number	Wire Range				Color Code				Hydraulic		Hydraulic		Mechanical		Dieless	
	Barrel A		Barrel B						Y750, Y35, Y46, PAT750, BAT750		BCT500HS, Y500CTHS		OUR840, MD7-34		Y/PAT644 Series, MY29-11	
	AWG	mm ²	AWG	mm ²	Barrel A	Barrel B	Barrel A	Barrel B	Barrel A	Barrel B	Barrel A	Barrel B	Barrel A	Barrel B		
YSR34FX28FXLTCKITC	350 kcmil Flex	240 mm ²	4/0 AWG Flex or Telco Flex	120 mm ²	Blue	Purple	19 or L80	15	U32RT (2)	U28RT (1)	W32VT (2) W32RT (2)	W28VT (2) W28RT (2) X28RT (3)	W32VT (2) W32RT (2)	W28VT (2) W28RT (2) X28RT (3)	Y644M (1), PAT644M (1)	Y644M (1), PAT644M (1)
YSR34FX28LTCKITC			4/0 AWG Code	—	Blue	Purple	19 or L80	15	U32RT (2)	U28RT (1)	W32VT (2) W32RT (2)	W28VT (2) W28RT (2) X28RT (3)	W32VT (2) W32RT (2)	W28VT (2) W28RT (2) X28RT (3)	Y644M (1), PAT644M (1)	MY29-11 (1), Y644M (1), PAT644M (1), MRC840 (2)
YSR34FX26FXLTCKITC			2/0 AWG Flex or Code	70 mm ² Class 5	Blue	Black	19 or L80	13	U32RT (2)	U26RT (1)	W32VT (2) W32RT (2)	W26VT (2) W26RT (2) X26RT (2)	W32VT (2) W32RT (2)	W26VT (2) W26RT (2) X26RT (2)	Y644M (1), PAT644M (1)	MY29-11 (1), Y644M (1), PAT644M (1)
YSR34FX25FXLTCKITC			1/0 AWG Flex or Code	50 mm ²	Blue	Pink	19 or L80	12	U32RT (2)	U25RT (1) U2CABT (1)	W32VT (2) W32RT (2)	W25VT (2) W25RT (2) X25RT (2)	W32VT (2) W32RT (2)	W25VT (2) W25RT (2) X25RT (2)	Y644M (1), PAT644M (1)	MY29-11 (1), Y644M (1), PAT644M (1)
YSR34FX2CFXLTCKITC			#2 AWG Flex or Code	35 mm ²	Blue	Brown	19 or L80	10	U32RT (2)	U2CRT (1)	W32VT (2) W32RT (2)	W2CVT (1) W2CRT (1) X2CRT (1)	W32VT (2) W32RT (2)	W2CVT (1) W2CRT (1) X2CRT (1)	Y644M (1), PAT644M (1)	Y1MRTC (2), MY29-11 (1), Y644M (1), PAT644M (1)
YSR34FX4CFXLTCKITC			#4 AWG Flex or Code	—	Blue	Gray	19 or L80	8	U32RT (2)	U4CRT (1)	W32VT (2) W32RT (2)	W4CVT (1) W4CRT (1) X4CRT (1)	W32VT (2) W32RT (2)	W4CVT (1) W4CRT (1) X4CRT (1)	Y644M (1), PAT644M (1)	Y1MRTC (2), MY29-11 (1), Y644M (1), PAT644M (1)
YSR34FX6CFXLTCKITC			#6 AWG Flex or Code	16 mm ²	Blue	Blue	19 or L80	7	U32RT (2)	U5CRT (1)	W32VT (2) W32RT (2)	W5CVT (1) W5CRT (1) X5CRT (1)	W32VT (2) W32RT (2)	W5CVT (1) W5CRT (1) X5CRT (1)	Y644M (1), PAT644M (1)	Y1MRTC (2), MY29-11 (1), Y644M (1), PAT644M (1)
YSR32FX29FXLTCKITC	300 kcmil Flex	185 mm ² Class 2	4/0 AWG Flex	120 mm ²	Red	Yellow	19 or L80	16	U31RT (2)	U29RT (1)	W31VT (2) W31RT (2)	W29VT (2) W29RT (2) X29RT (4)	W31VT (2) W31RT (2)	W29VT (2) W29RT (2) X29RT (4)	Y644M (1), PAT644M (1)	Y644M (1), PAT644M (1)
YSR32FX28FXLTCKITC			4/0 AWG Flex or Telco Flex	120 mm ²	Red	Purple	19 or L80	15	U31RT (2)	U28RT (1)	W31VT (2) W31RT (2)	W28VT (2) W28RT (2) X28RT (3)	W31VT (2) W31RT (2)	W28VT (2) W28RT (2) X28RT (3)	Y644M (1), PAT644M (1)	MY29-11 (1), Y644M (1), PAT644M (1), MRC840 (2)
YSR3129FXLTCKITC	350 kcmil Code	185 mm ² Class 2	4/0 AWG Flex	120 mm ²	Red	Yellow	18	16	U31RT (2)	U29RT (1)	W31VT (2)	W29RT (2) W31RT (2)	W29VT (2) W31VT (2) X29RT (4)	W29VT (2) W29RT (2) X29RT (4)	Y644M (1), PAT644M (1)	Y644M (1), PAT644M (1)
YSR3128FXLTCKITC			4/0 AWG Flex or Telco Flex	120 mm ²	Red	Purple	19 or L80	15	U31RT (2)	U28RT (1)	W31VT (2) W31RT (2)	W28VT (2) W28RT (2) X28RT (3)	W31VT (2)	W28VT (2) W28RT (2) X28RT (3)	Y644M (1), PAT644M (1)	Y644M (1), PAT644M (1)
YSR3128LTCKITC			4/0 AWG Code	—	Red	Purple	18	15	U31RT (2)	U28RT (1)	W31VT (2) W31RT (2)	W28VT (2) W28RT (2) X28RT (3)	W31VT (2)	W28VT (2) W28RT (2) X28RT (3)	Y644M (1), PAT644M (1)	MY29-11 (1), Y644M (1), MRC840 (2), PAT644M (1)

† Provided with 2 heat shrink tubings. One will overlap the other. Install the smaller first and larger second.

** Clear Heatshrink – UL224 VW1 Listed – passes TELCORDIA GR-347-CORE Abrasion and Cut Test. (Up to 750 kcmil Class B code cable. Contact factory for 750 flex cable applications.)

Note 1: All dimensions shown are for reference only.
Note 2: Non-inspection window versions are available. Please contact customer service.

(Installation Tooling Chart continued on next 3 pages)

Blue highlighted items are industry standard and most frequently ordered.

TYPE YSR-TC

INSTALLATION TOOLING CHART (Continued)

In-line Reducer Splice Kits for Telecommunications Applications

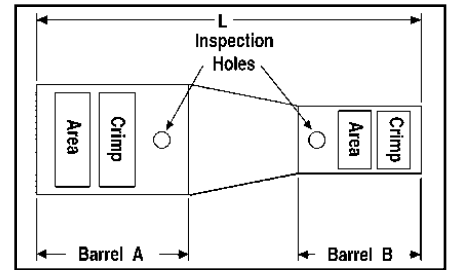
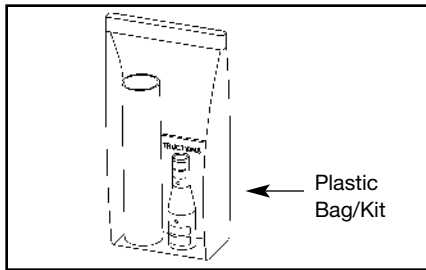

** Clear Heat Shrink Kit Catalog Number	Installation Tooling																	
	Wire Range				Color Code				Die Index		Hydraulic Y750, Y35, Y46, PAT750, BAT750		Hydraulic BCT500HS, Y500CTHS		Mechanical OUR840, MD7-34		Dieless Y/PAT644 Series, MY29-11	
	Barrel A		Barrel B		Barrel A	Barrel B	Barrel A	Barrel B	Barrel A	Barrel B	Barrel A	Barrel B	Barrel A	Barrel B	Barrel A	Barrel B		
	AWG	mm ²	AWG	mm ²														
YSR3126FXLTCKITC	350 kcmil Code	185 mm ² Class 2	2/0 AWG Flex or Code	70 mm ² Class 5	Red	Black	18	13	U31RT (2)	U26RT (1)	W31VT (2) W31RT (2)	W26VT (2) W26RT (2) X26RT (2)	W31VT (2)	W26VT (2) W26RT (2) X26RT (2)	Y644M (1), PAT644M (1)	MY29-11 (1), Y644M (1), PAT644M (1)		
YSR3125FXLTCKITC			1/0 AWG Flex or Code	50 mm ²	Red	Pink	18	12	U31RT (2)	U25RT (1)	W31VT (2) W31RT (2)	W25VT (2) W25RT (2) X25RT (2)	W31VT (2)	W25VT (2) W25RT (2) X25RT (2)	Y644M (1), PAT644M (1)	MY29-11 (1), Y644M (1), PAT644M (1)		
YSR312CFXLTCKITC	350 kcmil Code	185 mm ² Class 2	#2 AWG Flex or Code	35 mm ²	Red	Brown	18	10	U31RT (2)	U2CRT (1)	W31VT (2) W31RT (2)	W2CVT (1) W2CRT (1) X2CRT (1)	W31VT (2)	W2CVT (1) W2CRT (1) X2CRT (1)	Y644M (1), PAT644M (1)	Y1MRTC (2), MY29-11 (1), Y644M (1), PAT644M (1)		
YSR314CFXLTCKITC			#4 AWG Flex or Code	—	Red	Gray	18	8	U31RT (2)	U4CRT (1)	W31VT (2) W31RT (2)	W4CVT (1) W4CRT (1) X4CRT (1)	W31VT (2)	W4CVT (1) W4CRT (1) X4CRT (1)	Y644M (1), PAT644M (1)	Y1MRTC (2), MY29-11 (1), Y644M (1), PAT644M (1)		
YSR316CFXLTCKITC			#6 AWG Flex or Code	16 mm ²	Red	Blue	18	7	U31RT (2)	U5CRT (1)	W31VT (2) W31RT (2)	W5CVT (1) W5CRT (1) X5CRT (1)	W31VT (2)	W5CVT (1) W5CRT (1) X5CRT (1)	Y644M (1), PAT644M (1)	Y1MRTC (1), MY29-11 (1), Y644M (1), PAT644M (1)		
YSR29FX28LTCKITC	4/0 AWG Flex	120 mm ²	4/0 AWG Code	—	Yellow	Purple	16	15	U29RT (1)	U28RT (1)	W29VT (2) W29RT (2) X29RT (4)	W28VT (2) W28RT (2) X28RT (3)	W29VT (2) W29RT (2) X29RT (4)	W28VT (2) W28RT (2) X28RT (3)	Y644M (1), PAT644M (1)	MY29-11 (1), Y644M (1), PAT644M (1), MRC840 (2)		
YSR29FX25FXLTCKITC			1/0 AWG Flex or Code	50 mm ²	Yellow	Pink	16	12	U29RT (1)	U25RT (1)	W29VT (2) W29RT (2) X29RT (4)	W25VT (2) W25RT (2) X25RT (2)	W29VT (2) W29RT (2) X29RT (4)	W25VT (2) W25RT (2) X25RT (2)	Y644M (1), PAT644M (1)	MY29-11 (1), Y644M (1), PAT644M (1)		
YSR29FX2CFXLTCKITC			#2 AWG Flex or Code	35 mm ²	Yellow	Brown	16	10	U29RT (1)	U2CRT (1)	W29VT (2) W29RT (2) X29RT (4)	W2CVT (1) W2CRT (1) X2CRT (1)	W29VT (2) W29RT (2) X29RT (4)	W2CVT (1) W2CRT (1) X2CRT (1)	Y644M (1), PAT644M (1)	Y1MRTC (2), MY29-11 (1), Y644M (1), PAT644M (1)		
YSR28FX28LTCKITC	4/0 AWG Flex or Telco Flex	120 mm ²	4/0 AWG Code	—	Purple	Purple	15	15	U28RT (1)	U28RT (1)	W28VT (2) W28RT (2) X28RT (3)	W28VT (2) W28RT (2) X28RT (3)	W28VT (2) W28RT (2) X28RT (3)	W28VT (2) W28RT (2) X28RT (3)	Y644M (1), PAT644M (1)	MY29-11 (1), Y644M (1), PAT644M (1), MRC840 (2)		
YSR28FX26FXLTCKITC			2/0 AWG Flex or Code	70 mm ² Class 5	Purple	Black	15	13	U28RT (1)	U26RT (1)	W28VT (2) W28RT (2) X28RT (3)	W26VT (2) W26RT (2) X26RT (2)	W28VT (2) W28RT (2) X28RT (3)	W26VT (2) W26RT (2) X26RT (2)	Y644M (1), PAT644M (1)	MY29-11 (1), Y644M (1), PAT644M (1)		
YSR28FX25FXLTCKITC			1/0 AWG Flex or Code	50 mm ²	Purple	Pink	15	12	U28RT (1)	U25RT (1)	W28VT (2) W28RT (2) X28RT (3)	W25VT (2) W25RT (2) X25RT (2)	W28VT (2) W28RT (2) X28RT (3)	W25VT (2) W25RT (2) X25RT (2)	Y644M (1), PAT644M (1)	MY29-11 (1), Y644M (1), PAT644M (1)		
YSR28FX2CFXLTCKITC			#2 AWG Flex or Code	35 mm ²	Purple	Brown	15	10	U28RT (1)	U2CRT (10)	W28VT (2) W28RT (2) X28RT (3)	W2CVT (1) W2CRT (1) X2CRT (1)	W28VT (2) W28RT (2) X28RT (3)	W2CVT (1) W2CRT (1) X2CRT (1)	Y644M (1), PAT644M (1)	MY29-11 (1), Y644M (1), PAT644M (1), Y1MRTC (2)		

† Provided with 2 heat shrink tubings. One will overlap the other. Install the smaller first and larger second.

** Clear Heatshrink – UL224 VW1 Listed – passes TELCORDIA GR-347-CORE Abrasion and Cut Test. (Up to 750 kcmil Class B code cable. Contact factory for 750 flex cable applications.)

Note 1: All dimensions shown are for reference only.
Note 2: Non-inspection window versions are available. Please contact customer service.

(Installation Tooling Chart continued on next 2 pages)

Blue highlighted items are industry standard and most frequently ordered.

Compression Connections

BURNDY®

Copper Compression – Reducing Splice Kit – Code and Flex – Inspection Window

C-98

TYPE YSR-TC

INSTALLATION TOOLING CHART (Continued)

In-line Reducer Splice Kits for Telecommunications Applications

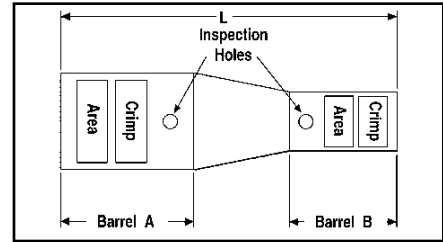
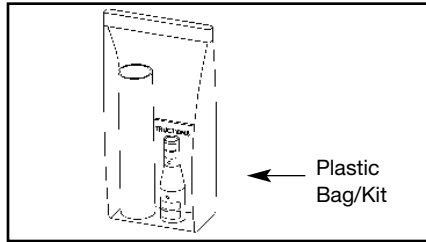

Installation Tooling																
** Clear Heat Shrink Kit Catalog Number	Wire Range				Color Code		Die Index		Hydraulic		Hydraulic		Mechanical		Dieless	
	Barrel A		Barrel B						Y750, Y35, Y46, PAT750, BAT750		BCT500HS, Y500CTHS		OUR840, MD7-34		Y/PAT644 Series, MY29-11	
	AWG	mm ²	AWG	mm ²	Barrel A	Barrel B	Barrel A	Barrel B	Barrel A	Barrel B	Barrel A	Barrel B	Barrel A	Barrel B		
YSR28FX4CFXLTKITC	4/0 AWG Flex or Telco Flex	120 mm ²	#4 AWG Flex or Code	—	Purple	Gray	15	8	U28RT (1)	U4CRT (1)	W28VT (2) W28RT (2) X28RT (3)	W4CVT (1) W4CRT (1) X4CRT (1)	W28VT (2) W28RT (2) X28RT (3)	W4CVT (1) W4CRT (1) X4CRT (1)	Y644M (1), PAT644M (1)	Y1MRTC (2), MY29-11 (1), Y644M (1), PAT644M (1)
YSR2825FXLTCKITC	4/0 AWG Code	—	1/0 AWG Flex or Code	50 mm ²	Purple	Pink	15	12	U28RT (1)	U25RT (1)	W28VT (2) W28RT (2) X28RT (3)	W25VT (2) W25RT (2) X25RT (2)	W28VT (2) W28RT (2) X28RT (3)	W25VT (2) W25RT (2) X25RT (2)	MY29-11 (1), Y644M (1), PAT644M (1)	MRC840 (2) MY29-11 (1), Y644M (1), PAT644M (1)
YSR282CFXLTKITC			#2 AWG Flex or Code	35 mm ²	Purple	Brown	15	10	U28RT (1)	U2CRT (1)	W28VT (2) W28RT (2) X28RT (3)	W2CVT (1) W2CRT (1) X2CRT (1)	W28VT (2) W28RT (2) X28RT (3)	W2CVT (1) W2CRT (1) X2CRT (1)	MY29-11 (1), Y644M (1), PAT644M (1), MRC840 (2)	Y1MRTC (2), MY29-11 (1), Y644M (1), PAT644M (1)
YSR284CFXLTKITC	4/0 AWG Code	—	#4 AWG Flex or Code	—	Purple	Gray	15	8	U28RT (1)	U4CRT (1)	W28VT (2) W28RT (2) X28RT (3)	W4CVT (1) W4CRT (1) X4CRT (1)	W28VT (2) W28RT (2) X28RT (3)	W4CVT (1) W4CRT (1) X4CRT (1)	MY29-11 (1), Y644M (1), PAT644M (1), MRC840 (2)	Y1MRTC (2), MY29-11 (1), Y644M (1), PAT644M (1)
YSR286CFXLTKITC			#6 AWG Flex or Code	16 mm ²	Purple	Blue	15	7	U28RT (1)	U5CRT (1)	W28VT (2) W28RT (2) X28RT (3)	W5CVT (1) W5CRT (1) X5CRT (1)	W28VT (2) W28RT (2) X28RT (3)	W5CVT (1) W5CRT (1) X5CRT (1)	MY29-11 (1), Y644M (1), PAT644M (1), MRC840 (2)	Y1MRTC (1), MY29-11 (1), Y644M (1), PAT644M (1)
YSR26FX25FXLTCKITC	2/0 AWG Flex or Code	70 mm ²	1/0 AWG Flex or Code	50 mm ²	Black	Pink	13	12	U26RT (1)	U25RT (1)	W26VT (2) W26RT (2) X26RT (2)	W25VT (2) W25RT (2) X25RT (2)	W26VT (2) W26RT (2) X26RT (2)	W25VT (2) W25RT (2) X25RT (2)	MY29-11 (1), Y644M (1), PAT644M (1)	MY29-11 (1), Y644M (1), PAT644M (1)
YSR26FX2CFXLTKITC			#2 AWG Flex or Code	35 mm ²	Black	Brown	13	10	U26RT (1)	U2CRT (1)	W26VT (2) W26RT (2) X26RT (2)	W2CVT (1) W2CRT (1) X2CRT (1)	W26VT (2) W26RT (2) X26RT (2)	W2CVT (1) W2CRT (1) X2CRT (1)	MY29-11 (1), Y644M (1), PAT644M (1)	Y1MRTC (2), MY29-11 (1), Y644M (1), PAT644M (1)
YSR26FX4CFXLTKITC			#4 AWG Flex or Code	—	Black	Gray	13	8	U26RT (1)	U4CRT (1)	W26VT (2) W26RT (2) X26RT (2)	W4CVT (1) W4CRT (1) X4CRT (1)	W26VT (2) W26RT (2) X26RT (2)	W4CVT (1) W4CRT (1) X4CRT (1)	MY29-11 (1), Y644M (1), PAT644M (1)	Y1MRTC (2), MY29-11 (1), Y644M (1), PAT644M (1)
YSR26FX6CFXLTKITC †			#6 AWG Flex or Code	16 mm ²	Black	Blue	13	7	U26RT (1)	U5CRT (1)	W26VT (2) W26RT (2) X26RT (2)	W5CVT (1) W5CRT (1) X5CRT (1)	W26VT (2) W26RT (2) X26RT (2)	W5CVT (1) W5CRT (1) X5CRT (1)	MY29-11 (1), Y644M (1), PAT644M (1)	Y1MRTC (1), MY29-11 (1), Y644M (1), PAT644M (1)
YSR25FX2CFXLTKITC	1/0 AWG Flex or Code	50 mm ²	#2 AWG Flex or Code	35 mm ²	Pink	Brown	12	10	U25RT (1)	U2CRT (1)	W25VT (2) W25RT (2) X25RT (2)	W2CVT (1) W2CRT (1) X2CRT (1)	W25VT (2) W25RT (2) X25RT (2)	W2CVT (1) W2CRT (1) X2CRT (1)	MY29-11 (1), Y644M (1), PAT644M (1)	Y1MRTC (2), MY29-11 (1), Y644M (1), PAT644M (1)
YSR25FX4CFXLTKITC			#4 AWG Flex or Code	—	Pink	Gray	12	8	U25RT (1)	U4CRT (1)	W25VT (2) W25RT (2) X25RT (2)	W4CVT (1) W4CRT (1) X4CRT (1)	W25VT (2) W25RT (2) X25RT (2)	W4CVT (1) W4CRT (1) X4CRT (1)	MY29-11 (1), Y644M (1), PAT644M (1)	Y1MRTC (1), MY29-11 (1), Y644M (1), PAT644M (1)
YSR25FX6CFXLTKITC †			#6 AWG Flex or Code	16 mm ²	Pink	Blue	12	7	U25RT (1)	U5CRT (1)	W25VT (2) W25RT (2) X25RT (2)	W5CVT (1) W5CRT (1) X5CRT (1)	W25VT (2) W25RT (2) X25RT (2)	W5CVT (1) W5CRT (1) X5CRT (1)	MY29-11 (1), Y644M (1), PAT644M (1)	Y1MRTC (1), MY29-11 (1), Y644M (1), PAT644M (1)

Note 1: All dimensions shown are for reference only.
 Note 2: Non-inspection window versions are available. Please contact customer service.

† Provided with 2 heat shrink tubings. One will overlap the other. Install the smaller first and larger second.
 ** Clear Heatshrink – UL224 VW1 Listed – passes TELCORDIA GR-347-CORE Abrasion and Cut Test.

(Up to 750 kcmil Class B code cable. Contact factory for 750 flex cable applications.)

Chart continued on next page

TYPE YSR-TC

INSTALLATION TOOLING CHART (Continued)

In-line Reducer Splice Kits for Telecommunications Applications

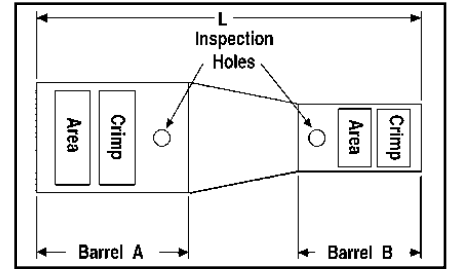
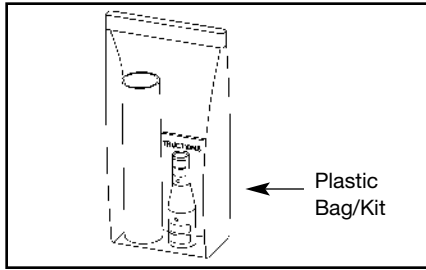

Installation Tooling																	
** Clear Heat Shrink Kit Catalog Number	Wire Range				Color Code		Die Index		Hydraulic		Hydraulic		Mechanical		Dieless		
	Barrel A		Barrel B						Y750, Y35, Y46, PAT750, BAT750		BCT500HS, Y500CHS		OUR840, MD7-34		Y/PAT644 Series, MY29-11		
	AWG	mm ²	AWG	mm ²	Barrel A	Barrel B	Barrel A	Barrel B	Barrel A	Barrel B	Barrel A	Barrel B	Barrel A	Barrel B			
YSR2CFX4CFXLTCKITC	#2 AWG Flex or Code	35 mm ²	#4 AWG Flex or Code	—	Brown	Gray	10	8	U2CRT (1)	U4CRT (1)	W2CVT (1) W2CRT (1) X2CRT (1)	W4CVT (1) W4CRT (1) X4CRT (1)	W2CVT (1) W2CRT (1) X2CRT (1)	W4CVT (1) W4CRT (1) X4CRT (1)	Y1MRTC (2), MY29-11 (1), Y644M (1), PAT644M (1)	Y1MRTC (2), MY29-11 (1), Y644M (1), PAT644M (1)	
YSR2CFX6CFXLTCKITC			#6 AWG Flex or Code	16 mm ²	Brown	Blue	10	7	U2CRT (1)	U5CRT (1)	W2CVT (1) W2CRT (1) X2CRT (1)	W5CVT (1) W5CRT (1) X5CRT (1)	W2CVT (1) W2CRT (1) X2CRT (1)	W5CVT (1) W5CRT (1) X5CRT (1)	Y1MRTC (2), MY29-11 (1), Y644M (1), PAT644M (1)	Y1MRTC (1), MY29-11 (1), Y644M (1), PAT644M (1)	
YSR2CFX8CFXLTCKITC			#8 AWG Flex or Code	10 mm ²	Brown	Red	10	49	U2CRT (1)	U8CRT (1)	W2CVT (1) W2CRT (1) X2CRT (1)	W8CVT (1) W8CRT (1) X8CRT (1)	W2CVT (1) W2CRT (1) X2CRT (1)	W8CVT (1) W8CRT (1) X8CRT (1)	Y1MRTC (2), MY29-11 (1), Y644M (1), PAT644M (1)	Y8MRB-1 (1), Y1MRTC (1), MY29-3 (1), MY29-11 (1)	
YSR4CFX6CFXLTCKITC	#4 AWG Flex or Code	—	#6 AWG Flex or Code	16 mm ²	Gray	Blue	8	7	U4CRT (1)	U5CRT (1)	W4CVT (1) W4CRT (1) X4CRT (1)	W5CVT (1) W5CRT (1) X5CRT (1)	W4CVT (1) W4CRT (1) X4CRT (1)	W5CVT (1) W5CRT (1) X5CRT (1)	Y1MRTC (2), MY29-11 (1), Y644M (1), PAT644M (1)	Y1MRTC (1), MY29-11 (1), Y644M (1), PAT644M (1)	
YSR4CFX8CFXLTCKITC			#8 AWG Flex or Code	10 mm ²	Gray	Red	8	49	U4CRT (1)	U8CRT (1)	W4CVT (1) W4CRT (1) X4CRT (1)	W8CVT (1) W8CRT (1) X8CRT (1)	W4CVT (1) W4CRT (1) X4CRT (1)	W8CVT (1) W8CRT (1) X8CRT (1)	Y1MRTC (2), MY29-11 (1), Y644M (1), PAT644M (1)	Y8MRB-1 (1), Y1MRTC (1), MY29-3 (1), MY29-11 (1)	
YSR4CFX10CLTCKITC			#10 AWG Flex or Code	6 mm ² Str. or 2.5 mm ² Flex	Gray	—	8	—	—	U4CRT (1)	—	W4CVT (1) W4CRT (1) X4CRT (1)	—	W4CVT (1) W4CRT (1) X4CRT (1)	—	Y1MRTC (2), MY29-11 (1), Y644M (1), PAT644M (1)	Y8MRB-1 (2), MR8G98 (2), Y10D (2)
YSR6CFX8CFXLTCKITC	#6 AWG Flex or Code	16 mm ²	#8 AWG Flex or Code	10 mm ²	Blue	Red	7	49	U5CRT (1)	U8CRT (1)	W5CVT (1) W5CRT (1) X5CRT (1)	W8CVT (1) W8CRT (1) X8CRT (1)	W5CVT (1) W5CRT (1) X5CRT (1)	W8CVT (1) W8CRT (1) X8CRT (1)	Y1MRTC (1), MY29-11 (1), Y644M (1), PAT644M (1)	Y8MRB-1 (1), Y1MRTC (1), MY29-3 (1), MY29-11 (1)	
YSR6CFX10CLTCKITC			#10 AWG Flex or Code	6 mm ² Str. or 2.5 mm ² Flex	Blue	—	7	—	—	U5CRT (1)	—	W5CVT (1) W5CRT (1) X5CRT (1)	—	W5CVT (1) W5CRT (1) X5CRT (1)	—	Y1MRTC (1), MY29-11 (1), Y644M (1), PAT644M (1)	Y8MRB-1 (2), MR8G98 (2), Y10D (2)
YSR8CFX10CLTCKITC	#8 AWG Flex or Code	10 mm ²	#10 AWG Flex or Code	6 mm ² Str. or 2.5 mm ² Flex	Red	—	49	—	—	U8CRT (1)	—	W8CVT (1) W8CRT (1) X8CRT (1)	—	W8CVT (1) W8CRT (1) X8CRT (1)	—	Y8MRB-1 (1), Y1MRTC (1), MY29-3 (1), MY29-11 (1)	Y8MRB-1 (2), MR8G98 (2), Y10D (2)
YSR8CFX14CLTCKITC			#14 AWG Flex or Code	6 mm ² Str. or 2.5 mm ² Flex	Red	—	49	—	—	—	U8CRT (1)	—	W8CVT (1) W8CRT (1) X8CRT (1)	—	W8CVT (1) W8CRT (1) X8CRT (1)	—	Y8MRB-1 (1), Y1MRTC (1), MY29-3 (1), MY29-11 (1)
YSR10CFX12CLTCKITC	#10 AWG Flex or Code	6 mm ² Str. or 2.5 mm ² Flex	#12 AWG Flex or Code	6 mm ² Str. or 2.5 mm ² Flex	—	—	—	—	—	—	—	—	—	—	—	Y8MRB-1 (2), MR8G98 (2), Y10D (2)	Y8MRB-1 (2), MR8G98 (2), Y10D (2)
YSR10CFX14CLTCKITC			#14 AWG Flex or Code	6 mm ² Str. or 2.5 mm ² Flex	—	—	—	—	—	—	—	—	—	—	—	—	Y8MRB-1 (2), MR8G98 (2), Y10D (2)

† Provided with 2 heat shrink tubings. One will overlap the other. Install the smaller first and larger second.

** Clear Heatshrink – UL224 WW1 Listed – passes TELCORDIA GR-347-CORE Abrasion and Cut Test. (Up to 750 kcmil Class B code cable. Contact factory for 750 flex cable applications.)

Note 1: All dimensions shown are for reference only.
Note 2: Non-inspection window versions are available. Please contact customer service.

Compression Connections

BURNDY®

Copper Compression — C-Tap — Thin Wall

C-100

TYPE YC-L

THIN-WALL COPPER C-TAP

UL Listed to 600 Volts

Type YC-L is a thin-wall high conductivity copper connector for making copper tap and parallel connections from #14 to 3/0 AWG.

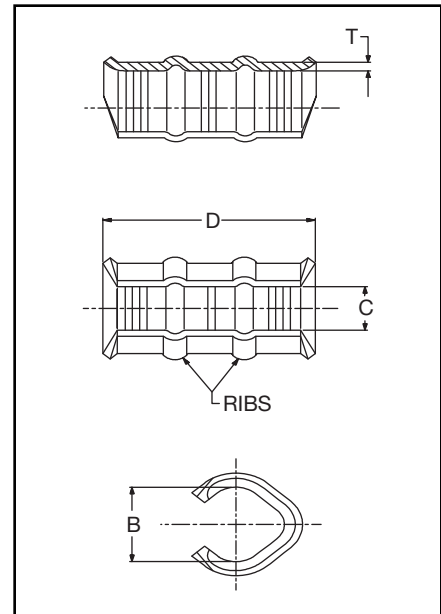
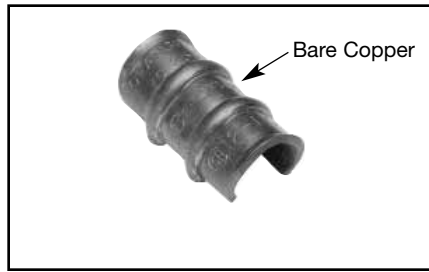

Features and Benefits

- Manufactured from high conductivity wrought copper.
 - ◇ Provides low resistance and excellent electrical conductivity.
- Range-taking connector.
 - ◇ Lowers inventory requirements.
- Reinforced ribs.
 - ◇ Provides maximum pull-out values.
- Compact size.
 - ◇ Easy to tape and insulate connection.
- Economical.
 - ◇ Provides low installed cost.



Catalog Number	Accommodates		No. of Ribs	Dimensions				Color Code	Installation Tooling					Wire Strip Length	
									Mechanical		Hydraulic				
									Y2MR	MD6, OUR840 & MD7-34R Die No. (# crimps)	Die ▲ Index Emboss- ment	BCT500, Y500CT, BAT500 (# crimps)	Y35, Y39, Y750, Y45 Y46* (# crimps)		Die ▲ Index Emboss- ment
YC10L12	14	16-14	0	.18	.11	.40	.060	Red	Red (1)	W8CVT (1)	49				3/8"
	12	16-14		[4.6]	[2.8]	[10.2]	[1.65]								
	10	14													
YC8L12	10	10	0	.25	.21	.60	.072	Blue	Blue (1)	W5CVT (1)	7				5/8"
	8	12		[6.4]	[3.8]	[15.2]	[1.83]								
YC6L12	8	10-8	0	.33	.25	.60	.072	Gray	Gray (2)	W4CVT (1)	8				5/8"
	6	12-10		[8.4]	[5.1]	[15.2]	[1.83]								
YC4L12	6	8-6	1	.38	.28	1.18	.072	Brown	Brown (2)	W2CVT (2)	10	WC4 (1)	UC4 (1)	10M	1-3/16"
	5.4	12-8		[9.7]	[6.1]	[30.2]	[1.83]								
YC3L12	5.4	6-5	1	.48	.37	1.18	.081	Green	—	W1CVT (2)	11				1-3/16"
	3	12-6		[11.4]	[6.4]	[30.2]	[2.06]								
YC2L12	4	4	1	.50	.36	1.18	.081	Pink	Pink (2)	W25VT (2)	12	WC2 (1)	UC2 (1)	12M	1-3/16"
	3	5		[12.7]	[7.6]	[30.2]	[2.06]								
	2	12-6													
YC1L12	3	4-3	2	.56	.45	1.75	.081	Black	—	W26VT (3)	13	WC1 (2)	UC1 (1)	13M	1-13/16"
	2	5-4		[14.2]	[8.6]	[44.4]	[2.06]								
	1	12-5													
YC25L12	2 Str. 2 Sol.	2 Str. 2 Sol.	2	.62	.50	1.75	.090	Orange	—	W27VT (3)	14	WC25 (2)	UC25 (1)	14M	1-13/16"
	1 Str. 4 Sol.	4 Str. 4 Sol.													
	1 Sol. 3 Str. 3 Sol.	3 Str. 3 Sol.													
YC26L12	1	2-1	2	.69	.53	1.75	.090	Purple	—	W28VT (3)	15		UC26 (1)		1-13/16"
	1/0	3-2													
	2/0	12-3													
YC27L12	1/0	1-1/0	2	.81	.54	1.75	.090	Yellow	—	W29VT (3)	16				1-13/16"
	2/0	2-1													
	3/0	12-2													

▲ See tooling section of this catalog for complete tool and die listings.

* Use PUADP-1 adapter with U dies in Y46 HYPRESS™
For Tin plating add TN suffix (example = YC10L12TN)

Note: All dimensions shown are for reference only.

Blue highlighted items are industry standard and most frequently ordered.

TYPES YC-C

COPPER CRIMPIT™

UL Listed 90° C,
600 Volts to 35 kV◆

Type YC-C copper CRIMPIT™ connector is a range-taking C shape compression connector for making tap or parallel copper connections from #12 sol. to 4/0 strand conductor.

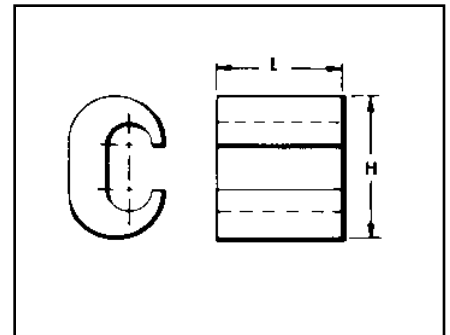
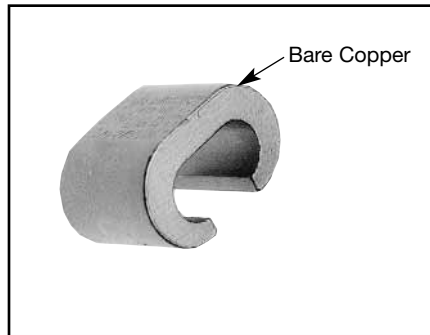

C-101

Features and Benefits

- Range-taking connector.
 - ◇ Lowers inventory requirements.
- Compact size.
 - ◇ Easy to tape and insulate connection.
- Manufactured from high conductivity wrought copper.
 - ◇ Provides low resistance and excellent electrical conductivity.
- Economical
 - ◇ Provides low installed cost.

Copperweld-Copper Conductors

- 8A - Use CRIMPITS™ accommodating 6 str. Copper
- 6A - Use CRIMPITS™ accommodating 4 Str. Copper
- 4A - Use CRIMPITS™ accommodating 2 Str. Copper
- 2A - Use CRIMPITS™ accommodating 1/0 and 2/0 Copper

Catalog Number	Run	Tap	L	▲ Die Index	Tools, Die Set, Catalog Number, and (±No. of Crimps) ▲			CRIMPIT™ for 1 Str. Copper	
					MD6	OUR840	Y35, Y750, Y45, Y46*	Run	Tap
YC10C10 †	12 Sol. - 10 Str.	12 Sol. - 10 Str.	3/8"	238	W238 (1)	W238 (1)	U-238 (1)		
YC8C8	8 Sol. - 8 Str.	10 Sol. - 8 Str.	1/2"	162 or K	W162 (2)	W162 (2)	U162** (1)		
YC4C8	6 Sol. - 4 Str.	8 Sol. - 8 Str.	5/8"	BG or 5/8	BG (2) W-BG** (1)	XNBG (2)	U-BG (1)	—	—
YC4C6		6 Sol. - 6 Str.							
YC4C4		4 Sol. - 4 Str.							
YC2C4	2 Sol. - 2 Str.	8 Sol. - 4 Str.	3/4"	C	W-C (2)	—	U-C (1)	1 Str.	6.8 Str., 8 Sol.
YC2C2		2 Sol. - 2 Str.						—	—
YC26C2	1/0 Sol. - 2/0 Str.	8 Sol. - 2 Str.	11/12"	E or O	—	—	U-E (3) U-O (1)	1 Str.	1 or 2 Str.
YC26C26		1/0 Sol. - 2/0 Str.						—	—
YC28C2	3/0 Sol. - 4/0 Str.	6 Sol. - 2 Str.	1-1/16"	F or D3	—	—	U-F (3) U-D3** (1)	—	—
YC28C26		1/0 Sol. - 2/0 Str.							
YC28C28		3/0 Sol. - 4/0 Str.							

† Not UL Listed.
 ‡ Number of Crimps.
 ▲ See tooling section of this catalog for complete tool and die listings.
 * Use PUADP-1 adapter when using U dies in the Y46 HYPRESS™.

** Multiple crimp die set. Makes more than one crimp per tool compression. Figure () indicates number of compressions.
 ◆ For applications greater than 2000 Volts consult cable manufacturer for voltage stress relief instructions.
Note: All dimensions shown are for reference only.

Blue highlighted items are industry standard and most frequently ordered.

Compression Connections

BURNDY®

Copper Compression – C-Tap

C-102

TYPE YCHC

C-TAP COPPER CRIMPIT™

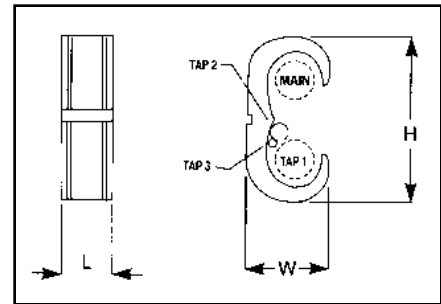
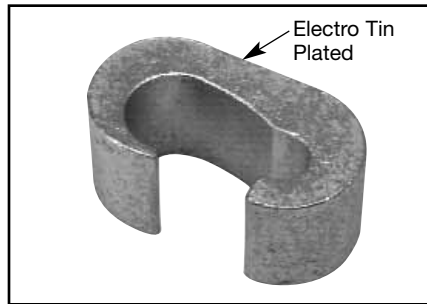

Features and Benefits

- Wide range of run/tap combinations including Class B code I and locomotive flexible conductor combinations. All (B/B, B/I, I/I) combinations are recommended.
 - ◇ Each connector accommodates many cable combinations, allowing maximum flexibility for the design and installation of a system.
- Color-coded on the connector that matches the die.
 - ◇ Provides matched system for fast and easy installation.
- Each connector has a recommended insulating cover available. Flame retardant type CF-FR covers meet oxygen index 28 and UL94 V-O requirements.
 - ◇ A complete insulated UL Listed installation is provided.
- Die index embossed on connector after completion of crimp.
 - ◇ Permanent inspectability of installed connector is insured consistently reliable and dependable connections.

BURNDY Catalog Number	Flame Retardant Cover		Conductor Sizes Code/(Flex) Cable				▲ Tooling († No. of Crimps)						▲ Die Index & Embossment	H	W	L	Strip Length	
	Clear Cat. No.	Black Cat. No. ‡	Main	Tap 1	Tap 2	Tap 3	Y35	†	Y750	†	Y46*	†						Color Code
YCHC44TC44	CCFR-FR	CFR-FR	1000-750 (750-500)	1000-750 (750-500)			—	—	—	—	P1102	1	White	1102	3.59	1.73	1.16	1-1/4"
YCHC39TC39	CCFR-FR	CFR-FR	750-500 (550-500)	750-350 (550-350)			—	—	—	—	P1103	1	Blue	1103	3.12	1.53	1.06	1-1/8"
YCHC39TC31	CCFR-FR	CFR-FR	750-500 (550-500)	350-2 (250-2)	2-6 Str./Sol. (2-8)	8-14 (8-14)	—	—	—	—	P1103	1	Blue	1103	2.96	1.53	1.31	1-3/8"
YCHC39TC2	CCFR-FR	CFR-FR	750-500 (550-500)	2-6 Str./Sol. (2-8)	8-14 (8-14)		—	—	—	—	P1103	1	Blue	1103	2.66	1.53	1.31	1-3/8"
YCHC34TC34	CCFN-FR	CFN-FR	500-4/0 (350-4/0)	500-4/0 (350-4/0)			—	—	U1104	2	P1104	1	Brown	1104	2.97	1.38	1.00	1-1/4"
YCHC34TC29	CCFN-FR	CFN-FR	500-4/0 (350-4/0)	250-2 (4/0-2)	2-6 Str./Sol. (2-8)	8-14 (8-14)	—	—	U1104	2	P1104	1	Brown	1104	2.45	1.26	.88	1"
YCHC34TC2	CCFN-FR	CFN-FR	500-4/0 (350-4/0)	2-6 Str./Sol. (2-8)	8-14 (8-14)		—	—	U1104	2	P1104	1	Brown	1104	2.45	1.26	.88	1"
YCHC29TC29	CCFDXFR	CFD-FR	250-2 (4/0-2)	250-2 (4/0-2)			—	—	U997	1	U997	1	Orange	997	2.12	.98	.94	1"
YCHC29TC2	CCFD-FR	CFD-FR	250-2 (4/0-2)	2-6 Str./Sol. (2-8)	8-14 (8-14)		—	—	U251	1	U251	1	Red	251	1.78	.97	.81	1"
YCHC2TC2	CCFO-FR	CFO-FR	2-6 Str./Sol. (2-8)	2-6 Str./Sol. (2-8)	8-14 (8-14)		U-C	1	U-C	1	U-C	1	Brown	C	1.22	.60	.81	1"
YCHC8TC8	◆	◆	8-12 (8-12)	8-12 (8-12)			U-240	1	U-240	1	U-240	1	Red	240	.53	.35	.56	5/8"

Note: To properly use tap 2 and/or tap 3 conductors in YCHC connector a conductor from the tap 1 cable range must be included in the tap 1 groove.

‡ To obtain covers made of polyethylene remove suffix-FR (example: CFO). CFO is not flame retardant.

* Use PUADP-1 adaptor with U dies in Y46.

▲ See tooling section of Master Catalog for complete tool and die listings.

◆ For applications requiring flame retardant cover, use either a CCFBG-FR (Clear) or CFBG-FR (Black) cover and YH2C2C connector by ordering YH8C8CWCC (Clear) or YH8C8CWC (Black).

Note: All dimensions shown are for reference only.

Blue highlighted items are industry standard and most frequently ordered.

TYPE YH

H-TAP COPPER CRIMPIT™



Features and Benefits

- Accommodates a wide range of run/tap copper cable combinations including both flexible and code combinations. All (B/B, B/I, I/B, I/I) combinations acceptable.
 - ◇ Each connector has many copper cable combination applications allowing maximum flexibility for the design and installation of a system.
- Tap grooves function independently of each other. Use of one tap is required. Balance may be used or left empty.
 - ◇ Provides maximum design and installation flexibility.
- Color code on the connector matches installation die.
 - ◇ Provides matched system for fast and easy installation.

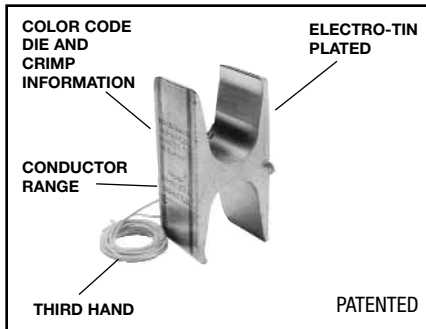

- Die index embossed on connector after completion of crimp.
 - ◇ Permanent inspectability of installed connectors to insure consistently reliable and dependable connections.
- Recommended flame retardant type CF-FR insulating covers meet oxygen index 28 and UL94 V-O requirements.
 - ◇ A complete insulated UL Listed installation is provided.
- Third Hand constrains conductors while installer completes crimp. Included with each connector.
 - ◇ Simplifies installation, reducing installed cost.

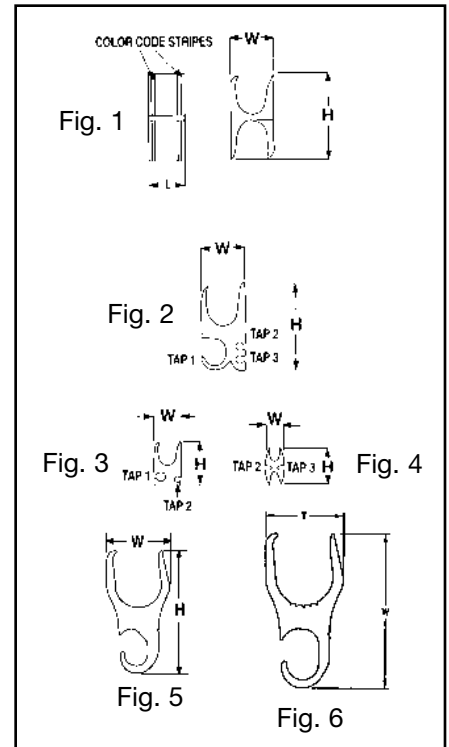

TABLE 1 CODE CONDUCTOR AND METRIC EQUIVALENT

H-Tap Connector	Kit Catalog Number		Fig. #	Conductor Sizes Code/(Flex Cable)				Metric Conductor Sizes (mm ²)			
	Flame Retardant Cover			Main	Tap 1	Tap 2	Tap 3	Main	Tap 1	Tap 2	Tap 3
	Clear	Black									
YH4444	YH4444WCC	YH4444WC	1	1000-750	1000-750	—	—	500-400	500-400	—	—
YH4434*	YH4434WCC*	YH4434WC	6	750-500 (750)	750-500 (350)	—	—	1000-750 (777-500) (777-750)	500-350 (350 FX)	—	—
YH4429	YH4429WCC	YH4429WC	5	1000-750 (777-500)	250-2 (4/0-2)	—	—	500-400	150-35	—	—
YH3939	YH3939WCC	YH3939WC	1	750-500 (550-500)	750-350 (550-350)	—	—	300-300	300-185	—	—
YH3931	YH3931WCC	YH3931WC	2	750-350 (550-500)	4/0-1/0 (250-1/0)	1-6 Str/Sol (1-8)	2-14 (2-14)	300-185	95-70	35-16	35-2.5
YH3434	YH3434WCC	YH3434WC	1	500-250 (350-4/0)	500-4/0 (350-4/0)	—	—	240-150	240-120	—	—
YH3429	YH3429WCC	YH3429WC	2	500-4/0 (350-4/0)	250/1/0 (4/0-1/0)	1-6 Str/Sol (1-8)	8-14 #8	240-120	120-70	35-16	6-2.5
YH2929	YH2929WCC	YH2929WC	1	250-2 (4/0-2)	250-2 (4/0-2)	—	—	120-35	120-35	—	—
YH292C	YH292CWCC	YH292CWC	3	250-2 (4/0-2)	2-6 Str/Sol (2-8)	8-14 (8-14)	—	120-35	35-16	6-2.5	—
YH298C	YH298CWCC	YH298CWC	3	250-2 (4/0-2)	8-14 (8-14)	8-14 (8-14)	—	120-35	6-2.5	6-2.5	—
YH2C2C	YH2C2CWCC	YH2C2CWC	4	2-6 Str/Sol (2-8)	2-6 Str/Sol (2-8)	8-14 (8-14)	8-14 (8-14)	35-16	35-16	6-2.5	6-2.5
YH6C6C	YH6C6CWCC	YH6C6CWC	1	6-10 (6-10)	6-14 (6-14)	—	—	10-6	10-2.5	—	—
YH8C8C	YH8C8CWCC	YH8C8CWC	1	8-14 (8-14)	8-14 (8-14)	—	—	6-2.5	6-2.5	—	—

• Use PUADP-1 adaptor with U dies in Y46.
 ▲ See tooling section of this catalog for complete tool and die listings.

* Not CSA approved.
 Note: All H-Taps ROHS compliant.
 Note: All dimensions shown are for reference only.

Blue highlighted items are industry standard and most frequently ordered.

TYPE YH

H-TAP COPPER CRIMPIT™

(Continued)

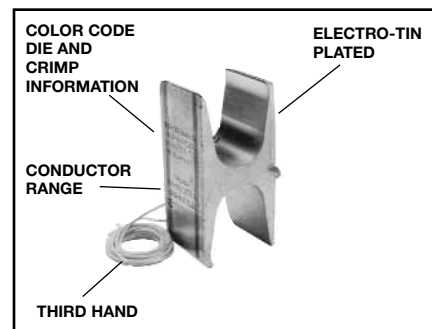

TABLE 2 FLEX AND METRIC CONDUCTOR RANGES

Catalog Number		Maximum Conductor in Range	Maximum Metric Dimensions	Diameter mm	Minimum Conductor in Range	Minimum Metric Dimensions	Diameter mm
		Flex Conductor (AWG/kcmil)	mm ²		Flex Conductor (AWG/kcmil)	mm ²	
YH4444	Main	777	393	28	500	253	24
	Tap 1	777	393	28	500	253	24
	Main	777	393	28	750	380	31
YH4434*	Tap 1	—	—	—	350	177	20
YH4429	Main	777	393	28	500	253	24
	Tap 1	4/0	107	15.5	2	33.6	8
YH3939	Main	550	278	25	500	253	24
	Tap 1	550	278	25	350	177	20
YH3931	Main	550	278	25	500	253	24
	Tap1	250	126	17	1/0	53.5	11
	Tap 2	1	42	9	8	8	4
	Tap 3	2	33.6	8	14	2	2
YH3434	Main	350	177	20	4/0	107	15.5
	Tap 1	350	177	20	4/0	107	15.5
YH3429	Main	350	177	20	4/0	107	15.5
	Tap 1	4/0	107	15.5	1/0	53	11
	Tap 2	1	42	9	8	8	4
	Tap 3	8	8	4	14	2	2
YH2929	Main	4/0	107	15.5	2	33.6	8
	Tap 1	4/0	107	15.5	2	33.6	8
YH292C	Main	4/0	107	15.5	2	33.6	8
	Tap1	2	33.6	8	8	8	4
	Tap 2	8	8	4	14	2	2
YH298C	Main	4/0	107	15.5	2	33.6	8
	Tap1	8	8	4	14	2	2
	Tap 2	8	8	4	14	2	2
YH2C2C	Main	2	33.6	8	8	8	4
	Tap 1	2	33.6	8	8	8	4
	Tap 2	8	8	4	14	2	2
	Tap 3	8	8	4	14	2	2
YH6C6C	Main	6	13	5	10	5	3
	Tap 1	6	13	5	14	2	2
YH8C8C	Main	8	8	4	14	2	2
	Tap 1	8	8	4	14	2	2

• Use PUADP-1 adaptor with U dies in Y46.
 ▲ See tooling section of this catalog for complete tool and die listings.

* Not CSA approved.
Note: All H-Taps ROHS compliant.
Note: All dimensions shown are for reference only.

Blue highlighted items are industry standard and most frequently ordered.

TYPE YH

H-TAP COPPER CRIMPIT™
(Continued)

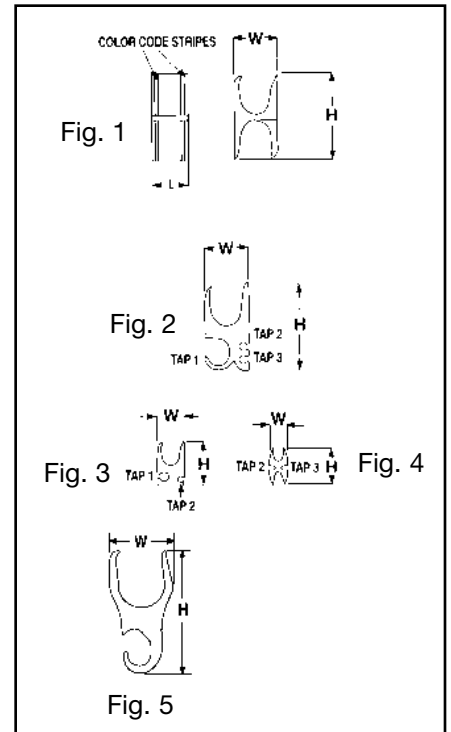
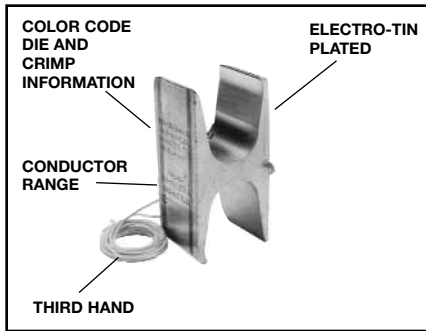

TABLE 3 INSTALLATION TOOLING + DIMENSIONS

BURNDY Catalog Number	Kit Catalog Number		▲ Tooling († No. of Crimps)								Color Code	▲ Die Index & Embossment	H	W	L	Strip Length
	Flame Retardant Cover	Clear	Black ‡	Fig. No.	Y35	†	Y750	†	Y46*	†						
YH4444	YH4444WCC	YH4444WC	1	—	—	—	—	P1102	1	White	1102	3.38	1.70	1.00	1-1/8"	
YH4434*	YH4434WCC*	YH4434WC	5	—	—	—	—	PYFR	1	Yellow	K-R	3.22	1.70	1.00	1-3/8"	
YH4429	YH4429WCC	YH4429WC	1	—	—	—	—	PYFR	1	Yellow	K-R	2.97	1.50	1.25	1-3/8"	
YH3939	YH3939WCC	YH3939WC	2	—	—	—	—	PYFR	1	Yellow	K-R	2.97	1.50	.95	1-1/16"	
YH3931	YH3931WCC	YH3931WC	1	—	—	U1104M	1	P1104	1	Brown	1104	2.43	1.15	1.00	1-1/8"	
YH3434	YH3434WCC	YH3434WC	2	—	—	U1104M	1	P1104	1	Brown	1104	2.23	1.31	1.00	1-1/8"	
YH3429	YH3429WCC	YH3429WC	1	—	—	U1104M	1	U654	1	Purple	654	1.85	.90	.90	1-1/16"	
YH2929	YH2929WCC	YH2929WC	3	—	—	U654	1	U654	1	Purple	654	1.52	.90	.90	1-1/16"	
YH292C	YH292CWCC	YH292CWC	3	—	—	U654	1	U654	1	Purple	654	1.52	.90	.90	1-1/16"	
YH298C	YH298CWCC	YH298CWC	4	U-C	1	U-C	1	U-C	1	Brown	C	1.25	.60	.75	7/8"	
YH2C2C	YH2C2CWCC	YH2C2CWC	1	UBGRT	1	UBGRT	1	UBGRT	1	Orange	BG	.81	.39	.60	3/4"	
YH6C6C	YH6C6CWCC	YH6C6CWC	1	U11T-1	1	U11T-1	1	U11T-1	1	Green	11	.63	.40	.60	3/4"	
YH8C8C	YH8C8CWCC	YH8C8CWC														

• Use PUADP-1 adaptor with U dies in Y46.
▲ See tooling section of this catalog for complete tool and die listings.

* Not CSA approved.
Note: All H-Taps ROHS compliant.
Note: All dimensions shown are for reference only.

Blue highlighted items are industry standard and most frequently ordered.

C-106

TYPE CF-FR

H-TAP — FLAME RETARDANT COVER

UL Listed to 600 Volts



600 VOLT 90° C



Features and Benefits

- One-piece design.
 - ◇ No extra parts or hardware required.

Features and Benefits (continued)

- Slips over connector and latches securely shut.
 - ◇ Fast, easy, reliable insulation of H-Tap compression.
- Eliminates tapping.
 - ◇ Economical, fast, easy installation.
- Flash barriers.
 - ◇ Protects against electrical flashover.
- CF-FR flame retardant design.
 - ◇ Self-extinguishing retardant properties.
- Minimum 28 oxygen index.
 - ◇ Self-extinguishing retardant properties.
- UL 94 V-O rated.
 - ◇ Self-extinguishing retardant properties.

Catalog Number	Max. Conductor Accommodated	Matched H Copper CRIMPIT™	Max. Connector Length	Connector Color Code
CFBG-FR	#8 AWG	YH8C8C	.65	Green
	#6 AWG	YH6C6C		Orange
CF0-FR	#2 AWG	YH2C2C	.80	Brown
CFD-FR	250 kcmil	YH292C, YH298C, YH2929	.95	Purple
CFN-FR	500 kcmil	YH3434, YH3429*	1.10	Brown
CFR-FR †	750 kcmil	YH3939, YH3931, YH4429	1.30	Yellow
	1000 kcmil	YH4434, YH4444	1.10	Yellow, White

* Use CFN-FR for single tap installation; use CFR-FR when 2 or more tap conductors are installed.

† Two-piece design packaged together.
Note: All dimensions shown are for reference only.

TYPE CCF-FR

CLEAR H-TAP — FLAME RETARDANT COVER

UL Listed to 600 Volts



600 VOLT 90° C

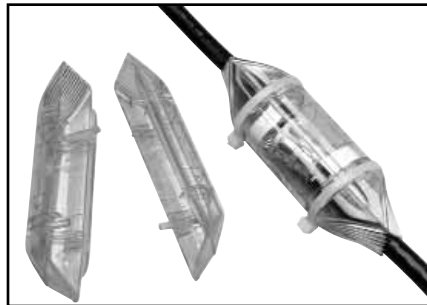

Features and Benefits (continued)

- Mounted Magnifying Lens provides increased visibility of Die Embossment on installed H-Tap Connectors.
- Made of Polished Clear Polycarbonate material that provides:
 - ◇ High visibility for inspection of installed connectors.

Features and Benefits (continued)

- ◇ Flame Retardant UL94 V-O Rated Material –self-extinguishing retardant properties
- ◇ High Impact design
- Built in Channels to accommodate and hold Cable ties, Hook & Loop ties, or Waxed Cord, securely in place after installation.
- Patented highly flexible fingers designed to contour around the conductor.
- Internal pockets designed to accommodate Identification tags (4 ID tags included).
- Molded barriers prevent installed H-Tap Connectors from Electrical Flashover.
- Covers come packaged complete with (2) Cover Halves, (2) Cable Ties and (4) Identification Labels.

Catalog Number	Max. Conductor Accommodated	Matched H Copper CRIMPIT™	Max. Connector Length	Connector Color Code
CCFBG-FR	#8 AWG	YH8C8C	.65	Green
	#6 AWG	YH6C6C		Orange
CCF0-FR	#2 AWG	YH2C2C	.80	Brown
CCFD-FR	250 kcmil	YH292C, YH298C	.95	Purple
CCFDX-FR	250 kcmil	YH2929	.95	Purple
CCFN-FR	500 kcmil	YH3434, YH3429*	1.10	Brown
CCFR-FR	750 kcmil	YH3939, YH3931, YH4429	1.30	Yellow
	1000 kcmil	YH4434, YH4444	1.10	White

* Use CCFN-FR for single tap installation; use CCFR-FR when 2 or more tap conductors are installed.

Note: All dimensions shown are for reference only.

Blue highlighted items are industry standard and most frequently ordered.

TYPES YSH

H COPPER CRIMPIT™

**COPPER SPLIT
COMPRESSION WYE TAP
CONNECTOR**

Type YSH heavy duty connectors are designed for insulated underground wye splices. The split H copper CRIMPIT™ connector is longer than our standard H copper CRIMPIT™ and is suitable for use on high voltage (15 kV) power cables with copper conductors. The connectors can not be used with oil filled or mass impregnated cables since no oil stop is provided. The connector is installed with standard BURNDY® HYPRESS™ tools and is made of tin-plated electrolytic copper.

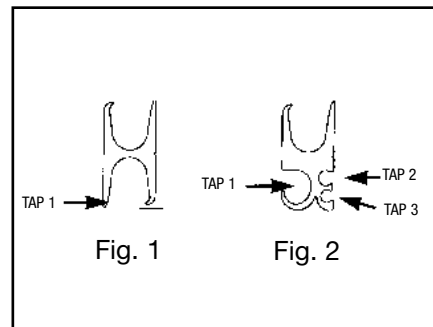
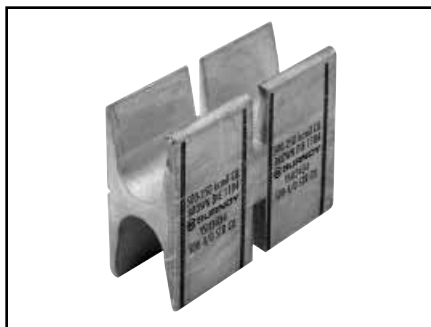

Features and Benefits

- Accommodates a wide range of run/tap copper cable combinations including both flexible and code combinations. All (B/B, B/I, I/B, I/I) combinations acceptable.
 - ◇ Each connector has many copper cable combination applications allowing maximum flexibility for the design and installation of a system.
- Tap grooves function independently from each other. Use of one tap is required. Balance may be used or left empty.
 - ◇ Provides maximum design and installation flexibility.
- Color code on the connector matches installation die.
 - ◇ Provides matched system for fast and easy installation.
- Die index embossed on connector after completion of crimp.
 - ◇ Permanent inspectability of installed connectors to ensure consistently reliable and dependable connections.
- Insulation is not provided. Insulation can be obtained from Raychem (800-272-9243) type HVSY Splice kits for 15 kV installations.
 - ◇ A complete IEEE 404 15 kV installation is provided.

Expanded Tap 1 Components	
Expanded Catalog Number	Tap 1 Range
YSH-292C-E	#2
YSH-2925-E	1/0

Catalog Number	Conductor Sizes Code Expanded Tap 1 (Flex Cable)				▲ Tooling (†Number of Crimps)				Die Index ▲ & Embossment	H	W	L	Strip Length	
	Fig.	Main	Tap 1	Tap 2	Tap 3	Y750	†	Y46*						†
YSH2929	1	250-2 (4/0-2)	250-2 (4/0-2)			U654	(4)	U654 P654	(4)/(2)	Purple	654	1.85	.90	See Application Notes Below
YSH3429	2	500-4/0 (350-4/0)	250-1/0 (4/0-1/0)	1-6 Str./Sol. (1-8)	8-14 (8-14)	U1104	(4)	U1104 P1104	(4)/(2)	Brown	1104	2.23	1.31	
YSH3434	1	500-250 (350-4/0)	500-4/0 (350-4/0)			U1104	(4)	U1104 P1104	(4)/(2)	Brown	1104	2.43	1.15	
YSH3931	2	750-350 (550-500)	350-1/0 (350-1/0)	1-6 Str./Sol. (1-8)	2-14 (2-14)	—	—	PYFR	2	Yellow	K-R	2.97	1.50	
YSH3939	1	750-350 (550-500)	750-350 (550-350)			—	—	PYFR	2	Yellow	K-R	2.97	1.50	

* Use PUADP-1 adaptor with U dies in Y46. The Y46 and P dies result in a smooth crimp surface and is recommended for voltages above 600 V.

▲ See tooling section of this catalog for complete tool and die listings.
† Number of crimps per connector. U -dies require double crimps.

Note: All dimensions shown are for reference only.

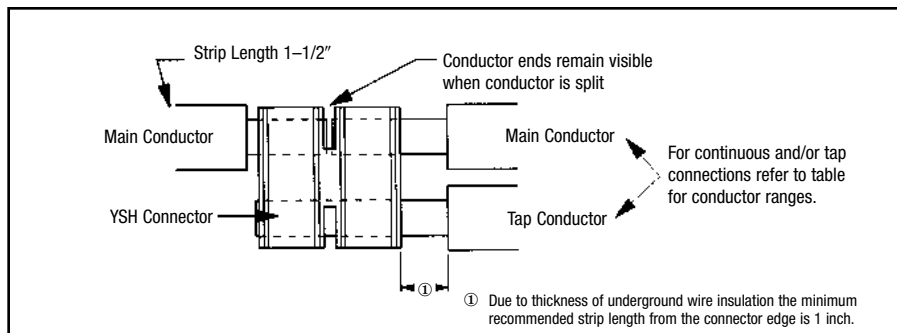

Blue highlighted items are industry standard and most frequently ordered.

C-108

TYPES YST

UNINSULATED T

COPPER HYTEE™ COUPLER

UL Listed 90° C,
600 Volts to 35 kV◆

Type YST copper compression tee is designed for connecting a run conductor with a perpendicular tap conductor.

YST connectors are commonly used in junction boxes and manholes to make a radial tap off a main run. They are needed in many industrial, utility generation and commercial applications. The most common cable combinations are listed below. BURNDY® Type Y-R reducers can be used to accommodate most cable combinations.

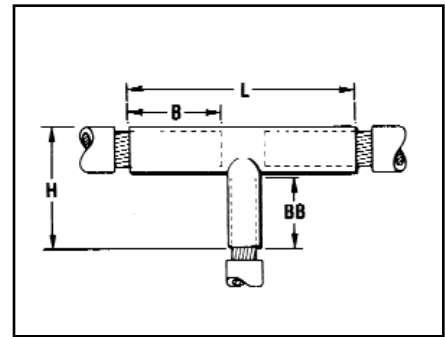
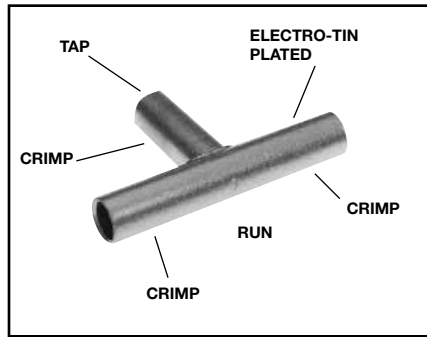

Features and Benefits

- Manufactured from seamless high conductivity electrolytic copper tubing with heavy duty wall thickness.
 - ◇ Provides maximum conductivity, low resistance and ductility for an excellent combination of electrical and crimp forming properties.
- Long barrel design on all three (3) legs.
 - ◇ Provides for an additional crimp or indent with almost twice the pull out strength properties as a standard length barrel plus a connection that will operate cooler under heavy loading.
- Long barrel permits the use of the Y-R reducers.
 - ◇ Affords total flexibility and versatility for virtually any conductor combination.
- Electro-tin plated.
 - ◇ Provides durable long-lasting corrosion resistance.
- Barrel diameter closely matches commercial (code) cable and Navy cable diameters.
 - ◇ Provides an excellent relationship of the conductor/ connector combination to produce a high quality electrical connection with the recommended tooling.

Catalog Number	Code • Conductors		Dimensions				Dieless (# of crimps)		Installation Tooling ▲						Wire Length		
									Run Conductors			Tap Conductors					
									Y35, ▲ Y39, Y750, Y46*			Y35, ▲ Y39, Y750, Y46*					
									Die Number (# of crimps)	Color Code	Die Index	Die Number (# of crimps)	Color Code	Die Index▲			Run
YST4C4C	4 str.	4 str.	1.44	1.38	1.72	3.25	Y81KFT (1) Y81KFTMBH (1) PAT81KFT-18V (1)	MY29-3 (2) MY29-11 (2) MD6 (4) ** MD7 (4) **	Y644HS (1)	U4CRT (2)	Gray	8 or 346	U4CRT (2)	Gray	8 or 346	1-3/16"	1-3/16"
YST2C2C	2 str.	2 str.	1.56	1.56	1.98	3.56				U2CRT (2)	Brown	10	U2CRT (2)	Brown	10	1-5/16"	1-5/16"
YST2525	1/0 str.	1/0 str.	1.62	1.56	1.91	3.81				U24RT (2)	Pink	12 or 348	U25RT (2)	Pink	12 or 348	1-7/16"	1-7/16"
YST2626	2/0 str.	2/0 str.	1.69	1.67	2.18	3.94				U26RT (2)	Black	13	U26RT (2)	Black	13	1-9/16"	1-9/16"
YST282C	4/0 str.	2 str.	1.75	1.50	2.12	3.94				U28RT (2)	Purple	15	U2CRT (2)	Brown	10	1-11/16"	1-5/16"
YST2825	4/0 str.	1/0 str.	1.75	1.56	2.25	4.00				U28RT (2)	Purple	15	U25RT (2)	Pink	12 or 348	1-11/16"	1-3/16"
YST2828	4/0 str.	4/0 str.	1.75	1.75	2.44	4.19				U28RT (2)	Purple	15	U28RT (2)	Purple	15	1-11/16"	1-11/16"
YST2929	250 kcmil	250 kcmil	1.75	1.78	2.53	4.25				U29RT (2)	Yellow	16	U29RT (2)	Yellow	16	1-11/16"	1-11/16"
YST3131	350 kcmil	350 kcmil	2.31	2.25	3.12	5.50				U31RT (4)	Red	18 or 324	U31RT (4)	Red	18 or 324	2"	2"
YST3428	500 kcmil	4/0 str.	2.56	1.75	2.81	5.81				U34RT (4)	Brown	20 or 299	U28RT (2)	Purple	15	2-5/16"	1-11/16"
YST3434	500 kcmil	500 kcmil	2.25	2.70	3.76	6.19	U34RT (4)	Brown	20 or 299	U34RT (4)	Brown	20 or 299	2-5/16"	2-5/16"			
YST3939	750 kcmil	750 kcmil	3.46	3.34	4.64	8.12	U39RT (4)	Black	24 or 473	U39RT (4)	Black	24 or 473	2-15/16"	2-15/16"			

* Use adapter PUADP-1 with U Dies in Y46 HYPRESS™.
 ** Use with appropriate W Dies (see page O-29).
 ■ The maximum size for the Y35 is 400 kcmil.
 ● Contact factory for conductor combinations not shown.
 ▲ See tooling section of this catalog for complete tool and die listings.

◆ For applications greater than 2000 Volts consult cable manufacturer for voltage stress relief instructions.
Note: All dimensions shown are for reference only.

Blue highlighted items are industry standard and most frequently ordered.

T-CONNECTOR

TYPE NYT

CABLE RUN – CABLE TAP

UL Listed 90° C,
 600 Volts to 35 kV ◆

A T connector designed to provide a clamp-type element on the run and a permanent HYPRESS™ connection on the tap. Recommended for use on ring buses or for applications where occasional disconnects from the run conductor are desired without disturbing the tap connection. Tin plated. For proper installation of tap cable, see table below.

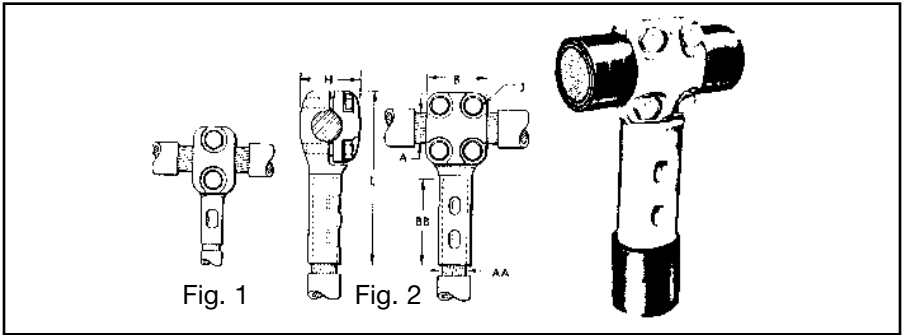

C-109

Conductor Size		Catalog Number	Fig. No.	Dimensions in Inches					Installation Information				(No. of Indents)	App. Ship. Wt. in Lbs.
									HYPRESS™ and Indentor Die					
Run A	Tap AA			B	BB	H	J	L	Y29B with Y29PR	Y34A with Y34PR	Y34B with Y34PR	Y48B with Y44PR		
4/0 Str.	4/0 Str.	NYT2828	2	2	1-5/8	1-3/8	3/8	4-5/16	D28L	A28D	B28D	E28D	(1)	2.2
250 kcmil	1/0 Str.	NYT2925	1	1-3/8	1-3/8	1-7/16	3/8	4-1/16	D25L	A25D	B25D	—	(1)	1.5
	250 kcmil	NYT2929	2	2	1-5/8	1-7/16	3/8	4-7/16	D29L	A29D	B29D	E29D	(1)	2.2
500 kcmil	2/0 Str.	NYT3426	1	1-3/8	1-1/2	1-5/8	3/8	4-7/16	D26L	A26D	B26D	—	(1)	1.7
	4/0 Str.	NYT3428	2	2	1-5/8	1-5/8	3/8	4-5/8	D28L	A28D	B28D	E28D	(1)	2.5
	250 kcmil	NYT3429	2	2	1-5/8	1-5/8	3/8	4-5/8	D29L	A29D	B29D	E29D	(1)	2.5
	500 kcmil	NYT3434	2	2	2-1/4	1-5/8	3/8	5-3/8	—	A34D	No Nest Die Req.	E34D	(2)	2.5
750 kcmil	250 kcmil	NYT3929	2	2	1-5/8	1-7/8	3/8	4-13/16	D29L	A29D	B29D	E29D	(1)	2.5
	500 kcmil	NYT3934	2	2	2-1/4	1-7/8	3/8	5-9/16	—	A34D	No Nest Die Req.	E34D	(2)	2.7
1000 kcmil	250 kcmil	NYT4429	2	2	1-5/8	2-1/8	3/8	5	D29L	A29D	B29D	E29D	(1)	2.5
	350 kcmil	NYT4431	2	2	2	2-1/8	3/8	5-7/16	—	A31D	B31D	E31D	(2)	2.5
	500 kcmil	NYT4434	2	2	2-1/4	2-1/8	3/8	5-3/4	—	A34D	No Nest Die Req.	E34D	(2)	2.7
	1000 kcmil	NYT4444	2	2-11/16	3	2-5/16	1/2	7	—	—	—	No Nest Die Req.	(2)	3.2
1500 kcmil	1500 kcmil	NYT4646	2	2-11/16	3-3/16	2-3/4	1/2	7-11/16	—	—	—	C46D*	(2)	8.0

* Y48B Hypress™ with Y48PR indentor.
 ◆ For applications greater than 2000 Volts consult cable manufacturer for voltage stress relief instructions.

Note: Circumferential dies may be used. For information contact BURNDY®.
Note: All dimensions shown are for reference only.

Blue highlighted items are industry standard and most frequently ordered.

Compression Connections

BURNDY®

Copper Compression – Adaptors

C-110

TYPES YE-P, YE-P-FX

HYPLUG™ FOR COPPER CONDUCTOR

Type YE-P copper compression adaptors are designed for reliable termination of **copper** conductor when the current capacity of the conductor is downsized, but larger conductor is utilized. Typical applications are for voltage drop protection when oversized conductors are used or flex conductor is used. These adaptors facilitate the termination into existing mechanical set screw connectors for various stranded copper cables.

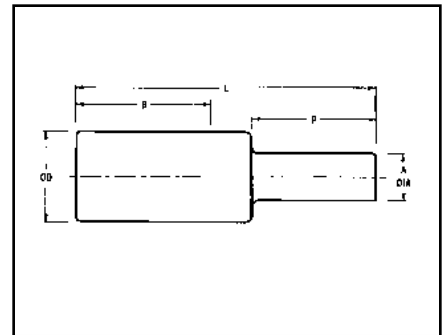

For Aluminum HYPLUG™ go to page C-118



Catalog Number	Accommodates Copper Wire Sizes			Pin Size	Dimensions					Installation Data													
	Flex Cable	Code AWG	Navy		Equiv	A Dia. [MM]	B [MM]	L [MM]	P [MM]	OD [MM]	Color Code	Die Index	Mech Tools (# of Crimps)				Hydraulic Tools (# of Crimps)					Y644M (Accommodates Expanded Wire Range)	Cable Strip Length
													MY	Y2MR	MD7-34R	MD6/MD7	Y35/Y39	Y45	④ Y46	Y60BHU			
YE4CP20X75FX	#4 Str (91/24-105/24)	#4	40	#4	.20 [5]	1.37 [35]	2.27 [58]	.75 [19]	.38 [10]	Gray	8	MY29-11 (2)	Y2MR (4)	W4CVT (4)	W4CRT (4)	U4CRT (2)	U4CRT (2)	U4CRT (2)	—	#4 - #6 AWG (1)	1-15/32"		
YE2CP26X75FX	#2 Str (125/24-150/24)	#2	60	#2	.26 [7]	1.65 [42]	2.60 [66]	.75 [19]	.46 [12]	Brown	10	MY29-11 (2)	Y2MR (4)	W2CVT (4)	W2CRT (4)	U2CRT (2)	U2CRT (2)	U2CRT (2)	—	#2 - #6 AWG (1)	1-3/4"		
YE1CP29X75FX	#1 Str (175/24-225/24)	#1	75	#1	.29 [8]	1.66 [42]	2.63 [67]	.75 [19]	.51 [13]	Green	11	MY29-11 (2)	—	W1CVT (4)	W1CRT (4)	U1CRT-1 (2)	U1CRT-1 (2)	U1CRT-1 (2)	—	#1 - #6 AWG (1)	1-3/4"		
YE25P33X75FX	1/0 Str (275/24)	1/0	100	1/0	.33 [8]	1.80 [46]	2.80 [71]	.75 [19]	.56 [14]	Pink	12	MY29-11 (2)	—	W25VT (4)	W25RT (4)	U25RT (2)	U25RT (2)	U25RT (2)	—	1/0 - #6 AWG (1)	1-7/8"		
YE26P37X75FX	2/0 Str (325/24)	2/0	125	2/0	.37 [9]	1.82 [46]	2.86 [73]	.75 [19]	.63 [16]	Black	13	MY29-11 (2)	—	W26VT (4)	W26RT (4)	U26RT (2)	U26RT (2)	U26RT (2)	—	2/0 - #4 AWG (1)	1-7/8"		
YE27P41X82FX	3/0 Str (450/24)	3/0	150	3/0	.41 [10]	1.97 [50]	3.11 [77]	.82 [21]	.70 [18]	Orange	14	MY29-11 (2)	—	W27VT (4)	W27RT (4)	U27RT (2)	U27RT (2)	U27RT (2)	—	3/0 - #2 AWG (1)	2-1/16"		
YE28P46X92FX	4/0 Str (550/24)	4/0	200	4/0	.46 [12]	1.99 [51]	3.28 [81]	.92 [23]	.77 [20]	Purple	15	MY29-11 (2)	—	W28VT (4)	W28RT (4)	U28RT (2)	U28RT (2)	U28RT (2)	—	4/0 - #1 AWG (1)	2-1/16"		
Flex Cable Only																							
YE30P50X100FX	250 kcmil Flex CLASS G 259 CLASS H 427	—	—	250 kcmil	.50 [10]	2.37 [60]	3.75 [95]	1.00 [25]	.81 [21]	Yellow	16	MY29-11 (2)	—	W29VT (4)	W29RT (4)	U29RT (2)	U29RT (2)	U29RT (2)	L29RT (1)	(1)	2-3/8"		
YE31P51X102FX	262.6 kcmil Flex 250 Flex CLASS I, K, M	—	—	262.6 kcmil	.51 [13]	2.39 [61]	3.82 [97]	1.02 [26]	.88 [22]	White	17	—	—	W30VT (8)	W30RT (8)	U30RT (4)	U30RT (4)	U30RT (4)	L30RT (1)	(1)	2-1/2"		
YE32P55X110FX	313.1 kcmil (775/24) (300 kcmil Nom)	—	—	300 kcmil	.55 [14]	2.53 [65]	4.08 [104]	1.10 [28]	.95 [24]	Red	18	—	—	W31VT (8)	W31RT (8)	U31RT (4)	U31RT (4)	U31RT (4)	L31RT (1)	(1)	2-5/8"		
YE34P59X118FX	373.7 kcmil (925/24) (350 kcmil Nom)	—	—	350 kcmil	.59 [15]	2.68 [68]	4.36 [111]	1.18 [30]	1.06 [27]	Blue	19	—	—	W32VT (8)	W32RT (8)	U32RT (4)	U32RT (4)	U32RT (4)	L32RT (2) 1	(1)	2-3/4"		
YE36P67X134FX	444.4 kcmil (1100/24) (450 kcmil Nom)	—	—	450 kcmil	.67 [17]	3.14 [80]	5.04 [128]	1.34 [34]	1.19 [30]	Brown	20	—	—	—	—	U34RT (4)	U34RT (4)	U34RT (4)	L34RT (2)	(1)	3-1/4"		
YE38P71X142FX	535.3 kcmil (1325/24) (500 kcmil Nom)	—	—	500 kcmil	.71 [18]	3.29 [84]	5.30 [135]	1.42 [36]	1.25 [32]	Pink	L99	—	—	—	—	U38XRT (4)	U38XRT (4)	U38XRT (4)	—	(1)	3-3/8"		
YE40P78X156FX	646 kcmil (1600/24) (600 kcmil Nom)	—	—	600 kcmil	.78 [20]	3.31 [84]	5.51 [140]	1.56 [40]	1.35 [34]	Black	24	—	—	—	—	U39RT (4)	U39RT (4)	U39RT (4)	L39RT (2)	(1)	3-7/16"		
YE44P87X174FX	777.7 kcmil (1925/24) (750 kcmil Nom)	—	—	750 kcmil	.87 [22]	3.54 [90]	5.99 [152]	1.74 [44]	1.50 [38]	Yellow	L115	—	—	—	—	U44XRT (4)	U44XRT (4)	U44XRT (4)	—	(1)	3-5/8"		
Code Conductor Only AWG																							
YE29P50X100	250 kcmil	250	—	250 kcmil	.50 [13]	1.99 [51]	3.33 [84]	1.00 [25]	.75 [19]	Yellow	16	MY29-11 (2)	—	W29VT (4)	W29RT (4)	U29RT (2)	U29RT (2)	U29RT (2)	L29RT (1)	250 kcmil - 1/0 AWG (1)	2-1/2"		
YE30P55X110	300 kcmil	300	—	300 kcmil	.55 [14]	2.37 [60]	3.85 [98]	1.10 [28]	.81 [21]	White	17	—	—	W30VT (8)	W30RT (8)	U30RT (4)	U30RT (4)	U30RT (4)	L30RT (1)	300 kcmil - 2/0 AWG (1)	2-5/8"		
YE31P59X118	350 kcmil	350	—	350 kcmil	.59 [15]	2.39 [61]	3.98 [101]	1.18 [30]	.88 [22]	Red	18	—	—	W31VT (8)	W31RT (8)	U31RT (4)	U31RT (4)	U31RT (4)	L31RT (1)	350 kcmil - 3/0 AWG (1)	2-3/4"		
YE32P63X126	400 kcmil	400	—	400 kcmil	.63 [16]	2.53 [65]	4.24 [108]	1.26 [32]	.95 [24]	Blue	19	—	—	W32VT (8)	W32RT (8)	U32RT (4)	U32RT (4)	U32RT (4)	L32RT (1)	450 kcmil - 4/0 AWG (1)	3-1/4"		
YE34P71X142	500 kcmil	—	—	500 kcmil	.71 [18]	2.68 [68]	4.60 [117]	1.42 [36]	1.06 [27]	Brown	20	—	—	W34VT (8)	W34RT (8)	U34RT (4)	U34RT (4)	U34RT (4)	L34RT (2)	500 kcmil - 4/0 AWG (1)	3-3/8"		
YE36P78X156	600 kcmil	—	—	600 kcmil	.78 [20]	3.14 [80]	5.25 [133]	1.56 [40]	1.19 [30]	Green	22	—	—	—	—	U36RT (4)	U36RT (4)	U36RT (4)	L36RT (2)	600 kcmil - 250 kcmil (1)	3-7/16"		
YE39P87X174	750 kcmil	—	—	750 kcmil	.87 [22]	3.37 [86]	5.73 [145]	1.74 [44]	1.30 [33]	Black	24	—	—	—	—	U39RT (4)	U39RT (4)	U39RT (4)	L39RT (2)	750 kcmil - 500 kcmil (1)	3-5/8"		

1 For sizes above 4/0 the MD6-6R2 must be used.

④ To use U Dies in Y46 HYPRESS™, catalog number PUADP-1 die adaptor is required.

Note: All dimensions shown are for reference only.

Blue highlighted items are industry standard and most frequently ordered.

Catalog Number	Accommodates Copper Wire Sizes				Pin Size	Dimensions					Installation Data														Cable Strip Length
	Flex Cable	Code AWG	Navy	Equiv- alent		A Dia. [MM]	B [MM]	L [MM]	P [MM]	OD [MM]	Color Code	Die Index	Mech Tools (# of Crimps)				Hydraulic Tools (# of Crimps)				Y644M (Accommodates Expanded Wire Range)				
													MY	Y2MR	MD7-34R	MD6/MD7	Y35/Y39	Y45	④ Y46	Y608HU					
YE20CP23X75FX	#2 Str. (125/24-150/24)	#2	60	#3	.23 [6]	1.65 [42]	2.60 [66]	.75 [19]	.46 [12]	Brown	10	MY29-11 (2)	Y2MR (4)	W25VT (2)	W2CVT (2)	U2CRT (2)	U2CRT (2)	U2CRT (2)	—	#2 - #6 AWG (1)	1-3/4"				
YE11CP26X75FX	#1 Str. (175/24-225/24)	#1	75	#2	.26 [7]	1.66 [42]	2.63 [67]	.75 [19]	.51 [13]	Green	11	MY29-11 (2)	—	W1CVT (2)	W1CVT (2)	U1CRT (2)	U1CRT (2)	U1CRT (2)	—	#1 - #6 AWG (1)	1-3/4"				
YE25P29X75FX	1/0 Str. (275/24)	1/0	100	#1	.29 [8]	1.80 [46]	2.80 [71]	.75 [19]	.56 [14]	Pink	12	MY29-11 (2)	—	W25VT (4)	W25VT (4)	U25RT (2)	U25RT (2)	U25RT (2)	—	1/0 - #6 AWG (1)	1-7/8"				
YE26P33X75FX	2/0 Str. (325/24)	2/0	125	1/0	.33 [8]	1.82 [46]	2.86 [73]	.75 [19]	.63 [16]	Black	13	MY29-11 (2)	—	W26VT (4)	W26VT (4)	U26RT (2)	U26RT (2)	U26RT (2)	—	2/0 - #4 AWG (1)	1-7/8"				
YE27P37X75FX	3/0 Str. (450/24)	3/0	150	2/0	.37 [9]	1.97 [50]	3.04 [77]	.75 [19]	.70 [18]	Orange	14	MY29-11 (2)	—	W27VT (4)	W27VT (4)	U27RT (2)	U27RT (2)	U27RT (2)	—	3/0 - #2 AWG (1)	2-1/16"				
YE28P41X75FX	4/0 Str. (550/24)	4/0	200	3/0	.41 [10]	1.99 [51]	3.18 [81]	.75 [21]	.77 [20]	Purple	15	MY29-11 (2)	—	W28VT (4)	W28VT (4)	U28RT (2)	U28RT (2)	U28RT (2)	—	4/0 - #1 AWG (1)	2-1/16"				
Flex Cable Only																									
YE30P46X92FX	250 kcmil Flex CLASS G 259 CLASS H 427	—	—	4/0	.46 [12]	2.37 [60]	3.67 [93]	.92 [23]	.81 [21]	Yellow	16	MY29-11 (2)	—	W29VT (4)	W29VT (4)	U29RT (2)	U29RT (2)	U29RT (2)	L29RT (1)	(1)	2-3/8"				
YE32P51X102FX	313.1 kcmil (775/24) (300 kcmil Nom)	—	—	250 kcmil	.51 [13]	2.53 [65]	4.00 [102]	1.02 [26]	.95 [24]	Red	18	—	—	W31VT (8)	—	U31RT (4)	U31RT (4)	U31RT (4)	L31RT (1)	(1)	2-5/8"				
YE34P55X110FX	373.7 kcmil (925/24) (350 kcmil Nom)	—	—	300 kcmil	.55 [14]	2.68 [68]	4.28 [109]	1.10 [28]	1.06 [27]	Blue	19	—	—	W32VT (8)	—	U32RT (4)	U32RT (4)	U32RT (4)	L32RT (2)	(1)	2-3/4"				
YE36P59X118FX	444.4 kcmil (1100/24) (450 kcmil Nom)	—	—	350 kcmil	.59 [15]	3.14 [80]	4.88 [124]	1.18 [30]	1.19 [30]	Brown	20	—	—	—	—	U34RT (4)	U34RT (4)	U34RT (4)	L34RT (2)	(1)	3-1/4"				
YE38P67X134FX	535.3 kcmil (1325/24) (500 kcmil Nom)	—	—	450 kcmil	.67 [17]	3.29 [84]	5.22 [133]	1.34 [34]	1.25 [32]	Pink	L99	—	—	—	—	U38XRT (4)	U38XRT (4)	U38XRT (4)	—	(1)	3-3/8"				
YE40P71X142FX	646 kcmil (1600/24) (600 kcmil Nom)	—	—	500 kcmil	.71 [18]	3.31 [84]	5.27 [136]	1.42 [36]	1.35 [34]	Black	24	—	—	—	—	U39RT (4)	U39RT (4)	U39RT (4)	L39RT (2)	(1)	3-7/16"				
YE44P78X156FX	777.7 kcmil (1925/24) (750 kcmil Nom)	—	—	600 kcmil	.78 [20]	3.54 [90]	5.81 [148]	1.56 [40]	1.50 [38]	Yellow	L115	—	—	—	—	U44XRT (4)	U44XRT (4)	U44XRT (4)	—	(1)	3-5/8"				
Code Conductor Only AWG																									
YE29P46X92	250 kcmil	250	—	4/0	.46 [12]	2.37 [60]	3.25 [82]	.92 [23]	.75 [19]	Yellow	16	MY29-11 (2)	—	W29VT (4)	W29RT (4)	U29RT (2)	U29RT (2)	U29RT (2)	L29RT (1)	250 kcmil - 1/0 AWG (1)	2-1/2"				
YE30P50X100	300 kcmil	300	—	250 kcmil	.51 [13]	2.39 [61]	3.75 [95]	1.00 [25]	.81 [21]	White	17	—	—	W30VT (8)	W30RT (8)	U30RT (4)	U30RT (4)	U30RT (4)	L30RT (1)	300 kcmil - 2/0 AWG (1)	2-5/8"				
YE31P55X110	350 kcmil	350	—	300 kcmil	.55 [14]	2.53 [65]	3.90 [99]	1.10 [28]	.88 [22]	Red	18	—	—	W31VT (8)	W31RT (8)	U31RT (4)	U31RT (4)	U31RT (4)	L31RT (1)	350 kcmil - 3/0 AWG (1)	2-3/4"				
YE32P59X118	400 kcmil	400	—	350 kcmil	.59 [15]	2.68 [68]	4.16 [106]	1.18 [30]	.95 [24]	Blue	19	—	—	W32VT (8)	W32RT (8)	U32RT (4)	U32RT (4)	U32RT (4)	L32RT (2)	450 kcmil - 4/0 AWG (1)	3-1/4"				
YE34P63X126	500 kcmil	—	—	400 kcmil	.63 [16]	3.14 [80]	4.44 [113]	1.26 [32]	1.06 [27]	Brown	20	—	—	W34VT (8)	W34RT (8)	U34RT (4)	U34RT (4)	U34RT (4)	L34RT (2)	500 kcmil - 4/0 AWG (1)	3-3/8"				
YE36P71X142	600 kcmil	—	—	500 kcmil	.71 [18]	3.37 [86]	5.11 [130]	1.42 [36]	1.19 [30]	Green	22	—	—	—	—	U36RT (4)	U36RT (4)	U36RT (4)	L36RT (2)	600 kcmil - 250 kcmil (1)	3-7/16"				
YE39P78X156	750 kcmil	—	—	600 kcmil	.78 [20]	3.37 [86]	5.55 [141]	1.56 [40]	1.30 [33]	Black	24	—	—	—	—	U39RT (4)	U39RT (4)	U39RT (4)	L39RT (2)	750 kcmil - 500 kcmil (1)	3-5/8"				

1 For sizes above 4/0 the MD6-6R2 must be used.
 ④ To use U Dies in Y46 HYPRESS™, Catalog number PUADP-1 die adaptor is required.
Note: All dimensions shown are for reference only.

Blue highlighted items are industry standard and most frequently ordered.

Compression Connections

BURNDY®

Copper Compression – Adaptors

REDUCED PIN DIAMETER

C-112

Catalog Number	Accommodates Copper Wire Sizes			Pin Size	Dimensions					Installation Data												
	Flex Cable	Code AWG	Navy		Equiv- alent	A Dia. [MM]	B [MM]	L [MM]	P [MM]	OD [MM]	Color Code	Die Index	Mech Tools (# of Crimps)				Hydraulic Tools (# of Crimps)					Cable Strip Length
													MY	Y2MR	MD7-34R	MD6/ MD7	Y35/Y39	Y750	Y45	④ Y46	Y60BHU	
YEV4CP16X75FX	#4 Str. (91/24-105/24)	#4	40	#6	.16 [4]	1.37 [35]	2.27 [58]	.75 [19]	.38 [10]	Gray	8	MY29-11 (2)	Y2MR (4)	W4CVT (4)	W4CRT (4)	U4CRT (2)	U4CRT (2)	U4CRT (2)	—	#4 - #6 AWG (1)	1-15/32"	
YEV2CP20X75FX	#2 Str. (125/24-150/24)	#2	60	#4	.20 [5]	1.65 [42]	2.60 [66]	.75 [19]	.46 [12]	Brown	10	MY29-11 (2)	Y2MR (4)	W2CVT (4)	W2CRT (4)	U2CRT (2)	U2CRT (2)	U2CRT (2)	—	#2 - #6 AWG (1)	1-3/4"	
YEV1CP23X75FX	#1 Str. (175/24-225/24)	#1	75	#3	.23 [6]	1.66 [42]	2.63 [67]	.75 [19]	.51 [13]	Green	11	MY29-11 (2)	—	W1CVT (4)	W1CRT (4)	U1CRT-1 (2)	U1CRT-1 (2)	U1CRT-1 (2)	—	#1 - #6 AWG (1)	1-3/4"	
YEV25P26X75FX	1/0 Str. (275/24)	1/0	100	#2	.26 [7]	1.80 [46]	2.80 [71]	.75 [19]	.56 [14]	Pink	12	MY29-11 (2)	—	W25VT (4)	W25RT (4)	U25RT (2)	U25RT (2)	U25RT (2)	—	1/0 - #6 AWG (1)	1-7/8"	
YEV26P29X75FX	2/0 Str. (325/24)	2/0	125	#1	.29 [8]	1.82 [46]	2.86 [73]	.75 [19]	.63 [16]	Black	13	MY29-11 (2)	—	W26VT (4)	W26RT (4)	U26RT (2)	U26RT (2)	U26RT (2)	—	2/0 - #4 AWG (1)	1-7/8"	
YEV27P33X75FX	3/0 Str. (450/24)	3/0	150	1/0	.33 [8]	1.97 [50]	3.04 [77]	.75 [19]	.70 [18]	Orange	14	MY29-11 (2)	—	W27VT (4)	W27RT (4)	U27RT (2)	U27RT (2)	U27RT (2)	—	3/0 - #2 AWG (1)	2-1/16"	
YEV28P37X75FX	4/0 Str. (550/24)	4/0	200	2/0	.37 [9]	1.99 [51]	3.11 [81]	.75 [19]	.77 [20]	Purple	15	MY29-11 (2)	—	W28VT (4)	W28RT (4)	U28RT (2)	U28RT (2)	U28RT (2)	—	4/0 - #1 AWG (1)	2-1/16"	
Flex Cable Only																						
YE31P41X82FX	262.6 kcmil Flex 250 Flex CLASS I, K, M	—	3/0	—	.41 [10]	2.39 [61]	3.62 [92]	.82 [21]	.88 [22]	White	17	—	—	W30VT (8)	W30RT (8)	U30RT (4)	U30RT (4)	U30RT (4)	L30RT (1)	(1)	2-1/2"	
YE34P51X102FX	373.7 kcmil (925/24) (350 kcmil Nom)	—	250	—	.51 [13]	2.68 [68]	4.20 [107]	1.02 [26]	1.06 [27]	Blue	19	—	—	W32VT (8)	W32RT (8)	U32RT (4)	U32RT (4)	U32RT (4)	L32RT (2) 1	(1)	2-3/4"	
YE38P59X118FX	535.3 kcmil (1325/24) (500 kcmil Nom)	—	350	—	.59 [15]	3.29 [84]	5.06 [129]	1.18 [30]	1.25 [32]	Pink	L99	—	—	—	—	U38XRT (4)	U38XRT (4)	U38XRT (4)	—	(1)	3-3/8"	
YE40P67X134FX	646 kcmil (1600/24) (600 kcmil Nom)	—	450	—	.67 [17]	3.31 [84]	5.29 [134]	1.34 [34]	1.35 [34]	Black	24	—	—	—	—	U39RT (4)	U39RT (4)	U39RT (4)	L39RT (2)	(1)	3-7/16"	
Code Conductor Only AWG																						
YE29P31X109	250 kcmil	250	#1	.31 [51]	1.99 [79]	3.32 [92]	1.09 [28]	.75 [19]	Yellow	16	MY29-11 (2)	—	W29VT (4)	W29RT (4)	U29RT (2)	U29RT (2)	U29RT (2)	L29RT (1)	250 kcmil - 1/0 AWG (1)	2-1/2"		
YE29P41X82			3/0	.41 [10]	1.99 [51]	3.15 [80]	.82 [21]	.75 [19]	Yellow	16	MY29-11 (2)	—	W29VT (4)	W29RT (4)	U29RT (2)	U29RT (2)	U29RT (2)	L29RT (1)	250 kcmil - 1/0 AWG (1)	2-1/2"		
YE30P46X92	300 kcmil	300	4/0	.46 [12]	2.37 [60]	3.67 [93]	.92 [23]	.81 [21]	White	17	—	—	W30VT (8)	W30RT (8)	U30RT (4)	U30RT (4)	U30RT (4)	L30RT (1)	300 kcmil - 2/0 AWG (1)	2-5/8"		
YE31P50X100	350 kcmil	350	250	.51 [13]	2.39 [61]	3.80 [96]	1.00 [25]	.88 [22]	Red	18	—	—	W31VT (8)	W31RT (8)	U31RT (4)	U31RT (4)	U31RT (4)	L31RT (1)	350 kcmil - 3/0 AWG (1)	2-3/4"		
YE32P55X110	400 kcmil	400	300	.55 [14]	2.53 [65]	4.08 [104]	1.10 [28]	.95 [24]	Blue	19	—	—	W32VT (8)	W32RT (8)	U32RT (4)	U32RT (4)	U32RT (4)	L32RT (1)	450 kcmil - 4/0 AWG (1)	3-1/4"		
YE34P59X118	500 kcmil	—	350	.59 [15]	2.68 [68]	4.36 [111]	1.18 [30]	1.06 [27]	Brown	20	—	—	W34VT (8)	W34RT (8)	U34RT (4)	U34RT (4)	U34RT (4)	L34RT (2)	500 kcmil - 4/0 AWG (1)	3-3/8"		
YE36P63X126	600 kcmil	—	400	.63 [16]	3.14 [80]	4.95 [126]	1.26 [32]	1.19 [30]	Green	22	—	—	—	—	U36RT (4)	U36RT (4)	U36RT (4)	L36RT (2)	600 kcmil - 250 kcmil (1)	3-7/16"		
YE39P71X142	750 kcmil	—	500	.71 [18]	3.37 [86]	5.41 [137]	1.42 [36]	1.30 [33]	Black	24	—	—	—	—	U39RT (4)	U39RT (4)	U39RT (4)	L39RT (2)	750 kcmil - 500 kcmil (1)	3-5/8"		

1 For sizes above 4/0 the MD6-6R2 must be used.

④ To use U Dies in Y46 HYPRESS™, Catalog number PUADP-1 die adaptor is required.

Note: All dimensions shown are for reference only.

Blue highlighted items are industry standard and most frequently ordered.

TYPE ASA-U

HYSTACK™

TERMINAL STACKING ADAPTOR FOR ALUMINUM AND COPPER TERMINALS

UL Listed 90° C, 600 Volts to 35 kV ◆

The Hystack™ adaptor is specially designed to allow standard terminals to be stacked on two or four hole NEMA transformer or equipment terminal pads. Hystack™ is tin-plated, high-conductivity aluminum to provide optimum corrosion resistance. Only three sizes accommodate terminals from 250 mcm through 1000 mcm to help keep costly inventories to a minimum.

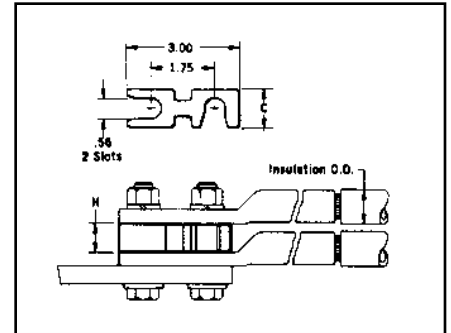
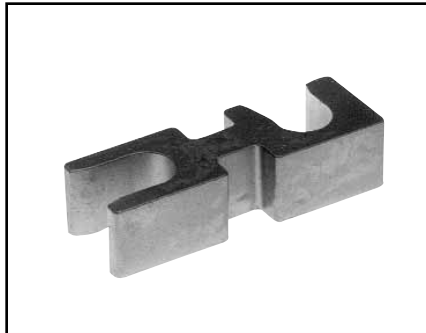

Accommodates Copper and Aluminum Compression Terminals		Catalog Number	C	H
Conductor Max.	Insulation O.D.			
250 kcmil	.868	ASA250U	1.00	.77
800 kcmil	1.372	ASA800U	1.00	1.13
1000 kcmil	1.494	ASA1000U	1.25	1.25

To stack 4 hole NEMA drilled terminals use 2 adaptors assembled side by side.

ASA-U stacking adaptors are recommended for use with any BURNDY® UL Listed compression terminal, 2 or 4 hole NEMA pad aluminum and copper lugs, types YA, YA-L, YA-A, and for all 2-hole NEMA spaced lugs in the OVERHEAD and UNDERGROUND catalog sections.

Note: All dimensions shown are for reference only.

TYPE CUSA

HYSTACK™

TERMINAL STACKING ADAPTOR

This Hystack™ adaptor is specially designed to get terminals to the back end of a bus bar or other areas that require terminals to be elevated off the mounting surface. This Hystack™ is made from high conductivity copper and tin-plated to provide optimum corrosion resistance. It will accommodate #10 AWG through 750 kcmil HYLUGS™.

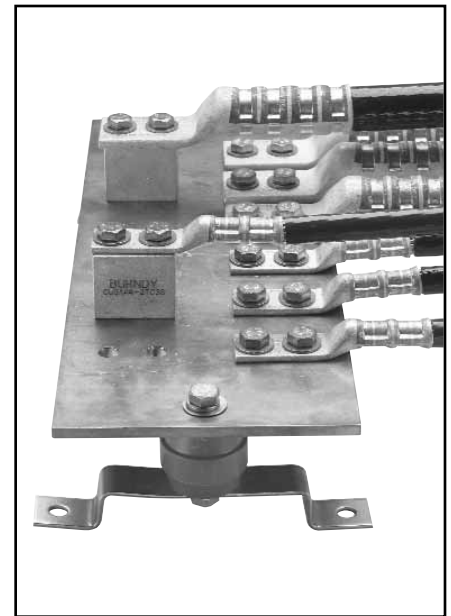
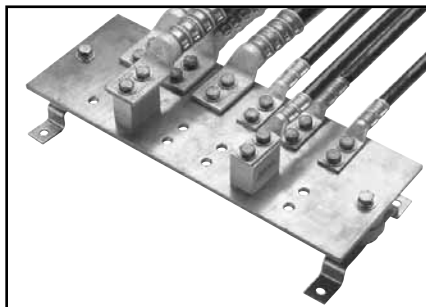

Catalog Number	Stud Hole Size	Stud Hole Spacing	Length	Width	Height
CUSA442TC38	3/8"	1"	1.75"	1.12"	1.50"
CUSA442NTC	1/2"	1 - 3/4"	2.50"	1.12"	1.50"

Reference: Catalog Number TMH332.

This TMH332 Kit has just the right hardware when using the CUSA442TC38 Hystack™ on a 1/4 bus bar with a 4/0 through 750 kcmil HYLUG™.

Note: All dimensions shown are for reference only.

Blue highlighted items are industry standard and most frequently ordered.

C-114

TYPES YA-A AND YA-A-TN

HYLUG™

UNINSULATED ALUMINUM COMPRESSION TERMINAL FOR ALUMINUM AND COPPER CONDUCTORS

1-HOLE DESIGN

UL Listed 90° C, 600 Volts to 35 kV◆

Type YA-A aluminum tin-plated compression HYLUG™ terminals are dual-rated and designed for use on both aluminum and copper conductors from #12 sol. through 2000 kcmil.

They are designed for heavy duty applications to 35KV. YA-A terminals are prefilled with PENETROX®, and assembled with color-coded end caps. Available with one, two, and four-hole NEMA tongues, the aluminum HYLUG™ terminals are designed for a permanent trouble-free electrical termination.

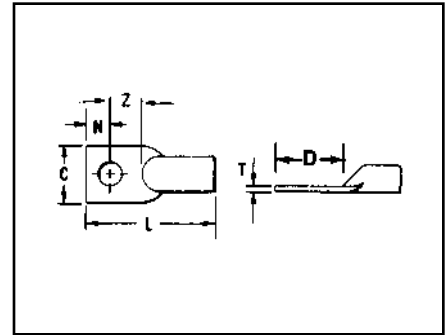
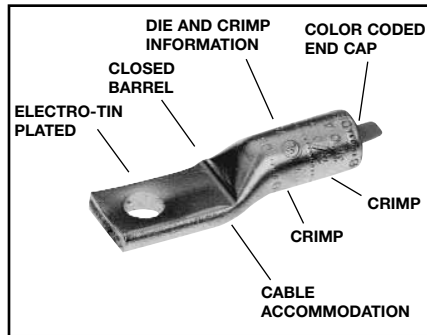

Features and Benefits

- Manufactured from high conductivity, wrought aluminum with heavy duty wall thickness.
 - ◇ Provides maximum conductivity, low resistance and ductility for an excellent combination of electrical and crimp forming properties.
- Electro-tin plated.
 - ◇ Provides durable long lasting corrosion resistance.
- Internally bevelled barrel.
 - ◇ Provides easy cable insertion.
- Meets UL486B 90° C requirements.
 - ◇ Provides a quality electrical dual connection.
- Connector is clearly marked with wire size, die index, color-code and the proper number and location of crimps.
 - ◇ Provides easy identification and tooling recommendation for a proper compression which forms a homogeneous mass resulting in an excellent electrical connection.
- Factory prefilled with PENETROX® oxide inhibiting compound.
 - ◇ Oxide inhibiting compound contains homogeneously suspended metallic particles to penetrate the wires' oxides, establish electrical continuity and forms an airtight connection.
- Color-coded end caps inserted in barrel end.
 - ◇ Prevents foreign materials from entering and contaminating the connector prior to usage plus identifies the proper color-coded die for a reliable connection.

Catalog Number	Code Conductor •	Stud Size	No. of Holes in Pad	Dimensions						Installation Tooling ▲					Wire Strip Length
				C	D	L	N	T Ref.	Z Min.	Dieless (# of crimps)		Y35, Y39, Y750, Y46*	▲ Die Index		
										Mechanical Tooling	Hydraulic HYPRESS™			Die Number (# of crimps)	
YA12A-TN ‡	12 str.	10	1	.41	.50	1.22	.20	.08	.30	MR8-27 (1)	—	—	①	—	5/8"
YA10A-TN ‡	10 str.	10	1	.41	.50	1.22	.20	.08	.30		MY29-3 (1) MRC840AL (1)	—	—	—	—
YA8CA1	8 str.	10	1	.53	.60	1.50	.20	.09	.40	Y81KFT (1) Y81KFTMBH (1) PAT81KFT-18V (1)		U8CABT (1)	Blue	374	5/8"
YA8CA3		1/4		.53	.75	1.65	.25	.09	.50	MY644M (1)		—	—	—	—
YA6CA1	6 str.	1/4	1	.47	.75	1.84	.33	.14	.42	Y81KFT (1) Y81KFTMBH (1) PAT81KFT-18V (1)		U6CABT (1)	Gray	346	3/4"
YA6CA3		3/8		.65	1.19	2.28	.44	.09	.75	—	—	—	—	—	—

- Contact BURNDY® for conductor, stud sizes and hole drillings not shown.
- ◆ See tooling section of this catalog for complete tool and die listings.
- ① No color code assigned.

- ‡ UL Listed for Aluminum only.
 - * Use PUADP-1 adaptor with U dies in Y46 Hypress™.
 - ◆ For applications greater than 2000 Volts consult cable manufacturer for voltage stress relief instructions.
- Note:** All dimensions shown are for reference only.

Blue highlighted items are industry standard and most frequently ordered.

TYPES YA-A AND YA-A-TN

(Continued)

HYLUG™

UNINSULATED ALUMINUM COMPRESSION TERMINAL FOR ALUMINUM AND COPPER CONDUCTORS

1-HOLE DESIGN

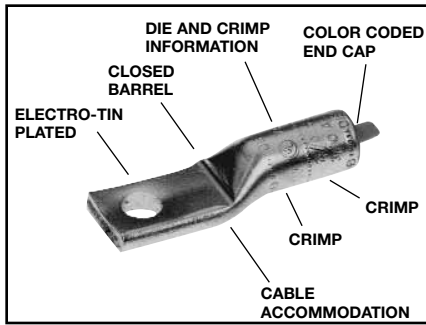

UL Listed 90° C, 600 Volts to 35 kV◆

Catalog Number	Code Conductor	Stud Size	No. of Holes in Pad	Dimensions						Installation Tooling ▲				Wire Strip Length	
				C	D	L	N	T REF.	Z Min.	Dieless (# of crimps)		Y35, Y39, Y750, Y46*	▲ Die Index		
										Mechanical Tooling	Hydraulic HYPRESS™				Die Number (# of crimps)
YA4CA1	4 str.	1/4	1	.47	.75	2.13	.33	.18	.42	MY29-3 (1) MRC840AL (1)	Y81KFT (1) Y81KFTMBH (1) PAT81KFT-18V (1) Y644HS (1)	U4CABT (1)	Green	375	7/8"
YA4CA3		5/16		.80	.87	2.25	.41	.12	.46						
YA4CA6		3/8		.80	.94	2.32	.44	.12	.50						
YA2CA5	2 str.	1/4	1	.50	.91	2.25	.32	.22	.43	MY29-3 (1) MRC840AL (1)	Y81KFT (2) Y81KFTMBH (2) Y644HS (1) PAT81KFT-18V (2)	U2CABT (1)	Pink	348	1-1/8"
YA2CA1		5/16		.88	1.03	2.50	.41	.16	.47						
YA2CA3		3/8		.88	1.03	2.56	.44	.16	.50						
YA1CA1	1 str.	3/8	1	.76	1.19	2.59	.44	.19	.75	MY29-3 (2) MRC840AL (2)	Y81KFT (2) Y81KFTMBH (2) Y644HS (1) PAT81KFT-18V (2)	U1CART (1)	Gold	471	15/16"
YA25A1	1/0 str.	5/16	1	.60	.87	2.31	.41	.21	.46						
YA25A3		3/8		.82	1.18	2.67	.63	.21	.55						
YA25A9		1/2		1.03	1.34	2.67	.63	.17	.71						
YA26A6	2/0 str.	3/8	1	.67	1.18	2.79	.44	.24	.74	MY29-3 (2) MRC840AL (2)	Y81KFTMBH (2) Y644HS (1) PAT81KFT-18V (2)	U26ART (2)	Olive	297	1-3/8"
YA26A1		1/2		1.03	1.36	3.03	.63	.20	.73						
YA27A1	3/0 str.	3/8	1	.73	1.18	2.88	.44	.26	.74	MY29-3 (2) MRC840AL (2)	Y81KFTMBH (2) Y644HS (1) PAT81KFT-18V (2)	U27ART (2)	Ruby	467	1-1/2"
YA27A3		1/2		1.04	1.37	3.27	.63	.26	.74						
YA28A1	4/0 str.	3/8	1	1.17	1.18	3.26	.44	.30	.74	—	Y644HS (1) Y81KFT (3) Y81KFTMBH (3) PAT81KFT-18V (3)	U28ART (2)	White	298	1-5/8"
YA28A3		1/2		1.17	1.36	3.44	.63	.30	.73						
YA29A1	250 kcmil	1/2	1	1.26	1.36	3.53	.63	.33	.73	—	Y644HS (1) Y81KFT (3) Y81KFTMBH (3) PAT81KFT-18V (3)	U29ART (2)	Red	324	1-5/8"
YA30A6	300 kcmil	3/8	1	1.38	1.37	3.90	.63	.36	.74						
YA30A1		1/2		1.38	1.37	3.90	.63	.36	.74						
YA31A1	350 kcmil	1/2	1	1.52	1.37	4.33	.63	.39	.74	—	Y644HS (1) Y81KFT (3) Y81KFTMBH (3) PAT81KFT-18V (3)	U31ART (2)	Brown	299	2-1/8"
YA32A1	400 kcmil	5/8	1	1.62	1.88	4.92	.88	.43	1.00						
YA34A1	500 kcmil	5/8	1	1.80	1.91	5.56	.88	.46	1.03						
YA36A1	600 kcmil	5/8	1	1.97	1.88	5.82	.88	.52	1.00	—	Y644HS (1) Y81KFT (4) Y81KFTMBH (4) PAT81KFT-18V (4)	U32ART (4)	Green	472	2-1/2"
YA39A1	700/750 kcmil	1/2	1	2.05	1.34	5.26	.63	.43	.71						
YA39A3	900 Compact AL +	5/8		2.05	1.88	5.80	.88	.43	1.00						
YA44A1	1000 kcmil	5/8	1	2.50	1.89	6.50	.88	.43	1.01	—	Y644HS (1) Y81KFT (4) Y81KFTMBH (4) PAT81KFT-18V (4)	U33ART (4)	Black	473	2-7/8"
										—	Y644HS (1) Y81KFT (4) Y81KFTMBH (4) PAT81KFT-18V (4)	U39ART-2 (4)	Yellow	936	2-7/8"
										—	Y644HS (1) Y81KFT (4) Y81KFTMBH (4) PAT81KFT-18V (4)	P44ART** (4)	Brown	302	3"

- Contact BURNDY® for conductor, stud sizes and hole drillings not shown.
- ▲ See tooling section of this catalog for complete tool and die listings.

- * Use PUADP-1 adaptor with U dies in Y46 HYPRESS™.
- ** P44ART for use with Y46 HYPRESS™ only. PUADP-1 adaptor not required.
- + Tested with Y644HS and PAT644 dieless tools only and

- not UL Listed with any tool on 900 Compact AL.
- ◆ For applications greater than 2000 Volts consult cable manufacturer for voltage stress relief instructions.
- Note: All dimensions shown are for reference only.

Y644HS DIELESS HYPRESS™ RANGE-TAKING CAPABILITIES

The following size HYDENT™ lugs and two way splices, when crimped with the Y644HS DIELESS HYPRESS™ tool, produce the following range taking capabilities:

Aluminum Connectors					
Standard Wire Size	Expanded Wire Range	Standard Wire Size	Expanded Wire Range	Standard Wire Size	Expanded Wire Range
#6 AWG	#6 AWG	1/0 AWG	1/0 - #1 AWG	250 kcmil	250 kcmil - 1/0 AWG
#4 AWG	#4 - #6 AWG	2/0 AWG	2/0 - #1 AWG	300 kcmil	300 kcmil - 2/0 AWG
#2 AWG	#2 - #6 AWG	3/0 AWG	3/0 - #1 AWG	350 kcmil	350 kcmil - 3/0 AWG
#1 AWG	#1 - #2 AWG	4/0 AWG	4/0 - #1 AWG	400 kcmil	400 kcmil - 4/0 AWG
				500 kcmil	500 kcmil - 4/0 AWG
				600 kcmil	600 - 250 kcmil
				750 kcmil	750 - 500 kcmil

C-116

TYPE YA-A

HYLUG™

UNINSULATED ALUMINUM COMPRESSION TERMINAL FOR ALUMINUM AND COPPER CONDUCTORS

2-HOLE AND 4-HOLE DESIGNS

UL Listed 90° C, 600 Volts to 35 kV◆

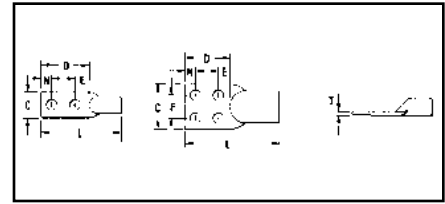
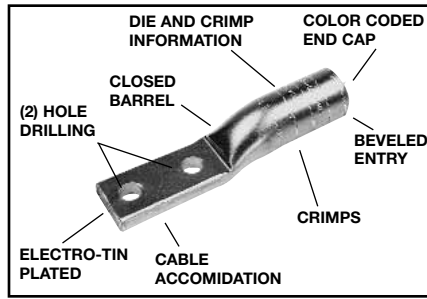

Type YA-A 2- and 4-hole pads inhibit connector rotation and increase area contact. These aluminum terminals have the same design features and benefits as the 1-hole YA-A

with an added stud hole for a more secure termination to various types of equipment pads. They are dual-rated for use on both aluminum and copper conductors.

Catalog Number	Code Conductor	Stud Size	No. of Holes in Pad	Dimensions							Installation Tooling ▲					Wire Strip Length
				C	D	E & F	L	N	T REF.	Z Min.	Dieless (# of crimps)		Y35, Y39, Y750, Y46*		Die Index	
											Mechanical Tooling	Hydraulic HYPRESS	Die Number (# of crimps)	Color Code		
YA2CA9	2 str.	1/2	2-NEMA	.88	3.11	1.75	4.73	.63	.16	.73	MY29-3 (1)	Y644HS (1) Y81KFT (1) Y81KFTMBH (1) PAT81KFT-18V (1)	U2CABT (1)	Pink	348	1-1/8"
YA25A5	1/0 str.	3/8	2	.82	2.24	1.06	3.73	.63	.21	.55	MY29-3 (1)	Y644HS (1) Y81KFT (2) Y81KFTMBH (2) PAT81KFT-18V (2)	U25ART (1)	Tan	296	1-1/16"
YA25A7		1/2	2-NEMA	1.03	3.10	1.75	4.59	.63	.17	.72						
YA26A3	2/0 str.	1/2	2-NEMA	1.03	3.11	1.75	4.78	.63	.20	.73	MY29-3 (2)	Y644HS (1) Y81KFT (2) Y81KFTMBH (2) PAT81KFT-18V (2)	U26ART (2)	Olive	297	1-3/8"
YA26A5		3/8	2	.92	1.89	1.00	3.56	.44	.24	.45						
YA27A5	3/0 str.	1/2	2-NEMA	1.04	3.12	1.75	5.02	.63	.26	.74	MY29-3 (2)	Y644HS (1) Y81KFT (2) Y81KFTMBH (2) PAT81KFT-18V (2)	U27ART (2)	Ruby	467	1-1/2"
YA27A7		3/8	2	1.04	1.89	1.00	3.79	.44	.26	.45						
YA28A5	4/0 str.	1/2	2-NEMA	1.17	3.11	1.75	5.19	.63	.30	.73	MY29-3 (2)	Y644HS (1) Y81KFT (2) Y81KFTMBH (2) PAT81KFT-18V (2)	U28ART (2)	White	298	1-5/8"
YA28A7		3/8	2	1.17	1.89	1.00	3.97	.44	.30	.45						
YA29A3	250 kcmil	1/2	2-NEMA	1.26	3.11	1.75	5.28	.63	.33	.73	MY29-3 (2)	Y644HS (1) Y81KFT (2) Y81KFTMBH (2) PAT81KFT-18V (2)	U29ART (2)	Red	324	1-5/8"
YA29A5		3/8	2	1.26	1.89	1.00	4.06	.44	.33	.45						
YA30A3	300 kcmil	1/2	2-NEMA	1.38	3.11	1.75	5.69	.63	.36	.73	MY29-3 (2)	Y644HS (1) Y81KFT (2) Y81KFTMBH (2) PAT81KFT-18V (2)	U30ART (2)	Blue	470	1-3/4"
YA30A5		3/8	2	1.38	1.89	1.00	5.64	.44	.36	.45						
YA31A5	350 kcmil	3/8	2	1.52	1.89	1.00	4.85	.44	.39	.45	MY29-3 (2)	Y644HS (1) Y81KFT (3) Y81KFTMBH (3) PAT81KFT-18V (3)	U31ART (2)	Brown	299	2-1/8"
YA31A3		1/2	2-NEMA	1.52	3.11	1.75	6.07	.63	.39	.73						
YA32A5	400 kcmil	3/8	2	1.62	1.89	1.00	4.93	.44	.43	.94	MY29-3 (2)	Y644HS (1) Y81KFT (3) Y81KFTMBH (3) PAT81KFT-18V (3)	U32ART (4)	Green	472	2"
YA34A3	500 kcmil	1/2	2-NEMA	1.62	3.15	1.75	6.80	.63	.46	.77	MY29-3 (2)	Y644HS (1) Y81KFT (4) Y81KFTMBH (4) PAT81KFT-18V (4)	U34ART (4)	Pink	300	2-5/8"
YA34A5		3/8	2	1.80	1.89	1.00	5.54	.44	.46	.45						
YA36A3	600 kcmil	1/2	2-NEMA	1.62	3.15	1.75	7.09	.63	.52	.77	MY29-3 (2)	Y644HS (1) Y81KFT (4) Y81KFTMBH (4) PAT81KFT-18V (4)	U36ART (4)	Black	473	2-7/8"
YA36A5		3/8	2	1.97	1.89	1.00	5.83	.44	.52	.45						
YA39A7	700/750 kcmil 900 Compact AL +	3/8	2	2.05	1.89	1.00	5.81	.44	.43	.45	MY29-3 (2)	Y644HS (1) Y81KFT (4) Y81KFTMBH (4) PAT81KFT-18V (4)	U39ART-2 (4)	Yellow	936	2-7/8"
YA39A5		1/2	2-NEMA	1.62	3.15	1.75	7.07	.63	.43	.77						
YA39AM2	900 Compact AL +	1/2	2-NEMA	1.69	3.12	1.75	7.31	.63	.57	.74	MY29-3 (2)	Y644HS (1) Y81KFT (4) Y81KFTMBH (4) PAT81KFT-18V (4)	U39ART-2 (4)	Yellow	936	2-7/8"
YA44A3		1000 kcmil	1/2	2-NEMA	1.65	3.15	1.75	7.76	.63	.66						
YA45A5	1250 kcmil	1/2	2-NEMA	1.65	3.15	1.75	7.76	.63	.66	.77	MY29-3 (2)	Y644HS (1) Y81KFT (4) Y81KFTMBH (4) PAT81KFT-18V (4)	P39ART** (4)	Red	301	2-7/8"
YA46A3	1500 kcmil	1/2	2-NEMA	3.09	3.16	1.75	8.75	.63	.81	.78	—	—	P44ART** (4)	Brown	302	3"
YA46A5	1500 kcmil	1/2	4-NEMA	3.09	3.16	1.75	8.75	.63	.81	.78	—	—	P44ART** (4)	Brown	302	3"
YA48A3	2000 kcmil	1/2	2-NEMA	3.57	3.11	1.75	8.49	.63	.90	.73	—	—	L46ART (2)	Red	478	2-3/4"
											—	—	L48ART (2)	Red	479	4-1/8"

• Contact BURNDY® or conductor, stud sizes and hole drillings not shown.

▲ See tooling section of this catalog for complete tool and die listings.

‡ Use Y60 BHU HYPRESS™ with L46ART and L48ART die sets.

90° C Rated.

Y644HS DIELESS HYPRESS™ RANGE-TAKING CAPABILITIES

The following size HYDENT™ lugs and two way splices, when crimped with the Y644HS DIELESS HYPRESS™ tool, produce the following range taking capabilities:

* Use PUADP-1 adaptor with U dies in Y46 HYPRESS™.

** P39ART and P44ART die sets for use with Y46 HYPRESS™ only. PUADP-1 adapter not required.

+ Tested with Y644HS and PAT644 dieless tools only and

not UL Listed with any tool on 900 Compact AL.

◆ For applications greater than 2000 Volts consult cable manufacturer for voltage stress relief instructions.

Note: All dimensions shown are for reference only.

Aluminum Connectors					
Standard Wire Size	Expanded Wire Range	Standard Wire Size	Expanded Wire Range	Standard Wire Size	Expanded Wire Range
#6 AWG	#6 AWG	1/0 AWG	1/0 - #1 AWG	250 kcmil	250 kcmil - 1/0 AWG
#4 AWG	#4 - #6 AWG	2/0 AWG	2/0 - #1 AWG	300 kcmil	300 kcmil - 2.0 AWG
#2 AWG	#2 - #6 AWG	3/0 AWG	3/0 - #1 AWG	350 kcmil	350 kcmil - 3/0 AWG
#1 AWG	#1 - #2 AWG	4/0 AWG	4/0 - #1 AWG	400 kcmil	400 kcmil - 4/0 AWG
				500 kcmil	500 kcmil - 4/0 AWG
				600 kcmil	600 - 250 kcmil
				750 kcmil	750 - 500 kcmil

TYPE YA-A-KIT

TRANSFORMER LUG KIT

Each kit contains the UL Listed and CSA certified AL9CU rated aluminum compression connectors and tongue mounting hardware needed to terminate aluminum or copper cables in dry type transformers. The KVA rating gives an approximate cross reference to the appropriate kit.



C-117

Features and Benefits

- UL Listed AL9CU dual rated compression terminals and CSA certified.
 - ◇ Ensure the transformer feeders and taps are terminated properly.
- Plated steel cap screws and hex nuts with captive conical washers or individual Belleville washers.
 - ◇ Terminal to bus connections are made using proper hardware resulting in true torque to pressure performance. Compensates for dissimilar metal expansion and contraction.
- Hardware packed in plastic bag.
 - ◇ No lost hardware prior to installation.

Catalog Number	KVA		Terminals		Wire Range with Y644HS	Bolt		Hardware		Washer
			Qty.	Cat. No.		Qty.		Qty.		
YA-A-KIT1	15-37.5	1Ø	8	YA2C-A5	#6-2 AWG	8	1/4-20 × 3/4	8	1/2 × 20HN	Captive
	15-45.3	3Ø	4	YA30-A7	2/0 AWG-300 kcmil					
YA-AKIT2	50-75	1Ø	12	YA30-A7	2/0 AWG-300 kcmil	8	1/4-20 × 3/4	16	1/4 × 20HN	Captive
	75-112.5	3Ø				8	1/4-20 × 2			
YA-AKIT3	100-167	1Ø	3	YA30-A7	2/0 AWG-300 kcmil	3	1/4-20 × 3/4	3	1/4 × 20	Captive
	150-300	3Ø	22	YA39-A1	500-750 kcmil	16	1-2-13 × 2	16	1/2-13	1/2 Belleville

HH- Hex Head
 HN- Hex Nut
 See Mechanical section for set screw terminal kits.
Note: All dimensions shown are for reference only.

Blue highlighted items are industry standard and most frequently ordered.

C-118

TYPE AYP, AYPO

HYPLUG™

FOR ALUMINUM AND COPPER CONDUCTOR

UL Listed 90° C,
600 Volts to 35 kV◆

Types AYP and AYPO aluminum compression adaptors are designed for reliable termination of aluminum and copper conductor in mechanical connectors. Typical applications include mechanical connectors in molded case circuit breakers, panel board equipment and meter sockets.

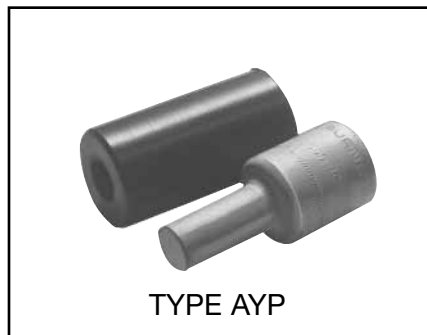

TYPE AYP



TYPE AYPO

For Copper HYPLUG™ go to page C-110

Features and Benefits

- All-aluminum electro-tin plated design.
 - ◇ Eliminates possible bi-metallic corrosion and provides the shortest connector length design possible.
 - Shortest connector length design possible.
 - ◇ Permits easy installation in equipment with limited working space.
 - Solid electro-tin plated aluminum plug.
 - ◇ Proper electrical connection made easily. Eliminates how tight is tight problem.
 - Smooth surface on the solid EC aluminum electro-tin plated plug.
 - ◇ Provides greater area contact establishing excellent electrical conductivity.
 - Solid plug has equivalent cross-sectional area as current carrying equivalent copper wire.
 - ◇ Permits use of larger aluminum wire to connect equipment.
 - Offset plug design available in sizes 2/0 through 750 kcmil.
 - ◇ Provides flexibility and maximizes the use of limited space eliminating interference between conductors and equipment.
 - ◆ For applications greater than 2000 Volts consult cable manufacturer for voltage stress relief instructions.
- Electro-tin plated.
 - ◇ Resists corrosion.
 - Factory prefilled with the proper amount of PENETROX® joint compound.
 - ◇ PENTROX®, BURNDY's oxide inhibiting compound with conductive metallic particles penetrates aluminum oxide between strands and forms an air-tight connection.
 - EPDM rubber covers are supplied with each connector and are rated for 600 V.
 - ◇ Eliminates taping.
 - Only (5) die sets install the complete line from #6 to 750 kcmil.
 - ◇ Lowers inventory requirements and saves money.
 - Supplied in a plastic convenience pack.
 - ◇ The cover and connector are kept together and free of foreign material until used.
 - Connectors are clearly marked with catalog number, wire size, and color coded die index.
 - ◇ Provides clear, easy to use information to lower installed cost.

Blue highlighted items are industry standard and most frequently ordered.

TYPES AYP, AYPO

HYPLUG™

FOR ALUMINUM AND COPPER CONDUCTOR

UL Listed 90° C, 600 Volts to 35 kV◆



AL9CU

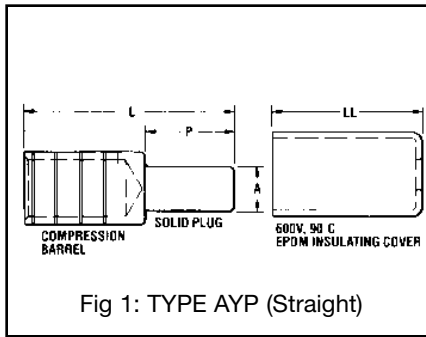

Fig 1: TYPE AYP (Straight)

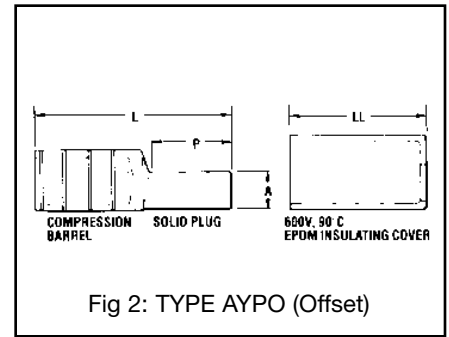

Fig 2: TYPE AYPO (Offset)

C-119

Catalog Number	Copper & Aluminum Conductor	Fig. No.	Dimensions				Installation Tooling ▲						Wire Strip Length
			A ▼ Plug Dia.	P Plug Length	L HYPLUG Length	LL Cover Length	HYTOOLS			Y35, Y39, Y750, Y46*		▲ Die Index & Embossment	
							Dieless Tools (# of crimps)	+ OH25	+ MD6	Die Number (# of crimps)	Color Code		
AYP6	#6 str	1	.23	.68	1.85	1.78	MY29-3 (2) **	1 crimp	W241	U25ART (1)	Tan	296	1-1/16"
AYP4	#4 str	1	.23	.68	1.85	1.78	Y644HS (1)						
AYP2	#2 str	1	.23	.68	1.85	1.78	Y81KFT (1)						
AYP1	#1 str	1	.26	.84	2.01	1.78	Y81KFTMBH (1)						
AYP1/0	1/0 str	1	.29	.84	2.01	1.78	PAT81KFT-18V (1)						
AYPO2/0	2/0 str	2	.33	1.09	2.70	2.44	MY29-3 (2) **	—	—	U28ART (2)	White	298	1-1/8"
AYPO3/0	3/0 str	2	.37	1.22	2.80	2.44	Y644HS (1)						
AYPO4/0	4/0 str	2	.42	1.22	2.80	2.44	Y81KFT (2)						
AYP250	250 kcmil	1	.47	1.22	2.63	2.54	Y81KFTMBH (2)						
AYPO250	250 kcmil	2	.47	1.22	2.98	2.88	PAT81KFT-18V (2)						
AYPO300	300 kcmil	2	.53	1.34	3.08	2.88	Hydraulic: Y644HS (1) Y81KFT (2) Y81KFTMBH (2) PAT81KFT-18V (2)						
AYP350	350 kcmil	1	.57	1.34	2.75	2.54							
AYPO350	350 kcmil	2	.57	1.34	3.08	2.88	U34ART (2)			Pink	300	1-1/8"	
AYPO400	400 kcmil	2	.63	1.60	3.43	3.16							
AYP500	500 kcmil	1	.68	1.60	3.08	2.81	Y644HS (1) Y81KFT (3) Y81KFTMBH (3) PAT81KFT-18V (3)						
AYPO500	500 kcmil	2	.68	1.60	3.43	3.16							
AYPO600	600 kcmil	2	.73	1.64	4.02	4.06	—	—	U39ART-2 (3)	Yellow	936	1-3/4"	
AYP750	700/750 kcmil 900 Compact AL†	1	.81	1.76	3.79	3.66							
AYPO750	700/750 kcmil 900 Compact AL†	2	.81	1.76	4.16	4.06							

Scratch brush aluminum conductor before installation.
▲ See tooling section of this catalog for complete tool and die listings.

** For MY29-3 use aluminum index plate at 1/0 setting for sizes #6 through 1/0 or at 4/0 setting for sizes 2/0 through 4/0.
+ Not UL Listed.

* Use PUADP-1 adaptor with U dies in Y46 HYPRESS™.
□ Also accommodates compressed and compact conductors (except for 700 kcmil in 750 kcmil barrel).
† Tested with Y644HS and PAT644 dieless tools only and not UL Listed with any tool on 900 Compact Al.

◆ For applications greater than 2000 Volts consult cable manufacturer for voltage stress relief instructions.
Note: All dimensions shown are for reference only.
▼ For copper equivalent wire size see page 0-11 (Aluminum 1350 Cable).

Y644HS DIELESS HYPRESS™ RANGE-TAKING CAPABILITIES

The following HYPLUG™ lugs and two way splices, when crimped with the Y644HS DIELESS HYPRESS™ tool, produce the following range- taking capabilities:

Aluminum Connectors					
Standard Wire Size	Expanded Wire Range	Standard Wire Size	Expanded Wire Range	Standard Wire Size	Expanded Wire Range
#6 AWG	#6 AWG	1/0 AWG	1/0 - #1 AWG	250 kcmil	250 kcmil - 1/0 AWG
#4 AWG	#4 - #6 AWG	2/0 AWG	2/0 - #1 AWG	300 kcmil	300 kcmil - 2/0 AWG
#2 AWG	#2 - #6 AWG	3/0 AWG	3/0 - #1 AWG	350 kcmil	350 kcmil - 3/0 AWG
#1 AWG	#1 - #2 AWG	4/0 AWG	4/0 - #1 AWG	400 kcmil	400 kcmil - 4/0 AWG
				500 kcmil	500 kcmil - 4/0 AWG
				600 kcmil	600 - 250 kcmil
				750 kcmil	750 - 500 kcmil

Blue highlighted items are industry standard and most frequently ordered.

C-120

TYPE YS-A

HYLINK™

UNINSULATED ALUMINUM COMPRESSION SPLICE

UL Listed 90° C,
600 Volts to 35 kV◆

Type YS-A is a high-conductivity aluminum tin-plated compression butt splice for use on all combinations of aluminum to aluminum, aluminum to copper, and copper to copper conductor combinations.

They are designed to accommodate conductors from #12 str. through 1,000 kcmil in standard and heavy duty applications. Prefilled with PENETROX™ oxide inhibiting compounds and assembled with color-coded end caps, the connectors provide a permanent trouble-free electrical splice with flexibility and low installed cost.

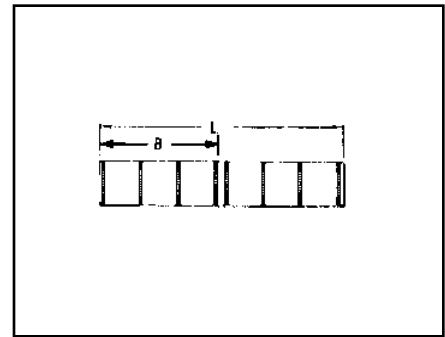
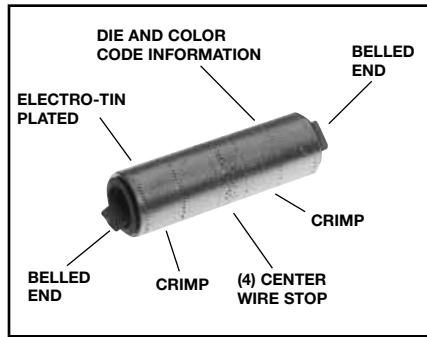

Features and Benefits

- Manufactured from high-conductivity wrought aluminum with heavy duty wall thickness.
 - ◇ Provides high-conductivity/low resistance and ductility for an excellent combination of electrical and crimp forming properties.
- Electro-tin plated.
 - ◇ Provides durable long lasting corrosion resistance.
- Internally bevelled barrel.
 - ◇ Provides easy cable entry.
- Solid center stop and prefilled with PENETROX™ oxide inhibiting compound.
 - ◇ Provides stop for proper conductor insertion and an aid in forcing the PENETROX™ between the individual wire strands.
- Color-coded end caps.
 - ◇ Provides easy wire size and die code identification plus prevents foreign materials from entering and contaminating the connector prior to usage.
- Connector is clearly marked with wire size, die index and the proper number and location of crimps.
 - ◇ Provides easy identification and tooling recommendation. Proper compression forms a homogeneous mass resulting in an excellent electrical connection.

Catalog Number	Code • Conductor	Dimensions B L		Installation Tooling ▲					
				Dieless (# of crimps/end)		Y35, ■ Y39, Y750, Y46*		Die Index & Embossment ▲	Wire Strip Length
				Mechanical HYTOOL™	Hydraulic HYPRESS™	Die Number (# of crimps per end)	Color Code		
YS12AG1 ‡	#12 Str.	.39	1.03	Ratchet: MR8-27 (1)	—	—	①	—	5/8"
YS10WAG1 ‡	#10 Str.	.44	1.12	MY29-3 (1) MRC840AL (1)	Y644HS (1)	U8CABT (1)	Blue	374	5/8"
YS8CA1	8 Str.	.59	1.44		Y81KFT (1)	U6CABT (1)	Gray	346	3/4"
YS6CA1	6 Str.	.72	1.70		Y81KFTMBH (1) PAT81KFT-18V (1)	U4CABT (1)	Green	375	7/8"
YS4CA1	4 Str.	.86	1.97	MY29-3 (1) MRC840AL (1)	Y644HS (1)	U2CABT (1)	Pink	348	1-1/8"
YS2CA1	2 Str.	1.09	2.44		Y81KFT (2)	U1CART (1)	Gold	471	15/16"
YS1CA1	1 Str.	.90	2.05		Y81KFTMBH (2) PAT81KFT-18V (2)	U25ART (1)	Tan	296	1-1/16"
YS25A1	1/0 Str.	1.06	2.37						

◆ See tooling section of this catalog for complete tool and die listing.
 ① No color code assigned.
 ‡ UL Listed for Aluminum only. Not CSA Certified.
 * Use PUADP-1 adaptor with U dies in Y46 HYPRESS™.

■ The largest size for the Y35 is 400 kcmil.
 ◆ For applications greater than 2000 Volts consult cable manufacturer for voltage stress relief instructions.
 • Also accommodates compressed and compact conductors (except for 700 kcmil in 750 kcmil barrel).
Note: All dimensions shown are for reference only.

Blue highlighted items are industry standard and most frequently ordered.

TYPE YS-A

(Continued)

HYLINK™

UNINSULATED ALUMINUM COMPRESSION SPLICE

UL Listed 90° C,
600 Volts to 35 kV◆

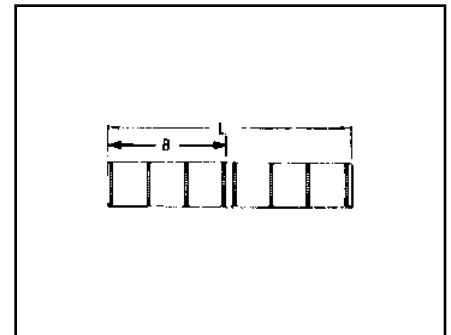
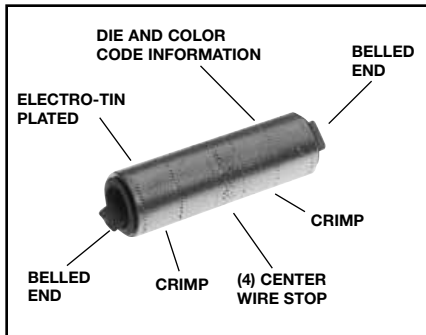

C-121

Catalog Number	Code Conductor	Dimensions B L		Installation Tooling ▲					
				Dieless (# of crimps/end)		Y35, ■ Y39, Y750, Y46*, Y60BHU		Die Index & Embossment ▲	Wire Strip Length
				Mechanical HYTOOL™	Hydraulic HYPRESS™	Die Number (# of crimps per end)	Color Code		
YS26A1	2/0 str.	1.18	2.61	MY29-3 (2) MRC840AL (2)	Y644HS (1)	U26ART (2)	Olive	297	1-3/8"
YS27A1	3/0 str.	1.31	2.88		Y81KFT (2)	U27ART (2)	Ruby	467	1-1/2"
YS28A1	4/0 str.	1.40	3.06	MY29-3 (2)	Y81KFTMBH (2)	U28ART (2)	White	298	1-5/8"
YS29A1	250 kcmil	1.46	3.18		PAT81KFT-18V (2)	U29ART (2)	Red	324	1-5/8"
YS30A1	300 kcmil	1.47	3.20			U30ART (2)	Blue	470	1-3/4"
YS31A1	350 kcmil	1.89	4.04		Y644HS (1) Y81KFT (3) Y81KFTMBH (3) PAT81KFT-18V (3)	U31ART (2)	Brown	299	2-1/8"
YS32A1	400 kcmil	2.30	4.86		Y644HS (1) Y81KFT (4) Y81KFTMBH (4) PAT81KFT-18V (4)	U32ART (4)	Green	472	2-1/2"
YS34A1	500 kcmil	2.38	5.00			U34ART (4)	Pink	300	2-5/8"
YS36A1	600 kcmil	2.44	5.14			U36ART (4)	Black	473	2-7/8"
YS39A1*	700/750 kcmil 900 Compact Al †	2.50	5.26			U39ART-2 (4)	Yellow	936	2-7/8"
YS39AM1*	700/750 kcmil 900 Compact Al †	2.63	5.58			P39ART** (4)	Red	301	2-7/8"
YS44A1	1000 kcmil	2.84	5.94			P44ART** (4)	Brown	302	3"
YS45A1	1250 kcmil	2.84	6.21			P48PR1/L44ART** (6)	Brown	302	2-7/8"
YS46A1	1500 kcmil	3.40	7.05			L46ART*** (2)	Blue	478	3-3/8"
YS47A1	1750 kcmil	3.99	8.31			L47ART*** (2)	White	587	4"
YS48A1	2000 kcmil	3.66	7.58			L48ART*** (2)	Red	479	3-5/8"
YS483A1	2250 kcmil ALUMINUM ONLY	3.66	7.58			L48ART*** (2)	Red	479	3-5/8"

▲ See tooling section of this catalog for complete tool and die listings.

‡ UL Listed for Aluminum only. Not CSA certified.

* Use PUADP-1 adaptor with U dies in Y46 HYPRESS™.

** P39ART and P44ART for use with Y46 HYPRESS™ only. PUADP-1 adapter not required.

■ The largest size for the Y35 is 400 kcmil.

*** Y60BHU only.

90° C Rated.

† Tested with Y644HS and PAT644 dieless tools only and not UL Listed with any tool on 900 Compact Al.

• Also accommodates compressed and compact conductors. (Except 700 kcmil in 750 kcmil barrel.)

Note: All dimensions shown are for reference only.

Y644HS DIELESS HYPRESS™ RANGE-TAKING CAPABILITIES

The following size HYDENT™ lugs and two way splices, when crimped with the Y644HS DIELESS HYPRESS™ tool, produce the following range-taking capabilities:

Aluminum Connectors					
Standard Wire Size	Expanded Wire Range	Standard Wire Size	Expanded Wire Range	Standard Wire Size	Expanded Wire Range
#6 AWG	#6 AWG	1/0 AWG	1/0 - #1 AWG	250 kcmil	250 kcmil - 1/0 AWG
#4 AWG	#4 - #6 AWG	2/0 AWG	2/0 - #1 AWG	300 kcmil	300 kcmil - 2.0 AWG
#2 AWG	#2 - #6 AWG	3/0 AWG	3/0 - #1 AWG	350 kcmil	350 kcmil - 3/0 AWG
#1 AWG	#1 - #2 AWG	4/0 AWG	4/0 - #1 AWG	400 kcmil	400 kcmil - 4/0 AWG
				500 kcmil	500 kcmil - 4/0 AWG
				600 kcmil	600 - 250 kcmil
				750 kcmil	750 - 500 kcmil

Blue highlighted items are industry standard and most frequently ordered.

TYPE YS-AT

HIGH VOLTAGE UNINSULATED ALUMINUM COMPRESSION SPLICE

Type YS-AT is a high-conductivity aluminum electro-tin plated compression butt splice with tapered ends for high voltage applications up to 35 kV.

The YS-AT provides the same benefits as the YS-A with the addition of tapered ends for easy installation of high voltage insulating kits. Tapered ends aid in preventing corona emission and insulation breakdown. Recommended for high voltage splice applications.

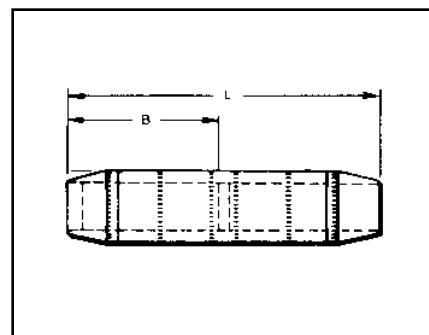
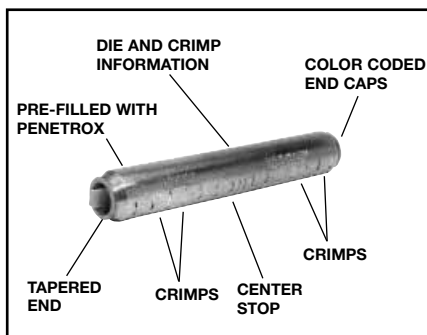

Features and Benefits

- Tapered ends for applications through 35kV.
 - ◇ Permits easy taping and aids in preventing corona emission and insulation breakdown.
- Heavy wall aluminum tubing.
 - ◇ For use with combinations of AL-AL, AL-CU, CU-CU

Catalog Number	• † Code Conductor	Dimensions		Installation Tooling ▲				Wire Strip Length
				Y35, ■ Y39, Y750, Y46*			Die Index & Embossment ▲	
				Die Number	(Crimps per End)	Color Code		
YS2CAT	2 str.	1.58	4.00	U2CART	(2)	Pink	348	2-1/4"
YS25AT	1/0 str.	1.96	4.73	U25ART	(2)	Tan	296	2-5/8"
YS26AT	2/0 str.	1.83	4.29	U26ART	(3)	Olive	297	2-3/8"
YS27AT	3/0 str.	2.04	4.69	U27ART	(3)	Ruby	467	2-5/8"
YS28AT	4/0 str.	2.16	5.05	U28ART	(3)	White	298	2-3/4"
YS29AT	250 kcmil	2.29	5.37	U29ART	(3)	Red	324	2-7/8"
YS30AT	300 kcmil	2.54	5.91	U30ART	(3)	Blue	470	3-1/8"
YS31AT	350 kcmil	2.68	6.23	U31ART	(3)	Brown	299	3-3/8"
YS34AT	500 kcmil	3.39	7.79	U34ART	(6)	Pink	300	4-1/8"
YS39AT	700/750 kcmil • 900 Compact AL▼	3.69	8.57	P39ART**	(6)	Red	301	4-1/2"
YS44AT	1000 kcmil 900 Compact AL▼	3.77	9.69	P44ART**	(6)	Brown	302	4-3/4"

† Contact BURNDY® for conductor sizes not shown.

* Use PUADP-1 adapter for U dies.

** P39ART and P44ART for use with Y46 HYPRESS™ only. PUADP-1 adapter not required.

■ The maximum size for the Y35 is 400 kcmil.

▲ See tooling section of this catalog for complete tool and die listings.

• Also accommodates compressed and compact conductors (except 700 kcmil in 750 kcmil barrel).

▼ Tested with Y644HS and PAT644 dieless tools only and not UL Listed with any tool on 900 Compact Al.

Note: All dimensions shown are for reference only.

Blue highlighted items are industry standard and most frequently ordered.

TYPE YRB

HYREDUCER™

**FOR ALUMINUM TO COPPER
 AND ALUMINUM TO
 ALUMINUM**

UL Listed 90° C,
 600 Volts to 35 kV◆

HYREDUCER™ type YRB reducer butt splice is designed to splice two different conductor sizes and is UL Listed for aluminum to copper and aluminum to aluminum applications. The outside diameter is held constant to minimize installation dies and is factory prefilled with PENETROX™.

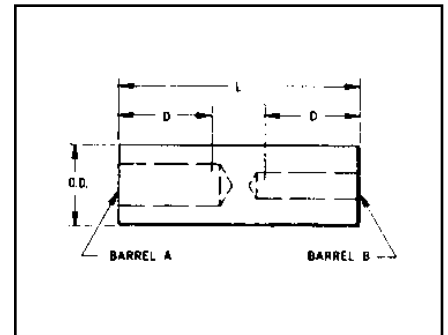
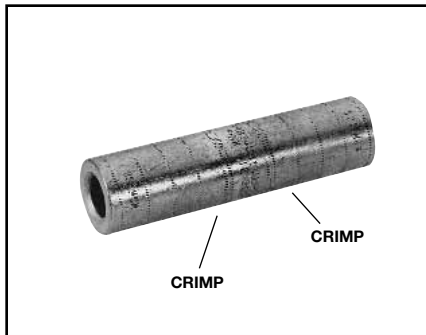

C-123

Features and Benefits

- Constant outside diameters. Electro tin-plated.
 - ◇ Minimizes installation dies and provides a smooth profile for easy taping. Provides durable long lasting corrosion resistance.
- Factory prefilled with BURNDY's PENETROX™ oxide inhibiting compound.
 - ◇ Contains Homogeneously suspended conductive metallic particles which penetrate oxides between conductor strands and forms an air tight connection.
- Solid center barrier.
 - ◇ Provides center stop for correct cable insertion and aids the thorough penetration of PENETROX™ oxide inhibiting compound between conductor strands.
- Connectors are clearly marked with catalog number, wire size, and color-coded die index.
 - ◇ Provides clear, easy to use information to lower installed costs.
- Each barrel end has a plastic end cap.
 - ◇ Keeps the connector barrels free of foreign materials.

Catalog Number	Conductor Range • Aluminum or Copper Size †		Dimensions			Installation Tooling ▲ Hydraulic Tools, Die Sets (No. of Crimps ‡)				Wire Strip Length
	Barrel A	Barrel B				Y35 ■, Y39, Y750 Y46*	‡	Die ▲ Index	Color Code	
			O.D.	B	L					
YRB2U4	1 str. 2 str.	4 str. 3 str.	.62	.88	2.00	U25ART	(1)	296	Tan	1-1/16"
YRB25U2	1/0 str.	1 str. 2 str.	.62	.88	2.00					
YRB27U25	3/0 str.	1/0 str.	.85	1.36	3.31	U28ART	(2)	298	White	1-5/8"
YRB27U26	3/0 str.	2/0 str.	.85	1.36	3.31					
YRB28U26	4/0 str.	2/0 str.	.85	1.36	3.31	U31ART	(2)	299	Brown	2-1/8"
YRB29U28	250 kcmil	4/0 str.	1.11	1.73	4.21					
YRB31U28	350 kcmil	4/0 str.	1.11	1.73	4.21	U34ART	(4)	300	Pink	2-5/8"
YRB31U29	350 kcmil	250 kcmil	1.11	1.73	4.21					
YRB34U31	500 kcmil	350 kcmil	1.31	2.11	5.12	U39ART-2	(4)	936	Yellow	2-7/8"
YRB36U31	600 kcmil	350 kcmil	1.46	2.25	5.57					
YRB36U34	600 kcmil	500 kcmil	1.46	2.25	5.57	U39ART-2	(4)	936	Yellow	2-7/8"
YRB39U34	700/750 kcmil • 900 Compact AL▼	500 kcmil	1.46	2.25	5.57					
YRB39U36	700/750 kcmil • 900 Compact AL▼	600 kcmil	1.46	2.25	5.57					

† Contact BURNDY® for conductor sizes not shown.

▲ See tooling section of this catalog for complete tool and die listings.

‡ Number of crimps.

* Use PUADP-1 adaptor with U dies shown in Y46 HYPRESS™.

■ The maximum size for the Y35 is 400 kcmil.

◆ For applications greater than 2000 Volts consult cable manufacturer for voltage stress relief instructions.

• Also accommodates compressed and compact conductors (except 700 kcmil in 750 kcmil barrel).

▼ Tested with Y644HS and PAT644 dieless tools only and not UL Listed with any tool on 900 Compact Al.

Note: All dimensions shown are for reference only.

Blue highlighted items are industry standard and most frequently ordered.

C-124

TYPES YFD, YFN, YFO AND YFR

H-CRIMPIT™

UNINSULATED ALUMINUM COMPRESSION TAP CONNECTOR

FOR ALUMINUM TO COPPER AND ALUMINUM TO ALUMINUM

UL Listed 90° C, 600 Volts to 35 kV◆

H-CRIMPIT™ compression tap connectors Types YFD, YFN, YFO and YFR are for use with aluminum to aluminum and aluminum to copper connections.

The H-CRIMPIT™ is ideal for making both parallel and tap compression connections in risers and gutters. It should only be installed with hydraulic tools.

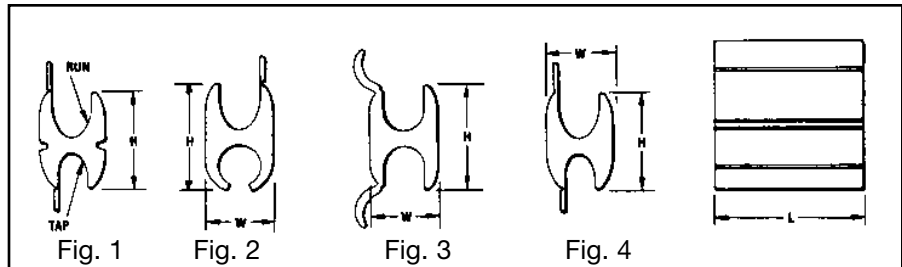
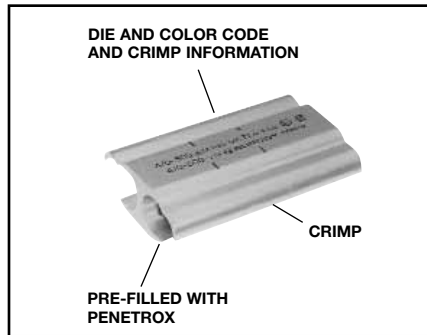

Features and Benefits

- Each connector is factory sealed in polyethylene.
 - ◇ Maintains the connector free of dirt and foreign materials prior to being used.
- When installed the connector has a smooth profile.
 - ◇ Easy to tape or to install an insulating crimpit cover (See Types CFA and CFA-FR) thereby lowering installed costs.
- Connectors are marked with color-codes to match installation die.
 - ◇ Easy die selections lower installed cost.
- UL 486B Listed.
 - ◇ Provides a quality electrical connection.

Accommodates ②						Installation Tooling ▲												
Copper or Aluminum		Compact ④		Dia. Range		Cat. No.	Fig. No.	Height	Length	Width	▲ Die Index	Color Code	Hydraulic Tools, Die Sets (No. of Crimps)			Dieless Tools Die Adaptor, (No. of Crimps)		Wire Strip Length
Run	Tap	Run	Tap	Run	Tap								Y750, Y35, Y39	Y46 ③	()	Y644M, Y644MBH	()	
1/0-6 Str	1-6 Str	2/0-6	1-6 Str	.398-.162	.332-.162	YFO-140*	1	1.15 (29.2)	1.62 (41.1)	.70 (17.8)	0	Green	UVFO, U-0		(2)	PT30541	(1)	1-7/8"
4/0-1 Str	2/0-1 Str	250-1/0	3/0-1/0	.563-.338	.477-.338	YFD-365*	1	1.42 (36.1)	2.50 (63.5)	.89 (22.6)	D3	Blue	U-D3 U-YFD		(3)	PT30540	(2)	2-3/4"
500-4/0	500-4/0	500-250	500-250	.815-.522	.815-.522	YFN-540	3	1.82 (46.2)	4.50 (114.3)	1.23 (31.2)	N	Red	U-N U-YFN	P-N P-YFN	(3)	—	—	4-7/8"
900-600	600-350	900-700	600-400	1.108-.877	.893-.659	YFR-865	4	3.04 (77.2)	4.62 (117.3)	1.74 (44.2)	KR	—	—	P-KR P-YFR	(4)	—	—	5"

▲ See tooling section of this catalog for complete tool and die listings.
 † Do not use U-YFN die set with P-UADP-1 adapter in Y46 HYPRESS™. Use P-YFN only.
 ◆ For applications greater than 2000 Volts consult cable manufacturer for voltage stress relief instructions.
 * CSA listed.
Note: All dimensions shown are for reference only.

Notes:
 1. Material: Aluminum.
 ② For Conductor combinations of AL to AL or AL to CU.
 ③ Catalog Number PUADP-1-Adaptor is required to use U type dies in Y46 tools.
 ④ Other conductors not listed in table can be accommodated as long as the conductor diameter falls within diameter range specified.

Blue highlighted items are industry standard and most frequently ordered.

TYPES CFA AND CFA-FR

H-CRIMPIT™ INSULATING COVERS

H-CRIMPIT™ FLAME RETARDANT INSULATING COVERS

FOR O, D3, N, AND KR DIE SIZE H-TAP COMPRESSION CONNECTORS

UL Listed to 600 Volts

Type CFA insulating covers are made of high impact, high density polyethylene to insulate H-tap CRIMPIT™ compression connectors. Overlapping flash barriers protect both seams against possible electrical flashover. End fingers remain closed or wrap closely around conductors. Multiple latches lock cover closed securely.

Type CFA-FR flame retardant insulating covers are made of high impact, high density polypropylene with a minimum 28 oxygen index. This cover incorporates all the features of the CF design plus the benefit of self-extinguishing flame retardant properties. Material is UL 94V-O rated.

Both CFA and CFA-FR types are suitable for indoor and outdoor use. Pliable in cool weather application.



Features and Benefits

- One-piece design.
 - ◊ No extra parts or hardware required.
- Slips over connector and latches securely shut.
 - ◊ Fast, easy, reliable insulation of H-Tap compression connectors.
- Eliminates taping.
 - ◊ Economical, fast, easy installation.
- Flash barriers.
 - ◊ Protects against electrical flashover.
- CFA-FR flame retardant design.
 - ◊ Minimum 28 oxygen index. UL 94 V-O rated.
 - ◊ Self-extinguishing flame retardant properties.



600 VOLTS 90° C

Catalog Number	Max. Conductor Accommodated	Insulated H-Tap CRIMPIT™ Connectors	Max. Conductor Length	Connector Die Index	Connector Color Code
CFAO CFAO-FR	1/0	YF0140	2-1/2"	O	Green
CFAD CFAD-FR	4/0	YFD265, YFD365, YFD415	3-1/8"	D	Blue
CFAN CFAN-FR	500 kcmil	YFN515, YFN565	2-1/2"	N-Short Connector	Red
CFANL CFANL-FR	500 kcmil	YFN465, YFN540, YFN615	5-1/2"	N-Long Connector	Red
CFAR * CFAR-FR *	900 kcmil	YFR715, YFR765, YFR815, YFR865 YFR915	4-7/8"	KR	Yellow

* Two piece design packaged together.

Note: All dimensions shown are for reference only.

Blue highlighted items are industry standard and most frequently ordered.

TABLE OF CONTENTS

DURIUM™ Hardware		Aluminum Hardware	
Bolts	D-2	Bolts	D-6
Nuts	D-3	Nuts	D-6
Flat Washer	D-3	Flat Washer	D-6
Split Lockwasher	D-3	Split Lockwashers	D-6
Internal Tooth Lockwasher	D-3	Stainless Steel Hardware	
TMH Hardware Kits		Bolts	D-7
DURIUM™	D-4	Nuts	D-7
Stainless Steel	D-4	Flat Washer	D-7
Galvanized Steel Hardware		Split Lockwashers	D-7
Bolts	D-5	Belleville Washers	D-7
Nuts	D-5	DURIUM™ U-Bolts	D-8
Flat Washer	D-5		
Internal Tooth Lockwashers	D-5		

D-1

Blue highlighted items are industry standard and most frequently ordered.

HARDWARE DATA

RECOMMENDED TIGHTENING TORQUE

D-2

The hardware used in connectors must be compatible with the connector material, have high mechanical strength and be corrosion resistant and correspond to NEMA recommendations.

Copper alloy connectors have hardware made of DURIMUM™, which is BURNDY's trade name for silicon bronze alloy ASTMB99 type B. This material was first introduced by BURNDY® in 1927 for use in outdoor construction, and today, is the standard throughout the industry.

DURIMUM™ and Steel Hardware		Aluminum Hardware	
Bolt Size	Recommended Torque (Inch Pounds)	Bolt Size	Recommended Torque (Inch Pounds)
1/4 - 20	80	1/2 - 13	300
5/16 - 18	180	5/8 - 11	480
3/8 - 16	240	3/4 - 10	650
1/2 - 13	480		
5/8 - 11	660		
3/4 - 10	1,050		

Aluminum connectors generally have aluminum alloy hardware. The bolts are 2024T4 and anodized to resist corrosion. The nuts are 6061T6, which is resistant to corrosion and does not require anodizing. Both nuts and bolts are lubricated to eliminate

galling and to provide consistent clamping forces.

To reduce or greatly exceed the recommended torque can adversely affect the performance of the connector.

DURIMUM™ BOLT

SILICON BRONZE

BURNDY® introduced silicon-bronze bolts, nuts, and other hardware items on outdoor connector applications in 1927. Today the DURIMUM™ trademark is a standard for this use.

DURIMUM™ bolts combine high strength with corrosion resistance. **Bolts up to 2 inches long are fully threaded; longer bolts are threaded for two inches.** Heads have

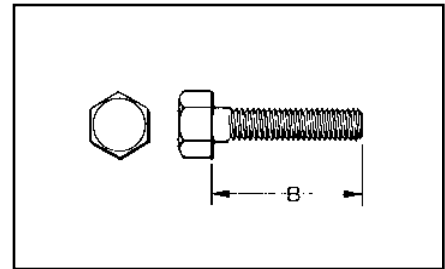

American Standard dimension, and the threads are per American National Coarse Series, Class #2 fit. The silicon bronze is per ASTM B99.

Catalog Number	Thread Size	B Length	Catalog Number	Thread Size	B Length	Catalog Number	Thread Size	B Length
25x50 HEB BOX	1/4-20	1/2"	38x125 HEB BOX	3/8-16	1-1/4"	50x300 HEB BOX	1/2-13	3"
25x62 HEB BOX	1/4-20	5/8"	38x150 HEB BOX	3/8-16	1-1/2"	50x325 HEB BOX	1/2-13	3-1/4"
25x75 HEB BOX	1/4-20	3/4"	38x175 HEB BOX	3/8-16	1-3/4"	50x350 HEB BOX	1/2-13	3-1/2"
25x100 HEB BOX	1/4-20	1"	38x200 HEB BOX	3/8-16	2"	50x375 HEB BOX	1/2-13	3-3/4"
25x125 HEB BOX	1/4-20	1-1/4"	38x225 HEB BOX	3/8-16	2-1/4"	50x400 HEB BOX	1/2-13	4"
25x150 HEB BOX	1/4-20	1-1/2"	38x250 HEB BOX	3/8-16	2-1/2"	50x450 HEB BOX	1/2-13	4-1/2"
25x200 HEB BOX	1/4-20	2"	38x275 HEB BOX	3/8-16	2-3/4"	50x500 HEB BOX	1/2-13	5"
25x250 HEB BOX	1/4-20	2-1/2"	38x300 HEB BOX	3/8-16	3"	50x550 HEB BOX	1/2-13	5-1/2"
25x300 HEB BOX	1/4-20	3"	38x325 HEB BOX	3/8-16	3-1/4"	50x600 HEB BOX	1/2-13	6"
31x50 HEB BOX	5/16-18	1/2"	38x350 HEB BOX	3/8-16	3-1/2"	62x100 HEB BOX	5/8-11	1"
31x62 HEB BOX	5/16-18	5/8"	38x400 HEB BOX	3/8-16	4"	62x125 HEB BOX	5/8-11	1-1/4"
31x75 HEB BOX	5/16-18	3/4"	38x450 HEB BOX	3/8-16	4-1/2"	62x150 HEB BOX	5/8-11	1-1/2"
31x100 HEB BOX	5/16-18	1"	38x500 HEB BOX	3/8-16	5"	62x175 HEB BOX	5/8-11	1-3/4"
31x125 HEB BOX	5/16-18	1-1/4"	44x150 HEB BOX	7/16-14	1-1/2"	62x200 HEB BOX	5/8-11	2"
31x150 HEB BOX	5/16-18	1-1/2"	44x200 HEB BOX	7/16-14	2"	62x225 HEB BOX	5/8-11	2-1/4"
31x175 HEB BOX	5/16-18	1-3/4"	50x75 HEB BOX	1/2-13	3/4"	62x250 HEB BOX	5/8-11	2-1/2"
31x200 HEB BOX	5/16-18	2"	50x100 HEB BOX	1/2-13	1"	62x275 HEB BOX	5/8-11	2-3/4"
31x250 HEB BOX	5/16-18	2-1/2"	50x125 HEB BOX	1/2-13	1-1/4"	62x300 HEB BOX	5/8-11	3"
31x300 HEB BOX	5/16-18	3"	50x150 HEB BOX	1/2-13	1-1/2"	62x325 HEB BOX	5/8-11	3-1/4"
38x50 HEB BOX	3/8-16	1/2"	50x175 HEB BOX	1/2-13	1-3/4"	62x350 HEB BOX	5/8-11	3-1/2"
38x62 HEB BOX	3/8-16	5/8"	50x200 HEB BOX	1/2-13	2"	62x400 HEB BOX	5/8-11	4"
38x75 HEB BOX	3/8-16	3/4"	50x225 HEB BOX	1/2-13	2-1/4"	62x450 HEB BOX	5/8-11	4-1/2"
38x88 HEB BOX	3/8-16	7/8"	50x250 HEB BOX	1/2-13	2-1/2"	62x500 HEB BOX	5/8-11	5"
38x100 HEB BOX	3/8-16	1"	50x275 HEB BOX	1/2-13	2-3/4"	62x600 HEB BOX	5/8-11	6"

Blue highlighted items are industry standard and most frequently ordered.

DURIUM™ NUT

SILICON BRONZE

DURIUM™ hexagon regular nuts are non-magnetic and are made to American Standard dimensions. American National Coarse Series threads, #2 fit.



Catalog Number	Thread Size
25C HEN BOX	1/4-20
31C HEN BOX	5/16-18
38C HEN BOX	3/8-16
44C HEN BOX	7/16-14
50C HEN BOX	1/2-13
62C HEN BOX	5/8-11

D-3

DURIUM™ FLAT WASHER

SILICON BRONZE

High strength DURIUM™ Flat Washers are non-magnetic and free from galvanic action when in contact with copper. Conforms to SAE standards.

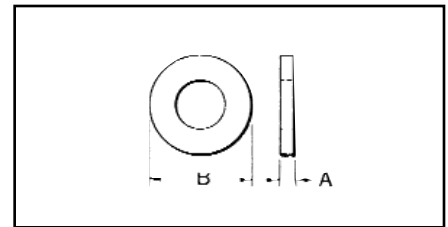

Catalog Number	For Bolt Size	Nominal Dimensions in Inches	
		A	B
25 FW BOX	1/4	1/16	5/8
31 FW BOX	5/16	1/16	11/16
38 FW BOX	3/8	1/16	13/16
44 FW BOX	7/16	1/16	15/16
50 FW BOX	1/2	3/32	1-1/16
62 FW BOX	5/8	3/32	1-5/16

DURIUM™ SPLIT LOCKWASHER

SILICON BRONZE

DURIUM™ spring type lockwasher has high resiliency and exerts constant pressure on the face of the nut, preventing vibration from loosening the nut.



Catalog Number	For Bolt Size
25 SW BOX	1/4
31 SW BOX	5/16
38 SW BOX	3/8
44 SW BOX	7/16
50 SW BOX	1/2
62 SW BOX	5/8

DURIUM™ INTERNAL TOOTH LOCKWASHER

SILICON BRONZE

DURIUM™ Internal Tooth Lockwashers are available as illustrated. The teeth are twisted slightly and present biting edges which grip the nut and the part being clamped, preventing the nut from backing off.

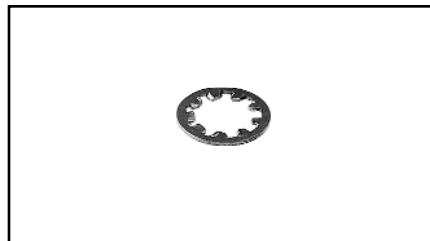

Catalog Number	For Bolt Size
25 NW BOX	1/4
31 NW BOX	5/16
38 NW BOX	3/8
44 NW BOX	7/16
50 NW BOX	1/2
62 NW BOX	5/8

Blue highlighted items are industry standard and most frequently ordered.

TYPE TMH

DURIUM™ SILICON BRONZE HARDWARE KITS

D-4

Type TMH are DURIUM™ silicon bronze hardware kits. The kits can be ordered for specific applications ensuring the proper type and amount of hardware for each installation. Packaged in separate sealed bags, they are convenient to use, eliminating mismatched quantities. DURIUM™ silicon bronze material provides long lasting corrosion resistance.

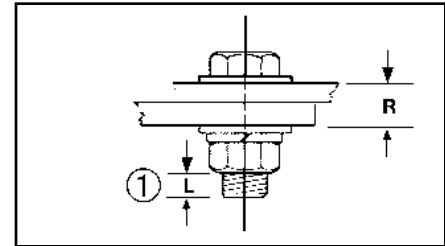

Catalog Number	Size	Each TMH Kit Includes:					Working Range R	Installation Torque (In-lbs)
		Bolt		Flat Washer	Split Washer	Hex Nut		
Length	Qty.							
TMH262	1/4-20	0.75	2	4	2	2	0.09 - 0.34	80
TMH263		1.00	2	4	2	2	0.34 - 0.59	
TMH264		1.25	2	4	2	2	0.59 - 0.84	
TMH265		1.50	2	4	2	2	0.84 - 1.09	
TMH266	3/8-16	0.75	2	4	2	2	0.00 - 0.19	240
TMH267		1.00	2	4	2	2	0.19 - 0.44	
TMH268		1.25	2	4	2	2	0.44 - 0.69	
TMH269		1.50	2	4	2	2	0.69 - 0.94	
TMH270		1.75	2	4	2	2	0.94 - 1.19	
TMH271		2.00	2	4	2	2	1.19 - 1.44	
TMH332 ²		2.75	2	4	2	2	—	
TMH261 †		3.00	2	4	2	2	2.15 - 2.40	
TMH289 ††	1.25	1	2	1	1	0.02 - 0.27		
TMH295	1/2-13	1.25	2	4	2	2	0.27 - 0.49	480
TMH272		1.50	2	4	2	2	0.49 - 0.74	
TMH294		1.75	2	4	2	2	0.74 - 0.99	
TMH69		2.00	2	4	2	2	0.99 - 1.24	

† For use with CUSA750-2TC38 copper spacer adaptor, (2) terminals and ^{††} thick equipment bus bar. For other combinations contact BURNDY®.
 †† For use with all GAR-TC connectors. "R" dimension is allowable pad thickness of terminal

* For other combinations contact BURNDY®.
 ① "L" dimension never exceeds .25"
² For use with CUSA442TC38 on 1/4" bus bar and HYLUG™ 4/0 - 750 kcmil.

TYPE TMH-SS

STAINLESS STEEL HARDWARE KITS

Type TMH-SS are stainless steel hardware kits. Just like the standard TMH kits, these kits can be ordered for specific applications ensuring the proper type and amount of hardware for each installation. They are packaged in separate sealed bags and convenient for use and ordering.

Catalog Number	Size	Each TMH Kit Includes:					Working Range R	Installation Torque (In-lbs)
		Bolt		Flat Washer	Split Washer	Hex Nut		
Length	Qty.							
TMH322SS	10 - 32	0.875	1	0	1	1	-	45
TMH262SS	1/4-20	0.75	2	4	2	2	0.09 - 0.34	80
TMH263SS		1.00	2	4	2	2	0.34 - 0.59	
TMH264SS		1.25	2	4	2	2	0.59 - 0.84	
TMH265SS		1.50	2	4	2	2	0.84 - 1.09	
TMH267SS	3/8-16	1.00	2	4	2	2	0.19 - 0.44	240
TMH268SS		1.25	2	4	2	2	0.44 - 0.69	
TMH269SS		1.50	2	4	2	2	0.69 - 0.94	
TMH270SS		1.75	2	4	2	2	0.94 - 1.19	
TMH271SS		2.00	2	4	2	2	1.19 - 1.44	
TMH261SS †		3.00	2	4	2	2	2.15 - 2.40	
TMH295SS	1/2-13	1.25	2	4	2	2	0.27 - 0.49	480
TMH272SS		1.50	2	4	2	2	0.49 - 0.74	
TMH294SS		1.75	2	4	2	2	0.74 - 0.99	
TMH69SS		2.00	2	4	2	2	0.99 - 1.24	

Blue highlighted items are industry standard and most frequently ordered.

GALVANIZED STEEL HARDWARE

Galvanized bolts, nuts, flatwashers, and internal tooth lockwashers are manufactured per ASTM307 Grade A. Bolts up to 2 inches long are fully threaded; longer bolts are threaded for 2 inches. Nut surfaces and bolt heads have American Standard dimensions, and the threads are per American National Coarse Series, Class #2 fit. Galvanizing is per ASTM A153.

BOLTS

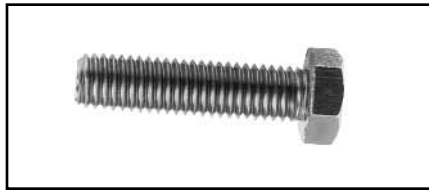

Catalog Number	Thread Size	Length (B)
38x125 HGSB	3/8-16	1.25
38x275 HGSB	3/8-16	2.75
38x225 HGSB	3/8-16	2.25
50x100 HGSB	1/2-13	1.00
50x150 HGSB	1/2-13	1.50
50x200 HGSB	1/2-13	2.00
62x100 HGSB	5/8-11	1.00
62x175 HGSB	5/8-11	1.75
75x125 HGSB	3/4-10	1.25

NUTS



Catalog Number	Thread Size
31CHGSN	5/16-18
38 HGSN-009	3/8-16
38 HGSN	3/8-16
50 HGSN	1/2-13
62 HGSN	5/8-11

FLATWASHER



Catalog Number	Bolt Size	Nominal Dimensions (Inches)	
		I.D. A	O.D. B
38x81 FWGS	3/8	0.406	0.813
50x106 FWGS	1/2	0.531	1.06

INTERNAL TOOTH LOCKWASHERS



Catalog Number	Bolt Size
38 NWGS	3/8
50 NWGS	1/2
62 NWGS	5/8
75 NWGS	3/4

Blue highlighted items are industry standard and most frequently ordered.

ALUMINUM
HARDWARE

D-6

BOLTS

BURNDY® aluminum hexagon head bolts are manufactured of alloy 2024-T4 and are finished with anodic coating and lubricated. Threads are coarse series, class 2A fit.

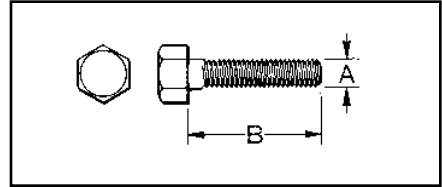
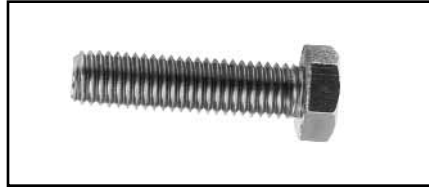

Catalog Number	Thread Size	B Length	Catalog Number	Thread Size	B Length
50x150 HAB BOX	1/2-13	1-1/2"	50x500 HAB BOX	1/2-13	5"
50x175 HAB BOX	1/2-13	1-3/4"	50x550 HAB BOX	1/2-13	5-1/2"
50x200 HAB BOX	1/2-13	2"	62x175 HAB BOX	5/8-11	1-3/4"
50x225 HAB BOX	1/2-13	2-1/4"	62x200 HAB BOX	5/8-11	2"
50x250 HAB BOX	1/2-13	2-1/2"	62x225 HAB BOX	5/8-11	2-1/4"
50x275 HAB BOX	1/2-13	2-3/4"	62x250 HAB BOX	5/8-11	2-1/2"
50x300 HAB BOX	1/2-13	3"	62x300 HAB BOX	5/8-11	3"
50x325 HAB BOX	1/2-13	3-1/4"	62x350 HAB BOX	5/8-11	3-1/2"
50x350 HAB BOX	1/2-13	3-1/2"	62x400 HAB BOX	5/8-11	4"
50x375 HAB BOX	1/2-13	3-3/4"	62x450 HAB BOX	5/8-11	4-1/2"
50x400 HAB BOX	1/2-13	4"	62x500 HAB BOX	5/8-11	5"
50x425 HAB BOX	1/2-13	4-1/4"	62x550 HAB BOX	5/8-11	5-1/2"
50x450 HAB BOX	1/2-13	4-1/2"	62x600 HAB BOX	5/8-11	6"

NUTS

BURNDY® aluminum nuts are manufactured of alloy 6061-T6, are finished type, coarse thread, class 2B fit.



Catalog Number	Thread Size
50 HAN BOX	1/2-13
62 HAN BOX	5/8-11

FLATWASHER

BURNDY® aluminum flat washers are manufactured of alloy 2024-T4 and are medium design.



Catalog Number	Description	For Bolt Size
50 FWA BOX	Flat Washer	1/2
62 FWA BOX	Flat Washer	5/8

SPLIT LOCKWASHERS

BURNDY® aluminum split lockwashers are manufactured of alloy 7075-T6 and are regular design.



Catalog Number	Description	For Bolt Size
50 SWAL BOX	Split Washer	1/2
62 SWAL BOX	Split Washer	5/8

Blue highlighted items are industry standard and most frequently ordered.

STAINLESS STEEL HARDWARE

Stainless steel bolts, nuts, flatwashers and split lockwashers are manufactured from 18-8 non-magnetic material. Bolts up to 2 inches long are fully threaded; longer bolts

are threaded for 2 inches. Nut surfaces and bolt heads have American National Coarse Series, Class #2 fit.

D-7

BOLTS

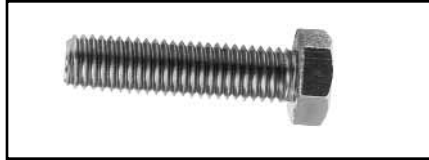

Catalog Number	Thread Size	Length B (Inches)
38X125 HSSB	3/8-16	1.25
38x225 HSSB	3/8-16	2.25
38x250 HSSB	3/8-16	2.50
38x275 HSSB	3/8-16	2.75
50x200 HSSB	1/2-13	2.00
50x250 HSSB	1/2-13	2.50
50x300 HSSB	1/2-13	3.00
62x300 HSSB	5/8-11	3.00

NUTS



Catalog Number	Thread Size
25 HSSN	1/4-20
38 HSSN	3/8-16
50 HSSN	1/2-13
62 HSSN	5/8-11

SPLIT LOCKWASHERS



Catalog Number	For Bolt Size
25 SWSS LT	1/4
38 SWSSMD	3/8
50 SWSSMD	1/2
62 SWSSMD	5/8

FLATWASHER



Catalog Number	Bolt Size	Nominal Dimensions (Inches)	
		I.D. A	O.D. B
25 FWSS	1/4	0.266	0.688
38 FWSS	3/8	0.406	1.000
50 FWSS	1/2	0.594	1.125
62 FWSS	5/8	0.656	1.312

BELLEVILLE WASHERS



Any bolted "pad to flat" electrical connection should include a bolt, two flatwashers, and the nut. In addition, if any of the flat components is aluminum, a properly designed Belleville washer should be interposed between one of the flatwashers and either the bolt head or the nut, with the hollow of the Belleville washer placed against the flat washer. BURNDY® Belleville washers are designed to maintain substantial force when tightened to NEMA - recommended values and finely finished to avoid galling.

Catalog Number	Material	Bolt Size	Nominal Dimensions		
			Thickness	I.D.	O.D.
38x75 BWSS	Stainless	3/8	.062	.388	.750
50x106 BWSS		1/2	.095	.530	1.06

The stainless washers are 301 stainless steel.

Blue highlighted items are industry standard and most frequently ordered.

TYPE UB

DURIUM™
SILICON BRONZE U-BOLTS

D-8

DURIUM™ U-BOLTS are specifically designed for electrical connections to pipe and rod. The U-BOLTS are threaded on the straight portion of the legs only allowing for more contact surface on the pipe or rod. American National Coarse Threads Class #2 fit. The silicon bronze is per ASTM B99.

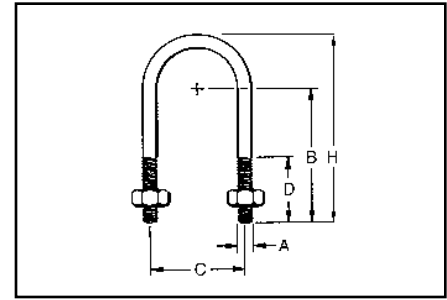

Catalog Number	Thread Size	H	C	D	B
UB101	1/4-20	1.38	0.75	0.75	0.88
UB104		1.81	1.12	0.88	1.12
UB105		2.03	1.31	1.00	1.25
UB106		2.31	1.62	1.12	1.38
UB107		2.66	1.94	1.31	1.56
UB336	3/8-16	1.50	0.88	0.62	0.88
UB337		1.94	1.12	0.75	1.19
UB178		2.00	0.88	0.75	1.38
UB354		2.44	1.25	1.00	1.62
UB187		2.47	1.16	1.06	1.69
UB271		2.50	1.00	1.19	1.81
UB222		2.69	1.50	1.12	1.75
UB242		2.72	1.16	1.31	1.94
UB383		2.75	0.94	1.47	2.09
UB269		2.78	1.19	1.38	2.00
UB357		2.78	1.69	1.12	1.75
UB384		2.91	1.44	1.38	2.00
UB249		3.00	1.50	1.44	2.06
UB1031		3.31	1.75	1.90	2.25
UB244		3.31	1.75	1.62	2.25
UB199		3.41	2.34	1.44	2.05
UB204		3.47	2.06	1.62	2.25
UB124		3.50	2.75	1.31	1.94
UB268		3.97	2.34	2.00	2.62
UB257		4.16	2.81	1.94	2.56
UB1032	4.41	2.81	2.56	2.81	
UB310	4.41	2.81	2.19	2.81	
UB266	4.97	3.31	2.50	3.12	
UB267	5.53	3.94	2.75	3.38	
UB258	5.56	4.00	2.75	3.38	
UB264	6.16	4.44	3.12	3.75	
UB1033	6.16	4.44	3.50	3.75	
UB261	6.34	4.94	3.06	3.69	
UB422	7.69	6.00	3.88	4.50	
UB1027	8.12	7.12	2.88	4.38	
UB1028	9.62	9.12	2.88	4.88	
UB1029	11.20	11.25	2.88	5.38	
UB1030	12.70	13.25	2.88	5.88	
UB224	1/2-13	2.44	1.12	0.88	1.62
UB358		2.66	1.31	1.00	1.75

Catalog Number	Thread Size	H	C	D	B
UB226	1/2-13	2.75	1.25	1.12	1.88
UB291		2.81	1.19	1.22	1.97
UB293		2.81	1.75	1.19	1.69
UB464		3.12	1.81	1.31	1.96
UB540		3.19	1.38	1.75	2.25
UB254		3.41	1.31	1.75	2.50
UB328		3.41	2.94	0.94	1.69
UB400		4.03	1.31	2.38	3.12
UB256		4.16	2.22	2.06	2.81
UB230		4.34	2.94	1.88	2.62
UB311		4.44	1.88	2.50	3.25
UB302		4.62	2.47	2.38	3.12
UB232		4.97	3.44	2.25	3.00
UB260		5.34	2.94	2.88	3.62
UB390		5.38	2.50	3.12	3.88
UB263	5.78	4.56	2.50	3.25	
UB282	6.31	4.12	3.25	4.00	
UB236	6.41	5.06	2.88	3.62	
UB399	6.66	1.31	5.00	5.75	
UB436	6.66	4.56	3.62	4.12	
UB262	6.78	5.06	3.25	4.00	
UB392	7.06	1.62	5.25	6.00	
UB416	7.53	5.06	4.00	4.75	
UB300	7.62	6.12	3.56	4.31	
UB306	7.88	6.12	3.81	4.56	
UB275	5.09	1.19	3.60	4.25	
UB437	8.56	6.12	4.50	5.25	
UB294	5/8-11	3.50	1.38	1.75	2.50
UB314		3.66	2.09	1.56	2.31
UB425		3.72	2.31	1.50	2.25
UB317	3/4-10	4.97	1.81	3.00	3.75
UB315		5.56	2.09	3.44	4.19
UB318		4.22	2.44	1.87	2.62
UB344	3/4-10	4.72	1.94	2.63	3.38
UB319		6.34	2.44	4.00	4.75

Blue highlighted items are industry standard and most frequently ordered.

TABLE OF CONTENTS

**HYGROUND® IRREVERSIBLE COMPRESSION GROUNDING
AND INSTALLATION TOOLING**

HYGROUND® Features and Benefits	E-5 - E-6		Type YGIB	E-20 - E-21
	Type YGL-C	E-7		Type GSTUD-HY
	Type YGLR-C	E-8		Types YGT & YTTAG
	Type YGHP-C	E-9		Type YG-B
	Type YGHP-C	E-10		
	Type YGHC-C	E-11		
	Type YGC	E-12		
	Type YSHG	E-13		MECHANICAL GROUNDING Types KC, K2C
	Type YGHR-C	E-14		Types KC22J12T13, EQC632C, KS-DB
	Type YGHR-C	E-15		Types KS, GKA, KPB, CL50-1
	Type YGHA	E-16		Type GAR
	Type YGHS	E-16		Types GAR-BU & GAR 3900 Series & GAR-RB
	Type YGA	E-17		Type GAR-TC
	Type YGS	E-18		
	Type YGF	E-19		

E-1

⚡ LIGHTNING PROTECTION INFO.

- Basic rules for selection are:
1. Must be like material to the conductor.
 2. Two bolts to ground rod — minimum, for mechanical.
 3. Cable to cable connections can be installed with – one bolt, two bolt, or compression.
 4. Cable to steel structure must have 8 in.² contact with steel.
 5. Heavy duty stacks — mechanical only.
 6. On all connectors with heavy duty stack rating, we must offer 1/16" thick lead plating as an option. Reason is closest 25 ft. to stack opening must use lead coated product.
 7. UL 96 Listing.

Blue highlighted items are industry standard and most frequently ordered.

TABLE OF CONTENTS
MECHANICAL GROUNDING (Continued)















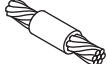









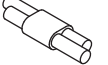

E-2

	Type GD	E-32		Types GC, GCM	E-48
	Type GP	E-33		Type GL	E-49
	Type GK	E-33		Type GZ	E-49
	Type BDT BONDIT™	E-34		Type GC-CT	E-50
	Water Pipe Grounding . .	E-35 - E-40		Type GTC1AC34RA	E-51
	Type GC-A	E-41		Type GIE-G	E-52
	Type GG	E-42		Rail Connector	E-53
	Type GQ	E-43		Type QGFL	E-54
	Type GX	E-44		Type GA-H	E-54
	Types GRC, GRL, GCRT1/0 . .	E-45		Type GRF Raised Floor Grounding	E-55
	Type B	E-46 - E-47		Types GP-G1, GPRT Raised Floor Grounding	E-56
	Types GB, GBM	E-48		Type BBB Copper BusBar	E-57 - E-58

Blue highlighted items are industry standard and most frequently ordered.

TABLE OF CONTENTS

BURNDYWeld®

BURNDYWeld® Introduction	E-60		Type BCR-17	E-72
Making a BURNDYWeld® Connection	E-61		Type BCR-24	E-73
 WELD METAL	E-62		Type BCS-1	E-75
	Type BCC-1		Type BCS-8	E-75
	Type BCC-2		Type BCS-2	E-76
	Type BCC-4		Type BCS-9	E-76
	Type BCC-11		Type BCS-3	E-77
	Type BCC-6		Type BCS-23	E-78
	Type BCC-14		Type BCS-4	E-79
	Type BCC-7		Type BCS-6	E-79
	Type BCR-1		Type BCS-7	E-80
	Type BCR-2		Type BCS-18	E-80
	Type BCR-3		Type BCS-5	E-81
			Type BCRE-1	E-82
			Type BCRE-2	E-83

E-3

Blue highlighted items are industry standard and most frequently ordered.

TABLE OF CONTENTS

BURNDYWeld® (Continued)

E-4

 Type **BCRE-3** E-84

 Type **BCRE-4** E-85

 Type **BCRE-6** E-86

BURNDY®
GROUNDMAX™ E-87 - E-88

 **BURNDY GRIDMAX™** E-89

 Types **B-106 & B-107**
Handle Clamps E-90

 **B40-0106-75**
Handle Attachment E-90

 Mold Support Clamp E-90

 Vertical Magnetic
Clamps E-91

 Horizontal & Vertical
Chain Clamps E-91

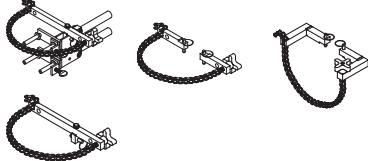

SINGLE SHOT MOLDS

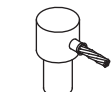
 Type **BCR-1** E-74

 Type **BCR-2** E-74

 Type **BCR-24** E-74

 Type **BCR-25** E-74

ACCESSORIES

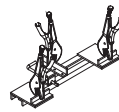
 **B38-0330-00** Cable Clamp ... E-92

 Cable Cleaning Brush E-92

 Card Cloth Brush E-92

 Mold Cleaning Brush E-92

 Mold Cleaners E-92

 Packing Material E-92

 **BURNDYWeld™** Tool Kit E-93

BURNDYWeld™ Tools E-93

 **B38-0101-00** Rasp E-93

 **B38-0309-00** Flint Ignitor E-93

 Ground Rod
Driving Sleeves E-94

 Shim Stock and
Adapter Sleeves E-94

Tips E-95 - D96

**THE HYGROUND®
IRREVERSIBLE
COMPRESSION
SYSTEM**

BURNDY® has developed an irreversible compression ground system which meets the most stringent safety and performance requirements, including those of OSHA and nuclear power plant design. Performance excellence and long life expectancy are the system's basic design guidelines. It is a complete system which consists of connectors for grid cross connections, taps, splices, cable to ground rod, ground plates and terminations.





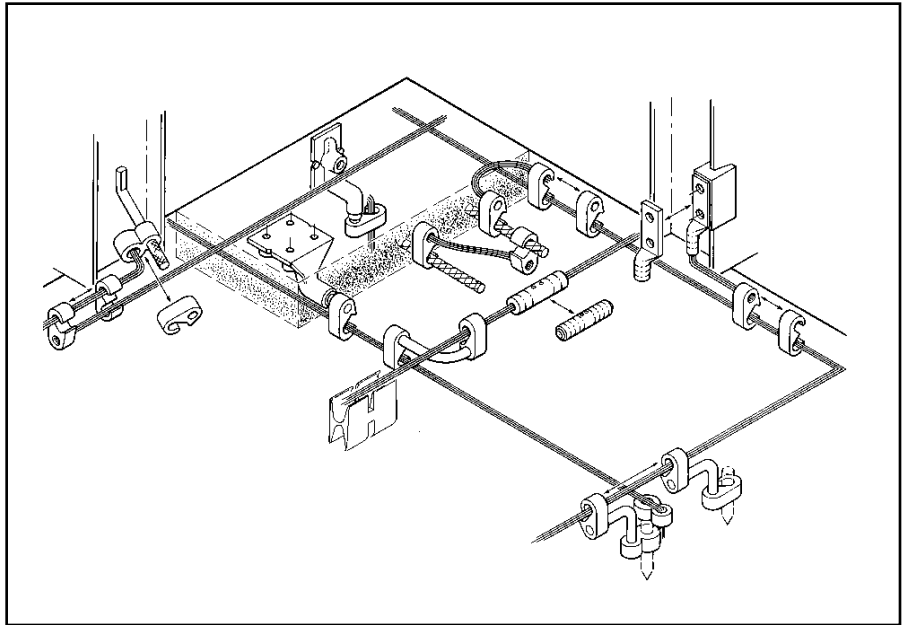



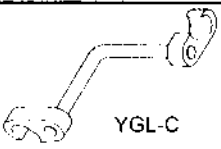

Our irreversible compression ground connectors employ well-proven design principles and technology that have been in existence for over 60 years.

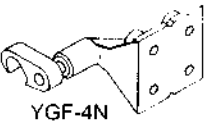
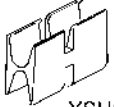
Connectors are just one component of our Irreversible Compression Ground System. Installation tooling is also an integral part of this system. BURNDY® pioneered the compression connector principle and continues today to be the leader in compression technology. Our tooling package is the most extensive in the industry and affords the user many options.

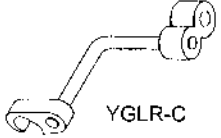

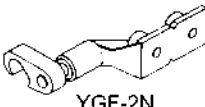
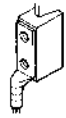
E-5

(LEGEND)

 YGHP-C	 YGL-C	 YGHA	 YGF-4N	 YSHG
 YGHR-C	 YGLR-C	 YGHS	 YGF-2N	 YGIB
 YGHC-C	 YGA	 YGS	 GSTUD-HY	

Blue highlighted items are industry standard and most frequently ordered.

THE HYGROUND® IRREVERSIBLE COMPRESSION SYSTEM

(Continued)

E-6

Features and Benefits

- Irreversible compression.
 - ◇ Meets 1999 NEC code, section 250-50 and 250-64.
- Material-pure wrought copper extrusions, rod and seamless tubing—identical material to the conductor.
 - ◇ Completely eliminates the possibility of corrosion due to dissimilar metals.
- Heavy duty connector design.
 - ◇ All connectors will carry the equivalent or greater current carrying capacity of the conductor while maintaining high mechanical strength and electrical integrity.
- Range taking design—minimum number of connector combinations required to install a conductor range of #6 solid to 500 kcmil plus 1/2", 5/8", 3/4", and 1" ground rods and rebar.
 - ◇ Inventories are kept to a minimum and product selection is simplified.
- System engineered tooling.
 - ◇ Each tooling recommendation has been designed to ensure reliability of the connection.
- Irreversible compression connectors can be installed in all kinds of weather.
 - ◇ Eliminates costly construction delays and enables the installer to better schedule his job.
- May be installed without special training or special tools. Y750 crimps entire range.
 - ◇ Low installed cost.
 - ◇ Simplified installation.
- Each connection can be made in less than 3 minutes.
 - ◇ Low installed cost.
 - ◇ Simplified installation.
- Each connector is clearly marked with catalog number, conductor size and installation die information.
 - ◇ Easy and accurate identification.
- Inspection ports are provided to assure proper insertion of the conductor.
 - ◇ Built-in quality assurance.
- The die index number is embossed on the connector after completion of the crimp.
 - ◇ Facilitates speedy inspection of installed connectors to insure consistently reliable and sound connections.
- Most HYGROUND® irreversible compression elements are prefilled with PENETROX™ and individually sealed in clear polyethylene sheet.
 - ◇ Ensures that all contact surfaces are in the proper condition for installation.
 - ◇ Ensures the electrical integrity of the finished connection by inhibiting moisture and contaminants from entering the contact area.
- All HYGROUND® irreversible compression connectors are Listed in conformance with Underwriters Laboratories Standard UL467 and conform to applicable sections of the National Electrical Code.
 - ◇ May be used in direct burial or concrete embedded grounding applications.
- All HYGROUND® irreversible connectors (with the exception of type YGA and YGS) have been tested successfully according to requirements of Standard IEEE 837.
 - ◇ Meets tough industry performance requirements.
 - ◇ UPRECRIMP dies give added mechanical strength. UPRECRIMP 34 for 3/4" rod, UPRECRIMP 12 for 1/2" rod, and UPRECRIMP 58 for 5/8" rod (now includes undersized U.S. market place rods).
- Allows connection to most sizes of structural steel with no drilling, tapping, or welding.
 - ◇ Safely installed at low cost. Hot work permits are not required to install in hazardous areas

Blue highlighted items are industry standard and most frequently ordered.

TYPE YGL-C

HYGRID CROSS CONNECTOR

An irreversible compression ground grid cross connector which allows adjustment of the compression elements prior to installation. Only six connectors and four dies are required to install all combinations from #6 solid through 500 kcmil. UL467 Listed. Acceptable for direct burial in earth and concrete. Prefilled with PENETROX™ compound and strip sealed.

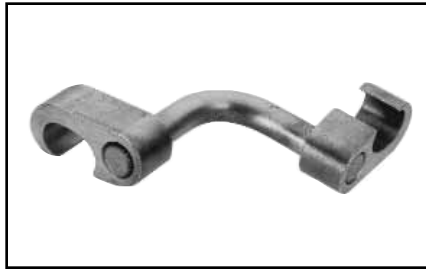

IEEE-837

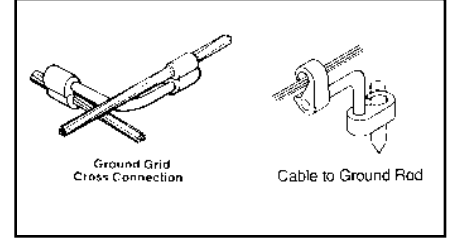
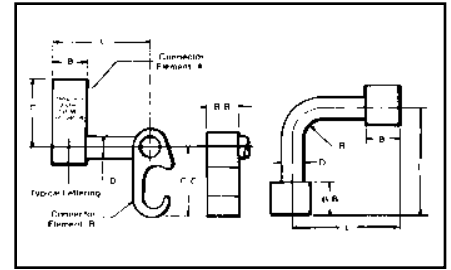

Catalog Number	B	B-B	C	C-C	D	L	R
YGL2C2	.75	.75	1.09	1.09	.313	2.50	.31
YGL29C2			1.66	1.66	.500		.50
YGL29C29			2.09	2.09	.313		.31
YGL34C2			1.66	1.66	.500		.50
YGL34C29			2.28	2.28	.750		.75
YGL34C34	1.10	1.10	2.28	2.28	.750		.75

⚡ UL96 Listed for Lightning Protection.



ORDERING INFORMATION

Catalog Number	Cable to Cable		Cable to Ground Rod		To Rebar
	Element "A"	Element "B"	Element "A"	Element "B"	Element "A"
YGL2C2	#6 Sol. (.162) – #2 Str. (.292) {59500} – {59500}	#6 Sol. (.162) – #2 Str. (.292) {59500} – {59500}			
YGL29C2	#1 Str. (.332) – 250 kcmil (.575) {98500} – {131500}	#1 Str. (.332) – 250 kcmil (.575) {98500} – {131500}	1/2" – 5/8" Rod	#6 Sol. (.162) – #2 Str. (.292)	3/8" – 1/2"
YGL29C29	#2 Str. (.292) – 250 kcmil (.575) {65500} – {131500}	#2 Str. (.292) – 250 kcmil (.575) {65500} – {131500}		#2 Str. (.292) – 250 kcmil (.575)	#3 – 4 Rebar
YGL34C2	250 kcmil (.575) – 500 kcmil (.813)	#6 Sol. (.162) – #2 Str. (.292)	5/8" – 3/4" Rod	#6 Sol. (.162) – #2 Str. (.292)	5/8" – 3/4"
YGL34C29		#2 Str. (.292) – 250 kcmil (.575)		#2 Str. (.292) – 250 kcmil (.575)	#5 – 6 Rebar
YGL34C34		250 kcmil (.575) – 500 kcmil (.813)		250 kcmil (.575) – 500 kcmil (.813)	250 kcmil (.575) – 500 kcmil (.813)

Dimensions in brackets { } represent lightning protection conductors.

Catalog Number	Installation Tools, Die Set Catalog Number (Number of Crimps)							
	Y750/Y35/Y39 HYPRESS™		PAT750-18V		Y45 HYPRESS™		Y46 HYPRESS™	
	Element "A"	Element "B"	Element "A"	Element "B"	Element "A"	Element "B"	Element "A"	Element "B"
YGL2C2	U-0 (1)	U-0 (1)	U-0 (1)	U-0 (1)	U-0 (1)	U-0 (1)	U-0 (1)	U-0 (1)
YGL29C2	U997 (1)	U-0 (1)	ⓐ U997P (1)	U-0 (1)	U997 (1)	U-0 (1)	U997 (1)	U-0 (1)
YGL29C29	U997 (1)	U997 (1)	ⓐ U997P (1)	ⓐ U997P (1)	U997 (1)	U997 (1)	U997 (1)	U997 (1)
YGL34C2*	PU998 (1)	U-0 (1)	PU998 (1)	U-0 (1)	S998 or PU998 (1)	U-0 (1)	P998 or PU998 (1)	U-0 (1)
YGL34C29*	PU998 (1)	U997 (1)	PU998 (1)	ⓐ U997P (1)	S998 or PU998 (1)	U997 (1)	PU998 or PU998 (1)	U997 (1)
YGL34C34*	U1011 (3)	U1011 (3)	U1011 (3)	U1011 (3)	S1011 (3)	S1011 (3)	P1011 (3)	P1011 (3)

- Where a "U" or "PU" die is recommended with Y45 HYPRESS™, a PT6515 adapter must be used.
 - Where a "U" or "PU" die is recommended with the Y46 HYPRESS™, a PUADP-1 adapter must be used.
- ⓐ Polarized die for the PAT750-18V.

* These connectors can only be installed using the Y750, Y45, or Y46 HYPRESS™ with the recommended dies. These connectors CANNOT be installed with the Y35 and Y39 HYPRESS™.

NOTES:

- Before crimping, both connector elements can be turned on rod diameter "D" to any desired position.
- Clean rust and/or protective coatings from rebar prior to installation.

- When attaching connector to ground rod, ground rod must be embossed with appropriate PRECRIMP™ die. For connections that must meet IEEE 837 requirements UPRECRIMP - type PRE crimp dies must be used for maximum clamping retention.

Ground Rod Dia.	PRECRIMP Dies	
1/2"	UPRECRIMP 12	U2CABT
5/8"	UPRECRIMP 58	
3/4"	UPRECRIMP 34	

Blue highlighted items are industry standard and most frequently ordered.

TYPE YGLR-C

GRIDLOK

High Strength
 Irreversible
 Compression Ground Rod to
 Grid Connector

E-8

Ground grid connector for a wide range of copper cable to ground rod. Provides high torque strength on ground rod. UL467 Listed. Acceptable for direct burial in earth and concrete. Prefilled with PENETROX™ compound and strip sealed.

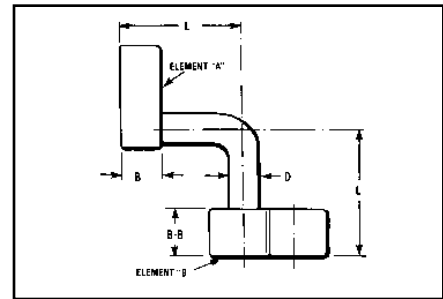
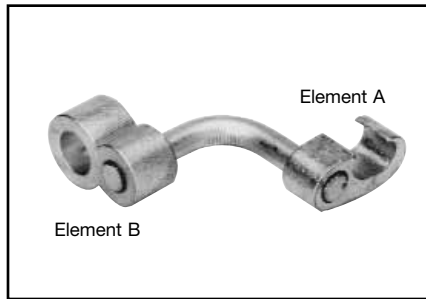

IEEE-837



Catalog Number	Commercial Copper Cable Range Element "A"	Metric Copper Cable Range Element "A"	Copper Weld Cable Range Element "A"	Ground Rod Dia. Element "B"	B	B-B	D	L	Installation Tools, Die Set Cat. No. (Number of Crimps)								
									Y35/Y39 HYPRESS™		Y750/PAT750		Y45 HYPRESS™		Y46 HYPRESS™		
									Element "A"	Element "B"	Element "A"	Element "B"	Element "A"	Element "B"	Element "A"	Element "B"	
YGLR29C12	#2 Str. (.292 Dia.) thru 250 kcmil (.575 Dia.)	35mm ² (7.62mm Dia.) thru 120 mm ² (14.40mm Dia.)	91.65 kcmil (.343 Dia.) thru 248.8 kcmil (.572 Dia.)	1/2"						U997 (1)	PU998 (1)	U997 (1)		U997 (1)			
YGLR34C12	250 kcmil (.575 Dia.) thru 500 kcmil (.813 Dia.)	120 mm ² (14.40mm Dia.) thru 240 mm ² (20.35mm Dia.)	248.8 kcmil (.572 Dia.) thru 498.8 kcmil (.810 Dia.)	[12.7]			.313 [7.9]	2.53 [64.3]		—		U1011 or PU998 (1)		S938 or PU998 (1)		P938 or PU998 (1)	
YGLR29C58	#2 Str. (.292 Dia.) thru 250 kcmil (.575 Dia.)	35 mm ² (7.62mm Dia.) thru 120 mm ² (14.40mm Dia.)	91.65 kcmil (.343 Dia.) thru 248.8 kcmil (.572 Dia.)	5/8"						U997 (1)	PU998 (1)	U997 (1)		U997 (1)		U997 (1)	
YGLR34C58	250 kcmil (.575 Dia.) thru 500 kcmil (.813 Dia.)	120 mm ² (14.40mm Dia.) thru 240 mm ² (20.35mm Dia.)	248.8 kcmil (.572 Dia.) thru 498.8 kcmil (.810 Dia.)	[15.9]						—		U1011 or PU998 (1)	U1011 (2) or PU998 (1)	S938 or PU998 (1)	S1012 (2) or PU998 (1)	P938 or PU998 (1)	P1011(2) or PU998 (1)
YGLR29C34	#2 Str. (.292 Dia.) thru 250 kcmil (.575 Dia.)	35 mm ² (7.62mm Dia.) thru 120 mm ² (14.40mm Dia.)	91.65 kcmil (.343 Dia.) thru 248.8 kcmil (.572 Dia.)	3/4"	[19.1]	[22.4]				U997 (1)	PU998 (1)	U997 (1)	PU998 (1)	U997 (1)	PU998 (1)	U997 (1)	PU998 (1)
YGLR34C34	250 kcmil (.575 Dia.) thru 500 kcmil (.813 Dia.)	120 mm ² (14.40mm Dia.) thru 240 mm ² (20.35mm Dia.)	248.8 kcmil (.572 Dia.) thru 496.8 kcmil (.810 Dia.)	[19.1]				.500 [12.7]	2.63 [66.8]			U1011 (2) or PU998	U1011 (2) or PU998	U1011 (2) or PU998	U1011 (2) or PU998	U1011 (2) or PU998	U1011 (2) or PU998
YGLR29C100	#2 Str. (.292 Dia.) thru 250 kcmil (.575 Dia.)	35 mm ² (7.62mm Dia.) thru 120 mm ² (14.40mm Dia.)	91.65 kcmil (.343 Dia.) thru 248.8 kcmil (.572 Dia.)	1"	[25.4]					—		U997 (1)		U997 (1)		U997 (1)	
YGLR34C100	250 kcmil (.575 Dia.) thru 500 kcmil (.813 Dia.)	120 mm ² (14.40mm Dia.) thru 240 mm ² (20.35mm Dia.)	248.8 kcmil (.572 Dia.) thru 498.8 kcmil (.810 Dia.)	1"	[25.4]							U1011 (2) or PU998 (1)	U1011 (2) or PU998	U1011 (2) or PU998	U1011 (2) or PU998	U1011 (2) or PU998	U1011 (2) or PU998

NOTES:

- Before crimping, both connector elements can be turned on rod diameter 'D' to any desired position.
- Grooves are filled with PENETROX™.
- Suitable for direct burial in earth or concrete.
- The catalog numbers shown are for unplated copper connectors for use on copper clad or stainless steel ground rod. To order electro-tin plated connectors for use on galvanized steel ground rod add suffix "TN" to the catalog number, only if the Figure 8 connector (Element "B") is tin plated, the Figure 6 connector (Element "A") is unplated. Note: The ground rod hole diameter is larger for galvanized steel ground rod in the tin plated connector.

- Ground rod must be pre-crimped with die U2CABT (Index No. 348) when crimping the ground rod element (Element "B") with the PU998 dies in the Y750, Y35, Y39, Y45, or Y46 tools. Pre-crimping is not required when the S1012, P1011 or U1011 dies are used. See precrimp die chart.
- Where a 'U' or 'PU' die is recommended with the Y45 HYPRESS™, a PT6515 adapter must be used.
- Where a 'U' or 'PU' die is recommended with the Y46 HYPRESS™, a PUADP-1 adapter must be used.
- Dimensions in bracket [] are in millimeters.
- Die "1011" appears on Element "B" of the connector only.

Ground Rod Dia.	PRECRIMP Dies	
1/2"	UPRECRIMP 12	U2CABT
5/8"	UPRECRIMP 58	
3/4"	UPRECRIMP 34	

When attaching connector to ground rod, ground rod must be embossed with appropriate PRECRIMP™ die. For connections that must meet IEEE 837 requirements UPRECRIMP - type PRE crimp dies must be used for maximum clamping retention.

Blue highlighted items are industry standard and most frequently ordered.

TYPE YGHP-C

HYTAP™ CONNECTOR

Irreversible compression ground tap figure 6 can be used as a tap connector or as a tap splice connector. Four die sets and eight connectors can accommodate a conductor range from #8 solid through 500 kcmil plus 1/2", 5/8", and 3/4" copper bonded ground rods. UL467 Listed. Acceptable for direct burial in earth and concrete. Prefilled with PENETROX™ compound and strip sealed.

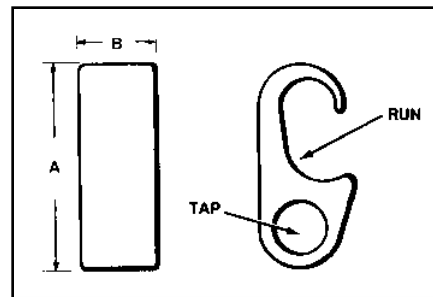

✓ UL96 Listed for Lightning Protection.

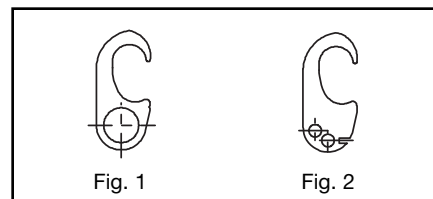

IEEE-837



Catalog Number	Fig. No.	Accommodates		⑤ Cable To Rebar		Die Index No.	Installation Data					
		Run	Tap	Run	Tap		B	Y750/Y35	PAT750-18V	③	④	No. of Crimps
								Y39 HYPRESS™		Y45 HYPRESS™	Y46 HYPRESS™	
YGHP2C2	1	#6 Sol. (0.162) {59500} – #2 Str. (0.292) {59500}	① #6 Sol. (0.162) {#2 Str.} – #2 Str. (0.292) {#2 Str.}	—	—	0	U0	U0	U0	U0	1	
YGHP2C6W6W⑧	2	#6 Sol. (0.162) – #2 Str. (0.292)	#8 Sol. (0.128) – 6 Str. (0.184) Qty. 2	—	—	.75 [19]	997	U997	⑦ U997P	U997	U997	1
YGHP29C6W6W⑧	2	1/0 Str. (0.372) {98500} – 250 kcmil (0.575) {131500} 1/2" – 5/8" Rod	#8 Sol. (0.128) – 6 Str. (0.184) Qty. 2	#3 Rebar 3/8	#8 Sol. – 6 Str.							
YGHP29C2	1		#4 Sol. (0.204) {#4 Sol.} – #2 Str. (0.292) {#2 Str.}	through	#2 Str.							
YGHP29C26	1		1/0 Str. (0.372) {98500} – 2/0 Str. (0.419) {98500}	1/2	1/0 Str. – 2/0 Str.							
YGHP29C29 ②	1		3/0 Str. (0.470) {131500} – 250 kcmil (0.575) {211500}	#4 Rebar	3/0 Str. – 250 kcmil							
YGHP34C2 ⑥	1	250 kcmil (0.575) {250 kcmil} – 500 kcmil (0.813) {500 kcmil} 5/8" – 3/4" Rod	#4 Sol. (0.204) – #2 Str. (0.292)	#5 Rebar 5/8	—	998	PU998	PU998	PU998 or S998	PU998 or P998	1	
YGHP34C26 ⑥	1		1/0 Str. (0.372) {98500} – 2/0 Str. (0.419) {98500}	through	1/0 Str. – 2/0 Str.							
YGHP34C29 ⑥	1		3/0 Str. (0.470) {131500} – 250 kcmil (0.575) {211500}	3/4	3/0 Str. – 250 kcmil							
YGHP34C34 ⑥	1	250 kcmil (0.575) – 500 kcmil (0.813) 5/8" – 3/4" Rod	350 kcmil (0.681) – 500 kcmil (0.843)	#6 Rebar	350 kcmil – 500 kcmil	1.10 [28]	1011	⑥U1011	U1011	S1011	P1011	3

Dimensions in brackets { } represent lightning protection conductors.

NOTES:

- ① When using #6 Sol. in tap, fold conductor double to improve fill in YGHP2C2.
- ② For YGHP29C29 when using 3/0 in tap, minimum run conductor is 2/0 Str.
- ③ Where a 'U' or 'PU' die is recommended with the Y45 HYPRESS™, a PT6515 adapter must be used.
- ④ Where a 'U' or 'PU' die is recommended with the Y45 HYPRESS™, a P-UADP-1 adapter must be used.
- ⑤ Clean rust and protective coatings from rebar before connector installation to provide a proper ground connection. Pre-crimping is not required.
- ⑥ These connectors can only be installed using the Y750, Y45 or Y46 HYPRESS™ with the recommended dies. These connectors can not be installed with the Y35 and Y39 HYPRESS™.
- ⑦ Polarized die for the PAT750-18V.
- ⑧ Not UL96/CSA.

Ground Rod Dia.	PRECRIMP Dies	
	1/2"	UPRECRIMP 12
5/8"	UPRECRIMP 58	
3/4"	UPRECRIMP 34	

For increased rotational resistance on ground rods, pre-crimp ground rod with U2CABT die Index 348 or uprecrimp dies may be used for even greater rotation and vibration resistance on ground rods.

**CABLE TO GROUND ROD
CABLE TO REBAR
CABLE TO CABLE
FOR CONCRETE ENCASED
ELECTRODE GROUNDING
APPLICATIONS**

Blue highlighted items are industry standard and most frequently ordered.

TYPE YGHP-C

HYTAP™ CONNECTOR

High Strength
Copper Irreversible
Compression

E-10

Ground Rod Tap Connector

Type YGHP-C irreversible compression ground tap figure 6 can be used as a ground rod tap connector for both continuous run and tapping applications. An open groove allows ground rod to be connected to a continuous run or tap. The second groove is for a tap only. Prefilled with PENETROX™ E and strip sealed. UL467 Listed for direct burial in earth or concrete.

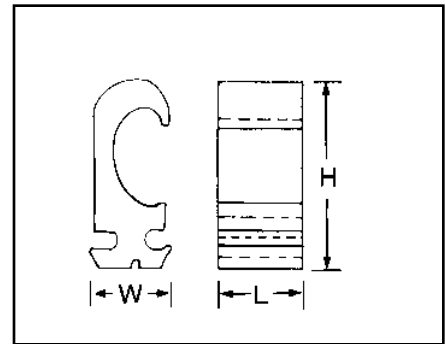
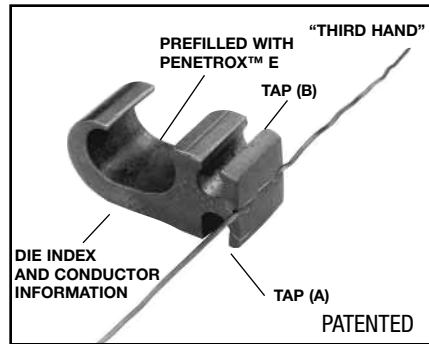

Features and Benefits

- Tap (A) accepts a continuous run on tap conductor
Tap (B) accepts a tap conductor only.
 - ◇ One connector style can be used for many applications, reducing number of connectors in inventory.
- Material is high conductivity wrought copper extrusion, identical material to the conductor.
 - ◇ High-conductivity copper minimizes resistance and voltage drop. Eliminates the possibility of corrosion due to dissimilar metals.
- System engineered tooling.
 - ◇ The tooling recommendation has been designed to ensure a reliable, dependable connection every time.
- The die index number is embossed on conductor after completion of crimp.
 - ◇ Facilitates speedy inspection of installed connectors to insure consistently reliable and dependable connections.
- Prefilled with PENETROX™ E and individually sealed in clear polyethylene sheet.
 - ◇ Ensures the electrical integrity of the finished connection by inhibiting moisture and contaminants from entering the contact area. Maintains long-term high-conductivity.
- UL467 Listed.
 - ◇ May be used in direct burial or concrete embedded grounding applications. Provides quality assurance to recognized industry NEC standards from an independent party.
- “Third Hand” constrains conductors while installer completes crimp. Included with each connector.
 - ◇ Simplifies installation, reducing installed cost.

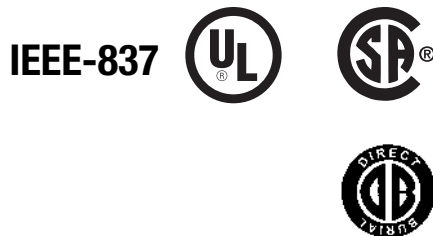

SINGLE TAP

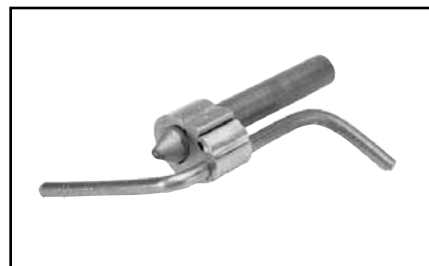

CONTINUOUS RUN



CONTINUOUS RUN AND TAP

Catalog Number	Ground Rod Dia. ■	Tap Conductor +	Dimensions			▲ Installation Tooling				Die Index
						Y35/Y750/PAT750		Y46 •		
			H	B	W	Die No.	No. of Crimps	Die No.	No. of Crimps	
YGHP58C2W-2	1/2" - 5/8"	#2 Sol. - #6 Sol. Copper (1) Continuous run and (1) Tap or up to (2) taps may be connected.	1.90"	.75"	.94"	U997	(1)	U997	(1)	997
YGHP58C2W-2TN										

NOTE: A 12" bend radius is recommended for the conductor.
 • Use PUADP-1 with 'U'-dies in Y46.
 ▲ See tooling section in Master Catalog for complete tool and die listing.
 + Either tap position may be left void when fewer than (2) conductors are used.

■ Ground rod must be precrimped with die U2CABT (Index No. 348).
 For even greater rotational resistance use UPRECRIMP die.
 For Galvanized Steel Rods order YGHP58C2W-2TN.

Blue highlighted items are industry standard and most frequently ordered.

New!
Ground Rod to Wire
UL467 Listed and
CSA Certified
for Direct Burial

TYPE YGHC-C

HYTAP™ CONNECTOR

Irreversible compression ground tap figure "C" connectors. Accommodates all cable combinations from #6 solid through 500 kcmil. "C"- shaped opening permits placing two continuous parallel cables into conductor groove. UL 467 Listed. Acceptable for direct burial in earth or concrete. Prefilled with PENETROX™ compound and strip sealed. Certain sizes are also UL467 Listed and CSA Certified for wire to ground rod.

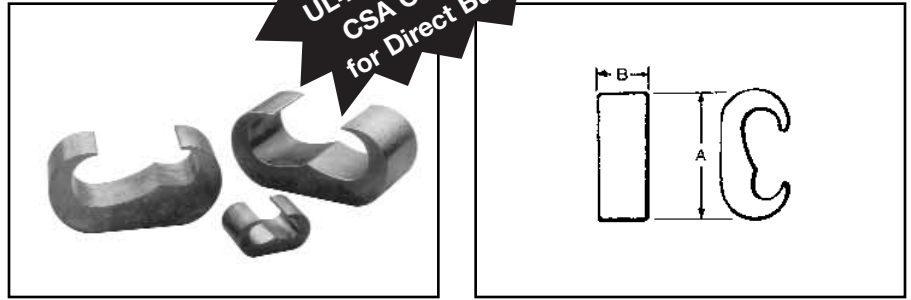

E-11



⚡ UL96 Listed for Lightning Protection.

Catalog Number	Commercial Copper Cable Range/ Ground Rod ③ to Copper Cable		Stranded Copper Cable Range		A	B	Die Index No.	Installation Data			No. of Crimps
	Run	Tap	Run	Tap				Y750/Y35/ PAT750/Y39 HYPRESS™	① Y45 HYPRESS™	② Y46 HYPRESS™	
								U-C	U-C	U-C	
YGHC2C2	#6 Sol. (0.162) #2 Str. (0.292) 1/4" Rod ⑦	#6 Sol. (0.162) #2 Str. (0.292)	10 mm² (4.12 mm) 35 mm² (7.62 mm)	10 mm² (4.12 mm) 35 mm² (7.62 mm)	1.16 [30]	0.75 [19]	C	U-C	U-C	U-C	1
YGHC26C2	1 Str. (0.328) {98500} 2/0 Str. (0.419) {98500} 3/8" Rod ⑦	#6 Sol. (0.162) {#6 Sol.} #2 Str. (0.292) {#2 Str.}	35 mm² (7.62 mm) 70 mm² (10.9 mm)	10 mm² (4.12 mm) 35 mm² (7.62 mm)	1.41 [36]	0.75 [19]	0	U-0	U-0	U-0	1
YGHC26C26	1 Str. (0.328) {98500} 2/0 Str. (0.419) {98500} 3/8" Rod ⑦	1 Str. (0.328) {98500} 2/0 Str. (0.419) {98500}	35 mm² (7.62 mm) 70 mm² (10.9 mm)	35 mm² (7.62 mm) 70 mm² (10.9 mm)	1.54 [39]	0.75 [19]	0	U-0	U-0	U-0	1
YGHC29C26	3/0 Str. (0.470) {3/0 Str.} 250 kcmil (0.575) {250 kcmil} 1/2" or 5/8" Rod ⑦	6 Sol. (0.162) {59500} 2/0 Str. (0.419) {98500}	95 mm² (12.5 mm) 120 mm² (14.4 mm)	10 mm² (4.12 mm) 70 mm² (10.9 mm)	1.97 [50]	0.75 [19]	997	U997	U997	U997	1
YGHC29C29	3/0 Str. (0.470) 250 kcmil (0.575) 1/2" or 5/8" Rod ⑦	3/0 Str. (0.470) 250 kcmil (0.575)	95 mm² (12.5 mm) 120 mm² (14.4 mm)	95 mm² (12.5 mm) 120 mm² (14.4 mm)	2.06 [52]	0.88 [22]	997	U997	U997	U997	1
YGHC34C26 ⑥	300 kcmil (0.630) {300 kcmil} 500 kcmil (0.813) {500 kcmil} 3/4" Rod ⑦	#6 Sol. (0.162) {59500} 2/0 Str. (0.419) {98500}	150 mm² (16 mm) 240 mm² (20.35 mm)	10 mm² (4.12 mm) 70 mm² (10.9 mm)	2.42 [62]	0.88 [22]	1011	U1011	S1011	P1011	2
YGHC34C29 ⑥	300 kcmil (0.630) 500 kcmil (0.813)	3/0 Str. (0.470) 250 kcmil (0.575)	150 mm² (16 mm) 240 mm² (20.35 mm)	95 mm² (12.5 mm) 120 mm² (14.4 mm)	2.67 [66]	0.88 [22]	1011	U1011	S1011	P1011	2
YGHC34C34 ⑥	300 kcmil (0.630) 500 kcmil (0.813)	300 kcmil (0.630) 500 kcmil (0.813)	150 mm² (16 mm) 240 mm² (20.35 mm)	150 mm² (16 mm) 240 mm² (20.35 mm)	2.91 [74]	1.1 [28]	1011	U1011	S1011	P1011	3

Dimensions in brackets { } represent lightning protection conductors.

NOTES:

- ① Where a "U" or "PU" die is recommended with the Y45 HYPRESS™, PT6515 adapter must be used.
- ② Where a "U" or "PU" die is recommended with the Y46 HYPRESS™, a PUADP-1 adapter must be used.
- 3. Listed under UL486A for copper wire connectors
- 4. Dimensions in brackets [] are in millimeters.
- 5. In referencing connectors without PENETROX™ oxide inhibitor add suffix "NP" to the end of the Catalog Number.
- ⑥ These connectors can only be installed using the Y750, Y45 or Y46 HYPRESS™ with the recommended dies.
These connectors cannot be installed with the Y35 and Y39 HYPRESS™.
- ⑦ Ground rod to copper cable is UL 467 Listed for direct burial in earth and concrete.

Ground Rod Dia.	PRECRIMP Dies	
1/2"	UPRECRIMP 12	U2CABT
5/8"	UPRECRIMP 58	
3/4"	UPRECRIMP 34	

⑧ For ground rod to wire applications, ground rod must be precrimped, see above table for appropriate precrimp dies.

Blue highlighted items are industry standard and most frequently ordered.

TYPE YGC

COPPER CRIMPIT™

UL 467 Listed for direct burial in earth or concrete. Prefilled with PENETROX™ E2 oxide inhibitor.

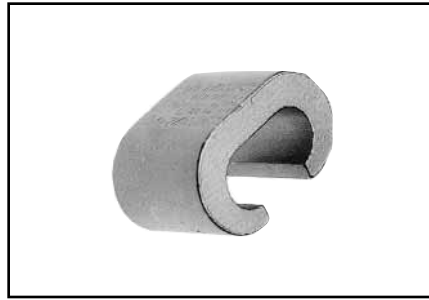

E-12



Catalog Number	Copper Conductor		H	L	Index	OUR840	MD6/MD7	Crimps
	Run	Tap						
YGC8C8	#8 Sol. #8 Str.	#8 Sol. #8 Str.	.46	.52	162	W162	W162	2
YGC6C8	#6 Sol. #6 Str.	#8 Sol. #8 Str.	.73	.62	BG	XBG	WBG	2
YGC6C6	#6 Sol. #6 Str.	#6 Sol. #6 Str.	.76	.62	BG	XBG	WBG	2

Blue highlighted items are industry standard and most frequently ordered.

TYPE YSHG

**HIGH STRENGTH
COPPER IRREVERSIBLE
COMPRESSION**

Double H-Tap Connector

Type YSHG Double H-Tap grounding series is comprised of five connectors designed to accommodate wire range sizes #14 through 500 kcmil, including ground rod sizes: 3/4", 1", and rebar sizes: #6, #8 and #9. Prefilled with PENETROX™ E2 and strip sealed.

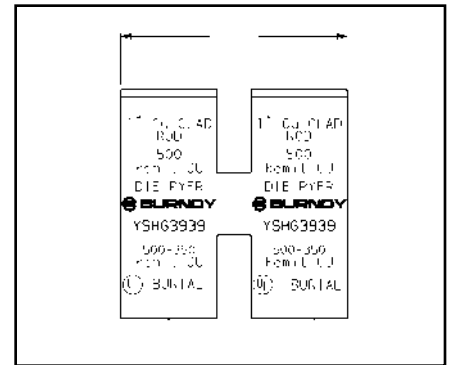

E-13

Features and Benefits

- UL467 Listed.
 - ◇ Suitable for direct burial in earth or concrete.
- Material is high conductivity copper extrusion.
 - ◇ Minimizes resistance, eliminates corrosion due to dissimilar metals.
- Grooves are prefilled with PENETROX™ E2 oxide inhibitor and individually sealed.
 - ◇ Inhibits moisture and contaminants ensuring electrical integrity.

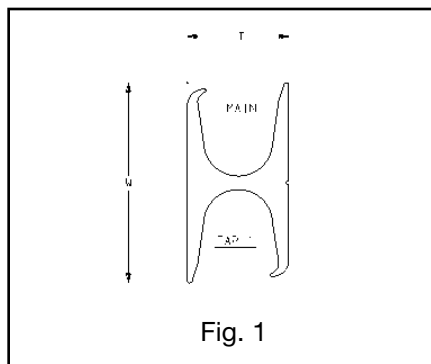

Fig. 1

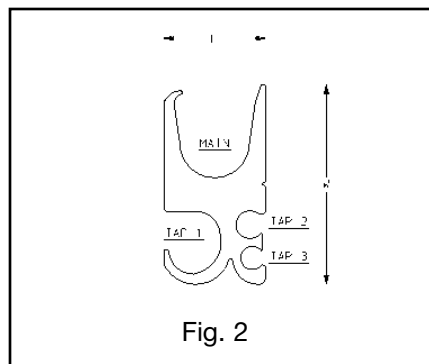

Fig. 2

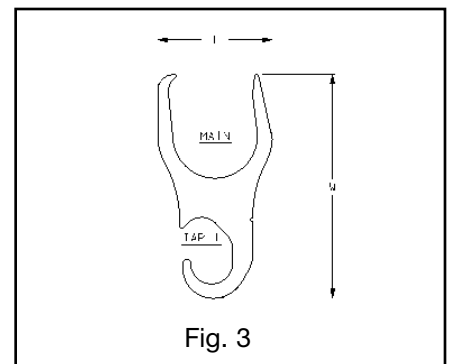

Fig. 3

Catalog Number	Fig. No.	Conductor Sizes				Tooling (number of crimps)		Index Embossment	W ±.06	T ±.04	L ±.06
		Main	Tap 1	Tap 2	Tap 3	PAT750/Y750	Y46				
YSHG4429	3	#9 & #8 Rebar, 1" [25] Ground Rod	250 - 2				PYFR (2)	K-R	3.22 [82]	1.70 [43]	2.44 [62]
* YSHG3931	2	#6 Rebar, 1" [25] Cu Clad Ground Rod, 3/4" Ground Rod 500 - 350 kcmil Copper	4/0 - 1/0	1 - 6	2 - 14		PYFR (2)	K-R	2.97 [75]	1.50 [38]	2.34 [59]
YSHG3434	1	#6 Rebar, 3/4" [19] Ground Rod 400 - 250 kcmil Copper	400 - 4/0			U1104 (4)	P1104 (2) †U1104 (4)	1104	2.43 [62]	1.15 [29]	2.44 [62]
YSHG3429	2	#6 Rebar, 3/4" [19] Ground Rod 400 - 4/0 kcmil Copper	3/0 - 1/0	1 - 4	8 - 14	U1104 (4)	P1104 (2) †U1104 (4)	1104	2.23 [57]	1.31 [33]	2.44 [62]

* NOTE: Not for use on 1" steel ground rod.
† Use PUADP-1 adapter.

Blue highlighted items are industry standard and most frequently ordered.

TYPE YGHR-C

HYTAIL™

High Strength Irreversible Compression Ground Rod Tap Connectors

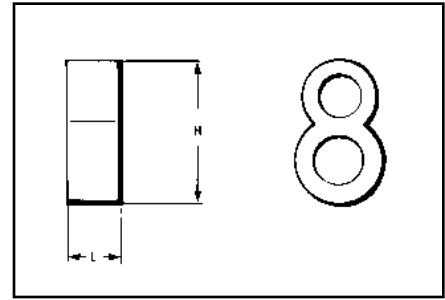
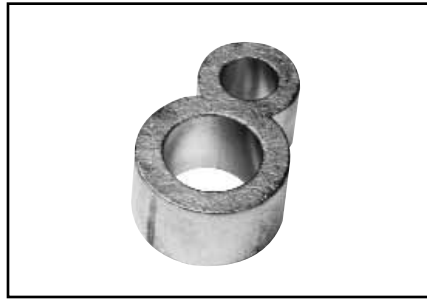

IEEE-837



Catalog Number	H	B
YGHR26C12	1.94" [49.3]	.88" [22.4]
YGHR26C58	1.97" [50.0]	
YGHR26C34	2.19" [55.6]	
YGHR26C100	2.55" [56.2]	
YGHR29C12	1.94" [49.3]	
YGHR29C58	2.14" [54.4]	
YGHR29C34	2.19" [55.6]	
YGHR29C100	2.45" [62.2]	
YGHR34C58	2.14" [54.4]	
YGHR34C34	2.44" [62.0]	
YGHR34C100	2.70" [68.6]	

E-14

High torque strength ground rod connectors. Accommodates a wide range of copper conductors to ground rod. UL467 Listed. Acceptable for direct burial in earth or concrete. Prefilled with PENETROX™ compound and strip sealed.

Catalog Number	Commercial Copper Cable Range	Nominal Ground Rod Dia.	Installation Tools, Die Set Catalog Number (Number of Crimps)						
			PAT750/Y750/Y35/Y39 ①	Y45 HYPRESS ①	Y46 HYPRESS ①				
YGHR26C12	#2 Str. (.292 Dia.) through	1/2" [12.7]	U1011 (2) ④ PU998 (1)	S1012 (2) ④	P1011 (2) ④ PU998 (1) ③				
YGHR26C58		5/8" [15.9]		PU998 (1) ②					
YGHR26C34		3/4" [19.0]		S1011 (2) S1012 (2) PU998 (1)					
YGHR26C100*	2/0 Str. (.419 Dia.)	1" [25.4]		S1012 (2) ④					
YGHR29C12	#4/0 Str. (.528 Dia.) through	1/2" [12.7]		U1011 (2) ④ PU998 (1)		S1012 (2) ④	P1011 (2) ④ PU998 (1) ③		
YGHR29C58		5/8" [15.9]				PU998 (1) ②			
YGHR29C34		3/4" [19.0]				S1011 (2) S1012 (2) ④ PU998 (1)			
YGHR29C100*	250 kcmil (.575 Dia.)	1" [25.4]				S1012 (2) ④			
YGHR34C58	300 kcmil (.630 Dia.) through	5/8" [15.9]				U1011 (2) ④ PU998 (1)		S1012 (2) ④	P1011 (2) ④ PU998 (1) ③
YGHR34C34*		3/4" [19.0]						PU998 (1) ②	
YGHR34C100*		1" [25.4]						S1011 (2)	

NOTES:

- The catalog numbers shown are for unplated copper connectors for use on copper clad or stainless steel ground rod. To order electro-tin plated connectors for use on galvanized steel ground rod add suffix "TN" to the catalog number. Note: The ground rod hole diameter is larger for galvanized steel ground rod in the tin plated connector.
- Ground rod must be pre-crimped with die U2CABT (Index No. 348) when the PU998 dies are used in the Y750, Y35, Y39, Y45, or Y46 tools. Pre-crimping is not required when the P1011, S1011, S1012 or U1011 dies are used. UPRECRIMP dies may be used for additional mechanical resistance on ground rods.

- Where a PU998 die is recommended with the Y45 HYPRESS™, a PT6515 adapter must be used.
- Where a PU998 die is recommended with the Y46 HYPRESS™, a PUADP-1 adapter must be used.
- These die numbers do not appear on the connector.
- * These connectors can only be installed using the Y750, Y45 or the Y46 HYPRESS™ with the recommended dies. These connectors CAN NOT be installed with the Y35 and Y39 HYPRESS™. When attaching connector to ground rod, ground rod must be embossed with appropriate PRECRIMP™ die. For connections that must meet IEEE 837 requirements UPRECRIMP - type PRE crimp dies must be used for maximum clamping retention.

Blue highlighted items are industry standard and most frequently ordered.

TYPE YGHR-C

HYTAIL™

High Strength Irreversible
Compression Ground Rod
Tap Connectors

Type YGHR-C irreversible compression grounding connector is engineered specifically for the Telecommunications Industry for (1, 2 or 3) #2 solid, tinned or bare conductor taps. UL467 Listed. Acceptable for direct burial in earth or concrete. BURNDY® has designed this connector to meet the stringent requirements of OSHA, the National Electric Code (NEC), UL, and the Telecommunications Industry. Performance and long life are this connector's basic design guidelines.

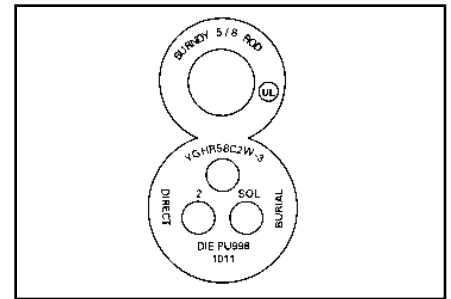

E-15

Features and Benefits

- Tap side 1, 2 or 3 conductors.
 - ◊ One connector style can be used for many applications.
- Material is high conductivity wrought copper extrusion, identical material to the conductor.
 - ◊ High-conductivity copper minimizes resistance and voltage drop. Eliminates the possibility of corrosion due to dissimilar metals.
- System engineered tooling.
 - ◊ Each tooling recommendation has been designed to provide a reliable, dependable connection.
- The die index number is embossed on connector after completion of crimp.
 - ◊ Facilitates speedy inspection of installed connectors to ensure consistently reliable and dependable connections.
- Prefilled with PENETROX™ and individually sealed in clear polyethylene sheet.
 - ◊ Ensures the electrical integrity of the finished connection by inhibiting moisture and contaminants from entering the contact area. Maintains long-term high-conductivity.
- UL 467 Listed. Acceptable for direct burial.
 - ◊ May be used in direct burial or concrete embedded grounding applications. Provides quality assurance to recognized industry NEC standards from an independent party.

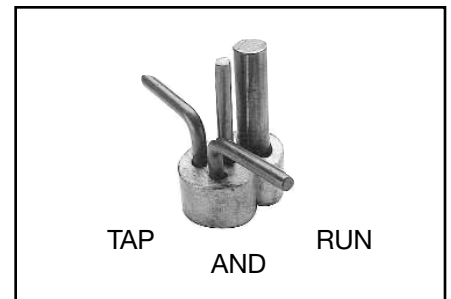

Catalog Number +	Ground Rod Diameter •	Tap Conductor ▲	Installation Tooling				Die Index
			PAT750/Y35/Y750**		Y46*		
			Die No.	No. of Crimps	Die No.	No. of Crimps	
YGHR58C2W-3	5/8"	#2 Sol. Copper 1, 2, or 3 may be connected	PU998†	(1)	PU998†	(1)	998 or 1011
					U1011	(2)	
			U1011	(2)	P998	(1)	
					P1011	(2)	

• Contact BURNDY® for other ground rod diameters.
 * PU998 and U1011 die sets require PUADP-1 adapter for use in the Y46 HYPRESS™.
 Tap positions may be left void when fewer than (3) conductors are used.
 + To order electro-tin plated connector for use on galvanized steel ground rod add suffix "-TN" to the catalog number.
NOTE: The ground rod hole diameter is larger for galvanized steel ground rod in the tin plated connector.

† Ground rod must be precrimped with die U2CABT (Index No. 348) when PU998 die set is used in the Y35, Y750 or Y46.
 ▲ HYPRESS™ tools. For even greater mechanical resistance use UPRECRIMP 58 dies.
 ** The Y750 utilizes PU dies and the U1011 die. The Y35 only uses PU998 die set.
NOTE: A 12" bend radius is recommended for the conductor.

Blue highlighted items are industry standard and most frequently ordered.

TYPE YGHA

HYLUG™

Heavy Duty Irreversible Compression Terminals

E-16

Heavy duty HYLUG™ irreversible compression terminals designed not only to carry short circuit load, but to also withstand high mechanical stress. Each conductor element has an inspection probe hole to ensure proper cable insertion. UL467 Listed. Acceptable for direct burial in earth or concrete. UL486A Listed. Prefilled with PENETROX™ compound and strip sealed.

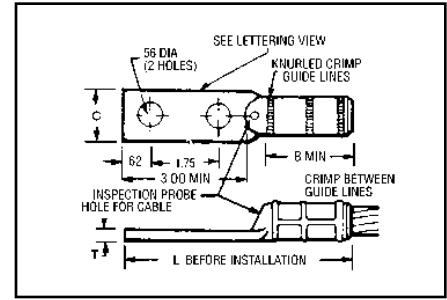

IEEE-837



Catalog Number	Copper Conductor Size	Installation Tools, Die Set Catalog Number, and (Number of Crimps)				B	C	L	T
		HYPRESS™ Y35/Y39/Y45 ① /Y46 ② /Y750 /PAT750							
YGHA2C-2N	2 str.	U1CRT (1)				.75	.97	4.21	.26
YGHA25-2N	1/0 str.	U27RT (1)				.83	.97	4.60	.19
YGHA26-2N	2/0 str.	U28RT (1)				.83	.97	4.38	.26
YGHA27-2N	3/0 str.	U29RT (1)				1.18	1.08	4.94	.29
YGHA28-2N	4/0 str.	U30RT (2)				1.18	1.22	4.94	.30
YGHA29-2N	250 kcmil	U31RT (2)				1.18	1.28	4.94	.34
YGHA31-2N	350 kcmil	U34RT (2)				1.18	1.62	5.00	.43
YGHA34-2N	500 kcmil	U36RT (3)				1.48	1.72	5.42	.40

① Where a "U" or "PU" die is recommended with the Y45 HYPRESS™, a PT6515 adapter must be used.

② Where a "U" or "PU" die is recommended with the Y46 HYPRESS™, a PUADP-1 adapter must be used.

TYPE YGHS

HYLINK™

Heavy Duty Irreversible Compression Terminals

Heavy duty HYLINK™ ground splice designed not only to carry short circuit load, but to also withstand high mechanical stress. Each conductor element has an inspection probe hole and a center stop to ensure proper cable insertion. UL467 Listed. Acceptable for direct burial in earth or concrete. UL486A Listed. Prefilled with PENETROX™ compound and strip sealed.

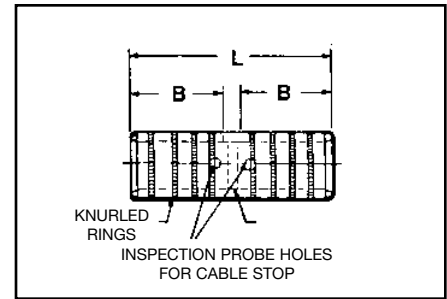

IEEE-837



Catalog Number	Copper Conductor Size	Installation Tools, Die Set Catalog Number, and (Number of Crimps)		B	L
		HYPRESS™ Y35/Y39/Y45 ① /Y46 ② /Y750 /PAT750			
YGHS2C	2 str.	U1CRT (1)		.75	1.73
YGHS25	1/0 str.	U27RT (1)		.83	1.89
YGHS26	2/0 str.	U28RT (1)		.83	1.89
YGHS27	3/0 str.	U29RT (1)		1.18	2.59
YGHS28	4/0 str.	U30RT (2)		1.18	2.59
YGHS29	250 kcmil	U31RT (2)		1.18	2.59
YGHS31	350 kcmil	U34RT (2)		1.18	2.59
YGHS34	500 kcmil	U36RT (3)		1.48	3.19

① Where a "U" or "PU" die is recommended with the Y45 HYPRESS™, a PT6515 adapter must be used.

② Where a "U" or "PU" die is recommended with the Y46 HYPRESS™, a PUADP-1 adapter must be used.

Blue highlighted items are industry standard and most frequently ordered.

TYPE YGA

HYLUG™

Grounding Irreversible
Compression Terminals

Irreversible compression HYLUG™ Ground terminal specifically designed for grounding applications. Each connector has an inspection probe hole to ensure proper cable insertion. UL467 Listed. Acceptable for direct burial in earth or concrete. UL486A Listed. Prefilled with PENETROX™ compound and strip sealed.

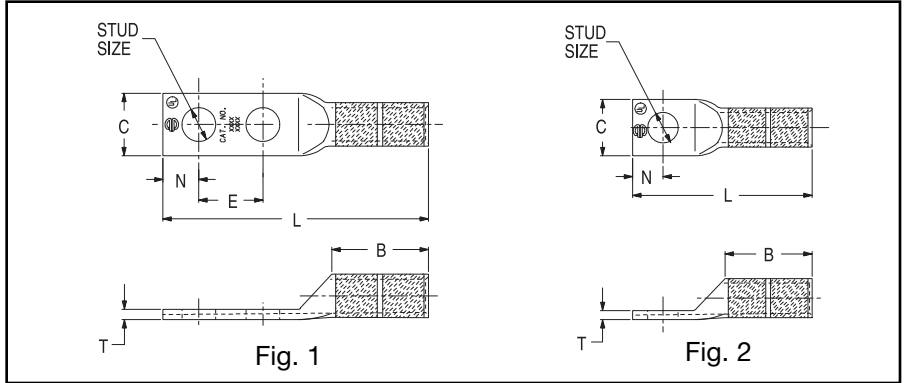

E-17

Catalog Number	Fig. No.	Copper Conductor Size	Installation Tools, Die Set Cat. No., and (number of crimps)				Stud Size	B	C	L	T	E
			Mechanical			Hydraulic						
			Y2MR	MD7-34R	OUR840	Y35/Y39/Y45/PAT750 ① /Y46 ② /Y750						
			Die # (# of crimps)	Die # (# of crimps)	Die # (# of crimps)	Die # (# of crimps)						
YGA8C-TC10	2	8 sol./8 str.	Red (4)	W8CVT (2) X8CRT (2)	U8CRT (2)	#10	.81	.41	1.57	.08	—	
YGA8C-TC14	2	8 sol./8 str.	Red (4)	W8CVT (2) X8CRT (2)	U8CRT (2)	1/4	.81	.44	1.69	.08	—	
YGA8C-TC516	2	8 sol./8 str.	Red (4)	W8CVT (2) X8CRT (2)	U8CRT (2)	5/16	.81	.51	1.75	.06	—	
YGA8C-2N	1	8 sol./8 str.	Red (4)	W8CVT (2) X8CRT (2)	U8CRT (2)	1/2	.81	.71	4.09	.05	1.75	
YGA6C-TC10	2	6 sol./6 str.	Blue (4)	W5CVT (2) X5CRT (2)	U5CRT (2)	#10	1.12	.42	1.89	.09	—	
YGA6C-TC14	2	6 sol./6 str.	Blue (4)	W5CVT (2) X5CRT (2)	U5CRT (2)	1/4	1.12	.45	2.02	.08	—	
YGA6C-TC516	2	6 sol./6 str.	Blue (4)	W5CVT (2) X5CRT (2)	U5CRT (2)	5/16	1.12	.51	2.08	.07	—	
YGA6C-2TC38E2G1	1	6 sol./6 str.	Blue (4)	W5CVT (2) X5CRT (2)	U5CRT (2)	3/8	1.12	.58	3.42	.06	.75	
YGA6C-2N	1	6 sol./6 str.	Blue (4)	W5CVT (2) X5CRT (2)	U5CRT (2)	1/2	1.12	.83	4.40	.12	1.75	
YGA2C-2TC38	1	2 sol./2 str.	Brown (4)	W2CVT (2) X2CRT (2)	U2CRT (2)	3/8	1.25	.60	3.48	.12	1.00	
YGA2C-2N	1	2 str.	Brown (4)	W2CVT (2) X2CRT (2)	U2CRT (2)	1/2	1.22	.81	4.71	.12	1.75	
YGA25-2N	1	1/0 str.	—	W25VT (4) X25RT (4)	U25RT (2)	1/2	1.35	.81	4.91	.12	1.75	
YGA26-2N	1	2/0 str.	—	W26VT (4) X26RT (4)	U26RT (2)	1/2	1.45	.81	4.89	.12	1.75	
YGA28-2N	1	4/0 str.	—	W28VT (4) X28RT (4)	U28RT (2)	1/2	1.57	1.00	5.06	.14	1.75	
YGA29-2N	1	250 kcmil	—	W29VT (4)	U29RT (2)	1/2	1.57	1.09	5.16	.16	1.75	
YGA34-2N	1	500 kcmil	—	W34VT (4)	U34RT (4)	1/2	2.20	1.52	5.94	.23	1.75	

① Where a "U" or "PU" die is recommended with the Y45 HYPRESS™, a PT6515 adapter must be used.

② Where a "U" or "PU" die is recommended with the Y46 HYPRESS™, a PUADP-1 adapter must be used.

Blue highlighted items are industry standard and most frequently ordered.

TYPE YGS

HYLINK™

Grounding Irreversible Compression Splices

E-18

Irreversible compression HYLINK™ ground splices specifically designed for grounding applications. Each conductor element has an inspection probe hole and a center stop to ensure proper cable insertion. UL467 Listed. Acceptable for direct burial in earth or concrete. UL486A Listed. Prefilled with PENETROX™ compound and strip sealed.

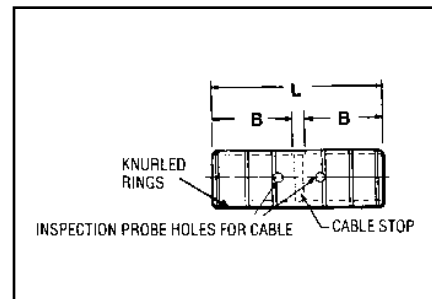
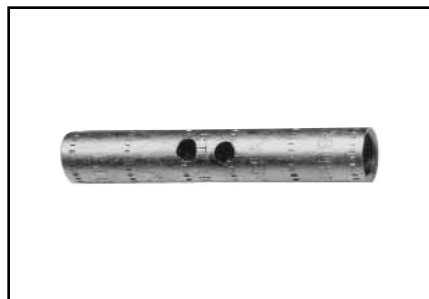

Catalog Number	Copper Conductor Size	Installation Tools, Die Set Catalog Number, and (Number of Crimps)				B	L
		Mechanical			Hydraulic		
		Y2MR	MD7-34R	OUR840	Y35/Y39/Y45 ^① /Y46 ^② /Y750/PAT750		
		Die # (# of Crimps)	Die # (# of Crimps)	Die # (# of Crimps)	Die # (# of Crimps)		
YGS8C	#8 sol./str.	—	X8CRT, W8CRT, W8CVT ^③		U8CRT (2)	.78	1.75
YGS6C	#6 sol./str.	—	X5CRT, W5CRT, W5CVT ^③		U5CRT (2)	1.09	2.38
YGS2C	2 str.	Brown (4)	W2CVT (2) X2CRT (2)		U2CRT (2)	1.22	2.67
YGS25	1/0 str.	—	W25VT (4) X25RT (4)		U25RT (2)	1.35	2.97
YGS26	2/0 str.	—	W26VT (4) X26RT (4)		U26RT (2)	1.45	3.13
YGS28	4/0 str.	—	W28VT (4) X28RT (4)		U28RT (2)	1.57	3.37
YGS29	250 kcmil	—	W29VT (4)		U29RT (2)	1.57	3.37
YGS34	500 kcmil	—	W34VT (4)	—	U34RT (4)	2.20	4.63

① Where a "U" or "PU" die is recommended with the Y45 HYPRESS™, a PT6515 adapter must be used.
 ② Where a "U" or "PU" die is recommended with the Y46 HYPRESS™, a PUADP-1 adapter must be used.
 ③ Use "X" with OUR840, "W" with MD6/MD7.

Blue highlighted items are industry standard and most frequently ordered.

TYPE YGF

GROUNDING PLATE

The irreversible compression ground plate is designed to withstand the rigors of concrete construction. The ground plates are made of high strength, high-conductivity cast copper alloy with a pure wrought copper compression element. In addition to the tapped NEMA size holes and spacing on the face, the plate comes with a tapped hole on the underside for ease of positioning prior to pouring the concrete. UL467 Listed. Acceptable for direct burial in earth or concrete. Prefilled with PENETROX™ compound and strip sealed.

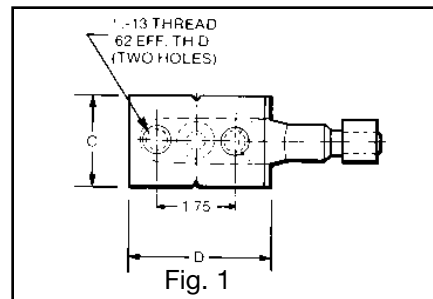
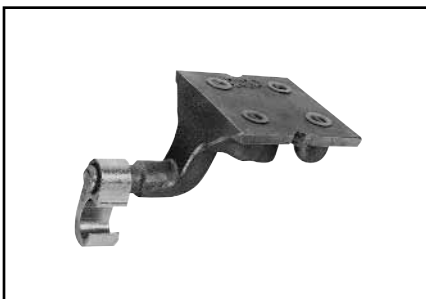

E-19



IEEE-837

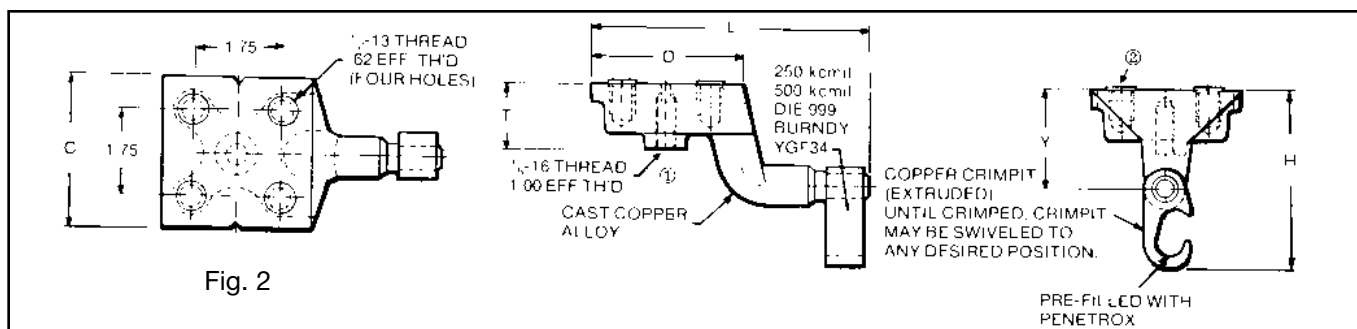

Catalog Number	Fig. No.	C	D	H	L	T	Y
YGF29-2N	1	2.00	3.25	3.62	5.78	1.31	2.00
YGF29-4N	2	3.25	3.25	3.62	5.78	1.31	2.00
YGF34-2N	1	2.00	3.25	4.62	5.40	1.31	2.19
YGF34-4N	2	3.75	3.75	4.62	5.90	1.31	2.19

NOTES:

- ① This tapped hole may be used to position the grounding plate on a threaded rod prior to placement of the concrete.
- ② Plastic plugs are provided to keep dirt out of the threaded holes until the attachment of grounding terminals.
- ③ 3/8-16 thread with 1.00 EFF. Thread is standard. If other thread is required, add appropriate Code No. to Catalog No. for desired thread.
-50 (1/2 -13, .94 EFF. Thread), -62 (5/8 -11, .94 EFF. Thread) and -75 (3/4 -10, .81 EFF. Thread)
Example: YGF34-4N-50 is YGF34-4N with 1/2 -13 Thread

Catalog Number	Copper Conductor Range	Tapped Holes		Installation Tools, Die Set Cat. No., and (number of crimps)		
				HYPRESS™		
		Size	Hole Centers	PAT750/Y750/Y35/Y39	Y45 ①	Y46 ②
YGF29-2N	2 - 250 kcmil	1/2 - 13	1-3/4	U997 (1)	U997 (1)	U997 (1)
YGF29-4N	2 - 250 kcmil	1/2 - 13	1-3/4	U997 (1)	U997 (1)	U997 (1)
YGF34-2N*	250 - 500 kcmil	1/2 - 13	1-3/4	U1011 (3)	S1011 (2)	P1011 (2)
YGF34-4N*	250 - 500 kcmil	1/2 - 13	1-3/4	U1011 (3)	S1011 (2)	P1011 (2)

ORDERING INFORMATION

- ① Where a "U" or "PU" die is recommended with the Y45 HYPRESS™, a PT6515 adapter must be used.
- ② Where a "U" or "PU" die is recommended with the Y46 HYPRESS™, a PUADP-1 adapter must be used.
- * These connectors can only be installed using the Y750, Y45 or Y46 HYPRESS™ with recommended dies. These connectors CAN NOT be installed with the Y35 or Y39 HYPRESS™.

Blue highlighted items are industry standard and most frequently ordered.

TYPE YGIB

GROUNDLINK™ CONNECTOR

An irreversible compression ground connection which allows attachment to a structural steel standard (angled) or wide flange (parallel) beam. Installed with a required 5-piece die set, Catalog PIBEAMKIT or UIBEAMKIT. Die index 1105. GROUNDLINK™ connectors are made of high-conductivity wrought copper and come pre-filled with PENETROX™ E compound and strip sealed. Order terminal mounting hardware separately.

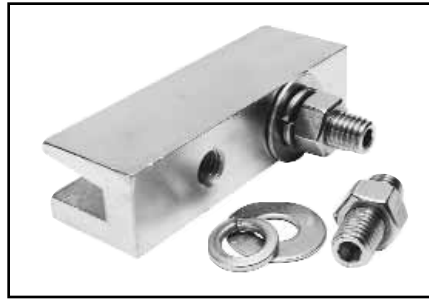

IEEE-837



Connector shipped with thread protection studs only. Order TMHG kits separately.

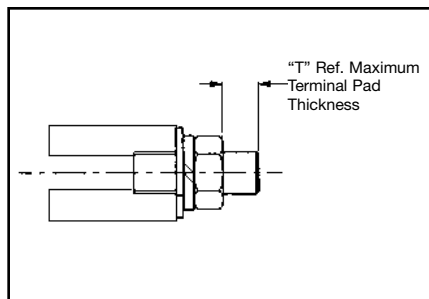
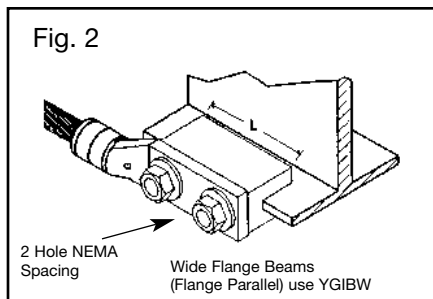
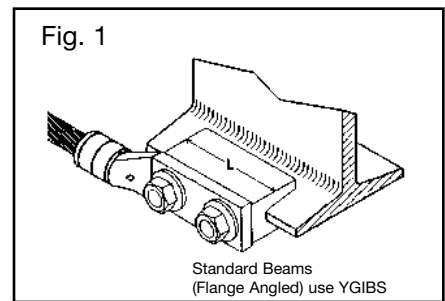
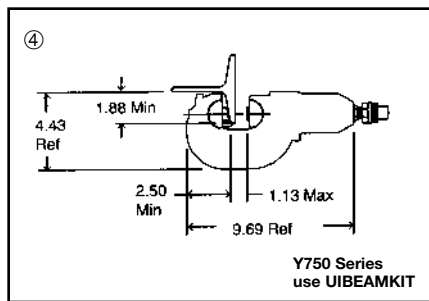
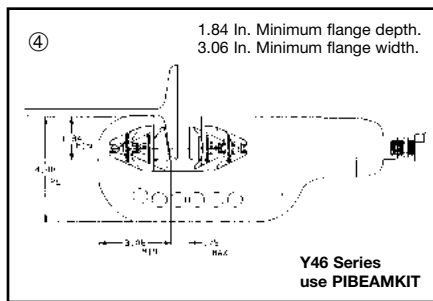

TERMINAL MOUNTING HARDWARE

Catalog Number	"T"
TMHG-42	.42
TMHG-92	.92

NOTE: Use TMHG-92 to double stack lugs.

NOTES:

1. Terminal connector to be ordered separately. When I-beam connector is used with type "YGHA" terminal, the connection meets IEEE 837-1989 requirements. YGA-2N, YA-2N and other BURNDY® 2-hole NEMA copper terminals are suitable.
2. Order "TMHG" Terminal Mounting Hardware Kit separately. Kit consists of 2 studs, 2 flat washers, 2 lockwashers and 2 hex nuts.
3. Using the 1/4 hex key wrench, screw the stud into the connector until stud bottoms out in connector. Install a "YGHA" terminal, flat washer, lockwasher and hex nut onto stud. Tighten and torque to 480 pound-inches.
4. Dimensions shown reflect the minimum dimensions required on a beam to properly install the I-beam connector.
5. To correctly determine the appropriate YGIB connector to use based on flange thickness, order either YGIBGAUGE1 or YGIBKIT1 (KIT1 contains wiremike).

Blue highlighted items are industry standard and most frequently ordered.

TYPE YGIB

(Continued)

GROUNDLINK™ CONNECTOR

Copper Conductor Range	Catalog Number	Fig. No.	"L"	"J"	i-Beam Flange Thickness	Suggested Terminals		"T" Ref.
						Copper Conductor	Terminal	
2 - 4/0 AWG	YGIBS28-338-2N	1	3.00	1/2 - 13	.250" to .338"	#2 Str. AWG	YGHA2C-2N	.26
	YGIBW28-338-2N	2	3.00			1/0 Str. AWG	YGHA25-2N	.19
250 - 500 kcmil	YGIBS34-338-2N	1	6.00			2/0 Str. AWG	YGHA26-2N	.26
	YGIBW34-338-2N	2				4/0 Str. AWG	YGHA28-2N	.30
2 - 4/0 AWG	YGIBS28-400-2N	1	3.00		.338" to .400"	250 kcmil	YGHA29-2N	.34
	YGIBW28-400-2N	2	3.00			500 kcmil	YGHA34-2N	.40
250 - 500 kcmil	YGIBS34-400-2N	1	6.00			#2 Str. AWG	YGHA2C-2N	.26
	YGIBW34-400-2N	2				1/0 Str. AWG	YGHA25-2N	.19
2 - 4/0 AWG	YGIBS28-462-2N	1	3.00		.400" to .462"	2/0 Str. AWG	YGHA26-2N	.26
	YGIBW28-462-2N	2	3.00			4/0 Str. AWG	YGHA28-2N	.30
250 - 500 kcmil	YGIBS34-462-2N	1	6.00			250 kcmil	YGHA29-2N	.34
	YGIBW34-462-2N	2				500 kcmil	YGHA34-2N	.40
2 - 4/0 AWG	YGIBS28-550-2N	1	3.00	4.62" to .550"	#2 Str. AWG	YGHA2C-2N	.26	
	YGIBW28-550-2N	2	3.00		1/0 Str. AWG	YGHA25-2N	.19	
250 - 500 kcmil	YGIBS34-550-2N	1	6.00		2/0 Str. AWG	YGHA26-2N	.26	
	YGIBW34-550-2N	2			4/0 Str. AWG	YGHA28-2N	.30	
2 - 4/0 AWG	YGIBS28-613-2N	1	3.00	.550" to	250 kcmil	YGHA29-2N	.34	
	YGIBW28-613-2N	2	3.00		500 kcmil	YGHA34-2N	.40	
250 - 500 kcmil	YGIBS34-613-2N	2	6.00		#2 Str. AWG	YGHA2C-2N	.26	
					1/0 Str. AWG	YGHA25-2N	.19	
2 - 4/0 AWG	YGIBS28-675-2N	1	3.00	.613" to .675"	2/0 Str. AWG	YGHA26-2N	.26	
	YGIBW28-675-2N	2	3.00		4/0 Str. AWG	YGHA28-2N	.30	
250 - 500 kcmil	YGIBS34-675-2N	1	6.00		250 kcmil	YGHA29-2N	.34	
	YGIBW34-675-2N	2			500 kcmil	YGHA34-2N	.40	

E-21

Blue highlighted items are industry standard and most frequently ordered.

TYPE GSTUD-HY

VERSITAIL™

Structural Steel Grounding Connector

INSTALLATION

E-22

1. Weld the VERSITAIL™ to the steel member.
2. Select the proper connector for your specific application.
 - a. FOR COMPRESSION CONNECTORS
Select the proper BURNDY® “YGHP;” connector. Clean the conductor, join the VERSITAIL™ and the grounding conductor together with the recommended tool and die set, then crimp the connector over the knurled area of the VERSITAIL™.
 - b. FOR MECHANICAL CONNECTORS
Select the properly sized BURNDY® connector. Clean the conductor, then apply PENETROX™ E oxide inhibiting compound on the contact area for increased effectiveness and service life. Put the connector over the knurled area of the VERSITAIL™ and apply the recommended torque value for correct installation.

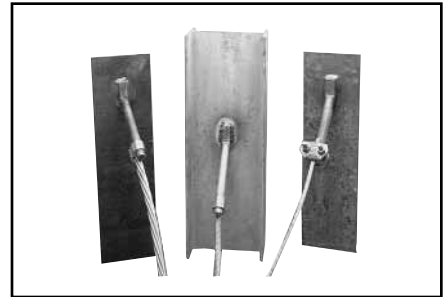

FEATURES

- The VERSITAIL™ may be welded to steel surfaces quickly and easily with normal construction equipment.
- The VERSITAIL™ eliminates costly disk grinding and the need to expose virgin metal. The welding process burns through the oxidation and “scale” to establish excellent electrical grounding continuity.
- The VERSITAIL™ may be installed by the welder in the field or at the steel fabricator based on customer preference.
- The VERSITAIL™ pure copper coating over low carbon, hot rolled steel is compatible with standard welding processes. No toxic gasses are generated.
- The VERSITAIL™ knurled surface is copper plated and specifically designed to ensure excellent mechanical gripping and electrical integrity for BURNDY® compression and mechanical connectors in all grounding applications.
- The VERSITAIL™ may be installed during adverse weather conditions thus eliminating costly construction delays.

SPECIFICATIONS

- Low Carbon, hot rolled steel.
- Pure copper plated finish.

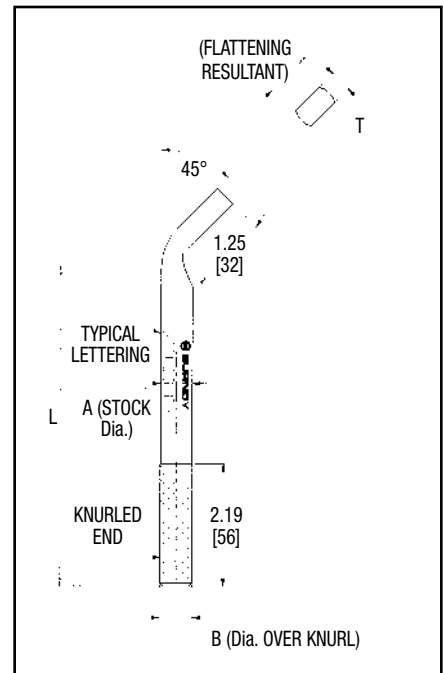

BENEFITS

- Low installation cost.
- No drilling . . . No cleaning . . .
 - No special preparation

Catalog Number	Nom. Rod Size	Dimensions				Electrical Equivalent Copper Conductor Size (AWG)*
		A	B	L	T	
		In. [mm]	In. [mm]	In. [mm]	In. [mm]	
GSTUD14HY	1/4"	.25 [6.3]	.26 [6.6]	4.81 [122.2]	.19 [4.8]	#6
GSTUD38HY	3/8"	.38 [9.7]	.39 [9.9]	5.81 [147.6]	.25 [6.4]	#3
GSTUD916HY	5/8"	.56 [14.2]	.57 [14.5]	5.68 [144.3]	.38 [9.7]	1/0
GSTUD34HY	3/4"	.75 [19.0]	.76 [19.3]	5.81 [147.6]	.51 [13.0]	4/0

* This is the equivalent rating for continuous service. Larger conductors may be connected using both compression and bolted connectors in potential ground fault applications.

Blue highlighted items are industry standard and most frequently ordered.

TYPES YGT & YTTAG

STATIC GROUNDING RECEPTACLE

Type YGT static grounding receptacles are designed for static grounding of equipment. The receptacle is connected to the ground grid with HYGROUND® compression connectors and finished flush with surface to provide a permanent corrosion proof grounding point.

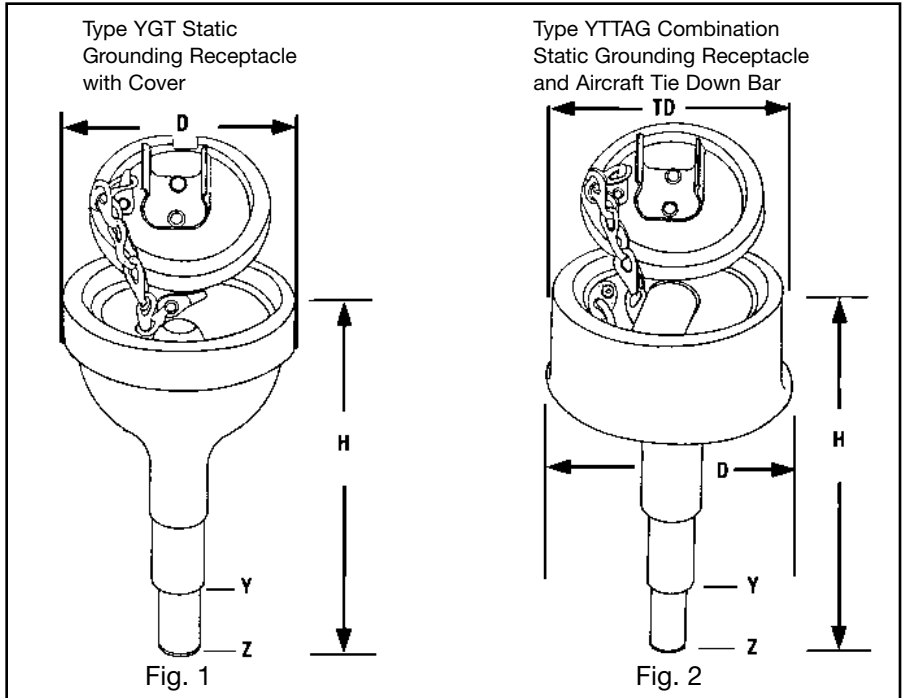

Catalog Number	Figure Number	* HYGROUND® Connector	Dimensions				
			H	D	Y Dia.	Z Dia.	TD
YGT275	1	Select suitable YGHR or YGLR for 3/4" ground rod and sized to ground conductor.	5.5	2.75	.75	.56	—
YTTAG388	2		6.5	4.75	.75	.56	4.3

* When using U or PU dies with Y46 HYPRESSTM, a PUADP-1 adapter is required.

NOTES:

1. Ground rod must be pre-crimped with U2CABT die set when PU998 die is used or for even higher mechanical resistance use special UPRECRIMP dies on ground rods.
2. Pre-crimping of ground is not necessary when P1011 die is used. Install YGHR or YGLR on hub Y. Hub Z is inserted into 1/2" rigid conduit. The conduit is driven into earth to provide support and provide correct level of receptacle prior to cement pour.

TYPE YG-B

BUS BAR CONNECTOR

BURNDY's YG14B2TC2C6C Compression Bus Bar Connector is ideally suited for cellular tower applications and is easier to use than exothermic connections. This high conductivity wrought copper connector allows attachment of the ground conductor to the ground bus with just one crimp using the BURNDY® Y750 HYPRESS™ Hydraulic Compression tool and the U1105 die set. This exclusive patent pending design allows the user to attach #2 AWG sol./str. and/or #6 sol./str. copper conductor to 1/4" thick copper bus bar. This connection is suitable using (1) or (2) conductors for power, grounding and bonding applications. UL Listed to both UL486 and UL467 (suitable for direct burial) ensures that this connector will meet the rigors of either application. Prefilled with PENETROX™ E compound and strip sealed.

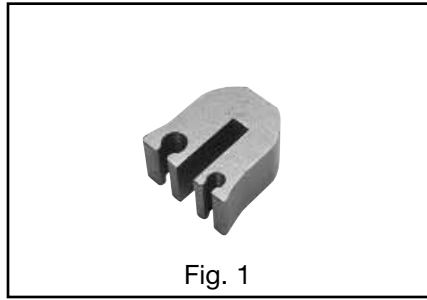

Fig. 1

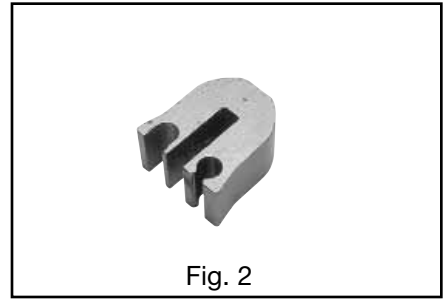

Fig. 2

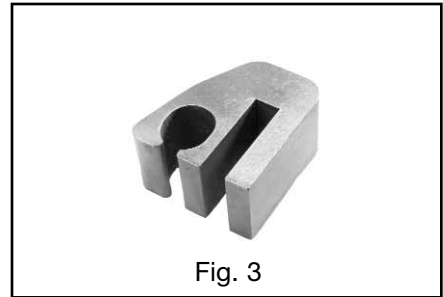
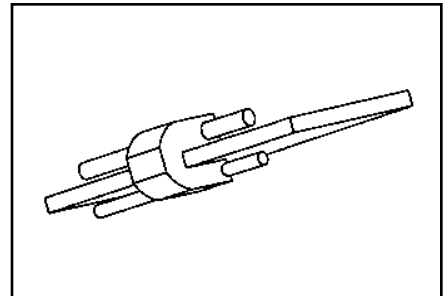
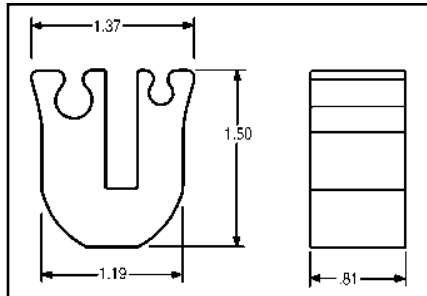

Fig. 3



Catalog Number	Fig No.	Ground Bar Thickness	Bus Bar Tap Conductors	Tooling	Installation Die No.	No. of Crimps
YG14B2TC2C6C	1	1/4"	#2 Sol./and/or Str. Copper #6 Sol./and/or Str. Copper	PAT750, Y750	U1105	1
YG14B2TC2C2C*	2	1/4"	#2 #2	PAT750, Y750	U1105	1
YG14B2TC28	3	1/4"	4/0 AWG Str. to 1/0 AWG Str. Copper	PAT750, Y750	U1105	1

NOTE: Suitable for use with either (1) or (2) conductors (excluding YG14B2TC26 and YG14B2TC28).

* For continuous uncut conductor applications.

Blue highlighted items are industry standard and most frequently ordered.

MECHANICAL GROUNDING CONNECTORS

More than 60 years of technological innovation has made BURNDY® mechanical grounding connectors one of the most widely used, highly respected lines in the industry. There is virtually no grounding application problem that this diversified line cannot help solve.

All BURNDY® mechanical grounding connectors have been designed for easy installation and for outstanding durability. Only the finest high copper alloys are used in their manufacture, ensuring top performance under the most extreme environmental conditions.

UL467 Listed for direct burial applications in earth or concrete.

E-25

TYPES KC, K2C

SERVIT POST™

For Copper Cable to Flat

SERVIT POST™ used to ground one or two cables to steel structures, fence posts, transformers. Also used to tap one or two cables from bus bar. One-wrench installation.

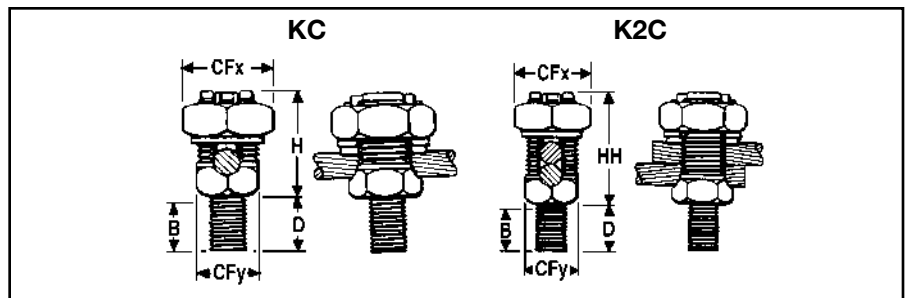
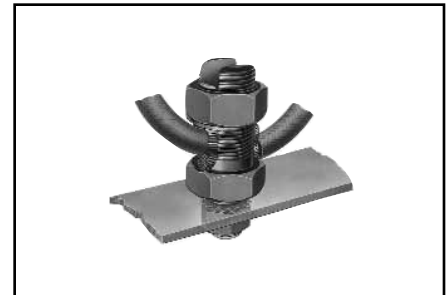

Catalog Number		Conductor		Stud Diameter	B	CFx	CFy	D	H	HH
Type KC †	Type K2C ‡	Stranded	Solid							
KC15	K2C15	12 - 9	12 - 8	1/4 - 20	3/8	1/2	3/8	1/2	5/8	7/8
KC15B1	K2C15B1				7/8					
KC17	K2C17	10 - 7	10 - 6	1/4 - 20	3/8	5/8	7/16	1/2	7/8	1
KC17B1	K2C17B1				7/8					
KC20	K2C20	10 - 5	10 - 4	5/16 - 18	13/32	11/16	1/2	5/8	7/8	1-1/8
KC20B1	K2C20B1				27/32					
KC22	K2C22	10 - 3	10 - 2	3/8 - 16	15/32	3/4	5/8	5/8	1	1-1/4
KC22B1	K2C22B1				31/32					
KC23	K2C23	8 - 2	10 - 1	3/8 - 16	15/32	13/16	5/8	5/8	1	1-3/8
KC23B1	K2C23B1				31/32					
KC25	K2C25	2 - 1/0	2 - 2/0	1/2 - 13	9/16	15/16	3/4	3/4	1-1/8	1-5/8
KC25B1	K2C25B1				1-1/16					
KC26	K2C26	2 - 2/0	2 - 3/0	1/2 - 13	17/32	1	7/8	3/4	1-3/8	1-7/8
KC26B1	K2C26B1				1-1/16					
KC28	K2C28	1 - 4/0	1 - 4/0	5/8 - 11	3/4	1-1/2	1-3/16	1	1-3/4	2-1/4
KC28B1	K2C28B1				1-1/4					
KC31	K2C31	1 - 350	—	5/8 - 11	3/4	1-11/16	1-3/8	1	2-1/4	2-7/8
KC31B1	K2C31B1				1-1/4					
KC34	K2C34	3/0 - 500	—	3/4 - 10	1	2	1-5/8	1-1/4	2-3/8	3-1/4
KC34B1	K2C34B1				1-1/2					

† For 1 conductor.
 ‡ For 1 or 2 conductors.
 Add "NSP" suffix to have connector supplied w/split lock-washer and nut.

Blue highlighted items are industry standard and most frequently ordered.

TYPES KC22J12T13, EQC632C

TRANSFORMER GROUND CONNECTORS

For Copper

Fits all standard EEI NEMA distribution transformers as a tank grounding terminal.

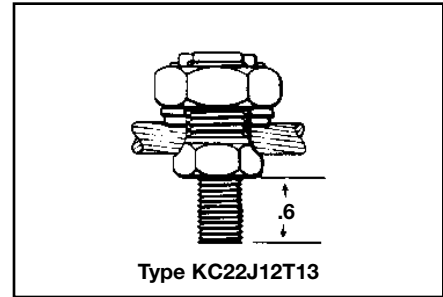
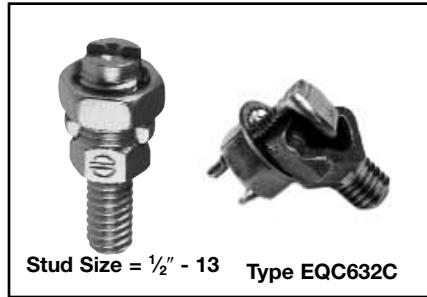

Catalog Number	Ranges
KC22J12T13	8 Sol. - 2 Sol.
KC26	2 Sol. - 2/0 Str.
KC34J12T13	3/0 - 500 Str.
EQC632C	8 Sol. - 2 Str.

Both, one-wrench installation.

E-26

TYPE KS

SERVIT®

For Copper

UL467 Listed for direct burial applications in earth or concrete. Compact, high-strength, high copper alloy SERVIT® split-bolt has free-running threads and easy to grip wrench flats. Highly resistant to cracking and corrosion.



Catalog Number	Cross Flats	L	W	Copper Conductor Range (Sol. - Str.)	Rebar w/ (1) No. 8 Sol. Cu	Recommended Torque (In. Lb.)
KS15	.50	.85	.38	12 AWG - 8 AWG	N/A	80
KS17	.63	1.14	.45	8 AWG - 6 AWG	N/A	165
KS20	.69	1.20	.51	8 AWG - 4 AWG	N/A	165
KS22	.75	1.50	.60	6 AWG - 3 AWG	N/A	275
KS23	.82	1.54	.62	6 AWG - 2 AWG	N/A	275
KS25	.94	1.77	.73	4 AWG - 1/0	N/A	385
KS26	1.05	1.94	.82	2 AWG - 2/0 6 AWG - 8 AWG Str./Sol.	#3 (3/8")	385
KS27	1.36	1.86	1.17	1 AWG - 3/0	N/A	500
KS29	1.36	2.07	1.17	1 AWG - 250 kcmil 6 AWG - 8 AWG Str./Sol.	#4 (1/2")	650
KS31	1.70	2.51	1.41	1/0 AWG - 350 kcmil 6 AWG - 8 AWG Str./Sol.	#5 (5/8")	650
KS34	1.82	2.79	1.48	2/0 AWG - 500 kcmil 6 AWG - 8 AWG Str./Sol.	#6 (3/4")	825

Blue highlighted items are industry standard and most frequently ordered.

TYPE GKA

For Copper

UL467 Listed for direct burial applications in earth or concrete. One-piece forged body construction insures mechanical integrity in an underground environment. Supplied with a stainless steel headless screw.

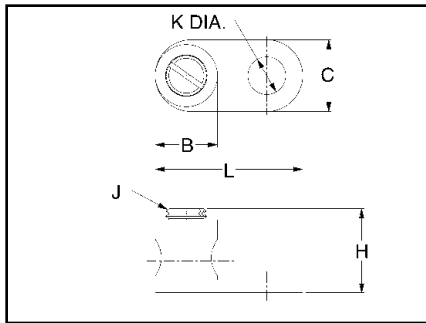

Catalog Number	Cable Range	B	C	H	J	K	L
GKA8C ¹	#10 Sol. - #8 Str.	.31	.38	.58	#10 - 32	.21	.81
GKA4C ²	#14 Sol. - #4 Str.	.46	.54	.71	5/16 - 24	.28	1.13

1. To be assembled with TMH322 stainless steel hardware kit. Ordered separately.

2. To be assembled with TMH 323 stainless steel hardware kit. Ordered separately.

TYPE KPB

For Copper

UL467 Listed for direct burial in earth or concrete. UL486 listed. This exclusive BURNDY® design accommodates #10 - #4 copper where continuous conductor runs are preferable.

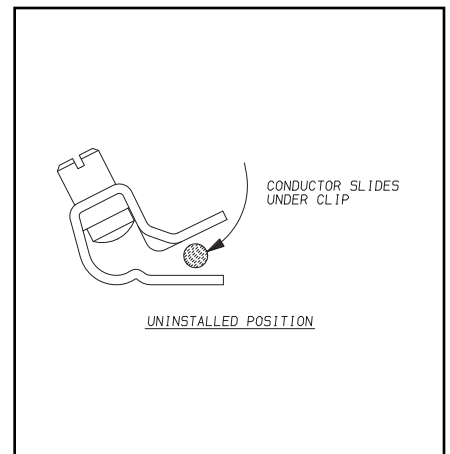
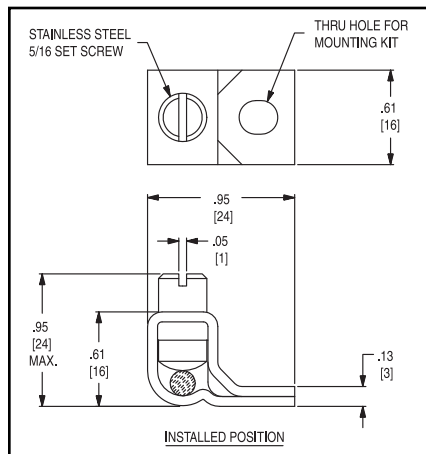

Catalog Number	Range	Stud Hole
KPB4CG1	#10 - #4 CU	#10 ¹

1. To be assembled with TMH322SS stainless steel hardware kit. Ordered separately.

TYPE CL50-1

COPPER LAY-IN QIKLUG™

For Copper

The Lay-In QIKLUG™ is manufactured from high strength pure electrolytic copper to ensure maximum strength and conductivity. UL467 Listed for direct burial in earth or concrete. The open-faced design allows for fast lay-in of the conductor without the need for cutting or breaking.

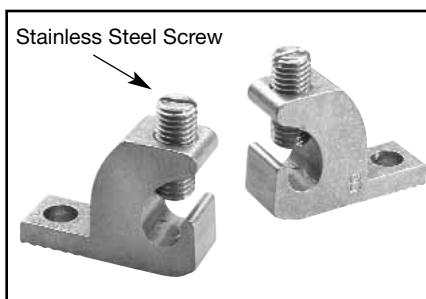

Catalog Number	Wire Range Copper	Stud Hole
CL50-1	#14 - #4 CU	#10
CL50-1TN*	#14 - #4 CU	#10

*-TN Version is tin plated. Commonly used for solar panel grounding.

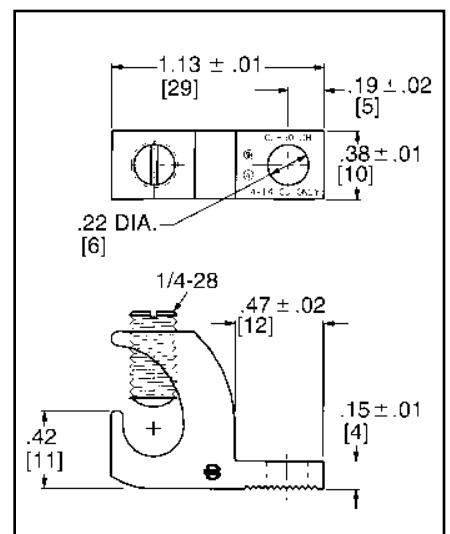

Blue highlighted items are industry standard and most frequently ordered.

New!
Rebar to Wire
UL Listed and
CSA Certified
for Direct Burial

TYPE GAR

- Wire to Rebar
- Fence Post Grounding Connector
- Wire to Pipe



Wire to Rebar

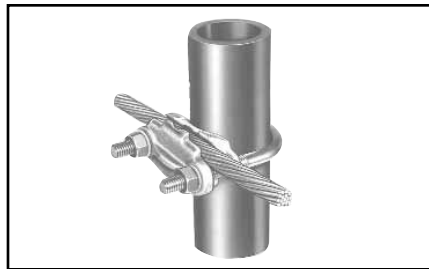
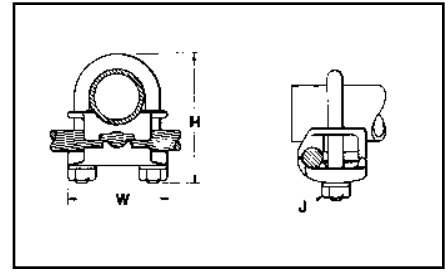

Wire at Right Angle to Pipe

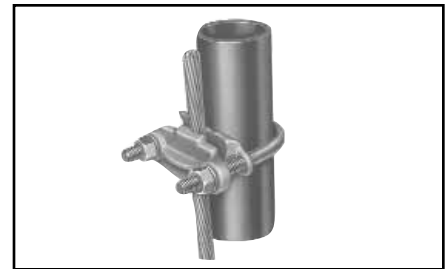

Wire Parallel to Pipe

For Parallel or 90° Copper Cable Connection to Rod or Pipe with the Same Connector

High copper alloy ground connector for joining a range of cable, parallel or at right angles to rod or tube. Especially good for fence posts. High copper alloy cast body with DURIMUM™ U-bolts, nuts and lockwashers, permit entire connection to be buried in ground or concrete without danger of corrosion.

- One-wrench installation.
- UL467 Listed.
- Acceptable for direct burial.



Catalog Number	Conductor				H	J	W
	Tube I.P.S.	Rod Size or O.D. Range	Rebar Size	Cable			
GAR114C	1/4	1/2	—	8 Sol. - 4 Str.	2-1/2	3/8	1-7/8
GAR1126				4 Sol. - 2/0 Str.			
GAR1129				2/0 Sol. - 250			
GAR644C	3/8	5/8 - 3/4	#5 (5/8") - #6 (3/4")	8 Sol. - 4 Str.	2-7/8	1/2	2-1/8
GAR6426				4 Sol. - 2/0 Str.			
GAR6429				2/0 Sol. - 250			
GAR6434	1/2 - 3/4	7/8 - 1	#7 (7/8") - #8 (1")	300 - 500	3-1/2	3/8	2-1/2
GAR144C				8 Sol. - 4 Str.			
GAR1426				4 Sol. - 2/0 Str.			
GAR1429	1	1-1/8 - 1-1/4	#9 (1-1/8") - #10 (1-1/4")	2/0 Sol. - 250	3	1/2	2-3/8
GAR1434				300 - 500			
GAR154C				8 Sol. - 4 Str.			
GAR164C	1-1/4	1-3/8 - 1-1/2	#11 (1-3/8")	4 Sol. - 2/0 Str.	3-1/2	3/8	3
GAR1626				2/0 Sol. - 250			
GAR1629				300 - 500			
GAR1634	1-1/2	1-5/8 - 1-7/8	—	8 Sol. - 4 Str.	4	1/2	3-3/8
GAR174C				4 Sol. - 2/0 Str.			
GAR1726				2/0 Sol. - 250			
GAR1729	2	2 - 2-3/8	—	300 - 500	4-1/4	3/8	3-1/4
GAR1734				4 Sol. - 2/0 Str.			
GAR184C				2/0 Sol. - 250			
GAR1826	2-1/2	2-1/2 - 2-7/8	—	8 Sol. - 4 Str.	4-1/2	1/2	2-5/8
GAR1829				4 Sol. - 2/0 Str.			
GAR1834				2/0 Sol. - 250			
GAR194C	2	2 - 2-3/8	—	300 - 500	4-1/4	3/8	3-3/4
GAR1926				4 Sol. - 2/0 Str.			
GAR1929				2/0 Sol. - 250			
GAR1934	2-1/2	2-1/2 - 2-7/8	—	8 Sol. - 4 Str.	5-1/4	1/2	4-1/8
GAR194C				4 Sol. - 2/0 Str.			
GAR1926				2/0 Sol. - 250			
GAR1934	2-1/2	2-1/2 - 2-7/8	—	300 - 500	5-5/8	3/8	4-1/4
GAR194C				4 Sol. - 2/0 Str.			
GAR1926				2/0 Sol. - 250			

Blue highlighted items are industry standard and most frequently ordered.

TYPE GAR

(Continued)

FENCE POST GROUNDING CONNECTOR

Catalog Number	Conductor			H	J	W
	Tube I.P.S.	Rod Size or O.D. Range	Cable			
GAR204C	3	3 - 3-1/2	8 Sol. - 4 Str.	5-5/8	3/8	4-3/4
GAR2026			4 Sol. - 2/0 Str.			
GAR2029			2/0 Sol. - 250	6-3/8	1/2	5-1/4
GAR2034			300 - 500			
GAR214C	3-1/2	3-1/2 - 4	8 Sol. - 4 Str.	6-1/4	3/8	5-3/8
GAR2126			4 Sol. - 2/0 Str.			
GAR2129			2/0 Sol. - 250	6-3/4	1/2	5-3/4
GAR2134			300 - 500			
GAR224C	4	4 - 4-1/2	8 Sol. - 4 Str.	6-3/8	3/8	5-7/8
GAR2226			4 Sol. - 2/0 Str.			
GAR2229			2/0 Sol. - 250	6-7/8	1/2	6-1/4
GAR2234			300 - 500			
GAR244C	5	—	8 Sol. - 4 Str.	7-3/4	3/8	6-7/8
GAR2426			4 Sol. - 2/0 Str.			
GAR2429			2/0 Sol. - 250	1/2	7-1/4	
GAR2434			300 - 500			
GAR8629	6	—	2/0 Sol. - 250	8-13/16	1/2	8-3/8

E-29

Contact BURNDY® for additional pipe and wire size combinations not shown.

Blue highlighted items are industry standard and most frequently ordered.

TYPES GAR-BU AND GAR3902 SERIES

GROUND CONNECTORS

E-30

Type GAR-BU is a high-conductivity copper ground connector for connecting a small to medium range copper ground conductor to water pipe as well as structural and reinforcing rod shapes. Universal acceptance of several sizes of cylindrical shapes makes this suitable for industrial construction and maintenance work as well as cathodic protection. Cable clamp swivels to permit parallel grounding of one pipe or 90° degree cable run for grounding several parallel pipes. Single wrench installation. UL467 Listed and CSA certified.

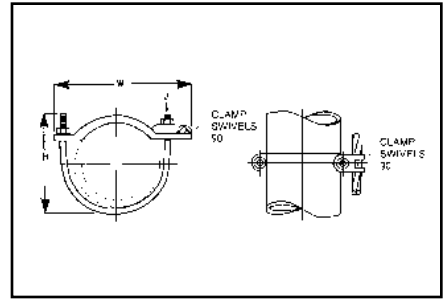

Features and Benefits

- Cable clamp swivels at 90°.
 - ◇ Permits parallel grounding of one pipe or a 90° cable run for grounding several parallel pipes.
- One-wrench installation.
 - ◇ Simplified installation.
- DURIUM™ silicon bronze hardware (-BU Series)*.
 - ◇ Long lasting corrosion resistance and acceptable for direct burial in earth or concrete.
- UL467 Listed.
 - ◇ Provides quality assurance to recognized industry NEC standards from an independent party.



Catalog Number *	Cable Range	IPS Size	O.D. Range	H	J	W	Recommended Tightening Torque
GAR3902-BU	#4 - 4/0 AWG	1/2" - 1"	.840 - 1.32	3.50	3/8" - 16	3.25	240 in. - lbs.
GAR3903-BU		1-1/4" - 2"	1.66 - 2.38	4.00		4.25	
GAR3904-BU		2-1/2" - 3-1/2"	2.88 - 4.00	6.50		6.00	
GAR3905-BU		4" - 5"	4.50 - 5.56	7.50		7.50	
GAR3906-BU		6"	6.62	8.50		8.62	
GAR3907-BU		8"	8.62	10.00		10.62	
GAR3908-BU		10"	10.75	12.00		12.75	
GAR3909-BU		12"	12.75	14.00		14.75	
GAR3902	#4 - 4/0 AWG	1/2" - 1"	.840 - 1.32	3.50	3/8" - 16	3.25	240 in. - lbs.
GAR3903		1-1/4" - 2"	1.66 - 2.38	4.00		4.25	
GAR3904		2-1/2" - 3-1/2"	2.88 - 4.00	6.50		6.00	
GAR3905		4" - 5"	4.50 - 5.56	7.50		7.50	
GAR3906		6"	6.62	8.50		8.62	
GAR3907		8"	8.62	10.00		10.62	
GAR3908		10"	10.75	12.00		12.75	
GAR3909		12"	12.75	14.00		14.75	

* Type GAR-BU is supplied with DURIUM™ silicon bronze hardware and is listed for direct burial.

TYPE GAR-RB

For Reinforcement Bar



Catalog Number	Rebar	IPS Size	O.D. Range	Rod	Copper Conductor	
					Min.	Max.
GAR644C-RB	#3 - 6 (.375 - .750)	3/8	.625 - .75	5/8 - 3/4	8 Sol.	4 Str.

UL467 listed for direct burial in earth or concrete.

Blue highlighted items are industry standard and most frequently ordered.

TYPE GAR-TC

**WATER PIPE
GROUND CONNECTOR**

Type GAR-TC is a high-conductivity copper ground connector that features a pre-drilled pad, allowing a 2-hole compression terminal to be directly connected to water pipe as well as structural and reinforcing rod shapes. Universal acceptance of several sizes of cylindrical shapes makes this suitable for industrial construction and maintenance work as well as telecommunications grounding. Terminal may be mounted parallel, 45° or 90° degrees to the pipe. Acceptable for direct burial.

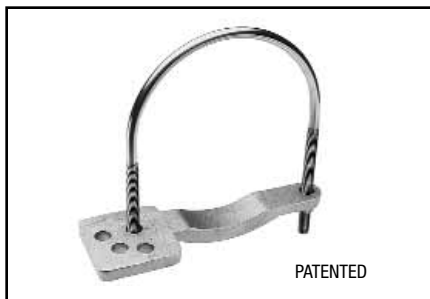

E-31

Features and Benefits

- Large, smooth connector contact area between pipe and ground clamp
 - ◇ Provides large surface contact area to maximize contact area between connector and pipe.
- The GAR-TC mounting pad permits parallel, 45° or 90° angle connections to the pipe.
 - ◇ Provides maximum flexibility for field installation.
- Pre-drilled pad for (2) 3/8" bolts on 1" centers.
 - ◇ Allows direct mounting of (2) hole compression terminals up to 750 kcmil to pipe.
- DURIMUM™ silicon bronze hardware.
 - ◇ Provide long lasting corrosion resistance acceptable for direct burial in earth or concrete.
- One-wrench installation.
 - ◇ Simplified installation.
- UL467 Listed.
 - ◇ Provides quality assurance to recognized industry NEC standards from an independent party. Type GAR-TC is acceptable for direct burial

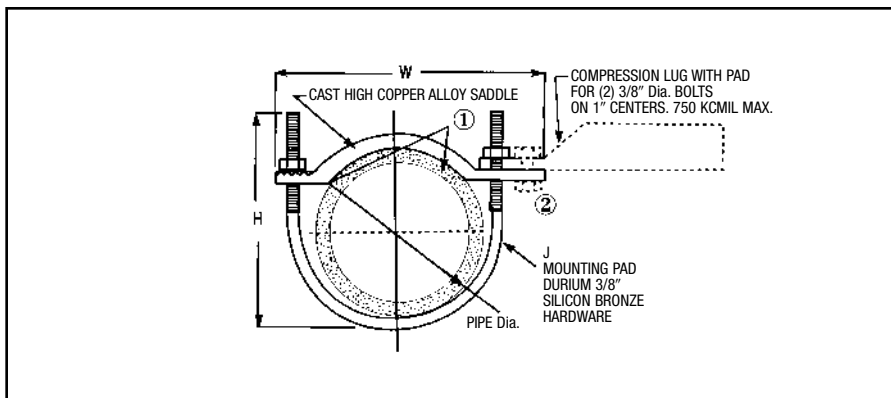
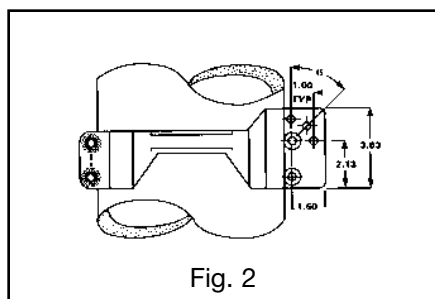
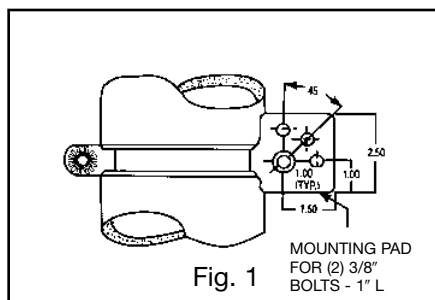

Catalog Number	Fig. No.	Accommodates		H	J	W	Recommended Tightening Torque
		I.P.S.	O.D. Size				
GAR3902TC	1	1/2" - 1"	.840 - 1.32	3.50	3/8" - 16	3.75	240 in.-lbs.
GAR3903TC	1	1-1/4" - 2"	1.66 - 2.38	4.00		4.75	
GAR3904TC	1	2-1/2" - 3-1/2"	2.88 - 4.00	6.50		6.50	
GAR3905TC	1	4" - 5"	4.50 - 5.56	7.50		8.00	
GAR3906TC	1	6"	6.62	8.50		9.12	
GAR3907TC	2	8"	8.62	10.00	3/8" - 16	11.25	240 in.-lbs.
GAR3908TC	2	10"	10.75	12.00		13.25	
GAR3909TC	2	12"	12.75	14.00		15.25	

① Add suffix "-TNET" for electro-tin plated connector and electro-tin plated DURIMUM™ silicon bronze hardware. Tin plated catalog number includes mounting hardware for second bolt hole.
 ② TMH-289 includes (1) 38 x 125 HEB, (1) 38 CHEN, (1) 38 SW and (2) 38 FW. Order separately.

NOTE: Clean pipe surface beneath saddle until virgin metal is exposed, install GAR-TC ground connector and for maximum conductivity, apply PENETROX® E oxide inhibiting compound around perimeter of the saddle.

Blue highlighted items are industry standard and most frequently ordered.

TYPE GD

CABLE TO ROD/TUBE GROUND CONNECTOR

For Two Copper Cables to Rod or Tube

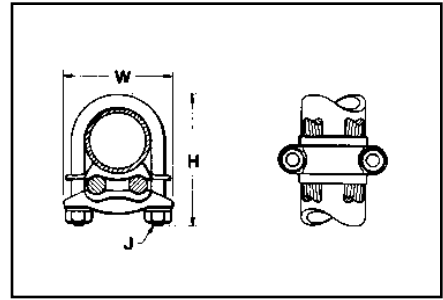

E-32

High copper alloy ground connector for joining a range of two parallel cables to rod or pipe. Especially good for grounding fence posts. High copper alloy cast body with DURIIUM™ U-bolts, nuts, and lockwashers make the GD suitable for burial in ground or concrete. One-wrench installation. UL467 Listed. Acceptable for direct burial in earth or concrete.



Catalog Number	Conductor			H	J	W	
	Tube I.P.S.	Rod Size or O.D. Range	Cable				
GD1526	1	1-1/8 - 1-1/4	4 Sol. - 2/0 Str.	3-3/8	3/8	2-5/8	
GD1529			2/0 Sol. - 250				
GD1626	1-1/4	1-3/8 - 1-1/2	4 Sol. - 2/0 Str.	3-1/2		3/8	3
GD1629			2/0 Sol. - 250				
GD174C	1-1/2	1-5/8 - 1-7/8	8 Sol. - 4 Str.	4		1/2	3-1/4
GD1726			4 Sol. - 2/0 Str.				
GD1729			2/0 Sol. - 250				
GD1734			300 - 500				
GD184C	2	2 - 2-3/8	8 Sol. - 4 Str.	4-3/8	3/8	3-3/4	
GD1826			4 Sol. - 2/0 Str.				
GD1829			2/0 Sol. - 250				
GD1834			300 - 500				
GD194C	2-1/2	2-1/2 - 2-7/8	8 Sol. - 4 Str.	5	3/8	4-1/4	
GD1926			4 Sol. - 2/0 Str.				
GD1929			2/0 Sol. - 250				
GD1934			300 - 500				
GD204C	3	3 - 3-1/2	8 Sol. - 4 Str.	5-5/8	3/8	4-7/8	
GD2026			4 Sol. - 2/0 Str.				
GD2029			2/0 Sol. - 250				
GD2034			300 - 500				
GD214C	3-1/2	3-1/2 - 4	8 Sol. - 4 Str.	6-3/8	1/2	5-1/4	
GD2126			4 Sol. - 2/0 Str.				
GD2129			2/0 Sol. - 250				
GD2134			300 - 500				
GD224C	4	4 - 4-1/2	8 Sol. - 4 Str.	6-3/8	3/8	5-7/8	
GD2226			4 Sol. - 2/0 Str.				
GD2229			2/0 Sol. - 250				
GD2234			300 - 500				

Complies with NFPA 78-86 HEAVY DUTY stacks.
(Order: LD for lead plating for HEAVY DUTY stack applications.)

Blue highlighted items are industry standard and most frequently ordered.

TYPE GP

GROUND CONNECTOR

For Two Copper Cables to Rod or Pipe

High copper alloy ground connector for joining a range of parallel cables perpendicular to rod, pipe or column. Also used with one groove for run, the other for tap to equipment. High copper alloy cast body and DURIMUM™ U-bolts, nuts, and lockwashers make the GP suitable for direct burial in the ground or concrete. One-wrench installation. UL467 Listed. Acceptable for direct burial in earth or concrete.

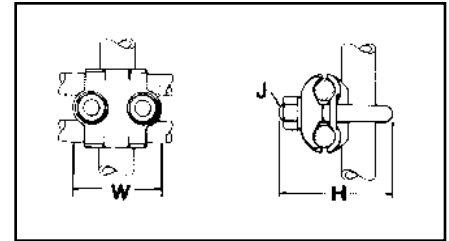

Catalog Number	Conductor			H	J	W	
	Tube I.P.S.	Rod Size or O.D. Range	Cable				
GP114C	1/4	1/2	8 Sol. - 4 Str.	2-1/2	3/8	1-7/8	
GP1126			4 Sol. - 2/0 Str.				
GP1129			2/0 Sol. - 250				
GP644C	3/8	5/8 - 3/4	8 Sol. - 4 Str.	2-7/8	1/2	2-1/8	
GP6426			4 Sol. - 2/0 Str.				
GP6429			2/0 Sol. - 250				
GP6434	1/2 - 3/4	7/8 - 1	300 - 500	3-1/2	38	2-1/2	
GP144C			8 Sol. - 4 Str.	2-3/4			
GP1426			4 Sol. - 2/0 Str.	3			
GP1429	1-1/4	1-5/8	3/0 Sol. - 250	3-3/4	1/2	2-3/4	
GP1434			300 - 500				
GP164C			8 Sol. - 4 Str.				3-1/2
GP1629	1-1/2	1-7/8	2/0 Sol. - 250	4	3/8	3	
GP1726			4 Sol. - 2/0 Str.				3-1/4
GP184C			8 Sol. - 4 Str.				4-1/8
GP1826	2	2-3/8	4 Sol. - 2/0 Str.	4-3/8	1/2	3-11/16	
GP2026			4 Sol. - 2/0 Str.				5-1/2
GP2226			4 Sol. - 2/0 Str.				6-3/8
GP2226	3	3-1/2	4 Sol. - 2/0 Str.	5-1/2	1/2	4-13/16	
GP2226	4	4-1/2	4 Sol. - 2/0 Str.	6-3/8	1/2	5-13/16	

TYPE GK

GROUND CONNECTOR

For Three Copper Cables to Rod or Pipe

High copper alloy ground connector for joining three equal cables to rod or tube. Cable grooves take a wide range of cable. High copper alloy cast body and DURIMUM™ U-bolts, nuts, and lockwashers make the GK suitable for direct burial in soil or concrete. One-wrench installation. UL467 Listed. Acceptable for direct burial in earth or concrete.

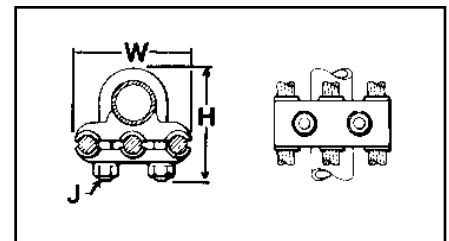
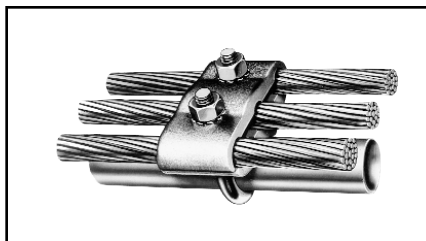

Catalog Number	Conductor			H	J	W	
	Tube I.P.S.	Rod Size or O.D. Range	Cable				
GK114C	1/4	1/2	8 Sol. - 4 Str.	2-1/2	3/8	2-1/2	
GK1126			4 Sol. - 2/0 Str.				
GK1129			2/0 Sol. - 250				
GK644C	3/8	5/8 - 3/4	8 Sol. - 4 Str.	2-7/8	3/8	2-5/8	
GK6426			4 Sol. - 2/0 Str.				
GK6429			2/0 Sol. - 250				
GK6434	1/2 - 3/4	7/8 - 1	300 - 500	3-1/2	1/2	3	
GP1426			4 Sol. - 2/0 Str.	2-3/4			
GK1429			2 Sol. - 250	3			
GK1434	1	1-1/8 - 1-1/4	300 - 500	3-3/4	1/2	4-3/8	
GK1526			4 Sol. - 2/0 Str.				3-3/8
GK1529			2/0 Sol. - 250				3-3/4
GK1626	1-1/4	1-3/8 - 1-1/2	4 Sol. - 2/0 Str.	3-1/2	3/8	3-7/8	
GK1629			2/0 Sol. - 250				
GK1726			2/0 Sol. - 250				4-1/4
GK1726	1-1/2	1-5/8 - 1-7/8	4 Sol. - 2/0 Str.	4	3/8	4-1/8	
GK1729			2/0 Sol. - 250				
GK1826			4 Sol. - 2/0 Str.				4-5/8
GK1826	2	2 - 2-3/8	4 Sol. - 2/0 Str.	4-1/4	3/8	4-5/8	
GK1829			2/0 Sol. - 250				
GK1926			4 Sol. - 2/0 Str.				4-3/8
GK1926	2-1/2	2-1/2 - 2-7/8	4 Sol. - 2/0 Str.	5	3/8	5-1/8	
GK1929			2/0 Sol. - 250				5
GK1929			2/0 Sol. - 250	5	1/2	5-5/8	

Blue highlighted items are industry standard and most frequently ordered.

TYPE BDT

BONDIT™ INTERSYSTEM BONDING CONNECTOR

House Mounted or
Meter Socket Mounted

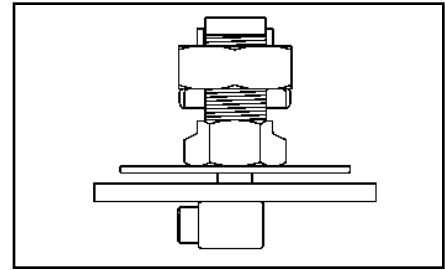
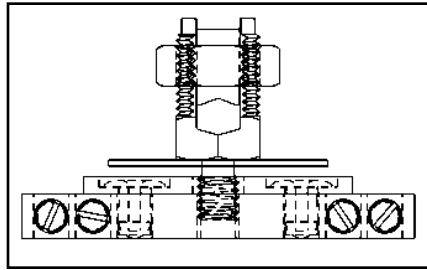

Features & Benefits

Designed to meet the requirements of 2008 NEC Article 250.94 "Bonding for Other Systems." Corrosion-resistant stainless steel set screws. Accepts main ground wire (#2-#8) and up to 4 intersystem wires (#6-#14). Same design can be mounted directly to the meter socket or mounted to the house. Innovative design does not damage meter socket and will not void warranty.

Catalog Number: **BDT1**

- Made in the USA!
- Meets Intersystem Bonding Requirements: NEC2008 250.94
- One connector does it all
- House mount or meter socket mount
- Incorporates proven BURNDY® SERVIT POST™ design
- Stainless steel set screws
- Accepts main ground wire (#2-#8), up to 4 intersystem wires (#6-#14)

- Easily mounts to meter box during new installation or can be wall mounted
- Easy to follow instructions included
- Does not damage meter socket; no worries about damaging the paint or voiding warranties
- Easily installed with a wrench and screwdriver
- Open design prevents buildup of hornets, bees, spiders



CONFIGURATION 1 – MOUNTED TO ENCLOSURE

1. Punch out a 1/2" or 3/4" knock out on the electrical enclosure.
2. Begin assembly by installing the ground electrode conductor in the SERVIT POST™ inside the electrical enclosure. Torque on SERVIT® nut: 275 in-lb max.
3. Install the rest of the connector as shown in figure 1 below, it is not necessary for the bus bar to be aligned parallel with the enclosure. (Note: the split washer is not used in this configuration.)
4. Tighten the intersystem ground wires with set screws in the bus bar to a maximum torque of 35 in-lb.
5. Adhere the BONDIT™ location sticker to the front of the electrical enclosure.

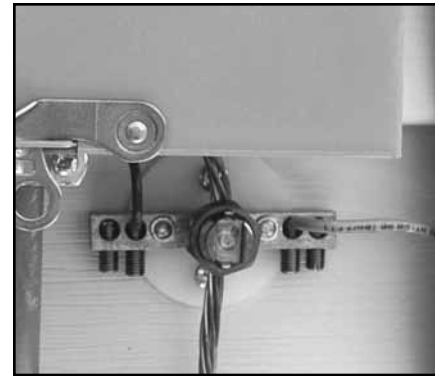

CONFIGURATION 2 – MOUNTED TO EXTERIOR WALL

1. Begin by assembling the connector as shown in figure 2 below. Be sure SERVIT POST™ is as tight as it can be while its groove is aligned with the ground electrode conductor. (Note: the flat washer is not used in this configuration.)
2. Use two mounting screws (not included) to secure the connector to the exterior wall so that the set screws in the bus bar face downward.
3. Install the ground electrode conductor into the SERVIT POST™ while turning the nut/pressure bar assembly to a maximum torque of 275 in-lb. (use 2 wrenches if necessary).
4. Tighten the intersystem ground wires with the set screws in the bus bar to a maximum torque of 35 in-lb.
5. If hidden from view, use the BONDIT™ location sticker to indicate the location.

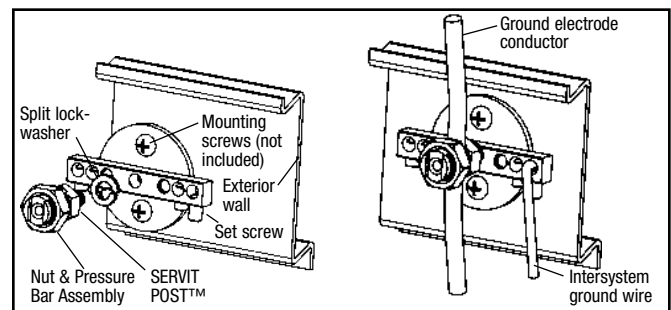
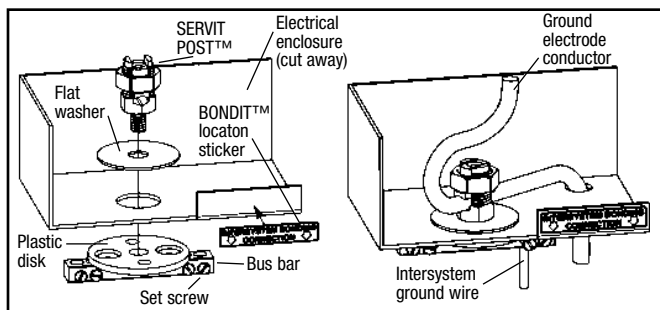

Blue highlighted items are industry standard and most frequently ordered.

CAST BRONZE CLAMPS FOR CONDUIT

Pressure bar type conduit hub adjusts for 1/2", 3/4" EMT or 1/2" rigid conduit. Hub swings 360° for easy alignment. Zinc plated hardware.



Catalog Number	Accommodates Conductor Range			Reference Dimensions			Recommended Screw Torque (Inch Pounds)	
	Water Pipe	Ground	Hub Size	H	L	W	Pipe Clamp	Wire Clamp
C-11JPT	1/2 - 1 [13 - 25]	10 - 6 Sol.	1/2 [13]	2.07 [53]	3.19 [81]	2.70 [69]	50 in.-lb.	50 in.-lb.
C-22JPT	1-1/4 - 2 [32 - 51]			2.70 [69]	3.83 [97]			
C-4JPT	2-1/2 - 4 [64 - 102]			4.39 [112]	5.15 [131]			

CAST BRONZE GROUND CLAMPS

For connecting grounding conductor to water pipe or copper tube. "D" indicates UL467 Listed for direct burial in earth and concrete and are supplied with silicon bronze hardware. "B" indicates brass hardware.



Catalog Number	Accommodates Conductor Range			Reference Dimensions				Recommended Screw Torque (Inch Pounds)	
	Water Pipe	Rebar	Ground	H	L	W	C	Pipe Clamp	Wire Clamp
C-11N	1/2 - 1 [13 - 25]	—	10 - 2 Str.	1.81 [46]	2.25 [56]	.63 [16]	.63 [16]	50 in.-lb.	50 in.-lb.
C-11D		#4 - #8							
C-11B		—							
C-22 *	1-1/4 - 2 [32 - 51]	—	10 - 2 Str.	2.38 [60]	3.63 [92]	.75 [19]	1.00 [25]		
C-22D									
C-4 *	2-1/2 - 4 [64 - 114]	—	10 - 2 Str.	4.13 [105]	6.25 [159]	.96 [24]	1.88 [48]		
C-8 *	4-1/2 - 6 [114 - 165]	—	10 - 2 Str.	4.29 [109]	8.34 [212]	1.25 [32]	1.88 [48]		

* Catalog numbers C-22, C-4, and C-8 are supplied with zinc plated steel hardware.

BUDGET PRICE CAST BRONZE GROUND CLAMP

Similar to above but lighter duty.



Catalog Number	Accommodates Conductor Range			Reference Dimensions				Recommended Screw Torque (Inch Pounds)	
	Water Pipe	Rebar	Ground	H	L	W	C	Pipe Clamp	Wire Clamp
C-5 (JUNIOR)	1/2 - 1 [13 - 25]	—	10 - 2 Str.	1.56 [40]	2.25 [56]	.56 [14]	.50 [13]	50 in.-lb.	50 in.-lb.

Blue highlighted items are industry standard and most frequently ordered.

CAST BRONZE GROUND CLAMPS

With Lay-in Feature

For connecting grounding conductor to water pipe, copper tube, ground rod or rebar. The open face design allows for fast lay-in of the tap conductor without the need for cutting. Simply reverse bottom clamp for smaller size rebar or rod. Connectors are provided with Silicon Bronze hardware.

E-36

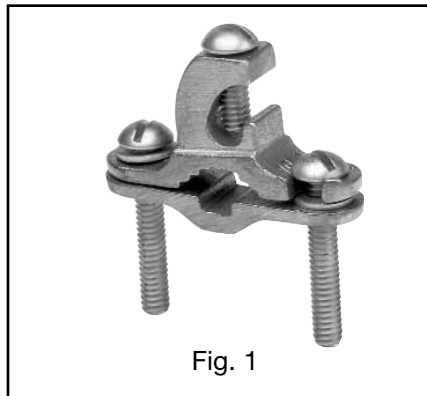

Fig. 1

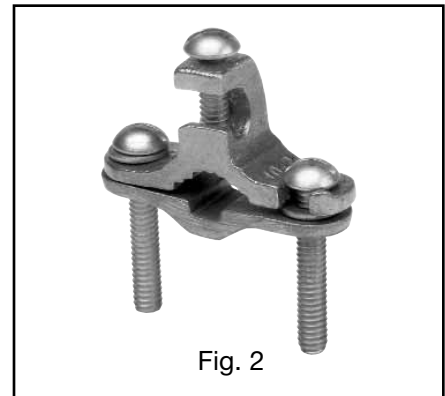

Fig. 2



Catalog Number	Fig. #	Accommodates Conductor Range				Reference Dimensions			Recommended Screw Torque (Inch Pounds)
		Main		Tap		H	L	W	
		Water Pipe	Rebar	Ground Rod	Ground				
C11K16D	Fig. 1	1/2" - 1"	#4 - #6	3/8" - 1"	#10 - #2 Str.	1.64"	2.28"	0.66"	50 in.-lbs.
C11K17D	Fig. 2	[13 - 25]							

DIE CAST CLAMPS

Die cast zinc with zinc plated screws.



Catalog Number	Accommodates Conductor Range		Reference Dimensions				Recommended Screw Torque (Inch Pounds)	
	Water Pipe	Ground	H	L	W	C	Pipe Clamp	Wire Clamp
CZ-11	1/2" - 1" [13 - 25]	10 - 2 Str.	1.56" [40]	2.25" [56]	.56" [14]	.50" [13]	50 in.-lb.	50 in.-lb.

Blue highlighted items are industry standard and most frequently ordered.

CAST BRONZE CLAMPS

To connect armored cable to water pipe. Zinc plated screws. Pressure bar grips armor or outer cable insulation. 360° swing hub for easy alignment.



Catalog Number	Accommodates Conductor Range		Reference Dimensions			Recommended Screw Torque (Inch Pounds)	
	Water Pipe	Armored Conductor	H	L	W	Pipe Clamp	Wire Clamp
C-11JA	1/2 - 1 [13 - 25]	10 - 6 Sol.	1.38 [35]	3.05 [77]	1.41 [36]	50 in.-lb.	50 in.-lb.
C-22JA	1-1/4 - 2 [32 - 51]		2.60 [66]	3.69 [94]			
C-4JA	2-1/2 - 4 [64 - 102]		4.29 [109]	5.01 [128]			

E-37

CAST BRONZE GROUND CLAMPS

For connecting grounding conductor, EMT or rigid conduit to water pipe, copper tube, ground rod or rebar. Hub swings 360° for easy alignment. Simply reverse bottom clamp for smaller size rebar or rod. Connectors are provided with Silicon Bronze hardware.

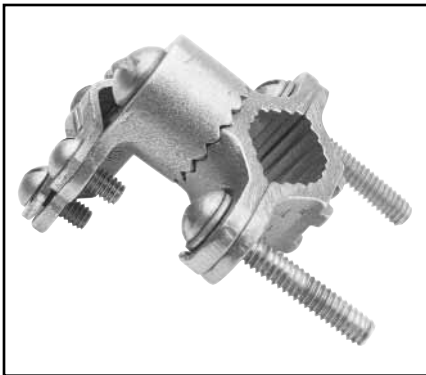

Catalog Number	Accommodates Conductor Range				Reference Dimensions			Recommended Screw Torque (Inch Pounds)
	Main			Tap	H	L	W	
	Water Pipe	Rebar	Ground Rod	Ground				
C11HD4/ODB	1/2" - 1" [13 - 25]	#4 - #6	3/8" - 1"	#8 - 4/0 AWG	2.25	2.65	1.56	50 in.-lbs.
C22HD4/ODB	1-1/4" - 2" [32 - 51]	—	—	#8 - 4/0 AWG	2.70	3.60	1.56	50 in.-lbs.

Blue highlighted items are industry standard and most frequently ordered.

CAST BRONZE CLAMPS

For connecting armored cable to water pipe. Zinc plated screws. "D" indicates UL467 for direct burial in earth and concrete, supplied with silicon bronze hardware.



E-38



Catalog Number	Accommodates Conductor Range			Reference Dimensions				Recommended Screw Torque (Inch Pounds)	
	Water Pipe	Ground	Ground Clamp	H	L	W	C	Pipe Clamp	Wire Clamp
C-6	1/2 - 1	10 - 2	Bare Armored Unarmored Wire Cables or Cords	1.60	2.34	1.06	.63	50 in.-lb.	50 in.-lb.
C-6D	[13 - 25]	Str.		[41]	[59]	[27]	[16]		
C-7	1-1/4 - 2	10 - 2		2.38	3.62	.94	1.00		
	[32 - 51]	Str.	[60]	[92]	[24]	[25]			

Blue highlighted items are industry standard and most frequently ordered.

CAST BRONZE CLAMP FOR RIGID CONDUIT

For grounding rigid conduit systems. Zinc plated screws.



Catalog Number	Accommodates Conductor Range			Reference Dimensions				Recommended Screw Torque (Inch Pounds)	
	Water Pipe	Ground	Hub Size	H	L	W	C	Pipe Clamp	Wire Clamp
C-61	1/2 - 1 [13 - 25]	#6 Sol. Max.	1/2 [13]	2.07 [53]	2.34 [59]	1.34 [34]	1.06 [27]	50 in.-lb.	50 in.-lb.
C-66	1-1/4 - 2 [32 - 51]			2.69 [68]	3.62 [92]	1.34 [34]	1.40 [36]		

CAST BRONZE CLAMPS FOR CONDUIT

For grounding rigid conduit systems. Continuity from rigid conduit systems to ground provided by cast bronze threaded conduit hub. Zinc plated screws.



Catalog Number	Accommodates Conductor Range			Reference Dimensions				Recommended Screw Torque (Inch Pounds)	
	Water Pipe	Ground	Hub Size	H	L	W	C	Pipe Clamp	Wire Clamp
C-11LH-1	1/2 - 1 [13 - 25]	10 Str. - 6 Sol.	1/2 [13]	2.25 [57]	3.23 [83]	.69 [18]	.97 [25]	50 in.-lb.	50 in.-lb.
C-22LH-1	1-1/4 - 2 [32 - 51]			2.88 [73]	3.50 [89]		1.34 [34]		
C-4LH-1	2-1/2 - 4 [54 - 102]			4.56 [116]	4.82 [122]		2.44 [62]		
C-11LH-2	1/2 - 1 [13 - 25]	2/0 - 10 Str.	3/4 [19]	2.56 [65]	2.86 [73]	1.00 [25]	1.13 [29]		
C-22LH-2	1-1/4 - 2 [32 - 51]			3.19 [65]	3.50 [89]		1.50 [38]		
C-4LH-2	2-1/2 - 4 [64 - 102]			4.88 [124]	4.82 [122]		2.38 [60]		
C-11LH-3	1/2 - 1 [13 - 25]	3/0 - 10 Str.	1 [25]	2.69 [68]	2.86 [73]	1.13 [29]	1.19 [30]		
C-22LH-3	1-1/4 - 2 [32 - 51]			3.32 [59]	3.50 [89]		1.56 [40]		
C-4LH-3	2-1/2 - 4 [63 - 102]			5.01 [127]	4.82 [122]		2.44 [62]		

* C-LH parts ending in "-1" have one screw and a washer, not shown. C-LH parts ending in "-2" or "-3" have two screws as shown.

Blue highlighted items are industry standard and most frequently ordered.

CAST BRONZE CLAMP WITH COPPER STRAP

For grounding rigid conduit systems. Strap helps protect conduit system from water system vibrations. Zinc plated screws. Strap ETP copper.

E-40

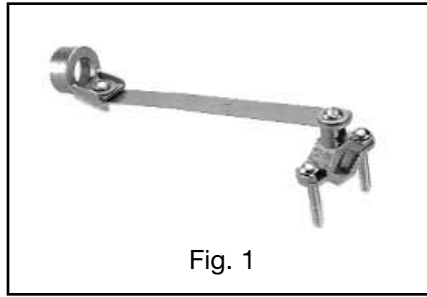

Fig. 1

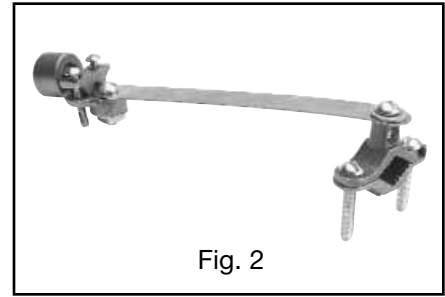

Fig. 2



Catalog Number	Fig. #	Accommodates Conductor Range			Reference Dimensions					Recommended Screw Torque (Inch Pounds)	
		Water Pipe	Ground	Hub Size	H	L	W	C	D	Pipe Clamp	Wire Clamp
C-11CSH-1	Fig. 1	1/2 - 1 [13 - 25]	6 Sol. Max.	1/2 [13]	1.75 [44]	8.50 [216]	1.06 [27]	1.06 [27]	6.12 [155]	50 in.-lb.	50 in.-lb.
C-11CSH-2	Fig. 1		4/0 Str. Max.	3/4 [19]			1.25 [32]	1.50 [38]			
C-11CSH-3	Fig. 1			1 [25]			1.50 [38]	1.75 [44]			
C11CSLH12	Fig. 2		#10 - 2/0 AWG	1/2 [13]			1.18	1.06 [27]		45 in.-lb.	

Blue highlighted items are industry standard and most frequently ordered.

TYPE GC-A

**DUAL RATED
GROUND CLAMP**

For Copper and
Aluminum Cable

GC-A ground clamps are UL Listed for use with either copper or aluminum conductors to copper water pipe, galvanized pipe or steel conduit. All clamps are constructed from tin plated high-strength extruded aluminum alloy. PENETROX™ oxide inhibiting joint compounds are recommended for all aluminum applications.



E-41

Features and Benefits

- Clamps are dual rated for both copper and aluminum conductors.
 - ◇ Maximum flexibility of application.
- All connectors are tin plated.
 - ◇ Provide low contact resistance and prevents galvanic corrosion.
- All clamps are range taking.
 - ◇ Only 3 catalog numbers covers complete range of applications from 1/2 - 4 inches.

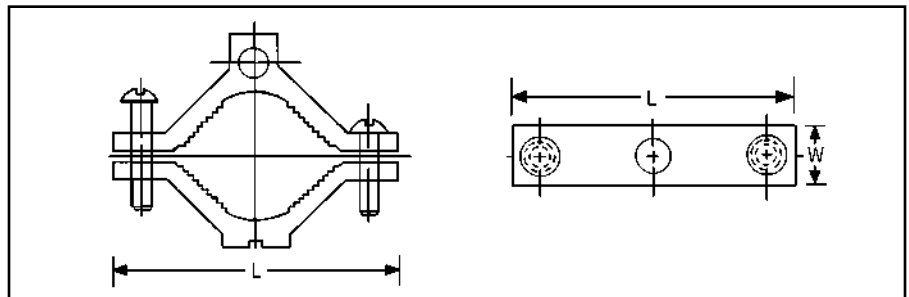

Catalog Number	Conduit, Pipe, or Water Tube Size	Wire Range	Screw Type	W	L	Hex Size
GC15A	1/2 - 3/4 - 1	1/0 - 14	Slotted	11/16	2-1/4	S
GC18A	1-1/4 - 1-1/2 - 2	250 kcmil - 6	Hex Socket	13/16	3-3/4	5/16
GC22A	2-1/2 - 3 - 3-1/2 - 4	250 kcmil - 6	Hex Socket	1	6-5/16	5/16

Blue highlighted items are industry standard and most frequently ordered.

TYPE GG

GROUND CONNECTOR

For Copper Bar, Strap, Braid or Cable to Rod or Tube

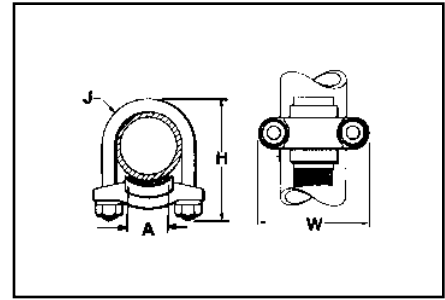

E-42

High copper alloy ground connector for joining bar, strap, braid or cable to rod or tube. High copper alloy cast body, DURIMUM™ U-bolts, nuts and lockwashers make the GG particularly effective for use with braid for ground rods, switch handles, fence posts and gates. One-wrench installation.

Catalog Number	Conductor		A	H	J	W
	Tube I.P.S.	Rod				
GG15-1	1	1-1/8 - 1-1/4	1	3-3/8	3/8	2-5/8
GG16-1	1-1/4	1-3/8 - 1-1/2		3		
GG17-1	1-1/2	1-5/8 - 1-7/8	1-1/2	3-1/2	3/8	3-1/4
GG17-15			1	4-1/4		3-3/4
GG18-1	2	2 - 2-3/8	1-1/2		4-3/8	1/2
GG18-15			2	5	4-5/8	
GG18-2			2		4-1/8	
GG19-2	2-1/2	2-1/2 - 2-7/8	2-1/2	6-3/8	1/2	4-5/8
GG19-25			2			5-7/8
GG20-2	3	3 - 3-1/2	2-1/2	6-1/2	1/2	
GG20-25			3			
GG20-3			3			
GG21-2	3-1/2	3-1/2 - 4	2	7-5/8	1/2	7-1/4
GG21-25			2-1/2			
GG21-3			3			
GG21-35			3-1/2			
GG22-2	4	4 - 4-1/2	2	6-1/2	1/2	6-1/4
GG22-25			2-1/2			
GG22-3			3			
GG22-4			4			
GG24-2	5	—	2	7-5/8	1/2	7-1/4

See note page E-1

Blue highlighted items are industry standard and most frequently ordered.

TYPE GQ

GROUND CONNECTOR

For Copper Cable to Tube

High copper alloy ground connector for cross connecting a wide range of cable. High copper alloy, cast body, DURIMUM™ U-bolts, nuts, and lockwashers make the GQ suitable for burial in soil or concrete. One-wrench installation. UL467 Listed. Acceptable for direct burial in earth or concrete.

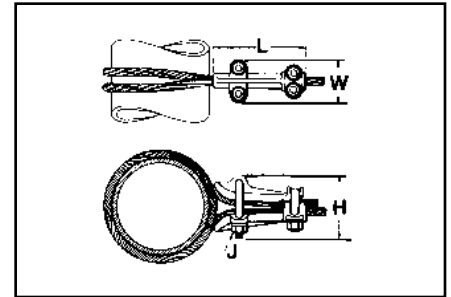

E-43

Catalog Number	Conductor		H	J	L	W
	Tube I.P.S.	Cable				
GQ2626	6" Max.	4 Str. - 2/0 Str.	4-1/2	1/2	5	2-1/2
GQ26-1	Above 6"		7-1/8			
GQ2929	6" Max.	2/0 Str. - 250	4-1/8		6	2-3/4
GQ29-1	Above 6"		7-1/2			

Blue highlighted items are industry standard and most frequently ordered.

TYPE GX

GROUND CONNECTOR

For Copper Cables

High copper alloy ground connector for cross connecting a wide range of cable. The high copper alloy cast body, DURIMUM™ U-bolts, nuts, and lockwashers make the GX suitable for burial in soil or concrete. One-wrench installation. UL467 Listed. Acceptable for direct burial in earth or concrete.

E-44

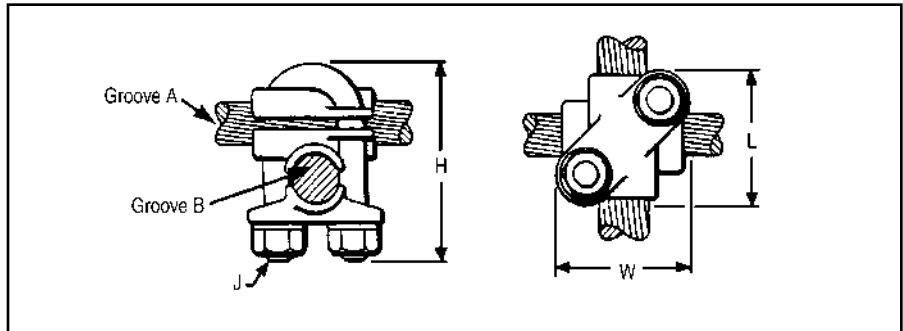

Catalog Number	Conductor		H	J	L	W
	Groove A	Groove B				
GX4C4C	8 Sol. - 4 Str.	8 Sol. - 4 Str.	1-7/8		1-5/8	1-5/8
GX264C	4 Sol. - 2/0 Str.	8 Sol. - 4 Str.	2-1/2		1-3/4	1-3/4
GX2626		4 Sol. - 2/0 Str.				
GX294C	2/0 Sol. - 250	8 Sol. - 4 Str.	2-3/4	3/8	1-7/8	1-7/8
GX2926		4 Sol. - 2/0 Str.				
GX2929		2/0 Sol. - 250				
GX344C	300 - 500	8 Sol. - 4 Str.	4-1/4	1/2	2-5/8	2-5/8
GX3426		4 Sol. - 2/0 Str.				
GX3429		2/0 Sol. - 250				
GX3434		300 - 500				

Blue highlighted items are industry standard and most frequently ordered.

TYPE GRC

**HIGH STRENGTH
GROUND ROD CLAMP**

For Copper Cable to Rod

High copper alloy ground connector for joining a range of cable to copper clad, galvanized steel, and stainless steel ground rods. Slips over end of rod, one-wrench installation. UL467 Listed for direct burial in earth and concrete.

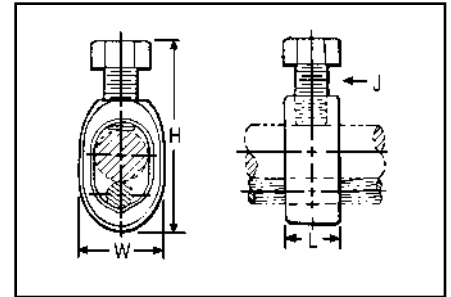

REA LISTED



Catalog Number	Drive Rod	Conductor Range		H	W	L	J
		Min.	Max.				
GRC12	1/2	10 Sol.	2 Str.	2.00	.89	.63	3/8
GRC58	5/8		1 Str.	2.19	.95	.63	
GRC34	3/4	8 Sol.	1/0 Str.	2.47	1.09	.65	

E-45

**TYPE GCRT1/0
GROUND
CONNECTORS**

**GROUND CLAMP
RANGE TAKING, UP TO 1/0**

The GCRT1/0 is a range taking ground rod clamp offering another choice from the BURNDY® family of connectors. The GCRT1/0 works on 1/2", 5/8" and 3/4" ground rods with a wire range of #8 through 1/0! The clamp is UL467 Listed for direct burial in earth and concrete. Catalog number **GCRT1/0**.



Features and Benefits

- Range taking design helps reduce inventory.
- UL Listed and CSA Certified.
- UL467 Listed for direct burial in earth and concrete.



TYPE GRL

**LIGHT DUTY
ECONOMICAL GROUND ROD
CLAMP**

UL467 Listed. Acceptable for direct burial.



Catalog Number	Rod Size	Conductor Range	
		Minimum	Maximum
GRL3*	3/8	10 AWG	4 AWG
GRL4	1/2	10 AWG	2 AWG
GRL5	5/8	10 AWG	2 AWG
GRL6	3/4	10 AWG	2 AWG

* GRL3 not UL Listed.

Blue highlighted items are industry standard and most frequently ordered.

TYPE B

FLEXIBLE COPPER BRAID

Flexible copper braid jumpers designed to take up linear expansion and contraction, compensate for misalignment and absorb vibratory movement of electrical equipment and devices.

Made of flat extra flexible, tinned, pure copper braid, with unplated, seamless, pure copper ferrules formed into a rectangular shape on each end.

Last two numbers in catalog number indicate total length of braid in inches (e.g., BD12N or BD12 is 12" long braid jumper).

Other lengths, plating and drilling are available. Refer to factory.

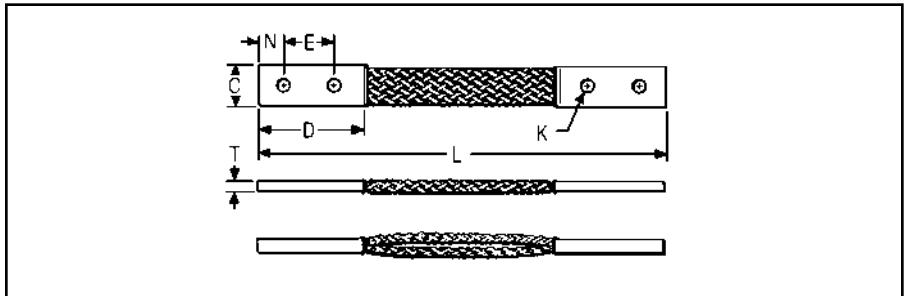
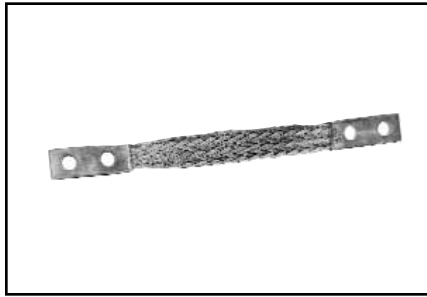

Catalog Number	Number of Braids in Ferrules	C	D	E	K	L	N	T	Approximate Ampere Rating	
									Indoor	Outdoor
BD12 †	1	.94	2.50	1.25	.44	12	.62	.13	190	225
BD12N** †			3.00	1.75	.56	12				
BD18 †			2.50	1.25	.44	18				
BD18N** †			3.00	1.75	.56	18				
BD24 †			2.50	1.25	.44	24				
BD24N** †			3.00	1.75	.56	24				
BE12 †	1	1.50	3.00	1.50	.44	12	.75	.17	340	405
BE12N** †				1.75	.56	12	.62			
BE18 †				1.50	.44	18	.75			
BE18N** †				1.75	.56	18	.62			
BE24 †				1.50	.44	24	.75			
BE24N** †				1.75	.56	24	.62			
BF12 †	1	1.19	3.00	1.50	.44	12	.75	.25	360	430
BF12N** †				1.75	.56	12	.62			
BF18 †				1.50	.44	18	.75			
BF18N** †				1.75	.56	18	.62			
BF24 †				1.50	.44	24	.75			
BF24N** †				1.75	.56	24	.62			
BG12	1	1.50	3.00	1.50	.44	12	.75	.25	415	495
BG12N**				1.75	.56	12	.62			
BG18				1.50	.44	18	.75			
BG18N**				1.75	.56	18	.62			
BG24				1.50	.44	24	.75			
BG24N**				1.75	.56	24	.62			

* This rating may vary with ambient conditions, orientation of the braid and other service conditions.

** Tongue drilled per (2) hole NEMA standard.

Note: All sizes are listed to UL467 and specific sizes (†) are certified to CSA C22.2, No. 41 Grounding and Bonding Equipment Standards. Equivalent sizes may be designated by suffix letters representing variations in length, mounting configurations, pad size and finish. Contact factory for details.

Blue highlighted items are industry standard and most frequently ordered.

TYPE B

FLEXIBLE COPPER BRAID

(Continued)



E-47

Catalog Number	Number of Braids in Ferrules	C	D	E	K	L	N	T	Approximate Ampere Rating	
									Indoor	Outdoor
B2D12 †	2	.94	2.50	1.25	.44	12	.62	.25	380	455
B2D12N** †			3.00	1.75	.56	12	.62			
B2E12		1.62	3.00	1.50	.44	12	.75	.25	530	635
B2E12N**			3.00	1.75	.56	12	.62			
B2F12		1.38	3.00	1.50	.44	12	.75	.38	600	720
B2F12N**			3.00	1.75	.56	12	.62			
B2G12N**	1.50	3.00	1.75	.56	12	.62	.50	700	840	
B3D12 †	3	1.19	2.50	1.25	.44	12	.62	.25	470	560
B3D12N** †			3.00	1.75	.56	12	.62			
B3E12		1.64	3.00	1.50	.44	12	.75	.31	700	840
B3E12N**			3.00	1.75	.56	12	.62			
B3F12		1.44	3.00	1.50	.44	12	.75	.56	820	980
B3F12N**			3.00	1.75	.56	12	.62			
B3G12	1.69	3.00	1.50	.44	12	.75	.69	960	1150	
B3G12N**		3.00	1.75	.56	12	.62				
B4D12	4	1.19	2.50	1.25	.44	12	.62	.32	600	720
B4D12N**			3.00	1.75	.56	12	.62			
B4E12		1.64	3.00	1.50	.44	12	.75	.36	850	1020
B4E12N**			3.00	1.75	.56	12	.62			
B4F12		1.50	3.00	1.50	.44	12	.75	.78	1000	1200
B4F12N**			3.00	1.75	.56	12	.62			
B4G12N**	1.69	3.00	1.75	.56	12	.62	.94	1200	1440	

* This rating may vary with ambient conditions, orientation of the braid and other service conditions.
 ** Tongue drilled per (2) hole NEMA standard.

Note: All sizes are listed to UL467 and specific sizes (†) are certified to CSA C22.2, No. 41 Grounding and Bonding Equipment Standards. Equivalent sizes may be designated by suffix letters representing variations in length, mounting configurations, pad size and finish. Contact factory for details.

Blue highlighted items are industry standard and most frequently ordered.

TYPES GB, GBM

GROUND CONNECTOR

For Copper Cable to Bar

High copper alloy ground connector for joining a range of cable to 1/4" thick bar.* Type GB separates cable from bar, GBM clamps cable directly on bar surface. One-wrench installation. UL467 Listed. The high copper alloy cast body and DURIMUM™ bolts, nuts, and lockwashers make the GB and GBM suitable for direct burial in concrete or ground.

E-48

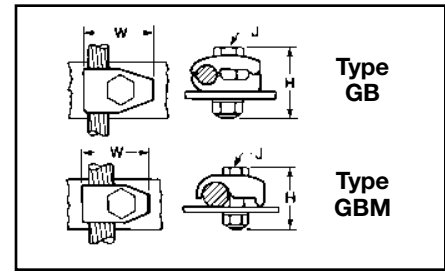
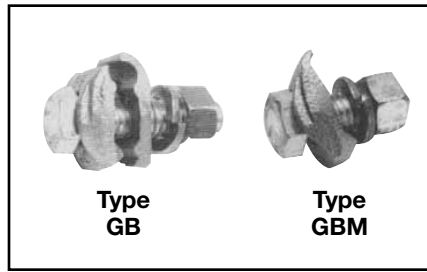

Catalog Number		Conductor	H Type GB/GBL	H Type GBM	J	W Type GB/GBL	W Type GBM
Type GB	Type GBM						
GB4C	GBM4C	8 Sol. - 4 Str.	1-1/2	1-1/2	3/8	1-1/4	1-1/4
GB26	GBM26	4 Sol. - 2/0 Str.	2	2		1-1/2	1-1/2
+GBL30		4 Sol. - 300					7/8
GB29	GBM29	2/0 Sol. - 250	3	2-1/4	1/2	2	2
GB34	GBM34	300 - 500				2-3/8	2-3/8

+ GBL30 is not UL listed.
Add "GS" suffix for galvanized steel hardware.
* For other bar thicknesses see note at bottom of page E-48.

TYPES GC, GCM

GROUND CONNECTOR

For Two Copper Cables to Bar

High copper alloy ground connector for joining a wide range of two parallel cables to 1/4" thick bar.* Type GC separates cable from bar, GCM clamps cable to bar surface. One-wrench installation. UL467 Listed. The high copper alloy cast body and DURIMUM™ bolts, nuts, and lockwashers make the GC and GCM suitable for direct burial in concrete or ground.

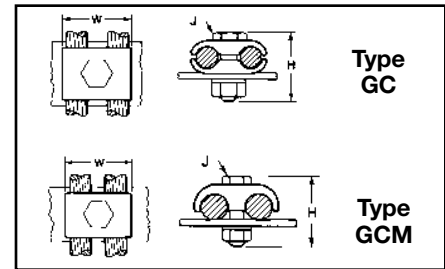
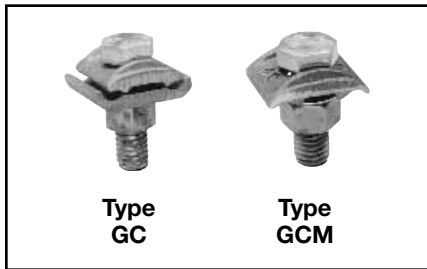

Catalog Number		Conductor	H Type GC/GCL	H Type GCM	J	W Type GC/GCL	W Type GCM
Type GC	Type GCM						
GC4C4C	GCM4C	8 Sol. - 4 Str.	1-1/2	1-1/2	3/8	1-3/8	1
GC2626	GCM26	4 Sol. - 2/0 Str.	2	—		1-3/4	1-3/8
GCL30	GCM30	4 Str. - 300	2	—	—	1	—
GC2929	GCM29	2/0 Sol. - 250	2-1/4	2	1/2	2-1/4	2
GC3434	GCM34	300 - 500	2-7/8	2-1/4		2-7/8	2-5/8

Smooth oval-shank bolts are available upon request for cable-tray applications (example: GC30G3). Also refer to type GC-CT.
Add "GS" suffix for galvanized steel hardware.
* For other bar thicknesses see note at bottom of page E-48.

Blue highlighted items are industry standard and most frequently ordered.

TYPE GL

GROUND CONNECTOR

For Two Copper Cables to Bar

High copper alloy ground connector for joining a wide range of two parallel cables to 1/4" thick bar.* Two-bolt design, separates cable from bar. One-wrench installation. UL467 Listed. The high copper alloy cast body and DURIMUM™ bolts, nuts, and lockwashers make them suitable for direct burial in concrete or ground.

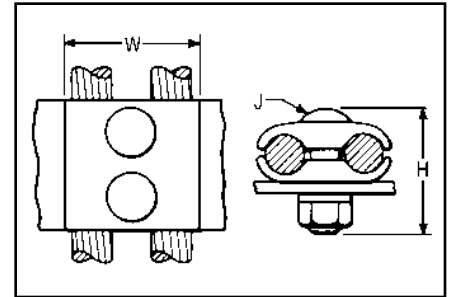

Catalog Number*	Conductor	H	J	W
GL4C4C	8 Sol. - 4 Str.	1-1/2	3/8	1-3/8
GL2626	4 Sol. - 2/0 Str.	2		1-3/4
GL2929	2/0 Sol. - 250	2-1/4	1/2	2-1/4
GL3434	300 - 500	2-7/8		2-7/8

* For other bar thicknesses see note at bottom of page.

E-49

TYPE GZ

GROUND CONNECTOR

For Copper Cable to Bar

High copper alloy ground connector for joining a wide range of cable to 1/4" thick bar*. Cable is gripped by curving it around the clamping bolt in connector groove. UL467 Listed. The high copper alloy cast body and DURIMUM™ bolts, nuts, and lockwashers make them suitable for direct burial in concrete or ground.

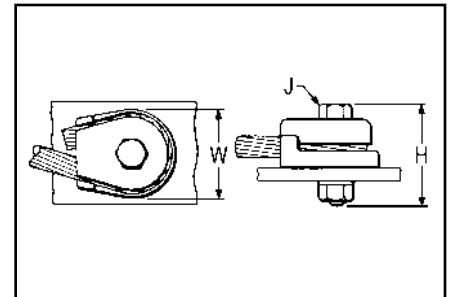

Catalog Number*	Conductor	H	J	W
GZ4C-38	8 Str. - 4 Str.	1-1/2	3/8	1-1/8
GZ4C-12		1-7/8	1/2	1-3/4
GZ4C-58		2	5/8	
GZ26-38	3 Str. - 2/0 Str.	2-1/8	3/8	1-5/8
GZ26-12			1/2	1-3/4
GZ26-58		2-1/4	5/8	
GZ29-38	3/0 Str. - 250	2-3/8	3/8	2-1/4
GZ29-12			1/2	
GZ29-58		2-1/2	5/8	

NOTE:

* The GB, GBM, GC, GCM, GL and GZ are all used for joining a range of cable to bar. The catalog numbers in each table accommodate the indicated cable range and up to 1/4" thick bar. Optional bolt lengths are available to accommodate up to 1" thick bar. For bar thicknesses from 1/4" to 1/2", add the suffix "T4" to the catalog number in the table. For bar thicknesses from 1/2" to 1", add the suffix "T8" to the catalog number in the table.

Blue highlighted items are industry standard and most frequently ordered.

TYPE GC-CT

CABLETRAY GROUND CLAMP

E-50

This unique connector incorporates features which are unmatched. Made of tin-plated cast copper alloy, it accommodates either one or two conductors, copper or aluminum cable. In addition to a low profile head with a deep Phillips recess, the galvanized steel bolt has a ribbed neck which prevents rotation during installation when installed in a .44 diameter hole. When used on aluminum conductor, the cable must be scratch brushed and PENETROX™ A joint compound must be used on cable and connector.

UL467 Listed for copper conductor only. Suitable for direct burial in concrete or earth.

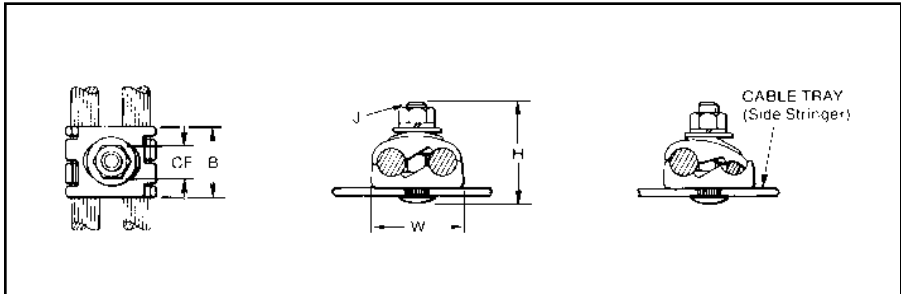

Catalog Number	Accommodates Copper or Aluminum Conductor in Either Groove	Dimensions				
		B	CF	H	J	W
GC2525CT	#6 Sol. (.162 Dia.) - 1/0 Str. (.372 Dia.)	1.12	.56	1.95	3/8" - 16	1.45
GC2626CT	#2 Sol. (.258 Dia.) - 2/0 Str. (.419 Dia.)	1.12	.56	1.95	3/8" - 16	1.70
GC2929CT	2/0 Str. (.414 Dia.) - 250 kcmil (.575 Dia.)	1.12	.56	2.20	3/8" - 16	1.98

NOTE:

The bolt head is mounted on the inside wall of cabletray to avoid damage to the cable insulation.
May be used with aluminum or galvanized steel cable tray.

Blue highlighted items are industry standard and most frequently ordered.

TYPE GTC1AC34RA

PROTECTIVE GROUNDING CLAMP

For Pad Mounted Equipment

A newly designed Protective Grounding Clamp for making secure connections when installing Protective Grounding Sets on Pad Mounted Equipment.

Features a 90° right angle side entry for ferrule. Cable connection will now exit clamp parallel with grounding bar allowing cable set to remain within the cabinet. Closing the cabinet doors will now be easier and will not require infringing on the safety clearance zone.

Eliminates awkward hotstick mounting and tightening of clamp jaws from elevated angles. Improves safety thanks to easier respect of minimum approach distance.

The clamp is used as a base for new grounding sets or can be retrofit on most grounding sets for pad mounted equipment.

Designed and manufactured in the U.S.A.

Catalog Number: **GTC1AC34RA**

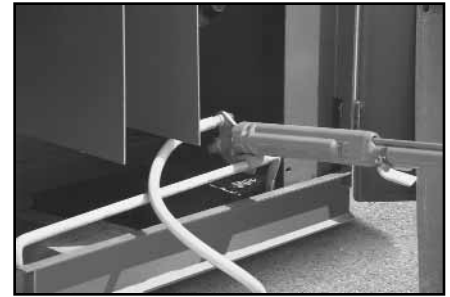

E-51

Features

- ASTM classification (F855-04):
 - Grade 3 (27kA for 15 cycles)
 - Class A/Type I/C-shape
 - Brass alloy
 - Weight: 1.85 Lbs.
- Jaw range: round section conductor 3/8" to 3/4" diameter.

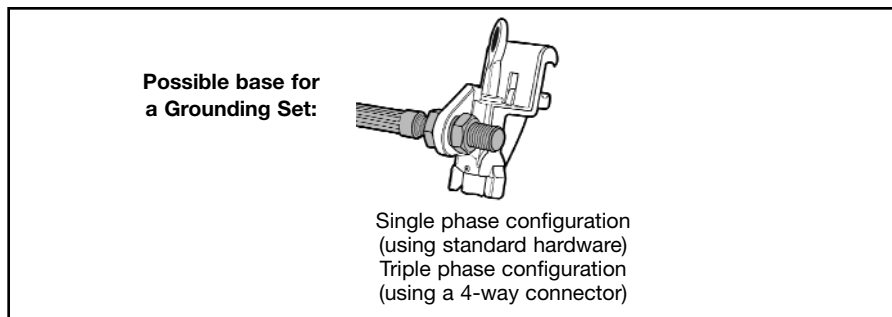
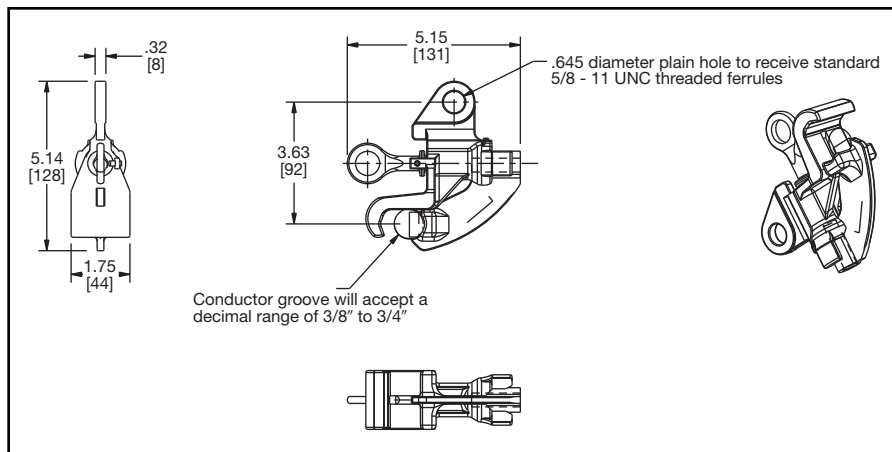

Blue highlighted items are industry standard and most frequently ordered.

TYPE GIE-G

GROUND CONNECTOR

For Vehicle Grounding
Heavy Duty Construction

E-52

High-strength copper alloy ground clamps for grounding gasoline trucks, tank cars, aircraft and other vehicles where danger of explosion due to static electricity exists. Corrosion resistant and supplied with non-sparking, adjustable, replaceable contact grip screws. Automatic safety release disconnects should a vehicle unexpectedly move from the grounded area. Accommodates 4 Str. flexible copper cable.

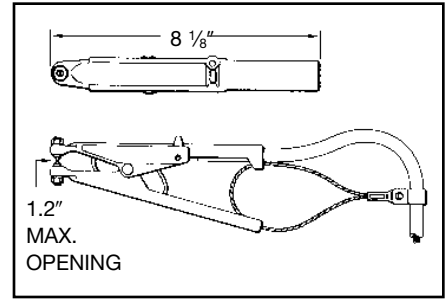
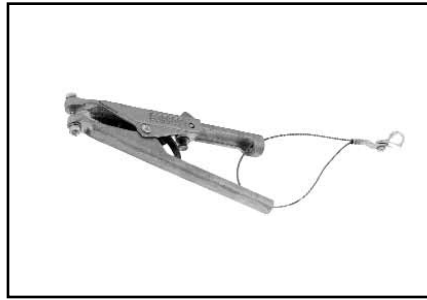

Catalog Number	Replaceable Contact Grip Screws		
	Catalog Number	Material	Point Configuration
GIE4CG3	GIE4CG3P5	Beryllium Copper	Cone Point
	GIE4CG3P7		Cup Point
GIE4CG4	GIE4CG4P5	Stainless Steel	Cone Point
	GIE4CG4P7		Cup Point

TYPE GIE-G

GROUND CONNECTOR

Accommodates flexible rubber sheath cable ranging from #6 to #2 conductor.

Catalog Number: **GIE2CG3**

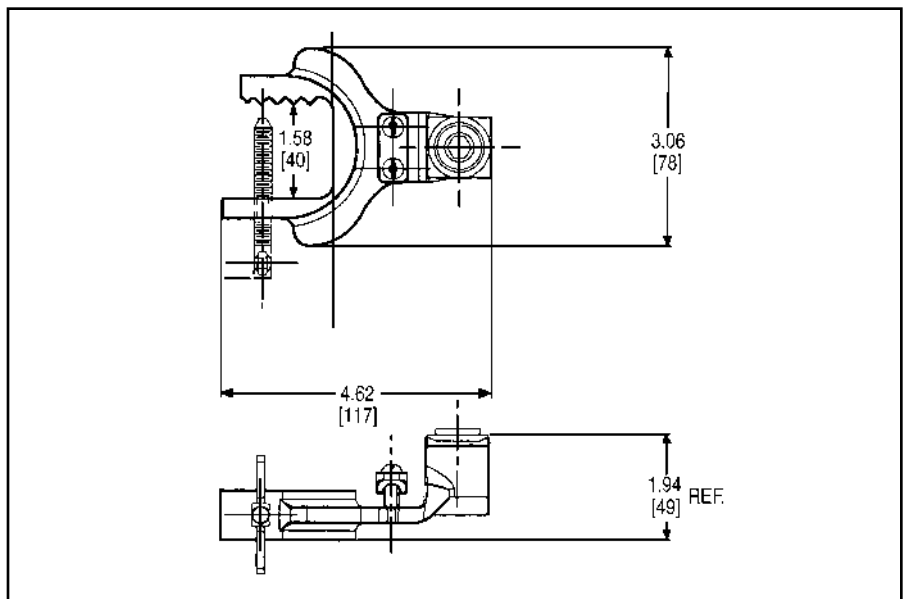
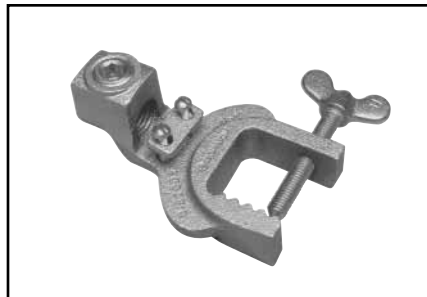

Blue highlighted items are industry standard and most frequently ordered.

RAIL CONNECTOR

Mechanical clamp connectors designed for use in power, contact or running rail applications. Connectors are cast of a high conductivity copper alloy, tin-plated, and assembled with high-strength DURIIUM™ hardware. Connectors designed for extended service life.

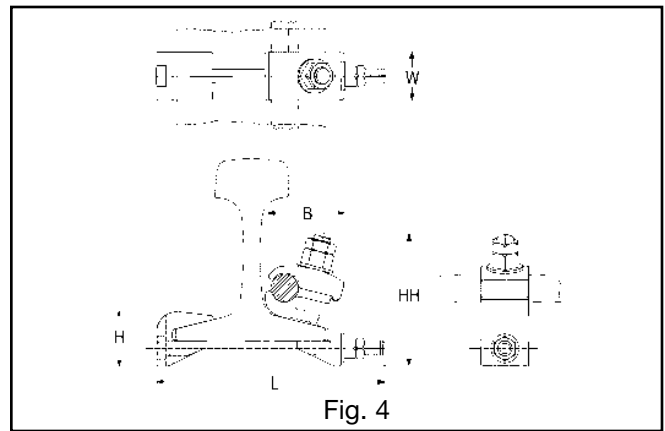
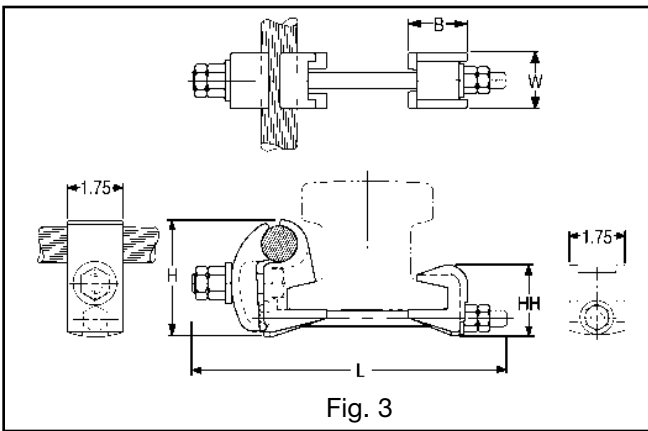
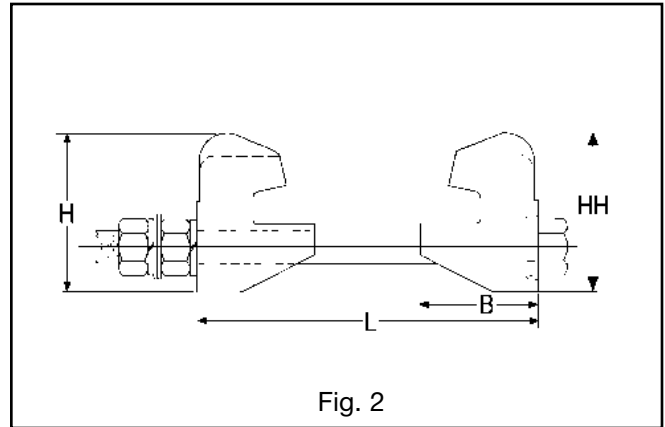
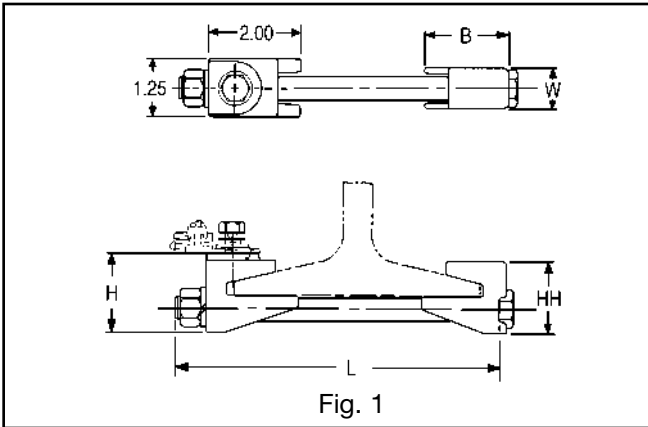

Catalog Number	Fig. No.	Accommodates	B	H	HH	L	W
J278	1	100 Lbs. A.R.E.A. Running Rail	1.81	1.88	1.72	7.50	.88
J279	1	75 or 90 Lbs. Running Rail	1.81	1.71	1.55	7.50	.88
J280	1	150 Lbs. Contact Rail	2.12	2.08	1.92	7.00	1.25
J295	2	150 Lbs. Third Rail	2.62	3.50	3.50	7.75	3.00
RGC44G1*	3	150 Lbs. NMC Contact Rail and (1) 800-1000 kcmil CU Cable	1.75	2.82	2.25	10.00	1.75
RGC39G1*	4	115 Lbs. Contact or Running Rail and (1) 500-750 kcmil CU Cable	2.75	2.00	4.78	8.32	1.25

* Tin-plated.

Blue highlighted items are industry standard and most frequently ordered.

TYPE QGFL

BARTAP™

For Copper Cable to Flat Bar or Pad

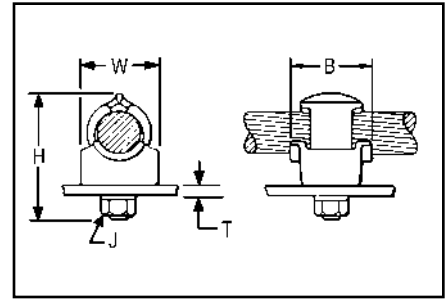
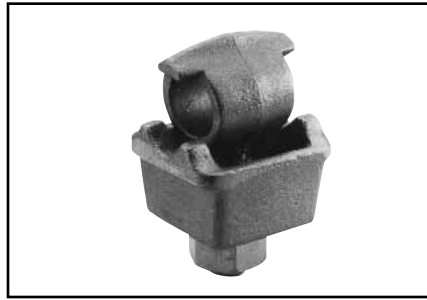

E-54

High copper alloy BARTAP™ for joining a range of cable to bar or pad. One-wrench installation. DURIU™ nut and lockwasher.



Catalog Number	Conductor	B	H	J	T (Max.)	W
QGFL1CB1	10 Sol. - 1 Str.	1-1/8	1-7/8	3/8	1/4	1
QGFL1CB1T6			2-3/8		3/4	
QGFL26B1	8 Sol. - 2/0 Str.	1-1/4	2-1/8	1/2	1/4	1-1/8
QGFL26B1T6			2-5/8		3/4	
QGFL26B2*		1-1/2	1-1/2		1/4	
QGFL26B2T6*			2-7/8		3/4	
QGFL29B1*	6 Str. - 250	1-5/8	2-5/8	1/2	1/4	1-3/8
QGFL29B1T6*			3-1/8		3/4	
QGFL31B1*	2 Sol. - 350	1-3/4	2-7/8	1/2	1/4	1-5/8
QGFL31B1T6*			3-1/4		3/4	
QGFL34B1	1/0 Sol. - 500	2	3-1/8	1/2	1/4	1-3/4
QGFL34B1T6			3-5/8		3/4	
QGFL39B1	350 - 750	2-1/4	3-1/4	1/2	1/4	1-3/4
QGFL39B1T6			3-5/8		3/4	
QGFL44B1	750 - 1000	2-1/4	3-3/8	1/2	1/4	2-1/8
QGFL44B1T6			4-1/8		3/4	
QGFL46B1	1000 - 1500	2-1/4	4	1/2	1/4	2-1/2
QGFL46B1T6			4-1/2		3/4	
QGFL48B1	1500 - 2000	2-1/4	4-3/4	1/2	1/4	3

* Can be installed side by side or in line on NEMA drilled bar.

TYPE GA-H

GROUND CONNECTOR

For Copper Cable to "H" Beam

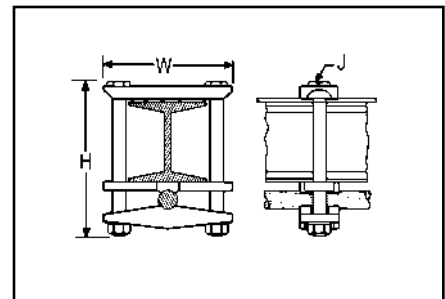

High copper alloy ground connector for joining a wide range of cable parallel to "H" beams or square tube. Hardware is made from DURIU™ for superior corrosion protection.

Catalog Number	Conductor		H	J	W
	"H" Beam	Cable			
GA25H26	1-7/8" × 1-7/8" - 2-1/2" × 2-1/2"	4 Sol. - 2/0 Str.	4-3/4	3/8	4

Blue highlighted items are industry standard and most frequently ordered.

TYPE GRF

UNIGROUND™ RAISED FLOOR GROUNDING CONNECTOR

The BURNDY® UNIGROUND™ is a universal grounding clamp, specifically designed for all raised flooring systems. It can be installed on round or square pedestals and can accommodate one or two grounding wires to make an efficient grid. The underfloor signal reference grid provides the low impedance ground path that attenuates high frequency static and 60 Hz transient noise for cleaner data output. UL467 Listed.



E-55

Features and Benefits

- One connector fits all applications.
 - ◇ Ease of specification and installation.
- Single bolt design.
 - ◇ Ease of installation:
 - No need to disassemble.
 - Single wrench installation.
- Accepts 1 or 2 ground conductors.
 - ◇ Requires less connectors to install signal reference grid.
- Tin plated cast bronze construction.
 - ◇ Resists corrosion and provides extended life ground connection.
- Grounds all pedestals (round or square).
 - Will handle up to 7/8" square and 1" round.
 - ◇ Ease of installation. One connector does it all
- Serves 3 needs:
 1. Signal Reference Grid.
 2. Static Ground.
 3. Fault Current Ground.
 - ◇ UNIGROUND™ solves all possible grounding problems found in computer applications today.

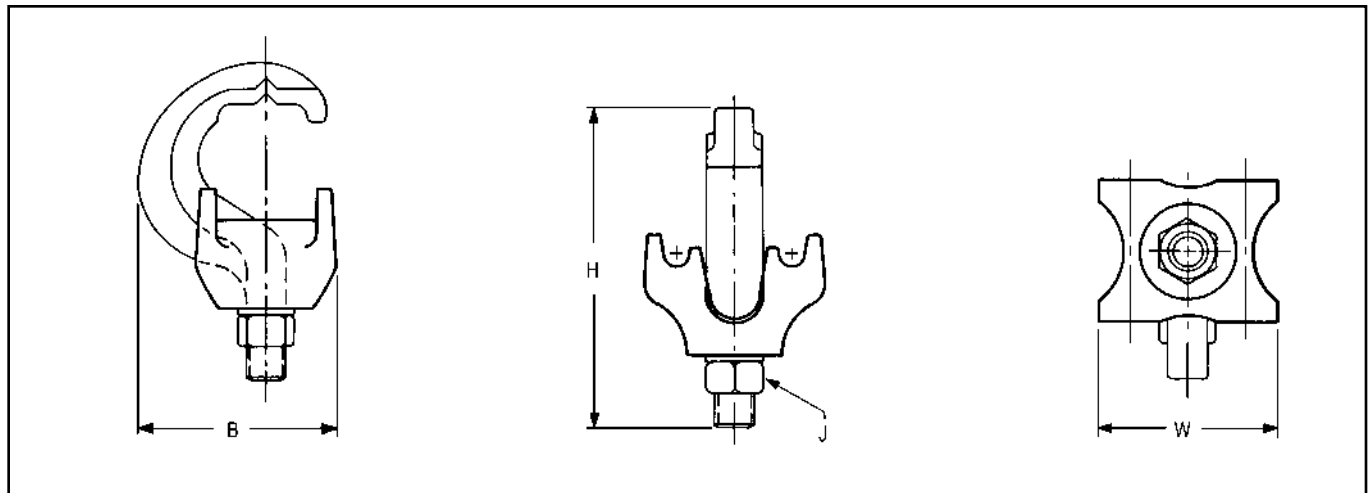

Catalog Number	Number of Conductors	Conductor Size Sol. & Str.	Pedestal Type		B	H	J	W
			Round	Square				
GRF4C-3	1 or 2	#8 - #2	Up to 1"	Up to 7/8"	1.96	3.14	3/8"	1.76
GRF4C-4	1 or 2	#8 - #2	Up to 3/4"	Up to 5/8"	1.79	3.13	3/8"	1.40

Blue highlighted items are industry standard and most frequently ordered.

TYPES GP-G1, GP-RT

RAISED FLOOR GROUNDING CLAMPS

High copper alloy ground connector for raised floor computer grounding applications. These connectors can be installed on round and square pedestal applications and will accommodate one or two grounding wires to make an efficient grid. The under-floor signal reference grid provides the low impedance ground path that attenuates high frequency static and 60 Hz transient noise for cleaner data output. UL467 Listed.

In addition we offer the GP1726RT, which is especially designed for penetrating epoxy paint on pedestals. This patented connector offers a low impedance, time saving connection between conductors and the Pedestal.



Features and Benefits

- Accepts 1 or 2 Ground Conductors
 - ◇ Requires less connectors to install signal reference grid.
- Made of copper alloy.
- DURIMUM™ U-Bolts, nuts and lockwashers.
 - ◇ Provides a low impedance ground path for maximum performance.
- Grounds all pedestals (round or square).
- Will handle from 3/4" to 1" round or square.
 - ◇ Ease of installation.
- Serves 3 needs.
 1. Signal Reference Grid.
 2. Static Ground.
 3. Fault Current Ground.
 - ◇ Connectors solves all possible grounding problems found in computer applications today.

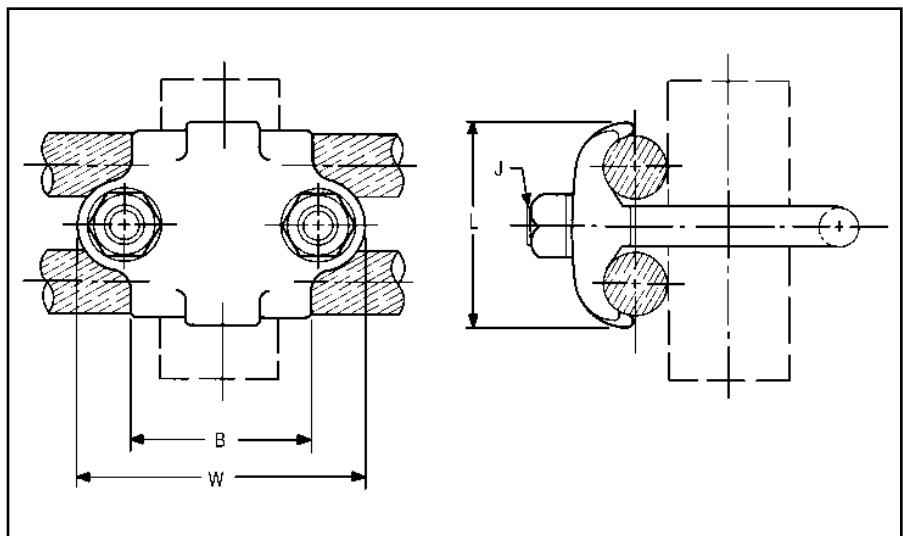

Catalog Number	Number of Conductors	Conductor Size Sol. & Str.	Pedestal Type	B	J	L	W
			Round or Square				
GP654CG1	1 or 2	#8 Sol. - 4 Str.	3/4" - 1" Round	1.5	3/8"	1.31	2.38
GP64526G1	1 or 2	#4 Sol. - 2/0 Str.	3/4" - 7/8" Square	1.5	3/8"	1.69	2.38
GP1526G1	1 or 2	#4 Sol. - 2/0 Str.	1-1/4" Round	1.75	3/8"	1.69	2.62
GP1726RT	1 or 2	#6 Sol. - 2/0 Str.	2" Round	2.12	3/8"	1.50	3.22
GP1726G1	1 or 2	#6 Sol. - 2/0 Str.	2" Round	2.12	3/8"	1.50	3.22

Blue highlighted items are industry standard and most frequently ordered.

TYPE BBB

BURNDY® BusBar

Copper BusBar

Bare copper BusBar, UL Listed for grounding. Available in many sizes and hole patterns. Brackets and insulators included with most styles. Also available in undrilled, horizontal and vertical versions.

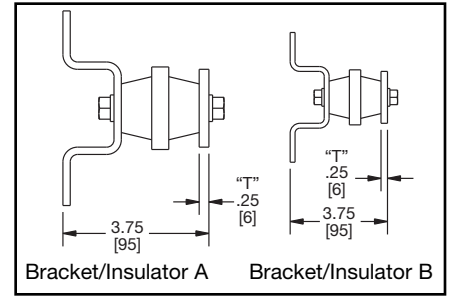
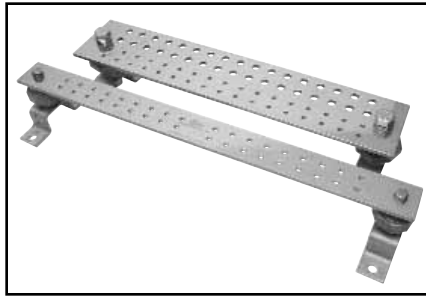

E-57

BusBar is used in a variety of applications. Can be used as a common ground point and "power" applications as well.



Catalog Number	Fig. No.	Insulator & Bracket	T - Bar Thickness	W - Bar Width	L - Bar Length	E1	E2	E3	F1	F2	No. of Holes	K
BBB14210A	1	A	1/4"	2"	10"	.63	—	—	1.00	—	16	.28
BBB14224B	2	A	1/4"	2"	24"	.625	.75	—	1.00	1.00	36	.28
BBB14410C	3	A	1/4"	4"	10"	.75	1.00	—	1.25	—	6	6-32 .28
BBB14410D	4	A	1/4"	4"	10"	1.25	1.00	—	1.13	1.13	6	6-32 .28
BBB14412E	5	A	1/4"	4"	12"	.75	—	—	2.00	1.25	18	.44
BBB14412F	6	A	1/4"	4"	12"	1.00	.75	—	2.00	1.25	12	.44 .28
BBB14416G	7	B	1/4"	4"	16"	.75	1.00	—	1.69	—	24	.44
BBB14416H	8	B	1/4"	4"	16"	1.00	1.00	.75	1.69	—	16	.44 .25
BBB14420J	9	B	1/4"	4"	20"	1.00	1.00	.75	1.00	—	34	.44 .25
BBB412UD	N/A	A	1/4"	4"	12"	N/A	N/A	N/A	N/A	N/A	N/A	N/A
BBB424UD	N/A	B	1/4"	4"	24"	N/A	N/A	N/A	N/A	N/A	N/A	N/A
BBBHR19*	N/A	N/A	3/16"	3/4"	19"	.38	Contact Factory for Dimensions					
BBBVR36*	N/A	N/A	1/4"	5/8"	36"	.32						

* Not UL Listed.

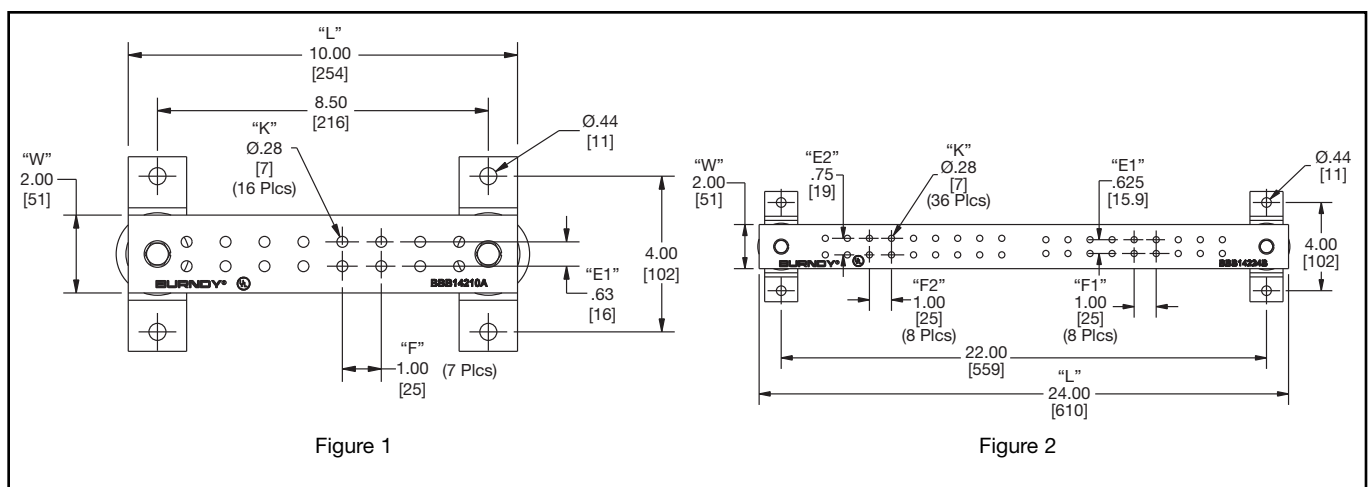

(Figures continued on next page)

Blue highlighted items are industry standard and most frequently ordered.

TYPE BBB

BURNDY® BusBar

Copper BusBar (Continued)

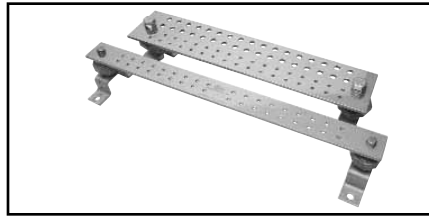

E-58

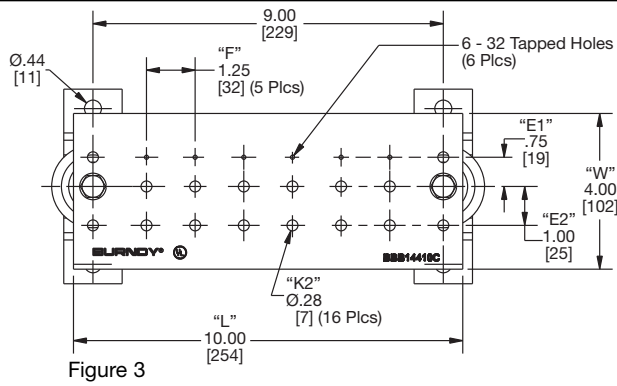

Figure 3

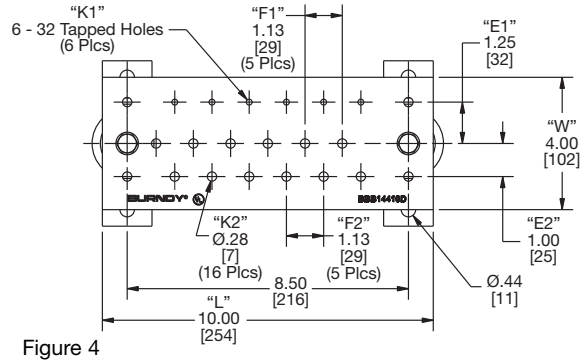

Figure 4

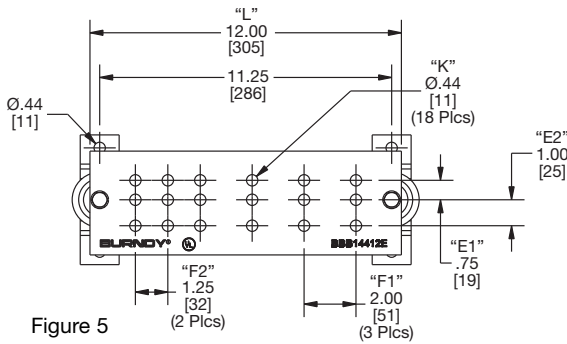

Figure 5

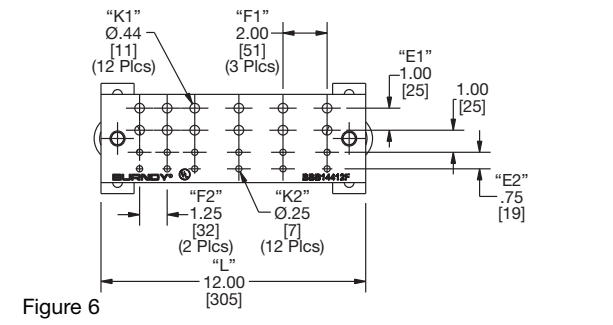

Figure 6

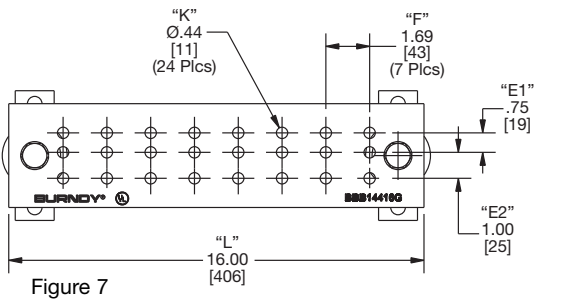

Figure 7

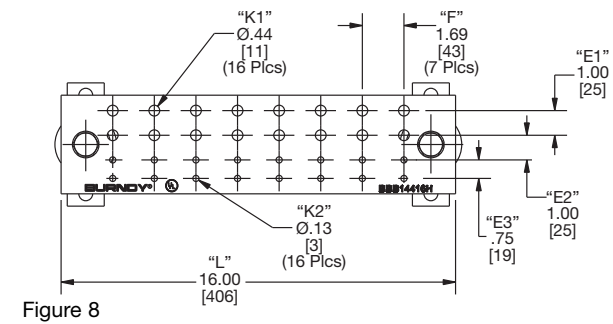

Figure 8

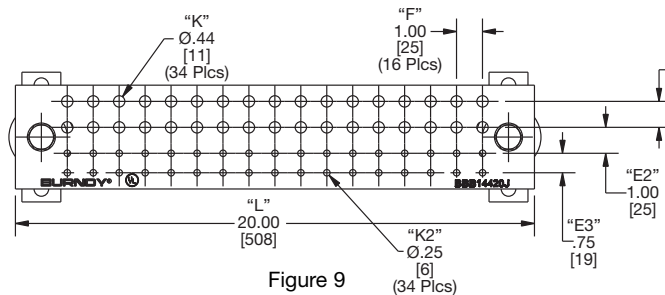



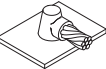
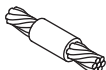
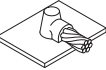







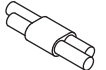











Figure 9

Blue highlighted items are industry standard and most frequently ordered.

TABLE OF CONTENTS

BURNDYWeld®

<p>BURNDYWeld® Introduction E-60</p>	 <p>Type BCR-24 E-73</p>
<p>Making a BURNDYWeld® Connection E-61</p>	 <p>Single Shot Molds E-74</p>
 <p>WELD METAL E-62</p>	 <p>Type BCS-1 E-75</p>
 <p>Type BCC-1 E-63</p>	 <p>Type BCS-8 E-75</p>
 <p>Type BCC-2 E-64</p>	 <p>Type BCS-2 E-76</p>
 <p>Type BCC-4 E-65</p>	 <p>Type BCS-9 E-76</p>
 <p>Type BCC-11 E-66</p>	 <p>Type BCS-3 E-77</p>
 <p>Type BCC-6 E-67</p>	 <p>Type BCS-23 E-78</p>
 <p>Type BCC-14 E-67</p>	 <p>Type BCS-4 E-79</p>
 <p>Type BCC-7 E-68</p>	 <p>Type BCS-6 E-79</p>
 <p>Type BCR-1 E-69 RUS Accepted</p>	 <p>Type BCS-7 E-80</p>
 <p>Type BCR-2 E-70</p>	 <p>Type BCS-18 E-80</p>
 <p>Type BCR-3 E-71</p>	<p>BURNDY® GROUNDMAX™ E-87 - E-88</p>
 <p>Type BCR-17 E-72</p>	<p>BURNDY® GRIDMAX™ E-89</p>

E-59

For mold types or BURNDYWeld® items not shown, please contact factory.

Blue highlighted items are industry standard and most frequently ordered.

E-60

BURNDYWeld®

The BURNDYWeld® connection process is a simple, efficient method of welding copper to copper or copper to steel. One advantage is that NO outside power is required when using the BURNDYWeld® exothermic process. The BURNDYWeld® process uses high temperature reaction of powdered copper oxide and aluminum. The reaction takes place in a semi-permanent graphite mold. These molds will last for fifty or more welds if proper care is given. The reaction takes place very rapidly, therefore the total amount of heat applied to the conductors or surfaces is considerably less than that of brazing or soldering. It is important to remember this when welding to insulated cable or thin wall pipe.

This system is very field friendly, since it is light and portable and requires no outside power source. It requires very little time or skill to obtain an efficient, maintenance free connection when using the BURNDYWeld® process.

For more information visit our website at www.burndy.com.

The BURNDYWeld® process has been used to weld materials other than copper for electrical purposes. Materials welded include:

Stainless Steel	Columbium	Brass
Copperweld®	Plain Steel	Bronze
Nichrome V	Everdur®	Niobium
Galvanized Steel	Kama	Chromax
Silcone Bronze	Steel Rail	Cast Iron
Copper Clad Steel	Cor-Ten®	Monel

When welding to galvanized steel it is recommended to resurface exposed bare steel.

The BURNDYWeld® connection is a molecular weld. The weld metal has the same melting point as copper. These factors along with the increased cross section of the connection, BURNDYWeld® connections:

1. Will not be affected by a high current surge. Tests have shown that the electrical conductor will melt before the BURNDYWeld® connection when subjected to high short circuit current. Consult IEEE Standard 837-1989.
2. Will not loosen or corrode at the point of weld. There are no contact surfaces or mechanical pressures involved. A BURNDYWeld® connection becomes an integral part of the conductor.
3. Have a current-carrying capacity equal to or greater than that of the conductors.

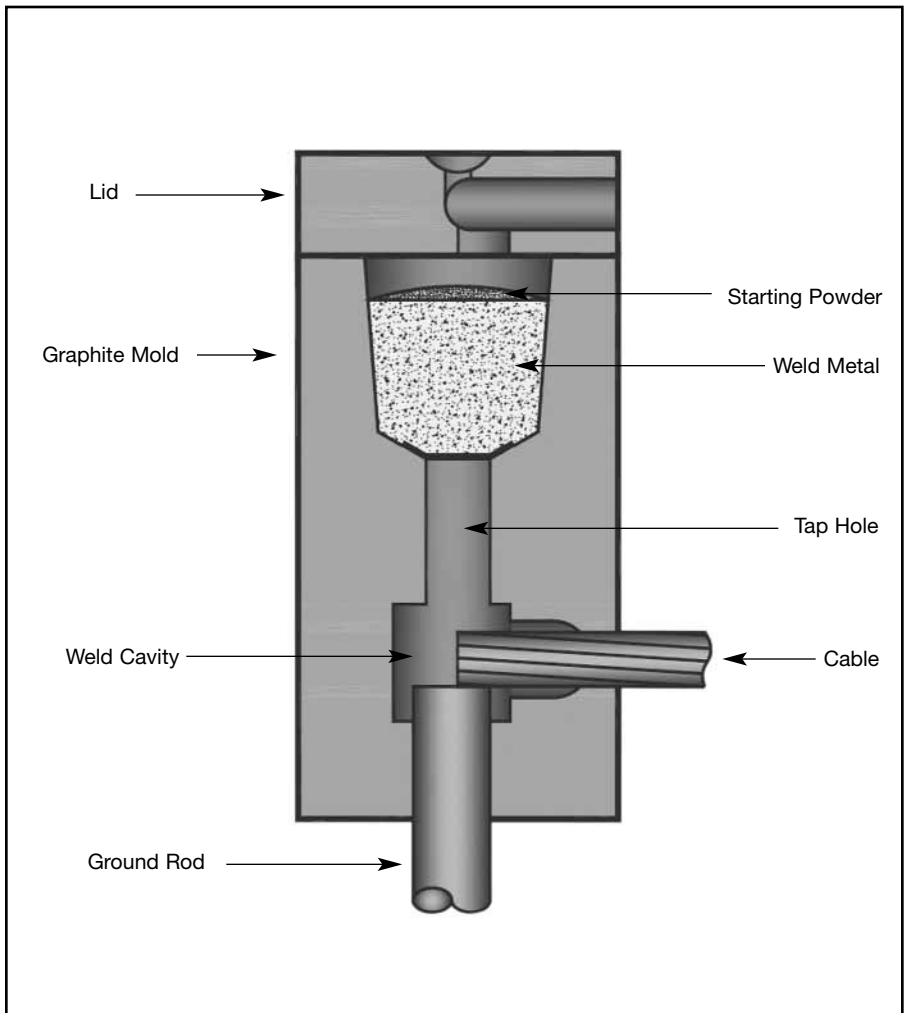

For mold types or BURNDYWeld® items not shown, please contact factory.

Blue highlighted items are industry standard and most frequently ordered.

Making a BURNDYWeld® Connection



Step 1

Position cleaned conductors in mold after making sure mold is dry, by pre-heating or making a test joint.



Step 2

Place metal disc in bottom of mold crucible.



Step 3

Dump powder into crucible, being careful not to loosen all the starting powder.



Step 4

Close lid and place a small amount of starting powder in the ignition pocket.



Step 5

Ignite the starting powder with the Flint Ignitor.

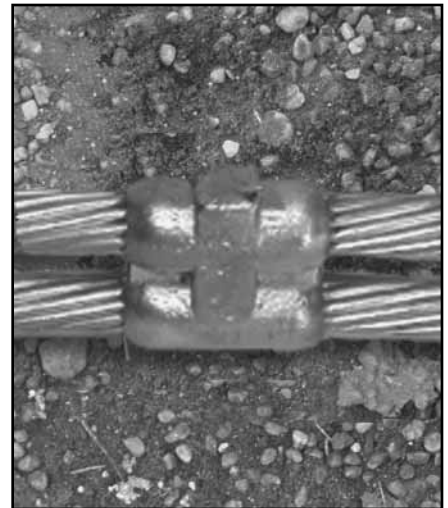

Step 6

Wait 15 seconds, then remove weld and clean mold before making next connection.

For mold types or BURNDYWeld® items not shown, please contact factory.

Blue highlighted items are industry standard and most frequently ordered.

WELD METAL

E-62

BURNDYWeld® Weld Metal is packed in moisture-resistant plastic cartridges that have tight fitting caps. These cartridges, along with the necessary steel discs, are then packed in boxes that are hermetically-sealed. This ensures the powder arriving in good condition, always dry and ready for fast positive ignition.



BURNDYWeld® Weld Metal comes in several types; one for welding copper to copper, copper to steel, copper to rail, copper to cast iron and one for welding copper to steel for cathodic protection. The size and weight (in grams) of the cartridge are marked on each individual cartridge.

Standard Cartridge Size	Cast Iron Cartridge Size	Cathodic Protection Cartridge Size	Rail Cartridge Size	Cartridges Per Box
15	15CI	15CP	15R	20
25	25CI	25CP	25R	20
32	32CI	32CP	32R	10
45	45CI	45CP	45R	20
65	65CI	65CP	65R	20
90	90CI	—	90R	10
115	115CI	—	115R	10
150	—	—	150R	10
200	—	—	200R	10
250	—	—	250R	10
500	—	—	500R	10

BURNDYWeld® Weld Metal is sold in box quantities only.

Steel Discs Sold Separately

Weld Metal Size	Catalog Number	Package Quantity
	Steel Discs Only	
15 to 65	B370320-01	20
90 to 115	B370320-02	10
150 to 500	B370320-03	10

For mold types or BURNDYWeld® items not shown, please contact factory.

Blue highlighted items are industry standard and most frequently ordered.

BCC-1 TYPE MOLDS

Horizontal End to End

BCC-1 Type Molds are used for horizontal end to end cable connections.

Size range is #6 through 1000 kcmil solid or concentric stranded copper conductors.

Contact BURNDY® for information on molds for conductors not listed below.

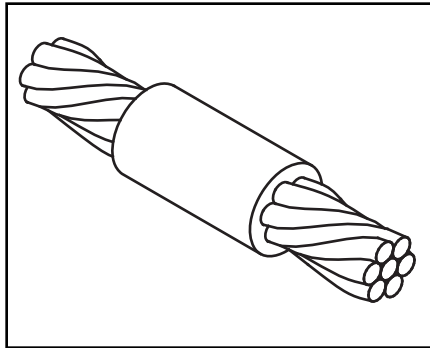

E-63

Cable	Mold Number	Price Key	Weld Metal	Handle Clamps
#8	Use Type BCC-14 on Page E-67	—	—	—
#6	Use Type BCC-14 on Page E-67	—	—	—
#4	B-5623	18 † *	25	N/A
#3	B-5624	18 † *	32	N/A
#2	B-5625	18 † *	32	N/A
#1	B-5626	18 † *	32	N/A
1/0	B-205	4	45	B-106
2/0	B-206	4	65	B-106
3/0	B-207	4	90	B-106
4/0	B-208	4	90	B-106
250 kcmil	B-209	4	115	B-106
300 kcmil	B-210	4	115	B-106
350 kcmil	B-211	4	150	B106
500 kcmil	B-213	4	200	B-107
750 kcmil	B-214	5	2-150	B-107
1000 kcmil	B-215	5	2-200	B-107

- For sizes not listed, contact BURNDY®.
- Molds listed are for concentric stranded cable. Add suffix “-S” to mold number for solid conductors.
- For heavy duty molds, molds with wear plates or molds for Copperweld® cable, contact BURNDY®.
- For expedited service, contact BURNDY®.

Required Tools:
 Handle Clamps (see chart for correct handles)
 † Sold complete with handles
 * **B38-0309-00** Flint Ignitor (included)
 Other recommended accessories:
B38-3922-00 Mold Cleaning Brush (pg E-92)
B38-0135-00 Cable Cleaning Brush (pg E-92)
B38-0330-00 Cable Clamp (pg E-92)

For mold types or BURNDYWeld® items not shown, please contact factory.

Blue highlighted items are industry standard and most frequently ordered.

TYPE BCC-2 MOLDS

Horizontal Cable Tap to Horizontal Cable Run

Type BCC-2 Molds are used to join horizontal cable tap to a horizontal run cable.

E-64

Size range is #6 through 750 kcmil solid or concentric stranded copper conductors.

Contact BURNDY® for information on molds for conductors not listed below.

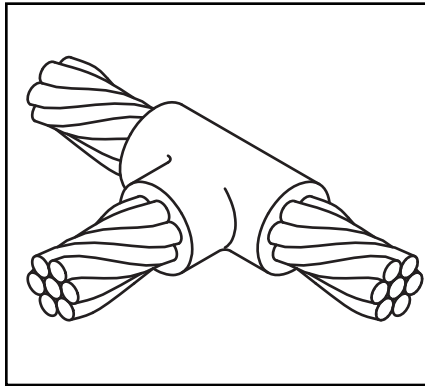

Cable		Mold Number	Price Key	Weld Metal	Handle Clamps
Run	Tap				
#6	#6	Use Type BCC-14 on Page E-67	—	—	—
#4	#4	B-221	4	32	B-106
#2	#2	B-223	4	45	B-106
	#4	B-224	4	45	B-106
#1	#1	B-225	4	45	B-106
	#2	B-226	4	45	B-106
	#4	B-227	4	45	B-106
1/0	1/0	B-228	4	90	B-106
	#1	B-229	4	45	B-106
	#2	B-230	4	45	B-106
2/0	#4	B-231	4	45	B-106
	2/0	B-232	4	90	B-106
	1/0	B-233	4	90	B-106
	#1	B-234	4	45	B-106
3/0	#2	B-235	4	45	B-106
	#4	B-5475	4	45	B-106
	3/0	B-236	4	115	B-106
	2/0	B-237	4	90	B-106
4/0	1/0	B-238	4	90	B-106
	#1	B-239	4	45	B-106
	#2	B-240	4	45	B-106
	#4	B-5574	4	45	B-106
	4/0	B-241	4	150	B-106
250 kcmil	3/0	B-242	4	115	B-106
	2/0	B-243	4	90	B-106
	1/0	B-244	4	90	B-106
	#1	B-245	4	90	B-106
	#2	B-246	4	90	B-106
	#4	B-5021	4	90	B-106
	250 kcmil	B-247	4	150	B-106
	4/0	B-248	4	150	B-106
3/0	B-249	4	150	B-106	
2/0	B-250	4	90	B-106	
1/0	B-251	4	90	B-106	
#1	B-252	4	90	B-106	
#2	B-253	4	90	B-106	

Cable		Mold Number	Price Key	Weld Metal	Handle Clamps
Run	Tap				
300 kcmil	300 kcmil	B-254	4	200	B-106
	250 kcmil	B-255	4	150	B-106
	4/0	B-256	4	150	B-106
	3/0	B-257	4	150	B-106
	2/0	B-258	4	90	B-106
	1/0	B-259	4	90	B-106
	#1	B-260	4	90	B-106
	#2	B-261	4	90	B-106
350 kcmil	350 kcmil	B-262	4	200	B-106
	300 kcmil	B-263	4	200	B-106
	250 kcmil	B-264	4	200	B-106
	4/0	B-265	4	150	B-106
	3/0	B-266	4	150	B-106
	2/0	B-267	4	90	B-106
	1/0	B-268	4	90	B-106
	#1	B-269	4	90	B-106
500 kcmil	#2	B-270	4	90	B-106
	500 kcmil	B-280	4	2-150	B-106
	350 kcmil	B-282	4	200	B-106
	300 kcmil	B-283	4	200	B-106
	250 kcmil	B-284	4	200	B-106
	4/0	B-285	4	150	B-106
	2/0	B-286	4	90	B-106
	1/0	B-287	4	90	B-106
750 kcmil	#1	B-288	4	90	B-106
	#2	B-289	4	90	B-106
	750 kcmil	B-290	5	500	B-107
	500 kcmil	B-291	5	2-200	B-107
	350 kcmil	B-293	4	250	B-106
	300 kcmil	B-294	4	200	B-106
	250 kcmil	B-295	4	200	B-106
	4/0	B-296	4	150	B-106
2/0	B-297	4	150	B-106	
1/0	B-298	4	150	B-106	

Required Tools:

Handle Clamps (see chart for correct handles)

B38-0309-00 Flint Ignitor

Other recommended accessories:

B40-0319-01 Mold Cleaner for cartridge sizes #15-#65 (pg E-92)

B40-0319-03 Mold Cleaner for cartridge sizes #90-#500 (pg E-92)

B38-3922-00 Mold Cleaning Brush (pg E-92)

B38-0135-00 Cable Cleaning Brush (pg E-92)

B38-0330-00 Cable Clamp (pg E-92)

For mold types or BURNDYWeld® items not shown, please contact factory.

Blue highlighted items are industry standard and most frequently ordered.

TYPE BCC-4 MOLDS

Horizontal to Horizontal Cable Cross

Type BCC-4 Molds are used to join two horizontal cables at right angles. One cable is cut and the other is a through run.

Size range is #6 through 500 kcmil solid or concentric stranded copper conductors.

Contact BURNDY® for information on molds for conductors not listed below.

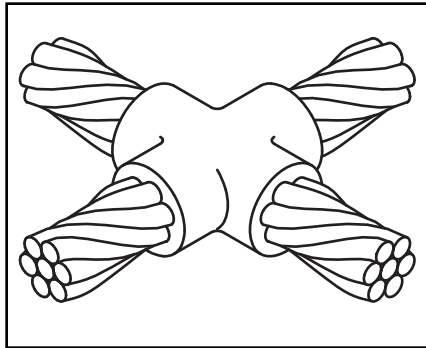

E-65

Cable		Mold Number	Price Key	Weld Metal	Handle Clamps
Run	Tap				
#6	#6	Use Type BCC-11 on Page E-66			
#4	#4	B-423	4	45	B-106
#3	#3	B-424	4	45	B-106
#2	#2	B-425	4	65	B-106
	#4	B-426	4	65	B-106
#1	#1	B-427	4	65	B-106
	#2	B-428	4	65	B-106
	#4	B-429	4	65	B-106
1/0	1/0	B-430	4	90	B-106
	#1	B-431	4	90	B-106
	#2	B-432	4	90	B-106
	#4	B-433	4	90	B-106
2/0	2/0	B-434	4	115	B-106
	1/0	B-435	4	115	B-106
	#1	B-436	4	115	B-106
	#2	B-437	4	115	B-106
3/0	3/0	B-438	4	150	B-106
	2/0	B-439	4	150	B-106
	1/0	B-440	4	115	B-106
	#1	B-441	4	115	B-106
4/0	#2	B-442	4	115	B-106
	4/0	B-443	4	200	B-106
	3/0	B-444	4	200	B-106
	2/0	B-445	4	150	B-106
250 kcmil	1/0	B-442	4	150	B-106
	#1	B-447	4	115	B-106
	#2	B-448	4	115	B-106
	250 kcmil	B-449	4	200	B-106
	4/0	B-450	4	200	B-106
	3/0	B-451	4	200	B-106
500 kcmil	2/0	B-452	4	150	B-106
	1/0	B-453	4	150	B-106
	#1	B-454	4	115	B-106
	#2	B-455	4	115	B-106

Cable		Mold Number	Price Key	Weld Metal	Handle Clamps
Run	Tap				
300 kcmil	300 kcmil	B-456	4	250	B-106
	250 kcmil	B-457	4	250	B-106
	4/0	B-458	4	200	B-106
	3/0	B-459	4	200	B-106
	2/0	B-460	4	150	B-106
	1/0	B-461	4	150	B-106
	#1	B-462	4	115	B-106
	#2	B-463	4	115	B-106
350 kcmil	350 kcmil	B-464	4	250	B-106
	300 kcmil	B-465	4	250	B-106
	250 kcmil	B-466	4	250	B-106
	4/0	B-467	4	200	B-106
	3/0	B-468	4	200	B-106
	2/0	B-469	4	200	B-106
	1/0	B-470	4	200	B-106
	#1	B-471	4	150	B-106
500 kcmil	#2	B-472	4	150	B-106
	500 kcmil	B-483	5	500	B-107
	350 kcmil	B-485	5	2-200	B-107
	300 kcmil	B-486	5	2-200	B-107
	250 kcmil	B-487	5	2-150	B-107
	4/0	B-488	5	2-150	B-107
	3/0	B-489	5	2-150	B-107
	2/0	B-490	4	250	B-106
500 kcmil	1/0	B-491	4	250	B-106
	#1	B-492	4	200	B-106
	#2	B-493	4	200	B-106

- Required Tools:
 Handle Clamps (see chart for correct handles)
B38-0309-00 Flint Ignitor
 Other recommended accessories:
B40-0319-01 Mold Cleaner for cartridge sizes #15-#65 (pg E-92)
B40-0319-03 Mold Cleaner for cartridge sizes #90-#500 (pg E-92)
B38-3922-00 Mold Cleaning Brush (pg E-92)
B38-0135-00 Cable Cleaning Brush (pg E-92)
B38-0330-00 Cable Clamp (pg E-92)

- For sizes not listed, contact BURNDY®.
- Molds listed are for concentric stranded cable. Add suffix "-S" to mold number for solid conductors.
- For heavy duty molds, molds with wear plates or molds for Copperweld® cable, contact BURNDY®.
- For expedited service, contact BURNDY®.

For mold types or BURNDYWeld® items not shown, please contact factory.

Blue highlighted items are industry standard and most frequently ordered.

TYPE BCC-11 MOLDS

Horizontal to Horizontal Cable Cross

Type BCC-11 Molds are used to join uncut horizontal cables at right angles to each other.

E-66

Size range is #6 through 500 kcmil solid or concentric stranded copper conductors.

Contact BURNDY® for information on molds for conductors not listed below.

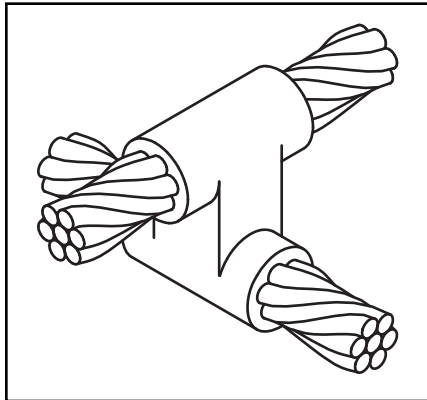

Cable		Mold Number	Price Key	Weld Metal	Handle Clamps
Run	Tap				
#6	#6	B-5432	191*	45	N/A
#4	#4	B-2687	4	65	B-106
#2	#2	B-2689	4	90	B-106
	#4	B-2690	4	65	B-106
#1	#1	B-2691	4	115	B-106
	#2	B-2692	4	90	B-106
	#4	B-2693	4	90	B-106
1/0	1/0	B-2694	22	150	B-106
	#1	B-2695	22	150	B-106
	#2	B-2696	22	115	B-106
	#4	B-2697	22	115	B-106
2/0	2/0	B-2698	22	200	B-106
	1/0	B-2699	22	200	B-106
	#1	B-2700	22	150	B-106
	#2	B-2701	22	150	B-106
3/0	3/0	B-2702	22	250	B-106
	2/0	B-2703	22	200	B-106
	1/0	B-2704	22	200	B-106
	#1	B-2705	22	150	B-106
	#2	B-2706	22	150	B-106

- For sizes not listed, contact BURNDY®.
- Molds listed are for concentric stranded cable. Add suffix "-S" to mold number for solid conductors.
- For heavy duty molds, molds with wear plates or molds for Copperweld® cable, contact BURNDY®.
- For expedited service, contact BURNDY®.

Cable		Mold Number	Price Key	Weld Metal	Handle Clamps
Run	Tap				
4/0	4/0	B-2707	22	250	B-106
	3/0	B-2708	22	250	B-106
	2/0	B-2709	22	200	B-106
	1/0	B-2710	22	200	B-106
	#1	B-2711	22	150	B-106
	#2	B-2712	22	150	B-106
250 kcmil	250 kcmil	B-2713	22	2-150	B-106
	4/0	B-2714	22	2-150	B-106
	3/0	B-2715	22	2-150	B-106
	2/0	B-2716	22	250	B-106
	1/0	B-2717	22	150	B-106
	#1	B-2718	22	200	B-106
500 kcmil	#2	B-2719	22	150	B-106
	500 kcmil	B-2747	23	3-250	B-107
	250 kcmil	B-2751	23	500	B-107
	4/0	B-2752	23	500	B-107
	3/0	B-2753	23	500	B-107
	2/0	B-2754	23	2-200	B-107
	1/0	B-2755	22	2-150	B-106
	#1	B-2756	22	250	B-106
#2	B-2757	22	250	B-106	

Required Tools:

Handle Clamps (see chart for correct handles)

† Sold complete with handles

* B38-0309-00 Flint Ignitor

Other recommended accessories:

B40-0319-01 Mold Cleaner for cartridge sizes #15-#65 (pg E-92)

B40-0319-03 Mold Cleaner for cartridge sizes #90-#500 (pg E-92)

B38-3922-00 Mold Cleaning Brush (pg E-92)

B38-0135-00 Cable Cleaning Brush (pg E-92)

B38-0330-00 Cable Clamp (pg E-92)

For mold types or BURNDYWeld® items not shown, please contact factory.

Blue highlighted items are industry standard and most frequently ordered.

BCC-6 TYPE MOLDS

Horizontal Parallel Tap

BCC-6 Type Molds are used to join horizontal parallel tap to run connections. The tap cable is over the run cable.

Size range is #6 through 4/0 solid or concentric stranded copper conductors.

Contact BURNDY® for information on molds for conductors not listed below.

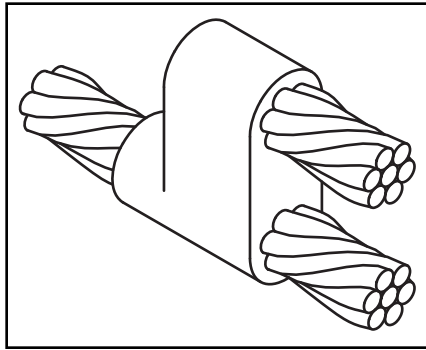

Cable		Mold Number	Price Key	Weld Metal	Handle Clamps
Run	Tap				
#6 Sol	#6 Sol	B-1270	4	25	B-106
#6	#6	B-1271	4	25	B-106
#4	#4	B-1272	4	32	B-106
	#6	B-1273	4	32	B-106
	#6 Sol	B-1274	4	32	B-106
#2	#8 Sol	B-1275	4	32	B-106
	#2	B-1276	4	65	B-106
	#4	B-1277	4	45	B-106
#1	#6	B-1278	4	32	B-106
	#6 Sol	B-1279	4	32	B-106
	#8 Sol	B-1280	4	32	B-106
#1	#1	B-1281	4	65	B-106
	#2	B-1282	4	65	B-106
	#4	B-1283	4	45	B-106
	#6	B-1284	4	45	B-106
	#6 Sol	B-1285	4	45	B-106
	#8 Sol	B-1286	4	45	B-106

- For sizes not listed, contact BURNDY®.
- Molds listed are for concentric stranded cable. Add suffix "-S" to mold number for solid conductors.
- For heavy duty molds, molds with wear plates or molds for Copperweld® cable, contact BURNDY®.
- For expedited service, contact BURNDY®.

Required Tools:

Handle Clamps (see chart for correct handles)
 Sold complete with handles
B38-0309-00 Flint Ignitor

Other recommended accessories:

B38-3922-00 Mold Cleaning Brush (pg E-92)
B38-0135-00 Cable Cleaning Brush (pg E-92)
B38-0330-00 Cable Clamp (pg E-92)

Cable		Mold Number	Price Key	Weld Metal	Handle Clamps
Run	Tap				
1/0	1/0	B-1287	4	90	B-106
	#1	B-1288	4	90	B-106
	#2	B-1289	4	65	B-106
	#4	B-1290	4	65	B-106
	#6	B-1291	4	45	B-106
	#6 Sol	B-1292	4	45	B-106
	#8 Sol	B-1293	4	45	B-106
	2/0	2/0	B-1294	4	115
1/0		B-1295	4	115	B-106
#1		B-1296	4	90	B-106
#2		B-1297	4	90	B-106
#4		B-1298	4	65	B-106
#6		B-1299	4	65	B-106
#6 Sol		B-1300	4	65	B-106
#8 Sol		B-1301	4	65	B-106
4/0	4/0	B-1302	4	150	B-106
	2/0	B-1303	4	115	B-106
	1/0	B-1304	4	115	B-106
	#1	B-1305	4	115	B-106
	#2	B-1306	4	115	B-106
	#4	B-1307	4	90	B-106
	#6	B-1308	4	90	B-106
	#6 Sol	B-1309	4	90	B-106
	#8 Sol	B-1310	4	90	B-106

BCC-14 TYPE MOLDS

Horizontal Parallel through Cables

BCC-14 Type Molds are used to join horizontal parallel through run cables. Cables run side by side in the mold.

Size range is #8 through #6 solid or concentric stranded copper conductors.

Contact BURNDY® for information on molds for conductors not listed.

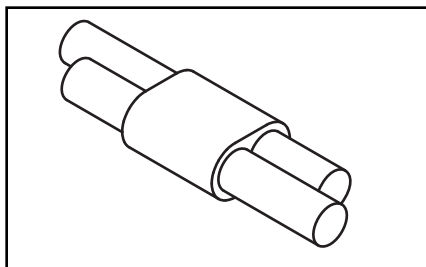

Cable		Mold Number	Price Key	Weld Metal	Handle Clamps
Run	Tap				
#8	#8	B-5709	18+	15	N/A
#6	#6	B-5618	18+	25	N/A

For mold types or BURNDYWeld® items not shown, please contact factory.

Blue highlighted items are industry standard and most frequently ordered.

BCC-7 TYPE MOLDS

Horizontal Parallel through Cables

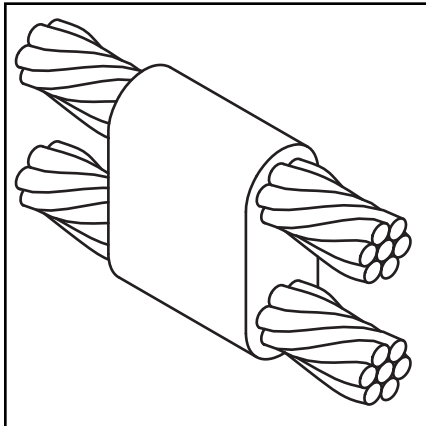

E-68

BCC-7 Type Molds are used to join horizontal parallel through run cables. One cable runs above the other cable in the mold.

Size range is #6 through 4/0 solid or concentric stranded copper conductors.

Contact BURNDY® for information on molds for conductors not listed below.

Cable		Mold Number	Price Key	Weld Metal	Handle Clamps
Run	Tap				
#6	#6	Use Type BCC-14 on Page E-67	—	—	—
#4	#4	B-1311	4	32	B-106
	#6	B-5627	4	32	B-106
	#6 Sol	B-8882	4	32	B-106
	#8	B-5629	4	32	B-106
	#8 Sol	B-5630	4	32	B-106
#2	#2	B-1313	4	65	B-106
	#4	B-1314	4	65	B-106
	#6	B-5631	4	45	B-106
	#6 Sol	B-5632	4	45	B-106
	#8	B-5634	4	45	B-106
#1	#8 Sol	B-5635	4	45	B-106
	#1	B-1315	4	65	B-106
	#2	B-1316	4	65	B-106
	#4	B-1317	4	65	B-106
	#6	B-5636	4	65	B-106
1/0	#6 Sol	B-5637	4	65	B-106
	#8	B-5638	4	45	B-106
	#8 Sol	B-5639	4	45	B-106
	1/0	B-1318	4	90	B-106
	#1	B-1319	4	65	B-106
	#2	B-1320	4	65	B-106
	#4	B-1321	4	65	B-106
	#6	B-5642	4	65	B-106
#6 Sol	B-1208	4	65	B-106	
#8	#8	B-5644	4	65	B-106
	#8 Sol	B-5645	4	65	B-106

- For sizes not listed, contact BURNDY®.
- Molds listed are for concentric stranded cable. Add suffix "-S" to mold number for solid conductors.
- For heavy duty molds, molds with wear plates or molds for Copperweld® cable, contact BURNDY®.
- For expedited service, contact BURNDY®.

Cable		Mold Number	Price Key	Weld Metal	Handle Clamps
Run	Tap				
2/0	2/0	B-1322	4	115	B-106
	1/0	B-1323	4	115	B-106
	#1	B-1324	4	90	B-106
	#2	B-1325	4	90	B-106
	#4	B-5659	4	90	B-106
	#6	B-5342	4	90	B-106
	#6 Sol	B-5652	4	90	B-106
	#8	B-5668	4	65	B-106
3/0	#8 Sol	B-5943	4	65	B-106
	3/0	B-1326	4	150	B-106
	2/0	B-1327	4	150	B-106
	1/0	B-1328	4	115	B-106
	#1	B-1329	4	115	B-106
	#2	B-1330	4	115	B-106
	#4	B-6046	4	115	B-106
	#6	B-5676	4	90	B-106
	#6 Sol	B-5679	4	90	B-106
	#8	B-5680	4	90	B-106
	#8 Sol	B-5682	4	90	B-106
	4/0	4/0	B-1331	4	200
3/0		B-1332	4	200	B-106
2/0		B-1333	4	150	B-106
1/0		B-1334	4	150	B-106
#1		B-1335	4	150	B-106
#2		B-1336	4	150	B-106
#4		B-5340	4	150	B-106
#6		B-5684	4	90	B-106
#6 Sol		B-6552	4	90	B-106
#8		B-5686	4	90	B-106
#8 Sol		B-5688	4	90	B-106

- Required Tools:
 Handle Clamps (see chart for correct handles)
B38-0309-00 Flint Ignitor
 Other recommended accessories:
B38-3922-00 Mold Cleaning Brush (pg E-92)
B38-0135-00 Cable Cleaning Brush (pg E-92)
B38-0330-00 Cable Clamp (pg E-92)

For mold types or BURNDYWeld® items not shown, please contact factory.

Blue highlighted items are industry standard and most frequently ordered.

TYPE BCR-1 MOLDS

Horizontal Cable Terminal to Ground Rod

Type BCR-1 Molds are used to terminate horizontal copper cable at the top of a vertical ground rod.

Size range is #6 through 1000 kcmil solid or concentric stranded copper conductors; 1/2" through 1" for the ground rod.

Contact BURNDY® for information on molds for conductors not listed below.

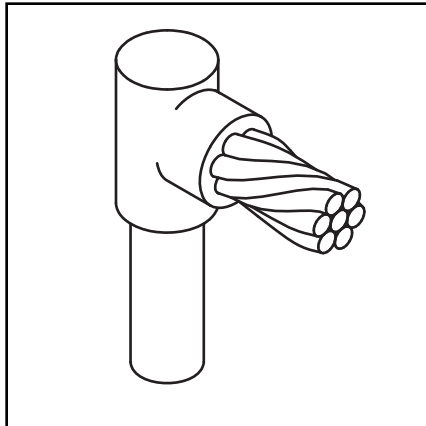

E-69

Cable		Mold Number	Price Key	Weld Metal	Handle Clamps
Grd Rod	Tap				
1/2"	#6	B-8402	18†*	25	N/A
	#4	B-8403	18†*	25	N/A
	#2	B-495	4	65	B-106
	#1	B-496	4	65	B-106
	1/0	B-497	4	90	B-106
	2/0	B-498	4	90	B-106
	3/0	B-499	4	90	B-106
	4/0	B-500	4	90	B-106
	250 kcmil	B-501	4	90	B-106
300 kcmil	B-502	4	90	B-106	
5/8"	#6	B-8414	18†	32	N/A
	#4	B-8415	18†	32	N/A
	#2	B-503	4	65	B-106
	#1	B-504	4	65	B-106
	1/0	B-505	4	90	B-106
	2/0	B-506	4	90	B-106
	3/0	B-507	4	90	B-106
	4/0	B-508	4	90	B-106
	250 kcmil	B-509	4	90	B-106
	300 kcmil	B-510	4	115	B-106
	350 kcmil	B-511	4	115	B-106
	500 kcmil	B-513	4	150	B-106

- For sizes not listed, contact BURNDY®.
- Molds listed are for concentric stranded cable. Add suffix "-S" to mold number for solid conductors.
- Molds listed are for copperclad ground rods. For welding to steel, stainless steel or galvanized steel ground rods add suffix "-N" to mold number.
- For heavy duty molds, molds with wear plates or molds for Copperweld® cable, contact BURNDY®.
- For expedited service, contact BURNDY®.

Cable		Mold Number	Price Key	Weld Metal	Handle Clamps
Grd Rod	Tap				
3/4"	#6	B-8422	181*	32	N/A
	#4	B-8426	191*	45	N/A
	#2	B-5781	4	90	B-106
	#1	B-514	4	90	B-106
	1/0	B-515	4	90	B-106
	2/0	B-516	4	90	B-106
	3/0	B-517	4	90	B-106
	4/0	B-518	4	90	B-106
	250 kcmil	B-519	4	90	B-106
	300 kcmil	B-520	4	115	B-106
	350 kcmil	B-521	4	115	B-106
	500 kcmil	B-523	4	150	B-106
	750 kcmil	B-524	4	250	B-106
1"	1/0	B-525	4	150	B-106
	2/0	B-526	4	150	B-106
	3/0	B-527	4	150	B-106
	4/0	B-528	4	150	B-106
	250 kcmil	B-529	4	150	B-106
	300 kcmil	B-530	4	200	B-106
	350 kcmil	B-531	4	200	B-106
	500 kcmil	B-533	4	200	B-106
	750 kcmil	B-534	4	250	B-106
	1000 kcmil	B-535	5	2-150	B-106

- Required Tools:
- Handle Clamps (see chart for correct handles)
 - † Sold complete with handles
 - * **B38-0309-00** Flint Ignitor (included)
- Other recommended accessories:
- B38-3922-00** Mold Cleaning Brush (pg E-92)
 - B38-0135-00** Cable Cleaning Brush (pg E-92)
 - B38-0304-00** File (pg E-93)
 - B38-0330-00** Cable Clamp (pg E-92)

For mold types or BURNDYWeld® items not shown, please contact factory.

Blue highlighted items are industry standard and most frequently ordered.

TYPE BCR-2 MOLDS

Horizontal Cable to Ground Rod

Type BCR-2 Molds are used to join horizontal through copper cable to the top of a vertical ground rod.

E-70

Size range is #6 through 1000 kcmil solid or concentric stranded copper conductors; 1/2" through 1" for the ground rod.

Contact BURNDY® for information on molds for conductors not listed below.

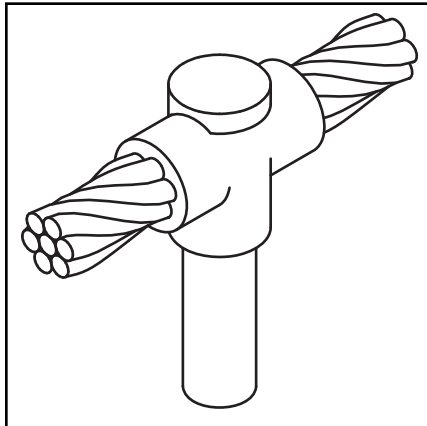

Cable		Mold Number	Price Key	Weld Metal	Handle Clamps
Grd Rod	Tap				
1/2"	#6	B-8434	181†*	32	N/A
	#4	B-8435	18†*	32	N/A
	#2	B-537	4	90	B-106
	#1	B-538	4	90	B-106
	1/0	B-539	4	90	B-106
	2/0	B-540	4	90	B-106
	3/0	B-541	4	115	B-106
	4/0	B-542	4	115	B-106
	250 kcmil	B-543	4	150	B-106
	300 kcmil	B-544	4	200	B-106
5/8"	#6	B-8441	18†*	32	N/A
	#4	B-8442	18†*	32	N/A
	#2	B-545	4	90	B-106
	#1	B-546	4	90	B-106
	1/0	B-547	4	90	B-106
	2/0	B-548	4	115	B-106
	3/0	B-549	4	115	B-106
	4/0	B-550	4	115	B-106
	250 kcmil	B-551	4	150	B-106
	300 kcmil	B-532	4	200	B-106
350 kcmil	B-553	4	200	B-106	
500 kcmil	B-555	4	250	B-106	

Cable		Mold Number	Price Key	Weld Metal	Handle Clamps
Grd Rod	Tap				
3/4"	#6	B-8452	19†*	45	N/A
	#4	B-8454	19†*	65	N/A
	#2	B-556	4	90	B-106
	#1	B-557	4	90	B-106
	1/0	B-558	4	115	B-106
	2/0	B-559	4	115	B-106
	3/0	B-560	4	115	B-106
	4/0	B-561	4	115	B-106
	250 kcmil	B-562	4	150	B-106
	300 kcmil	B-563	4	200	B-106
	350 kcmil	B-564	4	200	B-106
	500 kcmil	B-566	4	250	B-106
	750 kcmil	B-567	5	2-200	B-107
	1"	1/0	B-569	4	150
2/0		B-570	4	150	B-106
3/0		B-571	4	150	B-106
4/0		B-572	4	150	B-106
250 kcmil		B-573	4	200	B-106
300 kcmil		B-574	4	200	B-106
350 kcmil		B-575	4	200	B-106
500 kcmil		B-577	4	250	B-106
750 kcmil		B-578	5	2-200	B-107
1000 kcmil		B-579	5	500	B-107

- For sizes not listed, contact BURNDY®.
- Molds listed are for concentric stranded cable. Add suffix "-S" to mold number for solid conductors.
- Molds listed are for copperclad ground rods. For welding to steel, stainless steel or galvanized steel ground rods add suffix "-N" to mold number.
- For heavy duty molds, molds with wear plates or molds for Copperweld® cable, contact BURNDY®.
- For expedited service, contact BURNDY®.

- Required Tools:
 Handle Clamps (see chart for correct handles)
 † Sold complete with handles
 ***B38-0309-00** Flint Ignitor (included)
 Other recommended accessories:
B38-3922-00 Mold Cleaning Brush (pg E-92)
B38-0135-00 Cable Cleaning Brush (pg E-92)
B38-0304-00 File (pg E-93)
B38-0330-00 Cable Clamp (pg E-92)

For mold types or BURNDYWeld® items not shown, please contact factory.

Blue highlighted items are industry standard and most frequently ordered.

TYPE BCR-3 MOLDS

Horizontal Through Cable to Ground Rod

Type BCR-3 Molds are used to join horizontal through run cable to the side of a vertical ground rod.

Size range is #6 through 1000 kcmil solid or concentric stranded copper conductors; 1/2" through 1" for the ground rod.

Contact BURNDY® for information on molds for conductors not listed below.

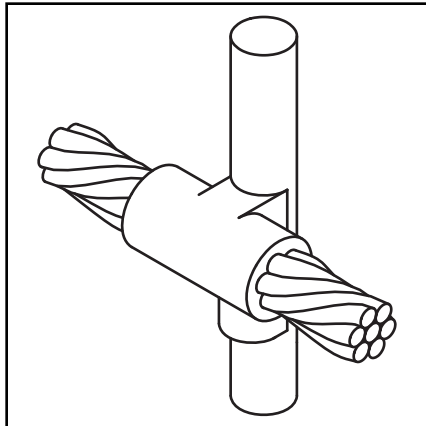

E-71

Cable		Mold Number	Price Key	Weld Metal	Handle Clamps
Grd Rod	Tap				
1/2"	#6	B-5321	24	65	B-106
	#4	B-2154	24	90	B-106
	#2	B-2155	24	90	B-106
	#1	B-2156	24	115	B-106
	1/0	B-1581	24	115	B-106
	2/0	B-1582	24	115	B-106
	4/0	B-1583	24	150	B-106
	250 kcmil	B-1584	24	150	B-106
5/8"	#6	B-5660	24	65	B-106
	#4	B-2157	24	90	B-106
	#2	B-2158	24	90	B-106
	#1	B-2159	24	115	B-106
	1/0	B-1586	24	115	B-106
	2/0	B-1587	24	115	B-106
	4/0	B-1588	24	150	B-106
	250 kcmil	B-1589	24	150	B-106
500 kcmil	B-1593	13	2-200	B-107	

- For sizes not listed, contact BURNDY®.
- Molds listed are for concentric stranded cable. Add suffix "-S" to mold number for solid conductors.
- Molds listed are for copperclad ground rods. For welding to steel, stainless steel or galvanized steel ground rods add suffix "-N" to mold number.
- For heavy duty molds, molds with wear plates or molds for Copperweld® cable, contact BURNDY®.
- For expedited service, contact BURNDY®.

Cable		Mold Number	Price Key	Weld Metal	Handle Clamps
Grd Rod	Tap				
3/4"	#6	B-6630	24	65	B-106
	#4	B-2160	24	90	B-106
	#2	B-2161	24	90	B-106
	#1	B-2162	24	115	B-106
	1/0	B-1594	24	115	B-106
	2/0	B-1595	24	115	B-106
	4/0	B-1596	24	150	B-106
	250 kcmil	B-1597	24	200	B-106
	500 kcmil	B-1601	13	500	B-107
	750 kcmil	B-1602	13	3-250	B-107
1"	#6	B-6906	24	90	B-106
	#4	B-2163	24	90	B-106
	#2	B-2164	24	90	B-106
	#1	B-2165	24	115	B-106
	1/0	B-1603	24	15	B-106
	2/0	B-1604	24	115	B-106
	4/0	B-1605	24	150	B-106
	250 kcmil	B-1606	24	200	B-106
	500 kcmil	B-1610	13	500	B-107
	750 kcmil	B-1611	13	3-250	B-107

- Required Tools:
 Handle Clamps (see chart for correct handles)
B38-0309-00 Flint Ignitor
 Other recommended accessories:
B38-3922-00 Mold Cleaning Brush (pg E-92)
B38-0135-00 Cable Cleaning Brush (pg E-92)
B38-0330-00 Cable Clamp (pg E-92)
B38-0304-00 File (pg E-93)

For mold types or BURNDYWeld® items not shown, please contact factory.

Blue highlighted items are industry standard and most frequently ordered.

TYPE BCR-17 MOLDS

Horizontal Run and Tap Cables to Ground Rod

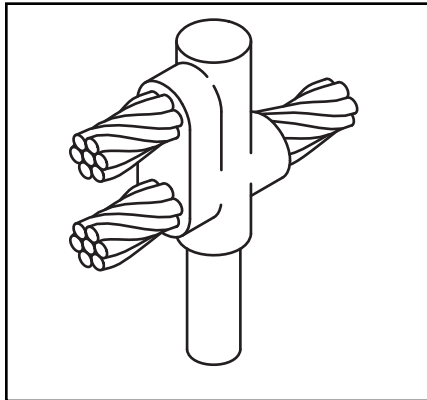

Type BCR-17 Molds are used to join horizontal run and tap cables to the top of a vertical ground rod.

Size range is #4 through 750 kcmil solid or concentric stranded copper conductors; 1/2" through 1" for the ground rod.

Contact BURNDY® for information on molds for conductors not listed below.

E-72

Cable		Mold Number	Price Key	Weld Metal	Handle Clamps
Grd Rod	Tap				
1/2"	#4	B-5416	4	90	B-106
	#2	B-6165	4	90	B-106
	#1	B-5830	4	90	B-106
	1/0	B-5940	4	115	B-106
	2/0	B-5850	4	150	B-106
	3/0	B-5833	4	200	B-106
	4/0	B-5380	4	200	B-106
5/8"	#4	B-5972	4	90	B-106
	#2	B-5935	4	115	B-106
	#1	B-5699	4	115	B-106
	1/0	B-5746	4	150	B-106
	2/0	B-5963	4	200	B-106
	3/0	B-5734	4	250	B-106
	4/0	B-5732	4	250	B-106
	250 kcmil	B-5722	5	2-150	B-107

- For sizes not listed, contact BURNDY®.
- Molds listed are for concentric stranded cable. Add suffix "-S" to mold number for solid conductors.
- Molds listed are for copperclad ground rods. For welding to steel, stainless steel or galvanized steel ground rods add suffix "-N" to mold number.
- For heavy duty molds, molds with wear plates or molds for Copperweld® cable, contact BURNDY®.
- For expedited service, contact BURNDY®.

Cable		Mold Number	Price Key	Weld Metal	Handle Clamps
Grd Rod	Tap				
3/4"	#4	B-5698	4	90	B-106
	#2	B-5294	4	115	B-106
	#1	B-5390	4	115	B-106
	1/0	B-6025	4	150	B-106
	2/0	B-5738	4	200	B-106
	3/0	B-6003	4	250	B-106
	4/0	B-2566	4	250	B-106
	250 kcmil	B-5904	5	2-150	B-107
	300 kcmil	B-5857	5	2-200	B-107
	350 kcmil	B-5777	5	2-200	B-107
	500 kcmil	B-5961	5	3-200	B-106
1"	#4	B-5556	4	115	B-106
	#2	B-5555	4	150	B-106
	#1	B-6048	4	150	B-106
	1/0	B-5992	4	200	B-106
	2/0	B-5877	4	250	B-106
	3/0	B-5821	5	2-150	B-107
	4/0	B-5820	5	2-150	B-107
	250 kcmil	B-5804	5	2-200	B-107
	300 kcmil	B-5803	5	500	B-107
	350 kcmil	B-5561	5	500	B-107
	500 kcmil	B-5515	6	3-250	B-107
750 kcmil	B-5513	6	2-500	B-107	

- Required Tools:
 Handle Clamps (see chart for correct handles)
B38-0309-00 Flint Ignitor
 Other recommended accessories:
B38-3922-00 Mold Cleaning Brush (pg E-92)
B38-0135-00 Cable Cleaning Brush (pg E-92)
B38-0330-00 Cable Clamp (pg E-92)
B38-0304-00 File (pg E-93)

For mold types or BURNDYWeld® items not shown, please contact factory.

Blue highlighted items are industry standard and most frequently ordered.

TYPE BCR-24 MOLDS

**Horizontal Parallel Run
 Cables to Ground Rod**

Type BCR-24 Molds are used to join horizontal parallel cables to the top of a vertical ground rod.

Size range is #4 through 750 kcmil solid or concentric stranded copper conductors; 1/2" through 1" for the ground rod.

Contact BURNDY® for information on molds for conductors not listed below.

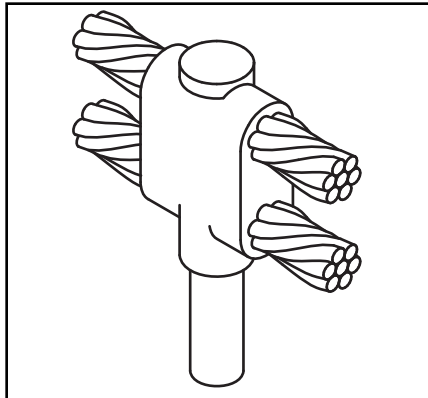

E-73

Cable		Mold Number	Price Key	Weld Metal	Handle Clamps
Grd Rod	Tap				
1/2"	#4	B-5640	4	115	B-106
	#2	B-5667	4	115	B-106
	#1	B-6002	4	115	B-106
	1/0	B-5767	4	150	B-106
	2/0	B-5604	4	200	B-106
	3/0	B-5560	4	250	B-106
	4/0	B-6766	4	250	B-106
5/8"	#4	B-6208	4	115	B-106
	#2	B-5702	4	150	B-106
	#1	B-5517	4	150	B-106
	1/0	B-5573	4	200	B-106
	2/0	B-8451	4	250	B-106
	3/0	B-2510	5	2-150	B-107
	4/0	B-5428	5	2-150	B-107
	250 kcmil	B-1212	5	2-200	B-107
	300 kcmil	B-2084	5	500	B-107
	350 kcmil	B-2558	5	500	B-107
500 kcmil	B-2450	5	3-250	B-107	

- For sizes not listed, contact BURNDY®.
- Molds listed are for concentric stranded cable. Add suffix "-S" to mold number for solid conductors.
- Molds listed are for copperclad ground rods. For welding to steel, stainless steel or galvanized steel ground rods add suffix "-N" to mold number.
- For heavy duty molds, molds with wear plates or molds for Copperweld® cable, contact BURNDY®.
- For expedited service, contact BURNDY®.

Cable		Mold Number	Price Key	Weld Metal	Handle Clamps
Grd Rod	Tap				
3/4"	#4	B-8011	4	115	B-106
	#2	B-2320	4	150	B-106
	#1	B-2235	4	150	B-106
	1/0	B-6051	4	200	B-106
	2/0	B-8802	4	250	B-106
	3/0	B-8726	5	2-150	B-107
	4/0	B-5677	5	2-150	B-107
	250 kcmil	B-8461	5	2-200	B-107
	300 kcmil	B-8428	5	500	B-107
	350 kcmil	B-6294	5	500	B-107
	500 kcmil	B-8214	5	3-250	B-107
	750 kcmil	B-8027	6	2-500	B-107
	1"	#4	B-5330	4	150
#2		B-5332	4	200	B-106
#1		B-5333	4	200	B-106
1/0		B-5334	4	250	B-106
2/0		B-5335	5	2-150	B-107
3/0		B-5336	5	2-200	B-107
4/0		B-5337	5	2-200	B-107
250 kcmil		B-5338	5	500	B-107
300 kcmil		B-5341	5	3-200	B-107
350 kcmil		B-5351	5	3-200	B-107
500 kcmil		B-5352	6	2-500	B-107
750 kcmil		B-5353	64	5-250	B-107

- Required Tools:
 Handle Clamps (see chart for correct handles)
B38-0309-00 Flint Ignitor
 ‡ Crucible B-181 required
 Other recommended accessories:
B38-3922-00 Mold Cleaning Brush (pg E-92)
B38-0135-00 Cable Cleaning Brush (pg E-92)
B38-0330-00 Cable Clamp (pg E-92)
B38-0304-00 File (pg E-93)

For mold types or BURNDYWeld® items not shown, please contact factory.

Blue highlighted items are industry standard and most frequently ordered.

SINGLE SHOT MOLDS

RUS Accepted

BURNDYWeld® Single Shot Molds are an economical way to make cable connections onto the top of a ground rod. The Single Shot is a disposable single use ceramic mold that comes complete with everything required except the Flint Ignitor.

E-74

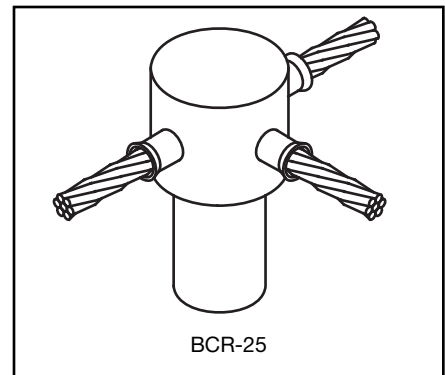
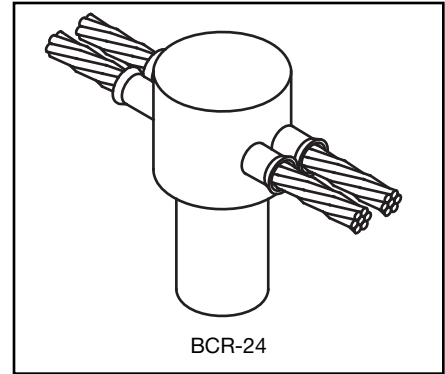
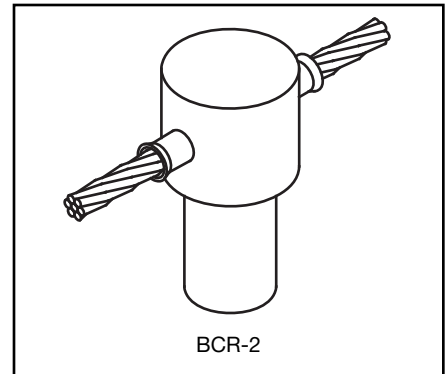
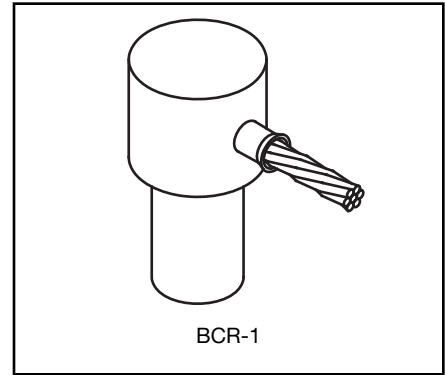

Ground Rod Size	Cable Size		Type	Mold Number	Cadweld® Part #	
	Solid	Stranded				
1/2"	#6, #8	#8	BCR-1 •	BS-2009	GR1-141G	
	#3, #4	#4, #6	BCR-1 •	BS-2010	GR1-141L	
	#1, #2	#2, #3	BCR-1 •	BS-2011	GR1-141V	
	#6, #8	#8	BCR-2 •	BS-2024	GT1-141G	
	#3, #4	#4, #6	BCR-2 •	BS-2025	GT1-141L	
	#1, #2	#2, #3	BCR-2 •	BS-2026	GT1-141V	
5/8"	#6, #8	#8	BCR-1 •	BS-2012	GT1-161G	
	#3, #4	#4, #6	BCR-1 •	BS-2013	GT1-141L	
	#1, #2	#2, #3	BCR-1 •	BS-2014	GR1-161V	
	2/0, 1/0	1/0, #1	BCR-1 •	BS-2015	GR1-162C	
		2/0	BCR-1 •	BS-2016	GR1-162G	
	#6, #8	#8	BCR-2 •	BS-2027	FRT1-161G	
	#3, #4	#4, #6	BCR-2 •	BS-2028	GT1-161L	
	#1, #2	#2, #3	BCR-2 •	BS-2029	GT1-161V	
	2/0, 1/0	1/0, #1	BCR-2 •	BS-2030	GT1-162C	
	#6, #8	#8	BCR-24	BS-2105	NX1-161G	
	#3, #4	#4, #6	BCR-14	BS-2106	NX1-161L	
	#1, #2	#2, #3	BCR-24	BS-2107	NX1-161V	
	#6, #8	#8	BCR-25	BS-2006	NT1-161G	
	#3, #4	#4, #6	BCR-25	BS-2007	NT1-161L	
	#1, #2	#2, #3	BCR-25	BS-2008	NT1-161V	
	3/4"	#6, #8	#8	BCR-1	BS-2017	GR1-181G
		#3, #4	#4, #6	BCR-1 •	BS-2018	GR1-181L
		#1, #2	#2, #3	BCR-1 •	BS-2019	GR1-181V
2/0, 1/0		1/0, #1	BCR-1 •	BS-2020	GR1-182C	
		2/0	BCR-1 •	BS-2021	GR1-182G	
#6, #8		#8	BCR-2 •	BS-2031	GT1-181G	
#3, #4		#4, #6	BCR-2 •	BS-2032	GT1-181L	
#1, #2		#2, #3	BCR-2 •	BS-2033	GT1-181V	
2/0, 1/0		1/0, #1	BCR-2 •	BS-2034	T1-182C	
#6, #8		#8	BCR-24	BS-2108	NX1-181G	
#3, #4		#4, #6	BCR-24	BS-2109	NX1-181L	
#1, #2		#2, #3	BCR-24	BS-2110	NX1-181V	
#6, #8		#8	BCR-25 •	BS-2068	NT1-181G	
#3, #4		#4, #6	BCR-25 •	BS-2069	NT1-181L	
#1, #2		#2, #3	BCR-25 •	BS-2070	NT1-181V	

Cadweld® is a registered trademark of the Erico International Corporation.
 • UL Listed.

For mold types or BURNDYWeld® items not shown, please contact factory.

Blue highlighted items are industry standard and most frequently ordered.

TYPE BCS-1 MOLDS

Horizontal Cable to Horizontal Steel Surface

Type BCS-1 Molds are used to terminate a horizontal copper cable to any horizontal steel surface. Note that the cable is **OFF** the surface.

Size range is 1/0 through 1000 kcmil solid or concentric stranded copper conductors.

Contact BURNDY® for information on molds for conductors not listed below.

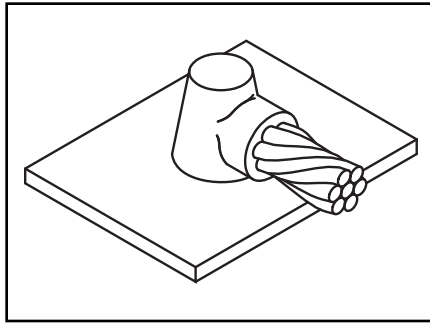

Cable Size	Mold Number	Price Key	Weld Metal	Handle Clamps
1/0	B-644	4	90	B-106
2/0	B-645	4	90	B-106
3/0	B-646	4	115	B-106
4/0	B-647	4	115	B-106
250 kcmil	B-648	4	115	B-106
300 kcmil	B-649	4	150	B-106
350 kcmil	B-650	4	200	B-106
500 kcmil	B-652	4	200	B-106
750 kcmil	B-653	5	2-150	B-106
1000 kcmil	B-654	5	2-200	B-107

- For sizes not listed, contact BURNDY®.
 - Molds listed are for concentric stranded cable. Add suffix “-S” to mold number for solid conductors.
 - For heavy duty molds, molds with wear plates or molds for Copperweld® cable, contact BURNDY®.
 - For expedited service, contact BURNDY®.
- Required Tools:
Handle Clamps (see chart for correct handles)
B38-0309-00 Flint Ignitor
- Other recommended accessories:
B38-3922-00 Mold Cleaning Brush (pg E-92)
B38-0135-00 Cable Cleaning Brush (pg E-92)
B38-0330-00 Cable Clamp (pg E-92)
B38-0101-00 Rasp (pg E-93)

TYPE BCS-8 MOLDS

Horizontal Cable to Horizontal Steel Surface

Type BCS-8 Molds are used to terminate a horizontal copper cable to any horizontal steel surface. Note that the cable is **ON** the surface.

Size range is #6 through 1000 kcmil solid or concentric stranded copper conductors.

Contact BURNDY® for information on molds for conductors not listed below.

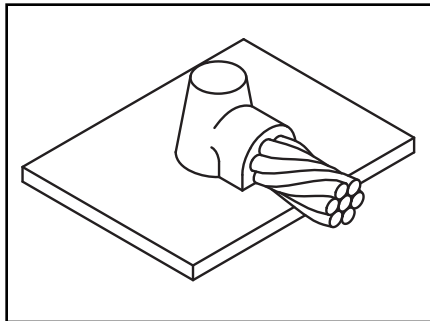

Cable Size	Mold Number	Price Key	Weld Metal	Handle Clamps
#6	B-628	3†**	45	N/A
#4	B-629	3†*	45	N/A
#2	B-630	3†*	45	N/A
#1	B-631	3†*	65	N/A
1/0	B-7146	4	90	B-106
2/0	B-7075	4	90	B-106
3/0	B-2199	4	115	B-106
4/0	B-6114	4	115	B-106
250 kcmil	B-2200	4	115	B-106
300 kcmil	B-2506	4	150	B-106
350 kcmil	B-2507	4	200	B-106
500 kcmil	B-2509	4	200	B-106
750 kcmil	B-2542	5	2-150	B-107
1000 kcmil	B-2511	5	2-200	B-107

- For sizes not listed, contact BURNDY®.
 - Molds listed are for concentric stranded cable. Add suffix “-S” to mold number for solid conductors.
 - For heavy duty molds, molds with wear plates or molds for Copperweld® cable, contact BURNDY®.
 - For expedited service, contact BURNDY®.
- Required Tools:
Handle Clamps (see chart for correct handles)
† Sold complete with frame
* **B38-0309-00** Flint Ignitor (included)
- Other recommended accessories:
B38-3922-00 Mold Cleaning Brush (pg E-92)
B38-0135-00 Cable Cleaning Brush (pg E-92)
B38-0330-00 Cable Clamp (pg E-92)
B38-0101-00 Rasp (pg E-93)

For mold types or BURNDYWeld® items not shown, please contact factory.

Blue highlighted items are industry standard and most frequently ordered.

TYPE BCS-2 MOLDS

Horizontal Through Cable to Horizontal Steel Surface

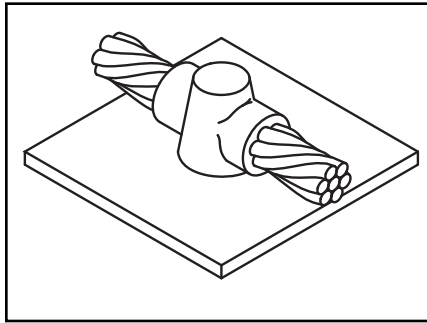

Type BCS-2 Molds are used to join horizontal through copper cable to any horizontal steel surface. Note the cable is **OFF** the surface.

Size range is 1/0 through 1000 kcmil solid or concentric stranded copper conductors.

Contact BURNDY® for information on molds for conductors not listed below.

Cable Size	Mold Number	Price Key	Weld Metal	Handle Clamps
1/0	B-616	4	90	B-106
2/0	B-617	4	115	B-106
3/0	B-618	4	115	B-106
4/0	B-619	4	150	B-106
250 kcmil	B-620	4	150	B-106
300 kcmil	B-621	4	200	B-106
350 kcmil	B-622	4	250	B-106
500 kcmil	B-624	5	2-150	B-107
750 kcmil	B-625-H	5	3-250	B-107
1000 kcmil	B-626-H	5	2-500	B-107

- For sizes not listed, contact BURNDY®.
- Molds listed are for concentric stranded cable. Add suffix “-S” to mold number for solid conductors.
- For heavy duty molds, molds with wear plates or molds for Copperweld® cable, contact BURNDY®.
- For expedited service, contact BURNDY®.

Required Tools:

Handle Clamps (see above for correct handles)
B38-0309-00 Flint Ignitor

Other recommended accessories:

- B38-3922-00** Mold Cleaning Brush (pg E-92)
- B38-0135-00** Cable Cleaning Brush (pg E-92)
- B38-0101-00** Rasp (pg E-93)

TYPE BCS-9 MOLDS

Horizontal Through Cable to Horizontal Steel Surface

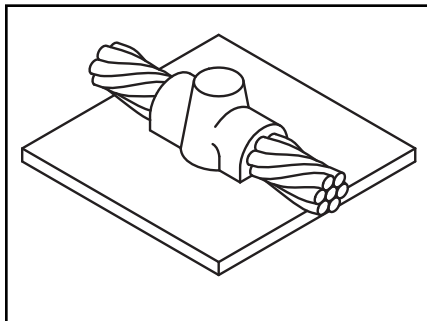

Type BCS-9 Molds are used to join horizontal through copper cable to any horizontal steel surface. Note the cable is **ON** the surface.

Size range is #6 through 500 kcmil solid or concentric stranded copper conductors.

Contact BURNDY® Products for information on molds for conductors not listed below.

Cable Size	Mold Number	Price Key	Weld Metal	Handle Clamps
#6	B-602	3†*	45	N/A
#4	B-603	3†*	45	N/A
#2	B-604	3†*	45	N/A
#1	B-605	3†*	65	N/A
1/0	B-8379	4	90	B-106
2/0	B-5331	4	115	B-106
3/0	B-8381	4	115	B-106
4/0	B-7192	4	150	B-106
250 kcmil	B-8413	4	150	B-106
300 kcmil	B-8423	4	200	B-106
350 kcmil	B-8410	4	250	B-106
500 kcmil	B-5065	5	2-150	B-107

- For sizes not listed, contact BURNDY®.
- Molds listed are for concentric stranded cable. Add suffix “-S” to mold number for solid conductors.
- For heavy duty molds, molds with wear plates or molds for Copperweld® cable, contact BURNDY®.
- For expedited service, contact BURNDY®.

Required Tools:

Handle Clamps (see chart for correct handles)
 † Sold complete with handle frame

* **B38-0309-00** Flint Ignitor (included)

Other recommended accessories:

- B40-0319-01** Mold Cleaner for cartridge sizes #15-#65 (pg E-92)
- B40-0319-03** Mold Cleaner for cartridge sizes #90-#500 (pg E-92)
- B38-3922-00** Mold Cleaning Brush (pg E-92)
- B38-0135-00** Cable Cleaning Brush (pg E-92)
- B38-0101-00** Rasp (pg E-93)

For mold types or BURNDYWeld® items not shown, please contact factory.

Blue highlighted items are industry standard and most frequently ordered.

TYPE BCS-3 MOLDS

Angular Cable Drop to Vertical Steel Surface

Type BCS-3 Molds are used to join the end of a copper cable at a 45° angle to a vertical steel surface.

Size range is #6 through 1000 kcmil solid or concentric stranded copper conductors.

Contact BURNDY® for information on molds for conductors not listed below.

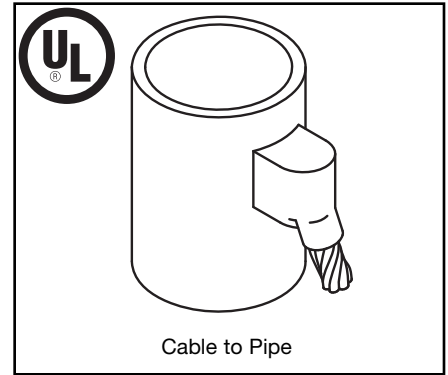
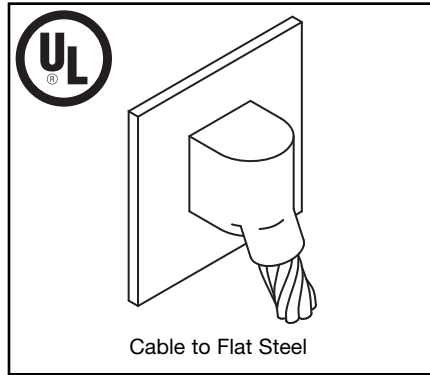

Cable to Flat Steel

Cable Size	Mold Number	Price Key	Weld Metal	Handle Clamps
#6	B-585	4	45	B-106
#4	B-586	4	45	B-106
#3	B-587	4	45	B-106
#2	B-588	4	45	B-106
#1	B-589	4	65	B-106
1/0	B-590	4	90	B-106
2/0	B-591	4	90	B-106
3/0	B-592	4	115	B-106
4/0	B-593	4	115	B-106
250 kcmil	B-594	4	115	B-106
300 kcmil	B-595	4	150	B-106
350 kcmil	B-596	4	200	B-106
500 kcmil	B-598	4	200	B-106
750 kcmil	B-599	5	2-150	B-107
1000 kcmil	B-600	5	2-200	B-107

- For sizes not listed, contact BURNDY®.
- Molds listed are for concentric stranded cable. Add suffix "-S" to mold number for solid conductors.
- For heavy duty molds, molds with wear plates or molds for Copperweld® cable, contact BURNDY®.
- For expedited service, contact BURNDY®.

Required Tools:

Handle Clamps (see chart for correct handles)
B38-0309-00 Flint Ignitor

Other recommended accessories:

Magnetic Clamps to hold molds against vertical steel (pg E-89)
B38-3922-00 Mold Cleaning Brush (pg E-92)
B38-0135-00 Cable Cleaning Brush (pg E-92)
B38-0101-00 Rasp (pg E-93)

Cable to Pipe

Cable Size	Pipe Size	Mold Number	Price Key	Weld Metal	Handle Clamps
#4	1-1/4" to 4"	B-2476	4	45	B-106
	4" to 6"	B-2477	4	45	B-106
	6" to 10"	B-2478	4	45	B-106
	12" & up	B-586 ‡	4	45	B-106
#2 Sol	1-1/4" to 4"	B-9233-S	4	45	B-106
	4" to 6"	B-2480-S	4	45	B-106
	6" to 10"	B-2583-S	4	45	B-106
	12" & up	B-588-S ‡	4	45	B-106
#2	1-1/4" to 4"	B-9233	4	45	B-106
	4" to 6"	B-2480	4	45	B-106
	6" to 10"	B-2583	4	45	B-106
	12" & up	B-588 ‡	4	45	B-106
#1	1-1/4" to 4"	B-2482	4	65	B-106
	4" to 6"	B-2483	4	65	B-106
	6" to 10"	B-2484	4	65	B-106
	12" & up	B-589 ‡	4	65	B-106
1/0	1-1/4" to 4"	B-2486	4	90	B-106
	4" to 6"	B-2487	4	90	B-106
	6" to 10"	B-2488	4	90	B-106
	12" & up	B-590 ‡	4	90	B-106
2/0	1-1/4" to 4"	B-8833	4	90	B-106
	4" to 6"	B-2490	4	90	B-106
	6" to 10"	B-2491	4	90	B-106
	12" & up"	B-591 ‡	4	90	B-106
3/0	1-1/4" to 4"	B-2493	4	115	B-106
	4" to 6"	B-2494	4	115	B-106
	6" to 10"	B-2495	4	115	B-106
	12" & up	B-592 ‡	4	115	B-106
4/0	1-1/4" to 4"	B-9021	4	115	B-106
	4" to 6"	B-2497	4	115	B-106
	6" to 10"	B-2498	4	115	B-106
	12" & up	B-593 ‡	4	115	B-106

- For sizes not listed, contact BURNDY®.
- Molds listed are for concentric stranded cable. Add suffix "-S" to mold number for solid conductors.
- For heavy duty molds, molds with wear plates or molds for Copperweld® cable, contact BURNDY®.
- For expedited service, contact BURNDY®.

Required Tools:

Handle Clamps (see chart for correct handles)
B38-0309-00 Flint Ignitor

Other recommended accessories:

B106-32 Vertical Chain Clamp w/ B-106 Handles for 4" Pipe & smaller
B40-0106-27 20" Chain Extension for 4" to 10" Pipe
Use (2) 20" Chain Extensions for pipe sizes between 10" and 16"
B38-3922-00 Mold Cleaning Brush (pg E-92)
B38-0135-00 Cable Cleaning Brush (pg E-92)
B38-0101-00 Rasp (pg E-93)

‡ Flat Surface Mold

For mold types or BURNDYWeld® items not shown, please contact factory.

Blue highlighted items are industry standard and most frequently ordered.

TYPE BCS-23 MOLDS

Vertical Cable Drop to Vertical Steel Surface

Type BCS-23 Molds are used to join vertical cable down to a vertical steel surface. Note that the cable is **OFF** the surface.

E-78

Size range is #6 through 500 kcmil solid or concentric stranded copper conductors.

Contact BURNDY® for information on molds for conductors not listed below.

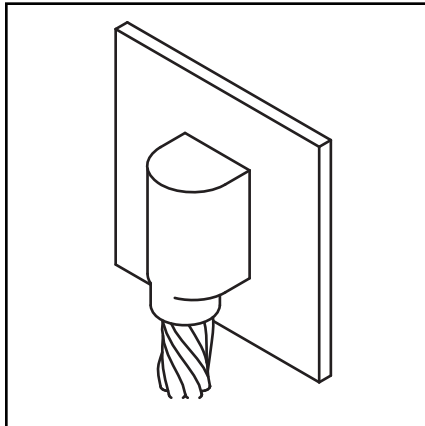

Cable Size	Mold Number	Price Key	Weld Metal	Handle Clamps
#6	B-5389	4	45	B-106
#4	B-5359	4	65	B-106
#2	B-2781	4	65	B-106
#1	B-5361	4	90	B-106
1/0	B-2189	4	115	B-106
2/0	B-2540	4	115	B-106
3/0	B-5362	4	150	B-106
4/0	B-8718	4	150	B-106
250 kcmil	B-8165	4	200	B-106
300 kcmil	B-5363	4	200	B-106
350 kcmil	B-9029	4	250	B-106
500 kcmil	B-8512	17	2-150	B-106

- For sizes not listed, contact BURNDY®.
- Molds listed are for concentric stranded cable. Add suffix "-S" to mold number for solid conductors.
- For heavy duty molds, molds with wear plates or molds for Copperweld® cable, contact BURNDY®.
- For expedited service, contact BURNDY®.

Required Tools:

Handle Clamps (see chart for correct handles)

B38-0309-00 Flint Ignitor

Other recommended accessories:

Magnetic Clamps to hold molds against vertical steel

B38-3922-00 Mold Cleaning Brush (pg E-92)

B38-0135-00 Cable Cleaning Brush (pg E-92)

B38-0101-00 Rasp (pg E-93)

For mold types or BURNDYWeld® items not shown, please contact factory.

Blue highlighted items are industry standard and most frequently ordered.

TYPE BCS-4 MOLDS

Vertical Through Cable to Vertical Steel Surface

Type BCS-4 Molds are used to join a vertical through copper cable to a vertical steel surface. Note that the cable is **OFF** the surface. For molds with the cable on the surface, contact BURNDY® Products.

Size range is #6 through 500 kcmil solid or concentric stranded copper conductors.

Contact BURNDY® for information on molds for conductors not listed below.

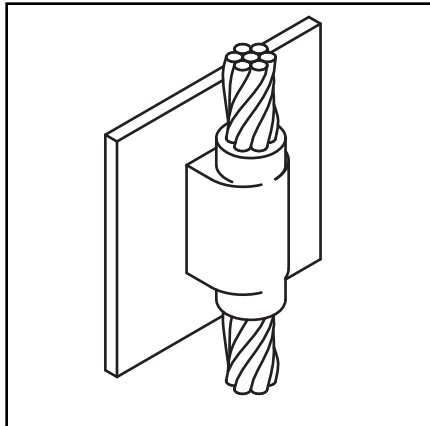

Cable Size	Mold Number	Price Key	Weld Metal	Handle Clamps
#6	B-1215	4	90	B-106
#4	B-1216	4	90	B-106
#2	B-1218	4	115	B-106
#1	B-1219	4	115	B-106
1/0	B-1220	17	200	B-106
2/0	B-1221	17	200	B-106
3/0	B-1222	17	250	B-106
4/0	B-1223	17	250	B-106
250 kcmil	B-1224	17	250	B-106
300 kcmil	B-1225-H	6	500	B-107
350 kcmil	B-1226-H	6	3-200	B-107
500 kcmil	B-1228-H	6	3-250	B-107

- For sizes not listed, contact BURNDY®.
- Molds listed are for concentric stranded cable. Add suffix "-S" to mold number for solid conductors.
- For heavy duty molds, molds with wear plates or molds for Copperweld® cable, contact BURNDY®.
- For expedited service, contact BURNDY®.

Required Tools:
Handle Clamps (see chart for correct handles)
B38-0309-00 Flint Ignitor

Other recommended accessories:
Magnetic Clamps to hold molds against vertical steel
B38-3922-00 Mold Cleaning Brush (pg E-92)
B38-0135-00 Cable Cleaning Brush (pg E-92)
B38-0101-00 Rasp (pg E-93)

TYPE BCS-6 MOLDS

Horizontal Through Cable to Vertical Steel Surface

Type BCS-6 Molds are used to join horizontal through copper cable to a vertical steel surface. Note that the cable is **OFF** the surface.

Size range is #6 through 250 kcmil solid or concentric stranded copper conductors.

Contact BURNDY® for information on molds for conductors not listed below.

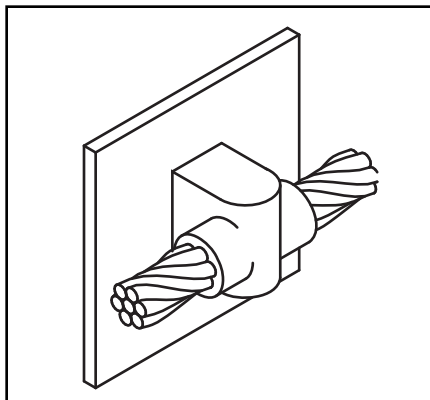

Cable Size	Mold Number	Price Key	Weld Metal	Handle Clamps
#6	B-1626	4	65	B-106
#4	B-1627	4	65	B-106
#2	B-1628	4	65	B-106
#1	B-1629	4	90	B-106
1/0	B-1630	4	115	B-106
2/0	B-1631	4	115	B-106
3/0	B-1632	4	150	B-106
4/0	B-1633	4	150	B-106
250 kcmil	B-1634	4	150	B-106

- For sizes not listed, contact BURNDY®.
- Molds listed are for concentric stranded cable. Add suffix "-S" to mold number for solid conductors.
- For heavy duty molds, molds with wear plates or molds for Copperweld® cable, contact BURNDY®.
- For expedited service, contact BURNDY®.

Required Tools:
Handle Clamps (see chart for correct handles)
B38-0309-00 Flint Ignitor

Other recommended accessories:
B40-0319-01 Mold Cleaner for cartridge sizes #15-#65 (pg E-92)
B40-0319-03 Mold Cleaner for cartridge sizes #90-#500 (pg E-92)
B38-3922-00 Mold Cleaning Brush (pg E-92)
B38-0135-00 Cable Cleaning Brush (pg E-92)
B38-0101-00 Rasp (pg E-93)

For mold types or BURNDYWeld® items not shown, please contact factory.

Blue highlighted items are industry standard and most frequently ordered.

TYPE BCS-7 MOLDS

Overhead Vertical Tap Cable to Vertical Steel Surface

Type BCS-7 Molds are used to join an overhead vertical copper conductor drop tap to a vertical steel surface.

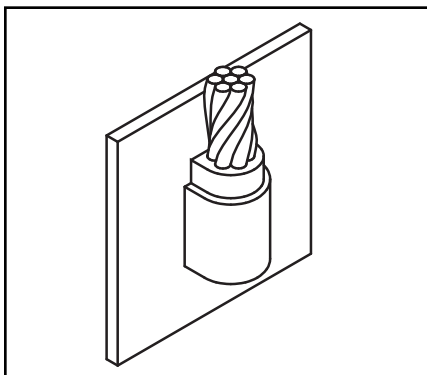

Size range is #6 through 1000 kcmil solid or concentric stranded copper conductors.

Contact BURNDY® for information on molds for conductors not listed below.

Cable Size	Mold Number	Price Key	Weld Metal	Handle Clamps
#6	B-1635	4	65	B-106
#4	B-1636	4	65	B-106
#3	B-1637	4	65	B-106
#2	B-1638	4	65	B-106
#1	B-1639	4	90	B-106
1/0	B-1640	4	150	B-106
2/0	B-1641	4	150	B-106
3/0	B-1642	17	200	B-106
4/0	B-1643	17	200	B-106
250 kcmil	B-1644	17	200	B-106
300 kcmil	B-1645	17	250	B-106
350 kcmil	B-1646	6	2-150	B-107
500 kcmil	B-1648	6	2-200	B-107
750 kcmil	B-1649	6	500	B-107
1000 kcmil	B-1650	6	3-200	B-107

- For sizes not listed, contact BURNDY®.
 - Molds listed are for concentric stranded cable. Add suffix "-S" to mold number for solid conductors.
 - For heavy duty molds, molds with wear plates or molds for Copperweld® cable, contact BURNDY®.
 - For expedited service, contact BURNDY®.
- Required Tools:
 Handle Clamps (see chart for correct handles)
B38-0309-00 Flint Ignitor
- Other recommended accessories:
 Magnetic Clamps to hold molds against vertical steel
B38-3922-00 Mold Cleaning Brush (pg E-92)
B38-0135-00 Cable Cleaning Brush (pg E-92)
B38-0101-00 Rasp (pg E-93)

TYPE BCS-18 MOLDS

Horizontal Tap Cable to Vertical Steel Surface

Type BCS-18 Molds are used to connect a horizontal conductor to a vertical steel surface. Note that the cable is **ON** the surface.

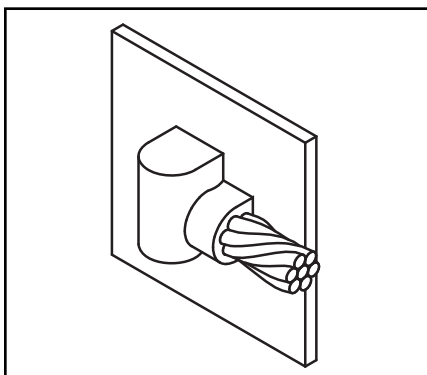

Size range is #6 through 500 kcmil solid or concentric stranded copper conductors.

Contact BURNDY® for information on molds for conductors not listed below.

Cable Size	Mold Number	Price Key	Weld Metal	Handle Clamps
#6	B-5910	4	45	B-106
#4	B-2761	4	45	B-106
#2	B-2569	4	45	B-106
#1	B-6060	4	65	B-106
1/0	B-5419	4	90	B-106
2/0	B-2567	4	90	B-106
3/0	B-6072	4	115	B-106
4/0	B-9253	4	115	B-106
250 kcmil	B-2568	4	115	B-106
300 kcmil	B-6061	4	150	B-106
350 kcmil	B-6067	4	200	B-106
500 kcmil	B-8359	4	200	B-106

- NOTE:** Add (-R) to mold number for right hand mold or (-L) for left hand mold. Right hand (-R) mold will be furnished if not specified.
- For sizes not listed, contact BURNDY®.
 - Molds listed are for concentric stranded cable. Add suffix "-S" to mold number for solid conductors.
 - For heavy duty molds, molds with wear plates or molds for Copperweld® cable, contact BURNDY®.
 - For expedited service, contact BURNDY®.
- Required Tools:
 Handle Clamps (see chart for correct handles)
B38-0309-00 Flint Ignitor
- Other recommended accessories:
 Vertical Chain Clamps
B38-3922-00 Mold Cleaning Brush (pg E-92)
B38-0135-00 Cable Cleaning Brush (pg E-92)
B38-0101-00 Rasp (pg E-93)

For mold types or BURNDYWeld® items not shown, please contact factory.

Blue highlighted items are industry standard and most frequently ordered.

TYPE BCS-5 MOLDS

Horizontal Cable Tap to Horizontal Cast Iron Surface

Type BCS-5 Molds are used to join horizontal cable taps to horizontal cast iron surfaces. Note that the cable is **ON** the surface.

Size range is #6 through #1 solid or concentric stranded copper conductors.

Contact BURNDY® for information on molds for conductors not listed below.

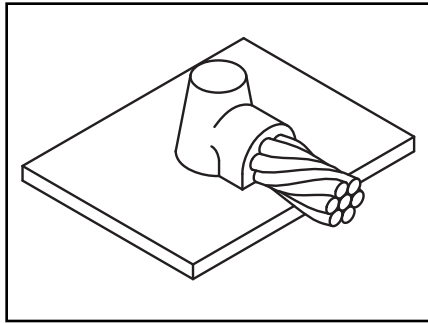

E-81

Cable Size	Mold Number	Price Key	Weld Metal	Handle Clamps
#6 Sol	B-1613	3+	2SCl	N/A
#6	B-1614	3+	25Cl	N/A
#4 Sol	B-1615	3+	45Cl	N/A
#4	B-1616	3+	45Cl	N/A
#2 Sol	B-1617	3+	45Cl	N/A
#2	B-1618	3+	45Cl	N/A
#1 Sol	B-1619	3+	65Cl	N/A
#1	B-1620	3+	65Cl	N/A

- For sizes not listed, contact BURNDY®.
- Molds listed are for concentric stranded cable. Add suffix “-S” to mold number for solid conductors.
- For heavy duty molds, molds with wear plates or molds for Copperweld® cable, contact BURNDY®.
- For expedited service, contact BURNDY®.

Required Tools:

† Sold complete with frame
B38-0309-00 Flint Ignitor (included)

Other recommended accessories:

- B38-3922-00** Mold Cleaning Brush (pg E-92)
- B38-0135-00** Cable Cleaning Brush (pg E-92)
- B38-0101-00** Rasp (pg E-93)

DO NOT use Type BCS-5 molds on Soil Pipe (ASTM A74-82). A test weld should be made on a section of the pipe being used to determine the possibility of detrimental metallurgical effects.

For mold types or BURNDYWeld® items not shown, please contact factory.

Blue highlighted items are industry standard and most frequently ordered.

TYPE BCRE-1 MOLDS

Horizontal Parallel Tap to Rebar

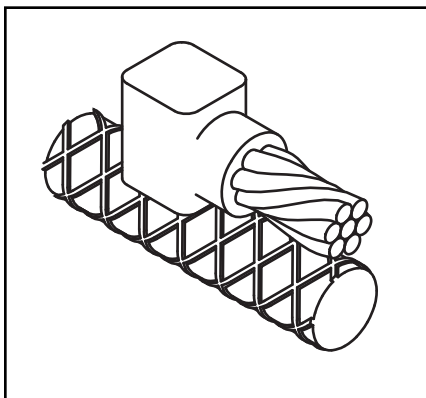

Type BCRE-1 Molds are recommended for parallel, horizontal connections for solid or concentric stranded conductors #6 through 4/0 joined to reinforcing bars #3 through #6 and larger. The high copper content joint has a higher current carrying capacity than the conductors being joined and is impervious to vibration and moisture.

Contact BURNDY® for information on molds for conductors not listed below.

Rebar Size	Cable Size	Mold Number	Packing Material ‡	Price Key	Weld Metal	Handle Clamps
#3	#6	B-7500	B38032900	4	25	B-106
	#4	B-7501	B38032900	4	32	B-106
	#2	B-7502	B38032900	4	45	B-106
	#1	B-7503	B38032900	4	65	B-106
	1/0	B-7504	B38032900	4	90	B-106
	2/0	B-7505	B38032900	4	90	B-106
	3/0	B-7506	B38032900	4	115	B-106
#4 & Larger	4/0	B-7507	B38032900	4	115	B-106
	#6	B-7508	B38406100	3+	25	N/A
	#4	B-7509	B38406100	3+	32	N/A
	#2	B-7510	B38406100	3+	45	N/A
#4	#1	B-7511	B38406100	3+	65	N/A
	1/0	B-7512	B38032900	4	90	B-106
	2/0	B-7513	B38032900	4	90	B-106
	3/0	B-7514	B38032900	4	115	B-106
#5	4/0	B-7515	B38032900	4	115	B-106
	1/0	B-7520	B38032900	4	90	B-106
	2/0	B-7521	B38032900	4	90	B-106
	3/0	B-7522	B38032900	4	115	B-106
#6 & Larger	4/0	B-7523	B38032900	4	115	B-106
	1/0	B-7528	B38406200	14+	90	N/A
	2/0	B-7529	B38406200	14+	90	N/A
	3/0	B-7530	B38406200	14+	115	N/A
	4/0	B-7531	B38406200	14+	115	N/A

‡ PACKING MATERIAL NOTE

A packing pad is necessary when making BURNDYWeld® connections to rebar. Packing material B38032900 is copper shim stock. Packing material numbers B38406100, B38406200 and B38406300 are a ceramic fiber material and can be used for **one** connection only. Be sure to specify packing material catalog number when ordering mold and weld metal.

- For sizes not listed, contact BURNDY®.
- Molds listed are for concentric stranded cable. Add suffix "-S" to mold number for solid conductors.
- For heavy duty molds, molds with wear plates or molds for Copperweld® cable, contact BURNDY®.
- For expedited service, contact BURNDY®.

Required Tools:

Handle Clamps (see chart for correct handles)

† Sold complete with frame

B38-0309-00 Flint Ignitor

Other recommended accessories:

B38-3922-00 Mold Cleaning Brush (pg E-92)

B38-0135-00 Cable Cleaning Brush (pg E-92)

B38-0304-00 File (pg E-93)

For mold types or BURNDYWeld® items not shown, please contact factory.

Blue highlighted items are industry standard and most frequently ordered.

TYPE BCRE-2 MOLDS

**Horizontal Cable Tap to
Horizontal Rebar Run**

Type BCRE-2 Molds are recommended for right angle, horizontal connections for solid or concentric stranded conductors #6 through 4/0 joined to reinforcing bars #3 through #6. The high copper content joint has a higher current carrying capacity than the conductors being joined and is impervious to vibration and moisture.

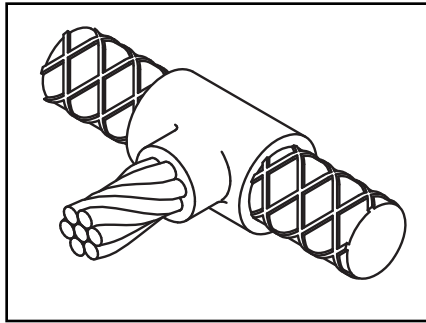

Contact BURNDY® for information on molds for conductors not listed below.

Rebar Size	Cable Size	Mold Number	Packing Material ‡	Price Key	Weld Metal	Handle Clamps
#3	#6	B-7588	B38032900	4	45	B-106
	#4	B-7589	B38032900	4	45	B-106
	#2	B-7590	B38032900	4	65	B-106
	#1	B-7591	B38032900	4	65	B-106
	1/0	B-7592	B38032900	4	90	B-106
	2/0	B-7593	B38032900	4	90	B-106
	3/0	B-7594	B38032900	4	115	B-106
#4	4/0	B-7595	B38032900	4	115	B-106
	#6	B-7596	B38032900	4	45	B-106
	#4	B-7597	B38032900	4	45	B-106
	#2	B-7598	B38032900	4	65	B-106
	#1	B-7599	B38032900	4	65	B-106
	1/0	B-7600	B38032900	4	90	B-106
	2/0	B-7601	B38032900	4	90	B-106
#5	3/0	B-7602	B38032900	4	115	B-106
	4/0	B-7603	B38032900	4	115	B-106
	#6	B-7604	B38032900	4	90	B-106
	#4	B-7605	B38032900	4	90	B-106
	#2	B-7606	B38032900	4	90	B-106
	#1	B-7607	B38032900	4	90	B-106
	1/0	B-7608	B38032900	4	115	B-106
#6	2/0	B-7609	B38032900	4	115	B-106
	3/0	B-7610	B38032900	4	150	B-106
	4/0	B-7611	B38032900	4	150	B-106
	#6	B-7612	B38032900	4	90	B-106
	#4	B-7613	B38032900	4	90	B-106
	#2	B-7614	B38032900	4	90	B-106
	#1	B-7615	B38032900	4	90	B-106
#6	1/0	B-7616	B38032900	4	115	B-106
	2/0	B-7617	B38032900	4	115	B-106
	3/0	B-7618	B38032900	4	150	B-106
	4/0	B-7619	B38032900	4	150	B-106

‡ PACKING MATERIAL NOTE

A packing pad is necessary when making BURNDYWeld® connections to rebar. Packing material B38032900 is copper shim stock. Packing material numbers B38406100, B38406200 and B38406300 are a ceramic fiber material and can be used for **one** connection only. Be sure to specify packing material catalog number when ordering mold and weld metal.

- For sizes not listed, contact BURNDY®.
 - Molds listed are for concentric stranded cable. Add suffix "-S" to mold number for solid conductors.
 - For heavy duty molds, molds with wear plates or molds for Copperweld® cable, contact BURNDY®.
 - For expedited service, contact BURNDY®.
- Required Tools:
Handle Clamps (see chart for correct handles)
B38-0309-00 Flint Ignitor

- Other recommended accessories
- B40-0319-01** Mold Cleaner for cartridge sizes #15-#65 (pg E-92)
 - B40-0319-03** Mold Cleaner for cartridge sizes #90-#500 (pg E-92)
 - B38-3922-00** Mold Cleaning Brush (pg E-92)
 - B38-0135-00** Cable Cleaning Brush (pg E-92)
 - B38-0304-00** File (pg E-93)

For mold types or BURNDYWeld® items not shown, please contact factory.

Blue highlighted items are industry standard and most frequently ordered.

TYPE BCRE-3 MOLDS

Horizontal through Cable to Vertical Rebar

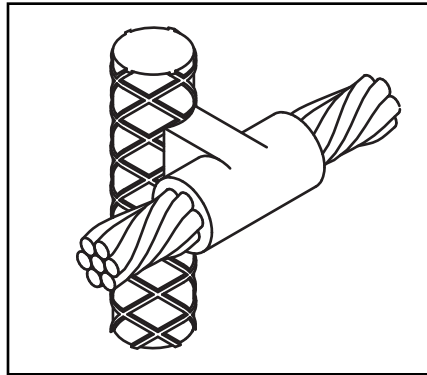

Type BCRE-3 Molds are recommended for horizontal conductors to vertical rebar connections for solid or concentric stranded conductors #6 through 4/0 joined to reinforcing bars #3 through #7 & larger. The high copper content joint has a higher current carrying capacity than the conductors being joined and is impervious to vibration and moisture.

Contact BURNDY® for information on molds for conductors not listed below.

Rebar Size	Cable Size	Mold Number	Packing Material ‡	Price Key	Weld Metal	Handle Clamps
#3	#6	B-7620	B38032900	24	90	B-106
	#4	B-7621	B38032900	24	90	B-106
	#2	B-7622	B38032900	24	90	B-106
	#1	B-7623	B38032900	24	115	B-106
	1/0	B-7624	B38032900	24	115	B-106
	2/0	B-7625	B38032900	24	115	B-106
	3/0	B-7626	B38032900	24	150	B-106
#4	4/0	B-7627	B38032900	24	150	B-106
	#6	B-7628	B38032900	24	90	B-106
	#4	B-7629	B38032900	24	90	B-106
	#2	B-7630	B38032900	24	90	B-106
	#1	B-7631	B38032900	24	115	B-106
	1/0	B-7632	B38032900	24	115	B-106
	2/0	B-7633	B38032900	24	115	B-106
#5	3/0	B-7634	B38032900	24	150	B-106
	4/0	B-7635	B38032900	24	150	B-106
	#6	B-7636	B38032900	24	90	B-106
	#4	B-7637	B38032900	24	90	B-106
	#2	B-7638	B38032900	24	90	B-106
	#1	B-7639	B38032900	24	115	B-106
	1/0	B-7640	B38032900	24	115	B-106
#6	2/0	B-7641	B38032900	24	115	B-106v
	3/0	B-7642	B38032900	24	150	B-106
	4/0	B-7643	B38032900	24	150	B-106
	#6	B-7644	B38032900	24	90	B-106
	#4	B-7645	B38032900	24	90	B-106
	#2	B-7646	B38032900	24	90	B-106
	#1	B-7647	B38032900	24	115	B-106
#7 & Larger	1/0	B-7648	B38032900	24	115	B-106
	2/0	B-7649	B38032900	24	115	B-106
	3/0	B-7650	B38032900	24	150	B-106
	4/0	B-7651	B38032900	24	150	B-106
	#6	B-7652	B38406300	4+	90	B-106-41
	#4	B-7653	B38406300	4+	90	B-106-41
	#2	B-7654	B38406300	4+	90	B-106-41
#7 & Larger	#1	B-7655	B38406300	4+	115	B-106-41
	1/0	B-7656	B38406300	4+	115	B-106-41
	2/0	B-7657	B38406300	4+	115	B-106-41
	3/0	B-7658	B38406300	4+	150	B-106-41
	4/0	B-7659	B38406300	4+	150	B-106-41

‡ PACKING MATERIAL NOTE

A packing pad is necessary when making BURNDYWeld® connections to rebar. Packing material B38032900 is copper shim stock. Packing material numbers B38406100, B38406200 and B38406300 are a ceramic fiber material and can be used for **one** connection only. Be sure to specify packing material catalog number when ordering mold and weld metal.

- For sizes not listed, contact BURNDY®.
 - Molds listed are for concentric stranded cable. Add suffix "-S" to mold number for solid conductors.
 - For heavy duty molds, molds with wear plates or molds for Copperweld® cable, contact BURNDY®.
 - For expedited service, contact BURNDY®.
- Required Tools:
 Handle Clamps (see chart for correct handles)
B38-0309-00 Flint Ignitor
 Other recommended accessories:
 Vertical Chain Clamps
 † **B40-0319-03** Mold Cleaner for cartridge sizes #90-#500 (pg E-92)
B38-3922-00 Mold Cleaning Brush (pg E-92)
B38-0135-00 Cable Cleaning Brush (pg E-92)
B38-0304-00 File (pg E-93)

For mold types or BURNDYWeld® items not shown, please contact factory.

Blue highlighted items are industry standard and most frequently ordered.

TYPE BCRE-4 MOLDS

Horizontal through Cable to Horizontal Rebar

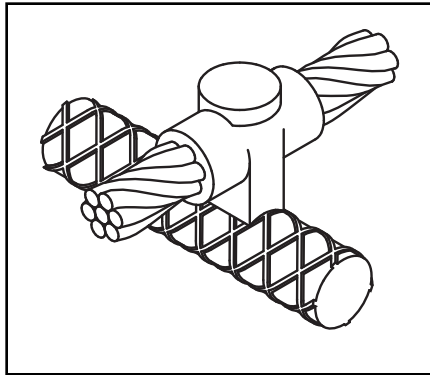

Type BCRE-4 Molds are recommended for horizontal through conductors to horizontal rebar at right angle connections for solid or concentric stranded conductors #6 through 4/0 joined to reinforcing bars #3 through #6 & larger. The high copper content joint has a higher current carrying capacity than the conductors being joined and is impervious to vibration and moisture.

Contact BURNDY® for information on molds for conductors not listed below.

Rebar Size	Cable Size	Mold Number	Packing Material ‡	Price Key	Weld Metal	Handle Clamps
#3	#6	B-7708	B38032900	4	90	B-106
	#4	B-7709	B38032900	4	90	B-106
	#2	B-7710	B38032900	4	90	B-106
	#1	B-7711	B38032900	4	115	B-106
	1/0	B-7712	B38032900	22	115	B-106
	2/0	B-7713	B38032900	22	115	B-106
	3/0	B-7714	B38032900	22	150	B-106
#4	4/0	B-7715	B38032900	22	150	B-106
	#6	B-7716	B38032900	4	90	B-106
	#4	B-7717	B38032900	4	90	B-106
	#2	B-7718	B38032900	4	90	B-106
	#1	B-7719	B38032900	22	115	B-106
	1/0	B-7720	B38032900	22	115	B-106
	2/0	B-7721	B38032900	22	115	B-106
#5	3/0	B-7722	B38032900	22	150	B-106
	4/0	B-7723	B38032900	22	150	B-106
	#6	B-7724	B38032900	4	90	B-106
	#4	B-7725	B38032900	4	90	B-106
	#2	B-7726	B38032900	4	90	B-106
	#1	B-7727	B38032900	22	115	B-106
	1/0	B-7728	B38032900	22	115	B-106
#6 & Larger	2/0	B-7729	B38032900	22	115	B-106
	3/0	B-7730	B38032900	22	150	B-106
	4/0	B-7731	B38032900	22	150	B-106
	#6	B-7732	B38406100	14+	90	N/A
	#4	B-7733	B38406100	14+	90	N/A
	#2	B-7734	B38406100	14+	90	N/A
	#1	B-7735	B38406100	14+	115	N/A
1/0	B-7736	B38406200	14+	115	N/A	
2/0	B-7737	B38406200	14+	115	N/A	
3/0	B-7738	B38406200	14+	150	N/A	
4/0	B-7739	B38406200	14+	150	N/A	

‡ PACKING MATERIAL NOTE

A packing pad is necessary when making BURNDYWeld® connections to rebar. Packing material B38032900 is copper shim stock. Packing material numbers B38406100, B38406200 and B38406300 are a ceramic fiber material and can be used for **one** connection only. Be sure to specify packing material catalog number when ordering mold and weld metal.

- For sizes not listed, contact BURNDY®.
 - Molds listed are for concentric stranded cable. Add suffix "-S" to mold number for solid conductors.
 - For heavy duty molds, molds with wear plates or molds for Copperweld® cable, contact BURNDY®.
 - For expedited service, contact BURNDY®.
- Required Tools:
 Handle Clamps (see chart for correct handles)
 † Sold complete with frame
B38-0309-00 Flint Ignitor

- Other recommended accessories:
B40-0319-03 Mold Cleaner for cartridge sizes #90-#500 (pg E-92)
B38-3922-00 Mold Cleaning Brush (pg E-92)
B38-0135-00 Cable Cleaning Brush (pg E-92)
B38-0304-00 File (pg E-93)

For mold types or BURNDYWeld® items not shown, please contact factory.

Blue highlighted items are industry standard and most frequently ordered.

TYPE BCRE-6 MOLDS

Horizontal Cable Tap to Vertical Rebar

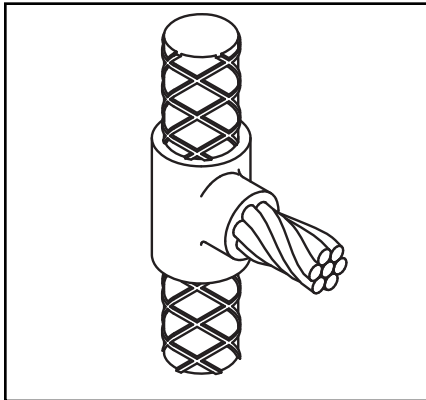

Type BCRE-6 Molds are recommended for horizontal conductors terminating at right angles to vertical rebar connections for solid or concentric stranded conductors #6 through 4/0 joined to reinforcing bars #3 through #7 and larger. The high copper content joint has a higher current carrying capacity than the conductors being joined and is impervious to vibration and moisture.

Contact BURNDY® for information on molds for conductors not listed below.

Rebar Size	Cable Size	Mold Number	Packing Material ‡	Price Key	Weld Metal	Handle Clamps
#3	#6	B-7884	B38032900	4	90	B-106
	#4	B-7885	B38032900	4	90	B-106
	#2	B-7886	B38032900	4	90	B-106
	#1	B-7887	B38032900	4	115	B-106
	1/0	B-7888	B38032900	4	115	B-106
	2/0	B-7889	B38032900	4	115	B-106
	3/0	B-7890	B38032900	4	150	B-106
#4	4/0	B-7891	B38032900	4	150	B-106
	#6	B-7892	B38032900	4	90	B-106
	#4	B-7893	B38032900	4	90	B-106
	#2	B-7894	B38032900	4	90	B-106
	#1	B-7895	B38032900	4	115	B-106
	1/0	B-7896	B38032900	4	115	B-106
	2/0	B-7897	B38032900	4	115	B-106
#5	3/0	B-7898	B38032900	4	150	B-106
	4/0	B-7899	B38032900	4	150	B-106
	#6	B-7900	B38032900	4	90	B-106
	#4	B-7901	B38032900	4	90	B-106
	#2	B-7902	B38032900	4	90	B-106
	#1	B-7903	B38032900	4	115	B-106
	1/0	B-7904	B38032900	4	115	B-106
#6	2/0	B-7905	B38032900	4	115	B-106
	3/0	B-7906	B38032900	4	150	B-106
	4/0	B-7907	B38032900	4	150	B-106
	#6	B-7908	B38032900	4	90	B-106
	#4	B-7909	B38032900	4	90	B-106
	#2	B-7910	B38032900	4	90	B-106
	#1	B-7911	B38032900	4	115	B-106
#7 & Larger	1/0	B-7912	B38032900	4	115	B-106
	2/0	B-7913	B38032900	4	115	B-106
	3/0	B-7914	B38032900	4	150	B-106
	4/0	B-7915	B38032900	4	150	B-106
	#6	B-7916	B38406300	4	90	B-106-32
	#4	B-7917	B38406300	4	90	B-106-32
	#2	B-7918	B38406300	4	90	B-106-32
#7 & Larger	#1	B-7919	B38406300	4	115	B-106-32
	1/0	B-7920	B38406300	4	115	B-106-32
	2/0	B-7921	B38406300	4	115	B-106-32
	3/0	B-7922	B38406300	4	150	B-106-32
	4/0	B-7923	B38406300	4	150	B-106-32

‡ PACKING MATERIAL NOTE

A packing pad is necessary when making BURNDYWeld® connections to rebar. Packing material B38032900 is copper shim stock. Packing material numbers B38406100, B38406200 and B38406300 are a ceramic fiber material and can be used for **one** connection only. Be sure to specify packing material catalog number when ordering mold and weld metal.

- For sizes not listed, contact BURNDY®.
- Molds listed are for concentric stranded cable. Add suffix "-S" to mold number for solid conductors.
- For heavy duty molds, molds with wear plates or molds for Copperweld® cable, contact BURNDY®.
- For expedited service, contact BURNDY®.

Required Tools:

- Handle Clamps (see chart for correct handles)
- B38-0309-00** Flint Ignitor
- Other recommended accessories:
- B38-3922-00** Mold Cleaning Brush (pg E-92)
- B38-0135-00** Cable Cleaning Brush (pg E-92)
- B38-0304-00** File (pg E-93)

*The B106-32 comes complete with a B-106 handle clamp and B40-0106-76 vertical chain clamp. Although good for use on all sizes of rebar, vertical chain clamps are strongly recommended on large size rebar as they hold the mold to the rebar securely. If you already have a B-106 handle clamp, you can purchase the vertical chain clamps separately. See page E-91 for a variety of options.

For mold types or BURNDYWeld® items not shown, please contact factory.

Blue highlighted items are industry standard and most frequently ordered.

BURNDY®
GROUNDMAX™

BURNDY® GROUNDMAX™ is an economical solution for areas with very difficult grounding issues. BURNDY® GROUNDMAX™ is highly conductive in a wet or dry application and does not require moisture to lower the resistance of your grounding system. BURNDY® GROUNDMAX™ contains a corrosion inhibitor which forms a film on copper, creating a barrier against corrosion.

BURNDY® GROUNDMAX™ can be poured in dry or pumped in slurry form. No tamping required. It is very contractor friendly. No special tools required.

BURNDY® GROUNDMAX™
Advantages:

- Easy to install.
- Electrically conductive.
- Environmentally friendly.
- Will not leach into the ground.
- Positive low resistance, electrical connection to earth.
- Does not contain any hazardous chemicals.
- Compatible with all copper grounding systems.
- Contains a corrosion inhibitor to protect copper.
- Will not expand or shrink.
- Not affected by freezing.
- Excellent shelf life.
- Typical resistivity <10 Ohm-cm

E-87

Material Required Per Linear Foot of Trench												
Width of Trench (Inches)												
Thickness of BURNDY® GROUNDMAX™ (Inches)		4	6	8	10	12	14	16	18	20	22	24
	2	4.1	6.2	8.1	10.1	12.1	14.1	16.2	18.2	20.2	22.2	24.2
	3	6.2	9.3	12.1	15.2	18.2	21.2	24.2	27.3	30.3	33.3	36.4
	4	8.2	12.3	16.2	20.2	24.2	28.3	32.3	36.4	40.4	44.5	48.5
	5	10.3	15.4	20.2	25.3	30.3	35.4	40.4	45.5	50.5	55.6	60.6
	6	12.3	18.5	24.2	30.3	36.4	42.4	48.5	54.6	60.6	66.7	72.7
	7	14.4	21.6	28.3	35.4	42.4	49.5	56.6	63.7	70.7	77.8	84.9
	8	16.4	24.7	32.3	40.4	48.5	56.0	64.7	72.7	80.8	88.9	97.0
	9	18.5	27.8	36.4	45.5	54.6	63.7	72.7	81.8	90.9	100.0	109.1
	10	20.6	30.8	40.4	50.5	60.6	70.7	80.8	90.9	101.0	111.1	121.2

To calculate the lbs. of material required to fill a trench:

- Determine desired thickness.
- Move to the right until you are under the known width of the trench. This number will be the weight of the material in lbs./linear ft.
- Take this number and multiply by the length of the trench in feet. Your answer will be the amount of BURNDY® GROUNDMAX™ material required to fill the trench to the desired level in lbs.

Example:

Thickness: = 6 inches
 Width = 18 inches
 54.6 lbs. per linear ft. (from the table above)
 Answer = 54.6 lbs. per linear ft. x 25 ft. trench = 1,365 lbs. of BURNDY® GROUNDMAX™
 = 28 (50 lb.) bags of BURNDY® GROUNDMAX™

For mold types or BURNDYWeld® items not shown, please contact factory.

Blue highlighted items are industry standard and most frequently ordered.

**BURNDY®
GROUNDMAX™**

Application Information

E-88

Vertical Installation

Drill or bore a hole the desired diameter and depth. Suspend ground electrode in center of hole to be filled. Pour BURNDY® GROUNDMAX™ until desired level is obtained. No tamping is required.

Dry Volume of BURNDY® GROUNDMAX™ vs. Hole Size		Ground Resistance Comparison of Bare Rod vs.	
Hole Size	Lbs. of BURNDY® GROUNDMAX™ Per Ft.	Hole Size with 5/8" x 10' Rod in Center of 15' Hole	Percent Resistance Compared to Rod Only (100%)
4"	6.5	4"	52%
6"	14.5	6"	47%
8"	25.8	8"	44%
10"	40.4	10"	42%
12"	58.1	12"	40%

Horizontal or Grid Construction†

Pour into horizontal trench until level of ground wire is reached. Place ground wire. Pour in additional BURNDY® GROUNDMAX™ until wire is covered to desired height. Cover with fill. No tamping required.

For grid construction, pour BURNDY® GROUNDMAX™ and spread over ground grid until desired thickness is achieved. Cover with fill.

Steady State Leakage Resistance‡ Using 4/0 Copper Wire vs. BURNDY® GROUNDMAX™					
Length	.475" Diameter Wire Only	Percentage of Resistance with .475" Wire Plus BURNDY® GROUNDMAX™ in Various Diameters Compared to Wire Only (100%)			
		2"	3"	4"	6"
25'	100%	83%	78%	74%	69%
50'	100%	85%	81%	77%	73%
75'	100%	86%	82%	79%	75%
100'	100%	87%	83%	80%	77%
150'	100%	88%	84%	82%	78%
200'	100%	88%	85%	83%	79%
250'	100%	89%	85%	83%	80%
300'	100%	89%	86%	84%	80%

† Entire grounding system should be surrounded by BURNDY® GROUNDMAX™. Conductors should be insulated as they exit BURNDY® GROUNDMAX™ column.

‡ The use of BURNDY® GROUNDMAX™ around the grounding system will also reduce surge impedance by increasing the effective contact area of the electrode to soil.

Horizontal Construction

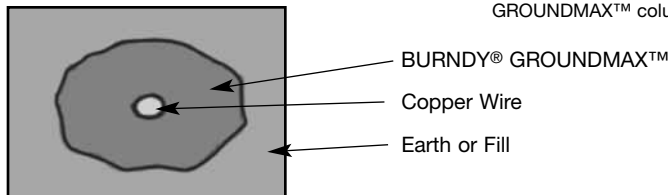

Grid Construction

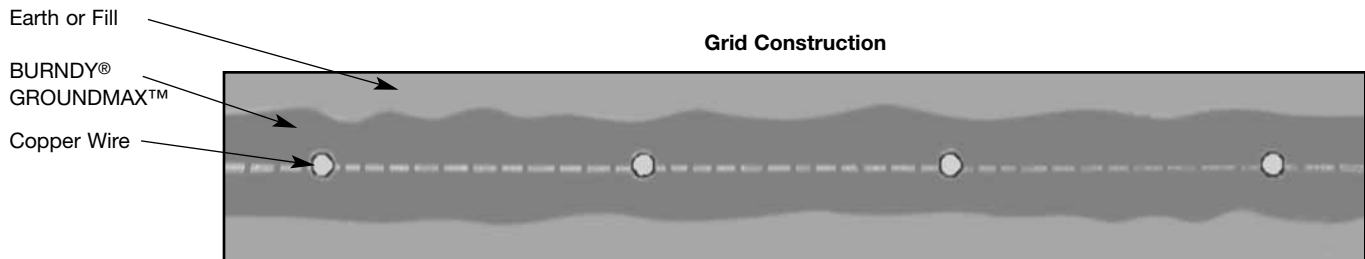

For mold types or BURNDYWeld® items not shown, please contact factory.

Blue highlighted items are industry standard and most frequently ordered.

BURNDY® GRIDMAX™

PREFABRICATED WIRE MESH

Grounding, Personnel Safety Mats, Equipotential Bonding, Pool and Spa Grounding

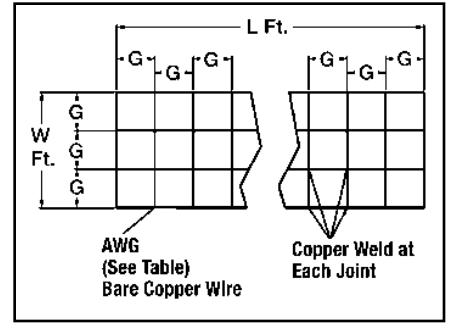
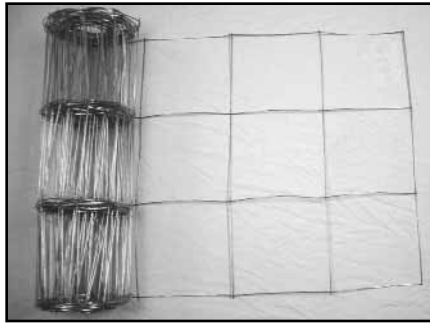

E-89

Features and Benefits

- Manufactured from bare solid copper.
- Spaced on 4", 6" or 12" centers.
- Copper to copper weld with 6% silver.
- Furnished in sections with lengths from 4' to 100'.
- Easily and economically installed using BURNDYWeld® HYGROUND® or our Mechanical connectors.
- Sizes made specifically for the Pool and Spa market 3' x 100' and 3' x 50'. But can be used where any large area grounds are required.

Catalog Number	Conductor	Dimensions		
		G (spacing)	L (length)	W (width)
BGM3100	8 AWG	12"	100'	3'
BGM3050	8 AWG	12"	50'	3'
BGM640044	6 AWG	4"	4'	4'
BGM640068	6 AWG	8"	6'	4'
BGM64006	6 AWG	12"	6'	4'
BGM640066	6 AWG	6"	6'	4'

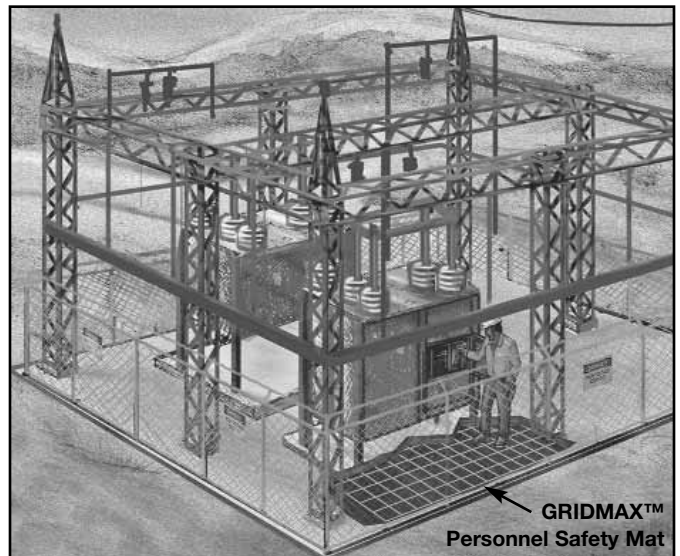

For mold types or BURNDYWeld® items not shown, please contact factory.

Blue highlighted items are industry standard and most frequently ordered.

E-90

B-106 & B-107 HANDLE CLAMPS

BURNDYWeld® Handle Clamps make possible the use of many different sizes and types of molds with only two different clamps. The two handle clamps are catalog numbers **B-106** and **B-107**. These will fit 95% of all standard BURNDYWeld® molds.

1. Use B-106 clamps for all molds having a price key 4, 7, 17, 22 or 24. These molds are a nominal 3 1/8" x 3 1/8" square.
2. Use B-107 clamps for all molds having a price key 5, 6, 8 or 23. These molds are a nominal 4" x 4" square.
3. All molds having a price key 2, 3, 9, 10, 11, 12, 14, 15 or 16 have an attached frame; separate handles are not required.

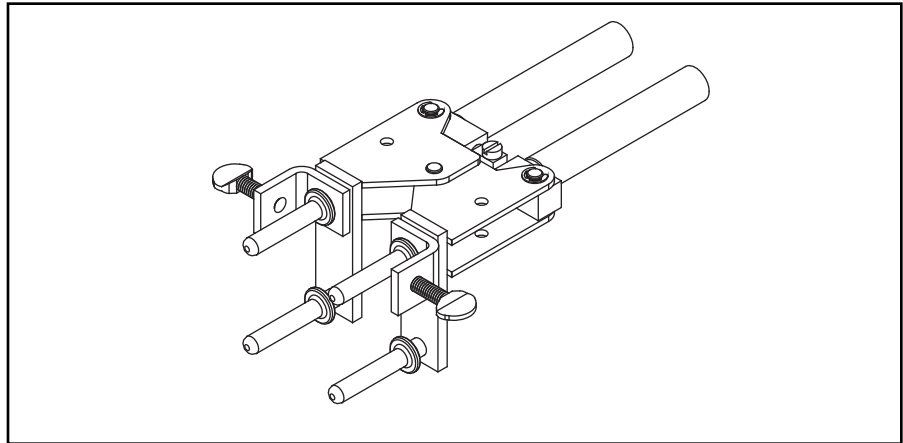

B40-0106-75 HANDLE ATTACHMENT

This Handle Attachment is used to hold Price Key-14 molds in position. It easily attaches to the B-106 Handle Clamp. This Handle Attachment can be used with weld types BCRE-1 and BCRE-4.

Catalog Number **B40-0106-75**

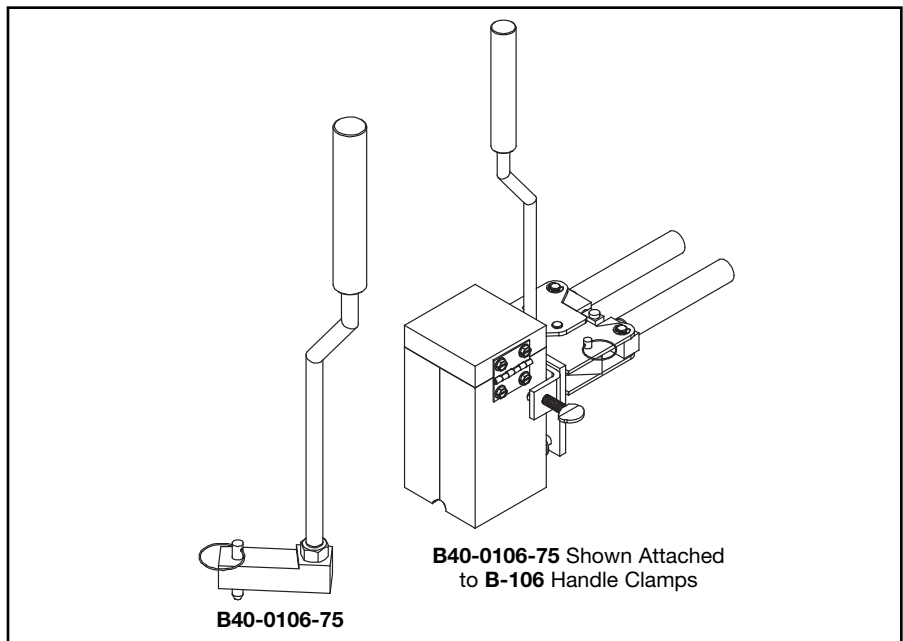

MOLD SUPPORT CLAMP

The Mold Support Clamp is used to hold a mold in position on a vertical steel column or angle. It is easily attached to the Handle Clamps. The Mold Support Clamp can be used with weld types BCS-3, BCS-18, BCS-23 and BCS-27.

Catalog Number **B40-3657-00**

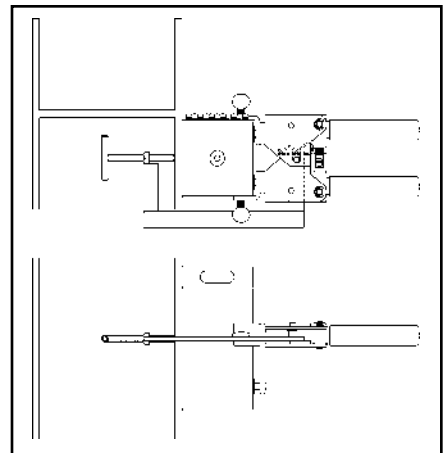
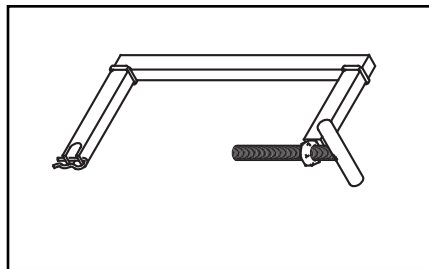

For mold types or BURNDYWeld® items not shown, please contact factory.

Blue highlighted items are industry standard and most frequently ordered.

VERTICAL MAGNETIC CLAMPS

Magnetic Clamps are used to hold a mold in position on a vertical steel surface. The magnetic clamp can be purchased complete with B-106 Handle Clamps or if you already have a set of handle clamps, you can order just the magnetic mounting assembly. The mounting assembly can easily be mounted on the prongs of your existing B-106 handle clamps. A minimum of 10" is required.

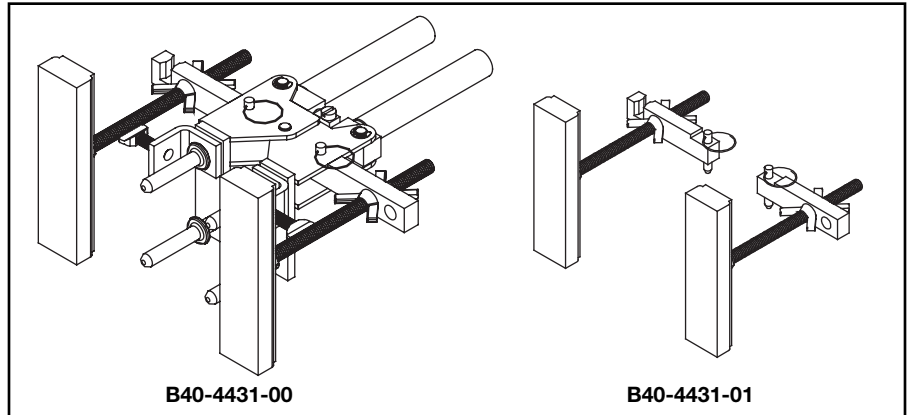

Magnetic Clamps With B106 Handle		
Catalog Number	Fits Molds W/Price Key	For Use With Weld Types
B404431-00	4 & 17	BCS-3, 4, 7 & 23

Magnetic Clamp Only		
Catalog Number	Fits Handle Clamps	For Use With Weld Types
B40-4431-01	B-106 & B-107	BCS-3, 4, 7 & 23

HORIZONTAL & VERTICAL CHAIN CLAMPS

Chain Clamps are used to hold a mold in position on horizontal or vertical pipe up to 4" in diameter. For larger pipe a 20" chain extension is available to allow the chain clamps to be used on pipe up to 10" in diameter. The chain clamp can be purchased complete with B-106 or B-107 Handle Clamps or if you already have a set of handle clamps, you can order just the chain clamp and mounting assembly. The mounting assembly can easily be attached to your existing handle clamps. 20" Chain Extension catalog number: B40-0106-27.

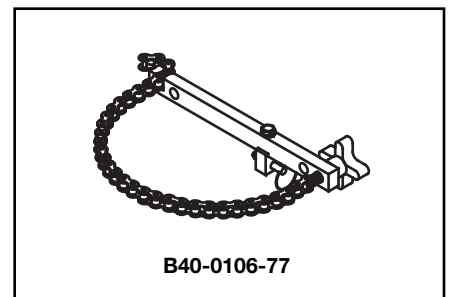
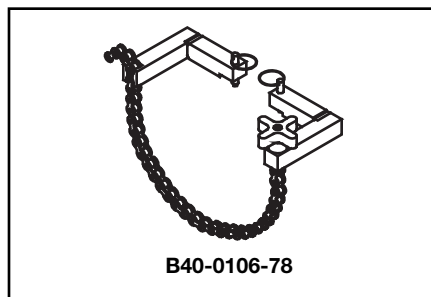
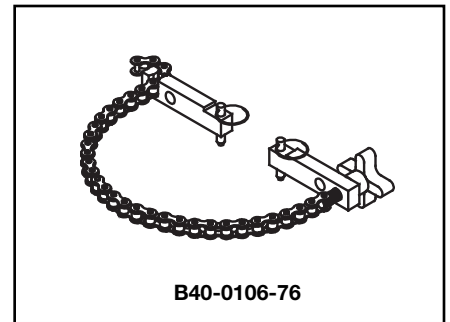
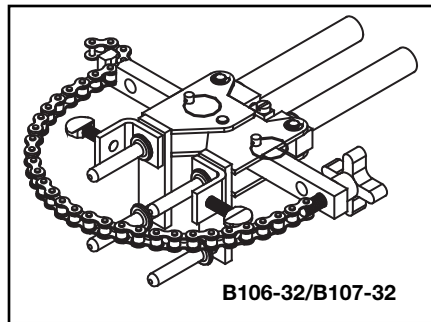

Chain Clamps			
Catalog Number	Fits Molds W/Price Key	For Use With Weld Types	Pipe Position
B106-32	4, 17, 22 & 24	BCS-3, 4, 7, 23 & BCRE-6	Vertical
B107-32	5, 6 & 23	BCS-3, 4, 7 & 23	Vertical
B106-37	4, 17, 22 & 24	BCS-1, 2, 5, 8 & 9	Horizontal
B107-37	5, 6 & 23	BCS-1, 2, 5, 8 & 9	Horizontal
B106-41	4, 17	BCS-6, 18 & BCRE-3	Vertical

Chain Clamp Only (Handle Clamps Not Included)			
Catalog Number	Fits Handle Clamp	For Use With Weld Types	Pipe Position
B40-0106-76	B-106 & B-107	BCS-3, 4, 7, 23 & BCRE-6	Vertical
B40-0106-78	B-106 & B-107	BCS-1, 2, 5, 8 & 9	Horizontal
B40-0106-77	B-106 & B-107	BCS-6, 18 & BCRE-3	Vertical

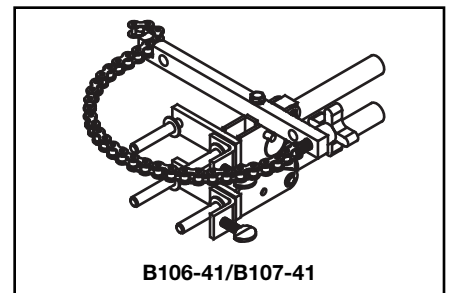

For mold types or BURNDYWeld® items not shown, please contact factory.

Blue highlighted items are industry standard and most frequently ordered.

E-91

BURNDYWeld® ACCESSORIES

B38-0330-00 CABLE CLAMP

The BURNDYWeld® Cable Clamp is recommended for holding a wide range of cables properly in place in molds when welding cables that are under tension. This prevents the cables from pulling out of the mold when the weld is made.

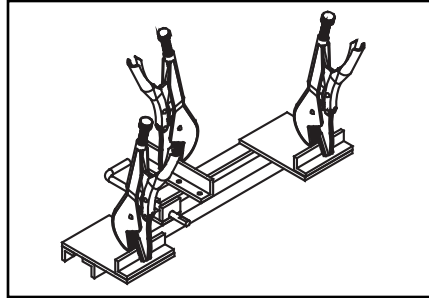

CABLE CLEANING AND CARD CLOTH BRUSH

The Cable Cleaning Brush is recommended for cleaning heavily oxidized cables. The V-shape brushes permit their use over a wide range of cable sizes. Brush assembly consists of a handle with two stiff wire bristle brushes that are rotatable, for longer life and are replaceable.

The Card Cloth Brush is used for cleaning large conductors and bus bar. It has short stiff bristles. These brushes are for cleaning cable only, not molds.

The Mold Cleaning Brush **B38-3922-00** is used to clean the graphite mold without scratching the mold.

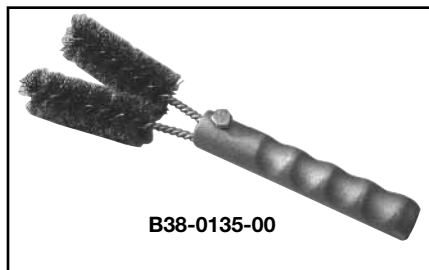

Cable Cleaning Brush	B38-0135-00
Replacement Brush	B38-0135-01
Card Cloth Brush	B38-0306-00
Mold Cleaning Brush	B38-3922-00



MOLD CLEANERS

Mold Cleaners are used to clean the slag from molds that are not split through the crucible.

- B40-0319-01** for cartridge sizes #15 through #65
- B40-0319-03** for cartridge sizes #90 through #500



PACKING MATERIAL

Packing material is used to prevent the molten weld metal from leaking out of the mold. When the cable opening becomes worn from heavy use, the packing material may be used to prolong mold use. It is also used around 7 strand cable to prevent leaking. Packing material comes in a 1 lb. or 5 lb. package.

Catalog Number	Description
B38412900	1 lb. package
B38412905	5 lb. package

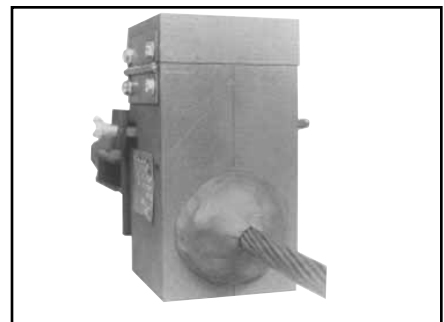

For mold types or BURNDYWeld® items not shown, please contact factory.

Blue highlighted items are industry standard and most frequently ordered.

BURNDYWeld® ACCESSORIES



BURNDYWeld® TOOL KIT

- B38-0302-00** Tool Kit with Tools Shown except Rasp
- B38-0302-02** Tool Kit with Tools Shown and Rasp
- B38-0303-00** Tool Box only



E-93

BURNDYWeld® TOOLS

- B38-0309-00** Flint Ignitor
- B38-0304-00** 8" File
- B38-0307-00** Crimping Tool
- B38-3922-00** Mold Cleaning Brush
- B38-0308-00** 6" Screwdriver
- B38-0305-00** Wire Brush
- B38-0101-00** Rasp
- B38-0306-00** Card Cloth Brush

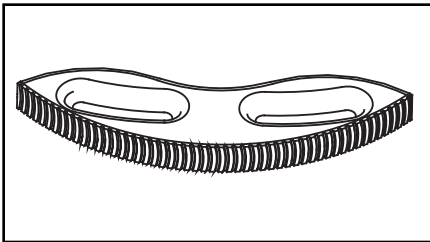

B38-0101-00 RASP

This tempered steel, curved rasp is recommended for removing rust and mill scale from steel and cast iron surfaces. The blade is replaceable. To order replacement rasp blade, specify catalog number **B38-0101-01**.

Not recommended for use on galvanized surfaces.

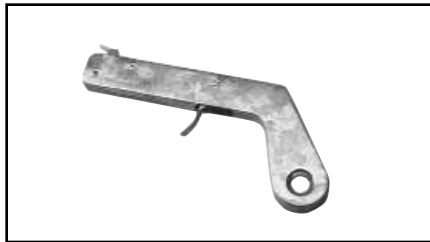

B38-0309-00 FLINT IGNITOR

The B38-0309-00 Flint Ignitor is used to ignite the starting powder. Each mold that is sold with a frame has a Flint Ignitor included. For added safety a Flint Ignitor extension is available, catalog number **B38-0904-00**, that attaches to the B38-0309-00 Flint Ignitor. This allows installers to stay approximately 36" away from the mold.

To order replacement flints, specify part number **B38-0309-01**.

For mold types or BURNDYWeld® items not shown, please contact factory.

Blue highlighted items are industry standard and most frequently ordered.

GROUND ROD DRIVING SLEEVES

Ground Rod Driving Sleeves are placed over the top of a ground rod while driving it into the ground. This prevents the top from mushrooming or flaring out. Ground rod driving sleeves are available in sizes to fit all standard unthreaded ground rods.

E-94

Catalog Number	For Use On
B38-3662-01	1/2" Copper Clad or Steel Ground Rod
B38-3662-02	5/8" Copper Clad Ground Rod
B38-3662-05	5/8" Steel Ground Rod
B38-3662-03	3/4" Copper Clad Ground Rod
B38-3662-06	3/4" Steel Ground Rod
B38-3662-04	1" Copper Clad Ground Rod

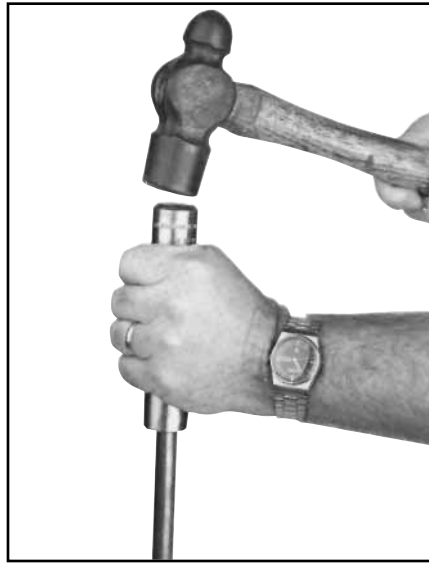

SHIM STOCK AND ADAPTER SLEEVES

BURNDYWeld® molds designed for larger cable sizes can be used on smaller diameter cables if copper adapter sleeves or shim stock are utilized. The copper shim stock, .0108" x 1-1/2" x 3", is normally wrapped around cable until the diameter is about equal to the cable opening. A tight fit is not necessary as the shim stock will unwrap slightly and prevent leakage of weld metal. To order shim stock use part number **B38-0329-00**. Shim stock comes 100 pieces per box.

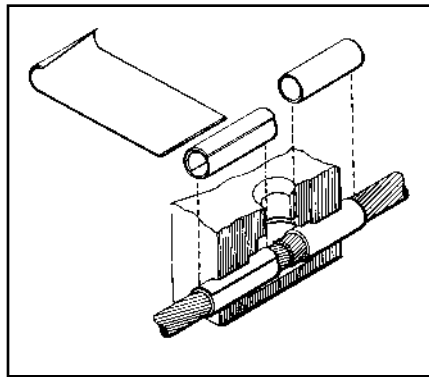

For Use on Cable Size		Part No.	Use in Mold Size	Sleeve Dimensions		
Stranded	Solid			O.D.	I.D.	Length
#12, #14	#10, #12, #14	BA-200	#6 Str & Sol	.156	.111	1.00
#9, #10	#8, #9, #10	BA-208	#4 Sol	.203	.140	1.00
#7, #8, #10	#6, #8	BA-201	#4	.227	.177	1.00
#6	#5	BA-202	#2	.292	.198	1.00
#4, #5	#3, #4	BA-207	#2	.302	.246	1.00
#4	#2	BA-204	#1	.340	.246	1.00
#2	#1	BA-203	1/0	.370	.307	1.00
#1	1/0	BA-209	2/0	.420	.359	1.00
1/0, #1	2/0	BA-205	3/0 & 4/0 Sol	.469	.385	1.00
2/0, 1/0	3/0	BA-240	4/0	.524	.437	1.50
4/0	—	BA-211	300 kcmil	.625	.545	1.25
250 kcmil	—	BA-212	350 kcmil	.677	.595	1.25
350,400 kcmil	—	BA-213	500 kcmil	.811	.762	1.50
250, 300, 350 kcmil	—	BA-214	500 kcmil	.811	.700	1.50
750,800 kcmil	—	BA-215	1000 kcmil	1.156	1.05	1.50

For mold types or BURNDYWeld® items not shown, please contact factory.

Blue highlighted items are industry standard and most frequently ordered.

TROUBLE SHOOTING TIPS

E-95

PROBLEM	PROBABLE CAUSE	CORRECTION TO MAKE
Insufficient metal to make weld.	Worn mold resulting in leaking weld metal.	Replace mold. If only worn around conductor opening, use duct seal around conductor. Do not get duct seal into mold cavity.
	Wrong size cartridge for mold.	Check ID plate for mold and compare with number on bottom of cartridge.
	Too much spillage when dumping powder.	Carefully open lid while holding over crucible and dump.
	Wrong mold for conductor being used.	Replace with correct mold. In some applications, shim stock or adapter sleeves can be used to enlarge cable to fit mold.
Mold does not close tightly causing weld metal to leak out.	Handle clamps not properly adjusted.	Remove cotter pin between the handles of the mold and adjust handle tension by backing out the eye bolt.
	Dirt or slag stuck in parting line of mold.	Clean mold thoroughly between connections.
	Bent or out-of-round cable.	Straighten or cut out bad section of cable.
Handle clamps will not lock closed.	Handle clamps not properly adjusted.	Remove cotter pin between the handles of the mold and adjust handle tension by backing out the eye bolt.
Excessively high weld, bubbly or gassy appearance, poor weld.	Moisture in mold.	Pre-heat mold to above 220° F with a propane torch, or ignite a sacrificial shot in mold with pieces of scrap conductor in it. If it is a horizontally split mold, shoot 3/4 of the recommended cartridge to make sure you do not lock up mold.
	Oil, grease, moisture or foreign material on conductors.	Pre-heat conductors with propane torch then use a clean wire brush on conductor to remove any residue left on conductors. If welding to cast iron or steel surface, weld area must be cleaned down to bright metal.
	Duct seal in weld cavity.	Take special precautions to keep duct seal out of weld cavity.
	Weld powder has gotten wet.	Replace with fresh, dry weld powder.
Weld metal blows out top of mold.	Mold worn or chipped around disc seal allowing powder to leak into mold cavity.	Replace mold.
	Forgot to use steel disc or did not seat it properly at bottom of crucible.	Make sure disc is seated at bottom of crucible before pouring the powder into crucible.

Blue highlighted items are industry standard and most frequently ordered.

TROUBLE SHOOTING TIPS
(Continued)

E-96

PROBLEM	PROBABLE CAUSE	CORRECTION TO MAKE
Cannot ignite powder.	Insufficient starting powder in ignition pocket on mold lid.	Place at least half of starting powder in ignition pocket of mold lid. Use all starting powder for each connection.
	Flint ignitor not shooting enough spark.	Clean flint ignitor according to directions on box or replace flint ignitor.
	Starting powder lumped together.	Break up starting powder on lid with edge of powder tube.
	Starting powder has gotten wet.	Remove shot from mold and replace with a dry cartridge.
Mold wearing out too fast.	Improper cleaning of mold.	Use mold cleaner, soft natural bristle brush or clean rag to clean mold between shots. Do not use wire brush or screwdriver on molds.
	Bent or out of round cable causes chipping and premature wear of the mold.	Use caution when closing mold. Do not force mold shut around bent, twisted or out of round conductors.
Poor weld to ground rod.	Weight of mold not supported during reaction causing mold to slip when cable melts.	Use locking pliers on ground rod under mold to support the weight of the mold during the reaction.
	Moisture or contaminant on cable or ground rod.	Pre-heat conductors with propane torch then use a clean wire brush on conductors to remove any residue left on conductors.
Weld will not stick to steel surface.	Improperly cleaned area on steel.	An area larger than the weld area should be cleaned down to bright clean metal.
	Moisture or contaminant on cable or ground rod.	Pre-heat conductors with propane torch then use a clean wire brush on conductors to remove any residue left on conductors.
	Cable is improperly positioned in mold, blocking the flow of weld metal.	Position cable in mold in accordance with directions for mold. If directions are not available, position top of cable in the center of where the liquid weld metal hits the steel.
Weld will not stick to cast iron surface.	All of the causes listed under welding to steel surface also apply to this section.	
	Not using CI (Cast Iron) powder.	Specify "CI" behind cartridge when ordering powder (i.e., 25 CI).
Cable pulls out of mold when it is fired.	Cables are either twisted or under tension.	Use B38-0330-00 cable clamp or other method to remove tension. Cut out severely twisted cable.

Blue highlighted items are industry standard and most frequently ordered.

TABLE OF CONTENTS

Introduction	F-2	Heavy Wall Heat Shrinkable End Cap ...	F-9
PENETROX™ (Install Connections)	F-2	Clear Heat Shrink Tubing	F-10
PENETROX™ A, PENA-1 LB, PENETROX™ A-13, PENETROX® E ...	F-3	Thin Wall Polyvinyl Chloride Heat Shrink Tubing	F-11
PENETROX™ Technical & Ordering Information	F-4	MISCELLANEOUS ACCESSORIES:	
Thin Wall Heat Shrink Tubing		Heat Gun	F-12
6 Inch Lengths	F-5	Type 145PTAG	F-12
4 Foot Reels	F-6		
25 Foot Reels	F-7		
Heavy Wall Heat Shrink Tubing			
4 Foot Sticks	F-8		
Cut Lengths	F-8		

F-1

Blue highlighted items are industry standard and most frequently ordered.

INTRODUCTION

BURNDY® wiring accessories have been designed to supplement and enhance BURNDY® connector selection and use. All have been designed and engineered for easy

installation and long life, reflecting over 65 years of experience and resulting contributions to all aspects of the electrical industry.

PENETROX™

HOW TO INSTALL CONNECTORS:

F-2

1. Select the right connector.

Always use an aluminum connector for aluminum or copper conductor. And choose a connector that's marked for the wire size you're using. Never use a copper connector on aluminum conductor.



2. Strip carefully.

Remove the insulation without nicking the wire.

3. Brush thoroughly.

Always wire-brush the stripped portion of the wire. An unplated terminal pad, and the surface to which the terminal will be attached should also be wire-brushed.



4. Apply PENETROX™

For mechanical connectors, apply PENETROX™ joint compound liberally to the conductor to prevent the formation of surface oxides once the connection is made. Also apply PENETROX™ to any terminal pad.



5. Tighten completely.

For mechanical connectors, use wrench or screwdriver to securely tighten the aluminum connectors, as recommended by BURNDY®.

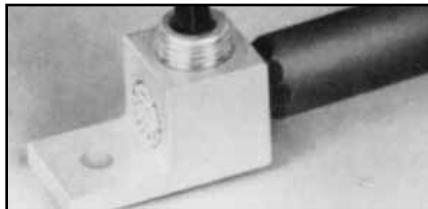

6. Crimp.

For compression connectors, choose the right die and the right tool. Insert the wire completely and make the recommended number of crimps. BURNDY® takes the guesswork out of aluminum connections because the connectors and crimp dies are color coded. Crimps can be easily located between marks.



Blue highlighted items are industry standard and most frequently ordered.

**TYPES PENETROX™
A, A-13, E AND HT**

**OXIDE-INHIBITING
JOINT COMPOUNDS**

PENETROX™ oxide-inhibiting compounds produce low initial contact resistance, seal out air and moisture, prevent oxidation or corrosion, exhibit superior weathering characteristics, are usable over wide temperature ranges, and provide a high conductivity "gas-tight" joint. All PENETROX™ compounds contain homogeneously suspended metal particles. The suspended metal particles assist in penetrating thin oxide films, act as electrical "bridges" between conductor strands, aid in gripping the conductor, improve electrical conductivity and enhance the integrity of the connection.

The specially formulated PENETROX™ compounds are for use with compression and bolted connectors providing an improved service life for both copper and aluminum connections. Additionally, the non-toxic compounds are an excellent lubricant for threaded applications reducing galling and seizing.



PENACARTRIDGE

PENACARTRIDGE is a 1 lb. cartridge filled with PENETROX-A. It's designed to fit standard caulking guns for easy insertion into transmission and distribution connectors. Additionally, this packaging design provides a convenient method for applying PENETROX™ to many different applications.



PENETROX™ A-13

PENETROX™ A-13 is a synthetic base compound with evenly suspended zinc particles. It is recommended for aluminum to aluminum, aluminum to copper connection plus aluminum conduit threads. It is compatible with rubber, polyethylene and other insulating materials. UL Listed for all voltages.

F-3



PENETROX™ A

PENETROX A is a natural (petroleum) base compound with evenly suspended zinc particles. It is recommended for aluminum to aluminum, aluminum to copper connections and aluminum conduit threads. It is not recommended for use with rubber or polyethylene insulated conductors. UL listed to 600V.



PENETROX™ E

PENETROX™ E is a synthetic base compound with evenly suspended copper particles. It is recommended for copper to copper, copper threads and all grounding applications. UL listed.



PENETROX™ HT

PENETROX™ HT is a synthetic silicone based compound with evenly suspended zinc particles and nickel-aluminum alloy particles. It is recommended for aluminum to aluminum connection. It is compatible with rubber. Designed for use with High Temperature ACSS and ACCC connectors. Not UL Listed.

Blue highlighted items are industry standard and most frequently ordered.

PENETROX A, A-13, E AND HT

TECHNICAL INFORMATION

PENETROX A

PENETROX A consists of a natural (petroleum) base vehicle in which zinc particles are suspended. For aluminum to aluminum, aluminum to copper applications and aluminum conduit threads. It is not recommended for use with rubber and polyethylene insulated conductors. UL Listed to 600 volts.

PENETROX A-13

PENETROX A-13 consists of a non-petroleum base vehicle in which zinc particles are suspended. Recommended for aluminum to aluminum, aluminum to copper applications and aluminum conduit threads. Compatible with insulating materials such as rubber, or polyethylene. UL Listed and recommended for all voltages.

PENETROX E

PENETROX E consists of a non-petroleum base vehicle in which copper granules are suspended. Recommended for copper to copper applications, grounding and for use on copper conduit threads. UL Listed.

PENETROX HT

PENETROX HT consists of a non-petroleum base vehicle in which zinc and nickel-aluminum particles are suspended. Recommended for use with aluminum to aluminum High Temperature rated ACSS and ACCC conductors. Not UL Listed.

Easy to apply:

1. Scratch brush the conductor surfaces until bright and clean.
2. Immediately apply PENETROX™ to the conductive surfaces.
3. For EHV applications, remove all excess PENETROX™ after installation is complete.



SHELF LIFE

When stored in its original container in cool (under 100°F) dry environment, PENETROX™ oxide inhibiting compound will remain workable and functional for 5 years from the date marked on the container provided it is mixed per instructions prior to use.

PROPERTIES OF PENETROX™

Property	Value PENETROX™ Definition	PENETROX™ HT	PENETROX™ E & A13	PENETROX™ A
Penetration (Unworked)	The value in accordance to ASTM D217 indicates the consistency of a grease. The higher the number, the softer the grease.	240	250	230
Dropping Point (Minimum)	The temperature at which the grease passes from the semi-solid to a liquid state under test conditions.	>580° F	500° F	230° F
Pour Point (Maximum)	The lowest temperature at which the compound will flow. Pour point is the lubricant's ability to perform in cold conditions.	-58° F	-10° F	-15° F

* MSDS sheets available through customer service.

ORDERING INFORMATION

Catalog Number				Container Type	Container Size
PENETROX™ A	PENETROX™ A-13	PENETROX™ E	PENETROX™ HT		
PENA 1/2	—	—	—	Tube	1/2 oz.
PEN A-4	PEN A13-4	PEN E-4	PENHT-4	Squeeze Bottle	4 oz.
P8A	PEN A13-8	PEN E-8	PENHT-8	Squeeze Bottle	8 oz.
PENACARTRIDGE	PENA13CARTRIDGE	—	PENHT-1LB	Cartridge	1 lb.*
PEN A-QT	PEN A13-QT	PEN E-QT	—	Plastic Tub	1 Quart
PEN A-GAL	PEN A13-GAL	PEN E-GAL	PENHT-GAL	Can	1 Gallon
PEN A-5GAL	PEN A13-5GAL	PEN E-5GAL	—	Pail	5 Gallons
PEN A-55GAL	PEN A13-55GAL	PEN E-55GAL	—	Drum	55 Gallons

* 1 lb. cartridge will fit standard caulking guns.

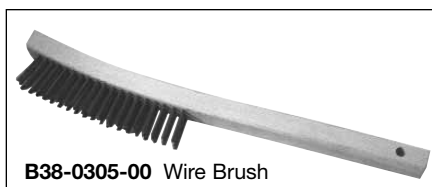

Blue highlighted items are industry standard and most frequently ordered.

TYPE HS-T-PF

THIN WALL HEAT SHRINK TUBING

Cross-Linked Polyolefin

6 Inch Lengths



Type HS-T-PF is a flexible thin wall, flame retardant heat shrink tubing made of cross-linked polyolefin. The 2:1 shrink ratio allows for faster shrink recovery, covering wire sizes: #18 AWG to 300 kcmil. Operating temperatures from -55° C to 135° C with a shrink temperature of 120° C.



Meets MIL-I-23053/5
600 VOLTS

F-5

Catalog Number	Nominal Diameter Inches	Min. Exp. I.D. In.	Max. Recov. I.D. In.	Nom. Wall Thickness In.	Conductor Range	Pcs. per Package	
						# Pcs. Black	# Pcs. Ea. Color
HSM116T6PF26	1/16	0.06	0.03	0.018	#18	8	3
HSB116T6PF26	1/16	0.06	0.03	0.018	#18	26	0
HSM332T6PF24	3/32	0.09	0.05	0.020	#18 - 16	6	3
HSB332T6PF24	3/32	0.09	0.05	0.020	#18 - 16	24	0
HSM18T6PF20	1/8	0.12	0.06	0.020	#18 - 14	2	3
HSB18T6PF20	1/8	0.12	0.06	0.020	#18 - 14	20	0
HSM316T6PF18	3/16	0.19	0.09	0.020	#18 - 12	6	2
HSB316T6PF18	3/16	0.19	0.09	0.020	#18 - 12	18	0
HSM14T6PF14	1/4	0.25	0.12	0.180	#14 - 10	2	2
HSB14T6PF14	1/4	0.25	0.12	0.180	#14 - 10	14	0
HSM38T6PF12	3/8	0.38	0.19	0.020	#8 - 6	6	1
HSB38T6PF12	3/8	0.38	0.19	0.020	#8 - 6	12	0
HSM12T6PF10	1/2	0.50	0.12	0.020	#6 - 2	4	1
HSB12T6PF10	1/2	0.50	0.12	0.020	#6 - 2	10	0
HSM34T6PF8	3/4	0.75	0.38	0.020	#1 - 3/0	2	1
HSB34T6PF8	3/4	0.75	0.38	0.020	#1 - 3/0	8	0
HSM100T6PF7	1	1.00	0.50	0.180	2/0 - 300	1	1
HSB100T6PF7	1	1.00	0.50	0.180	2/0 - 300	7	0

HSB series — all black

HSM series — multiple colors: black, blue, clear, green, red, white, yellow

HSB11612T6PF14	1/16, 3/32, 1/8, 3/16, 1/4, 3/8, 1/2					14	0
HSB38100T6PF8	3/8, 1/2, 3/4, 1"					8	0

Multiple diameter packages contain two pieces of each size listed: Black only.

Blue highlighted items are industry standard and most frequently ordered.

TYPE HS-T-PF

THIN WALL HEAT SHRINK TUBING

Cross-Linked Polyolefin

4 Foot Reels

Type HS-T-PF is a flexible thin wall, flame retardant heat shrink tubing made of cross-linked polyolefin. The 2:1 shrink ratio allows for faster shrink recovery, covering wire sizes #18 AWG to 300 kcmil. Operating temperatures from -55° C to 135° C with a shrink temperature of 120° C.

F-6



Meets MIL-I-23053/5
600 VOLTS

Specify Color Code in Third Position of Catalog Number:

Example: HSC316T48PF

- B:** BLACK
- BL:** BLUE
- C:** CLEAR
- G:** GREEN
- R:** RED
- W:** WHITE
- Y:** YELLOW

Catalog Number	Nominal Diameter Inches	Min. Exp. I.D. In.	Max. Recov. I.D. In.	Nom. Wall Thickness In.	Conductor Range
HS_116T48PF	1/16	0.06	0.03	0.018	#18
HS_332T48PF	3/32	0.09	0.05	0.020	#18 - 16
HS_18T48PF	1/8	0.12	0.06	0.020	#18 - 14
HS_316T48PF	3/16	0.19	0.09	0.020	#18 - 12
HS_14T48PF	1/4	0.25	0.12	0.180	#14 - 10
HS_38T48PF	3/8	0.38	0.19	0.020	#8 - 6
HS_12T48PF	1/2	0.50	0.12	0.020	#6 - 2
HS_34T48PF	3/4	0.75	0.38	0.020	#1 - 3/0
HS_100T48PF	1	1.00	0.50	0.180	2/0 - 300
HS_150T48PF	1-1/2	1.50	.75	0.180	350 - 750
HS_200T48PF	2	2.00	1.00	0.180	250 - 500

Blue highlighted items are industry standard and most frequently ordered.

TYPE HS-T-PF

THIN-WALL HEAT SHRINK TUBING

Cross-Linked Polyolefin

25 Foot Reels

Type HS-T-PF is a flexible thin wall, flame retardant heat shrink tubing made of cross-linked polyolefin. The 2:1 shrink ratio allows for faster shrink recovery, covering wire sizes #18 AWG to 300 kcmil. Operating temperatures from -55° C to 135° C with a shrink temperature of 120° C.

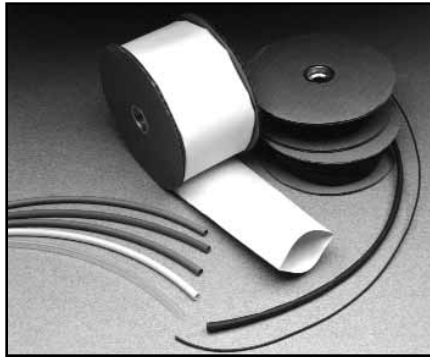

F-7



Meets MIL-I-23053/5
600 VOLTS

Specify Color Code in Third Position of Catalog Number:

Example: HSC116T300PF

- B:** BLACK
- BL:** BLUE
- C:** CLEAR
- G:** GREEN
- R:** RED
- W:** WHITE
- Y:** YELLOW

Catalog Number	Nominal Diameter Inches	Min. Exp. I.D. In.	Max. Recov. I.D. In.	Nom. Wall Thickness In.	Conductor Range
HS_116T300PF	1/16	0.06	0.03	0.018	#18
HS_332T300PF	3/32	0.09	0.05	0.020	#18 - 16
HS_18T300PF	1/8	0.12	0.06	0.020	#18 - 14
HS_316T300PF	3/16	0.19	0.09	0.020	#18 - 12
HS_14T300PF	1/4	0.25	0.12	0.180	#14 - 10
HS_38T300PF	3/8	0.38	0.19	0.020	#8 - 6
HS_12T300PF	1/2	0.50	0.12	0.020	#6 - 2
HS_34T300PF	3/4	0.75	0.38	0.020	#1 - 3/0
HS_100T300PF	1	1.00	0.50	0.180	2/0 - 300

Blue highlighted items are industry standard and most frequently ordered.

TYPE HS-H-PF

HEAVY WALL HEAT SHRINK TUBING

Cross-Linked Polyolefin

Cut Lengths and 4 Foot Sticks



F-8

Type HS-H-PF is a heavy wall, flame retardant heat shrink tubing made of cross-linked polyolefin. The shrink ratio is 3:1, and the inside diameter is coated with an adhesive sealant to protect against moisture and corrosion. UL486D Listed for direct burial applications. Accommodates #14 AWG - 500 kcmil conductors. Operating temperatures from -55° C to 135° C with a shrink temperature of 120° C.

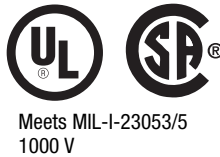

Catalog Number	Length	Nominal Diameter Inches	Min. Exp. ID In.	Max. Recov. ID In.	Nom. Wall Thickness In.	Conductor Range	Number of Pcs. Per Package
HSB35H3PF25	3"	.350	.350	.150	0.070	#14-10	25
HSB35H6PF25	6"	.350	.350	.150	0.070	#14-10	25
HSB35H48PF5	4'	.350	.350	.150	0.070	#14-10	5
HSB34H6PF10	6"	.750	.750	.220	0.090	#6-2	10
HSB34H9PF10	9"	.750	.750	.220	0.090	#6-2	10
HSB34H48PF5	4'	.750	.750	.220	0.090	#6-2	5
HSB110H6PF5	6"	1.100	1.100	.400	0.120	#1-3/0	5
HSB110H9PF5	9"	1.100	1.100	.400	0.120	#1-3/0	5
HSB110H48PF5	4'	1.100	1.100	.400	0.120	#1-3/0	5
HSB150H9PF3	9"	1.500	1.500	.500	0.160	2/0-350	3
HSB150H12PF3	12"	1.500	1.500	.500	0.160	2/0-350	3
HSB150H48PF5	4'	1.500	1.500	.500	0.160	2/0-350	5
HSB200H9PF2	9"	2.000	2.000	.750	0.160	250-500	2
HSB200H12PF2	12"	2.000	2.000	.750	0.160	250-500	2
HSB200H48PF2	4'	2.000	2.000	.750	0.160	250-500	2

Available in black only.

Blue highlighted items are industry standard and most frequently ordered.

TYPE HSIC - FR

HEAVY WALL HEAT SHRINKABLE END CAP

UL Listed to 600 Volts

Type HSIC-FR, **H**eat **S**hrink **I**nsulating **E**nd **C**ap **F**ire **R**etardant is a heavy wall, fire retardant end cap made of cross-linked thermally stabilized black polyolefin. Used to insulate exposed conductors in energized applications. The 3:1 shrink ratio offers greater range, accommodating copper wire sizes, #8 AWG thru 2500+ kcmil. Performs effectively over lead, aluminum, steel, polyethylene, EPR, and PVC jacketed materials. Blue thermal chromatic lines disappear indicating correct installation temperature and provide inspectability. I.D. adhesive provides superior moisture and weather resistant characteristics.



Features and Benefits

- Minimum 28 Oxygen index, UL94-VO rated.
 - ◊ Self-extinguishing flame retardant properties.
- 3:1 shrink ratio.
 - ◊ Minimum inventory required.
- Thermal chromatic lines.
 - ◊ Indicate proper installation.
- Low shrink temperature, 150°C.
 - ◊ Only requires common hot air gun to apply.
- Meets sealing requirements:
 - ANSI-C119.1, UL486D
 - ◊ Weather and moisture resistant.



Catalog Number	600V Cable		Internal Diameter		Wall Thickness		Length ± 20%		Number of Pcs. per Package
	Code	Flex	(Min.)	(Max.)	Exp.	Rec.	Exp.	Rec.	
			Exp.	Rec.		± 20%		± 20%	
HSIC8-1FR	#8 - #1	#8 - #4	.50	.16	.034	.080	3.0	2.50	10
HSIC4-40FR	#4 - 4/0	#4 - 2/0	.75	.24	.030	.080	3.5	2.50	10
HSIC10-500FR	1/0 - 500 kcmil	#1 - 313.1 kcmil	1.10	.35	.039	.120	4.0	3.00	5
HSIC30-1000FR	3/0 - 1000 kcmil	2/0 - 646 kcmil	1.50	.47	.054	.160	4.5	3.25	5
HSIC200FR	300 - 1750 kcmil	250 - 1111 kcmil	2.00	.63	.050	.160	4.5	3.50	5
HSIC269FR	600 - 2500 kcmil	—	2.68	.87	.050	.160	5.0	4.00	5
HSIC350FR	1250 kcmil (min)	—	3.50	1.18	.051	.160	5.0	4.50	5



1. Slide the HSIC-FR end cap onto the cable and hold in place using forefinger or thumb.



2. Beginning at closed end apply heat, blue thermochromatic lines will begin to disappear at 150° C. Gradually, move heat source to open end and around cap. Once lines are no longer visible and adhesive flows out of open end, discontinue heating.



3. HSIC-FR end cap installed on cable.

Blue highlighted items are industry standard and most frequently ordered.

TYPE HSC-FR

VISI-SHRINK

Fire Retardant Clear Heat Shrink Tubing

UL Recognized to 600 Volts

Type HSC-FR is a flexible polyvinyl chloride clear heat-shrink tubing. Excellent flame retardant properties and a 2:1 shrink ratio, the VISI-SHRINK tubing enables inspectors to read die index embossments on installed connectors easily. UL recognized, 105° C, 600V, the operating temperature from -20° C to 105° C with a shrink temperature of 135° C.

Features and Benefits

- UL 224, VW-1 Rated.
 - ◊ Self-extinguishing flame retardant properties.
- Clear Tubing.
 - ◊ Allows inspection of die index embossed and shiner after installation is complete. Should any corrosion occur it will be visible during inspection.
- Low Shrink Temperature.
 - ◊ Only requires common hot air guns to apply.
- Meets MIL-M-23053/Z-206C

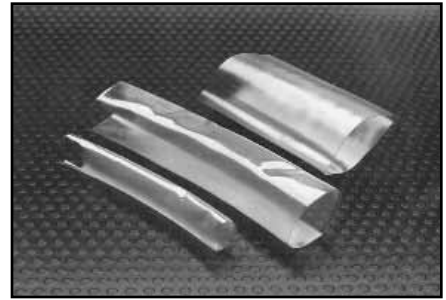

F-10

Catalog Number	I.D. Expanded	I.D. After Recovery	Wall Thickness	Conductor Range		Standard Reel Size (Feet)
				Code	Flex	
HSC18FR	.125	.062	.025	#16 - #14	#16 - #14	50
HSC18FR250	.125	.062	.025	#16 - #14	#16 - #14	250
HSC14FR	.250	.125	.025	#12 - #8	#12 - #10	50
HSC14FR250	.250	.125	.025	#12 - #8	#12 - #10	250
HSC38FR	.375	.187	.025	#6 - #4	#8 - #6	50
HSC38FR250	.375	.187	.025	#6 - #4	#8 - #6	250
HSC12FR	.500	.250	.025	#4 - #1	#6 - #4	50
HSC12FR250	.500	.250	.025	#4 - #1	#6 - #4	250
HSC34FR	.750	.375	.030	1/0 - 3/0	#2 - 1/0	50
HSC34FR250	.750	.375	.030	1/0 - 3/0	#2 - 1/0	250
HSC100FR	1.00	.500	.035	4/0 - 300	1/0 - 4/0	25
HSC100FR100	1.00	.500	.035	4/0 - 300	1/0 - 4/0	100
HSC112FR	1.50	.750	.040	350 - 750	250 - 500	25
HSC112FR100	1.50	.750	.040	350 - 750	250 - 500	100
HSC200FR	2.00	1.00	.045	800 - 1000	500 - 750	25
HSC200FR100	2.00	1.00	.045	800 - 1000	500 - 750	100

NOTES:

- 1 Shrink temperature is 135° C (275° F).
- 2 For best results move heat gun along the length of heat shrink to avoid concentrations.
- 3 To extend useful life, store material below 70°F.
- 4 For additional Heat Shrinkable Tubing see "URD" section Type RYAC and RK169-2, RK170-2 in this section.

Blue highlighted items are industry standard and most frequently ordered.

TYPE HS-FR

THIN-WALL HEAT SHRINK

Fire Retardant
Heat Shrink Tubing

UL Recognized to 600 Volts

Type HS-FR is a flexible polyvinyl chloride thin-wall heat-shrink. Offering insulating, color identification and strain relieving properties for terminations and splices. The 2:1 shrink ratio allows for faster shrink recovery, covering wire sizes: #16 AWG to 1000 kcmil. UL recognized, 105° C, 600V, operating temperatures from -20° C to 105° C with a shrink temperature of 135° C.

Features and Benefits

- UL 224, VW-1 Rated
 - ◊ Self-extinguishing flame retardant properties.
- Multi-use Tubing
 - ◊ Insulate, strain relief.
- Easy Identification
 - ◊ Available in wide range of colors.
- Low Shrink Temperature
 - ◊ Only requires common hot air guns to apply.
- Meets MIL-M-23053/Z-206C

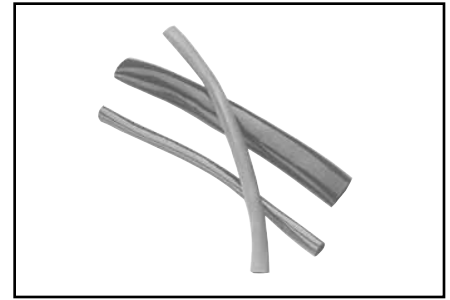

How to Order:

Example: HSB18FR

- B** - Black
- BLU** - Blue
- G** - Green
- R** - Red
- W** - White
- Y** - Yellow



F-11

Catalog Number	I.D. Expanded	I.D. After Recovery	Wall Thickness	Conductor Range		Standard Reel Size (Feet)
				Code	Flex	
HS_18FR	.125	.062	.025	#16 - #14	#16 - #14	50
HS_18FR250	.125	.062	.025	#16 - #14	#16 - #14	250
HS_14FR	.250	.125	.025	#12 - #8	#12 - #10	50
HS_14FR250	.250	.125	.025	#12 - #8	#12 - #10	250
HS_38FR	.375	.187	.025	#6 - #4	#8 - #6	50
HS_38FR250	.375	.187	.025	#6 - #4	#8 - #6	250
HS_12FR	.500	.250	.025	#4 - #1	#6 - #4	50
HS_12FR250	.500	.250	.025	#4 - #1	#6 - #4	250
HS_34FR	.750	.375	.030	1/0 - 3/0	#2 - 1/0	50
HS_34FR250	.750	.375	.030	1/0 - 3/0	#2 - 1/0	250
HS_100FR	1.00	.500	.035	4/0 - 300	1/0 - 4/0	25
HS_100FR100	1.00	.500	.035	4/0 - 300	1/0 - 4/0	100
HS_112FR	1.50	.750	.040	350 - 750	250 - 500	25
HS_112FR100	1.50	.750	.040	350 - 750	250 - 500	100
HS_200FR	2.00	1.00	.045	800 - 1000	500 - 750	25
HS_200FR100	2.00	1.00	.045	800 - 1000	500 - 750	100

NOTES:

- 1 Shrink temperature is 105° C (221° F).
- 2 For best results move heat gun along the length of heat shrink to avoid concentrations.
- 3 To extend useful life, store material below 70° F.
- 4 For additional Heat Shrinkable Tubing see "URD" section Type RYAC and RK169-2, RK170-2 in this section.

Blue highlighted items are industry standard and most frequently ordered.

MISCELLANEOUS ACCESSORIES

TYPE BHSG1100

HEAT GUN

F-12

250° - 1100° F (121° - 650° C)

Multi-purpose, low cost heat gun has an electronic variable thermal control dial. BHSG1100 is UL and CSA Listed. It has a temperature range of 250° - 1100° (121° - 650°C). 2 speed motor. Built-in safety stand heat guard included. Professional heat gun and accessories are recommended for all of your BURNDY® heat shrink applications.



TYPE 145PTAG

94V0 Rated Plastic Tag for Telecom, Transportation & OEM Markets

The new 145PTAG has been designed specifically for the Telecom market. The tag is manufactured from Flame Retardant Nylon with a 94V0 rating. The tag is durable, non-flammable and can be secured to cabling using a multi-ply cord. Within the telecom market these tags typically have P-Touch labels applied or are manually stenciled on both sides. The usual application is to mark the tags in the field with far end termination information, panel identification, voice and data identification and wire & cable marking.



For the OEM user, in addition to the P-Touch label or stenciling, tags can be marked with information using most inks or permanent markers, tags can be secured with a waxed cord, UNIRAP™ cable tie or some other equivalent.

Specifications

- Dimensions: 1" × 1-3/4" by .060" thick
- Material: White Nylon UL 94V0
- Packaging: 25 tags per polybag
- Tag Marking: Tags are shipped with no markings; markings applied in the field based on application.

Catalog Number	Description
145PTAG	94V0 Rated Plastic

Blue highlighted items are industry standard and most frequently ordered.

TABLE OF CONTENTS

UNIRAP™

Cable Tie Features and Specs . . . **G-2 - G-4**

Military Spec Cable Ties **G-5**

Standard Cable Ties **G-6 - G-7**

Type **UG** Universal Cable Ties **G-8**

Releaseable Cable Ties **G-9**

Identification Cable Ties **G-10**

Mounting Hole Cable Ties **G-10**

Halar® Cable Ties **G-11**

Tefzel® Cable Ties **G-11**

Type TFV-B

Hook and Loop Straps **G-12**

Mounting Bases

(4-Way) **G-13**

(2-Way) **G-13**

Cable Hangers **G-14**

Stainless Steel Accessories

Stainless Steel Ties **G-15**

Cable Tie Variety Pack **G-16**

Cable Tie Tools **G-16**

G-1

Blue highlighted items are industry standard and most frequently ordered.

UNIRAP™

NYLON CABLE TIES

UNIRAP™ cable ties are fabricated of one-piece Nylon with no metal parts. The straps are tough, resilient, lightweight and abrasion resistant. They offer high tensile strength and are chemically resistive to solvents, alkalis, oils, grease and diluted acids. Self-locking, they secure without twisting or leaving sharp projections.

Compact heads and pre-bent tips facilitate cable bundling in a minimum of time and space.

UNIRAP™ cable ties are designed for both field and production line use and may be installed easily by hand.

BURNDY® cable ties consist of three components: strap, head, and tail. These components are specifically designed to function together to make BURNDY® UNIRAP™ cable ties superior in quality and performance.

G-2

Component

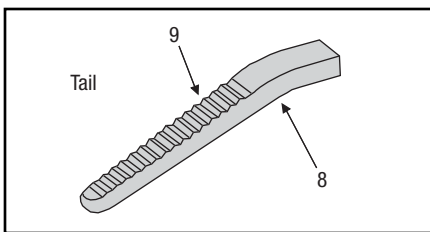
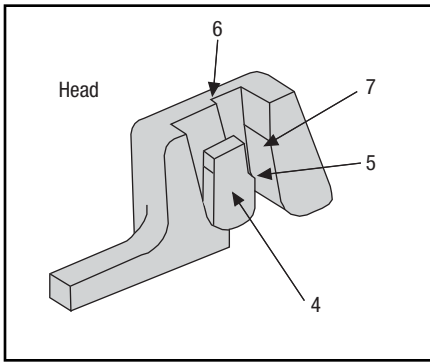
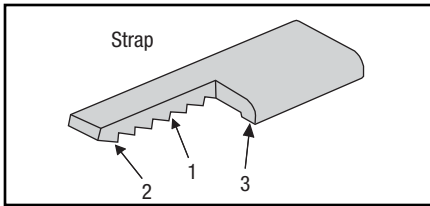

Precision Engineering

- 1. Includes load bearing **serrations**.
- 2. Features **flats** between the serrations.
- 3. Features the **double outer rail system**.

Enhanced Performance

- 1. Serrations provide complete adjustability within the fastening range.
- 2. Flats reduce stress concentrations and help make the tie stronger.
- 3. Smooth rails promote low drag, as well as minimize chafing.

- 4. The **pawl** is integrally formed with the head.
- 5. The **pawl** is stepped in order to wedge against the serrations in the strap to form the lock.
- 6. The **shoulders**, or the sides of the head, guide the strap and prevent it from disengaging from the pawl during loaded conditions.
- 7. The **back** supports the strap during the wedging of the lock formation.

- 4. The locking unit will not disengage. It also promotes low insertion with high pull out force for very easy installation.
- 5. The tie's ultimate strength achieves optimum levels.
- 6. Promotes cable tie strength, endurance, and longevity.
- 7. Ensures optimum locking capability.

- 8. Features a **bent tip**.
- 9. Includes a **ribbed grip**.

- 8. Easy pick-up for installers, which leads to fast assembly.
- 9. Allows for easy, no-slip grip.

Blue highlighted items are industry standard and most frequently ordered.

Available Materials

Nylon 6/6 — General Purpose

General purpose nylon 6/6 features light weight, high strength and a wide temperature range. It is halogen free so it does not release dangerous gases, such as chlorine, bromine, fluorine and iodine when burned. Nylon 6/6 is hygroscopic, and therefore, absorbs or releases moisture depending on its environment. Thus, the moisture level of the material will affect tensile strength, stiffness and elongation of the product.

Nylon 6/6 — Heat Stabilized

With similar properties and benefits as nylon 6/6, products manufactured with heat stabilized nylon 6/6 material have a chemical stabilizer added for higher continuous temperature applications.

Nylon 6/6 — UV Stabilized

Chemical inhibitors are used to give nylon 6/6 material added properties to fight against premature aging of products due to the effects of ultraviolet rays.

Nylon 6/6 — UV Stabilized (2% Carbon for Military Specification)

The physical properties of this material include carbon, which acts as a UV stabiliz-

er, prolonging the life of the product under ultraviolet conditions. It also allows cable ties to meet the particular military specification for cable ties.

Nylon 6/6 — V0 Flame Retardant

This material meets UL 94V-0 flammability requirements. Flame retardant additives generally reduce tensile strength when compared to general-purpose nylon 6/6, but this resin has been formulated to minimize such effects.

Nylon 6/6 — High Impact

Impact modifiers are added to increase flexibility. High impact nylon 6/6 has stable tensile strength due to its reduced influence from moisture. It is excellent for high vibration applications, as within the aircraft and automobile industries and performs better than nylon 6/6 against ultraviolet rays. Good for outdoor use.

Polypropylene

Polypropylene is used in environments where chemical effects on nylon are a concern. It is not affected by inorganic acids (hydrochloric), polyhydric alcohols (ethyleneglycol), neutral salts (sodium chloride) and basic

salts (sodium bicarbonate). Polypropylene also resists a number of other chemicals with good results, although it has lower tensile strength than nylon 6/6 (about half). Polypropylene has good UV resistance.

Tefzel®

Although about two-thirds the strength of nylon 6/6, Tefzel is resistant to a wide range of chemicals, such as concentrated hydrofluoric and sulfuric acids. It is also a low water absorbing material, therefore, is not adversely affected by water. Tefzel is radiation resistant up to 100 megarads and meets the fire and smoke requirements of IEEE 383. Tefzel also withstands high temperatures and ultraviolet light exposure. Products made from Tefzel material also have non-outgassing properties for zero gravity applications.

Halar®

Halar is similar to Tefzel in performance and benefits. Halar is recognized for its low smoke density attribute when burned. This makes products made out of Halar more desirable for use in areas where smoke generation is a concern, as when bundling wire and cable in air handling spaces.

G-3

Material Specifications

Material	Continuous* Operating Temperature		Tensile Strength at 73° F Dry as Molded ASTM D-638 (PSI)	UL Flame Rating	Oxygen Index %	Gamma Radiation Resistance	UV Resistance	Military, Federal, ASTM, and FDA Specifications
	Max.	Min.						
Nylon 6/6 — General Purpose (CT)	185° F 85° C	-40° F -40° C	12,000	94V-2	28	1 × 10 ⁵ Rads	Poor	ASTM D-4066PA0111 FDA CFR177.1500
Nylon 6/6 — Heat Stabilized (CTHS)	220° F 105° C	-40° F -40° C	12,000	94V-2	26	1 × 10 ⁵ Rads	Poor	ASTM D-4066PA0121
Nylon 6/6 — UV Stabilized (O)	185° C 85° C	-40° F -40° C	12,000	94V-2	26	1 × 10 ⁵ Rads	Good	ASTM D4066PA0191
Nylon 6/6 — 2% Carbon UV Stabilized (OO)	220° F 105° C	-40° F -40° C	12,000	94V-2	26	1 × 10 ⁵ Rads	Good	ASTM D-4066PA0181 MS3367/8
Nylon 6/6 — Flame Retardant (CTV)	185° F 85° C	-40° F -40° C	10,800	94V-0	34	1 × 10 ⁵ Rads	Poor	ASTM D-4066PA0110
Nylon 6/6 — High Impact	185° F 85° C	-40° F -40° C	8,800	94-HB	19	1 × 10 ⁵ Rads	Good	ASTM D-4066PA0150
Polypropylene — Chemical Resistant (CTPP)	185° F 85° C	-40° F -40° C	3,400	94-HB	N/A	1 × 10 ⁵ Rads	Good	ASTM D-4101PP0320 FDA CFR177.1520
Nylon 12 — UV Stabilized	176° F 80° C	-40° F -40° C	5,800	94-HB	N/A	9 × 10 ⁶ Rads	Good	ASTM D-4066PA411
Tefzel® (CTZ)	302° F 150° C	-50° F -46° C	5,800	94V-0	30	2 × 10 ⁸ Rads	Excellent	UL2043 Grade 1 ASTM D-3159 Type 1
Halar® (CTH)	284° F 140° C	-50° F -46° C	6,100	94V-0	52	2 × 10 ⁸ Rads	Excellent	ASTM D-3275 Type 3 FDA CRF177.1380

* Elevated temperatures, over time, will affect materials' properties such as tensile strength, stiffness, elongation and appearance.

BURNDY® recommends the evaluation of cable ties in the actual application to determine the suitability of the tie for that application.

Tefzel® is a registered trademark of E.I. DuPont Corporation. Halar® is a registered trademark of Ausimont Chemical Co.

Blue highlighted items are industry standard and most frequently ordered.

Material Performance Guide

Selection	Nylon 6/6 General Purpose	Nylon 6/6 Heat Stab.	Nylon 6/6 UV Stab.	Nylon 6/6 2% Carbon UV Stab.	Nylon 6/6 Flame Ret. V0	Nylon 6/6 High Impact	Poly- propylene	Nylon 12 UV Stab.	Tefzel®	Halar®
Tensile Strength	8	8	8	9	7	8	2	4	5	5
High Temp.	2	3	2	2	2	2	2	1	10	10
Flammability	5	5	5	5	10	2	2	2	10	10
UV Resistance	1	1	5	8	1	2	5	3	10	10
Radiation	3	3	3	3	3	3	6	3	10	10
Chemical	6	6	6	6	6	6	8	8	10	10
— Hydrocarbons	8	8	8	8	8	8	6	8	10	10
— Chlorinated	6	6	6	6	6	6	3	8	10	10
— Hydrocarbons	2	2	2	2	2	2	8	5	10	10
— Acids-Bases	6	6	6	6	6	6	8	6	10	10
— Salts	3	3	3	3	3	3	10	8	10	10
Relative Cost	Low	Low	Med.	Med.	Med.	Med.	Med.	Med.	High	High

1 = Least Recommended 10 = Most Recommended

The following chart is meant to help you understand BURNDY's cable tie catalog numbering system. Not every cable tie is available in every listed option. See below Catalog Numbering System Charts or

contact BURNDY® Customer Service for more information.

Gray bars contain catalog number examples.

Type	Tensile	Bundle Dia.	Feature	Package	Color
CT	50	175		C	
BET = BURNDY® Extended Tie	18 = 18 lbs. 30 = 30 lbs. 40 = 40 lbs.	075 = 3/4" 087 = 7/8" 100 = 1"	EPR = Extended Pawl Releasable ID = Single Head ID ID2 = Double Head ID ID3 = Triple Head ID FL = ID Flag	V = 5 X = 10 Q = 25 L = 50 C = 100 B = 250 D = 500 M = 1000	1 = Brown 2 = Red 3 = Orange 4 = Yellow 5 = Green 6 = Blue 7 = Purple 8 = Gray None = Natural 10 = White 11 = Telco Gray 0 = UV Black ¹ 00 = UV Black ² 02 = Red 20 = Black
CT = Nylon 6/6 Standard	50 = 50 lbs. 120 = 120 lbs. 175 = 175 lbs.	125 = 1-1/4" 137 = 1-3/8" 150 = 1-1/2"	MH4 = Mounting Hole #4 MH6 = Mounting Hole #6 MH8 = Mounting Hole #8 MH10 = Mounting Hole #10 MH14 = Mounting Hole #14 PM = Push Mount Tie PML = Push Mount Tie w/Louvers PMW = Push Mount Tie w/Wing R = Releasable Tie LP = Low Profile Tie PS = Positive Stop		
CTAS = Aerial Support	175 = 175 lbs. 250 = 250 lbs.	175 = 1-3/4" 200 = 2" 250 = 2-1/2"			
CTH = Halar®		300 = 3" 400 = 4" 500 = 5"			
CTZ = Tefzel®		600 = 6" 700 = 7" 800 = 8"			
CTHS = Nylon 6/6 Heat Stabilized		900 = 9" 1000 = 10" 1100 = 11"			
CTV = Nylon 6/6 Flame Retardant UL94V-0		1200 = 12" 1300 = 13" 1400 = 14"			
CTPP = Polypropylene		1500 = 15" 1600 = 16"			

¹Material: Nylon 6/6 — UV Stabilized

²Material: Nylon 6/6 — 2% Carbon UV Stabilized (Mil. Spec.)

Type	Tensile	Bundle Dia.	Package
CTSS	100	200	C
CTSS = 304 Stainless Steel	100 = 100 lbs. 250 = 250 lbs.	Same as above	Same as above

Type	Size	Mount Method	Feature	Quantity	Color
CTB	125	RA	4	C	0
CTB = Cable Tie Base	075 = 3/4" 125 = 1-1/4" 150 = 1-1/2"	RA = Rubber Adhesive AA = Acrylic Adhesive S = Screw Mounted	2 = 2 way 4 = 4 way	L = 50 C = 100 D = 500 M = 1000	0 = UV Black

Military Specification UNIRAP™ Cable Ties

The BURNDY® cable ties shown below meet the requirements of SAE AS23190A (formerly MIL-S-23190) in accordance with specification MS3367, MS3368, and QPL-23190.

Natural Cable Ties

Mil Spec	Distributor Pack Catalog Number	Bulk Pack Catalog Number	Description (Bundle Dia. - Tensile Strength)
MS3367-1-9	CT50175C	CT50175M	1.75" - 50 lbs.
MS3367-2-9	CT50400C	CT50400M	4" - 50 lbs.
MS3367-3-9	CT120400L	CT120400D	4" - 120 lbs.
MS3367-3-9	CT175400Q	N/A	4" - 175 lbs.
MS3367-3-9	CT175600Q	N/A	6" - 175 lbs.
MS3367-4-9	CT18075C	CT18075M	.75" - 18 lbs.
MS3367-5-9	CT30125C	CT30125M	1.25" - 30 lbs.
MS3367-6-9	CT120900L	CT120900D	9" - 120 lbs.
MS3367-6-9	CT175900Q	N/A	9" - 175 lbs.
MS3367-7-9	CT50300C	CT50300M	3" - 50 lbs.

G-5

UV Resistant Black Cable Ties

Mil Spec	Distributor Pack Catalog Number	Bulk Pack Catalog Number	Description (Bundle Dia. - Tensile Strength)
MS3367-1-0	CT50175C00	CT50175M00	1.75" - 50 lbs.
MS3367-2-0	CT50400C00	CT50400M00	4" - 50 lbs.
MS3367-3-0	CT120400L00	CT120400D00	4" - 120 lbs.
MS3367-3-0	N/A	N/A	4" - 175 lbs.
MS3367-3-0	CT175600Q00	N/A	6" - 175 lbs.
MS3367-4-0	CT18075C00	CT18075M00	.75" - 18 lbs.
MS3367-5-0	CT30125C00	CT30125M00	1.25" - 30 lbs.
MS3367-6-0	CT120900L00	CT120900D00	9" - 120 lbs.
MS3367-6-0	CT175900Q00	N/A	9" - 175 lbs.
MS3367-7-0	CT50300C00	CT50300M00	3" - 50 lbs.

Natural Identification Cable Ties

Mil Spec	Distributor Pack Catalog Number	Bulk Pack Catalog Number	Description (Bundle Dia. - Tensile Strength)
MS3368-1-A	CT50175IDC	N/A	1.75" - 50 lbs.
MS3368-2-A	CT50400IDC	N/A	4" - 50 lbs.
MS3368-3-C	CT50175ID2L	N/A	1.75" - 50 lbs. Double Strap
MS3368-4-D	CT50175ID3L	N/A	1.75" - 50 lbs. Triple Strap
MS3368-5-E	CT18075IDC	N/A	.75" - 18 lbs.

Blue highlighted items are industry standard and most frequently ordered.

UNIRAP™

STANDARD CABLE TIES

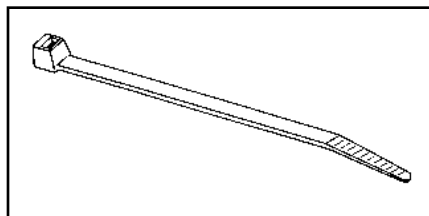

18 Lb. Minimum Tensile Strength



Standard Package Catalog Number	Material	Maximum Bundle Diameter Inches [mm]	Minimum Tensile Strength Lbs. (N)	Length Inches [mm]	Width Inches [mm]	Installation Tool	Tool Setting	Bulk Package Catalog Number
CT18075C	Natural Nylon 6/6	.75 [19]	18 (80)	4.00 [102]	.10 [2.5]	TWT1, MK7	Mini	CT18075M
CT18075CO	Black Nylon 6/6 UV							
CT18125C	Natural Nylon 6/6	1.25 [32]		5.67 [144]				CT18125M
CT18125CO	Black Nylon 6/6 UV							CT18125MO
CT18200C	Natural Nylon 6/6	2.00 [51]		8.00 [203]				CT18200M
CT18200CO	Black Nylon 6/6 UV							CT18200MO

G-6

30 Lb. Minimum Tensile Strength



Standard Package Catalog Number	Material	Maximum Bundle Diameter In. [mm]	Minimum Tensile Strength Lbs. (N)	Length In. [mm]	Width In. [mm]	Installation Tool	Tool Setting	Bulk Package Catalog Number
CT30125C	Natural Nylon 6/6	1.25 [32]	30 (133)	6.00 [152]	.14 [3.6]	TWT1, MK7	Intermediate	CT30125M
CT30125CO	Black Nylon 6/6 UV							CT30125MO

40 Lb. Minimum Tensile Strength



Standard Package Catalog Number	Material	Maximum Bundle Diameter Inches [mm]	Minimum Tensile Strength Lbs. (N)	Length Inches [mm]	Width Inches [mm]	Installation Tool	Tool Setting	Bulk Package Catalog Number
CT40200C	Natural Nylon 6/6	2.00 [51]	40 (178)	8.50 [216]	.15 [3.8]	TWT1, MK7	Intermediate	CT40200M
CT40200CO	Black Nylon 6/6 UV							CT40200MO
CT40300C	Natural Nylon 6/6	3.00 [76]		11.50 [292]				CT40300M
CT40300CO	Black Nylon 6/6 UV							CT40300MO
CT40400C	Natural Nylon 6/6	4.00 [102]		14.50 [368]				CT40400M
CT40400CO	Black Nylon 6/6 UV							CT40400MO

50 Lb. Minimum Tensile Strength



Standard Package Catalog Number	Material	Maximum Bundle Diameter Inches [mm]	Minimum Tensile Strength Lbs. (N)	Length Inches [mm]	Width Inches [mm]	Installation Tool	Tool Setting	Bulk Package Catalog Number
CT50175C	Natural Nylon 6/6	1.75 [44]	50 (222)	8.00 [203]	.18 [4.6]	TWT1, MK7	Standard	CT50175M
CT50175CO	Black Nylon 6/6 UV							CT50175MO
CT50300C	Natural Nylon 6/6	3.00 [76]		11.75 [298]				CT50300M
CT50300CO	Black Nylon 6/6 UV							CT50300MO
CT50400C	Natural Nylon 6/6	4.00 [102]		15.50 [394]				CT50400M
CT50400CO	Black Nylon 6/6 UV							CT50400MO

Blue highlighted items are industry standard and most frequently ordered.

UNIRAP™

STANDARD CABLE TIES
(Continued)

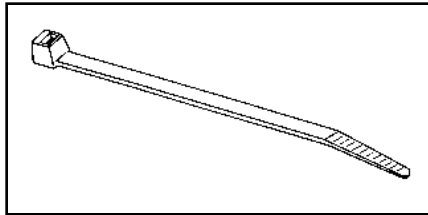

120 Lb. Minimum
Tensile Strength

Standard Package Catalog Number	Material	Maximum Bundle Diameter Inches [mm]	Minimum Tensile Strength Lbs. (N)	Length Inches [mm]	Width Inches [mm]	Installation Tool	Tool Setting	Bulk Package Catalog Number
CT120200L	Natural Nylon 6/6	2.00 [51]	120 (534)	8.87 [226]	.30 [7.6]	TWT2, MK9	Standard	CT120200D
CT120200LO	Black Nylon 6/6 UV							CT120200DO
CT120300L	Natural Nylon 6/6	3.00 [76]		11.87 [302]				CT120300D
CT120300LO	Black Nylon 6/6 UV							CT120300DO
CT120400L	Natural Nylon 6/6	4.00 [102]		15.25 [387]				CT120400D
CT120400LO	Black Nylon 6/6 UV							CT120400DO
CT120900L	Natural Nylon 6/6	9.00 [229]		29.75 [776]				
CT120900LO	Black Nylon 6/6 UV							

G-7

175 Lb. Minimum
Tensile Strength



Standard Package Catalog Number	Material	Maximum Bundle Diameter Inches [mm]	Minimum Tensile Strength Lbs. (N)	Length Inches [mm]	Width Inches [mm]	Installation Tool	Tool Setting	Bulk Package Catalog Number
CT175400Q	Natural Nylon 6/6	4.00 [102]	175 (778)	15.00 [381]	.35 [8.9]	TWT2, MK9	Heavy	
CT175400QO	Black Nylon 6/6 UV							
CT175600Q	Natural Nylon 6/6	6.00 [152]		21.00 [533]				
CT175600QO	Black Nylon 6/6 UV							
CT175900Q	Natural Nylon 6/6	9.00 [229]		32.00 [813]				
CT175900QO	Black Nylon 6/6 UV							
CT1751100Q	Natural Nylon 6/6	11.00 [279]		36.00 [914]				
CT1751100QO	Black Nylon 6/6 UV							
CT1751400Q	Natural Nylon 6/6	14.00 [356]		52.00 [1321]				
CT1751400QO	Black Nylon 6/6 UV							

250 Lb. Minimum
Tensile Strength



Standard Package Catalog Number	Material	Maximum Bundle Diameter Inches [mm]	Minimum Tensile Strength Lbs. (N)	Length Inches [mm]	Width Inches [mm]	Installation Tool	Tool Setting	Bulk Package Catalog Number
CT250600Q	Natural Nylon 6/6	6.00 [152]	250 (1112)	23.00 [584]	.50 [12.7]	TWT2, MK9	Heavy	
CT250600QO	Black Nylon 6/6 UV							
CT250800Q	Natural Nylon 6/6	8.00 [203]		29.00 [737]				
CT250800QO	Black Nylon 6/6 UV							
CT2501000Q	Natural Nylon 6/6	10.00 [254]		35.00 [889]				
CT2501000QO	Black Nylon 6/6 UV							
CT2501200Q	Natural Nylon 6/6	12.00 [305]		40.00 [1016]				
CT2501200QO	Black Nylon 6/6 UV							

Blue highlighted items are industry standard and most frequently ordered.

TYPE UG

UNIRAP™ Cable Ties

Features and Benefits

- Nylon 6/6 Standard
- Available in Black and Natural
- One piece injection molded
- Maximum strength and adjustability for versatility
- Chemically resistant to solvents, oils, grease, and diluted acids



- Rounded edges and bent tip for easy installation
- Self-Locking

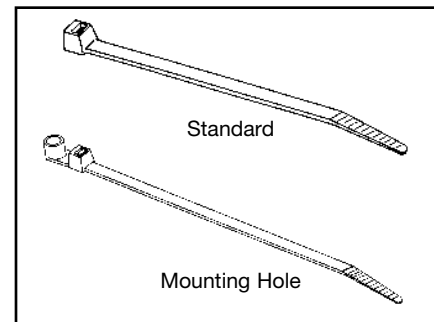

G-8

Standard Cable Ties

Standard Package Catalog Number	Material	Maximum Bundle Diameter Inches [mm]	Minimum Tensile Strength Lbs. (N)	Length Inches [mm]	Width Inches [mm]	Installation Tool	Tool Setting	Qty. per Package
CT18075CUG	Natural Nylon 6/6	.75 [19]	18 (80)	4.00 [102]	.10 [2.5]	TWT1, MK7	Mini	100
CT18075COUG	Black Nylon 6/6 UV			8.00 [203]				1000
CT18200MUG	Natural Nylon 6/6	2.00 [51]	30 (133)	6.00 [152]	.14 [3.6]		Intermediate	100
CT30125CUG	Natural Nylon 6/6	1.25 [32]	30 (133)	6.00 [152]				
CT30125COUG	Black Nylon 6/6 UV							
CT40200CUG	Natural Nylon 6/6	2.00 [51]	40 (178)	8.50 [216]	.15 [3.8]		Standard	1000
CT50175CUG	Natural Nylon 6/6	1.75 [44]	50 (222)	8.00 [203]				
CT50175COUG	Black Nylon 6/6 UV							
CT50175MUG	Natural Nylon 6/6	3.00 [76]	50 (222)	11.30 [288]	.18 [4.6]		Standard	100
CT50175MOUG	Black Nylon 6/6 UV							
CT50300CUG	Natural Nylon 6/6	3.00 [76]	50 (222)	11.30 [288]	.18 [4.6]	Standard	1000	
CT50300COUG	Black Nylon 6/6 UV							
CT50300MUG	Natural Nylon 6/6	4.00 [102]	120 (534)	15.50 [394]	.30 [7.6]	TWT2, MK9	100	
CT50300MOUG	Black Nylon 6/6 UV							
CT50400CUG	Natural Nylon 6/6	4.00 [102]	120 (534)	15.50 [394]	.30 [7.6]	TWT2, MK9	50	
CT50400COUG	Black Nylon 6/6 UV							
CT120400LUG	Natural Nylon 6/6							
CT120400LOUG	Black Nylon 6/6 UV							

Mounting Hole Cable Ties

Standard Package Catalog Number	Material	Screw Size	Maximum Bundle Diameter Inches [mm]	Minimum Tensile Strength Lbs. (N)	Length Inches [mm]	Width Inches [mm]	Installation Tool	Tool Setting	Qty. per Package
CT50175MH10CUG	Nylon 6/6	#10 (M5)	1.75 [44]	50 (222)	8.50 [216]	.18 [4.6]	MK7	Standard	100

Mounting Bases

Standard Package Catalog Number	Mounting Method	Maximum Tie Slot Width	Dimension A	Dimension B	Dimension C	Package Qty.
CTB125RA4CUG	Rubber Adhesive	.20"	1.125"	1.125"	.19"	100

Blue highlighted items are industry standard and most frequently ordered.

UNIRAP™

RELEASABLE CABLE TIES

Perfect for prototype construction, releasable cable ties are ideal for temporary installations. Releasable ties are also good for applications where service requires adding or subtracting wires from an existing wire bundle.

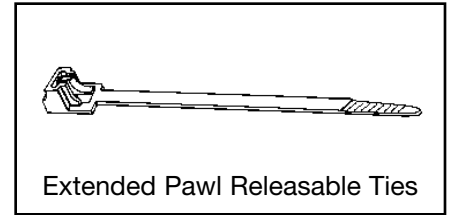
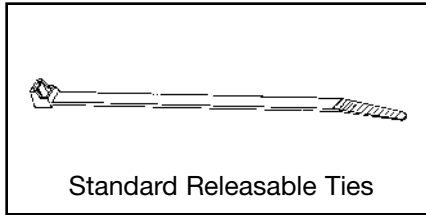

Standard Releasable Cable Ties

Standard Package Catalog Number	Material	Maximum Bundle Diameter Inches [mm]	Minimum Tensile Strength Lbs. (N)	Length Inches [mm]	Width Inches [mm]
CT40200RC	Natural Nylon 6/6	2.00 [51]	40 (178)	8.50 [216]	.16 [4]
CT40200RC0	Black Nylon 6/6 UV				
CT50137RC	Natural Nylon 6/6	1.38 [35]	50 (222)	6.50 [165]	.18 [4.6]
CT50137RC0	Black Nylon 6/6 UV				
CT50400RC	Natural Nylon 6/6	4.00 [102]		15.50 [394]	
CT50400RC0	Black Nylon 6/6 UV				

G-9

Extended Pawl Releasable Cable Ties

Standard Package Catalog Number	Material	Maximum Bundle Diameter Inches [mm]	Minimum Tensile Strength Lbs. (N)	Length Inches [mm]	Width Inches [mm]
CT50137EPRC	Natural Nylon 6/6	1.38 [35]	50 (222)	5.50 [140]	.291 [7.4]
CT50137EPRC0	Black Nylon 6/6 UV				
CT50250EPRC	Natural Nylon 6/6	2.50 [64]		9.80 [249]	
CT50250EPRC0	Black Nylon 6/6 UV				

Heavy Duty Releasable Cable Ties

Standard Package Catalog Number	Material	Maximum Bundle Diameter Inches [mm]	Minimum Tensile Strength Lbs. (N)	Length Inches [mm]	Width Inches [mm]
CT250200RQ	Natural Nylon 6/6	2.00 [51]	250 (1112)	9.00 [229]	.50 [12.7]
CT250200RQ0	Black Nylon 6/6 UV				
CT250500RQ	Natural Nylon 6/6	5.00 [127]		20.00 [508]	
CT250500RQ0	Black Nylon 6/6 UV				
CT250600RQ	Natural Nylon 6/6	6.00 [152]		23.00 [584]	
CT250600RQ0	Black Nylon 6/6 UV				
CT250800RQ	Natural Nylon 6/6	8.00 [203]		29.00 [737]	
CT250800RQ0	Black Nylon 6/6 UV				
CT2501000RQ	Natural Nylon 6/6	10.00 [254]		35.00 [889]	
CT2501000RQ0	Black Nylon 6/6 UV				
CT2501200RQ0	Black Nylon 6/6 UV	12.00 [305]		40.00 [1016]	

Blue highlighted items are industry standard and most frequently ordered.

UNIRAP™

IDENTIFICATION CABLE TIES

Identification cable ties are used in both bundling and identifying wire groups at the same time.

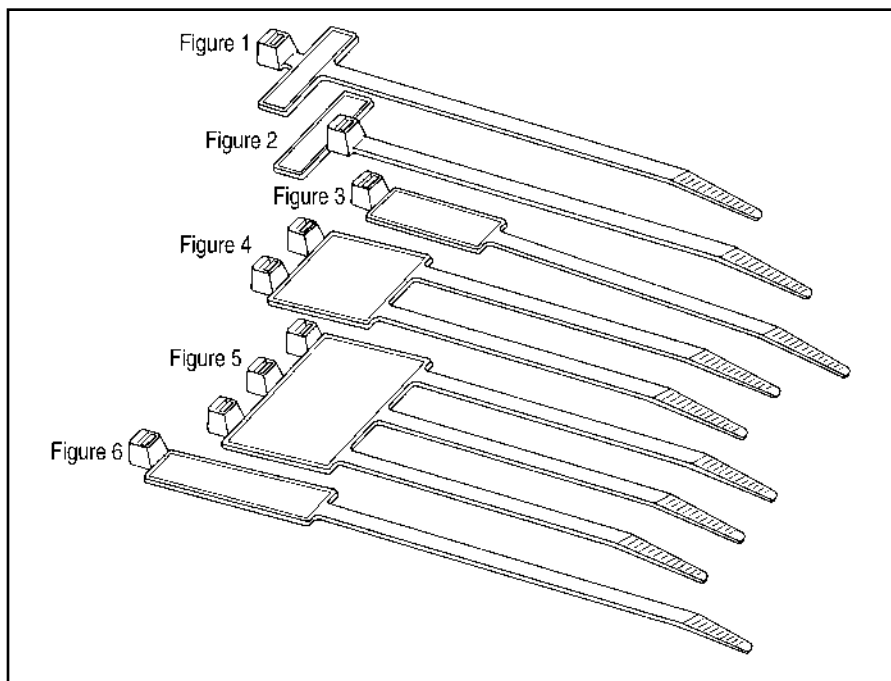

G-10

Standard Package Catalog Number	Material	Fig. No.	Marking Pad Size Inches [mm]	Maximum Bundle Diameter Inches [mm]	Minimum Tensile Strength Lbs. (N)	Length Inches [mm]	Width Inches [mm]	Installation Tool & (Setting)
CT18075IDC	Natural Nylon 6/6	1	1 × 19/64 [25.4 × 7.5]	.75 [19]	18 (80)	4.00 [102]	.10 [2.5]	MK7 (MIN)
CT18075FLC		2	13/16 × 5/16 [20.5 × 7.9]			4.25 [108]		
CT50175IDC		3	1 × 7/16 [25.4 × 11.1]	1.75 [44]	50 (222)	8.00 [203]	.18 [4.6]	MK7 (STD)
CT50175ID2L		4	1-11/16 × 5/16 [29.8 × 23.8]					
CT50175ID3L		5	1-13/16 × 15/16 [46 × 23.8]					
CT50400IDC		6	1/2 × 2-1/8 [12.7 × 54]			15.00 [381]		

UNIRAP™

MOUNTING HOLE CABLE TIES

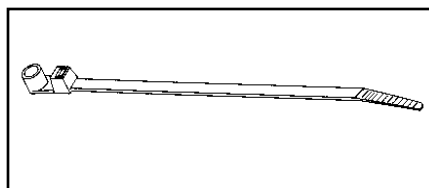

Standard Package Catalog Number	Material	Screw Size	Maximum Bundle Diameter Inches [mm]	Minimum Tensile Strength Lbs. (N)	Length Inches [mm]	Width Inches [mm]	Installation Tool & (Setting)	Bulk Package Catalog Number
CT18075MH4C	Natural Nylon 6/6	#4 (M2,5)	.75 [19]	18 (80)	4.25 [108]	.10 [2.5]	MK7 (MIN)	CT18075MH4M
CT18075MH4CO	Black Nylon 6/6 UV							—
CT30125MH8C	Nylon 6/6	#8 (M4)	1.25 [32]	30 (133)	6.25 [159]	.14 [3.6]	MK7 (INT)	—
CT30125MH8CO	Nylon 6/6 UV							—
CT50175MH10C	Nylon 6/6	#10 (M5)	1.75 [44]	50 (222)	8.50 [216]	.18 [4.6]	MK7 (STD)	CT50175MH10M
CT50175MH10CO	Nylon 6/6 UV							CT50175MH10MO
CT50400MH10C	Nylon 6/6 GP	#10 (M5)	4.00 [102]	50 (222)	16.00 [406]			—
CT50400MH10CO	Nylon 6/6 UV							CT50400MH10MO
CT120400MH14L	Nylon 6/6	1/4" (M6)	4.00 [102]	120 (534)	16.25 [413]	.30 [7.6]	MK9 (STD)	—
CT120400MH14LO	Nylon 6/6 UV							CT120400MH14DO

Blue highlighted items are industry standard and most frequently ordered.

UNIRAP™

HALAR® TIES

Halar® ties meet NEC regulations and can be used in applications where low smoke and low flame are a concern, as in air handling spaces. The raw material used to manufacture BURNDY® Halar® cable ties is UL 94V-0 rated. These ties come in a distinct color of red for easy identification.

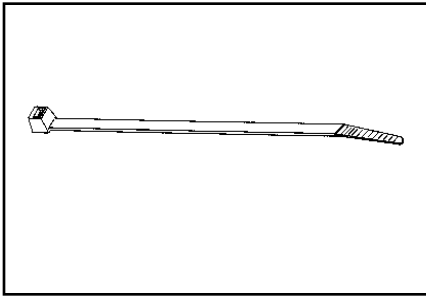

Halar® Cable Ties

Standard Package Catalog Number	Material	Maximum Bundle Diameter Inches [mm]	Minimum Tensile Strength Lbs. (N)	Length Inches [mm]	Width Inches [mm]	Installation Tool	Tool Setting	Bulk Package Catalog Number
CTH18075C	Halar	.75 [19]	18 (80)	4.00 [102]	.10 [2.5]	MK7	Mini	CTH18075M
CTH30200C		2.00 [51]	30 (133)	8.00 [203]	.14 [3.6]		Intermediate	—
CTH50175C		1.75 [44]	50 (222)	8.00 [203]	.18 [4.6]		Standard	CTH50175M
CTH120400L		4.00 [102]	120 (534)	15.25 [387]	.18 [4.6]	MK9		—

G-11

UNIRAP™

TEFZEL® TIES

Tefzel® ties provide excellent protection against radiation, ultraviolet light, and a wide range of chemicals. It is also rated for low outgassing applications. BURNDY® Tefzel® ties offer temperature stability to 150° C and come in a standard color of blue for easy identification.

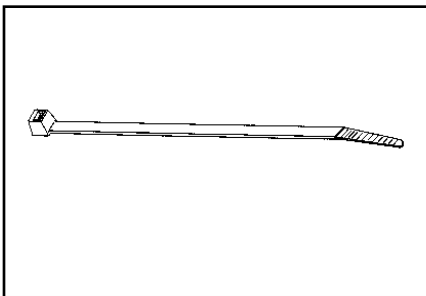

Tefzel® Cable Ties

Standard Package Catalog Number	Material	Maximum Bundle Diameter Inches [mm]	Minimum Tensile Strength Lbs. (N)	Length Inches [mm]	Width Inches [mm]	Installation Tool	Tool Setting	Bulk Package Catalog Number
CTZ18075C	Tefzel	.75 [19]	18 (80)	4.00 [102]	.10 [2.5]	MK7	Mini	—
CTZ30200C		2.00 [51]	30 (133)	8.00 [203]	.14 [3.6]		Intermediate	—
CTZ50175C		1.75 [44]	50 (222)	8.00 [203]	.18 [4.6]		Standard	—
CTZ120400L		4.00 [102]	120 (534)	15.25 [387]	.18 [4.6]	MK9		CTZ120400D

Blue highlighted items are industry standard and most frequently ordered.

TYPE TFV-B

HOOK AND LOOP STRAPS

Reusable and flexible BURNDY® Hook and Loop Straps are a unique self-gripping fastening system.

These ties are specifically used on fiberoptic applications.

The TFV-V2 flame retardant straps are UL Listed Wire Positioning Devices (ZODZ), UL94-V2 rated for use in air handling spaces in accordance with the NEC section 300-22 (c) and (d). Perfect for plenum areas.

25 straps are conveniently packaged in each polybag.



G-12

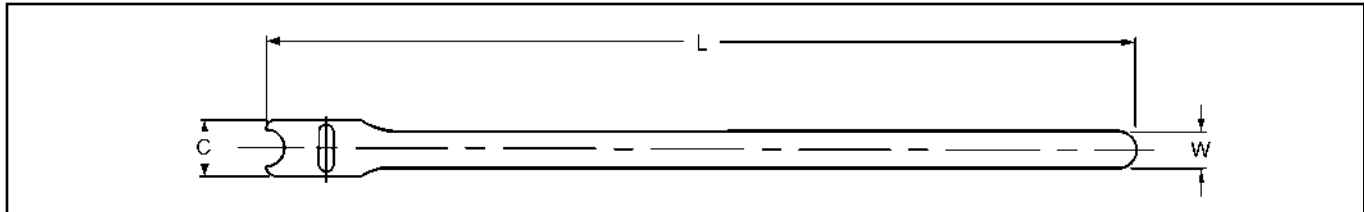

Catalog Number	Product Description	C	L	W	T	Maximum Bundle Dia.	Avg. Sheer (PSI)	Avg. Peel (PIW)	Pkg. Qty.
TFV3B12V2**	VELCRO® hook and loop strap, 3/4" × 12", Black, 25pk	0.75"	12.00"	.50"	.09"	3.0"	29	.6	*1
TFV3B18V2**	VELCRO® hook and loop strap, 3/4" × 18", Black, 25pk	0.75"	18.00"	.50"	.09"	5.0"	29	.6	*1
TFV3B6V2**	VELCRO® hook and loop strap, 3/4" × 6", Black, 25pk	0.75"	6.00"	.50"	.09"	1.0"	23	.6	*1
TFV3BLU12	VELCRO® hook and loop strap, 3/4" × 12", Royal Blue, 25pk	0.75"	12.00"	.50"	.09"	3.0"	23	.5	*1
TFV3BLU18	VELCRO® hook and loop strap, 3/4" × 18", Royal Blue, 25pk	0.75"	18.00"	.50"	.09"	5.0"	23	.5	*1

* Straps sold by the package, quantity 1 package equals 25 straps.

** UL94-V2 listed.

VELCRO® is a registered trademark of Velcro USA, Inc.

Blue highlighted items are industry standard and most frequently ordered.

MOUNTING BASES

BURNDY® offers a wide variety of mounting bases suited for many applications. Mounting bases are used in conjunction with cable ties to stabilize and secure wire bundles, both indoors and outdoors. Mounting bases can be secured to a surface using rubber based adhesive, acrylic adhesive, or also can be screw mounted.

BURNDY's 4-way mounting bases are available in four sizes to accommodate CT18 through CT50 series cable ties. Insertion of ties can be made from all sides. Each mount may be secured with two screws, with adhesive backing, or both, for ease of application and stability. For applications where higher temperatures, certain chemicals, or UV radiation are a concern and an adhesive is the preferred method for securing, the acrylic adhesive 4-way mounting bases are recommended.

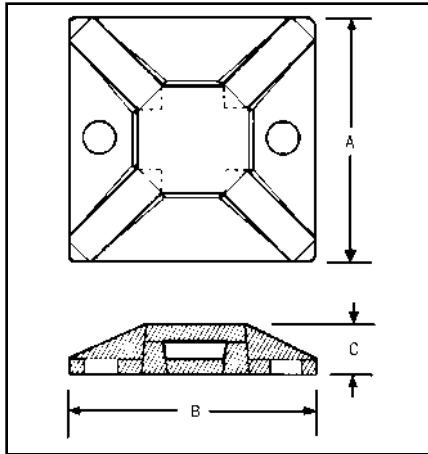

The 2-way mounting bases may be secured with one screw, with adhesive backing, or both, and allow ties to be inserted from two sides.

4-Way



Catalog Number	Mounting Method	Maximum Tie Slot Width	Dimension A	Dimension B	Dimension C	Pkg. Qty.
CTB075S4C	#4 Screw	.14"	.75"	.75"	.15"	100
CTB075AA4C	Acrylic Adhesive	.14"	.75"	.75"	.15"	100
CTB075RA4C	Rubber Adhesive	.14"	.75"	.75"	.15"	100
CTB075RA4M	Rubber Adhesive	.14"	.75"	.75"	.15"	1000
CTB125S4C	#8 Screw	.20"	1.125"	1.125"	.19"	100
CTB125AA4C	Acrylic Adhesive	.20"	1.125"	1.125"	.19"	100
CTB125RA4C	Rubber Adhesive	.20"	1.125"	1.125"	.19"	100
CTB125RA4L	Rubber Adhesive	.20"	1.125"	1.125"	.19"	50
CTB125RA4D	Rubber Adhesive	.20"	1.125"	1.125"	.19"	500
CTB150S4B	#8 Screw	.35"	1.5"	1.5"	.25"	250
CTB150AA4C	Acrylic Adhesive	.35"	1.5"	1.5"	.25"	100
CTB150RA4C	Rubber Adhesive	.35"	1.5"	1.5"	.25"	100
CTB150RA4B	Rubber Adhesive	.35"	1.5"	1.5"	.25"	250

All bases listed above are natural. UV Black mounting bases are also available in nearly every size. Insert "0" after the part number.

2-Way

Catalog Number	Mounting Method	Maximum Tie Slot Width	Dimension A	Dimension B	Dimension C	Pkg. Qty.
CTB125S2C	#6 Screw	.18"	1.125"	1.125"	.21"	100
CTB125RA2C	Rubber Adhesive	.18"	1.125"	1.125"	.21"	100

All bases listed above are natural. UV Black mounting bases are also available in nearly every size. Insert "0" after the part number.

Blue highlighted items are industry standard and most frequently ordered.

CABLE HANGERS

Cable Hangers provide a contact area range of 1/2" to 3/8" in width. All contact edges have a full radius for product protection, and sizes are clearly marked on each clamp.

Cable Hangers are injection molded. Available in white nylon 6/6 and black nylon 6/6.

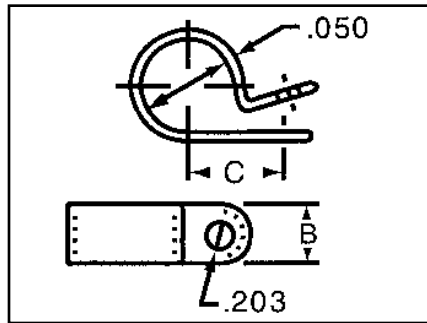

G-14

Catalog Number	Mounting Screw	Maximum Bundle	Dimension B (Width)	Dimension C (Mount Hole Centers)	Pkg. Qty.
CH2C	#10 Screw	.125"	.375"	.329"	100
CH2M	#10 Screw	.125"	.375"	.329"	1000
CH3C	#10 Screw	.187"	.375"	.430"	100
CH3M	#10 Screw	.187"	.375"	.430"	1000
CH4C	#10 Screw	.25"	.375"	.410"	100
CH4M	#10 Screw	.25"	.375"	.410"	1000
CH5C	#10 Screw	.312"	.375"	.495"	100
CH5M	#10 Screw	.312"	.375"	.495"	1000
CH6C	#10 Screw	.375"	.375"	.595"	100
CH6M	#10 Screw	.375"	.375"	.595"	1000
CH7C	#10 Screw	.437"	.375"	.574"	100
CH7M	#10 Screw	.437"	.375"	.574"	1000
CH8C	#10 Screw	.5"	.375"	.605"	100
CH8M	#10 Screw	.5"	.375"	.605"	1000
CH9C	#10 Screw	.563"	.375"	.606"	100
CH9M	#10 Screw	.563"	.375"	.606"	1000
CH10C	#10 Screw	.625"	.375"	.606"	100
CH10M	#10 Screw	.625"	.375"	.606"	1000
CH11C	#10 Screw	.625"	.5"	.655"	100
CH11M	#10 Screw	.625"	.5"	.655"	1000
CH12C	#10 Screw	.750"	.5"	.78"	100
CH12M	#10 Screw	.750"	.5"	.78"	1000
CH14C	#10 Screw	.875"	.5"	.845"	100
CH14M	#10 Screw	.875"	.5"	.845"	1000
CH16C	#10 Screw	1"	.5"	.91"	100
CH16M	#10 Screw	1"	.5"	.91"	1000
CH18C	#10 Screw	1.12"	.5"	.97"	100
CH18M	#10 Screw	1.12"	.5"	.97"	1000
CH24L	#10 Screw	1.5"	.5"	1.19"	50
CH24C	#10 Screw	1.5"	.5"	1.19"	100

All hangers listed above are natural. UV Black cable hangers are available in nearly every size. Insert "0" after the part number.

Blue highlighted items are industry standard and most frequently ordered.

UNIRAP™

STAINLESS STEEL TIES

BURNDY's Stainless Steel ties are designed to secure hoses, cables, poles, pipes, and more when harsh environmental conditions may adversely affect the bundling application. Used where corrosion, vibration, weathering, radiation, and temperature extremes are a concern, BURNDY's Stainless Steel ties can be used in virtually any indoor, outdoor, and underground application.

BURNDY® Stainless Steel ties are made from Grade 304 Stainless Steel. This tie is designed with a low profile clamping bearing head with fully adjustable strap accommodating many bundle diameters.



Features

- Smooth, rounded edges help ensure safe, efficient handling.
- Ergonomically designed installation tool consistently tensions and cuts off ties leaving flush edges.
- Flame retardant and non-toxic for applications where safety from fire is critical.

G-15

Standard Package Catalog Number	Material	Maximum Bundle Diameter Inches [mm]	Minimum Tensile Strength Lbs. (N)	Length Inches [mm]	Head Width Inches [mm]	Strap Width Inches [mm]	Installation Tool & (Setting)
CTSS100200C	304 SS	1.96 [50]	150 (670)	7.90 [201]	.26 [4.6]	.18 [4.6]	MK9SST (INT)
CTSS100400C		3.93 [100]		14.30 [363]			
CTSS100600C		5.90 [150]		20.50 [521]			
CTSS100800C		7.87 [200]		26.80 [681]			
CTSS1001000C		9.84 [250]		33.00 [838]			
CTSS250200L	304 SS	1.96 [50]	250 (1112)	7.90 [201]	.39 [9.8]	.31 [7.9]	MK9SST (STD)
CTSS250400L		3.93 [100]		14.30 [363]			
CTSS250600L		5.90 [150]		20.50 [521]			
CTSS250800L		7.87 [200]		26.80 [681]			

Blue highlighted items are industry standard and most frequently ordered.

UNIRAP™

CABLE TIE VARIETY PACK

UL Listed

Catalog Number: **CTASST**



Contents			
Quantity	Length	Color	Strength
100	4"	Natural	18# Strength
100	4"	Black	18# Strength
100	8"	Black	50# Strength
200	8"	Natural	50# Strength
50	11"	Natural	50# Strength
50	11"	Black	50# Strength

G-16

CABLE TIE TOOLS

Ergonomics and the prevention of repetitive motion injuries, coupled with the need to continually improve assembly efficiencies and procedures, are a major concern with most cable tie users. BURNDY® cable tie tools effectively address both issues. BURNDY® has world class cable tie tools to complement its line of high quality cable ties. BURNDY® cable tie tools are truly state-of-the-art in both design and performance.

BURNDY® tools make it easier for operators to install cable ties, while maintaining correct tension and flush cut-off. Worker safety is further enhanced as the tools can eliminate the sharp edges of a cut-off cable tie.



Catalog Number	Description	For Use On
MK7	Adjustable Tensioning Tool for Width .10" to .19"	CT18 - CT50 Series Ties
MK9	Adjustable Tensioning Tool for Width .19" to .35"	CT18 - CT250 Series Ties
TWT1	Non-adjustable Tensioning Tool for Width .10" to .19" Twist & Cut	CT18 - CT50 Series Ties
TWT2	Non-adjustable Tensioning Tool for Width .19" to .35" Twist & Cut	CT120 - CT175 Series Ties

Blue highlighted items are industry standard and most frequently ordered.

PRODUCT LINE

TABLE OF CONTENTS

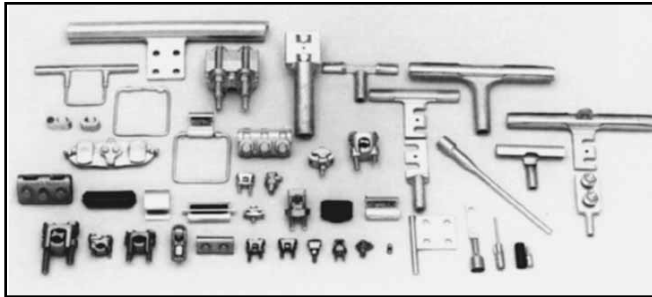

TAP CONNECTORS

Mechanical (Bolted) **H-3 - H-17**
 Compression **H-18 - H-37**
 Transformer and Equipment. **H-38 - H-40**

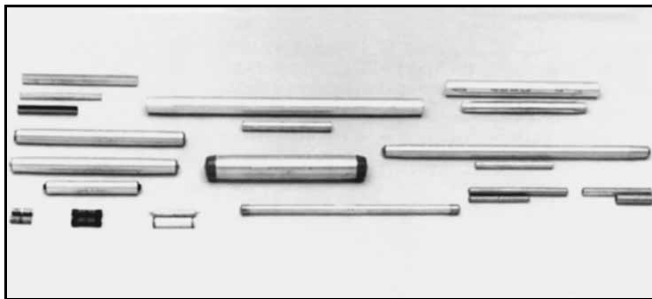

COMPRESSION SPLICES

Service Entrance **H-42 - H-45**
 Neutral **H-46**
 Jumper **H-47 - H-51**
 Repair Sleeve **H-51 - H-52**
 Full Tension **H-53 - H-63**

H-1

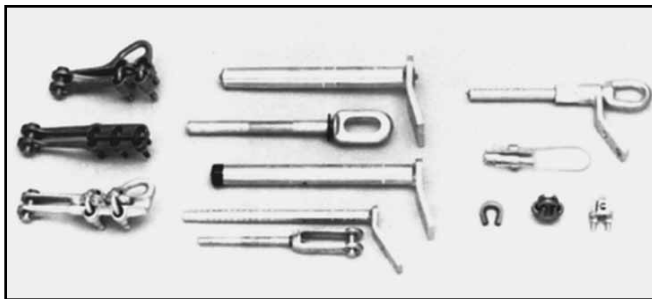

DEADEND FITTING AND ACCESSORIES

Loop **H-65 - H-66**
 Primary and Strain Bus **H-67 - H-68**

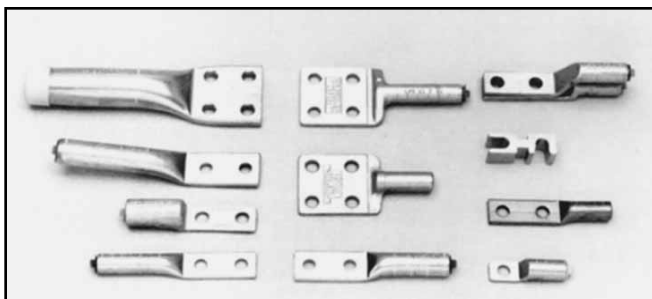

COMPRESSION TERMINALS

AND ACCESSORIES. H-69 - H-75

Blue highlighted items are industry standard and most frequently ordered.

TAP CONNECTORS

TABLE OF CONTENTS

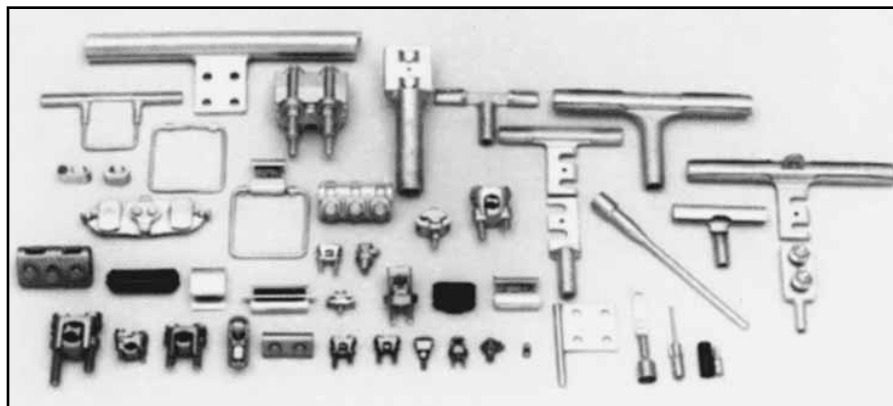

MECHANICAL (BOLTED)

Mechanical Tap Connectors	H-3
Types KS & KS-3	H-4
Type SC	H-4
Type KSU	H-5
Type KVS	H-5
Type KVSW	H-6
Types KVSU & KVS	H-7
Type KVS-A	H-8
Types UC-L, UC-K	H-9
Type CP-A	H-10
Type VP	H-11
Type UW-R	H-11
Type UC	H-12
Type CP	H-12
Type QPX	H-13
Type VT	H-14
Types UCG-R & UCG-RS	H-15
Types UC-R & UC-RS	H-15
Types UC KIT & UCCOVER1	H-16
Type LSC	H-17

COMPRESSION

Compression Tap Connectors	H-18
Type YC-C	H-19
Type YP-C	H-19
Type YC-A	H-20
Types YP-U, YPC-U	H-21
Type YPC-U	H-22
Type YC-U	H-23

Types YPC-A-U & YPC-R-U	H-23
Type CC	H-24
Seven Connector Selector Chart	H-25
Types YHO & YHD	H-26
Types YHN & YHR	H-27
LOKTAP™	H-28
Type YCT	H-29
Type YOT	H-29
Type YTU-R-R	H-30
Type YTA-R-2N	H-31
Types YKA-R-2N & YKA-A-2N	H-32
Type YSA-R-2N	H-33
Type YTA-2N	H-33
Type YKA-2N	H-34
Type YCB-R	H-35
Types YCB-U & YCB-R-U	H-36
Types J990 & J1252	H-36
Types YHO-J, YHD-J, YHN-J	H-37

TRANSFORMER AND EQUIPMENT

Type E-C-G	H-38
Types KC2 & EQC632C	H-39
Type YA-2LH	H-39
Type YE-LH	H-40
Type YE-R, YE-W	H-40

Blue highlighted items are industry standard and most frequently ordered.

MECHANICAL (BOLTED) TAP CONNECTORS

BURNDY’s line of mechanical tap connectors is the most complete, dependable and economical available. These mechanical connectors consist of service, parallel, and midspan types.

Generally the alloys and hardware used depend on whether the connector is for a strain or current carrying application, and is made of aluminum or copper. Particular alloys and hardware are selected for strength, conductivity, durability, ductility and resistance to corrosion.

In a copper connector high strength alloys are used in mechanical clamping components and high conductivity alloy in current carrying elements.

Aluminum clamp type connectors are made of alloy 356, which is impervious to stress corrosion. In its heat-treated state, it has high strength and is used for both current carrying and clamping elements.

Hardware is high strength and corrosion-resistant. In copper connectors, DURIMUM™, a silicone bronze alloy, is used. Anodized aluminum alloy 2024-T4 bolts and 6061-T6 nuts are used in aluminum connectors. They provide the best combination of strength, resistance to galling and corrosion, and their thermal coefficient of expansion is most suitable for aluminum. To insure dependable connections, bolts should be tightened to the recommended torque values shown below.

These mechanical tap connectors are mainly used in overhead distribution systems to provide primary service taps and/or secondary service drop connections to the end users.

A few of the key features and benefits of these connectors are:

Features and Benefits

- High strength alloys.
 - ◇ Provides efficient and reliable performance.
- Range taking.
 - ◇ Accommodates a large range of conductors in either groove reducing inventory to a minimum.
- Matched groove designs.
 - ◇ Ensures maximum contact with conductors accommodated.
- Hex bolts, nuts and washers.
 - ◇ Provides high contact pressure and rapid assembly.

H-3

Recommended Tightening Torque		Standard Wrench Size	
Bolt Size	Recommended Torque (Inch Lbs.)	Bolt	Nut
DURIMUM™ and Galvanized Hardware			
1/4 - 20	80	7/16	7/16
5/16 - 18	180	1/2	1/2
3/8 - 16	240	9/16	9/16
1/2 - 13	480	3/4	3/4
5/8 - 11	660	15/16	15/16
3/4 - 10	1050	1-1/8	1-1/8
Aluminum Hardware*			
1/2 - 13	300	3/4	3/4
5/8 - 11	480	15/16	15/16
3/4 - 10	650	1-1/8	1-1/8

* Aluminum bolts are lubricated.

Blue highlighted items are industry standard and most frequently ordered.

TYPES KS & KS-3

SERVIT®

For Copper, Copperweld

Compact, high strength, high copper alloy SERVIT® split-bolt has free-running threads and easy to grip wrench flats. Highly resistant to season cracking and corrosion, the SERVIT® provides maximum pressure and assures a secure connection on all combinations of run and tap conductors. Type KS-3 accommodates 3 maximum size conductors.

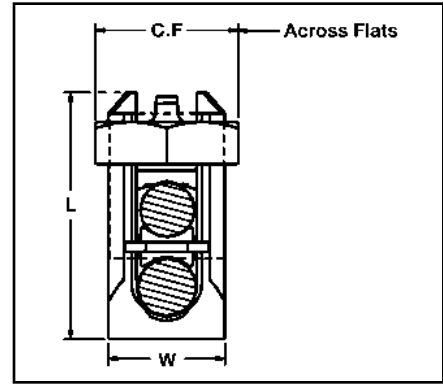

Catalog Number	Cross Flats	L	W	Conductor						▲ Recommended Tightening Torque in-lb
				Copper		Copperweld				
				Range for Equal Run and Tap	Min. Tap with Max. Run	Maximum Run and Tap				
				Sol.	Str.	Type A	Type D			
† KS90	.50	.85	.38	12 Str. - 10 Str.	16 Str.	#10	—	—	—	80
† KS15	.50	.85	.38	10 Str. - 8 Str.	14 Str.	#8	—	—	—	
† KS17	.63	1.14	.45	8 Str. - 6 Sol.	14 Str.	#6	3 #12	8A	9-1/2D	165
* KS17-3				8 Str. - 6 Sol.	16 Str.	#6	3 #12	8A	9-1/2D	
† KS20	.69	1.20	.51	8 Str. - 4 Sol.	14 Str.	#4	3 #10	6A	8D	
* KS20-3				8 Str. - 4 Sol.	14 Str.	#4	3 #10	6A	8D	
† KS22	.75	1.50	.60	6 Str. - 2 Sol.	14 Str.	#2	3 #8	4A	6D	275
* KS22-3				6 Str. - 2 Sol.	14 Str.	#2	3 #8	4A	6D	
† KS23	.82	1.54	.62	6 Str. - 2 Str.	14 Str.	#1	3 #7	3A	5D	
† KS25	.94	1.77	.73	4 Str. - 1/0 Str.	14 Str.	2/0	3 #5	2A	4D	385
† KS26	1.05	1.94	.82	2 Str. - 2/0 Str.	14 Str.	3/0	7 #7	—	—	
† KS27	1.36	1.86	1.17	1 Str. - 3/0 Str.	8 Sol.	—	—	—	—	500
† KS29	1.36	2.07	1.17	1 Str. - 250	8 Str.	4/0	7 #5	—	—	650
† KS31	1.70	2.51	1.41	1/0 Str. - 350	1/0 Str.	—	19 #8	—	—	
† KS34	1.82	2.79	1.48	2/0 Str. - 500	2/0 Str.	—	19 #6	—	—	825
KS39	2.31	3.29	1.94	4/0 Str. - 750	4/0 Str.	—	19 #5	—	—	1000
KS44	2.56	3.73	2.19	300 - 1000	4/0 Str.	—	—	—	—	1100

▲ Listed torque values are for maximum conductor combinations accommodated. Consult UL486 Tables 7-4, 7-5, 7-6 for smaller conductor combinations.

See note page A-2
* Not UL Listed or CSA Certified.

† In addition to UL Listed for wire connectors and CSA Certified, these items are also UL rated for direct burial.

TYPE SC

SERVIT® COVER

HUG-A-BUG

Used indoors or outdoors this compact, one-piece plastic SERVIT® cover, saves time and material, eliminates costly taping of split-bolts. Positive latch snaps easily and quickly over connector, ideal for tight quarters. Self positioning plastic fingers wrap around wires fully insulating joint. UL listed for 600 volt indoor application. Three covers accommodate a range of 6 SERVIT® sizes through 2/0 Str.



Catalog Number	Conductor Range				*For Use with	For Use with
	Range for Equal Run and Tap		Min. Tap with Max. Cable Run			
	Min.	Max.	Min.	Max.		
SC4	8 Str.	6 Sol.	14 Str.	6 Sol.	KS17	—
SC4	8 Str.	4 Sol.	14 Str.	4 Sol.	KS20	—
SC2	6 Str.	2 Sol.	14 Str.	2 Sol.	KS22	KSA6
SC2	6 Str.	2 Str.	14 Str.	2 Str.	KS23	KSA4
SC2/0	4 Str.	1/0 Str.	14 Str.	1/0 Str.	KS25	KSA2
SC2/0	2 Str.	2/0 Str.	14 Str.	2/0 Str.	KS26	KSA1/0

* UL listing of Type SC Cover applies to use on BURNDY® SERVIT® Type KS and to equivalent split-bolt connectors indicated strip length is maintained, maximum indicated

conductor sizes are not exceeded, and connector is properly located within recess provided for it.

Blue highlighted items are industry standard and most frequently ordered.

TYPE KSU

UNIVERSAL SERVIT®

For All Combinations of Copper, Aluminum, ACSR, AAAC, 5005, & Steel

Tin-plated, high strength copper alloy SERVIT® with spacer. Spacer separates dissimilar conductors and provides long contact length that prevents high pressure point contacts between run and tap conductors.

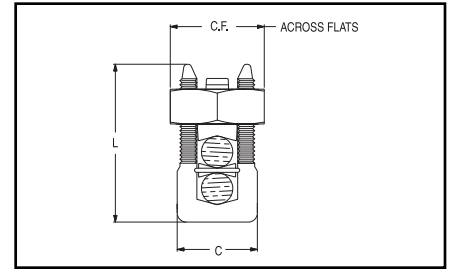

Use of PENETROX™ joint compound recommended with aluminum or ACSR.



Catalog Number	Cross Flat	L	W	Conductor				Maximum Conductor Steel Sol. 3 Str. Nom. BWG BWG Dia.	Recommended Tightening Torque in.-lb.
				Run		TAP			
				Copper & Aluminum	ACSR, AAAC, 5005	Copper & Aluminum	ACSR, AAAC, 5005		
KSU17	.62	.92	.70	12 Sol. - 6 Sol.	8 (6 - 1)	12 Sol. - 6 Sol.	8 (6 - 1)	8 — 5/32	
KSU20	.69	1.05	.78	10 Sol. - 4 Sol.	6 (6 - 1)	10 Sol. - 4 Sol.	6 (6 - 1)	6 8 7/32	165
KSU22	.74	1.25	.84	10 Sol. - 2 Sol.	6 (6 - 1) - 4 (7 - 1)	10 Sol. - 2 Sol.	6 (6 - 1) - 4 (7 - 1)	4 6 1/4	275
KSU23	.81	1.48	.94	8 Str. - 2 Str.	3 (6 - 1) - 2 (6 - 1)	8 Sol. - 2 Str.	6 (6 - 1) - 2 (6 - 1)	— 4 5/16	275
KSU25	.93	1.77	1.06	2 Str. - 1/0 Str.	3 (6 - 1) - 1 (6 - 1)	10 Str. - 1/0 Str.	6 (6 - 1) - 1 (6 - 1)	— — 3/8	385
KSU26	1.04	1.93	1.19	1/0 Str. - 2/0 Str.	1 (6 - 1) - 1/0 (6 - 1)	8 Str. - 2/0 Str.	6 (6 - 1) - 1/0 (6 - 1)	— — 7/16	385
KSU27	1.38	2.34	1.58	1 Str. - 3/0 Str.	1 (6 - 1) - 2/0 (6 - 1)	8 Sol. - 3/0 Str.	8 (6 - 1) - 2/0 (6 - 1)	— — 1/2	500
KSU29	1.38	2.50	1.58	1 Str. - 250	2/0 (6 - 1) - 4/0 (6 - 1)	8 Str. - 250	6 (6 - 1) - 4/0 (6 - 1)	— — 1/2	650
KSU31	1.69	2.88	1.91	4/0 Str. - 350	3/0 (6 - 1) - 4/0 (6 - 1)	4 Str. - 350	4 (6 - 1) - 4/0 (6 - 1)	— — 5/8	650
KSU34	2.00	3.12	2.28	400 - 500	336 (30 - 7) - 477 (18 - 1)	2 Str. - 500	2 (6 - 1) - 477 (18 - 1)	— — —	825

H-5

TYPE KVS

OKLIP™

Mechanical Connector for Copper and Copperweld

Compact, two-piece, high strength; high copper alloy BURNDY® OKLIP™ recommended for heavy duty connections. Neoprene rings hold bolts in place during installation. Installed with ordinary wrench.



Catalog Number	Conductor				
	Copper		Copperweld		
	Run	Tap	Sol.	Str.	Type V
KVS26	1 Str. - 2/0 Str.	6 Str. - 2/0 Str.	3/0	7 #8	—
KVS28	1/0 Str. - 4/0 Str.	10 Str. - 4/0 Str.	4/0	7 #6	V3/0
KVS31	250 - 350	10 Str. - 350	—	19 #8	V250
KVS34	400 - 500	10 Str. - 500	—	19 #6	V350
KVS40	400 - 800	3/0 Str. - 800	—	19 #5	—
KVS44	500 - 1000	3/0 Str. - 1000	—	—	—

Blue highlighted items are industry standard and most frequently ordered.

TYPE KVS

OKLIP™

Mechanical Connector for Copper and Copperweld

Similar to OKLIP™ Type KVS except for high copper alloy spacer that separates run and tap conductor. Provides high contact pressure, confines conductor strands, and assures vibration proof connection. Longer peened bolt, permits swivel action for easier installation.



Catalog Number	Conductor	
	Run	Tap
KVSW26	2 Str. - 2/0 Str.	6 Sol. - 2/0 Str.
KVSW28	1/0 Str. - 4/0 Str.	6 Sol. - 4/0 Str.
KVSW31	250 - 350	4 Sol. - 350
KVSW34	400 - 500	4 Str. - 500
KVSW40	400 - 800	4/0 - 800
KVSW44	500 - 1000	250 - 1000

H-6

Blue highlighted items are industry standard and most frequently ordered.

TYPES KVSU, KVS

UNIVERSAL OKLIP™

Mechanical Connector for All Combinations of Copper, Aluminum†, ACSR†, AAAC and 5005

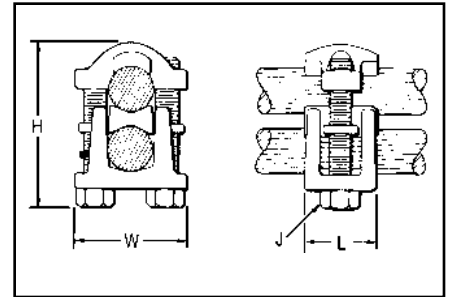

Compact, tin-plated, high strength, high copper allow two-piece connector with spacer and tin-plated silicone bronze DURIMUM™ hardware. Recommended for heavy duty connections. Spacer separates dissimilar conductors and provides long contact length. Neoprene ring prevents loss of shorter bolt during installation. Longer peened bolt, permits swivel action for easier installation.

Use of PENETROX™ joint compound recommended with aluminum and ACSR.

H-7

Catalog Number	Conductor			
	Run		Tap	
	Copper & Aluminum†	ACSR†, AAAC, & 5005	Copper & Aluminum†	ACSR†, AAAC, & 5005
KVSU26	2 Str. - 2/0 Str.	3 - 2/0	6 Str. - 2/0 Str.	6 - 2/0
KVSU28	1/0 Str. - 4/0 Str.	1/0 - 4/0	6 Str. - 4/0 Str.	6 - 4/0
KVSU31	250 - 350	4/0 - 300	5 - 350	6 - 300
KVSU34	400 - 500	336.4 - 397.5	4 - 500	5 - 397.5
KVSU40	400 - 800	336.4 - 715.5	4/0 - 800	3/0 - 715.5
KVSU44	500 - 1000	397.5 - 900	4/0 - 1000	4/0 - 900

† Accommodates compressed conductors within diameter range.

Catalog Number	Conductor				
	Copper		Copperweld		
	Run	Tap	Max. Run and Tap		
			Sol.	Str.	Type V
KVS26	1 Str. - 2/0 Str.	6 Str. - 2/0 Str.	3/0	7 #8	—
KVS28	1/0 Str. - 4/0 Str.	10 Str. - 4/0 Str.	4/0	7 #6	V3/0
KVS31	250 - 350	10 Str. - 350	—	19 #8	V250
KVS34	400 - 500	10 Str. - 500	—	19 #6	V350
KVS40	400 - 800	3/0 Str. - 800	—	19 #5	—
KVS44	500 - 1000	3/0 Str. - 1000	—	—	—

Blue highlighted items are industry standard and most frequently ordered.

TYPE KVS-A

ALUMINUM OKLIP™

Mechanical Connector for All Combinations of Copper, Aluminum†, ACSR†, AAAC & 5005

Three-piece, high-conductivity, non-copper bearing aluminum alloy connector with thick spacer and aluminum hardware. Hardware in KVS26A and KVS28A is stainless steel. Recommended for heavy duty dissimilar metal applications. Spacer separates conductors and provides long contact length.

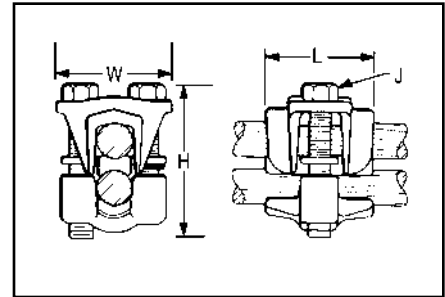

Belted entrances prevent chafing and permit easier assembly of conductors. Longer, peened bolt, permits swivel action for easier installation. Neoprene ring prevents loss of shorter bolt. PENETROX™ joint compound recommended with aluminum and ACSR.

H-8

Catalog Number	Conductor			
	Run		Tap	
	Copper & Aluminum†	ACSR†, AAAC, & 5005	Copper & Aluminum†	ACSR†, AAAC, 5005
KVS26A	2 Str. - 2/0 Str.	4 - 2/0	10 Str. - 2/0 Str.	6 - 2/0
KVS28A	1/0 Str. - 4/0 Str.	1/0 - 4/0	10 Str. - 4/0 Str.	6 - 4/0
KVS31A	250 - 350	4/0 - 336.4	6 Str. - 350	6 - 336.4
KVS34A	400 - 500	336.4 - 397.5	4 Str. - 500	5 - 397.5
KVS40A	400 - 800	336.4 - 715.5	3/0 Str. - 800	3/0 - 715.5
KVS44A	500 - 1000	397.5 - 900	3/0 Str. - 1000	3/0 - 900

† Accommodates compressed conductors within diameter range.

THESE CONNECTORS CAN ACCOMMODATE ACSR CONDUCTORS OVER ARMOR ROD WITHIN THE DIAMETER RANGE INDICATED.

Application Over Armor Rod

Catalog Number	Conductor Range by Diameter			H	J	L	W
	Min. Run Dia.	Min. Tap Dia.	Max. Run & Tap Dia.				
KVS26A	.281	.116	.447	2	5/16	1-3/8	1-5/8
KVS28A	.360	.116	.564	2-3/8	3/8	1-5/8	2
KVS31A	.565	.184	.681	3	1/2	2	2-5/8
KVS34A	.728	.216	.814	3-3/8	1/2	2-1/2	2-5/8
KVS40A	.728	.470	1.036	4	1/2	3-1/8	3
KVS44A	.806	.470	1.162	4-1/2	5/8	3-1/2	3-3/8

Blue highlighted items are industry standard and most frequently ordered.

TYPE UC-L

UNIVERSAL PARALLEL CLAMP

For All Combinations of Copper, Aluminum†, ACSR†, 6201, 5005, Steel and Copperweld

Interlocking finger design accommodates large range of conductor sizes. Tin-plated, cast of high copper alloy and clamped with plated steel bolt, PENETROX™ joint compound recommended with aluminum and ACSR.

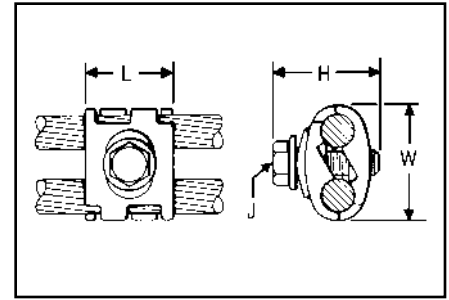
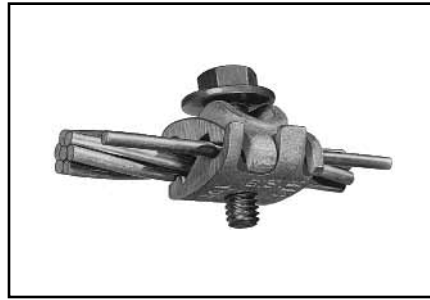

Catalog Number	Copper & Alum. (Either Groove)	ACSR†, 6201, 5005	Copperweld	Steel		Installation Tooling		Dimensions			
				Nom. Dia.	AWG	Copper Conductor Size (AWG)	Tightening Torque (in.-lbs.)	L	H	J	W
UC8W26-L	8 Sol. - 2/0 Str.	6 - 1/0	8 Sol. - 7 #7	5/32 - 7/16	8 Sol. - 4-3 Str.	#8	75	1	1-1/2	5/16	1-7/16
*UC2W28-L	2 Sol. - 4/0 Str.	3 - 4/0	3 #8 - 7 #6	9/32 - 9/16	4-3 Str. - 4-3 Str.	#6 - #4	110	1-1/8	1-1/2	3/8	1-3/4

† Accommodates compressed conductors within diameter range.

H-9

TYPE UC-K

UNIVERSAL PARALLEL CLAMP

For All Combinations of Copper, Aluminum†, ACSR, Steel and Copperweld

Interlocking finger design accommodates large range of conductor sizes. Tin-plated, cast of high copper alloy and clamped with silicon bronze DURIMUM™ bolt, PENETROX™

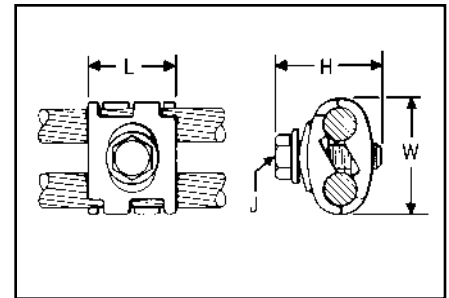
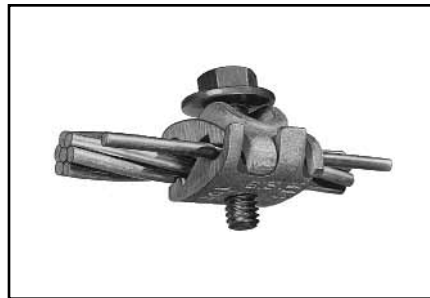

joint compound recommended with ACSR. Applications include grounding for the Cable TV industry.



Catalog Number	For Use with:	Conductor Range				Installation Torques		Dimensions			
		Groove A		Groove B		Conductor Size	Torque (in.-lbs.)	L	H	J	W
		Maximum Size	Minimum Size	Maximum Size	Minimum Size						
UCK-1UL†	Aluminum or Galvanized Steel Strand to Copper or Copper Bonded Steel Wire	1/0 ACSR or 7/16 Galvanized Steel Strand	#6 ACSR	2/0 Str. Copper 7/16 Copperweld, 2A Copperweld	#8 Sol. Copper 9-1/2D Copperweld	#8	75				
UCK-2UL	Aluminum or Galvanized Steel Strand to Aluminum or Galvanized Steel Strand	1/0 ACSR or 7/16 Galvanized Steel Strand	#6 ACSR	1/0 ACSR or 7/16 Galvanized Steel Strand	#6 ACSR	#6 - #4	110	1	1-7/16	5/16	1-7/16
UCK-3UL*	Copper to Copper	2/0 Str. Copper 7/16 Copperweld, 2A Copperweld	#8 Sol. Copper 9-1/2D Copperweld	2/0 Str. Copper 7/16 Copperweld 2A Copperweld	#8 Sol. Copper 9-1/2D Copperweld	1/0 - 2/0	150				

† Accommodates compressed conductors within diameter range.

Blue highlighted items are industry standard and most frequently ordered.

TYPES CP-A

PARALLEL CLAMP

For All Combinations of Copper, Aluminum†, ACSR†, 6201 & 5005

Type CP-A is recommended for tap or parallel connections. High strength, high conductivity aluminum body and hardware provide corrosion resistant assembly. Long contact surface insures excellent contact and full conductivity. PENETROX™ joint compound recommended for all combinations.

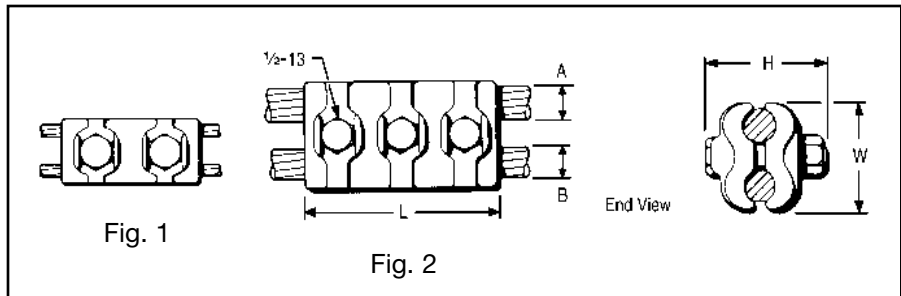

H-10

Catalog Number	Groove A		Groove B		Fig. No.	Dimensions		
	ACSR, 6201, 5005	Copper & Aluminum	ACSR, 6201, 5005	Copper & Aluminum		L	H	W
CP26A26A	1/0	3/0 Sol. - 2/0 Str.	1/0	3/0 Sol. - 2/0 Str.	1	4"	2-7/8"	2-1/8"
CP27A27A	2/0	4/0 Sol. - 3/0 Str.	2/0	4/0 Sol. - 3/0 Str.				
	101.8 (12-7) 110.8 (12-7)		101.8 (12-7) 110.8 (12-7)					
CP28A28A	3/0	4/0 Str.	3/0	4/0 Str.				
	134.6 (12-7)		134.6 (12-7)					
CP29A29A	4/0	250 266.8	4/0	250 266.8				
	159 (12-7) 203 (8-7)		159 (12-7) 203 (8-7)					
CP30A30A	176.9 (12-7) 190.8 (12-7) 266.8 (18-1, 6-7, 26-7)	300	176.9 (12-7) 190.8 (12-7) 266.8 (18-1, 6-7, 26-7)	300	2	4-1/2"	3"	2-3/8"
	211.3 (12-7) 300 (26-7, 30-7) 336.4 (18-1)		211.3 (12-7) 300 (26-7, 30-7) 336.4 (18-1)					
CP31A31A	336.4 (18-1)	397.5 400	336.4 (18-1)	397.5 400				
	203.2 (16-19) 336.4 (26-7, 30-7) 397.5 (18-1)		203.2 (16-19) 336.4 (26-7, 30-7) 397.5 (18-1)					
CP32A32A	397.5 (26-7, 30-7) 477 (18-1)	450 477 500	397.5 (26-7, 30-7) 477 (18-1)	450 477 500				
	500 (30-7) 556.5 (24-7, 26-7, 30-7) 636 (36-1) 605 (24-7)		500 (30-7) 556.5 (24-7, 26-7, 30-7) 636 (36-1) 605 (24-7)					
CP37A37A	636	636	636	636	5-1/4"	3-3/8"	3"	

† Accommodates compact and compressed conductors within diameter range.
For other sizes contact factory.

Blue highlighted items are industry standard and most frequently ordered.

TYPE VP

PARALLEL CLAMP

For Copper

Multiple V-bolt connector especially suited for flexible or extra flexible conductors. Made of high strength, high conductivity copper. Clamping elements accommodate a range of conductor sizes in either groove. V-bolts provide high pressure and compress the conductor over long contact area. Also recommended for jumper connections.

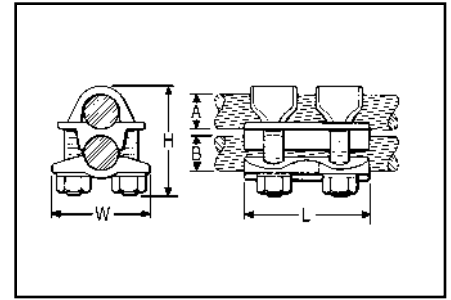

Catalog Number	Groove A	Groove B	Dimensions		
			H	L	W
VP2828	1/0 Str. - 4/0 Str.	1/0 Str. - 4/0 Str.	2-1/8"	2-3/4"	1-3/4"
VP3030	1/0 Str. - 300	1/0 Str. - 300	2-1/2"	3-1/8"	2"
VP3430	300 - 500		3-1/8"	3-1/4"	2-1/2"
VP4030		500 - 800	4-3/8"	3-1/2"	2-7/8"
VP4040	3-3/4"				
VP4440	750 - 1000	500 - 800	5"	3-7/8"	3-1/4"
VP4646	1000 - 1500	1000 - 1500	5-3/8"	4-1/2"	3-1/2"

H-11

TYPE UW-R

CLIPIT™

Deadend Clamp for Aluminum†, ACSR†, 6201 and 5005

High strength aluminum casting with galvanized steel U-bolt, extra long aluminum spacer, and caps that confine strands. Holding strength of installations using two CLIPIT™ deadends exceeds rated breaking strength of conductor. Use of PENETROX™ joint compound is recommended.

RUS Accepted

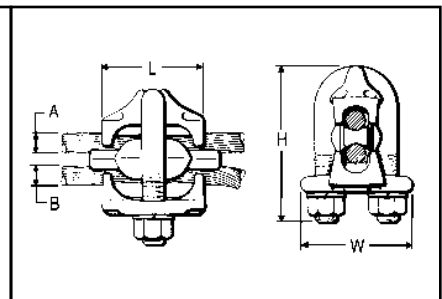

Catalog Number	Run A		Tap B		Dimensions		
	ACSR, 6201, 5005	Aluminum	ACSR, 6201, 5005	Aluminum	L	H	W
UW2R	6 - 2	6 Str. - 2 Str.	6 - 2	6 Str. - 2 Str.	1-1/2"	2-5/8"	1-7/8"
UW25R	6 - 1/0	6 Str. - 2/0 Str.	6 - 1/0	6 Str. - 2/0 Str.	1-7/8"	2-7/8"	2"

† Accommodates compressed conductors within diameter range.

Blue highlighted items are industry standard and most frequently ordered.

TYPE UC

PARALLEL CLAMP

For Range of Copper

Type UC connector accommodates large range of conductors in either groove, reducing inventory to a minimum. Interlocking finger design provides firm grip with maximum contact length. High strength, corrosion resistant silicone bronze hardware. One wrench installation.

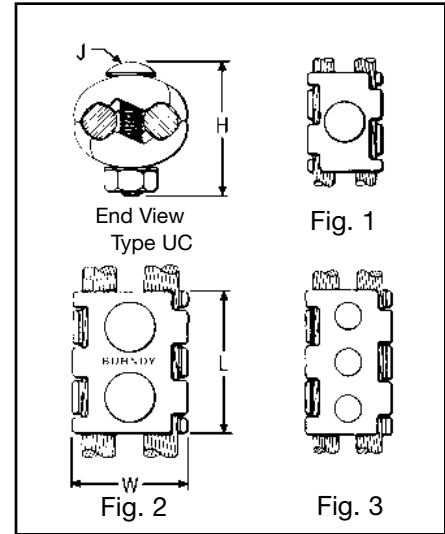

H-12

Catalog Number	Conductor (Either Groove)	Fig. No.	Dimensions			
			L	H	J	W
UC6W25	6 Sol. - 1/0 Str.	1	1-3/4"	1-5/8"	3/8"	1-3/8"
UC4W28	4 Sol. - 4/0 Str.	2	2-1/8"	2"	3/8"	1-3/4"
UC2W30	2 Sol. - 300	2	2-3/8"	2-1/8"	3/8"	2"
UC2834	4/0 Str. - 500	3	4-1/4"	2-7/8"	1/2"	2-1/2"
UC3040	300 - 800	3	4-1/4"	3-3/8"	1/2"	3"
UC3444	500 - 1000	3	4-1/4"	3-5/8"	1/2"	3-1/2"

TYPE CP

PARALLEL CLAMP

For Copper

High strength, high copper alloy Type CP is recommended for heavy duty parallel connections. Silicone bronze DURIMUM™ hardware and cast copper body provides corrosion resistant assembly. Long contact surface provides excellent contact and assures full conductivity.

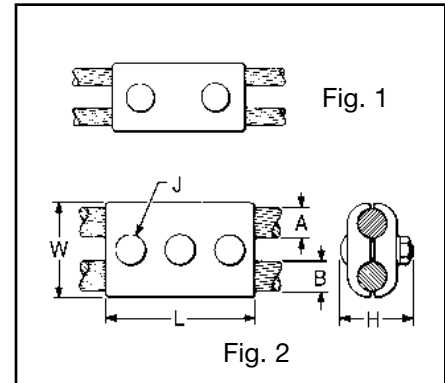

Catalog Number	Groove		Fig. No.	Dimensions		
	A	B		L	J	W
CP2C2C	2 Str.	2 Str.	1	2-1/2"	3/8"	1-1/4"
CP2525	1/0 Str.	1/0 Str.	1	3"	3/8"	1-5/8"
CP2626	2/0 Str.	2/0 Str.	1	3"	3/8"	1-5/8"
CP2828	4/0 Str.	4/0 Str.	2	4"	3/8"	2"
CP2929	250	250	2	4"	3/8"	2"
CP3434	500	500	2	5"	1/2"	2-1/2"

For other sizes contact factory.

Blue highlighted items are industry standard and most frequently ordered.

TYPE QPX

VERSITAP™ PARALLEL CLAMP

For Copper, Copperweld and Copperweld-Copper

The VERSITAP™ Type QPX is recommended for Tee, Cross, Parallel, Butt and Tap connections. Range-taking, only 10 connectors required to accommodate conductor sizes from #6 Str. to 1000 kcmil. Edges are rounded for easy taping. Made of high strength, high conductivity copper alloy and silicone bronze DURIMUM™ hardware.

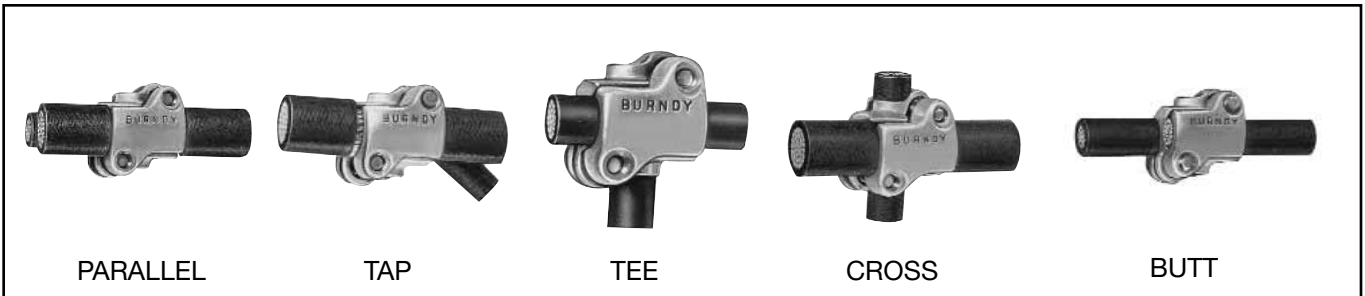
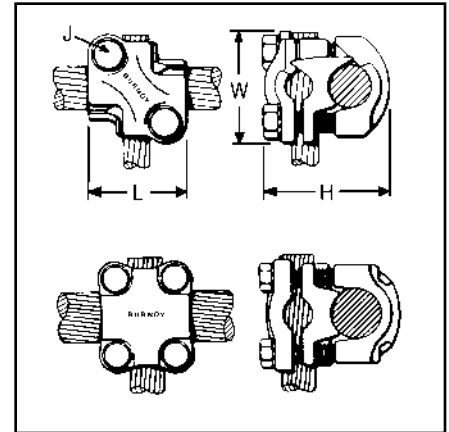
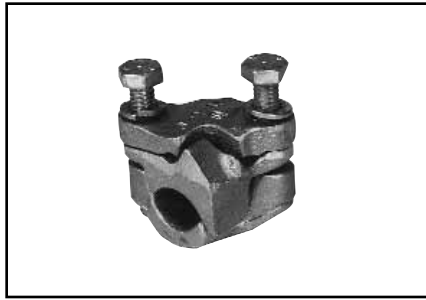

H-13

Catalog Number	Run			Tap			Dimensions			
	Copper	Copperweld	Copperweld -Copper	Copper	Copperweld	Copperweld -Copper	L	H	J	W
QPX2C2C	6 Str. - 2 Str.	5 Sol. - 3 #7	8A - 4A	6 Str. - 2 Str.	5 Sol. - 3 #7	8A - 4A	1-3/8	1-5/8	5/16	1-3/8
QPX282C	1 Str. - 4/0 Str.	7 #9 - 7 #5	3A - 3/0V					2		
QPX2828				1 Str. - 4/0 Str.	7 #9 - 7 #5	3A - 3/0V	1-7/8	2-1/8	3/8	1-7/8
QPX342C	250 - 500	19 #19 - 19 #6	4/0 EK	6 Str. - 2 Str.	5 Sol. - 3 #7	8A - 4A	1-3/8	2-1/2	3/8	2
QPX3428				1 Str. - 4/0 Str.	7 #9 - 7 #5	3A - 3/0V	1-3/4			
QPX3434				250 - 500	19 #9 - 19 #6	4/0 EK	2	2-3/4	3/8	2-1/8
QPX442C				6 Str. - 2 Str.	5 Sol. - 3 #7	8A - 4A	1-3/8	2-5/8	5/16	2-1/4
QPX4428	500 - 1000	19 #6	—	1 Str. - 4/0 Str.	7 #9 - 7 #5	3A - 3/0V	1-7/8	2-7/8	3/8	2-3/8
QPX4434				250 - 500	19 #19 - 19 #6	4/0 EK	2	3		
QPX4444				500 - 1000	19 #6	—	2-5/8	3-3/8	2-5/8	

Blue highlighted items are industry standard and most frequently ordered.

TYPE VT

T-CONNECTOR

For Copper Cable to Cable

High copper alloy T-connector for cable run, cable tap. DURIMUM™ V-bolt clamping elements accommodate large range of cable and are particularly suited for extra flexible cable. (One-wrench installation).

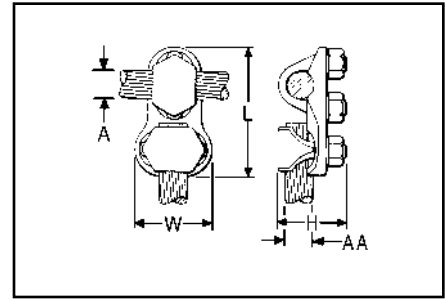
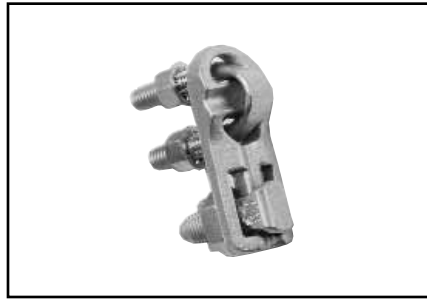

H-14

Catalog Number	Conductor		H	L	W
	Run (A)	Tap (AA)			
VT2C2C	8 Sol. - 2 Str.	8 Sol. - 2 Str.	1-3/8"	2-3/8"	1"
VT2525	6 Sol. - 1/0 Str.	6 Sol. - 1/0 Str.	1-5/8"	2-5/8"	1-1/4"
VT2825	1/0 Str. - 4/0 Str.			3-1/8"	
VT2828	1/0 Str. - 4/0 Str.	1/0 Str. - 4/0 Str.	1-7/8"	3-3/8"	1-3/4"
VT3025	1/0 Str. - 300	6 Sol. - 1/0 Str.			1-1/8"
VT3030		1/0 Str. - 300	2"		
VT3425	300 - 500	6 Sol. - 1/0 Str.	2-3/8"	3-1/4"	1-1/4"
VT3428		1/0 Str. - 4/0 Str.		3-1/2"	1-3/4"
VT3430		1/0 Str. - 300		3-5/8"	2"
VT3434		300 - 500		3-3/4"	2-1/4"
VT4040	500 - 800	500 - 800	2-5/8"	4-3/4"	2-5/8"
VT4425	750 - 1000	6 Sol. - 1/0 Str.	2-7/8"	4-3/8"	1-1/4"
VT4428		1/0 Str. - 4/0 Str.		4-1/8"	1-3/4"
VT4834	1500 - 2000	300 - 500	4-1/4"	5-1/4"	2-1/4"

Blue highlighted items are industry standard and most frequently ordered.

TYPES UCG-R & UCG-RS

TAPIT™ PARALLEL CLAMP

For All Combinations of Copper, Aluminum†, ACSR†, 6201 & 5005

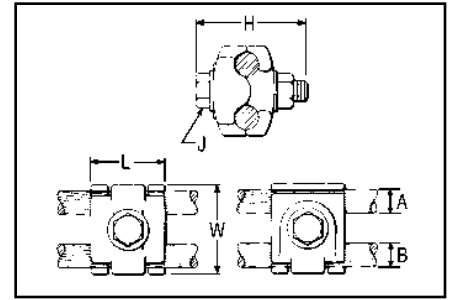
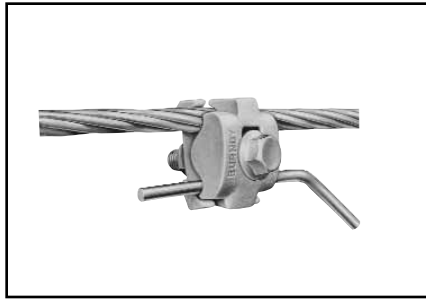

Multiple purpose parallel groove clamp made of high strength, high conductivity, non-copper bearing aluminum alloy. Properly proportioned to minimize stress corrosion and deterioration by galvanic action.

hex head, round collar, high strength galvanized steel bolt allows one or two-wrench installation.

Interlocking fingers on connector body halves prevent mismatching. Square shank,

Also supplied pre-filled with PENETROX™ joint compound and Stripsealed. RUS Accepted

Catalog Number		Groove A		Groove B		Dimensions			
With Stripseal	Without Stripseal	Copper & Aluminum†	ACSR†, 6201, & 5005	Copper & Aluminum†	ACSR†, 6201, 5005	L	H	J	W
UCG25R2RS**	UCG25R2R**	6 Sol. - 1/0 Str.	8 - 1/0	6 Sol. - 2 Str.	8 - 2	1-1/8"	1-7/8"	5/16"	1-3/8"
UCG25RS	UCG25R	8 Str. - 1/0 Str.	6 - 1/0	8 Str. - 1/0 Str.*	6 - 1/0	1-3/8"	2-1/8"	3/8"	1-5/8"
UCG28RS	UCG28R	1/0 Str. - 4/0 Str.	1/0 - 4/0	1/0 Str. - 4/0 Str.	6 - 4/0	1.38"	2.21"	3/8-16"	1.87"
UCG32RS	UCG32R	1/0 Str. - 397.5	1/0 - 336.4	8 Str. - 2/0 Str.	6 - 1/0	1-1/2"	2-5/8"	3/8"	2-1/8"

* Maximum recommended combinations: 1/0 Aluminum or ACSR Run - #2 Str. Copper Tap; 1/0 Copper Run - 1/0 Aluminum or ACSR Tap.

† Accommodates compact and compressed conductors within diameter range.

** Supplied with galvanized steel, square shank bolt.

H-15

TYPES UC-R & UC-RS

TAPIT™ PARALLEL CLAMP

For All Combinations of Copper, Aluminum†, ACSR†, 6201 & 5005

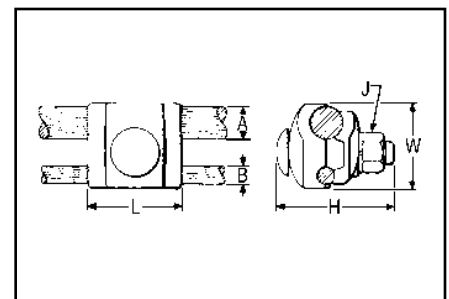

High strength, high conductivity, non-copper bearing aluminum alloy, properly proportioned to minimize stress corrosion and deterioration by galvanic action.

strength galvanized steel bolt allows one wrench installation.

Keying tabs on connector body halves prevent mismatching. Square shank, high

Also supplied pre-filled with PENETROX™ joint compound and Stripsealed. RUS Accepted

Catalog Number		Groove A		Groove B		Dimensions			
With Stripseal	Without Stripseal	Copper & Aluminum†	ACSR†, 6201, & 5005	Copper & Aluminum†	ACSR†, 6201, 5005	L	H	J	W
UC25R2RS	UC25R2R	8 Sol. - 1/0 Str.	6 - 1/0	8 Sol. - 2 Str.	6 - 2	1-1/8"	1-5/8"	5/16"	1-3/8"
UC28RS	UC28R	1/0 Str. - 4/0 Str.	1/0 - 4/0	8 Sol. - 1/0 Str.*	6 - 1/0	1-3/8"	2-3/8"	3/8"	1-7/8"
UC32RS	UC32R	1/0 Str. - 397.5	1/0 - 336.4 (26-7)	6 Sol. - 2/0 Str.	6 - 1/0	1-1/2"	2-3/8"	3/8"	2-1/4"
—	UC33R	4/0 Str. - 400	3/0 - 336.4 (30-7)	6 Sol. - 2/0 Str.	6 - 2/0	1-3/4"	2-3/4"	1/2"	2-1/4"

* Maximum recommended combinations: 4/0 aluminum or ACSR RUN - #2 Str. copper TAP.

† Accommodates compact and compressed conductors within diameter range.

Blue highlighted items are industry standard and most frequently ordered.

TYPE UC KIT

UC connector accommodates a large range of copper conductors in either groove. Kits include connector and cover

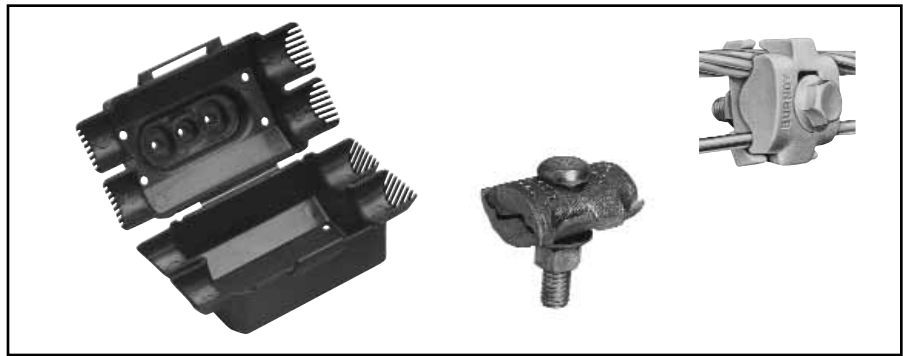

Catalog Number	Conductor (Either Groove)	Fig. No.	Dimensions			
			L	H	J	W
UC6W25CONKIT	6 Sol - 1/0 Str.	1	1-3/4"	1 5/8"	3/8"	1-3/8"
UC4W28CONKIT	4 Sol - 4/0 Str.	2	2-1/8"	2"	3/8"	1-3/4"

H-16

Note: For connectors with break-away bolt contact factory.

UCCOVER1BOX25

TAPIT™ COVER

For Selected UC and UCG Tap Connectors

High density Polyethylene cover accommodates several sizes of UC and UCG connectors. One piece design. Simply slip over the connector and snap shut. Supplied in black.

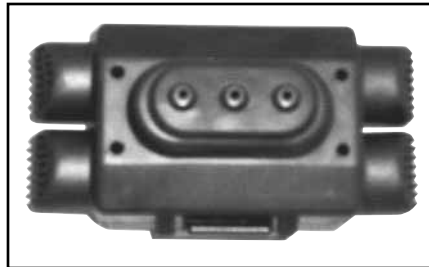

- UCCOVER1** for use with:
- UCG25R2RS UCG25R2R
 - UCG25RS UCG25R
 - UCG28RS UCG28R
 - UC25R2RS UC25R2R
 - UC28RS UC28R
 - UC6W25 UC4W25

Blue highlighted items are industry standard and most frequently ordered.

TYPE LSC

CATCHER

For Aluminum and ACSR
Primary Covered Conductor
(Tree Wire)

Cast aluminum lightning shield clamp with a galvanized steel eye bolt for use on covered aluminum and ACSR primary overhead distribution conductors (“Tree Wire”).

They are designed to protect the “Tree Wire” from burn-down causing service interruption during high lightning activity. For further application details contact the factory.

Conductor groove is pre-filled with PENE-TROX™ A13, which is compatible with cable insulation and individually bagged.

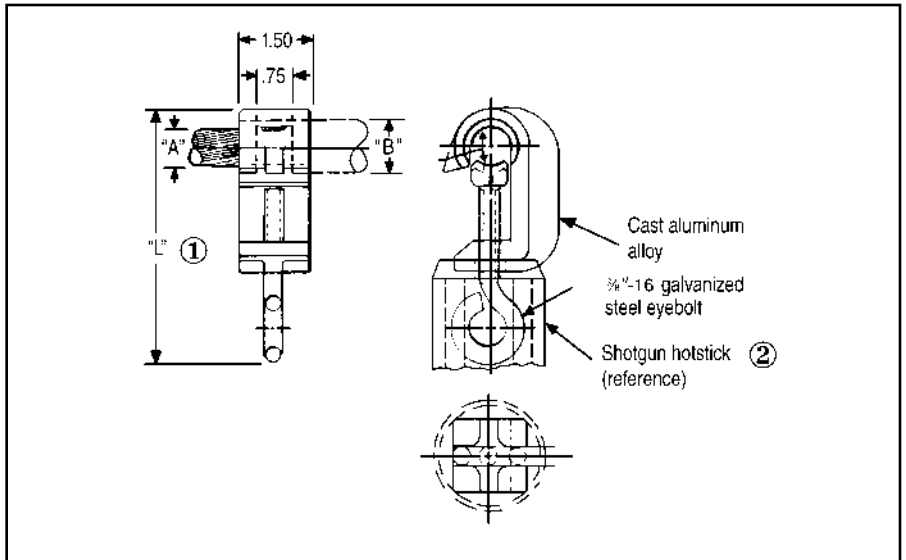

H-17

Catalog Number	Cable	Accommodates Cable Dia. "A"	Insul. Dia. "B" (Max.)	"L"
LSC1/0	1/0 Str. AAC - 1/0 ACSR	.368 - .398	.65"	4.5"
LSC1/0-1	1/0 Str. AAC - 1/0 ACSR	.368 - .398	.83"	4.5"
LSC556	4/0 Str. - 556.5 AAC	.528 - .858	1.16"	5.9"
LSC556-1	4/0 Str. - 556.5 AAC	.528 - .858	1.34"	5.9"

- ① Approx. assembly length over eyebolt with cable clamped. Also approx. eyebolt position when shipped.
- ② Assembly can be installed using a shotgun hotstick as shown. Assembly instructions are supplied with each connector.

Blue highlighted items are industry standard and most frequently ordered.

COMPRESSION TAP CONNECTORS

BURNDY® compression tap connectors are wide range-taking; accommodate copper, aluminum, and ACSR; are easy to install; and are dependable and economical. They are designed to be installed with BURNDY® “matched” hand, hydraulic, and power-driven hydraulic tooling. The connector line consists of C-shaped, Figure 3, Figure 6-shaped and HYCRIMP™ tap connectors, disconnectable T-taps, terminals and stirrups.

The copper CRIMPIT™ is a range-taking, reversible, C-shaped compression tap connector for combinations of copper conductors. Twelve connectors take tap combinations from #10 AWG through 4/0, and all sizes are installed with dies that also install aluminum connectors. Sizes accommodating conductors up to No. 2 may be installed with the MD6 and OUR840; all sizes may be installed with the Y35 or Y750. They make “hot” installation easy by permitting the lineman to grip the CRIMPIT™ in the compression tool and then place it on the line. The tap is then inserted and the CRIMPIT™ is compressed. Massive C-shape forces tap and line conductors together to form dependable, low-cost, low-resistance connections.

The CABELOK CRIMPIT™ is a range-taking, universal and reversible, Figure 3-shaped aluminum compression tap connector with an adjustable spacer which separates the

conductors. It accommodates combinations of copper, aluminum, and ACSR conductors from No. 6 up to 4/0, and is installed with the common O and D3 dies. The broad range capacity of each CABELOK CRIMPIT™ reduces the number of connectors required and simplifies connector selection.

The spacer holds the run or tap in place permitting the lineman either to approach the line with the connector held in the tool and with the tap in the connector, or to assemble the connector and tap on the line and then bring up the tool to crimp.

Each CABELOK CRIMPIT™ is pre-filled with PENETROX™ joint compound and individually bagged. These packages are clearly marked with the entire conductor range of the connector as well as pertinent tooling information. The open side of the CABELOK CRIMPIT™ makes “hot” installations easy by allowing the connector to be carried to the energized line in the crimping tool (MD6, Y35 or Y750 hot-line types).

The Figure 6-shaped aluminum compression tap connector is one of the widest range-taking compression tap connectors available. It accommodates copper, aluminum, or ACSR conductors in very broad ranges. Only four connectors are required to accommodate a range from No. 6 to 600 kcmil. This broad range is made possible by the long ram stroke of the Y35 and Y750.

HYCRIMP™ compression tap connectors accommodate ACSR, stranded copper or aluminum, solid copper or aluminum, and compact conductors. Seventeen sizes are available to accommodate all conductors from #6 solid to 954 MCM compact. All HYCRIMP™ connectors can be installed with industry standard O, D, N and R dies. Each connector is factory filled with BURNDY® PENETROX™ and individually boxed for ease of handling, identification, and installation.

BURNDY’s disconnectable T-taps and jumper loop splices offer an economical approach to sectionalizing or isolating equipment on energized lines. They combine the best features of compression and mechanical connectors. The pads can be easily assembled or separated from each other with hot-line tools.

The STIRRUP™ combines a compression C-shaped Figure 6-shaped or H-shaped element for the run conductor, and a factory installed bail which accommodates a hot-line clamp. The line element can be gripped in the tool and carried to the line and then crimped.

Note: Aluminum bodied compression tap connectors are not recommended for making copper to copper connections. Two connectors are recommended when feeding a line in both directions.

H-18

Blue highlighted items are industry standard and most frequently ordered.

YC-C

COPPER CRIMPIT™

Line Tap for Range of Copper

Range-taking compression tap connector made of pure copper. Designed to be gripped in the jaws or dies of installation tool, then slipped directly over line for easy installation. Also used for deadending.

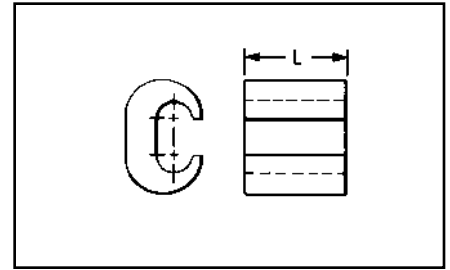
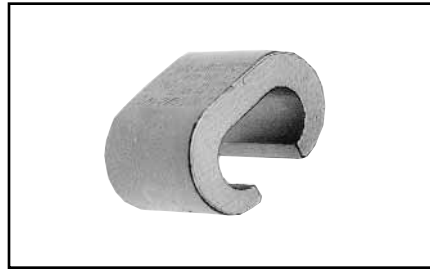

Copperweld-Copper Conductors
8A - Use CRIMPITS™ accommodating 6 str. Copper
6A - Use CRIMPITS™ accommodating 4 Str. Copper
4A - Use CRIMPITS™ accommodating 2 Str. Copper
2A - Use CRIMPITS™ accommodating 1/0 & 2/0 Copper



RUS Accepted

Catalog Number	Run	Tap	L	Die Index	Tools, Die Set Catalog Number, & (Number of Crimps)			CRIMPIT™ for 1 Str. Copper	
					MD7, MD6	OUR840	Y35, Y750, Y45†, Y46‡	Run	Tap
YC10C10*	12 Sol. - 10 Str.	12 Sol. - 10 Str.	3/8	238	W238 (1)	W238 (1)	U238 (1)		
YC8C8	8 Sol. - 8 Str.	10 Sol. - 8 Str.	1/2	162 or K	W 162 (2)	W162 (2)	U162** (1)		
YC4C8	6 Sol. - 4 Str.	8 Sol. - 8 Str.	5/8	BG or 5/8	BG (2) W-BG** (1)	XBG (2)	U-BG (1)		
YC4C6		6 Sol. - 6 Str.							
YC4C4		4 Sol. - 4 Str.							
YC2C4	2 Sol. - 2 Str.	8 Sol. - 4 Str.	3/4	C	W-C (2)		U-C (1)	1 Str.	6.8 Str., 8 Sol.
YC2C2		2 Sol. - 2 Str.							
YC26C2	1/0 Sol. - 2/0 Str.	8 Sol. - 2 Str.	7/8	E or O			U-E (3) U-O (1)	1 Str.	1 or 2 Str.
YC26C26		1/0 Sol. - 2/0 Str.							
YC28C2	3/0 Sol. - 4/0 Str.	6 Sol. - 2 Str.	1-1/16	F or D3			U-F (3) U-D3 ** (1)		
YC28C26		1/0 Sol. - 2/0 Str.							
YC28C28		3/0 Sol. - 4/0 Str.							

** Multiple crimp die set. Makes more than one crimp per tool compression. Figure () indicates number of compressions.
 † U Die with adapter PT-6515.
 ‡ U Die with adapter PUADP-1.
 * Not UL Listed.

H-19

TYPE YP-C

COPPER CRIMPIT™

Line Tap for Extra Wide Range of Copper

Figure "6" -shaped, wide range-taking copper, compression tap connector for primary service taps and secondary service drops. Connector can be gripped in tool and slipped over the line for easy installation.

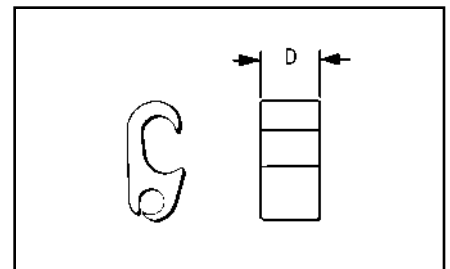

Catalog Number	D	Run	Tap	Die Index	Tools, Die Set Catalog No., & (Number of Crimps) Y35, Y750, Y45†, Y46‡
YP2C2	.75	6 Sol. - 2 Str.	6 Sol. - 2 Str.	0	U-O (1)
YP28C28	1.00	2/0 Str. - 4/0 Str.	2/0 Str. - 4/0 Str.	D	U-D3 (1)
YP29C26	.75	1/0 Str. - 250	4 Sol. - 2/0 Str.		

† U Die with adapter PT-6515.
 ‡ U Die with adapter PUADP-1.

Blue highlighted items are industry standard and most frequently ordered.

TYPE YC-A

ALUMINUM CRIMPIT™

Line Tap for Combinations of Aluminum, ACSR, 6201, 5005, Compressed and Compact Conductors

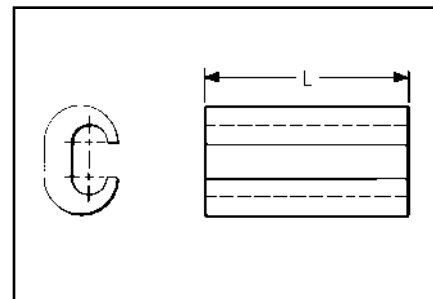

Range-taking, C-shaped aluminum compression tap, or dead-ending connector designed to eliminate effects of cold flow. Can be gripped in tool and slipped over line for easy crimping. Pre-filled with PEN-ETROX™ joint compound and Stripsealed.

H-20

Catalog Number	Run		Tap		L	Die Index	Tools, Die Set Catalog No., & (Number of Crimps)						
	Aluminum	ACSR, 6201, 5005	Aluminum	ACSR, 6201, 5005			MD7, MD6	Y35, Y750, Y45†, Y46‡					
YC4A6 YC4A4	6 Sol. - 4 Str.	6	6 Sol. & Str. 4 Sol. & Str.	— 6	1-1/4"	BG or 5/8	BG (4) W-BG (2)*	U-BG (2)*					
YC2A4 YC2A2	2 Sol. & Str.	4 - 2	4 Sol. & Str. 2 Sol. & Str.	6 4 - 2	1-1/2"	C	W-C (4)	U-C (2)*					
YC25A4 YC25A2	1/0 Str.	1/0	6 Str. - 4 Str. 2 Sol. & Str.	6 - 4 2	1-1/2" 2-1/4"	C C	W-C (4) W-C (6)	U-C (2)* U-C (3)*					
YC25A25	1/0 Str. - 2/0 Str.		1/0 Str. - 2/0 Str.	1/0	1/0	1-3/4"	Q	W-Q (6)*					
YC26A25 YC26A26	1/0 Str. - 2/0 Str.	1/0 - 2/0	1/0 Str. 2/0 Str.	1/0 2/0	2-1/2"	D**	—	U-D (3)					
YC28A2 YC28A25 YC28A26 YC28A28	3/0 Str. - 4/0 Str.	3/0 - 4/0	6 Sol. - 2 Str. 1/0 Str. 2/0 Str.	6 - 2 1/0 2/0	2-3/4"	H	—	U-H (3)					
YC33R26	300 - 397.5		336.4 (18-1) (26-7)	2 Str. - 2/0 Str.					2 - 1/0	1-1/2"	R	—	U-R (2)

* Multiple crimp die set; makes more than one crimp per tool compression. Figure indicates number of compressions.
 ** Index number "D" is not "D3" Cabelok CRIMPIT™ die.
 † U Die with adapter PT-6515.
 ‡ U Die with adapter PUADP-1.

Blue highlighted items are industry standard and most frequently ordered.

TYPES YP-U, YPC-U

CABELOK CRIMPIT™

Line Tap for Copper, Aluminum or ACSR

Wide range, universal and reversible, Figure “3” -shaped aluminum connector with adjustable overhanging spacer that separates conductors. Spacer holds run or tap in place permitting lineman to either approach the line ready to crimp, or to assemble connector and tap on run and then crimp. Massive aluminum design minimizes conductor corrosion due to galvanic action. Pre-filled with PENETROX™ joint compound and Stripsealed. Conductor range and tooling information clearly printed on connector and package.

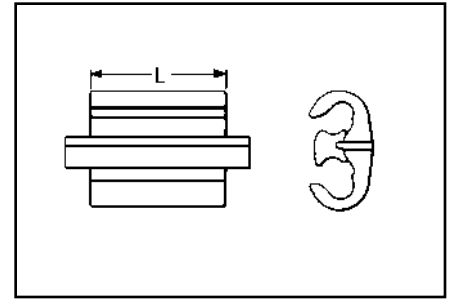
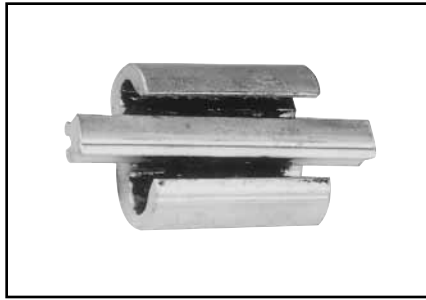

RUS Accepted

H-21

Catalog Number	Conductor (See Chart Below for Compressed Conductor)						L	Die Index	Tool, Die Set Catalog No., & (Number of Crimps)	
	Groove A			Groove B					MD7, MD6	Y35, Y750, Y45†, Y46‡
	Solid	Stranded	ACSR	Solid	Stranded	ACSR				
YP2U3*	6, 4, 3, 2	6, 4, 3,	6, 4	6, 4, 3, 2,	6, 4, 3	6, 4	1-1/2"	0	W-0 (4)	U-0(1)
YP26AU2	1, 1/0, 2/0, 3/0	2, 1, 1/0, 2/0	3, 2, 1, 1/0	6, 4, 3, 2, 1, 1/0	6, 4, 3, 2, 1	6, 4, 3, 2	1-5/8"	D3	MD6 (4)	U-D3 (1)
YP25U25**	2/0, 3/0	1, 1/0, 2/0	1, 1/0	2/0, 3/0	1, 1/0, 2/0	1, 1/0				
YP27AU4	2/0, 3/0, 4/0	1/0, 2/0, 3/0	1/0, 2/0	6, 4, 3, 2,	6, 4, 3	6, 4				
YP27AU2				2, 1, 1/0	3, 2, 1	4, 3, 2				
YP27AU26	3/0, 4/0	2/0, 3/0	2/0	2/0, 3/0	1/0, 2/0	1, 1/0, 2/0				
YP28U2	—	4/0	3/0, 4/0	2, 1, 1/0	4, 3, 2, 1	4, 3, 2				
YP28U26				2/0, 3/0	1/0, 2/0	1, 1/0, 2/0				
YPC28U28	4/0	3/0, 4/0		4/0	2/0, 3/0, 4/0	2/0, 3/0, 4/0	2-3/4"	MD6 (9)	U-D3 (2)	

Catalog Number	Compressed Conductor				L	Die Index	Tool, Die Set Catalog No., & (Number of Crimps)	
	Groove A		Groove B				MD7, MD6	Y36, Y750, Y45†, Y46‡
	Stranded Aluminum	ACSR	Stranded Aluminum	ACSR				
YP2U3*	6, 4, 3, 2	6, 4, 3	6, 4, 3, 2	6, 4, 3	1-1/2"	0	W-0 (4)	U-0 (1)
YP26AU2	2, 1, 1/0, 2/0	2, 1, 1/0, 2/0	6, 4, 3, 2, 1	6, 4, 3, 2, 1	1-5/8"	D3	MD (4)	U-D3 (1)
YP25U25**	1/0, 2/0	1/0, 2/0	1/0, 2/0	1/0, 2/0				
YP27AU4	2/0, 3/0	1/0, 2/0, 3/0	6, 4, 3	6, 4, 3				
YP27AU2			3, 2, 1	4, 3, 2, 1				
YP27AU26	3/0	2/0, 3/0	1/0, 2/0, 3/0	1/0, 2/0				
YP28U2	4/0, 250, 266.8	4/0, 266.8, (18/1)	3, 2, 1	4, 3, 2, 1				
YP28U26			1/0, 2/0, 3/0	1/0, 2/0				
YPC28U28	4/0	3/0, 4/0	3/0, 4/0	3/0, 4/0	2-3/4"		—	U-D3 (2)

* TAKES UP to #2 ACSR maximum in either groove if other wire is #2 solid or smaller.
 ** TAKES DOWN to #2 ACSR minimum in either groove if other groove wire is 1/0 stranded or larger.
 † U Die with adapter PT-6515.
 ‡ U Die with adapter PUADP-1.

Blue highlighted items are industry standard and most frequently ordered.

TYPE YPC-U

UNIVERSAL CRIMPIT™

Line Tap for Combinations of Copper, Aluminum, ACSR, 6201, 5005 and Compressed and Compact Conductors

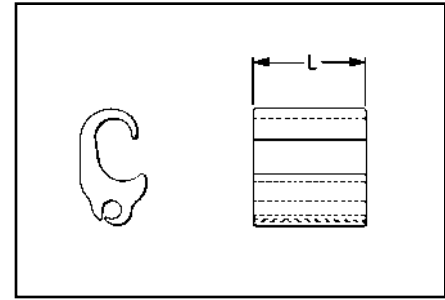

Extra wide range universal connector. Two dies and 5 connectors take run sizes 1/0-600, and tap sizes 6-400. Wide range made possible by long ram travel of BURNDY® HYPRESS™ tools. Figure “6”- shape separates run and tap wires, and minimizes galvanic corrosion of conductors. Connector

can be gripped in tool and slipped over line for easy installation. Pre-filled with PENETROX™ joint compound and Stripsealed.

H-22

Catalog Number	Run		Tap		L	Die Index	Tools, Die Set Catalog No., & (Number of Crimps)		
	Aluminum & Copper	ACSR, 5005	Aluminum & Copper	ACSR, 5005			Y35, Y750	Y45†	Y46‡
YPC28U4	3/0 - 4/0 Str. & 4/0, 250, 266.8 Alum. Compressed	3/0 - 4/0 & 4/0, 266.8 (18/1) ACSR Compressed	6, 4, 3 Str. 6, 4, 3, 2 Sol. & 6, 4, 3, Alum. Compressed	6, 4 & 6, 4, 3 ACSR Compressed	1-5/8	D3 ②	U-D3 (1)	U-D3 (1)	U-D3 (1)
YPC28U26	1/0 (7) - 4/0 (7)	1/0 - 4/0	3 Sol. - 2/0 (7)	4 - 1/0	2-3/4	D3	U-D3 (2)	—	—
YPC28U28 ①	3/0, 4/0 Str. 4/0 Sol. & 4/0, 250, 266.8 Alum. Compressed	3/0 - 4/0 & 3/0 - 4/0 266.8 (18/1) ACSR Compressed	2/0, 3/0, 4/0 Str. 4/0 Sol. & 3/0, 4/0, 250 266.8 Alum. Compressed	2/0, 3/0, 4/0 & 3/0, 4/0, 266.8 (18/1) ACSR Compressed	2-3/4	D3	U-D3 (2)	U-D3 (2)	U-D3 (2)
YPC28R28A	3/0, 4/0 Str. & 4/0, 250, 266.8 Alum. Compressed	3/0 - 4/0 & 4/0, 266.8 (18/1) ACSR Compressed	3/0 - 4/0 Str. & 4/0 Alum. Compressed	3/0 & 4/0 ACSR Compressed	2-3/4	D3	U-D3 (2)	U-D3 (2)	U-D3 (2)
YPC33R26U	250 (37) - 400 (37)	266.8 (18-1) - 397.5 (18-1)	6 Sol. - 2/0 (19)	6 - 1/0	2-1/8	N	U-N (2)	S-N (2)	P-N (2)
YPC33R28R	250 (37) - 477 (37)	266.8 (18-1) - 397.5 (18-1)	2/0 (19) - 4/0 (19)	2/0 - 4/0	8-7/8	N	U-N (3)	S-N (3)	P-N (3)
YPC33R33R	250 (37) - 400 (37)	266.8 (18-1) - 397.5 (18-1)	250 (37) - 400 (37)	266.8 (18-1) - 397.5 (18-1)	8-7/8	N	U-N (3)	S-N (3)	P-N (3)
YPC38R26U	477 (19) - 600 (61)	397.5 (26-7) - 556.5 (18-1)	6 Sol. - 2/0 (19)	6 - 1/0	2-1/8	N	U-N (2)	S-N (2)	P-N (2)
YPC36A32	397.5 (19) - 600 (61)	336.5 (26-7) - 556.5 (18-1)	2/0 (7) - 400 (37)	2/0 (6-1) - 397.5 (18-1)	5	Z	—	S-Z (3)	—
YPC36A36	397.5 (19) - 600 (61)	336.5 (26-7) - 556.5 (18-1)	397.5 (19) - 600 (61)	397.5 (26-7) - 556.5 (18-1)	6-3/4	Z	—	S-Z (4)	—
YPC40A32	600 (61) - 800 (61)	556.5 (18-1) - 795 (26-7)	2/0 (7) - 400 (37)	2/0 (6-1) - 397.5 (18-1)	5	T	—	S-T (3)	—
YPC40A36	600 (61) - 800 (61)	556.5 (18-1) - 795 (26-7)	397.5 (19) - 600 (61)	336.4 (26-7) - 556.5 (18-1)	5	T	—	S-T (3)	—
YPC40A40	600 (61) - 954 (61)	556.5 (18-1) - 795 (26-7)	600 (61) - 954 (61)	556.5 (18-1) - 795 (26-7)	9-7/8	T	—	S-T (6)	—

① 2/0 Str. Cu Aluminum and 2/0 ACSR may also be installed in run when tap is 3/0 Str. or larger.

② YPC28U4 only may be installed with MD6 HYTOOL™ and the BCT500HS with D³ groove.

† U Die with adapter PT-6515.

‡ U Die with adapter PUADP-1.

Blue highlighted items are industry standard and most frequently ordered.

TYPE YC-U

UNIVERSAL CRIMPIT™

Line Tap Combinations of Copper, Aluminum, ACSR, 6201, 5005 and Compressed and Compact Conductors

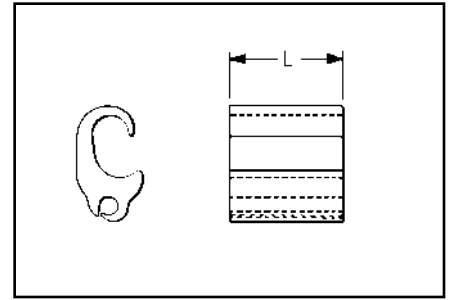
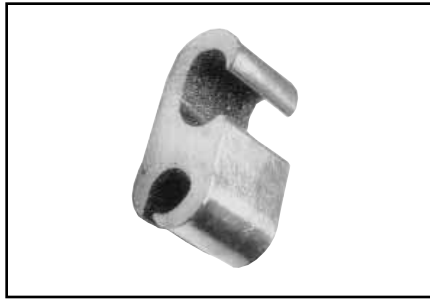

Figure “6” -shaped, wide range-taking aluminum compression tap connector for smaller primary service taps and secondary service drops. Minimizes galvanic corrosion of conductors. Connector can be gripped in

tool and slipped over line for easy installation. Installed with aluminum CRIMPIT™ dies. Pre-filled with PENETROX™ joint compound and Stripsealed.

Catalog Number	Run		Tap		L	Die Index	Tools, Die Set Catalog No., & (Number of Crimps) Y35, Y750, Y45†, Y46‡
	Aluminum & Copper	ACSR, 6201, & 5005	ACSR, 6201, & 5005	Aluminum & Copper			
YC4U1	4 Sol. - 4 Str.	4	6 - 1 Str.	6 Sol. - 2 Str.	1-7/8	D*	U-D (2)
YC1U1	2 Str. - 1 Str.	2					
YC28U26	1/0 Str. - 4/0 Str.	1/0 - 4/0	6 - 1/0	6 Sol. - 2/0 Str.	2-1/8	H	U-H (2)
YC33R26U	300 - 400	266.8 (6-7) - 336.4 (30-7)				R	U-R (2)

* Die Index “D” is not Die Index “D3” (Cabelok & Universal CRIMPIT™ Die).

† U Die with adapter PT-6515.

‡ U Die with adapter PUADP-1.

H-23

TYPES YPC-A-U, YPC-R-U

CRIMPIT™

Street Lighting Tap for Combinations of Copper, Aluminum, ACSR, Compressed and Compact Conductors

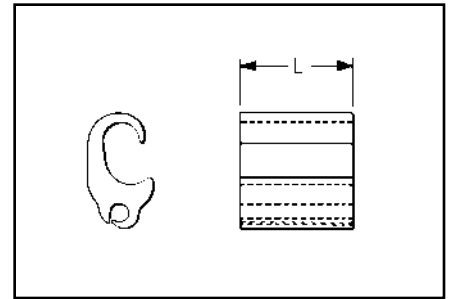
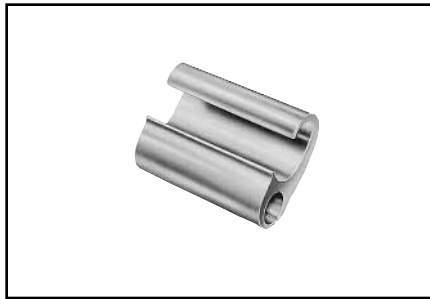

Compact compression connector designed to tap small lighting wires from secondaries. Figure “6” -shape separates run and tap, and minimizes galvanic corrosion. Connector can

be gripped in tool and slipped over line for easier installation. Pre-filled with PENETROX™ joint compound and Stripsealed.

Catalog Number	Run				Tap	L	Die Index	Tools, Die Set Catalog No., & (Number of Crimps)		OUR840
	ACSR	Compressed ACSR	Aluminum & Copper	Compressed Aluminum	Aluminum & Copper			MD7, MD6	Y35, Y750, Y45†, Y46‡	
YPC2A8U	6 - 4	6 - 2	4 - 2 Sol. 6 - 2 Str.	4 - 2	14 Sol. - 8 Str.	5/8	BG or 5/8	BG (2) W-BG (1)*	U-BG (1)*	XBG
YPC26R8U	2 - 3/0	1 - 3/0	1 - 3/0 Str.	1/0 - 3/0		3/4	0	W-0 (2)	U-0 (1)	W-0

* Multiple crimp die set, makes more than one crimp per tool compression. Figure indicates number of compressions.

† U Die with adapter PT-6515.

‡ U Die with adapter PUADP-1.

Blue highlighted items are industry standard and most frequently ordered.

TYPE CC

CRIMPIT™ COVER

For All O, D and N Die Tap Connectors



High density polyethylene cover accommodates most industry connectors in the O, D and N range. Four sizes cover the full #6-600 kcmil conductor range. One piece design. No extra hardware needed. Simply slip over connector and snap shut. Supplied in Black.

Catalog Number	Maximum Connector Length	Connector Series Accommodate
CCO	2-1/2	O Die
CCD	2-3/4	D Die
CCN	2-1/8	Short N Die
CCNL	5-3/16	Long N Die and YP28U26

H-24

Blue highlighted items are industry standard and most frequently ordered.

**SEVEN CONNECTOR
SELECTOR CHART**

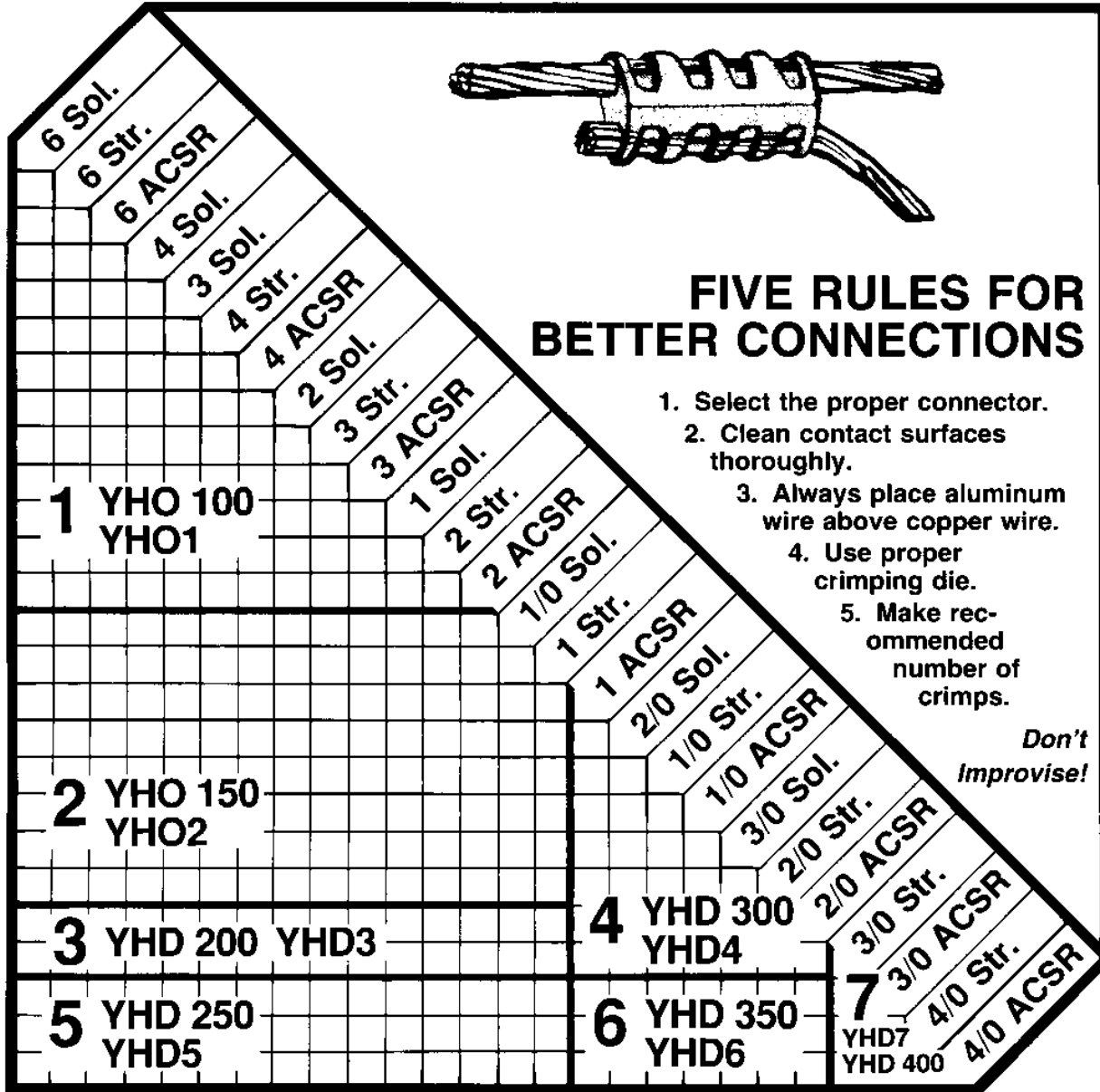

H-25

For Compression
Tap Connectors
**BURNDY® HYCRIMP™
and LOKTAP™**

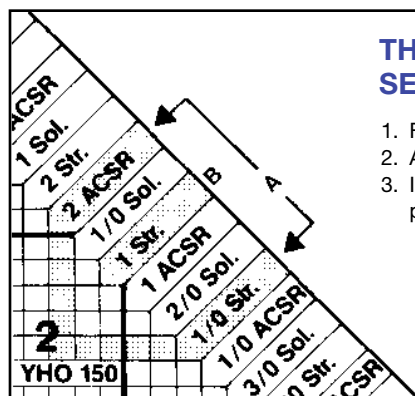

**THREE SIMPLE
SELECTION STEPS**

1. Follow down from the smaller wire.
2. Across from the larger wire.
3. Intersection is in the area of the proper connector.

Example:

- A. For #2 ACSR to #1/0 Str. select No. 2 connector.

TYPES YHO & YHD

HYCRIMP™

Line Tap for Copper, Aluminum or ACSR and Compact Conductors

Wide range, universal and reversible figure H shaped aluminum connector. Conductors are separated by the shape of the connector. Bendable tabs secure both run and tap conductors freeing the linemans hands to work with the installation tool. Massive

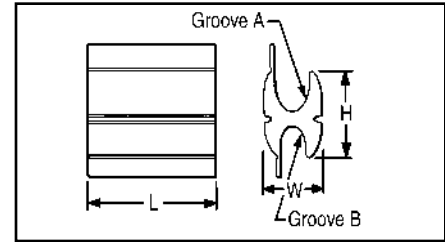

RUS Accepted

aluminum design minimizes corrosion due to galvanic corrosion. Prefilled with PENETROX™ joint compound and individual-

ly packaged. Conductor ranges and tooling clearly printed on connector and package.

H-26

Handtool or Hydraulic 7 Connector Program															
Catalog Number	① Code No.	Conductors (See Below for Compact Conductors)									Dimensions			Installation Data	
		Groove A (Run)			Groove B (Tap)			Die Index	Tool, Die Set Catalog No. & (No. of Crimps)						
		Wire Diameter Range	Sol.	Str.	ACSR	Wire Diameter Range	Sol.		Str.	ACSR	H	L	W	MD7-8	Y35, Y750, Y45†, Y46‡
YHO-100	1	.162 - .332	#6 - #1	#6 - #1; 7 Str.	#6 - #2	.162 - .332	#6 - #1	#6 - #1, 7 Str.	#6 - #2	1.12	1.25	.70	0	(4)	U-0 (2)
YHO-150	2	.260 - .419	#1 - 2/0	#3.3 Str. - 2/0	#3 - 1/0	.162 - .332	#6 - 1/0	#6 - 1, 19 Str.	#6 - #2	1.12	1.50	.70	0	(5)	U-0 (2)
YHD-200	3	.398 - .470	3/0 - 4/0	2/0 - 3/0	1/0 - 2/0	.162 - .332	#6 - 1/0	#6 - #1, 19 Str.	#6 - #2	1.44	1.62	.89	D3	(5)	UD3 (2)
YHD-250	5	.475 - .563	250 - 300	4/0	3/0 - 4/0	.162 - .332	#6 - 1/0	#6 - #1, 19 Str.	#6 - #2	1.47	1.62	.89	D3	② (5)	UD3 (2)
YHD-300	4	.336 - .470	2/0 - 4/0	#1, 3 Str. - 3/0	#1 - 2/0	.336 - .447	2/0 - 3/0	#1, 3 Str. - 2/0	#1 - 2/0	1.42	1.88	.89	D3	(5)	UD3 (2)
YHD-350	6	.461 - .563	250 - 300	3/0 - 4/0	3/0 - 4/0	.338 - .447	2/0 - 3/0	#1, 3 Str. - 2/0	#1 - 2/0	1.42	2.25	.89	D3	(7)	UD3 (3)
YHD-400	7	.461 - .563	250 - 200	3/0 - 4/0	3/0 - 4/0	.461 - .563	250 - 300	3/0 - 4/0	3/0 - 4/0	1.49	2.50	.89	D3	(7)	UD3 (3)

Compact Conductors															
Catalog Number	① Code No.	Conductors (See Below for Compact Conductors)						Dimensions			Installation Data				
		Groove A (Run)			Groove B (Tap)								Die Index	Tool, Die Set Catalog No. & (No. of Crimps)	
		Wire Diameter Range	Compact ACSR	Compact CU or AL	Wire Diameter Range	Compact ACSR	Compact CU or AL	H	L	W	MD6-8	Y35, Y750, Y45†, Y46‡			
YHO-100	1	.162 - .336	#6 - #3	#6 - #1	.162 - .268	#6 - #1	#6 - #3	#6 - #1	#6 - #1	1.12	1.25	.70	0	(4)	U-0 (2)
YHO-150	2	.260 - .414	#2 - 1/0	#2 - 2/0	.162 - .332	#6 - #1	#6 - #1	#6 - #1	#6 - #1	1.12	1.50	.70	0	(5)	U-0 (2)
YHD-200	3	.398 - .470	2/0 - 3/0	3/0	.162 - .332	#6 - #1	#6 - #1	#6 - #1	#6 - #1	1.44	1.62	.89	D3	(5)	UD3 (2)
YHD-250	5	.475 - .563	4/0 - 266 (18/1)	4/0 - 266	.162 - .332	#6 - #1	#6 - #1	#6 - #1	#6 - #1	1.47	1.62	.89	D3	② (5)	UD3 (2)
YHD-300	4	.336 - .470	1/0 - 3/0	1/0 - 3/0	.338 - .477	1/0 - 3/0	1/0 - 3/0	1/0 - 3/0	1/0 - 3/0	1.42	1.88	.89	D3	(5)	UD3 (2)
YHD-350	6	.461 - .563	3/0 - 266 (18/1)	4/0 - 266	.338 - .447	1/0 - 2/0	1/0 - 3/0	1/0 - 3/0	1/0 - 3/0	1.42	2.25	.89	D3	(7)	UD3 (3)
YHD-400	7	.461 - .563	3/0 - 266 (18/1)	4/0 - 266	.461 - .563	3/0 - 266 (18/1)	4/0 - 266	4/0 - 266	4/0 - 266	1.49	2.50	.89	D3	(7)	UD3 (3)

Hydraulic Tool Only 4 Connector Program														
Catalog Number	Wire Diameter Range	Conductors (See Below for Compact Conductors)							Dimensions			Installation Data		
		Groove A (Run)			Groove B (Tap)									Die Index
		Sol.	Str.	ACSR	Wire Diameter Range	Sol.	Str.	ACSR	H	L	W	Y35, Y750, Y45†, Y46‡		
YHO-125	.162 - .398	#6 - 2/0	#6 - 1/0	#6 - 1/0	.162 - .332	#6 - 1/0	#6 - #1, 19 Str.	#6 - #2	1.15	1.62	.70	0	(4)	U-0 (2)
YHD-250	.338 - .563	2/0 - 300	#1.3 Str. - 4/0	#1 - 4/0	.162 - .332	#6 - 1/0	#6 - #1, 19 Str.	#6 - #2	1.47	1.62	.89	D3	(5)	UD3 (2)
YHD-350	.338 - .563	2/0 - 300	#1, 3 Str. - 4/0	#1 - 4/0	.338 - .477	2/0 - 3/0	#1, 3 Str. - 2/0	#1 - 2/0	1.42	2.50	.89	D3	(7)	UD3 (3)
YHD-400	.426 - .563	4/0 - 300	3/0 - 4/0	2/0 - 4/0	.426 - .563	4/0 - 300	3/0 - 4/0	2/0 - 4/0	1.49	2.50	.89	D3	(7)	UD3 (3)

Compact Conductors													
Catalog Number	Wire Diameter Range	Conductors (See Below for Compact Conductors)						Dimensions			Installation Data		
		Groove A (Run)			Groove B (Tap)								Die Index
		Compact ACSR	Compact CU or AL	Wire Diameter Range	Compact ACSR	Compact CU or AL	H	L	W	Y35, Y750, Y45†, Y46‡			
YHO-125	.162 - .398	#6 - 1/0	#6 - 2/0	.162 - .332	#6 - #1	#6 - #1	1.15	1.62	.70	0	(4)	U-0 (2)	
YHD-250	.338 - .563	1/0 - 266 (18/1)	1/0 - 266	.162 - .332	#6 - #1	#6 - #1	1.47	1.62	.89	D3	(5)	UD3 (2)	
YHD-350	.338 - .563	1/0 - 266 (18/1)	1/0 - 266	.336 - .477	1/0 - 2/0	1/0 - 3/0	1.42	2.25	.89	D3	(7)	UD3 (3)	
YHD-400	.426 - .563	3/0 - 266 (18/1)	3/0 - 266	.426 - .563	3/0 - 266 (18/1)	3/0 - 266	1.49	2.50	.89	D3	(7)	UD3 (3)	

† U Die with adapter PT-6515
‡ U Die with adapter PUADP.

① See page H-25 for Seven Connector Selector Chart.
② Permanent dies in tool install all sizes.

TYPES YHN & YHR

HYCRIMP™

Line Tap for Copper, Aluminum or ACSR and Compact Conductors

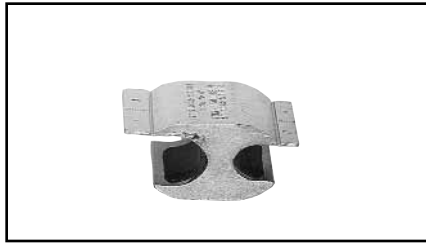

RUS Accepted

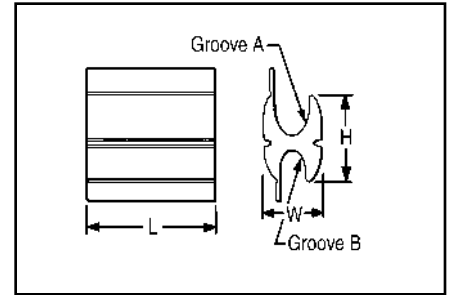

N Die Connectors*														
Catalog Number	Conductors (See Below for Compact Conductors)							Dimensions			Die Index	Installation Data		
	Groove A (Run)			Groove B (Tap)								Tool, Die Set Catalog No. & (No. of Crimps)		
	Wire Diameter Range	Str.	ACSR	Wire Diameter Range	Sol.	Str.	ACSR	H	L	W		Y35, Y750	Y45	Y46
	YHN-450	.522 - .750	4/0 - 400	4/0 - 397 (18/1)	.522 - .750	336 - 477	4/0 - 400	4/0 - 397 (18/1)	2.05	3.50	1.25	N	U-N (3)	S-N (3)
YHN-500	.522 - .815	4/0 - 500	4/0 - 477 (18/1)	.160 - .450	#6 - 2/0	#6 - 2/0	#6 - 2/0	2.00	1.62	1.28	N	U-N (2)	S-N (2)	P-N (2)
YHN-525	.522 - .814	4/0 - 500	4/0 - 477 (18/1)	.522 - .814	—	4/0 - 500	4/0 - 477 (18/1)	1.824	4.50	1.23	N	U-N (3)	S-N (3)	P-N (3)
YHN-550	.573 - .815	250 - 500	266 - 477 (18/1)	.410 - .505	3/0 - 300	2/0 - 4/0	2/0 - 4/0	1.96	2.00	1.28	N	U-N (2)	S-N (2)	P-N (2)
YHN-600	.573 - .815	250 - 500	266 - 477 (18/1)	.570 - .685	336 - 400	250 - 350	266 - 336.4 (18/1)	2.00	3.50	1.28	N	U-N (3)	S-N (3)	P-N (3)

H-27

Compact Conductors													
Catalog Number	Groove A (Run)			Groove B (Tap)			Dimensions			Die Index	Installation Data		
	Wire Diameter Range	Compressed ACSR	Compact CU or AL	Wire Diameter Range	Compressed ACSR	Compact CU or AL					Tool, Die Set Catalog No. & (No. of Crimps)		
	Wire Diameter Range	Compressed ACSR	Compact CU or AL	Wire Diameter Range	Compressed ACSR	Compact CU or AL	H	L	W		Y35, Y750	Y45	Y46
	YHN-450	.522 - .750	226 - 477 (18/1)	250 - 500	.522 - .750	266 - 477 (18/1)	250 - 500	2.05	3.50	1.25	N	U-N (3)	S-N (3)
YHN-500	.522 - .815	266 - 556	250 - 556	.160 - .450	#6 - 2/0	#6 - 3/0	2.00	1.62	1.28	N	U-N (2)	S-N (2)	P-N (2)
YHN-525	.522 - .814	266.8 - 556.5	250 - 556	.522 - .814	266.8 - 556.5	250 - 556	1.824	4.50	1.23	N	U-N (3)	S-N (3)	P-N (3)
YHN-550	.573 - .815	300 - 556	300 - 556	.410 - .565	2/0 - 266	3/0 - 266	1.96	2.00	1.28	N	U-N (2)	S-N (2)	P-N (2)
YHN-600**	.573 - .815	300 - 556	300 - 556	.570 - .685	300 - 397	300 - 397	2.00	3.50	1.28	N	U-N (3)	S-N (3)	P-N (3)

R Die Connectors*													
Catalog Number	Conductors (See Below for Compact Conductors)							Dimensions			Die Index	Installation Data	
	Groove A (Run)			Groove B (Tap)								Tool, Die Set Catalog No. & (No. of Crimps)	
	Wire Diameter Range	Str.	ACSR	Wire Diameter Range	Sol.	Str.	ACSR	H	L	W		Y45	Y46
	YHR-700	.666 - .893	336 - 600	300 - 556 (18/1)	.398 - .684	3/0 - 350	2/0 - 350	1/0 - 336.4 (18/1)	3.04	3.50	1.74	KR	S-KR (3)
YHR-750	.666 - .893	336 - 600	300 - 556 (18/1)	.666 - .893	—	300 - 600	300 - 556 (18/1)	3.04	4.62	1.74	KR	S-KR (4)	P-KR (4)
YHR-800	.879 - 1.108	600 - 900	556.5 (18/1) - 795 (26/7)	.398 - .684	3/0 - 350	2/0 - 350	1/0 - 336.4 (18/1)	3.05	3.50	1.74	KR	S-KR (3)	P-KR (3)
YHR-850	.879 - 1.108	600 - 900	556.5 (18/1) - 795 (26/7)	.666 - .893	—	336 - 600	300 - 556 (18/1)	3.04	4.62	1.74	KR	S-KR (4)	P-KR (4)
YHR-900	.879 - 1.108	600 - 900	556.5 (18/1) - 795 (26/7)	.879 - 1.108	—	600 - 900	556.5 (18/1) - 795 (26/7)	2.97	4.62	1.74	KR	S-KR (4)	P-KR (4)
YHR-950	.666 - 1.165	336.4 - 1000	556.5 (18/1) - 954 (45/7)	.666 - 1.165	—	336.4 - 1000	336.4 (18/1) - 954 (45/7)	3.14	6.00	1.66	KR	S-KR (5)	P-KR (5)

Compact Conductors													
Catalog Number	Groove A (Run)			Groove B (Tap)			Dimensions			Die Index	Installation Data		
	Wire Diameter Range	Compressed ACSR	Compact CU or AL	Wire Diameter Range	Compressed ACSR	Compact CU or AL					Tool, Die Set Catalog No. & (No. of Crimps)		
	Wire Diameter Range	Compressed ACSR	Compact CU or AL	Wire Diameter Range	Compressed ACSR	Compact CU or AL	H	L	W		Y45	Y46	
	YHR-700	.666 - .893	397 - 636	477 - 636	.398 - .684	2/0 - 397 (18/1)	3/0 - 397.5	3.04	3.50	1.74	KR	S-KR (3)	P-KR (3)
YHR-750	.666 - .893	397 - 636	477 - 636	.666 - .893	397 - 636	477 - 636	3.04	4.62	1.74	KR	S-KR (4)	P-KR (4)	
YHR-800	.879 - 1.108	795 - 954	795 - 954	.398 - .684	2/0 - 397 (18/1)	3/0 - 397.5	3.05	3.50	1.74	KR	S-KR (3)	P-KR (3)	
YHR-850	.879 - 1.108	795 - 954	795 - 954	.666 - .893	397 - 636	477 - 636	3.04	4.62	1.74	KR	S-KR (4)	P-KR (4)	
YHR-900	.879 - 1.108	795 - 954	795 - 954	.879 - 1.108	795 - 954	795 - 954	2.97	4.62	1.74	KR	S-KR (4)	P-KR (4)	
YHR-950	.666 - 1.165	—	—	.666 - 1.165	—	—	3.14	6.00	1.66	KR	S-KR (5)	P-KR (5)	

* HYCRIMP™ connectors can be installed with competitive R dies.

** Die Index S-T and S-Z may also be used on sizes 700-900 only. S-KR required for 950 and S-Z.

Blue highlighted items are industry standard and most frequently ordered.

LOKTAP™

LOKTAP™ compression connectors are high quality, range-taking devices which accommodate combinations of aluminum to copper, and aluminum to aluminum conductors. BURNDY® seven connector program accommodates a conductor range from #6 Sol. to 4/0 ACSR. In addition, LOKTAP™ products feature a “C” groove on both sides

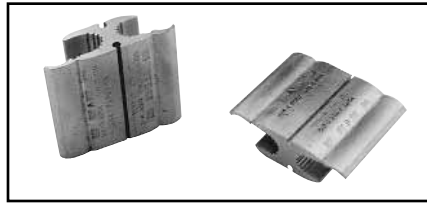

of the connector for use in street lighting applications from #14 Sol. to #10 Sol.

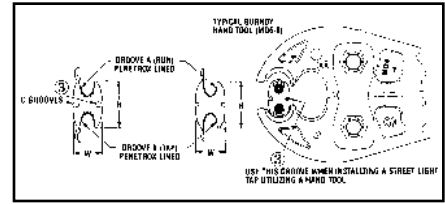

LOKTAP™ connectors are designed to be installed with BURNDY® mechanical or hydraulic tools and matching O and D³ die set.

H-28

Handtool or Hydraulic 7 Connector Program ①																
Catalog Number	Code No.	Conductors (See Below for Compact Conductors)									Dimensions			Installation Data		
		Groove A (Run)			Groove B (Tap)			Die Index	Tool, Die Set Catalog No. & (No. of Crimps)							
		Wire Diameter Range	Sol.	Str.	ACSR	Wire Diameter Range	Sol.		Str.	ACSR	H	L	W	MD7, MD6	Y35, Y750, Y45†, Y46‡	
YHO-1	1	.162 - .332	#6 - #1	#6 - #1, 7 Str.	#6 - #2	.162 - .332	#6 - #1	#6 - #1, 7 Str.	#6 - #2	1.11	1.25	.67	0	(4)	U-0 (2)	
YHO-2	2	.260 - .419	#1 - 2/0	#3.3 Str. - 2/0	#3 - 1/0	.162 - .332	#6 - 1/0	#6 - #1, 19 Str.	#6 - #2	1.12	1.50	.64	0	(5)	U-0 (2)	
YHD-3	3	.398 - .470	3/0 - 4/0	2/0 - 3/0	1/0 - 2/0	.162 - .332	#6 - 1/0	#6 - #1, 19 Str.	#6 - #2	1.47	1.88	.76	D3	(5)	UD3 (2)	
YHD-5	5	.475 - .563	250 - 300	4/0	3/0 - 4/0	.162 - .332	#6 - 1/0	#6 - #1, 19 Str.	#6 - #2	1.47	1.88	.87	D3	(5)	UD3 (2)	
YHD-4	4	.336 - .470	2/0 - 4/0	#1, 3 Str. - 3/0	#1 - 2/0	.336 - .477	2/0 - 3/0	#1, 3 Str. - 2/0	#1 - 2/0	1.42	1.88	.83	D3	(5)	UD3 (2)	
YHD-6	6	.461 - .563	250 - 300	3/0 - 4/0	3/0 - 4/0	.336 - .447	2/0 - 3/0	#1, 3 Str. - 2/0	#1 - 2/0	1.42	2.25	.83	D3	(6)	UD3 (3)	
YHD-7	7	.461 - .563	250 - 300	3/0 - 4/0	3/0 - 4/0	.461 - .563	250 - 300	3/0 - 4/0	3/0 - 4/0	1.40	2.52	.84	D3	(7)	UD3 (3)	
YHD-10**	—	.232 - .419**	#2 - #1**	#4 - 2/0**	#4 - 1/0	.232 - .419**	#2 - #1**	#4 - 2/0**	#4 - 1/0	1.18	1.50	.68	0	(4)	U-0 (2)	

Compact Conductors														
Catalog Number	Code No.	Conductors (See Below for Compact Conductors)						Dimensions			Installation Data			
		Groove A (Run)			Groove B (Tap)						Die Index	Tool, Die Set Catalog No. & (No. of Crimps)		
		Wire Diameter Range	Compact ACSR	Compact CU or AL	Wire Diameter Range	Compact ACSR	Compact CU or AL	H	L	W		MD6	Y35, Y750, Y45†, Y46‡	
YHO-1	1	.162 - .332	#6 - #1	#6 - #1	.162 - .332	#6 - #1	#6 - #1	1.11	1.25	.67	0	(4)	U-0 (2)	
YHO-2	2	.260 - .419	#2 - 1/0	#2 - 2/0	.162 - .332	#6 - #1	#6 - #1	1.12	1.50	.64	0	(5)	U-0 (2)	
YHD-3	3	.398 - .470	2/0 - 3/0	3/0	.162 - .332	#6 - #1	#6 - #1	1.47	1.88	.76	D3	(5)	UD3 (2)	
YHD-5	5	.475 - .563	4/0 - 266 (18/1)	4/0 - 256	.162 - .332	#6 - #1	#6 - #1	1.47	1.88	.87	D3	(5)	UD3 (2)	
YHD-4	4	.336 - .470	1/0 - 3/0	1/0 - 3/0	.338 - .447	1/0 - 2/0	1/0 - 3/0	1.42	1.88	.83	D3	(5)	UD3 (2)	
YHD-6	6	.461 - .563	3/0 - 266 (18/1)	4/0 - 266	.338 - .447	1/0 - 2/0	1/0 - 3/0	1.42	2.25	.83	D3	(6)	UD3 (3)	
YHD-7	7	.461 - .563	3/0 - 266 (18/1)	4/0 - 266	.461 - .563	3/0 - 266 (18/1)	4/0 - 266	1.40	2.52	.84	D3	(7)	UD3 (3)	
YHO-10**	—	.232 - .419**	#4 - 2/0	#2 - 2/0**	.232 - .419**	#4 - 2/0	#2 - 2/0**	1.18	1.50	.68	0	(4)	U-0 (2)	

Hydraulic Tool Only 4 Connector Program																
Catalog Number	Code No.	Conductors (See Below for Compact Conductors)									Dimensions			Installation Data		
		Groove A (Run)			Groove B (Tap)			Die Index	Tool, Die Set Catalog No. & (No. of Crimps)							
		Wire Diameter Range	Sol.	Str.	ACSR	Wire Diameter Range	Sol.		Str.	ACSR	H	L	W	Y35, Y750, Y45†, Y46‡		
—	—	.162 - .398	#6 - 2/0	#6 - 1/0	#6 - 1/0	.162 - .332	#6 - 1/0	#6 - #1, 19 Str.	#6 - #2	1.15	1.62	.70	0	U-0 (2)		
YHD-5	5	.336 - .563	2/0 - 300	#1.3 Str. - 4/0	#1 - 4/0	.162 - .332	#6 - 1/0	#6 - #1, 19 Str.	#6 - #2	1.47	1.88	.87	D3	UD3 (2)		
YHD-6	6	.336 - .563	2/0 - 300	#1, 3 Str. - 4/0	#1 - 4/0	.336 - .477	2/0 - 3/0	#1.3 Str. - 2/0	#1 - 2/0	1.42	2.25	.83	D3	UD3 (3)		
YHD-7	7	.414 - .563	4/0 - 300	3/0 - 4/0	2/0 - 4/0	.461 - .563	4/0 - 300	3/0 - 4/0	2/0 - 4/0	1.40	2.52	.86	D3	UD3 (3)		

Compact Conductors														
Catalog Number	Code No.	Conductors (See Below for Compact Conductors)						Dimensions			Installation Data			
		Groove A (Run)			Groove B (Tap)						Die Index	Tool, Die Set Catalog No. & (No. of Crimps)		
		Wire Diameter Range	Compact ACSR	Compact CU or AL	Wire Diameter Range	Compact ACSR	Compact CU or AL	H	L	W		Y35, Y750, Y45†, Y46‡		
—	—	.162 - .398	#6 - 1/0	#6 - 2/0	.162 - .332	#6 - #1	#6 - #1	1.15	1.62	.70	0	U-0 (2)		
YHD-5	5	.336 - .563	1/0 - 266 (18/1)	1/0 - .256	.162 - .332	#6 - #1	#6 - #1	1.47	1.88	.87	D3	UD3 (2)		
YHD-6	6	.336 - .563	1/0 - 266 (18/1)	1/0 - .256	.336 - .447	1/0 - 2/0	1/0 - 3/0	1.42	2.25	.83	D3	UD3 (3)		
YHD-7	7	.414 - .563	3/0 - 266 (18/1)	3/0 - .256	.414 - .563	3/0 - 266 (18/1)	3/0 - 266	1.40	2.52	.86	D3	UD3 (3)		

** YHO-10: These ranges are for aluminum only. Use only #4 Str. concentric copper tap.

† U Die with adapter PT-6515.
‡ U Die with adapter PUADP-1.

① See page H-25 for Seven Connector Selector Chart.

② PERMANENT DIES IN TOOL INSTALL ALL SIZES.

③ “C” grooves accommodate #10 Sol. - #14 Sol. RANGE, .116 in. - .064 in. No “C” grooves on CAT. NO. YH0125. When utilizing “C” groove(s) apply PENETROX™ A13 prior to wire

installation. When utilizing two (2) “C” groove taps, installation to be made with HYDRAULIC TOOL ONLY. All four (4) grooves CANNOT be utilized if using a hand tool. When hand tool is used, only one (1) “C” groove can be utilized and connector MUST be positioned as shown in FIG.5

TYPE YCT

HYTEE

T-Tap for Copper

One-piece, copper compression tap connector with U-shaped run element and tubular tap for joining hard and medium-hard drawn copper. Preformed run element simplifies installation on larger conductors. Uses same die as equivalent full-tension sleeve.

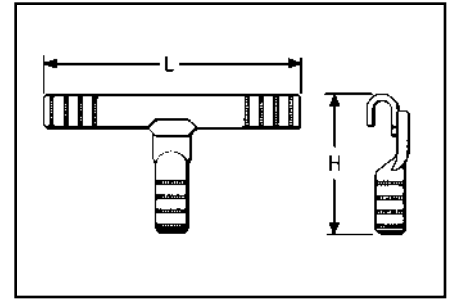

Conductors			H	L	Run			Tap		
Catalog Number	Run	Tap			Die Index	Tools, Die Set Catalog No., & (Crimps per End)		Die Index	Tools, Die Set Catalog No., & (Crimps per End)	
						MD7, MD6	Y35, Y750, Y45†, Y46‡		MD6	Y35, Y750, Y45†, Y46‡
YCT2626	2/0 (7, 12, 19)	2/0 (7, 12, 19)	3.26	5.62	166	W166 (4)	U166/U459 (2)	166	W166 (6)	U-166 (3)
YCT2828	4/0 (7, 12, 19)	4/0 (7, 12, 19)	4	5.72	168		U168 (2)	168		U-168 (3)

† U Die with adapter PT-6515.
‡ U Die with adapter PUADP-1.

H-29

TYPE YOT

HYTEE

T-Tap for Copper

Cast copper T-tap connector with two-piece line element and tubular tap for joining hard and medium drawn copper. Design simplifies installation on large conductors. Uses same die as equivalent sleeve.

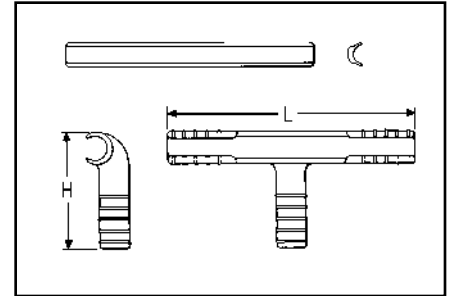

Conductors			H	L	Run			Tap		
Catalog Number	Run	Tap			Die Index	Tools, Die Set Catalog No., & (Crimps per End)		Die Index	Tools, Die Set Catalog No., & (Crimps per End)	
						Y35, Y750, Y45†, Y46‡	Y60B		Y35, Y750, Y45†, Y46‡	Y60BHU
YOT3434	500 (19, 37)	500 (19, 37)	4.82	10.38	210	U210 (6)	L210 (2)	210	U210 (6)	L210 (2)

† U Die with adapter PT-6515.
‡ U Die with adapter PUADP-1.

Blue highlighted items are industry standard and most frequently ordered.

TYPE YTU-R-R

T-TAP

For Combinations of Aluminum, Copper, ACSR, 6201, 5005 Compressed and Compact Conductors

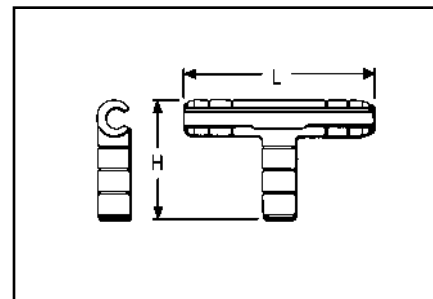
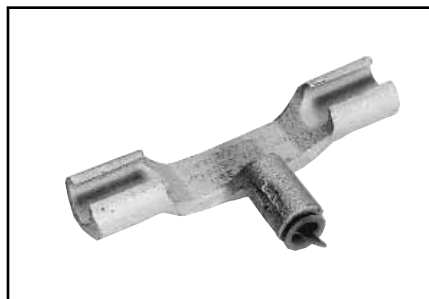

One-piece heavy-wall aluminum compression tap connector for secondary service drop and transformer tap to primary or secondary. Connector can be gripped in tool for easy installation. Pre-filled with PENETROX™ joint compound.

H-30

Catalog Number	Run			Tap			H	L	Die Index	Run		Tap					
	ACSR, 6201, 5005	Aluminum	Copper	ACSR, 6201, 5005	Aluminum	Copper				Tools, Die Set Catalog Number, & (Crimps per End)		Die Index	Tools, Die Set Catalog Number, & (Crimps per End)				
										MD7, MD6	Y35, Y750, Y45†, Y46‡		MD7, MD6	Y35, Y750, Y45, Y46‡			
YTU25R4W	1/0 80 (8-1)	1/0 (7, 19)	1/0 (7, 12, 19)	#6	#4 (7) #4 SLD	#4 (7) #4 Sol.	2-3/8	4-7/8	C	W-C (2)	U-C (1)*	BG	BG (3)	U-BG (1)*			
YTU25R25R				1/0 80 (8-1)	1/0 (7, 19)	—							—	—			
YTU26R26R	2/0	2/0 (7, 19)	2/0 (7, 12, 19)	2/0	2/0 (7, 19)	2/0 (7, 12, 19)	3-3/8	7	L	W-L (4)	U-L (2)	L	—	U-L (2)			
YTU27R27R	3/0	3/0 (7, 19)	3/0 (7, 12, 19)	3/0	3/0 (7, 19)	3/0 (7, 12, 19)											
YTU28R28R	4/0	4/0 (7, 19)	4/0 (7, 12, 19)	4/0	4/0 (7, 19)	4/0 (7, 12, 19)											
YTU30R30R	266.8 (18-1, 26-7, 6-7)	266.7 (7, 19, 37) 250 (19, 37) 300 (19, 37)	250 (12, 19, 37) 300 (19, 37)	266.8 (18-1, 26-7, 6-7)	266.7 (7, 19, 37) 250 (19, 37) 300 (19, 37)	250 (12, 19, 37)	4-3/8	8-3/4	M	—	U-M (3)	M	—	U-M (3)			
YTU321R2R	300 (26-7) 336.4 (18-1)	350 (19, 37) 336.4 (19, 37)	350 (19, 37)	2	2 (7 Str.)	2 (3, 7 Str.)	2-5/8	6-5/8				BG	BG (3) W-BG (1)*	U-BG (1)*			
YTU321R26R				2/0	2/0 (7, 19)	2/0 (7, 12, 19)	3-1/2	8-5/8				L	M	—	U-M (3)		
YTU321R27R				3/0	3/0 (7, 19)	3/0 (7, 12, 19)										U-L (2)	
YTU321R28R				4/0	4/0 (7, 19)	4/0 (7, 12, 19)										M	U-M (3)
YTU321R321R				336.4 (18-1) 300 (26-7)	336.4 (19, 37) 350 (19, 37)	350 (19, 37)										M	U-M (2)
YTU33R26R				336.4 (30.7) (26-7)	397.5 (19, 37) 400 (19, 37)	400 (19, 37)	2/0	2/0 (7, 19)				2/0 (7, 12, 19)	3-1/2	8-5/8	L	U-L (2)	
YTU33R28R	4/0	4/0 (7, 19)	4/0 (7, 12, 19)														
YTU33R33R	336.4 (30.7) (26-7) 397.5 (18-1)	397.5 (19, 37) 400 (19, 37)	400 (19, 37)				4-3/8	8-3/4				M					U-M (3)

* Multiple crimp die set, makes more than one crimp per tool compression. Figure indicates number of compressions.

† U Die with adapter PT-6515
‡ U Die with adapter PUADP-1.

Blue highlighted items are industry standard and most frequently ordered.

TYPE YTA-R-2N

DISCONNECTABLE T-TAP (WITH PAD)

For Copper, Aluminum, ACSR, 6201, 5005, Compressed and Compact Conductors

Aluminum primary T-tap connector with slotted tap pad designed for easy disconnecting of tap conductor. Tap pad accommodates compression terminals Types YKA-R-2N and YKA-A-2N, and has positioning socket for proper alignment. On sizes larger than 336.4 ACSR, the YTA-R-2N run element has two-piece interlocking-key with lifting eye that simplifies hotline installations. Catalog number does not include mating terminal.

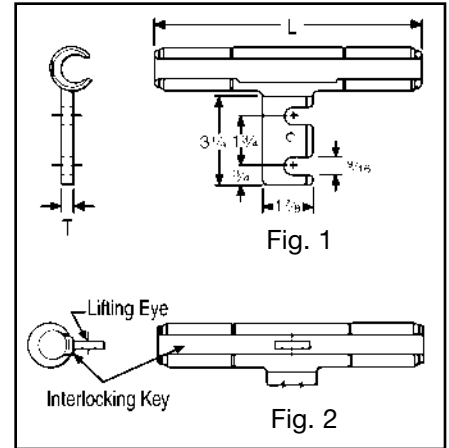
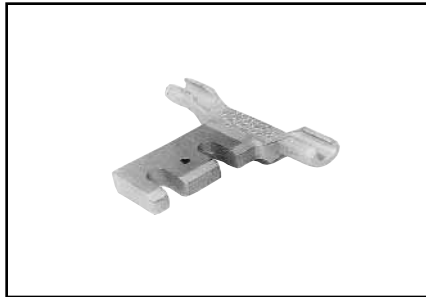

H-31

Catalog Number	ACSR, 6201, 5005	Copper	Aluminum	Fig. No.	L	T	Die Index	Tools, Die Set Catalog Number, & (Number of Crimps per End)					
								MD7, MD6	Y35, Y750	Y45†	Y46‡	Y48B	Y60BHU
YTA2R-2N	2	2 (3, 7) 1 (7)	2 (7) 1 (7)	1	6-1/8	3/8	BG or 243	BG (2) W-BG (1)* W243 (2)	U-BG (1)* U243 (1)				
YTA25R-2N	1/0	1/0 (7, 12, 19)	1/0 (7, 19)				659 C, 247	W-C (4) W247 (1)	U659 (1) U-C (1)* U247(1)				
YTA26R-2N	2/0	2/0 (7, 12, 19)	2/0 (7, 19)				L or 251	W-L (4)	U-L (2) U251 (3)				
YTA27R-2N	3/0	3/0 (7, 12, 19)	3/0 (7, 19)		7-7/8	1/2	M						
YTA28R-2N	4/0	4/0 (7, 12 19)	4/0 (7, 19)										
YTA321R-2N	300 (26-7) 336.4 (18-1)	350 (19, 37)	336.4 (19, 37, 61) 350 (19, 37, 61)	2	9-1/2	1/2			U-M (3) U317 (4)				
YTA33R-2N	336.4 (26-7, 30-7) 397.5 (18-1)	400 (19, 37)	397.5 (19, 37, 61) 400 (19, 37, 61)										
YTA361R-2N	477 (18-1)				13-1/8				U-M (5)				
YTA37R-2N	477 (24-7, 26-7, 30-7)		556.6 (19, 37)		16-1/4	608			U608 (9)		C608 (3)	L608 (3)	
YTA39R-2N	556.5 (24-7, 26-7)		636 (37) 650 (61)										
YTA43R-2N	605 (30-19) 605 (30-9) 636 (24-7, 26-7, 30-19) 666.6 (24-7)	—	795 (37, 61)	16-1/2	3/4	292 or 319			—	S292 (9) S319 (9)	P292 (9) P319 (9)	C292 (3) C319 (3)	L292 (3) L319 (3)
YTA391A-2N	—					342				S342 (9)	P342 (9)	C342 (3)	L342 (3)

* Multiple crimp die set, makes more than one crimp per tool compression. Figure indicates number of compressions.
 † U Die with adapter PT-6515.
 ‡ U Die with adapter PUADP-1.

Blue highlighted items are industry standard and most frequently ordered.

TYPES YKA-R-2N & YKA-A-2N

DISCONNECTABLE TERMINAL (WITH FIXED HARDWARE)

For Copper, Aluminum, ACSR, 6201, 5005, Compressed and Compact Conductors

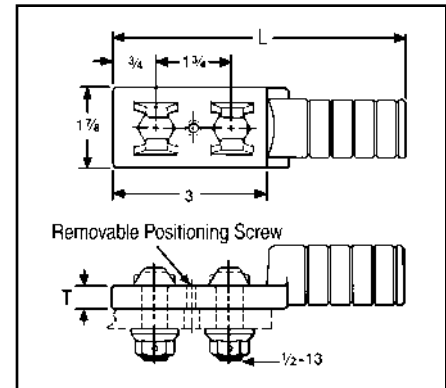

Aluminum compression terminal with fixed hardware and positioning pin for making disconnectable tap or jumper connections. Used with slotted YTA-R-2N T-tap or YSA-R-2N terminal. Supplied with aluminum bolts and washer-face, self locking nuts. Prefilled with PENETROX™ joint compound and capped.

H-32

Catalog Number	ACSR, 6201, 5005	Copper	Aluminum	L	T	Bolt Length	Die Index	Tools, Die Set Catalog Number, & (Number of Crimps)						
								MD7, MD6	Y35, Y750	Y45†	Y46‡	Y48B	Y60BHU	
YKA2R-2N	2	1 (7) 2 (3, 7)	1 (7) 2 (7)	5-1/2	3/8	1-3/4	BG or 243	BG (8) W-BG (4)* W243 (4)	U-BG (3)* U243 (2)	—	—	—	—	
YKA25R-2N	1/0	1/0 (7, 19)	1/0 (7, 19)	5-5/8			C or 659	W-C (6) —	U-C (3)* U659 (2)	—	—	—	—	
YKA26R-2N	2/0	2/0 (7, 19)	2/0 (7, 19)	6			L or 251	—	U-L (2) U251 (3)	—	—	—	—	
YKA27R-2N	3/0 110.8 (12-7)	3/0 (7, 19)	3/0 (7, 19)				—	M or 317	—	U-M (3) U317 (4)	—	—	—	—
YKA28R-2N	4/0	4/0 (7, 19)	4/0 (7, 19)											
YKA30R-2N	266.8 (18-1, 6-7, 26-7)	250 (12, 19, 37) 300 (19, 37)	250 (7, 37) 266 (19)	7-1/4										
YKA321R-2N	336.4 (18-1) 300 (26-7)	350 (19, 37)	300 (37, 61) 350 (37, 61)											
YKA33R-2N	336.4 (26-7, 30-7) 397.5 (18-1)	—	397.5 (19) 400 (37)											
YKA361R-2N	397.5 (26-7, 30-7) 477 (18-1)	—	477 (19, 37) 500 (37, 61)	7-3/8			M	—	U-M (3)	—	—	—	—	
YKA37R-2N	477 (24-7, 26-7, 30-7)	—	556.5 (19, 37)											
YKA34CA-2N	397.5 (26-7, 30-7) 477 (18-1)	500 (19, 37)	477 (19, 37) 500 (37, 61)	9-1/2	3/4	2-1/2	352 or 579	—	—	S352 (9) S579 (9)	P352 (9) P579 (9)	C352 (3) C579 (3)	L352 (3) L579 (3)	
YKA391A-2N	—	—	795 (37, 61)				342	—	—	S342 (9) P342 (9)	C342 (3) L342 (3)			

* Multiple crimp die set, makes more than one crimp per tool compression. Figure indicates number of compressions.

† U Die with adapter PT-6515
‡ U Die with adapter PUADP-1.

Blue highlighted items are industry standard and most frequently ordered.

TYPE YSA-R-2N

DISCONNECTABLE TERMINAL (WITH SLOTTED PAD)

For Copper, Aluminum, ACSR, 6201, 5005, Compressed and Compact Conductors

Aluminum compression terminal with slotted pad and positioning socket for making disconnectable tap or jumper connections. Used with YKA-R-2N fixed hardware terminal.

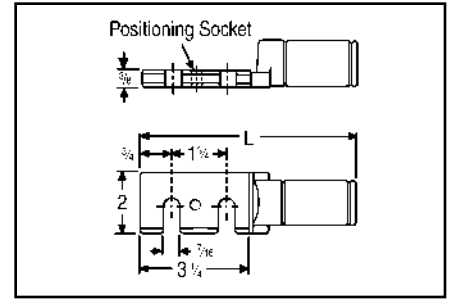
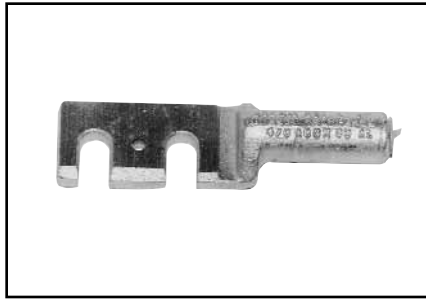

Pre-filled with PENETROX™ joint compound and capped.

Catalog Number	ACSR, 6201, 5005	Copper	Aluminum	L	Die Index	Tools, Die Set Catalog Number, & (Number of Crimps)	
						MD7, MD8	Y35, Y750, Y45†, Y46‡
YSA2R-2N	2	2 (3, 7) 1 (7)	2 (7) 1 (7)	6-1/4	BG or 243	BG (8) W-BG (4)* W243 (4)	U-BG (3)* U243 (2)
YSA25R-2N	1/0	1/0 (7, 19)	1/0 (7, 19)		C or 659	—	U-C (3)* U659 (2)
YSA26R-2N	2/0	2/0 (7, 19)	2/0 (7, 19)	6-5/8	L or 251	—	U-L U251
YSA28R-2N	4/0	4/0 (7, 19)	4/0 (7, 19)				
YSA30R-2N	266.8 (18-1, 6-7, 26-7)	250 (12, 19, 37) 300 (19, 37)	250 (37) 266.8 (7, 19)	7-3/4	M or 317	—	U-M (3) U317 (4)
YSA321R-2N	336.4 (18-1) 300 (26-7)	350 (19, 37)	300 (37, 61) 350 (37, 61)				
YSA37R-2N	477 (24-7, 26-7, 30-7)	—	556.5 (19, 37)	7-7/8	M	—	U-M (3)

* Multiple crimp die set, makes more than one crimp per tool compression. Figure indicates number of compressions.

† U Die with adapter PT-6515
‡ U Die with adapter PUADP-1.

H-33

TYPE YTA-2N

DISCONNECTABLE T-TAP

For Copper

Cast copper primary t-tap connector with slotted tap pad for easy disconnecting of tap conductor. Tap pad accommodates compression terminal Type YKA-2N. On sizes larger than 4/0, the YTA-2N run element has a two-piece, interlocking-key with lifting eye that simplifies hot installations. Catalog number does not include terminal or hardware.

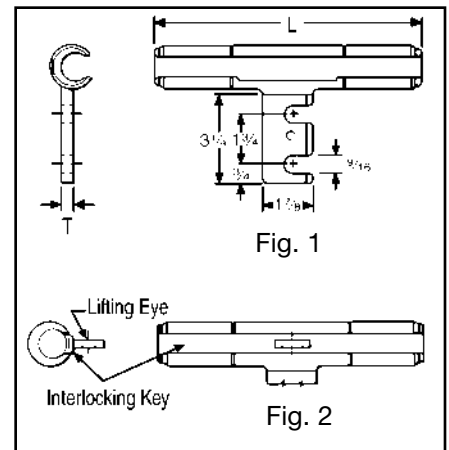

Catalog Number	Conductor	Fig. No.	C	L	T	Die Index	Tools, Die Set Catalog Number, & (Crimps per End)			
							MD7, MD6	Y35, Y750, Y45†, Y46‡	Y48B	Y60BHU
YTA2C-2N	2 (7)	1	1-1/2	5-5/8	3/8	163	W163 (3) Crimps Overlap	U163 (1)*	—	—
YTA26-2N	2/0 (7, 19)			7-3/8			W166 (6)	U166 (3)	—	—
YTA28-2N	4/0 (7, 12, 19)			7-5/8			—	U168 (4)	—	—
YTA34-2N	500 (19, 37, 61)	2	2	11-7/8	1/2	210	—	U210 (6)	C210 (2)	L210 (2)

* Multiple crimp die set, makes more than one crimp per tool compression. Figure indicates number of compressions.

† U Die with adapter PT-6515
‡ U Die with adapter PUADP-1.

Blue highlighted items are industry standard and most frequently ordered.

TYPE YKA-2N

DISCONNECTABLE TERMINAL (WITH FIXED HARDWARE)

For Copper

Tin-plated copper compression terminal with fixed hardware for making disconnectable tap or jumper connections. Used with slotted YTA-2N T-tap or YSA-R-2N terminal. Supplied with tin-plated DURIMUM™ bolts and washer-face nuts.

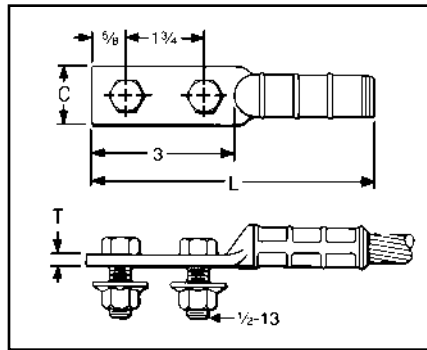

H-34

Catalog Number	Conductor	C	L	T	Die Index	Tools, Die Set Catalog Number, & (Number of Crimps)			
						MD7, MD6	Y35, Y750, Y45†, Y46‡	Y48B	Y60BHU
YKA6C-2N	6 (7)	7/8	5	3/8	163	W163 (2)	U163 (1)*	—	—
YKA2C-2N	2 (7)					Crimps Overlap			
YKA26-2N	2/0 (7, 19, 37)	1	5-1/4	1/4	166	W166 (4)	U166 (3)	—	—
YKA28-2N	4/0 (7, 12, 19, 37)	1-1/4	5-3/8	3/8	168	—	U168 (3)	C168 (1)	L168 (1)
YKA30-2N	300 (19, 37, 61)	1-1/2	5-1/2				170	U170 (5)	C170 (1)
YKA34-2N	500 (19, 37, 61)	1-7/8	6-1/2	1/2	210	—	U210 (6)	C210 (2)	L210 (2)
YKA44-2N	1000 (61)	2	7-5/8	1/2	345	—	—	C345 (4)	L345 (4)

* Multiple crimp die set, makes more than one crimp per tool compression. Figure indicates number of compressions.

† U Die with adapter PT-6515

‡ U Die with adapter PUADP-1.

Blue highlighted items are industry standard and most frequently ordered.

TYPE YCB-R

STIRRUP HOT-LINE CLAMP ADAPTERS

For Aluminum, ACSR, 6201, 5005, Compressed and Compact Conductors



Permanent compression hot-line clamp adapter with aluminum run and copper bail. Accommodates any standard copper hot-line clamp on bail elements. Permits hot-line tapping without arcing or chafing damage to aluminum conductor. Installed with standard tools and dies.

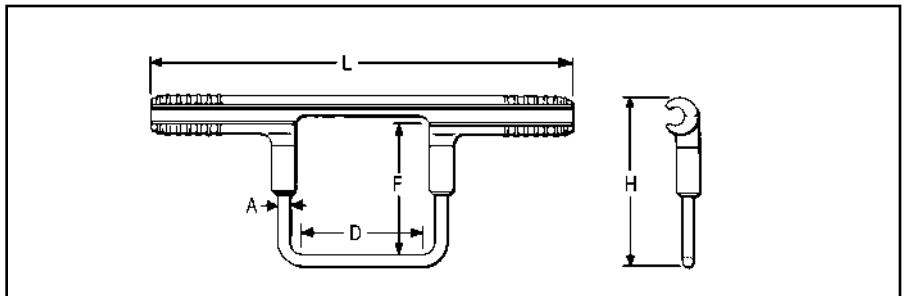

H-35

Catalog Number	Aluminum	ACSR, 6201, 5005	A	H	L	D	F	Die Index	Tools, Die Set Catalog Number, & (Crimps per End)	
									MD7, MD6	Y35, Y750, Y45†, Y46‡
YCB2R	2 Str. - 6 Sol.	2 - 4	2 Sol.	3-3/4	9	2-1/2	2-1/2	BG	BG (6) W-BG (2)*	U-BG (2)*
YCB25R	1/0 (7, 19)	1/0 - 80 (8-1)	1/0 Sol.	5	9-3/4	3-1/2	3-1/2	C	W-C (4)	U-C (2)*
YCB26R	2/0 (7, 19)	2/0			L			W-L (4)	U-L (2)	
YCB27R	3/0 (7, 19)	3/0			M			—	U-M (3)	
YCB28R	4/0 (7, 19)	4/0								
YCB321R	350 (19, 37) 336.4 (19, 37)	336.4 (18-1) 300 (26-7)	5-3/8	12-3/4	317	U317 (3)				
YCB33R	400 (19, 37) 397.5 (19, 37)	336.4 (26-7, 30-7) 397.5 (18-1)	5-1/4	13-1/4						
YCB35R	500 (37, 61) 477 (19, 37)	397.5 (26-7) (30-7)								
YCB361R	477 (19, 37)	477 (18-1)								

* Multiple crimp die set, makes more than one crimp per tool compression. Figure indicates number of compressions.

† U Die with adapter PT-6515

‡ U Die with adapter PUADP-1.

Blue highlighted items are industry standard and most frequently ordered.

TYPES YCB-U & YCB-R-U

CRIMPIT™ STIRRUP

Hot-Line Clamp Adapter for Aluminum, ACSR, 6201, 5005, Compressed and Compact Conductors

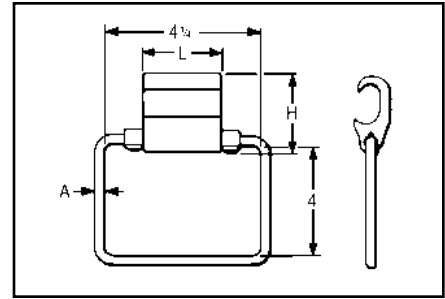

Combines Figure "6" -shaped aluminum CRIMPIT™ tap connector with tin-plated copper bail. Can be gripped in tool and

slipped over line for easy installation. Five sizes take range from #4 to 600 Mcm. Pre-filled with PENETROX™ joint compound and Stripsealed.

H-36

Catalog Number	Aluminum	ACSR, 6201, 5005	A	H	L	Die Index	Tools, Die Set Catalog Number, & (Number of Crimps)		
							Y35, Y750	Y45	Y46
YCB4U1	4 Sol. - 4 (7)	4	2 Sol.	1-1/2	1-7/8	D*	U-D (2)	†	‡
YCB1U1	2 (7) - 1 (7)	2		1-5/8					
YCB28U26	1/0 (7) - 4/0 (19)	1/0 - 4/0		2					
YCB33R26U	300 (37) - 400 (37)	266.8 (6-7) - 336.4 (30-7)	1/0 Sol.	2-1/4	2-1/8	H	U-H (2)		
YCB38R26U	397.5 (19) - 600 (61)	336.4 (26-7) - 556.5 (18-1)				R	U-R (2)		
						N	U-N (2)	S-N (2)	P-N (2)

* Index number "D" is not "D3" Cabelok CRIMPIT™ die.
 † U Die with adapter PT-6515
 ‡ U Die with adapter PUADP-1.

TYPES J990 & J1252

HOT-LINE CLAMP BAILS

Designed to make hot-line clamp adapter using HYCRIMP™, CABELOK CRIMPIT™ or Figure "6" -Shaped CRIMPIT™ connectors. Where hot sticks are used, the CABELOK CRIMPIT™ or Figure "6" -shaped CRIMPIT™ are recommended. The line can be approached with the connector and bail held in the tool. Bails are tin-plated, hard drawn copper.

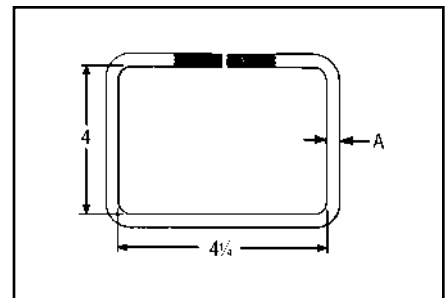

Recommended Connector & Bail Combinations						
HYCRIMP™ Cat. No.	CABELOK™ CRIMPIT™ Cat. No.	Bail	A	Run Conductors Accommodated*		
				Sol. Al	Str. Al	ACSR
YHO-100	YP2U3	J990	#2	6 - 2	6 - 3 (7 Str.)	6, 4
YHO-150	YP26AU2			1 - 2/0	3 (3 Str.) - 1/0	3 - 1/0
YHD-200	YP27AU4			3/0, 4/0	2/0 - 3/0	1/0, 2/0
YHD-250	YPC28U4			—	4/0	3/0, 4/0
YHD-300	YP27AU26	J1252	2/0	3/0	2/0, 3/0	2/0
YHD350	YP28U26			4/0	3/0, 4/0	
—	YPC28U26	J990	#2	—	1/0 (7) - 4/0	1/0 - 4/0
		J1252	2/0			
YHN-500	YPC33R26U	J990	#2		250 (37)	266.8 (18-1)
		J1252	2/0		400 (37)	397.5 (18-1)

* For additional run conductors see specific connector catalog page.

Blue highlighted items are industry standard and most frequently ordered.

TYPES YHO-J, YHD-J, YHN-J

HYCRIMP™ STIRRUP

Utilizing H-Framed Aluminum Tap Connectors with tin-plated copper bail. Bendable tabs secure run and bail freeing the lineman's hands to work with the installation tool conductor grooves. Prefilled with PENETROX™ joint compound.

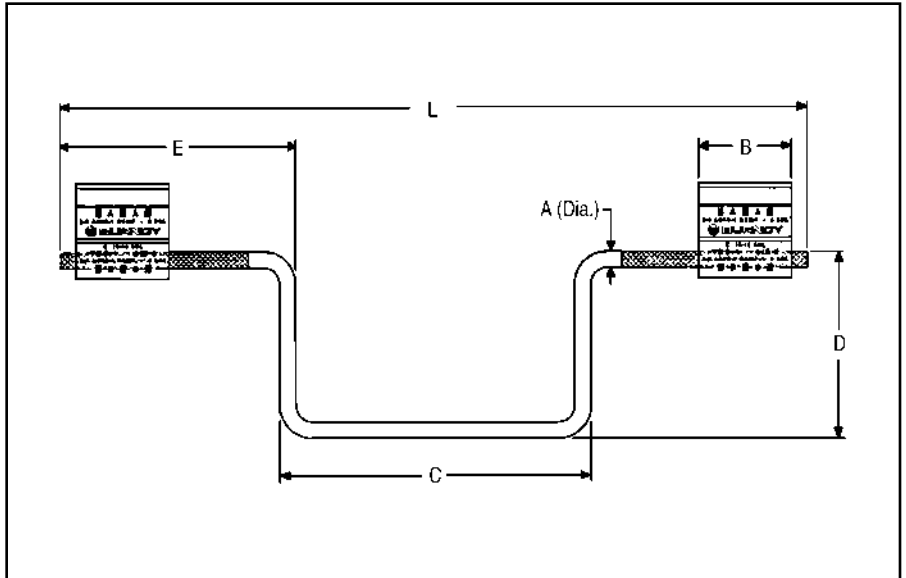

H-37

Catalog Number	Run Conductor Accommodates			A	B	C	D	E	L	Die Index	Tools, Die Set Catalog Number, & (Number of Crimps)		
	Sol. Al	Str. Al	ACSR								MD7-8	MD6-8 ①	Y35, Y750, Y45†, Y46‡
YHO100J1444	6 - 1	6 - 1 (7 Str.)	6 - 2	2 Sol. (.258 dia.)	1.50	5.00	3.00	3.75	12.0	0	(4)	U-0 (2)	
YHO150J1444	1 - 2/0	3 - 2/0	3 - 1/0		1.75	5.00	3.00	3.75	12.0	0	(5)	U-0 (2)	
YHD200J1444	3/0 - 4/0	2/0 - 3/0	1/0 - 2/0		1.88	5.00	3.00	3.75	12.0	D3	(5)	UD-3 (2)	
YHD250J1444	250 - 300	4/0	3/0 - 4/0	2/0 Sol. (.365 dia.)	1.88	5.00	3.00	3.75	12.0	D3	(5)	UD-3 (2)	
YHD300J1496	2/0 - 4/0	#1 (Str.) - 3/0	#1 - 2/0		1.88	5.00	4.75	5.62	15.5	D3	(5)	UD-3 (2)	
YHD350J1496	250 - 300	3/0 - 4/0	3/0 - 4/0		2.50	5.00	4.75	5.62	15.5	D3	(7)	UD-3 (2)	
YHN500J1496	—	4/0 - 500	4/0 - 477 (18/1)		2.00	5.00	4.75	5.62	15.5	N	—	U-N (2)	

① Permanent dies in tool install all sizes.

† U Die with adapter PT-6515

‡ U Die with adapter PUADP-1.

Blue highlighted items are industry standard and most frequently ordered.

TRANSFORMER AND EQUIPMENT TAP CONNECTORS

Transformer and equipment tap connectors are specifically designed to provide single or multi-tap connections from secondary transformer outlets, disconnects, circuit breaker panels, and other equipment pads or bar.

TYPE E-C-G

TRANSFORMER TAP ADAPTER

H-38

For Copper

Multi-tap, range-taking cast copper alloy connector designed to take 2, 3, or 4 conductors from a single secondary transformer outlet.

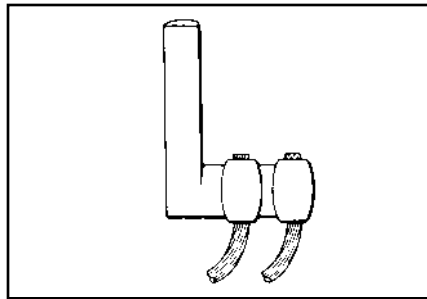
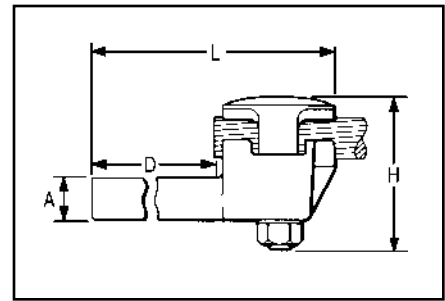
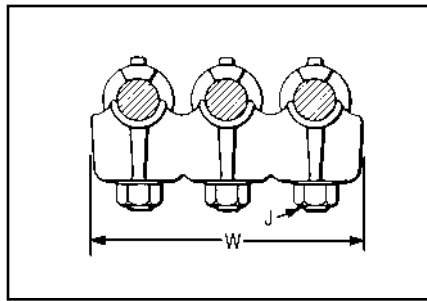

Catalog Number	Number of Conductors	Conductor Size	A Dia.	D	H	J	L	W
E2C34G1	2	1/0 Sol. - 500	.78	3-3/4	3-7/8	1/2-13	6-1/4	3-1/2
E3C34G1	3							5-1/4
E4C34G1	4							6-7/8

Blue highlighted items are industry standard and most frequently ordered.

TYPE KC22J12T13, EQC632C

TRANSFORMER GROUND CONNECTORS

For Copper

Fits all standard EEI-NEMA distribution transformers as a tank grounding terminal.



Type EQC632C

Catalog Number	Ranges
KC22J12T13	8 Sol. - 2 Sol.
KC26	2 Sol. - 2/0 Str.
KC34J12T13	3/0 - 500 Str.
EQC632C	8 Sol. - 2 Str.

Both, one-wrench installation.

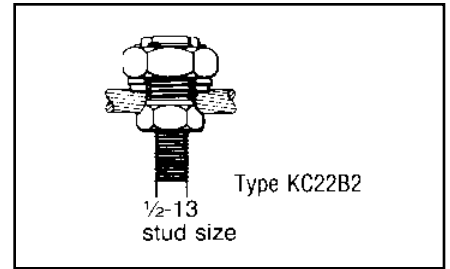

Type KC22B2
1/2-13
stud size

H-39

TYPE YA-2LH

HYSEALUG™

Terminal for Copper

Tin-plated, pure copper 2-hole NEMA compression terminal with shrouded barrel for terminating insulated copper conductor to transformers and other equipment. Shroud prevents seepage of water or moisture into conductor strands and minimizes taping.

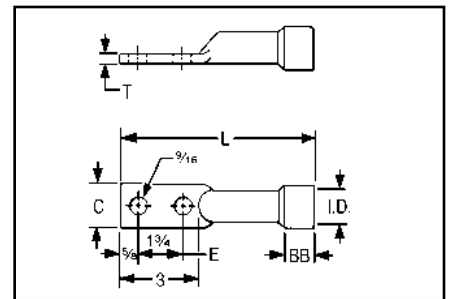

Catalog Number	Conductor	BB	Shroud Inside Diameter	C	L	T	Tools, Die Set Catalog Number, & (Number of Crimps)	
							MD7, MD6	Y35, Y750, Y45†, Y46‡
YAB4C-2LH72	4 Str.	5/8	.57	3/4	6-1/4	1/8	W161 (2)	U4CRT (2)
YAB2C-2LH74	2 Str.	3/4	.58		6-1/2		W162 (4)	U2CRT (2)
YAB2C2LH75			.91					
YAB25-2LH70	1/0 Str.	1	.69	7/8	6-3/4	3/8	W163 (4)	U25RT (2)
YAB25-2LH71			.98					
YA26-2LH89	2/0 Str.		1.04		6-1/4		W241 (2)	U26RT (2)
YA28-2LH114	4/0 Str.		.86	1	6-5/8	1/8	W-BG or W243 (2)	U28RT (2)
YA28-2LH115		1.24						
YA29-2LH91	250	1-1/4	1.25	1-1/8	7		W166 (4)	U29RT (2)
YA30-2LH85	300		.92	1-1/4			U30RT (2)	
YA31-2LH90	350		1.40	1-3/8			7-5/8	W-O (5)
YA34-2LH110	500	1-1/2	1.14	1-1/2	7-3/4	1/4	—	U34RT (2)
YA34-2LH111			1.88					

† U Die with adapter PT-6515
‡ U Die with adapter PUADP-1.

Blue highlighted items are industry standard and most frequently ordered.

TYPE YE-LH

HYSEALPLUG™

Terminal Plug for Copper

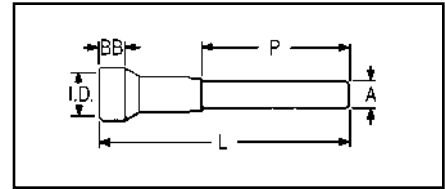
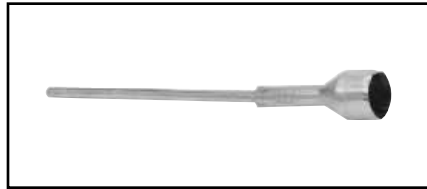

Oil and water-tight terminal with shrouded, tin-plated, copper barrel and brazed plug. Recommended for terminating insulated copper conductor at cutout, transformer and arrester; or for joining insulated copper riser to overhead conductor. Shroud prevents seepage of water or moisture into conductor strands and minimizes taping. To obtain a tight fit on some insulations in the shroud it may be necessary to either "pencil" the insulation down, or build it up with tape.

Catalog Number	Conductor	BB	Shroud Inside Dia.	A Dia.	L	P	Tools, Die Set Catalog Number, & (Number of Crimps)	
							MD7, MD6	Y35, Y750, Y45†, Y46‡
YE2C-LH128	2 Str.	3/4	.58	2 Sol.	9	6	W162 (4)	U2CRT (2)
YE2C-LH129			.91					
YE25-LH97	1/0 Str.	1	.98	1/0 Sol.	11-1/8	8	W163 (4)	U25RT (2)
YE26-LH88	2/0 Str.		.73	2/0 Sol.	11-3/8		W241 (2)	U26RT (2)
YE26-LH89			1.04				W-BG or W243 (2)	U28RT (2)
YE28-LH128	4/0 Str.		1.24	4/0 Sol.	11-1/2			U31RT (2)
YE31-LH96	350	1-1/4	1.03	4/0 Sol.	12-1/4	8	W-O (5)	U31RT (2)
YE34-LH119	500	1-1/2	1.14		13-1/4		—	U34RT (2)
YE34-LH120			1.88					

† U Die with adapter PT-6515.
‡ U Die with adapter PUADP-1.

H-40

TYPES YE-R, YE-W

HYPLUG™

Terminal Plug for Aluminum and ACSR

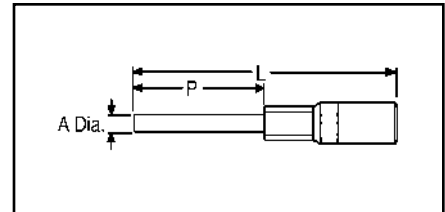
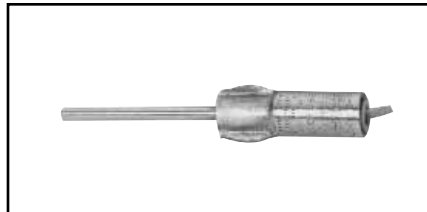

In 1989 BURNDY® began shipping an improved pin type connector. A proprietary coating system was developed through intense research efforts which vastly prolongs the life of this type of connection. To help identify the new product a hex shaped crimp is now used on the pin inter-

face crimp and BURNDY's overhead color coded end caps are utilized.

Aluminum HYPLUG™ with tin-plated copper plug for terminating aluminum or ACSR cable at cut-out, transformer and arrester. Plug

may be bent to desired angle for easier insertion. Three die sets accommodate 4 Str.-500 kcmil. Terminals are pre-filled with PENETROX™ A-13 joint compound and sealed with color coded end caps.

Catalog Number	Conductor		A Dia.	L	P	Color Code	Die Index	Tools, Die Set Catalog Number, & (Number of Crimps)*				
	Aluminum	ACSR						MD7, MD6	Y750, Y35, Y45†, Y46‡	Y48BH	Y60BH	
YE6R-25	5, 6 Str.	6	4 Sol.	4-5/8	2-1/2	Blue	BG or 243	BG WBG W243	U-BG	C243	L243	
YE4R-25	3, 4 Str.	4				Orange						
YE1WAG1	#1 Sol. (.289)	—	.257	8.58 (218)	6	Red						
YE2WAG5	#2 Sol. (.258)	—				Orange						
YE2R-25	1, 2 Str.	2	2 Sol.	4-5/8	2-1/2	Red	5/8 - 1	U243 UK5/8-1T	C249	L249		
YE25R-25	1/0 Str.	1/0	2 Sol.			Yellow						
YE26R-60	2/0 Str.	2/0	1/0 Sol.	9-1/2	6	Gray	249 or 840	W249 or W-K840	U249 U-K840T	C249	L249	
YE27R-60	3/0 Str.	3/0				Black						
YE28R-60	4/0 Str.	4/0	3/8	Pink								
YE30R-60	300	266.8 (26/7) (18/1)	4/0 Sol.	10-5/8		6	Blue	317, 705, 1-1/8 - 1	—	U317 U705 U-K1-18-1T	C317	L317
YE32R-60	350 - 400	336.4 (26/7) (18/1)			Green							
YE361R-60	477, 500	477 (18/1)	9/16	11-7/8	6		Pink	608	—	U608	C608	L608
YE39R-60	600	556.5 (24/7) (26/7)	5/8				Yellow					

* All crimps overlap
† U Die with adapter PT-6515.
‡ U Die with adapter PUADP-1.

• BURNDY® furnishes many special versions of YE-R including: pin length variations, factory applied pin angles, etc. Contact your BURNDY® representative for your special needs.

Blue highlighted items are industry standard and most frequently ordered.

COMPRESSION SPLICES

TABLE OF CONTENTS

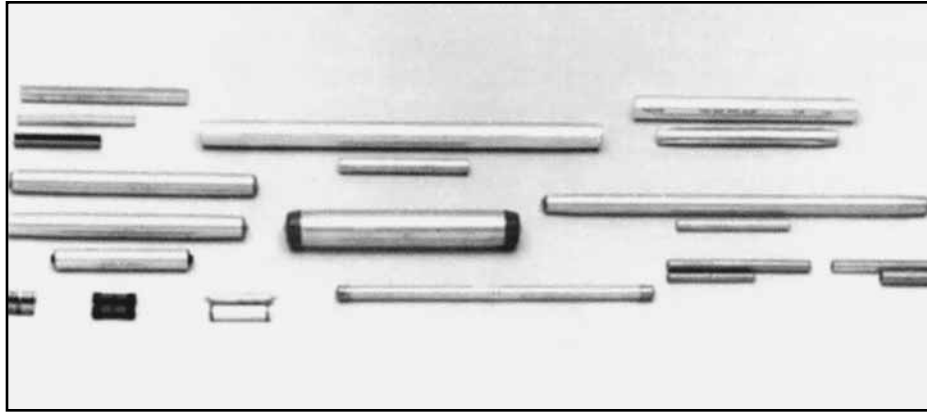

H-41

COMPRESSION SPLICES	H-42	Types YCU-R & YOU-R	H-52
		Type YCU-R (Static Wire)	H-52
SERVICE ENTRANCE		FULL TENSION	
Type ES	H-43	Types YDS-A & YDS-AT	H-53
Type YSU	H-44	Types YDS & YDS-C	H-54
Type YSD	H-45	Types YDS-W & YDS	H-55
NEUTRAL		Types YDS-R, YDS-RP1, YDS-RP2	H-56, H-57
Types YSS, YCS-R, YDS-AT	H-46	Type YDS-RLY	H-58
JUMPER		Types YDS-RL & YDS-LT	H-59, H-60
Type YCS-R	H-47	Types YDS-A & YDS-AT	H-60
Type YCS-RL	H-48	Types YDS-R & YDS-RE	H-61
Type YCS-A	H-49	Types YDS-E, YDS-H, YDS-U	H-61
Type YCR	H-49	Type YDS-K	H-62
Type YCR-R-G	H-50	Type YTS-E	H-62
Types YDS, YCS	H-51	Types YDS-KT & YDS-F	H-63
REPAIR SLEEVE		Type YDS-M-T	H-63
Type YCU-A	H-51		
Type YNU-R	H-52		

Blue highlighted items are industry standard and most frequently ordered.

COMPRESSION SPLICES

BURNDY® service, full-tension, and jumper sleeves provide a dependable, economical, and easy-to-install method of splicing overhead transmission and distribution lines.

A major part of the Total Burndy Compression Program, they are available for copper, aluminum, ACSR, COPPERWELD, ALUMOWELD, Steel, 6201, 5005, ACSR/AW, AWA, and compressed forms for aluminum and ACSR. Each is clearly marked with the installation Die Index number and knurls are provided which show the installer the correct number of crimps and the spacing required. Connections made with BURNDY® INSULINK™ and HYSPLICE™ sleeves have a lower resistance than an equal length of conductor.

HYSPLICE™ sleeves are tapered or chamfered at the ends; externally to provide gradual reduction of pressure on the conductor, and internally to facilitate conductor insertion.

Service Sleeve Design

Service entrance connectors are available insulated (INSULINK™) or uninsulated (LINKIT™). Both are installed with the one-hand OH25 and OUR840 HYTOOL™ or the MD6 HYTOOL™. The INSULINK™ feature polyethylene caps which seal out dirt and moisture, and grip the cable insulation leaving both hands free for crimping. The aluminum insert is anchored to the Nylon jacket so that it will not move when crimped, ensuring that the insert is always under the die. The jacket is color coded for easy identification of conductor size.

The aluminum LINKIT™ minimizes the effects of galvanic corrosion. It is designed for easy location of crimps, and is color coded.

The service HYSPLICE™ connectors are partial-tension sleeves for splicing the neutral conductor of triplex service. They are installed with MD6, OUR840 and the OH25 HYTOOL™ on aluminum and ACSR conductors from 6 to 1/0.

Copper HYSPLICE™ Sleeve Design

Full-tension holding strength and high conductivity of BURNDY® copper HYSPLICE™ sleeves are accomplished through the combined action of correct contact length, proper number of circular crimps of precisely controlled depth that perform a current carrying and keying function between the conductor and the sleeve.

Aluminum HYSPLICE™ Sleeve Design

HYSPLICE™ sleeves for aluminum conductor not only satisfy the basic tension requirements, but also deal with the problems of “cold flow” of aluminum and the oxide film which forms on the strands. “Cold flow” is compensated for by carefully coordinating the design of the sleeve and its associated installation die. To offset the effects of the non-conductive oxide film present on the surfaces of aluminum cable, BURNDY® HYSPLICE™ sleeves are pre-filled with PENETROX™ joint compound and capped or stripsealed. A solid center barrier forces the PENETROX™ around the cable strands during insertion.

ACSR HYSPLICE™ Sleeve Design

Two-piece, Full-tension HYSPLICE™

Two-piece, full-tension HYSPLICE™ for ACSR consists of an inner steel sleeve for joining the steel core, and an outer aluminum sleeve for connecting the aluminum strands. To install the two-piece HYSPLICE™, the cable is cut, the aluminum sleeve slid onto the cable, aluminum strands cut back and

the steel sleeve installed. The aluminum sleeve is then centered over the steel sleeve, PENETROX™ joint compound injected (PENETROX™ is brushed on cable prior to centering aluminum sleeve on smaller sizes), and the sleeve is crimped.

Single-sleeve, Full-tension UNISPLICE™

The UNISPLICE™ is as easy to install as aluminum full-tension sleeves. The single, heavy walled aluminum sleeve is filled with a special inhibiting compound containing grit particles which key the steel strand in place. The UNISPLICE™ eliminates cutting back of aluminum strands, the need for a separate steel sleeve, and careful positioning of the aluminum outer sleeve before crimping.

Since the standard pull-out tests are inadequate for evaluating UNISPLICE™ performance, BURNDY® has developed the sustained-tension test that subjects a connector-conductor assembly to a 168 hour sustained load equal to 90% of the conductor strength. This test simulates a service life of 30-40 years at 60% of the conductor strength.

Jumper Sleeves

Since the holding strength required for jumper sleeves is less than that required for full-tension sleeves, the jumper HYSPLICE™ sleeve is shorter. Aluminum, ACSR, sleeves are pre-filled with PENETROX™ joint compound and installed with the same tools and dies as the full-tension sleeves.

Blue highlighted items are industry standard and most frequently ordered.

TYPES ES

INSULINK™

Service Entrance Sleeve for Insulated Combinations of Copper, Aluminum, ACSR Compressed

For use in overhead distribution applications.

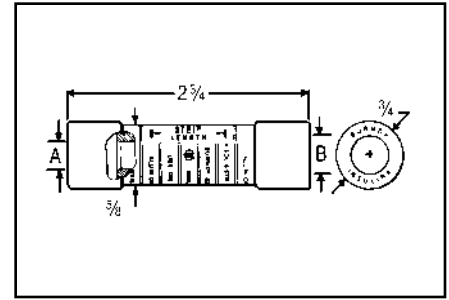
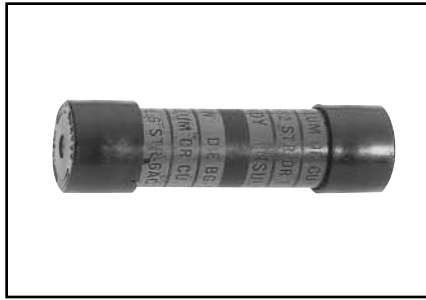

Pre-insulated service entrance compression connector installed with OH25, OUR840 and MD6 HYTOOL™ as well as Y35 and Y750 HYPRESS™ tools. Polyethylene caps prevent dirt from accumulating in barrel, grip cable for easy two-hand installation, and seal out moisture. Aluminum connector is

anchored to jacket, assuring the connector is under the die when crimping. Nylon jacket insulates connector electrically and protects against water and weather. Superior color coding. Pre-filled with PENETROX™ joint compound. Do not use insulated sealed connectors on bare conductors. Refer to LINKIT™ type connectors.

RUS Accepted

H-43

Catalog Number	Side A •			Side B •			Die Index	Tools, Die Set Catalog Number, & (Crimps per End)
	ACSR	Aluminum & Copper	Color Code	ACSR	Aluminum & Copper	Color Code		
ES8W8W	—	10 Str. 8 Sol.	Brown	—	10 Str. 8 Sol.	Brown	BG or 5/8	<p>HYTOOL™</p> <p>Tool Die (Crimps per End)</p> <p>OH25 (1)</p> <p>MD6, MD7 (3)</p> <p>MD6, MD7 W-BG (1)*</p> <p>OUR840 X-NBG (1)*</p> <p>HYPRESS™</p> <p>Tool Die (Crimps per End)</p> <p>Y35 U-BG (1)*</p> <p>Y750</p> <p>*Multiple crimp die set, makes more than one crimp per tool compression. Figure indicates number of compressions.</p>
ES6W8W	—	8 Str. 6 Sol.	Green	—	8 Str. 6 Sol.	Green		
ES6W6W	—	#8 AL Compt		—	#8 AL Compt	Green		
ES4W8W	6	5, 6 Str. 4 Sol.	Blue	—	10 Str. 8 Sol.	Brown		
ES4W6W				—	8 Str. 6 Sol.	Green		
ES4W4W				6	#8 AL Compt	Blue		
ES2W8W	4	3, 4 Str. 2 Sol.	Orange	—	10 Str. 8 Sol.	Brown		
ES2W6W				—	8 Str. 6 Sol.	Green		
ES2W4W				6	5, 6 Str. 4 Sol.	Blue		
ES2W2W				4	3, 4 Str. 2 Sol.	Orange		
ES2R8W	2	1 Str. 2 Str. #1 AL Compt #2 AL Compt	Red	—	10 Str. 8 Sol.	Brown		
ES2R6W				—	8 Str. 6 Sol.	Green		
ES2R4W				6	5, 6 Str. 4 Sol.	Blue		
ES2R2W				4	3, 4 Str. 2 Sol.	Orange		
ES2R2R				2	1 Str. 2 Str. #1 AL Compt #2 AL Compt	Red		
ES25R6W	1/0, 1	1/0 Str. 1-19 Str.	Yellow	—	8 Str. 6 Sol.	Green		
ES25R4W				6	5, 6 Str. 4 Sol.	Blue		
ES25R2W				4	3, 4 Str. 2 Sol.	Orange		
ES25R2R				2	2 Str. 1 Str. #1 AL Compt #2 AL Compt	Red		
ES25R25R	—	—	—	1/0, 1	1/0 Str.	Yellow		
ES25A25A	—	1/0 Str. ▲	Yellow	—	—	—		
ES25A4W	—			6	5, 6 Str., 4 Sol.	Blue		
ES25A2W	—			4	3, 4 Str., 2 Sol.	Orange		

^ Not for use on bare conductors.
▲ Accommodates 1/0 stranded aluminum and copper, concentric, compressed and compact conductors.

Blue highlighted items are industry standard and most frequently ordered.

TYPE YSU

5/8" LINKIT™

Service Entrance Sleeve for Combination of Copper, Aluminum and ACSR Compressed

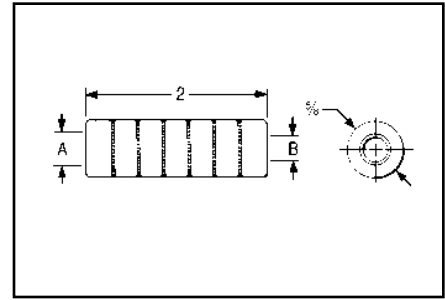

Heavy-walled aluminum tubing with solid barrier minimizes galvanic corrosion of conductors. Accommodates neutral strands of Type SE Service Entrance conductor as well as other conductors. Installed with standard tooling. Color Coded. Pre-filled with PENETROX™ joint compound and Stripsealed.

RUS Accepted

H-44

Catalog Number	Side A			Side B			Die Index	Tools, Die Set Catalog Number, & (Crimps per End)
	ACSR	Aluminum & Copper	Color Code	ACSR	Aluminum & Copper	Color Code		
YSU6W6W	—	8 Str. 6 Sol. #8 Al Compt	Green	—	8 Str. 6 Sol. #8 AL Compt	Green	BG or 5/8	<p>HYTOOL™</p> <p>Tool Die (Crimps per End)</p> <p>OH25 (1)</p> <p>MD6, MD7 (3)</p> <p>MD6, MD7 W-BG (1)*</p> <p>OUR840 X-NBG (1)*</p> <p>HYPRESS™</p> <p>Tool Die (Crimps per End)</p> <p>Y35 U-BG (1)*</p> <p>Y35L, Y750</p> <p>*Multiple crimp die set, makes more than one crimp per tool compression. Figure indicates number of compressions.</p>
YSU4W8W	6	5, 6 Str. 4 Sol. #4 Al Compt	Blue	—	8 Sol. 10 Str.	Brown		
YSU4W6W				—	6 Sol. 8 Str. #8 AL Compt	Green		
YSU4W4W				6	5, 6 Str. 4 Sol. #4 AL Compt	Blue		
YSU2W8W	4	3, 4 Str. 2 Sol.	Orange	—	8 Sol. 10 Str.	Brown		
YSU2W6W				—	6 Sol. 8 Str. #8 AL Compt	Green		
YSU2W4W				6	5, 6 Str. 4 Sol. #4 AL Compt	Blue		
YSU2W2W				4	3, 4 Str. 2 Sol.	Orange		
YSU2R8W	2	2 Str. 1 Str. #1 Al Compt #2 Al Compt	Red	—	8 Sol. 10 Str.	Brown		
YSU2R6W				—	6 Sol. 8 Str. #8 AL Compt	Green		
YSU2R4W				6	5, 6 Str. 4 Sol. #4 AL Compt	Blue		
YSU2R2W				4	3, 4 Str. 2 Sol.	Orange		
YSU2R2R				2	2 Str. 1 Str. #1 AL Compt #2 AL Compt	Red		
YSU25R6W	1/0	1/0 Str. 2/0 Al Compt 1/0 Al Compt	Yellow	—	8 Str. 6 Sol. #8 AL Compt	Green		
YSU25R4W				6	5, 6 Str. 4 Sol. #4 AL Compt	Blue		
YSU25R2W				4	3, 4 Str. 2 Sol.	Orange		
YSU25R2R				2	2 Str. 1 Str. #1 AL Compt #2 AL Compt	Red		
YSU25R25R				1/0	1/0 Str. 2/0 AL Compt 1/0 AL Compt	Yellow		
YSU25A25A	1-1	1/0 Str. ▲	Yellow	1/0	1/0 Str.	Yellow		

▲ Accommodates 1/0 standard aluminum and copper concentric, compressed and compact conductors.

Blue highlighted items are industry standard and most frequently ordered.

TYPE YSD

.840" LINKIT™

Service Entrance Sleeve for Combinations of Copper, Aluminum, ACSR, 6201, 5005 and Compressed

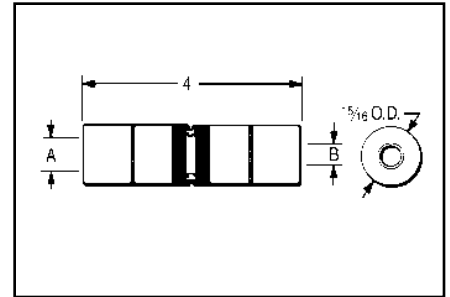

Aluminum compression sleeve with solid center barrier. Designed for commercial and heavy residential services. Installed with standard tooling. Pre-filled with PENETROX™ joint compound, and capped.

RUS Accepted

Catalog Number	Side A			Side B			Die Index	Tools, Die Set Catalog Number, & (Crimps per End)																													
	ACSR, 6201, 5005	Aluminum & Copper	Color Code	ACSR, 6201, 5005	Aluminum & Copper	Color Code																															
YSD25R25R	1/0	1/0 Str. 2/0 AL Compt	Yellow	1/0	1/0 2/0 AL Compt	Yellow	EII IIA 249 840	<p>HYTOOL™</p> <table border="1"> <thead> <tr> <th>Tool</th> <th>Die</th> <th>(Crimps per End)</th> </tr> </thead> <tbody> <tr> <td>MD6,</td> <td>WK-840</td> <td>(7)</td> </tr> <tr> <td>MD7</td> <td>W-249</td> <td>(4)</td> </tr> <tr> <td rowspan="2">OUR840</td> <td>X840</td> <td>(7)</td> </tr> <tr> <td>X249</td> <td>(8)</td> </tr> </tbody> </table> <p>HYPRESS™</p> <table border="1"> <thead> <tr> <th>Tool</th> <th>Die</th> <th>(Crimps per End)</th> </tr> </thead> <tbody> <tr> <td>Y35</td> <td>UK840</td> <td>(4)</td> </tr> <tr> <td>Y750*</td> <td></td> <td></td> </tr> <tr> <td>Y35</td> <td>U249</td> <td>(2)</td> </tr> <tr> <td>Y750*</td> <td></td> <td></td> </tr> </tbody> </table> <p>*Multiple crimp die set, makes more than one crimp per tool compression. Figure indicates number of compressions.</p>	Tool	Die	(Crimps per End)	MD6,	WK-840	(7)	MD7	W-249	(4)	OUR840	X840	(7)	X249	(8)	Tool	Die	(Crimps per End)	Y35	UK840	(4)	Y750*			Y35	U249	(2)	Y750*		
Tool	Die	(Crimps per End)																																			
MD6,	WK-840	(7)																																			
MD7	W-249	(4)																																			
OUR840	X840	(7)																																			
	X249	(8)																																			
Tool	Die	(Crimps per End)																																			
Y35	UK840	(4)																																			
Y750*																																					
Y35	U249	(2)																																			
Y750*																																					
YSD26R2W	2/0	2/0 Str. 3/0 AL Compt	Gray	4	3, 4 Str. 2 Sol. #2 AL Compt	Orange																															
YSD26R2R				2	2 Str. 1 Str. 1/0 AL Compt	Red																															
YSD26R25R				1/0	1/0 Str. 2/0 AL Compt	Yellow																															
YSD26R26R				2/0	2/0 Str. 3/0 AL Compt	Gray																															
YSD27R2W	3/0	3/0 Str. 4/0 AL Compt	Black	4	3, 4 Str. 2 Sol. #2 AL Compt	Orange																															
YSD27R2R				2	2 Str. 1 Str. 1/0 AL Compt	Red																															
YSD27R25R				1/0	1/0 Str. 2/0 AL Compt	Yellow																															
YSD27R26R				2/0	2/0 Str. 3/0 AL Compt	Gray																															
YSD27R27R				3/0	3/0 Str. 4/0 AL Compt	Black																															
YSD28R2W	4/0	4/0 Str. 300 AL Compt	Pink	4	3, 4 Str. 2 Sol. #2 AL Compt	Orange																															
YSD28R2R				2	2 Str. 1 Str. 1/0 AL Compt	Red																															
YSD28R25R				1/0	1/0 Str. 2/0 AL Compt	Yellow																															
YSD28R26R				2/0	2/0 Str. 3/0 AL Compt	Gray																															
YSD28R27R				3/0	3/0 Str. 4/0 AL Compt	Black																															
YSD28R28R				4/0	4/0 Str. 300 AL Compt	Pink																															

H-45

Blue highlighted items are industry standard and most frequently ordered.

TYPES YSS, YCS-R & YDS-AT

HYSPLICE™

For Aluminum, ACSR, 6201, 5005 and Compressed

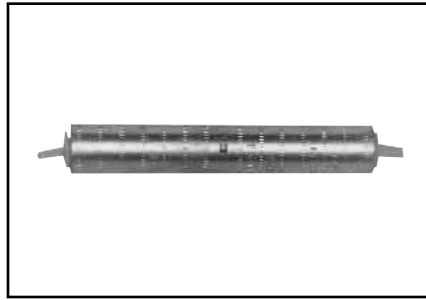

Single aluminum sleeve designed for service drop or short span overhead distribution lines. Installed with OH25 one-hand tool, and other standard tooling. Pre-filled with PENETROX™ joint compound and color coded capped.

H-46

Catalog Number	Conductor	L	Holding Strength Lbs.	Die Index	Color Code	Tools, Die Sets Catalog Number, & (Crimps per End)		OH25 Applications	
						MD7, MD6	Y35, Y750, Y45†, Y46‡	Conductor	OH25 (Indents per End)
YSS6RG2	6 ACSR 4 Sol. Al	4.00	900 700	BG or 5/8	Blue	BG (6) W-BG (3)*	U-BG (3)*	—	—
YSS6R		4.72	900 700	162	Blue	W162 (4)	U162 (2)*	—	—
YDS4WA YDS4CA	4 Sol. Al 4 Str. Al (7)	2.62	750** 700**	162	Orange	W162 (4)	U162 (1)*	—	—
YSS4R	4 ACSR	3.78	1000	BG or 5/8	Orange	BG (6) W-BG (3)*	U-BG (3)*	4 7 Al	(3)
	2 Sol. Al		800					4 5005 Al	(2)
	4 Al (7)		700					4 5005 Al	(3)
YSS2R	2 ACSR	3.78	1600	Red				4 (6-1) ACSR	(3)
	2 Al (7)		1200					4 (6-1) ACSR	(2)
YDS25AT	1/0 Al (7)	7.27	2000	BG, 5/8 or 243	Yellow	BG (12) W-BG (6)*	U-BG (6)*	4 (7-1) ACSR	(3)
YCS25R	1/0 ACSR	7.09	2320					2 Sol. Al	(2)
								2 (7-1) ACSR	(2)
								2 (7-1) ACSR	(2)
								2 7 Al	(3)
								1/0 7 Al	(4)
								1/0 (6-1) ACSR	(2)
								1/0 (6-1) ACSR	(3)

* Multiple crimp die set; makes more than one crimp per tool compression. Figure indicates number of compressions.

** Holding strength values up to 800 lbs. are obtained when HYPRESS™ tools are used for installations.

† U Die with adapter PT-6515
‡ U Die with adapter PUADP-1.

Blue highlighted items are industry standard and most frequently ordered.

TYPE YCS-R

HYSPLICE™

Jumper Sleeve for ACSR,
All Aluminum, 6201, 5005 and
Compressed



RUS Accepted

HYSPLICE™ sleeve designed to withstand jumper loop tensile and vibration stresses. Made of aluminum with staked-in cable stop. Installed with same die as equivalent full-tension sleeves. Pre-filled with PENETROX™ joint compound.

Catalog Number	Conductor		L	Die Index	Tools, Die Set Catalog Number, & (Crimps per End)					
	ACSR, 6201, 5005	All Aluminum			MD7, MD6	Y35, Y750	Y45	Y46	Y48B	Y60BHU
YCS4R	4	4 (7)	5	237	W237 (4)	U237 (2)	†	‡	—	—
YCS2R	2	2 (7)	5	239	W239 (4)	U239 (2)	†	‡	—	—
YCS25R	1/0	1/0 (7, 19)	7-1/8	243	WBG (10) or W243 (6)	UBG (6) or U243 (3)	†	‡	—	—
YCS26R	2/0	2/0 (7, 19)	7	245	W245 (6)	U245 (3)	†	‡	—	—
YCS27R	3/0 110.8 (12-7)	3/0 (7, 19)	5-3/4	247	W247 (6)	U247 (3)	†	‡	—	—
YCS28R	4/0	4/0 (7, 19)	5-3/4	249	W249 (6)	U249 (3)	†	‡	C249 (2)	L249 (2)
YCS30R	266.8 (6/7, 18/1, 26/7)	266.8	6.47	251	W251 (10)	U251 (6)	†	‡	C251 (3)	L251 (3)
YCS321R	336.4 (18-1) 300	336.4 (19)	6-1/2	490	—	U490 (5)	†	‡	C490 (3)	L490 (3)
YCS33R	336.4 (26-7, 30-7)	397.5 (19)	8-3/4	316	—	U316 (6)	†	‡	C316 (2)	L316 (2)
YCS35R	397.5 (18-1, 26-7, 30-7)	477 (19, 37) 500 (37, 61)	8-7/8	317	—	U317 (6)	†	‡	C317 (2)	L317 (2)
YCS361R	477 (18-1)	500 (37, 61)	8-1/4	327	—	U327 (6)	†	‡	C327 (2)	L327 (2)
YCS37R	477 (24-7, 26-7, 30-7) 556.5 (18-1)	556.5 (19, 37)	8-3/4	261	—	U261 (6)	†	‡	C261 (2)	L261 (2)
YCS39R	556.5 (24-7, 26-7)	—	10-3/4	608	—	U608 (9)	†	‡	C608 (3)	L608 (3)
YCS43R	605 (30-19) 636 (24-7, 26-7, 30-19) 666.6 (24-7, 54-7)	795 (37)	10-5/8	292 or 319	—	—	S292 (9) S319 (9)	P292 (9) P319 (9)	C292 (3) C319 (3)	L292 (3) L319 (3)
YCD453R	795 (36-1, 45-7)	—	10-5/8	292	—	—	S292 (9)	P292 (9)	C292 (3)	L292 (3)
YCS45R	795 (26-7, 54-7)	900 (61, 91)	10-5/8	352	—	—	S352 (9)	P352 (9)	C352 (3)	L352 (3)

† U Die with adapter PT-6515
‡ U Die with adapter PUADP-1.

H-47

Blue highlighted items are industry standard and most frequently ordered.

TYPE YCS-RL

UNISPLICE™

Jumper Sleeve for ACSR, All Aluminum 6201, 5005 Compressed and Compact Conductors

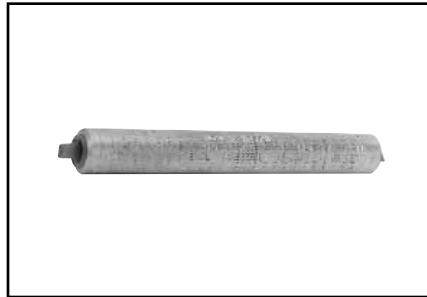

Aluminum jumper sleeve, with cable stop, designed to be installed with same dies as equivalent full-tension UNISPLICE™. Withstands jumper loop-tensile and vibration stresses. Pre-filled with PENETROX™ joint compound and capped.

H-48

Catalog Number	Conductor †††	L	Die Index	Tools, Die Set Catalog Number, & (Crimps per End)	
				MD7, MD6	Y35, Y750, Y45†, Y46‡
YCS25RL	1/0 ACSR (6-1)	6-1/4	C or 247 or 702	W-C (12)	—
	1/0 6201 (7)			—	U247 (3)
	1/0 5005 (7)			W702 (4)	—
	1/0 AAC (7)			NON-BOW*	—
YCS26RL	2/0 ACSR (6-1)	5-5/8	659	—	U659 (3)
	2/0 6201 (7)			—	—
	2/0 5005 (7)			—	—
	2/0 AAC (7)			—	—
YCS28RL	4/0 ACSR (6-1)	5-1/4	654	—	U654 (3)
	4/0 6201 (7)			—	—
	4/0 5005 (7)			—	—
	4/0 AAC (7)			—	—
YCS321RL	336.4 ACSR (18-1)	5-1/4	655	—	U655 (3)
	336.4 AAC (19)			—	—
YCS341RL	397.5 AAC (19)	5-5/8	327	—	U327 (4)
	397.5 ACSR (18-1)			—	—
	400 AAC (37, 61)			—	—
	336.4 ACSR (18-1, 26-7, 30-7)			—	—

* MD6 NON-BOW Dies produce straight sleeves without rotating tool.
 † U Die with adapter PT-6515
 ‡ U Die with adapter PUADP-1.
 ††† Accommodates ACSR with aluminized steel core.

Blue highlighted items are industry standard and most frequently ordered.

TYPE YCS-A

JUMPER SLEEVE

For All Aluminum, Compressed and Compact Conductors



HYSPLICE™ sleeve designed to withstand jumper loop tensile and vibration stresses. Made of aluminum with staked-in cable stop. Installed with same die as equivalent full-tension sleeve. Pre-filled with PENETROX™ joint compound and capped.

Catalog Number	Conductor	L	Die Index	Tools, Die Set Catalog Number, & (Crimps per End)					
				MD7, MD6	Y35, Y750	Y45	Y46	Y48B	Y60BHU
YCS26A	2/0 (7)	5-1/8	245	W245 (4)	U245 (2)	†	‡	—	—
YCS28A	4/0 (7, 19)	4	249	W249 (4)	U249 (2)	†	‡	C249 (1)	L249 (1)
YCS301A	336.4 (19, 37)	4-3/8	321	—	U321 (3)	†	‡	C321 (2)	L321 (2)
YCS311A	397.5 (19)	5-5/8	468	—	U468 (4)	†	‡	—	—
YCS331A	477 (19, 37, 61)	6-14	317	—	U317 (6)	†	‡	C317 (2)	L317 (2)
YCS331A	500 (19, 37, 61)	6-1/4	317	—	U317 (6)	†	‡	C317 (2)	L317 (2)
YCS351A	556.5 (19, 37)	8-3/4	261	—	U261 (6)	†	‡	C261 (2)	L261 (2)
YCS361A	636 (37)	7-3/8	469	—	—	S469 (6)	P469 (6)	C469 (2)	L469 (2)
YCS391A	795 (37, 61)	10-1/2	342	—	—	S342 (9)	P342 (9)	C342 (3)	L342 (3)

† U Die with adapter PT-6515
‡ U Die with adapter PUADP-1.

H-49

TYPE YCR

JUMPER SLEEVE REDUCER

For Copper Conductors

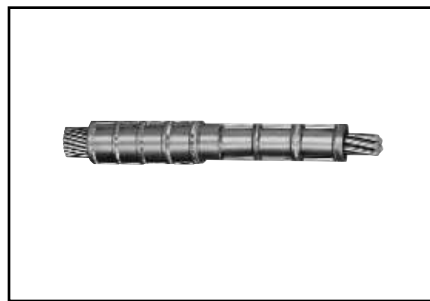

Copper sleeve designed to join different size copper conductors on transmission jumper applications. Installed with same dies as full-tension sleeves.

Catalog Number	Copper Conductor		L	Tools, Die Set Catalog Number, & (Crimps per End)					Tools, Die Set Catalog Number, & (Crimps per End)				
				Die Index	Side A				Die Index	Side B			
	Side A	Side B			MD7, MD6	Y35, Y750, Y45†, Y46‡	Y48B	Y60BHU		MD6	Y35, Y750, Y45†, Y46‡	Y48B	Y60BHU
YCR2625	2/0 (7, 12, 19)	1/0 (7, 19)	3-3/8	166	W166 (6)	U166/U459	C166 (1)	L166 (1)	165	W165 (3)	U165/U205	C165 (1)	L165 (1)
YCR2725	3/0 (7, 19)	1/0 (7, 19)	3-1/2	167	—	U167/U568	C167 (1)	L167 (1)	165	W165 (3)	U165/U205	C165 (1)	L165 (1)
YCR2825	4/0 (7, 12, 19)	1/0 (7, 19)	3-3/8	168	—	U168 (3)	C168 (1)	L168 (1)	165	W165 (3)	U165/205	C165 (1)	L165 (1)

* Multiple crimp die set; makes more than one crimp per tool compression. Figure indicates number of compressions.
† U Die with adapter PT-6515.
‡ U Die with adapter PUADP-1.

Blue highlighted items are industry standard and most frequently ordered.

TYPE YCR-R-G

HYSPLICE™

Jumper Sleeve Reducer for ACSR, AAAC and Aluminum to Copper

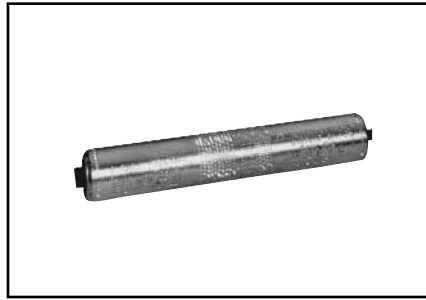

Heavy-walled aluminum sleeve designed to connect all aluminum or ACSR to copper conductors, in all service conditions encountered in transmission and distribution. Sleeve has solid center barrier and is pre-filled with PENETROX™ joint compound and capped.

H-50

Catalog Number	Side A		Side B		L	O.D.	Tools, Die Set Catalog Number, & (Crimps per End)		
	ACSR, 6201, 5005	Aluminum, Copper	ACSR, 6201, 5005	Aluminum, Copper			Die Index	Y35, Y750, Y45†, Y46‡	Y60B
YCR25RG6	1/0 (6-1)	1/0 (7, 12, 19)	1/0 (6-1)	1/0 (7, 12, 19)	6-3/8	1-1/16	654 or 705	U654 U705 Crimps Overlap	L654 — Crimps Overlap
YCR26RG2	2/0 (6-1)	2/0 (7, 12, 19)	1/0 (6-1)	1/0 (7, 12, 19)					
YCR26RG3			2/0 (6-1)	2/0 (7, 12, 19)					
YCR27RG5	3/0 (6-1)	3/0 (7, 12, 19)	1/0 (6-1)	1/0 (7, 12, 19)					
YCR27RG6			2/0 (6-1)	2/0 (7, 12, 19)					
YCR28RG5	4/0 (6-1)	4/0 (7, 12, 19)	1/0 (6-1)	1/0 (7, 12, 19)					
YCR28RG6			2/0 (6-1)	2/0 (7, 12, 19)					
YCR28RG7			3/0 (6-1)	3/0 (7, 12, 19)					
YCR28RG8			4/0 (6-1)	4/0 (7, 12, 19)					
YCR291RG2	266.8 (18-1)	250 (19, 37) 266.8 (7, 12, 19)	2/0 (6-10)	2/0 (7, 12, 19)	7-3/8	1-1/4	317 or 705	U317 U705 Crimps Overlap	L317 — Crimps Overlap
YCR291RG3			3/0 (6-1)	3/0 (7, 12, 19)					
YCR291RG4			4/0 (6-1)	4/0 (7, 12, 19)					
YCR291RG5			266.8 (18-1)	250 (19, 37) 266.8 (7, 12, 19)					
YCR30RG4	266.8 (26-7)	300 (19, 37) 336.4 (19)	1/0 (6-1)	1/0 (7, 12, 19)	7-3/8	1-1/4	317 or 705	U317 U705 Crimps Overlap	L317 — Crimps Overlap
YCR30RG6			3/0 (6-1)	3/0 (7, 12, 19)					
YCR30RG7			4/0 (6-1)	4/0 (7, 12, 19)					
YCR32RG1	336.4 (18-1) (26-7)	350 (19, 37) 397.5 (19)	1/0 (6-1)	1/0 (7, 12, 19)	7-3/8	1-1/4	317 or 705	U317 U705 Crimps Overlap	L317 — Crimps Overlap
YCR32RG2			2/0 (6-1)	2/0 (7, 12, 19)					
YCR32RG3			3/0 (6-1)	3/0 (7, 12, 19)					
YCR32RG4			4/0 (6-1)	4/0 (7, 12, 19)					
YCR32RG5			266.8 (18-1)	250 (19, 37) 266.8 (7, 12, 19)	6-5/8	1-1/4	317 or 705	U317 U705 Crimps Overlap	L317 — Crimps Overlap
YCR32RG6			266.8 (26-7)	300 (19, 37) 336.4 (19)					
YCR32RG7			336.4 (18-1) (26-7)	350 (19, 37) 397.5 (19)					

* Crimps overlap on both ends.
 † U Die with adapter PT-6515
 ‡ U Die with adapter PUADP-1.

Blue highlighted items are industry standard and most frequently ordered.

TYPES YDS & YCS

HYSPLICE™

Jumper Sleeve for
Copper Conductors



Loop HYSPLICE™ connector designed to withstand jumper loop tensile and vibration stresses. Made of pure copper tubing. Installed with standard HYSPLICE™ tools and dies.

RUS Accepted

Catalog Number	Conductor	L	Die Index	Tools, Die Set Catalog Number, & (Crimps per End)			
				MD7, MD6	Y750, Y35, Y45†, Y46‡	Y48B	Y60BHU
YDS8W	8 Sol.	1-5/8	171	W171 (1)	U171 (1)*	—	—
YDS6W	6 Sol.	2-5/8	161	W161 (2)	U161 (1)*	—	—
YDS4W	4 Sol.	2-1/2	162	W162 (4)	U162 (1)*	—	—
YDS2W	2 Sol.	3-3/4	163	W163 (6)	U163 (2)*	—	—
YDS6C	6 (7)	2-3/4	161	W161 (2)	U161 (1)*	—	—
YDS4C	4 (7)	2-5/8	162	W162 (4)	U162 (1)*	—	—
YDS2C	2 (7), 3 (3)	3-5/8	163	W163 (6)	U163 (2)*	—	—
YDS1C	1 (7, 19)	3-1/8	164	W164 (4)	U164 (2)*	—	—
YCS25	1/0 (7, 19)	3-3/8	165	W165 (3)	U165 (3)	—	—
YCS26	2/0 (7, 11, 12, 19)		166	W166 (6)	U166 (3)	—	—
YCS27	3/0 (7, 19)	3-1/4	167	—	U167 (3)	—	—
YCS28	4/0 (7, 12, 19)	3-1/8	168	—	U168 (3)	C168 (1)	L168 (1)
YCS29	250 (7, 19, 37)	3-5/8	169	—	U169 (4)	C169 (2)	L169 (2)
YCS30	300 (19, 37)		170	—	U170 (4)	C170 (1)	L170 (1)
YCS31	350 (12, 19, 37)	5-3/8	267	—	U267 (6)	C267 (2)	L267 (2)
YCS32	400 (19, 37)	5-3/4	209	—	U209 (6)	C209 (2)	L209 (2)
YCS34	500 (19, 37)	5-1/8	210	—	U210 (6)	C210 (2)	L210 (2)
YCS39	750 (37)	6-7/8	627	—	—	C627 (3)	L627 (3)
YCS44	1000 (37, 61)	7-3/4	345	—	—	C345 (4)	L345 (4)

* Multiple crimp die set; makes more than one crimp per tool compression. Figure indicates number of compressions.
 † U Die with adapter PT-6515
 ‡ U Die with adapter PUADP-1.

H-51

TYPE YCU-A

Repair Sleeve for All Aluminum,
Compressed and Compact
Conductors

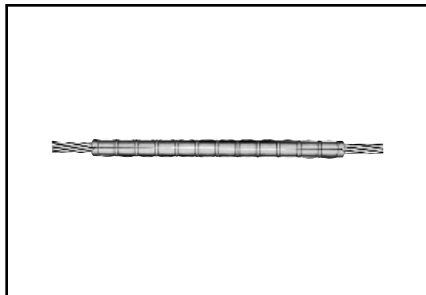

For restoring conductivity to damaged conductors. Made of cast aluminum. Use same die as equivalent full-tension sleeve. Use of PENETROX™ joint compound required.

Catalog Number	Conductor	L	Die Index	Tools, Die Set Catalog Number, & (Number of Crimps)					
				MD7, MD6	Y35, Y750	Y45	Y46	Y48B	Y60BHU
YCU2CA	2 (7)	7-5/8	163	W163 (27)	U163 (9)*	†	‡	—	—
YCU25A	1/0 (7)	8-3/4	243	W243 (20)	U243 (10)	†	‡	—	—
YCU28A	4/0 (7, 19)	11-7/8	249	W249 (28)	U249 (14)	†	‡	C249 (7)	L249 (7)
YCU291A	266.8 (7)	11-5/8	251	—	U251 (20)	†	‡	C251 (10)	L251 (10)
YCU301A	336.4 (19, 37)	11-5/8	321	—	U321 (20)	†	‡	C321 (10)	L321 (10)

* Multiple crimp die set; makes more than one crimp per tool compression. Figure indicates number of compressions.
 † U Die with adapter PT-6515.
 ‡ U Die with adapter PUADP-1.

Blue highlighted items are industry standard and most frequently ordered.

TYPES YCU-R & YOU-R

Repair Sleeve for ACSR and Compressed and Compact Conductors

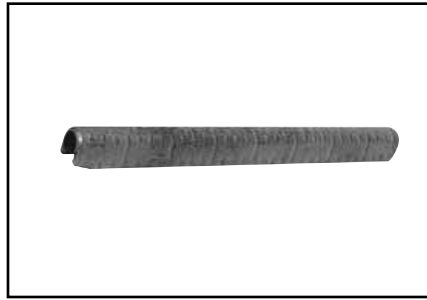

For restoring conductivity to damaged conductors. Made of cast aluminum. Sizes up thru 266.8 are U-shaped. For 300 and larger, sleeves are two-piece interlocking elements. Use same die as equivalent full-tension sleeve. Use of PENETROX™ joint compound required.

H-52

Catalog Number	Conductor	L	Die Index	Tools, Die Set Catalog Number, & (Number of Crimps)					
				MD7, MD6	Y35, Y750	Y45	Y46	Y48B	Y60BHU
YCU4R	4 (6-1, 7-1) 4AAC	6-1/4	237	W237 (12)	U237 (6)	†	‡	—	—
YCU4RG1	4 (7-1)	8-1/4	239	W239 (16)	U239 (8)	†	‡	—	—
YCU2R	2 (6-1, 7-1)					†	‡	—	—
YCU25R	1/0 (6-1)	8-3/4	243	W243 (20)	U243 (10)	†	‡	—	—
YCU26R	2/0 (6-1)	10	245	W245 (24)	U245 (12)	†	‡	—	—
YCU27R	3/0 (6-1)		247	W247 (24)	U247 (12)	†	‡	—	—
YCU28R	4/0 (6-1)	11-7/8	249	W249 (28)	U249 (14)	†	‡	C249 (7)	L249 (7)
YCU30R	266.8 (6-7, 18-1, 26-7)	11-5/8	251	—	U251 (20)	†	‡	C251 (10)	L251 (10)
YCU32R	300 (26-7)	13	316	—	U316 (21)	†	‡	C316 (7)	L316 (7)
YCU321R	336.4 (18-1)	11-5/8	490, 547	—	U490 (20)	†	‡	C490 (10)	L490 (10)
YOU33R	336.4 (26-7, 30-7)	13	316	—	U316 (21)	†	‡	C316 (7)	L316 (7)
YOU35R	397.5 (18-1, 26-7, 30-7)		317, 426	—	U317 (21)	†	‡	C317 (7)	L317 (7)
YOU361R	477 (18-1)		327	—	U327 (21)	†	‡	C327 (7)	L327 (7)
YOU37R	477 (24-7, 26-7, 30-7)		261, 318	—	U261 (21)	†	‡	C261 (7)	L261 (7)
YOU39R	556.5 (24-7, 26-7)		608	—	U608 (24)	†	‡	C608 (8)	L608 (8)
YOU41R	605 (24-7, 54-7)	13-3/4	292, 578	—	—	S292 (24)	P292 (24)	C292 (8)	L292 (8)
YOU43R	605 (30-19)			—	—	S319 (24)	P319 (24)	C319 (8)	L319 (8)
YOU43R	605 (30-19)		319	—	—	S319 (24)	P319 (24)	C319 (8)	L319 (8)
YOU421R	636 (36-1)		292, 578	—	—	S292 (24)	P292 (24)	C292 (8)	L292 (8)
YOU43R	636 (26-7, 30-19)			—	—	—	—	—	—
YOU43R	666.6 (24-7, 54-7)		319	—	—	S319 (24)	P319 (24)	C319 (8)	L319 (8)
YOU453R	715.5 (26-7)		292, 578	—	—	S292 (24)	P292 (24)	C292 (8)	L292 (8)
YOU453R	795 (36-1)		319	—	—	S319 (24)	P319 (24)	C319 (8)	L319 (8)
YOU453R	795 (36-1)		292, 578	—	—	S292 (24)	P292 (24)	C292 (8)	L292 (8)
YOU44R	715.5 (54-7)			—	—	—	—	—	—
YOU44R	715.5 (54-7)		319	—	—	S319 (24)	P319 (24)	C319 (8)	L319 (8)
YOU45R	795 (26-7, 54-7)		352, 579	—	—	S352 (24)	P352 (24)	C352 (8)	L352 (8)
YOU48R	900 (54-7) 954 (54-7)			—	—	—	S579 (24)	P579 (24)	C579 (8)
YOU49R	1033.5 (54-7)	14-1/4	575	—	—	—	—	C575 (10)	L575 (10)
			422	—	—	—	—	—	L422 (10)

† U Die with adapter PT-6515.

‡ U Die with adapter PUADP-1.

TYPE YCU-R

Repair Sleeve for ACSR “Static Wire”

Catalog Number	Conductor	L	Die Index	Tools, Die Set Catalog Number, & (Number of Crimps)			
				MD7, MD6	Y35, Y750, Y45†, Y46‡	Y48B	Y60BHU
YCU27R	110.8 (12-7)	10	247	W247 (24)	U247 (12)	—	—
YCU28R	159 (12-7)	11-7/8	249	W249 (28)	U249 (14)	C249 (7)	L249 (7)
YCU30R	190.8 (12-7)	11-5/8	251	—	U251 (20)	C251 (10)	L251 (10)

† U Die with adapter PT-6515.

‡ U Die with adapter PUADP-1.

Blue highlighted items are industry standard and most frequently ordered.

TYPES YDS-A & YDS-AT

HYSPLICE™

Full Tension Sleeve for All Aluminum Compressed and Compact Conductors



Full-Tension HYSPLICE™ sleeve made of aluminum tubing with staked-in cable stop. Sizes 1/0 and larger tapered for gradual transition of stress. Installed with HYSPLICE™ tools and dies. Pre-filled with PENETROX™ joint compound and capped.

Catalog Number	Conductor	L	Die Index	Tools, Die Set Catalog Number, & (Number of Crimps)					
				MD7, MD6	Y35, Y750	Y45	Y46	Y48B	Y60BHU
YDS6WA	6 Sol.	3	161	W161 (2)	U161 (1)*	†	‡	—	—
YDS4WA	4 Sol.	2-5/8	162	W162 (4)	U162 (1)*	†	‡	—	—
YDS2WA	2 Sol.	3-7/8	163	W163 (6)	U163 (2)*	†	‡	—	—
YDS6CA	6 (7)	3	161	W161 (2)	U161 (1)*	†	‡	—	—
YDS4CA	4 (7)	2-5/8	162	W162 (4)	U162 (1)*	†	‡	—	—
YDS2CA	2 (7)	3-7/8	163	W163 (6)	U163 (2)*	†	‡	—	—
YDS25AT	1/0 (7)	7-1/4	BG or 243	BG (12) or W243 (6)	BG (3) or U243 (3)	†	‡	—	—
YDS26AT	2/0 (7)	9-1/4	245	W245 (8)	U245 (4)	†	‡	—	—
YDS27AT	3/0 (7, 19)	7-1/4	247	W247 (8)	U247 (4)	†	‡	C247 (2)	L247 (2)
YDS28AT	4/0 (7, 19)	10-1/2	249	W249 (12)	U249 (6)	†	‡	C249 (3)	L249 (3)
YDS29AT	250 (19)	7-1/2	616	—	U616 (6)	†	‡	—	—
YDS291AT	266.8 (7, 19)	8-5/8	251	—	U251 (7)	†	‡	C251 (4)	L251 (4)
YDS301AT	336.4 (19, 37)	9-7/8	321	—	U321 (8)	†	‡	C321 (4)	L321 (4)
YDS31AT	350 (19)	11	490	—	U490 (9)	†	‡	C490 (5)	L490 (5)
YDS311AT	397.5 (19)	12-1/4	468	—	U468 (10)	†	‡	—	—
YDS331AT	477 (19)	12-3/4	317	—	U317 (9)	†	‡	C317 (3)	L317 (3)
YDS351AT	556.5 (19, 37)		261	—	U261 (9)	†	‡	C261 (3)	L261 (3)
YDS361AT	636 (37)		469	—	—	S469 (12)	P469 (8)	C469 (4)	L469 (4)
YDS391AT	795 (37, 800 (61))	13-5/8	342	—	—	S342 (8)	P342 (8)	C342 (4)	L342 (4)
YDS431AT	954 (37, 61)	17-5/8	352	—	—	S352 (10)	P352 (10)	C352 (5)	L352 (5)

* Multiple crimp die set; makes more than one crimp per tool compression. Figure indicates number of compressions.

† U Die with adapter PT-6515.

‡ U Die with adapter PUADP-1.

H-53

Blue highlighted items are industry standard and most frequently ordered.

TYPES YDS & YDS-C

HYSPLICE™

Full Tension Sleeve for Stranded Copper Conductors



Made of pure copper tubing. Designed to develop the full rated breaking strength of hard drawn or medium hard drawn copper conductor. Installed with standard tooling.

H-54

Catalog Number	Stranded Conductor	L	Die Index	Tools, Die Set Catalog Number, & (Number of Crimps)			
				MD7, MD6	Y35, Y750, Y45†, Y46‡	Y48B	Y60BHU
YDS6C	6 (7)	2-3/4	161	W161 (2)	U161 (1)*	—	—
YDS4C	4 (7)	2-5/8	162	W162 (4)	U162 (1)*	—	—
YDS3C-3	3 (3)	5-1/4	163	W163 (9)	U163 (3)*	—	—
YDS2C	2 (7)	3-5/8	163	W163 (6)	U163 (2)*	—	—
YDS2C-3	2 (3)	3-5/8	163	W163 (6)	U163 (2)*	—	—
YDS1C	1 (7, 19)	4-1/4	164	W164 (6)	U164 (3)*	—	—
YDS1C-3	1 (3)	6-1/4	459	—	U459 (6)	—	—
YDS25	1/0 (7, 19)	5-3/8	165	W165 (6)	U165/U205 (6)	—	—
YDS26	2/0 (7, 12, 19)	6	166	W166 (12)	U166/U459 (6)	—	—
YDS27	3/0 (7, 19)	6-3/4	167	—	U167/U568 (7)	—	—
YDS28	4/0 (7, 12, 19)	6-7/8	168	—	U168 (9)	C168 (3)	L168 (3)
YDS29	250 (7, 19, 37)	7-1/2	169	—	U169 (9)	C169 (3)	L169 (3)
YDS30	300 (19, 37)	8-1/8	170	—	U170 (13)	C170 (3)	L170 (3)
YDS31	350 (12, 19, 37)	10-1/4	267	—	U267 (12)	C267 (4)	L267 (4)
YDS32	400 (19, 37)	12-3/4	209	—	U209 (15)	C209 (5)	L209 (5)
YDS34	500 (19, 37)	11-5/8	210	—	U210 (15)	C210 (5)	L210 (5)
YDS39	750 (37)	12-3/4	627	—	—	C627 (7)	L627 (7)
YDS44	1000 (61, 37)	15-1/4	345	—	—	C345 (10)	L345 (10)

* Multiple crimp die set; makes more than one crimp per tool compression. Figure indicates number of compressions.

† U Die with adapter PT-6515.

‡ U Die with adapter PUADP-1.

Blue highlighted items are industry standard and most frequently ordered.

TYPES YDS-W & YDS

HYSPLICE™

Full Tension Sleeve for Solid Copper Conductors

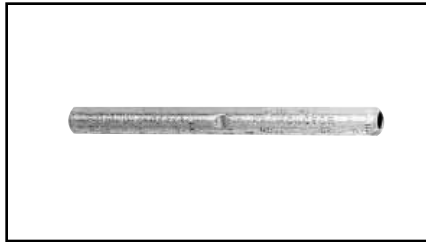

YDS-W is designed to develop full rated breaking strength of hard drawn and medium hard drawn solid copper conductor. Made of pure copper tubing. Installed with standard tooling.

RUS Accepted

Catalog Number	Solid Conductor	L	Die Index	Tools, Die Set Catalog Number, & (Crimps per End)			
				MD7, MD6	Y35, Y750, Y45†, Y46‡	Y48B	Y60BHU
YDS8WG1	8	1-7/8	161	W161 (1)	U161 (1)	—	—
YDS8W	8	1-1/2	171	W171 (1)	U171 (1)*	—	—
YDS6W	6	2-5/8	161	W161 (2)	U161 (1)*	—	—
YDS4W	4	2-1/2	162	W162 (4)	U162 (1)*	—	—
YDS3W	3	2-7/8	163 or 308	W163 (4) —	U163 (1)* U308 (2)*	—	—
YDS2W	2	3-3/4	163	W163 (6)	U163 (2)*	—	—
YDS1W	1	5-7/8	164	W164 (8)	U164 (4)*	—	—
YDS75	1/0	6-1/4	165	W165 (6)	U165/U205 (6)	—	—
YDS76	2/0	6-5/8	166	W166 (12)	U166/U459 (6)	—	—
YDS78	4/0	7-7/8	168	—	U168 (9)	C168 (3)	L168 (3)

* Multiple crimp die set; makes more than one crimp per tool compression. Figure indicates number of compressions.

† U Die with adapter PT-6515.

‡ U Die with adapter PUADP-1.

H-55

Blue highlighted items are industry standard and most frequently ordered.

**TYPES YDS-R SET,
YDS-RP1
(Aluminum Sleeve)
YDS-RP2
(Steel Sleeve)**

HYSPLICE™

Full Tension Sleeve for ACSR,
Compressed and Compact
Conductors

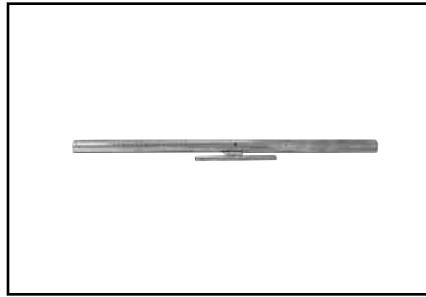

RUS Accepted

H-56

Two-piece, full tension HYSPLICE™, consists of aluminum outer sleeve and steel inner sleeve. Tapered outer sleeve provides gradual transition of stress. Filler holes provided for PENETROX™ joint compound. Sizes 1/0 and larger supplied with plugs for filler hole. Installed with standard HYSPLICE™ tools and dies (thru 556 with Y35 or Y750 HYPRESS™). Aluminum and steel sleeves can be ordered separately or in sets.

Catalog Number		Conductor	L	Die Index	Tools, Die Set Catalog Number, & (Crimps per End)				
Set	Sleeves				MD7, MD6	Y35, Y750, Y45†, Y46‡	Y48B	Y60BHU	
YDS021R	Steel	YDS25RP2	2 (7-1)	4-3/4 17	242	W242 (8)	U242 (4)	—	—
	Alum.	YDS021RP1				W241 (10)	U241 (5)		
YDS1R	Steel	YDS1RP2	1 (6-1)	4-1/8 16-5/8	240	W240 (6)	U240 (3)	—	—
	Alum.	YDS1RP1				W241 (10)	U241 (5)		
YDS25R	Steel	YDS25RP2	1/0 (6-1)	4-3/4 17	242	W242 (8)	U242 (4)	—	—
	Alum.	YDS25RP1				W243 (10)	U243 (5)		
YDS26R	Steel	YDS26RP2	2/0 (6-1)	5-1/4 19-3/4	242	W242 (8)	U242 (4)	—	—
	Alum.	YDS26RP1				W245 (12)	U245 (6)		
YDS27R	Steel	YDS27RP2	3/0 (6-1)	5-1/4 16-3/4	248	W246 (16)	U248 (8)	C248 (3)*	L248 (3)*
	Alum.	YDS27RP1				W247 (12)	U247 (6)	C247 (2)*	L247 (2)*
YDS28R	Steel	YDS28RP2	4/0 (6-1)	5-1/8 18-7/8	248	W248 (14)	U248 (7)	C248 (2)*	L248 (2)*
	Alum.	YDS28RP1				W249 (14)	U249 (7)	C249 (4)	L249 (4)
—	Steel	YDS1RP2	266.8 (18-1)	4-1/8 19-3/4	240	W240 (6)	U240 (3)	—	—
	Alum.	YDS291RP1				—	U251 (12)		
YDS30R	Steel	YDS30RP2	266.8 (26-7)	6 19-3/4	250	—	U250 (10)	C250 (8)	L250 (8)
	Alum.	YDS30RP1				—	U251 (10)	C251 (5)	L251 (5)
YDS321R	Steel	YDS25RP2	336.4 (18-1)	4-3/4 17-7/8	242	W242 (8)	U242 (4)	C242 (2)*	L242 (2)*
	Alum.	YDS321RP1				—	U490 (10)	C490 (5)	L490 (5)
YDS32R	Steel	YDS32RP2	336.4 (26-7)	6-7/8 22-1/4	252	—	U252 (9)	C252 (3)	L252 (3)
	Alum.	YDS33RP1				—	U316 (9)	C316 (3)	L316 (3)
YDS33R	Steel	YDS41RP2	336.4 (30-7)	8-5/8 22-1/4	305	—	U305 (9)	C305 (3)	L305 (3)
	Alum.	YDS33RP1				—	U316 (9)	C316 (3)	L316 (3)
YDS34R	Steel	YDS34RP2	397.5 (26-7)	6-1/4 25-5/8	253	—	U253 (9)	C253 (3)	L253 (3)
	Alum.	YDS35RP1				—	U317 (12)	C317 (4)	L317 (4)
YDS35R	Steel	YDS44RP2	397.5 (30-7)	8 25-5/8	255	—	U255 (12)	C255 (4)	L255 (4)
	Alum.	YDS35RP1				—	U317 (12)	C317 (4)	L317 (4)
YDS361R	Steel	YDS27RP2	477 (18-1)	5-1/4 25-3/8	248	W248 (16)	U248 (8)	C248 (4)*	L248 (4)*
	Alum.	YDS361RP1				—	U327 (16)	C327 (4)	L327 (4)
YDS326R	Steel	YDS34RP2	477 (24-7)	6-1/4 26-3/8	253	—	U253 (9)	C253 (3)	L253 (3)
	Alum.	YDS37RP1				—	U261 (12)	C261 (4)	L261 (4)
YDS36R	Steel	YDS36RP2	477 (26-7)	7-7/8 26-3/8	350	—	U350 (12)	C350 (4)	L350 (4)
	Alum.	YDS37RP1				—	U261 (12)	C261 (4)	L261 (4)

* Multiple crimp die set; makes more than one crimp per tool compression. Figure indicates number of compressions.
 † U Die with adapter PT-6515.
 ‡ U Die with adapter PUADP-1.

Blue highlighted items are industry standard and most frequently ordered.

**TYPES YDS-R SET,
YDS-RP1
(Aluminum Sleeve)
YDS-RP2
(Steel Sleeve)
(Continued)**

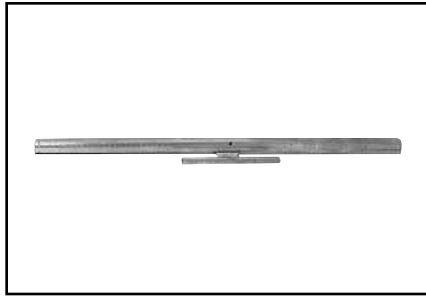

Full Tension Sleeve for ACSR and Compressed and Compact Conductors RUS Accepted

Catalog Number		Conductor	L	Die Index	Tools, Die Set Catalog Number, & (Crimps per End)						
Set	Sleeves				MD7, MD6	Y35, Y750	Y45	Y46	Y48B	Y60BHU	
YDS392R	Steel	YDS41RP2	556.5 (24-7)	8-5/8	305	—	U305 (9)	†	‡	C305 (3)	L305 (3)
	Alum.	YDS39RP1		26-1/8	608	—	U608 (15)	†	‡	C608 (5)	L608 (5)
—	Steel	YDS44RP2	556.5 (26-7)	8	255	—	U255 (12)	†	‡	C255 (4)	L255 (4)
	Alum.	YDS39RP1		26-1/8	608	—	U608 (15)	†	‡	C608 (5)	L608 (5)
—	Steel	YDS43RP2	636 (24-7)	8	254	—	—	S254 (15)	P254 (15)	C254 (5)	L254 (5)
	Alum.	YDS43RP1		32-1/2	319	—	—	S319 (18)	P319 (18)	C319 (6)	L319 (6)
YDS43R45RS	Steel	YDS45RP2	636 (26-7)	9	320	—	—	S320 (15)	P320 (15)	C320 (5)	L320 (5)
	Alum.	YDS43RP1		32-1/2	319	—	—	S319 (18)	P319 (18)	C319 (6)	L319 (6)
YDS43R43RS	Steel	YDS43RP2	666.6 (24-7)	8	254	—	—	S254 (15)	P254 (15)	C254 (5)	L254 (5)
	Alum.	YDS43RP1		32-1/2	319	—	—	S319 (18)	P319 (18)	C319 (6)	L319 (6)
YDS451R49RS	Steel	YDS49RP2	795 (26-7)	10	419	—	—	S419 (21)	P419 (21)	C419 (7)	L419 (7)
	Alum.	YDS451RP1		32-1/2	579	—	—	S579 (18)	P579 (18)	C579 (6)	L579 (6)
YDS45R45RS	Steel	YDS45RP2	795 (54-7)	9	320	—	—	S320 (15)	P320 (15)	C320 (5)	L320 (5)
	Alum.	YDS45RP1		32-1/2	352	—	—	S352 (18)	P352 (18)	C352 (6)	L352 (6)
YDS451R34RS	Steel	YDS34RP2	900 (45-7)	6-1/4	253	—	U253 (9)	†	‡	C253 (3)	L253 (3)
	Alum.	YDS451RP1		32-1/2	579	—	—	S579	P579	C579 (6)	L579 (6)
—	Steel	YDS49RP2	1033.5 (54-7)	10	419	—	—	—	—	C419 (7)	L419 (7)
	Alum.	YDS49RP1		37	422	—	—	—	—	—	L422 (8)
—	Steel	YDS36RP2	1113 (45-7)	7-7/8	350	—	U350 (12)	†	‡	C350 (4)	L350 (4)
	Alum.	YDS49RP1		37	422	—	—	—	—	—	L422 (8)

*† U Die with adapter PT-6515.
‡ U Die with adapter PUADP-1.

FOR ACSR “STATIC” WIRE

Catalog Number		Conductor	L	Die Index	Tools, Die Set Catalog Number, & (Crimps per End)				
Set	Sleeves				MD7, MD6	Y35, Y750, Y45†, Y46‡	Y48B	Y60BHU	
YDS011R	Steel	YDS27RP2	80 (1-8)	5-1/4	248	W248 (16)	U248 (8)	—	—
	Alum.	YDS011RP1		19-3/4	245	W245 912)	U245 (6)	—	—
YDS251R	Steel	YDS34RP2	101.8 (12-7)	6-1/4	253	—	U253 (9)	C253 (3)	L253 (3)
	Alum.	YDS251RP1		22-1/4	316	—	U316 (9)	C316 93)	L316 (3)
YDS261R	Steel	YDS41RP2	134.6 (12-7)	8-5/8	305	—	U305 (9)	C305 (3)	L305 (3)
	Alum.	YDS261RP1		22-1/4	316	—	U316 (9)	C316 (3)	L316 (3)
YDS271R	Steel	YDS44RP2	159 (12-7)	8	255	—	U255 (12)	C255 (4)	L255 (4)
	Alum.	YDS271RP1		25-5/8	317	—	U317 (12)	C317 (4)	L317 (4)

† U Die with adapter PT-6515.
‡ U Die with adapter PUADP-1.

Blue highlighted items are industry standard and most frequently ordered.

TYPE YDS-RLY

UNISPLICE™ SINGLE-SLEEVE

Tension Single Sleeve for ACSR, Aluminum, 6201 and 5005

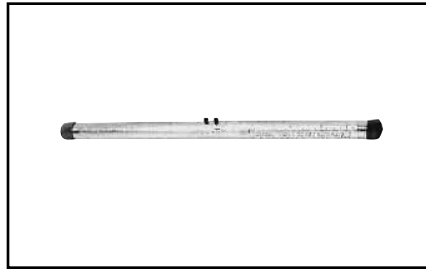

Single sleeve splice similar to UNISPLICE™ type YDS-RL, except designed to eliminate possible conductor basketing on ACSR. Installed by *crimping from end of connector towards center* with standard tooling. Supplied pre-filled with PENETROX™ joint compound and capped. Factory installed plugs in pressure relief holes must be in place when conductors are inserted. Plugs drop out when sleeve is crimped.

RUS Accepted

H-58

Catalog Number	Conductor †††	L	Die Index	Tools, Die Set Catalog Number, & (Crimps per End)			
				MD7, MD6	Y35, Y750, Y45†, Y46‡	Y48B	Y60BHU
YDS4RLY	4 ACSR (7-1) 4 ACSR (6-1) 4 6201 (7) 4 5005 (7) 4 AAC (7)	12-1/2	BG, or 687, or 243	BG (24)	U-BG (8)*	—	—
				W-BG (12)*	—	—	—
				Non-Bow**	—	—	—
				—	U243 (6)	C243 (3)	L243 (3)
YDS2RLY	2 ACSR (6-1) 2 6201 (7) 2 5005 (7) 2 AAC (7)	12-3/8	BG, or 687, or 243	BG (20)	U-BG (8)*	—	—
				W-BG (10)*	—	—	—
				W687 (10)	—	—	—
				Non-Bow**	—	—	—
YDS021RLY	2 ACSR (7-1) 2 ACSR (6-1) 2 6201 (7) 2 AAC (7)	14-3/8	C, or 167, or 247, or 702	W-C (28)	—	—	—
				—	U167 (14)	C167 (7)	L167 (7)
				—	U247 (7)	—	—
				W702 (11)	—	—	—
				Non-Bow*	—	—	—
YDS25RLY	1/0 ACSR (6-1) 1/0 6201 (7) 1/0 5005 (7) 1/0 AAC (7)	17	C, or 660, or 167, or 247, or 702	W-C (32)	—	—	—
				W660 (16)	U660 (8)	—	—
				—	U167 (16)	C167 (5)	L167 (5)
				—	U247 (8)	—	—
				W702 (12)	—	—	—
YDS26RLY	2/0 ACSR (6-1) 2/0 6201 (7) 2/0 5005 (7) 2/0 AAC (7)	15	659	—	U659 Crimps Overlap	—	—
				—	—	—	—
YDS27RLY	3/0 ACSR (6-1) 3/0 6201 (7) 3/0 5005 (7) 3/0 AAC (7)	21	658	—	U658 Crimps Overlap	—	—
				—	—	—	—
YDS28RLY	4/0 ACSR (6-1) 4/0 6201 (7) 4/0 5005 (7) 4/0 AAC (7)	21	654	—	U654 Crimps Overlap	—	—
				—	—	—	—
YDS321RLY	336.4 ACSR (18-1) 336.4 AAC (19)	20-1/2	655	—	U655 Crimps Overlap	—	—
				—	—	—	—

* Multiple crimp die set; makes more than one crimp per tool compression. Figure indicates number of compressions.

‡ U Die with adapter PUADP-1.

† U Die with adapter PT-6515.

** MD6 NON-BOW Dies produce straight sleeves without rotating tool.

††† Accommodates ACSR with aluminized steel core.

Blue highlighted items are industry standard and most frequently ordered.

TYPES YDS-RL & YDS-LT

UNISPLICE™

Tension Single Sleeve for ACSR, All Aluminum, 5005, 6201, Compressed Conductors

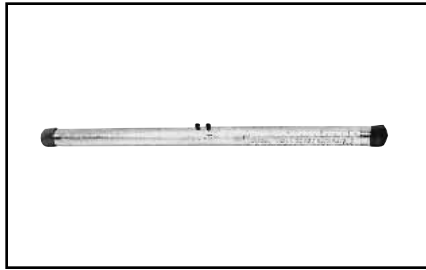

RUS Accepted

Single-sleeve aluminum UNISPLICE™ designed to splice ACSR as simply as all-aluminum. Pre-filled with PENETROX™ joint compound and capped. Eliminates strand stripping, installing separate steel sleeve and filling with joint compound. Ends ACSR joint

failure due to faulty positioning of sleeve and lack of joint compound. Simplifies hot-line splicing. Electrical and mechanical performance equal to two-piece sleeves.

Catalog Number	Conductor †††	L	Die Index	Tools, Die Set Catalog Number, & (Crimps per End)			
				MD7, MD6	Y35, Y750, Y45†, Y46‡	Y48B	Y60BHU
YDS4RL	4 ACSR (7-1)	11-7/8	BG, or 243, or 687	BG (24)	U-BG (8)*	—	—
	4 ACSR (6-1)			W-BG (12)*	—	—	
	4 6201 (7)			W243 (12)	U243 (6)	C243 (3)	L243 (3)
	4 5005 (7)			W687 (12)	—	—	—
	4 AAC (7)			Non-Bow**	—	—	—
YDS2RL	2 ACSR (6-1) (7-1)	10-1/4	BG, or 243, or 687	BG (20)	U-BG (8)*	—	—
	2 6201 (7)			W-BG (10)*	—	—	
	2 5005 (7)			W243 (10)	U243 (5)	C243 (3)	L243 (3)
	2 AAC (7)			W687 (10)	—	—	—
				Non-Bow**	—	—	—
YDS021RL	2 ACSR (7-1)	11-1/4	C, or 167, or 247, or 702	W-C (28)	—	—	—
	2 ACSR (6-1)			—	U167/U568 (16)	C167 (7)	L167 (7)
	2 6201 (7)			W247 (14)	U247 (7)	—	—
	2 AAC (7)			W702 (11)	—	—	—
				Non-Bow**	—	—	—
YDS25RL	1/0 ACSR (6-1)	13-7/8	C, or 167, or 660, or 247, or 702	W-C (32)	—	—	—
	1/0 6201 (7)			—	U167/U568 (14)	C167 (5)	L167 (5)
	1/0 5005 (7)			W660 (16)	U660 (8)	—	—
	1/0 AAC (7)			—	U247 (8)	—	—
				W702 (12)	—	—	—
	Non-Bow**	—	—	—			
YDS26RL	2/0 ACSR (6-1) 2/0 6201 (7) 2/0 5005 (7) 2/0 AAC (7)	13-1/2	659	—	U659 Crimps Overlap	—	—
YDS27RL	3/0 ACSR (6-1) 3/0 6201 (7) 3/0 5005 (7) 3/0 AAC (7)	18-1/4	658	—	U658 Crimps Overlap	—	—
YDS28RL	4/0 ACSR (6-1) 4/0 6201 (7) 4/0 5005 (7) 4/0 AAC (7)	18-1/4	654	—	U654 Crimps Overlap	—	—
YDS321RL	336.4 ACSR (18-1) 336.4 AAC (19) 350 AAC	18-1/4	655	—	U655 Crimps Overlap	—	—

H-59

* Multiple crimp die set; makes more than one crimp per tool compression. Figure indicates number of compressions.
 ** MD6 NON-BOW Dies produce straight sleeves without rotating tool.

‡ U Die with adapter PUADP-1.
 † U Die with adapter PT-6515.
 †† Accommodates compact conductor.
 ††† Accommodates ACSR with aluminized steel core.

Blue highlighted items are industry standard and most frequently ordered.

TYPES YDS-RL & YDS-LT (Continued)

UNISPLICE™

Tension Single Sleeve for ACSR, All Aluminum, 5005, 6201, Compressed Conductors

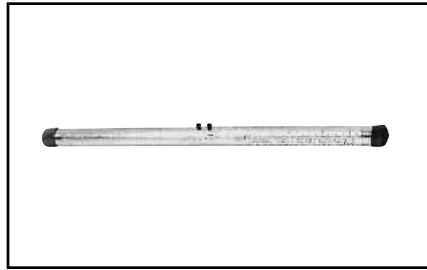

RUS Accepted

H-60

Catalog Number	Conductor	Code	L	Die Index	Tools, Die Set Catalog Number, & (Crimps per End)			
					MD7, MD6	Y35, Y750, Y45†, Y46‡	Y48B	Y60BHU
YDS30LT	312.8 6201	BUTTE		317		U317	C317	L317
YDS32LT	394.5 6201 394.5 5005 (336.4 E.C. Equiv.)	CANTON RADIANT	14-1/2	642	—	U642 (12)	C642 (4)	L642 (4)
YDS341RL	397.5 ACSR (18-1) 419.6 5005	REDE	22	327	—	U327 (18)	—	—
YDS361RL	477 (18-1) 556.5 (18-1) 587.2 5005	RUBLE	23-1/4	788 720	—	U-788 Crimps Overlap	—	L720 Crimps Overlap
YDS36LT	559.5 6201 559.5 5005 (477 E.C. Equiv.)	DARIEN REMEX	16	667	—	P667**	C667 Crimps Overlap	L667 Crimps Overlap

** Y46 HYPRESS™ only.

TYPES YDS-A & YDS-AT

HYSPLICE™

Full Tension Sleeve for Aluminum (Installed with BURNDY® or EEI Dies)

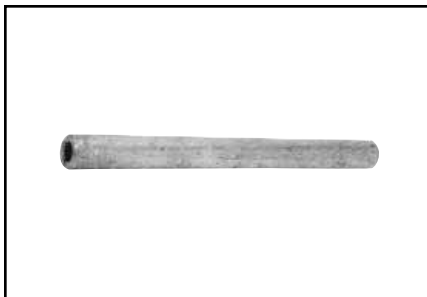

Full-tension HYSPLICE™ sleeve made of aluminum and with cable stop. Designed to be installed with BURNDY® or EEI dies. BURNDY® and EEI die index numbers clearly marked on sleeve. Sizes 1/0 and larger tapered for gradual transition of stress. Pre-filled with PENETROX™ joint compound and capped.

Catalog Number	Conductor	L	EEI Die Index	Index	Tools, Die Set Catalog Number, & (Crimps per End)	
					MD7, MD6	Y35, Y750, Y45†, Y46‡
YDS2CA	2 (7)	3-7/8	6A	693	W693 (8)	U693 (2)
YDS25AT	1/0 (7)	7-1/4	8A	243	W243 (6)	U243 (3)
YDS27AT	3/0 (7, 19)	7-1/4	10A	694	W694 (8)	U694 (4)
YDS28AT	4/0 (7, 19)	10-1/2	11A	249	W249 (12)	U249 (6)
YDS311AT	397.5 (19)	12-1/4	13A	655	—	U655 (10)
YDS331AT	477 (19)	12-3/4	14A	317	—	U317 (9)

† U Die with adapter PT-6515.
‡ U Die with adapter PUADP-1.

Blue highlighted items are industry standard and most frequently ordered.

TYPES YDS-R & YDS-RE

HYSPLICE™

Full Tension Sleeve for ACSR
(Installed with BURNDY®
EEI Dies)

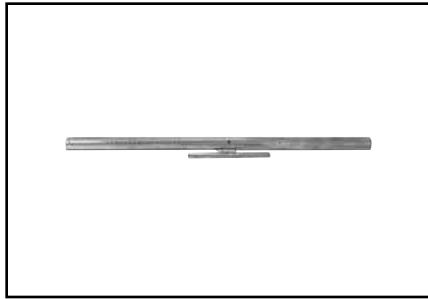

Two-piece, full-tension HYSPLICE™, made of aluminum outer sleeve and steel sleeve for steel core. Designed to be installed with BURNDY® EEI dies. BURNDY® and EEI die index numbers are clearly marked on the sleeve.

Catalog Number Alum. & Steel Sleeve Set	Catalog Number Aluminum Sleeve	CONDUCTOR	Aluminum Outer Sleeve					Catalog Number Steel Sleeve	Steel Inner Sleeve				
			L	EEI Die Number	Die Index	Tools, Die Set Catalog No., & (Crimps per End)			LL	EEI Die Number	Die Index	Tools, Die Set Catalog No., & (Crimps per End)	
						MD6	Y35, Y750, Y45†, Y46‡					MD6	Y35, Y750, Y45†, Y46‡
YDS2RE	YDS021REP1	2 (6-1)	17-1/8	6A	693	W693 (20)	U693 (5)	YDS2REP2	4-1/8	1S	690	W690 (8)	U690 (4)
YDS021RE	—	2 (7-1)		8A	243	W243 (10)	U243 (5)	YDS25REP2	4-3/4	2S	691	W691 (9)	U691 (3)
—	YDS25RP1	1/0 (6-1)		19-3/4	9A	245	W245 (12)	U245 (6)	—	5-1/4	4S	692	W692 (12)
—	YDS26RP1	2/0 (6-1)	19-3/4	9A	245	W245 (12)	U245 (6)	—	5-1/4	4S	692	W692 (12)	U692 (6)
YDS27RE	YDS27RP1	3/0 (6-1)	16-3/4	10A	694	W694 (12)	U694 (6)	YDS27RP2	5-1/4	5S	248	W248 (8)	U248 (8)
YDS28RE	YDS28RP1	4/0 (6-1)	18-7/8	11A	249	W249 (14)	U249 (7)	YD28REP2	5-1/4	5S	248	W248 (8)	U248 (8)
—	—	336.4 (18-1)	17-7/8	13A	655	—	U655 (9)	YDS25REP2	4-3/4	2S	691	W691 (9)	U691 (3)
YDS361R	YDS361RP1	477 (18-1)	25-1/2	14A	327	W327	U327 (16)	YDS27RP2	5-1/4	5S	248	W248 (8)	U248 (3)

H-61

† U Die with adapter PT-6515.
‡ U Die with adapter PUADP-1.

TYPES YDS-E, YDS-H, YDS-U

HYSPLICE™

Full Tension Sleeve for Steel



Full-tension HYSPLICE™ sleeves designed for HS, EHS, Utilities (UT) or Siemens-Martin (SM) galvanized steel guy, messenger, and “Static” conductors. Made of hot-dip galvanized seamless milled steel tubing lined with silicone carbide particles.

Catalog Number	Conductor			L	Die Index	Tools, Die Set Catalog Number, & (Crimps per End)		
	Size	Str.	Grade			Y35, Y750, Y45†, Y46‡	Y48B	Y60BHU
YDS250E	1/4	7	EHS	6-3/4	609	U609 (10)	—	—
YDS312H	5/16	7	HS	10-5/8	257	U257 (20)	C257 (5)*	L257 (5)*
YDS312E	5/16	7	EHS	8-1/2	305	U305 (6)	C305 (3)	L305 (3)
YDS375H	3/8	7	HS, UT	9	304	U304 (12)	C304 (4)	L304 (4)
YDS500H	1/2	7	HS	9-5/8	293	—	C293 (6)	L293 (6)

* Multiple crimp die set makes more than one crimp per tool compression. Figure indicates number of compressions.

† U Die with adapter PT-6515.
‡ U Die with adapter PUADP-1.

Blue highlighted items are industry standard and most frequently ordered.

TYPE YDS-K

HYSPLICE™

Full Tension Sleeve
for Copperweld

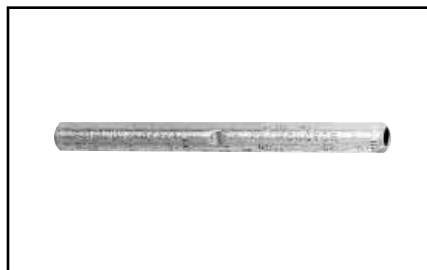

Full-tension HYSPLICE™ designed to exceed the minimum rated breaking strength of, 30% conductivity extra high strength Copperweld, and lower strength conductors. Made of pure copper tubing. Installed with HYSPLICE™ tools and dies.

H-62

Catalog Number	Conductor	L	Die Index	Tools, Die Set Catalog Number, & (Crimps per End)			
				MD7, MD6	Y35, Y750, Y45†, Y46‡	Y48B	Y60BHU
YDS8WK	8 Sol.	3-3/4	162 or 285	W162 (6)	U285 (2)	—	—
YDS6WK	6 Sol.	4-3/8	162 or 276	W162 (6)	U276 (6)	—	—
YDS3K10	(3 #10)	4-7/8	403	—	U403 (3)*	—	—
YDS3K8	(3 #8)	5-5/8	205	—	U205 (5)	—	—
YDS3K7	5/16 (7 #10) (3 #7)	10	167	—	U167/U568 (10)	C167 (4)	L167 (4)
YDS3K6	11/32 (7 #9) (3 #6)	9-1/2	331	—	U331 (9)	C331 (9)	L331 (3)
YDS3K5	3/8 (7 #8) (3 #5)	6-7/8	259	—	U259 (6)	C259 (2)	L259 (2)
YDS7K7	7/16 (7 #7)	6-7/8	328	—	—	C328 (3)	L328 (3)
YDS7K6	1/2 (7 #6)	9-3/8	260	—	—	C260 (4)	L260 (4)
YDS7K5	9/16 (7 #5)	11-3/8	344	—	—	C344 (6)	L344 (6)

* Multiple crimp die set; makes more than one crimp per tool compression. Figure indicates number of compressions.

† U Die with adapter PT-6515.

‡ U Die with adapter PUADP-1.

TYPE YTS-E

Full Tension Splice
for EHS Steel



Full tension splice for EHS steel guy, messenger or “static” cable. Sleeve is pre-filled with PENETROX™ joint compound and capped.

RUS Accepted

Catalog Number	Conductor †	L	Tools, Die Sets	
	EHS Steel		Die Index	Y60BHU*
YTS375E	3/8" 7 Str.	10-3/8	723	L723
YTS438E	7/16" 7 Str.	11-7/8	726	L726

* Overlap crimps.

† Sleeve is high strength aluminum alloy for optimum corrosion resistance.

Blue highlighted items are industry standard and most frequently ordered.

TYPES YDS-KT & YDS-F

HYSPLICE™

Full Tension Sleeve for Copperweld-Copper

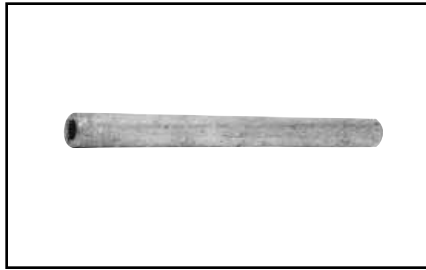

RUS Accepted

Full-tension HYSPLICE™ made of pure copper tubing. Type YDS-KT is tapered to provide gradual transition of stress on Type “A” conductor. HYSPLICE™ Type YDS-F is recommended for Type “F” conductor.

Catalog Number	Conductor	L	Die Index	Tools, Die Set Catalog Number, & (Crimps per End)			
				MD7, MD6	Y35, Y750, Y45†, Y46‡	Y48B	Y60BHU
YDS8KT	8A	5	162 or 202	W162 (4) —	— U202 (4)*	—	—
YDS6KT	6A	6-1/8	162 or 203	W162 (5) —	— U203 (5)*	—	—
YDS4KT	4A	6-3/8	163 or 204	W163 (5) —	— U204 (10)	—	—
YDS2KT	2A	7-3/4	205	—	U205 (8)	—	—
YDS3K6	4D	9-1/2	331	—	U331 (9)	C331 (3)	L331 (3)
YDS2F	2F	6-1/4	329	—	U329 (4)	—	—
YDS25F	1/0F	8-3/4	568	—	U167/U568 (8)	—	—
YDS26F	2/0F	9-5/8	552	—	U552 (11)	—	—
YDS28F	4/0F	11-7/8	331	—	U331 (12)	C331 (4)	L331 (4)

* Multiple crimp die set; makes more than one crimp per tool compression. Figure indicates number of compressions.

† U Die with adapter PT-6515.
‡ U Die with adapter PUADP-1.

H-63

TYPE YDS-M-T

Full Tension Sleeve for Alumoweld



RUS Accepted

Full-tension splice for Alumoweld transmission lines. Five connectors accommodate eight conductor sizes. Sleeve is pre-filled with PENETROX™ joint compound and capped.

Catalog ††† Number	Conductor	L	Die Index	Tools, Die Sets	
	ALUMOWELD			Y35, Y750, Y45†, Y46‡	Y60BHU*
YDS7M10T	7 #10, 3 #7	10	676 or 721	U676 (8) —	— L721
YDS7M9T	7 #9, 3 #6	10-3/8	677	U677 (10)	—
YDS7M8T	7 #8, 3 #5	12-1/4	668 or 723	U668 (13) —	— L723
YDS7M7T	7 #7	14-1/2	678 or 726	U678 (19) —	— L726
YDS7M6T	7 #6	15-1/8	679 or 726	U679 (2) —	— L726

* Overlap crimps.
† U Die with adapter PT-6515.
‡ U Die with adapter PUADP-1.

††† Sleeve is high strength aluminum alloy for optimum corrosion resistance.

Blue highlighted items are industry standard and most frequently ordered.

DEADEND FITTING AND ACCESSORIES

TABLE OF CONTENTS

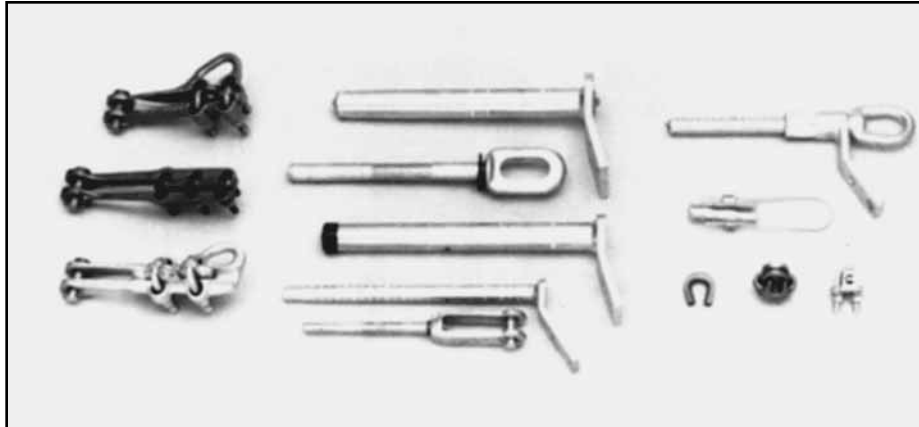

H-64

LOOP

Type UP-R	H-65
Type BC	H-66
Type M	H-66

PRIMARY AND STRAIN BUS

Type CUW-E	H-67
Type DUW	H-67
Type CUW-A-E & CUW-R-E	H-68
Type DUW-A & DUW-A-E	H-68

Blue highlighted items are industry standard and most frequently ordered.

DEADEND FITTINGS AND ACCESSORIES

The deadend method selected for any particular application will depend upon the nature of the application, the size of the conductor, holding strength required, and preference for mechanical or compression devices.

Secondaries are commonly deadended by bending wire around a spool insulator and snubbing with the same connectors used for the secondary to service drop connection. On copper conductor, connectors such as U-bolt Clip BC, SERVIT™ KS, OKLIP™ KVS or CRIMPIT™ YC-C are recommended. These connectors provide high holding strength without damaging conductor strands. On aluminum wires, CLIPIT™ UW-R, mechanical connector is recommended.

The same methods can also be used on primaries. However, the straight line clamp Type CUW-A-E is more popular for this application. They are easier to install on either hot or de-energized lines. They are particularly well suited to hot-line maintenance, and allow easy re-sagging of conductors.

Straight line types are also popular for dead-ending strain buses. These are normally large, hard to handle conductors that do not lend themselves to snub or “quadrant” types. Types DUW or CUW-E are recommended for copper conductor and DUW-A and DUW-A-E for aluminum and ACSR. The pulling eye on the DUW-A-E is in line with the cable to make installation easier.

H-65

TYPE UP-R

HEAVY DUTY PARALLEL CLAMP

For All Combinations of Copper, Aluminum†, ACSR†, 6201 and 5005

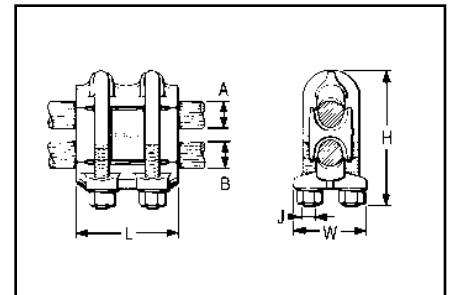

RUS Accepted

Heavy duty aluminum connector for feeder, subtransmission and primary distribution. Massive design and large spacer give maximum protection against galvanic action and overload conditions. Spacing of U-bolts, tapered bell mouths and modified V groove minimize cold flow, eliminate cable damage, and produce wiping action on conductors. Spacer taps confine cable strands to prevent splaying. Captured, heat treated aluminum alloy U-bolts. PENETROX™ joint compound recommended for all combinations.

Catalog Number	Groove A		Groove B		Dimensions			
	ACSR †, 6201, 5055	Copper or Aluminum†	ACSR †, 6201, 5005	Copper or Aluminum†	H	J	L	W
UP34R	110.8 (12-7) - 397.5 (18-1)	3/0 Str. - 400	110.8 (12.7) - 397.5 (18-1)	3/0 Str. - 400	4-5/8	1/2-13	4	2-5/8
UP45R36R	336.4 (30-7) - 795 (30-19)	397.5 - 954	110.8 (12-7) - 447 (18-1)	3/0 Str. - 500	5-1/4	1/2-13	4	2-7/8
UP45R	336.4 (30-7) - 795 (30-19)	397.5 - 954	336.4 (30-7) - 795 (30-19)	397.5 - 954	6-1/4	5/8-11	4-1/2	3-1/4

† Accommodates compact and compressed conductors within diameter range.

Blue highlighted items are industry standard and most frequently ordered.

TYPE BC

CLIP

Deadend Clamp for Guy Wire

Deadend CLIP with DURIMUM™ silicone bronze U-bolt, nuts, and washers. Saddle made of high strength corrosion resistant copper alloy.

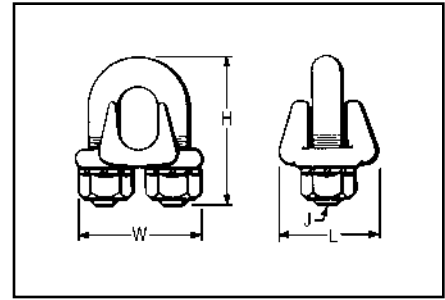
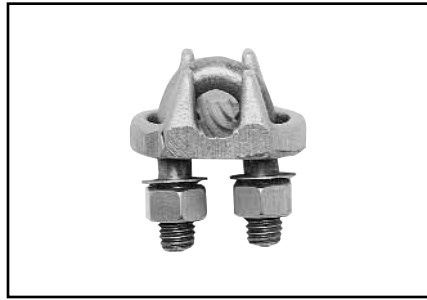

Catalog Number	Copper	Guy Wire	Dimensions			
			H	J	L	W
BC2C	2 Sol.	5/16	2	3/8	1-1/4	1-3/4
BC25	1/0 Str.	3/8			1-3/8	
BC28	2/0 Str. - 4/0 Str.	1/2	2-3/8	1/2	1-3/4	2-1/4

H-66

TYPE M

DEADEND THIMBLE

Deadend Copper Conductor or Guy Wire

High strength corrosion resistant copper alloy thimble groove to fit any size guy wire used for deadending. Generous radius prevents kinking or overstressing outer strands of wire.

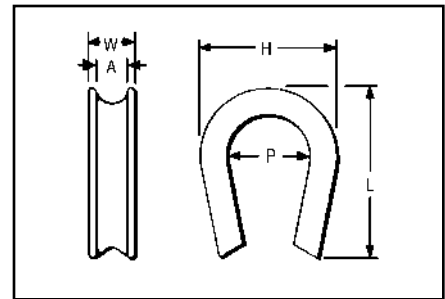

Catalog Number	Groove Size A	Dimensions			
		H	L	P	W
M20	5/16	1-5/8	1-7/8	7/8	5/8
M30	3/8	1-7/8	2-1/8	1	
M40	7/16	1-3/4	2-5/8	1-1/8	
M50	1/2	1-7/8	2-1/4	1-3/8	7/8
M60	5/8	2-1/4	2-5/8		1-1/2
M70	3/4	2-5/8	3-1/4	1-3/4	1-1/4
M80	7/8	3	3-3/8	2	1-3/8
M90	1	3-3/8	3-3/4		

Blue highlighted items are industry standard and most frequently ordered.

TYPE CUW-E

DEADEND CLAMP

For Copper

High strength, two-bolt, cast copper alloy strain clamp with single saddle designed for short span distribution and strain bus application. Galvanized steel clevis pin, and U-bolts.

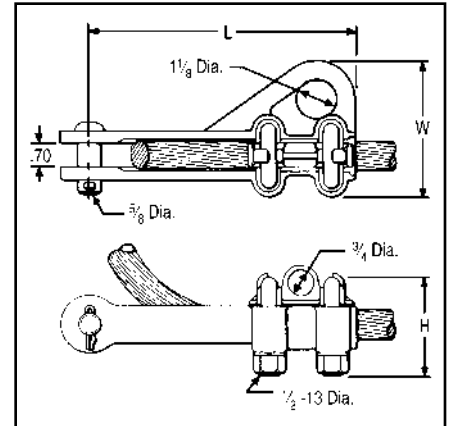
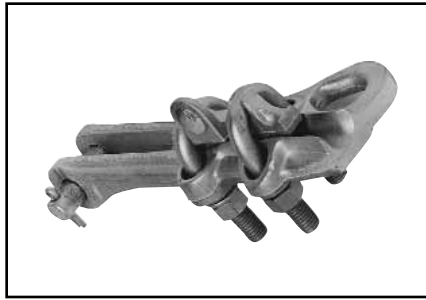

Catalog Number	Conductor Range	Dimensions		
		H	L	W
CUW34-E	4/0 Str. - 500	3	7-3/8	4
CUW44-E	500 - 1000	3-3/8	8-3/4	4-1/2

H-67

TYPE DUW

DEADEND CLAMP

For Copper

High strength corrosion resistant copper alloy strain clamp with three DURIMUM™ U-bolts and single serrated saddle. Galvanized steel clevis pin.

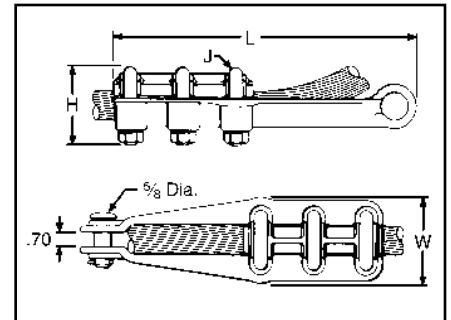
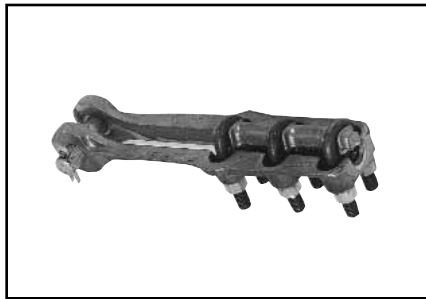

Catalog Number	Conductor	Dimensions			
		H	J	L	W
DUW28	1 Str. - 4/0 Str.	2-1/2	3/8	9-7/8	2-1/4
DUW31	4/0 Str. - 350	2			2-3/8
DUW34	350 - 500	2-5/8	1/2	11-3/8	2-3/4
DUW44	500 - 1000	2-7/8			3-1/4

Blue highlighted items are industry standard and most frequently ordered.

TYPES CUW-A-E & CUW-R-E

DEADEND CLAMP

For Aluminum†, ACSR†, 6201 and 5005

High strength aluminum clamp for deadending primary distribution lines. Straight-line design, with hot stick lifting-eye, pulling-eye, and captured, angled U-bolts, facilitates installation and maintenance, especially on hot-line work. Snub-pocket V-shaped, range-taking conductor groove and galvanized steel U-bolts provide high holding strength.

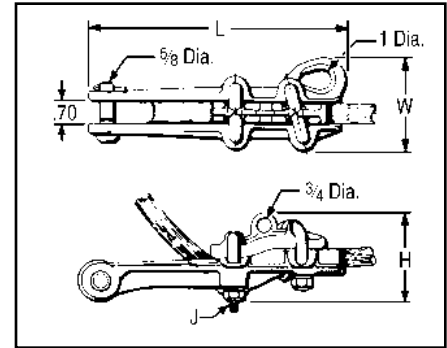

RUS Accepted

H-68

Catalog Number	Aluminum †	ACSR†, 6201, 5005	Dimensions			
			H	J	L	W
CUW26RE-1	2 Str. - 2/0 (19)	4 - 2/0	3	3/8-16	8	3
CUW30A-E	1/0 (7) - 300	1/0 - 266.8 (18-1)	3-5/8	1/2-13	10	3-1/2
CUW32R-E	3/0 (7) - 350	3/0 - 336.4 (26-7)	4	1/2-13	10	3-5/8
CUW361R-E	4/0 - 500	4/0 - 477 (18-1)	4-1/8	1/2-13	11	3-5/8
CUW391A-E	336.4 - 795	300 (26-7) 636 (26-7)	4-7/8	1/2-13	11	4-1/8

† Accommodates compressed conductors within diameter range.

TYPES DUW-A & DUW-A-E

DEADEND CLAMP

For Aluminum†, ACSR†, 6201 and 5005

High strength cast aluminum alloy clamp recommended for strain bus applications. Three galvanized steel U-bolts, single saddle and headed clevis pin provide high holding strength. Type DUW-A-E has pulling-eye in line with conductor for easier installation.

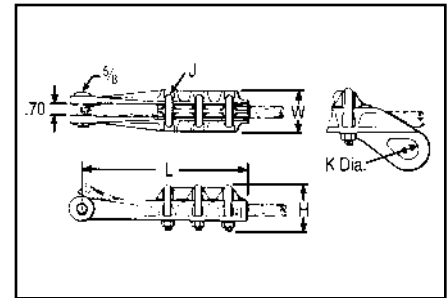
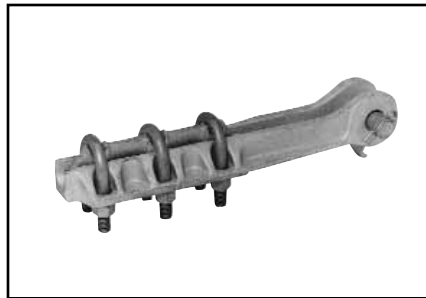

Catalog Number		Conductor		Dimensions				
Without Pulling Eye	With Pulling Eye	Aluminum†	ACSR†, 6201, 5005	H	J	K	L	W
DUW28A	—	1 - 4/0	2 (7-1) - 4/0	2	3/8	7/8	9-1/2	2-1/4
DUW44A	DUW44A-E	500 - 1000	397.5 (30-7) - 900 (54-7)	3-3/8	1/2	1-1/4	11-1/4	3-5/8

Blue highlighted items are industry standard and most frequently ordered.

COMPRESSION TERMINALS AND ACCESSORIES

TABLE OF CONTENTS

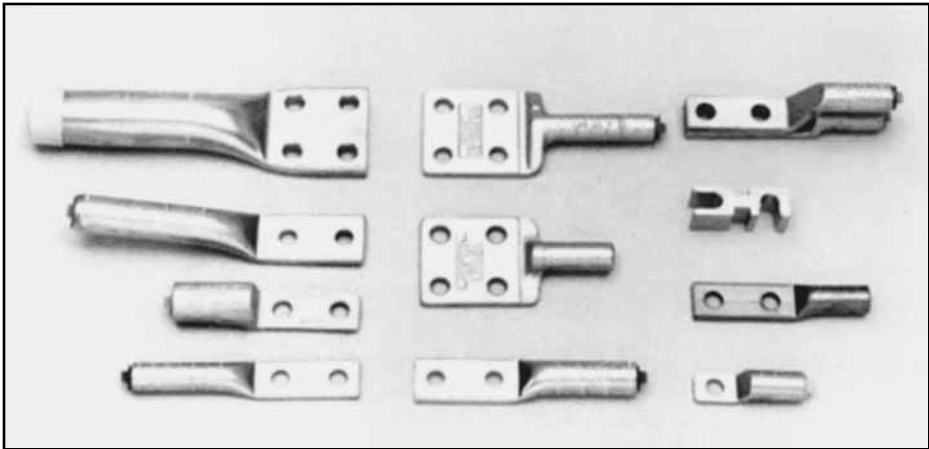

H-69

Types **YCA-2N & YCAB-4N** H-70
 Type **YCA-RL-2N** H-71
 Types **YCA-R-N & YCAK-R-N** H-72, H-73
 Type **YAK-A-2G** H-74
 Types **YCAK-A & YRA** H-75

Blue highlighted items are industry standard and most frequently ordered.

COMPRESSION TERMINALS & ACCESSORIES

Compression terminals are used to make convenient and reliable connections to switch pads, transformers, and other electrical equipment. They accommodate either copper, aluminum, ACSR, ACAR, Alumoweld, or steel conductor and come with one, two or four hole NEMA drilled pads to match the equipment drilling. Standard copper and aluminum terminals are also listed in the compression section B.

H-70

TYPES YCA-2N & YCAB-4N

HYLUG™

Compression Terminal for Copper

Compression HYLUG™ terminals designed for terminating copper conductors to switch pads and other substation or switch yard apparatus. NEMA standard mounting holes. Made of pure copper. Installed with same die as equivalent full-tension jumper loop and repair sleeves.

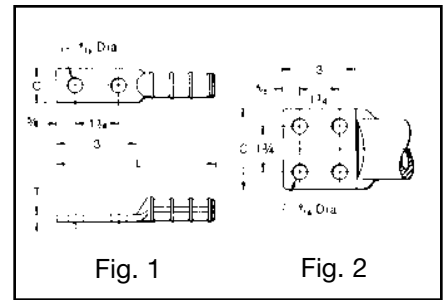

Catalog Number	Conductor	Fig. No.	C	L	T	Die Index	Tools, Die Set Catalog Number, & (Number of Crimps)			
							MD7, MD6	Y35, Y750, Y45†, Y46‡	Y48B	Y60BHU
YCA25-2N	1/0 (7, 19)	1	7/8	5-3/8	1/8	165	W165 (3)	U165/U205 (3)	—	—
YCA26-2N	2/0 (7, 19, 37)		1	5-1/4	1/4	166	W166 (6)	U166/U459 (3)	—	—
YCA27-2N	3/0 (7, 19)		1-1/8	5-3/8		167	—	U167/U568 (3)	C167 (1)	L167 (1)
YCA28-2N	4/0 (7, 12, 19)	2	1-1/4	5-5/8	3/8	168	—	U168 (3)	C168 (1)	L168 (1)
YCAB28-4N			3			—	—	—	—	
YCA29-2N	250 (7, 19, 37)	1	1-3/8	5-1/2	1/2	169	—	U169 (4)	C169 (1)	L169 (1)
YCA30-2N	300 (19, 37)		1-1/2			170	—	U170 (5)	C170 (1)	L170 (1)
YCA31-2N	350 (12, 19, 37)		1-5/8	6-1/2		267	—	U267 (6)	C267 (2)	L267 (2)
YCA32-2N	400 (19, 37)	2	6-3/4	7-1/8	1/2	209	—	U209 (6)	C209 (2)	L209 (2)
YCAB32-4N			3			—	—	—	—	
YCA34-2N	500 (19, 37)	1	1-7/8	6-1/2	3/8	210	—	U210 (6)	C210 (2)	L210 (2)
YCAB34-4N		2	3	6-7/8	1/2	—	—	—	—	—
YCA39-2N	750 (37, 61)	1	2-3/8	7-1/4	5/8	627	—	—	C627 (3)	L627 (3)
YCAB39-4N		2	3	7-1/2	1/2	—	—	—	—	—
YCAB44-4N	1000 (61)	2	3	7-7/8	5/8	345	—	—	C345 (4)	L345 (4)

YCAB have brazed pads.

† U Die with adapter PT-6515.

‡ U Die with adapter PUADP-1.

Blue highlighted items are industry standard and most frequently ordered.

TYPE YCA-RL-2N

HYLUG™

Compression Terminals for Aluminum, ACSR, 6201, 5005, Compressed and Compact Conductors

Aluminum compression HYLUG™ for terminating overhead conductors to switch pads and other substation or switch yard apparatus. NEMA standard mounting holes. Installed with same die as equivalent full-tension UNISPLICE™. Pre-filled with PENETROX™ joint compound and capped.

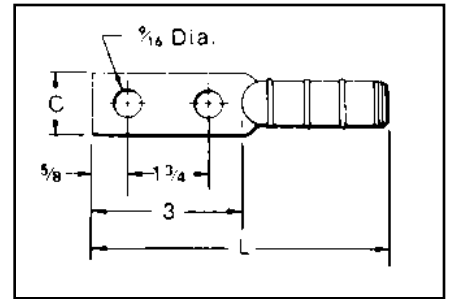
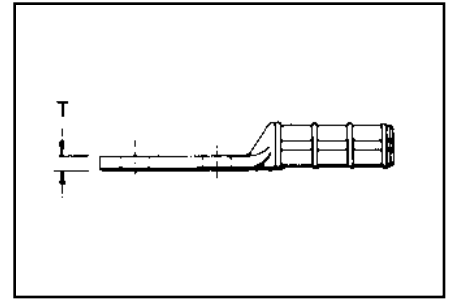
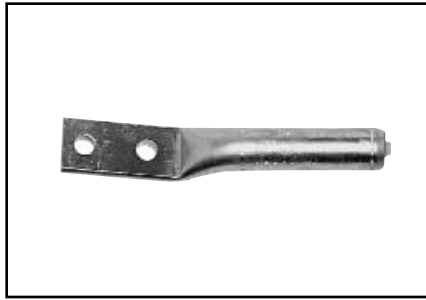

H-71

Catalog Number	Conductor	C	L	T	Die Index	Tools, Die Set Catalog Number, & Number of Crimps			
						MD7, MD6	Y35, Y750, Y45† Y46‡		
YCA4RL-2N	4 ACSR (6-1, 7-1) 4 6201 (7) 4 AAC (7)	7/8	6	3/8	BG, 687, 243	W-BG (8) Fixed BG (8) W687 (4)	U243		
YCA2RL-2N	2 ACSR (6-1, 7-1) 2 6201 (7) 2 AAC (7)	7/8	6		BG, 687, 243	W-BG (8) Fixed BG (8) W687 (4)	U243		
YCA25RL-2N	1/0 ACSR (6-1) 1/0 6201 (7) 1/0 5005 (7) 1/0 AAC (7)	1-1/8	7		C, or 247, or 702	WC	12	—	
						—	—	U247	3
YCA26RL-2N	2/0 ACSR (6-1) 2/0 6201 (7) 2/0 5005 (7) 2/0 AAC (7)	1-1/4	6-1/2		659	W702	4	—	
						Non-Bow	—	U659	3
YCA27RL-2N	3/0 ACSR (6-1) 3/0 6201 (7) 3/0 AAC (7) 3/0 AAC (7)	1-1/4	6-1/2		658	—	—	U658	3
YCA28RL-2N	4/0 ACSR (6-1) 4/0 6201 (7) 4/0 5005 (7) 4/0 AAC (7)	1-1/2	6-1/2		654	—	—	U654	3
YCA321RL-2N	336.4 ACSR (18-1) 336.4 AAC (19) 350 AAC	1-5/8	6-1/2	655	—	—	U655	3	

† U Die with adapter PT-6515.
‡ U Die with adapter PUADP-1.

Blue highlighted items are industry standard and most frequently ordered.

TYPES YCA-R-N & YCAK-R-N

Compression Terminals for Aluminum, ACSR, 6201, 5005, Compressed and Compact Conductors

Aluminum compression HYLUG™ for terminating jumper loops and equipment taps at switchpads and other substation apparatus, or to YDW-R deadends. NEMA standard mounting holes. Installed with same dies as equivalent full-tension sleeves. Pre-filled with PENETROX™ joint compound.

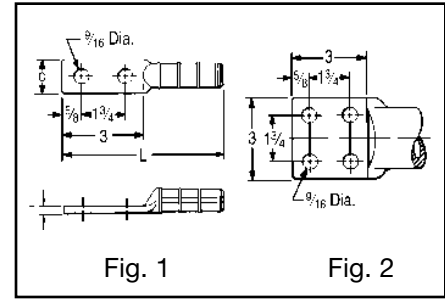
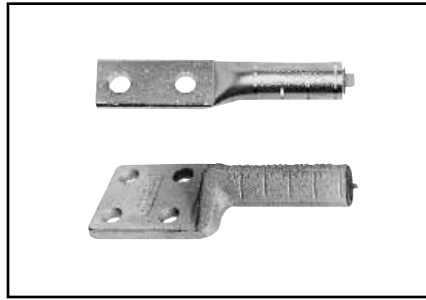

H-72

Catalog Number	Conductor		Fig. No.	C	L	T	Die Index	Tools, Die Set Catalog Number, & (Number of Crimps)					
	ACSR, 6201, 5005	Aluminum						MD7, MD6	Y35, Y750	Y45	Y46	Y48B	Y60BHU
YCA4R-2N	4	4 (7)	1	1-1/4	5-5/8	1/4	237	W237 (3)	U237 (2)	†	‡	—	—
YCA2R-2N	2	2 (7)					239	W239 (3)	U239 (2)	†	‡	—	—
YCA25R-2N	1/0	1/0 (7, 19)	2	3	6-7/8	3/8	KS18, BG, or	BG (8) W-BG (4)*	U-BG (4)	†	‡	—	—
YCAK25R-4N							243, 8A	U243 (2)	U243 (2)	†	‡	C243 (2)	L243 (1)
YCA26R-2N	2/0	2/0 (7, 19)	1	1-1/8	6-3/4	1/4	245, 9A	W245 (4)	U245 (2)	†	‡	C245 (2)	L245 (1)
YCA27R-2N	3/0 - 110.8 (12-7)	3/0 (7, 19)					247	W247 (6)	U247 (3)	†	‡	C247 (3)	L247 (2)
YCA28R-2N	4/0 (6-1, 6-7)	4/0 (7, 19)	2	3	7-3/8	3/8	K840, 249	W249 (6)	U249 (3)	†	‡	C249 (1)	L249 (2)
YCAK28R-4N							11A	—	—	†	‡	—	—
YCA30R-2N	266.8	266.8 (7, 19)	1	1-1/2	6-3/4	3/8	251	—	U251 (4)	†	‡	C251 (2)	L251 (2)
YCAK30R-4N	(18-1, 6-7, 26-7)						2	3	7-3/8	—	—	†	‡
YCA321R-2N	336.4 (18-1)	336.4 (19) - 350 (19, 37, 61)	1	1-1/2	7	3/8	321	—	U321 (4)	†	‡	C321 (2)	L321 (2)
YCAK321R-4N							2	3	7-1/8	—	—	—	—
YCA33R-2N	336.4 (26-7, 30-7)	397.5 (19)	1	1-5/8	7-1/4	3/8	316	—	U316 (4)	†	‡	C316 (2)	L316 (2)
YCAK33R-4N	397.5 (18-1)						2	3	7-3/8	—	—	—	
YCA35R-2N	397.5 (26-7, 30-7)	477 (19, 37) - 500 (37, 61)	1	1-7/8	7-1/2	3/8	317	—	U317 (4)	†	‡	C317 (2)	L317 (2)
YCAK35R-4N							2	3	7-3/8	—	—	—	—
YCA361R-2N	477 (18-1)	500 (37, 61)	1	1-7/8	7-5/8	7/16	327	—	U327 (4)	†	‡	C327 (2)	L327 (2)
YCAK361R-4N							2	3	—	—	—	—	—
YCA37R-2N	556.5 (18-1)	556.5 (19, 37)	1	2	8-1/8	3/8	261	—	U261 (5)	†	‡	C261 (2)	L261 (2)
YCAK37R-4N	477 (24-7, 26-7, 30-7)						2	3	—	—	—	—	
YCA39R-2N	556.5 (24-7, 26-7)	—	1	2-1/8	8-3/8	1/2	608	—	U608 (6)	†	‡	C608 (2)	L608 (2)
YCAK39R-4N							2	3	—	—	—	—	—
YCAK361A-4N	—	636 (37)	2	3	8-1/8	1/2	469	—	—	S469 (6)	P469 (6)	C469 (2)	L469 (2)

* Multiple crimp die set; makes more than one crimp per tool compression. Figure indicates number of compressions.

† U Die with adapter PT-6515.

‡ U Die with adapter PUADP-1.

YCA HYLUGS™ are made from heavy walled tubing.

YCA4R-2N, YCA2R-2N and all YCAK HYLUGS™ are cast aluminum alloy.

(Table continued on next page.)

Blue highlighted items are industry standard and most frequently ordered.

**TYPES YCA-R-N
& YCAK-R-N**

(Continued)

Compression Terminals for Aluminum, ACSR, 6201, 5005, Compressed and Compact Conductors

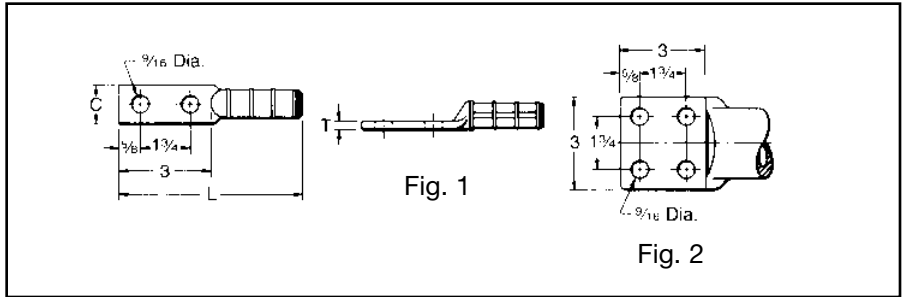

Catalog Number	Conductor		Fig. No.	C	L	T	Die Index	Tools, Die Set Catalog No., & (No. of Crimps)				
	ACSR, 6201, 5005	Aluminum						Y45	Y46	Y48B	Y60BHU	
YCA43R-2N	605 (30-19)	795 (37, 61)	1	2-1/2	10-1/4	3/4	292 or 319	S292 (6) S319 (6)	P292 (6) P319 (6)	C292 (3) C319 (3)	L292 (3) L319 (3)	
YCAK43R-4N	636 (24-7, 26-7, 30-19) 666.6 (24-7)	700 (61) 750 (61)	2	3	9-5/8	5/8	342	S342 (6)	P342 (6)	C342 (3)	L342 (3)	
YCA391A-2N	—	795 (37)	1	2-3/8	10-1/8							
YCAK391A-4N	—	750 (61)			9-7/8							
YCAK453R-4N	795 (36-1) 715.5 (26-7) 795 (45-7)	—	2	3	9-5/8							
YCA44A2NG2	—	1000	1	2-3/8	11		342	S342 (6)	P342 (6)	C342 (3)	L342 (3)	
YCA45R-2N	795 (26-7, 54-7)	900 (61, 91)	1	2-1/2	10-1/4		352	S352 (6) S579 (6)	P352 (6) P579 (6)	C352 (3) C579 (3)	L352 (3) L579 (3)	
YCAK45R-4N		954 (37, 61) 1000 (61)			9-5/8							
YCA48R-4N	900 (54-7) 954 (54-7) (45-7) 1033.5 (45-7) (36-1)	—	2	3	10		3/4	575	—	—	C575 (3)	L575 (3)
YCA441A-4N	—	1033.5 (37, 61) - 113 (61)									C575 (3)	L575 (3)
YCA451A-4N	1113 (54-19)	1272 (61)			10-1/4		5/8	422			—	L422 (3)

H-73

Blue highlighted items are industry standard and most frequently ordered.

TYPE YAK-A-2G

STACKING HYLUG™

For Aluminum

Cast aluminum HYLUG™ with a special tongue configuration for stacking of conductors on two and four hole NEMA transformer or equipment terminal pads. Up to eight conductors may be stacked on one four hole NEMA pad. HYLUG™ is pre-filled with PENETROX™ joint compound and capped.

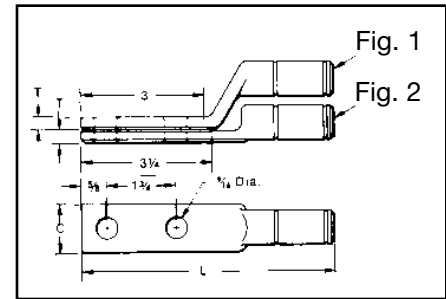
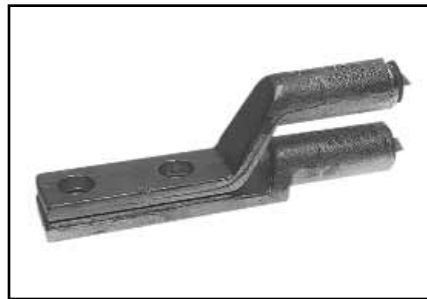

H-74

Catalog Number	Fig. No.	Conductor	C	L	T	Die Index	Tools, Die Set Catalog Number, & (Number of Crimps)			
							MD7, MD6 Series	Y35, Y750	Y45	Y46
YAK2CA2G1	1	2 Str.	7/8	5-5/8	1/4	BG	BG (3)	U-BG (1)	†	‡
YAK2CA2G2	2					K 5/8	W-BG (1)	UK 581T (3)	†	‡
YAK25A-2G1	1	1/0 Str.	1-1/8	6-1/4	5/16	243	W243 (1)	U243 (1)	†	‡
YAK25A-2G2	2									
YAK28A-2G1	1	4/0 Str.**	1-1/8	6-1/4	5/16	249	W249*	U249*	†	‡
YAK28A-2G2	2					K840	W-K840*		†	‡
YAK29A-2G1	1	250	1-5/8	6-7/8	3/8	299	—	U31ART*	†	‡
YAK31A-2G1	1	350				705		U705	†	‡
YAK31A-2G2	2	397.5		7-3/4	7/16	317		U317*	†	‡
YAK311A-2G1	1					705		U705*	†	‡
YAK34A-2G1	1	500		8-1/4	5/8	608		U608*	†	‡
YAK34A-2G2	2					786		U786*	S786*	P786*
YAK-361A-2G1	1	600		8-7/8		722		—	S44ART*	P44ART*
YAK-361A-2G2	2	636								
YAK39A-2G1	1	700								
YAK39A-2G2	2	750								
YAK44A-2NG8	1	1000	8-7/8		302					
YAK44A-2NG7	2									

* Overlap crimps.
 ** Accommodates 4/0 Str., Al or Cu.
 † U Die with adapter PT-6515.
 ‡ U Die with adapter PUADP-1.

Blue highlighted items are industry standard and most frequently ordered.

TYPES YCAK-A & YRA

ALUMINUM HYLUG™

For Aluminum, Copper or ACSR

Aluminum HYLUG™ for joining aluminum and copper cable to transformer and equipment pads. HYLUG™ is pre-filled with PENETROX™ joint compound and capped. Installed with standard tooling, five die sets install fourteen terminal size.

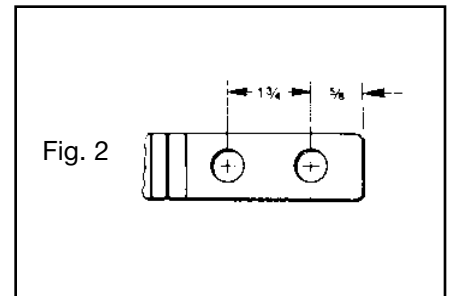
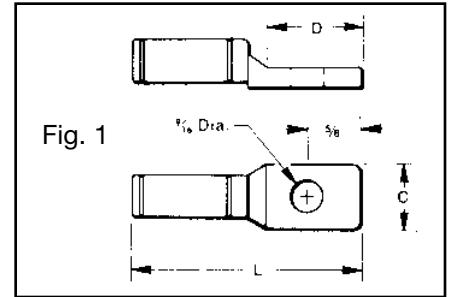
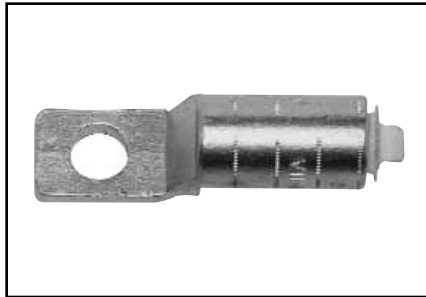

H-75

Catalog Number	Fig. No.	Conductor			C	D	L	Die Index	Die Set, Tools, Catalog Number, & (Number of Crimps)			
		Copper	Aluminum Conc. & Compact	ACSR					MD7, MD6 Series	Y35, Y750	Y45	Y46
YRA8CU-1	1	6 Sol. - 8 Sol.	8 Str.	—	15/16	1-1/16	2-9/16	BG 243	BG (3) K 5/8 243 (1)	U-BG (1) U-K-5/8-1T (3) U243 (1)	†	‡
YRA6CU-1		4 Sol. - 6 Str.	4 Sol. - 6 Str.	6 (6-1)								
YRA4CU-1		2 Sol. - 4 Str.	2 Sol. - 4 Str.	4 (6-1, 7-1)								
YRA1CU-1		1 Str. - 2 Str.	1 Str. - 2 Str.**	2 (6-1, 7-1)								
YRA25A-1		—	1/0 Str.	—								
YRAL4CU		2 Sol. - 4 Str.	2 Sol. - 4 Str.	4 (6-1, 7-1)								
YRAL1CU		1 Str. - 2 Str.	1 Str. - 2 Str.	2 (6-1, 7-1)								
YRA25U		1/0 Str.	1/0 Str.	1/0 (6-1)								
YRA26U		2/0 Str.	2/0 Str.	2/0 (6-1)								
YRA27U		3/0 Str.	3/0 Str.	—								
YRA28U	4/0 Str.	4/0 Str.	—									
YCAK28A-2G1*	2	250	250	4/0 (6-1)	1-1/4	3	5-5/8	317	—	U317* U705*	†	‡
YCAK29A-2G1*												
YCAK31AG1*	1	350	350	—		1-5/16	4-1/2	705	—	—	†	‡
YCAK31A-2G1*												
YCAK34A-2G3*	2	500	500	—		3	6-1/2	608 786	— —	U608* U786*	†	‡
YCAK36A-2G1*												
YCAK39A-2G2*												
YCAK44A-2G2*												
YCAK39A-2G2*	2	750	—	—		6-15/16	7-1/2	302	—	—	†	‡
YCAK44A-2G2*												
YCAK44A-2G2*	—	1000	—	—	1-11/16	—	—	—	—	S44ART*	P44ART*	

* Overlap crimps.
 ** YRA1CU-1 not recommended for 2 comp. conductor.
 † U Die with adapter PT-6515.
 ‡ U Die with adapter PUADP-1.

Blue highlighted items are industry standard and most frequently ordered.

TABLE OF CONTENTS

ACSR Conductor Accessories

Deadends Single Pad I-3
 Deadends Double Pad I-4
 Deadends Single Pad EHV I-5
 Deadends Double Pad EHV I-6
 Splices I-7
 Splices EHV I-8
 Jumper Terminals I-9
 Jumper Terminals EHV I-10
 Loop Splice I-11
 Loop Splice EHV I-12
 Compression T-Tap I-13
 T-Tap with Pad I-14
 Repair Sleeve I-15

AAC/ACAR Conductor Accessories

Deadends Single Pad I-16
 Deadends Single Pad EHV I-17
 Deadends Double Pad I-18
 Deadends Double Pad EHV I-19
 Splices, Stranded I-20
 Splices, Stranded EHV I-21
 Splices, ACAR I-22
 Splices, ACAR EHV I-23
 Jumper Terminals I-24
 Jumper Terminals EHV I-25
 Loop Splice I-26
 Loop Splice EHV I-27
 T-Tap with Pad I-28
 Compression T-Tap I-29
 Repair Sleeve, AAC and ACAR I-30

ACSS Conductor Accessories — High Temperature

Deadends Single Pad I-31
 Deadends Double Pad I-32
 Deadends Single Pad EHV I-33
 Deadends Double Pad EHV I-34
 Splices I-35
 Splices EHV I-36
 Jumper Terminals I-37
 Jumper Terminals EHV I-38
 Loop Splice I-39
 Loop Splice EHV I-40
 Compression T-Tap I-41
 T-Tap with Pad I-42
 Repair Sleeve I-43

Alumoweld and EHS Steel Conductor Accessories

Jumper Terminals I-44
 Splices, Alumoweld I-45
 Splices, EHS Steel I-46

ACCC® Composite Core Accessories — High Temperature

Deadends Single Pad I-47 - I-48
 Splices I-49
 Jumper Terminals I-50
 T-Tap with Pad I-51
 Repair Sleeve I-52

IMPLO™ Conductor Accessories

Deadends Single Pad I-53 - I-56
 Splices I-57 - I-60
 Jumper Terminals I-61 - I-63
 Repair Sleeve I-65 - I-68

Motion Control Accessories

Stockbridge Dampers I-69
 Spacer Dampers I-70
 Damping Study I-71

Oxide Inhibiting Joint Compounds

PENETROX™ I-72 - I-73

Installation Tooling and Accessories

Y60BHU, Y60BHUI I-74
 PAT46-18V I-75
 PATCUT129ACSR-18V I-76
 PATHCC10-18V Series I-77
 Y45 I-78
 Y46, Y46C I-79
 RHCC129ACSR I-80
 Y10AC9 I-81
 EPP10, EPP6 I-82
 GP10 I-83
 Hydraulic Hoses I-84
 Hydraulic Accessories I-85

Index

Quick Reference I-2

I-1

QUICK CATALOG REFERENCE

Deadends

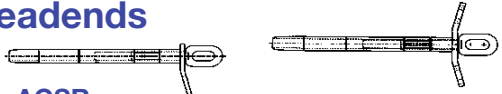

ACSR	I-3 - I-6
ACSS	I-31 - I-34
AAC/ACAR	I-16 - I-19
ACCC®	I-47 - I-48
IMPLO™	I-53 - I-56

Jumper Terminals

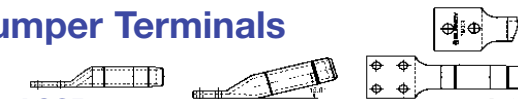

ACSR	I-9 - I-10
ACSS	I-37 - I-38
AAC/ACAR	I-24 - I-25
Steel	I-44
ACCC®	I-50
IMPLO™	I-61 - I-63

Compression T-Tap

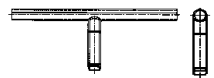

ACSR	I-13
AAC/ACAR	I-29
ACSS	I-41

Repair Sleeve



ACSR	I-15
ACSS	I-43
AAC/ACAR	I-30
ACCC®	I-52
IMPLO™	I-65 - I-68

Splices

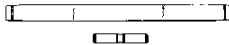

ACSR	I-7 - I-8
ACSS	I-35 - I-36
AAC/ACAR	I-20 - I-23
Alumoweld	I-45
EHS Steel	I-46
ACCC®	I-49
IMPLO™	I-57 - I-60

Loop Splice

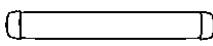

ACSR	I-11 - I-12
ACSS	I-39 - I-40
AAC/ACAR	I-26 - I-27

T-Tap with Pad

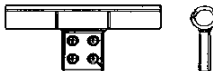

ACSR	I-14
AAC/ACAR	I-28
ACSS	I-42
ACCC®	I-51

Motion Control



Stockbridge Damper	I-69
Spacer Damper	I-70
Damping Study	I-71

I-2

Blue highlighted items are industry standard and most frequently ordered.

**TYPE YTW-R-REK,
YTW-R, YTW-RE,
YNA-R-H**

**Single Pad Full Tension
Deadend for ACSR Conductor**

Full tension compression deadend for ACSR transmission lines up to and including 230 kV. Standard 15° NEMA tap pad provides either 0° or 30° tap when YNA-R15 terminal is used.

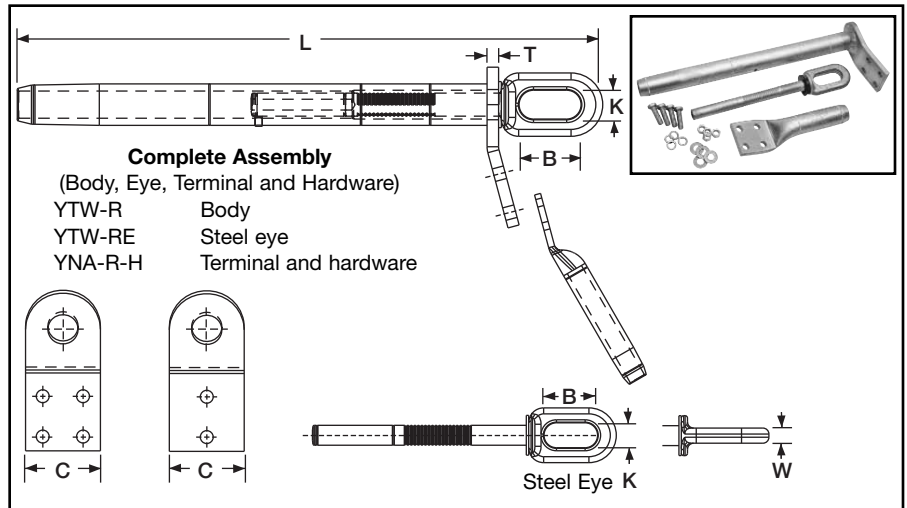

Conductor Name	ACSR		Stranding		Single Pad		Inches			Body Die*‡	Steel Eye*	Inches			Eye Die	Terminal with Hardware	Term Die*‡
	Size kcmil	Alum	Steel	Complete Assembly	Alum. Body	L	C	T	B			K	W				
Linnet	336.4	26	7	YTW32R34REK	YTW32R	17.53	2.25	0.50	L717	YTW34RE	2.50	0.88	0.62	L718	YNA32R15H	L717	
Oriole	336.4	30	7	YTW32R33REK	YTW32R	17.53	2.25	0.50	L717	YTW33RE	2.50	0.88	0.62	L718	YNA32R15H	L717	
Ibis	397.5	26	7	YTW34R34REK	YTW34R	17.60	2.25	0.50	L719	YTW34RE	2.50	0.88	0.62	L718	YNA34R15H	L719	
Flicker	477	24	7	YTW36R362REK	YTW36R	19.41	2.25	0.50	L720	YTW362RE	2.50	0.88	0.62	L721	YNA36R15H	L720	
Hawk	477	26	7	YTW36R36REK	YTW36R	19.41	2.25	0.50	L720	YTW36RE	2.50	0.88	0.62	L721	YNA36R15H	L720	
Parakeet	556.5	24	7	YTW39R43REK	YTW39R	19.66	2.25	0.50	L722	YTW43RE	2.50	0.88	0.69	L723	YNA39R15H	L722	
Dove	556.5	26	7	YTW39R43REK	YTW39R	19.66	2.25	0.50	L722	YTW43RE	2.50	0.88	0.69	L723	YNA39R15H	L722	
Peacock	605	24	7	YTW43R43REK	YTW43R	20.49	3.25	0.50	L724	YTW43RE	2.50	0.88	0.69	L723	YNA43R15H	L724	
Squab	605	26	7	YTW43R43REK	YTW43R	20.49	3.25	0.50	L724	YTW43RE	2.50	0.88	0.69	L723	YNA43R15H	L724	
Rook	636	24	7	YTW43R43REK	YTW43R	20.49	3.25	0.50	L724	YTW43RE	2.50	0.88	0.69	L723	YNA43R15H	L724	
Grosbeak	636	26	7	YTW43R43REK	YTW43R	20.49	3.25	0.50	L724	YTW43RE	2.50	0.88	0.69	L723	YNA43R15H	L724	
Flamingo	666.6	24	7	YTW43R43REK	YTW43R	20.49	3.25	0.50	L724	YTW43RE	2.50	0.88	0.69	L723	YNA43R15H	L724	
Starling	715.5	26	7	YTW451R48REK	YTW451R	25.41	3.25	0.50	L725	YTW48RE	2.69	1.25	0.75	L726	YNA451R15H	L725	
Cuckoo	795	24	7	YTW451R45REK	YTW451R	25.41	3.25	0.50	L725	YTW45RE	2.69	1.25	0.75	L726	YNA451R15H	L725	
Drake	795	26	7	YTW451R48REK	YTW451R	25.41	3.25	0.50	L725	YTW48RE	2.69	1.25	0.75	L726	YNA451R15H	L725	
Tern	795	45	7	YTW451R481REK	YTW451R	25.41	3.25	0.50	L725	YTW481RE	2.69	1.25	0.75	L726	YNA451R15H	L725	
Condor	795	54	7	YTW451R45REK	YTW451R	25.41	3.25	0.50	L725	YTW45RE	2.69	1.25	0.75	L726	YNA451R15H	L725	
Ruddy	900	45	7	YTW48R481REK	YTW48R	25.50	3.25	0.50	L727	YTW481RE	2.69	1.25	0.75	L726	YNA49R15H	L727	
Rail	954	45	7	YTW48R481REK	YTW48R	25.50	3.25	0.50	L727	YTW481RE	2.69	1.25	0.75	L726	YNA49R15H	L727	
Cardinal	954	54	7	YTW48R48REK	YTW48R	25.50	3.25	0.50	L727	YTW48RE	2.69	1.25	0.75	L726	YNA49R15H	L727	
Ortolan	1033.5	45	7	YTW49R483REK	YTW49R	27.35	3.25	0.50	L727	YTW483RE	2.69	1.25	1.00	L726	YNA49R15H	L727	
Curlew	1033.5	54	7	YTW49R50REK	YTW49R	27.35	3.25	0.50	L727	YTW50RE	2.69	1.25	1.00	L726	YNA49R15H	L727	
Bluejay	1113	45	7	YTW49R483REK	YTW49R	27.35	3.25	0.50	L727	YTW483RE	2.69	1.25	1.00	L726	YNA49R15H	L727	
Finch	1113	54	19	YTW52R50REK	YTW52R	31.55	4.00	0.62	L728	YTW50RE	2.69	1.25	1.00	L726	YNA52R15H	L728	
Bunting	1192.5	45	7	YTW52R521REK	YTW52R	31.55	4.00	0.62	L728	YTW521RE	2.69	1.25	1.00	L726	YNA52R15H	L728	
Bittern	1272	45	7	YTW52R521REK	YTW52R	31.55	4.00	0.62	L728	YTW521RE	2.69	1.25	1.00	L726	YNA52R15H	L728	
Pheasant	1272	54	19	YTW52R56REK	YTW52R	31.55	4.00	0.62	L728	YTW56RE	2.69	1.25	1.00	L726	YNA52R15H	L728	
Dipper	1351.5	45	7	YTW52R521REK	YTW52R	31.55	4.00	0.62	L728	YTW521RE	2.69	1.25	1.00	L726	YNA52R15H	L728	
Martin	1351.5	54	19	YTW52R56REK	YTW52R	31.55	4.00	0.62	L728	YTW56RE	2.69	1.25	1.00	L726	YNA52R15H	L728	
Nuthatch	1510.5	45	7	YTW549R521REK	YTW549R	31.55	4.00	0.62	L729	YTW521RE	2.69	1.25	1.00	L726	YNA56R15H	L729	
Parrot	1510.5	54	19	YTW549R56REK	YTW549R	31.55	4.00	0.62	L729	YTW56RE	2.69	1.25	1.00	L726	YNA56R15H	L729	
Lapwing	1590	45	7	YTW549R549REK	YTW549R	31.55	4.00	0.62	L729	YTW549RE	2.69	1.25	1.00	L726	YNA56R15H	L729	
Falcon	1590	54	19	YTW56R590REK	YTW56R	31.99	4.00	0.62	L729	YTW590RE	2.69	1.25	1.00	L726	YNA56R15H	L729	
Chukar	1780	84	19	YTW58R58REK	YTW58R	32.99	4.00	0.62	L735	YTW58RE	2.69	1.25	1.00	L726	YNA58R15H	L735	
Bluebird	2156	84	19	YTW59R59REK	YTW59R	33.34	4.00	0.62	L735	YTW59RE	2.69	1.25	1.00	L726	YNA59R15H	L735	
Kiwi	2167	72	7	YTW59R591REK	YTW59R	33.34	4.00	0.62	L735	YTW591RE	2.69	1.25	1.00	L726	YNA59R15H	L735	

Complete Assembly: Includes Aluminum body, Steel eye, 15 degree terminal and aluminum hardware. For stainless steel hardware add SS to end of catalog number for complete assembly (example: YTW32R34REKSS) or to terminal (YNA32R15SSH) if ordered separately.

For assembly without terminal and hardware add NT to end of complete assembly catalog number (example: YTW32R34REKNT). Two hole NEMA pads standard on conductors up to 556.5 kcmil; Four hole NEMA pads on larger conductor sizes.

* Overlap crimps.
‡ Wide dies may be used, add suffix "W" to part number (example: L725W).

Blue highlighted items are industry standard and most frequently ordered.

TYPES YTW-RD-REK, YTW-RD, YTW-RE, YNA-R-H

Double Pad Full Tension Deadend for ACSR Conductor

Full tension compression deadend for ACSR transmission lines up to and including 230 kV. Standard 15° NEMA tap pad provides either 0° or 30° tap when YNA-R15 terminal is used.

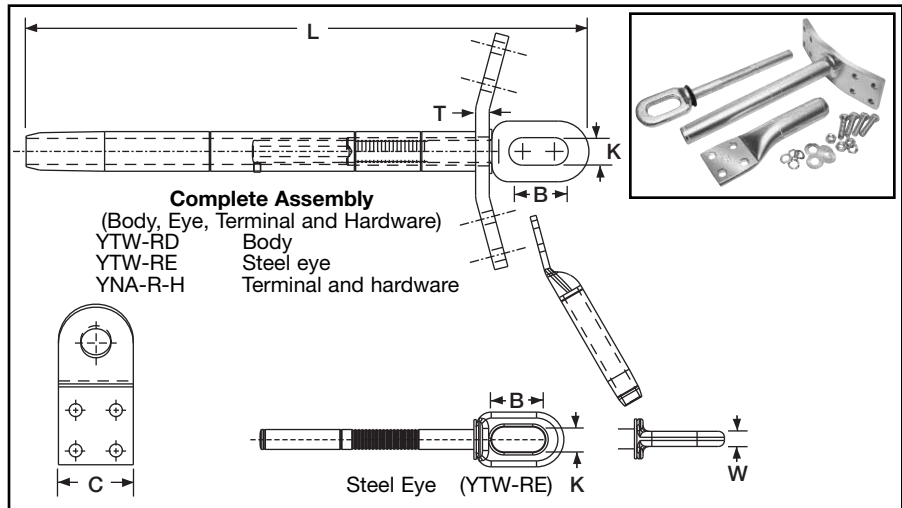

Conductor Name	ACSR		Double Pad		Inches			Body Die*‡	Steel Eye*	Inches			Eye Die	Terminal with Hardware	Term Die*‡
	Size kcmil	Stranding	Complete Assembly	Alum. Body	L	C	T			B	K	W			
Linnet	336.4	26 7	YTW32RD34REK	YTW32RD	17.53	2.25	0.50	L717	YTW34RE	2.50	0.88	0.62	L718	YNA32R15H	L717
Oriole	336.4	30 7	YTW32RD33REK	YTW32RD	17.53	2.25	0.50	L717	YTW33RE	2.50	0.88	0.62	L718	YNA32R15H	L717
Ibis	397.5	26 7	YTW34RD34REK	YTW34RD	17.60	2.25	0.50	L719	YTW34RE	2.50	0.88	0.62	L718	YNA34R15H	L719
Flicker	477	24 7	YTW36RD362REK	YTW36RD	15.44	2.25	0.50	L720	YTW362RE	2.50	0.88	0.62	L721	YNA36R15H	L720
Hawk	477	26 7	YTW36RD36REK	YTW36RD	19.41	2.25	0.50	L720	YTW36RE	2.50	0.88	0.62	L721	YNA36R15H	L720
Parakeet	556.5	24 7	YTW39RD43REK	YTW39RD	19.66	2.25	0.50	L722	YTW43RE	2.50	0.88	0.69	L723	YNA39R15H	L722
Dove	556.5	26 7	YTW39RD43REK	YTW39RD	19.66	2.25	0.50	L722	YTW43RE	2.50	0.88	0.69	L723	YNA39R15H	L722
Peacock	605	24 7	YTW43RD43REK	YTW43RD	20.49	3.25	0.50	L724	YTW43RE	2.50	0.88	0.69	L723	YNA43R15H	L724
Squab	605	26 7	YTW43RD43REK	YTW43RD	20.49	3.25	0.50	L724	YTW43RE	2.50	0.88	0.69	L723	YNA43R15H	L724
Rook	636	24 7	YTW43RD43REK	YTW43RD	20.49	3.25	0.50	L724	YTW43RE	2.50	0.88	0.69	L723	YNA43R15H	L724
Grosbeak	636	26 7	YTW43RD43REK	YTW43RD	20.49	3.25	0.50	L724	YTW43RE	2.50	0.88	0.69	L723	YNA43R15H	L724
Flamingo	666.6	24 7	YTW43RD43REK	YTW43RD	20.49	3.25	0.50	L724	YTW43RE	2.50	0.88	0.69	L723	YNA43R15H	L724
Starling	715.5	26 7	YTW451RD48REK	YTW451RD	25.41	3.25	0.50	L725	YTW48RE	2.69	1.25	0.75	L726	YNA451R15H	L725
Cuckoo	795	24 7	YTW451RD45REK	YTW451RD	25.41	3.25	0.50	L725	YTW45RE	2.69	1.25	0.75	L726	YNA451R15H	L725
Drake	795	26 7	YTW451RD48REK	YTW451RD	25.41	3.25	0.50	L725	YTW48RE	2.69	1.25	0.75	L726	YNA451R15H	L725
Tern	795	45 7	YTW451RD481REK	YTW451RD	25.41	3.25	0.50	L725	YTW481RE	2.69	1.25	0.75	L726	YNA451R15H	L725
Condor	795	54 7	YTW451RD45REK	YTW451RD	25.41	3.25	0.50	L725	YTW45RE	2.69	1.25	0.75	L726	YNA451R15H	L725
Ruddy	900	45 7	YTW48RD481REK	YTW48RD	25.50	3.25	0.50	L727	YTW481RE	2.69	1.25	0.75	L726	YNA49R15H	L727
Rail	954	45 7	YTW48RD481REK	YTW48RD	25.50	3.25	0.50	L727	YTW481RE	2.69	1.25	0.75	L726	YNA49R15H	L727
Cardinal	954	54 7	YTW48RD48REK	YTW48RD	25.50	3.25	0.50	L727	YTW48RE	2.69	1.25	0.75	L726	YNA49R15H	L727
Ortolan	1033.5	45 7	YTW49RD483REK	YTW49RD	27.35	3.25	0.50	L727	YTW483RE	2.69	1.25	1.00	L726	YNA49R15H	L727
Curlew	1033.5	54 7	YTW49RD50REK	YTW49RD	27.35	3.25	0.50	L727	YTW50RE	2.69	1.25	1.00	L726	YNA49R15H	L727
Bluejay	1113	45 7	YTW49RD483REK	YTW49RD	27.35	3.25	0.50	L727	YTW483RE	2.69	1.25	1.00	L726	YNA49R15H	L727
Finch	1113	54 19	YTW52RD50REK	YTW52RD	31.55	4.00	0.62	L728	YTW50RE	2.69	1.25	1.00	L726	YNA52R15H	L728
Bunting	1192.5	45 7	YTW52RD521REK	YTW52RD	31.55	4.00	0.62	L728	YTW521RE	2.69	1.25	1.00	L726	YNA52R15H	L728
Bittern	1272	45 7	YTW52RD521REK	YTW52RD	31.55	4.00	0.62	L728	YTW521RE	2.69	1.25	1.00	L726	YNA52R15H	L728
Pheasant	1272	54 19	YTW52RD56REK	YTW52RD	31.55	4.00	0.62	L728	YTW56RE	2.69	1.25	1.00	L726	YNA52R15H	L728
Dipper	1351.5	45 7	YTW52RD521REK	YTW52RD	31.55	4.00	0.62	L728	YTW521RE	2.69	1.25	1.00	L726	YNA52R15H	L728
Martin	1351.5	54 19	YTW52RD56REK	YTW52RD	31.55	4.00	0.62	L728	YTW56RE	2.69	1.25	1.00	L726	YNA52R15H	L728
Nuthatch	1510.5	45 7	YTW549RD521REK	YTW549RD	31.55	4.00	0.62	L729	YTW521RE	2.69	1.25	1.00	L726	YNA56R15H	L729
Parrot	1510.5	54 19	YTW549RD56REK	YTW549RD	31.55	4.00	0.62	L729	YTW56RE	2.69	1.25	1.00	L726	YNA56R15H	L729
Lapwing	1590	45 7	YTW549RD549REK	YTW549RD	31.55	4.00	0.62	L729	YTW549RE	2.69	1.25	1.00	L726	YNA56R15H	L729
Falcon	1590	54 19	YTW56RD590REK	YTW56RD	31.99	4.00	0.62	L729	YTW590RE	2.69	1.25	1.00	L726	YNA56R15H	L729
Chukar	1780	84 19	YTW58RD58REK	YTW58RD	32.99	4.00	0.62	L735	YTW58RE	2.69	1.25	1.00	L726	YNA58R15H	L735
Bluebird	2156	84 19	YTW59RD59REK	YTW59RD	33.34	4.00	0.62	L735	YTW59RE	2.69	1.25	1.00	L726	YNA59R15H	L735
Kiwi	2167	72 7	YTW59RD591REK	YTW59RD	33.34	4.00	0.62	L735	YTW591RE	2.69	1.25	1.00	L726	YNA59R15H	L735

Complete Assembly: Includes Aluminum body, Steel eye, 15 degree terminal and aluminum hardware. For stainless steel hardware add SS to end of catalog number for complete assembly (example: YTW32RD34REKSS) or to terminal (YNA32R15HSS) if ordered separately.

For assembly without terminal and hardware add NT to end of complete assembly catalog number (example: YTW32RD34REKNT). Two hole NEMA pads standard on conductors up to 556.5 kcmil; Four hole NEMA pads on larger conductor sizes.

* Overlap crimps.
‡ Wide dies may be used, add suffix "W" to part number (example: L725W).

Blue highlighted items are industry standard and most frequently ordered.

**TYPES YTW-RT-REK,
YTW-RT, YTW-RE,
YNA-RT-H EHV**

**Single Pad, EHV Full Tension
Deadend for ACSR Conductor**

Full tension compression deadend for ACSR transmission lines at 345 kV and over. Standard 15° NEMA tap pad provides either 0° or 30° tap when YNA-R15 terminal is used.

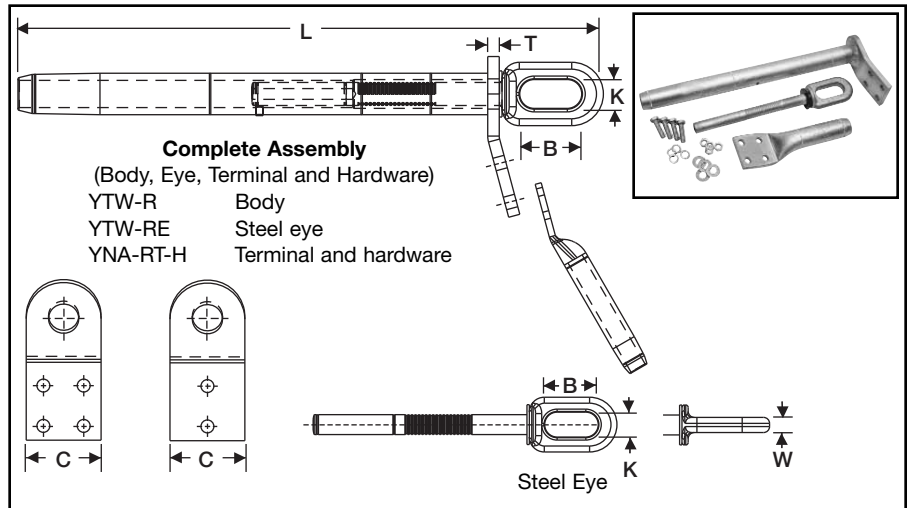

Conductor Name	ACSR		Stranding		Complete Assembly	Alum. Body	Inches			Body Die*‡	Steel Eye*	Inches			Eye Die	Terminal with Hardware	Term Die*‡
	Size kcmil	Alum	Steel	L			C	T	B			K	W				
Linnet	336.4	26	7	YTW32RT34REK	YTW32RT	17.53	2.25	0.50	L717	YTW34RE	2.50	0.88	0.62	L718	YNA32RT15H	L717	
Oriole	336.4	30	7	YTW32RT33REK	YTW32RT	17.53	2.25	0.50	L717	YTW33RE	2.50	0.88	0.62	L718	YNA32RT15H	L717	
Ibis	397.5	26	7	YTW34RT34REK	YTW34RT	17.60	2.25	0.50	L719	YTW34RE	2.50	0.88	0.62	L718	YNA34RT15H	L719	
Flicker	477	24	7	YTW36RT362REK	YTW36RT	19.41	2.25	0.50	L720	YTW362RE	2.50	0.88	0.62	L721	YNA36RT15H	L720	
Hawk	477	26	7	YTW36RT36REK	YTW36RT	19.41	2.25	0.50	L720	YTW36RE	2.50	0.88	0.62	L721	YNA36RT15H	L720	
Parakeet	556.5	24	7	YTW39RT43REK	YTW39RT	19.66	2.25	0.50	L722	YTW43RE	2.50	0.88	0.69	L723	YNA39RT15H	L722	
Dove	556.5	26	7	YTW39RT43REK	YTW39RT	19.66	2.25	0.50	L722	YTW43RE	2.50	0.88	0.69	L723	YNA39RT15H	L722	
Peacock	605	24	7	YTW43RT43REK	YTW43RT	20.49	3.25	0.50	L724	YTW43RE	2.50	0.88	0.69	L723	YNA43RT15H	L724	
Squab	605	26	7	YTW43RT43REK	YTW43RT	20.49	3.25	0.50	L724	YTW43RE	2.50	0.88	0.69	L723	YNA43RT15H	L724	
Rook	636	24	7	YTW43RT43REK	YTW43RT	20.49	3.25	0.50	L724	YTW43RE	2.50	0.88	0.69	L723	YNA43RT15H	L724	
Grosbeak	636	26	7	YTW43RT43REK	YTW43RT	20.49	3.25	0.50	L724	YTW43RE	2.50	0.88	0.69	L723	YNA43RT15H	L724	
Flamingo	666.6	24	7	YTW43RT43REK	YTW43RT	20.49	3.25	0.50	L724	YTW43RE	2.50	0.88	0.69	L723	YNA43RT15H	L724	
Starling	715.5	26	7	YTW451RT48REK	YTW451RT	25.41	3.25	0.50	L725	YTW48RE	2.69	1.25	0.75	L726	YNA451RT15H	L725	
Cuckoo	795	24	7	YTW451RT45REK	YTW451RT	25.41	3.25	0.50	L725	YTW45RE	2.69	1.25	0.75	L726	YNA451RT15H	L725	
Drake	795	26	7	YTW451RT48REK	YTW451RT	25.41	3.25	0.50	L725	YTW48RE	2.69	1.25	0.75	L726	YNA451RT15H	L725	
Tern	795	45	7	YTW451RT481REK	YTW451RT	25.41	3.25	0.50	L725	YTW481RE	2.69	1.25	0.75	L726	YNA451RT15H	L725	
Condor	795	54	7	YTW451RT45REK	YTW451RT	25.41	3.25	0.50	L725	YTW45RE	2.69	1.25	0.75	L726	YNA451RT15H	L725	
Ruddy	900	45	7	YTW48RT481REK	YTW48RT	25.50	3.25	0.50	L727	YTW481RE	2.69	1.25	0.75	L726	YNA49RT15H	L727	
Rail	954	45	7	YTW48RT481REK	YTW48RT	25.50	3.25	0.50	L727	YTW481RE	2.69	1.25	0.75	L726	YNA49RT15H	L727	
Cardinal	954	54	7	YTW48RT48REK	YTW48RT	25.50	3.25	0.50	L727	YTW48RE	2.69	1.25	0.75	L726	YNA49RT15H	L727	
Ortolan	1033.5	45	7	YTW49RT483REK	YTW49RT	27.35	3.25	0.50	L727	YTW483RE	2.69	1.25	1.00	L726	YNA49RT15H	L727	
Curlew	1033.5	54	7	YTW49RT50REK	YTW49RT	27.35	3.25	0.50	L727	YTW50RE	2.69	1.25	1.00	L726	YNA49RT15H	L727	
Bluejay	1113	45	7	YTW49RT483REK	YTW49RT	27.35	3.25	0.50	L727	YTW483RE	2.69	1.25	1.00	L726	YNA49RT15H	L727	
Finch	1113	54	19	YTW52RT50REK	YTW52RT	31.55	4.00	0.62	L728	YTW50RE	2.69	1.25	1.00	L726	YNA52RT15H	L728	
Bunting	1192.5	45	7	YTW52RT521REK	YTW52RT	31.55	4.00	0.62	L728	YTW521RE	2.69	1.25	1.00	L726	YNA52RT15H	L728	
Bittern	1272	45	7	YTW52RT521REK	YTW52RT	31.55	4.00	0.62	L728	YTW521RE	2.69	1.25	1.00	L726	YNA52RT15H	L728	
Pheasant	1272	54	19	YTW52RT56REK	YTW52RT	31.55	4.00	0.62	L728	YTW56RE	2.69	1.25	1.00	L726	YNA52RT15H	L728	
Dipper	1351.5	45	7	YTW52RT521REK	YTW52RT	31.55	4.00	0.62	L728	YTW521RE	2.69	1.25	1.00	L726	YNA52RT15H	L728	
Martin	1351.5	54	19	YTW52RT56REK	YTW52RT	31.55	4.00	0.62	L728	YTW56RE	2.69	1.25	1.00	L726	YNA52RT15H	L728	
Nuthatch	1510.5	45	7	YTW549RT521REK	YTW549RT	31.55	4.00	0.62	L729	YTW521RE	2.69	1.25	1.00	L726	YNA56RT15H	L729	
Parrot	1510.5	54	19	YTW549RT56REK	YTW549RT	31.55	4.00	0.62	L729	YTW56RE	2.69	1.25	1.00	L726	YNA56RT15H	L729	
Lapwing	1590	45	7	YTW549RT549REK	YTW549RT	31.55	4.00	0.62	L729	YTW549RE	2.69	1.25	1.00	L726	YNA56RT15H	L729	
Falcon	1590	54	19	YTW56RT590REK	YTW56RT	31.99	4.00	0.62	L729	YTW590RE	2.69	1.25	1.00	L726	YNA56RT15H	L729	
Chukar	1780	84	19	YTW58RT58REK	YTW58RT	32.99	4.00	0.62	L735	YTW58RE	2.69	1.25	1.00	L726	YNA58RT15H	L735	
Bluebird	2156	84	19	YTW59RT59REK	YTW59RT	33.34	4.00	0.62	L735	YTW59RE	2.69	1.25	1.00	L726	YNA59RT15H	L735	
Kiwi	2167	72	7	YTW59RT591REK	YTW59RT	33.34	4.00	0.62	L735	YTW591RE	2.69	1.25	1.00	L726	YNA59RT15H	L735	

Complete Assembly: Includes Aluminum body, Steel eye, 15 degree terminal and aluminum hardware. For stainless steel hardware add SS to end of catalog number for complete assembly (example: YTW32RD34REKSS) or to terminal (YNA32R15HSS) if ordered separately.

For assembly without terminal and hardware add NT to end of complete assembly catalog number (example: YTW32RD34REKNT). Two hole NEMA pads standard on conductors up to 556.5 kcmil; Four hole NEMA pads on larger conductor sizes.

* Overlap crimps.
‡ Wide dies may be used, add suffix "W" to part number (example: L725W).

Blue highlighted items are industry standard and most frequently ordered.

TYPES YTW-RDT-REK, YTW-RDT, YTW-RE, YNA-RT-H EHV

Double Pad, EHV Full Tension Deadend for ACSR

Full tension compression deadend for ACSR transmission lines at 345 kV and over. Standard 15° NEMA tap pad provides either 0° or 30° tap when YNA-R15 terminal is used.

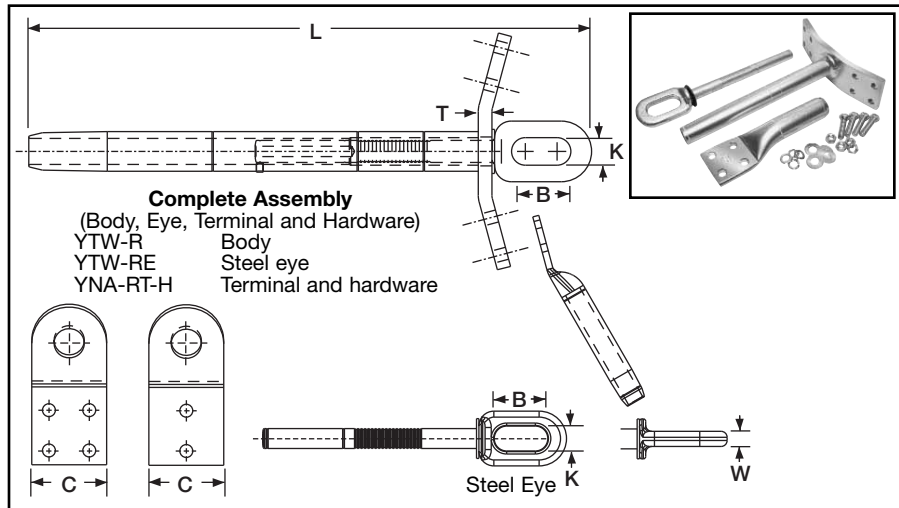

Conductor Name	ACSR		Double Pad		Inches			Body Die*‡	Steel Eye*	Inches			Eye Die	Terminal with Hardware	Term Die*‡	
	Size kcmil	Stranding Alum	Stranding Steel	Complete Assembly	Alum. Body	L	C			T	B	K				W
Linnet	336.4	26	7	YTW32RDT34REK	YTW32RDT	17.53	2.25	0.50	L717	YTW34RE	2.50	0.88	0.62	L718	YNA32RT15H	L717
Oriole	336.4	30	7	YTW32RDT33REK	YTW32RDT	17.53	2.25	0.50	L717	YTW33RE	2.50	0.88	0.62	L718	YNA32RT15H	L717
Ibis	397.5	26	7	YTW34RDT34REK	YTW34RDT	17.60	2.25	0.50	L719	YTW34RE	2.50	0.88	0.62	L718	YNA34RT15H	L719
Flicker	477	24	7	YTW36RDT362REK	YTW36RDT	15.44	2.25	0.50	L720	YTW362RE	2.50	0.88	0.62	L721	YNA36RT15H	L720
Hawk	477	26	7	YTW36RDT36REK	YTW36RDT	19.41	2.25	0.50	L720	YTW36RE	2.50	0.88	0.62	L721	YNA36RT15H	L720
Parakeet	556.5	24	7	YTW39RDT43REK	YTW39RDT	19.66	2.25	0.50	L722	YTW43RE	2.50	0.88	0.69	L723	YNA39RT15H	L722
Dove	556.5	26	7	YTW39RDT43REK	YTW39RDT	19.66	2.25	0.50	L722	YTW43RE	2.50	0.88	0.69	L723	YNA39RT15H	L722
Peacock	605	24	7	YTW43RDT43REK	YTW43RDT	20.49	3.25	0.50	L724	YTW43RE	2.50	0.88	0.69	L723	YNA43RT15H	L724
Squab	605	26	7	YTW43RDT43REK	YTW43RDT	20.49	3.25	0.50	L724	YTW43RE	2.50	0.88	0.69	L723	YNA43RT15H	L724
Rook	636	24	7	YTW43RDT43REK	YTW43RDT	20.49	3.25	0.50	L724	YTW43RE	2.50	0.88	0.69	L723	YNA43RT15H	L724
Grosbeak	636	26	7	YTW43RDT43REK	YTW43RDT	20.49	3.25	0.50	L724	YTW43RE	2.50	0.88	0.69	L723	YNA43RT15H	L724
Flamingo	666.6	24	7	YTW43RDT43REK	YTW43RDT	20.49	3.25	0.50	L724	YTW43RE	2.50	0.88	0.69	L723	YNA43RT15H	L724
Starling	715.5	26	7	YTW451RDT48REK	YTW451RDT	25.41	3.25	0.50	L725	YTW48RE	2.69	1.25	0.75	L726	YNA451RT15H	L725
Cuckoo	795	24	7	YTW451RDT45REK	YTW451RDT	25.41	3.25	0.50	L725	YTW45RE	2.69	1.25	0.75	L726	YNA451RT15H	L725
Drake	795	26	7	YTW451RDT48REK	YTW451RDT	25.41	3.25	0.50	L725	YTW48RE	2.69	1.25	0.75	L726	YNA451RT15H	L725
Tern	795	45	7	YTW451RDT481REK	YTW451RDT	25.41	3.25	0.50	L725	YTW481RE	2.69	1.25	0.75	L726	YNA451RT15H	L725
Condor	795	54	7	YTW451RDT45REK	YTW451RDT	25.41	3.25	0.50	L725	YTW45RE	2.69	1.25	0.75	L726	YNA451RT15H	L725
Ruddy	900	45	7	YTW48RDT481REK	YTW48RDT	25.50	3.25	0.50	L727	YTW481RE	2.69	1.25	0.75	L726	YNA48RT15H	L727
Rail	954	45	7	YTW48RDT481RE	YTW48RDT	25.50	3.25	0.50	L727	YTW481RE	2.69	1.25	0.75	L726	YNA49RT15H	L727
Cardinal	954	54	7	YTW48RDT48REK	YTW48RDT	25.50	3.25	0.50	L727	YTW48RE	2.69	1.25	0.75	L726	YNA49RT15H	L727
Ortolan	1033.5	45	7	YTW49RDT483REK	YTW49RDT	27.35	3.25	0.50	L727	YTW483RE	2.69	1.25	1.00	L726	YNA49RT15H	L727
Curlew	1033.5	54	7	YTW49RDT50REK	YTW49RDT	27.35	3.25	0.50	L727	YTW50RE	2.69	1.25	1.00	L726	YNA49RT15H	L727
Bluejay	1113	45	7	YTW49RDT483REK	YTW49RDT	27.35	3.25	0.50	L727	YTW483RE	2.69	1.25	1.00	L726	YNA49RT15H	L727
Finch	1113	54	19	YTW52RDT50REK	YTW52RDT	31.55	4.00	0.62	L728	YTW50RE	2.69	1.25	1.00	L726	YNA52RT15H	L728
Bunting	1192.5	45	7	YTW52RDT521REK	YTW52RDT	31.55	4.00	0.62	L728	YTW521RE	2.69	1.25	1.00	L726	YNA52RT15H	L728
Bittern	1272	45	7	YTW52RDT521REK	YTW52RDT	31.55	4.00	0.62	L728	YTW521RE	2.69	1.25	1.00	L726	YNA52RT15H	L728
Pheasant	1272	54	19	YTW52RDT56REK	YTW52RDT	31.55	4.00	0.62	L728	YTW56RE	2.69	1.25	1.00	L726	YNA52RT15H	L728
Dipper	1351.5	45	7	YTW52RDT521REK	YTW52RDT	31.55	4.00	0.62	L728	YTW521RE	2.69	1.25	1.00	L726	YNA52RT15H	L728
Martin	1351.5	54	19	YTW52RDT56REK	YTW52RDT	31.55	4.00	0.62	L728	YTW56RE	2.69	1.25	1.00	L726	YNA52RT15H	L728
Nuthatch	1510.5	45	7	YTW549RDT521REK	YTW549RDT	31.55	4.00	0.62	L729	YTW521RE	2.69	1.25	1.00	L726	YNA56RT15H	L729
Parrot	1510.5	54	19	YTW549RDT56REK	YTW549RDT	31.55	4.00	0.62	L729	YTW56RE	2.69	1.25	1.00	L726	YNA56RT15H	L729
Lapwing	1590	45	7	YTW549RDT549REK	YTW549RDT	31.55	4.00	0.62	L729	YTW549RE	2.69	1.25	1.00	L726	YNA56RT15H	L729
Falcon	1590	54	19	YTW56RDT590REK	YTW56RDT	31.99	4.00	0.62	L729	YTW590RE	2.69	1.25	1.00	L726	YNA56RT15H	L729
Chukar	1780	84	19	YTW58RDT58REK	YTW58RDT	32.99	4.00	0.62	L735	YTW58RE	2.69	1.25	1.00	L726	YNA58RT15H	L735
Bluebird	2156	84	19	YTW59RDT59REK	YTW59RDT	33.34	4.00	0.62	L735	YTW59RE	2.69	1.25	1.00	L726	YNA59RT15H	L735
Kiwi	2167	72	7	YTW59RDT591REK	YTW59RDT	33.34	4.00	0.62	L735	YTW591RE	2.69	1.25	1.00	L726	YNA59RT15H	L735

Complete Assembly: Includes Aluminum body, Steel eye, 15 degree terminal and aluminum hardware. For stainless steel hardware add SS to end of catalog number for complete assembly (example: YTW32RD34REKSS) or to terminal (YNA32R15HSS) if ordered separately.

For assembly without terminal and hardware add NT to end of complete assembly catalog number (example: YTW32RD34REKNT). Two hole NEMA pads standard on conductors up to 556.5 kcmil; Four hole NEMA pads on larger conductor sizes.

* Overlap crimps.
‡ Wide dies may be used, add suffix "W" to part number (example: L725W).

Blue highlighted items are industry standard and most frequently ordered.

TYPE YTS-R-RS

Full Tension Splice Kit for ACSR Conductor

Full tension, two-piece, compression splice for ACSR transmission lines up to and including 230 kV. Outer aluminum sleeve has filler hole and plug for PENETROX™ joint compound. Kit includes the outer aluminum and inner steel sleeve.

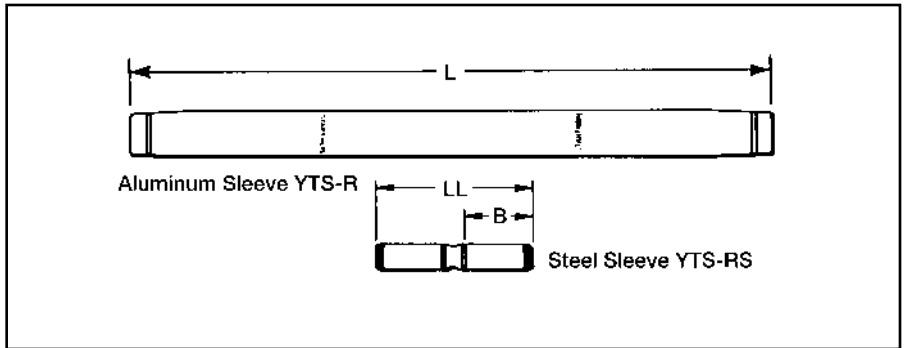
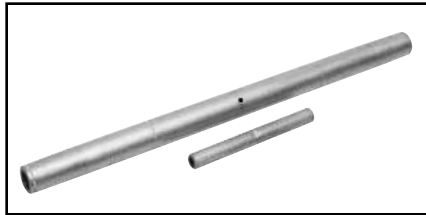

Conductor Name	ACSR		Splice Kit	Aluminum Sleeve			Steel Sleeve			
	Size kcmil	Stranding		Inches		Die*‡	Inches		Die*	
		Alum.		Steel	L		O.D.	LL		B
Linnet	336.4	26	7	YTS32R34RS	17.30	1.19	L717	5.75	2.64	L718
Oriole	336.4	30	7	YTS32R33RS	17.30	1.19	L717	5.75	2.64	L718
Ibis	397.5	26	7	YTS34R34RS	17.20	1.28	L719	5.75	2.64	L718
Flicker	477	24	7	YTS36R362RS	18.16	1.41	L720	5.75	2.66	L721
Hawk	477	26	7	YTS36R36RS	18.16	1.41	L720	5.75	2.66	L721
Parakeet	556.5	24	7	YTS39R43RS	19.88	1.50	L722	5.90	2.66	L723
Dove	556.5	26	7	YTS39R43RS	19.88	1.50	L722	5.90	2.66	L723
Peacock	605	24	7	YTS43R43RS	21.44	1.61	L724	5.90	2.66	L723
Squab	605	26	7	YTS43R43RS	21.44	1.61	L724	5.90	2.66	L723
Rook	636	24	7	YTS43R43RS	21.44	1.61	L724	5.90	2.66	L723
Grosbeak	636	26	7	YTS43R43RS	21.44	1.61	L724	5.90	2.66	L723
Flamingo	666.6	24	7	YTS43R43RS	21.44	1.61	L724	5.90	2.66	L723
Starling	715.5	26	7	YTS451R48RS	28.00	1.80	L725	9.00	4.19	L726
Cuckoo	795	24	7	YTS451R449RS	28.00	1.80	L725	9.00	4.19	L726
Drake	795	26	7	YTS451R48RS	28.00	1.80	L725	9.00	4.19	L726
Tern	795	45	7	YTS451R48RS	28.00	1.80	L725	9.16	4.19	L726
Condor	795	54	7	YTS451R449RS	28.00	1.80	L725	9.00	4.19	L726
Rail	954	45	7	YTS48R481RS	28.00	1.97	L727	9.16	4.19	L726
Cardinal	954	54	7	YTS48R48RS	28.00	1.97	L727	9.00	4.19	L726
Ortolan	1033.5	45	7	YTS49R483RS	28.00	1.97	L727	9.16	4.19	L726
Curlew	1033.5	54	7	YTS49R48RS	28.00	1.97	L727	9.00	4.19	L726
Bluejay	1113	45	7	YTS49R483RS	28.00	1.97	L727	9.16	4.19	L726
Finch	1113	54	19	YTS52R48RS	41.07	2.25	L728	9.00	4.19	L726
Bunting	1192.5	45	7	YTS52R521RS	41.07	2.25	L728	9.00	4.19	L726
Bittern	1272	45	7	YTS52R521RS	41.07	2.25	L728	9.00	4.19	L726
Pheasant	1272	54	19	YTS52R59RS	41.07	2.25	L728	9.10	4.25	L726
Dipper	1351.5	45	7	YTS52R521RS	41.07	2.25	L728	9.00	4.19	L726
Martin	1351.5	54	19	YTS52R59RS	41.07	2.25	L728	9.10	4.25	L726
Nuthatch	1510.5	45	7	YTS49R521RS	31.73	2.50	L729	9.00	4.19	L726
Parrot	1510.5	54	19	YTS49R59RS	31.73	2.50	L729	9.10	4.25	L726
Lapwing	1590	45	7	YTS49R549RS	31.73	2.50	L729	9.00	4.19	L726
Falcon	1590	54	19	YTS56R59RS	31.73	2.50	L729	9.10	4.25	L726
Chukar	1780	84	19	YTS58R48RS	34.20	2.50	L735	9.00	4.19	L726
Bluebird	2156	84	19	YTS59R59RS	41.93	2.50	L735	9.10	4.25	L726
Kiwi	2167	72	7	YTS59R521RS	41.93	2.50	L735	9.00	4.19	L726

Splice Kit: Includes aluminum sleeve and steel sleeve.
 * Overlap crimps.
 ‡ Wide dies may be used, add suffix "W" to part number (example: L725W).

Blue highlighted items are industry standard and most frequently ordered.

TYPE YTS-RT-RS EHV

Full Tension Splice Kit for ACSR Conductor

Full tension, two-piece, compression splice for ACSR transmission lines at 345 kV and over. Outer aluminum sleeve has filler hole and plug for PENETROX™ joint compound. Kit includes the outer aluminum and inner steel sleeve.

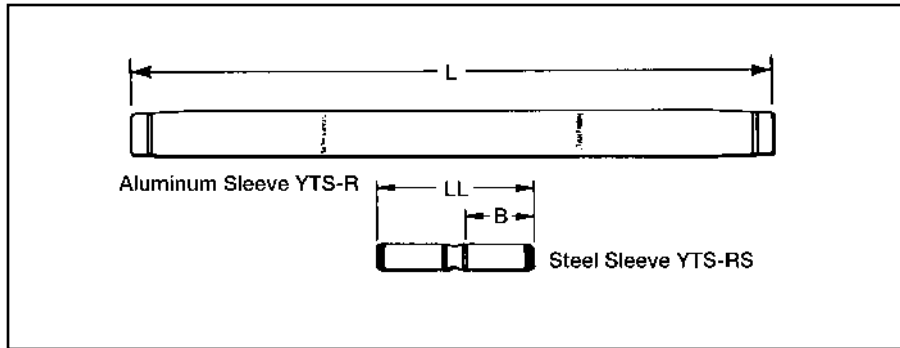
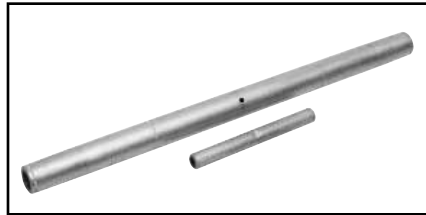

I-8

Conductor Name	ACSR		Splice Kit	Aluminum Sleeve			Steel Sleeve			
	Size kcmil	Stranding		Inches		Die*‡	Inches		Die*	
		Alum.		Steel	L		O.D.	LL		B
Linnet	336.4	26	7	YTS32RT34RS	17.30	1.19	L717	5.75	2.64	L718
Oriole	336.4	30	7	YTS32RT33RS	17.30	1.19	L717	5.75	2.64	L718
Ibis	397.5	26	7	YTS34RT34RS	17.20	1.28	L719	5.75	2.64	L718
Flicker	477	24	7	YTS36RT362RS	18.16	1.41	L720	5.75	2.66	L721
Hawk	477	26	7	YTS36RT36RS	18.16	1.41	L720	5.75	2.66	L721
Parakeet	556.5	24	7	YTS39RT43RS	19.88	1.50	L722	5.90	2.66	L723
Dove	556.5	26	7	YTS39RT43RS	19.88	1.50	L722	5.90	2.66	L723
Peacock	605	24	7	YTS43RT43RS	21.44	1.61	L724	5.90	2.66	L723
Squab	605	26	7	YTS43RT43RS	21.44	1.61	L724	5.90	2.66	L723
Rook	636	24	7	YTS43RT43RS	21.44	1.61	L724	5.90	2.66	L723
Grosbeak	636	26	7	YTS43RT43RS	21.44	1.61	L724	5.90	2.66	L723
Flamingo	666.6	24	7	YTS43RT43RS	21.44	1.61	L724	5.90	2.66	L723
Starling	715.5	26	7	YTS451RT48RS	28.00	1.80	L725	9.00	4.19	L726
Cuckoo	795	24	7	YTS451RT449RS	28.00	1.80	L725	9.00	4.19	L726
Drake	795	26	7	YTS451RT48RS	28.00	1.80	L725	9.00	4.19	L726
Tern	795	45	7	YTS451RT48RS	28.00	1.80	L725	9.16	4.19	L726
Condor	795	54	7	YTS451RT449RS	28.00	1.80	L725	9.00	4.19	L726
Rail	954	45	7	YTS48RT481RS	28.00	1.97	L727	9.16	4.19	L726
Cardinal	954	54	7	YTS48RT48RS	28.00	1.97	L727	9.00	4.19	L726
Ortolan	1033.5	45	7	YTS49RT483RS	28.00	1.97	L727	9.16	4.19	L726
Curlew	1033.5	54	7	YTS49RT48RS	28.00	1.97	L727	9.00	4.19	L726
Bluejay	1113	45	7	YTS49RT483RS	28.00	1.97	L727	9.16	4.19	L726
Finch	1113	54	19	YTS52RT48RS	41.07	2.25	L728	9.00	4.19	L726
Bunting	1192.5	45	7	YTS52RT521RS	41.07	2.25	L728	9.00	4.19	L726
Bittern	1272	45	7	YTS52RT521RS	41.07	2.25	L728	9.00	4.19	L726
Pheasant	1272	54	19	YTS52RT59RS	41.07	2.25	L728	9.10	4.25	L726
Dipper	1351.5	45	7	YTS52RT521RS	41.07	2.25	L728	9.00	4.19	L726
Martin	1351.5	54	19	YTS52RT59RS	41.07	2.25	L728	9.10	4.25	L726
Nuthatch	1510.5	45	7	YTS549RT521RS	31.73	2.50	L729	9.00	4.19	L726
Parrot	1510.5	54	19	YTS549RT59RS	31.73	2.50	L729	9.10	4.25	L726
Lapwing	1590	45	7	YTS549RT549RS	31.73	2.50	L729	9.00	4.19	L726
Falcon	1590	54	19	YTS56RT59RS	31.73	2.50	L729	9.10	4.25	L726
Chukar	1780	84	19	YTS58RT48RS	34.20	2.50	L735	9.00	4.19	L726
Bluebird	2156	84	19	YTS59RT59RS	41.93	2.50	L735	9.10	4.25	L726
Kiwi	2167	72	7	YTS59RT521RS	41.93	2.50	L735	9.00	4.19	L726

Splice Kit: Includes aluminum sleeve and steel sleeve.

* Overlap crimps.

‡ Wide dies may be used, add suffix "W" to part number (example: L725W).

Blue highlighted items are industry standard and most frequently ordered.

**TYPES YNA-R15,
YNA-R**

**Compression Terminal
for ACSR Conductor**

Compression terminal for ACSR transmission lines up to and including 230 kV. Two hole NEMA tongue through 556.5 kcmil and four hole on larger sizes. Includes PENETROX™ joint compound in barrel and oxide retardant on pad.

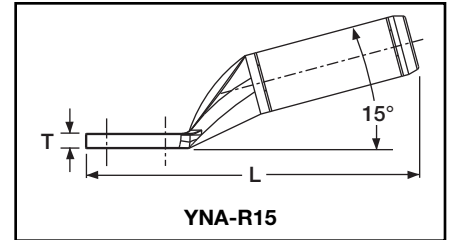
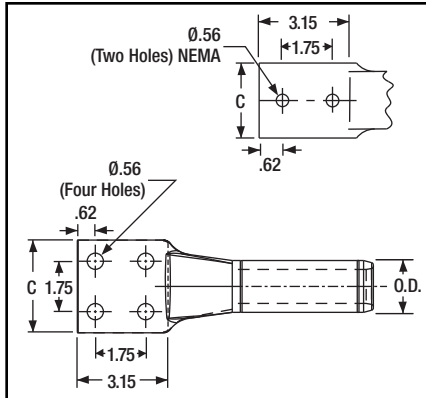
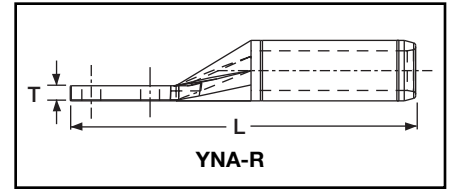
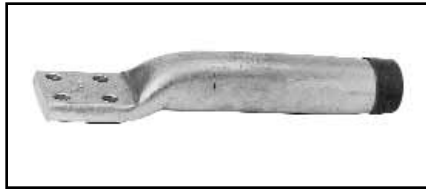

Conductor Name	ACSR Size		Stranding		15° Terminal		Straight Terminal		Inches		Die*‡
	kcmil		Alum.	Steel	Catalog Number	Inches L	Catalog Number	Inches L	C †	T	
Linnnet	336.4		26	7	YNA32R15	9.16	YNA32R	8.96	1.68	0.39	L717
Oriole	336.4		30	7	YNA32R15	9.16	YNA32R	8.96	1.68	0.39	L717
Ibis	397.5		26	7	YNA34R15	9.31	YNA34R	9.08	1.78	0.46	L719
Flicker	477		24	7	YNA36R15	9.62	YNA36R	9.47	1.96	0.48	L720
Hawk	477		26	7	YNA36R15	9.62	YNA36R	9.47	1.96	0.48	L720
Parakeet	556.5		24	7	YNA39R15	10.09	YNA39R	9.84	2.08	0.53	L722
Dove	556.5		26	7	YNA39R15	10.09	YNA39R	9.84	2.08	0.53	L722
Peacock	605		24	7	YNA43R15	10.16	YNA43R	10.07	3.22	0.36	L724
Squab	605		26	7	YNA43R15	10.16	YNA43R	10.07	3.22	0.36	L724
Rook	636		24	7	YNA43R15	10.16	YNA43R	10.07	3.22	0.36	L724
Grosbeak	636		26	7	YNA43R15	10.16	YNA43R	10.07	3.22	0.36	L724
Flamingo	666.6		24	7	YNA43R15	10.16	YNA43R	10.07	3.22	0.36	L724
Starling	715.5		26	7	YNA451R15	10.21	YNA451R	10.28	3.22	0.45	L725
Cuckoo	795		24	7	YNA451R15	10.21	YNA451R	10.28	3.22	0.45	L725
Drake	795		26	7	YNA451R15	10.21	YNA451R	10.28	3.22	0.45	L725
Tern	795		45	7	YNA451R15	10.21	YNA451R	10.28	3.22	0.45	L725
Condor	795		54	7	YNA451R15	10.21	YNA451R	10.28	3.22	0.45	L725
Ruddy	900		45	7	YNA49R15	10.35	YNA49R	10.46	3.22	0.52	L727
Rail	954		45	7	YNA49R15	10.35	YNA49R	10.46	3.22	0.52	L727
Cardinal	954		54	7	YNA49R15	10.35	YNA49R	10.46	3.22	0.52	L727
Ortolan	1033.5		45	7	YNA49R15	10.35	YNA49R	10.46	3.22	0.52	L727
Curlew	1033.5		54	7	YNA49R15	10.35	YNA49R	10.46	3.22	0.52	L727
Bluejay	1113		45	7	YNA49R15	10.35	YNA49R	10.46	3.22	0.52	L727
Finch	1113		54	19	YNA52R15	12.09	YNA52R	12.24	3.22	0.71	L728
Bunting	1192.5		45	7	YNA52R15	12.09	YNA52R	12.24	3.22	0.71	L728
Bittern	1272		45	7	YNA52R15	12.09	YNA52R	12.24	3.22	0.71	L728
Pheasant	1272		54	19	YNA52R15	12.09	YNA52R	12.24	3.22	0.71	L728
Dipper	1351.5		45	7	YNA52R15	12.09	YNA52R	12.24	3.22	0.71	L728
Martin	1351.5		54	19	YNA52R15	12.09	YNA52R	12.24	3.22	0.71	L728
Nuthatch	1510.5		45	7	YNA56R15	12.50	YNA56R	12.74	3.44	0.86	L729
Parrot	1510.5		54	19	YNA56R15	12.50	YNA56R	12.74	3.44	0.86	L729
Lapwing	1590		45	7	YNA56R15	12.50	YNA56R	12.74	3.44	0.86	L729
Falcon	1590		54	19	YNA56R15	12.50	YNA56R	12.74	3.44	0.86	L729
Chukar	1780		84	19	YNA58R15	13.25	YNA58R	13.34	3.47	0.86	L735
Bluebird	2156		84	19	YNA59R15	13.12	YNA59R	13.25	3.57	0.64	L735
Kiwi	2167		72	7	YNA59R15	13.12	YNA59R	13.25	3.57	0.64	L735

† Two hole NEMA pads standard for conductors up to 556.5 kcmil; Four hole NEMA pads on larger conductor sizes.

To specify hardware for bolting to corresponding deadends add the suffix H to the catalog number (example: YNA52RH).

* Overlap crimps.

‡ Wide dies may be used, add suffix "W" to part number (example: L725W).

TYPES YNA-RT15, YNA-RT EHV

Compression Terminal for ACSR Conductor

Compression terminal for ACSR transmission lines at 345 kV and over. Two hole NEMA tongue supplied through 636 kcmil and four hole on larger sizes. Includes PENETROX™ joint compound in barrel and oxide retardant on pad.

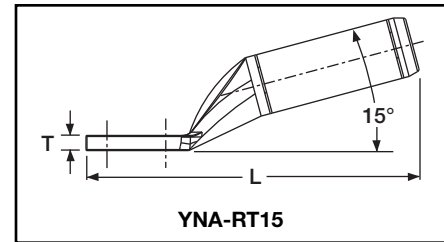
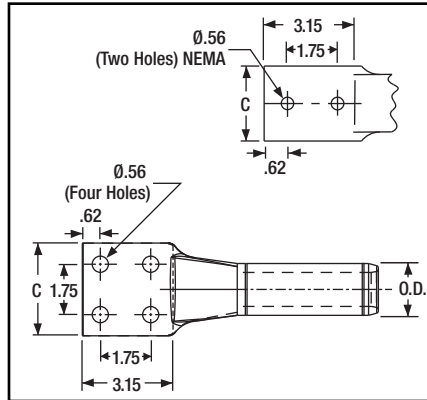
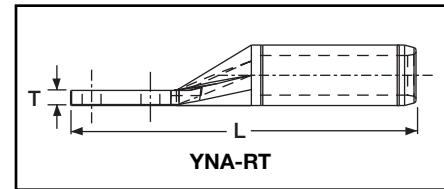
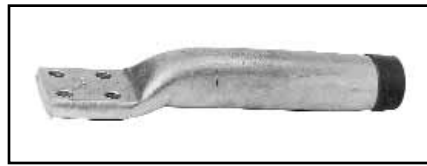

I-10

Conductor Name	ACSR		15° Terminal		Straight Terminal		Inches		Die*‡	
	Size kcmil	Stranding		Catalog Number	Inches L	Catalog Number	Inches L	C †		T
		Alum.	Steel							
Linnet	336.4	26	7	YNA32RT15	9.16	YNA32RT	8.96	1.68	0.39	L717
Oriole	336.4	30	7	YNA32RT15	9.16	YNA32RT	8.96	1.68	0.39	L717
Ibis	397.5	26	7	YNA34RT15	9.31	YNA34RT	9.08	1.78	0.46	L719
Flicker	477	24	7	YNA36RT15	9.62	YNA36RT	9.47	1.96	0.48	L720
Hawk	477	26	7	YNA36RT15	9.62	YNA36RT	9.47	1.96	0.48	L720
Parakeet	556.5	24	7	YNA39RT15	10.09	YNA39RT	9.84	2.08	0.53	L722
Dove	556.5	26	7	YNA39RT15	10.09	YNA39RT	9.84	2.08	0.53	L722
Peacock	605	24	7	YNA43RT15	10.16	YNA43RT	10.07	3.22	0.36	L724
Squab	605	26	7	YNA43RT15	10.16	YNA43RT	10.07	3.22	0.36	L724
Rook	636	24	7	YNA43RT15	10.16	YNA43RT	10.07	3.22	0.36	L724
Grosbeak	636	26	7	YNA43RT15	10.16	YNA43RT	10.07	3.22	0.36	L724
Flamingo	666.6	24	7	YNA43RT15	10.16	YNA43RT	10.07	3.22	0.36	L724
Starling	715.5	26	7	YNA451RT15	10.65	YNA451RT	10.57	3.22	0.45	L725
Cuckoo	795	24	7	YNA451RT15	10.65	YNA451RT	10.57	3.22	0.45	L725
Drake	795	26	7	YNA451RT15	10.65	YNA451RT	10.57	3.22	0.45	L725
Tern	795	45	7	YNA451RT15	10.65	YNA451RT	10.57	3.22	0.45	L725
Condor	795	54	7	YNA451RT15	10.65	YNA451RT	10.57	3.22	0.45	L725
Ruddy	900	45	7	YNA49RT15	10.94	YNA49RT	10.77	3.22	0.52	L727
Rail	954	45	7	YNA49RT15	10.94	YNA49RT	10.77	3.22	0.52	L727
Cardinal	954	54	7	YNA49RT15	10.94	YNA49RT	10.77	3.22	0.52	L727
Ortolan	1033.5	45	7	YNA49RT15	10.94	YNA49RT	10.77	3.22	0.52	L727
Curlew	1033.5	54	7	YNA49RT15	10.94	YNA49RT	10.77	3.22	0.52	L727
Bluejay	1113	45	7	YNA49RT15	10.94	YNA49RT	10.77	3.22	0.52	L727
Finch	1113	54	19	YNA52RT15	12.62	YNA52RT	13.82	3.22	0.71	L728
Bunting	1192.5	45	7	YNA52RT15	12.62	YNA52RT	13.82	3.22	0.71	L728
Bittern	1272	45	7	YNA52RT15	12.62	YNA52RT	13.82	3.22	0.71	L728
Pheasant	1272	54	19	YNA52RT15	12.62	YNA52RT	13.82	3.22	0.71	L728
Dipper	1351.5	45	7	YNA52RT15	12.62	YNA52RT	13.82	3.22	0.71	L728
Martin	1351.5	54	19	YNA52RT15	12.62	YNA52RT	13.82	3.22	0.71	L728
Nuthatch	1510.5	45	7	YNA56RT15	13.36	YNA56RT	13.76	3.44	0.86	L729
Parrot	1510.5	54	19	YNA56RT15	13.36	YNA56RT	13.76	3.44	0.86	L729
Lapwing	1590	45	7	YNA56RT15	13.36	YNA56RT	13.76	3.44	0.86	L729
Falcon	1590	54	19	YNA56RT15	13.36	YNA56RT	13.76	3.44	0.86	L729
Chukar	1780	84	19	YNA58RT15	13.81	YNA58RT	13.76	3.47	0.86	L735
Bluebird	2156	84	19	YNA59RT15	13.75	YNA59RT	14.06	3.57	0.64	L735
Kiwi	2167	72	7	YNA59RT15	13.75	YNA59RT	14.06	3.57	0.64	L735

† Two hole NEMA pads standard for conductors up to 556.5 kcmil; Four hole NEMA pads on larger conductor sizes. Shielding cap STS43A-4N required for EHV applications (two caps required).

To specify hardware for bolting to corresponding deadends add the suffix H to catalog number (example: YNA52RTH). * Overlap crimps.

‡ Wide dies may be used, add suffix "W" to part number (example: L725W).

Blue highlighted items are industry standard and most frequently ordered.

TYPE YNS-R

**Jumper Loop Sleeve
for ACSR Conductor**

Jumper sleeve for ACSR transmission lines up to and including 230 kV. Sleeve is pre-filled with PENETROX™ joint compound and capped.

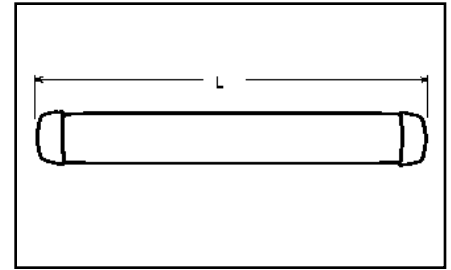
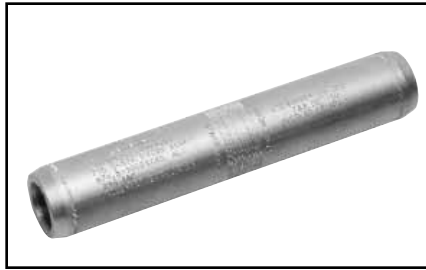

Conductor Name	ACSR		Catalog Number	Inches		Die*‡	
	Size kcmil	Stranding		L	O.D.		
		Alum.					Steel
Linnet	336.4	26	7	YNS32R	8.60	1.19	L717
Oriole	336.4	30	7	YNS32R	8.60	1.19	L717
Ibis	397.5	26	7	YNS34R	8.68	1.30	L719
Flicker	477	24	7	YNS36R	9.20	1.41	L720
Hawk	477	26	7	YNS36R	9.20	1.41	L720
Parakeet	556.5	24	7	YNS39R	9.76	1.50	L722
Dove	556.5	26	7	YNS39R	9.76	1.50	L722
Peacock	605	24	7	YNS43R	9.98	1.61	L724
Squab	605	26	7	YNS43R	9.98	1.61	L724
Rook	636	24	7	YNS43R	9.98	1.61	L724
Grosbeak	636	26	7	YNS43R	9.98	1.61	L724
Flamingo	666.6	24	7	YNS43R	9.98	1.61	L724
Starling	715.5	26	7	YNS451R	10.00	1.80	L725
Cuckoo	795	24	7	YNS451R	10.00	1.80	L725
Drake	795	26	7	YNS451R	10.00	1.80	L725
Tern	795	45	7	YNS451R	10.00	1.80	L725
Condor	795	54	7	YNS451R	10.00	1.80	L725
Ruddy	900	45	7	YNS49R	10.00	1.97	L727
Rail	954	45	7	YNS49R	10.00	1.97	L727
Cardinal	954	54	7	YNS49R	10.00	1.97	L727
Ortolan	1033.5	45	7	YNS49R	10.00	1.97	L727
Curlew	1033.5	54	7	YNS49R	10.00	1.97	L727
Bluejay	1113	45	7	YNS49R	10.00	1.97	L727
Finch	1113	54	19	YNS52R	15.48	2.25	L728
Bunting	1192.5	45	7	YNS52R	15.48	2.25	L728
Bittern	1272	45	7	YNS52R	15.48	2.25	L728
Pheasant	1272	54	19	YNS52R	15.48	2.25	L728
Dipper	1351.5	45	7	YNS52R	15.48	2.25	L728
Martin	1351.5	54	19	YNS52R	15.48	2.25	L728
Nuthatch	1510.5	45	7	YNS56R	14.80	2.50	L729
Parrot	1510.5	54	19	YNS56R	14.80	2.50	L729
Lapwing	1590	45	7	YNS56R	14.80	2.50	L729
Falcon	1590	54	19	YNS56R	14.80	2.50	L729
Chukar	1780	84	19	YNS58R	14.74	2.50	L735
Bluebird	2156	84	19	YNS59R	14.56	2.50	L735
Kiwi	2167	72	7	YNS59R	14.56	2.50	L735

* Overlap crimps
‡ Wide dies may be used, add suffix "W" to part number (example: L725W).

I-11

Blue highlighted items are industry standard and most frequently ordered.

TYPE YNS-RT EHV

Jumper Loop Sleeve for ACSR Conductor

Jumper sleeve for ACSR transmission lines over 230 kV. Sleeve is pre-filled with PENE-TROX™ joint compound and capped.

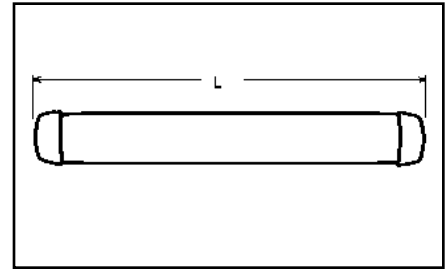
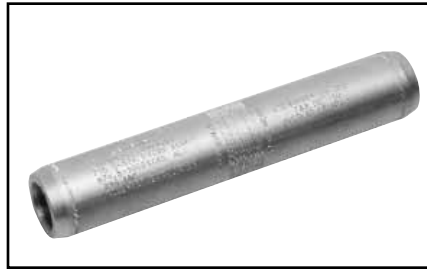

I-12

Conductor Name	ACSR		Jumper Sleeve	Inches		Die*‡	
	Size kcmil	Stranding		L	O.D.		
		Alum.	Steel				
Linnet	336.4	26	7	YNS32RT	8.96	1.19	L717
Oriole	336.4	30	7	YNS32RT	8.96	1.19	L717
Ibis	397.5	26	7	YNS34RT	9.10	1.30	L719
Flicker	477	24	7	YNS36RT	9.64	1.41	L720
Hawk	477	26	7	YNS36RT	9.64	1.41	L720
Parakeet	556.5	24	7	YNS39RT	10.26	1.50	L722
Dove	556.5	26	7	YNS39RT	10.26	1.50	L722
Peacock	605	24	7	YNS43RT	10.48	1.61	L724
Squab	605	26	7	YNS43RT	10.48	1.61	L724
Rook	636	24	7	YNS43RT	10.48	1.61	L724
Grosbeak	636	26	7	YNS43RT	10.48	1.61	L724
Flamingo	666.6	24	7	YNS43RT	10.48	1.61	L724
Starling	715.5	26	7	YNS451RT	10.60	1.80	L725
Cuckoo	795	24	7	YNS451RT	10.60	1.80	L725
Drake	795	26	7	YNS451RT	10.60	1.80	L725
Tern	795	45	7	YNS451RT	10.60	1.80	L725
Condor	795	54	7	YNS451RT	10.60	1.80	L725
Ruddy	900	45	7	YNS49RT	10.66	1.97	L727
Rail	954	45	7	YNS49RT	10.66	1.97	L727
Cardinal	954	54	7	YNS49RT	10.66	1.97	L727
Ortolan	1033.5	45	7	YNS49RT	10.66	1.97	L727
Curlew	1033.5	54	7	YNS49RT	10.66	1.97	L727
Bluejay	1113	45	7	YNS49RT	10.66	1.97	L727
Finch	1113	54	19	YNS52RT	16.20	2.25	L728
Bunting	1192.5	45	7	YNS52RT	16.20	2.25	L728
Bittern	1272	45	7	YNS52RT	16.20	2.25	L728
Pheasant	1272	54	19	YNS52RT	16.20	2.25	L728
Dipper	1351.5	45	7	YNS52RT	16.20	2.25	L728
Martin	1351.5	54	19	YNS52RT	16.20	2.25	L728
Nuthatch	1510.5	45	7	YNS56RT	15.58	2.50	L729
Parrot	1510.5	54	19	YNS56RT	15.58	2.50	L729
Lapwing	1590	45	7	YNS56RT	15.58	2.50	L729
Falcon	1590	54	19	YNS56RT	15.58	2.50	L729
Chukar	1780	84	19	YNS58RT	15.46	2.50	L735
Bluebird	2156	84	19	YNS59RT	15.14	2.50	L735
Kiwi	2167	72	7	YNS59RT	15.14	2.50	L735

* Overlap crimps

‡ Wide dies may be used, add suffix "W" to part number (example: L725W).

Blue highlighted items are industry standard and most frequently ordered.

TYPE YNT-R-R

**Compression T-Tap
for ACSR Conductor**

Two piece compression T-Tap for ACSR transmission lines that include up to 230 kV. Tap element is pre-filled with PENETROX™ joint compound and sealed.

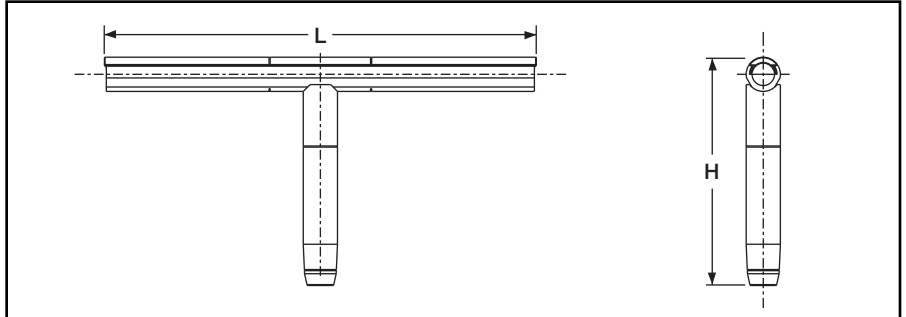
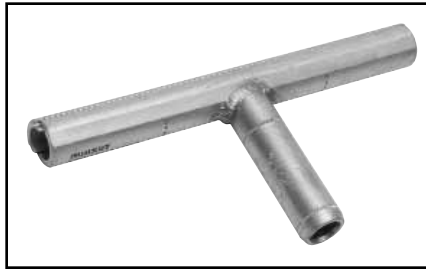

Conductor Name	ACSR		Stranding		T-Tap*	Inches		Die**‡
	Size kcmil	Alum.	Steel	L		H		
Linnnet	336.4	26	7	YNT32R32R	15.46	6.39	L717	
Oriole	336.4	30	7	YNT32R32R	15.46	6.39	L717	
Ibis	397.5	26	7	YNT34R34R	15.60	6.53	L719	
Flicker	477	24	7	YNT36R36R	16.29	6.85	L720	
Hawk	477	26	7	YNT36R36R	16.29	6.85	L720	
Parakeet	556.5	24	7	YNT39R39R	16.69	7.13	L722	
Dove	556.5	26	7	YNT39R39R	16.69	7.13	L722	
Peacock	605	24	7	YNT43R43R	17.48	7.20	L724	
Squab	605	26	7	YNT43R43R	17.48	7.20	L724	
Rook	636	24	7	YNT43R43R	17.48	7.20	L724	
Grosbeak	636	26	7	YNT43R43R	17.48	7.20	L724	
Flamingo	666.6	24	7	YNT43R43R	17.48	7.20	L724	
Starling	715.5	26	7	YNT451R451R	17.60	7.70	L725	
Cuckoo	795	24	7	YNT451R451R	17.60	7.70	L725	
Drake	795	26	7	YNT451R451R	17.60	7.70	L725	
Tern	795	45	7	YNT451R451R	17.60	7.70	L725	
Condor	795	54	7	YNT451R451R	17.60	7.70	L725	
Ruddy	900	45	7	YNT49R49R	17.66	7.90	L727	
Rail	954	45	7	YNT49R49R	17.66	7.90	L727	
Cardinal	954	54	7	YNT49R49R	17.66	7.90	L727	
Ortolan	1033.5	45	7	YNT49R49R	17.66	7.90	L727	
Curlew	1033.5	54	7	YNT49R49R	17.66	7.90	L727	
Bluejay	1113	45	7	YNT49R49R	17.66	7.90	L727	
Finch	1113	54	19	YNT52R52R	21.61	11.10	L728	
Bunting	1192.5	45	7	YNT52R52R	21.61	11.10	L728	
Bittern	1272	45	7	YNT52R52R	21.61	11.10	L728	
Pheasant	1272	54	19	YNT52R52R	21.61	11.10	L728	
Dipper	1351.5	45	7	YNT52R52R	21.61	11.10	L728	
Martin	1351.5	54	19	YNT52R52R	21.61	11.10	L728	
Nuthatch	1510.5	45	7	YNT56R56R	23.65	11.08	L729	
Parrot	1510.5	54	19	YNT56R56R	23.65	11.08	L729	
Lapwing	1590	45	7	YNT56R56R	23.65	11.08	L729	
Falcon	1590	54	19	YNT56R56R	23.65	11.08	L729	
Chukar	1780	84	19	YNT58R58R	23.53	11.02	L735	
Bluebird	2156	84	19	YNT59R59R	23.21	10.86	L735	
Kiwi	2167	72	7	YNT59R59R	23.21	10.86	L735	

* For EHV applications add suffix "T" to catalog number (example: YNT49R49RT).

** Overlap crimps

‡ Wide dies may be used, add suffix "W" to part number (example: L725W).

TYPE YNTA-R

T-Tap with Pad for ACSR Conductor

Two piece compression T-Tap to a NEMA pad for ACSR transmission lines. Up to and including 230 kV.

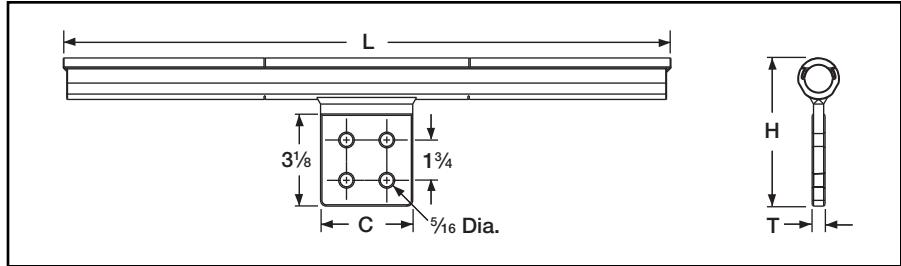
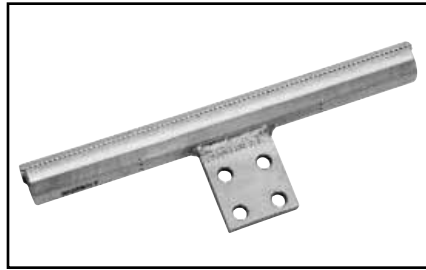

I-14

Conductor Name	ACSR		Stranding	T-Tap with Pad	Inches				Die*‡
	Size kcmil	Alum.			Steel	L	C	H	
Linnet	336.4	26	7	YNTA32R	15.46	2.00	4.94	0.50	L717
Oriole	336.4	30	7	YNTA32R	15.46	2.00	4.94	0.50	L717
Ibis	397.5	26	7	YNTA34R	15.60	2.00	5.05	0.50	L719
Flicker	477	24	7	YNTA36R	16.29	2.25	5.16	0.56	L720
Hawk	477	26	7	YNTA36R	16.29	2.25	5.16	0.56	L720
Parakeet	556.5	24	7	YNTA39R	16.69	2.25	5.25	0.56	L722
Dove	556.5	26	7	YNTA39R	16.69	2.25	5.25	0.56	L722
Peacock	605	24	7	YNTA43R	17.48	3.25	5.36	0.56	L724
Squab	605	26	7	YNTA43R	17.48	3.25	5.36	0.56	L724
Rook	636	24	7	YNTA43R	17.48	3.25	5.36	0.56	L724
Grosbeak	636	26	7	YNTA43R	17.48	3.25	5.36	0.56	L724
Flamingo	666.6	24	7	YNTA43R	17.48	3.25	5.36	0.56	L724
Starling	715.5	26	7	YNTA451R	17.60	3.25	5.55	0.56	L725
Cuckoo	795	24	7	YNTA451R	17.60	3.25	5.55	0.56	L725
Drake	795	26	7	YNTA451R	17.60	3.25	5.55	0.56	L725
Tern	795	45	7	YNTA451R	17.60	3.25	5.55	0.56	L725
Condor	795	54	7	YNTA451R	17.60	3.25	5.55	0.56	L725
Ruddy	900	45	7	YNTA49R	17.66	3.25	5.72	0.56	L727
Rail	954	45	7	YNTA49R	17.66	3.25	5.72	0.56	L727
Cardinal	954	54	7	YNTA49R	17.66	3.25	5.72	0.56	L727
Ortolan	1033.5	45	7	YNTA49R	17.66	3.25	5.72	0.56	L727
Curlew	1033.5	54	7	YNTA49R	17.66	3.25	5.72	0.56	L727
Bluejay	1113	45	7	YNTA49R	17.66	3.25	5.72	0.56	L727
Finch	1113	54	19	YNTA54R	21.61	3.25	6.00	0.69	L728
Bunting	1192.5	45	7	YNTA54R	21.61	3.25	6.00	0.69	L728
Bittern	1272	45	7	YNTA54R	21.61	3.25	6.00	0.69	L728
Pheasant	1272	54	19	YNTA54R	21.61	3.25	6.00	0.69	L728
Dipper	1351.5	45	7	YNTA54R	21.61	3.25	6.00	0.69	L728
Martin	1351.5	54	19	YNTA54R	21.61	3.25	6.00	0.69	L728
Nuthatch	1510.5	45	7	YNTA56R	23.65	3.59	6.25	0.69	L729
Parrot	1510.5	54	19	YNTA56R	23.65	3.59	6.25	0.69	L729
Lapwing	1590	45	7	YNTA56R	23.65	3.59	6.25	0.69	L729
Falcon	1590	54	19	YNTA56R	23.65	3.59	6.25	0.69	L729
Chukar	1780	84	19	YNTA58R	23.53	3.59	6.25	0.69	L735
Bluebird	2156	84	19	YNTA59R	23.21	3.59	6.25	0.69	L735
Kiwi	2167	72	7	YNTA59R	23.21	3.59	6.25	0.69	L735

Two hole NEMA pads standard for conductors up to 556.5 kcmil; Four hole NEMA pads on larger conductor sizes. For EHV applications add suffix "T" to catalog number (example: YNTA49RT).

For EHV applications order (2) two tap pad shielding caps STS43A4N-catalog number indicates (1) cap.

* Overlap crimps

‡ Wide dies may be used, add suffix "W" to part number (example: L725W).

TYPE YNU-R

Repair Sleeve for ACSR Conductor

For HV and EHV applications. Two-piece repair sleeve for temporary restoration of conductivity to damaged ACSR transmission lines. Use of PENETROX™ joint compound required.

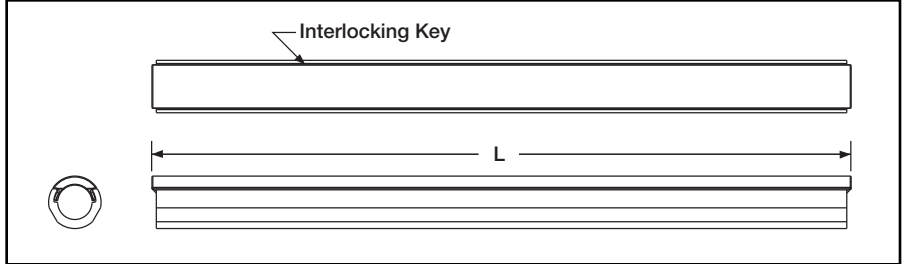
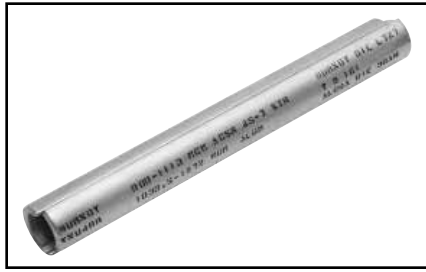

Conductor Name	ACSR Size kcmil		Stranding		Repair Sleeve	Inches	Die*‡
	Alum.	Steel	L				
Linnet	336.4	26	7	YNU32R	14.00	L717	
Oriole	336.4	30	7	YNU32R	14.00	L717	
Ibis	397.5	26	7	YNU34R	14.00	L719	
Flicker	477	24	7	YNU36R	14.00	L720	
Hawk	477	26	7	YNU36R	14.00	L720	
Parakeet	556.5	24	7	YNU39R	16.00	L722	
Dove	556.5	26	7	YNU39R	16.00	L722	
Peacock	605	24	7	YNU43R	16.00	L724	
Squab	605	26	7	YNU43R	16.00	L724	
Rook	636	24	7	YNU43R	16.00	L724	
Grosbeak	636	26	7	YNU43R	16.00	L724	
Flamingo	666.6	24	7	YNU43R	16.00	L724	
Starling	715.5	26	7	YNU451R	16.00	L725	
Cuckoo	795	24	7	YNU451R	16.00	L725	
Drake	795	26	7	YNU451R	16.00	L725	
Tern	795	45	7	YNU451R	16.00	L725	
Condor	795	54	7	YNU451R	16.00	L725	
Ruddy	900	45	7	YNU49R	16.00	L727	
Rail	954	45	7	YNU49R	16.00	L727	
Cardinal	954	54	7	YNU49R	16.00	L727	
Ortolan	1033.5	45	7	YNU49R	16.00	L727	
Curlew	1033.5	54	7	YNU49R	16.00	L727	
Bluejay	1113	45	7	YNU49R	16.00	L727	
Finch	1113	54	19	YNU54R	16.00	L728	
Bunting	1192.5	45	7	YNU54R	16.00	L728	
Bittern	1272	45	7	YNU54R	16.00	L728	
Pheasant	1272	54	19	YNU54R	16.00	L728	
Dipper	1351.5	45	7	YNU54R	16.00	L728	
Martin	1351.5	54	19	YNU54R	16.00	L728	
Nuthatch	1510.5	45	7	YNU56R	19.00	L729	
Parrot	1510.5	54	19	YNU56R	19.00	L729	
Lapwing	1590	45	7	YNU56R	19.00	L729	
Falcon	1590	54	19	YNU56R	19.00	L729	
Chukar	1780	84	19	YNU58R	19.00	L735	
Bluebird	2156	84	19	YNU59R	19.00	L735	
Kiwi	2167	72	7	YNU59R	19.00	L735	

* Overlap crimps
‡ Wide dies may be used, add suffix "W" to part number (example: L725W).

I-15

Blue highlighted items are industry standard and most frequently ordered.

TYPES YTW-A-AEK, YTW-A, YTW-AE, YNA-RH

Single Pad Full Tension Deadend for Stranded Aluminum Cable

Full tension compression deadend for SAC transmission lines. One design for applications up to and including 230 kV. Two hole NEMA tap pad supplied through 636 kcmil. Larger sizes have 4 hole NEMA pad. Standard 15° tap pad when used with YNA-R15H terminal provides either 0° or 30° tap. Aluminum body is pre-filled with PENETROX™ joint compound and capped.

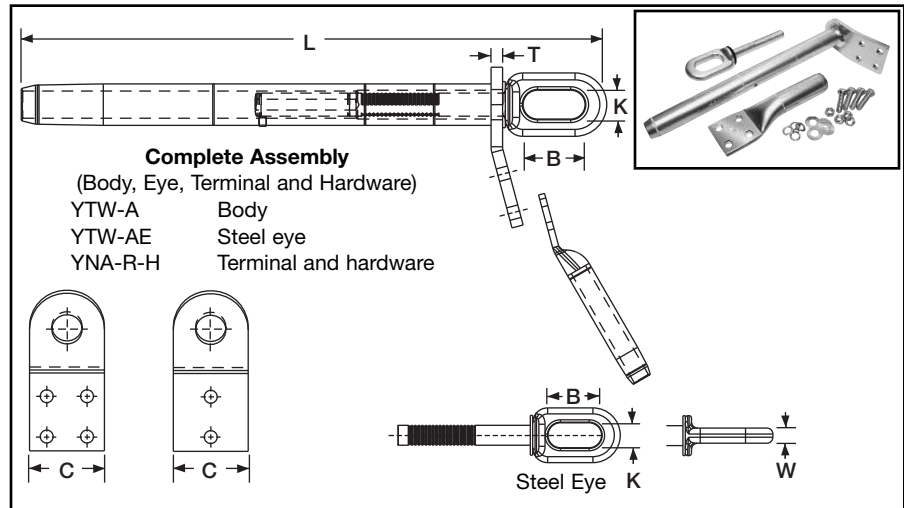

I-16

Conductor Name	Aluminum		Single Pad		Inches			Steel Eye	Inches			Tools		Terminal* with Hardware	Terminal Die*‡								
	kcmil	Str.	Complete Assembly	Aluminum Body	C	L	T		B	K	W	Die Index	Y60BHU*‡										
Tulip	336.4	19	YTW301A331AEK	YTW301A	2.25	9.62	0.50	YTW331AE	2.50	0.62	0.88	717	L717	YNA32R15H	L717								
	350	37																					
Canna	397.5	19	YTW311A331AEK	YTW311A		9.75										11.62	YTW351AE	0.88	0.69	719	L719	YNA34R15H	L719
	400	37																					
Cosmos	450	37	YTW331A331AE	YTW331A		12.25										12.75	YTW39AE	2.69	1.00	720	L720	YNA36R15H	L720
	477	19																					
Syringa	477	37	YTW351A351AEK	YTW351A		14.25										14.38	YTW431AE	2.69	1.00	722	L722	YNA39R15H	L722
Hyacinth	500	37																					
Dahlia	556.5	19	YTW361A39AEK	YTW361A		14.75										14.38	YTW431AE	2.69	1.00	724	L724	YNA43R15H	L724
	Mistletoe	556.5																					
Orchid	600	61	YTW39A39AEK	YTW39A	15.62	14.38	YTW431AE	2.69	1.00	725	L725	YNA45R15H	L725										
	636	37																					
Violet	715.5	37	YTW391A431AEK	YTW391A	15.62	14.38	YTW431AE	2.69	1.00	727	L727	YNA49R15H	L727										
Nasturtium	715.5	61																					
Cattail	750	61	YTW445A463AEK	YTW445A	16.50	16.38	YTW463AE	2.69	1.00	728	L728	YNA52R15H	L728										
	Arbutus	795												37									
Lilac	795	61	YTW451A463AEK	YTW451A	17.13	16.38	YTW463AE	2.69	1.00	728	L728	YNA54R15H	L728										
	800	61																					
Anemone	874.5	37	YTW457A463AEK	YTW457A	18.50	16.38	YTW47AE	2.69	1.00	735	L735	YNA58R15H	L735										
Crocus	874.5	61																					
Magnolia	954	37	YTW463A463AEK	YTW463A	18.50	16.38	YTW47AE	2.69	1.00	740	L740	YNA59R15H	L740										
	Goldenrod	954												61									
Bluebell	1033.5	37	YTW47A47AEK	YTW47A	18.50	16.38	YTW47AE	2.69	1.00	740	L740	YNA59R15H	L740										
	Larkspur	1033.5												61									
Marigold	1113	37	YTW48A484AEK	YTW48A	18.50	16.38	YTW484AE	2.69	1.00	740	L740	YNA59R15H	L740										
	1113	61																					
Hawthorn	1192.6	61	YTW484A484AEK	YTW484A	18.50	16.38	YTW484AE	2.69	1.00	740	L740	YNA59R15H	L740										
	Narcissus	1272												61									
Columbine	1351.5	61	YTW486A486AE	YTW486A	18.50	16.38	YTW486AE	2.69	1.00	740	L740	YNA59R15H	L740										
	Carnation	1431												61									
Coreopsis	1590	61	YTW486A486AE	YTW486A	18.50	16.38	YTW486AE	2.69	1.00	740	L740	YNA59R15H	L740										
	Jessamine	1750												61									
Cowslip	2000	91	YTW486A486AE	YTW486A	18.50	16.38	YTW486AE	2.69	1.00	740	L740	YNA59R15H	L740										
	Sagebrush	2250												91									
Lupine	2300	61	YTW486A486AE	YTW486A	18.50	16.38	YTW486AE	2.69	1.00	740	L740	YNA59R15H	L740										
	2500	91																					

* Overlap Crimp.

‡ Wide dies may be used, add suffix "W" to part number (example: L725W).

Complete Assembly: Includes Aluminum Body, Steel eye, 15 degree terminal and aluminum hardware.

For stainless steel hardware add SS to the end of the catalog number. For complete assembly (example: YTW391A431AEKSS) or to terminal (YNA43R15HSS) if ordered separately.

For assembly without terminal and hardware add NT to the end of the complete catalog number (example: YTW391A431AEKNT).

Blue highlighted items are industry standard and most frequently ordered.

**TYPES YTW-AT-AEK,
YTW-AT, YTW-AE,
YNA-RTH EHV**

**Single Pad, EHV Full Tension
Deadend for Stranded
Aluminum Cable**

Full tension compression deadend for SAC transmission lines at 345 kV and over. Two hole NEMA tap pad supplied through 636 kcmil. Larger sizes have 4 hole NEMA pad. Standard 15° tap pad when used with YNA-R15H terminal provides either 0° or 30° tap. Aluminum body is pre-filled with PENE-TROX™ joint compound and capped.

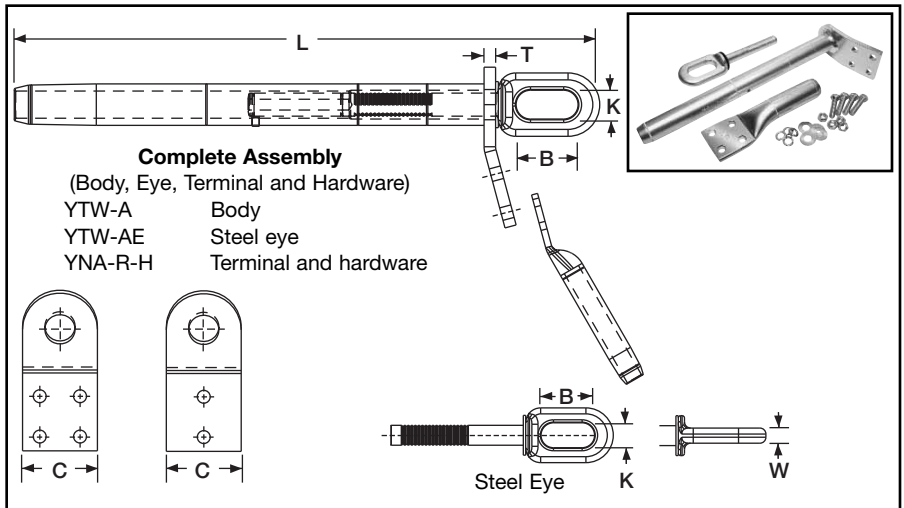

Conductor Name	Aluminum		Single Pad		Inches			Steel Eye	Inches			Tools		Terminal* with Hardware	Terminal Die*‡																			
	kcmil	Str.	Complete Assembly	Aluminum Body	C	L	T		B	K	W	Die Index	Y60BHU*‡																					
Tulip	336.4	19	YTW301AT331AEK	YTW301AT	2.25	9.62	0.50	YTW331AE	2.50	0.62	0.88	717	L717	YNA32RT15H	L717																			
	350	37																																
Canna	397.5	19	YTW311AT331AEK	YTW311AT		9.75										11.62	YTW351AE	0.88	0.69	719	L719	YNA34RT15H	L719											
	400	37																																
Cosmos	450	37	YTW331AT331AE	YTW331AT		12.25										12.75	YTW39AE	0.88	0.69	720	L720	YNA36RT15H	L720											
	477	19																																
Syringa	477	37	YTW351T351AEK	YTW351AT		12.25										12.75	YTW39AE	0.88	0.69	722	L722	YNA39RT15H	L722											
Hyacinth	500	37																																
	556.5	19																						YTW361AT39AEK	YTW361AT	14.38	14.75	YTW431AE	0.88	0.75	724	L724	YNA43RT15H	L724
Dahlia	556.5	37																																
Mistletoe	600	61			YTW39AT39AEK		YTW39AT	15.62	15.62	YTW463AE	1.25	1.00	727	L727	YNA49RT15H									L727										
	636	37																																
Orchid	715.5	37			YTW431AT431AEK		YTW431AT	16.50	17.13	YTW47AE	1.25	1.00	728	L728	YNA52RT15H									L728										
Violet	715.5	61																																
	750	61																							YTW445AT463AEK	YTW445AT	17.13	16.38	YTW484AE	1.25	1.00	735	L735	YNA58RT15H
Nasturtium	750	61																																
Cattail	750	61	YTW451AT463AEK	YTW451AT		18.50										18.50	YTW486AE	1.25	1.25	740	L740	YNA59RT15H	L735											
	Arbutus	795																							37									
Lilac	795	61	YTW463AT463AEK	YTW463AT		16.50										17.13	YTW47AE	1.25	1.00	735	L735	YNA59RT15H	L735											
	800	61																																
Anemone	874.5	37	YTW47AT47AEK	YTW47AT		16.50										17.13	YTW484AE	1.25	1.00	740	L740	YNA59RT15H	L740											
Crocus	874.5	61																																
	954	37			YTW484AT484AEK		YTW484AT	17.13	16.38	YTW484AE	1.25	1.00	740	L740	YNA59RT15H									L740										
Magnolia	954	37																																
Goldenrod	954	61			YTW484AT484AEK		YTW484AT	17.13	16.38	YTW484AE	1.25	1.00	740	L740	YNA59RT15H									L740										
	Bluebell	1033.5																							37									
Larkspur	1033.5	61			YTW486AT486AEK		YTW486AT	17.13	16.38	YTW486AE	1.25	1.00	740	L740	YNA59RT15H									L740										
	1113	37																																
Marigold	1113	61			YTW47AT47AEK		YTW47AT	17.13	16.38	YTW484AE	1.25	1.00	740	L740	YNA59RT15H									L740										
	1192.6	61																																
Hawthorn	1272	61	YTW484AT484AEK	YTW484AT	17.13	16.38	YTW484AE	1.25	1.00	740	L740	YNA59RT15H	L740																					
Narcissus	1351.5	61																																
	1431	61												YTW47AT47AEK	YTW47AT	17.13	16.38	YTW484AE	1.25	1.00	740	L740	YNA59RT15H	L740										
Columbine	1431	61																																
Carnation	1590	61												YTW47AT47AEK	YTW47AT	17.13	16.38	YTW484AE	1.25	1.00	740	L740	YNA59RT15H	L740										
	Coreopsis	1590																							61									
Jessamine	1750	61												YTW484AT484AEK	YTW484AT	17.13	16.38	YTW484AE	1.25	1.00	740	L740	YNA59RT15H	L740										
	Cowslip	2000																							91									
Sagebrush	2250	91												YTW484AT484AEK	YTW484AT	17.13	16.38	YTW484AE	1.25	1.00	740	L740	YNA59RT15H	L740										
	2300	61																																
Lupine	2300	61	YTW486AT486AEK	YTW486AT	17.13	16.38	YTW484AE	1.25	1.00	740	L740	YNA59RT15H	L740																					
	2500	91																																

* Overlap Crimp.

‡ Wide dies may be used, add suffix "W" to part number (example: L725W).

Complete Assembly: Includes Aluminum Body, Steel eye, 15 degree terminal and aluminum hardware.

For stainless steel hardware add SS to the end of the catalog number. For complete assembly (example: YTW391A431AEKSS) or to terminal (YNA43R15HSS) if ordered separately.

For assembly without terminal and hardware add NT to the end of the complete catalog number (example: YTW391A431AEKNT).

Blue highlighted items are industry standard and most frequently ordered.

TYPES YTW-AD-AEK, YTW-AD, YTW-AE, YNA-RH

Double Pad Full Tension Deadend for Stranded Aluminum Cable

Full tension compression deadend for SAC transmission lines. One design for applications up to and including 230 kV. Two hole NEMA tap pad supplied through 636 kcmil. Larger sizes have 4 hole NEMA pad. Standard 15° tap pad when used with YNA-R15H terminal provides either 0° or 30° tap. Aluminum body is pre-filled with PENE-TROX™ joint compound and capped.

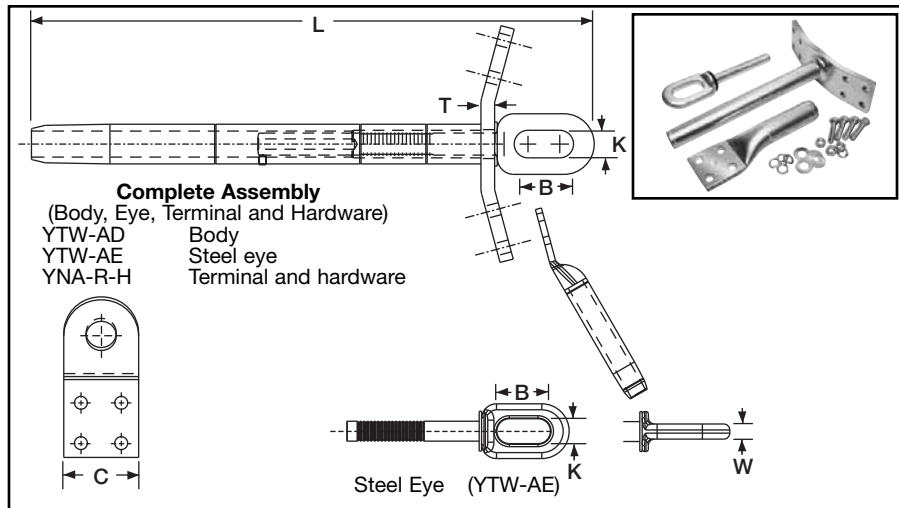

I-18

Conductor Name	Aluminum		Single Pad		Inches			Steel Eye	Inches			Tools		Terminal* with Hardware	Terminal Die*‡																					
	kcmil	Str.	Complete Assembly	Aluminum Body	C	L	T		B	K	W	Die Index	Y60BHU*‡																							
Tulip	336.4	19	YTW301AD331AEK	YTW301AD	2.25	9.62	0.50	YTW331AE	2.50	0.62	0.88	717	L717	YNA32R15H	L717																					
	350	37																																		
Canna	397.5	19	YTW311AD331AEK	YTW311AD		9.75										11.62	YTW351AE	0.88	0.69	720	L720	YNA36R15H	L720													
	400	37																																		
Cosmos	450	37	YTW331AD331AE	YTW331AD		12.25										12.75	YTW39AE	0.69	0.75	722	L722	YNA39R15H	L722													
	477	19																																		
Syringa	477	37	YTW39AD39AEK	YTW39AD		14.38										14.75	YTW431AE	2.69	1.25	1.00	724	L724	YNA43R15H	L724												
Hyacinth	500	37																																		
Dahlia	556.5	19																							YTW351AD351AEK	YTW351AD	15.62	16.5	YTW47AE	1.25	1.00	725	L725	YNA451R15H	L725	
Mistletoe	556.5	37																																		
Orchid	600	61			YTW361AD39AEK		YTW361AD	17.13	16.38	YTW484AE	1.25	1.00	727	L727	YNA49R15H										L727											
	636	37																																		
Violet	715.5	37			YTW445AD463AEK		YTW445AD	18.50	0.62	YTW486AE	3.12	1.25	740	L740	YNA52R15H										L728											
Nasturtium	715.5	61																																		
Cattail	750	61																								YTW451AD463AEK	YTW451AD	16.5	17.13	YTW47AE	1.25	1.00	728	L728	YNA54R15H	L729
Arbutus	795	37																																		
Lilac	795	61	YTW391AD431AEK	YTW391AD		14.75										16.38	YTW484AE	3.12	1.25	735	L735	YNA58R15H	L735													
	800	61																																		
Anemone	874.5	37	YTW431AD431AEK	YTW431AD		15.62										0.62	YTW486AE	3.12	1.25	740	L740	YNA59R15H	L740													
Crocus	874.5	61																																		
Magnolia	954	37																						YTW451AD463AEK		YTW451AD	16.5	17.13	YTW47AE	1.25	1.00	728	L728	YNA54R15H	L729	
Goldenrod	954	61																																		
Bluebell	1033.5	37			YTW445AD463AEK		YTW445AD	15.62	16.38	YTW484AE	3.12	1.25	735	L735	YNA58R15H									L735												
	Larkspur	1033.5																							61											
Marigold	1113	37			YTW451AD463AEK		YTW451AD	16.5	17.13	YTW47AE	3.12	1.25	740	L740	YNA52R15H									L728												
	1113	61																																		
Hawthorn	1192.6	61			YTW457AD463AEK		YTW457AD	16.5	0.62	YTW486AE	3.12	1.25	740	L740	YNA59R15H									L740												
Narcissus	1272	61																																		
Columbine	1351.5	61	YTW463AD463AEK	YTW463AD		17.13										16.38	YTW484AE	3.12	1.25	735	L735	YNA58R15H	L735													
	Carnation	1431																							61											
Coreopsis	1590	61	YTW484AD484AEK	YTW484AD		18.50										0.62	YTW486AE	3.12	1.25	740	L740	YNA59R15H	L740													
Jessamine	1750	61																																		
Cowslip	2000	91																							YTW486AD486AE	YTW486AD	16.5	17.13	YTW47AE	1.25	1.00	728	L728	YNA54R15H	L729	
Sagebrush	2250	91																																		
Lupine	2300	61																							YTW486AD486AE	YTW486AD	16.38	0.62	YTW484AE	3.12	1.25	735	L735	YNA58R15H	L735	
	2500	91																																		

* Overlap Crimp.

‡ Wide dies may be used, add suffix "W" to part number (example: L725W).

Complete Assembly: Includes Aluminum Body, Steel eye, 15 degree terminal and aluminum hardware.

For stainless steel hardware add SS to the end of the catalog number. For complete assembly (example: YTW391A431AEKSS) or to terminal (YNA43R15HSS) if ordered separately.

For assembly without terminal and hardware add NT to the end of the complete catalog number (example: YTW391A431AEKNT).

**TYPES YTW-ADT-AEK,
YTW-ADT, YTW-AE,
YNA-RTH EHV**

**Double Pad, EHV Full Tension
Deadend for Stranded
Aluminum Cable**

Full tension compression deadend for SAC transmission line at 345kV and over. Two hole NEMA tap pad supplied through 636 kcmil. Larger sizes have 4 hole NEMA pad. Standard 15° tap pad when used with YNA-R15H terminal provides either 0° or 30° tap. Aluminum body is pre-filled with PENE-TROX™ joint compound and capped.

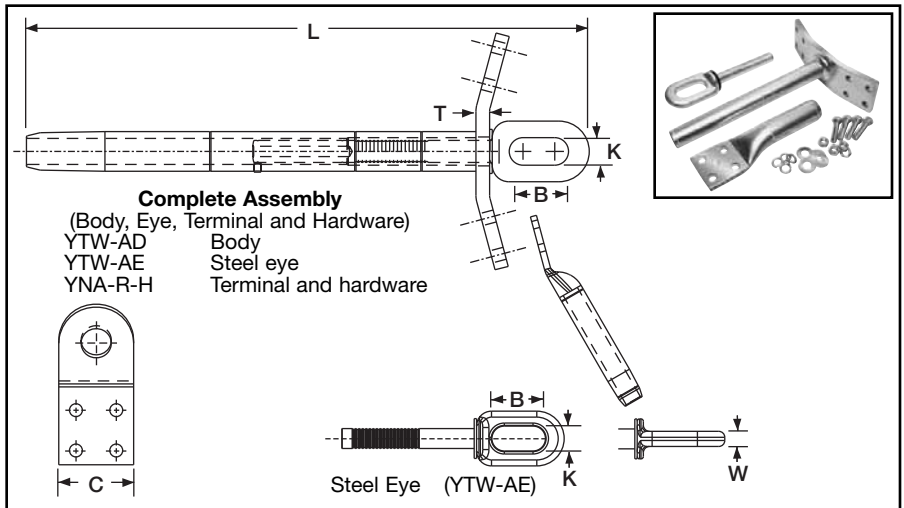

Conductor Name	Aluminum		Single Pad		Inches			Steel Eye	Inches			Tools		Terminal* with Hardware	Terminal Die*‡																		
	kcmil	Str.	Complete Assembly	Aluminum Body	C	L	T		B	K	W	Die Index	Y60BHU*‡																				
Tulip	336.4	19	YTW301ADT331AEK	YTW301ADT	2.25	9.62	0.50	YTW331AE	2.50	0.62	0.88	0.69	717	L717	YNA32R15H	L717																	
	350	37											719	L719	YNA34R15H	L719																	
Canna	397.5	19	YTW311ADT331AEK	YTW311ADT		9.75							11.62	YTW351AE	0.88	0.69	0.75	0.69	720	L720	YNA36R15H	L720											
	400	37																	722	L722	YNA39R15H	L722											
Cosmos	450	37	YTW331ADT331AE	YTW331ADT		12.25							12.75	YTW39AE	0.88	0.69	0.75	0.69	0.69	724	L724	YNA43R15H	L724										
	477	19																		725	L725	YNA451R15H	L725										
Syringa	477	37	YTW351ADT351AEK	YTW351ADT		14.38			14.75	YTW431AE	0.88	0.69	0.75	0.69	0.69	727	L727	YNA49R15H	L727														
Hyacinth	500	37																		YTW361ADT39AEK	YTW361ADT	15.62	15.62	YTW463AE	0.88	0.69	0.75	0.69	0.69	728	L728	YNA52R15H	L728
	Dahlia	556.5																															
Mistletoe		556.5																		37	YTW431ADT431AEK	YTW431ADT	17.13	17.13	YTW48AE	0.88	0.69	0.75	0.69	0.69	730	L730	YNA58R15H
	Orchid	600																		61													
Violet		636																		37	YTW451ADT463AEK	YTW451ADT	16.50	16.50	YTW486AE	0.88	0.69	0.75	0.69	0.69	732	L732	YNA59R15H
	Nasturtium	715.5			37		YTW463ADT463AEK	YTW463ADT												17.13													
Cattail		750			61																YTW47ADT47AEK	YTW47ADT	16.50	16.50	YTW484AE	0.88	0.69	0.75	0.69	0.69	734	L734	YNA59R15H
	Arbutus	795			37		YTW48ADT484AEK	YTW48ADT												17.13													
Lilac		795			61																YTW484ADT484AEK	YTW484ADT	18.50	18.50	YTW486AE	0.88	0.69	0.75	0.69	0.69	736	L736	YNA59R15H
	Anemone	800			61		YTW486ADT486AE	YTW486ADT												16.50													
Crocus		874.5			37																YTW486ADT486AE	YTW486ADT	17.13	17.13	YTW486AE	0.88	0.69	0.75	0.69	0.69	738	L738	YNA59R15H
	Magnolia	954	37	YTW486ADT486AE	YTW486ADT	17.13	17.13	YTW486AE	0.88	0.69	0.75	0.69	0.69	739	L739	YNA59R15H	L739																
Goldenrod		954	61															YTW486ADT486AE	YTW486ADT	18.50	18.50	YTW486AE	0.88	0.69	0.75	0.69	0.69	740	L740	YNA59R15H	L740		
	Bluebell	1033.5	37	YTW486ADT486AE	YTW486ADT	16.50	16.50	YTW486AE	0.88	0.69	0.75	0.69	0.69	741	L741	YNA59R15H	L741																
Larkspur		1033.5	61															YTW486ADT486AE	YTW486ADT	17.13	17.13	YTW486AE	0.88	0.69	0.75	0.69	0.69	742	L742	YNA59R15H	L742		
	Marigold	1113	37	YTW486ADT486AE	YTW486ADT	17.13	17.13	YTW486AE	0.88	0.69	0.75	0.69	0.69	743	L743	YNA59R15H	L743																
Hawthorn		1113	61															YTW486ADT486AE	YTW486ADT	18.50	18.50	YTW486AE	0.88	0.69	0.75	0.69	0.69	744	L744	YNA59R15H	L744		
	Columbine	1192.6	61	YTW486ADT486AE	YTW486ADT	16.50	16.50	YTW486AE	0.88	0.69	0.75	0.69	0.69	745	L745	YNA59R15H	L745																
Narcissus		1272	61															YTW486ADT486AE	YTW486ADT	17.13	17.13	YTW486AE	0.88	0.69	0.75	0.69	0.69	746	L746	YNA59R15H	L746		
	Coreopsis	1351.5	61	YTW486ADT486AE	YTW486ADT	17.13	17.13	YTW486AE	0.88	0.69	0.75	0.69	0.69	747	L747	YNA59R15H	L747																
Carnation		1431	61															YTW486ADT486AE	YTW486ADT	17.13	17.13	YTW486AE	0.88	0.69	0.75	0.69	0.69	748	L748	YNA59R15H	L748		
	Sagebrush	2250	91	YTW486ADT486AE	YTW486ADT	18.50	18.50	YTW486AE	0.88	0.69	0.75	0.69	0.69	749	L749	YNA59R15H	L749																
Lupine		2300	61															YTW486ADT486AE	YTW486ADT	18.50	18.50	YTW486AE	0.88	0.69	0.75	0.69	0.69	750	L750	YNA59R15H	L750		
	Lupine	2500	91	YTW486ADT486AE	YTW486ADT	18.50	18.50	YTW486AE	0.88	0.69	0.75	0.69	0.69	751	L751	YNA59R15H	L751																

* Overlap Crimp.

‡ Wide dies may be used, add suffix "W" to part number (example: L725W).

Complete Assembly: Includes Aluminum Body, Steel eye, 15 degree terminal and aluminum hardware.

For stainless steel hardware add SS to the end of the catalog number. For complete assembly (example: YTW391A431AEKSS) or to terminal (YNA43R15HSS) if ordered separately.

For assembly without terminal and hardware add NT to the end of the complete catalog number (example: YTW391A431AEKNT).

Blue highlighted items are industry standard and most frequently ordered.

TYPE YTS-A

Full Tension Splice for Stranded Aluminum Transmission Line

Full tension splice for Stranded Aluminum Transmission line up to and including 230 kV. Manufactured of aluminum tube with staked-in cable stop. Pre-filled with PENETROX™ joint compound and capped.

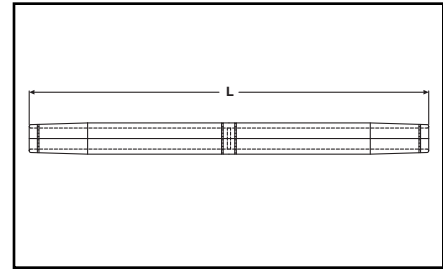
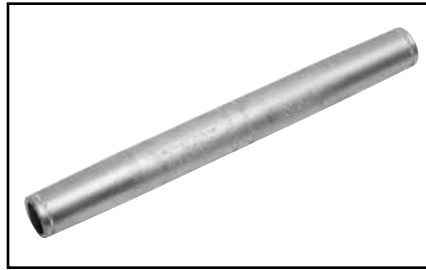

I-20

Conductor Name	Conductor		Catalog Number	Inches L	Tool, Die Sets			
	Aluminum kcmil	Strands			Die Index	Y45*	Y46*	Y60BHU* ‡
Tulip	336.4	19	YTS301A	9.13	717	S725	P725	L725
	350	37	YTS301A	9.13	717	S725	P725	L725
Canna	397.5	19	YTS311A	9.29	719	S719	P719	L719
	400	37	YTS311A	9.29	719	S719	P719	L719
	450	37	YTS331A	9.27	719	S719	P719	L719
Cosmos	477	19	YTS331A	9.27	719	S719	P719	L719
Syringa	477	37	YTS331A	9.27	719	S719	P719	L719
Hyacinth	500	37	YTS351A	11.18	720	S720	P720	L720
Dahila	556.5	19	YTS351A	11.18	720	S720	P720	L720
Mistletoe	556.5	37	YTS351A	11.18	720	S720	P720	L720
	600	61	YTS361A	12.14	722	S722	P722	L722
Orchid	636	37	YTS361A	12.14	722	S722	P722	L722
Violet	715.5	37	YTS39A	13.36	724	S724	P724	L724
Nasturtium	715.5	61	YTS39A	13.36	724	S724	P724	L724
Cattail	750	61	YTS39A	13.36	724	S724	P724	L724
Arbutus	795	37	YTS391A	15.81	724	S724	P724	L724
Lilac	795	61	YTS391A	15.81	724	S724	P724	L724
	800	61	YTS391A	15.81	724	S724	P724	L724
Anemone	874.5	37	YTS431A	16.51	725	S725	P725	L725
Crocus	874.5	61	YTS431A	16.51	725	—	—	L725
Magnolia	954	37	YTS431A	16.51	725	—	—	L725
Goldenrod	954	61	YTS431A	16.51	725	—	—	L725
Bluebell	1033.5	37	YTS445A	18.51	727	—	—	L727
Larkspur	1033.5	61	YTS445A	18.51	727	—	—	L727
	1113	37	YTS445A	18.51	727	—	—	L727
Marigold	1113	61	YTS445A	18.51	727	—	—	L727
Hawthorn	1192.6	61	YTS451A	18.40	727	—	—	L727
Narcissus	1272	61	YTS451A	18.40	727	—	—	L727
Columbine	1351.5	61	YTS457A	19.96	728	—	—	L728
Carnation	1431	61	YTS457A	19.96	728	—	—	L728
Coreopsis	1590	61	YTS463A	21.50	728	—	—	L728
	2300	61	YTS484A	20.19	735	—	—	L735
	2000	169	YTS48A	21.62	735	—	—	L735
Lupine	2500	91	YTS486A	24.28	740	—	—	L740
Jessamine	1750	61	YTS47A	19.96	725	S725	P725	L725

* Overlap Crimps.

‡ Wide dies may be used, add suffix "W" to part number (example: L725W).

Blue highlighted items are industry standard and most frequently ordered.

TYPE YTS-AT EHV

Full Tension Splice for Stranded Aluminum Transmission Line

Full tension splice for Stranded Aluminum Transmission line at 345 kV and over. Manufactured of aluminum tube with staked-in cable stop. Pre-filled with PENETROX™ joint compound and capped.

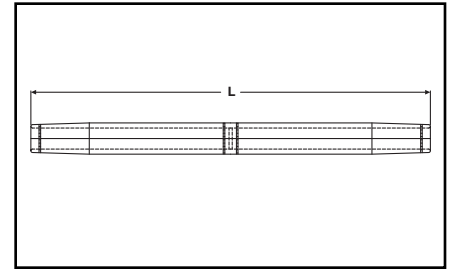
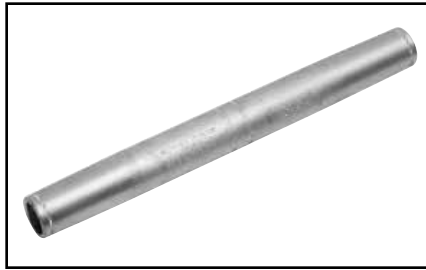

Conductor Name	Conductor		Catalog Number	Inches L	Tool, Die Sets			
	Aluminum kcmil	Strands			Die Index	Y45*	Y46*	Y60BHU* ‡
Tulip	336.4	19	YTS301AT	9.75	717	S725	P725	L725
	350	37	YTS301AT	9.75	717	S725	P725	L725
Canna	397.5	19	YTS311AT	9.99	719	S719	P719	L719
	400	37	YTS311AT	9.99	719	S719	P719	L719
	450	37	YTS331AT	10.01	719	S719	P719	L719
Cosmos	477	19	YTS331AT	10.01	719	S719	P719	L719
Syringa	477	37	YTS331AT	10.01	719	S719	P719	L719
Hyacinth	500	37	YTS351AT	11.88	720	S720	P720	L720
Dahila	556.5	19	YTS351AT	11.88	720	S720	P720	L720
Mistletoe	556.5	37	YTS351AT	11.88	720	S720	P720	L720
	600	61	YTS361AT	12.92	722	S722	P722	L722
Orchid	636	37	YTS361AT	12.92	722	S722	P722	L722
Violet	715.5	37	YTS39AT	14.36	724	S724	P724	L724
Nasturtium	715.5	61	YTS39AT	14.36	724	S724	P724	L724
Cattail	750	61	YTS39AT	14.36	724	S724	P724	L724
Arbutus	795	37	YTS391AT	16.56	724	S724	P724	L724
Lilac	795	61	YTS391AT	16.56	724	S724	P724	L724
	800	61	YTS391AT	16.56	724	S724	P724	L724
Anemone	874.5	37	YTS431AT	17.92	725	S725	P725	L725
Crocus	874.5	61	YTS431AT	17.92	725	S725	P725	L725
Magnolia	954	37	YTS431AT	17.92	725	S725	P725	L725
Goldenrod	954	61	YTS431AT	17.92	725	S725	P725	L725
Bluebell	1033.5	37	YTS445AT	19.57	727	—	—	L727
Larkspur	1033.5	61	YTS445AT	19.57	727	—	—	L727
	1113	37	YTS445AT	19.57	727	—	—	L727
Marigold	1113	61	YTS445AT	19.57	727	—	—	L727
Hawthorn	1192.6	61	YTS451AT	19.24	727	—	—	L727
Narcissus	1272	61	YTS451AT	19.24	727	—	—	L727
Columbine	1351.5	61	YTS457AT	21.08	728	—	—	L728
Carnation	1431	61	YTS457AT	21.08	728	—	—	L728
Coreopsis	1590	61	YTS463AT	22.56	728	—	—	L728
	2300	61	YTS484AT	23.00	735	—	—	L735
	2000	169	YTS48AT	23.02	735	—	—	L735
Lupine	2500	91	YTS486AT	25.40	740	—	—	L740
Jessamine	1750	61	YTS47AT	21.08	725	S725	P725	L725

* Overlap Crimps.

‡ Wide dies may be used, add suffix "W" to part number (example: L725W).

I-21

Blue highlighted items are industry standard and most frequently ordered.

TYPE YTS-AR

Full Tension Splice for ACAR

Full tension splice for ACAR transmission lines up to and including 230 kV. Manufactured of aluminum tube with staked-in cable stop. Pre-filled with PENETROX™ joint compound and capped.

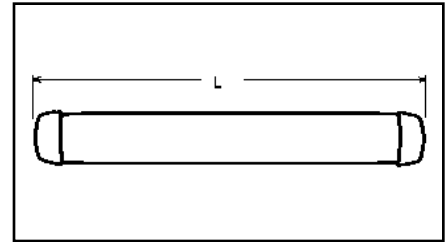
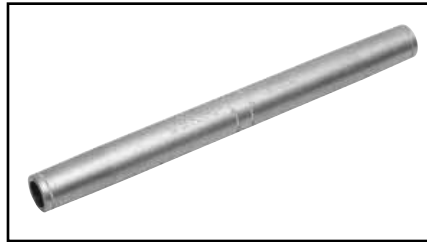

I-22

Catalog Number	Conductor		L	Tool, Die Sets			
	ACAR			Die Index	Y45*	Y46*	Y60BHU* ‡
	kcmil	Str.					
YTS32AR	395.1	12-7	15.25"	717	S717	P717	L717
	395.2	15-7					
YTS39AR	634.9	12-7	16.38"	722	S722	P722	L722
	649.5	18-19					
		15-4					
		12-7					
653.1	18-19						
YTS451AR	840.2	24-13	19.50"	725	S725	P725	L725
	853.7	30-7					
		24-13					
	862.7	18-19					
		30-7					
927.2	24-13						
YTS48AR	983.1	30-7	21.38"	727	—	—	L727
		24-13					
	1012.2	30-7					
		24-13					
		18-19					
	1024.5	30-7					
24-13							
18-19							
1081	30-7						
	24-13						
	18-19						
	30-7						
	24-13						
YTS49AR	1109	30-7	21.42"	727	—	—	L727
		24-13					
		18-19					
	1172	30-7					
		24-13					
		18-19					
1198	30-7						
	24-13						
	18-19						
	42-19						
YTS51AR	1277	42-19	21.50"	728	—	—	L728
		54-7					
	1280	30-7					
		24-13					
YTS55AR	1534	42-19	25.38"	728	—	—	L728
		54-7					
		48-13					
YTS59AR	2267	42-19	23.50"	814	—	—	**
		54-7					
	2338	48-13					
		42-19					
		72-19					
2335	30-61						
YTS592AR	2493	54-37	28.38"	990	—	—	***

* Overlap crimps.

‡ Wide dies may be used, add suffix "W" to part number (example: L725W).

** Use die H814 in Alcoa Press H2H, die M814 in Alcoa Press 150B and die MH814 in Alcoa Press 100A. These dies are manufactured by BURNDY®.

*** Use die H990 in Alcoa Press H2H, die M990 in Alcoa Press 150B and die MH990 in Alcoa Press 100A. These dies are manufactured by BURNDY®.

Blue highlighted items are industry standard and most frequently ordered.

TYPE YTS-ART EHV

Full Tension Splice for ACAR

Full tension splice for ACAR transmission lines at 345 kV and over. Manufactured of aluminum tube with staked-in cable stop. Pre-filled with PENETROX™ joint compound and capped.

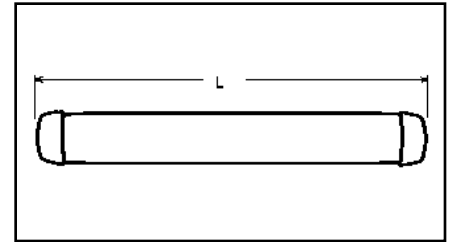
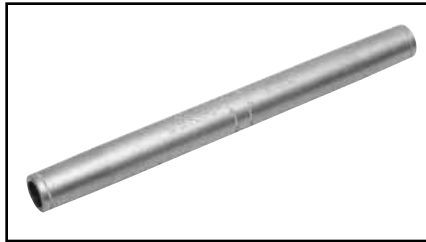

Catalog Number	Conductor		Inches L	Tool, Die Sets			
	ACAR			Die Index	Y45*	Y46*	Y60BHU* ‡
	kcmil	Str.					
YTS32ART	395.1	12-7	15.52	717	S717	P717	L717
	395.2	15-7					
YTS39ART	634.9	12-7	16.95	722	S722	P722	L722
	649.5	18-19					
	653.1	15-4					
		12-7					
YTS451ART	840.2	24-13	20.36	725	S725	P725	L725
	853.7	30-7					
		24-13					
	862.7	18-19					
		30-7					
927.2	24-13						
	18-19						
	30-7						
YTS48ART	983.1	30-7	22.36	727	—	—	L727
	1012.2	24-13					
		30-7					
		24-13					
	1024.5	18-19					
		30-7					
24-13							
1081	18-19						
	30-7						
	24-13						
	18-19						
	30-7						
YTS49ART	1109	30-7	22.38	727	—	—	L727
		24-13					
		18-19					
	1172	30-7					
		24-13					
		18-19					
1198	30-7						
	24-13						
	18-19						
YTS51ART	1277	42-19	22.46	728	—	—	L728
		54-7					
	1280	30-7					
		24-13					
YTS55ART	1534	18-19	26.40	728	—	—	L728
		42-19					
		54-7					
YTS59ART	2267	54-7	24.75	814	—	—	**
		48-13					
	2277	42-19					
		54-7					
	2338	48-13					
		42-19					
2335	72-19						
	30-61						
YTS592ART	2493	54-37	29.40	990	—	—	***

I-23

* Overlap crimps.
 ‡ Wide dies may be used, add suffix "W" to part number (example: L725W).
 ** Use die H814 in Alcoa Press H2H, die M814 in Alcoa Press 150B and die MH814 in Alcoa Press 100A. These dies are manufactured by BURNDY®.
 ***Use die H990 in Alcoa Press H2H, die M990 in Alcoa Press 150B and die MH990 in Alcoa Press 100A. These dies are manufactured by BURNDY®.

Blue highlighted items are industry standard and most frequently ordered.

TYPES YNA-R15 & YNA-R

Compression Terminal for ACAR and Stranded Aluminum Cable

Compression terminal ACAR and Stranded Aluminum Cable. Two hole NEMA tongue supplied through 650 kcmil Aluminum. For transmission line up to and including 230 kV supplied on tongue through 650 kcmil Aluminum. Four hole NEMA supplied on larger sizes. When used with YTW Deadends the 15° angle tongue provides either a 0° or 30° tap. Uses same dies as equivalent full-tension sleeve or deadend. Barrel pre-filled with PENETROX™ joint compound and capped. Pad coated with oxide-retardant.

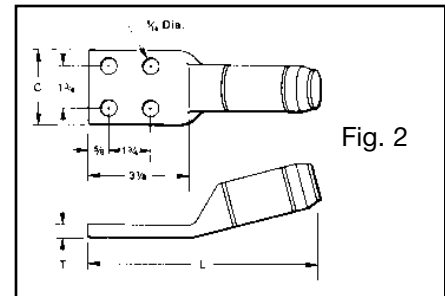
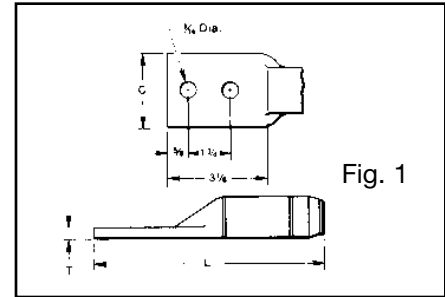
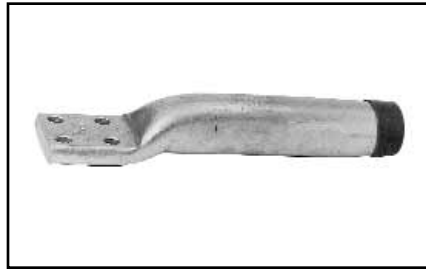

I-24

Catalog Number †		Conductor		Fig. No.	C	L 15°	L Straight	T	Tools, Die Sets				
15°	Straight	ACAR	Aluminum						Die Index	Y45*	Y46*	Y60BHU*‡	
YNA32R15	YNA32R	395.1 - 395.2	336.4 - 350	1	1.68"	9.16"	8.96"	0.39"	717	S717	P717	L717	
YNA34R15	YNA34R	—	397.5 - 477		1.78"	9.31"	9.08"	0.46"	719	S719	P719	L719	
YNA36R15	YNA36R	—	500 - 556.5		1.96"	9.62"	9.47"	0.48"	720	S720	P720	L720	
YNA39R15	YNA39R	634.9 - 653.1	600 - 650		2.08"	10.09"	9.84"	0.53"	722	S722	P722	L722	
YNA43R15	YNA43R	—	700 - 800	2	3.22"	10.16"	10.07"	0.36"	724	S724	P724	L724	
YNA451R15	YNA451R	840.2 927.2	795 1000			10.21"	10.28"	0.45"	725	S725	P725	L725	
YNA49R15	YNA49R	983.1 - 1198	1033.5 - 1272			10.35"	10.46"	0.52"	727			L727	
YNA52R15	YNA52R	1277 - 1280	1351.5 - 1510			12.09"	12.24"	0.71"	728			L728	
YNA54R15	YNA54R	1534	1590 - 1600			13.30"	13.46"	0.71"	728			L728	
YNA56R15	YNA56R	—	1700 - 1800			3.44"	12.50"	12.74"	0.81"	729	—	—	L729
YNA58R15	YNA58R	—	2000			3.47"	13.25"	13.34"	0.80"	735			L735
YNA59R15	YNA59R	—	2250 - 2300			3.57"	13.12"	13.25"	0.64"	735			L735
YNA594R15	YNA594R	2267 - 2500	2500	3.70"	12.81"	14.35"	0.68"	740			L740		

† To specify mounting hardware for bolting to corresponding deadend pad, add suffix "H" to catalog number (example: YNA54RTH).

* Overlap crimps.

‡ Wide dies may be used, add suffix "W" to part number (example: L725W).

Blue highlighted items are industry standard and most frequently ordered.

**TYPES YNA-RT15,
YNA-RT, EHV**

**Compression Terminal for
ACAR and Stranded
Aluminum Cable**

Compression terminal ACAR and Stranded Aluminum Cable. For transmission lines over 230 kV. Two hole NEMA supplied on tongue through 650 kcmil Aluminum. Four hole NEMA supplied on larger sizes. When used with YTW Deadends the 15° angle tongue provides either a 0° or 30° tap. Uses same dies as equivalent full-tension sleeve or deadend. Barrel pre-filled with PENETROX™ joint compound and capped. Pad coated with oxide-retardant.

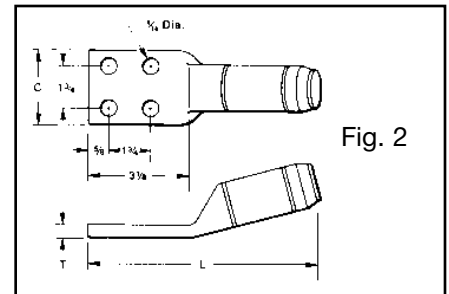
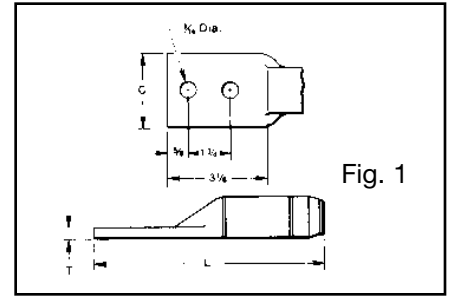
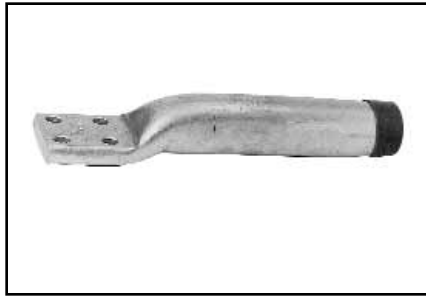

Catalog Number †		Conductor		Fig. No.	C	L 15°	L Straight	T	Tools, Die Sets				
15°	Straight	ACAR	Aluminum						Die Index	Y45*	Y46*	Y60BHU*‡	
YNA32RT15	YNA32RT	395.1 - 395.2	336.4 - 350	1	1.68"	9.04"	9.14"	0.39"	717	S717	P717	L717	
YNA34RT15	YNA34RT	—	397.5 - 477		1.78"	9.21"	9.30"	0.46"	719	S719	P719	L719	
YNA36RT15	YNA36RT	—	500 - 556.5		1.96"	9.63"	9.70"	0.48"	720	S720	P720	L720	
YNA39RT15	YNA39RT	634.9 - 653.1	600 - 650		2.08"	10.02"	10.09"	0.53"	722	S722	P722	L722	
YNA43RT15	YNA43RT	—	700 - 800				10.21"	10.32"	0.36"	724	S724	P724	L724
YNA451RT15 ‡	YNA451RT ‡	840.2 927.2	795 1000	2	3.22"	10.65"	10.57"	0.45"	725	S725	P725	L725	
YNA49RT15 ‡	YNA49RT ‡	983.1 - 1198	1033.5 - 1272			10.94"	10.71"	0.52"	727				L727
YNA52RT15 ‡	YNA52RT ‡	1277 - 1280	1351.5 - 1510			12.62"	13.82"	0.71"	728				L728
YNA54RT15 ‡	YNA54RT ‡	1534	1590 - 1600			14.02"	13.79"	0.71"	728				L728
YNA56RT15 ‡	YNA56RT ‡	—	1700 - 1800			3.44"	13.36"	13.76"	0.81"	729	—	—	L729
YNA58RT15 ‡	YNA58RT ‡	—	2000			3.47"	14.08"	13.70"	0.80"	735			L735
YNA59RT15 ‡	YNA59RT ‡	—	2250 - 2300			3.57"	13.75"	13.54"	0.64"	735			L735
YNA594RT15 ‡	YNA594RT ‡	2267 - 2500	2500			3.70"	13.50"	14.06"	0.68"	740			L740

† To specify mounting hardware for bolting to corresponding deadend pad, add suffix "H" to catalog number (example: YNA54RTH).
 * Overlap crimps.
 ‡ Wide dies may be used, add suffix "W" to part number (example: L725W).
 ‡‡ If shielding caps are required for this item, use Catalog Number STS43A-4N.

Blue highlighted items are industry standard and most frequently ordered.

TYPE YNS-R

**Jumper Loop Sleeve
for ACAR and Stranded
Aluminum Conductor**

Jumper sleeve for ACAR and Stranded Aluminum Cable up to and including 230 kV. Sleeve prefilled with PENETROX™ joint compound and capped.

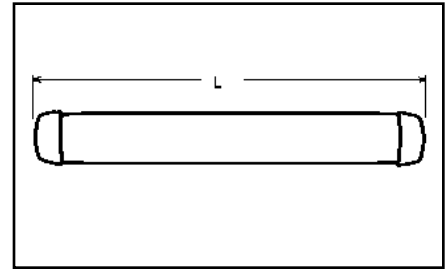
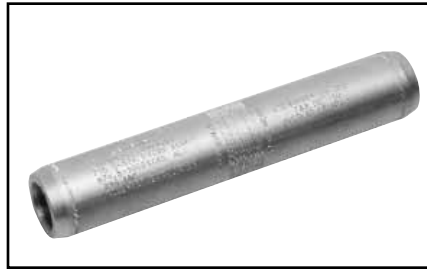

I-26

Catalog Number	Conductor		Inches L	Tools, Die Sets			
	ACAR	Aluminum		Die Index	Y45*	Y46*	Y60BHU*‡
YNS32R	395.1 - 395.2	336.4 - 350	8.60	717	S717	P717	L717
YNS34R	—	397.5 - 477	8.68	719	S719	P719	L719
YNS36R	—	500 - 556.5	9.20	720	S720	P720	L720
YNS39R	634.9 - 655.1	600 - 650	9.76	722	S722	P722	L722
YNS43R	—	700 - 800	9.98	724	S724	P724	L724
YNS451R	840.2 - 927.2	795 - 1000	10.04	725	S725	P725	L725
YNS49R	983.1 - 1198	1033.5 - 1272	10.08	727	—	—	L727
YNS52R	1277 - 1280	1351.5 - 1510	15.48	728	—	—	L728
YNS54R	1534	1590 - 1600	15.48	728	—	—	L728
YNS56R	—	1700 - 1800	14.80	729	—	—	L729
YNS58R	—	2000	14.74	735	—	—	L735
YNS59R	—	2250	14.56	735	—	—	L735
YNS594R	2267 - 2500	2500	14.04	740	—	—	L740

* Overlap crimps.

‡ Wide dies may be used, add suffix "W" to part number (example: L725W).

Blue highlighted items are industry standard and most frequently ordered.

TYPE YNS-RT EHV

**Jumper Loop Sleeve
for ACAR and Stranded
Aluminum Conductor**

Jumper sleeve for ACAR and Stranded Aluminum Cable over 230 kV. Sleeve prefilled with PENETROX™ joint compound and capped.

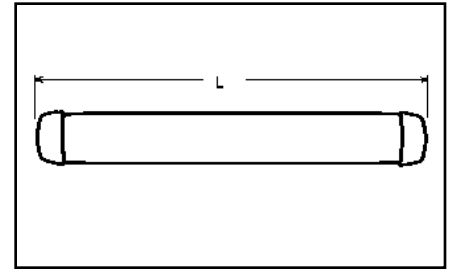
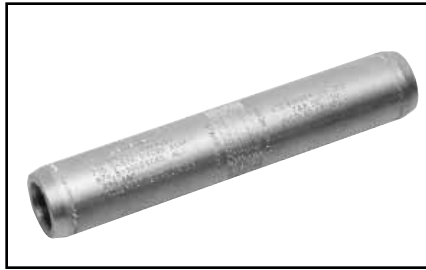

Catalog Number	Conductor		Inches L	Tools, Die Sets			
	ACAR	Aluminum		Die Index	Y45*	Y46*	Y60BHU*‡
YNS32RT	395.1 - 395.2	336.4 - 350	8.86	717	S717	P717	L717
YNS34RT	—	397.5 - 477	9.10	719	S719	P719	L719
YNS36RT	—	500 - 556.5	9.64	720	S720	P720	L720
YNS39RT	634.9 - 655.1	600 - 650	10.26	722	S722	P722	L722
YNS43RT	—	700 - 800	10.48	724	S724	P724	L724
YNS451RT	840.2 - 927.2	795 - 1000	10.60	725	S725	P725	L725
YNS49RT	983.1 - 1198	1033.5 - 1272	10.66	727	—	—	L727
YNS52RT	1277 - 1280	1351.5 - 1510	16.20	728	—	—	L728
YNS54RT	1534	1590 - 1600	16.11	728	—	—	L728
YNS56RT	—	1700 - 1800	15.58	729	—	—	L729
YNS58RT	—	2000	15.46	735	—	—	L735
YNS59RT	—	2250	15.14	735	—	—	L735
YNS594RT	2267 - 2500	2500	16.53	740	—	—	L740

* Overlap crimps.

‡ Wide dies may be used, add suffix "W" to part number (example: L725W).

I-27

Blue highlighted items are industry standard and most frequently ordered.

TYPE YNTA-R

T-Tap With Pad

For ACAR and Stranded Aluminum Cable

Two-piece compression T-Tap with pad for ACAR and Stranded aluminum transmission lines.

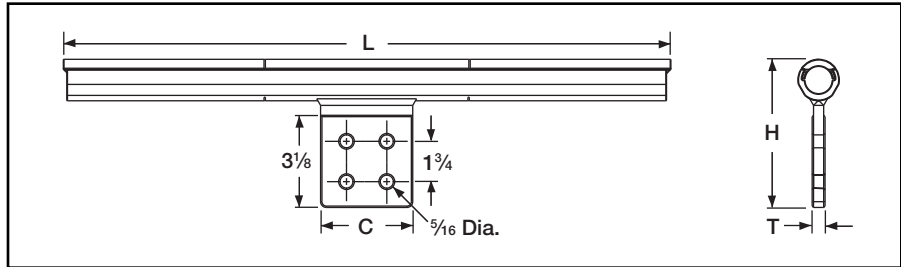
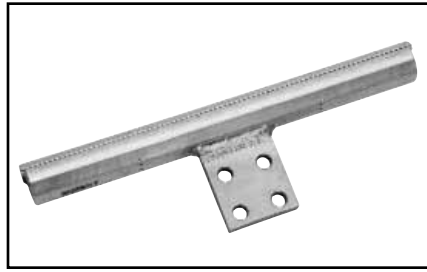

I-28

Catalog Number	Conductor		Fig. No.	Inches				Tools, Die Sets			
	ACAR	Aluminum		L	C	H	T	Die Index	Y45*	Y46*	Y60BHU*‡
YNTA32R	395.1 - 395.2	336.4 - 350	1	15.46	2.00	4.94	0.50	717	S717	P717	L717
YNTA34R		397.5 - 477	1	15.60	2.00	5.05	0.50	719	S719	P719	L719
YNTA36R		500 - 556.5	1	16.29	2.25	5.16	0.56	720	S720	P720	L720
YNTA39R	634.9 - 653.1	600 - 650	1	16.69	2.25	5.25	0.56	722	S722	P722	L722
YNTA43R		700 - 800	2	17.48	3.25	5.36	0.56	724	S724	P724	L724
YNTA451R	840.2 - 927.2	795 - 1000	2	17.60	3.25	5.55	0.56	725	S725	P725	L725
YNTA49R	983.1 - 1198	1033.5 - 1272	2	17.66	3.25	5.72	0.56	727	—	—	L727
YNTA54R		1351.5 - 1600	2	21.61	3.25	6.00	0.69	728	—	—	L728
YNTA56R	1650	1700 - 1800	2	23.65	3.59	6.25	0.69	729	—	—	L729
YNTA58R		2000	2	23.53	3.59	6.25	0.69	735	—	—	L735
YNTA59R		2300	2	23.21	3.59	6.25	0.69	735	—	—	L735
YNTA594R	2267 - 2500	2500	2	24.3	3.59	6.35	0.69	740	—	—	L740

Two hole NEMA pads standard for conductors up to 650 kcmil.

Four hole NEMA pads on larger conductor sizes.

* Overlap crimps.

** For Extra High Voltage (EHV) applications order two tap pad shielding caps STS43A4N. Catalog number indicates 1 cap. Two caps required per assembly.

‡ Wide dies may be used add suffix "W" to the part number (example: L725W).

Blue highlighted items are industry standard and most frequently ordered.

TYPE YNT-R-R

Compression T-Tap

Two-Piece Compression T-Tap for ACAR and Stranded Aluminum Transmission Lines

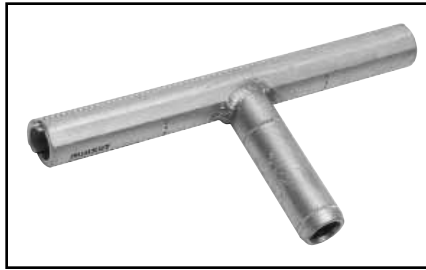

Installed with same dies as equivalent full tension splice. Tap element pre-filled with PENE-TROX™ joint compound.

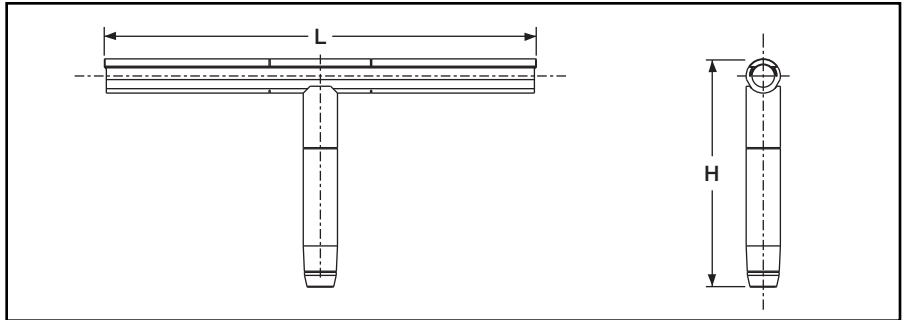

Catalog Number	Conductor		Inches		Tools, Die Sets			
	Run and Tap				Die Index	Y45*	Y46*	Y60BHU*‡
	ACAR	Aluminum	L	H				
YNT32R32R		336.4 - 350	15.46	6.39	717	S717	P717	L717
YNT34R34R		397.5 - 477	15.60	6.53	719	S719	P719	L719
YNT36R36R		500 - 556.5	16.29	6.85	720	S720	P720	L720
YNT39R39R		600 - 650	16.69	7.13	722	S722	P722	L722
YNT43R43R		700 - 800	17.48	7.20	724	S724	P724	L724
YNT451R451R	840.2 - 927.2	795 - 1000	17.60	7.70	725	S725	P725	L725
YNT49R49R		1033.5 - 1272	17.66	7.90	727	—	—	L727
YNT52R52R		1510	21.61	11.10	728	—	—	L728
YNT54R54R		1590 - 1600	21.61	11.10	728	—	—	L728
YNT56R56R	1650	1700 - 1800	23.65	11.08	729	—	—	L729
YNT58R58R		2000	23.53	11.02	735	—	—	L735
YNT59R59R		2300	23.21	10.88	735	—	—	L735
YNT594R594R	2267 - 2500	2500	24.30	11.45	740	—	—	L740

* Overlap Crimps.
 ** For Extra High Voltage (EHV) applications add suffix "T" to the catalog number (example: YBT49R49RT).
 ‡ Wide dies may be used add suffix "W" to the part number (example: L725W).

Blue highlighted items are industry standard and most frequently ordered.

TYPE YNU-R

Repair Sleeve for ACAR and Stranded Aluminum Cable

Two piece repair sleeves for restoring conductivity to damaged ACAR or Stranded Aluminum Cable transmission lines. Installed with same dies as equivalent full tension splice. Use of PENETROX™ joint compound required. For High Voltage and Extra High Voltage (EHV) Applications.

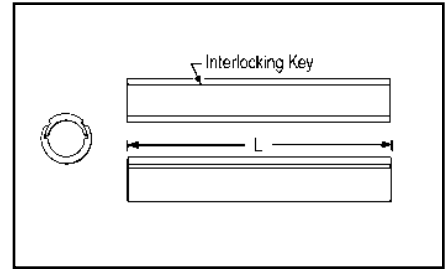

I-30

Catalog Number	Conductor		Inches L	Tools, Die Sets			
	ACAR	Aluminum		Die Index	Y45*	Y46*	Y60BHU*‡
YNU32R	—	336.4 - 350	14.00	717	S717	P717	L717
YNU34R	—	397.5 - 477	14.00	719	S719	P719	L719
YNU36R	—	500 - 556.5	14.00	720	S720	P720	L720
YNU39R	—	600 - 650	16.00	722	S722	P722	L720
YNU43R	—	700 - 800	16.00	724	S724	P724	L724
YNU451R	840.2 - 927.2	795 - 1000	16.00	725	S725	P725	L725
YNU49R	—	1033.5 - 1272	16.00	727	—	—	L727
YNU54R	—	1351.5 - 1600	16.00	728	—	—	L728
YNU56R	—	1700 - 1800	19.00	729	—	—	L729
YNU59R	—	2000 -2300	19.00	735	—	—	L735
YNU594R	2267 - 2500	2500	20.00	740	—	—	L740
YNU595R	2500	2500	24.60	791	—	—	L791

* Overlap Crimps.

‡ Wide dies may be used, add suffix "W" to part number (example: L725W).

Blue highlighted items are industry standard and most frequently ordered.

**TYPES YTW-R-REKHT,
YTW-RHT, YTW-REHT,
BYNA-R-HHT**

**Single Pad Full Tension
Deadend for ACSS Conductor**

Full tension compression deadend for 250°C rated ACSS transmission lines up to and including 230 kV. Standard 15° NEMA tap pad provides either 0° or 30° tap when BYNA-R15 terminal is used.

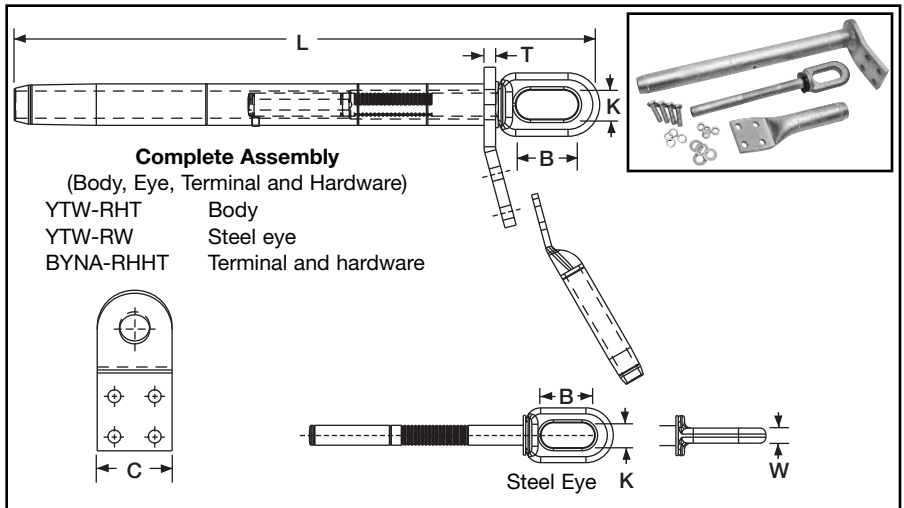

Conductor Name	ACSS		Single Pad		Inches			Body Die*†	Steel Eye	Inches			Eye Die*	Terminal † with Hardware	Term Die*‡	
	Size kcmil	Stranding Alum	Steel	Complete Assembly	Alum. Body	L	C			T	B	K				W
Linnet	336.4	26	7	YTW32R34REKHT	YTW32RHT	21.53	3.25	0.50	L717	YTW34REHT	2.50	0.88	0.62	L718	BYNA32R15HHT	L717
Oriole	336.4	30	7	YTW32R33REKHT	YTW32RHT	21.53	3.25	0.50	L717	YTW33REHT	2.50	0.88	0.62	L718	BYNA32R15HHT	L717
Ibis	397.5	26	7	YTW34R34REKHT	YTW34RHT	21.60	3.25	0.50	L719	YTW34REHT	2.50	0.88	0.62	L718	BYNA34R15HHT	L719
Flicker	477	24	7	YTW36R362REKHT	YTW36RHT	23.41	3.25	0.50	L720	YTW362REHT	2.50	0.88	0.62	L721	BYNA36R15HHT	L720
Hawk	477	26	7	YTW36R36REKHT	YTW36RHT	23.41	3.25	0.50	L720	YTW36REHT	2.50	0.88	0.62	L721	BYNA36R15HHT	L720
Parakeet	556.5	24	7	YTW39R43REKHT	YTW39RHT	23.66	3.25	0.50	L722	YTW43REHT	2.50	0.88	0.69	L723	BYNA39R15HHT	L722
Dove	556.5	26	7	YTW39R43REKHT	YTW39RHT	23.66	3.25	0.50	L722	YTW43REHT	2.50	0.88	0.69	L723	BYNA39R15HHT	L722
Peacock	605	24	7	YTW43R43REKHT	YTW43RHT	24.49	3.25	0.50	L724	YTW43REHT	2.50	0.88	0.69	L723	BYNA43R15HHT	L724
Squab	605	26	7	YTW43R43REKHT	YTW43RHT	24.49	3.25	0.50	L724	YTW43REHT	2.50	0.88	0.69	L723	BYNA43R15HHT	L724
Rook	636	24	7	YTW43R43REKHT	YTW43RHT	24.49	3.25	0.50	L724	YTW43REHT	2.50	0.88	0.69	L723	BYNA43R15HHT	L724
Grosbeak	636	26	7	YTW43R43REKHT	YTW43RHT	24.49	3.25	0.50	L724	YTW43REHT	2.50	0.88	0.69	L723	BYNA43R15HHT	L724
Flamingo	666.6	24	7	YTW43R43REKHT	YTW43RHT	24.49	3.25	0.50	L724	YTW43REHT	2.50	0.88	0.69	L723	BYNA43R15HHT	L724
Starling	715.5	26	7	YTW451R48REKHT	YTW451RHT	29.41	3.25	0.50	L725	YTW48REHT	2.69	1.25	0.75	L726	BYNA451R15HHT	L725
Cuckoo	795	24	7	YTW451R45REKHT	YTW451RHT	29.41	3.25	0.50	L725	YTW45REHT	2.69	1.25	0.75	L726	BYNA451R15HHT	L725
Drake	795	26	7	YTW451R48REKHT	YTW451RHT	29.41	3.25	0.50	L725	YTW48REHT	2.69	1.25	0.75	L726	BYNA451R15HHT	L725
Tern	795	45	7	YTW451R481REKHT	YTW451RHT	29.41	3.25	0.50	L725	YTW481REHT	2.69	1.25	0.75	L726	BYNA451R15HHT	L725
Condor	795	54	7	YTW451R45REKHT	YTW451RHT	29.41	3.25	0.50	L725	YTW45REHT	2.69	1.25	0.75	L726	BYNA451R15HHT	L725
Ruddy	900	45	7	YTW48R481REKHT	YTW48RHT	29.50	3.25	0.50	L727	YTW481REHT	2.69	1.25	0.75	L726	BYNA49R15HHT	L727
Rail	954	45	7	YTW48R481REKHT	YTW48RHT	29.50	3.25	0.50	L727	YTW481REHT	2.69	1.25	0.75	L726	BYNA49R15HHT	L727
Cardinal	954	54	7	YTW48R48REKHT	YTW48RHT	29.50	3.25	0.50	L727	YTW48REHT	2.69	1.25	0.75	L726	BYNA49R15HHT	L727
Ortolan	1033.5	45	7	YTW49R483REKHT	YTW49RHT	31.35	3.25	0.50	L727	YTW483REHT	2.69	1.25	1.00	L726	BYNA49R15HHT	L727
Curlew	1033.5	54	7	YTW49R50REKHT	YTW49RHT	31.35	3.25	0.50	L727	YTW50REHT	2.69	1.25	1.00	L726	BYNA49R15HHT	L727
Bluejay	1113	45	7	YTW49R483REKHT	YTW49RHT	31.35	3.25	0.50	L727	YTW483REHT	2.69	1.25	1.00	L726	BYNA49R15HHT	L727
Finch	1113	54	19	YTW52R50REKHT	YTW52RHT	35.55	3.25	0.50	L728	YTW50REHT	2.69	1.25	1.00	L726	BYNA52R15HHT	L728
Bunting	1192.5	45	7	YTW52R521REKHT	YTW52RHT	35.55	4.00	0.62	L728	YTW521REHT	2.69	1.25	1.00	L726	BYNA52R15HHT	L728
Bittern	1272	45	7	YTW52R521REKHT	YTW52RHT	35.55	4.00	0.62	L728	YTW521REHT	2.69	1.25	1.00	L726	BYNA52R15HHT	L728
Pheasant	1272	54	19	YTW52R56REKHT	YTW52RHT	35.55	4.00	0.62	L728	YTW56REHT	2.69	1.25	1.00	L726	BYNA52R15HHT	L728
Dipper	1351.5	45	7	YTW52R521REKHT	YTW52RHT	35.55	4.00	0.62	L728	YTW521REHT	2.69	1.25	1.00	L726	BYNA52R15HHT	L728
Martin	1351.5	54	19	YTW52R56REKHT	YTW52RHT	35.55	4.00	0.62	L728	YTW56REHT	2.69	1.25	1.00	L726	BYNA52R15HHT	L728
Nuthatch	1510.5	45	7	YTW549R521REKHT	YTW549RHT	35.55	4.00	0.62	L729	YTW521REHT	2.69	1.25	1.00	L726	BYNA56R15HHT	L729
Parrot	1510.5	54	19	YTW549R56REKHT	YTW549RHT	35.55	4.00	0.62	L729	YTW56REHT	2.69	1.25	1.00	L726	BYNA56R15HHT	L729
Lapwing	1590	45	7	YTW549R549REKHT	YTW549RHT	35.55	4.00	0.62	L729	YTW549REHT	2.69	1.25	1.00	L726	BYNA56R15HHT	L729
Falcon	1590	54	19	YTW56R590REKHT	YTW56RHT	35.99	4.00	0.62	L729	YTW590REHT	2.69	1.25	1.00	L726	BYNA56R15HHT	L729
Chukar	1780	84	19	YTW58R58REKHT	YTW58RHT	36.99	4.00	0.62	L735	YTW58REHT	2.69	1.25	1.00	L726	BYNA58R15HHT	L735
Bluebird	2156	84	19	YTW59R59REKHT	YTW59RHT	37.34	4.00	0.62	L735	YTW59REHT	2.69	1.25	1.00	L726	BYNA59R15HHT	L735
Kiwi	2167	72	7	YTW59R591REKHT	YTW59RHT	37.34	4.00	0.62	L735	YTW591REHT	2.69	1.25	1.00	L726	BYNA59R15HHT	L735

Complete Assembly: Includes Aluminum body, Steel eye, 15 degree terminal and aluminum hardware. For stainless steel hardware add SS to end of catalog number for complete assembly (example: YTW32R34REKHTSS) or to terminal if ordered separately (BYNA32R15HTSSHTSS).

For assembly without terminal and hardware add NT to end of complete assembly catalog number (example: YTW32R34REKHTNT).
† BYNA terminals must be crimped from cable end moving toward pad end.

* Overlap crimps
‡ Wide dies may be used, add suffix "W" to part number (example: L725W).

Blue highlighted items are industry standard and most frequently ordered.

TYPES YTW-RD-REKHT, YTW-RDHT, YTW-REHT, BYNA-R-HHT

Double Pad Full Tension Deadend for ACSS Conductor

Full tension compression deadend for 250°C rated ACSS transmission lines up to and including 230 kV. Standard 15° NEMA tap pads provide either 0° or 30° tap when BYNA-R15 terminal is used.

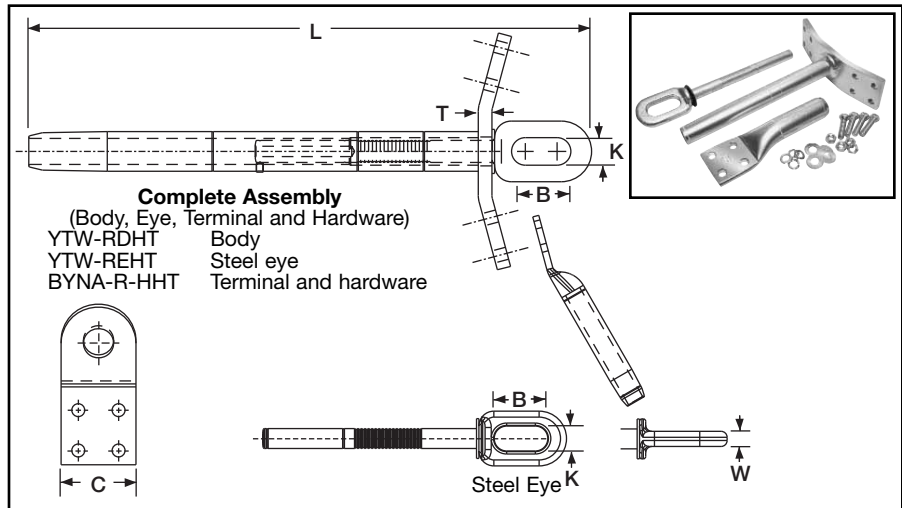

Conductor Name	ACSS		Double Pad		Inches			Body Die* †	Steel Eye	Inches			Eye Die*	Terminal † with Hardware	Term Die* †	
	Size kcmil	Stranding Alum	Stranding Steel	Complete Assembly	Alum. Body	L	C			T	B	K				W
Linnet	336.4	26	7	YTW32RD34REKHT	YTW32RDHT	21.53	3.25	0.50	L717	YTW34REHT	2.50	0.88	0.62	L718	BYNA32R15HHT	L717
Oriole	336.4	30	7	YTW32RD33REKHT	YTW32RDHT	21.53	3.25	0.50	L717	YTW33REHT	2.50	0.88	0.62	L718	BYNA32R15HHT	L717
Ibis	397.5	26	7	YTW34RD34REKHT	YTW34RDHT	21.60	3.25	0.50	L719	YTW34REHT	2.50	0.88	0.62	L718	BYNA34R15HHT	L719
Flicker	477	24	7	YTW36RD362REKHT	YTW36RDHT	23.41	3.25	0.50	L720	YTW362REHT	2.50	0.88	0.62	L721	BYNA36R15HHT	L720
Hawk	477	26	7	YTW36RD36REKHT	YTW36RDHT	23.41	3.25	0.50	L720	YTW36REHT	2.50	0.88	0.62	L721	BYNA36R15HHT	L720
Parakeet	556.5	24	7	YTW39RD43REKHT	YTW39RDHT	23.66	3.25	0.50	L722	YTW43REHT	2.50	0.88	0.69	L723	BYNA39R15HHT	L722
Dove	556.5	26	7	YTW39RD43REKHT	YTW39RDHT	23.66	3.25	0.50	L722	YTW43REHT	2.50	0.88	0.69	L723	BYNA39R15HHT	L722
Peacock	605	24	7	YTW43RD43REKHT	YTW43RDHT	24.49	3.25	0.50	L724	YTW43REHT	2.50	0.88	0.69	L723	BYNA43R15HHT	L724
Squab	605	26	7	YTW43RD43REKHT	YTW43RDHT	20.49	3.25	0.50	L724	YTW43REHT	2.50	0.88	0.69	L723	BYNA43R15HHT	L724
Rook	636	24	7	YTW43RD43REKHT	YTW43RDHT	24.49	3.25	0.50	L724	YTW43REHT	2.50	0.88	0.69	L723	BYNA43R15HT	L724
Grosbeak	636	26	7	YTW43RD43REKHT	YTW43RDHT	24.49	3.25	0.50	L724	YTW43REHT	2.50	0.88	0.69	L723	BYNA43R15HHT	L724
Flamingo	666.6	24	7	YTW43RD43REKHT	YTW43RDHT	24.49	3.25	0.50	L724	YTW43REHT	2.50	0.88	0.69	L723	BYNA43R15HHT	L724
Starling	715.5	26	7	YTW451RD48REKHT	YTW451RDHT	29.41	3.25	0.50	L725	YTW48REHT	2.69	1.25	0.75	L726	BYNA451R15HHT	L725
Cuckoo	795	24	7	YTW451RD45REKHT	YTW451RDHT	29.41	3.25	0.50	L725	YTW45REHT	2.69	1.25	0.75	L726	BYNA451R15HHT	L725
Drake	795	26	7	YTW451RD48REKHT	YTW451RDHT	29.41	3.25	0.50	L725	YTW48REHT	2.69	1.25	0.75	L726	BYNA451R15HHT	L725
Tern	795	45	7	YTW451RD481REKHT	YTW451RDHT	29.41	3.25	0.50	L725	YTW481REHT	2.69	1.25	0.75	L726	BYNA451R15HHT	L725
Condor	795	54	7	YTW451RD45REKHT	YTW451RDHT	29.41	3.25	0.50	L725	YTW45REHT	2.69	1.25	0.75	L726	BYNA451R15HHT	L725
Ruddy	900	45	7	YTW48RD481REKHT	YTW48RDHT	29.50	3.25	0.50	L727	YTW481REHT	2.69	1.25	0.75	L726	BYNA48R15HHT	L727
Rail	954	45	7	YTW48RD481REKHT	YTW48RDHT	29.50	3.25	0.50	L727	YTW481REHT	2.69	1.25	0.75	L726	BYNA48R15HHT	L727
Cardinal	954	54	7	YTW48RD48REKHT	YTW48RDHT	29.50	3.25	0.50	L727	YTW48REHT	2.69	1.25	0.75	L726	BYNA48R15HHT	L727
Ortolan	1033.5	45	7	YTW49RD483REKHT	YTW49RDHT	31.35	3.25	0.50	L727	YTW483REHT	2.69	1.25	1.00	L726	BYNA49R15HHT	L727
Curlew	1033.5	54	7	YTW49RD50REKHT	YTW49RDHT	31.35	3.25	0.50	L727	YTW50REHT	2.69	1.25	1.00	L726	BYNA49R15HHT	L727
Bluejay	1113	45	7	YTW49RD483REKHT	YTW49RDHT	31.35	3.25	0.50	L727	YTW483REHT	2.69	1.25	1.00	L726	BYNA49R15HHT	L727
Finch	1113	54	19	YTW52RD50REKHT	YTW52RDHT	35.55	3.25	0.50	L728	YTW50REHT	2.69	1.25	1.00	L726	BYNA52R15HHT	L728
Bunting	1192.5	45	7	YTW52RD521REKHT	YTW52RDHT	35.55	4.00	0.62	L728	YTW521REHT	2.69	1.25	1.00	L726	BYNA52R15HHT	L728
Bittern	1272	45	7	YTW52RD521REKHT	YTW52RDHT	35.55	4.00	0.62	L728	YTW521REHT	2.69	1.25	1.00	L726	BYNA52R15HHT	L728
Pheasant	1272	54	19	YTW52RD56REKHT	YTW52RDHT	35.55	4.00	0.62	L728	YTW56REHT	2.69	1.25	1.00	L726	BYNA52R15HHT	L728
Dipper	1351.5	45	7	YTW52RD521REKHT	YTW52RDHT	35.55	4.00	0.62	L728	YTW521REHT	2.69	1.25	1.00	L726	BYNA52R15HHT	L728
Martin	1351.5	54	19	YTW52RD56REKHT	YTW52RDHT	35.55	4.00	0.62	L728	YTW56REHT	2.69	1.25	1.00	L726	BYNA52R15HHT	L728
Nuthatch	1510.5	45	7	YTW549RD521REKHT	YTW549RDHT	35.55	4.00	0.62	L729	YTW521REHT	2.69	1.25	1.00	L726	BYNA56R15HHT	L729
Parrot	1510.5	54	19	YTW549RD56REKHT	YTW549RDHT	35.55	4.00	0.62	L729	YTW56REHT	2.69	1.25	1.00	L726	BYNA56R15HHT	L729
Lapwing	1590	45	7	YTW549RD549REKHT	YTW549RDHT	35.55	4.00	0.62	L729	YTW549REHT	2.69	1.25	1.00	L726	BYNA56R15HHT	L729
Falcon	1590	54	19	YTW56RD590REKHT	YTW56RDHT	35.99	4.00	0.62	L729	YTW590REHT	2.69	1.25	1.00	L726	BYNA56R15HHT	L729
Chukar	1780	84	19	YTW58RD58REKHT	YTW58RDHT	36.99	4.00	0.62	L735	YTW58REHT	2.69	1.25	1.00	L726	BYNA58R15HHT	L735
Bluebird	2156	84	19	YTW59RD59REKHT	YTW59RDHT	37.34	4.00	0.62	L735	YTW59REHT	2.69	1.25	1.00	L726	BYNA59R15HHT	L735
Kiwi	2167	72	7	YTW59RD591REKHT	YTW59RDHT	37.34	4.00	0.62	L735	YTW591REHT	2.69	1.25	1.00	L726	BYNA59R15HHT	L735

Complete Assembly: Includes Aluminum body, Steel eye, 15 degree terminal and aluminum hardware. For stainless steel hardware add SS to end of catalog number for complete assembly (example: YTW32R34REKHTSS) or to terminal if ordered separately (BYNA32R15HTSSHTSS).

For assembly without terminal and hardware add NT to end of complete assembly catalog number (example: YTW32R34REKHTNT).

† BYNA terminals must be crimped from cable end moving toward pad end.

* Overlap crimps

‡ Wide dies may be used, add suffix "W" to part number (example: L725W).

Blue highlighted items are industry standard and most frequently ordered.

TYPES
YTW-RT-REKHT,
YTW-RTHT, YTW-REHT,
BYNA-RT-HHT EHV

Single Pad, EHV
Full Tension Deadend
for ACSS Conductor

Full tension compression deadend for 250°C rated ACSS transmission lines at 345 kV and over. Standard 15° NEMA tap pad provides either 0° or 30° tap when BYNA-RT15 terminal is used.

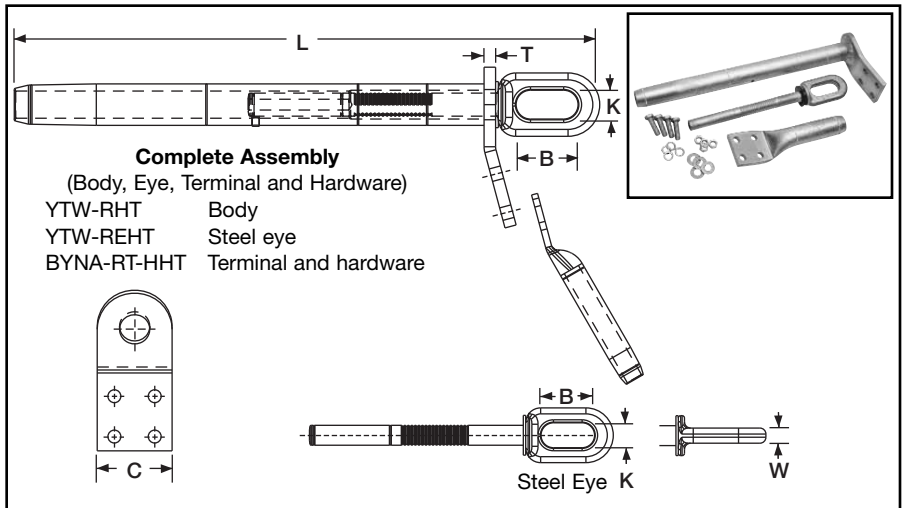

Conductor Name	ACSS			Single Pad		Inches			Body Die*†	Steel Eye	Inches			Eye Die*	Terminal † with Hardware	Term Die*‡
	Size kcmil	Stranding Alum	Steel	Complete Assembly	Alum. Body	L	C	T			B	K	W			
Linnet	336.4	26	7	YTW32RT34REKHT	YTW32RTHT	21.53	3.25	0.50	L717	YTW34REHT	2.50	0.88	0.62	L718	BYNA32RT15HHT	L717
Oriole	336.4	30	7	YTW32RT33REKHT	YTW32RTHT	21.53	3.25	0.50	L717	YTW33REHT	2.50	0.88	0.62	L718	BYNA32RT15HHT	L717
Ibis	397.5	26	7	YTW34RT34REKHT	YTW34RTHT	21.60	3.25	0.50	L719	YTW34REHT	2.50	0.88	0.62	L718	BYNA34RT15HHT	L719
Flicker	477	24	7	YTW36RT362REKHT	YTW36RTHT	23.41	3.25	0.50	L720	YTW362REHT	2.50	0.88	0.62	L721	BYNA36RT15HHT	L720
Hawk	477	26	7	YTW36RT36REKHT	YTW36RTHT	23.41	3.25	0.50	L720	YTW36REHT	2.50	0.88	0.62	L721	BYNA36RT15HHT	L720
Parakeet	556.5	24	7	YTW39RT43REKHT	YTW39RTHT	23.66	3.25	0.50	L722	YTW43REHT	2.50	0.88	0.69	L723	BYNA39RT15HHT	L722
Dove	556.5	26	7	YTW39RT43REKHT	YTW39RTHT	23.66	3.25	0.50	L722	YTW43REHT	2.50	0.88	0.69	L723	BYNA39RT15HHT	L722
Peacock	605	24	7	YTW43RT43REKHT	YTW43RTHT	24.49	3.25	0.50	L724	YTW43REHT	2.50	0.88	0.69	L723	BYNA43RT15HHT	L724
Squab	605	26	7	YTW43RT43REKHT	YTW43RTHT	24.49	3.25	0.50	L724	YTW43REHT	2.50	0.88	0.69	L723	BYNA43RT15HHT	L724
Rook	636	24	7	YTW43RT43REKHT	YTW43RTHT	24.49	3.25	0.50	L724	YTW43REHT	2.50	0.88	0.69	L723	BYNA43RT15HHT	L724
Grosbeak	636	26	7	YTW43RT43REKHT	YTW43RTHT	24.49	3.25	0.50	L724	YTW43REHT	2.50	0.88	0.69	L723	BYNA43RT15HHT	L724
Flamingo	666.6	24	7	YTW43RT43REKHT	YTW43RTHT	24.49	3.25	0.50	L724	YTW43REHT	2.50	0.88	0.69	L723	BYNA43RT15HHT	L724
Starling	715.5	26	7	YTW451RT48REKHT	YTW451RTHT	29.41	3.25	0.50	L725	YTW48REHT	2.69	1.25	0.75	L726	BYNA451RT15HHT	L725
Cuckoo	795	24	7	YTW451RT45REKHT	YTW451RTHT	29.41	3.25	0.50	L725	YTW45REHT	2.69	1.25	0.75	L726	BYNA451RT15HHT	L725
Drake	795	26	7	YTW451RT48REKHT	YTW451RTHT	29.41	3.25	0.50	L725	YTW48REHT	2.69	1.25	0.75	L726	BYNA451RT15HHT	L725
Tern	795	45	7	YTW451RT481REKHT	YTW451RTHT	29.41	3.25	0.50	L725	YTW481REHT	2.69	1.25	0.75	L726	BYNA451RT15HHT	L725
Condor	795	54	7	YTW451RT45REKHT	YTW451RTHT	29.41	3.25	0.50	L725	YTW45REHT	2.69	1.25	0.75	L726	BYNA451RT15HHT	L725
Ruddy	900	45	7	YTW48RT481REKHT	YTW48RTHT	29.50	3.25	0.50	L727	YTW481REHT	2.69	1.25	0.75	L726	BYNA48RT15HHT	L727
Rail	954	45	7	YTW48RT481REKHT	YTW48RTHT	29.50	3.25	0.50	L727	YTW481REHT	2.69	1.25	0.75	L726	BYNA48RT15HHT	L727
Cardinal	954	54	7	YTW48RT48REKHT	YTW48RTHT	29.50	3.25	0.50	L727	YTW48REHT	2.69	1.25	0.75	L726	BYNA48RT15HHT	L727
Ortolan	1033.5	45	7	YTW49RT483REKHT	YTW49RTHT	31.35	3.25	0.50	L727	YTW483REHT	2.69	1.25	1.00	L726	BYNA49RT15HHT	L727
Curlew	1033.5	54	7	YTW49RT50REKHT	YTW49RTHT	31.35	3.25	0.50	L727	YTW50REHT	2.69	1.25	1.00	L726	BYNA49RT15HHT	L727
Bluejay	1113	45	7	YTW49RT483REKHT	YTW49RTHT	31.35	3.25	0.50	L727	YTW483REHT	2.69	1.25	1.00	L726	BYNA49RT15HHT	L727
Finch	1113	54	19	YTW52RT50REKHT	YTW52RHT	35.55	4.00	0.62	L728	YTW50REHT	2.69	1.25	1.00	L726	BYNA52RT15HHT	L728
Bunting	1192.5	45	7	YTW52RT521REKHT	YTW52RTHT	35.55	4.00	0.62	L728	YTW521REHT	2.69	1.25	1.00	L726	BYNA52RT15HHT	L728
Bittern	1272	45	7	YTW52RT521REKHT	YTW52RTHT	35.55	4.00	0.62	L728	YTW521REHT	2.69	1.25	1.00	L726	BYNA52RT15HHT	L728
Pheasant	1272	54	19	YTW52RT56REKHT	YTW52RHT	35.55	4.00	0.62	L728	YTW56REHT	2.69	1.25	1.00	L726	BYNA52RT15HHT	L728
Dipper	1351.5	45	7	YTW52RT521REKHT	YTW52RTHT	35.55	4.00	0.62	L728	YTW521REHT	2.69	1.25	1.00	L726	BYNA52RT15HHT	L728
Martin	1351.5	54	19	YTW52RT56REKHT	YTW52RHT	35.55	4.00	0.62	L728	YTW56REHT	2.69	1.25	1.00	L726	BYNA52RT15HHT	L728
Nuthatch	1510.5	45	7	YTW549RT521REKHT	YTW549RTHT	35.55	4.00	0.62	L729	YTW521REHT	2.69	1.25	1.00	L726	BYNA549RT15HHT	L729
Parrot	1510.5	54	19	YTW549RT56REKHT	YTW549RTHT	35.55	4.00	0.62	L729	YTW56REHT	2.69	1.25	1.00	L726	BYNA56RT15HHT	L729
Lapwing	1590	45	7	YTW549RT549REKHT	YTW549RTHT	35.55	4.00	0.62	L729	YTW549REHT	2.69	1.25	1.00	L726	BYNA56RT15HHT	L729
Falcon	1590	54	19	YTW56RT590REKHT	YTW56RTHT	35.99	4.00	0.62	L729	YTW590REHT	2.69	1.25	1.00	L726	BYNA56RT15HHT	L729
Chukar	1780	84	19	YTW58RT58REKHT	YTW58RTHT	36.99	4.00	0.62	L735	YTW58REHT	2.69	1.25	1.00	L726	BYNA58RT15HHT	L735
Bluebird	2156	84	19	YTW59RT59REKHT	YTW59RTHT	37.34	4.00	0.62	L735	YTW59REHT	2.69	1.25	1.00	L726	BYNA59RT15HHT	L735
Kiwi	2167	72	7	YTW59RT591REKHT	YTW59RTHT	37.34	4.00	0.62	L735	YTW591REHT	2.69	1.25	1.00	L726	BYNA59RT15HHT	L735

Complete Assembly: Includes Aluminum body, Steel eye, 15 degree terminal and aluminum hardware. For stainless steel hardware add SS to end of catalog number for complete assembly (example: YTW32R34REKHTSS) or terminal if ordered separately (BYNA32R15HTSSHTSS).

For assembly without terminal and hardware add NT to end of complete assembly catalog number (example: YTW32R34REKHTNT).
† BYNA terminals must be crimped from cable end moving toward pad end.

* Overlap crimps
‡ Wide dies may be used, add suffix "W" to part number (example: L725W).

Blue highlighted items are industry standard and most frequently ordered.

TYPES YTW-RDT-REKHT, YTW-RDTHT, BYNA-RT-HHT EHV

Double Pad, EHV Full Tension Deadend for ACSS Conductor

Full tension compression deadend for 250°C rated ACSS transmission lines at 345 kV and over. Standard 15° NEMA tap pad provides either 0° or 30° tap when BYNA-R15 terminal is used.

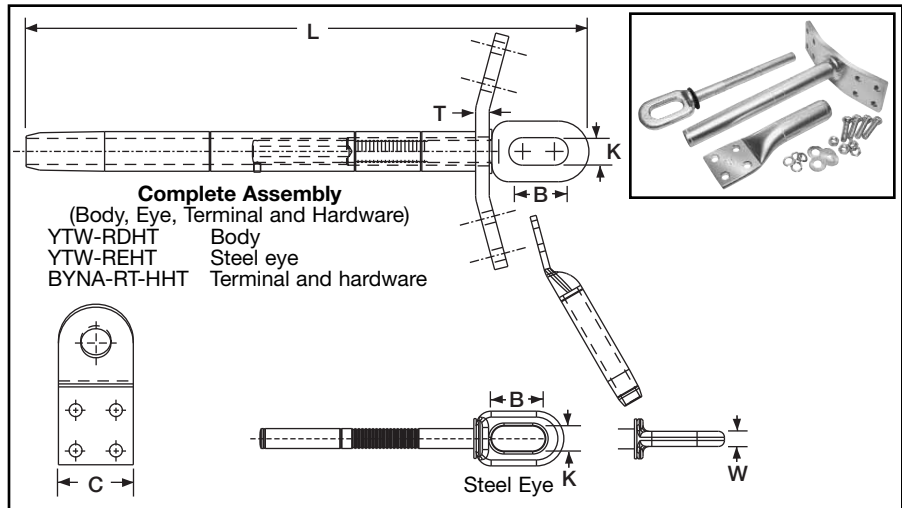

Conductor Name	ACSS		Double Pad		Inches			Body Die*‡	Steel Eye	Inches			Eye Die*	Terminal † with Hardware	Term Die*‡	
	Size kcmil	Stranding Alum	Stranding Steel	Complete Assembly	Alum. Body	L	C			T	B	K				W
Linnet	336.4	26	7	YTW32RDT34REKHT	YTW32RDTHT	21.53	3.25	0.50	L717	YTW34REHT	2.50	0.88	0.62	L718	BYNA32RT15HHT	L717
Oriole	336.4	30	7	YTW32RDT33REKHT	YTW32RDTHT	21.53	3.25	0.50	L717	YTW33REHT	2.50	0.88	0.62	L718	BYNA32RT15HHT	L717
Ibis	397.5	26	7	YTW34RDT34REKHT	YTW34RDTHT	21.60	3.25	0.50	L719	YTW34REHT	2.50	0.88	0.62	L718	BYNA34RT15HHT	L719
Flicker	477	24	7	YTW36RDT36REKHT	YTW36RDTHT	23.41	3.25	0.50	L720	YTW36REHT	2.50	0.88	0.62	L721	BYNA36RT15HHT	L720
Hawk	477	26	7	YTW36RDT36REKHT	YTW36RDTHT	23.41	3.25	0.50	L720	YTW36REHT	2.50	0.88	0.62	L721	BYNA36RT15HHT	L720
Parakeet	556.5	24	7	YTW39RDT43REKHT	YTW39RDTHT	23.66	3.25	0.50	L722	YTW43REHT	2.50	0.88	0.69	L723	BYNA39RT15HHT	L722
Dove	556.5	26	7	YTW39RDT43REKHT	YTW39RDTHT	23.66	3.25	0.50	L722	YTW43REHT	2.50	0.88	0.69	L723	BYNA39RT15HHT	L722
Peacock	605	24	7	YTW43RDT43REKHT	YTW43RDTHT	24.49	3.25	0.50	L724	YTW43REHT	2.50	0.88	0.69	L723	BYNA43RT15HHT	L724
Squab	605	26	7	YTW43RDT43REKHT	YTW43RDTHT	20.49	3.25	0.50	L724	YTW43REHT	2.50	0.88	0.69	L723	BYNA43RT15HHT	L724
Rook	636	24	7	YTW43RDT43REKHT	YTW43RDTHT	24.49	3.25	0.50	L724	YTW43REHT	2.50	0.88	0.69	L723	BYNA43RT15HHT	L724
Grosbeak	636	26	7	YTW43RDT43REKHT	YTW43RDTHT	24.49	3.25	0.50	L724	YTW43REHT	2.50	0.88	0.69	L723	BYNA43RT15HHT	L724
Flamingo	666.6	24	7	YTW43RDT43REKHT	YTW43RDTHT	24.49	3.25	0.50	L724	YTW43REHT	2.50	0.88	0.69	L723	BYNA43RT15HHT	L724
Starling	715.5	26	7	YTW451RDT48REKHT	YTW451RDTHT	29.41	3.25	0.50	L725	YTW48REHT	2.69	1.25	0.75	L726	BYNA451RT15HHT	L725
Cuckoo	795	24	7	YTW451RDT45REKHT	YTW451RDTHT	29.41	3.25	0.50	L725	YTW45REHT	2.69	1.25	0.75	L726	BYNA451RT15HHT	L725
Drake	795	26	7	YTW451RDT48REKHT	YTW451RDTHT	29.41	3.25	0.50	L725	YTW48REHT	2.69	1.25	0.75	L726	BYNA451RT15HHT	L725
Tern	795	45	7	YTW451RDT481REKHT	YTW451RDTHT	29.41	3.25	0.50	L725	YTW481REHT	2.69	1.25	0.75	L726	BYNA451RT15HHT	L725
Condor	795	54	7	YTW451RDT45REKHT	YTW451RDTHT	29.41	3.25	0.50	L725	YTW45REHT	2.69	1.25	0.75	L726	BYNA451RT15HHT	L725
Ruddy	900	45	7	YTW48RDT481REKHT	YTW48RDTHT	29.50	3.25	0.50	L727	YTW481REHT	2.69	1.25	0.75	L726	BYNA49RT15HHT	L727
Rail	954	45	7	YTW48RDT481REKHT	YTW48RDTHT	29.50	3.25	0.50	L727	YTW481REHT	2.69	1.25	0.75	L726	BYNA49RT15HHT	L727
Cardinal	954	54	7	YTW48RDT48REKHT	YTW48RDTHT	29.50	3.25	0.50	L727	YTW48REHT	2.69	1.25	0.75	L726	BYNA49RT15HHT	L727
Ortolan	1033.5	45	7	YTW49RDT483REKHT	YTW49RDTHT	31.35	3.25	0.50	L727	YTW483REHT	2.69	1.25	1.00	L726	BYNA49RT15HHT	L727
Curlew	1033.5	54	7	YTW49RDT50REKHT	YTW49RDTHT	31.35	3.25	0.50	L727	YTW50REHT	2.69	1.25	1.00	L726	BYNA49RT15HHT	L727
Bluejay	1113	45	7	YTW49RDT483REKHT	YTW49RDTHT	31.35	3.25	0.50	L727	YTW483REHT	2.69	1.25	1.00	L726	BYNA49RT15HHT	L727
Finch	1113	54	19	YTW52RDT50REKHT	YTW52RDTHT	35.55	3.25	0.50	L728	YTW50REHT	2.69	1.25	1.00	L726	BYNA52RT15HHT	L728
Bunting	1192.5	45	7	YTW52RDT521REKHT	YTW52RDTHT	35.55	4.00	0.62	L728	YTW521REHT	2.69	1.25	1.00	L726	BYNA52RT15HHT	L728
Bittern	1272	45	7	YTW52RDT521REKHT	YTW52RDTHT	35.55	4.00	0.62	L728	YTW521REHT	2.69	1.25	1.00	L726	BYNA52RT15HHT	L728
Pheasant	1272	54	19	YTW52RDT56REKHT	YTW52RDTHT	35.55	4.00	0.62	L728	YTW56REHT	2.69	1.25	1.00	L726	BYNA52RT15HHT	L728
Dipper	1351.5	45	7	YTW52RDT521REKHT	YTW52RDTHT	35.55	4.00	0.62	L728	YTW521REHT	2.69	1.25	1.00	L726	BYNA52RT15HHT	L728
Martin	1351.5	54	19	YTW52RDT56REKHT	YTW52RDTHT	35.55	4.00	0.62	L728	YTW56REHT	2.69	1.25	1.00	L726	BYNA52RT15HHT	L728
Nuthatch	1510.5	45	7	YTW549RDT521REKHT	YTW549RDTHT	35.55	4.00	0.62	L729	YTW521REHT	2.69	1.25	1.00	L726	BYNA56RT15HHT	L729
Parrot	1510.5	54	19	YTW549RDT56REKHT	YTW549RDTHT	35.55	4.00	0.62	L729	YTW56REHT	2.69	1.25	1.00	L726	BYNA56RT15HHT	L729
Lapwing	1590	45	7	YTW549RDT549REKHT	YTW549RDTHT	35.55	4.00	0.62	L729	YTW549REHT	2.69	1.25	1.00	L726	BYNA56RT15HHT	L729
Falcon	1590	54	19	YTW56RDT590REKHT	YTW56RDTHT	35.99	4.00	0.62	L729	YTW590REHT	2.69	1.25	1.00	L726	BYNA56RT15HHT	L729
Chukar	1780	84	19	YTW58RDT58REKHT	YTW58RDTHT	36.99	4.00	0.62	L735	YTW58REHT	2.69	1.25	1.00	L726	BYNA58RT15HHT	L735
Bluebird	2156	84	19	YTW59RDT59REKHT	YTW59RDTHT	37.34	4.00	0.62	L735	YTW59REHT	2.69	1.25	1.00	L726	BYNA59RT15HHT	L735
Kiwi	2167	72	7	YTW59RDT591REKHT	YTW59RDTHT	37.34	4.00	0.62	L735	YTW591REHT	2.69	1.25	1.00	L726	BYNA59RT15HHT	L735

Complete Assembly: Includes Aluminum body, Steel eye, 15 degree terminal and aluminum hardware. For stainless steel hardware add SS to end of catalog number for complete assembly (example: YTW32R34REKHTSS) or to terminal if ordered separately (BYNA32R15HTSSHTSS).

For assembly without terminal and hardware add NT to end of complete assembly catalog number (example: YTW32R34REKHTNT).

† BYNA terminals must be crimped from cable end moving toward pad end.

* Overlap crimps

‡ Wide dies may be used, add suffix "W" to part number (example: L725W).

Blue highlighted items are industry standard and most frequently ordered.

TYPE YTS-R-RSHT

Full Tension Splice Kit for ACSS Conductor

Full tension, two-piece, compression splice for 250°C ACSS transmission lines up to and including 230 kV. Outer aluminum sleeve has filler hole and plug for PENETROX™ joint compound. Kit includes the outer aluminum and inner steel sleeve.

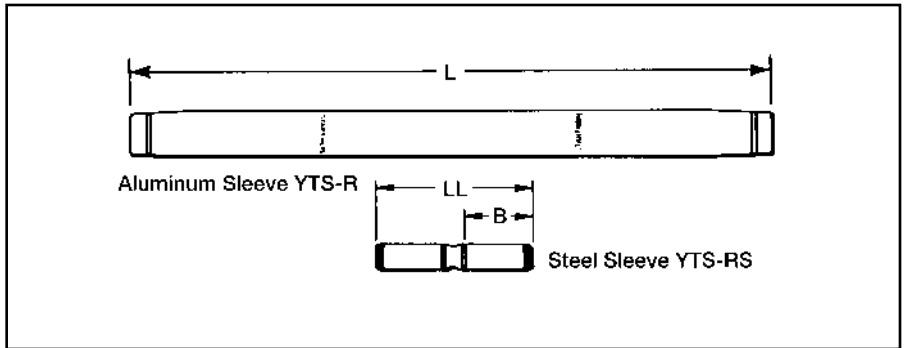
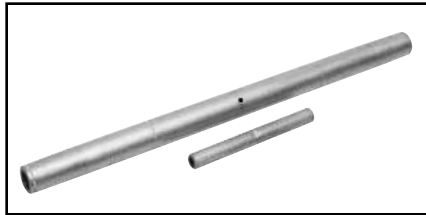

Conductor Name	ACSS		Splice Kit	Aluminum Sleeve			Steel Sleeve			
	Size kcmil	Stranding		Inches		Die*‡	Inches		Die*	
		Alum.		Steel	L		O.D.	LL		B
Linnet	336.4	26	7	YTS32R34RSHT	25.30	1.19	L717	5-1/4"	2.64	L718
Ibis	397.5	26	7	YTS34R34RSHT	25.20	1.28	L719	5-1/4"	2.64	L718
Flicker	477	24	7	YTS36R362RSHT	26.16	1.41	L720	5-7/8"	2.66	L721
Hawk	477	26	7	YTS36R36RSHT	26.16	1.41	L720	5-7/8"	2.66	L721
Parakeet	556.5	24	7	YTS39R43RSHT	27.88	1.50	L722	5-7/8"	2.66	L723
Dove	556.5	26	7	YTS39R43RSHT	27.88	1.50	L722	5-7/8"	2.66	L723
Peacock	605	24	7	YTS43R43RSHT	29.44	1.61	L724	5-7/8"	2.66	L723
Squab	605	26	7	YTS43R43RSHT	29.44	1.61	L724	5-7/8"	2.66	L723
Rook	636	24	7	YTS43R43RSHT	29.44	1.61	L724	5-7/8"	2.66	L723
Grosbeak	636	26	7	YTS43R43RSHT	29.44	1.61	L724	5-7/8"	2.66	L723
Flamingo	666.6	24	7	YTS43R43RSHT	29.44	1.61	L724	5-7/8"	2.66	L723
Starling	715.5	26	7	YTS451R48RSHT	36.00	1.80	L725	9"	4.19	L726
Cuckoo	795	24	7	YTS451R449RSHT	36.00	1.80	L725	9"	4.19	L726
Drake	795	26	7	YTS451R48RSHT	36.00	1.80	L725	9"	4.19	L726
Tern	795	45	7	YTS451R48RSHT	36.00	1.80	L725	9-1/8"	4.19	L726
Condor	795	54	7	YTS451R449RSHT	36.00	1.80	L725	9"	4.19	L726
Rail	954	45	7	YTS48R481RSHT	36.00	1.97	L727	9-1/8"	4.19	L726
Cardinal	954	54	7	YTS48R48RSHT	36.00	1.97	L727	9"	4.19	L726
Ortolan	1033.5	45	7	YTS49R483RSHT	36.00	1.97	L727	9-1/8"	4.19	L726
Curlew	1033.5	54	7	YTS49R48RSHT	36.00	1.97	L727	9"	4.19	L726
Bluejay	1113	45	7	YTS49R483RSHT	36.00	1.97	L727	9-1/8"	4.19	L726
Finch	1113	54	19	YTS52R48RSHT	49.07	2.25	L728	9"	4.19	L726
Bunting	1192.5	45	7	YTS52R521RSHT	49.07	2.25	L728	9"	4.19	L726
Bittern	1272	45	7	YTS52R521RSHT	49.07	2.25	L728	9"	4.19	L726
Pheasant	1272	54	19	YTS52R59RSHT	49.07	2.25	L728	9-1/8"	4.25	L726
Dipper	1351.5	45	7	YTS52R521RSHT	49.07	2.25	L728	9"	4.19	L726
Martin	1351.5	54	19	YTS52R59RSHT	49.07	2.25	L728	9-1/8"	4.25	L726
Nuthatch	1510.5	45	7	YTS549R521RSHT	39.73	2.50	L729	9"	4.19	L726
Parrot	1510.5	54	19	YTS549R59RSHT	39.73	2.50	L729	9-1/8"	4.25	L726
Lapwing	1590	45	7	YTS549R549RSHT	39.73	2.50	L729	9"	4.19	L726
Falcon	1590	54	19	YTS56R59RSHT	39.73	2.50	L729	9-1/8"	4.25	L726
Chukar	1780	84	19	YTS58R48RSHT	42.20	2.50	L735	4-1/4"	4.19	L726
Bluebird	2156	84	19	YTS59R59RSHT	49.93	2.50	L735	4-1/4"	4.25	L726
Kiwi	2167	72	7	YTS59R521RSHT	49.93	2.50	L735	4-1/4"	4.19	L726

Splice Kit: Includes aluminum sleeve and steel sleeve.
* Overlap crimps,
‡ Wide dies may be used, add suffix "W" to part number (example: L725W).

Blue highlighted items are industry standard and most frequently ordered.

TYPE YTS-RT-RSHT EHV

Full Tension Splice Kit for ACSS Conductor

Full tension, two-piece, compression splice for 250°C ACSS transmission lines at 345 kV and over. Outer aluminum sleeve has filler hole and plug for PENETROX™ joint compound. Kit includes the outer aluminum and inner steel sleeve.

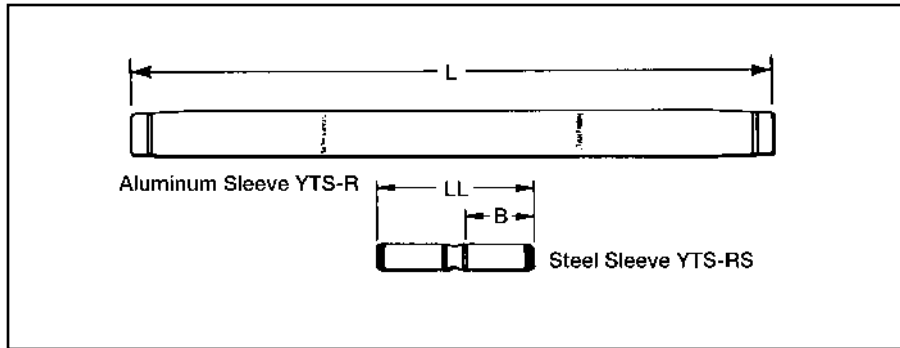
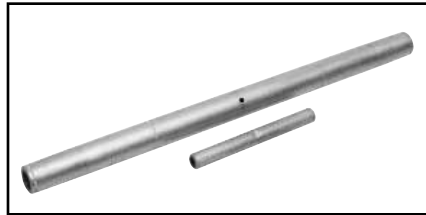

I-36

Conductor Name	ACSS		Splice Kit	Aluminum Sleeve			Steel Sleeve			
	Size kcmil	Stranding		Inches		Die*‡	Inches		Die*	
		Alum.		Steel	L		O.D.	LL		B
Linnet	336.4	26	7	YTS32RT34RSHT	25.30	1.19	L717	5.75	2.64	L718
Oriole	336.4	30	7	YTS32RT33RSHT	25.30	1.19	L717	5.75	2.64	L718
Ibis	397.5	26	7	YTS34RT34RSHT	25.20	1.28	L719	5.75	2.64	L718
Flicker	477	24	7	YTS36RT362RSHT	26.16	1.41	L720	5.75	2.66	L721
Hawk	477	26	7	YTS36RT36RSHT	26.16	1.41	L720	5.75	2.66	L721
Parakeet	556.5	24	7	YTS39RT43RSHT	27.88	1.50	L722	5.90	2.66	L723
Dove	556.5	26	7	YTS39RT43RSHT	27.88	1.50	L722	5.90	2.66	L723
Peacock	605	24	7	YTS43RT43RSHT	29.44	1.61	L724	5.90	2.66	L723
Squab	605	26	7	YTS43RT43RSHT	29.44	1.61	L724	5.90	2.66	L723
Rook	636	24	7	YTS43RT43RSHT	29.44	1.61	L724	5.90	2.66	L723
Grosbeak	636	26	7	YTS43RT43RSHT	29.44	1.61	L724	5.90	2.66	L723
Flamingo	666.6	24	7	YTS43RT43RSHT	29.44	1.61	L724	5.90	2.66	L723
Starling	715.5	26	7	YTS451RT48RSHT	36.00	1.80	L725	9.00	4.19	L726
Cuckoo	795	24	7	YTS451RT449RSHT	36.00	1.80	L725	9.00	4.19	L726
Drake	795	26	7	YTS451RT48RSHT	36.00	1.80	L725	9.00	4.19	L726
Tern	795	45	7	YTS451RT48RSHT	36.00	1.80	L725	9.16	4.19	L726
Condor	795	54	7	YTS451RT449RSHT	36.00	1.80	L725	9.00	4.19	L726
Rail	954	45	7	YTS48RT481RSHT	36.00	1.97	L727	9.16	4.19	L726
Cardinal	954	54	7	YTS48RT48RSHT	36.00	1.97	L727	9.00	4.19	L726
Ortolan	1033.5	45	7	YTS49RT483RSHT	36.00	1.97	L727	9.16	4.19	L726
Curlew	1033.5	54	7	YTS49RT48RSHT	36.00	1.97	L727	9.00	4.19	L726
Bluejay	1113	45	7	YTS49RT483RSHT	36.00	1.97	L727	9.16	4.19	L726
Finch	1113	54	19	YTS52RT48RSHT	49.07	2.25	L728	9.00	4.19	L726
Bunting	1192.5	45	7	YTS52RT521RSHT	49.07	2.25	L728	9.00	4.19	L726
Bittern	1272	45	7	YTS52RT521RSHT	49.07	2.25	L728	9.00	4.19	L726
Pheasant	1272	54	19	YTS52RT59RSHT	49.07	2.25	L728	9.10	4.25	L726
Dipper	1351.5	45	7	YTS52RT521RSHT	49.07	2.25	L728	9.00	4.19	L726
Martin	1351.5	54	19	YTS52RT59RSHT	49.07	2.25	L728	9.10	4.25	L726
Nuthatch	1510.5	45	7	YTS549RT521RSHT	39.73	2.50	L729	9.00	4.19	L726
Parrot	1510.5	54	19	YTS549RT59RSHT	39.73	2.50	L729	9.10	4.25	L726
Lapwing	1590	45	7	YTS549RT549RSHT	39.73	2.50	L729	9.00	4.19	L726
Falcon	1590	54	19	YTS56RT59RSHT	39.73	2.50	L729	9.10	4.25	L726
Chukar	1780	84	19	YTS58RT48RSHT	42.20	2.50	L735	9.00	4.19	L726
Bluebird	2156	84	19	YTS59RT59RSHT	49.93	2.50	L735	9.10	4.25	L726
Kiwi	2167	72	7	YTS59RT521RSHT	49.93	2.50	L735	9.00	4.19	L726

Splice Kit: Includes aluminum sleeve and steel sleeve.

* Overlap crimps.

‡ Wide dies may be used, add suffix "W" to part number (example: L725W).

Blue highlighted items are industry standard and most frequently ordered.

**TYPES BYNA-R15HT,
BYNA-RHT**

**Compression Terminal
for ACSS Conductor**

Compression terminal for ACSS transmission lines up to and including 230 kV.

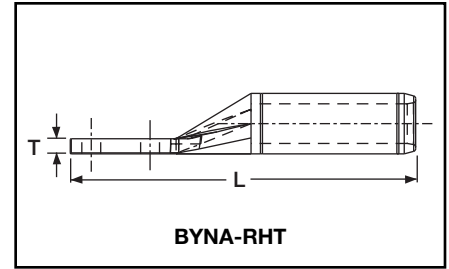
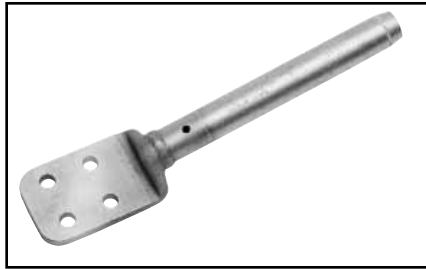

BYNA-RHT

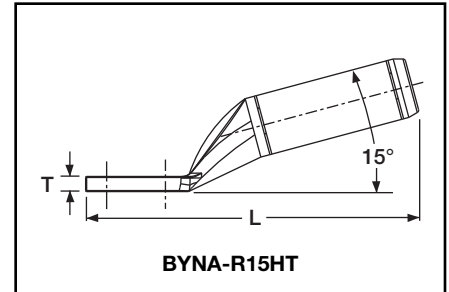
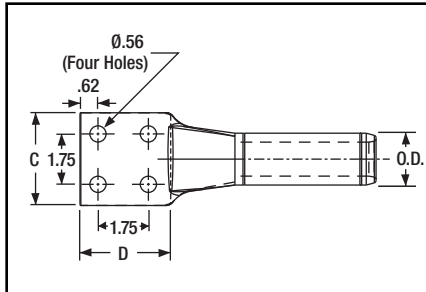

BYNA-R15HT

Conductor Name	Size kcmil	ACSS Stranding		15° Terminal		Straight Terminal		Inches			Die*‡
		Alum.	Steel	Catalog Number	Inches L	Catalog Number	Inches L	C	D	T	
Linnet	336.4	26	7	BYNA32R15HT	16.21	BYNA32RHT	16.56	3.25	4.50	0.39	L717
Oriole	336.4	30	7	BYNA32R15HT	16.21	BYNA32RHT	16.56	3.25	4.50	0.39	L717
Ibis	397.5	26	7	BYNA34R15HT	16.24	BYNA34RHT	16.60	3.25	4.50	0.46	L719
Flicker	477	24	7	BYNA36R15HT	16.51	BYNA36RHT	16.92	3.25	4.50	0.48	L720
Hawk	477	26	7	BYNA36R15HT	16.51	BYNA36RHT	16.92	3.25	4.50	0.48	L720
Parakeet	556.5	24	7	BYNA39R15HT	16.89	BYNA39RHT	17.30	3.25	4.50	0.53	L722
Dove	556.5	26	7	BYNA39R15HT	16.89	BYNA39RHT	17.30	3.25	4.50	0.53	L722
Peacock	605	24	7	BYNA43R15HT	14.41	BYNA43RHT	15.46	3.07	3.95	0.36	L724
Squab	605	26	7	BYNA43R15HT	14.41	BYNA43RHT	15.46	3.07	3.95	0.36	L724
Rook	636	24	7	BYNA43R15HT	14.41	BYNA43RHT	15.46	3.07	3.95	0.36	L724
Grosbeak	636	26	7	BYNA43R15HT	14.41	BYNA43RHT	15.46	3.07	3.95	0.36	L724
Flamingo	666.6	24	7	BYNA43R15HT	14.41	BYNA43RHT	15.46	3.07	3.95	0.36	L724
Starling	715.5	26	7	BYNA45R15HT	15.10	BYNA45RHT	15.46	3.22	3.95	0.45	L725
Cuckoo	795	24	7	BYNA45R15HT	15.10	BYNA45RHT	15.46	3.22	3.95	0.45	L725
Drake	795	26	7	BYNA45R15HT	15.10	BYNA45RHT	15.46	3.22	3.95	0.45	L725
Tern	795	45	7	BYNA45R15HT	15.10	BYNA45RHT	15.46	3.22	3.95	0.45	L725
Condor	795	54	7	BYNA45R15HT	15.10	BYNA45RHT	15.46	3.22	3.95	0.45	L725
Ruddy	900	45	7	BYNA49R15HT	15.14	BYNA49RHT	15.66	3.22	3.95	0.52	L727
Rail	954	45	7	BYNA49R15HT	15.14	BYNA49RHT	15.66	3.22	3.95	0.52	L727
Cardinal	954	54	7	BYNA49R15HT	15.14	BYNA49RHT	15.66	3.22	3.95	0.52	L727
Ortolan	1033.5	45	7	BYNA49R15HT	15.14	BYNA49RHT	15.66	3.22	3.95	0.52	L727
Curlew	1033.5	54	7	BYNA49R15HT	15.14	BYNA49RHT	15.66	3.22	3.95	0.52	L727
Bluejay	1113	45	7	BYNA49R15HT	15.14	BYNA49RHT	15.66	3.22	3.95	0.52	L727
Finch	1113	54	19	BYNA52R15HT	16.81	BYNA52RHT	18.71	3.22	3.95	0.71	L728
Bunting	1192.5	45	7	BYNA52R15HT	16.81	BYNA52RHT	18.71	3.22	3.95	0.71	L728
Bittern	1272	45	7	BYNA52R15HT	16.81	BYNA52RHT	18.71	3.22	3.95	0.71	L728
Pheasant	1272	54	19	BYNA52R15HT	16.81	BYNA52RHT	18.71	3.22	3.95	0.71	L728
Dipper	1351.5	45	7	BYNA52R15HT	16.81	BYNA52RHT	18.71	3.22	3.95	0.71	L728
Martin	1351.5	54	19	BYNA52R15HT	16.81	BYNA52RHT	18.71	3.22	3.95	0.71	L728
Nuthatch	1510.5	45	7	BYNA56R15HT	17.56	BYNA56RHT	18.65	3.44	3.95	0.86	L729
Parrot	1510.5	54	19	BYNA56R15HT	17.56	BYNA56RHT	18.65	3.44	3.95	0.86	L729
Lapwing	1590	45	7	BYNA56R15HT	17.56	BYNA56RHT	18.65	3.44	3.95	0.86	L729
Falcon	1590	54	19	BYNA56R15HT	17.56	BYNA56RHT	18.65	3.44	3.95	0.86	L729
Chukar	1780	84	19	BYNA58R15HT	18.28	BYNA58RHT	18.59	3.47	3.95	0.86	L735
Bluebird	2156	84	19	BYNA59R15HT	17.95	BYNA59RHT	18.43	3.57	3.95	0.64	L735
Kiwi	2167	72	7	BYNA59R15HT	17.95	BYNA59RHT	18.43	3.57	3.95	0.64	L735

To specify hardware for bolting to corresponding deadends add the suffix "H" to the catalog number (example: BYNA52RHHT).

* Overlap crimps.
‡ Wide dies may be used, add suffix "W" to part number (example: L725W).

TYPES BYNA-RT15HT, BYNA-RTHT EHV

Compression Terminal for ACSS Conductor

Compression terminal for 250°C ACSS transmission lines at 345 kV and over.

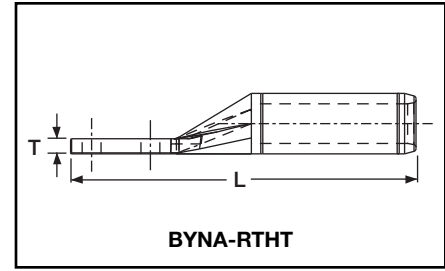
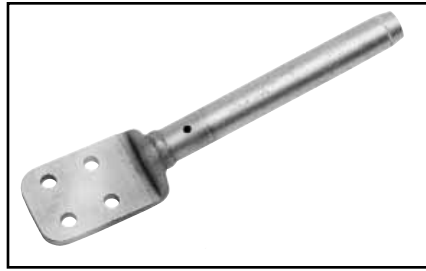

BYNA-RTHT

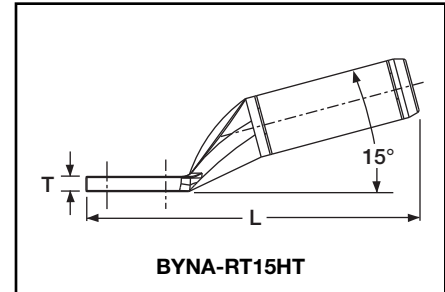
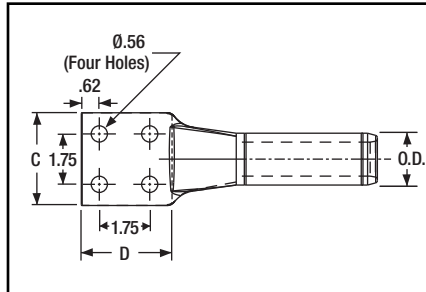

BYNA-RT15HT

I-38

Conductor Name	ACSS		15° Terminal		Straight Terminal		Inches			Die*‡	
	Size kcmil	Stranding		Catalog Number	Inches L	Catalog Number	Inches L	C	D		T
		Alum.	Steel								
Linnet	336.4	26	7	BYNA32RT15HT	16.41	BYNA32RTHT	16.56	3.25	4.50	0.39	L717
Oriole	336.4	30	7	BYNA32RT15HT	16.41	BYNA32RTHT	16.56	3.25	4.50	0.39	L717
Ibis	397.5	26	7	BYNA34RT15HT	16.45	BYNA34RTHT	16.60	3.25	4.50	0.46	L719
Flicker	477	24	7	BYNA36RT15HT	16.76	BYNA36RTHT	16.92	3.25	4.50	0.48	L720
Hawk	477	26	7	BYNA36RT15HT	16.76	BYNA36RTHT	16.92	3.25	4.50	0.48	L720
Parakeet	556.5	24	7	BYNA39RT15HT	17.12	BYNA39RTHT	17.30	3.25	4.50	0.53	L722
Dove	556.5	26	7	BYNA39RT15HT	17.12	BYNA39RTHT	17.30	3.25	4.50	0.53	L722
Peacock	605	24	7	BYNA43RT15HT	14.41	BYNA43RTHT	15.46	3.07	3.95	0.36	L724
Squab	605	26	7	BYNA43RT15HT	14.41	BYNA43RTHT	15.46	3.07	3.95	0.36	L724
Rook	636	24	7	BYNA43RT15HT	14.41	BYNA43RTHT	15.46	3.07	3.95	0.36	L724
Grosbeak	636	26	7	BYNA43RT15HT	14.41	BYNA43RTHT	15.46	3.07	3.95	0.36	L724
Flamingo	666.6	24	7	BYNA43RT15HT	14.41	BYNA43RTHT	15.46	3.07	3.95	0.36	L724
Starling	715.5	26	7	BYNA451RT15HT	15.10	BYNA451RTHT	15.46	3.22	3.95	0.45	L725
Cuckoo	795	24	7	BYNA451RT15HT	15.10	BYNA451RTHT	15.46	3.22	3.95	0.45	L725
Drake	795	26	7	BYNA451RT15HT	15.10	BYNA451RTHT	15.46	3.22	3.95	0.45	L725
Tern	795	45	7	BYNA451RT15HT	15.10	BYNA451RTHT	15.46	3.22	3.95	0.45	L725
Condor	795	54	7	BYNA451RT15HT	15.10	BYNA451RTHT	15.46	3.22	3.95	0.45	L725
Ruddy	900	45	7	BYNA49RT15HT	15.14	BYNA49RTHT	15.66	3.22	3.95	0.52	L727
Rail	954	45	7	BYNA49RT15HT	15.14	BYNA49RTHT	15.66	3.22	3.95	0.52	L727
Cardinal	954	54	7	BYNA49RT15HT	15.14	BYNA49RTHT	15.66	3.22	3.95	0.52	L727
Ortolan	1033.5	45	7	BYNA49RT15HT	15.14	BYNA49RTHT	15.66	3.22	3.95	0.52	L727
Curlew	1033.5	54	7	BYNA49RT15HT	15.14	BYNA49RTHT	15.66	3.22	3.95	0.52	L727
Bluejay	1113	45	7	BYNA49RT15HT	15.14	BYNA49RTHT	15.66	3.22	3.95	0.52	L727
Finch	1113	54	19	BYNA52RT15HT	16.81	BYNA52RTHT	18.71	3.22	3.95	0.71	L728
Bunting	1192.5	45	7	BYNA52RT15HT	16.81	BYNA52RTHT	18.71	3.22	3.95	0.71	L728
Bittern	1272	45	7	BYNA52RT15HT	16.81	BYNA52RTHT	18.71	3.22	3.95	0.71	L728
Pheasant	1272	54	19	BYNA52RT15HT	16.81	BYNA52RTHT	18.71	3.22	3.95	0.71	L728
Dipper	1351.5	45	7	BYNA52RT15HT	16.81	BYNA52RTHT	18.71	3.22	3.95	0.71	L728
Martin	1351.5	54	19	BYNA52RT15HT	16.81	BYNA52RTHT	18.71	3.22	3.95	0.71	L728
Nuthatch	1510.5	45	7	BYNA56RT15HT	17.56	BYNA56RTHT	18.65	3.44	3.95	0.86	L729
Parrot	1510.5	54	19	BYNA56RT15HT	17.56	BYNA56RTHT	18.65	3.44	3.95	0.86	L729
Lapwing	1590	45	7	BYNA56RT15HT	17.56	BYNA56RTHT	18.65	3.44	3.95	0.86	L729
Falcon	1590	54	19	BYNA56RT15HT	17.56	BYNA56RTHT	18.65	3.44	3.95	0.86	L729
Chukar	1780	84	19	BYNA58RT15HT	18.28	BYNA58RTHT	18.59	3.47	3.95	0.86	L735
Bluebird	2156	84	19	BYNA59RT15HT	17.95	BYNA59RTHT	18.43	3.57	3.95	0.64	L735
Kiwi	2167	72	7	BYNA59RT15HT	17.95	BYNA59RTHT	18.43	3.57	3.95	0.64	L735

To specify hardware for bolting to corresponding deadends add the suffix "H" to the catalog number (example: BYNA52RHHT).

* Overlap crimps.

‡ Wide dies may be used, add suffix "W" to part number (example: L725W).

TYPE BYNS-RHT

**Jumper Loop Sleeve
for ACSS Conductor**

Jumper sleeve for 250°C ACSS transmission lines up to and including 230 kV. Sleeve is pre-filled with PENETROX™ joint compound and capped.

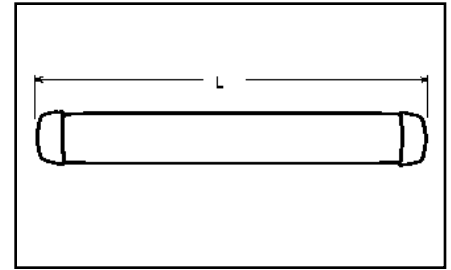
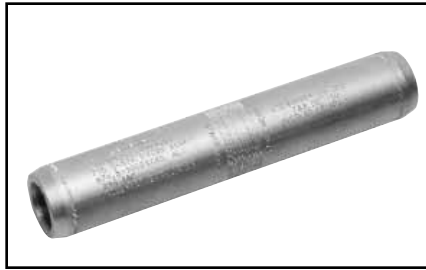

Conductor Name	ACSS		Jumper Sleeve	Inches		
	Size kcmil	Stranding		L	Die*‡	
		Alum.	Steel			
Linnet	336.4	26	7	BYNS32RHT	16.90	L717
Oriole	336.4	30	7	BYNS32RHT	16.90	L717
Ibis	397.5	26	7	BYNS34RHT	17.10	L719
Flicker	477	24	7	BYNS36RHT	17.60	L719
Hawk	477	26	7	BYNS36RHT	17.60	L719
Parakeet	556.5	24	7	BYNS39RHT	18.20	L720
Dove	556.5	26	7	BYNS39RHT	18.20	L720
Peacock	605	24	7	BYNS43RHT	18.50	L722
Squab	605	26	7	BYNS43RHT	18.50	L722
Rook	636	24	7	BYNS43RHT	18.50	L722
Grosbeak	636	26	7	BYNS43RHT	18.50	L722
Flamingo	666.6	24	7	BYNS43RHT	18.50	L722
Starling	715.5	26	7	BYNS451RHT	18.60	L725
Cuckoo	795	24	7	BYNS451RHT	18.60	L725
Drake	795	26	7	BYNS451RHT	18.60	L725
Tern	795	45	7	BYNS451RHT	18.60	L725
Condor	795	54	7	BYNS451RHT	18.60	L725
Ruddy	900	45	7	BYNS49RHT	18.70	L727
Rail	954	45	7	BYNS49RHT	18.70	L727
Cardinal	954	54	7	BYNS49RHT	18.70	L727
Ortolan	1033.5	45	7	BYNS49RHT	18.70	L727
Curlew	1033.5	54	7	BYNS49RHT	18.70	L727
Bluejay	1113	45	7	BYNS49RHT	18.70	L727
Finch	1113	54	19	BYNS52RHT	24.20	L728
Bunting	1192.5	45	7	BYNS52RHT	24.20	L728
Bittern	1272	45	7	BYNS52RHT	24.20	L728
Pheasant	1272	54	19	BYNS52RHT	24.20	L728
Dipper	1351.5	45	7	BYNS52RHT	24.20	L728
Martin	1351.5	54	19	BYNS52RHT	24.20	L728
Nuthatch	1510.5	45	7	BYNS56RHT	23.60	L729
Parrot	1510.5	54	19	BYNS56RHT	23.60	L729
Lapwing	1590	45	7	BYNS56RHT	23.60	L729
Falcon	1590	54	19	BYNS56RHT	23.60	L729
Chukar	1780	84	19	BYNS58RHT	23.40	L735
Bluebird	2156	84	19	BYNS59RHT	23.40	L735
Kiwi	2167	72	7	BYNS59RHT	23.20	L735

* Overlap crimps.
‡ Wide dies may be used, add suffix "W" to part number (example: L725W).

I-39

Blue highlighted items are industry standard and most frequently ordered.

TYPE BYNS-RTHT EHV

Jumper Loop Sleeve for ACSS Conductor

Jumper sleeve for 250°C ACSS transmission lines at 345 kV and over. Sleeve is pre-filled with PENETROX™ joint compound and capped.

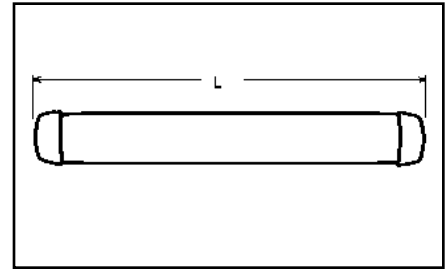
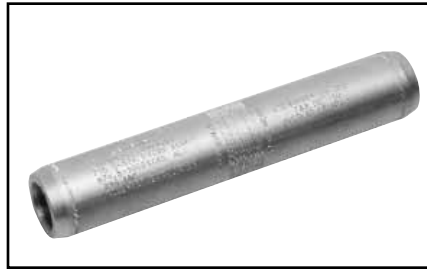

I-40

Conductor Name	ACSS		Stranding		Jumper Sleeve	Inches	Die*‡
	Size kcmil	Alum.	Steel	L			
Linnnet	336.4	26	7	BYNS32RTHT	16.90	L717	
Oriole	336.4	30	7	BYNS32RTHT	16.90	L717	
Ibis	397.5	26	7	BYNS34RTHT	17.10	L719	
Flicker	477	24	7	BYNS36RTHT	17.60	L719	
Hawk	477	26	7	BYNS36RTHT	17.60	L719	
Parakeet	556.5	24	7	BYNS39RTHT	18.20	L720	
Dove	556.5	26	7	BYNS39RTHT	18.20	L720	
Peacock	605	24	7	BYNS43RTHT	18.50	L722	
Squab	605	26	7	BYNS43RTHT	18.50	L722	
Rook	636	24	7	BYNS43RTHT	18.50	L722	
Grosbeak	636	26	7	BYNS43RTHT	18.50	L722	
Flamingo	666.6	24	7	BYNS43RTHT	18.50	L722	
Starling	715.5	26	7	BYNS451RTHT	18.60	L725	
Cuckoo	795	24	7	BYNS451RTHT	18.60	L725	
Drake	795	26	7	BYNS451RTHT	18.60	L725	
Tern	795	45	7	BYNS451RTHT	18.60	L725	
Condor	795	54	7	BYNS451RTHT	18.60	L725	
Ruddy	900	45	7	BYNS49RTHT	18.70	L727	
Rail	954	45	7	BYNS49RTHT	18.70	L727	
Cardinal	954	54	7	BYNS49RTHT	18.70	L727	
Ortolan	1033.5	45	7	BYNS49RTHT	18.70	L727	
Curlew	1033.5	54	7	BYNS49RTHT	18.70	L727	
Bluejay	1113	45	7	BYNS49RTHT	18.70	L727	
Finch	1113	54	19	BYNS52RTHT	24.20	L728	
Bunting	1192.5	45	7	BYNS52RTHT	24.20	L728	
Bittern	1272	45	7	BYNS52RTHT	24.20	L728	
Pheasant	1272	54	19	BYNS52RTHT	24.20	L728	
Dipper	1351.5	45	7	BYNS52RTHT	24.20	L728	
Martin	1351.5	54	19	BYNS52RTHT	24.20	L728	
Nuthatch	1510.5	45	7	BYNS56RTHT	23.60	L729	
Parrot	1510.5	54	19	BYNS56RTHT	23.60	L729	
Lapwing	1590	45	7	BYNS56RTHT	23.60	L729	
Falcon	1590	54	19	BYNS56RTHT	23.60	L729	
Chukar	1780	84	19	BYNS58RTHT	23.40	L735	
Bluebird	2156	84	19	BYNS59RTHT	23.40	L735	
Kiwi	2167	72	7	BYNS59RTHT	23.20	L735	

* Overlap crimps.

‡ Wide dies may be used, add suffix "W" to part number (example: L725W).

Blue highlighted items are industry standard and most frequently ordered.

TYPE YNT-R-RHT

**Compression T-Tap
for ACSS Conductor**

Two piece compression T-Tap for ACSR transmission lines that include up to 230 kV. Tap element is pre-filled with PENETROX™ joint compound and sealed.

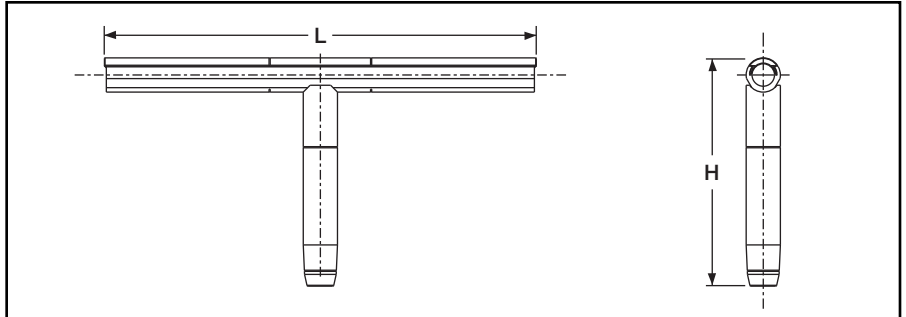
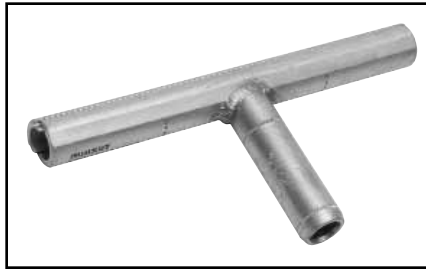

Conductor Name	ACSS		T-Tap*	Inches		Die*‡
	Size kcmil	Stranding		L	H	
		Alum. Steel				
Linnet	336.4	26 7	YNT32R32RHT	23.46	10.39	L717
Oriole	336.4	30 7	YNT32R32RHT	23.46	10.39	L717
Ibis	397.5	26 7	YNT34R34RHT	23.60	10.53	L719
Flicker	477	24 7	YNT36R36RHT	24.29	10.85	L720
Hawk	477	26 7	YNT36R36RHT	24.29	10.85	L720
Parakeet	556.5	24 7	YNT39R39RHT	24.69	11.13	L722
Dove	556.5	26 7	YNT39R39RHT	24.69	11.13	L722
Peacock	605	24 7	YNT43R43RHT	25.48	11.20	L724
Squab	605	26 7	YNT43R43RHT	25.48	11.20	L724
Rook	636	24 7	YNT43R43RHT	25.48	11.20	L724
Grosbeak	636	26 7	YNT43R43RHT	25.48	11.20	L724
Flamingo	666.6	24 7	YNT43R43RHT	25.48	11.20	L724
Starling	715.5	26 7	YNT451R451RHT	25.60	11.70	L725
Cuckoo	795	24 7	YNT451R451RHT	25.60	11.70	L725
Drake	795	26 7	YNT451R451RHT	25.60	11.70	L725
Tern	795	45 7	YNT451R451RHT	25.60	11.70	L725
Condor	795	54 7	YNT451R451RHT	25.60	11.70	L725
Ruddy	900	45 7	YNT49R49RHT	25.66	11.90	L727
Rail	954	45 7	YNT49R49RHT	25.66	11.90	L727
Cardinal	954	54 7	YNT49R49RHT	25.66	11.90	L727
Ortolan	1033.5	45 7	YNT49R49RHT	25.66	11.90	L727
Curlew	1033.5	54 7	YNT49R49RHT	25.66	11.90	L727
Bluejay	1113	45 7	YNT49R49RHT	25.66	11.90	L727
Finch	1113	54 19	YNT52R52RHT	29.61	15.10	L728
Bunting	1192.5	45 7	YNT52R52RHT	29.61	15.10	L728
Bittern	1272	45 7	YNT52R52RHT	29.61	15.10	L728
Pheasant	1272	54 19	YNT52R52RHT	29.61	15.10	L728
Dipper	1351.5	45 7	YNT52R52RHT	29.61	15.10	L728
Martin	1351.5	54 19	YNT52R52RHT	29.61	15.10	L728
Nuthatch	1510.5	45 7	YNT56R56RHT	31.65	15.08	L729
Parrot	1510.5	54 19	YNT56R56RHT	31.65	15.08	L729
Lapwing	1590	45 7	YNT56R56RHT	31.65	15.08	L729
Falcon	1590	54 19	YNT56R56RHT	31.65	15.08	L729
Chukar	1780	84 19	YNT58R58RHT	31.53	15.02	L735
Bluebird	2156	84 19	YNT59R59RHT	31.21	14.86	L735
Kiwi	2167	72 7	YNT59R59RHT	31.21	14.86	L735

* Overlap crimps.
‡ Wide dies may be used, add suffix "W" to part number (example: L725W).

For EHV applications add "T" to the catalog number (example: YNT49R49RHTT).

TYPE YNTA-RHT

T-Tap with Pad for ACSS Conductor

Two piece compression T-Tap to a NEMA pad for ACSS transmission lines. Up to and including 230 kV.

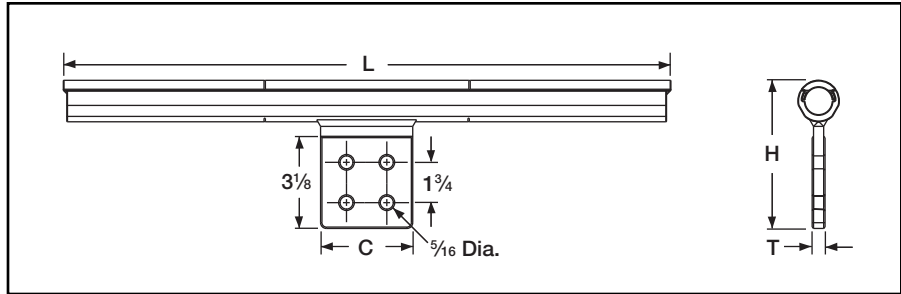
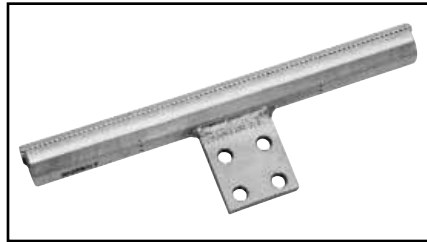

I-42

Conductor Name	ACSS		Stranding	T-Tap with Pad	Inches				Die*‡
	Size kcmil	Alum.			Steel	L	C	H	
Linnet	336.4	26	7	YNTA32RHT	23.46	3.25	4.94	0.50	L717
Oriole	336.4	30	7	YNTA32RHT	23.46	3.25	4.94	0.50	L717
Ibis	397.5	26	7	YNTA34RHT	23.60	3.25	5.05	0.50	L719
Flicker	477	24	7	YNTA36RHT	24.29	3.25	5.16	0.56	L720
Hawk	477	26	7	YNTA36RHT	24.29	3.25	5.16	0.56	L720
Parakeet	556.5	24	7	YNTA39RHT	24.69	3.25	5.25	0.56	L722
Dove	556.5	26	7	YNTA39RHT	24.69	3.25	5.25	0.56	L722
Peacock	605	24	7	YNTA43RHT	25.48	3.25	5.36	0.56	L724
Squab	605	26	7	YNTA43RHT	25.48	3.25	5.36	0.56	L724
Rook	636	24	7	YNTA43RHT	25.48	3.25	5.36	0.56	L724
Grosbeak	636	26	7	YNTA43RHT	25.48	3.25	5.36	0.56	L724
Flamingo	666.6	24	7	YNTA43RHT	25.48	3.25	5.36	0.56	L724
Starling	715.5	26	7	YNTA451RHT	25.60	3.25	5.55	0.56	L725
Cuckoo	795	24	7	YNTA451RHT	25.60	3.25	5.55	0.56	L725
Drake	795	26	7	YNTA451RHT	25.60	3.25	5.55	0.56	L725
Tern	795	45	7	YNTA451RHT	25.60	3.25	5.55	0.56	L725
Condor	795	54	7	YNTA451RHT	25.60	3.25	5.55	0.56	L725
Ruddy	900	45	7	YNTA49RHT	25.66	3.25	5.72	0.56	L727
Rail	954	45	7	YNTA49RHT	25.66	3.25	5.72	0.56	L727
Cardinal	954	54	7	YNTA49RHT	25.66	3.25	5.72	0.56	L727
Ortolan	1033.5	45	7	YNTA49RHT	25.66	3.25	5.72	0.56	L727
Curlew	1033.5	54	7	YNTA49RHT	25.66	3.25	5.72	0.56	L727
Bluejay	1113	45	7	YNTA49RHT	25.66	3.25	5.72	0.56	L727
Finch	1113	54	19	YNTA54RHT	29.61	3.25	6.00	0.69	L728
Bunting	1192.5	45	7	YNTA54RHT	29.61	3.25	6.00	0.69	L728
Bittern	1272	45	7	YNTA54RHT	29.61	3.25	6.00	0.69	L728
Pheasant	1272	54	19	YNTA54RHT	29.61	3.25	6.00	0.69	L728
Dipper	1351.5	45	7	YNTA54RHT	29.61	3.25	6.00	0.69	L728
Martin	1351.5	54	19	YNTA54RHT	29.61	3.25	6.00	0.69	L728
Nuthatch	1510.5	45	7	YNTA56RHT	31.65	3.59	6.25	0.69	L729
Parrot	1510.5	54	19	YNTA56RHT	31.65	3.59	6.25	0.69	L729
Lapwing	1590	45	7	YNTA56RHT	31.65	3.59	6.25	0.69	L729
Falcon	1590	54	19	YNTA56RHT	31.65	3.59	6.25	0.69	L729
Chukar	1780	84	19	YNTA58RHT	31.53	3.59	6.25	0.69	L735
Bluebird	2156	84	19	YNTA59RHT	31.21	3.59	6.25	0.69	L735
Kiwi	2167	72	7	YNTA59RHT	31.21	3.59	6.25	0.69	L735

For EHV applications add "T" to the catalog number (example: YNTA49RHTT).

For EHV applications order (2) two tap pad shielding caps, STS-A-NCG catalog number indicates (1) cap.

* Overlap crimps.
‡ Wide dies may be used, add suffix "W" to part number (example: L725W).

Blue highlighted items are industry standard and most frequently ordered.

TYPE YNU-RHT

Repair Sleeve for ACSS Conductor

For HV and EHV applications. Two-piece repair sleeve for temporary restoration of conductivity to damaged ACSS transmission lines. Use of PENETROX™ joint compound required.

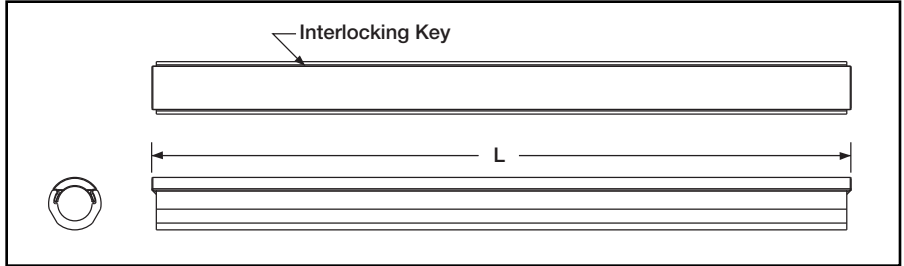

Conductor Name	ACSS		Repair Sleeve	Inches	Die*‡	
	Size kcmil	Stranding		L		
		Alum.	Steel			
Linnet	336.4	26	7	YNU32RHT	22.00	L717
Oriole	336.4	30	7	YNU32RHT	22.00	L717
Ibis	397.5	26	7	YNU34RHT	22.00	L719
Flicker	477	24	7	YNU36RHT	22.00	L720
Hawk	477	26	7	YNU36RHT	22.00	L720
Parakeet	556.5	24	7	YNU39RHT	24.00	L722
Dove	556.5	26	7	YNU39RHT	24.00	L722
Peacock	605	24	7	YNU43RHT	24.00	L724
Squab	605	26	7	YNU43RHT	24.00	L724
Rook	636	24	7	YNU43RHT	24.00	L724
Grosbeak	636	26	7	YNU43RHT	24.00	L724
Flamingo	666.6	24	7	YNU43RHT	24.00	L724
Starling	715.5	26	7	YNU451RHT	24.00	L725
Cuckoo	795	24	7	YNU451RHT	24.00	L725
Drake	795	26	7	YNU451RHT	24.00	L725
Tern	795	45	7	YNU451RHT	24.00	L725
Condor	795	54	7	YNU451RHT	24.00	L725
Ruddy	900	45	7	YNU49RHT	24.00	L727
Rail	954	45	7	YNU49RHT	24.00	L727
Cardinal	954	54	7	YNU49RHT	24.00	L727
Ortolan	1033.5	45	7	YNU49RHT	24.00	L727
Curlew	1033.5	54	7	YNU49RHT	24.00	L727
Bluejay	1113	45	7	YNU49RHT	24.00	L727
Finch	1113	54	19	YNU54RHT	24.00	L728
Bunting	1192.5	45	7	YNU54RHT	24.00	L728
Bittern	1272	45	7	YNU54RHT	24.00	L728
Pheasant	1272	54	19	YNU54RHT	24.00	L728
Dipper	1351.5	45	7	YNU54RHT	24.00	L728
Martin	1351.5	54	19	YNU54RHT	24.00	L728
Nuthatch	1510.5	45	7	YNU56RHT	27.00	L729
Parrot	1510.5	54	19	YNU56RHT	27.00	L729
Lapwing	1590	45	7	YNU56RHT	27.00	L729
Falcon	1590	54	19	YNU56RHT	27.00	L729
Chukar	1780	84	19	YNU58RHT	27.00	L735
Bluebird	2156	84	19	YNU59RHT	27.00	L735
Kiwi	2167	72	7	YNU59RHT	27.00	L735

* Overlap crimps.
‡ Wide dies may be used, add suffix "W" to part number (example: L725W).

Blue highlighted items are industry standard and most frequently ordered.

TYPE YNA-M-T

Compression Terminal for Alumoweld and EHS Steel

Compression terminal for joining Alumoweld and EHS steel to YTW-M-T or YTW-E dead-end. Installed with same dies as equivalent full tension splice and deadend. Barrel is pre-filled with PENETROX™ joint compound and capped.

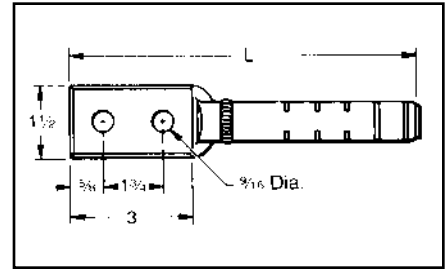
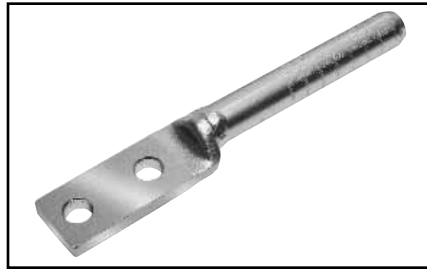

Catalog Number	Conductor		L	Tools, Die Sets, & (Number of Crimps)		
	Alumoweld	EHS Steel		DIE Index	Y35, Y750, Y45†, Y46‡‡	Y60BHU*
YNA7M10T	7 #10, 3 #7	5/16" 7 Str.	8-1/2	676 or 721	U676 (4) —	— L721
YNA7M8T	7 #8, 3 #5	3/8" 7 Str.	9-3/4	668 or 723	U688 (7) —	— L723
YNA7M7T	7 #7	7/16" 7 Str.	9-7/8	678 or 726	U678 (10) —	— L726
YNA7M6T	7 #6	1/2" 7 Str.	9-3/4	679 or 726	U679 (11) —	— L726

I-44

* Overlap crimps.
 † U Die with adapter PT-6515.
 ‡‡ U Die with adapter PUADP-1.

Blue highlighted items are industry standard and most frequently ordered.

TYPE YDS-M-T

Full Tension Sleeve for Alumoweld

Full-tension splice for Alumoweld transmission lines. Five connectors accommodate eight conductor sizes. Sleeve is pre-filled with PENETROX™ joint compound and capped.

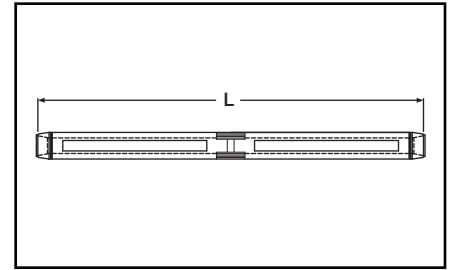
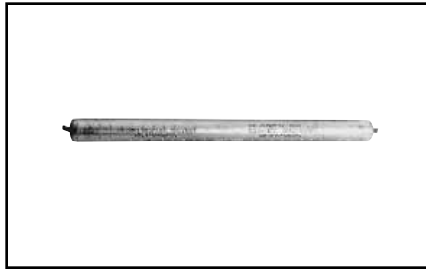

RUS Accepted

Catalog ††† Number	Conductor	L	Tools, Die Sets		
	Alumoweld		Die Index	Y35, Y750, Y45†, Y46††	Y60BHU*
YDS7M10T	7 #10, 3 #7	10	676 or	U676 (8)	—
			721	—	L721
YDS7M9T	7 #9, 3 #6	10-3/8	677	U677 (10)	—
YDS7M8T	7 #8, 3 #5	12-1/4	668 or	U668 (13)	—
			723	—	L723
YDS7M7T	7 #7	14-1/2	678 or	U678 (19)	—
			726	—	L726
YDS7M6T	7 #6	15-1/8	679 or	U679 (2)	—
			726	—	L726

* Overlap crimps.
† U Die with adapter PT-6515.
†† U Die with adapter PUADP-1.

††† Sleeve is high strength aluminum alloy for optimum corrosion resistance.

Blue highlighted items are industry standard and most frequently ordered.

TYPE YTS-E

**Full Tension Splice
for EHS Steel**

Full tension splice for EHS steel guy, messenger or "static" cable. Sleeve is pre-filled with PENETROX™ joint compound and capped.

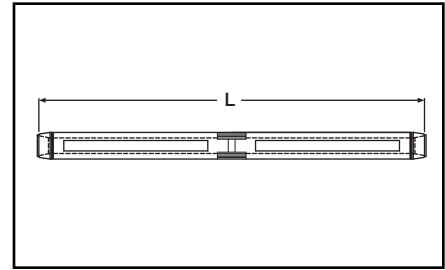
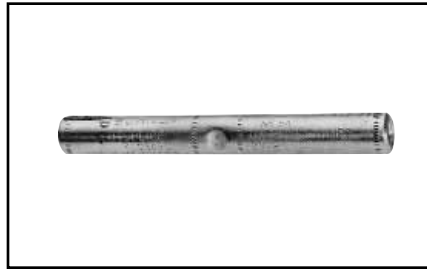

Catalog Number	Conductor †	L	Tools, Die Sets	
	EHS Steel		Die Index	Y60BHU*
YTS312E	5/16" 7 Str.	11.30"	721	L721
YTS375E	3/8" 7 Str.	10.38"	723	L723
YTS438E	7/16" 7 Str.	11.78"	726	L726
YTS500E	1/2" 7 Str.	16.63"	789	L789

* Overlap crimps.

† Sleeve is high strength aluminum alloy for optimum corrosion resistance.

Blue highlighted items are industry standard and most frequently ordered.

Full Tension Deadend Kit

Compression Deadend for ACCC® Conductor

Full tension deadends for ACCC® transmission lines up to and including 230 kV. Standard 15° NEMA tap pad provides either 0° or 30° tap when BYNA-RT15HACCC terminal is used.

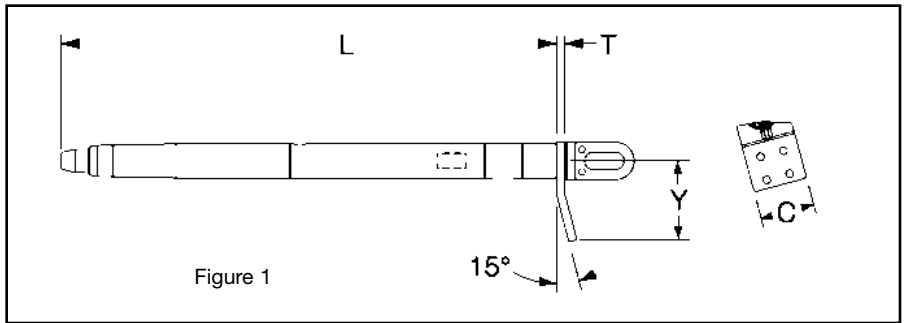
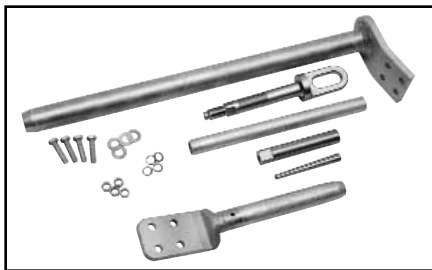

Figure 1

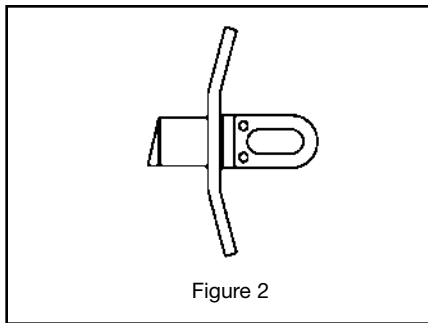

Figure 2

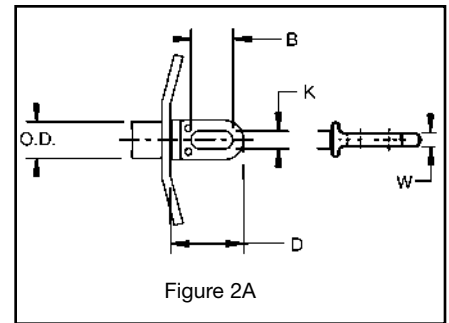

Figure 2A

I-47

Conductor Name	Size kcmil	Catalog Number	Kit Assembly	Fig. No.	Dimensions - Deadend Body (Fig. 1)				Dimensions - Steel Eye (Fig. 2A)				Kit Components Terminal	Installation Tooling																																																																																																																				
					L	T	C	Y	D	B	K	W		Y60BHU																																																																																																																				
														Die*†	Die*†	Inspection Pin Dia.																																																																																																																		
Linnet	431	5600-1020	1	31.25	[794]																																																																																																																													
		5600-1020D	2															BYNA32RT15HACCC	L717W	0.748																																																																																																														
Copenhagen	440	5600-1022	1																		BYNA245MRT15HACCC	L719W	0.892																																																																																																											
		5600-1022D	2																																																																																																																															
Glasgow	473	5600-1044	1															.62	[16]	4.00	5.60	[102]	[142]																																																																																																											
		5600-1044D	2																													BYNA36RT15HACCC	L720W	0.962																																																																																																
Casablanca	546	5600-1028	1																																BYNA39RT15HACCC	L722W	0.962																																																																																													
		5600-1028D	2																																																																																																																															
Hawk	611	5600-1030	1																													5.10	[130]	2.91	[74]	1.26	[32]	0.75	[19]																																																																																											
		5600-1030D	2																																											BYNA43RT15HACCC	L724W	1.042																																																																																		
Lisbon	629	5600-1032	1																																														BYNA39RT15HACCC	L722W	0.962																																																																															
		5600-1032D	2																																																																																																																															
Dove	713	5600-1040	1																																											5.10	[130]	2.91	[74]	1.26	[32]	0.75	[19]																																																																													
		5600-1040D	2																																																									BYNA451RT15HACCC	L725W	1.164																																																																				
Amsterdam	733	5600-1042	1																																																												36.19	[919]																																																																		
		5600-1042D	2																																																									BYNA39RT15HACCC	L722W	0.962																																																																				
Grosbeak	816	5600-1050	1																																																																										5.10	[130]	2.91	[74]	1.26	[32]	0.75	[19]																																														
		5600-1050D	2																																																									BYNA43RT15HACCC	L724W	1.042																																																																				
Brussels	839	5600-1052	1																																																																																								5.10	[130]	2.91	[74]	1.26	[32]	0.75	[19]																																
		5600-1052D	2																																																									BYNA39RT15HACCC	L722W	0.962																																																																				
Oslo	627	5600-1026	1	5.10	[130]	2.91	[74]	1.26	[32]	0.75	[19]																																																																																																																							
		5600-1026D	2																																																									BYNA451RT15HACCC	L725W	1.164																																																																				
Stockholm	913	5600-1054	1																																																																																																						36.19	[919]																								
		5600-1054D	2																																																									BYNA39RT15HACCC	L722W	0.962																																																																				
Warsaw	1016	5600-1056	1															5.10	[130]	2.91	[74]	1.26	[32]	0.75	[19]																																																																																																									
		5600-1056D	2																																																									BYNA451RT15HACCC	L725W	1.164																																																																				
Drake	1020	5600-1060	1																																																																																																																				36.19	[919]										
		5600-1060D	2																																																									BYNA39RT15HACCC	L722W	0.962																																																																				
Dublin	1043	5600-1062	1																													5.10	[130]	2.91	[74]	1.26	[32]	0.75	[19]																																																																																											
		5600-1062D	2																																																									BYNA451RT15HACCC	L725W	1.164																																																																				

Notes:

ACCC is a Registered Trade Mark of CTC Cable Corp.

1. Deadend Assembly consists of Aluminum Body, Steel Eye and Terminal with mounting hardware.

2. Designed for corona free operation up to 230 kV, contact factory for 345 kV and 500 kV operation.

3. For stainless steel hardware, contact factory.

4. Dimensions in brackets [] denotes metric units and are rounded to nearest whole numbers.

* Overlap crimps.

† Wide dies may be used, add suffix "W" to part number (example: L725W).

(Continued on next page)

Full Tension Deadend Kit

(Continued)

Compression Deadend for ACCC® Conductor

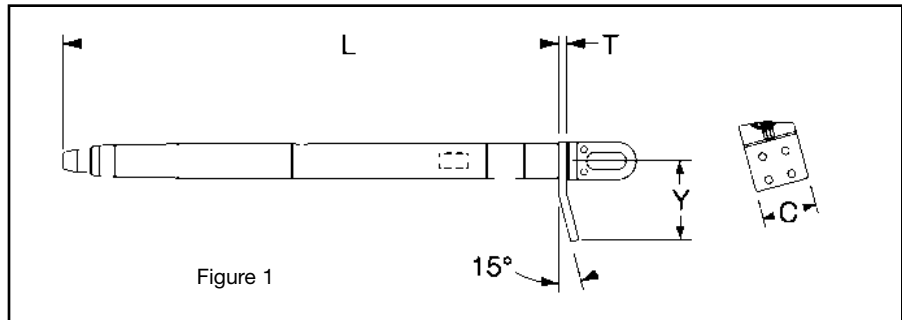

Figure 1

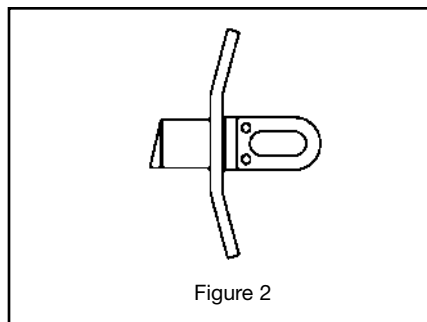

Figure 2

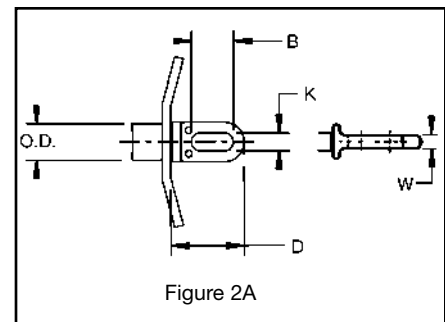

Figure 2A

I-48

Conductor Name	Size kcmil	Catalog Number Kit Assembly	Fig. No.	Dimensions - Deadend Body (Fig. 1)				Dimensions - Steel Eye (Fig. 2A)				Kit Components Terminal	Installation Tooling Y60BHU		
				L	T	C	Y	D	B	K	W		Die*‡ Die‡	Terminal	Inspection Pin Dia.
Hamburg	1092	5600-1058	1	36.19 [919]	0.62 [16]	4.00 [102]	5.60 [142]	5.10 [130]	2.91 [74]	1.26 [32]	0.75 [19]	BYNA590MRT15HACCC	L735W	L727W	1.24
		5600-1058D	2												
Milan	1134	5600-1064	1												
		5600-1064D	2												
Rome	1183	5600-1066	1												
		5600-1066D	2												
Cardinal	1222	5600-1070	1												
		5600-1070D	2												
Vienna	1255	5600-1072	1												
		5600-1072D	2												
Budapest	1332	5600-1074	1												
		5600-1074D	2												
Prague	1377	5600-1076													
		5600-1076D													
Munich	1461	5600-1078	1												
		5600-1078D	2												
London	1512	5600-1079	1												
		5600-1079D	2												
Bittern	1572	5600-1080	1												
		5600-1080D	2												
Paris	1620	5600-1082	1												
		5600-1082D	2												
											BYNA49RT15HACCC		L727W	1.313	
												BYNA760MRT15HACCC		L728W	1.35
												BYNA52RT15HACCC		L728W	1.454

Notes:

ACCC is a Registered Trade Mark of CTC Cable Corp.

1. Deadend Assembly consists of Aluminum Body, Steel Eye and Terminal with mounting hardware.

2. Designed for corona free operation up to 230 kV, contact factory for 345 kV and 500 kV operation.
3. For stainless steel hardware, contact factory.

4. Dimensions in brackets [] denotes metric units and are rounded to nearest whole numbers.

* Overlap crimps.

‡ Wide dies may be used, add suffix "W" to part number (example: L725W).

Blue highlighted items are industry standard and most frequently ordered.

Full Tension Splice Kit

**Compression Splice
for ACCC® Conductor**

Full tension two piece splice for ACCC® transmission lines up to and including 230 kV.

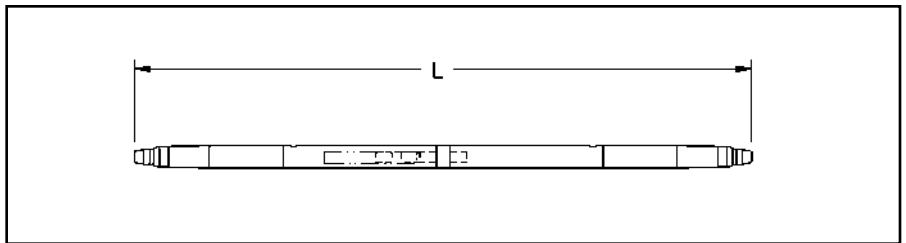
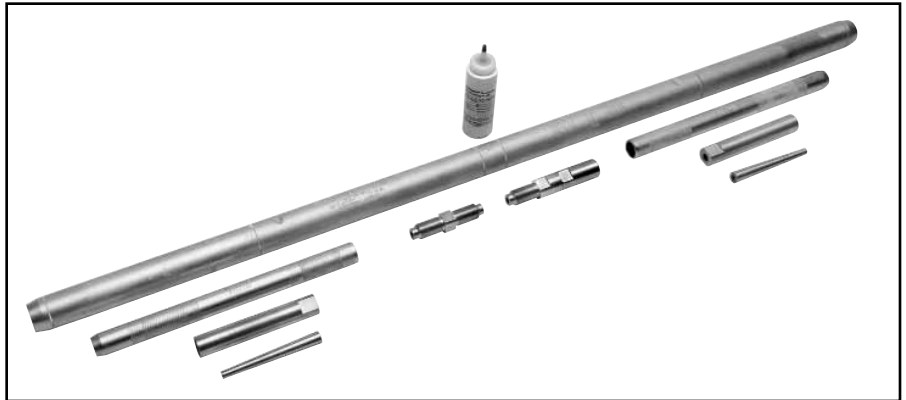

I-49

Conductor Name	Size kcmil	Catalog Number	Dimensions (Inches) L	Installation Tool	
				Die*‡	Tool
Linnet	431	5600-2020	60.80 [1544]	L727W	
Copenhagen	440	5600-2022			
Glasgow	473	5600-2044			
Casablanca	546	5600-2028			
Hawk	611	5600-2030			
Lisbon	629	5600-2032			
Dove	713	5600-2040			
Amsterdam	733	5600-2042			
Grosbeak	816	5600-2050			
Brussels	839	5600-2052			
Oslo	627	5600-2026	67.00 [1702]	L735W	Y60BHU
Stockholm	913	5600-2054			
Warsaw	1016	5600-2056			
Drake	1020	5600-2060			
Dublin	1043	5600-2062			
Hamburg	1092	5600-2058			
Milan	1134	5600-2064			
Rome	1183	5600-2066			
Cardinal	1222	5600-2070			
Vienna	1255	5600-2072			
Budapest	1332	5600-2074			
Prague	1377	5600-2076			
Munich	1461	5600-2078			
London	1512	5600-2079			
Bittern	1572	5600-2080			
Paris	1620	5600-2082			

1. Designed for corona free operation up to 230 kV, contact factory for 345 kV and 500 kV operation.
2. Dimensions in brackets [] denotes metric units and are rounded to nearest whole number.

* Overlap crimps.
‡ Wide dies may be used, add suffix "W" to part number (example: L725W).
ACCC is a Registered Trade Mark of CTC Cable Corp.

Blue highlighted items are industry standard and most frequently ordered.

TYPES BYNA-RTACCC, BYNA-RT15ACCC

Compression Terminals Straight and 15 Degree for ACCC® Conductor

Compression terminal for ACCC® transmission lines up to and including 230 kV.

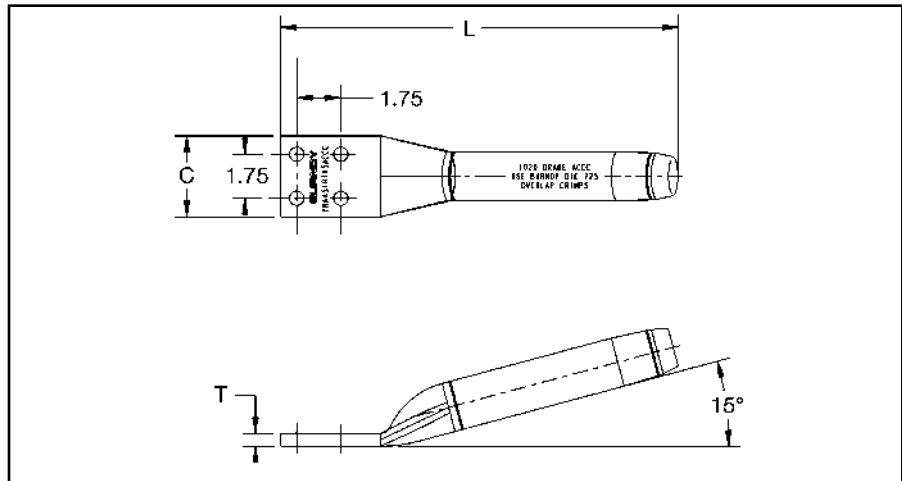

I-50

Conductor Name	Size kcmil	Straight Catalog Number	15 Degree Catalog Number	Dimensions (Inches)				Installation Tooling									
				Straight L	15 Degree L	C	T	Die Index	Y45*	Y46*	Y60BHU*‡						
Linnit	431	BYNA32RTACCC	BYNA32RT15ACCC	15.5	15.5	3.25	0.50	717	S717	P717	L717W						
Copenhagen	440			[393]	[393]												
Glasgow	473	BYNA245MRTACCC	BYNA245MRT15ACCC	15.8	15.8					719	S719	P719	L719W				
Casablanca	546	BYNA36RTACCC	BYNA36RT15ACCC	15.8	15.8					720	S720	P720	L720W				
Hawk	611			[402]	[402]												
Lisbon	629																
Oslo	627																
Dove	713	BYNA39RTACCC	BYNA39RT15ACCC	16.2	16.2					722	S722	P722	L722W				
Amsterdam	733	BYNA43RTACCC	BYNA43RT15ACCC	16.2	16.2					724	S724	P724	L724W				
Grosbeak	816			[411]	[411]												
Brussels	839																
Stockholm	913																
Warsaw	1016	BYNA451RTACCC	BYNA451RT15ACCC	15.3	15.0		0.45	725	S725	P725	L725W						
Drake	1020			[389]	[380]		[11]										
Dublin	1043																
Hamburg	1092	BYNA590MRTACCC	BYNA590MRT15ACCC	15.6	15.7		0.52	727	—	—	L727W						
Milan	1134			[397]	[399]		[13]										
Rome	1183																
Cardinal	1222																
Vienna	1255	BYNA49RTACCC	BYNA49RT15ACCC	15.6	15.7	3.22	0.52	727	—	—	L727W						
Budapest	1332			[397]	[399]								[13]				
Prague	1377																
Munich	1461	BYNA760MRTACCC	BYNA760MRT15ACCC	17.1	17.3		0.71	728	—	—	L728W						
London	1512	[435]	[438]		[18]												
Bittern	1572	BYNA52RTACCC	BYNA52RT15ACCC	17.1	17.3		0.71	728	—	—	L728W						
Paris	1620			[435]	[438]		[18]										

Notes:

ACCC is a Registered Trade Mark of CTC Cable Corp.

- To specify mounting hardware to correspondending deadend or pad add H to the part number (example: BYNA451RTHACCC).

- To specify stainless steel hardware add suffix SS to the catalog number (example: BYNA451RTACCCSS).
- Designed for corona free operation up to 230 kV, contact factory for 345 kV and 500 kV operation.

- Dimensions in brackets [] denotes metric units and are rounded to nearest whole numbers.

* Overlap crimps.
‡ Wide dies may be used, add suffix "W" to part number (example: L725W).

Blue highlighted items are industry standard and most frequently ordered.

TYPE YNTA-RTACCC

**Compression T-Tap
for ACCC® Conductor**

Two piece compression T-Tap to a NEMA pad for ACCC® transmission lines up to and including 230 kV.

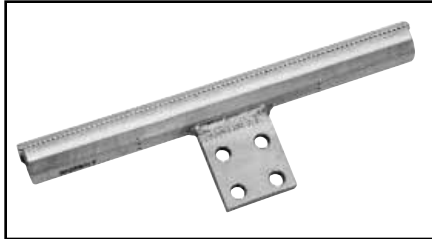
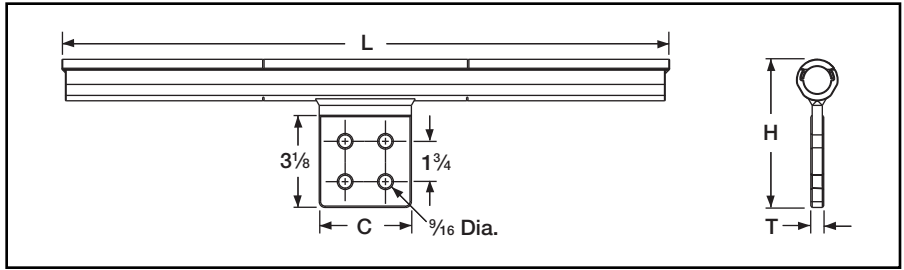

Conductor Name	Size kcmil	Catalog Number	Dimensions (Inches)				Installation Tooling							
			L	C	H	T	Die Index	Y45*	Y46*	Y60BHU*‡				
Linnet	431	YNTA32RTACCC	24.92	4.00 [102]	5.82	0.56 [14]	717	S717	P717	L717W				
Copenhagen	440		[633]		[148]									
Glasgow	473	YNTA245MRTACCC	25.50		5.93						719	S719	P719	L719W
Casablanca	546	YNTA36RTACCC	25.50 [648]		6.03						720	S720	P720	L720W
Hawk	611				[153]									
Lisbon	629													
Olso	627	YNTA39RTACCC	26.06 [662]		6.13						722	S722	P722	L722W
Dove	713				[156]									
Amsterdam	733	YNTA43RTACCC	26.28 [667]		6.24						724	S724	P724	L724W
Grosbeak	816				[158]									
Brussels	839	YNTA451RTACCC	26.38 [670]		6.43						725	S725	P725	L725W
Stockholm	913				[163]									
Warsaw	1016													
Drake	1020	YNTA49RTACCC	26.36 [669]		6.60 [168]						727	—	—	L727W
Dublin	1043													
Hamburg	1092													
Milan	1134													
Rome	1183													
Cardinal	1222													
Vienna	1255													
Budapest	1332													
Prague	1377	YNTA52RTACCC	29.32 [745]	7.00 [178]	728	—	—	L728W						
Munich	1461													
London	1512													
Bittern	1572													
Paris	1620													

I-51

ACCC is a Registered Trade Mark of CTC Cable Corp.

1. Designed for corona free operation up to 230 kV, contact factory for 345 kV and 500 kV operation.

2. Dimensions in brackets [] denotes metric units and are rounded to nearest whole number.

* Overlap crimps.

‡ Wide dies may be used, add suffix "W" to part number (example: L725W).

Blue highlighted items are industry standard and most frequently ordered.

TYPE YNU-RACCC

Compression Repair Sleeve for ACCC® Conductor

Two piece compression repair sleeve for temporary restoration of conductivity to damaged ACCC® transmission lines.

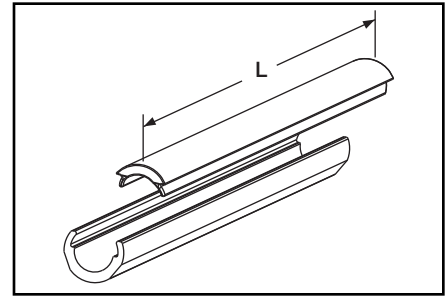

Conductor Name	Size kcmil	Catalog Number	Dimension (Inches) L	Installation Tooling																														
				Die Index	Y45*	Y46*	Y60BHU*‡																											
Linnet	431	YNU32RACCC	22.00 [559]	717	S717	P717	L717W																											
Copenhagen	440			719	S719	P719	L719W																											
Glasgow	473	YNU245MRACCC		720	S720	P720	L720W																											
Casablanca	546			722	S722	P722	L722W																											
Hawk	611	YNU36RACCC		724	S724	P724	L724W																											
Lisbon	629			725	S725	P725	L725W																											
Oslo	627	YNU39RACCC	24.00 [610]	727	—	—	L727W																											
Dove	713			YNU43RACCC	728	—	—	L728W																										
Amsterdam	733	YNU451RACCC							727	—	—	L727W																						
Grosbeak	816			YNU49RACCC									728	—	—	L728W																		
Brussels	839	YNU52RACCC															727	—	—	L727W														
Stockholm	913			YNU49RACCC																	728	—	—	L728W										
Warsaw	1016	YNU52RACCC																							727	—	—	L727W						
Drake	1020			YNU49RACCC	728	—	—	L728W																										
Dublin	1043	YNU52RACCC																											727	—	—	L727W		
Hamburg	1092			YNU49RACCC									728	—	—	L728W																		
Milan	1134	YNU52RACCC																															727	—
Rome	1183			YNU49RACCC																	728	—	—	L728W										
Cardinal	1222	YNU52RACCC	727																															
Vienna	1255			YNU49RACCC	728	—	—	L728W																										
Budapest	1332	YNU52RACCC							727	—	—	L727W																						
Prague	1377			YNU49RACCC									728	—	—	L728W																		
Munich	1461	YNU52RACCC															727	—	—	L727W														
London	1512			YNU49RACCC																	728	—	—	L728W										
Bittern	1572	YNU52RACCC																							727	—	—	L727W						
Paris	1620			YNU49RACCC	728	—	—	L728W																										

ACCC is a Registered Trade Mark of CTC Cable Corp.
Dimensions in brackets [] denotes metric units and are rounded to nearest whole number.

* Overlap crimps.
‡ Wide dies may be used, add suffix "W" to part number (example: L725W).

Blue highlighted items are industry standard and most frequently ordered.

TYPE IMPLO™

Dead End Joints

IMPLO™ Dead End Joints accommodate a wide range of ACSR, ACSS, ACSS/TW, ASC, and ASC/TW conductors; and provide a consistent, smooth, high quality installation every time . . . with no tools or dies. Various dead end configurations, tap pad angles, and eye-bolt versions available, 15 degree tap pad standard.



Conductor				Catalog Number	Length (mm)
Code	Type	Strand	kcmil		
Linnet	ACSR	26/7	336.4	2050	330
Oriole	ACSR	30/7	336.4		
Chickadee	ACSR	18/1	397.5		
Brant	ACSR	24/7	397.5		
Ibis	ACSR	26/7	397.5	2050 ACSS	330
Oriole	ACSS	30/7	336.4		
Lark	ACSR	30/7	397.5	2051	340
Hawk	ACSR	26/7	477		
Dove	ACSR	26/7	556.5	2052	350
Customer Specific	ACSR	26/7	585		
Rook	ACSR	24/7	636	2053	375
Flamingo	ACSR	24/7	666.6		
Stilt	ACSR	24/7	715.5		
Crow	ACSR	54/7	715.5		
Gannet	ACSR	26/7	666.6	2054	375
Grosbeak	ACSR	26/7	636		
Type 16 (Crowsnest)	ACSR/SD	—	636	2055	395
Customer Specific	ACSR	42/7	971.6		
Starling	ACSR	26/7	715.5	2056	385
Cuckoo	ACSR	24/7	795		
Condor	ACSR	54/7	795		
Crane	ACSR	54/7	874.5		
Type 13	ACSR/SD	20/7	795	2057	385
Drake	ACSR	26/7	795		
Drake	ACSS	26/7	795		
Cardinal	ACSS/TW	54/7	954		
Type 16	ACSR/SD	22/7	795	2058	395
Mallard	ACSR	30/19	795		
Ruddy	ACSR	45/7	900	2059	395
Rail	ACSR	45/7	954		
Canary	ACSR	54/7	900	2060	395
Canary	ACSS	54/7	900		
Cardinal	ACSR/SD	T.13	954		
Cardinal	ACSR	54/7	954		
Curlew	ACSR	54/7	1033.5	2061	415
Moose	ACSR	54/7	500 mm		
Ortolan	ACSR	45/7	1033.5	2062	415
Bluejay	ACSR	54/7	1113		
Finch	ACSR	54/19	1113	2063	435
Grackle	ACSR	54/19	1192.5		
Customer Specific	ACSR/TW	56/19	1443.7	2064	435
Bunting	ACSR	45/7	1192.5		
Bittern	ACSR	45/7	1272	2065	435
Potomac/TW	ACSR/TW	36/7	1557.4		

I-53

Blue highlighted items are industry standard and most frequently ordered.

TYPE IMPLO™

Dead End Joints
(Continued)

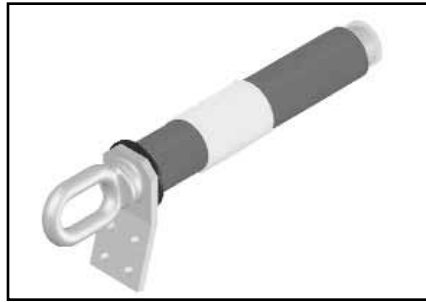

I-54

Conductor				Catalog Number	Length (mm)
Code	Type	Strand	kcmil		
Pheasant	ACSR	54/19	1272	2066	445
Martin	ACSR	54/19	1351.5		
Dipper	ACSR	45/7	1351.5	2067	445
Bobolink	ACSR	45/7	1431		
Plover	ACSR	54/19	1431	2070	455
Parrot	ACSR	54/19	1510.5		
Customer Specific	AACSR	26/7	811.5	2071	395
Nuthatch	ACSR	45/7	1510.5	2072	455
Lapwing	ACSR	45/7	1590		
Type 7 (Kepphill)	ACSR/SD	41/7	1590	2073	465
Falcon	ACSR	54/19	1590		
Chukar	ACSR	84/19	1780	2074	505
Bluebird	ACSR	84/19	2156	2075	495
Kiwi	ACSR	72/7	2167	2076	495
Nelson	ACSR	72/7	1843.3	2077	480
Customer Specific	ACSR	72/7	2032.1		
Mockingbird	ACSR	72/7	2034.5		
Customer Specific	ACSR	72/7	1843.2		
Seahawk	ACSR	68/7	1869	2079	480
Toutle/TW	ACSR/TW	17/7	795		
Customer Specific	ACSR	48/7	623.8	2080	350
Thrasher	ACSR	76/19	2312	2083	510
Skylark	ACSR	36/1	1272	2084	435
Meadowsweet	ASC	37	600	2085	350
Orchid	ASC	37	636		
Violet	ASC	37	715.5		
Nasturtium	ASC	61	715.5		
Arbutus	ASC/TW	17	795		
Baker	ASC/TW	34	795		
Bluebell	ASC	37	1033.5		
Larkspur	ASC	61	1033.5	2086	395
Marigold	ASC	61	1113	2089	435
Customer Specific	ACSR	42/7	1277.5		
Type 5 (Scissortail)	SDC	34/7	1272	2090	375
Deschutes/TW	ACSR/TW	35/7	1519		
Mica - Mica	ACSR	24/7 - 26/7E	666.9-648.2	2093	415
Hawthorn	ASC	61	1192.5		
Narcissus	ASC	61	1272	2094	455
Hornbill	ACSR	48/7	1590		
Athabasca/TW	ACSR/TW	42/7	1780	2095	385
Chukar/TW	ACSR/TW	52/19	1780		
Tern	ACSR	45/7	795	2097	340
Type 6.4	SDC	17/7	477	2100	340
Emu	ACSR	108/37	3364		
Coot	ACSR	36/1	795	2103	375
Pelican	ACSR	18/1	477	2112	340
Osprey	ACSR	18/1	556.5		

Blue highlighted items are industry standard and most frequently ordered.

TYPE IMPLO™

Dead End Joints
(Continued)

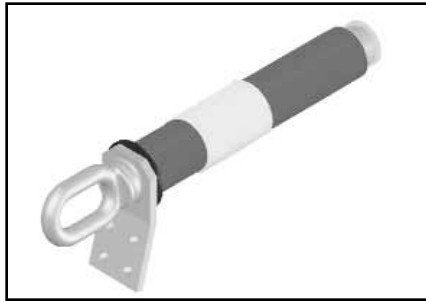

Code	Conductor			Catalog Number	Length (mm)
	Type	Strand	kcmil		
Flicker	ACSR	24/7	477	2113	340
Parakeet	ACSR/TW	18/7	556.5		
Hen	ACSR	30/7	477	2114	350
Heron	ACSR	30/7	500		
Peacock	ACSR	24/7	605	2117	350
Duck	ACSR	54/7	605		
Goose	ACSR	54/7	636		
Customer Specific	ACSR	54/7	605		
Parakeet	ACSR	18/7	556.5	2118	350
Eagle	ACSR	30/7	556.5		
Squab	ACSR	26/7	605	2120	375
Wood Duck	ACSR	30/7	605	2121	375
Teal	ACSR	30/19	605		
Scoter	ACSR	30/7	636		
Egret	ACSR	30/19	636		
Kingbird	ACSR	18/1	636	2123	350
Swift	ACSR	36/1	636		
Customer Specific	ACSR	18/1-18/7	583.2		
Rogue/TW	ACSR/TW	17/7	954	2124	385
Type 7	SDC	21/7	954		
Kettle	ACSR/TW	21/7	954		
Redwing	ACSR	30/19	715.5	2131	385
Grand Rapids	ACSR	22/7	685.4	2133	375
Type 5	SDC	17/7	795		
Macaw	ACSR	42/7	795		
Catbird	ACSR	36/1	954	2138	385
Phoenix	ACSR	42/7	954	2139	395
Towhee	ACSR	48/7	954	2140	385
Snowbird	ACSR	42/7	1033.5	2141	415
4/O	ACSR	6/1	211.6	2142	310
Penguin	ACSR	6/1	211.6		
Ostrich	ACSR	26/7	300	2143	320
Merlin	AACSR	18/1	336.4		
Partridge	ACSR	26/7	266.8	2144	320
Owl	ACSR	6/7	266.8		
Customer Specific	ACSR	22/7	490	2145	340
Road Runner	ACSR	76/19	2057	2146	505
Dotterel	ACSR	12/7	177 mm	2147	310
Canna	ASC	19	397.5	2149	330
Cosmos	ASC	19	477		
Neon	AAC	19	210 mm sq.		
Syringa	ASC	37	477		
Zinnia	ASC	19	500	2150	340
Hyacinth	ASC	37	500		
Dahlia	ASC	19	556.5		
Mistletoe	ASC	37	556.5		

I-55

Blue highlighted items are industry standard and most frequently ordered.

TYPE IMPLO™

Dead End Joints
(Continued)

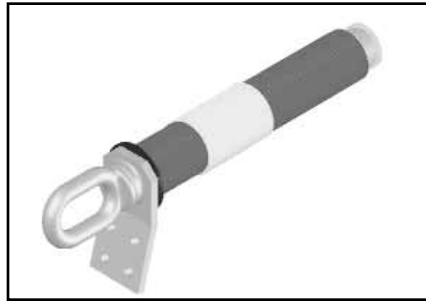

I-56

Conductor				Catalog Number	Length (mm)
Code	Type	Strand	kcmil		
Arbutus	AAC	37	795	2157	375
Phosphorus	AAAC	37	807		
Lilac	AAC	61	795		
Anemone	ASC	37	874.5	2158	385
Crocus	ASC	61	874.5		
Magnolia	ASC	37	954		
Golden Rod	ASC	61	954		
Greeley	AAAC	37	927.2		
Hood	ASC/TW	34	1589	2165	435
Sulphur	AASC	61	647 mm sq.		
Columbine	ASC	61	1351.5	2166	445
Carnation	AAAC	61	1431		
Gladiolus	ASC	61	1510.5		
Coreopsis	ASC	61	1590	2167	455
Moa	ACSR	76/7	1590		
Jessamine	ASC	61	1750	2169	455
Cowslip	ASC	91	2000	2170	505
Jefferson/TW	AAC/TW	52	2406		
Sagebrush	ASC	91	2250	2171	495
Customer Specific	ASC	91	2303		
Bitterroot	ASC	91	2750	2173	510
Tulip	ASC	19	336.4	2174	320
Daffodil	ASC	19	350		
Laurel	ASC	19	266.8	2179	310
Customer Specific	ASC	91	3000	2182	510
3640 kcmil	ASC	91	3640	2183	555
3500 kcmil	ASC	91	3500		
Sansum	ACSR	72/37	1273.5	2190	455
Customer Specific	ACSR	26/7	932.7	2192	415
Customer Specific	ACSR	28/19	1307.4	2300	552
Customer Specific	ACSR	69/19	1924	2301	610

Blue highlighted items are industry standard and most frequently ordered.

TYPE IMPLO™

Full Tension Joints

IMPLO™ Full Tension Joints accommodate a wide range of ACSR, ACSS, ACSS/TW, ASC, and ASC/TW conductors; and provide a consistent, smooth, high quality installation every time . . . with no tools or dies.

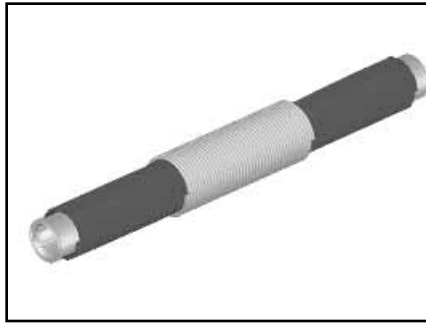

Conductor				Catalog Number	Length (mm)
Code	Type	Strand	kcmil		
Linnnet	ACSR	26/7	336.4	1050	480
Oriole	ACSR	30/7	336.4		
Chickadee	ACSR	18/1	397.5		
Brant	ACSR	24/7	397.5		
Ibis	ACSR	26/7	397.5		
Oriole	ACSS	30/7	336.4	1050 ACSS	480
Lark	ACSR	30/7	397.5	1051	500
Hawk	ACSR	26/7	477	1052	520
Dove	ACSR	26/7	556.5		
Customer Specific	ACSR	26/7	585		
Rook	ACSR	24/7	636		
Flamingo	ACSR	24/7	666.6		
Stilt	ACSR	24/7	715.5	1053	540
Crow	ACSR	54/7	715.5		
Gannet	ACSR	26/7	666.6		
Grosbeak	ACSR	26/7	636		
Type 16 (Crowsnest)	ACSR/SD	—	636		
Customer Specific	ACSR	42/7	971.6	1055	580
Starling	ACSR	26/7	715.5	1056	580
Cuckoo	ACSR	24/7	795		
Condor	ACSR	54/7	795		
Crane	ACSR	54/7	874.5		
Type 13	ACSR/SD	20/7	795		
Drake	ACSR	26/7	795	1057	580
Drake	ACSS	26/7	795		
Cardinal	ACSS/TW	54/7	954		
Type 16	ACSR/SD	22/7	795		
Mallard	ACSR	30/19	795		
Ruddy	ACSR	45/7	900	1058	580
Rail	ACSR	45/7	954	1059	580
Canary	ACSR	54/7	900		
Canary	ACSS	54/7	900		
Cardinal	ACSR/SD	T.13	954		
Cardinal	ACSR	54/7	954		
Curlew	ACSR	54/7	1033.5	1061	620
Moose	ACSR	54/7	500 mm		
Ortolan	ACSR	45/7	1033.5		
Bluejay	ACSR	54/7	1113		
Finch	ACSR	54/19	1113		
Grackle	ACSR	54/19	1192.5	1062	620
Customer Specific	ACSR/TW	56/19	1443.7		
Bunting	ACSR	45/7	1192.5		
Bittern	ACSR	45/7	1272		
Potomac/TW	ACSR/TW	36/7	1557.4		
				1063	660
				1064	660
				1065	660

I-57

Blue highlighted items are industry standard and most frequently ordered.

TYPE IMPLO™

Full Tension Joints
(Continued)

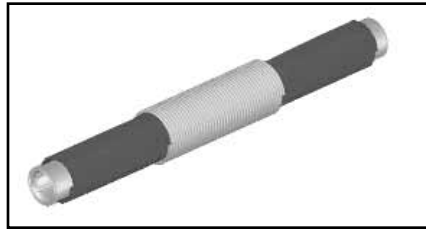

I-58

Conductor				Catalog Number	Length (mm)
Code	Type	Strand	kcmil		
Pheasant	ACSR	54/19	1272	1066	680
Martin	ACSR	54/19	1351.5		
Dipper	ACSR	45/7	1351.5		
Bobolink	ACSR	45/7	1431	1067	680
Plover	ACSR	54/19	1431		
Parrot	ACSR	54/19	1510.5		
Customer Specific	AACSR	26/7	811.5	1071	580
Nuthatch	ACSR	45/7	1510.5	1072	700
Lapwing	ACSR	45/7	1590		
Type 7 (Keephill)	ACSR/SD	41/7	1590		
Falcon	ACSR	54/19	1590	1073	720
Chukar	ACSR	84/19	1780	1074	800
Bluebird	ACSR	84/19	2156	1075	780
Kiwi	ACSR	72/7	2167	1076	780
Nelson	ACSR	72/7	1843.3	1077	750
Customer Specific	ACSR	72/7	2032.1		
Mockingbird	ACSR	72/7	2034.5		
Customer Specific	ACSR	72/7	1843.2		
Seahawk	ACSR	68/7	1869	1079	750
Toutle/TW	ACSR/TW	17/7	795	1080	520
Customer Specific	ACSR	48/7	623.8		
Thrasher	ACSR	76/19	2312	1083	810
Skylark	ACSR	36/1	1272	1084	660
Meadowsweet	ASC	37	600	1085	520
Orchid	ASC	37	636		
Violet	ASC	37	715.5		
Nasturtium	ASC	61	715.5		
Arbutus	ASC/TW	17	795		
Baker	ASC/TW	34	795		
Bluebell	ASC	37	1033.5		
Larkspur	ASC	61	1033.5	1086	580
Marigold	ASC	61	1113		
Customer Specific	ACSR	42/7	1277.5		
Type 5 (Scissortail)	SDC	34/7	1272	1089	660
Deschutes/TW	ACSR/TW	35/7	1519		
Mica - Mica	ACSR	24/7 - 26/7E	666.9-648.2	1090	540
Hawthorn	ASC	61	1192.5	1093	620
Narcissus	ASC	61	1272		
Hornbill	ACSR	48/7	1590	1094	700
Athabasca/TW	ACSR/TW	42/7	1780		
Chukar/TW	ACSR/TW	52/19	1780		
Tern	ACSR	45/7	795	1095	580
Type 6.4	SDC	17/7	477	1097	500
Emu	ACSR	108/37	3364	1100	1302
Coot	ACSR	36/1	795	1103	540
Pelican	ACSR	18/1	477		
Osprey	ACSR	18/1	556.5	1112	500
Flicker	ACSR	24/7	477		
Parakeet	ACSR/TW	18/7	556.5		
Hen	ACSR	30/7	477	1113	500
Heron	ACSR	30/7	500		
				1114	520

Blue highlighted items are industry standard and most frequently ordered.

TYPE IMPLO™

Full Tension Joints
(Continued)

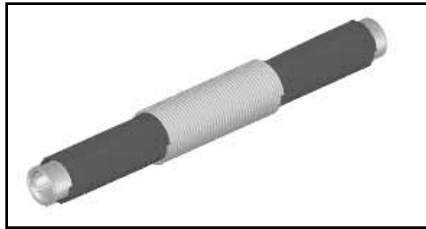

Conductor				Catalog Number	Length (mm)
Code	Type	Strand	kcmil		
Peacock	ACSR	24/7	605	1117	520
Duck	ACSR	54/7	605		
Goose	ACSR	54/7	636		
Customer Specific	ACSR	54/7	605		
Parakeet	ACSR	18/7	556.5		
Eagle	ACSR	30/7	556.5	1118	520
Squab	ACSR	26/7	605	1120	540
Wood Duck	ACSR	30/7	605	1121	540
Teal	ACSR	30/19	605		
Scoter	ACSR	30/7	636		
Egret	ACSR	30/19	636		
Kingbird	ACSR	18/1	636	1123	520
Swift	ACSR	36/1	636		
Customer Specific	ACSR	18/1-18/7	583.2		
Rogue/TW	ACSR/TW	17/7	954	1124	580
Type 7	SDC	21/7	954		
Kettle	ACSR/TW	21/7	954		
Redwing	ACSR	30/19	715.5	1131	580
Grand Rapids	ACSR	22/7	685.4	1133	540
Type 5	SDC	17/7	795		
Macaw	ACSR	42/7	795		
Catbird	ACSR	36/1	954	1138	580
Phoenix	ACSR	42/7	954	1139	580
Towhee	ACSR	48/7	954	1140	580
Snowbird	ACSR	42/7	1033.5	1141	620
4/O	ACSR	6/1	211.6	1142	440
Penguin	ACSR	6/1	211.6		
Ostrich	ACSR	26/7	300		
Merlin	AACSR	18/1	336.4	1143	460
Partridge	ACSR	26/7	266.8	1144	460
Owl	ACSR	6/7	266.8		
Customer Specific	ACSR	22/7	495		
Road Runner	ACSR	76/19	2057	1146	800
Dotterel	ACSR	12/7	177 mm	1147	440
Canna	ASC	19	397.5	1149	480
Cosmos	ASC	19	477		
Neon	AAC	19	210 mm sq.		
Syringa	ASC	37	477		
Zinnia	ASC	19	500		
Hyacinth	ASC	37	500	1150	500
Dahlia	ASC	19	556.5		
Mistletoe	ASC	37	556.5		
Arbutus	AAC	37	795	1157	540
Phosphorus	AAAC	37	807		
Lilac	AAC	61	795		
Anemone	ASC	37	874.5		
Crocus	ASC	61	874.5	1158	580
Magnolia	ASC	37	954		
Golden Rod	ASC	61	954		
Greeley	AAAC	37	927.2		

I-59

Blue highlighted items are industry standard and most frequently ordered.

TYPE IMPLO™

Full Tension Joints
(Continued)

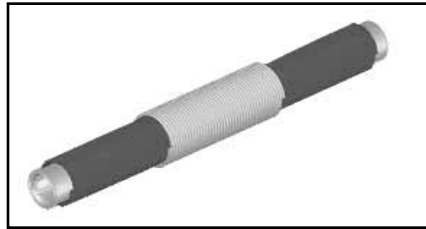

I-60

Conductor				Catalog Number	Length (mm)
Code	Type	Strand	kcmil		
Hood	ASC/TW	34	1589	1165	660
Sulphur	AASC	61	647 mm sq.		
Columbine	ASC	61	1351.5		
Carnation	AAAC	61	1431	1166	680
Gladiolus	ASC	61	1510.5		
Coreopsis	ASC	61	1590		
Moa	ACSR	76/7	1590	1167	700
Jessamine	ASC	61	1750	1169	700
Cowslip	ASC	91	2000	1170	800
Jefferson/TW	AAC/TW	52	2406		
Sagebrush	ASC	91	2250	1171	780
Customer Specific	ASC	91	2303		
Bitterroot	ASC	91	2750	1173	810
Tulip	ASC	19	336.4	1174	460
Daffodil	ASC	19	350		
Laurel	ASC	19	266.8	1179	440
Customer Specific	ASC	91	3000	1182	780
Customer Specific	ASC	91	3640	1183	870
Customer Specific	ASC	91	3500		
Sansum	ACSR	72/37	1273.5	1190	700
Customer Specific	ACSR	26/7	932.7	1192	620
Customer Specific	ACSR	28/19	1307.4	1300	240
Customer Specific	ACSR	69/19	1924	1301	950

Blue highlighted items are industry standard and most frequently ordered.

TYPE IMPLO™

Jumper Terminals

IMPLO™ Jumper Terminals accommodate a wide range of ACSR, ACSS, ACSS/TW, ASC, and ASC/TW conductors; and provide a consistent, smooth, high quality installation every time . . . with no tools or dies, 15 degree tap pad standard.

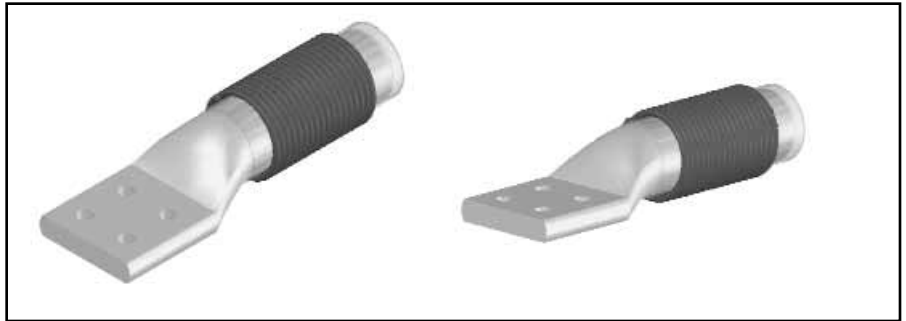

Code	Conductor			Catalog Number	Length (mm)
	Type	Strand	kcmil		
Linnnet	ACSR	26/7	336.4	3050	95
Oriole	ACSR	30/7	336.4		
Chickadee	ACSR	18/1	397.5		
Brant	ACSR	24/7	397.5		
Ibis	ACSR	26/7	397.5		
Oriole	ACSS	30/7	336.4	3050 ACSS	95
Lark	ACSR	30/7	397.5	3051	95
Hawk	ACSR	26/7	477	3052	120
Dove	ACSR	26/7	556.5		
Customer Specific	ACSR	26/7	585		
Rook	ACSR	24/7	636		
Flamingo	ACSR	24/7	666.6		
Stilt	ACSR	24/7	715.5	3053	135
Crow	ACSR	54/7	715.5		
Gannet	ACSR	26/7	666.6		
Grosbeak	ACSR	26/7	636		
Type 16 (Crowsnest)	ACSR/SD	—	636		
Customer Specific	ACSR	42/7	971.6	3055	145
Starling	ACSR	26/7	715.5	3056	135
Cuckoo	ACSR	24/7	795		
Condor	ACSR	54/7	795		
Crane	ACSR	54/7	874.5		
Type 13	ACSR/SD	20/7	795		
Drake	ACSR	26/7	795	3057	135
Drake	ACSS	26/7	795		
Cardinal	ACSS/TW	54/7	954		
Type 16	ACSR/SD	22/7	795		
Mallard	ACSR	30/19	795		
Ruddy	ACSR	45/7	900	3058	145
Rail	ACSR	45/7	954	3059	145
Canary	ACSR	54/7	900	3060	145
Canary	ACSS	54/7	900		
Cardinal	ACSR/SD	T.13	954		
Cardinal	ACSR	54/7	954		
Curlew	ACSR	54/7	1033.5		
Moose	ACSR	54/7	500 mm	3061	145
Ortolan	ACSR	45/7	1033.5	3062	145
Bluejay	ACSR	54/7	1113		
Finch	ACSR	54/19	1113	3063	155
Grackle	ACSR	54/19	1192.5	3064	155
Customer Specific	ACSR/TW	56/19	1443.7		
Bunting	ACSR	45/7	1192.5	3065	155
Bittern	ACSR	45/7	1272		
Potomac/TW	ACSR/TW	36/7	1557.4		

I-61

Blue highlighted items are industry standard and most frequently ordered.

TYPE IMPLO™

Jumper Terminals
(Continued)

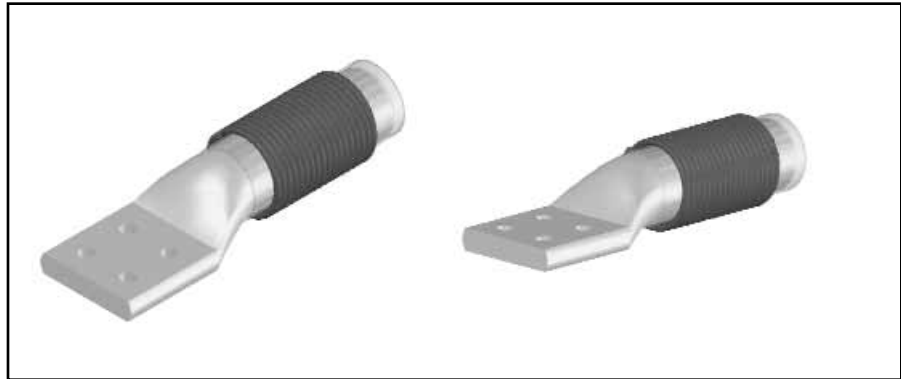

I-62

Code	Conductor			Catalog Number	Length (mm)
	Type	Strand	kcmil		
Pheasant	ACSR	54/19	1272	3066	165
Martin	ACSR	54/19	1351.5		
Dipper	ACSR	45/7	1351.5		
Bobolink	ACSR	45/7	1431	3067	165
Plover	ACSR	54/19	1431		
Parrot	ACSR	54/19	1510.5	3070	190
Customer Specific	AACSR	26/7	811.5		
Nuthatch	ACSR	45/7	1510.5	3071	145
Lapwing	ACSR	45/7	1590		
Type 7 (Keephill)	ACSR/SD	41/7	1590		
Falcon	ACSR	54/19	1590	3073	200
Chukar	ACSR	84/19	1780	3074	195
Bluebird	ACSR	84/19	2156	3075	195
Kiwi	ACSR	72/7	2167	3076	195
Nelson	ACSR	72/7	1843.3	3077	195
Customer Specific	ACSR	72/7	2032.1		
Mockingbird	ACSR	72/7	2034.5		
Customer Specific	ACSR	72/7	1843.2		
Seahawk	ACSR	68/7	1869	3079	195
Toutle/TW	ACSR/TW	17/7	795	3080	120
Customer Specific	ACSR	48/7	623.8		
Thrasher	ACSR	76/19	2312	3083	240
Skylark	ACSR	36/1	1272	3084	155
Meadowsweet	ASC	37	600	3085	120
Orchid	ASC	37	636		
Violet	ASC	37	715.5		
Nasturtium	ASC	61	715.5		
Arbutus	ASC/TW	17	795		
Baker	ASC/TW	34	795		
Bluebell	ASC	37	1033.5		
Larkspur	ASC	61	1033.5	3086	145
Marigold	ASC	61	1113		
Customer Specific	ACSR	42/7	1277.5		
Type 5 (Scissortail)	SDC	34/7	1272	3089	155
Deschutes/TW	ACSR/TW	35/7	1519		
Mica - Mica	ACSR	24/7 - 26/7E	666.9-648.2	3090	135
Hawthorn	ASC	61	1192.5	3093	145
Narcissus	ASC	61	1272		
Hornbill	ACSR	48/7	1590	3094	190
Athabasca/TW	ACSR/TW	42/7	1780		
Chukar/TW	ACSR/TW	52/19	1780		
Tern	ACSR	45/7	795	3095	135
Type 6.4	SDC	17/7	477	3097	95

Blue highlighted items are industry standard and most frequently ordered.

TYPE IMPLO™

Jumper Terminals
(Continued)

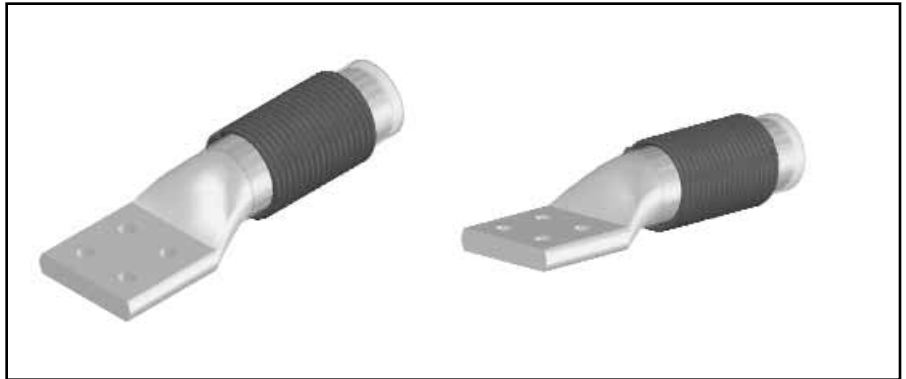

Code	Conductor			Catalog Number	Length (mm)
	Type	Strand	kcmil		
Coot	ACSR	36/1	795	3103	135
Pelican	ACSR	18/1	477	3112	95
Osprey	ACSR	18/1	556.5	3113	95
Flicker	ACSR	24/7	477		
Parakeet	ACSR/TW	18/7	556.5	3114	120
Hen	ACSR	30/7	477		
Heron	ACSR	30/7	500		
Peacock	ACSR	24/7	605		
Duck	ACSR	54/7	605		
Goose	ACSR	54/7	636		
Customer Specific	ACSR	54/7	605	3117	120
Parakeet	ACSR	18/7	556.5		
Eagle	ACSR	30/7	556.5	3118	120
Squab	ACSR	26/7	605	3120	135
Wood Duck	ACSR	30/7	605	3121	135
Teal	ACSR	30/19	605		
Scoter	ACSR	30/7	636		
Egret	ACSR	30/19	636		
Kingbird	ACSR	18/1	636	3123	120
Swift	ACSR	36/1	636		
Customer Specific	ACSR	18/1-18/7	583.2		
Rogue/TW	ACSR/TW	17/7	954	3124	135
Type 7	SDC	21/7	954		
Kettle	ACSR/TW	21/7	954		
Redwing	ACSR	30/19	715.5	3131	137
Grand Rapids	ACSR	22/7	685.4	3133	135
Type 5	SDC	17/7	795		
Macaw	ACSR	42/7	795		
Catbird	ACSR	36/1	954	3138	135
Phoenix	ACSR	42/7	954	3139	145
Towhee	ACSR	48/7	954	3140	135
Snowbird	ACSR	42/7	1033.5	3141	145
4/O	ACSR	6/1	211.6	3142	90
Penguin	ACSR	6/1	211.6		
Ostrich	ACSR	26/7	300	3143	90
Merlin	AACSR	18/1	336.4		
Partridge	ACSR	26/7	266.8	3144	90
Owl	ACSR	6/7	266.8		
Customer Specific	ACSR	22/7	490		
Road Runner	ACSR	76/19	2057	3146	195
Dotterel	ACSR	12/7	177 mm	3147	90

I-63

Blue highlighted items are industry standard and most frequently ordered.

TYPE IMPLO™

Jumper Terminals
(Continued)

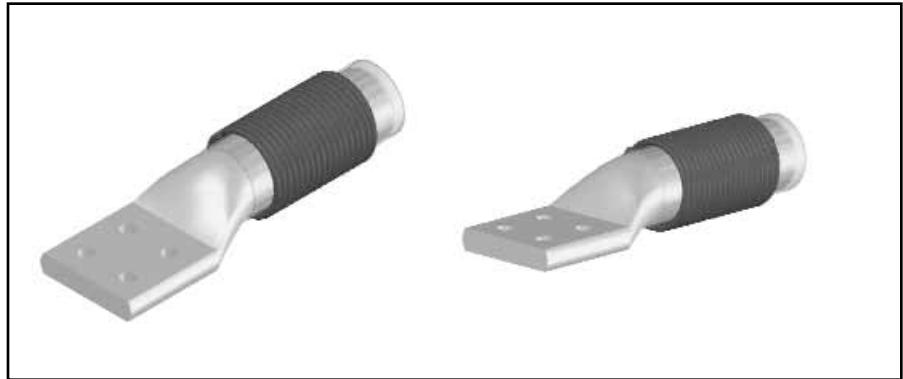

I-64

Code	Conductor			Catalog Number	Length (mm)
	Type	Strand	kcmil		
Canna	ASC	19	397.5	3149	95
Cosmos	ASC	19	477		
Neon	AAC	19	210 mm sq.		
Syringa	ASC	37	477		
Zinnia	ASC	19	500	3150	95
Hyacinth	ASC	37	500		
Dahlia	ASC	19	556.5		
Mistletoe	ASC	37	556.5	3157	135
Arbutus	AAC	37	795		
Phosphorus	AAAC	37	807		
Lilac	AAC	61	795	3158	135
Anemone	ASC	37	874.5		
Crocus	ASC	61	874.5		
Magnolia	ASC	37	954		
Golden Rod	ASC	61	954	3165	155
Greeley	AAAC	37	927.2		
Hood	ASC/TW	34	1589		
Sulphur	AASC	61	647 mm sq.	3166	165
Columbine	ASC	61	1351.5		
Carnation	AAAC	61	1431		
Gladiolus	ASC	61	1510.5		
Coreopsis	ASC	61	1590	3167	190
Moa	ACSR	76/7	1590		
Jessamine	ASC	61	1750	3169	190
Cowslip	ASC	91	2000		
Jefferson/TW	AAC/TW	52	2406	3170	195
Sagebrush	ASC	91	2250		
Customer Specific	ASC	91	2303	3171	195
Bitterroot	ASC	91	2750		
Tulip	ASC	19	336.4	3174	90
Daffodil	ASC	19	350		
Laurel	ASC	19	266.8	3179	90
Customer Specific	ASC	91	3000		
Customer Specific	ASC	91	3640	3182	240
Customer Specific	ASC	91	3500		
Sansum	ACSR	72/37	1273.5	3183	320
Customer Specific	ACSR	26/7	932.7		
Customer Specific	ACSR	28/19	1307.4	3190	190
Customer Specific	ACSR	69/19	1924		
Customer Specific	ACSR	69/19	1924	3192	145
Customer Specific	ACSR	28/19	1307.4	3300	
Customer Specific	ACSR	69/19	1924	3301	195

Blue highlighted items are industry standard and most frequently ordered.

TYPE IMPLO™

Repair Sleeve

IMPLO™ Repair Sleeves accommodate a wide range of ACSR, ACSS, ACSS/TW, ASC, and ASC/TW conductors; and provide a consistent, smooth, high quality installation every time . . . with no tools or dies.



Conductor				Catalog Number	Length (mm)
Code	Type	Strand	kcmil		
Linnet	ACSR	26/7	336.4	9050	406
Oriole	ACSR	30/7	336.4		
Chickadee	ACSR	18/1	397.5		
Brant	ACSR	24/7	397.5		
Ibis	ACSR	26/7	397.5		
Oriole	ACSS	30/7	336.4	9050 ACSS	406
Lark	ACSR	30/7	397.5	9051	406
Hawk	ACSR	26/7	477	9052	406
Dove	ACSR	26/7	556.5		
Customer Specific	ACSR	26/7	585		
Rook	ACSR	24/7	636	9053	406
Flamingo	ACSR	24/7	666.6		
Stilt	ACSR	24/7	715.5		
Crow	ACSR	54/7	715.5		
Gannet	ACSR	26/7	666.6		
Grosbeak	ACSR	26/7	636	9054	406
Type 16 (Crowsnest)	ACSR/SD	—	636	9055	406
Customer Specific	ACSR	42/7	971.6		
Starling	ACSR	26/7	715.5	9056	406
Cuckoo	ACSR	24/7	795		
Condor	ACSR	54/7	795		
Crane	ACSR	54/7	874.5		
Type 13	ACSR/SD	20/7	795		
Drake	ACSR	26/7	795	9057	406
Drake	ACSS	26/7	795		
Cardinal	ACSS/TW	54/7	954		
Type 16	ACSR/SD	22/7	795		
Mallard	ACSR	30/19	795		
Ruddy	ACSR	45/7	900	9059	406
Rail	ACSR	45/7	954	9060	406
Canary	ACSR	54/7	900		
Canary	ACSS	54/7	900		
Cardinal	ACSR/SD	T.13	954		
Cardinal	ACSR	54/7	954		
Curlew	ACSR	54/7	1033.5	9061	406
Moose	ACSR	54/7	500 mm		
Ortolan	ACSR	45/7	1033.5	9062	
Bluejay	ACSR	54/7	1113	9063	
Finch	ACSR	54/19	1113		
Grackle	ACSR	54/19	1192.5	9064	406
Customer Specific	ACSR/TW	56/19	1443.7		
Bunting	ACSR	45/7	1192.5	9065	406
Bittern	ACSR	45/7	1272		
Potomac/TW	ACSR/TW	36/7	1557.4		
Pheasant	ACSR	54/19	1272	9066	406
Martin	ACSR	54/19	1351.5		

I-65

Note: Repair Sleeves are generally supplied in one of 2 lengths: 406 mm and 460 mm, as appropriate.

Repair Sleeves for T-Taps can be supplied for any conductor requirement, as above. Dimensions may vary.

Blue highlighted items are industry standard and most frequently ordered.

TYPE IMPLO™

Repair Sleeve
(Continued)

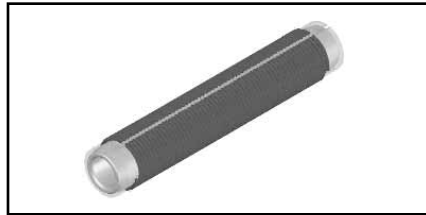

I-66

Conductor				Catalog Number	Length (mm)
Code	Type	Strand	kcmil		
Dipper	ACSR	45/7	1351.5	9067	460
Bobolink	ACSR	45/7	1431		
Plover	ACSR	54/19	1431		
Parrot	ACSR	54/19	1510.5	9070	460
Customer Specific	AACSR	26/7	811.5	1071	406
Nuthatch	ACSR	45/7	1510.5	9072	406
Lapwing	ACSR	45/7	1590		
Type 7 (Keephill)	ACSR/SD	41/7	1590		
Falcon	ACSR	54/19	1590	9073	406
Chukar	ACSR	84/19	1780	9074	406
Bluebird	ACSR	84/19	2156	9075	460
Kiwi	ACSR	72/7	2167	9076	460
Nelson	ACSR	72/7	1843.3	9077	406
Customer Specific	ACSR	72/7	2032.1		460
Mockingbird	ACSR	72/7	2034.5		460
Customer Specific	ACSR	72/7	1843.2		406
Seahawk	ACSR	68/7	1869	9079	406
Toutle/TW	ACSR/TW	17/7	795	9080	406
Customer Specific	ACSR	48/7	623.8		
Thrasher	ACSR	76/19	2312	9083	
Skylark	ACSR	36/1	1272	9084	406
Meadowsweet	ASC	37	600	9085	406
Orchid	ASC	37	636		
Violet	ASC	37	715.5		
Nasturtium	ASC	61	715.5		
Arbutus	ASC/TW	17	795		
Baker	ASC/TW	34	795		
Bluebell	ASC	37	1033.5		
Larkspur	ASC	61	1033.5	9086	406
Marigold	ASC	61	1113	9089	406
Customer Specific	ACSR	42/7	1277.5		
Type 5 (Scissortail)	SDC	34/7	1272		
Deschutes/TW	ACSR/TW	35/7	1519	9090	406
Mica - Mica	ACSR	24/7 - 26/7E	666.9-648.2		
Hawthorn	ASC	61	1192.5	9093	406
Narcissus	ASC	61	1272		
Hornbill	ACSR	48/7	1590	9094	406
Athabasca/TW	ACSR/TW	42/7	1780		
Chukar/TW	ACSR/TW	52/19	1780		
Tern	ACSR	45/7	795	9095	406
Type 6.4	SDC	17/7	477	9097	406
Emu	ACSR	108/37	3364	9100	700
Coot	ACSR	36/1	795	9103	406
Pelican	ACSR	18/1	477	9112	406
Osprey	ACSR	18/1	556.5		
Flicker	ACSR	24/7	477	9113	406
Parakeet	ACSR/TW	18/7	556.5		
Hen	ACSR	30/7	477	9114	406
Heron	ACSR	30/7	500		

Note: Repair Sleeves are generally supplied in one of 2 lengths: 406 mm and 460 mm, as appropriate.

Repair Sleeves for T-Taps can be supplied for any conductor requirement, as above. Dimensions may vary.

Blue highlighted items are industry standard and most frequently ordered.

TYPE IMPLO™

Repair Sleeve
(Continued)



Conductor				Catalog Number	Length (mm)
Code	Type	Strand	kcmil		
Peacock	ACSR	24/7	605	9117	406
Duck	ACSR	54/7	605		
Goose	ACSR	54/7	636		
Customer Specific	ACSR	54/7	605		
Parakeet	ACSR	18/7	556.5	9118	406
Eagle	ACSR	30/7	556.5		
Squab	ACSR	26/7	605	9120	406
Wood Duck	ACSR	30/7	605		
Teal	ACSR	30/19	605	9121	406
Scoter	ACSR	30/7	636		
Egret	ACSR	30/19	636		
Kingbird	ACSR	18/1	636		
Swift	ACSR	36/1	636	9123	406
Customer Specific	ACSR	18/1-18/7	583.2		
Rogue/TW	ACSR/TW	17/7	954	9124	406
Type 7	SDC	21/7	954		
Kettle	ACSR/TW	21/7	954		
Redwing	ACSR	30/19	715.5	9131	406
Grand Rapids	ACSR	22/7	685.4	9133	406
Type 5	SDC	17/7	795		
Macaw	ACSR	42/7	795	9138	406
Catbird	ACSR	36/1	954		
Phoenix	ACSR	42/7	954	9139	406
Towhee	ACSR	48/7	954	9140	406
Snowbird	ACSR	42/7	1033.5	9141	406
4/O	ACSR	6/1	211.6	9142	406
Penguin	ACSR	6/1	211.6		
Ostrich	ACSR	26/7	300	9143	406
Merlin	AACSR	18/1	336.4		
Partridge	ACSR	26/7	266.8	9144	406
Owl	ACSR	6/7	266.8		
Customer Specific	ACSR	22/7	490	9145	406
Road Runner	ACSR	76/19	2057	9146	406
Dotterel	ACSR	12/7	177 mm	9147	406
Canna	ASC	19	397.5	9149	406
Cosmos	ASC	19	477		
Neon	AAC	19	210 mm sq.		
Syringa	ASC	37	477		
Zinnia	ASC	19	500	9150	406
Hyacinth	ASC	37	500		
Dahlia	ASC	19	556.5		
Mistletoe	ASC	37	556.5	9157	406
Arbutus	AAC	37	795		
Phosphorus	AAAC	37	807		
Lilac	AAC	61	795		

I-67

Note: Repair Sleeves are generally supplied in one of 2 lengths: 406 mm and 460 mm, as appropriate.

Repair Sleeves for T-Taps can be supplied for any conductor requirement, as above. Dimensions may vary.

Blue highlighted items are industry standard and most frequently ordered.

TYPE IMPLO™

Repair Sleeve
(Continued)

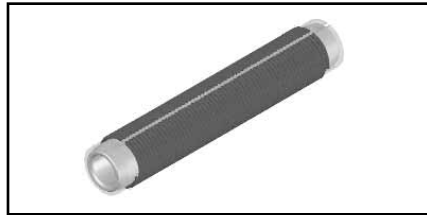

I-68

Conductor				Catalog Number	Length (mm)
Code	Type	Strand	kcmil		
Anemone	ASC	37	874.5	9158	406
Crocus	ASC	61	874.5		
Magnolia	ASC	37	954		
Golden Rod	ASC	61	954		
Greeley	AAAC	37	927.2		
Hood	ASC/TW	34	1589	9165	406
Sulphur	AASC	61	647 mm sq.		
Columbine	ASC	61	1351.5		
Carnation	AAAC	61	1431	9166	460
Gladiolus	ASC	61	1510.5		
Coreopsis	ASC	61	1590		
Moa	ACSR	76/7	1590		
Jessamine	ASC	61	1750	9169	406
Cowslip	ASC	91	2000	9170	406
Jefferson/TW	AAC/TW	52	2406		
Sagebrush	ASC	91	2250	9171	406
Customer Specific	ASC	91	2303		
Bitterroot	ASC	91	2750	9173	460
Tulip	ASC	19	336.4	9174	406
Daffodil	ASC	19	350		
Laurel	ASC	19	266.8	9179	406
Customer Specific	ASC	91	3000	9182	460
Customer Specific	ASC	91	3640		
Customer Specific	ASC	91	3500		
Sansum	ACSR	72/37	1273.5	9190	406
Customer Specific	ACSR	26/7	932.7	9192	406
Customer Specific	ACSR	28/19	1307.4	9300	406
Customer Specific	ACSR	69/19	1924	9301	406

Note: Repair Sleeves are generally supplied in one of 2 lengths: 406 mm and 460 mm, as appropriate.

Repair Sleeves for T-Taps can be supplied for any conductor requirement, as above. Dimensions may vary.

Blue highlighted items are industry standard and most frequently ordered.

TYPE TDM-RG1

Stockbridge Damper

The Stockbridge Damper is designed to enhance conductor life by lessening potential vibration-induced fatigue.



Standards

The Stockbridge Dampers meet the following standards:

- **IEC 61897** Overhead lines—Requirements and Test for Stockbridge Aeolian Vibration Dampers.
- **IEEE Std 664-1993** IEEE Guide for Laboratory Measurement of the Power Dissipation Characteristics of Aeolian Vibration Dampers for Single Conductors.

Features and Benefits

- Clamps designed around common conductor sizes
 - ◊ Ease of specification
- Single bolt design
 - ◊ Ease of installation
 - ◊ Single wrench installation
- Accurate components assembly represents greater energy dissipation
 - ◊ Provides extended life for overhead lines
- Messenger cable and weights have a corrosion resistant finish
 - ◊ Weight design eliminates water entrapment
 - ◊ Smooth surfaces and rounded edges to eliminate possible corona discharge

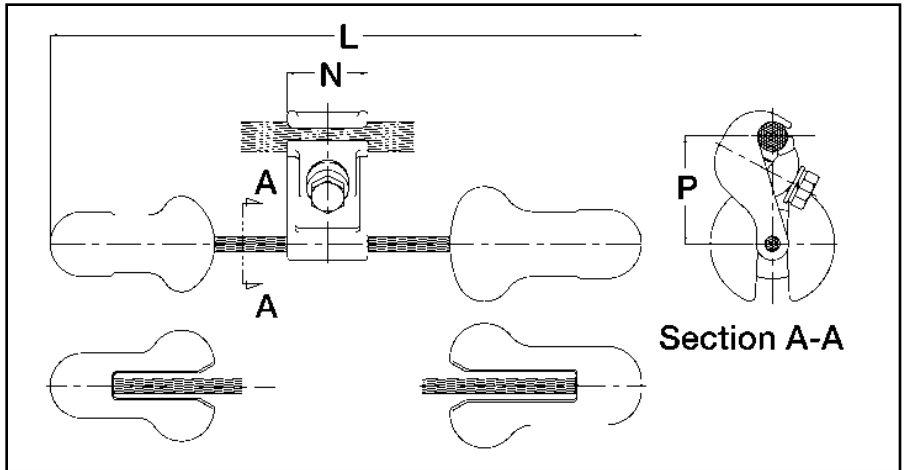

I-69

Conductors: ACSR, AAC, ACAR/Static Wires (Galvanized Steel, Alumoweld, Copperweld)

Catalog Number	Clamp Diameter Range	N	P	L	Wrench Size	Tightening Torque	Weight
TDM99RG1	Ø 0.24" – Ø 0.61" (6 mm – 15.5 mm)	1.70" 43 mm	2.20" 56 mm	12.20" 310 mm	7/16" 11.17 mm	265 in.-lb. 3.0 daN.m	3.7 lb. (1.68 kg)
TDM177RG1	Ø 0.59" – Ø 0.79" (15 mm – 20 mm)	2.00" 51 mm	3.00" 76 mm	14.40" 365 mm	1/2" 12.70 mm	355 in.-lb. 4.0 daN.m	6.2 lb. (2.81 kg)
TDM177RG2	Ø 0.71" – Ø 1.18" (18 mm – 30 mm)	2.00" 51 mm	3.60" 91 mm	14.40" 365 mm	5/8" 16 mm	530 in.-lb. 6.0 daN.m	6.4 lb. (2.9 kg)
TDM210RG1	Ø 0.79" – Ø 1.11" (20 mm – 28.2 mm)	2.40" 60 mm	3.20" 81 mm	19.70" 500 mm	5/8" 16 mm	530 in.-lb. 6.0 daN.m	9.5 lb. (4.30 kg)
TDM210RG2	Ø 1.30" – Ø 1.50" (33 mm – 38.1 mm)	2.40" 60 mm	3.75" 95 mm	19.70" 500 mm	5/8" 16 mm	530 in.-lb. 6.0 daN.m	9.9 lb. (4.50 kg)
TDM246RG1	Ø 0.71" – Ø 1.18" (18 mm – 30 mm)	2.70" 68 mm	3.60" 91 mm	21.00" 534 mm	5/8" 16 mm	530 in.-lb. 6.0 daN.m	13.2 lb. (5.99 kg)
TDM330RG1	Ø 1.18" – Ø 1.26" (30 mm – 32 mm)	2.70" 68 mm	3.60" 91 mm	21.00" 535 mm	5/8" 16 mm	530 in.-lb. 6.0 daN.m	13.2 lb. (5.99 kg)
TDM393RG1	Ø 1.26" – Ø 1.54" (32 mm – 39 mm)	2.70" 68 mm	3.75" 95 mm	21.00" 534 mm	5/8" 16 mm	530 in.-lb. 6.0 daN.m	13.5 lb. (6.12 kg)
TDM430RG1	Ø 1.54" – Ø 1.85" (39 mm – 47 mm)	2.70" 68 mm	4.09" 104 mm	21.00" 534 mm	5/8" 16 mm	530 in.-lb. 6.0 daN.m	14.0 lb. (6.35 kg)

For installation point contact factory at numbers below.

Blue highlighted items are industry standard and most frequently ordered.

TYPE S-D-R-SG

Spacer Damper

Since the 1960's BURNDY® Spacer Dampers have been used on bundled conductor transmission lines around the world. Over 850,000 units have been installed on over 40,000 phase miles of conductor. Projects have included 2, 3, 4 and 6 bundle arrangements at voltage levels from 230 kV to 800 kV AC and up to +/-600 kV DC.

BURNDY® motion control products are engineered per customer requirements and industry standards. Our engineering team has the experience and technology to provide the proper motion control answers to your bundled conductor transmission line projects.

Our history of design, testing and field installation experience enables us to provide Spacer Damper products along with placement recommendations for optimum performance.

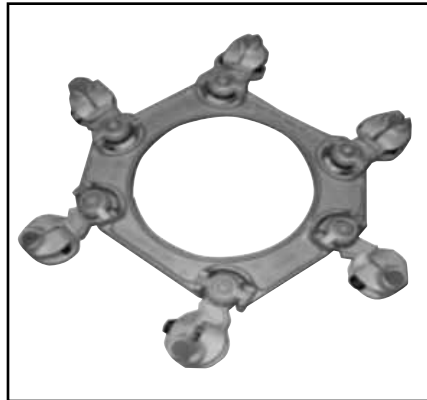

Conductors: ACSR, AAC, ACAR						
Catalog Number	Bundle Size	Conductor kcmil	Conductor Diameter	Spacing	Wrench Size	Tightening Torque
S2D451R-SG1	2	795	1.107" 28.1 mm	18" 457 mm	5/8" 16 mm	55 ft.-lb. 74.6 daN.m
S3D451R-SG1	3	795	1.107" 28.1 mm	18" 457 mm	5/8" 16 mm	55 ft.-lb. 74.6 daN.m
S3D55R-SG1	3	1590	1.54" 39 mm	18" 457 mm	5/8" 16 mm	55 ft.-lb. 74.6 daN.m
S4D48R-SG1	4	954	1.196" 30.4 mm	18" 457 mm	5/8" 16 mm	55 ft.-lb. 74.6 daN.m
S6D441R-SG1	6	957	1.06" 26.9 mm	30" Dia. 762 mm	5/8" 16 mm	55 ft.-lb. 74.6 daN.m

In most cases Spacer Dampers are custom designed for the specific transmission line requirements. Contact the factory for more information.
For installation points per span contact factory.

Information for Damping Study

Customer Contact:

Customer Name _____

Telephone/Email _____

Project Name _____

Request Date _____

Project Start Date _____

Stockbridge Damper

Spacer Damper

Conductor Information

Line Voltage _____

Number of Phases _____

Number of Conductors per Phase _____

Total Circuit Miles _____

Conductor Name/Size

(i.e., Drake 795 26/7)

Cable Name

AAC	AAAC	ACSR	ACAR	ACCC	ACSS	Steel	Other	Trapezoidal
<input type="checkbox"/>	<input type="checkbox"/>	<input type="checkbox"/>	<input type="checkbox"/>	<input type="checkbox"/>	<input type="checkbox"/>	<input type="checkbox"/>	<input type="checkbox"/>	<input type="checkbox"/>

Armor Rod Length Diameter Type: AR _____ AGS _____

Wind

Laminar _____

With small turbulences _____

With turbulences _____

Prevailing wind direction relative to line _____

Wind (mph) _____

Environment

Flat country (deserts, lakes) _____

Valley with small vegetation _____

Trees & Mountains _____

Special conditions (river crossings, etc.) _____

Temperature (F): Average Minimum

Ice Condition — specify loading zone: _____

Ice (inches)

Span

Ruling Span (ft) _____

Maximum Span Length (ft) _____

Optional to list Spans: 600, 950, 450, etc. _____

Tension

Design Tension — lbs.

Additional Comments: _____

I-71

THE WEJTAP™ SYSTEM

FOR ELECTRIC UTILITY
DISTRIBUTION AND
TRANSMISSION
CONNECTIONS



J-1

Blue highlighted items are industry standard and most frequently ordered.

TABLE OF CONTENTS

WEJTAP™ Connection System	J-3	WEJTAP™ Installation Tools	
		WTB, WTHRB1S,	
WEJTAP™ and Test Data	J-4	WTBGBW, WTHY1S	J-10
WEJTAP™ Ordering Information	J-5	Installation Tool Accessories	
		WTOCBR, WTOCY,	
WEJTAP™ Cover		WTCK, WTBASY1	J-10
WCCR, WCCB, WCCSY, WCCLY	J-5	WEJTAP™ Power Lug	J-11
WEJTAP™ Connector		WEJTAP™ Hotstick Accessories	
Selection Chart		WHSCWH, WHSPBC, WHSSADP,	
By Diameter	J-6 - J-8	WHSWADP, WCHAWAS, WHSTA,	
		WHSWB, WHSGB, WHHWB	J-12
WEJTAP™ STIRRUP™		WEJTAP™ Kit Ordering Instructions	J-13
and Power Boosters	J-9		
WEJTAP™ STIRRUP™		WEJTAP™	
Selection Chart	J-9	In-Line Disconnect	J-14



Blue highlighted items are industry standard and most frequently ordered.

BURNDY WEJTAP™

CONNECTION SYSTEM

BURNDY®, a leading manufacturer of quality electrical connectors for over 70 years, introduces the WEJTAP™ SYSTEM, a system that adds further dimension to the existing BURNDY® group of proven, reliable connection systems.

WEJTAP™ COMPONENTS are designed to provide a reliable system connection. The system consists of WEJTAP™ connectors, installation tools (including a variety of hot-line and lineman accessories) and a unique power-booster.

WEJTAP™ CONNECTORS use an aluminum alloy wedge that is power-driven between the run and the tap cables locking them into a “C” shaped tempered aluminum alloy spring-body. The spring-body maintains consistent pressure throughout the life of the connection to ensure reliability during severe electrical and climatic conditions. The wedge’s wiping action combined with factory installed PENTX 1530 provides superior contact integrity. The wedge is automatically locked onto the spring-body by a skiving action produced by a lance at the forward end of the WEJTAP™ installation tool.

THE WEJTAP™ TOOL is a one-piece assembly that consists of a head and power unit. Two color-coded interchangeable heads accept all WEJTAP™ connectors and STIR-RUP™. The design of the tool recognizes the need for simplicity and speed of operation as well as outstanding safety features such as automatic gas release vented away from the operator, fast simple breech loading and fast advance when engaging the connector assembly. No loose parts to drop or misplace and a booster ejection system that provides further safety to the operator. Fewer simplified hotline devices and handy lineman accessories complete an outstanding tool package.

THE WEJTAP™ POWER-BOOSTER Patented is a self-contained device that provides the force necessary to drive the wedge into direct contact with the conductors. The booster is activated only when properly positioned in the tool assembly. A power cell in the booster is recessed to guard against premature discharge. The tool/booster system is designed to activate and deactivate the booster automatically should the operator decide to remove the tool from a connector prior to completing the installation. The deactivated booster may be safely removed from the tool.

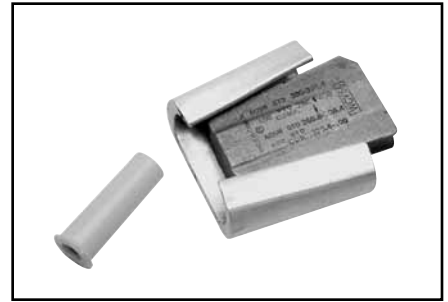

Features and Benefits

- Large conductor chamfer on ends of wedge.
 - ◊ Instant hand or visual identification of large run grooves. Ensures correct wedge orientation.
- Color-coded WEJTAP™ connector and booster packaged together.
 - ◊ Easy selection by installer.
- Factory coated grooves with PENTX 1530.
 - ◊ Maintains low contact resistance, assists in protection against climatic conditions and is compatible with common insulations.
- One-piece tool.
 - ◊ No project delays due to dropped or lost parts.
- Fewer and improved hotstick accessories
 - ◊ Simplifies hotline installation and saves time.
- Contained booster ejection system.
 - ◊ Safe for operator guards against the booster being ejected in direction of the installer.
- Automatic gas release vented away from operator.
 - ◊ Eliminates manual gas venting and improves safety.
- Simplified loading.
 - ◊ Speeds installation—no threads—just depress safety bar, twist and pull open—load—push and twist to close prior to applying connector.
- Acme-type threads.
 - ◊ Provides smooth, fast engagement of tool and connector-saves installer’s time.

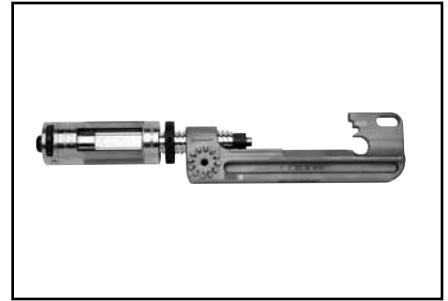

Blue highlighted items are industry standard and most frequently ordered.

WEJTAP™ AND TEST DATA

WEJTAP™ connectors have been subjected to extensive tests simulating the most severe service and weather conditions. In addition, the WEJTAP™ system meets or exceeds the industry standards of ANSI C119.4 Class 3, NEMA CC3 1973 Class AA, 500 Heat Cycles.

As with all BURNDY® connectors, the WEJTAP™ has been designed to operate cooler than the attached conductors. The WEJTAP™ connectors have also been subjected to the ASTM B117-73 Salt Spray Test. The results are shown to the right.

ANSI C119.4 - 1986 Heat Cycle Test
Average Temperature Rise vs. Current Cycles

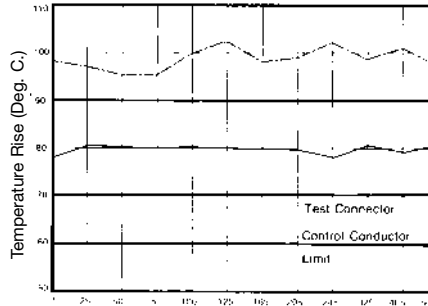

Detailed test report packages are available upon request.

ASTM Salt Spray Test
Average % Relative Resistance vs. Hours of Salt Spray Exposure

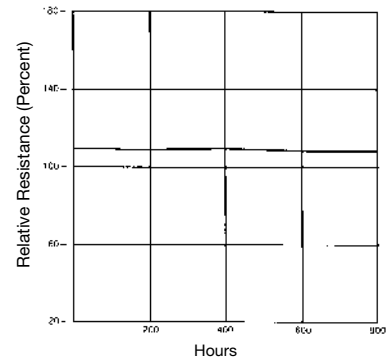

WEJTAP™

C-member bodies are color-coded and the wedges are marked with nominal conductor run and tap ranges. WEJTAP™ connector packages are labeled with a variety of common conductors with their nominal ranges.

J-4

- WEJTAP™ connector wedges are marked with nominal ACSR, Aluminum and Copper concentric standard conductors.
- Red WEJTAP™ connector range Run 8-1/0 Tap 8-2
- Blue WEJTAP™ connector range Run 2-300 Tap 6-300
- Yellow WEJTAP™ connector range Run 266.8-1590 Tap 6-1590

All WEJTAP™ wedges contain a clearly defined chamfer on the large end of the run conductor groove to identify the “large run” groove. Installers will appreciate the convenience of visual or hand identification for correct wedge positioning.

WEJTAP™ wedges are driven between the run and tap conductors and activate the spring characteristics of the “C” shaped body. This action maintains contact pressure even when the connection is subjected to severe climatic and electrical conditions.



RUS Accepted

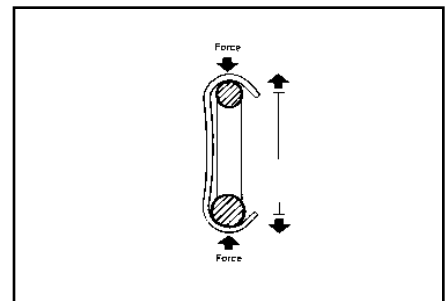
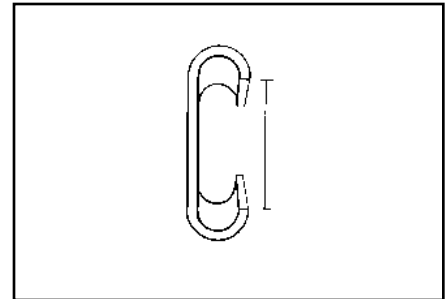

Blue highlighted items are industry standard and most frequently ordered.

The BURNDY® WEJTAP™ System has a wide variety of connectors available for many different conductor ranges.

Color coded boosters and connectors ensure proper matching during installation.

The BURNDY® Power Booster is designed and engineered for the highest reliability and safety. Proven rimfire design means misfires are almost nonexistent. Close manufacturing component tolerances provide maximum resistance to moisture or submersion.

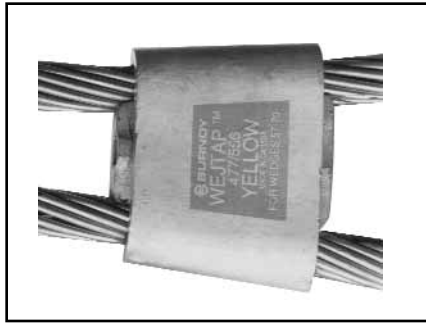

ORDERING INFORMATION

■ Power boosters may be ordered separately in boxes of 25.

- Red boosters Cat. # **WPBRN Box 25**
- Blue boosters Cat. # **WPBBN Box 25**
- Yellow boosters Cat. # **WPBYN Box 25**



Select appropriate connector from pages J-6 - J-10. Match with equal number of color coded boosters (see below).

WPB—Red, Blue, Yellow Boosters

For information about conductors which are not listed, and for further ordering information, please contact BURNDY® at 1-800-346-4175.

WEJTAP™ COVER

WEJTAP™ Covers are installed on WEJTAP™ connectors to prevent them from coming in contact with other taps or exposed ground points. The covers are rugged snap-on devices available in four sizes to cover all connector sizes.



Cover Catalog Number	WEJTAP™ Size	Nominal Conductor Range		Cover Color
		Run	Tap	
WCCR	Small Old Style Red	8 - 1/0	8 - 2	Black Weather Rated
WCCB	Red & Blue	2 - 300	6 - 300	
WCCSY	Small (Yellow)	300 - 556.5	6 - 556.5	
WCCLY	Large (Yellow)	556.5 - 1033.5	556.5 - 1033.5	

Blue highlighted items are industry standard and most frequently ordered.

**BURNDY WEJTAP™
SELECTION CHART**

By Diameter

Catalog Number	Sum of Diameters		Run		Tap	
	Max	Min	Max	Min	Max	Min
Installed with red booster						
WCR29	0.723	0.584	0.398	0.257	0.398	0.257
WCR30	0.649	0.516	0.398	0.257	0.325	0.206
WCR31	0.602	0.464	0.398	0.257	0.258	0.162
WCR32	0.530	0.410	0.326	0.204	0.258	0.162
WCR33	0.459	0.331	0.258	0.169	0.230	0.162
WCR34	0.324	0.256	0.162	0.128	0.162	0.128
WCR35	0.560	0.452	0.398	0.257	0.162	0.128
WCR36	0.487	0.387	0.398	0.257	0.162	0.128
WCR37	0.416	0.297	0.258	0.169	0.162	0.128
Installed with blue booster						
WCB10	0.795	0.621	0.482	0.316	0.437	0.257
WCB11	0.901	0.763	0.568	0.364	0.457	0.257
WCB12	0.707	0.526	0.568	0.364	0.204	0.162
WCB13	0.761	0.600	0.568	0.364	0.258	0.204
WCB14	0.839	0.690	0.568	0.364	0.398	0.257
WCB15	0.769	0.622	0.568	0.364	0.204	0.162
WCB16	0.823	0.664	0.568	0.364	0.258	0.204
WCB17	0.963	0.804	0.568	0.364	0.464	0.257
WCB18	1.011	0.867	0.568	0.364	0.572	0.364
WCB19	1.068	0.938	0.568	0.364	0.572	0.379
WCB20	1.130	0.975	0.568	0.364	0.572	0.386
WCB21	0.846	0.711	0.650	0.532	0.204	0.162
WCB22	0.900	0.765	0.650	0.532	0.258	0.204
WCB23	0.972	0.818	0.650	0.532	0.330	0.257
WCB24	1.052	0.897	0.650	0.532	0.500	0.324
WCB25	1.104	0.963	0.650	0.532	0.562	0.364
WCB26	1.163	1.015	0.650	0.532	0.562	0.409
WCB27	1.221	1.080	0.650	0.532	0.575	0.460
WCB28	1.284	1.141	0.650	0.532	0.650	0.525
WCB40	0.888	0.762	0.684	0.603	0.204	0.162
WCB41	0.942	0.794	0.684	0.600	0.258	0.204
WCB42	1.011	0.857	0.684	0.600	0.333	0.257
WCB43	1.094	0.936	0.684	0.600	0.500	0.324
WCB44	1.146	1.009	0.684	0.600	0.562	0.364
WCB45	1.204	1.057	0.684	0.600	0.562	0.409
WCB46	1.284	1.119	0.684	0.600	0.592	0.460
WCB47	1.368	1.188	0.684	0.600	0.684	0.600
Installed with yellow booster						
WCY48	0.932	0.765	0.750	0.537	0.204	0.162
WCY49	1.012	0.807	0.750	0.537	0.271	0.203
WCY50	1.069	0.860	0.750	0.537	0.355	0.257
WCY51	1.141	0.927	0.750	0.537	0.557	0.324

J-6

Blue highlighted items are industry standard and most frequently ordered.

**BURNDY WEJTAP™
SELECTION CHART**

By Diameter

Catalog Number	Sum Of Diameters		Run		Tap	
	Max.	Min.	Max.	Min.	Max.	Min.
Installed with yellow booster						
WCY52	1.190	1.001	0.750	0.537	0.588	0.364
WCY53	1.236	1.012	0.750	0.537	0.619	0.409
WCY54	1.302	1.063	0.750	0.537	0.630	0.46
WCY55	1.370	1.140	0.750	0.537	0.714	0.499
WCY56	1.456	1.245	0.750	0.537	0.750	0.524
WCY57	1.190	0.979	0.893	0.666	0.326	0.257
WCY58	1.087	0.931	0.893	0.666	0.258	0.198
WCY59	1.061	0.891	0.893	0.666	0.199	0.162
WCY60	1.854	1.686	0.950	0.722	0.950	0.722
WCY61	1.741	1.524	0.940	0.683	0.940	0.666
WCY62	1.594	1.379	0.940	0.683	0.750	0.573
WCY63	1.500	1.297	0.940	0.683	0.750	0.481
WCY64	1.421	1.216	0.940	0.683	0.650	0.436
WCY65	1.360	1.147	0.940	0.683	0.562	0.382
WCY66	1.305	1.097	0.940	0.683	0.562	0.336
WCY67	1.270	1.054	0.940	0.683	0.450	0.315
WCY68	1.253	1.115	0.940	0.683	0.326	0.257
WCY69	1.187	1.059	0.940	0.683	0.262	0.204
WCY70	1.130	1.013	0.940	0.683	0.204	0.162
WCY71	2.216	2.074	1.133	0.907	1.156	0.947
WCY72	2.133	1.999	1.133	0.907	1.142	0.927
WCY73	2.098	1.946	1.133	0.907	1.142	0.907
WCY74	2.035	1.891	1.133	0.907	1.142	0.858
WCY75	1.969	1.822	1.133	0.889	0.927	0.763
WCY76	1.901	1.741	1.133	0.889	0.900	0.700
WCY77	1.829	1.677	1.133	0.889	0.750	0.575
WCY78	1.750	1.599	1.133	0.889	0.729	0.525
WCY79	1.670	1.526	1.133	0.889	0.722	0.364
WCY80	1.610	1.466	1.133	0.889	0.608	0.364
WCY81	1.555	1.411	1.133	0.889	0.608	0.364
WCY82	1.506	1.362	1.133	0.889	0.436	0.324
WCY83	1.440	1.288	1.133	0.889	0.398	0.257
WCY84	1.369	1.221	1.133	0.889	0.333	0.203
WCY85	1.306	1.158	1.133	0.889	0.258	0.162
WCY86	2.496	2.332	1.250	0.893	1.250	0.999
WCY87	2.418	2.251	1.250	0.893	1.250	0.856
WCY88	2.354	2.194	1.250	0.893	1.211	0.971
WCY89	2.297	2.137	1.250	0.893	1.200	0.923
WCY90	2.238	2.083	1.250	0.893	1.159	0.868
WCY91	2.173	2.013	1.250	0.893	1.130	0.856
WCY92	2.104	1.950	1.250	0.893	0.904	0.720
WCY93	2.029	1.869	1.250	0.893	0.900	0.700
WCY94	1.967	1.831	1.250	0.893	0.750	0.588
WCY95	1.888	1.728	1.250	0.893	0.722	0.525
WCY96	1.811	1.648	1.250	0.893	0.609	0.364
WCY97	1.748	1.591	1.250	0.893	0.598	0.385
WCY98	1.695	1.533	1.250	0.893	0.598	0.364
WCY99	1.644	1.489	1.250	0.893	0.398	0.324

J-7

Blue highlighted items are industry standard and most frequently ordered.

**BURNDY WEJTAP™
SELECTION CHART**

By Diameter

Catalog Number	Sum Of Diameters		Run		Tap	
	Max.	Min.	Max.	Min.	Max.	Min.
Installed with yellow booster						
WCY100	1.572	1.400	1.250	0.893	0.351	0.257
WCY101	1.503	1.343	1.250	0.893	0.261	0.204
WCY102	1.454	1.284	1.250	0.893	0.198	0.162
WCY103	2.604	2.484	1.302	1.242	1.302	1.242
WCY104	2.567	2.407	1.302	1.242	1.265	1.165
WCY105	2.489	2.329	1.302	1.242	1.187	1.087
WCY106	2.418	2.258	1.302	1.242	1.116	1.016
WCY107	2.373	2.213	1.302	1.242	1.071	0.971
WCY108	2.318	2.158	1.302	1.242	1.016	0.916
WCY109	2.255	2.095	1.302	1.242	0.953	0.853
WCY110	2.179	2.019	1.302	1.242	0.877	0.777
WCY111	2.102	1.942	1.302	1.242	0.800	0.700
WCY112	2.044	1.884	1.302	1.242	0.742	0.642
WCY113	1.961	1.801	1.302	1.242	0.659	0.559
WCY114	1.940	1.740	1.350	1.242	0.590	0.498
WCY115	1.863	1.663	1.350	1.242	0.513	0.421
WCY116	1.812	1.612	1.350	1.242	0.462	0.370
WCY117	1.762	1.562	1.350	1.242	0.412	0.320
WCY118	1.703	1.503	1.350	1.242	0.353	0.261
WCY119	1.631	1.431	1.350	1.242	0.281	0.189
WCY120	1.580	1.380	1.350	1.242	0.230	0.138
WCY121	2.844	2.642	1.422	1.314	1.422	1.328
WCY122	2.764	2.562	1.422	1.314	1.342	1.248
WCY123	2.680	2.479	1.422	1.314	1.258	1.164
WCY124	2.596	2.394	1.422	1.314	1.174	1.080
WCY125	2.535	2.333	1.422	1.314	1.113	1.019
WCY126	2.481	2.279	1.422	1.314	1.059	0.965
WCY127	2.426	2.224	1.422	1.314	1.004	0.910
WCY128	2.376	2.174	1.422	1.314	0.954	0.860
WCY129	2.286	2.084	1.422	1.314	0.864	0.770
WCY130	2.216	2.014	1.422	1.314	0.794	0.700
WCY131	2.152	1.950	1.422	1.314	0.730	0.636
WCY132	2.070	1.868	1.422	1.314	0.648	0.554
WCY133	1.990	1.786	1.422	1.314	0.568	0.472
WCY134	1.931	1.729	1.422	1.314	0.509	0.415
WCY135	1.876	1.674	1.422	1.314	0.454	0.360
WCY136	1.831	1.629	1.422	1.314	0.409	0.315
WCY137	1.771	1.569	1.422	1.314	0.349	0.255
WCY138	1.706	1.504	1.422	1.314	0.284	0.190
WCY139	1.664	1.462	1.422	1.314	0.242	0.148
WCY140	3.045	2.090	1.533	1.471	1.547	1.471
WCY145	2.596	2.534	1.533	1.032	1.094	1.032

Blue highlighted items are industry standard and most frequently ordered.

**WEJTAP™
STIRRUP™ AND
POWER BOOSTERS**

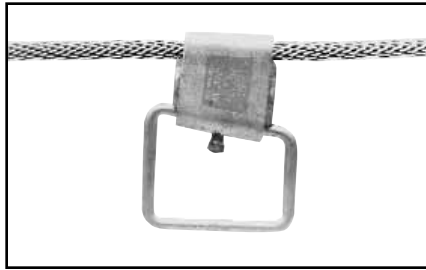

(Large) Run Conductor position is identified on all wedges via a distinct chamfer.

QIK Selector - for common ACSR, Aluminum and Copper Conductors

Catalog Number	Nominal Cable Range	Bail Size
Small Red Cable Range 6-2		
WSS1	6	2
WSS2	5, 4, 2	2
Medium Blue Cable Range 1-300		
WSM1	1, 1/0, 2/0	2
WSM2	2/0, 3/0	2
WSM3	3/0 - 4/0	2
WSM4	3/0 - 4/0	2/0
WSM5	266.8	2
WSM6	266.8	1/0
WSM7	350	1/0
WSM11	266.8 - 336.4	4/0

Catalog Number	Nominal Cable Range	Bail Size
Large Yellow Cable Range 300-1033.5		
WSL1	336.4	1/0
WSL2		2/0
WSL3		4/0
WSL4	397.5 - 477	1/0
WSL5		2/0
WSL6		4/0
WSL7	556.5	1/0
WSL8		2/0
WSL9		4/0
WSL10	636	4/0
WSL11		2/0
WSL12	795	2/0
WSL13		4/0
WSL14	1033.5	4/0

**BURNDY WEJTAP™
STIRRUP™
SELECTION CHART**

By Diameter

Catalog Number	Sum of Diameters		Run		Tap	
	Max.	Min.	Max.	Min.	Max.	Min.
Small stirrups						
WSS1	0.454	0.412	0.204	0.162	0.25	0.25
WSS2	0.575	0.456	0.325	0.206	0.25	0.25
Medium sized stirrups						
WSM1	0.697	0.575	0.447	0.325	0.25	0.25
WSM10	0.887	0.784	0.563	0.46	0.324	0.324
WSM2	0.752	0.615	0.502	0.365	0.25	0.25
WSM3	0.813	0.66	0.563	0.41	0.25	0.25
WSM4	0.938	0.835	0.563	0.46	0.375	0.375
WSM5	0.892	0.787	0.642	0.537	0.25	0.25
WSM6	0.968	0.861	0.642	0.537	0.324	0.324
WSM7	1.008	0.898	0.684	0.574	0.324	0.324
WSM8	0.934	0.824	0.684	0.574	0.25	0.25
WSM9	0.771	0.649	0.447	0.325	0.324	0.324
Large stirrups						
WSL1	1.05	0.927	0.726	0.603	0.324	0.324
WSL10	1.479	1.389	1.019	0.929	0.46	0.46
WSL11	1.394	1.304	1.019	0.929	0.375	0.375
WSL12	1.515	1.399	1.14	1.024	0.375	0.375
WSL13	1.6	1.484	1.14	1.024	0.46	0.46
WSL14	1.708	1.606	1.248	1.146	0.46	0.46
WSL2	0.976	0.853	0.726	0.603	0.25	0.25
WSL3	1.186	1.063	0.726	0.603	0.46	0.46
WSL4	1.186	1.046	0.862	0.722	0.324	0.324
WSL5	1.237	1.097	0.862	0.722	0.375	0.375
WSL6	1.322	1.182	0.862	0.722	0.46	0.46
WSL7	1.251	1.17	0.927	0.846	0.324	0.324
WSL8	1.302	1.221	0.927	0.846	0.375	0.375
WSL9	1.387	1.306	0.927	0.846	0.46	0.46

Blue highlighted items are industry standard and most frequently ordered.

WEJTAP™ INSTALLATION TOOLS

Patented



Type WTB

WEJTAP™ tool body one-piece assembly basic drive mechanism used to install WEJTAP™ connectors and STIRRUPS range - #8 awg through 1590 kcmil ACSR.

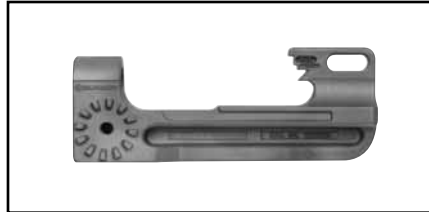

Type WTHRB1S

WEJTAP™ tool head operating platform for small and medium range (red/blue coded) connectors.

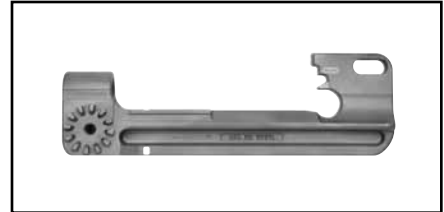

Type WTHY1S

WEJTAP™ tool head operating platform for medium and large range (yellow coded) connectors.

J-10

WEJTAP™ INSTALLATION TOOL ACCESSORIES



Type WTOCBR

WEJTAP™ removal clip for red type II and medium (blue coded) tap connectors used with type WTHRB tool head.



Type WTOCY

WEJTAP™ removal clip for large (yellow coded) tap connectors used with type WTHY tool head.

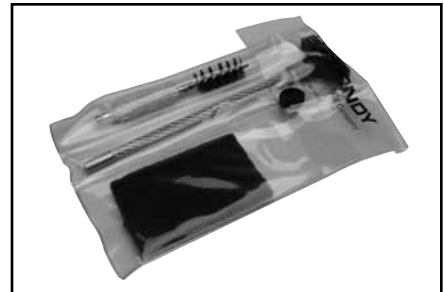

Type WTCK

WEJTAP™ tool cleaning/maintenance kit for use with type WTB tool body.

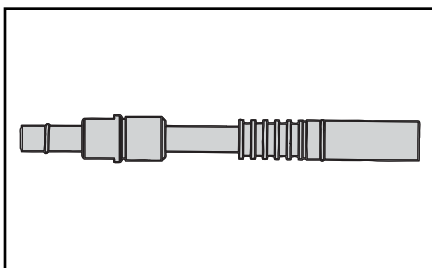

Type WTBASY1

WEJTAP™ ram replacement assembly.

Blue highlighted items are industry standard and most frequently ordered.

**WEJTAP™
POWERLUG™**

WEJTAP™ POWERLUG™ terminals are made of cast aluminum alloy for termination of ACSR and Aluminum conductors.

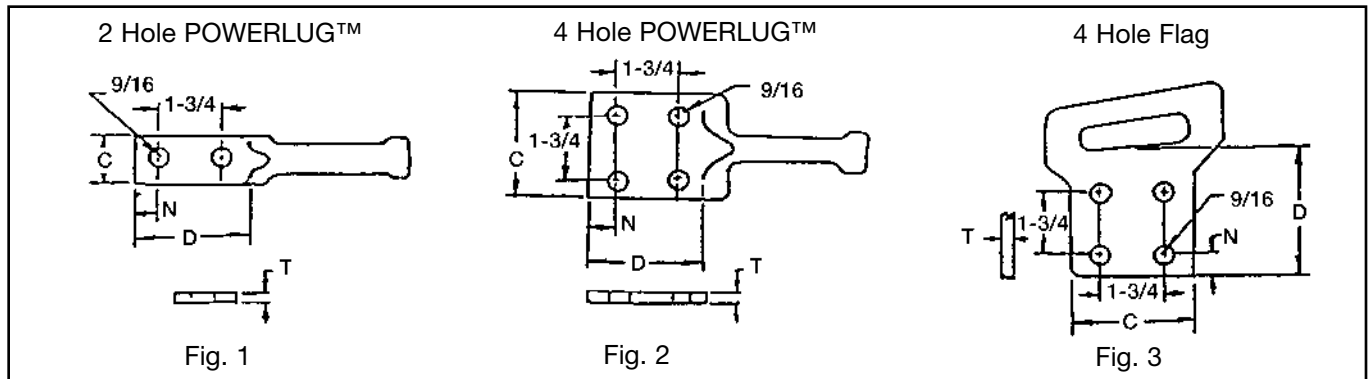
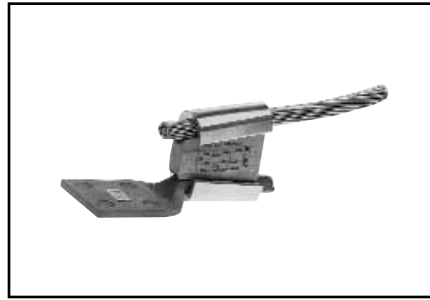

Tap Groove for Connector Selection	Catalog Number	Standard Conductor		Figure No.	Holes in Pad	Dimensions			
		ACSR	ASC/AAC			C	D	N	T
4/0 Standard ACSR	WCAB30R-2N	6 Str. - 266.8	6 Str. - 300	1	2	1-1/4	3	5/8	0.34
	WCAB30R-4N			2	4	3	3	5/8	0.30
	WCBB30R-4N			3	4	3	3	5/8	0.30
336.4 Standard ACSR	WCAY39R-2N	266.8 - 556.5	336.4 - 636	1	2	1-3/4	3	5/8	0.34
	WCAY39R-4N			2	4	3	3	5/8	0.30
	WCBY39R-4N			3	4	3	3	5/8	0.30
795 Standard ACSR	WCAY49R-2N	605 - 1033.5	715.5 - 1113	1	2	1-3/4	3-1/2	7/8	0.69
	WCAY49R-4N			2	4	3-1/2	3-1/2	7/8	0.69
	WCBY49R-4N			3	4	3-1/2	3-1/2	7/8	0.69

NOTE: The recommended connector and booster are ordered separately. Catalog number is for the POWERLUG™ only.

MULTIPLE CONDUCTOR TAP APPLICATION

Connector	*Run Groove	*Tap Groove
WCY 64 PB	Three - 1/0 ACSR (6/1) Diameter = 0.398"	One - 4/0 ACSR (6/1) Diameter = 0.563"
WCY 65 PB	Three - 1/0 ACSR (6/1) Diameter = 0.398"	One - 3/0 ACSR (6/1) Diameter = 0.502"
WCY 63 PB	Three - 2/0 ACSR (6/1) Diameter = 0.447"	One - 4/0 ACSR (6/1) Diameter = 0.563"
WCB 11 PB	Three - #4 stranded Diameter = 0.232"	One - 1/0 ACSR (6/1) Diameter = 0.398"
WCY 54 PB	Three - 1/0 stranded Diameter = 0.368"	One - 4/0 stranded Diameter = 0.522"
WCY 53 PB	Three - 1/0 stranded Diameter = 0.368"	One - 3/0 stranded Diameter = 0.464"
WCY 64 PB	Three - 2/0 stranded Diameter = 0.414"	One - 4/0 stranded Diameter = 0.522"
WCB 11 PB	Three - #4 stranded Diameter = 0.232"	One - 1/0 stranded Diameter = 0.368"

* Electrically, the three smaller conductors are the likely taps, however, during installation, they are located in the larger run groove due to their larger aggregate sum.

Blue highlighted items are industry standard and most frequently ordered.

WEJTAP™ HOTSTICK ACCESSORIES

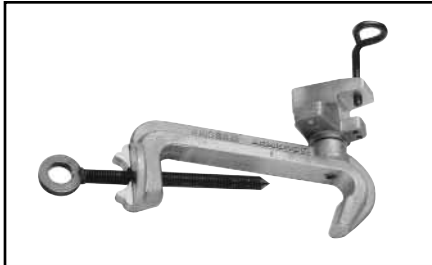

Type WHSCWH

WEJTAP™ hotstick connector clamp used to hold the tap connector spring-body and wedge for installation on energized lines with the shotgun hotstick.



Type WHSWHADP

WEJTAP™ hotstick angle wedge holder adapter attaches wedge clamp to universal hotstick for hotline installation.

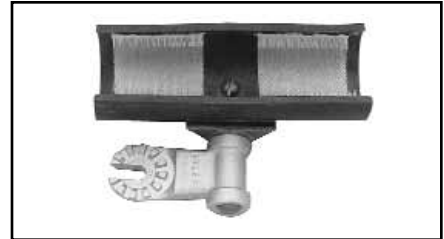

Type WHSWB

WEJTAP™ hotstick wirebrush attaches to the universal hotstick for cleaning the contact surface of the line conductor.

J-12

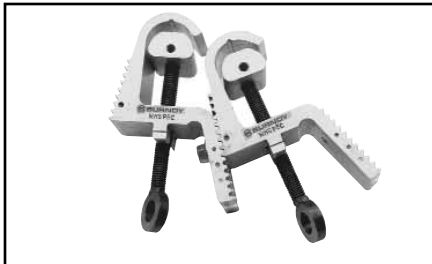

Type WHSPBC

WEJTAP™ hotstick dual cable clamp used to hold run and tap conductors in position during hotline installation. Universal for all applications from #8-1272 ACSR.



Type WCHAWAS

WEJTAP™ hotstick angle wedge holder adapter attaches wedge clamp to universal hotstick for hotline installation with shotgun stick.



Type WHSGB

WEJTAP™ hotstick breech drive. Geared shotgun hotstick adapter easily latches to the breech end of WEJTAP installation tool without disassembly for use on energized lines.

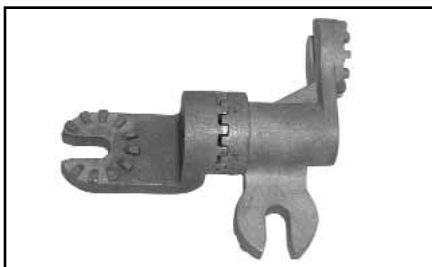

Type WHSSADP

WEJTAP™ hotstick spring loaded 90 degree adapter, used to attach tool to universal hotstick for hotline installations.



Type WHSTA

WEJTAP™ hotstick tool (actuator) hammer attaches to the universal hotstick for striking the tool actuator button to complete the installation.

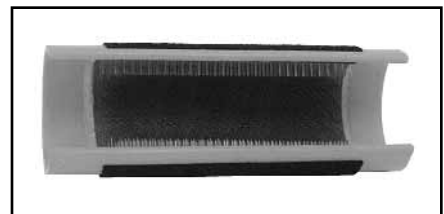

Type WHHWB

WEJTAP™ hand-held wire brush for cleaning surface contact areas on non-energized conductors.

Blue highlighted items are industry standard and most frequently ordered.

**WEJTAP™ KIT
ORDERING
INSTRUCTIONS**



Type WTCC
(Carrying Case Only)

WEJTAP™ plastic carrying case. Designed for rugged use in all weather conditions. It accommodates WEJTAP™ installation tool, removal clips, and cleaning kit.

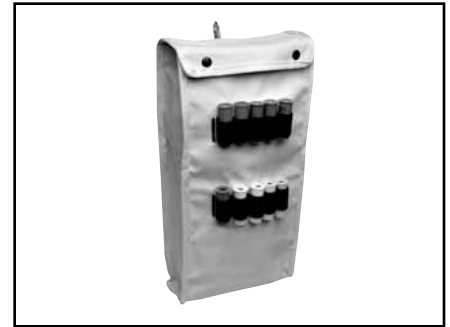

Type WABAG

WEJTAP™ accessories bag is designed for use in carrying installation tool(s), removal clips, and cleaning kit. Hotstick accessories may be accommodated as well. Holders for power boosters are conveniently located on the outside of the bag.

Tools Included in Kit (Quantity)

Component	*Non-Hot Stick Power Unit	Hot Stick Power Unit	Self-Firing Tool	Large Frame (Yellows)	Large Frame Take Off Clip	Small Frame (Red, Blue)	Cleaning Kit	Small Frame Take Off Clip	Molded Carrying Case	Canvas Style Tool Bag
Kit Catalog No.	WTBNHS	WTB	WTBGBW	WTHY-1S	WTOCY	WTHRB-1S	WTCK	WTOCBR	WTCC	WABAG
WT2B2RBYWABAG		2		1	1	1	1	1		1
WT2BRBYWABAG		2				1	1	1		1
WTRBYK		1		1	1	1	1	1	1	
WTRBYKNHS	1			1	1	1	1	1	1	
WTYK		1		1	1		1			
WTYKNHS	1			1	1		1			
WTRBK		1				1	1	1	1	
WTRBKNHS	1					1	1	1	1	
WT2BRBYK		2		1	1	1	1	1	1	
WT2B2RBYK		2		1	1	2	1	1	1	
WTY		1		1			1			
WTRB		1				1	1			
WTYWABAG		1		1	1		1			1
WTYKNHSBAG	1			1	1		1			1
WTRBWABAG		1				1	1	1		1
WTRBKNHSBAG	1					1	1	1		1
WTBGBWRBYK			1	1	1	1	1	1	1	
WTRBYWABAG		1		1	1	1	1	1		1
WTRBYKNHSGAB	1			1	1	1	1	1		1

* Non-Hotstick power units do not contain features allowing activation with Hotsticks. They are not upgradeable.

**Contact your BURNDY® representative for a WEJTAP™ demonstration
or contact the factory at 1-800-346-4175**

Blue highlighted items are industry standard and most frequently ordered.

WEJTAP™ In-Line Disconnect

BURNDY's new In-Line Disconnect utilizes proven WEJTAP™ Technology in combination with industry standard components to provide reliable performance of switch applications.

1. Utilizes WEJTAP™ connectors for securing the switch to the distribution line in tension applications.
2. Utilizes industry recognized and proven GST&D Products, LTD. blade components along with dual Advance Rubber Products, Inc., Insulators attached to a BURNDY® designed yoke plate assembly.
3. WEJTAP™ In-Line Disconnect designed for use in gloving and hot stick applications in conjunction with an industry standard load break tool.
4. Dual insulators minimize the switch movement during opening and closing of the blade.
5. Installation steps are minimized. The switch can be snapped directly on the line and secured with our conductor pivot retainer, designed into the switch frame.
6. WEJTAP™ tooling is used to secure the "C Member" to the built-in wedge feature of the frame. Providing reliable mechanical and electrical performance.
7. The blade is positioned on the switch to simplify cutting the conductor during installation.
8. In-Line Disconnect is removable and reusable.
9. Other conductor sizes available. Please contact factory.

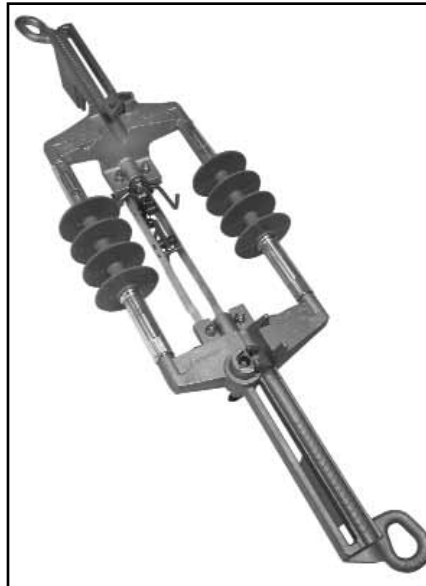

Product Specifications

Voltage:	15 kV (110 kV BIL), 29 kV (150 kV BIL), 35 kV (200 kV BIL)
Current:	900 Ampere RMS
Short Circuit:	Momentary Current 40,000 Ampere RMS, Asymmetrical Three Second Current 25,000 Ampere RMS, Symmetrical
Strength:	Body 10,000 lbs. Pulling Eye 6,000 lbs.
Insulators:	Silicone
Meets Industry Standards:	ANSI C119.4, C37.32 IEEE C37.30, C37.34 CSA C83.71 ASTM B117 Salt Fog

J-14

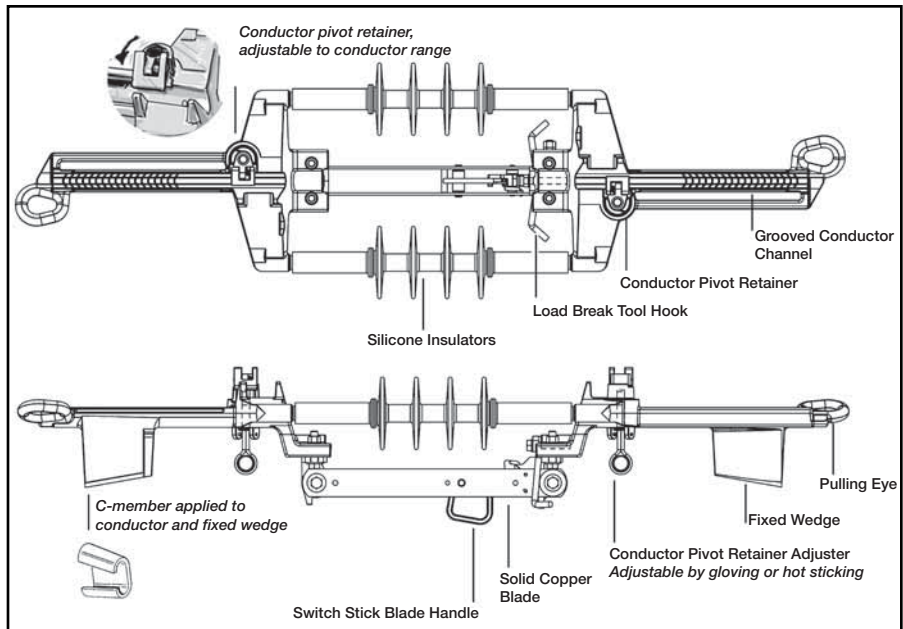

Conductor		In-Line Disconnect			Replacement Tap
ACSR	AAC	15 kV (110 kV BIL)	29 kV (150 kV BIL)	35kV (200 kV BIL)	
266.8 26/7	397.5	WAD336-15	WAD336-29	WAD336-35	WAD336S
266.8 30/7	336.4				
336.4 18/1					
336.4 26/7					
336.4 30/7	350				
397.5 18/1	450	WAD477-15	WAD477-29	WAD477-35	WAD477S
397.5 26/7	477				
397.5 30/7	500				
477 18/1					
477 26/7	556.5	WAD556-15	WAD556-29	WAD556-35	WAD556S
556.5 18/1	795				

Blue highlighted items are industry standard and most frequently ordered.

PRODUCTS FOR UNDERGROUND NETWORK AND RESIDENTIAL DISTRIBUTION SYSTEMS

TABLE OF CONTENTS

UNDERGROUND NETWORK DISTRIBUTION PRODUCTS

Technical Data “Underground Systems Connection and Protection” **K-3 - K-4**

Technical data on specific types of BURNDY® Connectors precedes each section below.

MOLE™



Multiple Outlet Connectors (Technical Data) **K-5 - K-7**

How to Order Your BURNDY® MOLE™ **K-8**

MOLE™ Types **K-9 - K-31**

MOLE™ Accessories **K-31 - K-36**

HYCRAB™

HYCRAB™ Connectors (Technical Data) **K-37**

HYCRAB™ and Accessories **K-38 - K-39**

LIMITERS



Network Protection (Technical Data) **K-40 - K-42**

Limiters and Accessories **K-43 - K-65**

UNDERGROUND RESIDENTIAL DISTRIBUTION PRODUCTS

MOLE™

Types **RDMD-28G, RDMD-2858D, RDMD-28CR, RDM-28** **K-67**

Type **RDM-28T** **K-68**

MOLE™ Tap Kits

RYA-UC, RYA-AC, RYA-UCR, RYA-ACR Tap Kits **K-68**

Street Lighting Tap Kits

Types **RA6UC-SL, RA6UCR-SL** **K-69**

Insulated Splice Kit

Type **YS-CG** **K-70**

Y-LOK **K-70**

HYREDUCER™ Splices

Type **YRB-U** **K-71 - K-73**

Type **YRB-T** **K-74 - K-75**

Service Taps and Terminals

Types **K-P-C, YPC-C** **K-76**

Types **K6B, K33B** **K-77**

Types **F-A, K5A34U-6N, K-P-UC** **K-78**

Power Distribution Blocks

Types **BPD, BPD2** **K-79**

K-1

All dimensions are subject to revision and should not be used for detailed engineering or inspection purposes. Current sales drawings are available upon request.

Blue highlighted items are industry standard and most frequently ordered.

PRODUCTS FOR UNDERGROUND NETWORK DISTRIBUTION SYSTEMS

TABLE OF CONTENTS

MOLE™**1500 AMP**

Type ZM	K-9
Type ZMT	K-10
Type ZME	K-11
Type ZML	K-12
Type ZMX	K-13
Type ZMK	K-14

2000-2500 AMP

Type ZM	K-15
Type ZMT	K-16
Type ZME	K-17
Type ZML	K-18
Type ZMX	K-19
Type ZMK	K-20

3000 AMP

Type ZM	K-21
Type ZMT	K-22
Type ZME	K-23
Type ZML	K-24
Type ZMX	K-25
Type ZMK	K-26
Type ZMLDN Stud Connector.....	K-27 - K-28
Type Z2MLDN Stud Connector.....	K-29
Type ZMDN Stud Connector.....	K-30
Type ZMTDN Stud Connector.....	K-31
Types Z-P, KP Outlet Plugs.....	K-31
Type Z-NR Socket & Nut Assembly.....	K-32
Type Z Compression Cone.....	K-33 - K-34
Type ZMS Coupler.....	K-35
Type CM Sleeve.....	K-35
Type Z-C Sleeve.....	K-36

HYCRAB™

Type YM	K-38
Type YNM	K-39

LIMITERS

Types YFS-CR, YFS-CP	K-43
Type YFS-CPL	K-44
Type YFSR, YFSP	K-45
Type YFSP-L	K-45
Types YFSH, YFSH-P	K-46
Type YFSC	K-46
Types YFA-CR, YFA-CP	K-47
Type YFA-CPL	K-48
Types YFAR, YFAP	K-49
Type YFAP-L	K-50
Type YFAH	K-51
Type YFAC	K-51
Types YFM-CR, YFM-CP	K-52
Type YFM-CPL	K-52
Types YFMR, YFMP	K-53
Type YFMP-L	K-53
Types YFMH, YFMH-P	K-54
Type YFMC	K-54
Type YVFT	K-55
Type NYFT	K-55
Type LYS	K-56
Type LYM	K-57
Type LF	K-58
Type LYS34P1	K-59
Type LYS34P2	K-59
Type LYS-P5	K-60
Type LYM34P3	K-61
Type LYS-P6	K-61

HIGH CAPACITY LIMITERS

Types HYA, HYM & HYS	K-64 - K-65
---------------------------------------	--------------------

NETWORK PROTECTOR FUSES

Types Y, Z	K-62
-------------------------	-------------

T-CONNECTOR

Type NYT	K-63
-----------------------	-------------

Blue highlighted items are industry standard and most frequently ordered.

UNDERGROUND SYSTEM CONNECTION AND PROTECTION

Nowhere in the distribution of electric power are the problems of connecting conductors and protecting them and equipment against the effects of fault currents as complex as in underground systems. For more than 70 years, BURNDY® engineers have worked closely with utilities to develop devices for connecting and protecting conductors and associated equipment in underground systems. These devices, with their inherent dependability and economy, have contributed to the rapid growth of underground systems throughout the country. To assist utility personnel in more effectively selecting and applying these devices, the engineering talent and experience of BURNDY® have been pooled to prepare this technical section, and the catalog information that follows.

The devices are designed for use in both radial and network type underground systems. Radial systems (Fig. 1) distribute power economically except in high load density areas where a high degree of service reliability is required.

Network systems (Fig. 2) have become standard for AC power distribution where load density is high and service continuity must be assured under nearly all conditions. The improved equipment and methods which are described in this catalog have been designed

to meet these secondary network system requirements and to reduce the cost of installation and maintenance.

Early Problems in Underground Connections

Despite the many advantages of underground distribution, a major problem was that of making connections in congested manholes or junction boxes. The necessary procedure—soldering conductors, taping joints, and wiping lead covered cable—was so complex, that it demanded considerable skill and was time consuming and costly. This involved procedure had to be repeated each time a service was added to a main. When completed, the multiple-branch joints were excessively bulky and their electrical and mechanical performance suffered from the shortcomings of soldered connections.

The installation of underground distribution made greater strides as those early connection methods gave way to specialized products and techniques developed by BURNDY® at the request of, and in close collaboration with, engineers of leading utilities. These specialized connectors were easier and more economical to install, more compact, and more dependable electrically and mechanically.

For installation in conjunction with these connectors, BURNDY® also developed products to protect the secondary system from the effects of fault currents. The continuing improvement of these products, based on field experience and laboratory research, is contributing to even greater dependability and economy in underground distribution.

Design Objectives in Connectors for Underground

While each of the principal types of equipment described in the following pages has been designed to meet particular service requirements, all have several basic objectives in common:

Reliability: To minimize outages and their serious consequences in the high load density areas served by underground systems.

Ease of Installation: Compact for easy installation in the confined space of a manhole and transformer vaults. Mechanical connections that eliminate difficult solder joints.

Economy: By reducing the time and skill required for installation of a dependable, insulated compact connection.

Versatility: For permitting easier changes, expansion, and additional services with a minimum of system shutdown.

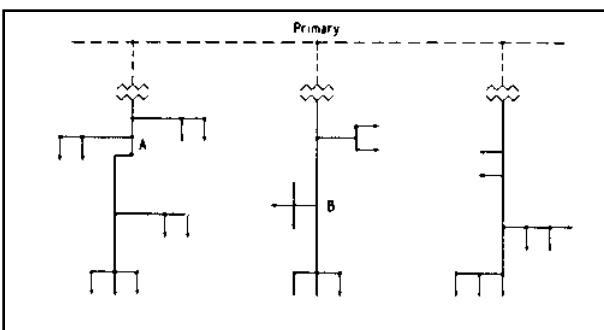

Figure 1 Radial Secondary Distribution System

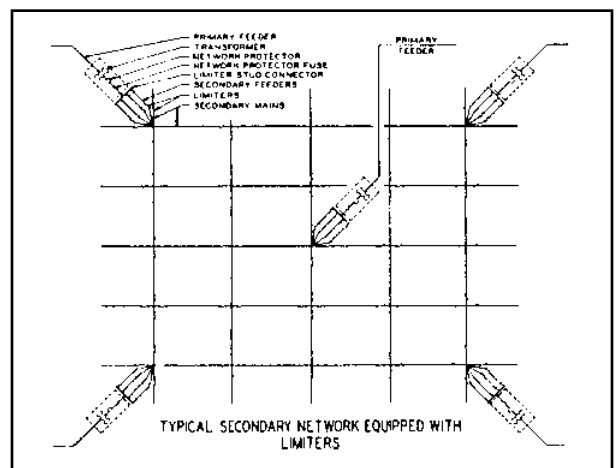

Figure 2

Blue highlighted items are industry standard and most frequently ordered.

TYPES OF BURNDY® UNDERGROUND CONNECTORS AND ACCESSORIES

The MOLE™ and HYCRAB™

The most popular of the engineered connectors developed specifically for underground manholes and transformer vaults are the MOLE™ and the HYCRAB™ that provide for multiple connections at a single junction point of main, feeder, and service cables. Pre-insulated to eliminate extensive taping, these connectors are essentially bus bars with several cable outlets: mechanical installation in the MOLE™, and compression installation in the HYCRAB™.

Limiters and Fuses

To prevent “roasting” of cable insulation, resulting from fault current, BURNDY® has developed cable limiters that are inserted in each secondary cable at all junction points. Network protector fuses have been designed to back up the protector breaker in the event of a malfunction during a transformer or primary cable fault. By coordinating the time current characteristics of the fuse with those of the cable limiters, the possibility of limiter blowing on primary faults is eliminated, which in turn reduces the fault finding task. Also, limiter, fuse, and cable insulation characteristics must be carefully coordinated to assure isolating a fault on the secondary before it can cause extensive damage or interrupt service in other sections of the secondary system.

High Capacity Limiter 200,000 Amperes at 600 Volts

The BURNDY® High Capacity Limiter is designed to economically protect electrical distribution systems from the destructive effect of high energy faults. The increasing number of 600 volt secondary network installations for industrial and commercial applications demand a cable limiter that can safely interrupt 200,000 amperes (symmetrical available) and one that will also completely coordinate with the higher voltage network protector fuses.

Available fault currents as high as 200,000 amperes rms at 600 volts across the fusible elements have been interrupted during tests on the BURNDY® High Capacity Limiter. The power factor during these tests was less than 15%, thereby imposing the most difficult clearing conditions. No external disturbance is experienced upon clearing fault currents from the “float” value to 200,000 amperes. The quartz filler absorbs the intense energy generated by interrupting the fault current. The quartz fuses into tubular fulgurites, with a high dielectric strength, and forms an insulating barrier between the melted link sections. This action prevents restrike of the internal arc. The rugged glass melamine housing provides a vessel that completely contains the developed energy.

The carefully developed time-current characteristics and rigid manufacturing tolerances assure proper coordination with the network protector fuses and the insulation damage characteristics of 4/0, 250, 350, 500 and 750 kcmil cable.

The High Capacity Limiter is available in four variations to accommodate a variety of installation practices. The Type HYS has cable sockets at both ends, which allow for indenting to the cable ends with a hydraulic BURNDY® HYPRESS™. The HYO has an offset lug on one end which permits back-to-back mounting on bus bar.

For those installations where BURNDY® MOLEs™ are used for manhole junctions or transformer vault buses, the Type HYM permits a replaceable connection of the limiter directly to the MOLE outlet at one end and a compression cable connection at the other.

Modern electrical distribution systems require low cost protection to safeguard costly equipment and quickly isolate faults, so that the undamaged portions of the system may function normally. BURNDY® High Capacity Limiters assure positive, economical protection when installed in properly designed systems.

Compression Connectors

BURNDY® HYDENT™ compression type connectors, and installation tools, have been designed for splicing and terminating copper as well as aluminum underground cables, in both primary and secondary circuits. BURNDY® tools and dies are custom designed to produce sound electrical, and mechanical joints on BURNDY® connectors. The use of BURNDY’s matched tools and connectors assures optimum results.

Residential Underground

The trend toward improvement in neighborhood appearances, and the elimination of storm outages, tree trimming, etc., has created the need for residential underground distribution. To meet these needs, BURNDY® offers: Mechanical type pre-insulated multi-conductor terminal connectors for submersible transformer locations; and compact multi-conductor connectors for above ground transformer and enclosures. For service taps, BURNDY® offers: Pre-insulated, multi-conductor compression and mechanical connectors; and a range taking compression connector for below grade service. Power pedestals for direct burial, above ground application, and conduit systems are offered. Residential Underground Fuse Block assembly with replaceable fuse for each service cable is also available.



Blue highlighted items are industry standard and most frequently ordered.

MULTIPLE OUTLET CONNECTORS

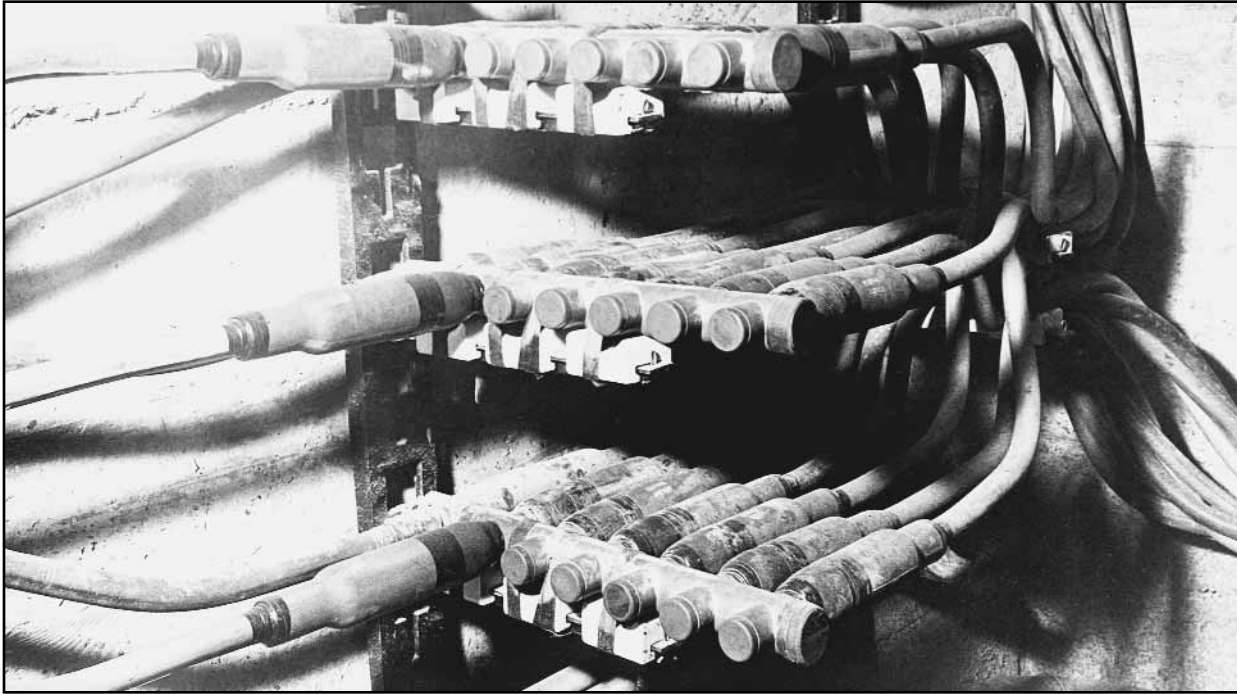

Connectors for Aluminum

For systems where aluminum is used, connectors especially designed for aluminum conductors are available in bolted and compression types: HYCRAB™, HYPLUG™, HYREDUCER™, and HYSOCKET. Aluminum conductors can be connected to standard MOLE™ connectors by using HYPLUG™ adapters.

Multiple Outlet Connectors

The increasing use in modern electrical distribution systems of junction points where several relatively large cables must be connected, has brought about the development of BURNDY® MOLE™ line equipment to speed up and simplify the making of such connections. The modern tendency toward network systems not only in underground utility practice but also in industrial wiring, has greatly increased the number of multi-connection joints.

The BURNDY® MOLE™ and HYCRAB™ connectors are insulated bus bars with multiple connector outlets for service cables,

secondary mains, or equipment leads. In the MOLE™, clamping action secures conductors to the connector; in the HYCRAB™, connections are made by indenting with a compression tool. Both lines of insulated connectors offer the following basic advantages:

- 1. Ease and Economy of Installations:* The ease and reduction of time required to make and insulate dependable multi-connections greatly reduces the cost of installation. The compact design makes maximum use of space and provides for simplified racking.
- 2. Versatility for System Modification:* The MOLE™ and HYCRAB™ are designed to accommodate the standard secondary main and service cables, and permit easy modification or later additions. The numerous available connector configurations permit a wide variety of arrangements of cables and equipment connections. The 600 volt rating of the MOLE™ and HYCRAB™ insulation provides for

efficient operation at all standard utilization voltages.

- 3. Efficient, Dependable Performance:* The MOLE™ and HYCRAB™ connectors assure permanent, high conductivity connections, good moisture seal, and insulation that resists the severest condition encountered in underground installations.

MOLE™ and HYCRAB™ Insulation

The location in vaults and manholes often exposes these connectors to immersion in water, chemical, and other contaminants, as well as to heat from overload or fault currents. The MOLE™ and HYCRAB™ insulations provide electrical, mechanical, and thermal properties essential to assure the service continuity of underground distribution systems.

Recognizing the importance of proper connector insulation, BURNDY® established performance specifications exceeding those of 600 volt cable insulation.

Blue highlighted items are industry standard and most frequently ordered.

MULTIPLE OUTLET CONNECTORS (Continued)

MOLE™ and MOLE™ Accessories

The BURNDY® MOLE™ is a multi-cable connector that consists of a pre-insulated copper bus bar with threaded outlets that permit a minimum of two cables to be connected by means of a socket, nut, and cone assembly (Illustration A). The clamping action of the socket, nut and cone assembly on the cable develops high contact pressures that maintain joint conductivities greater than 100% of the continuous conductor. A compression socket that is threaded into the MOLE™ insert is also available. The MOLE™ design affords exceptional versatility in four ways:

1. MOLE™ outlets can be plugged-off until needed for the addition of cables.
2. Installed cables can be easily removed.
3. Cable sizes can be increased by changing the socket, nut and cone assembly.
4. The number of outlets may be increased by joining MOLE™ connectors with a MOLE™ coupler.

Insulation

The copper bus bar insert is encased in a molded insulating jacket that eliminates crotch taping. The thickness of the jacket prevents any possibility of the insert weight to cause the insulation at the supports to flow away at the high temperatures of fault conditions.

Ratings

MOLE™ connectors are rated at 1500, 2000, 2500, and 3000 amperes, based on the maximum current the insert cross-section can carry. Each outlet can carry the full rated current of the cable connected to it.

To avoid exceeding the insert rating, the cables should be arranged in such a manner that most current flows directly across the insert. (See Illustration B)

Installation

Cables are connected to the MOLE™ by means of a socket, nut and compression cone assembly. The socket is threaded into the MOLE™ insert. The stripped cable end is inserted into nut and compression cone, and then into the socket where it is securely clamped by tightening the nut. The joint is then sealed watertight in one of three ways:

- Taping;
- MOLE™ Outlet Insulating Sleeves, sealed with a minimum of taping;
- or NOTAPE™ MOLE™ Sleeve, sealed to the cable and mole insulation by two non-corrosive hose clamps.

Tests under flooding and other adverse conditions demonstrate that such joints are impervious to water.

Accessories

A socket, cone and nut assembly is screwed into each MOLE™ outlet to which a cable is to be connected. The socket has a tapered recess into which the clamping nut forces the cable and the compression cone. The cone is slotted to controlled widths and depths for maximum flexibility, and its inside surface is serrated for low contact resistance and high pullout strength.

A compression socket is available that threads directly into the MOLE™ outlet and provides a compression sleeve for connecting the cable with HYPRESS™ tools.

Plugs seal MOLE™ outlets not in use. The MOLE™ is delivered with one-fourth of its outlets sealed with plugs. Additional plugs may be ordered.

MOLE™ couplers facilitate system expansion by joining additional MOLE™ connectors to those already installed. Couplers are easily installed in end or side outlets of the MOLE™, and make connections that are effective both electrically and mechanically.



Illustration A

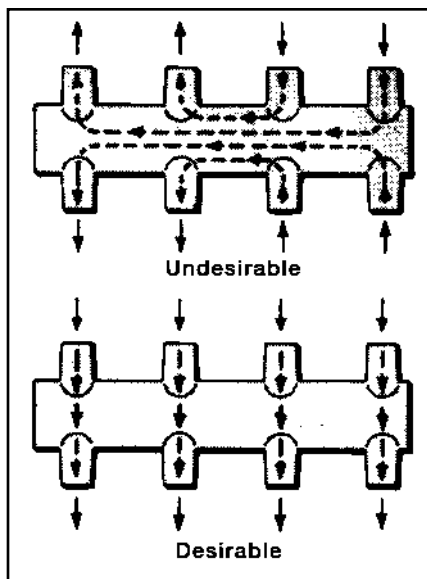

Illustration B

Blue highlighted items are industry standard and most frequently ordered.

MULTIPLE OUTLET CONNECTORS (Continued)



K-7

Blue highlighted items are industry standard and most frequently ordered.

HOW TO ORDER YOUR BURNDY MOLE™

This MOLE™ connector section is arranged so that all the information necessary for ordering standard MOLE™ connections is contained on a single page.

BURNDY™ Underground Products
for Network and Residential Distribution

MOLE™ TYPE ZM
1500 AMPERES



MOLE™ DIMENSIONS

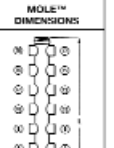

Cable Range	No. of Outlets	Cable Size	Length (inches)	Approx. Weight (lb.)
600	2	#6 Str.	12.5	1.5
750	2	#6 Str.	12.5	1.5
1000	2	#2 Str.	12.5	2.5
1500	2	#2 Str.	12.5	2.5
1500	4	#2 Str.	12.5	4.5
1500	6	#2 Str.	12.5	6.5
1500	8	#2 Str.	12.5	8.5
1500	10	#2 Str.	12.5	10.5
1500	12	#2 Str.	12.5	12.5
1500	14	#2 Str.	12.5	14.5
1500	16	#2 Str.	12.5	16.5

MOLE™ CONNECTORS ARE ORDERED BY THE FOLLOWING PROCEDURE:

- Determine amperage that meets requirements and locate it in the MOLE™ ampere page listings: pages 9-31.
- Choose MOLE™ configuration desired, by Type (ZM, ZME, ZMT, etc.) within ampere group.
- Decide on the number of outlets that meets your requirements.
- Decide on the cable ranges required for each outlet.
- Select cable outlet arrangement for MOLE™ listing: outlet #1, "A": all others "B", etc.

EXAMPLE:
Installation load capacity: 2000 ampere.
Configuration: outlets on two sides and one end.
Cable ranges: End outlet to accommodate a 1000 kcmil cable; other outlets: two 700 kcmil, two 600 kcmil and two 500 kcmil cables.

PROCEDURE:

- Locate 2000 through 2500 ampere MOLE™ groups: pages 15-20.
- MOLE™ Type ZMT has outlets on two sides and one end.
- Cable outlet symbol "B" = #2 Str. - 1000 kcmil. MOLE™ outlet arrangement: Outlet #1 = "B", all other outlets = "A".
- Catalog Number ZMT7-25B is the correct number. See pages K-32 - K-34 for socket and nut assembly, compression cones and Insulating Sleeves.

K-8 MOLE™ Connector listings are arranged by:

Amperes: 1,500; 2,000 - 2,500; 3,000.

MOLE™ Type: ZM, ZMT, ZME, etc., within each ampere group.

Cable Outlet Ranges:

- Symbol "A" = #6 Str. - 600 kcmil; 5/8"
- Symbol "B" = #2 Str. - 1000 kcmil; 7/8"
- Symbol "C" = 500 - 1500 kcmil; 1-1/8"

Cable Outlet Arrangement:

Depending on ampere group, outlets may be all "A" or "B" cable size, or may be combinations of sizes; outlet #1, "A": all the other outlets "B", etc. (See suffix list below.)

Number of Outlets Per MOLE™:

From 2 to 16 outlets depending on MOLE™ Type (any number can be supplied).

Catalog Number, Dimensions, and Weights.

MOLE™ CONNECTORS ARE ORDERED BY THE FOLLOWING PROCEDURE:

- Determine amperage that meets requirements and locate it in the MOLE™ ampere page listings: pages 9-31.
- Choose MOLE™ configuration desired, by Type (ZM, ZME, ZMT, etc.) within ampere group.
- Decide on the number of outlets that meets your requirements.
- Decide on the cable ranges required for each outlet.
- Select cable outlet arrangement for MOLE™ listing: outlet #1, "A": all others "B", etc.

4. Decide on the cable ranges required for each outlet.

5. Select cable outlet arrangement for MOLE™ listing: outlet #1, "A": all others "B", etc.

EXAMPLE:

Installation load capacity: 2000 ampere.
Configuration: outlets on two sides and one end.
Cable ranges: End outlet to accommodate a 1000 kcmil cable; other outlets: two 700 kcmil, two 600 kcmil and two 500 kcmil cables.

PROCEDURE:

- Locate 2000 through 2500 ampere MOLE™ groups: pages 15-20.
- MOLE™ Type ZMT has outlets on two sides and one end.
- Cable outlet symbol "B" = #2 Str. - 1000 kcmil. MOLE™ outlet arrangement: Outlet #1 = "B", all other outlets = "A".
- Catalog Number ZMT7-25B is the correct number. See pages K-32 - K-34 for socket and nut assembly, compression cones and Insulating Sleeves.

Suffix List:

- A3: Outlet #1 = B; all others = A
- A4: Outlets #1 and X = B; all others = A
- A7: Outlet #1 and X = C; all others = A
- A9: Outlet #1 = C; all others = A
- B12: Outlet #1 = A; all others = B
- B72: Outlet #1 and X = C; all others = B
- B92: Outlet #1 = C; all others = B

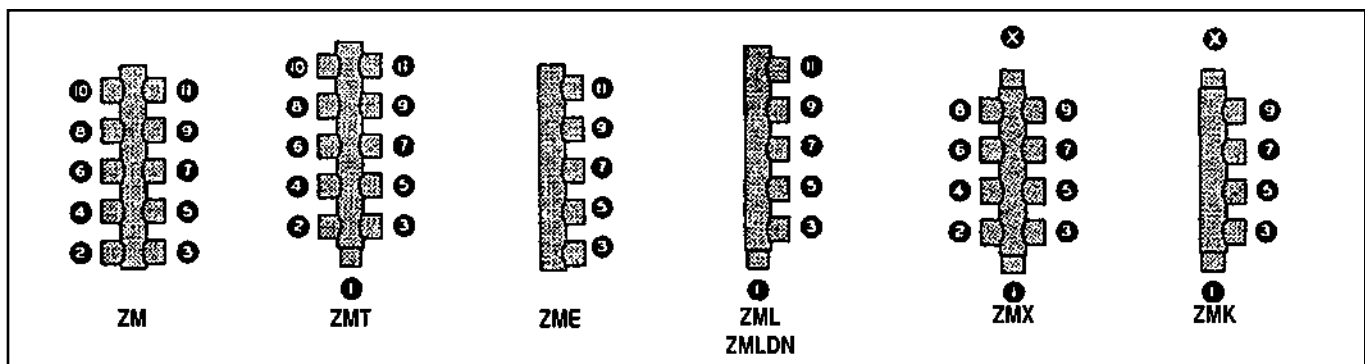

Blue highlighted items are industry standard and most frequently ordered.

MOLE™ TYPE ZM

1500 AMPERES

MOLE™ Type ZM — A compact pre-insulated junction for secondary network cables, with multiple outlets for each cable clamping elements.

Outlet Plugs — MOLE™ outlet plugs that facilitate sealing outlets not being used are available on page K-31, Types Z-P and K-P.

Insulating Sleeves — Taping operations for watertight joints are greatly simplified by the use of BURNDY® NOTAPE™ Sleeves Type CM or MOLE™ Insulating Sleeves Type Z-C shown on pages K-35 - K-36.

Clamping Elements — Outlet Symbols A or B, refer to socket and nut Type Z-NR, and cone Type Z cable clamping elements accommodated. These must be ordered separately. Refer to pages K-32 - K-34 for complete listings.

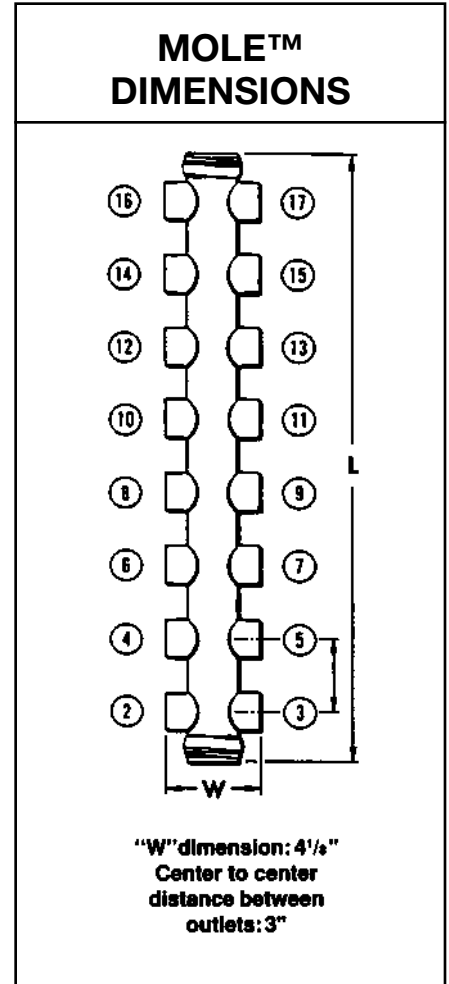
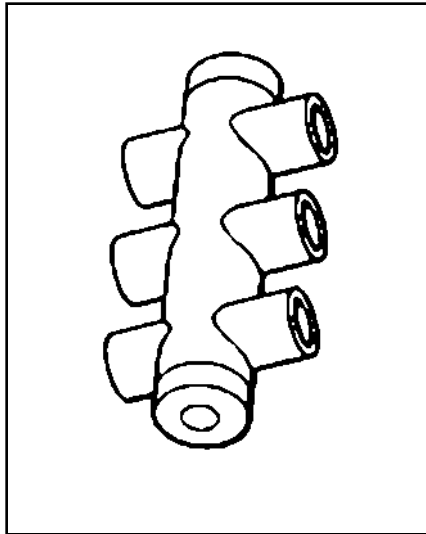

OUTLET RANGE: "A" 6 Str. - 600 kcmil

Cable Outlet Arrangement	No. of Outlets	Catalog Number	Length Inches L	Approx. Ship. Wt. Lbs.
All Outlets A	4	ZM4-15	7-1/8	2.6
	6	ZM6-15	10-1/8	4.4
	8	ZM8-15	13-1/8	6.2
	10	ZM10-15	16-1/8	7.8
	12	ZM12-15	19-1/8	9.5
	14	ZM14-15	22-1/8	11
	16	ZM16-15	25-1/8	13

For outlet combinations not listed call customer service

Blue highlighted items are industry standard and most frequently ordered.

MOLE™ TYPE ZMT

1500 AMPERES

MOLE™ Type ZMT — A compact pre-insulated junction for secondary network cables, with multiple outlets for cable clamping elements. Future expansion is provided for by an end outlet which can be joined to an additional MOLE™ by Type ZMS couplers.

Outlet Plugs — Mole outlet plugs that facilitate sealing outlets not being used are available on page K-31, Types Z-P and K-P.

Insulating Sleeves — Taping operations for watertight joints are greatly simplified by the use of BURNDY® NOTAPE™ Sleeves Type CM or MOLE™ Insulating Sleeves Type Z-C shown on pages K-35 - K-36.

Clamping Elements — Outlet Symbols A or B, refer to socket and nut Type Z-NR, and cone Type Z cable clamping elements accommodated. These must be ordered separately. Refer to pages K-32 - K-34 for complete listings.

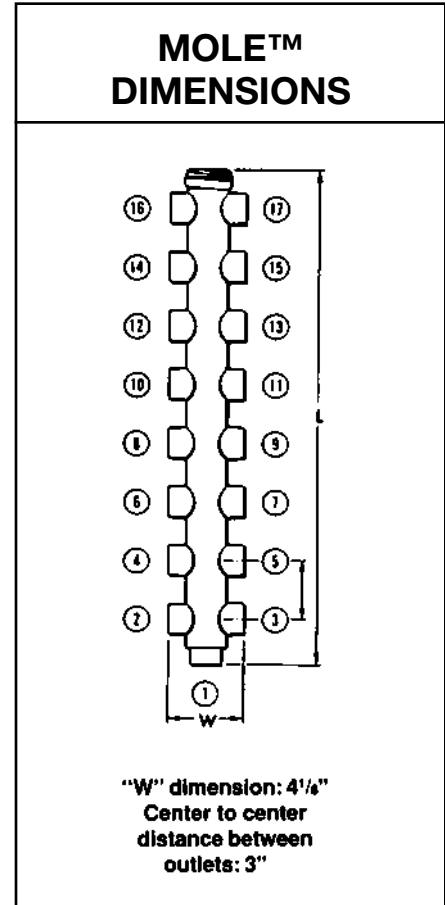
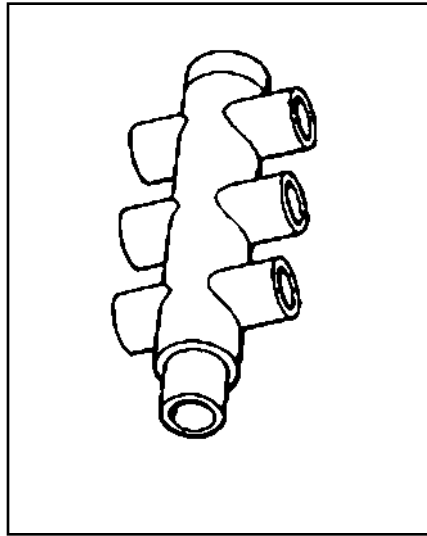

OUTLET RANGE: "A" 6 Str. - 600 kcmil
"B" 2 Str. - 1000 kcmil

K-10

Cable Outlet Arrangement	No. of Outlets	Catalog Number	Length Inches L	Approx. Ship. Wt. Lbs.
All Outlets A	3	ZMT3-15	5	1.3
	5	ZMT5-15	8	3.0
	7	ZMT7-15	11	4.5
	9	ZMT9-15	14	6.2
	11	ZMT11-15	17	7.9
	13	ZMT13-15	20	9.7
	15	ZMT15-15	23	12
	17	ZMT17-15	26	13
Outlet #1 B	3	ZMT3-15A3	5	1.3
All Other Outlets A	5	ZMT5-15A3	8	3.0
	7	ZMT7-15A3	11	4.5
	9	ZMT9-15A3	14	6.2
	11	ZMT11-15A3	17	7.9
	13	ZMT13-15A3	20	9.7
	15	ZMT15-15A3	23	12
	17	ZMT17-15A3	26	13

For outlet combinations not listed call customer service.

Blue highlighted items are industry standard and most frequently ordered.

MOLE™ TYPE ZME

1500 AMPERES

MOLE™ Type ZME — A compact pre-insulated junction for secondary network cables, with multiple outlets for cable clamping elements.

Outlet Plugs — Mole outlet plugs that facilitate sealing outlets not being used are available on page K-31, Types Z-P and K-P.

Insulating Sleeves — Taping operations for watertight joints are greatly simplified by the use of BURNDY® NOTAPE™ Sleeves Type CM or MOLE™ Insulating Sleeves Type Z-C shown on pages K-35 - K-36.

Clamping Elements — Outlet Symbols A or B, refer to socket and nut Type Z-NR, and cone Type Z cable clamping elements accommodated. These must be ordered separately. Refer to pages K-32 - K-34 for complete listings.

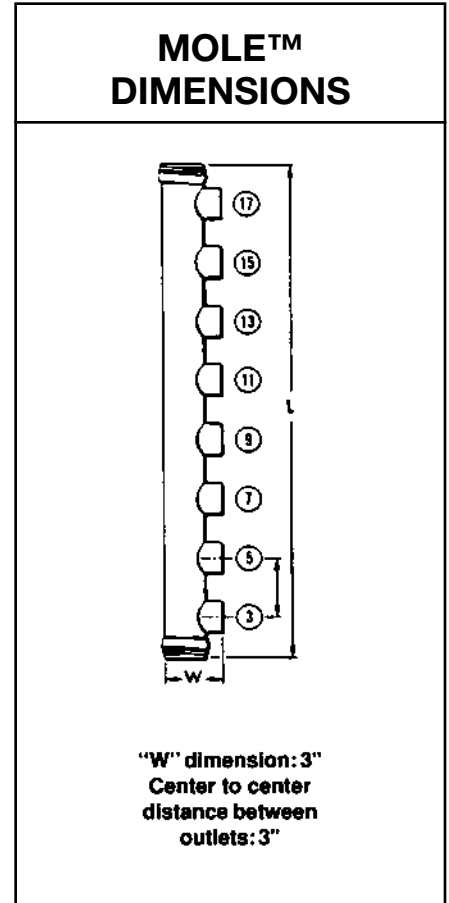
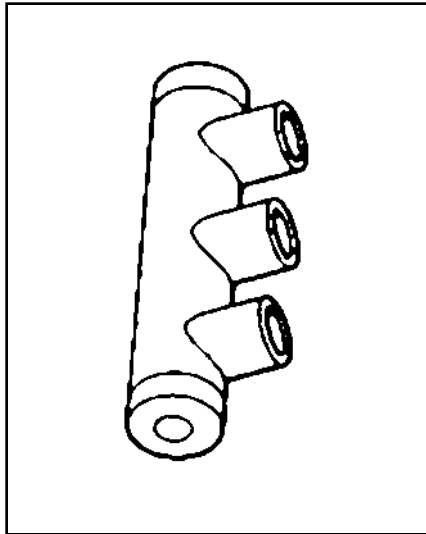

OUTLET RANGE: "A" 6 Str. - 600 kcmil

Cable Outlet Arrangement	No. of Outlets	Catalog Number	Length Inches L	Approx. Ship. Wt. Lbs.
All Outlets A	2	ZME2-15	7-1/8	2.5
	3	ZME3-15	10-1/8	4.4
	4	ZME4-15	13-1/8	6.1
	5	ZME5-15	16-1/8	7.7
	6	ZME6-15	19-1/8	9.4
	7	ZME7-15	22-1/8	11
	8	ZME8-15	25-1/8	13

For outlet combinations not listed call customer service

Blue highlighted items are industry standard and most frequently ordered.

MOLE™ TYPE ZML

1500 AMPERES

MOLE™ Type ZML — A compact pre-insulated junction for secondary network cables, with multiple outlets for cable clamping elements. Future expansion is provided for by an end outlet which can be joined to an additional MOLE™ by Type ZMS coupler.

Outlet Plugs — MOLE™ outlet plugs that facilitate sealing outlets not being used are available on page K-31, Types Z-P and K-P.

Insulating Sleeves — Taping operations for watertight joints are greatly simplified by the use of BURNDY® NOTAPE™ Sleeves Type CM or MOLE™ Insulating Sleeves Type Z-C shown on pages K-35 - K-36.

Clamping Elements — Outlet Symbols A or B, refer to socket and nut Type Z-NR, and cone Type Z cable clamping elements accommodated. These must be ordered separately. Refer to pages K-32 - K-34 for complete listings.

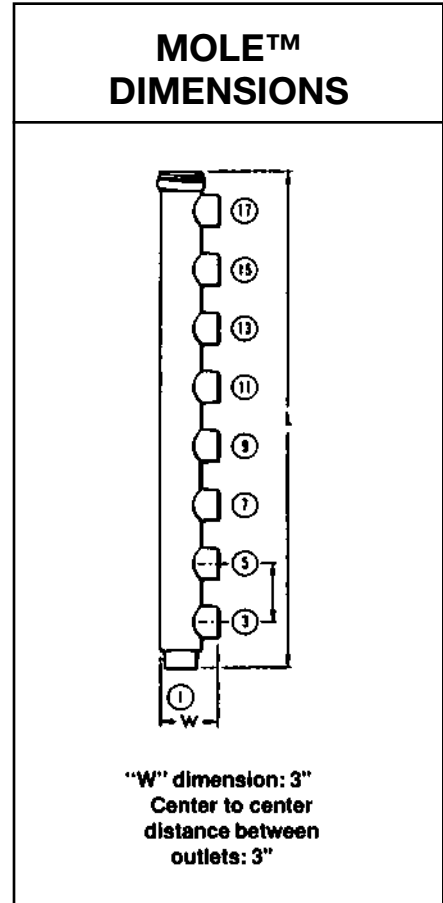
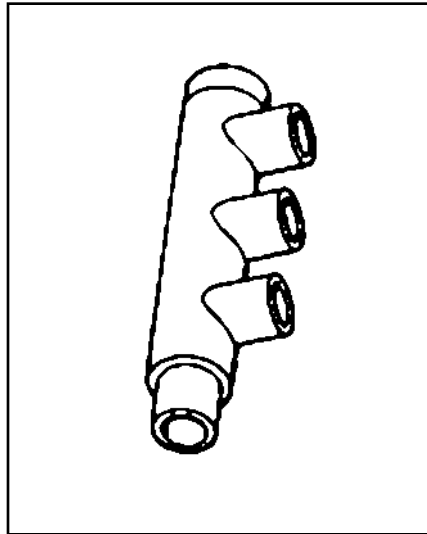

OUTLET RANGE: “A” 6 Str. - 600 kcmil
 “B” 2 Str. - 1000 kcmil

K-12

Cable Outlet Arrangement	No. of Outlets	Catalog Number	Length Inches L	Approx. Ship. Wt. Lbs.
All Outlets A	2	ZML2-15	5	1.2
	3	ZML3-15	8	3.0
	4	ZML4-15	11	4.3
	5	ZML5-15	14	5.9
	6	ZML6-15	17	7.6
	7	ZML7-15	20	9.4
	8	ZML8-15	23	11
	9	ZML9-15	26	13
	Outlet #1 B	2	ZML2-15A3	5
All Other Outlets A	3	ZML3-15A3	8	3.0
	4	ZML4-15A3	11	4.3
	5	ZML5-15A3	14	5.9
	6	ZML6-15A3	17	7.6
	7	ZML7-15A3	20	9.4
	8	ZML8-15A3	23	11
	9	ZML9-15A3	26	13

For outlet combinations not listed call customer service.

Blue highlighted items are industry standard and most frequently ordered.

MOLE™ TYPE ZMX

1500 AMPERES

MOLE™ Type ZMX — A compact pre-insulated junction for secondary network cables, with multiple outlets for cable clamping elements. Future expansion is provided for by an end outlet which can be joined to an additional MOLE™ by Type ZMS coupler.

Outlet Plugs — MOLE™ outlet plugs that facilitate sealing outlets not being used are available on page K-31, Types Z-P and K-P.

Insulating Sleeves — Taping operations for watertight joints are greatly simplified by the use of BURNDY® NOTAPE™ Sleeves Type CM or MOLE™ Insulating Sleeves Type Z-C shown on pages K-35 - K-36.

Clamping Elements — Outlet Symbols A or B, refer to socket and nut Type Z-NR, and cone Type Z cable clamping elements accommodated. These must be ordered separately. Refer to pages K-32 - K-34 for complete listings.

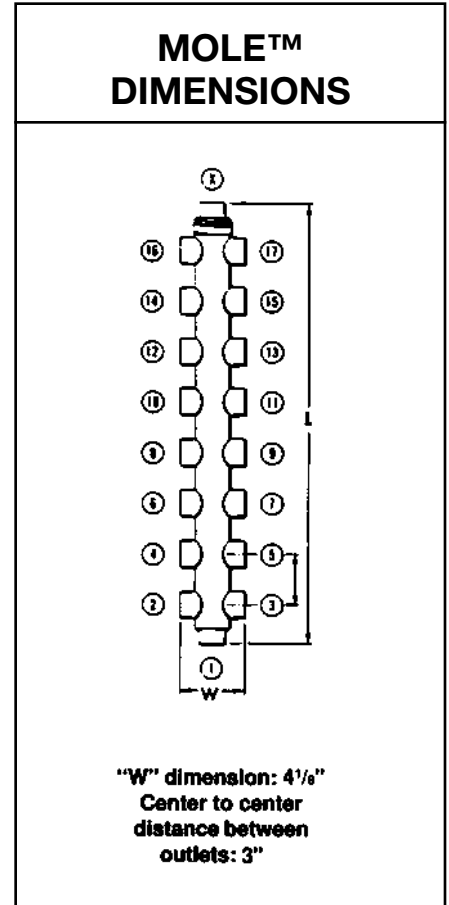
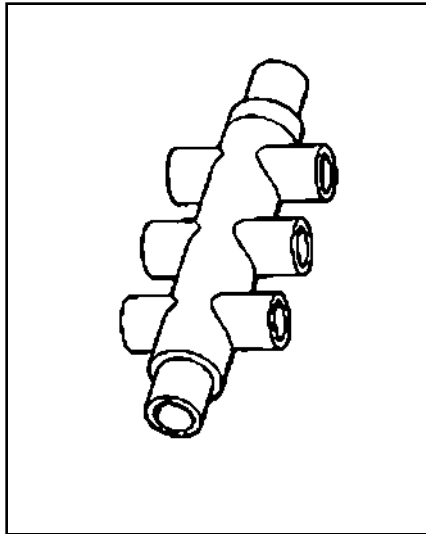

OUTLET RANGE: “A” 6 Str. - 600 kcmil
“B” 2 Str. - 1000 kcmil

Cable Outlet Arrangement	No. of Outlets	Catalog Number	Length Inches L	Approx. Ship. Wt. Lbs.
All Outlets A	4	ZMX4-15	6	1.7
	6	ZMX6-15	9	3.4
	8	ZMX8-15	12	5.2
	10	ZMX10-15	15	6.9
	12	ZMX12-15	18	8.8
	14	ZMX14-15	21	11
	16	ZMX16-15	24	12
Outlets #1 and X B	4	ZMX4-15A4	6	1.7
	6	ZMX6-15A4	9	3.4
	8	ZMX8-15A4	12	5.2
	10	ZMX10-15A4	15	6.9
	12	ZMX12-15A4	18	8.8
	14	ZMX14-15A4	21	11
	16	ZMX16-15A4	24	12
All Other Outlets B	4	ZMX4-15A3	6	1.7
	6	ZMX6-15A3	9	3.4
	8	ZMX8-15A3	12	5.2
	10	ZMX10-15A3	15	6.9
	12	ZMX12-15A3	18	8.8
	14	ZMX14-15A3	21	11
	16	ZMX16-15A3	24	12
All Other Outlets A	16	ZMX16-15A3	24	12
	18	ZMX18-15A3	27	14

For outlet combinations not listed call customer service.

Blue highlighted items are industry standard and most frequently ordered.

MOLE™ TYPE ZMK

1500 AMPERES

MOLE™ Type ZMK — A compact pre-insulated junction for secondary network cables, with multiple outlets for cable clamping elements. Future expansion is provided for by an end outlet which can be joined to an additional MOLE™ by Type ZMS couplers.

Outlet Plugs — MOLE™ outlet plugs that facilitate sealing outlets not being used are available on page K-31, Types Z-P and K-P.

Insulating Sleeves — Taping operations for watertight joints are greatly simplified by the use of BURNDY® NOTAPE™ Sleeves Type CM or MOLE™ Insulating Sleeves Type Z-C shown on pages K-35 - K-36.

Clamping Elements — Outlet Symbols A or B, refer to socket and nut Type Z-NR, and cone Type Z cable clamping elements accommodated. These must be ordered separately. Refer to pages K-32 - K-34 for complete listings.

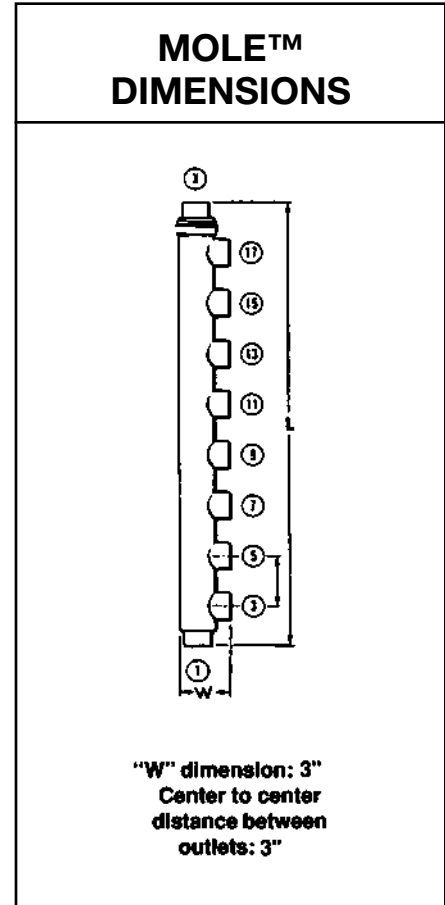
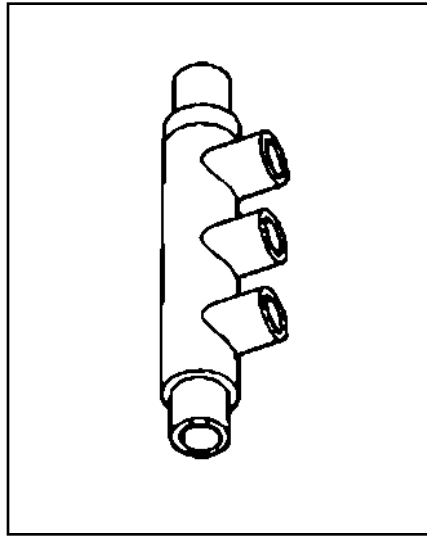

OUTLET RANGE: "A" 6 Str. - 600 kcmil
"B" 2 Str. - 1000 kcmil

K-14

Cable Outlet Arrangement	No. of Outlets	Catalog Number	Length Inches L	Approx. Ship. Wt. Lbs.
All Outlets A	4	ZMK4-15	9	3.3
	5	ZMK5-15	12	5.0
	6	ZMK6-15	15	6.8
	7	ZMK7-15	18	8.7
	8	ZMK8-15	21	11
	9	ZMK9-15	24	12
Outlets #1 and X B All Other Outlets A	10	ZMK10-15	27	14
	4	ZMK4-15A4	9	3.3
	5	ZMK5-15A4	12	5.0
	6	ZMK6-15A4	15	6.8
	7	ZMK7-15A4	18	8.7
	8	ZMK8-15A4	21	11
Outlets #1 or X B All Other Outlets A	9	ZMK9-15A4	24	12
	10	ZMK10-15A4	27	14
	4	ZMK4-15A3	9	3.3
	5	ZMK5-15A3	12	5.0
	6	ZMK6-15A3	15	6.8
	7	ZMK7-15A3	18	8.7
All Other Outlets A	8	ZMK8-15A3	21	11
	9	ZMK9-15A3	24	12
	10	ZMK10-15A3	27	14

For outlet combinations not listed call customer service.

Blue highlighted items are industry standard and most frequently ordered.

MOLE™ TYPE ZM

2000-2500 AMPERES

MOLE™ Type ZM — A compact pre-insulated junction for secondary network cables, with multiple outlets for cable clamping elements.

Outlet Plugs — MOLE™ outlet plugs that facilitate sealing outlets not being used are available on page K-31, Types Z-P and K-P.

Insulating Sleeves — Taping operations for watertight joints are greatly simplified by the use of BURNDY® NOTAPE™ Sleeves Type CM or MOLE™ Insulating Sleeves Type Z-C shown on pages K-35 - K-36.

Clamping Elements — Outlet Symbols A or B, refer to socket and nut Type Z-NR, and cone Type Z cable clamping elements accommodated. These must be ordered separately. Refer to pages K-32 - K-34 for complete listings.

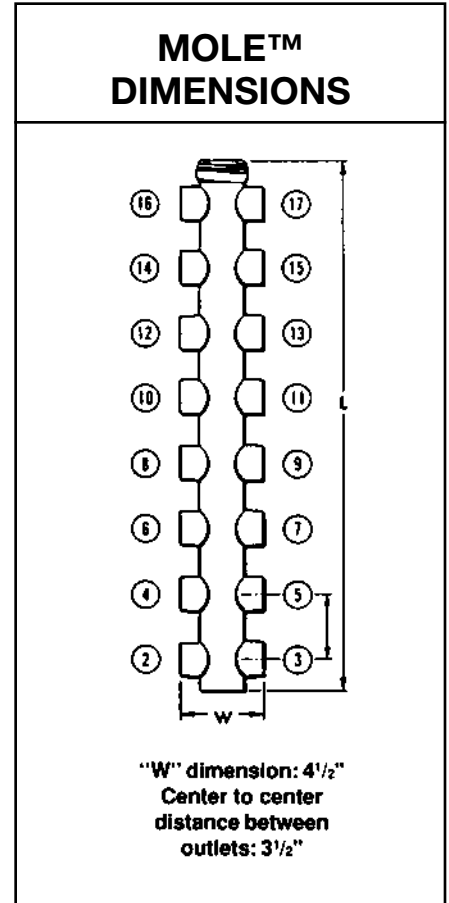
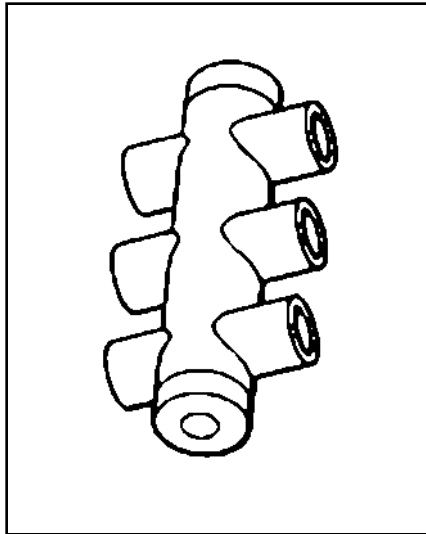

OUTLET RANGE: “A” 6 Str. - 600 kcmil
“B” 2 Str. - 1000 kcmil

Cable Outlet Arrangement	No. of Outlets	Catalog Number	Length Inches L	Approx. Ship. Wt. Lbs.
All Outlets A	4	ZM4-25	8	4.4
	6	ZM6-25	11-1/2	7.0
	8	ZM8-25	15	9.7
	10	ZM10-25	18-1/2	13
	12	ZM12-25	22	14
	14	ZM14-25	25-1/2	15
All Outlets B	16	ZM16-25	29	18
	4	ZM4-25B	8	4.4
	6	ZM6-25B	11-1/2	7.0
	8	ZM8-25B	15	9.7
	10	ZM10-25B	18-1/2	13
	12	ZM12-25B	22	14
	14	ZM14-25B	25-1/2	15
	16	ZM16-25B	29	18

For outlet combinations not listed call customer service.

Blue highlighted items are industry standard and most frequently ordered.

MOLE™ TYPE ZMT

2000-2500 AMPERES

MOLE™ Type ZMT — A compact pre-insulated junction for secondary network cables, with multiple outlets for cable clamping elements. Future expansion is provided for by an end outlet which can be joined to an additional MOLE™ by Type ZMS coupler.

Outlet Plugs — MOLE™ outlet plugs that facilitate sealing outlets not being used are available on page K-31, Types Z-P and K-P.

Insulating Sleeves — Taping operations for watertight joints are greatly simplified by the use of BURNDY® NOTAPE™ Sleeves Type CM or MOLE™ Insulating Sleeves Type Z-C shown on pages K-35 - K-36.

Clamping Elements — Outlet Symbols A or B, refer to socket and nut Type Z-NR, and cone Type Z cable clamping elements

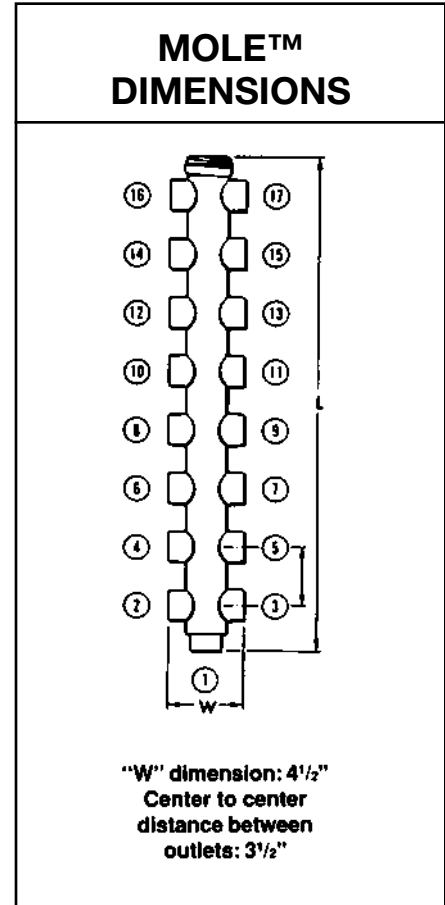
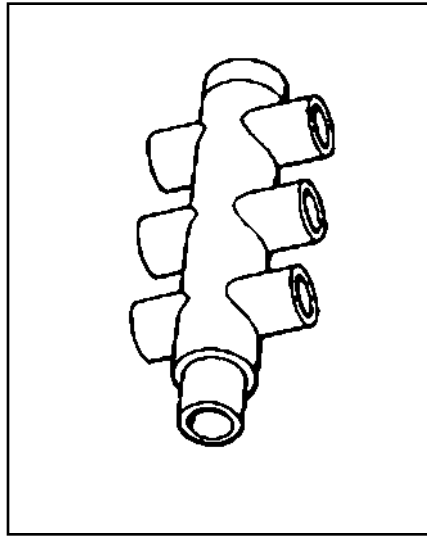

accommodated. These must be ordered separately. Refer to pages K-32 - K-34 for complete listings.

OUTLET RANGE: **“A” 6 Str. - 600 kcmil**
 “B” 2 Str. - 1000 kcmil

K-16

Cable Outlet Arrangement	No. of Outlets	Catalog Number	Length Inches L	Approx. Ship. Wt. Lbs.	
All Outlets A	3	ZMT3-25	5-1/2	1.9	
	5	ZMT5-25	9	5.8	
	7	ZMT7-25	12-1/2	8.0	
	9	ZMT9-25	16	12	
	11	ZMT11-25	19-1/2	14	
	13	ZMT13-25	23	17	
	15	ZMT15-25	26-1/2	18	
Outlet #1 B	3	ZMT3-25A3	5-1/2	1.9	
	5	ZMT5-25A3	9	5.8	
	7	ZMT7-25A3	12-1/2	8.0	
	9	ZMT9-25A3	16	12	
	All Other Outlets A	11	ZMT11-25A3	19-1/2	14
		13	ZMT13-25A3	23	17
		15	ZMT15-25A3	26-1/2	18
Outlet #1 A	3	ZMT3-25B12	5-1/2	1.9	
	5	ZMT5-25B12	9	5.8	
	7	ZMT7-25B12	12-1/2	8.0	
	9	ZMT9-25B12	16	12	
	All Other Outlets B	11	ZMT11-25B12	19-1/2	14
		13	ZMT13-25B12	23	17
		15	ZMT15-25B12	26-1/2	18
All Outlets B	17	ZMT17-25B12	30	19	
	3	ZMT3-25B	5-1/2	1.9	
	5	ZMT5-25B	9	5.8	
	7	ZMT7-25B	12-1/2	8.0	
	9	ZMT9-25B	16	12	
	11	ZMT11-25B	19-1/2	14	
	13	ZMT13-25B	23	17	
15	ZMT15-25B	26-1/2	18		
17	ZMT17-25B	30	19		

For outlet combinations not listed call customer service.

Blue highlighted items are industry standard and most frequently ordered.

MOLE™ TYPE ZME

2000-2500 AMPERES

MOLE™ Type ZME — A compact pre-insulated junction for secondary network cables, with multiple outlets for cable clamping elements.

Outlet Plugs — MOLE™ outlet plugs that facilitate sealing outlets not being used are available on page K-31, Types Z-P and K-P.

Insulating Sleeves — Taping operations for watertight joints are greatly simplified by the use of BURNDY® NOTAPE™ Sleeves Type CM or MOLE™ Insulating Sleeves Type Z-C shown on pages K-35 - K-36.

Clamping Elements — Outlet Symbols A or B, refer to socket and nut Type Z-NR, and cone Type Z cable clamping elements accommodated. These must be ordered separately. Refer to pages K-32 - K-34 for complete listings.

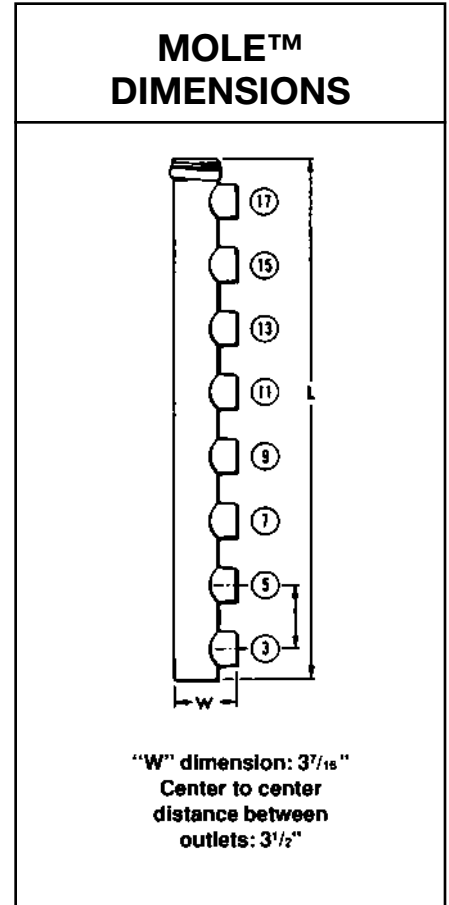
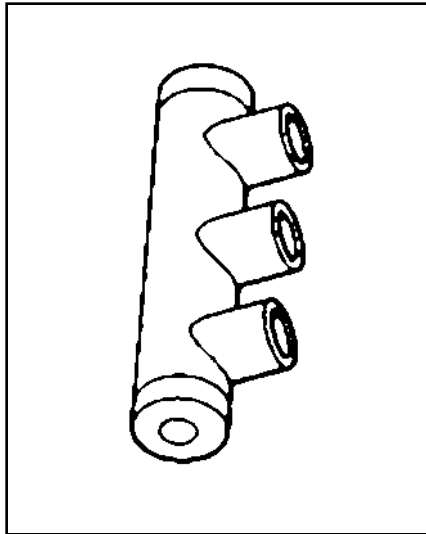

OUTLET RANGE: **“A” 6 Str. - 600 kcmil**
 “B” 2 Str. - 1000 kcmil

Cable Outlet Arrangement	No. of Outlets	Catalog Number	Length Inches L	Approx. Ship. Wt. Lbs.
All Outlets A	2	ZME2-25	8	4.3
	3	ZME3-25	11-1/2	6.9
	4	ZME4-25	15	9.5
	5	ZME5-25	18-1/2	12
	6	ZME6-25	22	14
	7	ZME7-25	25-1/2	15
	8	ZME8-25	29	17
	All Outlets B	2	ZME2-25B	8
3		ZME3-25B	11-1/2	6.9
4		ZME4-25B	15	9.5
5		ZME5-25B	18-1/2	12
6		ZME6-25B	22	14
7		ZME7-25B	25-1/2	15
8		ZME8-25B	29	17

For outlet combinations not listed call customer service.

Blue highlighted items are industry standard and most frequently ordered.

MOLE™ TYPE ZML

2000-2500 AMPERES

MOLE™ Type ZML — A compact pre-insulated junction for secondary network cables, with multiple outlets for cable clamping elements. Future expansion is provided for by an end outlet which can be joined to an additional MOLE™ by Type ZMS coupler.

Outlet Plugs — MOLE™ outlet plugs that facilitate sealing outlets not being used are available on page K-31, Types Z-P and K-P.

Insulating Sleeves — Taping operations for watertight joints are greatly simplified by the use of BURNDY® NOTAPE™ Sleeves Type CM or MOLE™ Insulating Sleeves Type Z-C shown on pages K-35 - K-36.

Clamping Elements — Outlet Symbols A or B, refer to socket and nut Type Z-NR, and cone Type Z cable clamping elements

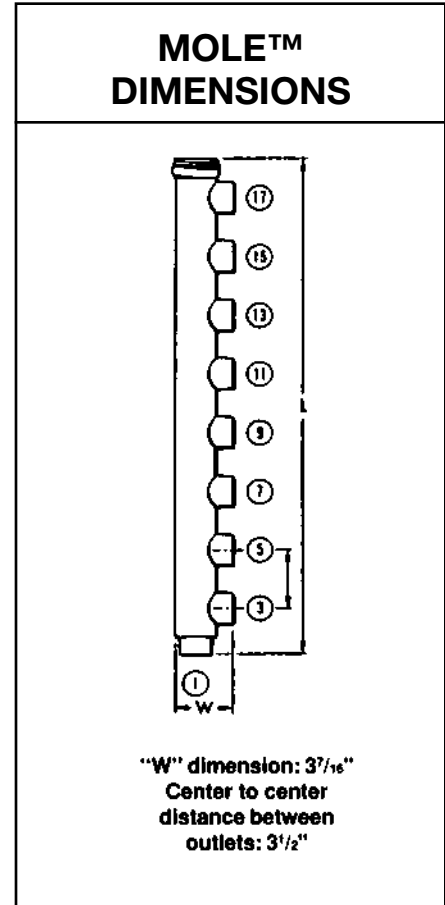
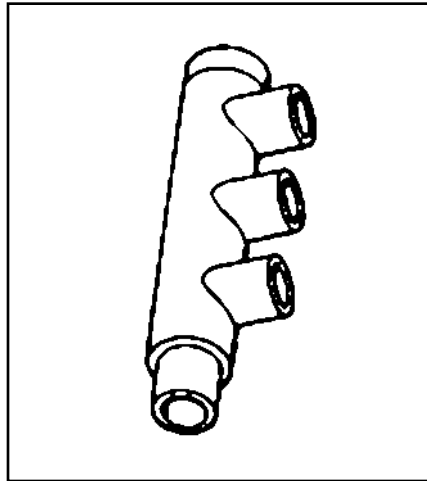

accommodated. These must be ordered separately. Refer to pages K-32 - K-34 for complete listings.

OUTLET RANGE: “A” 6 Str. - 600 kcmil
“B” 2 Str. - 1000 kcmil

K-18

Cable Outlet Arrangement	No. of Outlets	Catalog Number	Length Inches L	Approx. Ship. Wt. Lbs.
All Outlets A	2	ZML2-25	5-1/2	1.8
	3	ZML3-25	9	5.8
	4	ZML4-25	12-1/2	7.9
	5	ZML5-25	16	12
	6	ZML6-25	19-1/2	14
	7	ZML7-25	23	16
	8	ZML8-25	26-1/2	17
	9	ZML9-25	30	19
	Outlet #1 B All Other Outlets A	2	ZML2-25A3	5-1/2
3		ZML3-25A3	9	5.8
4		ZML4-25A3	12-1/2	7.9
5		ZML5-25A3	16	12
6		ZML6-25A3	19-1/2	14
7		ZML7-25A3	23	16
8		ZML8-25A3	26-1/2	17
9		ZML9-25A3	30	19
Outlet #1 A All Other Outlets B		2	ZML2-25B12	5-1/2
	3	ZML3-25B12	9	5.8
	4	ZML4-25B12	12-1/2	7.9
	5	ZML5-25B12	16	12
	6	ZML6-25B12	19-1/2	14
	7	ZML7-25B12	23	16
	8	ZML8-25B12	26-1/2	17
	9	ZML9-25B12	30	19
	All Outlets B	2	ZML2-25B	5-1/2
3		ZML3-25B	9	5.8
4		ZML4-25B	12-1/2	7.9
5		ZML5-25B	16	12
6		ZML6-25B	19-1/2	14
7		ZML7-25B	23	16
8		ZML8-25B	26-1/2	17
9		ZML9-25B	30	19

For outlet combinations not listed call customer service.

Blue highlighted items are industry standard and most frequently ordered.

MOLE™ TYPE ZMX

2000-2500 AMPERES

MOLE™ Type ZMX — A compact pre-insulated junction for secondary network cables, with multiple outlets for cable clamping elements. Future expansion is provided for by an outlet on each end which can be joined to additional MOLEs by Type ZMS coupler.

Outlet Plugs — MOLE™ outlet plugs that facilitate sealing outlets not being used are available on page K-31, Types Z-P and K-P.

Insulating Sleeves — Taping operations for watertight joints are greatly simplified by the use of BURNDY® NOTAPE™ Sleeves Type CM or MOLE™ Insulating Sleeves Type Z-C shown on pages K-35 - K-36.

Clamping Elements — Outlet Symbols A or B, refer to socket and nut Type Z-NR, and cone Type Z cable clamping elements

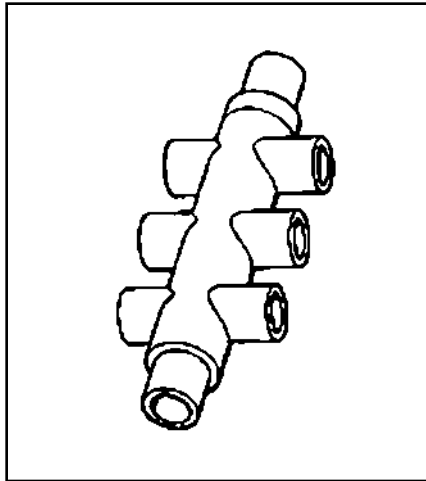

accommodated. These must be ordered separately. Refer to pages K-32 - K-34 for complete listings.

OUTLET RANGE: “A” 6 Str. - 600 kcmil
 “B” 2 Str. - 1000 kcmil

Cable Outlet Arrangement	No. of Outlets	Catalog Number	Length Inches L	Approx. Ship. Wt. Lbs.
All Outlets A	4	ZMX4-25	6-1/2	2.5
	6	ZMX6-25	10	6.5
	8	ZMX8-25	13-1/2	9.3
	10	ZMX10-25	17	12
	12	ZMX12-25	20-1/2	15
	14	ZMX14-25	24	17
	16	ZMX16-25	27-1/2	18
	18	ZMX18-25	31	19
Outlet #1 and X B All Other Outlets A	4	ZMX4-25A4	6-1/2	2.5
	6	ZMX6-25A4	10	6.5
	8	ZMX8-25A4	13-1/2	9.3
	10	ZMX10-25A4	17	12
	12	ZMX12-25A4	20-1/2	15
	14	ZMX14-25A4	24	17
	16	ZMX16-25A4	27-1/2	18
	18	ZMX18-25A4	31	19
Outlet #1 A All Other Outlets B	4	ZMX4-25B12	6-1/2	2.5
	6	ZMX6-25B12	10	6.5
	8	ZMX8-25B12	13-1/2	9.3
	10	ZMX10-25B12	17	12
	12	ZMX12-25B12	20-1/2	15
	14	ZMX14-25B12	24	17
	16	ZMX16-25B12	27-1/2	18
	18	ZMX18-25B12	31	19
All Outlets B	4	ZMX4-25B	6-1/2	2.5
	6	ZMX6-25B	10	6.5
	8	ZMX8-25B	13-1/2	9.3
	10	ZMX10-25B	17	12
	12	ZMX12-25B	20-1/2	15
	14	ZMX14-25B	24	17
	16	ZMX16-25B	27-1/2	18
	18	ZMX18-25B	31	19

For outlet combinations not listed call customer service.

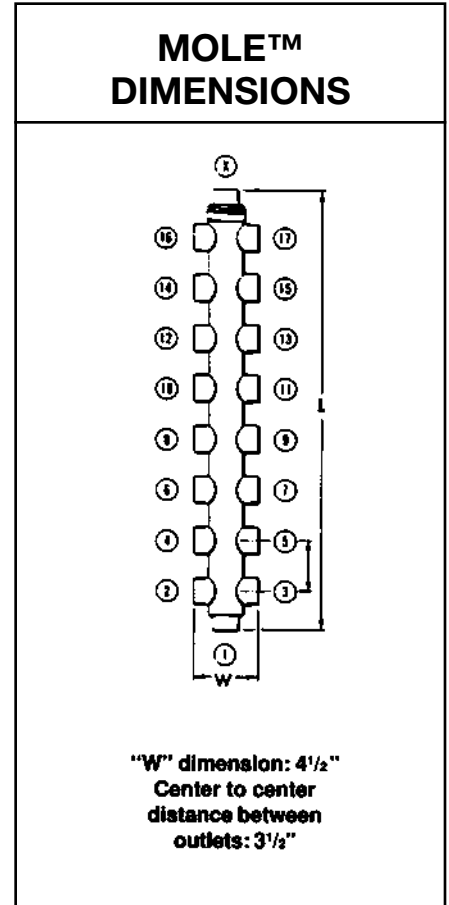

Blue highlighted items are industry standard and most frequently ordered.

MOLE™ TYPE ZMK

2000-2500 AMPERES

MOLE™ Type ZMK — A compact pre-insulated junction for secondary network cables, with multiple outlets for cable clamping elements. Future expansion is provided for by an outlet on each end which can be joined to additional MOLE™ by Type ZMS coupler.

Outlet Plugs — MOLE™ outlet plugs that facilitate sealing outlets not being used are available on page K-31, Types Z-P and K-P.

Insulating Sleeves — Taping operations for watertight joints are greatly simplified by the use of BURNDY® NOTAPE™ Sleeves Type CM or MOLE™ Insulating Sleeves Type Z-C shown on pages K-35 - K-36.

Clamping Elements — Outlet Symbols A or B, refer to socket and nut Type Z-NR, and cone Type Z cable clamping elements

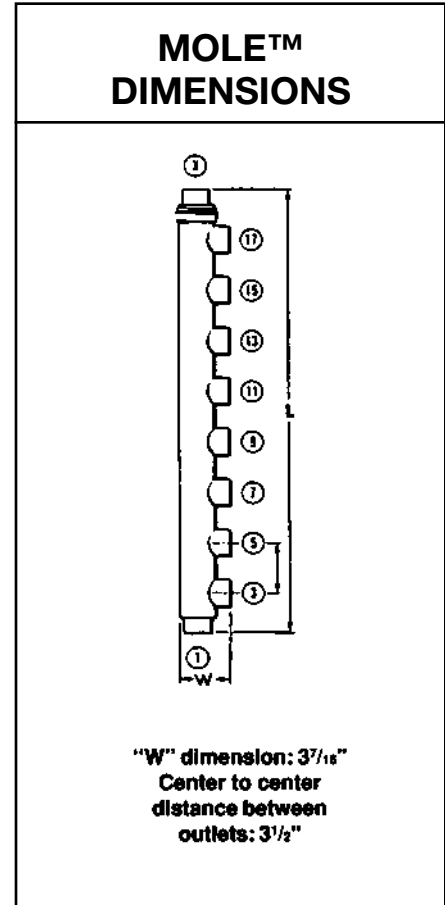
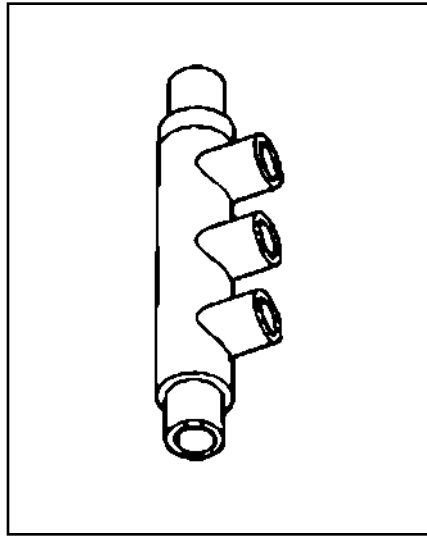

accommodated. These must be ordered separately. Refer to pages K-32 - K-34 for complete listings.

OUTLET RANGE: "A" 6 Str. - 600 kcmil
 "B" 2 Str. - 1000 kcmil

K-20

Cable Outlet Arrangement	No. of Outlets	Catalog Number	Length Inches L	Approx. Ship. Wt. Lbs.
All Outlets A	4	ZMK4-25	10	6.3
	5	ZMK5-25	13-1/2	9.1
	6	ZMK6-25	17	12
	7	ZMK7-25	20-1/2	15
	8	ZMK8-25	24	17
	9	ZMK9-25	27-1/2	18
Outlet #1 and X B	4	ZMK4-25A4	10	6.3
	5	ZMK5-25A4	13-1/2	9.1
	6	ZMK6-25A4	17	12
	7	ZMK7-25A4	20-1/2	15
	8	ZMK8-25A4	24	17
	9	ZMK9-25A4	27-1/2	18
All Other Outlets A	10	ZMK10-25A4	31	19
	4	ZMK4-25B12	10	6.3
	5	ZMK5-25B12	13-1/2	9.1
	6	ZMK6-25B12	17	12
	7	ZMK7-25B12	20-1/2	15
	8	ZMK8-25B12	24	17
All Other Outlets B	9	ZMK9-25B12	27-1/2	18
	10	ZMK10-25B12	31	19
	4	ZMK4-25B	10	6.3
	5	ZMK5-25B	13-1/2	9.1
All Outlets B	6	ZMK6-25B	17	12
	7	ZMK7-25B	20-1/2	15
	8	ZMK8-25B	24	17
	9	ZMK9-25B	27-1/2	18
	10	ZMK10-25B	31	19

For outlet combinations not listed call customer service.

Blue highlighted items are industry standard and most frequently ordered.

MOLE™ TYPE ZM

3000 AMPERES

MOLE™ Type ZM — A compact pre-insulated junction for secondary network cables, with multiple outlets for cable clamping elements.

Outlet Plugs — MOLE™ outlet plugs that facilitate sealing outlets not being used are available on page K-31, Types Z-P and K-P.

Insulating Sleeves — Taping operations for watertight joints are greatly simplified by the use of BURNDY® NOTAPE™ Sleeves Type CM or MOLE™ Insulating Sleeves Type Z-C shown on pages K-35 - K-36.

Clamping Elements — Outlet Symbols A or B, refer to socket and nut Type Z-NR, and cone Type Z cable clamping elements accommodated. These must be ordered separately. Refer to pages K-32 - K-34 for complete listings.

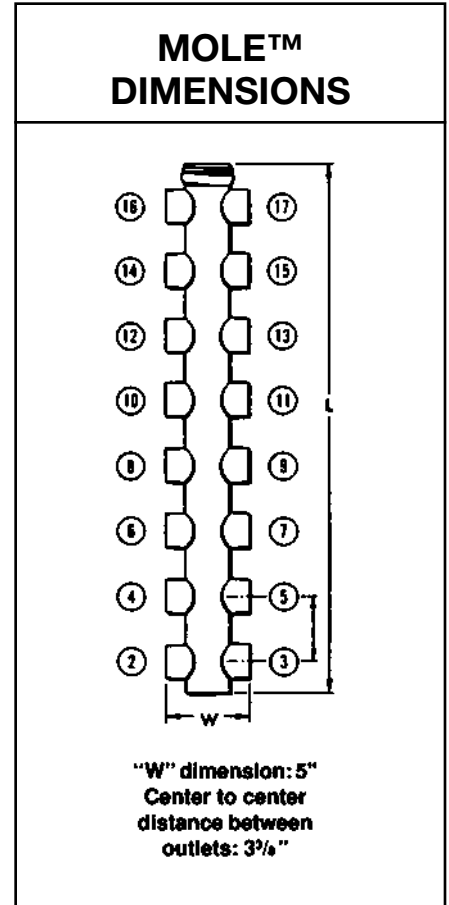
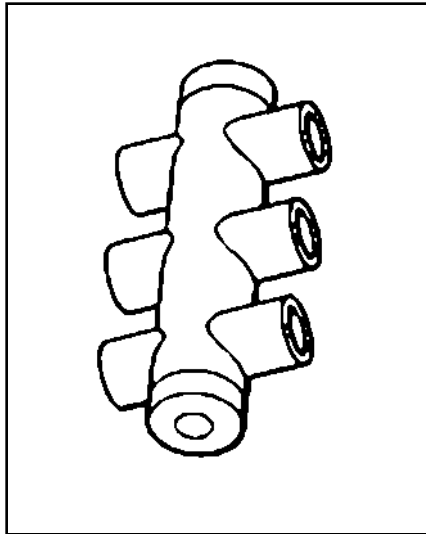

OUTLET RANGE: "A" 6 Str. - 600 kcmil
"B" 2 Str. - 1000 kcmil

Cable Outlet Arrangement	No. of Outlets	Catalog Number	Length Inches L	Approx. Ship. Wt. Lbs.
All Outlets A	4	ZM4-30	6-15/16	6.8
	6	ZM6-30	10-5/16	11
	8	ZM8-30	13-11/16	15
	10	ZM10-30	17-1/16	20
	12	ZM12-30	20-7/16	24
	14	ZM14-30	23-13/16	28
All Outlets B	16	ZM16-30	27-3/16	33
	4	ZM4-30B	6-15/16	6.8
	6	ZM6-30B	10-5/16	11
	8	ZM8-30B	13-11/16	15
	10	ZM10-30B	17-1/16	20
	12	ZM12-30B	20-7/16	24
14	ZM14-30B	23-13/16	28	

For outlet combinations not listed call customer service.

Blue highlighted items are industry standard and most frequently ordered.

MOLE™ TYPE ZMT

3000 AMPERES

MOLE™ Type ZMT — A compact pre-insulated junction for secondary network cables, with multiple outlets for cable clamping elements. Future expansion is provided for by an end outlet which can be joined to an additional MOLE™ by Type ZMS coupler.

Outlet Plugs — MOLE™ outlet plugs that facilitate sealing outlets not being used are available on page K-31, Types Z-P and K-P.

Insulating Sleeves — Taping operations for watertight joints are greatly simplified by the use of BURNDY® NOTAPE™ Sleeves Type CM or MOLE™ Insulating Sleeves Type Z-C shown on pages K-35 - K-36.

Clamping Elements — Outlet Symbols A or B, refer to socket and nut Type Z-NR, and cone Type Z cable clamping elements

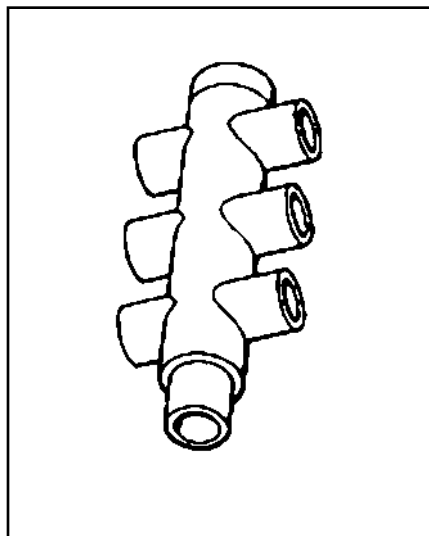

accommodated. These must be ordered separately. Refer to pages K-32 - K-34 for complete listings.

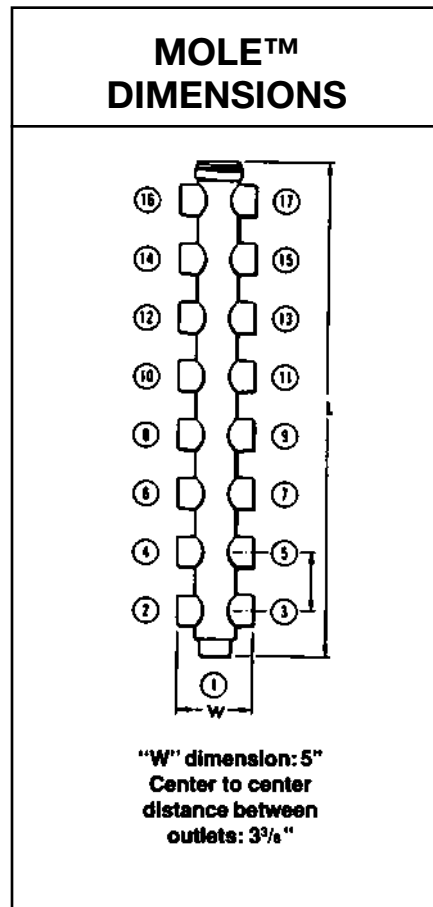

OUTLET RANGE: **“A” 6 Str. - 600 kcmil**
 “B” 2 Str. - 1000 kcmil

K-22

Cable Outlet Arrangement	No. of Outlets	Catalog Number	Length Inches L	Approx. Ship. Wt. Lbs.
All Outlets A	3	ZMT3-30	5-1/2	2.8
	5	ZMT5-30	9-1/8	7.4
	7	ZMT7-30	12-1/2	12
	9	ZMT9-30	15-7/8	16
	11	ZMT11-30	19-1/4	21
	13	ZMT13-30	22-5/8	26
	15	ZMT15-30	26	30
All Outlets B	3	ZMT3-30B	5-1/2	2.8
	5	ZMT5-30B	9-1/8	7.4
	7	ZMT7-30B	12-1/2	12
	9	ZMT9-30B	15-7/8	16
	11	ZMT11-30B	19-1/4	21
	13	ZMT13-30B	22-5/8	26
	15	ZMT15-30B	26	30
17	ZMT17-30B	29-3/8	35	

For outlet combinations not listed call customer service.

Blue highlighted items are industry standard and most frequently ordered.

MOLE™ TYPE ZME

3000 AMPERES

MOLE™ Type ZME — A compact pre-insulated junction for secondary network cables, with multiple outlets for cable clamping elements.

Outlet Plugs — MOLE™ outlet plugs that facilitate sealing outlets not being used are available on page K-31, Types Z-P and K-P.

Insulating Sleeves — Taping operations for watertight joints are greatly simplified by the use of BURNDY® NOTAPE™ Sleeves Type CM or MOLE™ Insulating Sleeves Type Z-C shown on pages K-35 - K-36.

Clamping Element — Outlet Symbols A or B, refer to socket and nut Type Z-NR, and cone Type Z cable clamping elements accommodated. These must be ordered separately. Refer to pages K-32 - K-34 for complete listings.

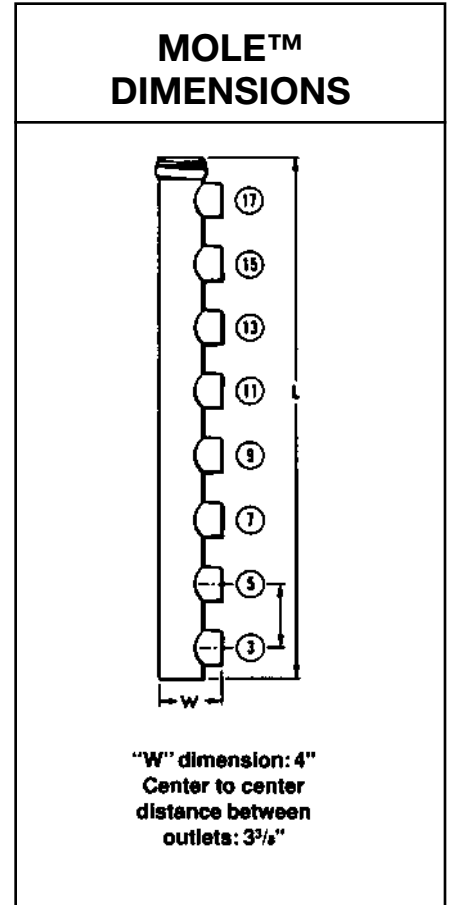
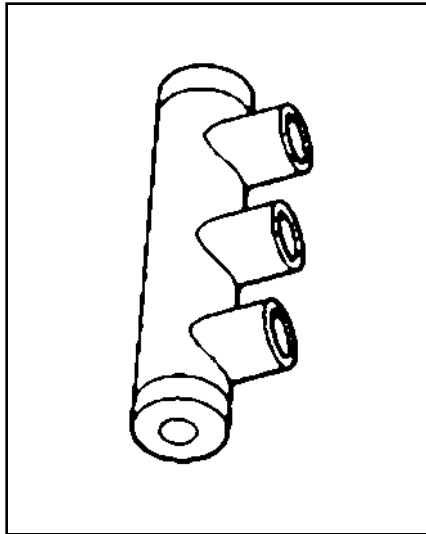

OUTLET RANGE: "A" 6 Str. - 600 kcmil
"B" 2 Str. - 1000 kcmil

Cable Outlet Arrangement	No. of Outlets	Catalog Number	Length Inches L	Approx. Ship. Wt. Lbs.
All Outlets A	2	ZME2-30	6-15/16	6.5
	3	ZME3-30	10-5/16	11
	4	ZME4-30	13-11/16	15
	5	ZME5-30	17-1/16	19
	6	ZME6-30	20-7/16	24
	7	ZME7-30	23-13/16	28
	8	ZME8-30	27-3/16	32
	All Outlets B	2	ZME2-30B	6-15/16
3		ZME3-30B	10-5/16	11
4		ZME4-30B	13-11/16	15
5		ZME5-30B	17-1/16	19
6		ZME6-30B	20-7/16	24
7		ZME7-30B	23-13/16	28
8		ZME8-30B	27-3/16	32

For outlet combinations not listed call customer service.

Blue highlighted items are industry standard and most frequently ordered.

MOLE™ TYPE ZML

3000 AMPERES

MOLE™ Type ZML — A compact pre-insulated junction for secondary network cables, with multiple outlets for cable clamping elements. Future expansion is provided for by an end outlet which can be joined to an additional MOLE™ by Type ZMS coupler.

Outlet Plugs — MOLE™ outlet plugs that facilitate sealing outlets not being used are available on page K-31, Types Z-P and K-P.

Insulating Sleeves — Taping operations for watertight joints are greatly simplified by the use of BURNDY® NOTAPE™ Sleeves Type CM or MOLE™ Insulating Sleeves Type Z-C shown on pages K-35 - K-36.

Clamping Elements — Outlet Symbols A or B, refer to socket and nut Type Z-NR, and cone Type Z cable clamping elements accommodated. These must be ordered separately. Refer to pages K-32 - K-34 for complete listings.

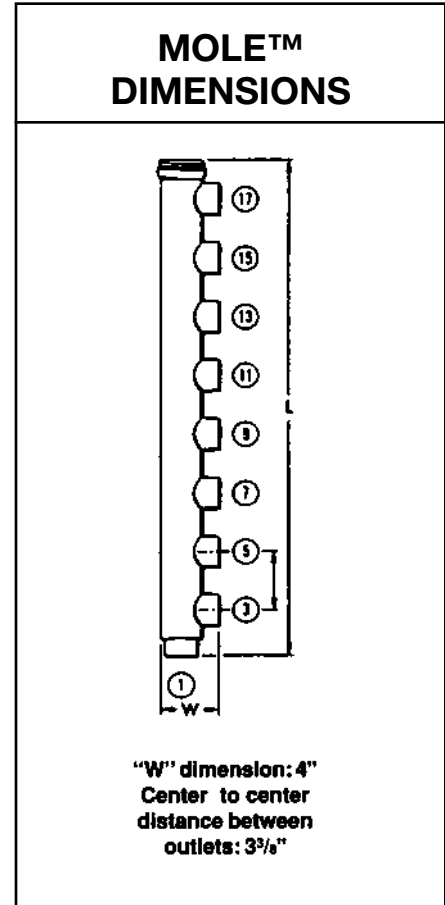
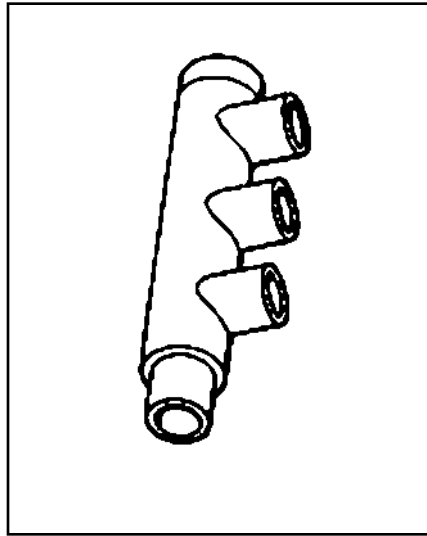

OUTLET RANGE: “A” 6 Str. - 600 kcmil
 “B” 2 Str. - 1000 kcmil

K-24

Cable Outlet Arrangement	No. of Outlets	Catalog Number	Length Inches L	Approx. Ship. Wt. Lbs.
All Outlets A	2	ZML2-30	5-1/2	2.7
	3	ZML3-30	9-1/8	7.3
	4	ZML4-30	12-1/2	12
	5	ZML5-30	15-7/8	16
	6	ZML6-30	19-1/4	21
	7	ZML7-30	22-5/8	25
	8	ZML8-30	26	30
	9	ZML9-30	29-3/8	35
	All Outlets B	2	ZML2-30B	5-1/2
3		ZML3-30B	9-1/8	7.3
4		ZML4-30B	12-1/2	12
5		ZML5-30B	15-7/8	16
6		ZML6-30B	19-1/4	21
7		ZML7-30B	22-5/8	25
8		ZML8-30B	26	30
9		ZML9-30B	29-3/8	35

For outlet combinations not listed call customer service.

Blue highlighted items are industry standard and most frequently ordered.

MOLE™ TYPE ZMX

3000 AMPERES

MOLE™ Type ZMX — A compact pre-insulated junction for secondary network cables, with multiple outlets for cable clamping elements. Future expansion is provided for by an end outlet which can be joined to additional MOLE™ by Type ZMS couplers.

Outlet Plugs — MOLE™ outlet plugs that facilitate sealing outlets not being used are available on page K-31, Types Z-P and K-P.

Insulating Sleeves — Taping operations for watertight joints are greatly simplified by the use of BURNDY® NOTAPE™ Sleeves Type CM or MOLE™ Insulating Sleeves Type Z-C shown on pages K-35 - K-36.

Clamping Elements — Outlet Symbols A or B, refer to socket and nut Type Z-NR, and cone Type Z cable clamping elements accommodated. These must be ordered separately. Refer to pages K-32 - K-34 for complete listings.

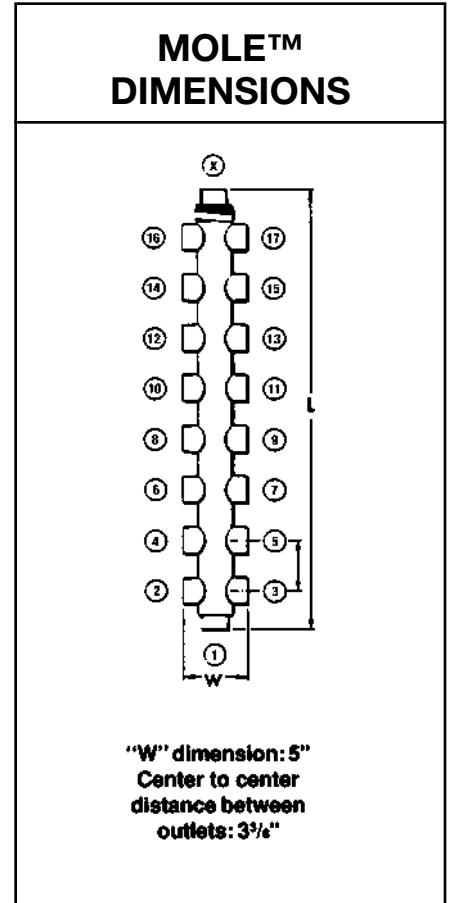
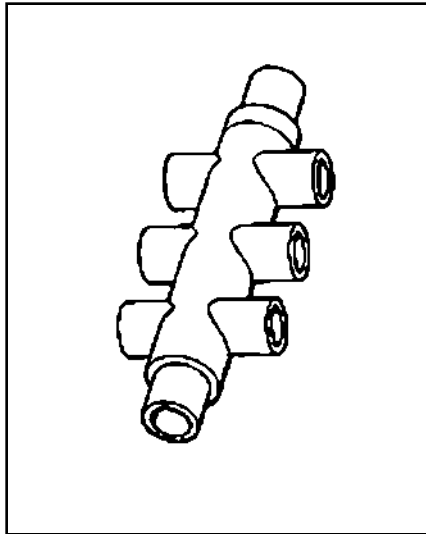

OUTLET RANGE: “A” 6 Str. - 600 kcmil
“B” 2 Str. - 1000 kcmil

Cable Outlet Arrangement	No. of Outlets	Catalog Number	Length Inches L	Approx. Ship. Wt. Lbs.
All Outlets A	4	ZMX4-30	6-1/2	3.9
	6	ZMX6-30	10-1/8	8.9
	8	ZMX8-30	13-1/2	13
	10	ZMX10-30	16-7/8	18
	12	ZMX12-30	20-1/4	23
	14	ZMX14-30	23-5/8	27
	16	ZMX16-30	27	31
	18	ZMX18-30	30-3/8	35
All Outlets B	4	ZMX4-30B	6-5/8	3.9
	6	ZMX6-30B	10-1/4	8.9
	8	ZMX8-30B	13-5/8	13
	10	ZMX10-30B	17	18
	12	ZMX12-30B	20-3/8	23
	14	ZMX14-30B	23-3/4	27
	16	ZMX16-30B	27-1/8	31
	18	ZMX18-30B	30-1/2	35

For outlet combinations not listed call customer service.

Blue highlighted items are industry standard and most frequently ordered.

MOLE™ TYPE ZMK

3000 AMPERES

MOLE™ Type ZMK — A compact pre-insulated junction for secondary network cables, with multiple outlets for cable clamping elements. Future expansion is provided for by an outlet on each end which can be joined to additional MOLE™ by Type ZMS couplers.

Outlet Plugs — MOLE™ outlet plugs that facilitate sealing outlets not being used are available on page K-31, Types Z-P and K-P.

Insulating Sleeves — Taping operations for watertight joints are greatly simplified by the use of BURNDY® NOTAPE™ Sleeves Type CM or MOLE™ Insulating Sleeves Type Z-C shown on pages K-35 - K-36.

Clamping Elements — Outlet Symbols A or B, refer to socket and nut Type Z-NR, and cone Type Z cable clamping elements accommodated. These must be ordered separately. Refer to pages K-32 - K-34 for complete listings.

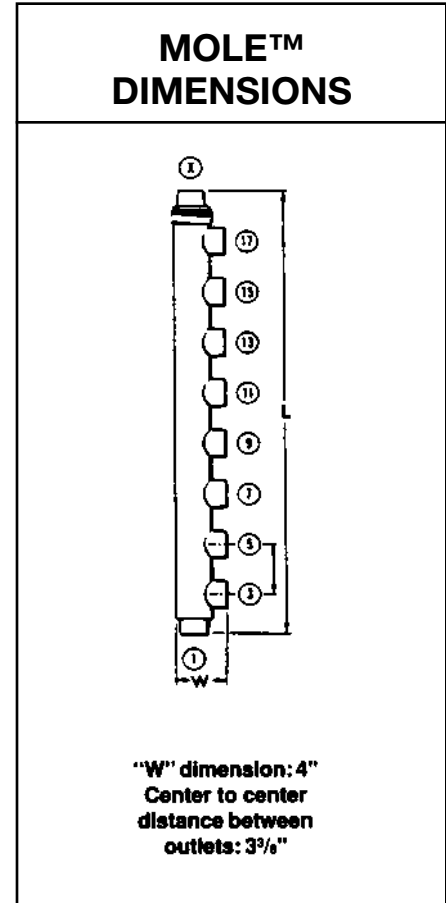
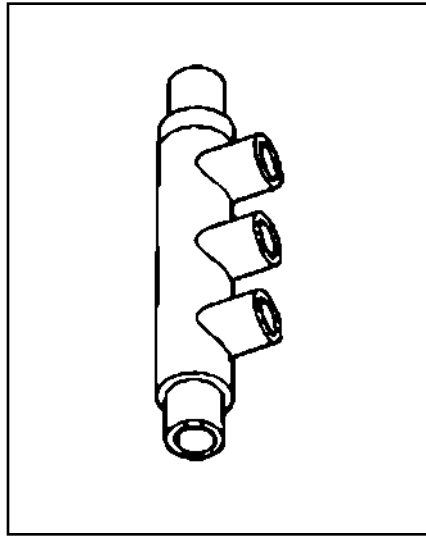

OUTLET RANGE: **“A” 6 Str. - 600 kcmil**
 “B” 2 Str. - 1000 kcmil

K-26

Cable Outlet Arrangement	No. of Outlets	Catalog Number	Length Inches L	Approx. Ship. Wt. Lbs.
All Outlets A	4	ZMK4-30	10-1/8	8.8
	5	ZMK5-30	13-1/2	13
	6	ZMK6-30	16-7/8	18
	7	ZMK7-30	20-1/4	23
	8	ZMK8-30	23-5/8	27
	9	ZMK9-30	27	31
All Outlets B	4	ZMK4-30B	10-1/4	8.8
	5	ZMK5-30B	13-5/8	13
	6	ZMK6-30B	17	18
	7	ZMK7-30B	20-3/8	23
	8	ZMK8-30B	23-3/4	27
	9	ZMK9-30B	27-1/8	31
	10	ZMK10-30B	30-1/2	35

For outlet combinations not listed call customer service.

Blue highlighted items are industry standard and most frequently ordered.

TYPE ZMLDN

MOLE™ STUD CONNECTOR

For Connecting Copper Cables to Network Protector

To terminate one or more cables at the studs of distribution transformers, network protectors or other apparatus. The body, except for the stud clamping element is completely insulated. A separate clamping cap over the stud is provided that permits easy removal of the MOLE™ Stud Connector. This permits work to be done on the Network Protector without unduly disturbing the cables.

Outlet Plugs — MOLE™ outlet plugs that facilitate sealing outlets not being used are available on page K-31, Types Z-P and K-P.

Insulating Sleeves — Taping operations for watertight joints are greatly simplified by the use of BURNDY® NOTAPE™ Sleeves Type CM or MOLE™ Insulating Sleeves Type Z-C shown on pages K-35 - K-36.

Clamping Elements — Outlet Symbols A or B, refer to socket and nut Type Z-NR, and cone Type Z cable clamping elements accommodated. These must be ordered separately. Refer to pages K-32 - K-34 for complete listings.

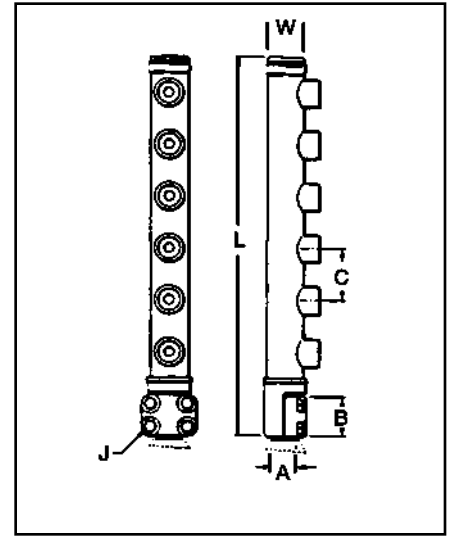

OUTLET RANGE: “A” 6 Str. - 600 kcmil
 “B” 2 Str. - 1000 kcmil

Ampere Capacity	Cable Outlet Arrangement	*No. of Outlets	Catalog Number	A		Dimensions in Inches					Approx. Ship Wt. Lbs.
				Stud Dia.	Threads per Inch	B	C	J	L	W	
1500	All Outlets A	1	ZMLDN1-15	1-1/2	12	2-11/16	—	1/2	7-3/8	3	4.7
		2	ZMLDN2-15	1-1/2	12	2-11/16	3	1/2	10-3/8	3	6.8
		3	ZMLDN3-15	1-1/2	12	2-11/16	3	1/2	13-3/8	3	8.8
		4	ZMLDN4-15	1-1/2	12	2-11/16	3	1/2	16-3/8	3	11
		5	ZMLDN5-15	1-1/2	12	2-11/16	3	1/2	19-3/8	3	13.3
		6	ZMLDN6-15	1-1/2	12	2-11/16	3	1/2	22-3/8	3	15.5
2000	All Outlets A	1	ZMLDN1-20	1-1/2	12	2-11/16	—	1/2	7-7/8	3-7/16	8.5
		2	ZMLDN2-20	1-1/2	12	2-11/16	3-1/2	1/2	11-3/8	3-7/16	12
		3	ZMLDN3-20	1-1/2	12	2-11/16	3-1/2	1/2	14-7/8	3-7/16	14
		4	ZMLDN4-20	1-1/2	12	2-11/16	3-1/2	1/2	18-3/8	3-7/16	17
		5	ZMLDN5-20	1-1/2	12	2-11/16	3-1/2	1/2	21-7/8	3-7/16	20
		6	ZMLDN6-20	1-1/2	12	2-11/16	3-1/2	1/2	25-3/8	3-7/16	23
	All Outlets B	1	ZMLDN1-20B	1-1/2	12	2-11/16	—	1/2	7-7/8	3-7/16	8.5
		2	ZMLDN2-20B	1-1/2	12	2-11/16	3-1/2	1/2	11-3/8	3-7/16	12
		3	ZMLDN3-20B	1-1/2	12	2-11/16	3-1/2	1/2	14-7/8	3-7/16	14
		4	ZMLDN4-20B	1-1/2	12	2-11/16	3-1/2	1/2	18-3/8	3-7/16	17
		5	ZMLDN5-20B	1-1/2	12	2-11/16	3-1/2	1/2	21-7/8	3-7/16	20
		6	ZMLDN6-20B	1-1/2	12	2-11/16	3-1/2	1/2	25-3/8	3-7/16	23

*Can be furnished with more than 6 outlets.

Blue highlighted items are industry standard and most frequently ordered.

TYPE ZMLDN

MOLE™ STUD CONNECTOR

(Continued)

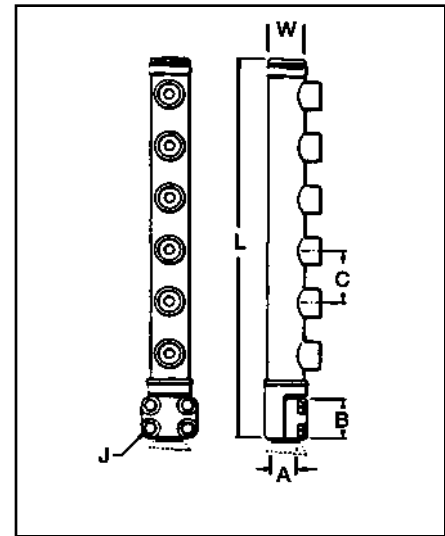

OUTLET RANGE: "A" 6 Str. - 600 kcmil
"B" 2 Str. - 1000 kcmil

K-28

Ampere Capacity	Cable Outlet Arrangement	*No. of Outlets	Catalog Number	A		Dimensions in Inches					Approx. Ship Wt. Lbs.
				Stud Dia.	Threads per Inch	B	C	J	L	W	
2500	All Outlets A	1	ZMLDN1-25	3	12	3-1/4	—	5/8	8-27/32	3-7/16	11.8
		2	ZMLDN2-25	3	12	3-1/4	3-1/2	5/8	12-11/32	3-7/16	17
		3	ZMLDN3-25	3	12	3-1/4	3-1/2	5/8	15-27/32	3-7/16	19.5
		4	ZMLDN4-25	3	12	3-1/4	3-1/2	5/8	19-11/32	3-7/16	23.7
		5	ZMLDN5-25	3	12	3-1/4	3-1/2	5/8	22-27/32	3-7/16	28
		6	ZMLDN6-25	3	12	3-1/4	3-1/2	5/8	26-11/32	3-7/16	32
	All Outlets B	1	ZMLDN1-25B	3	12	3-1/4	—	5/8	8-27/32	3-7/16	11.8
		2	ZMLDN2-25B	3	12	3-1/4	3-1/2	5/8	12-11/32	3-7/16	17
		3	ZMLDN3-25B	3	12	3-1/4	3-1/2	5/8	15-27/32	3-7/16	19.5
		4	ZMLDN4-25B	3	12	3-1/4	3-1/2	5/8	19-11/32	3-7/16	23.7
		5	ZMLDN5-25B	3	12	3-1/4	3-1/2	5/8	22-27/32	3-7/16	28
		6	ZMLDN6-25B	3	12	3-1/4	3-1/2	5/8	26-11/32	3-7/16	32
3000	All Outlets A	1	ZMLDN1-30	3	12	3-1/4	—	5/8	7-5/8	4	11.5
		2	ZMLDN2-30	3	12	3-1/4	3-3/8	5/8	11-1/4	4	16.8
		3	ZMLDN3-30	3	12	3-1/4	3-3/8	5/8	14-5/8	4	19
		4	ZMLDN4-30	3	12	3-1/4	3-3/8	5/8	18	4	23
		5	ZMLDN5-30	3	12	3-1/4	3-3/8	5/8	21-3/8	4	27
		6	ZMLDN6-30	3	12	3-1/4	3-3/8	5/8	24-3/4	4	31
	All Outlets B	1	ZMLDN1-30B	3	12	3-1/4	—	5/8	7-5/8	4	11.5
		2	ZMLDN2-30B	3	12	3-1/4	3-3/8	5/8	11-1/4	4	16.8
		3	ZMLDN3-30B	3	12	3-1/4	3-3/8	5/8	14-5/8	4	19
		4	ZMLDN4-30B	3	12	3-1/4	3-3/8	5/8	18	4	23
		5	ZMLDN5-30B	3	12	3-1/4	3-3/8	5/8	21-3/8	4	27
		6	ZMLDN6-30B	3	12	3-1/4	3-3/8	5/8	24-3/4	4	31

*Can be furnished with more than 6 outlets.
 For outlet combinations not listed call customer service.

Blue highlighted items are industry standard and most frequently ordered.

TYPE Z2MLDN

MOLE™ STUD CONNECTOR

For Connecting Copper Cables to Network Protector

To terminate two or more cables at the studs of distribution transformers, network protectors or other apparatus. The body, except for the stud clamping element is completely insulated. A separate clamping cap over the stud is provided that permits easy removal of the MOLE™ Stud Connector. This permits work to be done on the Network Protector without unduly disturbing the cables.

Outlet Plugs — MOLE™ outlet plugs that facilitate sealing outlets not being used are available on page K-31, Types Z-P and K-P.

Insulating Sleeves — Taping operations for watertight joints are greatly simplified by the use of BURNDY® NOTAPE™ Sleeves Type CM or MOLE™ Insulating Sleeves Type Z-C shown on pages K-35 - K-36.

Clamping Elements — Outlet Symbols A or B, refer to socket and nut Type Z-NR, and cone Type Z cable clamping elements accommodated. These must be ordered separately. Refer to pages K-32 - K-34 for complete listings.

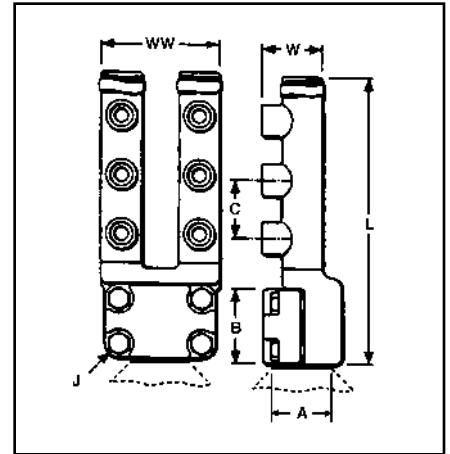

OUTLET RANGE: "A" 6 Str. - 600 kcmil
 "B" 2 Str. - 1000 kcmil

Ampere Capacity	Cable Outlet Arrangement	*No. of Outlets	Catalog Number	A		Dimensions in Inches						Approx. Ship Wt. Lbs.
				Stud Dia.	Threads per Inch	B	C	J	L	W	WW	
2000 & Smaller	All Outlets A	2	Z2MLDN-2-20	1-1/2	12	2-11/16	—	1/2	8	3	5-3/16	5.8
		4	Z2MLDN4-20	1-1/2	12	2-11/16	3	1/2	11	3	5-3/16	9.4
		6	Z2MLDN6-20	1-1/2	12	2-11/16	3	1/2	14	3	5-3/16	13.2
2500 & 3000	All Outlets A	2	Z2MLDN2-30	3	12	3-1/4	—	5/8	9	3	6-1/2	7.3
		4	Z2MLDN4-30	3	12	3-1/4	3	5/8	12	3	6-1/2	12.5
		6	Z2MLDN6-30	3	12	3-1/4	3	5/8	15	3	6-1/2	16.3
	All Outlets B	2	Z2MLDN2-30B	3	12	3-1/4	—	5/8	9	3-1/2	6-1/2	11.2
		4	Z2MLDN4-30B	3	12	3-1/4	3-1/2	5/8	12-1/2	3-1/2	6-1/2	16.1
		6	Z2MLDN6-30B	3	12	3-1/4	3-1/2	5/8	16	3-1/2	6-1/2	21.3

*Can be furnished with more than 6 outlets.
 For outlet combinations not listed call customer service.

Blue highlighted items are industry standard and most frequently ordered.

TYPE ZMDN

MOLE™ STUD CONNECTOR

For Connecting Copper Cables to Network Protector

To terminate one or more cables at the studs of distribution transformers, network protectors or other apparatus. The body, except for the stud clamping element is completely insulated. A separate clamping cap over the stud is provided that permit easy removal of the MOLE™ Stud Connector. This permits work to be done on the Network Protector without unduly disturbing the cables.

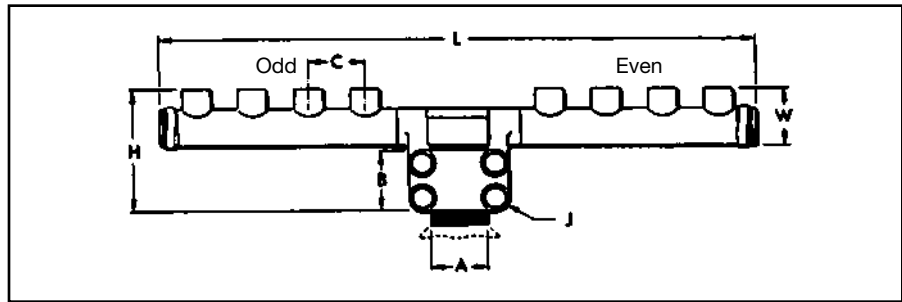

Outlet Plugs — MOLE™ outlet plugs that facilitate sealing outlets not being used are available on page K-31, Types Z-P and K-P.

Insulating Sleeves — Taping operations for watertight joints are greatly simplified by the use of BURNDY® NOTAPE™ Sleeves Type CM or MOLE™ Insulating Sleeves Type Z-C shown on pages K-35 - K-36.

Clamping Elements — Outlet Symbols A or B, refer to socket and nut Type Z-NR, and cone Type Z cable clamping elements accommodated. These must be ordered separately. Refer to pages K-32 - K-34 for complete listings.

K-30

OUTLET RANGE: "A" 6 Str. - 600 kcmil
"B" 2 Str. - 1000 kcmil

Ampere Capacity	Cable Outlet Arrangement	*No. of Outlets	Catalog Number	A		Dimensions in Inches						Approx. Ship Wt. Lbs.
				Stud Dia.	Threads per Inch	B	C	J	H	L	W	
2000 & Smaller	All Outlets A	3	ZMDN3-20	1-1/2	12	2-11/16	3-1/2	1/2	8-1/16	11-1/2	3-7/16	14.5
		4	ZMDN4-20	1-1/2	12	2-11/16	3-1/2	1/2	8-1/16	15	3-7/16	17.5
		5	ZMDN5-20	1-1/2	12	2-11/16	3-1/2	1/2	8-1/16	18-1/2	3-7/16	20.5
		6	ZMDN6-20	1-1/2	12	2-11/16	3-1/2	1/2	8-1/16	22	3-7/16	23.5
	All Outlets B	3	ZMDN3-20B	1-1/2	12	2-11/16	3-1/2	1/2	8-1/16	11-1/2	3-7/16	14.5
		4	ZMDN4-20B	1-1/2	12	2-11/16	3-1/2	1/2	8-1/16	15	3-7/16	17.5
2000 Through 2500	All Outlets A	3	ZMDN3-25	3	12	3-1/4	3-1/2	5/8	8-5/8	11-1/2	3-7/16	26.5
		4	ZMDN4-25	3	12	3-1/4	3-1/2	5/8	8-5/8	15	3-7/16	20.5
		5	ZMDN5-25	3	12	3-1/4	3-1/2	5/8	8-5/8	18-1/2	3-7/16	23.5
		6	ZMDN6-25	3	12	3-1/4	3-1/2	5/8	8-5/8	22	3-7/16	26.5

*Can be furnished with more than 6 outlets.
 For outlet combinations not listed call customer service.
 For connectors with an odd number of outlets the odd and even split of outlets will be as indicated in the diagram.

Blue highlighted items are industry standard and most frequently ordered.

TYPE ZMTDN

MOLE™ STUD CONNECTOR

For Connecting Copper Cables to Network Protector

To terminate two or more cables at the studs of distribution transformers, network protectors or other apparatus. The body, except for the stud clamping element is completely insulated. A separate clamping cap over the stud is provided that permits easy removal of the MOLE™ Stud Connector. This permits work to be done on the Network Protector without unduly disturbing the cables.

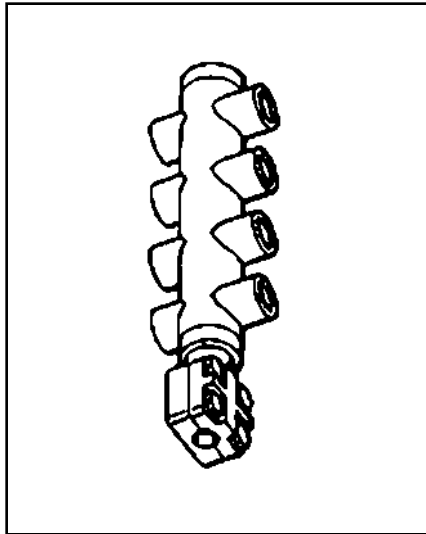

K-31

TYPES Z-P AND K-P

MOLE™ OUTLET PLUGS

These plugs facilitate sealing MOLE™ outlets not being used.

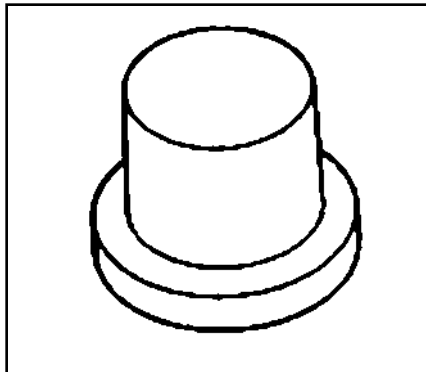

Catalog Number	Used On Outlet Size
Z29P	A
Z34P	B
K29P	KM MOLE
Z40P	C

Blue highlighted items are industry standard and most frequently ordered.

TYPE Z-NR

SOCKET AND NUT ASSEMBLY

Designed for use with BURNDY® MOLEs. With the use of the proper compression cones (see pages 33-34) 14 sizes take a range of cables from No. 6 to 1000 kcmil. Their compact design lends them to easy effective taping. Insulating sleeves are available to keep taping to a minimum.

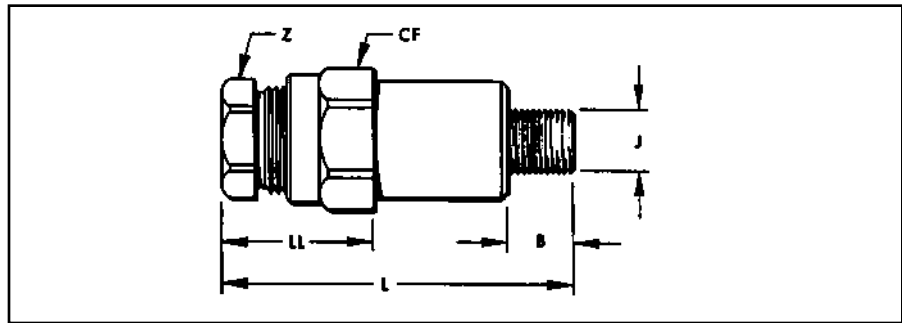

OUTLET RANGE: "A" 6 Str. - 600 kcmil
"B" 2 Str. - 1000 kcmil

To be Used in MOLE™ Outlet Size	Maximum Cable Accommodated by Socket	Stud Size J	Catalog Number	Dimensions in Inches					Approx. Ship Wt. in Lbs.
				B	CF (Cross Flats)	L	LL	Z (Cross Flats)	
A	4/0 Str.	5/8-18	Z28NR	17/32	1-1/8	3-7/16	1-1/2	7/8	.72
	250 kcmil	5/8-18	Z29NR	17/32	1-3/16	3-9/16	1-5/8	15/16	.76
	300 kcmil	5/8-18	Z30NR	17/32	1-1/4	3-5/8	1-11/16	1	.80
	400 kcmil	5/8-18	Z32NR	17/32	1-3/8	3-5/8	1-11/16	1-1/8	.90
	500 kcmil	5/8-18	Z34NR	17/32	1-1/2	3-11/16	1-3/4	1-1/4	1.2
	600 kcmil	5/8-18	Z36NR	17/32	1-1/2	3-13/16	1-7/8	1-5/16	1.4
B	800 kcmil	5/8-18	Z40NRA ①	17/32	1-13/16	5-17/32	2-1/4	1-1/2	2.4
	500 kcmil	7/8-14	Z34NRB ②	11/16	1-1/2	3-11/16	1-3/4	1-1/4	1.5
	800 kcmil	7/8-14	Z40NR	11/16	1-13/16	4-3/8	2-1/4	1-1/2	1.9
	1000 kcmil	7/8-14	Z44NR	11/16	1-15/16	6-1/16	2-7/16	1-5/8	2.5

K-32

① Uses Insulating Sleeve Z104C4434 (see page 36).

② Uses Insulating Sleeve Z88C3429 (see page 36).

Blue highlighted items are industry standard and most frequently ordered.

TYPE Z

MOLE™ COMPRESSION CONE

For use with Socket and Nut assembly shown on page 32; the Z cone is machined to close tolerances to provide maximum secureness in gripping a wide range of cable sizes. Annular grooves in the inner barrel of the cone serve to further accomplish this result.

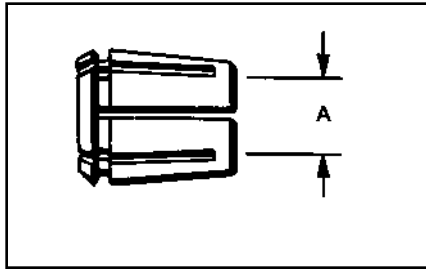

Cable Size	For Use with Socket and Nut Assembly. See Page K-32	Catalog Number	A	App. Ship Wt. in Lbs. per C	
			Inches	C	
#6 Str.	Z28NR	Z6C28	.183	8.0	
#4 Str.		Z4C28	.231	7.5	
#2 Str.		Z2C28	.291	7.0	
1/0 Str.		Z2528	.373	6.0	
3/0 Str.		Z2728	.470	4.3	
4/0 Str.		Z2828	.528	3.3	
#6 Str.	Z29NR	Z6C29	.183	9.5	
#4 Str.		Z4C29	.231	9.3	
#2 Str.		Z2C29	.291	8.5	
#1 Str.		Z1C29	.330	8.0	
1/0 Str.		Z2529	.373	7.0	
2/0 Str.		Z2629	.416	6.3	
4/0 Str.		Z2829	.528	3.8	
250 kcmil		Z2929	.575	3.3	
#6 Str.		Z30NR	Z6C30	.183	16
#4 Str.	Z4C30		.231	15	
#2 Str.	Z2C30		.291	14	
#1 Str.	Z1C30		.330	14	
1/0 Str.	Z2530		.373	13	
2/0 Str.	Z2630		.416	12	
3/0 Str.	Z2730		.470	11	
4/0 Str.	Z2830		.528	9.3	
250 kcmil	Z2930		.575	8.0	
300 kcmil	Z3030		.630	6.3	
#2 Str.	Z32NR		Z2C32	.291	21
#1 Str.			Z1C32	.330	20
1/0 Str.			Z2532	.373	19
2/0 Str.		Z2632	.416	18	
3/0 Str.		Z2732	.470	17	
4/0 Str.		Z2832	.528	15	
250 kcmil		Z2932	.575	14	
300 kcmil		Z3032	.630	12	
350 kcmil		Z3132	.681	9.8	
400 kcmil		Z3232	.728	8.0	
#2 Str.	Z34NR & Z34NRB	Z2C34	.291	29	
#1 Str.		Z1C34	.330	28	
1/0 Str.		Z2534	.373	27	
2/0 Str.		Z2634	.416	26	
3/0 Str.		Z2734	.470	25	

Cable Size	For Use with Socket and Nut Assembly. See Page K-32	Catalog Number	A	App. Ship Wt. in Lbs. per C
			Inches	C
4/0 Str.	Z34NR & 34NRB	Z2834	.528	22
250 kcmil		Z2934	.575	21
300 kcmil		Z3034	.630	19
350 kcmil		Z3134	.681	17
400 kcmil		Z3234	.728	15
450 kcmil		Z3334	.772	13
500 kcmil		Z3434	.814	11
250 kcmil	Z36NR	Z2936	.575	32
300 kcmil		Z3036	.630	30
350 kcmil		Z3136	.681	28
400 kcmil		Z3236	.728	26
450 kcmil		Z3336	.772	23
500 kcmil		Z3436	.814	21
550 kcmil		Z3536	.855	19
600 kcmil		Z3636	.893	17
250 kcmil	Z40NR & Z40NRA	Z2940	.575	49
300 kcmil		Z3040	.630	47
350 kcmil		Z3140	.681	44
400 kcmil		Z3240	.728	41
450 kcmil		Z3340	.772	39
500 kcmil		Z3440	.814	36
550 kcmil		Z3540	.855	33
600 kcmil		Z3640	.893	31
650 kcmil		Z3740	.929	29
700 kcmil		Z3840	.964	25
750 kcmil		Z3940	.998	23
800 kcmil		Z4040	1.031	21
500 kcmil	Z44NR	Z3444	.814	55
550 kcmil		Z3544	.855	51
600 kcmil		Z3644	.893	49
650 kcmil		Z3744	.929	47
700 kcmil		Z3844	.964	43
750 kcmil		Z3944	.998	40
800 kcmil		Z4044	1.031	38
850 kcmil		Z4144	1.062	35
900 kcmil		Z4244	1.093	32
950 kcmil		Z4344	1.123	28
1000 kcmil	Z4444	1.152	24	

K-33

Blue highlighted items are industry standard and most frequently ordered.

MOLE™ TYPE Z

COMPRESSION CONE

For Compact Conductor

For use with Socket and Nut assembly shown on page 32; the Z cone is machined to close tolerances to provide maximum secureness in gripping a wide range of cable sizes. Annular grooves in the inner barrel of the cone serve to further accomplish this result.

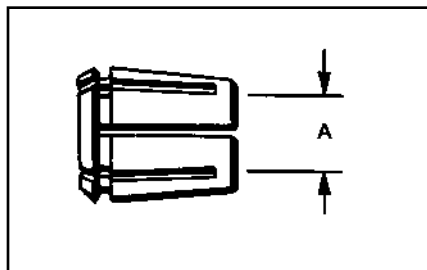

K-34

Compact Stranded Copper Cable			
Compact Cable Size	Nominal Conductor Diameter	Type Z Cone	Socket and Nut Assembly
#2	0.268	Z3C28	Z28NR
#1	0.299	Z2C28	
1/0	0.336	Z1C28	
2/0	0.376	Z2528	
3/0	0.423	Z2628	
4/0	0.475	Z2728	
#1	0.299	Z2C29	Z29NR
1/0	0.336	Z1C29	
2/0	0.376	Z2529	
3/0	0.423	Z2629	
4/0	0.475	Z2729	
250 kcmil	0.520	Z2829	
300 kcmil	0.570	Z2929	Z30NR
1/0	0.336	Z1C30	
2/0	0.376	Z2530	
3/0	0.423	Z2630	
4/0	0.475	Z2730	
250 kcmil	0.520	Z2830	
300 kcmil	0.570	Z2930	Z32NR
1/0	0.336	Z1C32	
2/0	0.376	Z2532	
3/0	0.423	Z2632	
4/0	0.475	Z2732	
250 kcmil	0.520	Z2832	
300 kcmil	0.570	Z2932	Z34NR
500 kcmil	0.736	Z3232	
2/0	0.376	Z2534	
3/0	0.423	Z2634	
4/0	0.475	Z2734	
250 kcmil	0.520	Z2834	
300 kcmil	0.570	Z2934	
500 kcmil	0.736	Z3234	
550 kcmil	0.775	Z3334	
600 kcmil	0.813	Z3434	

Compact Stranded Copper Cable				
Compact Cable Size	Nominal Conductor Diameter	Type Z Cone	Socket and Nut Assembly	
2/0	0.376	Z2536	Z36NR	
3/0	0.423	Z2636		
4/0	0.475	Z2736		
250 kcmil	0.520	Z2836		
300 kcmil	0.570	Z2936		
500 kcmil	0.736	Z3236		
550 kcmil	0.775	Z3336		
600 kcmil	0.813	Z3436		
750 kcmil	0.908	Z3636		
3/0	0.423	Z2640		Z40NR
4/0	0.475	Z2740		
250 kcmil	0.520	Z2840		
300 kcmil	0.570	Z2940		
500 kcmil	0.736	Z3240		
550 kcmil	0.775	Z3340		
600 kcmil	0.813	Z3440		
750 kcmil	0.908	Z3640		
250 kcmil	0.520	Z2844	Z44NR	
300 kcmil	0.570	Z2944		
500 kcmil	0.736	Z3244		
550 kcmil	0.775	Z3344		
600 kcmil	0.813	Z3444		
750 kcmil	0.908	Z3644		

Blue highlighted items are industry standard and most frequently ordered.

TYPE ZMS

MOLE™ COUPLER

For Connecting MOLEs

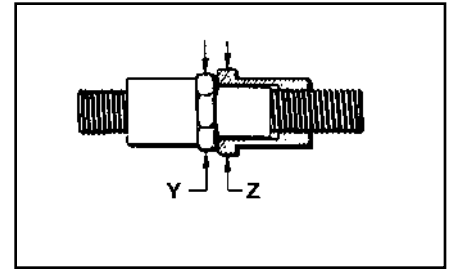

A compact, easy-to-tape MOLE™ Coupler for joining MOLEs end-to-end. Allows for expansion of underground systems by joining MOLEs to existing MOLE™ installations. Easily assembled to the end outlets of MOLE™ Types ZMT, ZMX, ZML, and ZMK.

Can also be used in side outlets for other types of MOLE™ arrangements. The MOLE™ Coupler has a lock-nut feature which permits pre-positioning of the added MOLE™, and facilitates training of new cables. Makes an effective electrical and mechanical connection.

OUTLET RANGE: “A” (5/8”) 6 Str. - 600 kcmil
 “B” (7/8”) 2 Str. - 1000 kcmil
 “C” (1-1/8”) 500 - 1500 kcmil

MOLE™ Outlet Size	MOLE™ Coupler	MOLE™ Coupler Ampere Capacity	Dimensions in Inches			Approx. Ship Wt. Lbs.
			Overall Length	Cross Flats		
				Y	Z	
A	ZMS29	1200	4-21/32	1-3/16	1-3/8	1.3
B	ZMS34	1600	5-7/32	1-1/2	1-3/4	2.3
C	ZMS40	2000	5-3/4	1-3/4	2-1/8	3.3

TYPE CM

NOTAPE™ MOLE™ SLEEVE

The BURNDY® NOTAPE MOLE™ Sleeve effectively eliminates the necessity of taping from the MOLE™ outlet to the insulation of the incoming cable. The sleeve fits snugly over the MOLE™ outlet and is held securely in place by a non-corrosive clamp. Bushings inside the sleeve are supplied to fit closely over the insulation of the cable. The other end of the assembly is clamped to the cable insulation. For rubber insulated cable two clamps are supplied. For oil filled cables a third clamp is provided to effect an oil-tight joint.

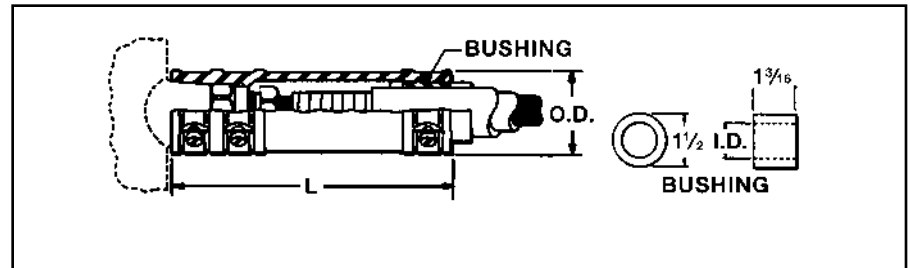

OUTLET RANGE: “A” 6 Str. - 600 kcmil

To be Used Over Outlet Size	Type of Cable Insulation	Cable Range Accommodated	Sleeve & Clamps				App. Ship. Wt. Ea. in Lbs.	Bushing		
			Catalog No. Sleeve & Clamps Only	For Use Sockets & Nut Ass'y	Dimensions in Inches			Catalog No. Bushing Only	I.D.	App. Ship. Wt. Ea. in Lbs.
					L	O.D.				
A	Rubber or Rubber-Lead	#6 Str. to 600 kcmil	CM29L	Z28NR to Z36NR	6-1/4	2-1/4	1.1	CMB-29R	†	.20
		#6-4/0 Str.	CM2829P	Z28NR	6-1/4	2-1/4	1.1	CMB-29P	‡	.20
	#6-250 kcmil	CM2929P	Z29NR							
	#6-300 kcmil	CM3029P	Z30NR							
	#2-400 kcmil	CM3229P	Z32NR							
	Paper-Lead or Vanished Cambric	#2-500 kcmil	CM3429P	Z34NR	250-600 kcmil	CM3629P	Z36NR			

† Diameter over rubber insulation or lead sheath to be specified by customer.
 ‡ Diameter over lead sheath to be specified by customer.

Bushings must be ordered separately. They are not supplied with the sleeve. The bushing inside diameter is sized in 64ths (e.g., CMB4829R has a 0.750” or 48/64ths inside diameter).

Blue highlighted items are industry standard and most frequently ordered.

TYPE Z-C

**MOLE™ OUTLET
INSULATING SLEEVE**

An effective aid in insulating MOLE™ outlets to produce a secure watertight joint with a minimum of taping. Fits over the MOLE™ outlet and over the maximum outer diameter of insulated cable. The difference between the I.D. of the standard sleeve and the O.D. of the cable insulation is taken up by wrapping the cable with several turns of rubber tape. The only external taping required to effectively seal the joint is the small area at each end of the sleeve.

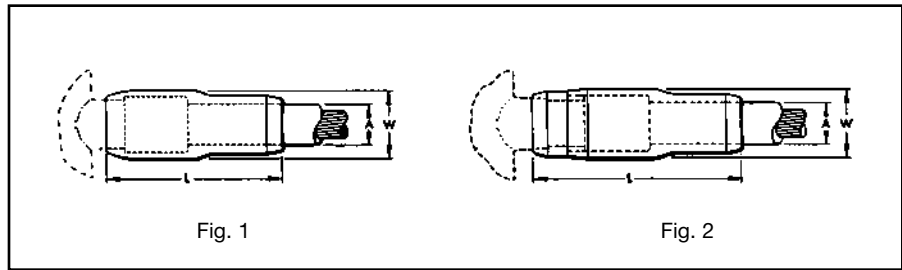

K-36

Catalog Number	For Use with Socket and Nut Assemblies See page K-32	Fig. No.	Dimensions in Inches			Approx. Ship. Wt. in Lbs. per C
			*A (Max.)	L	W	
Z72C3029	Z28NR Z29NR Z30NR	1	1-1/8	4-3/4	1-7/8	20
Z88C3429	Z32NR Z34NR Z34NRB Z36NR	1	1-3/8	5-3/16	2-1/8	30
Z104C4034	Z40NR	1	1-5/8	5-13/16	2-11/6	60
Z104C4434	Z44NR Z40NRA	2	1-5/8	7-3/16	2-11/6	70
Z144C4840	Z45NR Z46NR Z47NR Z48NR	2	2-1/4	9-5/16	3-1/2	130

* Build up insulation of MOLE™ Joint with rubber tape to equal inner diameter of Insulating Sleeve.
For insulating sleeve with inner diameter other than standard call customer service.

Blue highlighted items are industry standard and most frequently ordered.

HYCRAB™ CONNECTORS

One of the most economical devices for connecting several cables to a common junction point is the HYCRAB™, which is essentially a bus bar with a number of compression-type connector outlets, pre-insulated to eliminate taping. Like the MOLE™, the HYCRAB™ fits into a limited space, is simple to rack, and facilitates adding future cables.

Insert and Insulation

Having an insert similar to that of the MOLE™, the HYCRAB™ has connector outlets of the BURNDY® HYDENT™ compression type. These tubular elements are indented to the cable by BURNDY® HYPRESS™ installation tools and dies, designed to compress connector and cable together with indents of controlled depth. HYDENT™ compression connections are made quickly and easily, have relative conductivities of 100% or higher, are electrically stable, and mechanically secure.

The HYCRAB™ is insulated by a jacket of molded rubber to resist prolonged exposure to oil or other contaminants.

Installation

Insulation fingers are rolled back to expose the tubular outlets, sufficiently spaced to allow for the convenient operation of BURNDY® HYPRESS™ compression tools. Cable ends are inserted into the outlets. Each is crimped with one or two indents, and the fingers are rolled forward again to cover the outlets. Installation is completed by taping the short space between the tip of the finger and the cable insulation.

Variations and Accessories

Uninsulated HYCRAB™ connectors for joining bare neutral cables are available in the same range of sizes and number of outlets as the insulated HYCRAB™. By using reducing adapters the HYCRAB™ can accommodate service wires as small as #6, in addition to the 4/0 or 500 kcmil cable sizes for which these connectors are ordinarily used.

Blue highlighted items are industry standard and most frequently ordered.

TYPE YM

INSULATED HYCRAB™

A compact insulated crab joint for connecting underground cables at junction points. Two outlets, one on either side of the HYCRAB™ body are ready for immediate use. All other outlets are sealed with vulcanized rubber plugs which are easily removed when future installations are made. This unit eliminates bulky, difficult crotch taping. By using Reducing Adapters, Type Y-R the HYCRAB™ can be installed on cable sizes from #6 to 500 kcmil (e.g., use Y3428R to install 4/0 into YM4-34).

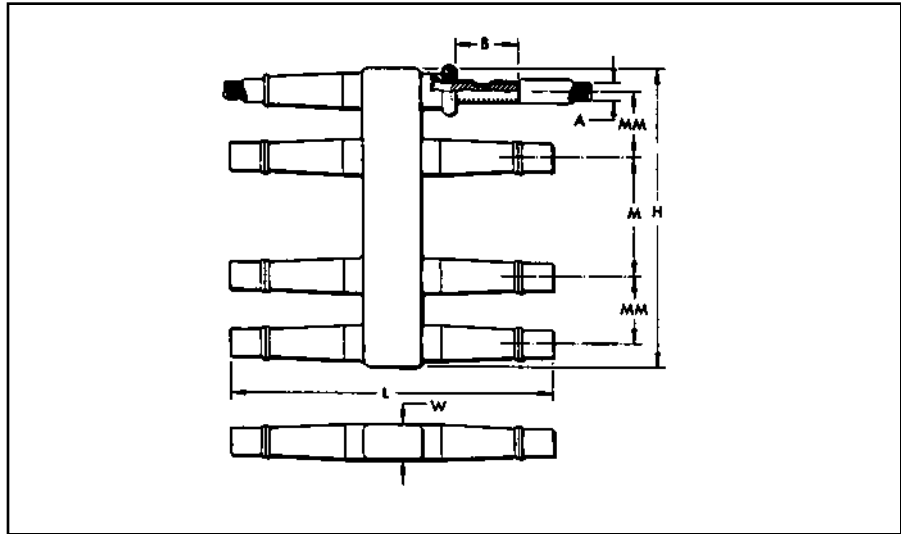

K-38

Cable Size A	No. of Outlets	Catalog Number	Dimensions in Inches						Installation Information			
									HYPRESS™ & Indentor Die		Nest Die	No. of Indents
			Y34A with V34PR	Y34BH with Y34PR								
4/0 Str.	4	YM4-28	2	3-11/16	10-3/16	—	2-3/16	1-1/8	A28D	B28D	1	1.8
	6	YM6-28	2	7-9/16	10-3/16	3-7/8	2-3/16	1-1/8	A28D	B28D	1	3.0
	8	YM8-28	2	9-3/4	10-3/16	3-7/8	2-3/16	1-1/8	A28D	B28D	1	4.3
	10	YM10-28	2	13-1/2	8-3/4	3-1/2	2-1/2	1-1/8	A28D	B28D	1	5.5
500 kcmil	12	YM12-28	2	16	8-3/4	3-1/2	2-1/2	1-1/8	A28D	B28D	1	6.7
	4	YM4-34	2-1/2	4-3/8	12-5/8	—	2-3/8	1-1/2	A34D	No Nest Die	2	4.5
	6	YM6-34	2-1/2	8-5/8	12-5/8	4-1/4	2-3/8	1-1/2	A34D	Die	2	7.0
	8	YM8-34	2-1/2	11	12-5/8	4-1/4	2-3/8	1-1/2	A34D	Required.	2	11
	10	YM10-34	2-1/2	14-1/2	12-1/2	3-3/4	2-1/2	1-1/2	A34D	Use Indentor	2	15
	12	YM12-34	2-1/2	17	12-1/2	3-3/4	2-1/2	1-1/2	A34D	Only.	2	19

Blue highlighted items are industry standard and most frequently ordered.

TYPE YNM

HYCRAB™

For Joining Bare Neutral Cables

A compact uninsulated multiple connector for joining bare neutral underground cables. For insulated crab joints, see HYCRAB™, Type YM. Reducing adapters, Type Y-R, permit the HYCRABS listed below to take a full range of cable sizes from #6 to 500 kcmil. For proper installation, see table below.

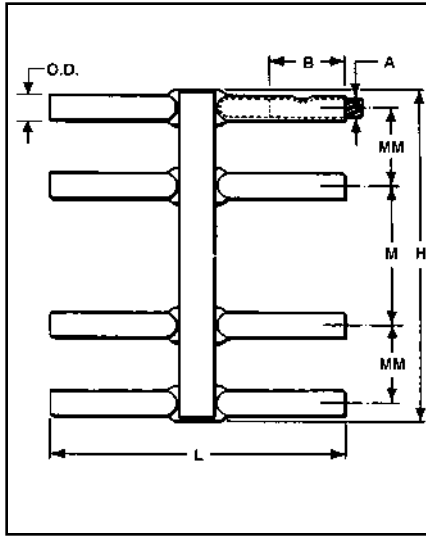

Cable Size A	No. of Outlets	Catalog Number	Dimensions in Inches						Installation Information			App. Ship. Wt. in Lbs.
									HYPRESS™ & Indentor Die		No. of Indents	
			B	H	L	M	MM	O.D.	Y34A with Y34PR	Y34BH with Y34PR		
4/0 Str.	4	YNM4-28	2	3-3/16	8-3/16	—	2-3/16	11/16	A28D	B28D	1	1.0
	6	YNM6-28	2	7-1/16	8-3/16	3-7/8	2-3/16	11/16	A28D	B28D	1	1.8
	8	YNM8-28	2	9-1/4	8-3/16	3-7/8	2-3/16	11/16	A28D	B28D	1	2.5
500 kcmil	4	YNM4-34	2-1/2	3-15/16	10-5/8	—	2-3/8	1-1/16	A34D	No Nest Die Required. Use Indentor Only.	2	3.0
	6	YNM6-34	2-1/2	8-3/16	10-5/8	4-1/4	2-3/8	1-1/16	A34D		2	5.0
	8	YNM8-34	2-1/2	10-9/16	10-5/8	4-1/4	2-3/8	1-1/16	A34D		2	7.3

* Bare Hycrab™ can be furnished to accommodate both 4/0 and 500 kcmil cables.

K-39

Blue highlighted items are industry standard and most frequently ordered.

NETWORK PROTECTION

The primary purpose of network protection is the controlled interruption of fault currents before damage occurs to cable insulations and associated equipment, and the elimination of unnecessary service interruptions. The limiter and fuses for network protection are closely associated with the connectors and are equally vital to the safe, continuous operation of an underground system.

BURNDY® has developed protective devices that have played a major role in reducing underground system outages and the subsequent expenses incurred in the loss of service and replacement of damaged cables. A basic objective has been the design of limiter-connector combinations that, in addition to protecting against the effects of fault currents, economize on both space and installation costs.

Limiters are designed to protect underground secondary cable from damage by fault currents of two principal kinds: high energy arcing faults and sustained faults. The arcing fault, usually of shorter duration and lesser intensity, is more common. While this type of fault may sputter briefly and then clear, some may be sustained long enough to “roast” the insulation.

A sustained fault occurs when two conductors come solidly into contact and permit the flow of heavy short-circuit currents. Without suitable protection, these fault currents are heavy enough to damage cable insulation and often produce combustible fumes accompanied by fire and explosion.

Installed at each end of cable sections, limiters have time-current characteristics designed to avoid unnecessary outages. Network protector fuses, installed in the network protector on the load side of the breaker, provide back-up protection against failure of a network protector to open on a primary fault. Coordinated characteristics of limiters and fuses provide for fault currents to be interrupted before they can cause damage, but only under predetermined time-current conditions, and only in those parts of the system where interruption is necessary.

Limiters

Engineered to interrupt the circuit before cables carrying a fault current are visually damaged, limiters act to confine damage to the section of cable where the fault occurred. The limiters are designed to prevent unnecessary clearing and will “hang on” during:

1. Faults which would clear without damaging cable insulation.
2. Overloads from motor starting, load transfer because of primary fault, or temporary overload during fault conditions.
3. Overloads from loss of secondary conductors caused by clearing of other limiters.
4. Reverse current flow through the network protector on primary faults.
5. Faults on other secondary cables.

K-40

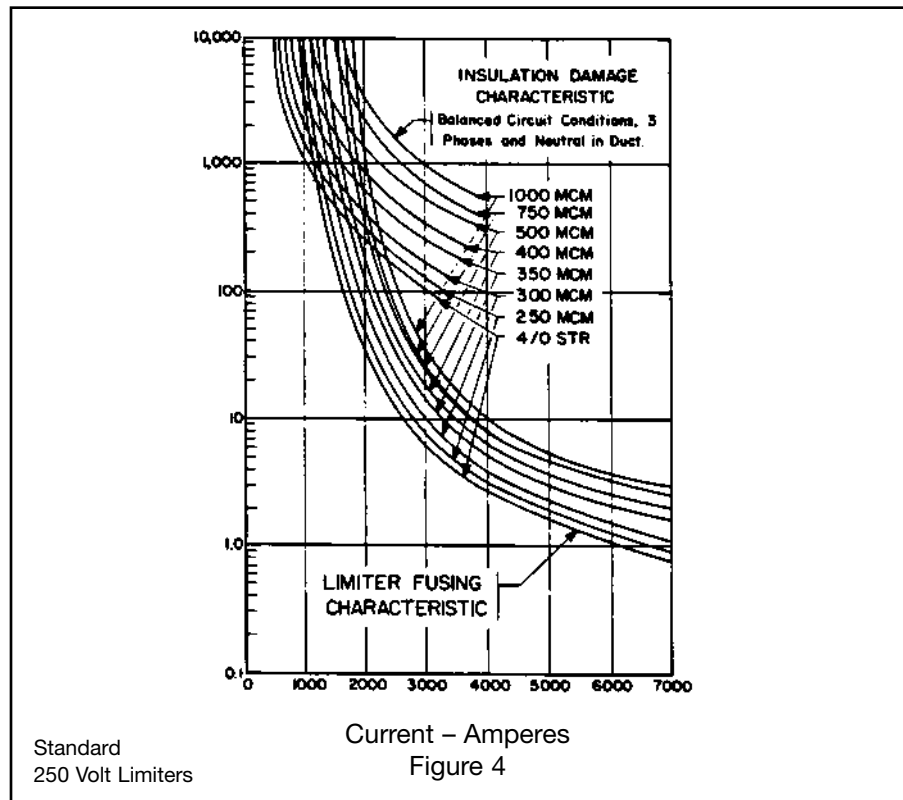

Blue highlighted items are industry standard and most frequently ordered.

NETWORK PROTECTION (Continued)

For proper protection, BURNDY® limiters are designed with time-current characteristics approximating the insulation damage curve of the cable with which they will be used. Figure 4 shows time-current characteristic curves for a range of standard (250 volt) limiters, superimposed on insulation damage curves for several cable sizes. Although the limiter curve crosses the insulation damage curves, in practice the limiters will blow before the insulation can deteriorate. The insulation damage characteristics represent three phases equally loaded in a duct. Since low-current faults seldom affect more than one phase at a time, the rate of heat generated in the conduit is much less than for a balanced 3-phase fault, and the time to reach the damage point is appreciably longer. Practical experience confirms that limiters provide protection during low-current, as well as high-current faults.

Construction

The limiter is essentially a compression-type electrical connector with its center section accurately formed to provide a fusible element. This fusible element is enclosed in a molded composition shell and the assembly encased in an insulated sleeve.

Interrupting capacities are as follows:

- Standard Limiters . . . 30,000 amps at 250V
- Replaceable-link
Limiters 20,000 amps at 250V

The protection probably lies in the fact that the fault impedance reduces the actual fault current to a value considerably less than calculated.

Replaceable-Link Limiters

Replaceable-link limiters, which provide faster time-current characteristics (Figure 5), are used in smaller networks, on the fringes of larger networks, at points where radial feeders leave a network, and for fusing service cables. As its name implies, this limiter is also distinctive in that its fusible link is replaceable.

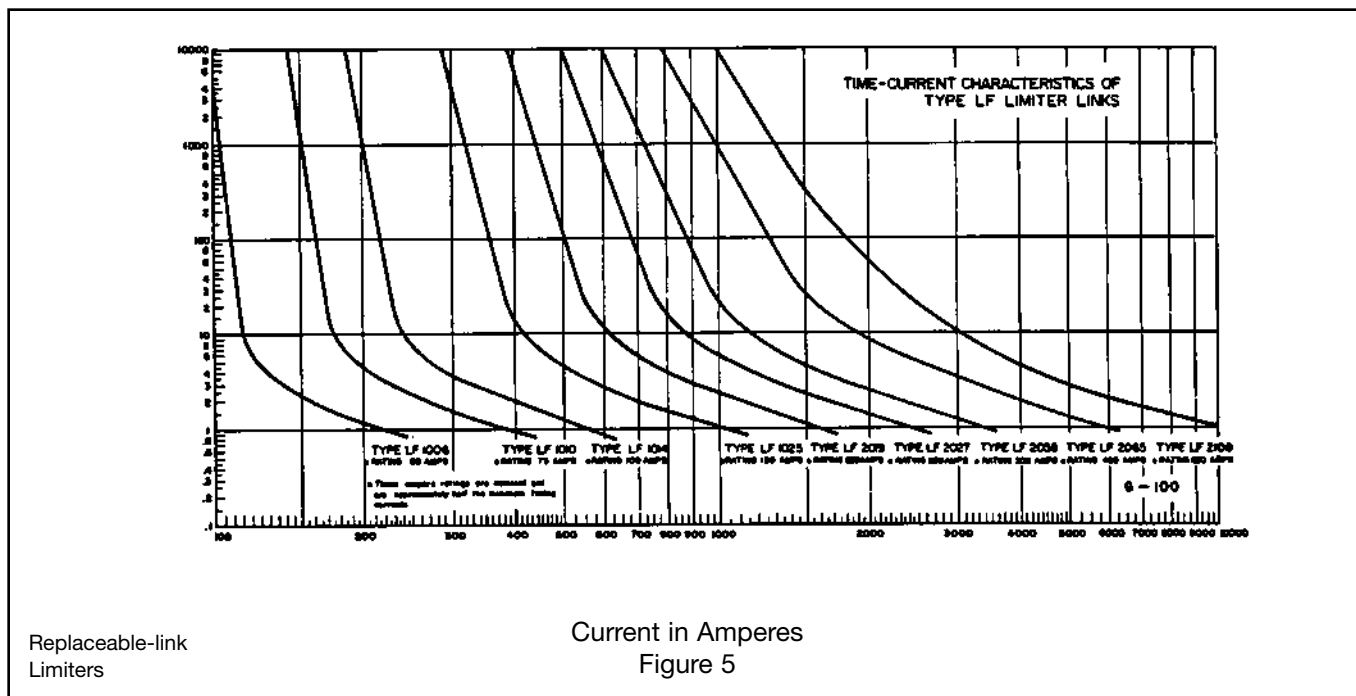

K-41

Blue highlighted items are industry standard and most frequently ordered.

NETWORK PROTECTION (Continued)

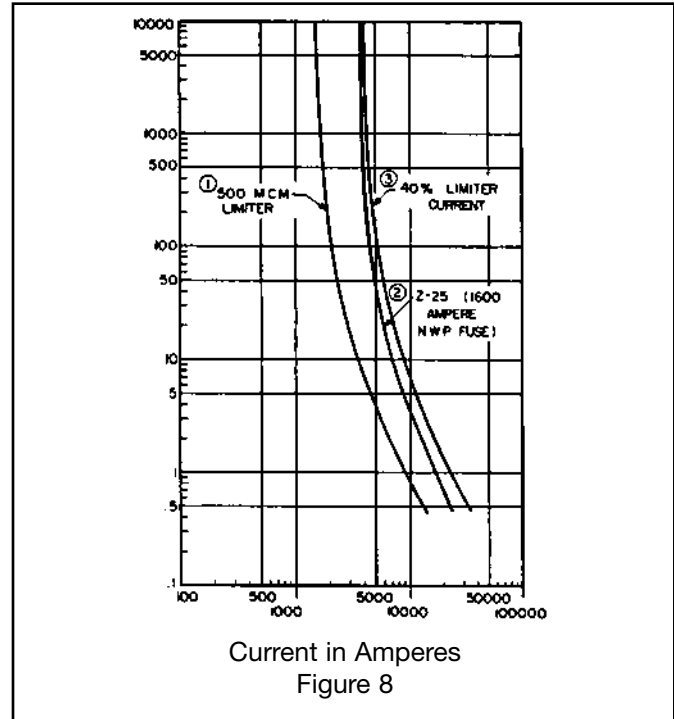
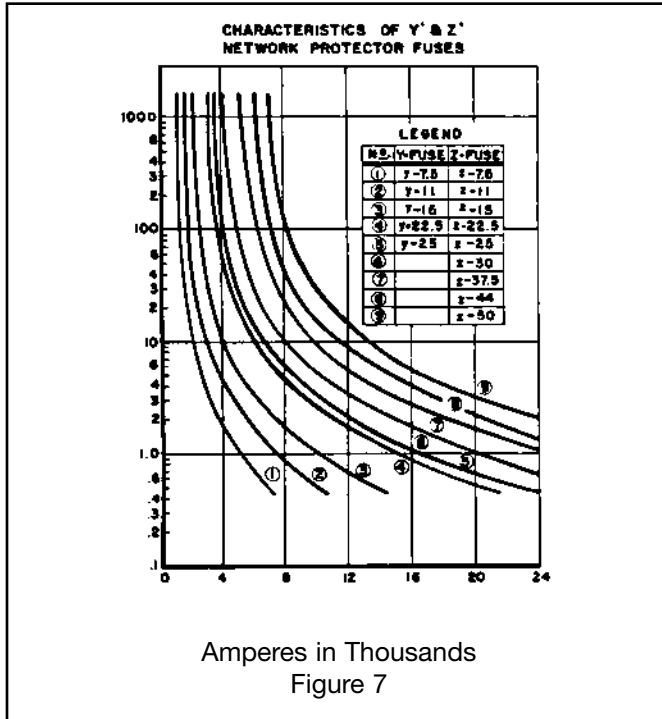

K-42

Limiter Variations

The Limiter Lug provides a fusible connection between a cable and a flat surfaced terminal of a transformer or other apparatus. The Limiter Tap incorporates a Limiter Lug assembly, modified to terminate cable to a ring bus. The straight Limiter is made for installation in a single conductor cable. The Molimiter is a Limiter designed so that one end is crimped onto a cable and the other fits the clamping element of a MOLE™ outlet. The Limiter HYCRAB™ connector is essentially a HYCRAB™ with a fusible section in each of its outlets.

Network Protector Fuses

Type Y and Z Network Protector Fuses provide back-up protection in case the protector breaker fails to operate during a primary fault. The fuse time-current curves (Figure 7), are similar to those of the limiter, thus permitting correct fuse-limiter coordination for complete network protection.

Design and Construction

The fusible element for a Type Y or Type Z Fuse is a tin-plated copper bar with reduced section, encased in an arc-resistant molded transite enclosure. One-piece construction eliminates possibility of joint failure and assures maximum reliability.

Limiter-Fuse Coordination

To isolate a fault before it can cause extensive damage, and without interrupting service in other sections of the network, limiters and fuses must clear at the proper time and in proper sequence, depending on the fault's location in the primary or secondary system. When a primary fault occurs, the fuse should clear before any limiters blow. For a secondary fault, limiters should clear the fault before the network protector fuse opens. Failure of limiters and network protector fuses to function in proper sequence could cause cascading of other Fuses, or clearing of secondary faults by Fuses rather than limiters. Premature blowing of Limiters not in the faulted section could cause unnecessary service interruption in sections remote from the fault.

To assure the coordinated functioning of fuses and limiters throughout a system, proper rating must be selected. The four-step "Coordination Study" (Figure 8) used in a 4-parallel cable feed system from the protector to the first secondary junction is a typical example of how to select proper ratings.

1. Plot the damage characteristic curve of the cable insulation in the system. Curves for Class L620 (260° C. or 500° F.), appear in (Figure 5).

2. Plot the time-current characteristic curve of the limiter for the cable size in the system.
3. Plot the time-current characteristic curve of the same limiter in Parallel secondary mains, assuming it carries 40% of total backfeed current. Allowing for the possibility of unequal current distribution of secondary mains, the "40% Cable Limiter Curve" provides a conservative basis for selection network protector fuses.
4. Select a fuse with its time-current characteristics (Figure 7) lying between the limiter curves plotted in steps 2 and 3.

This procedure avoids the selection of fuses so light that they might overheat the network protector or clear unnecessarily, possibly cascading other fuses in the network; or so heavy that transformer secondaries might be damaged or limiters blow before the fuse. Proper limiter-fuse coordination, facilitated by the use of fuses and limiters that are precisely matched, assures effective protection without unnecessary interruption.

Blue highlighted items are industry standard and most frequently ordered.

TYPES YFS-CR AND YFS-CP

LIMITER ASSEMBLY

With DURICOMP™ Shell and Rubber Sleeve for Insulated Cables

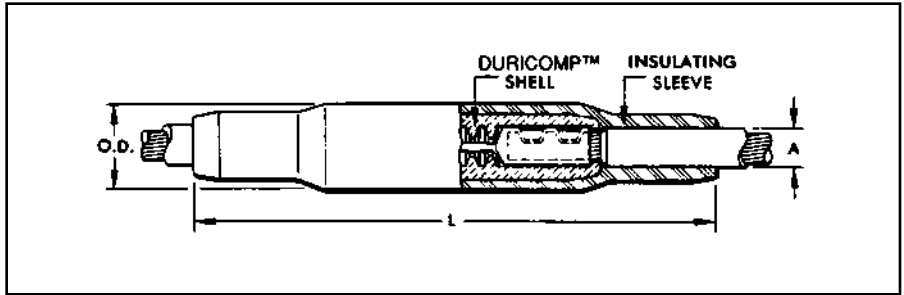

The Limiter combines the functions of tuse and connector. The fusible element which is an integral part of the connector will clear faults that are great enough to cause damage to the cable insulation. However it will not clear on minor overloads of short duration. Fusing characteristics of the limiter are shown in technical section. For HYPRESS™ installation, see table below.

Cable Size	For Use on Rubber Insulated Cable Catalog Number	For Use on Paper Insulated Cable-Oil Tight Cable Sockets Catalog Number	Dimensions in Inches			Installation Information				
			Max. Cable Dia. over Insulation A	L	O.D.	HYPRESS™ and Indentor Die			Number of Indents	App. Ship. Wt. in Lbs.
						Y34A with Y34PR	Y34BH with Y34PR	Y44B with Y44PR		
4/0 Str.	YFS28CR	YFS28CP	1	12-3/4	1-15/16	A28D	B28D	E28D	1	1.4
250 kcmil	YFS29CR	YFS29CP	1	12-3/4	1-15/16	A29P	B29D	E29D	1	1.4
300 kcmil	YFS30CR	YFS30CP	1-1/8	13-1/2	2-3/16	A30D	B30D	E30D	2	2.0
350 kcmil	YFS31CR	YFS31CP	1-1/8	13-1/2	2-3/16	A31D	B31D	E31D	2	2.0
400 kcmil	YFS32CR	YFS32CP	1-1/8	13-1/2	2-3/16	A32D	B32D	E32D	2	2.1
500 kcmil	YFS34CR	YFS34CP	1-11/32	15-7/8	2-3/8	A34D	No Nest Die Required	E34D	2	2.9
750 kcmil	YFS39CR	YFS39CP	1-1/2	15-9/16	2-9/16	—	—	E39D	2	3.7

For conductor sizes not listed call customer service.
 DURICOMP™ acquired July 1990. Replaces ASBESTITE and the Generic Refractory references.
 To specify a fast acting limiter in any configuration insert an "F" before the conductor number (e.g., YFSE34CR specifies a 1/2 thick limiter section).

K-43

Blue highlighted items are industry standard and most frequently ordered.

TYPE YFS-CPL

LONG LIMITER ASSEMBLY

With DURICOMP™ Shell and Rubber Sleeve for Paper-Lead Cables

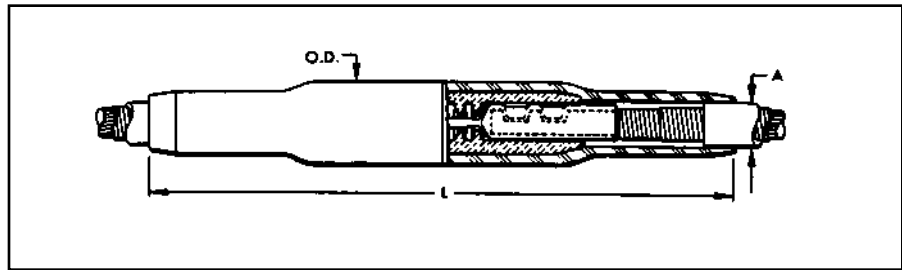

The Long Limiter performs the same functions as the Limiter shown on opposite page. It differs in that it has extra long cable sockets which are preferred by some for use on paper insulated cable. The end seams are sealed to make the sockets oil tight. Fusing characteristics of the Limiter are shown in technical section. For proper HYPRESS™ installation, see table below.

Cable Size	Catalog Number	Dimensions in Inches			Installation Information			Number of Indents	App. Ship Wt. in Lbs.
		Max. Cable Dia. Over Insul. A	L	O.D.	HYPRESS™ and Indentor				
					Y34A with Y34PR	Y34BH with Y34PR	Y44B with Y44PR		
4/0 Str.	YFS28CPL	1	12-3/4	1-15/16	A28D	B28D	E28D	1	1.5
250 kcmil	YFS29CPL	1	12-3/4	1-15/16	A29P	B29D	E29D	1	1.5
300 kcmil	YFS30CPL	1-1/8	13-1/2	2-3/16	A30D	B300	E30D	2	2.2
350 kcmil	YFS31CPL	1-1/8	13-1/2	2-3/16	A31D	B31D	E31D	2	2.2
400 kcmil	YFS32CPL	1-1/8	13-1/2	2-3/16	A32D	B32D	E32D	2	2.3
500 kcmil	YFS34CPL	1-11/32	15-7/8	2-3/8	A34D	No Nest Die Required	E34D	2	3.2
750 kcmil	YFS39CPL	1-1/2	15-9/16	2-9/16	—	—	E39D	2	4.1

For conductor sizes not listed call customer service. To specify a fast acting limiter in any configuration insert an "F" before the conductor number (example: YFSE34CR specifies and 1/2 thick limiter section).

K-44

Blue highlighted items are industry standard and most frequently ordered.

TYPES YFSR, YFSP

LIMITER

For Use with Limiter Assembly

The Limiter serves the double function of a fuse and a coupler. The fusible element is an integral part of the coupler and is closely and carefully sized to insure excellent performance. Fusing characteristics of the Limiter are

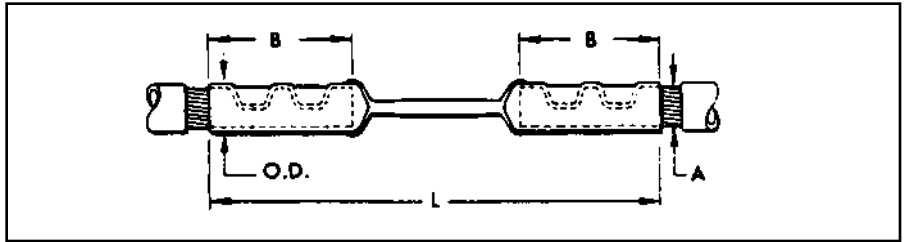

shown in technical section. For proper HYPRESS™ installation, see table below.

Cable Size	For Use on Rubber Insulated Cable Catalog Number	For Use on Paper Insulated Cable-Oil Tight Cable Sockets Catalog Number	Dimensions in Inches			Installation Information				App. Ship. Wt. in Lbs.
						HYPRESS™ and Indentor Die			Number of Indents	
			B	L	O.D.	Y34A with Y34PR	Y34BH with Y34PR	Y44B with Y44PR		
4/0 Str.	YFSR28	YFSP28	1-3/4	6-3/8	11/16	A28D	B28D	E28D	1	.23
250 kcmil	YFSR29	YFSP29	1-7/8	6-3/8	3/4	A29D	B29D	E29D	1	.27
300 kcmil	YFSR30	YFSP30	2	6-3/4	13/16	A30D	B30D	E30D	2	.33
350 kcmil	YFSR31	YFSP31	2	6-3/4	7/8	A31D	B31D	E31D	2	.37
400 kcmil	YFSR32	YFSP32	2-1/8	7	31/32	A32D	B32D	E32D	2	.46
500 kcmil	YFSR34	YFSP34	2-7/8	8-3/4	1-1/16	A34D	No Nest Die Required	E34D	2	.79
750 kcmil	YFSR39	YFSP39	2-7/8	9	1-5/16	—	—	E39D	2	1.2

TYPE YFSP-L

LONG LIMITER

For Use with Long Limiter Assembly

The Long Limiter serves the same purpose as the Limiter shown above but has extra long oil tight cable sockets which may be preferred by some for use on paper insulated cables. Similarly designed to clear on overloads that will damage the insulation of the

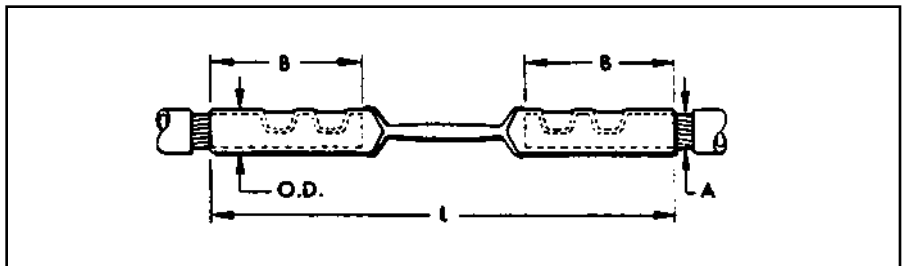

cable. Fusing characteristics of the Long Limiter are shown in technical section. For HYPRESS™ installation, see table below.

Cable Size	Catalog Number	Dimensions in Inches			Installation Information				App. Ship. Wt. in Lbs.
					HYPRESS™ and Indentor			Number of Indents	
		B	L	O.D.	Y34A with Y34PR	Y34BH with Y34PR	Y44B with Y44PR		
4/0 Str.	YFSP28L	2-15/16	8-3/4	11/16	A28D	B28D	E28D	1	.34
250 kcmil	YFSP29L	3-1/16	8-3/4	3/4	A29D	B29D	E29D	1	.40
300 kcmil	YFSP30L	3-3/8	9-1/2	13/16	A30D	B30D	E30D	2	.50
350 kcmil	YFSP31L	3-3/8	9-1/2	7/8	A31D	B31D	E31D	2	.58
400 kcmil	YFSP32L	3-3/8	9-1/2	31/32	A32D	B32D	E32D	2	.68
500 kcmil	YFSP34L	4-3/16	11-3/8	1-1/16	A34D	No Nest Die Required	E34D	2	1.1
750 kcmil	YFSP39L	4-3/16	11-5/8	1-5/16	—	—	E39D	2	1.6

For conductor sizes not listed call customer service.

Blue highlighted items are industry standard and most frequently ordered.

TYPES YFSH, YFSH-P

DURICOMP™ LIMITER SHELL

For Use with Limiter Assemblies

A molded composition shell in which heat-proof barriers restrain the arc which is formed when the fusible section of the Limiter melts under overload conditions. Shells may be ordered separately to replace those damaged in service. Contains no asbestos.

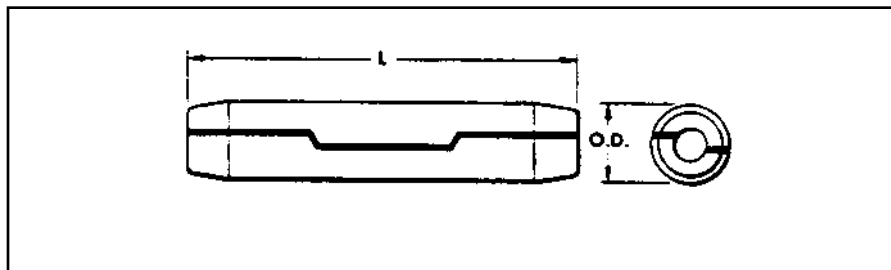

Cable Range	For Use on Rubber Insulated Cable Catalog Number	For Use on Paper Insulated Cable Long and Short Socket Type Catalog Number	Dimensions in Inches		App. Ship. Wt. in Lbs.
			L	O.D.	
4/0 Str. to 250 kcmil	YFSH2829	YFSH2829P	6-3/4	1-7/16	.50
300 kcmil to 400 kcmil	YFSH3032	YFSH3032P	7-1/2	1-11/16	.76
500 kcmil	YFSH34	YFSH34P	9-3/8	1-7/8	1.0
750 kcmil	YFSH39	YFSH39P	9	2-1/16	1.1

K-46

TYPE YFSC

INSULATING SLEEVE

For Use with Limiter Assemblies

A molded sleeve for insulating the Limiter and DURICOMP™ Shell Assembly. Molded in two sections, its use simplifies the insulation of the assembly.

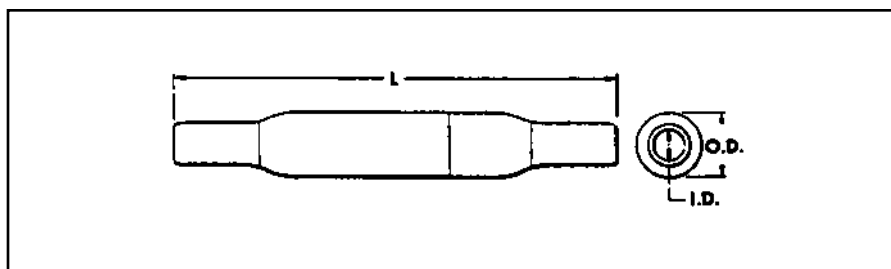

Cable Range	Catalog Number	Dimensions in Inches			App. Ship. Wt. in Lbs.
		I.D.	L	O.D.	
4/0 Str. to 250 kcmil	YFSC6429	1	12-3/4	1-15/16	.62
300 kcmil to 400 kcmil	YFSC7232	1-1/8	13-1/2	2-3/16	.86
500 kcmil	YFSC8634	1-11/32	15-7/8	2-3/8	1.1
750 kcmil	YFSC9639*	1-1/2	15-9/16	2-9/16	1.4

* YFSC9639 is straight tubular sleeve with two bushings. For conductor sizes or sleeve inside diameters not listed call customer service.

Blue highlighted items are industry standard and most frequently ordered.

**TYPES YFA-CR,
YFA-CP**

LIMITER LUG ASSEMBLY

With DURICOMP™ Shell and Rubber Sleeve

The Limiter Lug combines the functions of terminal and fuse. The fusible element is an integral part of the connector and is so designed that it will clear overloads which are great enough to cause damage to the cable insulation. Unlike an ordinary fuse, however, it will not clear on minor overloads of short duration. Fusing characteristics of the Limiter Lugs are shown in the technical section. Component parts shown in the table below may be purchased separately. For proper HYPRESS™ installation, see table below.

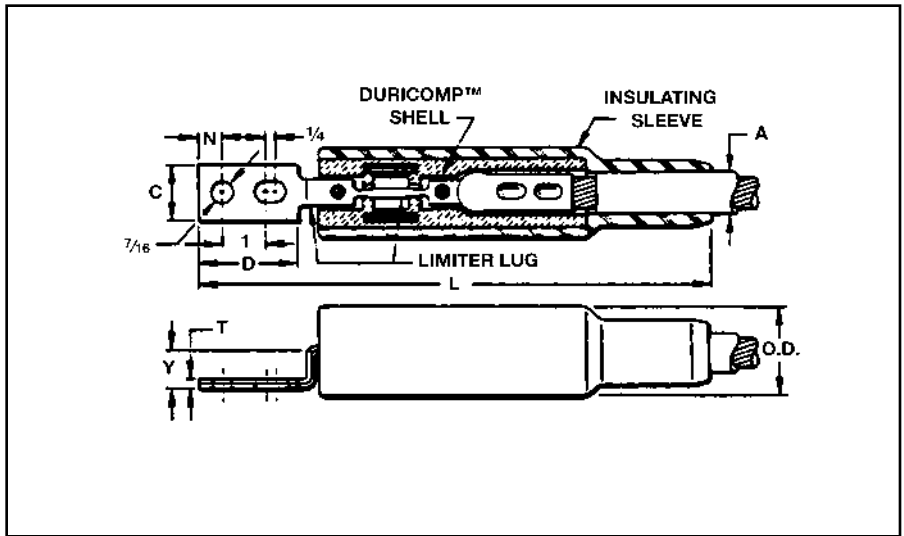

Cable Size	For Use on Rubber Insul. Cable Catalog No.	For Use on Paper Insul. Cable-Oil Tight Cable Socket Catalog No.	Dimensions in Inches								Installation Information				App. Wt. in Lbs.
			(Max. Cable Dia. over Insul.) A	C	D	L	N	T	Y	O.D.	HYPRESS™ & Indentor Die			No. of Indents	
											Y34A with Y34PR	Y34BH with Y34PR	Y44B with Y44PR		
4/0 Str.	YFA28CR-2	YFA28CP-2	1	1	2-3/16	11-9/16	7/16	9/64	27/32	1-15/16	A28D	B28D	E28D	1	1.2
250 kcmil	YFA29CR-2	YFA29CP-2	1	1-1/8	2-3/16	11-9/16	7/16	5/32	27/32	1-15/16	A29D	B29D	E29D	1	1.2
300 kcmil	YFA30CR-2	YFA30CP-2	1-7/32	1-3/16	2-5/16	13-3/16	1/2	5/32	1	2-3/8	A30D	B30D	E30D	2	1.8
350 kcmil	YFA31CR-2	YFA31CP-2	1-7/32	1-5/16	2-5/16	13-3/16	1/2	3/16	1	2-3/8	A31D	B31D	E31D	2	2.2
400 kcmil	YFA32CR-2	YFA32CP-2	1-7/32	1-7/16	2-5/16	13-3/16	1/2	3/16	1	2-3/8	A32D	B32D	E32D	2	2.3
500 kcmil	YFA34CR-2	YFA34CP-2	1-11/32	1-1/2	2-3/4	13-5/8	1/2	7/32	1	2-3/8	A34D	No Nest Die Req'd.	E34D	2	2.5
750 kcmil	YFA39CR-2	YFA39CP-2	1-1/2	1-15/16	2-3/4	13-5/8	1/2	1/4	1	2-3/8	—	—	E39D	2	2.8

For conductor sizes not listed call customer service. To specify a fast acting limiter in any configuration insert an "F" before the conductor number (example: YFSE34CR specifies and 1/2 thick limiter section).

K-47

Blue highlighted items are industry standard and most frequently ordered.

TYPE YFA-CPL

LONG LIMITER LUG ASSEMBLY

With DURICOMP™ Shell and Rubber Sleeve — for Paper-Lead Cables

A Limiter Lug similar to Type YFA-CR or YFA-CP shown on page 47. In this case, however, we supply an extra long cable socket which is sometimes preferred for use on paper insulated cable. The end seams are sealed to make sockets oil tight. Fusing characteristics of the Limiter Lugs are shown in the technical section. For proper HYPRESS™ installation, see table below.

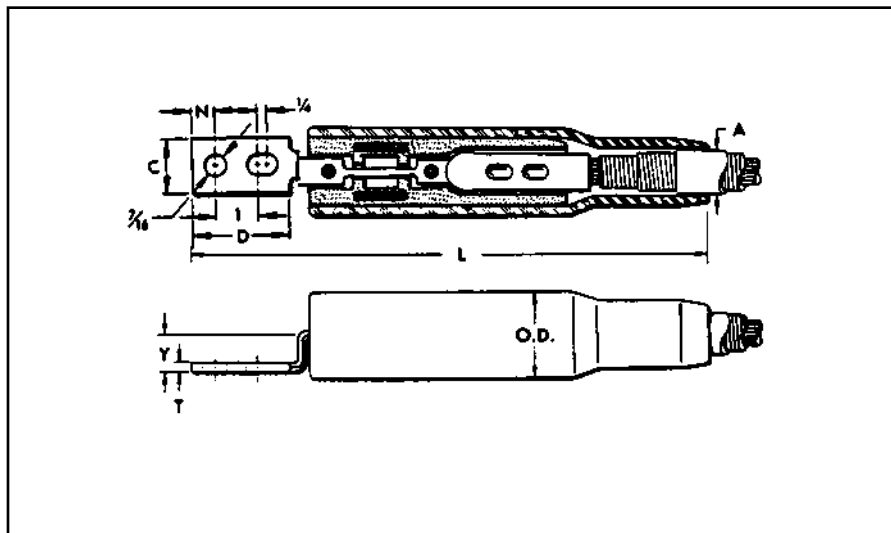

Cable Size	Catalog Number	(Max. Cable Dia. over Insul.) A	Dimensions in Inches								No of Indents in Cable Socket	Installation Information				App. Wt. in Lbs.
			C	D	L	N	T	Y	O.D.	HYPRESS™ & Indentor Die			No. of Indents			
										Y34A with Y34PR		Y34BH with Y34PR		Y44B with Y44PR		
4/0 Str.	YFA28CPL-2	1	1	2-3/16	11-9/16	7/16	9/64	27/32	1-15/16	1	A28D	B28D	E28D	1	1.2	
250 kcmil	YFA29CPL-2	1	1-1/8	2-3/16	11-9/16	7/16	5/32	27/32	1-15/16	1	A29D	B29D	E29D	1	1.3	
300 kcmil	YFA30CPL-2	1-7/32	1-3/16	2-5/16	13-3/16	1/2	5/32	1	2-3/8	2	A30D	B30D	E30D	2	1.9	
350 kcmil	YFA31CPL-2	1-7/32	1-5/16	2-5/16	13-3/16	1/2	3/16	1	2-3/8	2	A31D	B31D	E31D	2	2.3	
400 kcmil	YFA32CPL-2	1-7/32	1-7/16	2-5/16	13-3/16	1/2	3/16	1	2-3/8	2	A32D	B32D	E32D	2	2.4	
500 kcmil	YFA34CPL-2	1-11/32	1-1/2	2-3/4	13-5/8	1/2	7/32	1	2-3/8	2	A34D	No Nest Die Req'd.	E34D	2	2.7	
750 kcmil	YFA39CPL-2	1-1/2	1-15/16	2-3/4	13-5/8	1/2	1/4	1	2-3/8	2	—	—	E39D	2	3.1	

For conductor sizes not listed call customer service.
To specify a fast acting limiter in any configuration insert an "F" before the conductor number (e.g., YFSE34CR specifies a 1/2 thick limiter section).

Blue highlighted items are industry standard and most frequently ordered.

TYPES YFAR, YFAP

LIMITER LUG

For Use with Limiter Lug Assembly

The Limiter Lug incorporates an accurately determined fusible section as an integral part with its terminal end. The fusible section is so selected that it will prevent the cable from roasting or damage from a short circuit, although it will not clear on minor overloads of short duration not harmful to cable insulation. For proper HYPRESS™ installation, see table below.

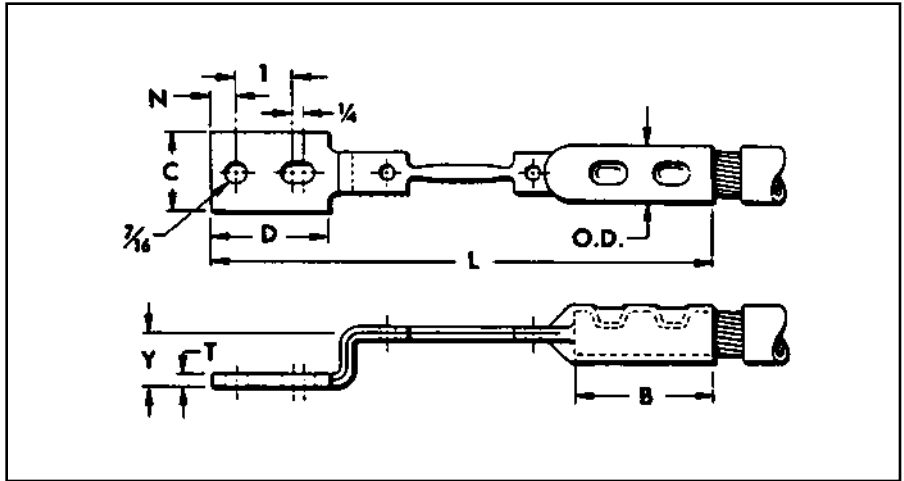

Cable Size	For Use on Rubber Insul. Cable Catalog No.	For Use on Paper Insul. Cable-Oil Tight Cable Socket Catalog No.	Dimensions in Inches								Installation Information				App. Wt. in Lbs.
			B	C	D	L	N	T	Y	O.D.	HYPRESS™ & Indentor Die			No. of Indents	
											Y34A with Y34PR	Y34BH with Y34PR	Y44B with Y44PR		
4/0 Str.	YFAR28-2	YFAP28-2	1-7/8	1	2-3/16	8-1/4	7/16	9/64	27/32	11/16	A28D	B28D	E28D	1	.28
250 kcmil	YFAR29-2	YFAP29-2	1-7/8	1-1/8	2-3/16	8-1/4	7/16	5/32	27/32	3/4	A29D	B29D	E29D	1	.33
300 kcmil	YFAR30-2	YFAP30-2	2	1-3/16	2-5/16	8-7/8	1/2	5/32	1	13/16	A30D	B30D	E30D	2	.42
350 kcmil	YFAR31-2	YFAP31-2	2	1-5/16	2-5/16	8-7/8	1/2	3/16	1	7/8	A31D	B31D	E31D	2	.46
400 kcmil	YFAR32-2	YFAP32-2	2-1/8	1-7/16	2-5/16	9	1/2	3/16	1	31/32	A32D	B32D	E32D	2	.55
500 kcmil	YFAR34-2	YFAP34-2	2-9/16	1-1/2	2-3/4	10	1/2	7/32	1	1-1/16	A34D	No Nest Die Req'd.	E34D	2	.83
750 kcmil	YFAR39-2	YFAP39-2	2-1/2	1-15/16	2-3/4	10	1/2	1/4	1	1-5/16	—	—	E39D	2	1.2

For conductor sizes not listed call customer service.

K-49

Blue highlighted items are industry standard and most frequently ordered.

TYPE YFAP-L

LONG LIMITER LUG

For Use with Long Limiter Lug Assembly

Similar to Limiter Lug Types YFAR and YFAP, except that this type provides a long oil tight cable socket, preferred by some users of paper-insulated cables. Fusing characteristics shown in technical section. For HYPRESS™ installation, see table below.

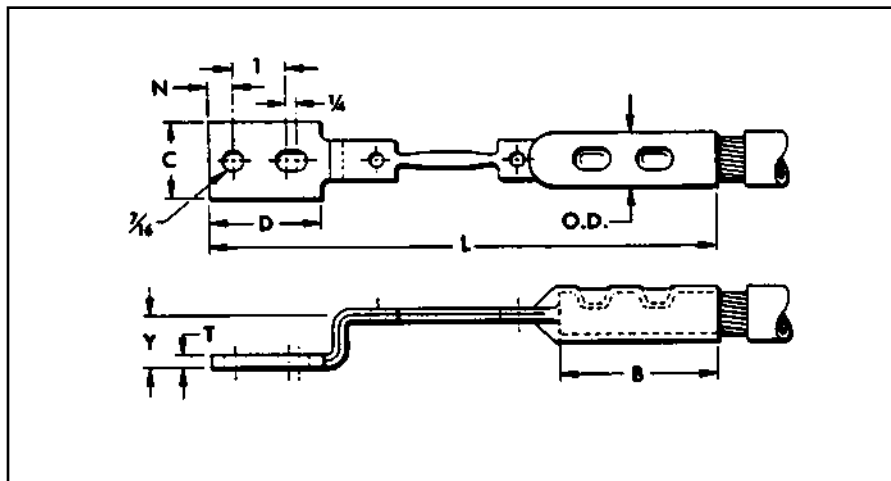

Cable Size	Catalog Number	Dimensions in Inches								Installation Information				App. Ship. Wt. in Lbs.
		B	C	D	L	N	T	Y	O.D.	HYPRESS™ & Indentor Die			No. of Indents	
										Y34A with Y34PR	Y34BH with Y34PR	Y44B with Y44PR		
4/0 Str.	YFAP28L-2	3-9/16	1	2-3/16	9-15/16	7/16	9/64	27/32	11/16	A28D	B28D	E28D	1	.36
250 kcmil	YFAP29L-2	3-9/16	1-1/8	2-3/16	9-15/16	7/16	5/32	27/32	3/4	A29D	B29D	E29D	1	.42
300 kcmil	YFAP30L-2	3-11/16	1-3/16	2-5/16	10-9/16	1/2	5/32	1	13/16	A30D	B30D	E30D	2	.52
350 kcmil	YFAP31L-2	3-11/16	1-5/16	2-5/16	10-9/16	1/2	3/16	1	7/8	A31D	B31D	E31D	2	.58
400 kcmil	YFAP32L-2	3-13/16	1-7/16	2-5/16	10-11/16	1/2	3/16	1	31/32	A32D	B32D	E32D	2	.70
500 kcmil	YFAP34L-2	4-1/4	1-1/2	2-3/4	11-11/16	1/2	7/32	1	1-1/16	A34D	No Nest Die Req'd.	E34D	2	1.0
750 kcmil	YFAP39L-2	4-3/16	1-15/16	2-3/4	11-11/16	1/2	1/4	1	1-5/16	—	—	E39D	2	1.5

For further information call customer service.

K-50

Blue highlighted items are industry standard and most frequently ordered.

TYPE YFAH

DURICOMP™ LIMITER SHELL

For Use with Limiter Lug Assemblies

A composite shell composed of two halves with heat proof arcing chamber to confine and break the fusing arc. Shells may be ordered separately to replace those damaged in service. Contains no asbestos.

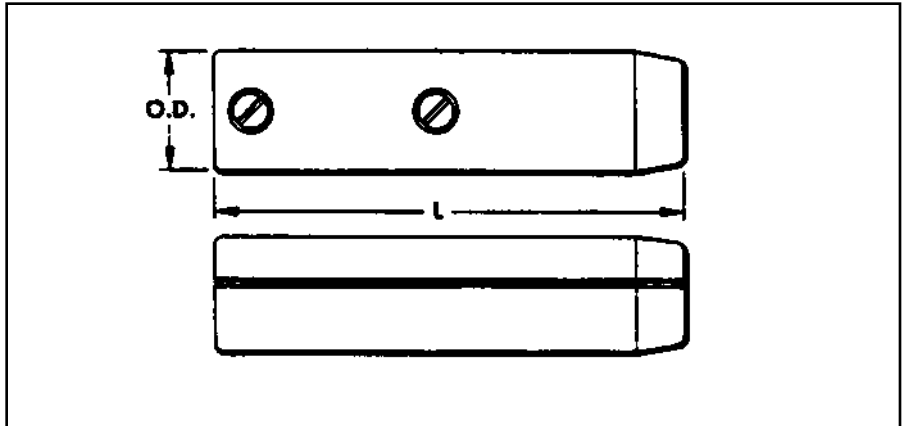

Cable Range	Catalog Number	Dimensions in Inches		App. Ship.
		L	O.D	Wt. in Lbs.
4/0 Str. to 250 kcmil	YFAH2829	5-11/16	1-7/16	.50
300 kcmil to 400 kcmil	YFAH34	7-1/8	1-7/8	.92
750 kcmil	YFAH39*	7-1/8	1-7/8	.92

* Note: Replacement screws a #10 x 32 x 1" standard roundhead.

TYPE YFAC

INSULATING SLEEVES

For Use with Limiter Lug Assemblies

A molded sleeve for insulating the Limiter Lug and shell assembly. Fitting closely over the shell, the problem of insulating the assembly is greatly simplified.

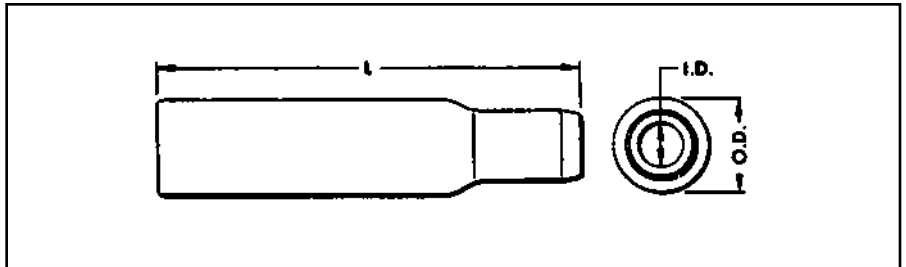

Cable Range	Catalog Number	Dimensions in Inches			App. Ship.
		I.D.	L	O.D	Wt. in Lbs.
4/0 Str. to 250 kcmil	YFAC6429	1	9-3/4	1-7/8	.37
300 kcmil to 400 kcmil	YFAC7834	1-7/32	10-3/8	2-3/8	.77
500 kcmil	YFAC8634	1-11/32	10-3/8	2-3/8	.75
750 kcmil	YFAC9634	1-1/2	10-3/8	2-3/8	.72

For conductor sizes not listed call customer service.

K-51

Blue highlighted items are industry standard and most frequently ordered.

TYPES YFM-CR, YFM-CP

MOLIMITER™ ASSEMBLY

With DURICOMP™ Shell and Rubber Sleeve for Insulated Cables

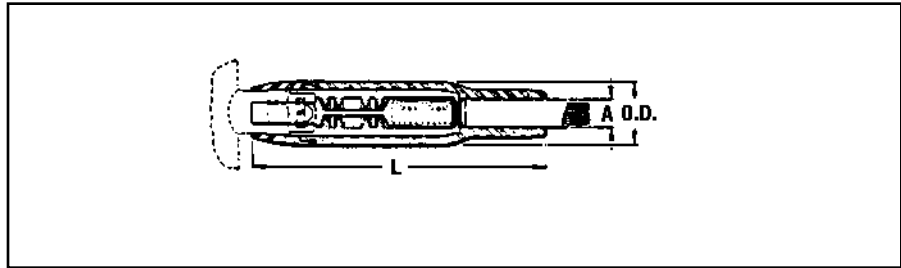

The MOLIMITER™ is used for fusing underground cables at junction points. The unit is designed for use with the BURNDY® MOLE™ and provides Limiter protection for cables

which terminate at the MOLE™. The cable end is installed in the MOLIMITER™ cable socket (see Installation Information in table below) and then the MOLE™ end is installed

in the MOLE™ outlet Socket and Nut assembly. MOLIMITERS which have burned clear may be quickly replaced. For time current characteristics see the technical section.

Cable Size	For Use on Rubber Insulated Cable Catalog No.	For Use on Paper Insulated Cable-Oil Tight Cable Socket Catalog No.	Dimensions in Inches			For Connection to MOLE™ Use		MOLE™ Outlet Size	Installation Information				App. Ship Wt. in Lbs.
			(Max. Cable Dia. Over Insul.) A	L	O.D.	Socket and Nut Assembly See Page K-32	Z Cone See Page K-33		HYPRESS™ & Indentor Die			Number of Indents	
									Y34A with Y34PR	Y34BH with Y34PR	Y44B with Y44R		
									Nest Die				
4/0 Str.	YFM28CR	YFM28CP	1	9-3/4	1-7/8	Z28NR	Z2828	A	A28D	B28D	E28D	1	1.1
250 kcmil	YFM29CR	YFM29CP	1	9-3/4	1-7/8	Z29NR	Z2929	A	A29D	B29D	E29D	1	1.1
300 kcmil	YFM30CR	YFM30CP	1-1/8	10-5/16	2-3/16	Z30NR	Z3030	A	A30D	B30D	E30D	2	1.7
350 kcmil	YFM31CR	YFM31CP	1-1/8	10-5/16	2-3/16	Z32NR	Z3132	A	A31D	B31D	E31D	2	1.8
400 kcmil	YFM32CR	YFM32CP	1-1/8	10-5/16	2-3/16	Z32NR	Z3232	A	A32D	B32D	E32D	2	1.9
500 kcmil	YFM34CR	YFM34CP	1-11/32	11-11/16	2-3/8	Z34NR	Z3434	A	A34D	No Nest Die Req'd.	E34D	2	2.6
750 kcmil	YFM39CR	YFM39CP	1-1/2	12-3/16	2-9/16	Z34NRB	Z3434	B	—	—	E39D	2	3.4

K-52

TYPE YFM-CPL

LONG MOLIMITER™ ASSEMBLY

With DURICOMP™ Shell and Rubber Sleeve for Paper-Lead Cables

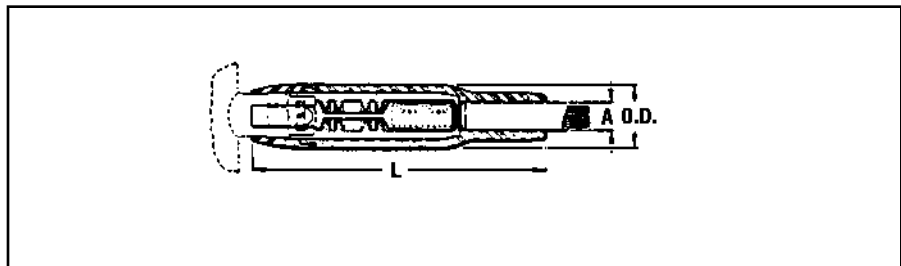

The Long MOLIMITER™ differs from the standard MOLIMITER™ only in its extra long cable socket. This socket, with the end seam

sealed oil tight, is preferred by some for use on paper insulated cables. Time-current characteristics are shown in the technical section.

For proper HYPRESS™ installation, see table below.

Cable Size	Catalog Number	Dimensions in Inches			For Connection to MOLE™ Use		MOLE™ Outlet Size	Installation Information				Ship Wt. in Lbs.
		(Max. Cable Dia. Over Insul.) A	L	O.D.	Socket and Nut Assembly See Page K-32	Z Cone See Page K-33		HYPRESS™ & Indentor Die			Number of Indents	
								Y34A with Y34PR	Y34BH with Y34PR	Y44B with Y44R		
								Nest Die				
4/0 Str.	YFM28CPL	1	9-3/4	1-7/8	Z28NR	Z2828	A	A28D	B28D	E28D	1	1.0
250 kcmil	YFM29CPL	1	9-3/4	1-7/8	Z29NR	Z2929	A	A29D	B29D	E29D	1	1.0
300 kcmil	YFM30CPL	1-1/8	10-5/16	2-3/16	Z30NR	Z3030	A	A30D	B30D	E30D	2	1.7
350 kcmil	YFM31CPL	1-1/8	10-5/16	2-3/16	Z32NR	Z3132	A	A31D	B31D	E31D	2	1.7
400 kcmil	YFM32CPL	1-1/8	10-5/16	2-3/16	Z32NR	Z3232	A	A32D	B32D	E32D	2	1.8
500 kcmil	YFM34CPL	1-11/32	11-11/16	2-3/8	Z34NR	Z3434	A	A34D	No Nest Die Req'd.	E34D	2	2.5
750 kcmil	YFM39CPL	1-1/2	12-3/16	2-9/16	Z34NRB	Z3434	B	—	—	E39D	2	3.2

For conductor sizes not listed call customer service.

TYPES YFMR, YFMP

MOLIMITER™

For Use with MOLIMITER™ Assembly

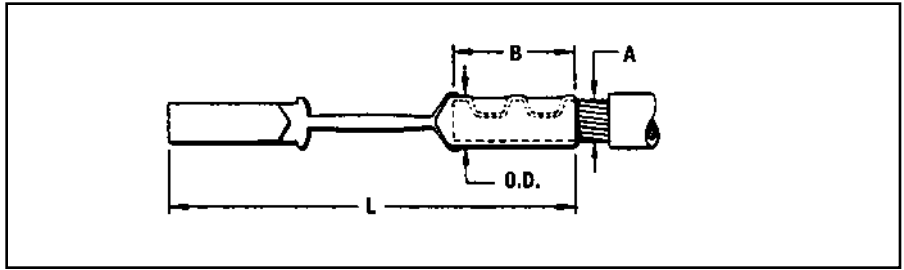

The MOLIMITER™ combines an accurately determined fusible section with both a MOLE™ Socket end and a cable socket. Designed to clear on overloads that would injure the cable insulation, the MOLIMITER™

may be easily and quickly replaced. For time current characteristics of MOLIMITERS see

the technical section. For proper HYPRESS™ installation, see table below.

Cable Size A	For Use on Rubber Insulated Cable Catalog No.	For Use on Paper Insulated Cable-Oil Tight Cable Socket Catalog No.	Dimensions in Inches			For Connection to MOLE™ Use		MOLE™ Outlet Size	Installation Information				App. Ship Wt. in Lbs.
			B	L	O.D.	Socket and Nut Assembly See Page 32	Z Cone See Page 33		HYPRESS™ & Indentor Die			Number of Indents	
									Y34A with Y34PR	Y34BH with Y34PR	Y44B with Y44R		
									Nest Die				
4/0 Str.	YFMR28	YFMP28	1-7/8	6-1/8	11/16	Z28NR	Z2828	A	A28D	B28D	E28D	1	.21
250 kcmil	YFMR29	YFMP29	1-7/8	6-1/8	3/4	Z29NR	Z2929	A	A29D	B29D	E29D	1	.25
300 kcmil	YFMR30	YFMP30	2	6-9/16	13/16	Z30NR	Z3030	A	A30D	B30D	E30D	2	.31
350 kcmil	YFMR31	YFMP31	2	6-15/16	7/8	Z32NR	Z3132	A	A31D	B31D	E31D	2	.38
400 kcmil	YFMR32	YFMP32	2-1/8	7-1/16	31/32	Z32NR	Z3232	A	A32D	B32D	E32D	2	.43
500 kcmil	YFMR34	YFMP34	2-13/16	8-1/8	1-1/16	Z34NR	Z3434	A	A34D	No Nest Die Req'd.	E34D	2	.79
750 kcmil	YFMR39	YFMP39	2-3/4	9-1/16	1-5/16	Z34NRB	Z3434	B	—	—	E39D	2	1.1

TYPE YFMP-L

LONG MOLIMITER™ ASSEMBLY

For Use with Long MOLIMITER™ Assembly

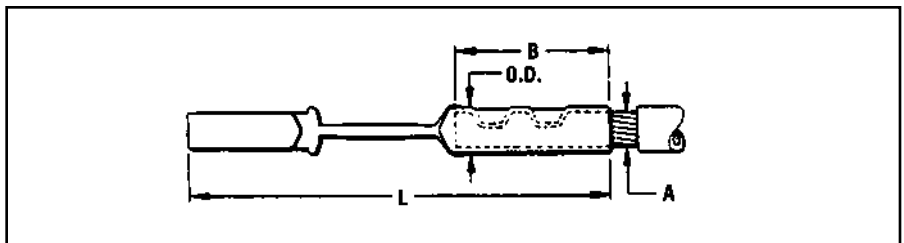

Similar to Type YFMR and YFMP except for a long oil tight cable socket preferred by some users of paper-insulated cable. Fusing char-

acteristics shown in the technical sections. For proper HYPRESS™ installation, see table below.

Cable Size	Catalog Number	Dimensions in Inches			For Connection to MOLE™ Use		MOLE™ Outlet Size	Installation Information				Ship Wt. in Lbs.
		B	L	O.D.	Socket and Nut Assembly See Page 32	Z Cone See Page 33		HYPRESS™ & Indentor Die			Number of Indents	
								Y34A with Y34PR	Y34BH with Y34PR	Y44B with Y44R		
								Nest Die				
4/0 Str.	YFMP28L	3-1/16	7-5/16	11/16	Z28NR	Z2828	A	A28D	B28D	E28D	1	.27
250 kcmil	YFMP29L	3-1/16	7-5/16	11/16	Z29NR	Z2929	A	A29D	B29D	E29D	1	.32
300 kcmil	YFMP30L	3-3/8	7-15/16	13/16	Z30NR	Z3030	A	A30D	B30D	E30D	2	.39
350 kcmil	YFMP31L	3-3/8	8-5/16	7/8	Z32NR	Z3132	A	A31D	B31D	E31D	2	.48
400 kcmil	YFMP32L	3-3/8	8-5/16	31/32	Z32NR	Z3232	A	A32D	B32D	E32D	2	.54
500 kcmil	YFMP34PL	4-1/8	9-7/16	1-1/16	Z34NR	Z3434	A	A34D	No Nest Die Req'd.	E34D	2	.94
750 kcmil	YFMP39PL	4-3/16	10-3/8	1-5/16	Z34NRB	Z3434	B	—	—	E39D	2	1.3

For conductor sizes not listed call customer service.

To specify a fast acting limiter in any configuration insert an "F" before the conductor number (e.g. YFSE34CR specifies a 1/2 thick limiter section).

Blue highlighted items are industry standard and most frequently ordered.

TYPES YFMH, YFMH-P

DURICOMP™ MOLIMITER™ SHELL

For Use with MOLIMITER™ Assemblies

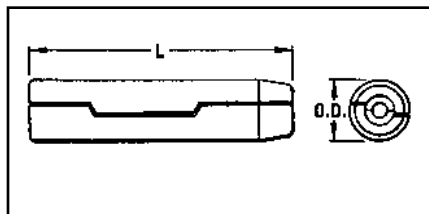

A molded composite shell with heat proof arcing chamber to confine and break the arc created by fusing under overload conditions. Shells may be ordered separately to replace those damaged. Contains no asbestos.

Cable Range	For Use on Rubber Insulated Cable	For Use on Paper Insulated Cable Long and Short Socket Type	Dimensions in Inches		App. Ship. Wt. in Lbs.
	Catalog Number	Catalog Number	L	O.D.	
4/0 Str. to 250 kcmil	YFMH2829	YFMH2829P	5-7/16	1-1/2	.42
300 kcmil to 400 kcmil	YFMH3032	YFMH3032P	6	1-11/16	.62
500 kcmil	YFMH34	YFMH34P	7-1/8	1-7/8	.73
750 kcmil	YFMH39	YFMH39P	7-1/8	2-1/16	.88

K-54

TYPE YFMC

INSULATING SLEEVE

For Use with MOLIMITER™ Assemblies

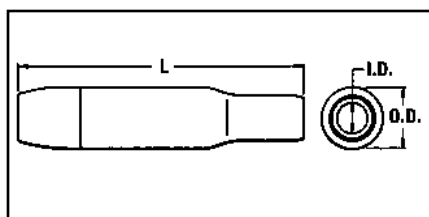

A two-part molded sleeve for insulating the MOLIMITER™ and composite shell assembly. Fitting closely over the shell, complete insulation is effected in a minimum of time.

Cable Range	Catalog Number	Dimensions in Inches			App. Ship. Wt. in Lbs.
		I.D.	L	O.D.	
4/0 Str. to 250 kcmil	YFMC6429	1	9-3/4	1-7/8	.37
300 kcmil to 400 kcmil	YFMC7232	1-1/8	10-5/16	2-3/16	.70
500 kcmil	YFMC8634	1-11/32	11-11/16	2-3/8	.93
750 kcmil	YFMC9639	1-1/2	12-3/16	2-9/16	1.2

For conductor sizes or sleeve inside diameters not listed call customer service.

Blue highlighted items are industry standard and most frequently ordered.

TYPE VYFT

LIMITER TAP ASSEMBLY

For Insulated Cables

The Limiter Tap is suitable for making Limiter connections to a cable ring bus in a manhole or transformer vault. It can be installed on oil-impregnated, paper insulated, or rubber insulated cable. Fusing characteristics of the Limiter are the same as Type YFA shown in the technical section. The rubber sleeve and insulating hood reduce taping to a minimum. Catalog Numbers shown include hoods. If no hood is required, eliminate one "C" from the Catalog Number. Replaceable Link Limiter Taps can be ordered. For proper HYPRESS™ installation, see table below.

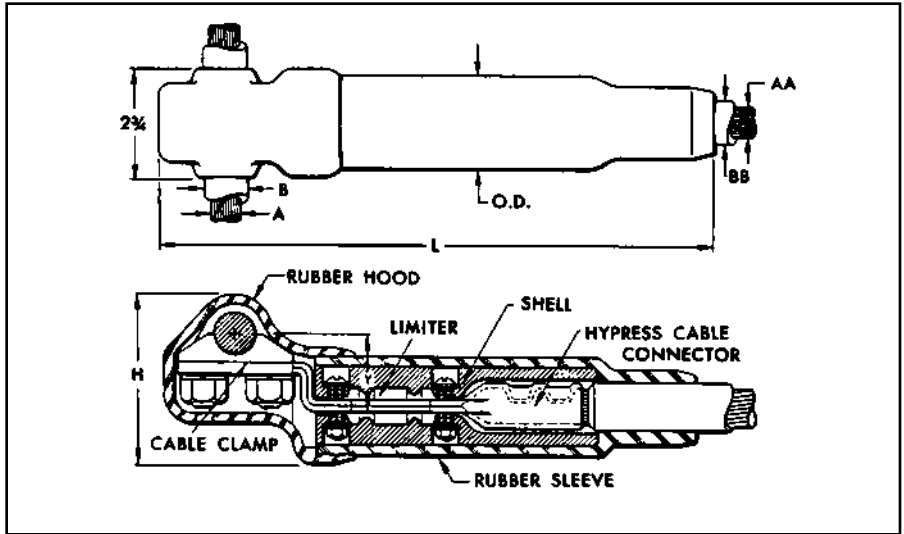

Paper-Lead Cables

If a long cable socket is preferred for use on paper insulated cable add "L" to the catalog number (e.g., VYFT3428CCP becomes VYFT3428CCPL).

Cable Size		For Use on Rubber Insul. Cable	For Use on Paper Insul. Cable-Oil Tight Cable Socket	Dimensions in Inches						Installation Information			App. Ship. Wt. in Lbs.
				B Max. Cable Dia. Over Insul.	BB Max. Cable Dia. Over Insul.	H	L	Y	O.D.	HYPRESS™ & Indentor Die	No. of Indents		
A Run	AA Tap	Catalog No.	Catalog No.							Y34A with Y34PR			Y34BH with Y34PR
500 kcmil	4/0 Str.	VYFT3428CCR	VYFT3428CCP	1-3/32	1	4	12-3/16	1-3/4	1-15/16	A28D	B28D	1	2.2
500 kcmil	500 kcmil	VYFT3434CCR	VYFT3434CCP	1-3/32	1-11/32	4	14-3/16	1-3/4	2-3/8	A34D	No Nest Die Req'd.	2	3.5
750 kcmil	500 kcmil	VYFT3934CCR	VYFT3934CCP	1-5/16	1-11/32	4	14-3/16	1-3/4	2-3/8	A34D	No Nest Die Req'd.	2	3.7
1000 kcmil	500 kcmil	VYFT4434CCR	VYFT4434CCP	1-1/2	1-11/32	4-1/8	14-3/16	2-3/32	2-3/8	A34D	No Nest Die Req'd.	2	4.0

To specify a fast acting limiter in any configuration insert an "F" before the conductor number (e.g., YFSE34CR specifies a 1/2 thick limiter section).

K-55

TYPE NYFT

LIMITER TEE TAP

For Rubber or Paper Insulated Cables

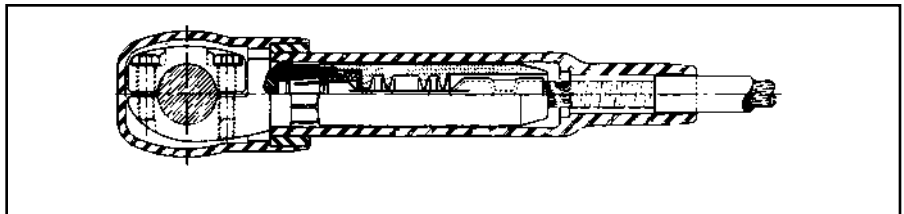

The NYFT Limiter is similar to Type VYFT except the run conductor is clamped with a four bolt cap and the Limiter Tap is removable by means of a socket and nut assembly.

The Limiter current characteristics are the same as Type YFA shown in the technical section.

Blue highlighted items are industry standard and most frequently ordered.

TYPE LYS

REPLACEABLE LINK LIMITER

With DURICOMP™ Shell and Rubber Sleeve for Insulated Cables

The Replaceable Link Limiter incorporates the functions of both fuse and coupler. For use with rubber and paper-insulated cable, it is designed to facilitate rapid and inexpensive replacement of Limiter Links upon clearing. It also permits, if desired, the use of a Link rated for a lower ampere capacity than supplied with our standard Limiter. For proper HYPRESS™ installation, see table below.

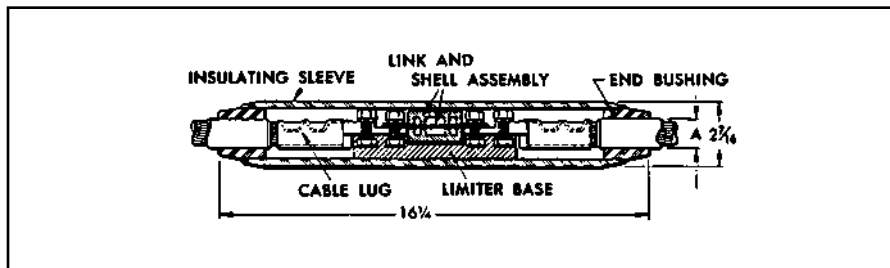

Cable Size	Catalog Number	**(Max. Cable Dia. Over Insul. Inches) A	Number of Indents in Cable Socket	*Link Supplied		Installation Information						
						HYPRESS™ & Indentor Die			No. of Indents	App. Ship. Wt. in Lbs.		
						Y29B with Y29PR	Y34A with Y34PR	Y34BH with Y34PR			Nest Die	
						Ampere Capacity	Catalog Number					
#4 Str.	LYS4CC	1/2	1	75A	LF1010	D4CL	A4CD	B4CD	1	2.1		
#2 Str.	LYS2CC	3/4	1	100A	LF1014	D2CL	A2CD	B2CD	1	2.2		
#1 Str.	LYS1CC		1	100A	LF1014	D1CL	A1cD	B1CD	1	2.2		
1/0 Str.	LYS25C		1	150A	LF1025	D25L	A25D	B25D	1	2.2		
2/0 Str.	LYS26C	1	1	150A	LF1025	D26L	A26D	B26D	1	2.3		
3/0 Str.	LYS27C		1	200A	LF2019	D27L	A27D	B27D	1	2.3		
4/0 Str.	LYS28C		1	250A	LF2027	D28L	A28D	B28D	1	2.4		
250 kcmil	LYS29C		1	250A	LF2027	D29L	A29D	B29D	1	2.4		
300 kcmil	LYS30C	1-1/4	2	300A	LF2038	—	A30D	B30D	2	2.5		
350 kcmil	LYS31C		2	300A	LF2038	—	A31D	B31D	2	2.6		
400 kcmil	LYS32C		2	400A	LF2065	—	A32D	B32D	2	2.7		
500 kcmil	LYS34C		2	400A	LF2065	—	A34D	No Nest Die Req'd.	2	3.1		

* Fuse link supplied is selected on the basis of a minimum blowing current of approximately twice the NEC rubber-insulated cable rating. Refer to Time Current curves shown and specify if another size is desired.

** The standard end bushing supplied is for maximum cable insulation diameters as shown. Compact cable will require a bushing with a smaller inside diameter to accommodate the smaller insulation diameter of the cable. If other than standard bushing is required, contact customer service.

To specify a fast acting limiter in any configuration insert an "F" before the conductor number (e.g., YFSE34CR specifies a 1/2 thick limiter section).

K-56

Blue highlighted items are industry standard and most frequently ordered.

TYPE LYM

**REPLACEABLE LINK
MOLIMITER™**

With DURICOMP™ Shell
and Rubber Sleeve for
Insulated Cables

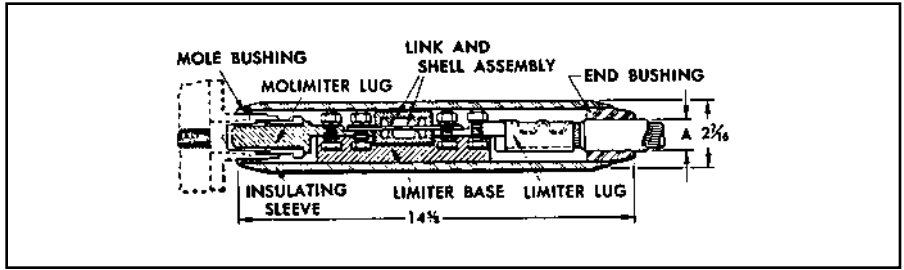

The Replaceable Link MOLIMITER™ is used to fuse underground cables at junction points with BURNDY® MOLEs. The “Replaceable Link” feature permits the selection of one of several links. In addition, the replacement of links that have burned clear is both rapid and inexpensive. For use with both rubber and paper insulated cables. The MOLE™ end of the MOLIMITER™ is installed in the MOLE™ Socket and Nut Assembly, while the cable socket end is HYPRESS™ installed, see table below for proper installation.

Cable Size	Catalog Number	**(Max. Cable Dia. Over Insul. Inches) A	Number of Indents in Cable Socket	*Link Supplied		For Connection to MOLE™ Use		Installation Information				App. Ship. Wt. in Lbs.				
						Ampere Capacity	Catalog Number	Socket and Nut Assembly see pg. K-32	Z Cone see pg. K-33	HYPRESS™ & Indentor Die			No. of Indents			
										Catalog Number	Catalog Number			Y29B with Y29PR	Y34A with Y34PR	Y34BH with Y34PR
														Nest Die		
#2 Str.	LYM2CC	3/4	1	100A	LF1014	Z28NR	Z2828	D2CL	A2CD	B2CD	1	2.0				
#1 Str.	LYM1CC		1	100A	LF1014	Z28NR	Z2828	D1CL	A1CD	B1CD	1	2.1				
1/0 Str.	LYM25C		1	150A	LF1025	Z28NR	Z2828	D25L	A25D	B25D	1	2.1				
2/0 Str.	LYM26C		1	150A	LF1025	Z28NR	Z2828	D26L	A26D	B26D	1	2.1				
3/0 Str.	LYM27C	1	1	200A	LF2019	Z28NR	Z2828	D27L	A27D	B27D	1	2.1				
4/0 Str.	LYM28C		1	250A	LF2027	Z28NR	Z2828	D28L	A28D	B28D	1	2.1				
250 kcmil	LYM29C		1	250A	LF2027	Z29NR	Z2929	D29L	A29D	B29D	1	2.2				
300 kcmil	LYM30C	1-1/4	2	300A	LF2038	Z30NR	Z3030	—	A30D	B30D	2	2.3				
350 kcmil	LYM31C		2	300A	LF2038	Z32NR	Z3132	—	A31D	B31D	2	2.5				
400 kcmil	LYM32C		2	400A	LF2065	Z32NR	Z3232	—	A32D	B32D	2	2.6				
500 kcmil	LYM34C		2	400A	LF2065	Z34NR	Z3434	—	A34D	No Nest Die Req'd.	2	2.9				

* Fuse link supplied is selected on the basis of a minimum blowing current of approximately twice the NEC rubber-insulated cable rating. Refer to Time Current curves shown and specify if another size is desired.

** The standard end bushing supplied is for maximum cable insulation diameters as shown. Compact cable will require a bushing with a smaller inside diameter to accommodate the smaller insulation diameter of the cable. If other than standard bushing is required, contact customer service.

K-57

Blue highlighted items are industry standard and most frequently ordered.

TYPE LF

LIMITER LINK

For Use with All Replaceable Limiters

Made of pure copper, the Limiter Link is controlled dimensionally to close tolerances to maintain accurate fusing characteristics. Refer to Time-Current Characteristic curve shown below and specify rating desired. The Limiter Link is supplied enclosed in a shell with heat-proof chamber to confine and break the arc created by fusing.

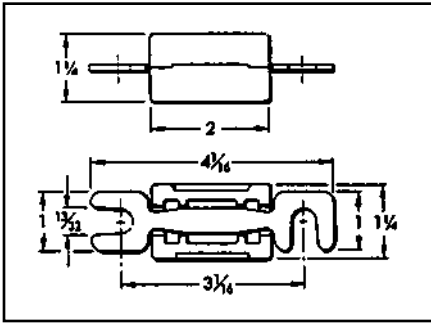

Ampere Capacity	*Catalog Number	Approx. Ship. Wt. in Lbs.
50A	LF1006	.08
75A	LF1010	.08
100A	LF1014	.08
150A	LF1025	.08
200A	LF2019	.09
250A	LF2027	.09
300A	LF2038	.11
400A	LF2065	.12
500A	LF2108	.15

* For use with LYS and LYM.

K-58

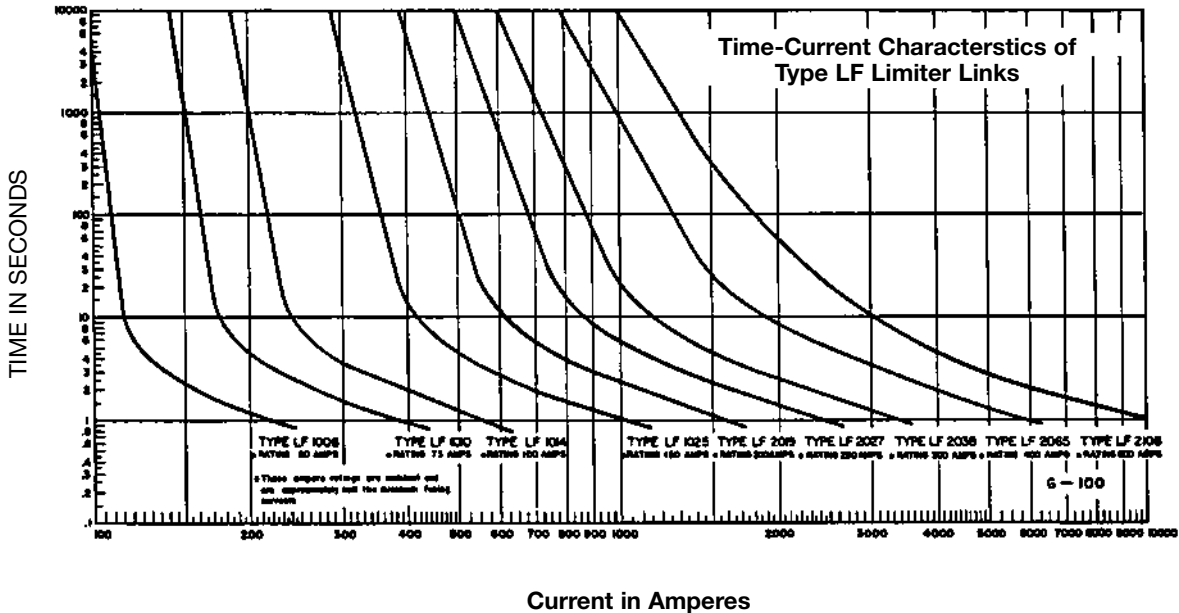

Time-Current Fusing Characteristics of Type LF Limiter Links
 The nominal current ratings of these Limiter Links are approximately one-half the minimum currents required to clear the fuses. The general slope and shape of the curves are similar to those of the time-current curves of the Limiters. The Type LF Limiter Links are made of pure copper with dimensions carefully controlled in order to maintain accurate fusing characteristics.

Blue highlighted items are industry standard and most frequently ordered.

TYPE LYS34P1

LIMITER BASE

For Use With All Replaceable Limiters

A heat resisting, high impact, molded phenolic base for mounting HYDENT™ Cable lugs or MOLIMITER™-lugs. The bases are supplied with molded in studs, enabling the lugs to be easily assembled to BURNDY® Replaceable Limiter Links. They may be purchased separately for use with all Replaceable Limiters.

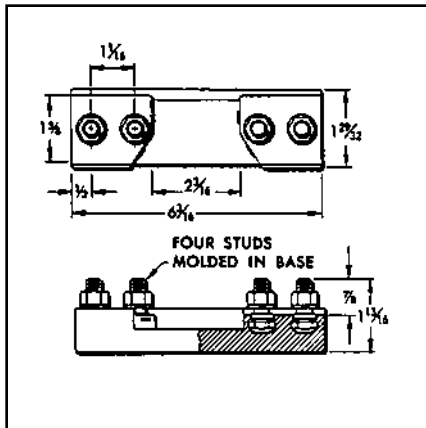

Catalog Number	For Use with	Approx. Ship. Wt. in Lbs.
LYS34P1G5	LYM	.32
	LYS	

K-59

TYPE LYS34P2

LIMITER SLEEVE

For Use With Replaceable Limiters

A molded sleeve for insulating the Replaceable Limiter and MOLIMITER™ assemblies. Similar to other component parts, the insulating sleeves may be purchased separately. These sleeves are used in conjunction with the LYS-P6 bushings.

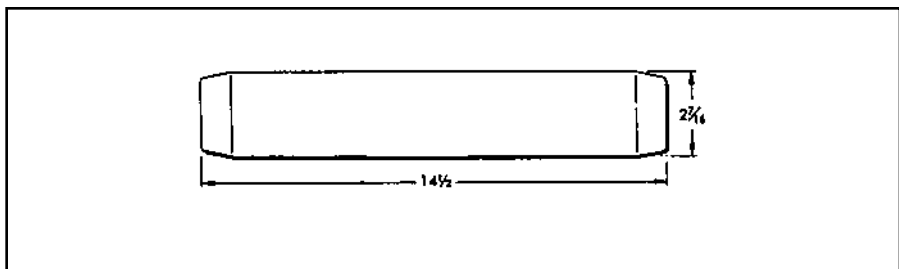

Catalog Number	For Use with	Approx. Ship. Wt. in Lbs.
LYS34P2	LYS	1.2
	LYM	

Blue highlighted items are industry standard and most frequently ordered.

TYPE LYS-P5

HYLUG™

For Use with Replaceable Limiters

Fabricated of high copper alloy, this terminal has a sealed cable socket for use with paper-insulated, oil-impregnated cables as well as rubber-insulated cables. Tin plated to retard corrosion and prevent discoloration. The HYLUG™ is for use with LYS and LYM.

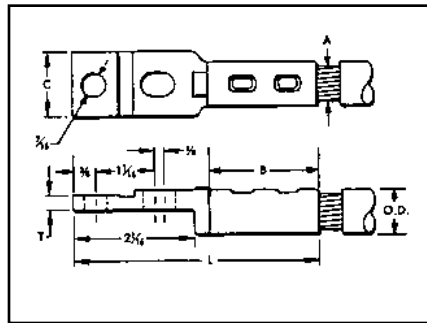

K-60

Cable Size A	Catalog Number	Dimensions in Inches					Installation Information			No. of Indents	App. Ship. Wt. in Lbs.
							HYPRESS™ & Indentor Die				
		B	C	L	T	O.D.	Y29B with Y29PR	Y34A with Y34PR	Y34B with Y34PR		
#6 Str.	LYS6CP5	1-1/4	3/4	3-9/16	3/16	5/16	D6CL	A6CD	B6CD	1	.16
#4 Str.	LYS4CP5	1-1/4	3/4	3-5/8	3/16	11/32	D4CL	A4CD	B4CD	1	.16
#2 Str.	LYS2CP5	1-9/32	3/4	3-3/4	3/16	13/32	D2CL	A2CD	B2CD	1	.17
#1 Str.	LYS1CP5	1-3/8	3/4	3-29/32	3/16	15/32	D1CL	A1CD	B1CD	1	.20
1/0 Str.	LYS25P5	1-3/8	3/4	3-15/16	3/16	17/32	D25L	A25D	B25D	1	.22
2/0 Str.	LYS26P5	1-1/2	13/16	4-1/16	3/16	9/16	D26L	A26D	B26D	1	.24
3/0 Str.	LYS27P5	1-1/2	29/32	4-1/16	3/16	5/8	D27L	A27D	B27D	1	.28
4/0 Str.	LYS28P5	1-5/8	1-1/8	4-3/16	3/16	11/16	D28L	A28D	B28D	1	.31
250 kcmil	LYS29P5	1-5/8	1-1/8	4-3/16	1/4	3/4	D29L	A29D	B29D	1	.37
300 kcmil	LYS30P5	2	1-3/8	4-9/16	1/4	13/16	—	A30D	B30D	2	.42
350 kcmil	LYS31P5	2	1-9/16	4-9/16	1/4	7/8	—	A31D	B31D	2	.53
400 kcmil	LYS32P5	2-1/8	1-9/16	4-11/16	1/4	31/32	—	A32D	B 32D	2	.61
500 kcmil	LYS34P5	2 1/4	1-9/16	4-13/16	1/4	1-1/16	—	A34D	No Nest Die Req.	2	.70

Blue highlighted items are industry standard and most frequently ordered.

TYPE LYM34P3

BUSHING

For Use with Replaceable Limiters

Type LYM34P3 is for assembly of Replaceable MOLIMITERS™ to the MOLE™ outlet. It fills the space between Limiter sleeve and the MOLE™ outlet to allow easy taping.

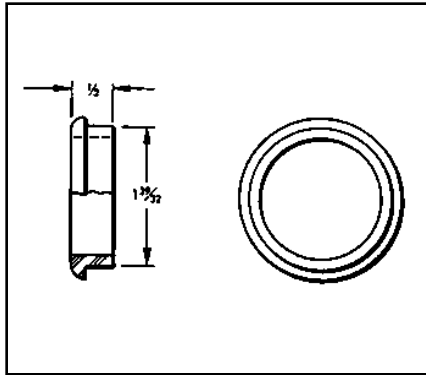

Catalog Number	For Use With	MOLE™ Outlet Size	App. Ship. Wt. in Lbs.
LYM34P3	LYM	A	.01
	LZM		

TYPE LYS-P6

BUSHING

For Use with Replaceable Limiters

The LYS-P6 bushing is designed to fit closely over the cable insulation when used with the LYS34P2 Limiter sleeve. It fills the space between the Limiter sleeve and cable. The tapered bushing facilitates taping at installation.

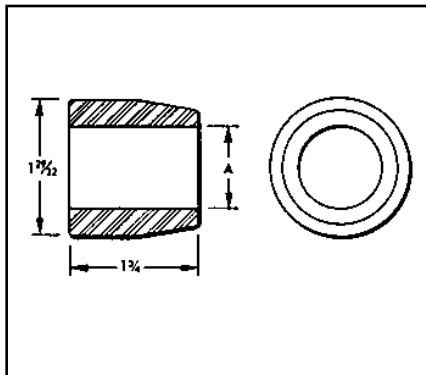

Catalog Number	(Max. Cable Dia. Over Insul.) A	For Use With	App. Ship. Wt. in Lbs.
LYS32P6	1/2	LYS LYM	.19
LYS48P6	3/4		.19
LYS64P6	1		.16
LYS80P6	1-1/4		.12

K-61

Blue highlighted items are industry standard and most frequently ordered.

TYPES Y, Z

NETWORK PROTECTOR FUSES AND DURICOMP™ ENCLOSURES

Type Z Network Protector Fuses are designed to coordinate with the fusible sections of the Limiters as well as the Protector characteristic itself. A DURICOMP™ enclosure is designed especially to form an arcing chamber for these fuses and contains no asbestos. The hole spacings in the tongues of these fuses are such that they will fit standard Network Protectors. See Time Current characteristic curve below. The Fuse element and the housing must be purchased separately.

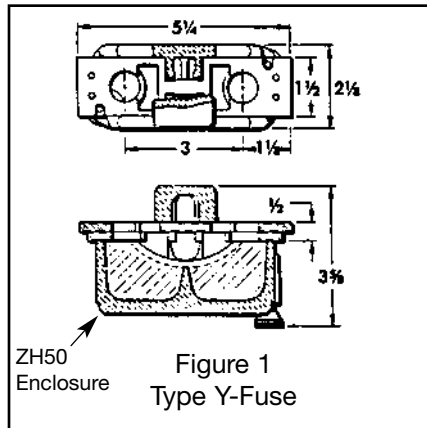

Figure 1
Type Y-Fuse

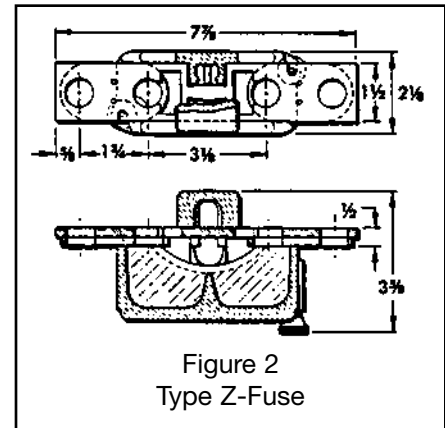
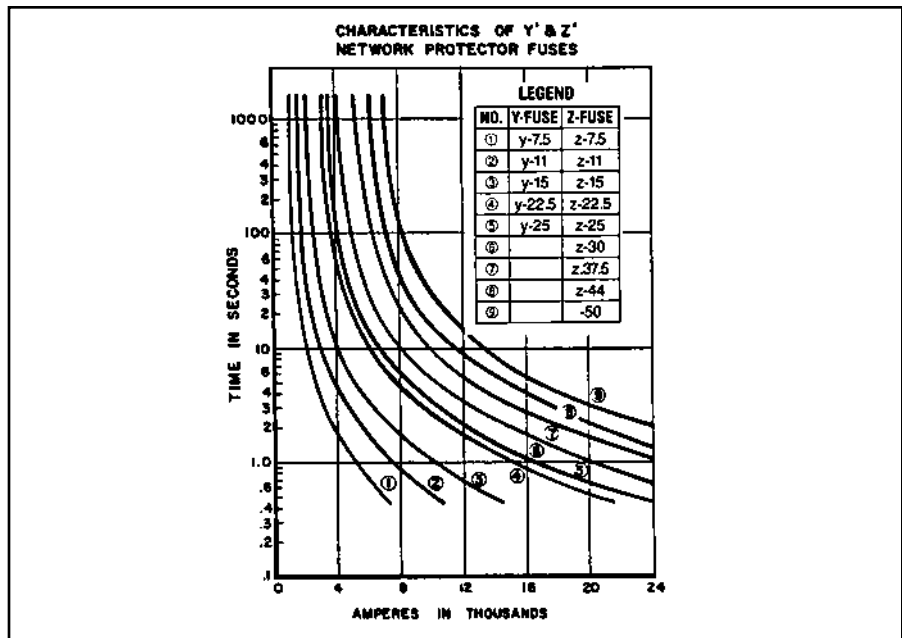

Figure 2
Type Z-Fuse



K-62

Fuse Designation Catalog Number				Transformer Full Load (Normal) Amperes	DURICOMP™ Enclosure
Y-Fuse Fig. 1	App. Ship. Wt. in Lbs.	Z-Fuse Fig. 2	App. Ship. Wt. in Lbs.		
Y-7.5	.45	Z-7.5	.95	400	ZH50
Y-11	.46	Z-11	.96	600	
Y-15	.48	Z-15	.98	800	
Y-22.5	.50	Z-22.5	1.0	1200	
Y-25	.63	Z-25	1.13	1333	
—	.75	Z-30	1.25	1600	
Y-37.5	.78	Z-37.5	1.28	2000	
—	—	Z-44	1.29	2500	
Y-50	.80	Z-50	1.30	3000	

Blue highlighted items are industry standard and most frequently ordered.

TYPE NYT

T-CONNECTOR

Cable Run — Cable Tap

A “T” connector designed to provide a clamp-type element on the run and a permanent HYPRESS™ connection on the tap. Recommended for use on ring buses or for applications where occasional disconnects

from the run conductor are desired without disturbing the tap connection. Tin plated. For proper installation of tap cable, see table below.

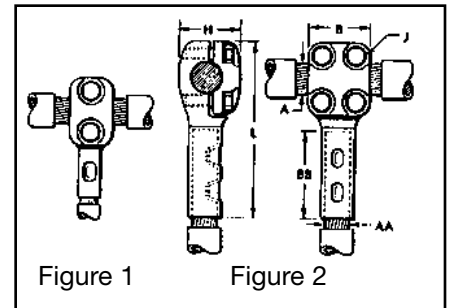

Figure 1

Figure 2

Conductor Size		Catalog Number	Fig. No.	Dimensions in Inches					Installation Information				No. of Indents	App. Ship. Wt. in Lbs.				
									HYPRESS™ and Indentor Die						Nest Die			
									Y29B with Y29PR	Y34A with Y34PR	Y34B with Y34PR	Y44B with Y44PR						
Run A	Tap AA		B	BB	H	J	L											
4/0 Str.	#2 Str.	NYT282C	1	1-3/8	1-1/4	1-3/8	3/8	3-13/16	D2CL	A2CD	B2CD	—	1	1.5				
	1/0 Str.	NYT2825	1	1-3/8	1-3/8	1-3/8	3/8	4	D25L	A25D	B25D	—	1	1.5				
	2/0 Str.	NYT2526	1	1-3/8	1-1/2	1-3/8	3/8	4-1/8	D26L	A26D	B26D	—	1	1.5				
	4/0 Str.	NYT2828	2	2	1-5/8	1-3/8	3/8	4-5/16	D28L	A28D	B28D	E28D	1	2.2				
250 kcmil	#2 Str.	NYT292C	1	1-3/8	1-1/4	1-7/16	3/8	3-13/16	D2CL	A2CD	B2CD	—	1	1.5				
	1/0 Str.	NYT2925	1	1-3/8	1-3/8	1-7/16	3/8	4-1/16	D25L	A25D	B25D	—	1	1.5				
	2/0 Str.	NYT2926	1	1-3/8	1-1/2	1-7/16	3/8	4-3/16	D26L	A26D	B26D	—	1	1.5				
	4/0 Str.	NYT2928	2	2	1-5/8	1-7/16	3/8	4-3/8	D28L	A28D	B28D	E28D	1	2.2				
	250 kcmil	NYT2929	2	2	1-5/8	1-7/16	3/8	4-7/16	D29L	A29D	B29D	E29D	1	2.2				
350 kcmil	1/0 Str.	NYT3125	1	1-3/8	1-3/8	1-1/2	3/8	4-1/8	D25L	A25D	B25D	—	1	1.5				
	2/0 Str.	NYT3126	1	1-3/8	1-1/2	1-1/2	3/8	4-5/16	D26L	A26D	B26D	—	1	1.5				
	4/0 Str.	NYT3128	2	2	1-5/8	1-1/2	3/8	4-1/2	D28L	A28D	B28D	E28D	1	2.2				
	250 kcmil	NYT3129	2	2	1-5/8	1-1/2	3/8	4-9/16	D29L	A29D	B29D	E29D	1	2.2				
	350 kcmil	NYT3131	2	2	2	1-1/2	3/8	5	—	A31D	B31D	E31D	2	2.5				
500 kcmil	2/0 Str.	NYT3426	1	1-3/8	1-1/2	1-5/8	3/8	4-7/16	D26L	A26D	B26D	—	1	1.7				
	4/0 Str.	NYT3428	2	2	1-5/8	1-5/8	3/8	4-5/8	D28L	A28D	B28D	E28D	1	2.5				
	250 kcmil	NYT3429	2	2	1-5/8	1-5/8	3/8	4-5/8	D29L	A29D	B29D	E29D	1	2.5				
	350 kcmil	NYT3431	2	2	2	1-5/8	3/8	5-1/16	—	A31D	B31D	E31D	2	2.5				
	500 kcmil	NYT3434	2	2	2-1/4	1-5/8	3/8	5-3/8	—	A34D	No Nest Die Req'd.	E34D	2	2.5				
750 kcmil	2/0 Str.	NYT3926	1	1-3/8	1-1/2	1-7/8	3/8	4-5/8	D26L	A26D	B26D	—	1	1.7				
	4/0 Str.	NYT3928	2	2	1-5/8	1-7/8	3/8	4-13/16	D28L	A28D	B28D	E28D	1	2.5				
	250 kcmil	NYT3929	2	2	1-5/8	1-7/8	3/8	4-13/16	D29L	A29D	B29D	E29D	1	2.5				
	350 kcmil	NYT3931	2	2	2	1-7/8	3/8	5-1/4	—	A31D	B31D	E31D	2	2.5				
	500 kcmil	NYT3934	2	2	2-1/4	1-7/8	3/8	5-9/16	—	A34D	No Nest Die Req'd.	E34D	2	2.7				
	750 kcmil	NYT3939	2	2	2-7/8	1-7/8	3/8	6-1/4	—	—	—	E39D	2	3.0				
1000 kcmil	2/0 Str.	NYT4426	1	1-3/8	1-1/2	2-1/8	3/8	4-3/4	D26L	A26D	B26D	—	1	1.7				
	4/0 Str.	NYT4428	2	2	1-5/8	2-1/8	3/8	4-15/16	D28L	A28D	B28D	E28D	1	2.5				
	250 kcmil	NYT4429	2	2	1-5/8	2-1/8	3/8	5	D29L	A29D	B29D	E29D	1	2.5				
	350 kcmil	NYT4431	2	2	2	2-1/8	3/8	5-7/16	—	A31D	B31D	E31D	2	2.5				
	500 kcmil	NYT4434	2	2	2-1/4	2-1/8	3/8	5-3/4	—	A34D	No Nest Die Req'd.	E34D	2	2.7				
	750 kcmil	NYT4439	2	2	2-7/8	2-1/4	3/8	6-3/8	—	—	—	E39D	2	3.0				
	1000 kcmil	NYT4444	2	2-11/16	3	2-5/16	1/2	7	—	—	—	No Nest Die Req'd.	2	3.2				
1500 kcmil	4/0 Str.	NYT4628	2	2	1-5/8	2-11/16	3/8	5-3/8	D28L	A28D	B28D	E28D	1	4.7				
	250 kcmil	NYT4629	2	2	1-5/8	2-11/16	3/8	5-7/16	D29L	A29D	B29D	E29D	1	4.7				
	350 kcmil	NYT4631	2	2	2	2-11/16	3/8	5-7/8	—	A31D	B31D	E31D	2	4.7				
	500 kcmil	NYT4634	2	2	2-1/4	2-11/16	3/8	6-3/16	—	A34D	No Nest Die Req'd.	E34D	2	4.7				
	750 kcmil	NYT4639	2	2	2-7/8	2-11/16	3/8	6-3/4	—	—	—	E39D	2	5.2				
	1000 kcmil	NYT4644	2	2-11/16	3	2-3/4	1/2	7-1/8	—	—	—	No Nest Die Req'd.	2	7.5				
	1500 kcmil	NYT4646	2	2-11/16	3-3/16	2-3/4	1/2	7-11/16	—	—	—	C46D*	2	8.0				

* Y48B HYPRESS™ with Y48PR indentor.

HIGH CAPACITY LIMITER

200,000 AMPERES AT 600 VOLTS

The BURNDY® High Capacity Limiter is designed to economically protect electrical distribution systems from the destructive effect of high energy faults. The increasing number of 600 volt secondary network installations for industrial and commercial applications demand a cable limiter that can safely interrupt 200,000 amperes (symmetrical available) and one that will also completely coordinate with the higher voltage network protector fuses.

Available fault currents as high as 200,000 amperes rms at 600 volts across the fusible elements have been interrupted during tests on the BURNDY® High Capacity Limiter. The power factor during these tests was less than 15%, thereby imposing the most difficult clearing conditions. No external disturbance is experienced upon clearing fault currents from the "float" value to 200,000 amperes. The quartz tiller absorbs the intense energy

generated by interrupting the fault current. The quartz fuses into tubular fulgurites, with a high dielectric strength, and forms an insulating barrier between the melted link sections. This action prevents restrike of the internal arc. The rugged aluminum housing and cast epoxy end seals provide a vessel that completely contains the developed energy.

The carefully developed time-current characteristics and rigid manufacturing tolerances assure proper coordination with the network protector fuses and the insulation damage characteristics of 4/0, 250, 350, 500 kcmil and 750 cable.

The High Capacity Limiter is available in four variations to accommodate a variety of installation practices. The Type HYS cable sockets at both ends, which allow for indenting to the cable ends with a hydraulic BURNDY® HYPRESS™. The HYA has an off-set lug on

one end which permits back-to-back mounting on bus bar. The HYA also allows cable to installation with no off-set.

For those installations where BURNDY® MOLEs are used for manhole junctions or transformer vault buses, the Type HYM permits a replaceable connection of the limiter directly to the MOLE™ outlet at one end and a compression cable connection at the other.

Modern electrical distribution systems require low cost protection to safeguard costly equipment and quickly isolate faults, so that the undamaged portions of the system may function normally. BURNDY® High Capacity Limiters assure positive, economical protection when installed in properly designed systems.

NOTE: Today's fault currents are growing. If you need higher fault current ratings please contact factory.

HIGH CAPACITY LIMITER

200,000 AMPERES AT 600 VOLTS

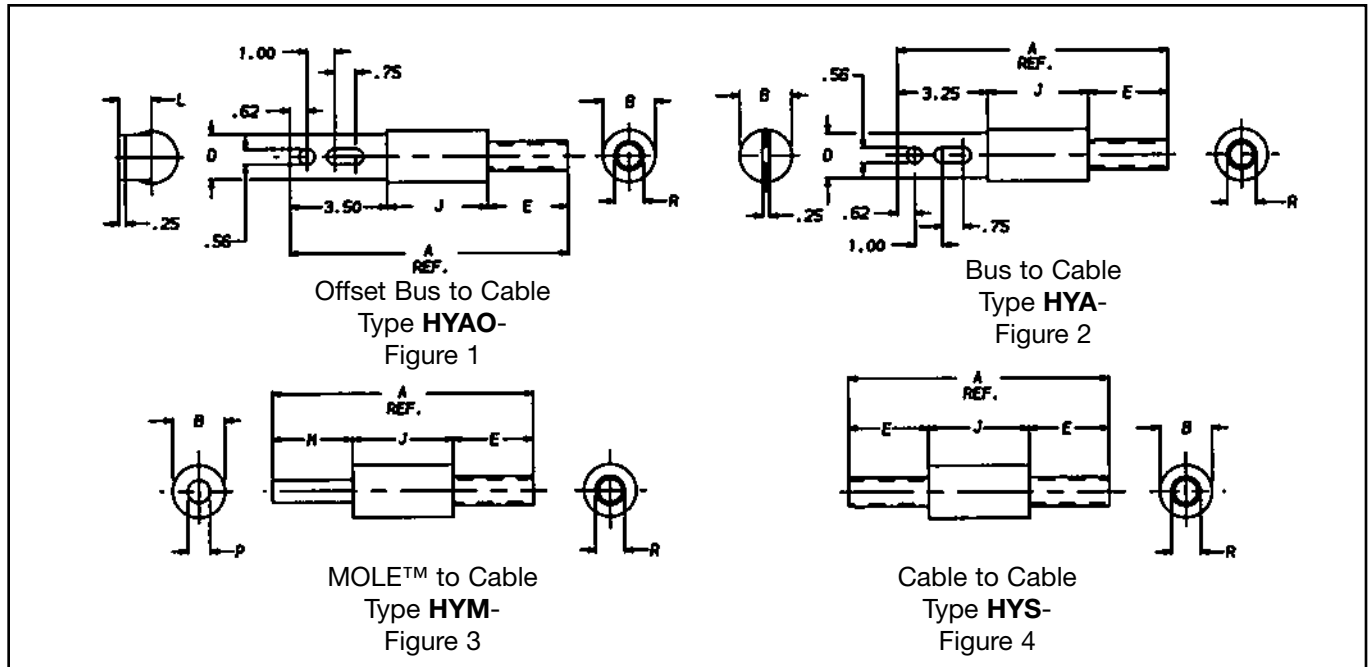

④ Catalog Number	Cable Size	Fig. No.	A		B		D		E		J		L		M		P		R		Die Index	Die	No. of Crimps per End
			In	mm	In	mm	In	mm	In	mm	In	mm	In	mm	In	mm	In	mm	In	mm			
HYAO_28	4/0	1	8.87	225	1.44	37	1.12	28	1.75	44	3.62	92	.96	24	—	—	—	—	.68	17	15	U28RT	2
HYAO_29	250 kcmil	1	9.00	229	1.44	37	1.12	28	1.88	48	3.62	92	.96	24	—	—	—	—	.75	19	16	U29RT	2
HYAO_31	350 kcmil	1	9.12	232	1.62	41	1.12	28	2.00	51	3.62	92	.96	24	—	—	—	—	.88	22	18	U31RT	4
HYAO_34	500 kcmil	1	10.00	254	1.88	48	1.62	41	2.88	73	3.62	92	1.19	30	—	—	—	—	1.05	27	20	U34RT	4
HYAO_39	750 kcmil	1	10.13	257	2.50	64	2.00	51	2.88	73	3.75	95	1.31	33	—	—	—	—	1.32	34	24	U39RT	4
HYA_28	4/0	2	8.62	219	1.44	37	1.12	28	1.75	44	3.62	92	—	—	—	—	—	—	.68	17	15	U28RT	2
HYA_29	250 kcmil	2	8.75	222	1.44	37	1.12	28	1.88	48	3.62	92	—	—	—	—	—	—	.75	19	16	U29RT	2
HYA_31	350 kcmil	2	8.87	225	1.62	41	1.12	28	2.00	51	3.62	92	—	—	—	—	—	—	.88	22	18	U31RT	4
HYA_34	500 kcmil	2	9.75	248	1.88	48	1.62	41	2.88	73	3.62	92	—	—	—	—	—	—	1.05	27	20	U34RT	4
HYA_39	750 kcmil	2	9.88	251	2.50	64	2.00	51	2.88	73	3.75	95	—	—	—	—	—	—	1.32	34	24	U39RT	4
HYM_28	4/0	3	7.87	200	1.44	37	—	—	1.75	44	3.62	92	—	—	2.50	64	.52	13	.68	17	15	U28RT	2
HYM_29	250 kcmil	3	8.00	203	1.44	37	—	—	1.88	48	3.62	92	—	—	2.50	64	.58	14	.75	19	16	U29RT	2
HYM_31	350 kcmil	3	8.12	206	1.62	41	—	—	2.00	51	3.62	92	—	—	2.50	64	.68	17	.88	22	18	U31RT	4
HYM_34	500 kcmil	3	9.38	238	1.88	48	—	—	2.88	73	3.62	92	—	—	2.88	73	.81	21	1.05	27	20	U34RT	4
HYM_39	750 kcmil	3	9.51	242	2.50	64	—	—	2.88	73	3.75	95	—	—	2.88	73	1.00	25	1.32	34	24	U39RT	4
HYS_28	4/0	4	7.12	180	1.44	37	—	—	1.75	44	3.62	92	—	—	—	—	—	—	.68	17	15	U28RT	2
HYS_29	250 kcmil	4	7.38	188	1.44	37	—	—	1.88	48	3.62	92	—	—	—	—	—	—	.75	19	16	U29RT	2
HYS_31	350 kcmil	4	7.62	194	1.62	41	—	—	2.00	51	3.62	92	—	—	—	—	—	—	.88	22	18	U31RT	4
HYS_34	500 kcmil	4	9.38	238	1.88	48	—	—	2.88	73	3.62	92	—	—	—	—	—	—	1.05	27	20	U34RT	4
HYS_39	750 kcmil	4	9.51	242	2.50	64	—	—	2.88	73	3.75	95	—	—	—	—	—	—	1.32	34	24	U39RT	4

Notes:

- For insulated version add suffix "-C" to Catalog Number (example: HYM5340C).
- High Capacity Limiter. 200kA interrupting capacity at 600V AC.

3. Cable end utilize dies with Y35, Y39, Y46, Y45, Y750 tools (750 kcmil size units cannot be installed with the Y35 HYPRESS™).

④ For fast operating limiter use "F"; for slow or standard operating limiter use "S" before conductor number (example: HYMF34 or HYMS34) see Time-Current Characteristics.

Blue highlighted items are industry standard and most frequently ordered.

PRODUCTS FOR UNDERGROUND RESIDENTIAL DISTRIBUTION SYSTEMS

For over 70 years, BURNDY® has pioneered and produced economical, dependable connectors and protective devices for urban underground distribution systems. This extensive experience has been applied to the development of equipment for low cost underground distribution systems for light commercial and residential areas.

Increasing interest by home buyers and developers has created a need for URD components comparable in cost with those used in overhead systems.

Using connectors designed for other purposes, early URD installations were relatively expensive. Recognizing the need to reduce





installation costs BURNDY® developed a line of connectors specifically for URD.

These products are shown in this section. They are the result of a continuing search for new materials and more efficient production methods to bring down cost to meet the requirements of low cost underground construction.

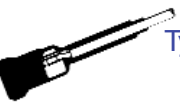

TABLE OF CONTENTS

K-66

MOLEs

	Type RDMD-28G	K-67
	Type RDMD-2858D	K-67
	Type RDMD-28 CR	K-67
	Type RDM-28	K-67
	Type RDM-28T	K-68

Tap Kits





	Types RYA-UC, RYA-AC RYA-UCR, RYA-ACR Tap Kits	K-68
	Types RA6UC-SL, RA6UCR-SL Tap Kits	K-69
	Type YS-CG Insulated Splice Kit	K-70

	Type Y-LOK	K-70
---	-----------------------------	-------------

HYREDUCER™ Splices

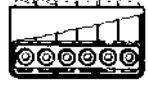
	Type YRB-U	K-71 - K-73
	Type YRB-T	K-74 - K-75

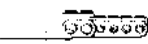
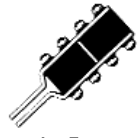
Service Taps & Transformer Terminals

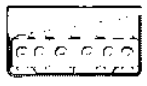
	Type K-P-C	K-76
	Type YPC-C	K-76
	Types K6B, K33B	K-77
	Type F-A	K-78
	Type K6A34U-6N	K-78
	Type K-P-UC	K-78

Power Distribution Blocks

	Types BPD, BPD2	K-79
---	----------------------------------	-------------

Blue highlighted items are industry standard and most frequently ordered.

TYPE RDMD-28G

URD STUD MOLE™

The RDMD-28G Stud MOLE™ is a submersible junction designed to accommodate a range of copper and aluminum conductors. The Stud MOLE™ is designed for use on transformers where a dead front secondary is required. It is insulated with molded EPT rubber. Mates with a 5/8"-11 copper stud. A jam nut is supplied with the MOLE™ to secure and lock it to the stud.

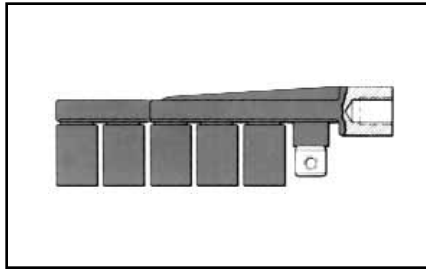

It is available with either four or six outlets. All outlets except one have factory installed removable sealing caps. Tap kits are ordered separately. REA listed.

Also available without insulation and sealing caps.

Catalog Number	Number of Outlets	Insulated
RDMD4-28G3	4	Yes
RDMD6-28G3	6	Yes

TYPE RDMD-2858D

STUD MOLE™

The RDMD-2858D Stud MOLE™ is identical to the insulated RDMD-28G except an adapter is supplied, allowing MOLE™ to be removed from transformer stud without disconnecting the individual services.

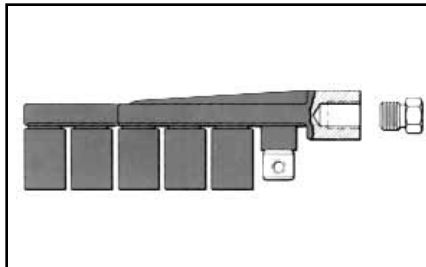

Catalog Number	Number of Outlets	Insulated
RDMD4-2858D	4	Yes
RDMD6-2858D	6	Yes

K-67

TYPE RDMD-28CR

RUBBER INSULATING BOOT

The EPDM rubber force fit boot is designed to provide a completely dead-front and moisture tight installation when used with either the Type RDMD-28G3 or Type RDMD-2858D Stud MOLE™. Bushing end will seal any diameter from .875 to 1.125 inch.



TYPE RDM-28

URD MOLE™

For Aluminum or Copper

Type RDM-28 MOLE™ is an economical, insulated, submersible service junction suitable for direct burial or for use in enclosures. Disconnectable joints allow additions of new services without disturbing previous installations. Taping is eliminated, heat-shrink or force-fit rubber sleeves insulate each joint. Rubber is used to insulate the MOLE™ body. Removable sealing covers are supplied on all

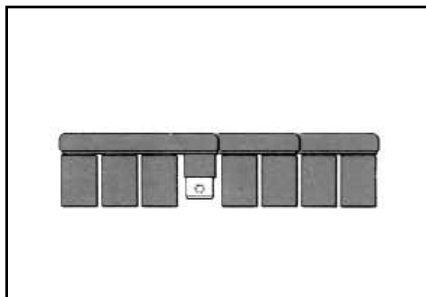

outlets but two. REA listed Tap Kits, including HYLUG™, hardware and sleeve are ordered separately.

Catalog Number	Number of Outlets
RDM4-28	4
RDM6-28	6
RDM8-28	8

Blue highlighted items are industry standard and most frequently ordered.

TYPE RDM-28T

URD MOLE™

For Aluminum and Copper

The RDM-28T MOLE™ is available with five or seven outlets. The single hole outlets are the same size as the RDM-28 series and accommodate the same RYA-UC or RYA-UCR tap kits. The larger two-hole outlet accommodates the 500 or 350 kcmil copper cable secondary supplied with many sub-surface transformers. These cables are extended to a junction point where secondary mains or services are connected. Tin-plated copper RYA-C-2 tap kits are used to join the 500 or 350 kcmil copper secondaries to the RDM-28T MOLE™.

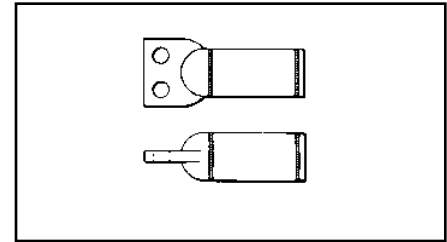
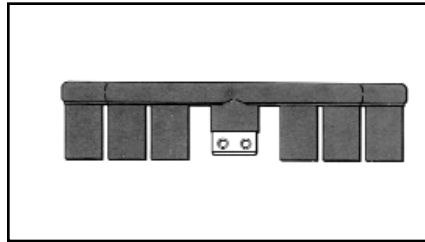

Catalog Number	Number of Outlets	
	12 Sol. - 350	350 - 500
RDM5-28T	4	1
RDM7-28T	6	1

Copper Conductor	Catalog Number		Die Index	Tools, Die Set, Catalog No. & (No. of Crimps)	
	Heat Shrink	Force Fit		Y34A	Y35* Series Y750, 739
350	RYA31C-2	RYA31CR-2	20	A34R (4)	U34RT (4)
500	RYA34C-2	RYA34CR-2			

* Y35 U-Dies with adapter PT6515 can also be used in Y45 series HYPRESSES™. Same number of crimps as Y35.

TYPES RYA-UC, RYA-AC

MOLE™ TAP KITS

For Aluminum or Copper
For Use with Type RDM-28 URD MOLE™



Conductor		Catalog Number			EEL Die Index	Die Index	Tools, Die Set Catalog Number, & (Number of Crimps)		
		Heat Shrink		Force Fit			MD6 Series	Y39, Y750 Series	OUR840
		Complete Set	Shrink Sleeve Only	Complete Set					
2 Sol. - 4 Str.	2 Sol. - 4 Str. 4 Str. Comp.	RYA4UC	RYAC25	RYA4UCR	8A	BG or 5/8 - 1 or 243	W-BG (1) BG3 or W243	U-BG (1) UK58-IT (3) U243 (1)	XBG (3) XNBG (2)
2 Str. - 1/0 Sol.	2 Str. - 1/0 Sol. 2-1 Str. Comp.	RYA2UC		RYA2UCR					
1/0 Str.	1/0 Str. - 2/0 Sol. 1/0 Str. Comp.	RYA25UC		RYA25UCR					
	2 Sol. EC-0	RYA2WAC		RYA2WACR					
	1/0 Sol. EC-0	RYA75AC		RYA75ACR					
2/0 Str.	2/0 Str. 2/0 Str. Comp.	RYA26UC		RYA26UCR					
3/0 Str.	3/0 Str. 3/0 Str. Comp. 4/0 Sol. EC-0**	RYA27UC	RYA27UCR	11	249 or 840	W249 (4) WK840 (7)	U249 (2) UK840T (4)	X249 (8) X840 (7)	
4/0 Str.	4/0 Str. 4/0 Str. - 250 Comp.	RYA28UC	RYA28UCR						13A
250 kcmil	250 250 Comp.	RYA29UC	RYA29UCR						
—	300 - 350 300 - 350 Comp.	RYA31AC	RYA31ACR						

* Overlap Crimps.

** Do not use EEL Die. (11A) to install 4/0 Sol. EC-0.

NOTE: Standard mounting hardware is 3/8" button head socket cap screw with captive conical washer. For HEX HEAD bolt with captive conical washer add "HEX" suffix.

NOTE: Example: RYA4UCR-HEX. For HEX HEAD bolt and captive flat washer add suffix "HEX1". For HEX HEAD bolt and non-captive flat washer add suffix "HEX2". For HEX HEAD bolt and non-captive conical washer add suffix "HEX3". For Stainless Steel HEX HEAD bolt add "HEX355" suffix.

Blue highlighted items are industry standard and most frequently ordered.

**TYPES RA6UC-SL,
RA6UCR-SL**

**URD STREET LIGHTING
TAP KIT**

For Aluminum or Copper

URD tap kit for making street lighting taps from URD MOLE™ types RDM-28 and RDM-28T. Each kit accommodates 6 str. - 12 sol. Kits include connector, mounting hardware and insulating sleeve.

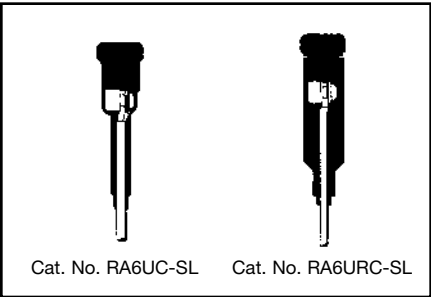

Conductor	Catalog Number	
	Heat Shrink	Force Fit
6 Str. - 12 Sol.	RA6UC-SL	RA6UCR-SL

Blue highlighted items are industry standard and most frequently ordered.

TYPE YS-CG

URD INSULATED SPLICE KIT

For All Aluminum
or Copper/Aluminum
Combinations

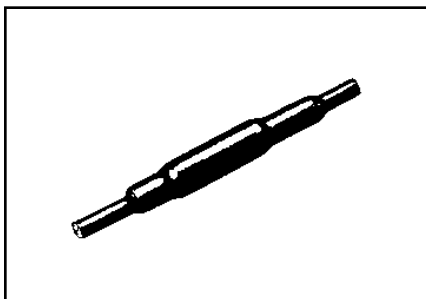

Type YS-CG URD insulated splice kit consists of a standard YSU or YSD LINKIT™ and a heat-shrink sleeve. Used to splice URD secondary lines up to 600 volts. It is installed with common installation tools. Heat-shrink sleeve is installed with standard propane torch, or 500° F electric heat gun. Acetylene is not recommended.

Conductor			Catalog Number		Die Index	Tools, Die Set Catalog No., & (No. of Crimps)		
Both Sides			Complete Splice Kit	Heat Shrink Sleeve		MD6 Series	Y34A	Y35 Series
Aluminum	ACSR	Copper*						
1-2 Str.	2 (6-1, 7-1)	1-2 Str.	YS2UCGI	RYAC25	BG 243	BG (3) W-BG (1)** W243 (2)	— A243 (1)	U-BG (1)** U243 (1)
1/0 Str. 1/0 Comp.	1/0 (6-1)	1/0 Str.	YS25UCGI					
2/0 Str. 2/0 Comp.	2/0 (6-1)	2/0 Str.	YS26UCGI					
3/0 Str. 3/0 Comp.	3/0 (6-1)	3/0 Str.	YS27UCGI	RYAC31-1	249/840	W249 (4) W-K840 (7)	A249 (2) —	U249 (2) U-K840T (4)
4/0 Str. 4/0 Comp.	4/0 (6-1)	4/0 Str.	YS28UCGI					
350 350 Comp.	—	350	YS31ACGI	RYAC31	299/705	—	—	U299 (2) U705 (1)

* Use to join copper to aluminum or ACSR not copper to copper.
** Multiple crimp die set makes more than one crimp per compression.

K-70

TYPES J1592, J1207

Y-LOK

For Locking Enclosures

Assembly consists of aluminum-clad steel wire loop and a compression type aluminum connector. Installed with BG groove of MD6 or OUR840 Compression Tools. Can also be installed with 5/8 or 5/8-1 grooves.

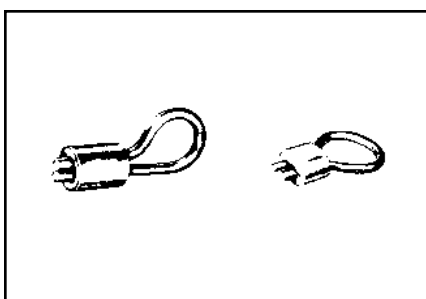

J1592 J1207

Compression Y-LOK installed with BG or 5/8 groove

Catalog Number	Installation Tooling			L	C	D
	D1D6, OUR840	Y35, Y750, Y46				
J1207	WBG	UBG		2.28	.75	1.00
J1592	XBG			2.31	.75	.75

Blue highlighted items are industry standard and most frequently ordered.

TYPE YRB-U

HYREDUCER™ SPLICE

For Aluminum-to-Aluminum and Aluminum-to-Copper

Type YRB-U splice is designed for use within underground systems. Aluminum splices are tin-plated and recommended for use on Aluminum-to-Aluminum and Aluminum-to-Copper cables. All splices have solid center stop for use with oil filled and non-oil filled cables. The Outside Diameter is held constant to minimize installation dies and connectors are prefilled with PENETROX™. Rated up to 35 kV.

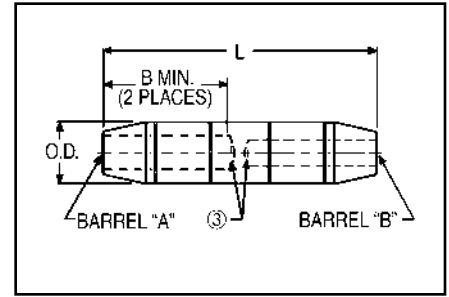

Catalog Number	Conductor Range		Dimensions		O.D.	Wire Strip Length		Die Number	Color Code
	Barrel "A" Copper & Aluminum	Barrel "B" Copper & Aluminum	B Min.	L		Barrel "A"	Barrel "B"		
YRB2U3TTN	#2 (.292 Dia.) 7 Str.	#3 (.260 Dia.) 7 Str.	1.35 [34]	3.25 [83]	.65 [17]	1-3/4"	1-3/4"	296	Tan
YRB1CU2TTN	#1 (.332 Dia.) 19 Str. or 1/0 Compact (.336 Dia.) 19 Str.	#2 (.292 Dia.) 7 Str.							
YRB1CU1TTN	#1 (.332 Dia.) 19 Str. or 1/0 Compact (.336 Dia.) 19 Str.	#1 (.332 Dia.) 19 Str. or 1/0 Compact (.336 Dia.) 19 Str.							
YRB25U3TTN	1/0 (.373 Dia.) 19 Str. or 1/0 Compact (.336 Dia.) 19 Str.	#3 (.260 Dia.) 7 Str.							
YRB25U2TTN	1/0 (.373 Dia.) 19 Str. or 1/0 Compact (.336 Dia.) 19 Str.	#2 (.292 Dia.) 7 Str.							
YRB25U25TTN	1/0 (.373 Dia.) 19 Str. or 1/0 Compact (.336 Dia.) 19 Str.	1/0 (.373 Dia.) 19 Str. or 1/0 Compact (.336 Dia.) 19 Str.							
YRB27U25TW	3/0 (.470 Dia.) 19 Str. or 3/0 Compact (.423 Dia.) 19 Str.	1/0 (.373 Dia.) 19 Str. or 1/0 Compact (.336 Dia.) 19 Str.	1.53 [39]	3.69 [94]	.85 [22]	1-1/2"	1-1/2"	298	White
YRB28U3TW	4/0 (.528 Dia.) 19 Str. or 4/0 Compact (.475 Dia.) 19 Str.	#3 (.260 Dia.) 7 Str.							
YRB28U1TW	4/0 (.528 Dia.) 19 Str. or 4/0 Compact (.475 Dia.) 19 Str.	#1 (.332 Dia.) 19 Str. or 1/0 Compact (.299 Dia.) 7 Str.							
YRB28U25TW	4/0 (.528 Dia.) 19 Str. or 4/0 Compact (.475 Dia.) 19 Str.	1/0 (.373 Dia.) 19 Str. or 1/0 Compact (.336 Dia.) 19 Str.							
YRB28U26TW	4/0 (.528 Dia.) 19 Str. or 4/0 Compact (.475 Dia.) 19 Str.	2/0 (.419 Dia.) 19 Str. or 2/0 Compact (.376 Dia.) 19 Str.	1.53 [39]	3.69 [94]					
YRB28U28TW	4/0 (.528 Dia.) 19 Str. or 4/0 Compact (.475 Dia.) 19 Str.	4/0 (.528 Dia.) 19 Str. or 4/0 Compact (.475 Dia.) 19 Str.							
YRB31U25TW	350 kcmil (.681 Dia.) 37 Str. or 350 kcmil Compact (.616 Dia.) 19 Str. Al; 37 Str. Al & Cu	1/0 (.373 Dia.) 19 Str. or 1/0 Compact (.336 Dia.) 19 Str.	2.34 [59]	5.43 [138]	1.11 [28]	2-1/4"	2-1/4"	299	Brown
YRB31U28TW	350 kcmil (.681 Dia.) 37 Str. or 350 kcmil (.616 Dia.) 19 Str. Al; 37 Str. Al & Cu	4/0 (.528 Dia.) 19 Str. or 250 kcmil Compact (.520 Dia.) 37 Str.							
YRB31U31TW	350 kcmil (.681 Dia.) 37 Str. or 350 kcmil Compact (.616 Dia.) 19 Str. Al; 37 Str. Al & Cu	350 kcmil (.681 Dia.) 37 Str. or 350 kcmil Compact (.616 Dia.) 19 Str. Al; 37 Str. Al & Cu							

K-71

1 Material: Aluminum.
 2 Finish: Electro-tin plated.
 ③ Barrels are partially filled with PENETROX™ and sealed.
 4 Scratch brushing of all conductors before making installation is recommended.
 5 Not for use with Copper-to-Copper applications.
 6 Dimensions in brackets [] are in millimeters rounded off to the nearest millimeter, unless otherwise noted and are for reference only.

⑦ Catalog number PT6515 Adaptor is required to use "U" dies in Y45 series tools.
 ⑧ Catalog number PUADP-1 Adaptor is required to use "U" dies in Y46 series tools.
 9 On MY29-3 HYTOOL™ use alum. Index plate settings as follows, for 1/0 conductor use 1/0 setting. For conductor smaller than 1/0 size use 2/0 setting.

Blue highlighted items are industry standard and most frequently ordered.

TYPE YRB-U

HYREDUCER™ SPLICE

(Continued)

For Aluminum-to-Aluminum and Aluminum-to-Copper

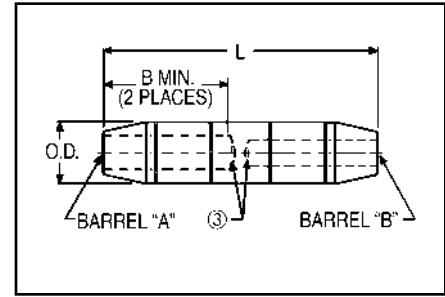

K-72

Catalog Number	Conductor Range		Dimensions		O.D.	Wire Strip Length		Die Number	Color Code
	Barrel "A" Copper & Aluminum	Barrel "B" Copper & Aluminum	B Min.	L		Barrel "A"	Barrel "B"		
YRB34U25TW	500 kcmil (.813 Dia.) 37 Str. or 500 kcmil Compact (.736 Dia.) 19 Str. Al; 37 Str. Al & Cu	1/0 (.373 Dia.) 19 Str.	2.70 [69]	6.00 [152]	1.31 [33]	1-1/8"	1-1/8"	300	Pink
YRB34U28TW	500 kcmil (.813 Dia.) 37 Str. or 500 kcmil Compact (.736 Dia.) 19 Str. Al; 37 Str. Al & Cu	4/0 (.528 Dia.) 19 Str. or 4/0 Compact (.475 Dia.) 19 Str.							
YRB34U29TW	500 kcmil (.813 Dia.) 37 Str. or 500 kcmil Compact (.736 Dia.) 19 Str. Al; 37 Str. Al & Cu	250 kcmil (.575 Dia.) 37 Str.							
YRB34U30TW	500 kcmil (.813 Dia.) 37 Str. or 500 kcmil Compact (.736 Dia.) 19 Str. Al; 37 Str. Al & Cu	300 kcmil (.630 Dia.) 37 Str.							
YRB34U31TW	500 kcmil (.813 Dia.) 37 Str. or 500 kcmil Compact (.736 Dia.) 19 Str. Al; 37 Str. Al & Cu	350 kcmil (.681 Dia.) 37 Str. 350 kcmil Compact (.616 Dia.) 19 Str. Al; 37 Str. Al & Cu							
YRB34U34TW	500 kcmil (.813 Dia.) 37 Str. or 500 kcmil Compact (.736 Dia.) 19 Str. Al; 37 Str. Al & Cu	500 kcmil (.813 Dia.) 37 Str. or 500 kcmil Compact (.736 Dia.) 19 Str. Al; 37 Str. Al & Cu							
YRB39U31TW	750 kcmil (.998 Dia.) 61 Str. or 750 kcmil Compact (.908 Dia.) 61 Str.	350 kcmil (.681 Dia.) 37 Str. or 350 kcmil Compact (.616 Dia.) 19 Str. Al; 37 Str. Al & Cu	2.87 [73]	6.74 [171]	1.46 [37]	3"	3-11/16"	936	Yellow
YRB39U34TW	750 kcmil (.998 Dia.) 61 Str. or 750 kcmil Compact (.908 Dia.) 61 Str.	500 kcmil (.813 Dia.) 37 Str. or 500 kcmil Compact (.736 Dia.) 19 Str. Al; 37 Str. Al & Cu							
YRB39U39TW	750 kcmil (.998 Dia.) 61 Str. or 750 kcmil Compact (.908 Dia.) 61 Str.	750 kcmil (.998 Dia.) 61 Str. or 750 kcmil Compact (.908 Dia.) 61 Str.							
YRB44U31TW	1000 kcmil (1.152 Dia.) 61 Str.	350 kcmil (.681 Dia.) 37 Str. or 350 kcmil Compact (.616 Dia.) 19 Str. Al; 37 Str. Al & Cu							
YRB44U34TW	1000 kcmil (1.152 Dia.) 61 Str.	500 kcmil (.813 Dia.) 37 Str. or 500 kcmil Compact (.736 Dia.) 19 Str. Al; 37 Str. Al & Cu							
YRB44U39TW	1000 kcmil (1.152 Dia.) 61 Str.	750 kcmil (.998 Dia.) 61 Str. or 750 kcmil Compact (.908 Dia.) 61 Str.							
YRB44U44TW	1000 kcmil (1.152 Dia.) 61 Str.	1000 kcmil (1.152 Dia.) 61 Str.							

- 1 Material: Aluminum.
- 2 Finish: Electro-tin plated.
- ③ Barrels are partially filled with PENETROX™ and sealed.
- 4 Scratch brushing of all conductors before making installation is recommended.
- 5 Not for use with Copper-to-Copper applications.
- 6 Dimensions in brackets [] are in millimeters rounded off to the nearest millimeter, unless otherwise noted and are for reference only.

- ⑦ Catalog number PT6515 Adaptor is required to use "U" dies in Y45 series tools.
- ⑧ Catalog number PUADP-1 Adaptor is required to use "U" dies in Y46 series tools.
- 9 On MY29-3 HYTOOL™ use alum. Index plate settings as follows, for 1/0 conductor use 1/0 setting. For conductor smaller than 1/0 size use 2/0 setting.

Blue highlighted items are industry standard and most frequently ordered.

TYPE YRB-U

HYREDUCER™ SPLICE

(Continued)

For Aluminum-to-Aluminum and Aluminum-to-Copper

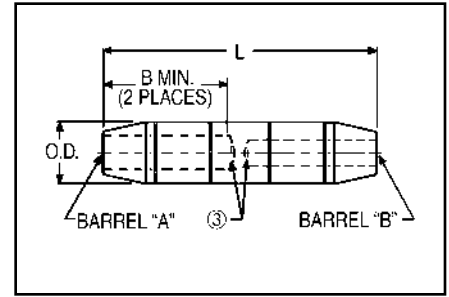

Installation (Number of Crimps per End)									
Color Code	Die Index	Mechanical Ratchet		Hydraulic					⑤ Dieless (# of Crimps) Mechanical: MY29-3 (1), MY29-11 (1) Hydraulic: Y644M (1), PAT644-18V (1)
		OUR840	MD6, MD7	Y35, Y39, Y750 BAT35, BAT750, PAT750	⑧ Y46	⑦ Y45	Y48B	Y60BHU	
Tan	296	—	—	U25ART (1)	U25ART (1)	U25ART (1)	C25AR (1)	—	MY29-3 (1) MY29-11 (1)
White	298	—	—	U28ART (2)	U28ART (2)	U28ART (2)	C28AR (2)	—	Y644M (1) PAT644-18V (1)
Brown	299	—	—	U31ART Overlap Crimp	U31ART Overlap Crimp	U31ART Overlap Crimp	C31AR (1)	L31ART (1)	Y644M (1) PAT644-18V (1)
Pink	300	—	—	U34ART Overlap Crimp	U34ART Overlap Crimp	U34ART Overlap Crimp	C34AR (1)	L34ART	
Yellow	936	—	—	U39ART-2 (4)	U39ART-2 (4)	U39ART-2 (4)	C39AR (2)	L39ART (2)	—

- 1 Material: Aluminum.
- 2 Finish: Electro-tin plated.
- ③ Barrels are partially filled with PENETROX™ and sealed.
- 4 Scratch brushing of all conductors before making installation is recommended.
- 5 Not for use with Copper-to-Copper applications.
- 6 Dimensions in brackets [] are in millimeters rounded off to the nearest millimeter, unless otherwise noted and are for reference only.

- ⑦ Catalog number PT6515 Adaptor is required to use "U" dies in Y45 series tools.
- ⑧ Catalog number PUADP-1 Adaptor is required to use "U" dies in Y46 series tools.
- 9 On MY29-3 HYTOOL™ use alum. Index plate settings as follows for 1/0 conductor use 1/0 setting. For conductor smaller than 1/0 size use 2/0 setting.

K-73

Blue highlighted items are industry standard and most frequently ordered.

TYPE YRB-T

HYREDUCER™ SPLICE

For Copper-to-Copper

Type YRB-T splice is designed for use within underground systems. Copper splices are tapered and recommended for use on copper-to-copper cables.

All splices have solid center stops for use with oil filled and non-oil filled cables.

The Outside Diameter is held constant to minimize installation dies. Rated up to 35 kV.

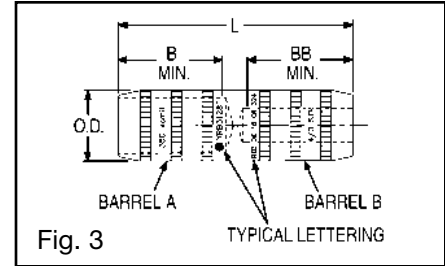
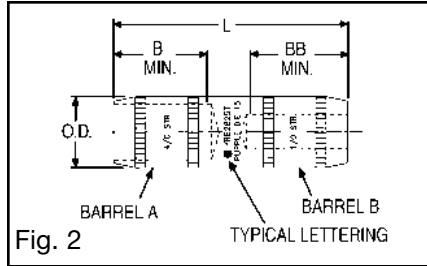
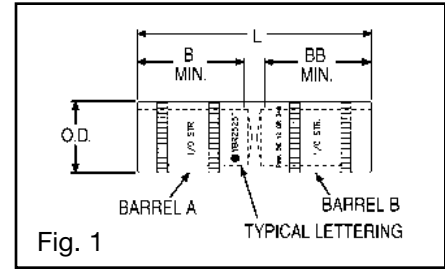

Catalog Number ②	Figure No.	Conductor Size		Dimensions			
		Barrel "A"	Barrel "B"	B Min.	BB Min.	L	O.D.
YRB2825T	2	4/0 (.528)	1/0 (.372)	1.16 [29]	1.16 [29]	2.84 [73]	.69 [18]
YRB3428T	3	500 kcmil (.813)	4/0 (.528)	1.73 [44]	1.73 [44]	4.50 [114]	1.06 [27]

K-74

- 1 Material: Copper.
- ② For Tin-Plating, add suffix "TN" to the Catalog Number (example: YRB2825TN). For Hot Tin dipped add suffix "W" to the catalog number (example: YRB2825TW).
- ③ Catalog Number PT6515 Adaptor is required to use "U" dies in Y45 series tools.
- ④ Catalog Number PUADP-1 is required to use "U" dies in Y46 series tools.
- 5 Dimensions in brackets [] are in millimeters rounded off to the nearest millimeter, unless otherwise specified, and are for reference only.
- ⑥ For use by customers that have this HYPRESS™. No new Y34 HYPRESS™ tools are being processed.
- ⑦ Suffix "TN" and "W" will not be stamped on part.

Blue highlighted items are industry standard and most frequently ordered.

TYPE YRB-T

HYREDUCER™ SPLICE

(Continued)

For Copper-to-Copper

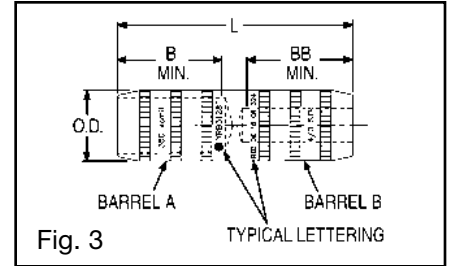
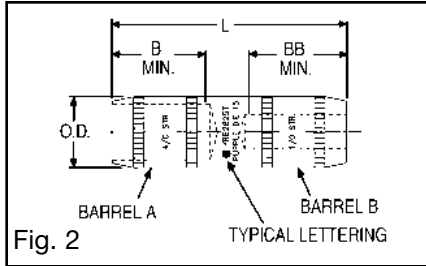
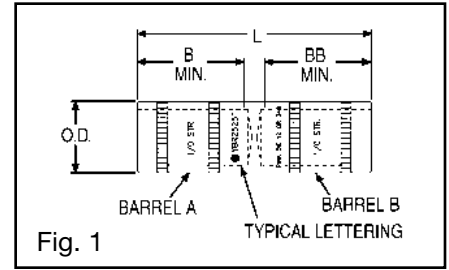

Catalog ② Number ⑦	Color Code	Installation Tooling (Number of Crimps)												Dieless (# of Crimps)	Wire Strip Length
		Die Information		Mechanical				Hydraulic							
		Die Index	Type	OUR840	MD7 MD7-34R	MD6	Y34A ⑥	Y35, Y39, Y750, BAT35, BAT750, PAT750	BCT500, Y500CT	Y46 ④	Y45 ③	Y48B	Y60BHU		
YRB2825T	Purple	Die 15	Purple Die Set	X28VT (4) X28RT (4)	X28VT (4)	X28RT (4)	—	U28RT (1)	—	U28RT (1)	—	C28R (1)	L29ART (1)	Hydraulic: Y644M (1)	1-7/32"
YRB3428T	Brown	Die 20 or 299	Brown Die Set	—	—	—	—	U34RT (2) U31ART (2)	W34VT (2) W34RT (2)	U34RT (2) U31ART (2)	U34RT (2) U31ART (2)	C34R (1) C31AR (1)	L34RT (1)	BAT644M (1) PAT644M (1)	1-13/16"

- 1 Material: Copper.
- ② For Tin-Plating, add suffix "TN" to the Catalog Number (example: YRB2825TN). For Hot Tin dipped add suffix "W" to the catalog number (example: YRB2825TW).
- ③ Catalog Number PT6515 Adaptor is required to use "U" dies in Y45 series tools.
- ④ Catalog Number PUADP-1 is required to use "U" dies in Y46 series tools.

- 5 Dimensions in brackets [] are in millimeters rounded off to the nearest millimeter, unless otherwise specified, and are for reference only.
- ⑥ For use by customers that have this HYPRESS™. No new Y34 HYPRESS™ tools are being processed.
- ⑦ Suffix "TN" and "W" will not be stamped on part.

Blue highlighted items are industry standard and most frequently ordered.

TYPE K-P-C

URD

URD Service Tap for Copper Conductors

These compact, wide-range-taking, multiple outlet connectors are made of high conductivity copper alloy. Spherical point Allen set screws provide even clamping forces on conductors up to 4/0 Str. Each connector is supplied with an insulating cover. The mechanical clamping elements allow individual cables to be disconnected without disturbing adjacent connections.

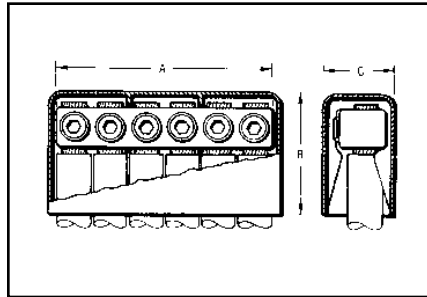

Conductor	Catalog Number			Number of Outlets	A	B	C
	Complete Assembly	Connector Only	Cover Only				
6 Str. - 4/0 Str.	K6P28C	K6P28	K-PC28	6	5-1/8	2-3/4	1-5/8

COMPRESSION SERVICE TAPS AND TRANSFORMER TERMINALS

K-76

Where compression-type service taps are required, the wide-range-taking, figure "6" shaped, tap connectors are recommended. They can be gripped in a HYPRESS™ and slipped over the secondary main for easy installation. For above-grade installation, commercially available insulating tubes are often used to cover a series of these taps on each main cable stub. Separation of run and tap cables simplifies taping.

TYPE YPC-C

TIN-PLATED COPPER CRIMPIT™

For Copper Conductors

Made of tin-plated pure copper this connector is recommended for copper service taps in above-grade enclosures or for direct burial. The streamlined design facilitates taping. The plating eliminates reaction with insulators.

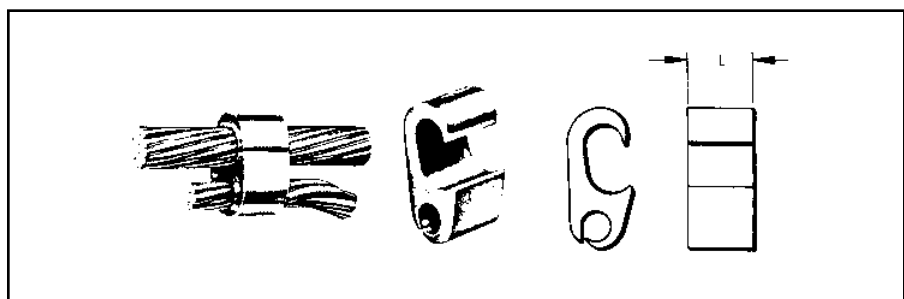

Conductor		Catalog Number	L	Die Index	Installation Tooling	
Run	Tap				Die Cat. No.	(No. of Crimps)
2/0 Str. - 250	4 Str. - 2/0 Str	YPC29C26	1.00	D3	U-D3	(1)

* Y35 HYPRESS™ U-Dies with adapter PUADP-1 can also be used with Y46. Same number of crimps as Y35.

Blue highlighted items are industry standard and most frequently ordered.

TYPES K6B, K33B

**URD TRANSFORMER
TERMINALS**

For Copper Conductors

These terminals are companion connectors of the various types of DOME-TAP, and possess the same advantages of wide conductor range and compactness. These features simplify cable terminations in the secondary compartments of pad-mounted transformers. The design also permits individual cables to be disconnected without disturbing adjacent joints.

Made of a high conductivity copper alloy, these compact range-taking connectors provide for connecting up to six copper cables at the transformer terminals. The outlets are equipped with spherical point, tin-plated brass socket set-screws to provide even clamping forces on the conductors throughout the cable range.

Where cable sizes exceed 4/0 Str., a pressure bar is added to assure optimum performance.

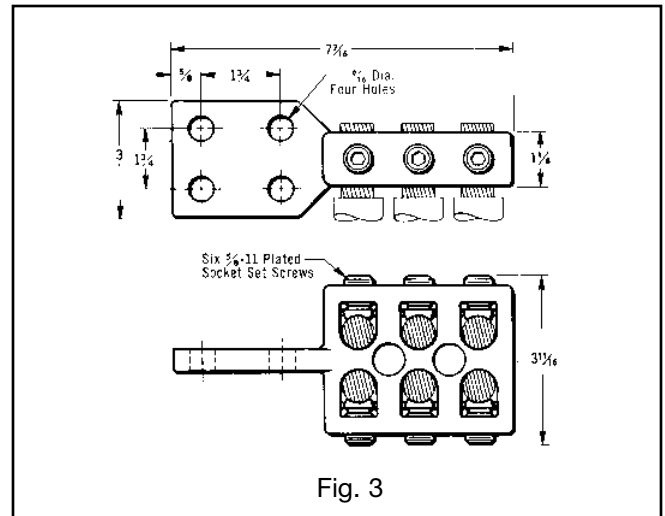
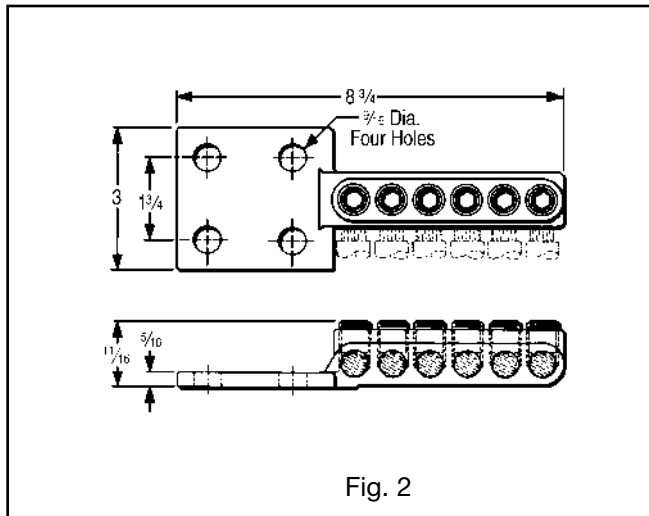
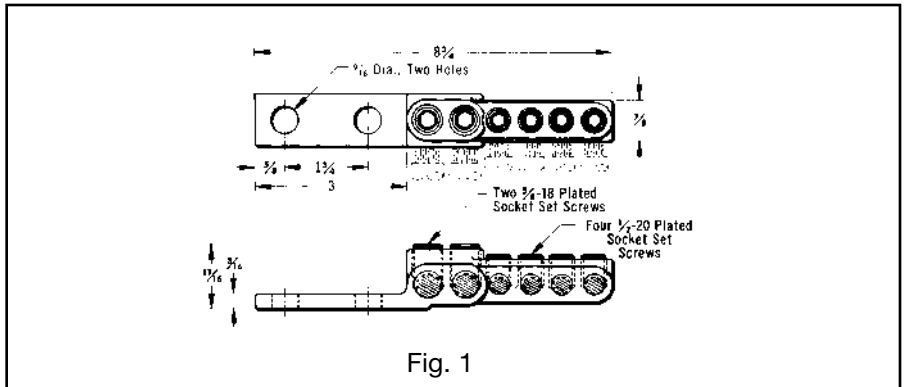
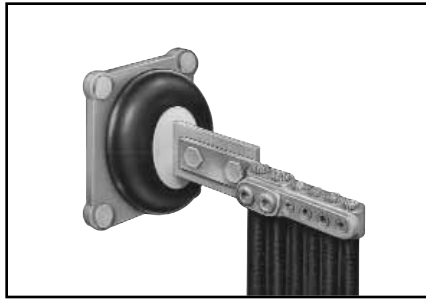

Conductor	Catalog Number	Fig. No.	NEMA Tongue
Two Outlets: #6 - 4/0	K6B2826-2N	1	2-Hole
Four Outlets: 6 Str. - 2/0	K6B28-4N	2	4-Hole
Six Outlets: 6 Str. - 4/0 Str.	K6B28-4N	2	4-Hole
Six Outlets: 4/0 Str. - 500	K33B34-4N	3	4-Hole

Blue highlighted items are industry standard and most frequently ordered.

TYPE F-A

URD FUSED TRANSFORMER TERMINALS

These Transformer Tap assemblies bolt directly to the secondary terminal pad. They provide for up to eight cables to be fused directly at the secondary terminals. This may be all service taps or combinations of secondary mains and service taps.

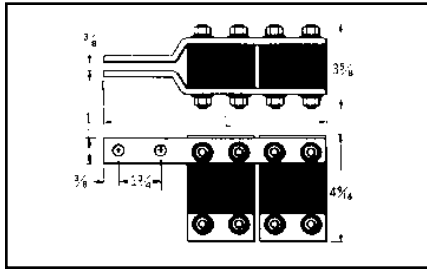

Catalog Number	Number of Fuses	L Inches
F22A28	4	6-1/2

Type LF Limiter and HYLUG™ (copper or aluminum)
Compression terminals must be ordered separately.

TYPE K6A34U

TRANSFORMER TERMINALS

For Aluminum and Copper Conductors

Made of aluminum alloy, the massive design minimizes conductor corrosion due to galvanic action. Each outlet is pre-filled with PENETROX™ joint compound and sealed. Plated aluminum socket head pressure screws and aluminum pressure bars prevent conductor damage. Six hole pad allows for adjustable positioning on four hole NEMA spades.

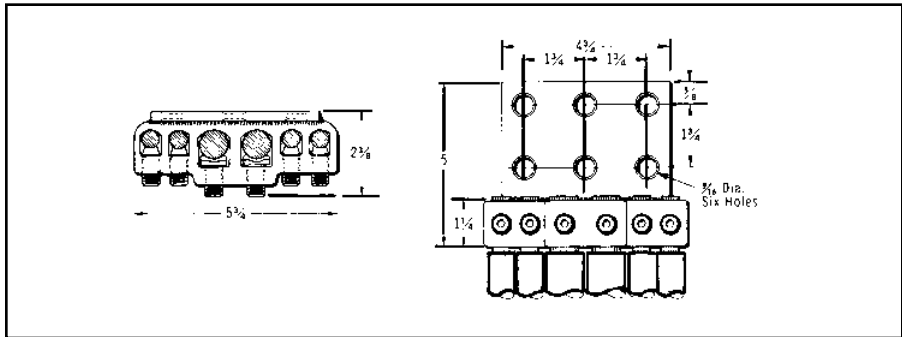

Conductor	Catalog Number	Number of Outlets
Two Outlets 2 Str. - 500 Four Outlets 6 Str. - 4/0 Str.	K6A34U-6N	6

K-78

TYPE K-P-UC

UNIVERSAL URD SERVICE TAP

For Aluminum or Copper

Made of aluminum alloy, the massive design minimizes conductor corrosion due to galvanic action. Each outlet is pre-filled with PENETROX™ joint compound and sealed. Plated aluminum socket head pressure screws and aluminum pressure bars prevent conductor damage. Each connector is supplied with an insulating cover.

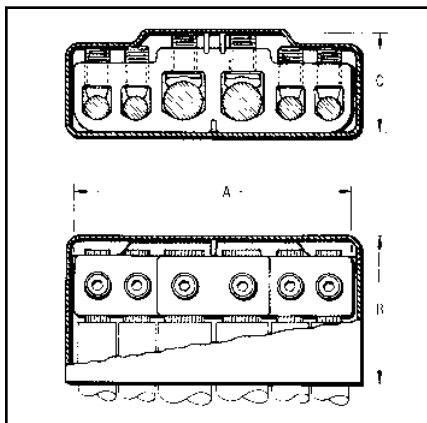

Conductor	Catalog Number			Number of Outlets	A	B	C
	Complete Assembly	Connector Only	Cover Only				
Two Outlets 2 Str. - 500 Four Outlets 6 Str. - 4/0 Str.	K6P34UC	K6P34U	K6PC34U	6	5-3/4	3-1/8	2-1/8

Blue highlighted items are industry standard and most frequently ordered.

TYPES BPD & BPD2

POWER DISTRIBUTION BLOCKS

Dual rated ground pedestal lugs. Rated for 600 volt. Constructed from high strength aluminum alloy 6061-T6. Connectors are all plated to provide low contact resistance.

Plastisol covers dielectric strength rating of 120 volts per mil. Nominal thickness is 156 mils. Covers purchased separately.

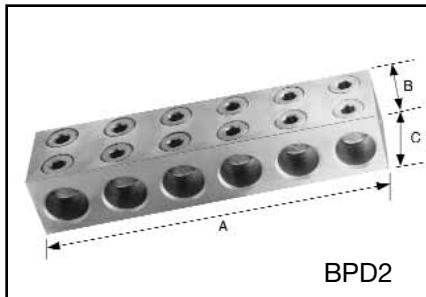
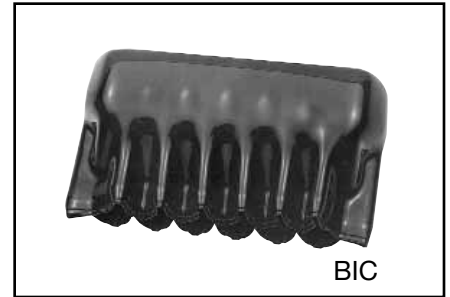
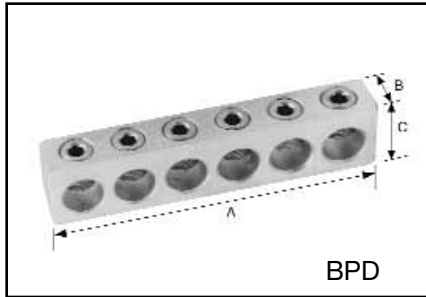

Catalog Number	Wire Range Aluminum or Copper	Number of Conductors	Dimensions			Insulating Cover
			A	B	C	
BPD-4-350	#6 - 350	4	3.88	1.38	1.00	BIC-4-350
BPD-6-350	#6 - 350	6	5.69	1.38	1.00	BIC-6-350
BPD-8-350	#6 - 350	8	7.50	1.38	1.00	BIC-8-350
BPD-4-500	#2 - 500	4	4.75	1.63	1.00	BIC-4-500
BPD-6-500	#2 - 500	6	7.00	1.63	1.00	BIC-6-500
BPD-8-500	#2 - 500	8	9.25	1.63	1.00	BIC-8-500
BPD2-4-750	#2 - 750	4	6.56	2.00	2.50	BIC2-4-750
BPD2-6-750	#2 - 750	6	9.88	2.00	2.50	BIC2-6-750
BPD2-8-750	#2 - 750	8	13.81	2.00	2.50	BIC2-8-750

K-79

Blue highlighted items are industry standard and most frequently ordered.

TABLE OF CONTENTS

COPPER SUBSTATION

Introduction L-3



Type **NA**
Tube to Flat L-4



Type **XA**
Tube to Flat, Expandable . . . L-4



Types **NAS, NAH**
Cable to Flat (Terminal) L-5

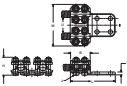

Type **N2AH**
Two Cables to Flat L-6



Types **VA, VVA**
Cable to Flat (Terminal) L-7



Type **NT**
Tube to Tube L-8



Types **NSNT, NHNT**
Tube to Cable L-9



Types **NSNT, NHNT**
Cable to Cable L-10



Type **VT**
Cable to Cable L-11



Type **NS**
Tube to Tube L-11



Type **XP**
Tube to Tube L-12



Type **UH**
Bus Support, Tube L-13



Type **UHR**
Bus Support,
Tube or Cable L-13



Types **LH, LHR**
Bus Support,
Tube or Cable L-14



Type **NDR**
Stud Connector, Cable,
Tube, Flat Bar L-15

L-1

Blue highlighted items are industry standard and most frequently ordered.

TABLE OF CONTENTS (Continued)

	Type FD Stud Connector, Stud to Flat Bar L-16		Type NS-A Tube to Tube L-24
	Type QGFL Bar Tap, Cable to Flat L-17		Type NA-A Tube to Flat L-25
	Type FCB Transformer Tap Adapter . . . L-17		Type XA-A Tube to Flat L-25
	Type E-C-G Transformer Tap Adapter . . L-18		Type NBC-A Tube to Flat L-26 -L-27
	Type HFBW Bar Clamp L-19		Type NAR-A Cable to Flat L-28
	Type HFB-P1 Bar Clamp L-20		Type UHG-A Bus Support, Tube L-29
	Type HFB-N Tap Pad Adapter L-21		Type UHKR-A Bus Support, Tube or Cable L-29
	Type FN L-21		Type LB-A End Cap, Aluminum Tube . . L-30
ALUMINUM SUBSTATION			Type WAS-A Terminal Connector L-31
	Type NNT-A Tube to Tube L-23		Type WASC-A-N Centerformed Terminal L-32
	Type NNTR-A Tube to Cable, Cable to Cable. . . L-23 - L-24		Type WG-A Weldment Ground Stud . . . L-33

L-2

Blue highlighted items are industry standard and most frequently ordered.

COPPER SUBSTATION CONNECTORS

INTRODUCTION

BURNDY® electrical connectors are designed to be installed with a minimum of effort, to run cooler than the conductors being joined and to provide optimum performance under all operating conditions.

To achieve this type of performance, extensive research and development time is spent by BURNDY® engineers and scientists to improve manufacturing techniques, materials and designs. As these improvements become available, they are incorporated into both existing and new product lines. This continuous program of product innovation and improvement insures that, as new and more critical applications evolve, high quality connectors from BURNDY® will be available to meet the need.

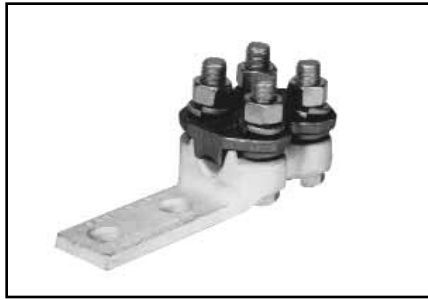

N-Line connectors are two-piece copper alloy castings assembled with DURIMUM™ (silicon bronze) hex bolts, nuts and washers. They are available for connecting tube or cable.

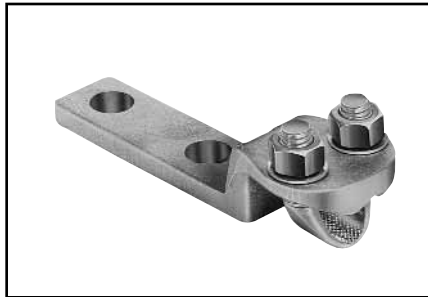

The Variline incorporates a modified V-bolt as the clamping element for heavy-duty applications. This line is particularly suited for use with flexible and extra flexible cables.



Flat pad connectors used to join cable or tubing terminals to equipment studs.



A variety of bus supports are also available for tube or cable. Some can be adjusted for either a rigid or slide-fit by rotating the clamping cap 180°.

Expansion connectors are used to absorb the stress imposed on the bus by settling ground, thermal expansion and shocks, as in circuit breaker operations. The flexible elements are flat-tinned, copper braid, with sufficient cross sectional area to carry the rated current of the conductors being joined.

Blue highlighted items are industry standard and most frequently ordered.

TYPE NA

TERMINAL

For Copper Tube to Flat

High copper alloy terminal for joining copper tube to a flat pad. Letter "N" on end of catalog number indicates pad drilled to NEMA standards. One-wrench installation.

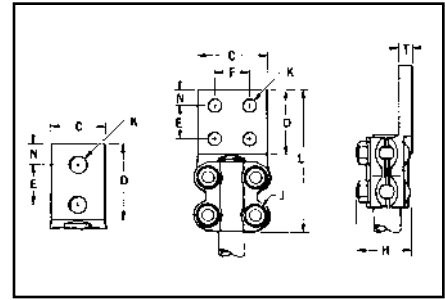
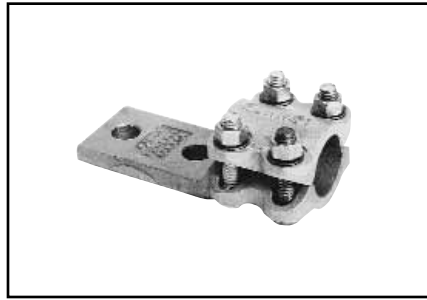

Catalog Number	Conductor	No. of Holes in Pad	C	D	E & F	H	J	K	L	N	T	
NA13-2N	1/2	2	1-1/2	3	1-3/4	1-3/4	3/8	9/16	5-1/4	5/8	3/8	
NA14-2N	3/4	2	1-5/8			2	3/8				3/8	
NA15-2N	1	2	1-7/8			2-1/8	3/8				3/8	
NA15-4N	1	4	3			2-1/8	3/8				3/8	
NA16-2N	1-1/4	2	2-1/4			2-5/8	1/2				1/2	
NA16-4N	1-1/4	4	3			2-5/8	1/2				1/2	
NA17-2N	1-1/2	2	2-1/2			2-3/4	1/2		1/2		6	1/2
NA17-4N	1-1/2	4	3			2-3/4	1/2		1/2			1/2
NA18-4N	2	4	3-1/8			3-1/	1/2		1/2			1/2
NA19-4N	2-1/2	4	3-1/4			3-3/4	1/2		1/2			3/4
NA21-4N	3-1/2	4	4-3/8			5	5/8		5/8			7/8
NA22-4N	4	4	5-1/4			5-1/2	5/8		5/8			6-5/8

TYPE XA

EXPANSION TERMINAL

L-4

For Copper Tube to Flat

High copper alloy expansion terminal for tube to flat. Provides for longitudinal movement of tubing. Extra flexible braid carries full load of joint. One-wrench installation.

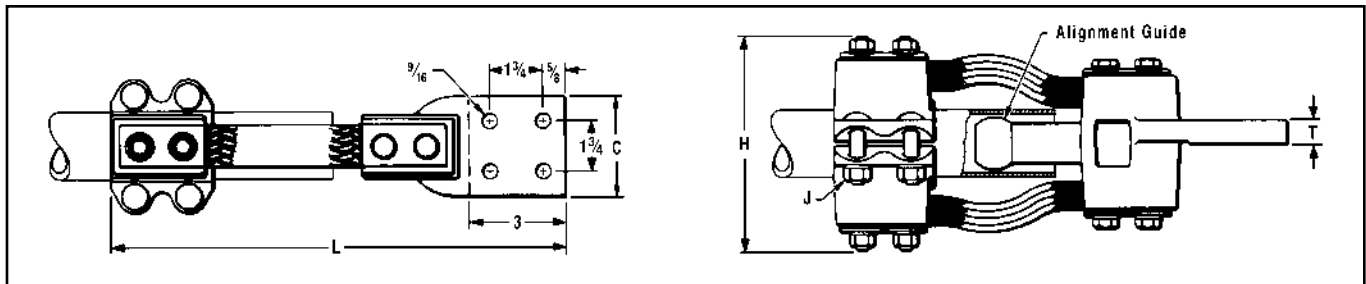

Catalog Number Standard I.P.S. With Guide	Conductor	Number of Holes in Pad*	C	H	J	L	T
XA18-4N	2	4	3	7	1/2	15-1/4	1/2
XA19-4N	2-1/2		3-3/4	7-1/2		16-1/8	5/8
XA20-4N	3		4-3/8	8	5/8	16-3/4	3/4
XA21-4N	3-1/2		4-3/4	8-1/4		17	7/8
XA22-4N	4		5-1/4	9-1/2		17	7/8

* Conforms to NEMA Standards

Blue highlighted items are industry standard and most frequently ordered.

TYPES NAS, NAH

TERMINAL

For Copper Cable

High copper alloy reversible cap terminal for joining a wide range of cable to equipment pads. Tongue is side formed to provide adequate clearance and terminal is designed for one-wrench installation.

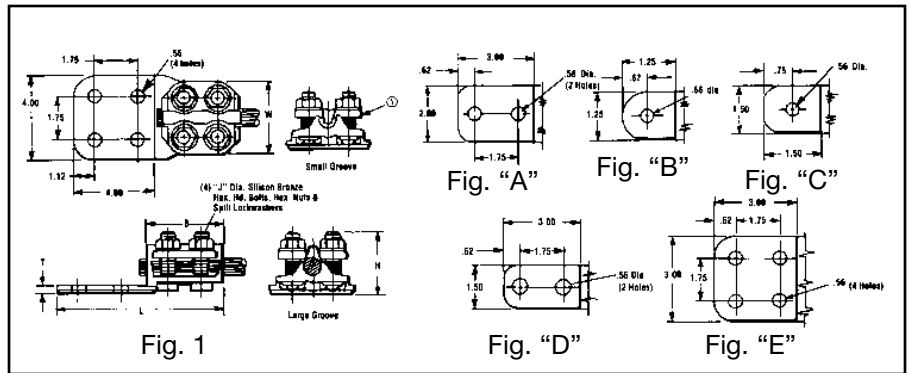

Catalog Number	Fig. No.	Copper Cable Range			B	H	J Dia.	L	T	W								
		Complete Cable Range	Small Groove	Large Groove														
NAS29-N	1B				2.38	1.80	3/8"-16	3.58		2.00								
NAS29-2N	1D	6 Sol. (.162 Dia.) to 250 kcmil (.575 Dia.)	6 Sol. (.162 Dia.) to 1/0 Str. (.373 Dia.)	2/0 Str. (.419 Dia.) to 250 kcmil (.575 Dia.)	2.62	2.12	1/2"-13	5.88	.25	2.44								
NAS29-34N	1E				2.38	1.80	3/8"-16	5.62		2.00								
NAS34-N	1C				2.38	2.05	3/8"-16	4.12		2.20								
NAS34-2N	1A	1/0 Sol. (.325 Dia.) to 500 kcmil (.813 Dia.)	1/0 Sol. (.325 Dia.) to 4/0 Str. (.529 Dia.)	250 kcmil (.575 Dia.) to 500 kcmil (.813 Dia.)	2.62	2.38	1/2"-13	5.88	.31	2.56								
NAH34-2N	1A				2.38	2.05	3/8"-16	5.62		2.20								
NAS34-34N	1E				2.30	1.75	1/2"-13	5.88	.25	2.56								
NAH34-34N	1E				2.30	1.75	3/8"-16											
NAS40-2N	1A	2/0 Sol. (.365 Dia.) to 800 kcmil (1.031 Dia.)	2/0 Sol. (.365 Dia.) to 500 kcmil (.813 Dia.)	500 kcmil (.813 Dia.) to 800 kcmil (1.031 Dia.)	2.62	2.62	1/2"-13	6.88	.38	2.44								
NAH40-2N	1A						3/8"-16			2.81								
NAS40-34N	1E						1/2"-13			2.44								
NAH40-34N	1E						3/8"-16			2.44								
NAH40-44N	1							.31	2.44									
NAH44-2N	1A	4/0 Str. (.528 Dia.) to 1000 kcmil (1.152 Dia.)	4/0 Str. (.528 Dia.) to 750 kcmil (.998 Dia.)	750 kcmil (.998 Dia.) to 1000 kcmil (1.152 Dia.)	2.88	2.62	1/2"-13		6.88	2.81								
NAH44-34N	1E																	
NAH44-44N	1							.44	2.88									
NAH46-2N	1A	1000 kcmil (1.152 Dia.) to 1500 kcmil (1.412 Dia.)	—	1000 kcmil (1.152 Dia.) to 1500 kcmil (1.412 Dia.)	3.06	2.88	1/2"-13			6.12	.38							
NAH46-34N	1E							7.12	.31									
NAH46-44N	1							6.31	.50									
NAH48-2N	1A	500 kcmil (.813 Dia.) to 2000 kcmil (1.632 Dia.)	500 kcmil (.813 Dia.) to 1500 kcmil (1.412 Dia.)	1500 kcmil (1.412 Dia.) to 2000 kcmil (1.632 Dia.)	3.25	3.12	1/2"-13	7.31	.38	3.38								
NAH48-34N	1E										6.50	.69						
NAH48-44N	1																	

L-5

Blue highlighted items are industry standard and most frequently ordered.

TYPE N2AH

TERMINAL

For Two Copper Cables to Flat

High copper alloy, reversible cap terminal for joining a wide range of two copper cables to equipment pads. Tongue is side formed to provide adequate clearance and terminal is designed for one-wrench installation.

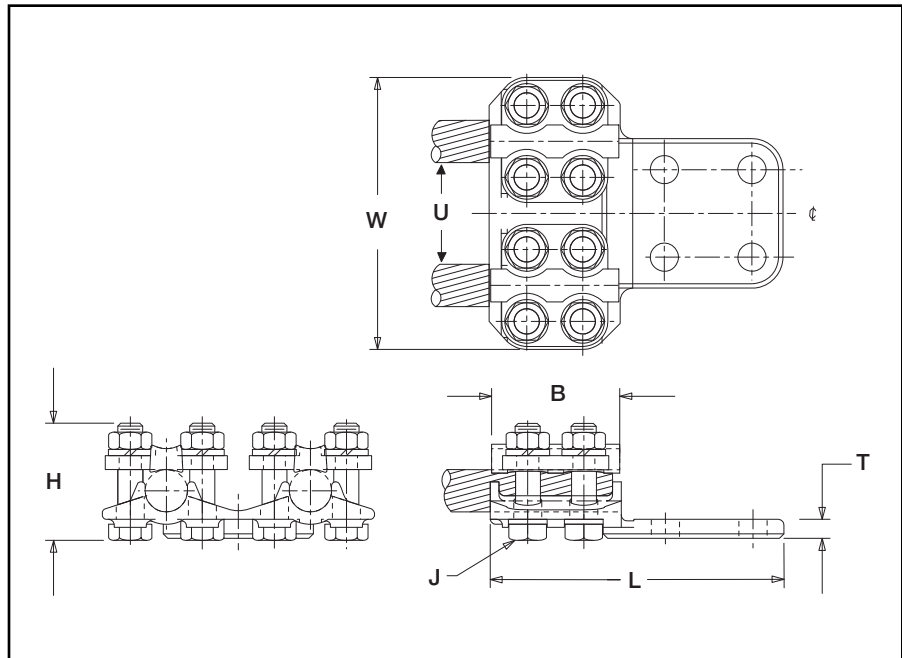

Catalog Number	Fig. No.	Copper Cable Range			Dimensions Inches/[mm]						
		Complete Cable Range	Small Groove	Large Groove	B	H	U	J Dia.	L	T	W
N2AH34-34N	1	1/0 Str. (.325) to 500 kcmil (.813)	1/0 Sol. (.325) to 4/0 Str. (.529)	250 kcmil (.575) to 500 kcmil (.813)	2.63 [67]	2.30 [58]	2.88	1/2 - 13	6.13 [156]	.31 [8]	3.88 [99]
N2AH40-34N	1	2/0 Str. (.420) to 800 kcmil (1.031)	2/0 Str. (.420) to 500 kcmil (.813)	500 kcmil (.813) to 800 kcmil (1.031)	2.63 [67]	2.62 [67]	2.92		5.88 [149]	.31 [8]	5.70 [145]
N2AH44-34N	1	4/0 Str. (.529) to 1000 kcmil (1.152)	4/0 Str. (.529) to 750 kcmil (.998)	750 kcmil (.998) to 1000 kcmil (1.152)	2.88 [73]	2.62 [67]	3.12		6.38 [175]	.50 [13]	4.69 [119]
N2AH44-44N	2	4/0 Str. (.529) to 1000 kcmil (1.152)	4/0 Sol. (.529) to 750 kcmil (.998)	750 kcmil (.998) to 1000 kcmil (1.152)	2.88 [73]	2.25 [57]	3.12		7.32 [186]	.50 [13]	6.12 [155]
N2AH46-44N	2	1000 kcmil (1.152) to 1500 kcmil (1.411)	—	—	3.07 [78]	2.50 [64]	3.36		7.46 [189]	.75 [19]	6.50 [165]

L-6

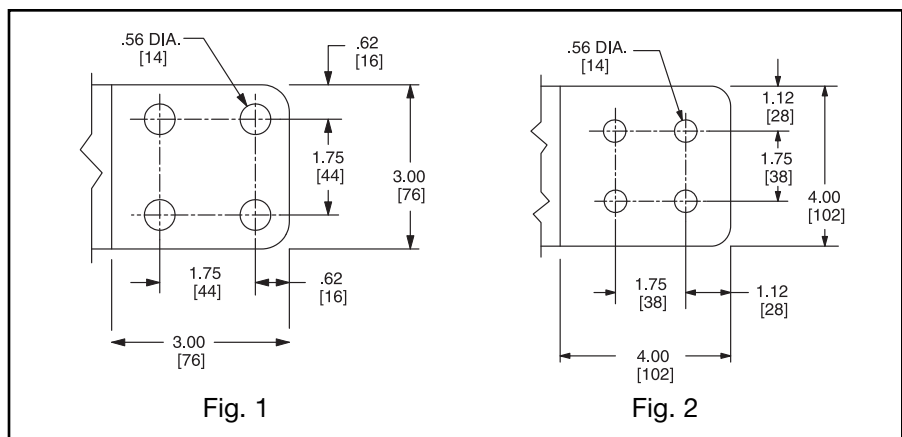

Blue highlighted items are industry standard and most frequently ordered.

TYPES VA, VVA

VARILUG

For Copper Cable

High copper alloy terminal for joining a wide range of cable to equipment pads or bar. Particularly suitable for use on extra flexible cable. One-wrench installation. Type VVA, twin elements secure joint against vibration and flexing. Particularly recommended for use on extra flexible cables. One-wrench installation.

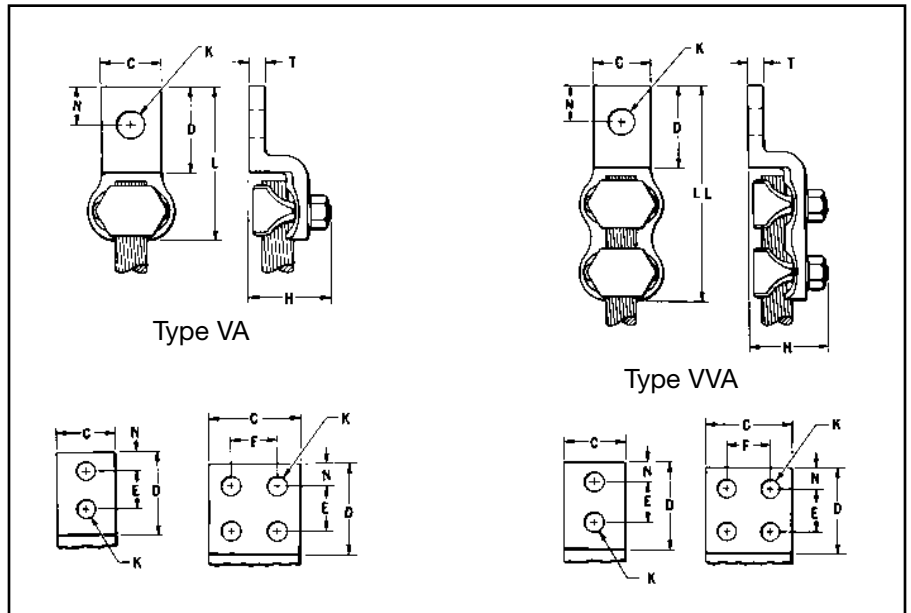
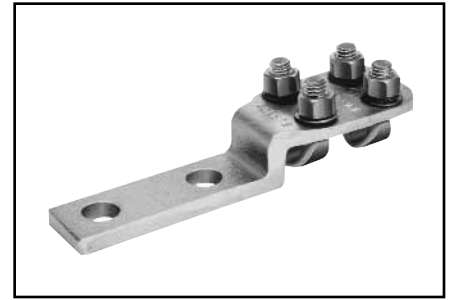
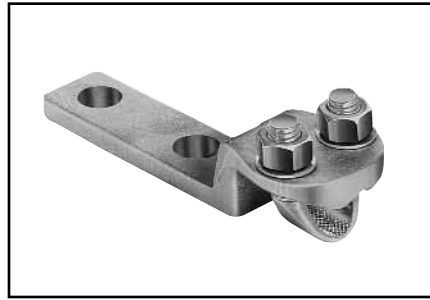

L-7

Catalog Number*		Conductor	No. of Holes in Pad	C	D	E & F	H	K	L	LL	N	T
Type VA	Type VVA											
VA2C	—	8 Sol. - 2 Str.	1	13/16	1-1/4	—	1-1/2	7/16	2-3/4	4-1/8	3/8	1/4
VA25	—	6 Sol. - 1/0 Str.		7/8	1-3/8	—	1-7/8		2-1/8	4-3/8	1/2	
VA28	VVA28	1/0 Str. - 4/0 Str.	1	1-1/16	1-1/2	—	1-7/8	7/16	2-5/8	4-1/8	1/2	5/16
VA28-2N	VVA28-2N		2 NEMA		3-1/2	1-3/4			9/16	5	6-1/4	
VA30	VVA30	1/0 Str. - 300	1	1-1/8	1-5/8	—	2-1/4	7/16	3-1/4	4-5/8	5/8	3/8
VA30-2N	VVA30-2N		2 NEMA		3-5/8	1-3/4			9/16	5-1/4	6-5/8	
VA34	VVA34	300 - 500	1	1-3/8	2	—	2-5/8	9/16	3-7/8	5-3/8	7/8	3/8
VA34-2N	VVA34-2N		2 NEMA		3-5/8	1-3/4			9/16	5-3/8	6-1/8	
—	VVA34-4N		4 NEMA	3	3-1/16	1-3/4	2-9/16	9/16	5-3/8	6-7/8	5/8	
VA40	VVA40	500 - 800	1	1-5/8	2-3/8	—	2-1/8	9/16	4-1/2	6-3/8	1	3/8
VA40-2N	VVA40-2N		2 NEMA		3-5/8	1-3/4			9/16	5-7/8	7-3/4	
VA40-4N	VVA40-4N		4 NEMA	3	2-5/8	1-3/4	9/16	5-7/8	7-3/4	5/8		

* "N" indicates NEMA standard stud holes.

Blue highlighted items are industry standard and most frequently ordered.

TYPE NT

T-CONNECTOR

For Copper Tube to Tube

High copper alloy T-Connector for tubing run and tap. Slots between bolts provide independent high-pressure areas of contact. One-wrench installation.

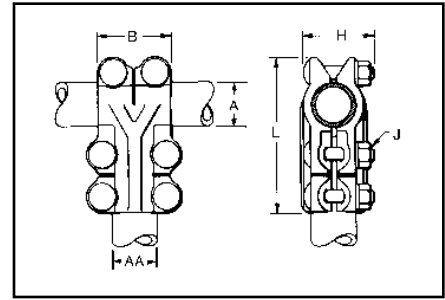
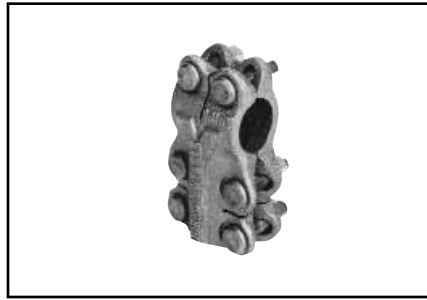

Catalog Number	Conductor		B	H	J	L	
	Run 'A'	Tap 'AA'					
NT1313	1/2"	1/2"	2"	1-3/4"	3/8"	4"	
NT1413	3/4"	1/2"		2"		4-1/8"	
NT1414		3/4"		4-3/8"			
NT1514		3/4"		4-1/2"			
NT1515	1"	1"		2-1/8"		4-3/4"	
NT1614	1-1/4"	3/4"	2-3/4"	2-1/2"	1/2"	5-3/4"	
NT1615		1"		2-5/8"		6-1/8"	
NT1616	1-1/2"	1-1/4"	2"	2-3/4"	3/8"	5-1/8"	
NT1714		3/4"				6-5/8"	
NT1715		1"				3-1/4"	7-1/4"
NT1717		1-1/2"				3-1/8"	8-5/8"
NT1816	2"	1-1/4"	2-3/4"	3-1/4"	1/2"	9-1/4"	
NT1817		1-1/2"				9-7/8"	
NT1818		2"				3-5/8"	5-3/4"
NT1919	2-1/2"	2-1/2"	3-1/8"	3-7/8"	5/8"	8-5/8"	
NT2020	3"	3"	3-5/8"	4-5/8"		9-1/4"	
NT2121	3-1/2"	3-1/2"	4-3/8"	5-1/4"		9-7/8"	
NT2222	4"	4"	4-7/8"	5-3/4"			

Blue highlighted items are industry standard and most frequently ordered.

TYPES NSNT, NHNT

T-CONNECTOR

For Copper Tube to Cable

High copper alloy T-Connector for joining copper tubing run to a wide range of copper tap cable. Tap utilizes reversible cap to achieve large conductor range and the connector is designed for one-wrench installation.

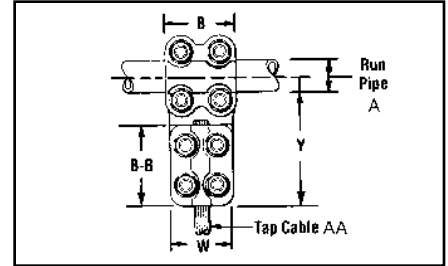
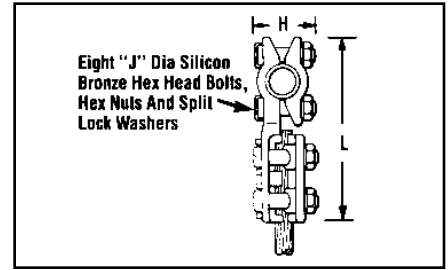

Catalog Number	Run IPS or EHPS A	Commercial Copper Cable Range			B	B-B	H	"J" Dia.	L	W	Y
		Complete ① Tap Cable Range AA	Small Tap Groove	Large Tap Groove							
NSNT1329	1/2" (.840 Dia.)	6 Sol. (.162 Dia.) to 250 kcmil (.575 Dia.)	6 Sol. (.162 Dia.) to 1/0 Str. (.372 Dia.)	2/0 Str. (.420 Dia.) to 250 kcmil (.575 Dia.)	2.00	2.38	2.00	3/8"-16	5.08	1.96	3.89
NHNT1429		6 Sol. (.162 Dia.) to 250 kcmil (.575 Dia.)	6 Sol. (.162 Dia.) to 1/0 Str. (.372 Dia.)	2/0 Str. (.420 Dia.) to 250 kcmil (.575 Dia.)	2.25	2.62	2.32	1/2"-13	5.82	2.44	4.38
NSNT1429	3/4" (1.050 Dia.)	6 Sol. (.162 Dia.) to 250 kcmil (.575 Dia.)	6 Sol. (.162 Dia.) to 1/0 Str. (.372 Dia.)	2/0 Str. (.420 Dia.) to 250 kcmil (.575 Dia.)	2.00	2.38	2.00	3/8"-16	5.08	1.96	3.89
NHNT1434		1/0 Sol. (.325 Dia.) to 500 kcmil (.813 Dia.)	1/0 Sol. (.325 Dia.) to 4/0 Str. (.529 Dia.)	250 kcmil (.575 Dia.) to 500 kcmil (.813 Dia.)	2.25	2.62	2.32	1/2"-13	5.82	2.44	4.38
NSNT1529	1" (1.315 Dia.)	6 Sol. (.162 Dia.) to 250 kcmil (.575 Dia.)	6 Sol. (.162 Dia.) to 1/0 Str. (.372 Dia.)	2/0 Str. (.420 Dia.) to 250 kcmil (.575 Dia.)	2.00	2.38	2.00	3/8"-16	5.34	1.96	4.02
NHNT1534		1/0 Sol. (.325 Dia.) to 500 kcmil (.813 Dia.)	1/0 Sol. (.325 Dia.) to 4/0 Str. (.529 Dia.)	250 kcmil (.575 Dia.) to 500 kcmil (.813 Dia.)	2.25	2.62	2.57	1/2"-13	5.92	2.44	4.43
NSNT1629	1-1/4" (1.660 Dia.)	6 Sol. (.162 Dia.) to 250 kcmil (.575 Dia.)	6 Sol. (.162 Dia.) to 1/0 Str. (.372 Dia.)	2/0 Str. (.420 Dia.) to 250 kcmil (.575 Dia.)	2.00	2.38	2.37	3/8"-16	5.78	1.96	4.24
NHNT1634		1/0 Sol. (.325 Dia.) to 500 kcmil (.813 Dia.)	1/0 Sol. (.325 Dia.) to 4/0 Str. (.529 Dia.)	250 kcmil (.575 Dia.) to 500 kcmil (.813 Dia.)	2.25	2.62	2.60	1/2"-13	6.32	2.56	4.63
NSNT1644	1-1/2" (1.900 Dia.)	2/0 Str. (.420 Dia.) to 800 kcmil (1.031 Dia.)	2/0 Str. (.420 Dia.) to 500 kcmil (.813 Dia.)	500 kcmil (.813 Dia.) to 800 kcmil (1.031 Dia.)	2.69	2.62	2.68	1/2"-13	6.58	2.90	4.89
NHNT1729		4/0 Str. (.529 Dia.) to 1000 kcmil (1.152 Dia.)	4/0 Str. (.529 Dia.) to 750 kcmil (.998 Dia.)	750 kcmil (.998 Dia.) to 1000 kcmil (1.152 Dia.)	2.88	2.69	2.70	1/2"-13	7.02	2.90	5.11
NSNT1734	2" (2.375 Dia.)	6 Sol. (.162 Dia.) to 250 kcmil (.575 Dia.)	6 Sol. (.162 Dia.) to 1/0 Str. (.372 Dia.)	2/0 Str. (.420 Dia.) to 250 kcmil (.575 Dia.)	2.69	2.62	2.70	1/2"-13	7.44	2.56	5.19
NHNT1740		1/0 Sol. (.325 Dia.) to 500 kcmil (.813 Dia.)	1/0 Sol. (.325 Dia.) to 4/0 Str. (.529 Dia.)	250 kcmil (.575 Dia.) to 500 kcmil (.813 Dia.)	2.88	2.62	2.78	1/2"-13	7.70	2.90	5.45
NSNT1844	2-1/2" (2.875 Dia.)	4/0 Str. (.529 Dia.) to 1000 kcmil (1.152 Dia.)	4/0 Str. (.529 Dia.) to 750 kcmil (.998 Dia.)	750 kcmil (.998 Dia.) to 1000 kcmil (1.152 Dia.)	3.06	3.06	3.23	1/2"-13	7.88	3.16	5.63
NHNT1846		1000 kcmil (1.152 Dia.) to 1500 kcmil (1.412 Dia.)	—	1000 kcmil (1.152 Dia.) to 1500 kcmil (1.412 Dia.)	3.06	3.06	3.23	1/2"-13	8.06	3.16	5.94
NSNT1944	3" (3.500 Dia.)	6 Sol. (.162 Dia.) to 250 kcmil (.575 Dia.)	6 Sol. (.162 Dia.) to 1/0 Str. (.372 Dia.)	2/0 Str. (.420 Dia.) to 250 kcmil (.575 Dia.)	2.69	2.62	2.88	1/2"-13	8.32	2.90	5.76
NHNT1946		1/0 Sol. (.325 Dia.) to 500 kcmil (.813 Dia.)	1/0 Sol. (.325 Dia.) to 4/0 Str. (.529 Dia.)	250 kcmil (.575 Dia.) to 500 kcmil (.813 Dia.)	3.06	2.62	3.06	1/2"-13	8.50	3.16	5.94
NSNT2044	3" (3.500 Dia.)	2/0 Str. (.420 Dia.) to 800 kcmil (1.031 Dia.)	2/0 Str. (.420 Dia.) to 500 kcmil (.813 Dia.)	500 kcmil (.813 Dia.) to 800 kcmil (1.031 Dia.)	2.69	2.62	2.88	1/2"-13	8.95	2.90	6.07
NHNT2044		4/0 Str. (.529 Dia.) to 1000 kcmil (1.152 Dia.)	4/0 Str. (.529 Dia.) to 750 kcmil (.998 Dia.)	750 kcmil (.998 Dia.) to 1000 kcmil (1.152 Dia.)	5.75	4.26	4.26	1/2"-13	8.95	2.90	6.07

① Complete cable range may be accommodated by reversing cap.

Blue highlighted items are industry standard and most frequently ordered.

TYPES NSNT, NHNT

T-CONNECTOR

For Copper Cable to Cable

High copper alloy reversible T-Connector for joining a wide range of run and tap cables. Connector is designed for one-wrench installation. “S” standard 3/8” hardware and “H” heavy duty 1/2” hardware.

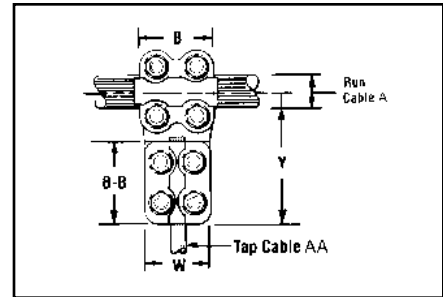
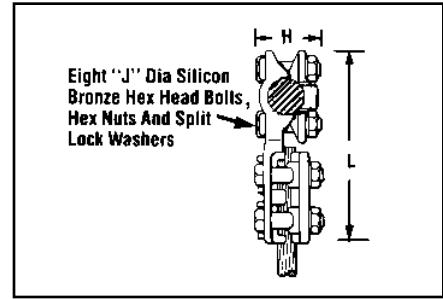

Catalog Number	Commercial Copper Cable Range					
	Complete Run Cable Range A ①	Small Run Groove	Large Run Groove	Complete Tap Cable Range AA ①	Small Tap Groove	Large Tap Groove
NSNT2929	6 Sol. (.162 Dia.) to 250 kcmil (.575 Dia.)	6 Sol. (.162 Dia.) to 1/0 Str. (.372 Dia.)	2/0 Str. (.420 Dia.) to 250 kcmil (.575 Dia.)	6 Sol. (.162 Dia.) to 250 kcmil (.575 Dia.)	6 Sol. (.162 Dia.) to 1/0 Str. (.372 Dia.)	2/0 Str. (.420 Dia.) to 250 kcmil (.575 Dia.)
NHNT2929	1/0 Sol. (.325 Dia.) to 500 kcmil (.813 Dia.)	1/0 Sol. (.325 Dia.) to 4/0 Str. (.529 Dia.)	250 kcmil (.575 Dia.) to 500 kcmil (.813 Dia.)	1/0 Sol. (.325 Dia.) to 500 kcmil (.813 Dia.)	1/0 Sol. (.325 Dia.) to 4/0 Str. (.529 Dia.)	250 kcmil (.575 Dia.) to 500 kcmil (.813 Dia.)
NSNT3429	4/0 Str. (.529 Dia.) to 1000 kcmil (1.152 Dia.)	4/0 Str. (.529 Dia.) to 750 kcmil (.998 Dia.)	750 kcmil (.998 Dia.) to 1000 kcmil (1.152 Dia.)	6 Sol. (.162 Dia.) to 250 kcmil (.575 Dia.)	6 Sol. (.162 Dia.) to 1/0 Str. (.372 Dia.)	2/0 Str. (.420 Dia.) to 250 kcmil (.575 Dia.)
NHNT3429				1/0 Sol. (.325 Dia.) to 500 kcmil (.813 Dia.)	1/0 Sol. (.325 Dia.) to 4/0 Str. (.529 Dia.)	250 kcmil (.575 Dia.) to 500 kcmil (.813 Dia.)
NSNT3434				6 Sol. (.162 Dia.) to 250 kcmil (.575 Dia.)	6 Sol. (.162 Dia.) to 1/0 Str. (.372 Dia.)	2/0 Str. (.420 Dia.) to 250 kcmil (.575 Dia.)
NHNT3434				1/0 Sol. (.325 Dia.) to 500 kcmil (.813 Dia.)	1/0 Sol. (.325 Dia.) to 4/0 Str. (.529 Dia.)	250 kcmil (.575 Dia.) to 500 kcmil (.813 Dia.)
NHNT4429	500 kcmil (.813 Dia.) to 2000 kcmil (1.632 Dia.)	500 kcmil (.813 Dia.) to 1500 kcmil (1.412 Dia.)	1500 kcmil (1.412 Dia.) to 2000 kcmil (1.632 Dia.)	6 Sol. (.162 Dia.) to 250 kcmil (.575 Dia.)	6 Sol. (.162 Dia.) to 1/0 Str. (.372 Dia.)	2/0 Str. (.420 Dia.) to 250 kcmil (.575 Dia.)
NHNT4434				1/0 Sol. (.325 Dia.) to 500 kcmil (.813 Dia.)	1/0 Sol. (.325 Dia.) to 4/0 Str. (.529 Dia.)	250 kcmil (.575 Dia.) to 500 kcmil (.813 Dia.)
NHNT4440				2/0 Str. (.420 Dia.) to 800 kcmil (1.031 Dia.)	2/0 Str. (.420 Dia.) to 500 kcmil (.813 Dia.)	500 kcmil (.813 Dia.) to 800 kcmil (1.031 Dia.)
NHNT4444				4/0 Str. (.529 Dia.) to 1000 kcmil (1.152 Dia.)	4/0 Str. (.529 Dia.) to 750 kcmil (.998 Dia.)	750 kcmil (.998 Dia.) to 1000 kcmil (1.152 Dia.)
NHNT4834	1000 kcmil (1.152 Dia.) to 1500 kcmil (1.412 Dia.)	500 kcmil (.813 Dia.) to 1500 kcmil (1.412 Dia.)	1500 kcmil (1.412 Dia.) to 2000 kcmil (1.632 Dia.)	1/0 Sol. (.325 Dia.) to 500 kcmil (.813 Dia.)	1/0 Sol. (.325 Dia.) to 4/0 Str. (.529 Dia.)	250 kcmil (.575 Dia.) to 500 kcmil (.813 Dia.)
NHNT4840				2/0 Str. (.420 Dia.) to 800 kcmil (1.031 Dia.)	2/0 Str. (.420 Dia.) to 500 kcmil (.813 Dia.)	500 kcmil (.813 Dia.) to 800 kcmil (1.031 Dia.)
NHNT4844				4/0 Str. (.529 Dia.) to 1000 kcmil (1.152 Dia.)	4/0 Str. (.529 Dia.) to 750 kcmil (.998 Dia.)	750 kcmil (.998 Dia.) to 1000 kcmil (1.152 Dia.)
NHNT4846				1000 kcmil (1.152 Dia.) to 1500 kcmil (1.412 Dia.)	—	1000 kcmil (1.152 Dia.) to 1500 kcmil (1.412 Dia.)
NHNT4848	500 kcmil (.813 Dia.) to 2000 kcmil (1.632 Dia.)	500 kcmil (.813 Dia.) to 1500 kcmil (1.412 Dia.)	1500 kcmil (1.412 Dia.) to 2000 kcmil (1.632 Dia.)	500 kcmil (.813 Dia.) to 1500 kcmil (1.412 Dia.)	500 kcmil (.813 Dia.) to 1500 kcmil (1.412 Dia.)	1500 kcmil (1.412 Dia.) to 2000 kcmil (1.632 Dia.)

① Complete cable range may be accommodated by reversing cap.

Catalog Number	B	B-B	H	“J” Dia.	L	W	Y
NSNT2929	2.38	2.38	1.75	3/8”-16	4.60	1.96	3.62
NHNT2929	2.62	2.62	2.07	1/2”-13	5.32	2.44	4.10
NSNT3429	2.38	2.38	2.00	3/8”-16	4.84	1.96	3.74
NHNT3429	2.62	2.62	2.32	1/2”-13	5.44	2.44	4.16
NSNT3434	2.38	2.38	2.00	3/8”-16	4.84	2.20	3.74
NHNT3434	2.62	2.62	2.32	1/2”-13	5.38	2.56	4.10
NHNT4429	2.88	2.62	2.57		5.78	2.44	4.33
NHNT4434					5.78	2.56	
NHNT4440					5.78	2.78	
NHNT4444					6.03	2.90	4.58
NHNT4834	3.25	2.62	3.07		6.26	2.56	4.57
NHNT4840					6.26	2.78	
NHNT4844					6.51	2.90	4.82
NHNT4846					6.76	3.16	5.07
NHNT4848					6.94	3.38	5.25

TYPE VT

T-CONNECTOR

For Copper Cable to Cable

High copper alloy T-Connector for cable run, cable tap, V-bolt clamping elements accommodate large range of cable and are particularly suited for extra flexible cable. One-wrench installation.

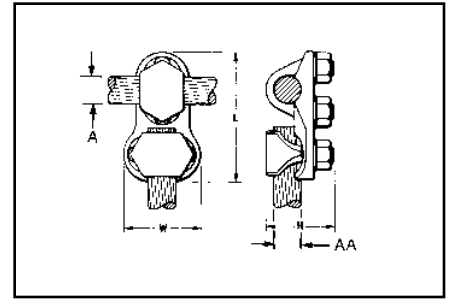

Catalog Number	Conductor		H	L	W
	Run - A	Tap - AA			
VT2C2C	8 Sol. - 2 Str.	8 Sol. - 2 Str.	1-3/8	2-3/8	1
VT2525	6 Sol. - 1/0 Str.	6 Sol. - 1/0 Str.	1-5/8	2-5/8	1-1/4
VT2825	1/0 Str. - 4/0 Str.	6 Sol. - 1/0 Str.		3-1/8	
VT2828	1/0 Str. - 4/0 Str.	1/0 Str. - 4/0 Str.			1-1/8
VT3025	1/0 Str. - 300	6 Sol. - 1/0 Str.	1-7/8	3-3/8	2
VT3030	1/0 Str. - 300	1/0 Str. - 300	2-3/8	3-3/4	1-1/4
VT3425	300 - 500	6 Sol. - 1/0 Str.		3-1/2	1-3/4
VT3428	300 - 500	1/0 Str. - 4/0 Str.		3-5/8	2
VT3430	300 - 500	1/0 Str. - 300		3-3/4	2-1/4
VT3434	300 - 500	300 - 500		2-5/8	4-1/2
VT4040	500 - 800	500 - 800	2-7/8	4-3/8	1-1/4
VT4425	750 - 1000	6 Sol. - 1/0 Str.		4-1/8	1-3/4
VT4428	750 - 1000	1/0 Str. - 4/0 Str.		4-1/4	5-1/4
VT4834	1500 - 2000	300 - 500			

L-11

TYPE NS

COUPLER

For Copper Tube to Tube

High copper alloy coupler for joining equal sizes of tube end to end. Slots between bolts provide independent high pressure areas of contact. One-wrench installation.

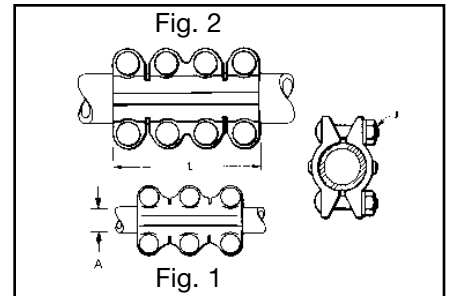

Catalog Number	Conductor - A	Conductor - B	J	L	Fig. No.
NS1313	1/2	1/2	3/8	3-1/4	1
NS1414HC	3/4	3/4		4	
NS1515	1	1		4-1/4	
NS1616HC	1-1/4	1-1/4	1/2	5-3/4	2
NS1717	1-1/2	1-1/2			
NS1818	2	2			
NS1919	2-1/2	2-1/2			
NS2020	3	3			
NS2121	3-1/2	3-1/2	5/8	7-1/4	
NS2222	4	4		8	
				8-1/2	

Blue highlighted items are industry standard and most frequently ordered.

TYPE XP

EXPANSION COUPLER

For Copper Tube to Tube

High alloy copper expansion coupler for joining equal size tube on end. Extra flexible tinned copper braid allows longitudinal movement of the tube. Type XP has alignment guide. One-wrench installation.

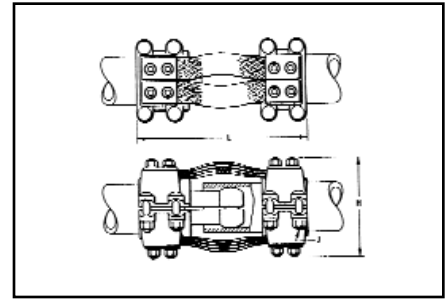
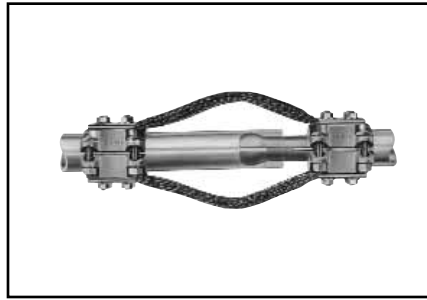

Catalog Number Standard IPS With Guide	Conductor	H	J	L
XP1818	2	7	1/2	12
XP2222	4	9-1/8	5/8	13-5/8

Blue highlighted items are industry standard and most frequently ordered.

TYPE UH

BUS SUPPORT

For Copper Tube

High copper alloy bus support for mounting tube on a post or pedestal type insulator. Single bolt allows rotation to any angle. Rotate cap 180° for slip or rigid fit. One-wrench installation. Supplied with hardware for mounting to cap of insulator. Specify base mounting hardware, if required, by adding suffix “B” to Catalog No.

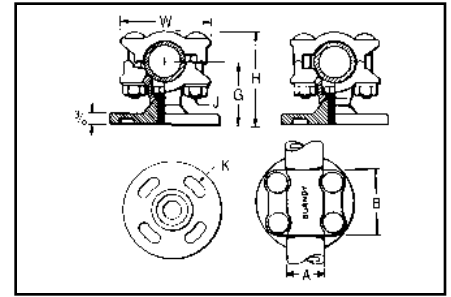
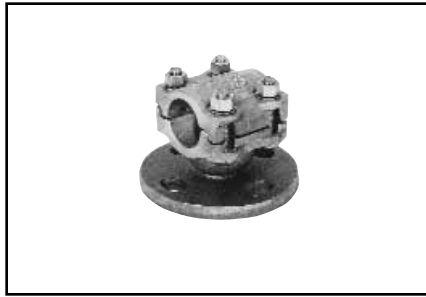

Catalog Number	Copper Conductor IPS “A”	Bolt Circle	B	G	H	J	K	W
UH14-3	3/4	3	2-1/2	2	2-7/8	3/8	9/16	2-5/8
UH15-3	1	3		2	3		9/16	2-7/8
UH15-5		5		3-1/4	11/16			
UH16-3	1-1/4	3	2-11/16	2-1/4	3-1/2	1/2	9/16	3-1/2
UH16-5		5		2-3/8	3-5/8		11/16	
UH17-3	1-1/2	3	3	2-1/2	3-7/8	1/2	9/16	4
UH17-5		5		2-3/4	4-3/8		11/16	
UH18-3	2	3	3	2-3/4	4-3/8	1/2	9/16	4-5/8
UH18-5		5						
UH19-3	2-1/2	3	3	3-1/8	5	1/2	9/16	5-1/4
UH19-5		5						
UH20-3	3	3	3-1/4	3-5/8	5-7/8	5/8	9/16	6-1/4
UH20-5		5						
UH22-5	4	5	3-1/4	4-1/2	7-1/4	5/8	11/16	7-1/2

L-13

TYPE UHR

BUS SUPPORT

For Copper Cable or Tube

High copper alloy bus support clamp for mounting a wide range of cable or tube on post or pedestal type insulators. Single bolt allows rotation to any angle. Supplied with hardware for mounting to cap of insulator. Specify base mounting hardware, if required, by adding suffix “-B” to Catalog No.

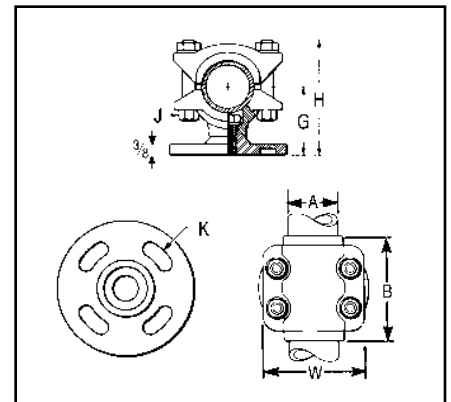

Catalog Number	Copper Conductor “A”		Bolt Circle	B	G*	H	J	K	W
	Cable	Tube							
UHR13-3	6 Str. - 500	1/8 - 1/2	3	3-5/8	1-3/4	3	3/8	9/16	2-1/4
UHR13-5			5		2-1/8	3-3/8		11/16	
UHR15-3	4/0 Str. - 1250	1/4 - 1	3	3-3/4	2	3-1/2	1/2	9/16	2-3/4
UHR15-5			5		2-1/4	3-3/4		11/16	
UHR17-3	750 - 2500	3/4 - 1-1/2	3	2-7/8	2-1/2	4-1/4	1/2	9/16	4
UHR17-5			5					11/16	

* With maximum conductor in place.

Blue highlighted items are industry standard and most frequently ordered.

TYPES LH, LHR

BUS SUPPORT

For Copper Cable or Tube

High copper alloy, light duty bus support for mounting a wide range of cable or tube on post or pedestal type insulators. One-wrench installation. Supplied with hardware for mounting to cap of insulator. Specify base mounting hardware, if required, by adding suffix “-B” to Catalog No.

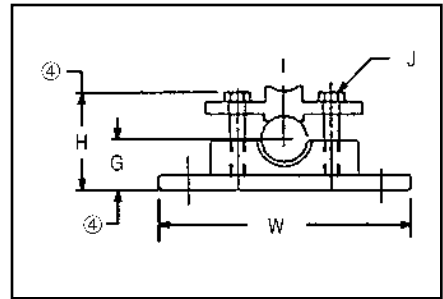
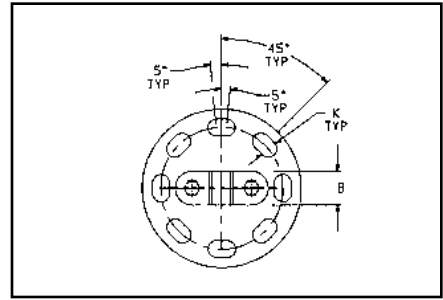

Copper Cable Range Complete Range	Tubing Schedule 40/80	⑤ Bolt ⑥ Circle	Catalog Number	Dimensions Inches/[mm]					
				B	G ④	H ④	J	K	W
6 Sol. - 4/0 Str.	—	3"	LH28-3	1.69 [43]	1.25 [32]	2.62 [66.5]	3/8 - 16	.56 [14]	4.25 [108]
③ #8 - 250 kcmil	1/8 - 1/4	3"	LHR29-3	1.00 [25]	1.23 [31]	2.03 [52]		.56 [14]	4.25 [108]
2/0 Str. - 500 kcmil	1/4 - 1/2	3"	LH34-3	1.38 [35]	1.38 [35]	2.50 [63.5]		.56 [14]	4.25 [108]

NOTES:

- 1 Material:
Connector: Cast copper alloy
Clamping Hardware: Silicon bronze
Mounting Hardware: Galvanized steel
- 2 Dimensions in brackets [] are in millimeters.
- ③ Complete range may be accommodated by reversing the cap.
- ④ Dimension with maximum conductor in place.

- ⑤ Cap mounting hardware is supplied as standard. 3.00 Dia. bolt circle furnished with four 1/2 -13 3 1.00 long galvanized steel hex head bolts and split lockwashers. 5.00 Dia. bolt circle furnished as above except bolts are .625 3 1.75.
- ⑥ If base mounting is desired, add “-B” to the Catalog Number and the following hardware will be supplied: 3.00 Dia. bolt circle furnished 1/2 -13 3 1-1/2 long galvanized steel hex head bolt, hex nuts, and 5.00 Dia. bolt circle furnished as above except bolts are .625 3 1.75.

L-14

Blue highlighted items are industry standard and most frequently ordered.

TYPE NDR

STUD CONNECTOR

For Copper Cable,
Tube, Flat Bar

High copper alloy reversible and rotatable cap stud connector joins cable, tube and flat bar in-line or at right angles to equipment studs. Accommodates a wide range of cables or tubes. One-wrench installation.

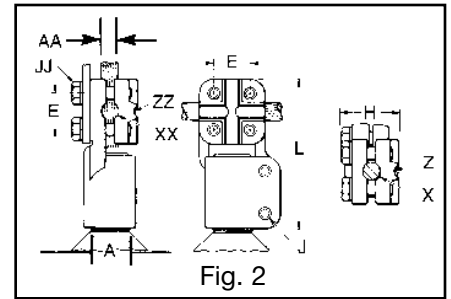
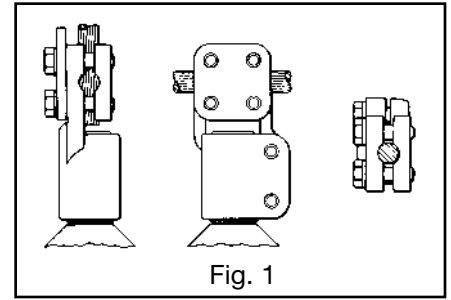
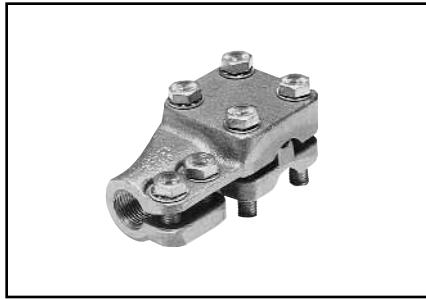

Catalog Number	Stud A	Complete Range AA		Fig. No.	X Groove	XX Groove	Z Groove	ZZ Groove	E	H	J	JJ	L
		Cable	Tube I.P.S.										
NDR6328T13	1/2-13	6 Sol. - 4/0 Str.	—	1	6 Sol. - 1 Str.	2/0 Sol. - 4/0 Str.			1-1/16	1-3/4	3/8	3-5/8	
NDR6428T16		6 Sol. - 4/0 Str.	—		6 Sol. - 1 Str.	2/0 Sol. - 4/0 Str.							
NDR6434T16	3/4-16	6 Sol. - 500	3/8 - 1/2	2	250 - 350	400 - 500	6 Sol. - 2 Str.	1/0 Sol. - 4/0 Str.	1-7/16	2-1/4	3/8	4-1/8	
NDR6444T16		2 Sol. - 1000	3/8 - 3/4		550 - 700	750 - 1000	2 Sol. - 250	300 - 500	1-7/8	2-7/8		1/2	4-5/8
NDR6528T14	1-14	6 Sol. - 4/0 Str.	—	1	6 Sol. - 1 Str.	2/0 Sol. - 4/0 Str.			1-1/16	1-3/4	3/8	4-1/8	
NDR6534T14		6 Sol. - 500	3/8 - 1/2	2	250 - 350	400 - 500	6 Sol. - 2 Str.	1/0 Sol. - 4/0 Str.	1-7/16	2-1/4		4	
NDR6544T14		2 Sol. - 1000	3/8 - 3/4		550 - 700	750 - 1000	2 Sol. - 250	300 - 500	1-7/8	2-7/8		1/2	4-3/4
NDR65528T12	1-1/8-12	6 Sol. - 4/0 Str.	—	1	6 Sol. - 1 Str.	2/0 Sol. - 4/0 Str.			1-1/16	1-3/4	3/8	4-1/8	
NDR65534T12		6 Sol. - 500	3/8 - 1/2	2	250 - 350	400 - 500	6 Sol. - 2 Str.	1/0 Sol. - 4/0 Str.	1-7/16	2-1/4		4	
NDR65544T12		2 Sol. - 1000	3/8 - 3/4		550 - 700	750 - 1000	2 Sol. - 250	300 - 500	1-7/8	2-7/8		1/2	4-5/8
NDR6644T12	1-1/4-12	2 Sol. - 1000	3/8 - 3/4		550 - 700	750 - 1000	2 Sol. - 250	300 - 500	1-7/8	2-7/8	1/2	4-5/8	
NDR6728T12	1-1/2-12	6 Sol. - 4/0 Str.	—	1	6 Sol. - 1 Str.	2/0 Sol. - 4/0 Str.			1-1/16	2-1/4	1/2	4-3/4	
NDR6734T12		6 Sol. - 500	3/8 - 1/2	2	250 - 350	400 - 500	6 Sol. - 2 Str.	1/0 Sol. - 4/0 Str.	1-7/16	2-3/8		3/8	5
NDR6744T12		2 Sol. - 1000	3/8 - 3/4		550 - 700	750 - 1000	2 Sol. - 250	300 - 500	1-7/8	2-7/8		1/2	5-1/8
NDR6748T12		4/0 Str. - 2000	3/8-1-1/4	1250 - 1600	1700 - 2000	4/0 Str. - 600	650 - 1200	2-3/8	3-1/4	5-3/4			
NDR6844T12	2-12	2 Sol. - 1000	3/8 - 3/4		550 - 700	750 - 1000	2 Sol. - 250	300 - 500	1-7/8	2-7/8	1/2	6-1/8	
NDR6848T12		4/0 Str. - 2000	3/8-1-1/4	1250 - 1600	1700 - 2000	4/0 Str. - 600	650 - 1200	2-3/8	2-7/8	6-5/8			

L-15

Blue highlighted items are industry standard and most frequently ordered.

TYPE FD

STUD CONNECTOR

For Stud to Flat Bar

High copper alloy stud connector allows bolting cable and tubing terminals to equipment studs. Hex head captured bolts provide one-wrench installation. One pad contact surface is on centerline of stud. Pad is finished on both sides. All pads are four hole NEMA drilled.

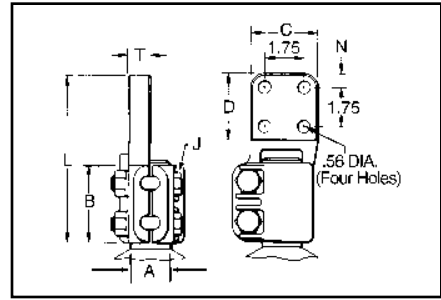
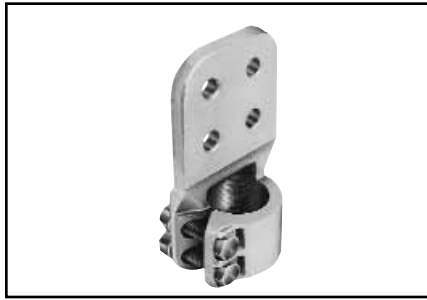

Catalog Number	Stud A	Nominal Ampere Rating ①	B	C	D	J	L	N	T	
FD64C5T16	3/4" -16	1000	1.75	3.00	3.00	3/8" -16	5.72	.62	.31	
FD65C6T14	1" -14	1075		3.00	3.00		5.72	.62	.38	
FD655C6	1-1/8" -12	1075		3.00	3.00		5.80	.62	.38	
FD655D6		1300		4.00	4.00		6.86	1.12	.38	
FD66C6	1-1/4" -12	1075		3.00	3.00		5.78	.62	.38	
FD66D6		1300		4.00	4.00		6.84	1.12	.38	
FD67C6	1-1/2" -12	1075	2.18	3.00	3.00	1/2" -13	6.23	.62	.38	
FD67D8		1450		4.00	4.00		7.30	1.12	.50	
FD675C8	1-3/4" -12	1220		3.00	3.00		6.32	.62	.50	
FD675D8		1450		4.00	4.00		7.39	1.12	.50	
FD68C8	2" -12	1220		3.00	3.00		6.35	.62	.50	
FD68D8		1450		4.00	4.00		7.42	1.12	.50	
FD68D12	2-1/4" -12	2100	2.50	4.00	4.00	5/8" -11	7.42	1.12	.75	
FD685C8		1220		3.00	3.00		6.71	.62	.50	
FD685D8		1450		4.00	4.00		7.77	1.12	.50	
FD685D12		2100		4.00	4.00		7.77	1.12	.75	
FD69C8		2-1/2" -12		1220	3.00		3.00	6.77	.62	.50
FD69D8				1450	4.00		4.00	8.03	1.12	.50
FD69D12	3" -12	2100	2.88	4.00	4.00	8.03	1.12	.75		
FD70D12		2100		4.00	4.00	8.26	1.12	.75		
FD70D16		3000		4.00	4.00		8.24	1.12	1.00	

NOTES:

- ① Indoor Rating
- 2. Contact factory for other variations in drilling, plating, etc.

L-16

Blue highlighted items are industry standard and most frequently ordered.

TYPE QGFL

BARTAP™

For Copper Cable to Flat

High copper alloy BARTAP™ for joining a range of cable to bar or pad. One-wrench installation.

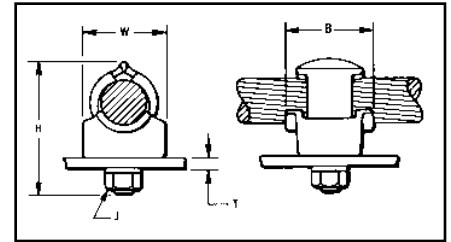
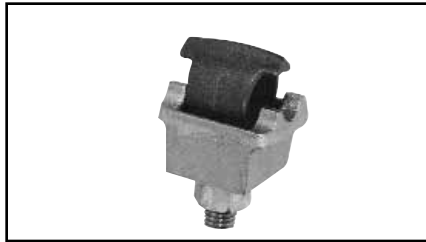

Catalog Number	Conductor	B	H	J	T (Max.)	W
QGFL1CB1	10 Sol. - 1 Str.	1-1/8	1-7/8	3/8	1/4	1
QGFL1CB1T6			2-3/8		3/4	
QGFL26B1	8 Sol. - 2/0 Str.	1-1/4	2-1/8	1/2	1/4	1-1/8
QGFL26B1T6			2-5/8		3/4	
QGFL26B2*			1-1/2		1/4	
QGFL26B2T6*			2-7/8		3/4	
QGFL29B1*	6 Str. - 250	1-5/8	2-5/8	1/2	1/4	1-3/8
QGFL29B1T6*			3-1/8		3/4	
QGFL31B1*	2 Sol. - 350	1-3/4	2-7/8	1/2	1/4	1-5/8
QGFL31B1T6*			3-1/4		3/4	
QGFL34B1	1/0 Sol. - 500	2	3-1/8	1/2	1/4	1-3/4
QGFL34B1T6			3-5/8		3/4	
QGFL39B1	350 - 750	2-1/4	3-1/4	1/2	1/4	1-3/4
QGFL39B1T6			3-5/8		3/4	
QGFL44B1	750 - 1000	2-1/4	3-3/8	1/2	1/4	2-1/8
QGFL44B1T6			4-1/8		3/4	
QGFL46B1	1000 - 1500	2-1/4	4	1/2	1/4	2-1/2
QGFL46B1T6			4-1/2		3/4	
QGFL48B1	1500 - 2000	2-1/4	4-3/4	1/2	1/4	3

* Can be installed side by side or in-line on NEMA drilled bar.

TYPE FCB

TRANSFORMER TAP ADAPTER

For Copper and Aluminum

Cast in one piece from copper alloy. Transformer tap adapter designed to accommodate from 1 to 6 NEMA drilled copper or aluminum terminal taps from a single secondary transformer outlet. Tin-plated. Order mounting hardware and tap terminals separately.

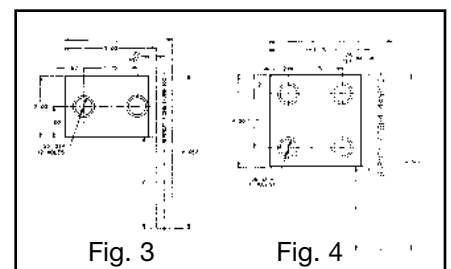
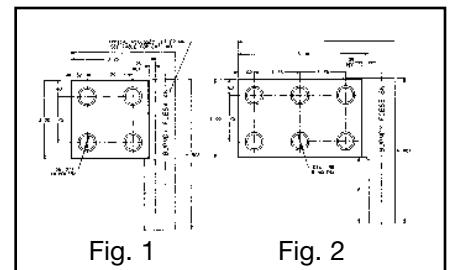
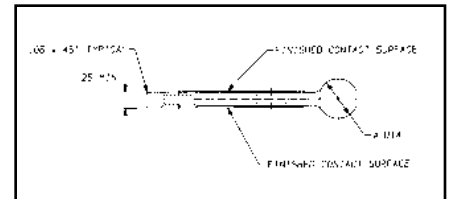
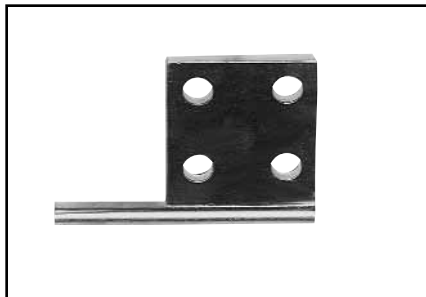

Fig. No.	Catalog Number	A Dia.	H REF	L	P
1	FCB63-4N	.50	5.25	3.75	2.25
2	FCB63-6N	.50	5.25	5.50	2.25
1	FCB64-4N	.75	5.75	4.00	2.75
2	FCB64-6N	.75	5.75	5.75	2.75
1	FCB65-4N	1.00	7.00	4.25	4.00
3	FCB63-2NP300	.50	5.00	3.50	3.00
4	FCB64-44NP50	.75	9.00	5.00	5.00

Blue highlighted items are industry standard and most frequently ordered.

TYPE E-C-G

**TRANSFORMER
TAP ADAPTER**

For Copper Cable

Multi-tap, range-taking cast copper alloy connector designed to take 2, 3, or 4 conductors from a single secondary transformer outlet.

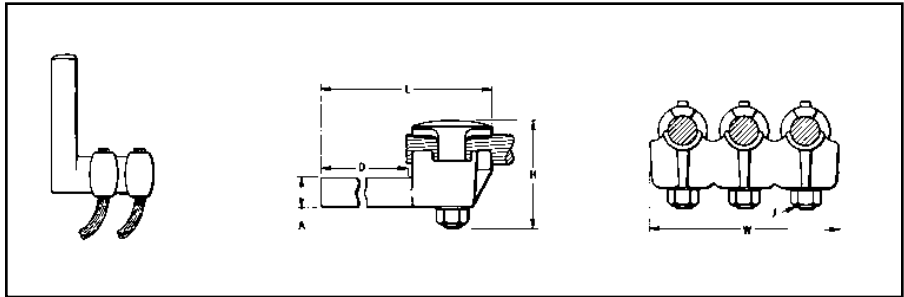
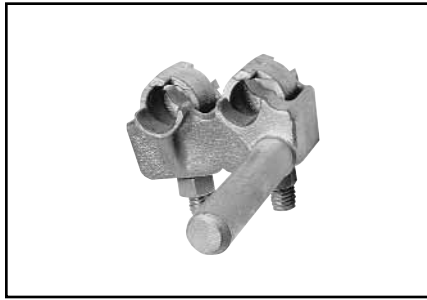

Catalog Number	Number of Conductors	Conductor Size	A Dia.	D	H	J	L	W
E2C34G1	2	1/0 Sol. to 500	.78	3-3/4	3-7/8	1/2-13	6-1/4	3-1/2
E3C34G1	3							5-1/4
E4C34G1	4							6-7/8

Blue highlighted items are industry standard and most frequently ordered.

TYPE HFBW

BAR CLAMP

For Copper Bar

The clamp assembly eliminates the need for drilling the flat bar and is used in indoor and outdoor applications.

The open web design provides a uniform clamping pressure while minimizing the weight of the connector.

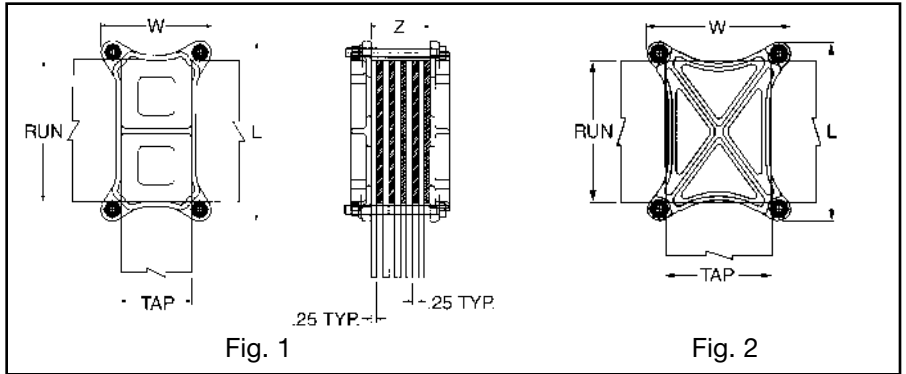
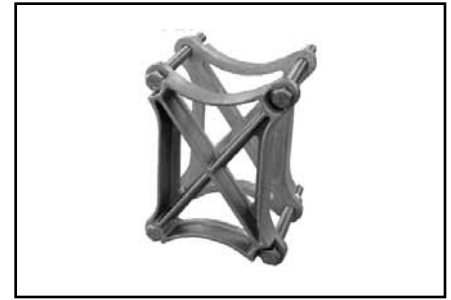
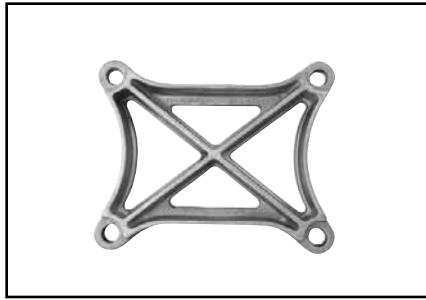

FEATURES

- Web design cast copper body.
- Fully threaded yellow galvanized bolts with split-lockwashers and nuts included.
- Flat bar accommodation molded into body.

BENEFITS

- Increased torsional resistance.
- Reduced weight.
- Simple installation.
- Easy identification.

Catalog Number *	Conductor		Figure Number	Standard Maximum 'Z' Dimension	Total Number of Flat Bars (Standard 1/4" Thick)	Bolt Size	Dimensions	
	Run	Tap					W	L
HFBW86T20CG1	8.0	6.0	2	5.00	20	5/8"-11	8.13	10.13
HFBW66T16CG1	6.0	6.0	2	4.00	16	1/2"-13	7.75	7.75
HFBW64T17CG1	6.0	4.0	2	4.25	17	1/2"-13	5.75	7.75
HFBW44T17CG1	4.0	4.0	2	4.25	17	1/2"-13	5.68	5.68
HFBW43T10CG1	4.0	3.0	2	2.50	10	3/8"-16	4.42	5.42
HFBW42T10CG1	4.0	2.0	1	2.50	10	3/8"-16	3.54	5.55

* Catalog number based on standard maximum "Z" dimension. Refer to your FCI representative for non-standard "Z" dimensions.
Add TN suffix for tin plating (example: HFBW86T20CG1TN).
All dimensions in inches.

L-19

Blue highlighted items are industry standard and most frequently ordered.

TYPE HFB-P1

BAR CLAMP ASSEMBLY COMPONENTS

For Copper Bar

To build your own high strength clamp assembly for multiple flat bar using type HFB-P1 bar clamps & clamping hardware, the following tables have been provided. The clamp assembly eliminates the need for drilling the flat bar and is used in indoor and outdoor applications.

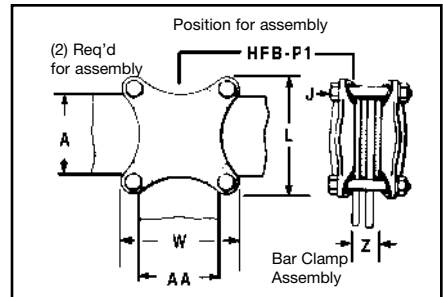

One Clamp Half					
Bar Clamp Catalog Number	Bus Bar		"J" Bolt Dia.	L	W
	Run 'A'	Tap 'AA'			
HFB33P1	3.00	3.00	3/8	4.38	4.38
HFB44P1	4.00	4.00	1/2	5.75	5.75
HFB63P1	6.00	3.00	1/2	7.75	4.75
HFB66P1	6.00	6.00	5/8	8.12	8.12
HFB88P1	8.00	8.00	3/4	10.50	10.50

Copper Bus Bar Width (Inches)	Bar Clamp Assembly Components †								
	Bar Clamp		Silicon Bronze Clamping Hardware						
			Bolts**		Nuts		Split Lockwashers		
Run-A	Tap-AA	Qty.	Cat. No.	Qty.	Cat. No.	Qty.	Cat. No.	Qty.	Cat. No.
3	3	2	HFB33P1	4	38 X (*) HEB	4	38CHEN	4	38SW
4	4	2	HFB44P1	4	50 X (*) HEB	4	50CHEN	4	50SW
6	3	2	HFB63P1	4	50 X (*) HEB	4	50CHEN	4	50SW
6	6	2	HFB66P1	4	62 X (*) HEB	4	62CHEN	4	62SW
8	8	2	HFB88P1	4	75 X (*) HEB	4	75CHEN	4	75SW

L-20

† Ordered separately from BURNDY®.

* Z = Space between the bar clamp contact surfaces.

** See table below when ordering assembly clamping bolts to specify correct bolt length in Cat. #.

Clamp Number	'J' Bolt Dia.	Bolt Length**							
		When Z=1.25*	When Z=1.50*	When Z=1.75*	When Z=2.00*	When Z=2.25*	When Z=2.50*	When Z=2.75*	When Z=3.00*
HFB33P1	3/8"(-16)	3.00	3.25	3.50	4.00	4.00	4.50	4.50	5.00
HFB44P1	1/2"(-13)	3.25	3.50	3.75	4.00	4.50	4.50	5.00	5.00
HFB63P1	1/2"(-13)	3.25	3.50	3.75	4.00	4.50	4.50	5.00	5.00
HFB66P1	5/8"(-11)	3.50	4.00	4.00	4.50	4.50	5.00	5.00	6.00
HFB88P1	3/4"(-10)	3.75	4.00	4.50	4.50	5.00	5.00	5.50	5.50

Blue highlighted items are industry standard and most frequently ordered.

TYPE HFB-N

**BAR CLAMP
TAP PAD ADAPTER**

For Copper Bar

High conductivity copper, tap pad adapter provides a NEMA drilled contact pad when assembled to the HFB-P1 clamps. Tap connections can be made from copper bus bar(s) without drilling by bolting standard mechanical or compression terminal pads directly to the pre-drilled tap pad adapter.

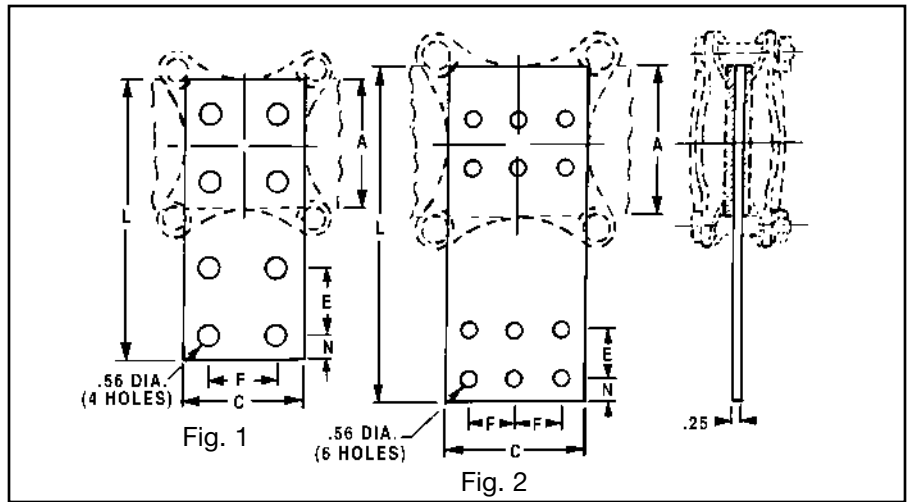
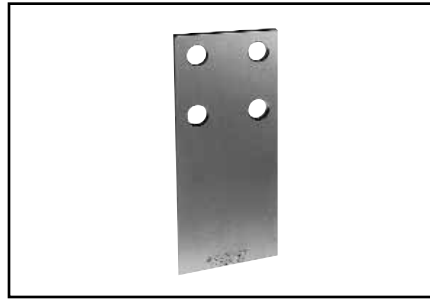

Catalog Number	Fig. No.	A-C	E & F	L	N	① Use With 'H' Clamp Cat. No.
HFB33-4N	1	3.00	1.75	7.00	.62	HFB33P1
HFB44-4N	1	4.00	1.75	9.12	1.12	HFB44P1
HFB66-6N	2	6.00	1.75	11.31	1.12	HFB66P1

① 'H' Clamp (two required per assembly) and hardware (as shown) not included with bar clamp tap pad, order separately.

L-21

TYPE FN

CONTACT NUT

Flat to Stud

High copper alloy contact nut for joining bar or terminal pads to studs. Designed to carry full current load from flat to stud.

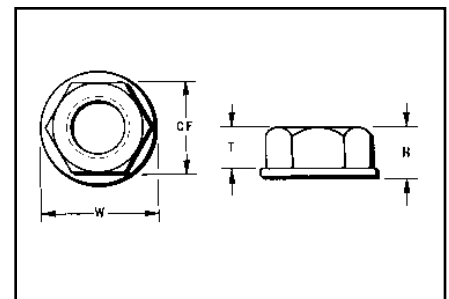

Catalog Number Type FN	Stud Dia. and Threads per Inch	CF (Cross Flats)	H	T	W
FN62T16	3/8 - 16	3/4	3/8	5/16	7/8
FN63T13	1/2 - 13	1	15/32	3/8	1-1/4
FN64T16	3/4 - 16	1-1/4	3/4	9/16	1-1/2
FN65T12	1-1/8 - 12	1-3/4	1	3/4	2-1/8
FN66T14	1-1/4 - 14	2	1-1/8	7/8	2-3/8
FN67T12	1-1/2 - 12	2-3/8			2-3/4

Blue highlighted items are industry standard and most frequently ordered.

ALUMINUM INTRODUCTION

CONNECTORS FOR ALUMINUM CONDUCTORS

Bolted aluminum connectors are cast of aluminum alloy and assembled with aluminum alloy bolts, nuts and galvanized steel washers. The hex head bolts are captured for one-wrench installation. The connectors accommodate aluminum or copper conductor. The “mass anode” design pioneered by BURNDY® minimizes the effect of galvanic corrosion on aluminum (anode+) connectors when used with copper (cathode -) conductor (Reference Fig. 1).

Joint deterioration caused by relaxation or “cold flow” of the aluminum is eliminated by the massive design. Generous contact areas distribute clamping forces evenly over the conductor, eliminating points of high stress that cause “cold flow.” These contact areas are factory treated to remove surface oxides and coated with an oxide inhibitor to prevent their reformation. Large radiating surfaces allow the connectors to run cooler than the copper conductor compensating for the fact that aluminum has a higher coefficient of thermal expansion. Connector and conductor expand and contract together during load cycles, eliminating stresses on the aluminum body that can cause relaxation of the joint.

CONNECTOR SELECTION

Generally, copper connectors are recommended for copper conductor and aluminum connectors for aluminum conductor. Where aluminum connectors are recommended for use on both aluminum and copper conductors, the copper must be positioned parallel to or below the aluminum to prevent contamination of the aluminum by copper salts washed down by rain.

Except where indicated, all rigid connectors accept standard or extra heavy I.P.S. and all flexible connectors standard I.P.S. If extra heavy I.P.S. is to be used with a flexible joint, it must be spelled out at the time of ordering so that the proper cross sectional area of the flexible element may be supplied for the increased conductor rating.

CONDUCTOR PREPARATION

To obtain optimum performance from any connector, the conductor surface must be thoroughly cleaned before installation. The surface oxides that form on all conductors act as insulation. Failure to remove them can result in high resistance joint and, ultimately, failure.

Conductor contact surfaces should be scratch brushed until bright and shiny. Aluminum conductor (new or old) should be coated with BURNDY® PENETROX™ after scratch brushing. PENETROX™ is a joint compound that aids in the establishment of low resistance joints and prevents aluminum oxides from reforming.

L-22

Many aluminum ions removed by current flow

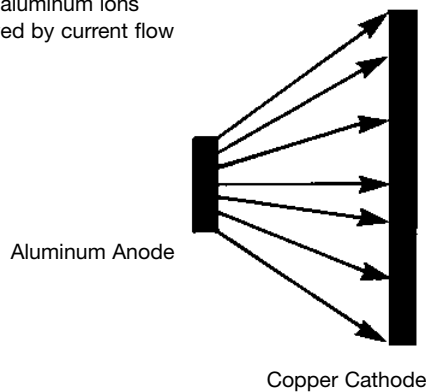

Few aluminum ions removed by current flow

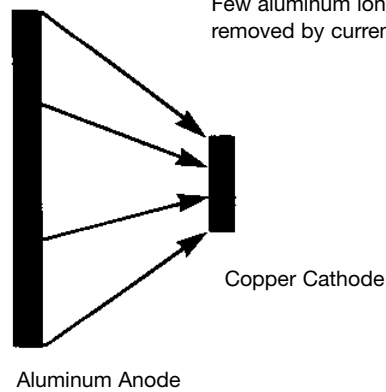

Fig. 1

Blue highlighted items are industry standard and most frequently ordered.

TYPE NNT-A

T-CONNECTOR

For Aluminum and Copper Tube to Tube

Aluminum alloy T-Connector for tubing run and tap. Properly proportioned to permit use on copper-aluminum conductor combinations. Captured hex head bolts permit one-wrench installation. PENETROX™ joint compound recommended on contact surfaces.

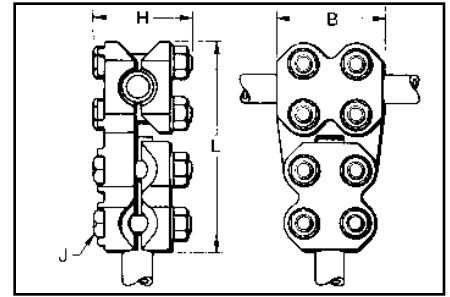
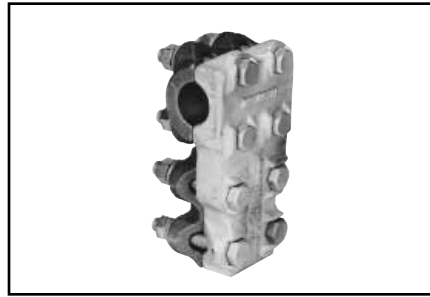

Catalog Number	Conductor		B	H	J	L
	Run	Tap				
NNT15A15A	1	1	3-1/2	3-3/8	1/2	6-7/8
NNT16A16A	1-1/4	1-1/4	3-3/4	3-3/8	1/2	7-1/2
NNT17A17A	1-1/2	1-1/2	4	3-7/8	1/2	7-7/8
NNT18A18A	2	2	4-1/4	4-1/2	5/8	9
NNT19A19A	2-1/2	2-1/2	4-1/2	5	5/8	9
NNT20A20A	3	3	5	5	5/8	11
NNT21A20A	3-1/2	3	5-1/2	5-5/8	5/8	11-5/8
NNT22A22A	4	4	6	6-1/4	5/8	12-5/8

TYPE NNTR-A

T-CONNECTOR

For Aluminum and Copper Tube to Cable

Aluminum alloy T-Connector for tube run, range of cable tap. Properly proportioned to permit use on copper-aluminum combinations. One-wrench installation. PENETROX™ joint compound recommended on contact surfaces.

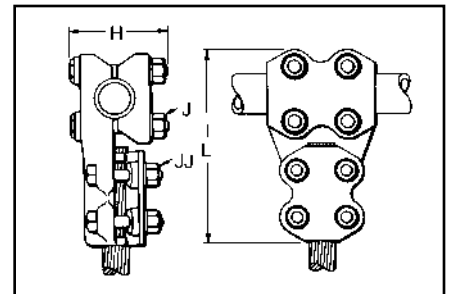

L-23

Catalog Number	Conductor			H	J	JJ	L
	Tap						
	Run	Alum. or Cu.	ACSR				
NNTR14A29A	3/4	1/0 Str. - 250	1/0 (6-1) - 4/0 (6-1)	3-1/8	1/2	1/2	5-7/8
NNTR14A36A	3/4	350 - 600	336.4 (18-1) - 477 (30-7)	3-1/8			6-3/8
NNTR15A36A	1	350 - 600	336.4 (18-1) - 477 (30-7)	3-3/8			6-5/8
NNTR15A42A	1	600 - 900	477 (30-7) - 795 (54-7)	3-3/8			6-7/8
NNTR16A29A	1-1/4	1/0 Str. - 250	1/0 (6-1) - 4/0 (6-1)	3-3-7/8			6-1/2
NNTR16A32A	1-1/4	250 - 400	4/0 (6-1) - 397.5 (18-1)	3-3/8			6-3/4
NNTR16A42A	1-1/4	600 - 900	477 (30-7) - 795 (54-7)	3-7/8			7-1/4
NNTR17A29A	1-1/2	1/0 Str. - 250	1/0 (6-1) - 4/0 (6-1)	3-7/8			6-3/4
NNTR18A29A	2	1/0 Str. - 250	1/0 (6-1) - 4/0 (6-1)	4-1/2			7-5/8
NNTR19A42A	2-1/2	600 - 900	477 (30-7) - 795 (54-7)	4-5/8			8-7/8
NNTR20A32A	3	250 - 400	4/0 (6-1) - 397.5 (18-1)	5			9
NNTR22A46A	4	1250 - 1600	1113 (54-9) - 1431 (45-7)				9-1/4

Blue highlighted items are industry standard and most frequently ordered.

TYPE NNTR-A

T-CONNECTOR

For Aluminum and Copper Cable to Cable

Aluminum alloy T-Connector for a range of copper, aluminum and ACSR cable on run and tap. Properly proportioned to permit use on copper-aluminum conductor combinations. One-wrench installation. PENETROX™ joint compound recommended on contact surfaces.

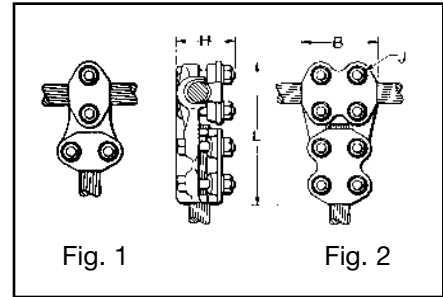
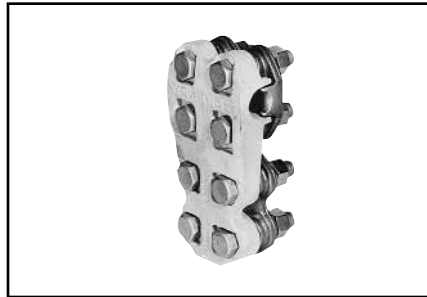

Catalog Number	Conductor				Fig. No.	B	H	J	L
	Run		Tap						
	Alum. or Copper	ACSR	Alum. or Copper	ACSR					
NNTR29A29A	1/0 Str. - 250	1/0 (6-1) - 4/0 (6-1)	1/0 Str. - 250	1/0 (6-1) - 4/0 (6-1)	2	2-3/4	2-5/8	1/2	5-5/8
NNTR32A25A	250 - 400	4/0 (6-1) - 397.5 (18.1)	4 Str. - 1/0 Str.	4 (6-1) - 1/0 (6-1)	1	1-7/8	2-5/8		4-7/8
NNTR32A32A	250 - 400	4/0 (6-1) - 397.5 (18-1)	250 - 400	4/0 (6-1) - 397.5 (18-1)	2	3	2-5/8		6
NNTR36A29A	350 - 600	336.4 (18-1) - 477 (30-7)	1/0 Str. - 250	1/0 (6-1) - 4/0 (6-1)	2	3-1/4	2-5/8		5-7/8
NNTR36A36A	350 - 600	336.4 (18-1) - 477 (30-7)	350 - 600	336.4 (18-1) - 477 (30-7)	2	3-1/4	2-5/8		6-3/8
NNTR42A32A	600 - 900	477 (30-7) - 795 (54-7)	250 - 400	4/0 (6-1) - 397.5 (18-1)	2	3-1/2	3-1/8		6-3/8
NNTR42A36A	600 - 900	477 (30-7) - 795 (54-7)	350 - 600	336.4 (18-1) - 477 (30-7)	2	3-1/2	3-1/8		6-5/8
NNTR42A42A	600 - 900	477 (30-7) - 795 (54-7)	600 - 900	477 (30-7) - 795 (54-7)	2	3-1/2	3-1/8		6-7/8
NNTR45A45A	900 - 1250	715.5 (30-19) - 1113 (54-19)	900 - 1250	715.5 (30-19) - 1113 (54-19)	2	3-3/4	3-1/4		7-3/8
NNTR46A42A	1250 - 1600	1113 (54-19) - 1431 (45-7)	600 - 900	477 (30-7) - 795 (54-7)	2	3-3/4	3-1/2		7-1/4
NNTR46A46A	1250 - 1600	1113 (54-19) - 1431 (45-7)	1250 - 1600	1113 (54-19) - 1431 (45-7)	2	4-3/8	3-3/4	5/8	8-3/8
NNTR48A48A	1500 - 2000	1272 (54-19) - 1780 (84-19)	1500 - 2000	1272 (54-19) - 1780 (84-19)	2	4-3/8	3-7/8	5/8	8-5/8

L-24

TYPE NS-A

COUPLER

For Aluminum and Copper Tube to Tube

Aluminum alloy coupler for joining equal sizes of tube end to end. Properly proportioned to permit use on aluminum-copper conductor combinations. One-wrench installation. PENETROX™ joint compound recommended on contact surfaces.

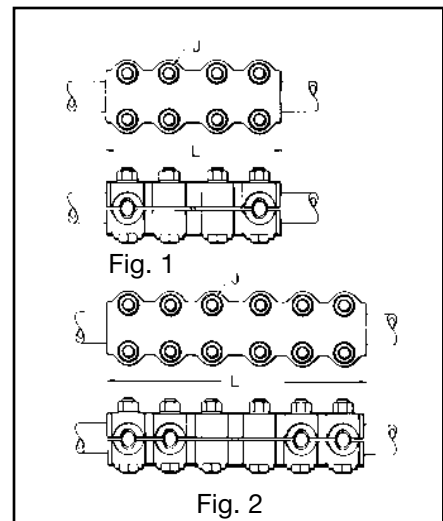

Catalog Number	Conductor I.P.S.	Fig. No.	J	L
NS14A14A	3/4	1	1/2	6-3/4
NS15A15A	1			7-1/4
NS17A17A	1-1/2			8-1/4
NS18A18A	2			8-3/4
NS19A19A	2-1/2		5/8	9-1/4
NS20A20A	3			10-1/4
NS21A21A	3-1/2			11-1/4
NS22A22A	4			12-1/4
NS24A24A	5	2		14-1/4

Blue highlighted items are industry standard and most frequently ordered.

TYPE NA-A

TERMINAL

For Aluminum and Copper Tube to Flat

Aluminum alloy terminal for joining copper or aluminum tube to copper or aluminum pad. Properly proportioned to minimize conductor corrosion due to galvanic action. Drilling in pad conforms to NEMA standards. One-wrench installation. PENETROX™ joint compound recommended on contact surfaces.

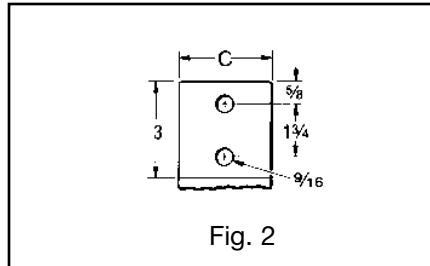
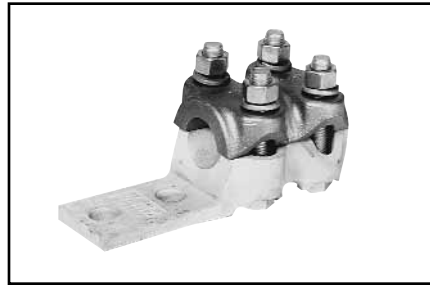

Fig. 2

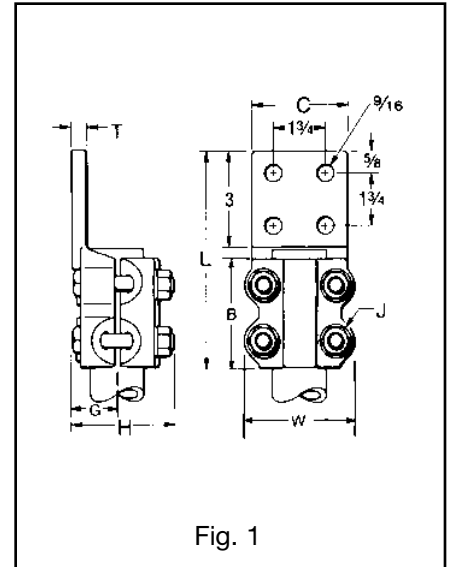

Fig. 1

Catalog Number	Conductor	Fig. No.	B	C	G	H	J	L	T	W
NA15A-2N	1	2	3-1/2	1-7/8	1.50	3-3/8	1/2	6-3/4	3/8	3-1/16
NA15A-4N	1	1	3-1/2	3	1.50	3-3/8	1/2	6-3/4	3/8	3-1/16
NA16A-4N	1-1/4	1	3-3/4	3	1.60	3-3/8	1/2	7	1/2	3-7/16
NA17A-2N	1-1/2	2	4	2-1/2	1.76	3-7/8	1/2	7-1/2	1/2	3-11/16
NA17A-4N	1-1/2	1	4	3	1.76	3-7/8	1/2	7-1/2	1/2	3-11/16
NA18A-2N	2	2	4-1/4	2-3/4	2.05	4-1/2	5/8	7-1/2	1/2	4-1/2
NA18A-4N	2	1	4-1/4	3-1/8	2.05	4-1/2	5/8	7-1/2	1/2	4-1/2
NA19A-4N	2-1/2	1	4-1/2	3-3/4	2.19	5	5/8	7-3/4	3/4	5
NA20A-4N	3	1	5	4-3/8	2.43	5-1/2	5/8	8-3/8	3/4	5-5/8
NA22A-4N	4	1	6	5-1/4	2.94	6-1/4	5/8	9-3/8	7/8	6-5/8

TYPE XA-A

EXPANSION TERMINAL

For Aluminum and Copper Tube to Flat

Aluminum alloy expansion connector for joining tube to copper or aluminum bar or equipment pads. Flexible aluminum straps allow longitudinal or lateral movement and carries full current load of the joint. PENETROX™ joint compound recommended on contact surfaces. Pad contact surface is on centerline of conductor.

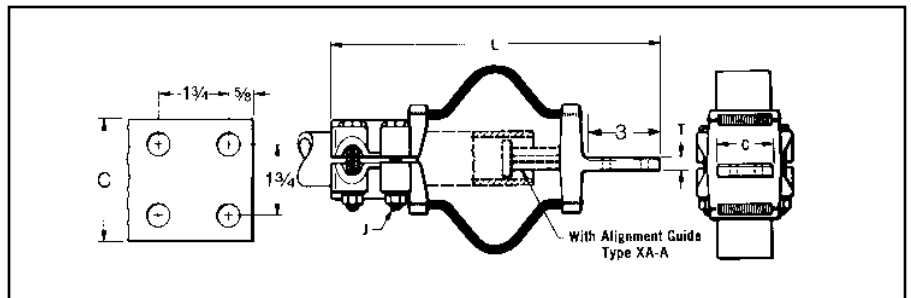

Catalog Number* Standard I.P.S. (Schedule 40) With Guide	Conductor	C	J	L	T
XA15A-4N	1	3	1/2	12-3/4	3/8
XA16A-4N	1-1/4	3		13-5/8	1/2
XA18A-4N	2	3		15-1/2	1/2
XA19A-4N	2-1/2	3-3/4	5/8	17	5/8
XA20A-4N	3	4-3/8		18-5/8	5/8
XA21A-4N	3-1/2	4-3/4		20	7/8
XA22A-4N	4	5-1/4		21	7/8
XA24A-4N	5	6-1/2		24-1/8	7/8

* Conforms to 4-hole NEMA mounting standards.

Blue highlighted items are industry standard and most frequently ordered.

TYPE NBC-A

BARTAP™

Aluminum alloy bolted type terminal for joining aluminum tube to copper or aluminum pads. Drilling in pad conforms to NEMA Standards. PENETROX™ joint compound recommended on contact surfaces.

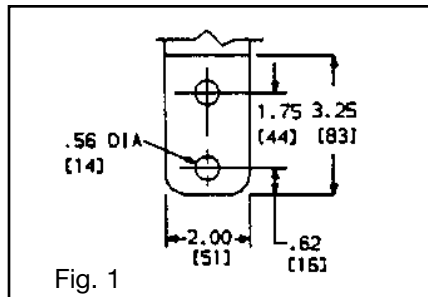
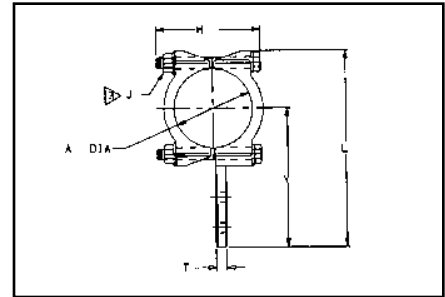
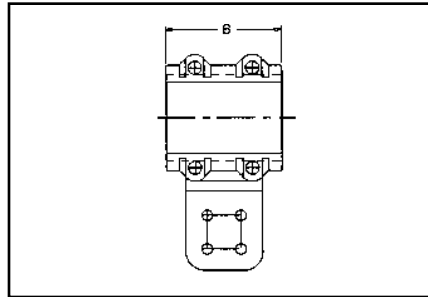

Fig. 1

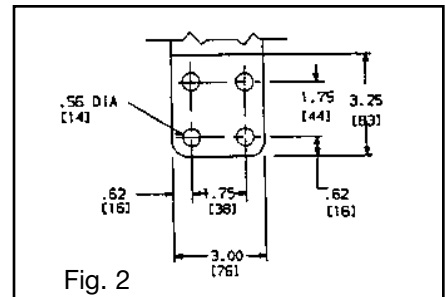

Fig. 2

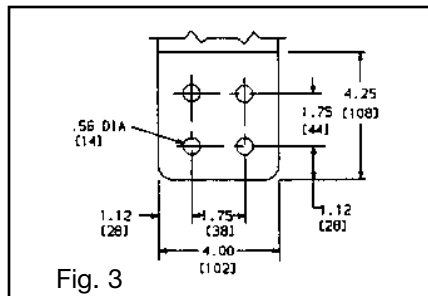

Fig. 3

L-26

Blue highlighted items are industry standard and most frequently ordered.

TYPE NBC-A

(Continued)

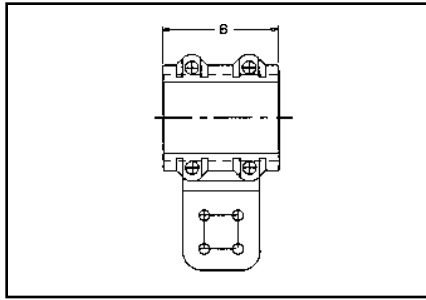

Conductor Aluminum		Catalog Number	Fig. No.	Dimensions In. [mm]					
IPS/EHPS	A			B	H	J	L	T	Y
1"	1.32 [33]	NBC15A-2N	1	3.50	3.00	1/2 - 13	6.81	.38	5.28
		NBC15A-34N	2	[89]	[76]		[173]	[10]	[134]
1-1/4"	1.66 [42]	NBC16A-2N	1	3.75	3.25	1/2 - 13	7.15	.38	5.45
		NBC16A-34N	2	[95]	[76]		[182]	[10]	[138]
		NBC16A-44N	3	3.75	3.25		8.15	.38	6.45
1-1/2"	1.90 [48]	NBC17A-2N	1	4.00	3.50	1/2 - 13	7.39	.38	5.57
		NBC17A-34N	2	[102]	[89]		[188]	[10]	[141]
		NBC17A-44N	3	4.00	3.50		8.39	.38	6.57
2"	2.38 [42]	NBC18A-2N	1	4.25	4.00	5/8 - 11	8.25	.38	6.00
		NBC18A-34N	2	[108]	[76]		[210]	[10]	[152]
		NBC18A-44N	3	4.25	4.00		9.25	.38	7.00
2-1/2"	2.88 [73]	NBC19A-34N	2	4.50	4.50	5/8 - 11	8.75	.50	6.25
		NBC19A-44N	3	[114]	[114]		[222]	[13]	[159]
3"	3.00 [76]	NBC20A-34N	2	5.00	4.50	5/8 - 11	9.37	.50	6.56
		NBC20A-44N	3	[127]	[114]		[238]	[13]	[167]
3-1/2"	4.50 [33]	NBC21A-44N	3	5.50	5.00	5/8 - 11	10.89	.62	7.82
				[140]	[127]		[277]	[16]	[199]
4"	4.50 [114]	NBC22A-34N	2	6.00	5.50	5/8 - 11	10.37	.62	7.06
		NBC22A-44N	3	[152]	[140]		[263]	[16]	[179]
5"	5.56 [141]	NBC24A-34N	2	7.00	6.00	5/8 - 11	12.45	.62	8.60
				[178]	[152]		[316]	[16]	[218]
6"	6.62 [168]	NBC86A-44N	3	8.00	7.25	5/8 - 11	13.51	.75	9.13
				[203]	[184]		[343]	[19]	[232]

NOTES:

- Materials:
Connector: Cast Aluminum Alloy
Hardware: Aluminum Alloy
- Scratch brush connector contact, surface dry then apply an oxide inhibitor, "PENETROX™ A". "PENETROX™ A" can be purchased from BURNDY® in cans or plastic squeeze bottles.

3. Recommended Tightening Torque:

- 1/2-13 300 Inch Pounds
- 5/8-11 480 Inch Pounds

- All dimensions in brackets [] are in millimeters.

L-27

Blue highlighted items are industry standard and most frequently ordered.

TYPE NAR-A

TERMINAL

For Aluminum and Copper Cable to Flat

Aluminum alloy terminal for joining a wide range of copper or aluminum cable to copper or aluminum pad. Properly proportioned to minimize conductor corrosion due to galvanic action. Drilling in pad conforms to NEMA standards. One-wrench installation. PENETROX™ A joint compound recommended on contact surfaces.

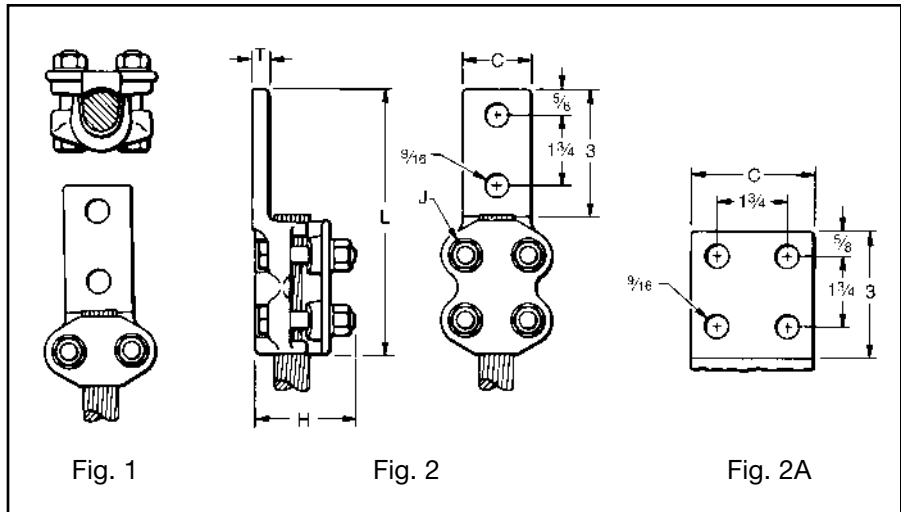
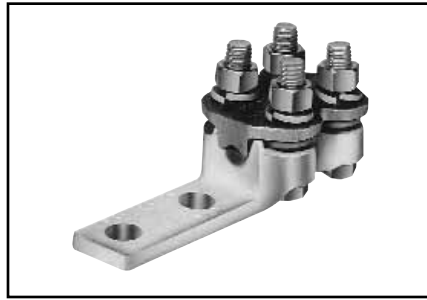

Fig. 1

Fig. 2

Fig. 2A

L-28

Catalog Number	Conductor		No. of Holes in Pad	Fig. No.	C	H	J	L	T	
	Alum. or Copper	ACSR								
NAR25A-2N	4 Str. - 1/0 Str.	4 (6-1) - 1/0 (6-1)	2 NEMA	1	1-1/4	2-3/8	1/2	5-1/4	5/16	
NAR29A-2N*	1/0 Str. - 250	1.0 (6-1) - 4/0 (6-1)		2	1-5/8	2-7/8				
NAR29A-4N*			4 NEMA	2A	3	2-3/4				
NAR32A-2N	250 - 400	4/0 (6-1) - 397.5 (18-1)	2 NEMA	2	1-5/8	2-7/8		6-3/8		3/8
NAR32A-4N			4 NEMA	2A	3					
NAR36A-2N	350 - 600	336.4 (18-1) - 477 (30-7)	2 NEMA	2	1-3/4	3-3/8	6-5/8	1/2		
NAR36A-4N*			4 NEMA	2A	3					
NAR42A-2N**	600 - 900	477 (30-7) - 795 (54-7)	2 NEMA	2	2		3-3/8		6-7/8	1/2
NAR42A-4N*			4 NEMA	2A	3					
NAR45A-2N	900 - 1250	715 (30-19) - 1113 (54-19)	2 NEMA	2	2-5/8	3-3/4	7-1/8	5/8		
NAR45A-4N			4 NEMA	2A	3					
NAR46A-2N	1250 - 1600	1113 (54-19) - 1431 (54-7)	2 NEMA	2	2-3/4		3-3/4		7-3/4	5/8
NAR46A-4N*			4 NEMA	2A	3					
NAR48A-2N	1500 - 2000	1272 (54-19) - 1780 (84-19)	2 NEMA	2	2-3/4	4	7-7/8	3/4		
NAR48A-4N			4 NEMA	2A	3					

* Available with 90 degree pad as shown (example: NAR36A-4N90).

** Available with 45 degree pad as shown (example: NAR42A-2N45).

Blue highlighted items are industry standard and most frequently ordered.

TYPE UHG-A

BUS SUPPORT

For Aluminum and Copper Tube

Aluminum alloy bus support for mounting tube on post or pedestal insulators. Properly proportioned to minimize conductor corrosion due to galvanic action. Rotate caps 180° for slip or rigid fit. One-wrench installation. Supplied with hardware for mounting to cap of insulator. Specify base mounting hardware, if required, by adding suffix “-B”

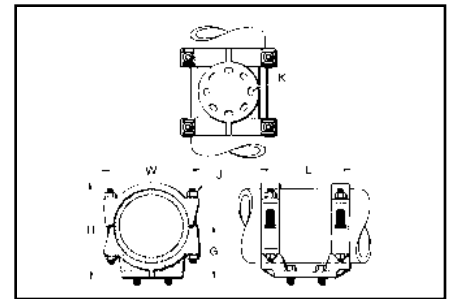

to Catalog Number. For static clips add “-CH” to Catalog Number.

Catalog Number	Conductor	Bolt Circle	G	H	J	K	L	W
UHG14A-3	3/4	3	2	3-1/2	1/2	9/16	7-1/2	3
UHG15A-3	1	3	2	3-5/8		9/16	7-1/2	3-1/8
UHG15A-5		5	2-1/4			11/16	9-7/8	
UHG17A-3	1-1/2	3	2-1/2	4-1/8		9/16	7-3/4	3-3/4
UHG17A-5		5				11/16	10-1/8	
UHG18A-3	2	3	2-3/4	5-1/4		9/16	7-3/4	4-1/8
UHG18A-5		5				11/16	10-1/8	
UHG19A-3	2-1/2	3	3-1/8	5-1/4		9/16	7-3/4	4-5/8
UHG20A-3	3	3	3-5/8	6-1/8		9/16	8-1/4	5-5/8
UHG20A-5		5				11/16	10-5/8	
UHG21A-3	3-1/2	3	4	6-3/4	5/8	9/16	8-1/4	6-1/4
UHG22A-5	4	5	4-1/2	7-1/2		11/16	10-5/8	6-5/8
UHG24A-3	5	3	5-1/4	8-7/8		9/16	8-3/4	7-3/4
UHG24A-5		5				11/16	11-5/8	

TYPE UHKR-A

BUS SUPPORT

For Aluminum Cable or Tube

Aluminum alloy bus support for mounting a wide range of cable or tube on post or pedestal type insulators. Supplied with hardware for mounting to cap of insulator. Specify base mounting hardware, if required, by adding suffix “-B” to Catalog Number.

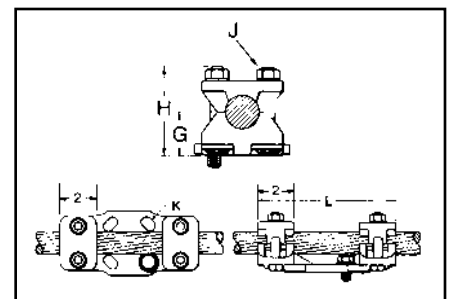

L-29

Catalog Number	Conductor			Bolt Circle	G *	H	J	K	L
	Aluminum	ACSR	Tube Sch. 40/80						
UHKR11A-3	4 Sol. - 4/0 Str.	6 (6-1) - 4/0 (6-1)	1/4	3	1-1/8	2-5/8	1/2	9/16	7-5/8
UHKR11A-5				5				11/16	9-1/2
UHKR13A-3	250 - 550	266.8 (6-7) - 477 (30-7)	3/8 - 1/2	3	1-3/8	2-7/8		9/16	7-5/8
UHKR13A-5				5				11/16	8-7/8
UHKR14A-3	600 - 1113	556.5 (26-7) - 1033.5 (54-7)	3/4	3	1-3/4	3-5/8		9/16	7-5/8
UHKR14A-5				5				1-1/2	3-3/8
UHKR16A-3	1000 - 2000	1113 (54-19) - 1780 (84-19)	1 - 1-1/4	3	1-31/32	4-1/16	1/2	9/16	7-9/16
UHKR16A-5				5			1-13/16	3-7/8	11/16

* With maximum conductor in place.

Blue highlighted items are industry standard and most frequently ordered.

TYPE LB-A

END CAP

Aluminum alloy end cap for aluminum tube. Driven into place for a secure fit. Seals out moisture, reduces electrostatic loss and eliminates hazards created by nesting birds.

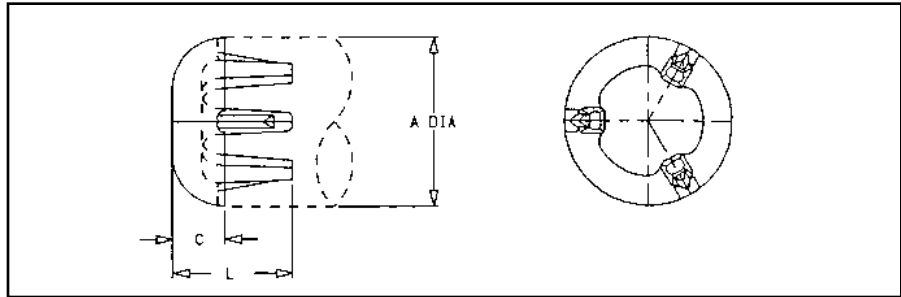

Conductor Aluminum Pipe Size	Dimensions In./[mm]			Catalog Number	
	A	C	L	Schd. 40	Schd. 80
1/2"	.84 [21]	.38 [9.7]	1.25 [32]	LB13A	LB53A
3/4"	1.05 [27]	.50 [13]	1.37 [35]	LB14A	LB54A
1"	1.32 [34]	.50 [13]	1.43 [36]	LB15A	LB55A
1-1/4"	1.66 [42]	.50 [13]	1.43 [36]	LB16A	LB56A
1-1/2"	1.90 [48]	.50 [13]	1.45 [37]	LB17A	LB57A
2"	2.38 [60]	.88 [22]	1.85 [47]	LB18A	LB58A
2-1/2"	2.88 [73]	.88 [22]	2.01 [51]	LB19A	LB59A
3"	3.50 [89]	.88 [22]	2.10 [53]	LB20A	LB90A
3-1/2"	4.00 [102]	.88 [22]	2.15 [55]	LB21A	LB91A
4"	4.50 [114]	.88 [22]	2.22 [56]	LB22A	LB92A
5"	5.56 [141]	.88 [22]	2.34 [59]	LB24A	LB94A
6"	6.63 [168]	.88 [22]	2.46 [62]	LB86A	LB96A

L-30

NOTES:

1. Material: Cast Aluminum Alloy.
2. Dimensions in brackets [] are in millimeters.

Blue highlighted items are industry standard and most frequently ordered.

TYPE WAS-A

TERMINAL CONNECTOR

Aluminum alloy weld type terminal for joining aluminum tube to copper or aluminum pads. Drilling in pad conforms to NEMA standards. PENETROX™ joint compound recommended on pad contact surfaces.

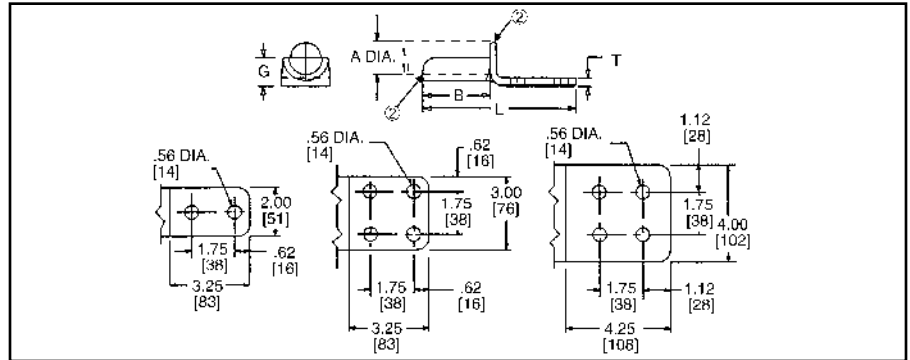

Conductor Aluminum		Catalog Number	Dimensions In./[mm]			
Sch. 40/Sch. 80	A		B	G	L	T
3/4"	1.05 [27]	WAS14A-2N	2.50 [64]	1.50 [38]	6.50 [165]	.38 [9.7]
1"	1.32 [34]	WAS15A-2N	2.75 [70]	1.19 [30]	6.75 [171]	.38 [9.7]
		WAS15A-34N	2.75 [70]	1.19 [30]	6.75 [171]	.38 [9.7]
1-1/4"	1.66 [42]	WAS16A-2N	3.00 [76]	1.38 [35]	7.00 [178]	.38 [9.7]
		WAS16A-34N	3.00 [76]	1.38 [35]	7.00 [178]	.38 [9.7]
1-1/2"	1.90 [48]	WAS17A-2N	3.25 [83]	1.50 [38]	7.25 [184]	.44 [11]
		WAS17A-34N	3.25 [83]	1.50 [38]	7.25 [184]	.38 [9.7]
2"	2.38 [60]	WAS18A-2N	3.50 [89]	1.75 [44]	7.50 [191]	.44 [11]
		WAS18A-34N	3.50 [89]	1.75 [44]	7.50 [191]	.38 [9.7]
		WAS18A-44N	3.63 [92]	1.75 [44]	8.62 [219]	.50 [13]
2-1/2"	2.88 [73]	WAS19A-2N	3.63 [92]	2.00 [51]	7.87 [200]	.56 [14]
		WAS19A-34N	3.63 [92]	2.00 [51]	7.87 [200]	.56 [14]
		WAS19A-44N	3.63 [92]	2.00 [51]	8.87 [225]	.50 [13]
3"	3.50 [89]	WAS20A-2N	3.67 [93]	2.38 [60]	8.25 [211]	.69 [18]
		WAS20A-34N	3.75 [95]	2.38 [60]	8.25 [211]	.62 [16]
		WAS20A-44N	3.75 [95]	2.38 [60]	9.25 [235]	.62 [16]
3-1/2"	4.00 [102]	WAS21A-34N	4.25 [108]	2.62 [67]	8.50 [216]	.62 [16]
		WAS21A-44N	4.25 [108]	2.62 [67]	9.50 [241]	.62 [16]
4"	4.50 [114]	WAS22A-44N	4.25 [108]	2.88 [73]	9.50 [241]	.75 [19]
5"	5.56 [141]	WAS24A-44N	4.25 [108]	3.62 [92]	9.50 [241]	.75 [19]
6"	6.63 [168]	WAS86A-44N	4.25 [108]	4.00 [102]	9.75 [248]	1.00 [25]

NOTES:

- 1 Material: Cast Aluminum Alloy.
- 2 WELDING TO BE DONE BY THE CUSTOMER. For welding recommendation see drawing SD73608

- 3 After welding, scratch brush connector contact surface dry then apply an oxide inhibitor "PENETROX™ A". "PENETROX™ A" can be purchased from BURNDY® in cans or plastic squeeze bottles.

- 4 Dimensions in brackets [] are in millimeters.
- 5 Tongue finished on ONE SIDE ONLY (bottom). For tongue finished on both sides, add suffix letter "Q" to Catalog Number (example: WAS22A-44NQ).

TYPE WASC-A-N

CENTERFORMED WELDMENT TERMINAL

Aluminum alloy weldment terminal. Type WASC-A-N has one contact surface on the center line of the tube. Holes are NEMA spaced for terminating aluminum or copper mating pads. PENETROX™ joint compound recommended for use on contact surfaces.

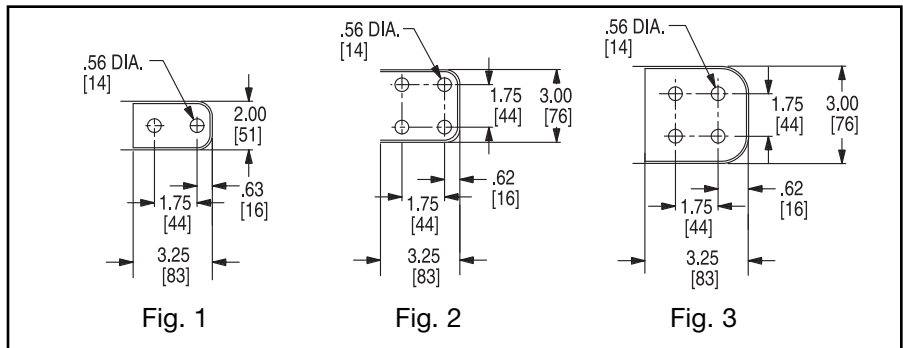
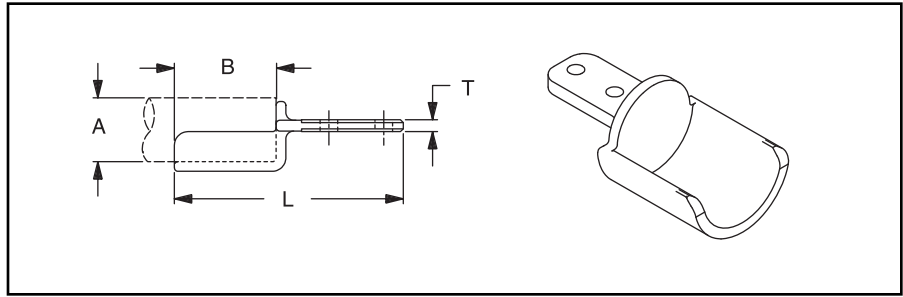

Catalog Number	Aluminum Conductor		Fig. No.	Dimensions Inches/[mm]		
	Schedule 40/80	A [mm]		B	L	T
WASC14A2N	3/4"	1.05 [27]	1	2.50 [64]	6.44 [164]	.22 [6]
WASC15A2N	1"	1.32 [33]	1	2.75 [70]	6.69 [170]	.38 [10]
WASC15A34N			2			
WASC16A2N	1-1/4"	1.66 [42]	1	3.00 [76]	7.00 [178]	.38 [10]
WASC16A34N			2			
WASC17A34N	1-1/2"	1.90 [48]	2	3.25 [83]	7.31 [186]	.44 [11]
WASC18A34N	2"	2.38 [60]	2	3.50 [90]	7.56 [192]	.50 [13]
WASC18A44N			3		8.56 [217]	
WASC19A2N	2-1/2"	2.88 [73]	1	3.75 [95]	7.88 [200]	.56 [14]
WASC19A34N			2		8.88 [226]	
WASC19A44N			3			
WASC20A2N	3"	3.50 [89]	1	4.00 [102]	8.13 [207]	.62 [16]
WASC20A34N			2		9.13 [232]	
WASC20A44N			3			
WASC21A2N	3-1/2"	4.00 [102]	1	4.25 [108]	8.38 [213]	
WASC21A34N			2		9.38 [238]	
WASC21A44N			3			
WASC22A2N	4"	4.50 [114]	1	4.25 [108]	8.38 [213]	.75 [19]
WASC22A34N			2		9.38 [238]	
WASC22A44N			3			
WASC24A34N	5"	5.56 [141]	2	4.25 [108]	8.50 [216]	.75 [19]
WASC24A44N			3		9.50 [241]	
WASC86A44N	6"	6.63 [168]	3	4.25 [108]	9.50 [241]	1.00 [25]

For tongue finished on both sides add suffix letter "Q" to Catalog Number (example: WASC14A2NQ).

Blue highlighted items are industry standard and most frequently ordered.

TYPE WG-A

WELDMENT GROUND STUD

Range-taking weldment stud for grounding Aluminum tube.

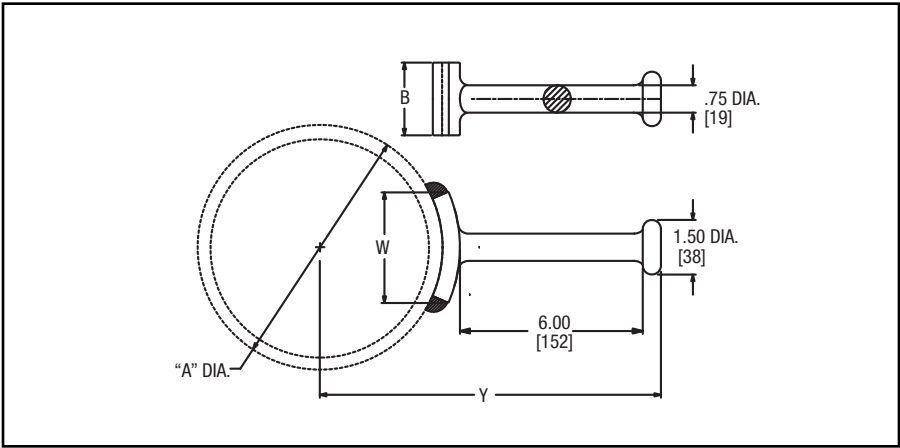

Catalog Number	Aluminum IPS	Dimensions Inches/[mm]			
		A	B	W	Y
WG19A	1" - 2-1/2"	1.315 - 2.88 [33] - [73]	3.00 [76]	1.32 [34]	8.19 [208]
WG86A	3" - 6"	3.50 - 6.62 [89] - [168]	2.00 [51]	3.06 [78]	10.31 [262]

Dimensions in brackets [] are in millimeters

Blue highlighted items are industry standard and most frequently ordered.

TABLE OF CONTENTS

Introduction M-3
 Nomogram M-4
 Gradient Calibrator M-5
 Formula Gradient M-6
 Nomogram M-7
 Interference & Contamination M-8

APPLICATION SELECTOR

TERMINALS

 **Straight Tubing
SWA-A-N**
550 kV M-9

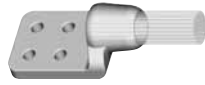
 **Straight Cable
SWA-A-N**
550 kV M-10

 **Center Formed Tubing
SWAC-A-N**
550 kV M-11

 **Expansion
SWXA-A-NK**
345 kV M-12

 **Expansion
SWXA-A-N**
550 kV M-13

COUPLERS

 **Light Design
WSLB-A**
550 kV M-14

 **Standard Design
WS-A**
550 kV M-15

 **Expansion
SWXP-A-A**
550 kV M-16

TEE CONNECTORS

 **Tap-off Pad
SWAB-A-N** M-17

 **Standard T
SWT-A-A** M-18 - M-19

 **75 Degree T
SWT-A-A-75** M-20

 **V Tap
SWAT-A-A-30** M-21

BUS SUPPORTS

 **Rigid
SWOH-A**
550 kV M-22

 **Rigid/Slip
SWHRH-A**
550 kV M-23

 **Vertical
SWVH-A**
550 kV M-24

 **Expansion
SWXHP-A**
550 kV M-25

MISCELLANEOUS

 **90 Degree Elbow
SWL-A**
550 kV M-26

 **End Plug
WLB-A**
550 kV M-27

 **Corona Bell
SCB-A**
500 kV M-27

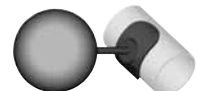
 **Ground Stud
SWCB-A**
500 kV M-28

M-1







Blue highlighted items are industry standard and most frequently ordered.



TABLE OF CONTENTS (Continued)

MISCELLANEOUS
(Continued)

	Shielding Cap (Two Piece) STS-A-N 550 kV..... M-29
	Shielding Cap (One Piece) STS-A-NCG 550 kV..... M-29

CABLE SPACERS
(Two Conductor)

	Single Bolt Spacer S2GBP-A 550 kV..... M-30 - M-31
	Single Bolt Tap S2GBPA-A 550 kV..... M-30 - M-31
	Single Bolt Bus Support SH2GBP-A 550 kV..... M-30 - M-31
	Two Bolt Spacer S2GBP-AB2 550 kV..... M-32 - M-33
	Two Bolt Tap S2GBPA-AB2 550 kV..... M-32 - M-33
	Two Bolt Bus Support SH2GBP-A-B2 550 kV..... M-32 - M-33

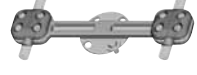
	Four Bolt Spacer S2GBP-AB4 550 kV..... M-34 - M-35
	Four Bolt Tap S2GBPA-AB4 550 kV..... M-34 - M-35
	Four Bolt Bus Support SH2GBP-A-B4 550 kV..... M-34 - M-35



CABLE SPACERS
(Three Conductor)

	Spacer S3GBP-A 550 kV..... M-36
---	--

**BIFURCATING
TERMINAL**

	Terminal SF2A-NL-EX 550 kV..... M-37
---	---

**TRIFURCATING
CONNECTORS**

	Coupler SW3A-A44N8 550 kV..... M-38
	T-Tap SW3AB-A44N8 550 kV..... M-39
	Terminal SF3A44N8 550 kV..... M-40

Blue highlighted items are industry standard and most frequently ordered.

INTRODUCTION

Connectors for use in EHV Substations must meet essentially the same electrical and mechanical requirements as those for other power connectors. However, operation at extra high voltages imposes an important additional requirement. They must not produce corona discharges that interfere with radio reception and cause energy loss.

Corona forms when the voltage gradient at the surface of a conducting material exceeds a critical value and ionizes the surrounding air. For conductors, the four basic factors that determine surface voltage gradient are distance from ground, conductor diameter, phase spacing and voltage.

In A.C. circuits, there are two basic kinds of corona. Negative corona forms during the negative half cycle, and positive corona during the positive half cycle. Negative corona generally appears as a glow on conventional conductors at about 20 kV rms/cm. Its amplitude is relatively low and causes no significant radio interference. Positive corona appears as a plume at above 30 kV rms/cm. Its amplitude is about 50 times higher than that for negative corona and is the major cause of radio interference.

BURNDY® EHV Connectors are designed so that under fair weather operating conditions, the voltage gradient at the connector surface will be at a level that will not cause corona and the resultant radio interference. (RIV)

BURNDY® DESIGN CRITERIA

Cable Connectors

For reasons of economy, EHV systems using stranded conductor are generally designed to operate at voltage gradients close to the negative corona onset level. It is essential, therefore, that connectors provide corona-free performance superior to that of the cable. So our design criterion calls for the voltage at which corona extinguishes from the connector to be higher than the voltage at which it extinguishes from the cable. This criterion is met by eliminating all projections and by providing smooth contours on all sur-

faces. On compression elements, the ends are especially critical. Carefully designed tapers are provided to keep the voltage gradient at a level lower than that on the conductor. Of course, it is still necessary during installation to smooth crimped elements.

On accessories, like spacers for bundled lines, the critical areas are those at the edges of the bundle. The bundle itself generally shields those parts that fall within it. Many projections that would cause corona on a single conductor line are quiet when they fall within the shielding influence of a bundle. However, those parts that fall at the edges are carefully finished at the factory to insure corona-free operation.

Tubular Bus Connectors

Station designers choose tubular bus sizes on the basis of mechanical rather than electrical requirements. For instance, stations that only need 4" IPS to meet electrical and corona requirements often have 6" IPS as main buses. The resultant voltage gradient on these buses is very low, perhaps only 10 kV rms/cm, well below the corona onset level.

It is impractical, therefore, to require that connectors operate quieter than the bus regardless of voltage. Under some circumstances, it might be impossible to meet such criteria. In most cases, it would be prohibitively expensive to do so.

Of course, theoretically optimum connectors could be designed for each application, based on the design voltage gradient for individual stations. However, in most cases even differences as great as that between 345 and 500 kV don't have a meaningful impact on connector costs. So, from a practical point of view, it is feasible to design most connectors for 500 kV operation. This makes it more convenient for station designers to select and order connectors.

Bus connectors are designed to provide corona-free performance under conditions of actual operation. This is done by calculating the voltage gradient on the surface of the bus

at 500 kV, using the phase spacing and ground distance typical for this voltage. Connectors are then designed to operate corona free when the voltage gradient on the bus is 10% above this value.

The exceptions to this rule are the flexible expansion connectors. Those designed for 345 kV are self-shielding. Those for 500 kV have separate shielding rings. Experimental work on self-shielding 500 kV expansion connectors indicates that the margin of safety is too small to justify recommending them for this voltage.

CONTROLLING CORONA

Since corona is caused when the voltage gradient at the surface of a conducting material reaches a level that causes the surrounding air to break down, then obviously, the way to prevent corona is to keep the gradient below this critical level.

From the point of view of the connector designer, this can be accomplished in three ways:

1. By providing generous radii on all outside surfaces to keep the voltage stresses to a minimum.
2. By providing shielding rings.
3. By placing the connector within the shielding influence of some part of the bus structure.

Since it is impossible for the connector designer to know the exact configuration of every bus system where the connectors might be used, the third approach is not practical. So, for purposes of developing a standard line, we concentrate on the first two.

Whenever possible, connectors are designed to be self-shielding. This approach leads to less costly and less obtrusive designs. Only in the case of complicated connector configurations do BURNDY® EHV designs use corona rings. Examples of such applications are disconnectable equipment taps, expansion couplers and equipment terminals which often have configurations that preclude the use of self-shielding designs.

Blue highlighted items are industry standard and most frequently ordered.

NOMOGRAM FOR DETERMINING THE EQUIVALENT

HEIGHT (he) OF A THREE PHASE LINE

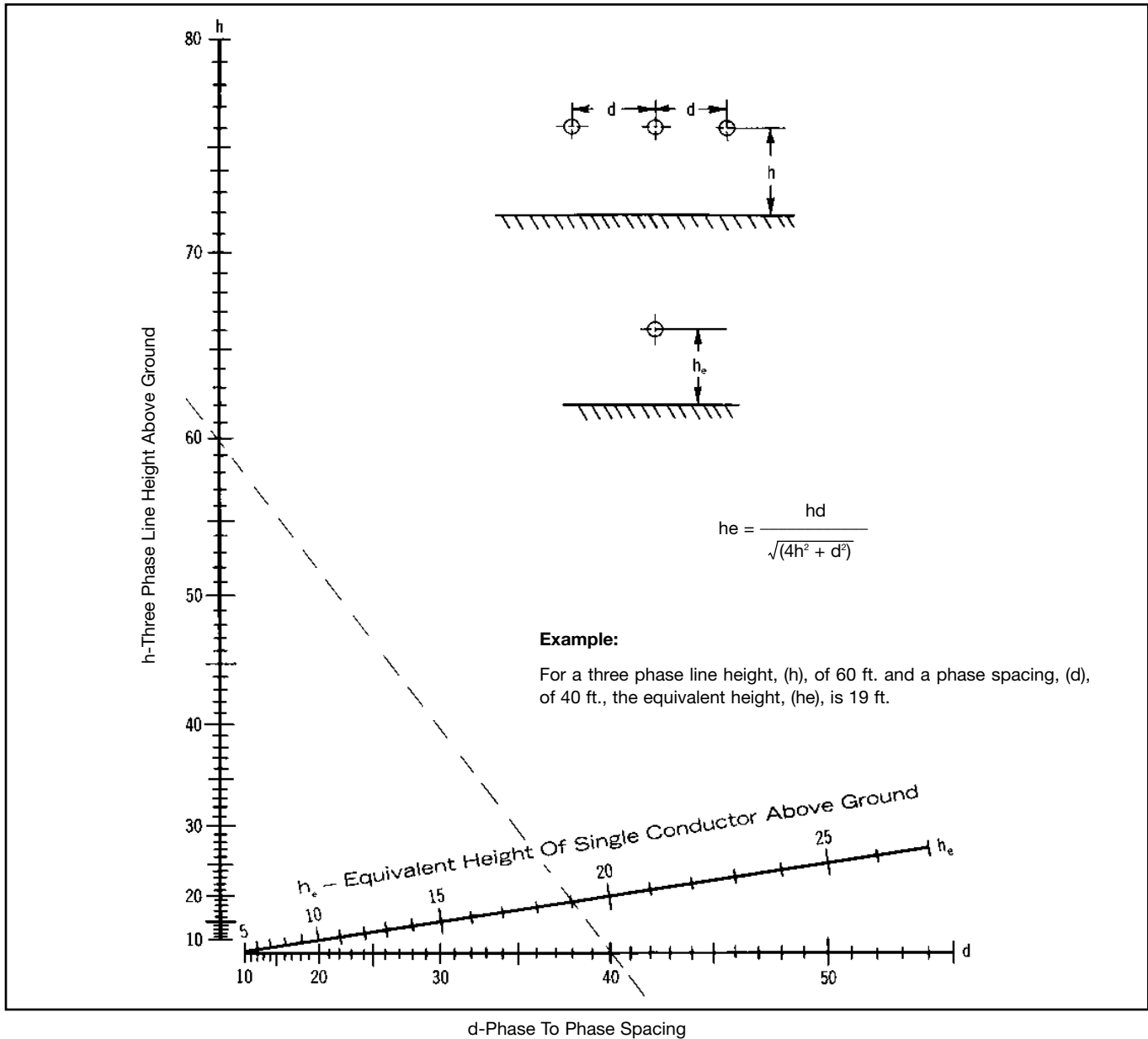

M-4

Nomogram for determining the equivalent height of a single conductor line having the same average voltage of gradient as the CENTER conductor of a horizontally spaced

three phase line, with the same line to ground voltage and the same conductor size. All dimensions measured in the same units.

Blue highlighted items are industry standard and most frequently ordered.

The use of the laboratory is based on the fact that it is the surface voltage gradient that causes corona. Although most systems consist of 3 phase conductors and a ground plane, it is a rather simple matter to duplicate in the laboratory the conductor surface voltage gradient as it exists on any of these phase conductors with a single conductor and a ground plane.

The following formula and nomograms give this three phase to single phase equivalency. Because this conversion is possible, all EHV testing is done single phase; and there is no necessity for 3 phase testing with its high cost in terms of equipment and space.

Since voltage gradient is the significant factor, the single phase test does not have to be done at the full voltage of an operation

system. By setting up the test closer to the ground plane, the operation voltage gradient can be obtained with a lower test voltage. There is a limit, however, below which the height cannot be lowered lest corona onset and flashover occur simultaneously. Generally, the minimum test height should be about 10 times the diameter of the test conductor.

GRADIENT CALIBRATOR

Normally, the conductor surface voltage gradient at the extinction of corona in the laboratory is calculated using the accompanying equations. However, for test setups involving unusual conductor configurations, the conductor gradient cannot be readily calculated. In these cases, a gradient calibrator

may be used. This is a small sphere mounted on the conductor. It has previously been calibrated for each conductor size to establish the surface voltage gradient that starts positive corona on the sphere. With it tests can be duplicated in any number of laboratories. The applied voltages and ground distances could all be different. But the voltage gradient on the surface of the conductor when the corona occurs on the sphere will always be the same. The calibrator provides a convenient bench mark for measuring the corona performance of connectors.

In use, the sphere is mounted on the conductor in a connector test setup. The voltage is raised until there is a corona on the sphere. We already know from previous calibration what the voltage gradient on the surface of the conductor is at this point.

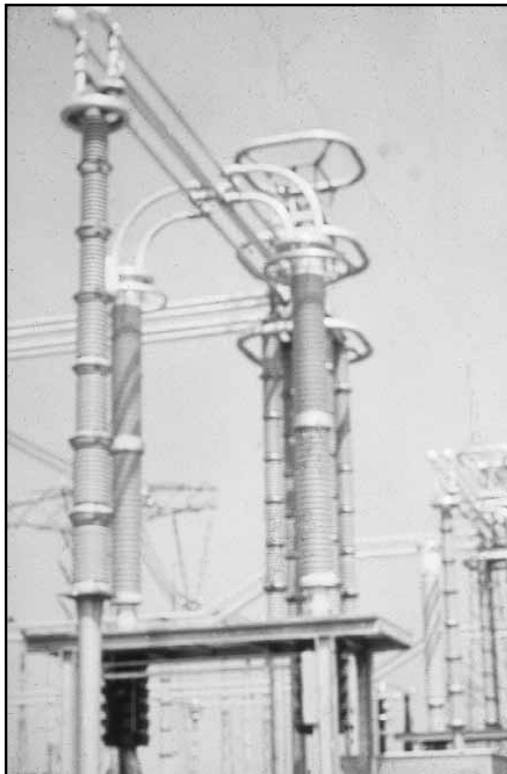

Blue highlighted items are industry standard and most frequently ordered.

The sphere is removed and the voltage raised until there is a corona on the connector. Since the voltage gradient increases directly with increases in applied voltage, the gradient on the conductor at this point can be readily calculated.

It is important to note that the significant parameter is the voltage gradient on the surface of the conductor. It is not necessary

to know the gradient on the connector. The conductor gradient in any given substation is controlled by its design parameters and may be calculated using the following formulae and nomograms. Once the gradient is known, it is unnecessary to have any other information to design connectors. As long as connectors are corona-free at a conductor voltage gradient higher than that planned for the conductor, the connector

will be corona-free under fair weather operating conditions.

There may on occasion be unusual situations where choice of *conductor*, station geometry or clearance problems cause the need for connectors of special design. Where this is the case, BURNDY® is prepared to design corona-free devices to operate under such conditions.

Formula for Determining The Voltage Gradient

Notations Used

- h** = line to ground distance (cm)
- r** = radius of the individual conductor (cm)
- s** = conductor spacing in the bundle (cm)
- d** = phase to phase spacing of the line (cm)
- V** = line to ground voltage (kV)
- E_a** = average gradient at the surface of the conductor (kV/cm)
- E_m** = maximum gradient on the surface of a single conductor
- h_e** = equivalent single phase line to ground distance (cm)
- r_e** = equivalent single conductor radius (cm) of bundled conductors
- n** = number of conductors in the bundle

$$E_a = \frac{V}{r \cdot 1n \cdot \frac{2h}{r}} \qquad E_m = \frac{h}{h - r} E_a$$

The maximum gradient (E_m) occurs on the side facing the ground plane.

The center conductor has a gradient about 5% higher than the outside conductors. The gradient on the center phase may be calculated using the formula for the single conductor. Single phase system and substituting (h_e) from the following formula or attached nomograms for the height above ground (h). For the center phase:

$$E_a = \frac{V}{r \cdot 1n \cdot \frac{2h_e}{r}} \qquad h_e = \frac{hd}{\sqrt{(4h^2 + d^2)}}$$

It should be noted that h_e is somewhat smaller than $\frac{d}{2}$

$$E_a = \frac{V}{n \cdot r \cdot 1n \cdot \frac{2h}{r_e}} \qquad \text{in which } r_e = r \left(\frac{s}{r} \right)^{\frac{n-1}{n}}$$

The value of "n" is unity for 1-, 2-, and 3- conductor bundles and 1.12 for 4- conductor bundles.

Bundled Conductor - Three Phase

This case may be reduced to the single bundled conductor case by replacing h with h_e in the equation. The definition of h_e is identical to that given for the single conductor — three phase situation.

Fig. 1

NOMOGRAM FOR FINDING THE AVERAGE CONDUCTOR-SURFACE VOLTAGE-GRADIENT FROM LINE DIMENSIONS AND VOLTAGE.

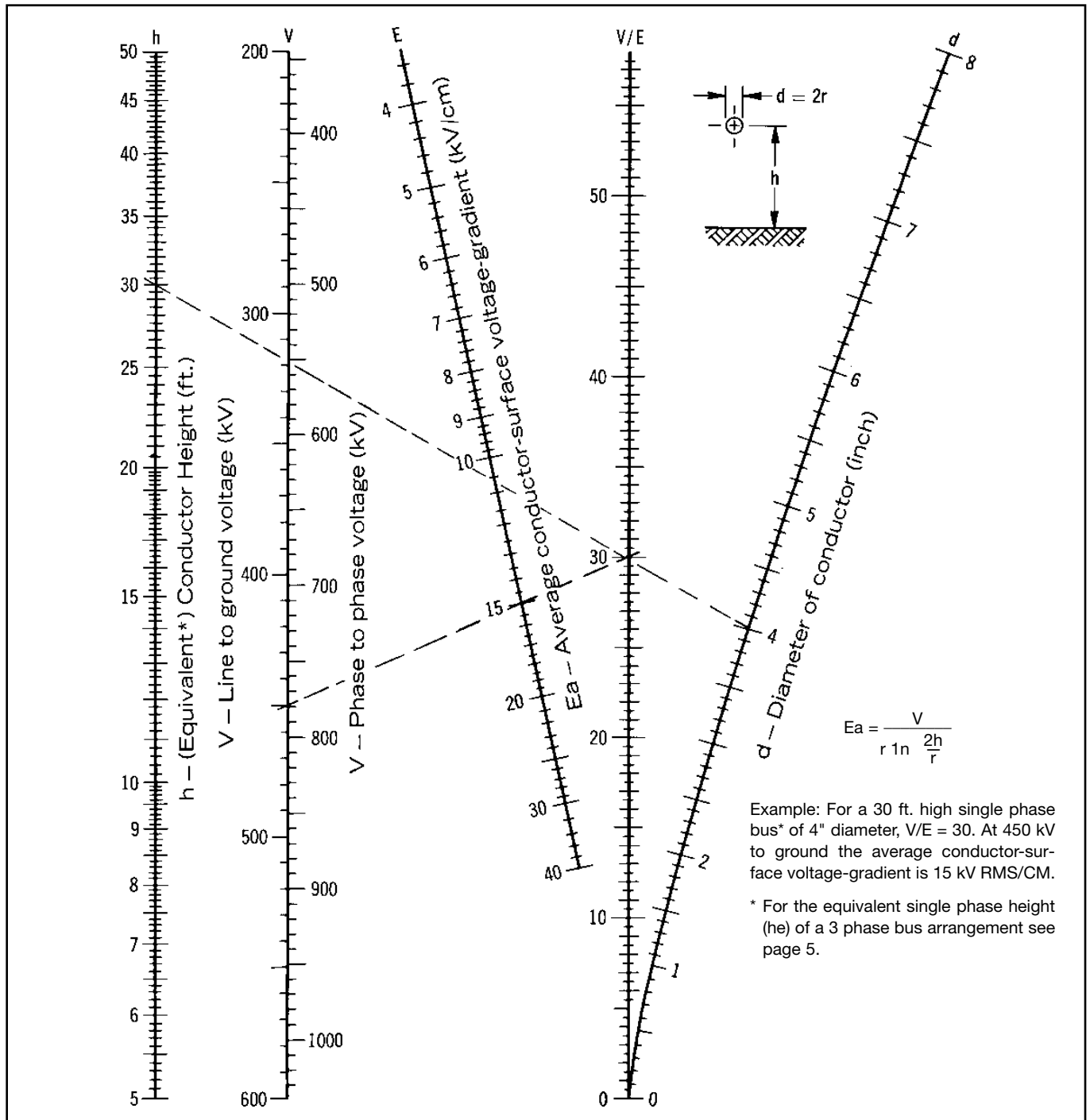

M-7

Blue highlighted items are industry standard and most frequently ordered.

RADIO INTERFERENCE VOLTAGE

There is serious question as to whether measurement of RIV on connectors makes a meaningful contribution to quieter station operation.

Under test conditions, there is generally no significant indication on the radio noise meter until the onset of visible positive corona. At this point, the RIV reading goes into the hundreds of thousands of microvolts. The effect of this phenomenon is to provide a visibly discernable point at which RIV will become excessive. It eliminates the necessity to make, record and plot RIV measurements. Where there is no corona, there is no RIV. So our test criterion calling for no visible corona insures that there will be no radio interference generated by the connector under operating conditions.

EFFECT OF CONDUCTOR SIZE ON TESTING

Conductor diameter has a significant effect on potential corona problems. The larger the diameter, the lower the surface voltage gradient for a given test voltage. This means that smaller conductors produce corona at lower voltages than larger ones.

Many connector designs have the same basic configuration for various conductor sizes. The only difference being the size of the attaching elements. This is particularly true for many of the welded type connectors. Where this is the case, it is often sufficient to test the connector only on the smallest conductor, since it yields the lowest corona extinction voltage. When there is any doubt, each size is tested.

CONTAMINATION

Much work has been done to establish the relationship between the corona onset voltage for contaminated as compared to clean hardware. Experiments in the

BURNDY® laboratory indicate that this value can be reduced to half of the voltage for clean hardware. However, the relationship varies with the kind of contamination, atmospheric condition and type of connector.

There have been a number of attempts to produce artificial contamination and atmospheres in laboratories. However, there is as yet no clearly established relationship between the corona performance of hardware contaminated in the laboratory. Until such a relationship is established, the only testing that provides comparable data is on clean hardware under fair weather conditions.

CONCLUSION

For more than 80 years, BURNDY® has been designing connectors for the industry's most critical applications. Connectors for EHV are an outgrowth of this tradition. Whether your need is for catalog items or special designs, you can count on electrical, mechanical and corona-free performance, commensurate with the application.

TYPICAL CURVE

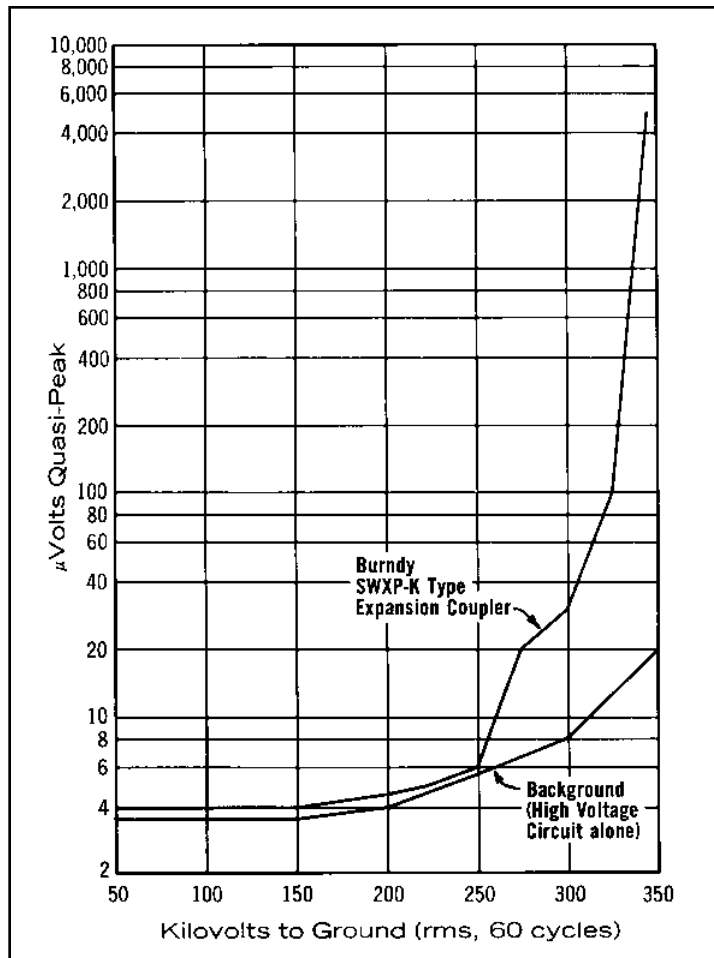

M-8

WELDED TERMINAL CONNECTOR

SWA-A-N

Weld type
Application: Bus to Two or Four Hole Pad (offset terminal)

EHV RATED: UP TO 550 kV
when used with
Shielding Caps

Material: Cast 356 Aluminum Alloy

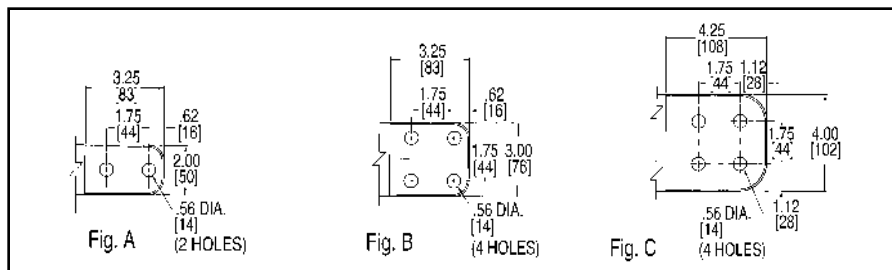
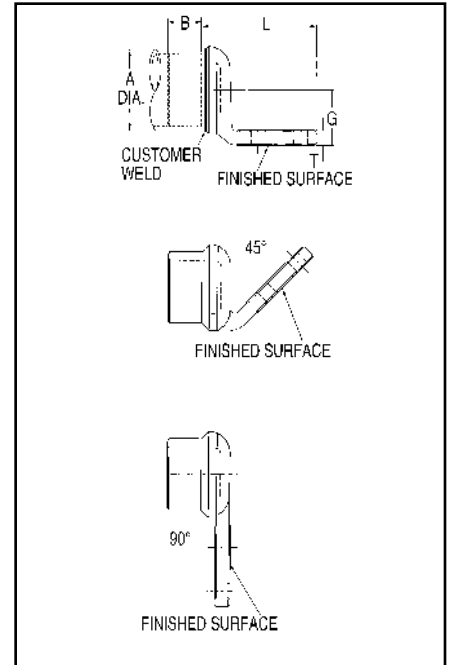
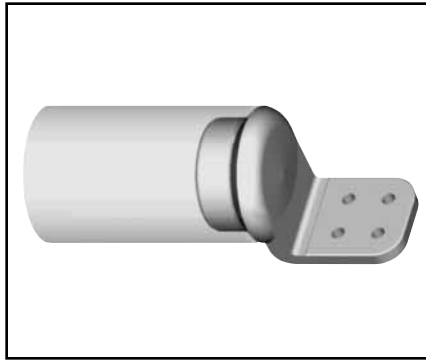

Catalog Numbers		Accommodates "A" Dia. Alum. Tube	Fig.	B	G	L	T
IPS (Sch. 40)	EHPS (Sch. 80)						
SWA18A-2N	SWA58A-2N	2" (2.375 Dia.)	A	1.25 [32]	1.72 [44]	5.88 [149]	.50 [13]
SWA18A-34N	SWA58A-34N		B	1.25 [32]	1.72 [44]	5.88 [149]	.50 [13]
SWA18A-44N	SWA58A-44N		C	1.25 [32]	1.72 [44]	6.95 [177]	.50 [13]
SWA19A-2N	SWA59A-2N	2-1/2" (2.875 Dia.)	A	1.50 [38]	1.97 [50]	6.36 [162]	.56 [14]
SWA19A-34N	SWA59A-34N		B	1.50 [38]	1.97 [50]	6.36 [162]	.56 [14]
SWA19A-44N	SWA59A-44N		C	1.50 [38]	1.97 [50]	7.40 [188]	.56 [14]
SWA20A-2N	SWA90A-2N	3" (3.500 Dia.)	A	1.75 [44]	2.34 [59]	6.41 [163]	.62 [16]
SWA20A-34N	SWA90A-34N		B	1.75 [44]	2.34 [59]	6.41 [163]	.62 [16]
SWA20A-44N	SWA90A-44N		C	1.75 [44]	2.34 [59]	7.46 [189]	.62 [16]
SWA21A-34N	SWA91A-34N	3-1/2" (4.000 Dia.)	B	1.75 [44]	2.59 [66]	6.40 [163]	.62 [16]
SWA21A-44N	SWA91A-44N		C	1.75 [44]	2.59 [66]	7.47 [190]	.62 [16]
SWA22A-44N	SWA92A-44N	4" (4.500 Dia.)	C	2.00 [51]	2.84 [72]	7.51 [191]	.75 [19]
SWA23A-44N	SWA93A-44N	4-1/2" (5.000 Dia.)	C	2.00 [51]	3.09 [78]	7.77 [197]	.75 [19]
SWA24A-34N	SWA94A-34N	5" (5.563 Dia.)	B	2.00 [51]	3.38 [86]	6.80 [173]	.75 [19]
SWA24A-44N	SWA94-44N		C	2.00 [51]	3.38 [86]	7.82 [199]	.75 [19]
SWA86A-44N	SWA96A-44N	6" (6.625 Dia.)	C	2.50 [64]	4.00 [102]	7.90 [201]	1.00 [25]

- NOTES:**
 1. Dimensions in brackets [] are in millimeters.
 2. Conductor smaller than 3 inch bus size not recommended for 550 kV.
 3. DOES NOT INCLUDE SHIELDING CAPS. For EHV applications, shielding caps are required. Order separately

- (type STS) shown on page 32 or ADD SUFFIX "STS" to catalog number (example: SWA22A44NSTS), includes one shielding cap.
 4. One surface of pad finished. For finished pad on both sides add SUFFIX "Q" to the catalog number (example: SWA22A-44NQ).

5. For 45 or 90 degree angle add SUFFIX "45" or "90" to catalog number (example: SWA22A44N90).
 6. For six hole NEMA pad contact factory.

WELDED TERMINAL CONNECTOR

SWA-A-N for Cable

Weld type
Application: Cable to Two or Four Hole Pad (offset terminal)

EHV RATED: UP TO 550 kV
when used with shielding caps

Material: Cast 356 Aluminum Alloy

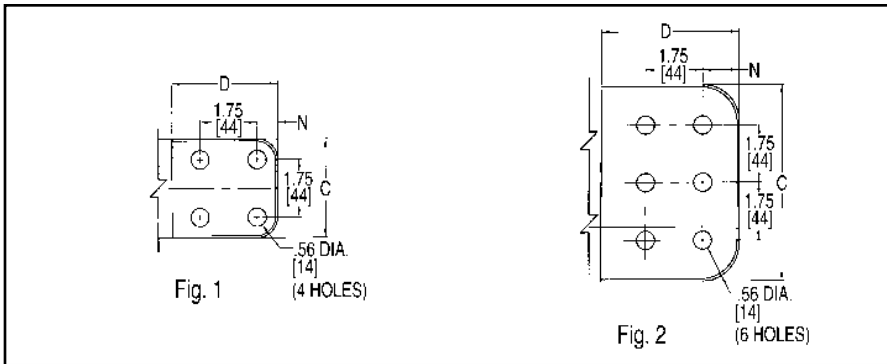
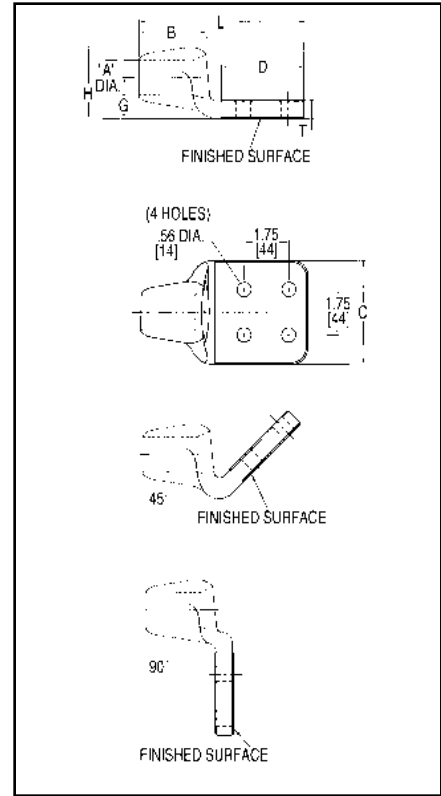
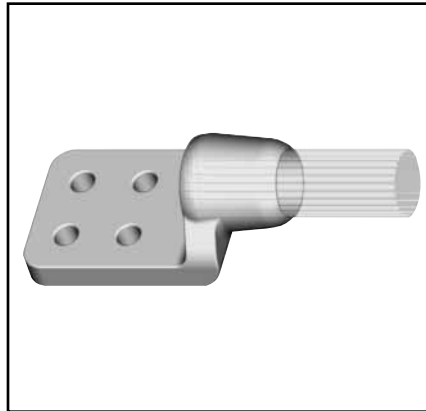

Catalog Numbers	Accommodates "A" Dia.		Str.	Max. Dia.	Max. Dia.	Fig. No.	B	C	D	G	H	L	N	T
	Alum. Cable	Acsr Cable												
SWA44R-44N	700 kcmil thru 874.5 kcmil	605 kcmil thru 874.5 kcmil	26-7 30-19	.961 [24]	1.085 [28]	1	1.50 [38]	4.00 [102]	4.25 [108]	1.12 [28]	2.00 [51]	6.25 [159]	1.12 [28]	.50 [13]
SWA48A-44N	2000 kcmil thru 2250 kcmil	2167 kcmil	72-7	1.606 [41]	1.740 [44]	1	2.62 [67]	4.00 [102]	4.25 [108]	1.83 [47]	3.18 [81]	7.50 [191]	1.12 [28]	.82 [21]
SWA54R-44N	1400 kcmil thru 1600 kcmil	1272 kcmil thru 1510.5 kcmil	45-7	1.341 [34]	1.470 [37]	1	2.00 [51]	4.00 [102]	4.25 [108]	1.38 [35]	2.56 [65]	6.56 [167]	1.12 [28]	.56 [14]
SWA58R-44N	1700 kcmil thru 1900 kcmil	1510.5 kcmil thru 1780 kcmil	54-49 54-19	1.471 [37]	1.605 [41]	1	2.50 [64]	4.00 [102]	4.25 [108]	1.58 [40]	2.83 [72]	7.25 [184]	1.12 [28]	.69 [18]
SWA444A-44N	900 kcmil thru 1100 kcmil	795 kcmil thru 954 kcmil	54-7	1.086 [28]	1.210 [31]	1	1.75 [44]	4.00 [102]	4.25 [108]	1.21 [31]	2.19 [56]	6.56 [167]	1.12 [28]	.50 [13]
SWA454A-4N	1113 kcmil thru 1351.1 kcmil	1033.5 kcmil thru 1192.5 kcmil	45-7 54-19	1.211 [31]	1.340 [34]	1	2.00 [51]	3.00 [76]	3.00 [76]	1.22 [31]	2.31 [59]	5.44 [138]	.62 [57]	.50 [13]
SWA486A-4N	2300 kcmil thru 2500 kcmil	2156 kcmil thru 2300 kcmil	84-19 96-19	1.741 [44]	1.875 [48]	1	2.62 [67]	3.00 [76]	3.00 [76]	1.84 [47]	3.31 [84]	6.12 [156]	.62 [57]	1.12 [28]
SWA486A-44N	2300 kcmil thru 2500 kcmil	2156 kcmil thru 2300 kcmil	84-19 96-19	1.741 [44]	1.875 [48]	1	2.62 [67]	4.00 [102]	4.25 [108]	1.84 [47]	3.31 [84]	7.50 [191]	1.12 [28]	1.12 [28]
SWA486A-66N	2300 kcmil thru 2500 kcmil	2156 kcmil thru 2300 kcmil	84-19 96-19	1.741 [44]	1.875 [48]	2	2.62 [67]	6.00 [152]	4.25 [108]	1.84 [47]	3.31 [84]	7.50 [191]	1.12 [28]	1.12 [28]
SWA493R-4N	3000 kcmil	—	127 169	1.876 [48]	2.05 [52]	1	3.00 [76]	3.00 [76]	3.00 [76]	2.12 [54]	3.75 [92]	6.75 [172]	.62 [16]	1.00 [25]

NOTES:

- Dimensions in brackets [] are in millimeters.
- DOES NOT INCLUDE SHIELDING CAPS. For EHV applications, shielding caps are required. Order separately (type) shown on page 32 or ADD SUFFIX "STS" to catalog number (example: SWA54R-44NSTS), includes one shielding cap.
- One surface of pad finished. For finished pad on both sides add SUFFIX "Q" to the catalog number (example: SWA22A-44NQ).
- For 45 or 90 degree angle add SUFFIX "45" or "90" to catalog number (example: SWA54R-44N90).

Blue highlighted items are industry standard and most frequently ordered.

WELDED TERMINAL CONNECTOR

SWAC-A-N

Weld type
Application: Bus to Two or Four Hole Pad (center formed)

EHV RATED: UP TO 550 kV
when used with
Shielding Caps

Material: Cast 356 Aluminum Alloy

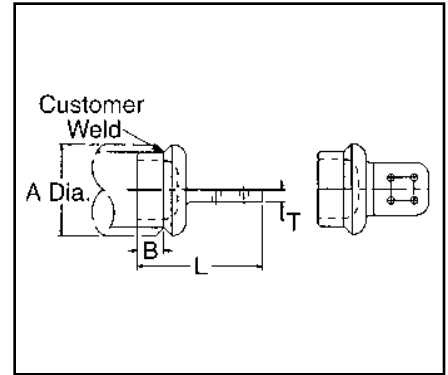
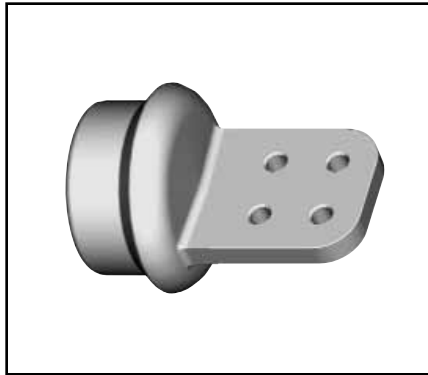

Catalog Number		Conductor		Fig. No.	Dimensions In./[mm]		
IPS (Sch. 40)	EHPS (Sch. 80)	IPS	A		B	L	T
SWAC18A-2N	SWAC58A-2N	2"	2.38 [60]	1	1.25 [32]	5.80 [147]	.50 [13]
SWAC18A-34N	SWAC58A-34N			2	1.25 [32]	5.80 [147]	.50 [13]
SWAC18A-44N	SWAC58A-44N			3	1.25 [32]	6.86 [174]	.50 [13]
SWAC19A-2N	SWAC59A-2N	2-1/2"	2.88 [73]	1	1.50 [38]	6.23 [158]	.56 [14]
SWAC19A-34N	SWAC59A-34N			2	1.50 [38]	6.23 [158]	.56 [14]
SWAC19A-44N	SWAC59A-44N			3	1.50 [38]	7.29 [185]	.56 [14]
SWAC20A-2N	SWAC90A-2N	3"	3.50 [89]	1	1.75 [44]	6.30 [160]	.62 [16]
SWAC20A-34N	SWAC90A-34N			2	1.75 [44]	6.30 [160]	.62 [16]
SWAC20A-44N	SWAC90A-44N			3	1.75 [44]	7.36 [187]	.62 [16]
SWAC21A-34N	SWAC91A-34N	3-1/2"	4.00 [102]	2	1.75 [44]	6.30 [160]	.62 [16]
SWAC21A-44N	SWAC91A-44N			3	1.75 [44]	7.36 [187]	.62 [16]
SWAC22A-34N	SWAC92A-34N	4"	4.50 [114]	2	2.00 [51]	6.40 [163]	.75 [19]
SWAC22A-44N	SWAC92A-44N			3	2.00 [51]	7.40 [188]	.75 [19]
SWAC23A-34N	SWAC93A-34N	4-1/2"	5.00 [127]	2	2.00 [51]	6.23 [158]	.56 [14]
SWAC24A-34N	SWAC94A-34N	5"	5.56 [141]	2	2.00 [51]	6.68 [170]	.75 [19]
SWAC24A-44N	SWAC94A-44N			3	2.00 [51]	7.72 [196]	.75 [19]
SWAC86A-44N	SWAC96A-44N			3	2.50 [64]	7.75 [197]	1.00 [25]

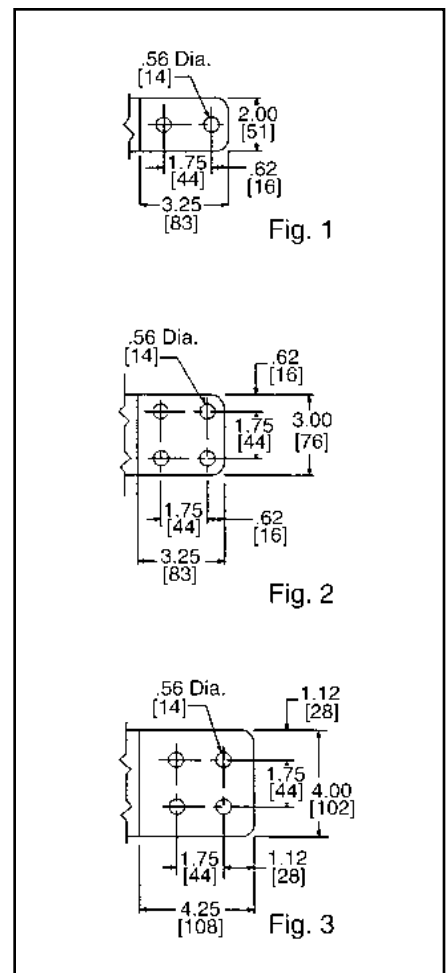

- NOTES:**
1. Dimensions in brackets [] are in millimeters.
 2. Conductor smaller than 3 inch bus size not recommended for 550 kV.
 3. DOES NOT INCLUDE SHIELDING CAPS. For EHV applications, shielding caps are required. Order separately (Type STS) shown on page 32 or ADD SUFFIX "STS" to Catalog Number (example: SWAC22A44NSTS), includes two shielding caps.
 4. Pad surface finished on both sides of tongue.
 5. For six hole NEMA pad contact factory.

Blue highlighted items are industry standard and most frequently ordered.

WELDED EXPANSION TERMINAL CONNECTOR

SWXA-A-NK

Welded type

Application: Bus to Four Hole Pad
(Expansion Terminal
with Corona
protection)

EHV RATED: SELF-SHIELDING UP TO 345 kV

Material: Cast 356 Aluminum Alloy
Straps: Aluminum Cables
Rings: Aluminum Alloy Cable

Hardware:
Ring mounting: Aluminum
Base mounting: Galvanized Steel

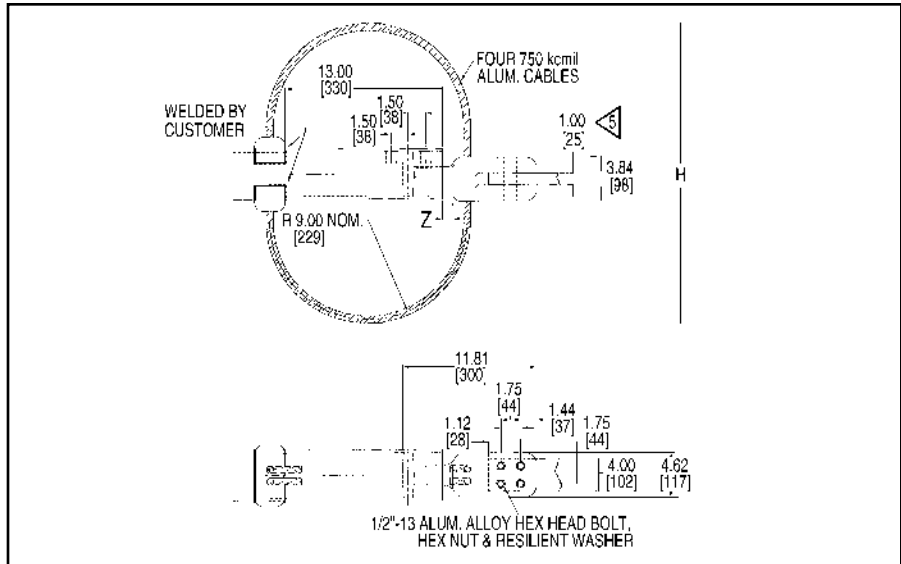
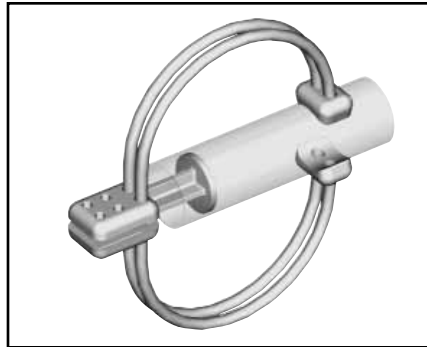

M-12

Catalog Number	Accommodates "A" Dia. Alum. Tube	H	Hardware Length
SWXA20A-4NK8	3" IPS (3.500 Dia.) Sch 40	26.38 [670]	1/2"-13 × 2-3/4" LG.
SWXA22A-4NK8	4" IPS (5.500 Dia.) Sch 40	27.00 [686]	
SWXA24A-4NK8	5" IPS (5.563 Dia.) Sch 40	28.06 [713]	
SWXA86A-4NK8	6" IPS (6.625 Dia.) Sch 40	29.12 [740]	
SWXA92A-4NK8	4" IPS (4.500 Dia.) Sch 80	27.00 [686]	
SWXA94A-4NK8	5" IPS (5.563 Dia.) Sch 80	28.06 [713]	
SWXA96A-4NK8	6" IPS (6.625 Dia.) Sch 80	29.12 [740]	

Installation Data	
Bus Temp F°	3" Total Movement Z
-20	3.50
-10	3.36
0	3.23
10	3.09
20	2.95
30	2.82
40	2.68
50	2.54
60	2.41
70	2.27
80	2.14
90	2.00 ← NOMINAL POSITION
100	1.86
110	1.73
120	1.59
130	1.45
140	1.32
150	1.18
160	1.04
170	.91
180	.77
190	.64
200	.50

NOTES:

- Table is based on 90/ft. max BUS run.
- Dimensions in brackets [] are in millimeters.
- Shielding caps not required.
- One side of pad finished. On Centerline of tubing. For finish pad on both sides add SUFFIX "Q" to catalog number (example: SWXA22A4NK8Q).
- Accommodates maximum pad thickness of 1.00".

Blue highlighted items are industry standard and most frequently ordered.

WELDED EXPANSION TERMINAL CONNECTOR

SWXA-A-N

Welded type
Application: Bus to four or six hole
pad (Expansion
Terminal with Corona
Rings)

EHV RATED: SELF-SHIELDING UP TO 550 kV

Material: Cast 356 Aluminum Alloy
Straps: Laminated Aluminum
Rings: Aluminum Alloy

Hardware:
Ring mounting: Aluminum
Base mounting: Galvanized Steel

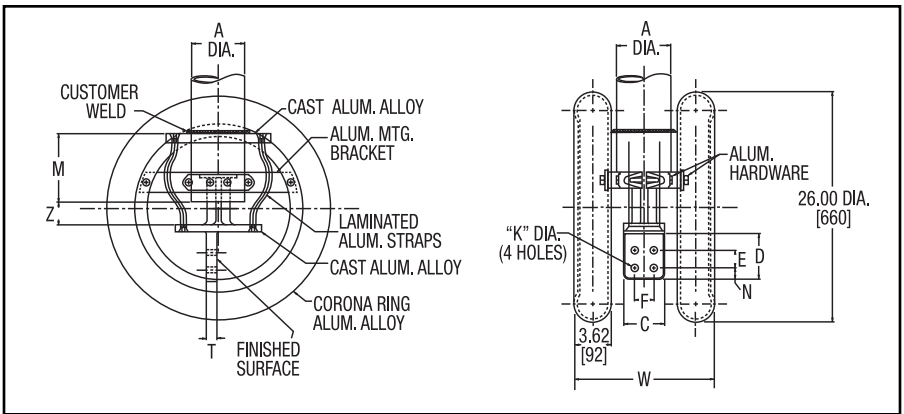
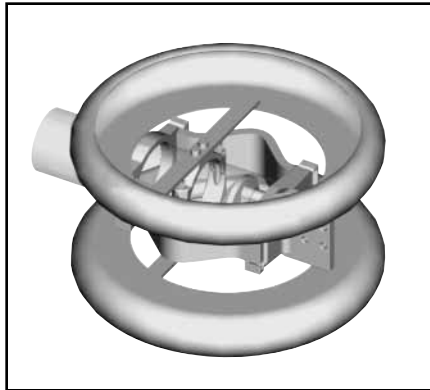

Catalog Number	Accommodates "A" Dia. Alum. Tube	C	D	E	F	K	M	N	T	W Ref.	Total Movement	Installation Data		
												Bus. Temp. of	Z	
SWXA20A-44N	3" (3.500 Dia.) Sch 40	4.00 [101]	4.25 [108]	1.75 [44]	1.75 [44]	.56 [14]	7.87 [200]	.62 [16]	.75 [19]	13.18 [335]	2.00 [51]	-20	2.50	
SWXA22A-44N	4" (4.500 Dia.) Sch 40	4.00 [101]	4.25 [108]	1.75 [44]	1.75 [44]	.56 [14]	9.56 [243]	.62 [16]	.86 [22]	13.87 [352]		0	2.32	
SWXA24A-44N	5" (5.563 Dia.) Sch 40	4.00 [101]	4.25 [108]	1.75 [44]	1.75 [44]	.56 [14]	10.77 [274]	.62 [16]	.81 [21]	14.50 [368]		10	2.21	
SWXA86A-44N	6" (6.625 Dia.) Sch 40	4.00 [101]	4.25 [108]	1.75 [44]	1.75 [44]	.56 [14]	11.63 [295]	1.12 [28]	1.00 [25]	15.50 [394]		20	2.14	
SWXA92A-44N	4" (4.500 Dia.) Sch 80	4.00 [101]	4.25 [108]	1.75 [44]	1.75 [44]	.56 [14]	9.56 [243]	.62 [16]	.86 [22]	13.87 [352]		30	2.01	
SWXA94A-44N	5" (5.563 Dia.) Sch 80	4.00 [101]	4.25 [108]	1.75 [44]	1.75 [44]	.56 [14]	10.77 [274]	1.12 [28]	.86 [22]	14.50 [368]		40	1.95	
NOTES: 1. Table is based on 60/ft. max BUS run. 2. Dimensions in brackets [] are in millimeters. 3. Shielding caps not required. 4. One side of pad finished. On Centerline of tubing. For finish pad on both sides add SUFFIX "Q" to catalog number (example: SWXA22A4NQ). 5. For six hole NEMA pad change the suffix to 66N (example: SWXA22A66N).												50	1.86	
												60	1.77	
												70	1.68	
												80	1.57	
												90	1.50	
												100	1.41	
												110	1.32	
												120	1.23	
												130	1.14	
												140	1.04	
150	.95													
160	.86													
170	.77													
180	.68													
190	.59													
200	.50													

M-13

Blue highlighted items are industry standard and most frequently ordered.

WELDED RIGID COUPLER

WSLB-A

Weld type

Application: Bus to Bus Coupler

EHV RATED: SELF-SHIELDING UP TO 550 kV

Material: Cast 356 Aluminum Alloy

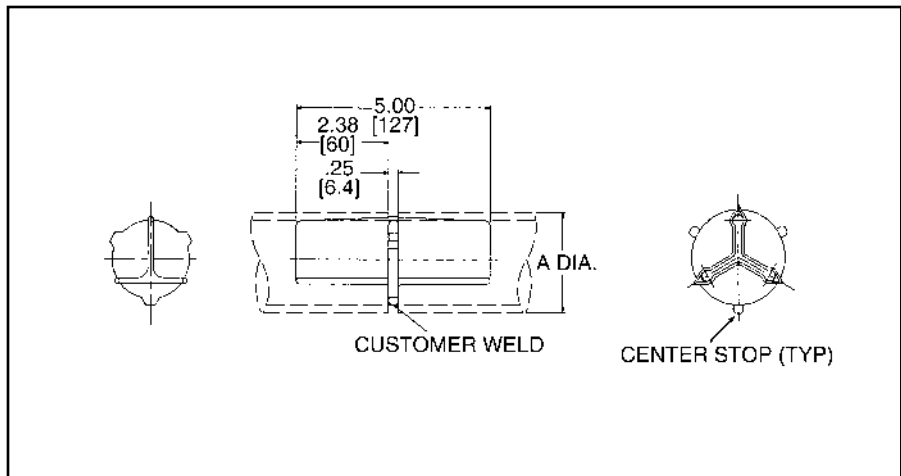
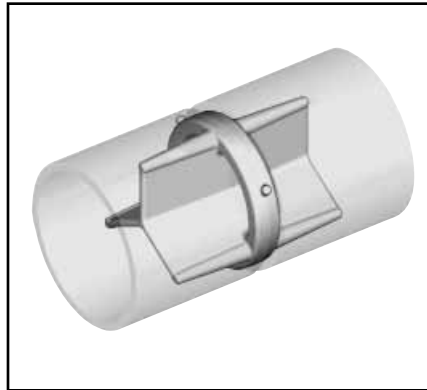

Catalog Number		OD	Conductor Aluminum Tubing Size
Sch. 40	Sch. 80		
WSLB15A	WSLB55A	1.32 [34]	1"
WSLB16A	WSLB56A	1.66 [42]	1-1/4"
WSLB17A	WSLB57A	1.90 [48]	1-1/2"
WSLB18A	WSLB58A	2.38 [60]	2"
WSLB19A	WSLB59A	2.88 [73]	2-1/2"
WSLB20A	WSLB90A	3.50 [89]	3"
WSLB21A	WSLB91A	4.00 [102]	3-1/2"
WSLB22A	WSLB92A	4.50 [114]	4"
WSLB24A	WSLB94A	5.56 [141]	5"
WSLB86A	WSLB96A	6.62 [168]	6"

NOTES:
 1. Dimensions in brackets [] are in millimeters.
 2. Conductors smaller than 3 inch bus size are not recommended for 550 kV.

Blue highlighted items are industry standard and most frequently ordered.

M-14

WELDED RIGID COUPLER

WS-A

Weld type
Application: Bus to Bus Coupler

EHV RATED: SELF-SHIELDING UP TO 550 kV

Material: Cast 356 Aluminum Alloy

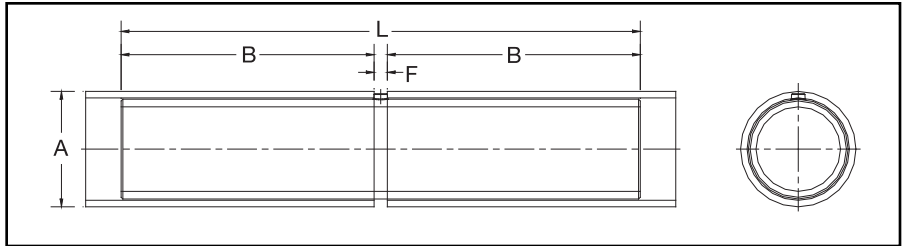
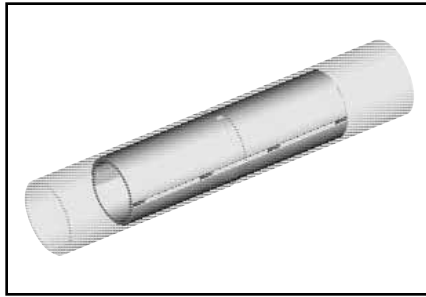

Catalog Number	Conductor (IPS) "A" Schedule 40	Conductor (EHPS) "A" Schedule 80	Dimensions Inches/[mm]		
			B	F	L
WS14A	3/4" (1.050 Dia.)	—	2.13 [54.1]	.23 [5.8]	4.50 [114.3]
WS15A	1" (Dia.)	—	2.13 [54.1]	.23 [5.8]	4.50 [114.3]
WS16A	1-1/4" (1.660 Dia.)	—	3.60 [91.4]	.28 [7.1]	7.50 [190.5]
WS17A	1-1/2" (1.900 Dia.)	—	4.36 [110.7]	.29 [7.4]	9.00 [228.6]
WS18A	2" (2.375 Dia.)	—	5.88 [149.4]	.31 [7.9]	12.00 [304.8]
WS19A	2-1/2" (2.875)	—	7.31 [185.7]	.39 [9.9]	15.00 [381.0]
WS20A	3" (3.500 Dia.)	—	8.81 [223.8]	.44 [11.2]	18.00 [457.2]
WS21A	3-1/2" (4.000 Dia.)	—	8.75 [222.3]	.47 [11.9]	18.00 [457.2]
WS22A	4" (4.500 Dia.)	—	8.75 [222.3]	.47 [11.9]	18.00 [457.2]
WS24A	5" (5.563 Dia.)	—	8.75 [222.3]	.50 [12.7]	18.00 [457.2]
WS86A	6" (6.625 Dia.)	—	8.75 [222.3]	.56 [14.2]	18.00 [457.2]
WS58A	—	2" (2.375 Dia.)	5.88 [149.4]	.31 [7.9]	12.00 [304.8]
WS59A	—	2-1/2" (2.875)	7.31 [185.7]	.39 [9.9]	15.00 [381.0]
WS90A	—	3" (3.500 Dia.)	8.81 [223.8]	.44 [11.2]	18.00 [457.2]
WS91A	—	3-1/2" (4.000 Dia.)	8.75 [222.3]	.47 [11.9]	18.00 [457.2]
WS92A	—	4" (4.500 Dia.)	8.75 [222.3]	.47 [11.9]	18.00 [457.2]
WS94A	—	5" (5.563 Dia.)	8.75 [222.3]	.50 [12.7]	18.00 [457.2]
WS96A	—	6" (6.625 Dia.)	8.75 [222.3]	.56 [14.2]	18.00 457.2]

NOTES:

1. Dimensions in brackets [] are in millimeters.
2. Conductor smaller than 3 inch bus size not recommended for 550 kV.

Blue highlighted items are industry standard and most frequently ordered.

WELDED EXPANSION COUPLER

SWXP-A-A

Weld type
Application: Bus to Bus Expansion

**EHV RATED: SELF-SHIELDING
UP TO 550 kV**

Material: Cast 356 Aluminum Alloy
Hardware: Aluminum Alloy
Corona Rings: Aluminum Alloy
Straps: Laminated Aluminum Strap

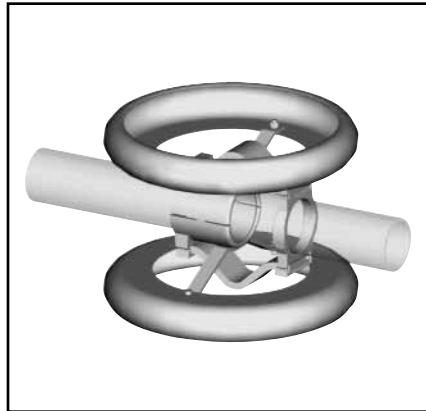

Installation Data	
Bus Temp F°	3" Total Movement
	Z
-20	.50
-10	.64
0	.77
10	.91
20	1.04
30	1.18
40	1.32
50	1.45
60	1.59
70	1.73
80	1.86
90	2.00
100	2.14
110	2.27
120	2.41
130	2.54
140	2.68
150	2.82
160	2.95
170	3.09
180	3.23
190	3.36
200	3.50

NOMINAL POSITION

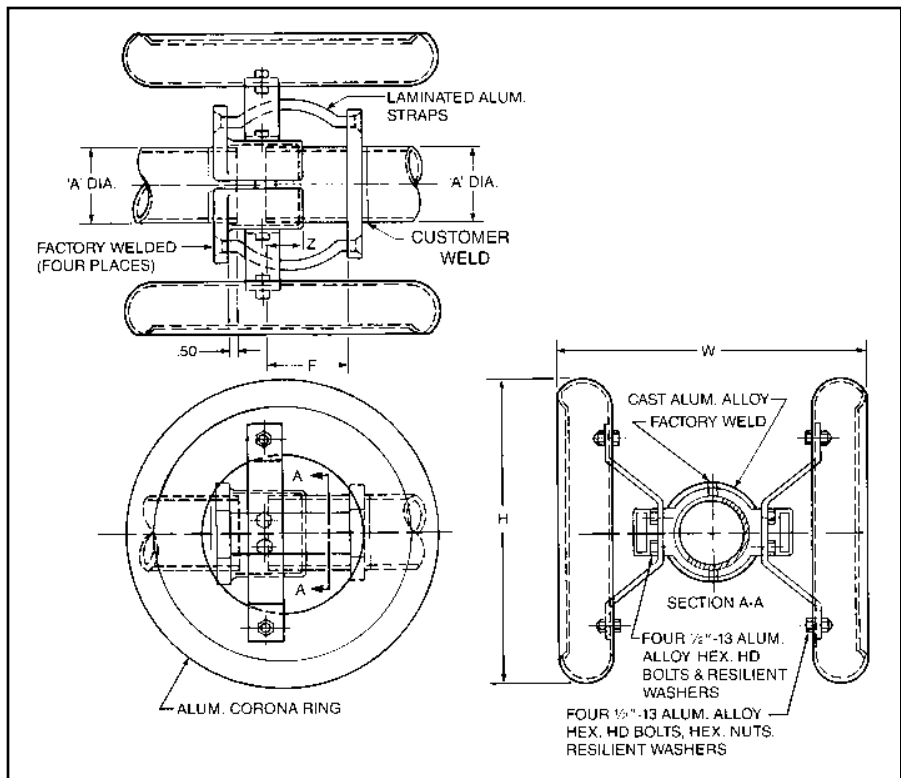

M-16

Catalog Number		"A" Dia. Alum. Tube	F	H	W	Total ① Movement
Sch. 40	Sch. 80					
SWXP20A20A	SWXP90A90A	3" (3.50 Dia.) [89]	5.25 [133]	22.00 [559]	17.05 [433]	3.00 [76]
SWXP22A22A	SWXP92A92A	4" (4.50 Dia.) [114]	6.38 [162]	22.00 [559]	18.89 [480]	4.00 [102]
SWXP24A24A	SWXP94A94A	5" (5.56 Dia.) [141]	7.88 [200]	26.00 [660]	19.25 [489]	4.00 [102]
SWXP86A86A	SWXP96A96A	6" (6.63 Dia.) [168]	8.88 [226]	26.00 [660]	20.31 [516]	4.00 [102]

NOTES:

- ① Maximum movement per end equals one-half of total movement specified in table. Table is based on 90 ft. bus run (total) or 45 ft. per end.
2. Dimensions in brackets [] are in millimeters.
3. Conductors smaller than 3 inch not recommended for 550 kV.

Blue highlighted items are industry standard and most frequently ordered.

**WELDED
T-CONNECTOR**

SWAB-A-N

Weld type
Application: Bus to Pad

**EHV RATED: UP TO 550 kV
when used with
Shielding Caps**

Material: Cast 356 Aluminum Alloy

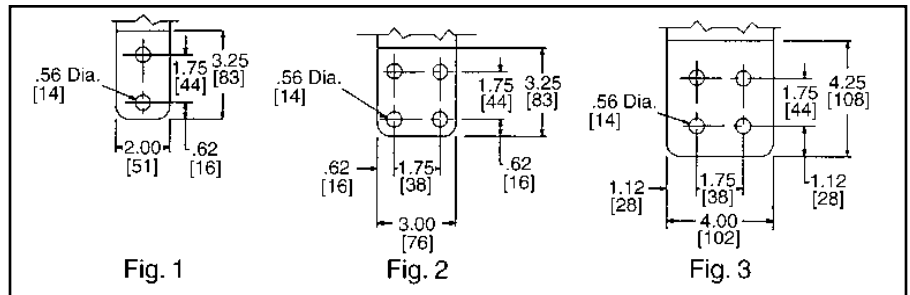
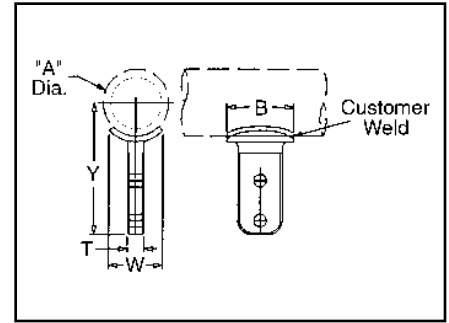

Catalog Number	Complete Range Aluminum Tube	Figure Number	Dimensions – Inches/[mm]					
			B	T	W	Aluminum IPS Pipe		
						Nominal	A	Y
SWAB19A-2N	1" to 2-1/2"	1	3.00 [76]	.38 [10]	1.32 [34]	1"	1.32 [34]	4.45 [113]
						1-1/4"	1.66 [42]	4.67 [119]
						1-1/2"	1.90 [48]	4.80 [122]
SWAB19A-34N		2	4.00 [102]	.50 [13]		2"	2.38 [60]	5.08 [129]
						2-1/2"	2.88 [73]	5.32 [135]
SWAB22A-2N	2-1/2" to 4"	1	3.00 [76]	.75 [19]	2.40 [61]	2-1/2"	2.88 [73]	5.25 [133]
SWAB22A-34N		2	4.00 [102]			3-1/2"	4.00 [102]	5.92 [150]
		SWAB22A-44N	3			4.50 [114]	4"	4.50 [114]
SWAB86A-2N	3" to 6"	1	3.00 [76]	1.00 [25]	2.62 [67]	3"	3.50 [89]	5.58 [142]
SWAB86A-34N						3-1/2"	4.00 [102]	6.08 [154]
						4"	4.50 [114]	6.36 [162]
SWAB86A-44N		2	4.00 [102]			4-1/2"	5.00 [127]	6.36 [162]
						3	4.50 [114]	5"
						6"	6.62 [168]	7.24 [184]

NOTES:

1. Dimensions in brackets [] are in millimeters.
2. Conductor smaller than 3 inch bus size not recommended for 550 kV.
3. DOES NOT INCLUDE SHIELDING CAPS. For EHV applications, shielding caps are required. Order separately

- (Type STS) shown on page 32 or ADD SUFFIX "STS" to Catalog Number (example: SWAB22A44NSTS), includes two shielding caps.
4. Pad surface finished on both sides of tongue.
5. For six hole NEMA pad contact factory.

Blue highlighted items are industry standard and most frequently ordered.

**WELDED
T-CONNECTOR**

SWT-A-A

Weld type
Application: Bus to Bus
T-Connector

**EHV RATED: SELF-SHIELDING
UP TO 550 kV**

Material: Cast 356 Aluminum Alloy

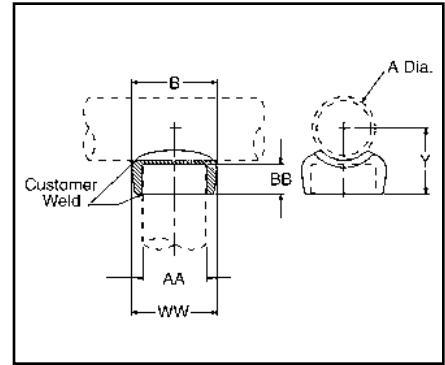

Catalog Number	Run 'A' Aluminum Tube	Tap 'AA' Aluminum Tube		Run Data		Dimensions Inches/[mm]				
		Tube	AA	Nom. Tube	A	B	BB	W	WW	Y
SWT17A17A	1-1/2"	1/2"	1.90 [48]	1-1/2"	1.90 [48]	3.19 [81]	1.00 [25]	2.64 [67]	2.52 [64]	2.16 [55]
SWT19A19A	2-1/2"	2-1/2"	2.88 [27]	2-1/2"	2.88 [73]	4.00 [54]	1.38 [35]	3.78 [96]	3.78 [96]	3.02 [37]
SWT21A14A		3/4"	1.05 [28]	2"	2.38 [60.4]	2.12 [54]	.75 [19]	1.75 [44]	1.64 [42]	2.13 [54]
				2-1/2"	2.88 [73]					2.47 [42]
				3"	3.50 [89]					2.84 [72]
				3-1/2"	4.00 [102]					3.12 [51]
SWT21A15A	2" To 3-1/2"	1"	1.32 [34]	2"	2.38 [60.4]	2.38 [60.4]	.75 [19]	2.28 [60]	1.88 [48]	2.12 [54]
				2-1/2"	2.88 [73]					2.50 [64]
				3"	3.50 [89]					2.87 [73]
				3-1/2"	4.00 [102]					3.16 [80]
SWT21A16A		1-1/4"	1.66 [42]	2"	2.38 [60.4]	2.69 [68]	1.00 [25]	2.36 [60]	2.26 [57]	2.38 [60]
				2-1/2"	2.88 [73]					2.76 [70]
				3"	3.50 [89]					3.14 [80]
				3-1/2"	4.00 [102]					3.42 [87]

(Table continued on next page)

NOTES:

1. Dimensions in brackets [] are in millimeters.
2. Conductor smaller than 3 inch bus size not recommended for 550 kV.

Blue highlighted items are industry standard and most frequently ordered.

WELDED T-CONNECTOR

(Continued)

SWT-A-A

Catalog Number	Run 'A' Aluminum Tube	Tap 'AA' Aluminum Tube		Run Data		Dimensions Inches/[mm]				
		Tube	AA	Nom. Tube	A	B	BB	W	WW	Y
SWT21A17A	2" to 3-1/2"	1-1/2"	1.90 [48]	2"	2.38 [60.4]	3.19 [81]	1.00 [25]	2.62 [67]	2.52 [64]	2.35 [60]
				2-1/2"	2.88 [73]					2.75 [70]
				3"	3.50 [89]					3.14 [80]
				3-1/2"	4.00 [102]					3.43 [87]
SWT21A18A	2" to 3-1/2"	2"	2.38 [60.4]	2"	2.38 [60.4]	4.00 [102]	1.00 [25]	3.33 [84]	3.00 [76]	2.40 [61]
				2-1/2"	2.88 [73]					2.71 [69]
				3"	3.50 [90]					3.07 [78]
				3-1/2"	4.00 [102]					3.34 [85]
SWT21A19A	2-1/2" to 3-1/2"	2-1/2"	2.88 [73]	2-1/2"	2.88 [73]	4.00 [102]	1.38 [35]	3.78 [96]	3.68 [93]	3.02 [77]
				3"	3.50 [90]					3.40 [86]
				3-1/2"	4.00 [102]					3.70 [94]
SWT21A20A	2" to 3-1/2"	3"	3.50 [90]	3"	3.50 [102]	4.56 [116]	1.38 [35]	4.52 [115]	4.34 [110]	3.33 [87]
				3-1/2"	4.00 [102]					3.70 [55]
SWT22A18A	4"	2"	2.38 [60.4]	4"	4.50 [114]	4.00 [102]	1.00 [13]	3.50 [102]	3.00 [76]	3.45 [87]
SWT22A19A		2-1/2"	2.88 [73]							3.83 [97]
SWT22A20A		3"	3.50 [102]							3.83 [97]
SWT22A21A		3-1/2"	4.00 [102]							3.87 [98]
SWT22A22A		4"	4.50 [114]							3.89 [99]
SWT24A20A	5"	3"	3.50 [48]	5"	5.56 [141]	4.72 [120]	1.38 [35]	4.30 [109]	4.40 [112]	4.33 [110]
SWT24A21A		3-1/2"	4.00 [102]							4.41 [112]
SWT24A22A		4"	4.50 [114]							4.41 [112]
SWT24A24A		5"	5.56 [141]							4.66 [118]
SWT86A20A	6"	3"	3.50 [90]	6"	6.62 [168]	4.56 [116]	1.88 [48]	5.00 [127]	4.40 [112]	4.89 [124]
SWT86A21A		3-1/2"	4.00 [102]							4.94 [125]
SWT86A22A		4"	4.50 [114]							4.75 [121]
SWT86A24A		5"	5.56 [141]							5.17 [131]
SWT86A86A		6"	6.62 [168]							5.00 [127]

M-19

NOTES:
1. Dimensions in brackets [] are in millimeters.

2. Conductor smaller than 3 inch bus size not recommended for 550 kV.

WELDED T-CONNECTOR

SWT-A-A-75

Weld type
Application: Bus “A” Frame
Connector (75°)

**EHV RATED: SELF-SHIELDING
UP TO 550 kV**

Material: Cast 356 Aluminum Alloy

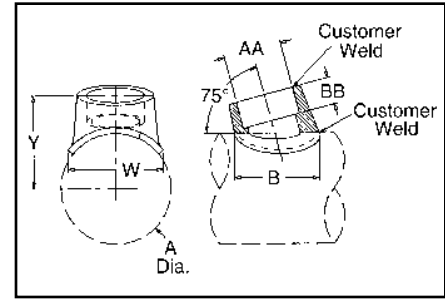
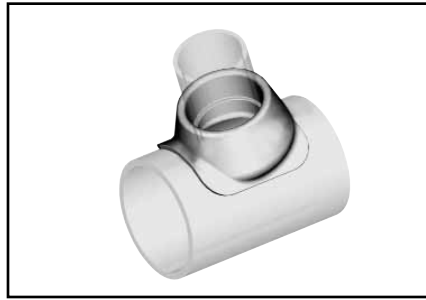

Catalog Number	Aluminum Tube				Dimensions In./[mm]			
	Run		Tap		B	BB	W	Y
	Nominal	A	Nominal	AA				
SWT18A16A-75	2"	2.38 [60.4]	1-1/4"	1.66 [42]	2.69 [68]	1.00 [25]	2.36 [60]	2.57 [65]
SWT18A17A-75			1-1/2"	1.90 [48]	3.19 [81]	1.00 [25]	2.60 [66]	2.60 [66]
SWT19A16A-75	2-1/2"	2.88 [73]	1-1/4"	1.66 [42]	2.69 [68]	1.00 [25]	2.72 [69]	2.83 [72]
SWT19A17A-75			1-1/2"	1.90 [48]	3.19 [81]	1.00 [25]	2.60 [66]	2.87 [73]
SWT19A18A-75			2"	2.38 [60]	4.00 [102]	1.00 [25]	3.10 [79]	2.92 [74]
SWT20A17A-75	3"	3.50 [89]	1-1/2"	1.90 [48]	3.19 [81]	1.00 [25]	2.48 [63]	3.17 [81]
SWT20A18A-75			2"	2.38 [60]	4.00 [102]	1.00 [25]	3.10 [79]	3.23 [82]
SWT20A19A-75			2-1/2"	2.88 [73]	4.00 [102]	1.38 [35]	3.80 [97]	3.65 [93]
SWT21A16A-75	3-1/2"	4.00 [102]	1-1/4"	1.66 [42]	2.69 [68]	1.00 [25]	2.80 [71]	3.37 [86]
SWT21A17A-75			1-1/2"	1.90 [48]	3.19 [81]	1.00 [25]	3.00 [76]	3.41 [87]
SWT21A18A-75			2"	2.38 [60]	4.00 [102]	1.00 [25]	3.50 [89]	3.47 [88]
SWT21A19A-75			2-1/2"	2.88 [73]	4.00 [102]	1.38 [35]	3.78 [96]	3.89 [99]
SWT22A18A-75	4"	4.50 [114]	2"	2.38 [60]	4.12 [105]	1.00 [25]	3.75 [95]	3.71 [94]
SWT22A19A-75			2-1/2"	2.88 [73]	4.00 [102]	1.38 [35]	4.20 [107]	4.16 [106]
SWT22A20A-75			3"	3.50 [89]	4.56 [116]	1.38 [35]	4.50 [114]	4.24 [108]
SWT24A18A-75	5"	5.56 [141]	2"	2.38 [60]	4.00 [102]	1.00 [25]	3.60 [91]	4.26 [108]
SWT24A19A-75			2-1/2"	2.88 [73]	4.00 [102]	1.38 [35]	4.90 [124]	4.76 [121]
SWT24A20A-75			3"	3.50 [89]	4.56 [116]	1.38 [35]	4.98 [126]	4.77 [121.2]
SWT86A20A-75	6"	6.62 [168]	3"	3.50 [89]	4.56 [116]	1.38 [35]	5.08 [129]	5.31 [135]
SWT86A21A-75			3-1/2"	4.00 [102]	5.50 [140]	1.38 [35]	5.47 [139]	5.43 [138]
SWT86A22A-75			4"	4.50 [114]	6.00 [152]	1.38 [35]	6.06 [154]	5.47 [139]

NOTES:

1. Dimensions in brackets [] are in millimeters.
2. Conductor smaller than 3 inch bus size not recommended for 550 kV.

Blue highlighted items are industry standard and most frequently ordered.

**WELDED
V-CONNECTOR**

SWAT-A-A-30

Weld type
Application: Bus "A" Frame
Connector (30°)

**EHV RATED: SELF-SHIELDING
UP TO 550 kV**

Material: Cast 356 Aluminum Alloy

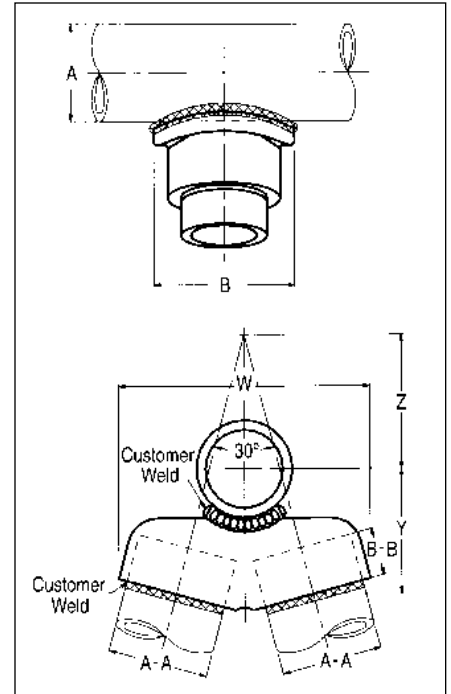

Catalog Number	Aluminum I.P.S.		B	B-B	W	Y	Z
	Run "A"	Tap "A-A"					
SWAT18A16A-30	2" (2.375 Dia.)	1-1/4" (1.660 Dia.)	3.25 [83]	1.00 [25]	4.81 [122]	3.19 [81]	1.76 [45]
SWAT18A17A-30		1-1/2" (1.900 Dia.)	3.50 [89]	1.00 [25]	5.25 [133]	3.00 [76]	2.34 [59]
SWAT18A18A-30		2" (2.375 Dia.)	4.00 [102]	1.00 [25]	6.38 [160]	3.12 [71]	3.46 [88]
SWAT19A16A-30	2-1/2" (2.875 Dia.)	1-1/4" (2.375 Dia.)	3.25 [83]	1.00 [25]	4.82 [122]	3.31 [84]	1.74 [44]
SWAT19A17A-30		1-1/2" (1.900 Dia.)	3.50 [89]	1.00 [25]	5.25 [132]	3.28 [83]	2.00 [51]
SWAT19A18A-30		2" (2.375 Dia.)	4.00 [102]	1.00 [25]	6.19 [157]	3.19 [81]	3.04 [77]
SWAT20A17A-30	3" (3.500 Dia.)	1-1/2" (1.900 Dia.)	3.50 [89]	1.00 [25]	5.12 [130]	3.44 [87]	1.87 [47]
SWAT20A18A-30		2" (2.375 Dia.)	4.00 [102]	1.00 [25]	6.25 [159]	3.50 [89]	2.71 [69]
SWAT20A19A-30		2-1/2" (2.875 Dia.)	4.38 [111]	1.38 [35]	7.19 [183]	3.88 [99]	3.41 [87]
SWAT21A16A-30	3-1/2" (4.000 Dia.)	1-1/4" (2.375 Dia.)	3.25 [83]	1.00 [25]	5.06 [129]	3.34 [85]	2.07 [53]
SWAT21A17A-30		1-1/2" (1.900 Dia.)	3.50 [89]	1.00 [25]	5.25 [132]	3.44 [87]	1.97 [50]
SWAT21A18A-30		2" (2.375 Dia.)	4.00 [102]	1.00 [25]	6.31 [160]	3.16 [80]	2.68 [68]
SWAT21A19A-30		2-1/2" (2.0875 Dia.)	4.38 [111]	1.38 [35]	7.38 [187]	4.00 [102]	3.09 [78]
SWAT21A20A-30		3" (3.500 Dia.)	5.00 [127]	1.38 [35]	8.38 [213]	4.12 [105]	4.21 [107]
SWT22A18A-30	4" (4.500 Dia.)	2" (2.375 Dia.)	4.00 [102]	1.00 [25]	6.50 [165]	3.81 [97]	2.82 [72]
SWT22A19A-30		2-1/2" (2.875 Dia.)	4.38 [111]	1.38 [35]	7.41 [188]	4.09 [104]	3.13 [80]
SWAT22A20A-30		3" (3.500 Dia.)	5.12 [130]	1.38 [1.38]	8.62 [219]	4.28 [109]	4.05 [103]
SWAT24A18A-30	5" (5.563 Dia.)	2" (2.375 Dia.)	4.00 [102]	1.00 [25]	6.50 [165]	3.81 [97]	3.06 [78]
SWAT24A19A-30		2-1/2" (2.875 Dia.)	4.38 [111]	1.38 [35]	7.38 [187]	4.47 [114]	2.87 [73]
SWAT24A20A-30		3" (3.500 Dia.)	2.12 [130]	1.38 [35]	8.62 [219]	4.62 [117]	3.76 [96]
SWAT86A20A-30	6" (6.625 Dia.)	3" (3.500 Dia.)	5.12 [130]	1.38 [35]	8.69 [221]	4.81 [122]	3.57 [91]
SWAT86A21A-30		3-1/2" (4.000 Dia.)	5.88 [149]	1.38 [35]	9.69 [246]	5.19 [132]	4.11 [104]
SWAT86A22A-30		4" (4.500 Dia.)	6.25 [159]	1.38 [35]	10.62 [270]	5.00 [127]	5.15 [131]

NOTES:
1. Dimensions in brackets [] are in millimeters

2. Conductor smaller than 3 inch bus size not recommended for 550 kV.

WELDED RIGID BUS SUPPORT

SWOH-A

Weld type
Application: Fixed Bus Support to Insulator

EHV RATED: SELF-SHIELDING UP TO 550 kV—
When used on Corona free Post Insulators

Material: Cast 356 Aluminum Alloy

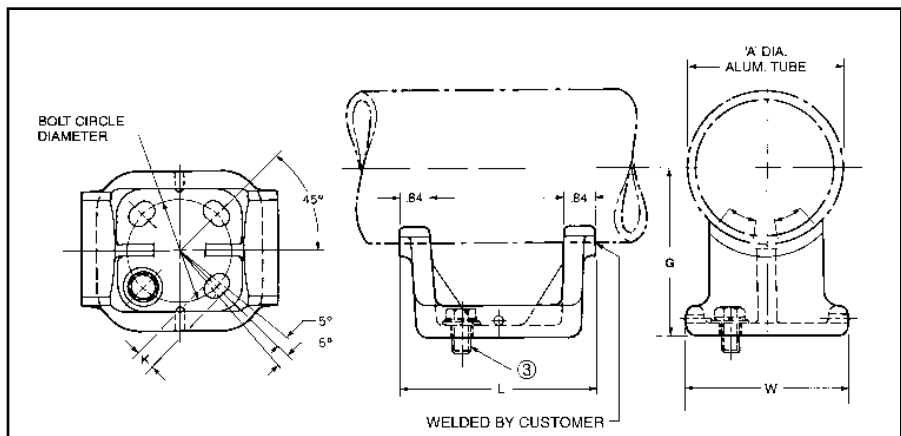
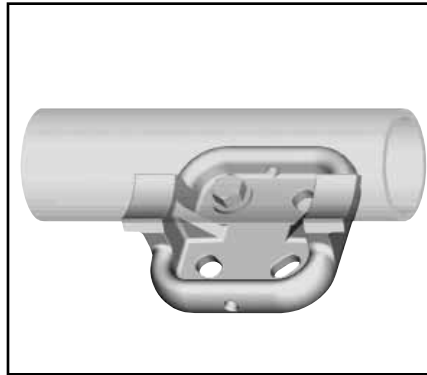

M-22

Catalog Number	"A" Dia. Alum. Tube	Bolt Circle Dia.	G	K	L	W
SWOH18A-3	2" (2.375 Dia.) [60]	3.00 [76]	2.75 [70]	.56 [14]	5.60 [142]	4.96 [126]
SWOH18A-5		5.00 [127]		.69 [18]	7.48 [190]	6.76 [172]
SWOH19A-3	2-1/2" (2.875 Dia.) [73]	3.00 [76]	3.12 [79]	.56 [14]	6.06 [154]	5.19 [132]
SWOH19A-5		5.00 [127]		.69 [18]	7.62 [194]	6.80 [173]
SWOH20A-3	3" (3.500 Dia.) [89]	3.00 [76]	3.00 [76]	.56 [14]	5.78 [147]	4.96 [126]
SWOH20A-5		5.00 [127]		.69 [18]	7.20 [183]	6.29 [160]
SWOH21A-3	3-1/2" (4.000 Dia.) [102]	3.00 [76]	4.00 [102]	.56 [14]	5.80 [147]	4.96 [126]
SWOH21A-5		5.00 [127]		.69 [18]	7.58 [193]	6.76 [172]
SWOH22A-3	4" (4.500 Dia.) [114]	3.00 [76]	4.50 [114]	.56 [14]	5.82 [148]	4.96 [126]
SWOH22A-5		5.00 [127]		.69 [18]	7.68 [195]	6.57 [167]
SWOH24A-5	5" (5.563 Dia.) [141]	5.00 [127]	5.00 [127]	.69 [18]	7.68 [195]	6.57 [167]
SWOH86A-5	6" (6.625 Dia.) [168]	5.00 [127]	5.50 [140]	.69 [18]	7.68 [195]	6.57 [167]

NOTES:

- Dimensions in brackets [] are in millimeters.
- "G" dimension conforms to NEMA standards.
- Cap mounting (galvanized steel) hardware supplied as standard. For Base Mounting hardware add SUFFIX "B" to catalog number (example: SWOH22A-5B).
- Conductors smaller than 3 inch bus size not recommended for 550 kV.

Blue highlighted items are industry standard and most frequently ordered.

WELDED RIGID OR SLIP FIT BUS SUPPORT

SWHRH-A

Welded type
Application: Fixed or Slip Fit Bus Support to Insulator.

EHV RATED: SELF-SHIELDING UP TO 550 kV—
When used on corona free Post Insulators.

Material: Cast 356 Aluminum Alloy

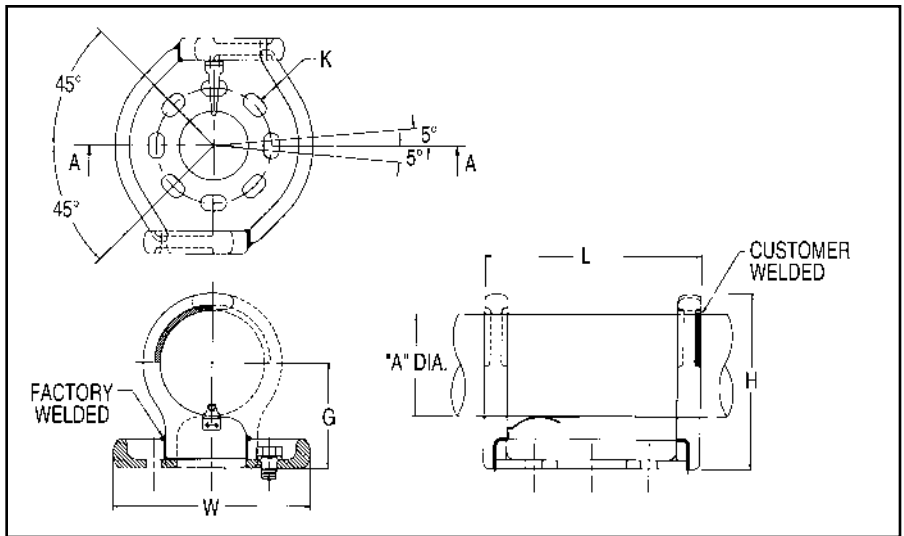
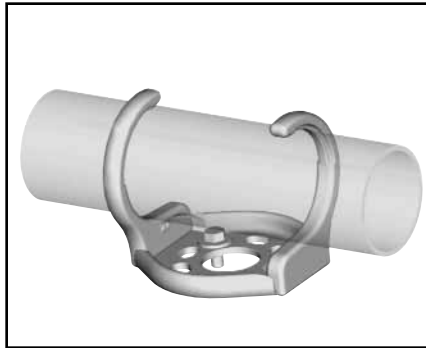

Catalog Number	Catalog Number	Aluminum Conductor		G	H	3" Bolt Circle			5" Bolt Circle						
		3" Bolt Circle	5" Bolt Circle			IPS/EHPS	"A" Dia.	K	L	W	K	L	W		
SWHRH18A-3CH	SWHRH18A-5CH			2"	2.38 [60]	2.75 [70]	4.58 [116]								
SWHRH19A-3CH	SWHRH19A-5CH			2-1/2"	2.88 [73]	3.12 [79]	5.21 [132]								
SWHRH20A-3CH	SWHRH20A-5CH			3"	3.50 [89]	3.62 [92]	6.15 [156]								
SWHRH21A-3CH	SWHRH21A-5CH			3-1/2"	4.00 [102]	4.00 [102]	6.77 [172]	.56 × .75 [14 × 19]	7.76 [197]	6.26 [159]	.69 × .88 [18 × 22]	9.37 [238]	8.61 [219]		
SWHRH22A-3CH	SWHRH22A-5CH			4"	4.50 [114]	4.50 [114]	7.52 [191]								
SWHRH24A-3CH	SWHRH24A-5CH			5"	5.56 [141]	5.00 [127]	8.68 [220]								
SWHRH86A-3CH	SWHRH86A-5CH			6"	6.63 [168]	5.50 [140]	9.71 [247]			8.61 [219]					

NOTES:

- Dimensions in brackets [] are in millimeters.
- G dimension conforms to NEMA standards.
- Cap mounting (galvanized steel) hardware supplied as standard. For Base mounting hardware add SUFFIX "B" to catalog number (example: SWHRH22A-5B).
- Conductors smaller than 3 inch bus size not recommended for 550 kV.

M-23

Blue highlighted items are industry standard and most frequently ordered.

WELDED VERTICAL BUS SUPPORT

SWVH-A

Weld type
Application: Bus to insulator
(Vertical Position)

**EHV RATED: SELF-SHIELDING
UP TO 550 kV**

Material: Cast 356 Aluminum Alloy
Hardware: Galvanized Steel

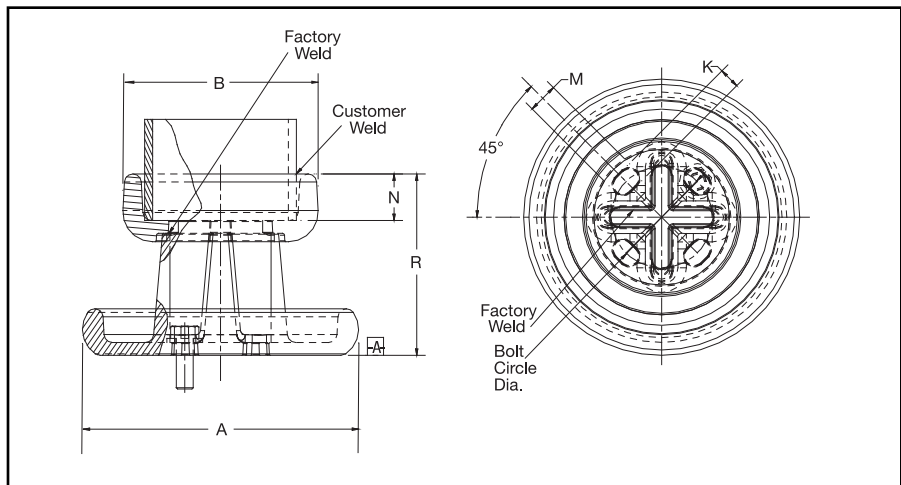
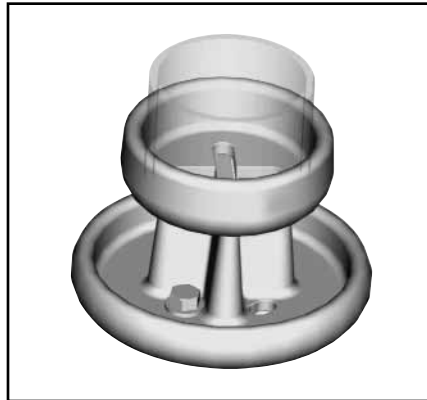

M-24

Catalog No.	Accommodates	Bolt Circle Dia.	"A" Dia.	"B" Dia.	"K" & "M" Slot	N	R
SWVH19A-5	2-1/2" IPS (2.88 Dia.) [73]	5"	8.19 [208]	4.16 [106]	.69 × 1.12 [18] [28]	1.38 [35]	5.38 [137]
SWVH19A-7	Alum. Tube	7"	10.25 [260]		.81 × 1.44 [21] [37]		
SWVH20A-5	3" IPS (3.50 Dia.) [89]	5"	8.19 [208]	4.79 [122]	.69 × 1.12 [18] [28]		
SWVH20A-7	Alum. Tube	7"	10.25 [260]		.81 × 1.44 [21] [37]		
SWVH22A-5	4" IPS (4.50 Dia.) [114]	5"	8.19 [208]	5.79 [147]	.69 × 1.12 [18] [28]		
SWVH22A-7	Alum. Tube	7"	10.25 [260]		.81 × 1.44 [21] [37]		
SWVH24A-5	5" IPS (5.56 Dia.) [141]	5"	8.19 [208]	6.87 [175]	.69 × 1.12 [18] [28]		
SWVH24A-7	Alum. Tube	7"	10.25 [260]		.81 × 1.44 [21] [37]		
SWVH86A-5	6" IPS (6.63 Dia.) [168]	5"	8.19 [208]	7.93 [201]	.69 × 1.12 [18] [28]		
SWVH86A-7	Alum. Tube	7"	10.25 [260]		.81 × 1.44 [21] [37]		

NOTES:

- Dimensions in brackets [] are in millimeters.
- Cap mounting hardware supplied. For base mounted hardware add SUFFIX "B" to catalog number (example: SWVH22A5B).
- Conductors smaller than 3 inch not recommended for 550 kV.

Blue highlighted items are industry standard and most frequently ordered.

**WELDED EXPANSION
BUS SUPPORT
COUPLER**

SWXHP-A

Weld type
Application: Bus to Bus Expansion
Coupler to Insulator

**EHV RATED: SELF-SHIELDING
up to 550 kV**

Material: Cast 356 Aluminum Alloy
Corona Rings: Aluminum Alloy
Straps: Laminated Aluminum Strap

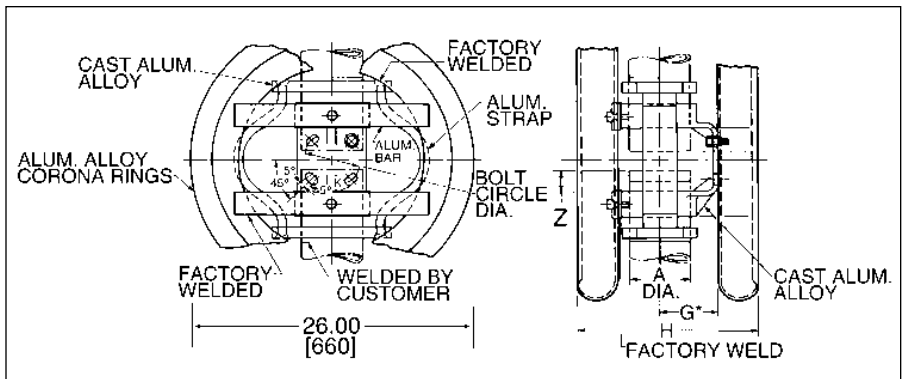
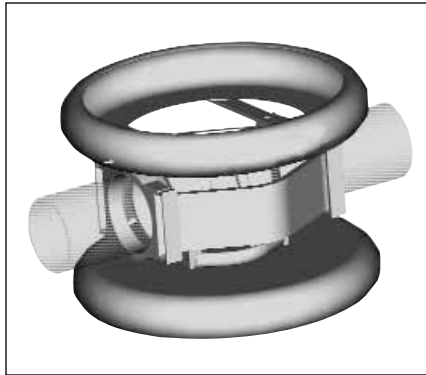

Catalog Number		"A" Dia. Alum. Tube	Bolt Circle Dia.	G*	K	H	Total ① Movement
Sch 40	Sch 80						
SWXHP19A-5	SWXHP59A-5	2-1/2" (2.88 Dia.) [73]	5.00 [127]	3.12 [79]	.69 [18]	12.77 [324]	3.00 [76]
SWXHP20A-5	SWXHP90A-5	3" (3.50 Dia.) [89]	5.00 [127]	3.62 [92]	.69 [18]	13.62 [346]	3.00 [76]
SWXHP21A-5	SWXHP91A-5	3-1/2" (4.00 Dia.) [102]	5.00 [127]	4.00 [102]	.69 [18]	14.25 [362]	3.00 [76]
SWXHP22A-5	SWXHP92A-5	4" (4.50 Dia.) [114]	5.00 [127]	4.50 [114]	.69 [18]	14.90 [378]	4.00 [102]
SWXHP24A-5	SWXHP94A-5	5" (5.56 Dia.) [141]	5.00 [127]	5.25 [133]	.69 [18]	16.31 [414]	4.00 [102]
SWXHP86A-5	SWXHP96A-5	6" (6.63 Dia.) [168]	5.00 [127]	5.50 [140]	.69 [18]	17.34 [440]	4.00 [102]

Bus Temp F°	Installation Data	
	3" Total Movement Z ⑥	4" Total Movement Z ⑦
-20	.75	.75
-10	.82	.84
0	.89	.83
10	.95	1.02
20	1.02	1.11
30	1.09	1.20
40	1.16	1.29
50	1.23	1.39
60	1.30	1.48
70	1.36	1.57
80	1.43	1.66
90	1.50	1.75
100	1.57	1.84
110	1.64	1.93
120	1.70	2.02
130	1.77	2.11
140	1.84	2.20
150	1.91	2.29
160	1.98	2.39
170	2.05	2.48
180	2.11	2.57
190	2.18	2.66
200	2.25	2.75

NOTES:

- *Conforms to NEMA standards.
- ① Maximum movement per end equals one-half of total movement specified in table.
- 2. Dimensions in brackets [] are in millimeters.
- 3. Cap mounting hardware supplied (Galvanized Steel). For base mounted hardware add SUFFIX "B" to catalog number (example: SWXHP20A5B).
- 4. Conductors smaller than 3 inch not recommended for 550 kV.
- 5. Bus support couplers are supplied without bus end plugs. If end plugs are required, add SUFFIX "EP" to catalog number (example: SWXHP20A5EP).
- ⑥ Table is based on 80 ft. max. bus run (total) or 40 ft. per end.
- ⑦ Table is based on 110 ft. max. bus run (total) or 55 ft. per end.

← NOMINAL POSITION

M-25

Blue highlighted items are industry standard and most frequently ordered.

WELDED 90° ELBOW

SWL-A

Weld type
Application: Bus to Bus Elbow, 90°

**EHV RATED: SELF-SHIELDING
UP TO 550 kV**

Material: Cast 356 Aluminum Alloy

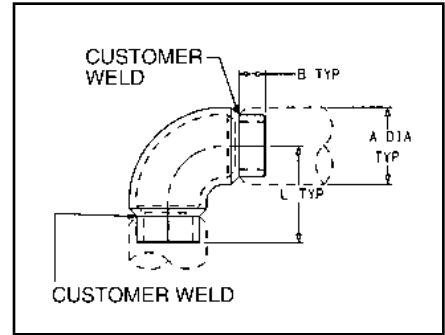
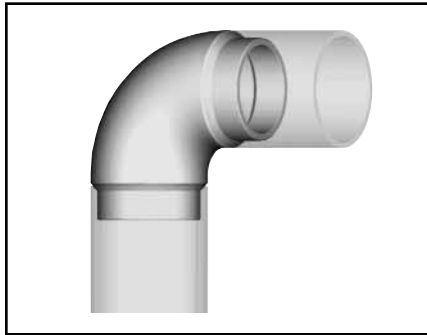

Catalog Number		Conductor Aluminum Tubing Size	Dimensions In./[mm]		
Sch. 40	Sch. 80		A Dia.	B	L
SWL18A	SWL58A	2"	2.38 [60.4]	1.00 [25]	3.50 [89]
SWL19A	SWL59A	2-1/2"	2.88 [73]	1.38 [35]	3.88 [99]
SWL20A	SWL90A	3"	3.50 [89]		4.68 [119]
SWL21A	SWL91A	3-1/2"	4.00 [102]		5.12 [130]
SWL22A	SWL92A	4"	4.50 [114]	1.62 [41]	5.63 [143]
SWL24A	SWL93A	5"	5.56 [141]		6.16 [156]
SWL86A	SWL96A	6"	6.63 [168]		6.16 [156]

- NOTES:**
1. Dimensions in brackets [] are in millimeters.
 2. Conductor smaller than 3 inch bus size not recommended for 550 kV
 3. For 45° angle ADD SUFFIX "45" to catalog number (example: SWL22A-45).

Blue highlighted items are industry standard and most frequently ordered.

WELDED END PLUG

WLB-A

Weld type
 Application: Bus to End Cap, used with shielded bus support/expansion couplers

EHV RATED: UP TO 550 kV when used with shielded bus and expansion connectors

Material: Cast 356 Aluminum Alloy

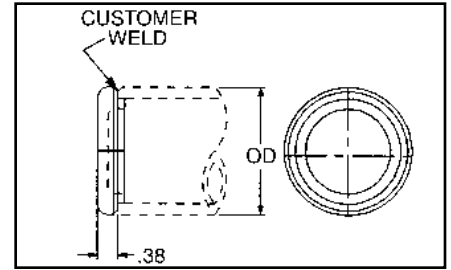
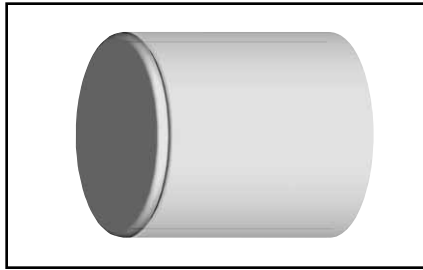

Catalog Number		O.D.	Conductor Aluminum Tubing Size
Sch. 40	Sch. 80		
WLB15A	WLB55A	1.32 [34]	1"
WLB16A	WLB56A	1.66 [42]	1-1/4"
WLB17A	WLB57A	1.90 [48]	1-1/2"
WLB18A	WLB58A	2.38 [60]	2"
WLB19A	WLB59A	2.88 [73]	2-1/2"
WLB20A	WLB90A	3.50 [89]	3"
WLB21A	WLB91A	4.00 [102]	3-1/2"
WLB22A	WLB92A	4.50 [114]	4"
WLB24A	WLB94A	5.56 [141]	5"
WLB86A	WLB96A	6.62 [168]	6"

- NOTES:**
 1. Dimensions in brackets [] are in millimeters.
 2. Conductor smaller than 3 inch bus size not recommended for 550 kV.

M-27

WELDED CORONA BELL

SCB-A

Weld type
 Application: Bus to Corona Bell

EHV RATED: SELF-SHIELDING UP TO 550 kV

Material: Aluminum Alloy

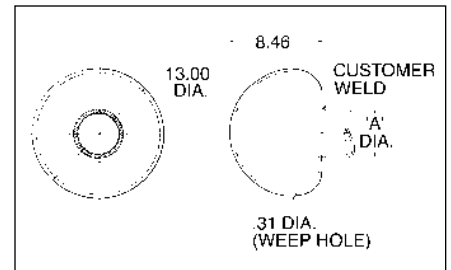
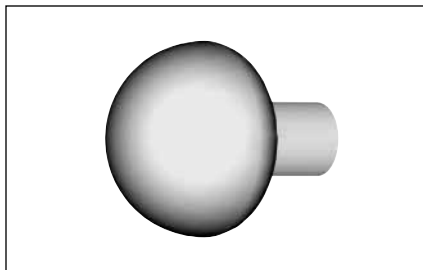

Catalog Number	Accommodates 'A' Dia. Aluminum Tube
SCB19A	2-1/2" (2.875 Dia.)
SCB20A	3" (3.500 Dia.)
SCB21A	3-1/2" (4.000 Dia.)
SCB22A	4" (4.500 Dia.)
SCB24A	5" (5.563 Dia.)
SCB86A	6" (6.625 Dia.)

- NOTES:**
 1. For bolted design contact factory.
 2. Dimensions in brackets [] are in millimeters.
 3. Conductor smaller than 3 inch bus size not recommended for 550 kV.

Blue highlighted items are industry standard and most frequently ordered.

WELDED GROUND STUD

SWCB-A

Weld type
Application: Bus to corona sphere

**EHV RATED: SELF-SHIELDING
UP TO 550 kV**

Material: Cast 356 Aluminum Alloy
Corona Sphere: Aluminum Alloy

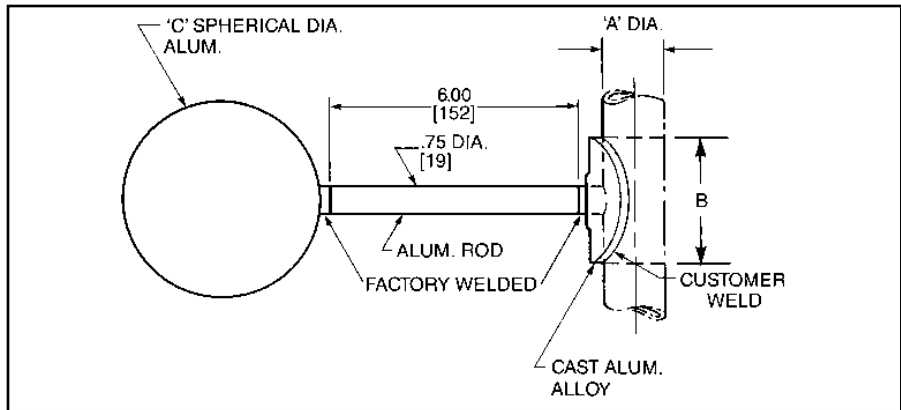
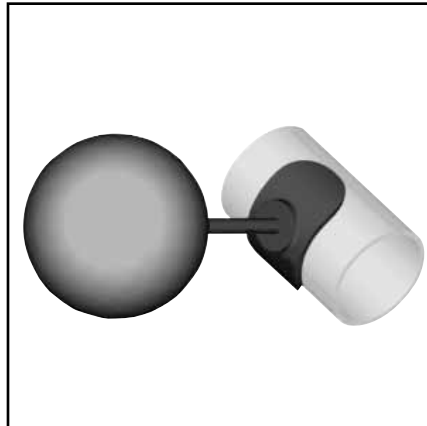

Catalog Number	'A' Dia. Aluminum Tube	'C' Dia.	B
SWCB19A	2-1/2" I.P.S. (2.875 Dia.) [73]	9.00 [229]	1.50 [38]
SWCB20A	3" I.P.S. (3.500 Dia.) [89]		3.00 [76]
SWCB22A	4" I.P.S. (4.500 Dia.) [114]		4.00 [102]
SWCB24A	5" I.P.S. (5.563 Dia.) [141]		
SWCB86A	6" I.P.S. (6.625 Dia.) [168]		

NOTES:

- Dimensions in brackets [] are in millimeters.
- Conductor smaller than 3 inch bus size not recommended for 550 kV.

M-28

Blue highlighted items are industry standard and most frequently ordered.

TERMINAL PAD CAP

(Two Piece)

STS-A-N

Bolted type
Application: Pad shielding

EHV RATED: SELF-SHIELDING UP TO 550 kV

Material: Cast 356 Aluminum Alloy
Hardware: 1/4"-20 × 3-3/4" LG Stainless Steel Hex Hd. Bolt and Split Lockwasher

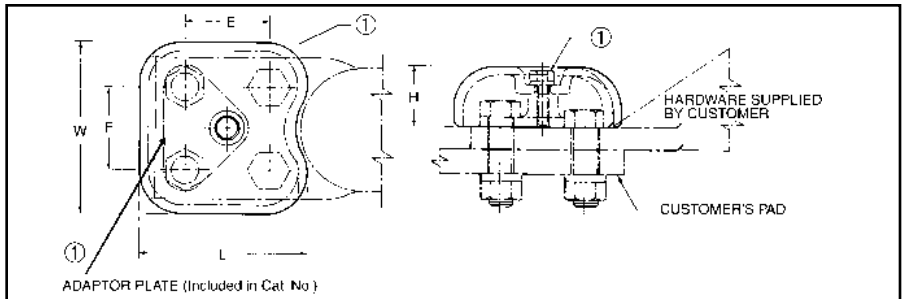
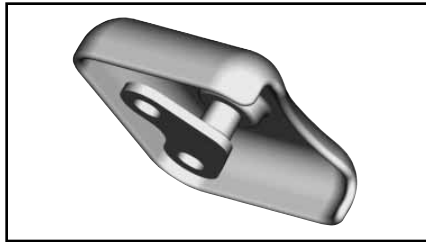

Catalog Number ①	E	F	H	L	W	Maximum Shielded Area
STS33A-4N	1.75 [44]	1.75 [44]	1.25 [32]	3.48 [88]	3.62 [92]	3 × 3 [76] × [76]
STS43A-4N	1.75 [44]	1.75 [44]	1.31 [33]	3.36 [85]	4.50 [114]	4.00 × 3.12 [102 × 79]
STS44A-4N ②	1.75 [44]	1.75 [44]	1.25 [32]	4.50 [114]	4.62 [117]	4 × 4 [102 × 102]

① Catalog number includes one pad cap, one adapter plate, and stainless steel adaptor hardware.

② Used with YNA451R-T and YNA451R-T15 through YNA594R-T and YNA594R-T15 compression terminals.

TERMINAL PAD CAP

(One Piece)

STS-A-NCG

Bolted type
Application: Pad shielding

EHV RATED: SELF-SHIELDING UP TO 550 kV

Material: Cast 356 Aluminum Alloy

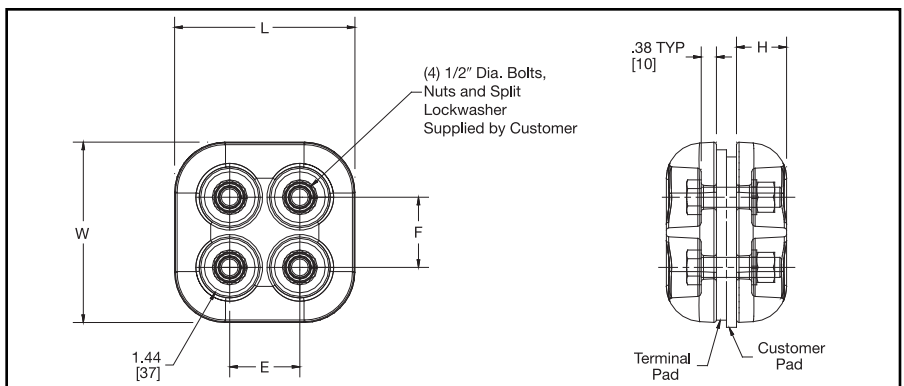
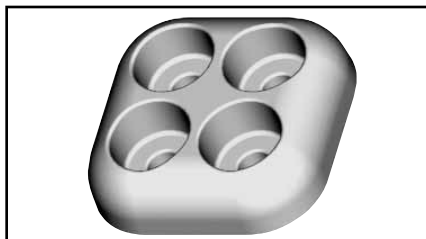

Catalog Number	E	F	H	J Dia.	L	W	Maximum Shielded Area
STS44A-4NCG2	1.75 [44]	1.75 [44]	1.25 [32]	1/2-13	4.50 [114]	4.50 [114]	4 × 4
STS46A-6NCG1	1.75 [44]	1.75 [44]	1.25 [32]	1/2-13	4.50 [114]	6.50 [165]	6 × 4

NOTES:
1. Dimensions in brackets [] are in millimeters.

2. Catalog number is for one shielding cap only. If more than one is required, specify total quantity.

BOLTED BUNDLED CABLE SPACER

S2GBP-A (Spacer)
 S2GBPA-A (Terminal Tap)
 SH2GBP-A (Bus Support)

Bolted type

Applications: Cable to Cable spacer (Two Cables), Cable spacer with four hole pad, and Cable spacer to insulator.

EHV RATED: SELF-SHIELDING UP TO 550 kV

Material: Cast 356 Aluminum Alloy
 Hardware: Aluminum Alloy

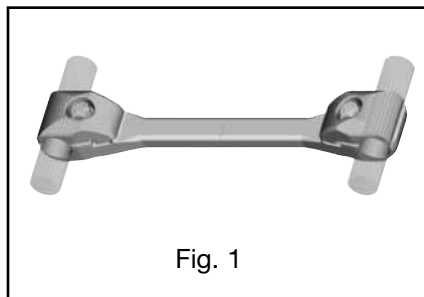

Fig. 1

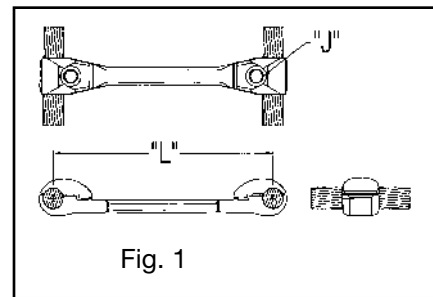

Fig. 1

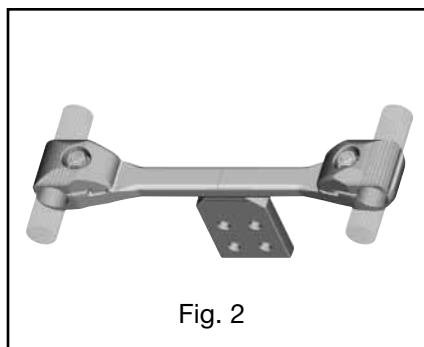

Fig. 2

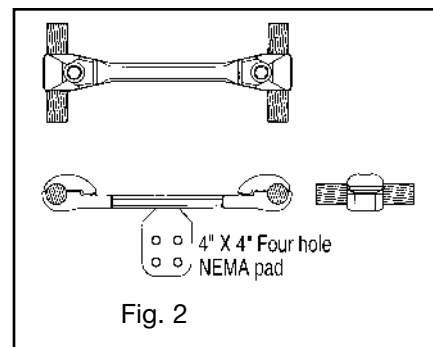

Fig. 2

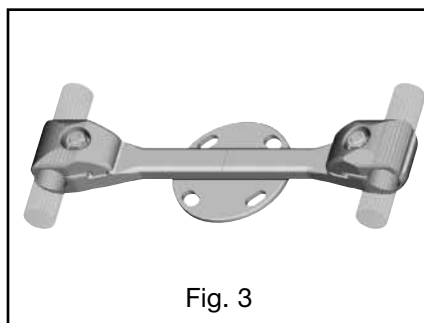

Fig. 3

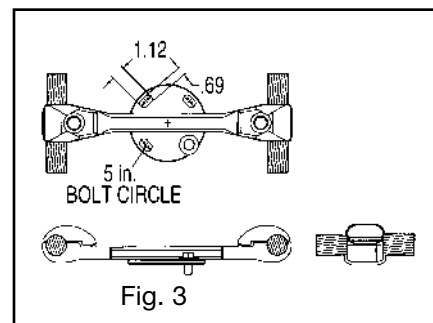

Fig. 3

M-30

Catalog Number			Cable Range		Cable Dia.		"L"	"J" Dia.
Fig. 1	Fig. 2	Fig. 3	AAC	ACSR	Min.	Max.		
S2GBP41A	S2GBPA41A	SH2GBP41A5	795 kcmil 37 Str. (1.026 Dia.)	715 kcmil 24/7 Str. (1.036 Dia.)	1.026	1.092	18.00	5/8"-11 X 1-1/2" LG. Alum. Alloy
S2GBP41A12	S2GBPA41A12	SH2GBP41A512	874.5 kcmil 61 Str. (1.077 Dia.)	715.5 kcmil 26/7 Str. (1.051 Dia.)	[26]	[28]	[457] 12.00 [305]	
S2GBP44A	S2GBPA44A	SH2GBP44A5	954 kcmil 61 Str. (1.126 Dia.)	795 kcmil 24/7 Str. (1.092 Dia.)	1.092	1.165	18.00	5/8"-11 X 1-3/4" LG. Alum. Alloy
S2GBP44A12	S2GBPA44A12	SH2GBP44A512		795 kcmil 54/7 Str. (1.093 Dia.)	[28]	[30]	[457] 12.00 [305]	
S2GBP445A	S2GBPA445A	SH2GBP445A5	1033.5 kcmil 37 Str. (1.170 Dia.) 1113 kcmil 61 Str. (1.216 Dia.)	954 kcmil 45/7 Str. (1.165 Dia.)	1.165	1.246	18.00	
S2GBP445A12	S2GBPA445A12	SH2GBP445A512		1033.5 kcmil 45/7 Str. (1.213 Dia.)	[30]	[32]	[457] 12.00 [305]	
S2GBP45A	S2GBPA45A	SH2GBP45A5	1192 kcmil 61 Str. (1.258 Dia.) 1272 kcmil 61 Str. (1.300 Dia.)	1033.5 kcmil 54/7 Str. (1.246 Dia.)	1.246	1.382	18.00	5/8"-11 X 1-3/4" LG. Alum. Alloy
S2GBP45A12	S2GBPA45A12	SH2GBP45A512		1192.5 kcmil 54/19 Str. (1.333 Dia.)	[32]	[35]	[457] 12.00 [305]	

(Table continued on next page)

NOTES:

1. Dimensions in brackets [] are in millimeters.
2. For stainless steel hardware add SUFFIX "SS" to catalog number (example: S2GBP41ASS).
3. For variations in cable spacing contact factory.

4. For pad rotated 90° on S2GBPA-A add suffix R90 to the catalog number (example: S2GBPA44AR90).
5. For Bolt Circles other than 5 inch on type SH2GBP-A contact factory.

6. S2GBPA-A connectors rated 550 kV when used with type "STS" Shielding Caps. Ordered separately, refer to page 32.

Blue highlighted items are industry standard and most frequently ordered.

**BOLTED BUNDLED
CABLE SPACER**

(Continued)

**S2GBP-A (Spacer)
S2GBPA-A (Terminal Tap)
SH2GBP-A (Bus Support)**

Catalog Number			Cable Range		Cable Dia.		"L"	"J" Dia.
Fig. 1	Fig. 2	Fig. 3	AAC	ACSR	Min.	Max.		
S2GBP46A	S2GBPA46A	SH2GBP46A5	1590 kcmil 61 Str. (1.453 Dia.) 1600 kcmil 127 Str. (1.454 Dia.)	1272 kcmil 54/19 Str. (1.382 Dia.) 1431 kcmil 54/19 Str. (1.465 Dia.)	1.382 [35]	1.504 [38]	18.00 [457] 12.00 [305]	5/8"-11 X 1-3/4" LG. Alum. Alloy
S2GBP46A12	S2GBPA46A12	SH2GBP46A512						
S2GBP48A	S2GBPA48A	SH2GBP48A5	1750 kcmil 127 Str. (1.526 Dia.) 2000 kcmil 91 Str. (1.630 Dia.)	1590 kcmil 45/7 Str. (1.502 Dia.) 1750 kcmil 84/19 Str. (1.602 Dia.)	1.504 [38]	1.632 [41]	18.00 [457] 12.00 [305]	5/8"-11 X 2" LG. Alum. Alloy
S2GBP48A12	S2GBPA48A12	SH2GBP48A512						
S2GBP483A	S2GBPA483A	SH2GBP483A5	2000 kcmil 91 Str. (1.630 Dia.) 2250 kcmil 91 Str. (1.729 Dia.)	1890 kcmil 84/19 Str. (1.650 Dia.) 2167 kcmil 72/7 Str. (1.737 Dia.)	1.632 [41]	1.737 [44]	18.00 [457] 12.00 [305]	
S2GBP483A12	S2GBPA483A12	SH2GBP483A512						
S2GBP486A	S2GBPA486A	SH2GBP486A5	2300 kcmil 61 Str. (1.750 Dia.) 2500 kcmil 127 Str. (1.823 Dia.)	2167 kcmil 72/7 Str. (1.737 Dia.) 2156 kcmil 84/19 Str. (1.762 Dia.)	1.737 [44]	1.824 [46]	18.00 [457] 12.00 [305]	
S2GBP486A12	S2GBPA486A12	SH2GBP486A512						

NOTES:

1. Dimensions in brackets [] are in millimeters.
2. For stainless steel hardware add SUFFIX "SS" to catalog number (example: S2GBP41ASS).
3. For variations in cable spacing contact factory.
4. For pad rotated 90° on S2GBPA-A add suffix R90 to the catalog number (example: S2GBPA44AR90).
5. For Bolt Circles other than 5 inch on type SH2GBP-A contact factory.
6. **S2GBPA-A connectors rated 550 kV when used with type "STS" Shielding Caps. Ordered separately, refer to page 32.**

Blue highlighted items are industry standard and most frequently ordered.

BOLTED BUNDLED CABLE SPACER (Two Bolt Clamping)

S2GBP-AB2 (Spacer)
S2GBPA-AB2 (Terminal Tap)
SH2GBP-A-B2 (Bus Support)

Bolted type

Applications: Cable to Cable spacer (Two Cables), Cable spacer with four hole pad, and Cable spacer to insulator.

EHV RATED: SELF-SHIELDING UP TO 550 kV

Material: Cast 356 Aluminum Alloy
 Hardware: Aluminum Alloy

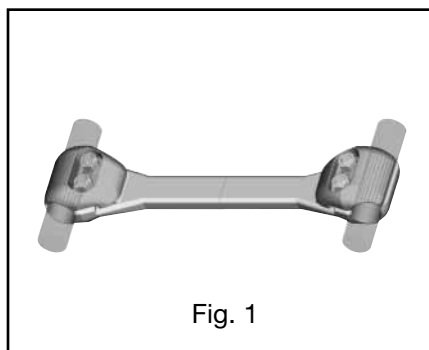

Fig. 1

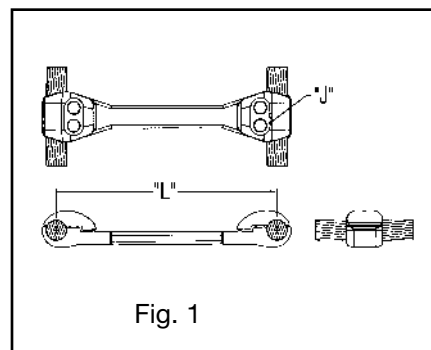

Fig. 1

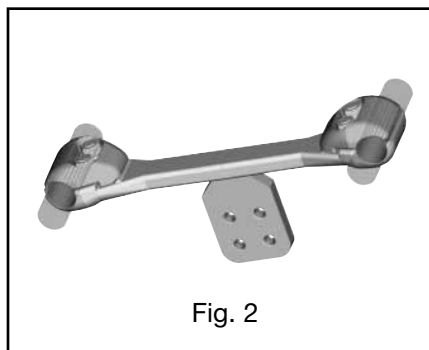

Fig. 2

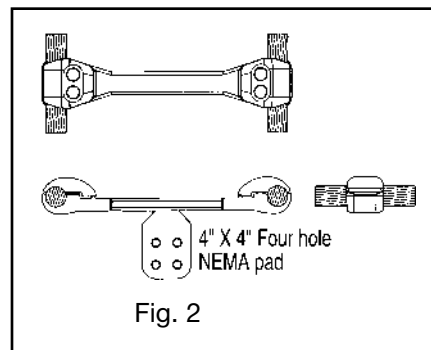

Fig. 2

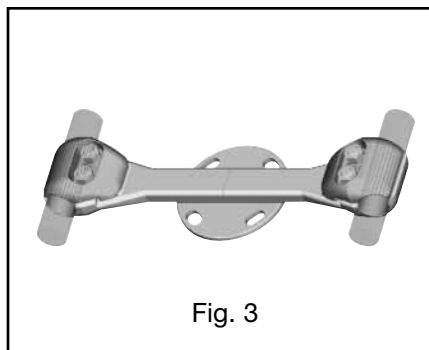

Fig. 3

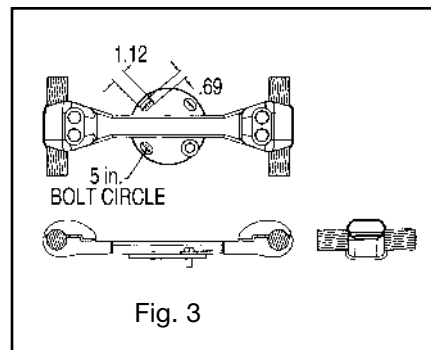

Fig. 3

M-32

Catalog Number			Cable Range		Cable Dia.		"L"	"J" Dia.
Fig. 1	Fig. 2	Fig. 3	AAC	ACSR	Min.	Max.		
S2GBP41AB2	S2GBPA41AB2	SH2GBP41A5B2	795 kcmil 37 Str. (1.026 Dia.) 874.5 kcmil 61 Str. (1.077 Dia.)	715 kcmil 24/7 Str. (1.036 Dia.) 715.5 kcmil 26/7 Str. (1.051 Dia.)	1.026 [26]	1.092 [28]	18.00 [457] 12.00 [305]	5/8"-11 X 1-1/2" LG. Alum. Alloy
S2GBP41A12B2	S2GBPA41A12B2	SH2GBP41A512B2	954 kcmil 61 Str. (1.126 Dia.)	795 kcmil 24/7 Str. (1.092 Dia.) 795 kcmil 54/7 Str. (1.093 Dia.)	1.092 [28]	1.165 [30]	18.00 [457]	
S2GBP44AB2	S2GBPA44AB2	SH2GBP44A5B2					18.00 [457]	
S2GBP44A12B2	S2GBPA44A12B2	SH2GBP44A512B2	1033.5 kcmil 37 Str. (1.170 Dia.) 1113 kcmil 61 Str. (1.216 Dia.)	954 kcmil 45/7 Str. (1.165 Dia.) 1033.5 kcmil 45/7 Str. (1.213 Dia.)	1.165 [30]	1.246 [32]	12.00 [305]	5/8"-11 X 1-3/4" LG. Alum. Alloy
S2GBP445AB2	S2GBPA445AB2	SH2GBP445A5B2					18.00 [457]	
S2GBP445A12B2	S2GBPA445A12B2	SH2GBP445A512B2	1192 kcmil 61 Str. (1.258 Dia.) 1272 kcmil 61 Str. (1.300 Dia.)	1033.5 kcmil 54/7 Str. (1.246 Dia.) 1192.5 kcmil 54/19 Str. (1.333 Dia.)	1.246 [32]	1.382 [35]	18.00 [457]	
S2GBP45AB2	S2GBPA45AB2	SH2GBP45A5B2					12.00 [305]	
S2GBP45A12B2	S2GBPA45A12B2	SH2GBP45A512B2						

(Table continued on next page)

NOTES:

- Dimensions in brackets [] are in millimeters.
- For stainless steel hardware add SUFFIX "SS" to catalog number (example: S2GBP41AB2SS).
- For variations in cable spacing contact factory.

- For pad rotated 90° on S2GBPA-AB2 add suffix R90 to the catalog number (example: S2GBPA44AB2R90).
- For Bolt Circles other than 5 inch on type SH2GBP-A-B2 contact factory.

- S2GBPA-B2 connectors rated 550 kV when used with type "STS" Shielding Caps. Ordered separately, refer to page 32.

**BOLTED BUNDLED
CABLE SPACER**

(Continued)

(Two Bolt Clamping)

S2GBP-AB2 (Spacer)

S2GBPA-AB2 (Terminal Tap)

SH2GBP-A-B2 (Bus Support)

Catalog Number			Cable Range		Cable Dia.		"L"	"J" Dia.
Fig. 1	Fig. 2	Fig. 3	AAC	ACSR	Min.	Max.		
S2GBP46AB2	S2GBPA46AB2	SH2GBP46A5B2	1590 kcmil 61 Str. (1.453 Dia.) 1600 kcmil 127 Str. (1.454 Dia.)	1272 kcmil 54/19 Str. (1.382 Dia.) 1431 kcmil 54/19 Str. (1.465 Dia.)	1.382 [35]	1.504 [38]	18.00	5/8"-11 X 1-3/4" LG. Alum. Alloy
S2GBP46A12B2	S2GBPA46A12B2	SH2GBP46A512B2					12.00 [305]	
S2GBP48AB2	S2GBPA48AB2	SH2GBP48A5B2	1750 kcmil 127 Str. (1.526 Dia.) 2000 kcmil 91 Str. (1.630 Dia.)	1590 kcmil 45/7 Str. (1.502 Dia.) 1750 kcmil 84/19 Str. (1.602 Dia.)	1.504 [38]	1.632 [41]	18.00	5/8"-11 X 2" LG. Alum. Alloy
S2GBP48A12B2	S2GBPA48A12B2	SH2GBP48A512B2					12.00 [305]	
S2GBP483AB2	S2GBPA483AB2	SH2GBP483A5B2	2000 kcmil 91 Str. (1.630 Dia.) 2250 kcmil 91 Str. (1.729 Dia.)	1890 kcmil 84/19 Str. (1.650 Dia.) 2167 kcmil 72/7 Str. (1.737 Dia.)	1.632 [41]	1.737 [44]	18.00	5/8"-11 X 2" LG. Alum. Alloy
S2GBP483A12B2	S2GBPA483A12B2	SH2GBP483A512B2					12.00 [305]	
S2GBP486AB2	S2GBPA486AB2	SH2GBP486A5B2	2300 kcmil 61 Str. (1.750 Dia.) 2500 kcmil 127 Str. (1.823 Dia.)	2167 kcmil 72/7 Str. (1.737 Dia.) 2156 kcmil 84/19 Str. (1.762 Dia.)	1.737 [44]	1.824 [46]	18.00	5/8"-11 X 2" LG. Alum. Alloy
S2GBP486A12B2	S2GBPA486A12B2	SH2GBP486A512B2					12.00 [305]	

NOTES:

1. Dimensions in brackets [] are in millimeters.
2. For stainless steel hardware add SUFFIX "SS" to catalog number (example: S2GBP41AB2SS).
3. For variations in cable spacing contact factory.

4. For pad rotated 90° on S2GBPA-AB2 add suffix R90 to the catalog number (example: S2GBPA44AB2R90).
5. For Bolt Circles other than 5 inch on type SH2GBP-A-B2 contact factory.

6. **S2GBPA-B2 connectors rated 550 kV when used with type "STS" Shielding Caps. Ordered separately, refer to page 32.**

Blue highlighted items are industry standard and most frequently ordered.

BOLTED BUNDLED CABLE SPACER (Four Bolt Clamping)

S2GBP-AB4 (Spacer)
S2GBPA-AB4 (Terminal Tap)
SH2GBP-A-B4 (Bus Support)

Bolted type

Applications: Cable to Cable spacer (Two Cables), Cable spacers with four hole pad, and Cable spacer to bus support insulator.

EHV RATED: SELF-SHIELDING UP TO 550 kV

Material: Cast 356 Aluminum Alloy
 Hardware: Aluminum Alloy

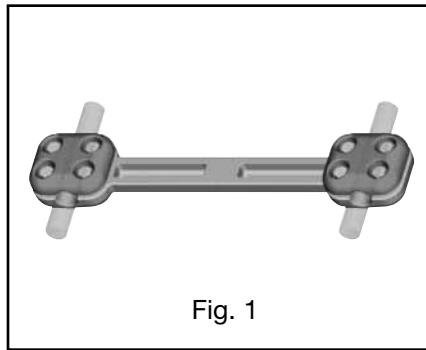

Fig. 1

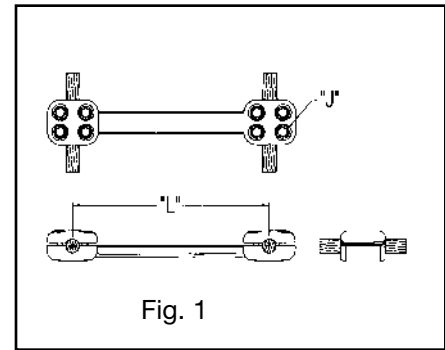

Fig. 1

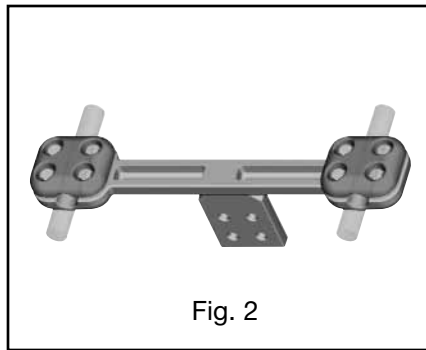

Fig. 2

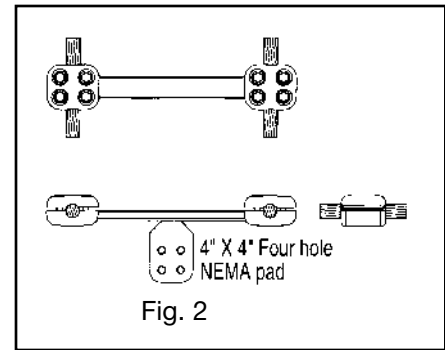

Fig. 2

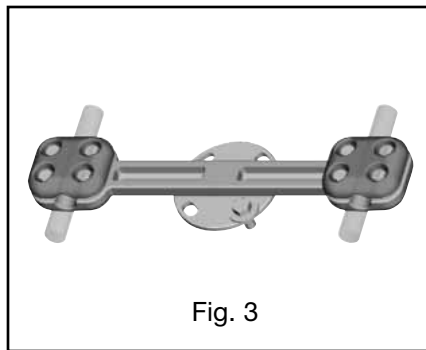

Fig. 3

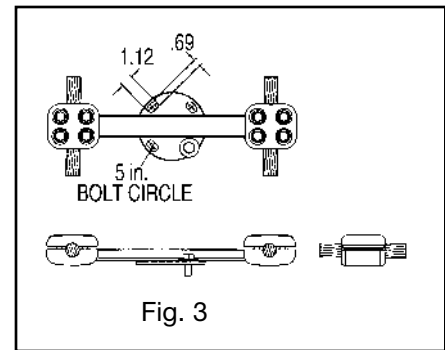

Fig. 3

M-34

Catalog Number			Cable Range		Cable Dia.		"L"	"J" Dia.
Fig. 1	Fig. 2	Fig. 3	AAC	ACSR	Min.	Max.		
S2GBP41AB4	S2GBPA41AB4	SH2GBP41A5B4	795 kcmil 37 Str. (1.026 Dia.) 874.5 kcmil 61 Str. (1.077 Dia.)	715 kcmil 24/7 Str. (1.036 Dia.) 715.5 kcmil 26/7 Str. (1.051 Dia.)	1.026 [26]	1.092 [28]	18.00 [457] 12.00 [305]	5/8"-11 X 1-1/2" LG. Alum. Alloy
S2GBP44AB4	S2GBPA44AB4	SH2GBP44A5B4	954 kcmil 61 Str. (1.126 Dia.)	795 kcmil 24/7 Str. (1.092 Dia.) 795 kcmil 54/7 Str. (1.093 Dia.)	1.092 [28]	1.165 [30]	18.00 [457]	
S2GBP44A12B4	S2GBPA44A12B4	SH2GBP44A512B4					12.00 [305]	
S2GBP445AB4	S2GBPA445AB4	SH2GBP445A5B4	1033.5 kcmil 37 Str. (1.170 Dia.) 1113 kcmil 61 Str. (1.216 Dia.)	954 kcmil 45/7 Str. (1.165 Dia.) 1033.5 kcmil 45/7 Str. (1.213 Dia.)	1.165 [30]	1.246 [32]	18.00 [457]	5/8"-11 X 1-3/4" LG. Alum. Alloy
S2GBP445A12B4	S2GBPA445A12B4	SH2GBP445A512B4					12.00 [305]	
S2GBP45AB4	S2GBPA45AB4	SH2GBP45A5B4	1192 kcmil 61 Str. (1.258 Dia.) 1272 kcmil 61 Str. (1.300 Dia.)	1033.5 kcmil 54/7 Str. (1.246 Dia.) 1192.5 kcmil 54/19 Str. (1.333 Dia.)	1.246 [32]	1.382 [35]	18.00 [457]	
S2GBP45A12B4	S2GBPA45A12B4	SH2GBP45A512B4					12.00 [305]	

(Table continued on next page)

NOTES:

- Dimensions in brackets [] are in millimeters.
- For stainless steel hardware add SUFFIX "SS" to catalog number (example: S2GBP41AB4SS).
- For variations in cable spacing contact factory.
- For pad rotated 90° on S2GBPA-AB4 add suffix R90 to the catalog number (example: S2GBPA44AB4R90).
- For Bolt Circles other than 5 inch on type SH2GBP-A-B2 contact factory.
- S2GBPA-B4 connectors rated 550 kV when used with type "STS" Shielding Caps. Ordered separately, refer to page 32.

**BOLTED BUNDLED
CABLE SPACER**

(Continued)

(Four Bolt Clamping)

**S2GBP-AB4 (Spacer)
S2GBPA-AB4 (Terminal Tap)
SH2GBP-A-B4 (Bus Support)**

Catalog Number			Cable Range		Cable Dia.		"L"	"J" Dia.
Fig. 1	Fig. 2	Fig. 3	AAC	ACSR	Min.	Max.		
S2GBP46AB4	S2GBPA46AB4	SH2GBP46A5B4	1590 kcmil 61 Str. (1.453 Dia.)	1272 kcmil 54/19 Str. (1.382 Dia.)	1.382	1.504	18.00	5/8"-11 X 1-3/4" LG. Alum. Alloy
S2GBP46A12B4	S2GBPA46A12B4	SH2GBP46A512B4	1600 kcmil 127 Str. (1.454 Dia.)	1431 kcmil 54/19 Str. (1.465 Dia.)	[35]	[38]	12.00 [305]	
S2GBP48AB4	S2GBPA48AB4	SH2GBP48A5B4	1750 kcmil 127 Str. (1.526 Dia.)	1590 kcmil 45/7 Str. (1.502 Dia.)	1.504	1.632	18.00	5/8"-11 X 2" LG. Alum. Alloy
S2GBP48A12B4	S2GBPA48A12B4	SH2GBP48A512B4	2000 kcmil 91 Str. (1.630 Dia.)	1750 kcmil 84/19 Str. (1.602 Dia.)	[38]	[41]	12.00 [305]	
S2GBP483AB4	S2GBPA483AB4	SH2GBP483A5B4	2000 kcmil 91 Str. (1.630 Dia.)	1890 kcmil 84/19 Str. (1.650 Dia.)	1.632	1.737	18.00	5/8"-11 X 2" LG. Alum. Alloy
S2GBP483A12B4	S2GBPA483A12B4	SH2GBP483A512B4	2250 kcmil 91 Str. (1.729 Dia.)	2167 kcmil 72/7 Str. (1.737 Dia.)	[41]	[44]	12.00 [305]	
S2GBP486AB4	S2GBPA486AB4	SH2GBP486A5B4	2300 kcmil 61 Str. (1.750 Dia.)	2167 kcmil 72/7 Str. (1.737 Dia.)	1.737	1.824	18.00	5/8"-11 X 2" LG. Alum. Alloy
S2GBP486A12B4	S2GBPA486A12B4	SH2GBP486A512B4	2500 kcmil 127 Str. (1.823 Dia.)	2156 kcmil 84/19 Str. (1.762 Dia.)	[44]	[46]	12.00 [305]	

NOTES:

- Dimensions in brackets [] are in millimeters.
- For stainless steel hardware add SUFFIX "SS" to catalog number (example: S2GBP41AB4SS).
- For variations in cable spacing contact factory.
- For pad rotated 90° on S2GBPA-AB4 add suffix R90 to the catalog number (example: S2GBPA44AB4R90).
- For Bolt Circles other than 5 inch on type SH2GBP-A-B2 contact factory.
- S2GBPA-B4 connectors rated 550 kV when used with type "STS" Shielding Caps. Ordered separately, refer to page 32.**

Blue highlighted items are industry standard and most frequently ordered.

BOLTED BUNDLED CABLE SPACER (Three Conductor)

S3GBP-A

Bolted type
Application: Cable to Cable Spacer (three cables)

EHV RATED: SELF-SHIELDING UP TO 550 kV

Material: Cast 356 Aluminum Alloy
Hardware: Aluminum Alloy

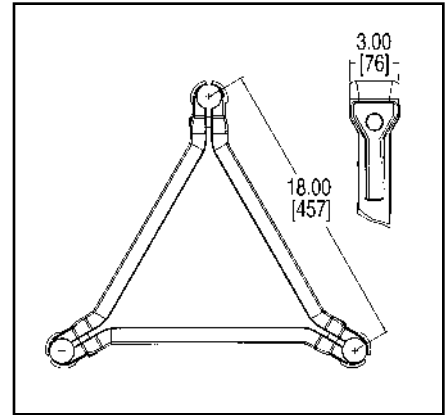
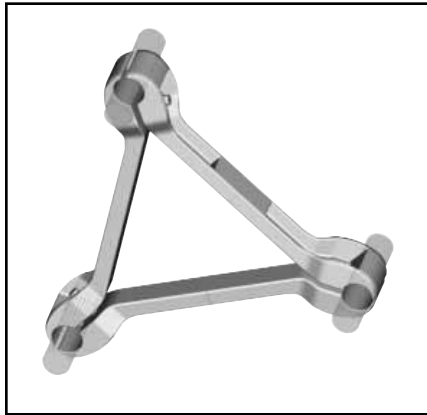

Catalog Number	Cable Range		Cable Dia.		"J" Dia.
	AAC	ACSR	Min.	Max.	
S3GBP41A	795 kcmil 37 Str. (1.026 Dia.) 874.5 kcmil 61 Str. (1.077 Dia.)	715 kcmil 24/7 Str. (1.036 Dia.) 715.5 kcmil 26/7 Str. (1.051 Dia.)	1.026 [26]	1.092 [28]	5/8"-11 × 1-1/2" LG. Alum. Alloy
S3GBP44A	954 kcmil 61 Str. (1.126 Dia.)	795 kcmil 24/7 Str. (1.092 Dia.) 795 kcmil 54/7 Str. (1.093 Dia.)	1.092 [28]	1.165 [30]	
S3GBP445A	1033.5 kcmil 37 Str. (1.170 Dia.) 1113 kcmil 61 Str. (1.216 Dia.)	954 kcmil 45/7 Str. (1.165 Dia.) 1033.5 kcmil 45/7 Str. (1.213 Dia.)	1.165 [30]	1.246 [32]	5/8"-11 × 1-3/4" LG. Alum. Alloy
S3GBP45A	1192 kcmil 61 Str. (1.258 Dia.) 1272 kcmil 61 Str. (1.300 Dia.)	1033.5 kcmil 54/7 Str. (1.246 Dia.) 1192.5 kcmil 54/19 Str. (1.333 Dia.)	1.246 [32]	1.382 [35]	
S3GBP46A	1590 kcmil 61 Str. (1.453 Dia.) 1600 kcmil 127 Str. (1.454 Dia.)	1272 kcmil 54/19 Str. (1.382 Dia.) 1431 kcmil 54/19 Str. (1.465 Dia.)	1.382 [35]	1.504 [38]	
S3GBP48A	1750 kcmil 127 Str. (1.526 Dia.) 2000 kcmil 91 Str. (1.630 Dia.)	1590 kcmil 45/7 Str. (1.502 Dia.) 1750 kcmil 84/19 Str. (1.602 Dia.)	1.504 [38]	1.632 [41]	5/8"-11 × 2" LG. Alum Alloy
S3GBP483A	2000 kcmil 91 Str. (1.630 Dia.) 2250 kcmil 91 Str. (1.729 Dia.)	1890 kcmil 84/19 Str. (1.650 Dia.) 2167 kcmil 72/7 Str. (1.737 Dia.)	1.632 [41]	1.737 [44]	
S3GBP486A	2300 kcmil 61 Str. (1.750 Dia.) 2500 kcmil 127 Str. (1.823 Dia.)	2167 kcmil 72/7 Str. (1.737 Dia.) 2156 kcmil 84/19 Str. (1.762 Dia.)	1.737 [44]	1.824 [46]	

NOTES:

1. Dimensions in brackets [] are in millimeters.
2. For stainless steel hardware add SUFFIX "SS" to catalog number (example: S3GBP48ASS).
3. For variations in cable spacing contact factory.
4. For four hole straight pad tap or 90° version or bus support three bundled cable spacer, contact the factory.

M-36

Blue highlighted items are industry standard and most frequently ordered.

BIFURCATING TERMINAL CONNECTOR

SF2A-NL-EX

Bolted type
Application: Four to Six Hole
NEMA Pad to Two
Four Hole NEMA
Recessed Pads
Bifurcating Terminal

**EHV RATED: SELF-SHIELDING
UP TO 550 kV**

Material: Cast 356 Aluminum Alloy

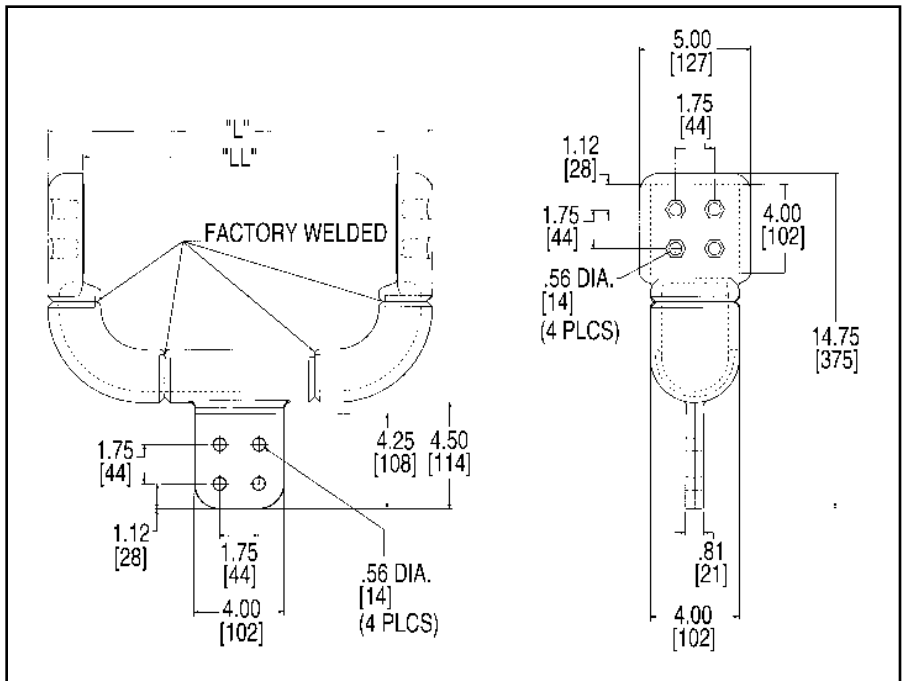

Catalog Number	"L"	"LL"
SF2A44NL12EX	17.21 [437]	13.97 [355]
SF2A44NL18EX	21.51 [546]	18.27 [464]

- NOTES:**
- Dimensions in brackets [] are in millimeters.
 - One surface of pad finished. For finished pad on both sides add SUFFIX "Q" to the catalog number (example: SF2A44NL12EXQ).
 - Shielding caps are not required when terminals are installed within the recessed Housing. Hardware ordered separately.
 - Shielding caps are required when installing to center (non recessed) four hole NEMA Pad. Reference STS type shielding caps on page 32.
 - For six hole NEMA pad add "66" to catalog number (example: SF2A66NL12EX).

M-37

Blue highlighted items are industry standard and most frequently ordered.

TRIFURCATING COUPLER CONNECTOR

SW3A-A44N8

Weld type
Application: Bus to Trifurcating
Terminals

**EHV RATED: SELF-SHIELDING
UP TO 550 kV**

Material: Cast 356 Aluminum Alloy

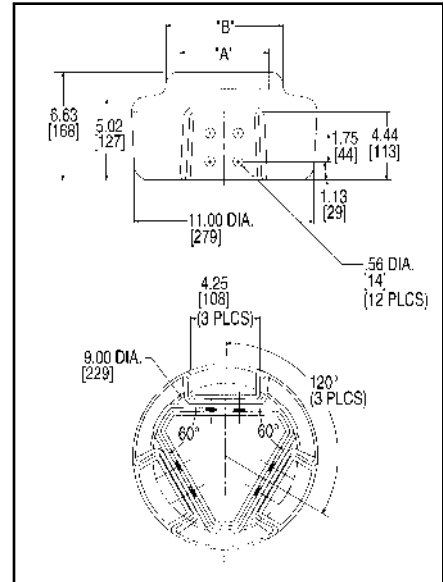
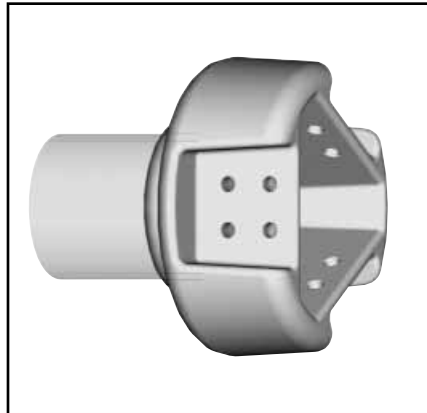

Catalog Number	Accommodates		
	Alum. Tubing Size	"A" Dia.	"B" Dia.
SW3A20A44N8	3" [76]	3.56 [90]	5.06 [129]
SW3A22A44N8	4" [101]	4.57 [116]	6.09 [155]
SW3A24A44N8	5" [127]	5.65 [144]	7.16 [182]
SW3A86A44N8	6" [152]	6.72 [171]	8.00 [203]

NOTES:

1. Dimensions in brackets [] are in millimeters.
2. Shielding caps are not required when terminals are installed within the recessed housing. Hardware ordered separately.

TRIFURCATING TEE CONNECTOR

SW3AB-A44N8

Weld type
Application: Bus to Trifurcating
Terminals

**EHV RATED: SELF-SHIELDING
UP TO 550 kV**

Material: Cast 356 Aluminum Alloy

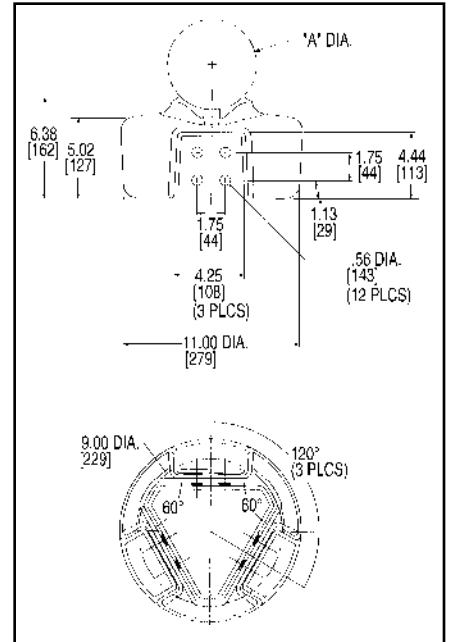

Catalog Number	Accommodates	
	Alum. Tubing Size	"A" Dia.
SW3AB20A44N8	3" [76]	3.50 [89]
SW3AB22A44N8	4" [101]	4.50 [114]
SW3AB24A44N8	5" [127]	5.56 [141]
SW3AB86A44N8	6" [152]	6.62 [168]

- NOTES:**
1. Dimensions in brackets [] are in millimeters.
 2. Shielding caps are not required when terminals are installed within the recessed housing. Hardware ordered separately.

Blue highlighted items are industry standard and most frequently ordered.

TRIFURCATING TERMINAL CONNECTOR

SF3A44N8

Bolted type
Application: Pad-to-Pad
Trifurcating Terminal

**EHV RATED: SELF-SHIELDING
UP TO 550 kV**

Material: Cast 356 Aluminum Alloy

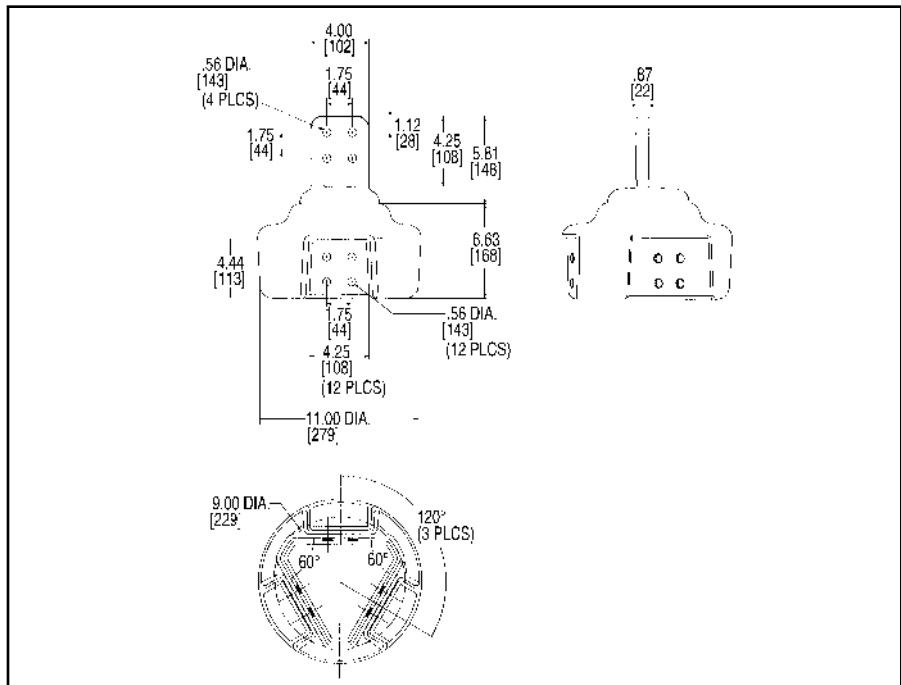
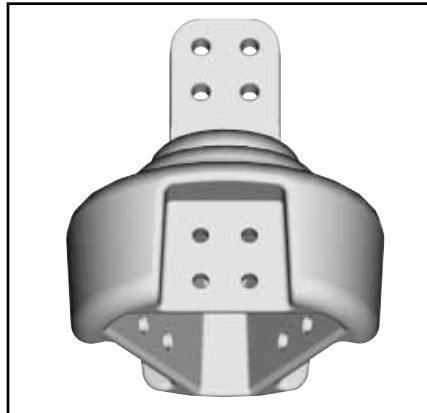

NOTES:

1. Dimensions in brackets [] are in millimeters.
2. One surface of pad finished. For finished pad on both sides add SUFFIX 'Q' to the catalog number (example: SF3A44N8Q).
3. Shielding caps are not required when terminals are installed within the recessed housing. Hardware ordered separately. For terminals not installed within the recessed housing shielding caps are required. Reference STS shielding caps page 32. Ordered separately.
4. For six hole NEMA external (non-recessed) pad order SF3A44N866N.

M-40

Blue highlighted items are industry standard and most frequently ordered.

TABLE OF CONTENTS

DIES

12 Ton U Dies N-4
 W Dies N-4
 UDIEKITCU, UDIEKITAL,
 UDIEKITHYGRD U Die Kits N-5

CRIMPERS



MECHANICAL AND RATCHET

Y10D N-6
 Y10-22 N-7
 YF-TOOL N-8
 Y8MRB-1 N-9
 MR8 N-10
 MR15, MR18, MR20 N-11
 MR4C N-12
 Y1MRTC N-13
 M8ND N-14
 MRC840, MRC840AL N-15
 MY29, MY28 N-16
 OH25 N-17
 OUR840 N-18
 MD6, MD6-4, MD6-6, MD6-8, MD6-12,
 MD6-14, MD6-37, MD6-38, MD6-K ... N-19
 MD7, MD7-6, MD7-8 N-20
 MD7-34R N-21
 MD6/MD7 Accessories N-22
 MD6R N-23
 MD6 Hotstick Tools N-24
 RK147-2 & WIREMIKE N-25

SELF-CONTAINED HYDRAULIC



Y500CT-HS N-26
 Y35 & Y35-2 N-27
 Y35 Accessories N-28
 Y39 N-29
 Y750HSXT & Y750CHSXT N-30
 Y644HSXT N-31
 Y81KFT N-32
 Y4PC834 N-33

BATTERY ACTUATED

PAT750XT-18V N-34
 PAT750K-18V N-35
 PAT644XT-18V N-36
 PAT46-18V N-37

PAT81KFT-18V N-38
 PAT4PC834-18V N-39
 PATMD6-14V N-40
 PAT600-18V N-41

REMOTE HYDRAULIC

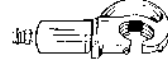

Y35BH (10,000 PSI) N-42
 Y39BH (10,000 PSI) N-43
 Y34BH (10,000 PSI) N-44
 Y29BH (6,000 PSI) N-45
 Y750BHXT & Y750CBHXT
 (10,000 PSI) N-46
 Y644MBH N-47
 Y81KFTMBH N-48
 Y4PC834MBH N-49
 Y45 (10,000 PSI) N-50
 Y46, Y46C (10,000 PSI) N-51
 Y60BHU & Y60BHUD N-52

PNEUMATIC

Y29NC N-53
 TFM Tape Fed Machine N-54
 TFM Installation Tooling Chart N-55

CUTTERS

MECHANICAL AND RATCHET

MCC500, MCC1000 N-56
 RCC336, RCC556, RCC600, RCC750HD,
 RCC954ACSR, RCC1000 N-57

SELF-CONTAINED HYDRAULIC

Y CUT129ACSR N-58

BATTERY ACTUATED

PATHCC10-18V N-59
 PATCUT129ACSR-18V N-60
 PATCUT245CUAL-18V N-61
 BCC1000CUAL N-62

REMOTE HYDRAULIC

RHCC129ACSR N-63
 RHCC245CUAL N-64

N-1

(Table of Contents continued on page 2)

Blue highlighted items are industry standard and most frequently ordered.

TABLE OF CONTENTS

(Continued)

HYDRAULIC PUMPS

HP10 (10,000 PSI) **N-65**
HP8 (8,800 PSI) **N-65**
HP6 (6,000 PSI) **N-65**
FP10 (10,000 PSI) **N-66**
FP8 (8,800 PSI) **N-66**
FP6 (6,000 PSI) **N-66**
Y10AC9 **N-67**
EPP10, EPP6 **N-68**
EPAC10, EPAC8, EPAC6 **N-69**
EP10, EP10-2, EP8, EP6 **N-70**
EP10-1HP, EP10-1HP-2 **N-71**
GP10 (10,000 PSI) **N-72**
Hydraulic Hoses **N-73**
Accessories **N-74**

LOW PRESSURE HYDRAULIC

ENFORCER™ HIW716ENF
 Impact Wrench **N-75**
HIW-716R1, HIW716VTR1
 Impact Wrenches **N-76**
KOMPRESSOR™ LPHY750XT,
LPHY750CXT **N-77**
HBR40, HBR66 Hydraulic Breakers **N-78**
HTP3, HP3 3" Submersible Pumps **N-79**
HP2HV 2" Submersible Pump **N-79**
HPTR1 Pole Tampers
 and Accessories **N-80**
HHS, HPS Chain Saws **N-81**
HPP18, HPP18-2
 Hydraulic Power Packs **N-82**
HPP5 Hydraulic Power Pack **N-82**
LPHT Accessories **N-83**

KNOCKOUTS

MECHANICAL AND RATCHET

BKOM50125 Knockout Set **N-84**
BKOM152 Knockout Set **N-85**
BKOH2540 Knockout Set **N-86**
BKOW520 Knockout Set **N-87**
BKOR520 Knockout Set **N-88**

HYDRAULIC

BKOS5290 Knockout Set **N-89**
BKOS520 Knockout Set **N-90**
BKOH520A Knockout Set **N-91**
BKOH540A Knockout Set **N-92**

BKOF520 Knockout Set **N-93**
BKOF540 Knockout Set **N-94**

BENDERS

HAND BENDERS

B12E, B34E12R, B1E34R
 Conduit Hand Benders **N-95**

ELECTRIC BENDERS

BEB122 Electric Conduit Bender **N-96**

WIRE MANAGEMENT

THE SMARTCART®

BSC2H 2 Wheel Heavy Duty Cart **N-97**
BSC2L 2 Wheel Light Duty Cart **N-98**
BSCWS40, BSCWS80
 Wall Wire Reel Storage Systems **N-99**

WIRE CADDIES

BWC04EHC Economy Hand Caddy **N-100**
BWC06FHC Folding Wire Caddy **N-100**
BWC01CMC
 Compact Medium Caddy **N-100**
BWC01CDC Compact Caddy **N-100**
BWC46CWD Wire Dispenser **N-101**
BWC01FCMR Folding
 Caddy Mount Reel **N-101**
BWC28FAC Folding A-Frame Caddy **N-101**
BWC01FSMC Folding
 Stud Mount Caddy **N-102**
BWC01FAR Folding Add-On Reel **N-102**
BWC01FFMC Folding
 Floor Mount Caddy **N-102**
BWC46RC 6 Spindle Reel Caddy **N-103**
BWC410RC 10 Spindle Reel Caddy **N-103**
BWC420MSC Multi-Spool Caddy **N-103**
BWC24HTC Hand Truck Caddy **N-104**
BWC24LHTC, BWC00ADP,
BWC27LHTCADP Wire Caddies **N-104**
BWC24MTHTC Wire Caddy **N-104**
BWC00JS Jack Stand **N-105**
BWC20PRSF Portable
 Reel Support Frame **N-105**
BWC32DCC Double Coil Caddy **N-105**
BWC40PC Push Cart Caddy **N-106**
BWC43UC Utility Cart Caddy **N-106**
BWC43TRC Triple Reel Caddy **N-106**

Blue highlighted items are industry standard and most frequently ordered.

INTRODUCTION

INSTALLATION TOOLS

BURNDY's total compression program offers the most complete line of installation tools, mechanical, full cycle ratchet, self contained hydraulic, remote controlled hydraulic, power actuated pumps, hoses and accessories, available to the electrical industry. These tools have been designed to integrate with the complete line of BURNDY® compression connectors. Whether you're a small contractor working with #22 wire or a large utility working with 2500 kcmil conductor, there's a BURNDY® compression tool available to do the job.

The benefits of compression are many, however, probably the most significant benefit is reliability. There's nothing more important to the electrical industry today than reliability. It represents the one area that leads to economical installations that will endure for the life of the installation.

TOOL CENTER

An important element of the BURNDY® compression program is the Tool Center, 150 Burndy Road, Littleton, NH 03561 (800-426-8720). This center provides advice and information on the operation, maintenance and repair of BURNDY® tools. The repair center is staffed with specialized technicians who provide the best possible tool repair service, for all BURNDY® tools, pumps and accessories.

We designed and produced the first self contained hydraulic compression electrical connector installation tool in 1934. In our continuing efforts to provide the highest quality and highest value connection systems, we offer the current BURNDY® tool policy.

LIMITED WARRANTY

The full line of BURNDY® tools are warranted to be free of defects in materials and workmanship for a period of five (5) years from the date of shipment. If inspection by a certified tool technician shows the trouble is caused by defective workmanship or material, BURNDY® will repair (or at our option), replace the tool.

This Warranty does not apply where:

- Repairs or alterations have been made or attempted by others.
- Repairs are required because of normal wear and tear.
- The tool has been abused, misused or improperly maintained.
- The use of any non-BURNDY® products has resulted in damage to the tool.

STANDARD LIMITED WARRANTY AND LIMITATION OF LIABILITY

BURNDY® warrants that the goods and services stated on the face hereof, when furnished to Buyer by BURNDY®, conform with BURNDY's current written specifications and drawings (or with those of the Buyer specifically accepted by BURNDY® in writing), and will be free of defects in materials and workmanship. BURNDY's sole obligation (and Buyer's sole and exclusive remedy) for any breach of warranty under the foregoing warranty shall be to repair (at location designated by BURNDY®) or, at BURNDY's option: To replace FOB the original point of delivery any goods which are non-conforming or defective and are so specified by buyer in a written certified mail notice to an officer of BURNDY® within the applicable warranty period. BURNDY® expressly disclaims any and all express or implied warranties other than the warranty of its title to goods and the warranty hereinabove set forth. Such disclaimer includes, without limitation, warranty of fitness for a particular purpose and warranty of merchantable quality.

Limitation of Liability— BURNDY® will not, under any circumstances, be liable for the cost of removal or reinstallation of goods or the cost of disassembly or reassembly of equipment in connection therewith, or for loss of the use of Buyer's equipment or facilities, or for loss of business or good will or profits, or for cost of inspection or storage, or for any incidental or consequential damages of any nature or description whatever which may arise from BURNDY's sale of goods to Buyer.

REPAIR POLICY

All non-warranty repaired tools are completely reconditioned and receive a limited 1-year warranty. Non-warranty repair returns tools to like new condition at a maximum cost of 40% of a new tool. A nominal service charge of \$5.00 is applied to all repairs to cover shop supplies, oil disposal and other miscellaneous services not covered as part of the standard repair.

If the decision is made not to repair, a handling charge of \$25.00 will be applied plus return freight costs.

RETURN PROCEDURE

All tools sent to the Burndy Tool Center or an authorized repair center must be accompanied by a purchase order with detailed bill to and ship to address authorizing repair. Requests for repair charges before work is done must be stated on the purchase order. All tools sent to the Burndy Tool Center or an authorized repair center as a warranty claim must be accompanied by a proof of purchase such as a BURNDY® invoice or invoice from any BURNDY® distributor.

All tools must be shipped at the owner's expense, prepaid. BURNDY® pays for the return freight, same surface freight as received. Airfreight returns will be returned same way collect for non-warranty repair and prepaid for warranty repairs.

This warranty and repair policy supercedes all previous policies and is in effect January 1, 2005.

Blue highlighted items are industry standard and most frequently ordered.

12-TON U DIES*

BURNDY® Die Sets

Fits Y35, Y39, Y750 Series,
PAT750-18V Series,
PAT46-18V, Y46
(W/PUADP-1 Adapter)

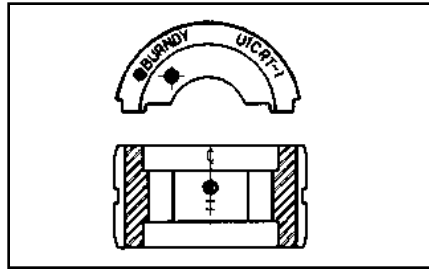

U die case Part# **PT29291**, holds up to 15 dies

	Wire Size	Copper	Aluminum
Small	#8	U8CRT	U8CABT
	#6	U5CRT	U6CABT
	#4	U4CRT	U4CABT
	#3	U3CRT	N/A
	#2	U2CRT	U2CABT
	#1	U1CRT-1	U1CART
	1/0	U25RT	U25ART
	2/0	U26RT	U26ART
	3/0	U27RT	U27ART
	4/0	U28RT	U28ART
	250 kcmil	U29RT	U29ART
	300 kcmil	U30RT	U30ART
	350 kcmil	U31RT	U31ART
	400 kcmil	U32RT	U32ART
500 kcmil	U34RT	U34ART	
535 Flex kcmil	U38XRT	N/A	
600 kcmil	U36RT	U36ART	
750 kcmil	U39RT	U39ART-2	
Large	777 Flex	U44XRT	N/A

* Non-tension U-type 12-ton dies for YA, YS, YA-A, YS-A style connectors.
NOTE: N/A = not applicable.

W DIES

BURNDY® Die Sets

Fits Tools MD6, MD7,
Y500CTHS, PAT600-18V,
PATMD6

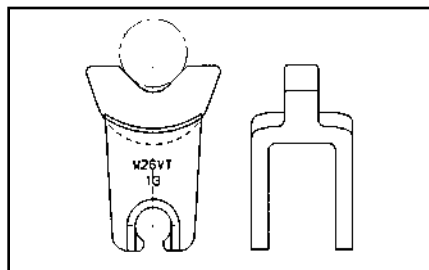

W die case Part# **PT4946**, holds up to 12 dies

	Wire Size	Copper	Copper	Aluminum
Small	#8	W8CVT	W8CRT	X8CART
	#6	W5CVT	W5CRT	W161
	#4	W4CVT	W4CRT	W162
	#3	W3CRT	W3CRT	N/A
	#2	W2CVT	W2CRT	W239
	#1	W1CVT	W1CRT	W163
	1/0	W25VT	W25CRT	W241
	2/0	W26VT	W26CRT	W245
	3/0	W27VT	W27CRT	W166
	4/0	W28VT	W28CRT	W660
	250	*W29VT	W29CRT	N/A
	300	*W30VT	W30CRT	N/A
	350	*W31VT	W31CRT	*W31ART
	400	*W32VT	W32CRT	N/A
450	W33VT	W33CRT	N/A	
500	*W34VT	W34CRT	N/A	
Large	600	**W36RT	W36CRT	N/A

* These sizes (250-500) for Y5000CTHS, MD7-34(R), BAT500, BCT500HS only.
** For PAT600-18V only.
NOTE: N/A = not applicable.
Suitable for use on YA, YS, YA-A, YS-A type non-tension connectors.

Blue highlighted items are industry standard and most frequently ordered.

**UDIEKITCU,
UDIEKITAL,
UDIEKITHYGRD**

BURNDY® U DIE KITS

Each UDIEKITCU and UDIEKITAL die kit includes 15 sets of “U” dies and the PT29291 die case. These stainless steel color coded dies are for crimping BURNDY® YA, YS, YA-A and YS-A type HYLUG™ and HYLINK™ color coded terminals and splices ranging from #6 AWG through 750 kcmil.



The UDIEKITHYGRD kit includes eight die sets. Seven dies sets are used to install the BURNDY® HYGROUND® irreversible compression grounding connectors, and the U2CABT die set for pre-crimping 1/2”, 5/8” and 3/4” ground rods for increased rotational resistance.

BURNDY® “U” dies are used in the Y35, Y39, Y750 series, PAT750-18V series, Y46, and PAT46-18V (with PUADP-1 adapter) tools.

UDIEKITHYGRD Includes	
Catalog Number	
UC	
U0	
U997	
PU998	
U1011	
U1104	
U1105	
U2CABT (Ground rod pre-crimp die)	
PT29291 (Die case)	

UDIEKITCU Includes		UDIEKITAL Includes	
Copper Wire Size	Catalog Number	Aluminum Wire Size	Catalog Number
#6 AWG	U5CRT	#6 AWG	U6CABT
#4 AWG	U4CRT	#4 AWG	U4CABT
#2 AWG	U2CRT	#2 AWG	U2CABT
#1 AWG	U1CRT-1	#1 AWG	U1CART
1/0 AWG	U25RT	1/0 AWG	U25ART
2/0 AWG	U26RT	2/0 AWG	U26ART
3/0 AWG	U27RT	3/0 AWG	U27ART
4/0 AWG	U28RT	4/0 AWG	U28ART
250 kcmil	U29RT	250 kcmil	U29ART
300 kcmil	U30RT	300 kcmil	U30ART
350 kcmil	U31RT	350 kcmil	U31ART
400 kcmil	U32RT	400 kcmil	U32ART
500 kcmil	U34RT	500 kcmil	U34ART
600 kcmil	U36RT	600 kcmil	U36ART
750 kcmil	U39RT	750 kcmil	U39ART-2
Die Case	PT29291	Die Case	PT29291

N-5

Blue highlighted items are industry standard and most frequently ordered.

Y10D

HYTOOL™

Two Tools in One—
#22-10 AWG Nylon Insulated Connectors,
#22-10 AWG Uninsulated Connectors

Hand-held plier type tool that will install #10-22 AWG nylon insulated and uninsulated terminals and splices, with a precision machined wire cutter for aluminum and copper wire in the nose of the tool. Long handles provide greater mechanical advantage. 5-year limited warranty.



SPECIFICATIONS

Length: 9-3/4"
Weight: 13.5 oz.

FOR USE ON

#10-22 AWG Nylon Insulated Terminals

Box Cat. Types	Bulk Cat. Types
TN	YAES
TN-F	YAES-E
YAE-N BOX	YAE-N
YAE-N-F BOX	YAE-N-F
YAE-Z BOX	YAE-Z
YAEV BOX	YAEV

#10-22 AWG Nylon Insulated Splices

Box Cat. Types	Bulk Cat. Types
SN	YSE-HN *
SNM	YSES
YSE-H BOX *	YSE-H *

#10-22 AWG Uninsulated (Bare) Terminals

Box Cat. Types	Bulk Cat. Types
T	YAD
T-F	YAD-F
YAV BOX	YAV
YAV-T-F BOX	YAV-T-F
YAV-H BOX *	YAV-H *
YAV-H-F BOX *	YAV-H-F *
YAV-Z BOX	YAV-Z

#10-22 AWG Uninsulated (Bare) Splices

Box Cat. Types	Bulk Cat. Types
YSV BOX	YSV
YSV-H BOX *	YSV-H *

BENEFITS

- Easy wire cutting with precision machined cutting blade.
- Save time, money and lower installed costs with one tool for both nylon insulated and uninsulated (bare) connectors.
- Easy tool operation out of the carton. No need to break in the tool prior to actual usage.
- A heavy duty forged steel tool, that has a rust resistant finish will provide a long durable life.

BENEFITS (Continued)

- Easier crimping on #22-10 bare and nylon insulated connectors because of the longer handles that provides greater mechanical advantage.*
- Comfort grip handles fit hands comfortably helping make the tool easy to use.
- Terminals and splice connectors are UL listed and CSA certified when installed with the Y10D HYTOOL™.
- 5-year limited warranty.

* Conductor crimp only.

Features

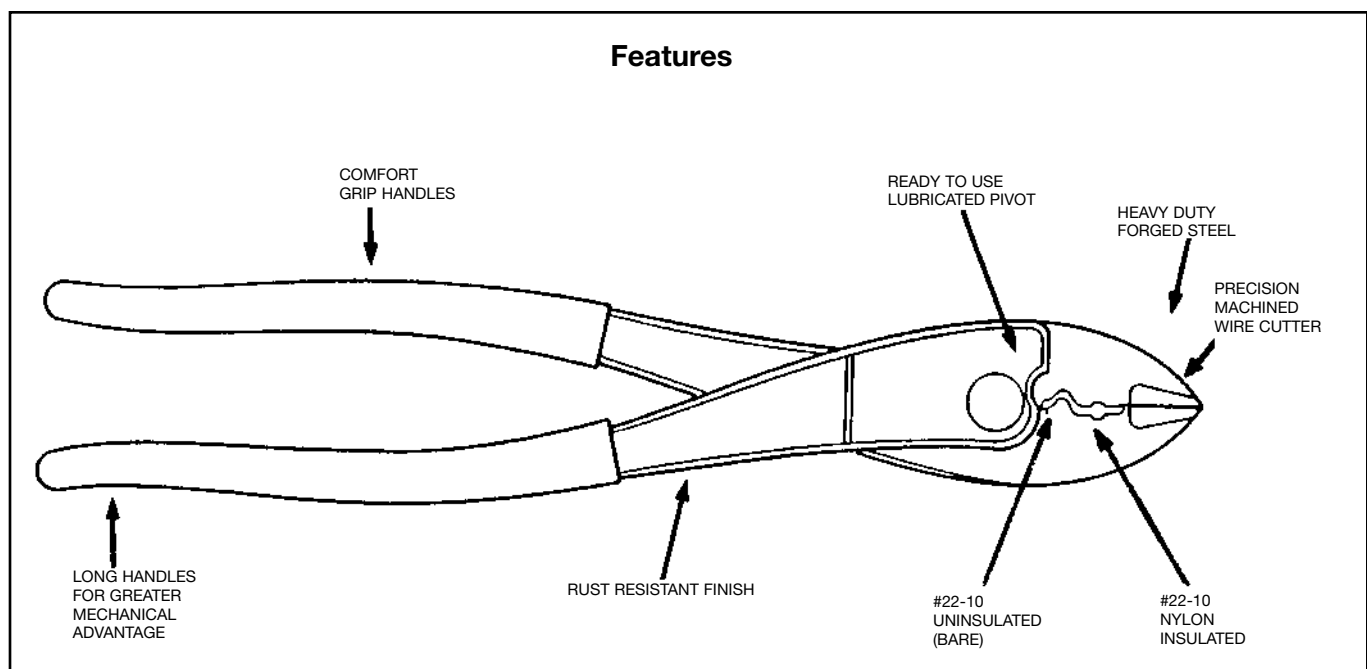

Blue highlighted items are industry standard and most frequently ordered.

Y10-22

HYTOOL™

#22-10 AWG Insulated Connectors,
#22-10 AWG Uninsulated Connectors

Hand-held plier type tool to install #10-22 AWG insulated and uninsulated terminals and splices with a wire cutter in the nose of the tool. Will strip #10-22 AWG wire and cut common size mild steel and non-ferrous screws. 5-year limited warranty.



BENEFITS

- Easy wire cutting with anvil type wire cutter design.
- Crimps full range of insulated terminals and splices #22-10 AWG.
- Cut off dies for common size mild steel and non-ferrous screws.
- Crimps full range of uninsulated terminals and splices #22-10 AWG.
- Full range insulation strippers for wire sizes #22-10. One step stripping.
- Comfort grip handles fit hands comfortably helping make the tool easy to use.
- 5-year limited warranty.

* Conductor crimp only.

SPECIFICATIONS

Length: 8-5/8"
Weight: 11 oz.

FOR USE ON

#10-22 AWG Nylon Insulated Terminals

<u>Box Cat. Types</u>	<u>Bulk Cat. Types</u>
TN	YAES
TN-F	YAES-F
YAE-N BOX	YAE-N
YAE-N-F BOX	YAE-N-F
YAE-Z BOX	YAE-Z
YAEV BOX	YAEV

#10-22 AWG Nylon Insulated Splices

<u>Box Cat. Types</u>	<u>Bulk Cat. Types</u>
SN	YSE-HN *
SNM	YSES
YSE-H BOX	*YSE-H *

#10-22 AWG Vinyl Insulated Terminals

<u>Box Cat. Types</u>	<u>Bulk Cat. Types</u>
TP	BA
TP-F	BA-EF
TP-ZBA-EZ	

#10-22 AWG Vinyl Insulated Splices

<u>Box Cat. Types</u>	<u>Bulk Cat. Types</u>
SP	BS

#10-22 AWG Uninsulated (Bare) Terminals

<u>Box Cat. Types</u>	<u>Bulk Cat. Types</u>
T	YAD
T-F	YAD-F
YAV BOX	YAV
YAV-T-F BOX	YAV-T-F
YAV-H-F BOX *	YAV-H-F *
YAV-Z BOX	YAV-Z

#10-22 AWG Uninsulated (Bare) Splices

<u>Box Cat. Types</u>	<u>Bulk Cat. Types</u>
YSV BOX	YSV
YSV-H BOX *	YSV-H *

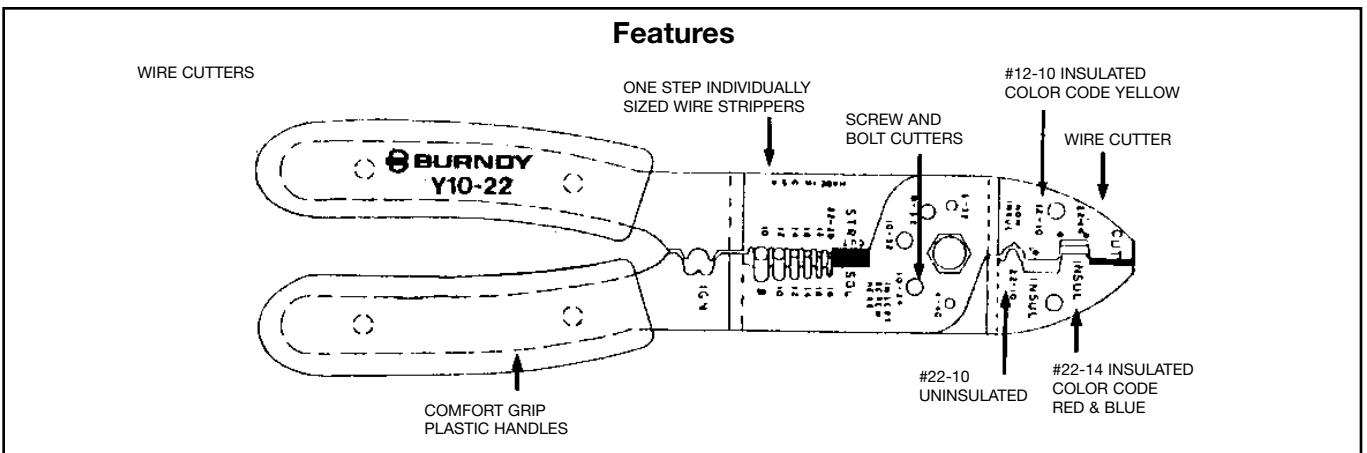

Blue highlighted items are industry standard and most frequently ordered.

YF-TOOL

Installation Ratchet Tool for Bare and Insulated Ferrules

For Use On Copper Ferrules

These tools have been specifically designed to work with both the insulated and uninsulated ferrules type YF. Unless otherwise noted, the tools have a trapezoidal crimp type.

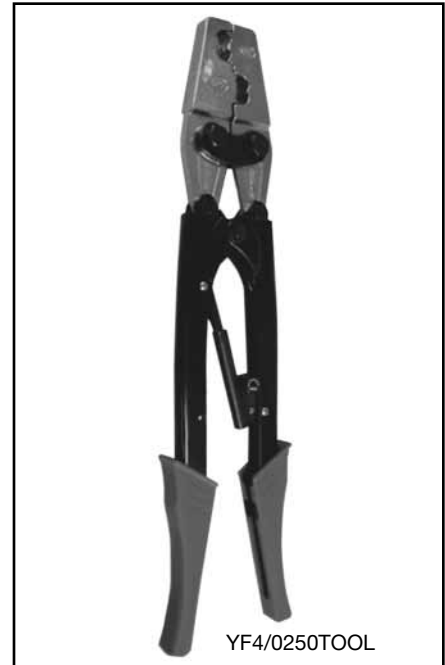

Features and Benefits

- Ergonomic handle design to help ease installer fatigue
- Release mechanism
- Low handle force required

Catalog Number	Capacity	Crimp Profile	Weight	Handle Color
YF3206TOOL	32-6 AWG	Square	1.10 lbs	Black/Orange
YF2610TOOL	26-10 AWG	Trapezoidal	1.02 lbs	Blue
YF2214TOOL	22-14 AWG	Trapezoidal	1.05 lbs	Red
YF2210TOOL	22-10 AWG	Trapezoidal	1.05 lbs	Red
YF1006TOOL	10-6 AWG	Trapezoidal	1.05 lbs	Red
YF0801TOOL	8-1 AWG	Trapezoidal	1.80 lbs	Red
YF0401TOOL	4-1 AWG	Trapezoidal	1.50 lbs	Red/Blue
YF/03/0TOOL	1/0-3/0 kcmil	Trapezoidal	1.80 lbs	Red
YF4/0250TOOL	4/0-250 kcmil	Trapezoidal	1.80 lbs	Red

N-8



YF2214TOOL has one groove to accept 22-14 AWG range.



YF2610TOOL, YF2210TOOL, and YF1006TOOL have multiple grooves for range capacity.

Blue highlighted items are industry standard and most frequently ordered.

Y8MRB-1

HYTOOL™

#22-8 AWG

Hand-held full cycle ratchet tool for #8-22 AWG uninsulated terminals and splices. Full cycle feature builds in reliability and removes the human factor from the finished installation. 5-year limited warranty.

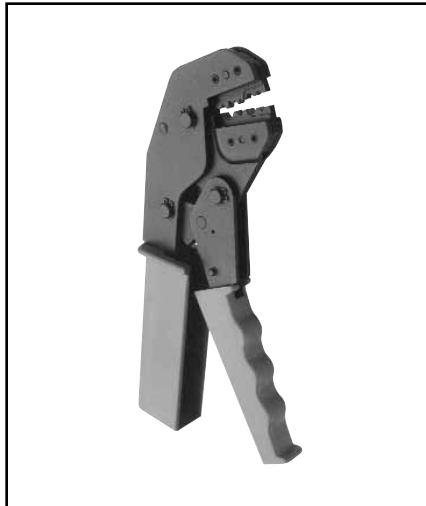

SPECIFICATIONS

Length: 9-1/2"
Weight: 1.21 lbs.

FOR USE ON

BOX CAT. TYPES BULK CAT. TYPES

Uninsulated Terminals

T	YAD
T-F	YAD-F
YAV BOX	YAV
YAV-L BOX	YAV-L
YAV-T-F BOX	YAV-T-F
YAV-Z BOX	YAV-Z

Uninsulated Splices

YSV BOX	YSV
YSV-L BOX	YSV-L

BENEFITS

- One tool to accommodate #22-8 AWG.
- Lightweight.
- Full cycle ratchet for positive crimping.
- Inspection (PG) gauges available to check each groove.

Groove Gauge#

#18	PG395-1
#14	PG396-1
#10	PG397-1
# 8	PG398-1

- Each indenter has its own identifying mark for inspectability.
- Jaw opening orientation, molded finger and palm grips and the easy reach frame minimize user fatigue.

Features

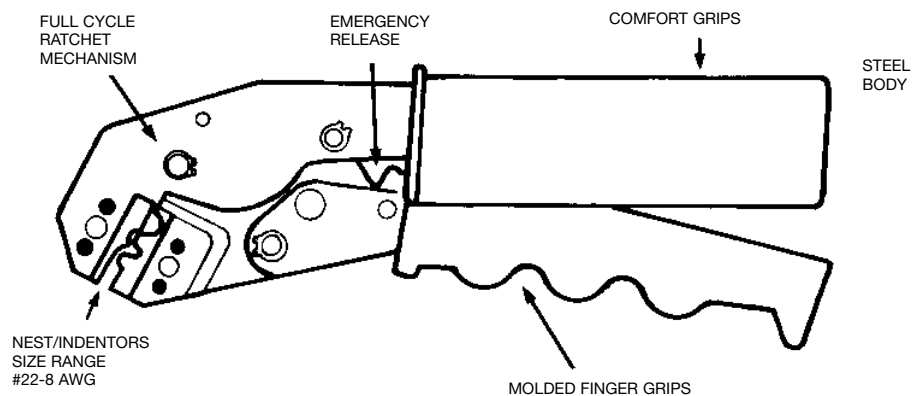

N-9

Blue highlighted items are industry standard and most frequently ordered.

MR8

HYTOOL™

Full Cycle Ratchet Hand Tools

The Type MR8 series HYTOOLS™ incorporate a full cycle ratchet mechanism that provides a complete, positive crimp each time. Once started the ratchet mechanism does not allow the handles to be opened until after the full ratcheting cycle is completed. This provides for a completed crimp before a connector can be removed from the tool. The MR8 series of tools are specifically designed with the ratchet mechanism completely inside the body of the tool without a path to reach and defeat the mechanism. This permits the tools to be used in the most critical applications including nuclear-class 1E terminations, heavy duty industrial, utility generation, OEM, aircraft, and other applications where a dependable electrical termination is needed. 5-year limited warranty.



BENEFITS

- Lightweight aluminum permits easier continuous usage.
- One tool to accommodate #22-10 AWG.
- Easy groove identification with color-coded dies.
- Long life expectancy with fully protected ratchet mechanism.
- Easy one-hand tool operation with long handle length for greater mechanical advantage.
- 5-year limited warranty.

SPECIFICATIONS

Length: 10-1/2"
Weight: 1-1/2 lbs.

FOR USE ON

Tool	AWG Size Range	Connectors	
		Box Catalog Types	Bulk Catalog Types
MR8-1A	#10-22 AN Copper Cable	INSULUG™	YAE
MR8-9Q	#8-18 AN Copper Cable #10-22 AWG Sol. Cable #8-22 Str. AWG Cable	YAV BOX YSV BOX T T-F	YAV, YSV YAD, YAD-F
MR8-33S-1	#10-18	YSE BOX	YSE
MR8-33T-1	MIL-W-5086 Str.	YSE-H BOX	YSE-H
MR8-G96	#14-22	TP	BA
MR8-G98	#10-22	YAV, T	YAD, YAV

Features

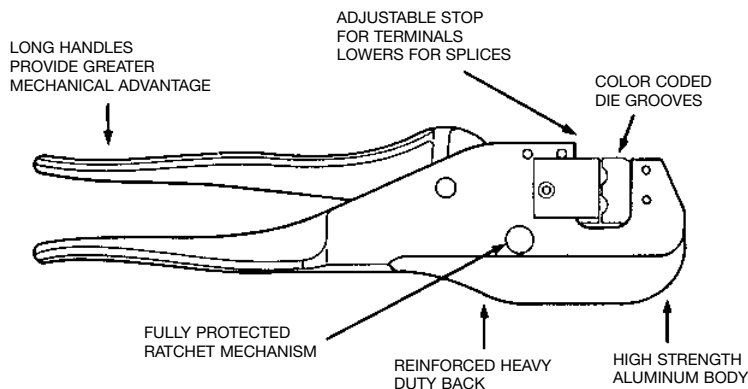

N-10

Blue highlighted items are industry standard and most frequently ordered.

MR15, MR18, MR20

HYTOOL™

Full Cycle Ratchet Hand Tools

The Types MR15, MR18 and MR20 series HYTOOL™ incorporate a full cycle ratchet mechanism that provides a complete, positive crimp each time. Once started the ratchet mechanism does not allow the handles to be opened until after the full ratcheting cycle is completed, unless the user actuates the emergency release lever. This provides for a completed crimp before a connector can be removed from the tool.

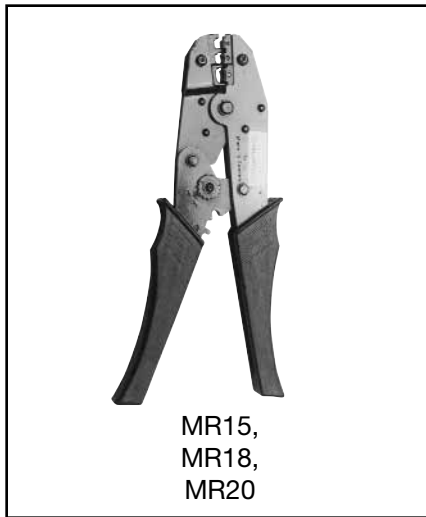

SPECIFICATIONS

- Length:** 8.86"
- Weight:** 1.10 lbs.
- Open:** 5.90"
- Closed:** 2.50"
- Wire Range:** #22-10 AWG

BENEFITS

- UL listed for use with BURNDY® connectors.
- Fully ratcheted tool to assure properly crimped connections.
- Easy groove identification with color coded dies.
- Maximum crimping comfort grips.
- Compact, narrow nose to work in confined areas.
- 5-year limited warranty.

FOR USE ON

MR15 Vinyl Insulated Terminals and Splices (Wire Range 22-10 AWG)

Vinyl Terminals		Vinyl Splices	
TP	BA	SP	BS
TP-F	BA-EF		
TP-Z	BA-EZ		
TP-LF	BA-EL		

MR18 Nylon Insulated Terminals and Splices

Nylon Terminals		Nylon Splices	
TN		SN	
TN-F		SNM	
YAES		YSE-HN	
YAES-F		YSES	

MR20 Uninsulated Terminals and Splices

Terminals		Splices	
T	YAD-F	YSV	
T-F	YAV-H*	YSV-H*	
YAV	YAV-H-F*		
YAD			
YAV-T-F			

*Conductor crimps only.

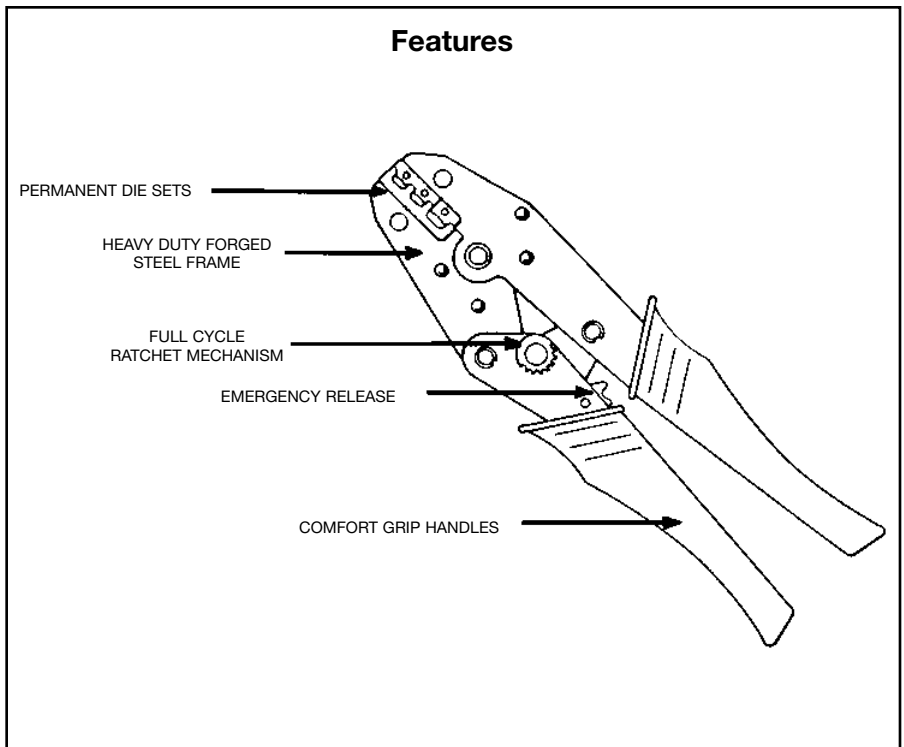

Blue highlighted items are industry standard and most frequently ordered.

MR4C

FULL CYCLE RATCHET HAND TOOL

For #9-4 AWG Uninsulated Terminals and Splices

Hand-held full cycle ratchet tool for #9-4 AWG uninsulated terminals and splices. Full cycle feature builds in reliability and removes the human factor from the completed installation. Long handles provide greater leverage. 5-year limited warranty.



SPECIFICATIONS

Length: 11-3/4"
Weight: 2-1/4 lbs.

FOR USE ON

Terminals	YAV-L YA-L
Splices	YSV YSM YS-L

BENEFITS

- High strength aluminum body.
- Fully protected ratchet mechanism.
- Reinforced heavy duty back.
- Long handles provide greater mechanical advantages.
- Lightweight aluminum permits easier continuous usage.
- One tool to accommodate #9-4 AWG.
- Inspection (PG) gauges available to check each groove.

Groove		Gauge#
9-8	-	PG121-1
6	-	PG125-1
4	-	PG133-1

- Spring loaded indenter jaw holds connector in groove prior to crimping or ratchet engaging.
- 5-year limited warranty.

N-12

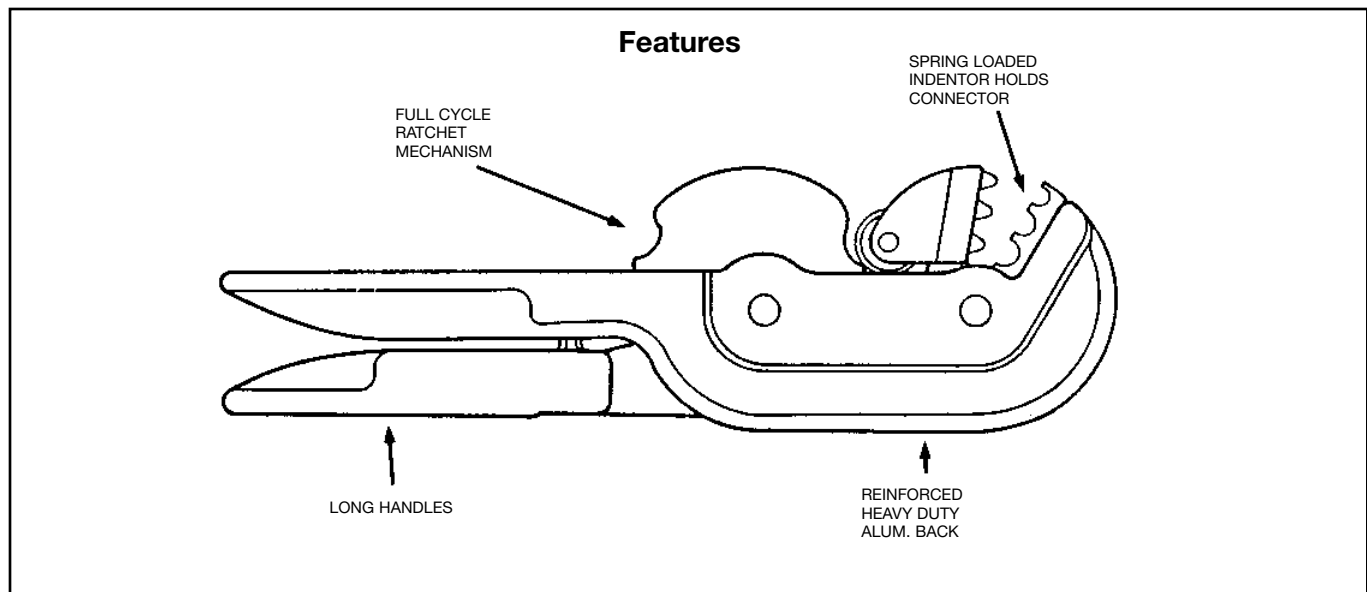

Blue highlighted items are industry standard and most frequently ordered.

Y1MRTC

HYTOOL™

#8 – #1 Copper HYDENT™ Terminals, Splices, and #6 – #6 Thin-Wall C-Taps

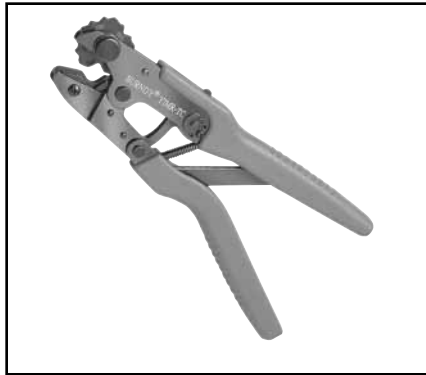

Type Y1MRTC mechanical full cycle ratchet HYTOOL™ will accommodate copper compression HYDENT™ connectors for #8 through #1 code conductor, #8 through #2 Class I flexible strand copper conductor, and #2 solid. The color coded die wheel rotates to provide a proper match of the die and color coded connector. The die index is embossed on the crimped connector for permanent inspectability. A ratchet mechanism assures the tool must complete a full cycle before releasing.

SPECIFICATIONS

- Length:** 9.875"
- Height:** 2.72" (closed)
- Width:** .73"
- Weight:** 1.7 lbs.
- Wire Range:** #8-#1 code conductor, #8-#2 Class I Flex, #2 Solid
Up to #6-#6 (Brown) type "YC-L C-TAP"

BENEFITS

- Rotating die is color coded to match color coded connectors
- Die index embossment allows permanent inspectability of installed connectors to insure consistently reliable and dependable connections.
- Molded comfort grips reduce fatigue during continuous use.
- Ratchet mechanism assures a complete crimp every time.
- Emergency release mechanism allows tool to be removed from connector in case of mistaken die choice or to reposition tool.
- 5-year limited warranty.

FOR USE ON

Cu Lug and Splice Connectors				
Copper Wire Size	Connector Catalog Types	Die Index # (Color)	# of Crimps Per Barrel Length	
			Std	Long
# 8 AWG Code & Flex	YA8C- YS8C- YAV8C- YSV8C-	49 (Red)	1	2
#6 AWG Code	YA6C- YS6C-	7 (Blue)	1	2
#6 AWG Code & Flex	YAV6C- YSV6C-			
#4 AWG Code	YA4C- YS4C-	8 (Grey)	2	4
#4 AWG Code & Flex	YAV4C- YSV4C-			
#3 AWG #2 Sol.	YA3C- YS3C-	9 (White)	2	4
#2 AWG Code	YA2C- YS2C-	10** (Brown)	2	4
#2 AWG Code & Flex	YAV2C- YSV2C-			
#1 AWG Code	YA1C- YS1C-	11** (Green)	2	4

** Die Index 10 (Brown Die) and 11 (Green Die) use the same die wheel crimp groove.

Die Index Number Embossment on Connector after Crimp for inspection verification.

Y1MRTC

Wire Range: #8-#1 AWG Class B, #8-#2 Class I Flex, #2 Solid & #3 Stranded

Y1MRKIT

Kit Contains:
Y1MRTC Full-cycle Ratchet Tool
Sturdy Metal Carrying Case

Terminals:
YA8CL, YA8CL1, YA6CL, YAV6CLTC14FX, YA4CL, YAV4CLTC14FX, YA2CL, YAV2CLTC516FX, YA1CL

Splices:
YS8CL, YS6CL, YS4CL, YS2CL, YS1CL

Y1MRTCKIT

Kit Contains:
Y1MRTC Full-cycle Ratchet Tool
Sturdy Metal Carrying Case

Terminals:
YA8CL2TC14, YA8CL2TC38, YA6C2TC38, YA6CL2TC14, YA6CL2TC14E1, YA6CL2TC14E2, YA6CL2TC38, YAV6CL2TC14E2FX, YAV6CL2TC14FX, YA4CL2TC14, YA4CL2TC38, YA3C2TC38, YA2C2TC38, YA2CL2TC38, YA2CL2TC14

Thin-Wall C-Taps:
YC4L12

Cu C-Tap Connectors				
Catalog Number	Wire Size Cu Str. AWG		Die Index # (Color)	# of Crimps
	Run	Tap		
YC10L12	14	16-14	49 (Red)	1
	12	16-14		
	10	16		
YC8L12	10	10	7 (Blue)	1
	8	12		
YC6L12	8	10-8	8 (Grey)	1
	6	12-10		
YC4L12	6	8-6	10 (Brown)	2
	5,4	12-8		

Blue highlighted items are industry standard and most frequently ordered.

M8ND

HYTOOL™

Full Cycle Ratchet Hand Tool

#8-26 AWG Terminals and Splices

Hand-held full cycle ratchet tool for #8-26 AWG terminals and splices. Full cycle feature builds in reliability and removes the human element from the completed installation. Long handles provide greater leverage. 5-year limited warranty.



SPECIFICATIONS

Length: 10-3/4"
Width: 1-3/4"

FOR USE ON

Terminals

YAD	BA-E
YAD-F	BA-EF
YAE	BA-ES
YAE-F	BA-EZ
YAE-Z	BA-EL
YAES	
YAEV-H	
YAEV-L	
YAV	
YAV-F	
YAV-H	
YAV-H-F	

Splices

YSV	YSM
YSV-H	YRV-L

BENEFITS

- Fully protected ratchet mechanism.
- Reinforced heavy duty back.
- Long handles provide greater mechanical advantages.
- Uses all standard BURNDY® "N" dies.
- Easy groove identification with color-coded dies.
- 5-year limited warranty.

Features

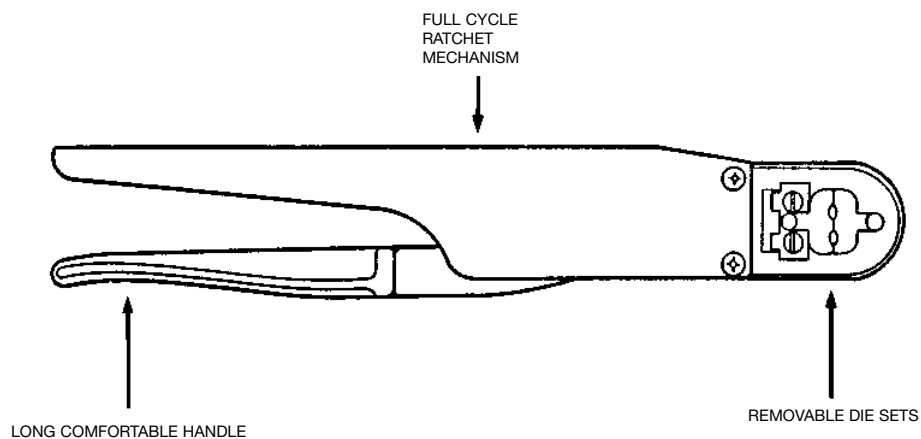

N-14

Blue highlighted items are industry standard and most frequently ordered.

MRC840 AND MRC840AL

HYTOOL™

Hand-Operated Tool

#8 - 4/0 AWG Non-Insulated Copper and Aluminum Terminals and Splices

The MRC840 Mechanical Rotating Crimp tool will accommodate BURNDY® copper compression YA and YS series of HYLUG™ and HYLINK™ terminals and splices from #8 - 4/0 AWG stranded copper conductor. The MRC840AL Mechanical Rotating Crimp tool for Aluminum HYLUG™ and HYLINK™ terminals and splices from #8 - 4/0 AWG aluminum and copper conductors. Butting steel jaws and over center cam action assure full crimp force.

The rotatable die wheel is color-coded and stamped with the conductor size to provide an easy match of the die and color-coded BURNDY® HYDENT™ terminals and splices. YA, YS, YA-A and YS-A series of copper and aluminum terminals and splices are UL Listed when installed with these tools. Each tool comes complete with a 5-year limited warranty.



SPECIFICATIONS

Length: 26"
Height: 8"
Weight: 8-1/4 lbs.

FOR USE ON

- MRC840** #8 - 4/0 AWG Copper Terminals and Splices (YA, YA-L, YS, YS-L)
- MRC840AL** #8 - 4/0 AWG Aluminum Terminals and Splices (YA-A, YS-A)

Features and Benefits

- Comfort grip handles.
 - ◇ Aids in prevention of hand slippage.
 - Reduces fatigue during continuous use.
- Heat treated steel jaws
 - ◇ Reduces jaw buckling and misalignment under heavy loading.
- Approximately 9,000 crimp cycle life.
 - ◇ Lasts longer than imitations and will still be working when others have worn out.
- Multiple grip selections on rotatable die wheels.
 - ◇ No lost dies, 9 position color-coded rotatable die wheels.
- High strength fasteners.
 - ◇ Increase tool life by reducing tool wear.
- Plated jaws.
 - ◇ Provide enhanced corrosion protection.
- Engraved crimp groove (Die index number).
 - ◇ Die index embossment allows permanent inspectability of installed connectors to ensure consistently reliable and dependable connections.

N-15

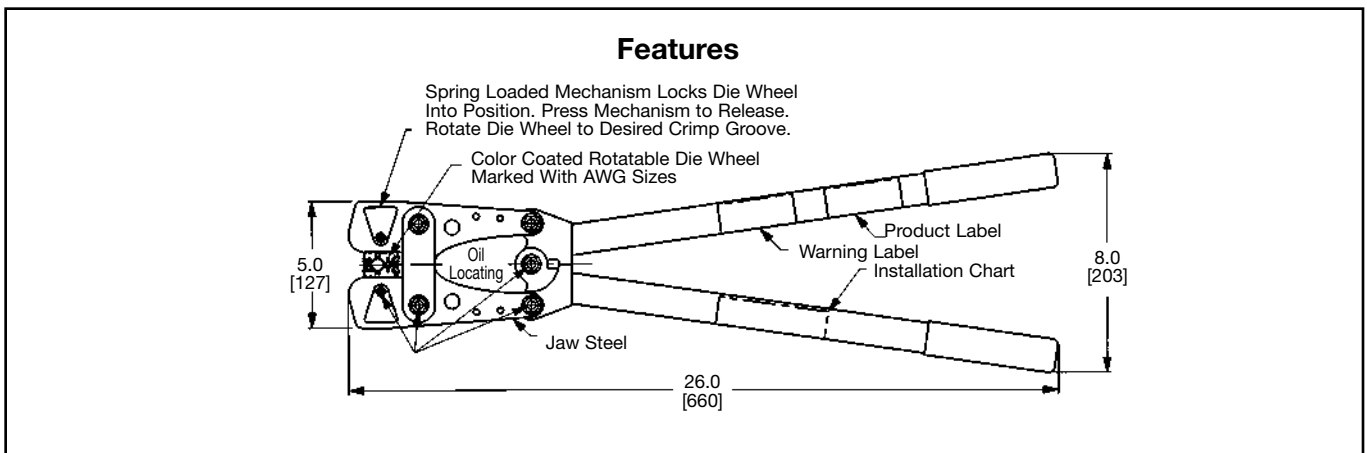

Blue highlighted items are industry standard and most frequently ordered.

MY

DIELESS HYTOOL™

#8 Str. through 250 kcmil Copper,
#8 Str. through 4/0 Str. Aluminum
Conductors

BENEFITS

- Save on capital investment with the type MY HYTOOL™ that accommodates a wide range of connector/conductor combinations from #8 str.-250 kcmil.
- Save time, money, and lower installed cost with the original dieless MY tool design. No separate dies required to purchase or to lose.
- Fast and easy tool setting for the connector/conductor combination simply by aligning the white scribe on the nest die with the wire size on the gauge for proper crimping results.
- Easy to adjust nest die with knurled steel knob and machine threads.
- Quality tool with precision machines indenter, component parts and tool body.
- Fast, medium and high volume crimping is easily accomplished by bench mounting the type MY tool in the BMY-BCH-MT bench mount adapter. A single bolt holds the MY HYTOOL™ securely using the .31 dia. mounting hole in the bench mount adapter.



BENEFITS (Continued)

- High quality rugged tool design manufactured from heavy duty forged steel with strong reinforced back and handles.
- Covered handles available on the MY29-3C, MY29-11C and MY29-3CF HYTOOL™.
- Comfort grip handles for long periods of usage.
- Compression terminals and splices are UL listed and CSA Certified when installed with type MY HYTOOL™.
- 5-year limited warranty.

SPECIFICATIONS

- Length:** 22.65"
- Width:** 8 lbs. approx.
- Depth:** 4.86"
- Width:** 1.12"

Bench Mount Adapter
Cat. No. **BMY-BCH-MT**

FOR USE ON

Tool	Connectors
MY29-3	
MY29-3C	Copper-YA, YA-L, YS-L
MY29-3CF	Aluminum-YA-A, YS-A
MY29-11	Copper-YA, YA-L, YS
MY29-11C	YAV-FX YS-L, YAV-L, YSV-L
MY28	YAV-L, YSV-L
MY28-4	YAV-A-L, YSV-A-L, YAV-A-R
MY28-6	YAE-L, YAEV-RS, YAEV-H, YAEV-RH

ACCESSORIES

BMY-BCH-MT Bench Mount Adapter

MY29 UNIVERSAL KIT Contents:

1 EA	MY29-11
50 EA	YA8CLBOX
50 EA	YAV6CLTC14FX
50 EA	YAV4CLTC516FX
50 EA	YAV2CLTC516FX
50 EA	YAV1CLTC38FX
10 EA	YAV25LTC38FX
10 EA	YAV26LTC516FX
10 EA	YAV27LTC12FX
10 EA	YAV28LTC12FX
10 EA	YA29LBOX
1 EA	CASE

MY29-3	#8 str.-250 kcmil Copper commercial (code) cable
MY29-3C (covered handles)	30 Navy-250 Navy Copper Navy Cable
MY29-3CF (fully covered)	#8 str.-4/0 str. Aluminum commercial (code) cable
MY29 UNIVERSAL KIT	#8 str.-250 kcmil Copper commercial (code) cable
MY29-11	30 Navy-250 Navy Copper Navy cable
MY29-11C (covered handles)	#8 str.-4/0 str. Flexible copper mine machine cable
MY28	#8 str.-4/0 str. Copper aircraft cable
MY28-4	#8 str.-4/0 str. Aluminum aircraft cable
MY28-6 (nylon covered connector)	#8 str.-2/0 str. Copper aircraft cable (flexible)

N-16

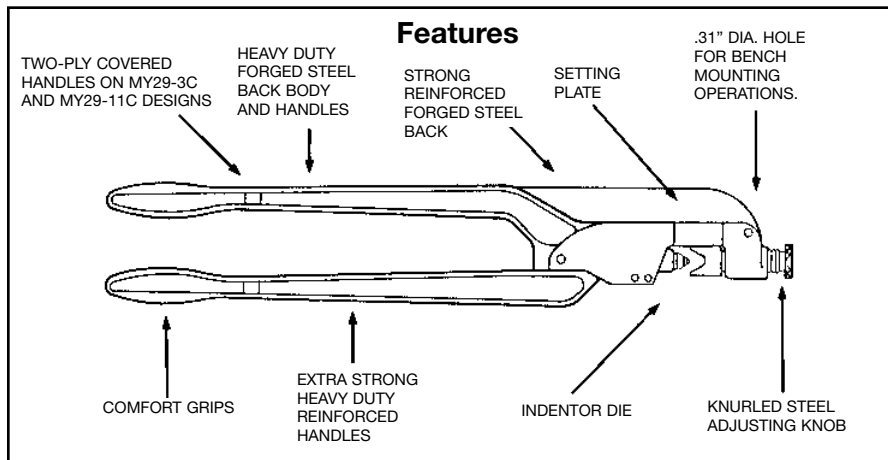

Blue highlighted items are industry standard and most frequently ordered.

OH25

HYTOOL™

**One-Hand Operation,
Dieless, Full Cycle Ratchet Tool**

Installs service entrance splice connectors. Conductor range: #10 through 1/0.

The OH25 incorporates a full cycle ratchet and cam mechanism allowing an easy, one-hand crimping operation. The ratchet mechanism provides for properly completed crimps every time before the tool can be removed from the connection. The OH25 is designed to install 5/8" INSULINK™ and LINKIT™ service entrance connectors with only (1) crimp per connector end, speeding installation time. The single crimp covers the complete contact area, eliminating possible overlapping or failure to make the proper number of crimps. 5-year limited warranty.



SPECIFICATIONS

- Handle force:** 50 lbs. max.
- Max force developed:** 6,000 lbs.
- Weight:** 2 lbs. 11 oz.
- Length:** 12-1/4"

ACCESSORIES

Leather Holster
Cat. No. **PT4583**

No-Go Gauge
Cat. No. **PT8504**

The PT8504 NO-GO Gauge is used to check the OH25 HYTOOL™ crimp dimensions.

FOR USE ON

- 5/8" Service entrance sleeves
- INSULINK™ Type ES (insulated) #10 through 1/0 str.
- LINKIT™ type YSU (bare) #8 through 1/0 str.
- 5/8" neutral tension sleeves HYSPLICE™ types YS-S YCS-R YDS-AT #4 through 1/0.
- AYP HYPLUG™ #6-1/0 str.

BENEFITS

- One crimp speeds installation.
- No dies to lose.
- Long dependable life with forged steel jaws and stainless steel indenter.
- Convenient hole to hang tool.
- Protection of internal parts provides long life.
- Ratchet mechanism provides proper crimp and uniform quality installations.
- Easy one-hand tool operation with spring loaded comfort grip handles.
- Proven reliable with years of dependable service.
- 5-year limited warranty.

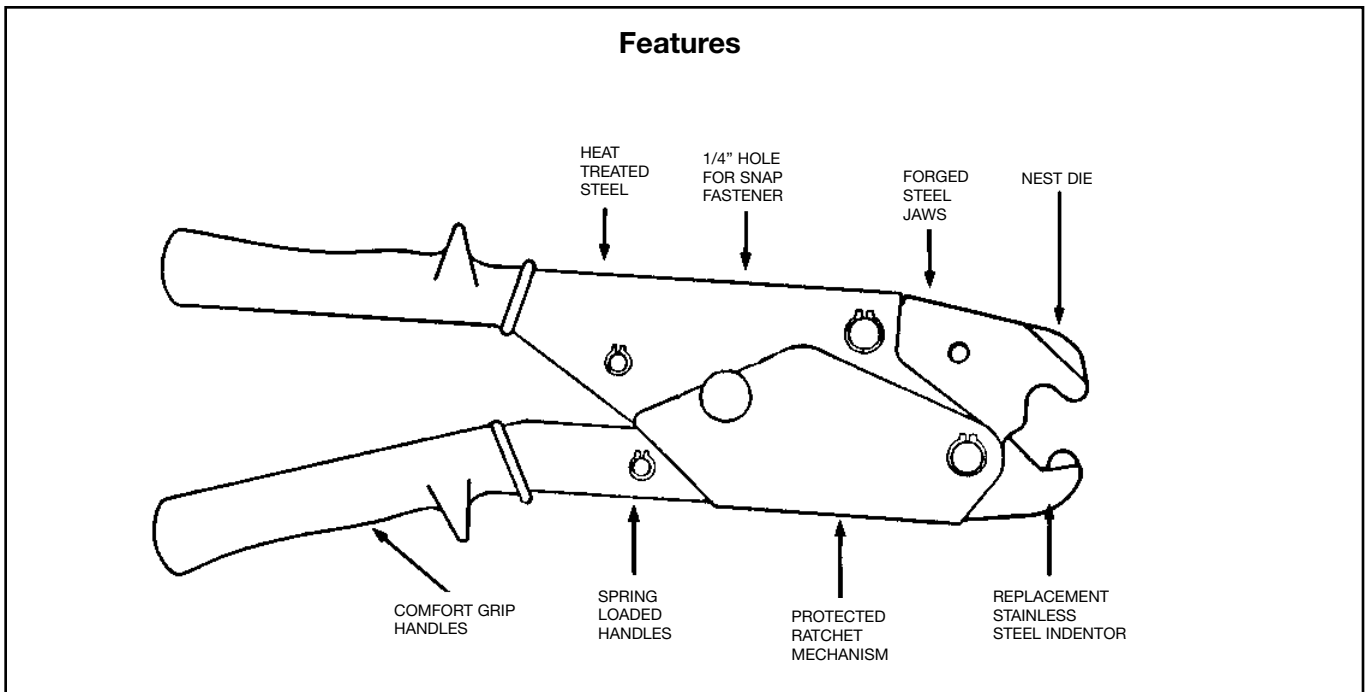

Blue highlighted items are industry standard and most frequently ordered.

OUR840

840 POPPER HYTOOL™

One-Handed Operation,
Overhead/Underground,
Full Cycle Ratchet Tool
Installs a Range of Connectors
(Taps, Splices, Terminals)

The OUR840 incorporates a full cycle ratchet and cam mechanism allowing an easy, one hand crimping action. Designed for low maintenance operation. The OUR840 has a five (5) year warranty. The ratchet mechanism provides for properly completed crimps every time before the tool can be removed from the connection. With nest and indenter dies, it will install 5/8" INSULINK™ and LINKIT™ service entrance connectors with only one (1) crimp per end. With the use of reduced handle force "X" dies, additional splices, taps, and terminals can be properly installed. The die inserts snap into the permanent groove easily with one hand and lock securely in the tool with the spring loaded positive lock die retainer buttons. Tool operation is simple:

- A. Slip the tool over the connector.
- B. The first few strokes grip the connector.
- C. Stroke until automatic tool release signifies a completed compression.

INSTALLATION TOOLING

Conductor (Copper)	Connector (Copper)			Die	OUR-840		
	HYLUG™ Terminal	HYLINK™ Splice	Color Code		Die Index	Std.	(# Crimps) Long
#8 AWG Str.	YA8C-	YS8C-	Red	X8CRT	49	1	2
#6 AWG Str.	YA6C-	YS6C-	Blue	X6CRT	7	1	2
#5 AWG Str.	YA5C-	YS5C-	Blue	X5CRT	7	1	2
#4 AWG Str.	YA4C-	YS4C-	Gray	X4CRT	8	1	2
#2 AWG Str.	YA2C-	YS2C-	Brown	X2CRT	10	1	2
#1 AWG Str.	YA1C-	YS1C-	Green	X1CRT	11	1	2
1/0 AWG Str.	YA25-	YS25-	Pink	X25RT	12	2	4
2/0 AWG Str.	YA26-	YS26-	Black	X26RT	13	2	4
3/0 AWG Str.	YA27-	YS27-	Orange	X27RT	14	3	6
4/0 AWG Str.	YA28-	YS28-	Purple	X28RT	15	3	6
250 kcmil	YA29-	YS29-	Yellow	X29RT	16	4	8

WVT Dies may be substituted

Conductor (Aluminum)	Connector (Aluminum)			Die	OUR-840		
	HYLUG™ Terminal	HYLINK™ Splice	Color Code		Die Index	No. of Crimps	
#8 AWG Str.	YA8CA-	YS8CA-	Blue	X8CART	374	2	
#6 AWG Str.	YA6CA-	YS6CA-	Gray	X6CART	346	2	
#4 AWG Str.	YA4CA-	YS4CA-	Green	X4CART	375	3	
#2 AWG Str.	YA2CA-	YS2CA-	Pink	X2CART	348	4	
#1 AWG Str.	YA1CA-	YS1CA-	Gold	X1CART	471	3	
1/0 AWG Str.	YA25A-	YS25A-	Tan	X25ART	296	4	
2/0 AWG Str.	YA26A-	YS26A-	Olive	X26ART	297	4	
3/0 AWG Str.	YA27A-	YS27A-	Ruby	X27ART	467	4	
4/0 AWG Str.	YA28A-	YS28A-	White	X28ART	298	6	



BENEFITS

- Allows proper crimping of sleeves and terminations in crimping underground applications.
- Proper crimps are assured with butting surface inspection and full cycle ratchet mechanism.
- Uses reduced handle force "X" dies.
- One tool for most service applications.
- Improved service through redesign and improvement of many internal parts.
- Easy visual field check for proper tool adjustment with butting surfaces.
- Easier tool operation is provided with mini strokes and anti-slip grips.
- Nest and indenter dies available.
- W-28K cutter die permits use of OUR840 tool as a cable cutter. Conductor range: #4-4/0 ACSR. Aluminum and Copper.
- UL Listed connections when color coded "X" dies are used on BURNDY® connectors.
- 5-year limited warranty.

SPECIFICATIONS

Max. Crimp Force: 8,000 lbs.
Max Handle Force: 8 lbs. approx.
Weight: 2 lbs. 14 oz.
Length: 13"

FOR USE ON

SELECTED APPLICATIONS

Copper connectors from #8 AWG to 250 kcmil
 Aluminum connectors from #8 AWG to 4/0 AWG

ACCESSORIES

Cat. No. **PT4583** Leather Holster

- Top grain cowhide saddle leather.
- Large grommet. (Order Separately)

OUR840-WC Metal carrying case with die tray.

- Holds one (1) OUR840 and up to eleven (11) "X" dies. Dies not included. (Order Separately) OUR840 DIES

X-Dies Catalog Number	Die Index	Recommended "W" Die Crimp Ratio
XNBG	BG	2*
XBG	BG	2
X161	161	3*
X241	241	2
X245	245	2
X247	247	2
X249	249	2
X660	660	2
X840	840	1
XOH25	-	OH 25 Equiv.

* Overlap crimps

• "W" Dies with a die index listed above are not recommended for the OUR840. Since the standard "W" Dies are wider than the "X" Dies, additional crimps are required depending on the connector and the die index.

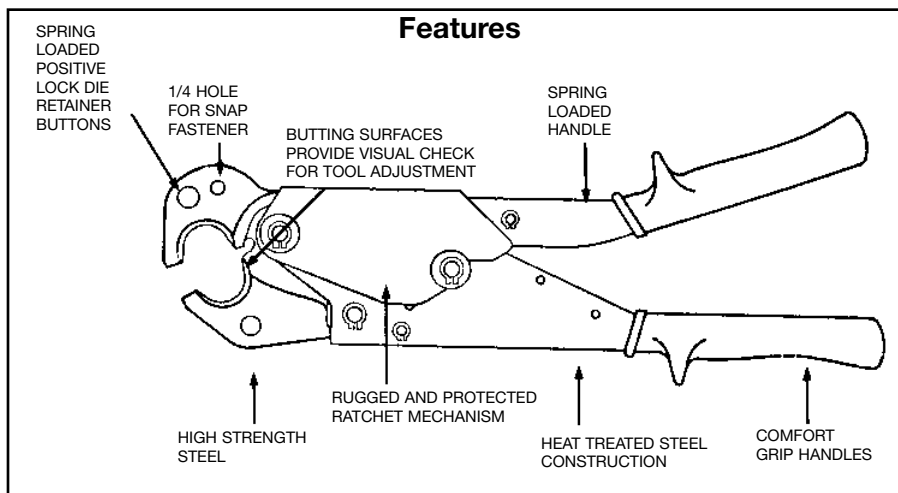

Blue highlighted items are industry standard and most frequently ordered.

MD6-8

HYTOOL™

Hand-Operated Tool

Installs full range of connectors (taps, splices, terminals): #14 through 4/0. Applications: Full Tension and Non-Tension.

The MD6-8 has a five (5) year warranty and is designed to provide over 90,000 reliable crimps installing full-tension and non-tension connectors.

The MD6-8 installs almost all of the line, pole and house connections in the Burndy Compression Connector Program with only one (1) extra die set (W-BG). The tool has two (2) permanent die grooves, “O” and “D₃” for distribution tap connectors. The “D₃” groove also serves as a seat for die inserts to install additional splices, taps and terminal connectors. The die inserts snap into the D₃ groove easily with one hand and lock securely in the tool with the spring loaded positive lock die retainer buttons.

The MD6-K accepts KEARNEY™ type “O” dies and BURNDY® “W” and “X” dies with the KWADP adapter.

KEARNEY™ is a registered trademark of COOPER TECHNOLOGIES COMPANY.

BENEFITS

- Proper crimps are assured with butting steel jaws.
- No additional dies required for “O” and “D₃” size tap connectors.
- Increased strength and greater bearing area is provided with larger steel bolts.
- Fast, easy, one-hand die insertion.
- No lost dies with spring loaded positive lock die retainer buttons.
- Easy visual field check for proper tool adjustment with orange alignment guide lines.
- Over 90,000 crimps provided with Teflon impregnated steel backed bronze bushings.
- Full crimp force assured with over center cam action.
- Easy tool adjustment with allen wrench.
- Operator protection provided with butt stops and heat shrink tubing.
- Long life expectancy provided with select clear hickory handles and lightweight high strength aluminum alloy castings.
- Easier tool operation is provided with bent handles and anti-slip grips.
- The “D₃” groove accommodates the complete line of type “W-” die inserts.
- 5-year limited warranty.



MD6 Tool Variations

- MD6** Standard MD6 with permanent “BG” (5/8”) and “D₃” grooves. Installs CABLELOK CRIMPIT and HYCRIMP™ Tap Connectors with one additional die insert (W-O). All other tool features and connector ranges are the same as the MD6-8 described above.
- MD6-4** Standard MD6 with permanent “BG” (5/8”) and “D₃” grooves and straight fiberglass handles 24” long. Fiberglass rated at 100 kV per foot for 5 minutes.
- MD6-14** Standard MD6 with permanent “BG” (5/8”) and “D₃” grooves and straight fiberglass handles 19” long including bent aluminum grips. Fiberglass rated at 100 kV per foot for 5 minutes.
- MD6-12** Standard MD6-8 jaws with permanent “O” and “D₃” grooves and straight fiberglass handles 24” long. Fiberglass rated at 100 kV per foot for 5 minutes.
- MD6-6** “Snub-Nose” variation of MD6 has a permanent “D₃” groove in jaw. Recommended for use where space for tool jaw is limited.
- MD6-37** Permanent 161, 162, 163, 171 dies in the jaw (J, M&P, T & X).
- MD6-38** Permanent K, BG, C, dies in the jaw.
- MD6-K** “Snub-Nose” permanent KEARNEY™ groove.

SPECIFICATIONS

Crimp Force: 9,000 lbs.
Length: 25-3/8”
Weight: 6 lbs.

Quality Unsurpassed!

Life cycle tested under full operating forces for over 90,000 cycles successfully without adjustment or any parts replacement.

FOR USE ON

- Copper, Aluminum, ACSR, Copperweld, Alumoweld, Steel, 6201, 5005, Compressed and compact conductors.
- Copper Taps: #10 sol.-2/0 str.
- Aluminum, ACSR Taps: #14 sol.-4/0 ACSR
- Stirrups: #6 ACSR-4/0 ACSR
- Overhead Full Tension Deadend, Full Tension Splices, Non Tension Splices, and Terminals Conductor Range: #10 str.-4/0 ACSR.
- Code conductor connectors: #6-4/0 str. Copper and Aluminum

To Check Tool Adjustment

Simply close the tool handles until the jaws initially butt. When the orange alignment grooves are in line, the tool is in correct adjustment.

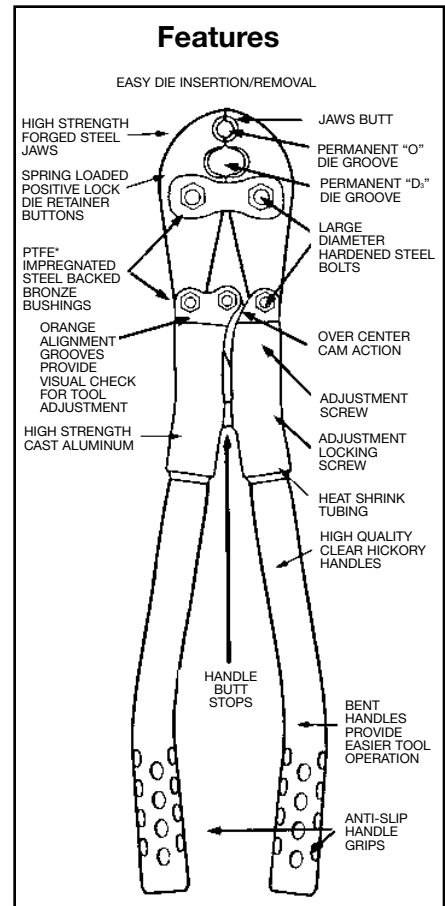

N-19

Blue highlighted items are industry standard and most frequently ordered.

MD7 POSI-PRESS

HYTOOL™

Hand-Operated Tool

The MD7 POSI-PRESS HYTOOL™ is a composite polymer handle installation tool that requires no adjustment for the life of the tool. This assures users of the MD7 tool, that all connections installed with the MD7 POSI-PRESS HYTOOL™ are consistent and reliable over the life of the tool. This new technology tool provides a visual wear indicator that makes verification of the tool's condition easy to determine. Once the tool has worn beyond its useful life, it can be returned to BURNDY's Tool Repair Center for re-fitting at a fraction of the price of a new tool.

Installs full range of connectors, (taps, splices, terminals): #14 Awg through 4/0 AWG.

Applications: Full-Tension and Non-Tension.

The MD7 series of tooling has a five (5) year warranty and is designed to provide over 99,000 reliable crimps installing both full-tension and non-tension connectors.

The MD7-8 POSI-PRESS HYTOOL™ installs almost all of the line, pole, and house connections in the Burndy Compression Connector Program with only one (1) extra die set (W-BG). The MD7-8 tool has two (2) permanent die grooves, "O" and D₃ for distribution tap connectors. For other tool versions, see the MD7 Tool Variations sections below. The "D₃" groove also serves as a seat for die inserts to install splices, taps, and terminal connectors. The die inserts snap into the "D₃" groove easily with only one hand, and lock securely in the tool with the spring loaded, positive lock, die retainer buttons. Handles have been tested at 100 kV per foot for five (5) minutes.



FEATURES

- Ergonomically designed, one-piece, composite polymer handles.
- Comfort grip handles.
- Time-proven steel jaw designs.
- No tool adjustment required.
- 99,000 crimp/cycle life.
- Positive lock, spring loaded die retainer buttons.
- Permanent "D₃" die groove.
- PTFE impregnated steel/bronze bushings and stainless steel pins.
- Electroless nickel plated jaws and jaw links.

BENEFITS

- Easier tool operation due to unique handle design, and anti-slip grips.
- Improves operation by preventing slipping.
- Proper crimps are assured with butting jaws.
- Provides reliable and consistent crimps every time.
- Lasts up to 6 times longer than cheap imitations, and will still be working when others have long since worn out.
- No lost dies and one-hand die insertion.
- Allows use of the complete line of Burndy "W" and "X" die inserts.
- Increases life of tool by reducing tool wear.
- 5-year limited warranty.

SPECIFICATIONS

- Crimp force:** 9,000 lbs.
60 lbs. Handle Force
- Length:** 25"
- Width:** 8" (at handle end)
4-1/2" (at jaw end)
- Width:** 7 lbs.

Unsurpassed Quality that no one else can match!

Life cycle tested under the full range of operating forces for over 99,000 cycles successfully without failure or any parts replacement.

FOR USE ON

- Copper, Aluminum, ACSR, Copperweld, Alumoweld, Steel, 6201 5005.
- Compressed and compact conductors
- Copper Taps: #10 sol. - 2/0 str.
- Aluminum, ACSR Taps: #14 sol. - 4/0 ACSR
- Stirrups: #6 ACSR - 4/0 ACSR
- Overhead Full Tension Deadend, Full Tension Splices, Non Tension Splices, and Terminals Conductor Range: #10 str. - 4/0 ACSR
- Code conductor connectors: #6 - 4/0 str. Copper and Aluminum

MD7 Tool Variations

MD7-8 MD7 with permanent "O" and "D₃" grooves. Installs almost all of the line, pole, and house connections in the Burndy Compression Connector Program with only one (1) extra die set (W-BG).

MD7-6 "Snub-Nose" variation of MD7 has a permanent "D₃" groove jaw. Accepts the full-line of BURNDY® "W" and "X" die inserts. Recommended for use where space for tool jaw is limited.

MD7 Standard MD7 with permanent "BG" (5/8") and "D₃" grooves. Installs Cablelok Crimpit and HYCRIMP™ Tap connectors with one (1) additional die insert (W-O). All other tool features and connector ranges are the same as the MD7-8.

N-20

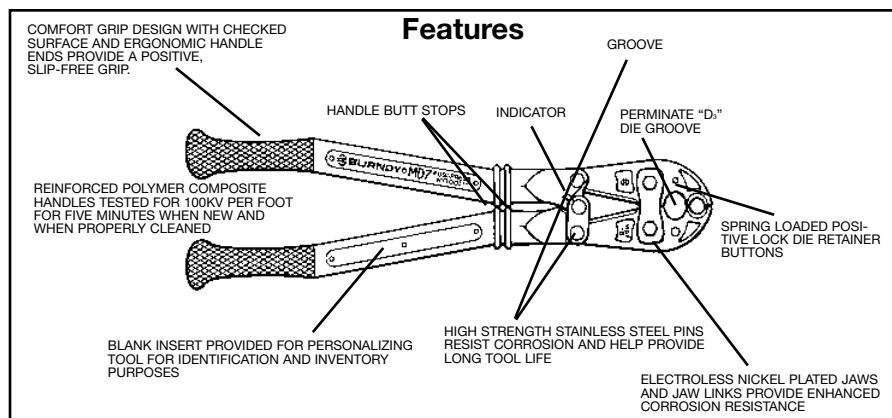

Blue highlighted items are industry standard and most frequently ordered.

MD7-34R POSI-PRESS

HYTOOL™

Hand-Operated Full Cycle Ratchet Tool

The MD7-34R POSI-PRESS HYTOOL™ has a full stroke ratchet that assures the user has cycled the tool completely for a consistent crimp every time. The tool handles are manufactured from a new reinforced composite polymer that requires no adjustment for the life of the tool. This new tool design assures users that all connections installed with the MD7-34R are consistent and reliable over the life of the tool. A visual wear indicator provides easy verification of the tool's condition. An emergency ratchet release allows tool removal in case of mistaken die choice or to reposition tool. The MD7-34R crimps color coded lugs and splices for #8-500 kcmil class B code conductor and #8-350 kcmil Cu Flex conductor. It will also crimp thin wall C-Taps from #12 - 3/0 AWG class B code conductor. The color coded W-VT dies snap into the jaw grooves easily with only one hand and lock securely into the tool with the spring loaded, positive lock, die retainer buttons. The die index number is engraved in the crimping groove to emboss the finished connection. This makes inspection and verification of proper installation an easy process. Due to the one piece handle design, if the tool ever wears beyond it's useful life, it can be returned to BURNDY's Tool Repair Center for refitting at a fraction of the price of a new tool. A rubber covered version, the MD7-34R-C, is available.



FEATURES

- Full Stroke Ratchet Mechanism.
- Ergonomically designed, one piece, composite polymer handles.
- Comfort grip handles.
- Time-proven forged steel jaw designs.
- No tool adjustment required.
- Positive lock, spring loaded die retainer buttons.
- PTFE impregnated steel/bronze bushings and stainless steel pins.
- Color Coded Dies.
- DIE index embossed on finished connection.

SPECIFICATIONS

- Crimp force:** 9,000 lbs.
- Length:** 26"
- Width:** 8" at handles 4-1/2" at jaws
- Jaw Covering:** EPDM Rubber (MD7-34RC).
- Handle Material:** Reinforced composite polymer
- Warranty:** 5 years

MD7-34 Tool Variations

- MD7-34R** - #8-500 Cu HYDENT™, Full Stroke Ratchet
- MD7-34R-KIT1** - MD7-34R, metal carrying case and all dies for #8-500 kcmil Cu HYDENT™ and C-Taps
- MD7-34** - Supplied without the ratchet mechanism
- MD7-34-KIT1** - MD7-34, metal carrying case, and all dies for #8-500 kcmil Cu HYDENT™ and C-Taps for #12 - 3/0 AWG.

FOR USE ON

- Copper Lugs and Splices #8-500 kcmil. Types YA, YA-L, YA-L-TC, YA-L-NT, YS-L, YS, YST, YA-TC
- Copper Lugs and Splices #8-350 kcmil Flex. Types YAV-L-TC-FX, YA-LB, YA-TC-FXB, YSV-L, YAV-L-NT-FX, YAV-L-FX, YAV-FXB
- Copper Battery Lugs #8-350 kcmil Flex. Types YAG-TC-LD
- Thin wall C-taps #12 - 3/0 AWG. Types YC-L

BENEFITS

- Easier tool operation due to unique handle design, and anti-slip grips.
- Grips and handle knobs improve operation by preventing slipping.
- Butting jaws assure proper crimps.
- Wear indicator allows instant inspection of calibration.
- Full cycle ratchet assures complete consistent crimp.
- High grade hardware increases tool life and durability.
- Allows use of complete line of BURNDY® W-VT, W-RT and X-RT series dies.
- Color Coded dies simplify selection of correct connector and die combinations.
- Die index embossment on crimp provides easy inspection and quality assurance.
- 99,000 crimps without needing adjustment.
- 5-year limited warranty.

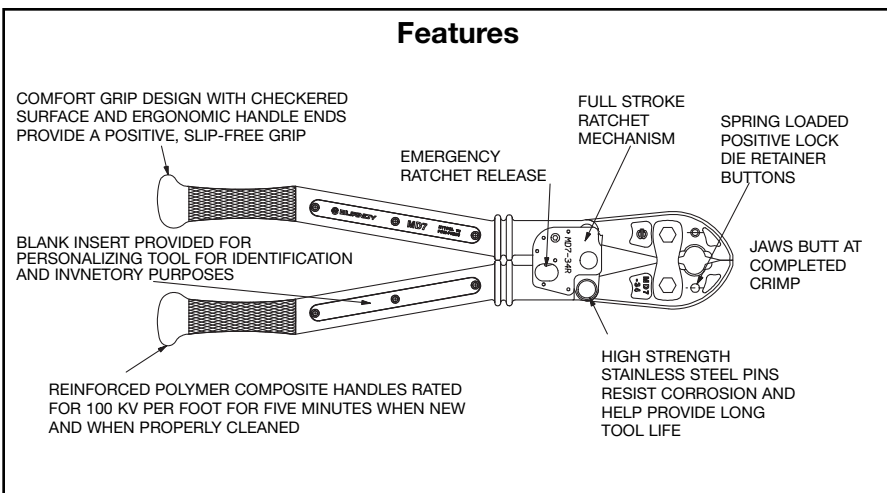

Blue highlighted items are industry standard and most frequently ordered.

MD6/MD7

TOOLING ACCESSORIES

Dies for Special Applications

(See present installation tool index in reference section for complete W-Die listing.)

W-BG

The W-BG die is a double groove die set requiring only one (1) crimp groove on service entrance sleeves and only 1/2 the number of crimps on other 5/8" sleeves.

W-28K

The W-28K cutter die permits use of MD6/MD7 type tools as a cable cutter. Conductor range: 4-4/0 ACSR, Aluminum or Copper.

Protective Jaw Covers



Cat. No. MD6-CP1

The laminated vinyl covers, are provided for the MD6/MD7 HYTOOL™ to avoid damage. Compact in size, the covers snap easily into place over the jaw edges without obstructing vision.

The MD6-CP1 fits all MD6/MD7 tool variations except the Snub-Nose MD6-6/MD7-6 type design. Supplied as a set.



Cat. No. PT6744

The semi-rigid Neoprene cover, a non-conductive material, is provided for the MD6-6 "Snub-Nose" HYTOOL™ to avoid damage. Fits all MD6-6 Snub-Nose variations.

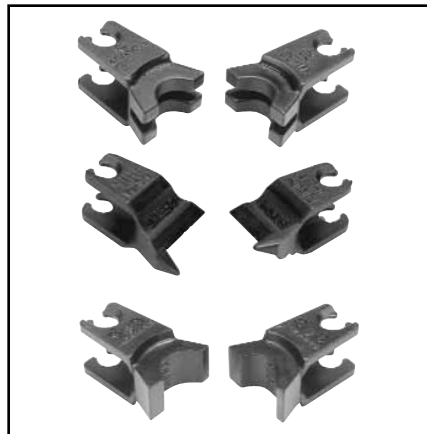

Non-Bowing Dies

Cat. Nos. W-687 and W-702

The Non-Bowing die sets install one-piece, full-tension UNISPLICE™ sleeves on ACSR conductors without bowing.

UNISPLICE™ ONE-PIECE SLEEVES:

W-687 Installs: #4 ACSR 6/1, 7/1-YDS4RL and YDS4RLY
#2 ACSR 6/1-YDS2RL and YDS2RLY

W-702 Installs: #2 ACSR 7/1-YDS021RL and YDS021RLY
1/0 ACSR-YDS25RL and YDS25RLY

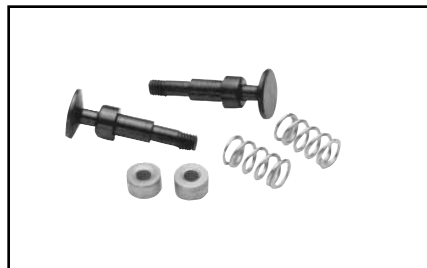

PT4931-1 Die Button Repair Kit



Cat. No. PT4925

Canvas Bag
The PT4925 is a sturdy canvas bag for protecting the MD6/MD7 tools with or without rubber covers plus up to (9) die sets. Dies purchased separately.



Cat. No. CASEWDIES Compact Die Case

Compact die case for (12) "W" or "X" die sets. Dies purchased separately.

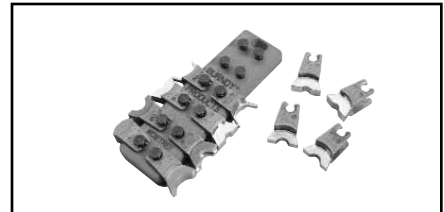

Cat. No. WDIETREE

W Die Holder

This innovative W-Die Holder replaces the standard metal carrying case designed for BURNDY® W-Dies. Its straight forward design allows for easy insertion of the W-Dies onto the holder, providing greater flexibility and secure storage.



Cat. No. PT4952-1 Steel Carrying Case

The PT4952-1 steel carrying case provides storage and protection for the MD6 tools with or without rubber covers plus up to (18) die sets. Tool and die sets not included. Fits MD6, MD6-6, MD6-8, MD6-14, MD6-37, MD6-38, MD7 and MD7-6.



Cat. No. PT6733

Hot-Line Tool Carrying Bag

The PT6733 is a heavy-duty, adjustable canvas bag for the storage and protection of Hot-Line Tools. The bag accommodates 48", 60" and 72" variations of the MD6 and Y35 Hot-Line Tools.

Blue highlighted items are industry standard and most frequently ordered.

MD6R

HYTOOL™

Full-Cycle Ratchet Tool

Installs full range of connectors (Taps, Splices, Terminals): #6 through 4/0 AWG.

Applications: Overhead and underground — full-tension and non-tension. Use MD6-6R2 for code cable terminals and splices through 500 kcmil copper.

The MD6R full-cycle ratchet tool installs all the same connectors using the same “W”-type dies that the MD6 tool installs plus the addition of code cable connectors through 500 kcmil copper.

A maximum handle force of 40 lbs. plus short handle opening and angled head combine to provide an ideal tool for difficult overhead and tight underground applications. 5-year limited warranty.



BENEFITS

- Precise crimping everytime is provided with the ratchet mechanism and automatic release only after five (5) handle strokes.
- Easy tool operation is provided with 40 lbs. maximum handle force reducing possible back strain.
- Convenient operator usage for difficult to reach overhead and tight underground trench applications is provided with the angled head, short handle stroke and minimal handle force requirements.
- Easy handling and insertion is provided with spring loaded handles.
- The D₃ groove accommodates the complete line of “W” die inserts.
- 5-year limited warranty

MD6R Variations:

Cat. No.	Permanent Die Grooves
MD6R	BG (5/8”) and D ₃
MD6-6R	D ₃ Snub-Nose
MD6-6R-2	D ₃ Modified for copper color coded dies #8 through 500 kcmil.
MD6-8R	O and D ₃

Accessories:

Cat. No. **PT4925**
The PT4925 is a heavy-duty canvas carrying bag for the storage and protection of the MD6...R tools. Pockets for dies are included.

Cat. No. **PT17188**
ABS Cover Kit
The PT17188 is the heavy-duty ABS plastic cover kit including (3) piece ABS cover, label and hardware.

SPECIFICATIONS

- Output force:** 12,000 lbs.
- Handle input force:** 40 lbs.
- Number of strokes:** 5
- Weight:** 10 lbs.
- Length:** 24”

FOR USE ON

- Copper, Aluminum, ACSR, Copperweld, Alumoweld, Steel, 6201, 5005, Compressed and compact conductors.
- Copper Taps: #10 sol.- 2/0 str.
- Aluminum, ACSR Taps: #14 sol.- 4/0 ACSR.
- Stirrups: #6 ACSR- 4/0 ACSR.
- Overhead Full Tension Deadends, Full Tension Splices, Non Tension Splices, and Terminals Conductor Range: #10 str.-4/0 ACSR.
- Code conductor connectors: #6-500 kcmil. Copper.

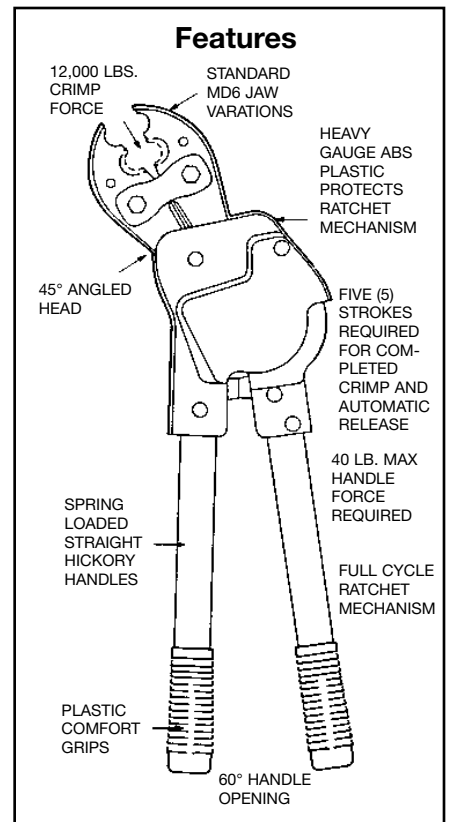

MD6 HOTSTICK TOOLS

The MD6 Type Hotstick tools incorporate either a pantograph toggle action handle or straight handles. They use standard MD6 Type jaws so that they will do everything the standard MD6 will do only they can be used for energized installations. The fiberglass handles are rated at 100 kV/ft for 5 minutes. 5-year limited warranty.



SPECIFICATIONS

Cat. No.	Handle Length	Weight/Lbs.
MD6HS60	60"	15.5
MD6HS72	72"	16.5
MD6-6HS60	60"	15.5
MD6-6HS72	72"	16.5
MD6-8HS60	60"	15.5
MD6-8HS72	72"	16.5
MD6-AH48	48"	13.75
MD6-8AH48	48"	13.75

FOR USE ON

- Copper, Aluminum, ACSR, Copperweld, Alumoweld, Steel, 6201, 5005. Compressed and compact conductors.
- Copper Taps: #10 sol.-2/0 str.
- Aluminum, ACSR Taps: #14 sol.-4/0 ACSR.
- Stirrups: #6 ACSR-4/0 ACSR.
- Overhead Full Tension Deadends, Full Tension Splices, Non Tension Splices, and Terminals Conductor Range: #10 str.- 4/0 ACSR.
- Code conductor connectors: #6 - 4/0 str. Copper and Aluminum.

BENEFITS

- The MD6-HS type Hot-Line Tool incorporates a pantograph, toggle-action design to install connectors with the same handle force as the standard MD6-type tooling.
- All fiberglass handles rated at 100 kV per foot for five minutes.
- Angled head and lightweight makes connector installation easier.
- Supplied with MD6, MD6-6, and MD6-8 jaw variations.
- The MD6-AH type Hot-Line Tool incorporates an angled head to make hard to reach hot-line connections easier.
- Straight 48" fiberglass handles rated at 100 kV per foot for five minutes.
- Supplied in MD6, MD6-6 and MD6-8 jaw variations.
- 5-year limited warranty.

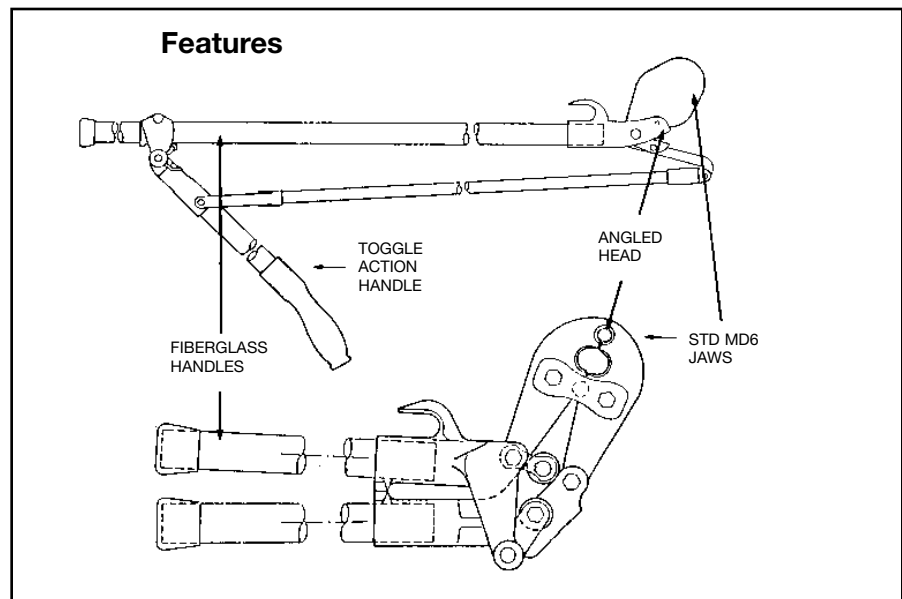

Blue highlighted items are industry standard and most frequently ordered.

RK147-2

**CONSTRUCTION/
MAINTENANCE
WIRE STRIPPERS**

These two lightweight strippers feature precision ground blades that give a precise and rapid strip for small wire applications. The RK190-2 has precise stripping grooves for #10-#20 AWG solid and a copper wire cutting blade. The RK147-2 is an adjustable stripper cutter with a simple cam screw adjustment for multi-varied wire sizes and insulation thickness up to #12 AWG solid or stranded wire. Both tools are part of BURNDY’s convenience package program and are shipped on merchandising rack cards.



RK147-2

Wire Stripping Range: No minimum, up to #12 AWG
Overall Length: 5.31”
Weight: .18 lbs.

WIREFIKE

RK194-2

The wire mike is a useful instrument designed for measuring ACSR, stranded and solid conductors, I.P.S. tubing, rigid and thin-wall conduit, plus inside and outside dimensions of tubing and pipe sizes. A ruler is also included.

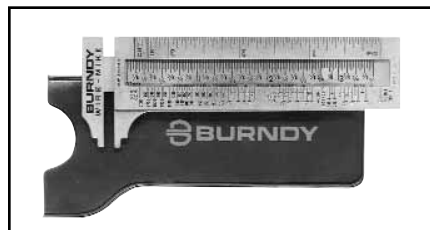

FOR USE ON:

- ACSR: #6 - 336.4 (26/7) str.
- Stranded: #18 str. - 2,000 kcmil
- Solid: #20 sol. - 4/0 sol.
- IPS Tubing (Cu/Al) & Rigid conduit: 1/4” - 2-1/2”
- Tubing sizes: 3-11/8” inside max. 2-15/16” outside max.
- Thinwall conduit: 3/8” - 2-1/2”

BENEFITS:

- Provides quick and easy identification of commonly used conductors (ACSR, stranded and solid AWG).
- Provides quick and easy identification of IPS tubing and rigid conduit.
- Provides quick and easy identification of thinwall conduit.
- Measures I.D. and O.D. of tubing.
- Provides easy conversion of information.
- Strong, durable, long lasting, high quality stainless steel wire mike.
- Convenient size makes it easy to carry.
- Available with your company name and logo. Customer must supply camera ready artwork. Contact BURNDY® for details. Minimum order required.

N-25

Blue highlighted items are industry standard and most frequently ordered.

Y500CT-HS

L'IL CRIMP™

6 Ton Hydraulic Crimp Tool

The BURNDY® Y500CT-HS HYPRESS™ connector installation tool provides 6 U.S. Short tons of force in a compact and easy to use, hand-held hydraulic tool. The Y500CT-HS incorporates a specialized latch style head with a generous working stroke for a wide variety of crimping applications. The specialized head allows interference-free closures on tap connectors up to the BURNDY® YHD-400 size. The head is fitted onto a lightweight tool body with handles that are ergonomically designed to provide slip-free grip and easier crimping. The tool features a patented high speed ram advance mechanism that minimizes crimp cycle time along with an ergonomic trigger drain mechanism that allows the ram to return to the preset position. The tool accommodates all BURNDY® “X”, “W”, and “W-VT” style dies that seat in the permanent “D₃” crimping groove. Installation applications include #6 AWG to 600 kcmil copper lugs and splices, #6 AWG to 350 AWG aluminum lugs and splices, and up to 4/0 aluminum tap connections. The permanent “D₃” groove and 180 degree rotatable head are standard on the Y500CT-HS.

Each Y500CT-HS HYPRESS™ tool uses BURNDY® dies and off-the-shelf connectors that are available worldwide. Your Y500CT-HS HYPRESS™ comes equipped with a durable metal carry case to hold the tool and a multitude of die sets.



Features and Benefits

- Lightweight latch head design.
 - ◇ Provides enhanced clearance for tap connectors.
- 180° head rotation.
 - ◇ Versatile tool head allowing user crimp access into tight spaces.
- Ergonomic handle design.
 - ◇ Easier operation, helping reduce fatigue.
- Audible pressure “pop-off” valve.
 - ◇ Indicates properly completed crimp.
- Permanent “D₃” crimp groove accepts all BURNDY® “W” and “X” dies.
 - ◇ Standard die design with proven performance.
- Durable metal carrying case.
 - ◇ Provides superior protection and stores all accessories.
- High speed ram advance.
 - ◇ Provides faster crimps.
- Handle trigger drain.
 - ◇ Convenient ram retraction.
- 5-year limited warranty.
 - ◇ Customer satisfaction and technical support.

SPECIFICATIONS

- Output Force:** 6 tons (5.4 metric tons)
- Tool Weight:** 7.8 lbs. (3.5 kg)
- Total Strokes:** 7 (w/o connector)
- Height:** 6.0" (152 mm)
- Length:** 17.6" (447 mm)

FOR USE ON

- Copper, Aluminum, ASCR, Steel, Copperweld, Alumoweld, 6201, 5005, Compressed, Compact, Stranded & Solid conductors
- Installs splices, taps, or terminations:
 - #8 - 600 kcmil Copper Str.
 - #8 - 350 kcmil Flex
 - #8 - 350 AWG Aluminum



RANGE TAKING DIES

- WDC4500:** #4-500 Cu Str.
#2-4/0 Cu Flex
UL and CSA for use on YA and YS series.
Also for use on YAV and YSV series.
- WDA8300:** #8-300 Al
#6-400 Cu Str.
#2-4/0 Cu Flex
UL and CSA for use on YA, YS, YA-A, and YS-A series. Also for use on YAV and YSV series.

N-26

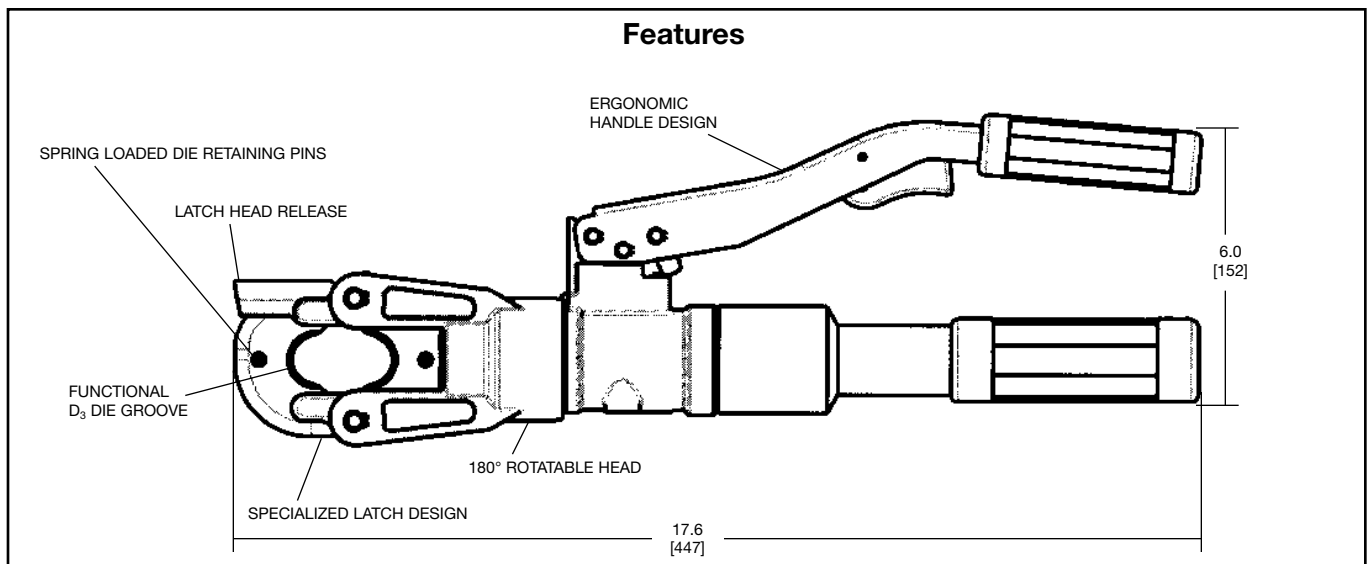

Blue highlighted items are industry standard and most frequently ordered.

Y35 AND Y35-2

HYPRESS™

Hand-Operated Hydraulic Tool

The Y35 HYPRESS™ Tool incorporates a C-shaped, rotatable head for overhead line work and compression grounding applications. The hook style head with extensive ram travel provides for easy tapping and splicing of overhead lines as well as HYGROUND® compression grounding systems.

The Y35-2 HYPRESS™ head, body and handles are covered with 3/16" rubber for tool impact protection.

Order the hot-line handle assembly, "U" dies and accessories separately. 5-year limited warranty.



SPECIFICATIONS

	Y35	Y35-2
Force developed:	12 tons	12 tons
Operating pressure:	10,000 psi	10,000 psi
Weight (less case):	13 lbs.	13-1/2 lbs.
Overall length:	23-1/4"	24"
Head width:	4-3/4"	6"
Molded Covering:	Body & Handles	Head, Body and Handles

FOR USE ON

Copper #8 str.-500 kcmil Code Cables	Terminals-grounding YGH, YGHA, YGF Splices-grounding YGS, YGHS
Copper #8 str.-kcmil and up to 3/4" ground rod	Taps-grounding YGHC-C, YGHP-C YGHR-C
Copper #8 str.-750 kcmil Code Cables N30-N500 Navy Cables Flexible and Extra Flex	Terminals Uninsulated YA, YA-2N, YA-L, YA-LB YA-2LN Terminals Insulated YAEV-L Box, YAEV-L YAEV-H, YAEV-RS, YAEV-RH Splices To Size 400 kcmil YS, YS-T, YS-L YS-LB, YSV-L Box YSV-L, YSM
Aluminum #8 str.-750 kcmil Code Cables	Terminals YA-A AYP, AYPO Splices To Size 350 kcmil YSA, YRB, YS-AT
ACSR	See Burndy Overhead Transmission and Distribution Catalog Module

BENEFITS

- Compact "C" shaped head allows easy placement and removal from continuous conductor lengths.
- Easy to position tool for work with 180° head rotation.
- Versatile and economical-tool works with all commonly used copper, aluminum and ACSR conductors from #6 str. to #556.5 26/7 stranding.
- Body and handles covered with 3/16" molded rubber for tool impact protection.
- Easy die change accomplished with push button die locks.
- Quality assurance is provided with automatic 10,000 PSI blow-off pressure release valve for positive crimping.

BENEFITS (Continued)

- Rapid ram advance reduces installation time by eliminating need to pump handles to advance ram to connector.
- Saves installation time with trigger controlled return release which returns ram to its preset starting point.
- Long continuous usage is aided with comfort grip handles.
- Compression terminal and splice connectors are UL Listed and CSA Certified when installed with recommended die set.
- 5-year limited warranty.

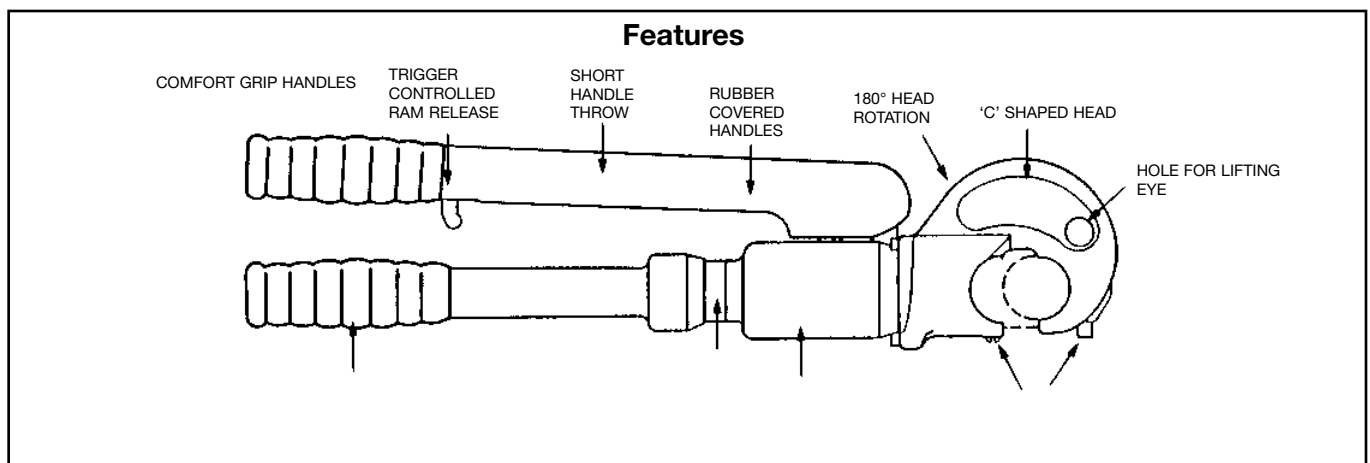

Blue highlighted items are industry standard and most frequently ordered.

Y35 SERIES ACCESSORIES



PT 29279-2

Force Test Gauge

The PT 29279-2 Force Test Gauge is designed to provide an accurate visual reading of the output force produced by the hand-hydraulic Y35, Y35-2, Y39 and Y750 HYPRESS™ tools. It is not recommended for any remote powered HYPRESS™ heads such as the Y35BH. The PT 29279-2 Force Test Gauge is factory calibrated and inspected to very stringent tolerances providing the customer accuracy and an excellent means for quality assurance control. Supplied with padded storage case.

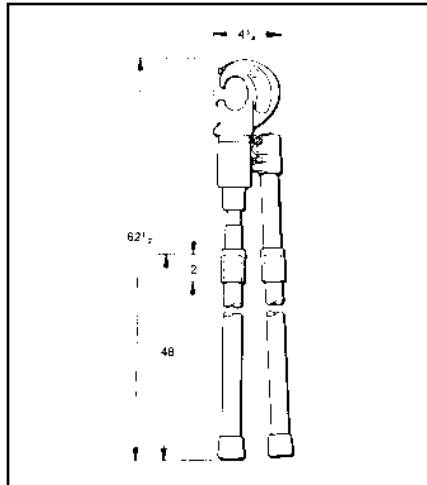

Cat. No. HH5-RL48

Hot-Line Handle Assembly

The HH5-RL48 is a 48" long fiberglass handle assembly that easily attaches to a standard Y35 HYPRESS™ tool. Rotation of the handles controls the rapid ram advance and release mechanisms. The handles are rated at 100KV per foot for five minutes. The Catalog Number does not include the Y35.

For factory assembled unit order Catalog Number **Y35-16**.



Cat. No. PT29291

Die Case

Steel case designed for storage and protection of "U" dies used with the Y35 and other BURNDY® tools. Holds 15 die sets. Length 9 1/2", width 6", height 1-1/2". Dies sold separately.

Y34A Indentor Adaptor:

To use Y34A indentors in a Y35, Y39, or Y750 tool.

Cat. No. **Y35P3**

Seal Repair Kit:

Cat. No. **Y35/Y39 REP KIT A**

Steel Carrying Case

Cat. No. **PT2972** for Y35

Cat. No. **PT29360** for Y35-2

BENEFITS

N-28

- Easy to read
- Provides means for quality assurance control.
- Blank (test) "U" dies are provided for testing procedure.
- Tool output force is applied to load cell for visual read out of the resulting force on the dial.
- The blank (test) "U" set is included with the Force Test Gauge.
- An easy to read operating and maintenance manual is included.



Cat. No. PT6733

Hot-Line Tool (Heavy-Duty) Carrying Bag

The PT6733 is a heavy-duty, adjustable canvas bag for the storage and protection of hot-line tools. The bag accommodates 48" through 72" variations of the Y35 and MD6 hot-line tools.

Blue highlighted items are industry standard and most frequently ordered.

Y39

HYPRESS™

Hand-Operated Hydraulic Tool

The versatile, lightweight Y39 weighs 13 lbs., and its small 3-1/8" wide head rotates 180° for convenience and flexibility. The tool provides 12 tons of crimping power, while its built-in overload valve automatically releases pressure when the crimp is completed.

The Y39 is designed for easy die insertion and removal without ball checks or set screws. Its rapid ram advance and trigger-controlled release eliminate unnecessary pumping after every crimp. 5-year limited warranty.



SPECIFICATIONS

- Force developed:** 12 tons
- Operating force:** 10,000 PSI
- Weight - less case:** 12 lbs.
- Overall length:** 23"
- Max. head width:** 3-1/8"
- Die accommodation:** U-dies

FOR USE ON

Copper

- #6 AWG -750 kcmil str. Code Cable
- N30 - N650 Navy Cable
- Flexible and Extra Flexible
- Terminals -Uninsulated
- YA, YA-L, YA-LB, YGH, YGHA
- Splices & Tees - Uninsulated
- YS, YS-L, YS-LB, YS-T, YSP-T, YST

Copper- AN or AIR

- #6 AWG-#4/0 str. Code Cable
- AN6-AN #4/0 Aircraft Cable
- Flexible and Extra Flexible
- Terminals - Uninsulated
- YAV-L Box, YAV-L, YAV-Rs Box, YAV-RS
- Splices - Uninsulated
- YSV-L Box, YSV-L

Copper-Insulated Terminals

- #8 AWG - #2/0 str. Code Cable
- AN8 - AN #2/0 Aircraft Cable
- Flexible and Extra Flexible
- Terminals-Insulated
- YAEV- L Box, YAEV- L, YAEV- RS Box, YAEV- RS, YAEV-RH

Copper-Taps

- #12 AWG Solid-250 kcmil
- Taps -YC-C, YGHC -C, YGHP -C, YGHR -C

Aluminum

- #8 AWG-750 kcmil str. Code Cable
- Terminals-YA-A
- Splices-YS-A, YS-AT, YRB

Aluminum

- #6 str.-500 kcmil
- Taps -YFD, YFN, YFO

BENEFITS

- Easy to work in small tight spaces with only a 3-1/8" wide compression head and short handle throw.
- Easy to position tool for work with 180° head rotation.
- Versatile and economical-tool works on all commonly used copper and aluminum conductors from #6 str. to 750 kcmil.
- Body and handles covered with 3/16" rubber.
- Easy to locate and hold dies in position with the positive push button die locks plus die changing is accomplished easily without ball checks or set screws.
- Easy to remove or lock into position die holder with recessed spring latch plus leather strap to prevent loss.

BENEFITS (Continued)

- Quality assurance is provided with automatic 10,000 psi "blow off" pressure release valve for positive crimping.
- Rapid ram advance eliminates requirement for pumping handles to advance ram to connector.
- Trigger release allows ram to return to preset position.
- Long continuous usage is aided with comfort grip handles.
- Compression terminal, tap and splice connectors are UL Listed and CSA Certified when installed with the Y39 tool and recommended die set.
- 5-year limited warranty.

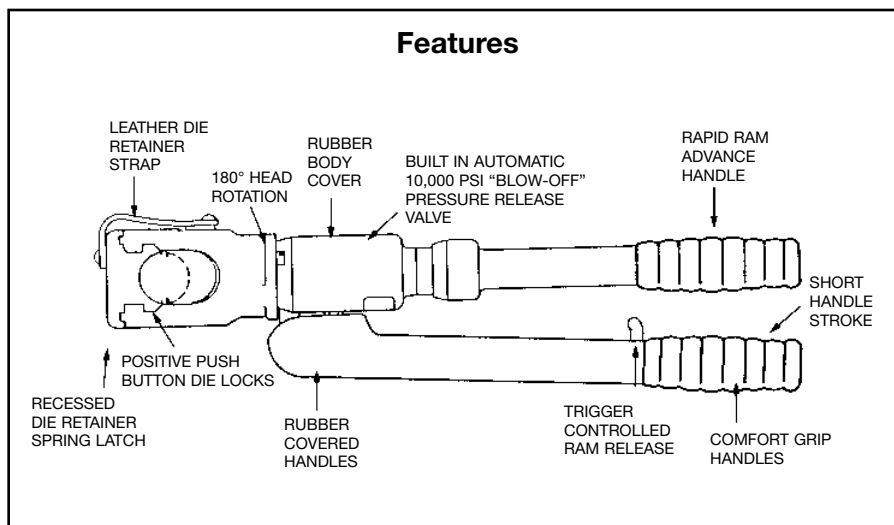

Blue highlighted items are industry standard and most frequently ordered.

Y750HSXT AND Y750CHSXT RUBBER COVERED HEAD

750 REVOLVER HYPRESS™

Hydraulic Hand Operated Tool—12 Ton Crimp Force

Conductor Range:
#14 - 750 kcmil Cu/Al
#4 - 556.5 kcmil ACSR

The BURNDY® Y750HSXT Series HYPRESS™ is a wide mouth (1.65") hand operated hydraulic 12 ton crimping tool for use on virtually all compression applications. The C-shaped head rotates 355° relative to the handle and is mated to a patented rapid advance pump. The Y750HSXT provides easy tapping, splicing, and terminating of overhead lines, the full line of HYGROUNDO® compression grounding connectors, NEC cable connections, and N30 - N650 Navy cable connections.

The Y750HSXT accepts all BURNDY® "U" dies for use on conductor ranges of #14 - 750 kcmil AL/CU and #4 - 556.5 kcmil ACSR conductors.

The Y750CHSXT HYPRESS™ has a rubber-covered head and handles for tool impact protection.

Each Y750HSXT uses standard BURNDY® dies and off-the-shelf connectors available world-wide. Supplied with a durable high impact formed carrying case to hold the tool, and die compartment to hold "U" die sets. (Dies sold separately.) All BURNDY® Y750HSXT series tools are provided with a 5-year limited warranty.



BENEFITS

- Covers a wide range of applications with a lightweight, self-contained system and provides easy tool removal from continuous conductors with its C-shaped head.
- Easy tool positioning with its 355° head rotation.
- Patented rapid advance pump for faster crimps.
- Exposed positive die lock buttons for easy die change out and die retention.
- Handle trigger drain for convenient ram retraction.
- Quality assurance is provided with an audible "Pop-Off" pressure relief valve.
- Comfort grip handles help ease operator fatigue with continuous use.
- Long life expectancy from the company that provided the industry with the first self-contained hydraulic tool in 1934.
- Rubber covered head and handles on Y750CHSXT for tool impact protection.
- Supplied with high impact plastic carrying case.
- 5-year limited warranty.

SPECIFICATIONS

Force developed: 12 tons
Weight: 14.5 lbs. (6.6 kg)
Length: 23.96" (608 mm)
Height: 2.86" (78 mm)
Width: 8.71" (222 mm)
Jaw opening: 1.65" (42 mm)

FOR USE ON

- Tension Sleeves
 - Copper #8 sol. - 500 kcmil
 - Aluminum #8 sol. - 556.5 kcmil
 - ACSR #4 - 556.5 kcmil
- Taps
 - Copper #14 sol. - 500 kcmil
 - Aluminum #8 - 500 kcmil
- Aerial Cable
 - Copper #6 - 500 kcmil
- Terminals & Splices
 - Aluminum #8 - 750 kcmil
 - Copper #8 - 750 kcmil
 - ACSR #4 - 556 kcmil
- HYGROUNDO® (Compression Grounding)
 - Copper #8 - 500 kcmil (cable/ground rod)
 - Ground Rods 1/2" - 1" Diameter

ACCESSORIES:

Cat. No.	Description
Y750HSCASE	Plastic Carrying Case for Y750HSXT or Y750CHSXT.
PT29279-2	Force test gauge for accurate visual reading of output force.
PT29291	Die Case Steel case for storage and protection of "U" dies.
WIREMIKE	Provides quick and easy identification of commonly used conductors.

N-30

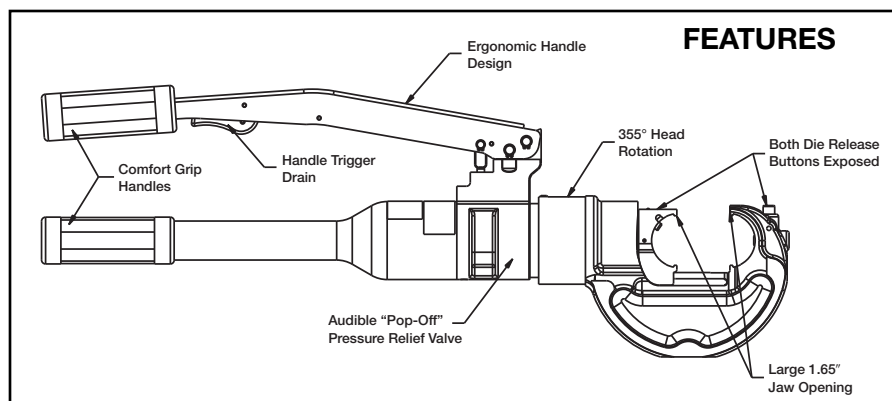

Blue highlighted items are industry standard and most frequently ordered.

**Y644HSXT
DIELESS HYPRESS™**

**THE “1” CRIMP RANGE
TAKING TOOL**

Hydraulic Hand Operated Tool—
11 Ton Crimp Force

#6 - 1000 kcmil Copper
HYLUG™ Terminals and
HYLINK™ Splices

#6 - 750 kcmil Aluminum
HYLUG™ Terminals and
HYLINK™ Splices

The Y644HSXT dieless HYPRESS™ is a hand operated 11 ton hydraulic crimping tool. Only 1 crimp is required for each wire termination for both long and standard length barrels on HYLUG™ terminals and HYLINK™ splices.

The Y644HSXT has a latch style head which provides easy tool removal from continuous conductor runs. The head rotates 355° relative to the handles and is mated to a patented rapid advance pump. The Y644HSXT weighs only 15 pounds and delivers 11 tons of crimping force. The result is easy terminating and splicing using BURNDY® HYLUG™ and HYLINK™ terminals and splices.

Y644HSXT Dieless HYPRESS™ Range Taking Capabilities. The following size HYDENT™ lugs and two way splices, when crimped with the Y644HSXT Dieless HYPRESS™ Tool, produce the following UL Listed range taking capabilities.

Aluminum Connectors		Copper Connectors	
Standard Wire Size	Expanded Wire Range	Standard Wire Size	Expanded Wire Range
#6 AWG	#6 AWG	#6 AWG	#6 AWG
#5 AWG	#5-#6 AWG	#5 AWG	#5-#6 AWG
#4 AWG	#4-#6 AWG	#4 AWG	#4-#6 AWG
#3 AWG	#3-#6 AWG	#3 AWG	#3-#6 AWG
#2 AWG	#2-#6 AWG	#2 AWG	#2-#6 AWG
#1 AWG	#1-#2 AWG	#1 AWG	#1-#6 AWG
1/0 AWG	1/0-#1 AWG	1/0 AWG	1/0-#6 AWG
2/0 AWG	2/0-#1 AWG	2/0 AWG	2/0-#4 AWG
3/0 AWG	3/0-#1 AWG	3/0 AWG	3/0-#2 AWG
4/0 AWG	4/0-#1 AWG	4/0 AWG	4/0-#1 AWG
250 kcmil	250-1/0 AWG	250 kcmil	250-1/0
300 kcmil	300-2/0 AWG	300 kcmil	300-2/0
350 kcmil	350-3/0 AWG	350 kcmil	350-3/0
400 kcmil	400-4/0 AWG	400 kcmil	400-4/0
500 kcmil	500-4/0 AWG	500 kcmil	500-4/0
600 kcmil	600-250 kcmil	600 kcmil	600-250
750 kcmil	750-500 kcmil	750 kcmil	750-500
		800 kcmil	800-500
		1000 kcmil	1000-750

Blue highlighted items are industry standard and most frequently ordered.

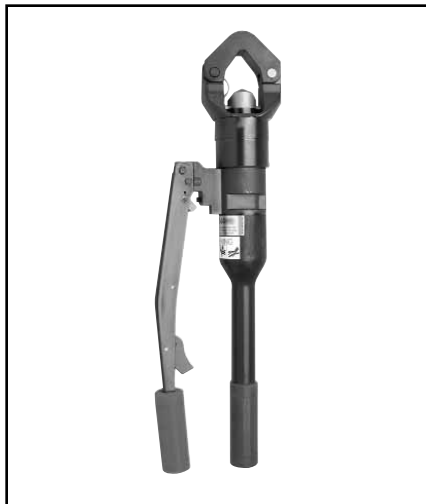

BENEFITS

- Dieless system, eliminates the need to purchase and maintain dies.
- Patented rapid advance pump for faster crimps.
- Pressure relief “Pop-Off” valve provides audible indication that crimp is complete.
- Handle trigger drain for convenient ram retraction.
- 355° head rotation for versatile tool head positioning in tight areas.
- Easy inspection and positive identification is provided with the BURNDY® “⊕”.
- Comfort grip handles help ease fatigue with continuous use.
- Supplied with high impact plastic carrying case.
- 5-year limited warranty.

SPECIFICATIONS

- Output Force:** 11 tons (22,000 lbs.)
- Weight:** 15 lbs. (5.6 kg)
- Length:** 23.20” (589 mm)
- Height:** 3.00” (76 mm)
- Width:** 7.04” (179 mm)

FOR USE ON

AWG/kcmil Size Range	Connector Type
Copper #6 - 1000 kcmil	Terminals YA-L, YA-2LN, YA, YA-FXB YA-2N, YA-L-2TC, YA-L-FX YAB-4N, YA-L-TC, YA-2L, YA-4N, YEV-P-FX, YE-P, YE-P-FX Splices YS-L, YS, YS-T
Aluminum #6 - 750 kcmil	Terminals YA-A, YA-A-TN Splices YS-A
Aluminum #6 - 750 kcmil	HYPLUG™ AYP, AYPO

ACCESSORIES

Cat. No.	Description
WIREMIKE	Provides quick and easy identification of commonly used conductors.
Y644HSCASE	Plastic carrying case.

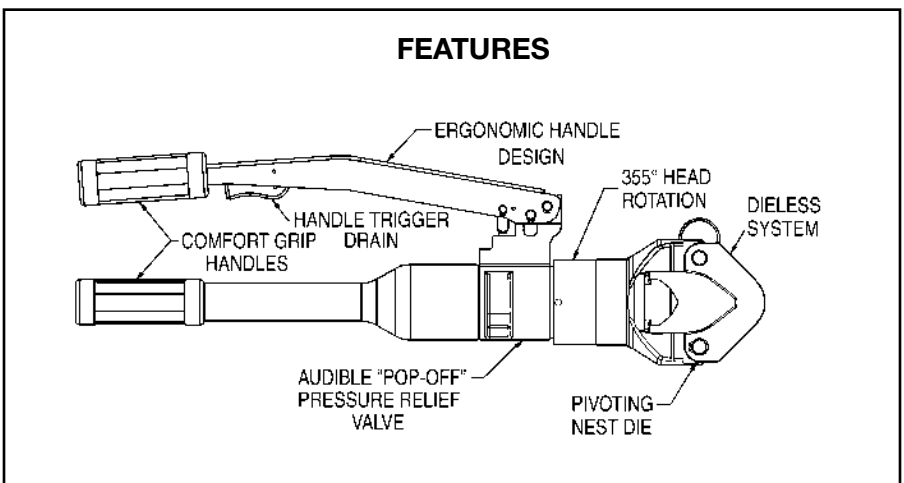

N-31

4-POINT® Y81KFT

DIELESS HYPRESS™

Hydraulic Hand Operated Crimping Tool

#8 – 1000 kcmil Copper HYLUG™ Terminals and HYLINK™ Splices

#8 – 750 kcmil Aluminum HYLUG™ Terminals and HYLINK™ Splices

The Y81KFT 4-POINT® dieless HYPRESS™ is a hand operated 6 ton hydraulic crimping tool for use on a wide variety of terminal and splice compression applications. The Y81KFT incorporates a dieless latch style head that provides easy tool removal from continuous conductor runs and eliminates the need to purchase and maintain dies. The head rotates 360° relative to the handles and is mated to a patented rapid advance pump. The Y81KFT weighs only 12 pounds and delivers 6 tons of crimping force. The result is easy termination and splicing using BURNDY® HYLUG™ and HYLINK™ terminals and splices.

The Y81KFT is supplied with a molded high impact plastic case and comes complete with a 5-year limited warranty.

Y81KFT dieless HYPRESS™ Range Taking Capabilities: The Y81KFT provides range taking capabilities that is UL Listed and CSA Certified for Copper (Code, Compact and Flex) and Aluminum (Code and Compact) conductors when used in conjunction with BURNDY® HYLUG™ terminals and HYLINK™ splices. *See chart for connector, conductor and range taking combinations on pages C-7 and C-8.*



SPECIFICATIONS

Output Force: 6 tons (12,000 lbs)
(5450 kg)
Weight: 12 lbs. (5.45 kg)
Length: 25.6 in. (650 mm)
Height: 7.7 in. (196 mm)
Width: 2.5 in. (64 mm)

FOR USE ON

- Copper, Aluminum, Compressed, Compact, Stranded, Solid and Flex Conductors.
- Installs Splices, Taps and Terminations:
 - #8 - 1000 kcmil Copper (YA, YA-L, YS, YS-L, YS-T, Y-R)
 - #8 - 777.7 (750 Nominal Flex Wire Size) kcmil Flex (YA-FX, YAV, YA-L-FX, YS, YSV-FXB)
 - #8 - 750 kcmil Aluminum (YA-A, YS-A)
 - #8 - 750 kcmil Aluminium Pin Adapters (AYP, AYPO)

Features and Benefits

- Dieless installation system.
 - ◇ Eliminates the need to purchase and maintain dies.
- UL Listed and CSA Certified with Range Taking Capabilities
 - ◇ Provides the installer with a UL Listed and CSA Certified crimps with Range Taking Capabilities when used in conjunction with BURNDY® HYLUG™ Terminals and HYLINK™ Splices
- Flip top head design.
 - ◇ For easy loading and removal of installed terminals and splices, saving time.
- Audible pressure “pop-off” valve and die embossment providing 360° inspectability.
 - ◇ Assures proper crimps with both audible and visual indicators for the installer.
- Handle Trigger release.
 - ◇ Convenient ram release located in the handle.
- Advanced high speed pump design.
 - ◇ Provides fast crimps, longer life, efficiency, and reliability.
- 360 Degree head rotation.
 - ◇ Versatile tool head positioning lets the user get into tight areas easier.
- Durable high impact formed carrying case.
 - ◇ Provides tool protection and stores all accessories.
- 5-year limited warranty.
 - ◇ Customer satisfaction and support.

N-32

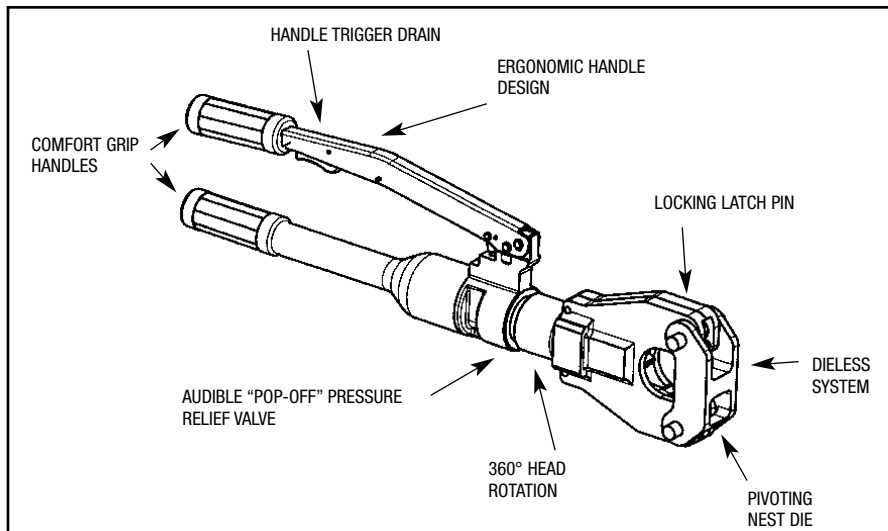

Blue highlighted items are industry standard and most frequently ordered.

4-POINT® Y4PC834

DIELESS HYPRESS™

Hydraulic Hand Operated Crimping Tool

The 4-POINT® C-shaped head dieless HYPRESS™ is a hand operated 6 ton hydraulic crimping tool for use on a wide variety of tap, terminate, and splice compression applications. The dieless capability of this tool eliminates the need to purchase or maintain additional dies. The Y4PC834 incorporates a C-shaped head design making it ideal for crimping in tight areas and is easily removed from continuous conductor runs. The head rotates 360° and is mated to a patented rapid advance pump. The Y4PC834 weighs only 12 pounds and delivers 6 tons of crimping force. The result allows for easy tap, termination and splicing of compression connectors.

The Y4PC834 is supplied with a molded high impact carry case and comes with a 5-year limited warranty.

The Y4PC834 provides range taking capabilities that are UL Listed and CSA Certified for Copper (Code, Compact and Flex) and Aluminum (Code and Compact) conductors when used in conjunction with BURNDY® HYLUG™ terminals and HYLINK™ splices as listed on pages C-7 and C-8 in the Master Catalog.



Features and Benefits

- Dieless installation system
 - ◊ Eliminates the need to purchase and maintain dies.
- UL Listed and CSA Certified with range taking capabilities
 - ◊ Provides the installer with UL Listed and CSA Certified crimps when used in conjunction with BURNDY® HYLUG™ and HYLINK™ compression connectors.
- C-shaped head design
 - ◊ For easily removing tool from continuous run conductors – simply slide the opening of the head off the conductor. Also ideal for use in tight or constraint spaces.
- Audible pressure “pop-off” valve and die embossment providing 360° inspectability.
 - ◊ Assures proper crimps with both audible and visual indicators for the installer.

SPECIFICATIONS

- Output Force:** 6 Tons (5.4 Metric Tons)
- Weight:** 11.85 lbs (5.38 kg)
- Length:** 25.6 in (651 mm)
- Height:** 7.7 in (196 mm)
- Width:** 2.5 in (64mm)

FOR USE ON

Copper, Aluminum, Compressed, Compact, Stranded, Solid and Flex Conductors

Installs Splices, Taps and Terminations

- #8 – 1000 kcmil Copper (YA, YA-L)
- #8 – 500 kcmil Copper (YS, YS-T, YS-L, Y-R)
- #8 – 777 (750 Nominal Flex Wire Size) kcmil Flex ((YA-FX, YAV, YA-L-FX)
- #8 – 535 (500 kcmil nominal flex wire size) kcmil flex (YS, YS-LB, YSV-FXB)
- #8 – 750 kcmil Aluminum (YA-A)
- #8 – 350 kcmil Aluminum (YS-A)
- #8 – 750 kcmil Aluminum Pin Adaptors (AYP, AYP0)

- Handle Trigger release
 - ◊ Convenient ram release located in the handle.
- Advanced high speed pump design
 - ◊ Provides fast crimps, longer life, efficiency, and reliability.
- 360° head rotation
 - ◊ Versatile tool head positioning lets the user get into tight areas easier.
- Durable high impact formed carrying case
 - ◊ Provides tool protection and stores all accessories.
- 5-year limited warranty
 - ◊ Customer satisfaction and support.

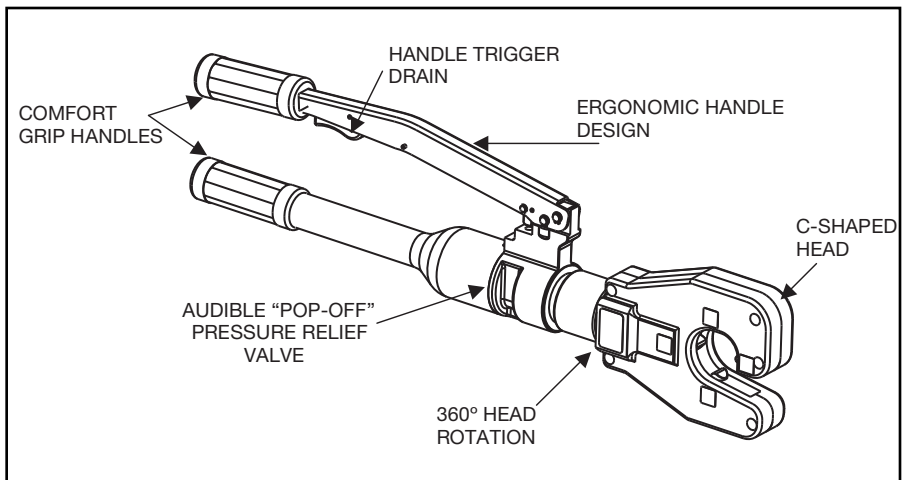

Blue highlighted items are industry standard and most frequently ordered.

PATRIOT® HIGH PERFORMANCE PAT750XT-18V

Battery Actuated Tool

Hydraulic Self-Contained 12 Ton Crimping Tool

The BURNDY® PATRIOT® High Performance PAT750XT-18V tool is 25% faster than previous models. In addition to faster crimp cycles, the High Performance PAT750XT-18V has newly designed electronics that are field proven for ultimate reliability and proven to handle the harshest work environments.

The High Performance PAT750XT-18V incorporates the latest engineering technology with a refined hydraulic system for ultra performance, speed and reliability. All PATRIOT® tools feature the BURNDY INFINITY DRIVE® transmission which has a lifetime warranty.

The High Performance PAT750XT-18V features BURNDY's Y750 tool head, capable of using all "U" style dies, and incorporates a bearing and alignment guide for use on HYGROUND® and other asymmetrical connectors. Features reliable head rotation design for operation in virtually any position. All PATRIOT® battery actuated hydraulic tools provide a consistent, reliable connection every time.

Each PATRIOT® tool uses standard BURNDY® dies and off-the-shelf connectors available world-wide. Supplied with a durable high impact formed carrying case to hold the tool, battery charger, two batteries, tool retention lanyard, and die compartment to hold "U" die sets. (Dies sold separately.) All BURNDY® PATRIOT® 18V series tools are provided with a 5-year limited warranty.



Features and Benefits

- Refined hydraulic system for ultra performance, speed and reliability.
- Field proven electronics for ultimate reliability in the harshest environments.
- True, one-handed operation for advance, retract, and hold.
- 12 tons of output force for use on virtually all compression applications.
- State of the art crimping head design, 360° head rotation lets user get into tight areas easier.
- Allows use of standard BURNDY® dies already in use.
- Ergonomically balanced tool design eases operation and helps lessen fatigue.
- Durable high impact formed carrying case provides superior protection and stores all accessories.
- PAT750CXT-18V — with rubber covered head is available.
- 18 volt Ni-MH battery eliminates voltage depression (memory issues).
- 5-year limited warranty on tool.
- Lifetime warranty on INFINITY DRIVE®.
- 1-year warranty on batteries and charger.

SPECIFICATIONS

Output force:	12 tons (10.9 metric tons)
Tool Weight:	16.5 lbs (7.5 kg) With Battery
Length:	15.75" (40 cm)
Width:	3.5" (8.89 cm)
Height:	13.5" (34.29 cm)
Operating Voltage:	18 V-DC
Recharge Time:	< 45 minutes

FOR USE ON

- Tension Sleeves
 - Copper #8 sol. - 500 kcmil
 - Aluminum #8 sol. - 587.2 kcmil
 - ACSR #4 - 556.5 kcmil
- Taps
 - Copper #14 sol. - 500 kcmil
 - Aluminum #8 - 500 kcmil
- Aerial Cable
 - Copper #6 - 500 kcmil
- Terminals & Splices
 - Aluminum #8 - 750 kcmil
 - Copper #8 - 750 kcmil
 - ACSR #4 - 556 kcmil
- HYGROUND®
 - Copper #8 - 500 kcmil
(cable/ground rod)
 - Ground Rods 1/2" - 1" Diameter

ACCESSORIES

Battery: Cat# **BAT18V**
Hi-capacity (2.6 AH)

Chargers:
120V-AC Cat# **PATCHGR18V**
12/24V-DC Cat# **BCT/PATDCCHGR**
240/250V-AC Cat# **PATCHGR250V**

Lanyard: Cat# **PT208620**

N-34

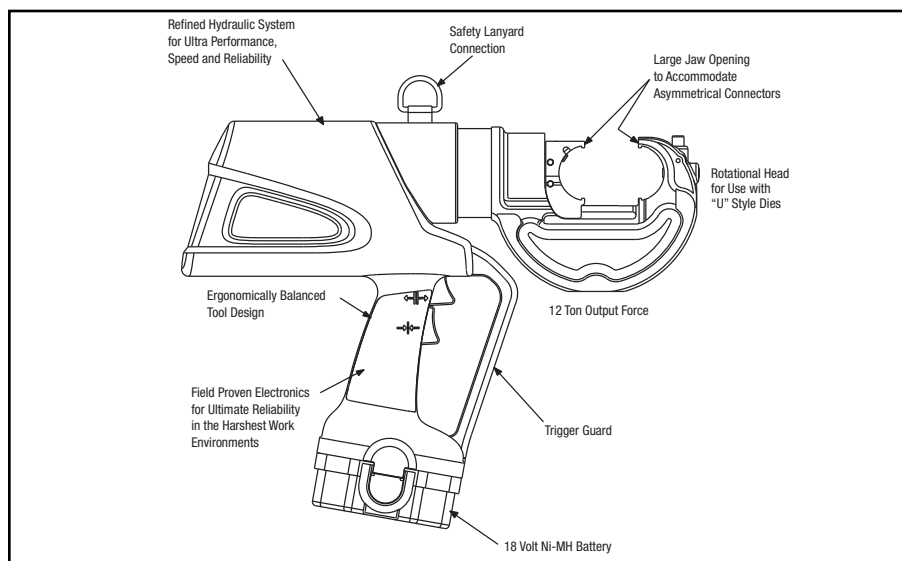

Blue highlighted items are industry standard and most frequently ordered.

**PATRIOT®
PAT750K-18V**

BATTERY ACTUATED TOOL

Hydraulic Self-Contained—
12 Ton

The BURNDY® PATRIOT® tools can be operated with only one hand, making them the most ergonomic, one-handed battery powered crimping and cutting tools available in the world today.

The PAT750K-18V incorporates the latest engineering technology with the patented high speed hydraulic pump. Our battery actuated hydraulic tool provides a consistent, reliable connection every time. The PAT750K-18V is capable of using KEARNEY™ WH1 and WH2 and BURNDY “U” style dies with the KUADP adapter. The PAT750K-18V head rotates 355° for operation in virtually any position.

Each PATRIOT® tool uses standard BURNDY® dies and off-the-shelf connectors available world-wide. The PAT750K-18V is supplied with a durable high impact formed carrying case to hold the tool, battery charger, two batteries, tool retention lanyard, and die compartment to hold “U” die sets. (Dies sold separately.) All BURNDY® PATRIOT® 18V series tools are provided with a 5-year limited warranty.



Features and Benefits

- True, one-handed operation for advance, retract, and hold.
- 12 ton output force.
- State of the art crimping head design with 355° rotation.
- Positive lock die buttons to secure dies or die adapter.
- Allows use of standard BURNDY® “U” dies with KUADP adapter, and KEARNEY™ WH1 and WH2 dies.
- Smoother, quieter, more efficient tool operation.
- PAT750CK-18V with rubber covered head is available.
- Ergonomically balanced tool design to help lessen operator fatigue.
- Durable high impact formed carrying case.
- 18 volt Ni-MH battery eliminates voltage depression (memory issues).
- 5-year limited warranty on tool.
- Lifetime warranty on INFINITY DRIVE®.
- 1-year warranty on battery and charger.

SPECIFICATIONS

- Output Force:** 12 tons (10.9 metric tons)
- Tool Weight:** 18.4 lbs. (8.3 kg) with battery
- Length:** 17.5” (44.45 cm)
- Width:** 3.5” (8.89 cm)
- Height:** 13.5” (34.29 cm)
- Operating Voltage:** 18 V-DC
- Recharge Time:** < 45 minutes

FOR USE ON

- Tension Sleeves up to 477 ACSR
- Taps through 500 kcmil
- Terminals up to 1033 kcmil

ACCESSORIES

- “U” Die Adapter: **KUADP**
- Battery: **BAT18V**
Hi-capacity (2.6 AH)
- Charger:
120V-AC **PATCHGR18V**
12/24V-DC **BCT/PATDCCHGR**
240/250V-AC **PATCHGR250V**
- Lanyard: **PT208620**

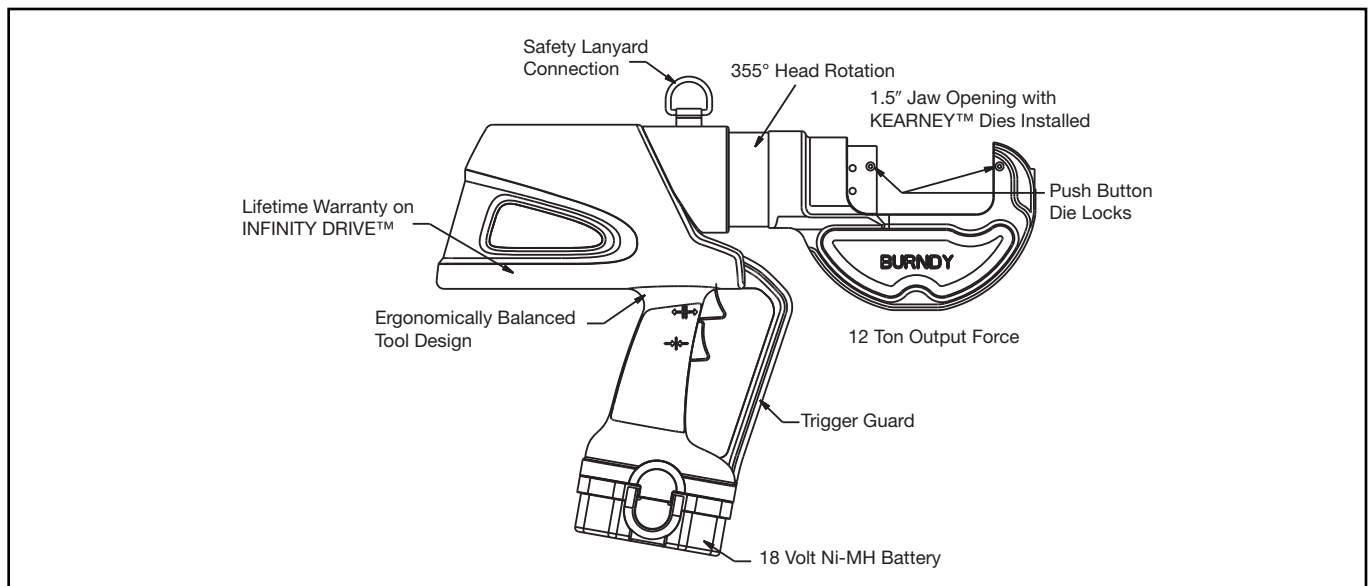

N-35

Blue highlighted items are industry standard and most frequently ordered.

PATRIOT® PAT644XT-18V

BATTERY ACTUATED TOOL

Hydraulic Self-Contained—
11 Ton

The BURNDY® PATRIOT® series of battery actuated tools can be operated with only one hand, which allows the other hand to be free to position the connector and conductor prior to crimping.

The BURNDY® PATRIOT® PAT644XT-18V incorporates the latest engineering technology with patent pending pump, transmission and piston component designs. Our self-contained hydraulic tool provides a consistent, reliable connection every time. The PAT644XT-18V features BURNDY's Y644 dieless latch head tool which eliminates the need to purchase and maintain dies. Features reliable head rotation design for operation in virtually any position.

Each PATRIOT® uses standard BURNDY® off-the-shelf connectors available worldwide. Supplied with a durable high impact formed carrying case to hold the tool, battery charger, two batteries, and tool retention lanyard. All BURNDY® PATRIOT® 18V series tools are provided with a 5-year limited warranty.

PAT644XT-18V Range Taking Capabilities:
Please refer to the individual connector pages for detailed information on the PAT644XT-18V range taking capabilities.



FEATURES

- Dieless system.
- True, one-handed operation for advance, retract, and hold.
- 11-ton output force.
- State of the art crimping head design, 360° head rotation.
- Audible “pop-off” indicates properly completed crimps.
- Ergonomically balanced tool design.
- Durable High Impact Formed carrying case.
- Ni-MH battery eliminates voltage depression (memory issues).
- 5-year limited warranty on tool. 1-year warranty on batteries and charger.

SPECIFICATIONS

- Crimp Force:** 11 Tons
(10.9 metric tons)
- Tool Weight:** 17 lbs (7.7 kg)
- Length:** 14.9" (37.8 cm)
- Width:** 3.7" (9.4 cm)
- Height:** 14" (35.6 cm)
- Operating Voltage:** 18 V-DC
- Recharge Time:** < 45 mins.

BENEFITS

- Eliminates the need to purchase and maintain dies.
- Easier tool operation.
- Versatile tool head positioning lets user get into tight areas easier.
- Less “down-time” due to high capacity, high voltage 18 volt battery.
- Assures proper crimps with both audible and visual indicators, leaving no doubt for the tool user.
- Ergonomically balanced tool eases operation and helps lessen fatigue.
- Smoother, quieter, more efficient tool operation.
- Durable high impact formed case provides superior protection and stores all accessories.

FOR USE ON

AWG/kcmil Wire Size Range	Connector Types
Copper #6 - 1000 kcmil	Terminals YA-L, YA-2LN, YA, YA-2N, YA-L-2TC, YAB-4N, YA-L-TC, YA-2L, YA-4N Splices YS-L, YS, YS-T
Aluminum #6 - 750 kcmil	Terminals YA-A, YA-A-TN Splices YS-A
Aluminum #6 - 750 kcmil	HYPLUG™ AYP, AYP0

ACCESSORIES

- **Battery:** Cat# **BAT18V**
Hi-capacity Ni-MH
(2600 mA-hr)
- **Charger:** Cat# **PATCHGR18V**
120V-AC
12/24V-DC
240/250V-AC
Cat# **BCT/PATDCCHGR**
Cat# **PATCHGR250V**
- **Lanyard:** Cat# **PT208620**

N-36

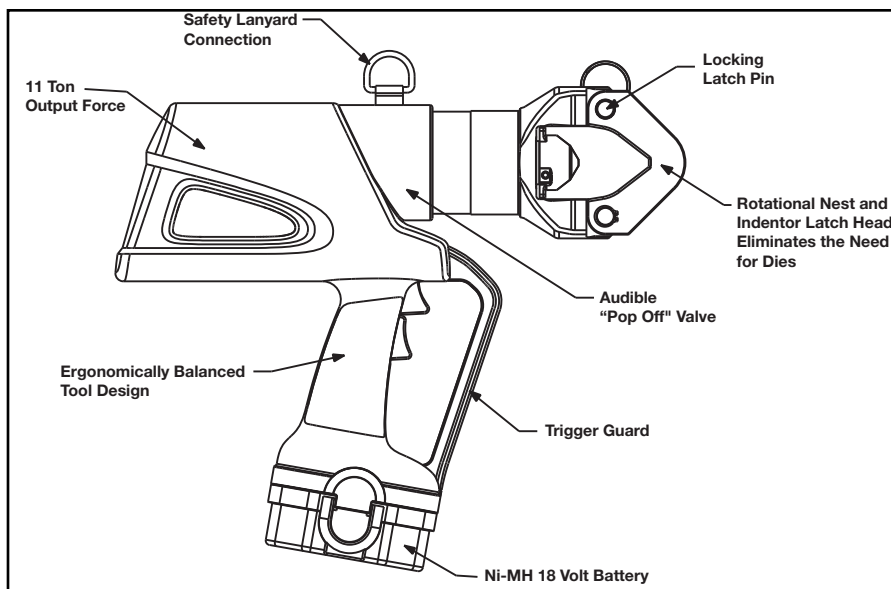

Blue highlighted items are industry standard and most frequently ordered.

PATRIOT® PAT46-18V

BATTERY ACTUATED TOOL

**Hydraulic Self-Contained
15-Ton Crimping Tool**

The BURNDY® PATRIOT® PAT46-18V incorporates the latest engineering technology with a patented high speed hydraulic pump. Our battery actuated hydraulic tool provides a consistent, reliable connection every time. The PAT46-18V features BURNDY's Y46 tool head, capable of using all "P" and "U" style dies.

Each PATRIOT® uses standard BURNDY® dies and off-the-shelf connectors available worldwide. Supplied with a durable high impact formed carrying case to hold the tool, battery charger, two batteries, tool retention lanyard, and die compartments to hold both "P" and "U" die sets (dies sold separately). All BURNDY® PATRIOT® PAT46 tools are provided with a 5-year limited warranty.

PAT46C-18V — with rubber covered head is available.



Features and Benefits

- BURNDY's largest battery actuated crimp tool, providing 15-tons of output force with a 2" jaw opening.
 - ◊ Allows users to install the largest variety of splices, taps and terminals with one tool. Also provides easy placement and removal from continuous conductor lengths.
- State of the art C-Head crimp design with 355° head rotation.
 - ◊ Versatile tool head positioning lets user get into tight areas easier.
- Retractable assist handle under head of tool for better handling of tool.
 - ◊ Allows for better balance of tool and retractable for getting head into tight areas.
- Durable high impact formed carrying case.
 - ◊ Provides superior protection and stores all accessories.
- 18-volt Ni-MH battery eliminates voltage depression (memory issues).
 - ◊ Less "down-time" due to high capacity, high voltage 18-volt battery
- 5-year limited warranty on tool. 1-year warranty on battery and charger.

SPECIFICATIONS

- Output Force:** 15 tons (13.6 metric tons)
- Weight:** 26.2 lbs. (11.88 kg)
- Length:** 20.77" (52.76 cm)
- Height:** 14.43" (36.65 cm)
- Width:** 3.70" (9.40 cm)
- Operating Voltage:** 18V-DC
- Battery Recharge Time:** <45 minutes

FOR USE ON

Connector Type	Conductor Range
Copper, #8 AWG str. - 1500 kcmil Code Cable, Navy Cable, Flexible and Extra Flexible 1/2" - 1" Ground Rods	Terminals, grounding: to 500 kcmil YGA, YGHA, YGF Terminals, uninsulated: #8 to 1500 kcmil: YA, YA-2N, YA-L, YA-LB, YA-TC, YA-2LN, YAB-4N, YAV-L Box, YAV-L, YAV-RS Box, YAV-RS, YA-TC-FX Terminals, insulated: #8 to 2/0 YAEV-L Box, YAEV-L, YAEV-H, YAEV-RS, YAEV-RH Splices: #8 to 1500 kcmil YS, YS-T, YS-L, YS-LB, YST, YSP-T, YGS, YGHS Taps: YH, YCHC #14 to 1000 kcmil, YC-C to 4/0 AWG Taps, grounding: to 500 kcmil YGHC-C, YGHP-C, YGHR-C
Aluminum #8 AWG - 1250 kcmil Code Cables	Terminals: YA-A, AYP, AYPO Splices: YS-A, YS-AT, YRB Taps: YFD, YFN, YFO, YFR
ACSR	See BURNDY® Overhead Transmission and Distribution Catalog Module

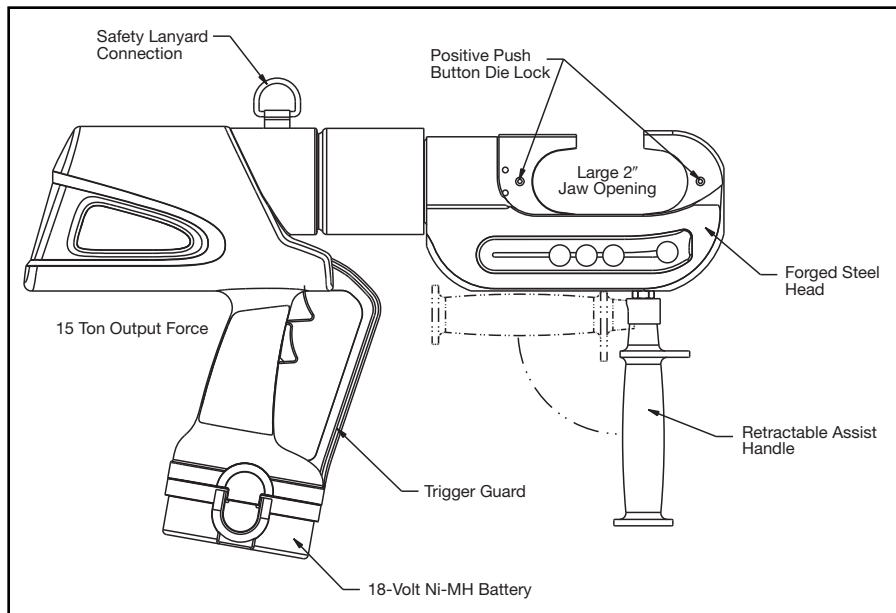

ACCESSORIES

- **Cutter Die:** Cat# **P15K**
Die max. 1.2" dia.
- **"U" Die Adapter:** Cat# **PUADP-1**
- **Battery:** Cat# **BAT18V**
High Capacity Ni-MH (2.6 AH)
- **Chargers:**
 - 120V-AC Cat# **PATCHGR18V**
 - 12/24V-DC Cat# **BCT/PATDCCHGR**
 - 240/250V-AC Cat# **PATCHGR250V**

Blue highlighted items are industry standard and most frequently ordered.

4-POINT® PATRIOT® PAT81KFT-18V

BATTERY ACTUATED TOOL

Hydraulic Self-Contained Crimping Tool

#8-1000 kcmil Copper HYLUG™ Terminals and HYLINK™ Splices

#8-750 kcmil Aluminum HYLUG™ Terminals and HYLINK™ Splices

The BURNDY® PAT81KFT-18V is a battery powered crimping tool that provides a powerful 6 tons of crimping force. It is compact, fast, easy to use and incorporates the latest in battery tool technology. The ergonomic design allows for one hand operation so that the other is free to position the connectors and conductor prior to crimping. The PAT81KFT-18V features a dieless latch head design which eliminates the need to purchase and maintain dies. Featuring 360° head rotation, the PAT81KFT-18V is designed for easy operation in virtually any position.

The PAT81KFT-18V is supplied with a high impact carrying case, battery charger, lanyard and two batteries. The PAT81KFT-18V comes complete with a 5-year limited warranty on the tool and 1 year limited warranty on the batteries.

PAT81KFT-18V Dieless HYPRESS™ Range Taking Capabilities: The PAT81KFT-18V provides range taking capabilities that is UL and CSA listed for Copper (Code, Compact and Flex) and Aluminum (Code and Compact) conductors when used in conjunction with BURNDY® HYLUG™ terminals and HYLINK™ splices. See chart for connector, conductor and range taking combinations.



Features and Benefits

- Dieless installation system.
 - ◊ Eliminates the need to purchase and maintain dies.
- UL Listed and CSA Certified with Range Taking Capabilities
 - ◊ Provides the installer with UL Listed and CSA Certified crimps with Range Taking Capabilities when used in conjunction with BURNDY® HYLUG™ Terminals and HYLINK™ Splices
- Audible pressure “pop-off” valve and die embossment providing 360° inspectability.
 - ◊ Assures proper crimps with both audible and visual indicators for the installer.
- Battery powered crimp technology.
 - ◊ Easy Tool Operation and portability.
- Advanced high speed pump design.
 - ◊ Provides faster crimps, longer life, efficiency, and reliability.
- Ergonomic design allows one hand operation for ram advance and ram retraction.
 - ◊ User always has one hand free to manipulate connector and conductor.
- 360 Degree head rotation.
 - ◊ Versatile tool head positioning lets the user get into tight areas easier.

SPECIFICATIONS

Output Force:	6 tons (5.4 Metric Tons)
Weight:	14 lbs. (6.35 kg)
Length:	17.6 (447 mm)
Height:	13.9 in (354 mm)
Width:	3.7 in (94 mm)
Operating Voltage:	18V-DC
Battery Recharge Time:	<45 Mins

FOR USE ON

- Copper, Aluminum, Compressed, Compact, Stranded, Solid and Flex Conductors.
- Installs Splices, Taps and Terminations:
 - #8 - 1000 kcmil Copper (YA, YA-L, YS, YS-L, YS-T, Y-R)
 - #8 - 777.7 (750 Nominal Flex Wire Size) kcmil Flex (YA-FX, YAV, YA-L-FX, YS, YSV-FXB)
 - #8 - 750 kcmil Aluminum (YA-A, YS-A)
 - #8 - 750 kcmil Aluminium Pin Adapters (AYP, AYPO)

ACCESSORIES

- **Battery:** Cat# **BAT18V**
Hi Capacity Ni-MH (2.6 AH)
- **Charger:** 120V-AC Cat# **PATCHGR18V**
12/240V-DC Cat# **BCT/PATDCCHGR**
- **Lanyard** Cat# **PT208620**

Features and Benefits (Continued)

- Ram holds position when trigger is released.
 - ◊ Provides the ability to hold the connector between the indentors and check for alignment prior to crimping action.
- Mechanical ram release.
 - ◊ Reliable ram release (no battery consumption).
- Uses 18 volt Ni-MH batteries.
 - ◊ Eliminates voltage depression or “memory”.
- Audible pressure “pop-off” value.
 - ◊ Indicates properly completed crimps.
- Durable high impact formed carrying case.
 - ◊ Provides tool protection and stores all accessories.
- 5-year limited warranty on tool, 1-year on batteries and charger.
 - ◊ Customer satisfaction and support.

N-38

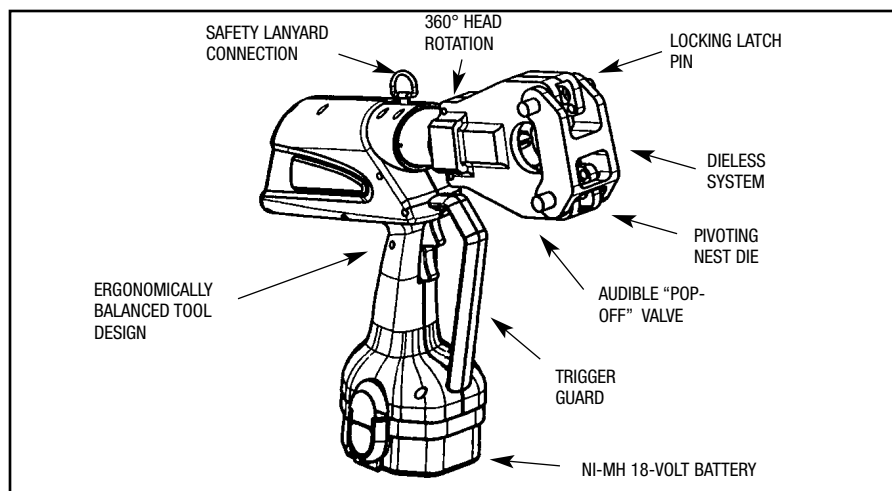

Blue highlighted items are industry standard and most frequently ordered.

**4-POINT® PATRIOT®
PAT4PC834-18V**

BATTERY ACTUATED TOOL

Hydraulic Self-Contained—6 Ton

The BURNDY® PATRIOT® 4-POINT® C-shaped head dieless HYPRESS™ is a battery actuated 6 ton hydraulic crimping tool for use on a wide variety of tap, terminate, and splice compression applications. The dieless capability of this tool eliminates the need to purchase or maintain additional dies. It is compact, fast, easy to use and incorporates the latest in battery tool technology. The ergonomic design allows for one hand operation so that the other is free to position the connector and conductor prior to crimping. The PAT4PC834-18V incorporates a C-shaped head design making it ideal for crimping in tight areas and can be easily removed from continuous conductor runs. The head rotates 360° and is mated to a patented rapid advance pump. The PAT4PC834-18V weighs only 13.8 pounds and delivers 6 tons of crimping force. The result allows for easy tap, termination and splicing of compression connectors.

The PAT4PC834-18V is supplied with a molded high impact carry case, battery charger, lanyard, and two batteries. The PAT4PC834-18V comes with a 5-year limited warranty.

The PAT4PC834-18V provides range taking capabilities that are UL and CSA Listed for Copper (Code, Compact and Flex) and Aluminum (Code and Compact) conductors when used in conjunction with BURNDY® HYLUG™ terminals and HYLINK™ splices as listed on page C-7 in the Master Catalog.



Features and Benefits

- Dieless installation system
 - ◇ Eliminates the need to purchase and maintain dies.
- UL Listed and CSA Certified with range taking capabilities
 - ◇ Provides the installer with a UL Listed and CSA Certified crimp when used in conjunction with BURNDY® HYLUG™ and HYLINK™ compression connectors.
- C-shaped head Design
 - ◇ For easily removing tool from continuous run conductors – simply slide the opening of the head off the conductor. Also ideal for use in tight or constrained spaces.
- Audible pressure “pop-off” valve and die embossment providing 360° inspectability.
 - ◇ Assures proper cimps with both audible and visual indicators for the installer.
- Handle Trigger release
 - ◇ Convenient ram release located in the handle.

SPECIFICATIONS

- Output Force:** 6 Ton (5.4 Metric Tons)
- Weight:** 13.85 lbs (6.28 kg)
- Length:** 17.6 in (448 mm)
- Height:** 13.9 in (354 mm)
- Width:** 3.7 in (94 mm)

FOR USE ON

Copper, Aluminum, Compressed, Compact, Stranded, Solid and Flex Conductors

Installs Splices, Taps and Terminations

- #8 - 1000 kcmil Copper (YA, YA-L)
- #8 - 500 kcmil Copper (YS, YS-T, YS-L, Y-R)
- #8 - 777 (750 Nominal Flex Wire Size) kcmil Flex (YA-FX, YAV, YA-L-FX)
- #8 - 535 (500 kcmil nominal flex wire size) kcmil flex (YS, YS-LB, YSV-FXB)
- #8 - 750 kcmil Aluminum (YA-A)
- #8 - 350 kcmil Aluminum (YS-A)
- #8 - 750 kcmil Aluminum Pin Adaptors (AYP, AYPO)

**Features and Benefits
(Continued)**

- Advanced high speed pump design.
 - ◇ Provides fast crimps, longer life, efficiency, and reliability.
- 360° head rotation
 - ◇ Versatile tool head positioning lets the user get into tight areas easier.
- Durable high impact formed carrying case
 - ◇ Provides tool protection and stores all accessories.
- 5-year limited warranty
 - ◇ Customer satisfaction and support.

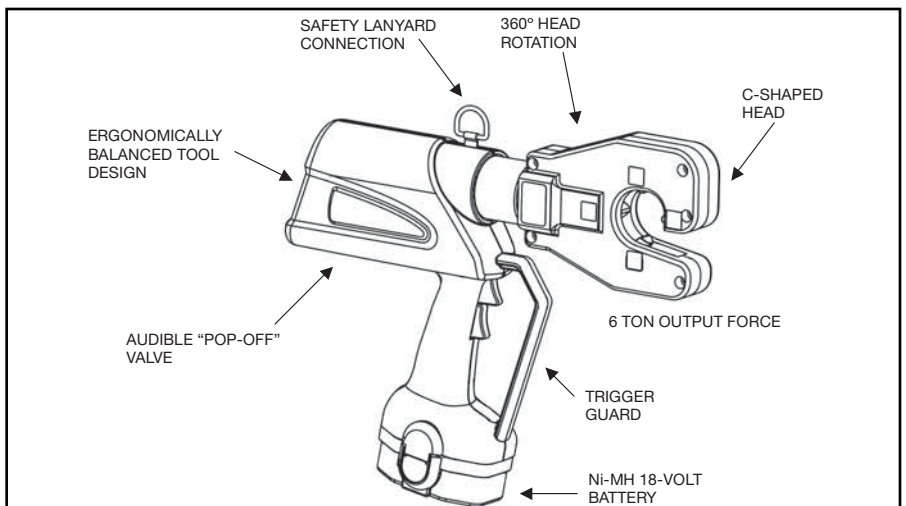

Blue highlighted items are industry standard and most frequently ordered.

PATRIOT® IN-LINE® PATMD6-14V SERIES

BATTERY ACTUATED TOOL

Hydraulic Self Contained—6 Ton

The BURNDY® IN-LINE® tools are battery actuated and can be operated with one hand allowing for advance, retract and hold functions for easier operation. One hand operation allows the operator one free hand to position the connector and conductor while crimping. The PATRIOT® PATMD6-14V series of tools incorporate a high speed hydraulic pump generating 6 tons of crimping force. This design provides a consistent, reliable connection every time.

The IN-LINE® tool features interchangeable MD6 series heads, capable of using “W” and “X” style dies in the permanent D3 groove. The PATMD6-K-14V accepts KEARNEY™ type “O” dies and BURNDY® “W” and “X” style dies with KWADP adapter. When ordering choose the tool that best suits your crimping needs. The IN-LINE® tools feature 350° rotatable heads for operation in virtually any position.

Each PATRIOT® IN-LINE® tool uses standard BURNDY® dies and off-the-shelf connectors available world-wide. IN-LINE® tools are supplied with a durable high impact formed carrying case, battery charger, two batteries, and die compartment to hold dies. (Dies are sold separately.) All BURNDY® IN-LINE® tools are provided with a 3-year limited warranty.

KEARNEY™ is a registered trademark of COOPER TECHNOLOGIES COMPANY.



Features and Benefits

- True, one-handed operation for advance, retract, and hold.
- 6-ton output force for reliable compression connections.
- Pressure “pop-off” valve indicates completion of crimp.
- Interchangeable scissor action crimp jaws allow easier access to tight spaces.
- Ram holds position when trigger is released to allow the operator to check alignment prior to crimping.
- Allows the use of standard BURNDY® “W” and “X” dies already in use.
- Large hand grip area allows easier operation with gloves.
- Ergonomically balanced tool design helps lessen operator fatigue.
- Durable high impact formed carrying case.
- High capacity 2.6 AH batteries provide more crimps per charge.
- 14.4 volt Ni-MH battery eliminates voltage depression (memory issues).
- 3-year limited warranty on tool.
- 1-year warranty on batteries and charger.

SPECIFICATIONS

- Output force:** 6 tons (5.4 metric tons)
- Tool Weight:** 7.8 lbs (3.5 kg)
With Battery
- Length:** 20.91” (53.11cm)
- Width:** 3.69” (9.37 cm)
- Height:** 5.48” (13.91 cm)
- Operating Voltage:** 14.4 V-DC
- Recharge Time:** < 45 minutes

FOR USE ON

- Copper, Aluminum, ACSR. Steel, Copperweld, Alumoweld, 6201, 5005, Compressed, and Compact conductors
- Copper Taps: #10 solid - 2/0 stranded
- Aluminum and ACSR Taps: #14 solid - 4/0 ACSR
- Stirrups: #6 - 4/0 ACSR
- Overhead Full Tension Deadends, Full Tension Splices and Terminals #10 str. - 4/0 ACSR
- Installs splices, taps or terminations:
 - #8 - 500 kcmil Copper Str. (YA, YA-L, YS, YS-L)
 - #8 - 350 kcmil flex
 - #8 - 350 kcmil Aluminum (YA-A, & YS-A)

ACCESSORIES

- Battery:** Cat# **BAT14V**
(2.6 AH) Hi-capacity Ni-MH
- Chargers:**
 - 120V-AC Cat# **PATCHGR18V**
 - 12/24V-DC Cat# **BCT/PATDCCHGR**
 - 240/250V-AC Cat# **PATCHGR250V**
- Cutter Dies:** Cat# **W28K**
For cutting #4-4/0 Copper, Aluminum & ACSR
- Interchangeable Jaw Assemblies:**
 - “BG” and “D3” Grooves **PATJAWSMD6**
 - “O” and “D3” Grooves **PATJAWSMD6-8**
 - “D3” Only (“Snub-Nose”) **PATJAWSMD6-6**
 - KEARNEY Groove **PATJAWSMD6K**
 (“Snub-Nose”)
- Jaw Covers:** **PATMD6JC, PATMD66JC, PATMD6KJC**

N-40

PATRIOT® IN-LINE® VARIATIONS

- PATMD6-14V** Permanent “BG” (5/8”) and “D3” grooves.
- PATMD6-8-14V** Permanent “O” and “D3” grooves.
- PATMD6-6-14V** “Snub-Nose” version with permanent “D3” groove.
- PATMD6-K-14V** Accepts KEARNEY™ “O” type dies and BURNDY® “W” and “X” dies with KWADP adapter.

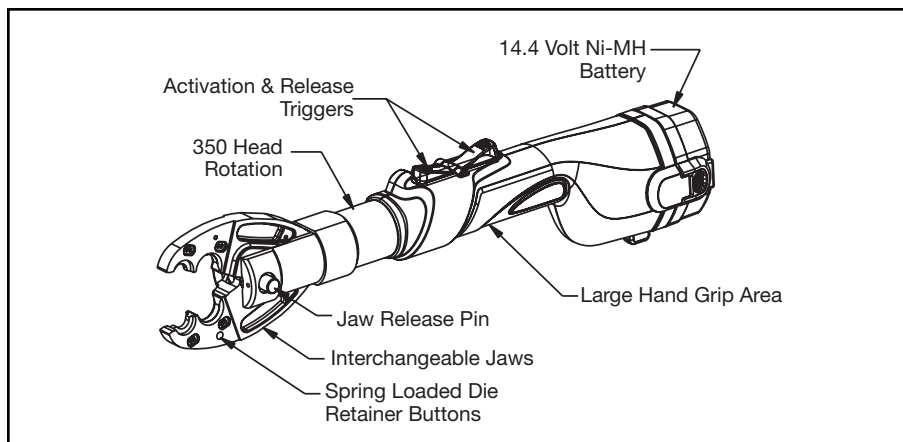

Blue highlighted items are industry standard and most frequently ordered.

PATRIOT® PAT600-18V

BATTERY ACTUATED TOOL

Hydraulic Self-Contained—6 Ton

The BURNDY® PAT600-18V battery powered crimping tool provides a powerful 6 tons of crimping force and completes a crimp in approximately 3 seconds. The PAT600-18V is compact, easy to use and incorporates the latest in battery tool technology. The PAT600-18V tool incorporates a specialized latch style head with enhanced working stroke and clearance capabilities. The specialized head allows interference-free closure on tap connections up to the BURNDY® YHD-400 size including 350 kcmil aluminum connectors. Die selection with this tool includes all BURNDY® “W” and “W-VT” style dies which seat in the permanent “D₃” crimping groove. Installation applications include #8 AWG to 600 kcmil copper lugs and splices, #8 AWG to 350 kcmil aluminum lugs and splices (YA-A and YS-A), and up to 4/0 aluminum tap connections. The permanent “D₃” groove and 180 degree rotatable head are standard on the PAT600-18V.

Each PAT600-18V tool uses BURNDY® dies and off-the-shelf connectors available worldwide. The PAT600-18V comes equipped with a high impact formed carrying case to hold the tool, a battery charger and two batteries. The case houses up to 10 “W” dies (dies purchased separately). The PAT600-18V uses industry standard batteries and chargers. The PAT600-18V comes complete with a 5-year limited warranty and one year on batteries and charger.



Features and Benefits

- Battery powered crimp technology.
 - ◊ Easy tool operation and portability.
- Advance design high speed pump completes crimp in approximately 3 seconds.
 - ◊ Longer life, efficiency, and reliability.
- Ergonomic design allows one hand operation for ram advance and ram retraction.
 - ◊ User always has one hand free to manipulate connector and conductor.
- Variable speed trigger.
 - ◊ Provides flexibility in speed of ram advance.
- Ram holds position when trigger is released.
 - ◊ Provides ability to hold the connector between dies and check for proper alignment prior to crimping action.
- Mechanical ram release.
 - ◊ Reliable ram release (no battery power consumption).
- Specialized latch head design.
 - ◊ Provides enhanced clearance on tap connectors when compared with competitive designs.

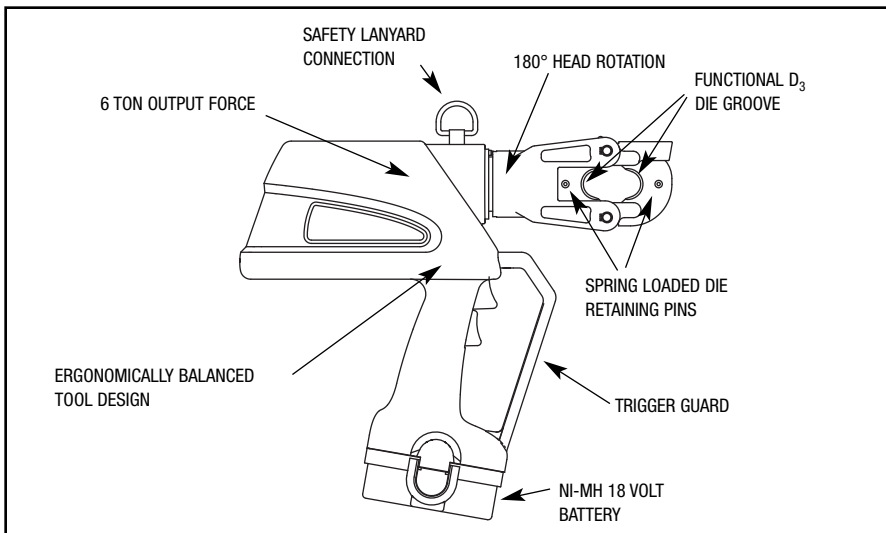

Blue highlighted items are industry standard and most frequently ordered.

SPECIFICATIONS

- Crimp Force:** 6 Tons (US)
(5.4 metric tons)
- Tool Weight:** 10.9 lbs. (4.9 kg)
- Length:** 14.5" (36.8 cm)
- Width:** 3.5" (8.9 cm)
- Height:** 13.75" (34.9 cm)
- Operating Voltage:** 18 V-DC
- Crimp Time:** Approx. 3 seconds
- Recharge Time:** < 45 mins.

FOR USE ON

- Copper, Aluminum, ACSR, Steel, Copperweld, Alumoweld, 6201, 5005, Compressed, Compact, Stranded & Solid
- Installs splices, taps, or terminations:
 - #8 - 600 kcmil Copper Str. (YA, YA-L, YS, YS-L)
 - #8 - 350 kcmil Flex
 - #8 - 350 kcmil Aluminum (YA-A & YS-A)

ACCESSORIES

- **Lanyard:** Cat# **PT208620**
- **W Die Holder** Cat# **WDIETREE**
- **Battery:** Hi-capacity Cat# **BAT18V** (2.6 AH)
- **Charger:**
 - 120V-AC Cat# **PATCHGR18V**
 - 12/24V-DC Cat# **BCT/PATDCCHGR**
 - 240/250V-AC Cat# **PATCHGR250V**

Features and Benefits (Continued)

- 180 degree head rotation.
 - ◊ Versatile tool head positioning lets user get into tight areas easier.
- Uses 18 volt Ni-MH batteries.
 - ◊ Eliminates voltage depression or "memory".
- Audible pressure "pop-off" valve.
 - ◊ Indicates properly completed crimp.
- Permanent D₃ crimp groove accepts all "W-Dies".
 - ◊ Uses standard die design with proven performance.
- PAT600C-18V with covered head is available.
 - ◊ Covered head for impact protection.
- Durable high impact formed carrying case.
 - ◊ Provides tool protection and stores all accessories.
- 5-year limited warranty on tool, 1-year on batteries and charger.
 - ◊ Customer satisfaction and support.

Y35BH HYPRESS™ 10,000 PSI

REMOTE POWER OPERATED COMPRESSION TOOLS

The Y35BH series remote head is designed for remote power operation and incorporates the same C-shaped head as the Y35. The hook style head with extensive ram travel provides for easy tapping and splicing of overhead lines as well as HYGROUND® compression grounding systems. Uses all standard BURNDY® “U” dies.

The remote power operated Y35 heads are available covered with 3/16” molded rubber for tool impact protection.

Order head, hose, pump, dies and accessories separately. Five-year limited warranty.



BENEFITS

- Easy tool removal from line conductor after compression taps are installed with the open “C” shaped head.
- Easily lifted into working position using the lifting eye.
- Easy die changing plus secure die alignments provided with the positive die lock buttons.
- Uses all standard BURNDY® “U” dies.
- Long life expectancy is provided with heavy duty reinforced back.
- Mates with all universal type Hot-stick tooling.
- Rapid assembly and disassembly is provided with the quick disconnect hydraulic fitting.
- Type Y35BH-4 head is covered with 3/16” molded rubber.
- 5-year limited warranty.

SPECIFICATIONS

	Y35BH	Y35BH-4
Operating pressure:	10,000 psi	10,000 psi
Jaw Opening:	.95”	.95”
Force developed:	12 tons	12 tons
Weight (less case):	8 lbs.	9 lbs.
Maximum width:	4-3/4”	6”
Maximum height:	9-1/4”	10-1/2”
Molded covering:	—	Yes

FOR USE ON

Connector Type	Conductor Range	
Tension Sleeves	Copper	#8 sol.-500 kcmil
	Aluminum	#6 sol.-636 kcmil
	ACSR	#4 -556.5 (26/7)
Taps	#14-556.5 ACSR (18/1)	
Aerial Cable Connectors	Copper	#6 str.-500 kcmil
	Aluminum	#4 str.-600 kcmil
Code Conductors	Copper	#8 str.-750 kcmil Term (400 kcmil splices)
	Aluminum	#6 str.-750 kcmil Term (400 kcmil splices)
HYGROUND® Compression Grounding	Copper (cable/cable)	#6-500 kcmil
	Copper (cable/grd. rod)	#6-250 kcmil
	Ground Rods	1/2”-3/4”

Y35BH Variations:

- Y35BH** Head Only.
- Y35H** Includes the Y35BH HYPRESS™ head, PT29402-1 universal hot-stick adapter, and steel carrying case.
- Y35B** Includes the Y35BH HYPRESS™ head, PT91 steel reinforced hydraulic hose and an FP10 foot pump in a steel carrying case. Note: NOT for use on energized conductors.
- Y35BH-4** Permanent Molded Rubber Head. The Y35BH-4 is covered with 3/16” molded rubber for tool impact protection (not insulation).

FEATURES

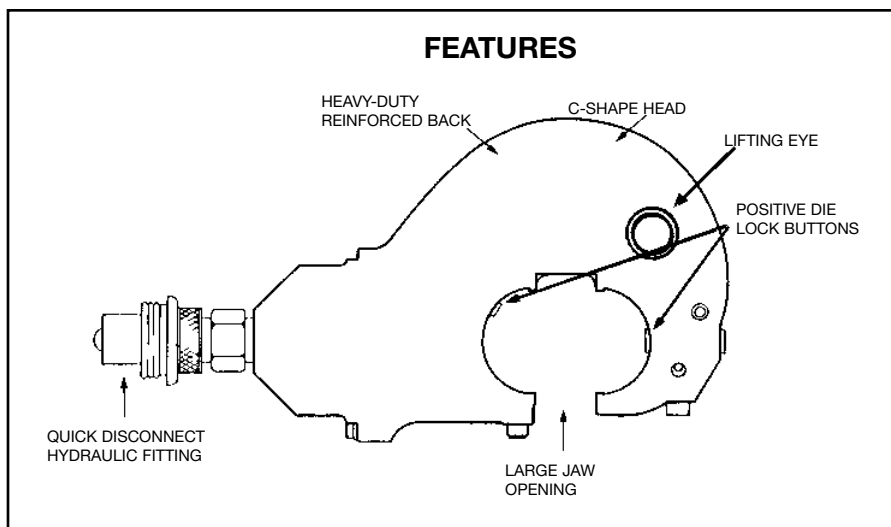

Blue highlighted items are industry standard and most frequently ordered.

**Y39BH HYPRESS™
10,000 PSI**

**REMOTE POWER OPERATED
COMPRESSION TOOL**

The Y39BH Remote Head is designed for remote power operation and incorporates the same small head as the Y39. Convenient die holder with recessed spring latch makes it easy to remove or lock into position. Dies are located and held in position with positive push button die locks. Dies sold separately. Uses all standard BURNDY® “U” dies. Five-year limited warranty.



BENEFITS

- Easy to work in small tight spaces with only a 3-1/8" wide compression head.
- Easy to locate and hold dies in position with the positive push button die locks plus die changing is accomplished easily without ball checks or set screws.
- Easy to remove or lock into position die holder with recessed spring latch plus leather strap to prevent loss.
- Compression terminal, tap and splice connectors are UL Listed and CSA Certified when installed with the Y39 tool and recommended die set.
- Uses all standard BURNDY® “U” dies.
- Very versatile tool that is able to work with 10,000 PSI pumps.
- 5-year limited warranty.

SPECIFICATIONS

- Operating pressure:** 10,000 psi
- Force developed:** 12 tons
- Weight:** 6-1/2 lbs.
- Maximum head width:** 3-1/8"
- Minimum height:** 9-1/8"

FOR USE ON

COPPER

- #6 AWG - 750 kcmil str. Code Cable
- N30-N650 Navy Cable
- Flexible and Extra Flexible
- Terminals—Uninsulated
YA, YA-L, YA-LB, YGH, YGHA
- Splices and Tees—Uninsulated
YS, YS-L, YS-LB, YS-T, YSP-T, YST

COPPER-AN or AIR

- #6 AWG - 4/0 str. Code Cable
- AN6-AN 4/0 Aircraft Cable
- Flexible and Extra Flexible
- Terminals—Uninsulated
YAV-L Box, YAV-L, YAV-RS Box, YAV-RS
- Splices and Tees—Uninsulated
YSV-L Box, YSV-L

COPPER-INSULATED TERMINALS

- #8-AWG - 2/0 str. Code Cable
- AN8-AN 2/0 Aircraft Cable
- Flexible and Extra Flexible
- Terminals—Insulated
YAEV-L Box, YAEV-L, YAEV-RS Box, YAEV-RS, YAEV-RH

COPPER - TAPS

- #12 AWG Solid - 250 kcmil
- Taps—YC-C, YGHC-C, YGHP-C, YGHR-C, YH, YCHC

ALUMINUM

- #8 AWG - 750 kcmil str. Code Cable
- Terminals—YA-A
- Splices—YS-A, YS-AT, YRB

ALUMINUM

- #6 str. - 500 kcmil
- Taps—YFD, YFN, YFO

FEATURES

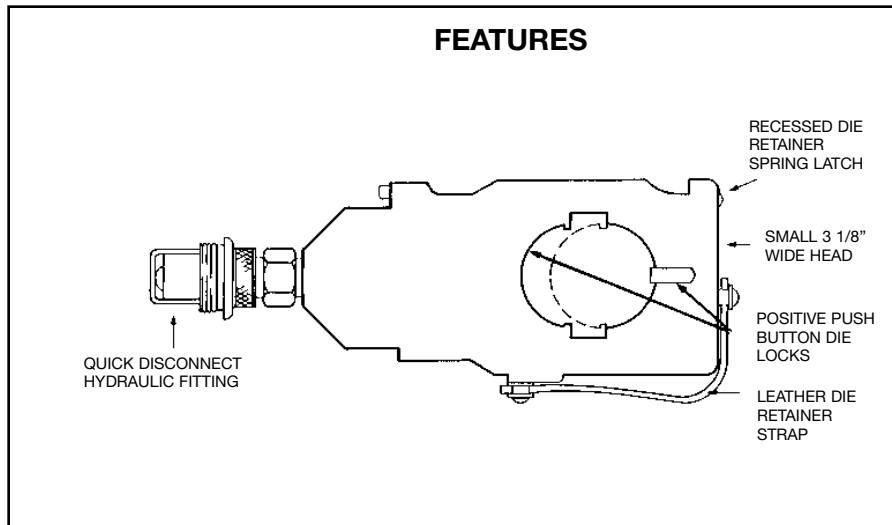

Blue highlighted items are industry standard and most frequently ordered.

Y34BH

HYPRESS™

Hydraulic Tool—
Remote Operated 10,000 PSI

9 ton remote power operated hydraulic tool. The Y34BH HYPRESS™ tool is designed for remote hydraulic power operation. Its new 10,000 PSI operating pressure makes it easily adaptable to most remote power systems. Its small C-shaped head is light-weight, compact and with a relatively large jaw opening ideally suited for NETWORK UNDERGROUND systems. The tool comes standard with permanent molded head with 3/16" rubber and includes a separate molded rubber boot that covers the lower body and hydraulic coupler for tool impact protection. Together, with other BURNDY® hydraulic accessories, the Y34BH HYPRESS™ tool may be used on lines. The Y34BH-1 has a ten foot non-conductive 10,000 PSI hose attached at the factory. The Y34BH Series tool has a 5-year limited warranty.



BENEFITS

- Allows for easy placement and removal from continuous conductor lengths.
- Long life.
- Fast ram retraction.
- Molded rubber covering on head, body, and hose fittings.
- Standard operating pressure.
- Ease in handling.
- Greater reliability.
- Reduced tool life cycle cost.
- 5-year limited warranty.

SPECIFICATIONS

- **Operating pressure:** 10,000 psi
- **Jaw opening:** 1-1/2"
- **Max force generated:** 9 Tons
- Head and body rubberized
- Accommodates "B" dies
- **Head length:** 11-1/2"
- **Overall dimensions:** 16-3/4" (incl. boot)
- **Total weight:** Approx. 8 lbs.

FOR USE ON

- Copper: #4-500 kcmil str.
- Welding Cable: 350 kcmil
- N40 to N500 Navy Cable
- Flexible and Extra Flexible
- #4 to 4/0 Aircraft Cable
- HYLUG™: Terminals-Uninsulated
- HYLINK™: Splices and Tees-Uninsulated
- HYCRAB™: BURNDY® Network Connector System.
- Copper: #4-500 kcmil str.
- Aluminum: #6-300 kcmil

Installation	Die	Maximum Conductor Size	
		Copper	Aluminum
B4CD	Y34PA	#6 Str.	
B1CD	Y34PA	#4 Str.	
B26D	Y34PA	#2 Str.	
B26D	Y34PR-5	#1 Str.	
B27D	Y34PR-5	1/0 Str.	
B29D	Y34PR-5	2/0 Str.	
B30D	Y34PR-5	3/0 Str.	
B31D	Y34PR-5	4/0 Str.	
B32D	Y34PR-5	250 kcmil	
No die req'd.	Y34PR-11	300 kcmil	

Installation	Die	Maximum Conductor Size	
		Copper	Aluminum
B4CD	Y34PR	#4 Str.	
B2CD	Y34PR	#2 Str.	
B1CD	Y34PR	#1 Str.	
B25D	Y34PR	1/0 Str.	
B26D	Y34PR	2/0 Str.	
B27D	Y34PR	3/0 Str.	
B28D	Y34PR	4/0 Str.	
B29D	Y34PR	250 kcmil	
B30D	Y34PR	300 kcmil	
B31D	Y34PR	350 kcmil	
No die req'd.	Y34PR	500 kcmil	

N-44

FEATURES

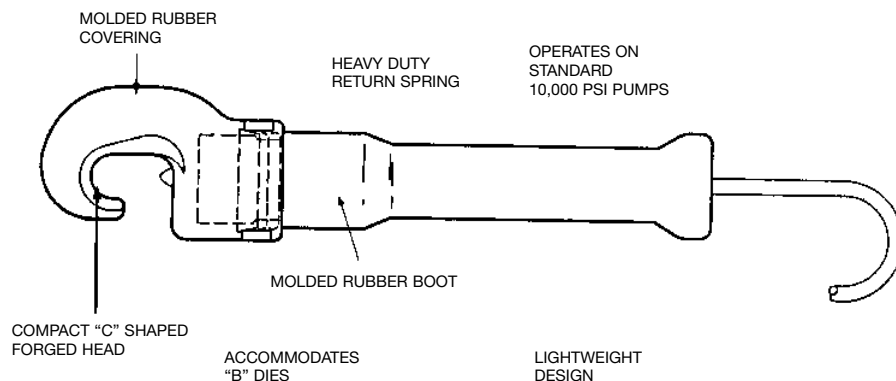

Blue highlighted items are industry standard and most frequently ordered.

Y29BH

HYPRESS™

Hydraulic Tool—
Remote Operated 6,000 PSI

4.5 Ton remote power operated hydraulic tool. The Y29BH HYPRESS™ tool is designed for remote hydraulic power operation. Its small, “C” shaped head is lightweight, designed for use in confined areas, where visibility and space is limited. Accommodates D-(series) nest dies and Y29-(series) indenter dies, for use with code or flex connector/conductor applications. Ideal for OEM applications. Dies sold separately. The Y29BH has a 5-year limited warranty.



SPECIFICATIONS

- Operating Pressure:** 6,000 psi
- Height:** 3"
- Length:** 10.75" (including coupler fitting)
- Head Width:** 1.15"
- Jaw Opening:** 1.2"
- Weight:** 5 lbs.
- Output Force:** 4.5 tons (9000 lbs)
- Crimp Type:** Nest/Indenter

FOR USE ON

- Copper #8 - 4/0 AWG, Code/Flex
 - Nylon Insulated Lugs**
(Connectors meet MIL-T-7928 requirements)
 - YAEV-L, YAEV-H, YAEV-RS, YAEV-RH
 - Non-Insulated Lugs**
(Connectors meet MIL-T-7928 requirements)
 - YAV-L, YAV-R, YAV-RS
 - Non-Insulated Splices**
(Type YSV-L connectors UL Listed, CSA Certified)
 - YSM, YSV-L
- (Consult “Section B” of Catalog for detailed connector descriptions)

BENEFITS

- Easy placement/removal on continuous conductor lengths.
- Lightweight, portable head design
- Companion tool of Y29NC pneumatic HYPRESS™.
- Installs a wide variety of lugs and splices
- Ideal for AN, Flex and Code conductor terminations.
- 5-year limited warranty.

Uninsulated Connectors		Maximum Conductor SIZE	Insulated Connectors	
NEST	IND.		NEST	IND
DV8L-1	Y29PL	#8 AWG	DEV8L	Y29PLE-1
DV6L	Y29PL	#6 AWG	DEV6L	Y29PLE-1
DV4L	Y29PL	#4 AWG	DEV4L	Y29PLE-1
DV2L	Y29PL	#2 AWG	DEV2L	Y29PLE
DV1L	Y29PL	#1 AWG	DEV1L	Y29PLE
DV25L	Y29PL	1/0 AWG	DEV25L	Y29PLE
DV26L	Y29PL	2/0 AWG	DEV26L	Y29PLE

N-45

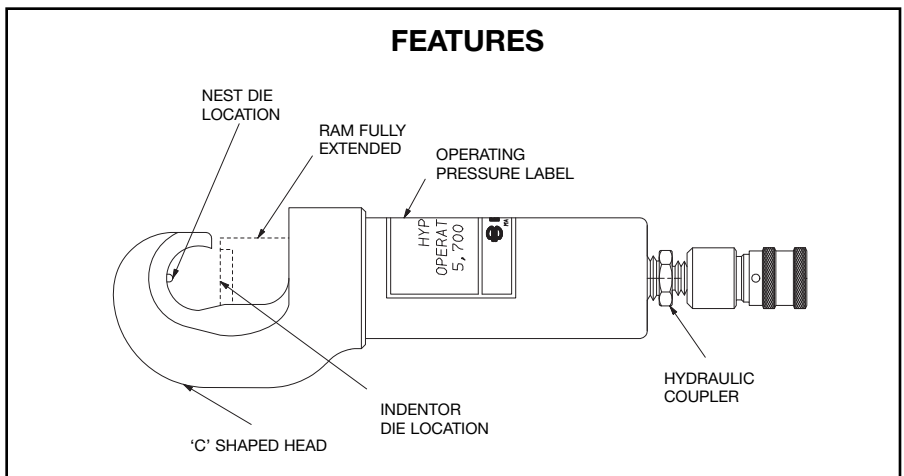

Blue highlighted items are industry standard and most frequently ordered.

Y750BHXT AND Y750CBHXT RUBBER COVERED HEAD

HYPRESS™

12 Ton Remote Power Operated Hydraulic Tool

Conductor Range:
 #14 - 750 kcmil Al/Cu
 #4 - 556.5 kcmil ACSR

12 ton remote power operated hydraulic tool. The Y750BHXT HYPRESS™ incorporates a wide mouth (1.65") C-shaped head for all compression applications. The hook style head provides for easy tapping, splicing, and terminating of overhead lines as well as the full range of HYGROUND® compression grounding system connectors, NEC cable connections and N30 - N650 Navy cable applications.

All standard BURNDY® "U" dies fit the Y750BHXT and Y750CBHXT HYPRESS™. Dies and accessories sold separately.

The Y750CBHXT has a permanently molded rubber covered head and includes a separate rubber molded boot that covers the lower body and hydraulic fitting for tool impact protection. 5-year limited warranty.



BENEFITS

- Covers a wide range of applications and provides easy tool removal from continuous conductors with its C-shaped head (1.65" opening).
- Easy die change out and retention with exposed positive die lock buttons.
- Uses all standard BURNDY® U-dies.
- Y750CBHXT provides molded rubber covering on head, body and hose fittings.
- Hot stick adapter sold separately.
- Infinitely rotatable head, so hydraulic couplers won't easily loosen.
- 5-year limited warranty.

SPECIFICATIONS

- Operating pressure: 10,000 psi
- Force developed: 12 tons
- Jaw opening: 1.65" (42 mm)
- Length: 12.8" (325 mm)
- Weight: 10.3 lbs. (4.7 kg)
- Head width: 5.2" (132 mm)

FOR USE ON

- **Tension Sleeves**
 - Copper #8 sol - 500 kcmil
 - Aluminum #6 sol. - 556.5 kcmil
 - ACSR #4 - 556.5 kcmil
- **Taps**
 - Copper #14 solid - 500 kcmil
 - Aluminum #6 - 500 kcmil
- **Aerial Cable**
 - Copper #6 - 500 kcmil
- **Terminals and Splices**
 - Aluminum #8 - 750 kcmil
 - Copper #8 - 750 kcmil
 - ACSR #4 - 556 kcmil
- **HYGROUND® (Compression Grounding)**
 - Copper #6 - 500 kcmil (cable/ground rod)
 - Ground Rods 1/2" - 1" Diameter

ACCESSORIES:

Cat. No.	Description
PT29402-1	Adjustable head grip for joining head to universal hot sticks.
PT29279-2	Force test gauge for accurate visual reading of output force.
PT29291	Die Case Steel case for storage and protection of "U" dies.
WIREMIKE	Provides quick and easy identification of commonly used conductors.

N-46

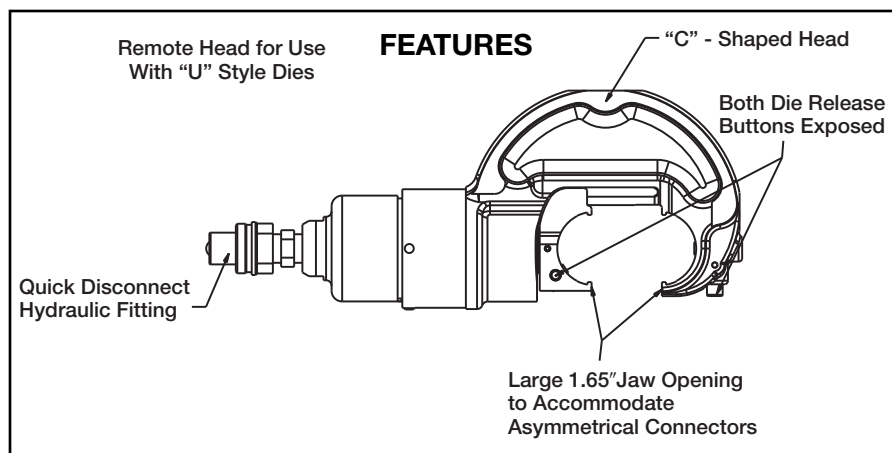

Blue highlighted items are industry standard and most frequently ordered.

Y644MBH

DIELESS HYPRESS™

Hydraulic Tool—
Remote Operated 10,000 PSI

The “1” Crimp-Range Taking 11-Ton Force - Hydraulic Remote Tool #6-1000 kcmil Copper HYLUG™ Terminals and HYLINK™ Splices #6-1000 kcmil Aluminum HYLUG™ Terminal and HYLINK™ Splices

The “1” Crimp Type Y644MBH Dieless HYPRESS™ Remote Tool, crimps 195 different copper and aluminum HYLUG™ terminals and HYLINK™ splices, which cover the breadth of 38 code conductor sizes and 15 Navy cable sizes.

Only one (1) crimp is required for each wire termination for both long and standard length barrels on BURNDY® HYLUG™ and HYLINK™ connectors throughout the entire conductor range. The Y644MBH dieless remote head tool operates on 10,000 psi hydraulic pressure and develops an output force of 11 tons, the same as the self-contained Y644M Dieless HYPRESS™. Five-year limited warranty.

The following size HYDENT™ lugs and two way splices, when crimped with the Y644MBH Dieless HYPRESS™ Tool, produce the following range taking capabilities.

Aluminum Connectors		Copper Connectors	
Standard Wire Size	Expanded Wire Range	Standard Wire Size	Expanded Wire Range
#6 AWG	#6 AWG	#6 AWG	#6 AWG
#5 AWG	#5-#6 AWG	#5 AWG	#5-#6 AWG
#4 AWG	#4-#6 AWG	#4 AWG	#4-#6 AWG
#3 AWG	#3-#6 AWG	#3 AWG	#3-#6 AWG
#2 AWG	#2-#6 AWG	#2 AWG	#2-#6 AWG
#1 AWG	#1-#2 AWG	#1 AWG	#1-#6 AWG
1/0 AWG	1/0-#1 AWG	1/0 AWG	1/0-#6 AWG
2/0 AWG	2/0-#1 AWG	2/0 AWG	2/0-#4 AWG
3/0 AWG	3/0-#1 AWG	3/0 AWG	3/0-#2 AWG
4/0 AWG	4/0-#1 AWG	4/0 AWG	4/0-#1 AWG
250 kcmil	250-1/0 AWG	250 kcmil	250-1/0
300 kcmil	300-2/0 AWG	300 kcmil	300-2/0
350 kcmil	350-3/0 AWG	350 kcmil	350-3/0
400 kcmil	400-4/0 AWG	400 kcmil	400-4/0
500 kcmil	500-4/0 AWG	500 kcmil	500-4/0
600 kcmil	600-250 kcmil	600 kcmil	600-250
750 kcmil	750-500 kcmil	750 kcmil	750-500
1000 kcmil	1000-750 kcmil	800 kcmil	800-500
		1000 kcmil	1000-750



SPECIFICATIONS

- Force Developed:** 11 Tons
- Operating Pressure:** 10,000 psi
- Head Width:** 3.93"
- Overall Length:** 12"
- Weight (less case):** 9-1/2 lbs.

FOR USE ON

AWG/kcmil Wire Size Range	Connector Type
Copper #6 - 1000 kcmil	Terminals YA-L, YA-2LN, YA, YA-2N, YA-L-2TC, YAB-4N, YA-L-TC, YA-2L, YA-4N Splices YS-L, YS-T, YS
Aluminum #6 - 1000 kcmil	Terminals YA-A, YA-A-TN Splices YS-A
Aluminum #6 - 750 kcmil	HYPLUG™ AYP, AYPO

BENEFITS

- Dieless system, eliminates the need to purchase and maintain dies.
- Easy tool positioning with its infinitely rotatable head.
- Easy inspection and positive identification is provided with the BURNDY® logo.
- Five-year limited warranty.

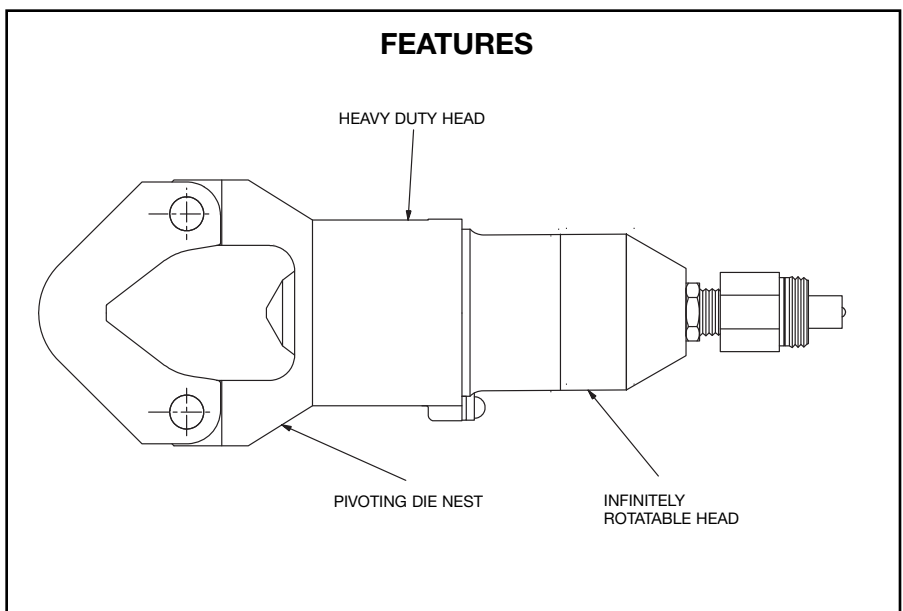

Blue highlighted items are industry standard and most frequently ordered.

4-POINT® Y81KFTMBH

DIELESS HYPRESS™

10,000 PSI Dieless Hydraulic Tool—Remote Operated

#8 - 1000 kcmil Copper
HYLUG™ Terminals and
HYLINK™ Splices

#8 - 750 kcmil Aluminum
HYLUG™ Terminals and
HYLINK™ Splices

The Y81KFTMBH 4-POINT® dieless HYPRESS™ is a remote powered 6 ton hydraulic crimping tool for use on a wide variety of terminal and splice compression applications. The Y81KFTMBH incorporates a dieless latch style head that provides easy tool removal from continuous conductor runs and eliminates the need to purchase and maintain dies. The Y81KFTMBH dieless remote head tool operates on 10,000 psi hydraulic pressure and develops an output force of 6 tons, the same as the self contained Y81KFTMBH. The result is easy termination and splicing using BURNDY® HYLUG™ and HYLINK™ terminals and splices.

The Y81KFTMBH is supplied with a canvas bag and quick connect fittings and comes complete with a 5-year limited warranty.

Y81KFTMBH dieless HYPRESS™ Range Taking Capabilities: The Y81KFTMBH provides range taking capabilities that is UL and CSA listed for Copper (Code, Compact and Flex) and Aluminum (Code and Compact) conductors when used in conjunction with BURNDY® HYLUG™ terminals and HYLINK™ splices. See chart for connector, conductor and range taking combinations.

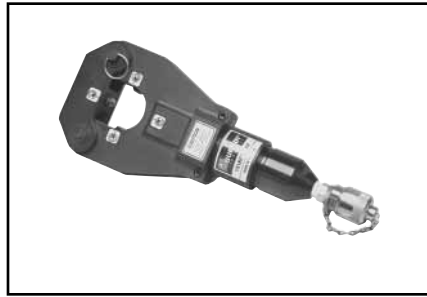

Features and Benefits

- Dieless installation system.
 - ◇ Eliminates the need to purchase and maintain dies.
- UL Listed and CSA Certified with Range Taking Capabilities
 - ◇ Provides the installer with UL Listed and CSA Certified crimps with Range Taking Capabilities when used in conjunction with BURNDY® HYLUG™ Terminals and HYLINK™ Splices.
- Flip top head design.
 - ◇ For easy loading and removal of installed terminals and splices, saving time.
- Incorporates Parker type quick connect couplers.
 - ◇ Eases installation time.
- Audible pressure “pop-off” valve and die embossment providing 360° inspectability.
 - ◇ Assures proper crimps with both audible and visual indicators for the installer.
- 5-year limited warranty on tool.
 - ◇ Customer satisfaction and support.

SPECIFICATIONS

- Output Force:** 6 tons (12,000 lbs.)
(5.4 Metric Tons)
- Weight:** 8.5 lbs. (3.86 kg)
- Overall Length:** 13.9 in. (354 mm)
- Head Width:** 5.4 in. (138 mm)
- Operating Pressure:** 10,000 psi
(68.9 MPa)

FOR USE ON

- Copper, Aluminum, Compressed, Compact, Stranded, Solid and Flex Conductors.
- Installs Splices, Taps and Terminations:
 - #8 - 1000 kcmil Copper (YA, YA-L, YS, YS-L, YS-T, Y-R)
 - #8 - 777.7 (750 Nominal Flex Wire Size) kcmil Flex (YA-FX, YAV, YA-L-FX, YS, YSV-FXB)
 - #8 - 750 kcmil Aluminum (YA-A, YS-A)
 - #8 - 750 kcmil Aluminium Pin Adapters (AYP, AYPO)

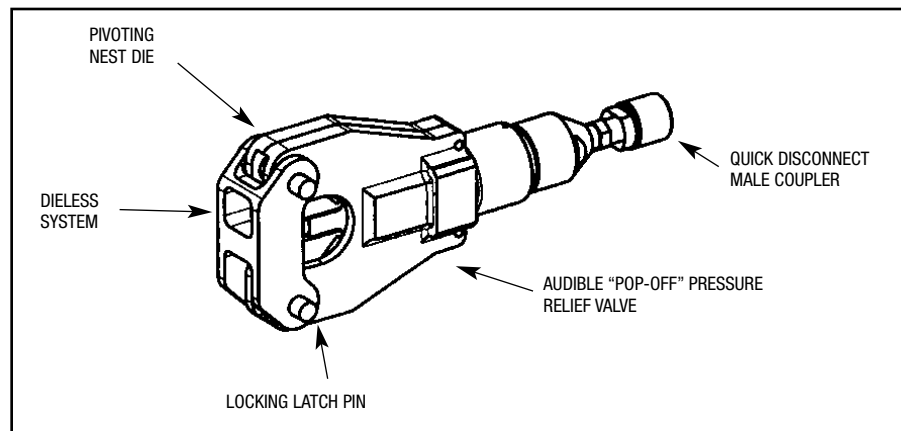

**4-POINT®
Y4PC834MBH**

DIELESS HYPRESS™

**10,000 PSI Dieless Hydraulic
Tool—Remote Operated**

The Y4PC834MBH 4-POINT® C-head dieless HYPRESS™ is a remote powered 6 ton hydraulic crimping tool for use on a wide variety of tap, terminate, and splice compression applications. The dieless capability of this tool eliminates the need to purchase or maintain additional dies. The Y4PC834MBH incorporates a C-shaped head design making it ideal for crimping in tight areas and is easily removed from continuous conductor runs. The head rotates 360° and is mated to a patented rapid advance pump. The Y4PC834MBH weighs only 8.35 pounds and delivers 6 tons of crimping force. The result allows for easy tap, termination and splicing of compression connectors.

The Y4PC834MBH is supplied with a canvas bag, quick connect fittings and comes with a 5-year limited warranty.

The Y4PC834MBH provides range taking capabilities that are UL Listed and CSA Certified for Copper (Code, Compact and Flex) and Aluminum (Code and Compact) conductors when used in conjunction with BURNDY® HYLUG™ terminals and HYLINK™ splices as listed on page C-7 in the Master Catalog.



Features and Benefits

- Dieless installation system
 - ◇ Eliminates the need to purchase and maintain dies.
- UL Listed and CSA Certified with range taking capabilities
 - ◇ Provides the installer with a UL Listed and CSA Certified crimps when used in conjunction with BURNDY HYLUG™ and HYLINK™ compression connectors.
- C-shaped head design
 - ◇ For easily removing tool from continuous run conductors – Simply slide the opening of the head off the conductor. Also ideal for use in tight or constrained spaces.
- Visual 360° inspectability
 - ◇ Assures proper crimps with visual indicators for the installer.
- 5-year limited warranty
 - ◇ Customer satisfaction and support.

SPECIFICATIONS

- Output Force:** 6 Tons (5.4 Metric Tons)
- Weight:** 8.35 lbs (3.7 kg)
- Length:** 13.9 in (354 mm)
- Width:** 5.4 in (178 mm)

FOR USE ON

- Copper, Aluminum, Compressed, Compact, Stranded, Solid and Flex Conductors
- Installs Splices, Taps and Terminations:
 - #8 - 1000 kcmil Copper (YA, YA-L)
 - #8 - 500 kcmil Copper (YS, YS-T, YS-L, Y-R)
 - #8 - 777 (750 Nominal Flex Wire Size) kcmil Flex ((YA-FX, YAV, YA-L-FX)
 - #8 - 535 (500 kcmil nominal flex wire size) kcmil flex (YS, YS-LB, YSV-FXB)
 - #8 - 750 kcmil Aluminum (YA-A)
 - #8 - 350 kcmil Aluminum (YS-A)
 - #8 - 750 kcmil Aluminum Pin Adaptors (AYP, AYPO)

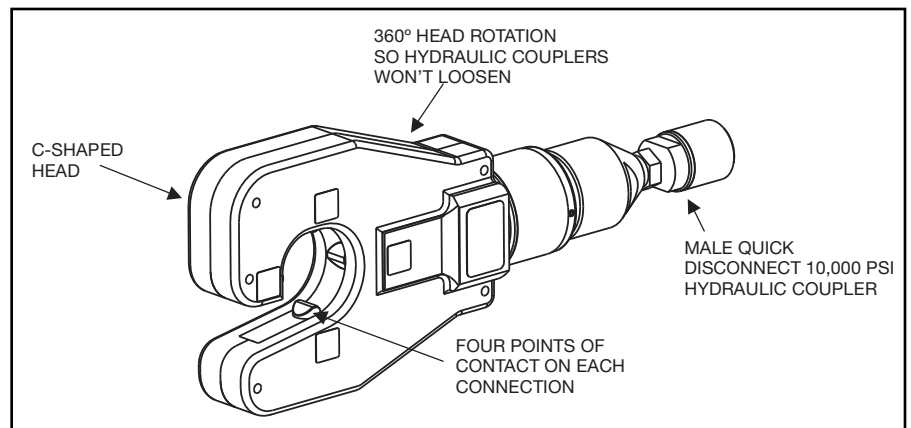

Blue highlighted items are industry standard and most frequently ordered.

Y45

HYPRESS™

15 Ton Remote Power Operated Hydraulic Tool—10,000 PSI

The Y45 Series is designed for remote hydraulic operation. A C-shaped head design provides easy installation of tap and splice connectors. The hook style head with extensive ram travel operates easily on large distribution and transmission conductors. Together with accessories, the Y45 Series tooling may be used on overhead lines. The small light-weight head design is very adaptable for work in underground trenches and manholes. Uses standard BURNDY® “S” Dies.

Cat. No. **PT6515** is required to use “U-” type dies in all Y45 variations. Order Head, Hose, Pump, Dies, and accessories separately. 5-year limited warranty.



SPECIFICATIONS

	Y45
Operating pressure:	10,000 psi
Force developed:	15 Tons
Weight (less case):	15-3/4 lbs.
Maximum Width:	7-1/4"
Maximum Height:	14-1/4"

FOR USE ON

AWG/kcmil Wire Size Range		Connector Type
Tension Sleeves	Copper	#8 sol.-500 kcmil
	Aluminum	#6 sol.-954 kcmil
	ACSR	#4 -795 (26/7)
Taps	Aluminum	#14-954 (18/1) ACSR
	ACSR	#6-795 (54/7)
Aerial Cable Connectors	Copper	#6 str.-1500 kcmil
	Aluminum	#4 str.-1000 kcmil
HYGROUND®		
Compression Grounding	Copper	#6-500 kcmil 1/2" - 1" ground rods
Code Cable Terminals and Splices	Copper	#8-1500 kcmil
	Aluminum	#8-1000 kcmil
Taps	Copper	#14-1000 kcmil
	Aluminum	#14-900 kcmil

BENEFITS

- Easy connector installation and tool removal from line conductors with the open C-shaped head.
- Easily lifted into working position using lifting eye.
- Easy die changing plus secure die alignment is provided with the positive die lock buttons.
- Long life expectancy is provided with fully protected ram and die buttons.
- Rapid assembly and disassembly is provided with the quick disconnect hydraulic coupler.
- Rugged design provides long life expectancy.
- 5-year limited warranty.

ACCESSORIES:

Cat. No. **PT6515**
Description:
Adapter for use with “U-” die sets.

Cat. No. **PT6545**
Description:
Die carrying case for “S” and “P” type dies. Holds eight (8) die sets. (Dies sold separately.)

N-50

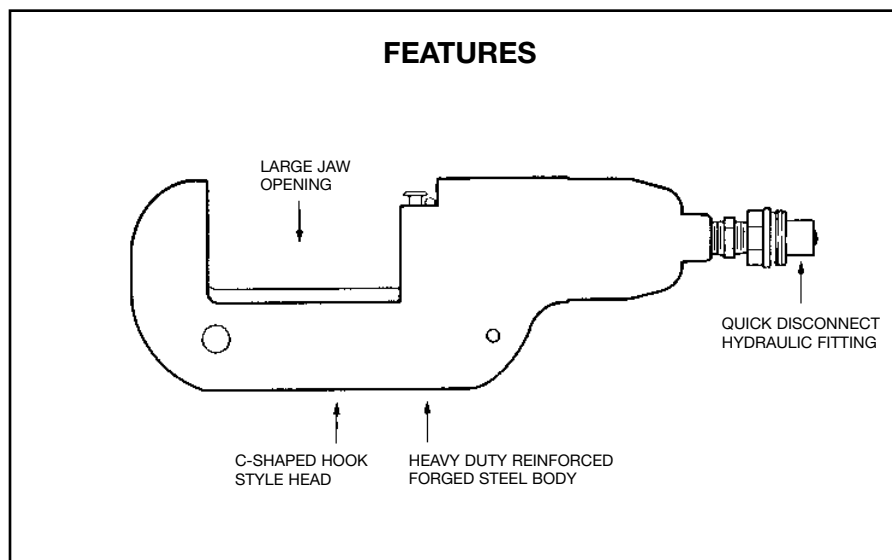

Blue highlighted items are industry standard and most frequently ordered.

Y46 AND Y46C

HYPRESS™

15 Ton Force Remote Operated Hydraulic Tool—10,000 PSI

The Y46 standard tool and Y46C rubber covered tools are lightweight, compact and versatile with installation dies for both circumferential and nest-indentor types. Accessories include “U-” die adapter, a cable cutting die for 1.2” diameter non-steel conductors, plus a lifting eye and universal hot-stick adapter for overhead line construction. 5-year limited warranty.



BENEFITS

- Compact “C” shaped head allows easy placement and removal from continuous conductor lengths.
- Versatile and economical-HYPRESS™ tools work on all commonly used copper and aluminum products.
- Dies and adapters lock into or remove from tool head easily with the positive push button die locks.
- Safety, strength and high quality is provided with strong forged steel and precision machined components.
- Excellent for HYGROUND® compression grounding applications through 1” ground rods and up to 500 kcmil taps, terminals and splices.
- Compression terminal, splice and tap connectors are UL Listed and CSA Certified when installed with the Y46 and Y46C HYPRESS™ and recommended die set.
- Y46C has a permanently molded head of 3/16” rubber and includes a separate molded rubber boot to cover the lower HYPRESS™ body and hydraulic coupler for impact protection.

SPECIFICATIONS

	Y46	Y46C
Force developed:	15 Tons	15 Tons
Operating pressure:	10,000 psi	10,000 psi
Jaw opening:	2”	2”
Maximum width:	4-1/2”	4-3/4”
Overall length:	15”	21-3/4” (incl. boot)
Weight (less case):	16 lbs.	17-1/2 lbs.
Molded Covering:	No	Yes

FOR USE ON

Connector Type	Conductor Range
Copper	Terminals-Grounding to 500 kcmil
#8 AWG str.-	YGA, YGHA, YGF
1500 kcmil	Terminals-Uninsulated #8 to
Code Cable	1500 kcmil YA, YA-2N, YA-L,
Navy Cables	YA-LB, YA-TC, YA-2LN, YAB-4N,
Flexible and	
Extra Flexible	YAV-L Box, YAV-L, YAV-RS Box,
1/2”-1” Ground Rods	YAV-RS, YA-TC-FX
	Terminals-Insulated #8 to 2/0
	YAEV-L Box, YAEV-L, YAEV-H,
	YAEV-RS, YAEV-RH
	Splices #8 to 1500 kcmil
	YS, YS-T, YS-L, YS-LB, YST,
	YSP-T, YGS, YGHS
	Taps
	YH, YCHC #14 to 1000 kcmil
	YC-C to 4/0 AWG
	Taps-Grounding to 500 kcmil
	YGHC-C, YGHP-C, YGHR-C
Aluminum	Terminals
#8 AWG-	YA-A, AYP, AYPO
1250 kcmil	Splices
Code Cables	YS-A, YS-AT, YRB
	Taps
	YFD, YFN, YFO, YFR
ACSR	See Burndy Overhead Transmission and Distribution Catalog Module

N-51

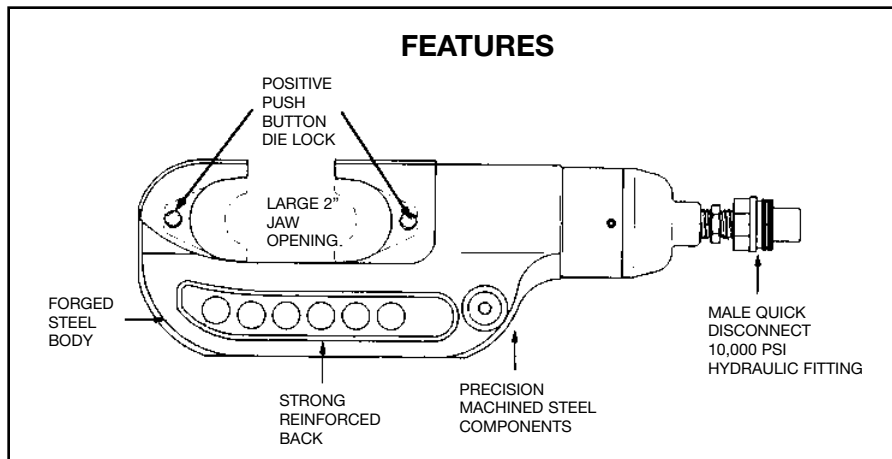

ACCESSORIES:

- Cat. No.**
- P15K** Cutter die max. 1.2” dia.
 - PUADP-1** “U-”die adapter
 - PT10128** Universal hotstick adapter-Y46
- Y46-2** Same as Y46 with Female coupler

Blue highlighted items are industry standard and most frequently ordered.

Y60BHU AND Y60BHUD

HYPRESS™

60 Ton Remote Power Operated Hydraulic Tools

Single and Double Acting Hydraulic Tool Designs

The Y60BHU HYPRESS™, single acting, and Y60BHU-D HYPRESS™, double acting, are both designed to provide fast, easy operation plus a durable and substantially longer design life expectancy. Both Y60BHU and Y60BHU-D HYPRESS™ tools accommodate the same “L” dies. The “L” dies are designed for copper and aluminum code cables and aerial conductor sizes through 2500 kcmil and will accommodate ACSR through 2156 (84/19) str. Five-year limited warranty.

TYPE “L” DIES

For Use With Y60BHU and Y60BHUD

BURNDY® offers two types of “L” dies. Our standard width L dies (example: L735).

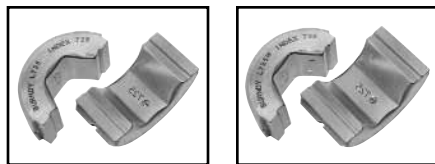

Standard L Die

Wide L Die

Wider “L” dies with Indicia marks (example: L735W). Indicia marks on the die provide the installer with the start location for the next overlap crimp consistently on aluminum connector surfaces. Reduces the number of crimps and installation time.



The following dies are available in this series:

- | | |
|-------|-------|
| L717W | L719W |
| L720W | L722W |
| L724W | L725W |
| L727W | L728W |
| L729W | L735W |

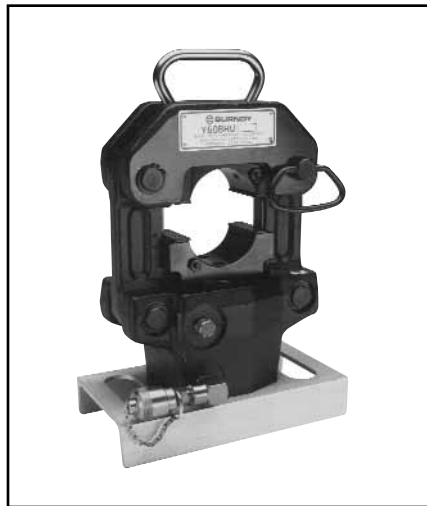

BENEFITS

- Easy to carry with heavy duty handle.
- Easy to remove splices with nest that pivots open.
- Safety and security is provided with captive locking pin for nest die.
- Long life expectancy (50,000 cycles) with heavy duty steel frame.
- Fast easy die changing and secure die positioning with positive die release locking pins.
- Faster retraction with double acting hydraulic system (Y60BHUD).
- Protected male coupler with captive cap.
- Stability is provided with sturdy steel base.
- Easy, less costly repairs with fewer parts that are easily accessible (example: Bottom die holder).
- 5-year limited warranty.

SPECIFICATIONS

- Force developed:** 60 tons
- Operating pressure:** 10,000 psi
- Hydraulic oil:** BURNDY® ALFLUID™
- Life expectancy:** 50,000 cycles min.
- Height:** 16.62”
- Weight (less case):** 70 lbs.
- Shipping weight:** 97 lbs.

FOR USE ON

Copper

- 300 kcmil-2000 kcmil Str. Code Cable
- Terminals
YA, YA-2N, YAB-4N, YA-L, YA-2LN, YA-LB
- Splices
YS, YST, YS-L, YS-T, YSP-T

Aluminum

- 250 kcmil-2000 kcmil Str. Code Cable
- Terminals
YA-A
- Splices
YS-A, YS-AT

Transmission and Distribution Connectors

Tension Sleeves:

- Copper: 1/0 str. - 1000 kcmil
- Aluminum: 1/0 str. - 2300 kcmil
- ACSR: 1/0 - 2156 (84/19 str.)

Aerial:

- Copper: 4/0 str. - 2500 kcmil
- Aluminum: 3/0 str. - 2500 kcmil
- YTS, YTN, YNS, YNA, YNT, YNTA, YNU, YDS, YDN, YCS, YCA, YCU

FEATURES

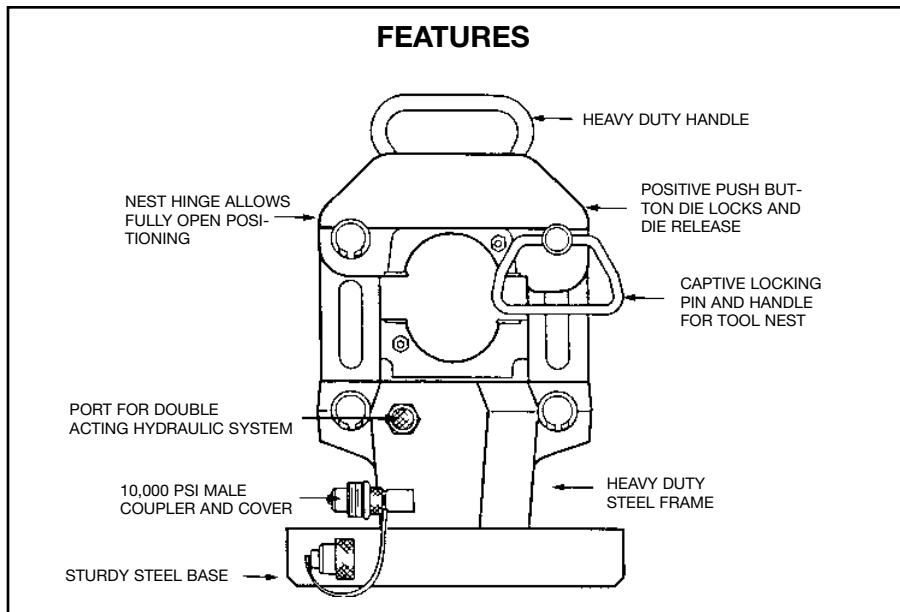

Blue highlighted items are industry standard and most frequently ordered.

Y29NC

PNEUMATIC HYPRESS™

The Y29NC Pneumatic HYPRESS™ operates on 85-100 PSI and will install insulated and uninsulated terminals from #8 - 2/0 copper. Uses DV type nest with Y29 type indenter.

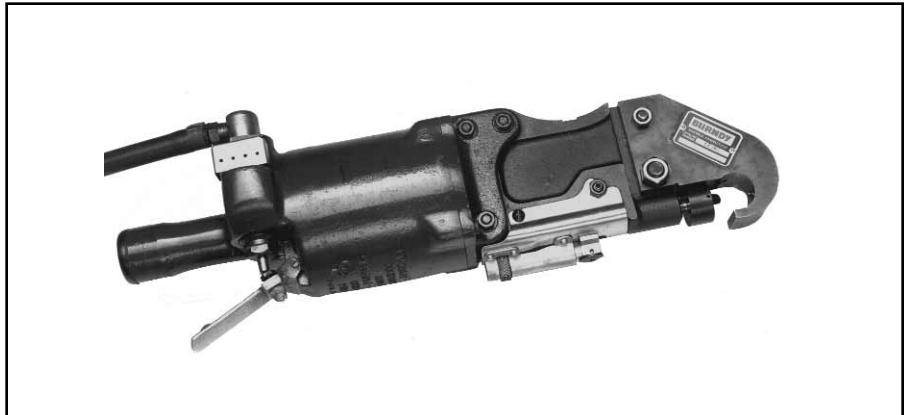

BENEFITS

- Portable or bench mounted.
- Adjustable blow off valve to ensure proper indenting force.
- Uses DV type nest with Y29 type indenter.
- Hand operated.
- 5-year limited warranty.

SPECIFICATIONS

Weight: 12-1/2 lbs.
Length: 17-1/2"
Air line pressure: 85 - 100 PSI

FOR USE ON

Wire Range: #8-2/0 Cu
YAEV-L, YAEV-H, YAEV-RS, YAEV-RH,
YAV-L, YAV-R
YAV-RS, YSV-L, YSM

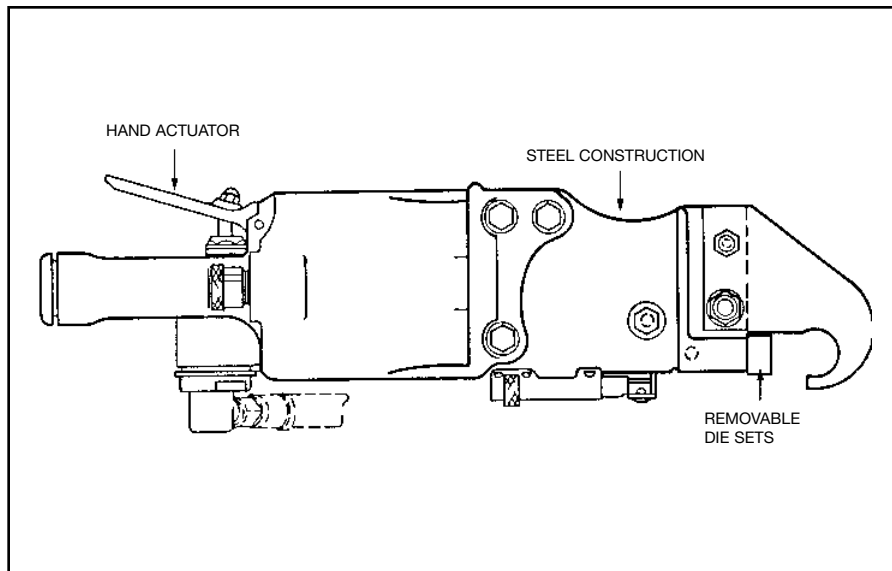

Die Index	Nest/Indenter
38/631	DV8L/Y29PL
6/631	DV8L/Y29PL
39/632	DV6LY29PL
7	D6CL/Y29PL
40/633	DV4L/Y29PL
9	D3CL/Y29PR
41/634	DV2CL/Y29PL
42	DVIL/Y29PR
43	DV256/Y29PR
13	D26L/Y29PR
44	DV26L/Y29PR
49	DV8L/Y29PL

N-53

Blue highlighted items are industry standard and most frequently ordered.

TFM

TAPE FED MACHINE

For Automatic Installation of Tape Mounted Terminals

The BURNDY® TFM machine installs vinyl insulated, nylon insulated and uninsulated terminal sizes #26-#10 without time-consuming die changes. A rotating turret die holder consists of three die sets. With the new TFM, your operators can crimp from 1,500 to 2,500 terminals per hour.

BURNDY® has made a breakthrough in die changing—the TFM is the first and only turret die holder to crimp terminals automatically. No long complicated setups or paying for duplicate machines: Once the dies are secure to the die holder there's never a need to remove them. No adjustments. No calibrations. Just a simple twist of the wrist. An operator can change reels, terminals and dies in seconds flat.



SPECIFICATIONS

Height: 16"
Width: 13"
Depth: 6"
Weight: 35 lbs.

FOR USE ON

#26 - #10 AWG Cu

Vinyl Insulated Terminals:

BA-EF-M, BA-EL-M, BA-EM, BA-EZ-M

Nylon Insulated Terminals:

YAE-M, YAE-FM, YAE-ZM

Non-Insulated Terminals:

YAD-M, YAD-FM

Vinyl Insulated Disconnects:

PQ-M

FEATURES

- Positive wire locator.
- Foot-actuated crimp.
- Lightweight Reel.
- Quiet operation.
- Lease policy.
- Can crimp up to 1,500 to 2,500 terminals per hour.
- An operator can change reels, terminals and dies in 30 seconds.
- Rotating turret die holder permits terminal change over in seconds.

BENEFITS

- Ensures proper wire termination.
- Minimizes repetitive hand motion injuries.
- Smooth rotation advance of connectors.
- Eliminates need for earplugs/noise dampeners.
- Inexpensive alternative to buying.
- High volume production capability.
- Minimizes production downtime.

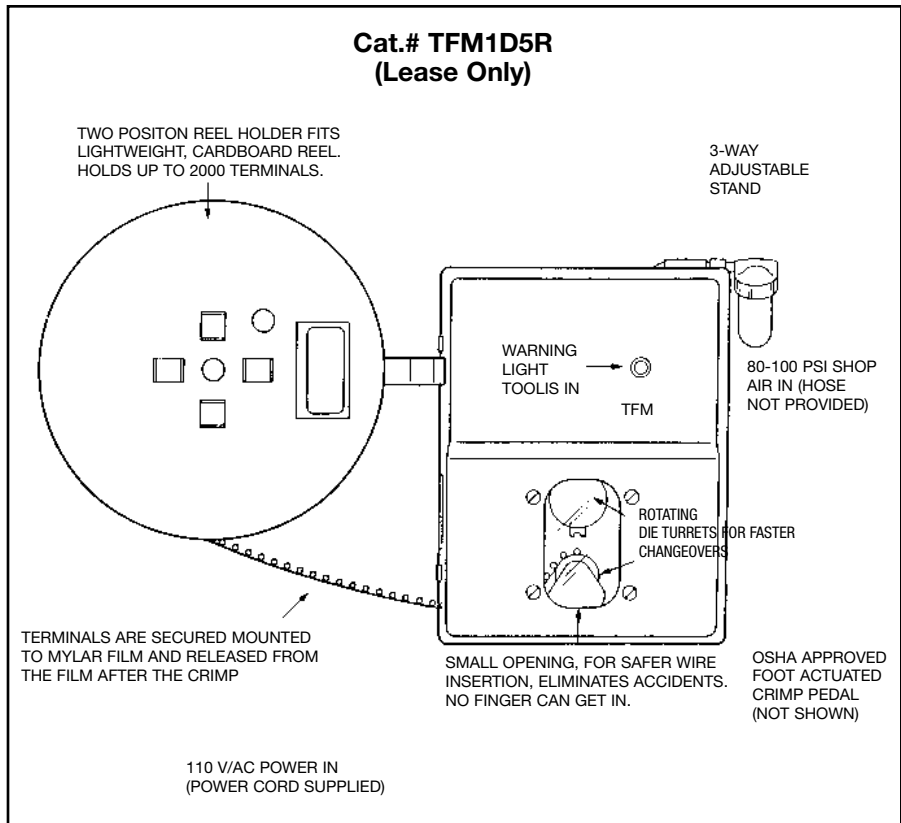

TFM INSTALLATION TOOLING CHART

Tape Mounted Catalog Number 2000/Reel	Installation Tooling
BA16E4M	TFM with DFM3-1 Die
BA16E6M	
BA16E8M	
BA16E10M	
BA16E14M	
BA16E38M	
BA14E4M	TFM with DFM2-1 Die
BA14E6M	
BA14E8M	
BA14E10M	
BA14E14M	
BA14E516M	
*BA10E6M	TFM with DFM1D5 Die
*BA10E8M	
*BA10E10M	
*BA10E14M	
*BA10E38M	

BA16EF2M	TFM with DFM3-1 Die
BA16EF6M	
BA16EF8M	
BA16EF10M	
BA14EF8M	TFM with DFM2-1 Die
BA14EF10M	
*BA10EF6M	TFM with DFM1D5 Die
*BA10EF8M	
*BA10EF10M	

BA16EL6M	TFM with DFM20D1 (20-22 AWG) DFM3-1 (16-10 AWG)
BA16EL8M	
BA16EL10M	
BA14EL6M	TFM with DFM2-1 Die
BA14EL8M	
BA14EL10M	TFM with DFM1D5 Die
*BA10EL6M	
*BA10EL8M	
*BA10EL10M	

* 1000 per Reel

Tape Mounted Catalog Number 2000/Reel	Installation Tooling
YAD18-4M	TFM with DFM6-1 Die
YAD18-6M	
YAD18-8M	
YAD18-10M	
YAD18-14M	
YAD14-4M	TFM with DFM5D1 Die
YAD14-6M	
YAD14-8M	
YAD14-10M	
YAD14-14M	
YAD14-38M	TFM with DFM4D1 Die
*YAD10-8M	
*YAD10-14M	
*YAD10-516M	
*YAD10-38M	

YAE22N65FM	TFM with DFM11D1 Die
YAE22N66FM	
YAE18G43FM	TFM with DFM10D1 Die
YAE18N56FM	
YAE18N57FM	TFM with DFM9D1 Die
YAE14N76FM	
YAE14N77FM	TFM with DFM9D1 Die
YAE14N78FM	

* 1000 per Reel

Tape Mounted Catalog Number 2000/Reel	Installation Tooling
YAE22G18M	TFM with DFM11D1 Die
YAE22G16M	
YAE22G13M	TFM with DFM10D1 Die
YAE18N29M	
YAE18N27M	
YAE18-N7M	
YAE18N26M	
YAE18N21M	
YAE18N25M	
YAE18G43M	
YAE-18N24M	
YAE18N1M	
YAE18NM	
YAE18N2M	TFM with DFM7D1 Die
YAE18N3M	
YAE14N43M	
YAE14N1M	
YAE14NM	
YAE14N2M	
YAE14N3M	
YAE14N4M	
YAE12N9M	
YAE12N1M	
YAE12NM	
YAE12N2M	
YAE12N3M	
*YAE10N5M	
*YAE10N11M	
*YAE10NM	
*YAE10N3M	
*YAE10N2M	
*YAE10N4M	

* 1000 per Reel

Tape Mounted Catalog Number 2000/Reel	Installation Tooling
YAE22Z1M	TFM with DFM11D1 Die
YAE22Z2M	
YAE22Z3M	TFM with DFM10D1 Die
YAE18Z1M	
YAE18Z3M	TFM with DFM9D1 Die
YAE18Z4M	
YAE14Z3M	TFM with DFM7D1 Die
YAE14Z4M	
YAE12Z2M	TFM with DFM7D1 Die
YAE12Z3M	

BA16EZ2M	TFM with DFM3-1 Die
BA16EZ6M	
BA16EZ10M	
BA14EZ6M	TFM with DFM2-1 Die
BA14EZ8M	
BA14EZ10M	TFM with DFM1D5 Die
*BA10EZ8M	

PQ18R257M	TFM with DFM13D1 Die
PQ18R258M	
PQ14R257M	TFM with DFM12D1 Die
PQ14R258M	
PQ10R258M	TFM with DFM16D1 Die

PQ18R256M	TFM with DFM15D1 Die
PQ14R256M	TFM with DFM14D1 Die

PQ18R187M	TFM with DFM13D1 Die
PQ18R188M	
PQ14R187M	TFM with DFM12D1 Die
PQ14R188M	

* 1000 per Reel

Blue highlighted items are industry standard and most frequently ordered.

MCC500, MCC1000

MANUAL CABLE CUTTERS

The MCC series cable cutters are precision cable cutters incorporating high leverage shear-type design capable of cutting up to 1000 kcmil copper and aluminum cables. Rugged steel blades and fiberglass construction provide cutting ease, long life and minimum cable distortion. MCC20 has non-slip grip covered forged steel handles.

The MCC series cable cutters are warranted to be free from defects in material (excluding blades) and workmanship for one year.



FEATURES

- High quality design and construction.
- Rugged high quality steel blades.
- Fiberglass handles with soft grips.
- MCC20 has forged steel handles with non-slip grips.

BENEFITS

- Easy cutting with minimal cable distortion.
- Excellent cutting edge performance.
- Provides comfortable tool operation and long life.

Catalog Number	Overall Length	Max. Capacity		Max. Insulation Diameter	Weight
		Copper	Aluminum		
MCC500	21" [533 mm]	500 kcmil	500 kcmil	1.25" [32 mm]	3.5 lbs. (1.5 kg)
MCC1000	32" [813 mm]	1000 kcmil	1000 kcmil	1.90" [48 mm]	9.0 lbs. (4.0 kg)

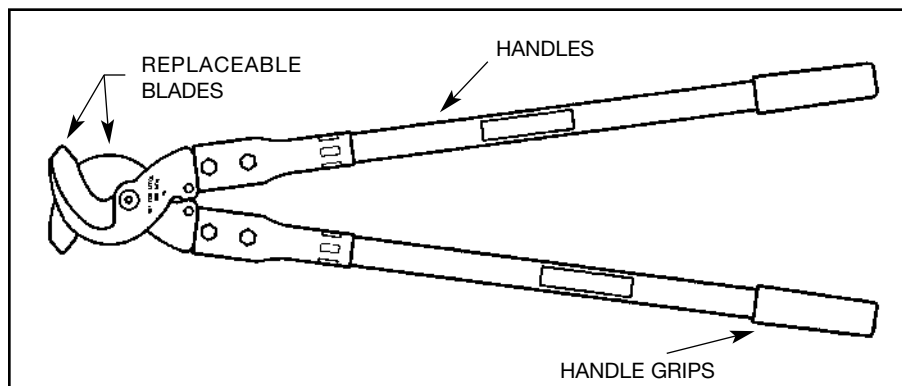

N-56

Replacement Blades

Catalog Number	Description
MCC500BLADESET	Replacement blades for MCC500
MCC1000BLADESET	Replacement blades for MCC1000

Blue highlighted items are industry standard and most frequently ordered.

**RCC336, RCC556,
RCC600, RCC750HD,
RCC954ACSR,
RCC1000**

RATCHET CABLE CUTTERS

The RCC series cable cutters are precision high quality tools designed to cut up to 954 ACSR and 1000 kcmil copper and aluminum. The tools are equipped with rugged steel blades, and a precision bi-directional ratchet mechanism for positive blade control, including where applicable, a fast action thumb slide collar for rapid blade advance and rugged fiberglass or non-slip grip handles. RCC600 and RCC750HD have cushion grip covered steel handles.

The RCC series cable cutters are warranted to be free from defects in material (excluding blades) and workmanship for one year.

For replacement blades, consult factory for details.

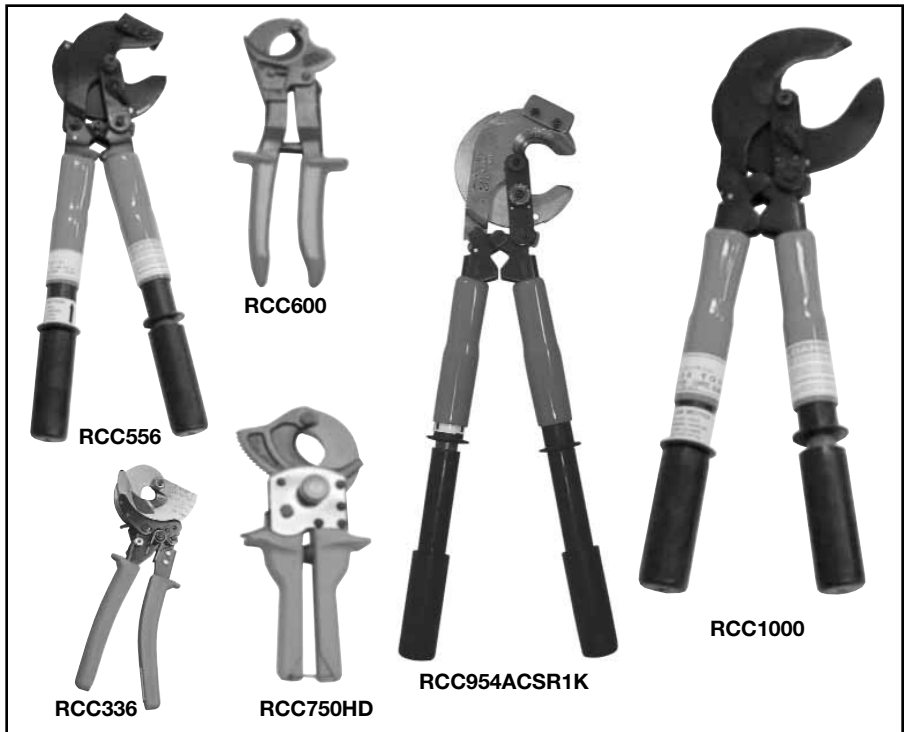

FEATURES

- Patented high strength steel blades.
- Quick release, bi-directional ratchet mechanism.
- Rapid blade advance.

BENEFITS

- Easy cutting with minimal cable distortion.
- Excellent cutting edge performance.
- Provides comfortable tool operation and long life.

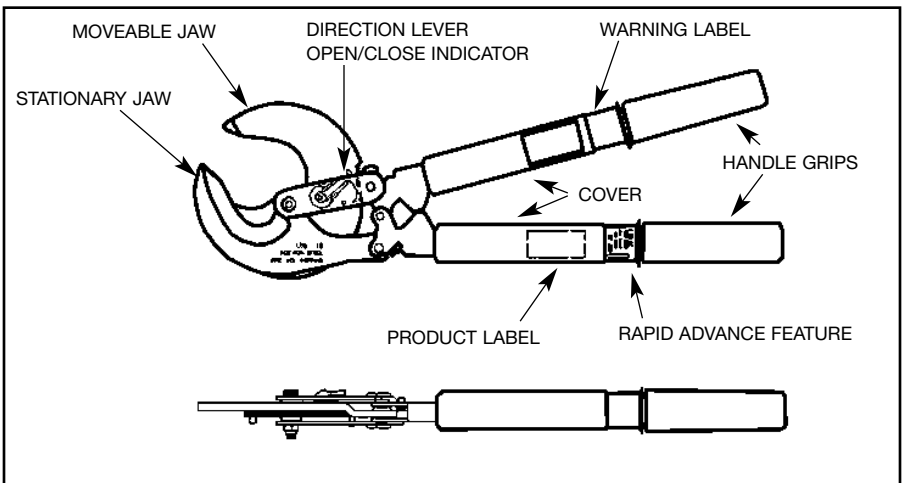

Catalog Number	Overall Length	Maximum Capacity			Maximum Insulation Diameter	Weight
		Copper	Aluminum	ACSR		
RCC336	10.5" [267 mm]	350 kcmil [177 mm]	500 kcmil [253 mm]	336 kcmil [18.31 mm]	0.74" [18.8 mm]	1.2 Lbs. (0.5 kg)
RCC556	20" [508 mm]	500 kcmil [26.70 mm]	500 kcmil [26.70 mm]	556 kcmil [23.55 mm]	1.25" [31.75 mm]	4.5 Lbs. (2.0 kg)
RCC600	10" [254 mm]	600 kcmil [26.70 mm]	600 kcmil [26.70 mm]	—	1.25" [31.75 mm]	1.27 Lbs. (.57 kg)
RCC750HD	10.5" [267 mm]	750 kcmil [29.36 mm]	750 kcmil [29.36 mm]	—	1.62" [41.15 mm]	2.43 Lbs. (1.1 kg)
RCC954ACSR1K	22.75" [578 mm]	1000 kcmil [33.27 mm]	1000 kcmil [33.27 mm]	954 kcmil [30.38 mm]	1.38" [35.05 mm]	6.5 Lbs. (2.95 kg)
RCC1000	20" [508 mm]	1000 kcmil [33.27 mm]	1000 kcmil [33.27 mm]	—	2.375" [60.32 mm]	4.5 Lbs. (2.0 kg)

Blue highlighted items are industry standard and most frequently ordered.

YCUT129ACSR

HYDRAULIC HAND OPERATED CUTTER

The BURNDY® YCUT129ACSR incorporates a specialized latch style cutting head that allows interference-free closure for mid-span cuts. The cutter head rotates 180 degrees to allow users to get into tight areas easier. The YCUT129ACSR weighs only 11.4 pounds, yet delivers 7 tons of cutting force. The YCUT129ACSR with its hardened steel blades is capable of cutting up to 1.29" diameter bare or insulated copper and aluminum cable, 1113 ACSR, 5/8" ground rod, 1/2" rebar and 5/8" diameter soft steel bolts 1/2" standard guy strand and up to 3/8" EHS guy strand.

The YCUT129ACSR comes equipped with a high impact formed carrying case to hold the tool and accessories. The BURNDY® YCUT129ACSR is provided with a 5-year limited warranty (excluding blades).



SPECIFICATIONS

- Force Developed:** 7 U.S. short tons
- Tool Weight:** 11.4 lbs. (5.1 kg)
- Length:** 22.4" (56.9 cm)
- Width:** 2.5" (6.4 cm)
- Height:** 6.6" (16.8 cm)

FOR USE ON

- Copper Cable: up to 1.29"
- Aluminum Cable: up to 1.29"
- ACSR: up to 1113 ACSR
- Ground Rod: up to 5/8"
- Rebar: up to 1/2"
- Soft Steel Bolts: up to 5/8"
- Standard Guy Strand: up to 1/2"
- EHS Guy Strand: up to 3/8"

ACCESSORIES

- **Carrying Case:** Cat# PT10024162
- **Replacement Blades:**
 - Cat# PT10037388 (Moving Blade)
 - Cat# PT10037384 (Fixed Blade)

Features and Benefits

- Patented rapid advance pump.
 - ◊ Faster cuts with less hand strokes.
- Specialized latch head design.
 - ◊ Interference free closure on mid-span cuts.
- Handle trigger drain
 - ◊ For convenient blade retraction.
- Hardened steel blades.
 - ◊ Ability to cut ACSR, ground rods, rebar and guy wire.
- Comfort grip handles.
 - ◊ Help ease fatigue with continuous use.
- 180-degree head rotation.
 - ◊ Versatile head positioning to get into tight areas easier.
- Durable high impact formed carrying case.
 - ◊ Provides tool protection and stores accessories.
- 5-year limited warranty on tool (excluding blades).
 - ◊ Customer satisfaction and support.

N-58

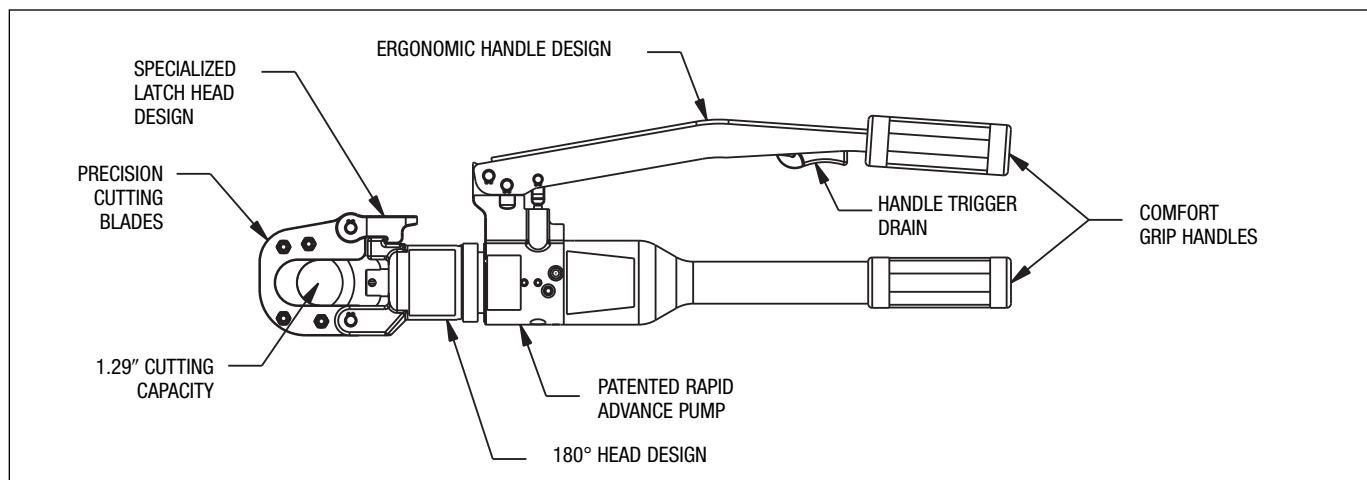

Blue highlighted items are industry standard and most frequently ordered.

**PATRIOT®
PATHCC10-18V SERIES**

BATTERY ACTUATED TOOL

Hydraulic Self-Contained Cutter

The BURNDY® PATHCC10-18V series C-head cutter is an innovative compact and mobile cutting tool that allows users to interchange different cutting blades customized for their application. With a “C”-shaped style head and large opening, it’s easy to scoop and cut without the need to open or close a latch. The tool head swivels 355° and comes with a retractable assist handle to help maneuver the cutting head into position. The PATHCC10-18V blade alignment technology ensures a clean cut and maximum blade life.

The PATHCC10-18V series tool accommodates four different interchangeable blade types: HCCACSR, HCCSOL, HCCCUAL, and HCCGUY. The PATHCC10-18V series tool comes in a variety of options to include a covered head version (PATHCC10C-18V), and the ability to order the tool with specific blades only. See the table for individual catalog numbers.

The PATHCC10-18V series cutters operate on 18-volt Ni-MH batteries. Each tool comes equipped with an impact resistant formed carrying case along with a tool retention lanyard, battery charger and two batteries. The carrying case also has pre-formed pockets to house all four blade types. The PATHCC10-18V series tools are provided with a 5-year limited warranty (excluding blades) and a lifetime power-train warranty on the INFINITY DRIVE®. The batteries and charger are provided with a 1-year limited warranty.



Tool Catalog Number	Blade Provided
PATHCC10-18V	HCCACSR, HCCGUY, HCCSOL, HCCCUAL
PATHCC10ACSR-18V	HCCACSR
PATHCC10GUY-18V	HCCGUY
PATHCC10SOL-18V	HCCSOL
PATHCC10CUAL-18V	HCCCUAL
PATHCC10*	None

* The PATHCC10 is an economical solution for those customers already set up with batteries and chargers. The PATHCC10 is strictly the tool and carrying case; it does not include blades, batteries or a charger. Order blades separately.

Each BURNDY® HCC blade kit is designed specifically for the material it is intended to cut. Each blade is made from high strength tool steel and then hardened to ensure a long life. Each blade kit comes complete with screws and wrench for installation. The HCCGUY and HCCSOL blade kits are also provided with a blade holder. This holder provides additional support when cutting. The blade table points out the materials each blade is designed to cut.

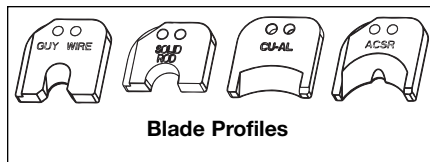

Blade Profiles

SPECIFICATIONS

- Tool Weight:** 20.4 lbs
- Length:** 21.4"
- Width:** 3.7"
- Height:** 12.8"
- Operating Voltage:** 18V
- Recharge Time:** < 45 minutes

FOR USE ON

- Reference Blade Table*
- ACSR: up to 1590 (Falcon)
 - EHS guy strand: up to 9/16"
 - Standard guy strand: up to 9/16"
 - Ground Rod: up to 3/4"
 - Rebar: up to 5/8"
 - Soft steel bolts: up to 5/8"
 - Copper: up to 1.50"
 - Aluminum: up to 1.50"

ACCESSORIES

- Battery:** Cat# **BAT18V**
Hi-capacity 18V (2.6AH)
- Chargers:**
120V-AC Cat# **PATCHGR18V**
12/24V-DC Cat# **BCT/PATDCCHGR**
240/250V-AC Cat# **PATCHGR250V**

Blade Table		
Catalog Number	Cutting Material	Max. O.D.
HCCACSR	ACSR	1590 kcmil
HCCCUAL	Cu & Al	1.5" (38 mm)
	Ground Rod	3/4" (19 mm)
HCCSOL	Rebar	5/8" (16 mm)
	Soft Steel Bolts	5/8" (16 mm)
HCCGUY	Std. Guy Wire	9/16" (14 mm)
	EHS Guy Wire	9/16" (14 mm)

The HCCSOL and HCCGUY blade kits include a blade holder for the stationary blade. To order replacement blades without the blade holder order catalog number HCC-SOLRPLBLDS or HCCGUYRPLBLDS.

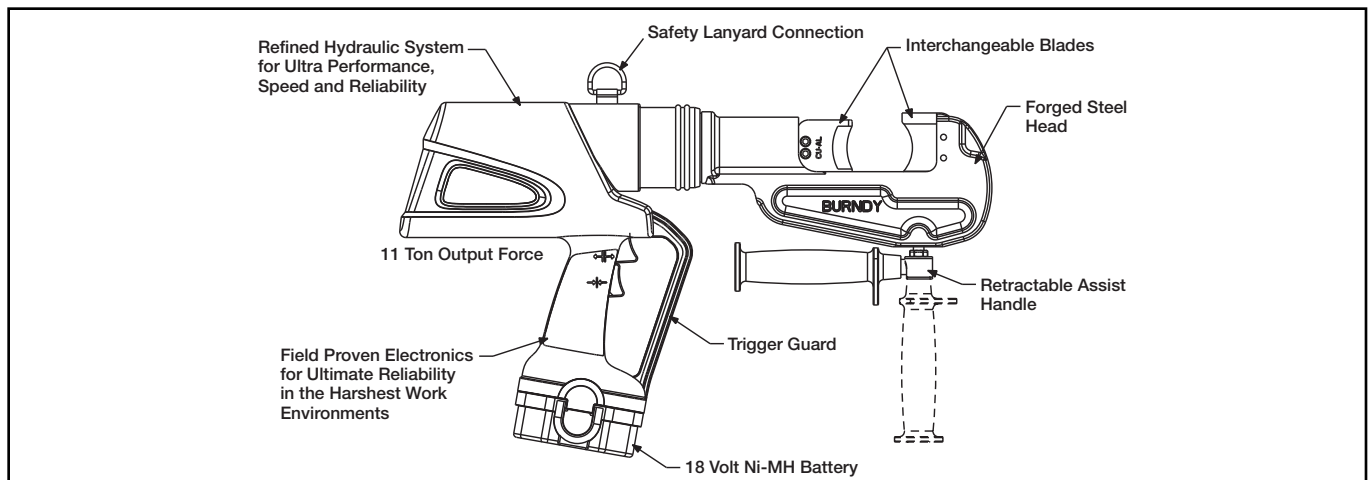

Blue highlighted items are industry standard and most frequently ordered.

PATRIOT® PATCUT129ACSR-18V

BATTERY ACTUATED TOOL

Hydraulic Self-Contained Cutter

The BURNDY® PATCUT129ACSR-18V battery powered cutting tool is compact, fast, easy to use and incorporates the latest in battery tool technology. The ergonomic design allows one hand operation so that the other is free to manipulate the conductor in the proper cutting position. The PATCUT129ACSR-18V incorporates a specialized latch style cutting head that allows interference-free closure for mid-span cuts. The cutter head rotates 180 degrees to allow users to get into tight areas easier. The PATCUT129ACSR-18V is capable of cutting up to 1.29" diameter copper and aluminum cable, 1113 ACSR, 5/8" ground rod, 1/2" rebar, 5/8" diameter soft steel bolts, up to 1/2" standard guy strand, and up to 3/8" EHS guy strand.

The PATCUT129ACSR-18V operates on industry standard 18-volt Ni/MH batteries that eliminate voltage depression or "memory" issues. The PATCUT129ACSR-18V comes equipped with a high impact formed carrying case to hold the tool, a tool retention lanyard, a battery charger and two batteries. The PATCUT129ACSR-18V is provided with a 5-year limited warranty (excluding blades), and 1-year on batteries and charger.



Features and Benefits

- Battery powered cutting technology.
 - ◊ Easy tool operation and portability.
- Advance design high-speed pump completes tough cuts faster.
 - ◊ Longer life, efficiency, and reliability.
- Specialized latch head design.
 - ◊ Interference free closure for mid-span cuts.
- Ergonomic design allows one hand operation.
 - ◊ User has one hand free to manipulate material to be cut.
- 180 degree head rotation.
 - ◊ Versatile head positioning allows user to get into tight areas easier.
- Mechanical ram release.
 - ◊ Reliable ram release (no battery power consumption).
- Operates on 18 volt Ni-MH batteries.
 - ◊ Eliminates voltage depression or "memory" issues.
- Durable high impact formed carrying case.
 - ◊ Provides tool protection and stores all accessories.
- 5-year limited warranty on tool (excluding blades) and 1 year on batteries and charger.
 - ◊ Customer satisfaction and support.

SPECIFICATIONS

- Tool Weight: 11 lbs.
- Length: 14.5"
- Width: 3.5"
- Height: 13.5"
- Operating Voltage: 18 V-DC
- Recharge Time: < 45 mins.

FOR USE ON

- Copper Cable: up to 1.29"
- Aluminum Cable: up to 1.29"
- ACSR: up to 1113 ACSR
- Ground Rod: up to 5/8"
- Rebar: up to 1/2"
- Soft Steel Bolts: up to 5/8"
- Standard Guy Strand: up to 1/2"
- EHS Guy Strand: up to 3/8"

ACCESSORIES

- Lanyard: Cat# PT208620
- Battery: Hi-capacity (2.6 AH) Cat# BAT18V
- Charger: 120V-AC Cat# PATCHGR18V
12/24V-DC Cat# BCT/PATDCCHGR
240/250V-AC Cat# PATCHGR250V
- Replacement Blades: Cat# PT10037388 (Moving Blade)
Cat# PT10037384 (Fixed Blade)

N-60

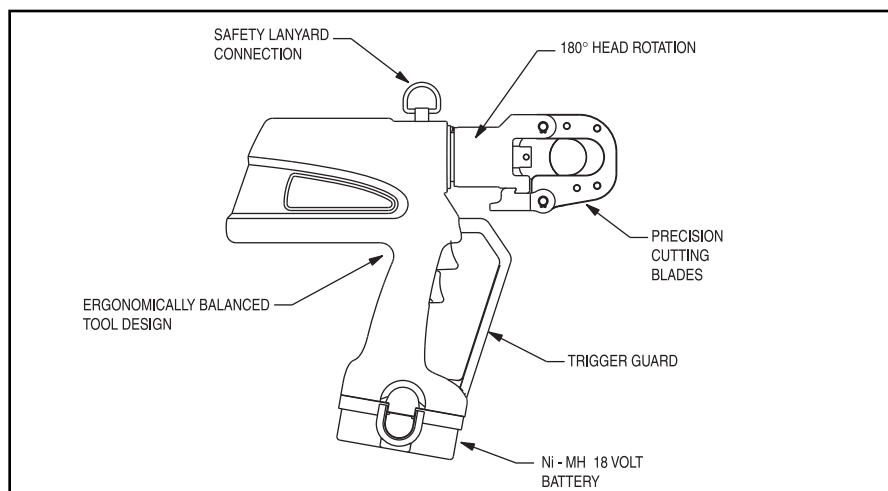

Blue highlighted items are industry standard and most frequently ordered.

**PATRIOT®
PATCUT245CUAL-18V**

BATTERY ACTUATED TOOL

Hydraulic Self Contained Cutter

The BURNDY® PATCUT245CUAL-18V battery powered cutting tool is compact, fast, easy to use and incorporates the latest in battery tool technology. The ergonomic design allows one hand operation so that the other is free to manipulate the conductor in the proper cutting position. The PATCUT245CUAL-18V incorporates a specialized latch style cutting head that allows interference-free closure for mid-span cuts. The cutter head rotates 180 degrees to allow users to get into tight areas easier. The PATCUT245CUAL-18V is capable of cutting up to 2.45" diameter copper and aluminum cable.

The PATCUT245CUAL-18V operates on industry standard 18-volt Ni/MH batteries that eliminate voltage depression or "memory" issues. The PATCUT245CUAL-18V comes equipped with a high impact formed carrying case to hold the tool, a tool retention lanyard, a battery charger and two batteries. The PATCUT245CUAL-18V is provided with a 5-year limited warranty (excluding blades), and 1-year on batteries and charger.



Features and Benefits

- Battery powered cutting technology.
 - ◇ Easy tool operation and portability.
- Advance design high-speed pump completes tough cuts faster.
 - ◇ Longer life, efficiency, and reliability.
- Specialized latch head design.
 - ◇ Interference free closure for mid-span cuts.
- Ergonomic design allows one hand operation.
 - ◇ User has one hand free to manipulate material to be cut.
- 180-degree head rotation.
 - ◇ Versatile head positioning allows user to get into tight areas easier.
- Mechanical ram release.
 - ◇ Reliable ram release (no battery power consumption).
- Operates on 18-volt Ni/MH batteries.
 - ◇ Eliminates voltage depression or "memory" issues.
- Durable high impact formed carrying case.
 - ◇ Provides tool protection and stores all accessories.
- 5-year limited warranty on tool (excluding blades) and 1-year on batteries and charger.
 - ◇ Customer satisfaction and support.

SPECIFICATIONS

- Tool Weight:** 14.5 lbs. (5.4 kg)
With Battery
- Length:** 18" (45.7 cm)
- Width:** 3.75" (9.5 cm)
- Height:** 14.75" (37.5 cm)
- Operating Voltage:** 18 V-DC
- Recharge Time:** < 45 mins.

FOR USE ON

- Copper and Aluminum Cable: Up to 2.45" O.D. (62.2 mm)

For Copper and Aluminum cable only. Do not cut steel, ground rod, rebar, or guy wire.

ACCESSORIES

- **Carrying Case:** Cat# **PT10044980**
- **Lanyard:** Cat# **PT208620**
- **Battery:** Hi-capacity (2.6 AH) Cat# **BAT18V**
- **Charger:** 120V-AC Cat# **PATCHGR18V**
12/24V-DC Cat# **BCT/PATDCCHGR**
240/250V-AC Cat# **PATCHGR250V**
- **Replacement Blades:** Cat# **PT10038657** (Moving Blade)
Cat# **PT10040663** (Fixed Blade)

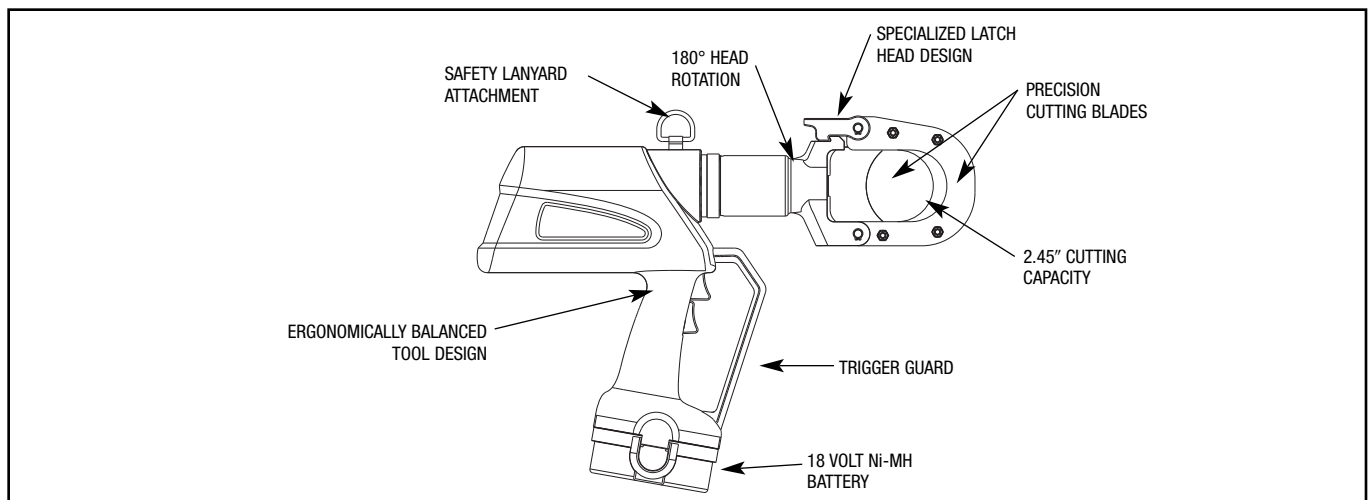

Blue highlighted items are industry standard and most frequently ordered.

BCC1000QUAL

BATTERY ACTUATED CABLE CUTTER

The BURNDY® BCC1000QUAL is a 12-V-DC battery actuated cable cutter capable of cutting up to 750 kcmil hard drawn copper cable, and up to 1000 kcmil soft drawn copper and up to 2" O.D. aluminum cable. DO NOT CUT STEEL or ACSR. The BCC1000QUAL comes with battery powered cutting tool, sealed nickel cadmium 12V battery, 120V AC charger, carrying case, and wrist loop which provides added security when making cuts overhead.

The BURNDY® BCC1000QUAL is designed to cut copper and aluminum cables in a limited amount of space. The BCC1000QUAL makes fast reliable cuts without stress to the user. Just squeeze the trigger and it will cut through your toughest copper and aluminum cables. The BCC1000QUAL has a three-way switch (forward, reverse, and neutral) which allows the user to make partial cuts, back off cables, or make adjustments during cutting.

The battery charge time is approximately 1 hour for a fast charge (80%), 4 to 6 hours for a quick charge, and 14 to 16 hours for a standard charge (100%). The 12V battery can be recharged approximately 1,000 times.

The BCC1000QUAL (excluding cutting blades) is warranted to be free of defects in material and workmanship for a period of 90 days, except in the case of abuse or modification.

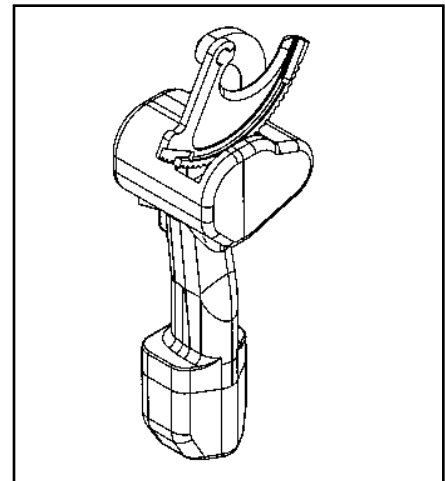

FEATURES

- Hook head design.
- Three way switch.
- Hardened steel blades.
- Ergonomic design.
- Wrist loop.

BENEFITS

- Simplifies conductor cutting and allows working in tight spaces.
- Allows backing off cable, partial cuts, and adjusting during cutting.
- Helps ensure consistent cuts and longer blade life.
- Prevents hand/wrist injury.
- Withstands rugged use. Resists oil and solvents.
- Added security when cutting cables overhead.

ACCESSORIES

Catalog Number	Item Description
BCCBAT12V	BCC1000QUAL Battery
BCCCHGR	BCC1000QUAL Charger
BCCCASE	BCC1000QUAL Carrying Case
RP50RP03	BCC1000QUAL Moving Blade
RP50RP02	BCC1000QUAL Fixed Blade

SPECIFICATIONS

Cutting Tool

Specifications	Description
Drive Unit:	12.0V DC Motor
Dimensions:	4"L × 4.5"W × 14.5" H
Weight:	6 lbs.
Cutting Capacity:	1000 kcmil soft drawn copper, 750 kcmil hard drawn copper and up to 2" O.D. aluminum

Battery

Specifications	Description
Battery Type:	Sealed nickel cadmium
Voltage:	12.0V DC
Rated Capacity:	1.2A/hr
Charge Time:	Fast, approx. 1 hour Quick, 4-6 hours Standard, 14-16 hours
Dimensions:	2.75"L × 2.7"W × 4.75"H
Weight:	1.4 lb.

Battery Charger

Specifications	Description
Input Voltage:	120V AC
Input Frequency:	60 Hz
Input Current:	110/120V
Dimensions:	5.7"L × 3"W × 2.8"H
Weight:	2.2 lbs.

FOR USE ON

Maximum conductors accommodated:
750 kcmil hard drawn copper
1000 kcmil soft drawn copper
1000 kcmil aluminum

RHCC129ACSR

10,000 PSI Remote Cable Cutter

Remote Power Operated Hydraulic Cable Cutter

The BURNDY® RHCC129ACSR remote hydraulic cable cutter incorporates a specialized latch style cutting head that allows interference-free closure for mid-span cuts. The RHCC129ACSR with its precision cutting blades is capable of cutting up to 1.29" diameter bare or insulated copper and aluminum cable, 1113 ACSR, 5/8" ground rod, 1/2" rebar, 5/8" diameter soft steel bolts, 1/2" standard guy strand, and up to 3/8" EHS guy strand.

The RHCC129ACSR is provided with a 5-year limited warranty (excluding blades).



Features and Benefits

- Specialized latch head design.
 - ◇ Interference free closure for mid-span cuts.
- Precision cutting blades.
 - ◇ For clean cuts on Cu/Al, ACSR, ground rods, rebar, guy strand, and soft steel bolts.
- High strength steel cylinder.
 - ◇ For durability and long life.
- Lightweight ergonomic design allows one hand operation.
 - ◇ User has one hand free to manipulate material to be cut.
- Durable canvas carrying bag.
 - ◇ Provides tool protection and stores all accessories.
- 5-year limited warranty on tool (excluding blades).
 - ◇ Customer satisfaction and support.

SPECIFICATIONS

- Operating Pressure:** 10,000 psi (700 bar)
- Tool Weight:** 5.85 lbs. (2.65 kg)
- Length:** 11.25" (286 mm)
- Width:** 3.7" (94 mm)

FOR USE ON

- Copper Cable: up to 1.29"
- Aluminum Cable: up to 1.29"
- ACSR: up to 1113 ACSR
- Ground Rod: up to 5/8"
- Rebar: up to 1/2"
- Soft Steel Bolts: up to 5/8"
- Standard Guy Strand: up to 1/2"
- EHS Guy Strand: up to 3/8"

ACCESSORIES

- Canvas Bag:** Cat# **PT10043890**
- Replacement Blades:** Cat# **PT10037388** (Moving Blade)
Cat# **PT10037384** (Fixed Blade)
- Hot Stick Adapter:** Cat# **RHCCHSA**

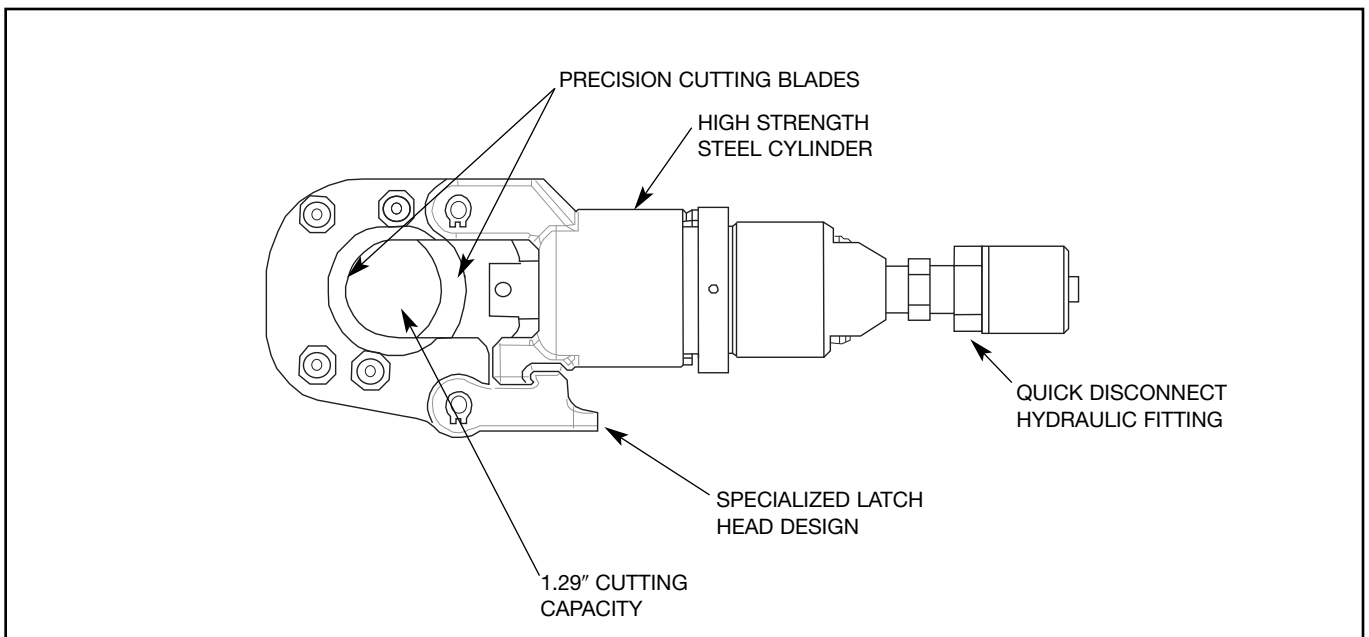

Blue highlighted items are industry standard and most frequently ordered.

RHCC245CUAL

10,000 PSI Remote Cable Cutter

Remote Power Operated Hydraulic Cable Cutter

The BURNDY® RHCC245CUAL remote hydraulic cable cutter incorporates a specialized latch style cutting head that allows interference-free closure for mid-span cuts. The RHCC245CUAL with its precision cutting blades is capable of cutting up to 2.45" diameter copper and aluminum cable.

The RHCC245CUAL is provided with a 5-year limited warranty (excluding blades).



Features and Benefits

- Specialized latch head design.
 - ◇ Interference free closure for mid-span cuts.
- Precision cutting blades.
 - ◇ For clean cuts on copper and aluminum cable.
- High strength steel body.
 - ◇ For durability and long life
- Lightweight ergonomic design allows one hand operation.
 - ◇ User has one hand free to manipulate material to be cut.
- Durable canvas carrying bag.
 - ◇ Provides tool protection and stores all accessories.
- 5-year limited warranty on tool (excluding blades).
 - ◇ Customer satisfaction and support.

SPECIFICATIONS

Operating Pressure: 10,000 psi (700 bar)
Tool Weight: 8.3 lbs. (3.8 kg)
Length: 14.8" (376 mm)
Width: 4.75" (121 mm)

FOR USE ON

Copper & Aluminum 2.45" O.D. (62 mm)

ACCESSORIES

Canvas Bag: Cat# **PT10054094**
Replacement Blades: Cat# **PT10038657** (Moving Blade)
 Cat# **PT10040663** (Fixed Blade)

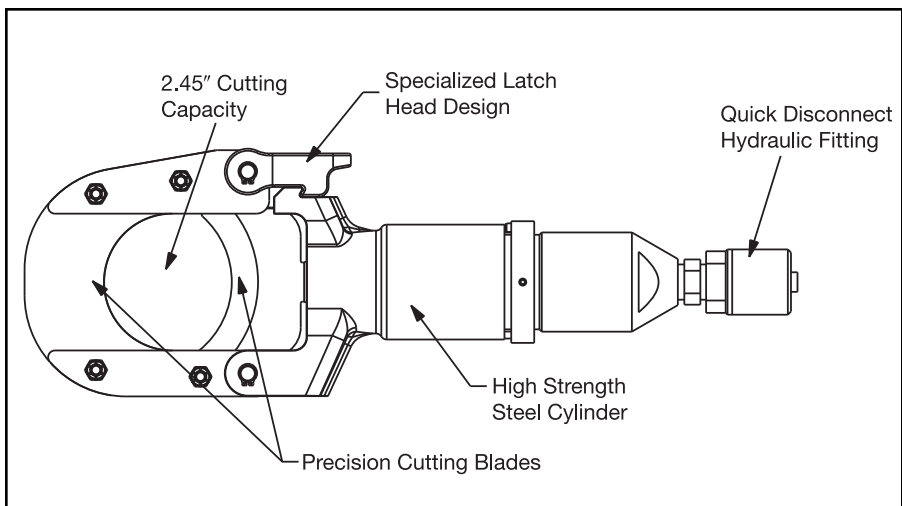

HP10, HP8, AND HP6

HP Series Manual Hydraulic Hand Pumps

Hydraulic Output Pressures of 10,000 PSI, 8,800 PSI, and 6,000 PSI

Hand pumps are designed to match the output pressure requirements of HYPRESS™ heads and cutters. Each pump is equipped with a built-in, factory set pressure release valve with audible click to signal completion of crimp cycle.



BENEFITS

- Durable, long life expectancy.
- Easy to transport and move tool around job site with built in handle.
- Maximum mechanical advantage provided with long handle.
- Solid tool base provided with sturdy broad leg stabilizers.
- Save time with quick disconnect hydraulic fitting.
- High quality crimps provided with built-in, factory set pressure release valve and audible click to signal completion of crimp.
- 5-year limited warranty.

SPECIFICATIONS

Reservoir volume: 1-1/8 qts.
Length: 24-3/4"
Width: 5"
Weight: 18 lbs.
Closed height: 6-3/4"
Height (with handle open): 20"

FOR USE ON

HP10 10,000 Y34BH, Y35BH, Y35BH-4, Y750BH, Y750BH-2, Y39BH, Y45, Y46C, Y46, Y60BHU, RHCC Series Cutters

HP8 8,800 Y48BH

HP6 6,000 Y35-L

ACCESSORIES

Extended leg pad stabilizes (w/hardware)
 Cat # **BP10PADKIT**

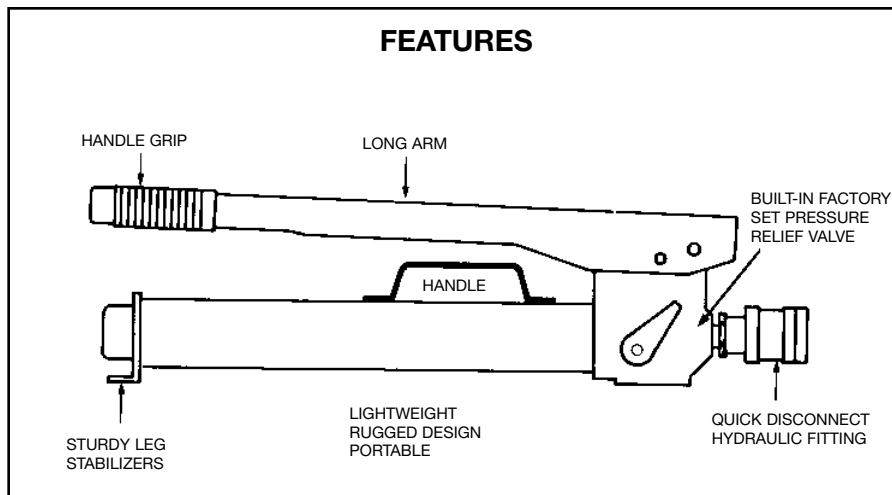

Blue highlighted items are industry standard and most frequently ordered.

FP10, FP8, AND FP6

FP Series Manual Hydraulic Foot Pumps

Hydraulic Output Pressures of 10,000 PSI, 8,800 PSI, and 6,000 PSI

Foot pumps are designed to match the output pressure requirements for use with all HYPRESS™ heads and cutters. Each pump is equipped with a built-in, factory set pressure release valve with audible click to signal completion of a crimp cycle.



BENEFITS

- Easy to lift and carry.
- Durable. Long life expectancy.
- Easy to transport and move tool around job site with built in handle.
- Easy operation provided with spring assisted return arm.
- Maximum mechanical advantage provided with long arm extending beyond pump body.
- Quality, heavy duty foot pad provided with diamond plate steel.
- Solid tool base provided with sturdy broad leg stabilizers.
- Time saving quick disconnect hydraulic fitting.
- High quality crimps provided with factory set pressure release valve with audible click to signal completion of crimp.
- 5-year limited warranty.

SPECIFICATIONS

Reservoir volume: 1-1/8 qts.

Length: 24-3/4"

Width: 5"

Weight: 19 lbs.

Closed height: 6-1/2"

Height (with handle open): 17"

FOR USE ON

FP-10 10,000 Y34BH, Y35BH, Y35BH-4, Y750BH, Y750BH-2, Y39BH, Y45, Y46C, Y46, Y60BHU, Y750BH, RHCC Series Cutters

FP-8 8,800 Y48BH

FP-6 6,000 Y35-L

ACCESSORIES

Extended leg pad stabilizes (w/hardware)
Cat # **BP10PADKIT**

FEATURES

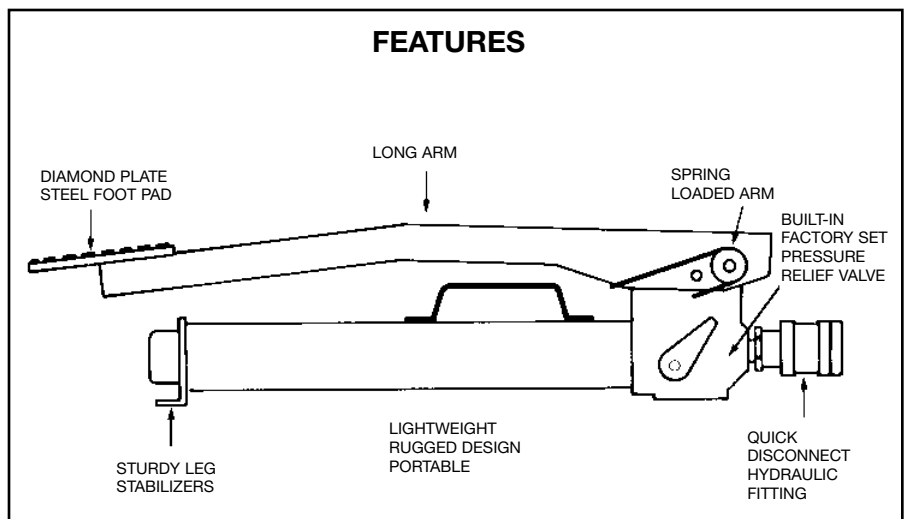

Y10AC9

Electric Hydraulic Pump

Hydraulic Output Pressure of 10,000 PSI

The Y10AC9 electric hydraulic pump is for use with all HYPRESS™ heads and cutters requiring 10,000 PSI operating pressure. The Y10AC9 is equipped with a built-in, factory set pressure relief valve. An audible “pop” and recycling of the pump as well as relaxing of the hose signal completion of the crimping/cutting cycle. Pump is supplied with a durable hand-held electric pendant switch.

Features and Benefits

- Lightweight, small size.
 - ◊ Easy to lift, carry and transport tool around job site with lightweight body and handle.
- Factory set relief valve.
 - ◊ High quality crimps are achieved with built-in, factory set pressure relief valve and audible recycling of pump to signal completion of crimp cycle.
- 100,000 (+) life cycles.
 - ◊ Long durable life expectancy with lightweight cast aluminum reservoir body.
- Convenient 115V AC electric powered motor.
- Saves time with quick disconnect hydraulic fitting.
- Sealed electric pendant switch.
 - ◊ Easy operation with durable remote pendant switch with 10-foot cord.
- 5-year limited warranty.

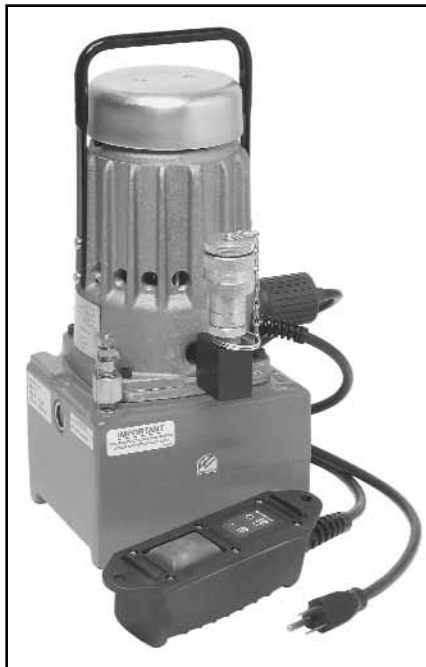

Specifications

- Motor:** 115V AC 50/60 Hz
5/8 HP, 10,000 rpm
11 amp current draw
- Reservoir Volume:** 1.61 quarts
- Height:** 14.38"
- Base:** 6.5" × 8.25"
- Weight:** 28 lbs. (with oil)

FOR USE ON

- Y34BH, Y35BH, Y35BH4, Y39BH, Y45, Y46, Y46C, Y750BHXT, Y750CBHXT, Y644MBH, Y4PC834MBH, Y81KFTMBH, Y60BHU, RHCC129ACSR, RHCC245CUAL

ACCESSORIES

- Catalog Number:** YAC-CASE
Steel carrying case with handle and locking latch.

The BURNDY® **Y10AC9OEM** is an additional electric hydraulic pump offering that comes equipped with a foot switch and “jog-and-hold” feature. Keep both hands on the connection with the Y10AC9OEM pump kit. For further details please contact customer service.

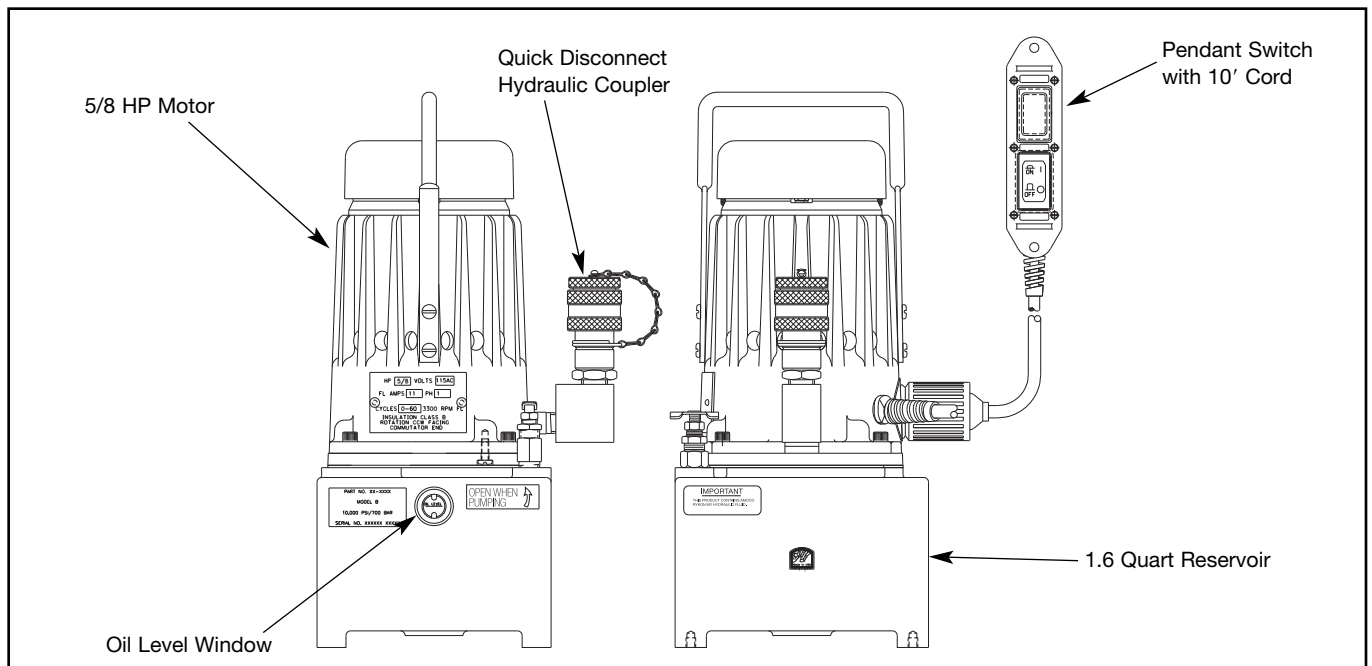

Blue highlighted items are industry standard and most frequently ordered.

EPP10 AND EPP6

EPP Series Electric/Hydraulic Pump

Hydraulic Output Pressures of 10,000 PSI and 6,000 PSI

The lightweight and durable EPP10 electric/hydraulic pump is for use with all BURNDY® HYPRESS™ remote heads and cutters requiring 10,000 PSI operating pressure. Both the EPP10 and the EPP6 are equipped with a built-in, factory set pressure relief valve. An audible “pop” and recycling of the pump and relaxing of the hose, signals completion of the crimping/cutting cycle. Both pumps are supplied with a durable hand-held electric pendant switch, for remote operation of the unit, and have a manual selection switch mounted for operation of the unit at the pump. The operator can select which method is best suited for the application.

An optional carry/shipping case can be ordered. All EPP Series pumps have been life cycle tested to over 100,000 cycles without failure, and are warranted to be free of defects in materials and workmanship for five (5) years when properly maintained and operated.



FEATURES

- Lightweight.
- Small size.
- Factory set relief valve.
- 100,000 (+) life cycles.
- Sealed electric pendant switch.

BENEFITS

- High quality crimps are achieved with built in, factory set pressure release valve and audible recycling of pump to signal completion of crimp cycle.
- Easy to lift, carry and transport tool around job site with lightweight body and handle.
- Convenient 115 V-AC electric powered motor.
- Durable remote pendant switch.
- Easy operation controlled with pendant switch, or manual switch.
- Saves time with quick disconnect hydraulic fitting.
- Long durable life expectancy with lightweight cast aluminum reservoir body.
- 5-year limited warranty.

SPECIFICATIONS

Motor:	115 V-AC/60 Hz 1/2 HP @ 3450 RPM
Maximum current draw:	12.5 amperes
Reservoir volume:	2 qts.
Height:	16"
Base:	6" × 8"
Weight:	30 lbs.

FOR USE ON

EPP10	10,000	Y34BH, Y35BH, Y35BH-4, Y39BH, Y45, Y46, Y46C, Y60BHU, 750BH, Y750BH-2, Y644MBH, RHCC Series Cutters
EPP6	6,000	Y35L, Y28B

ACCESSORIES

Cat. No. **EPPCASE-1**

Steel carrying case with handle and locking latch.

EPAC10, EPAC8, AND EPAC6

**EPAC Series
Electric/Hydraulic Pump,
Air Control**

Hydraulic Output Pressures of 10,000 PSI, 8,800 PSI, and 6,000 PSI

The EPAC10, EPAC8, and EPAC6 electrically driven hydraulic pumps feature exclusive automatic or manual “jog and hold” operation control provided by a unique air control switch, which provides the safest operation method of any pump available. All EPAC’s are remotely controlled by an improved air control switch which electrically isolates the operator from the unit, and can be operated by either hand or foot activation. A three (3) position toggle switch mounted on the control box allows the operator to select either full automatic, off, or manual operation.

The automatic mode advances the remote tool into a “hold” position without crimping the connector so the operator can inspect the orientation before completing the crimp. Once the crimp is completed, the pump automatically turns the pump off, allowing the retraction of the remote tool and resets itself for the next operation.

The manual position allows the operator to jog the tool forward without the tool ram retracting. To retract the tool prior to completing the crimp, turn the control switch to “off,” the pump will stop and the tool will retract. In the manual mode the pump advances only while the control is being depressed. To complete a crimp, squeeze and hold the air control switch until the pump reaches the pre-set pressure and shuts off.

The EPAC Series of electrically driven hydraulic pumps incorporate a heavy-duty roll cage design that is both rugged and portable. All EPAC Series pumps have been life cycle tested to over 100,000 cycles without failure, and are warranted to be free of defects in material and workmanship for five (5) years when properly maintained and operated.



FEATURES

- Roll cage
- 3 position switch and control box
- Factory set output pressure
- Quick disconnect hydraulic coupler
- Oil level window
- 8 quart reservoir

BENEFITS

- Permits final inspection of connector before completing crimp cycle.
- Extra supply hydraulic fluid 8-quart reservoir.
- Full automatic or manual “Jog and Hold” cycles.
- Operator safety with power loss “smart circuit,” freezes unit in event of power disruption.
- Method of operation desired is permitted with 3-position selection switch.
- Safety is provided against hazardous shock with airbulb actuator and air line.
- Saves time with quick disconnect hydraulic fitting.
- Windows allows easy inspection of proper oil level.
- High quality crimps are achieved with built-in factory set pressure release valve.
- 5-year limited warranty.

SPECIFICATIONS

- Motor:** 1/2 HP 115/230 V-AC, 60 Cycle
- Maximum current draw:** 10 amperes
- Reservoir volume:** 8 quarts max., 2 quarts min.
- Height:** 17-1/2”
- Base:** 11-3/4” × 18-1/2”
- Dry weight:** 68 lbs. (82 lbs. w/max. fluid) (1/2 Hp @ 3450 RPM)

FOR USE ON

- EPAC10** 10,000 Y34BH, Y35BH,
- EPAC-8** 8,800 Y48BH
- EPAC-6** 6,000 Y35L

Blue highlighted items are industry standard and most frequently ordered.

EP10, EP10-2, EP8, AND EP6

EP SERIES ELECTRIC/ HYDRAULIC PUMPS

Hydraulic Output Pressures of 10,000 PSI, 8,800 PSI, and 6,000 PSI

Electrically driven hydraulic pumps are supplied with a durable, hand-held electric pendant switch that remotely controls the pump and matches the output requirements of all HYPRESS™ remote heads and cutters. Each pump is equipped with a built-in, factory set, pressure relief valve. An audible “pop” and recycling of the pump and relaxing of the hose, signals completion of the crimping/cutting cycle.

All EP series pumps are supplied with 115/230 - 220/230 voltage, 60/50 hertz, 1/2 horsepower motor and can be wired for use with any electric power source worldwide. A three prong, grounded plug is wired standard on the units. All EP Series pumps have been life cycle tested to over 100,000 cycles without failure, and are warranted to be free of defects in materials and workmanship for five (5) years when properly maintained and operated.



SPECIFICATIONS

- Motor:** 1/2 HP 115/230 V-AC, 60 cycle
(EP**-2 versions): 1/2 HP 220/230 V-AC, 50 cycle
- Maximum current draw:** 10 amperes
- Reservoir volume:** 8 quarts max., 2 quarts min.
- Height:** 17-1/2"
- Base:** 11-3/4" × 18-1/2"
- Dry weight:** 68 lbs. (86 lbs. with max. fluid)
- (1/2 Hp @ 3450 RPM)

BENEFITS

- Provides fast sure pump action plus a long life expectancy.
- It's portable. Roll cage allows easy moving on the job site.
- Durable 1/2 HP dual voltage motor.
- Extra supply of hydraulic fluid with 8 quart reservoir.
- Saves time with quick-disconnect hydraulic fitting.
- Easy operator control is provided with remote pendant switch.
- Easy inspection of proper oil level is provided by see through window.
- High quality crimps are achieved with built-in, factory set, pressure release valve and audible recycling of pump which signals completion of crimp.
- 5-year limited warranty.

FOR USE ON

EP10	10,000	Y34BH, Y35BH, Y35BH-4,
EP10-2		Y39BH, Y45, Y46, Y46-C, Y60BHU, Y750BH, Y750BH-2, RHCC Series Cutters
EP8	8,800	Y48BH
EP6	6,000	Y35L

FEATURES

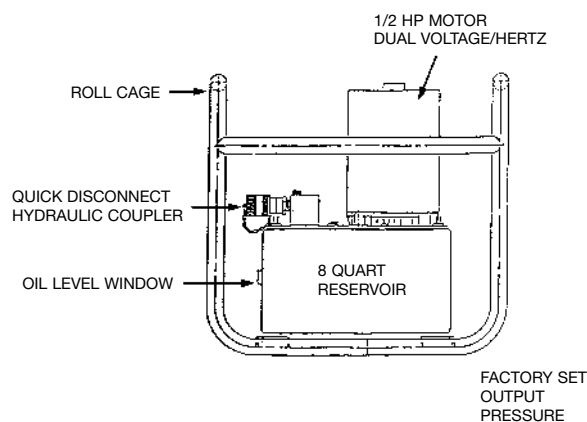

**EP10-1HP AND
EP10-1HP-2**

**EP-1HP SERIES ELECTRIC/
HYDRAULIC PUMPS**

Hydraulic Output Pressures
of 10,000 PSI, 8,800 PSI,
and 6,000 PSI

Heavy duty electrically driven hydraulic pumps are supplied with a durable, hand-held electric pendant switch that remotely controls the pump and matches the output requirements of all HYPRESS™ remote heads and cutters. Each pump is equipped with a built-in, factory set, pressure relief valve. An audible “pop” and recycling of the pump and relaxing of the hose, signals completion of the crimping/cutting cycle.

All EP-1HP series pumps are supplied with 115/230 - 220/230 voltage, 60/50 hertz, 1 horsepower motors and can be wired for use with any electric power source worldwide. A three prong, grounded plug is wired standard on the units. All EP-1HP Series pumps have been life cycle tested to over 100,000 cycles without failure, and are warranted to be free of defects in materials and workmanship for five (5) years when properly maintained and operated.



FEATURES

- Heavy duty design.
- Roll cage.
- Quick disconnect hydraulic coupler.
- Oil level window.
- 8 quart reservoir.
- Factory set output pressure.
- 1 HP motor dual voltage/hertz.

BENEFITS

- Provides fast sure pump action plus a long life expectancy.
- Its portable roll cage allows easy moving on the job site.
- Strong durable motor provided with (1) H.P. dual voltage design.
- Extra supply of hydraulic fluid with 8 quart reservoir.
- Saves time with quick-disconnect hydraulic fitting.
- Easy operator control is provided with remote pendant switch.
- Easy inspection of proper oil level is provided by see through window.
- High quality crimps are achieved with built-in, factory set, pressure release valve and audible recycling of pump which signals completion of crimp.
- 5-year limited warranty.

SPECIFICATIONS

- Motor:** 1 HP 115/230 V-AC, 60 cycle
- (EP**-2 versions): 1/2 HP 220/230 V-AC, 50 cycle
- Maximum current draw:** 10 amperes
- Reservoir volume:** 8 quarts max., 2 quarts min.
- Height:** 17-1/2"
- Base:** 11-3/4" × 18-1/2"
- Dry weight:** 68 lbs. (86 lbs. with max. fluid)
- (1/2 Hp @ 3450 RPM)

FOR USE ON

- EP10-1HP** 10,000 Y34BH, Y35BH,
- EP10-1HP-2** Y35BH-4, Y39BH, Y45, Y46, Y46-C, Y60BHU, Y750BH, Y750BH-2, RHCC Series Cutters

Blue highlighted items are industry standard and most frequently ordered.

GP10

GP Series Gasoline Engine Driven Hydraulic Pump

Hydraulic Output Pressures of 10,000 PSI

The GP series gasoline engine driven hydraulic pump is a heavy-duty design that is rugged and portable. Supplied with a four (4) H.P. engine, the pump operates all BURNDY® remote compression heads and cable cutters.

All GP style pumps have a built-in, factory pre-set, automatic pressure release overload valve with a definite pulsing and recycling to signal the completion of a crimp. The manual control valve allows user to “Jog and Hold” due to the unique check valve design that keeps pressure in the output line until retracted.

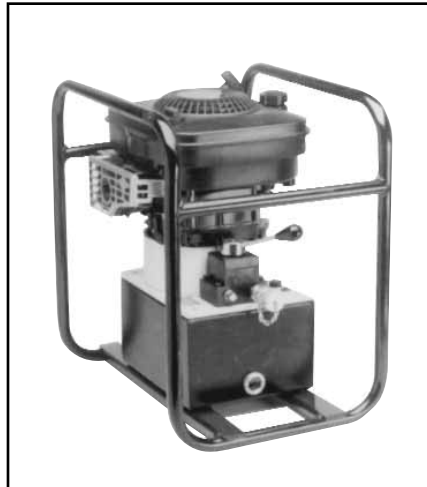

Specifications

Engine: 4 H.P., 4 cycle
Reservoir volume: 2 gallons (8 qts.)
Pump height: 19-3/4"
Pump width: 13"
Pump length: 18"
Overall height: 22-1/4"
Overall width: 16"
Overall length: 21"
Pump and motor dry weight: 64-1/4 lbs.
Overall dry weight: 77-3/4 lbs.

FOR USE ON

Pump	PSI	Hydraulic Tools and Cutter
GP10	10,000	Y34BH, Y35BH, Y35BH-4, Y39BH, Y45, Y46, Y46C, Y60BHU, Y60BHU-D, Y750BH, Y750BH-2, RHCC Series Cutters

BENEFITS

- Portable pump with sturdy steel roll cage.
- Durable heavy-duty four (4) H.P. engine for all HYPRESS™ applications and long life expectancy.
- Manual control valve permits easy control of crimping or cutting operations.
- Fast hose assembly with quick disconnect pressure matched hydraulic couplers.
- Ample hydraulic capacity with (8) quart reservoir.
- 5-year limited warranty.

FEATURES

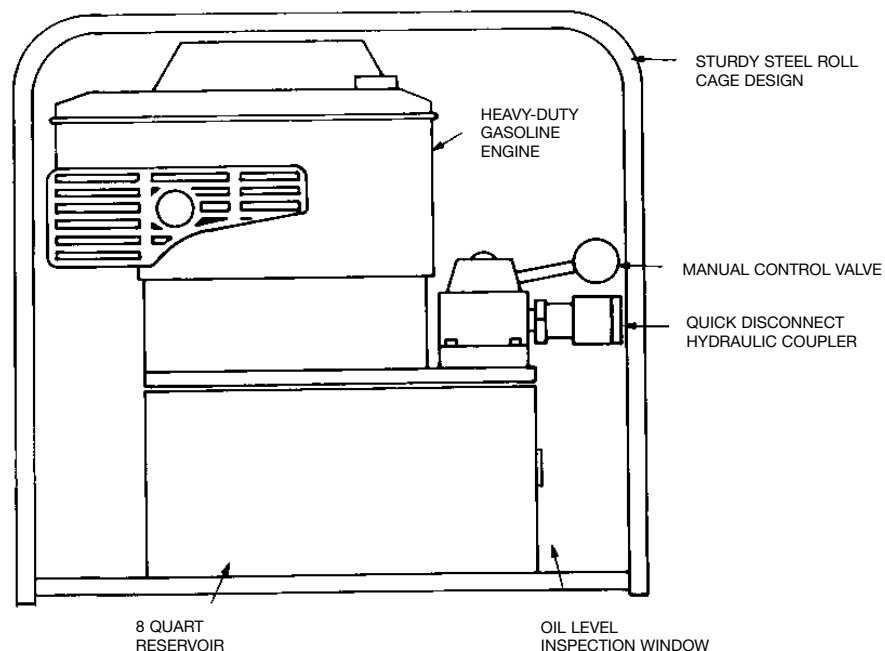

Blue highlighted items are industry standard and most frequently ordered.

HYDRAULIC HOSES

NON CONDUCTIVE HOSES*



10,000 PSI

- | Cat. No. | Description |
|--------------------|---|
| PT 29900-10 | 10' - 3/16" diameter - non conductive hose with stackable couplers (male/female) - orange |
| PT 29900-15 | 15' - 3/16" diameter - non conductive hose with stackable couplers (male/female) - orange |
| PT 29900-25 | 25' - 3/16" diameter - non conductive hose with stackable couplers (male/female) - orange |
| PT 29901-10 | 10' - 1/4" diameter - non conductive hose with stackable couplers (male/female) - orange |
| PT 29901-15 | 15' - 1/4" diameter - non conductive hose with stackable couplers (male/female) - orange |
| PT 29901-25 | 25' - 1/4" diameter - non conductive hose with stackable couplers (male/female) - orange |

Note: 1/4" diameter hose provides higher flow rate for faster ram movement.

* For proper care and maintenance of hydraulic hoses, consult the "Hydraulic Hose Care" manual, Form No. 7828

NON CONDUCTIVE HOSES*



6,000 PSI

- | Cat. No. | Description |
|--------------------|--|
| PT 29902-10 | 10' - non conductive hose with stackable couplers (male/female) - orange |
| PT 29902-15 | 15' - non conductive hose with stackable couplers (male/female) - orange |
| PT 29902-25 | 25' - non conductive hose with stackable couplers (male/female) - orange |
| PT 29074-1 | Non conductive hose carrying bag |

* For proper care and maintenance of hydraulic hoses, consult the "Hydraulic Hose Care" manual, Form No. 7828

CONDUCTIVE HOSES*

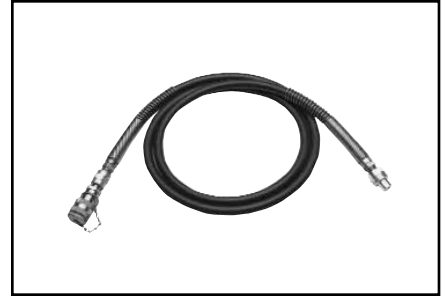

10,000 PSI

- | Cat. No. | Description |
|-----------------|---|
| PT 91 | 8' - steel braided hose with steel spring reinforced ends. Stackable couplers (male/female) - Black. No electrical rating. DO NOT use on energized conductor. |

8,800 PSI

- | Cat No. | Description |
|----------------|---|
| PT 76 | 8' - steel braided hose with steel spring reinforced ends. Stackable couplers (male/female) - Black. No electrical rating. DO NOT use on energized conductor. |

* For proper care and maintenance of hydraulic hoses, consult the "Hydraulic Hose Care" manual, Form No. 7828.



N-73

Do not attempt to repair or recouple the hose yourself!

Blue highlighted items are industry standard and most frequently ordered.

ACCESSORIES



PT 29074-1 Insulated hose carrying bag

Designed to provide protection and cleanliness of non-conductive hoses. Accommodates 100 ft. of non-conductive coiled to 17-1/2" O.D. and 3-3/4" wide. Maximum carrying capacity: 10 lbs.



Adjustable Head Grip For joining HYPRESS™ heads to universal hot sticks

PT 29075 (for Y35L)
PT 29402-1 (for Y35BH)
PT 10128 (for Y46)



DIE CASES

PT 29291
 (Y750, Y35/Y39) die case for "U" -type die sets

PT 6545
 (Y45 and Y46) die case for "S" and "P" -type die sets



Replacement Coupler 6,000 PSI operating pressure

PT 29091 (male)
PT 29214-1 (female)



HYFLUID™

HYFLUID™ QT.
HYFLUID™ GAL.

(available in quart and gallon size containers)

Hydraulic fluid for BURNDY® HYPRESS™ hand operated tools:

Y35 and Y35-2 HYPRESS™ tools
 Y39 HYPRESS™ tool
 Y750 REVOLVER HYPRESS™ tools



ALFLUID™

ALFLUID™ QT.
ALFLUID™ GAL.

(available in quart and gallon size containers)

Use ALFLUID™ in hand operated tools during extended use below 32 degrees.

All weather HYDRAULIC fluid for BURNDY® pumps:

HP hand pump
 FP foot pump
 GP gasoline pump

EPP electric pump
 AC-3H auto/man. elect. pump
 DC-3H auto/man. elect. pump



Replacement Coupler 10,000 PSI operating pressure

PT 94 (male)
PT 93 (female)

N-74



In-line Pressure Gauge 10,000 PSI operating pressure for hydraulic pumps

PT 11018

Blue highlighted items are industry standard and most frequently ordered.

**ENFORCER™
HIW716ENF**

**HYDRAULIC IMPACT WRENCH
VARIABLE TORQUE**

7/16" Quick Chuck

When it comes to drilling holes or tightening and loosening hardware the ENFORCER™ hydraulic impact wrench (Catalog Number HIW716ENF) provides a powerful punch with 515 ft-lbs of torque that is unsurpassed in the 7/16" series of low pressure wrenches. Utilizing the very latest in CNC machining technology and superior materials, BURNDY® is proud to provide one of the toughest, lightweight wrenches ever offered in this class.

The ENFORCER™ wrench comes with a 7/16" Tri-ball quick chuck with a wide flange that will provide a secure hold on all standard 7/16" hex drive bits and accessories. The adjustable torque selector allows users to choose between a low setting of 200 ft-lbs and high setting of 515 ft-lbs of output torque. The dual acting spool allows the user to change from Open to Closed center operating circuits. In addition to our standard five-year limited warranty, the ENFORCER™ wrench comes with a full one-year unlimited warranty on the shaft seal.

The ENFORCER™ wrench comes equipped with an internal safety relief valve to protect the tool against hydraulic pressure spikes. This regulates pressure to the motor, and therefore allows excessive flow (flow which is beyond that which is required to do the work) to bypass back to the return side of the circuit.



Features and Benefits

- Industry exclusive torque selector.
 - ◇ Dual torque selector spool allows users to switch between 200 and 515 ft-lb torque settings.
- 7/16" Tri-ball quick chuck.
 - ◇ Allows users to quickly change bits, sockets or other hardware adaptors.
- CNC Machined billet aluminum.
 - ◇ Provides superior strength, reliability and makes for the lightest tool in its class. Also provides for tighter tolerancing to ensure higher quality.
- Cartridge style valves.
 - ◇ Provides for greater accuracy and more economical servicing
- Dual spool operation.
 - ◇ Allows tool to be used in either an OPEN or CLOSED center hydraulic system.

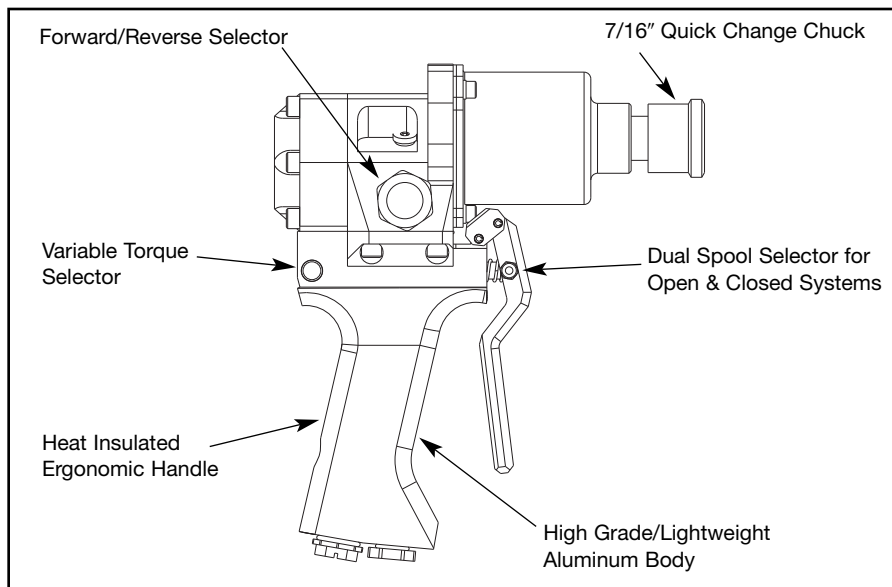

SPECIFICATIONS

- Chuck Type: 7/16" Quick Change
- Optimal Pressure: 750-2000 PSI
- Flow Range: 4-12 GPM
- Optimal Flow Range: 4-8 GPM
- Operation: Open/Closed option
- Torque: 515 ft-lbs
- Weight: 5.95 lbs
- Length: 7.80 in.
- Height: 8.90 in.
- Width: 3.10 in.

ACCESSORIES

Cat. No.	Description
HIW716ENFTGKIT	Trigger guard assembly kit
HIW716ENFTG	HIW716ENF wrench provided with a factory installed HIW716ENFTGKIT
LPHTADPMMOP66	Male to Male adaptor for use with couplers listed below *(Qty. 2)
LPHTHTMANOSE66	Male Coupling 3/8" NPT *(Qty. 1)
LPHTHTMABODY66	Female Coupling 3/8" NPT *(Qty. 1)
LPHTHOSNCR66668	3/8" x 8 Ft. Hose Set *(Qty. 1)

*(Recommended quantity for use with HIW716ENF.)



The picture above shows the HIW716ENF model with trigger guard, adaptors, and couplers as listed under Accessories.

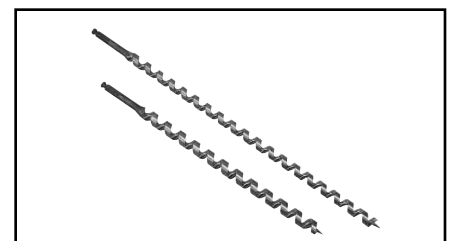

See our complete line of Dominator Drill Bits on page N83 in the Master Catalog.

Blue highlighted items are industry standard and most frequently ordered.

HIW-716R1

IMPACT WRENCH

7/16" Quick Chuck

Features and Benefits

- Gerotor motor has a lifetime warranty and greater efficiency with longer life than gear type motor tools
- High torque output provides unmatched power, yet controllable, with 500 ft-lbs of torque @ 7 GPM
- Dual action for Open or Closed center operation
- Innovative 3 part design allows tool sub-assemblies to be quickly removed/replaced if service is required.
- 7/16" Tri-ball Quick Chuck accommodates standard 7/16" hex drive bits and accessories
- Eyelet Kit included
- 5-year limited warranty
- Optional trigger guard kit **HIW71612TGKIT**



SPECIFICATIONS

Specifications	Description
Chuck Type:	7/16" Quick Chuck
Pressure:	1000-2000 psi (70-140 BAR)
Flow:	4-7 GPM (15-27 LPM)
Operation:	Open/Closed center
Torque:	450 ft-lbs @ 6 GPM
Motor:	Gerotor
Max. Back Pressure:	250 psi (17 BAR)
Weight:	7.25 lbs. (3.29 kg)
Length:	9 in. (23 cm)
Height:	9 in. (23 cm)
Width:	3 in. (7.6 cm)
Tool Ports:	#6 SAE O-Ring (F)



Cat.# **HIW71612TGKIT**

Trigger Guard

HIW716VTR1

VARIABLE IMPACT WRENCH

Features and Benefits

- Adjustable torque setting allows user to select proper power and torque for any job application
- Torque is controlled by dumping hydraulic flow back to tank, therefore, no heat build-up or over-taxing of hydraulic power source
- Gerotor type motor
- Lightweight—Most powerful wrench in the industry
- Dual action spool (Open/Closed center operation) allows the user to quickly change from Open to Closed Center circuits
- 7/16" Tri-ball Quick Chuck with wide flared flange accommodates standard 7/16" hex drive bits and accessories. Tri-Ball design provides a secure hold on attachments
- Eyelet Kit included
- 5-year limited warranty
- Optional trigger guard kit **HIW71612TGKIT**



SPECIFICATIONS

Specifications	Description
Chuck Type:	7/16" Quick Chuck
Pressure:	1000-2000 psi (70-140 BAR)
Flow:	4-7 GPM (15-27 LPM)
Operation:	Open/Closed center
Torque:	Adjustable 200-500 ft-lbs
Max. Back Pressure:	250 psi (17 BAR)
Weight:	7.25 lbs. (3.29 kg)
Length:	9 in. (23 cm)
Height:	9 in. (23 cm)
Width:	3 in. (7.6 cm)
Tool Ports:	#6 SAE O-Ring (F)

N-76

Blue highlighted items are industry standard and most frequently ordered.

**KOMPRESSOR™
LPHY750XT AND
LPHY750CXT**

**Remote Operated 12 Ton
Low Pressure Hydraulic
Compression Tool**

The BURNDY® LPHY750XT KOMPRESSOR™ is a lightweight, compact, low pressure, hydraulic 12 ton crimping tool. The LPHY750XT is double acting for hydraulic ram advance and retract. The KOMPRESSOR™ also has an industry exclusive spring back up for ram retraction in case of loss of hydraulic pressure. The LPHY750XT comes equipped with an ergonomic handle designed for better balance, which helps lessen fatigue to the operator.

The LPHY750XT KOMPRESSOR™ features the BURNDY® 750XT tool head with a 1.65" jaw opening capable of using all industry standard BURNDY® "U" dies. The LPHY750XT also has an industry exclusive visual crimp indicator to assure the operator of a properly completed crimp. The LPHY750XT also has an audible crimp indicator.

The LPHY750XT is powered directly from open center or closed center hydraulic tool circuits present on most utility line trucks or can be operated from individual low-pressure hydraulic power units. The LPHY750XT can be switched from open center to closed center operation with a simple external adjustment. The LPHY750XT does not require any additional tooling such as boosters, intensifiers, or hand controls in the bucket. Five-year limited warranty.

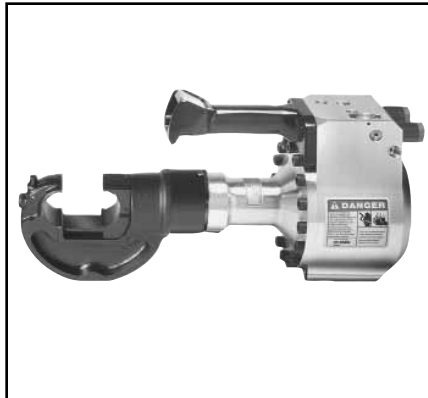

FEATURES

- LPHY750CXT covered version available. (See picture below.)
- Visual and audible crimp indicator assures properly completed crimps with 12 tons of force.
- Covers a wide range of applications with its 1.65" jaw opening.
- 350° head rotation for versatile tool head positioning allowing the user to get into tight areas easier.
- Uses all standard BURNDY® "U" dies.
- Operates on open center or closed center hydraulic systems.
- Ergonomic handle design for better balance and helps lessen fatigue.
- Double acting tool for hydraulic ram advance and retraction.
- Spring back up for ram retraction if hydraulic system shuts down.
- 5-year limited warranty.

SPECIFICATIONS

- Flow Rate:** 3 - 9 GPM (11 - 34 LPM)
- Operating Pressure:** 1,500 - 2,500 psi (103 - 172 BAR)
- Force Developed:** 12 Tons
- Weight:** 21 lbs. (9.5 kg)
- Overall Length:** 20.65 in. (524 mm)
- Width:** 15 in. (381 mm)
- Jaw Opening:** 1.65 in. (42 mm)
- Max. Back Pressure:** 250 psi (17 BAR)
- Crimp Time:** Approximately 2 seconds

FOR USE ON

- **Tension Sleeves**
 - Copper #8 sol - 500 kcmil
 - Aluminum #8 sol - 587.2 kcmil
 - ACSR #4 - 556.5 kcmil
- **Taps**
 - Copper #14 sol - 500 kcmil
 - Aluminum #8 sol - 500 kcmil
- **Aerial Cable**
 - Copper #6 - 500 kcmil
- **Terminals and Splices**
 - Copper #8 - 750 kcmil
 - Aluminum #8 - 750 kcmil
 - ACSR #4 - 556.5 kcmil
- **HYGROUND®**
 - Copper #8 - 500 kcmil
 - Ground Rods 1/2" - 1" diameter

ACCESSORIES

Hoses:

- Cat No. **LPHTHOSNCR66668OP**
Direct connect 8' non-conductive hose set
- Cat No. **LPHTHOSNCR666610OP**
Direct connect 10' non-conductive hose set
- *Cat No. **LPHTHOSNCR66668**
8' non-conductive hose set
- *Cat No. **LPHTHOSNCR666610**
10' non-conductive hose set

Hydraulic Fittings:

- Cat No. **LPHTHTMANOSE66**
Male coupler 3/8" HTMA
- Cat No. **LPHTHTMABODY66**
Female coupler 3/8" HTMA
- Cat No. **LPHTADPSMFOP66**
Swivel Adapter

*These hoses are used with the LPHTADPSMFOP66 swivel adapter.

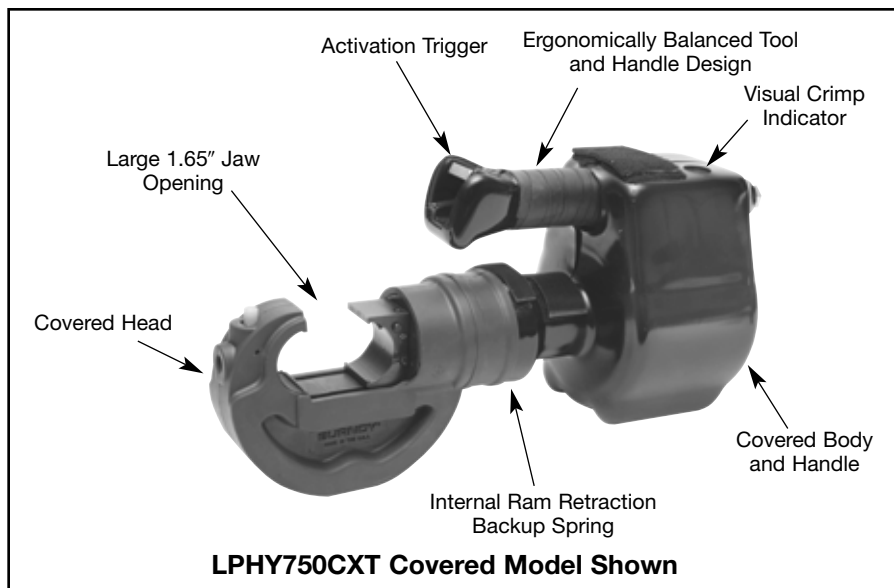

Blue highlighted items are industry standard and most frequently ordered.

HBR40

HYDRAULIC BREAKER

Light and Medium Duty

Features and Benefits

- Light to Medium Duty breakers powerful enough for most breaking applications.
- Control trigger built into handle.
- Provided with 18" braided whip hoses (order HTMA couplers separately).
- Standard tool attachment mechanism allows use of all standard tool bits.
- No compressed air exploding into atmosphere spreading dirt, dust and noise.
- Hydraulic cushioning of return stroke reduces operator shock and fatigue.
- Hand grips at comfortable working height.
- Hydraulic operation provides continuous lubrication of all moving parts.
- 5-year limited warranty.

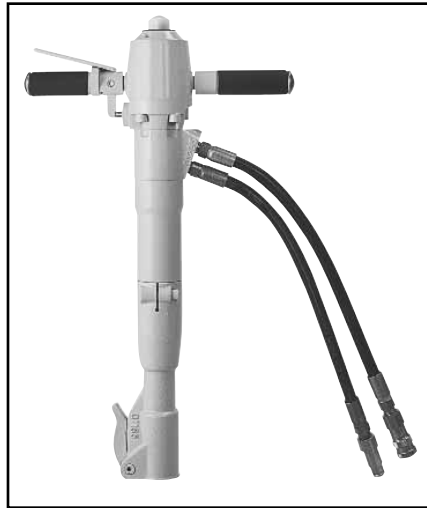

SPECIFICATIONS

- Flow:** 4-7 GPM (15-27 LPM)
- Optimum Flow:** 4 GPM (15 LPM)
- Pressure:** 1200-2000 psi (85-140 BAR)
- Max. Back Pressure:** 150 psi (11 BAR)
- Weight:** 40-48 lbs.
- Length:** 25"
- Tool Steel Capacity:** 1" x 4-1/4"
- Performance:** (1500 BPM) 45-55 lb. class breakers
- Whip Hoses:** 18" with 3/8" NPT fittings

HBR66

HYDRAULIC BREAKER

Medium and Heavy Duty

Features and Benefits

- Medium to Heavy Duty breakers suitable for extended periods of operation.
- Control trigger built into handle.
- Provided with 18" braided whip hoses (order HTMA couplers separately).
- Standard tool attachment mechanism allows use of all standard tool bits.
- No compressed air exploding into atmosphere spreading dirt, dust and noise.
- Hydraulic cushioning of return stroke reduces operator shock and fatigue.
- Hand grips at comfortable working height.
- Hydraulic operation provides continuous lubrication of all moving parts.
- HBR67HF capable of handling 7-10 GPM.
- 5-year limited warranty.

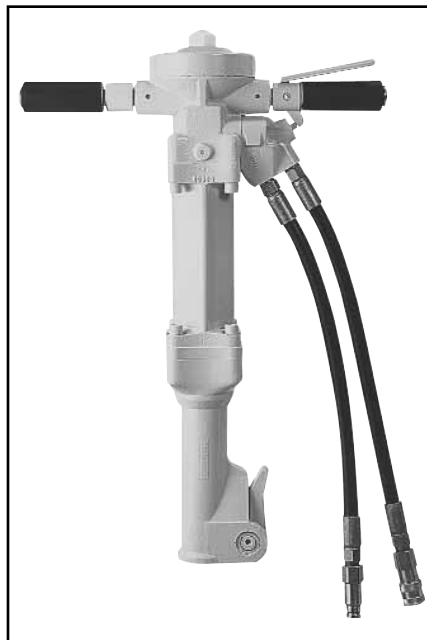

SPECIFICATIONS

- Flow:** 4-7 GPM (15-27 LPM)
- Optimum Flow:** 4 GPM (15 LPM)
- Pressure:** 1200-2000 psi (85-140 BAR)
- Max. Back Pressure:** 150 psi (11 BAR)
- Weight:** 50-67 lbs.
- Length:** 27" to 35"
- Tool Steel Capacity:** 1-1/4" x 6"
- Performance:** 60-80 lb. class series
- Whip Hoses:** 18" with 3/8" NPT fittings

N-78

Blue highlighted items are industry standard and most frequently ordered.

HTP3, HP3

3" SUBMERSIBLE PUMPS

The HP3 and HTP3 hydraulic submersible pumps are designed to reliably pump large volumes of liquids and solids (per specifications). HP and HTP models are durable and offer a very high performance-to-weight ratio. These pumps are self-lubricating, utilizing the hydraulic fluid in a closed loop to ensure consistent, reliable lubrication. The units can be run dry as they do not require water for cooling purposes whether submersed or not.

The high output and compact nature of these pumps make them ideal for pumping out vaults, trenches, ditches, ponds, tanks, pools, etc. in a multitude of industries including agriculture, construction, mining, utilities, public works, departments of transportation, and more.

Features and Benefits

- Totally submersible
- Pumps solids without blockage or damage
- Self lubricating design
- Cast aluminum pump body
- Double-sealed hydraulic motor shaft protects hydraulic source from water
- Thumb screw secured lid so cover is easy to remove without special tools
- Provided with whip hoses
- High impact, abrasion resistant liner
- 5-year limited warranty

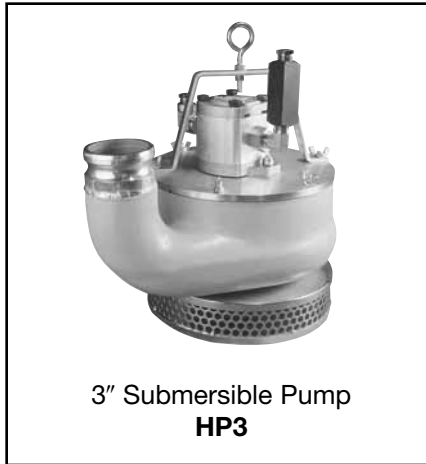

3" Submersible Pump
HP3

SPECIFICATIONS

HP3

- Flow:** 7-10 GPM (27-38 LPM)
- Pressure:** 1000-2000 PSI (70-140 BAR)
- Weight:** 36 lbs. (16.34 kg)
- Pump capacity:** 750 GPM (2800 LPM)
- Operation:** Open/Closed center
- Discharge size:** 3" outlet (3" Male Cam-Lock)
- Maximum lift:** 50 ft. (21.34 m)
- Motor:** Gear Motor

ACCESSORIES

<u>Cat. No.</u>	<u>Description</u>
HOSE325	25 ft. long hose
HOSE350	50 ft. long hose

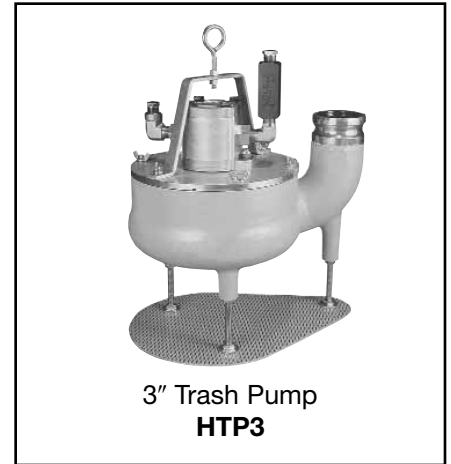

3" Trash Pump
HTP3

SPECIFICATIONS

HTP3

- Flow:** 7-10 GPM (27-38 LPM)
- Pressure:** 1000-2000 psi (70-140 BAR)
- Max. Back Pressure:** 250 psi (17 BAR)
- Weight:** 40 lbs. (18.16 kg)
- Pump capacity:** 500 GPM (1900 LPM)
- Operation:** Open/Closed center
- Discharge size:** 3" outlet (3" Male Cam-Lock)
- Motor:** Gear Motor
- Diameter:** 12 in (30.5 cm)
- Maximum lift:** 40 ft. (18.29 m)
- Ports:** 1/2" x 14 (#8) NPT (F)

HP2HV (HIGH VOLUME)

2" SUBMERSIBLE PUMPS

Features and Benefits

- Totally submersible
- Self lubricating design
- Lightweight cast aluminum pump body
- Built-in lifting handle/eye
- Self-priming pump
- Provided with whip hoses
- Unit can run dry without damage
- HP2HV adaptable to either 2" or 2-1/2" discharge
- 5-year limited warranty



SPECIFICATIONS

- Flow:** 4-9 GPM
- Pressure:** 1000-2000 psi (70-140 BAR)
- Weight:** 13 lbs.
- Pump Capacity:** 340 GPM
- Operation:** Open/Closed center
- Maximum Lift:** 80 GPM @ 70 ft
- Motor:** Gerotor Motor

ACCESSORIES

<u>Cat. No.</u>	<u>Description</u>
HOSE2	Hose

N-79

Blue highlighted items are industry standard and most frequently ordered.

HPTR1 SERIES

POLE TAMPERS

The HPT hydraulic pole tampers are designed to provide trouble-free service for compacting around poles, posts, footings and other objects.

The pole tamper operates best on a flow rate of 4 gal/min. Operating pressure. Force of blow, and frequency of blow will be a function of the flow rate provided. A minimum of 1000 lb/in² operating pressure is essential in order to obtain the maximum output performance.

The unique patented valving of the HPT pole tamper provides low maintenance, long life and superior handling characteristics because there is no mechanical impacting of the ram within the tamper. The oil reverses the stroke before bottoming out, preventing the tamper from hammering itself when running free between compaction strokes.

These features provide unexcelled compaction while virtually eliminating kick-back to the operator's hand.

Tamper shoes sold separately.



Pole Tamper With On/Off Valve



Pole Tamper With No On/Off Valve

Features and Benefits

- Available with or without On/Off control valve
- Patented valving prevents impacting of the ram within the tamper
- Stroke amplitude of 1 5/8"
- Stroke frequency of 1375 blows/min. is ideal for compacting around poles, posts, footings, and other objects
- Interchangeable heavy duty tamper shoes allows for flexibility
- 5-year limited warranty

SPECIFICATIONS

- Flow:** 4-10 GPM (15-38 LPM)
- Pressure:** 1000-2000 PSI (70-140 BAR)
- Max. Back Pressure:** 250 psi (17 BAR)
- Operation:** Open/Closed center
- Stroke Amplitude:** 1 5/8 in.
- Stroke Frequency:** 1375 per minute
- Tool Ports:** #6 SAE O-Ring (F)

With On/Off Valve			No On/Off Valve		
Catalog Number	Overall Length	Weight (Approx.)	Catalog Number	Overall Length	Weight (Approx.)
HPT-60-R1	60" (152 cm)	29 lbs (13 kg)	HPT-59-R1	59" (150 cm)	26 lbs. (12 kg)
HPT-72-R1	72" (183 cm)	30 lbs (14 kg)	HPT-71-R1	71" (180 cm)	28 lbs. (13 kg)
HPT-84-R1	84" (213 cm)	32 lbs (15 kg)	HPT-83-R1	83" (211 cm)	31 lbs. (14 kg)
HPT-96-R1	96" (244 cm)	34 lbs (15.4 kg)	—	—	—

ACCESSORIES

Tamper shoes must be ordered separately

N-80

Cat # **TS-KD**: Kidney shoe, 3" × 8" (7.6 × 20.3 cm)

Cat # **TS-RD**: Round show, 6" dia. (15.2 cm dia.)

Cat # **TS-SQ**: Square shoe, 8" × 8" (20.3 × 20.3 cm)

Whip Hoses must be ordered separately.

Cat # **LPHTWHP-BCS66606-18** (Incl. set of [2] hoses) Stk # 002045



Kidney Shoe

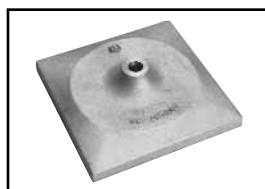

Square Shoe



Round Shoe

Blue highlighted items are industry standard and most frequently ordered.

HHS Series

HAND CHAIN SAWS

The lightweight Hydraulic Hand-held Chain Saw was designed for the ease of handling, balance and dependability. A Gerotor motor provides the hand-held chain saw with a high level of torque and horsepower for long and trouble-free operation. The handle remains cooler because no hydraulic fluid flows through the grip. An automatic chain oiler is another feature of the saw. In addition, the guide bar contains a nose sprocket for improved cutting performance and reduced wear of the guide bar. The saws are furnished with a .325 pitch anti-kick back chain. The dual spool trigger design enables operation of the tool on both open-center and closed-center systems.



Features and Benefits

- Gerotor type motor has lifetime warranty.
- Supplied with .325" pitch anti-kickback chain for maximum safety.
- Dual action spool quickly and easily changes from Open to Closed center operation.
- Automatic, adjustable chain oiler enables longer running time without damage to chain/bar due to lack of lubrication.
- Low RPM and high torque—minimizes saw kickback.
- Choice of 11", 13", 16" or 20" bars.
- 5-year limited warranty.

Catalog Number	Overall Length	Bar Length	Cutting Capacity	Weight (Approx.)
HHS-O/C-B11	21"	13-1/2"	11"	7-1/4 lbs.
HHS-O/C-B13	24"	15-1/2"	13"	7-1/2 lbs.
HHS-O/C-B16	27"	18-1/2"	16"	8 lbs.
HHS-O/C-B20	30"	22-1/2"	20"	8-1/2 lbs.

HPS Series

POLE CHAIN SAWS

The HPS hydraulic pole saws are designed for safety, convenience and function. The fiberglass extension provides lightweight strength reducing operator fatigue. The trigger guard helps to prevent accidental motor start. The high speed, high performance Gerotor motor enables these pole saws to tackle the toughest of pruning or clearing jobs. Pole circular saw models incorporate a nose and blade guard for stability and fewer chips thrown towards the operator. Pole chain saw models have a disk next to the sprocket to lessen the danger of a poorly adjusted chain from coming off the sprocket. In addition, the guide bar contains a self-lubricating oiling system to help reduce wear and increase performance. Non-conducting fiberglass poles tested to meet OSHA regulation 1910.269.



SPECIFICATIONS

HHS & HPS

- Flow:** 5-8 GPM (19-30 LPM)
- Pressure:** 1000-2000 psi (70-140 BAR)
- Operation:** Open/Closed center
- Motor:** Gerotor
- Chain:** .325" pitch anti-kickback
- Tool Ports:** #6 SAE O-Ring (F)
- Max. Back Pressure:** 250 psi (17 BAR)

Catalog Number	Overall Length	Handle Length	Bar Length	Cutting Capacity	Weight (Approx.)
HPS-O/C-4-B11	73" (6'1")	48"	13-1/2"	11"	8-3/4 lbs.
HPS-O/C-4-B13	76" (6'4")	48"	15-1/2"	13"	9 lbs.
HPS-O/C-5-B11	85" (7'1")	60"	13-1/2"	11"	9-1/4 lbs.
HPS-O/C-5-B13	88" (7'4")	60"	15-1/2"	13"	9-1/2 lbs.

Features and Benefits

- Gerotor motor has lifetime warranty.
- Dual action spool quickly and easily changes from Open to Closed center operation.
- Automatic, adjustable chain oiler enables longer running time without damage to chain/bar due to lack of lubrication.
- .325" pitch anti-kick back chain supplied standard.
- Low RPM and high torque—minimize saw kickback.
- Choice of 11" or 13" bars.
- 5-year limited warranty.

Blue highlighted items are industry standard and most frequently ordered.

HPP18, HPP18-2

HYDRAULIC POWER PACK

Cat # **HPP18** (Single Circuit)
 Cat # **HPP18-2** (Dual Circuit)

The HPP18-2 Hydraulic Power Pack is designed to provide hydraulic flow and pressure for operation of HTMA Type I and Type II hydraulic tools. The power pack is equipped with an 18 HP gas engine. The power packs are all equipped with air-to-oil coolers with suction fan mounted to the power shaft on the engine. The fuel and hydraulic systems are self-contained with the required reservoir, filtration and level indicators.

The hydraulic system consists of a hydraulic system fluid reservoir; filter assembly, single (HPP18) or tandem pump (HPP18-2), and a wide variety of flow controls. The filter element is a "spin on" type element for easy replacement. The filter housing has a pressure bypass valve to divert fluid directly to the tank in the event of a restricted filter. Only the hydraulic pumps are called out in the parts section of this manual. Pressure hoses from the pumps are connected directly to a control module, which contains a relief valve, a flow control valve, and pressure and return ports. 5 gallon hydraulic reservoir for cooler oil operation.

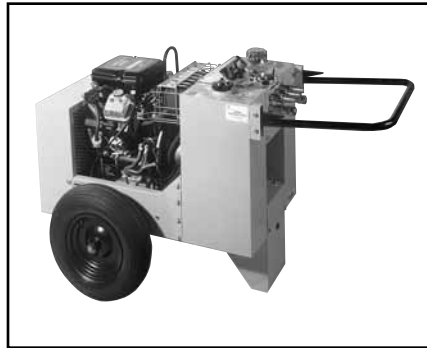

Features and Benefits

- Briggs & Stratton 18 HP VANGUARD gas engine (twin OHV cylinders.)
- Integral oil cooling system with fully shrouded fan and changeable oil filter.
- Fold away locking handle for easy job site portability.
- Electronic ignition with key start, 12 Volt battery.
- Features manual choke and an adjustable throttle mechanism with lock/adjustment.
- Variable GPM output valve provides fluid flow from 1-10 GPM @ 2,000 psi (HPP18 only).
- HPP18-2 is a dual circuit unit: (1) 10 GPM or (2) 5 GPM.
- HPP18-2 has the ability to operate two (2) 5 GPM tools simultaneously or one (1) tool up to 10 GPM.

SPECIFICATIONS

HPP18

Output/Flow: 1 @ 2,000 PSI @ 1-10 GPM
 (138 Bar @ 0-38 LPM)
Dry Weight: 233 lbs. (105.6 kg)
Length: 35" (88.9 cm)
Width: 29" (73.6 cm)
Height: 32" (81.2 cm)
Motor: 18 Hp @ 3500 RPM

HPP18-2

Output/Flow 2 @ 2,000 PSI @ 5 GPM
 or 1 @ 2,000 PSI @ 10 GPM
Dry Weight: 233 lbs. (105.6 kg)
Length: 35" (88.9 cm)
Width: 29" (73.6 cm)
Height: 32" (81.2 cm)
Motor: 18 Hp @ 3500 RPM

HPP5

HYDRAULIC POWER PACK

N-82

Features and Benefits

- Honda 5.5 HP engine with recoil start for reliability, ease of use and minimal maintenance.
- Lightweight and compact, weighing only 83 lbs. Easily transported and can be picked up by one person.
- Air blast oil cooler/radiator system with thermostatic control. Prevents overheating of the hydraulic oil.



- Built with a robust stainless steel frame and wheel kit. Provides outstanding protection during use and transport.
- Operating controls are basic and easy to use.

SPECIFICATIONS

Specifications	Description
Engine:	Honda 5.5 Hp recoil start
Operating Pressure:	1450 psi
Flow:	5.4 GPM
Dry Weight:	83 lbs.
Fuel Tank Capacity:	1 gallon
Hyd. Oil Capacity:	1.25 gallons
Length:	20"
Width:	17"
Height:	18"

Blue highlighted items are industry standard and most frequently ordered.

LPHT ACCESSORIES

This is a generic sample of the more than 200 accessory items available. If you do not see what you are looking for, call us at 1-800-346-4175. BURNDY® and we will get it for you:

Catalog Number	Description
LPHT3CHISEL11418	3" Chisel, 1-1/4" hex, 18" Long
LPHTASPHALTCUT118	Asphalt Cutter, 1-1/8" hex
LPHTCLAYSPADE118	Clay Spade, 1-1/8" hex
LPHTGRDVR11458	Ground Rod Driver, 1-1/4" hex, 5/8" Rod
LPHTGRDVR11858	Ground Rod Driver, 1-1/8" hex, 5/8" Rod
LPHTMOILPT118	Moil Point, 1" hex, 18" Long
LPHTMOILPT11814	Moil Point, 1-1/8" hex, 14" Long
LPHTNARCHISEL11814	Narrow Chisel, 1-1/8" hex, 14" Long
LPHTADPMM71612	7/16" Quick Chuck Adaptor × 1/2" Square
HIW71612GKIT	Trigger Guard for HIW-716, HIW-12
LPHTADPMMOP66	ADP Male/Male SAE #6, 3/8 NPT (2 required per tool)
Auger Bits (call for many additional options)	
LPHTBIT111618D	11/16" × 18" Long × 7/16 QC; Dominator
LPHTBIT111624D	11/16" × 24" Long × 7/16 QC; Dominator
LPHTBIT131618D	13/16" × 18" Long × 7/16 QC; Dominator
LPHTBIT131624D	13/16" × 24" Long × 7/16 QC; Dominator
LPHTBIT151618D	15/16" × 18" Long × 7/16 QC; Dominator
LPHTBIT151624D	15/16" × 24" Long × 7/16 QC; Dominator
Hoses (call for many additional options) red or orange	
LPHTHOSNCR666610	Hose - Insulated, 10 ft., 3/8 NPT, 3/8 NPT
LPHTHOSNCR66668	Hose - Insulated, 8 ft., 3/8 NPT, 3/8 NPT
LPHTHOSNCR66668QP	Hose - Insulated, 8 ft., SAE #6, 3/8 NPT
LPHTHOSNCR666610QP	Hose - Insulated, 10 ft., SAE #6, 3/8 NPT
Couplers (call for many additional options)	
LPHTDRIPBODY66	Dripless Body - 3/8 Body, 3/8 NPT
LPHTDRIPBODY88	Dripless Body - 1/2 Body, 1/2 NPT
LPHTDRIPNOSE66	Dripless Nose - 3/8 Body, 3/8 NPT
LPHTDRIPNOSE88	Dripless Nose - 1/2 Body, 1/2 NPT
LPC38S	3/8, 3/8 NPT Flush Face Coupler Set - Body & Nose
LPC12S	3/8, 1/2 NPT Flush Face Coupler Set - Body & Nose
LPHTHTMADUSTCAPF	HTMA Dust Cap - Body
LPHTHTMADUSTCAPM	HTMA Dust Cap - Nose
Sockets	
LPHTSOC121/118	Dual Socket - 1/2" Drive × 1" × 1-1/8"
LPHTSOC121316/1516	Dual Socket - 1/2" Drive × 13/16" & 15/16"
LPHTSOC121	Socket - 1/2" Drive × 1"
LPHTSOC121116	Socket - 1/2" Drive × 11/16"
LPHTSOC12112	Socket - 1/2" Drive × 1-1/2"
LPHTSOC12114	Socket - 1/2" Drive × 1-1/4"
LPHTSOC12118	Socket - 1/2" Drive × 1-1/8"
LPHTSOC121188PT	Socket - 1/2" Drive × 1-1/8", 8 Point
LPHTSOC1212	Socket - 1/2" Drive × 1/2"
LPHTSOC12128PT	Socket - 1/2" Drive × 1/2", 8 Point
LPHTSOC121316	Socket - 1/2" Drive × 13/16"
LPHTSOC1213168PT	Socket - 1/2" Drive × 13/16", 8 Point
LPHTSOC12138	Socket - 1/2" Drive × 1-3/8"
LPHTSOC1215168PT	Socket - 1/2" Drive × 15/16", 8 Point
LPHTSOC121716	Socket - 1/2" Drive × 1-1/16"
LPHTSOC1217168PT	Socket - 1/2" Drive × 1-1/16", 8 Point
LPHTSOC1218PT	Socket - 1/2" Drive × 1", 8 Point
LPHTSOC1234	Socket - 1/2" Drive × 3/4"
LPHTSOC12348PT	Socket - 1/2" Drive × 3/4", 8 Point
LPHTSOC1258	Socket - 1/2" Drive × 5/8"
LPHTSOC12588PT	Socket - 1/2" Drive × 5/8", 8 Point
LPHTSOC1278	Socket - 1/2" Drive × 7/8"
LPHTSOC12788PT	Socket - 1/2" Drive × 7/8", 8 Point
LPHTSOC12916	Socket - 1/2" Drive × 9/16"
HIW12SOCSET	Socket Set - 1/2" Drive DP IMP 6 Point

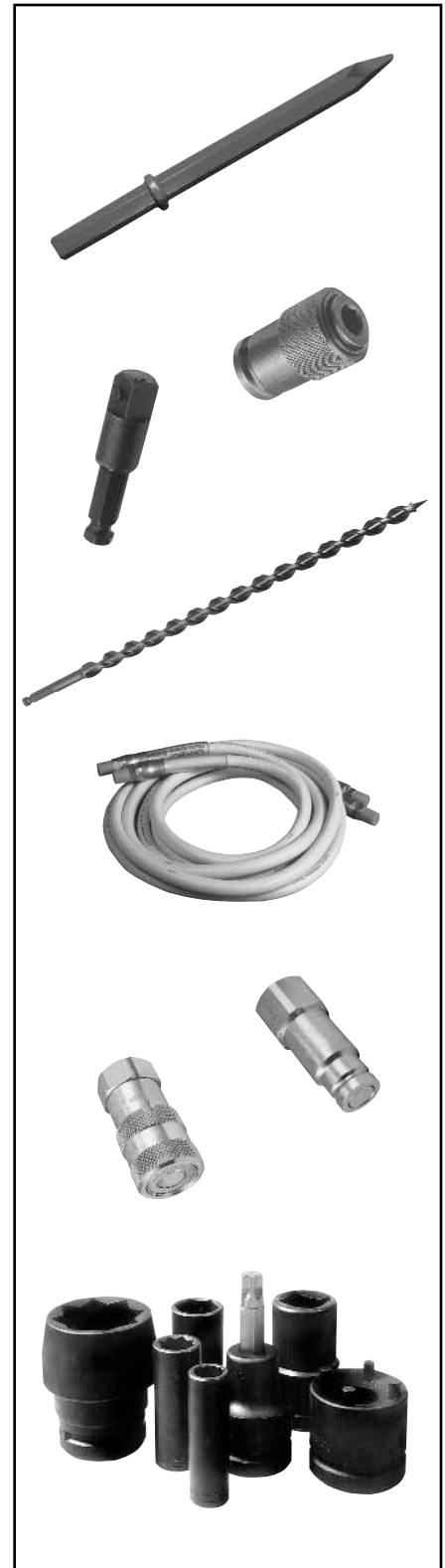

N-83

BKOM50125

KNOCKOUT SET

For 1/2" – 1-1/4" Conduit Size

The BURNDY® Knockout Set is designed to punch holes for 1/2" – 1-1/4" conduit in distribution boxes, electrical panels and troughs.

The Knockout Set is provided with a 1-year limited warranty.



BKOM50125 SPECIFICATIONS

Description	Weight
1/2" – 1-1/4" Knockout Set	3 lbs.

ACCESSORIES

Components for kit listed above can be purchased separately.

Features and Benefits

- Four-point design allows slug to drop automatically without splitting.
- Punches up to 10-gauge mild steel.
- Set includes the four most popular sizes of punches and dies packed in a sturdy storage case.
- 1-year limited warranty.

SET INCLUDES

Catalog Number	Description	Hole	Weight
BKP500B	1/2" Punch	7/8"	.4 lb.
BKD500B	1/2" Die	7/8"	1 lb.
BKP750B	3/4" Punch	1-3/32"	.4 lb.
BKD750B	3/4" Die	1-3/32"	1 lb.
BKP1000B	1" Punch	1-11/32"	1 lb.
BKD1000B	1" Die	1-11/32"	1 lb.
BKP1250B	1-1/4" Punch	1-11/16"	2 lb.
BKD1250B	1-1/4" Die	1-11/16"	2 lb.
BKSB50B	1/2" Bearing & Drive Screw		1 lb.
BKS752B	3/4" – 2" Bearing & Drive Screw		1 lb.
BK88004	Storage Case		1.5 lb.

BKOM152

KNOCKOUT SET

For 1-1/2" – 2" Conduit Size

The BURNDY® Knockout Set is designed to punch holes for 1-1/2" – 2" conduit in distribution boxes, electrical panels and troughs.

The Knockout Set is provided with a 1-year limited warranty.



BKOM152 SPECIFICATIONS

Description	Weight
1-1/2" – 2" Knockout Set	4 lbs.

ACCESSORIES

Components for kit listed above can be purchased separately.

Features and Benefits

- Four-point design allows slug to drop automatically without splitting.
- Punches up to 10-gauge mild steel.
- Durable storage case.
- 1-year limited warranty.

SET INCLUDES

Catalog Number	Description	Hole	Weight
BKP1500B	1-1/2" Punch	1-15/16"	2 lb.
BKD1500B	1-1/2" Die	1-15/16"	2 lb.
BKP2000B	2" Punch	2-3/8"	2 lb.
BKD2000B	2" Die	2-3/8"	2 lb.
BKS752B	3/4" – 2" Bearing & Drive Screw	—	1 lb.
BK88001	Storage Case	—	1.5 lb.

Blue highlighted items are industry standard and most frequently ordered.

BKOH2540

ASSORTED KNOCKOUT KIT

For 2-1/2" – 4" Conduit Size

The BURNDY® Assorted Knockout Kit is designed to punch holes for 2-1/2" – 4" conduit in distribution boxes, electrical panels and troughs.

The Knockout Kit is provided with a 1-year limited warranty.



BKOH2540 SPECIFICATIONS

Description	Weight
2-1/2" – 4" Knockout Kit	22 lbs.

ACCESSORIES

Components for kit listed above can be purchased separately.

Features and Benefits

- Expand capability of 1/2" – 2" sets.
- Four-point design allows slug to drop automatically without splitting.
- Punches up to 10-gauge mild steel.
- Packed in metal storage case.
- 1-year limited warranty.

SET INCLUDES

Catalog Number	Description	Hole	Weight
BKP2500	2-1/2" Punch	2-7/8"	3 lb.
BKD2500	2-1/2" Die	2-7/8"	3 lb.
BKP3000	3" Punch	3-1/2"	4 lb.
BKD3000	3" Die	3-1/2"	4 lb.
BKP3500	3-1/2" Punch	4"	4 lb.
BKD3500	3-1/2" Die	4"	4 lb.
BKP4000	4" Punch	4-1/2"	4 lb.
BKD4000	4" Die	4-1/2"	4 lb.
BK88008	Metal Storage Case	—	5 lb.

BKOW520

KNOCKOUT SET WITH RATCHET WRENCH

For 1/2" – 2" Conduit

The BURNDY® Knockout Set with Ratchet Wrench is designed to punch holes for 1/2" – 2" conduit in distribution boxes, electrical panels and troughs.

The Knockout Set with Ratchet Wrench is provided with a 1-year limited warranty.



BKOW520 SPECIFICATIONS

Description	Weight
1/2" – 2" Knockout Set with Ratchet Wrench (BKW52)	12 lbs.

ACCESSORIES

Components for the kit listed above can be purchased separately.

Features and Benefits

- Four-point design allows slug to drop automatically without splitting.
- Punches up to 10-gauge mild steel.
- Set includes ratchet wrench, six sizes of punches and dies, and two drive screws; all packaged in a rugged storage case.
- 1-year limited warranty.

SET INCLUDES

Catalog Number	Description	Hole	Weight
BKP500B	1/2" Punch	7/8"	.4 lb.
BKD500B	1/2" Die	7/8"	1 lb.
BKP750B	3/4" Punch	1-3/32"	.4 lb.
BKD750B	3/4" Die	1-3/32"	1 lb.
BKP1000B	1" Punch	1-11/32"	1 lb.
BKD1000B	1" Die	1-11/32"	1 lb.
BKP1250B	1-1/4" Punch	1-11/16"	2 lb.
BKD1250B	1-1/4" Die	1-11/16"	2 lb.
BKP1500B	1-1/2" Punch	1-15/16"	2 lb.
BKD1500B	1-1/2" Die	1-15/16"	2 lb.
BKP2000B	2" Punch	2-3/8"	2 lb.
BKD2000B	2" Die	2-3/8"	2 lb.
BKW52	Hand Ratchet Wrench	—	1 lb.
BKSB50B	1/2" Bearing & Drive Screw	—	1 lb.
BKS752B	3/4" – 2" Bearing & Drive Screw	—	1 lb.
BK88007	Storage Case	—	1.5 lb.

Blue highlighted items are industry standard and most frequently ordered.

BKOR520

QUICK HAND RATCHET KNOCKOUT SET

For 1/2" – 2" Conduit

The BURNDY® Hand Ratchet Knockout Set is designed to punch holes for 1/2" – 2" conduit in distribution boxes, electrical panels and troughs.

The Hand Ratchet Knockout Set is provided with a 1-year limited warranty.



BKOR520 SPECIFICATIONS

Description	Weight
1/2" – 2" Quick Hand Ratchet Knockout Set	16 lbs.

ACCESSORIES

Components for kit listed above can be purchased separately.

Features and Benefits

- Four-point design allows slug to drop automatically without splitting.
- Smooth operating ratchet handles up to 10-gauge mild steel or 12-gauge stainless steel.
- 1-year limited warranty.

SET INCLUDES

Catalog Number	Description	Hole	Weight
BKP500B	1/2" Punch	7/8"	.4 lb.
BKD500B	1/2" Die	7/8"	1 lb.
BKP750B	3/4" Punch	1-3/32"	.4 lb.
BKD750B	3/4" Die	1-3/32"	1 lb.
BKP1000B	1" Punch	1-11/32"	1 lb.
BKD1000B	1" Die	1-11/32"	1 lb.
BKP1250B	1-1/4" Punch	1-11/16"	2 lb.
BKD1250B	1-1/4" Die	1-11/16"	2 lb.
BKP1500B	1-1/2" Punch	1-15/16"	2 lb.
BKD1500B	1-1/2" Die	1-15/16"	2 lb.
BKP2000B	2" Punch	2-3/8"	2 lb.
BKD2000B	2" Die	2-3/8"	2 lb.
BKOR14	Ratchet	—	12 lb.
BKOR50	1/2" Screw Adapter	—	.4 lb.
BKOR75125	3/4" – 1-1/4" Screw Adapter	—	1 lb.
BKOR152	1-1/2" – 2" Screw Adapter	—	1 lb.
BK88020	Metal Storage Case	—	4 lb.

BKOS5290

**SELF-CONTAINED
 HYDRAULIC 360°
 KNOCKOUT SET**

For 1/2" – 2" Conduit

The BURNDY® Self-Contained 360° Knockout Set is designed to punch holes for 1/2" – 2" conduit in distribution boxes, electrical panels and troughs.

The self-contained 360° Knockout Set is provided with a 1-year limited warranty.



BKOS5290 SPECIFICATIONS

Description	Weight
1/2" – 2" Self-Contained Hydraulic Knockout Set – head swivels 360°	7-1/2 lbs.

Features and Benefits

- Right-angle head swivels 360° for flexible punching in tight work spaces.
- Punches up to 2-1/2" conduit sizes, up to 10-gauge mild steel or 12-gauge stainless steel.
- No cumbersome "spacers" required.
- Compact, lightweight size: 7-1/2 pounds and 13" in length.
- Operating pressure rated at 10,000 psi.
- Set includes the most popular drawstuds, punches, and dies for punching holes for 1/2" to 2" conduit; all packed in a sturdy storage case.
- 1-year limited warranty.

SET INCLUDES

Catalog Number	Description	Hole	Weight
BKP500B	1/2" Punch	7/8"	.4 lb.
BKD500B	1/2" Die	7/8"	1 lb.
BKP750B	3/4" Punch	1-3/32"	.4 lb.
BKD750B	3/4" Die	1-3/32"	1 lb.
BKP1000B	1" Punch	1-11/32"	1 lb.
BKD1000B	1" Die	1-11/32"	1 lb.
BKP1250B	1-1/4" Punch	1-11/16"	2 lb.
BKD1250B	1-1/4" Die	1-11/16"	2 lb.
BKP1500B	1-1/2" Punch	1-15/16"	2 lb.
BKD1500B	1-1/2" Die	1-15/16"	2 lb.
BKP2000B	2" Punch	2-3/8"	2 lb.
BKD2000B	2" Die	2-3/8"	2 lb.
BKLP6	Hydraulic Driver	—	10 lb.
BKPR7520	Drawstud	—	1 lb.
BKPS50	Drawstud	—	.2 lb.
BKSA50	Drawstud Adapter	—	.3 lb.

ACCESSORIES

Components for the kit listed above can be purchased separately.

BKLP6K1 Seal Repair Kit

Blue highlighted items are industry standard and most frequently ordered.

BKOS520

SELF-CONTAINED HYDRAULIC KNOCKOUT SET

For 1/2" – 2" Conduit

The BURNDY® Self-Contained Hydraulic Knockout Set is designed to punch holes for 1/2" – 2" conduit in distribution boxes, electrical panels and troughs.

The Self-Contained Hydraulic Knockout Set is provided with a 1-year limited warranty.

Optional 2-1/2" and 3" punch and die available.



BKOS520 SPECIFICATIONS

Description	Weight
1/2" – 2" Self-Contained Hydraulic Set	14 lbs.

Features and Benefits

- Hydraulic driver punches up to 10-gauge mild steel or 12-gauge stainless steel.
- Four-point design allows slug to drop automatically without splitting.
- Lightweight and easy to use.
- Hydraulic driver operates in any position.
- 1-year limited warranty.

SET INCLUDES

Catalog Number	Description	Hole	Weight
BKP500B	1/2" Punch	7/8"	.4 lb.
BKD500B	1/2" Die	7/8"	1 lb.
BKP750B	3/4" Punch	1-3/32"	.4 lb.
BKD750B	3/4" Die	1-3/32"	1 lb.
BKP1000B	1" Punch	1-11/32"	1 lb.
BKD1000B	1" Die	1-11/32"	1 lb.
BKP1250B	1-1/4" Punch	1-11/16"	2 lb.
BKD1250B	1-1/4" Die	1-11/16"	2 lb.
BKP1500B	1-1/2" Punch	1-15/16"	2 lb.
BKD1500B	1-1/2" Die	1-15/16"	2 lb.
BKP2000B	2" Punch	2-3/8"	2 lb.
BKD2000B	2" Die	2-3/8"	2 lb.
BKLP2	Hydraulic Driver	—	10 lb.
BKPR7520	Drawstud	—	1 lb.
BKPS50	Drawstud	—	.2 lb.
BKSA50	Drawstud Adapter	—	.3 lb.
BK88020	Metal Storage Case	—	4.1 lb.

ACCESSORIES

Components for the kit listed above can be purchased separately. Additional accessories, not included in kit, are listed below.

Catalog Number	Description	Hole	Weight
BKP2500	2-1/2" Punch	2-7/8"	3 lb.
BKD2500	2-1/2" Die	2-7/8"	3 lb.
BKP3000	3" Punch	3-1/2"	4 lb.
BKD3000	3" Die	3-1/2"	4 lb.
BKLP2K1	Seal Repair Kit	—	—

N-90

Blue highlighted items are industry standard and most frequently ordered.

BKOH520A

HYDRAULIC KNOCKOUT SET

For 1/2" – 2" Conduit

The BURNDY® Hydraulic Knockout Set is designed to punch holes for 1/2" – 2" conduit in distribution boxes, electrical panels and troughs. Provided with hand pump.

The Hydraulic Knockout Set is provided with a 1-year limited warranty.



BKOH520A SPECIFICATIONS

Description	Weight
1/2" – 2" Hydraulic Knockout Set with BPH20 Hand Pump	31 lb.

Features and Benefits

- Four-point design allows slug to drop automatically without splitting.
- Punches up to 10-gauge mild steel or 12-gauge stainless steel.
- Hand-powered hydraulic pump.
- Assortment of punches, dies and accessories.
- Includes metal storage case (11-1/8" x 18-3/4" x 6-1/4").
- Competitors' punches and dies are interchangeable.
- 1-year limited warranty.

BKOH520A SET INCLUDES

Catalog Number	Description	Hole	Weight
BKP500B	1/2" Punch	7/8"	.4 lb.
BKD500B	1/2" Die	7/8"	1 lb.
BKP750B	3/4" Punch	1-3/32"	.4 lb.
BKD750B	3/4" Die	1-3/32"	1 lb.
BKP1000B	1" Punch	1-11/32"	1 lb.
BKD1000B	1" Die	1-11/32"	1 lb.
BKP1250B	1-1/4" Punch	1-11/16"	2 lb.
BKD1250B	1-1/4" Die	1-11/16"	2 lb.
BKP1500B	1-1/2" Punch	1-15/16"	2 lb.
BKD1500B	1-1/2" Die	1-15/16"	2 lb.
BKP2000B	2" Punch	2-3/8"	2 lb.
BKD2000B	2" Die	2-3/8"	2 lb.
BPH20	Hand Pump — 2 speed	—	5 lb.
BKPR7540	Drawstud for 3/4" – 4" Punches & Dies	—	2.5 lb.
BKPS50*	Stainless Steel Drawstud, 3/8" dia.	—	.2 lb.
BKC3540**	Converter	—	.4 lb.
BCH1211	12-ton Hydraulic Cylinder	—	6 lb.
BH864	6' Rubber Hose Coupler	—	2 lb.
BCM5	Metal Case	—	11 lb.

* Must be used with 1/2" punch and die.

** Must be used with 3-1/2" – 4" punch and die.

ACCESSORIES

Components for kit listed above can be purchased separately.

Blue highlighted items are industry standard and most frequently ordered.

BKOH540A

HYDRAULIC KNOCKOUT SET

For 1/2" – 4" Conduit

The BURNDY® Hydraulic Knockout Set is designed to punch holes for 1/2" – 4" conduit in distribution boxes, electrical panels and troughs. Provided with hand pump.

The Hydraulic Knockout Set is provided with a 1-year limited warranty.



BKOH540A SPECIFICATIONS

Description	Weight
1/2" – 4" Hydraulic Knockout Set with BPH20 Hand Pump	50 lb.

Features and Benefits

- Four-point design allows slug to drop automatically without splitting.
- Punches up to 10-gauge mild steel or 12-gauge stainless steel.
- Hand-powered hydraulic pump.
- Assortment of punches, dies and accessories.
- Includes metal storage case (11-1/8" x 18-3/4" x 6-1/4").
- Competitors' punches and dies are interchangeable.
- 1-year limited warranty.

BKOH540A SET INCLUDES

Catalog Number	Description	Hole	Weight
BKP500B	1/2" Punch	7/8"	.4 lb.
BKD500B	1/2" Die	7/8"	1 lb.
BKP750B	3/4" Punch	1-3/32"	.4 lb.
BKD750B	3/4" Die	1-3/32"	1 lb.
BKP1000B	1" Punch	1-11/32"	1 lb.
BKD1000B	1" Die	1-11/32"	1 lb.
BKP1250B	1-1/4" Punch	1-11/16"	2 lb.
BKD1250B	1-1/4" Die	1-11/16"	2 lb.
BKP1500B	1-1/2" Punch	1-15/16"	2 lb.
BKD1500B	1-1/2" Die	1-15/16"	2 lb.
BKP2000B	2" Punch	2-3/8"	2 lb.
BKD2000B	2" Die	2-3/8"	2 lb.
BKP2500	2-1/2" Punch	2-7/8"	3 lb.
BKD2500	2-1/2" Die	2-7/8"	3 lb.
BKP3000	3" Punch	3-1/2"	4 lb.
BKD3000	3" Die	3-1/2"	4 lb.
BKP3500	3-1/2" Punch	4"	4 lb.
BKD3500	3-1/2" Die	4"	4 lb.
BKP4000	4" Punch	4-1/2"	4 lb.
BKD4000	4" Die	4-1/2"	4 lb.
BPH20	Hand Pump — 2 speed	—	5 lb.
BKPR7540	Drawstud for 3/4" – 4" Punches & Dies	—	2.5 lb.
BKPS50*	Stainless Steel Drawstud, 3/4" dia.	—	.2 lb.
BKC3540**	Converter	—	.4 lb.
BCH1211	12-ton Hydraulic Cylinder	—	6 lb.
BH864	6' Rubber Hose Coupler	—	2 lb.
BCM5	Metal Case	—	11 lb.

* Must be used with 1/2" punch and die.

** Must be used with 3-1/2" – 4" punch and die.

ACCESSORIES

Components for kit listed above can be purchased separately.

BKOF520

HYDRAULIC KNOCKOUT SET

For 1/2" – 2" Conduit

The BURNDY® Hydraulic Knockout Set is designed to punch holes for 1/2" – 2" conduit in distribution boxes, electrical panels and troughs. Provided with foot pump.

The Hydraulic Knockout Set is provided with a 1-year limited warranty.



BKOF520 SPECIFICATIONS

Description	Weight
1/2" – 2" Hydraulic Knockout Set with BPF20 Foot Pump	31 lb.

Features and Benefits

- Four-point design allows slug to drop automatically without splitting.
- Punches up to 10-gauge mild steel or 12-gauge stainless steel.
- Foot-powered hydraulic pump.
- Assortment of punches, dies and accessories.
- Includes metal storage case (11-1/8" x 18-3/4" x 6-1/4").
- Competitors' punches and dies are interchangeable.
- 1-year limited warranty.

BKOF520 SET INCLUDES

Catalog Number	Description	Hole	Weight
BKP500B	1/2" Punch	7/8"	.4 lb.
BKD500B	1/2" Die	7/8"	1 lb.
BKP750B	3/4" Punch	1-3/32"	.4 lb.
BKD750B	3/4" Die	1-3/32"	1 lb.
BKP1000B	1" Punch	1-11/32"	1 lb.
BKD1000B	1" Die	1-11/32"	1 lb.
BKP1250B	1-1/4" Punch	1-11/16"	2 lb.
BKD1250B	1-1/4" Die	1-11/16"	2 lb.
BKP1500B	1-1/2" Punch	1-15/16"	2 lb.
BKD1500B	1-1/2" Die	1-15/16"	2 lb.
BKP2000B	2" Punch	2-3/8"	2 lb.
BKD2000B	2" Die	2-3/8"	2 lb.
BPF20	Foot Pump — 2 speed	—	5 lb.
BKPR7540	Drawstud for 3/4" – 4" Punches & Dies	—	2.5 lb.
BKPS50*	Stainless Steel Drawstud, 3/8" dia.	—	.2 lb.
BKC3540**	Converter	—	.4 lb.
BCH1211	12-ton Hydraulic Cylinder	—	6 lb.
BH864	6' Rubber Hose Coupler	—	2 lb.
BCM5	Metal Case	—	11 lb.

* Must be used with 1/2" punch and die.

** Must be used with 3-1/2" – 4" punch and die.

ACCESSORIES

Components for kit listed above can be purchased separately.

Blue highlighted items are industry standard and most frequently ordered.

BKOF540

HYDRAULIC KNOCKOUT SET

For 1/2" – 4" Conduit

The BURNDY® Hydraulic Knockout Set is designed to punch holes for 1/2" – 4" conduit in distribution boxes, electrical panels and troughs. Provided with foot pump.

The Hydraulic Knockout Set is provided with a 1-year limited warranty.



BKOH540A SPECIFICATIONS

Description	Weight
1/2" – 4" Hydraulic Knockout Set with BPF20 Foot Pump	50 lb.

Features and Benefits

- Four-point design allows slug to drop automatically without splitting.
- Punches up to 10-gauge mild steel or 12-gauge stainless steel.
- Foot-powered hydraulic pump.
- Assortment of punches, dies and accessories.
- Includes metal storage case (11-1/8" x 18-3/4" x 6-1/4").
- Competitors' punches and dies are interchangeable.
- 1-year limited warranty.

BKOH540A SET INCLUDES

Catalog Number	Description	Hole	Weight
BKP500B	1/2" Punch	7/8"	.4 lb.
BKD500B	1/2" Die	7/8"	1 lb.
BKP750B	3/4" Punch	1-3/32"	.4 lb.
BKD750B	3/4" Die	1-3/32"	1 lb.
BKP1000B	1" Punch	1-11/32"	1 lb.
BKD1000B	1" Die	1-11/32"	1 lb.
BKP1250B	1-1/4" Punch	1-11/16"	2 lb.
BKD1250B	1-1/4" Die	1-11/16"	2 lb.
BKP1500B	1-1/2" Punch	1-15/16"	2 lb.
BKD1500B	1-1/2" Die	1-15/16"	2 lb.
BKP2000B	2" Punch	2-3/8"	2 lb.
BKD2000B	2" Die	2-3/8"	2 lb.
BKP2500	2-1/2" Punch	2-7/8"	3 lb.
BKD2500	2-1/2" Die	2-7/8"	3 lb.
BKP3000	3" Punch	3-1/2"	4 lb.
BKD3000	3" Die	3-1/2"	4 lb.
BKP3500	3-1/2" Punch	4"	4 lb.
BKD3500	3-1/2" Die	4"	4 lb.
BKP4000	4" Punch	4-1/2"	4 lb.
BKD4000	4" Die	4-1/2"	4 lb.
BPF20	Foot Pump — 2 speed	—	5 lb.
BKPR7540	Drawstud for 3/4" – 4" Punches & Dies	—	2.5 lb.
BKPS50*	Stainless Steel Drawstud, 3/4" dia.	—	.2 lb.
BKC3540**	Converter	—	.4 lb.
BCH1211	12-ton Hydraulic Cylinder	—	6 lb.
BH864	6' Rubber Hose Coupler	—	2 lb.
BCM5	Metal Case	—	11 lb.

* Must be used with 1/2" punch and die.

** Must be used with 3-1/2" – 4" punch and die.

ACCESSORIES

Components for kit listed above can be purchased separately.

**B12E, B34E12R,
 B1E34R**

CONDUIT HAND BENDERS

The BURNDY® Aluminum Hand Bender is designed to bend EMT and Rigid conduit. The size range is 1/2" - 1" EMT.

The conduit hand bender is provided with a 5-year limited warranty.

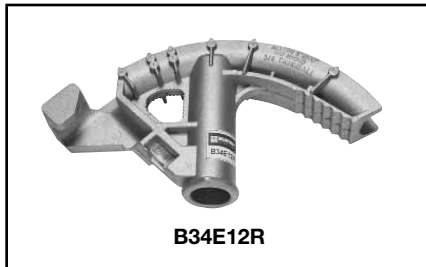
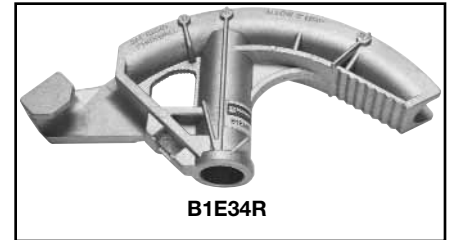
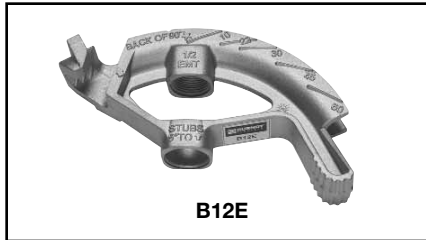

Features and Benefits

- All models include embossment with sight lines for 10°, 22°, 30°, 45°, 60° and 90°.
- Industry standard markings — 30° bend when handle is straight up.
- The non-slip foot pedal is contoured allowing more foot room.
- 3/4" and 1" bender heads have levels which makes aligning easy.
- Designed with a channel to bend conduit back if you have an over-bend.
- 5-year limited warranty.

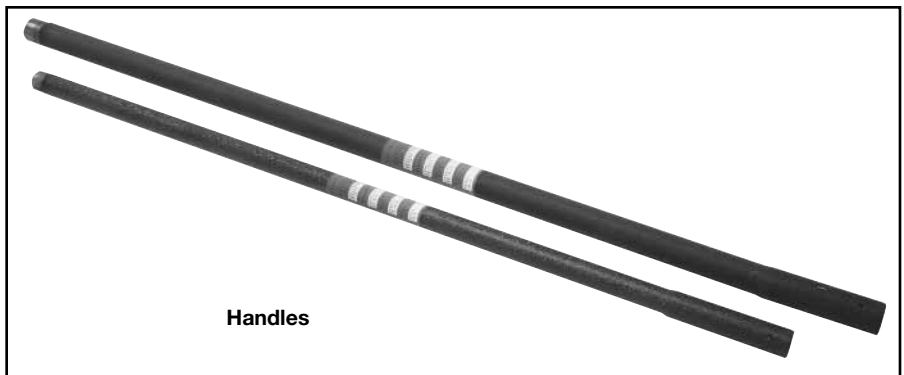

Bender Part Number	Description	Weight
B12E	1/2" EMT (bender head only)	.90 lbs
B34E12R	3/4" EMT – 1/2" RIGID (bender head only)	1.80 lbs
B1E34R	1" EMT – 3/4" RIGID (bender head only)	3.55 lbs
Handle Part Number	Description	Weight
H12E	Handle for 1/2" bender	3.65 lbs
H34E12R	Handle for 3/4" bender	3.65 lbs
H1E34R	Handle for 1" bender	5.45 lbs
Assembly (Bender & Handle)	Description	Weight
BHA12E	1/2" EMT bender with handle	4.55 lbs
BHA34E12R	3/4" EMT – 1/2" RIGID bender with handle	5.45 lbs
BHA1E34R	1" EMT – 3/4" RIGID bender with handle	9 lbs

Blue highlighted items are industry standard and most frequently ordered.

Benders—Electric Benders

BEB122

ELECTRIC CONDUIT BENDER

For 1/2" - 2" Conduit and Pipe

The BURNDY® BEB122 electric conduit bender is designed to bend 1/2" - 2" rigid conduit, IMC, EMT and 2" PVC coated conduit. The BEB122 bender assists the electrical contractor on larger jobs and will save time and labor.

The BEB122 electrical bender is provided with a 2-year limited warranty.

Features and Benefits

- The electric bender is available for Rigid, EMT, IMC or PVC. Bender can also be purchased without shoes.
- Shoes and roller supports interchange with the Gardner Bender® GB2555, Greenlee® 555 and Current Tools® 77 series. (Only exception is using the Greenlee® four groove rigid shoe #00571. You must use roller support #00936.)
- Reliable electrical system that offers ease of repairs (does not contain any circuit boards).
- Proudly "Made in the USA."
- Maximum schedule 40 conduit.
- Will produce 180 degree bends in a single cycle.
- Limit stop control for bend angle settings.
- Operates on 115-120VAC 60Hz.
- Built in bend angle protractor bends 90 degrees quickly and efficiently.
- 2-year limited warranty.



ACCESSORIES

Part Number	Description	Weight
BEBSHOECASE	Metal storage box	36 lbs.

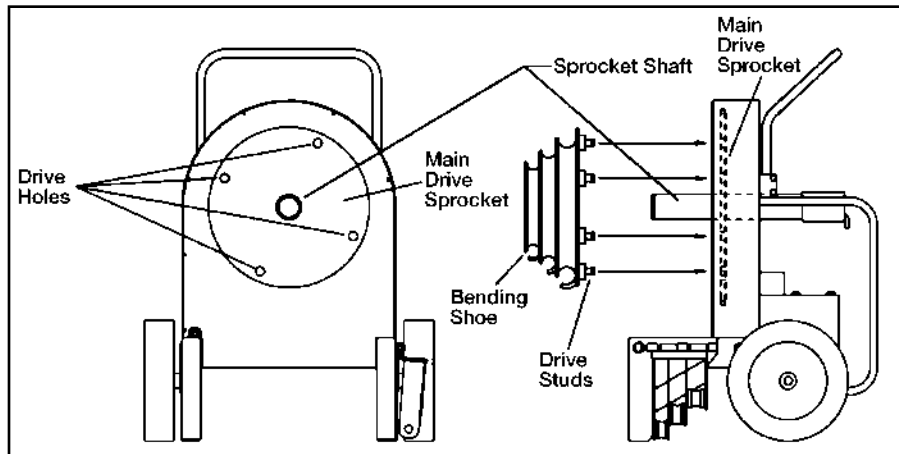

Part Number	Description	Weight
BEB122	Electric Bender Power Unit only, without shoes and roller supports	270 lbs.
BEB122RIG	Electric Bender with shoes and roller supports for 1/2" through 2" RIGID conduit schedule 40 pipe and 1/2" through 1-1/4" IMC conduit	365 lbs.
BEB122EMT*	Electric Bender with shoes and roller supports for 1/2" through 2" EMT conduit	430 lbs.
BEB122PVC*	Electric Bender with shoes and roller supports for 1/2" through 2" PVC coated RIGID conduit	365 lbs.
122RIG	Shoes and roller supports only, for bending 1/2" thru 2" RIGID conduit, 1/2" through 1-1/4" IMC conduit and 1/2" through 2" Schedule 40 pipe	74 lbs.
122EMT*	Shoes and roller supports only, for bending 1/2" through 2" EMT (thinwall)	160 lbs.
122IMC*	Shoes and roller supports only, for bending 1-1/2" and 2" IMC	127 lbs.
122PVC*	Shoes and roller supports only, for bending 1/2" through 2" 40 mil PVC coated RIGID	110 lbs.

* Shoes and roller supports come with BEBSHOECASE metal box.

BSC2H

The SmartCart®

2 Wheel Heavy Duty Cart

The SmartCart® is a versatile wire management system consisting of 2 wheeled carts, various modular wire racks for carrying spools of wire and wall storage units to organize and store racks with wire when not in use. The SmartCart® wire management system will assist the electrical contractor with wire installations, improves wire storage, and saves time and labor.

Heavy duty carts are rated for 600 lbs. capacity.

The SmartCart® is provided with a 1-year limited warranty.

Features and Benefits

- Order as standard configuration or customize to your needs with various size racks
- Two holders provided for up to 1" conduit benders
- Built-in tray to hold fish tapes and tools
- Handles are pre-dimpled for mounting material tool boxes (MTB and MTX)
- Cart base plate is pre-punched to accommodate mounting of the extension base plate with built-in wire guide
- Spools are easily changed by placing rack on its side, removing hitch pin and shaft, roll-out and roll-in desired new spool
- Motionless vise attached to the back of cart for cutting 1/2", 3/4" and 1" conduit



BSC2H

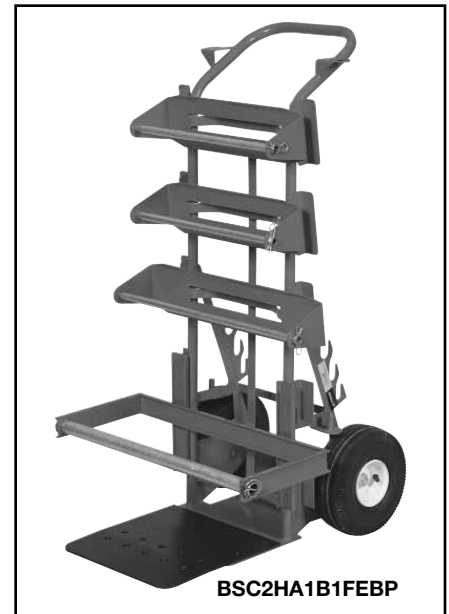

BSC2HA1B1FEBP

Catalog Number	Description	Weight
BSC2H	2-Wheel Heavy Duty without racks	37 lbs.
BSC2H5A	2-Wheel Heavy Duty with (5) R17A racks	62 lbs.
BSC2H3A2B	2-Wheel Heavy Duty with (3) R17A racks and (2) R22B racks	64 lbs.
BSC2H5B	2-Wheel Heavy Duty with (5) R22B racks	67 lbs.
BSC2H1C2DEBP	2-Wheel Heavy Duty with (1) R17C rack, (2) R25D racks and (1) EBP	86 lbs.
BSC2H2C1DEBP	2-Wheel Heavy Duty with (2) R17C racks, (1) R25D rack and (1) EBP	82 lbs.
BSC2H2A1B1FEBP	2-Wheel Heavy Duty with (2) R17A racks (1) R22B rack (1) R24F rack and (1) EBP	81 lbs.

ACCESSORIES

- EBP** Extension Base Plate with built-in wire guide
- MTB** Material Tool Box
11" L x 6" W x 5" D
- MTX** Material Tool Box (MTB) with Dividers 6-Pockets:
3-5/8" L x 3" W x 3" D
- R17A** 17" wide rack for 7-1/2" diameter spools with 1/2" EMT spindles
- R22B** 22" wide rack for 7-1/2" diameter spools with 1/2" EMT spindles
- R17C *** 17" wide rack for 12" diameter spools with 1" EMT spindles
- R25D *** 25" wide rack for 12" diameter spools with 1" EMT spindles
- R24F *** 24" wide rack for 2-16" diameter reels with 1" EMT spindles
- BSCWS40** 40" Wall Wire Reel Storage System
- BSCWS80** 80" Wall Wire Reel Storage System

*Note: The R17C, R25D, and R24F racks are designed for oversized reels. The Extension Base Plate (EBP) is required when used on The SmartCart®.

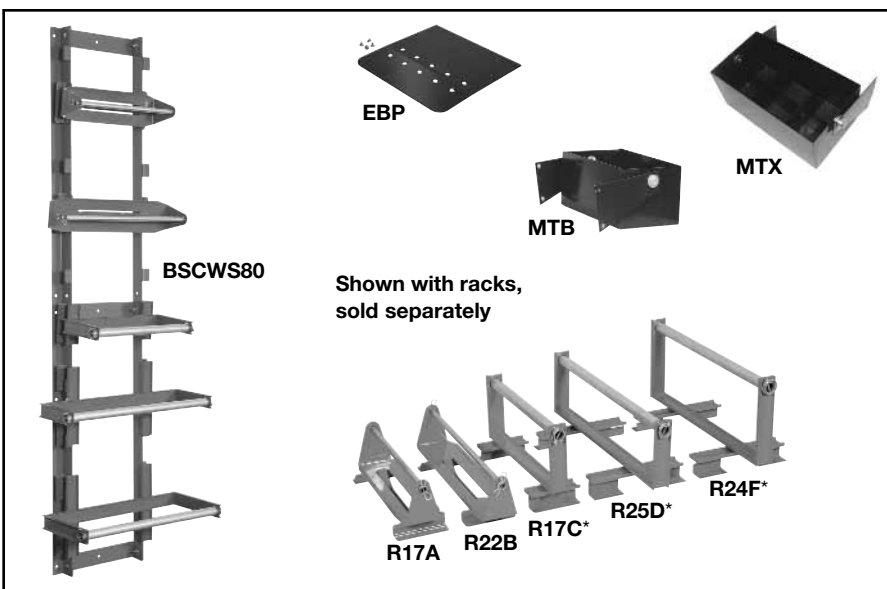

Shown with racks, sold separately

Blue highlighted items are industry standard and most frequently ordered.

BSC2L

The SmartCart®

2 Wheel Light Duty Cart

The SmartCart® is a versatile wire management system consisting of 2 wheeled carts, various modular wire racks for carrying spools of wire and wall storage units to organize and store racks with wire when not in use. The SmartCart® wire management system will assist the electrical contractor with wire installations, improves wire storage, and saves time and labor.

Light duty carts are rated for 300 lbs capacity.

The SmartCart® is provided with a 1-year limited warranty.

Features and Benefits

- Order as standard configuration or customize to your needs with various size racks
- Two holders provided for up to 1" conduit benders
- Built-in tray to hold fish tapes and tools
- Handles are pre-dimpled for mounting material tool boxes (MTB and MTX)
- Cart base plate is pre-punched to accommodate mounting of the extension base plate with built-in wire guide
- Spools are easily changed by placing rack on its side, removing hitch pin and shaft, roll-out and roll-in desired new spool
- Motionless vise attached to the back of cart for cutting 1/2", 3/4" and 1" conduit



BSC2L

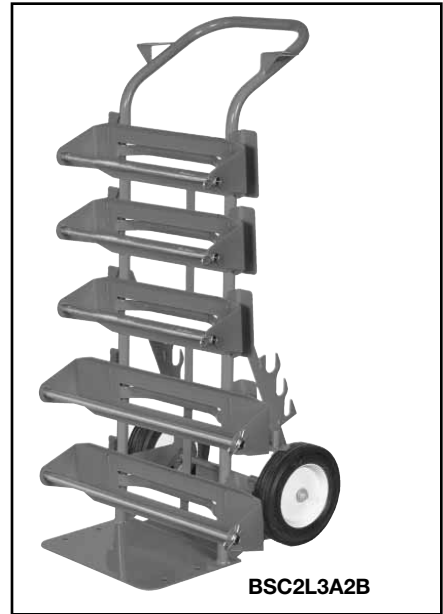

BSC2L3A2B

Catalog Number	Description	Weight
BSC2L	2-Wheel Light Duty without racks	37 lbs.
BSC2L5A	2-Wheel Light Duty with (5) R17A racks	62 lbs.
BSC2L3A2B	2-Wheel Light Duty with (3) R17A racks and (2) R22B racks	64 lbs.
BSC2L5B	2-Wheel Light Duty with (5) R22B racks	67 lbs.
BSC2L1C2DEBP	2-Wheel Light Duty with (1) R17C rack, (2) R25D racks and (1) EBP	86 lbs.
BSC2L2C1DEBP	2-Wheel Light Duty with (2) R17C racks, (1) R25D rack and (1) EBP	82 lbs.

ACCESSORIES

- EBP** Extension Base Plate with built-in wire guide
- MTB** Material Tool Box
11" L × 6" W × 5" D
- MTX** Material Tool Box (MTB) with Dividers 6-Pockets:
3-5/8" L × 3" W × 3" D
- R17A** 17" wide rack for 7-1/2" diameter spools with 1/2" EMT spindles
- R22B** 22" wide rack for 7-1/2" diameter spools with 1/2" EMT spindles
- R17C *** 17" wide rack for 12" diameter spools with 1" EMT spindles
- R25D *** 25" wide rack for 12" diameter spools with 1" EMT spindles
- R24F *** 24" wide rack for 2-16" diameter reels with 1" EMT spindles
- BSCWS40** 40" Wall Wire Reel Storage System
- BSCWS80** 80" Wall Wire Reel Storage System

*Note: The R17C, R25D, and R24F racks are designed for oversized reels. The Extension Base Plate (EBP) is required when used on The SmartCart®.

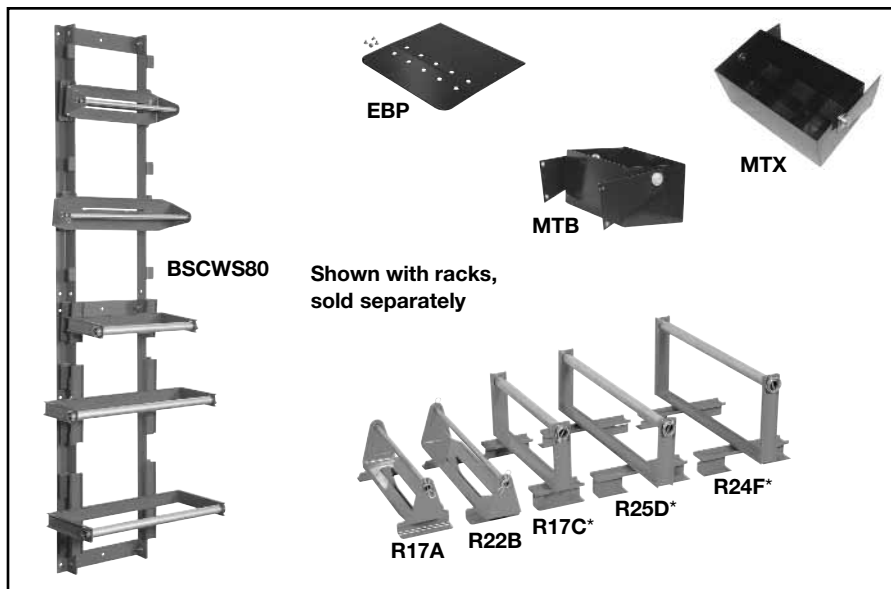

Shown with racks, sold separately

Blue highlighted items are industry standard and most frequently ordered.

BSCWS40 AND BSCWS80

The SmartCart®

Wall Wire Reel Storage System

The BSCWS40, 40" high and BSCWS80, 80" high Wall Wire Reel Storage Systems are designed to work in a van, panel truck or shop and handles all 2 wheel SmartCart® racks.

Provides a time saving advantage by storing wire on racks which can be easily moved to 2 wheel carts for transporting and wire pulling.

Sizes: 40" high, 17" wide, 2-3/4" deep
80" high, 17" wide, 2-3/4" deep

The SmartCart® is provided with a 1-year limited warranty.

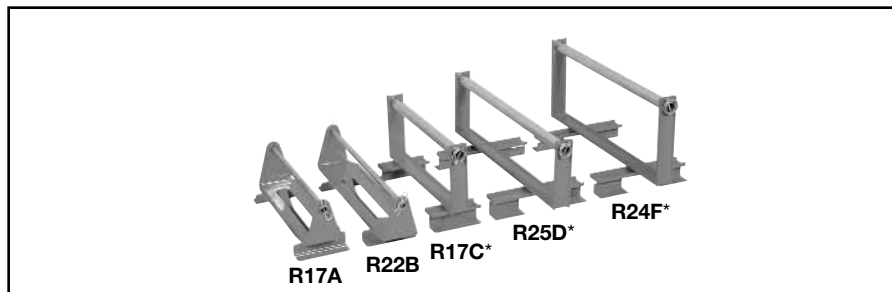
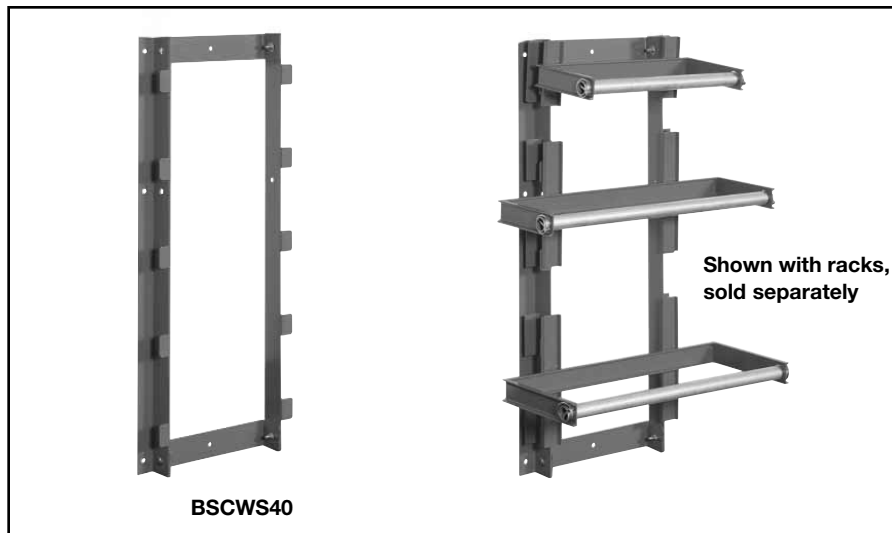
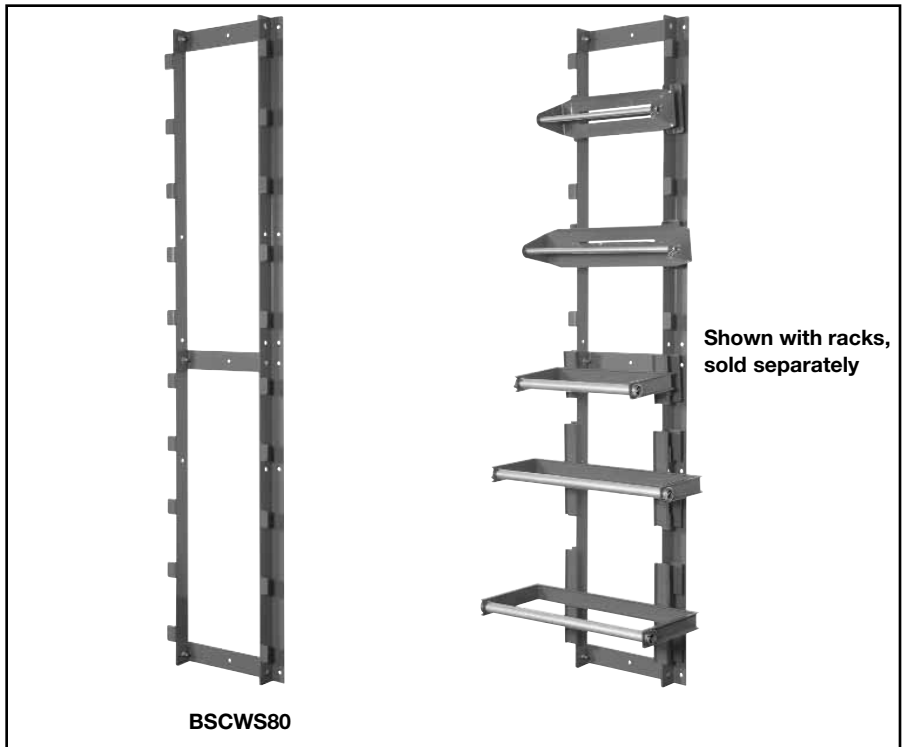

Modular Racks for 2 Wheel Carts

(sold separately)

- R17A** 17" wide rack for 7-1/2" diameter spools with 1/2" EMT spindles
- R22B** 22" wide rack for 7-1/2" diameter spools with 1/2" EMT spindles
- R17C*** 17" wide rack for 12" diameter spools with 1" EMT spindles
- R25D*** 25" wide rack for 12" diameter spools with 1" EMT spindles
- R24F*** 24" wide rack for 2-16" diameter reels with 1" EMT spindles

*Note: The R17C, R25D, and R24F racks are designed for oversized reels. The Extension Base Plate (EBP) is required when used on The SmartCart®.

Blue highlighted items are industry standard and most frequently ordered.

BWC04EHC

BURNDY® Wire Caddies

Economy Hand Caddy

The BWC04EHC Economy Hand Caddy is designed for 500' spools of #10 AWG and smaller. No hitch pins to lose as retaining washers keep spools on spindles. (Can also be mounted on the BWC24MTHTC.)

Maximum Weight Capacity: 200 lbs.
Spool capacity: (8) 500' spools of #12 AWG (4) 500' spools of #10 AWG
Size: 10-1/2" high, 13-1/2" wide, 21" long
Weight: 4 lbs.

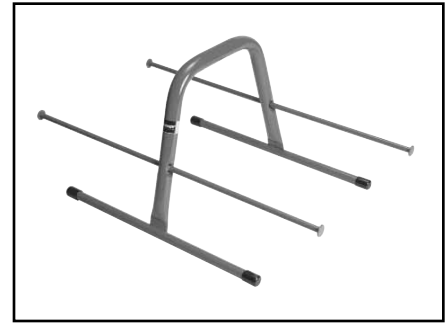

BWC06FHC

BURNDY® Wire Caddies

Folding Hand Caddy

The BWC06FHC Folding Hand Caddy is designed for 500' spools of #10 AWG and smaller. No hitch pins to lose as retaining washers keep spools on spindles. Caddy folds down to 2-1/2" for compact storage.

Maximum Weight Capacity: 120 lbs.
Spool capacity: (6) 500' spools of up to #10 AWG
Size: 10" high, 18" wide
Weight: 5 lbs.

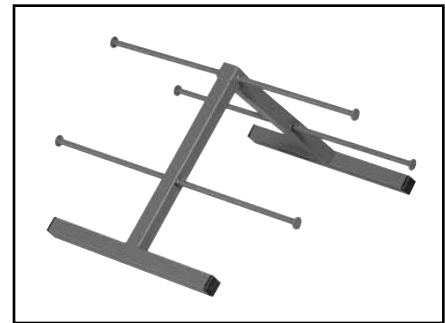

BWC01CMC

BURNDY® Wire Caddies

Compact Medium Caddy

The BWC01CMC is designed for medium size heavier reels. No hitch pins to lose. 3/4" solid steel spindle under 1" tubing sleeves for easy payout. Folds down for compact storage. (Can also be mounted on the BWC-24MTHTC.)

Maximum Weight Capacity: 300 lbs.
Reel capacity: 24-1/2" traverse, 30" diameter, 250 lbs.
Size: 24" high, 35" spindle length
Weight: 15 lbs.

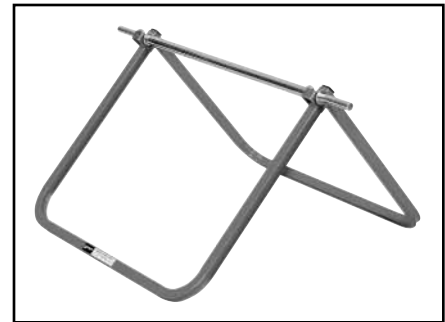

BWC01CDC

BURNDY® Wire Caddies

Compact Data Caddy

The BWC01CDC Compact Data Caddy is designed for medium size reels like Cat 5 or even 1000' NM-B mounted on a 5/8" solid steel spindle. No hitch pins to lose and folds down for compact storage.

Maximum Weight Capacity: 300 lbs.
Reel capacity: 24-1/2" traverse, 20" diameter, 250 lbs.
Size: 16" high, 28-1/2" long
Weight: 9 lbs.



Blue highlighted items are industry standard and most frequently ordered.

BWC46CWD

BURNDY® Wire Caddies

Caddy Wire Dispenser

The BWC46CWD is designed for spools up to 9" diameter. No hitch pins to lose with (6) 1/2" solid steel spindles. Retaining washers keep spools on spindles. Removable handle with built in wire guide. (2) locking swivel casters and (2) swivel casters.

Maximum Weight Capacity: 350 lbs.
Spool capacity: 12-1/4" traverse, 9" diameter (per spindle)
Size: 16-1/2" high, 26" wide, 16" long
Weight: 19 lbs.



BWC01FCMR

BURNDY® Wire Caddies

Folding Caddy Mount Reel

The BWC01FCMR Folding Caddy Mount Reel is designed for dispensing coiled NM-B or MC. Attaches to the BWC28FAC for portability and accepts add-on BWC01FAR for additional coils. Caddy folds down for compact storage.

Maximum Weight Capacity: 100 lbs.
Capacity: (2) 250' coils of NM-B; (1) 250' coil of MC
Size: 15" high x 18" wide
Weight: 8 lbs.



BWC28FAC

BURNDY® Wire Caddies

Folding A-Frame Caddy

The BWC28FAC Folding A-Frame Caddy is designed for 500' spools of #10 AWG and smaller. No hitch pins to lose with (8) 1/2" solid steel spindles, (2) 8 x 1-1/2" semi-pneumatic tires. Folds down for compact storage and wire can be left on caddy when folded. BWC01FCMR can be mounted for portability.

Maximum Weight Capacity: 400 lbs.
Spool capacity: 18" traverse, 6-3/4" diameter (per spindle)
Size: 47" High, 28-1/4" wide, 15-1/2" deep (when folded)
Weight: 45 lbs.



Blue highlighted items are industry standard and most frequently ordered.

BWC01FSMC

BURNDY® Wire Caddies

Folding Stud Mount Caddy

The BWC01FSMC Folding Stud Mount Caddy is designed for dispensing coiled NM-B or MC while attached to wood studs. Caddy offers a universal mounting device for 2" x 4" or 2" x 6" studs. Caddy folds down for compact storage; accepts add-on BWC01FAR for additional coils.

Maximum Weight Capacity: 125 lbs.
Capacity: (2) 250' coils of NM-B,
(1) 250' coil of MC
Size: 16" high, 20-3/4" (open),
5" (folded) wide
Weight: 6 lbs.

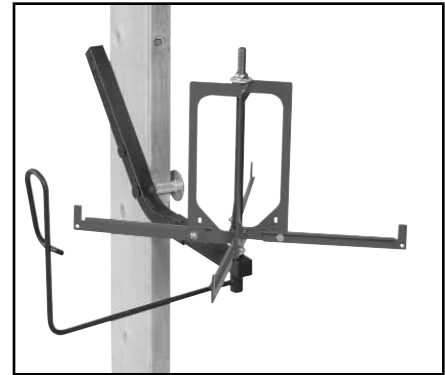

BWC01FAR

BURNDY® Wire Caddies

Folding Add-On Reel

The BWC01FAR Folding Add-On Reel is designed for dispensing coiled NM-B or MC while attached to BWC01FSMC or BWC01FFMC. Caddy folds down for compact storage.

Maximum Weight Capacity: 100 lbs.
Capacity: (2) 250' coils of NM-B,
(1) 250' coil of MC
Size: 16" high, 20-3/4" (open),
5" (folded) wide
Weight: 4 lbs.

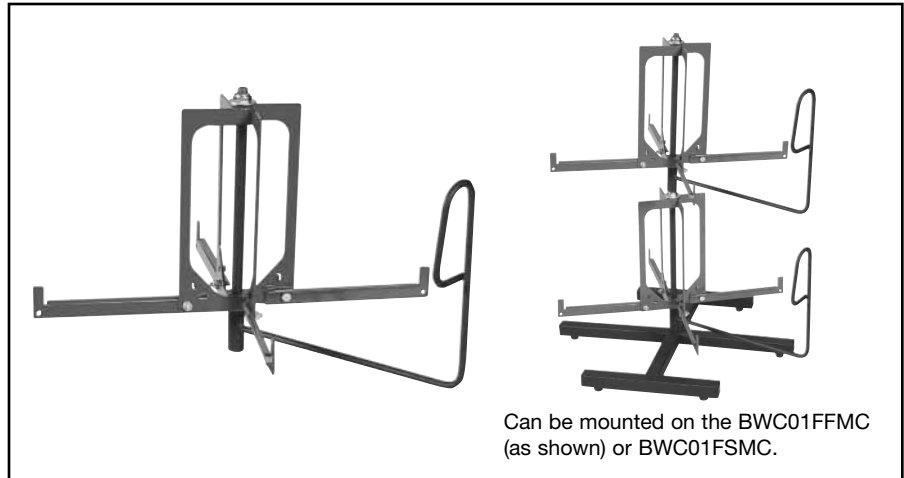

Can be mounted on the BWC01FFMC (as shown) or BWC01FSMC.

BWC01FFMC

BURNDY® Wire Caddies

Folding Floor Mount Caddy

The BWC01FFMC Folding Floor Mount Caddy is designed for dispensing coiled NM-B or MC. Caddy folds down for compact storage; accepts add-on reel BWC01FAR for additional coils. (Can also be mounted on the BWC24MTHTC.)

Maximum Weight Capacity: 125 lbs.
Capacity: (2) 250' coils of NM-B,
(1) 250' coil of MC
Size: 16" high, 20-3/4" (open),
5" (folded) wide
Weight: 8 lbs.

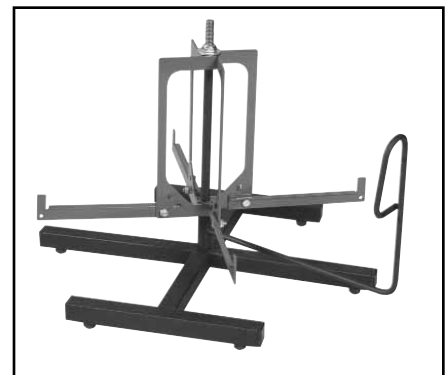

BWC46RC

BURNDY® Wire Caddies

6 Spindle Reel Caddy

The BWC46RC 6 Spindle Reel Caddy is designed for 2500' reels of #10 AWG and smaller. No hitch pins to lose with (6) 3/4" solid steel spindles under 1" tubing sleeves for easy pay out. Retaining washers to keep reels on spindles. Folds down for compact storage. (2) 4" locking swivel casters and (2) 8" molded rubber wheels.

Maximum Weight Capacity: 750 lbs.
Reel capacity: 14-3/4" traverse, 15" diameter (per spindle)
Size: 40-1/2" high, 33" wide
Weight: 66 lbs.



BWC410RC

BURNDY® Wire Caddies

10 Spindle Reel Caddy

The BWC410RC 10 Spindle Reel Caddy is designed for 2500' reels of #10 AWG and smaller. No hitch pins to lose with (10) 3/4" solid steel spindles under 1" tubing sleeves for easy pay out. Retaining washers to keep reels on spindles. Folds down for compact storage. (2) 4" locking swivel casters and (2) 8" molded rubber wheels.

Maximum Weight Capacity: 1200 lbs.
Reel capacity: 14-3/4" traverse, 15" diameter (per spindle)
Size: 51-1/2" high, 34-1/2" wide
Weight: 91 lbs.



BWC420MSC

BURNDY® Wire Caddies

Multi-Spool Caddy

The BWC420MSC Multi-Spool Caddy is designed for 500' reels of #10 AWG and smaller. No hitch pins to lose with (20) 1/2" solid steel spindles. Retaining washers to keep reels on spindles. Folds down for compact storage. (2) 4" locking swivel casters and (2) 8" molded rubber wheels.

Maximum Weight Capacity: 1000 lbs.
Reel capacity: 14-3/4" traverse, 7" diameter (per spindle)
Size: 45" high, 34-1/2" wide
Weight: 80 lbs.



Blue highlighted items are industry standard and most frequently ordered.

BWC24HTC

BURNDY® Wire Caddies

Hand Truck Caddy

The BWC24HTC Hand Truck Caddy is designed for 500' spools of #10 AWG and smaller. No hitch pins to lose with (4) 1/2" solid steel spindles. (2) 10" x 4" wheels with pneumatic tube tires.

Maximum Weight Capacity: 400 lbs.
Spool capacity: 18" traverse; 6-3/4" diameter (per spindle)
Size: 47" High, 28-1/4" wide, 15-1/2" deep
Weight: 38 lbs.



BWC24HTC

BWC25LHTC, BWC00ADP AND BWC27LHTCADP

BURNDY® Wire Caddies

Large Hand Truck Caddy

The BWC25LHTC is designed for 500' spools of #10 AWG and smaller. Accommodates larger spools with BWC00ADP attached. No hitch pins to lose with (5) 1/2" solid steel spindles. (2) 8" x 1-1/2" semi pneumatic tires.

BWC25LHTC and BWC00ADP sold separately or combined as BWC27LHTCADP.

Maximum Weight Capacity: 400 lbs.
Spool capacity: 17-1/2" traverse, 7" diameter (per spindle)
With BWC00ADP: Max: 5 x 17-1/2" traverse, 4 x 15", 1 x 12" diameter

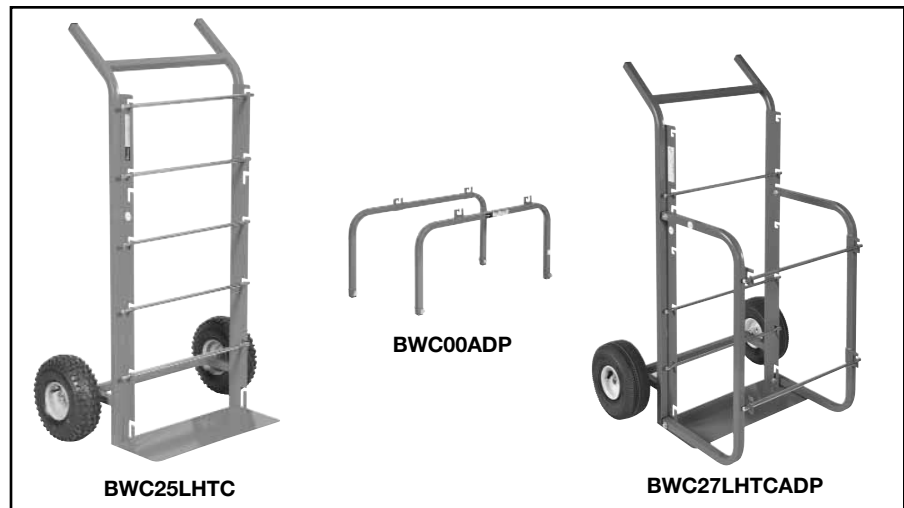

BWC25LHTC

BWC00ADP

BWC27LHTCADP

Size: 48" high, 27" wide, 16-1/2" deep
Weight: BWC25LHTC 38 lbs.
 BWC00ADP 9 lbs.
 BWC27LHTCADP 47 lbs.

BWC24MTHTC

BURNDY® Wire Caddies

Multi-Task Hand Truck Caddy

The BWC24MTHTC Multi-Task Hand Truck Caddy is designed for 500' spools of #10 AWG and smaller. No hitch pins to lose with (4) 1/2" solid steel spindles, (2) 8 x 1-1/2" semi-pneumatic tires. Base platform to carry (2) BWC04EHC, or (2) BWC01FFMC, or (1) BWC01CMC.

Maximum Weight Capacity: 400 lbs.
Spool capacity: 14" traverse, 6-3/4" diameter (per spindle)
Size: 46" high, 21" wide, 16" deep
Weight: 36 lbs.

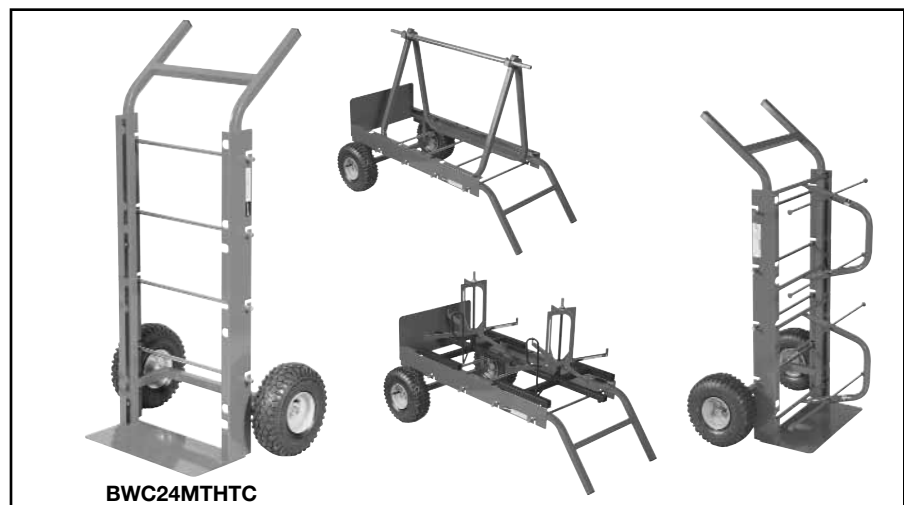

BWC24MTHTC

Blue highlighted items are industry standard and most frequently ordered.

BWC00JS**BURNDY® Wire Caddies**

Jack Stand

The BWC00JS Jack Stand is designed for:

Maximum Height &

Weight Capacity: 26-1/2" high, 2500 lbs.

Capacity: 26" to 52" reel diameter

Size: 15" high, 20" long, 14-1/2" wide

Weight: 30 lbs. each



Jack Stands are sold individually.
Note: EMT not included.

BWC20PRSF**BURNDY® Wire Caddies**

Portable Reel Support Frame

The BWC20PRSF Portable Reel Support Frame is designed to support 1" conduit for multi use spindle. (1) locking swivel caster and (1) swivel caster per frame. Sold in sets of two frames.

Maximum Weight Capacity: 400 lbs.

Capacity: 27" diameter reels, 200 lbs. per frame

Size: 14" high, 17-1/2" wide

Weight: 14 lbs. per set

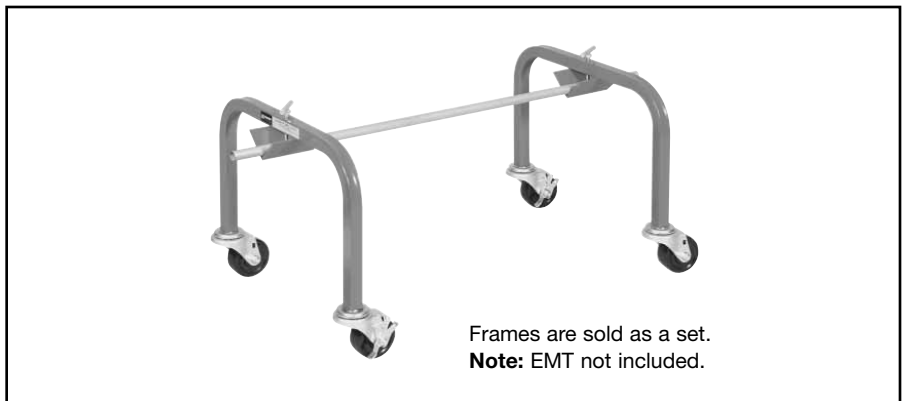

Frames are sold as a set.
Note: EMT not included.

BWC32DCC**BURNDY® Wire Caddies**

Double Coil Caddy

The BWC32DCC Double Coil Caddy is designed for dispensing MC cable from portable cart. (1) locking swivel caster and (2) 8" x 2" molded rubber wheels.

Maximum Weight Capacity: 300 lbs.

Capacity: (2) MC coils per reel

Size: 26" high, 52-1/2" long, 27" wide

Weight: 46 lbs.

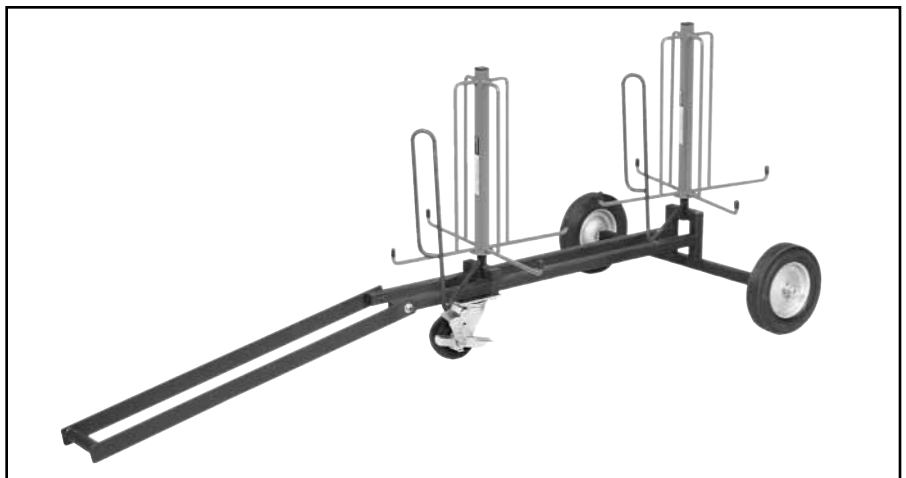

Blue highlighted items are industry standard and most frequently ordered.

BWC40PC

BURNDY® Wire Caddies

Push Cart

The BWC40PC Push Cart is designed with:

- (2) 20-1/2" × 35-1/2" trays
- (2) Pull out supports for ladder transport
- (2) 2" × 4" wheels
- (2) 2" × 4" locking swivel casters

Maximum Weight Capacity: 800 lbs.

Size: 36" high, 44" long, 21" wide

Weight: 81 lbs.



BWC43UC

BURNDY® Wire Caddies

Utility Cart

The BWC43UC Utility Cart is designed with:

- (2) 20-1/2" × 35-1/2" trays
- (2) Pull out supports for ladder transport
- (3) 1/2" solid steel spindles with 16" traverse
- (2) Slots for conduit benders
- (1) Fish tape holder

Trays and bins for fittings and hardware

- (2) 2" × 4" wheels
- (2) 2" × 4" locking swivel casters

Maximum Weight Capacity: 800 lbs.

Size: 36" high, 44" long, 21" wide

Weight: 114 lbs.



Note: Chain Vise and Bracket are not included.

BWC43TRC

BURNDY® Wire Caddies

Triple Reel Caddy

The BWC43TRC Triple Reel Caddy is designed for dispensing medium diameter, heavy reels. Great for 1,000' reels of MC or THHN. (3) 3/4" solid steel spindles under 1" tubing sleeves for easy pay out.

Maximum Weight Capacity: 750 lbs.

Capacity: 21" traverse, 36" diameter (per spindle)

Size: 20-1/2" high, 52-1/2" long, 28" wide

Weight: 98 lbs.



Blue highlighted items are industry standard and most frequently ordered.

TABLE OF CONTENTS

Introduction		Compact ACSR Cable	O-15
Basic Connection Principles	O-2	ACSR/TW Cable (Trap Wire) . . .	O-15 - O-16
Hardware Data		AAC/TW Cable (All Aluminum Trap Wire)	O-16
DURIUM™ Steel/Aluminum Tightening Torques	O-6	ACAR Cable	O-16
DURIUM™ Hex Bolts Data	O-6	SSAC Cable	O-17
UL Tightening Torque UL486	O-7		
Cable Data (Tables)		Steel Conductors	
Copper Cable		Copperweld Cable	O-18
Copper Tube	O-8	Copperweld - Copper Cable	O-18
Solid Copper Wire	O-8	Galvanized Steel Cable	O-18
Stranded Copper Cable	O-8	Alumoweld Cable	O-19
Compact Stranded Copper Cable	O-9	AWG vs Metric Wire Sizes	O-19
Flexible Copper Stranded Cable	O-10	Inches - Millimeters Conversion Chart	O-20
Aluminum and ACSR Cable		Terminal Stud Size Chart	O-21
Aluminum Tube	O-11	Die Set Conversion Chart (Obsolete Dies)	O-22 - O-28
Aluminum 1350 Cable Bare-Classes AA and A	O-11	12-Ton U Dies	O-29
Aluminum 1350 Cable Bare-Class B	O-11	W Dies	O-29
ACSR Cable	O-12	Installation Tool Index	O-30 - O-40
High Strength ACSR Cable	O-12	Catalog Numbers Requiring MSDS	O-41
Compact Aluminum 1350 Cable	O-13	Color Coding for Overhead Connectors	O-41
Aluminum Alloy 5005 Cable	O-13	Color Coding for AL/CU Connectors	O-42
Aluminum 6201 Cable	O-13	Color Coding for Copper Lugs and Splices	O-42
Aluminum Alloy 8000 Series "O" Temper Cable	O-14 - O-15	Alpha-Numeric Index	O-43 - O-
		Product/Trade Name Index	O-

INTRODUCTION

BASIC ELECTRICAL CONNECTION PRINCIPLES

Basic Factors:

The basic factors which influence the design and performance of pressure wire connections are as follows:

1. Creep
2. Surface Oxide
3. Corrosion

A fourth factor, known as thermal effects, is also a consideration, but due to the technical nature and length of the topic, it will not be discussed in this publication.

At the outset it should be pointed out that these factors give rise to much more difficult problems in connections involving aluminum conductors than those encountered in copper to copper connections.

CREEP (COLD FLOW)

Creep is the cold flow of the metal under pressure, and it continues until the pressure reduces to a value at which any further creep is negligible. Creep properties depend on the particular metal or alloy and on its hardness; alloys having less creep than pure metals, and harder metals have less creep than soft metals. In a typical connection, the conductors are generally of pure metal and often of soft temper and therefore, subject to considerable creep. In addition, the condition is further exaggerated when aluminum is the conductor as compared to copper, since its creep rate is many times that of copper.

Effect of Creep: Figure 2 shows typical curves of total contact resistance plotted against total contact force. Curve A shows how the contact resistance continually decreases with increasing contact force. When the full contact force F_1 is reached, the contact resistance reaches the low value of R_1 . In general, the full tightening force on a connector greatly exceeds the maximum force for which there is no appreciable creep. Therefore, the force will gradually settle down to a value after which there will be no further significant creep. Fortunately, however, the

resistance does not climb back up along curve A, the tightening curve, but instead it follows a new curve B, the relaxing curve, along which the resistance changes very little, until the force relaxes to a value such as F_2 .

Admittedly, the point of "no appreciable creep" is difficult to define. For pure metals, especially in the soft state, there is always some creep, even at very low pressures at room temperature. However, we do know that the pressure required to produce the same creep rate is several times greater for copper than for aluminum. Thus, to permit the same contact force F_2 for aluminum and copper, the contact area A required for aluminum can be expected to be considerably greater than that required for copper. This explains why the contact areas for connectors for aluminum must be considerably greater than for copper, and why many light duty connectors for copper are entirely inadequate for aluminum, even when specially plated and when recommended compounds are used on the contact surfaces.

Relaxation: Relaxation of pressure due to creep, or for any other reason, would be a much more difficult factor in a pressure connection were it not for the relationship of contact pressure to contact resistance on the relaxation curve as shown in Figure 2. It is frequently observed that some time after the bolts of a clamp type connector are tightened, the bolt tensions are relaxed appreciably. The question arises as to whether it is necessary to retighten the bolts to the original torque value. In a properly designed connector, retightening is unnecessary since the contact resistance should increase very little due to the relaxation of pressure, as shown by the relaxation curve of Figure 2.

This fact is largely responsible for the successful operation of a compression connector. The application of the compression tool applies very high pressure, establishing very low contact resistance. The removal of the compression tool releases a very large proportion of this pressure, and creep further relaxes this pressure. Fortunately, the contact resistance increases very little due to this pressure relaxation.

Contact Force: The previous analysis shows that the total contact force largely determines the contact resistance. Thus, to achieve the desired low value of contact resistance, the proper size and number of bolts in a clamp type connector must be supplied, and the compression tool must apply the proper force to a compression connector. In addition, the connector must be

designed with sufficient structural strength, contact area, and resilience, to assure that the contact force cannot relax beyond the point where contact resistance begins to rise appreciably, as shown in Figure 2.

SURFACE OXIDE

The contact of pure metallic surfaces cannot be assured in practical connections. Surface contamination must be expected, especially surface oxidation. These surface films are insulators as far as contact resistance is concerned, and they must be broken to achieve metal to metal contact to make an adequate electrical connection. The difficulty of breaking the film depends on the nature of the film, its thickness, and the metal on which it is formed.

Copper oxide is generally broken down by reasonably low values of contact pressure. Unless the copper is badly oxidized, good contact can be obtained with very little or no cleaning.

Silver oxide is even more easily broken down by the contact pressure; and since silver oxide forms less readily at elevated temperatures, silver contact surfaces are preferred over copper when used for higher temperatures. For this reason, it is considered good practice to silver plate copper contact surfaces that must operate at temperatures over 200° C.

On the other hand, aluminum oxide is a hard, tenacious, high resistance film that forms very rapidly on the surface of aluminum exposed to air. In fact, it is the toughness of this film that gives aluminum its good corrosion resistance. The oxide film that forms after more than a few hours is too thick and tough to permit a low resistance contact without cleaning. The aluminum oxide film is transparent so that even the bright and clean appearance of an aluminum connector is no assurance that the low contact resistance can be attained without cleaning.

In addition to the necessity for cleaning the oxide from aluminum, the surface should be covered with a good connector compound to prevent the oxide from reforming. Common practice is to clean the surface with a wire brush or emery cloth. The compound should be applied immediately after cleaning, or the compound should be put on first and the surface scraped through the compound. Present practice is to scratch brush dry and to apply the compound immediately thereafter. This allows a more thorough job of cleaning the conductor.

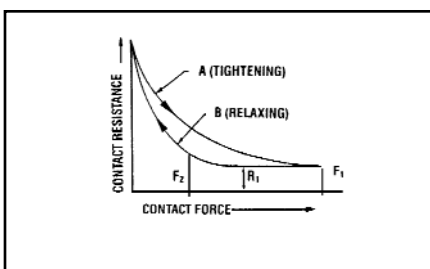

INTRODUCTION (Continued)

Contact Compounds: Petrolatum or No-Oxid are good contact surface compounds for aluminum, but BURNDY® PENETROX A, a petroleum type compound containing zinc dust, has the additional advantage of assisting in the breaking down of the contact resistance. How this is accomplished is not certain, but it appears that the zinc particles of PENETROX A probably act as current bridges in the breaks in the oxide film. For more complete information about the PENETROX™ line of compounds, refer to the Accessories Section of this catalog.

Interstrand Resistance: The high contact resistance due to the oxide on the strands of an aluminum cable may be responsible for a poor distribution of current among the strands on the cable. Thus, the outer strands may carry much more than their share of the current and overheating of the cable may result. Tests have shown that even on new cable this effect of interstrand resistance can be considerable unless a good contact compound is used. The clamping action tends to break down the oxide and force the compound between the strands. This is particularly true of compression connectors due to the very high unit pressures developed.

The most effective way to break down interstrand resistance of aluminum cable is to use compression connectors filled with a compound having zinc particles. Then, when the end of the cable is inserted in the connector, the compound is forced between the strands where it very effectively breaks down the interstrand resistance upon application of the compressive force.

Plating Aluminum: Plating the contact surfaces of aluminum connectors will prevent the formation of aluminum oxide. Electro-tin, cadmium and zinc platings have been used for this purpose. However, the use of a plated aluminum conductor, does not make it less necessary to scratch brush the aluminum conductor, nor does it reduce the need for a good contact compound. Additional problems are introduced due to the plating on aluminum which render it of very doubtful value over the proper use of bare aluminum. This will be more fully discussed later.

CORROSION

The electrical conductivity and mechanical strength of an electrical connection must remain stable under the deteriorating influences of the environment. This deterioration is corrosion. It is the electrolytic action of moisture and other elements of the atmos-

phere in conjunction with the metals of the connection. If the conductors and connectors are of copper or a corrosion resistant copper alloy, corrosion is usually a minor factor. However, it is a very vital factor if aluminum is involved.

If moisture can be kept away from the connection, corrosion will not be a factor. The electrical connection of a high voltage splice on insulated cable is generally free from corrosion since the taping must be moisture-proof. Similarly, taping may be used to avoid corrosion on bare cable, provided it excludes moisture. It is difficult to get a good tape seal to the conductor itself, especially on stranded cable. If moisture does penetrate the taping, it will not dry out as readily as if the joint were untaped. Various plastic materials are available today for covering low voltage connections or for bare conductor connections on high voltage. Unless such coverings are completely moisture-proof, it is better to rely on installation with a good contact compound, using a connector designed to resist corrosion.

Galvanic Action: Whenever dissimilar metals are in the presence of an electrolyte, a difference in electric potential is developed. One metal becomes the cathode and receives a positive charge. The other becomes the anode and receives a negative charge. When these metals are in contact, an electrical current will flow, as in the case of any short-circuited electric cell. This electrolytic action causes an attack of the anodic metal, leaving the cathodic metal unharmed. The extent of the attack is proportional to the strength of the electrolytic current, which in turn is proportional to the electric potential difference developed.

The magnitude of the potential difference generated between two dissimilar metals can be seen by the position of these metals in the electrolytic series. Figure 3 is such a series. When two metals are in contact in an electrolyte, the one higher up in this series is the anode, the corroded metal, while the one lower is the cathode, the protected metal. The further apart the metals are in this series, the greater the electrolytic potential difference, and the greater the attack to the anodic metal.

Note that copper and aluminum are quite far apart in the series, copper being cathodic and aluminum anodic. Hence, when aluminum and copper are in contact in an electrolyte, the aluminum can be expected to be severely attacked.

Crevice Corrosion: Electrolytic attack can also occur between like metals due to a phenomenon known as oxygen concentration cell or crevice corrosion. Since oxygen is necessary for corrosive action, a variation in the concentration of oxygen where a metal is exposed to an electrolyte will generate a difference of potential, and cause a corrosive attack in the oxygen starved area. Thus, since an electrolyte in a deep crevice is freely exposed to the air at the outside, the concentration of oxygen will be greatest at the mouth of the crevice. Then corrosion can be expected to occur in the crevice remote from the surface. Crevice corrosion can be prevented if the crevice is filled with a compound to exclude moisture. Thus, within the contact groove of an aluminum connector containing an aluminum conductor, there will be numerous crevices in which corrosion will take place unless a good connector compound is applied during installation. Copper, being a more noble metal, appears to be much less subject to crevice corrosion.

Corrosion Testing: The effectiveness of an electrical connection to resist corrosion can be tested in the laboratory under conditions designed to greatly accelerate the natural corrosive conditions of actual service. The most widely accepted means is the standard salt spray chamber. In this chamber the specimens are placed in a salt fog made by atomizing a 20% salt solution at 100 deg. F.

BURNDY® Electrical as well as other manufacturers and utility companies, have done a great deal of testing and a considerable area of agreement has been reached. There are, however, minor differences in recommended practices. The problem is concerned with aluminum and aluminum to copper connections since the effect of corrosion on copper to copper connections is far less serious. Let us study the recommended practices.

Aluminum to Aluminum Connections: For joining aluminum to aluminum conductors, there is little disagreement that an aluminum bodied connector is the proper choice, since this obviously eliminates the galvanic corrosion of dissimilar metals. However, even in this case, care must be taken to prevent crevice corrosion and to select an alloy of aluminum for the connector body that is free from cracking due to stress corrosion.

Aluminum to Copper Connections: Similarly, for joining aluminum to copper conductors, an aluminum bodied connector is the best choice since it prevents galvanic corrosion of the aluminum conductor, the

INTRODUCTION (Continued)

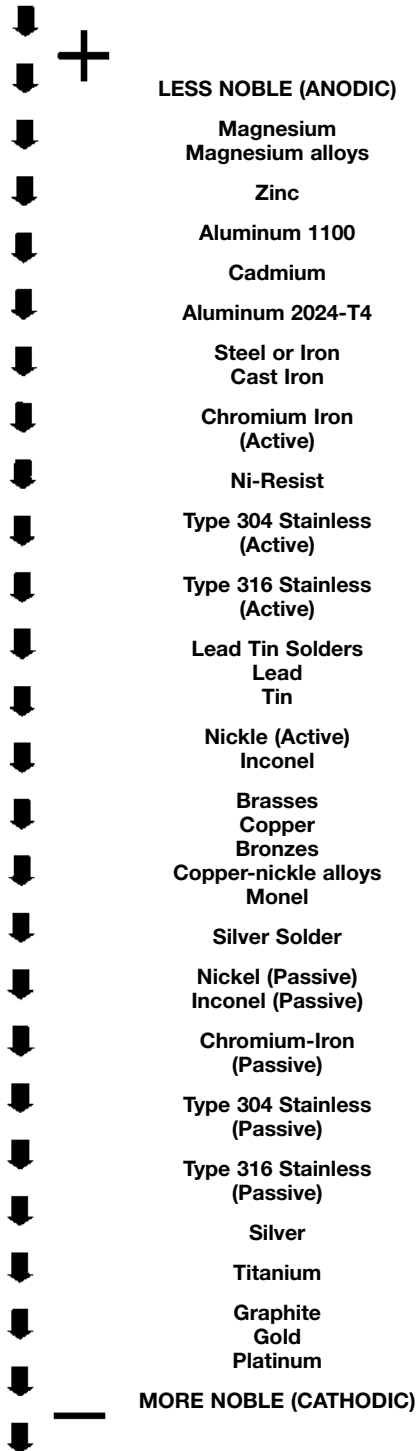
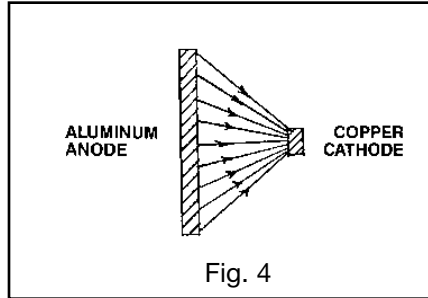

Fig. 3

most vulnerable element to attack in the connection. Realizing this, BURNDY® initiated a research program aimed at finding the best way to make an aluminum connector suitable for joining aluminum to copper conductors.

This led to the evolution of the “Massive Anode Principal” of connector design for joining conductors of dissimilar metal. On the basis of this principal, properly designed, all-aluminum connectors became available for universal use in joining aluminum to aluminum or aluminum to copper conductors.

Massive Anode Principle: By making the aluminum connector massive in comparison to the copper conductor, when the copper conductor emerges from the connector, the electrolytic current density over the exposed face of the aluminum connector is greatly reduced. This is schematically represented in Figure 4. Since the rate of corrosion is directly related to the current density on the surface of the anodic material, the relatively large face of the aluminum connector will suffer only minor attack.



In addition, because the aluminum connector body is massive in the region where the corrosion occurs, the small loss of metal caused by corrosion is insignificant, even after long periods of service. Furthermore, the connector design should be such that clamping bolts, and areas of high stress which provide structural strength, are not in the regions subject to galvanic attack.

The effectiveness of this theory has been amply demonstrated in salt spray corrosion tests in which the connectors were subject to 1,000 hours in the salt spray fog with only minor corrosive pitting adjacent to the copper conductor, as seen in Figure 5. In addition, the aluminum conductor was completely protected, and the joint resistance remained virtually unchanged. The test involved a wide variety of sizes and types of connectors showing the effectiveness for small service connectors as well as large power connectors. Figure 6 shows a large all aluminum

clamp type T connector installed on 3/2” diameter copper run and 750 kcmil aluminum tap. The figure shows this connector opened up after the 1,400 hours of the salt spray test. Note that the contact surfaces are bright and clean and the only evidence is minor pitting along the faces adjacent to the copper.

*It should be emphasized that a good compound should be used on the contact surfaces whether aluminum or copper is used in an aluminum connector.

Position of Conductor: A properly designed aluminum connector for joining aluminum to copper must provide adequate separation between the conductors to prevent electrolytic attack on the aluminum conductor. Even then, it is good practice to install the aluminum conductor above the copper conductor if possible. This will prevent pitting of the aluminum conductor due to copper salts being washed over the aluminum.

Plated Aluminum Connectors: Plating has been used as a means to make an aluminum connector suitable for copper conductor. Such platings as copper, zinc, tin and cadmium have been used. The plating of aluminum is much more critical than plating a more noble metal such as copper. In addition, a preplate, usually of copper or brass, must be applied, thus introducing numerous metals and further possibilities for galvanic corrosion.

To be effective in reducing galvanic corrosion between the copper conductor and the aluminum connector, the plated metal must be closer in the Electrolytic Series to copper than is aluminum. It must therefore, be cathodic to aluminum. Since porosity and minor scratches are always present, galvanic action can be expected in the presence of moisture, resulting in attack of the aluminum under the plating. Corrosion tests reveal attack in the form of a mottled appearance and flaking of the plating.

In addition, the presence of plated metal can cause galvanic attack of the aluminum conductor, thus reducing the protection offered to this conductor in an aluminum connector.

Cleaning and the Use of Compound: It should be emphasized that when aluminum connectors or conductors are involved, proper cleaning of the aluminum and the use of a good connector compound, such as BURNDY® PENETROX A, are essential for trouble-free service. BURNDY®, as well as other manufacturers, provide the contact grooves with a coating to make it unnecessary to clean the connectors, but in all cases,

INTRODUCTION (Continued)

the aluminum conductor should be cleaned by means such as scratch brushing, and immediately coated with the connector compound.

To simplify the application of the compound, and to assure its use, almost all BURNDY® aluminum connectors, except the large clamp type substation connectors, are supplied factory filled with PENETROX compound. For the tubular compression connectors, the tubular barrels are sufficiently filled with PENETROX and capped. For other types, the contact grooves are filled with PENETROX and enclosed in plastic packaging in a process called "Stripsealing".

Clamp vs. Compression: In general, a compression connection can be expected to be more corrosion resistant than a clamp connection. The high pressures applied in a compression connector more effectively seal the contact against the penetration of moisture. The tubular sleeve of a compression connector has no side openings such as exist in clamp connectors between the clamping members. On the other hand, the clamp connector can be made more corrosion resistant if the conductor grooves conform more closely with the conductor contour. Thus a clamp connector made to accommodate a wide range of conductor sizes cannot be expected to be as corrosion resistant as one designed for one specific conductor size. Nevertheless, the differences in effectiveness of various designs can be minimized if a good contact compound is used.

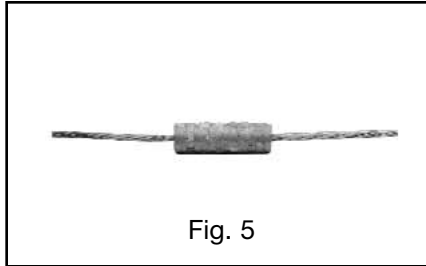

Fig. 5

Negligible Corrosion of Severe Salt Spray on Compression Connector Joining Aluminum to Copper.

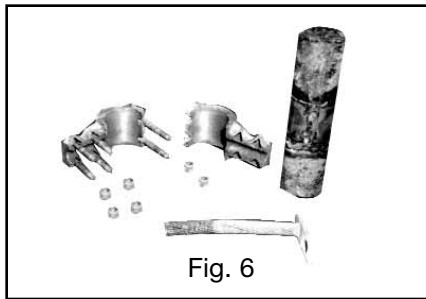

Fig. 6

Large Aluminum Bolted Connector Joining Copper Run to Aluminum Tap After Severe Salt Spray Test.

HARDWARE DATA

RECOMMENDED TIGHTENING TORQUE

The hardware used in connectors must be compatible with the connector material, have high mechanical strength and be corrosion resistant.

Copper alloy connectors have hardware made of DURIUM™, which is BURNDY's trade name for silicon bronze alloy ASTMB99. This material was first introduced by BURNDY® in 1927 for use in outdoor construction, and today, is the standard throughout the industry.

Aluminum connectors generally have aluminum alloy hardware. The bolts are 2024T4 and anodized to resist corrosion. The nuts are 6061T6, which is resistant to corrosion

Steel Hardware		Aluminum Hardware	
Bolt Size	Recommended Torque (Inch Pounds)	Bolt Size	Recommended Torque (Inch Pounds)
1/4 - 20	80	1/2 - 13	300
5/16 - 18	180	5/8 - 11	480
3/8 - 16	240	3/4 - 10	650
1/2 - 13	480		
5/8 - 11	660		
3/4 - 10	1050		

and does not require anodizing. Bolts are lubricated to eliminate galling and to provide consistent clamping forces.

The size material for clamping hardware are selected to provide the required force when tightened to the recommended torque. To reduce or greatly exceed the recommended torque can adversely affect the performance of the connector.

DURIUM™ (SILICON BRONZE)

HEXAGONAL BOLT DATA

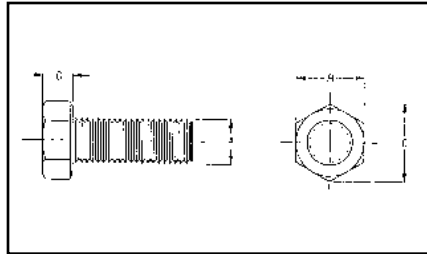

② CATALOG NO. SERIES	"A" (BOLT SIZE)	"B"	"C"	"D"	③ RECOMMENDED TORQUE (in-lb)	MIN. BREAKING FORCE (lb)	MIN. SHEARING FORCE (lb)
25X__HEB	1/4 - 20 UNC	7/16	.50	.16	80	1,780	990
31X__HEB	5/16 - 18 UNC	1/2	.56	.21	180	2,930	1,640
38X__HEB	3/8 - 16 UNC	9/16	.65	.24	240	4,350	2,430
50X__HEB	1/2 - 13 UNC	3/4	.87	.32	480	7,950	4,460
62X__HEB	5/8 - 11 UNC	15/16	1.08	.40	660	12,700	7,100
75X__HEB	3/4 - 10 UNC	1-1/8	1.30	.48	1050	17,510	10,540

- 1. Material: DURIUM™ (Silicon Bronze)
- ② "___" is substituted for bolt length. Consult sales representative for available lengths.
- ③ These torque values develop maximum bolt preload.
- 4. This drawing is based on BURNDY® engineering spec.

RECOMMENDED TERMINATION HARDWARE

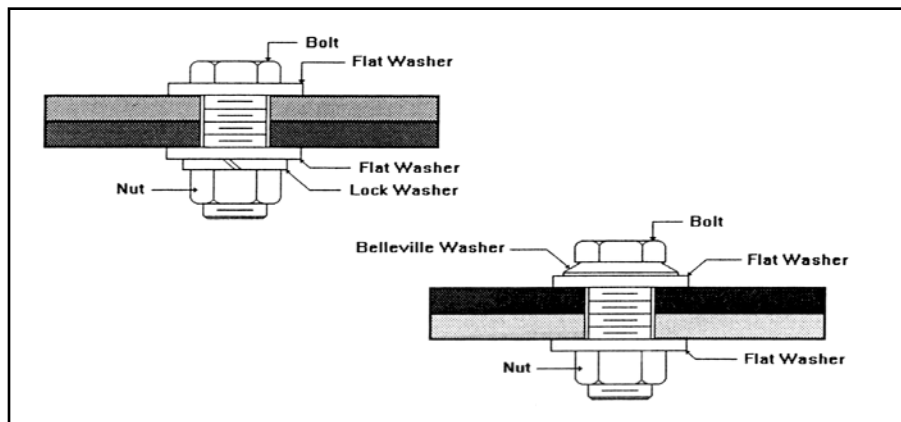

**RECOMMENDED
TIGHTENING TORQUE**

PER UL486A AND UL486B

Table 21 – Tightening torque for screws

Test Conductor Size Installed in Connector		Tightening Torque, N•m (lbf-in)							
		Slotted Head No. 10 and Larger ^a				Hexagonal Head — External Drive Socket Wrench			
		Slot Width — 1.2 mm (0.047 in.) or Less and Slot Length — 6.4 mm (1/4 in.) or less		Slot Width — Over 1.2 mm (0.047 in.) or Slot Length — Over 6.4 mm (1/4 in.)					
						Split-Bolt Connectors		Other Connectors	
AWG or kcmil	(mm ²)	A	B	A	B	A	B	A	B
30 - 10	(0.05 - 5.3)	1.7 (15)	2.3 (20)	2.8 (25)	4.0 (35)	7.3 (65)	9.0 (80)	6.8 (60)	8.5 (75)
8	(8.4)	2.3 (20)	2.8 (25)	3.4 (30)	4.5 (40)	7.3 (65)	9.0 (80)	6.8 (60)	8.5 (75)
6 - 4	(13.2 - 21.2)	2.8 (25)	4.0 (35)	4.0 (35)	5.1 (45)	15.3 (135)	18.6 (165)	10.2 (90)	12.4 (110)
3	(26.7)	2.8 (25)	4.0 (35)	4.5 (40)	5.6 (50)	25.4 (225)	31.1 (275)	14.1 (125)	16.9 (150)
2	(33.6)	3.4 (30)	4.5 (40)	4.5 (40)	5.6 (50)	25.4 (225)	31.1 (275)	14.1 (125)	16.9 (150)
1	(42.4)	—	—	4.5 (40)	5.6 (50)	25.4 (225)	31.1 (275)	14.1 (125)	16.9 (150)
1/0 - 2/0	(53.5 - 67.4)	—	—	4.5 (40)	5.6 (50)	35.6 (315)	43.5 (385)	16.9 (150)	20.3 (180)
3/0 - 4/0	(85.0 - 107.2)	—	—	4.5 (40)	5.6 (50)	45.2 (400)	56.5 (500)	22.6 (200)	28.2 (250)
250 - 350	(127 - 177)	—	—	4.5 (40)	5.6 (50)	62.1 (550)	73.4 (650)	28.2 (250)	36.7 (325)
400	(203)	—	—	4.5 (40)	5.6 (50)	76.3 (675)	93.2 (825)	28.2 (250)	36.7 (325)
500	(253)	—	—	4.5 (40)	5.6 (50)	76.3 (675)	93.2 (825)	33.9 (300)	42.4 (375)
600 - 750	(304 - 380)	—	—	4.5 (40)	5.6 (50)	90.4 (800)	113.0 (1000)	33.9 (300)	42.4 (375)
800 - 1000	(406 - 508)	—	—	4.5 (40)	5.6 (50)	111.7 (900)	124.3 (1100)	45.2 (400)	56.5 (500)
1250 - 2000	(635 - 1000)	—	—	—	—	111.7 (900)	124.3 (1100)	56.5 (500)	67.8 (600)

^a For values of slot width or length not corresponding to those specified, select the largest torque value associated with the conductor size. Slot width is the nominal design value. Slot length shall be measured at the bottom of the slot.

Table 22 – Tightening torque for slotted head screws smaller than No. 10 intended for use with 8 AWG (8.4 mm²) or smaller conductors

Slot Length of Screw ^a		Tightening Torque, N•m (lbf-in)			
		Slot Width of Screw Smaller than 1.2 mm (0.047 in.) ^b		Slot Width of Screw 1.2 mm (0.047 in.) and larger ^b	
		A	B	A	B
mm	(in.)				
Less than 4	(Less than 5/32)	0.68 (6)	0.79 (7)	0.79 (7)	1.0 (9)
4	(5/32)	0.68 (6)	0.79 (7)	1.1 (10)	1.4 (12)
4.8	(3/16)	0.68 (6)	0.79 (7)	1.1 (10)	1.4 (12)
5.6	(7/32)	0.68 (6)	0.79 (7)	1.1 (10)	1.4 (12)
6.4	(1/4)	0.79 (7)	1.0 (9)	1.1 (10)	1.4 (12)
7.1	(9/32)	—	—	1.4 (12)	1.7 (15)
Above 7.1	(Above 9/32)	—	—	1.8 (16)	2.3 (20)

^a For slot lengths of intermediate values, select torques pertaining to next shorter slot length. Also, see Table 21 for screws with multiple tightening means. Slot length shall be measured at the bottom of the slot.

^b Slot width is the nominal design value.

Table 23 – Tightening torque for screws with recessed allen or square drives

Socket Width Across Flats ^a		Tightening Torque, N•m (lbf-in)	
		A	B
mm	(in.)		
3.2	(1/8)	4.0 (35)	5.1 (45)
4.0	(5/32)	9.0 (80)	11.3 (100)
4.8	(3/16)	11.3 (100)	136.6 (120)
5.6	(7/32)	13.6 (120)	16.9 (150)
6.4	(1/4)	16.9 (150)	22.6 (200)
7.9	(5/16)	25.4 (225)	31.1 (275)
9.5	(3/8)	33.9 (300)	42.4 (375)
12.7	(1/2)	45.2 (400)	56.5 (500)
14.3	(9/16)	56.5 (500)	67.8 (600)

^a See Table 21 for screws with multiple tightening means.

CABLE DATA

COPPER TUBE (BUS)

SIZE OF TUBE IPS	DIAMETER OF TUBE (Inches)		WALL THICKNESS (Inches)
	OUTSIDE	INSIDE	
STANDARD PIPE SIZES			
1/4"	0.540	0.375	0.082 5
3/8"	0.675	0.494	0.090 5
1/2"	0.840	0.625	0.107 5
3/4"	1.050	0.822	0.114 0
1"	1.315	1.062	0.126 5
1-1/4"	1.660	1.368	0.146 0
1-1/2"	1.900	1.600	0.150 0
2"	2.375	2.062	0.156 5
2-1/2"	2.875	2.500	0.187 5
3"	3.500	3.062	0.219 0
3-1/2"	4.000	3.500	0.250 0
4"	4.500	4.000	0.250 0
4-1/2"	5.000	4.500	0.250 0
5"	5.563	5.063	0.250 0
6"	6.625	6.125	0.250 0
EXTRA HEAVY PIPE SIZES			
1/4"	0.540	0.294	0.123
3/8"	0.675	0.421	0.127
1/2"	0.840	0.542	0.149
3/4"	1.050	0.736	0.157
1"	1.315	0.951	0.182
1-1/4"	1.660	1.272	0.194
1-1/2"	1.900	1.494	0.203
2"	2.375	1.933	0.221
2-1/2"	2.875	2.315	0.280
3"	3.500	2.892	0.304
3-1/2"	4.000	3.358	0.321
4"	4.500	3.818	0.341
4-1/2"	5.000	4.250	0.375
5"	5.563	4.813	0.375
6"	6.625	5.751	0.437
DOUBLE EXTRA HEAVY PIPE SIZES			
1/2"	0.840	0.252	0.294
3/4"	1.050	0.434	0.308
1"	1.315	0.599	0.358
1-1/4"	1.660	0.896	0.382
1-1/2"	1.900	1.100	0.400
2"	2.375	1.503	0.436
2-1/2"	2.875	1.771	0.552
3"	3.500	2.300	0.600
3-1/2"	4.000	2.728	0.636
4"	4.500	3.152	0.674
4-1/2"	5.000	3.580	0.710
5"	5.563	4.063	0.750
6"	6.625	4.897	0.864

Tube dimensions (excepting wall thickness, of double extra heavy) taken from A.S.T.M. Specification B42-33. Tubular values based on a density of 0.322 pound per cubic inch.

* Conductivity of 98% I.A.C.S. at 20° C or 68° F.

SOLID COPPER WIRE

(ASTM B1, B2, & B3)

SIZE AWG (SOLID)	WIRE DIA Inch	HARD DRAWN	MEDIUM DRAWN	SOFT DRAWN
		NORMAL BREAKING LOAD Pounds	MINIMUM BREAKING LOAD Pounds	ELONGATION IN 10 IN. % MIN.
18	.040 30	85.76	67.61	25
17	.045 26	107.5	84.71	25
16	.050 82	135.2	106.2	25
15	.057 07	170.0	133.0	25
14	.064 08	213.8	166.6	25
13	.071 96	268.2	208.0	25
12	.080 81	337.0	261.6	25
11	.090 74	422.5	327.6	25
10	.101 9	529.2	410.4	25
9	.114 4	661.0	514.2	30
8	.128 5	826.0	643.9	30
7	.144 3	1,030	806.6	30
6	.162 0	1,280	1,010	30
5	.181 9	1,591	1,265	30
4	.204 3	1,970	1,584	30
3	.229 4	2,439	1,984	30
2	.257 6	3,003	2,450	30
1	.289 3	3,688	3,024	30
1/0	.324 9	4,519	3,730	35
2/0	.364 8	5,518	4,599	35
3/0	.409 6	6,722	5,667	35
4/0	.460 0	8,143	6,980	35

STRANDED COPPER WIRE

(ASTM B8 EXCLUDING BREAKING LOADS)

SIZE		A.S.T.M. STRANDINGS			HARD DRAWN	MEDIUM DRAWN	SOFT DRAWN
Circular Mills	AWG	Class	No. of Wires	Cable Diameter Inches	Minimum Breaking Load Pounds	Minimum Breaking Load Pounds	Minimum Breaking Load Pounds
					1,022	20	B
1,624	18	B	7	0.045 6	78.99	63.91	51.03
2,583	16	B	7	0.057 6	124.7	100.4	81.14
4,107	14	B	7	0.072 6	197.1	157.7	124.2
6,530	12	B	7	0.091 5	311.1	247.7	197.5
10,380	10	B	7	0.116	491.7	388.9	314.0
13,090	9	B	7	0.130	618.2	487.4	395.9
16,510	8	B	7	0.146	777.2	610.7	499.2
20,820	7	B	7	0.164	977.1	765.2	629.5
26,250	6	B	7	0.184	1,288	958.6	793.8
33,100	5	B	7	0.206	1,542	1,201	1001
41,740	4	AA	3	0.254	1,879	1,465	1213
41,740	4	B&A	7	0.232	1,938	1,505	1262
52,630	3	AA	3	0.285	2,359	1,835	1530

CABLE DATA (Continued)

STRANDED COPPER WIRE (Continued)
(ASTM B8 EXCLUDING BREAKING LOADS)

SIZE		A.S.T.M. STRANDINGS			HARD DRAWN	MEDIUM DRAWN	SOFT DRAWN
STRANDED		Class	No. of Wires	Cable Diameter Inches	Minimum Breaking Load Pounds	Minimum Breaking Load Pounds	Minimum Breaking Load Pounds
Circular Mills	AWG						
52,630	3	B&A	7	0.260	2,433	1,885	1592
66,370	2	AA	3	0.320	2,913	2,299	1929
66,370	2	B&A	7	0.292	3,045	2,361	2007
83,690	1	AA	3	0.360	3,621	2,879	2432
83,690	1	A	7	0.328	3,804	2,958	2432
83,690	1	B	19	0.332	3,899	3,037	2531
105,500	1/0	A&A	7	0.368	4,752	3,705	3067
105,500	1/0	—	12	0.390	4,841	3,755	3191
105,500	1/0	B	19	0.373	4,901	3,805	3191
133,100	2/0	A&A	7	0.414	5,926	4,640	3867
133,100	2/0	—	12	0.438	6,048	4,703	3867
133,100	2/0	B	19	0.419	6,152	4,765	4024
167,800	3/0	A&A	7	0.464	7,366	5,812	4876
167,800	3/0	—	12	0.492	7,556	5,890	4876
167,800	3/0	B	19	0.470	7,698	5,970	5074
211,600	4/0	A&A	7	0.522	9,154	7,278	6149
211,600	4/0	—	12	0.522	9,483	7,378	6149
211,600	4/0	B	19	0.528	9,617	7,479	6149

SIZE		A.S.T.M. STRANDINGS			HARD DRAWN	MEDIUM DRAWN	SOFT DRAWN
Circular Mills	Class	No. of Wires	Cable Diameter Inches	Minimum Breaking Load Pounds	Minimum Breaking Load Pounds	Minimum Breaking Load Pounds	
							250
250	A	19	0.574	11,360	8,986	7265	
250	B	37	0.575	11,560	8,952	7559	
300	AA	12	0.657	13,170	10,390	8718	
300	A	19	0.628	13,510	10,530	8718	
300	B	37	0.630	13,870	10,740	9071	
350	AA	12	0.710	15,140	12,040	10170	
350	A	19	0.679	15,590	12,200	10170	
350	B	37	0.681	16,060	12,450	10580	
400	A&AA	19	0.726	17,810	13,950	11620	
400	B	37	0.728	18,320	14,140	11620	
450	AA	19	0.770	19,750	15,590	13080	
450	B&A	37	0.772	20,450	15,900	13080	
500	AA	19	0.811	21,950	17,320	14530	
500	B&A	37	0.813	22,510	17,550	14530	
600	A&AA	37	0.891	27,020	21,060	17440	
600	B	61	0.893	27,530	21,350	18140	
700	AA	37	0.963	31,170	24,410	20340	
700	B&A	61	0.964	31,820	24,740	20340	
750	AA	37	0.997	33,400	26,150	21790	
750	B&A	61	0.998	34,090	26,510	21790	
800	AA	37	1.029	35,120	27,710	23250	
800	B&A	61	1.031	36,360	28,270	23250	
900	AA	37	1.092	39,510	31,170	26150	
900	B&A	61	1.094	40,520	31,590	26150	
1,000	AA	37	1.151	43,830	34,400	29060	
1,000	B&A	61	1.152	45,030	35,100	29060	
1,250	A	61	1.288	55,670	43,590	36320	
1,250	B	91	1.289	56,280	43,880	36320	
1,500	A	61	1.411	65,840	51,950	43590	
1,500	B	91	1.412	67,540	52,650	43590	
1,750	A	91	1.526	77,930	61,020	50850	
1,750	B	127	1.526	78,800	61,430	50850	
2,000	A	91	1.630	87,790	69,270	58120	
2,000	B	127	1.632	90,050	70,210	58120	

COMPACT STRANDED COPPER CABLE
(ASTM SPEC. B496)

CONDUCTOR SIZE		NUMBER OF WIRES	CONDUCTOR DIAMETER (IN.)
KCMIL (OR)	AWG		
1000		61 ¹	1.060
900		61 ¹	0.999
800		61 ¹	0.938
750		61 ¹	0.908
700		61 ¹	0.877
650		61 ¹	0.845
600		61 ¹	0.813
550		61 ¹	0.775
500		37 ²	0.736
450		37 ²	0.700
400		37 ²	0.659
350		37 ²	0.616
300		37 ²	0.570
250		37 ²	0.520
	4/0	19 ³	0.475
	3/0	19 ³	0.423
	2/0	19 ³	0.376
	1/0	19 ³	0.336
	1	19 ³	0.299
	2	7	0.268
	4	7	0.213
	6	7	0.169
	8	7	0.134

¹ 58 Wires Minimum
² 35 Wires Minimum
³ 18 Wires Minimum

CABLE DATA (Continued)

FLEXIBLE COPPER STRANDED CABLE

CONDUCTOR SIZE KCMIL OR B & S G (AWG)	STRANDING AND DIAMETER	NOMINAL DIAMETER	CLASS
8	41/.0201	.156	I
8	49/.0184	.166	G
8	133/.0111	.167	H
8	168/.010	.157	K
8	420/.0063	.162	M
7	49/.0206	.185	G
7	52/.0201	.185	I
7	133/.0125	.188	H
7	210/.010	.179	K
7	532/.0063	.196	M
6	49/.0231	.208	G
6	63/.0201	.207	I
6	133/.0140	.210	H
6	266/.010	.210	K
6	665/.0063	.215	M
5	49/.0260	.234	G
5	84/.0201	.235	I
5	133/.0158	.237	H
5	336/.010	.235	K
5	836/.0063	.240	M
4	49/.0292	.263	G
4	105/.0201	.263	I
4	133/.0177	.266	H
4	420/.010	.272	K
4	1064/.0063	.269	M
3	49/.0328	.295	G
3	133/.0199	.299	H
3	133/.0201	.291	I
3	532/.010	.304	K
3	1323/.0063	.305	M
2	49/.0368	.331	G
2	133/.0223	.335	H
2	161/.0201	.319	I
2	665/.010	.338	K
2	1666/.0063	.337	M
1	133/.0251	.377	G
1	210/.0201	.367	I
1	259/.018	.378	H
1	836/.010	.397	K
1	2107/.0063	.376	M
1/0	133/.0282	.423	G
1/0	259/.0202	.424	H
1/0	266/.0201	.441	I
1/0	1064/.010	.451	K
1/0	2646/.0063	.423	M
2/0	133/.0316	.474	G
2/0	259/.0227	.477	H
2/0	342/.0201	.500	I
2/0	1323/.010	.470	K
2/0	3325/.0063	.508	M
3/0	133/.0355	.533	G
3/0	259/.0255	.536	H
3/0	418/.0201	.549	I
3/0	1666/.010	.533	K
3/0	4256/.0063	.576	M
4/0	133/.0399	.599	G
4/0	259/.0286	.601	H
4/0	532/.0201	.613	I
4/0	2107/.010	.627	K
4/0	5320/.0063	.645	M

CONDUCTOR SIZE KCMIL OR B & S G (AWG)	STRANDING AND DIAMETER	NOMINAL DIAMETER	CLASS
250	259/.0311	.650	G
250	427/.0242	.653	H
250	637/.0201	.682	I
250	2499/.010	.682	K
250	6384/.0063	.713	M
300	259/.0340	.714	G
300	427/.0265	.716	H
300	735/.0201	.737	I
300	2989/.010	.768	K
300	7581/.0063	.768	M
350	259/.0368	.773	G
350	427/.0286	.772	H
350	882/.0201	.800	I
350	3458/.010	.809	K
350	8806/.0063	.825	M
400	259/.0393	.825	G
400	427/.0306	.826	H
400	980/.0201	.831	I
400	3990/.010	.878	K
400	10101/.0063	.901	M
450	259/.0417	.876	G
450	427/.0325	.878	H
450	1127/.0201	.894	I
450	4522/.010	.933	K
450	11396/.0063	.940	M
500	259/.0439	.922	G
500	427/.0342	.923	H
500	1225/.0201	.941	I
500	5054/.010	.988	K
500	12691/.0063	.997	M
600	427/.0375	1.013	G
600	703/.0292	1.022	H
600	1470/.0201	1.027	I
600	5985/.010	1.125	K
600	14945/.0063	1.084	M
700	427/.0405	1.094	G
700	703/.0316	1.106	H
700	1729/.0201	1.194	I
700	6916/.010	1.207	K
700	17507/.0063	1.183	M
800	427/.0433	1.169	G
800	703/.0337	1.180	H
800	1995/.0201	1.290	I
800	7980/.010	1.305	K
800	20069/.0063	1.256	M
900	427/.0459	1.239	G
900	703/.0358	1.253	H
900	2261/.0201	1.372	I
900	9065/.010	1.323	K
900	22631/.0063	1.331	M
1000	427/.0484	1.307	G
1000	703/.0377	1.320	H
1000	2527/.0201	1.427	I
1000	10101/.010	1.419	K
1000	25193/.0063	1.404	M

CABLE DATA (Continued)

ALUMINUM TUBE

Size of Tube IPS	Diameter of Tube (In.)		Wall Thickness
	Outside	Inside	
Standard Pipe Sizes			
1/4	0.540	0.364	0.088
3/8	0.675	0.493	0.091
1/2	0.840	0.622	0.109
3/4	1.050	0.824	0.113
1	1.315	1.049	0.133
1-1/4	1.660	1.380	0.140
1-1/2	1.900	1.610	0.145
2	2.375	2.067	0.154
2-1/2	2.875	2.469	0.203
3	3.500	3.068	0.216
3-1/2	4.000	3.548	0.226
4	4.500	4.026	0.237
4-1/2	5.000	4.506	0.247
5	5.563	5.047	0.258
6	6.625	6.065	0.280
Extra Heavy Pipe Sizes			
1/4	0.540	0.302	0.119
3/8	0.675	0.423	0.126
1/2	0.840	0.546	0.147
3/4	1.050	0.742	0.154
1	1.315	0.957	0.179
1-1/4	1.660	1.278	0.191
1-1/2	1.900	1.500	0.200
2	2.375	1.939	0.218
2-1/2	2.875	2.323	0.276
3	3.500	2.900	0.300
3-1/2	4.000	3.364	0.318
4	4.500	3.826	0.337
4-1/2	5.000	4.290	0.355
5	5.563	4.813	0.375
6	6.625	5.761	0.432

ALUMINUM 1350 CABLE BARE-CLASS B

Size Circular Mils or AWG	Copper Equivalent based upon equal D.C. resistance, Cu 97% Al 51%	Stranding No. of Wires	Cable Dia. Inches	Ultimate Strength Pounds	Minimum Ultimate Strength Pounds	Minimum Ultimate Strength Pounds Inter Temper
				Hard Drawn	3/4 Hard	
250000	157300	37	0.575	4860	3338	2946
300000	188800	37	0.629	5831	4005	3534
350000	220200	37	0.681	6680	4673	4123
400000	251500	37	0.728	7352	5341	4713
450000	283000	37	0.772	8110	6007	5301
500000	314500	37	0.813	9012	6675	5890
550000	346000	61	0.855	10490	7344	6480
600000	377000	61	0.893	11450	8010	7068
650000	409000	61	0.929	11940	8678	7657
700000	440000	61	0.964	12860	9346	8247
750000	472000	61	0.998	13510	10010	8835
800000	503000	61	1.031	14410	10680	9424
900000	566000	61	1.094	15900	12010	10600
1000000	629000	61	1.152	17670	13350	11780
1100000	692000	91	1.209	20210	14680	12950
1200000	755000	91	1.263	21630	16020	14130
1250000	786000	91	1.289	22530	16690	14720
1300000	818000	91	1.315	23430	17350	15310
1400000	880000	91	1.364	24750	18700	16500
1500000	943000	91	1.412	26500	20020	17670
1600000	1006000	127	1.459	28840	21360	18850
1700000	1069000	127	1.504	30630	22690	20020
1750000	1101000	127	1.526	31530	23350	20610
1800000	1132000	127	1.548	32450	24030	21210
1900000	1195000	127	1.590	33570	25360	22380
2000000	1258000	127	1.632	35340	26700	23560
2500000	1570000	127	1.824	43300	33380	29460
3000000	1890000	169	1.998	53010	40050	35340
3500000	2200000	169	2.158	60610	46730	41230

ALUMINUM 1350 CABLE BARE-CLASSES AA AND A
Hard Drawn

Cable Code Word	Size Circular mils or AWG	Copper Equivalent based upon equal D.C. resistance, Cu 97% Al 61%	No. of Wires	Cable Dia. Inches	Ultimate Strength
					Pounds
Peachbell	6	8	7	0.184	528
Rose	4	6	7	0.232	826
Lily	3	5	7	0.260	1022
Iris	2	4	7	0.292	1266
Pansy	1	3	7	0.328	1537
Poppy	1/0	2	7	0.368	1865
Aster	2/0	1	7	0.414	2350
Phlox	3/0	1/0	7	0.464	2845
Oxlip	4/0	2/0	7	0.522	3590
Daisy	266800	3/0	7	0.586	4525
Laurel	266800	3/0	19	0.593	4800
Tulip	336400	4/0	19	0.666	5940
Canna	397500	250000	19	0.724	6880
Cosmos	477000	300000	19	0.793	8090
Syringa	477000	300000	37	0.795	8600
Dahlia	556500	350000	19	0.856	9440

Cable Code Word	Size Circular mils or AWG	Copper Equivalent based upon equal D.C. resistance, Cu 97% Al 61%	No. of Wires	Cable Dia. Inches	Ultimate Strength
					Pounds
Mistletoe	556500	350000	37	0.858	9830
Orchid	636000	400000	37	0.918	11240
Violet	715500	450000	37	0.974	12640
Nasturtium	715500	450000	61	0.975	13150
Arbutus	795000	500000	37	1.026	13770
Lilac	795000	500000	61	1.028	14330
Anemone	874500	550000	37	1.077	14830
Crocus	874500	550000	61	1.078	15760
Magnolia	954000	600000	37	1.124	16180
Goldenrod	954000	600000	61	1.126	16860
Bluebell	1033500	650000	37	1.170	17530
Larkspur	1033500	650000	61	1.172	18260
Marigold	1113000	700000	61	1.216	19660
Narcissus	1272000	800000	61	1.300	22000
Carnation	1431000	900000	61	1.379	24300
Coreopsis	1590000	1000000	61	1.454	27000
Dogwood	1590000	100000	91	1.454	28100

CABLE DATA (Continued)

ACSR

Code Word	ASCR		Diameter		Copper Equivalent based upon equal D.C. resistance Cu 97% Al 61%	Ultimate Strength Pounds	
	Cir. Mils. or AWG	Stranding Number of Strands		Inches			
		Alum.	Steel	Complete cable			Steel Core
Turkey	6	6	1	0.198	0.0661	8	1170
Thrush	5	6	1	0.223	0.0743	7	1460
Swan	4	6	1	0.250	0.0834	6	1830
Swanate	4	7	1	0.257	0.1029	6	2288
Swallow	3	6	1	0.281	0.0937	5	2250
Sparrow	2	6	1	0.316	0.1052	4	2790
Sparate	2	7	1	0.325	0.1299	4	3525
Robin	1	6	1	0.355	0.1182	3	3480
Raven	1/0	6	1	0.398	0.1327	2	4280
Quail	2/0	6	1	0.447	0.1490	1	5345
Pigeon	3/0	6	1	0.502	0.1672	1/0	6675
Penquin	4/0	6	1	0.563	0.1878	2/0	8420
Waxwing	266800	18	1	0.609	0.1217	3/0	7100
Owl	266800	26	7	0.633	0.2109	3/0	9645
Partridge	266800	26	7	0.642	0.2364	3/0	11250
Ostrich	300000	26	7	0.680	0.2505	188700	12650
Merlin	336400	18	1	0.684	0.1367	4/0	8950
Linnet	336400	26	7	0.721	0.2655	4/0	14050
Oriole	336400	30	7	0.741	0.3177	4/0	17040
Chickadee	397500	18	1	0.743	0.1486	250000	10400
Brant	397500	24	7	0.771	0.2575	250000	14690
Ibis	397500	26	7	0.783	0.2883	250000	16190
Lark	397500	30	7	0.806	0.3453	250000	19980
Pelican	477000	18	1	0.814	0.1628	300000	12300
Flicker	477000	24	7	0.846	0.2820	300000	17200
Hawk	477000	26	7	0.858	0.3162	300000	19430

Code Word	ASCR		Diameter		Copper Equivalent based upon equal D.C. resistance Cu 97% Al 61%	Ultimate Strength Pounds	
	Cir. Mils. or AWG	Stranding Number of Strands		Inches			
		Alum.	Steel	Complete cable			Steel Core
Hen	477000	30	7	0.883	0.3783	300000	23300
Parakeet	556500	24	7	0.914	0.3045	350000	19850
Dove	556500	26	7	0.927	0.341	350000	22400
Eagle	556500	30	7	0.953	0.409	350000	27200
Peacock	605000	24	7	0.953	0.318	380500	21500
Squab	605000	26	7	0.966	0.356	380500	24100
Teal	605000	30	19	0.994	0.426	380500	30000
Rook	636000	24	7	0.977	0.326	400000	22600
Grosbeak	636000	26	7	0.990	0.365	400000	25000
Egret	636000	30	19	1.019	0.437	400000	31500
Flamingo	666600	24	7	1.000	0.333	419000	23700
Crow	715500	54	7	1.036	0.345	450000	26300
Starling	715500	26	7	1.051	0.387	450000	28100
Redwing	715500	30	19	1.081	0.463	450000	34600
Condor	795000	54	7	1.093	0.364	500000	28500
Drake	795000	26	7	1.108	0.408	500000	31200
Mallard	795000	30	19	1.140	0.489	500000	38400
Crane	874500	54	7	1.146	0.382	550000	31400
Canary	900000	54	7	1.162	0.387	566000	32300
Cardinal	954000	54	7	1.196	0.399	600000	34200
Curlew	1033500	54	7	1.246	0.415	650000	37100
Finch	1113000	54	19	1.293	0.431	700000	40200
Pheasant	1272000	54	19	1.382	0.461	800000	44800
Plover	1431000	54	19	1.465	0.489	900000	50400
Falcon	1590000	54	19	1.545	0.515	1000000	56000

HIGH STRENGTH ACSR

Code Word	ASCR		Diameter		Copper Equivalent based upon equal D.C. resistance Cu 97% Al 61%	Ultimate Strength Pounds	
	Cir. Mils. or AWG	Stranding Number of Strands		Inches			
		Alum.	Steel	Complete cable			Steel Core
Grouse	80000	8	1	0.367	0.1670	50310	5200
Petrel	101800	12	7	0.461	0.2763	64160	9860
Minorca	110800	12	7	0.481	0.2883	69700	10730
Leghorn	134600	12	7	0.530	0.3177	84600	12920
Guinea	159000	12	7	0.576	0.3453	100000	15200
Dotterel	176900	12	7	0.607	0.3642	111200	16440
Dorking	190800	12	7	0.631	0.3783	120000	17730
Cochin	211300	12	7	0.663	0.3981	132900	19640
Brahma	203200	16	9	0.714	0.4885	127800	27500

CABLE DATA (Continued)

**COMPACT ALUMINUM 1350 CABLE
(ASTM B400) EXTRA HARD**

Conductor Size		Class	Number of Wire	Conductor Diameter Inches	Breaking Strength Lbs.
KCMIL	AWG				
1000		B	61 ¹	1.060	17,700
900		B	61 ¹	0.999	15,900
800		B	61 ¹	0.938	14,400
750		B	61 ¹	0.908	13,500
700		B	61 ¹	0.877	12,900
650		B	61 ¹	0.845	11,900
600		B	61 ¹	0.813	11,500
556		AA	19 ³	0.780	9,750
550		B	61 ¹	0.775	10,500
500		B	37 ²	0.736	9,110
500		AA	19 ³	0.736	8,760
477		AA	19 ³	0.722	8,360
450		B	37 ²	0.700	8,200
400		B	37 ²	0.659	7,440
397		AA, A	19 ³	0.659	7,110
350		B	37 ²	0.616	6,760
350		A	19 ³	0.616	6,390
336		A	19 ³	0.603	6,150
336		AA	7	0.603	5,960
300		B	37 ²	0.570	5,890
300		A	19 ³	0.570	5,480
300		AA	7	0.570	5,430
266		A	19 ³	0.537	4,970
266		AA	7	0.537	4,830
250		B	37 ²	0.520	4,910
250		A	19 ³	0.520	4,660
250		AA	7	0.520	4,520
	4/0	B	19 ³	0.475	4,020
	4/0	AA, A	7	0.475	3,830
	3/0	B	19 ³	0.423	3,310
	3/0	AA, A	7	0.423	3,040
	2/0	B	19 ³	0.376	2,670
	2/0	AA, A	7	0.376	2,510
	1/0	B	19 ³	0.336	2,160
	1/0	AA, A	7	0.336	1,990
	1	B	19 ³	0.299	1,740
	1	AA, A	7	0.299	1,640
	2	AA, A, B	7	0.268	1,350
	3	A, B	7	0.238	1,090
	4	A, B	7	0.213	.881
	6	A, B	7	0.169	.563
	8	A, B	7	0.134	.312

¹ 58 wires minimum
² 35 wires minimum
³ 18 wires minimum

**ALUMINUM ALLOY 5005 CABLE
(ASTM B397)**

Conductor Size cmil	Number of Wires	Approx. Aluminum 1350 Size having Equivalent Resistance		Size & Stranding of ACSR with Equal Diameter			Rated Strength Lbs.
		cmil	AWG	cmil	AWG	Stranding	
927,200	37	795,000	—	795,000	—	26/7	23,900
740,800	37	636,000	—	636,000	—	26/7	19,300
652,400	19	556,500	—	556,500	—	26/7	16,200
587,200	19	506,500	—	556,500	—	18/1	14,600
559,500	19	477,000	—	477,000	—	26/7	13,900
503,600	19	435,500	—	477,000	—	18/1	12,500
465,400	19	397,500	—	397,500	—	26/7	12,200
419,400	19	362,000	—	397,500	—	18/1	11,200
394,500	19	336,400	—	336,400	—	26/7	10,500
355,100	19	306,400	—	336,400	—	18/1	9,600
312,800	19	266,800	—	266,800	—	26/7	8,450
281,400	19	242,900	—	266,800	—	18/1	7,610
246,900	7	211,600	4/0	211,600	4/0	6/1	6,330
195,700	7	167,800	3/0	167,800	3/0	6/1	5,020
155,400	7	133,100	2/0	133,100	2/0	6/1	4,280
123,300	7	105,600	1/0	105,600	1/0	6/1	3,440
77,470	7	66,360	2	66,360	2	6/1	2,200
48,690	7	41,740	4	41,740	4	6/1	1,430
30,580	7	26,240	6	26,240	6	6/1	922

**ALUMINUM ALLOY 6201 CABLE
(ASTM B399)**

Conductor Size cmil	Number of Wires	Approx. Aluminum 1350 Size having Equivalent Resistance		Size & Stranding of ACSR with Equal Diameter			Rated Strength Lbs.
		cmil	AWG	cmil	AWG	Stranding	
1439,200	61	1272,000	—	1272,000	—	54/7	46,800
1348,800	61	1192,500	—	1192,500	—	54/7	43,900
1259,600	61	1113,000	—	1113,000	—	54/7	41,000
1165,100	61	1033,500	—	1033,500	—	54/7	37,900
1077,400	61	954,000	—	954,000	—	54/7	35,000
927,200	37	795,000	—	795,000	—	26/7	30,500
740,800	37	636,000	—	636,000	—	26/7	24,400
652,400	19	556,500	—	556,500	—	26/7	21,900
559,500	19	477,000	—	477,000	—	26/7	18,800
465,400	19	397,500	—	397,500	—	26/7	15,600
394,500	19	336,400	—	336,400	—	26/7	13,300
312,800	19	266,800	—	266,800	—	26/7	11,000
246,900	7	211,600	4/0	211,600	4/0	6/1	8,560
195,700	7	167,800	3/0	167,800	3/0	6/1	6,790
155,400	7	133,100	2/0	133,100	2/0	6/1	5,390
123,300	7	105,600	1/0	105,600	1/0	6/1	4,460
77,470	7	66,360	2	66,360	2	6/1	2,800
48,690	7	41,740	4	41,740	4	6/1	1,760
30,580	7	26,240	6	26,240	6	6/1	1,110

CABLE DATA (Continued)

**ALUMINUM ALLOY 8000 SERIES “O” TEMPER CABLE
(ASTM B801)**

CONDUCTOR SIZE		NUMBER OF WIRES†	CLASS	CONDUCTOR DIAMETER			MIN. BREAKING STRENGTH LBS.
KCMIL	AWG			Conventional In.	Compressed In.	Compact In.	
1000		127	D	1.153	1.119	1.060	6010
1000		91	C	1.153	1.118	1.060	6010
1000		61	B, A	1.152	1.117	1.060	6010
900		127	D	1.095	1.062	0.999	5400
900		91	C	1.093	1.060	0.999	5400
900		61	B, A	1.093	1.060	0.999	5400
800		127	D	1.032	1.001	0.938	4800
800		91	C	1.032	1.001	0.938	4800
800		61	B, A	1.031	1.000	0.938	4800
750		127	D	0.998	0.968	0.908	4500
750		91	C	0.999	0.969	0.908	4500
750		61	B, A	0.998	0.968	0.908	4500
700		127	D	0.965	0.936	0.877	4200
700		91	C	0.965	0.936	0.877	4200
700		61	B, A	0.964	0.935	0.877	4200
650		127	D	0.930	0.902	0.845	3900
650		91	C	0.930	0.902	0.845	3900
650		61	B	0.929	0.901	0.845	3900
650		37	A	0.928	0.900	0.845	3950
600		127	D	0.893	0.866	0.813	3600
600		91	C	0.893	0.866	0.813	3600
600		61	B	0.893	0.866	0.813	3600
600		37	A	0.891	0.864	0.813	3640
556		127	D	0.861	0.835	0.780	3340
556		91	C	0.860	0.834	0.780	3340
556		61	B	0.860	0.834	0.780	3340
556		37	A	0.858	0.832	0.780	3380
550		127	D	0.855	0.829	0.775	3300
550		91	C	0.855	0.829	0.775	3300
550		61	B	0.855	0.829	0.775	3300
550		37	A	0.853	0.827	0.775	3340
500		91	D	0.815	0.791	0.736	3000
500		61	C	0.815	0.791	0.736	3000
500		37	B, A	0.813	0.789	0.736	3040
477		91	D	0.796	0.772	0.722	2860
477		61	C	0.796	0.772	0.722	2860
477		37	B, A	0.795	0.771	0.722	2900
450		91	D	0.773	0.750	0.700	2700
450		61	C	0.773	0.750	0.700	2700
450		37	B, A	0.772	0.749	0.700	2730
400		91	D	0.729	0.707	0.659	2400
400		61	C	0.729	0.707	0.659	2400
400		37	B, A	0.728	0.706	0.659	2430
397		91	D	0.727	0.705	0.659	2390
397		61	C	0.726	0.704	0.659	2390
397		37	B	0.725	0.703	0.659	2410
397		19	A	0.724	0.702	0.659	2470
350		91	D	0.682	0.661	0.616	2100
350		61	C	0.681	0.661	0.616	2100
350		37	B	0.681	0.661	0.616	2130
350		19	A	0.679	0.659	0.616	2170
336		61	C	0.669	0.649	0.603	2020
336		37	B	0.668	0.648	0.603	2040
336		19	A	0.666	0.646	0.603	2090
300		61	C	0.631	0.612	0.570	1800
300		37	B	0.630	0.611	0.570	1820
300		19	A	0.629	0.610	0.576	1860
266		61	C	0.595	0.577	0.537	1600
266		37	B	0.594	0.576	0.537	1620
266		19	A	0.593	0.575	0.537	1660
250		61	C	0.576	0.559	0.520	1500

CABLE DATA (Continued)

ALUMINUM ALLOY 8000 SERIES “O” TEMPER CABLE (Continued)

CONDUCTOR SIZE		NUMBER OF WIRES†	CLASS	CONDUCTOR DIAMETER			MIN. BREAKING STRENGTH LBS.
KCMIL	AWG			Conventional In.	Compressed In.	Compact In.	
250		37	B	0.575	0.558	0.520	1520
250		19	A	0.574	0.557	0.520	1550
	4/0	37	C	0.529	0.513	0.475	1280
	4/0	19	B	0.528	0.512	0.475	1310
	4/0	7	A	0.522	0.506	0.475	1360
	3/0	37	C	0.471	0.457	0.423	1020
	3/0	19	B	0.470	0.456	0.423	1040
	3/0	7	A	0.464	0.450	0.423	1070
	2/0	19	B	0.419	0.406	0.376	826
	2/0	7	A	0.414	0.402	0.376	853
	1/0	19	B	0.373	0.362	0.336	655
	1/0	7	A	0.368	0.357	0.336	676
	1	19	B	0.332	0.322	0.229	519
	2	7	B, A	0.292	0.283	0.268	425
	3	7	B, A	0.260	0.252	0.238	337
	4	7	B, A	0.232	0.225	0.213	267
	6	7	B, A	0.184	0.178	0.169	168
	8	7	B, A	0.146	0.142	0.134	106

† For compact-stranded constructions, the number of wires may be reduced as follows:
 19-Wire Constructions - 18 Wires Minimum
 37-Wire Constructions - 35 Wires Minimum
 61-Wire Constructions - 58 Wires Minimum
 91-Wire Constructions - 87 Wires Minimum
 127-Wire Constructions - 122 Wires Minimum

COMPACT ACSR (ASTM B401)

CONDUCTOR SIZE		CONDUCTOR DIAMETER (IN.)	BREAKING STRENGTH (LB)
KCMIL	AWG		
336.4		0.628	8,260
266.8		0.559	6,540
	4/0	0.517	7,420
	3/0	0.461	5,880
	2/0	0.410	4,880
	1/0	0.365	3,980
	1	0.326	3,290
	2	0.298	3,260
	2	0.290	2,640
	3	0.258	2,130
	4	0.236	2,160
	4	0.229	1,760
	6	0.182	1,120

ACSR/TW (TRAP WIRE) CABLE (ASTM B779)

CONDUCTOR SIZE KCMIL	STRANDING		NOMINAL DIAMETER INCHES	RATED STRENGTH LBS
	Number of Aluminum Wires	Number of Steel Wires		
336.4	14	1	0.63	8,600
477.0	18	7	0.78	17,200
477.0	18	7	0.79	19,400
556.5	18	7	0.84	20,000
556.5	20	7	0.85	22,600
636.0	27	1	0.85	13,500
636.0	18	7	0.89	22,900
636.0	20	7	0.91	25,400
795.0	17	7	0.96	21,000
795.0	18	7	0.98	25,900

ACSR/TW (TRAP WIRE) CABLE (Continued)

CONDUCTOR SIZE KCMIL	STRANDING		NOMINAL DIAMETER INCHES	RATED STRENGTH LBS
	Number of Aluminum Wires	Number of Steel Wires		
405.1	14	1	0.68	10,200
571.7	18	7	0.85	20,600
565.3	20	7	0.86	22,900
664.8	20	7	0.93	26,600
666.6	20	7	0.91	24,000
762.8	20	7	0.99	30,500
768.2	20	7	0.98	27,700
768.9	27	1	0.93	16,400
795.0	20	7	0.99	28,200
795.0	20	7	1.01	31,800
946.7	35	7	1.08	29,600
954.0	30	7	1.05	23,700
954.0	32	7	1.06	25,900
954.0	20	7	1.08	33,500
957.2	32	7	1.06	26,000
1033.5	30	7	1.09	25,700
1033.5	32	7	1.10	28,100
1033.5	21	7	1.13	36,300
1113.0	30	7	1.13	27,500
1113.0	33	7	1.14	30,000
1113.0	38	19	1.19	39,100
1192.5	30	7	1.17	29,500
1192.5	33	7	1.18	32,400
1192.5	38	19	1.22	41,900
1272.0	30	7	1.20	31,400
1272.0	35	7	1.22	34,600
1272.0	39	19	1.26	44,100
1351.5	35	7	1.26	36,700
1351.5	39	19	1.30	46,800
1431.0	36	7	1.29	38,900
1431.0	39	19	1.34	49,600
1590.0	36	7	1.36	42,200
1590.0	42	19	1.41	55,100
1780.0	37	19	1.45	50,700
2156.0	64	19	1.61	61,100

CABLE DATA (Continued)

ACSR/TW (TRAP WIRE) CABLE (Continued)

CONDUCTOR SIZE KCMIL	STRANDING		NOMINAL DIAMETER INCHES	RATED STRENGTH LBS
	Number of Aluminum Wires	Number of Steel Wires		
959.6	22	7	1.11	37,000
966.2	21	7	1.09	34,000
1158.0	33	7	1.17	31,600
1158.4	25	7	1.20	39,600
1168.1	30	7	1.16	28,900
1233.6	38	19	1.25	42,900
1257.1	35	7	1.21	34,200
1272.0	30	7	1.20	31,400
1334.6	39	19	1.29	46,300
1359.7	36	7	1.26	36,900
1372.5	30	7	1.25	33,400
1433.6	39	19	1.34	49,700
1455.3	36	7	1.30	39,200
1467.8	33	7	1.29	35,800
1533.3	39	19	1.38	53,200
1557.4	36	7	1.35	41,900
1569.0	33	7	1.33	38,200
1622.0	39	19	1.42	57,500
1657.4	36	7	1.39	44,000
1730.6	39	19	1.47	59,400
1758.6	37	19	7.14	34,600
1926.9	42	19	1.55	65,300
1949.6	42	7	1.50	51,900
2153.8	64	19	1.60	61,100
2627.3	64	19	1.76	74,500

AAC/TW (ALL ALUMINUM TRAP WIRE)
(ASTM B778)

CONDUCTOR SIZE, KCMIL	NOMINAL DIAMETER, IN.	NUMBER OF WIRES	RATED STRENGTH, LBF
336.4	0.612	17	6,220
397.5	0.661	17	7,230
477.0	0.720	17	8,530
500.0	0.736	17	8,940
556.5	0.775	17	9,950
600.0	0.803	17	10,700
636.0	0.825	17	11,400
700.0	0.864	17	12,500
750.0	0.893	17	13,400
795.0	0.919	17	13,900
900.0	0.990	31	15,800
954.0	1.018	31	16,700
1000.0	1.041	31	17,500
1033.5	1.057	31	18,100
1113.0	1.095	31	19,500
1192.5	1.132	31	20,900
1272.0	1.168	31	22,300
1351.5	1.202	31	23,700
1431.0	1.236	31	24,600
1590.0	1.315	49	27,300
1750.0	1.377	49	30,000
2000.0	1.468	49	34,300

ACAR CABLE‡
(ASTM B524)

CONDUCTOR SIZE		NUMBER OF WIRES	NOMINAL OUTSIDE DIAMETER
KCMIL	AWG		
2000		91	1.630
2000		61	1.630
1900		61	1.588
1800		61	1.546
1750		61	1.525
1700		61	1.502
1600		61	1.458
1500		61	1.411
1400		61	1.364
1300		61	1.314
1300		37	1.312
1250		61	1.288
1250		37	1.287
1200		61	1.263
1200		37	1.261
1100		61	1.209
1100		37	1.207
1000		61	1.152
1000		37	1.151
950		37	1.121
900		37	1.092
850		37	1.061
800		37	1.029
750		37	0.997
700		37	0.962
650		37	0.928
600		37	0.891
600		19	0.888
550		37	0.853
550		19	0.850
500		37	0.813
500		19	0.811
450		19	0.770
400		19	0.726
350		19	0.678
300		19	0.628
250		19	0.574
246.9		7	0.563
	4/0	7	0.522
195.7		7	0.502
	3/0	7	0.464
155.4		7	0.447
	2/0	7	0.414
123.3		7	0.398
	1/0	7	0.368
77.4		7	0.316
	2	7	0.292
48.6		7	0.250
	4	7	0.232
30.5		7	0.198

CABLE DATA (Continued)

SSAC CABLE

SIZE AWG OR KCMIL	STRANDING		CONDUCTOR DIAMETER	RATED STRENGTH POUNDS
	ALUMINUM	STEEL		
266.8	22	7	.622	6030
266.8	24	7	.633	7410
266.8	26	7	.642	8880
266.8	30	7	.660	11700
300.0	26	7	.680	9970
336.4	20	7	.692	5990
336.4	22	7	.701	7610
336.4	24	7	.710	9340
336.4	26	7	.720	11200
336.4	30	7	.741	14800
397.5	20	7	.752	7090
397.5	22	7	.762	8990
397.5	24	7	.772	11000
397.5	26	7	.783	13000
397.5	30	7	.806	17500
477.0	20	7	.823	8490
477.0	22	7	.834	10800
477.0	24	7	.846	13000
477.0	26	7	.858	15600
477.0	30	7	.883	21000
500.0	30	7	.904	22000
556.5	20	7	.890	9910
556.5	22	7	.901	12600
556.5	24	7	.914	15200
556.5	26	7	.927	18200
556.5	30	7	.953	24500
605.0	24	7	.953	16500
605.0	26	7	.966	19700
605.0	30	7	.994	26000
605.0	30	19	.994	26600
636.0	20	7	.951	11300
636.0	22	7	.963	14100
636.0	24	7	.977	17300
636.0	26	7	.990	20700
636.0	30	7	1.019	27400
636.0	30	19	1.019	28000
666.6	24	7	1.000	18200
666.6	26	7	1.104	21700
715.5	24	7	1.036	19500
715.5	26	7	1.051	23300
715.5	30	19	1.081	30800
795.0	42	7	1.055	11800
795.0	20	7	1.063	14200
795.0	45	7	1.063	14200
795.0	22	7	1.077	17700
795.0	24	7	1.092	21700
795.0	54	7	1.092	21700
795.0	26	7	1.108	25900
795.0	30	19	1.140	34300
900.0	45	7	1.131	15800
900.0	54	7	1.162	24600
954.0	42	7	1.155	14200
954.0	20	7	1.185	16700
954.0	45	7	1.165	16700
954.0	48	7	1.175	19700
954.0	24	7	1.196	26000
954.0	54	7	1.196	26000
954.0	30	19	1.248	41100

SSAC CABLE (Continued)

SIZE AWG OR KCMIL	STRANDING		CONDUCTOR DIAMETER	RATED STRENGTH POUNDS
	ALUMINUM	STEEL		
1033.5	42	7	1.203	15400
1033.5	45	7	1.212	18100
1033.5	48	7	1.222	21300
1033.5	54	7	1.245	28200
1113.0	42	7	1.248	16300
1113.0	45	7	1.259	19500
1113.0	48	7	1.269	23000
1113.0	54	19	1.293	30400
1192.5	42	7	1.292	17500
1192.5	45	7	1.302	20900
1192.5	48	7	1.313	24600
1192.5	54	19	1.338	32600
1272.0	42	7	1.334	18700
1272.0	45	7	1.345	22300
1272.0	48	7	1.357	26200
1272.0	54	19	1.382	34100
1351.5	42	7	1.376	19900
1351.5	45	7	1.386	23700
1351.5	48	7	1.398	27900
1351.5	54	19	1.424	36200
1431.0	42	7	1.415	21000
1431.0	45	7	1.427	25100
1431.0	48	7	1.439	29500
1431.0	54	19	1.465	38400
1510.5	45	7	1.466	26500
1510.5	54	19	1.505	40500
1590.0	42	7	1.492	23400
1590.0	45	7	1.504	27900
1590.0	48	7	1.517	32200
1590.0	54	19	1.545	42600
1780.0	84	19	1.602	35400
1869.0	68	7	1.603	21500
2034.5	72	7	1.681	27200

CABLE DATA

SOLID COPPERWELD CABLE (ASTM B227)

Conductor Size (AWG)	Nominal Diameter (Inches)	Circular Mils	Minimum Breaking Load (lbs.)			
			Grade 40 HS	Grade 40 EHS	Grade 30 HS	Grade 30 EHS
4	0.2043	41,740	3,540	—	3,934	4,671
5	0.1819	33,090	2,937	—	3,249	3,911
—	0.1650*	27,230	2,779	—	2,779	3,367
6	0.1620	26,240	2,679	—	2,679	3,246
7	0.1443	20,820	2,207	—	2,207	2,681
8	0.1285	16,510	1,816	—	1,816	2,205
—	0.1280*	16,380	1,802	—	1,802	2,188
9	0.1144	13,090	1,491	—	1,491	1,790
—	0.1040*	10,820	1,283	1,325	1,283	1,487
10	0.1019	10,380	1,231	—	1,231	1,460
12	0.0808	6,530	774	—	774	918
—	0.0800*	6,400	759	—	759	900
—	0.0640*	4,096	485	—	485	576
18	0.0403	1,624	193	—	193	228
—	0.0390*	1,521	180	—	180	214
20	0.0320	1,024	121	—	121	144

* These diameters are often employed by purchasers for communication lines BUT are not in the American Wire Gauge (B & S Wire Gauge) series, as are the other diameters listed.

STRANDED COPPERWELD CABLE (ASTM B228)

Nominal Diameter† (Inch) Size A.W.G.‡	Circular Mils	Diameter* (Inch)	Breaking Load Lbs.**		
			High Strength		Extra High Strength
			40% Cond.	30% Cond.	30% Cond.
7/8 (19 No. 5)	628,900	.910	50,240	55,570	66,910
13/16 (19 No. 6)	498,800	.810	41,600	45,830	55,530
23/32 (19 No. 7)	395,500	.721	34,390	37,740	45,850
27/32 (19 No. 8)	313,700	.642	28,380	31,040	37,690
9/16 (19 No. 9)	248,800	.572	23,390	25,500	30,610
5/8 (7 No. 4)	292,200	.613	22,310	24,780	29,430
9/16 (7 No. 5)	231,700	.546	18,510	20,470	24,650
1/2 (7 No. 6)	183,800	.486	15,330	16,890	20,460
7/16 (7 No. 7)	145,700	.433	12,670	13,910	16,890
3/8 (7 No. 8)	115,600	.385	10,460	11,440	13,890
11/32 (7 No. 9)	91,650	.343	8,616	9,393	11,280
5/16 (7 No. 10)	72,680	.306	7,121	7,758	9,196
3 No. 5	99,310	.392	8,373	9,262	11,860
3 No. 6	78,750	.349	6,934	7,639	9,754
3 No. 7	62,450	.311	5,732	6,291	7,922
3 No. 8	49,530	.277	4,730	5,174	6,282
3 No. 9	39,280	.247	3,898	4,250	5,129
3 No. 10	31,150	.220	3,221	3,509	4,160
3 No. 12	19,590	.174	2,236	—	—

COPPERWELD-COPPER CABLE (ASTM B229)

Conductor Size Hard Drawn Copper Equivalent	cmil	AWG	TYPE	Nominal Diameter of Conductor (inches)	Minimum Breaking Load (pounds)
350,000	—	EK	0.735	23,850	
350,000	—	V	0.754	23,480	
300,000	—	E	0.729	27,770	
300,000	—	EK	0.680	20,960	
300,000	211,600	V	0.698	20,730	
250,000	—	E	0.666	23,920	
250,000	—	EK	0.621	17,840	
250,000	—	V	0.637	17,420	
250,000	—	E	0.613	20,730	
211,600	4/0	G	0.583	15,640	
211,600	4/0	EK	0.571	15,370	
211,600	4/0	V	0.586	15,000	
211,600	4/0	F	0.550	12,290	
167,800	3/0	E	0.545	16,800	
167,800	3/0	J	0.555	16,170	
167,800	3/0	G	0.519	12,860	
167,800	3/0	EK	0.509	12,370	
167,800	3/0	V	0.522	12,200	
167,800	3/0	F	0.490	9,990	
133,100	2/0	K	0.534	17,600	
133,100	2/0	J	0.494	13,430	
133,100	2/0	G	0.463	10,510	
133,100	2/0	V	0.465	9,846	
133,100	2/0	F	0.436	8,094	
105,600	1/0	K	0.475	14,490	
105,600	1/0	J	0.440	10,970	
105,600	1/0	G	0.412	8,563	
105,600	1/0	F	0.388	6,536	
83,690	1	N	0.464	15,410	
83,690	1	K	0.423	11,900	
83,690	1	J	0.392	9,000	
83,690	1	G	0.367	6,956	
83,690	1	F	0.346	5,266	
66,360	2	P	0.462	16,870	
66,360	2	N	0.413	12,680	
66,360	2	K	0.377	9,730	
66,360	2	J	0.349	7,322	
66,360	2	A	0.366	5,876	
66,360	2	F	0.327	5,626	
66,360	2	G	0.308	4,233	
55,820	3	P	0.411	13,910	
52,620	3	N	0.368	10,390	
52,620	3	K	0.336	7,910	
52,620	3	J	0.311	5,955	
52,620	3	A	0.326	4,810	
41,740	4	P	0.366	11,420	
41,740	4	N	0.328	8,460	
41,740	4	D	0.348	7,340	
41,740	4	A	0.290	3,938	
33,090	5	P	0.326	9,311	
33,090	5	D	0.310	6,035	
33,090	5	A	0.258	3,193	
26,240	6	D	0.276	4,942	
26,240	6	A	0.230	2,585	
26,240	6	C	0.225	2,143	
20,820	7	D	0.246	4,022	
20,820	7	A	0.223	2,754	
16,510	8	D	0.219	3,256	
16,510	8	A	0.199	2,233	
16,510	8	C	0.179	1,362	
11,750	9	D	0.174	1,743	

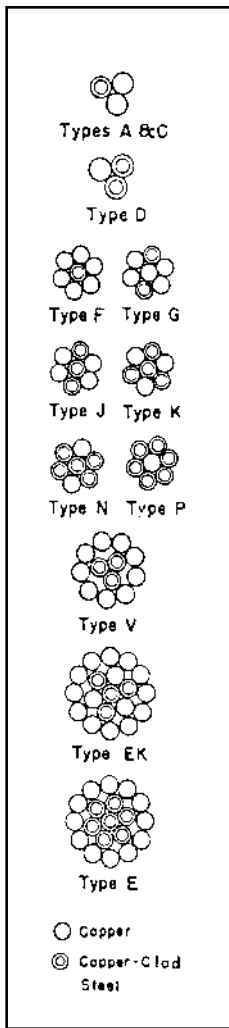

† The designation "Inch" is the approximate diameter in proper fraction of an inch.
 ‡ The designation of "AWG" is a combination of the number of wires each of the American Wire Gauge size indicated by "No."
 * Diameter of circumscribing.
 ** Breaking loads of 7-wire and 19-wire conductors are taken as 90% of the sum of the breaking loads of individual wires; breaking load of 3-wire conductors is taken as 95% of the sum of the breaking loads of the individual wires.

GALVANIZED STEEL CABLE (ASTM A475)

Inches	Nominal Diameter of Strand (mm)	Number of Wires in Strand	Minimum Breaking Load (lbs.)				
			Utilities Grade	Common Grade	Siemens-Martin Grade	High-Strength Grade	Extra High-Strength Grade
1/8	(3.18)	7	—	540	910	1,330	1,830
5/32	(3.97)	7	—	870	1,470	2,140	2,940
3/16	(4.76)	7	—	1,150	1,900	2,850	3,990
3/16	(4.76)	7	2,400	—	—	—	—
7/32	(5.56)	3	—	1,400	2,340	3,500	4,900
7/32	(5.56)	7	—	1,540	2,560	3,850	5,400
1/4	(6.35)	3	3,150	1,860	3,040	4,730	6,740
1/4	(6.35)	3	4,500	—	—	—	—
1/4	(6.35)	7	—	1,900	3,150	4,750	6,650
9/32	(7.14)	3	—	2,080	3,380	5,260	7,500
9/32	(7.14)	7	4,600	2,570	4,250	6,400	8,950
5/16	(7.94)	3	6,500	2,490	4,090	6,350	9,100
5/16	(7.94)	7	—	3,200	5,350	8,000	11,200
5/16	(7.94)	7	6,000	—	—	—	—
3/8	(9.52)	3	8,500	3,330	5,560	8,360	11,800
3/8	(9.52)	7	11,500	4,250	6,950	10,800	15,400
7/16	(11.11)	7	18,000	5,700	9,350	14,500	20,800
1/2	(12.70)	7	25,000	7,400	12,100	18,800	26,900
1/2	(12.70)	19	—	7,620	12,700	19,100	26,700
9/16	(14.29)	7	—	9,600	15,700	24,500	35,000
9/16	(14.29)	19	—	9,640	16,100	24,100	33,700
5/8	(15.88)	7	—	11,600	19,100	29,600	42,400
5/8	(15.88)	19	—	11,000	18,100	28,100	40,200
3/4	(19.05)	19	—	16,000	26,200	40,800	58,300
7/8	(22.22)	19	—	21,900	35,900	55,800	79,700
1	(25.40)	9	—	28,700	47,000	73,200	104,500
1	(25.40)	37	—	28,300	46,200	71,900	102,700
1-1/8	(28.58)	37	—	36,000	58,900	91,600	130,800
1-1/4	(31.75)	37	—	44,600	73,000	113,600	162,200

CABLE DATA

ALUMINUM-COATED STEEL CABLE (ASTM A474)

NOMINAL DIAMETER OF STRAND (IN.)	NUMBER OF WIRES IN STRAND	MINIMUM BREAKING STRENGTH, lbf				
		UTILITIES GRADE*	COMMON GRADE	SIEMANS-MARTIN GRADE	HIGH-STRENGTH GRADE	EXTRA HIGH-STRENGTH GRADE
3/16	7		1,150	1,900	2,850	
3/16	7	2,400				
1/4	3	3,150				
1/4	3	4,500				
1/4	7		1,900	3,150	4,750	6,650
9/32	7	4,600				
5/16	3	6,500				
5/16	7		3,200	5,350	8,000	11,200
5/16	7	6,000				
3/8	3	8,500				
3/8	7	11,500	4,250	6,950	10,800	15,400
7/16	7	18,000	5,350	9,350	14,500	20,800
1/2	7	25,000	7,400	12,100	18,800	26,900

* The Utilities Grade is used principally by communications and power and light industries.

















AWG VS. METRIC WIRE SIZES

CIRC. MILS	EQUIVALENT CIRC. MILS	AWG. SIZE	METRIC WIRE SIZE MM	STRANDING/WIRE DIAMETER PER STRAND		APPROXIMATE OVERALL DIAMETER		CIRC. MILS	EQUIVALENT CIRC. MILS	AWG. SIZE	METRIC WIRE SIZE MM	STRANDING/WIRE DIAMETER PER STRAND		APPROXIMATE OVERALL DIAMETER	
				IN.	MM	IN.	MM					IN.	MM	IN.	MM
—	937	—	0.50	1/.032	1/.813	.032	.061	83690	—	1	—	19/.0064	19/1.50	.332	8.43
1020	—	20	—	7/.0121	1/.307	.036	0.91	—	98680	—	50	19/.073	19/1.85	.365	9.27
—	1480	—	.75	1/.039	1/.091	.039	0.99	10500	—	1/0	—	19/.0745	19/1.59	.373	9.46
1620	—	18	—	1/.0103	1/1.02	.040	1.02	133100	—	2/0	—	19/.0837	19/2.13	.419	10.6
1620	—	18	—	7/.0152	7/.386	.046	1.16	—	138100	—	70	19/.086	19/2.18	.430	10.9
—	1974	—	1.0	1/.045	1/1.14	.045	1.14	167800	—	3/0	—	19/.094	19/2.59	.470	11.9
—	1974	—	1.0	7/.017	7/.422	.061	1.30	167800	—	3/0	—	36/.0673	37/1.71	.471	12.0
2580	—	16	—	1/.0503	1/1.29	.051	1.29	—	187500	—	95	19/.101	19/2.57	.505	12.8
2580	—	16	—	7/.0192	7/.468	.058	1.46	—	187500	—	95	37/.072	37/1.83	.504	12.5
—	2960	—	1.5	1/.055	1/1.40	.055	1.40	211600	—	4/0	—	19/.1055	19/2.89	.528	13.4
—	2960	—	1.5	7/.021	7/5.33	.063	1.60	—	237.8 kcmil	—	120	37/.081	37/2.06	.567	14.4
4110	—	14	—	1/.0641	1/1.63	.064	1.63	250 kcmil	—	—	—	37/.0822	37/2.07	.575	14.6
4110	—	14	—	7/.0242	7/.615	.073	1.84	300 kcmil	—	—	150	37/.090	37/2.29	.630	16.0
—	4934	—	2.5	1/.071	1/1.80	.071	1.80	350 kcmil	—	—	—	37/.0973	37/2.47	.681	17.3
—	4934	—	2.5	7/.027	7/6.66	.081	2.06	—	365.1 kcmil	—	185	37/.100	37/2.54	.700	17.8
6530	—	12	—	1/.0308	1/2.05	.081	2.05	400 kcmil	—	—	—	37/.104	37/2.64	.728	18.5
6530	—	12	—	7/.0305	7/.775	.092	2.32	—	473.6 kcmil	—	240	37/.114	37/2.90	.798	20.3
—	7894	—	4	1/.089	1/2.26	.089	2.26	—	473.6 kcmil	—	240	61/.089	61/2.26	.801	20.3
—	7894	—	4	7/.034	7/.864	.102	2.59	500 kcmil	—	—	—	37/.1162	37/2.95	.813	20.7
10380	—	10	—	1/.1019	1/2.59	.102	2.59	500 kcmil	—	—	—	61/.0905	61/2.30	.814	20.7
10380	—	10	—	7/.0355	7/.978	.116	2.93	—	592.1 kcmil	—	300	61/.099	61/2.51	.891	22.6
—	11840	—	6	1/.109	1/2.77	.109	2.77	600 kcmil	—	—	—	61/.0992	61/2.52	.893	22.7
—	11840	—	6	7/.042	7/.107	.126	3.21	700 kcmil	—	—	—	61/.1071	61/2.72	.964	24.5
13000	—	9	—	1/.1144	1/2.91	.114	2.91	750 kcmil	—	—	—	61/.1109	61/2.82	.998	25.4
13090	—	9	—	7/.0432	7/1.10	.130	3.30	750 kcmil	—	—	—	91/.0908	91/2.31	.998	25.4
16510	—	8	—	1/.1285	1/3.26	.128	3.25	—	789.4 kcmil	—	400	61/.114	61/2.90	1.026	26.1
16510	—	8	—	7/.0486	7/1.23	.146	3.70	800 kcmil	—	—	—	61/.1145	61/2.91	1.031	26.2
—	19740	—	10	1/.141	1/3.58	.141	3.58	800 kcmil	—	—	—	91/.0938	91/2.38	1.032	26.2
—	19740	—	10	7/.054	7/1.37	.162	4.12	1000 kcmil	986.8 kcmil	—	500	61/.1280	61/3.25	1.152	28.3
20520	—	7	—	1/.1443	1/3.67	.144	3.67	1000 kcmil	—	—	—	91/.1048	91/2.66	1.153	29.3
20520	—	7	—	7/.0545	7/1.38	.164	4.15	—	1233.7 kcmil	—	625	91/.117	91/2.97	1.287	32.7
26240	—	6	—	1/.162	1/4.11	.162	4.11	1250 kcmil	—	—	—	91/.1172	91/2.93	1.289	32.7
26240	—	6	—	7/.0612	7/1.55	.184	4.66	1250 kcmil	—	—	—	127/.0992	127/2.52	1.200	32.8
—	31580	—	16	7/.008	7/1.73	.204	5.13	1500 kcmil	—	—	—	91/.1284	91/3.26	1.412	36.9
33090	—	5	—	7/.0688	7/1.75	.206	5.24	1500 kcmil	—	—	—	127/.1087	127/2.76	1.413	36.9
41740	—	4	—	7/.0772	7/1.96	.232	5.88	—	1578.8 kcmil	—	800	91/.132	91/3.35	1.452	36.9
—	49340	—	25	7/.085	7/2.16	.255	6.48	—	1973.5 kcmil	—	1000	91/.147	91/3.73	1.617	41.1
—	49340	—	25	19/.052	10/1.32	.260	6.60	2000 kcmil	—	—	—	127/.1255	127/3.19	1.632	41.5
52620	—	3	—	7/.0867	7/2.20	.260	6.61	2000 kcmil	—	—	—	169/.1088	169/2.76	1.632	41.5
66300	—	2	—	7/.0974	7/2.47	.292	7.42	—	—	—	—	—	—	—	—
—	69070	—	35	7/.100	7/2.54	.300	7.62	—	—	—	—	—	—	—	—
—	69070	—	35	19/.001	19/1.55	.305	7.75	—	—	—	—	—	—	—	—

INCHES & MILLIMETERS CONVERSION CHART

INCHES		MM	INCHES		MM	MM	INCHES	MM	INCHES	
$\frac{1}{64}$.015625	—	$\frac{33}{64}$.515625	—	.1	.0039	46	—	1.8110
$\frac{1}{32}$.03125	—	$\frac{17}{32}$.53125	—	.2	.0079	47	—	1.8504
$\frac{3}{64}$.046875	—	$\frac{35}{64}$.546875	—	.3	.0118	48	—	1.8898
$\frac{1}{16}$.0625	—	$\frac{9}{16}$.5625	—	.4	.0157	48	—	1.9291
$\frac{5}{64}$.078125	—	$\frac{37}{64}$.578125	—	.5	.0197	50	—	1.9685
$\frac{3}{32}$.09375	—	$\frac{19}{32}$.59375	—	.6	.0236	51	—	2.0079
$\frac{7}{64}$.109375	—	$\frac{39}{64}$.609375	—	.7	.0276	52	—	2.0472
$\frac{1}{8}$.1250	—	$\frac{5}{8}$.6250	—	.8	.0315	53	—	2.0866
$\frac{9}{64}$.140625	—	$\frac{41}{64}$.640625	—	.9	.0354	54	—	2.1260
$\frac{5}{32}$.15625	—	$\frac{21}{32}$.65625	—	1	.0394	55	—	2.1654
$\frac{11}{64}$.171875	—	$\frac{43}{64}$.671875	—	2	.0787	56	—	2.2047
$\frac{3}{16}$.1875	—	$\frac{11}{16}$.6875	—	3	.1181	57	—	2.2441
$\frac{13}{64}$.203125	—	$\frac{45}{64}$.703125	—	4	.1575	58	—	2.2835
$\frac{7}{32}$.21875	—	$\frac{23}{32}$.71875	—	5	.1969	59	—	2.3228
$\frac{15}{64}$.234375	—	$\frac{47}{64}$.734375	—	6	.2362	60	—	2.3622
$\frac{1}{4}$.2500	—	$\frac{3}{4}$.7500	—	7	.2756	61	—	2.4016
$\frac{17}{64}$.265625	—	$\frac{49}{64}$.765625	—	8	.3150	62	—	2.4409
$\frac{9}{32}$.28125	—	$\frac{25}{32}$.78125	—	9	.3543	63	—	2.4803
$\frac{19}{64}$.296875	—	$\frac{51}{64}$.796875	—	10	.3937	64	—	2.5197
$\frac{5}{16}$.3125	—	$\frac{13}{16}$.8125	—	11	.4331	65	—	2.5591
$\frac{21}{64}$.328125	—	$\frac{45}{64}$.828125	—	12	.4724	66	—	2.5984
$\frac{11}{32}$.34375	—	$\frac{27}{32}$.84375	—	13	.5118	67	—	2.6378
$\frac{23}{64}$.359375	—	$\frac{55}{64}$.859375	—	14	.5512	68	—	2.6772
$\frac{3}{8}$.3750	—	$\frac{7}{8}$.8750	—	15	.5906	69	—	2.7165
$\frac{25}{64}$.390625	—	$\frac{57}{64}$.890625	—	16	.6299	70	—	2.7559
$\frac{13}{32}$.40625	—	$\frac{29}{32}$.90625	—	17	.6693	71	—	2.7953
$\frac{27}{64}$.421875	—	$\frac{59}{64}$.921875	—	18	.7087	72	—	2.8346
$\frac{7}{16}$.4375	—	$\frac{15}{16}$.9375	—	19	.7480	73	—	2.8740
$\frac{29}{64}$.453125	—	$\frac{61}{64}$.953125	—	20	.7874	74	—	2.9134
$\frac{15}{32}$.46875	—	$\frac{31}{32}$.96875	—	21	.8268	75	—	2.9528
$\frac{31}{64}$.484375	—	$\frac{63}{64}$.984375	—	22	.8661	76	—	2.9921
$\frac{1}{2}$.5000	—	1	1.000	—	23	.9055	77	—	3.0315
						24	.9449	78	—	3.0709
						25	.9843	79	—	3.1102
						26	1.0236	80	—	3.1496
						27	1.0630	81	—	3.1890
						28	1.1024	82	—	3.2283
						29	1.1417	83	—	3.2677
						30	1.1811	84	—	3.3071
						31	1.2205	85	—	3.3465
						32	1.2598	86	—	3.3858
						33	1.2992	87	—	3.4252
						34	1.3386	88	—	3.4646
						35	1.3780	89	—	3.5039
						36	1.4173	90	—	3.5433
						37	1.4567	91	—	3.5827
						38	1.4961	92	—	3.6220
						39	1.5354	93	—	3.6614
						40	1.5748	94	—	3.7008
						41	1.6142	95	—	3.7402
						42	1.6535	96	—	3.7795
						43	1.6929	97	—	3.8189
						44	1.7323	98	—	3.8583
						45	1.7717	99	—	3.8976
								100	—	3.9370

TERMINAL STUD SIZE CHART*

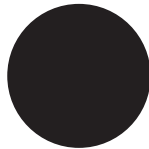
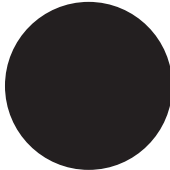
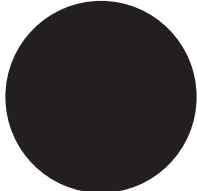
STUD SIZE	#0	#1	#2	#3	#4	#5	#6	#8	#10	#12	#14	1/4"	5/16"	3/8"
Stud Diameter	.060	.073	.086	.090	.112	.125	.138	.164	.190	.216	.242	.250	.312	.375
														
Stud Hole	.067	.093	.119			.145	.171	.197	.223	.250	17/64	21/64	25/64	
STUD SIZE	7/16"	1/2"	5/8"	3/4"	7/8"	1"								
Stud Diameter	.437	.500	.625	.750	.875	1.000								
														
Stud Hole	29/64	33/64	21/32	29/32	29/32	1 - 1/32								

* Tolerance .003" on decimal and .005" on fractional dimensions

DIE SET CONVERSION CHART FOR OBSOLETE DIES AND TOOLS

This catalog uses the new, BURNDY® simplified overhead lines die set catalog numbering system, based on Die Index numbers and letters.

The Die Index numbers are marked on the connectors and die sets. Where a die set has more than one Die Index, the catalog number

will generally be the lowest number assigned or all indexes may be marked.

The Die Index numbers and letters in this conversion chart are arranged in numerical or alphabetical order.

To determine the new catalog number for old die sets, cross reference the Die Index on the

connector, or the old die set, with the Die Index shown on the chart. The new die set catalog number or letters appear for each tool in the previous table. **NOTE: Many "A" dies are available. Contact the factory.** The gage column lists quality control inspection gages for the corresponding die index.

DIE INDEX		MECHANICAL TOOLS	HYDRAULIC TOOLS					GAGE NO.
		MD5	Y34A	Y35 & Y35L	Y45L	Y48B	Y486RB	
A	OLD		A8YC	U8YCMT				
	NEW		A-A	U-A				
BG	OLD	MD5-3		U2YLCMT				UG-BG
	NEW	MD5-3		U-BG				UG-BG-YSU
C	OLD	MD5-3	A2YC	U2YCMT				
	NEW	MD5-3	A-C	U-C				
D	OLD		A26AYC	U26AYCT				
	NEW		A-D	U-D				
D3	OLD			U28YPT				
	NEW			U-D3				
E	OLD		A26YC	U26YCT				
	NEW		A-E	U-E				
F	OLD			U28YCT				
	NEW			U-F				
H	OLD			U28AYCT				
	NEW			U-H				
K	OLD	MD5-3						
	NEW	MD5-3						
K-840	OLD							
	NEW			U-K840				
L	OLD			U28YTT				
	NEW			U-L				
M	OLD			U33YTT				
	NEW			U-M				
N	OLD			U33YPCT	S33YPT			
	NEW			U-N	S-N			
O	OLD			U26YPT				
	NEW			U-O				
Q	OLD							
	NEW							
R	OLD			U33RYCT				
	NEW			U-R				
161	OLD	MD5-2	A6CYD	U6CYDMT				
	NEW	MD5-2	A161	U161				
162	OLD	MD5-2	A4CYD	U4CYDMT		C4CYD	F4CYD	UG4C
	NEW	MD5-2	A162	U162		C162	F162	
163 Same as 505	OLD	MD5-2	A2CYD	U2CYDMT		C2CYD	F2CYD	UG2C
	NEW	MD5-2	A163	U163		C163	F163	
164 Same as 275	OLD		A1CYD	U1CYDMT		C1CYD	F1CYD	UG1C
	NEW		A164	U164		C164	F164	

DIE SET CONVERSION CHART (Continued)
FOR OBSOLETE DIES AND TOOLS

DIE INDEX		MECHANICAL TOOLS	HYDRAULIC TOOLS						GAGE NO.
		MD5	Y34A	Y35 & Y35L	Y45L	Y48B	Y486RB	Y60B	
165 Same as 287	OLD		A25YD	U25YDT		C25YD	F25YD	L25YDT	UG25
	NEW		A165	U165		C165	F165	L165	
166 Same as 206	OLD		A26YD	U26YDT		C26YD	F26YD	L26YDT	UG26
	NEW		A166	U166		C166	F166	L166	
167 Same as 207, 211, 256	OLD		A27YD	U27YDT		C27YD	F27YD	L27YDT	UG27
	NEW		A167	U167		C167	F167	L167	
168 Same as 208	OLD		A28YD	U28YDT		C28YD	F28YD	L28YDT	UG28
	NEW		A168	U168		C168	F168	L168	
169	OLD		A29YD	U29YDT		C29YD	F29YD	L29YDT	UG29
	NEW		A169	U169		C169	F169	L169	
170 Same as 306	OLD		A30YD	U30YDT		C30YD	F30YD	L30YDT	UG30
	NEW		A170	U170		C170	F170	L170	
171	OLD	MD5-2	A8WYD	U8WYDMT					
	NEW	D5-2	A171	U171					
192	OLD		A31RYD						
	NEW		A192						
193	OLD		A33RYD	U33RYDT		C33RYD		L33RYDT	
	NEW		A193	U193		C193		L193	
202	OLD		A8KYD	U8KYDMT					
	NEW		A202	U202					
203	OLD		A6KYD	U6KYDMT					
	NEW		A203	U203					
204	OLD		A4KYD	U4KYDT					
	NEW		A204	U204					
205 Same as 339	OLD		A2KYD	U2KYDT					UG2K
	NEW		A205	U205					
206 Same as 166	OLD		A26YD	U26YDT		C26YD	F26YD	L26YDT	UG26
	NEW		A166	U166		C166	F166	L166	
207 Same as 167, 211, 256	OLD		A27YD	U27YDT		C27YD	F27YD	L27YDT	UG27
	NEW		A167	U167		C167	F167	L167	
208 Same as 168	OLD		A28YD	U28YDT		C28YD	F28YD	L28YDT	UG28
	NEW		A168	U168		C168	F168	L168	
209	OLD			U32YDT		C32YD	F32YD	L32YDT	
	NEW			U209		C209	F209	L209	
210	OLD			U34YDT		C34YD	F34YD	L34YDT	UG34
	NEW			U210		C210	F210	L210	
211 Same as 167, 211, 256	OLD		A27YD	U27YDT		C27YD	F27YD	L27YDT	UG27
	NEW		A167	U167		C167	F167	L167	
236	OLD		A4RSYF	U4RSYFT		C4RSYF			UG4RS
	NEW		A236	U236		C236			
237	OLD		A4RYF	U4RYFT		C4RYF			UG4R
	NEW		A237	U237		C237			
238	OLD	MD5-1	A2RSYF	U2RSYFT		C2RSYF			UG2RS
	NEW	MD5-1	A238	U238		C238			
239	OLD		A2RYF	U2RYFT		C2RYF			UG2R
	NEW		A239	U239		C239			
240	OLD		A1RSYF	U1RSYFT		C1RSYF			
	NEW		A240	U240		C240			

DIE SET CONVERSION CHART (Continued)
FOR OBSOLETE DIES AND TOOLS

DIE INDEX		MECHANICAL TOOLS	HYDRAULIC TOOLS					GAGE NO.
		MD5	Y34A	Y35 & Y35L	Y45L	Y48B	Y486RB	
241	OLD		A1RYF	U1RYFT		C1RYF		UG1R
	NEW		A241	U241		C241		
24 Same as 244	OLD		A26RSYF	U26RSYFT		C26RSYF	L26RSYFT	UG26RS
	NEW		A242	U242		C242	L242	
243	OLD		A25RYF	U25RYFT		C25RYF	L25RYFT	UG25R
	NEW		A243	U243		C243	L243	
244 Same as 242	OLD		A26RSYF	U26RSYFT		C26RSYF	L26RSYFT	UG26RS
	NEW		A242	U242		C242	L242	
245	OLD		A26RYF	U26RYFT		C26RYF	L26RYFT	UG26R
	NEW		A245	U245		C245	L245	
246 Same as 248	OLD		A28RSYF	U28RSYFT		C28RSYF	L28RSYFT	UG28RS
	NEW		A248	U248		C248	L248	
247	OLD		A27RYF	U27RYFT		C27RYF	L27RYFT	UG27R
	NEW		A247	U247		C247	L247	
248 Same as 246	OLD		A28RSYF	U28RSYFT		C28RSYF	L28RSYFT	UG28RS
	NEW		A248	U248		C248	L248	
249	OLD		A28RYF	U28RYFT		C28RYF	L28RYFT	UG28R
	NEW		A249	U249		C249	L249	
250	OLD		A30RSYF	U30RSYFT		C30RSYF	F30RSYF L30RSYFT	UG30RS
	NEW		A250	U250		C250	F250 L250	
251	OLD		A30RYF	U30RYFT		C30RYF	F30RYF L30RYFT	UG30R
	NEW		A251	U251		C251	F251 L251	
252	OLD			U32RSYFT		C32RSYF	F32RSYF L32RSYFT	UG32RS
	NEW			U252		C252	F252 L252	
253	OLD			U34RSYFT		C34RSYF	F34RSYF L34RSYFT	UG34RS
	NEW			U253		C253	F253 L253	
254	OLD					C43RSYF	F34RSYF L34RSYFT	
	NEW				S254	C254	F254 L254	
255	OLD			U44RSYFT		C44RSYF	F44RSYF L44RSYFT	
	NEW			U255		C255	F255 L255	
256 Same as 167, 207, 211	OLD		A27YD	U27YDT		C27YD	F27YD L27YDT	UG27
	NEW		A167	U167		C167	F167 L167	
257	OLD		A312HYD	U312HYDT		C312HYD	L312HYDT	
	NEW		A257	U257		C257	L257	
259	OLD			U3K5YDT		C3K5YD		UG3K5
	NEW			U259		C259		
260	OLD					C7K6YD	F7K6YD L7K6YDT	
	NEW					C260	F260 L260	
261 Same as 318	OLD			U37RYFT		C37RYF	F37RYF L37RYFT	UG37R
	NEW			U261		C261	F261 L261	
263	OLD		A26YD-1	U26YDT-1				
	NEW		A263	U263				
267	OLD			U31YDT		C31YD	F31YD L31YDT	UG31
	NEW			U267		C267	F267 L267	
275 Same as 164	OLD		A1CYD	U1CYDMT		C1CYD	F1CYD	UG1C
	NEW		A164	U164		C164	F164	
276	OLD		A6WKYD	U6WKYDT				
	NEW		A276	U276				

DIE SET CONVERSION CHART (Continued)
FOR OBSOLETE DIES AND TOOLS

DIE INDEX		MECHANICAL TOOLS	HYDRAULIC TOOLS						GAGE NO.
		MD5	Y34A	Y35 & Y35L	Y45L	Y48B	Y486RB	Y60B	
285	OLD		A8WKYD	U8WKYDMT					
	NEW		A285	U285					
287 Same as 165	OLD		A25YD	U25YDT		C25YD	F25YD	L25YDT	UG25
	NEW		A165	U165		C165	F165	L165	
292 Same as 578	OLD					C412RYF-1	F412RYF-1	L412RYFT-1	UG412R1
	NEW				S292	C292	F292	L292	
293	OLD					C412RSYF	F412RSYF	L412RSYFT	
	NEW					C293	F293	L293	
294 Same as 293	OLD					C412RSYF	F412RSYF	L412RSYFT	
	NEW				S293	C293	F293	L293	
304	OLD			U375HYDT		C375HYD		L375HYDT	UG375H
	NEW			U304		C304		L304	
305 Same as 341	OLD			U41RSYFT		C41RSYF	F41RSYF	L41RSYFT	
	NEW			U305		C305	F305	L305	
306 Same as 170	OLD		A30YD	U30YDT		C30YD	F30YD	L30YDT	UG30
	NEW		A170	U170		C170	F170	L170	
308	OLD		A3WYD	U3WYDT					
	NEW		A308	U308					
313	OLD			U47RSYFT		C47RSYF	F47RSYF	L47RSYFT	
	NEW			U313		C313	F313	L313	
314 Same as 376	OLD					C48RSYF	F48RSYF	L48RSYFT	
	NEW					C314	F314	L314	
316	OLD			U33RYFT		C33RYF	F33RYF	L33RYFT	UG33R
	NEW			U316		C316	F316	L316	
317 Same as 426	OLD			U35RYFT		C35RYF	F35RYF	L35RYFT	UG35R
	NEW			U317		C317	F317	L317	
318 Same as 261	OLD			U37RYFT		C37RYF	F37RYF	L37RYFT	UG37R
	NEW			U261		C261	F261	L261	
319	OLD					C43RYF	F43RYF	L43RYFT	
	NEW				S319	C319	F319	L319	
320	OLD					C45RSYF	F45RSYF	L45RSYFT	
	NEW				S320	C320	F320	L320	
321	OLD		A301AYD	U301AYDT		C301AYD			UG301A
	NEW		A321	U321		C321			
322	OLD		A30AYD	U30AYDT					
	NEW		A322	U322					
327	OLD			U361RYFT		C361RYF		L361RYFT	UG361R
	NEW			U327		C327		L327	
328	OLD					C7K7YD			
	NEW					C328			
329	OLD		A2FYD	U2FYDT					
	NEW		A329	U329					
331	OLD			U3K6YDT		C3K6YD			
	NEW			U331		C331			
339 Same as 205	OLD		A2KYD	U2KYDT					UG2K
	NEW		A205	U205					
341 Same as 205	OLD			U41RSYFT		C41RSYF	F41RSYF	L41RSYFT	
	NEW			U305		C305	F305	L305	

DIE SET CONVERSION CHART (Continued)
FOR OBSOLETE DIES AND TOOLS

DIE INDEX		MECHANICAL TOOLS	HYDRAULIC TOOLS						GAGE NO.
		MD5	Y34A	Y35 & Y35L	Y45L	Y48B	Y486RB	Y60B	
342	OLD					C391AYD	F391AYD	L391AYDT	UG361A
	NEW				S342	C342	F342	L342	
344	OLD					C7K5YD			
	NEW					C344			
345	OLD					C44YD	F44YD	L44YDT	
	NEW					C345	F345	L345	
350	OLD			U36RSYFT		C36RSYF	F36RSYF	L36RSYFT	UG36RS
	NEW			U350		C350	F350	L350	
352	OLD					C45RYF	F45RYF	L45RYFT	
	NEW				S352	C352	F352	L352	
373	OLD		A25YD-1	U25YDT-1					
	NEW		A373	U373					
376 Same as 314	OLD					C48RSYF	F48RSYF	L48RSYFT	
	NEW					C314	F314	L314	
403	OLD		A1CYD-1	U1CYDT-1					
	NEW		A403	U403					
406	OLD		A26GYD						
	NEW		A406						
419	OLD					C49RSYF	F49RSYF	L49RSYFT	UG49RS
	NEW					C419	F419	L419	
422	OLD						F49RYF	L49RYFT	
	NEW						F422	L422	
426 Same as 317	OLD			U35RYFT		C35RYF		L35RYFT	UG35R
	NEW			U317		C317		L317	
459	OLD		A1CYD-3	U1CYDT-3					
	NEW		A459	U459					
468	OLD		A311AYD	U311AYDT					
	NEW		A468	U468					
469	OLD					C361AYD	F361AYD	L361AYDT	
	NEW				S469	C469	F469	L469	
490 Same as 547	OLD		A321RYF	U321RYFT		C321RYF	F321RYF	L321RYFT	UG321R
	NEW		A490	U490		C490	F490	L490	
495	OLD					C47RYF	R47RYF	L47RYFT	
	NEW					C495	F495	L495	
505 Same as 163	OLD	MD5-2	A2CYD	U2CYDMT		C2CYD	F2CYD	L2CYDT	UG2C
	NEW	MD5-2	A163	U163		C163	F163	L163	
547 Same as 490	OLD		A321RYF	U321YRFT		C321RYF	F321RYF	L321RYFT	UG321R
	NEW		A490	U490		C490	F490	L490	
552	OLD		A26FYD	U26FYDT					
	NEW		A552	U552					
568	OLD		A25FYD	U25FYDT					
	NEW		A568	U568					
575	OLD					C48RYF	F48RYF	L48RYFT	UG48R
	NEW					C575	F575	L575	
576	OLD					C36YD	F36YD	L36YDT	
	NEW					C576	F576	L576	
578 Same as 292	OLD					C412RYF-1	F412RYF-1	L412RYFT-1	UG412R1
	NEW				S292	C292	F292	L292	

DIE SET CONVERSION CHART (Continued)
FOR OBSOLETE DIES AND TOOLS

DIE INDEX		MECHANICAL TOOLS	HYDRAULIC TOOLS						GAGE NO.
		MD5	Y34A	Y35 & Y35L	Y45L	Y48B	Y486RB	Y60B	
579	OLD					C451RYF	F451RYF	L451RYFT	
	NEW					C579	F579	L579	
607	OLD			U281UYDT					
	NEW			U607					
608	OLD			U39RYFT		C39RYF	F39RYF	L39RYFT	
	NEW			U608		C608	F608	L608	
609	OLD		A250EYD	U250EYDT		C250EYD			
	NEW		A609	U609		C609			
614	OLD					C38RYF			
	NEW					C614			
616	OLD		A29AYD						
	NEW		A616						
627	OLD					C39YD	F39YD	L39YDT	
	NEW					C627	F627	L627	
642	OLD			U32LYDT		C32LYD			
	NEW			U642		C642			
643	OLD			U32RLYDT					
	NEW			U643					
648	OLD						F49RYF-1	L49RYFT-1	UG49R
	NEW						F648	L648	
654	OLD		A28RLYR	U28RLYRT				L28RLYRT	
	NEW		A654	U654				L654	
655	OLD			U321RLYRT					
	NEW			U655					
657	OLD					C39LYR			
	NEW					C657			
658	OLD		A27RLYR	U27RLYRT					UG27RL
	NEW		A658	U658					
659	OLD		A26RLYR	U26RLYRT					UG26RL
	NEW		A659	U659					
660	OLD		A25RLYR	U25RLYRT					
	NEW		A660	U660					
667	OLD					C36RLYR-1			
	NEW					C667			
668	OLD			U7M8YRT					
	NEW			U668					
676	OLD			U7M10YRT					
	NEW			U676					
677	OLD			U7M9YRT					UG7M9
	NEW			U677					
678	OLD			U7M7YRT					
	NEW			U678					
679	OLD			U7M6YRT					
	NEW			U679					
684	OLD						F51RYR	L51RYRT	
	NEW						F684	L684	
687	OLD								
	NEW								

DIE SET CONVERSION CHART (Continued)
FOR OBSOLETE DIES AND TOOLS

DIE INDEX		MECHANICAL TOOLS	HYDRAULIC TOOLS					GAGE NO.
		MD5	Y34A	Y35 & Y35L	Y45L	Y48B	Y486RB	
690	OLD			U1SET				
	NEW			U690				
691	OLD			U2SET				
	NEW			U691				
692	OLD			U4SET				
	NEW			U692				
693	OLD			U6AET				
	NEW			U693				
694	OLD			U10AET				
	NEW			U694				
702	OLD							
	NEW							

12-TON U DIES*

BURNDY® Die Sets

Fits Y35, Y39, Y750HS, PAT750, PAT750XT-18V, PAT46-18V, Y46 (with PUADP-1 Adapter)

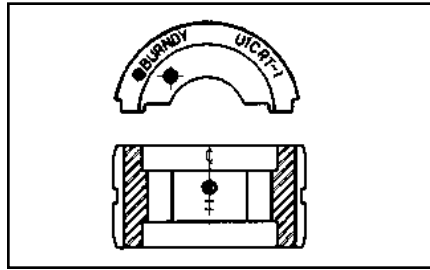

U die case Part# **PT29291**, holds up to 15 dies

	Wire Size	Copper	Aluminum
Small	#8	U8CRT	U8CABT
	#6	U5CRT	U6CABT
	#4	U4CRT	U4CABT
	#3	U3CRT	N/A
	#2	U2CRT	U2CABT
	#1	U1CRT-1	U1CART
	1/0	U25RT	U25ART
	2/0	U26RT	U26ART
	3/0	U27RT	U27ART
	4/0	U28RT	U28ART
Large	250 kcmil	U29RT	U29ART
	300 kcmil	U30RT	U30ART
	350 kcmil	U31RT	U31ART
	400 kcmil	U32RT	U32ART
	500 kcmil	U34RT	U34ART
	535 Flex kcmil	U38XRT	N/A
	600 kcmil	U36RT	U36ART
	750 kcmil	U39RT	U39ART-2
	777 Flex	U44XRT	N/A

* Non-tension U-type 12-ton dies for YA, YS, YA-A, YS-A style connectors.
NOTE: N/A = not applicable.

W DIES

BURNDY® Die Sets

Fits Tools MD6, MD7, Y500CTHS, PAT600-18V, PATMD6 Series

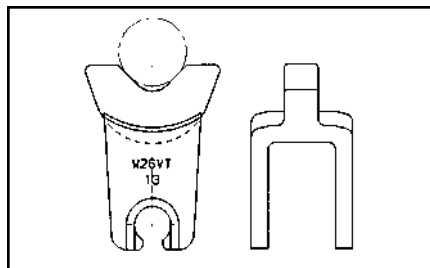

W die case Part# **PT4946**, holds up to 12 dies

	Wire Size	Copper	Aluminum
Small	#8	W8CVT	X8CART
	#6	W5CVT	W161
	#4	W4CVT	W162
	#3	W3CRT	N/A
	#2	W2CVT	W239
	#1	W1CVT	W163
	1/0	W25VT	W241
	2/0	W26VT	W245
	3/0	W27VT	W166
	4/0	W28VT	W660
Large	250	*W29VT	N/A
	300	*W30VT	N/A
	350	*W31VT	*W31ART
	400	*W32VT	N/A
	500	*W34VT	N/A
	600	**W36RT	N/A

* These sizes (250-500) for Y500CT, MD7-34(R), BCT500HS, PAT600-18V only.
 ** For PAT600-18V only.
NOTE: N/A = not applicable.
 Suitable for use on YA, YS, YA-A, YS-A type non-tension connectors.

Throughout the catalog you will notice blue highlighted items. These are the most frequently ordered BURNDY® Products.

PRESENT INSTALLATION TOOL INDEX

This chart provides a cross-reference between die index numbers marked on **BURNDY® COMPRESSION CONNECTORS** and the **CORRESPONDING DIE SETS** used with the various **BURNDY® INSTALLATION TOOLS**. This is the only way to have a BURNDY® compression system.

A die index number has been assigned to each required groove configuration. A prefix letter is used to indicate the specific installation tool for which the die has been designed, as shown below.

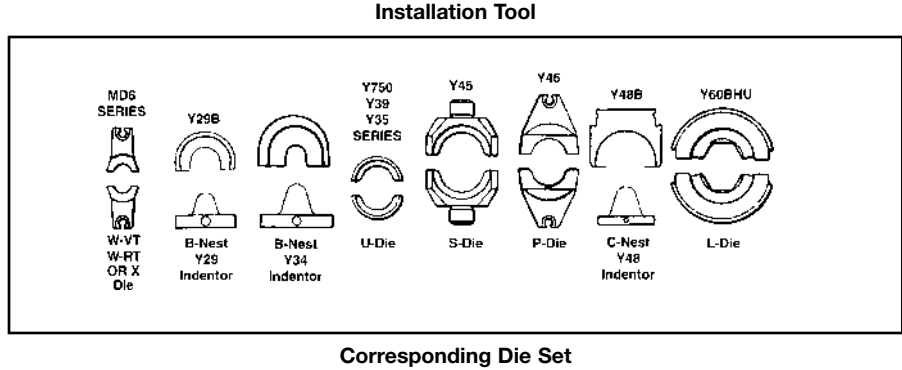

DIE IDENTIFICATION NUMBERING SYSTEM

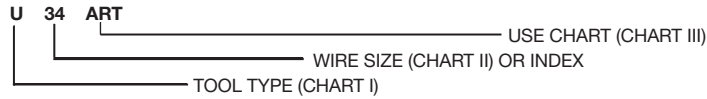

CHART I			
A - Y34A	E - Y44B	P - Y46	X - OUR840/MD-6
B - Y34BH	F - Y486RB	S - Y45	
C - Y48B	G - Y34C	U - Y35	
	L - Y60B	W - MD-6/OUR840	

CHART II				
12 - #12	4C - #4	26 - 2/0	31 - 350 MCM	OR INDEX
10 - #10	3C - #3	27 - 3/0	32 - 400 MCM	i.e., U312
8C - # 8	2C - #2	28 - 4/0	34 - 500 MCM	312 Die Index
6C - # 6	1C - #1	29 - 250 MCM	36 - 600 MCM	
5C - # 5	25 - 1/0	30 - 300 MCM	39 - 750 MCM	
			44 - 1000 MCM	

CHART III
A - ALUMINUM
B - INDENTOR NEST (USED WITH INDENTOR DIE # Y34P**)
R - ROUND DIE (CIRCUMFERENTIAL)
T - TWIN DIE (BOTH HALVES)

PRESENT INSTALLATION TOOL INDEX

DIE		DIELESS TOOLS		INSTALLATION TOOLING USING DIES												
GROOVE		MECH.	HYDR.	DIE INFORMATION		MECHANICAL			HYDRAULIC							
BURNDY	EEL	MR, MY	Y644	TYPE	COLOR	MD6	OUR840	Y29B ^⑤	Y34B	Y35 ①	Y39	Y750 ①	Y45 ②	Y46 ③	Y48B	Y60BHU
A				DIE SET						U-A	U-A	U-A	U-A	U-A		
BG				DIE SET		Perm GR W-BG	X-BG X-NBG			U-BG	U-BG	U-BG	U-BG	U-BG		
C				DIE SET	BROWN	W-C				U-C	U-C	U-C	U-C	U-C		
D				DIE SET						U-D	U-D	U-D	U-D	U-D		
D3				DIE SET	BLUE					U-YFD	U-YFD	U-YFD	U-YFD	U-YFD		
						Perm GR				U-D3	U-D3	U-D3	U-D3	U-D3		
E				DIE SET						U-E	U-E	U-E	U-E	U-E		
F				DIE SET						U-F	U-F	U-F	U-F	U-F		
H				DIE SET						U-H	U-H	U-H	U-H	U-H		
K-1/4				DIE SET		WK14										
K-5/16				DIE SET		WK516				UK516T	UK516T	UK516T	UK516T	UK516T		
K-3/8				DIE SET		WK38				UK38T	UK38T	UK38T	UK38T	UK38T		
K-1/2				DIE SET		WK12										
K-9/16				DIE SET		WK916				UK916T	UK916T	UK916T	UK916T	UK916T		
K-19/32				DIE SET		WK1932										
K-5/8-1				DIE SET						UK581T	UK581T	UK581T	UK581T	UK581T		
K-11/16				DIE SET		WK1116				UK1116T	UK1116T	UK1116T	UK1116T	UK1116T		
K-3/4				DIE SET						UK34T	UK34T	UK34T	UK34T	UK34T		
K-1				DIE SET						UK1T	UK1T	UK1T	UK1T	UK1T		
K-1-5/16				DIE SET						UK1516T	UK1516T	UK1516T	UK1516T	UK1516T		
K-635				DIE SET		WK737				UK737T	UK737T	UK737T	UK737T	UK737T		
K-747				DIE SET		WK747										
K-781				DIE SET		WK781										
K-840				DIE SET		W-K840				U-K840	U-K840	U-K840	U-K840	U-K840		
KB				DIE SET		WKB				UKBT	UKBT	UKBT	UKBT	UKBT		
KBKT				DIE SET						UKBKTT	UKBKTT	UKBKTT	UKBKTT	UKBKTT		
KC				DIE SET						UKCT	UKCT	UKCT	UKCT	UKCT		
KK				DIE SET		WKK										
KR				DIE SET	YELLOW									P-YFR		
														S-KR	P-KR	
KT				DIE SET		WKT										
KU				DIE SET						UKUT	UKUT	UKUT	UKUT	UKUT		
L				DIE SET		W-L				U-L	U-L	U-L	U-L	U-L		
L80				DIE SET	—					U32XRT	U32XRT	U32XRT	U32XRT	U32XRT		
L99				DIE SET	PINK					U38XRT	U38XRT	U38XRT	U38XRT	U38XRT		
L115				DIE SET	YELLOW					U44XRT	U44XRT	U44XRT	U44XRT	U44XRT		
M				DIE SET						U-M	U-M	U-M	U-M	U-M		
N				DIE SET	RED					U-YFN	U-YFN	U-YFN	U-YFN	P-YFN		
										U-N	U-N	U-N	S-N	P-N		
O				DIE SET	GREEN					U-YFO	U-YFO	U-YFO	U-YFO	U-YFO		
						Perm GR W-O					U-O	U-O	U-O	U-O	U-O	
Q				DIE SET		W-Q										

① Cat. No. Y35P3 Adaptor is required to use "Y34PR" type indentors with "U" type nest dies in Y35 and Y750 series tools.
 ② Cat. No. PT6515 Adaptor is required to use "U" type dies in Y45 series tools.

③ Cat. No. PUADP-1 Adaptor is required to use "U" type dies in Y46 series tools.
 ④ The MD6-6R2 ratchet tool is required on these sizes. The standard MD6 or MD6R ratchet tools will not work.
 ⑤ Also pneumatic version Y29NC.

PRESENT INSTALLATION TOOL INDEX (Continued)

DIE		DIELESS TOOLS		INSTALLATION TOOLING USING DIES												
GROOVE		MECH.	HYDR.	DIE INFORMATION		MECHANICAL		HYDRAULIC								
BURNDY	EEI	MR, MY	Y644	TYPE	COLOR	MD6	OUR840	Y29B ⑤	Y34B	Y35 ①	Y39	Y750 ①	Y45 ②	Y46 ③	Y48	Y60BHU
R				DIE SET						U-R	U-R	U-R	U-R	U-R		
T				DIE SET									S-T			
Z				DIE SET									S-Z			
7 94		MR4C MY29-3 MY29-11	1 CRIMP	DIE SET	BLUE	W5CRT				U5CRT	U5CRT	U5CRT	U5CRT	U5CRT		
				NEST INDENTOR				D6CL	B6CD	U6CD-1	U6CD-1	U6CD-1	U6CD-1	U6CD-1	U6CD-1	
8 95		MR4C MY29-3 MY29-11	1 CRIMP	DIE SET	GRAY	W4CRT	W4CRT			U4CRT	U4CRT	U4CRT	U4CRT	U4CRT		
				NEST INDENTOR				D4CL	B4CD	U4CD-1	U4CD-1	U4CD-1	U4CD-1	U4CD-1	U4CD-1	
9 96		MY29-3 MY29-11	1 CRIMP	DIE SET	WHITE	W3CRT	W3CRT			U3CRT	U3CRT	U3CRT	U3CRT	U3CRT		
				NEST INDENTOR				D3CL	B3CD	U3CD-1	U3CD-1	U3CD-1	U3CD-1	U3CD-1	U3CD-1	
10 97		MY29-3 MY29-11	1 CRIMP	DIE SET	BROWN	W2CRT				U2CRT	U2CRT	U2CRT	U2CRT	U2CRT		
				NEST INDENTOR				D2CL	B2CD	U2CD-1	U2CD-1	U2CD-1	U2CD-1	U2CD-1	U2CD-1	
11 98		MY29-3 MY29-11	1 CRIMP	DIE SET	GREEN	W1CRT				U1CRT	U1CRT	U1CRT	U1CRT	U1CRT		
				NEST INDENTOR				D1CL	B1CD	U1CD-1	U1CD-1	U1CD-1	U1CD-1	U1CD-1	U1CD-1	
12 99		MY29-3 MY29-11	1 CRIMP	DIE SET	PINK	W25RT	W25RT			U25RT	U25RT	U25RT	U25RT	U25RT		
				NEST INDENTOR				D25L	B25D	U25D-1	U25D-1	U25D-1	U25D-1	U25D-1	U25D-1	
13 100		MY29-3 MY29-11	1 CRIMP	DIE SET	BLACK	W26RT				U26RT	U26RT	U26RT	U26RT	U26RT		
				NEST INDENTOR				D26CL	B26D	U26D-1	U26D-1	U26D-1	U26D-1	U26D-1	U26D-1	
14 101		MY29-3 MY29-11	1 CRIMP	DIE SET	ORANGE	W27RT				U27RT	U27RT	U27RT	U27RT	U27RT		
				NEST INDENTOR				D27L	B27D	U27D-1	U27D-1	U27D-1	U27D-1	U27D-1	U27D-1	
15		MY29-3 MY29-11	1 CRIMP	DIE SET	PURPLE	W28RT				U28RT	U28RT	U28RT	U28RT	U28RT	C28R	
				NEST INDENTOR				D28L	B28D	U28D-1	U28D-1	U28D-1	U28D-1	U28D-1	U28D-1	C28D
16		MY29-3 MY29-11	1 CRIMP	DIE SET	YELLOW	W29RT ④				U29RT	U29RT	U29RT	U29RT	U29RT	C29R	
				NEST INDENTOR				D29L	B29D		U29D-1	U29D-1	U29D-1	U29D-1	U29D-1	C29D
17			1 CRIMP	DIE SET	WHITE	W30RT ④				U30RT	U30RT	U30RT	U30RT	U30RT	C30R	L30RT
				NEST INDENTOR						B30D		U30D-1	U30D-1	U30D-1	U30D-1	C30D
18			1 CRIMP	DIE SET	RED	W31RT ④				U31RT	U31RT	U31RT	U31RT	U31RT	C31R	L31RT
				NEST INDENTOR						B31D		U31D-1	U31D-1	U31D-1	U31D-1	C31D
19			1 CRIMP	DIE SET	BLUE	W32RT ④				U32RT	U32RT	U32RT	U32RT	U32RT	C32R	L32RT
				NEST INDENTOR						B32D		U32D-1	U32D-1	U32D-1	U32D-1	C32D
20			1 CRIMP	DIE SET	BROWN	W34RT ④				U34RT	U34RT	U34RT	U34RT	U34RT	C34R	L34RT
				NEST INDENTOR						NO DIE		U34D-1	U34D-1	U34D-1	U34D-1	C34D

① Cat. No. Y35P3 Adapter is required to accommodate "Y34PR" type indentor in Y35, Y39, Y750 HYTOOLS and with the PUADP-1 adapter in the Y46 and with the PT6515 adapter in the Y45.
 ② Cat. No. PT6515 Adapter is required to use "U" type dies in Y45 series tools.
 ③ Cat. No. PUADP-1 Adapter is required to use "U" type dies in Y46 series tools.

④ The MD6-6R2 ratchet tool is required on these sizes. The standard MD6 or MD6R ratchet tools will not work.
 ⑤ Also pneumatic version Y29NC.
 ⑥ Use U11T-1 for YH8C8C.
 ⑦ Hexagonal crimp.
 ⑧ Die 302 recommended for 1.84 O.D. barrel.

PRESENT INSTALLATION TOOL INDEX (Continued)

DIE		DIELESS TOOLS		INSTALLATION TOOLING USING DIES													
GROOVE		MECH.	HYDR.	DIE INFORMATION		MECHANICAL				HYDRAULIC							
BURNDY	EI	MR, MY	Y644	TYPE	COLOR	MD6	OUR840	Y29B ⑤	Y34B	Y35 ①	Y39	Y750 ①	Y45 ②	Y46 ③	Y48	Y60BHU	
21			1 CRIMP	DIE SET	YELLOW						U35RT	U35RT	U35RT	U35RT			
				NEST INDENTOR													C35D
22			1 CRIMP	DIE SET	GREEN						U36RT	U36RT	U36RT	U36RT	C36R	L36RT	
				NEST INDENTOR											P36D	C36D	
23			1 CRIMP	DIE SET	ORANGE											C37R	
				NEST INDENTOR													C37D
24			1 CRIMP	DIE SET	BLACK						U39RT	U39RT	S39RT	P39RT	C39R	L39RT	
				NEST INDENTOR											P39D	C39D	
25			1 CRIMP	DIE SET	ORANGE								S40RT	P40RT	C40R	L40RT	
				NEST INDENTOR											P40D	C40D	
26			1 CRIMP	DIE SET	GOLD												
				NEST INDENTOR													C41D
27			1 CRIMP	DIE SET	WHITE								S44RT	P44RT	C44R	L44RT	
				NEST INDENTOR											P44D	C44D	
28				DIE SET													
				NEST INDENTOR													C443D
29				DIE SET	YELLOW									P45RT	C45R	L45RT	
				NEST INDENTOR													C45D
30				DIE SET	ORANGE												
				NEST INDENTOR													C453D
31				DIE SET	GREEN								S46RT	P46RT	C46R	L46RT	
				NEST INDENTOR												No Nest	C46D
33				DIE SET	GRAY											C47R	L47RT
				NEST INDENTOR													C47D
34				DIE SET	BROWN												L48RT
				NEST INDENTOR													C48D
38		MR4C MR8G98 MR89Q MY28 Y8MRB-1		NEST INDENTOR				DV8L	BV8L	UV8L	UV8L	UV8L	UV8L	UV8L			
								Y29PL	Y34PL	Y34PL	Y34PL	Y34PL	Y34PL	Y34PL			
39		MR4C MY28		NEST INDENTOR				DV6L	BV6L	UV6L	UV6L	UV6L	UV6L	UV6L			
								Y29PL	Y34PLA	Y34PLA	Y34PLA	Y34PLA	Y34PLA	Y34PLA			

① Cat. No. Y35P3 Adapter is required to accommodate "Y34PR" type indenter in Y35, Y39, Y750 HYTOOLS and with the PUADP-1 adapter in the Y46 and with the PT6515 adapter in the Y45.
 ② Cat. No. PT6515 Adapter is required to use "U" type dies in Y45 series tools.

③ Cat. No. PUADP-1 Adapter is required to use "U" type dies in Y46 series tools.
 ⑤ Also pneumatic version Y29NC.

PRESENT INSTALLATION TOOL INDEX (Continued)

DIE		DIELESS TOOLS		INSTALLATION TOOLING USING DIES												
GROOVE		MECH.	HYDR.	DIE INFORMATION		MECHANICAL		HYDRAULIC								
BURNDY	EEI	MR, MY	Y644	TYPE	COLOR	MD6	OUR840	Y29B ⑤	Y34B	Y35 ①	Y39	Y750 ①	Y45 ②	Y46 ③	Y48	Y60BHU
40		MR4C MY28		NEST INDENTOR				DV4L	BV4L	UV4L	UV4L	UV4L	UV4L	UV4L		
								Y29PL	Y34PLA	Y34PLA	Y34PLA	Y34PLA	Y34PLA	Y34PLA		
41		MY28		NEST INDENTOR				DV2L	BV2L	UV2L	UV2L	UV2L	UV2L	UV2L		
								Y29PL	Y34PLA	Y34PLA	Y34PLA	Y34PLA	Y34PLA	Y34PLA		
42		MY28		NEST INDENTOR				DV1L	BV1L	UV1L	UV1L	UV1L	UV1L	UV1L		
								Y29PL	Y34PLA	Y34PLA	Y34PLA	Y34PLA	Y34PLA	Y34PLA		
43		MY28		NEST INDENTOR				DV25L	BV25L	UV25L	UV25L	UV25L	UV25L	UV25L		
								Y29PL	Y34PA	Y34PA	Y34PA	Y34PA	Y34PA	Y34PA		
44		MY28		NEST INDENTOR				DV26L	BV26L	UV26L	UV26L	UV26L	UV26L	UV26L		
								Y29PL	Y34PA	Y34PA	Y34PA	Y34PA	Y34PA	Y34PA		
45		MY28		NEST INDENTOR					BV27L	UV27L	UV27L	UV27L	UV27L	UV27L		
									Y34PA	Y34PA	Y34PA	Y34PA	Y34PA	Y34PA		
46		MY28		NEST INDENTOR					BV28L	UV28L	UV28L	UV28L	UV28L	UV28L		
									Y34PA	Y34PA	Y34PA	Y34PA	Y34PA	Y34PA		
49				DIE SET	RED	W8CRT			*	U8CRT	U8CRT	U8CRT	U8CRT	U8CRT		
161				DIE SET		W161	X-161			U161	U161	U161	U161	U161		
162				DIE SET		W162	W162			U162	U162	U162	U162	U162	C162	
163 505				DIE SET		W163	W163			U163	U163	U163	U163	U163	C163	
164 275				DIE SET		W164				U164	U164	U164	U164	U164	C164	
165 205,287 339				DIE SET		W165	X-165			U165/ U205	U165/ U205	U165/ U205	U165/ U205	U165/ U205	C165	L165
166 206,459				DIE SET		W166				U166/ U459	U166/ U459	U166/ U459	U166/ U459	U166/ U459	C166	L166
167 207,211 256,568				DIE SET		W167				U167/ U568	U167/ U568	U167/ U568	U167/ U568	U167/ U568	C167	L167
168 208				DIE SET						U168	U168	U168	U168	U168	C168	L168
169				DIE SET						U169	U169	U169	U169	U169	C169	L169
170 306				DIE SET						U170	U170	U170	U170	U170	C170	L170
171				DIE SET		W171				U171	U171	U171	U171	U171		
193				DIE SET						U193	U193	U193	U193	U193	C193	L193
202				DIE SET						U202	U202	U202	U202	U202		
203				DIE SET						U203	U203	U203	U203	U203		
204				DIE SET						U204	U204	U204	U204	U204		
205 165,287 339				DIE SET			X-165			U165/ U205	U165/ U205	U165/ U205	U165/ U205	U165/ U205		
206 166 459				DIE SET	W166					U166/ U459	U166/ U459	U166/ U459	U166/ U459	U166/ U459		L166
207 167,211 256,568				DIE SET	W167					U167/ U568	U167/ U568	U167/ U568	U167/ U568	U167/ U568	C167	L167
208 168				DIE SET						U168	U168	U168	U168	U168	C168	L168
209				DIE SET						U209	U209	U209	U209	U209	C209	L209
210				DIE SET						U210	U210	U210	U210	U210	C210	L210

① Cat. No. Y35P3 Adapter is required to accommodate "Y34PR" type indenter in Y35, Y39, Y750 HYTOOLS and with the PUADP-1 adapter in the Y46 and with the PT6515 adapter in the Y45.
 ② Cat. No. PT6515 Adapter is required to use "U" type dies in Y45 series tools.

③ Cat. No. PUADP-1 Adapter is required to use "U" type dies in Y46 series tools.
 ⑤ Also pneumatic version Y29NC.
 * Add Nest (BV8L) & Indentor (Y34PL) for Y34B.

PRESENT INSTALLATION TOOL INDEX (Continued)

DIE		DIELESS TOOLS		INSTALLATION TOOLING USING DIES												
GROOVE		MECH.	HYDR.	DIE INFORMATION		MECHANICAL		HYDRAULIC								
BURNDY	EEL	MR, MY	Y644	TYPE	COLOR	MD6	OUR840	Y29B ⑤	Y34B	Y35 ①	Y39	Y750 ①	Y45 ②	Y46 ③	Y48	Y60BHU
211 167, 211 256, 568				DIE SET		W167				U167/ U568	U167/ U568	U167/ U568	U167/ U568	U167/ U568	C167	L167
236				DIE SET		W236				U236	U236	U236	U236	U236		
237				DIE SET		W237	X-237			U237	U237	U237	U237	U237		
238				DIE SET		W238				U238	U238	U238	U238	U238		
239				DIE SET		W239	X-239			U239	U239	U239	U239	U239		
240				DIE SET	RED	W240				U240	U240	U240	U240	U240		
241				DIE SET		W241	X-241			U241	U241	U241	U241	U241		
242 244	3S/ 4S			DIE SET		W242				U242	U242	U242	U242	U242	C242	L242
243	8A			DIE SET		W243				U243	U243	U243	U243	U243	C243	L243
244 242	3S			DIE SET		W242				U242	U242	U242	U242	U242	C242	L242
245	9A			DIE SET		W245	X-245			U245	U245	U245	U245	U245	C245	L245
246 248	5S			DIE SET		W248				U248	U248	U248	U248	U248	C248	L248
247				DIE SET		W247	X-247			U247	U247	U247	U247	U247	C247	L247
248 246	5S			DIE SET		W248				U248	U248	U248	U248	U248	C248	L248
249	11A			DIE SET		W249	X-249			U249	U249	U249	U249	U249	C249	L249
250				DIE SET						U250	U250	U250	U250	U250	C250	L250
251	12A			DIE SET	RED	W251				U251	U251	U251	U251	U251	C251	L251
252				DIE SET						U252	U252	U252	U252	U252	C252	L252
253				DIE SET						U253	U253	U253	U253	U253	C253	L253
254				DIE SET									S254	P254	C254	L254
255				DIE SET						U255	U255	U255	U255	U255	C255	L255
256 167, 207 211, 568				DIE SET		W167				U167/ U568	U167/ U568	U167/ U568	U167/ U568	U167/ U568	C167	L167
257				DIE SET						U257	U257	U257	U257	U257	C257	L257
259				DIE SET						U259	U259	U259	U259	U259		
260				DIE SET											C260	L260
261 318	15A			DIE SET						U261	U261	U261	U261	U261	C261	L261
263				DIE SET						U263	U263	U263	U263	U263		
267				DIE SET						U267	U267	U267	U267	U267	C267	L267
275 164				DIE SET		W164				U164	U164	U164	U164	U164	C164	
276				DIE SET						U276	U276	U276	U276	U276		
285				DIE SET						U285	U285	U285	U285	U285		
287 165, 205 339				DIE SET		W165				U165/ U205	U165/ U205	U165/ U205	U165/ U205	U165/ U205		L165
292 578				DIE SET									S292	P292	C292	L292
293 294				DIE SET									S293	P293	C293	L293
296		MY29-3	1 CRIMP	DIE SET	TAN					U25ART	U25ART	U25ART	U25ART	U25ART	C25AR	
				NEST INDENTER										P27D		
297		MY29-3	1 CRIMP	DIE SET	OLIVE					U26ART	U26ART	U26ART	U26ART	U26ART	C26AR	
				NEST INDENTER										P29D		
															P34PR5	

① Cat. No. Y35P3 Adapter is required to accommodate "Y34PR" type indenter in Y35, Y39, Y750 HYTOOLS and with the PUADP-1 adapter in the Y46 and with the PT6515 adapter in the Y45.

② Cat. No. PT6515 Adapter is required to use "U" type dies in Y45 series tools.
 ③ Cat. No. PUADP-1 Adapter is required to use "U" type dies in Y46 series tools.
 ⑤ Also pneumatic version Y29NC.

PRESENT INSTALLATION TOOL INDEX (Continued)

Die		Dieless Tools		Installation Tooling Using Dies												
Groove		Mech.	Hydr.	Die Information		Mechanical				Hydraulic						
BURNDY	EEI	MR, MY	Y644	Type	Color	MD6	OUR840	Y29B ⑤	Y34B	Y35 ①	Y39	Y750 ①	Y45 ②	Y46 ③	Y48	Y60BHU
298		MY29-3	1 Crimp	Die Set	White					U28ART	U28ART	U28ART	U28ART	U28ART	C28AR	L28ART
				Nest Indentor											P31D	
299			1 Crimp	Die Set	Brown					U31ART	U31ART	U31ART	U31ART	U31ART	C31AR	L31ART
				Nest Indentor												P35D
300			1 Crimp	Die Set	Pink					U34ART	U34ART	U34ART	U34ART	U34ART	C34AR	L34ART
				Nest Indentor												
301			1 Crimp	Die Set	Red								S39ART	P39ART	C39AR ⑥	L39ART
				Nest Indentor												
302			1 Crimp	Die Set	Brown								S44ART	P44ART	C44AR	L44ART
				Nest Indentor												
304				Die Set						U304	U304	U304	U304	U304	C304	L304
305 341				Die Set						U305	U305	U305	U305	U305	C305	L305
306 170				Die Set						U170	U170	U170	U170	U170	C170	L170
308				Die Set						U308	U308	U308	U308	U308		
313				Die Set						U313	U313	U313	U313	U313	C313	L313
314 376				Die Set											C314	L314
316				Die Set						U316	U316	U316	U316	U316	C316	L316
317 426				Die Set						U317	U317	U317	U317	U317	C317	L317
318 261				Die Set						U261	U261	U261	U261	U261	C261	L261
319				Die Set									S319	P319	C319	L319
320				Die Set									S320	P320	C320	L320
321				Die Set						U321	U321	U321	U321	U321	C321	L321
322				Die Set						U322	U322	U322	U322	U322		
324			1 Crimp	Die Set	Red					U29ART	U29ART	U29ART	U29ART	U29ART	C29AR	L29ART
				Nest Indentor												
326 538				Die Set						U33RT	U33RT	U33RT	U33RT	U33RT		
327	14A			Die Set						U327	U327	U327	U327	U327	C327	L327
328				Die Set											C328	L328
329				Die Set						U329	U329	U329	U329	U329		
331				Die Set						U331	U331	U331	U331	U331		
339 165, 205 287				Die Set			X-339			U165/ U205	U165/ U205	U165/ U205	U165/ U205	U165/ U205		
341 305				Die Set						U305	U305	U305	U305	U305	C305	L305
342				Die Set									S342	P342	C342	L342
344				Die Set											C344	L344
345				Die Set											C345	L345
346 ⑦			1 Crimp	Die Set	Gray					U6CABT	U6CABT	U6CABT	U6CABT	U6CABT		

① Cat. No. Y35P3 Adapter is required to accommodate "Y34PR" type indentor in Y35, Y39, Y750 HYTOOLS and with the PUADP-1 adapter in the Y46 and with the PT6515 Adapter in the Y45.
 ② Cat. No. PT6515 Adapter is required to use "U" type dies in Y45 series tools.
 ③ Cat. No. PUADP-1 Adapter is required to use "U" type dies in Y46 series tools.

④ The MD6-6R2 ratchet tool is required on these sizes. The standard MD6 or MD6R ratchet tools will not work.
 ⑤ Also pneumatic version Y29NC.
 ⑥ Use C39AR round die 301 for 1.60 O.D. barrel. Use C39AR-2 hex die 936 for 1.46 O.D. barrel.
 ⑦ Hexagonal crimp.
 ⑧ Die 302 recommended for 1.84 O.D. barrel.

PRESENT INSTALLATION TOOL INDEX (Continued)

DIE		DIELESS TOOLS		INSTALLATION TOOLING USING DIES												
GROOVE		MECH.	HYDR.	DIE INFORMATION		MECHANICAL			HYDRAULIC							
BURNDY	EEL	MR, MY	Y644	TYPE	COLOR	MD6	OUR840	Y29B	Y34B	Y35 ①	Y39	Y750 ①	Y45 ②	Y46 ③	Y48	Y60BHU
348		1 CRIMP		DIE SET	PINK					U2CABT	U2CABT	U2CABT	U2CABT	U2CABT		
350				DIE SET						U350	U350	U350	U350	U350	C350	L350
352				DIE SET									S352	P352	C352	L352
373				DIE SET						U373	U373	U373	U373	U373		
374		MY29-3		DIE SET	BLUE					U8CABT	U8CABT	U8CABT	U8CABT	U8CABT		
375		MY29-3	1 CRIMP	DIE SET	GREEN					U4CABT	U4CABT	U4CABT	U4CABT	U4CABT		
376	314			DIE SET											C314	L314
403				DIE SET						U403	U403	U403	U403	U403		
419				DIE SET									S419	P419	C419	L419
422				DIE SET												L422
426	317			DIE SET						U317	U317	U317	U317	U317	U317	
459	166			DIE SET						U166/459	U166/459	U166/459	U166/459	U166/459		
467		MY29-3	1 CRIMP	DIE SET	RUBY					U27ART	A27ART	U27ART	U27ART	U27ART	C27AR	
				NEST INDENTOR										P30D		
468				DIE SET						U468	U468	U468	U468	U468		
469				DIE SET									S469	P469	C469	L469
470			1 CRIMP	DIE SET	BLUE					U30ART	U30ART	U30ART	U30ART	U30ART	C30AR	L30ART
				NEST INDENTOR											P34D	C34D
471		MY29-3	1 CRIMP	DIE SET	GOLD					U1CART	U1CART	U1CART	U1CART	U1CART		
				NEST INDENTOR												
472			1 CRIMP	DIE SET	GREEN					U32ART	U32ART	U32ART	U32ART	U32ART	C32AR	L32ART
				NEST INDENTOR												P35D
473			1 CRIMP	DIE SET	BLACK					U36ART	U36ART	U36ART	U36ART	U36ART	C36AR	L36ART
				NEST INDENTOR												P44D
474			1 CRIMP	DIE SET	GOLD								S40ART	P40ART	C40AR	L40ART
				NEST INDENTOR												
478			1 CRIMP	DIE SET	BLUE										C46AR	L46ART
				NEST INDENTOR												
479				DIE SET	RED											L48ART
490	547			DIE SET						U490	U490	U490	U490	U490	C490	L490
495				DIE SET											C495	L495
505	163			DIE SET		W163				U163	U163	U163	U163	U163		L163
511		MY29-3		NEST INDENTOR					B6CD							
									Y34PA							
512		MY29-3		NEST INDENTOR					B4CD							
									Y34PA							
513		MY29-3		NEST INDENTOR					B1CD							
									Y34PA							
514		MY29-3		NEST INDENTOR					B26D							
									Y34PA							

① Cat. No. Y35P3 Adapter is required to accommodate "Y34PR" type indenter in Y35, Y39, Y750 HYTOOLS and with the PUADP-1 adapter in the Y46 and with the PT6515 adapter in the Y45.
 ② Cat. No. PT6515 Adapter is required to use "U" type dies in Y45 series tools.

③ Cat. No. PUADP-1 Adapter is required to use "U" type dies in Y46 series tools.
 ④ The MD6-6R2 ratchet tool is required on these sizes. The standard MD6 or MD6R ratchet tools will not work.
 ⑤ Also pneumatic version Y29NC.
 ⑥ Hexagonal crimp.

PRESENT INSTALLATION TOOL INDEX (Continued)

DIE		DIELESS TOOLS		INSTALLATION TOOLING USING DIES												
GROOVE		MECH.	HYDR.	DIE INFORMATION		MECHANICAL			HYDRAULIC							
BURNDY	EEL	MR, MY	Y644	TYPE	COLOR	MD6	OUR840	Y29B ⑤	Y34B	Y35 ①	Y39	Y750 ①	Y45 ②	Y46 ③	Y48	Y60BHU
515		MY29-3		NEST INDENTOR					B26D							
									Y34PR5							
516		MY29-3		NEST INDENTOR					B27D							
									Y34PR5							
517		MY29-3		NEST INDENTOR					B29D							
									Y34PR5							
518		MY29-3		NEST INDENTOR					B30D							
									Y34PR5							
519		MY29-3		NEST INDENTOR					B31D							
									Y34PR5							
520		MY29-3		NEST INDENTOR					B32D							
									Y34PR5							
521				NEST INDENTOR					No Nest						C34D	
									Y34PR11							Y48PR-1
522				NEST INDENTOR											C35D	
																Y48PR-1
523				NEST INDENTOR											C35D	
																Y48PR-1
524				NEST INDENTOR											C39D	
																Y48PR-1
525				NEST INDENTOR											C44D	
																Y48PR-1
526				NEST INDENTOR											C45D	
																Y48PR-1
527				NEST INDENTOR											C45D	
																Y48PR-1
528				NEST INDENTOR											C46D	
																Y48PR-1
529				NEST INDENTOR											C46AD	
																Y48PR-11
538	326			DIE SET						U33RT	U33RT	U33RT	U33RT	U33RT		
547	490			DIE SET						U490	U490	U490	U490	U490	C490	L490
552				DIE SET						U552	U552	U552	U552	U552		
568	167, 207			DIE SET		W167				U167/ U568	U167/ U568	U167/ U568	U167/ U568	U167/ U568		
575				DIE SET											C575	L575
576				DIE SET											C576	L576
578	292			DIE SET								S292	P292	C292	L292	
579				DIE SET								S579	P579	C579	L579	
587				DIE SET												L47ART
607				DIE SET						U607	U607	U607	U607	U607		
608				DIE SET						U608	U608	U608	U608	U608	C608	L608
609				DIE SET						U609	U609	U609	U609	U609	C609	
627				DIE SET											C627	L627
642				DIE SET						U642	U642	U642	U642	U642	C642	L642
643				DIE SET						U643	U643	U643	U643	U643		
647	⑤			DIE SET											C45AR	L45ART

① Cat. No. Y35P3 Adapter is required to accommodate "Y34PR" type indenter in Y35, Y39, Y750 HYTOOLS and with the PUADP-1 adapter in the Y46 and with the PT6515 adapter in the Y45.
 ② Cat. No. PT6515 Adapter is required to use "U" type dies in Y45 series tools.

③ Cat. No. PUADP-1 Adapter is required to use "U" type dies in Y46 series tools.
 ④ Also pneumatic version Y29NC.
 ⑤ Die 302 recommended for 1.84 O.D. barrel.

PRESENT INSTALLATION TOOL INDEX (Continued)

Die		Dieless Tools			Installation Tooling Using Dies											
Groove	EEI	Mech.	Hydr.	Die Information		Mechanical				Hydraulic						
BURNDY		MR, MY	Y644	Type	Color	MD6	OUR840	Y29B ^⑤	Y34B	Y35 ^①	Y39	Y750 ^①	Y45 ^②	Y46 ^③	Y48	Y60BHU
648				Die Set												L648
654				Die Set	Purple					U654	U654	U654	U654	P654		L654
655	13A			Die Set						U655	U655	U655	U655	U655		
658				Die Set						U658	U658	U658	U658	U658		
659				Die Set		W659				U659	U659	U659	U659	U659		
660				Die Set		W660	X-660			U660	U660	U660	U660	U660		
667				Die Set											C667	L667
668				Die Set						U668	U668	U668	U668	U668	C668	
676				Die Set						U676	U676	U676	U676	U676		
677				Die Set						U677	U677	U677	U677	U677		L677
678				Die Set						U678	U678	U678	U678	U678		
679				Die Set						U679	U679	U679	U679	U679		
684				Die Set												L684
687				Die Set		W687	X-687									
690	1S			Die Set		W690				U690	U690	U690	U690	U690		
691	2S			Die Set		W691				U691	U691	U691	U691	U691		
692	4S			Die Set		W692				U692	U692	U692	U692	U692		
693	6A			Die Set		W693				U693	U693	U693	U693	U693		
694	10A			Die Set		W694				U694	U694	U694	U694	U694		
702				Die Set		W702										
705				Die Set						U705	U705	U705	U705	U705		
717 ^⑦				Die Set									S717	P717		L717/L717W
718 ^⑦				Die Set												L718
719 ^⑦				Die Set									S719	P719		L719/L719W
720 ^⑦				Die Set									S720	P720		L720/L720W
721 ^⑦				Die Set												L721
722 ^⑦				Die Set									S722	P722	C722	L722/L722W
723 ^⑦				Die Set											C723	L723
724 ^⑦				Die Set									S724	P724	C724	L724/L724W
725 ^⑦				Die Set									S725	P725	C725	L725/L725W
726 ^⑦				Die Set												L726
727 ^⑦				Die Set												L727/L727W
728 ^⑦				Die Set												L728/L728W
729 ^⑦				Die Set												L729/L729W
735 ^⑦				Die Set												L735/L735W
740 ^⑦				Die Set												L740
786				Die Set						U786	U786	U786	U786	U786		
788				Die Set						U788	U788	U788	U788	U788		
789				Die Set												L789
936 ^⑦			1 Crimp	Die Set	Yellow					U39ART-2	U39ART-2	U39ART-2	U39ART-2	U39ART-2	C39ART-2	L39ART-2
997				Die Set	Orange					U997	U997	U997	U997	U997		
998				Die Set								PU998	S998	P998		
999				Die Set									S999	P999		
1011				Die Set								U1011	S1011	P1011		
1012				Die Set									S1012			
1013		MY29-11		Nest Indentor						UV8L	UV8L	UV8L	UV8L	UV8L		
										Y34PL	Y34PL	Y34PL	Y34PL	Y34PL		

① Cat. No. Y35P3 Adapter is required to accommodate "Y34PR" type indenter in Y35, Y39, Y750 HYTOOLS and with the PUADP-1 adapter in the Y46 and with the PT6515 adapter in the Y45.
 ② Cat. No. PT6515 Adapter is required to use "U" type dies in Y45 series tools.
 ③ Cat. No. PUADP-1 Adapter is required to use "U" type dies in Y46 series tools.

④ The MD6-6R2 ratchet tool is required on these sizes. The standard MD6 or MD6R ratchet tools will not work.
 ⑤ Also pneumatic version Y29NC.
 ⑥ Use C39AR round die 301 for 1.60 O.D. barrel. Use C39AR-2 hex die 936 for 1.46 O.D. barrel.
 ⑦ Hexagonal crimp.

PRESENT INSTALLATION TOOL INDEX (Continued)

Die		Dieless Tools		Installation Tooling Using Dies												
Groove		Mech.	Hydr.	Die Information		Mechanical		Hydraulic								
BURNDY	EEI	MR, MY	Y644	Type	Color	MD6	OUR840	Y29B ④	Y34B	Y35 ①	Y39	Y750 ①	Y45 ②	Y46 ③	Y48B	Y608HU
1014		MY29-11		Nest Indentor						U6CD1	U6CD1	U6CD1	U6CD1	U6CD1		
										Y34PR	Y34PR	Y34PR	Y34PR	Y34PR		
1015		MY29-11		Nest Indentor						U4CD1	U4CD1	U4CD1	U4CD1	U4CD1		
										Y34PR	Y34PR	Y34PR	Y34PR	Y34PR		
1016		MY29-11		Nest Indentor						U3CD1	U3CD1	U3CD1	U3CD1	U3CD1		
										Y34PR	Y34PR	Y34PR	Y34PR	Y34PR		
1017		MY29-11		Nest Indentor						U2CD1	U2CD1	U2CD1	U2CD1	U2CD1		
										Y34PR	Y34PR	Y34PR	Y34PR	Y34PR		
1018		MY29-11		Nest Indentor						U1CD1	U1CD1	U1CD1	U1CD1	U1CD1		
										Y34PR	Y34PR	Y34PR	Y34PR	Y34PR		
1019		MY29-11		Nest Indentor						U25D1	U25D1	U25D1	U25D1	U25D1		
										Y34PR2	Y34PR2	Y34PR2	Y34PR2	Y34PR2		
1020		MY29-11		Nest Indentor						U26D1	U26D1	U26D1	U26D1	U26D1		
										Y34PR2	Y34PR2	Y34PR2	Y34PR2	Y34PR2		
1021		MY29-11		Nest Indentor						U27D1	U27D1	U27D1	U27D1	U27D1		
										Y34PR2	Y34PR2	Y34PR2	Y34PR2	Y34PR2		
1022		MY29-11		Nest Indentor						U28D1	U28D1	U28D1	U28D1	U28D1		
										Y34PR2	Y34PR2	Y34PR2	Y34PR2	Y34PR2		
1023		MY29-11		Nest Indentor						U29D1	U29D1	U29D1	U29D1	U29D1		
										Y34PR2	Y34PR2	Y34PR2	Y34PR2	Y34PR2		
1024				Nest Indentor						U30D1	U30D1	U30D1	U30D1	U30D1		
										Y34PR2	Y34PR2	Y34PR2	Y34PR2	Y34PR2		
1025				Nest Indentor						U31D1	U31D1	U31D1	U31D1	U31D1		
										Y34PR2	Y34PR2	Y34PR2	Y34PR2	Y34PR2		
1026				Nest Indentor						U32D1	U32D1	U32D1	U32D1	U32D1		
										Y34PR2	Y34PR2	Y34PR2	Y34PR2	Y34PR2		
1027				Nest Indentor						U34D1	U34D1	U34D1	U34D1	U34D1		
										Y34PR2	Y34PR2	Y34PR2	Y34PR2	Y34PR2		
1028				Nest Indentor										P36D	C36D	
														P48PR1	Y48PR1	
1029				Nest Indentor										P38D	C38D	
														P48PR1	Y48PR1	
1030				Nest Indentor										P39D	C39D	
														P48PR1	Y48PR1	
1031				Nest Indentor										P40D	C40D	
														P48PR1	Y48PR1	
1032				Nest Indentor										P44D	C44D	
														P48PR1	Y48PR1	
1102				Die Set	White									P1102		
1103				Die Set	Blue									P1103		
1104				Die Set	Brown							U1104		P1104		
1105												U1105		P1105		
400				Die Set	Purple					U38RT	U38RT	U38RT	U38RT	U38RT		
				Nest Indentor											C38D	
															Y48PR	
2000				Nest Indentor						U27B	U27B	U27B				
										Y34PR15	Y34PR15	Y34PR15				

① Cat. No. Y35P3 Adapter is required to accommodate "Y34PR" type indentor in Y35, Y39, Y750 HYTOOLS and with the PUADP-1 adapter in the Y46 and with the PT6515 adapter in the Y45.

② Cat. No. PT6515 Adapter is required to use "U" type dies in Y45 series tools.

③ Cat. No. PUADP-1 Adapter is required to use "U" type dies in Y46 series tools.

④ Also pneumatic version Y29NC. Available in PIPEAM KIT

**CATALOG NUMBERS
REQUIRING MSDS**

POWERCELL	PENA13-4	PENE 5GAL
P8A	PENA13-8	PENE 55GAL
PENA1/2	PENA13QT	PENHT-4
PENA-4	PENA13GAL	PENHT-8
PENACARTRIDGE	PENA13 5GAL	PENHT-1LB
PENA QT	PENA13 55GAL	PENHT-GAL
PENA GAL	PENE-4	ALFLUID QT
PENA 5GAL	PENE-8	ALFLUID GAL
PENA 55GAL	PENE QT	HYFLUID QT
PENA13CARTRIDGE	PENE GAL	HYFLUID GAL

* All Wejtap catalog numbers ending in PB require MSDS for Power Cell.

**COLOR CODING FOR
OVERHEAD CONNECTORS**

Color Code	Aluminum & Copper			
	Str.	Compact	Sol.	ASCR
Brown	10		8	
Green	8		6	
Blue	5, 6		4	6
Orange	3, 4	#2	2	4
Red	1-19, 2	1/0	1	2
Yellow	1/0	2/0		1/0, 1
Gray	2/0	3/0		2/0
Black	3/0	4/0		3/0
Pink	4/0	266, 300		4/0
Red	250			
White	266			
Blue	300	350	266.8	(26/7, 18/1)
Brown	336			
Green	350, 397, 400			336.4 (26/7, 18/1)
Gray	450			
Pink	500			477 (18/1)
Green	556			
Purple	600			
Yellow				556.5 (24/7, 26/7)
Blue	650			
Red	700			
Yellow	750			
Orange	800			
White	900			
Brown	1000			

COLOR CODING FOR AL/CU CONNECTORS

COLOR CODE	STR	COLOR CODE	STR
BLUE	8	BLUE	300
GRAY	6	BROWN	350
GREEN	4	GREEN	400
PINK	2	PINK	500
GOLD	1	BLACK	600
TAN	1/0	YELLOW	700/750
OLIVE	2/0	RED	700/750
RUBY	3/0	BROWN	1000
WHITE	4/0	BLUE	1500
RED	250	RED	2000

NOTE: This chart is only intended as a guide. For specific applications refer to your catalog.

COLOR CODING FOR COPPER LUGS AND SPLICES

COLOR CODE	CODE SIZE		FLEX CABLE
	STR	SOL	
RED	8	6	8
BLUE	6		6
BLUE	5		
GRAY	4		4
WHITE	3	2	
BROWN	2		2
GREEN	1		1
PINK	1/0		1/0
BLACK	2/0		2/0
ORANGE	3/0		3/0
PURPLE	4/0		4/0
YELLOW	250		4/0 & 250
WHITE	300		250
RED	350		313.1
BLUE	400		373.7
BROWN	500		444.4
GREEN	600		
PINK	700		535.3
PURPLE			600
BLACK	750		646
YELLOW			777.7
ORANGE	800		
WHITE	1000		
YELLOW			1111
GREEN	1500		
BROWN	2000		

NOTE: This chart is only intended as a guide. For specific applications refer to your catalog.

CATALOG NO.	PAGE NO.	CATALOG NO.	PAGE NO.	CATALOG NO.	PAGE NO.	CATALOG NO.	PAGE NO.	CATALOG NO.	PAGE NO.
1050	157	1165	I60	2051	153	2171	156	3095	I62
1050 ACSS	157	1166	I60	2052	153	2173	156	3097	I62
1051	157	1167	I60	2053	153	2174	156	31 FW BOX	D3
1052	157	1169	I60	2054	153	2179	156	31 NW BOX	D3
1053	157	1170	I60	2055	153	2182	156	31 SW BOX	D3
1054	157	1171	I60	2056	153	2183	156	3103	I63
1055	157	1173	I60	2057	153	2190	156	3112	I63
1056	157	1174	I60	2058	153	2192	156	3113	I63
1057	157	1179	I60	2059	153	2300	156	3114	I63
1058	157	1182	I60	2060	153	2301	156	3117	I63
1059	157	1183	I60	2061	153	25	E62	3118	I63
1060	157	1190	I60	2062	153	25 FW BOX	D3	3120	I63
1061	157	1192	I60	2063	153	25 FWSS	D7	3121	I63
1062	157	122EMT	N96	2064	153	25 HSSN	D7	3123	I63
1063	157	122IMC	N96	2065	153	25 NW BOX	D3	3124	I63
1064	157	122PVC	N96	2066	154	25 SW BOX	D3	3131	I63
1065	157	122RIG	N96	2067	154	25 SWSS LT	D7	3133	I63
1066	158	1300	I60	2070	154	250	E62	3138	I63
1067	158	1301	I60	2071	154	250R	E62	3139	I63
1070	158	145PTAG	F12	2072	154	25C HEN BOX	D3	3140	I63
1071	158, 166	15	E62	2073	154	25CI	E62	3141	I63
1072	158	150	E62	2074	154	25CP	E62	3142	I63
1073	158	150R	E62	2075	154	25R	E62	3143	I63
1074	158	15CI	E62	2076	154	25x100 HEB BOX	D2	3144	I63
1075	158	15CP	E62	2077	154	25x125 HEB BOX	D2	3145	I63
1076	158	15R	E62	2079	154	25x150 HEB BOX	D2	3146	I63
1077	158	1PBS1/0	A54	2080	154	25x200 HEB BOX	D2	3147	I63
1079	158	1PBS2	A54	2083	154	25x250 HEB BOX	D2	3149	I64
1080	158	1PBS250	A54	2084	154	25x300 HEB BOX	D2	3150	I64
1083	158	1PBS350	A54	2085	154	25x50 HEB BOX	D2	3157	I64
1084	158	1PBS500	A54	2086	154	25x62 HEB BOX	D2	3158	I64
1085	158	1PL2/02	A54	2089	154	25x75 HEB BOX	D2	3165	I64
1086	158	1PL2/03	A54	2090	154	3050	I61	3166	I64
1089	158	1PL2502	A54	2093	154	3050 ACSS	I61	3167	I64
1090	158	1PL2503	A54	2094	154	3051	I61	3169	I64
1093	158	1PL3502	A54	2095	154	3052	I61	3170	I64
1094	158	1PL42	A54	2097	154	3053	I61	3171	I64
1095	158	1PL43	A54	2100	154	3054	I61	3173	I64
1097	158	1PL44	A54	2103	154	3055	I61	3174	I64
1100	158	1PL6002	A54	2112	154	3056	I61	3179	I64
1103	158	1PLD2/02	A54	2113	155	3057	I61	3182	I64
1112	158	1PLD2/03	A54	2114	155	3058	I61	3183	I64
1113	158	1PLD2/04	A54	2117	155	3059	I61	3190	I64
1114	158	1PLD2/06	A54	2118	155	3060	I61	3192	I64
1117	159	1PLD2502	A54	2120	155	3061	I61	31C HEN BOX	D3
1118	159	1PLD2503	A54	2121	155	3062	I61	31CHGSN	D5
1120	159	1PLD2504	A54	2123	155	3063	I61	31x100 HEB BOX	D2
1121	159	1PLD2506	A54	2124	155	3064	I61	31x125 HEB BOX	D2
1123	159	1PLD3502	A54	2131	155	3065	I61	31x150 HEB BOX	D2
1124	159	1PLD3503	A54	2133	155	3066	I62	31x175 HEB BOX	D2
1131	159	1PLD3504	A54	2138	155	3067	I62	31x200 HEB BOX	D2
1133	159	1PLD3506	A54	2139	155	3070	I62	31x250 HEB BOX	D2
1138	159	1PLD3508	A54	2140	155	3071	I62	31x300 HEB BOX	D2
1139	159	1PLD43	A54	2141	155	3072	I62	31x50 HEB BOX	D2
1140	159	1PLD44	A54	2142	155	3073	I62	31x62 HEB BOX	D2
1141	159	1PLD6002	A54	2143	155	3074	I62	31x75 HEB BOX	D2
1142	159	1PLD6003	A54	2144	155	3075	I62	32	E62
1143	159	1PLD6004	A54	2145	155	3076	I62	32CI	E62
1144	159	1PLD6005	A54	2146	155	3077	I62	32CP	E62
1145	159	1PLD6006	A54	2147	155	3079	I62	32R	E62
1146	159	1PLD6008	A54	2149	155	3080	I62	3300	I64
1147	159	1PLO2/02	A54	2150	155	3083	I62	3301	I64
1149	159	1PLO2502	A54	2157	156	3084	I62	34NRB	K33
115	E62	1PLO42	A54	2158	156	3085	I62	38 FW BOX	D3
1150	159	1PLO6002	A54	2165	156	3086	I62	38 FWSS	D7
1157	159	200	E62	2166	156	3089	I62	38 HGSN	D5
1158	159	200R	E62	2167	156	3090	I62	38 HGSN-009	D5
115CI	E62	2050	I53	2169	156	3093	I62	38 HSSN	D7
115R	E62	2050 ACSS	I53	2170	156	3094	I62	38 NW BOX	D3

Alpha-Numeric Index

CATALOG NO.	PAGE NO.	CATALOG NO.	PAGE NO.	CATALOG NO.	PAGE NO.	CATALOG NO.	PAGE NO.	CATALOG NO.	PAGE NO.
38 NWGS	D5	50x125 HEB BOX	D2	5600-1064	I48	62x225 HEB BOX	D6	90R	E62
38 SW BOX	D3	50x150 HAB BOX	D6	5600-1064D	I48	62x225 HEB BOX	D2	9100	I66
38 SWSSMD	D7	50x150 HEB BOX	D2	5600-1066	I48	62x250 HAB BOX	D6	9103	I66
38 X (*) HEB	A22, L20	50x150 HGSB	D5	5600-1066D	I48	62x250 HEB BOX	D2	9112	I66
38C HEN BOX	D3	50x175 HAB BOX	D6	5600-1070	I48	62x275 HEB BOX	D2	9113	I66
38CHEN	A22, L20	50x175 HEB BOX	D2	5600-1070D	I48	62x300 HAB BOX	D6	9114	I66
38SW	A22, L20	50x200 HAB BOX	D6	5600-1072	I48	62x300 HEB BOX	D2	9117	I67
38x100 HEB BOX	D2	50x200 HEB BOX	D2	5600-1074	I48	62x300 HSSB	D7	9118	I67
38x125 HEB BOX	D2	50x200 HGSB	D5	5600-1074D	I48	62x325 HEB BOX	D2	9120	I67
38x125 HGSB	D5	50x200 HSSB	D7	5600-1076	I48	62x350 HAB BOX	D6	9121	I67
38X125 HSSB	D7	50x225 HAB BOX	D6	5600-1076D	I48	62x350 HEB BOX	D2	9123	I67
38x150 HEB BOX	D2	50x225 HEB BOX	D2	5600-1078	I48	62x400 HAB BOX	D6	9124	I67
38x175 HEB BOX	D2	50x250 HAB BOX	D6	5600-1078D	I48	62x400 HEB BOX	D2	9131	I67
38x200 HEB BOX	D2	50x250 HEB BOX	D2	5600-1079	I48	62x450 HAB BOX	D6	9133	I67
38x225 HEB BOX	D2	50x250 HSSB	D7	5600-1079D	I48	62x450 HEB BOX	D2	9138	I67
38x225 HGSB	D5	50x275 HAB BOX	D6	5600-1080	I48	62x500 HAB BOX	D6	9139	I67
38x225 HSSB	D7	50x275 HEB BOX	D2	5600-1080D	I48	62x500 HEB BOX	D2	9140	I67
38x250 HEB BOX	D2	50x300 HAB BOX	D6	5600-1082	I48	62x550 HAB BOX	D6	9141	I67
38x250 HSSB	D7	50x300 HEB BOX	D2	5600-1082D	I48	62x600 HAB BOX	D6	9142	I67
38x275 HEB BOX	D2	50x300 HSSB	D7	5600-2020	I49	62x600 HEB BOX	D2	9143	I67
38x275 HGSB	D5	50x325 HAB BOX	D6	5600-2022	I49	65	E62	9144	I67
38x275 HSSB	D7	50x325 HEB BOX	D2	5600-2026	I49	65CI	E62	9145	I67
38x300 HEB BOX	D2	50x350 HAB BOX	D6	5600-2028	I49	65CP	E62	9146	I67
38x325 HEB BOX	D2	50x350 HEB BOX	D2	5600-2030	I49	65R	E62	9147	I67
38x350 HEB BOX	D2	50x375 HAB BOX	D6	5600-2032	I49	75 NWGS	D5	9149	I67
38x400 HEB BOX	D2	50x375 HEB BOX	D2	5600-2040	I49	75 X (*) HEB	A22, L20	9150	I67
38x450 HEB BOX	D2	50x400 HAB BOX	D6	5600-2042	I49	75CHEN	A22, L20	9157	I67
38x50 HEB BOX	D2	50x400 HEB BOX	D2	5600-2044	I49	75SW	A22, L20	9158	I68
38x500 HEB BOX	D2	50x425 HAB BOX	D6	5600-2050	I49	75x125 HGSB	D5	9165	I68
38x62 HEB BOX	D2	50x450 HAB BOX	D6	5600-2052	I49	90	E62	9166	I68
38x75 BWSS	D7	50x450 HEB BOX	D2	5600-2054	I49	9050	I65	9167	I68
38x75 HEB BOX	D2	50x500 HAB BOX	D6	5600-2056	I49	9050 ACSS	I65	9169	I68
38x81 FWGS	D5	50x500 HEB BOX	D2	5600-2058	I49	9051	I65	9170	I68
38x88 HEB BOX	D2	50x550 HAB BOX	D6	5600-2060	I49	9052	I65	9171	I68
3S	A39	50x550 HEB BOX	D2	5600-2062	I49	9053	I65	9173	I68
3U	A39	50x600 HEB BOX	D2	5600-2064	I49	9054	I65	9174	I68
44 FW BOX	D3	50x75 HEB BOX	D2	5600-2066	I49	9055	I65	9179	I68
44 NW BOX	D3	5600-1020	I47	5600-2070	I49	9056	I65	9182	I68
44 SW BOX	D3	5600-1020D	I47	5600-2072	I49	9057	I65	9183	I68
44C HEN BOX	D3	5600-1022	I47	5600-2074	I49	9058	I65	9190	I68
44x150 HEB BOX	D2	5600-1022D	I47	5600-2076	I49	9059	I65	9192	I68
44x200 HEB BOX	D2	5600-1026	I47	5600-2078	I49	9060	I65	9300	I68
45	E62	5600-1026D	I47	5600-2079	I49	9061	I65	9301	I68
45CI	E62	5600-1028	I47	5600-2080	I49	9062	I65	AGSKIT2	A31
45CP	E62	5600-1028D	I47	5600-2082	I49	9063	I65	AGSKIT250	A31
45R	E62	5600-1030	I47	62 FW BOX	D3	9064	I65	ALFLUID GAL	O41
4S	A39	5600-1030D	I47	62 FWA BOX	D6	9065	I65	ALFLUID QT	O41
4U	A39	5600-1032	I47	62 FWSS	D7	9066	I65	ALFLUID™ GAL.	N74
50 FW BOX	D3	5600-1032D	I47	62 HAN BOX	D6	9067	I66	ALFLUID™ QT.	N74
50 FWA BOX	D6	5600-1040	I47	62 HGSN	D5	9070	I66	AMS-0	A30
50 FWSS	D7	5600-1040D	I47	62 HSSN	D7	9072	I66	AMS-1000	A30
50 HAN BOX	D6	5600-1042	I47	62 NW BOX	D3	9073	I66	AMS-2	A30
50 HGSN	D5	5600-1042D	I47	62 NWGS	D5	9074	I66	AMS-250	A30
50 HSSN	D7	5600-1044	I47	62 SW BOX	D3	9075	I66	AMS-350	A30
50 NW BOX	D3	5600-1044D	I47	62 SWAL BOX	D6	9076	I66	AMS-4/0	A30
50 NWGS	D5	5600-1050	I47	62 SWSSMD	D7	9077	I66	AMS-500	A30
50 SW BOX	D3	5600-1050D	I47	62 X (*) HEB	A22, L20	9079	I66	AMS-750	A30
50 SWAL BOX	D6	5600-1052	I47	62C HEN BOX	D3	9080	I66	ASA1000U	C113
50 SWSSMD	D7	5600-1052D	I47	62CHEN	A22, L20	9083	I66	ASA250U	C113
50 X (*) HEB	A22, L20	5600-1054	I47	62SW	A22, L20	9084	I66	ASA800U	C113
500	E62	5600-1054D	I47	62x100 HEB BOX	D2	9085	I66	AYP1	C119
500R	E62	5600-1056	I47	62x100 HGSB	D5	9086	I66	AYP1/0	C119
50C HEN BOX	D3	5600-1056D	I47	62x125 HEB BOX	D2	9089	I66	AYP2	C119
50CHEN	A22, L20	5600-1058	I48	62x150 HEB BOX	D2	9090	I66	AYP250	C119
50SW	A22, L20	5600-1058D	I48	62x175 HAB BOX	D6	9093	I66	AYP350	C119
50x100 HEB BOX	D2	5600-1060	I47	62x175 HEB BOX	D2	9094	I66	AYP4	C119
50x100 HGSB	D5	5600-1060D	I47	62x175 HGSB	D5	9095	I66	AYP500	C119
50x106 BWSS	D7	5600-1062	I47	62x200 HAB BOX	D6	9097	I66	AYP6	C119
50x106 FWGS	D5	5600-1062D	I47	62x200 HEB BOX	D2	90CI	E62	AYP750	C119

CATALOG NO.	PAGE NO.	CATALOG NO.	PAGE NO.	CATALOG NO.	PAGE NO.	CATALOG NO.	PAGE NO.	CATALOG NO.	PAGE NO.
AYPO2/0	C119	B-1314	E68	B-1643	E80	B-2483	E77	B-2709	E66
AYPO250	C119	B-1315	E68	B-1644	E80	B-2484	E77	B-2710	E66
AYPO3/0	C119	B-1316	E68	B-1645	E80	B-2486	E77	B-2711	E66
AYPO300	C119	B-1317	E68	B-1646	E80	B-2487	E77	B-2712	E66
AYPO350	C119	B-1318	E68	B-1648	E80	B-2488	E77	B-2713	E66
AYPO4/0	C119	B-1319	E68	B-1649	E80	B-249	E64	B-2714	E66
AYPO400	C119	B-1320	E68	B-1650	E80	B-2490	E77	B-2715	E66
AYPO500	C119	B-1321	E68	B-205	E63	B-2491	E77	B-2716	E66
AYPO600	C119	B-1322	E68	B-206	E63	B-2493	E77	B-2717	E66
AYPO750	C119	B-1323	E68	B-207	E63	B-2494	E77	B-2718	E66
B-106	E90	B-1324	E68	B-208	E63	B-2495	E77	B-2719	E66
B-107	E90	B-1325	E68	B-2084	E73	B-2497	E77	B-2747	E66
B-1208	E68	B-1326	E68	B-209	E63	B-2498	E77	B-2751	E66
B-1212	E73	B-1327	E68	B-210	E63	B-250	E64	B-2752	E66
B-1215	E79	B-1328	E68	B-211	E63	B-2506	E75	B-2753	E66
B-1216	E79	B-1329	E68	B-213	E63	B-2507	E75	B-2754	E66
B-1218	E79	B-1330	E68	B-214	E63	B-2509	E75	B-2755	E66
B-1219	E79	B-1331	E68	B-215	E63	B-251	E64	B-2756	E66
B-1220	E79	B-1332	E68	B-2154	E71	B-2510	E73	B-2757	E66
B-1221	E79	B-1333	E68	B-2155	E71	B-2511	E75	B-2761	E80
B-1222	E79	B-1334	E68	B-2156	E71	B-252	E64	B-2781	E78
B-1223	E79	B-1335	E68	B-2157	E71	B-253	E64	B-280	E64
B-1224	E79	B-1336	E68	B-2158	E71	B-254	E64	B-282	E64
B-1225-H	E79	B-1581	E71	B-2159	E71	B-2540	E78	B-283	E64
B-1226-H	E79	B-1582	E71	B-2160	E71	B-2542	E75	B-284	E64
B-1228-H	E79	B-1583	E71	B-2161	E71	B-255	E64	B-285	E64
B-1270	E67	B-1584	E71	B-2162	E71	B-2558	E73	B-286	E64
B-1271	E67	B-1586	E71	B-2163	E71	B-256	E64	B-287	E64
B-1272	E67	B-1587	E71	B-2164	E71	B-2566	E72	B-288	E64
B-1273	E67	B-1588	E71	B-2165	E71	B-2567	E80	B-289	E64
B-1274	E67	B-1589	E71	B-2189	E78	B-2568	E80	B-290	E64
B-1275	E67	B-1593	E71	B-2199	E75	B-2569	E80	B-291	E64
B-1276	E67	B-1594	E71	B-2200	E75	B-257	E64	B-293	E64
B-1277	E67	B-1595	E71	B-221	E64	B-258	E64	B-294	E64
B-1278	E67	B-1596	E71	B-223	E64	B-2583	E77	B-295	E64
B-1279	E67	B-1597	E71	B-2235	E73	B-2583-S	E77	B-296	E64
B-1280	E67	B-1601	E71	B-224	E64	B-259	E64	B-297	E64
B-1281	E67	B-1602	E71	B-225	E64	B-260	E64	B-298	E64
B-1282	E67	B-1603	E71	B-226	E64	B-261	E64	B-423	E65
B-1283	E67	B-1604	E71	B-227	E64	B-262	E64	B-424	E65
B-1284	E67	B-1605	E71	B-228	E64	B-263	E64	B-425	E65
B-1285	E67	B-1606	E71	B-229	E64	B-264	E64	B-426	E65
B-1286	E67	B-1610	E71	B-230	E64	B-265	E64	B-427	E65
B-1287	E67	B-1611	E71	B-231	E64	B-266	E64	B-428	E65
B-1288	E67	B-1613	E81	B-232	E64	B-267	E64	B-429	E65
B-1289	E67	B-1614	E81	B-2320	E73	B-268	E64	B-430	E65
B-1290	E67	B-1615	E81	B-233	E64	B-2687	E66	B-431	E65
B-1291	E67	B-1616	E81	B-234	E64	B-2689	E66	B-432	E65
B-1292	E67	B-1617	E81	B-235	E64	B-269	E64	B-433	E65
B-1293	E67	B-1618	E81	B-236	E64	B-2690	E66	B-434	E65
B-1294	E67	B-1619	E81	B-237	E64	B-2691	E66	B-435	E65
B-1295	E67	B-1620	E81	B-238	E64	B-2692	E66	B-436	E65
B-1296	E67	B-1626	E79	B-239	E64	B-2693	E66	B-437	E65
B-1297	E67	B-1627	E79	B-240	E64	B-2694	E66	B-438	E65
B-1298	E67	B-1628	E79	B-241	E64	B-2695	E66	B-439	E65
B-1299	E67	B-1629	E79	B-242	E64	B-2696	E66	B-440	E65
B-1300	E67	B-1630	E79	B-243	E64	B-2697	E66	B-441	E65
B-1301	E67	B-1631	E79	B-244	E64	B-2698	E66	B-442	E65
B-1302	E67	B-1632	E79	B-245	E64	B-2699	E66	B-443	E65
B-1303	E67	B-1633	E79	B-2450	E73	B-270	E64	B-444	E65
B-1304	E67	B-1634	E79	B-246	E64	B-2700	E66	B-445	E65
B-1305	E67	B-1635	E80	B-247	E64	B-2701	E66	B-447	E65
B-1306	E67	B-1636	E80	B-2476	E77	B-2702	E66	B-448	E65
B-1307	E67	B-1637	E80	B-2477	E77	B-2703	E66	B-449	E65
B-1308	E67	B-1638	E80	B-2478	E77	B-2704	E66	B-450	E65
B-1309	E67	B-1639	E80	B-248	E64	B-2705	E66	B-451	E65
B-1310	E67	B-1640	E80	B-2480	E77	B-2706	E66	B-452	E65
B-1311	E68	B-1641	E80	B-2480-S	E77	B-2707	E66	B-453	E65
B-1313	E68	B-1642	E80	B-2482	E77	B-2708	E66	B-454	E65

Alpha-Numeric Index

CATALOG NO.	PAGE NO.	CATALOG NO.	PAGE NO.	CATALOG NO.	PAGE NO.	CATALOG NO.	PAGE NO.	CATALOG NO.	PAGE NO.
B-455	E65	B-5330	E73	B-5629	E68	B-5904	E72	B-7502	E82
B-456	E65	B-5331	E76	B-563	E70	B-591	E77	B-7503	E82
B-457	E65	B-5332	E73	B-5630	E68	B-5910	E80	B-7504	E82
B-458	E65	B-5333	E73	B-5631	E68	B-592	E77	B-7505	E82
B-459	E65	B-5334	E73	B-5632	E68	B-593	E77	B-7506	E82
B-460	E65	B-5335	E73	B-5634	E68	B-5935	E72	B-7507	E82
B-461	E65	B-5336	E73	B-5635	E68	B-594	E77	B-7508	E82
B-462	E65	B-5337	E73	B-5636	E68	B-5940	E72	B-7509	E82
B-463	E65	B-5338	E73	B-5637	E68	B-5943	E68	B-7510	E82
B-464	E65	B-534	E69	B-5638	E68	B-595	E77	B-7511	E82
B-465	E65	B-5340	E68	B-5639	E68	B-596	E77	B-7512	E82
B-466	E65	B-5341	E73	B-564	E70	B-5961	E72	B-7513	E82
B-467	E65	B-5342	E68	B-5640	E73	B-5963	E72	B-7514	E82
B-468	E65	B-535	E69	B-5642	E68	B-5972	E72	B-7515	E82
B-469	E65	B-5351	E73	B-5644	E68	B-598	E77	B-7520	E82
B-470	E65	B-5352	E73	B-5645	E68	B-599	E77	B-7521	E82
B-471	E65	B-5353	E73	B-5652	E68	B-5992	E72	B-7522	E82
B-472	E65	B-5359	E78	B-5659	E68	B-600	E77	B-7523	E82
B-483	E65	B-5361	E78	B-566	E70	B-6002	E73	B-7528	E82
B-485	E65	B-5362	E78	B-5660	E71	B-6003	E72	B-7529	E82
B-486	E65	B-5363	E78	B-5667	E73	B-602	E76	B-7530	E82
B-487	E65	B-537	E70	B-5668	E68	B-6025	E72	B-7531	E82
B-488	E65	B-538	E70	B-567	E70	B-603	E76	B-7588	E83
B-489	E65	B-5380	E72	B-5676	E68	B-604	E76	B-7589	E83
B-490	E65	B-5389	E78	B-5677	E73	B-6046	E68	B-7590	E83
B-491	E65	B-539	E70	B-5679	E68	B-6048	E72	B-7591	E83
B-492	E65	B-5390	E72	B-5680	E68	B-605	E76	B-7592	E83
B-493	E65	B-540	E70	B-5682	E68	B-6051	E73	B-7593	E83
B-495	E69	B-541	E70	B-5684	E68	B-6060	E80	B-7594	E83
B-496	E69	B-5416	E72	B-5686	E68	B-6061	E80	B-7595	E83
B-497	E69	B-5419	E80	B-5688	E68	B-6067	E80	B-7596	E83
B-498	E69	B-542	E70	B-569	E70	B-6072	E80	B-7597	E83
B-499	E69	B-5428	E73	B-5698	E72	B-6114	E75	B-7598	E83
B-500	E69	B-543	E70	B-5699	E72	B-616	E76	B-7599	E83
B-501	E69	B-5432	E66	B-570	E70	B-6165	E72	B-7600	E83
B-502	E69	B-544	E70	B-5702	E73	B-617	E76	B-7601	E83
B-5021	E64	B-545	E70	B-5709	E67	B-618	E76	B-7602	E83
B-503	E69	B-546	E70	B-571	E70	B-619	E76	B-7603	E83
B-504	E69	B-547	E70	B-572	E70	B-620	E76	B-7604	E83
B-505	E69	B-5475	E64	B-5722	E72	B-6208	E73	B-7605	E83
B-506	E69	B-548	E70	B-573	E70	B-621	E76	B-7606	E83
B-5065	E76	B-549	E70	B-5732	E72	B-622	E76	B-7607	E83
B-507	E69	B-550	E70	B-5734	E72	B-624	E76	B-7608	E83
B-508	E69	B-551	E70	B-5738	E72	B-625-H	E76	B-7609	E83
B-509	E69	B-5513	E72	B-574	E70	B-626-H	E76	B-7610	E83
B-510	E69	B-5515	E72	B-5746	E72	B-628	E75	B-7611	E83
B-511	E69	B-5517	E73	B-575	E70	B-629	E75	B-7612	E83
B-513	E69	B-553	E70	B-5767	E73	B-6294	E73	B-7613	E83
B-514	E69	B-555	E70	B-577	E70	B-630	E75	B-7614	E83
B-515	E69	B-5555	E72	B-5777	E72	B-631	E75	B-7615	E83
B-516	E69	B-5556	E72	B-578	E70	B-644	E75	B-7616	E83
B-517	E69	B-556	E70	B-5781	E69	B-645	E75	B-7617	E83
B-518	E69	B-5560	E73	B-579	E70	B-646	E75	B-7618	E83
B-519	E69	B-5561	E72	B-5803	E72	B-647	E75	B-7619	E83
B-520	E69	B-557	E70	B-5804	E72	B-648	E75	B-7620	E84
B-521	E69	B-5573	E73	B-5820	E72	B-649	E75	B-7621	E84
B-523	E69	B-5574	E64	B-5821	E72	B-650	E75	B-7622	E84
B-524	E69	B-558	E70	B-5830	E72	B-652	E75	B-7623	E84
B-525	E69	B-559	E70	B-5833	E72	B-653	E75	B-7624	E84
B-526	E69	B-560	E70	B-585	E77	B-654	E75	B-7625	E84
B-527	E69	B-5604	E73	B-5850	E72	B-6552	E68	B-7626	E84
B-528	E69	B-561	E70	B-5857	E72	B-6630	E71	B-7627	E84
B-529	E69	B-5618	E67	B-586	E77	B-6766	E73	B-7628	E84
B-5294	E72	B-562	E70	B-587	E77	B-6906	E71	B-7629	E84
B-530	E69	B-5623	E63	B-5877	E72	B-7075	E75	B-7630	E84
B-531	E69	B-5624	E63	B-588	E77	B-7146	E75	B-7631	E84
B-532	E70	B-5625	E63	B-588-S	E77	B-7192	E76	B-7632	E84
B-5321	E71	B-5626	E63	B-589	E77	B-7500	E82	B-7633	E84
B-533	E69	B-5627	E68	B-590	E77	B-7501	E82	B-7634	E84

CATALOG NO.	PAGE NO.	CATALOG NO.	PAGE NO.	CATALOG NO.	PAGE NO.	CATALOG NO.	PAGE NO.	CATALOG NO.	PAGE NO.
B-7635	E84	B-7897	E86	B2D12	E47	BA-204	E94	BA16E10	B15
B-7636	E84	B-7898	E86	B2D12N	E47	BA-205	E94	BA16E10M	B15, N55
B-7637	E84	B-7899	E86	B2E12	E47	BA-207	E94	BA16E14	B15
B-7638	E84	B-7900	E86	B2E12N	E47	BA-208	E94	BA16E14M	B15, N55
B-7639	E84	B-7901	E86	B2F12	E47	BA-209	E94	BA16E38	B15
B-7640	E84	B-7902	E86	B2F12N	E47	BA-211	E94	BA16E38M	B15, N55
B-7641	E84	B-7903	E86	B2G12N	E47	BA-212	E94	BA16E4	B15
B-7642	E84	B-7904	E86	B34E12R	N95	BA-213	E94	BA16E4M	B15, N55
B-7643	E84	B-7905	E86	B370320-01	E62	BA-214	E94	BA16E6	B15
B-7644	E84	B-7906	E86	B370320-02	E62	BA-215	E94	BA16E6M	B15, N55
B-7645	E84	B-7907	E86	B370320-03	E62	BA-240	E94	BA16E8	B15
B-7646	E84	B-7908	E86	B38-0101-00	E93	BA10E10	B15	BA16E8M	B15, N55
B-7647	E84	B-7909	E86	B38-0101-01	E93	BA10E10M	B15, N55	BA16EF10	B39
B-7648	E84	B-7910	E86	B38-0135-00	E92	BA10E14	B15	BA16EF10M	B39, N55
B-7649	E84	B-7911	E86	B38-0135-01	E92	BA10E14M	B15, N55	BA16EF2	B39
B-7650	E84	B-7912	E86	B38-0302-00	E93	BA10E38	B15	BA16EF2M	B39, N55
B-7651	E84	B-7913	E86	B38-0302-02	E93	BA10E38M	B15, N55	BA16EF6	B39
B-7652	E84	B-7914	E86	B38-0303-00	E93	BA10E6	B15	BA16EF6M	B39, N55
B-7653	E84	B-7915	E86	B38-0304-00	E93	BA10E6M	B15, N55	BA16EF8	B39
B-7654	E84	B-7916	E86	B38-0305-00	E93, F4	BA10E8	B15	BA16EF8M	B39, N55
B-7656	E84	B-7917	E86	B38-0306-00	E92-E93	BA10E8M	B15, N55	BA16EL10	B42
B-7657	E84	B-7918	E86	B38-0307-00	E93	BA10EF10	B39	BA16EL10M	B42, N55
B-7658	E84	B-7919	E86	B38-0308-00	E93	BA10EF10M	B39, N55	BA16EL6	B42
B-7659	E84	B-7920	E86	B38-0309-00	E93	BA10EF6	B39	BA16EL6M	B42, N55
B-7708	E85	B-7921	E86	B38-0309-01	E93	BA10EF6M	B39, N55	BA16EL8	B42
B-7709	E85	B-7922	E86	B38-0330-00	E92	BA10EF8	B39	BA16EL8M	B42, N55
B-7710	E85	B-7923	E86	B38-0904-00	E93	BA10EF8M	B39, N55	BA16EZ10	B41
B-7711	E85	B-8011	E73	B38-3662-01	E94	BA10EL10	B42	BA16EZ10M	N55
B-7712	E85	B-8027	E73	B38-3662-02	E94	BA10EL10M	B42, N55	BA16EZ2	B41
B-7713	E85	B-8165	E78	B38-3662-03	E94	BA10EL6	B42	BA16EZ2M	N55
B-7714	E85	B-8214	E73	B38-3662-04	E94	BA10EL6M	B42, N55	BA16EZ6	B41
B-7715	E85	B-8359	E80	B38-3662-05	E94	BA10EL8	B42	BA16EZ6M	N55
B-7716	E85	B-8379	E76	B38-3662-06	E94	BA10EL8M	B42, N55	BA16EZ8	B41
B-7717	E85	B-8402	E69	B38-3922-00	E92-E93	BA10EZ10	B41	BAT14V	N40
B-7718	E85	B-8403	E69	B38-4129-00	E92	BA10EZ6	B41	BAT18V	N34-N38, N41, N59-N61
B-7719	E85	B-8410	E76	B38-4129-05	E92	BA10EZ8	B41	BBB14210A	E57
B-7720	E85	B-8413	E76	B38032900	E82-E86	BA10EZ8M	N55	BBB14224B	E57
B-7721	E85	B-8414	E69	B38406100	E82-E86	BA14E10	B15	BBB14410C	E57
B-7722	E85	B-8415	E69	B38406200	E82-E86	BA14E10M	B15, N55	BBB14410D	E57
B-7723	E85	B-8422	E69	B38406300	E82-E86	BA14E14	B15	BBB14412E	E57
B-7724	E85	B-8423	E76	B3D12	E47	BA14E14M	B15, N55	BBB14412F	E57
B-7725	E85	B-8426	E69	B3D12N	E47	BA14E38	B15	BBB14416G	E57
B-7726	E85	B-8428	E73	B3E12	E47	BA14E4	B15	BBB14416H	E57
B-7727	E85	B-8434	E70	B3E12N	E47	BA14E4M	B15, N55	BBB14420J	E57
B-7728	E85	B-8435	E70	B3F12	E47	BA14E516	B15	BBB412UD	E57
B-7729	E85	B-8441	E70	B3F12N	E47	BA14E516M	B15, N55	BBB424UD	E57
B-7730	E85	B-8442	E70	B3G12	E47	BA14E6	B15	BBBHR19	E57
B-7731	E85	B-8451	E73	B3G12N	E47	BA14E6M	B15, N55	BBBVR36	E57
B-7732	E85	B-8452	E70	B40-0106-27	E91	BA14E8	B15	BC25	H66
B-7733	E85	B-8454	E70	B40-0106-75	E90	BA14E8M	B15, N55	BC28	H66
B-7734	E85	B-8461	E73	B40-0106-76	E91	BA14EF10	B39	BC2C	H66
B-7735	E85	B-8512	E78	B40-0106-77	E91	BA14EF10M	B39, N55	BCC1000CUAL	N62
B-7736	E85	B-8718	E78	B40-0106-78	E91	BA14EF2	B39	BCCBAT12V	N62
B-7737	E85	B-8726	E73	B40-0319-01	E92	BA14EF6	B39	BCCCASE	N62
B-7738	E85	B-8802	E73	B40-0319-03	E92	BA14EF8	B39	BCCCHGR	N62
B-7739	E85	B-8833	E77	B40-3657-00	E90	BA14EF8M	B39, N55	BCH1211	N91-N94
B-7884	E86	B-8882	E68	B40-4431-01	E91	BA14EL10	B42	BCM5	N91-N94
B-7885	E86	B-9021	E77	B404431-00	E91	BA14EL10M	B42, N55	BCT/PATDCCHGR	N34-N38, N40-N41, N59-N61
B-7886	E86	B-9029	E78	B4D12	E47	BA14EL6	B42	BD12	E46
B-7887	E86	B-9233	E77	B4D12N	E47	BA14EL6M	B42, N55	BD12N	E46
B-7888	E86	B-9233-S	E77	B4E12	E47	BA14EL8	B42	BD18	E46
B-7889	E86	B-9253	E80	B4E12N	E47	BA14EL8M	B42, N55	BD18N	E46
B-7890	E86	B106-32	E91	B4F12	E47	BA14EZ10	B41	BD24	E46
B-7891	E86	B106-37	E91	B4F12N	E47	BA14EZ10M	N55	BD24N	E46
B-7892	E86	B106-41	E91	B4G12N	E47	BA14EZ2	B41	BDA-11-2/0-1	A47, A49
B-7893	E86	B107-32	E91	BA-200	E94	BA14EZ6	B41	BDA-11-500	A45, A48
B-7894	E86	B107-37	E91	BA-201	E94	BA14EZ6M	N55	BDA-112-350	A45, A48
B-7895	E86	B12E	N95	BA-202	E94	BA14EZ8	B41		
B-7896	E86	B1E34R	N95	BA-203	E94	BA14EZ8M	N55		

Alpha-Numeric Index

CATALOG NO.	PAGE NO.	CATALOG NO.	PAGE NO.	CATALOG NO.	PAGE NO.	CATALOG NO.	PAGE NO.	CATALOG NO.	PAGE NO.
BDA-14-2/0-1	A47, A49	BE18	E46	BIBD350-5	A52	BIBS350-8	A51	BK88007	N87
BDA-16-350	A45, A48	BE18N	E46	BIBD350-6	A52	BIBS35010MT	A53	BK88008	N86
BDA-16-500	A45, A48	BE24	E46	BIBD350-8	A52	BIBS35012MT	A53	BK88020	N88, N90
BDA-212-500	A45, A48	BE24N	E46	BIBD35010MT	A53	BIBS3504MT	A53	BKC3540	N91-N94
BDA-22-350	A45, A48	BEB122	N96	BIBD35012MT	A53	BIBS3506MT	A53	BKD1000B	N84, N87-N94
BDA-22-500	A45, A48	BEB122EMT	N96	BIBD3504MT	A53	BIBS3508MT	A53	BKD1250B	N84, N87-N94
BDA-24-500	A45, A48	BEB122PVC	N96	BIBD3506MT	A53	BIBS4-3	A51	BKD1500B	N85, N87-N94
BDA-26-350	A45, A48	BEB122RIG	N96	BIBD3508MT	A53	BIBS4-4	A51	BKD2000B	N85, N87-N94
BDA-26-500	A45, A48	BEBSHOECASE	N96	BIBD4-2	A52	BIBS4-5	A51	BKD2500	N86, N90, N92, N94
BDB-11-2/0-1	A47, A49	BF12	E46	BIBD4-3	A52	BIBS4-6	A51	BKD3000	N86, N90, N92, N94
BDB-11-2/0-2	A47, A49	BF12N	E46	BIBD4-4	A52	BIBS4-8	A51	BKD3500	N86, N92, N94
BDB-11-2/0-3	A47, A49	BF18	E46	BIBD4-5	A52	BIBS600-10	A51	BKD4000	N86, N92, N94
BDB-11-350-1	A47, A49	BF18N	E46	BIBD4-6	A52	BIBS600-12	A51	BKD500B	N84, N87-N94
BDB-11-350-2	A47, A49	BF24	E46	BIBD4-8	A52	BIBS600-14	A51	BKD750B	N84, N87-N94
BDB-11-350-3	A47, A49	BF24N	E46	BIBD600-10	A52	BIBS600-3	A51	BKLP2	N90
BDB-11-500-1	A47-A48	BG12	E46	BIBD600-12	A52	BIBS600-4	A51	BKLP2K1	N90
BDB-11-500-2	A47-A48	BG12N	E46	BIBD600-14	A52	BIBS600-5	A51	BKLP6	N89
BDB-11-500-3	A47-A48	BG18	E46	BIBD600-2	A52	BIBS600-6	A51	BKLP6K1	N89
BDB-112-350-1	A46, A48	BG18N	E46	BIBD600-3	A52	BIBS600-8	A51	BKOF520	N93
BDB-112-350-2	A46, A48	BG24	E46	BIBD600-4	A52	BIBS60010MT	A53	BKOF540	N94
BDB-112-350-3	A46, A48	BG24N	E46	BIBD600-5	A52	BIBS60012MT	A53	BKOH2540	N86
BDB-14-500-1	A46, A49	BGBL-1/0	A15	BIBD600-6	A52	BIBS6004MT	A53	BKOH520A	N91
BDB-14-500-2	A46, A49	BGBL-250	A15	BIBD600-8	A52	BIBS6006MT	A53	BKOH540A	N92
BDB-14-500-3	A46, A49	BGBL-4	A15	BIBD60010MT	A53	BIBS6008MT	A53	BKOM152	N85
BDB-16-2/0-1	A46, A49	BGM3050	E89	BIBD60012MT	A53	BIBS750-10	A51	BKOM50125	N84
BDB-16-2/0-2	A46, A49	BGM3100	E89	BIBD6004MT	A53	BIBS750-12	A51	BKOR14	N88
BDB-16-2/0-3	A46, A49	BGM640044	E89	BIBD6006MT	A53	BIBS750-14	A51	BKOR152	N88
BDB-16-350-1	A46, A48	BGM64006	E89	BIBD6008MT	A53	BIBS750-3	A51	BKOR50	N88
BDB-16-350-2	A46, A48	BGM640066	E89	BIBD750-10	A52	BIBS750-4	A51	BKOR520	N88
BDB-16-350-3	A46, A48	BGM640068	E89	BIBD750-12	A52	BIBS750-6	A51	BKOR75125	N88
BDB-16-500-1	A46, A48	BH864	N91-N94	BIBD750-14	A52	BIBS750-8	A51	BKOS520	N90
BDB-16-500-2	A46, A48	BHA12E	N95	BIBD750-2	A52	BIC-4-350	K79	BKOS5290	N89
BDB-16-500-3	A46, A48	BHA1E34R	N95	BIBD750-3	A52	BIC-4-500	K79	BKOW520	N87
BDB-162-500-1	A46, A49	BHA34E12R	N95	BIBD750-4	A52	BIC-6-350	K79	BKP1000B	N84, N87-N94
BDB-162-500-2	A46, A49	BHSG1100	F12	BIBD750-6	A52	BIC-6-500	K79	BKP1250B	N84, N87-N94
BDB-162-500-3	A46, A49	BIBD2/0-10	A52	BIBD750-8	A52	BIC-8-350	K79	BKP1500B	N85, N87-N94
BDB-212-500-1	A46, A48	BIBD2/0-12	A52	BIBS2/0-10	A51	BIC-8-500	K79	BKP2000B	N85, N87-N94
BDB-212-500-2	A46, A48	BIBD2/0-14	A52	BIBS2/0-12	A51	BIC2-4-750	K79	BKP2500	N86, N90, N92, N94
BDB-212-500-3	A46, A48	BIBD2/0-2	A52	BIBS2/0-14	A51	BIC2-6-750	K79	BKP3000	N86, N90, N92, N94
BDB-22-2/0-1	A47, A49	BIBD2/0-3	A52	BIBS2/0-3	A51	BIC2-8-750	K79	BKP3500	N86, N92, N94
BDB-22-2/0-2	A47, A49	BIBD2/0-4	A52	BIBS2/0-4	A51	BIPC1/0-2	A37	BKP4000	N86, N92, N94
BDB-22-2/0-3	A47, A49	BIBD2/0-5	A52	BIBS2/0-5	A51	BIPC350-350	A37	BKP500B	N84, N87-N94
BDB-22-350-1	A47-A48	BIBD2/0-6	A52	BIBS2/0-6	A51	BIPC350-4/0	A37	BKP750B	N84, N87-N94
BDB-22-350-2	A47-A48	BIBD2/0-8	A52	BIBS2/0-8	A51	BIPC4/0-1/0	A37	BKPR7520	N89-N90
BDB-22-350-3	A47-A48	BIBD2/010MT	A53	BIBS2/010MT	A53	BIPC4/0-6	A37	BKPR7540	N91-N94
BDB-22-500-1	A47-A48	BIBD2/012MT	A53	BIBS2/012MT	A53	BIPCS500-4/0	A37	BKPS50	N89-N94
BDB-22-500-2	A47-A48	BIBD2/04MT	A53	BIBS2/04MT	A53	BISR1-DB	A33	BKS752B	N84-N85, N87
BDB-22-500-3	A47-A48	BIBD2/06MT	A53	BIBS2/06MT	A53	BISR1/0	A50	BKSA50	N89-N90
BDB-24-500-1	A46, A48	BIBD2/08MT	A53	BIBS2/08MT	A53	BISR2	A50	BKSB50B	N84, N87
BDB-24-500-2	A46, A48	BIBD250-10	A52	BIBS250-10	A51	BISR250	A50	BKW52	N87
BDB-24-500-3	A46, A48	BIBD250-12	A52	BIBS250-12	A51	BISR250-DB	A33	BMV-BCH-MT	N16
BDB-26-2/0-1	A46, A49	BIBD250-14	A52	BIBS250-14	A51	BISR3/0-DB	A33	BP10PADKIT	N65-N66
BDB-26-2/0-2	A46, A49	BIBD250-2	A52	BIBS250-3	A51	BISR350	A50	BPD-4-350	K79
BDB-26-2/0-3	A46, A49	BIBD250-3	A52	BIBS250-4	A51	BISR4-DB	A33	BPD-4-500	K79
BDB-26-350-1	A46, A48	BIBD250-4	A52	BIBS250-5	A51	BISR500	A50	BPD-6-350	K79
BDB-26-350-2	A46, A48	BIBD250-5	A52	BIBS250-6	A51	BIT2/0	A50	BPD-6-500	K79
BDB-26-350-3	A46, A48	BIBD250-6	A52	BIBS250-8	A51	BIT250	A50	BPD-8-350	K79
BDB-26-500-1	A46, A48	BIBD250-8	A52	BIBS25010MT	A53	BIT350	A50	BPD-8-500	K79
BDB-26-500-2	A46, A48	BIBD25010MT	A53	BIBS25012MT	A53	BIT4	A50	BPD2-4-750	K79
BDB-26-500-3	A46, A48	BIBD25012MT	A53	BIBS2504MT	A53	BIT600	A50	BPD2-6-750	K79
BDB-430-500-1	A48	BIBD2504MT	A53	BIBS2506MT	A53	BIT750	A50	BPD2-8-750	K79
BDBCOVER1	A46	BIBD2506MT	A53	BIBS2508MT	A53	BITO2/0	A50	BPF20	N93-N94
BDBCOVER2	A46	BIBD2508MT	A53	BIBS350-10	A51	BITO250	A50	BPH20	N91-N92
BDBCOVER3	A47	BIBD350-10	A52	BIBS350-12	A51	BITO350	A50	BS-2006	E74
BDC-11-2/0-1	A47, A49	BIBD350-12	A52	BIBS350-14	A51	BITO4	A50	BS-2007	E74
BDC-14-2/0-1	A47, A49	BIBD350-14	A52	BIBS350-3	A51	BITO600	A50	BS-2008	E74
BDT1	E34	BIBD350-2	A52	BIBS350-4	A51	BITO750	A50	BS-2009	E74
BE12	E46	BIBD350-3	A52	BIBS350-5	A51	BK88001	N85	BS-2010	E74
BE12N	E46	BIBD350-4	A52	BIBS350-6	A51	BK88004	N84	BS-2011	E74

CATALOG NO.	PAGE NO.	CATALOG NO.	PAGE NO.	CATALOG NO.	PAGE NO.	CATALOG NO.	PAGE NO.	CATALOG NO.	PAGE NO.
BS-2012	E74	BWC420MSC	N103	BYNA52R15HT	I37	C-22LH-1	E39	CH5M	G14
BS-2013	E74	BWC43TRC	N106	BYNA52RHT	I37	C-22LH-2	E39	CH6C	G14
BS-2014	E74	BWC43UC	N106	BYNA52RT15ACCC	I50	C-22LH-3	E39	CH6M	G14
BS-2015	E74	BWC46CWD	N101	BYNA52RT15HACCC	I48	C-4	E35	CH7C	G14
BS-2016	E74	BWC46RC	N103	BYNA52RT15HHT	I33-I34	C-4JA	E37	CH7M	G14
BS-2017	E74	BYNA245MRT15ACCC	I50	BYNA52RT15HT	I38	C-4JPT	E35	CH8C	G14
BS-2018	E74	BYNA245MRT15HACCC	I47	BYNA52RTACCC	I50	C-4LH-1	E39	CH8M	G14
BS-2019	E74	BYNA245MRTACCC	I50	BYNA52RTHHT	I38	C-4LH-2	E39	CH9C	G14
BS-2020	E74	BYNA32R15HHT	I31-I32	BYNA56R15HHT	I31-I32	C-4LH-3	E39	CH9M	G14
BS-2021	E74	BYNA32R15HT	I37	BYNA56R15HT	I37	C-5 (Junior)	E35	CKS4	A4
BS-2024	E74	BYNA32RHT	I37	BYNA56RHT	I37	C-6	E38	CL50-1	A15, E27
BS-2025	E74	BYNA32RT15ACCC	I50	BYNA56RT15HHT	I33-I34	C-61	E39	CL50-1TN	A15, E27
BS-2026	E74	BYNA32RT15HACCC	I47	BYNA56RT15HT	I38	C-66	E39	CM2829P	K35
BS-2027	E74	BYNA32RT15HHT	I33-I34	BYNA56RTHHT	I38	C-6D	E38	CM2929P	K35
BS-2028	E74	BYNA32RT15HT	I38	BYNA58R15HHT	I31-I32	C-7	E38	CM29L	K35
BS-2029	E74	BYNA32RTACCC	I50	BYNA58R15HT	I37	C-8	E35	CM3029P	K35
BS-2030	E74	BYNA32RTHHT	I38	BYNA58RHT	I37	C11CSLH12	E40	CM3229P	K35
BS-2031	E74	BYNA34R15HHT	I31-I32	BYNA58RT15HHT	I33-I34	C11HD4/ODB	E37	CM3429P	K35
BS-2032	E74	BYNA34R15HT	I37	BYNA58RT15HT	I38	C11K16D	E36	CM3629P	K35
BS-2033	E74	BYNA34RHT	I37	BYNA58RTHHT	I38	C11K17D	E36	CMB-29P	K35
BS-2034	E74	BYNA34RT15HHT	I33-I34	BYNA590MRT15ACCC	I50	C22HD4/ODB	E37	CMB-29R	K35
BS-2068	E74	BYNA34RT15HT	I38	BYNA590MRT15HACCC	I48	CASEWDIES	C9, N22	CP2525	H12
BS-2069	E74	BYNA34RTHHT	I38	BYNA590MRTACCC	I50	CCD	H24	CP2626	H12
BS-2070	E74	BYNA36R15HHT	I31-I32	BYNA59R15HHT	I31-I32	CCFBG-FR	C106	CP26A26A	H10
BS-2105	E74	BYNA36R15HT	I37	BYNA59R15HT	I37	CCFD-FR	C102, C106	CP27A27A	H10
BS-2106	E74	BYNA36RHT	I37	BYNA59RHT	I37	CCFDX-FR	C106	CP2828	H12
BS-2107	E74	BYNA36RT15ACCC	I50	BYNA59RT15HHT	I33-I34	CCFDXFR	C102	CP28A28A	H10
BS-2108	E74	BYNA36RT15HACCC	I47	BYNA59RT15HT	I38	CCFN-FR	C102, C106	CP2929	H12
BS-2109	E74	BYNA36RT15HHT	I33-I34	BYNA59RTHHT	I38	CCFO-FR	C102, C106	CP29A29A	H10
BS-2110	E74	BYNA36RT15HT	I38	BYNA760MRT15ACCC	I50	CCFR-FR	C102, C106	CP2C2C	H12
BS10	B54	BYNA36RTACCC	I50	BYNA760MRT15HACCC	I48	CCN	H24	CP30A30A	H10
BS14	B54	BYNA36RTHHT	I38	BYNA760MRTACCC	I50	CCNL	H24	CP31A31A	H10
BS16	B54	BYNA39R15HHT	I31-I32	BYNS32RHT	I39	CCO	H24	CP32A32A	H10
BSC2H	N97	BYNA39R15HT	I37	BYNS32RTHHT	I40	CFAD	C125	CP3434	H12
BSC2H1C2DEBP	N97	BYNA39RHT	I37	BYNS34RHT	I39	CFAD-FR	C125	CP34A34A	H10
BSC2H2A1B1FEBP	N97	BYNA39RT15ACCC	I50	BYNS34RTHHT	I40	CFAN	C125	CP37A37A	H10
BSC2H2C1DEBP	N97	BYNA39RT15HACCC	I47	BYNS36RHT	I39	CFAN-FR	C125	CPB10	A43
BSC2H3A2B	N97	BYNA39RT15HHT	I33-I34	BYNS36RTHHT	I40	CFANL	C125	CPB12	A43
BSC2H5A	N97	BYNA39RT15HT	I38	BYNS39RHT	I39	CFANL-FR	C125	CPB14	A43
BSC2H5B	N97	BYNA39RTACCC	I50	BYNS39RTHHT	I40	CFAO	C125	CPB16-5/8	A43
BSC2L	N98	BYNA39RTHHT	I38	BYNS43RHT	I39	CFAO-FR	C125	CPB21-1/4	A43
BSC2L1C2DEBP	N98	BYNA43R15HHT	I31-I32	BYNS43RTHHT	I40	CFAR	C125	CPB6	A43
BSC2L2C1DEBP	N98	BYNA43R15HT	I32, I37	BYNS451RHT	I39	CFAR-FR	C125	CPB8	A43
BSC2L3A2B	N98	BYNA43RHT	I37	BYNS451RTHHT	I40	CFBG-FR	C106	CPT10	A43
BSC2L5A	N98	BYNA43RT15ACCC	I50	BYNS49RHT	I39	CFD-FR	C102, C106	CPT12	A43
BSC2L5B	N98	BYNA43RT15HACCC	I47	BYNS49RTHHT	I40	CFN-FR	C102, C106	CPT16	A43
BSCWS40	N97-N99	BYNA43RT15HHT	I33-I34	BYNS52RHT	I39	CFO-FR	C102, C106	CPT6	A43
BSCWS80	N97-N99	BYNA43RT15HT	I34, I38	BYNS52RTHHT	I40	CFR-FR	C102, C106	CPT8	A43
BURNDY® GROUNDMAX™		BYNA43RTACCC	I50	BYNS56RHT	I39	CH10C	G14	CT120200D	G7
	E87-E88	BYNA43RTHHT	I38	BYNS56RTHHT	I40	CH10M	G14	CT120200D0	G7
BWC00ADP	N104	BYNA451R15HHT	I31-I32	BYNS58RHT	I39	CH11C	G14	CT120200L	G7
BWC00JS	N105	BYNA451R15HT	I37	BYNS58RTHHT	I40	CH11M	G14	CT120200L0	G7
BWC01CDC	N100	BYNA451RHT	I37	BYNS59RHT	I39	CH12C	G14	CT120300D	G7
BWC01CMC	N100	BYNA451RT15ACCC	I50	BYNS59RTHHT	I40	CH12M	G14	CT120300D0	G7
BWC01FAR	N102	BYNA451RT15HACCC	I47	C-11B	E35	CH14C	G14	CT120300L	G7
BWC01FCMR	N101	BYNA451RT15HHT	I33-I34	C-11CSH-1	E40	CH14M	G14	CT120300L0	G7
BWC01FFMC	N102	BYNA451RT15HT	I38	C-11CSH-2	E40	CH16C	G14	CT120400D	G5, G7
BWC01FSMC	N102	BYNA451RTACCC	I50	C-11CSH-3	E40	CH16M	G14	CT120400D0	G7
BWC04EHC	N100	BYNA451RTHHT	I38	C-11D	E35	CH18C	G14	CT120400D00	G5
BWC06FHC	N100	BYNA49R15HHT	I31-I32	C-11JA	E37	CH18M	G14	CT120400L	G5, G7
BWC20PRSF	N105	BYNA49R15HT	I37	C-11JPT	E35	CH24C	G14	CT120400L0	G7
BWC24HTC	N104	BYNA49RHT	I37	C-11LH-1	E39	CH24L	G14	CT120400L00	G5
BWC24MTHTC	N104	BYNA49RT15ACCC	I50	C-11LH-2	E39	CH2C	G14	CT120400LOUG	G8
BWC25LHTC	N104	BYNA49RT15HACCC	I48	C-11LH-3	E39	CH2M	G14	CT120400LUG	G8
BWC27LHTCADP	N104	BYNA49RT15HHT	I33-I34	C-11N	E35	CH3C	G14	CT120400MH14D0	G10
BWC28FAC	N101	BYNA49RT15HT	I38	C-22	E35	CH3M	G14	CT120400MH14L	G10
BWC32DCC	N105	BYNA49RTACCC	I50	C-22D	E35	CH4C	G14	CT120400MH14L0	G10
BWC40PC	N106	BYNA49RTHHT	I38	C-22JA	E37	CH4M	G14	CT120900D	G5
BWC41ORC	N103	BYNA52R15HHT	I31-I32	C-22JPT	E35	CH5C	G14	CT120900D00	G5

Alpha-Numeric Index

CATALOG NO.	PAGE NO.	CATALOG NO.	PAGE NO.	CATALOG NO.	PAGE NO.	CATALOG NO.	PAGE NO.	CATALOG NO.	PAGE NO.
CT120900L	G5, G7	CT40200M	G6	CTB125RA4D	G13	ES25A2W	H43	FQN14F25X03B	B47
CT120900LO	G7	CT40200M0	G6	CTB125RA4L	G13	ES25A4W	H43	FQN14F25X03D	B47
CT120900L00	G5	CT40200RC	G9	CTB125S2C	G13	ES25R25R	H43	FQN14M25X03B	B47
CT1751100Q	G7	CT40200RC0	G9	CTB125S4C	G13	ES25R2R	H43	FQN14M25X03D	B47
CT1751100Q0	G7	CT40300C	G6	CTB150AA4C	G13	ES25R2W	H43	FQN18F25X03B	B47
CT1751400Q	G7	CT40300C0	G6	CTB150RA4B	G13	ES25R4W	H43	FQN18F25X03D	B47
CT1751400Q0	G7	CT40300M	G6	CTB150RA4C	G13	ES25R6W	H43	FQN18M25X03B	B47
CT175400Q	G5, G7	CT40300M0	G6	CTB150S4B	G13	ES2R2R	H43	FQN18M25X03D	B47
CT175400Q0	G7	CT40400C	G6	CTH120400L	G11	ES2R2W	H43	FT3B4/0	A39
CT175600Q	G5, G7	CT40400C0	G6	CTH18075C	G11	ES2R4W	H43	FT3B500	A39
CT175600Q0	G7	CT40400M	G6	CTH18075M	G11	ES2R6W	H43	FT4B4/0	A39
CT175600Q00	G5	CT40400M0	G6	CTH30200C	G11	ES2R8W	H43	FT4B500	A39
CT175900Q	G5, G7	CT50137EPRC	G9	CTH50175C	G11	ES2W2W	H43	GA25H26	E54
CT175900Q0	G7	CT50137EPRC0	G9	CTH50175M	G11	ES2W4W	H43	GAR1126	E28
CT175900Q00	G5	CT50137RC	G9	CTSS1001000C	G15	ES2W6W	H43	GAR1129	E28
CT18075C	G5-G6	CT50137RC0	G9	CTSS100200C	G15	ES2W8W	H43	GAR114C	E28
CT18075C0	G6	CT50175C	G5-G6	CTSS100400C	G15	ES4W4W	H43	GAR1426	E28
CT18075C00	G5	CT50175C0	G6	CTSS100600C	G15	ES4W6W	H43	GAR1429	E28
CT18075C0UG	G8	CT50175C00	G5	CTSS100800C	G15	ES4W8W	H43	GAR1434	E28
CT18075CUG	G8	CT50175C0UG	G8	CTSS250200L	G15	ES6W6W	H43	GAR144C	E28
CT18075FLC	G10	CT50175CUG	G8	CTSS250400L	G15	ES6W8W	H43	GAR1526	E28
CT18075IDC	G5, G10	CT50175ID2L	G5, G10	CTSS250600L	G15	ES8W8W	H43	GAR1529	E28
CT18075M	G5-G6	CT50175ID3L	G5, G10	CTSS250800L	G15	F22A28	K78	GAR1534	E28
CT18075M0	G6	CT50175IDC	G5, G10	CTZ120400D	G11	FCB63-2NP300	A35, L17	GAR154C	E28
CT18075M00	G5	CT50175M	G5-G6	CTZ120400L	G11	FCB63-4N	A35, L17	GAR1626	E28
CT18075MH4C	G10	CT50175M0	G6	CTZ18075C	G11	FCB63-6N	A35, L17	GAR1629	E28
CT18075MH4C0	G10	CT50175M00	G5	CTZ30200C	G11	FCB64-44NP50	A35, L17	GAR1634	E28
CT18075MH4M	G10	CT50175M0UG	G8	CTZ50175C	G11	FCB64-4N	A35, L17	GAR164C	E28
CT18125C	G6	CT50175MH10C	G10	CUSA442NTC	C113	FCB64-6N	A35, L17	GAR1726	E28
CT18125C0	G6	CT50175MH10C0	G10	CUSA442TC38	C113	FCB65-4N	A35, L17	GAR1729	E28
CT18125M	G6	CT50175MH10CUG	G8	CUW26RE-1	H68	FD64C5T16	L16	GAR1734	E28
CT18125M0	G6	CT50175MH10M	G10	CUW30A-E	H68	FD655C6	L16	GAR174C	E28
CT18200C	G6	CT50175MH10M0	G10	CUW32R-E	H68	FD655D6	L16	GAR1826	E28
CT18200C0	G6	CT50175MUG	G8	CUW34-E	H67	FD65C6T14	L16	GAR1829	E28
CT18200M	G6	CT50250EPRC	G9	CUW361R-E	H68	FD66C6	L16	GAR1834	E28
CT18200M0	G6	CT50250EPRC0	G9	CUW391A-E	H68	FD66D6	L16	GAR184C	E28
CT18200MUG	G8	CT50300C	G5-G6	CUW44-E	H67	FD675C8	L16	GAR1926	E28
CT2501000Q	G7	CT50300C0	G6	CZ-11	E36	FD675D8	L16	GAR1929	E28
CT2501000Q0	G7	CT50300C00	G5	DUW28	H67	FD67C6	L16	GAR1934	E28
CT2501000RQ	G9	CT50300C0UG	G8	DUW28A	H68	FD67D8	L16	GAR194C	E28
CT2501000RQ0	G9	CT50300CUG	G8	DUW31	H67	FD685C8	L16	GAR2026	E29
CT2501200Q	G7	CT50300M	G5-G6	DUW34	H67	FD685D12	L16	GAR2029	E29
CT2501200Q0	G7	CT50300M0	G6	DUW44	H67	FD685D8	L16	GAR2034	E29
CT2501200RQ0	G9	CT50300M00	G5	DUW44A	H68	FD68C8	L16	GAR204C	E29
CT250200RQ	G9	CT50300M0UG	G8	DUW44A-E	H68	FD68D12	L16	GAR2126	E29
CT250200RQ0	G9	CT50300MUG	G8	E2C34G1	A20, H38, L18	FD68D8	L16	GAR2129	E29
CT250500RQ	G9	CT50400C	G5-G6	E3C34G1	A20, H38, L18	FD69C8	L16	GAR2134	E29
CT250500RQ0	G9	CT50400C0	G6	E4C34G1	A20, H38, L18	FD69D12	L16	GAR214C	E29
CT250600Q	G7	CT50400C00	G5	EA25	A14	FD69D8	L16	GAR2226	E29
CT250600Q0	G7	CT50400C0UG	G8	EA28	A14	FD70D12	L16	GAR2229	E29
CT250600RQ	G9	CT50400CUG	G8	EA28-2N	A14	FD70D16	L16	GAR2234	E29
CT250600RQ0	G9	CT50400IDC	G5, G10	EA2C	A14	FL1025X03D	B48	GAR224C	E29
CT250800Q	G7	CT50400M	G5-G6	EA34	A14	FL1425X03B	B48	GAR2426	E29
CT250800Q0	G7	CT50400M0	G6	EA34-2N	A14	FL1425X03D	B48	GAR2429	E29
CT250800RQ	G9	CT50400M00	G5	EBP	N97-N98	FL1825X03B	B48	GAR2434	E29
CT250800RQ0	G9	CT50400MH10C	G10	EP10	N70	FL1825X03D	B48	GAR244C	E29
CT30125C	G5-G6	CT50400MH10C0	G10	EP10-1HP	N71	FN62T16	L21	GAR3902	E30
CT30125C0	G6	CT50400MH10M0	G10	EP10-1HP-2	N71	FN63T13	L21	GAR3902-BU	E30
CT30125C00	G5	CT50400RC	G9	EP10-2	N70	FN64T16	L21	GAR3902TC	E31
CT30125C0UG	G8	CT50400RC0	G9	EP6	N70	FN65T12	L21	GAR3903	E30
CT30125CUG	G8	CTASST	G16	EP8	N70	FN66T14	L21	GAR3903-BU	E30
CT30125M	G5-G6	CTB075AA4C	G13	EPAC-6	N69	FN67T12	L21	GAR3903TC	E31
CT30125M0	G6	CTB075RA4C	G13	EPAC-8	N69	FP-10	N66	GAR3904	E30
CT30125M00	G5	CTB075RA4M	G13	EPAC10	N69	FP-6	N66	GAR3904-BU	E30
CT30125MH8C	G10	CTB075S4C	G13	EPP10	N68	FP-8	N66	GAR3904TC	E31
CT30125MH8C0	G10	CTB125AA4C	G13	EPP6	N68	FQN10F25X03B	B47	GAR3905	E30
CT40200C	G6	CTB125RA2C	G13	EPPCASE-1	N68	FQN10F25X03D	B47	GAR3905-BU	E30
CT40200C0	G6	CTB125RA4C	G13	EQC632C	E26, H39	FQN10M25X03B	B47	GAR3905TC	E31
CT40200CUG	G8	CTB125RA4CUG	G8	ES25A25A	H43	FQN10M25X03D	B47	GAR3906	E30

CATALOG NO.	PAGE NO.	CATALOG NO.	PAGE NO.	CATALOG NO.	PAGE NO.	CATALOG NO.	PAGE NO.	CATALOG NO.	PAGE NO.
GAR3906-BU	E30	GD2234	E32	GP1726RT	E56	HFBW42T10CG1	L19	HS_34FR250	F11
GAR3906TC	E31	GD224C	E32	GP1826	E33	HFBW43T10CG1	L19	HS_34T300PF	F7
GAR3907	E30	GG15-1	E42	GP184C	E33	HFBW44T17CG1	L19	HS_34T48PF	F6
GAR3907-BU	E30	GG16-1	E42	GP2026	E33	HFBW64T17CG1	L19	HS_38FR	F11
GAR3907TC	E31	GG17-1	E42	GP2226	E33	HFBW66T16CG1	L19	HS_38FR250	F11
GAR3908	E30	GG17-15	E42	GP6426	E33	HFBW86T20CG1	L19	HS_38T300PF	F7
GAR3908-BU	E30	GG18-1	E42	GP6429	E33	HH5-RL48	N28	HS_38T48PF	F6
GAR3908TC	E31	GG18-15	E42	GP6434	E33	HHS-O/C-B11	N81	HSB100T6PF7	F5
GAR3909	E30	GG18-2	E42	GP644C	E33	HHS-O/C-B13	N81	HSB110H48PF5	F8
GAR3909-BU	E30	GG19-2	E42	GP64526G1	E56	HHS-O/C-B16	N81	HSB110H6PF5	F8
GAR3909TC	E31	GG19-25	E42	GP654CG1	E56	HHS-O/C-B20	N81	HSB110H9PF5	F8
GAR6426	E28	GG20-2	E42	GQ26-1	E43	HIW-716R1	N76	HSB11612T6PF14	F5
GAR6429	E28	GG20-25	E42	GQ2626	E43	HIW12SOCSET	N83	HSB116T6PF26	F5
GAR6434	E28	GG20-3	E42	GQ29-1	E43	HIW71612TGKIT	N76, N83	HSB12T6PF10	F5
GAR644C	E28	GG21-2	E42	GQ2929	E43	HIW716ENF	N75	HSB14T6PF14	F5
GAR644C-RB	E30	GG21-25	E42	GRC12	E45	HIW716ENFTG	N75	HSB150H12PF3	F8
GAR8629	E29	GG21-3	E42	GRC34	E45	HIW716ENFTGKIT	N75	HSB150H48PF5	F8
GB26	E48	GG21-35	E42	GRC58	E45	HIW716VTR1	N76	HSB150H9PF3	F8
GB29	E48	GG22-2	E42	GRF4C-3	E55	HOSE2	N79	HSB18T6PF20	F5
GB34	E48	GG22-25	E42	GRF4C-4	E55	HOSE325	N79	HSB200H12PF2	F8
GB4C	E48	GG22-3	E42	GRL3	E45	HOSE350	N79	HSB200H48PF2	F8
GBL30	E48	GG22-4	E42	GRL4	E45	HP10	N65	HSB200H9PF2	F8
GBM26	E48	GG24-2	E42	GRL5	E45	HP2HV	N79	HSB316T6PF18	F5
GBM29	E48	GIE2CG3	E52	GRL6	E45	HP3	N79	HSB332T6PF24	F5
GBM34	E48	GIE4CG3	E52	GSTUD14HY	E22	HP6	N65	HSB34H48PF5	F8
GBM4C	E48	GIE4CG3P5	E52	GSTUD34HY	E22	HP8	N65	HSB34H6PF10	F8
GC15A	E41	GIE4CG3P7	E52	GSTUD38HY	E22	HPP18	N82	HSB34H9PF10	F8
GC18A	E41	GIE4CG4	E52	GSTUD916HY	E22	HPP18-2	N82	HSB34T6PF8	F5
GC22A	E41	GIE4CG4P5	E52	GTC1AC34RA	E51	HPP5	N82	HSB35H3PF25	F8
GC2525CT	E50	GIE4CG4P7	E52	GX2626	E44	HPS-O/C-4-B11	N81	HSB35H48PF5	F8
GC2626	E48	GK1126	E33	GX264C	E44	HPS-O/C-4-B13	N81	HSB35H6PF25	F8
GC2626CT	E50	GK1129	E33	GX2926	E44	HPS-O/C-5-B11	N81	HSB38100T6PF8	F5
GC2929	E48	GK114C	E33	GX2929	E44	HPS-O/C-5-B13	N81	HSB38T6PF12	F5
GC2929CT	E50	GK1426	E33	GX294C	E44	HPT-59-R1	N80	HSC100FR	F10
GC3434	E48	GK1429	E33	GX3426	E44	HPT-60-R1	N80	HSC100FR100	F10
GC4C4C	E48	GK1434	E33	GX3429	E44	HPT-71-R1	N80	HSC112FR	F10
GC130	E48	GK1526	E33	GX3434	E44	HPT-72-R1	N80	HSC112FR100	F10
GCM26	E48	GK1529	E33	GX344C	E44	HPT-83-R1	N80	HSC12FR	F10
GCM29	E48	GK1626	E33	GX4C4C	E44	HPT-84-R1	N80	HSC12FR250	F10
GCM30	E48	GK1629	E33	GZ26-12	E49	HPT-96-R1	N80	HSC14FR	F10
GCM34	E48	GK1726	E33	GZ26-38	E49	HS_100FR	F11	HSC14FR250	F10
GCM4C	E48	GK1729	E33	GZ26-58	E49	HS_100FR100	F11	HSC18FR	F10
GCRT1/0	E45	GK1826	E33	GZ29-12	E49	HS_100T300PF	F7	HSC18FR250	F10
GD1526	E32	GK1829	E33	GZ29-38	E49	HS_100T48PF	F6	HSC200FR	F10
GD1529	E32	GK1926	E33	GZ29-58	E49	HS_112FR	F11	HSC200FR100	F10
GD1626	E32	GK1929	E33	GZ4C-12	E49	HS_112FR100	F11	HSC34FR	F10
GD1629	E32	GK6426	E33	GZ4C-38	E49	HS_116T300PF	F7	HSC34FR250	F10
GD1726	E32	GK6429	E33	GZ4C-58	E49	HS_116T48PF	F6	HSC38FR	F10
GD1729	E32	GK6434	E33	H12E	N95	HS_12FR	F11	HSC38FR250	F10
GD1734	E32	GK644C	E33	H1E34R	N95	HS_12FR250	F11	HSIC10-500FR	F9
GD174C	E32	GKA4C	E27	H34E12R	N95	HS_12T300PF	F7	HSIC200FR	F9
GD1826	E32	GKA8C	E27	HBR40	N78	HS_12T48PF	F6	HSIC269FR	F9
GD1829	E32	GL2626	E49	HBR66	N78	HS_14FR	F11	HSIC30-1000FR	F9
GD1834	E32	GL2929	E49	HCCACSR	N59	HS_14FR250	F11	HSIC350FR	F9
GD184C	E32	GL3434	E49	HCCUJAL	N59	HS_14T300PF	F7	HSIC4-40FR	F9
GD1926	E32	GL4C4C	E49	HCCGUY	N59	HS_14T48PF	F6	HSIC8-1FR	F9
GD1929	E32	GP10	N72	HCCGUYRPLBLDS	N59	HS_150T48PF	F6	HSKIT	B13
GD1934	E32	GP1126	E33	HCCSOL	N59	HS_18FR	F11	HSM100T6PF7	F5
GD194C	E32	GP1129	E33	HCCSOLRPLBLDS	N59	HS_18FR250	F11	HSM116T6PF26	F5
GD2026	E32	GP114C	E33	HFB22P1	A22	HS_18T300PF	F7	HSM12T6PF10	F5
GD2029	E32	GP1426	E33	HFB33-4N	A23, L21	HS_18T48PF	F6	HSM14T6PF14	F5
GD2034	E32	GP1429	E33	HFB33P1	A22-A23, L20-L21	HS_200FR	F11	HSM18T6PF20	F5
GD204C	E32	GP1434	E33	HFB42P1	A22	HS_200FR100	F11	HSM316T6PF18	F5
GD2126	E32	GP144C	E33	HFB44-4N	A23, L21	HS_200T48PF	F6	HSM332T6PF24	F5
GD2129	E32	GP1526G1	E56	HFB44P1	A22-A23, L20-L21	HS_316T300PF	F7	HSM34T6PF8	F5
GD2134	E32	GP1629	E33	HFB63P1	A22, L20	HS_316T48PF	F6	HSM38T6PF12	F5
GD214C	E32	GP164C	E33	HFB66-6N	A23, L21	HS_332T300PF	F7	HSSHRACK	B12
GD2226	E32	GP1726	E33	HFB66P1	A22-A23, L20-L21	HS_332T48PF	F6	HTP3	N79
GD2229	E32	GP1726G1	E56	HFB88P1	A22, L20	HS_34FR	F11	HYA_28	K65

Alpha-Numeric Index

CATALOG NO.	PAGE NO.	CATALOG NO.	PAGE NO.	CATALOG NO.	PAGE NO.	CATALOG NO.	PAGE NO.	CATALOG NO.	PAGE NO.
HYA_29	K65	K3A25U-2	A26	KC34J12T13	E26, H39	KSU23	A5, H5	LF1010	K56, K58
HYA_31	K65	K3A25U-4	A27	KK3A36U-2N	A26	KSU25	A5, H5	LF2019	K56-K58
HYA_34	K65	K3A26U-2N	A26	KK3A36U-4N	A27	KSU26	A5, H5	LF2027	K56-K58
HYA_39	K65	K3A27U-2N	A26	KK3A40U-2N	A26	KSU27	A5, H5	LF2038	K56-K58
HYAO_28	K65	K3A27U-4N	A27	KK3A40U-4N	A27	KSU29	A5, H5	LF2065	K56-K58
HYAO_29	K65	K3A29U-2N	A26	KK3A44U-2N	A26	KSU31	A5, H5	LF2108	K58
HYAO_31	K65	K3A29U-4N	A27	KK3A44U-4N	A27	KSU34	A5, H5	LH28-3	L14
HYAO_34	K65	K3A2U-2	A26	KK4A36U-4N	A28	KUADP	N35	LH34-3	L14
HYAO_39	K65	K3A2U-4	A27	KK4A40U-4N	A28	KVS26	A7, H5, H7	LHR29-3	L14
HYFLUID GAL	041, N74	K3A31U-2N	A26	KK4A31U-2N	A24	KVS26A	A8, H8	LPC12S	N83
HYFLUID QT	041, N74	K3A31U-4N	A27	KLU125	A13	KVS28	A7, H5, H7	LPC38S	N83
HYM_28	K65	K3A36U-2N	A26	KLU125TP	A13	KVS28A	A8, H8	LPHT3CHISEL11418	N83
HYM_29	K65	K3A36U-4N	A27	KLU175	A13	KVS31	A7, H5, H7	LPHTADPMM71612	N83
HYM_31	K65	K3A40U-4N	A27	KLU175TP	A13	KVS31A	A8, H8	LPHTADPMMOP66	N75, N83
HYM_34	K65	K4A29U-4N	A28	KLU225	A13	KVS34	A7, H5, H7	LPHTADPSMFOP66	N77
HYM_39	K65	K4A31U-4N	A28	KLU225TP	A13	KVS34A	A8, H8	LPHTASPHALTCUT118	N83
HYS_28	K65	K6A34U-6N	K78	KLU25	A13	KVS40	A7, H5, H7	LPHTBIT111618D	N83
HYS_29	K65	K6B28-4N	K77	KLU25TP	A13	KVS40A	A8, H8	LPHTBIT111624D	N83
HYS_31	K65	K6B2826-2N	K77	KLU300	A13	KVS44	A7, H5, H7	LPHTBIT131618D	N83
HYS_34	K65	K6P28	K76	KLU300TP	A13	KVS44A	A8, H8	LPHTBIT131624D	N83
J1207	K70	K6P28C	K76	KLU35	A13	KVSU26	A7, H7	LPHTBIT151618D	N83
J1252	H36	K6P34U	K78	KLU35TP	A13	KVSU28	A7, H7	LPHTBIT151624D	N83
J1592	K70	K6P34UC	K78	KLU400	A13	KVSU31	A7, H7	LPHTCLAYSPADE118	N83
J278	E53	K6PC34U	K78	KLU400TP	A13	KVSU34	A7, H7	LPHTDRIPBODY66	N83
J279	E53	KA25	A14	KLU70	A13	KVSU40	A7, H7	LPHTDRIPBODY88	N83
J280	E53	KA25-2TC 38	A14	KLU70TP	A13	KVSU44	A7, H7	LPHTDRIPNOSE66	N83
J295	E53	KA25U	A24	KPA25	A11	KVSW26	A8, H6	LPHTDRIPNOSE88	N83
J990	H36	KA26U	A24	KPA28	A11	KVSW28	A8, H6	LPHTGRDVR11458	N83
K-PC28	K76	KA28	A14	KPA34	A11	KVSW31	A8, H6	LPHTGRDVR11858	N83
K11A30U	A28	KA29U	A29	KPA4C	A11	KVSW34	A8, H6	LPHTHOSNCR666610N77	N83
K11A34U-2	A28	KA2U	A24, A29	KPA4CUP	A12	KVSW40	A8, H6	LPHTHOSNCR666610OP	N77, N83
K11A36U-2	A28	KA30U	A24	KPA8C	A11	KVSW44	A8, H6	LPHTHOSNCR66668	N75, N77, N83
K11A39U-2	A28	KA31U	A24	KPA8CUP	A12	L717W	N52	LPHTHOSNCR666680P	N77
K21A36U-2	A28	KA34	A14	KPB4CG1	E27	L719W	N52	LPHTHOSNCR66668QP	N83
K22A36U-2	A28	KA34U	A24	KPU29A26AC	A36	L720W	N52	LPHTHTMABODY66	N75, N77
K22A39U-2	A28	KA36U	A24	KPU29A29AC	A36	L722W	N52	LPHTHTMADUSTCAPF	N83
K29P	K31	KA36U-2N	A24	KPU34A26AC	A36	L724W	N52	LPHTHTMADUSTCAPM	N83
K2A25U	A25	KA40U	A24	KPU34A34AC	A36	L725W	N52	LPHTHTMANOSE66	N75, N77
K2A26U	A25	KA40U-2N	A24	KPU39A26AC	A36	L727W	N52	LPHTMOILPT118	N83
K2A29U	A25	KA44U	A24	KPU39A39AC	A36	L728W	N52	LPHTMOILPT11814	N83
K2A31U	A25, A29	KA44U-2N	A24	KS	H4	L729W	N52	LPHTNARCHISEL11814	N83
K2A31U-2N	A25	KA4C	A14	KS15	A4, E26, H4	L735W	N52	LPHTSOC121	N83
K2A36U	A25	KA6U	A24	KS17	A4, E26	LB13A	L30	LPHTSOC1211/118	N83
K2A36U-2N	A25	KA8C	A14	KS17-3	A4, H4	LB14A	L30	LPHTSOC121116	N83
K2A40U	A25, A29	KAU-KIT1	A29	KS20	A4, E26, H4	LB15A	L30	LPHTSOC121112	N83
K2A40U-2N	A25	KAU-KIT2	A29	KS20-3	A4, H4	LB16A	L30	LPHTSOC121114	N83
K2A44U	A25	KAU-KIT3	A29	KS22	A4, E26, H4	LB17A	L30	LPHTSOC121114	N83
K2A44U-2N	A25	KAU-KIT4	A29	KS22-3	A4, H4	LB18A	L30	LPHTSOC121118	N83
K2C15	E25	KC15	E25	KS23	A4, E26, H4	LB19A	L30	LPHTSOC121188PT	N83
K2C15B1	E25	KC15B1	E25	KS25	A4, E26, H4	LB20A	L30	LPHTSOC1212	N83
K2C17	E25	KC17	E25	KS26	A4, E26, H4	LB21A	L30	LPHTSOC12128PT	N83
K2C17B1	E25	KC17B1	E25	KS27	A4, E26, H4	LB22A	L30	LPHTSOC121316	N83
K2C20	E25	KC20	E25	KS29	A4, E26, H4	LB24A	L30	LPHTSOC121316/1516	N83
K2C20B1	E25	KC20B1	E25	KS31	A4, E26, H4	LB53A	L30	LPHTSOC1213168PT	N83
K2C22	E25	KC22	E25	KS34	A4, E26, H4	LB54A	L30	LPHTSOC12138	N83
K2C22B1	E25	KC22B1	E25	KS39	A4, H4	LB55A	L30	LPHTSOC1215168PT	N83
K2C23	E25	KC22J12T13	E26, H39	KS44	A4, H4	LB56A	L30	LPHTSOC121716	N83
K2C23B1	E25	KC23	E25	KS90	A4, H4	LB57A	L30	LPHTSOC1217168PT	N83
K2C25	E25	KC23B1	E25	KSA 1/0	A6	LB58A	L30	LPHTSOC1218PT	N83
K2C25B1	E25	KC25	E25	KSA 2/0	A6	LB59A	L30	LPHTSOC1234	N83
K2C26	E25	KC25B1	E25	KSA 350	A6	LB86A	L30	LPHTSOC12348PT	N83
K2C26B1	E25	KC26	E25, E26, H39	KSA 4/0	A6	LB90A	L30	LPHTSOC1258	N83
K2C28	E25	KC26B1	E25	KSA 500	A6	LB91A	L30	LPHTSOC12588PT	N83
K2C28B1	E25	KC28	E25	KSA2	A6	LB92A	L30	LPHTSOC1278	N83
K2C31	E25	KC28B1	E25	KSA4	A6	LB94A	L30	LPHTSOC12788PT	N83
K2C31B1	E25	KC31	E25	KSA6	A6	LB96A	L30	LPHTSOC12916	N83
K2C34	E25	KC31B1	E25	KSU17	A5, H5	LF1006	K58	LPHTWHP-BCS66606-18	N80
K2C34B1	E25	KC34	E25	KSU20	A5, H5	LF1025	K56-K58	LPHY750CXT	N77
K33B34-4N	K77	KC34B1	E25	KSU22	A5, H5	LF1014	K56-K58		

CATALOG NO.	PAGE NO.	CATALOG NO.	PAGE NO.	CATALOG NO.	PAGE NO.	CATALOG NO.	PAGE NO.	CATALOG NO.	PAGE NO.
LPHY750XT	N77	MD6-6HS72	N24	NA21-4N	L4	NDR65534T12	L15	NNTR36A29A	L24
LSC1/0	H17	MD6-6R	N23	NA22-4N	L4	NDR65544T12	L15	NNTR36A36A	L24
LSC1/0-1	H17	MD6-6R-2	N23	NA22A-4N	L25	NDR6644T12	L15	NNTR42A32A	L24
LSC556	H17	MD6-8AH48	N24	NAH29-2N	L5	NDR6728T12	L15	NNTR42A36A	L24
LSC556-1	H17	MD6-8HS60	N24	NAH34-2N	L5	NDR6734T12	L15	NNTR42A42A	L24
LYM1CC	K57	MD6-8HS72	N24	NAH34-34N	L5	NDR6744T12	L15	NNTR45A45A	L24
LYM25C	K57	MD6-8R	N23	NAH40-2N	L5	NDR6748T12	L15	NNTR46A42A	L24
LYM26C	K57	MD6-AH48	N24	NAH40-34N	L5	NDR6844T12	L15	NNTR46A46A	L24
LYM27C	K57	MD6-CP1	N22	NAH40-44N	L5	NDR6848T12	L15	NNTR48A48A	L24
LYM28C	K57	MD6-K	N19	NAH44-2N	L5	NHNT1329	L9	NS1313	L11
LYM29C	K57	MD6HS60	N24	NAH44-34N	L5	NHNT1429	L9	NS1414HC	L11
LYM2CC	K57	MD6HS72	N24	NAH44-44N	L5	NHNT1434	L9	NS14A14A	L24
LYM30C	K57	MD6R	N23	NAH46-2N	L5	NHNT1529	L9	NS1515	L11
LYM31C	K57	MD7	N20	NAH46-34N	L5	NHNT1534	L9	NS15A15A	L24
LYM32C	K57	MD7-34	N21	NAH46-44N	L5	NHNT1540	L9	NS1616HC	L11
LYM34C	K57	MD7-34-KIT1	N21	NAH48-2N	L5	NHNT1629	L9	NS1717	L11
LYM34P3	K61	MD7-34R	N21	NAH48-34N	L5	NHNT1634	L9	NS17A17A	L24
LYS1CC	K56	MD7-34R-KIT1	N21	NAH48-44N	L5	NHNT1640	L9	NS1818	L11
LYS1CP5	K60	MD7-6	N20	NAR25A-2N	L28	NHNT1644	L9	NS18A18A	L24
LYS25C	K56	MD7-8	N20	NAR29A-2N	L28	NHNT1729	L9	NS1919	L11
LYS25P5	K60	MK7	G16	NAR29A-4N	L28	NHNT1734	L9	NS19A19A	L24
LYS26C	K56	MK9	G16	NAR32A-2N	L28	NHNT1740	L9	NS2020	L11
LYS26P5	K60	MR15	N11	NAR32A-4N	L28	NHNT1744	L9	NS20A20A	L24
LYS27C	K56	MR18	N11	NAR36A-2N	L28	NHNT1829	L9	NS2121	L11
LYS27P5	K60	MR20	N11	NAR36A-4N	L28	NHNT1834	L9	NS21A21A	L24
LYS28C	K56	MR4C	N12	NAR42A-2N	L28	NHNT1840	L9	NS2222	L11
LYS28P5	K60	MR8-1A	N10	NAR42A-4N	L28	NHNT1844	L9	NS22A22A	L24
LYS29C	K56	MR8-33S-1	N10	NAR45A-2N	L28	NHNT1846	L9	NS24A24A	L24
LYS29P5	K60	MR8-33T-1	N10	NAR45A-4N	L28	NHNT1929	L9	NSNT1329	L9
LYS2CC	K56	MR8-9Q	N10	NAR46A-2N	L28	NHNT1934	L9	NSNT1429	L9
LYS2CP5	K60	MR8-G96	N10	NAR46A-4N	L28	NHNT1940	L9	NSNT1434	L9
LYS30C	K56	MR8-G98	N10	NAR48A-2N	L28	NHNT1944	L9	NSNT1529	L9
LYS30P5	K60	MRC840	N15	NAR48A-4N	L28	NHNT1946	L9	NSNT1629	L9
LYS31C	K56	MRC840AL	N15	NAS29-2N	L5	NHNT2044	L9	NSNT2929	L10
LYS31P5	K60	MTB	N97-N98	NAS29-34N	L5	NHNT2929	L10	NSNT3429	L10
LYS32C	K56	MTX	N97-N98	NAS29-N	L5	NHNT3429	L10	NSNT3434	L10
LYS32P5	K60	MY28	N16	NAS34-2N	L5	NHNT3434	L10	NT1313	L8
LYS32P6	K61	MY28-4	N16	NAS34-34N	L5	NHNT4429	L10	NT1413	L8
LYS34C	K56	MY28-6	N16	NAS34-N	L5	NHNT4434	L10	NT1414	L8
LYS34P1G5	K59	MY29 UNIVERSAL KIT	N16	NAS40-2N	L5	NHNT4440	L10	NT1514	L8
LYS34P2	K59	MY29-11	N16	NAS40-34N	L5	NHNT4444	L10	NT1515	L8
LYS34P5	K60	MY29-11C	N16	NBC15A-2N	L27	NHNT4834	L10	NT1614	L8
LYS48P6	K61	MY29-3	N16	NBC15A-34N	L27	NHNT4840	L10	NT1615	L8
LYS4CC	K56	MY29-3C	N16	NBC16A-2N	L27	NHNT4844	L10	NT1616	L8
LYS4CP5	K60	MY29-3CF	N16	NBC16A-34N	L27	NHNT4846	L10	NT1714	L8
LYS64P6	K61	N2AH34-34N	L6	NBC16A-44N	L27	NHNT4848	L10	NT1715	L8
LYS6CP5	K60	N2AH40-34N	L6	NBC17A-2N	L27	NNT15A15A	L23	NT1717	L8
LYS80P6	K61	N2AH44-34N	L6	NBC17A-34N	L27	NNT16A16A	L23	NT1816	L8
M20	H66	N2AH44-44N	L6	NBC17A-44N	L27	NNT17A17A	L23	NT1817	L8
M30	H66	N2AH46-44N	L6	NBC18A-2N	L27	NNT18A18A	L23	NT1818	L8
M40	H66	NA13-2N	L4	NBC18A-34N	L27	NNT19A19A	L23	NT1919	L8
M50	H66	NA14-2N	L4	NBC18A-44N	L27	NNT20A20A	L23	NT2020	L8
M60	H66	NA15-2N	L4	NBC19A-34N	L27	NNT21A20A	L23	NT2121	L8
M70	H66	NA15-4N	L4	NBC19A-44N	L27	NNT22A22A	L23	NT2222	L8
M80	H66	NA15A-2N	L25	NBC20A-34N	L27	NNTR14A29A	L23	NYFT	K55
M8ND	N14	NA15A-4N	L25	NBC20A-44N	L27	NNTR14A36A	L23	NYT2526	K63
M90	H66	NA16-2N	L4	NBC21A-44N	L27	NNTR15A36A	L23	NYT2825	K63
MCC1000	N56	NA16-4N	L4	NBC22A-34N	L27	NNTR15A42A	L23	NYT2828	C109, K63
MCC1000BLADESET	N56	NA16A-4N	L25	NBC22A-44N	L27	NNTR16A29A	L23	NYT282C	K63
MCC500	N56	NA17-2N	L4	NBC24A-34N	L27	NNTR16A32A	L23	NYT2925	C109, K63
MCC500BLADESET	N56	NA17-4N	L4	NBC86A-44N	L27	NNTR16A42A	L23	NYT2926	K63
MD6	N19	NA17A-2N	L25	NDR6328T13	L15	NNTR17A29A	L23	NYT2928	K63
MD6-12	N19	NA17A-4N	L25	NDR6428T16	L15	NNTR18A29A	L23	NYT2929	C109, K63
MD6-14	N19	NA18-4N	L4	NDR6434T16	L15	NNTR19A42A	L23	NYT292C	K63
MD6-37	N19	NA18A-2N	L25	NDR6444T16	L15	NNTR20A32A	L23	NYT3125	K63
MD6-38	N19	NA18A-4N	L25	NDR6528T14	L15	NNTR22A46A	L23	NYT3126	K63
MD6-4	N19	NA19-4N	L4	NDR6534T14	L15	NNTR29A29A	L24	NYT3128	K63
MD6-6	N19	NA19A-4N	L25	NDR6544T14	L15	NNTR32A25A	L24	NYT3129	K63
MD6-6HS60	N24	NA20A-4N	L25	NDR65528T12	L15	NNTR32A32A	L24	NYT3131	K63

Alpha-Numeric Index

CATALOG NO.	PAGE NO.	CATALOG NO.	PAGE NO.	CATALOG NO.	PAGE NO.	CATALOG NO.	PAGE NO.	CATALOG NO.	PAGE NO.
NYT3426	C109, K63	PEN A13-8	F4	PT 29402-1	N74	Q2A34-2N	A17	QGFL39B1	A34, E54, L17
NYT3428	C109, K63	PEN A13-GAL	F4	PT 29900-10	N73	Q2A34-4N	A17	QGFL39B1T6	A34, E54, L17
NYT3429	C109, K63	PEN A13-QT	F4	PT 29900-15	N73	Q2A40-2N	A17	QGFL44B1	A34, E54, L17
NYT3431	K63	PEN E-4	F4	PT 29900-25	N73	Q2A40-4N	A17	QGFL44B1T6	A34, E54, L17
NYT3434	C109, K63	PEN E-55GAL	F4	PT 29901-10	N73	Q2A44-4N	A17	QGFL46B1	A34, E54, L17
NYT3926	K63	PEN E-5GAL	F4	PT 29901-15	N73	Q2A46-4N	A17	QGFL46B1T6	A34, E54, L17
NYT3928	K63	PEN E-8	F4	PT 29901-25	N73	Q2B28-2N	A18	QGFL48B1	A34, E54, L17
NYT3929	C109, K63	PEN E-GAL	F4	PT 29902-10	N73	Q2B31-2N	A18	QN10F25X03B	B44
NYT3931	K63	PEN E-QT	F4	PT 29902-15	N73	Q2B40-4N	A18	QN10F25X03D	B44
NYT3934	C109, K63	PENA 1/2	F4	PT 29902-25	N73	Q3A28-2N	A17	QN14F18X02B	B44
NYT3939	K63	PENA 55GAL	O41	PT 6545	N74	Q3A28-4N	A17	QN14F18X02D	B44
NYT4426	K63	PENA 5GAL	O41	PT 76	N73	Q3A31-2N	A17	QN14F25X03B	B44
NYT4428	K63	PENA GAL	O41	PT 91	N73	Q3A31-4N	A17	QN14F25X03D	B44
NYT4429	C109, K63	PENA QT	O41	PT 93	N74	Q3A34-2N	A17	QN14M18X02B	B45
NYT4431	C109, K63	PENA-4	O41	PT 94	N74	Q3A34-4N	A17	QN14M18X02D	B45
NYT4434	C109, K63	PENA1/2	O41	PT10024162	N58	Q3A40-4N	A17	QN14M25X03B	B45
NYT4439	K63	PENA13 55GAL	O41	PT10037384	N58, N60, N63	Q3A44-4N	A17	QN14M25X03D	B45
NYT4444	C109, K63	PENA13 5GAL	O41	PT10037388	N58, N60, N63	Q3A46-4N	A17	QN18F18X02B	B44
NYT4639	K63	PENA13QT	O41	PT10038657	N61, N64	QA1C-2B	A16	QN18F18X02D	B44
NYT4629	K63	PENA13-8	O41	PT10040663	N61, N64	QA1C-B	A16	QN18F25X03B	B44
NYT4631	K63	PENA13CARTRIDGE	F4, O41	PT10043890	N63	QA26-2B	A16	QN18F25X03D	B44
NYT4634	K63	PENA13GAL	O41	PT10044980	N61	QA26-B	A16	QN18M18X02B	B45
NYT4639	K63	PENA13QT	O41	PT10054094	N64	QA28-2B	A16	QN18M18X02D	B45
NYT4644	K63	PENACARTRIDGE	F3-F4, O41	PT10128	N51	QA28-2N	A16	QN18M25X03D	B45
NYT4646	C109, K63	PENE 55GAL	O41	PT17188	N23	QA28-B	A16	QP10F25X03B	B43
OH25	N17	PENE 5GAL	O41	PT208620	N34-N36, N38, N41, N60-N61	QA31-2B	A16	QP10F25X03D	B43
OUR840	N18	PENE GAL	O41	PT29279-2	N30, N46	QA31-2N	A16	QP14F110X02D	B43
OUR840-WC	N18	PENE QT	O41	PT29291	C9, N4-N5, N28, N30, N46	QA31-B	A16	QP14F18X02B	B43
P15K	N37, N51	PENE-4	O41			QA34-2B	A16	QP14F18X02D	B43
P8A	F4, O41	PENE-8	O41			QA34-2N	A16	QP14F25X03B	B43
PAT46-18V	N37	PENETROX A	F3	PT29360	N28	QA34-4B	A16	QP14F25X03D	B43
PAT46C-18V	N37	PENETROX A-13	F3	PT29402-1	N46	QA34-B	A16	QP14M18X02B	B45
PAT4PC834-18V	N39	PENETROX E	F3	PT2972	N28	QA40-2N	A16	QP14M18X02D	B45
PAT600-18V	N41	PENETROX™ HT	F3	PT4583	N17-N18	QA40-B	A16	QP14M25X03B	B45
PAT644XT-18V	N36	PENHT-1LB	F4, O41	PT4925	N22-N23	QA44-2N	A16	QP14M25X03D	B45
PAT750K-18V	N35	PENHT-4	F4, O41	PT4931-1	N22	QA44-4N	A16	QP18F110X02D	B43
PAT750XT-18V	N34	PENHT-8	F4, O41	PT4946	N4	QA44-B	A16	QP18F18X02B	B43
PAT81KFT-18V	N38	PENHT-GAL	F4, O41	PT4952-1	N22	QA46-2N	A16	QP18F18X02D	B43
PATCHGR18V	N34-N38, N40-N41, N59-N61	PG121-1	N12	PT6515	N50	QA46-B	A16	QP18F25X03B	B43
PATCHGR250V	N34-N37, N40-N41, N59-N61	PG125-1	N12	PT6545	N50	QA4C-2B	A16	QP18F25X03D	B43
		PG133-1	N12	PT6733	N22, N28	QA4C-B	A16	QP18M18X02B	B45
		PGN1425X03B	B46	PT6744	N22	QA8C-2B	A16	QP18M18X02D	B45
		PGN1425X03D	B46	PT8504	N17	QA8C-B	A16	QP18M25X03B	B45
		PGN1825X03B	B46	PU998	N5	QB1C	A18	QP18M25X03D	B45
		PGN1825X03D	B46	PUADP-1	N37, N51	QB26	A18	QPX2828	A9, H13
		PGP1425X03B	B46	Q14F11X02B	B43	QB28	A18	QPX2828-Y	A10
		PGP1425X03D	B46	Q14F11X02D	B43	QB31-2N	A18	QPX282C	A9, H13
		PGP1825X03B	B46	Q14F18X02B	B43	QB4C	A18	QPX282C-Y	A10
		PGP1825X03D	B46	Q14F18X02D	B43	QB8C	A18	QPX2C2C	A9, H13
		POWERCELL	O41	Q14F25X03B	B43	QDA1C	A19	QPX2C2C-Y	A10
		PQ10R258M	N55	Q14F25X03D	B43	QDA26	A19	QPX3428	A9, H13
		PQ14R187M	N55	Q14M18X02B	B44	QDA28	A19	QPX3428-Y	A10
		PQ14R188M	N55	Q14M18X02D	B44	QDA31	A19	QPX342C	A9, H13
		PQ14R256M	N55	Q14M25X03B	B44	QDA34	A19	QPX342C-Y	A10
		PQ14R257M	N55	Q14M25X03D	B44	QDA40	A19	QPX3434	A9, H13
		PQ14R258M	N55	Q18F18X02B	B43	QDA4C	A19	QPX3434-Y	A10
		PQ18R187M	N55	Q18F18X02D	B43	QDA8C	A19	QPX4428	A9, H13
		PQ18R188M	N55	Q18F25X03B	B43	QGFL1CB1	A34, E54, L17	QPX442C	A9, H13
		PQ18R256M	N55	Q18F25X03D	B43	QGFL1CB1T6	A34, E54, L17	QPX4434	A9, H13
		PQ18R257M	N55	Q18M18X02B	B44	QGFL26B1	A34, E54, L17	QPX4444	A9, H13
		PQ18R258M	N55	Q18M18X02D	B44	QGFL26B1T6	A34, E54, L17	QPX4444-Y	A10
		PT 10128	N74	Q18M25X03B	B44	QGFL26B2	A34, E54, L17	QQA1C	A16
		PT 11018	N74	Q18M25X03D	B44	QGFL26B2T6	A34, E54, L17	QQA1C-2	A16
		PT 29074-1	N73-N74	Q2A1C-2	A17	QGFL29B1	A34, E54, L17	QQA26	A16
		PT 29075	N74	Q2A26-2N	A17	QGFL29B1T6	A34, E54, L17	QQA26-2	A16
		PT 29091	N74	Q2A28-2N	A17	QGFL31B1	A34, E54, L17	QQA28	A16
		PT 29214-1	N74	Q2A28-4N	A17	QGFL31B1T6	A34, E54, L17	QQA28-2N	A16
		PT 29279-2	N28	Q2A31-2N	A17	QGFL34B1	A34, E54, L17	QQA31	A16
		PT 29291	N74	Q2A31-4N	A17	QGFL34B1T6	A34, E54, L17	QQA31-2N	A16

CATALOG NO.	PAGE NO.	CATALOG NO.	PAGE NO.	CATALOG NO.	PAGE NO.	CATALOG NO.	PAGE NO.	CATALOG NO.	PAGE NO.
QQA34	A16	RYA2UCR	K68	S2GBP441AB2	M32	SH2GBP41A512	M30	SWA18A-34N	M9
QQA34-2N	A16	RYA2WAC	K68	S2GBP441AB4	M34	SH2GBP41A512B2	M32	SWA18A-44N	M9
QQA40-2N	A16	RYA2WACR	K68	S2GBP4445A	M30	SH2GBP41A512B4	M34	SWA19A-2N	M9
QQA40-4N	A16	RYA31AC	K68	S2GBP4445A12	M30	SH2GBP41A5B2	M32	SWA19A-34N	M9
QQA44-2N	A16	RYA31ACR	K68	S2GBP4445A12B2	M32	SH2GBP41A5B4	M34	SWA19A-44N	M9
QQA4C	A16	RYA31C-2	K68	S2GBP4445A12B4	M34	SH2GBP445A5	M30	SWA20A-2N	M9
QQA4C-2	A16	RYA31CR-2	K68	S2GBP4445AB2	M32	SH2GBP445A512	M30	SWA20A-34N	M9
QR1C	A19	RYA34C-2	K68	S2GBP4445AB4	M34	SH2GBP445A512B2	M32	SWA20A-44N	M9
QR26	A19	RYA34CR-2	K68	S2GBP444A	M30	SH2GBP445A512B4	M34	SWA21A-34N	M9
QR28	A19	RYA4UC	K68	S2GBP444A12	M30	SH2GBP445A5B2	M32	SWA21A-44N	M9
QR31	A19	RYA4UCR	K68	S2GBP444A12B2	M32	SH2GBP445A5B4	M34	SWA22A-44N	M9
QR34	A19	RYA75AC	K68	S2GBP444A12B4	M34	SH2GBP444A5	M30	SWA23A-44N	M9
QR40	A19	RYA75ACR	K68	S2GBP444AB2	M32	SH2GBP444A512	M30	SWA24A-34N	M9
QR4C	A19	RYAC25	K68, K70	S2GBP444AB4	M34	SH2GBP444A512B2	M32	SWA24A-44N	M9
R17A	N97-N99	RYAC31	K68, K70	S2GBP445A	M30	SH2GBP444A512B4	M34	SWA444A-44N	M10
R17C	N97-N99	RYAC31-1	K70	S2GBP445A12	M30	SH2GBP444A5B2	M32	SWA44R-44N	M10
R22B	N97-N99	S2D451R-SG1	I70	S2GBP445A12B2	M32	SH2GBP444A5B4	M34	SWA454A-4N	M10
R24F	N97-N99	S2GBP41A	M30	S2GBP445A12B4	M34	SH2GBP45A5	M30	SWA486A-44N	M10
R25D	N97-N99	S2GBP41A12	M30	S2GBP445AB2	M32	SH2GBP45A512	M30	SWA486A-4N	M10
RA6UC-SL	K69	S2GBP41A12B2	M32	S2GBP445AB4	M34	SH2GBP45A512B2	M32	SWA486A-66N	M10
RA6UCR-SL	K69	S2GBP41A12B4	M34	S2GBP446A	M31	SH2GBP45A512B4	M34	SWA48A-44N	M10
RCC1000	N57	S2GBP41AB2	M32	S2GBP446A12	M31	SH2GBP45A5B2	M32	SWA493R-4N	M10
RCC336	N57	S2GBP41AB4	M34	S2GBP446A12B2	M33	SH2GBP45A5B4	M34	SWA54R-44N	M10
RCC556	N57	S2GBP445A	M30	S2GBP446A12B4	M35	SH2GBP46A5	M31	SWA58A-2N	M9
RCC600	N57	S2GBP445A12	M30	S2GBP446AB2	M33	SH2GBP46A512	M31	SWA58A-34N	M9
RCC750HD	N57	S2GBP445A12B2	M32	S2GBP446AB4	M35	SH2GBP46A512B2	M33	SWA58A-44N	M9
RCC954ACSR1K	N57	S2GBP445A12B4	M34	S2GBP4483A	M31	SH2GBP46A512B4	M35	SWA58R-44N	M10
RDM4-28	K67	S2GBP445AB2	M32	S2GBP4483A12	M31	SH2GBP46A5B2	M33	SWA59A-2N	M9
RDM5-28T	K68	S2GBP445AB4	M34	S2GBP4483A12B2	M33	SH2GBP46A5B4	M35	SWA59A-34N	M9
RDM6-28	K67	S2GBP44A	M30	S2GBP4483A12B4	M35	SH2GBP483A5	M31	SWA59A-44N	M9
RDM7-28T	K68	S2GBP44A12	M30	S2GBP4483AB2	M33	SH2GBP483A512	M31	SWA86A-44N	M9
RDM8-28	K67	S2GBP44A12B2	M32	S2GBP4483AB4	M35	SH2GBP483A512B2	M33	SWA90A-2N	M9
RDMD-28CR	K67	S2GBP44A12B4	M34	S2GBP4486A	M31	SH2GBP483A512B4	M35	SWA90A-34N	M9
RDMD4-2858D	K67	S2GBP44AB2	M32	S2GBP4486A12	M31	SH2GBP483A5B2	M33	SWA90A-44N	M9
RDMD4-28G3	K67	S2GBP44AB4	M34	S2GBP4486A12B2	M33	SH2GBP483A5B4	M35	SWA91A-34N	M9
RDMD6-2858D	K67	S2GBP45A	M30	S2GBP4486A12B4	M35	SH2GBP486A5	M31	SWA91A-44N	M9
RDMD6-28G3	K67	S2GBP45A12	M30	S2GBP4486AB2	M33	SH2GBP486A512	M31	SWA92A-44N	M9
RGC39G1	E53	S2GBP45A12B2	M32	S2GBP4486AB4	M35	SH2GBP486A512B2	M33	SWA93A-44N	M9
RGC44G1	E53	S2GBP45A12B4	M34	S2GBP448A	M31	SH2GBP486A512B4	M35	SWA94-44N	M9
RHCC129ACSR	N63	S2GBP45AB2	M32	S2GBP448A12	M31	SH2GBP486A5B2	M33	SWA94A-34N	M9
RHCC245CUAL	N64	S2GBP45AB4	M34	S2GBP448A12B2	M33	SH2GBP486A5B4	M35	SWA96A-44N	M9
RHCCHSA	N63	S2GBP46A	M31	S2GBP448A12B4	M35	SH2GBP48A5	M31	SWAB19A-2N	M17
RK141-2	B58	S2GBP46A12	M31	S2GBP448AB2	M33	SH2GBP48A512	M31	SWAB19A-34N	M17
RK141ABOX100	B58	S2GBP46A12B2	M33	S2GBP448AB4	M35	SH2GBP48A512B2	M33	SWAB22A-2N	M17
RK142-2	B58	S2GBP46A12B4	M35	S3D451R-SG1	I70	SH2GBP48A512B4	M35	SWAB22A-34N	M17
RK142ABOX100	B58	S2GBP46AB2	M33	S3D55R-SG1	I70	SH2GBP48A5B2	M33	SWAB22A-44N	M17
RK147-2	N25	S2GBP46AB4	M35	S3GBP41A	M36	SH2GBP48A5B4	M35	SWAB86A-2N	M17
RK149-2	A38	S2GBP483A	M31	S3GBP445A	M36	SN10	B55	SWAB86A-34N	M17
RK150-2	A38	S2GBP483A12	M31	S3GBP44A	M36	SN14	B55	SWAB86A-44N	M17
RK151-2	A38	S2GBP483A12B2	M33	S3GBP45A	M36	SN18	B55	SWAC18A-2N	M11
RK152-2	A38	S2GBP483A12B4	M35	S3GBP46A	M36	SNM14	B56	SWAC18A-34N	M11
RK153-2	A38	S2GBP483AB2	M33	S3GBP483A	M36	SNM18	B56	SWAC18A-44N	M11
RK194-2	N25	S2GBP483AB4	M35	S3GBP486A	M36	SP10	B54	SWAC19A-2N	M11
RK225-2	A38	S2GBP486A	M31	S3GBP48A	M36	SP14	B54	SWAC19A-34N	M11
RK226-2	A38	S2GBP486A12	M31	S4D48R-SG1	I70	SP16	B54	SWAC19A-44N	M11
RK227-2	A38	S2GBP486A12B2	M33	S6D441R-SG1	I70	STS33A-4N	M29	SWAC20A-2N	M11
RP50RP02	N62	S2GBP486A12B4	M35	SC2	A4, H4	STS43A-4N	M29	SWAC20A-34N	M11
RP50RP03	N62	S2GBP486AB2	M33	SC2/0	A4, H4	STS44A-4N	M29	SWAC20A-44N	M11
RYA25UC	K68	S2GBP486AB4	M35	SC4	A4, H4	STS44A-4NCG2	M29	SWAC21A-34N	M11
RYA25UCR	K68	S2GBP48A	M31	SCB19A	M27	STS46A-6NCG1	M29	SWAC21A-44N	M11
RYA26UC	K68	S2GBP48A12	M31	SCB20A	M27	SW3A20A44N8	M38	SWAC22A-34N	M11
RYA26UCR	K68	S2GBP48A12B2	M33	SCB21A	M27	SW3A22A44N8	M38	SWAC22A-44N	M11
RYA27UC	K68	S2GBP48A12B4	M35	SCB22A	M27	SW3A24A44N8	M38	SWAC23A-34N	M11
RYA27UCR	K68	S2GBP48AB2	M33	SCB24A	M27	SW3A86A44N8	M38	SWAC24A-34N	M11
RYA28UC	K68	S2GBP48AB4	M35	SCB86A	M27	SW3AB20A44N8	M39	SWAC24A-44N	M11
RYA28UCR	K68	S2GBP4A1A	M30	SF2A44NL12EX	M37	SW3AB22A44N8	M39	SWAC58A-2N	M11
RYA29UC	K68	S2GBP4A1A12	M30	SF2A44NL18EX	M37	SW3AB24A44N8	M39	SWAC58A-34N	M11
RYA29UCR	K68	S2GBP4A1A12B2	M32	SF3A44N8	M40	SW3AB86A44N8	M39	SWAC58A-44N	M11
RYA2UC	K68	S2GBP4A1A12B4	M34	SH2GBP41A5	M30	SWA18A-2N	M9	SWAC59A-2N	M11

Alpha-Numeric Index

CATALOG NO.	PAGE NO.	CATALOG NO.	PAGE NO.	CATALOG NO.	PAGE NO.	CATALOG NO.	PAGE NO.	CATALOG NO.	PAGE NO.
SWAC59A-34N	M11	SWOH18A-5	M22	SWXA22A-44N	M13	TDM177RG2	I69	TN1412G1	B16
SWAC59A-44N	M11	SWOH19A-3	M22	SWXA22A-4NK8	M12	TDM210RG1	I69	TN146G1	B16
SWAC86A-44N	M11	SWOH19A-5	M22	SWXA24A-44N	M13	TDM210RG2	I69	TN18-10	B16
SWAC90A-2N	M11	SWOH20A-3	M22	SWXA24A-4NK8	M12	TDM246RG1	I69	TN18-10F	B37
SWAC90A-34N	M11	SWOH20A-5	M22	SWXA86A-44N	M13	TDM330RG1	I69	TN18-14	B16
SWAC90A-44N	M11	SWOH21A-3	M22	SWXA86A-4NK8	M12	TDM393RG1	I69	TN18-14F	B37
SWAC91A-34N	M11	SWOH21A-5	M22	SWXA92A-44N	M13	TDM430RG1	I69	TN18-38	B16
SWAC91A-44N	M11	SWOH22A-3	M22	SWXA92A-4NK8	M12	TDM99RG1	I69	TN18-4	B16
SWAC92A-34N	M11	SWOH22A-5	M22	SWXA94A-44N	M13	TFM1D5R	N54	TN18-516	B16
SWAC92A-44N	M11	SWOH24A-5	M22	SWXA94A-4NK8	M12	TFV3B12V2	G12	TN18-6	B16
SWAC93A-34N	M11	SWOH86A-5	M22	SWXA96A-4NK8	M12	TFV3B18V2	G12	TN18-6F	B37
SWAC94A-34N	M11	SWT17A17A	M18	SWXHP19A-5	M25	TFV3B6V2	G12	TN18-8	B16
SWAC94A-44N	M11	SWT18A16A-75	M20	SWXHP20A-5	M25	TFV3BLU12	G12	TN18-8F	B37
SWAC96A-44N	M11	SWT18A17A-75	M20	SWXHP21A-5	M25	TFV3BLU18	G12	TN186G1	B16
SWAT18A16A-30	M21	SWT19A16A-75	M20	SWXHP22A-5	M25	TMH261	D4	TN20-2F	B37
SWAT18A17A-30	M21	SWT19A17A-75	M20	SWXHP24A-5	M25	TMH261SS	D4	TN20-6F	B37
SWAT18A18A-30	M21	SWT19A18A-75	M20	SWXHP59A-5	M25	TMH262	D4	TP10-10	B15
SWAT19A16A-30	M21	SWT19A19A	M18	SWXHP86A-5	M25	TMH262SS	D4	TP10-10F	B39
SWAT19A17A-30	M21	SWT20A17A-75	M20	SWXHP90A-5	M25	TMH263	D4	TP10-10LF	B42
SWAT19A18A-30	M21	SWT20A18A-75	M20	SWXHP91A-5	M25	TMH263SS	D4	TP10-10Z	B41
SWAT2019A-30	M21	SWT20A19A-75	M20	SWXHP92A-5	M25	TMH264	D4	TP10-14	B15
SWAT20A17A-30	M21	SWT21A14A	M18	SWXHP94A-5	M25	TMH264SS	D4	TP10-38	B15
SWAT20A18A-30	M21	SWT21A15A	M18	SWXHP96A-5	M25	TMH265	D4	TP10-6	B15
SWAT21A16A-30	M21	SWT21A16A	M18	SWXP20A20A	M16	TMH265SS	D4	TP10-6F	B39
SWAT21A17A-30	M21	SWT21A16A-75	M20	SWXP22A22A	M16	TMH266	D4	TP10-6LF	B42
SWAT21A18A-30	M21	SWT21A17A	M19	SWXP24A24A	M16	TMH267	D4	TP10-6Z	B41
SWAT21A19A-30	M21	SWT21A17A-75	M20	SWXP86A86A	M16	TMH267SS	D4	TP10-8	B15
SWAT21A20A-30	M21	SWT21A18A	M19	SWXP90A90A	M16	TMH268	D4	TP10-8F	B39
SWAT22A20A-30	M21	SWT21A18A-75	M20	SWXP92A92A	M16	TMH268SS	D4	TP10-8LF	B42
SWAT24A18A-30	M21	SWT21A19A	M19	SWXP94A94A	M16	TMH269	D4	TP10-8Z	B41
SWAT24A19A-30	M21	SWT21A19A-75	M20	SWXP96A96A	M16	TMH269SS	D4	TP14-10	B15
SWAT24A20A-30	M21	SWT21A20A	M19	T10-10	B14	TMH270	D4	TP14-10F	B39
SWAT86A20A-30	M21	SWT22A18A	M19	T10-10F	B34	TMH270SS	D4	TP14-10LF	B42
SWAT86A21A-30	M21	SWT22A18A-30	M21	T10-14	B14	TMH271	D4	TP14-10Z	B41
SWAT86A22A-30	M21	SWT22A18A-75	M20	T10-14F	B34	TMH271SS	D4	TP14-14	B15
SWCB19A	M28	SWT22A19A	M19	T10-38	B14	TMH272	D4	TP14-2F	B39
SWCB20A	M28	SWT22A19A-30	M21	T10-516	B14	TMH272SS	D4	TP14-2Z	B41
SWCB22A	M28	SWT22A19A-75	M20	T10-6	B14	TMH289	D4	TP14-38	B15
SWCB24A	M28	SWT22A20A	M19	T10-6F	B34	TMH294	D4	TP14-4	B15
SWCB86A	M28	SWT22A20A-75	M20	T10-8	B14	TMH294SS	D4	TP14-516	B15
SWHRH18A-3CH	M23	SWT22A21A	M19	T10-8F	B34	TMH295	D4	TP14-6	B15
SWHRH18A-5CH	M23	SWT22A22A	M19	T14-10	B14	TMH295SS	D4	TP14-6F	B39
SWHRH19A-3CH	M23	SWT24A18A-75	M20	T14-10F	B34	TMH322SS	D4	TP14-6LF	B42
SWHRH19A-5CH	M23	SWT24A19A-75	M20	T14-14	B14	TMH332	C113, D4	TP14-6Z	B41
SWHRH20A-3CH	M23	SWT24A20A	M19	T14-14F	B34	TMH69	D4	TP14-8	B15
SWHRH20A-5CH	M23	SWT24A20A-75	M20	T14-38	B14	TMH69SS	D4	TP14-8F	B39
SWHRH21A-3CH	M23	SWT24A21A	M19	T14-4	B14	TMHG-42	E20	TP14-8LF	B42
SWHRH21A-5CH	M23	SWT24A22A	M19	T14-516	B14	TMHG-92	E20	TP14-8Z	B41
SWHRH22A-3CH	M23	SWT24A24A	M19	T14-6	B14	TN10-10	B16	TP16-10	B15
SWHRH22A-5CH	M23	SWT86A20A	M19	T14-6F	B34	TN10-10F	B37	TP16-10F	B39
SWHRH24A-3CH	M23	SWT86A20A-75	M20	T14-8	B14	TN10-14	B16	TP16-10LF	B42
SWHRH24A-5CH	M23	SWT86A21A	M19	T14-8F	B34	TN10-14F	B37	TP16-10Z	B41
SWHRH86A-3CH	M23	SWT86A21A-75	M20	T18-10	B14	TN10-38	B16	TP16-14	B15
SWHRH86A-5CH	M23	SWT86A22A	M19	T18-10F	B34	TN10-516	B16	TP16-2F	B39
SWL18A	M26	SWT86A22A-75	M20	T18-14	B14	TN10-6	B16	TP16-2Z	B41
SWL19A	M26	SWT86A24A	M19	T18-14F	B34	TN10-6F	B37	TP16-38	B15
SWL20A	M26	SWT86A86A	M19	T18-38	B14	TN10-8	B16	TP16-4	B15
SWL21A	M26	SWWH19A-5	M24	T18-4	B14	TN10-8F	B37	TP16-6	B15
SWL22A	M26	SWWH19A-7	M24	T18-516	B14	TN14-10	B16	TP16-6F	B39
SWL24A	M26	SWWH20A-5	M24	T18-6	B14	TN14-10F	B37	TP16-6LF	B42
SWL58A	M26	SWWH20A-7	M24	T18-6F	B34	TN14-14	B16	TP16-6Z	B41
SWL59A	M26	SWWH22A-5	M24	T18-8	B14	TN14-14F	B37	TP16-8	B15
SWL86A	M26	SWWH22A-7	M24	T18-8F	B34	TN14-38	B16	TP16-8F	B39
SWL90A	M26	SWWH24A-5	M24	TAD10-14M	N55	TN14-4	B16	TP16-8LF	B42
SWL91A	M26	SWWH24A-7	M24	TBPT-10	A40	TN14-516	B16	TP16-8Z	B41
SWL92A	M26	SWWH86A-5	M24	TBPT-12	A40	TN14-6	B16	TS-KD	N80
SWL93A	M26	SWWH86A-7	M24	TBPT-6	A40	TN14-6F	B37	TS-RD	N80
SWL96A	M26	SWXA20A-44N	M13	TBPT-8	A40	TN14-8	B16	TS-SQ	N80
SWOH18A-3	M22	SWXA20A-4NK8	M12	TDM177RG1	I69	TN14-8F	B37	TWT1	G16

CATALOG NO.	PAGE NO.	CATALOG NO.	PAGE NO.	CATALOG NO.	PAGE NO.	CATALOG NO.	PAGE NO.	CATALOG NO.	PAGE NO.
TWT2	G16	UB258	D8	UCG25RS	H15	VA30-2N	A21, L7	W28K	N40
U1011	N5	UB260	D8	UCG28R	H15	VA34	A21, L7	W28VT	C9, N4, 029
U1104	N5	UB261	D8	UCG28RS	H15	VA34-2N	A21, L7	W29CRT	C9, N4
U1105	N5	UB262	D8	UCG32R	H15	VA34-4N	A21	W29VT	C9, N4, 029
U1CART	C9, N4-N5, 029	UB263	D8	UCG32RS	H15	VA40	A21, L7	W2CRT	C9, N4
U1CRT-1	C9, N4-N5, 029	UB264	D8	UCK-1UL	H9	VA40-2N	A21, L7	W2CVT	C9, N4, 029
U25ART	C9, N4-N5, 029	UB266	D8	UCK-2UL	H9	VA40-4N	A21, L7	W30CRT	C9, N4
U25RT	C9, N4-N5, 029	UB267	D8	UCK-3UL	H9	VP2828	H11	W30VT	C9, N4, 029
U26ART	C9, N4-N5, 029	UB268	D8	UCU28AC	A36	VP3030	H11	W31ART	C9, N4, 029
U26RT	C9, N4-N5, 029	UB269	D8	UDIEKITAL	N5	VP3430	H11	W31CRT	C9, N4
U27ART	C9, N4-N5, 029	UB271	D8	UDIEKITCU	N5	VP3434	H11	W31VT	C9, N4, 029
U27RT	C9, N4-N5, 029	UB275	D8	UDIEKITHYGRD	N5	VP4030	H11	W32CRT	C9, N4
U28ART	C9, N4-N5, 029	UB282	D8	UGS350ULDB	A32	VP4040	H11	W32VT	C9, N4, 029
U28RT	C9, N4-N5, 029	UB291	D8	UGSKIT2	A31	VP4440	H11	W33CRT	C9, N4
U29ART	C9, N4-N5, 029	UB293	D8	UGSKIT250	A31	VP4646	H11	W33VT	C9, N4
U29RT	C9, N4-N5, 029	UB294	D8	UGSKIT8	A32	VT2525	A20, H14, L11	W34CRT	C9, N4
U2CABT	C9, N4-N5, 029	UB300	D8	UH14-3	L13	VT2825	A20, H14, L11	W34VT	C9, N4, 029
U2CRT	C9, N4-N5, 029	UB302	D8	UH15-3	L13	VT2828	A20, H14, L11	W36CRT	C9, N4
U30ART	C9, N4-N5, 029	UB306	D8	UH15-5	L13	VT2C2C	A20, H14, L11	W36RT	C9, N4, 029
U30RT	C9, N4-N5, 029	UB310	D8	UH16-3	L13	VT3025	A20, H14, L11	W3CRT	C9, N4, 029
U31ART	C9, N4-N5, 029	UB311	D8	UH16-5	L13	VT3030	A20, H14, L11	W4CRT	C9, N4
U31RT	C9, N4-N5, 029	UB314	D8	UH17-3	L13	VT3425	A20, H14, L11	W4CVT	C9, N4, 029
U32ART	C9, N4-N5, 029	UB315	D8	UH17-5	L13	VT3428	A20, H14, L11	W5CRT	C9, N4
U32RT	C9, N4-N5, 029	UB317	D8	UH18-3	L13	VT3430	A20, H14, L11	W5CVT	C9, N4, 029
U34ART	C9, N4-N5, 029	UB318	D8	UH18-5	L13	VT3434	A20, H14, L11	W660	C9, N4, 029
U34RT	C9, N4-N5, 029	UB319	D8	UH19-3	L13	VT4040	A20, H14, L11	W8CRT	C9, N4
U36ART	C9, N4-N5, 029	UB328	D8	UH19-5	L13	VT4425	A20, H14, L11	W8CVT	C9, N4, 029
U36RT	C9, N4-N5, 029	UB336	D8	UH20-3	L13	VT4428	A20, H14, L11	WABAG	J13
U38XRT	C9, N4, 029	UB337	D8	UH20-5	L13	VT4834	A20, H14, L11	WAD336-15	J14
U39ART-2	C9, N4-N5, 029	UB344	D8	UH22-5	L13	VVA2	A21	WAD336-29	J14
U39RT	C9, N4-N5, 029	UB354	D8	UHG14A-3	L29	VVA25	A21	WAD336-35	J14
U3CRT	C9, N4, 029	UB357	D8	UHG15A-3	L29	VVA28	A21, L7	WAD336S	J14
U44XRT	C9, N4, 029	UB358	D8	UHG15A-5	L29	VVA28-2N	A21, L7	WAD477-15	J14
U4CABT	C9, N4-N5, 029	UB383	D8	UHG17A-3	L29	VVA30	A21, L7	WAD477-29	J14
U4CRT	C9, N4-N5, 029	UB384	D8	UHG17A-5	L29	VVA30-2N	A21, L7	WAD477-35	J14
U5CRT	C9, N4-N5, 029	UB390	D8	UHG18A-3	L29	VVA34	A21, L7	WAD477S	J14
U6CABT	C9, N4-N5, 029	UB392	D8	UHG18A-5	L29	VVA34-2N	A21, L7	WAD556-15	J14
U8CABT	C9, N4, 029	UB399	D8	UHG19A-3	L29	VVA34-4N	A21, L7	WAD556-29	J14
U8CRT	C9, N4, 029	UB400	D8	UHG20A-3	L29	VVA40	A21, L7	WAD556-35	J14
U997	N5	UB416	D8	UHG20A-5	L29	VVA40-2N	A21, L7	WAD556S	J14
UB101	D8	UB422	D8	UHG21A-3	L29	VVA40-4N	A21, L7	WAS14A-2N	L31
UB1027	D8	UB425	D8	UHG22A-5	L29	VYFT3428CCP	K55	WAS15A-2N	L31
UB1028	D8	UB436	D8	UHG24A-3	L29	VYFT3428CCR	K55	WAS15A-34N	L31
UB1029	D8	UB437	D8	UHG24A-5	L29	VYFT3434CCP	K55	WAS16A-2N	L31
UB1030	D8	UB464	D8	UHKR11A-3	L29	VYFT3434CCR	K55	WAS16A-34N	L31
UB1031	D8	UB540	D8	UHKR11A-5	L29	VYFT3934CCP	K55	WAS17A-2N	L31
UB1032	D8	UC	N5	UHKR13A-3	L29	VYFT3934CCR	K55	WAS17A-34N	L31
UB1033	D8	UC25R2R	H15	UHKR13A-5	L29	VYFT4434CCP	K55	WAS18A-2N	L31
UB104	D8	UC25R2RS	H15	UHKR14A-3	L29	VYFT4434CCR	K55	WAS18A-34N	L31
UB105	D8	UC2834	H12	UHKR14A-5	L29	W-28K	N22	WAS18A-44N	L31
UB106	D8	UC28R	H15	UHKR16A-3	L29	W-687	N22	WAS19A-2N	L31
UB107	D8	UC28RS	H15	UHKR16A-5	L29	W-702	N22	WAS19A-34N	L31
UB124	D8	UC2W28-L	H9	UHR13-3	L13	W-BG	N22	WAS19A-44N	L31
UB178	D8	UC2W30	H12	UHR13-5	L13	W161	C9, N4, 029	WAS20A-2N	L31
UB187	D8	UC3040	H12	UHR15-3	L13	W162	C9, N4, 029	WAS20A-34N	L31
UB199	D8	UC32R	H15	UHR15-5	L13	W163	C9, N4, 029	WAS20A-44N	L31
UB204	D8	UC32RS	H15	UHR17-3	L13	W166	C9, N4, 029	WAS21A-44N	L31
UB222	D8	UC33R	H15	UHR17-5	L13	W1CRT	C9, N4	WAS22A-44N	L31
UB224	D8	UC3444	H12	UO	N5	W1CVT	C9, N4, 029	WAS24A-44N	L31
UB226	D8	UC4W28	H12	UP34R	H65	W239	C9, N4, 029	WAS86A-44N	L31
UB230	D8	UC4W28CONKIT	H16	UP45R	H65	W241	C9, N4, 029	WASC14A2N	L32
UB232	D8	UC6W25	H12	UP45R36R	H65	W245	C9, N4, 029	WASC15A2N	L32
UB236	D8	UC6W25CONKIT	H16	UW25R	H11	W25CRT	C9, N4	WASC15A34N	L32
UB242	D8	UC8W26-L	H9	UW2R	H11	W25VT	C9, N4, 029	WASC16A2N	L32
UB244	D8	UCCOVER1	H16	VA25	A21, L7	W26CRT	C9, N4	WASC16A34N	L32
UB249	D8	UCCOVER1BOX25	H16	VA28	A21, L7	W26VT	C9, N4, 029	WASC17A34N	L32
UB254	D8	UCG25R	H15	VA28-2N	A21, L7	W27CRT	C9, N4	WASC18A34N	L32
UB256	D8	UCG25R2R	H15	VA2C	A21, L7	W27VT	C9, N4, 029	WASC18A44N	L32
UB257	D8	UCG25R2RS	H15	VA30	A21, L7	W28CRT	C9, N4	WASC19A2N	L32

Reference

BURNDY®

Alpha-Numeric Index

CATALOG NO.	PAGE NO.	CATALOG NO.	PAGE NO.	CATALOG NO.	PAGE NO.	CATALOG NO.	PAGE NO.	CATALOG NO.	PAGE NO.
WASC19A34N	L32	WCY 65 PB	J11	WCY74	J7	WS20A	M15	WTCC	J13
WASC19A44N	L32	WCY100	J8	WCY75	J7	WS21A	M15	WTCK	J10, J13
WASC20A2N	L32	WCY101	J8	WCY76	J7	WS22A	M15	WTHRB-1S	J13
WASC20A34N	L32	WCY102	J8	WCY77	J7	WS24A	M15	WTHRB1S	J10
WASC20A44N	L32	WCY103	J8	WCY78	J7	WS58A	M15	WTHY-1S	J13
WASC21A2N	L32	WCY104	J8	WCY79	J7	WS59A	M15	WTHY1S	J10
WASC21A34N	L32	WCY105	J8	WCY80	J7	WS86A	M15	WTOCBR	J10, J13
WASC21A44N	L32	WCY106	J8	WCY81	J7	WS90A	M15	WTOCY	J10, J13
WASC22A2N	L32	WCY107	J8	WCY82	J7	WS91A	M15	WTRB	J13
WASC22A34N	L32	WCY108	J8	WCY83	J7	WS92A	M15	WTRBK	J13
WASC22A44N	L32	WCY109	J8	WCY84	J7	WS94A	M15	WTRBKNHS	J13
WASC24A34N	L32	WCY110	J8	WCY85	J7	WS96A	M15	WTRBKNHSBAG	J13
WASC24A44N	L32	WCY111	J8	WCY86	J7	WSA21A-34N	L31	WTRBWABAG	J13
WASC86A44N	L32	WCY112	J8	WCY87	J7	WSL1	J9	WTRBYK	J13
WCAB30R-2N	J11	WCY113	J8	WCY88	J7	WSL10	J9	WTRBYKNHS	J13
WCAB30R-4N	J11	WCY114	J8	WCY89	J7	WSL11	J9	WTRBYKNHSBAG	J13
WCAY39R-2N	J11	WCY115	J8	WCY90	J7	WSL12	J9	WTRBYWABAG	J13
WCAY39R-4N	J11	WCY116	J8	WCY91	J7	WSL13	J9	WTY	J13
WCAY49R-2N	J11	WCY117	J8	WCY92	J7	WSL14	J9	WTYK	J13
WCAY49R-4N	J11	WCY118	J8	WCY93	J7	WSL2	J9	WTYKNHS	J13
WCB 11 PB	J11	WCY119	J8	WCY94	J7	WSL3	J9	WTYKNHSBAG	J13
WCB10	J6	WCY120	J8	WCY95	J7	WSL4	J9	WTYWABAG	J13
WCB11	J6	WCY121	J8	WCY96	J7	WSL5	J9	X161	N18
WCB12	J6	WCY122	J8	WCY97	J7	WSL6	J9	X241	N18
WCB13	J6	WCY123	J8	WCY98	J7	WSL7	J9	X245	N18
WCB14	J6	WCY124	J8	WCY99	J7	WSL8	J9	X247	N18
WCB15	J6	WCY125	J8	WDA8300	N26	WSL9	J9	X249	N18
WCB16	J6	WCY126	J8	WDC4500	N26	WSLB15A	M14	X660	N18
WCB17	J6	WCY127	J8	WDIETREE	N22, N41	WSLB16A	M14	X840	N18
WCB18	J6	WCY128	J8	WG19A	L33	WSLB17A	M14	X8CART	C9, N4, O29
WCB19	J6	WCY129	J8	WG86A	L33	WSLB18A	M14	XA15A-4N	L25
WCB20	J6	WCY130	J8	WHHWB	J12	WSLB19A	M14	XA16A-4N	L25
WCB21	J6	WCY131	J8	WHSCWH	J12	WSLB20A	M14	XA18-4N	L4
WCB22	J6	WCY132	J8	WHSGB	J12	WSLB21A	M14	XA18A-4N	L25
WCB23	J6	WCY133	J8	WHSPBC	J12	WSLB22A	M14	XA19-4N	L4
WCB24	J6	WCY134	J8	WHSSADP	J12	WSLB24A	M14	XA19A-4N	L25
WCB25	J6	WCY135	J8	WHSTA	J12	WSLB55A	M14	XA20-4N	L4
WCB26	J6	WCY136	J8	WHSWB	J12	WSLB56A	M14	XA20A-4N	L25
WCB27	J6	WCY137	J8	WHSWHADP	J12	WSLB57A	M14	XA21-4N	L4
WCB28	J6	WCY138	J8	WIREMIKE	N25, N30-N31, N46	WSLB58A	M14	XA21A-4N	L25
WCB40	J6	WCY139	J8	WLB15A	M27	WSLB59A	M14	XA22-4N	L4
WCB41	J6	WCY140	J8	WLB16A	M27	WSLB86A	M14	XA22A-4N	L25
WCB42	J6	WCY145	J8	WLB17A	M27	WSLB90A	M14	XA24A-4N	L25
WCB43	J6	WCY48	J6	WLB18A	M27	WSLB91A	M14	XBG	N18
WCB44	J6	WCY49	J6	WLB19A	M27	WSLB92A	M14	XNBG	N18
WCB45	J6	WCY50	J6	WLB20A	M27	WSLB94A	M14	XOH25	N18
WCB46	J6	WCY51	J6	WLB21A	M27	WSLB96A	M14	XP1818	L12
WCB47	J6	WCY52	J7	WLB22A	M27	WSM1	J9	XP2222	L12
WCB30R-4N	J11	WCY53	J7	WLB24A	M27	WSM10	J9	Y-11	K62
WCBY39R-4N	J11	WCY54	J7	WLB55A	M27	WSM11	J9	Y-15	K62
WCBY49R-4N	J11	WCY55	J7	WLB56A	M27	WSM2	J9	Y-22.5	K62
WCCB	J5	WCY56	J7	WLB57A	M27	WSM3	J9	Y-25	K62
WCCLY	J5	WCY57	J7	WLB58A	M27	WSM4	J9	Y-37.5	K62
WCCR	J5	WCY58	J7	WLB59A	M27	WSM5	J9	Y-7.5	K62
WCCSY	J5	WCY59	J7	WLB86A	M27	WSM6	J9	Y-S0	K62
WCHAWAS	J12	WCY60	J7	WLB90A	M27	WSM7	J9	Y10-22	N7
WCR29	J6	WCY61	J7	WLB91A	M27	WSM8	J9	Y10AC9	N67
WCR30	J6	WCY62	J7	WLB92A	M27	WSM9	J9	Y10AC9OEM	N67
WCR31	J6	WCY63	J7	WLB94A	M27	WSS1	J9	Y10D	N6
WCR32	J6	WCY64	J7	WLB96A	M27	WSS2	J9	Y1MRKIT	N13
WCR33	J6	WCY65	J7	WPBBN Box 25	J5	WT2B2RBYK	J13	Y1MRTCKIT	N13
WCR34	J6	WCY66	J7	WPBRN Box 25	J5	WT2B2RBYWABAG	J13	Y1MRTCKIT	N13
WCR35	J6	WCY67	J7	WPBYN Box 25	J5	WT2BRBYK	J13	Y281CR	C84
WCR36	J6	WCY68	J7	WS14A	M15	WT2BRBYWABAG	J13	Y2825R	C84
WCR37	J6	WCY69	J7	WS15A	M15	WTB	J10, J13	Y2826R	C84
WCY 53 PB	J11	WCY70	J7	WS16A	M15	WTBASY1	J10	Y2827R	C84
WCY 54 PB	J11	WCY71	J7	WS17A	M15	WTBGBW	J13	Y282CR	C84
WCY 63 PB	J11	WCY72	J7	WS18A	M15	WTBGBWRBYK	J13	Y284CR	C84
WCY 64 PB	J11	WCY73	J7	WS19A	M15	WTBNHS	J13	Y284WR	C84

CATALOG NO.	PAGE NO.	CATALOG NO.	PAGE NO.	CATALOG NO.	PAGE NO.	CATALOG NO.	PAGE NO.	CATALOG NO.	PAGE NO.
Y286CR	C84	YA1C2TC14	C37	YA26L-2TC14E1	C31	YA29-2LH91	H39	YA30A1	C115
Y2928R	C84	YA1C2TC14E2	C37	YA26L-2TC14E2	C31	YA29-2LN	C32	YA30A1N131T12E	C80
Y29BH	N45	YA1C2TC38	C37	YA26L-2TC38	C31	YA29-LB	C51	YA30A3	C116
Y29NC	N53	YA1CA1	C115	YA26L-BOX	C18	YA292N	C37	YA30A5	C116
Y3025R	C84	YA1CL-2TC14	C31	YA26L2-BOX	C18	YA292NU	C15	YA30A6	C115
Y3026R	C84	YA1CL-2TC14E2	C31	YA26L2NT14	C34	YA292TC38	C37	YA30A6N100T38E	C80
Y3027R	C84	YA1CL-2TC38	C31	YA26L2NT14E1	C34	YA29A1	C115	YA30A9N100T516E	C80
Y3028R	C84	YA1CL-BOX	C18	YA26L6-BOX	C18	YA29A3	C116	YA30L	C19
Y302CR	C84	YA1CL2	C18	YA26L60	C18	YA29A5	C116	YA30L-2TC-38	C32
Y304CR	C84	YA1CL2NT14	C34	YA26LN50T14E	C80	YA29L-2TC38	C32	YA30L-TC12-FX	C45
Y3126R	C84	YA1CL2NT14E2	C34	YA26LNT10	C21	YA29L-BOX	C19	YA30L-TC34-FX	C45
Y3128R	C84	YA1CL4-BOX	C18	YA26LNT38	C21	YA29L2	C19	YA30L-TC38-FX	C45
Y3129R	C84	YA1CL6-BOX	C18	YA26LNT516	C18, C21	YA29L2NT38	C35	YA30L-TC516-FX	C45
Y3425R	C84	YA1CLNT10	C21	YA26N	C25	YA29L2NT38E16	C35	YA30L-TC58-FX	C45
Y3426R	C84	YA1CLNT14	C21	YA27	C25	YA29L4	C19	YA30L1	C19
Y3427R	C84	YA1CN	C24	YA27-2LN	C31	YA29L7	C19	YA30L24	C19
Y3428R	C84	YA1CTC10	C24	YA27-LB	C51	YA29L9TC38	C22	YA30L24N100T38E	C80
Y3429R	C84	YA25	C24	YA272N	C37	YA29LENT516	C22	YA30L27	C19
Y342CR	C84	YA25-2L	C31	YA272NU	C15	YA29LNT38	C19, C22	YA30L28	C19
Y3430R	C84	YA25-2LN	C31	YA272TC14E2	C37	YA29LTC78	C19	YA30L7	C19
Y3431R	C84	YA25-LB	C51	YA272TC38	C37	YA2C	C24	YA30LNT14	C22
Y3432R	C84	YA252N	C37	YA27A1	C115	YA2C-2L	C31	YA30LNT38	C22
Y34BH	N44	YA252NTC38	C37	YA27A10S76T516E	C80	YA2C-2LN	C31	YA31	C26
Y35	N27	YA252NU	C15	YA27A3	C115	YA2C-LB	C51	YA31-2LH90	H39
Y35-16	N28	YA252TC14	C37	YA27A5	C116	YA2C2N	C37	YA31-2LN	C32
Y35-2	N27	YA252TC14E2	C37	YA27A7	C116	YA2C2NTC38	C37	YA31-L2NTC-FX	C58
Y35/Y39 REP KIT A	N28	YA252TC38	C37	YA27L-2TC14E2	C31	YA2C2NU	C14	YA31-L2NTC38-FX	C58
Y35B	N42	YA252TC516	C37	YA27L-2TC38	C31	YA2C2TC14	C37	YA31-L2TC12-FX	C58
Y35BH	N42	YA25A1	C115	YA27L-BOX	C18	YA2C2TC14E2	C37	YA31-L2TC38-FX	C58
Y35BH-4	N42	YA25A1S60T516E	C80	YA27L2NT14	C35	YA2C2TC38	C37	YA31-LB	C51
Y35H	N42	YA25A3	C115	YA27L2NT38	C35	YA2C2TC38E2	C37	YA31-TC12-FXB	C55
Y35P3	N28	YA25A3N69T38E	C80	YA27L3	C18	YA2C2TC38E6	C37	YA312N	C38
Y39	N29	YA25A5	C116	YA27L4-BOX	C18	YA2C2TC516E2	C37	YA312N-FXB	C64
Y3934R	C84	YA25A7	C116	YA27LENT516	C35	YA2CA1	C115	YA312NU	C15
Y3936R	C84	YA25A9	C115	YA27LNT14	C22	YA2CA1S91T516E	C80	YA312TC14E2	C38
Y39BH	N43	YA25L-2TC14	C31	YA27LNT38	C18, C22	YA2CA3	C115	YA312TC38	C38
Y4439R	C84	YA25L-2TC14E1	C31	YA27LNT516	C22	YA2CA5	C115	YA312TC38-FXB	C64
Y45	N50	YA25L-2TC14E2	C31	YA28	C25	YA2CA5S53T14E	C80	YA31A1	C115
Y46	N51	YA25L-2TC38	C31	YA28-2LH114	H39	YA2CA9	C116	YA31A11N100T516E	C80
Y46-2	N51	YA25L-BOX	C18	YA28-2LH115	H39	YA2CL-2TC14	C31	YA31A3	C116
Y46C	N51	YA25L2-BOX	C18	YA28-2LN	C32	YA2CL-2TC14E1	C31	YA31A5	C116
Y4PC834	N33	YA25L2NT14	C34	YA28-LB	C51	YA2CL-2TC14E2	C31	YA31A9N100T38E	C80
Y4PC834MBH	N49	YA25L2NT14E1	C34	YA282N	C37	YA2CL-2TC38	C31	YA31L	C19
Y500CT-HS	N26	YA25L4-BOX	C18	YA282NTC38	C37	YA2CL-2TC516	C31	YA31L-2NTC516	C32
Y60BHU	N52	YA25L6-BOX	C18	YA282NU	C15	YA2CL-BOX	C18	YA31L-2TC12	C32
Y60BHUD	N52	YA25LN50T14E	C80	YA282TC14E2	C37	YA2CL2-BOX	C18	YA31L-2TC14E2	C32
Y644HSCASE	N31	YA25LN64T516E	C80	YA282TC38	C37	YA2CL2NT14	C34	YA31L-2TC38	C32
Y644HSXT	N31	YA25LNT10	C21	YA28A1	C115	YA2CL2NT14E1	C34	YA31L-NT12-FX	C46
Y644MBH	N47	YA25LNT14	C21	YA28A14N100T516E	C80	YA2CL2NT14E2	C34	YA31L-TC12-FX	C46
Y750BHXT	N46	YA25N	C25	YA28A1N100T38E	C80	YA2CL4-BOX	C18	YA31L-TC14-FX	C46
Y750CBHXT	N46	YA25TC10	C24	YA28A3	C115	YA2CL6-BOX	C18	YA31L-TC34-FX	C46
Y750CHSXT	N30	YA25TC38	C24	YA28A5	C116	YA2CLNT10	C21	YA31L-TC38-FX	C46
Y750HSCASE	N30	YA26	C25	YA28A7	C116	YA2CLNT14	C21	YA31L-TC516-FX	C46
Y750HSXT	N30	YA26-2L	C31	YA28L-2NTC516	C32	YA2CLNT516	C21	YA31L-TC58-FX	C46
Y81KFT	N32	YA26-2LH89	H39	YA28L-2TC14E1	C32	YA2CN	C24	YA31L11	C19
Y81KFTMBH	N48	YA26-2LN	C31	YA28L-2TC14E2	C32	YA2CTC10	C24	YA31L2NT38	C35
Y8MRB-1	N9	YA26-LB	C51	YA28L-2TC38	C32	YA2CTC14	C24	YA31L2NT38E16	C35
YA-A-KIT1	C117	YA262N	C37	YA28L-2TC38E2	C32	YA30	C26	YA31L2NT38FX	C60
YA-AKIT2	C117	YA262NU	C15	YA28L-BOX	C18	YA30-2LH85	H39	YA31L36	C19
YA-AKIT3	C117	YA262TC14	C37	YA28L2-BOX	C18	YA30-2LN	C32	YA31L7	C19
YA10A-TN	C114	YA262TC14E2	C37	YA28L2NT14	C35	YA30-L2NTC-FX	C58	YA31LNT12	C22
YA12A-TN	C114	YA262TC38	C37	YA28L3	C18	YA30-L2TC12-FX	C58	YA31LNT12FX	C47
YA15ALKIT	C16	YA26A1	C115	YA28L4-BOX	C18	YA30-L2TC38-FX	C58	YA31LNT38	C19, C22
YA1C	C24	YA26A13N100T516E	C80	YA28L56	C18	YA30-LB	C51	YA32	C26
YA1C-2L	C31	YA26A3	C116	YA28LNT14	C22	YA30-TC12-FXB	C55	YA32-2L	C32
YA1C-2LN	C31	YA26A5	C116	YA28LNT38	C18, C22	YA302N	C38	YA32-2LN	C32
YA1C-LB	C51	YA26A6	C115	YA28LNT516	C22	YA302N-FXB	C64	YA32-L2NTC-FX	C58
YA1C2N	C37	YA26A6N100T38E	C80	YA28TC38	C25	YA302NU	C15	YA32-L2TC38-FX	C58
YA1C2NU	C15	YA26L-2TC14	C31	YA29	C25	YA302TC38	C38	YA32-LB	C51

Alpha-Numeric Index

CATALOG NO.	PAGE NO.	CATALOG NO.	PAGE NO.	CATALOG NO.	PAGE NO.	CATALOG NO.	PAGE NO.	CATALOG NO.	PAGE NO.
YA32-TC12-FXB	C55	YA34L37	C19	YA38L-TC38-FX	C46	YA402N	C38	YA472N	C38
YA322N	C38	YA34L6	C19	YA38L-TC516-FX	C46	YA402N-FXB	C65	YA472NU	C15
YA322N-FXB	C64	YA34L6N131T12E	C80	YA38L-TC58-FX	C46	YA402NU	C15	YA47N	C26, C43
YA322NU	C15	YA34L8	C19	YA38L2ENT38FX	C60	YA40L	C20	YA48	C26
YA322TC38	C38	YA34L9	C19	YA38L2NNTFX	C60	YA40L-2TC38	C33	YA482N	C38
YA322TC38-FXB	C64	YA34LNT12	C22	YA38L2NT38FX	C60	YA40L-TC12-FX	C46	YA482NU	C15
YA32A1	C115	YA34LNT38	C22	YA38LNT12FX	C48	YA40L-TC38-FX	C46	YA484N	C43
YA32A5	C116	YA34N	C26	YA38LNTM20FX	C48	YA40L-TC516-FX	C46	YA4864N	C43
YA32A8N106T516E	C80	YA35	C26	YA38N	C26	YA40L-TC58-FX	C46	YA48A3	C116
YA32L	C19	YA35-2L	C32	YA39	C26	YA40L2NNTFX	C60	YA48L	C20, C79
YA32L-2TC38	C32	YA35-2LN	C32	YA39-2L	C33	YA41	C26	YA48N	C26
YA32L-2TC38E5	C32	YA352N	C38	YA39-2LN	C33	YA41-2L	C33	YA4C	C23
YA32L-TC12-FX	C46	YA35L	C19	YA39-L2NTC-FX	C58	YA412N	C38	YA4C-2L	C31
YA32L-TC38-FX	C46	YA35N	C26	YA39-LB	C51	YA41L	C20	YA4C-2LN	C31
YA32L-TC58-FX	C46	YA36	C26	YA392LNN131T12E	C80	YA41N	C26	YA4C-LB	C51
YA32L1	C19	YA36-2LN	C32	YA392N	C38	YA44	C26	YA4C2N	C36
YA32L14	C19	YA36-L2NTC-FX	C58	YA392NT38	C38	YA44-2L	C33	YA4C2NU	C14
YA32L2NT38FX	C60	YA36-L2TC38-FX	C58	YA392NU	C15	YA44-2LN	C33	YA4C2TC14	C36
YA32LNT12	C22	YA36-LB	C51	YA392TC38	C38	YA44-L2NNT-FX	C58	YA4C2TC14E2	C36
YA32LNT38	C22	YA36-TC12-FXB	C55	YA39A1	C115	YA44-L2NT38-FX	C58	YA4C2TC38	C36
YA32LNT38FX	C48	YA36-TC58-FXB	C55	YA39A1N131TD12E	C81	YA44-L2NTC-FX	C58	YA4CA1	C115
YA32LNT516FX	C48	YA362MFXB	C64	YA39A3	C115	YA44-L2TC12-FX	C58	YA4CA3	C115
YA32LTC78	C19	YA362N	C38	YA39A5	C116	YA44-L2TC12E3-FX	C58	YA4CA6	C115
YA32N	C26	YA362NU	C15	YA39A5N131TD12E	C81	YA44-L2TC38-FX	C58	YA4CL-2TC14	C31
YA33	C26	YA362TC38	C38	YA39A7	C116	YA44-L2TC58-FX	C58	YA4CL-2TC14E1	C31
YA33-2LN	C32	YA36A1	C115	YA39AM2	C116	YA44-LB	C51	YA4CL-2TC14E2	C31
YA332N	C38	YA36A3	C116	YA39L	C19	YA44-TC58-FXB	C55	YA4CL-2TC38	C31
YA33L	C19	YA36A3N131TD12E	C81	YA39L-2TC12E3	C33	YA442N	C38	YA4CL-2TC516	C31
YA33N	C26	YA36A5	C116	YA39L-2TC38	C33	YA442N-FXB	C65	YA4CL-BOX	C18
YA34	C26	YA36A9N131TD12E	C81	YA39L-2TC58	C33	YA442NU	C15	YA4CL1-BOX	C18
YA34-2L	C32	YA36L	C19	YA39L2	C19	YA442TC38	C38	YA4CL3-BOX	C18
YA34-2LH110	H39	YA36L-2TC38	C32	YA39L2NT12E1	C35	YA442TC38-FXB	C65	YA4CL4-BOX	C18
YA34-2LH111	H39	YA36L-TC12-FX	C46	YA39L2NT38	C35	YA444N	C43	YA4CL6-BOX	C18
YA34-2LN	C32	YA36L-TC58-FX	C46	YA39L2NT38E16	C35	YA444NU	C15	YA4CLNT10	C21
YA34-L2NTC38-FX	C58	YA36L11	C19	YA39L6	C19	YA44A1	C115	YA4CN	C24
YA34-L2NTC-FX	C58	YA36L2NNT	C35	YA39L6N131T12E	C80	YA44A3	C116	YA4CTC10	C23
YA34-L2NTC38-FX	C58	YA36L2NT38FX	C60	YA39L9	C19	YA44L	C20	YA4CTC38	C24
YA34-L2TC12-FX	C58	YA36LNT12	C22	YA39LNT12	C22	YA44L-2TC12	C33	YA5C	C23
YA34-L2TC38-FX	C58	YA36LNT38	C22	YA39LNT38	C19, C22	YA44L-TC12-FX	C46	YA5C-2L	C30
YA34-L2TC516-FX	C58	YA36LTC78	C19	YA39LNT58	C22	YA44L-TC58-FX	C46	YA5C-LB	C51
YA34-LB	C51	YA36N	C26	YA39N	C26	YA44L2	C20	YA5C2N	C36
YA34-TC12-FXB	C55	YA37	C26	YA3C	C24	YA44L23	C20	YA5CL-BOX	C17
YA342LNN119T12E	C80	YA37-2L	C32	YA3C-2L	C31	YA44L2NNTFX	C60	YA5CN	C23
YA342LNN131T12E	C80	YA37-2LN	C32	YA3C-LB	C51	YA44L2NT38FX	C60	YA6C	C23
YA342N	C38	YA372N	C38	YA3C2N	C36	YA44LNT12FX	C48	YA6C-2L	C30
YA342N-FXB	C64	YA37L	C19	YA3C2N-FXB	C63	YA44LNT38FX	C48	YA6C-2L51	C30
YA342NU	C15	YA37L1	C19	YA3C2NU	C14	YA44N	C26	YA6C-2L52	C30
YA342TC14E2	C38	YA37N	C26	YA3C2TC14	C36	YA45	C26	YA6C-2LN	C30
YA342TC38	C38	YA38	C26	YA3C2TC14E2	C36	YA452N	C38	YA6C2N	C36
YA342TC38-FXB	C64	YA38-2L	C33	YA3C2TC38	C36	YA452NU	C15	YA6C2NU	C14
YA34A1	C115	YA38-2LN	C33	YA3C2TC38-FXB	C63	YA4532N	C38	YA6C2TC14	C36
YA34A3	C116	YA38-L2NNT-FX	C58	YA3C2TC38E2	C36	YA453L	C20	YA6C2TC14E1	C36
YA34A3N131T12E	C81	YA38-L2NT38-FX	C58	YA3C2TC516-FXB	C63	YA454N	C43	YA6C2TC14E2	C36
YA34A5	C116	YA38-L2NTC-FX	C58	YA3CL	C18	YA454NU	C15	YA6C2TC38	C36
YA34A7N131T12E	C81	YA38-L2TC12-FX	C58	YA3CL-2TC14	C31	YA45A5	C116	YA6C2TC38E2	C36
YA34A8N131T38E	C81	YA38-L2TC38-FX	C58	YA3CL-2TC38	C31	YA45L	C20	YA6C2TC38E6	C36
YA34L	C19	YA38-L2TC516-FX	C58	YA3CLNT14	C21	YA45L2NT38FX	C60	YA6CA1	C114
YA34L-2TC12	C32	YA38-LB	C51	YA3CLNT516	C21	YA46	C26	YA6CA3	C114
YA34L-2TC14E2	C32	YA38-TC58-FXB	C55	YA3CN	C24	YA46-TC58-FXB	C55	YA6CL-2TC10	C30
YA34L-2TC38	C32	YA382-FXBG2	C64	YA3CTC14	C24	YA462N	C38	YA6CL-2TC14	C30
YA34L-TC12-FX	C46	YA382-FXBG3	C64	YA3CTC38	C24	YA462N-FXB	C65	YA6CL-2TC14E	C30
YA34L-TC38-FX	C46	YA382N	C38	YA40	C26	YA462NU	C15	YA6CL-2TC14E1	C30
YA34L-TC516-FX	C46	YA382N-FXB	C64	YA40-2L	C33	YA464N	C43	YA6CL-2TC14E2	C30
YA34L-TC58-FX	C46	YA382TC38	C38	YA40-2LN	C33	YA464NU	C15	YA6CL-2TC38	C30
YA34L20	C19	YA382TC38-FXB	C64	YA40-L2NNT-FX	C58	YA46A3	C116	YA6CL-2TC516	C30
YA34L2NT38	C35	YA38L	C19	YA40-L2NTC-FX	C58	YA46A5	C116	YA6CL-2TC516E2	C30
YA34L2NT38E16	C35	YA38L-2TC12	C33	YA40-L2TC38-FX	C58	YA46L	C20	YA6CL-BOX	C17
YA34L2NT38FX	C60	YA38L-2TC38	C33	YA40-LB	C51	YA46N	C26	YA6CL1-BOX	C17
YA34L2NTE1	C35	YA38L-TC12-FX	C46	YA40-TC58-FXB	C55	YA47	C26	YA6CL3-BOX	C17

CATALOG NO.	PAGE NO.	CATALOG NO.	PAGE NO.	CATALOG NO.	PAGE NO.	CATALOG NO.	PAGE NO.	CATALOG NO.	PAGE NO.
YA6CL4-BOX	C17	YAD14-38M	B14, N55	YAE14-N1	B4	YAE18N24	B18	YAE22Z3 BOX	B40
YA6CL6-BOX	C17	YAD14-4	B14	YAE14-N2	B4	YAE18N24 BOX	B18	YAE22Z3M	N55
YA6CLNT6	C21	YAD14-4M	B14, N55	YAE14-N3	B4	YAE18N24M	B18	YAES10-N11	B4
YA6CN	C23	YAD14-516	B14	YAE14-N4	B4	YAE18N25	B18	YAES10-N12	B4
YA6CTC10	C23	YAD14-6	B14	YAE14-N43	B4	YAE18N25M	B18, N55	YAES10-N13	B4
YA8C-2LN	C30	YAD14-6F	B34	YAE14N	B4, B18	YAE18N26	B18	YAES10-N14	B4
YA8C-L1-BOX	C44	YAD14-6M	B14, N55	YAE14N BOX	B18	YAE18N26M	B18, N55	YAES10-N56	B4
YA8C-L2-BOX	C44	YAD14-8	B14	YAE14N1	B18	YAE18N27	B18	YAES10-N57	B4
YA8C-L2TC10	C56	YAD14-8F	B34	YAE14N1 BOX	B18	YAE18N27 BOX	B18	YAES10-N58	B4
YA8C-L2TC14	C56	YAD14-8M	B14, N55	YAE14N1M	B18, N55	YAE18N27M	B18, N55	YAES10K-11	B20
YA8C-L2TC14E1	C56	YAD18-10	B14	YAE14N2	B18	YAE18N29	B18	YAES10K-11T1	B20
YA8C-L2TC14E2	C56	YAD18-10M	B14, N55	YAE14N2 BOX	B18	YAE18N29 BOX	B18	YAES10K-12	B20
YA8C-L2TC38	C56	YAD18-14	B14	YAE14N2M	B18, N55	YAE18N29M	B18, N55	YAES10K-13	B20
YA8C-L3-BOX	C44	YAD18-14F	B34	YAE14N3	B18	YAE18N2M	B18, N55	YAES10K-14	B20
YA8C-L4-BOX	C44	YAD18-14M	B14, N55	YAE14N3 BOX	B18	YAE18N3	B18	YAES10K-56	B20
YA8C-LB	C51	YAD18-38	B14	YAE14N3M	B18, N55	YAE18N3 BOX	B18	YAES10K-57	B20
YA8C-TC14-FXB	C54	YAD18-4	B14	YAE14N4	B18	YAE18N3M	B18, N55	YAES10K-58	B20
YA8C2NU	C14	YAD18-4M	B14, N55	YAE14N4 BOX	B18	YAE18N56F	B38	YAES10N11	B16
YA8C2TC14	C36	YAD18-516	B14	YAE14N43	B18	YAE18N56FM	B38, N55	YAES10N11F	B37
YA8C2TC14E2	C36	YAD18-6	B14	YAE14N43 BOX	B18	YAE18N57F	B38	YAES10N12	B16
YA8C2TC14E2-FXB	C63	YAD18-6F	B34	YAE14N43M	B18, N55	YAE18N57F BOX	B38	YAES10N12F	B37
YA8C2TC38	C36	YAD18-6M	B14, N55	YAE14N4M	B18, N55	YAE18N57FM	B38, N55	YAES10N13	B16
YA8C2TC38-FXB	C63	YAD18-8	B14	YAE14N52	B16	YAE18N60F	B38	YAES10N14	B16
YA8CA1	C114	YAD18-8F	B34	YAE14N76F	B38	YAE18N60F BOX	B38	YAES10N56	B16
YA8CA3	C114	YAD18-8M	B14, N55	YAE14N76FM	B38, N55	YAE18NM	B18, N55	YAES10N56F	B37
YA8CA3S56T14E	C80	YAE-18N24M	N55	YAE14N77F	B38	YAE18Z1	B40	YAES10N57	B16
YA8CL-2TC10	C30	YAE10-N11	B4	YAE14N77F BOX	B38	YAE18Z1 BOX	B40	YAES10N57F	B37
YA8CL-2TC10E2	C30	YAE10-N2	B4	YAE14N77FM	B38, N55	YAE18Z1M	N55	YAES14-N10	B4
YA8CL-2TC14	C30	YAE10-N3	B4	YAE14N78F	B38	YAE18Z2	B40	YAES14-N52	B4
YA8CL-2TC14E1	C30	YAE10-N4	B4	YAE14N78F BOX	B38	YAE18Z2 BOX	B40	YAES14-N53	B4
YA8CL-2TC14E2	C30	YAE10-N5	B4	YAE14N78FM	B38, N55	YAE18Z3	B40	YAES14-N54	B4
YA8CL-2TC38	C30	YAE10N	B4, B18	YAE14NM	B18, N55	YAE18Z3 BOX	B40	YAES14-N6	B4
YA8CL-BOX	C17, C44	YAE10N BOX	B18	YAE14Z2	B40	YAE18Z3M	N55	YAES14-N7	B4
YA8CL1-BOX	C17	YAE10N11	B18	YAE14Z2 BOX	B40	YAE18Z4	B40	YAES14-N8	B4
YA8CL2-BOX	C17	YAE10N11 BOX	B18	YAE14Z3	B40	YAE18Z4 BOX	B40	YAES14-N9	B4
YA8CL3-BOX	C17	YAE10N11M	B18, N55	YAE14Z3 BOX	B40	YAE18Z4M	N55	YAES14K-10	B20
YA8CL4-BOX	C17	YAE10N2	B18	YAE14Z3M	N55	YAE10N2M	B18	YAES14K-53	B20
YA8CLNT6	C21	YAE10N2M	N55	YAE14Z4	B40	YAE22-G13	B4	YAES14K-54	B20
YA8CLNT8	C21	YAE10N3	B18	YAE14Z4 BOX	B40	YAE22-G14	B4	YAES14K-6	B20
YA8CTC10	C23	YAE10N3 BOX	B18	YAE14Z4M	N55	YAE22-G15	B4	YAES14K-7	B20
YA8CTC14	C23	YAE10N3M	B18, N55	YAE18-G43	B4	YAE22-G16	B4	YAES14K-8	B20
YA8CTC38	C23	YAE10N4	B18	YAE18-N15	B4	YAE22-G18	B4	YAES14K-9	B20
YAB25-2LH70	H39	YAE10N4M	B18, N55	YAE18-N17	B4	YAE22G12	B17	YAES14N10	B16
YAB25-2LH71	H39	YAE10N5	B18	YAE18-N2	B4	YAE22G12 BOX	B17	YAES14N53	B16
YAB2C-2LH74	H39	YAE10N5 BOX	B18	YAE18-N21	B4	YAE22G13	B17	YAES14N53F	B37
YAB2C2LH75	H39	YAE10N5M	B18, N55	YAE18-N3	B4	YAE22G13 BOX	B17	YAES14N54	B16
YAB344N	C43	YAE10NM	B18, N55	YAE18-N7	B18	YAE22G13M	B17, N55	YAES14N54F	B37
YAB394N	C43	YAE12N	B18	YAE18-N7M	B18, N55	YAE22G14	B17	YAES14N55	B16
YAB4C-2LH72	H39	YAE12N BOX	B18	YAE18G43	B18	YAE22G14 BOX	B17	YAES14N6	B16
YAC-CASE	N67	YAE12N1	B18	YAE18G43 BOX	B18	YAE22G15	B17	YAES14N6F	B37
YAD10-10	B14	YAE12N1 BOX	B18	YAE18G43F	B38	YAE22G15 BOX	B17	YAES14N7	B16
YAD10-10F	B34	YAE12N1M	B18, N55	YAE18G43F BOX	B38	YAE22G16	B17	YAES14N8	B16
YAD10-14	B14	YAE12N2	B18	YAE18G43FM	B38, N55	YAE22G16 BOX	B17	YAES14N8F	B37
YAD10-14M	B14	YAE12N2 BOX	B18	YAE18G43M	B18, N55	YAE22G16M	B17, N55	YAES14N9	B16
YAD10-38	B14	YAE12N2M	B18, N55	YAE18G60FM	B38	YAE22G18	B17	YAES18-N1	B4
YAD10-38M	B14, N55	YAE12N3M	N55	YAE18N	B4, B18	YAE22G18 BOX	B17	YAES18-N2	B4
YAD10-516	B14	YAE12N7	B18	YAE18N21	B4	YAE22G18M	B17, N55	YAES18-N3	B4
YAD10-516M	B14, N55	YAE12N9	B18	YAE18N3	B4	YAE22N65F	B38	YAES18-N4	B4
YAD10-6	B14	YAE12N9 BOX	B18	YAE18N1 BOX	B18	YAE22N65F BOX	B38	YAES18-N48	B4
YAD10-6F	B34	YAE12N9M	B18, N55	YAE18N15	B18	YAE22N65FM	B38, N55	YAES18-N49	B4
YAD10-8	B14	YAE12NM	B18, N55	YAE18N15 BOX	B18	YAE22N66F	B38	YAES18-N5	B4
YAD10-8F	B34	YAE12Z2	B40	YAE18N15M	B18	YAE22N66F BOX	B38	YAES18-N50	B4
YAD10-8M	B14, N55	YAE12Z2 BOX	B40	YAE18N17	B18	YAE22N66FM	B38, N55	YAES18K-1	B20
YAD14-10	B14	YAE12Z2M	N55	YAE18N1M	B18, N55	YAE22Z1 BOX	B40	YAES18K-2	B20
YAD14-10F	B34	YAE12Z3	B40	YAE18N2	B18	YAE22Z1M	N55	YAES18K-3	B20
YAD14-10M	B14, N55	YAE12Z3 BOX	B40	YAE18N2 BOX	B18	YAE22Z2	B40	YAES18K-4	B20
YAD14-14F	B34	YAE12Z3M	N55	YAE18N21	B18	YAE22Z2 BOX	B40	YAES18K-49	B20
YAD14-14M	B14, N55	YAE12Z4	B40	YAE18N21 BOX	B18	YAE22Z2M	N55	YAES18K-5	B20
YAD14-38	B14	YAE12Z4 BOX	B40	YAE18N21M	B18, N55	YAE22Z3	B40	YAES18K-50	B20

Alpha-Numeric Index

CATALOG NO.	PAGE NO.	CATALOG NO.	PAGE NO.	CATALOG NO.	PAGE NO.	CATALOG NO.	PAGE NO.	CATALOG NO.	PAGE NO.
YAES18K48	B20	YAEV2C-L	B4, B28	YAG1CL-2TC38-LD	C72	YAG28LTC516FX	C49	YAG34L-2TC516-LD	C73
YAES18N1	B16	YAEV2C-L1	B4, B28	YAG1CL-2TC516-LD	C72	YAG28LTC516LD	C69	YAG34LNT516N66LD	C70
YAES18N1F	B37	YAEV2C-L2	B28	YAG1CLTC10LD	C68	YAG28LTC516N66LD	C69	YAG34LTC12FX	C50
YAES18N2	B16	YAEV2C-L3	B28	YAG1CLTC12FX	C49	YAG28LTC58LD	C69	YAG34LTC12LD	C70
YAES18N3	B16	YAEV2C-L4	B4, B28	YAG1CLTC12LD	C68	YAG29L-2NT38-LD	C72	YAG34LTC38FX	C50
YAES18N3F	B37	YAEV2C-RH	B33	YAG1CLTC14FX	C49	YAG29L-2NTC-LD	C73	YAG34LTC38LD	C70
YAES18N4	B16	YAEV2C-RH1	B33	YAG1CLTC14LD	C68	YAG29L-2TC12-LD	C73	YAG34LTC516FX	C50
YAES18N48	B16	YAEV2C-RS	B32	YAG1CLTC38FX	C49	YAG29L-2TC12E1-LD	C73	YAG34LTC516LD	C70
YAES18N49	B16	YAEV2C-RS1	B32	YAG1CLTC38LD	C68	YAG29L-2TC14-LD	C72	YAG34LTC516N66LD	C70
YAES18N5	B16	YAEV4C-H	B29	YAG1CLTC516FX	C49	YAG29L-2TC14E2-LD	C72	YAG34LTC58FX	C50
YAES18N50	B16	YAEV4C-H2	B29	YAG1CLTC516LD	C68	YAG29L-2TC38-LD	C72	YAG34LTC58LD	C70
YAEV10	B27	YAEV4C-H3	B29	YAG25L-2NTC-LD	C72	YAG29L-2TC516-LD	C72	YAG36L-2NTC-LD	C73
YAEV10 BOX	B27	YAEV4C-H4	B29	YAG25L-2TC12E1-LD	C72	YAG29LTC12FX	C50	YAG36L-2TC38-LD	C73
YAEV10-L36	B27	YAEV4C-H5	B29	YAG25L-2TC14E2-LD	C72	YAG29LTC12LD	C69	YAG36LTC12LD	C70
YAEV10-L36 BOX	B27	YAEV4C-L	B4, B28	YAG25L-2TC38-LD	C72	YAG29LTC34LD	C69	YAG36LTC38FX	C50
YAEV10-T11	B27	YAEV4C-L2	B4, B28	YAG25L-2TC516-LD	C72	YAG29LTC38FX	C50	YAG36LTC58LD	C70
YAEV10-T11 BOX	B27	YAEV4C-L3	B28	YAG25L-2TC516E2-LD	C72	YAG29LTC38LD	C69	YAG38L-2NT38-LD	C73
YAEV10-T2	B27	YAEV4C-L4	B4, B28	YAG25LTC12FX	C49	YAG29LTC516LD	C69	YAG38L-2NTC-LD	C73
YAEV10-T2 BOX	B27	YAEV4C-L5	B28	YAG25LTC12LD	C69	YAG29LTC58FX	C50	YAG38L-2TC12-LD	C70
YAEV10-T3	B27	YAEV4C-RH	B33	YAG25LTC14FX	C49	YAG2CL-2NTC-LD	C72	YAG38L-2TC38-LD	C73
YAEV10-T3 BOX	B27	YAEV4C-RH2	B33	YAG25LTC14LD	C69	YAG2CL-2TC14-LD	C71	YAG38L-2TC516-LD	C73
YAEV10-T4	B27	YAEV4C-RS	B32	YAG25LTC38FX	C49	YAG2CL-2TC14E1-LD	C71	YAG38LTC12FX	C50
YAEV10-T4 BOX	B27	YAEV4C-RS2	B32	YAG25LTC38LD	C69	YAG2CL-2TC14E2-LD	C71	YAG38LTC12LD	C70
YAEV10-T7	B27	YAEV6C-H	B29	YAG25LTC516FX	C49	YAG2CL-2TC38-LD	C71	YAG38LTC38FX	C50
YAEV10-T7 BOX	B27	YAEV6C-H1	B29	YAG25LTC516LD	C69	YAG2CL-2TC516-LD	C72	YAG38LTC38LD	C70
YAEV14	B27	YAEV6C-H10	B29	YAG26L-2NTC-LD	C72	YAG2CLTC10LD	C68	YAG38LTC516FX	C50
YAEV14 BOX	B27	YAEV6C-H2	B29	YAG26L-2TC14-LD	C72	YAG2CLTC12FX	C49	YAG38LTC516LD	C70
YAEV18	B27	YAEV6C-H4	B29	YAG26L-2TC14E2-LD	C72	YAG2CLTC12LD	C68	YAG38LTC58LD	C70
YAEV18 BOX	B27	YAEV6C-L	B28	YAG26L-2TC38-LD	C72	YAG2CLTC14FX	C49	YAG39L-2NTC-LD	C73
YAEV1C-H	B29	YAEV6C-L1	B28	YAG26L-2TC516-LD	C72	YAG2CLTC14LD	C68	YAG40L-2NNT-LD	C73
YAEV1C-H1	B29	YAEV6C-L10	B28	YAG26LTC10LD	C69	YAG2CLTC38FX	C49	YAG40L-2NTC-LD	C73
YAEV1C-H2	B29	YAEV6C-L1M	B4	YAG26LTC12FX	C49	YAG2CLTC38LD	C68	YAG40L-2TC38-LD	C73
YAEV1C-H3	B29	YAEV6C-L2	B28	YAG26LTC12LD	C69	YAG2CLTC516FX	C49	YAG40LTC12FX	C50
YAEV1C-L	B4, B28	YAEV6C-L2M	B4	YAG26LTC14FX	C49	YAG2CLTC516LD	C68	YAG40LTC12LD	C70
YAEV1C-L1	B4, B28	YAEV6C-L4	B28	YAG26LTC14LD	C69	YAG30L-2NTC-LD	C73	YAG40LTC14FX	C50
YAEV1C-L2	B28	YAEV6C-L4M	B4	YAG26LTC34LD	C69	YAG30L-2TC12-LD	C73	YAG40LTC38FX	C50
YAEV1C-L3	B4, B28	YAEV6C-LM	B4	YAG26LTC38FX	C49	YAG30L-2TC38-LD	C73	YAG40LTC38LD	C70
YAEV1C-RH	B33	YAEV6C-RH	B33	YAG26LTC38LD	C69	YAG30LTC12FX	C50	YAG40LTC516FX	C50
YAEV1C-RH2	B33	YAEV6C-RH1	B33	YAG26LTC516FX	C49	YAG30LTC34LD	C69	YAG40LTC516LD	C70
YAEV1C-RS	B32	YAEV6C-RS	B32	YAG26LTC516LD	C69	YAG30LTC38FX	C50	YAG40LTC58LD	C70
YAEV1C-RS2	B32	YAEV6C-RS1	B32	YAG26LTC58LD	C69	YAG30LTC58FX	C50	YAG44L-2NTC-LD	C73
YAEV25-H	B30	YAEV8C-H	B29	YAG27L-2NTC-LD	C72	YAG30LTC58LD	C69	YAG44L-2TC12-LD	C73
YAEV25-H1	B30	YAEV8C-H1	B29	YAG27L-2TC14-LD	C72	YAG31L-2NTC-LD	C73	YAG44L-2TC12E3-LD	C73
YAEV25-H2	B30	YAEV8C-H14	B29	YAG27L-2TC14E2-LD	C72	YAG31L-2NTC38-LD	C73	YAG44L-2TC38-LD	C73
YAEV25-H3	B30	YAEV8C-H2	B29	YAG27L-2TC38-LD	C72	YAG31L-2TC12-LD	C73	YAG44L-2TC58-LD	C73
YAEV25-H4	B30	YAEV8C-H3	B29	YAG27L-2TC516-LD	C72	YAG31L-2TC38-LD	C73	YAG44LTC12FX	C50
YAEV25-L	B4, B28	YAEV8C-H4	B29	YAG27LTC10LD	C69	YAG31LNT12LD	C69	YAG44LTC12LD	C70
YAEV25-L1	B4, B28	YAEV8C-L	B4, B28	YAG27LTC12FX	C49	YAG31LTC12FX	C50	YAG44LTC38FX	C50
YAEV25-L2	B28	YAEV8C-L BOX	B28	YAG27LTC12LD	C69	YAG31LTC12LD	C69	YAG44LTC516FX	C50
YAEV25-L3	B4, B28	YAEV8C-L1	B4, B28	YAG27LTC14FX	C49	YAG31LTC14FX	C50	YAG44LTC58LD	C70
YAEV25-L4	B28	YAEV8C-L1 BOX	B28	YAG27LTC14LD	C69	YAG31LTC14LD	C69	YAG4CL-2NT10-LD	C71
YAEV25-RH	B33	YAEV8C-L14	B28	YAG27LTC38FX	C49	YAG31LTC34LD	C69	YAG4CL-2NT10E1-LD	C71
YAEV25-RS	B32	YAEV8C-L14 BOX	B28	YAG27LTC38LD	C69	YAG31LTC38FX	C50	YAG4CL-2NTC-LD	C71
YAEV26-H	B30	YAEV8C-L2	B4, B28	YAG27LTC516FX	C49	YAG31LTC38LD	C69	YAG4CL-2TC14-LD	C71
YAEV26-H1	B30	YAEV8C-L2 BOX	B28	YAG27LTC516LD	C69	YAG31LTC516FX	C50	YAG4CL-2TC14E1-LD	C71
YAEV26-H12	B30	YAEV8C-L3	B4, B28	YAG28L-2NT38-LD	C72	YAG31LTC516LD	C69	YAG4CL-2TC14E2-LD	C71
YAEV26-H2	B30	YAEV8C-L3 BOX	B28	YAG28L-2NTC-LD	C72	YAG31LTC58FX	C50	YAG4CL-2TC38-LD	C71
YAEV26-H3	B30	YAEV8C-L4	B28	YAG28L-2TC12-LD	C72	YAG31LTC58LD	C69	YAG4CL-2TC516-LD	C71
YAEV26-L	B4, B28	YAEV8C-L4 BOX	B28	YAG28L-2TC12E1-LD	C72	YAG32L-2NTC-LD	C73	YAG4CLNT10LD	C68
YAEV26-L1	B28	YAEV8C-RH	B33	YAG28L-2TC14-LD	C72	YAG32L-2TC38-LD	C73	YAG4CLTC10LD	C68
YAEV26-L2	B4, B28	YAEV8C-RH1	B33	YAG28L-2TC14E2-LD	C72	YAG32LTC12FX	C50	YAG4CLTC12FX	C49
YAEV26-L3	B4, B28	YAEV8C-RS	B32	YAG28L-2TC38-LD	C72	YAG32LTC12LD	C69	YAG4CLTC12LD	C68
YAEV26-RH	B33	YAEV8C-RS1	B32	YAG28L-2TC516-LD	C72	YAG32LTC38LD	C69	YAG4CLTC14FX	C49
YAEV26-RS	B32	YAFX15CLKIT	C16	YAG28LTC12FX	C49	YAG32LTC58FX	C50	YAG4CLTC14LD	C68
YAEV2C-H	B29	YAG18TC516LD	C68	YAG28LTC12LD	C69	YAG32LTC58LD	C69	YAG4CLTC38FX	C49
YAEV2C-H1	B29	YAG1CL-2NTC-LD	C72	YAG28LTC14LD	C69	YAG34L-2NT38-LD	C73	YAG4CLTC38LD	C68
YAEV2C-H2	B29	YAG1CL-2TC14-LD	C72	YAG28LTC14LD	C69	YAG34L-2NTC-LD	C73	YAG4CLTC516FX	C49
YAEV2C-H3	B29	YAG1CL-2TC14E1-LD	C72	YAG28LTC38FX	C49	YAG34L-2TC12-LD	C73	YAG4CLTC516LD	C68
YAEV2C-H4	B29	YAG1CL-2TC14E2-LD	C72	YAG28LTC38LD	C69	YAG34L-2TC38-LD	C73	YAG6CL-2NTC-LD	C71

CATALOG NO.	PAGE NO.	CATALOG NO.	PAGE NO.	CATALOG NO.	PAGE NO.	CATALOG NO.	PAGE NO.	CATALOG NO.	PAGE NO.
YAG6CL-2TC10-LD	C71	YAV10-BOX	C17	YAV14-R	B31	YAV1C-L2TC14E1-FX	C57	YAV25M8	C75
YAG6CL-2TC10E-LD	C71	YAV10-H	B25	YAV14-RL33	B31	YAV1C-L2TC14E2-FX	C57	YAV26-L	B4, B24
YAG6CL-2TC10E2-LD	C71	YAV10-H BOX	B25	YAV14-T1	B22	YAV1C-L2TC38-FX	C57	YAV26-L BOX	B24
YAG6CL-2TC10E4-LD	C71	YAV10-H25	B25	YAV14-T1 BOX	B22	YAV1C-L2TC516-FX	C57	YAV26-L1	B4, B24
YAG6CL-2TC14-LD	C71	YAV10-H25 BOX	B25	YAV14-T2	B22	YAV1C-L3	B4, B24	YAV26-L1 BOX	B24
YAG6CL-2TC14E1-LD	C71	YAV10-H3	B25	YAV14-T2 BOX	B22	YAV1C-L3 BOX	B24	YAV26-L12	B24
YAG6CL-2TC14E2-LD	C71	YAV10-H3 BOX	B25	YAV14-T3	B22	YAV1C-L4	B4	YAV26-L12 BOX	B24
YAG6CL-2TC38-LD	C71	YAV10-HF	B36	YAV14-T3 BOX	B22	YAV1C-L6	B24	YAV26-L16	B4
YAG6CL-2TC516-LD	C71	YAV10-HF BOX	B36	YAV14-T32F	B35	YAV1C-RS1	B31	YAV26-L2	B4, B24
YAG6CLT516FX	C49	YAV10-L36	B22	YAV14-T32F BOX	B35	YAV1C-RS2	B31	YAV26-L2 BOX	B24
YAG6CLT10LD	C68	YAV10-L36 BOX	B22	YAV14-T34F	B35	YAV1C-TC10-FXB	C54	YAV26-L2NTC-FX	C57
YAG6CLT12FX	C49	YAV10-R	B31	YAV14-T34F BOX	B35	YAV1C-TC516-FXB	C54	YAV26-L2TC12E1-FX	C57
YAG6CLT12LD	C68	YAV10-R3 BOX	B31	YAV14-T5	B22	YAV1C2N-FXB	C63	YAV26-L2TC14-FX	C57
YAG6CLT14FX	C49	YAV10-T11	B22	YAV14-T5 BOX	B22	YAV1C2TC38-FXB	C63	YAV26-L2TC14E2-FX	C57
YAG6CLT14LD	C68	YAV10-T11 BOX	B22	YAV14-Z5	B36	YAV1CL-TC10-FX	C45	YAV26-L2TC38-FX	C57
YAG6CLT38FX	C49	YAV10-T2	B4, B22	YAV14-Z5 BOX	B36	YAV1CL-TC12-FX	C45	YAV26-L2TC516-FX	C57
YAG6CLT38LD	C68	YAV10-T2 BOX	B22	YAV14-Z6	B36	YAV1CL-TC14-FX	C45	YAV26-L3	B4, B24
YAG6CLT516LD	C68	YAV10-T21F BOX	B35	YAV14-Z6 BOX	B36	YAV1CL-TC38-FX	C45	YAV26-L3 BOX	B24
YAG8CL-2TC10-LD	C71	YAV10-T23F BOX	B35	YAV14T3	C75	YAV1CL-TC516-FX	C45	YAV26-RS	B31
YAG8CL-2TC14-LD	C71	YAV10-T3	B22	YAV150FM12	C78	YAV1CL2NT14FX	C59	YAV26-RS3	B31
YAG8CL-2TC14E1-LD	C71	YAV10-T3 BOX	B22	YAV150M10	C78	YAV1CL2NT516FX	C59	YAV26-TC12-FXB	C55
YAG8CL-2TC14E2-LD	C71	YAV10-T4	B4, B22	YAV150M12	C78	YAV240FM10	C78	YAV26-TC38-FXB	C55
YAG8CL-2TC38-LD	C71	YAV10-T4 BOX	B22	YAV150M14	C78	YAV240FM12	C78	YAV262N-FXB	C64
YAG8CLT10LD	C68	YAV10-T7	B4, B22	YAV150M16	C78	YAV240M10	C78	YAV262NTC38-FXB	C64
YAG8CLT12FX	C49	YAV10-T7 BOX	B22	YAV150M20	C78	YAV240M12	C78	YAV262TC14-FXB	C64
YAG8CLT12LD	C68	YAV10M10	C75	YAV16M10	C75	YAV240M14	C78	YAV262TC14E2-FXB	C64
YAG8CLT14FX	C49	YAV10M12	C75	YAV16M12	C75	YAV240M16	C78	YAV262TC38-FXB	C64
YAG8CLT14LD	C68	YAV10M6	C75	YAV16M6	C75	YAV240M20	C78	YAV26L-TC10-FX	C45
YAG8CLT38LD	C68	YAV10M8	C75	YAV16M8	C75	YAV25-L	B4, B24	YAV26L-TC12-FX	C45
YAG8CLT516FX	C49	YAV10R-BOX	C17	YAV18	B22, C75	YAV25-L BOX	B24	YAV26L-TC14-FX	C45
YAG8CLT516LD	C68	YAV10R3-BOX	C17	YAV18 BOX	B22	YAV25-L1	B4, B24	YAV26L-TC34-FX	C45
YAK-361A-2G1	H74	YAV10T2-BOX	C17	YAV18-H	B25	YAV25-L1 BOX	B24	YAV26L-TC38-FX	C45
YAK-361A-2G2	H74	YAV10T23F	B35	YAV18-H BOX	B25	YAV25-L16	B4	YAV26L-TC516-FX	C45
YAK25A-2G1	H74	YAV10T3-BOX	C17	YAV18-H19 BOX	B36	YAV25-L2	B4, B24	YAV26L-TC58-FX	C45
YAK25A-2G2	H74	YAV10T38	C75	YAV18-H19F	B36	YAV25-L2 BOX	B24	YAV26L2NT14FX	C59
YAK28A-2G1	H74	YAV10T4-BOX	C17	YAV18-H21F	B36	YAV25-L2NTC-FX	C57	YAV26L2NT38FX	C59
YAK28A-2G2	H74	YAV12-G2	B22	YAV18-H21F BOX	B36	YAV25-L2TC12E1-FX	C57	YAV26L2NT516FX	C59
YAK29A-2G1	H74	YAV12-G2 BOX	B22	YAV18-H6F	B36	YAV25-L2TC14-FX	C57	YAV26LNT12FX	C47
YAK2CA2G1	H74	YAV12-G3	B22	YAV18-H6F BOX	B36	YAV25-L2TC14E2-FX	C57	YAV26LNT38FX	C47
YAK2CA2G2	H74	YAV12-G3 BOX	B22	YAV18-L33	B22	YAV25-L2TC38-FX	C57	YAV26LNT516FX	C47
YAK311A-2G1	H74	YAV120FM10	C77	YAV18-L33 BOX	B22	YAV25-L2TC516-FX	C57	YAV27-L	B4, B24
YAK311A-2G2	H74	YAV120FM12	C77	YAV18-R	B31	YAV25-L2TC516E2-FX	C57	YAV27-L BOX	B24
YAK31A-2G1	H74	YAV120FM16	C77	YAV18-T1	B22	YAV25-L3	B4, B24	YAV27-L1	B4, B24
YAK31A-2G2	H74	YAV120M10	C77	YAV18-T1 BOX	B22	YAV25-L3 BOX	B24	YAV27-L1 BOX	B24
YAK34A-2G1	H74	YAV120M12	C77	YAV18-T19F	B35	YAV25-L4	B24	YAV27-L15	B24
YAK34A-2G2	H74	YAV120M14	C77	YAV18-T19F BOX	B35	YAV25-L4 BOX	B24	YAV27-L15 BOX	B24
YAK39A-2G1	H74	YAV120M16	C77	YAV18-T21F	B35	YAV25-RS	B31	YAV27-L18	B4
YAK39A-2G2	H74	YAV120M20	C77	YAV18-T21F BOX	B35	YAV25-RS3	B31	YAV27-L20	B4
YAK44A-2NG7	H74	YAV120M8	C77	YAV18-T4	B22	YAV25-TC10-FXB	C55	YAV27-L2TC-FX	C57
YAK44A-2NG8	H74	YAV14	B22	YAV18-T4 BOX	B22	YAV25-TC12-FXB	C55	YAV27-L2TC14-FX	C57
YASG6CL-2TC14E2-FX	C74	YAV14 BOX	B22	YAV18-T5	B22	YAV25-TC38-FXB	C55	YAV27-L2TC38-FX	C57
YASV6CL-2TC14E2-FX	C74	YAV14-H	B25	YAV18-T5 BOX	B22	YAV25-TC516-FXB	C55	YAV27-RS	B31
YASV6CL-2TC14E2-FX-60	C74	YAV14-H BOX	B25	YAV185FM10	C78	YAV252N-FXB	C64	YAV27-TC12-FXB	C55
YAV025M6	C75	YAV14-H1	B25	YAV185M10	C78	YAV252TC14-FXB	C64	YAV272N-FXB	C64
YAV04M6	C75	YAV14-H1 BOX	B25	YAV185M12	C78	YAV252TC14E2-FXB	C64	YAV272TC14E2-FXB	C64
YAV06FM6	C75	YAV14-H2	B25	YAV185M14	C78	YAV252TC38-FXB	C64	YAV272TC38-FXB	C64
YAV06M35	C75	YAV14-H2 BOX	B25	YAV185M16	C78	YAV25L-TC12-FX	C45	YAV27L-TC10-FX	C45
YAV06M4	C75	YAV14-H32F	B36	YAV185M20	C78	YAV25L-TC14-FX	C45	YAV27L-TC12-FX	C45
YAV06M5	C75	YAV14-H32F BOX	B36	YAV18T1	C75	YAV25L-TC38-FX	C45	YAV27L-TC14-FX	C45
YAV06M6	C75	YAV14-H34F	B36	YAV18T4	C75	YAV25L-TC516-FX	C45	YAV27L-TC38-FX	C45
YAV06M8	C75	YAV14-H34F BOX	B36	YAV18T5	C75	YAV25L2NT14E1FX	C59	YAV27L-TC516-FX	C45
YAV10	B4, B22	YAV14-H56F	B36	YAV1C-L	B24	YAV25L2NT14FX	C59	YAV28-L	B4, B24
YAV10 BOX	B22	YAV14-H56F BOX	B36	YAV1C-L BOX	B24	YAV25L2NT516FX	C59	YAV28-L BOX	B24
YAV10-21F	B35	YAV14-HF	B36	YAV1C-L1	B4, B24	YAV25LNT14FX	C47	YAV28-L12	B4, B24
YAV10-2TC10	C30	YAV14-HF BOX	B36	YAV1C-L1 BOX	B24	YAV25LNT38FX	C47	YAV28-L12 BOX	B24
YAV10-2TC14	C30	YAV14-L33	B22	YAV1C-L2	B4, B24	YAV25LNT516FX	C47	YAV28-L13	B4, B24
YAV10-2TC14E1	C30	YAV14-L33 BOX	B22	YAV1C-L2 BOX	B24	YAV25M10	C75	YAV28-L13 BOX	B24
YAV10-2TC14E2	C30	YAV14-L36	B22	YAV1C-L2NTC-FX	C57	YAV25M12	C75	YAV28-L14	B4, B24
YAV10-2TC38	C30	YAV14-L36 BOX	B22	YAV1C-L2TC14-FX	C57	YAV25M6	C75	YAV28-L14 BOX	B24

Alpha-Numeric Index

CATALOG NO.	PAGE NO.	CATALOG NO.	PAGE NO.	CATALOG NO.	PAGE NO.	CATALOG NO.	PAGE NO.	CATALOG NO.	PAGE NO.
YAV28-L2NT38-FX	C57	YAV2C-RS2	B31	YAV4CL2NT14FX	C59	YAV8C-L2 BOX	B23	YAZ2CTC38	C28
YAV28-L2NTC-FX	C57	YAV2C-TC10-FXB	C54	YAV4CLNT10FX	C47	YAV8C-L3	B4, B23	YAZ30-2N	C41
YAV28-L2TC12-FX	C57	YAV2C-TC516-FXB	C54	YAV500M12	C79	YAV8C-L3 BOX	B23	YAZ30-2TC38	C41
YAV28-L2TC14-FX	C57	YAV2C2N-FXB	C63	YAV500M14	C79	YAV8C-L4	B4, B23	YAZ302TC38FX	C62
YAV28-L2TC14E2	C57	YAV2C2TC14-FXB	C63	YAV500M20	C79	YAV8C-L4 BOX	B23	YAZ30TC12	C29
YAV28-L2TC14E2-FX	C57	YAV2C2TC14E1-FXB	C63	YAV50FM12	C76	YAV8C-RS	B31	YAZ30TC38	C29
YAV28-L2TC38-FX	C57	YAV2C2TC14E2-FXB	C63	YAV50FM14	C76	YAV8C-RS1	B31	YAZ30TC38FX	C53
YAV28-L2TC516-FX	C57	YAV2C2TC38-FXB	C63	YAV50M10	C76	YAV8C-RS3	B31	YAZ31-2N	C41
YAV28-L54	B4	YAV2C2TC516-FXB	C63	YAV50M12	C76	YAV95FM12	C77	YAZ31-2TC14E2	C41
YAV28-L56	B4	YAV2CL-TC10-FX	C44	YAV50M14	C76	YAV95M10	C76	YAZ31-2TC38	C41
YAV28-L60	B4	YAV2CL-TC12-FX	C44	YAV50M16	C76	YAV95M12	C76	YAZ312TC14E2FX	C62
YAV28-LTC12E1-FX	C57	YAV2CL-TC14-FX	C44	YAV50M5	C76	YAV9C-L36	B22	YAZ312TC38FX	C62
YAV28-RS	B31	YAV2CL-TC38-FX	C44	YAV50M6	C76	YAV9C-L36 BOX	B22	YAZ31TC12	C29
YAV28-TC12-FXB	C55	YAV2CL-TC516-FX	C44	YAV50M8	C76	YAV9C-T4 BOX	B22	YAZ31TC38	C29
YAV28-TC38-FXB	C55	YAV2CL2NT10FX	C59	YAV5C-TC14-FXB	C54	YAV9C-T9	B22	YAZ31TC38FX	C53
YAV282N-FXB	C64	YAV2CL2NT14E1FX	C59	YAV5C2TC14-FXB	C63	YAV9C-T9 BOX	B22	YAZ32-2N	C41
YAV282NT38-FXB	C64	YAV2CL2NT14FX	C59	YAV630FM20	C79	YAZ1C-2N	C40	YAZ32-2TC38	C41
YAV282NTC38-FXB	C64	YAV2CLNT14FX	C47	YAV6C-L	B4, B23	YAZ1C-2TC14	C40	YAZ322TC38FX	C62
YAV282TC14E2-FXB	C64	YAV2CLNT516FX	C47	YAV6C-L BOX	B23	YAZ1C-2TC14E2	C40	YAZ32TC12	C29
YAV282TC38-FXB	C64	YAV300FM14	C78	YAV6C-L1	B4, B23	YAZ1C-2TC38	C40	YAZ32TC38	C29
YAV28L-TC12-FX	C45	YAV300M12	C78	YAV6C-L1 BOX	B23	YAZ1CTC12	C28	YAZ32TC38FX	C53
YAV28L-TC14-FX	C45	YAV300M14	C78	YAV6C-L10	B4, B23	YAZ1CTC14	C28	YAZ33-2N	C41
YAV28L-TC34-FX	C45	YAV300M16	C78	YAV6C-L10 BOX	B23	YAZ1CTC38	C28	YAZ33TC12	C29
YAV28L-TC38-FX	C45	YAV300M20	C78	YAV6C-L2	B4, B23	YAZ25-2N	C40	YAZ34-2N	C41
YAV28L-TC516-FX	C45	YAV35M10	C76	YAV6C-L2 BOX	B23	YAZ25-2NTC38	C40	YAZ34-2TC14E2	C41
YAV28L-TC58-FX	C45	YAV35M12	C76	YAV6C-L2NTC-FX	C56	YAZ25-2TC14	C40	YAZ34-2TC38	C41
YAV28L2ENT14FX	C59	YAV35M5	C76	YAV6C-L2TC10-FX	C56	YAZ25-2TC14E1	C40	YAZ342NT38FX	C62, C66
YAV28L2NT38FX	C59	YAV35M6	C76	YAV6C-L2TC10E2-FX	C56	YAZ25-2TC14E2	C40	YAZ342NTCFX	C62
YAV28LNT12FX	C47	YAV35M8	C76	YAV6C-L2TC10E4-FX	C56	YAZ25-2TC38	C40	YAZ342TC14E2FX	C62
YAV28LNT38FX	C47	YAV375M12	C79	YAV6C-L2TC10E9-FX	C56	YAZ25-2TC516	C40	YAZ342TC38FX	C62
YAV28LNT516FX	C47	YAV375M16	C79	YAV6C-L2TC14-FX	C56	YAZ25-2TC516E6	C40	YAZ34NT38FX	C53
YAV29-L2NT38-FX	C58	YAV375M20	C79	YAV6C-L2TC14E1-FX	C56	YAZ25TC12	C28	YAZ34TC12	C29
YAV29-L2NTC-FX	C58	YAV4C-L	B4, B23	YAV6C-L2TC14E2-FX	C56	YAZ25TC14	C28	YAZ34TC12FX	C53
YAV29-L2TC12-FX	C58	YAV4C-L BOX	B23	YAV6C-L2TC38-FX	C56	YAZ25TC38	C28	YAZ34TC38	C29
YAV29-L2TC14-FX	C58	YAV4C-L2	B4, B23	YAV6C-L2TC516-FX	C56	YAZ25TC516	C28	YAZ34TC38FX	C53
YAV29-L2TC14E2-FX	C58	YAV4C-L2 BOX	B23	YAV6C-L4	B4, B23	YAZ26-2N	C41	YAZ35-2N	C41
YAV29-L2TC38-FX	C58	YAV4C-L2NT10-FX	C56	YAV6C-L4 BOX	B23	YAZ26-2TC14	C41	YAZ35TC12	C29
YAV29-L2TC516-FX	C58	YAV4C-L2NT10E1-FX	C56	YAV6C-RS	B31	YAZ26-2TC14E2	C41	YAZ36-2N	C41
YAV29-LTC12E1-FX	C58	YAV4C-L2NTC-FX	C56	YAV6C-RS1	B31	YAZ26-2TC38	C41	YAZ36-2TC38	C41
YAV292N-FXB	C64	YAV4C-L2TC14-FX	C56	YAV6C-RS2	B31	YAZ26TC12	C28	YAZ362TC38FX	C62
YAV292NT38-FXB	C64	YAV4C-L2TC14E1-FX	C56	YAV6C-RS4	B31	YAZ26TC14	C28	YAZ36TC12	C29
YAV292NTC38-FXB	C64	YAV4C-L2TC14E2-FX	C56	YAV6C-TC10-FXB	C54	YAZ26TC38	C28	YAZ36TC38	C29
YAV292TC14E2-FXB	C64	YAV4C-L2TC38-FX	C56	YAV6C-TC14-FXB	C54	YAZ27-2N	C41	YAZ36TC38FX	C53
YAV292TC38-FXB	C64	YAV4C-L2TC516-FX	C56	YAV6C2N-FXB	C63	YAZ27-2TC14E2	C41	YAZ37-2N	C41
YAV29L-TC12-FX	C45	YAV4C-L3	B4, B23	YAV6C2TC14-FXB	C63	YAZ27-2TC38	C41	YAZ37TC12	C29
YAV29L-TC14-FX	C45	YAV4C-L3 BOX	B23	YAV6C2TC14E2-FXB	C63	YAZ27TC12	C28	YAZ38-2N	C41
YAV29L-TC34-FX	C45	YAV4C-L4	B4, B23	YAV6C2TC38-FXB	C63	YAZ27TC38	C28	YAZ382ENT38FX	C66
YAV29L-TC38-FX	C45	YAV4C-L4 BOX	B23	YAV6C-TC10-FX	C44	YAZ28-2N	C41	YAZ382NNTFX	C62, C67
YAV29L-TC516-FX	C45	YAV4C-L5	B4, B23	YAV6CL-TC12-FX	C44	YAZ28-2NTC38	C41	YAZ382NT38FX	C62, C67
YAV29L-TC58-FX	C45	YAV4C-L5 BOX	B23	YAV6CL-TC14-FX	C44	YAZ28-2TC14E2	C41	YAZ382NTCFX	C62
YAV29L2NT38FX	C60	YAV4C-RS	B31	YAV6CL-TC34-FX	C44	YAZ28-2TC38	C41	YAZ382TC38FX	C62
YAV2C-L	B4, B23	YAV4C-RS2	B31	YAV6CL-TC38-FX	C44	YAZ28TC12	C28	YAZ38NT12FX	C53
YAV2C-L BOX	B23	YAV4C-RS3	B31	YAV6CL-TC516-FX	C44	YAZ28TC38	C28	YAZ38NT38FX	C53
YAV2C-L1	B4, B23	YAV4C-RS4	B31	YAV70FM10	C76	YAZ29-2N	C41	YAZ38TC12	C29
YAV2C-L1 BOX	B23	YAV4C-TC10-FXB	C54	YAV70FM12	C76	YAZ29-2TC38	C41	YAZ38TC12FX	C53
YAV2C-L11	B4	YAV4C-TC14-FXB	C54	YAV70M10	C76	YAZ29TC12	C28	YAZ38TC38FX	C53
YAV2C-L2	B4, B23	YAV4C-TC516-FXB	C54	YAV70M12	C76	YAZ29TC38	C28	YAZ39-2N	C42
YAV2C-L2 BOX	B23	YAV4C2N-FXB	C63	YAV70M14	C76	YAZ2C-2N	C40	YAZ39-2NNT	C42
YAV2C-L2NTC-FX	C57	YAV4C2TC14-FXB	C63	YAV70M16	C76	YAZ2C-2NTC38	C40	YAZ39-2NT38	C42
YAV2C-L2TC14-FX	C57	YAV4C2TC14E2-FXB	C63	YAV70M5	C76	YAZ2C-2TC10E2	C40	YAZ39-2TC38	C42
YAV2C-L2TC14E1-FX	C57	YAV4C2TC38-FXB	C63	YAV70M6	C76	YAZ2C-2TC14	C40	YAZ39NT12	C29
YAV2C-L2TC14E2-FX	C57	YAV4C2TC516-FXB	C63	YAV70M8	C76	YAZ2C-2TC14E1	C40	YAZ39TC12	C29
YAV2C-L2TC38-FX	C57	YAV4CL-TC10-FX	C44	YAV800M20	C79	YAZ2C-2TC14E2	C40	YAZ39TC38	C29
YAV2C-L2TC516-FX	C57	YAV4CL-TC12-FX	C44	YAV8C-L	B4, B23	YAZ2C-2TC38	C40	YAZ3C-2N	C40
YAV2C-L3	B4, B23	YAV4CL-TC14-FX	C44	YAV8C-L BOX	B23	YAZ2C-2TC38E2	C40	YAZ3C-2TC14	C40
YAV2C-L4	B4, B23	YAV4CL-TC38-FX	C44	YAV8C-L1	B4, B23	YAZ2C-2TC38E6	C40	YAZ3C-2TC14E2	C40
YAV2C-L4 BOX	B23	YAV4CL-TC516-FX	C44	YAV8C-L1 BOX	B23	YAZ2C-2TC516E2	C40	YAZ3C-2TC38	C40
YAV2C-RS	B31	YAV4CL2NT10E1FX	C59	YAV8C-L14	B4, B23	YAZ2C2CTC12	C28	YAZ3C-2TC38E2	C40
YAV2C-RS1	B31	YAV4CL2NT10FX	C59	YAV8C-L2	B4, B23	YAZ2CTC14	C28	YAZ3CTC12	C28

CATALOG NO.	PAGE NO.	CATALOG NO.	PAGE NO.	CATALOG NO.	PAGE NO.	CATALOG NO.	PAGE NO.	CATALOG NO.	PAGE NO.
YAZ3CTC14	C28	YAZV1CTC516FX	C53	YBA39	C12	YC8C8	C101, H19	YCB27R	H35
YAZ3CTC38	C28	YAZV252NTCFX	C62	YBA39A	C13	YC8L12	C100, N13	YCB28R	H35
YAZ40-2N	C42	YAZV252TC14E2FX	C62	YBA44A	C13	YCA25-2N	H70	YCB28U26	H36
YAZ402NTCFX	C62	YAZV252TC14FX	C62	YBA44FX	C12	YCA25R-2N	H72	YCB2R	H35
YAZ40TC12	C29	YAZV252TC38FX	C62	YBA44FX58	C12	YCA25RL-2N	H71	YCB321R	H35
YAZ41-2N	C42	YAZV252TC12FX	C53	YBAFX15CLKIT	C16	YCA26-2N	H70	YCB33R	H35
YAZ41TC12	C29	YAZV252TC14FX	C53	YBAV25FX14	C11	YCA26R-2N	H72	YCB33R26U	H36
YAZ44-2N	C42	YAZV252TC38FX	C53	YBAV26FX14	C11	YCA26RL-2N	H71	YCB35R	H35
YAZ44-2TC38	C42	YAZV262NTCFX	C62	YBAV27FX14	C11	YCA27-2N	H70	YCB361R	H35
YAZ442NT38FX	C62, C67	YAZV262TC14E2FX	C62	YBAV28FX	C11	YCA27R-2N	H72	YCB38R26U	H36
YAZ44TC12	C29	YAZV262TC14FX	C62	YBM1C-L	B26	YCA27RL-2N	H71	YCB4U1	H36
YAZ44TC38	C29	YAZV262TC38FX	C62	YBM1C-L3	B26	YCA28-2N	H70	YCD453R	H47
YAZ45-2N	C42	YAZV262TC12FX	C53	YBM25-L	B26	YCA28R-2N	H72	YCHC29TC2	C102
YAZ453-2N	C42	YAZV262TC14FX	C53	YBM25-L1	B26	YCA28RL-2N	H71	YCHC29TC29	C102
YAZ453TC12	C29	YAZV262TC38FX	C53	YBM25-L2	B26	YCA29-2N	H70	YCHC2TC2	C102
YAZ45TC12	C29	YAZV272TC14E2FX	C62	YBM26-L	B26	YCA2R-2N	H72	YCHC34TC2	C102
YAZ46-2N	C42	YAZV272TC38FX	C62	YBM28-1/4	B26	YCA2RL-2N	H71	YCHC34TC29	C102
YAZ46TC12	C29	YAZV272TC38FX	C53	YBM2C-L	B26	YCA30-2N	H70	YCHC34TC34	C102
YAZ47-2N	C42	YAZV282NT38FX	C62, C66	YBM2C-L1	B26	YCA30R-2N	H72	YCHC39TC2	C102
YAZ47TC12	C29	YAZV282NTCFX	C62	YBM2C-L2	B26	YCA31-2N	H70	YCHC39TC31	C102
YAZ48-2N	C42	YAZV282TC14E2FX	C62	YBM4C-L	B26	YCA32-2N	H70	YCHC39TC39	C102
YAZ48TC12	C29	YAZV282TC38FX	C62	YBM4C-L1	B26	YCA321R-2N	H72	YCHC44TC44	C102
YAZ4C-2N	C40	YAZV28NT38FX	C53	YBM4C-L2	B26	YCA321RL-2N	H71	YCHC8TC8	C102
YAZ4C-2TC10-E2	C40	YAZV28TC12FX	C53	YBM4C-L4	B26	YCA33R-2N	H72	YCR25RG6	H50
YAZ4C-2TC14	C40	YAZV28TC38FX	C53	YBM6C-L	B26	YCA34-2N	H70	YCR2625	H49
YAZ4C-2TC14E2	C40	YAZV292NT516FX	C62, C66	YBM6C-L2	B26	YCA35R-2N	H72	YCR26RG2	H50
YAZ4C-2TC38	C40	YAZV29NT516FX	C53	YBM6C-L3	B26	YCA361R-2N	H72	YCR26RG3	H50
YAZ4CTC12	C27	YAZV29NT14E2FX	C66	YBM6C-L9	B26	YCA37R-2N	H72	YCR2725	H49
YAZ4CTC14	C27	YAZV2C2NTCFX	C61	YBM8C	B26	YCA39-2N	H70	YCR27RG5	H50
YAZ4CTC38	C27	YAZV2C2TC14E2FX	C61	YBM8C-T2	B26	YCA391A-2N	H73	YCR27RG6	H50
YAZ5C-2N	C39	YAZV2C2TC14FX	C61	YBM8CT4	B26	YCA39R-2N	H72	YCR2825	H49
YAZ5CTC12	C27	YAZV2C2TC38FX	C61	YC10C10	C101, H19	YCA43R-2N	H73	YCR28RG5	H50
YAZ6C-2N	C39	YAZV2CTC12FX	C52	YC10L12	C100, N13	YCA441A-4N	H73	YCR28RG6	H50
YAZ6C-2TC10E2	C39	YAZV2CTC14FX	C52	YC1L12	C100	YCA44A2NG2	H73	YCR28RG7	H50
YAZ6C-2TC14	C39	YAZV2CTC38FX	C52	YC1U1	H23	YCA451A-4N	H73	YCR28RG8	H50
YAZ6C-2TC14E1	C39	YAZV4C2NT14E2FX	C66	YC25A2	H20	YCA45R-2N	H73	YCR291RG2	H50
YAZ6C-2TC14E2	C39	YAZV4C2TC14E2FX	C61	YC25A25	H20	YCA48R-4N	H73	YCR291RG3	H50
YAZ6C-2TC38	C39	YAZV4C2TC14FX	C61	YC25A4	H20	YCA4R-2N	H72	YCR291RG4	H50
YAZ6C-2TC38E2	C39	YAZV4C2TC38E2-FX	C61	YC25L12	C100	YCA4RL-2N	H71	YCR291RG5	H50
YAZ6C-2TC38E6	C39	YAZV4C2TC38FX	C61	YC26A25	H20	YCA28-4N	H70	YCR30RG4	H50
YAZ6CTC12	C27	YAZV4CTC14FX	C52	YC26A26	H20	YCA32-4N	H70	YCR30RG6	H50
YAZ6CTC14	C27	YAZV4CTC38FX	C52	YC26C2	C101, H19	YCA34-4N	H70	YCR30RG7	H50
YAZ6CTC38	C27	YAZV6C2TC10E2FX	C61	YC26C26	C101, H19	YCA39-4N	H70	YCR32RG1	H50
YAZ8C-2TC10	C39	YAZV6C2TC14E1FX	C61	YC26L12	C100	YCA44-4N	H70	YCR32RG2	H50
YAZ8C-2TC10E2	C39	YAZV6C2TC14E2FX	C61	YC27L12	C100	YCAK25R-4N	H72	YCR32RG3	H50
YAZ8C-2TC14	C39	YAZV6C2TC14FX	C61	YC28A2	H20	YCAK28A-2G1	H75	YCR32RG4	H50
YAZ8C-2TC14E1	C39	YAZV6C2TC38E2FX	C61	YC28A25	H20	YCAK28R-4N	H72	YCR32RG5	H50
YAZ8C-2TC14E2	C39	YAZV6C2TC38E6FX	C61	YC28A26	H20	YCAK29A-2G1	H75	YCR32RG6	H50
YAZ8C-2TC38	C39	YAZV6C2TC38FX	C61	YC28A28	H20	YCAK30R-4N	H72	YCR32RG7	H50
YAZ8C2TC10E2FX	C61	YAZV6CTC14FX	C52	YC28C2	C101, H19	YCAK31A-2G1	H75	YCS25	H51
YAZ8C2TC10FX	C61	YAZV6CTC38FX	C52	YC28C26	C101, H19	YCAK31AG1	H75	YCS25R	H46-H47
YAZ8C2TC14E1FX	C61	YBA15ALKIT	C16	YC28C28	C101, H19	YCAK321R-4N	H72	YCS25RL	H48
YAZ8C2TC14E2FX	C61	YBA25A	C13	YC28U26	H23	YCAK33R-4N	H72	YCS26	H51
YAZ8C2TC14FX	C61	YBA26A	C13	YC2A2	H20	YCAK34A-2G3	H75	YCS26A	H49
YAZ8C2TC38FX	C61	YBA27A	C13	YC2A4	H20	YCAK35R-4N	H72	YCS26R	H47
YAZ8CTC10	C27, C52	YBA28A	C13	YC2C2	C101, H19	YCAK361A-4N	H72	YCS26RL	H48
YAZ8CTC14	C27, C52	YBA29	C11	YC2C4	C101, H19	YCAK361R-4N	H72	YCS27	H51
YAZ8CTC38	C27, C52	YBA29A	C13	YC2L12	C100	YCAK36A-2G1	H75	YCS27R	H47
YAZV10-2TC14	C39	YBA30A	C13	YC33R26	H20	YCAK37R-4N	H72	YCS28	H51
YAZV10-2TC14E2	C39	YBA31A	C13	YC33R26U	H23	YCAK391A-4N	H73	YCS28A	H49
YAZV10TC14	C27	YBA31FX	C11	YC3L12	C100	YCAK39A-2G2	H75	YCS28R	H47
YAZV1C2TC14E1FX	C61	YBA32A	C13	YC4A4	H20	YCAK39R-4N	H72	YCS28RL	H48
YAZV1C2TC14E2FX	C61	YBA32FX	C11	YC4A6	H20	YCAK43R-4N	H73	YCS29	H51
YAZV1C2TC14FX	C61	YBA34A	C13	YC4C4	C101, H19	YCAK44A-2G2	H75	YCS2R	H47
YAZV1C2TC38FX	C61	YBA34FX	C11	YC4C6	C101, H19	YCAK453R-4N	H73	YCS30	H51
YAZV1C2TC516E6FX	C61	YBA36A	C13	YC4C8	C101, H19	YCAK45R-4N	H73	YCS301A	H49
YAZV1C2TC516FX	C61	YBA36FX	C12	YC4L12	C100, N13	YCB1U1	H36	YCS30R	H47
YAZV1CTC14FX	C52	YBA36FX58	C12	YC4U1	H23	YCB25R	H35	YCS31	H51
YAZV1CTC38FX	C53	YBA38FX	C12	YC6L12	C100, N13	YCB26R	H35	YCS311A	H49

Alpha-Numeric Index

CATALOG NO.	PAGE NO.	CATALOG NO.	PAGE NO.	CATALOG NO.	PAGE NO.	CATALOG NO.	PAGE NO.	CATALOG NO.	PAGE NO.
YCS32	H51	YDS26R	H56	YDS361AT	H53	YE26-LH89	H40	YEV27P37X75FX	C111
YCS321R	H47	YDS26RL	H59	YDS361R	H56, H61	YE26R-60	H40	YEV27P41X82FX	C110
YCS321RL	H48	YDS26RLY	H58	YDS361RL	H60	YE27R-60	H40	YEV28P37X75FX	C112
YCS331A	H49	YDS26RP1	H56, H61	YDS361RP1	H56, H61	YE28-LH128	H40	YEV28P41X75FX	C111
YCS33R	H47	YDS26RP2	H56	YDS36LT	H60	YE28R-60	H40	YEV28P46X92FX	C110
YCS34	H51	YDS27	H54	YDS36R	H56	YE29P31X109	C112	YEV2CP20X75FX	C112
YCS341RL	H48	YDS271R	H57	YDS36RP2	H56-H57	YE29P41X82	C112	YEV2CP23X75FX	C111
YCS351A	H49	YDS271RP1	H57	YDS375H	H61	YE29P46X92	C111	YEV2CP26X75FX	C110
YCS35R	H47	YDS27AT	H53, H60	YDS37RP1	H56	YE29P50X100	C110	YEV4CP16X75FX	C112
YCS361A	H49	YDS27R	H56	YDS39	H54	YE2C-LH128	H40	YEV4CP20X75FX	C110
YCS361R	H47	YDS27RE	H61	YDS391AT	H53	YE2C-LH129	H40	YF/03/0TOOL	N8
YCS37R	H47	YDS27RL	H59	YDS392R	H57	YE2R-25	H40	YF0112I	B8
YCS39	H51	YDS27RLY	H58	YDS39RP1	H57	YE2WAG5	H40	YF0116I	B8
YCS391A	H49	YDS27RP1	H56, H61	YDS3C-3	H54	YE30P46X92	C112	YF0120I	B8
YCS39R	H47	YDS27RP2	H56-H57, H61	YDS3K10	H62	YE30P46X92FX	C111	YF0122I	B8
YCS43R	H47	YDS28	H54	YDS3K5	H62	YE30P50X100	C111	YF0122UI	B6
YCS44	H51	YDS28AT	H53, H60	YDS3K6	H62-H63	YE30P50X100FX	C110	YF0125I	B8
YCS45R	H47	YDS28F	H63	YDS3K7	H62	YE30P55X110	C110	YF0125UI	B6
YCS4R	H47	YDS28R	H56	YDS3K8	H62	YE30R-60	H40	YF0130I	B8
YCT2626	H29	YDS28RE	H61	YDS3W	H55	YE31-LH96	H40	YF0132UI	B6
YCT2828	H29	YDS28RL	H59	YDS41RP2	H56-H57	YE31P41X82FX	C112	YF0215UI	B6
YCU25A	H51	YDS28RLY	H58	YDS431AT	H53	YE31P50X100	C112	YF0216I	B8
YCU25R	H52	YDS28RP1	H56, H61	YDS43R43RS	H57	YE31P51X102FX	C110	YF0218I	B8
YCU26R	H52	YDS28RP2	H56	YDS43R45RS	H57	YE31P55X110	C111	YF0220UI	B6
YCU27R	H52	YDS29	H54	YDS43RP1	H57	YE31P59X118	C110	YF0222I	B8
YCU28A	H51	YDS291AT	H53	YDS43RP2	H57	YE32P51X102FX	C111	YF0225I	B8
YCU28R	H52	YDS291RP1	H56	YDS44	H54	YE32P55X110	C112	YF0225UI	B6
YCU291A	H51	YDS29AT	H53	YDS44RP2	H56-H57	YE32P55X110FX	C110	YF0232UI	B6
YCU2CA	H51	YDS2C	H51, H54	YDS451R34RS	H57	YE32P59X118	C111	YF0401TOOL	N8
YCU2R	H52	YDS2C-3	H54	YDS451R49RS	H57	YE32P63X126	C110	YF0412I	B8
YCU301A	H51	YDS2CA	H53, H60	YDS451RP1	H57	YE32R-60	H40	YF0412UI	B6
YCU30R	H52	YDS2F	H63	YDS45R45RS	H57	YE34-LH119	H40	YF0415I	B8
YCU321R	H52	YDS2KT	H63	YDS45RP1	H57	YE34-LH120	H40	YF0415UI	B6
YCU4R	H52	YDS2RE	H61	YDS45RP2	H57	YE34P51X102FX	C112	YF0416I	B8
YCU4RG1	H52	YDS2REP2	H61	YDS49RP1	H57	YE34P55X110FX	C111	YF0418I	B8
YUCUT129ACSR	N58	YDS2RL	H59	YDS49RP2	H57	YE34P59X118	C112	YF0418UI	B8
YD14-14	B14	YDS2RLY	H58	YDS4C	H51, H54	YE34P59X118FX	C110	YF0420UI	B6
YD28REP2	H61	YDS2W	H51, H55	YDS4CA	H46, H53	YE34P63X126	C111	YF0422I	B8
YDS011R	H57	YDS2WA	H53	YDS4KT	H63	YE34P71X142	C110	YF0425I	B8
YDS011RP1	H57	YDS30	H54	YDS4RL	H59	YE361R-60	H40	YF0425UI	B6
YDS021R	H56	YDS301AT	H53	YDS4RLY	H58	YE36P59X118FX	C111	YF0432UI	B6
YDS021RE	H61	YDS30LT	H60	YDS4W	H51, H55	YE36P63X126	C112	YF0612I	B8
YDS021REP1	H61	YDS30R	H56	YDS4WA	H46, H53	YE36P67X134FX	C110	YF0612UI	B5
YDS021RL	H59	YDS30RP1	H56	YDS500H	H61	YE36P71X142	C111	YF0615UI	B5
YDS021RLY	H58	YDS30RP2	H56	YDS6C	H51, H54	YE36P78X156	C110	YF0618I	B8
YDS021RP1	H56	YDS31	H54	YDS6CA	H53	YE38P59X118FX	C112	YF0618UI	B5
YDS1C	H51, H54	YDS311AT	H53, H60	YDS6KT	H63	YE38P67X134FX	C111	YF0625UI	B5
YDS1C-3	H54	YDS312E	H61	YDS6W	H51, H55	YE38P71X142FX	C110	YF0801TOOL	N8
YDS1R	H56	YDS312H	H61	YDS6WA	H53	YE39P71X142	C112	YF0812I	B8
YDS1RP1	H56	YDS31AT	H53	YDS6WK	H62	YE39P78X156	C111	YF0812UI	B5
YDS1RP2	H56	YDS32	H54	YDS75	H55	YE39P87X174	C110	YF0815I	B8
YDS1W	H55	YDS321R	H56	YDS76	H55	YE39R-60	H40	YF0815UI	B5
YDS25	H54	YDS321RL	H59	YDS78	H55	YE40P67X134FX	C112	YF0818I	B8
YDS25OE	H61	YDS321RLY	H58	YDS7K5	H62	YE40P71X142FX	C111	YF0818UI	B5
YDS251R	H57	YDS321RP1	H56	YDS7K6	H62	YE40P78X156FX	C110	YF1006TOOL	N8
YDS251RP1	H57	YDS326R	H56	YDS7K7	H62	YE44P78X156FX	C111	YF1010I	B8
YDS25AT	H46, H53, H60	YDS32LT	H60	YDS7M10T	H63, I45	YE44P87X174FX	C110	YF1010UI	B5
YDS25F	H63	YDS32R	H56	YDS7M6T	H63, I45	YE4R-25	H40	YF1012I	B8
YDS25R	H56	YDS32RP2	H56	YDS7M7T	H63, I45	YE6R-25	H40	YF1012UI	B5
YDS25REP2	H61	YDS331AT	H53, H60	YDS7M8T	H63, I45	YEV1CP23X75FX	C112	YF1015UI	B5
YDS25RL	H59	YDS33R	H56	YDS7M9T	H63, I45	YEV1CP26X75FX	C111	YF1018I	B8
YDS25RLY	H58	YDS33RP1	H56	YDS8KT	H63	YEV1CP29X75FX	C110	YF1018UI	B5
YDS25RP1	H56, H61	YDS34	H54	YDS8W	H51, H55	YEV25P26X75FX	C112	YF1209I	B8
YDS25RP2	H56	YDS341RL	H60	YDS8WG1	H55	YEV25P29X75FX	C111	YF1209UI	B5
YDS26	H54	YDS34R	H56	YDS8WK	H62	YEV25P33X75FX	C110	YF1210I	B8
YDS261R	H57	YDS34RP2	H56-H57	YE1WAG1	H40	YEV26P29X75FX	C112	YF1212I	B8
YDS261RP1	H57	YDS351AT	H53	YE25-LH97	H40	YEV26P33X75FX	C111	YF1212UI	B5
YDS26AT	H53	YDS35R	H56	YE25R-25	H40	YEV26P37X75FX	C110	YF1215UI	B5
YDS26F	H63	YDS35RP1	H56	YE26-LH88	H40	YEV27P33X75FX	C112	YF1218I	B8

CATALOG NO.	PAGE NO.	CATALOG NO.	PAGE NO.	CATALOG NO.	PAGE NO.	CATALOG NO.	PAGE NO.	CATALOG NO.	PAGE NO.
YF1218UI	B5	YF2610TOOL	N8	YFD-365	C124	YFS32CPL	K44	YGA6C-TC14	E17
YF1407UI	B5	YF2806I	B7	YFM28CP	K52	YFS32CR	K43	YGA6C-TC516	E17
YF1408I	B7	YF2807UI	B5	YFM28CPL	K52	YFS34CP	K43	YGA8C-2N	E17
YF1408UI	B5	YF2808I	B7	YFM28CR	K52	YFS34CPL	K44	YGA8C-TC10	E17
YF1410I	B7	YF3/025ID	B8	YFM29CP	K52	YFS34CR	K43	YGA8C-TC14	E17
YF1410UI	B5	YF3/025UI	B6	YFM29CPL	K52	YFS39CP	K43	YGA8C-TC516	E17
YF1412I	B7	YF3/030ID	B8	YFM29CR	K52	YFS39CPL	K44	YGC6C6	E12
YF1412UI	B5	YF3/030UI	B6	YFM30CP	K52	YFS39CR	K43	YGC6C8	E12
YF1418I	B7	YF3/032UI	B6	YFM30CPL	K52	YFS30CP	K43	YGC8C8	E12
YF1418UI	B5	YF3206TOOL	N8	YFM30CR	K52	YFS30CR	K43	YGF29-2N	E19
YF1425I	B7	YF35032UI	B6	YFM31CP	K52	YFSC6429	K46	YGF29-4N	E19
YF1606I	B7	YF35040UI	B6	YFM31CPL	K52	YFSC7232	K46	YGF34-2N	E19
YF1607UI	B5	YF4/0250TOOL	N8	YFM31CR	K52	YFSC8634	K46	YGF34-4N	E19
YF1608I	B7	YF4/027ID	B8	YFM32CP	K52	YFSC9639	K46	YGHA25-2N	E16
YF1608UI	B5	YF4/030ID	B8	YFM32CPL	K52	YFSH2829	K46	YGHA26-2N	E16
YF1610I	B7	YF4/032ID	B8	YFM32CR	K52	YFSH2829P	K46	YGHA27-2N	E16
YF1610UI	B5	YF4/032UI	B6	YFM34CP	K52	YFSH3032	K46	YGHA28-2N	E16
YF1612I	B7	YF4/034ID	B8	YFM34CPL	K52	YFSH3032P	K46	YGHA29-2N	E16
YF1612UI	B5	YF4/034UI	B6	YFM34CR	K52	YFSH34	K46	YGHA2C-2N	E16
YF1615I	B7	YF4/040UI	B6	YFM39CP	K52	YFSH34P	K46	YGHA31-2N	E16
YF1618I	B7	YFA28CP-2	K47	YFM39CPL	K52	YFSH39	K46	YGHA34-2N	E16
YF1618UI	B5	YFA28CPL-2	K48	YFM39CR	K52	YFSH39P	K46	YGHC26C2	E11
YF1806I	B7	YFA28CR-2	K47	YFMC6429	K54	YFSP28	K45	YGHC26C26	E11
YF1806UI	B5	YFA29CP-2	K47	YFMC7232	K54	YFSP28L	K45	YGHC29C26	E11
YF1808I	B7	YFA29CPL-2	K48	YFMC8634	K54	YFSP29	K45	YGHC29C29	E11
YF1808UI	B5	YFA29CR-2	K47	YFMC9639	K54	YFSP29L	K45	YGHC2C2	E11
YF1810I	B7	YFA30CP-2	K47	YFMH2829	K54	YFSP30	K45	YGHC34C26	E11
YF1810UI	B5	YFA30CPL-2	K48	YFMH2829P	K54	YFSP30L	K45	YGHC34C29	E11
YF1812I	B7	YFA30CR-2	K47	YFMH3032	K54	YFSP31	K45	YGHC34C34	E11
YF1812UI	B5	YFA31CP-2	K47	YFMH3032P	K54	YFSP31L	K45	YGHP29C2	E9
YF1818I	B7	YFA31CPL-2	K48	YFMH34	K54	YFSP32	K45	YGHP29C26	E9
YF2/020ID	B8	YFA31CR-2	K47	YFMH34P	K54	YFSP32L	K45	YGHP29C29	E9
YF2/025ID	B8	YFA32CP-2	K47	YFMH39	K54	YFSP34	K45	YGHP29C6W6W	E9
YF2/025UI	B6	YFA32CPL-2	K48	YFMH39P	K54	YFSP34L	K45	YGHP2C2	E9
YF2/027ID	B8	YFA32CR-2	K47	YFMP28	K53	YFSP39	K45	YGHP2C6W6W	E9
YF2/032UI	B6	YFA34CP-2	K47	YFMP28L	K53	YFSP39L	K45	YGHP34C2	E9
YF2006I	B7	YFA34CPL-2	K48	YFMP29	K53	YFSR28	K45	YGHP34C26	E9
YF2006UI	B5	YFA34CR-2	K47	YFMP29L	K53	YFSR29	K45	YGHP34C29	E9
YF2008I	B7	YFA39CP-2	K47	YFMP30	K53	YFSR30	K45	YGHP34C34	E9
YF2010I	B7	YFA39CPL-2	K48	YFMP30L	K53	YFSR31	K45	YGHP58C2W-2	E10
YF2010UI	B5	YFA39CR-2	K47	YFMP31	K53	YFSR32	K45	YGHP58C2W-2TN	E10
YF2012I	B7	YFAC6429	K51	YFMP31L	K53	YFSR34	K45	YGHR26C100	E14
YF2012UI	B5	YFAC7834	K51	YFMP32	K53	YFSR39	K45	YGHR26C12	E14
YF2018I	B7	YFAC8634	K51	YFMP32L	K53	YFTW0614	B9	YGHR26C34	E14
YF2205I	B7	YFAC9634	K51	YFMP34	K53	YFTW0814	B9	YGHR26C58	E14
YF2206I	B7	YFAH2829	K51	YFMP34PL	K53	YFTW1014	B9	YGHR29C100	E14
YF2206UI	B5	YFAH34	K51	YFMP39	K53	YFTW1212	B9	YGHR29C12	E14
YF2208I	B7	YFAH39	K51	YFMP39PL	K53	YFTW1410	B9	YGHR29C34	E14
YF2208UI	B5	YFAP28-2	K49	YFMR28	K53	YFTW1413	B9	YGHR29C58	E14
YF2210I	B7	YFAP28L-2	K50	YFMR29	K53	YFTW1608	B9	YGHR34C100	E14
YF2210TOOL	N8	YFAP29-2	K49	YFMR30	K53	YFTW1612	B9	YGHR34C34	E14
YF2210UI	B5	YFAP29L-2	K50	YFMR31	K53	YFTW1808	B9	YGHR34C58	E14
YF2212I	B7	YFAP30-2	K49	YFMR32	K53	YFTW1810	B9	YGHR58C2W-3	E15
YF2212UI	B5	YFAP30L-2	K50	YFMR34	K53	YFTW2008	B9	YGHS25	E16
YF2214TOOL	N8	YFAP31-2	K49	YFMR39	K53	YFTW2010	B9	YGHS26	E16
YF2405UI	B5	YFAP31L-2	K50	YFN-540	C124	YFTW2208	B9	YGHS27	E16
YF2406I	B7	YFAP32-2	K49	YFO-140	C124	YG14B2TC2C2C	E24	YGHS28	E16
YF2407UI	B5	YFAP32L-2	K50	YFR-865	C124	YG14B2TC2C6C	E24	YGHS29	E16
YF2408I	B7	YFAP34-2	K49	YFS28CP	K43	YG14BTC28	E24	YGHS2C	E16
YF25025ID	B8	YFAP34L-2	K50	YFS28CPL	K44	YGA25-2N	E17	YGHS31	E16
YF25027ID	B8	YFAP39-2	K49	YFS28CR	K43	YGA26-2N	E17	YGHS34	E16
YF25032ID	B8	YFAP39L-2	K50	YFS29CP	K43	YGA28-2N	E17	YGIBS28-338-2N	E21
YF25032UI	B6	YFAR28-2	K49	YFS29CPL	K44	YGA29-2N	E17	YGIBS28-400-2N	E21
YF25038ID	B8	YFAR29-2	K49	YFS29CR	K43	YGA2C-2N	E17	YGIBS28-462-2N	E21
YF25040UI	B6	YFAR30-2	K49	YFS30CPL	K44	YGA2C-2TC38	E17	YGIBS28-550-2N	E21
YF2605UI	B5	YFAR31-2	K49	YFS31CP	K43	YGA34-2N	E17	YGIBS28-613-2N	E21
YF2606I	B7	YFAR32-2	K49	YFS31CPL	K44	YGA6C-2N	E17	YGIBS28-675-2N	E21
YF2607UI	B5	YFAR34-2	K49	YFS31CR	K43	YGA6C-2TC38E2G1	E17	YGIBS34-338-2N	E21
YF2608I	B7	YFAR39-2	K49	YFS32CP	K43	YGA6C-TC10	E17	YGIBS34-400-2N	E21

Alpha-Numeric Index

CATALOG NO.	PAGE NO.	CATALOG NO.	PAGE NO.	CATALOG NO.	PAGE NO.	CATALOG NO.	PAGE NO.	CATALOG NO.	PAGE NO.
YGIBS34-462-2N	E21	YH4444WC	C103, C105	YHSA18K14RK	B10	YNA34RT	110, 125	YNA7M10T	I44
YGIBS34-550-2N	E21	YH4444WCC	C103, C105	YHSA18K38	B10	YNA34RT15	110, 125	YNA7M6T	I44
YGIBS34-675-2N	E21	YH6C6C	C103-C105	YHSA18K38RK	B10	YNA34RT15H	15-16, 117	YNA7M7T	I44
YGBW28-338-2N	E21	YH6C6CWC	C103, C105	YHSA18K6	B10	YNA36R	9, 124	YNA7M8T	I44
YGBW28-400-2N	E21	YH6C6CWCC	C103, C105	YHSA18K6RK	B10	YNA36R15	9, 124	YNM4-28	K39
YGBW28-462-2N	E21	YH8C8C	C103-C105	YHSA18K8	B10	YNA36R15H	I3-I4, I16, I18-I19	YNM4-34	K39
YGBW28-550-2N	E21	YH8C8CWC	C103, C105	YHSA18K8RK	B10	YNA36RT	110, 125	YNM6-28	K39
YGBW28-613-2N	E21	YH8C8CWCC	C103, C105	YHSFQ10F25X03	B11	YNA36RT15	110, 125	YNM6-34	K39
YGBW28-675-2N	E21	YHD-10	H28	YHSFQ10F25X03RK	B11-B12	YNA36RT15H	15-16, 117	YNM8-28	K39
YGBW34-338-2N	E21	YHD-200	H26, H36	YHSFQ14F25X03	B11	YNA39R	9, 124	YNM8-34	K39
YGBW34-400-2N	E21	YHD-250	H26, H36	YHSFQ14F25X03RK	B11-B12	YNA39R15	9, 124	YNS32R	I11, I26
YGBW34-462-2N	E21	YHD-3	H28	YHSFQ18F25X03	B11	YNA39R15H	I3-I4, I16, I18-I19	YNS32RT	I12, I27
YGBW34-550-2N	E21	YHD-300	H26, H36	YHSFQ18F25X03RK	B11-B12	YNA39RT	110, 125	YNS34R	I11, I26
YGBW34-613-2N	E21	YHD-350	H26	YHSQ10F25X03	B11	YNA39RT15	110, 125	YNS34RT	I12, I27
YGBW34-675-2N	E21	YHD-4	H28	YHSQ10F25X03RK	B11	YNA39RT15H	15-16, 117	YNS36R	I11, I26
YGL29C2	E7	YHD-400	H26	YHSQ10M25X03	B11	YNA43R	9, 124	YNS36RT	I12, I27
YGL29C29	E7	YHD-5	H28	YHSQ10M25X03RK	B11	YNA43R15	9, 124	YNS39R	I11, I26
YGL2C2	E7	YHD-6	H28	YHSQ14F25X03	B11	YNA43R15H	I3-I4, I16, I18-I19	YNS39RT	I12, I27
YGL34C2	E7	YHD-7	H28	YHSQ14F25X03RK	B11	YNA43RT	110, 125	YNS43R	I11, I26
YGL34C29	E7	YHD200J1444	H37	YHSQ14M25X03	B11	YNA43RT15	110, 125	YNS43RT	I12, I27
YGL34C34	E7	YHD250J1444	H37	YHSQ14M25X03RK	B11	YNA43RT15H	15-16, 117	YNS451R	I11, I26
YGLR29C100	E8	YHD300J1496	H37	YHSQ18F25X03	B11	YNA451R	9, 124	YNS451RT	I12, I27
YGLR29C12	E8	YHD350	H36	YHSQ18F25X03RK	B11	YNA451R15	9, 124	YNS49R	I11, I26
YGLR29C34	E8	YHD350J1496	H37	YHSQ18M25X03	B11	YNA451R15H	I3-I4, I16, I18-I19	YNS49RT	I12, I27
YGLR29C58	E8	YHN-450	H27	YHSQ18M25X03RK	B11	YNA451RT	110, 125	YNS52R	I11, I26
YGLR34C100	E8	YHN-500	H27, H36	YHSS10	B11	YNA451RT15	110, 125	YNS52RT	I12, I27
YGLR34C12	E8	YHN-525	H27	YHSS10RK	B11-B12	YNA451RT15H	15-16, 117	YNS54R	I26
YGLR34C34	E8	YHN-550	H27	YHSS14	B11	YNA49R	9, 124	YNS54RT	I27
YGLR34C58	E8	YHN-600	H27	YHSS14RK	B11-B12	YNA49R15	9, 124	YNS56R	I11, I26
YGS25	E18	YHN500J1496	H37	YHSS18	B11	YNA49R15H	I3-I4, I16, I18-I19	YNS56RT	I12, I27
YGS26	E18	YHO-1	H28	YHSS18RK	B11-B12	YNA49RT	110, 125	YNS58R	I11, I26
YGS28	E18	YHO-10	H28	YKA25R-2N	H32	YNA49RT15	110, 125	YNS58RT	I12, I27
YGS29	E18	YHO-100	H26, H36	YKA26-2N	H34	YNA49RT15H	15-16, 117	YNS594R	I26
YGS2C	E18	YHO-125	H26	YKA26R-2N	H32	YNA52R	9, 124	YNS594RT	I27
YGS34	E18	YHO-150	H26, H36	YKA27R-2N	H32	YNA52R15	9, 124	YNS59R	I11, I26
YGS6C	E18	YHO-2	H28	YKA28-2N	H34	YNA52R15H	I3-I4, I16, I18-I19	YNS59RT	I12, I27
YGS8C	E18	YH0100J1444	H37	YKA28R-2N	H32	YNA52RT	110, 125	YNT32R32R	I13, I29
YGT275	E23	YH0150J1444	H37	YKA2C-2N	H34	YNA52RT15	110, 125	YNT32R32RHT	I41
YH2929	C103-C105	YHR-700	H27	YKA2R-2N	H32	YNA52RT15H	15-16, 117	YNT34R34R	I13, I29
YH2929WC	C103, C105	YHR-750	H27	YKA30-2N	H34	YNA54R	124	YNT34R34RHT	I41
YH2929WCC	C103, C105	YHR-800	H27	YKA30R-2N	H32	YNA54R15	124	YNT36R36R	I13, I29
YH292C	C103-C105	YHR-850	H27	YKA321R-2N	H32	YNA54R15H	116, I18-I19	YNT36R36RHT	I41
YH292CWC	C103, C105	YHR-900	H27	YKA33R-2N	H32	YNA54RT	125	YNT39R39R	I13, I29
YH292CWCC	C103, C105	YHR-950	H27	YKA34-2N	H34	YNA54RT15	125	YNT39R39RHT	I41
YH298C	C103-C105	YHSA10K10	B10	YKA34CA-2N	H32	YNA54RT15H	117	YNT43R43R	I13, I29
YH298CWC	C103, C105	YHSA10K10F	B10	YKA361R-2N	H32	YNA56R	9, 124	YNT43R43RHT	I41
YH298CWCC	C103, C105	YHSA10K10FRK	B10, B12	YKA37R-2N	H32	YNA56R15	9, 124	YNT451R451R	I13, I29
YH2C2C	C103-C105	YHSA10K10RK	B10, B12	YKA391A-2N	H32	YNA56R15H	I3-I4, I16, I18-I19	YNT451R451RHT	I41
YH2C2CWC	C103, C105	YHSA10K12	B10	YKA44-2N	H34	YNA56RT	110, 125	YNT49R49R	I13, I29
YH2C2CWCC	C103, C105	YHSA10K12RK	B10	YKA6C-2N	H34	YNA56RT15	110, 125	YNT49R49RHT	I41
YH3429	C103-C105	YHSA10K14	B10	YM10-28	K38	YNA56RT15H	15-16, 117	YNT52R52R	I13, I29
YH3429WC	C103, C105	YHSA10K14RK	B10	YM10-34	K38	YNA58R	9, 124	YNT52R52RHT	I41
YH3429WCC	C103, C105	YHSA10K38	B10	YM12-28	K38	YNA58R15	9, 124	YNT54R54R	I29
YH3434	C103-C105	YHSA10K38RK	B10	YM12-34	K38	YNA58R15H	I3-I4, I16, I18-I19	YNT56R56R	I13, I29
YH3434WC	C103, C105	YHSA14K10	B10	YM4-28	K38	YNA58RT	110, 125	YNT56R56RHT	I41
YH3434WCC	C103, C105	YHSA14K10F	B10	YM4-34	K38	YNA58RT15	110, 125	YNT58R58R	I13, I29
YH3931	C103-C105	YHSA14K10FRK	B10, B12	YM6-28	K38	YNA58RT15H	15-16, 117	YNT58R58RHT	I41
YH3931WC	C103, C105	YHSA14K10RK	B10, B12	YM6-34	K38	YNA594R	124	YNT594R594R	I29
YH3931WCC	C103, C105	YHSA14K14	B10	YM8-28	K38	YNA594R15	124	YNT594R594RHT	I13, I29
YH3939	C103-C105	YHSA14K14RK	B10	YM8-34	K38	YNA594R15H	116, I18-I19	YNT594R594RHT	I41
YH3939WC	C103, C105	YHSA14K38	B10	YNA32R	9, 124	YNA594RT	125	YNTA245MRTACCC	I51
YH3939WCC	C103, C105	YHSA14K38RK	B10	YNA32R15	9, 124	YNA594RT15	125	YNTA32R	I14, I28
YH4429	C103-C105	YHSA14K8	B10	YNA32R15H	I3-I4, I16, I18-I19	YNA594RT15H	117	YNTA32RHT	I42
YH4429WC	C103, C105	YHSA14K8RK	B10	YNA32RT	110, 125	YNA59R	9, 124	YNTA32RTACCC	I51
YH4429WCC	C103, C105	YHSA18K10	B10	YNA32RT15	110, 125	YNA59R15	9, 124	YNTA34R	I14, I28
YH4434	C103-C105	YHSA18K10F	B10	YNA32RT15H	15-16	YNA59R15H	I3-I4, I16, I18-I19	YNTA34RHT	I42
YH4434WC	C103, C105	YHSA18K10FRK	B10, B12	YNA34R	9, 124	YNA59RT	110, 125	YNTA36R	I14, I28
YH4434WCC	C103, C105	YHSA18K10RK	B10, B12	YNA34R15	9, 124	YNA59RT15	110, 125	YNTA36RHT	I42
YH4444	C103-C105	YHSA18K14	B10	YNA34R15H	I3-I4, I16, I18-I19	YNA59RT15H	15-16, 117	YNTA36RTACCC	I51

CATALOG NO.	PAGE NO.	CATALOG NO.	PAGE NO.	CATALOG NO.	PAGE NO.	CATALOG NO.	PAGE NO.	CATALOG NO.	PAGE NO.
YNTA39R	114, 128	YP25U25	H21	YRB34U31	C123	YS2C-LB	C85-C86	YS4CA1	C120
YNTA39RHT	142	YP26AU2	H21, H36	YRB34U31TW	K72	YS2C-T	C87	YS4CFXLTCKITC	C89
YNTA39RTACCC	151	YP27AU2	H21	YRB34U34TW	K72	YS2CA1	C120	YS5C	C83
YNTA43R	114, 128	YP27AU26	H21, H36	YRB36U31	C123	YS2CAT	C122	YS5C-L BOX	C82
YNTA43RHT	142	YP27AU4	H21, H36	YRB36U34	C123	YS2CFXLTCKITC	C89	YS5C-LB	C85-C86
YNTA43RTACCC	151	YP28C28	H19	YRB39U31TW	K72	YS2CLTCKITC	C89	YS6C	C83
YNTA451R	114, 128	YP28U2	H21	YRB39U34	C123	YS2UCGI	K70	YS6C-L BOX	C82
YNTA451RHT	142	YP28U26	H21, H36	YRB39U34TW	K72	YS30	C83	YS6C-T	C87
YNTA451RTACCC	151	YP29C26	H19	YRB39U36	C123	YS30-FXB	C88	YS6CA1	C120
YNTA49R	114, 128	YP2C2	H19	YRB39U39TW	K72	YS30-L	C82	YS6CFXLTCKITC	C89
YNTA49RHT	142	YP2U3	H21, H36	YRB44U31TW	K72	YS30-LB	C85-C86	YS8C	C83
YNTA49RTACCC	151	YPC26R8U	H23	YRB44U34TW	K72	YS30-T	C87	YS8C-FXB	C88
YNTA52RTACCC	151	YPC28R28A	H22	YRB44U39TW	K72	YS30A1	C121	YS8C-L-BOX	C82
YNTA54R	114, 128	YPC28U26	H22, H36	YRB44U44TW	K72	YS30AT	C122	YS8CA1	C120
YNTA54RHT	142	YPC28U28	H21-H22	YRV2CV6C-L	B57	YS31	C83	YS8CFXLTCKITC	C89
YNTA56R	114, 128	YPC28U4	H22, H36	YRV4CV6C-L	B57	YS31-FXB	C88	YSA25R-2N	H33
YNTA56RHT	142	YPC29C26	K76	YRV6CV10-L	B57	YS31-L	C82	YSA26R-2N	H33
YNTA58R	114, 128	YPC2A8U	H23	YRV6CV8C-L	B57	YS31-T	C87	YSA28R-2N	H33
YNTA58RHT	142	YPC33R26U	H22, H36	YRV8CV10-L	B57	YS31A1	C121	YSA2R-2N	H33
YNTA594R	128	YPC33R28R	H22	YRV8CV14-L	B57	YS31ACGI	K70	YSA30R-2N	H33
YNTA59R	114, 128	YPC33R33R	H22	YS-T	C87	YS31AT	C122	YSA321R-2N	H33
YNTA59RHT	142	YPC36A32	H22	YS10WAG1	C120	YS31LTCKITC	C89	YSA37R-2N	H33
YNU245MRACCC	152	YPC36A36	H22	YS12AG1	C120	YS32	C83	YSCM104	B52
YNU32R	115, 130	YPC38R26U	H22	YS1C	C83	YS32-FXB	C88	YSCM133	B52
YNU32RACCC	152	YPC40A32	H22	YS1C-L BOX	C82	YS32-L	C82	YSCM167	B52
YNU32RHT	143	YPC40A36	H22	YS1C-LB	C85-C86	YS32A1	C121	YSCM17	B52
YNU34R	115, 130	YPC40A40	H22	YS1C-T	C87	YS34	C83	YSCM212	B52
YNU34RHT	143	YQE-91	B58	YS1CA1	C120	YS34-FXB	C88	YSCM231	B52
YNU36R	115, 130	YR2C2WT	C83	YS25	C83	YS34-L	C82	YSCM27	B52
YNU36RACCC	152	YRA1CU-1	H75	YS25-L BOX	C82	YS34-T	C87	YSCM42	B52
YNU36RHT	143	YRA25A-1	H75	YS25-LB	C85-C86	YS34A1	C121	YSCM66	B52
YNU39R	115, 130	YRA25U	H75	YS25-T	C87	YS34AT	C122	YSCM80	B52
YNU39RACCC	152	YRA26U	H75	YS25A1	C120	YS34FXLTCKITC	C89	YSD25R25R	H45
YNU39RHT	143	YRA27U	H75	YS25AT	C122	YS34LTCKITC	C89	YSD26R25R	H45
YNU43R	115, 130	YRA28U	H75	YS25FXLTCKITC	C89	YS36	C83	YSD26R26R	H45
YNU43RACCC	152	YRA4CU-1	H75	YS25LTCKITC	C89	YS36-FXB	C88	YSD26R2R	H45
YNU43RHT	143	YRA6CU-1	H75	YS25UCGI	K70	YS36-L	C82	YSD26R2W	H45
YNU451R	115, 130	YRA8CU-1	H75	YS26	C83	YS36A1	C121	YSD27R25R	H45
YNU451RACCC	152	YRAL1CU	H75	YS26-L BOX	C82	YS38-FXB	C88	YSD27R26R	H45
YNU451RHT	143	YRAL4CU	H75	YS26-LB	C85-C86	YS38-L	C82	YSD27R27R	H45
YNU49R	115, 130	YRB1CU1TTN	K71	YS26-T	C87	YS38FXLTCK	C89	YSD27R2R	H45
YNU49RACCC	152	YRB1CU2TTN	K71	YS26A1	C121	YS39	C83	YSD27R2W	H45
YNU49RHT	143	YRB25U2	C123	YS26AT	C122	YS39-L	C82	YSD28R25R	H45
YNU52RACCC	152	YRB25U25TTN	K71	YS26FXLTCKITC	C89	YS39-T	C87	YSD28R26R	H45
YNU54R	115, 130	YRB25U2TTN	K71	YS26LTCKITC	C89	YS39A1	C121	YSD28R27R	H45
YNU54RHT	143	YRB25U3TTN	K71	YS26UCGI	K70	YS39AM1	C121	YSD28R28R	H45
YNU56R	115, 130	YRB27U25	C123	YS27	C83	YS39AT	C122	YSD28R2R	H45
YNU56RHT	143	YRB27U25TW	K71	YS27-L BOX	C82	YS39LTCKITC	C89	YSD28R2W	H45
YNU58R	115	YRB27U26	C123	YS27-LB	C85-C86	YS3C	C83	YSE10	B56
YNU58RHT	143	YRB2825T	K74-K75	YS27A1	C121	YS3C-L	C82	YSE10-BOX	B56
YNU594R	130	YRB28U1TW	K71	YS27AT	C122	YS3C-LB	C85-C86	YSE10HN	B55
YNU595R	130	YRB28U25TW	K71	YS27UCGI	K70	YS40-FXB	C88	YSE14H	B56
YNU59R	115, 130	YRB28U26	C123	YS28	C83	YS44	C83	YSE14H-BOX	B56
YNU59RHT	143	YRB28U26TW	K71	YS28-L BOX	C82	YS44-FXB	C88	YSE14HN	B55
YOT3434	H29	YRB28U28TW	K71	YS28-LB	C85-C86	YS44-L	C82	YSE18H	B56
YOU32R	H52	YRB28U3TW	K71	YS28-T	C87	YS44A1	C121	YSE18H-BOX	B56
YOU33R	H52	YRB29U28	C123	YS28A1	C121	YS44AT	C122	YSE18HN	B55
YOU35R	H52	YRB2U3TTN	K71	YS28AT	C122	YS44FXLTCKITC	C89	YSES10K	B53
YOU361R	H52	YRB2U4	C123	YS28LTCKITC	C89	YS45A1	C121	YSES14-2	B56
YOU37R	H52	YRB31U25TW	K71	YS28UCGI	K70	YS46	C83	YSES14K	B53
YOU39R	H52	YRB31U28	C123	YS29	C83	YS46A1	C121	YSES18-1	B56
YOU41R	H52	YRB31U28TW	K71	YS29-L BOX	C82	YS47A1	C121	YSES18K	B53
YOU421R	H52	YRB31U29	C123	YS29-LB	C85-C86	YS48	C83	YSH-2925-E	C107
YOU43R	H52	YRB31U31TW	K71	YS29-T	C87	YS483A1	C121	YSH-292C-E	C107
YOU44R	H52	YRB3428T	K74-K75	YS29A1	C121	YS48A1	C121	YSH2929	C107
YOU453R	H52	YRB34U25TW	K72	YS29AT	C122	YS4C	C83	YSH3429	C107
YOU45R	H52	YRB34U28TW	K72	YS29FXLTCKITC	C89	YS4C-L BOX	C82	YSH3434	C107
YOU48R	H52	YRB34U29TW	K72	YS2C	C83	YS4C-LB	C85-C86	YSH3931	C107
YOU49R	H52	YRB34U30TW	K72	YS2C-L BOX	C82	YS4C-T	C87	YSH3939	C107

Alpha-Numeric Index

CATALOG NO.	PAGE NO.	CATALOG NO.	PAGE NO.	CATALOG NO.	PAGE NO.	CATALOG NO.	PAGE NO.	CATALOG NO.	PAGE NO.
YSHG3429	E13	YSR34FX26FXTCKITC	C91, C96	YSU2W4W	H44	YTS311AT	I21	YTS486A	I20
YSHG3434	E13	YSR34FX28FXTCKITC	C91, C96	YSU2W6W	H44	YTS312E	I46	YTS486AT	I21
YSHG3931	E13	YSR34FX28LTCKITC	C91, C96	YSU2W8W	H44	YTS32AR	I22	YTS48A	I20
YSHG4429	E13	YSR34FX29FXTCKITC	C91, C95	YSU4W4W	H44	YTS32ART	I23	YTS48AR	I23
YSM10	B51	YSR34FX2CFXLTCKITC	C91, C96	YSU4W6W	H44	YTS32R33RS	I7	YTS48ART	I22
YSM14	B51	YSR34FX31LTCKITC	C91, C95	YSU4W8W	H44	YTS32R34RS	I7	YTS48AT	I21
YSM18	B51	YSR34FX4CFXLTCKITC	C91, C96	YSU6W6W	H44	YTS32R34RSHT	I35	YTS48R481RS	I7
YSM1C	B51	YSR34FX6CFXLTCKITC	C91, C96	YSV10	B49	YTS32RT33RS	I8	YTS48R481RSHT	I35
YSM25	B51	YSR38FX26FXTCKITC	C90, C95	YSV10 BOX	B49	YTS32RT33RSHT	I36	YTS48R48RS	I7
YSM26	B51	YSR38FX28FXTCKITC	C90, C95	YSV10-H	B49	YTS32RT34RS	I8	YTS48R48RSHT	I35
YSM27	B51	YSR38FX28LTCKITC	C90, C95	YSV10-H BOX	B49	YTS32RT34RSHT	I36	YTS48RT481RS	I8
YSM28	B51	YSR38FX29FXTCKITC	C90, C95	YSV1014-G2	B57	YTS331A	I20	YTS48RT481RSHT	I36
YSM2C	B51	YSR38FX30LTCKITC	C90, C95	YSV1214-G1	B57	YTS331AT	I21	YTS48RT48RS	I8
YSM4C	B51	YSR38FX31LTCKITC	C90, C95	YSV14	B49	YTS331AT	I7	YTS48RT48RSHT	I36
YSM6C	B51	YSR38FX34FXTCKITC	C90, C95	YSV14 BOX	B49	YTS34R34RS	I35	YTS49AR	I22
YSM8C	B51	YSR38FX34LTCKITC	C90, C95	YSV14-H	B49	YTS34R34RSHT	I8	YTS49ART	I23
YSP-T	C87	YSR3928FXTCKITC	C90, C94	YSV14-H BOX	B49	YTS34RT34RS	I8	YTS49ART483RS	I7
YSP1C-T	C87	YSR3928LTCKITC	C90, C94	YSV1418	B57	YTS34RT34RSHT	I36	YTS49R483RSHT	I35
YSP25-T	C87	YSR3929FXTCKITC	C90, C94	YSV18	B49	YTS351A	I20	YTS49R48RSHT	I7
YSP26-T	C87	YSR3930LTCKITC	C90, C94	YSV18 BOX	B49	YTS351AT	I21	YTS49R48RS	I7
YSP28-T	C87	YSR3931LTCKITC	C90, C94	YSV18-H	B49	YTS361A	I20	YTS49R48RSHT	I35
YSP29-T	C87	YSR3934FXTCKITC	C90, C94	YSV18-H BOX	B49	YTS361AT	I21	YTS49RT483RS	I8
YSP2C-T	C87	YSR3934LTCKITC	C90, C94	YSV18-L	B49	YTS36R362RS	I7	YTS49RT483RSHT	I36
YSP30-T	C87	YSR3938FXTCKITC	C90, C94	YSV1C-FXB	C88	YTS36R362RSHT	I35	YTS49RT48RS	I8
YSP31-T	C87	YSR3939LTCKITC	C90, C94	YSV1C-L	B50	YTS36R36RS	I7	YTS49RT48RSHT	I36
YSP34-T	C87	YSR44FX28FXTCKITC	C90, C94	YSV1C-L BOX	B50	YTS36R36RSHT	I35	YTS500E	I46
YSP39-T	C87	YSR44FX28LTCKITC	C90, C94	YSV25-FXB	C88	YTS36RT362RS	I8	YTS51AR	I22
YSP4C-T	C87	YSR44FX29FXTCKITC	C90, C94	YSV25-L	B50	YTS36RT362RSHT	I36	YTS51ART	I23
YSR10CFX12CLTCKITC	C93, C99	YSR44FX30LTCKITC	C90, C94	YSV25-L BOX	B50	YTS36RT36RS	I8	YTS52R48RS	I7
YSR10CFX14CLTCKITC	C93, C99	YSR44FX31LTCKITC	C90, C94	YSV26-FXB	C88	YTS36RT36RSHT	I36	YTS52R48RSHT	I35
YSR25FX2CFXLTCKITC	C92, C98	YSR44FX31LTCKITC	C90, C94	YSV26-L	B50	YTS375E	H62, I46	YTS52R521RS	I7
YSR25FX4CFXLTCKITC	C92, C98	YSR44FX34LTCKITC	C90, C94	YSV26-L BOX	B50	YTS391A	I20	YTS52R521RSHT	I35
YSR25FX6CFXLTCKITC	C92, C98	YSR44FX34LTCKITC	C90, C94	YSV27-FXB	C88	YTS391AT	I21	YTS52R59RS	I7
YSR26FX25FXTCKITC	C92, C98	YSR44FX38FXTCKITC	C90, C94	YSV27-L	B50	YTS39A	I20	YTS52R59RSHT	I35
YSR26FX2CFXLTCKITC	C92, C98	YSR44FX39LTCKITC	C90, C94	YSV27-L BOX	B50	YTS39AR	I22	YTS52RT48RS	I8
YSR26FX4CFXLTCKITC	C92, C98	YSR4CFX10CLTCKITC	C92, C99	YSV28-FXB	C88	YTS39ART	I23	YTS52RT48RSHT	I36
YSR26FX6CFXLTCKITC	C92, C98	YSR4CFX8CFXLTCKITC	C92, C99	YSV28-L	B50	YTS39AT	I21	YTS52RT521RS	I8
YSR2825FXTCKITC	C92, C98	YSR6CFX10CLTCKITC	C93, C99	YSV28-L BOX	B50	YTS39R43RS	I7	YTS52RT521RSHT	I36
YSR282CFXLTCKITC	C92, C98	YSR6CFX10CLTCKITC	C93, C99	YSV2C-FXB	C88	YTS39R43RSHT	I35	YTS52RT59RS	I8
YSR284CFXLTCKITC	C92, C98	YSR8CFX10CLTCKITC	C93, C99	YSV2C-L	B50	YTS39RT43RS	I8	YTS52RT59RSHT	I36
YSR286CFXLTCKITC	C92, C98	YSR8CFX14CLTCKITC	C93, C99	YSV2C-L BOX	B50	YTS39RT43RSHT	I36	YTS54959RSHT	I35
YSR28FX25FXTCKITC	C92, C97	YSS2R	H46	YSV4C-FXB	C88	YTS431A	I20	YTS549R521RS	I7
YSR28FX26FXTCKITC	C92, C97	YSS4R	H46	YSV4C-L	B50	YTS431AT	I21	YTS549R521RSHT	I35
YSR28FX28LTCKITC	C92, C97	YSS6R	H46	YSV4C-L BOX	B50	YTS43BE	H62, I46	YTS549R549RS	I7
YSR28FX2CFXLTCKITC	C92, C97	YSS6RG2	H46	YSV6C-FXB	C88	YTS43R43RS	I7	YTS549R549RSHT	I35
YSR28FX4CFXLTCKITC	C92, C98	YST2525	C108	YSV6C-L	B50	YTS43R43RSHT	I35	YTS549R59RS	I7
YSR29FX25FXTCKITC	C91, C97	YST2626	C108	YSV6C-L BOX	B50	YTS43RT43RS	I8	YTS549RT521RS	I8
YSR29FX28LTCKITC	C91, C97	YST2825	C108	YSV8C-L	B49-B50	YTS43RT43RSHT	I36	YTS549RT521RSHT	I36
YSR29FX2CFXLTCKITC	C91, C97	YST2828	C108	YSV8C-L BOX	B49-B50	YTS445A	I20	YTS549RT549RS	I8
YSR2CFX4CFXLTCKITC	C92, C99	YST282C	C108	YSV9C-L	B49	YTS445AT	I21	YTS549RT549RSHT	I36
YSR2CFX6CFXLTCKITC	C92, C99	YST2929	C108	YSV9C-L BOX	B49	YTS451A	I20	YTS549RT59RS	I8
YSR3125FXTCKITC	C91, C97	YST2C2C	C108	YTA25R-2N	H31	YTS451AR	I22	YTS549RT59RSHT	I36
YSR3126FXTCKITC	C91, C97	YST3131	C108	YTA26-2N	H33	YTS451ART	I23	YTS55AR	I22
YSR3128FXTCKITC	C91, C96	YST3428	C108	YTA26R-2N	H31	YTS451AT	I21	YTS55ART	I23
YSR3128LTCKITC	C91, C96	YST3434	C108	YTA27R-2N	H31	YTS451R449RS	I7	YTS55R59RS	I7
YSR3129FXTCKITC	C91, C96	YST3939	C108	YTA28-2N	H33	YTS451R449RSHT	I35	YTS56R59RSHT	I35
YSR312CFXLTCKITC	C91, C97	YST4C4C	C108	YTA28R-2N	H31	YTS451R48RS	I7	YTS56RT59RS	I8
YSR314CFXLTCKITC	C91, C97	YSU25A25A	H44	YTA2C-2N	H33	YTS451R48RSHT	I35	YTS56RT59RSHT	I36
YSR316CFXLTCKITC	C91, C97	YSU25R25R	H44	YTA2R-2N	H31	YTS451RT449RS	I8	YTS58R48RS	I7
YSR32FX28FXTCKITC	C91, C96	YSU25R2W	H44	YTA321R-2N	H31	YTS451RT449RSHT	I36	YTS58R48RSHT	I35
YSR32FX29FXTCKITC	C91, C96	YSU25R4W	H44	YTA33R-2N	H31	YTS451RT48RS	I8	YTS58RT48RS	I8
YSR3425FXTCKITC	C90, C95	YSU25R6W	H44	YTA34-2N	H33	YTS451RT48RSHT	I36	YTS58RT48RSHT	I36
YSR3428FXTCKITC	C90, C95	YSU2R2R	H44	YTA361R-2N	H31	YTS457A	I20	YTS592AR	I22
YSR3428LTCKITC	C90, C95	YSU2R2W	H44	YTA37R-2N	H31	YTS457AT	I21	YTS592ART	I23
YSR3429FXTCKITC	C90, C95	YSU2R4W	H44	YTA391A-2N	H31	YTS463A	I20	YTS59AR	I22
YSR3431LTCKITC	C90, C95	YSU2R6W	H44	YTA39R-2N	H31	YTS463AT	I21	YTS59ART	I23
YSR3434FXTCKITC	C90, C95	YSU2R8W	H44	YTA43R-2N	H31	YTS47A	I20	YTS59R521RS	I7
YSR34FX25FXTCKITC	C91, C96	YSU2W2W	H44	YTS301A	I20	YTS47AT	I21	YTS59R521RSHT	I35
				YTS301AT	I21	YTS484A	I20	YTS59R59RS	I7
				YTS311A	I20	YTS484AT	I21	YTS59R59RSHT	I35

CATALOG NO.	PAGE NO.	CATALOG NO.	PAGE NO.	CATALOG NO.	PAGE NO.	CATALOG NO.	PAGE NO.	CATALOG NO.	PAGE NO.
YTS59RT521RS	18	YTW33REHT	I31-I34	YTW391ADT431AEK	I19	YTW451AT	I17	YTW484AD484AEK	I18
YTS59RT521RSHT	I36	YTW34R	I3	YTW391AT	I17	YTW451AT463AEK	I17	YTW484ADT	I19
YTS59RT59RS	18	YTW34R34REK	I3	YTW391AT431AEK	I17	YTW451R	I3	YTW484ADT484AEK	I19
YTS59RT59RSHT	I36	YTW34R34REKHT	I31	YTW39A	I16	YTW451R45REK	I3	YTW484AE	I16-I19
YTTAG388	E23	YTW34RD	I4	YTW39A39AEK	I16	YTW451R45REKHT	I31	YTW484AT	I17
YTU25R25R	H30	YTW34RD34REK	I4	YTW39AD	I18	YTW451R481REK	I3	YTW484AT484AEK	I17
YTU25R4W	H30	YTW34RD34REKHT	I32	YTW39AD39AEK	I18	YTW451R481REKHT	I31	YTW486A	I16
YTU26R26R	H30	YTW34RDHT	I32	YTW39ADT	I19	YTW451R48REK	I3	YTW486A486AE	I16
YTU27R27R	H30	YTW34RDT	I6	YTW39ADT39AEK	I19	YTW451R48REKHT	I31	YTW486AD	I18
YTU28R28R	H30	YTW34RDT34REK	I6	YTW39AE	I16-I19	YTW451RD	I4	YTW486AD486AE	I18
YTU30R30R	H30	YTW34RDT34REKHT	I34	YTW39AT	I17	YTW451RD45REK	I4	YTW486ADT	I19
YTU321R26R	H30	YTW34RDTH	I34	YTW39AT39AEK	I17	YTW451RD45REKHT	I32	YTW486ADT486AE	I19
YTU321R27R	H30	YTW34RE	I3-I6	YTW39R	I3	YTW451RD481REK	I4	YTW486AE	I16-I19
YTU321R28R	H30	YTW34REHT	I31-I34	YTW39R43REK	I3	YTW451RD481REKHT	I32	YTW486AT	I17
YTU321R2R	H30	YTW34RHT	I31	YTW39R43REKHT	I31	YTW451RD48REK	I4	YTW486AT486AEK	I17
YTU321R321R	H30	YTW34RT	I5	YTW39RD	I4	YTW451RD48REKHT	I32	YTW48A	I16
YTU33R26R	H30	YTW34RT34REK	I5	YTW39RD43REK	I4	YTW451RDHT	I32	YTW48A484AEK	I16
YTU33R28R	H30	YTW34RT34REKHT	I33	YTW39RD43REKHT	I32	YTW451RDT	I6	YTW48AD	I18
YTU33R33R	H30	YTW34RTH	I33	YTW39RDHT	I32	YTW451RDT45REK	I6	YTW48AD484AEK	I18
YTW301A	I16	YTW351A	I16	YTW39RDT	I6	YTW451RDT45REKHT	I34	YTW48ADT	I19
YTW301A331AEK	I16	YTW351A351AEK	I16	YTW39RDT43REK	I6	YTW451RDT481REK	I6	YTW48ADT484AEK	I19
YTW301AD	I18	YTW351AD	I18	YTW39RDT43REKHT	I34	YTW451RDT481REKHT	I34	YTW48AT	I17
YTW301AD331AEK	I18	YTW351AD351AEK	I18	YTW39RDTH	I34	YTW451RDT48REK	I6	YTW48AT484AEK	I17
YTW301ADT	I19	YTW351ADT	I19	YTW39RHT	I31	YTW451RDT48REKHT	I34	YTW48R	I13
YTW301ADT331AEK	I19	YTW351ADT351AEK	I19	YTW39RT	I5	YTW451RDTH	I34	YTW48R481REK	I3
YTW301AT	I17	YTW351AE	I16-I19	YTW39RT43REK	I5	YTW451RHT	I31	YTW48R481REKHT	I31
YTW301AT331AEK	I17	YTW351AT	I17	YTW39RT43REKHT	I33	YTW451RT	I5	YTW48R48REK	I3
YTW311A	I16	YTW351T351AEK	I17	YTW39RTH	I33	YTW451RT45REK	I5	YTW48R48REKHT	I31
YTW311A331AEK	I16	YTW361A	I16	YTW431A	I16	YTW451RT45REKHT	I33	YTW48RD	I4
YTW311AD	I18	YTW361A39AEK	I16	YTW431A431AEK	I16	YTW451RT481REK	I5	YTW48RD481REK	I4
YTW311AD331AEK	I18	YTW361AD	I18	YTW431AD	I18	YTW451RT481REKHT	I33	YTW48RD481REKHT	I32
YTW311ADT	I19	YTW361AD39AEK	I18	YTW431AD431AEK	I18	YTW451RT48REK	I5	YTW48RD48REK	I4
YTW311ADT331AEK	I19	YTW361ADT	I19	YTW431ADT	I19	YTW451RT48REKHT	I33	YTW48RD48REKHT	I32
YTW311AT	I17	YTW361ADT39AEK	I19	YTW431ADT431AEK	I19	YTW451RTHT	I33	YTW48RDHT	I32
YTW311AT331AEK	I17	YTW361AT	I17	YTW431AE	I16-I19	YTW457A	I16	YTW48RDT	I6
YTW32R	I3	YTW361AT39AEK	I17	YTW431AT	I17	YTW457A463AEK	I16	YTW48RDT481RE	I6
YTW32R33REK	I3	YTW362RE	I3-I6	YTW431AT431AEK	I17	YTW457AD	I18	YTW48RDT481REK	I6
YTW32R33REKHT	I31	YTW362REHT	I31-I34	YTW43R	I3	YTW457AD463AEK	I18	YTW48RDT481REKHT	I34
YTW32R34REK	I3	YTW36R	I3	YTW43R43REK	I3	YTW457ADT	I19	YTW48RDT48REK	I6
YTW32R34REKHT	I31	YTW36R362REK	I3	YTW43R43REKHT	I31	YTW457ADT463AEK	I19	YTW48RDT48REKHT	I34
YTW32RD	I4	YTW36R362REKHT	I31	YTW43RD	I4	YTW457AT	I17	YTW48RDTH	I34
YTW32RD33REK	I4	YTW36R36REK	I3	YTW43RD43REK	I4	YTW457AT463AEK	I17	YTW48RE	I3-I6
YTW32RD33REKHT	I32	YTW36R36REKHT	I31	YTW43RD43REKHT	I32	YTW45RE	I3-I6	YTW48REHT	I31-I34
YTW32RD34REK	I4	YTW36RD	I4	YTW43RDHT	I32	YTW45REHT	I31-I34	YTW48RHT	I31
YTW32RD34REKHT	I32	YTW36RD362REK	I4	YTW43RDT	I6	YTW463A	I16	YTW48RT	I5
YTW32RDHT	I32	YTW36RD362REKHT	I32	YTW43RDT43REK	I6	YTW463A463AEK	I16	YTW48RT481REK	I5
YTW32RDT	I6	YTW36RD36REK	I4	YTW43RDT43REKHT	I34	YTW463AD	I18	YTW48RT481REKHT	I33
YTW32RDT33REK	I6	YTW36RD36REKHT	I32	YTW43RDTH	I34	YTW463AD463AEK	I18	YTW48RT48REK	I5
YTW32RDT33REKHT	I34	YTW36RDHT	I32	YTW43RE	I3-I6	YTW463ADT	I19	YTW48RT48REKHT	I33
YTW32RDT34REK	I6	YTW36RDT	I6	YTW43REHT	I31-I34	YTW463ADT463AEK	I19	YTW48RTH	I33
YTW32RDT34REKHT	I34	YTW36RDT362REK	I6	YTW43RHT	I31	YTW463AE	I16-I19	YTW49R	I13
YTW32RDTH	I34	YTW36RDT362REKHT	I34	YTW43RT	I5	YTW463AT	I17	YTW49R483REK	I3
YTW32RHT	I31	YTW36RDT36REK	I6	YTW43RT43REK	I5	YTW463AT463AEK	I17	YTW49R483REKHT	I31
YTW32RT	I5	YTW36RDT36REKHT	I34	YTW43RT43REKHT	I33	YTW47A	I16	YTW49R50REK	I3
YTW32RT33REK	I5	YTW36RDTH	I34	YTW43RTH	I33	YTW47A47AEK	I16	YTW49R50REKHT	I31
YTW32RT33REKHT	I33	YTW36RE	I3-I6	YTW445A	I16	YTW47AD	I18	YTW49RD	I4
YTW32RT34REK	I5	YTW36REHT	I31-I34	YTW445A463AEK	I16	YTW47AD47AEK	I18	YTW49RD483REK	I4
YTW32RT34REKHT	I33	YTW36RHT	I31	YTW445AD	I18	YTW47ADT	I19	YTW49RD483REKHT	I32
YTW32RTH	I33	YTW36RT	I5	YTW445AD463AEK	I18	YTW47ADT47AEK	I19	YTW49RD50REK	I4
YTW331A	I16	YTW36RT362REK	I5	YTW445ADT	I19	YTW47AE	I16-I19	YTW49RD50REKHT	I32
YTW331A331AE	I16	YTW36RT362REKHT	I33	YTW445ADT463AEK	I19	YTW47AT	I17	YTW49RDHT	I32
YTW331AD	I18	YTW36RT36REK	I5	YTW445AT	I17	YTW47AT47AEK	I17	YTW49RDT	I6
YTW331AD331AE	I18	YTW36RT36REKHT	I33	YTW445AT463AEK	I17	YTW481RE	I3-I6	YTW49RDT483REK	I6
YTW331ADT	I19	YTW36RTH	I33	YTW451A	I16	YTW481REHT	I31-I34	YTW49RDT483REKHT	I34
YTW331ADT331AE	I19	YTW391A	I16	YTW451A463AEK	I16	YTW483RE	I3-I6	YTW49RDT50REK	I6
YTW331AE	I16-I19	YTW391A431AEK	I16	YTW451AD	I18	YTW483REHT	I31-I34	YTW49RDT50REKHT	I34
YTW331AT	I17	YTW391AD	I18	YTW451AD463AEK	I18	YTW484A	I16	YTW49RDTH	I34
YTW331AT331AE	I17	YTW391AD431AEK	I18	YTW451ADT	I19	YTW484A484AEK	I16	YTW49RHT	I31
YTW33RE	I3-I6	YTW391ADT	I19	YTW451ADT463AEK	I19	YTW484AD	I18	YTW49RT	I5

Reference

BURNDY®

Alpha-Numeric Index

CATALOG NO.	PAGE NO.	CATALOG NO.	PAGE NO.	CATALOG NO.	PAGE NO.	CATALOG NO.	PAGE NO.	CATALOG NO.	PAGE NO.
YTW49RT483REK	15	YTW549RT521REKHT	I33	YTW59RT59REK	15	Z2MLDN6-20	K29	ZM12-25B	K15
YTW49RT483REKHT	I33	YTW549RT549REK	15	YTW59RT59REKHT	I33	Z2MLDN6-30	K29	ZM12-30	K21
YTW49RT50REK	15	YTW549RT549REKHT	I33	YTW59RTHT	I33	Z2MLDN6-30B	K29	ZM12-30B	K21
YTW49RT50REKHT	I33	YTW549RT56REK	15	Z-11	K62	Z3030	K33, K57	ZM14-15	K9
YTW49RTHT	I33	YTW549RT56REKHT	I33	Z-15	K62	Z3032	K33	ZM14-25	K15
YTW50RE	I3-16	YTW549RTHT	I33	Z-22.5	K62	Z3034	K33	ZM14-25B	K15
YTW50REHT	I31-I34	YTW56R	I3	Z-25	K62	Z3036	K33	ZM14-30	K21
YTW521RE	I3-16	YTW56R590REK	I3	Z-30	K62	Z3040	K33	ZM14-30B	K21
YTW521REHT	I31-I34	YTW56R590REKHT	I31	Z-37.5	K62	Z30NR	K32-K34, K57	ZM16-15	K9
YTW52R	I3	YTW56RD	I4	Z-44	K62	Z3132	K33, K57	ZM16-25	K15
YTW52R50REK	I3	YTW56RD590REK	I4	Z-50	K62	Z3134	K33	ZM16-25B	K15
YTW52R50REKHT	I31	YTW56RD590REKHT	I32	Z-7.5	K62	Z3136	K33	ZM16-30	K21
YTW52R521REK	I3	YTW56RDHT	I32	Z104C4034	K36	Z3140	K33	ZM16-30B	K21
YTW52R521REKHT	I31	YTW56RDT	I6	Z104C4434	K36	Z3232	K33-K34, K57	ZM4-15	K9
YTW52R56REK	I3	YTW56RDT590REK	I6	Z144C4840	K36	Z3234	K33-K34	ZM4-25	K15
YTW52R56REKHT	I31	YTW56RDT590REKHT	I34	Z1C28	K34	Z3236	K33-K34	ZM4-25B	K15
YTW52RD	I4	YTW56RDTHT	I34	Z1C29	K33-K34	Z3240	K33-K34	ZM4-30	K21
YTW52RD50REK	I4	YTW56RE	I3-16	Z1C30	K33-K34	Z3244	K34	ZM4-30B	K21
YTW52RD50REKHT	I32	YTW56REHT	I31-I34	Z1C32	K33-K34	Z32NR	K32-K34, K57	ZM6-15	K9
YTW52RD521REK	I4	YTW56RHT	I31	Z1C34	K33	Z3334	K33-K34	ZM6-25	K15
YTW52RD521REKHT	I32	YTW56RT	I5	Z2528	K33-K34	Z3336	K33-K34	ZM6-25B	K15
YTW52RD56REK	I4	YTW56RT590REK	I5	Z2529	K33-K34	Z3340	K33-K34	ZM6-30	K21
YTW52RD56REKHT	I32	YTW56RT590REKHT	I33	Z2530	K33-K34	Z3344	K34	ZM6-30B	K21
YTW52RDHT	I32	YTW56RTHT	I33	Z2532	K33-K34	Z3434	K33-K34, K57	ZM8-15	K9
YTW52RDT	I6	YTW56R	I3	Z2534	K33-K34	Z3436	K33-K34	ZM8-25	K15
YTW52RDT50REK	I6	YTW56R58REK	I3	Z2536	K34	Z3440	K33-K34	ZM8-25B	K15
YTW52RDT50REKHT	I34	YTW56R58REKHT	I31	Z2628	K34	Z3444	K33-K34	ZM8-30	K21
YTW52RDT521REK	I6	YTW56RD	I4	Z2629	K33-K34	Z34NR	K32-K34, K57	ZM8-30B	K21
YTW52RDT521REKHT	I34	YTW56RD58REK	I4	Z2630	K33-K34	Z34NRB	K32-K33	ZMDN3-20	K30
YTW52RDT56REK	I6	YTW56RD58REKHT	I32	Z2632	K33-K34	Z34P	K31	ZMDN3-20B	K30
YTW52RDT56REKHT	I34	YTW56RDHT	I32	Z2634	K33-K34	Z3536	K33	ZMDN3-25	K30
YTW52RDHT	I34	YTW56RDT	I6	Z2636	K34	Z3540	K33	ZMDN4-20	K30
YTW52RHT	I31, I33	YTW56RDT58REK	I6	Z2640	K34	Z3544	K33	ZMDN4-20B	K30
YTW52RT	I5	YTW56RDT58REKHT	I34	Z2728	K33-K34	Z3636	K33-K34	ZMDN4-25	K30
YTW52RT50REK	I5	YTW56RDHT	I34	Z2729	K34	Z3640	K33-K34	ZMDN5-20	K30
YTW52RT50REKHT	I33	YTW56RE	I3-16	Z2730	K33-K34	Z3644	K33-K34	ZMDN5-20B	K30
YTW52RT521REK	I5	YTW56REHT	I31-I34	Z2732	K33-K34	Z36NR	K32-K34	ZMDN5-25	K30
YTW52RT521REKHT	I33	YTW56RHT	I31	Z2734	K33-K34	Z3740	K33	ZMDN6-20	K30
YTW52RT56REK	I5	YTW56RT	I5	Z2736	K34	Z3744	K33	ZMDN6-20B	K30
YTW52RT56REKHT	I33	YTW56RT58REK	I5	Z2740	K34	Z3840	K33	ZMDN6-25	K30
YTW52RTHT	I33	YTW56RT58REKHT	I33	Z2828	K33, K57	Z3844	K33	ZME2-15	K11
YTW549R	I3	YTW56RTHT	I33	Z2829	K33-K34	Z3940	K33	ZME2-25	K17
YTW549R521REK	I3	YTW590RE	I3-16	Z2830	K33-K34	Z3944	K33	ZME2-25B	K17
YTW549R521REKHT	I31	YTW590REHT	I31-I34	Z2832	K33-K34	Z3C28	K34	ZME2-30	K23
YTW549R549REK	I3	YTW591RE	I3-16	Z2834	K33-K34	Z4040	K33	ZME2-30B	K23
YTW549R549REKHT	I31	YTW591REHT	I31-I34	Z2836	K34	Z4044	K33	ZME3-15	K11
YTW549R56REK	I3	YTW59R	I3	Z2840	K34	Z40NR	K32-K34	ZME3-25	K17
YTW549R56REKHT	I31	YTW59R591REK	I3	Z2844	K34	Z40NRA	K32-K33	ZME3-25B	K17
YTW549RD	I4	YTW59R591REKHT	I31	Z28NR	K32-K34, K57	Z40P	K31	ZME3-30	K23
YTW549RD521REK	I4	YTW59R59REK	I3	Z2929	K33-K34, K57	Z4144	K33	ZME3-30B	K23
YTW549RD521REKHT	I32	YTW59R59REKHT	I31	Z2930	K33-K34	Z4244	K33	ZME4-15	K11
YTW549RD549REK	I4	YTW59RD	I4	Z2932	K33-K34	Z4344	K33	ZME4-25	K17
YTW549RD549REKHT	I32	YTW59RD591REK	I4	Z2934	K33-K34	Z4444	K33	ZME4-25B	K17
YTW549RD56REK	I4	YTW59RD591REKHT	I32	Z2936	K33-K34	Z44NR	K32-K34	ZME4-30	K23
YTW549RD56REKHT	I32	YTW59RD59REK	I4	Z2940	K33-K34	Z4C28	K33	ZME4-30B	K23
YTW549RDHT	I32	YTW59RD59REKHT	I32	Z2944	K34	Z4C29	K33	ZME5-15	K11
YTW549RDT	I6	YTW59RDHT	I32	Z29NR	K32-K34, K57	Z4C30	K33	ZME5-25	K17
YTW549RDT521REK	I6	YTW59RDT	I6	Z29P	K31	Z6C28	K33	ZME5-25B	K17
YTW549RDT521REKHT	I34	YTW59RDT591REK	I6	Z2C28	K33-K34	Z6C29	K33	ZME5-30	K23
YTW549RDT549REK	I6	YTW59RDT591REKHT	I34	Z2C29	K33-K34	Z6C30	K33	ZME5-30B	K23
YTW549RDT549REKHT	I34	YTW59RDT59REK	I6	Z2C30	K33	Z72C3029	K36	ZME6-15	K11
YTW549RDT56REK	I6	YTW59RDT59REKHT	I34	Z2C32	K33	Z88C3429	K36	ZME6-25	K17
YTW549RDT56REKHT	I34	YTW59RDHT	I34	Z2C34	K33	ZM10-15	K9	ZME6-25B	K17
YTW549RDHT	I34	YTW59RE	I3-16	Z2MLDN-2-20	K29	ZM10-25	K15	ZME6-30	K23
YTW549RE	I3-16	YTW59REHT	I31-I34	Z2MLDN2-30	K29	ZM10-25B	K15	ZME6-30B	K23
YTW549REHT	I31-I34	YTW59RHT	I31	Z2MLDN2-30B	K29	ZM10-30	K21	ZME7-15	K11
YTW549RHT	I31	YTW59RT	I5	Z2MLDN4-20	K29	ZM10-30B	K21	ZME7-25	K17
YTW549RT	I5	YTW59RT591REK	I5	Z2MLDN4-30	K29	ZM12-15	K9	ZME7-25B	K17
YTW549RT521REK	I5	YTW59RT591REKHT	I33	Z2MLDN4-30B	K29	ZM12-25	K15	ZME7-30	K23

CATALOG NO.	PAGE NO.	CATALOG NO.	PAGE NO.	CATALOG NO.	PAGE NO.	CATALOG NO.	PAGE NO.	CATALOG NO.	PAGE NO.
ZME7-30B	K23	ZMK9-25A4	K20	ZML9-25B	K18	ZMT13-30	K22	ZMX14-15	K13
ZME8-15	K11	ZMK9-25B	K20	ZML9-25B12	K18	ZMT13-30B	K22	ZMX14-15A3	K13
ZME8-25	K17	ZMK9-25B12	K20	ZML9-30	K24	ZMT15-15	K10	ZMX14-15A4	K13
ZME8-25B	K17	ZMK9-30	K26	ZML9-30B	K24	ZMT15-15A3	K10	ZMX14-25	K19
ZME8-30	K23	ZMK9-30B	K26	ZMLDN1-15	K27	ZMT15-25	K16	ZMX14-25A4	K19
ZME8-30B	K23	ZML2-15	K12	ZMLDN1-20	K27	ZMT15-25A3	K16	ZMX14-25B	K19
ZMK10-15	K14	ZML2-15A3	K12	ZMLDN1-20B	K27	ZMT15-25B	K16	ZMX14-25B12	K19
ZMK10-15A3	K14	ZML2-25	K18	ZMLDN1-25	K28	ZMT15-25B12	K16	ZMX14-30	K25
ZMK10-15A4	K14	ZML2-25A3	K18	ZMLDN1-25B	K28	ZMT15-30	K22	ZMX14-30B	K25
ZMK10-30	K20	ZML2-25B	K18	ZMLDN1-30	K28	ZMT15-30B	K22	ZMX16-15	K13
ZMK10-25A4	K20	ZML2-25B12	K18	ZMLDN1-30B	K28	ZMT17-15	K10	ZMX16-15A3	K13
ZMK10-25B	K20	ZML2-30	K24	ZMLDN2-15	K27	ZMT17-15A3	K10	ZMX16-15A4	K13
ZMK10-25B12	K20	ZML2-30B	K24	ZMLDN2-20	K27	ZMT17-25	K16	ZMX16-25	K19
ZMK10-30	K26	ZML3-15	K12	ZMLDN2-20B	K27	ZMT17-25A3	K16	ZMX16-25A4	K19
ZMK10-30B	K26	ZML3-15A3	K12	ZMLDN2-25	K28	ZMT17-25B	K16	ZMX16-25B	K19
ZMK4-15	K14	ZML3-25	K18	ZMLDN2-25B	K28	ZMT17-25B12	K16	ZMX16-25B12	K19
ZMK4-15A3	K14	ZML3-258	K18	ZMLDN2-30	K28	ZMT17-30	K22	ZMX16-30	K25
ZMK4-15A4	K14	ZML3-25A3	K18	ZMLDN2-30B	K28	ZMT17-30B	K22	ZMX16-30B	K25
ZMK4-25	K20	ZML3-25B12	K18	ZMLDN3-15	K27	ZMT3-15	K10	ZMX18-15	K13
ZMK4-25A4	K20	ZML3-30	K24	ZMLDN3-20	K27	ZMT3-15A3	K10	ZMX18-15A3	K13
ZMK4-25B	K20	ZML3-30B	K24	ZMLDN3-20B	K27	ZMT3-25	K16	ZMX18-15A4	K13
ZMK4-25B12	K20	ZML4-15	K12	ZMLDN3-25	K28	ZMT3-258	K16	ZMX18-25	K19
ZMK4-30	K26	ZML4-15A3	K12	ZMLDN3-25B	K28	ZMT3-25A3	K16	ZMX18-25A4	K19
ZMK4-30B	K26	ZML4-25	K18	ZMLDN3-30	K28	ZMT3-25B12	K16	ZMX18-25B	K19
ZMK5-15	K14	ZML4-25A3	K18	ZMLDN3-30B	K28	ZMT3-30	K22	ZMX18-25B12	K19
ZMK5-15A3	K14	ZML4-25B	K18	ZMLDN4-15	K27	ZMT3-30B	K22	ZMX18-30	K25
ZMK5-15A4	K14	ZML4-25B12	K18	ZMLDN4-20	K27	ZMT5-15	K10	ZMX18-30B	K25
ZMK5-25	K20	ZML4-30	K24	ZMLDN4-20B	K27	ZMT5-15A3	K10	ZMX10-25	K19
ZMK5-25A4	K20	ZML4-308	K24	ZMLDN4-25	K28	ZMT5-25	K16	ZMX10-25A4	K19
ZMK5-25B	K20	ZML5-15	K12	ZMLDN4-25B	K28	ZMT5-25A3	K16	ZMX10-25B	K19
ZMK5-25B12	K20	ZML5-15A3	K12	ZMLDN4-30	K28	ZMT5-25B	K16	ZMX10-25B12	K19
ZMK5-30	K26	ZML5-25	K18	ZMLDN4-30B	K28	ZMT5-25B12	K16	ZMX10-30	K25
ZMK5-30B	K26	ZML5-25A3	K18	ZMLDN5-15	K27	ZMT5-30	K22	ZMX4-15	K13
ZMK6-15	K14	ZML5-25B	K18	ZMLDN5-20	K27	ZMT5-30B	K22	ZMX4-15A3	K13
ZMK6-15A3	K14	ZML5-25B12	K18	ZMLDN5-20B	K27	ZMT7-15	K10	ZMX4-15A4	K13
ZMK6-15A4	K14	ZML5-30	K24	ZMLDN5-25	K28	ZMT7-15A3	K10	ZMX4-25	K19
ZMK6-25	K20	ZML5-30B	K24	ZMLDN5-25B	K28	ZMT7-25	K16	ZMX4-25A4	K19
ZMK6-25A4	K20	ZML6-15	K12	ZMLDN5-30	K28	ZMT7-25A3	K16	ZMX4-25B	K19
ZMK6-25B	K20	ZML6-15A3	K12	ZMLDN5-30B	K28	ZMT7-25B	K16	ZMX4-25B12	K19
ZMK6-25B12	K20	ZML6-25	K18	ZMLDN6-15	K27	ZMT7-25B12	K16	ZMX4-30	K25
ZMK6-30	K26	ZML6-25A3	K18	ZMLDN6-20	K27	ZMT7-30	K22	ZMX4-30B	K25
ZMK6-30B	K26	ZML6-25B	K18	ZMLDN6-20B	K27	ZMT7-30B	K22	ZMX6-15	K13
ZMK7-15	K14	ZML6-25B12	K18	ZMLDN6-25	K28	ZMT9-15	K10	ZMX6-15A3	K13
ZMK7-15A3	K14	ZML6-30	K24	ZMLDN6-25B	K28	ZMT9-15A3	K10	ZMX6-15A4	K13
ZMK7-15A4	K14	ZML6-30B	K24	ZMLDN6-30	K28	ZMT9-25	K16	ZMX6-25	K19
ZMK7-25	K20	ZML7-15	K12	ZMLDN6-30B	K28	ZMT9-25A3	K16	ZMX6-25A4	K19
ZMK7-25A4	K20	ZML7-15A3	K12	ZML0-15A3	K12	ZMT9-25B	K16	ZMX6-25B	K19
ZMK7-25B	K20	ZML7-25	K18	ZMS29	K35	ZMT9-25B12	K16	ZMX6-25B12	K19
ZMK7-25B12	K20	ZML7-25A3	K18	ZMS34	K35	ZMT9-30	K22	ZMX6-30	K25
ZMK7-30	K26	ZML7-25B	K18	ZMS40	K35	ZMT9-30B	K22	ZMX6-30B	K25
ZMK7-30B	K26	ZML7-25B12	K18	ZMT11-15	K10	ZMTDN	K31	ZMX8-15	K13
ZMK8-15	K14	ZML7-30	K24	ZMT11-15A3	K10	ZMX10-15	K13	ZMX8-15A3	K13
ZMK8-15A3	K14	ZML7-30B	K24	ZMT11-25	K16	ZMX10-15A3	K13	ZMX8-15A4	K13
ZMK8-15A4	K14	ZML8-15	K12	ZMT11-25A3	K16	ZMX10-15A4	K13	ZMX8-25	K19
ZMK8-25	K20	ZML8-25	K18	ZMT11-25B	K16	ZMX10-30B	K25	ZMX8-25A4	K19
ZMK8-25A4	K20	ZML8-25A3	K18	ZMT11-25B12	K16	ZMX12-15	K13	ZMX8-25B	K19
ZMK8-25B	K20	ZML8-25B	K18	ZMT11-30	K22	ZMX12-15A3	K13	ZMX8-25B12	K19
ZMK8-25B12	K20	ZML8-25B12	K18	ZMT11-30B	K22	ZMX12-15A4	K13	ZMX8-30	K25
ZMK8-30	K26	ZML8-30	K24	ZMT13-15	K10	ZMX12-25	K19	ZMX8-30B	K25
ZMK8-30B	K26	ZML8-30B	K24	ZMT13-15A3	K10	ZMX12-25A4	K19		
ZMK9-15	K14	ZML9-15	K12	ZMT13-25	K16	ZMX12-25B	K19		
ZMK9-15A3	K14	ZML9-15A3	K12	ZMT13-25A3	K16	ZMX12-25B12	K19		
ZMK9-15A4	K14	ZML9-25	K18	ZMT13-25B	K16	ZMX12-30	K25		
ZMK9-25	K20	ZML9-25A3	K18	ZMT13-25B12	K16	ZMX12-30B	K25		

PRODUCT/TRADE NAME INDEX

PRODUCT/TRADE NAME	CATALOG SECTION	PRODUCT/TRADE NAME	CATALOG SECTION	PRODUCT/TRADE NAME	CATALOG SECTION
ALFLUID™	N	HYDRAULIC FLUID	N	REFERENCE DATA	O
AUTOMATIC CRIMP	N	HYDRAULIC HOSE	N	REMOTE HEADS	N
BARTAP™	A, G	HYFLUID™	N	REVOLVER	N
BATOOL™	N	HYGRID™	D	RISERTAP	A
BATTERY CHARGER	N	HYGROUND™	D	SCRULINK™	A
BATTERY CRIMPER	N	HYLINK™	C	SCRULUG™	A
BATTERY TOOLS	N	HYLUG™	C	SERVIT™	A, E
BOLTS	L	HYPLUG™	C	SERVIT™ POST	D
BOOSTERS	F, N	HYPRESS™	N	SILCON BRONZE	L
BRAID	D, G	HYRACK™	B	SPANTAP	E
BURNDY®		HYREDUCER™	C	SPEC-BLOK™	A
BURNDYWELD™	D	HYSEALPLUG™	E	SPLICE	
B-CRIMP	B	HYSEALUG™	E	SPLICE KITS	J
C COPPER CRIMPIT™	C, E	HYSPLICE™	C, E, J	SPLICE-BLOK	A
CABELOK™	E	HYSTACK™	C, E	SPLICIT	B
CABLE CLAMP		HYTAIL™	D	SPLIT BOLT	A, E
CABLE CUTTERS	N	HYTAP™	C, E	STAINLESS HARDWARE	L
CABLE TIES	M	HYTEE™	C, E	STEP-TAP™	J
CABLE TRAY CLAMP	D	HYTOOL™	N	STIRRUP	E
CALIPERS	M	I-BEAM CLAMP	D	STRIPPERS	N
CABLE STRIPPERS	N	INSULINK™	E	STUD MOLE™	I, J
CIRCUIT TESTER	M	INSULUG™	B	SUBSTATION	G, H
CLIPIT™	E	INTENSIFIERS	N	TAPIT™	E
COAXIAL	K	KA-LUG™	A	TERMINAL	
COMPRESSION CONNECTOR	B, C	KITS		TERMINAL BLOCKS	M, A
COUPLINGS	N	LIGHTNING	D	TEST LEADS	M
CRIMPERS	N	LINKIT™	E	TOOL BAGS	F, N
CRIMPIT™	E	L'IL CRIMP	N	TOOL CASES	N
CRIMPS		LOCK WASHERS	L	TOOL KITS	B, N, C
CUTTERS	M, N	LOKTAP™	E	TOOLS	N, M
DIE INDEX	O	LUG		TRITAP™	A
DIES	N	MOLE™	I, J	TRITAP™ SERVIT™	A
DURICOMP™	I	MOLIMITER™	I	TUBING	M, J
DURIUM™	L	MOUNTING BASES	M	UNIGROUND™	D
ELECTRO-RAIL™	A	NOTAPE™	I	UNIRAP™	M
E-LINE™ HYLUG™	C	NUTS	L	UNITAP™	A
FINGRIP™	B	NYLOCLIP™	M	UNISPLICE™	E
FINLINK™	B	OKLIP™	A	URD	J
FLAGLOK™	B	OXIDE INHIBITOR	M	U-BLOK™	A
FLEXI-TAP™	A	PATOOLS™	N	U-TAP™	A
FORKLOK	B	PATRIOT™	N	VARILINK™	A
GRIDLOK™	D	PENETROX™	M	VARITAP™	A
GROUNDEM	D	POLYTAP™	A	VERSILUG™	A
GROUNDING	D	POPPER	N	VERSITAP™	A
GROUNDIT™	D	POSI-PRESS	N	VINYLINK™	B
GUAGES	N	POWERLINK™	I	VINYLUG™	B
GUTTER TAP	A	POWERLUG™	F	VISI-SHRINK	M
H-CRIMPIT™	E, C	PRESSES	N	WASHERS	L
H COPPER CRIMPIT™	C	PRESSURE GAUGES	N	WEJIT™	E
HARDWARE	L	PUMPS	N	WEJTAP™	F
HEAT SHRINK	M, J	NETWORK UNDGRD	I	WIRE BRUSH	M
HOSES	N	QIKLINK™	A	WIRE CONNECTOR	
HOT LINE TOOLS	F, N	QIKLUG™	A	WIRE CUTTERS	N
HYBOOST™	N	QIKPWR™	C	WIRE MARKERS	M
HYBUTTIN™	B	QIKSLEEVE™	E	WIRE NUTS	M
HYCRAB™	I	QIKSTOCK™	B, C	WIRE STRIPPERS	N
HYCRIMP™	E, C	QIKSTOP™	B, C	Y-LOK™	B
HYDENT™	C	QIKTAP™	A		
HYDRAULIC COUPLING	N	RAISED FLOOR	D		
HYDRAULIC FITTINGS	N	REDUCERS	B, C, E		