



Table of Contents

.....

Finishes and Materials	A2
Channels and Concrete Inserts.....	A3–A7
Threaded Products and Hardware	A8–A12
Fittings and Brackets	A13–A23
Beam Clamps	A24–A32
Pipe Straps, Pipe Clamps and Hangers	A33–A46
Hanger Accessories.....	A47
Surface Raceway and Lighting Systems	A48–A54
Right Angle Slotted Metal Framing.....	A55–A56
Engineering Data & Specifications.....	A57–A73

Finishes and Materials

Finishes on Steel

Bare (Suffix BC)

Pregalvanized (Suffix PGC)

A zinc coating is applied to the steel coil at the mill prior to fabrication. Once the material is worked by roll-forming, cutting, or punching, minimal protection is provided for raw edges. This weakness is typical with pre-coated material and affects the channel section around holes, extreme ends, and the edges of the U-shape lips. Superstrut® pregalvanized material is in conformance with ASTM-A-525/G-90 specification standards, representing 0.90 oz. of zinc per square foot of steel. This finish is often referred to as "mill galvanized."

Electrogalvanized (Suffix EGC)

Often referred to as "zinc plated" or "electroplated zinc," the steel and 0.5 mils of zinc are bonded by an electrolysis process. Electrogalvanizing is most commonly applied to small fittings, hardware, and threaded products.

GoldGalv® (No Suffix)

Gold coloured zinc dichromate is applied over the zinc, producing a chemically bonded non porous barrier for protection from moisture and air. This extends the protective life of the zinc, and provides an excellent base for paint, if desired. The GoldGalv® hardware finish also provides a low electrical resistance when grounding of the system is required. Superstrut® channel and fittings are plated after fabrication, so there are no unprotected edges from cutting or punching. Where field cutting is necessary or scratches occur due to construction handling, you still have the sacrificial protection of the plated zinc to minimize the corrosion of raw edges and prevent spreading.

Hot-Dipped Galvanized (Suffix HDGC)

The material is zinc coated after fabrication providing total product protection on all surfaces. The fabricated channel or fitting is suspended and then dipped into tanks of hot zinc for a prolonged period, creating a coherent bond. The result is superior corrosion resistance as compared to pregalvanized material. Hot-dipped galvanizing is not recommended for threaded products, considering the zinc coating thickness will often disrupt the threads. Superstrut® hot-dipped galvanized is in conformance with ASTM Specifications A-123 (formerly A-386) and A-153. Superstrut channels maintain a minimum 1.5 oz. of zinc per square foot of steel or 2.5 mils (ASTM A-123, Thickness Grade 65). This finish is also referred to as "Hot-dipped galvanized after fabrication".

Epoxy Powder Coated — Green, Grey or White (Suffix GR, GY or WH)

Epoxy powder resins are applied electrostatically to the steel after fabrication. Once the material is completely covered with the powder-form epoxy, it proceeds through a 400°F (204°C) baking process for ten minutes, creating a chemical bond. This results in a minimum of 1.5 mil thickness of epoxy coating providing excellent resistance to chipping or peeling.

Special Materials

Aluminum (Suffix ALC)

Superstrut® channel is available in aluminum. Fittings in HDG finish or fiberglass material are suggested for fastening products.

Stainless Steel (Suffix SS)

Superstrut® channel is supplied in Type 316 (T316L) stainless steel. All fittings and accessories are in 316SS (SS6). Contact your Regional Sales Office for availability.

Thomas & Betts reserves the right to change material and finish specifications without notice, to improve its products.

Bare (suffix BC) is available upon request.

Channels and Concrete Inserts

.....

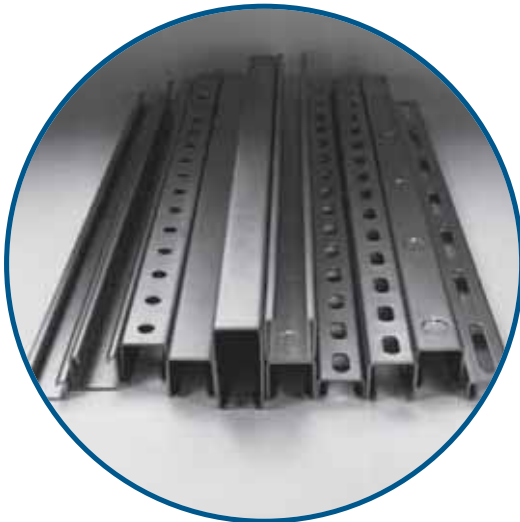

Channels

Material

Steel channels are cold-roll formed from strip steel. Aluminum and Fiberglass channels are extruded profiles.

Material Thickness

- All Series 1200 12 gauge material
- All Series 1400 14 gauge material
- All Series 1600 16 gauge ribbed material

Standard Lengths

Standard lengths for channels are 10 ft. and 20 ft. with a tolerance of +1/8 in. Special lengths can be requested; however, minimum quantities may apply. Channels are sold per foot.

Warning

.....
Load tables, charts, and design criteria provided in this catalogue are intended as guides only. Selection of proper product, support spacing, erection, and placement are the responsibility of the user.

When improperly used as tools of erection, pipe hanger products have occasionally failed. To avoid an accident, the user is cautioned to use the product only as it was intended.



Concrete Inserts

Material

Superstrut continuous insert channel is manufactured from 12 gauge hot rolled strip steel in two basic sizes as follows:

Cat. No. A302

1-5/8 in. x 1-5/8 in. 7/8 in. slot

Cat. No. C302

1-5/8 in. x 1-3/8 in. 7/8 in. slot

Standard Lengths

Standard lengths are 10 ft. and 20 ft. Product is supplied with foam filler and end caps to prevent concrete from seeping into channel.

Application

For casting into concrete walls, floors or ceilings to provide for attachment anywhere along the continuous slot.

Design Data

Load ratings as shown have a safety factor of 3 in 3000 lb. hard rock concrete. Where sound concrete does not exist, the load ratings shall not apply.

GoldGalv® hardware finish is standard for all Superstrut Concrete insert products. This is a multi-process finish of electro-plated zinc, followed by gold coloured zinc dichromate to give excellent corrosion resistance and a superior paint base.

For more information on load design, see page A57 for Engineering Data and Specifications.

Channels and Concrete Inserts

Channels at Full Scale
Available in 10 and 20 foot length

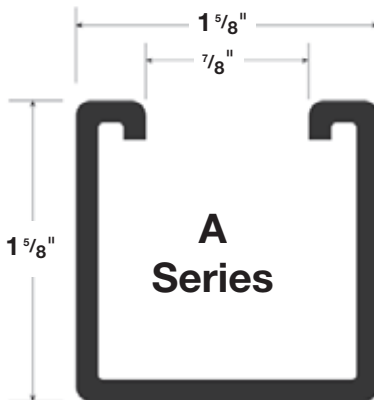

A Series
A1200 12 gauge
A1400 14 gauge

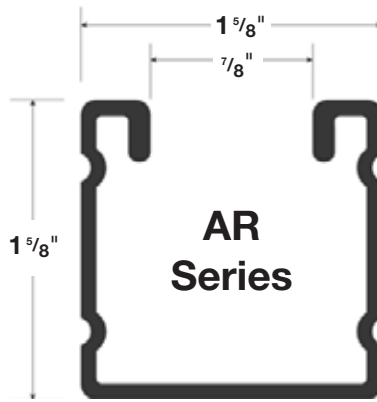

AR Series
16 gauge only

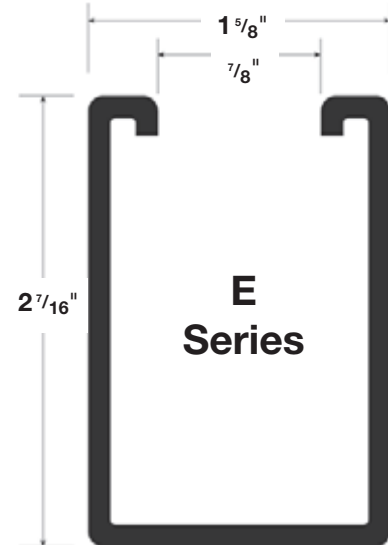

E Series
E1200 12 gauge

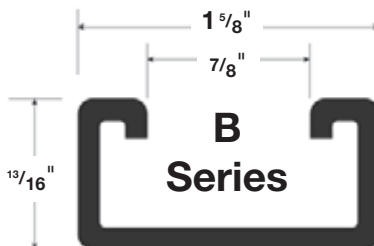

B Series
B1200 12 gauge
B1400 14 gauge

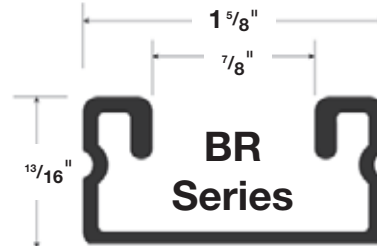

BR Series
16 gauge only

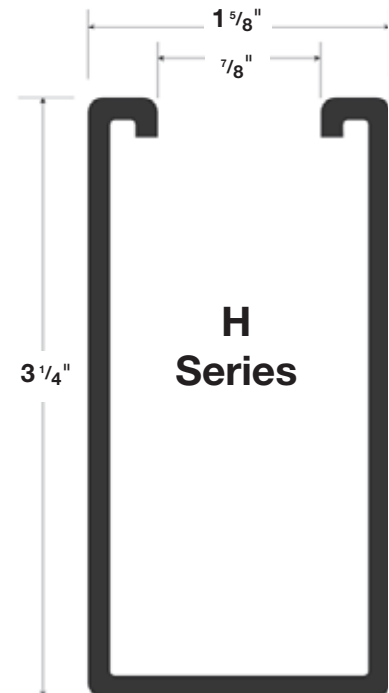

H Series
H1200 12 gauge

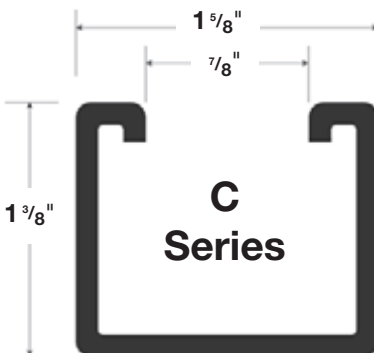

C Series
C1200 12 gauge

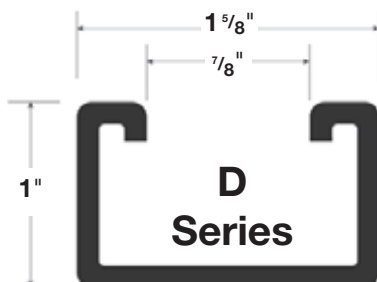

D Series
D1200 12 gauge

Channels and Concrete Inserts

Channel Selection Chart

CHANNEL	HOLE CONFIGURATIONS					LENGTH	FINISH ON STEEL					SPECIAL MATERIALS					
	Series	HS	S	SW	P		KO	ft.	BC	PG(C)	EG(C)	GoldGalv®	HDG(C)	GR,GY,WH	PV(C)	AL(C)	T316L
A1200						10 or 20											
A1400						10 or 20											
AR1600						10 or 20											
B1200						10 or 20											
B1400						10 or 20											
BR1600						10 or 20											
C1200						10 or 20											
D1200						10 or 20											
E1200						10 or 20											
H1200						10 or 20											

Legend

EXAMPLES	HOLE CONFIGURATION		FINISH ON STEEL		SPECIAL MATERIALS	
A120010PG Plain channel, 10 ft., pre- galvanized finish	Suffix		Suffix		Suffix	
	blank	Plain, no holes	BC	Bare	AL	Aluminum
	HS	Half slot	PGC	Pre-galvanized	SS6 (C)	Stainless Steel Type 316
B1400P10 Punched channel, 10 ft., GoldGalv® finish	S	Slotted	EGC	Electrogalvanized	T316L	Stainless Steel Type 316L
	SW	Slotted wide	Blank	GoldGalv®		
	P	Punched	HDGC	Hot dipped galvanized		
E1200HS20HDG Half slot channel, 20 ft. hot dipped galvanized	KO	Knockout	GR,GY,WH	Epoxy paint in green (GR), grey (GY), or white (WH)		
		Standard offering		A minimum order quantity may apply		

Hole Configuration

Half Slot Channel

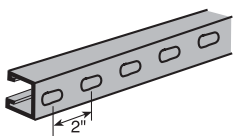

Slots: 9/16 in. X 1-1/8 in.

Slotted Channel

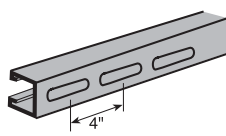

Slots: 7/16 in. X 3 in.

SW "Slotted Wide" Channel

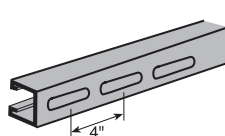

Slots: 9/16 in. X 3 in.

Punched Channel

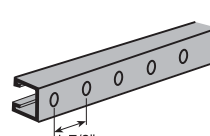

Holes: 9/16 in.

Channel with Knockouts

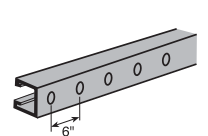

KO: 1/2 in.

Channels and Concrete Inserts

Welded Combinations

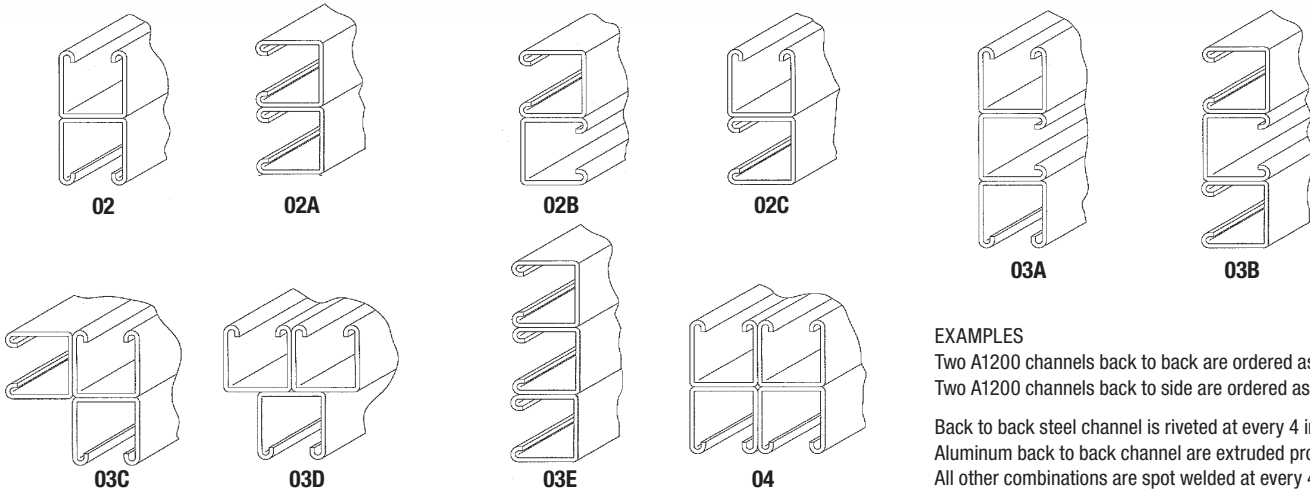

EXAMPLES

Two A1200 channels back to back are ordered as A1202.
Two A1200 channels back to side are ordered as A1202C.

Back to back steel channel is riveted at every 4 inches.
Aluminum back to back channel are extruded profiles.
All other combinations are spot welded at every 4 inches.

End Caps and Closure Strips

A804 End Cap

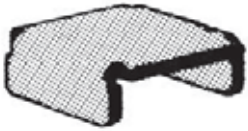

Cat. No.	For Channel	Wt./C lb.
A804EG	A1200	10
	A1400 AR1600	10
B804EG	B1400 BR1600	5
C804EG	C1200	8
E804EG	E1200	15
H804	H1200	20

Safety End Cap

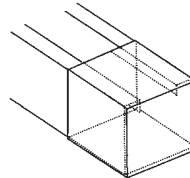

1-5/8 in. x 1-5/8 in. White Plastisol

Cat. No.	For Channel	Wt./C lb.
A804NEOPWH	A1200 AR1600	1.75
	A1400	
B804NEOPWH	B1200 BR1600	5
H804NEOPWH	H1200	2

A243-1EGC End Cap



For A1200 Channel

Wt./C 16 lb.

A208

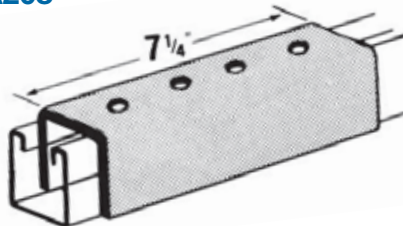

A208HDGC
A208EG

Does not include stud nut or bolts.

A208
A208SS6C

For A and AR Series channel. Wt./C 275 lb.

A213 Inside Joiner

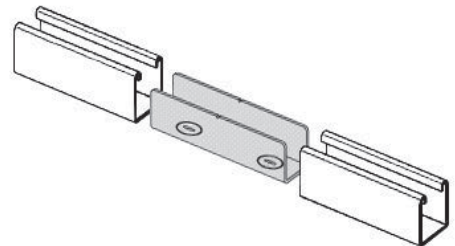

For A1200 Series only.
Available only in GoldGal® finish.

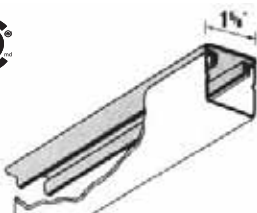

AB844PGC
Pre-Galvanized
Closure Strip

For all channel. Standard lengths 10 ft.

AB844PCGY
Plastic Closure Strip
Colour: Grey

AB844PC
Plastic Closure Strip
Colour: Gold

Channels and Concrete Inserts

Concrete inserts

Concrete Channel Inserts

***Finishes**

- HDGC
- GoldGalv®
- PGC

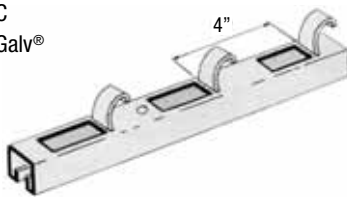

Insert with end caps and foam closure strip installed.

Cat. No.	Length (ft.)	Gauge	Wt. (lb./ft.)
A302-10*	10	12	2.19
A302-20*	20		2.19
B302-10*	10		1.36
B302-20*	20		1.36

Design Load 2000 lb. per foot in hard rock concrete with a safety factor of 3.

Standard lengths: 10 ft. and 20 ft.

Length tolerance: 3/16 in.

Anchor Caps

***Finishes**

- EGC
- GoldGalv®

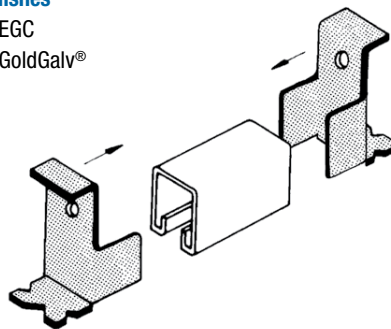

12 gauge, Wt./C: 30 lb./C

A450* For A Series

C450* For C Series

From pieces of A, B, C channel and a pair of anchor caps, short concrete inserts can be fabricated in the field.

460-10TB Removable Plastic Closure Strip

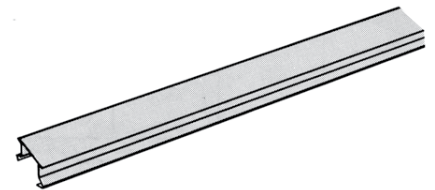

Designed as an added precaution to keep insert free of concrete. Closure strip fits all 1-5/8 in. wide strip inserts, regardless of depth.

Order per 10 foot, standard length is 10 ft.

Material – Black Plastic

Wt./C 52 lb.

SI400 Spot Insert Kit

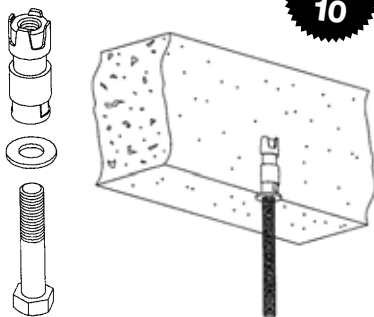

Cat. No.	Thred size	O.D. Insert	Wt./C lb.
SI400-3/8	3/8 – 16	2x5/8	10
SI400-1/2	1/2x13x1-1/4	2-1/2x7/8	35

Other sizes available.

Maximum recommended load:

SI400-3/8 = 450 lb./204 kg

SI400-1/2 = 1000 lb./454 kg

452TB Spot Insert

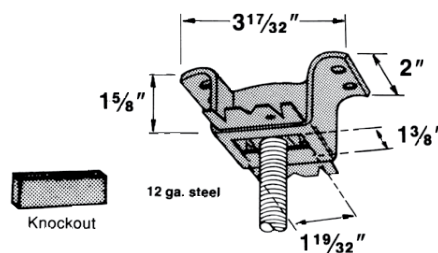

Standard Finish – GoldGalv®

An insert with a knockout saves covering the opening. Accommodates hanger rod sizes from 1/4 in. through 7/8 in. by means of an AB102 insert nut, to be ordered separately.

Design load: 1350 lb. in 3000 lb. hard rock concrete with a safety factor of 3.

Complies with Specification MSS SP69, Type 18.

Threaded Products and Hardware

Channel Nuts

Superstrut® channel nuts are manufactured from Grade 2 mild steel and are case hardened.

Design Data

Superstrut® self aligning channel nuts are designed to provide resistance to pullout and resistance to side slip in excess of the full strength of the channels with which they are used. The extreme resistance to side slip results from the unique design of the alternate teeth, spaced and designed to develop a wedging action that increases with pressure or load.

Screw Threads

All threaded products are American Standard thread, free fit class 2.

Thread Size	1/4	5/16	3/8	1/2	5/8	3/4	7/8	1
Threads per inch	20	18	16	13	11	10	9	8
Design Torque (ft.-lb.)	6	11	19	50	100	125	185	275

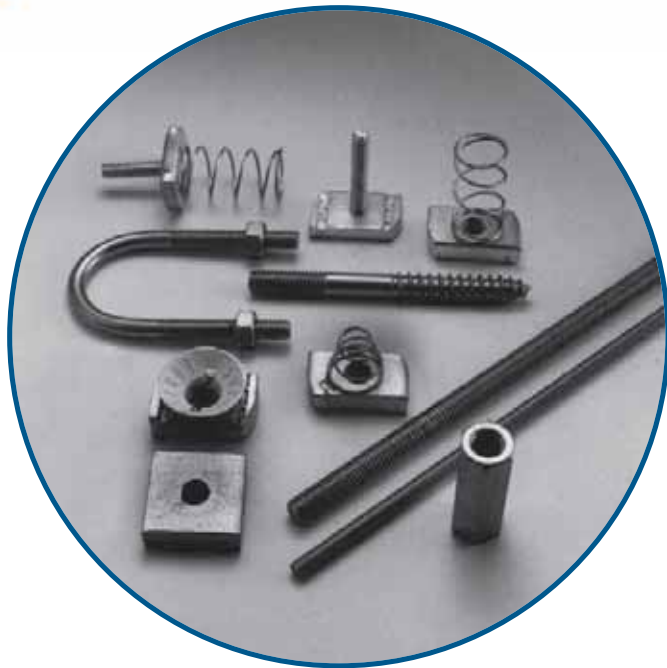

Spring Nut Selector Chart

SPRING NUT	CHANNEL SERIES					
	A - AR	B - BR	C	D	E	H
A100-1/4EGC	■		■			
A100-5/16EGC	■		■			
A100-3/8EGC	■		■			
A100-1/2EGC	■		■			
A100-3/4	■		■			
B100-1/4EGC		■		■		
B100-5/16EGC		■		■		
B100-3/8EGC		■		■		
B100-1/2EGC		■		■		
H100-3/8EGC					■	■
H100-1/2EGC					■	■
CM100-1/4	■		■	■	■	■
CM100-3/8	■		■	■	■	■
CM100-1/2	■		■	■	■	■
CM100-1/2B		■				
UC100-1/4	■	■	■	■	■	■
UC100-3/8	■	■	■	■	■	■
UC100-1/2	■	■	■	■	■	■

Finish and special materials

Standard finish for all hardware is ElectroGalvanized (EGC) or GoldGalv®. Stainless Steel Type 316 is also available. Contact your Regional Sales Office for availability and minimum quantities.

Threaded Products and Hardware

A100 Regular Spring Nut*

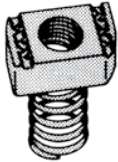

Available in Stainless Steel 316. Nut is square over 1/2 in. size. For all A and C Series channel and inserts.

Cat. No.	Size (in.)	Wt./C lb.
A100-1/4EGC	1/4	8
A100-5/16EGC	5/16	9
A100-3/8EGC	3/8	10
A100-1/2EGC	1/2	12
A100-5/8EGC	5/8	19
A100-3/4	3/4	19
A100-7/8	7/8	18

STD. PACK 100

B100 Short Spring Nut*

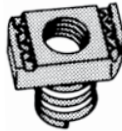

For all B and D Series channel and inserts.

Cat. No.	Size (in.)	Wt./C lb.
B100-1/4EGC	1/4	7
B100-5/16EGC	5/16	8
B100-3/8EGC	3/8	9
B100-1/2EGC	1/2	9

STD. PACK 100

H100 Long Spring Nut*

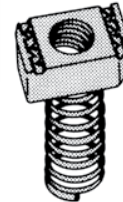

For all E and H Series channel and inserts.

Cat. No.	Size (in.)	Wt./C lb.
H100-3/8EGC	3/8	10
H100-1/2EGC	1/2	14

STD. PACK 100

AB100 Springless Nut 1/4 in. thick



For use with all channels. Nut is square over 1/2 in. size.

Cat. No.	Size (in.)	Wt./C lb.
AB100-1/4EGC	1/4	7
AB100-5/16EGC	5/16	8
AB100-3/8EGC	3/8	9
AB100-1/2EGC	1/2	9
AB100-5/8EGC	5/8	10
AB100-3/4EGC	3/4	10

STD. PACK 100

AC100 Springless Nut Heavy duty 3/8 in. thick



For all A, C, E and H Series channel and inserts. Nut is square over 1/2 in. size.

Cat. No.	Size (in.)	Wt./C lb.
AC100-3/8EGC	3/8	9
AC100-1/2EGC	1/2	11
AC100-5/8EGC	5/8	18
AC100-3/4EGC	3/4	18

STD. PACK 100

813EG Springless Nut Light Duty

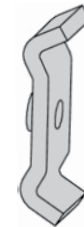

For use with all channels.

Cat. No.	Size (in.)	Wt./C lb.
813EG	1/4	5

STD. PACK 100

A182 to A185 Regular Spring Stud Nut*



For all A and C Series channels.

Cat. No.	Bolt Dia (in.)	Length A (in.)	Wt./C lb.
A182-1/4x100EG	1/4	1	10
A182-1/4x125EG	1/4	1-1/4	15
A184-3/8x100EG	3/8	1	10
A184-3/8x125EG	3/8	1-1/4	15
A185-1/2x100EG	1/2	1	10
A185-1/2x125EG	1/2	1-1/4	15

STD. PACK 100

A177 to A179 Springless Stud Nut

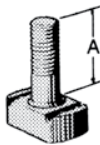

For use with all channels.

Cat. No.	Bolt Dia (in.)	Length A (in.)	Wt./C lb.
A177-1/4x100EG	1/4	1	8
A177-1/4x125EG	1/4	1-1/4	10
A179-3/8x100EG	3/8	1	13
A179-3/8x125EG	3/8	1-1/4	13.5

STD. PACK 100

812 Stud Nut

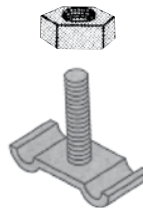

For attaching fixture to channel slot down or to channel slot up knockouts. Specify length. Hex nut included.

Cat. No.	For Channel	Wt./C lb.
812-1EG	1/4 x 1	6

STD. PACK 100

CM100 Nylon Cone Nut

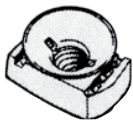

GoldGalv® only
For all 1-5/8 in. channel.
*Will not fit B Series channel.
**For B Series channel.

Cat. No.	Size (in.)	Wt./C lb.
CM100-1/4	1/4	8
CM100-3/8	3/8	10
*CM100-1/2	1/2	12
** CM100B-1/2	1/2	10

STD. PACK 100

UC100 Universal Nylon Cone Nut

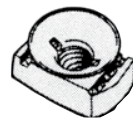

GoldGalv® only
For all 1-5/8 in. and 1-1/2 in. channels.
May be used with ALL Strut Depths.
Can be used for CM100 Series, A100 Series, B100 Series and AB100 Series.

Cat. No.	Size (in.)	Wt./C lb.
UC100-1/4	1/4	8
UC100-3/8	3/8	10
UC100-1/2	1/2	12

STD. PACK 100

AB102 Unhardened Square Nut

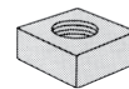

Cat. No.	Size (in.)	Wt./C lb.
AB102-1/4	1/4	13
AB102-3/8	3/8	14
AB102-1/2	1/2	14
AB102-5/8	5/8	12
AB102-3/4	3/4	11
AB102-7/8	7/8	10

STD. PACK 100

E145 Standard Hex Nut

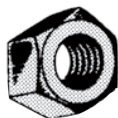

Cat. No.	Size (in.)	Wt./C lb.
E145-1/4EGC	1/4	.72
E145-3/8EGC	3/8	1.60
E145-1/2EGC	1/2	2.78
E145-5/8EGC	5/8	6.92
E145-3/4EGC	3/4	12.70
E145-7/8EGC	7/8	19.00
E145-1EGC	1	28.00

STD. PACK 100

ES145 Swivel Nut and Jam Nut Combinations

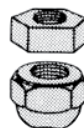

Cat. No.	Size (in.)	Wt./C lb.
ES145-3/8	3/8	5.5
ES145-1/2	1/2	6.0

STD. PACK 100

E146 Standard Square Nut



Cat. No.	Size (in.)	Wt./C lb.
E146-1/4EGC	1/4	.93
E146-5/16EGC	5/16	1.60
E146-3/8EGC	3/8	2.65
E146-1/2EGC	1/2	5.83
E146-5/8EGC	5/8	10.80

STD. PACK 100

*Supplied with a plastic sleeve over the spring portion to prevent tangling inside the carton.

Threaded Products and Hardware

E147 Flat Steel Washer

STD. PACK: 100

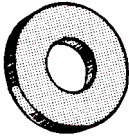

Cat. No.	Size (in.)	Wt./C lb.
E147-1/4EG	1/4	0.67
E147-5/16EG	5/16	1.11
E147-3/8EG	3/8	1.49
E147-1/2EG	1/2	3.85
E147-5/8EG	5/8	7.69
E147-3/4EG	3/4	9.89
E147-7/8EG	7/8	15.40

Available in Stainless Steel.

EF147 Fender Washer

STD. PACK: 100

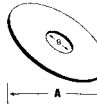

Cat. No.	Size (in.)	A (in.)	B (in.)	Wt./C lb.
EF147-1/4EGC	1/4	1-1/4	5/16	3.1
EF147-3/8EGC	3/8	1-1/2	7/16	2.9
EF147-1/2EGC	1/2	2	9/16	5.0

Available in Stainless Steel.

E148 Lock Washer

STD. PACK: 100



Cat. No.	Size (in.)	Wt./C lb.
E148-1/4EG	1/4	0.26
E148-3/8EG	3/8	0.50
E148-1/2EG	1/2	1.09
E148-5/8EG	5/8	2.57

Available in Stainless Steel.

E142 Hex Head Cap Screw

STD. PACK: 100

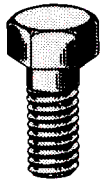

Cat. No.	Size (in.)	Wt./C lb.
E142-1/4x100EG	1/4x1	1.74
E142-1/4x150EG	1/4x1-1/2	2.43
E142-3/8x100EG	3/8x1	4.17
E142-3/8x150EG	3/8x1-1/2	5.64
E142-1/2x100EG	1/2x1	8.94
E142-1/2x150EG	1/2x1-1/2	10.00
E142-1/2x200EG	1/2x2	11.19
E142-1/2x225EG	1/2x2-1/4	11.90
E142-1/2x250EG	1/2x2-1/2	12.52
E142-1/2x275EG	1/2x2-3/4	13.22

Available in Stainless Steel.

E150S Lag Bolt

STD. PACK: 50



Cat. No.	Drill Size (in.)	Size (in.)	Wt./C lb.
E150S-3/8x1-1/2EG	1/4	3/8x1-1/2	5
E150S-3/8x2EG	1/4	3/8x2	7
E150S-3/8x2-1/2EG	1/4	3/8x2-1/2	8
E150S-3/8x3EG	1/4	3/8x3	9
E150S-1/2x1-1/2EG	11/32	1/2x1-1/2	12
E150S-1/2x2EG	11/32	1/2x2	13
E150S-1/2x2-1/2EG	11/32	1/2x2-1/2	15
E150S-1/2x3EG	11/32	1/2x3	18

E151 Coach Screw Rod



Cat. No.	Rod Size (in.)	Std Rod Lengths (in.)	Wt./C lb.
E151-3/8x4EG	3/8	4	9
E151-3/8x6EG	3/8	6	14
E151-3/8x8EG	3/8	8	22
E151-3/8x10EG	3/8	10	29
E151-3/8x12EG	3/8	12	35
E151-1/2x4EG	1/2	4	17
E151-1/2x6EG	1/2	6	22
E151-1/2x8EG	1/2	8	40
E151-1/2x10EG	1/2	10	51

Machine threaded opposite end, carbon steel.

H104 Hanger Rod Continuous Threaded



STD. PACK: 3

Cat. No.	Thread Size (in.)	Wt./lb. 100 ft.	Design Load lb.
H104-1/4x10EGC	1/4	12.5	150
H104-3/8x10EGC	3/8	29	610
H104-1/2x10EGC	1/2	53.5	1130
H104-5/8x10EGC	5/8	85	1810
H104-3/4x10EGC	3/4	123	2710
H104-7/8x10EG	7/8	130	3770
H104-1x10EG	1	214	4960

- Black available upon request
- Sold per foot; standard length, 10 ft.
- Also available in stainless steel (316) standard length 6 ft.
- National coarse thread

H119 Rod Couplings

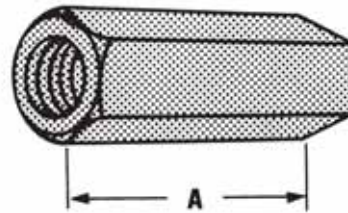

Rod Size	A (in.)	Wt./C lb.
1/4	7/8	1.90
5/16	7/8	3.75
3/8	1-1/8	3.50
1/2	1-1/4	5.50
5/8	2-1/8	18.00
3/4	2-1/4	28.00
7/8	2-1/2	55.00
1	2-1/4	56.00

Standard Rod Coupling
Example: H119-1/2EG

Order by product number, rod size, and finish.
Available in Stainless Steel.

Rod Size	A (in.)	Wt./C lb.
1/4 to 3/8	1-1/2	3.50
3/8 to 1/2	1-1/4	6.70
1/2 to 5/8	1-1/4	14.00
5/8 to 3/4	1-1/2	21.00
3/4 to 7/8	1-3/4	40.00

Rod Reducer Coupling
Example: H119-1/4x3/8EG

Threaded Products and Hardware

H122 Trapnut™ Strut Fastener



Cat. No.	Size (in.)	Design Load lb.	Std. Ctn.
H 122 1/4	1/4	150	50
H 122 3/8	3/8	590	
H 122 1/2	1/2	1080	
H 122 1/4 EG	1/4	150	
H 122 3/8 EG	3/8	590	
H 122 1/2 EG	1/2	1080	
H 122 1/4 SS6	1/4	150	

Finishes: Electrogalvanized (EG), GoldGalv®, Stainless Steel Type 316 (SS6)



M117 Eye Socket

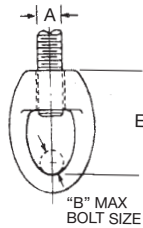
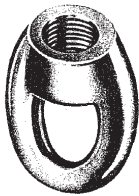

Rod Size A (in.)	Pipe Size (in.)	B (in.)	E (in.)	Wt./C lb.	Design Load, lb.
1/4	3/8	1/4	1-11/32	5	230
3/8	1/2 - 2	1/4	1-11/32	7	610
1/2	2-1/2 - 3-1/2	1/4	1-17/32	13	1130
5/8	4 - 5	3/8	1-13/16	19	1810
3/4	6	1/2	2-5/32	31	2400
7/8	8	1/2	2-11/32	44	2800

Standard Finishes - Bare (B), Electrogalvanized (EG)

Malleable iron. For attaching hanger rod to various types of hangers and beam clamps.

Order by product number, rod size, and finish. **Example: M117-1/4B**

Complies with Specification MSS SP69, Type 16.

E120 Swivel Joint

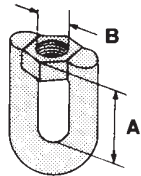

Cat. No.	Size (in.)	A (in.)	B (in.)	Wt./C lb.	Design Load, lb.
E120-3/8	3/8	1-3/8	3/8	15	1000
E120-1/2	1/2	1-1/2	1/2	25	1800

E120A Weldless Eye Nut

Standard Finish - Bare (B)

Drop Forged Steel.

For use on high temperature piping installations.

Order by product number and rod size.

Example: E120A-3/8B

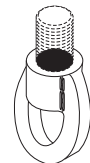

Rod Size T	A (in.)	B (in.)	C (in.)	D (in.)	E (in.)	F (in.)	Wt./C lb.	Design Load, lb.
3/8	7/8	5/8	1-1/4	2	2-1/2	3/8	20	2700
1/2	7/8	5/8	1-1/4	2	2-1/2	3/8	22	2700
5/8	1-3/8	3/4	1-1/2	2-1/2	3	1/2	60	5000
3/4	1-3/8	3/4	1-1/2	2-1/2	3	1/2	56	5000
7/8	1-1/2	1-5/8	1-5/16	3-5/8	4-1/2	3/4	174	10000
1	1-1/2	1-5/8	1-5/16	3-5/8	4-1/2	3/4	168	10000

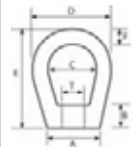

E122 Swivel Joint

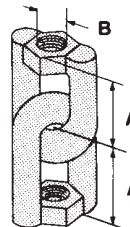

Cat. No.	Size (in.)	A (in.)	B (in.)	Wt./C lb.	Design Load, lb.
E122-3/8	3/8	1-3/8	3/8	28	1000
E122-1/2	1/2	1-1/2	1/2	48	1800

E130 Swivel Joint

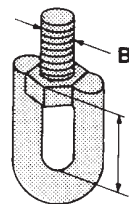

Cat. No.	Size (in.)	A (in.)	B (in.)	Wt./C lb.	Design Load, lb.
E130-3/8	3/8	1-3/8	3/8	23	1000
E130-1/2	1/2	1-1/2	1/2	28	1800

E131 Swivel Joint

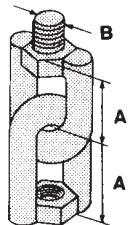

Cat. No.	Size (in.)	A (in.)	B (in.)	Wt./C lb.	Design Load, lb.
E131-3/8	3/8	1-3/8	3/8	25	1000
E131-1/2	1/2	1-1/2	1/2	52	1800

Threaded Products and Hardware

C781 Square Washer

STD.
PACK:
50

Cat. No.	Rod Size (in.)	Hole Size (in.)	Overall Dimensions (in.)	Wt./C lb.
C781-3/8*	3/8	7/16	3 x 3 x 3/16	27
C781-1/2*	1/2	9/16	3 x 3 x 3/16	27
C781-5/8*	5/8	11/16	3 x 3 x 1/4	47
C781-3/4*	3/4	13/16	3 x 3 x 1/4	42
C781-7/8*	7/8	15/16	4 x 4 x 3/8	85
C781-1*	1	1-1/8	4 x 4 x 3/8	160

*Finishes

- B
- HDG
- EG
- SS6

Used for beam applications.
For channel applications use AB241.

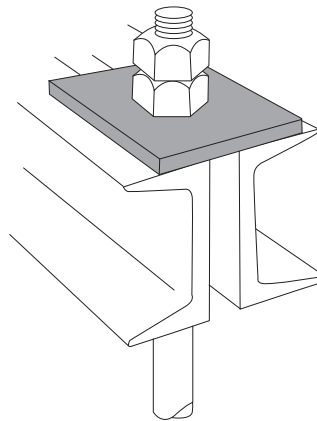

H115 Standard U-Bolt

Pipe Size (in.)	A (in.)	B (in.)	C (in.)	D (in.)	E (in.)	Wt./C lb.	Design Load, lb.
1/2	15/16	1-3/4	1-1/2	1/4	2-3/4	13	1500
3/4	1-1/8	1-3/4	1-5/8	1/4	3-1/16	15	2000
1	1-3/8	1-7/8	1-5/8	1/4	3-5/16	16	2500
1-1/4	1-23/32	1-3/4	1-15/32	3/8	3-1/2	17	2500
1-1/2	2	1-3/4	1-7/16	3/8	3-3/4	18	2500
2	2-7/16	2-1/16	1-7/8	3/8	4-11/16	32	3300
2-1/2	2-15/16	2-1/16	1-13/16	1/2	5-1/8	34	4000
3	3-9/16	2	1-3/4	1/2	5-11/16	38	4000
3-1/2	4-3/32	2	1-23/32	1/2	6-3/16	40	4000
4	4-19/32	2-1/4	1-31/32	1/2	6-15/16	46	4000
5	5-5/8	3	2-7/32	1/2	8-5/16	101	4000
6	6-3/4	3-3/4	2-13/16	5/8	10-1/8	197	4000
8	8-3/4	3-3/4	2-13/16	5/8	12-1/8	233	4000
10	10-7/8	4	3	3/4	14-9/16	491	5400
12	12-7/8	4-1/4	3-1/4	7/8	16-15/16	773	7500

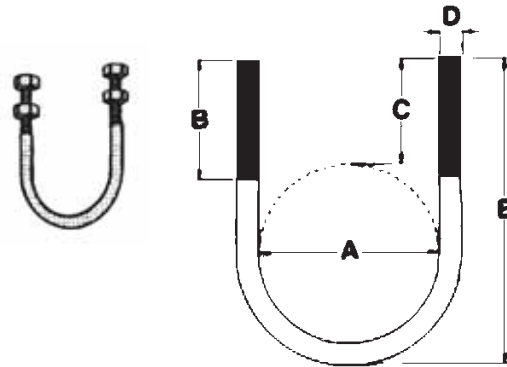

Standard Finishes - Electrogalvanized (EG), GoldGalv®, Stainless Steel or Bare (B)

Example: H115-1/2EG

Sizes through 4 in. furnished with one hex nut per leg.

Sizes 5 in. and above furnished with two hex nuts per leg.

Order by Cat. No., pipe size, finish.

Complies with Specification MSS SP69, Type 24.

Fittings and Brackets

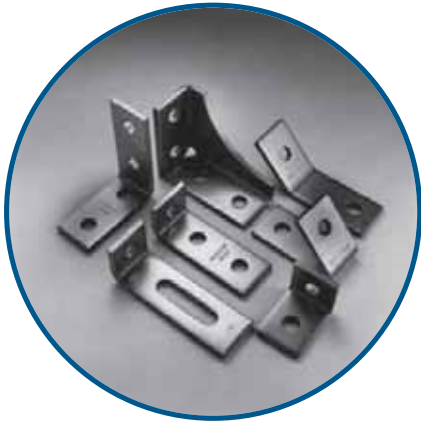

Material

Superstrut® fittings and brackets are manufactured from hot rolled carbon steel.

Dimensions

The following standard dimensions apply to all fittings except as indicated on the individual drawings.

Hole spacing	13/16 in. from end of fittings
Hole spacing	1-7/8 in. centers
Hole size	9/16 in. diameter
Material	1-5/8 in. wide
Material	1/4 in. thick

Application Instructions

Parts drawings illustrate a typical use for the fitting, and in many cases other uses for the part are appropriate.

Design Data

Load ratings vary depending fittings and brackets are used with 12, *14 or 16 gauge channel. Ratings are shown for each channel material. (See page A57 for Engineering Data and Specifications).

Nuts and Bolts Required

Unless otherwise noted, nuts and bolts for use with fittings and brackets should be ordered separately.

The standard bolt for the 9/16 in. hole is a 1/2 in. hex head cap screw 1 in. long. The 1 in. length may be used with all Series channel.

Design Load

For more information on design load, see page A57 Engineering Data and Specifications.

Finishes and Special Materials

Standard finishes are Hot Dipped Galvanized (HDGC) and GoldGalv® (no suffix). Fittings are also available in ElectroGalvanized (EG) and Stainless Steel 316 (SS6C). Contact your Regional Sales Office for availability and minimum quantities.

Aluminum channel

For Aluminum channel, we suggest fittings in HDG (C) or SS6 (C).

Fittings and Brackets

Flat Fittings

AB206

AB206HDGC
AB206EG
AB206
AB206SS6C
Wt./C 35 lb.

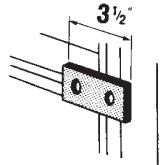

AB207

AB207HDGC
AB207EG
AB207
AB207SS6C
Wt./C 52 lb.

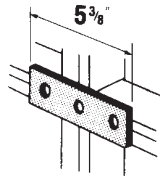

X207

X207HDG
X207EG
X207
X207SS6
Wt./C 78 lb.

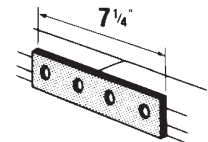

X208

X208HDG
X208EG
X208
X208SS6C
Wt./C 88 lb.

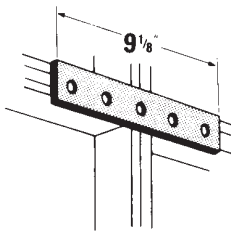

AB219

AB219HDGC
AB219EG
AB219
AB219SS6C
Wt./C 53 lb.

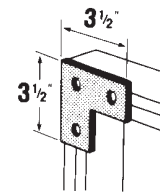

AB220

AB220HDGC
AB220EG
AB220
AB220SS6C
Wt./C 78 lb.

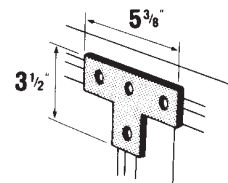

AB240

AB240HDG
AB240EG
AB240
Wt./C 69 lb.

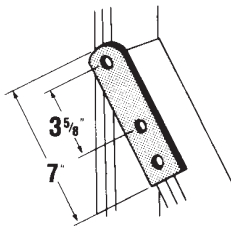

AB241

*Finishes
• HDGC
• EG
• GoldGalv®
• SS6C

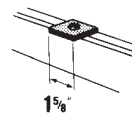

Cat. No.	Bolt Size (in.)	Wt./C lb.
AB241-1/4*	1/4	18
AB241-5/16*	5/16	18
AB241-3/8*	3/8	18
AB241-1/2*	1/2	17
AB241-5/8*	5/8	15
AB241-3/4*	3/4	14

AB242

AB242HDGC
AB242EG
AB242
Wt./C 9 lb.

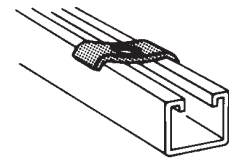

For use with either
3/8 in. or 1/2 in. hanger rod.

AB253

AB253HDGC
AB253EG
AB253
AB253SS6C
Wt./C 97 lb.

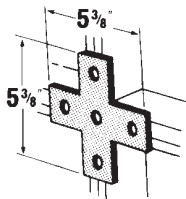

AB255

AB255HDGC
AB255EG
AB255
Wt./C 70 lb.

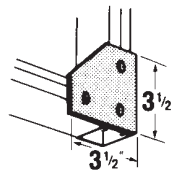

AB257

AB257HDGC
AB257EG
AB257
Wt./C 105 lb.

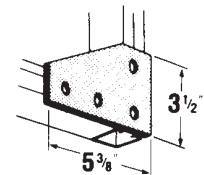

AB261

AB261HDGC
AB261EG
AB261
Wt./C 148 lb.

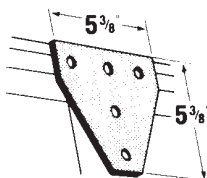

AB263

AB263HDGC
AB263EG
AB263
AB263SS6
Wt./C 150 lb.

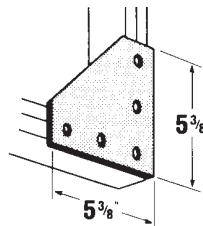

AB265

AB265HDGC
AB265EG
AB265
Wt./C 105 lb.

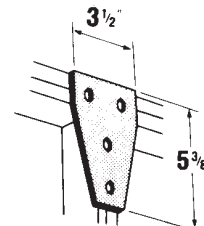

Standard Dimensions

Hole Spacing
Hole Spacing
Hole Size
Material
Material

13/16 in. From End
1-7/8 in. Centers
9/16 in. Diam.
1-5/8 in. Width
1/4 in. Thick

Materials

HDG(C)
EG(C)
(No suffix)
SS6(C)

Hot-Dipped Galvanized
ElectroGalvanized
GoldGalv®
Stainless Steel 316

Fittings and Brackets

90° Fittings

AB201

AB201HDGC

AB201EG

AB201

AB201SS6C

Wt./C 35 lb.

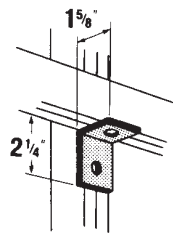

AB202

AB202HDGC

AB202EG

AB202

AB202SS6C

Wt./C 35 lb.

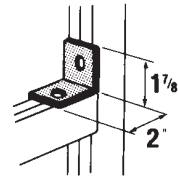

AB203

AB203HDGC

AB203EG

AB203

AB203SS6C

Wt./C 58 lb.

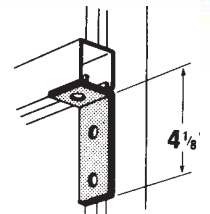

AB204

AB204HDGC

AB204EG

AB204

AB204SS6

Wt./C 58 lb.

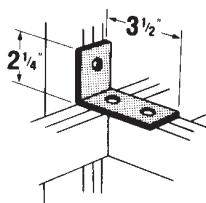

AB205

AB205HDGC

AB205EG

AB205

AB205SS6C

Wt./C 78 lb.

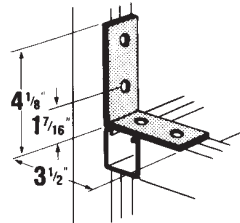

AB213

AB213HDGC

AB213EG

AB213

Wt./C 125 lb.

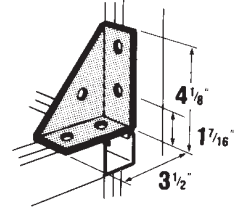

AB214

AB214HDGC

AB214EG

AB214

AB214SS6

Wt./C 125 lb.

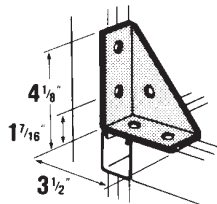

AB216

AB216HDGC

AB216EG

AB216SS6C

Wt./C 135 lb.

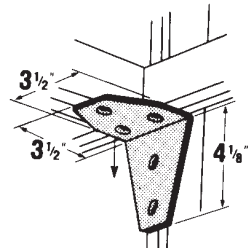

AB252

*Finishes

- HDGC
- GoldGalv®
- EG

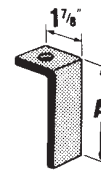

Cat. No.	A (in.)	Wt./C lb.
AB252-1*	3-7/8	61
AB252-2*	5-7/8	84
AB252-3*	7-7/8	107
AB252-4*	9-7/8	130

AB254R

AB254RHDGC

AB254REG

AB254R

Wt./C 105 lb.

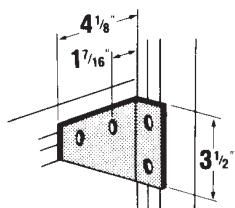

AB254L

AB254LHDGC

AB254LEG

AB254L

Wt./C 105 lb.

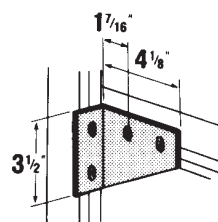

AB260R

AB260RHDGC

AB260REG

AB260R

Wt./C 58 lb.

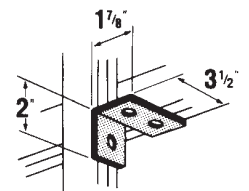

AB260L

AB260LHDGC

AB260LEG

AB260L

Wt./C 58 lb.

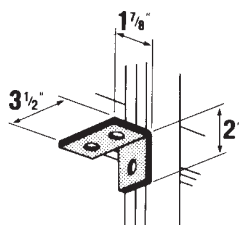

AB274

AB274HDG

AB274EG

AB274

Wt./C 70 lb.

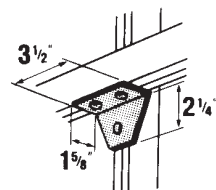

AB275

AB275HDGC

AB275EG

AB275SS6C

Wt./C 77 lb.

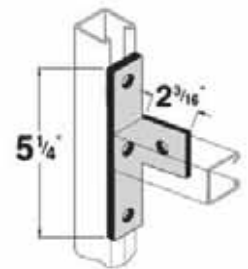

Standard Dimensions

Hole Spacing 13/16 in. From End
Hole Spacing 1-7/8 in. Centers
Hole Size 9/16 in. Diam.
Material 1-5/8 in. Width
Material 1/4 in. Thick

Materials

HDG(C)
EG(C)
(No suffix)
SS6(C)
Hot-Dipped Galvanized
ElectroGalvanized
GoldGalv®
Stainless Steel 316

Fittings and Brackets

90° Fittings

AB284R

AB284RHDG
AB284REG
AB284R
Wt./C 230 lb.

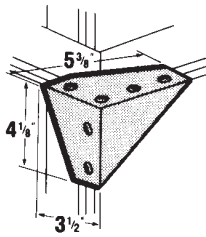

AB284L

AB284LHDG
AB284LEG
AB284L
Wt./C 230 lb.

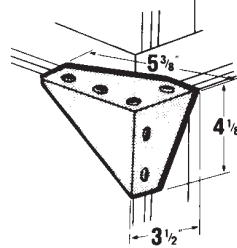

AB299

AB299HDG
AB299EG
AB299
Wt./C 40 lb.

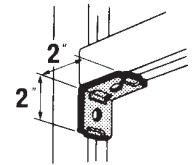

X201

X201HDG
X201EG
X201
Wt./C 65 lb.

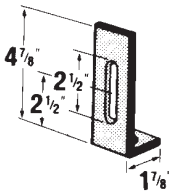

X204

X204HDG
X204EG
X204
Wt./C 1-90 lb.

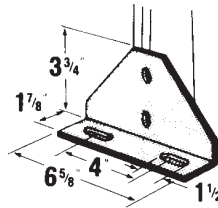

X289

X289HDGC
X289EG
X289
Wt./C 105 lb.

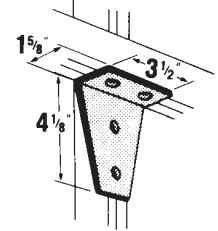

X299

X299HDGC
X299EG
X299
Wt./C 38 lb.

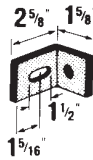

N205

N205HDGC
N205EG
N205
N205SS6C
Wt./C 74 lb.

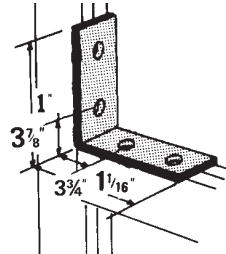

N219

N219HDG
N219EG
N219
N219SS6
Wt./C 71 lb.

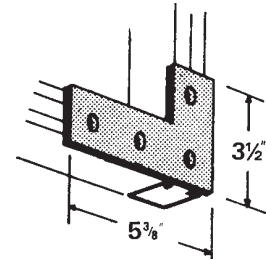

Standard Dimensions

Hole Spacing
Hole Spacing
Hole Size
Material
Material

13/16 in. From End
1-7/8 in. Centers
9/16 in. Diam.
1-5/8 in. Width
1/4 in. Thick

Materials

HDG(C)
EG(C)
(No suffix)
SS6(C)

Hot-Dipped Galvanized
ElectroGalvanized
GoldGal®
Stainless Steel 316

Fittings and Brackets

Angular Fittings

AB225

AB225HDGC
AB225EG
AB225
AB225SS6
Wt./C 58 lb.

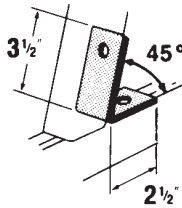

Other angles available. Contact your Regional Sales Office.

AB226

AB226HDGC
AB226SS6
Wt./C 119 lb.

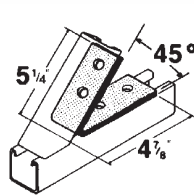

Other angles available. Contact your Regional Sales Office.

AB227

AB227HDGC
AB227EG
AB227
AB227SS6
Wt./C 58 lb.

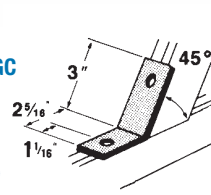

Other angles available. Contact your Regional Sales Office.

AB228

AB228HDGC
AB228SS6
Wt./C 69 lb.

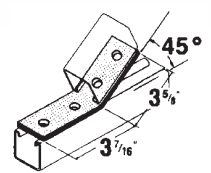

Other angles available. Contact your Regional Sales Office.

AB231

AB231EG

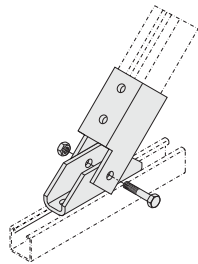
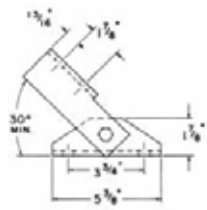

AB232

AB232EG

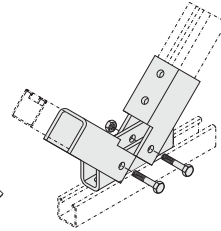
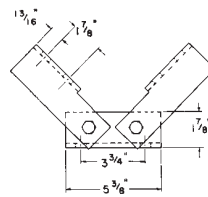

AB239

*Finishes

- HDGC
- GoldGalv®
- EG

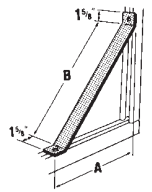

Cat. No.	A (in.)	B (in.)	Wt./C lb.
AB239-1*	7-13/16	8-1/2	148
AB239-2*	13-3/4	17	255
AB239-3*	19-3/4	25-1/2	363

"Z" Shape Fittings

A209

A209HDGC
A209EG
A209
A209SS6
Wt./C 55 lb.

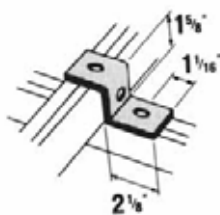

For attaching A and AR Series channel.

B209

B209HDGC
B209EG
B209
Wt./C 43 lb.

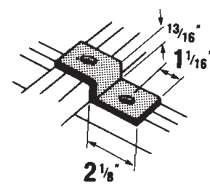

For attaching B and BR Series channel.

C209

C209
Wt./C 49 lb.

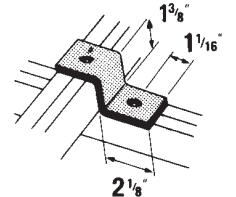

For attaching C Series channel.

D209

Wt./C 45 lb.

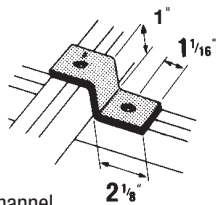

For attaching D Series channel.

CZ209

For attaching H Series and A back to back.

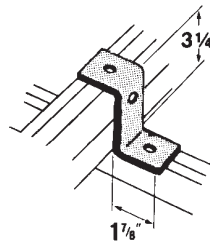

EZ209

EZ209HDGC
EZ209EG
EZ209
EZ209SS6

For attaching E Series channel.

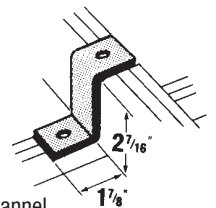

Standard Dimensions

Hole Spacing
Hole Spacing
Hole Size
Material

13/16 in. From End
1-7/8 in. Centers
9/16 in. Diam.
1-5/8 in. Width
1/4 in. Thick

Materials

HDG(C)
EG(C)
(No suffix)
SS6(C)

Hot-Dipped Galvanized
ElectroGalvanized
GoldGalv®
Stainless Steel 316

Fittings and Brackets

"U" Shape Fittings

A208

A208HDGC
A208EG
A208
A208SS6C

Wt./C 275 lb.

Does not include stud nut or bolts.

For A and AR Series channel.

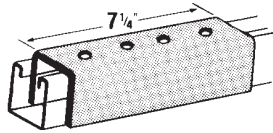

A213 Inside Joiner

Wt./C 40 lb.

For A1200 Series.
Available only in GoldGalv® finish.

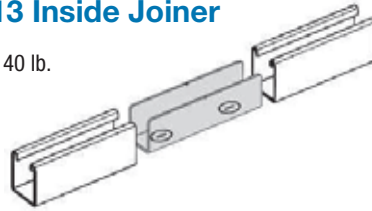

A210

A210HDGC
A210EG
A210
A210SS6C

Wt./C 88 lb.

For attaching A and AR Series channel.

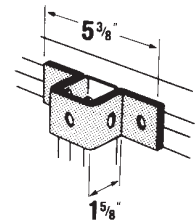

A211

A211HDGC
A211EG
A211

Wt./C 128 lb.

For attaching A and AR Series double channel, and H Series.

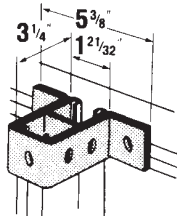

AN211

AN211HDG
AN211EG
AN211

Wt./C 181 lb.

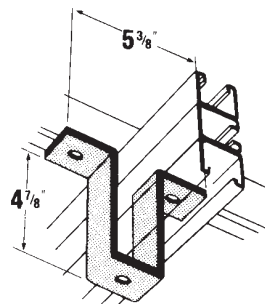

A212

A212HDG
A212EG
A212
A212SS6

Wt./C 113 lb.

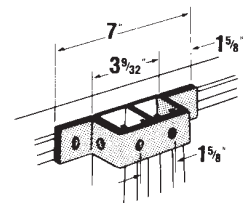

B210

B210HDG
B210EG
B210
B210SS6

Wt./C 65 lb.

For attaching B and BR Series.

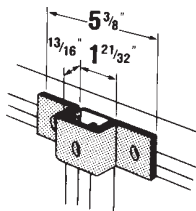

C210

C210HDG
C210EG
C210

Wt./C 77 lb.

For attaching C Series channel.

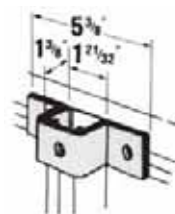

D210

D210HDG
D210EG
D210
D210SS6

Wt./C 71 lb.

For attaching D Series channel.

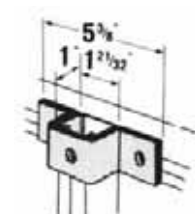

E210

E210HDGC
E210EG
E210

Wt./C 112 lb.

For attaching E Series channel.

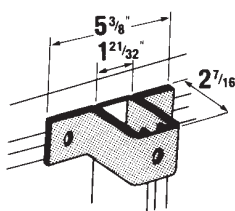

AB245

AB245HDG
AB245EG
AB245

Wt./C 70 lb.

For attaching A and AR Series double channel.

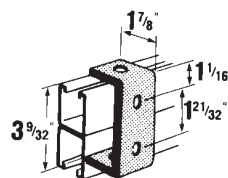

AB288

*Finishes

- HDGC
- GoldGalv®
- EG

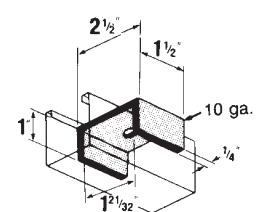

Cat. No.	Bolt Size (in.)	Wt./C lb.
AB288-3/8*	3/8	37
AB288-1/2*	1/2	
AB288-5/8*	5/8	

Standard Dimensions

Hole Spacing 13/16 in. From End
Hole Spacing 1-7/8 in. Centers
Hole Size 9/16 in. Diam.
Material 1-5/8 in. Width
Material 1/4 in. Thick

Materials

HDG(C)
EG(C)
(No suffix)
SS6(C)
Hot-Dipped Galvanized
ElectroGalvanized
GoldGalv®
Stainless Steel 316

Fittings and Brackets

Wing Fittings

AW204

AW204HDG
AW204EG
AW204
Wt./C 76 lb.

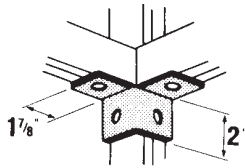

AW214

AW214HDG
AW214EG
AW214
Wt./C 115 lb.

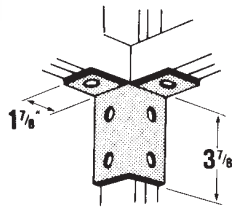

A217

AW217HDG
A217EG
A217
Wt./C 155 lb.

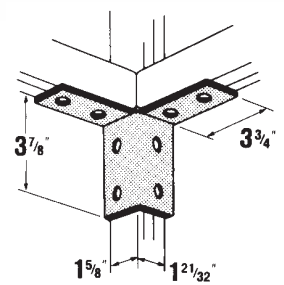

AW205L

AW205LHDG
AW205LEG
AW205L
Wt./C 59 lb.

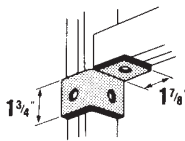

AW205R

AW205REG
AW205R
Wt./C 59 lb.

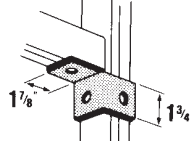

AW215L

AW215LHDG
AW215LEG
AW215L
Wt./C 98 lb.

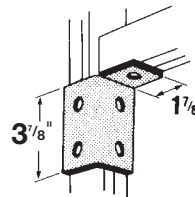

AW215R

AW215RHDG
AW215REG
AW215R
Wt./C 98 lb.

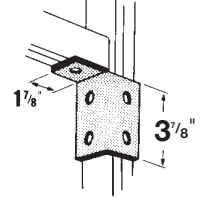

AW220

AW220HDGC
AW220EG
AW220
Wt./C 90 lb.

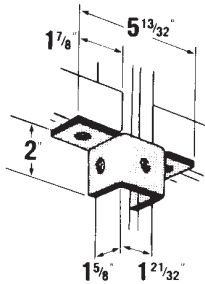

AW224

AW224HDGC
AW224EG
AW224
Wt./C 147 lb.

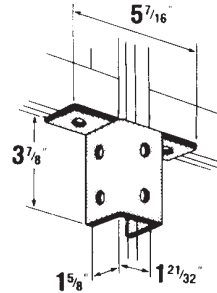

AW219

AW219HDGC
AW219EG
AW219
Wt./C 187 lb.

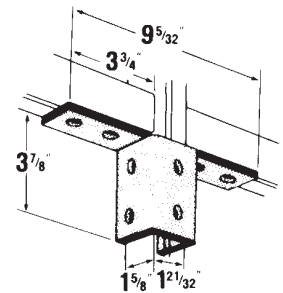

AW226

AW226HDG
AW226
Wt./C 113 lb.

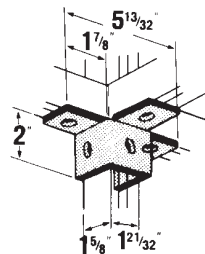

A218

A218HDG
A218EG
A218
Wt./C 177 lb.

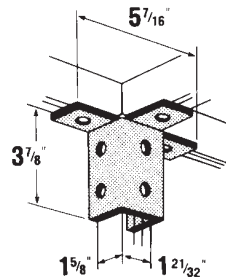

AW228

AW228HDG
AW228EG
AW228
Wt./C 230 lb.

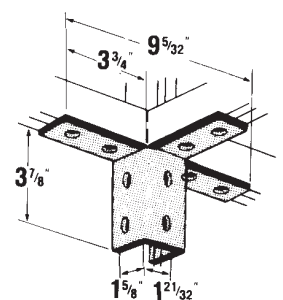

Standard Dimensions

Hole Spacing
Hole Spacing
Hole Size
Material

13/16 in. From End
1-7/8 in. Centers
9/16 in. Diam.
1-5/8 in. Width
1/4 in. Thick

Materials

HDG(C)
EG(C)
(No suffix)
SS6(C)

Hot-Dipped Galvanized
ElectroGalvanized
GoldGalv®
Stainless Steel 316

Fittings and Brackets

Brackets

S202

***Finishes**

- HDG

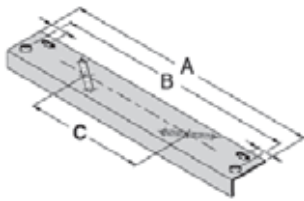

Cat. No.	A (in.)	B (in.)	C (in.)	Wt./C lb.
S202-6*	6	5	—	75
S202-9*	9	8	2	100
S202-15*	15	14	18	175
S202-21*	21	20	14	250
S202-27*	27	26	20	325
S202-33*	33	32	26	400

S203

***Finishes**

- HDG

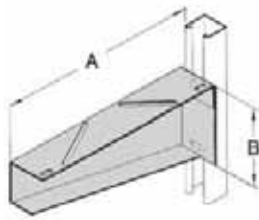

Cat. No.	A (in.)	B (in.)	Design Load/lb.	Wt./C lb.
S203-8*	8-1/2	4-1/16	1200	180
S203-14*	14-1/2	5-3/8		325
S203-20*	20-1/2	6-11/16		525
S203-26*	26-1/2	8		675
S203-32*	32-1/2	8		840
S203-38*	38-1/2	8		1050

S249

***Finishes**

- HDG
- SS6C

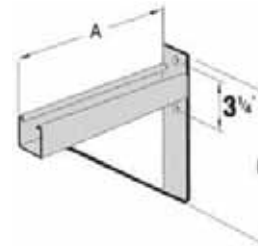

Cat. No.	A (in.)	B (in.)	Design Load/lb.	Wt./C lb.
S249-8*	8-1/2	8	1500	320
S249-14*	14-1/2	9		520
S249-20*	20-1/2	9		660
S249-26*	26-1/2	11-1/2		870
S249-32*	32-1/2	11-1/2		1030
S249-38*	38-1/2	11-1/2		1230

S250

***Finishes**

- HDG
- SS6C

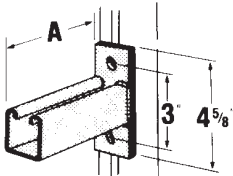

Cat. No.	A (in.)	Design Load/lb.	Wt./C lb.
S250-6*	6	1500	150
S250-8*	8-1/2	1500	150
S250-12*	12	800	250
S250-14*	14-1/2	800	250
S250-18*	18	550	350
S250-20*	20-1/2	550	350
S250-24*	24	400	450
S250-26*	26-1/2	400	450

May be installed inverted with no change in load ratings.

S251

***Finishes**

- HDG
- SS6C

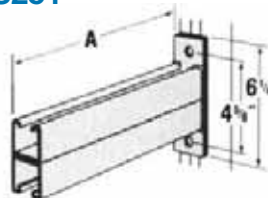

Cat. No.	A (in.)	Design Load/lb.	Wt./C lb.
S251-12*	12	1650	514
S251-14*	14-1/2	1650	514
S251-18*	18	1050	714
S251-20*	20-1/2	1050	714
S251-24*	24	800	914
S251-26*	26-1/2	800	914
S251-30*	30	650	1114
S251-32*	32-1/2	650	1114
S251-36*	36	500	1314
S251-38*	38-1/2	500	1314

S256

***Finishes**

- HDG
- SS6C

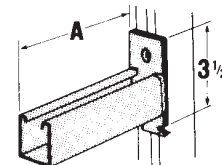

Cat. No.	A (in.)	Design Load/lb.	Wt./C lb.
S256-6*	6	1000	151
S256-8*	8-1/2	1000	151
S256-12*	12	500	251
S256-14*	14-1/2	500	251
S256-18*	18	300	351
S256-20*	20-1/2	300	351
S256-24*	24	250	451
S256-26*	26-1/2	250	451

When installed in inverted position reduce load rating 40%.

S247

S247HDG

S247

S247SS6

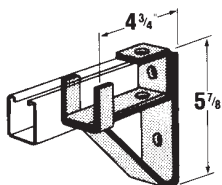

Design Moment

(channel upright as shown)

When Supported By

A-1200 5250 inch lb.

A-1400 3650 inch lb.

Applies to fitting only, not to the arm.

S248

S248HDGC

S248

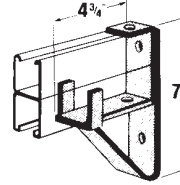

Design Moment

(channel upright as shown)

When Supported By

A-1202 10 800 inch lb.

A-1402 7550 inch lb.

Applies to fitting only, not to the arm.

Standard Dimensions

Hole Spacing
Hole Spacing
Hole Size
Material
Material

13/16 in. From End
1-7/8 in. Centers
9/16 in. Diam.
1-5/8 in. Width
1/4 in. Thick

Materials

HDG(C)
EG(C)
(No suffix)
SS6(C)

Hot-Dipped Galvanized
ElectroGalvanized
GoldGalv®
Stainless Steel 316

Fittings and Brackets

Brackets

S204

S204HDGC

S204

Wt./C 174 lb.

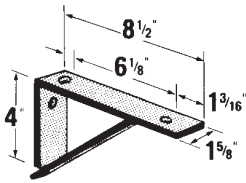

Design Uniform Load/lb.	
A-1200	750
A-1400	500

S205

S205HDGC

S205

Wt./C 264 lb.

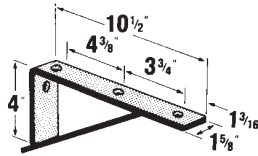

Design Uniform Load/lb.	
A-1200	750
A-1400	500

S217

S217HDG

S217

S217SS6

Wt./C 264 lb.

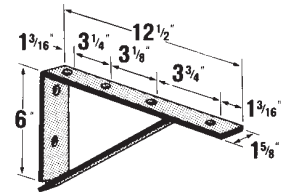

Design Uniform Load/lb.	
A-1200	750
A-1400	650

S218

S218HDG

S218

Wt./C 295 lb.

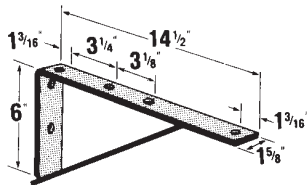

Design Uniform Load/lb.	
A-1200	750
A-1400	650

S222

S222HDG

S222

Wt./C 385 lb.

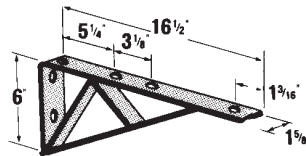

Design Uniform Load/lb.	
A-1200	1000
A-1400	750

S226

S226HDG

S226

Wt./C 421 lb.

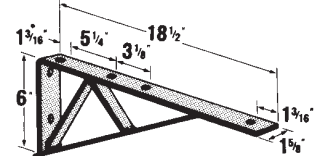

Design Uniform Load/lb.	
A-1200	1000
A-1400	750

Fittings and Brackets

Post Bases

AP232

AP232HDGC

AP232EG

AP232

Wt./C 384 lb.

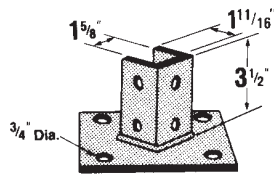

AP235

AP235HDGC

AP235EG

AP235

Wt./C 400 lb.

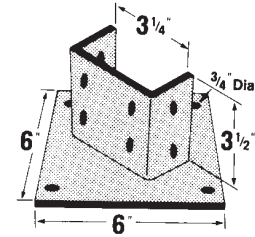

AP232SQ

AP232SQHDGC

AP232SQEG

AP232SQSS6

Wt./C 384 lb.

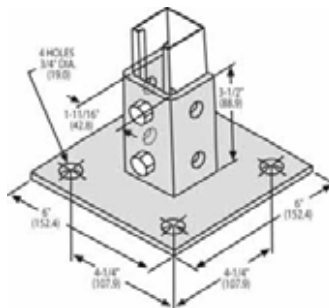

AP235SQ

AP235SQHDGC

AP235SQEG

AP235SQ

AP235SQSS6

Wt./C 400 lb.

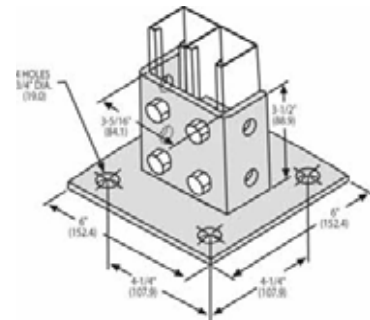

AN270

*Finishes

- HDG
- EG

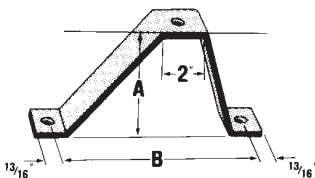

TS272 Track Support

TS272HDG

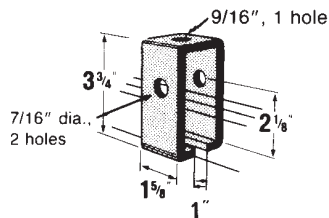

Requires 3/8 in. x 2-1/2 in. bolt and nut (not included)

Design load: 1000 lb.

Wt./C 104 lb.

TS273 Track Support

TS273HDG

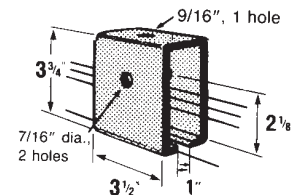

For use over channel splice

Requires 3/8 in. x 2-1/2 in. bolt and nut (not included)

Design load: 2000 lb.

Wt./C 228 lb.

Cat. No.	A	B	Wt./C lb.
AN270-1*	2-3/8	6	113
AN270-2*	4-3/8	8	151
AN270-3*	6-3/8	10	199
AN270-4*	8-3/8	12	246
AN270-5*	10-3/8	14	293

Fittings and Brackets

Special Application Fittings and Brackets

TR292

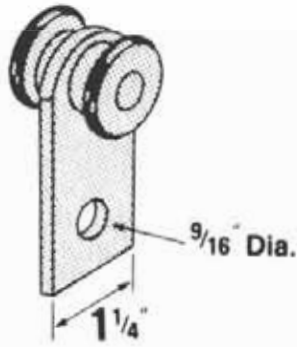

Can be used for Series A, E and H channels only.

Standard finish is Electrogalvanized.

Frictionless needle bearings.

Design load: 500 lb.

Safety factor of 5.

Wt./C 59 lb.

TR294

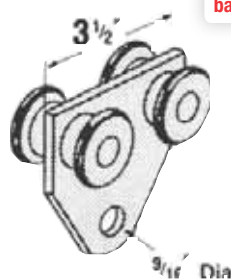

Do not use with back to back Strut

Can be used for Series A, E and H channels only.

Standard finish is Electrogalvanized.

Frictionless needle bearings.

Design load: 1000 lb.

Safety factor of 5.

Wt./C 106 lb.

C728 Pipe Roller (Pair)

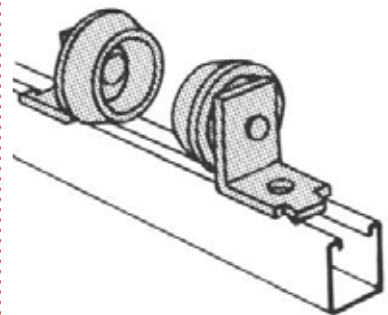

Cast aluminum rollers, steel brackets. Designed for standard saddles. Order separately for each pair of rollers: two 1/2 in. x 5/16 in. hex head cap screws and two 1/2 in. channel nuts. Space to suit O.D. of pipe and wrapping.

Design Load: 2350 lb.

Wt./C : 300 lb.

Adjustable Universal Support

Support building services and access equipment on flat roofs and flat surfaces



The T&B Adjustable Universal Support (AUS) provides an easy method for supporting pipes, conduit and equipment on flat roofs, below raised floors and even on level ground applications. The AUS reduces installation time compared to other support solutions such as wooden blocks, cement blocks, straps and clips. These labor intensive solutions also increase the danger of roof membrane penetration.

The AUS system also allows for tool free adjustment of the pedestal height from 6 to 9 inches with a twist of the wrist. This ensures that the supported objects or pipes are uniformly supported and no high stress supports are carrying a disproportionate load in a single location.

Cat. No.	Description	Qty.
AUS14-96	Adjustable Universal Support (Base only)	1
AUS-RISER-KIT	Riser Kit	
A1200HS100PG	14 in. strut	1
H104-1/2X10EGC	12 in. threaded rod	2
E145-1/2EGC	Nut	8
E147-1/2EGC	Washer	8
E148-1/2EGC	Lock washer	4
AUS-STRUT-KIT	Bolt Kit	
A1200HS100PG	14 in. strut	1
E142-1/2X200EGC	Bolt	2
E145-1/2EGC	Nut	2
E147-1/2EGC	Washer	4
E148-1/2EGC	Lock washer	2
AUS125PCSS6	4-1/2 in. stainless steel 316 strap (to restrain 1-1/4 in. pipe)	2
AUS150PCSS6	5 in. strap (to restrain 1-1/2 in. pipe)	2
AUS200PCSS6	6 in. strap (to restrain 2 in. pipe)	2

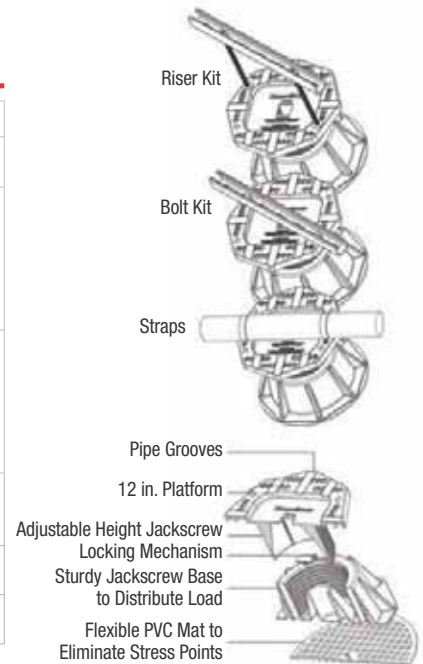

Beam Clamps

.....



Design Loads

Where design loads are indicated, they provide for a safety factor of 3 in conformance with the American Standard Code for Pressure Piping. For more information, see page A57 for Engineering Data and Specifications.

Finishes and Special Materials

Hot-Dipped Galvanized (HDGC) is standard for all Superstrut® beam clamps. The material is zinc coated after fabrication providing total product protection on all surfaces. The fabricated beam clamps are suspended and then dipped into tanks of hot zinc for a prolonged period, creating a coherent bond.

Selected beam clamps can also be available in GoldGalv® (no suffix) or Stainless Steel Type 316 (SS6C). Contact your Regional Sales Office for availability and minimum quantities.

Beam Clamps

Beam Clamps for Mounting Channel

U501, U502

***Finishes**

- HDG
- EG
- GoldGalv®
- SS6C

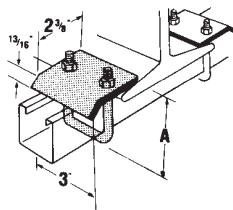

Cat. No.	For Channel Size (in.)	Wt./C lb.
U501*	A1200 A1400	3-3/16 90
	B1200 B1400	
	C1200 B1402	
U502*	A1202 A1402	4-13/16 100
	C1202 H1200	

Furnished complete.

Design Load U501 : 2150 lb.

U502 : 3000 lb.

U504

- U504HDG
- U504EG
- U504
- U504SS6

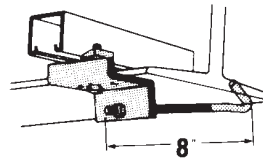

Can be used with all channels.

Wt./C 140 lb.

U505

- U505HDG
- U505EG
- U505

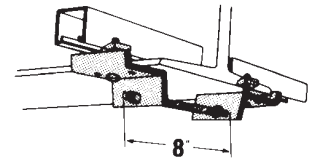

Can be used with all channels.

Wt./C 270 lb.

U510

- U510HDGC
- U510EG
- U510
- U510SS6

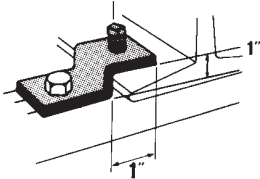

Design Load/lb.	Channel
1000	A-1200
800	A-1400

1/2 in. x 1-1/2 in. set screw included.

Order separately one 1/2 in. x 1-1/2 in. hex head cap screw and 1/2 in. channel nut.

Wt./C 75 lb.

512U

- 512UHDG
- 512UEG
- 512U

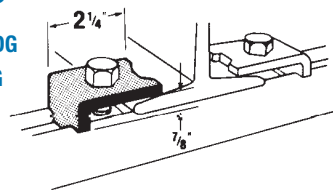

Design Load/lb.	Channel
1000	A-1200
800	A-1400

Order separately one 1/2 in. x 1-1/2 in. hex head cap screw and 1/2 in. channel nut.

Wt./C 26 lb.

U514

- U514HDGC
- U514EG
- U514
- U514SS6

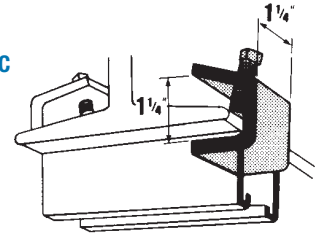

3/8 in. x 1-1/2 in. set screw included.

Design Load 750 lb./pair

Wt./C 40 lb.

U514-A

- U514-AHDGC
- U514-AEG
- U514-A
- U514-ASS6

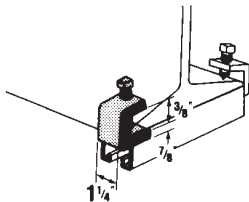

1/2 in. x 1-1/2 in. set screw included.

Design Load 1650 lb./pair

Wt./C 59 lb.

U515

- U515HDGC
- U515EG
- U515
- U515SS6

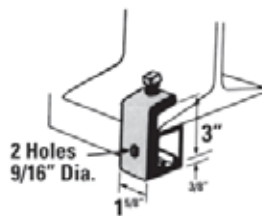

For all A Series channel.

1/2 in. x 1-1/2 in. set screw included.

Design Load 800 lb.

Wt./C 95 lb.

U515B

- U515BHDG
- U515BEG
- U515B
- U515BSS6

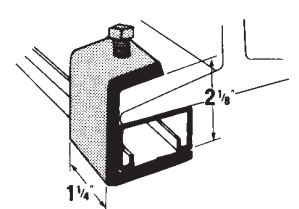

For all B Series channel.

1/2 in. x 1-1/2 in. set screw included.

Design Load 800 lb.

Wt./C 91 lb.

Materials
 HDG(C) Hot-Dipped Galvanized
 EG(C) Electrogalvanized
 (No suffix) GoldGalv®
 SS6(C) Stainless Steel 316

Beam Clamps

Beam Clamps for Mounting Channel

U520, U521, U522

***Finishes**

- GoldGalv®

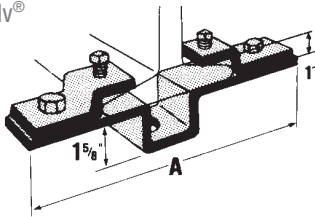

Nuts, cap screws and set screws included.

Cat. No.	Flange Width	A	Wt./C lb.	Design Load lb./ea
U520*	2-3/8 - 4-1/2	8-3/4	328	2000
U521*	3-3/4 - 5-3/4	10	343	1300
U522*	5-5/8 - 7-5/8	11-7/8	353	900

A597

***Finishes**

- HDGC
- SS6C

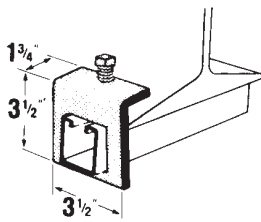

Cat. No.	Channel Series	Wt./C lb.	Design Load lb./ea
A597*	A	108	800

U544 Single Adjusting Screw End Cap Set

U544EG

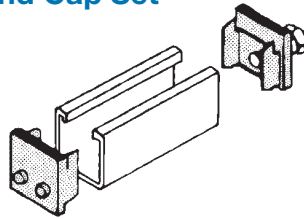

Should be ordered as one set.
Wt./C 39 lb.

U543 Adjusting Screw End Caps

U543HDG

U543EG

U543

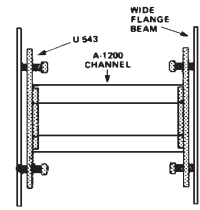

Should be ordered in multiples of two (2).
Wt./C 44 lb.

U570-1, U570-2

***Finishes**

- HDGC

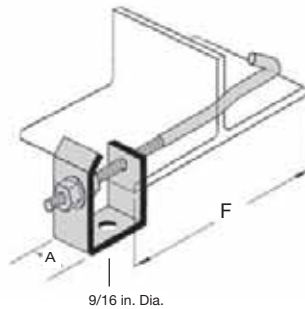

Cat. No.	A (in.)	F (in.)	Wt./C lb.	Design Load lb./ea
U570-1*	1-1/2	4 to 9	240	800
U570-2*	1-1/2	7 to 17	300	800

Materials

HDG(C)
EG(C)
(No suffix)
SS6(C)

Hot-Dipped Galvanized
ElectroGalvanized
GoldGalv®
Stainless Steel 316

Beam Clamps

Beam Clamps for Hanging Rod

U562 Beam Clamp

- U562HDG
- U562EG
- U562
- U562SS6

Optional Use of
U562HDG
Beam Clamp

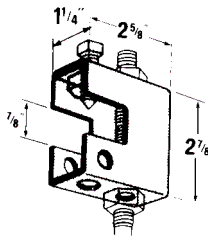
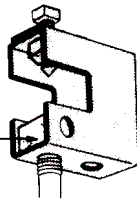

E146 square nut order separately.

1/2 in. set screw included.

Rod Size (in.)	Wt./C lb.	Design Load lb./ea
1/2	80	800

For 20° swivel application use ES-145-1/2 nut.

1/2 in. set screw included.

Rod Size (in.)	Wt./C lb.	Design Load lb./ea
1/2	80	500

UM562 Beam Clamp

- UM562HDGC
- UM562EG
- UM562
- UM562SS6

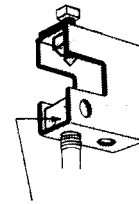

E146 square nut order separately.

1/2 in. set screw included.

Rod Size (in.)	Wt./C lb.	Design Load lb./ea
1/2	100	1200

For 20° swivel application use ES-145-1/2 nut.

US562 Beam Clamp with Swing Hanger

- US562HDG
- US562EG
- US562

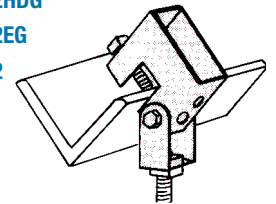

1/2 in. set screw included.

Rod Size (in.)	Wt./C lb.	Design Load lb./ea
1/2	113	800

U563 Beam Clamp

- U563HDG
- U563EG
- U563
- U563SS6

Optional Use of
U563HDG
Beam Clamp

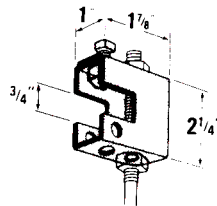
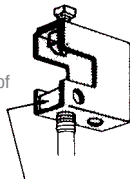

Square nut order separately.

3/8 in. set screw included.

Rod Size (in.)	Wt./C lb.	Design Load lb./ea
3/8	33	400

3/8 in. set screw included.

Rod Size (in.)	Wt./C lb.	Design Load lb./ea
3/8	33	240

US563 Beam Clamp with Swing Hanger

- US563HDG
- US563

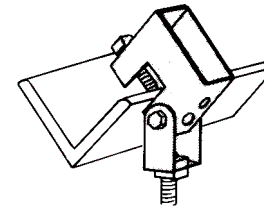

3/8 in. set screw included.

Rod Size (in.)	Wt./C lb.	Design Load lb./ea
3/8	50	400

U569 Beam Clamp

- U569HDG
- U569

Maximum flange width 5 in.

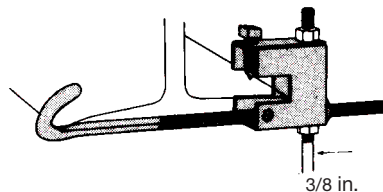

Cat. No.	A Size (in.)	Wt./C lb.	Design Load lb./ea
U569	3/8	150	400

A570 Beam Clamp with Safety Rod

Flange width 4 in. min. - 8 in. max.
For use with 3/8 in. rod see U-569.

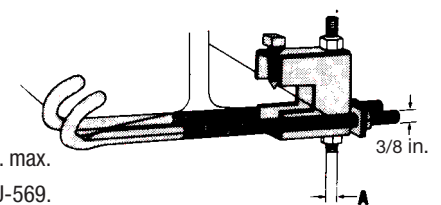

Cat. No.	A Size (in.)	Wt./C lb.	Design Load lb./ea
A570HDG	1/2	220	500

Materials HDG(C) Hot-Dipped Galvanized
EG(C) ElectroGalvanized
(No suffix) GoldGal®
SS6(C) Stainless Steel 316

Beam Clamps

Beam Clamps for Hanging Rod

U560 Heavy Duty Beam Clamp

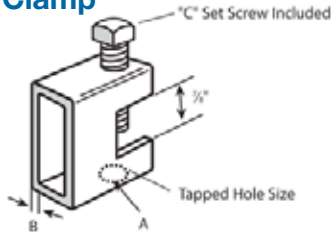

- *Finishes
- GoldGalv®
 - EG

Cat. No.	A (in.)	B (in.)	C (in.)	Wt./C lb.	Design Load, lb.
U560-1/4*	1/4	1/8	3/8 x 1-1/2	67	1050
U560-3/8*	3/8	1/8	3/8 x 1-1/2	67	1050
U560-1/2*	1/2	1/4	1/2 x 1-1/2	130	2650
U560-5/8*	5/8	1/4	1/2 x 1-1/2	130	2650

U564 Heavy Duty Beam Clamp

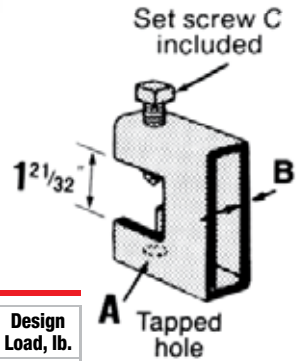

- *Finishes
- GoldGalv®
 - EG

Cat. No.	A (in.)	B (in.)	C (in.)	Wt./C lb.	Design Load, lb.
U564-3/8*	3/8	1/8	3/8 x 2-3/4	109	1300
U564-1/2*	1/2	1/4	1/2 x 2-3/4	201	3150
U564-5/8*	5/8	1/4	1/2 x 2-3/4	201	3150

U568 Beam Clamp Safety Strap

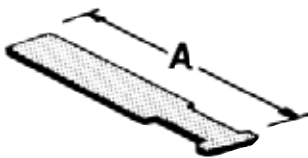

For U563 beam clamp.

Cat. No.	Beam Flange Width (in.)	A (in.)	Wt./C lb.
U568-1EG	6	8	18
U568-2EG	9	11	28

16 gauge material

U568 Beam Clamp Safety Strap



For U562 and UM562 beam clamp.

Cat. No.	Beam Flange Width (in.)	A (in.)	Wt./C lb.
U568-3EG	6	9	25
U568-4EG	9	12	33
U568-5EG	12	15	42

16 gauge material

U568 Beam Clamp Safety Strap



For U560 and U564 beam clamp.

Cat. No.	Beam Flange Width (in.)	A (in.)	Wt./C lb.
U568-4EG	6	9	33
U568-5EG	9	12	42
U568-6EG	12	15	24

16 gauge material

C775L / M775L Clamp with Lock Nut

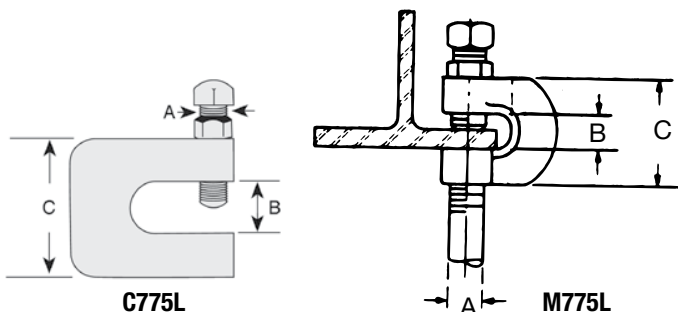

Standard Finish - Electrogalvanized (EG)

Malleable Iron (M775L)

Carbon Steel (C775L)

Cat. No.	Pipe Size (in.)	Dimensions			Wt./C lb.	Design Load, lb.
		A (in.)	B (in.)	C (in.)		
C775L-3/8EG	3/8	3/8	3/8	3/4	38	400
C775L-1/2EG	1/2	3/8	3/8	3/4	39	500
C775L-5/8EG	5/8	1/2	1/2	3/4	60	550
C775L-3/4EG	3/4	5/8	5/8	3/4	69	600
C775L-7/8EG	7/8	3/4	3/4	1	184	900
M775L-3/8EG	3/8	3/8	3/4	1-3/4	27	400
M775L-1/2EG	1/2	1/2	3/4	1-3/4	35	400
M775L-5/8EG	5/8	5/8	3/4	2	52	440
M775L-3/4EG	3/4	3/4	3/4	2	63	500

Materials	Legend
HDG(C)	→ Hot-Dipped Galvanized
EG(C)	→ Electrogalvanized
(No suffix)	→ GoldGalv®
SS6(C)	→ Stainless Steel 316

Beam Clamps

Beam Clamps for Hanging Rod

500SC, 502, 503SC, 507, 508, 509, 510, 511 Beam Clamp

Standard Finish -

Electrogalvanized (no suffix)

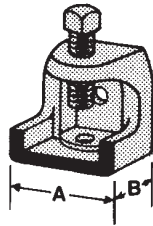

Cat. No.	Tapped Holes	Base Dim.		Jaw Opening (in.)	Wt./C lb.	Design Load/lb.
		A (in.)	B (in.)			
500SC	1/4 - 20	1	1-1/4	15/16	18	450
502	3/8 - 16	2	2	1	92	1300
503SC	1/2 - 13	2-5/8	2-1/2	1	164	1300
507	1/2 - 13	2-1/2	2-3/8	1-3/8	165	1700
508	1/2 - 13	2-1/2	2-3/8	2-1/8	184	1700
509	10 - 24	1	1-1/4	15/16	22	375
510	1/4 - 20	27/32	1-1/8	5/8	15	400
511	10 - 24	27/32	1-1/8	5/8	15	400

6H Series in combination with 500 Series Beam Clamp Conduit and Pipe Hanger



Features

- Accommodates 1/2 in. through 4 in. EMT or rigid conduit
- Can be used for either vertical or horizontal installation
- 6H-TB Series is threaded so there are less parts to handle or drop
- Installs easily with a screwdriver

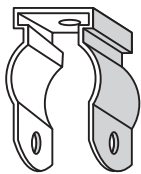

6H Series
without bolt
Fig. 1



6H-B Series
with bolt and hex nut
Fig. 2



6H-T Threaded Series
threaded without bolt
Fig. 3



6H-TB Threaded Series
threaded with bolt
Fig. 4

Without Bolt		With Bolt		EMT (in.)	Rigid Conduit or Pipe (in.)	Qty. per Box
Cat. No.	Fig. No.	Cat. No.	Fig. No.			
6H0	1	6H0-B	2	1/2	3/8-1/2	100
6H0-T	3	6H0-TB	4			
6H1	1	6H1-B	2	3/4	3/4	
6H1-T	3	6H1-TB	4			
6H2	1	6H2-B	2	1	1	
		6H2-TB	4			
6H2 1/2	1	6H2 1/2B	2	1-1/4	-	
		6H2 1/2-TB	4			
6H3-SC	1	6H3-B	2	1-1/2	1-1/4	
		6H3-TB	4			
6H4	1	6H4-B	2	-	1-1/2	
		6H4-TB	4			
6H5	1	6H5-B	2	2	2	
		6H5-TB	4			
6H6	1	6H6-B	2	2-1/2	2-1/2	
6H7	1	6H7-B	2	3	3	
6H8	1	6H8-B	2	3-1/2	3-1/2	
6H9	1	6H9-B	2	4	4	

Standard Finish - Electrogalvanized (no suffix). Use SS suffix for Stainless Steel.

Load rating: 500 lb. with a safety factor of 3. (For weight per 100 see page A38.)

Beam Clamps

Beam Clamps for Mounting Pipe and Conduit

U571, U572 Conduit Clamp

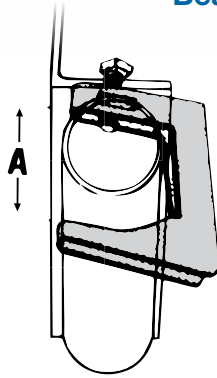

For attaching 1/2 in. thru 1-1/2 in. conduit to beam, channel, angle or column. Secures conduit to the support parallel or at right angles to it.

5/16 in. set screw

12 gauge material

Standard Finish - GoldGalv®

Wt./C 38 lb.

Cat. No.	Conduit Size (in.)	Max. Flange Thickness (in.)	Dim. A (in.)	Wt./C lb.
U571	1/2	1	1-3/4	36
	3/4	3/4		
	1	1/2		
U572	3/4	1-1/2	2-1/2	59
	1	1-1/4		
	1-1/4	1		
	1-1/2	5/8		

Pipe Supports

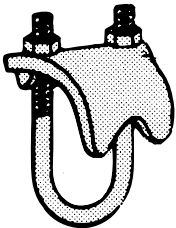

Type RC and RCS

- Malleable Iron
- For mounting pipe or conduit at right angles to the beam
- Use SS316 suffix for 316 Stainless Steel
- Use HDG suffix for Hot-Dipped Galvanized

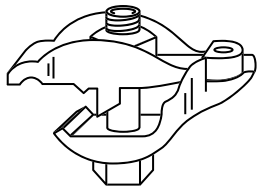

Type EC

- Malleable Iron
- For mounting pipe or conduit vertically across the beam
- Use HDG suffix for Hot-Dipped Galvanized
- CSA Certified

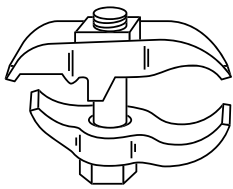

Type PC

- Malleable Iron
- For mounting pipe or conduit parallel to the beam
- Use HDG suffix for Hot-Dipped Galvanized

Pipe Supports

Three types of pipe clamps are available to provide right angle, vertical and parallel attachment to a beam. Types RC, EC and PC are malleable iron clamps with an edge that grips the structural member for maximum holding power when tightened.

Type RCS clamps are all steel, providing two bearing surfaces for strong attachment for mounting pipe or conduit at right angles to the beam.

All parts are electrogalvanized (no suffix) including the threads. The clamps are designed for clamping to a wide variety of beam thicknesses and tapers. Can be installed using only a wrench.

Cat. No. and Size	O.D. of Conduit or Pipe (in.)	Nom. Conduit or Pipe Size (in.)	Std. Ctn.	Wt./C lb.
RCS-3/8	0.675	3/8	50	31
RCS-1/2	0.840	1/2		34
RCS-3/4	1.050	3/4		39
RCS-1	1.315	1		42
RCS-1-1/4	1.660	1-1/4		43
RCS-1-1/2	1.900	1-1/2		60
RCS-2	2.375	2		72
RC-1/2	0.840	1/2		36
RC-3/4	1.050	3/4		43
RC-1	1.315	1		49
RC-1-1/4	1.660	1-1/4	51	
RC-1-1/2	1.900	1-1/2	54	
RC-2-SC	2.375	2	76	
RC-2-1/2	2.875	2-1/2	107	
RC-3	3.500	3	25	116
RC-3-1/2	4.000	3-1/2	134	
RC-4-SC	4.500	4	20	158
EC-1/2	0.840	1/2	50	69
EC-3/4	1.050	3/4		78
EC-1	1.315	1	25	83
EC-1-1/4	1.660	1-1/4		108
EC-1-1/2	1.900	1-1/2		112
EC-2	2.375	2	10	140
EC-2-1/2	2.875	2-1/2		183
EC-3	3.500	3	50	203
PC-3/8	0.675	3/8		32
PC-1/2	0.840	1/2	25	53
PC-3/4	1.050	3/4		53
PC-1	1.315	1	10	61
PC-1-1/4	1.660	1-1/4		79
PC-1-1/2	1.900	1-1/2	25	56
PC-2	2.375	2		116
PC-2-1/2	2.875	2-1/2	10	148
PC-3	3.500	3		175
PC-3-1/2	4.000	3-1/2	10	199
PC-4	4.500	4		224

Beam Clamps

Beam Fittings

C781 Square Washer

***Finishes**

- B
- EDG
- EG
- SS6

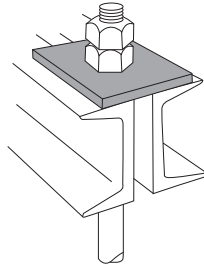

Used for beam applications.

For channel applications use AB241.

STD.
PACK:
50

Cat. No.	Rod Size (in.)	Hole Size (in.)	Overall Dimensions	Wt./C lb.
C781-3/8*	3/8	7/16	3 x 3 x 3/16	27
C781-1/2*	1/2	9/16	3 x 3 x 3/16	27
C781-5/8*	5/8	11/16	3 x 3 x 1/4	47
C781-3/4*	3/4	13/16	3 x 3 x 1/4	42
C781-7/8*	7/8	15/16	4 x 4 x 3/8	85
C781-1*	1	1-1/8	4 x 4 x 3/8	160

M742R Ceiling Flange

***Finishes**

- B
- EG

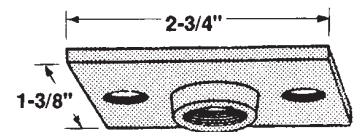

Cat. No.	Rod Size (in.)	Wt./C lb.
M742R-3/8*	3/8	16
M742R-1/2*	1/2	16

540 Side Beam Hanger Clip

***Finishes**

- B
- EG
- GoldGalv®

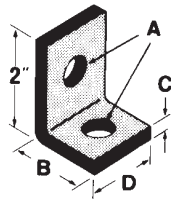

Cat. No.	A (in.)	B (in.)	C (in.)	D (in.)	Wt./C lb.
540-3/8*	7/16	1-7/8	1/4	7/8	38
540-1/2*	9/16	1-7/8	1/4	1-5/8	36
540-5/8*	11/16	2-1/2	3/8	2	84
540-3/4*	13/16	2-1/2	3/8	2	113

542 Side Beam Hanger Clip

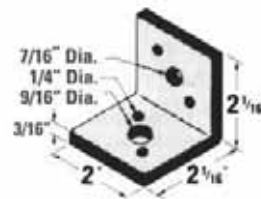

Cat. No.	Rod Size (in.)	Design Load/lb.	Wt./C lb.
542-3/8	3/8	610	35
542-1/2	1/2	1000	38

Standard Finish - GoldGalv®

For 3/8 in. and 1/2 in. rods.

S541 Swing Connector

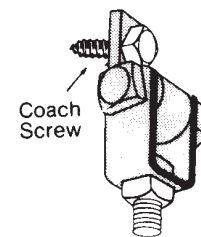

3/8 in. x 1-3/4 in. bolt, nut and clevis included.

Cat. No.	Rod Size (in.)	Wt./C lb.
S541-3/8	3/8	31

Standard Finish - GoldGalv®

For use with wood beam.

Materials

HDG(C)
EG(C)
(No suffix)

Hot-Dipped Galvanized
Electrogalvanized
GoldGalv®

SS6(C)
B

Stainless Steel 316
Bare

Beam Clamps

Beam Fittings

U577 Clevis and Swing Connector

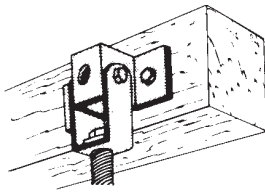

Cat. No.	Rod Size (in.)	Wt./C lb.
U577-1/2	1/2	69

Standard Finish - GoldGalv®

For use with wood beam.

U576 Hanger Clevis

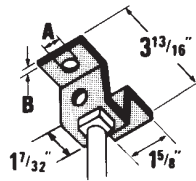

Cat. No.	Hole A (in.)	Material Thickness B (in.)	Wt./C lb.
U576-3/8	7/16	3/16	27
U576-1/2	9/16		

Standard Finish - GoldGalv®

- For rods up to 1/2 in.
- Mounting holes 7/16 in. diameter.
- For use with wood beam.

U579 Ceiling Flange

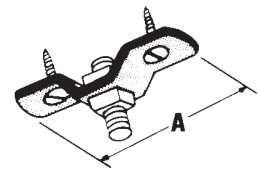

Cat. No.	A (in.)	Wt./C lb.
U579-3/8	3-1/2	30
U579-1/2	4-1/4	50

Standard Finish - GoldGalv®

- Malleable Iron
- Nuts and wood screws not included.
- Mounting holes 13/32 in.

Materials

HDG(C)
EG(C)
(No suffix)

Hot-Dipped Galvanized
Electrogalvanized
GoldGalv®

SS6(C)
B

Stainless Steel 316
Bare

Pipe Straps, Pipe Clamps and Hangers

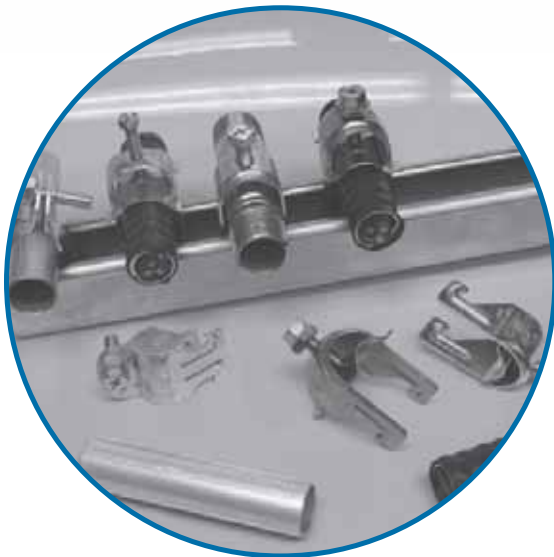

Design Loads

Where design loads are indicated, they provide for a safety factor of 3 in conformance with the American Standard Code for Pressure Piping.

Hanger Design

Pipe hangers are of advanced design to be user friendly.

Finishes and Special Materials

The standard finish is Electrogalvanized (EGC) or GoldGalv®. Some products are offered in Aluminum and Stainless Steel where noted.

701 O.D. Pipe and Conduit Clamp

Machine screw and nut included.

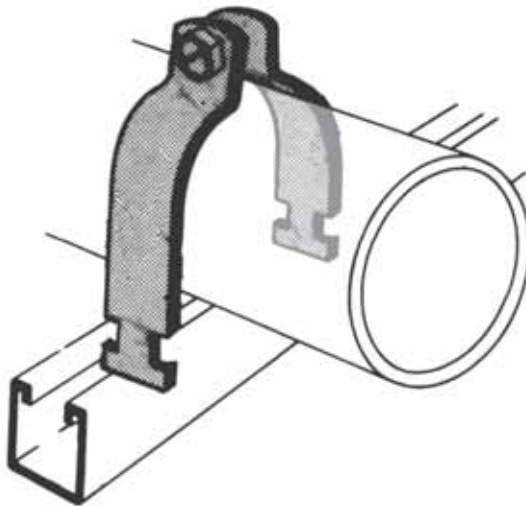

Standard Finishes and Materials

- PG** = Pregalvanized (i.e. 701-045PG)
- AL** = Aluminum (i.e. 701-045AL) with zinc plated hardware
- SS6** = Stainless Steel Type 316 (i.e. 701-045SS6)

N° de cat.	O.D. of pipe		Rigid Cond.	EMT Cond.	WT./C. lb.	Std. Pack
	(in.)	(mm)				
701-045PG	0.36-0.45	9-11.5	-	-	9	10
701-055PG	0.46-0.55	11.5-14	-	-	10	
701-065PG	0.56-0.65	14-17	-	-	11	
701-075PG	0.66-0.75	17-19.5	-	1/2	13	
701-088PG	0.76-0.88	19.5-22.5	1/2	-	15	
701-100PG	0.89-1.00	22.5-25.4	-	3/4	16	
701-113PG	1.01-1.13	25.5-29	3/4	-	17	
701-126PG	1.14-1.26	29-32	-	1	18	
701-140PG	1.27-1.40	32-36	1	-	18	
701-153PG	1.41-1.53	36-39	-	1-1/4	19	
701-167PG	1.54-1.67	39-42.5	1-1/4	-	20	
701-180PG	1.68-1.80	42.5-46	-	1-1/2	23	
701-193PG	1.81-1.93	46-49	1-1/2	-	26	
701-204PG	1.93-2.04	49-52	-	-	30	
701-225PG	2.10-2.25	53-57.5	-	2	32	
701-237PG	2.26-2.37	57.5-60	2	-	34	
701-245PG	2.33-2.45	59.5-62.5	-	-	36	
701-257PG	2.46-2.57	62.5-65.5	-	-	38	
701-287PG	2.75-2.87	70-73	2-1/2	2-1/2	40	
701-294PG	2.88-2.94	73-75	-	-	42	
701-306PG	2.95-3.06	75-78	-	-	42.5	
701-319PG	3.07-3.19	78-81	-	-	43	
701-350PG	3.36-3.50	85.5-89	3	3	45	
701-356PG	3.51-3.56	89-90	-	-	46	
701-379PG	3.70-3.79	94-96.5	-	-	48	
701-400PG	3.80-4.00	96.5-101.5	3-1/2	3-1/2	49	
701-450PG	4.25-4.50	108-114	4	4	70	
701-556PG	5.25-5.56	121-141	5	5	75	
701-665PG	6.25-6.65	146-170	6	6	80	
701-876PG	8.50-8.75	197-222	8	8	85	

Pipe Straps, Pipe Clamps and Hangers

Conduit and Cable Clamps

703 Universal Clamp

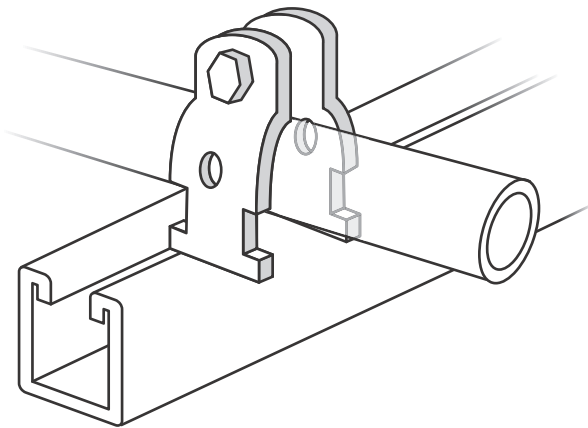

Cat. No.	EMT/ Rigid (in.)	Conduit O.D.O	Material Thickness	Wt./C lb.	Std. Ctn.
703-1/2EG	1/2	0.706 - 0.840	16 ga.	13	100
703-3/4EG	3/4	0.932 - 1.050	14 ga.	14	100
703-1EG	1	1.163 - 1.315	14 ga.	15	100
703-1-1/4EG	1-1/4	1.508 - 1.660	14 ga.	18	50
703-1-1/2EG	1-1/2	1.738 - 1.900	14 ga.	28	50
703-2EG	2	2.195 - 2.375	14 ga.	29	50

Standard Finishes - GoldGalv® (i.e.) 703-1/2

Electrogalvanized (EG suffix) (i.e.) 703-1-1/2EG

One size fits both Rigid and Electric Metal Tubing (EMT).

Individually assembled with screw and nut.

Quik Clamp II™



Design Load 1 has a safety factor of 4.
Design Loads 2 and 3 have a safety factor of 1.

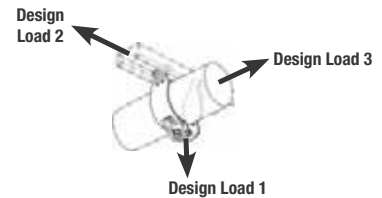
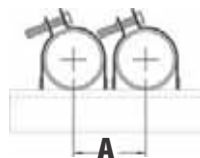

Cat. No.	Dimension A EMT in. (mm)	Dimension A Rigid Conduit in. (mm)	Quantity per Box	Wt./C lb.
TBQC050	1-5/16 (33.5)	1-1/4 (31.5)	100	10
TBQC075	1-3/4 (44.5)	1-11/16 (43)	100	12
TBQC100	1-13/16 (46)	1-3/4 (44.5)	100	13
TBQC125	2-1/8 (54)	2 (51)	50	15
TBQC150	2-3/8 (60.5)	2-3/16 (55.5)	50	16
TBQC200	2-5/8 (66.5)	2-1/2 (63.5)	50	19
TBQC250	3-1/16 (78)	3-1/16 (78)	25	29
TBQC300	3-11/16 (93.5)	3-11/16 (93.5)	25	34
TBQC350	4-3/16 (106.5)	4-3/16 (106.5)	25	38
TBQC400	4-11/16 (119)	4-11/16 (119)	25	42

Design Load 1 Static Load Limit lb. (kg)	Design Load 2 lb. (kg)	Design Load 3 lb. (kg)
200 (90)	50 (23)	50 (23)
200 (90)		
200 (90)		
200 (90)		
200 (90)		
200 (90)		
200 (90)		
350 (158)		
350 (158)		
350 (158)		

Pipe Straps, Pipe Clamps and Hangers

Conduit and Cable Clamps

Cobra®



Standard material is commercial-grade, bright electrogalvanized steel. Stainless steel 316L is also available; add the suffix "SS6" to catalogue no. (i.e.: CPC050SS6). Stainless steel bolt head is hexagonal and slotted only. **Now available in aluminum.**

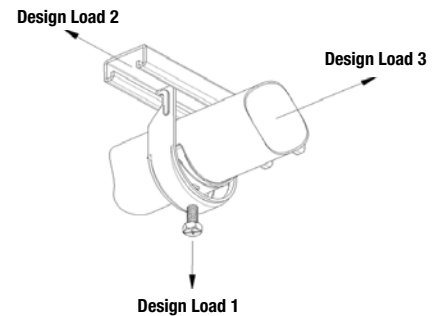

Cat. No.	EMT Trade Size (in.)	Rigid Cond. Trade Size (in.)	Cable O.D. Range (in.)	Static Load Limit (lb.) Safety Factor = 4	Qty. per Box	Wt./C lb.
CPC025	1/4	1/4	0.312 - 0.600	200	100	8
CPC050	1/2	1/2	0.500 - 0.890	200	100	10
CPC075	3/4	3/4	0.860 - 1.110	200	100	12
CPC100	1	1	1.100 - 1.400	200	100	14
CPC125	1 1/4	1 1/4	1.400 - 1.725	200	50	16
CPC150	1 1/2	1 1/2	1.690 - 1.980	200	50	18
CPC200	2	2	1.980 - 2.576	200	50	24
CPC250	2 1/2	2 1/2	2.576 - 3.060	350	25	36
CPC300	3	3	3.060 - 3.626	350	25	42
CPC350	3 1/2	3 1/2	3.626 - 4.126	350	25	46
CPC400	4	4	4.126 - 4.626	350	25	50

Design Load 1 Static Load Limit lb. (kg)	Design Load 2 lb. (kg)	Design Load 3 lb. (kg)
200 (91)	50 (23)	50 (23)
200 (91)		
200 (91)		
200 (91)		
200 (91)		
200 (91)		
350 (159)		
350 (159)		
350 (159)		
350 (159)		

Loc-King Cobra™

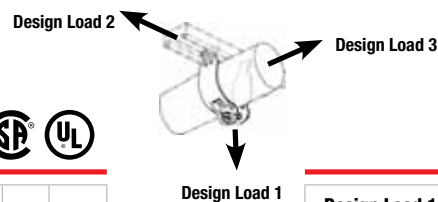

Cat. No.	EMT Trade Size (in.)	Rigid Cond. Trade Size (in.)	Cable O.D. Range (in.)	Static Load Limit (lb.) Safety Factor = 4	Qty. per Box	Wt./C lb.
LKPC050	1/2	1/2	0.650 - 0.890	100	15	10
LKPC075	3/4	3/4	0.860 - 1.110	100	16	12
LKPC100	1	1	1.100 - 1.400	50	19	14
LKPC125	1 1/4	1 1/4	1.400 - 1.725	50	23	16
LKPC150	1 1/2	1 1/2	1.690 - 1.980	50	27	18
LKPC200	2	2	1.980 - 2.576	50	38	24
LKPC250	2 1/2	2 1/2	2.576 - 3.060	25	44	36
LKPC300	3	3	3.060 - 3.626	25	53	42
LKPC350	3 1/2	3 1/2	3.626 - 4.126	25	58	46
LKPC400	4	4	4.126 - 4.626	25	66	50

Design Load 1 Static Load Limit lb. (kg)	Design Load 2 lb. (kg)	Design Load 3 lb. (kg)
350 (159)	50 (23)	50 (23)
350 (159)		
350 (159)		
350 (159)		
350 (159)		
350 (159)		
350 (159)		
450 (204)		
450 (204)		
450 (204)		

Pipe Straps, Pipe Clamps and Hangers

Conduit and Cable Clamps

CH118 Heavy Duty Cable Clamp

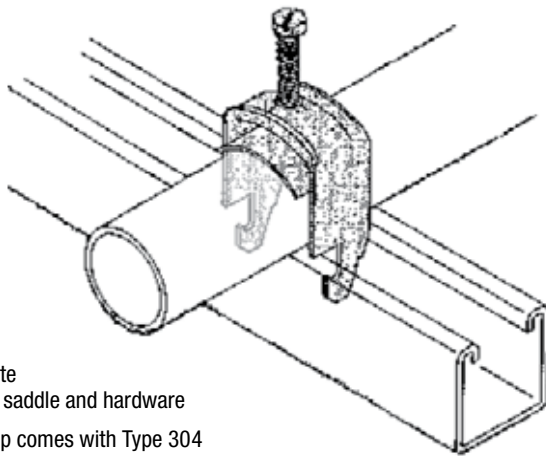

Standard Finishes:

Electrogalvanized (EG)

Aluminum (AL) comes complete with Stainless Steel Type 304 saddle and hardware

Stainless Steel Type 316 clamp comes with Type 304 stainless steel hardware.

Cat. No.	O.D. of cable or pipe		Rigid Cond.	EMT Cond.	WT./C. lb.
	(in.)	(mm)			
CH118-055EG	0.40-0.55	10-14	-	-	8
CH118-081EG	0.50-0.81	13-21	1/2	1/2	9
CH118-110EG	0.70-1.10	18-28	3/4	3/4	17
CH118-125EG	0.85-1.25	22-27	3/4	1	18
CH118-135EG	1.00-1.35	26-36	1	1	19
CH118-175EG	1.33-1.75	34-44	1-1/4	1-1/4	21
CH118-205EG	1.65-2.05	42-52	1-1/2	1-1/2	24
CH118-250EG	2.12-2.50	54-64	2	2	48
CH118-300EG	2.60-3.00	66-76	2-1/2	2-1/2	54
CH118-325EG	2.75-3.25	70-82	-	-	65
CH118-375EG	3.25-3.75	82-94	3	3	105
CH118-425EG	3.75-4.25	94-110	3-1/2	3-1/2	113
CH118-475EG	4.25-4.75	110-120	4	4	124

Available in double or triple configurations.
Example: **Double - CH128-047EG**
Triple - CH138-047EG

CB118 Counterbed EB118 Extended Bed DB118 Double Bed

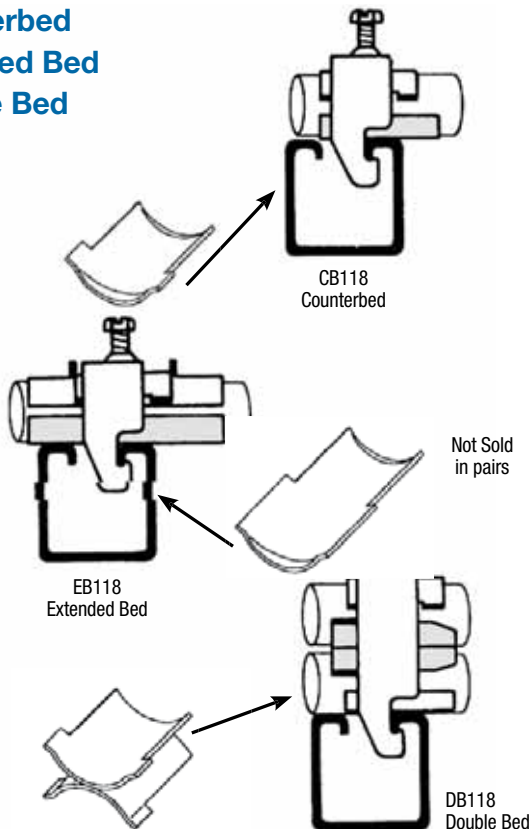

Cat. No.	Wt./C. lb.
Counterbed	
CB118-055PG	1
CB118-090PG	2
CB118-110PG	3-1/2
CB118-140PG	4
CB118-175PG	4-1/2
CB118-200PG	5
CB118-250PG	11
CB118-300PG	13
Extended bed	
EB118-047PG	4
EB118-055PG	4-1/2
EB118-090PG	6
EB118-110PG	13-1/2
EB118-140PG	16
EB118-175PG	17
EB118-200PG	20
EB118-250PG	30
EB118-300PG	38
Double Bed	
DB118-047PG	2
DB118-055PG	2
DB118-070PG	3

Standard Finishes - Pregalvanized (PG)

Pipe Straps, Pipe Clamps and Hangers

Conduit and Cable Clamps

A716 Snap•Guard® Cushioned Clamp Tube Series

P716 Snap•Guard® Cushioned Clamp Pipe Series

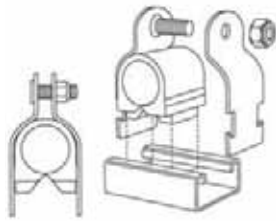

A716 / P716

- Assembly consisting of GoldGalv® finish steel clamp with bolt/locknut and cushion
- Secure pipes, tubes and hoses for fluid conductors.
- Installation is easy and requires no more time than a simple pipe clamp installation
- Cushion absorbs the shocks and associated vibrations from fluid surges in tubes, pipes and hoses
- It can handle temperatures from 149°C to -40°C (300°F to -40°F)
- Cushioned Clamp assemblies are available individually bagged

Standard Finishes GoldGalv®

Available in Stainless Steel 316 use SS316 suffix.

(i.e) A716-1SS316

Electrogalvanized (Silver) - use EG suffix.

(i.e) A716-1EG

Assembly Cat. No.	Tubing		Assembly Cat. No.	Standard Pipe		Wt./C lb.
	Tube O.D. (in.)	Wt./C lb.		Nominal Pipe Size (in.)	Std. Ctn.	
A716-1/4	1/4	10	P716-1/4	1/4	25	10
A716-3/8	3/8	14	P716-3/8	3/8		14
A716-1/2	1/2	16	P716-1/2	1/2		16
A716-5/8	5/8	16	P716-3/4	3/4		18
A716-3/4	3/4	18	P716-1	1	10	22
A716-7/8	7/8	18	P716-1-1/4	1-1/4		27
A716-1	1	22	P716-1-1/2	1-1/2		36
A716-1-1/8	1-1/8	24	P716-2	2		43
A716-1-1/4	1-1/4	27	P716-2-1/2	2-1/2		49
A716-1-3/8	1-3/8	27	P716-3	3		60
A716-1-1/2	1-1/2	36	P716-3-1/2	3-1/2		62
A716-1-5/8	1-5/8	37	P716-4	4		94
A716-1-3/4	1-3/4	37	-	-		
A716-1-7/8	1-7/8	43	-	-		
A716-2	2	43	-	-		
A716-2-1/8	2-1/8	44	-	-		
A716-2-3/8	2-3/8	49	-	-		
A716-2-5/8	2-5/8	53	-	-		
A716-3-1/8	3-1/8	62	-	-		
A716-4-1/8	4-1/8	94	-	-		

U716 Two Hole Cushioned Clamp



U716

- Guides, protects, and uniformly spaces line runs. Low cost, time saving method of attaching tubing and hose to equipment.
- Cushion is built to withstand the effects of most oils, chemical and industrial cleaning compounds, in temperatures from -45°C to 121°C (-50°F to 275°F). Interlock edge insures cushion remains in place.
- Attached with two standard fasteners to any flat surface, this clamp eliminates the use of special channels, providing a savings in both space requirements and cost
- Cushioned clamps reduce vibration, shock, and noise in fluid systems and eliminates electrolysis

Standard Finish – GoldGalv®

Assembly Cat. No.	Copper and Steel Tubing O.D. (in.)	Copper Water Pipe (nom.) (in.)	Normal Pipe Size (in.)	Std. Ctn.	Wt./C lb.
U716-1/4	1/4	-	-	25	3
U716-3/8	3/8	1/4	-		4
U716-1/2	1/2	3/8	1/4		6
U716-5/8	5/8	1/2	3/8		6
U716-3/4	3/4	5/8	-	10	7
U716-7/8	7/8	3/4	1/2		7
U716-1	1	-	-		8
U716-1-1/8	1-1/8	1	-		8
U716-1-1/4	1-1/4	-	-		17
U716-1-3/8	1-3/8	1-1/4	-		20
U716-1-1/2	1-1/2	-	-		22
U716-1-5/8	1-5/8	1-1/2	-		23
U716-2	2	-	-		41
U716-2-1/8	2-1/8	-	-		41
U716-2-3/8	2-3/8	-	-	44	

Pipe Straps, Pipe Clamps and Hangers

Conduit and Cable Clamps

6H Series Conduit and Pipe Hanger



6H Series



6H-B Series
with Bolt and
Hex Nut

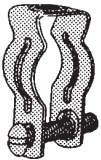

6H-TB

Threaded Series



6H-T

Threaded Series

Features

- Accommodates 1/2 in. through 4 in. EMT or rigid conduit
- Can be used for either vertical or horizontal installation
- 6HTB Series have a built-in nut so there are fewer parts to handle or drop
- Installs easily with a screwdriver

**Standard Finish - Electrogalvanized
(no suffix)**

Cat. No.	Conduit Size		Wt./C. lb.
	Rigid (in.)	EMT (in.)	
6H0			5
6H0-B	3/8 - 1/2	1/2	7
6H0-T			5
6H0-TB			6
6H1			6
6H1-B	3/4	3/4	7
6H1-T			6
6H1-TB			7
6H2			7
6H2-B	1	1	9
6H2-1/2			8
6H2-1/2-B			10
6H3-SC			8
6H3-B	1-1/4	1-1/2	10
6H3-TB			10
6H4			17
6H4-B			19
6H4-TB	1-1/2	-	19
6H5			24
6H5-B			26
6H5-TB			26
6H6	2-1/2	2-1/2	28
6H6-B			30
6H7			36
6H7-B			38
6H8	3-1/2	3-1/2	39
6H8-B			41
6H9			44
6H9-B			47

Cable Tie Mounting Bases For Framing Channel



Cat. No.	Channel Size (in.)	Maximum Tie Width Accom. (in.)	Unit Qty.	Std. Pkg.
TC5363X	1-1/2 & 1-5/8	0.301	50	250

Installation

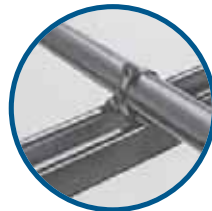

- Installs with a push and twist
- Designed for indoor or outdoor use
- Smooth design protects cable insulation
- Takes range of cable diameters

When fastening wire bundles, cables, or hoses to framing channels, you can cut costs considerably by using this mounting base. It is made of smooth, weather-resistant nylon and designed to protect cable insulation and hoses from the wear or damage that can occur with metal clamps. The mounting base may be used for both indoor or outdoor applications. It installs in the framing channel with a simple push and twist. It requires no screws, nuts or tools. The mounting base fits all 1-1/2 in. and 1-5/8 in. channels regardless of channel depth. Ty-Rap® and Ty-Fast® to be ordered separately.

Pipe Straps, Pipe Clamps and Hangers

Conduit and Cable Clamps

W716 Maple Hardwood Clamps

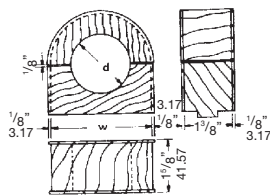
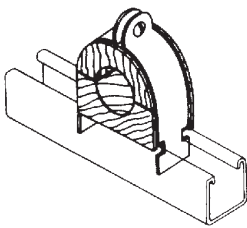

Standard Finishes -
Pregalvanized (PG)
Aluminum (AL)

Paraffin impregnated maple.

Cat. No.	Dimensions			
	Depth		Width	
Hardwood	(in.)	(mm)	(in.)	(mm)
W716-3/4PG	3/4	19.0	2-1/8	53.9
W716-1PG	1	25.4	2-1/8	53.9
W716-1-1/4PG	1-1/4	31.7	2-5/8	66.6
W716-1-1/2PG	1-1/2	38.1	2-5/8	66.6
W716-1-3/4PG	1-3/4	44.4	3	76.2
W716-2PG	2	50.8	3-5/8	92.0
W716-2-1/4PG	2-1/4	57.1	3-5/8	92.0
W716-2-1/2PG	2-1/2	63.5	4-5/8	117.7
W716-2-3/4PG	2-3/4	69.8	4-5/8	117.7
W716-3PG	3	76.2	4-5/8	117.7
W716-4PG	4	98.0	5-5/8	143.4

Note: Holding clamp is included with W716 maple hardwood clamps.
It is not necessary to order 701 Series separately.

U861, U862 and 863 Maple Cable Clamp

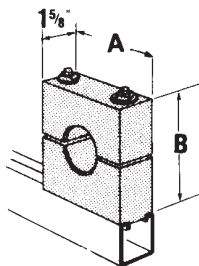

Electrogalvanized hardware included.

Custom made to your needs			
Step 1		Cat. No.	Number of holes
	i.e.	U861	1 hole
		U862	2 holes
		U863	3 holes
Step 2	Specify O.D. of cable i.e. 3/4 in. hole	U861 - 0.75	

Contact your Regional Sales Office for quotation.

WS716 Maple Hardwood Saddle

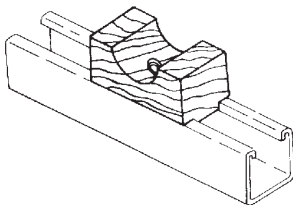

Paraffin impregnated maple.

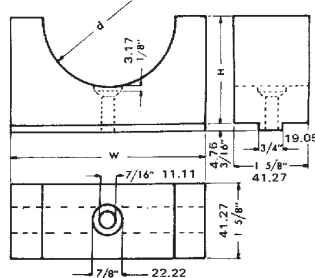

To fasten saddle, use 3/8 in. x 2 in. screw bolt.

Cat. No.	Dimensions				
	Depth		Width		Height
Hardwood	(in.)	(mm)	(in.)	(mm)	(in.)
WS716-3/4	3/4	19.0	3	76.2	1-3/4
WS716-1	1	25.4	3	76.2	1-3/4
WS716-1-1/4	1-1/4	31.7	3-1/2	88.9	2
WS716-1-1/2	1-1/2	38.1	3-1/2	88.9	2
WS716-1-3/4	1-3/4	44.4	4	101.6	2-1/4
WS716-2	2	50.8	4	101.6	2-1/4
WS716-2-1/4	2-1/4	57.1	4-1/2	114.3	2-1/2
WS716-2-1/2	2-1/2	63.5	4-1/2	114.3	2-1/2
WS716-2-3/4	2-3/4	69.8	5	127	2-3/4
WS716-3	3	76.2	5	127	2-3/4
WS716-3-1/4	3-1/4	82.5	5-1/2	139.7	2-3/4
WS716-3-1/2	3-1/2	88.9	5-1/2	139.7	3
WS716-3-3/4	3-3/4	95.2	6	152.4	3-1/4
WS716-4	4	101	6	152.4	3-1/4
WS716-4-1/2	4-1/2	114.3	6-1/2	165.1	3-1/2
WS716-5	5	127	7	177.8	3-3/4
WS716-5-1/2	5-1/2	139.7	7-1/2	190.5	4
WS716-6	6	152.4	8	203.2	4-1/4
WS716-6-1/2	6-1/2	165.1	8-1/2	215.9	4-1/2
WS716-7	7	177.8	9	228.6	4-3/4

STD. PACK. 10

Pipe Straps, Pipe Clamps and Hangers

Conduit and Cable Clamps

**AB880 3 in.
Porcelain Saddle**

**AB881 4 in.
Porcelain Saddle**

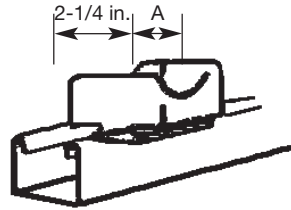

Cat. No.	A (in.)	Max. Cable Diam. (in.)	Wt./C lb.
AB880	3	3	73
AB881	4	4-1/2	104

C755 Porcelain Cable Clamps

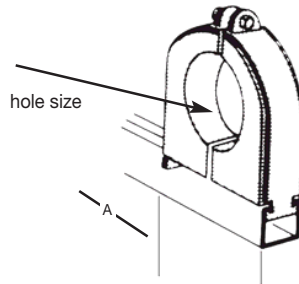

Cat. No.	Hole Size (in.)	A (in.)	Wt./C lb.
C755-1A	3/8	1-9/16	50
C755-1B	1/2	1-9/16	50
C755-1C	5/8	1-9/16	50
C755-2	3/4	2-5/32	91
C755-2A	7/8	2-5/32	90
C755-2B	1	2-5/32	85
C755-2C	1-1/8	2-5/32	82
C755-3	1-1/4	2-5/8	114
C755-3A	1-3/8	2-5/8	110
C755-3B	1-1/2	2-5/32	105
C755-3C	1-5/8	2-5/8	102
C755-4	1-3/4	3-3/4	220
C755-4A	1-7/8	3-3/4	214
C755-4B	2	3-3/4	205
C755-4C	2-1/8	3-3/4	200
C755-5	2-1/4	4-1/4	260
C755-5A	2-3/8	4-1/4	250
C755-5B	2-1/2	4-1/4	243

Cat. No.	Hole Size (in.)	A (in.)	Wt./C lb.
C755-5C	2-5/8	4-1/4	240
C755-6	2-3/4	4-3/4	250
C755-6A	2-7/8	4-3/4	240
C755-6B	3	4-3/4	230
C755-6C	3-1/8	4-3/4	220
C755-7	3-1/4	5-13/16	340
C755-7A	3-3/8	5-13/16	330
C755-7B	3-1/2	5-13/16	318
C755-7C	3-5/8	5-13/16	387
C755-8	3-3/4	6-7/8	565
C755-8A	3-7/8	6-7/8	550
C755-8B	4	6-7/8	535
C755-8C	4-1/8	6-7/8	520
C755-8D	4-1/4	6-7/8	490
C755-8E	4-3/8	6-7/8	475
C755-8F	4-1/2	6-7/8	460

Standard Finish -

GoldGalv® with bronze hardware

Also fits 1-1/2 in. wide channel.

For minimum order quantities, contact your Regional Sales Office.

Pipe Straps, Pipe Clamps and Hangers

Conduit and Cable Clamps

S716 Cushioned Strip for Isolation and Vibration Applications

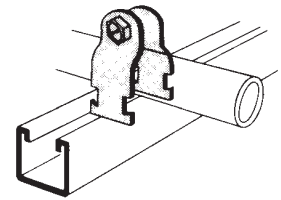
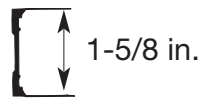
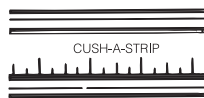

For use with 701 O.D. tubing and pipe clamp. To determine 701 clamp size add 1/4 in. to O.D. tube size to allow for the Cushioned Strip material.

1/4 in. markings for fast measuring and cutting. Measurement chart is printed on back of carton. 20 feet included in each carton.

Order 701 clamp separately.

Prevent metal to metal contact with the Cushioned Strip material. It aids in sound insulation, shock absorption and protects against corrosion, distortion and abrasion. Cushioned Strip material is designed for optimal use between -1°C and 149°C (30°F and 300°F). Cushioned Strip material combined with the Superstrut 701 pipe strap can handle clamping assignments from 1/4 in. to 6 in.

C708U Short Strap for Channel or Wall Mounting

Standard Finish - GoldGalv®

Example: C708U-1/2

No clearance between pipe and channel.

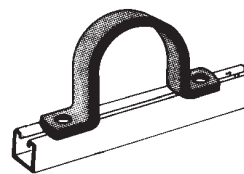
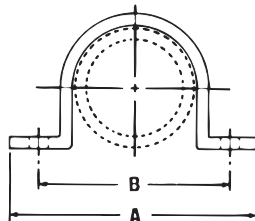

Carbon Steel

Pipe Size (in.)	A (in.)	B (in.)	Thickness (in.)	Width (in.)	Hole Size (in.)	Design Load lb.	Wt./C lb.
1/2	2-7/8	2	1/8	1-5/8	9/32	650	23
3/4	3-1/16	2-3/16					26
1	3-3/8	2-1/2					31
1-1/4	3-11/16	2-13/16					35
1-1/2	3-15/16	3-1/16					39
2	5-3/4	4-1/8					94
2-1/2	6-3/16	4-9/16	1/4	7/16	1000	114	
3	6-13/16	5-3/16				133	
3-1/2	7-5/16	5-11/16				152	
4	7-13/16	6-3/16				176	
5	8-7/8	7-1/4				198	
6	9-15/16	8-5/16				246	

Pipe Straps, Pipe Clamps and Hangers Conduit and Cable Clamps

C711 "J" Pipe Hanger

Standard Finishes - GoldGalv®, Electrogalvanized (EG)

Complies with Specification MSS SP69, Type 5.
Hole provided for side mounting to wall as bracket.

Example: C711-1/2

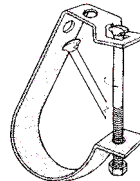

Standard

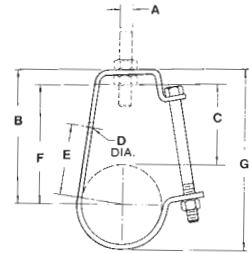

Pipe Size (in.)	A Rod Size (in.)	B (in.)	C (in.)	Overall Dimension D (in.)	E (in.)	F (in.)	Bolt Size (in.)	G	Thickness	Width (in.)	Max. Rec. Load lb.	Approx. Wt./C lb.	
1/2	3/8	2-5/8	1-3/4	7/16	1-1/2	1-15/16	1/4	3-5/32	12 ga	3/4	400	18	
3/4	3/8	2-7/8	1-7/8		1-11/16	2-1/8		3-1/2				21	
1	3/8	2-15/16	1-15/16		1-13/16	2-5/16		3-11/16				22	
1-1/4	3/8	3-1/4	2		2-1/16	2-5/8		4-1/8				25	
1-1/2	3/8	3-9/16	2-3/16		2-7/16	2-7/8		4-5/8				27	
2	3/8	3-11/16	2-1/8		2-9/16	3-1/16		5				29	
2-1/2	1/2	4-7/16	2-7/16		3-3/16	3-5/8		6				64	
3	1/2	4-13/16	2-9/16		3-1/2	4-1/16		6-21/32				72	
3-1/2	1/2	5-1/8	2-5/8	3-3/4	4-3/8	7-5/16	84						
4	5/8	6-1/8	3-3/16	9/16	4-5/8	5-3/16	3/8	3/16	1-1/4	550	138		
5	5/8	6-3/4	3-1/4		5-1/16	5-3/5					9-23/32	162	
6*	3/4	7-3/4	3-9/16		5-13/16	6-5/8					11-1/4	249	
8*	7/8	9-3/16	3-15/16		6-15/16	8					13-11/16	760	291

*Hangers 6 in. and over have hole instead of slot.

C727 Adjustable Ring

Standard Finish - Pregalvanized (no suffix)

Carbon steel. For suspension of non-insulated pipe lines.
Complies with Specification MSS SP69, Type 10.

Example: C727-1/2

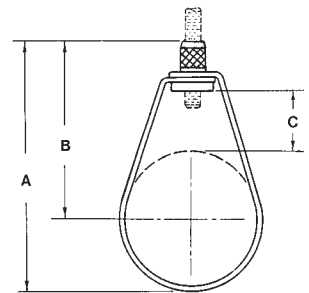
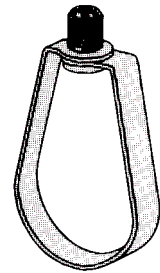

Tube Size (in.)	Rod Size (in.)	A (in.)	B (in.)	C (in.)	Thickness	Width (in.)	Approx Max. Rec. Load	Wt./C lb.
1/2	3/8	3-1/8	2-5/8	1-3/8	16 ga	1	400	9
3/4		3-1/8	2-1/2	1-1/8				9
1		3-3/8	2-5/8	1-1/8				9
1-1/4		3-3/4	2-7/8	1-1/8				10
1-1/2		3-7/8	2-7/8	1				11
2		4-1/4	3	1				12
2-1/2	1/2*	5-3/4	4-1/4	1-5/8	14 ga	1-3/16	600	28
3		6	4-1/8	1-1/4				30
3-1/2		7-3/8	5-1/4	2-1/8				34
4	5/8*	7-3/8	5	2-5/8	14 ga	1-1/4	1000	37
5		9	6-1/8	2-1/4				83
6		9-3/8	6-1/2	1-7/8				1250

*3/8 in. nut is used when NFPA rod sizing is requested.

**1/2 in. nut is used when NFPA rod sizing is requested.

Pipe Straps, Pipe Clamps and Hangers

Pipe Hangers

C710 Adjustable Clevis Hanger

Standard Finishes - GoldGalv®, Electrogalvanized (EG)
Complies with Specification MSS SP69, Type 1.

Example: C710-1/2EG

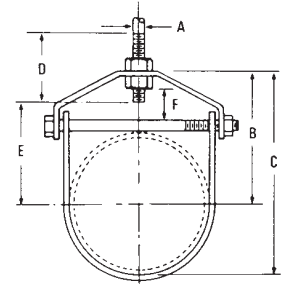

Pipe Size (in.)	Size of Steel		A (in.)	B (in.)	C (in.)	D (in.)	E (in.)	F (in.)	Max. Rec. Load, lb.	Wt./C lb.						
	Upper	Lower														
1/2	1/8x1	1/8x1	3/8	1-11/16	2-1/8	2-1/2	7/8	7/16	610	30						
3/4											1-7/8	2-7/16	1	1/2	32	
1											2-1/8	2-13/16	1-1/4	5/8	36	
1-1/4											2-9/16	3-7/16	1-3/4	7/8	42	
1-1/2											3	4	2-1/8	1-1/16	55	
2											3-11/16	4-7/8	2-15/16	1-5/8	60	
2-1/2	3/16x1-1/4	3/16x1-1/4	1/2	4-11/16	6-1/8	3	3-13/16	2	1130	115						
3											4-3/4	6-9/16	3-7/8	1-3/4	132	
3-1/2											4-15/16	6-15/16	4-1/16	1-3/4	156	
4											5-9/16	7-13/16	4-1/2	1-15/16	190	
5	1/4x1-1/4	3/16x1-1/2	5/8	6-3/16	9	3-1/2	5-1/8	1-3/4	1430	240						
6	1/4x1-1/2										6-13/16	10-1/8	4	5-5/8	1-7/8	320
8	1/4x1-3/4										8-5/16	12-5/8	4-1/4	7	2-1/8	500

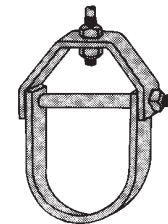

CL710 Light Duty Adjustable Clevis Hanger

Standard Finishes - GoldGalv®, Bare (B), Electrogalvanized (EG), Fiberglass (FG).

Carbon Steel

Used on non-insulated, stationary pipelines.

A lock nut above the clevis yoke is required for full rated load.

Example: CL710-3/8B

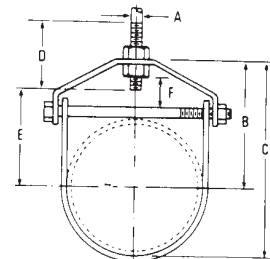

Pipe Size (in.)	Thickness of Steel		A (in.)	B (in.)	C (in.)	D (in.)	E (in.)	F (in.)	Max. Rec. Load, lb.	Wt./C lb.						
	Upper	Lower														
3/8	16 ga x 7/8	16 ga x 7/8	3/8	1-7/8	2-3/16	2-1/2	1-1/4	9/16	150	12						
1/2											1-3/4	2-3/16	2-1/2	1-1/8	9/16	13
3/4											1-7/8	2-1/4	2-1/2	1-1/4	1/2	15
1											2-3/16	2-3/4	2-1/2	1-1/2	3/4	18
1-1/4	13 ga x 7/8	13 ga x 7/8	3/8	2-5/8	3-3/8	2-1/2	1-3/4	1	250	20						
1-1/2											3	3-7/8	2-1/2	2-1/4	1-3/16	30
2											3-9/16	4-3/4	2-1/2	2-13/16	1-5/8	38
2-1/2	1/8 x 1-1/4	1/8 x 1-1/4	1/2	4	5-1/2	3	3-1/4	1-3/8	350	80						
3											4-9/16	6-1/2	3	3-9/16	1-1/2	89
3-1/2											5	7	3	4-1/8	1-3/4	106
4	3/16 x 1-1/4	3/16x1-1/2	3/4	5-1/4	7-1/2	3-1/2	4-1/4	1-7/8	400	146						
6	1/4x1-1/2										6-13/16	10-1/8	4	5-5/8	1-7/8	320
8	1/4x1-3/4										8-5/16	12-5/8	4-1/4	7	2-1/8	500



Pipe Straps, Pipe Clamps and Hangers

Pipe Hangers

M718 Split Pipe Ring

Standard Finishes - Bare (B) or Electrogalvanized (EG)

Malleable iron.

For suspension of non-insulated, stationary pipelines.

Example: M718-3/8B

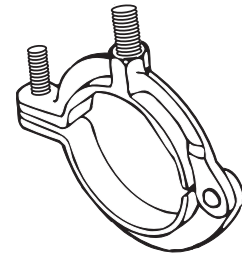

Pipe Size (in.)	A (in.)	B (in.)	Max. Rec. Load, lb.	Wt./C Approx.
3/8	3/8	13/16	180	10
1/2		7/8		13
3/4		1		14
1		1-1/8		16
1-1/4		1-5/16		22
1-1/2		1-7/16		24
2		1-11/16		31
2-1/2	1/2	2-1/8	300	60
3		2-7/16		74
4		2-15/16		116

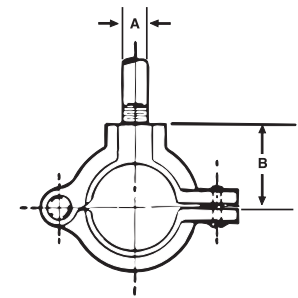

C725 Medium Pipe Clamp

Standard Finishes - GoldGalv®, Bare (B), Electrogalvanized (EG)

Carbon steel. For suspension of pipelines where little or no insulation is required.

Complies with Specification MSS SP69, Type 23.

Example: C725-1/2B

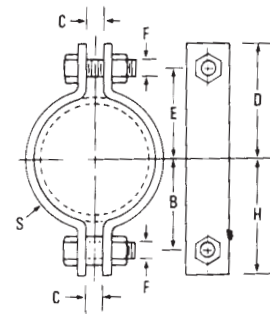

Pipe Size (in.)	B (in.)	C (in.)	D (in.)	E (in.)	F (in.)	H (in.)	S (in.)	Max. Rec. Load, lb.	Wt./C Approx.
1/2	1	7/16	1-5/8	1	5/16	1-1/2	1/8 x 1	500	29
3/4	1-1/8		1-3/4	1-1/4		1-3/4			32
1	1-1/4		1-13/16	1-1/4		1-13/16			33
1-1/4	1-7/16	1/2	2	1-7/16	1/2	2	1/4 x 1	715	38
1-1/2	1-5/8		2-1/16	1-1/2		2-1/4			39
2	2-1/8	9/16	3-1/8	2-1/4	1/2	3	1/4 x 1	1040	117
2-1/2	2-5/16		3-5/16	2-1/2		3-1/4			128
3	2-3/4		3-3/4	2-3/4		3-5/8			140
3-1/2	3-7/8	5/8	3-3/4	3	5/8	3-7/8	1/4 x 1-1/4	1615	145
4	3-5/16	3/4	4-1/4	3-5/16		5/8			4-1/4
6	4-7/8	7/8	5-7/8	5	3/4	5-3/4	3/8 x 1-1/2	2490	542
8	6	1	7	6-1/8	3/4	6-7/8	1/2 x 2		651
10	7-5/16		8-9/16	7-7/16	7/8	8-7/16		1360	
12	8-1/4		9-9/16	8-7/16	7/8	9-3/8		1605	

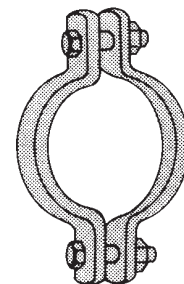

Based on the allowable stresses shown in ANSI Code for pressure piping.

For sizes 14 to 24, contact your Regional Sales Office.

Pipe Straps, Pipe Clamps and Hangers

Pipe Hangers

C720 Riser Clamp

Standard Finishes - GoldGalv®, Bare (B)

Available in sizes 1/2 in. through 10 in.

Complies with Specification MSS SP69, Type 8.

Example: C720-1-1/2B

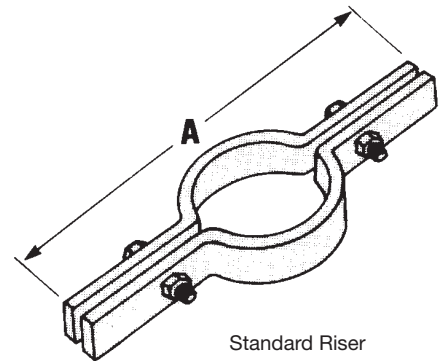

Standard Riser

Pipe Size (in.)	A (in.)	Thickness (in.)	Width (in.)	Bolt (in.)	Max. Rec. Load, lb.	Wt./Ea. Approx.
1/2	9-1/8	3/16	1	3/8 x 1-1/2	220	1.01
3/4	9-1/4					1.06
1	9-5/8					1.07
1-1/4	9-7/8					1.12
1-1/2	10	1/4		1-1/2	250	1.20
2	10-1/2					1.25
2-1/2	11-1/16					1.67
3	11-13/16					1.81
3-1/2	13	1-1/2	1-1/2	1/2 x 1-1/2	600	2.12
4	13-1/2				750	2.22
5	14				1500	3.44
6	15-3/16				1600	3.65
8	19	3/8	1-1/2	5/8 x 2-1/2	2500	7.24

C726 Double Bolt Pipe Clamp

Standard Finish - Bare (B)

Carbon Steel. For the suspension of insulated pipelines.

Normally used with weldless eye nut.

Example: C726-1/2B



Pipe Size (in.)	B (in.)	C (in.)	D (in.)	E (in.)	F (in.)	H (in.)	S (in.)	Max. Rec. Load, lb.	Wt./C Approx.
3/4	1-1/16	5/8	3-3/16	2-1/2	3/8	1-11/16	3/16 x 1	950	66
1	1-1/2		3-3/4	2-1/2		2-1/16			69
1-1/4	1-1/2	3/4	3-11/16	2-7/8	5/8	2-1/4	1/4 x 1-1/4	1545	75
1-1/2	1-13/16		4-7/8	3-3/4		2-13/16			181
2	2-1/4	1-1/16	5-11/16	4-11/16	3/4	3-3/16	3/8 x 2	2500	200
2-1/2	2-5/8		6-1/2	5-3/8		3-1/2			232
3	2-3/4		6-7/8	6		3-3/4			258
3-1/2	3		7-1/16	6-3/16		4			264
4	3-3/8	1-7/16	7-5/8	6-1/2	1	4-1/2	3/8 x 2-1/2	2865	750
5	3-15/16		8-1/8	7		5			813
6	4-3/4	10-15/16	9-15/16	8-9/16	1	6-1/8	3/8 x 2-1/2	2865	1311
8	5-3/4		10-15/16	9-9/16		7-1/8			1467

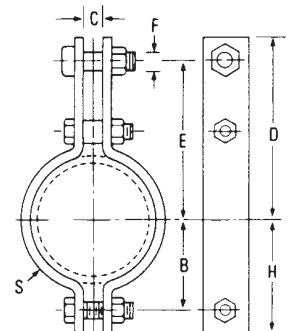

Pipe Straps, Pipe Clamps and Hangers

Seismic Bracing

C749N Seismic Brace

Standard Finish - GoldGalv®

1650 lb. load
safety factor 3
Wt./C 61 lb.

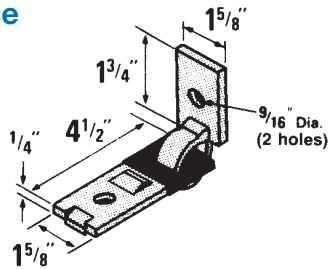

C749N-5/8 Seismic Brace

Standard Finish - GoldGalv®

1650 lb. load
safety factor 3
Wt./C 56 lb.

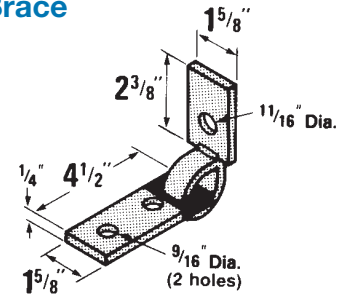

C749N-7/8 Seismic Brace

Standard Finish - GoldGalv®

1650 lb. load
safety factor 3
Wt./C 74 lb.

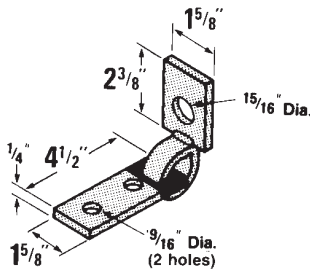

C749N-1 1/8 Seismic Brace

Standard Finish - GoldGalv®

1650 lb. load
safety factor 3
Wt./C 72 lb.

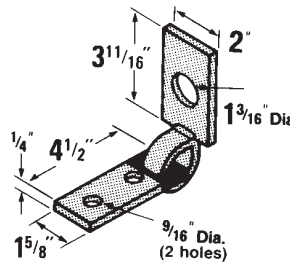

ES142

Standard Finish - GoldGalv®

Seismic bracing rod
stiffener connector.
Wt./C 21 lb.

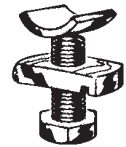

Cat. No.	Bolt Dia.	Wt./C lb.
ES-142-1/2 x 1-1/2	1/2	21

All braces have plastisol coating on the flat member.

Plastisol insulates against vibration noise transmission and eliminates rattle at the connection points.

Hanger Accessories

Other products available. Contact your Regional Sales Office.

C704A

Offset J-Hook



Sizes 1/2 in. thru 3 in. IPS

M732H

I-Beam w/Eye Nut



MSS SP69 Type 28

M732 / M732 Ext

I-Beam Clamp w/Swing Nut



Sizes 3/8 in. thru 7/8 in. Rod
MSS SP69 Type 30

C736

Light Welded Steel Bracket



Max. Load 750 Lb.
MSS SP69 Type 31

C739M

Medium Welded Steel Bracket



Max. Load 1500 Lb.
MSS SP69 Type 32

C739H

Heavy Welded Steel Bracket



Max. Load 3000 Lb.
MSS SP69 Type 33

M750

Side Beam Bracket



Sizes 3/8 in. thru 7/8 in. Rod
MSS SP69 Type 34

C785A

Pipe Stanchion Saddle



Sizes 4 in. thru 36 in. IPS
MSS SP69 Type 37

C786

Adj. Pipe Saddle Support



Sizes 2-1/2 in. thru 36 in. IPS
MSS SP69 Type 38

C789

Steel Pipe Covering Protection Saddle



MSS SP69 Type 39

C790

Insulation Protection Shield for PVC coated pipe lines and insulated copper tubing

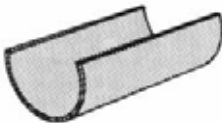

Sizes 3/4 in. thru 12 in. IPS
MSS SP69 Type 40

RC729A

Single Pipe Roll



Sizes 1 in. thru 24 in. IPS
MSS SP69 Type 41

C729

Adj. Roller Hanger



Sizes 1 in. thru 20 in. IPS
MSS SP69 Type 43

S730C

Pipe Roll + Base



MSS SP69 Type 44

S730D

Adj. Pipe Roll & Base



MSS SP69 Type 46

C769

Top I-Beam Clamp



Sizes 3/4 in. thru 7/8 in. Rod
MSS SP69 Type 25

C755 T / C757 T

Center I-Beam Clamp

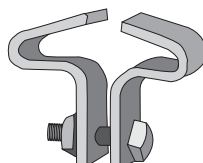

MSS SP69 Type 21

C780

Weld attachment as shown or inverted less bolt



MSS SP69 Type 22

M778

Top Beam C-Clamp



Sizes 3/8 in. thru 3/4 in. Rod
MSS SP69 Type 19

M777

Junior Top Beam C-Clamp



Sizes 3/8 in. thru 1/2 in. Rod
MSS SP69 Type 18

Surface Raceway and Lighting Systems

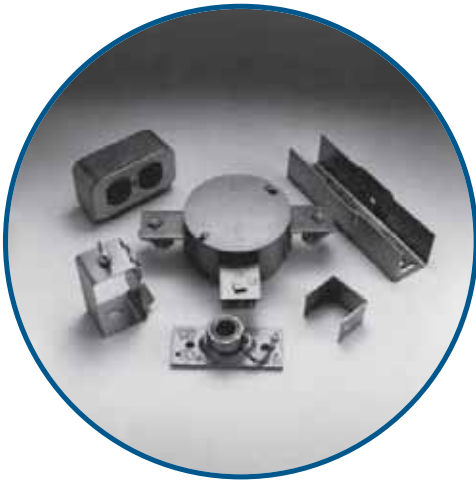

Material

Superstrut® electrical raceway, fixture hanging channel, closure strip and accessories are manufactured from hot rolled strip steel. Standard finish for the accessories is GoldGalv®.

Design Data

Deflections at various hanger rod spacings for raceway channels based on 40 to 45 lb. per fixture.

Channel	Deflection		
	at 10 ft. (in.)	at 12 ft. (in.)	at 14 ft. (in.)
A1200	1/4	1/2	3/4
C1200			*
A1400	3/8	3/4	*

Channel	Deflection		
	at 6 ft. (in.)	at 7 ft. (in.)	at 9 ft. (in.)
B1200	3/8	9/16	5/8
B1400	1	1/2	*

*Not recommended for this spacing.

Electrical Raceway

Superstrut channel together with snap-in closure strip is listed by Underwriters Laboratories as a surface metal raceway. Other accessories listed by Underwriters Laboratories are identified on the drawings.

Wire Size AWG	Maximum Number of Wires							
	Raceway							
	With or Without KO A1200 A1400		B1200 B1400		C1200		E1200 H1200	
	A	B	A	B	A	B	A	B
14	6	10	4	6	5	10	6	10
12	6	10	3	6	4	10	6	10
10	5	8			4	6	5	8
8	4	6			3	4	4	6
6	2	3			2	2	2	3

COLUMN A: Suitable for number of wires indicated when used as a raceway. Also suitable for number of wires indicated when installed to support and supply electrical fixtures when raceway wiring is suitable for not less than 75°C.

By providing clearance between fixture and raceway of not less than 1/2 in., where suitable for 60°C may be used.

COLUMN B: Suitable for number of wires indicated when used as a raceway. Also suitable for number of wires indicated when installed to support electrical fixtures when clearance of not less than 1/8 in. is provided between raceway and fixture and when wiring is suitable for 75°C.

Applicable Channels	
A1200	B1200
A1200-KO	B1400
A1400	C1200
A1400-KO	E1200
	H1200



Surface Raceway and Lighting Systems

Fixture Fittings

802 Raceway Joiner With Reinforcing Plate

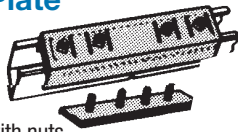

Furnished complete with nuts.

Cat. No.	For Channel	Wt./C lb.
A802EG	A Series	158
B802EG	B Series	112
E802EG	E Series	170
H802	H Series	182

822 Raceway Joiner & Seal

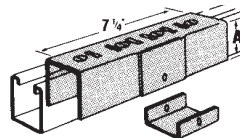

Furnished complete with 1/4 in. x 5/8 in. machine screws and AB100-1/4 nuts.

Cat. No.	A (in.)	For Channel	Wt./C lb.
A822	1-11/16	A Series	75
B822	7/8	B Series	56

A213 Inside Joiner

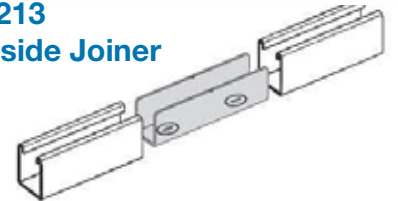

For A1200 Series channel. Only available in GoldGalv® finish.

805 End Cap With Knockout

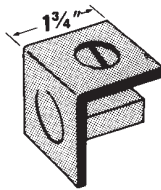

KO for 1/2 in. conduit. Furnished complete with 1/4 in. x 5/8 in. flat head machine screw and AB100-1/4 nut.

Cat. No.	For Channel	Wt./C lb.
A805EG	A Series	21
H805EG	H Series	31

809 Tapped End Cap

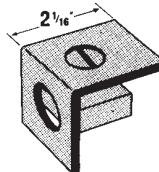

12 ga. steel. For 3/4 in. or 1 in. conduit. Furnished complete with 1/4 in. x 5/8 in. flat head machine screw and AB100-1/4 nut.

Rod Size	For Channel	Wt./C lb.
A809-3/4EG	A Series	2
E809-3/4EG	E Series	26

A853 Channel Hanger



Use hanger rod 3/8 in. or 1/2 in. Use with A, AR, B, BR or C Series single channel. Wt./C 25 lb.

A853L Channel Hanger - Long

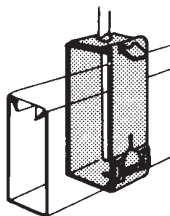

Long type for all Series channel. Wt./C 48 lb.

A854 Channel Hanger

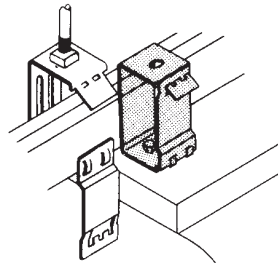

Illustration showing A854 with nut and bolt furnished to attach to fluorescent fixture. Use with A, B, C or D Series channel. Wt./C 34 lb.

A854L Channel Hanger - Long

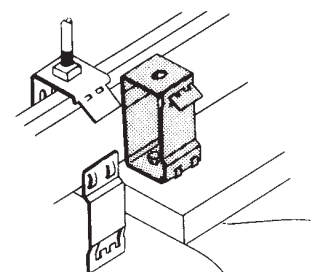
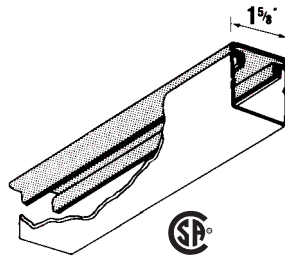

Illustration showing A854L with nut and bolt furnished to attach to fluorescent fixture. Use with E and H Series channel as well as A, B, C or D Series channel. Wt./C 51 lb.

Surface Raceway and Lighting Systems

Fixture Fittings

AB844PGC
Steel Closure Strip
AB844PC
Plastic Closure Strip Colour: Gold
AB844PCGY
Plastic Closure Strip Colour: Grey



- When used as a raceway, channel is normally installed with the slot up. After wiring has been completed the closure strip is installed.
- For all channels
- Standard length: 10 ft.

AB803
Cast Conduit Connector

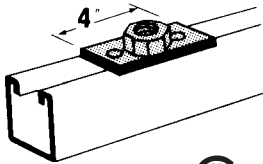

To connect 1/2 in. or 3/4 in. conduit to raceway channel. Furnished complete with stud nuts and hex nuts. Part has removable bushing to increase size from 1/2 in. to 3/4 in.
 Wt./C 60 lb.

AB815
Swing Connector

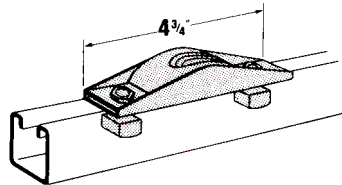

Nuts and bolts to clamp to channel is included. For 1/2 in. or 3/4 in. conduit.
 Wt./C 95 lb.

AB885
15° Swivel

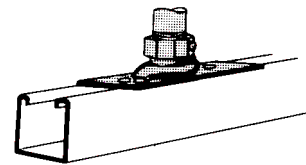

Nuts and bolts to clamp to channel included. For 1/2 in. or 3/4 in. conduit.
 Wt./C 25 lb.

AB867
Spacer

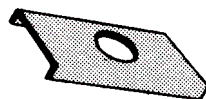

For use with AB866 wiring stud nuts.
 Wt./C 24 lb.

AB866
Wiring Stud Nut

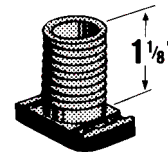

1/2 in. Pipe thread
 Wt./C 21 lb.

811
Stud Nut

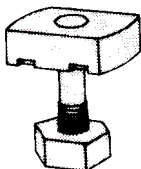

Cat. No.	For Channel	Wt./C lb.
811-1STR	1/4 x 1	8
811-2STR	1/4 x 1-1/4	9

812
Stud Nut

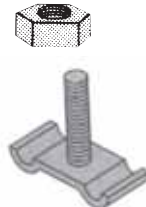

For attaching fixture to slot down channel or to slot up knockouts. Specify length. Hex nut included.

Cat. No.	For Channel	Wt./C lb.
812-1EG	1/4 x 1	6

AB868
Fiber Retainer for Cables Until Closure Strip is Installed

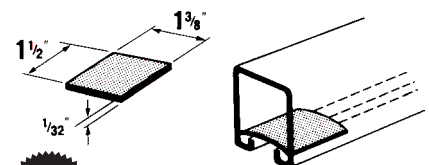

STD. PACK: 100

Wt./C 3 lb.

Surface Raceway and Lighting Systems

Kindorf® Channel Boxes and Receptacles

G2000

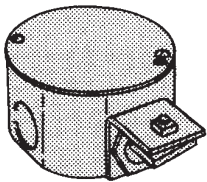

Finish - GoldGalv® Wt./C 110 lb.

G2001

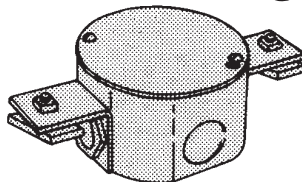

Finish - GoldGalv® Wt./C 120 lb.

G2002

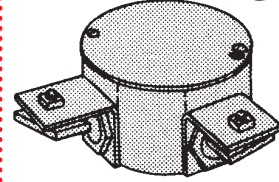

Finish - GoldGalv® Wt./C 120 lb.

G2003

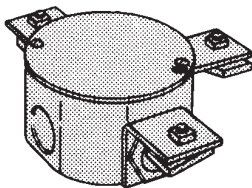

Finish - GoldGalv® Wt./C 130 lb.

G2004

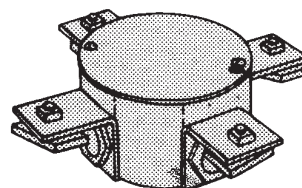

Finish - GoldGalv® Wt./C 140 lb.

G1038 Duplex Outlet

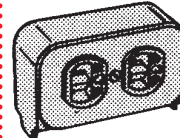

Complete unit including housing, standard DUPLEX 3-wire, 15 Amp., 125 volt, ground receptacle and cover plate.

Finish - GoldGalv® Wt./C 55 lb.

G1038A Single Outlet

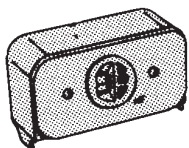

Complete unit including housing, standard SINGLE 3-wire, 15 Amp., 125 volt, ground receptacle and cover plate.

Finish - GoldGalv® Wt./C 50 lb.

G1038D Raceway Outlet



Complete unit including housing, duplex, 3-wire, 15 amp., 277 volt-twistlock receptacle and cover plate.

Finish - GoldGalv® Wt./C 60 lb.

G1038E Raceway Outlet



Complete unit including housing, single, 3-wire, 15 amp., 277 volt-twistlock receptacle and cover plate.

Finish - GoldGalv® Wt./C 50 lb.

G1038B Housing Only

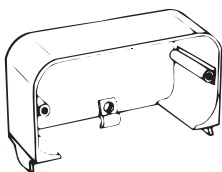

Finish - GoldGalv® Wt./C 25 lb.

G1038C Duplex Cover Plate

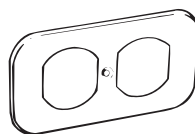

Finish - GoldGalv® Wt./C 12 lb.

G1038CA Single Cover Plate

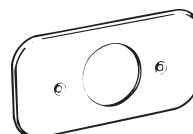

Size of opening: 1.391 diameter

Finish - GoldGalv® Wt./C 14 lb.

G1038CX Blank Cover Plate



Finish - GoldGalv® Wt./C 15 lb.

Surface Raceway and Lighting Systems

Kindorf® Fixture Accessories

G1017 Mercury Vapor Hanger

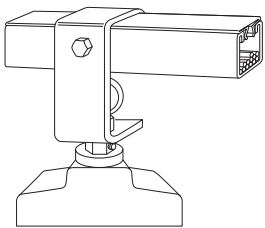

Finish - GoldGalv®

To support high or low bay mercury vapor or heavy incandescent fixtures from raceway channels. Permits plug-in connections with G-1038 raceway outlets.

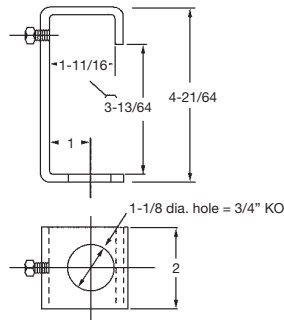

G972HB1/2 Steel Fixture Hanger Adapter

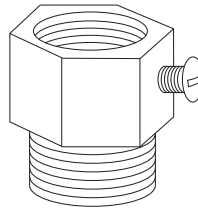

Finish - GoldGalv®

The hanger adapter securely mounts the fixture hanger or box to the channel through the 1/2 in. KO in the base. No special tools are needed for installation of fittings and fixtures.

Superstrut® channels, with 1/2 in. KO's every 6 in., hangs and feeds the fixtures thereby simplifying installation.

Wt./C 17 lb.

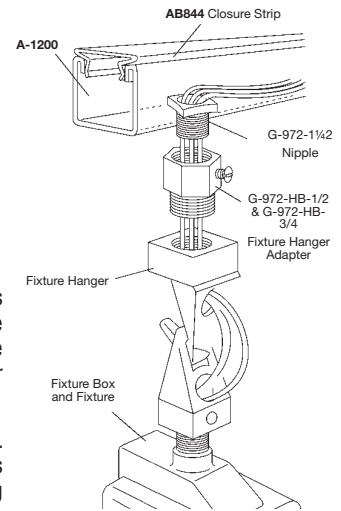

Used with Channel	Depth (in.)	Wt./C lb.
A-1200	4-1/4	76

Electrical Applications

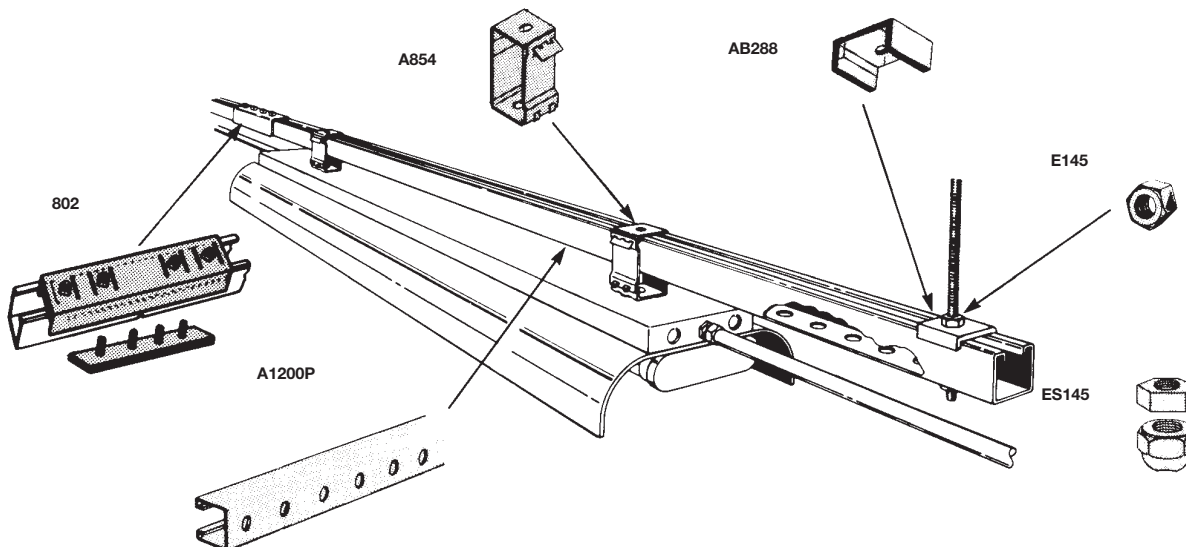

Surface Raceway and Lighting Systems

Electrical Applications

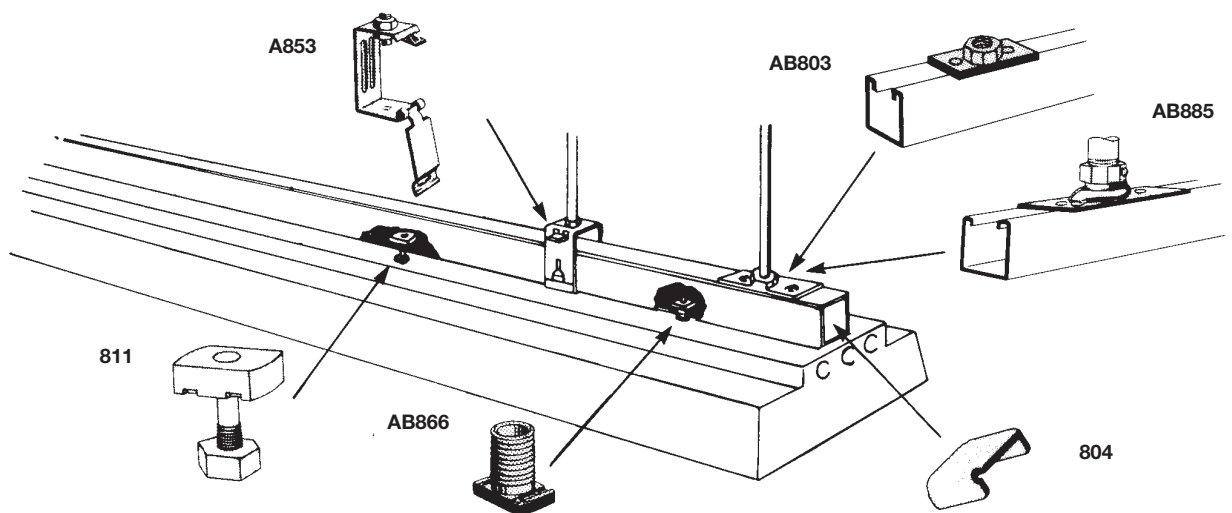
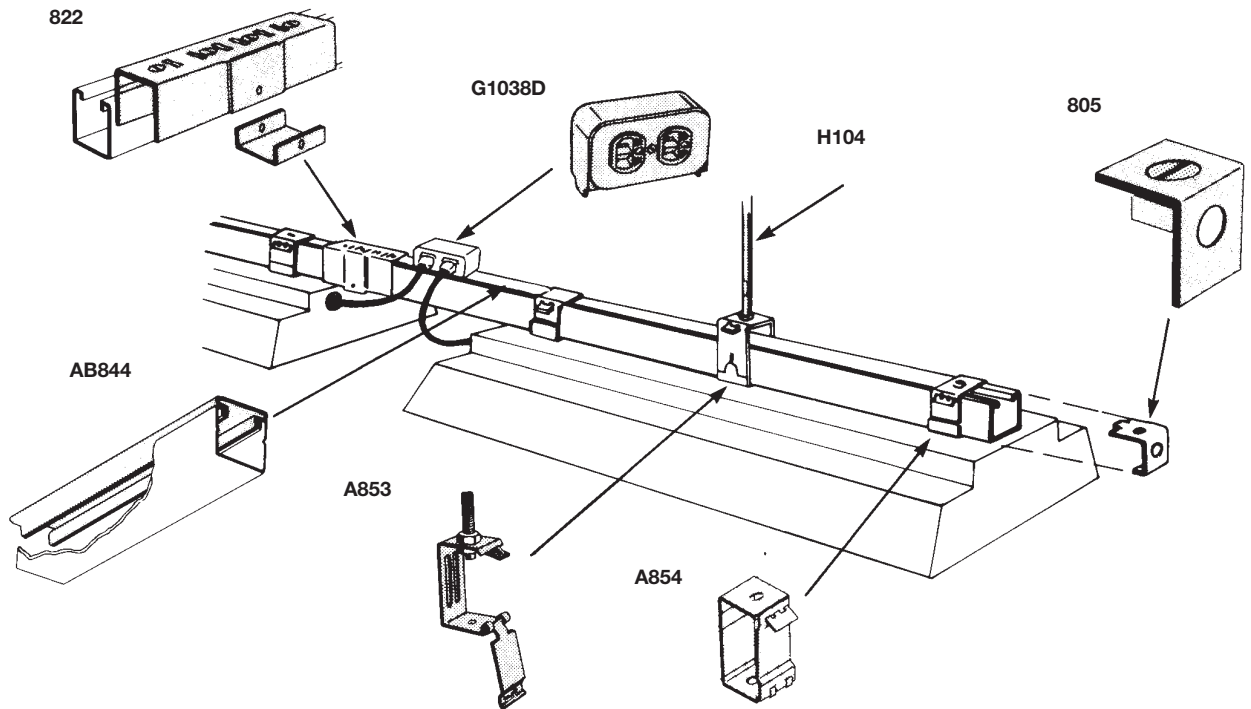

Surface Raceway and Lighting Systems
.....
Electrical Applications

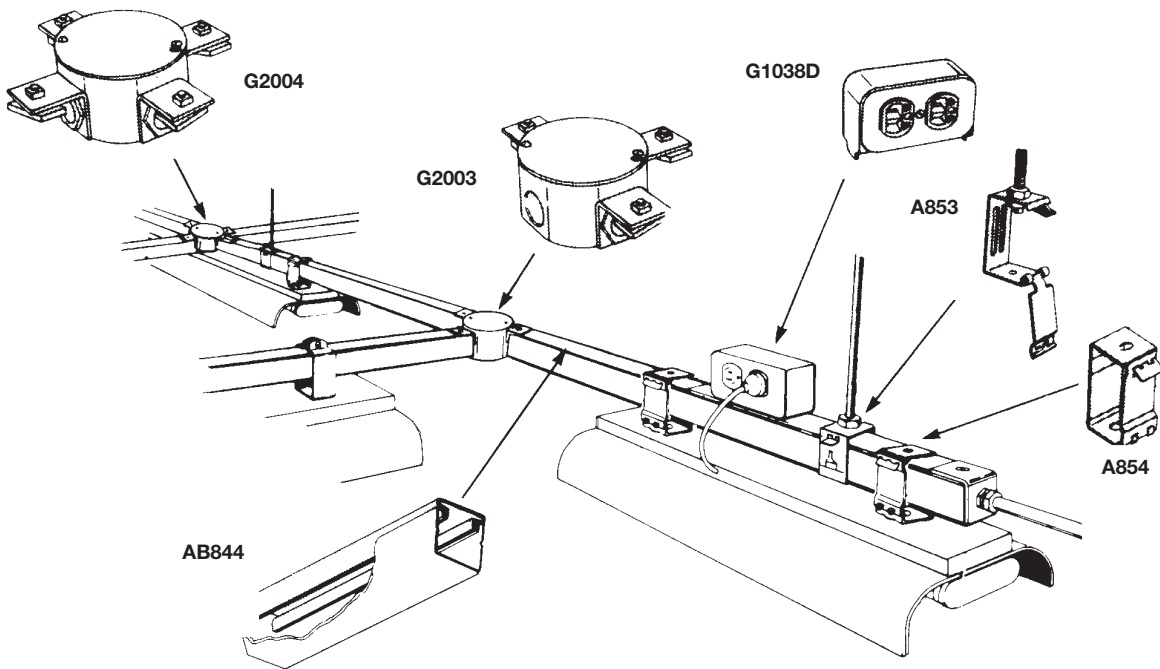
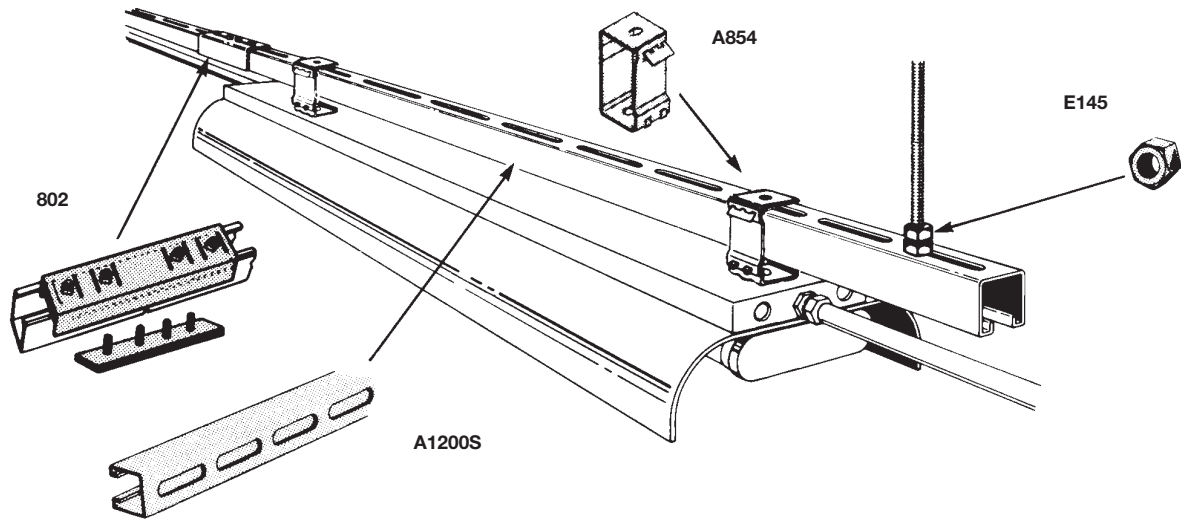

Right Angle Slotted Metal Framing



Create the support framing you need

Right Angle Metal Framing is manufactured from commercial quality steel in three different sizes. The small sizes are 14 ga. steel, the larger is 12 ga. steel. With this offering, an endless variety of metal framing requirements can be met, from lightweight supporting needs to larger shelving for inventory storage.

One of the legs on all sizes is 1-5/8 in. wide, while the other is either 1-5/8 in., 2-3/8 in. or 3-1/8 in. long. Depending on the frame requirements, a single size can be utilized throughout, or the sizes can be interchanged to get the most efficient usage from the material.

This section will serve as a guide to plan and build your structure.

Installation time is reduced - inventory space is minimal

Scribe marks are placed every 3/4 in. which saves planning, layout and cutting time and ensures accuracy. The exclusive slot and hole pattern, repeated every 3 in., is scientifically designed for ease of assembly and rigidity. No welding is necessary, no holes to drill. A 9/16 in. wrench is the only tool required for assembly. The proper nuts and bolts are included with the material to ensure fast and easy erection.

Right angle metal framing is packaged in 10' and 12' lengths to minimize cut offs and ensure maximum use of material.

120 feet, 10, 12 foot lengths of right angle metal framing take up the same amount of space as one 2x4. A standard package includes 5 pieces to a bundle, significantly reducing handling and storage space.

The importance of cutting right angle easily, quickly and accurately is the key to time saving assembly. The portable cutter provides these advantages and makes layout and erection of any structure a "light-work" job.

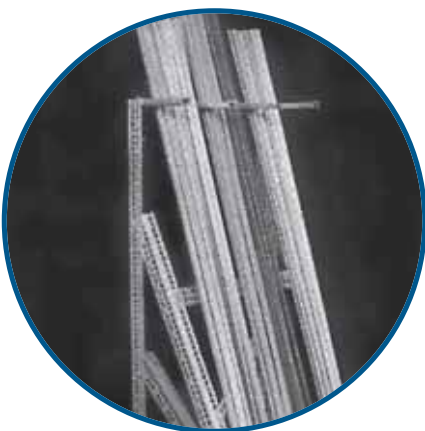
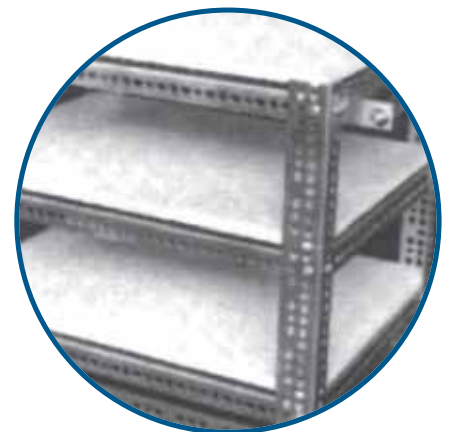

Finish is designed for long lasting durability

The standard GoldGalv® hardware finish is applied to all Right Angle Metal Framing after rolling and punching of the holes. This provides you with a number of benefits. First, raw ends resulting from cuts will be protected by the sacrificial quality of zinc. Second, the edges of all holes are protected against formation of rust, to provide a call back free installation. Third, the electrogalvanizing provides an excellent bonding surface for paint if desired for aesthetic reasons.

Note: Product is also available in pregalvanized (PG) sections.

FLEXIBILITY

SIMPLICITY

ECONOMY

Right Angle Slotted Metal Framing

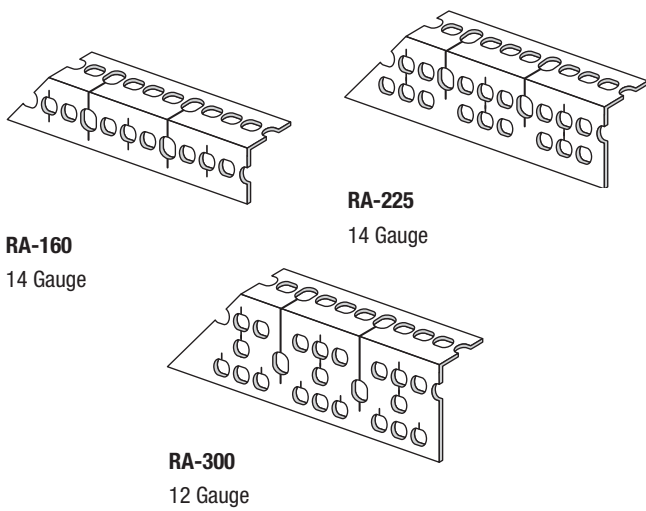

Extra Nuts and Bolts

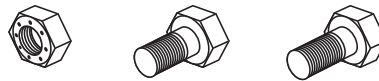

Cat. No.	Length ft.	No. of ft./per Pkg.
RA-160-10	10	50
RA-160-12	12	60
RA-225-10	10	50
RA-225-12	12	60
RA-300-10	10	50
RA-300-12	12	60

Each package includes 36 nuts and bolts.

Cat. No.	Package 100 Sets	Std. Ctn.
RA-BN-5/8 Use with RA-160 & RA-225	2-3/8 in. - 16 x 1-5/8 in.	100
RA-BN-3/4 Use with RA-300	2-3/8 in. - 16 x 3/4 in.	100

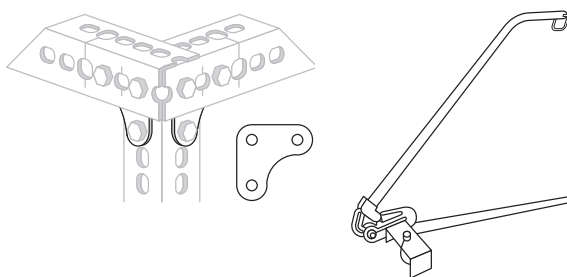

RA-GP
Gusset Plate
For extra rigid assembly

RA-C
Portable Cutter

Cat. No.	Package	Std. Ctn.
RA-GP	25	100
RA-RC	2	2
RA-SC	2	2
RA-C	1	1



RA-RC



RA-SC

Rigid & Swivel Casters.
Hard rubber composition 3-1/2 in. dia.
with load rating of 225 lb. per wheel.

Engineering Data & Specifications

Design Data – Metal Framing Channel

TABLE 1
Elements of Sections
Properties for Design

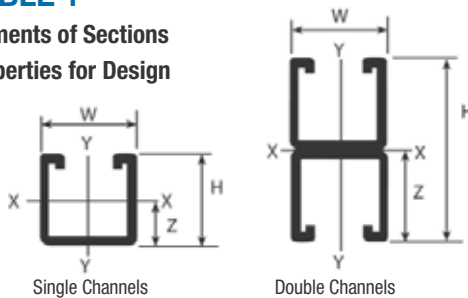

Nominal Thickness (inches)
12 ga = 0.105
14 ga = 0.075
16 ga = 0.060

LEGEND	
I	Moment of inertia
S	Section Modulus
r	Radius of Gyration
Z	Nominal Axis
A	Area

Section Member	WT. lb./ft.	H (in.)	W (in.)	A (in.) ²	X-X AXIS				Y-Y AXIS		
					I (in.) ⁴	S (in.) ³	r (in.)	Z (in.)	I (in.) ⁴	S (in.) ³	r (in.)
Single Channel											
A1200	1.90	1.625	1.625	0.557	0.192	0.212	0.587	0.719	0.237	0.292	0.652
B1200	1.28	0.813	1.625	0.381	0.031	0.063	0.283	0.331	0.137	0.168	0.600
C1200	1.70	1.375	1.625	0.500	0.121	0.155	0.492	0.595	0.205	0.252	0.640
D1200	1.44	1.000	1.625	0.424	0.053	0.092	0.356	0.403	0.159	0.196	0.616
E1200	2.47	2.438	1.625	0.726	0.529	0.399	0.853	1.112	0.335	0.413	0.679
Double Channel											
H1200	3.05	3.250	1.625	0.897	1.100	0.635	1.107	1.507	0.436	0.536	0.697
A1400	1.40	1.625	1.625	0.401	0.134	0.146	0.577	0.707	0.184	0.226	0.677
B1400	0.97	0.813	1.625	0.280	0.024	0.051	0.295	0.338	0.103	0.127	0.607
Double Channel											
A1202	3.80	3.250	1.625	1.114	0.948	0.583	0.992	1.625	0.474	0.584	0.652
B1202	2.56	1.626	1.625	0.762	0.147	0.181	0.439	0.813	0.274	0.337	0.600
C1202	3.40	2.750	1.625	1.000	0.595	0.433	0.772	1.375	0.409	0.504	0.640
D1202	2.88	2.000	1.625	0.847	0.257	0.257	0.552	1.090	0.319	0.393	0.616
E1202	4.94	4.876	1.625	1.450	2.854	1.171	1.402	2.438	0.672	0.827	0.680
Double Channel											
H1202	6.10	6.500	1.625	1.794	6.273	1.930	1.870	3.250	0.871	1.072	0.697
A1402	2.80	3.250	1.625	0.801	0.668	0.411	0.913	1.625	0.367	0.452	0.677
B1402	1.94	1.626	1.625	0.560	0.112	0.138	0.447	0.813	0.206	0.254	0.607

TABLE 2
Maximum Pullout and Slip Loads for Steel Channel and Channel Nuts

Channel Nuts Size / Thread	Channel	Pull Out Strength		Slip Resistance		Torque	
		lb.	kN	lb.	kN	lb.	kN
1/4 - 20	A1200	600	2.7	300	1.3	6	8
5/16 - 18	B1200	800	3.6	500	2.2	11	15
3/8 - 16	C1200	1000	4.4	800	3.6	19	25
1/2 - 13	D1200	2000	8.9	1500	6.7	50	70
5/8 - 11	E1200	2500	11.1	1500	6.7	100	135
3/4 - 10	H1200	2500	11.1	1700	7.6	125	170
Aluminum Channels							
1/4 - 20	A1400	600	2.7	300	1.3	6	8
5/16 - 18		800	3.6	400	1.8	11	15
3/8 - 16	B1400	1000	4.4	750	3.3	19	25
1/2 - 13		1400	6.2	1000	4.4	50	70

For aluminum channel the pull out load is calculated by multiplying the appropriate data by 50%. For slip resistance multiply by 75%.

Maximum Pullout and Slip Loads for Fiber Glass Channel and Channel Nuts

Channel Nuts Size / Thread	Channel	Pull Out Strength		Slip Resistance		Torque	
		lb.	kN	lb.	kN	lb.	kN
1/4 - 20	-	-	-	-	-	-	-
5/16 - 18	-	-	-	-	-	-	-
3/8 - 16	A1200	300	1.3	150	0.6	200	22.6
1/2 - 13	D1200	300	1.3	150	0.6	200	22.6

Engineering Data & Specifications

Design Data – Metal Framing Channel

TABLE 3
Design loads for channel used as beam or column

BEAM LOADS

Table 3 contains simple beam, uniformly-distributed loads calculated at 25,000 psi material stress. Beam loads are based on channel being loaded across the x-x axis. Loads are also listed at reduced deflections for long spans.

Maximum loads at 25,000 psi stress

Maximum allowable deflections and maximum uniform loads for all spans at 25,000 psi material stress.

Reduced load for all 1/180 Span Deflection

For moderate deflections on the longer spans, reduced loads are listed which will produce a deflection equal to 1/180 of the span. When maximum loads do not induce deflections exceeding 1/180 x the span length reduced loads are not required.

Reduced load for 1/360 Span Deflection

For very slight deflections on the longer spans, reduced loads are listed which will produce a deflection equal to 1/360 of the span. When maximum loads do not induce deflections exceeding 1/360 x the span length reduced loads are not required.

Concentrated loads

To obtain values for concentrated loads from Table 3, multiply uniform load by 0.5 and deflection by 1.25.

Slotted, Punched, or KO Channel

Reduce load rating by 5%.

Long span deep beams

Support in a manner to prevent rotation at supports and tie between supports to prevent twist.

COLUMN LOADS

Allowable column loads given are for uniform axial loading with pinned ends. For eccentric loading or other end conditions reduce allowable loads according to standard engineering practice.

DYNAMIC LOADS

Allowable dynamic loads may be calculated by dividing the static loads shown in Table 3, by 2.08.

Maximum beam and column loading for special materials is multiplied with the following factors:

Channel Type	Beam Type	Column Load
Stainless Steel	1	1
Aluminum	0.33	0.33

Warning

Load tables, charts and design criteria provided in this section are intended as guides only. Selection of proper product, installation intervals, erection, and placement are the responsibility of the user.

Thomas & Betts reserves the right to change material and finish specifications without notice, to improve its products.

Engineering Data & Specifications

Design Data – Metal Framing Channel

TABLE 3 (cont'd.)

Single Channel										
Cat. No.	Depth (in.)	Ga.	Maximum Uniform		1/180 Span		1/360 Span		Col. Load	
			Load	Defl.	Load	Defl.	Load	Defl.		
12 in. Beam or Column										
A1200	1-5/8	12	3,534	0.014	0.067			0.033	10,533	
B1200	13/16		1,050	0.026					6,683	
C1200	1-3/8		2,584	0.016					9,345	
D1200	1		1,538	0.022					8,670	
E1200	2-7/16		6,650	0.010					13,830	
H1200	3-1/4		10,583	0.008					17,106	
A1400	1-5/8	14	2,434	0.015	0.067		0.033	7,575		
B1400	13/16		850	0.028				4,950		
18 in. Beam or Column										
A1200	1-5/8	12	2,355	0.033	0.100			0.050	10,210	
B1200	13/16		700	0.059					6,058	
C1200	1-3/8		1,723	0.038					8,970	
D1200	1		1,025	0.052					7,930	
E1200	2-7/16		4,434	0.023					13,482	
H1200	3-1/4		7,055	0.016					16,693	
A1400	1-5/8	14	1,623	0.031	0.100		453	0.050	7,334	
B1400	13/16		566	0.063					4,150	
24 in. Beam or Column										
A1200	1-5/8	12	1,766	0.058	0.133			0.067	9,842	
B1200	13/16		525	0.105					333	5,315
C1200	1-3/8		1,291	0.066					8,545	
D1200	1		769	0.087					490	7,050
E1200	2-7/16		3,325	0.039					13,082	
H1200	3-1/4		5,291	0.030					16,277	
A1400	1-5/8	14	1,216	0.056	0.133		258	0.067	7,058	
B1400	13/16		425	0.110					4,000	
30 in. Beam or Column										
A1200	1-5/8	12	1,414	0.089	0.167			0.083	9,419	
B1200	13/16		420	0.164					266	4,465
C1200	1-3/8		1,034	0.104					1,040	8,060
D1200	1		615	0.129					389	6,650
E1200	2-7/16		2,660	0.063					12,640	
H1200	3-1/4		4,234	0.046					15,698	
A1400	1-5/8	14	974	0.088	0.167		165	0.083	6,753	
B1400	13/16		340	0.172					3,420	

When no numbers are shown, use the maximum uniform load.

Deflections are given in inches; loads in lb.

Double Channel									
Cat. No.	Depth (in.)	Ga.	Maximum Uniform		1/180 Span		1/360 Span		Col. Load
			Load	Defl.	Load	Defl.	Load	Defl.	
12 in. Beam or Column									
A1202	3-1/4	12		0.008	0.067		0.033	21,177	
B1202	1-5/8	12	3,016	0.016				14,110	
C1202	2-3/4	12		0.010				18,990	
D1202	2	12		0.012				18,312	
E1202	4-7/8	12		0.005				27,623	
H1202	6-1/2	12		0.004				34,210	
A1402	3-1/4	14		0.008	0.067		0.033	15,250	
B1402	1-5/8	14	2,300	0.016				10,390	
18 in. Beam or Column									
A1202	3-1/4	12		0.018	0.100		0.050	20,609	
B1202	1-5/8	12	2,011	0.036				13,440	
C1202	2-3/4	12	4,811	0.021				18,470	
D1202	2	12		0.028				17,942	
E1202	4-7/8	12		0.013				16,926	
H1202	6-1/2	12		0.009				33,390	
A1402	3-1/4	14		0.018	0.100		0.050	14,867	
B1402	1-5/8	14	1,534	0.036				9,910	
24 in. Beam or Column									
A1202	3-1/4	12	4,858	0.031	0.133		0.067	19,974	
B1202	1-5/8	12	1,509	0.064				12,670	
C1202	2-3/4	12	3,609	0.038				17,890	
D1202	2	12	2,680	0.042				17,160	
E1202	4-7/8	12		0.021				26,143	
H1202	6-1/2	12		0.016				32,435	
A1402	3-1/4	14	3,425	0.033	0.133		0.067	14,426	
B1402	1-5/8	14	1,150	0.064				9,350	
30 in. Beam or Column									
A1202	3-1/4	12	3,886	0.049	0.167		0.083	19,261	
B1202	1-5/8	12	1,206	0.100				11,803	
C1202	2-3/4	12	2,886	0.059				17,230	
D1202	2	12	2,128	0.084				16,480	
E1202	4-7/8	12	7,806	0.034				25,259	
H1202	6-1/2	12		0.025				31,395	
A1402	3-1/4	14	2,740	0.050	0.167		0.083	13,937	
B1402	1-5/8	14	920	0.100				8,730	

Engineering Data & Specifications

Design Data – Metal Framing Channel

TABLE 3 (cont'd.)

Single Channel										
Cat. No.	Depth (in.)	Ga.	Maximum Uniform		1/180 Span		1/360 Span		Col. Load	
			Load	Defl.	Load	Defl.	Load	Defl.		
36 in. Beam or Column										
A1200	1-5/8	12	1,178	0.129	0.200		917	0.100	8,962	
B1200	13/16		350	0.236			148		3,498	
C1200	1-3/8		861	0.149			578		7,525	
D1200	1		513	0.198			217		4,335	
E1200	2-7/16		2,216	0.088					12,160	
H1200	3-1/4		3,528	0.068					15,132	
A1400	1-5/8	14	811	0.126	0.200		640	0.100	6,416	
B1400	13/16		284	0.248			115		2,755	
42 in. Beam or Column										
A1200	1-5/8	12	1,010	0.175	0.233		674	0.117	8,466	
B1200	13/16		300	0.323			217		109	2,579
C1200	1-3/8		738	0.203			425		6,945	
D1200	1		440	0.264			319		3,280	
E1200	2-7/16		1,900	0.120					11,698	
H1200	3-1/4		3,024	0.091					14,514	
A1400	1-5/8	14	695	0.160	0.233		470	0.117	6,051	
B1400	13/16		243	0.336			168		84	2,060
48 in. Beam or Column										
A1200	1-5/8	12	884	0.228	0.267		516	0.133	7,943	
B1200	13/16		263	0.420			167		83	1,981
C1200	1-3/8		646	0.265			325		6,325	
D1200	1		384	0.352			244		2,439	
E1200	2-7/16		1,663	0.156					11,092	
H1200	3-1/4		2,646	0.120					13,850	
A1400	1-5/8	14	609	0.120	0.267		360	0.133	5,658	
B1400	13/16		213	0.440			129		64	1,580
54 in. Beam or Column										
A1200	1-5/8	12	785	0.289	0.300		408	0.150	7,369	
B1200	13/16		234	0.533			132		66	1,555
C1200	1-3/8		574	0.335			257		5,650	
D1200	1		341	0.466			193		96	2,012
E1200	2-7/16		1,478	0.198					1,123	10,505
H1200	3-1/4		2,351	0.151						13,150
A1400	1-5/8	14	541	0.286	0.300		284	0.150	5,241	
B1400	13/16		189	0.556			102		51	1,250

Double Channel										
Cat. No.	Depth (in.)	Ga.	Maximum Uniform		1/180 Span		1/360 Span		Col. Load	
			Load	Defl.	Load	Defl.	Load	Defl.		
36 in. Beam or Column										
A1202	3-1/4	12	3,239	0.071	0.200			0.100	18,470	
B1202	1-5/8		1,005	0.144					702	10,840
C1202	2-3/4		2,400	0.085					1248	16,500
D1202	2		1,428	0.114						15,057
E1202	4-7/8		6,505	0.048						24,316
H1202	6-1/2			0.036						30,265
A1402	3-1/4	14	2,284	0.071	0.200			0.100	13,416	
B1402	1-5/8		766	0.144					535	8,050
42 in. Beam or Column										
A1202	3-1/4	12	2,776	0.098	0.233			0.117	17,635	
B1202	1-5/8		863	0.195					516	9,790
C1202	2-3/4		2,063	0.115					1069	15,730
D1202	2		1,224	0.166						13,042
E1202	4-7/8		5,576	0.065						23,272
H1202	6-1/2			0.049						29,025
A1402	3-1/4	14	1,958	0.225	0.233			0.117	12,832	
B1402	1-5/8		658	0.195					393	7,300
48 in. Beam or Column										
A1202	3-1/4	12	2,429	0.128	0.267			0.133	16,730	
B1202	1-5/8		754	0.255					395	8,640
C1202	2-3/4		1,804	0.151					702	14,890
D1202	2		1,071	0.203						11,387
E1202	4-7/8		4,879	0.085						22,170
H1202	6-1/2			0.064						27,700
A1402	3-1/4	14	1,713	0.128	0.267			0.133	12,223	
B1402	1-5/8		575	0.255					301	6,480
54 in. Beam or Column										
A1202	3-1/4	12	2,159	0.161	0.300			0.150	15,763	
B1202	1-5/8		670	0.323					312	7,405
C1202	2-3/4		1,604	0.190					1,263	13,990
D1202	2		952	0.266					624	10,391
E1202	4-7/8		4,338	0.108						20,980
H1202	6-1/2		7,149	0.081						16,280
A1402	3-1/4	14	1,523	0.161	0.300			0.150	11,566	
B1402	1-5/8		511	0.323					238	5,580

When no numbers are shown, use the maximum uniform load.
Deflections are given in inches; loads in lb.

Engineering Data & Specifications

Design Data – Metal Framing Channel

TABLE 3 (cont'd.)

Single Channel										Double Channel										
Cat. No.	Depth (in.)	Ga.	Maximum Uniform		1/180 Span		1/360 Span		Col. Load	Cat. No.	Depth (in.)	Ga.	Maximum Uniform		1/180 Span		1/360 Span		Col. Load	
			Load	Defl.	Load	Defl.	Load	Defl.					Load	Defl.	Load	Defl.	Load	Defl.		
60 in. Beam or Column										60 in. Beam or Column										
A1200	1-5/8	12	706	0.358			330		6,762	A1202	3-1/4	12	1,944	0.199					14,738	
B1200	13/16		210	0.658	107		53		-	B1202	1-5/8		604	0.398			253		6,100	
C1200	1-3/8		516	0.414			208	0.167	4,920	C1202	2-3/4		1,444	0.235			1,023	0.167	13,050	
D1200	1		308	0.550	157		78		1,561	D1202	2		257	0.318			449		7,531	
E1200	2-7/16		1,330	0.244			909		9,874	E1202	4-7/8		3,904	0.133					19,734	
H1200	3-1/4		2,116	0.186					12,406	H1202	6-1/2		6,434	0.100					24,810	
A1400	1-5/8	14	486	0.353			231		4,792	A1402	3-1/4	14	1,370	0.199			0.333		10,878	
B1400	13/16		170	0.687	82	0.333	41	0.167	-	B1402	1-5/8		460	0.399			193	.167	4,640	
66 in. Beam or Column										66 in. Beam or Column										
200	1-5/8	12	643	0.432			273		6,127	A1202	3-1/4	12	1,766	0.240			1,347		13,646	
B1200	13/16		191	0.795	88		44		-	B1202	1-5/8		549	0.481	418		209		5,055	
C1200	1-3/8		470	0.501	344		172	0.183	4,145	C1202	2-3/4		1,313	0.285			846	0.183	12,030	
D1200	1		280	0.675	129		65		1,280	D1202	2		779	0.377	593		360		6,581	
E1200	2-7/16		1,210	0.295			753		9,211	E1202	4-7/8		3,549	0.180					18,415	
H1200	3-1/4		1,924	0.226					11,616	H1202	6-1/2		5,849	0.120					23,230	
A1400	1-5/8	14	443	0.426			190		4,311	A1402	3-1/4	14	1,245	0.241			0.367	949	0.183	10,133
B1400	13/16		155	0.831	68	0.367	35	0.183	-	B1402	1-5/8		419	0.483	318	0.367	159	0.183	3,840	
72 in. Beam or Column										72 in. Beam or Column										
A1200	1-5/8	12	589	0.514	459		299		5,436	A1202	3-1/4	12	1,620	0.286			1,132		12,500	
B1200	13/16		175	0.946	74		37		-	B1202	1-5/8		503	0.574	351		176		4,230	
C1200	1-3/8		430	0.595	289		144	0.200	3,485	C1202	2-3/4		1,203	0.339			710	0.200	10,980	
D1200	1		256	0.792	108		54		1,084	D1202	2		714	0.457	468		312		5,230	
E1200	2-7/16		1,108	0.351			632		8,509	E1202	4-7/8		3,253	0.191					17,023	
H1200	3-1/4		1,839	0.269			1,313		10,782	H1202	6-1/2		5,361	0.143					21,560	
A1400	1-5/8	14	405	0.506	320	0.400	160	0.200	3,809	A1402	3-1/4	14	1,141	0.286			0.400	798	0.200	9,340
B1400	13/16		141	0.989	57		29		-	B1402	1-5/8		384	0.574	267	0.400	134	0.200	3,220	
84 in. Beam or Column										84 in. Beam or Column										
A1200	1-5/8	12	505	0.700	337		168		4,061	A1202	3-1/4	12	1,388	0.390			832		9,992	
B1200	13/16				54		27		-	B1202	1-5/8		431	0.780	258		129		3,100	
C1200	1-3/8		369	0.811	212		106	0.233	2,565	C1202	2-3/4		1,031	0.461			522	0.233	8,670	
D1200	1		220	1.079	92		58		796	D1202	2		612	0.623	344		229		3,842	
E1200	2-7/16		950	0.479			464		6,991	E1202	4-7/8		2,788	0.260					13,993	
H1200	3-1/4		1,513	0.366			965		8,988	H1202	6-1/2		4,595	0.195					17,975	
A1400	1-5/8	14	348	0.691	235	0.467	118	0.233	2,827	A1402	3-1/4	14	979	0.390			0.467	586	0.233	7,682
B1400	13/16				42		21		-	B1402	1-5/8		329	0.781	197	0.467	98	0.233	2,370	

When no numbers are shown, use the maximum uniform load.
Deflections are given in inches; loads in lb.

Engineering Data & Specifications

Design Data – Metal Framing Channel

TABLE 3 (cont'd.)

Single Channel											
Cat. No.	Depth (in.)	Ga.	Maximum Uniform		1/180 Span		1/360 Span		Col. Load		
			Load	Defl.	Load	Defl.	Load	Defl.			
96 in. Beam or Column											
A1200	1-5/8	12	441	0.914	258	0.533	129	0.267	3,108		
B1200	13/16				42				21		-
C1200	1-3/8		323	1.059	163				81		1,960
D1200	1		192	1.400	998				49		-
E1200	2-7/16		831	0.730					355		5,423
H1200	3-1/4		1,323	0.478					739		7,059
108 in. Beam or Column											
A1400	1-5/8	14	304	0.903	180	0.533	90	0.267	2,615		
B1400	13/16				32				16		-
108 in. Beam or Column											
A1200	1-5/8	12	393	1.156	204	0.600	102	0.300	2,456		
B1200	13/16				33				16		-
C1200	1-3/8		288	1.350	128				64		-
D1200	1		171	1.783	76				38		-
E1200	2-7/16		739	0.790	561				281		4,291
H1200	3-1/4		1,176	0.605					584		5,579
120 in. Beam or Column											
A1400	1-5/8	14	270	1.141	142	0.600	71	0.300	1,708		
B1400	13/16				25				13		-
120 in. Beam or Column											
A1200	1-5/8	12	354	1.425	165	0.667	83	0.333	-		
B1200	13/16				27				13		-
C1200	1-3/8		259	1.663	104				52		-
D1200	1		154	2.202	62				31		-
E1200	2-7/16		665	0.976	455				227		3,478
H1200	3-1/4		1,059	0.746					473		4,521
144 in. Beam or Column											
A1400	1-5/8	14	244	1.413	114	0.667	57	0.333	-		
B1400	13/16				21				10		-
144 in. Beam or Column											
A1200	1-5/8	12			115	0.800	57	0.400	-		
-											-
C1200	1-3/8				72				36		-
E1200	2-7/16		554	1.400	315				158		0.400
H1200	3-1/4		883	1.075	657				328		-
A1400	1-5/8		14				80		0.800	40	0.400

When no numbers are shown, use the maximum uniform load.
Deflections are given in inches; loads in lb.

Double Channel												
Cat. No.	Depth (in.)	Ga.	Maximum Uniform		1/180 Span		1/360 Span		Col. Load			
			Load	Defl.	Load	Defl.	Load	Defl.				
96 in. Beam or Column												
A1202	3-1/4	12	1,215	0.509		0.533		0.267	637	0.267	7,675	
B1202	1-5/8		378	1.019	197				99			-
C1202	2-3/4		903	0.603					400			6,640
D1202	2		535	0.813	263				176			2,942
E1202	4-7/8		2,440	0.340					1,917			10,875
H1202	6-1/2		4,021	0.255								14,120
108 in. Beam or Column												
A1402	3-1/4	14	856	0.509		0.533		0.267	449	0.267	5,951	
B1402	1-5/8				288		1.020		150			75
108 in. Beam or Column												
A1202	3-1/4	12	1,080	0.644		0.600		0.300	503	0.300	6,071	
B1202	1-5/8		355	1.290	156				78			-
C1202	2-3/4		801	0.763	632				316			5,250
D1202	2		476	1.029	208				139			2,324
E1202	4-7/8		2,169	0.430					1,515			8,599
H1202	6-1/2		3,574	0.323								11,160
120 in. Beam or Column												
A1402	3-1/4	14	761	0.644		0.600		.300	355	.300	4,702	
B1402	1-5/8				255		1.290		119			59
120 in. Beam or Column												
A1202	3-1/4	12	971	0.795		0.667		0.333	408	0.333	-	
B1202	1-5/8		301	1.588	126				63			-
C1202	2-3/4		721	0.941	512				256			4,250
D1202	2		428	1.271	168				112			1,883
E1202	4-7/8		1,951	0.531					1,227			6,946
H1202	6-1/2		3,216	0.398								9,040
144 in. Beam or Column												
A1402	3-1/4	14	685	0.796		0.667		0.333	287	0.333	3,805	
B1402	1-5/8				230		1.600		96			48
144 in. Beam or Column												
A1202	3-1/4	12	810	1.145	566	0.800		0.400	283	0.400	-	
B1202	1-5/8				88				44			-
C1202	2-3/4		601	1.350	355				178			-
E1202	4-7/8		1,626	0.764					852			-
H1202	6-1/2		2,680	0.573					1,873			-
A1402	3-1/4		14	571	1.146		399		0.800			0.400
B1402	1-5/8				67		33			-		

Engineering Data & Specifications

Design Data – Metal Framing Channel

TABLE 3 (cont'd.)

Single Channel									
Cat. No.	Depth (in.)	Ga.	Maximum Uniform		1/180 Span		1/360 Span		Col. Load
			Load	Defl.	Load	Defl.	Load	Defl.	
168 in. Beam or Column									
A1200	1-5/8	12			84	0.933	42	0.467	-
-	-	-							-
C1200	1-3/8				53		27		-
E1200	2-7/16	12	475	1.912	233	0.933	116	0.467	-
H1200	3-1/4		756	1.463	482		241		-
A1400	1-5/8	14			60	0.933	30	0.467	-
192 in. Beam or Column									
-	-	-							-
-	-	-							-
E1200	2-7/16	12			178	1.07	89	0.533	-
H1200	3-1/4		661	1.91	369		185		-
-	-	-							-
216 in. Beam or Column									
-	-	-							-
-	-	-							-
E1200	2-7/16	12			140	1.20	70	0.600	-
H1200	3-1/4				292		146		-
-	-	-							-
240 in. Beam or Column									
-	-	-							-
-	-	-							-
E1200	2-7/16	12			114	0.334	57	0.667	-
H1200	3-1/4				236		118		-
-	-	-							-

When no numbers are shown, use the maximum uniform load.
Deflections are given in inches; loads in lb.

Double Channel										
Cat. No.	Depth (in.)	Ga.	Maximum Uniform		1/180 Span		1/360 Span		Col. Load	
			Load	Defl.	Load	Defl.	Load	Defl.		
168 in. Beam or Column										
A1202	3-1/4		694	1.563	916		208		-	
B1202	1-5/8				64		32		-	
C1202	2-3/4	12	515	1.850	261	0.933	130	0.467	-	
E1202	4-7/8		1,394	1.040	1,255		626		-	
H1202	6-1/2		2,298	0.780			1,326		-	
A1402	3-1/4	14	489	1.563	293	0.933	147	0.467	-	
B1402	1-5/8				49		25		-	
192 in. Beam or Column										
A1202	3-1/4	12			318	1.07	159	0.533	-	
-	-	-							-	
C1202	2-3/4				200		100		-	
E1202	4-7/8	12	1,220	1.363	958	1.07	479	0.533	-	
H1202	6-1/2		2,010	1.019			1,053		-	
A1402	3-1/4	14			224	1.07	112	0.533	-	
-	-	-							-	
216 in. Beam or Column										
A1202	3-1/4	12			252	1.20	126	0.600	-	
-	-	-							-	
C1202	2-3/4				158		79		-	
E1202	4-7/8	12	1,084	1.725	757	1.20	379	0.600	-	
H1202	6-1/2		1,788	1.288			832		-	
A1402	3-1/4	14			177	1.20	89	0.600	-	
-	-	-							-	
240 in. Beam or Column										
A1202	3-1/4	12			204	1.33	102	0.667	-	
-	-	-							-	
C1202	2-3/4				128		64		-	
E1202	4-7/8	12			613	1.33	307	0.667	-	
H1202	6-1/2		1,609	1.588			674		-	
A1402	3-1/4	14			144	1.33	72	.667	-	
-	-	-							-	

Engineering Data & Specifications

Design Data – Metal Framing Channel

TABLE 4

Safe bearing loads for 1-5/8 in. channel and combinations.

Safety factor of 2-1/2

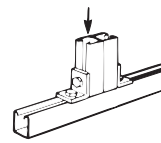
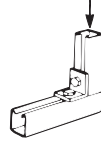
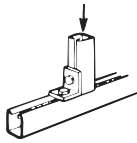

Section	Recommended Load in lb.
A1200	5000
A1400	3500
B1200	6000
B1400	3400
C1200	5000
E1200	5000
H1200	4000

Section	Recommended Load in lb.
A1200	3500
A1400	2500
B1200	4000
B1400	2600
C1200	3500
E1200	3500
H1200	2000

Section	Recommended Load in lb.
A1200	8000
A1400	5500
B1200	9000
B1400	4800
C1200	8000
E1200	8000
H1200	5500

TABLE 5

Design load table for typical channel connections.

Safety factor of 2-1/2 based on ultimate strength of the connection. Load diagrams indicate up to three design loads, for 12 gauge and 14 gauge channel applications.

90° Fittings (When used in position shown)

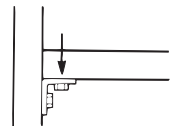

Both ends supported

AB202	A1200	1500 lb.
	A1400	1000 lb.

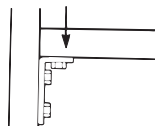

Both ends supported

AB203	A1200	2000 lb.
	A1400	1500 lb.



AB201	AB203
700 lb.	700 lb.

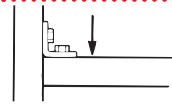

Both ends supported

AB202	A1200	1000 lb.
	A1400	650 lb.

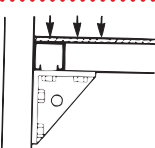

Both ends supported

AB213	A1200	3000 lb.
AB214	A1400	2000 lb.

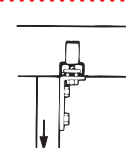

AB20	1500 lb.
------	----------

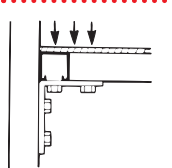

Both ends supported

AB205	A1200	2000 lb.
AB216	A1400	2000 lb.

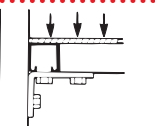

Both ends supported

AB204	A1200	1500 lb.
AB215	A1400	1000 lb.

Flat Plate Fittings



Both ends supported

AB206	A1200	1000 lb.
	A1400	800 lb.

Engineering Data & Specifications

Design Applications

CANTILEVER BEAMS

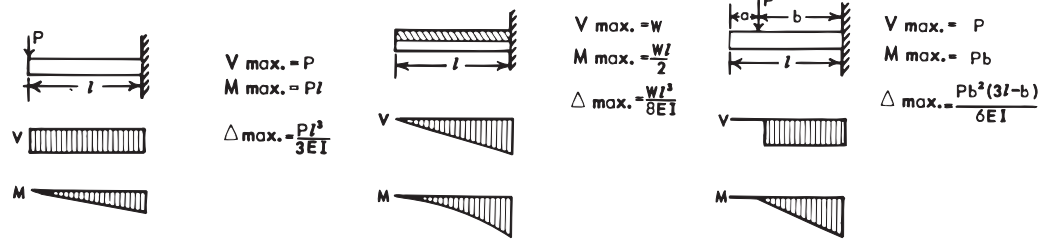

SIMPLE BEAMS

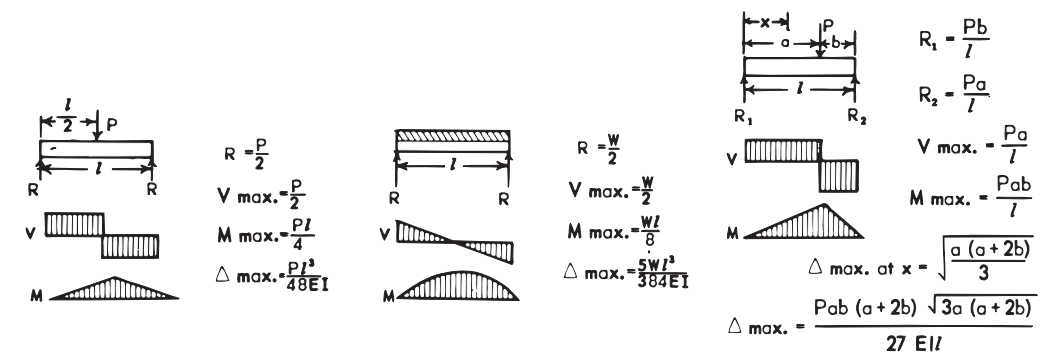

BEAMS FIXED ON ONE END, SUPPORTED AT THE OTHER END

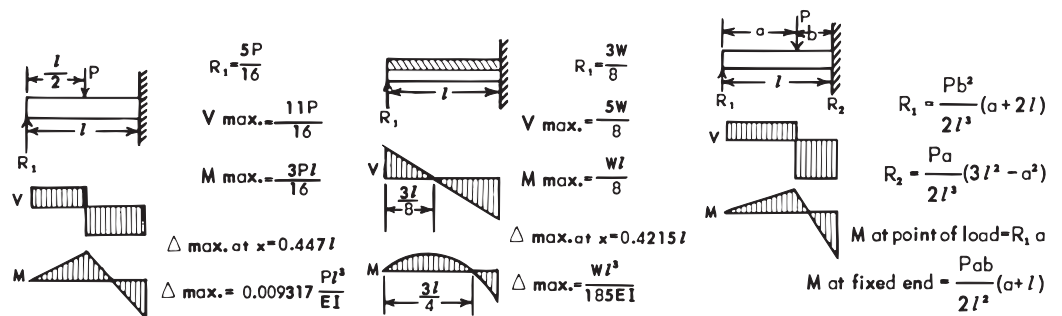

BEAMS FIXED AT BOTH ENDS

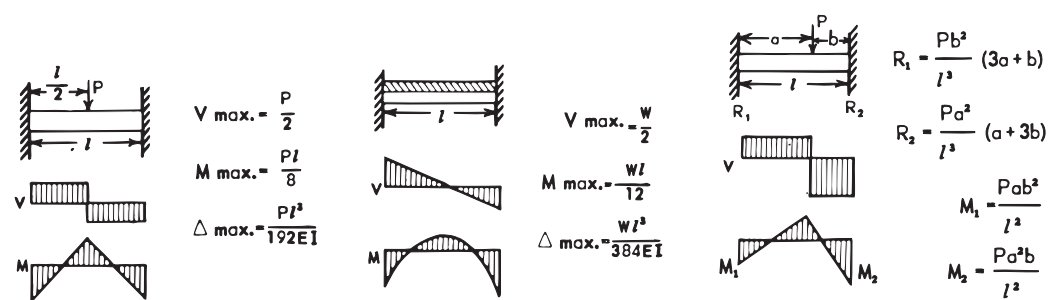

R - Reaction
 M - Moment
 P - Concentrated load

W - Total uniform load
 V - Shear

Δ - Deflection
 E - Modulus of Elasticity
 I - Moment of Inertia









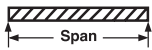

Engineering Data & Specifications

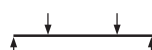
Design Applications

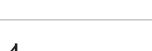
TABLE 6

Conversion Factors for Beams with Various Static Loading Conditions

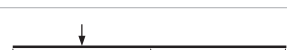
Load tables on pages A59 through A63 for A, B, C, E, and H Series channel are for single span beams supported at the ends. These can be used in the majority of cases. There are times when it is necessary to know what happens with other loading and support conditions. Some common arrangements are shown in Table 6. Simply multiply the loads from the Design Load Tables times the factors given in Table 6.

LOAD AND SUPPORT CONDITION		LOAD FACTOR	DEFLECTION FACTOR
1.	Simple Beam - Uniform Load 	1.00	1.00
2.	Simple Beam - Concentrated Load at Center 	0.50	1.25
3.	Simple Beam - Two Equal Concentrated Loads at 1/4 Points 	1.00	1.10
4.	Beam Fixed at Both Ends - Uniform Load 	1.50	0.30
5.	Beam Fixed at Both Ends - Concentrated Load at Center 	1.00	0.40
6.	Cantilever Beam - Uniform Load 	0.25	2.40
7.	Cantilever Beam - Concentrated Load at End 	0.12	3.20
8.	Continuous Beam - Two Equal Spans - Uniform Load on One Span 	1.30	0.92
9.	Continuous Beam - Two Equal Spans - Uniform Load on Both Ends 	1.00	0.42
10.	Continuous Beam - Two Equal Spans - Concentrated Load at Center of One Span 	0.62	0.71
11.	Continuous Beam - Two Equal Spans - Concentrated Load at Center of Both Spans 	0.67	0.48

Engineering Data & Specifications

Design Applications

EXAMPLE I

PROBLEM:

Determine the load and deflection of an A1200 beam continuous over one support and loaded uniformly on one span.



SOLUTION:

- A. From load table 3 for A1200 the load for a 5 ft. 0 in. span is 706 lb. and deflection is 0.358 in.
- B. Multiply by factors from Table 6.
 Load = 706 lb. x 1.30 = 917.8 lb.
 Deflection = 0.358 x 0.92 = 0.329 in.

EXAMPLE II

PROBLEM:

Determine load and deflection of an E1200 cantilever beam with a concentrated load on the end.



SOLUTION:

- A. From load table 3 for E1200 the load for a 3 ft. 0 in. span is 2216 lb. and deflection is 0.088 in.
- B. Multiply by factors from Table 6.
 Load = 2216 lb. x .12 = 265.9 lb.
 Deflection = 0.088 x 3.20 = 0.282 in.

COLUMN LOADING

The load bearing capacity of column or compression members is a function of the inherent configurational strength, the unbraced length and design of the end connections.

Values of axial column loading given in Table 3 were calculated using a rotationally free and translation fixed correction at each end (see illustration I). This gives an end condition constant (K) of 1.

If other end conditions are used, axial loading should be calculated using procedures in the AISI specification for the design of cold formed steel structural members (SG671) and the engineering values for Superstrut® channel given in Table 1.

ILLUSTRATION I

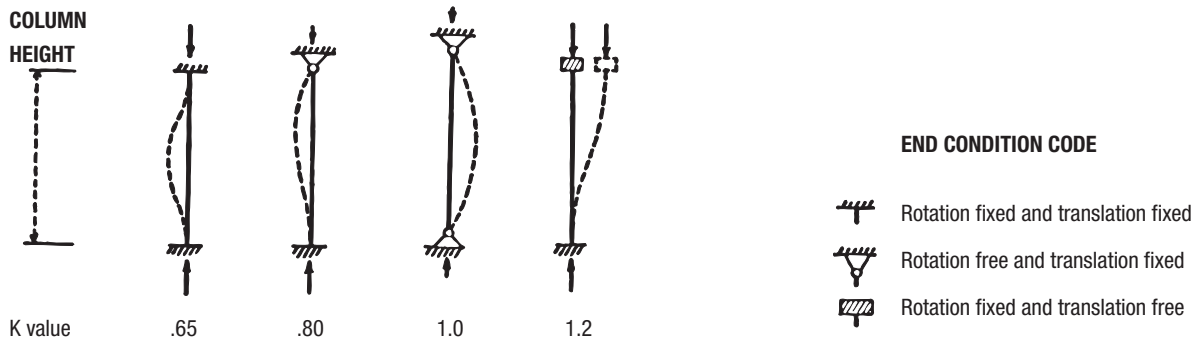

TABLE 7

Load Carrying Capacities of Hot Rolled Steel Rod

Nominal Rod Dia. (in.)	Root Area Thread (in.)	Design Load lb. for Serv. Temperature	
		343°C (650°F)	399°C (750°F)
3/8	0.068	610	540
1/2	0.126	1130	1010
5/8	0.202	1810	1610
3/4	0.302	2710	2420
7/8	0.419	3770	3360

Safety factor of 5.

TABLE 8

Rod Size Determined by Pipe Size for Fire Protection

Pipe Size (in.)	Rod Size (in.)
3/4 to 2	3/8
2-1/2 to 3-1/2	1/2
4 to 5	5/8
6	3/4
8 to 12	7/8

Engineering Data & Specifications

Design Applications

TABLE 9

Maximum Spacing between Pipe Supports

Steel Pipe																			
Nom. Pipe Size (in.)	1/2	3/4	1		1-1/2	2	2-1/2	3	3-1/2	4	5	6	8	10	12	14	16	18	20
Max. Spacing (ft.)	5	6	7		9	10	11	12	13	14	16	17	19	22	23	25	27	28	30
Copper Pipe																			
Nom. Pipe Size (in.)	1/2	3/4	1	1-1/4	1-1/2	2	2-1/2	3	3-1/2	4									
Max. Spacing (ft.)	5	6	6	7	8	9	10	10	11	12									

TABLE 10

Minimum Spacing (inches) between Centers of Standard Pipe When Using Superstrut #702 Pipe Straps

Nom. Pipe Size (in.)	1/2	3/4	1	1-1/4	1-1/2	2	2-1/2	3	3-1/2	4	5	6	8
1/2	1-3/16												
3/4	1-5/16	1-7/16											
1	1-1/2	1-5/8	1-3/4										
1-1/4	1-3/4	1-7/8	2	2-1/4									
1-1/2	1-15/16	2-1/16	2-3/16	2-7/16	2-9/16								
2	2-3/16	2-5/16	2-1/2	2-3/4	2-7/8	3-1/8							
2-1/2	2-7/16	2-9/16	2-3/4	3	3-1/8	3-3/8	3-5/8						
3	2-13/16	2-15/16	3-1/16	3-5/16	3-7/16	3-3/4	4	4-5/16					
3-1/2	3-1/8	3-1/4	3-3/8	3-5/8	3-3/4	4-1/16	4-5/16	4-5/8	4-15/16				
4	3-7/16	3-9/16	3-15/16	4-1/16	4-3/8	4-5/8	4-15/16	5-1/4	5-9/16				
6	4-3/4	4-7/8	5	5-1/4	5-3/8	5-5/8	5-7/8	6-3/16	6-1/2	6-13/16	7-7/16	8-1/8	
8	5-7/16	6	6-1/8	6-3/8	6-1/2	6-3/4	7	7-5/16	7-5/8	8	8-9/16	9-1/4	10-3/8

Engineering Data & Specifications

Design Applications

TABLE 11

Standard Dimensions and Weights of Piping Materials and Conduit

Mechanical (ANSI & API Standard, Schedule 40)					
Nominal Std. Pipe Size (in.)	Pipe O.D. (in.)	Coupling O.D. (in.)	Weight of Pipe lb./ft.	Weight of Pipe Filled w/Water lb./ft.	
1/2	.84	1.06	0.85	0.98	
3/4	1.05	1.31	1.13	1.36	
1	1.32	1.58	1.68	2.05	
1- 1/4	1.66	1.90	2.27	2.92	
1- 1/2	1.90	2.20	2.72	3.60	
2	2.38	2.75	3.65	5.11	
2- 1/2	2.88	3.25	5.79	7.87	
3	3.50	4.00	7.58	10.78	
3- 1/2	4.00	4.63	9.11	13.39	
4	4.50	5.00	10.79	16.30	
5	5.56	6.30	14.62	23.28	
6	6.63	7.39	18.97	31.48	
8	8.63	9.23	28.56	50.24	
10	10.75		41.00	74.00	
12	12.75		50.00	99.00	
14	14.00		64.00	122.00	
16	16.00		63.00	142.00	
18	18.00		71.00	172.00	
20	20.00		79.00	205.00	
22	22.00		87.00	240.00	
24	24.00		95.00	277.00	
26	26.00		103.00	322.00	
28	28.00		111.00	364.00	
30	30.00		119.00	410.00	

Electrical Conduit					
Nominal Conduit Size (in.)	Rigid Steel			Thin Wall (EMT)	
	Conduit O.D. (in.)	Weight of Conduit lb./ft.	Weight of Conduit w/Non-lead Covered Conductor lb./ft.	Conduit O.D. (in.)	Weight of Conduit lb./ft.
1/2	0.84	0.85	1.04	0.71	0.29
3/4	1.05	1.13	1.40	0.92	0.44
1	1.32	1.68	2.35	1.16	0.64
1- 1/4	1.66	2.28	3.58	1.51	0.95
2	2.38	3.68	7.21	2.20	1.40
2- 1/2	2.88	5.82	10.22	2.88	2.30
3	3.50	7.62	14.51	3.50	2.70
4	4.50	10.89	21.48	4.50	4.00

Includes weight of heaviest conductor combination.

Engineering Data & Specifications

Design Applications

TABLE 12

Extra Strong Pipe (ANSI & API Standard, Schedule 80)

A.S.A. B36.10 SCHEDULE NOS. AND NOMINAL WALL THICKNESS DESIGNATIONS	Nominal Pipe Size (in.)	O.D. (in.)	Wall Thickness (in.)	I.D. (in.)	Weight of Pipe lb./ft.	Water Weight per ft. of Pipe lb.	Weight of Pipe Filled w/Water lb./ft.
EXTRA STRONG PIPE and SCHEDULE 80 PIPE (through 8 in.)	3/8	0.675	0.126	0.423	0.74	0.061	4.395
	1/2	0.840	0.147	0.546	1.09	0.101	1.191
	3/4	1.050	0.154	0.742	1.47	0.188	1.668
	1	1.315	0.179	0.957	2.17	0.311	2.481
	1-1/4	1.660	0.191	1.278	3.00	0.555	3.555
	1-1/2	1.900	0.200	1.500	3.63	0.765	4.395
	2	2.375	0.218	1.939	5.03	1.279	6.309
	2-1/2	2.875	0.276	2.323	7.66	1.834	9.497
	3	3.500	0.300	2.900	10.30	2.860	13.16
	3-1/2	4.000	0.318	3.364	12.55	3.850	16.35
	4	4.500	0.337	3.826	15.00	4.98	19.98
	5	5.563	0.375	4.813	20.80	7.89	28.69
	6	6.625	0.432	5.761	28.60	11.29	39.89
	8	8.625	0.500	7.625	43.40	19.79	63.20
EXTRA STRONG PIPE (10 in. through 24 in. OD)	10	10.750	0.500	9.750	54.70	32.30	87.00
	12	12.750	0.500	11.750	65.40	47.00	112.40
	14 OD	14.000	0.500	13.000	72.10	57.50	129.60
	16 OD	16.000	0.500	15.000	82.80	76.50	159.30
	18 OD	18.000	0.500	17.000	93.50	98.40	191.90
	20 OD	20.000	0.500	19.000	104.10	122.80	226.90
	24 OD	24.000	0.500	23.000	125.50	180.10	305.60
SCHEDULE 80 PIPE (10 in. through 24 in. OD)	10	10.750	0.593	9.564	64.300	31.10	95.40
	12	12.750	0.687	11.376	88.50	44.00	132.50
	14 OD	14.000	0.750	12.500	106.10	53.20	159.30
	16 OD	16.000	0.842	14.314	136.50	69.70	206.20
	18 OD	18.000	0.937	16.126	170.80	88.50	259.30
	20 OD	20.000	1.031	17.938	208.90	109.40	318.30
	24 OD	24.000	1.218	21.564	296.40	158.30	454.70

TABLE 13

Pipe Covering Weights (Thickness intended as guide, only)

Nominal Pipe Size (in.)	260°		360°		440°		525°		600°		700°		800°	
	Thick. (in.)	lb./ft.	Thick. (in.)	lb./ft.	Thick. (in.)	lb./ft.	Thick. (in.)	lb./ft.	Thick. (in.)	lb./ft.	Thick. (in.)	lb./ft.	Thick. (in.)	lb./ft.
1	1	0.68	1	0.68	1	0.68	1	0.68	1-1/2	1.19	1-1/2	1.19	1-1/2	1.19
1-1/4	1	0.75	1	0.75	1	0.75	1	0.75	1-1/2	1.27	1-1/2	1.27	2	1.82
1-1/2	1	0.88	1	0.88	1	0.88	1	0.88	1-1/2	1.45	1-1/2	1.45	2	1.87
2	1	1.01	1	1.01	1	1.01	1-1/2	1.53	1-1/2	1.53	2	2.50	2	2.50
2-1/2	1	1.15	1	1.15	1	1.15	1-1/2	1.69	1-1/2	1.69	2	2.50	2-1/2	3.22
3	1	1.28	1	1.28	1	1.28	1-1/2	2.09	1-1/2	2.09	2	2.98	2-1/2	3.98
3-1/2	1	1.44	1	1.44	1-1/2	2.29	1-1/2	2.29	2	3.00	2	3.12	2-1/2	4.30
4	1	1.60	1	1.60	1-1/2	2.49	1-1/2	2.49	2	3.49	2	3.49	2-1/2	4.62
5	1	1.84	1	1.84	1-1/2	2.84	1-1/2	2.84	2	3.97	2	3.97	2-1/2	5.92
6	1-1/2	3.13	1-1/2	3.13	1-1/2	3.13	1-1/2	3.13	2	4.54	2	4.54	2-1/2	6.75
8	1-1/2	4.06	1-1/2	4.06	1-1/2	4.06	1-1/2	4.06	2	5.56	2	5.56	2-1/2	7.61

Thickness and weight of calcium silicate covering.

Engineering Data & Specifications

Design Applications

TABLE 14

Column Loading For Rack Construction

Typical general storage rack for use with plywood or other decking.

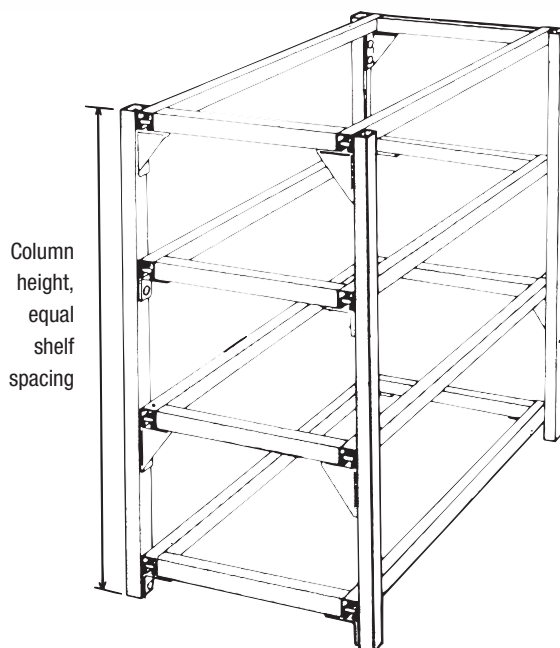

- GENERAL STORAGE RACKS
- PALLET RACKS
- BARREL RACKS
- BULK FURNITURE RACKS
- CABLE RACKS
- BAR STOCK RACKS
- DISPLAY RACKS
- SPECIAL PURPOSE RACKS

For Uniform Loads on Horizontal Members

See Table 3

Allowable load in lb. per upright										
Column Height	Cat. No.	Number of Shelves per upright								
		2	3	4	5	6	7	8	9	10
6'	A1200	2237	1925	1650	1437	1290				
	A1202	4170	3580	3100	2730	2450				
	B1400	800	820	790	700	630				
	B1402	1930	1700	1500	1300	1190				
7'	A1200	2150	1850	1630	1425	1280	1150			
	A1202	4000	3525	3000	2700	2430	2200			
	B1400	650	790	760	685	615	550			
	B1402	1800	1650	1450	1300	1180	750			
8'	A1200	2000	1820	1600	1400	1250	1150	1050		
	A1202	3900	3475	3000	2700	2400	2185	2000		
	B1400	580	750	730	660	610	540	510		
	B1402	1650	1610	1450	1300	1160	940	970		
9'	A1200	1950	1780	1575	1400	1250	1130	1030	950	
	A1202	3800	3400	3020	2675	2400	2180	1975	1800	
	B1400		600	665	600	580	540	500	475	
	B1402	1500	1500	1430	1275	1160	1000	900	800	
10'	A1200	1870	1700	1500	1300	1200	1100	1000	900	800
	A1202	3600	3300	3000	2650	2350	2000	1975	1800	1650
	B1400		550	650	625	580	535	490	450	425
	B1402	1450	1480	1400	1250	1140	1040	960	885	825

Engineering Data & Specifications

Design Applications – Mechanical Support

Example 1

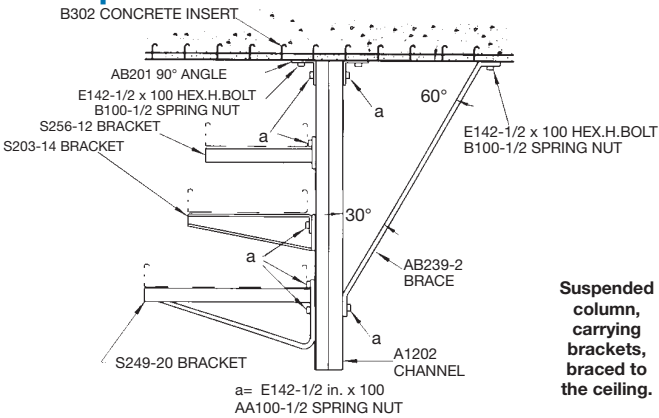

Suspended column, carrying brackets, braced to the ceiling.

Example 2

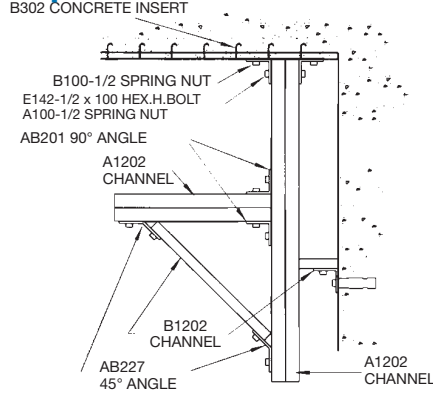

Suspended column, holding bracket and console braced to wall.

Example 3

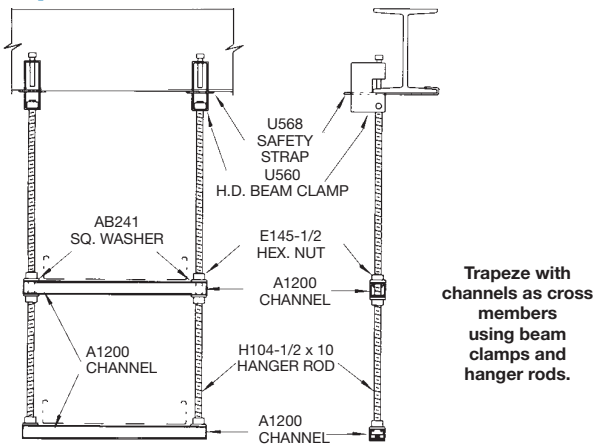

Trapeze with channels as cross members using beam clamps and hanger rods.

Example 4

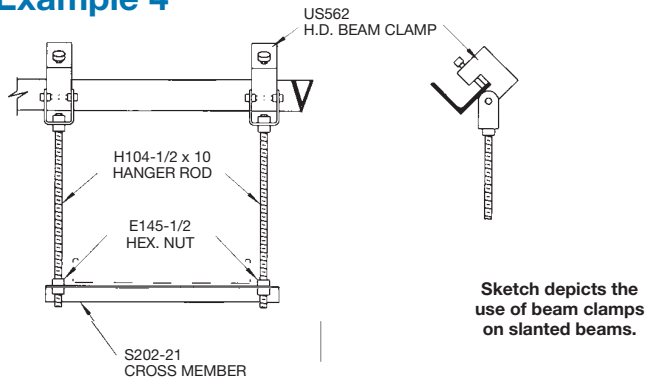

Sketch depicts the use of beam clamps on slanted beams.

Example 5

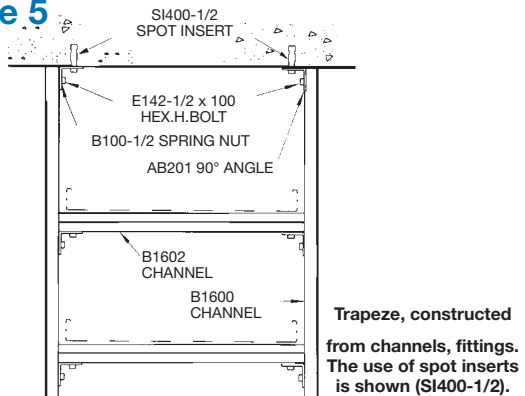

Example 6

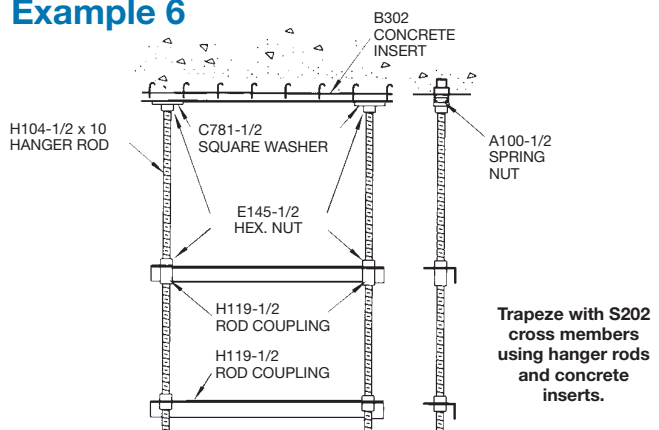

Engineering Data & Specifications

Design Applications – Mechanical Support

Example 7

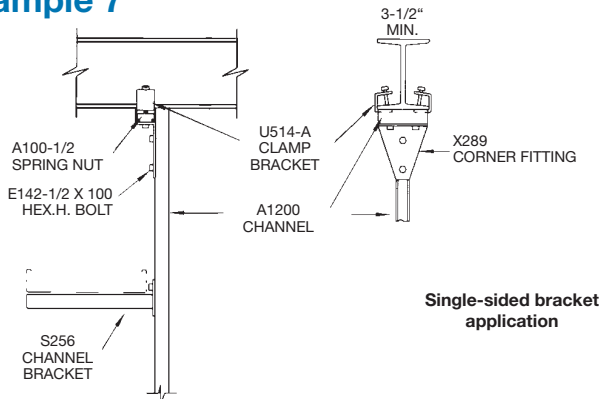

* NOTE: BRACE SHOULD BE USED FOR LENGTHS GREATER THEN 30 IN.

Example 8

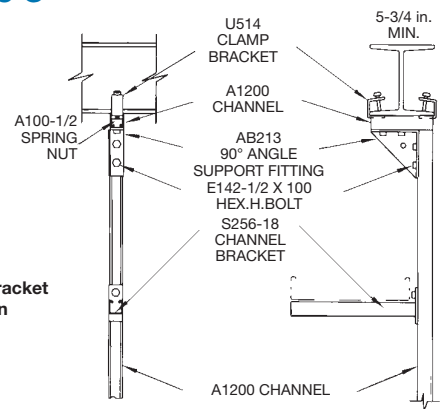

Example 9

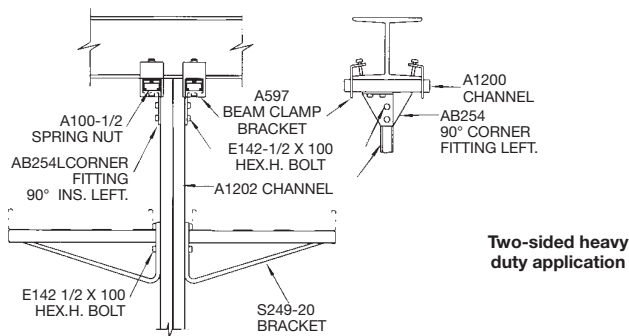

Example 10

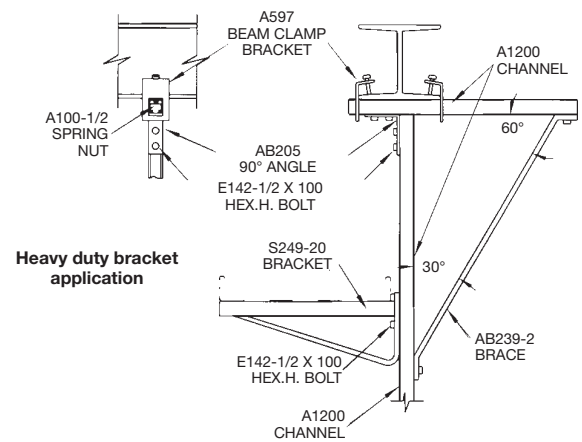

Example 11

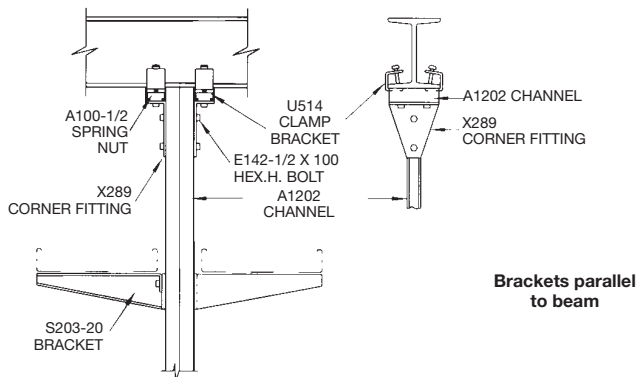

Example 12

